

GENERAC[®]
POWER SYSTEMS, INC.

6.8 LITER

***FORD
GAS
ENGINE***

***SERVICE
MANUAL***

FOREWORD

This manual has been published by GENERAC[®] POWER SYSTEMS, INC. to aid our dealers' mechanics, company service personnel and general consumers when servicing the products described herein.

It is assumed that these personnel are familiar with the servicing procedures for these products, or like or similar products, manufactured and marketed by GENERAC[®] POWER SYSTEMS, INC. It is also assumed that they have been trained in the recommended servicing procedures for these products, which includes the use of mechanics hand tools and any special tools that might be required.

Proper service and repair is important to the safe, economical and reliable operation of the products described herein. The troubleshooting, testing, service and repair procedures recommended by GENERAC[®] POWER SYSTEMS, INC. and described in this manual are effective methods of performing such operations. Some of these operations or procedures may require the use of specialized equipment. Such equipment should be used when and as recommended.

We could not possibly know of and advise the service trade of all conceivable procedures or methods by which a service might be performed, nor of any possible hazards and/or results of each procedure or method. We have not undertaken any such wide evaluation. Therefore, anyone who uses a procedure or method not recommended by the manufacturer must first satisfy himself that neither his safety, nor the product's safety, will be endangered by the service or operating procedure selected.

All information, illustrations and specifications contained in this manual are based on the latest product information available at the time of publication. However, GENERAC[®] POWER SYSTEMS, INC. reserves the right to change, alter or otherwise improve the product at any time without prior notice.

Some components or assemblies of the product described in this manual may not be considered repairable. Disassembly, repair and reassembly of such components may not be included in this manual.

The engines described herein may be used to power a wide variety of products. Service and repair instructions relating to any such products are not covered in this manual. For information pertaining to use of these engines with other products, refer to any owner's or service manuals pertaining to said products.

SERVICE RECOMMENDATIONS A_2
6.8 LITER FORD CONTENTS.....

The 6.8 Liter Gas Engine has been engineered for use in Generac Power Systems products. The contents of this manual have been reprinted from the original manufacturer's service and repair manual. The exploded view section at the front of this manual is for reference only.

6.8 Liter Gas Engine Service Recommendations

◆ ENGINE OIL RECOMMENDATIONS

The unit has been filled with “break in” engine oil at the factory. Use a high-quality detergent oil classified “For Service CC, SD, SE or SF.” Detergent oils keep the engine cleaner and reduce carbon deposits. Use oil having the following SAE viscosity rating, based on the ambient temperature range anticipated before the next oil change:

Engine Lubrication System:

Type of Oil PumpGear
Oil FilterFull Flow, Cartridge
Crankcase Oil Capacity6.8 L (7.0 U.S. qts.)

Temperature	Oil Grade (Recommended)
Above 86° F (30° C)	SAE 40 or 15W-40
32° to 86° F (0° to 30° C)	SAE 30 or 15W-40
Below 32° F (0° C)	SAE 20W or 15W-40
All Seasons	SAE 15W-40

◆ COOLANT

Use a mixture of half low silicate, ethylene glycol base antifreeze and half soft water. Use only soft water and only low silicate antifreeze. If desired, you may add a high quality rust inhibitor to the recommended coolant mixture. When adding coolant, always add the recommended 50-50 mixture.

Cooling System:

Type.....Pressurized, Closed Recovery
Coolant Capacity
System.....23.7 L (6.3 U.S. gals.)
Engine12.3 L (3.3 U.S. gals.)



Do not remove the radiator pressure cap while the engine is hot or serious burns from boiling liquid or steam could result.



Ethylene glycol base antifreeze is poisonous. Do not use your mouth to siphon coolant from the radiator, recovery bottle or any container. Wash your hands thoroughly after handling. Never store used antifreeze in an open container because animals are attracted to the smell and taste of antifreeze even though it is poisonous to them.



Do not use any chromate base rust inhibitor with ethylene glycol base antifreeze, or chromium hydroxide (“green slime”) will form and cause overheating. Engines that have been operated with a chromate base rust inhibitor must be chemically cleaned before adding ethylene glycol base antifreeze. Using any high silicate antifreeze boosters or additives also will cause overheating. We also recommend that you DO NOT use any soluble oil inhibitor for this equipment.

PERIODIC MAINTENANCE SCHEDULE:

SERVICE SCHEDULE

◆ AUTHORIZED OPERATOR MAINTENANCE FUNCTIONS

Every Month or 100 Hours

(whichever comes first)

- Test standby generator system.
- Inspect battery and cables.
- Check engine oil level.
- Check gearbox oil level (if so equipped).
- Check engine coolant level.
- Check generator ground connections.
- Test/inspect starting aids.

Every Three Months or Every 120 Hours

(whichever comes first)

- Inspect and test fuel system and connections.
- Inspect exhaust system.
- Inspect/test fuel supply system.

◆ AUTHORIZED SERVICE TECHNICIAN MAINTENANCE FUNCTIONS

After First 30 Hours of Operation

- Inspect wiring.
- Change engine crankcase oil and oil filter.
- Inspect engine fan belts.
- Inspect battery and cables.

Every Six Months or Every 100 Hours

(whichever comes first)

- Change engine oil and filter.
- Lubricate engine controls.
- Service engine air cleaner.
- Service engine fuel filter.
- Inspect AC generator.
- Test engine safety controls.
- Inspect fan belts.
- Check engine coolant level.
- Inspect engine cooling system hoses.
- Check optional starting aids.
- Check battery.
- Check engine compression.
- Check electrical connections.
- Check/test annunciator panel.
- Perform operational test.

Annually or Every 600 Hours

(whichever comes first)

- Check engine valve clearance.
- Test fuel injection nozzles.
- Test injection timing.
- Inspect all wiring.
- Test engine starter operation.
- Drain water from fuel tank.
- Retorque fan bolts.
- Drain and refill gearbox (if so equipped)

Every Two Years

- Replace all rubber hoses.
- Replace engine fan belts.
- Inspect the Standby Generator System.
- Drain, flush, refill cooling system.

Every 1,000 Operating Hours

- Inspect engine DC alternator.
- Inspect engine starter.
- Retorque engine mounting brackets.
- Remove/test fuel injection pump.
- Remove/test cooling system thermostat.

As Required

- Bleed engine fuel system.



The Source for Power...
Worldwide™

WSG-1068 6.8 LITER

INDUSTRIAL ENGINE SERVICE MANUAL

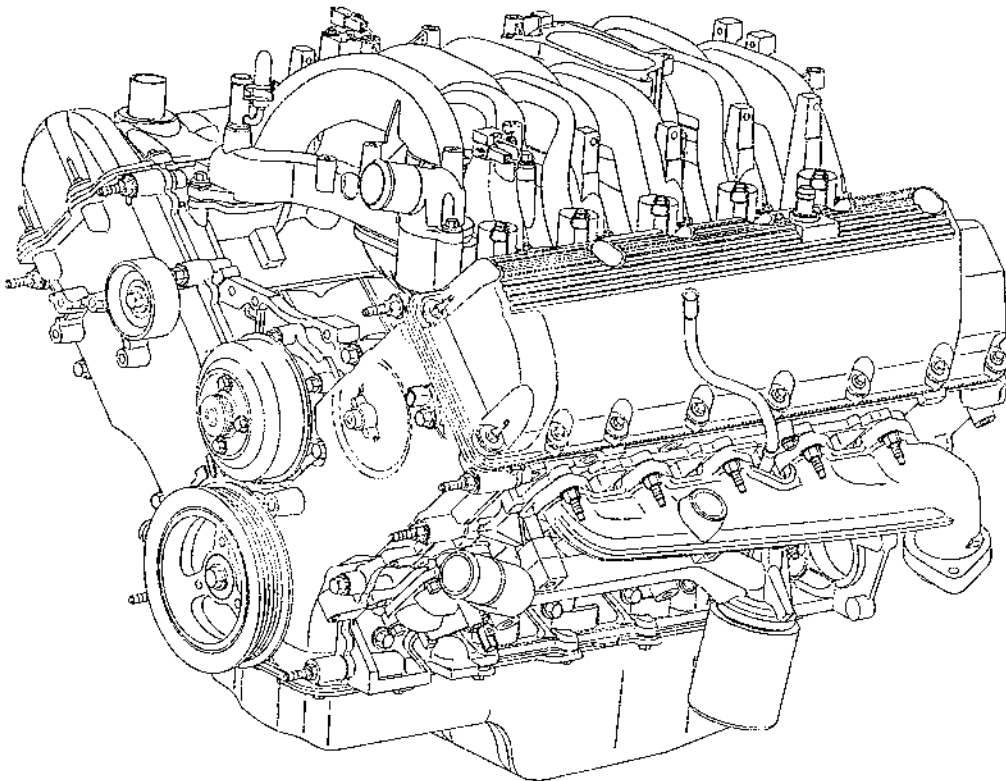

HEALTH & SAFETY



WARNING: THE FOLLOWING HEALTH AND SAFETY RECOMMENDATIONS SHOULD BE CAREFULLY OBSERVED

WARNING: CARRYING OUT CERTAIN OPERATIONS AND HANDLING SOME SUBSTANCES CAN BE DANGEROUS OR HARMFUL TO THE OPERATOR IF THE CORRECT SAFETY PRECAUTIONS ARE NOT OBSERVED. SOME SUCH PRECAUTIONS ARE RECOMMENDED AT THE APPROPRIATE POINTS IN THIS BOOK.

WARNING: WHILE IT IS IMPORTANT THAT THESE RECOMMENDED SAFETY PRECAUTIONS ARE OBSERVED, CARE NEAR MACHINERY IS ALWAYS NECESSARY, AND NO LIST CAN BE EXHAUSTIVE. ALWAYS BE CAUTIOUS TO AVOID POTENTIAL SAFETY RISKS.

The following recommendations are for general guidance:

1. Always wear correctly fitting protective clothing which should be laundered regularly. Loose or baggy clothing can be extremely dangerous when working on running engines or machinery. Clothing which becomes impregnated with oil or other substances can constitute a health hazard due to prolonged contact with the skin even through underclothing.
2. So far as practicable, work on or close to engines or machinery only when they are stopped. If this is not practicable, remember to keep tools, test equipment and all parts of the body well away from the moving parts of the engine or equipment—fans, drive belts and pulleys are particularly dangerous. The electric cooling fan used on some installations is actuated automatically when the coolant reaches a specified temperature. For this reason, care should be taken to ensure that the ignition/isolating switch is OFF when working in the vicinity of the fan as an increase in coolant temperature may cause the fan suddenly to operate.
3. Avoid contact with exhaust pipes, exhaust manifolds and silencers when an engine is, or has recently been running; these can be very hot and can cause severe burns.
4. Many liquids used in engines or vehicles are harmful if taken internally or splashed into the eyes. In the event of accidentally swallowing gasoline (petrol), oil, diesel fuel, antifreeze, battery acid etc, do NOT encourage vomiting and OBTAIN QUALIFIED MEDICAL ASSISTANCE IMMEDIATELY.

Wear protective goggles when handling liquids which are harmful to the eyes; these include ammonia and battery acid. If any of these substances are splashed in the eyes, wash out thoroughly with clean water and OBTAIN QUALIFIED MEDICAL ASSISTANCE IMMEDIATELY.



WARNING:



WARNING: ENGINE EXHAUST, SOME OF ITS CONSTITUENTS, AND CERTAIN VEHICLE COMPONENTS CONTAIN OR EMIT CHEMICALS KNOWN TO THE STATE OF CALIFORNIA TO CAUSE CANCER AND BIRTH DEFECTS OR OTHER REPRODUCTIVE HARM. IN ADDITION, CERTAIN FLUIDS CONTAINED IN VEHICLES AND CERTAIN PRODUCTS OF COMPONENT WEAR CONTAIN OR EMIT CHEMICALS KNOWN TO THE STATE OF CALIFORNIA TO CAUSE CANCER AND BIRTH DEFECTS OR OTHER REPRODUCTIVE HARM.

IMPORTANT SAFETY NOTICE

Appropriate service methods and proper repair procedures are essential for the safe, reliable operation of all industrial engines as well as the personal safety of the individual doing the work. This Service Manual provides general directions for accomplishing service and repair work with tested, effective techniques. Following them will help assure reliability.

Section Index

Reproduction in any manner, in whole or in part, is prohibited without the express permission in writing from:

*Ford Power Products,
Publications Department*

Ford Power Products policy is one of continuous improvement and while every effort is made to ensure that this publication is up to date and correct in all respects, the right to change prices, specifications and equipment at any time without notice is reserved. Accordingly this publication is not to be regarded as a final description of any individual engine.

Section 01 **GENERAL INFO**

Section 02 **ENGINE**

Section 03 **IGNITION**

Section 04 **FUEL**

Section 05 **COOLING**

Section 06 **CHARGING**

Section 07 **STARTER**

Section 08 **ENG. CONTROLS**

Section 09 **METRICS**

Section 10 **DEALERS**

INDEX

Subject	Page
General Information	
Introduction	01 - 3
Safety Notice	01 - 4
Notes, Cautions, and Warnings.....	01 - 4
Battery Handling and Charging	01 - 5
Forward	01 - 6
Engine Identification	01 - 7
Parts and Service	01 - 8
Diagnosis and Testing	
Special Tools	01 - 9
Inspection and Verification	01 - 10
Symptom Chart	01 - 11
Engine Oil Leaks	01 - 13
Compression Tests	01 - 14
Cylinder Leakage Detection	01 - 15
Intake Manifold Vacuum Test.....	01 - 15
Excessive Engine Oil Consumption	01 - 17
Oil Pressure Test.....	01 - 18
Valve Train Analysis – Static.....	01 - 19
Valve Train Analysis – Dynamic.....	01 - 19
Camshaft Lobe Lift	01 - 20
Hydraulic Lash Adjuster	01 - 21
General Service Procedures	
Camshaft Journal Diameter.....	01 - 22
Camshaft Journal Clearance.....	01 - 22
Camshaft Lobe Surface.....	01 - 22
Camshaft Lobe Lift	01 - 23
Camshaft Runout	01 - 23
Crankshaft Main Bearing Journal Diameter	01 - 24
Crankshaft Main Bearing Journal Taper.....	01 - 24
Crankshaft Main Bearing Journal Clearance.....	01 - 25
Bearing Inspection	01 - 25
Crankshaft End Play.....	01 - 26
Crankshaft Runout	01 - 26
Cylinder Bore Taper	01 - 26
Cylinder Bore Out-of-Round.....	01 - 27
Piston Inspection	01 - 27
Piston Diameter	01 - 27
Piston to Cylinder Bore Clearance	01 - 27
Piston Selection	01 - 28
Piston Ring End Gap.....	01 - 28
Piston Ring-to-Groove Clearance	01 - 29
Crankshaft Connecting Rod Journal Diameter.....	01 - 29
Crankshaft Connecting Rod Journal Taper.....	01 - 29
Connecting Rod Cleaning	01 - 29
Connecting Rod Larger End Bore	01 - 30
Piston Pin Diameter.....	01 - 30
Connecting Rod Bushing Diameter	01 - 30
Connecting Rod Bend	01 - 30
Connecting Rod Twist	01 - 30
Connecting Rod Piston Pin Side Clearance.....	01 - 31
Connecting Rod Journal Clearance	01 - 31

INDEX (CONT.)

Subject	Page
General Service Procedures	
Bearing Inspection	01 - 32
Roller Follower Inspection	01 - 32
Hydraulic Lash Adjuster Inspection	01 - 32
Valve Stem Diameter	01 - 33
Valve Stem-to-Valve Guide Clearance.....	01 - 33
Valve Inspection	01 - 33
Valve Guide Inner Diameter	01 - 34
Valve Guide Reaming	01 - 34
Valve Spring Installed Length.....	01 - 34
Valve Spring Free Length.....	01 - 34
Valve Spring Out-of-Square	01 - 34
Valve Spring Compression Pressure	01 - 35
Valve and Seat Refacing Measurements	01 - 35
Valve Seat Width.....	01 - 35
Valve Seat Runout	01 - 35
Flywheel Inspection.....	01 - 36
Oil Pump Gear Radial Clearance	01 - 36
Oil Pump Rotor Inspection	01 - 36
Oil Pump Side Clearance	01 - 36
Cylinder Bore Honing	01 - 37
Cylinder Bore Cleaning	01 - 37
Cylinder Block Repair - Cast Iron Porosity Defects.....	01 - 38
Cylinder Block Core Plug Replacement	01 - 38
Cylinder Head - Distortion	01 - 38
Spark Plug Thread Repair.....	01 - 40
Exhaust Manifold Straightness.....	01 - 41
SPECIFICATIONS	01 - 41

GENERAL INFORMATION

Introduction

This section covers various engine tests, adjustments, service procedures and cleaning/inspection procedures. Engine assembly and service specifications appear at the end of the Section 02.

For engine disassembly, assembly, installation, adjustment procedures and specifications, refer to Section 02.

This WSG-1068 engine incorporates a closed-type crankcase ventilation system.

To maintain the required performance level, the fuel system, ignition system and engine must be kept in good operating condition and meet recommended adjustment specifications.

Before replacing damaged or worn engine components such as the crankshaft, cylinder head, valve guide, valves, camshaft or cylinder block, make sure part(s) is not serviceable.



WARNING: TO AVOID THE POSSIBILITY OF PERSONAL INJURY OR DAMAGE, DO NOT OPERATE THE ENGINE UNTIL THE FAN BLADE HAS FIRST BEEN EXAMINED FOR POSSIBLE CRACKS OR SEPARATION.

CAUTION: Use of abrasive grinding discs to remove gasket material from the engine sealing surfaces during repair procedures can contribute to engine damage and wear. Airborne debris and abrasive grit from the grinding disc may enter the engine through exposed cavities causing premature wear and eventual engine damage.

Ford Power Products does not recommend using abrasive grinding discs to remove engine gasket material. Use manual gasket scrapers for removing gasket material from the engine sealing surfaces.

Take added care to prevent scratching or gouging aluminum sealing surfaces.

Safety Notice

There are numerous variations in procedures, techniques, tools and parts for servicing equipment, as well as in the skill of the individual doing the work. This manual cannot possibly anticipate all such variations and provide advice or cautions as to each. Accordingly, anyone who departs from the instructions provided in this Manual must first establish that neither personal safety nor equipment integrity are compromised by the choice of methods, tools or parts.

Notes, Cautions, and Warnings

As you read through the procedures, you will come across NOTES, CAUTIONS, and WARNINGS. Each one is there for a specific purpose. NOTES gives you added information that will help you to complete a particular procedure. CAUTIONS are given to prevent you from making an error that could damage the equipment. WARNINGS remind you to be especially careful in those areas where carelessness can cause personal injury. The following list contains some general WARNINGS that you should follow when you work on the equipment.



GENERAL WARNINGS:

TO HELP AVOID INJURY:

- **ALWAYS WEAR SAFETY GLASSES FOR EYE PROTECTION.**
- **USE SAFETY STANDS WHENEVER A PROCEDURE REQUIRES YOU TO BE UNDER THE EQUIPMENT.**
- **BE SURE THAT THE IGNITION SWITCH IS ALWAYS IN THE OFF POSITION, UNLESS OTHERWISE REQUIRED BY THE PROCEDURE.**
- **SET THE PARKING BRAKE (IF EQUIPPED) WHEN WORKING ON THE EQUIPMENT. IF YOU HAVE AN AUTOMATIC TRANSMISSION, SET IT IN PARK (ENGINE OFF) OR NEUTRAL (ENGINE ON) UNLESS INSTRUCTED OTHERWISE FOR A SPECIFIC OPERATION. PLACE WOOD BLOCKS (4" X 4" OR LARGER) TO THE FRONT AND REAR SURFACES OF THE TIRES TO PROVIDE FURTHER RESTRAINT FROM INADVERTENT EQUIPMENT MOVEMENT.**
- **OPERATE THE ENGINE ONLY IN A WELL VENTILATED AREA TO AVOID THE DANGER OF CARBON MONOXIDE.**
- **KEEP YOURSELF AND YOUR CLOTHING AWAY FROM MOVING PARTS WHEN THE ENGINE IS RUNNING, ESPECIALLY THE FAN BELTS.**
- **TO PREVENT SERIOUS BURNS, AVOID CONTACT WITH HOT METAL PARTS SUCH AS THE RADIATOR, EXHAUST MANIFOLD, TAIL PIPE, CATALYTIC CONVERTER AND MUFFLER.**
- **DO NOT SMOKE WHILE WORKING ON THE EQUIPMENT.**
- **ALWAYS REMOVE RINGS, WATCHES, LOOSE HANGING JEWELRY, AND LOOSE CLOTHING BEFORE BEGINNING TO WORK ON THE EQUIPMENT. TIE LONG HAIR SECURELY BEHIND THE HEAD.**
- **KEEP HANDS AND OTHER OBJECTS CLEAR OF THE RADIATOR FAN BLADES. ELECTRIC COOLING FANS CAN START TO OPERATE AT ANY TIME BY AN INCREASE IN UNDERHOOD TEMPERATURES, EVEN THOUGH THE IGNITION IS IN THE OFF POSITION. THEREFORE, CARE SHOULD BE TAKEN TO ENSURE THAT THE ELECTRIC COOLING FAN IS COMPLETELY DISCONNECTED WHEN WORKING UNDER THE HOOD.**

Battery Handling and Charging

The handling and correct use of lead acid batteries is not as hazardous provided that sensible precautions are observed and that operatives have been trained in their use and are adequately supervised.

It is important that all labelling on the battery is carefully read, understood and complied with. The format of the following symbols and labels is common to most brands of lead acid battery.



Typical Battery Labelling

	Explosive gases		Read relevant instructions
	Eye protection must be WORN.		Keep away from children
	No smoking or naked flames.		Do not dispose of as household waste.
	Corrosive acid		Recycle (via recognized disposal system).
	Flush eyes immediately when contacted with acid		Electrical current may cause injury to personnel
	Caution/important notice.		

NOTE: Observe all manufacturers' instructions when using charging equipment.

CAUTION: Batteries should not be charged in the vehicle or equipment. May damage electrical components.

Forward

This book contains operating and maintenance instructions for the engine(s) listed on the title page.

The life of your engine unit and the delivery of the high performance built into it will depend on the care it receives throughout its life. It is the operator's responsibility to ensure that the engine is correctly operated and that the maintenance operations outlined in this book are carried out regularly after the specified hours of operation have been reached. We consider it to be in your interests to enlist the aid of an authorized Ford Power Products Distributor not only when repairs are required but also for regular maintenance. Distributors are listed at the back of this manual.

Regular maintenance will result in minimal operating costs.

Engines manufactured by Ford Motor Company are available through Ford Power Products Distributors. When in need of parts or service, contact your local Authorized Distributor. In overseas territories, in the event of difficulties, communicate directly with the supervising Ford affiliated Company in your area whose address appears at the end of this book.

Where the terms "Right" or "Left" occur in this publication, they refer to the respective sides of the engine when viewed from the rear or flywheel end.

Pistons and valves are numbered from the front or timing cover end of the engine commencing at No. 1.



You may find that your engine assembly includes optional equipment not specifically covered in the following text. Nevertheless, the maintenance procedures outlined in this book still apply to your engine.

Engine Identification

Because Ford Power Products markets such a wide range of industrial engines – manufactured both in the U.S. and overseas – it is important that you have as complete identification of the engine as possible in order to provide the correct replacement parts. New engines being shipped include a standard parts listing describing the parts which does not tell the owner the part number. It remains a distributor function to identify the part number. The key to identifying the engine is the identification decal mounted on the engine rocker cover. That decal provides not only the engine serial number, but also the exact model or type, options and S.O. (Special Order). The combination of that data permits you to isolate the precise engine, build level and customer so you can determine the correct replacement parts.

U.S.A. Engine Identification Decal

An identification Decal is affixed to the valve cover of the engine. The decal contains the engine serial number which identifies this unit from all others. Use all numbers when seeking information or ordering replacement parts for this engine.

 <table border="1" style="width: 100%; border-collapse: collapse;"> <tr> <td colspan="2">Serial Number: 01234-05-00</td> </tr> <tr> <td colspan="2">Model Number: WSG-1068I-6007-AA</td> </tr> <tr> <td>Base Engine Code: 6C-680-AA</td> <td>Build Date: 01-18-2000</td> </tr> <tr> <td colspan="2">Distributor S.O. Number: FORD POWER PRODUCTS</td> </tr> </table> <p align="center"><small>FPP01102</small></p> <p align="center">Prior 2001</p>	Serial Number: 01234-05-00		Model Number: WSG-1068I-6007-AA		Base Engine Code: 6C-680-AA	Build Date: 01-18-2000	Distributor S.O. Number: FORD POWER PRODUCTS		 <table border="1" style="width: 100%; border-collapse: collapse;"> <tr> <td colspan="2">Serial Number: 37827-1-04-98</td> </tr> <tr> <td colspan="2">Model Number: XXX-XXX</td> </tr> <tr> <td>Base Engine Code: 6C-276-AA</td> <td>Base Engine Build Date: 01/02/2001</td> </tr> <tr> <td>Distributor S.O. Number:</td> <td>Reference:</td> </tr> </table> <p align="center">2001</p>	Serial Number: 37827-1-04-98		Model Number: XXX-XXX		Base Engine Code: 6C-276-AA	Base Engine Build Date: 01/02/2001	Distributor S.O. Number:	Reference:
Serial Number: 01234-05-00																	
Model Number: WSG-1068I-6007-AA																	
Base Engine Code: 6C-680-AA	Build Date: 01-18-2000																
Distributor S.O. Number: FORD POWER PRODUCTS																	
Serial Number: 37827-1-04-98																	
Model Number: XXX-XXX																	
Base Engine Code: 6C-276-AA	Base Engine Build Date: 01/02/2001																
Distributor S.O. Number:	Reference:																

For a handy reference, this information is recorded on your Ford Power Products Operations Engine Registration copy (Form #194-103-D).

Engine Code Decal

An engine code decal is attached to the engine front cover. The symbol code on the decal identifies each engine for determining parts usage.

<p align="center">ENGINE CODE</p> <p align="center" style="font-size: 2em;">JA</p>	<p align="center">ENGINE PLANT CODE</p> <p align="center">SG612AB</p> <p align="center">E</p> <p align="center">MADE IN ESSEX, CANADA</p> <p align="center">11/07/99</p> <p align="center">ENGINE BUILD DATE</p>
<p align="center">E = ESSEX</p>	

FPP03502

European Service Identification plate

This plate is fixed to the engine in a prominent position. Panels 1 to 11 on the plate shown to the right, refer to various engine details as listed below:

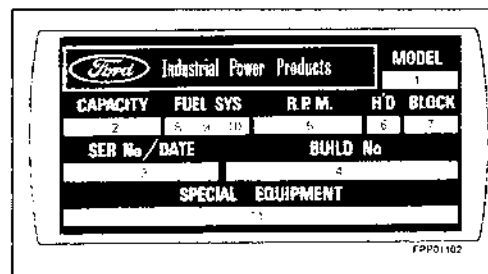

1. Engine model identification.
2. Engine capacity.
3. **Serial No:** This identifies the engine as supplied by Power Products Engineering.

Date: The two letters following the serial No. indicate the year and month in which the specified build components were assembled - refer to the chart below:

NOTE: These markings should not be confused with any that may be stamped or etched into the crankcase of the basic engine.

YEAR		JAN	FEB	MAR	APRIL	MAY	JUNE	JULY	AUG	SEP	OCT	NOV	DEC
1997	U	B	R	A	G	C	K	D	E	L	Y	S	T
1998	V	J	U	M	P	B	R	A	G	C	K	D	E
1999	W	L	Y	S	T	J	U	M	P	B	R	A	G
2000	X	C	K	D	E	L	Y	S	T	J	U	M	P
2001	Y	B	R	A	G	C	K	D	E	L	Y	S	T
2002	Z	J	U	M	P	B	R	A	G	C	K	D	E
2003	A	L	Y	S	T	J	U	M	P	B	R	A	G
2004	B	C	K	D	E	L	Y	S	T	J	U	M	P
2005	C	B	R	A	G	C	K	D	E	L	Y	S	T
2006	D	J	U	M	P	B	R	A	G	C	K	D	E

NOTE: The letters I, O and Q are not used in the year column. The letter representing the month repeats every five years.

4. Selective Build Number indicates the complete specification. The digit to the extreme right hand side is the build chart issue number.
5. Engine operating rpm. An asterisk denotes speed set by customer.
6. Not applicable.
7. Not applicable.
8. Applicable to diesel engines only.
9. Applicable to diesel engines only.
10. Applicable to diesel engines only.
11. This box is provided for Equipment Manufacturers' use when extra equipment is fitted outside of the Ford Motor Company. Reference should be made to the Equipment Manufacturer for any information or parts required.







Parts and Service

Replacement parts can be obtained through your local Ford Power Products Distributors listed in the back portion of this manual. They also may be found in the yellow pages under "Engines" or contact Ford Power Products.

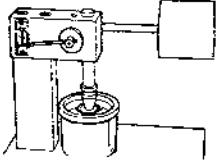
Ford Power Products Distributors are equipped to perform major and minor repairs. They are anxious to see that all of your maintenance and service needs are quickly and courteously completed.

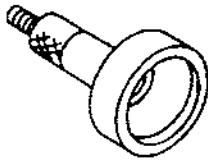
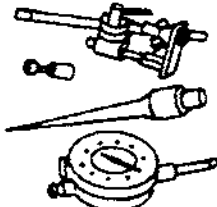
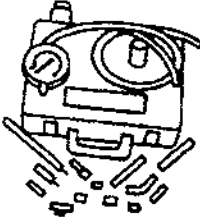
DIAGNOSIS AND TESTING

Special Tools

 <p>FPP10023</p>	<p>Commercially Available Leakdown Tester</p>	 <p>FPP10024</p>	<p>Compression Tester 014-00707 or Equivalent</p>
 <p>FPP10025</p>	<p>Cup Shaped Adapter TOOL-6565-AB or Equivalent</p>	 <p>FPP10036</p>	<p>Dial Indicator with Bracketry TOOL-4201-C or Equivalent</p>
 <p>FPP10027</p>	<p>Engine Cylinder Leak Detection/Air Pressurization Kit 014-00705 or Equivalent</p>	 <p>FPP10028</p>	<p>Engine Oil Pressure Gauge T73L-6600-A</p>
 <p>FPP10029</p>	<p>12 Volt Master UV Diagnostic Inspection Kit 164-R0756 or Equivalent</p>	 <p>FPP10030</p>	<p>Vacuum/Pressure Tester 164- R0253 or Equivalent</p>

Special Service Tools called for by the procedures can be obtained by calling:
1-800-ROTUNDA (1-800-768-8632).

Inspection and Verification

1. Verify the customer concern by operating the engine to duplicate the condition.
2. Visually inspect for obvious signs of mechanical and electrical damage:
 - Engine coolant leaks.
 - Engine oil leaks.
 - Fuel leaks.
 - Damaged or severely worn pads.
 - Loose mounting bolts, studs, and nuts.
3. If the inspection reveals obvious concerns that can be readily identified, repair as required.
4. If the concerns remain after the inspection, determine the symptoms and go to the symptom chart.

Symptom Chart

Condition	Possible Source	Action
Difficult Starting	Damaged starting system.	Refer to Section 07.
	Damaged charging system/battery.	Refer to Section 06.
	Burnt valve.	Replace valve.
	Worn piston.	Replace piston and pin.
	Worn piston rings or worn cylinder.	Repair or replace cylinder blocks.
	Damaged cylinder head gasket.	Replace cylinder head gasket.
	Damaged fuel system.	Refer to Section 04.
	Damaged ignition system.	Refer to Section 03.
	Damaged hydraulic lash adjuster or hydraulic lash adjuster.	Replace tappet or lash adjuster.
Poor Idling	Damaged hydraulic lash adjuster or hydraulic lash adjuster.	Replace hydraulic lash adjuster or hydraulic lash adjuster.
	Damaged hydraulic lash adjuster guide or hydraulic lash adjuster.	Replace hydraulic lash adjuster guide or hydraulic lash adjuster.
	Improper valve-to-valve seat contact.	Replace valve or valve seat.
	Damaged cylinder head gasket.	Replace cylinder head gasket.
	Malfunctioning or damaged fuel system.	Refer to Section 04 of this manual.
	Malfunctioning or damaged ignition system.	Refer to Section 03 of this manual.
Abnormal combustion	Damaged hydraulic lash adjuster or hydraulic lash adjuster.	Replace hydraulic lash adjuster or hydraulic lash adjuster
	Damaged hydraulic lash adjuster guide or hydraulic lash adjuster.	Replace hydraulic lash adjuster guide or hydraulic lash adjuster.
	Burnt or sticking valve.	Repair or replace valve.
	Weak or broken valve spring	Replace valve spring
	Carbon accumulation in combustion chamber.	Eliminate carbon buildup.
	Malfunctioning or damaged fuel system	Refer to Section 04 of this manual.
	Malfunctioning or damaged ignition system.	Refer to Section 03 of this manual.
Excessive Oil Consumption	Worn piston ring groove.	Replace piston and pin.
	Sticking piston rings.	Repair or replace piston rings.
	Worn piston or cylinders.	Repair or replace piston or cylinder blocks.
	Worn valve stem seal.	Replace valve stem seal.
	Worn valve stem or valve guide.	Replace valve stem and guide.
	Leaking oil.	Repair oil leakage.

WSG-1068 GENERAL INFORMATION

Condition	Possible Source	Action
Engine Noise	Excessive main bearing oil clearance.	Adjust clearance or replace main bearing.
	Seized or heat damaged main bearing.	Replace main bearing.
	Excessive crankshaft end play.	Replace crankshaft thrust main bearing.
	Excessive connecting rod bearing oil clearance.	Replace connecting rod.
	Heat damaged connecting rod bearing.	Replace connecting rod bearing.
	Damaged connecting rod bushing.	Replace connecting rod bushing.
	Worn cylinder.	Repair or replace cylinder blocks.
	Worn piston or piston pin.	Replace piston or piston pin.
	Damaged piston rings.	Replace piston rings.
	Bent connecting rod.	Replace connecting rod.
	Malfunctioning hydraulic lash adjuster or hydraulic lash adjuster.	Replace hydraulic lash adjuster or hydraulic lash adjuster.
	Excessive hydraulic lash adjuster or hydraulic lash adjuster clearance.	Adjust clearance or replace hydraulic lash adjuster guide or hydraulic lash adjuster.
	Broken valve spring.	Replace valve spring.
	Excessive valve guide clearance.	Repair clearance or replace valve guide/stem.
	Malfunctioning or damaged cooling system.	Refer to Section 05.
	Malfunctioning or damaged fuel system.	Refer to Section 04.
	Leaking exhaust system.	Repair exhaust leakage.
	Improper drive belt tension.	Refer to Section 05.
	Malfunctioning generator bearing.	Refer to Section 06 for diagnosis and testing of the generator.
	Loose timing chain/belt.	Adjust or replace timing chain/belt.
Damaged timing belt tensioner.	Replace timing belt tensioner.	
Malfunctioning water pump bearing.	Replace water pump.	
Insufficient Power	Malfunctioning hydraulic lash adjuster or hydraulic lash adjuster.	Replace hydraulic lash adjuster or hydraulic lash adjuster.
	Damaged hydraulic lash adjuster guide or hydraulic lash adjuster.	Replace hydraulic lash adjuster guide or hydraulic lash adjuster.
	Compression leakage at valve seat.	Repair or replace valve, valve seat or cylinder head.
	Seized valve stem.	Replace valve stem.
	Weak or broken valve spring.	Replace valve spring.
	Damaged cylinder head gasket.	Replace cylinder head gasket.
	Cracked or distorted cylinder head.	Replace cylinder head.
	Damaged, worn or sticking piston ring(s).	Repair or replace piston ring(s).
	Worn or damaged piston.	Replace piston.
	Malfunctioning or damaged fuel system.	Refer to Section 04.
	Malfunctioning or damaged ignition system.	Refer to Section 03.
	Damaged or plugged exhaust system.	Repair or replace exhaust system.

Engine Oil Leaks

NOTE: When diagnosing engine oil leaks, the source and location of the leak must be positively identified prior to service.

Prior to performing this procedure, clean the cylinder block, cylinder heads, valve covers, oil pan and flywheel with a suitable solvent to remove all traces of oil.

Fluorescent Oil Additive Method

Use the 12 Volt Master UV Diagnostic Inspection Kit to perform the following procedure for oil leak diagnosis.

1. Clean the engine with a suitable solvent to remove all traces of oil.
2. Drain engine oil crankcase and refill with recommended oil, premixed with Diesel Engine Oil Dye 164-R3705 meeting Ford specification ESE-M9C103-B1 or equivalent. Use a minimum 14.8 ml (0.5 ounce) to a maximum 29.6 ml (1 ounce) of fluorescent additive to all engines. If the oil is not premixed, fluorescent additive must first be added to crankcase.
3. Run the engine for 15 minutes. Stop the engine and inspect all seal and gasket areas for leaks using the 12 Volt Master UV diagnostic Inspection Kit. A clear bright yellow or orange area will identify the leak. For extremely small leaks, several hours may be required for the leak to appear.
4. If necessary, pressurize the main oil gallery system to locate leaks due to improperly sealed, loose or cocked plugs.
5. Repair all leaks as required.

Pressure Method

The crankcase can be pressurized to locate oil leaks. The following materials are required to fabricate the tool to be used:

- air supply and air hose
- air pressure gauge that registers pressure in 4 kPa (1 psi) increments
- air line shutoff valve
- appropriate fittings to attach the above parts to oil fill, PCV grommet hole and crankcase ventilation tube
- appropriate plugs to seal any openings leading to the crankcase
- a solution of liquid detergent and water to be applied with a suitable applicator such as a squirt bottle or brush

Fabricate the air supply hose to include the air line shutoff valve and the appropriate adapter to permit the air to enter the engine through the crankcase ventilation tube. Fabricate the air pressure gauge to a suitable adapter for installation on the engine at the oil filler opening.

Testing Procedure

- Open the air supply valve until the pressure gauge maintains 34 kPa (5 psi).
- Inspect sealed or gasketed areas for leaks by applying a solution of liquid detergent and water over areas for formation of bubbles which indicates leakage.

Leakage Points - Above Engine

Examine the following areas for oil leakage.

- valve cover gaskets
- intake manifold gaskets
- cylinder head gaskets
- oil bypass filter
- oil level indicator tube connection
- oil pressure sensor

Leakage Points - Under Engine

- oil pan gaskets
- oil pan sealer
- oil pan rear seal
- engine front cover gasket
- crankshaft front seal
- crankshaft rear oil seal
- crankshaft main bearing cap side bolts

Leakage Points - with Flywheel Removed

NOTE: Air leakage in the area around a crankshaft rear oil seal does not necessarily indicate a crankshaft rear oil seal leak. However, if no other cause can be found for oil leakage, assume that the crankshaft rear oil seal is the cause of the oil leak.

NOTE: Light foaming equally around valve cover bolts and crankshaft seals is not detrimental; no repairs are required.

- crankshaft rear oil seal
- rear main bearing cap parting line
- rear main bearing cap and seals
- flywheel mounting bolt holes (with flywheel installed)
- camshaft rear bearing covers or pipe plugs at the end of oil passages

Oil leaks at crimped seams in sheet metal parts and cracks in cast or stamped parts can be detected when pressurizing the crankcase.

Compression Tests

Compression Gauge Check

1. Make sure the oil in the crankcase is of the correct viscosity and at the proper level and that the battery is properly charged. Operate until the engine is at normal operating temperature. Turn the ignition switch to the OFF position, then remove all the spark plugs.
2. Set the throttle plates in the wide-open position.
3. Install a Compression Tester in the No. 1 cylinder.
4. Install an auxiliary starter switch in the starting circuit. With the ignition switch in the OFF position, and using the auxiliary starter switch, crank the engine a minimum of five compression strokes and record the highest reading. Note the approximate number of compression strokes required to obtain the highest reading.
5. Repeat the test on each cylinder, cranking the engine approximately the same number of compression strokes.

Test Results

The indicated compression pressures are considered within specification if the lowest reading cylinder is within 75 percent of the highest reading. Refer to the Compression Pressure Limit Chart.

If one or more cylinders reads low, squirt approximately one tablespoon of clean engine oil meeting Ford specification ESE-M2C153-E on top of the pistons in the low-reading cylinders. Repeat the compression pressure check on these cylinders.

Compression Pressure Limit Chart

MAX-MIN kPa (psi)	MAX-MIN kPa (psi)	MAX-MIN kPa (psi)	MAX-MIN kPa (psi)
924 - 696 (134 - 101)	1131 - 848 (164 - 123)	1338 - 1000 (194 - 146)	1154 - 1158 (224 - 168)
938 - 703 (136 - 102)	1145 - 855 (166 - 124)	1351 - 1014 (196 - 147)	1558 - 1165 (226 - 169)
952 - 717 (138 - 104)	1158 - 869 (168 - 126)	1365 - 1020 (198 - 148)	1572 - 1179 (228 - 171)
965 - 724 (140 - 106)	1172 - 876 (170 - 127)	1379 - 1034 (200 - 150)	1586 - 1186 (230 - 172)
979 - 738 (142 - 107)	1186 - 889 (172 - 129)	1303 - 1041 (202 - 151)	1600 - 1200 (232 - 174)
933 - 745 (144 - 109)	1200 - 903 (174 - 131)	1407 - 1055 (204 - 153)	1055 - 1207 (153 - 175)
1007 - 758 (146 - 110)	1214 - 910 (176 - 132)	1420 - 1062 (206 - 154)	1627 - 1220 (154 - 177)
1020 - 765 (148 - 111)	1227 - 917 (178 - 133)	1434 - 1075 (208 - 156)	1641 - 1227 (238 - 178)
1034 - 779 (150 - 113)	1241 - 931 (180 - 135)	1448 - 1083 (210 - 157)	1655 - 1241 (240 - 180)
1048 - 786 (152 - 114)	1225 - 936 (182 - 136)	1462 - 1089 (212 - 158)	1669 - 1248 (242 - 181)
1062 - 793 (154 - 115)	1269 - 952 (184 - 138)	1476 - 1103 (214 - 160)	1682 - 1262 (244 - 183)
1076 - 807 (156 - 117)	1282 - 965 (186 - 140)	1489 - 1117 (216 - 162)	1696 - 1269 (246 - 184)
1089 - 814 (158 - 118)	1296 - 972 (188 - 141)	1503 - 1124 (218 - 163)	1710 - 1202 (248 - 186)
1103 - 872 (160 - 120)	1310 - 979 (190 - 142)	1517 - 1138 (220 - 165)	1724 - 1289 (250 - 187)
1110 - 834 (161 - 121)	1324 - 993 (192 - 144)	1631 - 1145 (222 - 166)	

Interpreting Compression Readings

1. If compression improves considerably, with the addition of oil, piston rings are faulty.
2. If compression does not improve with oil, valves are sticking or seating improperly.
3. If two adjacent cylinders indicate low compression pressures and squirting oil on each piston does not increase compression, the head gasket may be leaking between cylinders. Engine oil or coolant in cylinders could result from this condition.

Use the Compression Pressure Limit Chart when checking cylinder compression so that the lowest reading is within 75 percent of the highest reading.

Cylinder Leakage Detection

When a cylinder produces a low reading, use of the Engine Cylinder Leak Detection/Air Pressurization Kit will be helpful in pinpointing the exact cause.

The leakage detector is inserted in the spark plug hole, the piston is brought up to dead center on the compression stroke, and compressed air is admitted.

Once the combustion chamber is pressurized, a special gauge included in the kit will read the percentage of leakage. Leakage exceeding 20 percent is excessive.

While the air pressure is retained in the cylinder, listen for the hiss of escaping air. A leak at the intake valve will be heard in the throttle body. A leak at the exhaust valve can be heard at the tail pipe. Leakage past the piston rings will be audible at the positive crankcase ventilation (PCV) connection. If air is passing through a blown head gasket to an adjacent cylinder, the noise will be evident at the spark plug hole of the cylinder into which the air is leaking. Cracks in the cylinder blocks or gasket leakage into the cooling system may be detected by a stream of bubbles in the radiator.

Oil Leak and Valve Stem Seal Test

The cylinder leakage detector tests for engine oil leaks and checks the valve stem seals for leakage.

1. Plug all crankcase openings except the one used for connecting the leakage detector.
2. Connect the Engine Cylinder Leak Detection/Air Pressurization Kit to a crankcase opening (an oil level indicator tube is convenient). Adjust the air pressure to approximately 34 kPa (5 psi).
3. Using a solution of liquid soap and water, brush the solution along the gasket sealing surfaces and bearing seals. Look for bubbles or foam.
4. Remove the spark plugs and rotate the crankshaft slowly with a wrench. Check for large amounts of air escaping into the cylinders as each intake valve and exhaust valve opens.
5. The spark plugs on the leaking cylinders will probably show deposits of burned oil.

Intake Manifold Vacuum Test

Bring the engine to normal operating temperature. Connect the Vacuum/Pressure Tester to the intake manifold. Run the engine at the specified idle speed.

The vacuum gauge should read between 51-74 kPa (15-22 in-Hg) depending upon the engine condition and the altitude at which the test is performed. Subtract 4.0193 kPa (1 in-Hg) from the specified reading for every 304.8 m (1,000 feet) of elevation above sea level.

The reading should be steady. If necessary, adjust the gauge damper control (where used) if the needle is fluttering rapidly. Adjust the damper until the needle moves easily without excessive flutter.

Interpreting Vacuum Gauge Readings

A careful study of the vacuum gauge reading while the engine is idling will help pinpoint trouble areas. Always conduct other appropriate tests before arriving at a final diagnostic decision. Vacuum gauge readings, although helpful, must be interpreted carefully.

Most vacuum gauges have a normal band indicated on the gauge face.

The following are potential gauge readings. Some are normal; others should be investigated further.

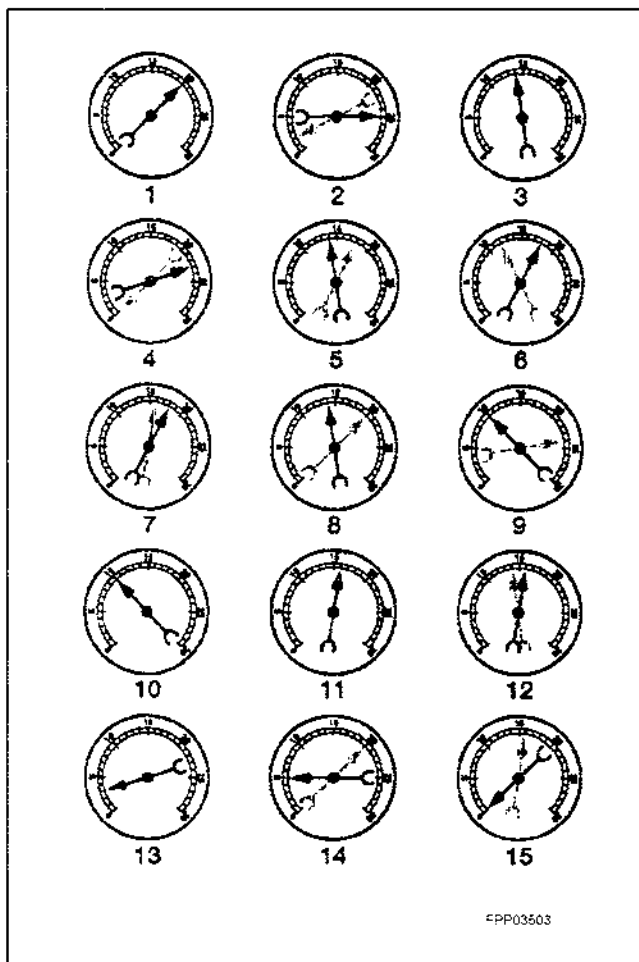

1. **NORMAL READING:** Needle between 51-74 kPa (15-22 in-Hg) and holding steady.
2. **NORMAL READING DURING RAPID ACCELERATION AND DEACCELERATION:** When the engine is rapidly accelerated (dotted needle), the needle will drop to a low reading (not to zero). When the throttle is suddenly released, the needle will snap back up to a higher than normal figure.
3. **NORMAL FOR HIGH-LIFT CAMSHAFT WITH LARGE OVERLAP:** The needle will register as low as 51 kPa (15 in-Hg) but will be relatively steady. Some oscillation is normal.

4. **WORN RINGS OR DILUTED OIL:** When the engine is accelerated (dotted needle), the needle drops to 0 kPa (0 in-Hg). Upon deceleration, the needle runs slightly above 74 kPa (22 in-Hg).
5. **STICKING VALVES:** When the needle (dotted) remains steady at a normal vacuum but occasionally flicks (sharp, fast movement) down and back about 13 kPa (4 in-Hg), one or more valves may be sticking.
6. **BURNED OR WARPED VALVES:** A regular, evenly-spaced, downscale flicking of the needle indicates one or more burned or warped valves. Insufficient hydraulic lash adjuster or hydraulic lash adjuster (HLA) clearance will also cause this reaction.
7. **POOR VALVE SEATING:** A small but regular downscale flicking can mean one or more valves are not seating.
8. **WORN VALVE GUIDES:** When the needle oscillates over about a 13 kPa (4 in-Hg) range at idle speed, the valve guides could be worn. As engine speed increases, the needle will become steady if guides are responsible.
9. **WEAK VALVE SPRINGS:** When the needle oscillation becomes more violent as engine rpm is increased, weak valve springs are indicated. The reading at idle could be relatively steady.
10. **LATE VALVE TIMING:** A steady but low reading could be caused by late valve timing.
11. **IGNITION TIMING RETARDING:** Retarded ignition timing will produce a steady but somewhat low reading.
12. **INSUFFICIENT SPARK PLUG GAP:** When spark plugs are gapped too close, a regular, small pulsation of the needle can occur.
13. **INTAKE LEAK:** A low, steady reading can be caused by an intake manifold or throttle body gasket leak.
14. **BLOWN HEAD GASKET:** A regular drop of fair magnitude can be caused by a blown head gasket or warped cylinder head-to-cylinder block surface.
15. **RESTRICTED EXHAUST SYSTEM:** When the engine is first started and is idled, the reading may be normal, but as the engine rpm is increased, the back pressure caused by a clogged muffler, kinked tail pipe or other concerns will cause the needle to slowly drop to 0 kPa (0 in-Hg). The needle then may slowly rise. Excessive exhaust clogging will cause the needle to drop to a low point even if the engine is only idling.

When vacuum leaks are indicated, search out and correct the cause. Excess air leaking into the system will upset the fuel mixture and cause concerns such as rough idle, missing on acceleration or burned valves. If the leak exists in an accessory unit such as the power brake booster, the unit will not function correctly. Always fix vacuum leaks.

Excessive Engine Oil Consumption

The amount of oil an engine uses will vary with the way the equipment is driven in addition to normal engine-to-engine variation. This is especially true during the first 340 hours or 16,100 km (10,000 miles) when a new engine is being broken in or until certain internal engine components become conditioned. Engines used in heavy-duty operation may use more oil. The following are examples of heavy-duty operation:

- severe loading applications
- sustained high speed operation

Engines need oil to lubricate the following internal components:

- cylinder block, cylinder walls
- pistons, piston pins and rings
- intake and exhaust valve stems
- intake and exhaust valve guides
- all internal engine components

When the pistons move downward, a thin film of oil is left on the cylinder walls. As the engine is operated, some oil is also drawn into the combustion chambers past the intake and exhaust valve stem seals and burned.

The following is a partial list of conditions that can affect oil consumption rates:

- engine size
- operator driving habits
- ambient temperature
- quality and viscosity of the oil

Operating under varying conditions can frequently be misleading. An engine that has been run for short hours or in below-freezing ambient temperatures may have consumed a "normal" amount of oil. However, when checking engine oil level, it may measure up to the full mark on the oil level dipstick due to dilution (condensation and fuel) in the engine crankcase. The engine might then be run at high speeds where the condensation and fuel boil off. The next time the engine oil is checked, it may appear that a liter (quart) of oil was used in about 3 to 3-1/2 hours. This perceived 3 to 3-1/2 hours per liter (quart) oil consumption rate causes customer concern even though the actual overall oil consumption rate is about 50 hours per liter (quart).

Make sure the selected engine oil meets Ford specification WSS-M2C153-F and the recommended API performance category "SJ" or higher and SAE viscosity grade as shown in the equipment Owner's or Operators Engine handbook. It is also important that the engine oil is changed at the intervals specified. Refer to the Engine Operator's handbook.

Oil Consumption Test

The following diagnostic procedure is used to determine the source of excessive internal oil consumption.

NOTE: Oil use is normally greater during the first 300 hours of service. As hours increase, oil use generally decreases. Engines in normal service should get at least 31.7 hours per quart (900 miles per quart) after 300 hours of service. High speeds, heavy loads, high ambient temperature and other factors may result in greater oil use.

1. Determine customer's engine load habits, such as sustained high speed operation, extended idle, heavy work loads and other considerations.
2. Verify that the engine has no external oil leak as described under Engine Oil Leaks in the Diagnosis and Testing portion of this section.
3. Verify that the engine has the correct oil level dipstick.
4. Verify that the engine is not being run in an overfilled condition. Check the oil level at least five minutes after a hot shutdown with the engine/vehicle parked on a level surface. In no case should the level be above the top of the cross-hatched area and the letter F in FULL. If significantly overfilled, perform steps 5 through 9. If not proceed to step 10.
5. Drain the engine oil, remove and replace the oil bypass filter and refill with one quart less than the recommended amount.
6. Run the engine for three minutes (10 minutes if cold), and allow the oil to drain back for at least five minutes with the engine/vehicle on a level surface.
7. Remove oil level dipstick and wipe clean.

CAUTION: Do not wipe with anything contaminated with silicone compounds.

8. Reinstall the oil level dipstick, being sure to seat it firmly in the oil level indicator tube. Remove the oil level dipstick and draw a mark on the back (unmarked) surface at the indicated oil level. This level should be about the same as the ADD mark on the face of the oil level dipstick.
9. Add one quart of oil. Restart the engine and allow to idle for at least two minutes. Shut off the engine and allow the oil to drain back for at least five minutes. Mark the oil level dipstick, using the procedure above. This level may range from slightly below the top of the cross-hatched area to slightly below the letter F in FULL.
10. Record the vehicle mileage or hours.

11. Instruct the customer to run engine as usual and perform the following:
 - Check the oil level regularly at intervals of 3 to 3-1/2 hours.
 - Return to the service point when the oil level drops below the lower (ADD) mark on the oil level dipstick.
 - Add only full quarts of the same oil in an emergency. Note the mileage at which the oil is added.
 12. Check the oil level under the same conditions and at the same location as in Steps 7-9.
 - Measure the distance from the oil level to the UPPER mark on the oil level dipstick and record.
 - Measure the distance between the two scribe marks and record.
 - Divide the first measurement by the second.
 - Divide the hours run during the oil test by the result. This quantity is the approximate oil consumption rate in hours per quart.
 13. If the oil consumption rate is unacceptable, proceed to next step.
 14. Check the positive crankcase ventilation (PCV) system. Make sure the system is not plugged.
 15. Check for plugged oil drain-back holes in the cylinder heads and cylinder blocks.
 16. If the condition still exists after performing the above steps, proceed to next step.
 17. Perform a cylinder compression test or perform a cylinder leak detection test with Engine Cylinder Leak Detection/Air Pressurization Kit. This can help determine the source of oil consumption such as valves, piston rings or other areas.
- NOTE:** After determining if worn parts should be replaced, make sure correct replacement parts are used.
18. Check valve guides for excessive guide clearances. REPLACE all valve stem seals after verifying valve guide clearance.
 19. Worn or damaged internal engine components can cause excessive oil consumption. Small deposits of oil on the tips of spark plugs can be a clue to internal oil consumption. If internal oil consumption still persists, proceed as follows:
 - Remove the engine from the vehicle and place it on an engine work stand. Remove the intake manifolds, cylinder heads, oil pan and oil pump.
 - Check piston ring clearance, ring gap and ring orientation. Repair as required.
 - Check for excessive bearing clearance. Repair as required.
 20. Perform the oil consumption test to confirm the oil consumption concern has been resolved.

Oil Pressure Test

1. Disconnect and remove the oil pressure sensor from the engine.
2. Connect the Engine Oil Pressure Gauge and Transmission Test Adapter to the oil pressure sender oil gallery port.
3. Run the engine until normal operating temperature is reached.
4. Run the engine at 3000 rpm and record the gauge reading.
5. The oil pressure should be within specifications.
6. If the pressure is not within specification, check the following possible sources:
 - insufficient oil
 - oil leakage
 - worn or damaged oil pump
 - oil pump screen cover and tube
 - excessive main bearing clearance
 - excessive connecting rod bearing clearance

Valve Train Analysis – Static

With engine off and valve cover removed, check for damaged or severely worn parts and correct assembly. Make sure correct parts are used with the static engine analysis as follows.

Rocker Arm

- Check for loose mounting bolts, studs and nuts.
- Check for plugged oil feed in the rocker arms or cylinder head.

Camshaft Roller Followers and Hydraulic Lash Adjusters

- Check for loose mounting bolts on camshaft carriers.
- Check for plugged oil feed in the camshaft roller followers, hydraulic lash adjusters (HLA) or cylinder heads.

Camshaft

- Check for broken or damaged parts.
- Check the bolts on the intake manifold.

Valve Springs

- Check for broken or damaged parts.

Valve Spring Retainer and Valve Spring Retainer Keys

- Check for proper seating of the valve spring retainer key on the valve stem and in valve spring retainer.

Valve Spring Retainer Keys

- Check for proper seating on the valve stem.

Valves and Cylinder Head

- Check the head gasket for proper installation.
- Check for plugged oil drain back holes.
- Check for worn or damaged valve tips.
- Check for missing or damaged guide-mounted valve stem seal.
- Check collapsed lash adjuster gap.
- Check installed valve spring height.
- Check for missing or worn valve spring seats.
- Check for plugged oil metering orifice in cylinder head oil reservoir (if equipped).

Static checks (engine off) are to be made on the engine prior to the dynamic procedure.

Valve Train Analysis – Dynamic

Start the engine and, while idling, check for proper operation of all parts. Check the following:

Rocker Arm

- Check for plugged oil in the rocker arms or cylinder head.
- Check for proper overhead valve train lubrication.

If insufficient oiling is suspected, accelerate the engine to 1200 rpm \pm 100 rpm with the transmission in NEUTRAL or load removed and the engine at normal operating temperature. Oil should spurt from the rocker arm oil holes such that valve tips and rocker arms are well oiled or, with the valve covers off, oil splash may overshoot the rocker arms. If oiling is insufficient for this to occur, check oil passages for blockage.

Positive Rotator and Valve Spring Retainer Keys

- Check for proper operation of positive rotator.

Valves and Cylinder Head

- Check for plugged oil drain back holes.
- Check for missing or damaged valve stem seals or guide mounted valve stem seals.

If insufficient oiling is suspected, check oil passages for blockage, then accelerate the engine to 1200 rpm with the transmission in NEUTRAL or load removed and the engine at normal operating temperature. Oil should spurt from the rocker arm oil holes such that valve tips and camshaft roller followers are well oiled. With the valve covers off, some oil splash may overshoot camshaft roller followers.

Camshaft Lobe Lift

Check the lift of each lobe in consecutive order and make a note of the readings.

1. Remove the valve covers.
2. Remove the rocker arm seat bolts, rocker arm seat and rocker arms.

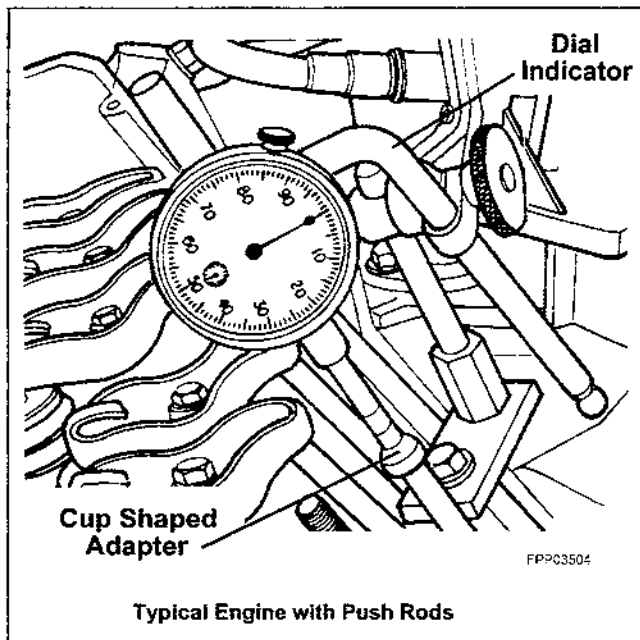

3. Make sure the lash adjuster is seated against camshaft. Install the dial Indicator with Bracketry so the ball socket adapter of the indicator is on top of the hydraulic lash adjuster or the Cup Shaped Adapter is on top of the push rod and in the same plane as the lash adjuster push rod movement.
4. Remove the spark plugs.
5. Connect an auxiliary starter switch in the starting circuit. Crank the engine with the ignition switch in the OFF position. Bump the crankshaft over until the hydraulic lash adjuster is on the base circle of the camshaft lobe. At this point, the hydraulic lash adjuster will be in its lowest position. If checking during engine assembly, turn the crankshaft using a socket or ratchet.
6. Zero the dial indicator. Continue to rotate the crankshaft slowly until the camshaft lobe is in the fully-raised position (highest indicator reading).

NOTE: If the lift on any lobe is below specified service limits, the camshaft and any component operating on worn lobes must be replaced.

7. Compare the total lift recorded on the dial indicator with specifications.
8. To check the accuracy of the original dial indicator reading, continue to rotate the crankshaft until the indicator reads zero.
9. Remove the dial indicator, adapter and auxiliary starter switch.

CAUTION: After installing rocker arms, do not rotate the crankshaft until lash adjusters have had sufficient time to bleed down. To do otherwise may cause serious valve damage. Manually bleeding-down lash adjusters will reduce waiting time.

10. Install the rocker arm seats, rocker arms and rocker arm seat bolts.
11. Install the valve covers.
12. Install the spark plugs.

Hydraulic Lash Adjuster

Hydraulic lash adjuster noise can be caused by any of the following:

- excessive collapsed lash adjuster gap
- sticking lash adjuster plunger
- lash adjuster check valve not functioning properly
- air in lubrication system
- leakdown rate too rapid
- excessive valve guide wear

Excessive collapsed lash adjuster gap can be caused by loose rocker arm seat bolts/nuts, incorrect initial adjustment or wear of lash adjuster face, or worn roller lash adjusters, push rod, rocker arm, rocker arm seat or valve tip. With lash adjuster collapsed, check gap between the valve tip and the rocker arm to determine if any other valve train parts are damaged, worn or out of adjustment.

A sticking lash adjuster plunger can be caused by dirt, chips or varnish inside the lash adjuster.

A lash adjuster check valve that is not functioning can be caused by an obstruction such as dirt or chips that prevent it from closing when the camshaft lobe is lifting the lash adjuster. It may also be caused by a broken check valve spring.

Air bubbles in the lubrication system will prevent the lash adjuster from supporting the valve spring load. This can be caused by too high or too low an oil level in the oil pan or by air being drawn into the system through a hole, crack or leaking gasket on the oil pump screen cover and tube.

If the leakdown time is below the specified time for used lash adjusters, noisy operation can result. If no other cause for noisy lash adjusters can be found, the leakdown rate should be checked and any lash adjusters outside the specification should be replaced.

Assembled lash adjusters can be tested with Hydraulic lash adjuster Leakdown Tester to check the leakdown rate. The leakdown rate specification is the time in seconds for the plunger to move a specified distance while under a 22.7 kg (50 lb.) load. Test the lash adjusters as follows:

Leakdown Testing

NOTE: Do not mix parts from different hydraulic valve tappets/lash adjusters. Parts are select-fit and are not interchangeable.

1. Clean the lash adjuster to remove all traces of engine oil.

NOTE: lash adjusters/lash adjuster cannot be checked with engine oil in them. Use only testing fluid. New hydraulic lash adjusters/lash adjusters are already filled with testing fluid.

2. Place the lash adjuster in the tester with the plunger facing upward. Position the steel ball provided in the plunger cap. Add testing fluid to cover the hydraulic tappet/lash adjuster and compress Hydraulic Tappet Leakdown Tester until the hydraulic lash adjuster is filled with testing fluid and all traces of air bubbles have disappeared. The fluid can be purchased from the tester's manufacturer. Using kerosene or any other fluid will not provide an accurate test.

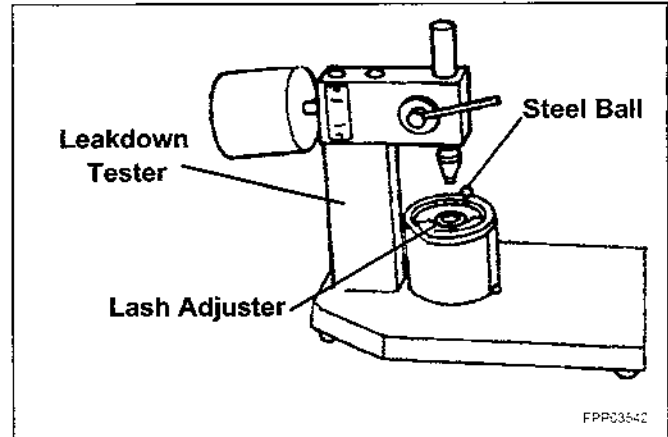

3. Adjust the length of the ram so the pointer is just below the start timing mark when the ram contacts the hydraulic lash adjuster. Start Timing as the pointer passes the start timing mark and end timing as the pointer reaches the center mark.

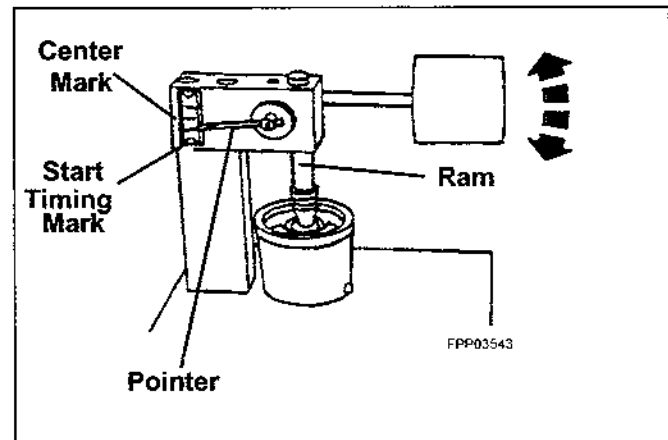

4. A satisfactory lash adjuster must have a leakdown rate (time in seconds) within specified minimum and maximum limits.
5. If the lash adjuster is not within specification, replace it with a new lash adjuster. Do not disassemble and clean new lash adjusters/lash adjuster before testing because oil contained in the new lash adjuster is test fluid.
6. Remove the fluid from the cup and bleed the fluid from the lash adjuster by working the plunger up and down. This step will aid in depressing the lash adjuster plungers when checking valve clearance.

GENERAL SERVICE PROCEDURES



WARNING: TO AVOID THE POSSIBILITY OF PERSONAL INJURY OR DAMAGE TO THE EQUIPMENT, DO NOT OPERATE THE ENGINE WITH THE HOOD OPEN UNTIL THE FAN BLADE HAS BEEN EXAMINED FOR POSSIBLE CRACKS AND SEPARATION.

NOTE: Specifications show the expected minimum or maximum condition.

NOTE: If a component fails to meet the specifications, it is necessary to replace or refinish. If the component can be refinished, wear limits are provided as an aid to making a decision. Any component that fails to meet specifications and cannot be refinished must be replaced.

Camshaft Journal Diameter

- Measure each camshaft journal diameter in two directions.
- If it is out of specification, replace as necessary.

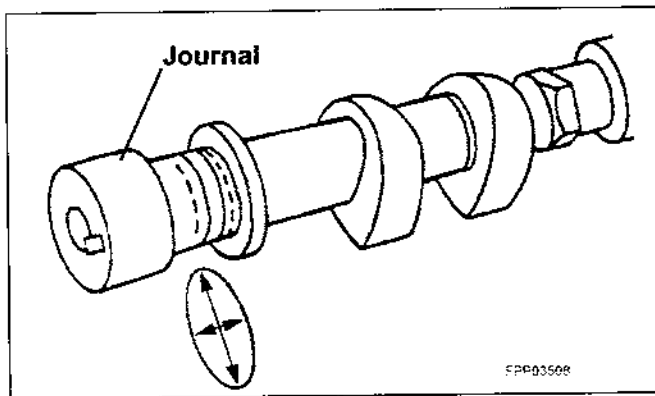

Camshaft Journal Clearance

NOTE: The camshaft journals must meet specifications before checking camshaft journal clearance.

- Measure each camshaft bearing in two directions.
- Subtract the camshaft journal diameter from the camshaft bearing diameter

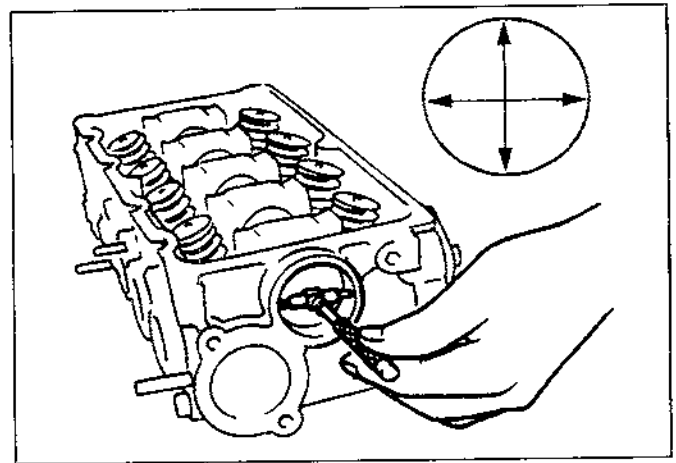

Camshaft Lobe Surface

- Inspect camshaft lobes for pitting or damage in the active area. Minor pitting is acceptable outside the active area

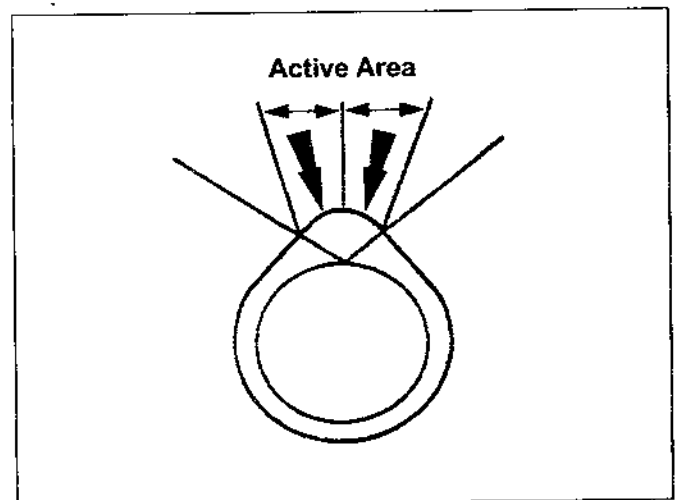

Camshaft Lobe Lift

Special Tool(s)

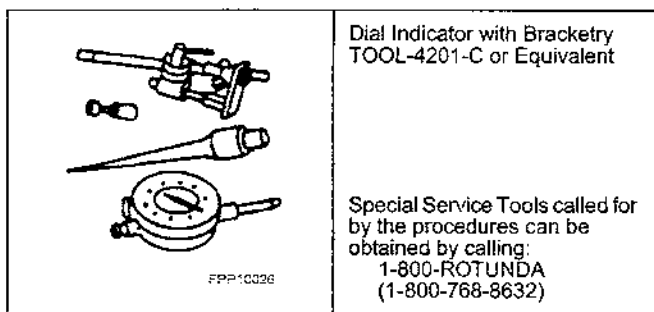

1. Use the Dial Indicator with Bracketry to measure camshaft intake lobe lift.

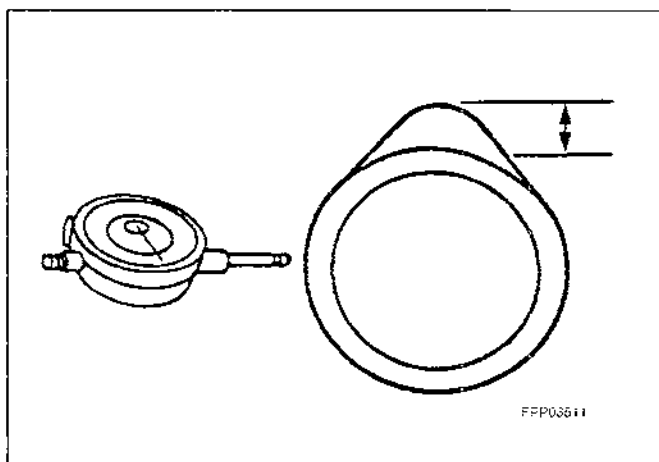

2. Rotate the camshaft and subtract the lowest dial indicator reading from the highest dial indicator reading to figure the camshaft lobe lift.
3. Use the Dial Indicator with Bracketry to measure camshaft exhaust lobe lift.
4. Rotate the camshaft and subtract the lowest dial indicator reading from the highest dial indicator reading to figure the camshaft lobe lift.

Camshaft Runout

Special Tool(s)

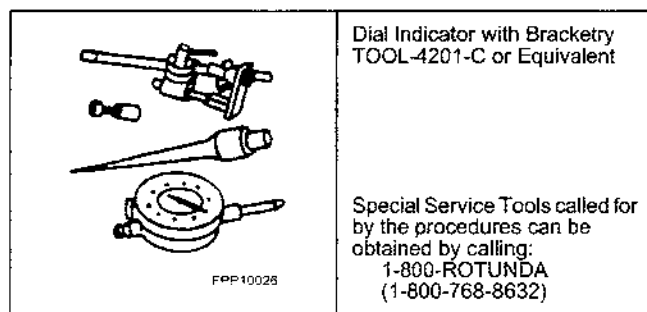

NOTE: Camshaft journals must be within specifications before checking runout.

- Use the Dial Indicator with Bracketry to measure the camshaft runout.
- Rotate the camshaft and subtract the lowest dial indicator reading from the highest dial indicator reading.

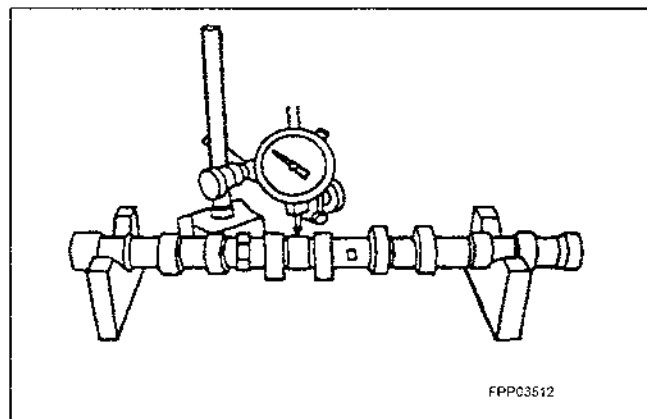

Crankshaft Main Bearing Journal Diameter

- Measure each of the crankshaft main bearing journal diameters in at least two directions.
- If it is out of specification, replace as necessary.

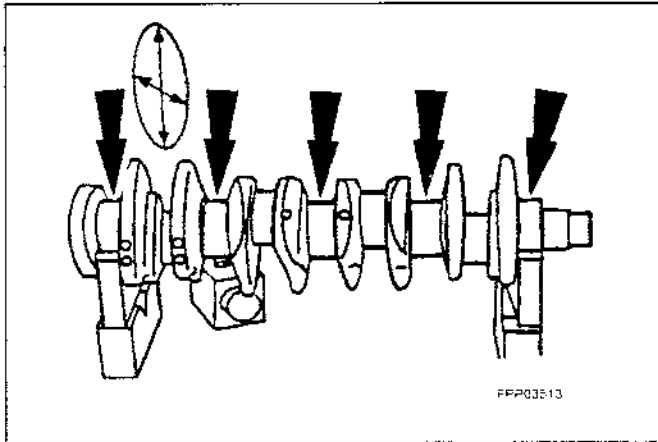

Crankshaft Main Bearing Journal Taper

- Measure each of the crankshaft main bearing journal diameters in at least two directions at each end of the main bearing journal.
- If it is out of specifications, replace as necessary.

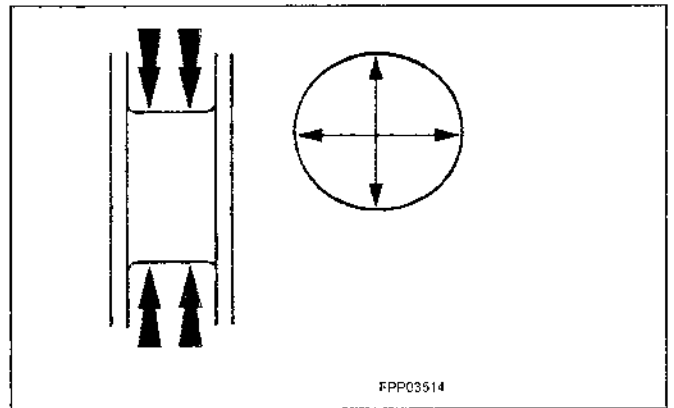

Crankshaft Main Bearing Journal Clearance

Special Tool(s)

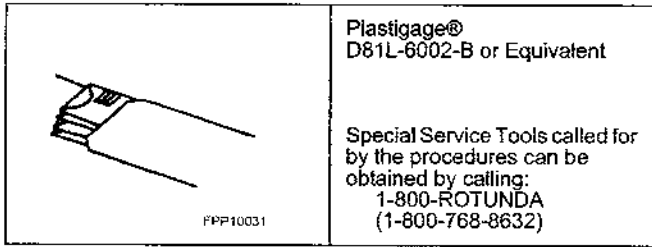

NOTE: Crankshaft main bearing journals must be within specifications before checking journal clearance.

1. Remove the crankshaft main bearing caps and bearings.
2. Lay a piece of Plastigage® across the face of each crankshaft main surface.

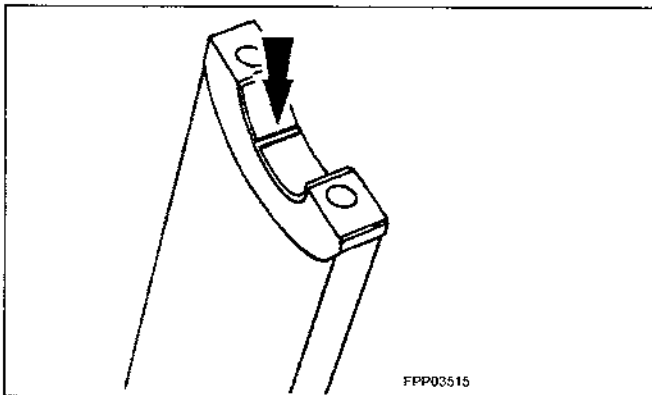

NOTE: Do not turn the crankshaft while doing this procedure.

3. Install and remove the crankshaft main bearing cap.

4. Verify the crankshaft journal clearance.
 - If it is out of specification, replace as necessary

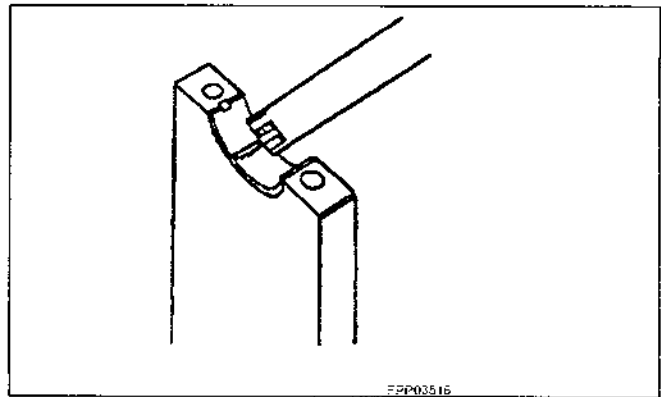

Bearing Inspection

Inspect bearings for the following defects. Possible causes are shown:

- Cratering – fatigue failure (A)
- Spot polishing – improper seating (B)
- Scratching – dirty (C)
- Base exposed – poor lubrication (D)
- Both edges worn – journal damaged (E)
- One edge worn – journal tapered or bearing not seated (F)

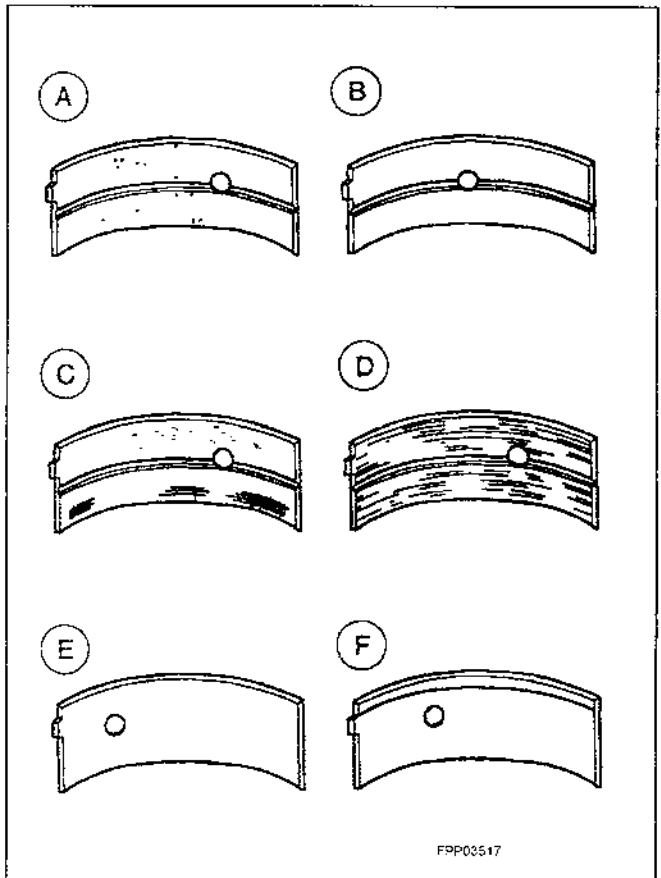

Crankshaft End Play

Special Tool(s)

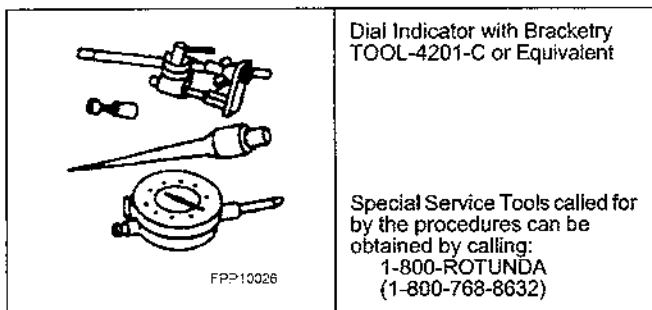

1. Measure the crankshaft end play. Use the Dial Indicator with Bracketry to measure crankshaft end play.
2. Position the crankshaft to the rear of the cylinder block.
3. Zero the Dial Indicator with Bracketry.

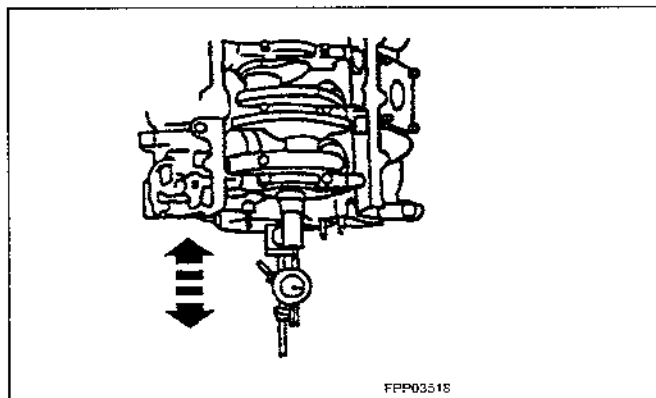

4. Move the crankshaft to the front of the cylinder block. Note and record the camshaft end play.
 - If camshaft end play exceeds specifications, replace the crankshaft thrust washers or thrust bearing.

Use the Dial Indicator with Bracketry to measure the crankshaft runout.

- Rotate the crankshaft and subtract the lowest dial indicator reading from the highest dial indicator reading to figure the crankshaft runout. If it is out of specification, replace as necessary.

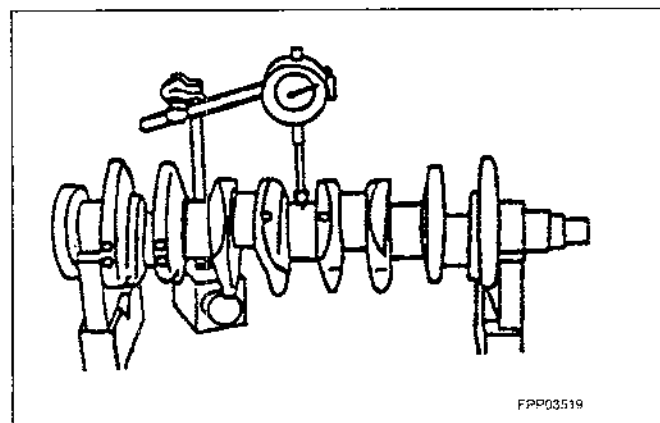

Cylinder Bore Taper

Measure the cylinder bore at the top and bottom. Verify the cylinder bore is within the wear limit. The difference indicates the cylinder bore taper. Bore the cylinder to the next oversize.

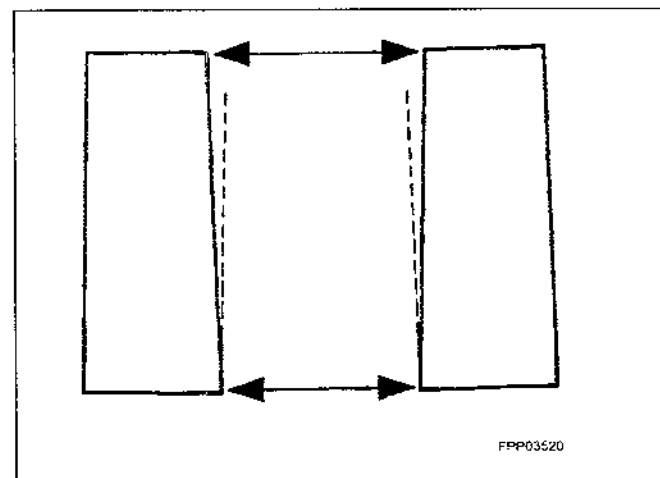

Crankshaft Runout

Special Tool(s)

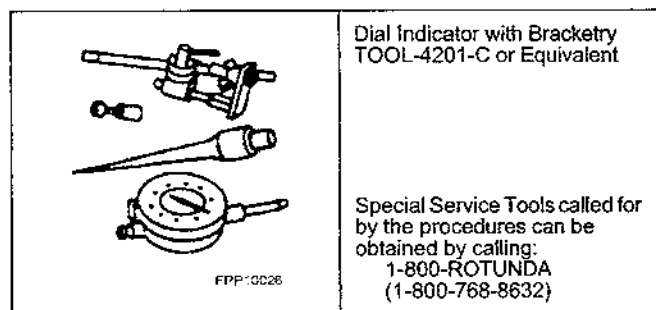

NOTE: Crankshaft main bearing journals must be within specifications before checking runout.

Cylinder Bore Out-of-Round

Measure the cylinder bore in two directions. The difference is the out-of-round. Verify the out-of-round is within the wear limit and bore the cylinder to the next oversize limit.

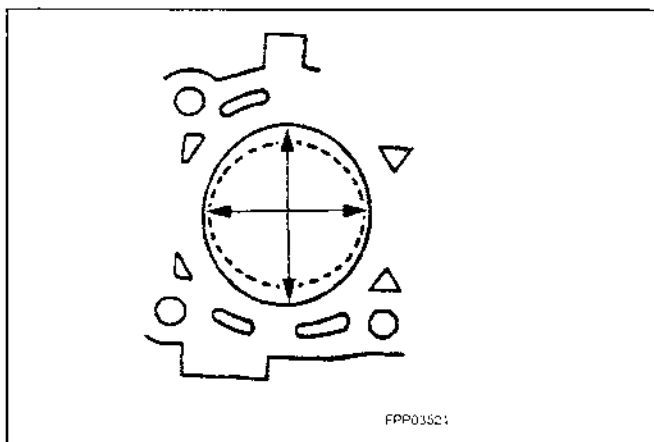

- Make sure the oil ring holes are clean.

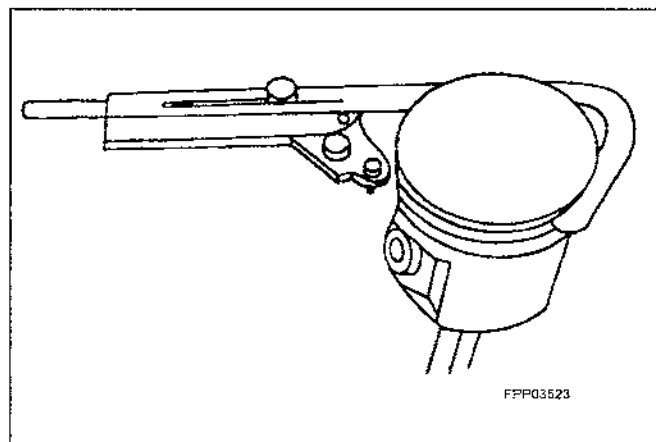

Piston Diameter

- Measure the piston skirt diameter.

Piston Inspection

Special Tool(s)

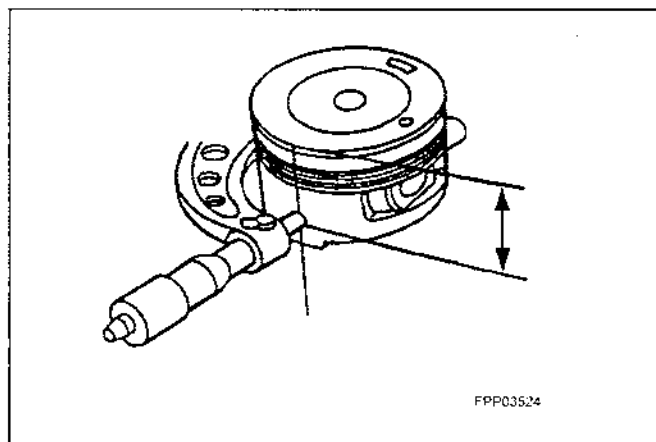
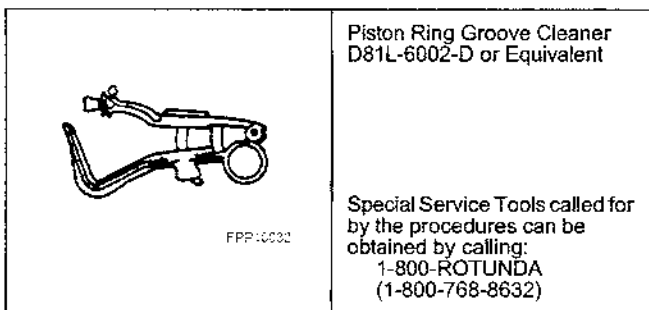

CAUTION: Do not use a caustic cleaning solution or a wire brush to clean the pistons or possible damage can occur.

1. Clean and inspect the ring lands, skirts, pin bosses, and the tops of the pistons. If wear marks or polishing is found on the piston skirt, check for a bent or twisted connecting rod.

Piston to Cylinder Bore Clearance

Subtract the piston diameter from the cylinder bore diameter to find the piston-to-cylinder bore clearance.

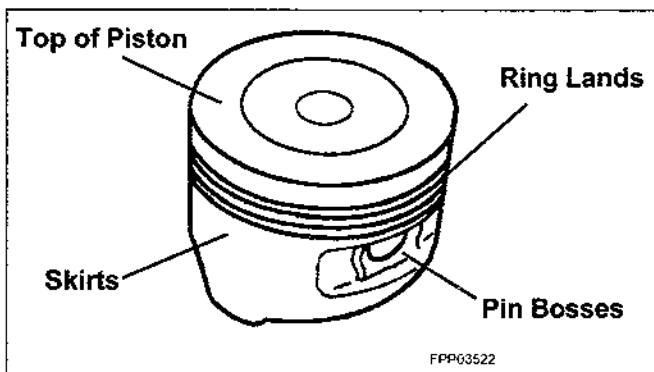

2. Use the Piston Ring Groove Cleaner to clean the piston ring grooves.

Piston Selection

NOTE: The cylinder bore must be within the specifications for taper and out-of-round before fitting a piston.

1. Select a piston size based on the cylinder bore.

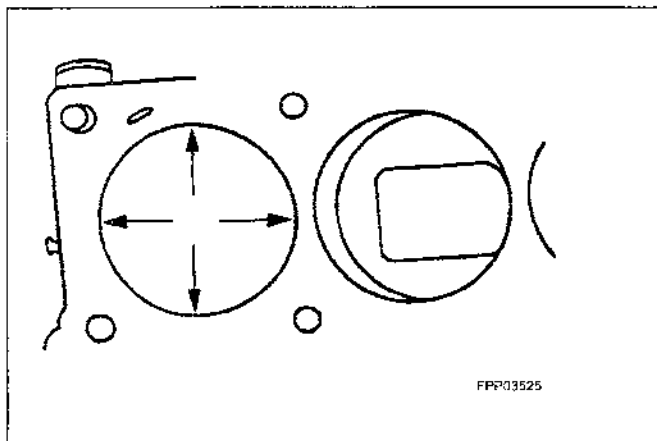

NOTE: For precision fit, new pistons are divided into three categories within each size range based on their relative position within the range. A paint spot on the new pistons indicates the position within the size range.

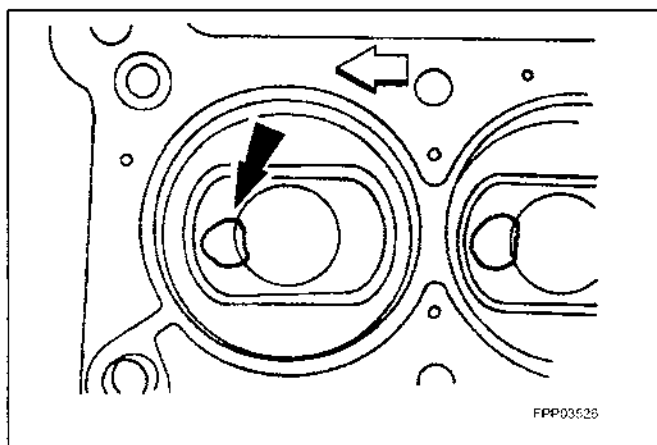

2. Choose the piston with the proper paint color.
 - Red – in the lower third of the size range.
 - Blue – in the middle third of the size range.
 - Yellow – in the upper third of the size range.

CAUTION: Use care when fitting piston rings to avoid possible damage to the piston ring or the cylinder bore.

CAUTION: Piston rings should not be transferred from one piston to another to prevent damage to cylinder worn or piston.

NOTE: Cylinder bore must be within specification for taper and out-of-round to fit piston rings.

1. Use a piston without rings to push a piston ring in a cylinder to the bottom of ring travel.

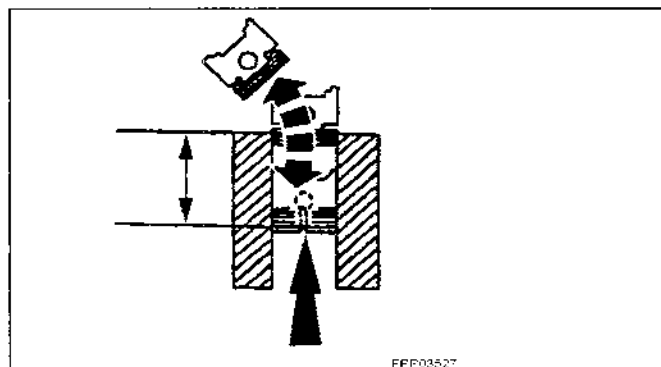

2. Use a feeler gauge to measure the top piston ring end gap and the second piston ring end gap.

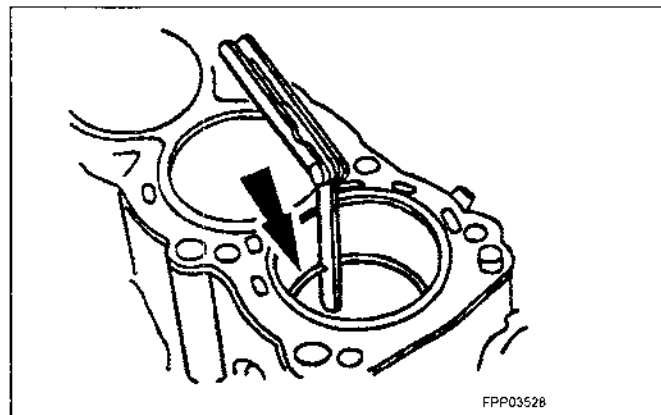

Piston Ring End Gap

Special Tool(s)

<p>FPP10033</p>	<p>Feeler Gauge D81L-4201-A or Equivalent</p> <p>Special Service Tools called for by the procedures can be obtained by calling: 1-800-ROTUNDA (1-800-768-8632)</p>
-----------------	--

Piston Ring-to-Groove Clearance

Special Tool(s)

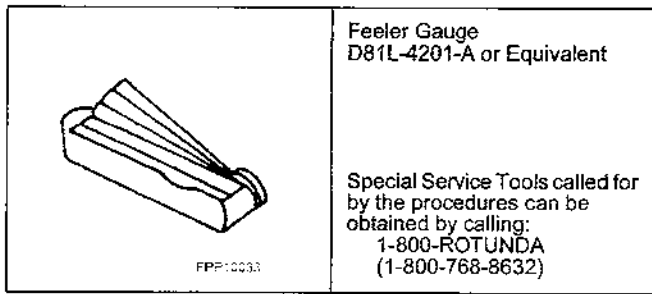

1. Inspect for a stop in the grooves.
2. Measure the piston-to-groove clearance.

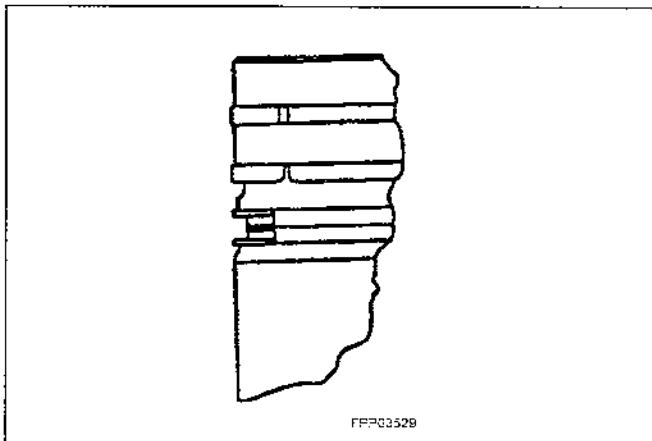

Crankshaft Connecting Rod Journal Diameter

- Measure the crankshaft connecting rod journal diameters in at least two directions perpendicular to one another. The difference between the measurements is the out-of-round. Verify the journal is within the wear limit specification.

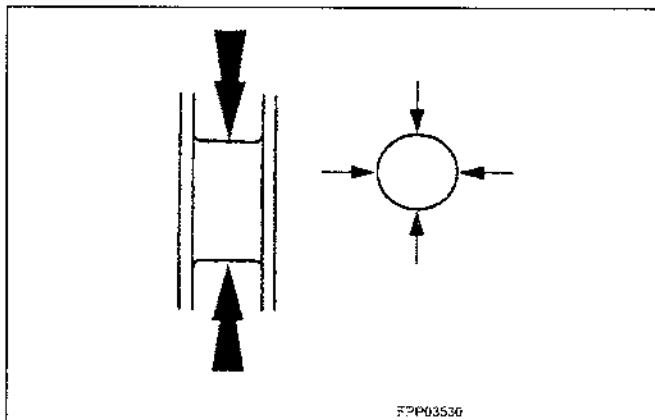

Crankshaft Connecting Rod Journal Taper

- Measure the crankshaft rod journal diameters in two directions perpendicular to one another at each end of the connecting rod journal. The difference in the measurements from one end to the other is the taper. Verify measurement is within the wear limit.

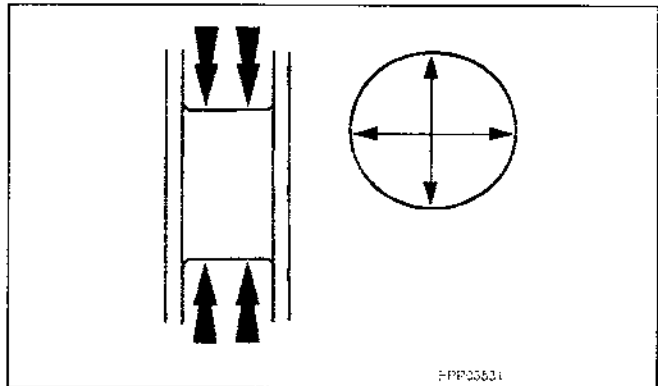

Connecting Rod Cleaning

CAUTION: Do not use a caustic cleaning solution or damage to connecting rods can occur.

NOTE: The connecting rod large end is mechanically split or cracked to produce a unique parting face. This produces a locking joint. Parts are not interchangeable.

- Mark and separate the parts and clean with solvent. Clean the oil passages.

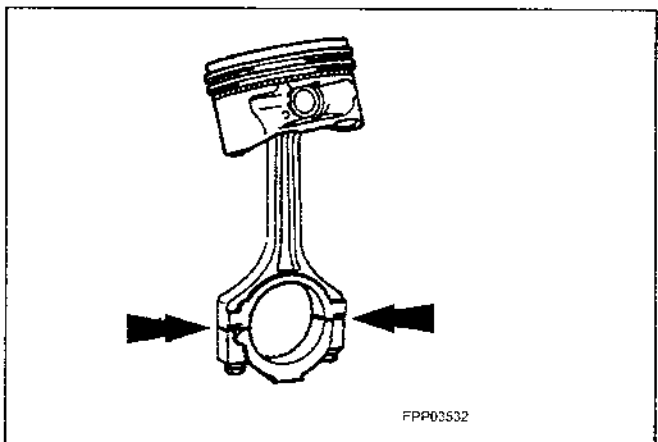

Connecting Rod Larger End Bore

CAUTION: The connecting rod bolts are torque to yield and must be discarded and replaced after this diagnostic test.

- Measure the bore in two directions. The difference is the connecting rod bore out-of-round. Verify the out-of-round is within specification.

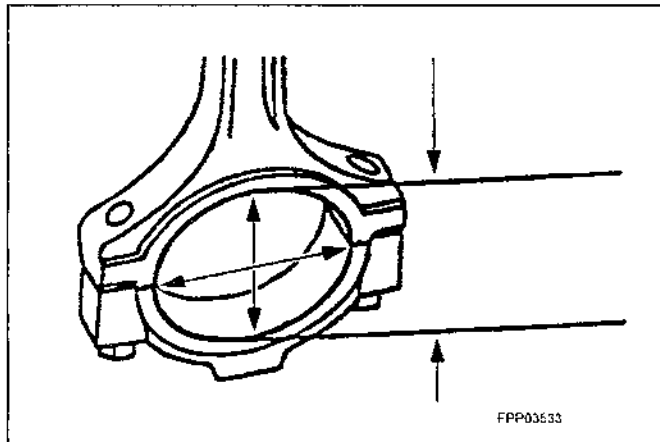

Piston Pin Diameter

- Measure the piston pin diameter in two directions at the points shown. Verify the diameter is within specifications.

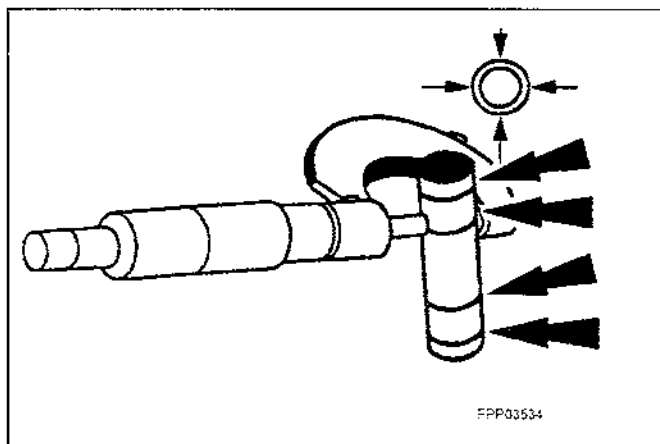

Connecting Rod Bushing Diameter

- Measure the inner diameter of the connecting rod bushing. Verify the diameter is within specification.

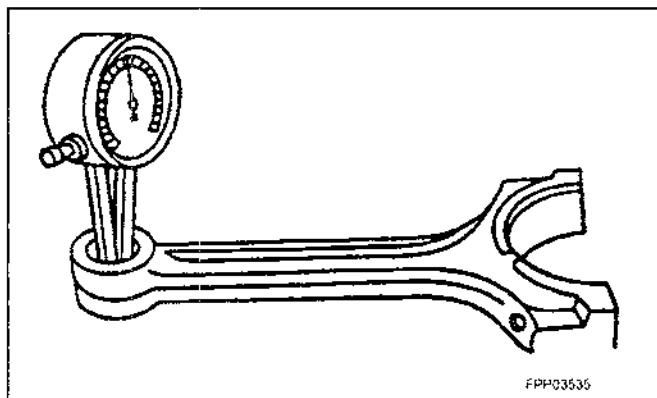

Connecting Rod Bend

- Measure the connecting rod bend on a suitable alignment fixture. Follow the instructions of the fixture manufacturer. Verify the bend measurement is within specification.

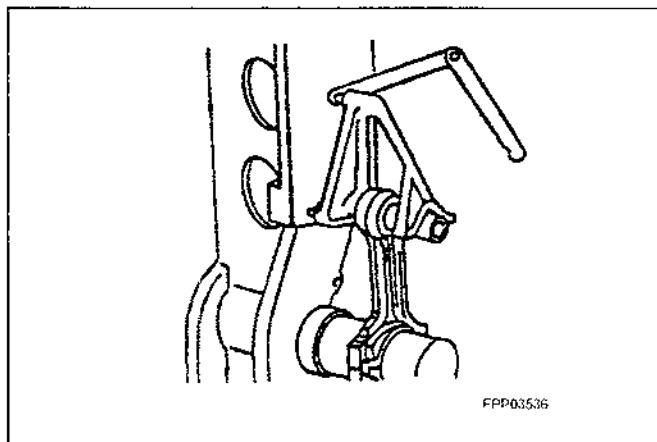

Connecting Rod Twist

- Measure the connecting rod twist on a suitable alignment fixture. Follow the instructions of the fixture manufacturer. Verify the measurement is within specification.

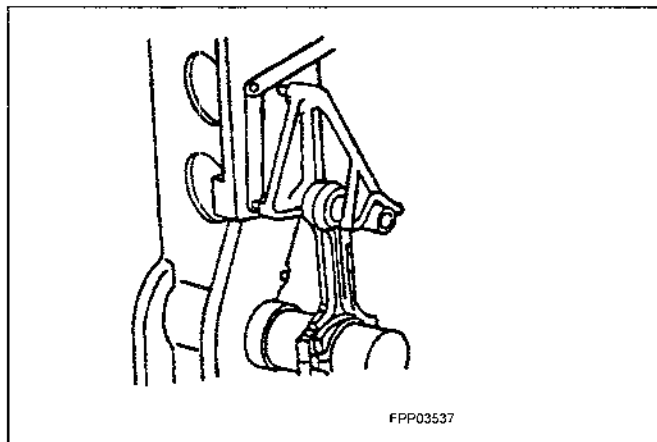

Connecting Rod Piston Pin Side Clearance

- Measure the clearance between the connecting rod and the piston. Verify the measurement is within specification.

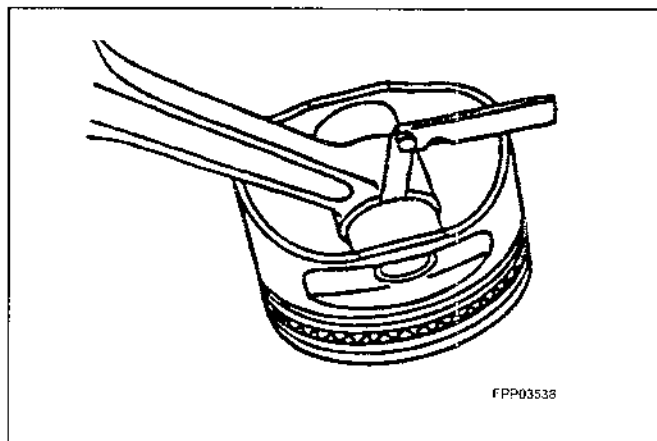

3. Install and torque to specifications, then remove the connecting rod bearing cap.
4. Measure the Plastigage® to get the connecting rod bearing journal clearance. The Plastigage® should be smooth and flat. A change width indicates a tapered or damaged connecting rod bearing or connecting rod.

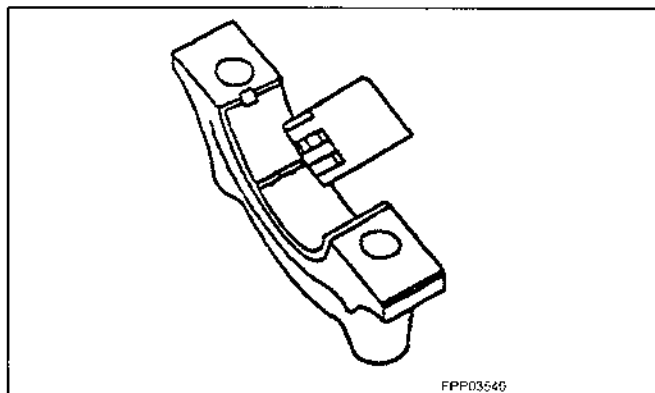

Connecting Rod Journal Clearance

Special Tool(s)

<p>FPP10031</p>	<p>Plastigage® D81L-6002-B or Equivalent</p> <p>Special Service Tools called for by the procedures can be obtained by calling: 1-800-ROTUNDA (1-800-768-8632)</p>
-----------------	---

NOTE: The crankshaft connecting rod journals must be within specifications to check the connecting rod bearing journal clearances.

CAUTION: The connecting rod bolts are torque to yield and must be discarded and replaced after this diagnostic test.

1. Remove the connecting rod bearing cap.
2. Position a piece of Plastigage® across the bearing surface.

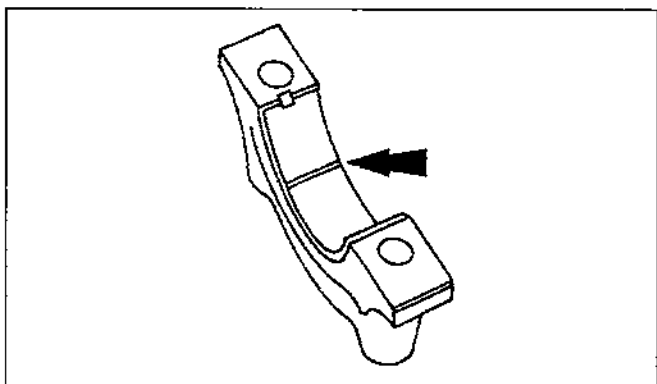

NOTE: Do not turn the crankshaft during this step.

Bearing Inspection

Inspect bearings for the following defects. Possible causes are shown:

- Cratering – fatigue failure (A)
- Spot polishing – improper seating (B)
- Scratching – dirty (C)
- Base exposed – poor lubrication (D)
- Both edges worn – journal damaged (E)
- One edge worn – journal tapered or bearing not seated (F)

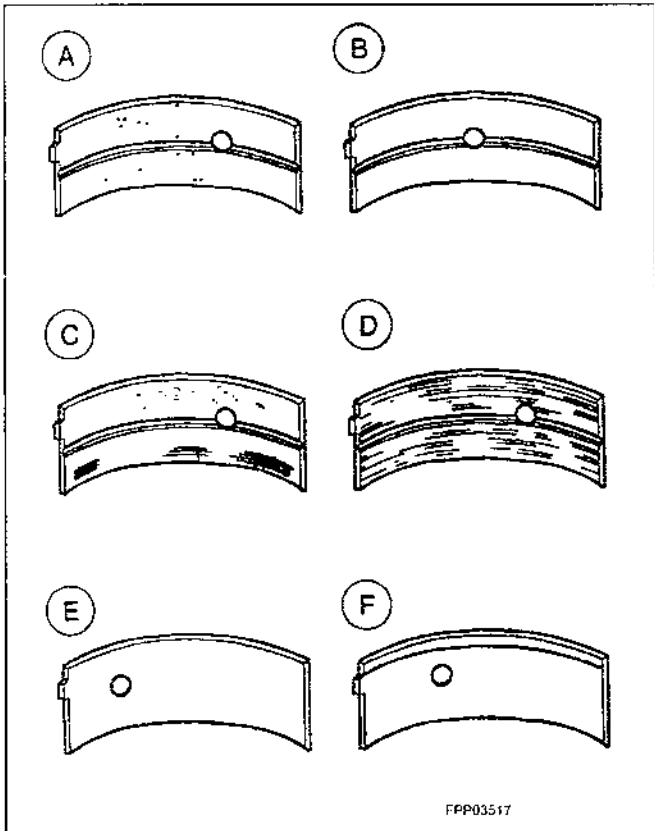

Roller Follower Inspection

- Inspect the roller for flat spots or scoring. If any damage is found, inspect the camshaft lobes and hydraulic lash adjusters for damage.

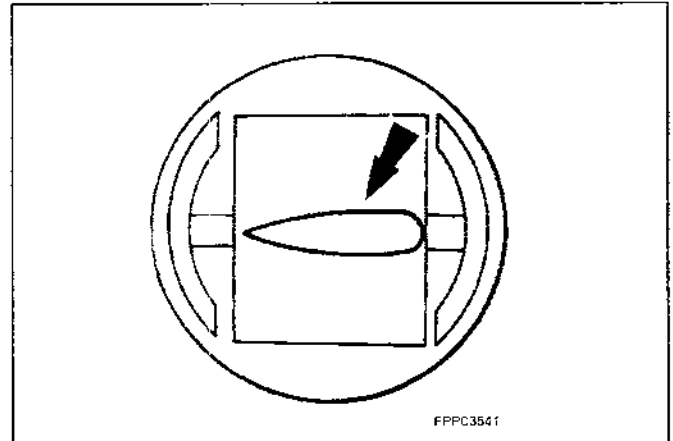

Hydraulic Lash Adjuster Inspection

- Inspect the hydraulic lash adjuster and roller for damage. If any damage is found, inspect the camshaft lobes and valves for damage.

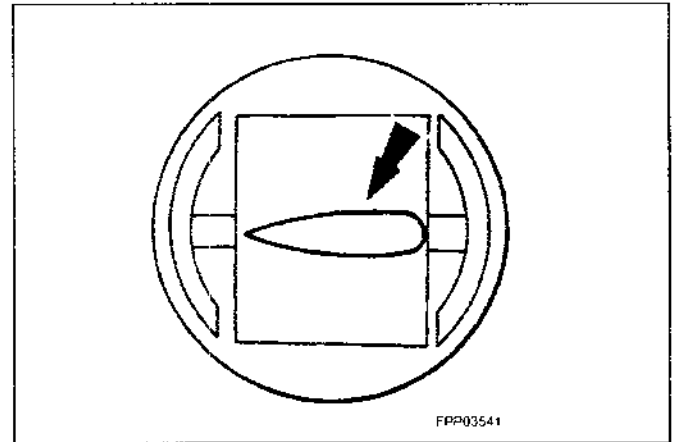

Valve Stem Diameter

- Measure the diameter of each intake and exhaust valve stem at the points shown. Verify the diameter is within specification.

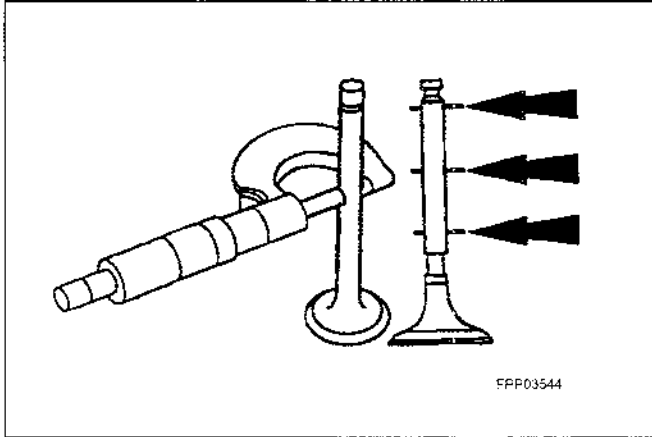

2. Move the Valve Stem Clearance Tool toward the Dial Indicator and zero the Dial Indicator. Move the Valve Stem Clearance Tool away from the Dial Indicator and note the reading. The reading will be double the valve stem-to-valve guide clearance. Valves with oversize stems will need to be installed if out of specification.

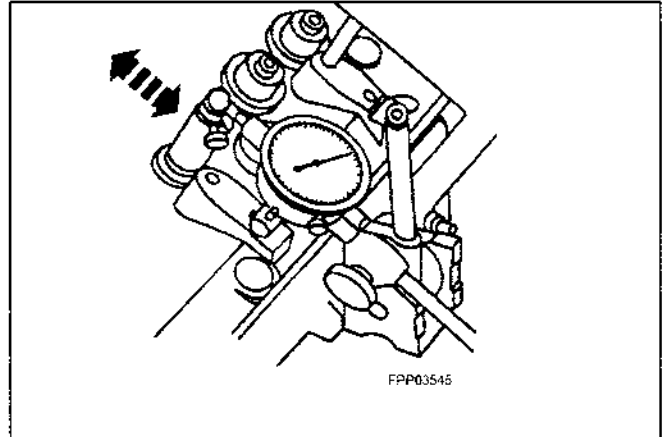

Valve Stem-to-Valve Guide Clearance

Special Tool(s)

	<p>Dial Indicator with Bracketry TOOL-4201-C or Equivalent</p>
	<p>Valve Stem Clearance Tool TOOL-6505-E or Equivalent</p> <p>Special Service Tools called for by the procedures can be obtained by calling: 1-800-ROTUNDA (1-800-768-8632)</p>

NOTE: Valve stem diameter must be within specifications before checking valve stem to valve guide clearance.

NOTE: If necessary, use a magnetic base.

1. Install the Valve Stem Clearance Tool on the valve stem and install the Dial Indicator with Bracketry. Lower the valve until the Valve Stem Clearance Tool contacts the upper surface of the valve guide.

Valve Inspection

Inspect the following valve areas:

- The end of the stem for grooves or scoring.
- The valve face and the edge for pits, grooves or scores.
- The valve head for signs of burning, erosion, warpage and cracking. Minor pits, grooves and other abrasions may be removed.
- The valve head thickness for wear.

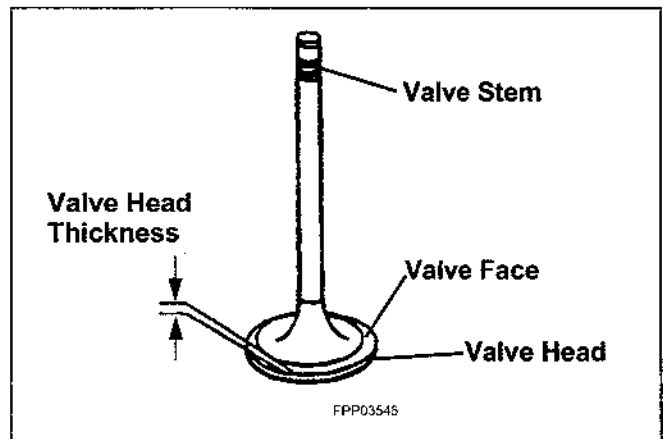

Valve Guide Inner Diameter

1. Measure the inner diameter of the valve guides in two directions where indicated.
2. If the valve guide is not within specifications, ream the valve guide and install a valve with an oversize stem or remove the valve guide and install a new valve guide.

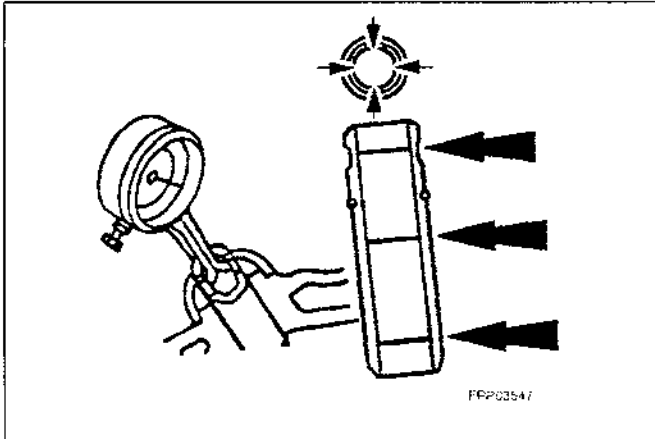

Valve Guide Reaming

1. Use a hand-reaming kit to ream the valve guide.

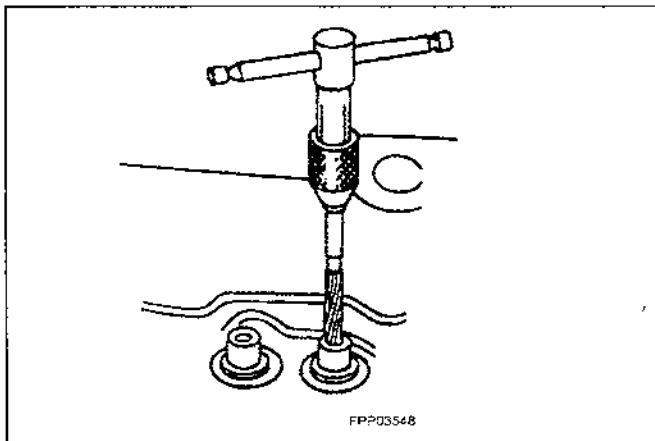

2. Reface the valve seat.
3. Clean the sharp edges left by reaming.

Valve Spring Installed Length

- Measure the installed length of each valve spring.

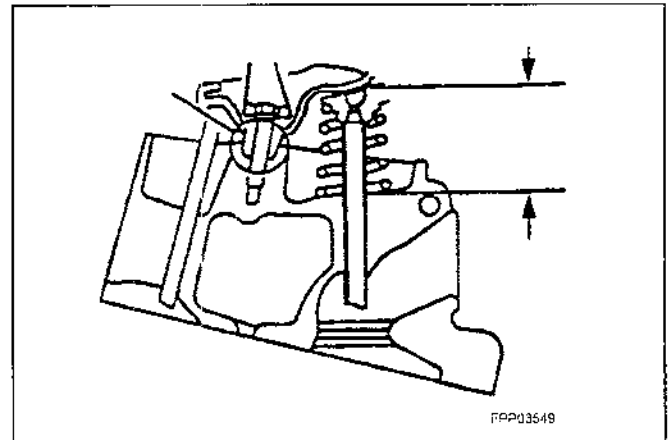

Valve Spring Free Length

- Measure the free length of each valve spring.

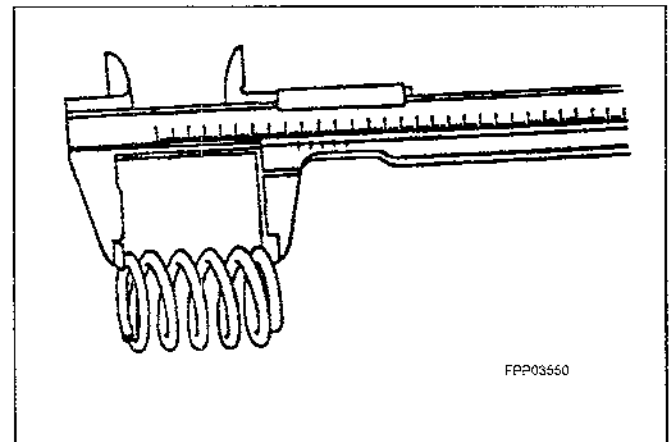

Valve Spring Out-of-Square

Measure the out-of-square on each valve spring.

- Turn the valve spring and observe the space between the top of the valve spring and the square. Replace the valve spring if out of specification.

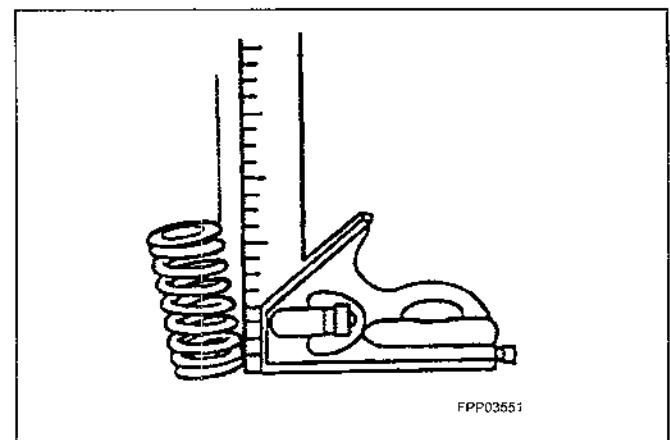

Valve Spring Compression Pressure

Special Tool(s)

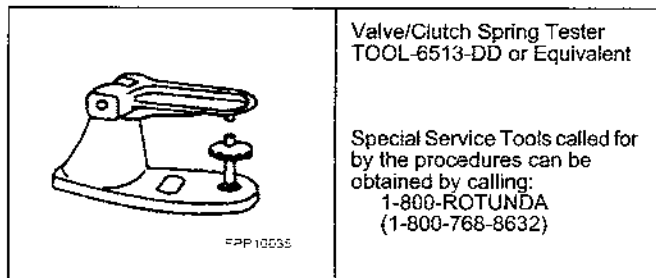

- Use the Valve/Clutch Spring Tester to check the valve springs for proper strength at the specified valve spring length.

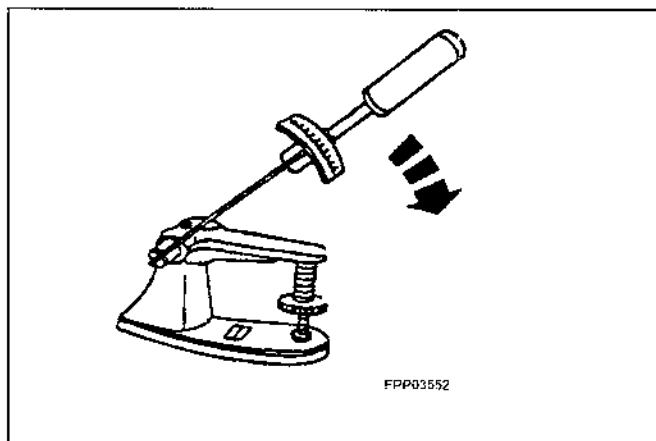

Valve and Seat Refacing Measurements

NOTE: After grinding valves or valve seats, check valve clearance.

- Check the valve seat and valve angles.

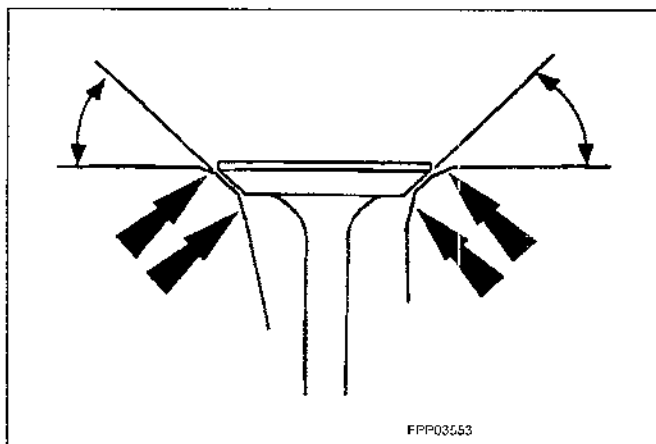

Valve Seat Width

- Measure the valve seat width. If necessary, grind the valve seat to specification.

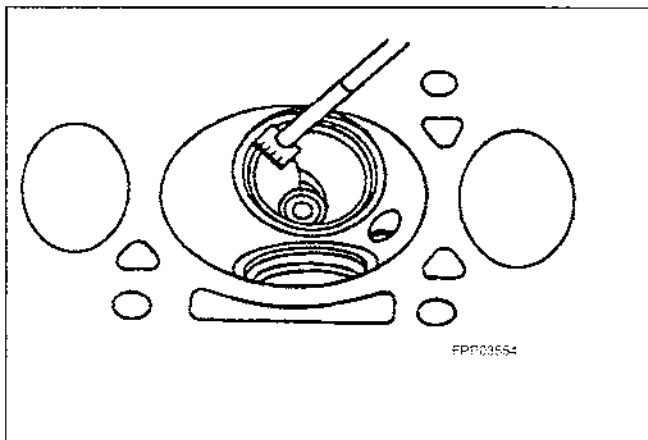

Valve Seat Runout

- Use the Valve Seat Runout Gauge to check valve seat runout.

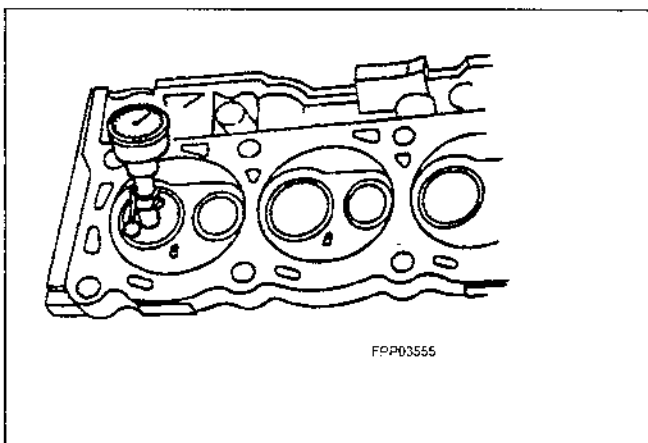

Flywheel Inspection

Special Tool(s)

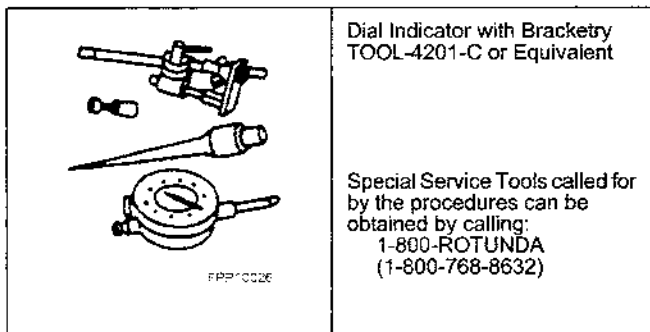

1. Inspect the flywheel for:
 - Cracks (A).
 - Worn ring gear teeth (B).
 - Chipped or cracked ring gear teeth (C).
2. Inspect the flywheel ring gear runout.

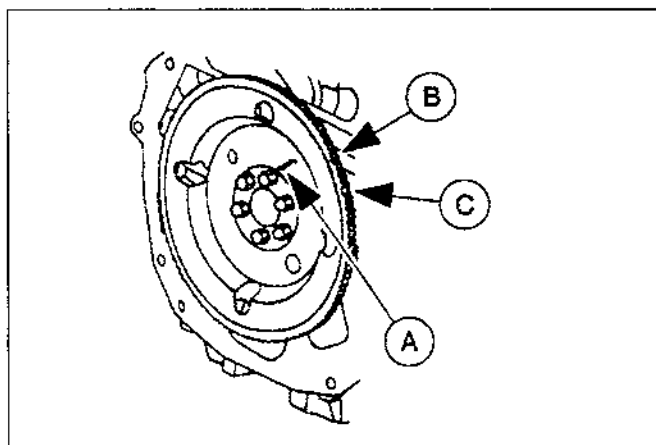

Oil Pump Gear Radial Clearance

- Measure the clearance between the rotor and the pump housing.

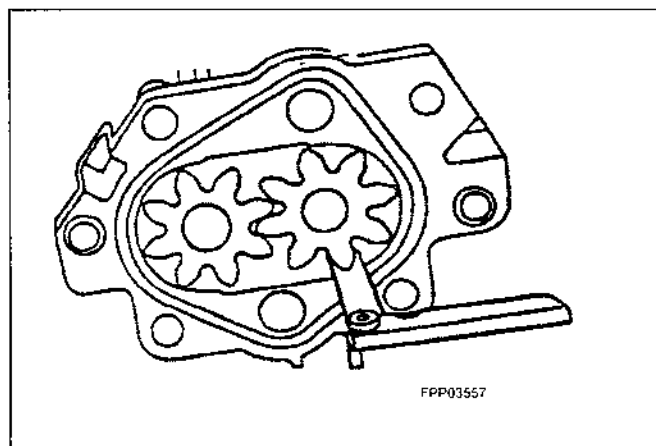

Oil Pump Rotor Inspection

- Inspect the oil pump rotor tips for damage or wear.

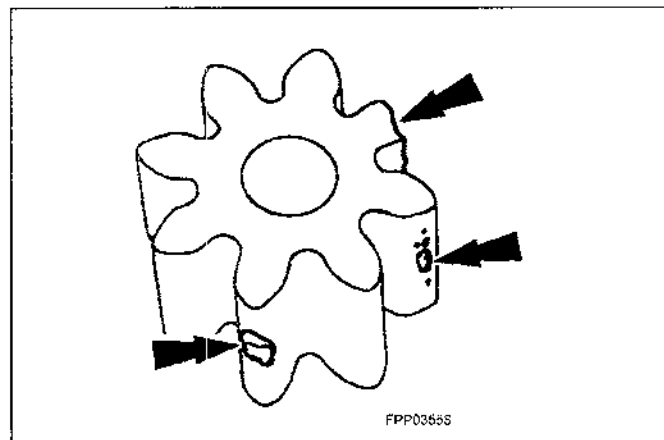

Oil Pump Side Clearance

Special Tool(s)

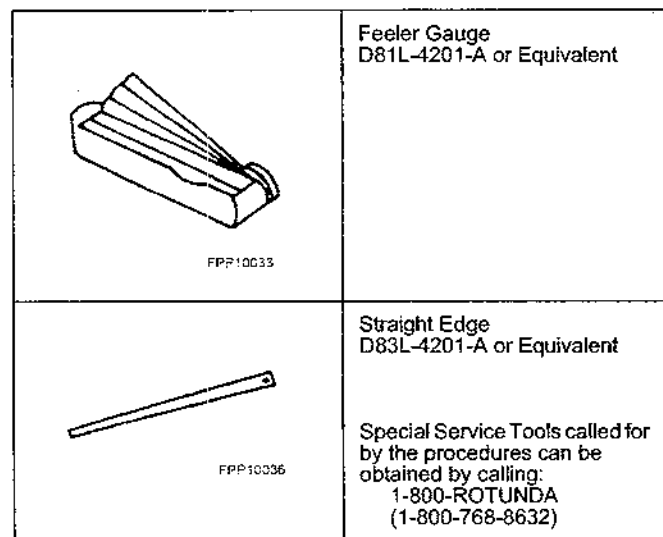

- Place the Straight Edge across the top of the oil pump and rotors and use the Feeler Gauge to measure the clearance between the rotors and the Straight Edge.

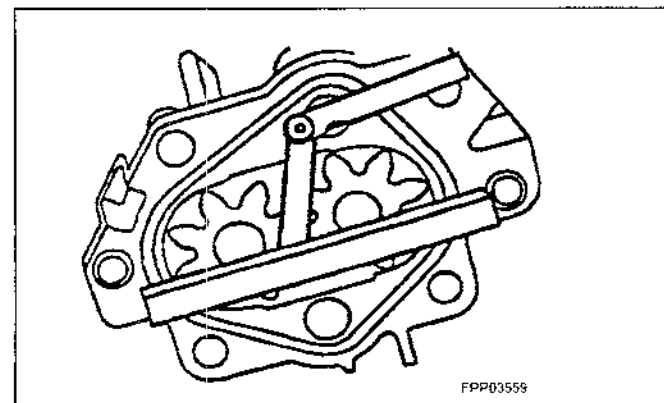

Cylinder Bore Honing

Special Tool(s)

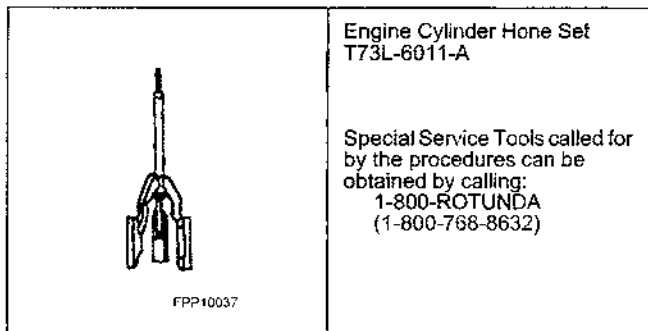

NOTE: Before any cylinder bore is honed, all main bearing caps must be installed so the crankshaft bearing bores will not become distorted.

NOTE: To correct taper or out-of-round, bore the cylinder block.

NOTE: Honing should be done when fitting new piston rings or to remove minor surface.

- hone with the Engine Cylinder Hone Set, at a speed of 300-500 rpm and a hone grit of 180-220 to provide the desired cylinder bore surface finish.

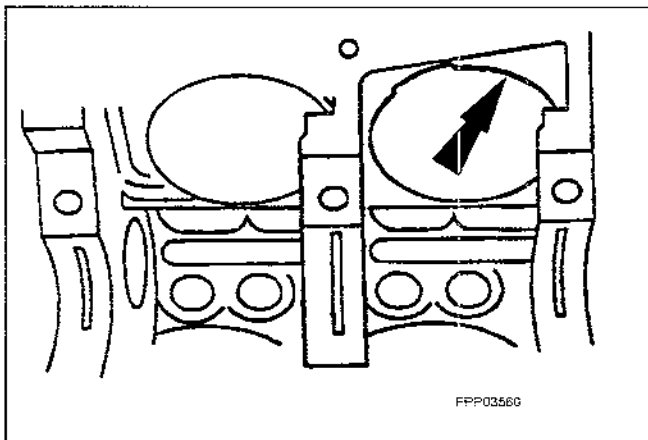

Cylinder Bore Cleaning

CAUTION: If these procedures are not followed, rusting of the cylinder bores may occur.

1. Clean the cylinder bores with soap or detergent and water.
2. Thoroughly rinse with clean water and wipe dry with a clean, lint-free cloth.
3. Use a clean, lint-free cloth and lubricate the cylinder bores.
 - Use Engine Oil XO-10W30-QSP or -DSP or equivalent meeting Ford specification ESE-M2C153-E.

Cylinder Block Repair - Cast Iron Porosity Defects

CAUTION: Do not attempt to repair cracks, areas where temperature will exceed 260°C (500°F) or areas exposed to engine coolant or oil. These areas will not repair and could cause future failure.

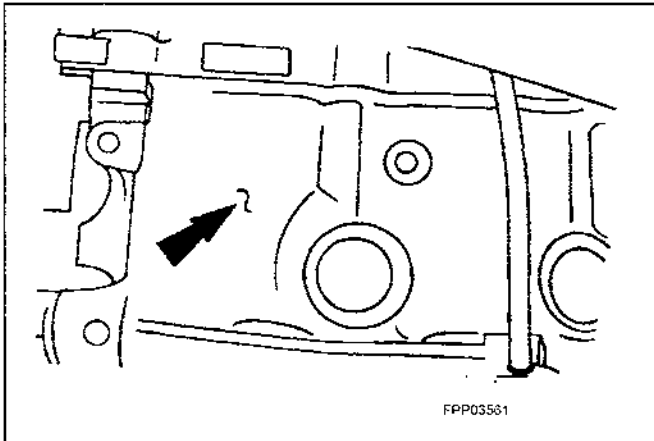

Repair porosity defects with an epoxy sealer meeting Ford specification M3D35-A (E).

1. Clean the surface to be repaired to a bright, oil-free metal surface.
2. Chamfer or undercut the repair area to a greater depth than the rest of the cleaned surface. Solid metal must surround the area to be repaired.
3. Apply the epoxy sealer and heat-cure with a 250-watt lamp placed 254 mm (10 inches) from the repaired surface, or air dry for 10-12 hours at a temperature above 10°C (50°F).
4. Sand or grind the repaired area to blend with the general contour of the surface.
5. Paint the surface to match the rest of the cylinder block.

Cylinder Block Core Plug Replacement

Special Tool(s)

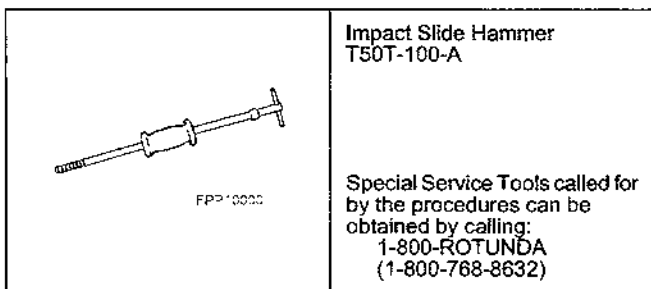

1. Use a slide hammer or tools suitable to remove the cylinder block core plug.

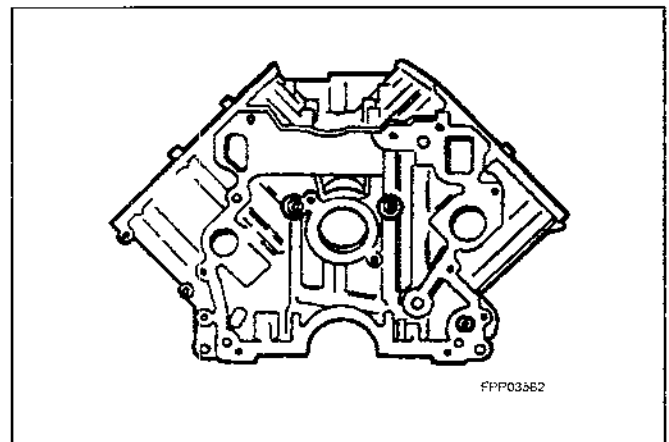

2. Inspect the cylinder block plug bore for any damage that would interfere with the proper sealing of the plug. If the cylinder block plug bore is damaged, bore for the next oversize plug.

NOTE: Oversize plugs are identified by the OS stamped in the flat located on the cup side of the plug.

3. Coat the cylinder block core plug and bore lightly with Threadlock® 262 E2FZ-19554-B or equivalent meeting Ford specification WSK-M2G351-A6 and install the cylinder block core plug.

Cylinder Head - Distortion

Special Tool(s)

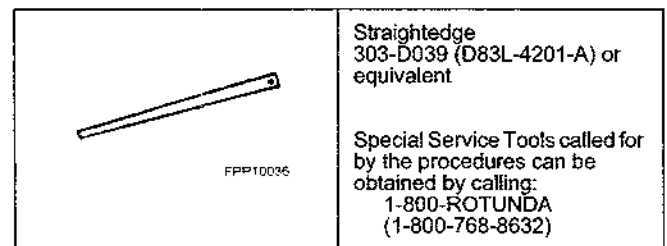

- Use a straight edge and a feeler gauge to inspect the cylinder head for flatness. If the cylinder head is distorted, install a new cylinder head.

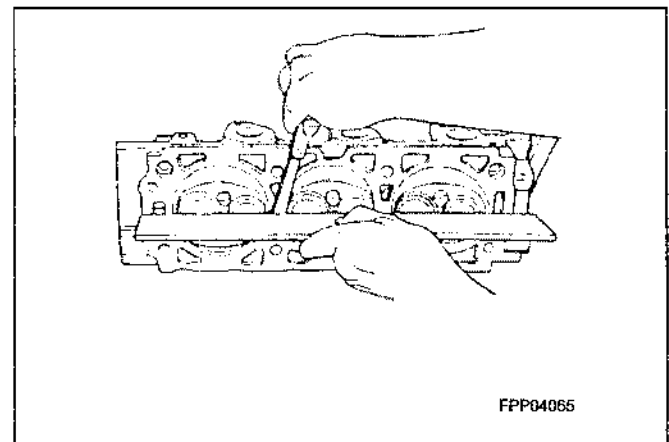

Cylinder Block Core Plug – Cup-Type

CAUTION: Do not contact the flange when installing a cup type cylinder block core plug as this could damage the sealing edge and result in leakage.

NOTE: When installed, the flanged edge must be below the chamfered edge of the bore to effectively seal the bore.

- Use a fabricated tool to seat the cup type cylinder block core plug.

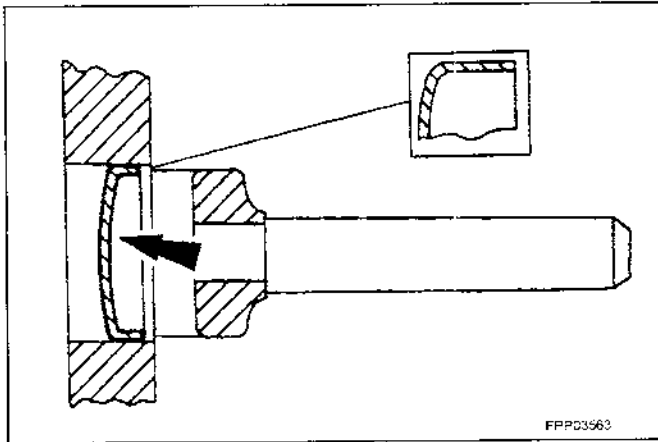

Cylinder Block Core Plug – Expansion-Type

CAUTION: Do not contact the crown when installing an expansion type cylinder block core plug. This could expand the plug before seating and result in leakage.

- Use a fabricated tool to seat the expansion type cylinder block core plug.

Spark Plug Thread Repair

Special Tool(s)

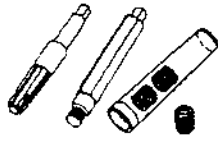
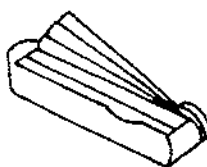
 <p>FPP10035</p>	<p>Tapersert Installation Kit 107-R0921 or Equivalent</p>
 <p>FPP10033</p>	<p>Feeler Gauge D81L-4201-A or Equivalent</p> <p>Special Service Tools called for by the procedures can be obtained by calling: 1-800-ROTUNDA (1-800-768-8632)</p>

CAUTION: The cylinder head must be removed from the engine before installing a tapersert. If this procedure is done with the cylinder head on the engine, the cylinder walls can be damaged by metal chips produced by the thread cutting process.

CAUTION: Do not use power or air-driven tools for finishing taperserts.

NOTE: This repair is permanent and will have no effect on cylinder head or spark plug life.

1. Clean the spark plug seat and threads.

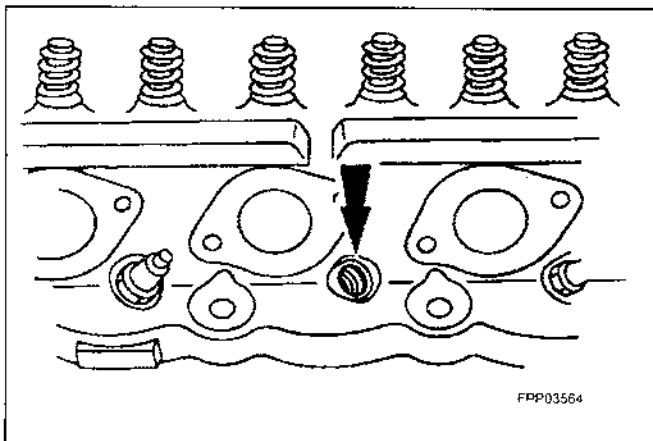

2. Start the tap into the spark plug hole, being careful to keep it properly aligned. As the tap begins to cut new threads, apply aluminum cutting oil

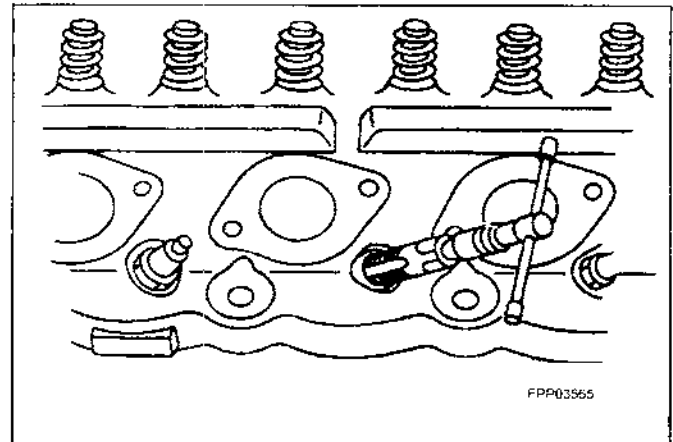

3. Continue cutting the threads and applying oil until the stop ring bottoms against the spark plug seat.
4. Remove the tap and metal chips.
5. Coat the threads of the mandrel with cutting oil. Thread the tapersert onto the mandrel until one thread of the mandrel extends beyond the tapersert.

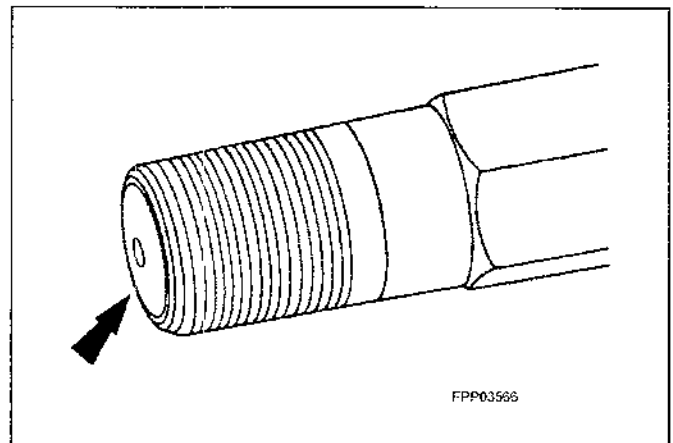

NOTE: A properly installed tapersert will be either flush with or 1.0 mm (0.039 inch) below the spark plug gasket seat.

6. Tighten the fapersert into the spark plug hole.

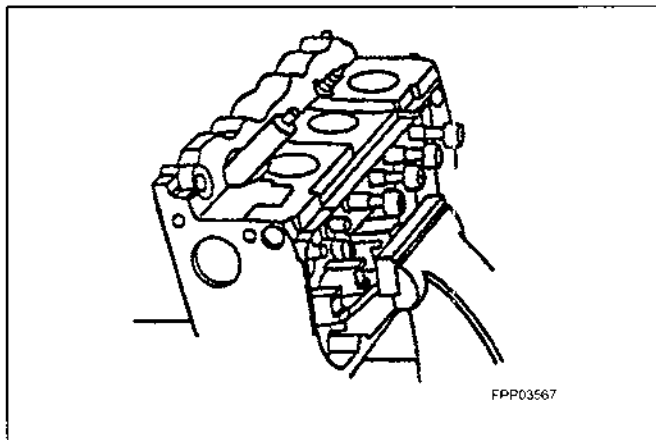

7. Turn the mandrel body approximately one-half turn counterclockwise and remove.

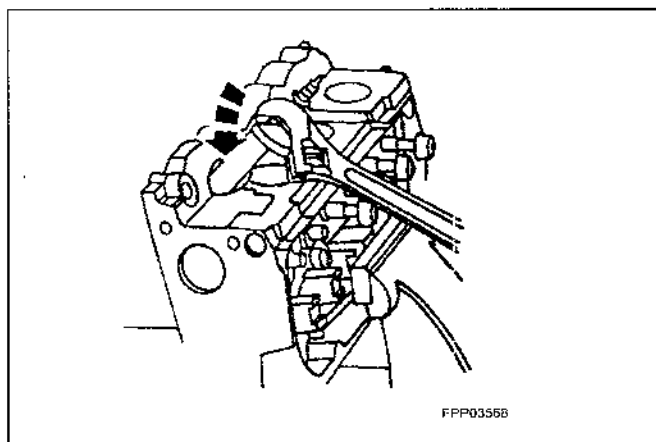

Exhaust Manifold Straightness

Special Tool(s)

	Straightedge 303-D039 (D83L-4201-A) or equivalent
	Special Service Tools called for by the procedures can be obtained by calling: 1-800-ROTUNDA (1-800-768-8632)

- Place the Straightedge across the exhaust manifold flanges and check for warping with a feeler gauge.

NOTE: The exhaust manifold shown is a typical exhaust manifold.

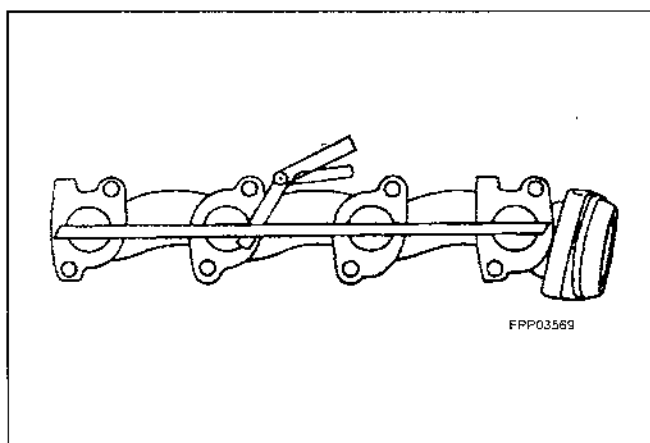

SPECIFICATIONS

GENERAL SPECIFICATIONS	
Epoxy Sealer	M3D35-A (E)
Threadlock 262 E2FZ-19554-B	WSK-M2G351-A6
Engine Oil SAE 5W30	D9AZ-19579A

NOTE: Ford Power Products industrial engines are designed to perform with engine oils that are licensed by the American Petroleum Institute (API), and oils carrying the most current API classification should be used.

INDEX

Subject	Page
General Information	
Description	02 - 3
Engine Identification	02 - 3
Engine Code Information	02 - 3
Module View	02 - 4
Engine Intake Components	02 - 5
Low End Components	02 - 7
Upper End Components	02 - 9
Major Front End Components	02 - 11
Diagnosis and Testing	02 - 12
Engine Repair	
Intake Manifold - Variable Resonance Induction System (VRIS) - Removal	02 - 13
Intake Manifold - Variable Resonance Induction System (VRIS) - Installation	02 - 15
Valve Cover - Left - Removal	02 - 19
Valve Cover - Left - Installation	02 - 20
Valve Cover - Right - Removal	02 - 22
Valve Cover - Right - Installation	02 - 22
Crankshaft Pulley - Removal	02 - 25
Crankshaft Pulley - Installation	02 - 26
Crankshaft Front Oil Seal - Removal	02 - 27
Crankshaft Front Oil Seal - Installation	02 - 28
Front Engine Cover - Removal	02 - 29
Front Engine Cover - Installation	02 - 30
Timing Drive Components - Removal	02 - 34
Timing Drive Components - Installation	02 - 38
Camshaft - Removal	02 - 48
Camshaft - Installation	02 - 49
Exhaust Manifold - RH - Removal	02 - 53
Exhaust Manifold - RH - Installation	02 - 54
Exhaust Manifold - LH - Removal	02 - 55
Exhaust Manifold - LH - Installation	02 - 56
Cylinder Head - Removal	02 - 56
Cylinder Head - Installation	02 - 58
Oil Level Indicator Tube - Removal	02 - 60
Oil Level Indicator Tube - Installation	02 - 60
Oil Pan - Removal	02 - 61
Oil Pan - Installation	02 - 63
Oil Pump - Removal	02 - 65
Oil Pump - Installation	02 - 65
Flywheel - Removal	02 - 66
Flywheel - Installation	02 - 66
Crankshaft Rear Oil Seal - Removal	02 - 67
Crankshaft Rear Oil Seal - Installation	02 - 68
Crankshaft Rear Oil Seal (with retainer plate) - Removal	02 - 69
Crankshaft Rear Oil Seal (with retainer plate) - Installation	02 - 70
Engine - Removal	02 - 72
Engine - Disassembly	02 - 76
Cylinder Head - Disassembly	02 - 93
Cylinder Head - Assembly	02 - 96
Engine - Assembly	02 - 100
Engine - Installation	02 - 125

INDEX (CONT.)

Subject	Page
Specifications	
Torque Specifications.....	02 - 128
General Specifications	02 - 128

GENERAL INFORMATION

Description

The 6.8 liter engine consists of four basic modules that can be repaired individually. Remove only those components required to repair the module.

The induction module consists of an upper and lower intake manifold (9424).

Each aluminum cylinder head module utilizes a single overhead camshaft (6250) to operate the two-valves-per-cylinder design. Individual ignition coils (12029) are used for each spark plug (12405).

The cylinder block module is a cast iron, 90-degree V-10 cylinder block (6010).

The basic engine components consist of the following:

- Two overhead camshafts.
- Engine dynamic balance shaft.
- Two valves per cylinder.
- Aluminum cylinder heads (6049).
- Cast iron, 90-degree V-10 cylinder block.
- Two-piece aluminum intake manifold system.

Engine Identification

It is important the engine codes and the calibration number be used when ordering parts or making inquiries about the engine.

Engine Code Information

The engine code information label, located on the valve cover, contains the following:

- Engine build date.
- Engine code.

Module View

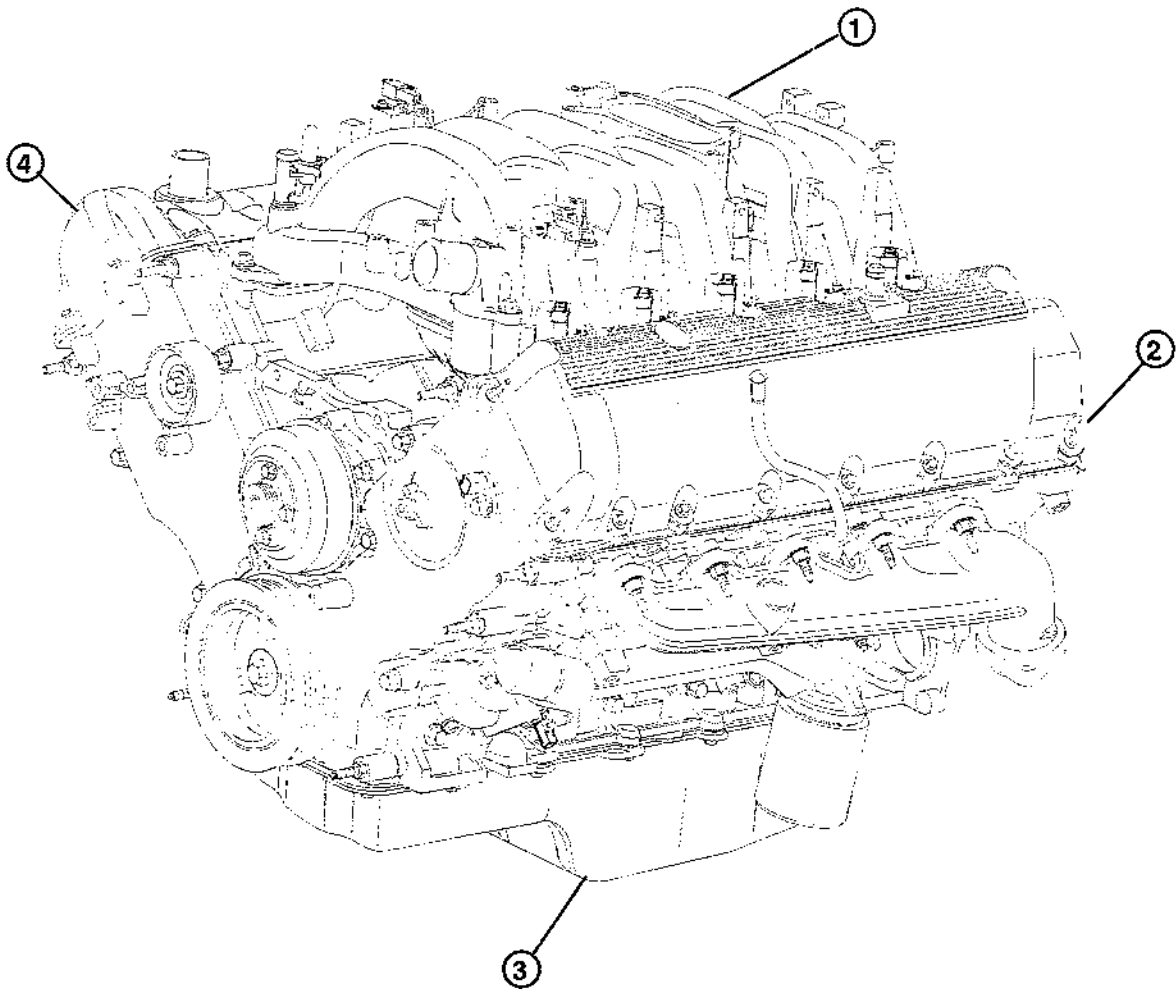

Item	Part Number	Description
1	-	Induction Module
2	-	Cylinder Head Module (LH)
3	-	Cylinder Block Module
4	-	Cylinder Head Module (RH)

Engine Intake Components

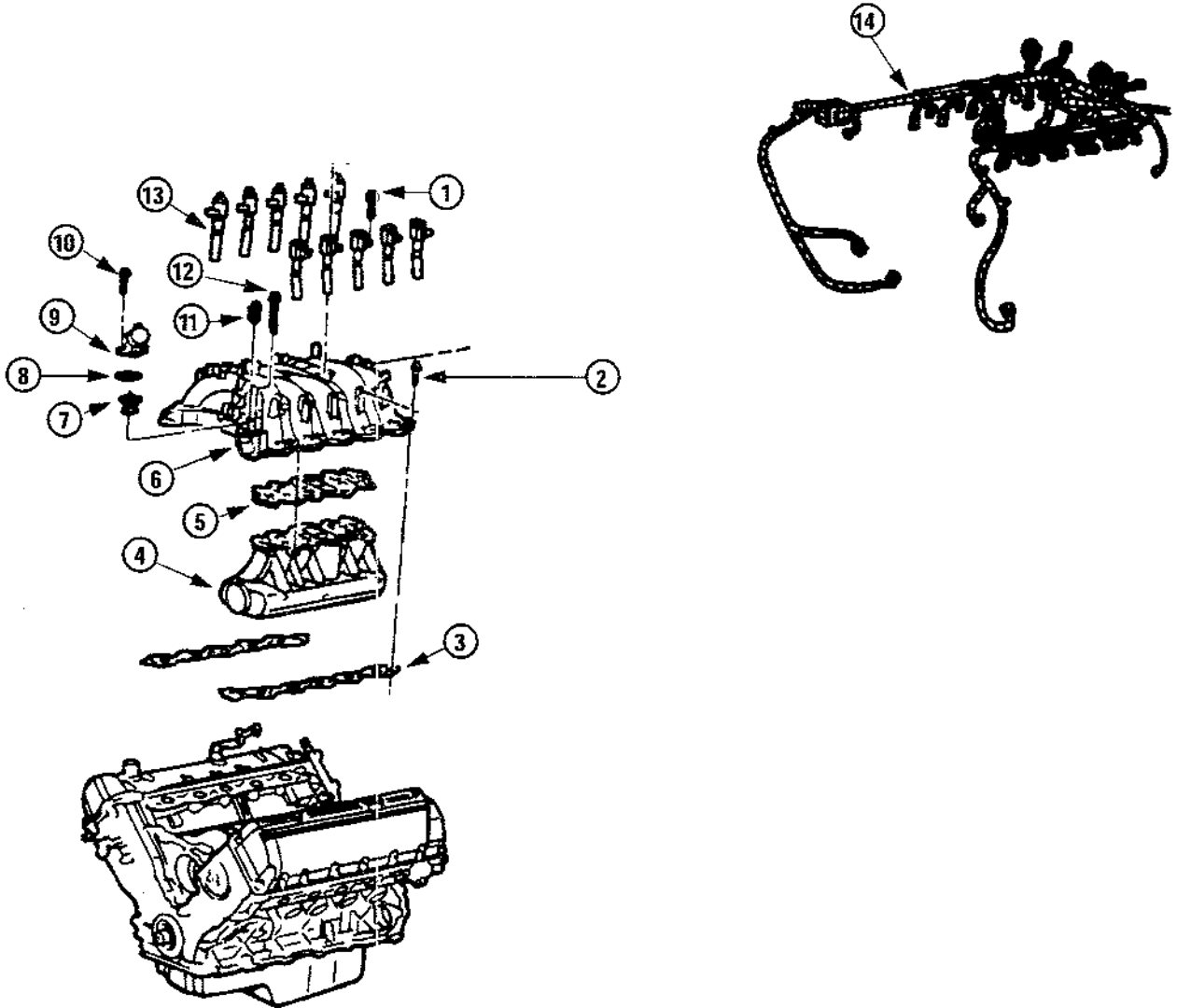

DA0443-A

Item	Part Number	Description
1	N606500	Bolt (10 Req'd)
2	N806156	Bolt (11 Req'd)
3	9439	Intake Manifold Gasket
4	9424	Intake Manifold
5	9461	Intake Manifold Gasket
6	9424	Intake Manifold (Upper)
7	9575	Water Thermostat
8	N806807	O-Ring Seal
9	8494	Water Outlet Connection
10	N806178	Bolt (3 Req'd)
11	10884	Water Temperature Indicator Sender Unit
12	N806178	Bolt (2 Req'd)
13	12A366	Ignition Coil and Boot (10 Req'd)
14	12B637	Ignition Harness

Low End Components

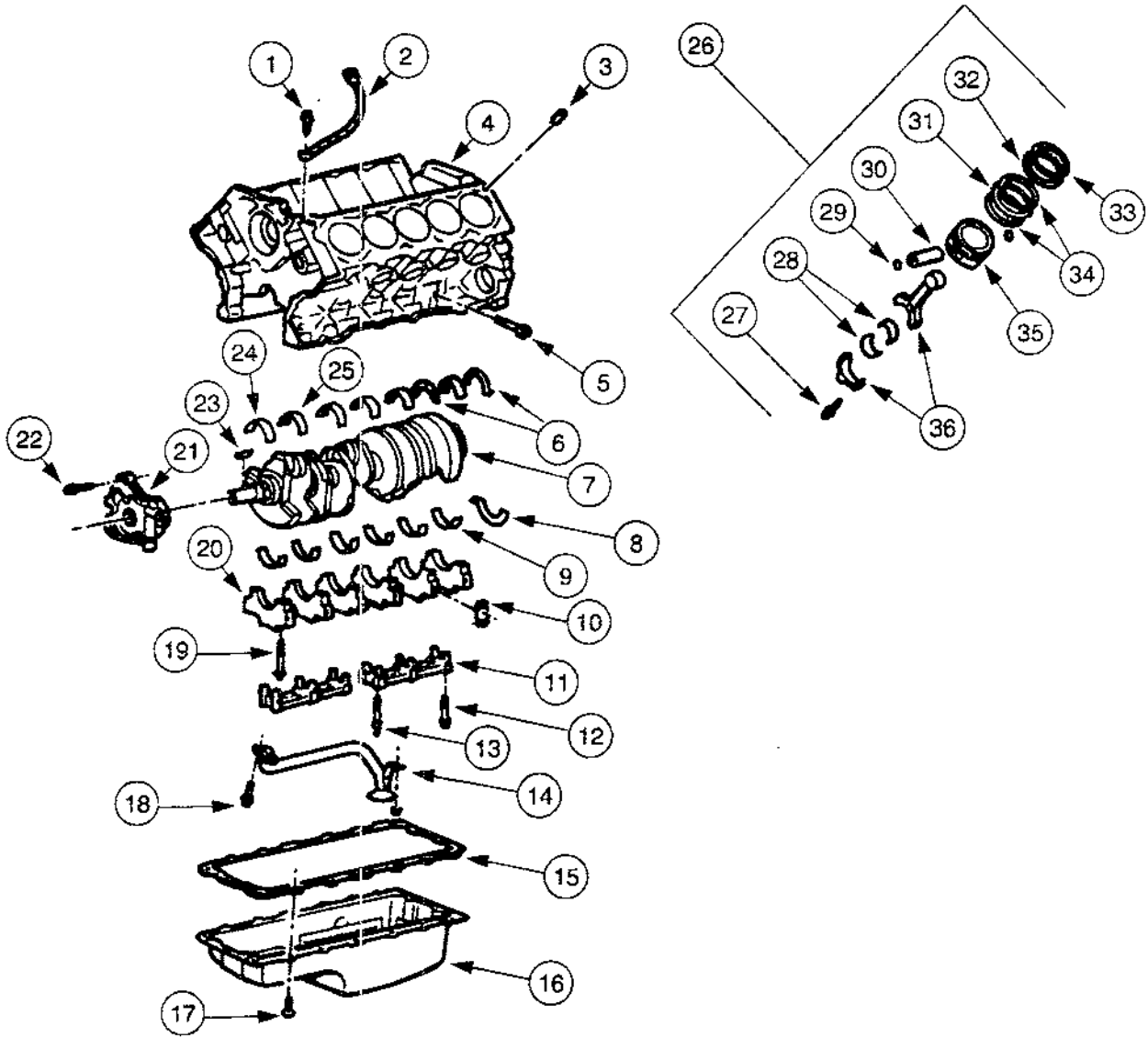

DA0442-A

WSG-1068 ENGINE

Item	Part Number	Description
1	W500225	Bolt
2	12A699	Knock Sensor
3	N806459	Dowel (4 Req'd)
4	6010	Cylinder Block
5	6345	Crankshaft Main Bearing Cap Stud
6	6334	Crankshaft Thrust Washer (Upper) (2 Req'd)
7	6303	Crankshaft
8	6K302	Crankshaft Thrust Washer (Lower)
9	6333	Crankshaft Main Bearing (Lower)
10	6A346	Dowel
11	6F098	Support
12	N811025	Bolt
13	N811026	Stud
14	6622	Oil Pump Screen Cover and Tube
15	6710	Oil Pan Gasket
16	6675	Oil Pan
17	W701605	Bolt
18	N806155	Bolt

Item	Part Number	Description
19	6345	Crankshaft Main Bearing Cap Stud
20	6325	Crankshaft Main Bearing Cap
21	6600	Oil Pump
22	N806183	Bolt
23	N806201	Key
24	6W337	Crankshaft Upper Main Bearing Shell
25	6333	Crankshaft Main Bearing (Upper)
26	6100	Piston/Connecting Rod Assy.
27	6214	Connecting Rod Bolt
28	6211	Connecting Rod Bearing
29	6140	Piston Pin Retainer
30	6135	Piston Pin
31	6161	Piston Ring, Spacer Oil Control
32	6152	Compression Ring (Lower)
33	6150	Compression Ring (Upper)
34	6159	Piston Ring, Segment Oil Control
35	6108	Piston
36	6200	Connecting Rod

Upper End Components

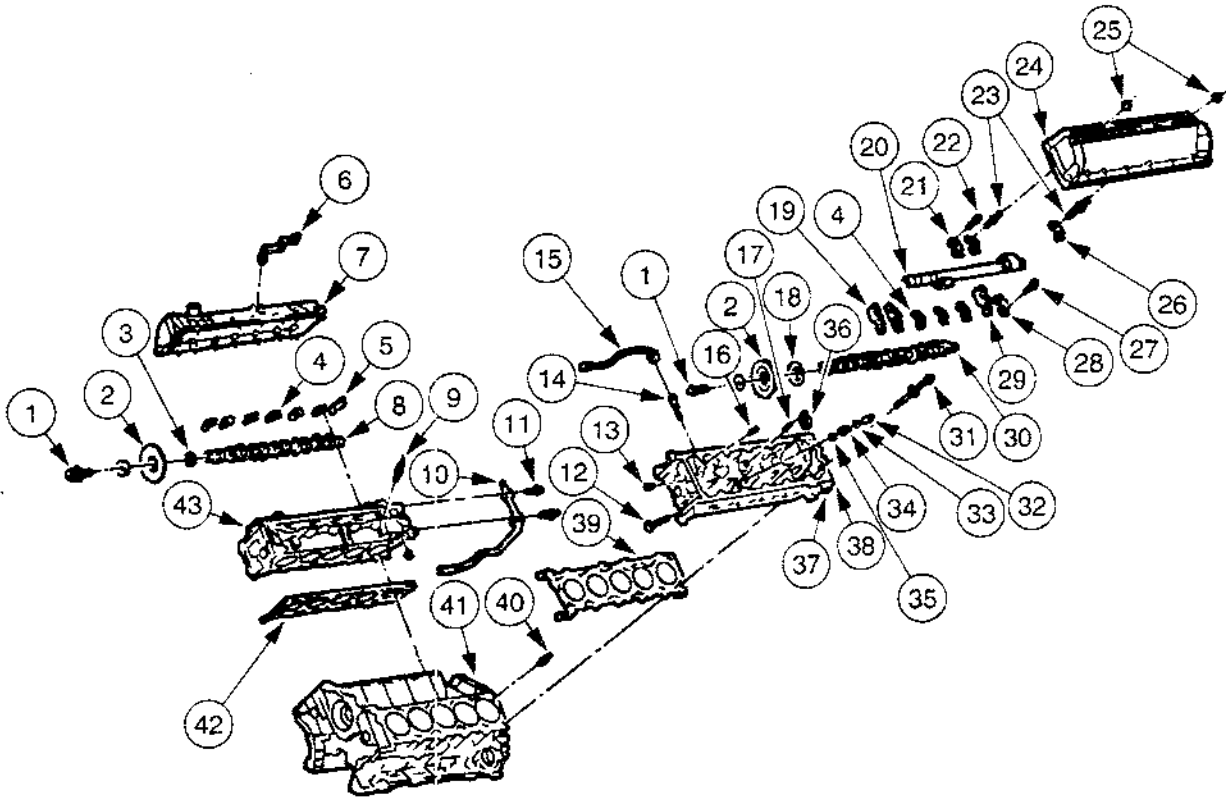

DA0444-B

WSG-1068 ENGINE

Item	Part Number	Description
1	N811085	Bolt
2	6256	Camshaft Sprocket
3	6265	Camshaft Sprocket Spacer
4	6C268	Camshaft Bearing Cap
5	6B284	Camshaft Bearing Cap
6	6C324	Crankcase Vent Connector and Hose
7	6582	Valve Cover
8	6250	Camshaft
9	12405	Spark Plug
10	18663	Heater Water Outlet Tube
11	N808897	Bolt (2 Req'd)
12	-	Valve (Part of 6049)
13	87838	Plug (6 Req'd)
14	6G004	Cylinder Head Temperature Sensor
15	14B102	Electrical Connector
16	6F087	Cylinder Head Oil Reservoir Restrictor
17	6500	Hydraulic Lash Adjuster
18	6A303	Balance Shaft Drive Gear
19	7C272	Balance Shaft Journal
20	6A305	Balance Shaft
21	6C267	Balance Shaft Journal Cap

Item	Part Number	Description
22	N808777	Bolt (4 Req'd)
23	N808775	Bolt
24	6582	Valve Cover
25	N805320	Nut (2 Req'd)
26	6C266	Balance Shaft Journal Cap (2 Req'd)
27	N807834	Fastener (26 Req'd)
28	6B280	Camshaft Bearing Cap
29	6C266	Balance Shaft Journal (2 Req'd)
30	6250	Camshaft
31	6065	Cylinder Head Stud
32	6518	Valve Spring Retainer Key
33	6514	Valve Spring Retainer
34	6513	Valve Spring
35	6571	Valve Stem Seal
36	6564	Rocker Arm
37	87836	Plug (2 Req'd)
38	6049	Cylinder Head
39	6051	Head Gasket
40	N806459	Dowel (4 Req'd)
41	6010	Cylinder Block
42	6051	Head Gasket
43	6049	Cylinder Head

Major Front End Components

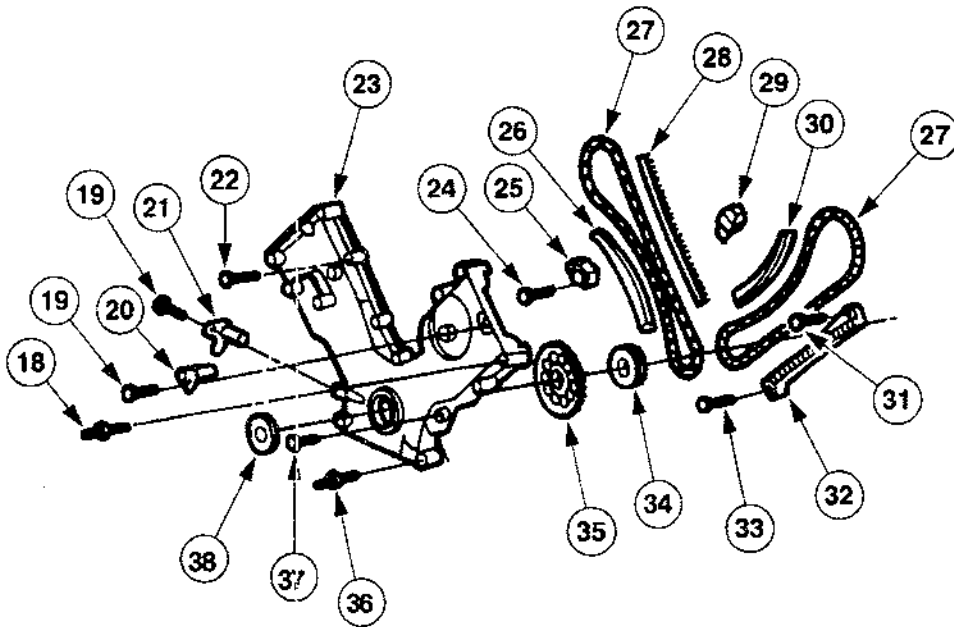
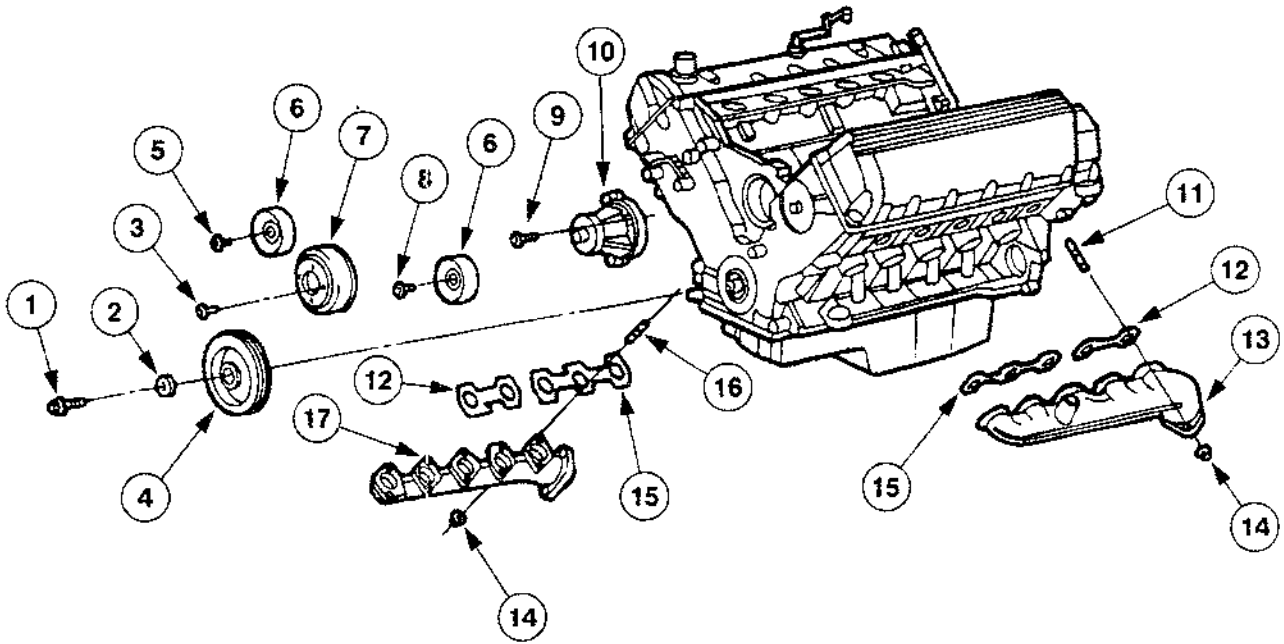

AA2902-A

Item	Part Number	Description
1	N806139	Damper Bolt
2	N806165	Washer
3	N806282	Bolt (4 Req'd)
4	6316	Front Crankshaft Damper
5	N806102	Bolt
6	12A216	Idler Pulley
7	8509	Water Pump Pulley
8	N808102	Bolt
9	-	Bolt (4 Req'd)
10	8501	Water Pump
11	811313	Stud (10 Req'd)
12	9448	Exhaust Manifold Gasket
13	9430	Exhaust Manifold
14	W701706	Bolt (10 Req'd)
15	9448	Exhaust Manifold Gasket
16	W701706	Stud (10 Req'd)
17	9430	Exhaust Manifold
18	N808140	Fastener (5 Req'd)
19	N806155	Bolt
20	6B288	Camshaft Position Sensor

Item	Part Number	Description
21	6C315	Crankshaft Position Sensor
22	N808142	Bolt (3 Req'd)
23	6019	Engine Front Cover
24	N606543	Bolt (4 Req'd)
25	6L266	Timing Chain Tensioner (RH)
26	6L253	Timing Chain Tensioner Arm (RH)
27	6268	Timing Chain/Belt (2 Req'd)
28	6K297	Timing Chain Guide (RH)
29	6L266	Timing Chain Tensioner (LH)
30	6L253	Timing Chain Tensioner Arm (LH)
31	N605892	Bolt (3 Req'd)
32	6K297	Timing Chain Guide (LH)
33	N606427	Bolt
34	6306	Crankshaft Sprocket
35	12A227	Crankshaft Sensor Ignition Pulse Ring
36		Fasteners (2 Req'd)
37	N806177	Bolt (5 Req'd)
38	6700	Crankshaft Front Seal

DIAGNOSIS AND TESTING

Refer to Section 01 for basic mechanical concerns.

ENGINE REPAIR

Intake Manifold – Variable Resonance Induction System (VRIS) - Removal

 **WARNING: DO NOT SMOKE OR CARRY LIGHTED TOBACCO OR OPEN FLAME OF ANY TYPE WHEN WORKING ON OR NEAR ANY FUEL-RELATED COMPONENTS. HIGHLY FLAMMABLE MIXTURES ARE ALWAYS PRESENT AND CAN BE IGNITED, RESULTING IN POSSIBLE PERSONAL INJURY.**

 **WARNING: FUEL IN THE FUEL SYSTEM REMAINS UNDER HIGH PRESSURE EVEN WHEN THE ENGINE IS NOT RUNNING.**

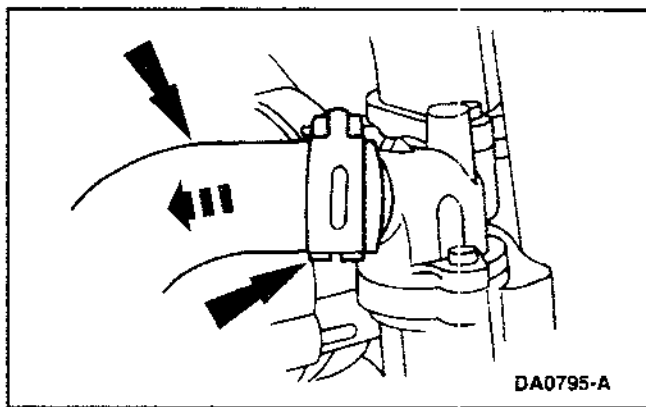

1. Disconnect the battery ground cable (14301).
2. Drain the coolant system.
3. Loosen and slide the hose clamp and disconnect the water outlet hose.
4. Remove the engine vacuum hoses.

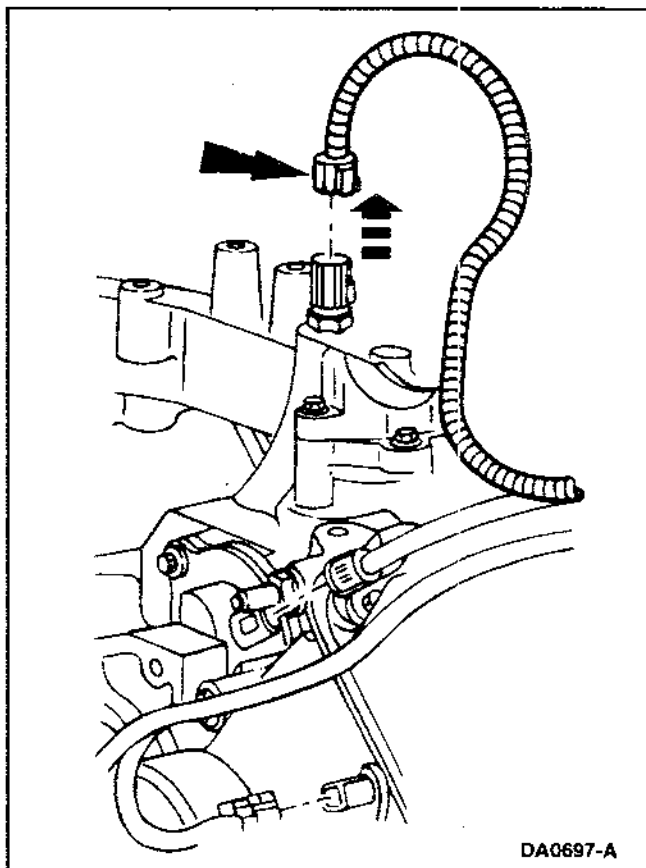

5. Disconnect the water temperature indicator sender unit electrical connectors.
6. Disconnect and remove the ten ignition coils (12029); refer to Section 03.
7. Remove the drive belt (8620); refer to Section 05.
8. Remove the generator (GEN) (10300); refer to Section 06.

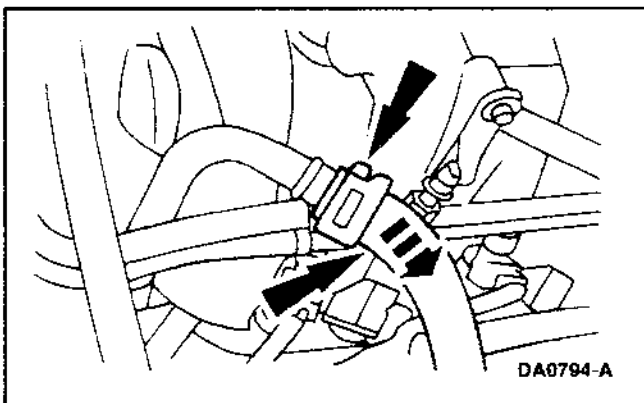

9. Disconnect the hose clamps and remove the heater water hose (18472).
10. Remove the water thermostat (8575).
11. Remove the two studs retaining the heater water return tube.

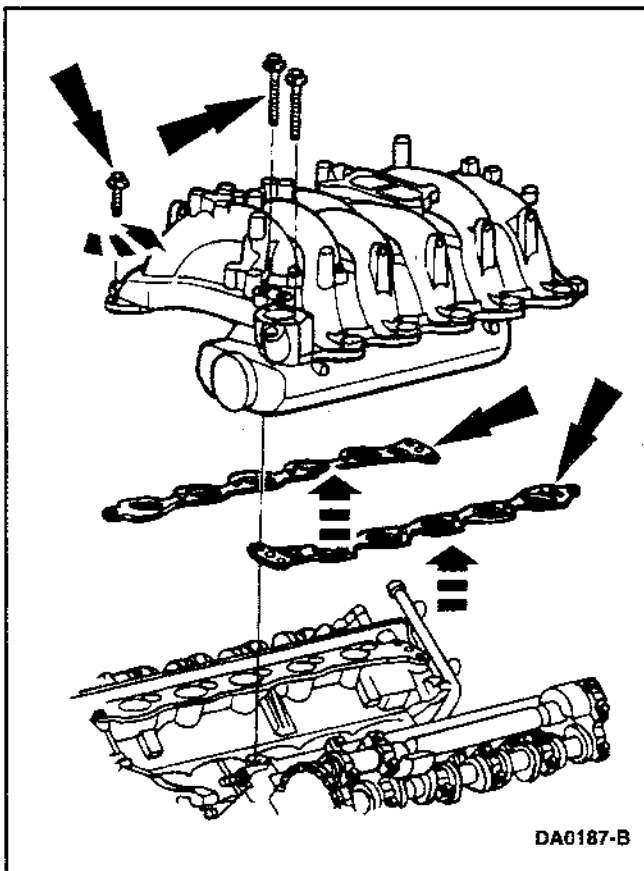

12. Remove the bolts, the upper intake manifold and the intake manifold gasket (9439). Discard the intake manifold gaskets.

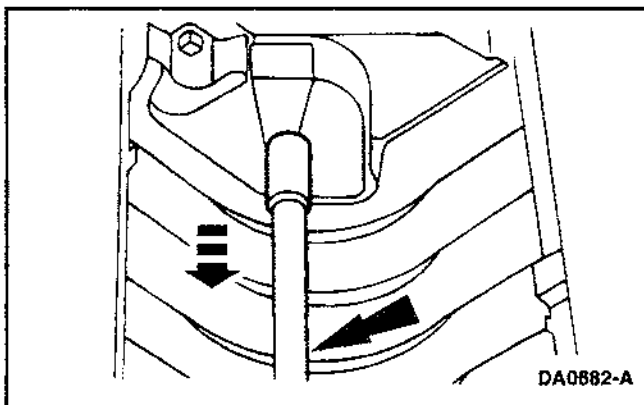

13. Pull back and remove the heater water return tube. Inspect the O-rings and replace if required.

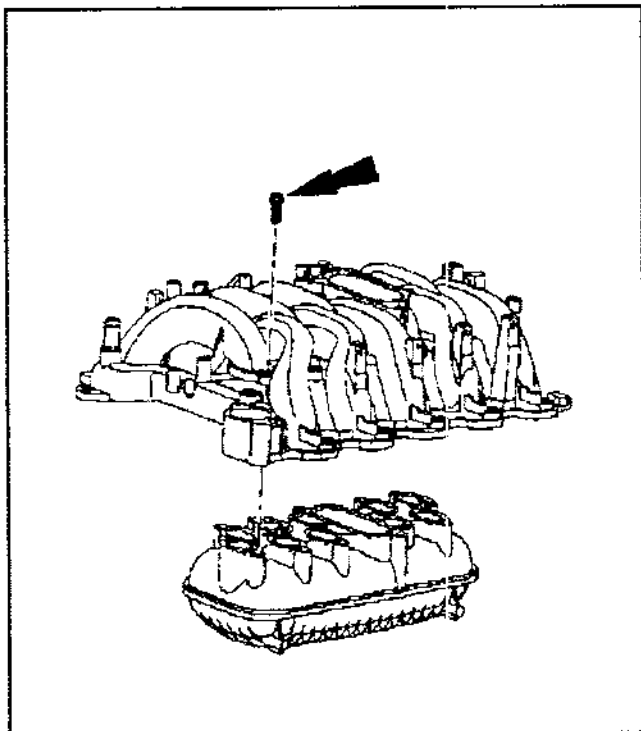

14. Separate the upper and lower intake manifolds (9424).
 - Remove the ten bolts.
 - Discard the intake manifold gasket.
15. Clean all mating surfaces.

Intake Manifold – Variable Resonance Induction System (VRIS) - Installation

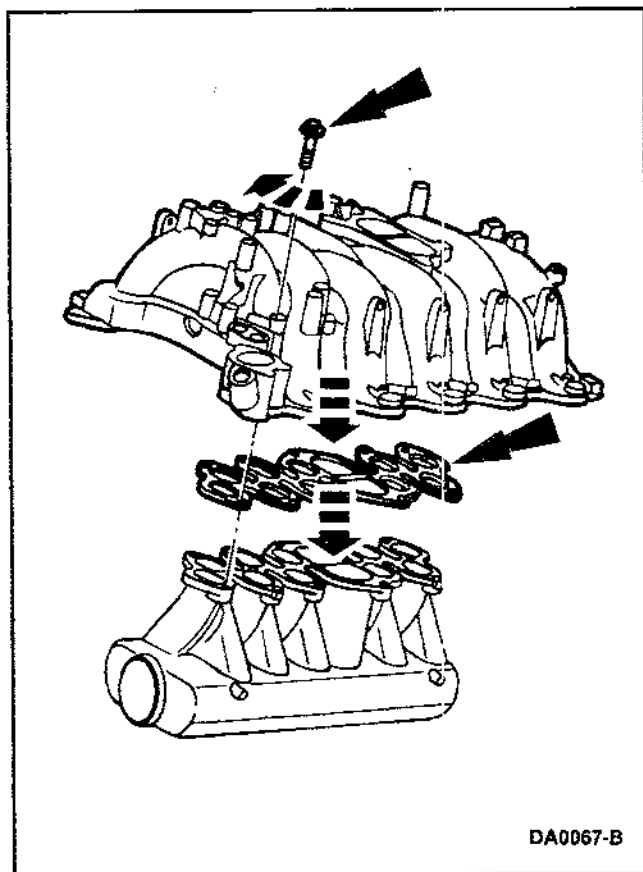

1. Position the lower intake manifold gasket (9461) and the upper intake manifold on the intake manifold and loosely install the ten bolts.

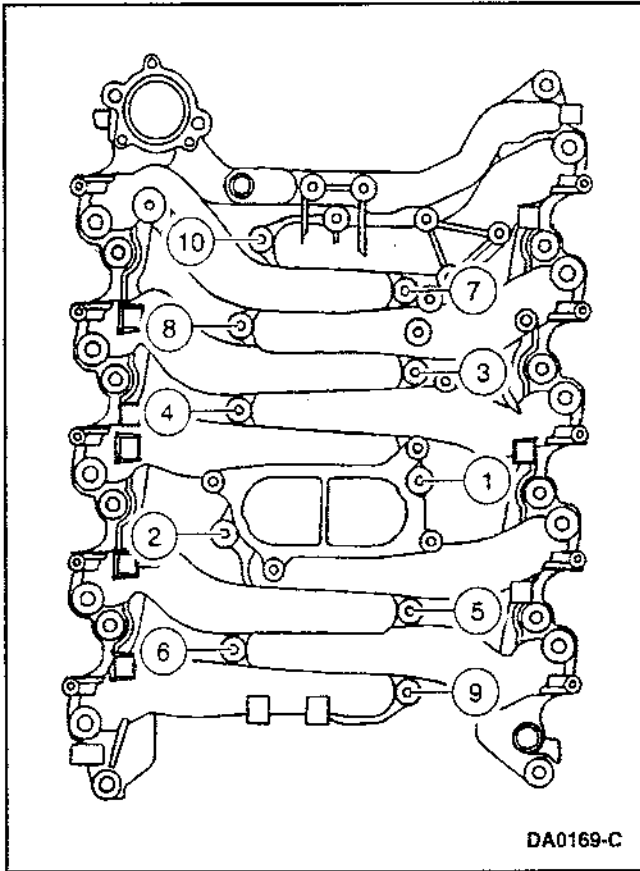

2. **NOTE:** Tighten the bolts in two stages.

Tighten the bolts in the sequence shown.

- Stage 1: Tighten to 2 Nm (18 lb/in).
- Stage 2: Tighten to 8-12 Nm (71-106 lb/in).

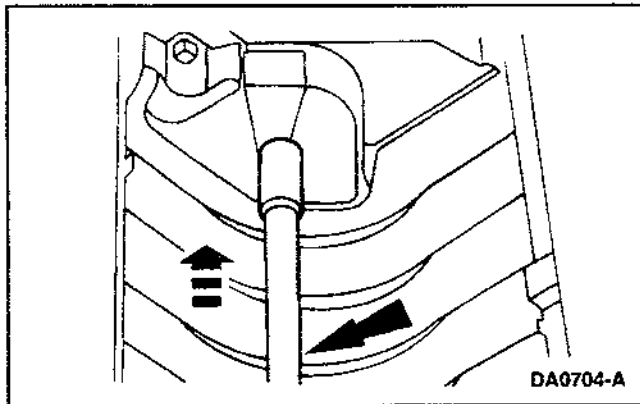

3. Position the water return tube as shown.

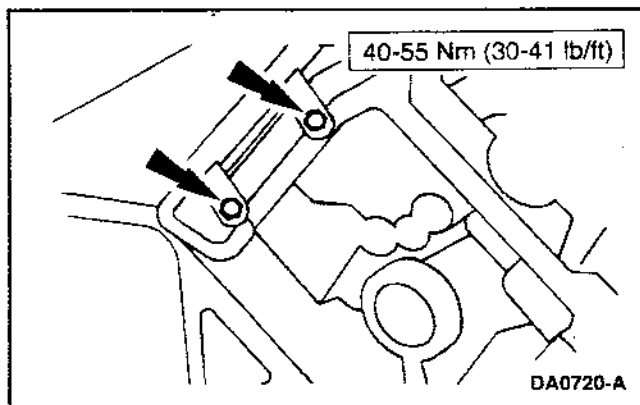

4. Install the heater water return tube studs.

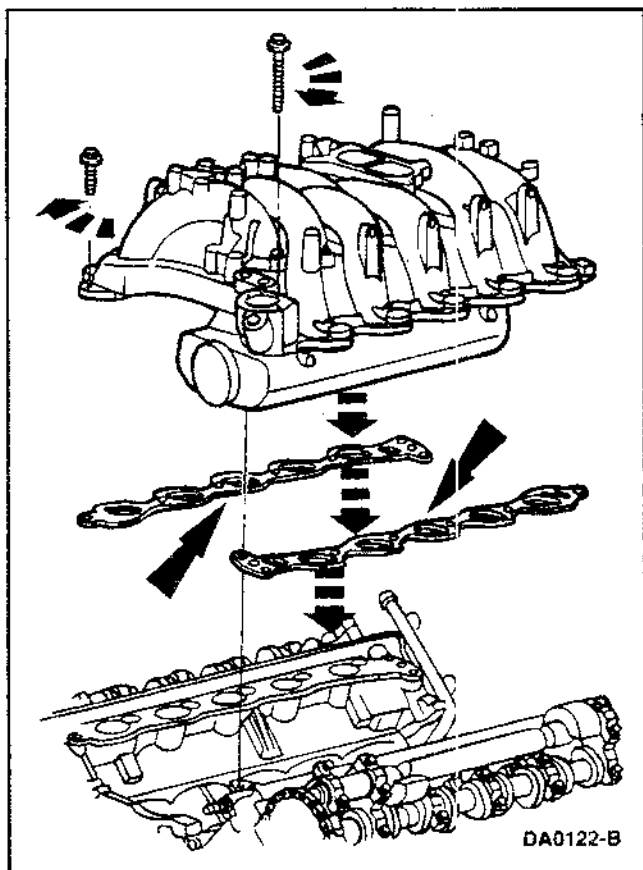

5. Install the upper intake manifold.
 - Position the upper intake manifold gaskets and the intake manifold, and loosely install the bolts.

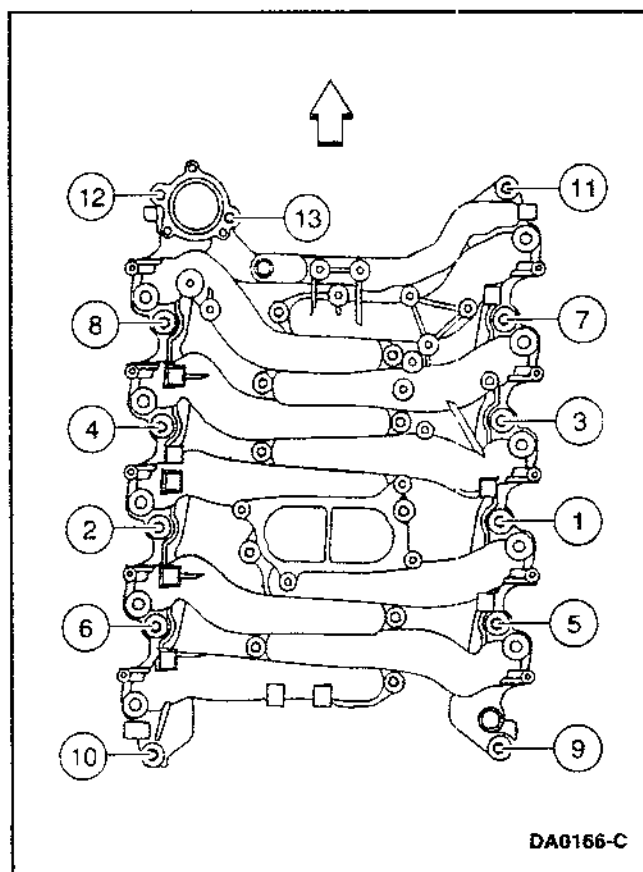

6. Install the thermostat, gasket and the thermostat housing and loosely install the bolts.
7. **NOTE:** Be sure to tighten the bolts in two stages.

Tighten the bolts in the sequence shown.

 - Stage 1: Tighten to 2 Nm (18 lb/in).
 - Stage 2: Tighten to 20-30 Nm (15-22 lb/ft).

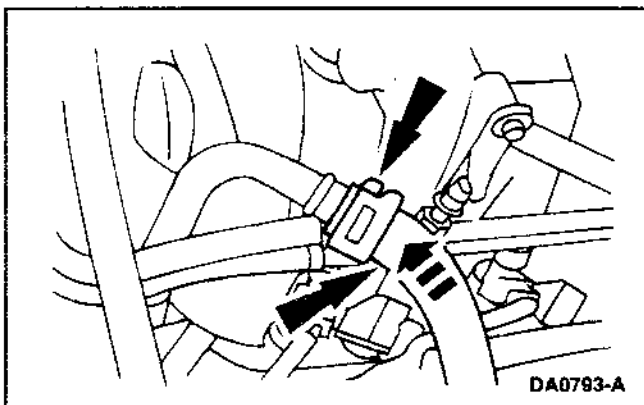

8. Install the heater water hose and position the clamp.

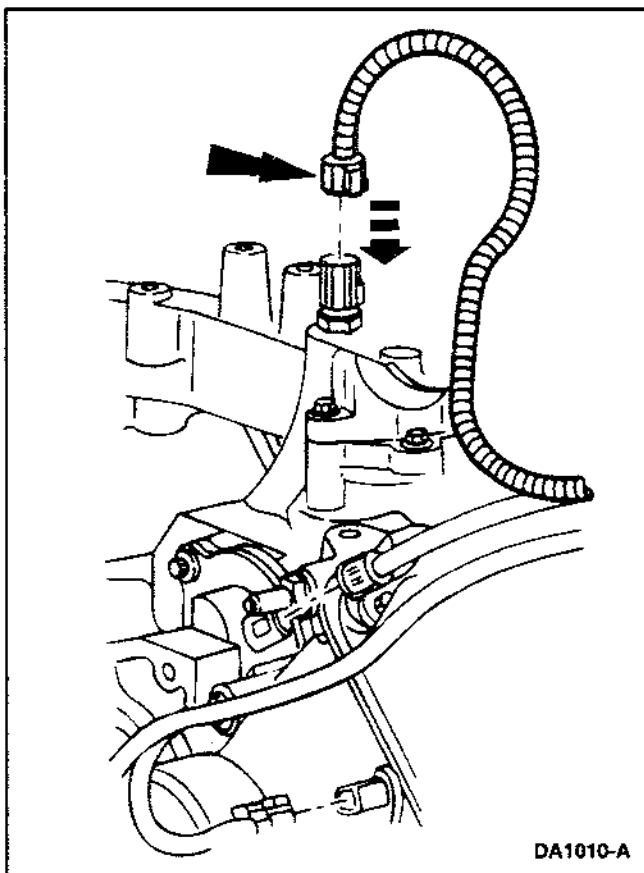

9. Connect the water temperature indicator sending unit electrical connector.

10. Install the generator.

11. Install the drive belt

12. Install the ignition coils.

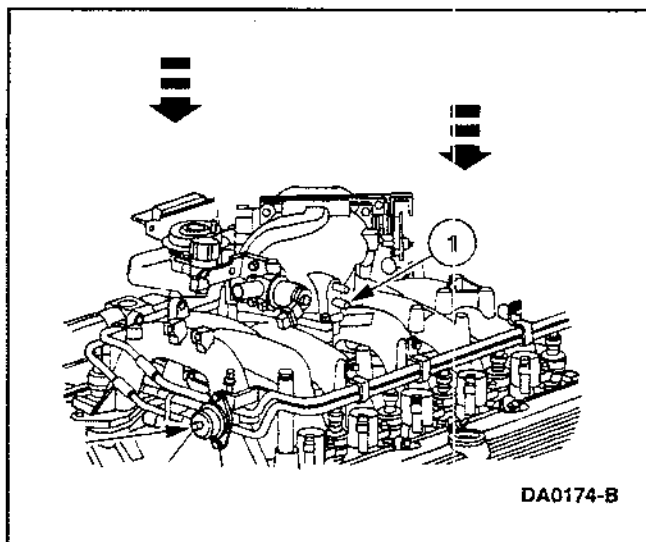

13. Connect the engine vacuum hoses.

- Vacuum source.

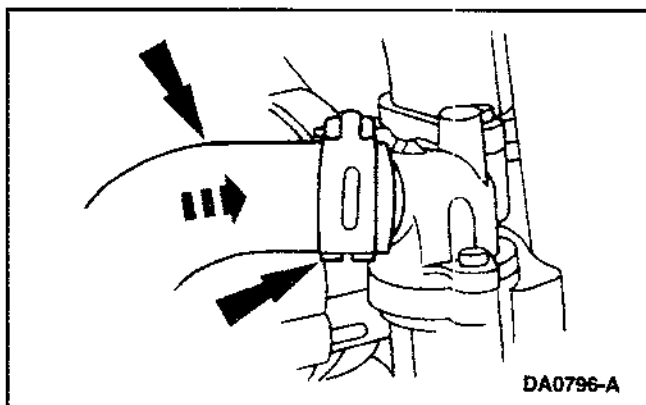

14. Connect the engine water outlet hose and position the hose clamp.

15. Install the air cleaner outlet tube (9B659).

16. Fill the cooling system; refer to Section 05.

17. Install the engine cover.

18. Connect the battery ground cable.

Valve Cover – Left - Removal

1. **NOTE:** The bolts are a part of the valve cover (6582) and are not to be removed.

Fully loosen the valve cover.

- Remove the two nuts and the sixteen bolts, and remove the valve cover and the valve cover gasket (6584).

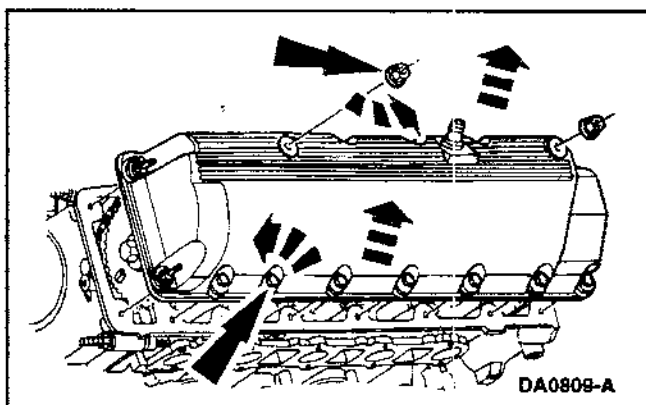

Valve Cover – Left - Installation

1. **⚠ CAUTION:** Mating parts must make contact to each other within 4 minutes and connecting bolts must be torqued within 15 minutes after applying sealant. Failure to follow this procedure can cause future oil leakage.

- Use silicone gasket and sealant F6AZ-19562-AA or equivalent meeting Ford specification WSE-M4G323-A6.

NOTE: Sealant must be removed and area cleaned with solvent if above instructions are not followed.

- Use metal surface cleaner F4AZ-19A536-RA or equivalent meeting Ford specification WSE-M5B292-A.

2. Apply silicone in two places where the engine front cover (6019) meets the cylinder head.

- Use Silicone Gasket and Sealant F6AZ-19562-AA or equivalent meeting Ford specification WSE-M4G323-A6.

3. Position the valve cover and the valve cover gasket on the cylinder head and loosely install the bolts and nuts.

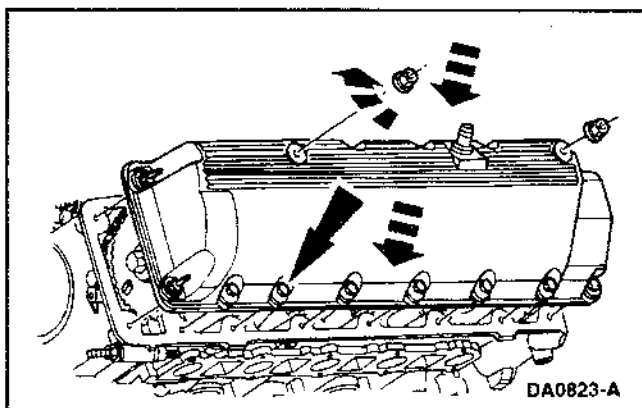
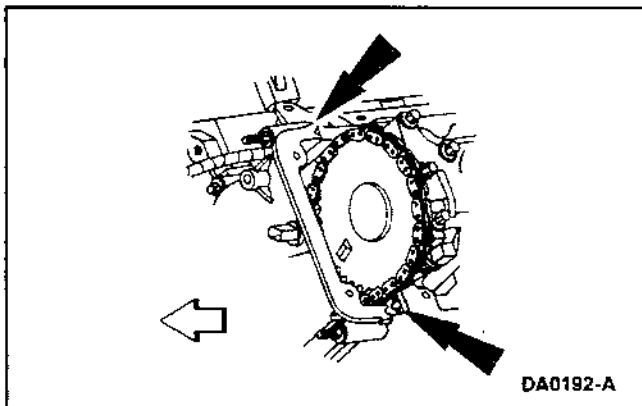

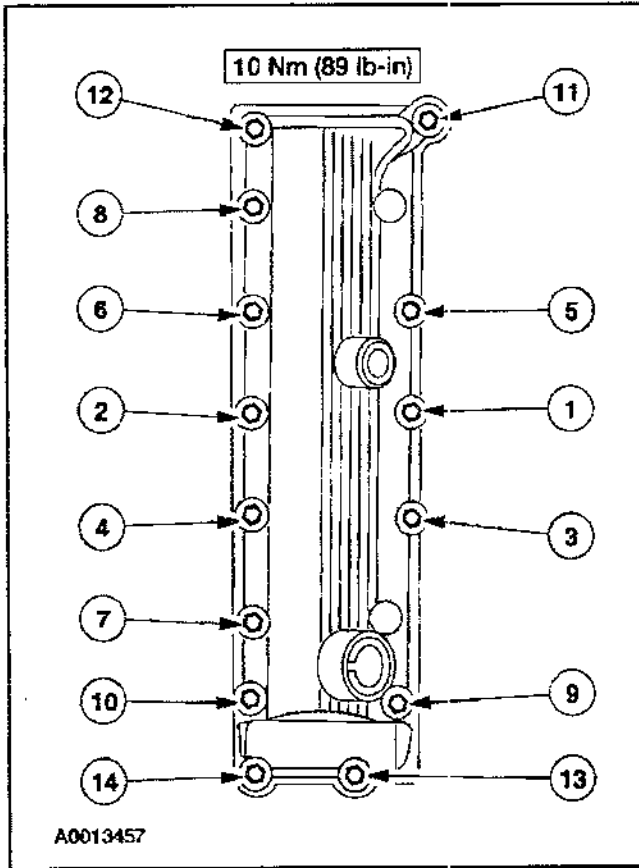

4. Tighten the nuts and bolts in the sequence shown.

Valve Cover – Right - Removal

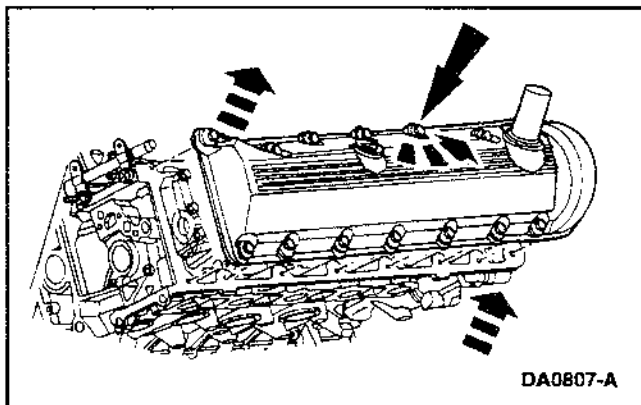
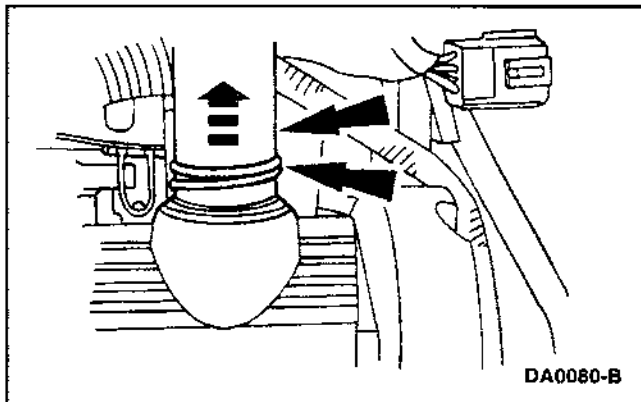

1.  **WARNING: DO NOT SMOKE OR CARRY LIGHTED TOBACCO OR OPEN FLAME OF ANY TYPE WHEN WORKING ON OR NEAR ANY FUEL-RELATED COMPONENTS. HIGHLY FLAMMABLE MIXTURES ARE ALWAYS PRESENT AND CAN BE IGNITED, RESULTING IN POSSIBLE PERSONAL INJURY.**

2. **NOTE:** The bolts are a part of the valve cover and are not to be removed.

Fully loosen the bolts, and remove the valve cover and the valve cover gasket (6584).

Valve Cover – Right - Installation

1. Remove the PCV valve.

 **CAUTION: Mating parts must make contact to each other within 4 minutes and connecting bolts must be torqued within 15 minutes after applying sealant. Failure to follow this procedure can cause future oil leakage.**

- Use silicone gasket and sealant F6AZ-19562-AA or equivalent meeting Ford specification WSE-M4G323-A6.

NOTE: Sealant must be removed and area cleaned with solvent if above instructions are not followed.

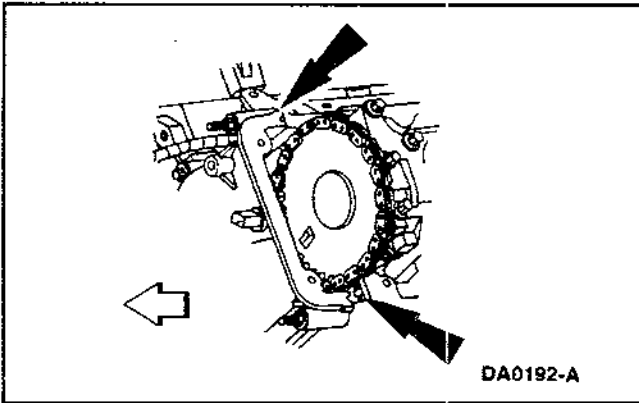

- Use metal surface cleaner F4AZ-19A536-RA or equivalent meeting Ford specification WSE-M5B292-A.
2. Apply silicone in two places where the engine front cover (6019) meets the cylinder head (6049).

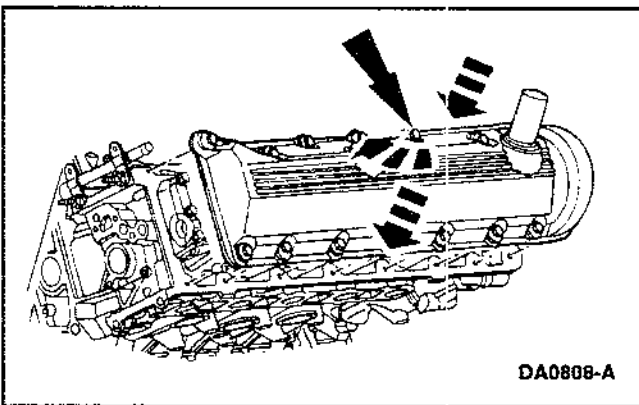

3. Position the valve cover on the cylinder head and loosely install the bolts.

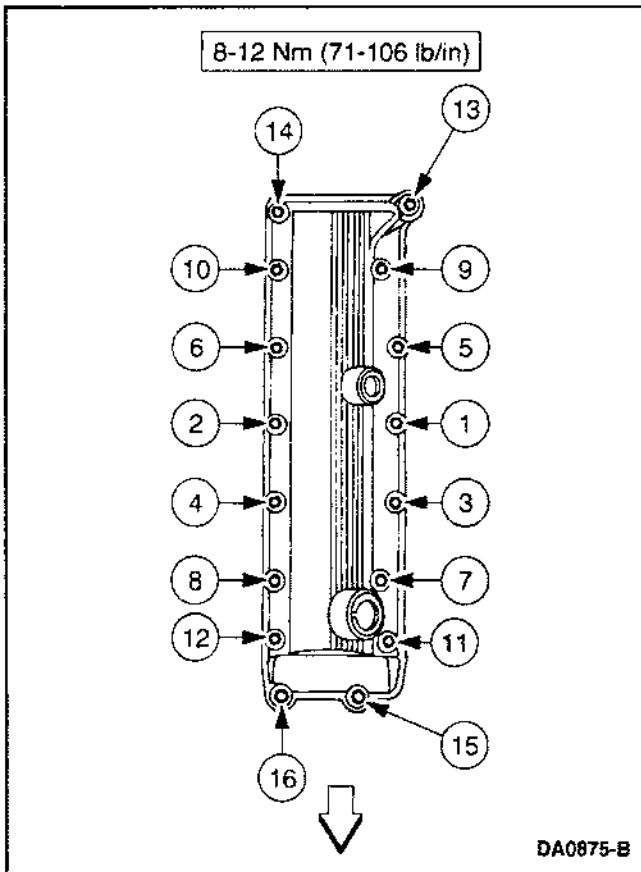

4. Tighten the bolts in the sequence shown.
5. Reinstall the PCV valve.

Crankshaft Pulley - Removal

Special Tool(s)

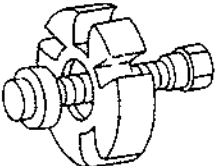
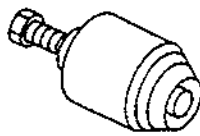
 <p>ST1286-A</p>	<p>Crankshaft Damper Remover 303-009 (T58P-6316-D)</p>
 <p>ST1288-A</p>	<p>Front Cover Seal Remover 303-107 (T74P-6700-A)</p>

Special Service Tools called for by the procedures can be obtained by calling:

1-800-ROTUNDA (1-800-768-8632).

1. Remove the engine cooling fan and fan shroud (8146).
2. Remove the drive belt (8620).
3. Remove the crankshaft pulley bolt (6A340).
4. Using the Crankshaft Damper Remover, remove the crankshaft pulley (6312).

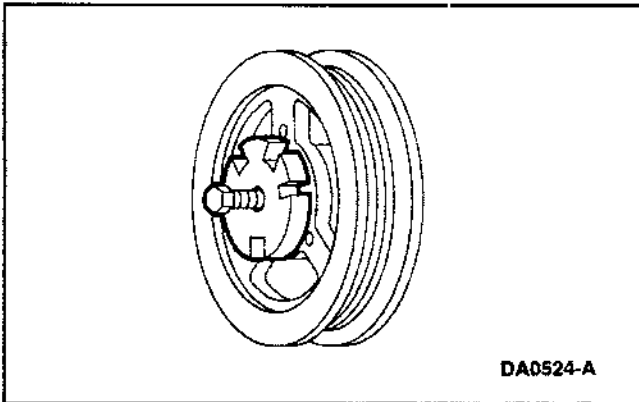

Crankshaft Pulley - Installation

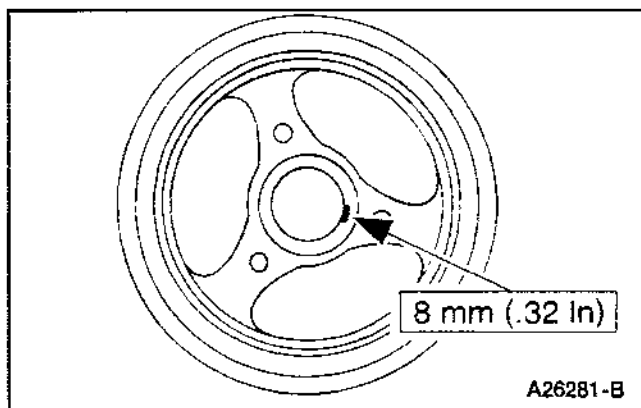

CAUTION: Mating parts must make contact to each other within 4 minutes and connecting bolts must be torqued within 15 minutes after applying sealant. Failure to follow this procedure can cause future oil leakage.

- Use silicone gasket and sealant F6AZ-19562-AA or equivalent meeting Ford specification WSE-M4G323-A6.

NOTE: Sealant must be removed and area cleaned with solvent if above instructions are not followed.

- Use metal surface cleaner F4AZ-19A536-RA or equivalent meeting Ford specification WSE-M5B292-A.

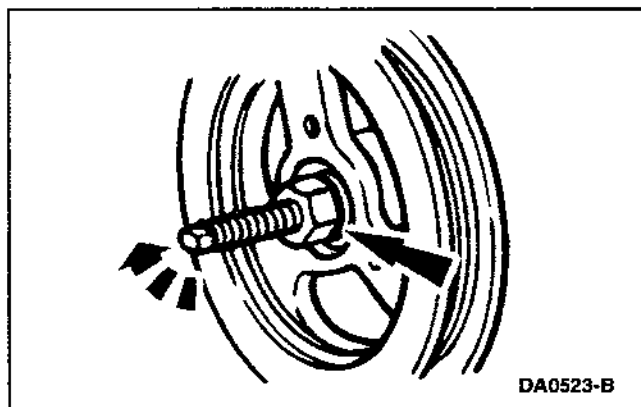

1. Use the Crankshaft Damper Replacer to install the crankshaft pulley.

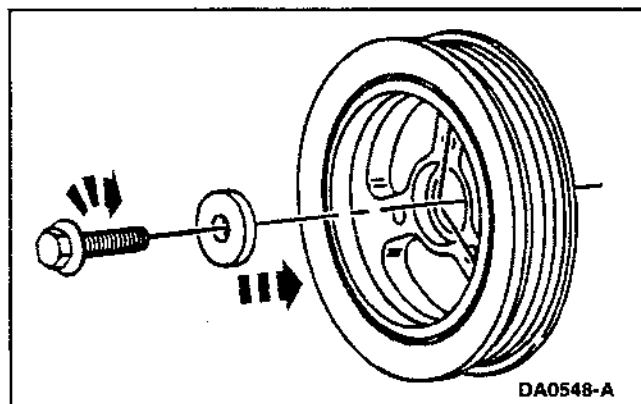

2. Tighten the crankshaft pulley bolt in four stages.
 - Stage 1: Tighten to 90 Nm (66 lb/ft).
 - Stage 2: Loosen 360 degrees.
 - Stage 3: Tighten to 47-53 Nm (35-39 lb/ft).
 - Stage 4: Tighten an additional 85-95 degrees.

Crankshaft Front Oil Seal - Removal

Special Tool(s)

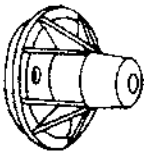
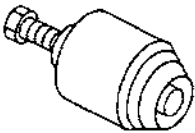
 ST1506-A	Crankshaft Rear Seal Replacer T88T-6701-B1
 ST1288-A	Front Cover Seal Remover 303-107 (T74P-6700-A)

Special Service Tools called for by the procedures can be obtained by calling:
1-800-ROTUNDA (1-800-768-8632).

1. Remove the crankshaft pulley (6312); refer to this section.
2. Using the (a) Front Cover Seal Remover, remove the (B) crankshaft front seal (6700).

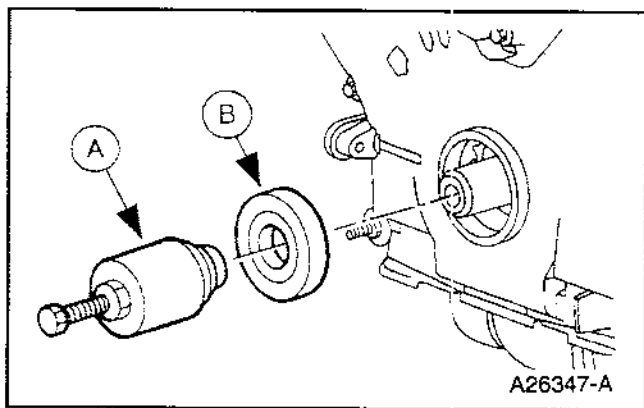

Crankshaft Front Oil Seal - Installation

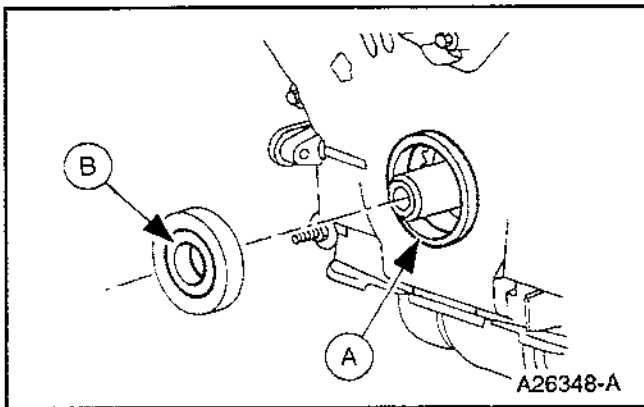

1. Lubricate the (A) engine front cover (6019) and the (B) crankshaft front seal inner lip.
 - Use Super Premium SAE 5W30 Motor Oil XO-5W30-GSP or equivalent meeting Ford specification WSS-M2C153-G.

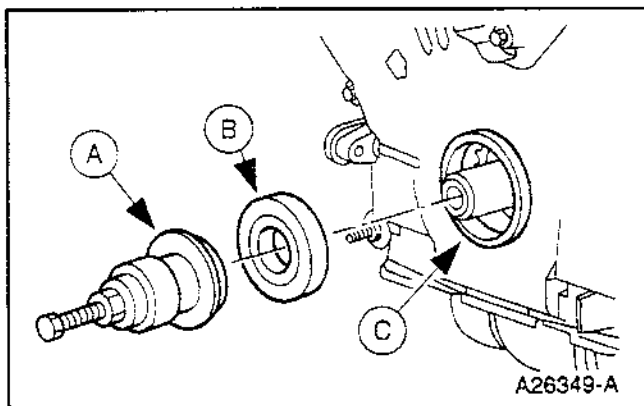

2. Use the (A) Crankshaft Seal Replacer to install the (B) crankshaft front seal into the (C) engine front cover.
3. Install crankshaft pulley; refer to Crankshaft Pulley in this section.

Front Engine Cover - Removal

1.  **WARNING: DO NOT SMOKE OR CARRY LIGHTED TOBACCO OR OPEN FLAME OF ANY TYPE WHEN WORKING ON OR NEAR ANY FUEL-RELATED COMPONENTS. HIGHLY FLAMMABLE MIXTURES ARE ALWAYS PRESENT AND CAN BE IGNITED, RESULTING IN POSSIBLE PERSONAL INJURY.**

Disconnect the battery ground cable (14301).

2. Remove the valve covers (6582); refer to Valve Cover in this section.
3. Remove the radiator (8005).
4. Disconnect the camshaft position sensor (CMP sensor) (6B288).
5. Remove the drive belt (8620).
6. Disconnect the crankshaft position (CKP) sensor electrical connector.
7. Remove the drain plug and drain the engine oil.
8. Remove the crankshaft front seal (6700); refer to Crankshaft Front Oil Seal in this section.

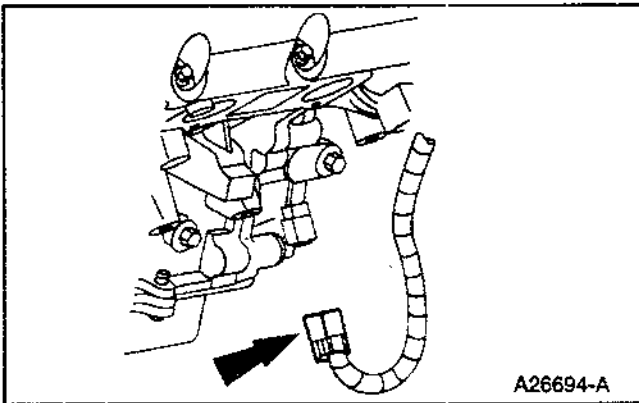

9. Remove the bolts from the front of the oil pan that hold the front cover.

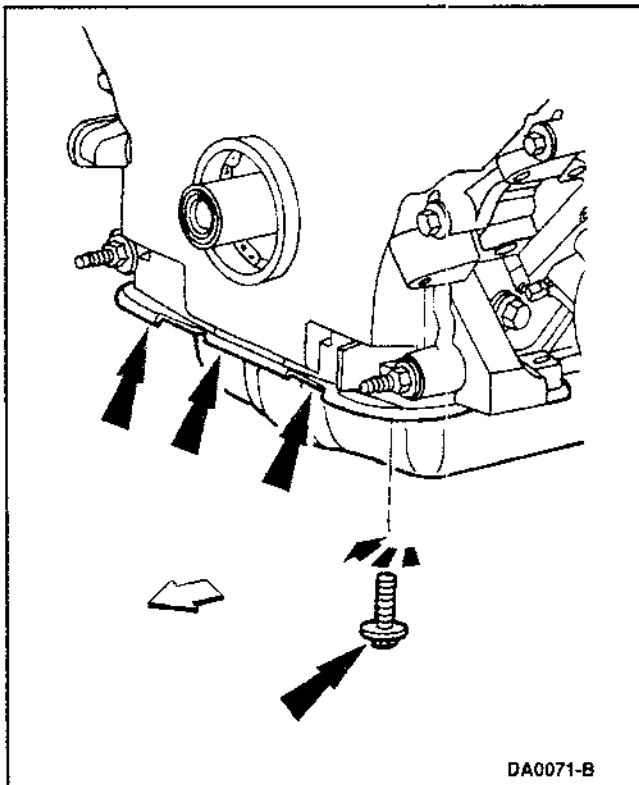

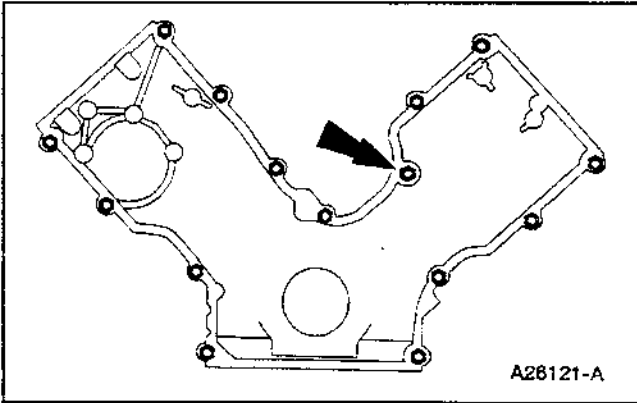

10. Remove the engine front cover fasteners.

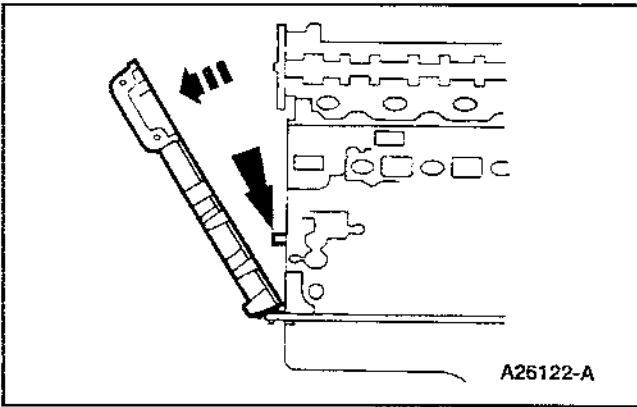

11. Remove the engine front cover (6019) from the front cover to cylinder block dowels (6C002).

Front Engine Cover - Installation

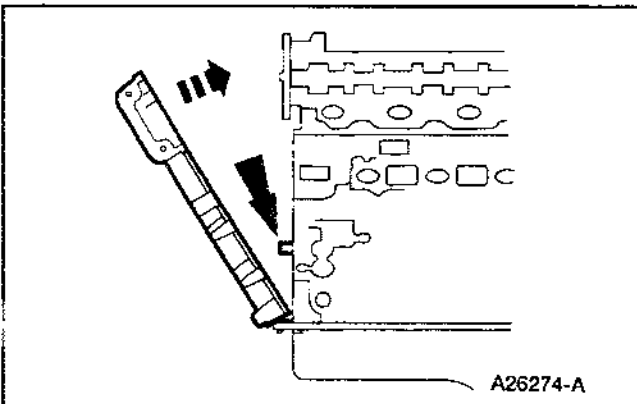

1. Install a new engine front cover gasket (6020) on the engine front cover, then position the engine front cover on the front cover to cylinder block dowels.

WSG-1068 ENGINE

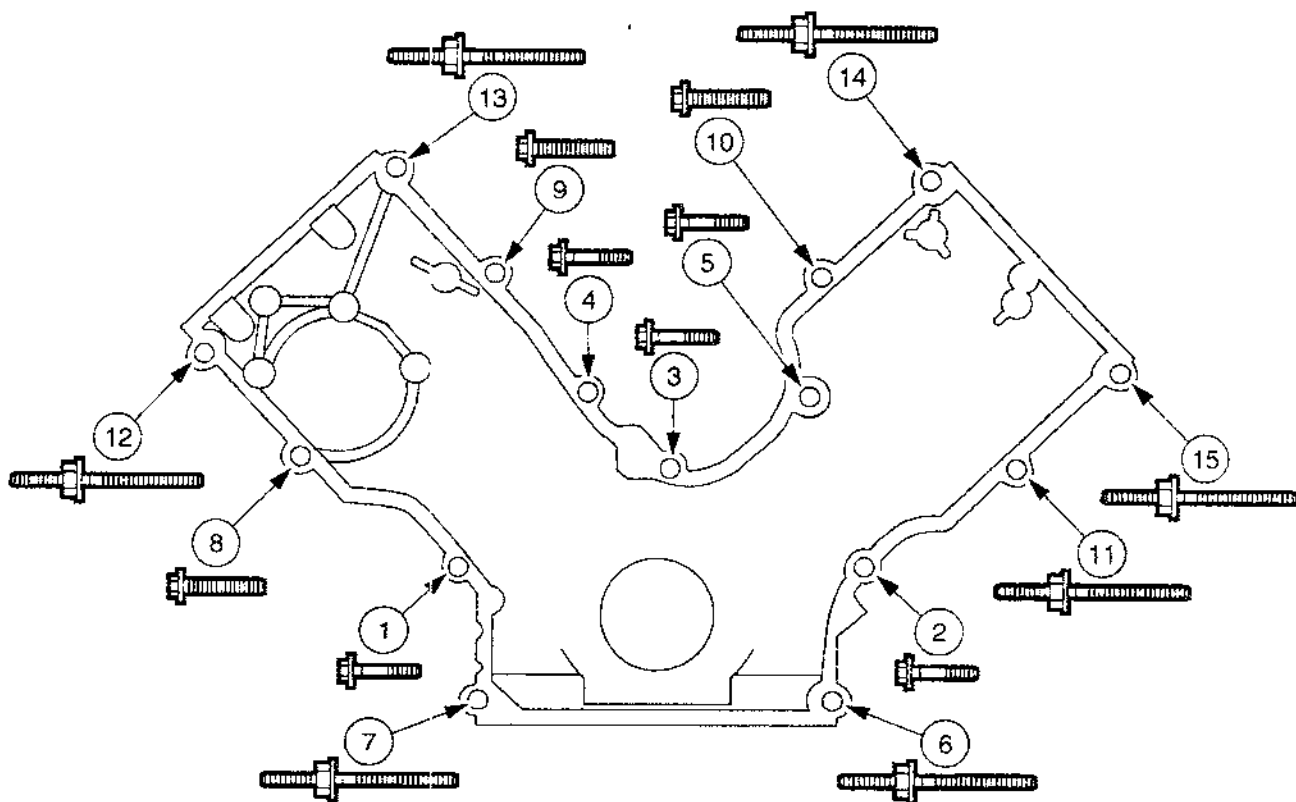

DA0568-A

Item	Part Number	Description
1	N806177	Bolt, Hex Flange Head Pilot, M8 x 1.25 x 53
2	N806177	Bolt, Hex Flange Head Pilot, M8 x 1.25 x 53
3	N806177	Bolt, Hex Flange Head Pilot, M8 x 1.25 x 53
4	N806177	Bolt, Hex Flange Head Pilot, M8 x 1.25 x 53
5	N806177	Bolt, Hex Flange Head Pilot, M8 x 1.25 x 53
6	N808529	Stud, Hex-Head Pilot, M10 x 1.5 x 1.5 x 103.1
7	N808529	Stud, Hex-Head Pilot, M10 x 1.5 x 1.5 x 103.1
8	N808142	Screw and Washer, Hex Pilot, M10 x 1.5 x 57.5

Item	Part Number	Description
9	N808142	Screw and Washer, Hex Pilot, M10 x 1.5 x 57.5
10	N808142	Screw and Washer, Hex Pilot, M10 x 1.5 x 57.5
11	N808140	Stud and Washer, Hex-Head Pilot, M10 x 1.5 x M8 x 1.25 x 109.6
12	N808140	Stud and Washer, Hex-Head Pilot, M10 x 1.5 x M8 x 1.25 x 109.6
13	N808140	Stud and Washer, Hex-Head Pilot, M10 x 1.5 x M8 x 1.25 x 109.6
14	N808140	Stud and Washer, Hex-Head Pilot, M10 x 1.5 x M8 x 1.25 x 109.6
15	N808140	Stud and Washer, Hex-Head Pilot, M10 x 1.5 x M8 x 1.25 x 109.6

2. Tighten the fasteners in two stages following the sequence shown.

- Stage 1: Tighten fasteners 1 through 5 to 20-30 Nm (15-22 lb/ft).
- Stage 2: Tighten fasteners 6 through 15 to 40-55 Nm (30-41 lb/ft).

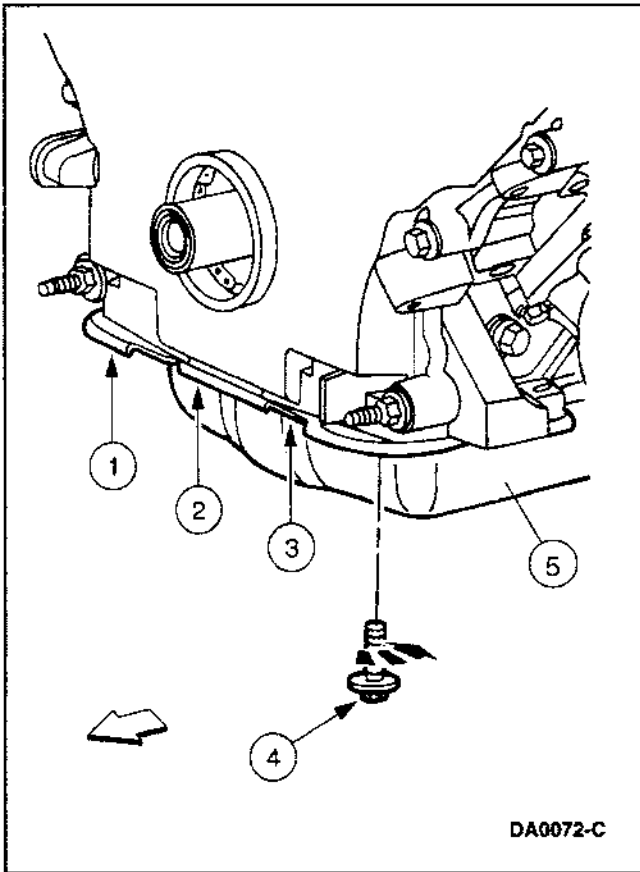

3. **NOTE:** Be sure to tighten the bolts through the front of the oil pan (5) in two stages.

- Stage 1: Tighten to 20 Nm (15 lb/ft).
- Stage 2: Tighten an additional 60 degrees.

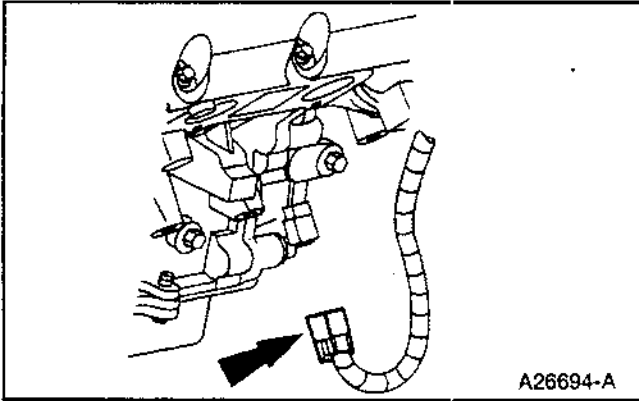

4. Connect the CKP sensor electrical connector.
5. Install the water pump pulley.

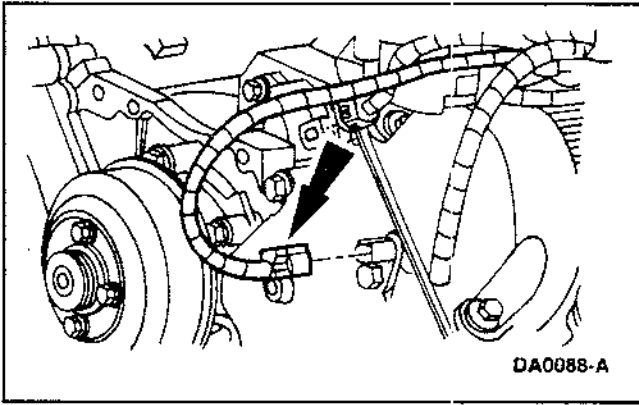

6. Connect the CMP electrical connector.
7. Install a new crankshaft front seal and the crankshaft pulley (6312); refer to Crankshaft Pulley in this section.
8. Install the drive belt (8620).
9. Install the valve covers; refer to Valve Cover in this section.
10. Fill the engine (6007) with oil.
 - Use engine oil meeting Ford specification D9AZ-19579A.

Timing Drive Components - Removal

Special Tool(s)

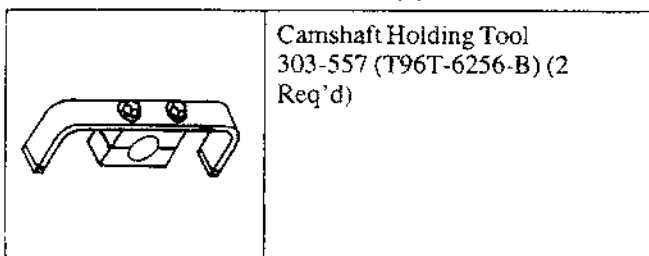

Special Service Tools called for by the procedures can be obtained by calling:
1-800-ROTUNDA (1-800-768-8632).

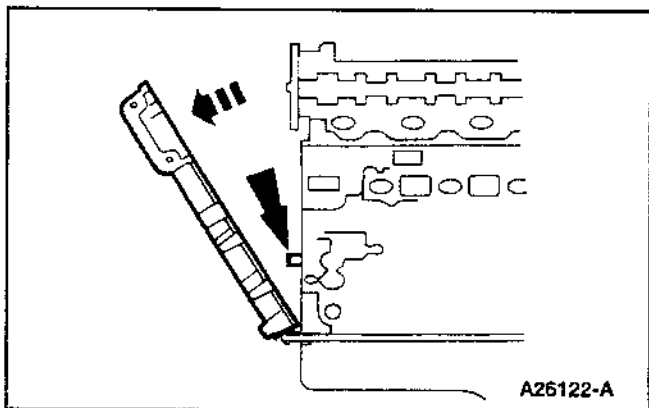

1. Remove the engine front cover (6019); refer to Engine Front Cover in this section.

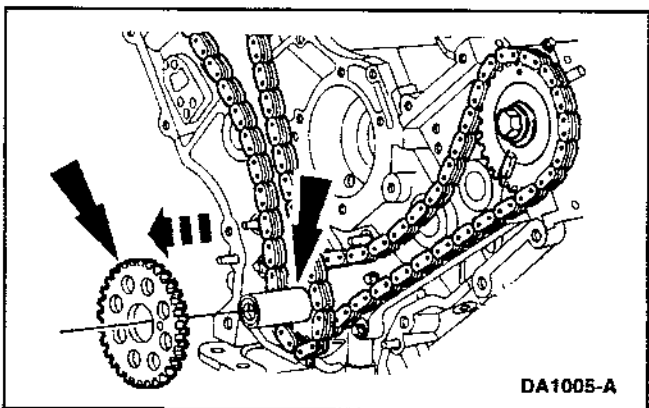

2. Remove the crankshaft sensor ring from the crankshaft (6303).

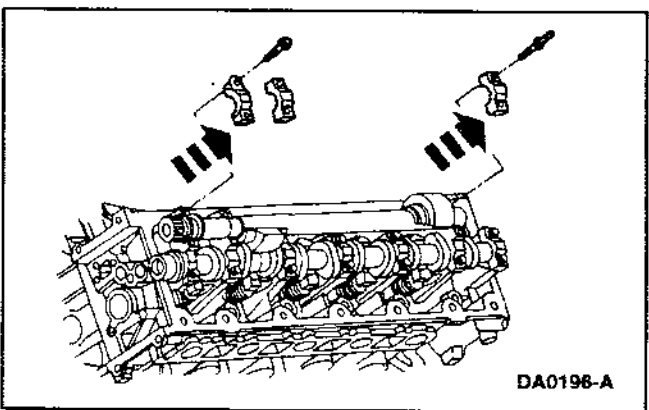

3. Remove the six bolts and remove the balance shaft bearing caps.

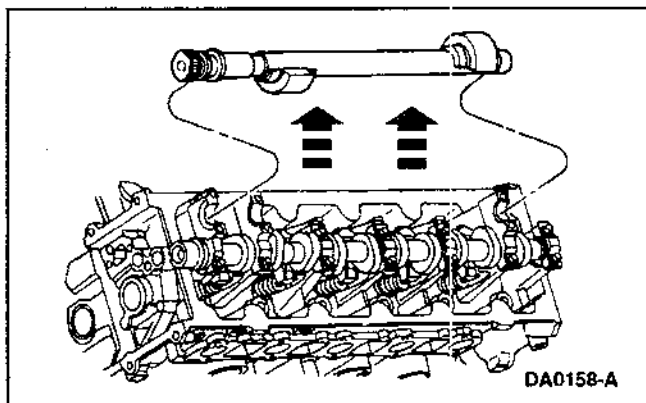

4. Remove the balance shaft.

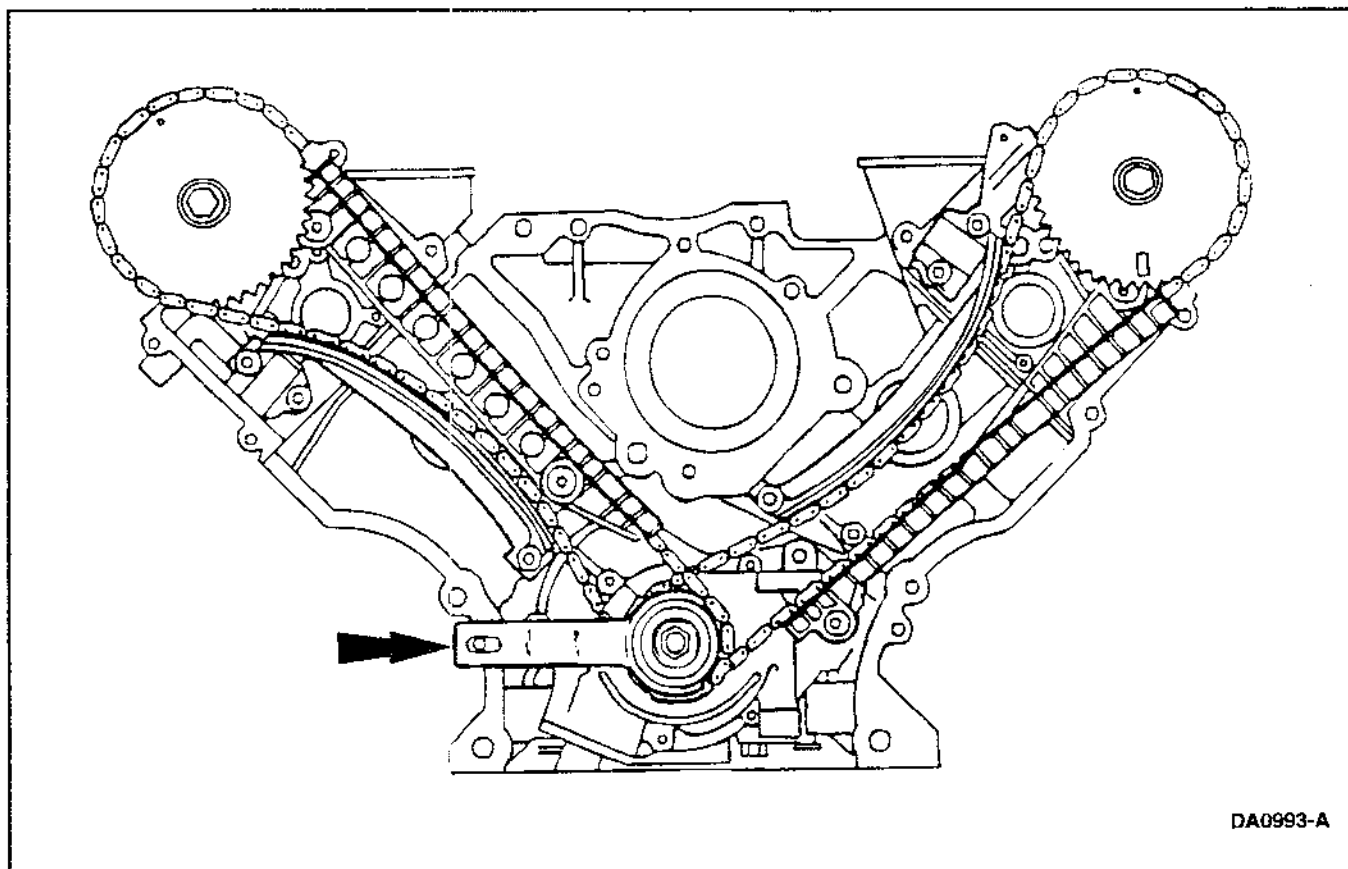

5. **⚠ CAUTION:** Unless otherwise instructed, at no time when the timing chains (6268) are removed and the cylinder heads (6049) are installed may the crankshaft or camshaft (6250) be rotated. Severe piston (6108) and valve damage could occur.

Use the Crankshaft Holding Tool to position the crankshaft as shown.

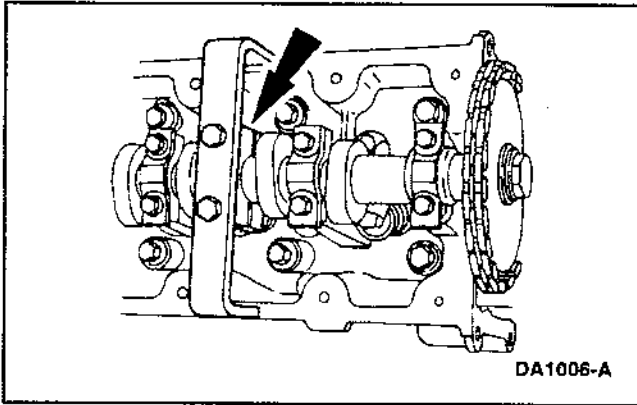

6. Install the Camshaft Holding Tools on the camshafts.

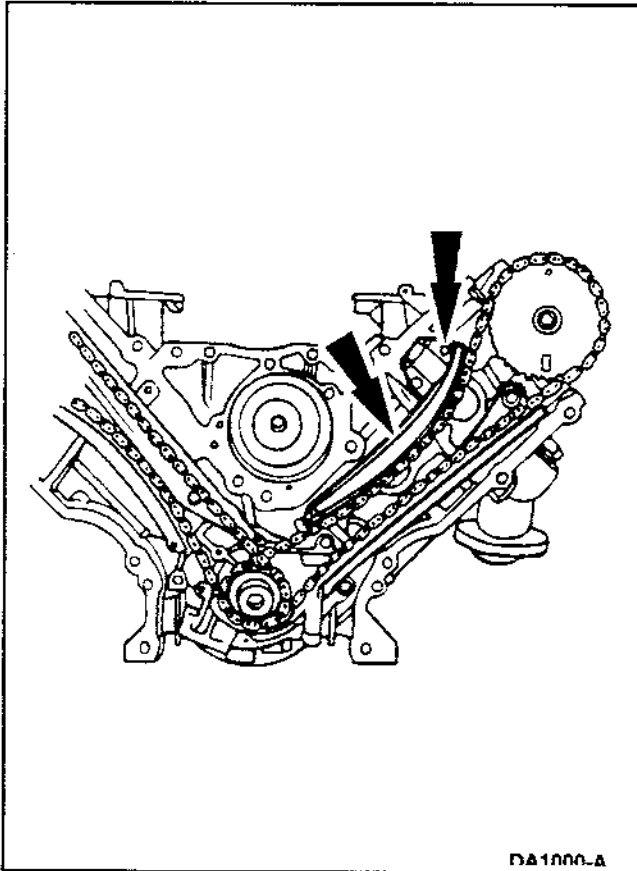

7. Remove the bolts and the timing chain tensioners (6L266). Remove the timing chain tensioner arms (6L253) from the dowel pins.

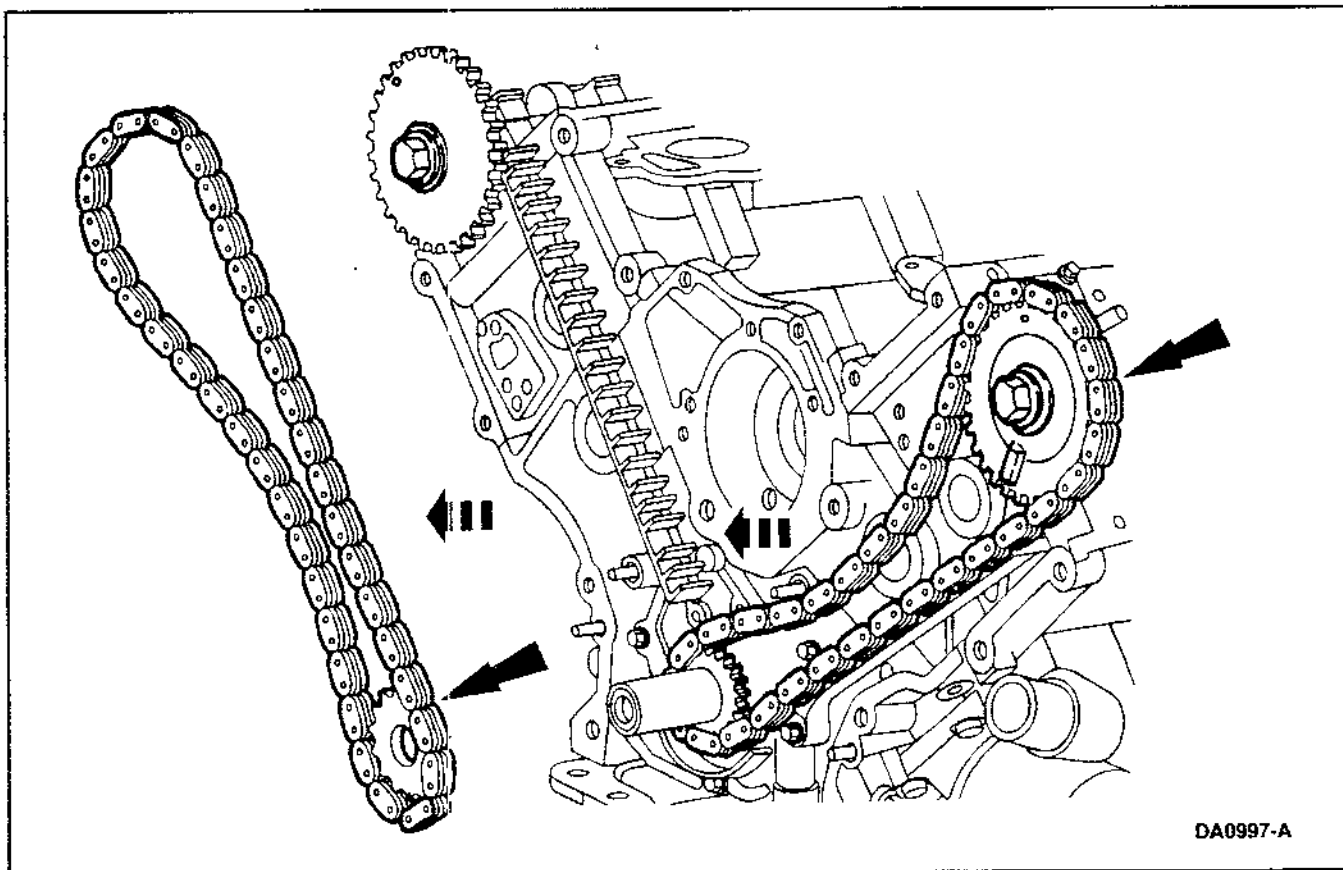

8. Remove the LH and RH timing chain and the crankshaft sprockets (6306).

1. Remove the RH timing chain from the camshaft sprocket (6256).

2. Remove the RH timing chain and outer crankshaft sprocket from the crankshaft.

3. Repeat for the LH timing chain and crankshaft sprocket.

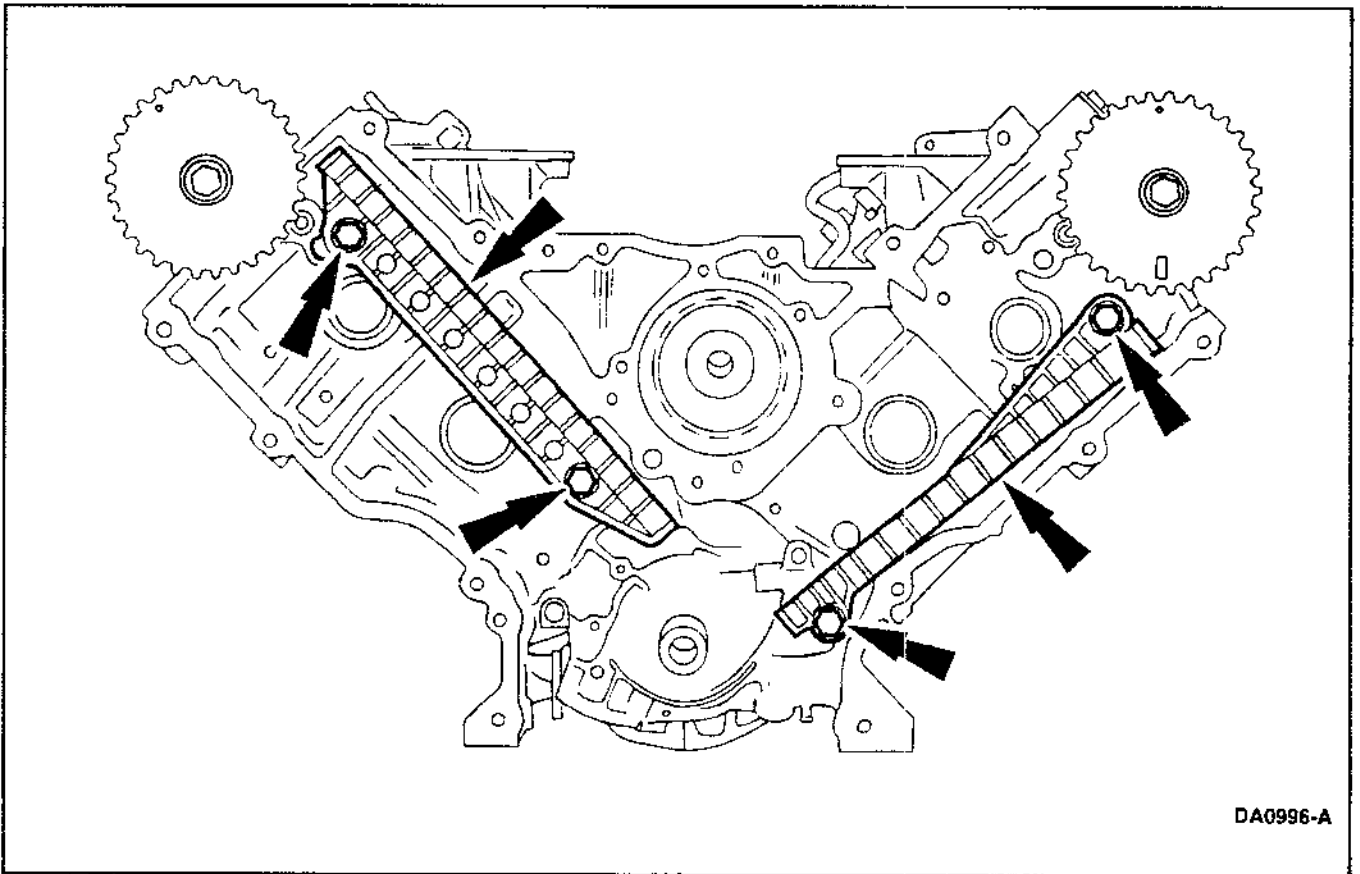

9. Remove the timing chain guides (6K297).

- Remove the bolts.
- Remove the timing chain guides.

Timing Drive Components - Installation

1. **CAUTION:** Timing chain procedures must be followed exactly or damage to valves and pistons will result.

CAUTION: Do not compress the ratchet assembly. This will damage the ratchet assembly.

Compress the tensioner plunger, using an edge of a vise.

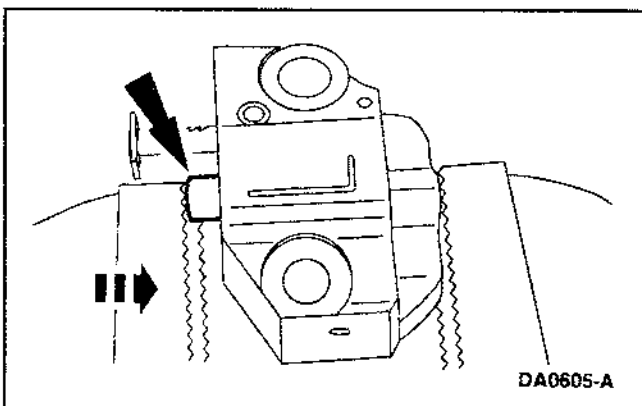

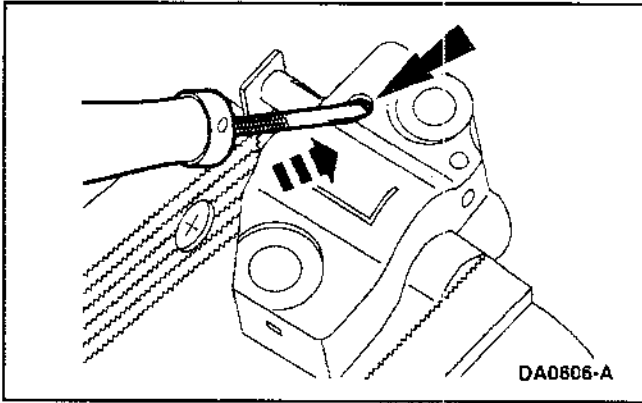

2. Using a small screwdriver or pick, push back and hold the ratchet mechanism.

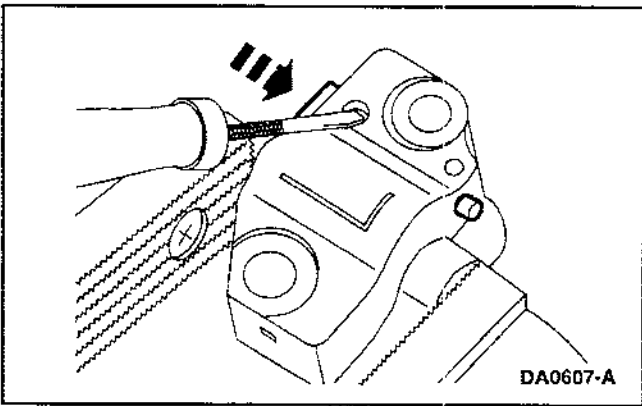

3. While holding the ratchet mechanism, push the ratchet arm back into the tensioner housing.

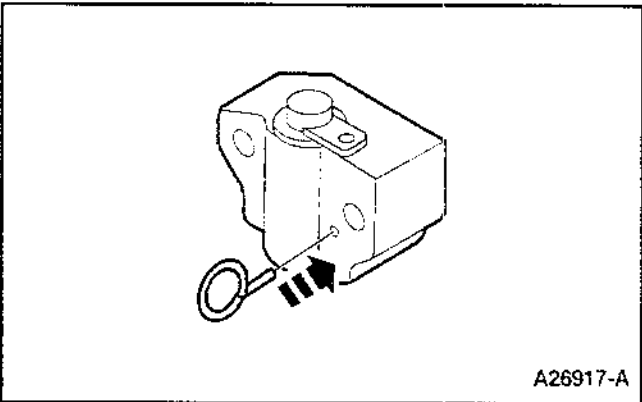

4. Install a paper clip into the hole in the tensioner housing to hold the ratchet assembly and plunger in during installation.

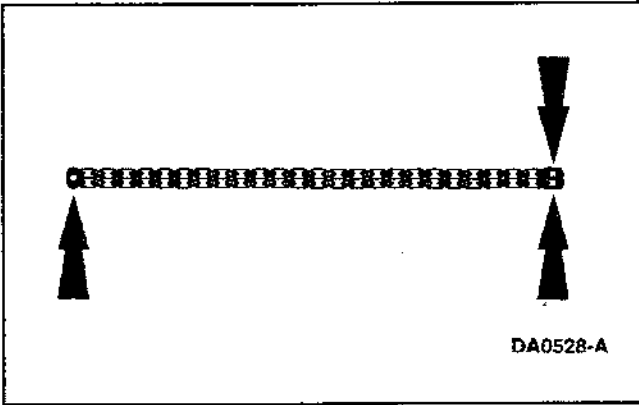

5. If copper links are not visible, mark two links on one end and one link on the other end, and use as timing marks.

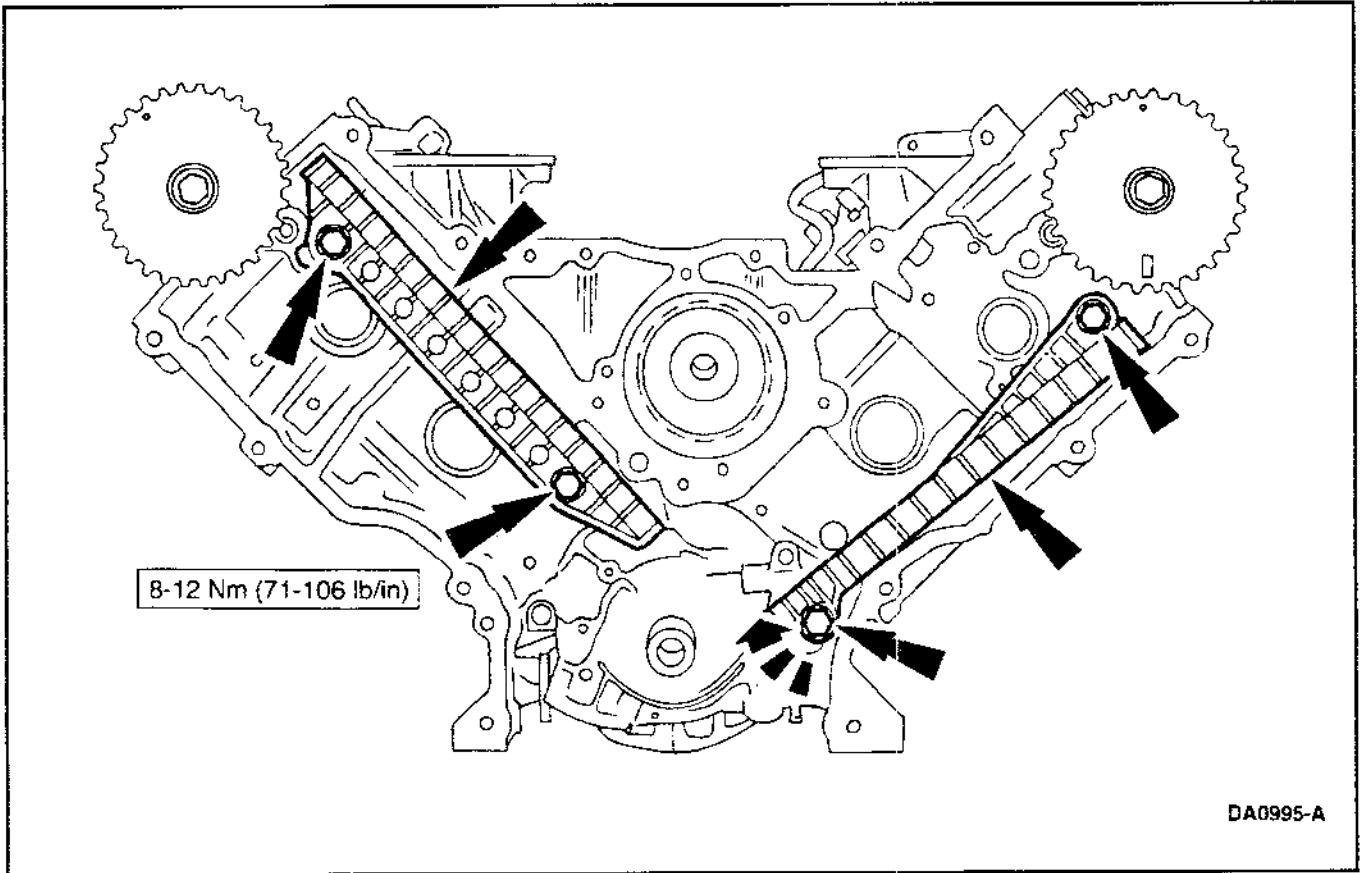

6. Install the timing chain guides.

7. Remove the Crankshaft Holding Tool

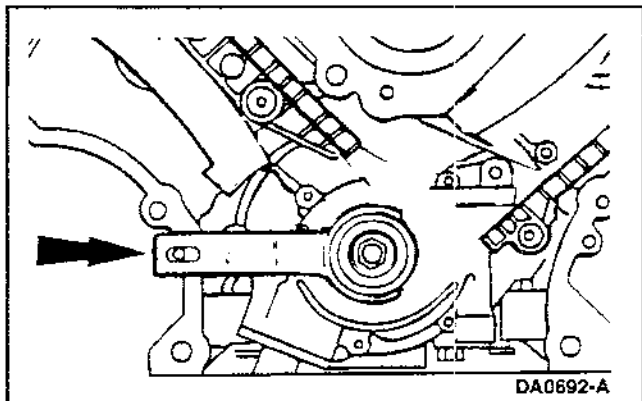

8. Install the inner crankshaft sprocket with the long hub facing outward.

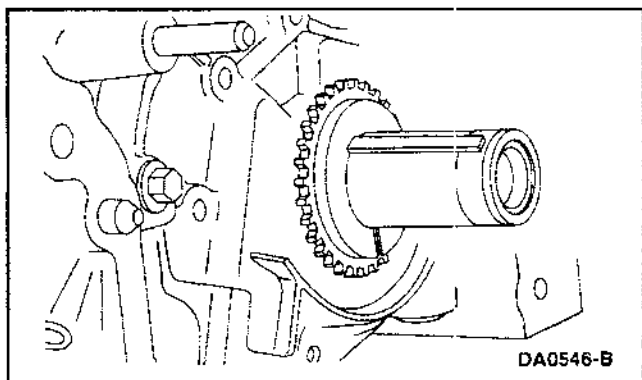

9. Install the inner timing chain on the crankshaft sprocket with the timing marks aligned.

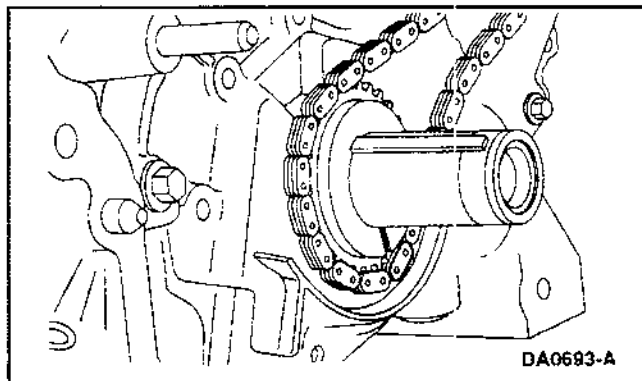

10. **NOTE:** Be sure the upper half of the timing chain is below the tensioner

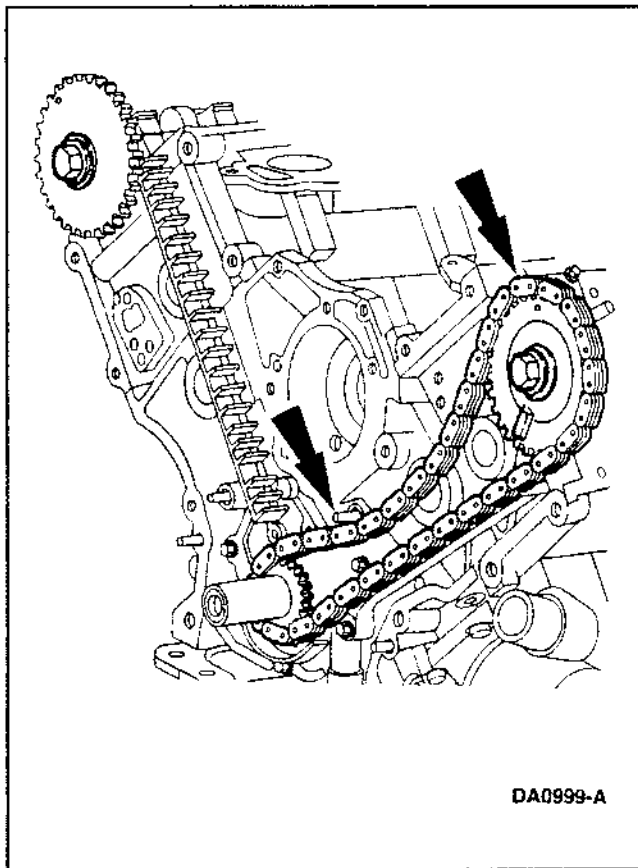

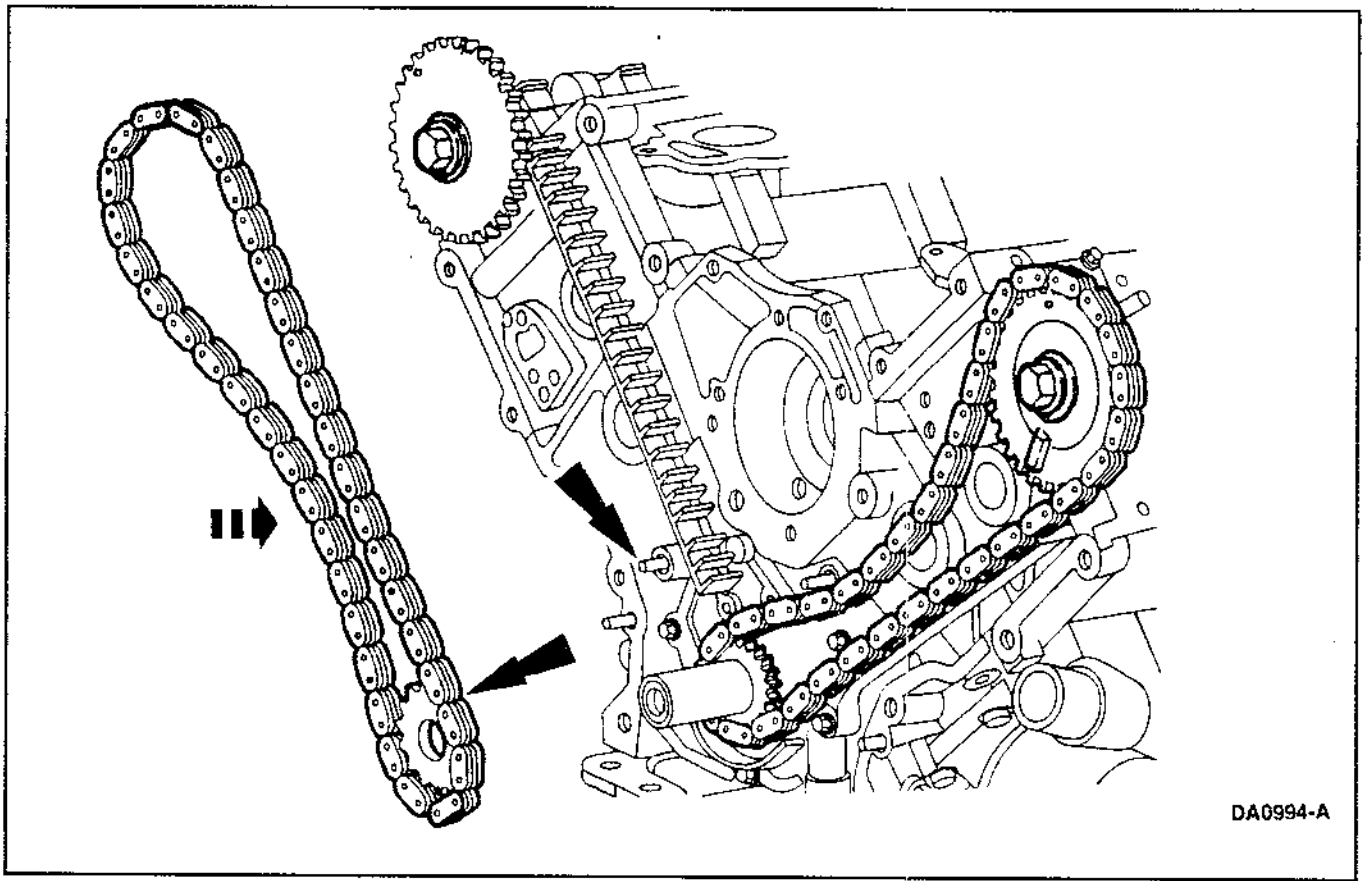

11. **⚠ CAUTION:** The camshaft sprocket can jump time if the Camshaft Holding Tool is not secured.

NOTE: Be sure the chain link and crankshaft sprocket timing marks are aligned.

NOTE: The lower half of the timing chain must be positioned above the dowel.

Install the outer crankshaft sprocket and timing chain/belt with the long hub of the crankshaft sprocket facing inward.

12. Position the timing chain on the camshaft sprocket. Make sure the two copper-colored links align with the camshaft sprocket timing mark.
13. Check for proper alignment of all timing marks.

Camshaft Assembly Timing Mark Alignment

NOTE:
CAMSHAFT D-SLOT MUST MAINTAIN A 90° CLOCKED POSITION RELATIVE TO CAM COVER RAIL (AS SHOWN). USE APPROPRIATE TOOL.

CRANKSHAFT KEYWAY MUST BE CLOCKED @ 315° (TDC) AFTER INSTALLATION OF CYLINDER HEAD ASY (AS SHOWN) AND PRIOR TO INSTALLATION OF TIMING CHAIN ASY TO PREVENT PISTON CROWN AND VALVE DAMAGE.

NOTE:
ROTATE CRANKSHAFT TO TDC AFTER INSTALLATION OF CYLINDER HEAD ASSEMBLY TO CYLINDER BLOCK ASSEMBLY AS SHOWN.

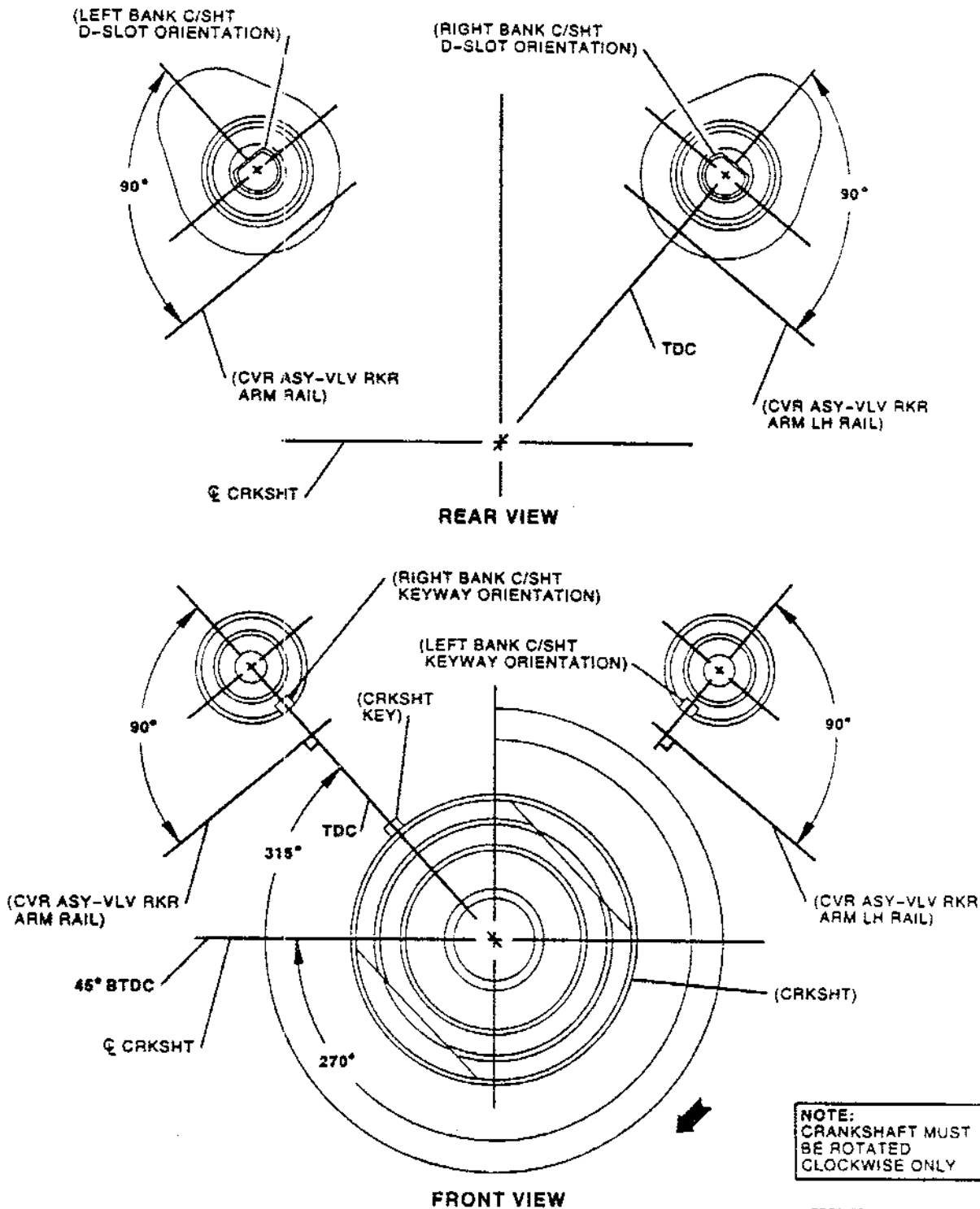

FPP0406

Timing Chains, Camshaft Gears and Crankshaft Gears Alignment

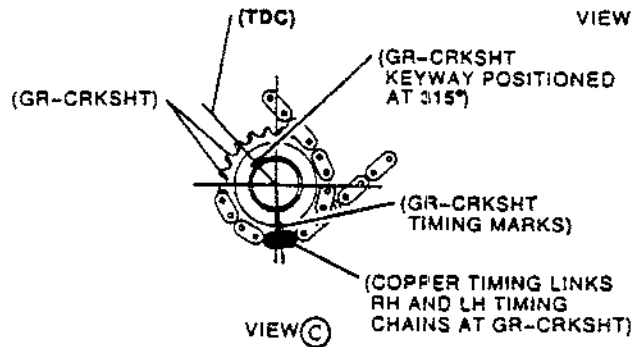
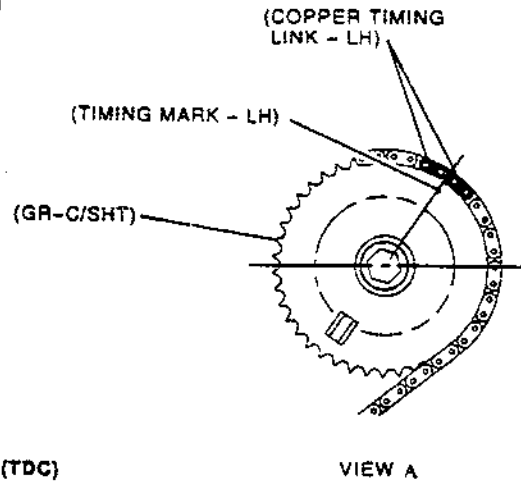
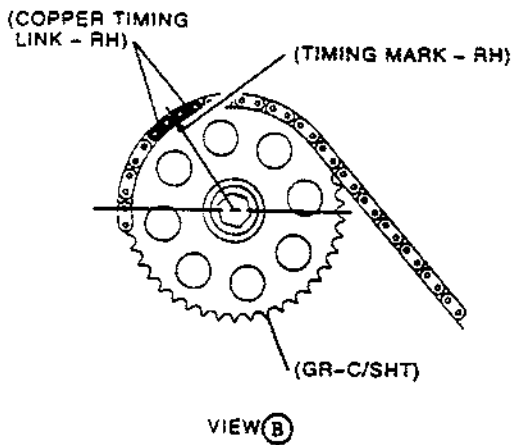
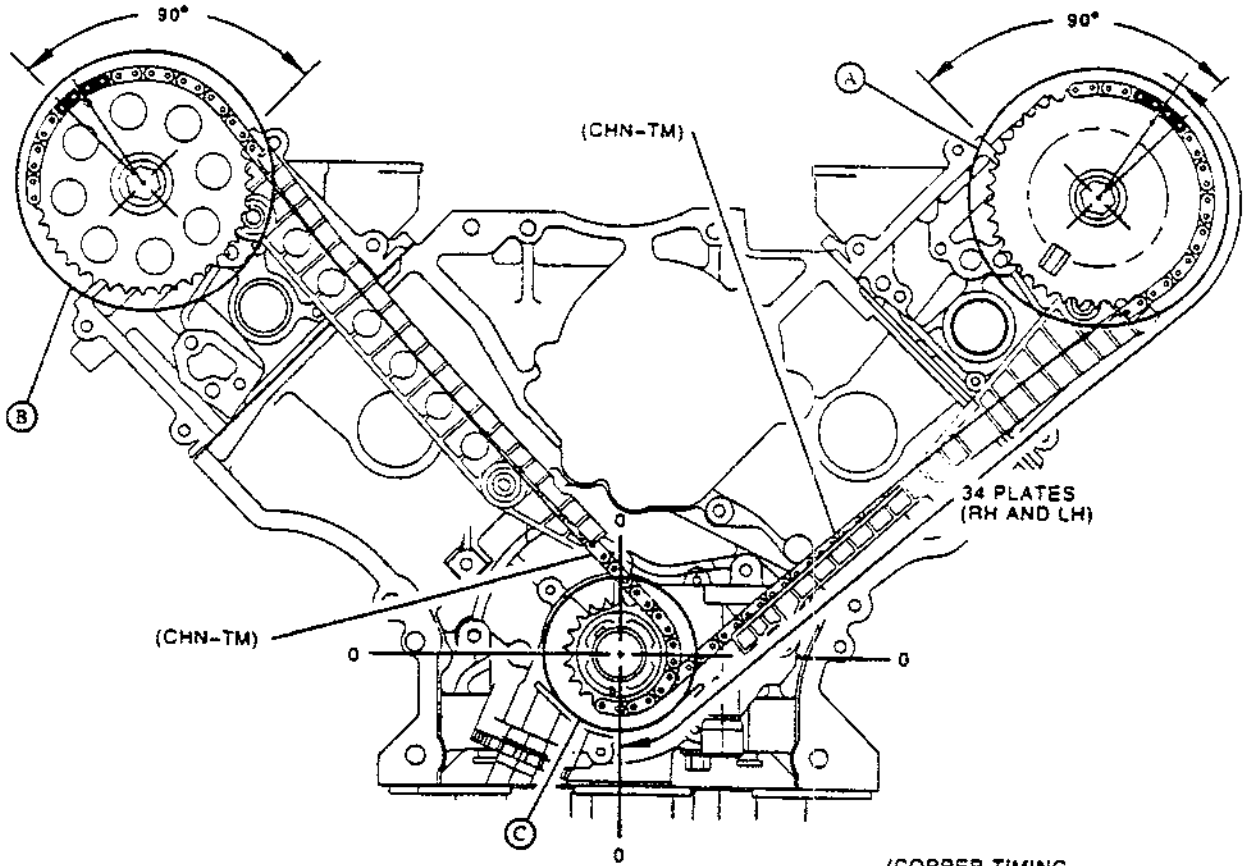

FPP04052

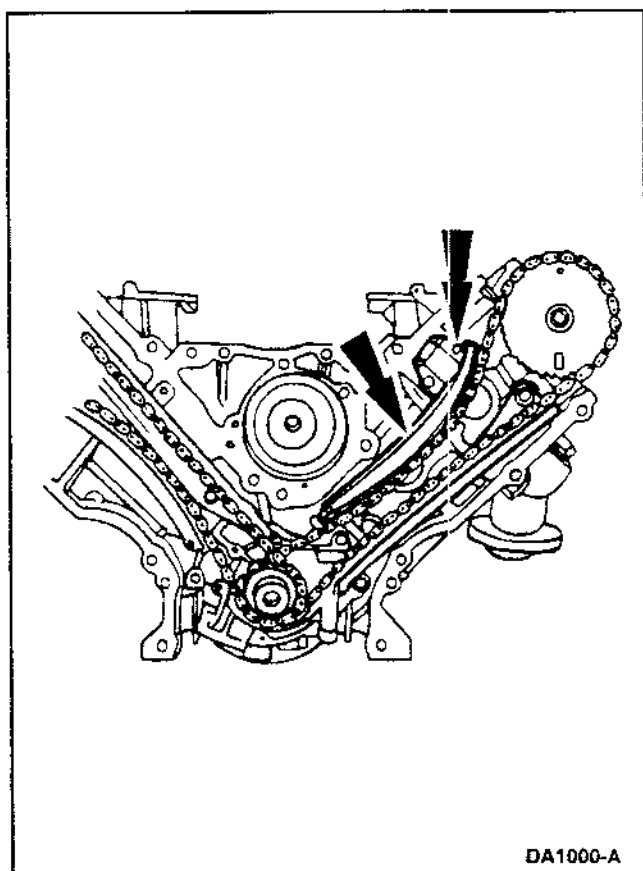

14. Position the LH and RH timing chain tensioner arms on the dowel pins. Position the timing chain tensioners and install the bolts.

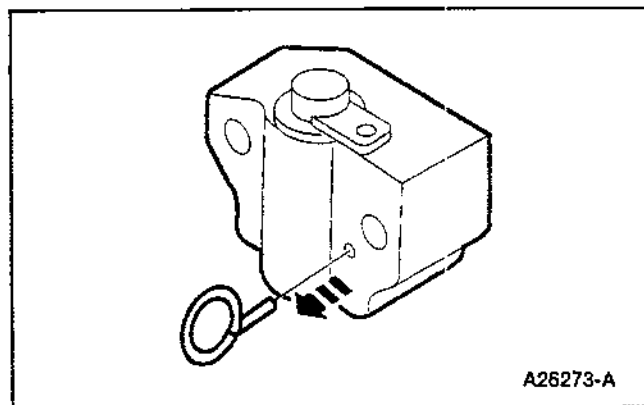

15. Remove the retaining pins from the RH and LH timing chain tensioners.

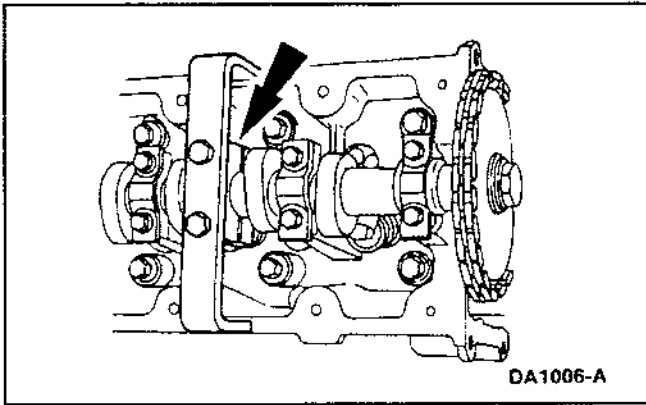

16. Remove the Camshaft Holding Tools from the camshafts.

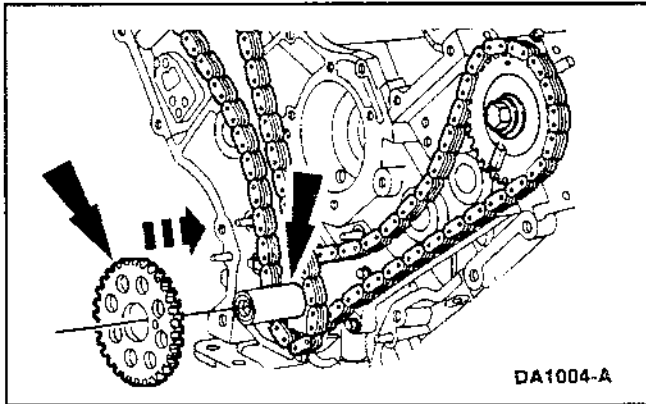

17. Install the crankshaft sensor ring on the crankshaft.

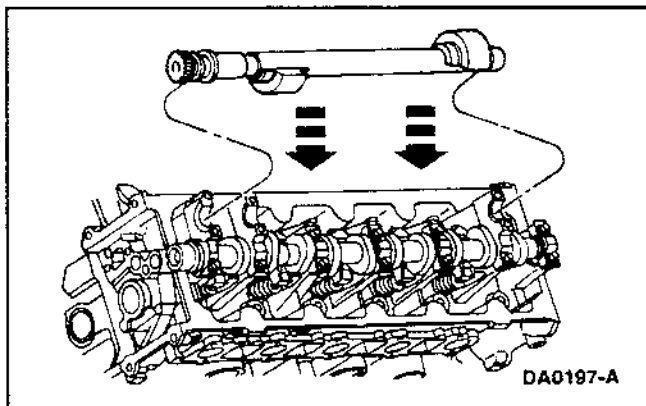

18. Lubricate the balance shaft journals with engine oil.

- Use Super Premium SAE 5W30 Motor Oil XO-5W30-CSP or equivalent meeting Ford specification WSS-M2C153-G.

19. Position the balance shaft on the journals.

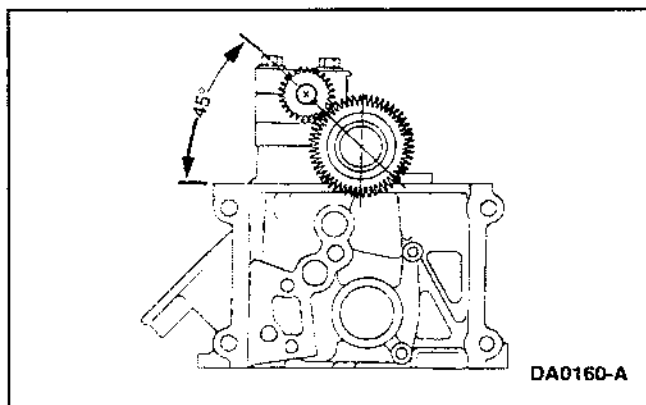

20. Align the balance shaft timing marks as shown.

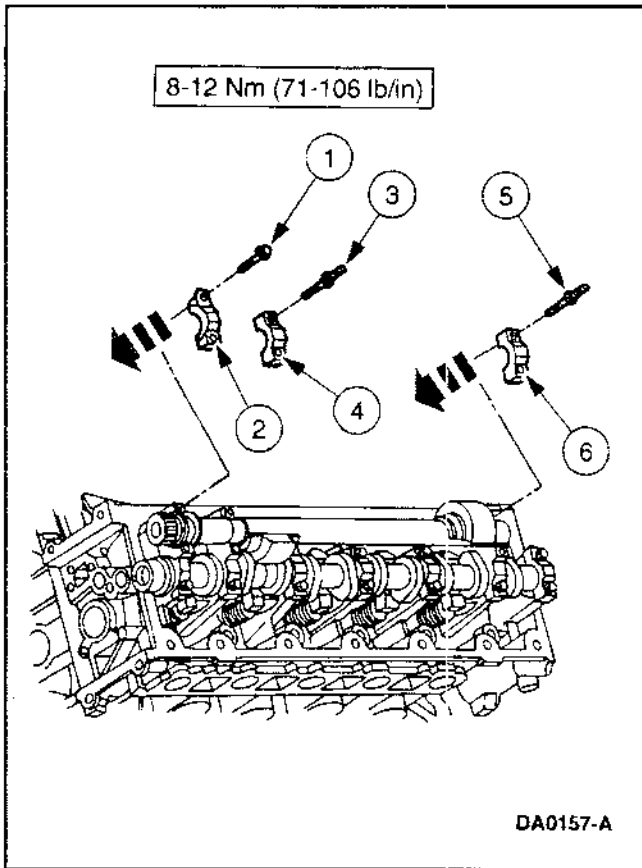

21. Lubricate the bearing caps with engine oil.

- Use Super Premium SAE 5W30 Motor Oil XO-5W30-QSP or equivalent meeting Ford specification WSS-M2C153-G.

22. Install the bearing caps, the bolts and tighten the bolts in the sequence shown.

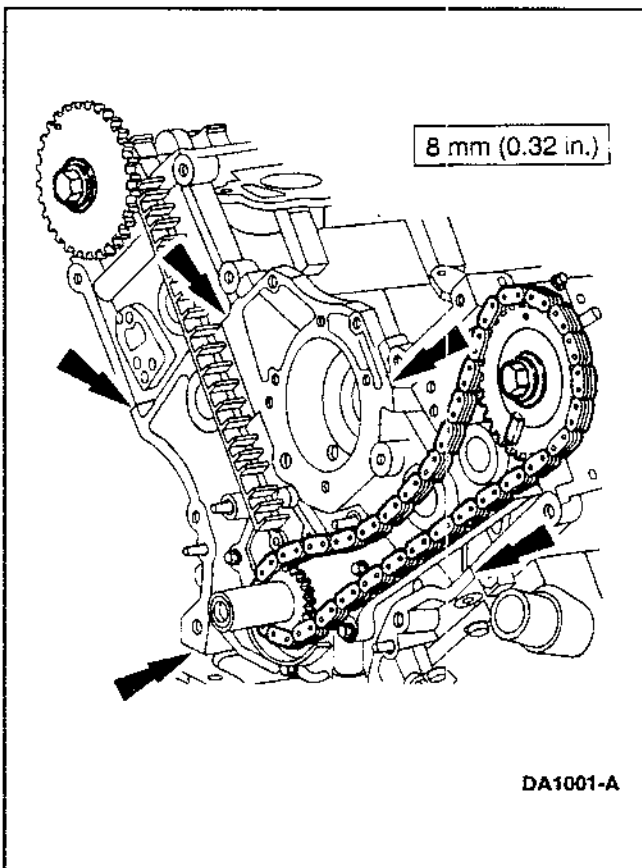

23. **NOTE:** The timing chain is removed for clarity.

CAUTION: Mating parts must make contact to each other within 4 minutes and connecting bolts must be torqued within 15 minutes after applying sealant. Failure to follow this procedure can cause future oil leakage.

- Use silicone gasket and sealant F6AZ-19562-AA or equivalent meeting Ford specification WSE-M4G323-A6.

NOTE: Sealant must be removed and area cleaned with solvent if above instructions are not followed.

- Use metal surface cleaner F4AZ-19A536-RA or equivalent meeting Ford specification WSE-M5B292-A.

24. Install engine front cover; refer to Engine Front Cover in this section.

Camshaft - Removal

Special Tool(s)

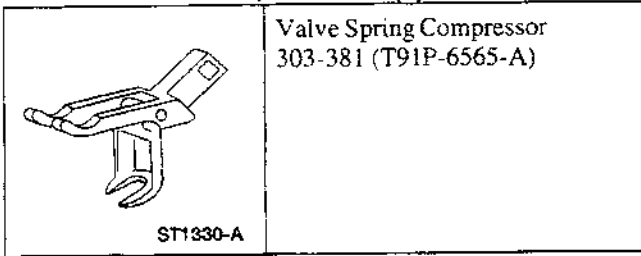

Special Service Tools called for by the procedures can be obtained by calling:
1-800-ROTUNDA (1-800-768-8632).

 **WARNING: DO NOT SMOKE OR CARRY LIGHTED TOBACCO OR OPEN FLAME OF ANY TYPE WHEN WORKING ON OR NEAR ANY FUEL-RELATED COMPONENTS. HIGHLY FLAMMABLE MIXTURES ARE ALWAYS PRESENT AND CAN BE IGNITED, RESULTING IN POSSIBLE PERSONAL INJURY.**

1. Disconnect the battery ground cable (14301).
2. Remove the intake manifold (9424); refer to Intake Manifold – Variable Resonance Induction System (VRIS) in this section.
3. Remove the timing chains (6268); refer to Timing Drive Components in this section.

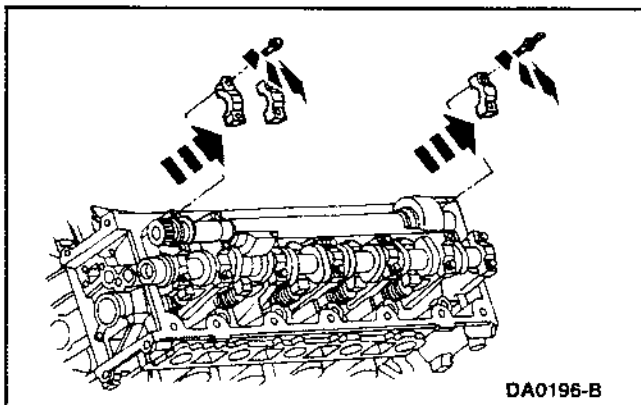

 **CAUTION: The caps must be marked for installation in their original location or damage to the engine may occur.**

4. Remove the six bolts retaining the balance shaft bearing caps and remove the bearing caps.
5. Remove the balance shaft.

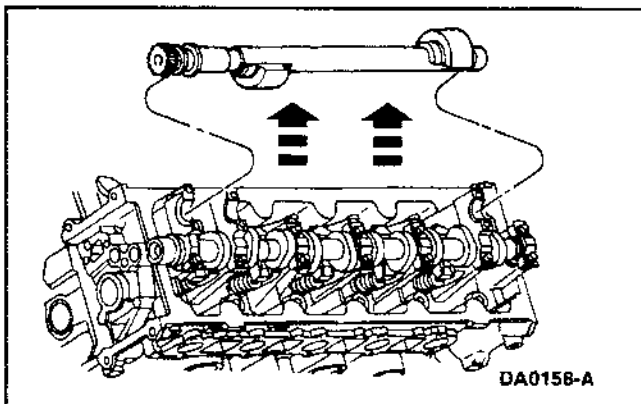

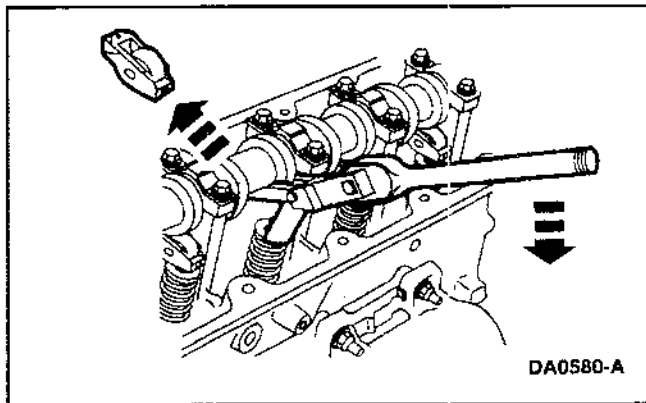

6. Use the Valve Spring Compressor to compress the valve springs (6513) and remove the camshaft roller followers.

CAUTION: The caps must be marked for installation in their original location or damage to the engine may occur.

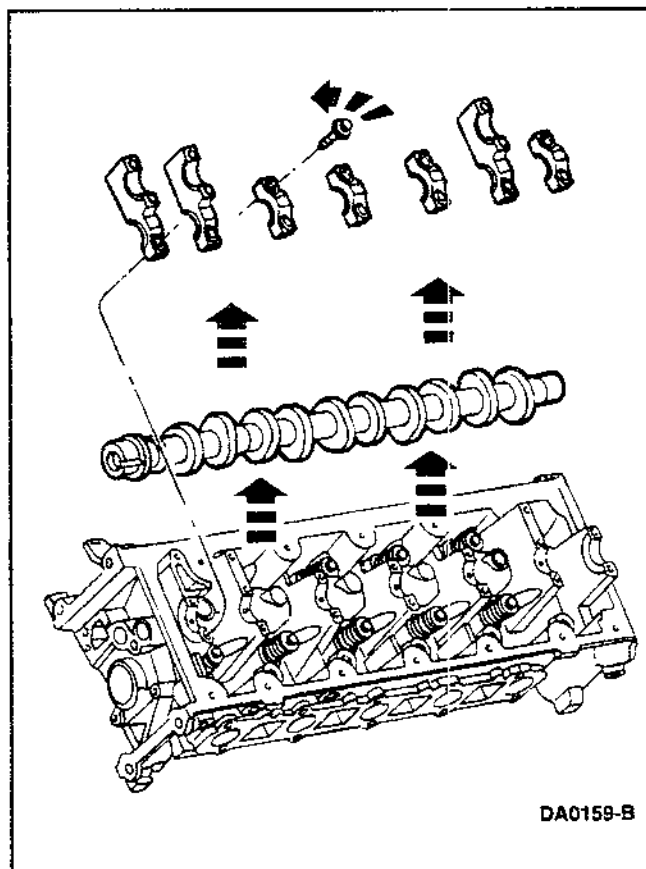

7. Remove the bolts, the camshaft bearing caps (6B280) and the camshaft (6250) from the cylinder block (6010).

Camshaft - Installation

1. Lubricate the camshaft journals and bearing caps.
 - Use Super Premium SAE 5W30 Motor Oil D9AZ-19579-A or equivalent meeting Ford specification WSS-M2C153-G.

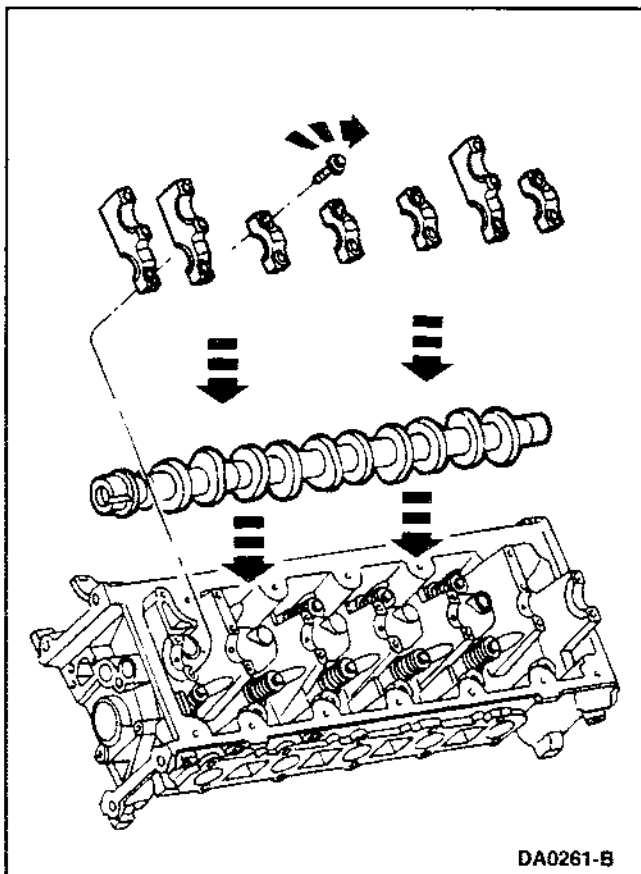

2. Install the bearing caps in their original locations and the bolts.

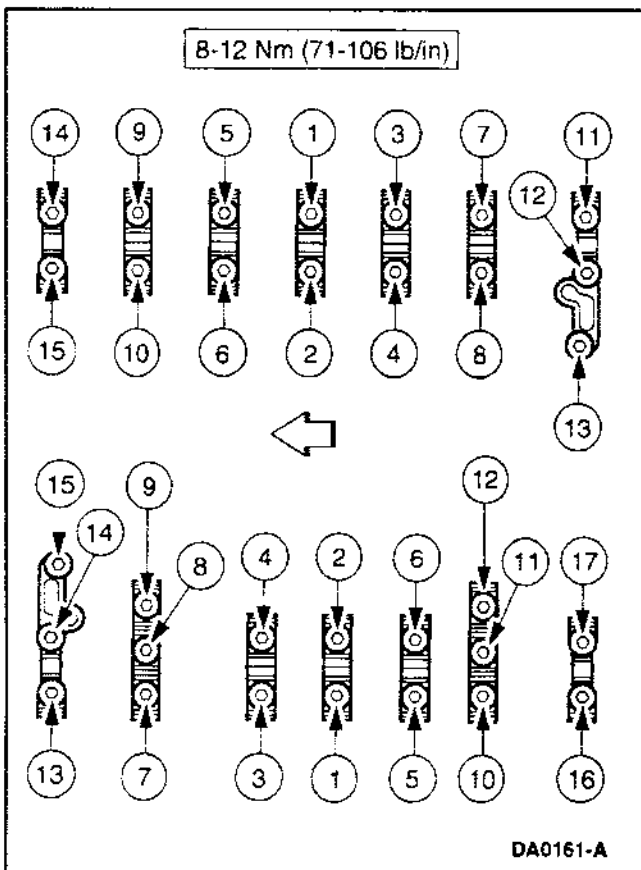

3. Tighten the bolts in the sequence shown.

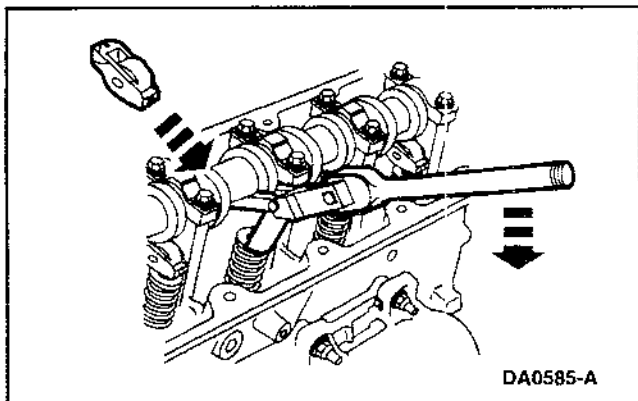

4. Use the Valve Spring Compressor to compress the valve springs and install the camshaft roller followers.
5. Lubricate the balance shaft journals with engine oil.
 - Use Super Premium SAE 5W30 Motor Oil D9AZ-19579-A or equivalent meeting Ford specification WSS-M2C153-G.

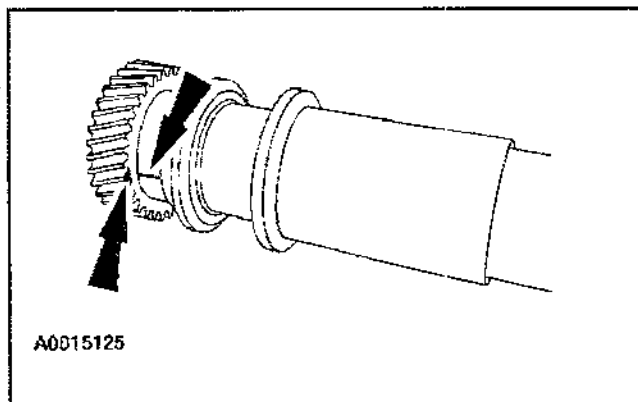

6. Using the index mark on the balance shaft, mark the corresponding teeth on the gear with chalk.
7. Position the balance shaft on the journals.

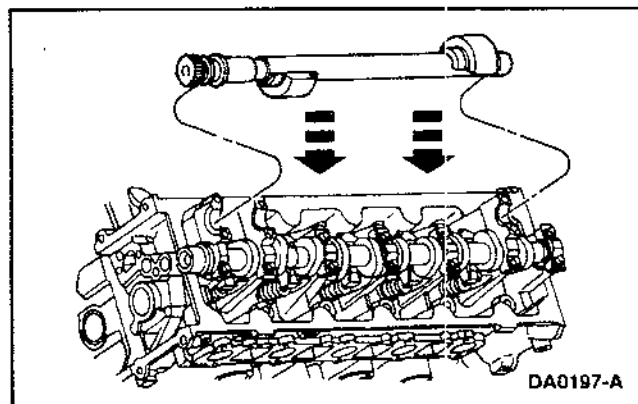

8. Align the balance shaft timing marks as shown. Align the chalk mark on the balance shaft with the camshaft timing mark as shown.

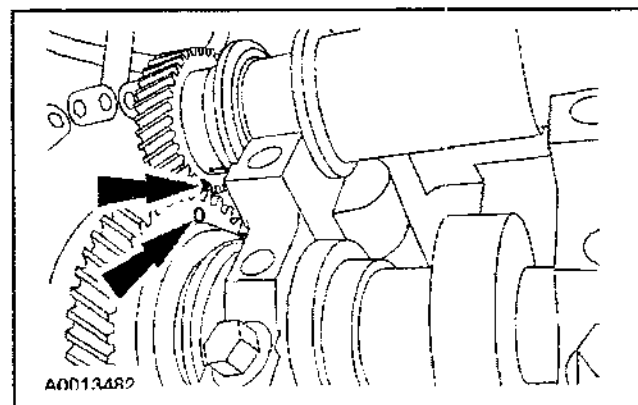

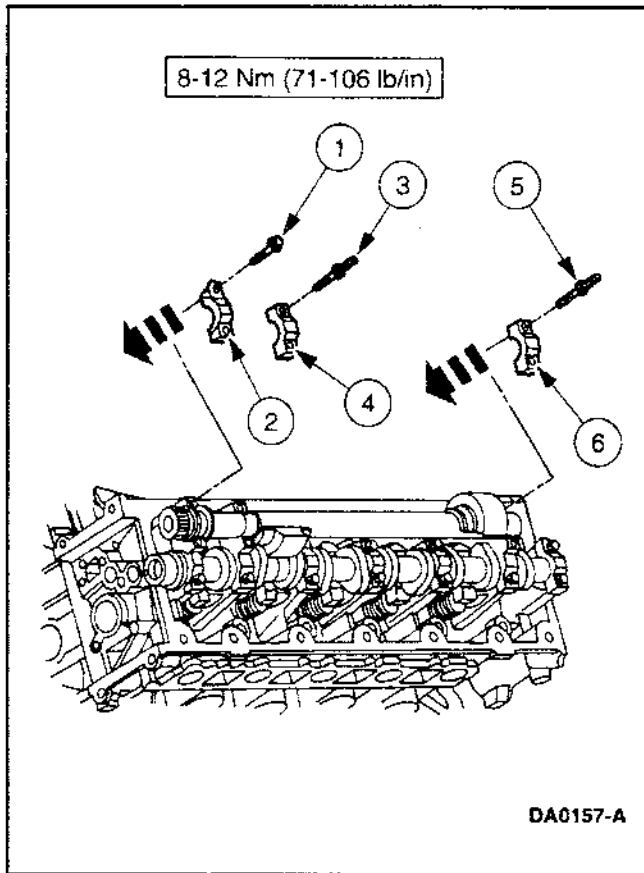

9. Lubricate the balance shaft journals with engine oil.
 - Use Super Premium SAE 5W30 Motor Oil D9AZ-19579-A or equivalent meeting Ford specification WSS-M2C153-G.
10. Position the bearing caps in their original locations and the bolts. Tighten the bolts in the sequence shown.
11. Install the intake manifold; refer to Intake Manifold – Variable Resonance Induction System (VRIS) in this section.
12. Install the timing chains; refer to Timing Drive Components in this section.

Exhaust Manifold – RH - Removal

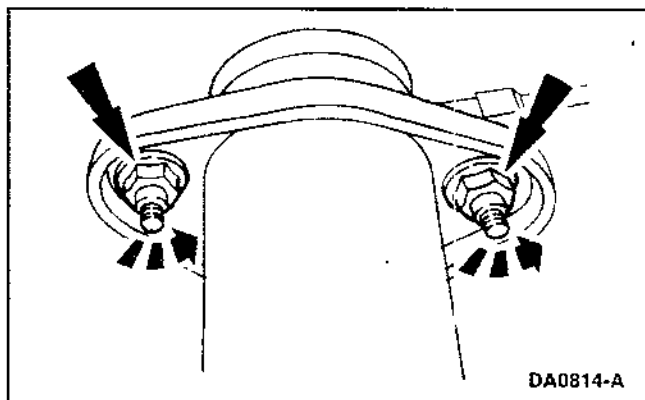

1. Remove the nuts from exhaust pipe and remove exhaust pipe.

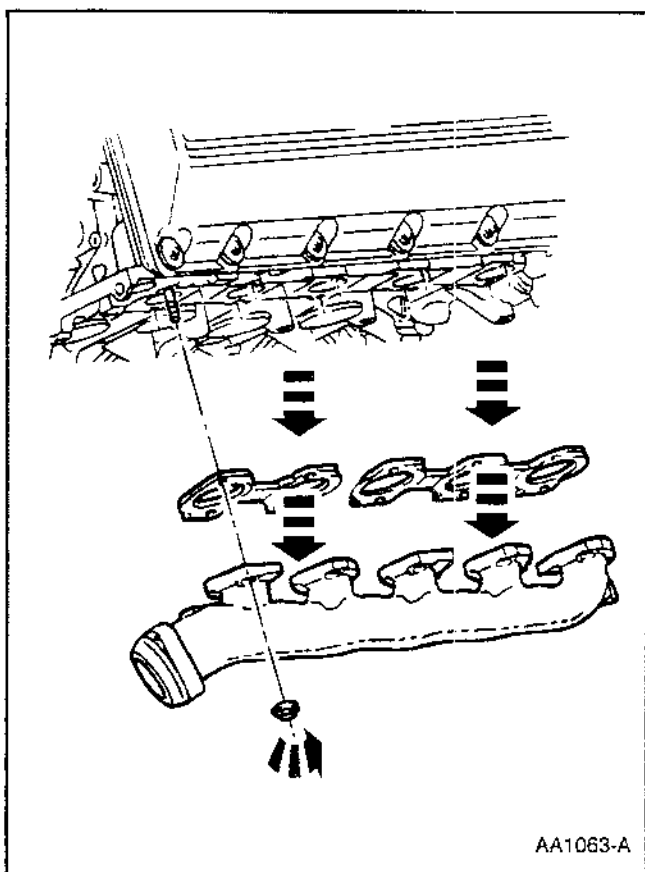

2. Remove the ten nuts and the exhaust manifold (9430) and exhaust manifold gasket (9448). Discard the exhaust manifold gasket.
3. Clean and inspect the exhaust manifold; refer to Section 01.

Exhaust Manifold - RH - Installation

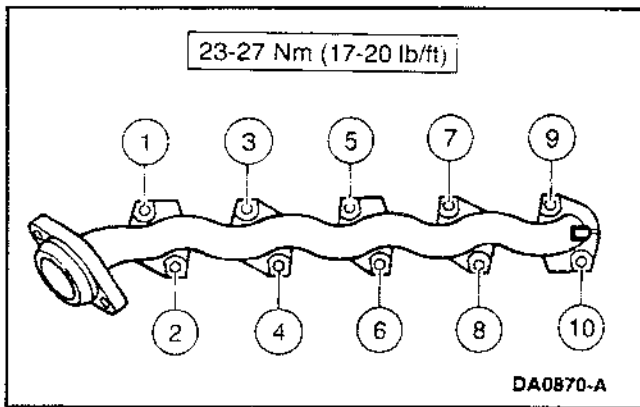

1. Follow the removal procedure in reverse order.

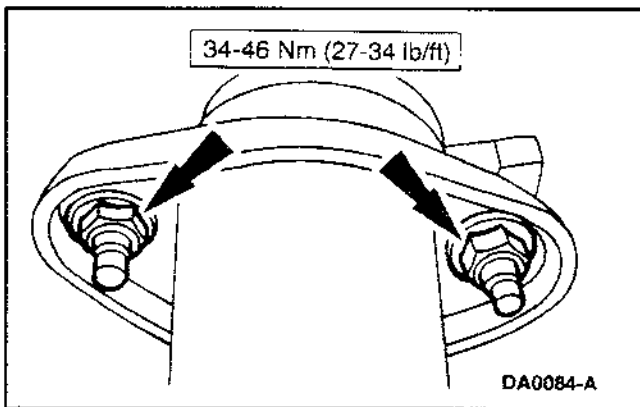

Exhaust Manifold – LH - Removal

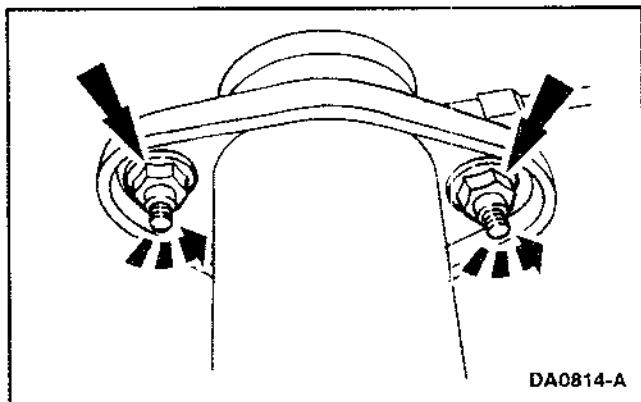

1. Remove the nuts from the exhaust pipe and remove pipe.

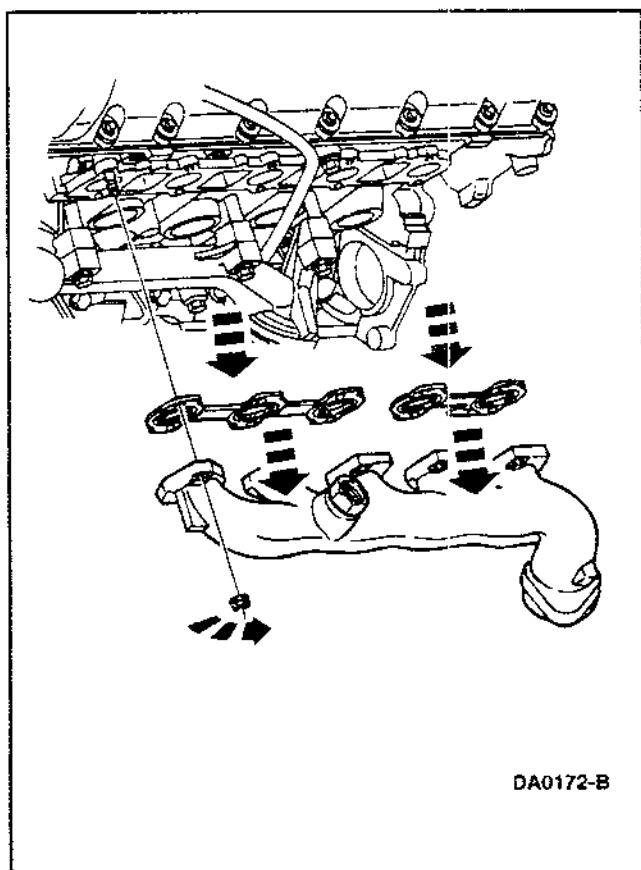

2. Remove the exhaust manifold nuts and the exhaust manifold (9430). Discard the exhaust manifold gaskets (9448).
3. Clean and inspect the exhaust manifold; refer to Section 01.

Exhaust Manifold – LH - Installation

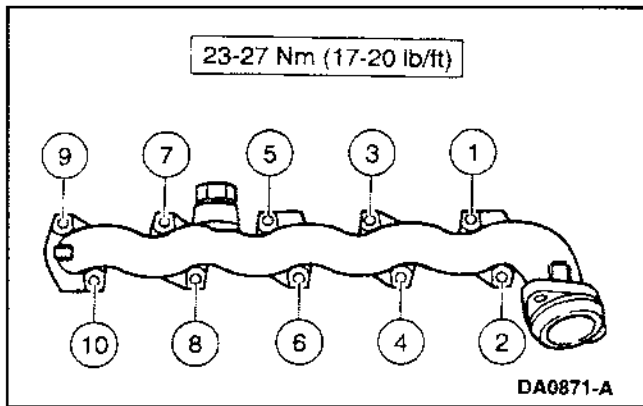

1. Follow the removal procedure in reverse order.

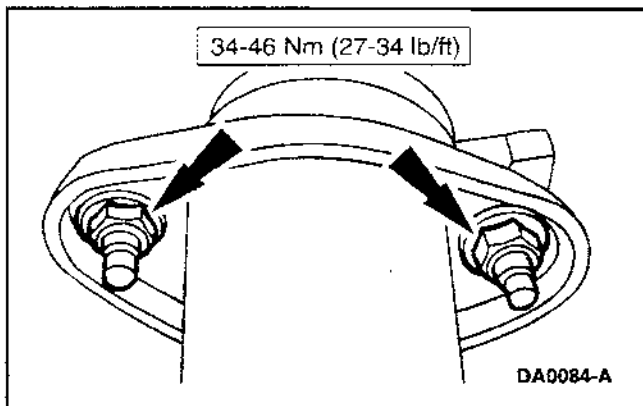

Cylinder Head - Removal

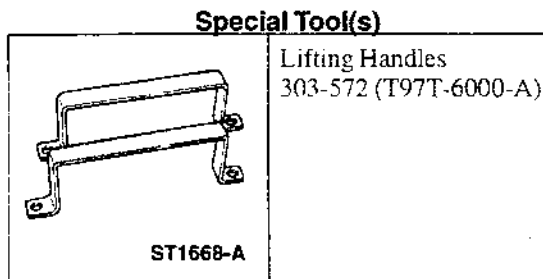

Special Service Tools called for by the procedures can be obtained by calling:
1-800-ROTUNDA (1-800-768-8632).

1.  **WARNING: DO NOT SMOKE OR CARRY LIGHTED TOBACCO OR OPEN FLAME OF ANY TYPE WHEN WORKING ON OR NEAR ANY FUEL-RELATED COMPONENTS. HIGHLY FLAMMABLE MIXTURES ARE ALWAYS PRESENT AND CAN BE IGNITED, RESULTING IN POSSIBLE PERSONAL INJURY.**

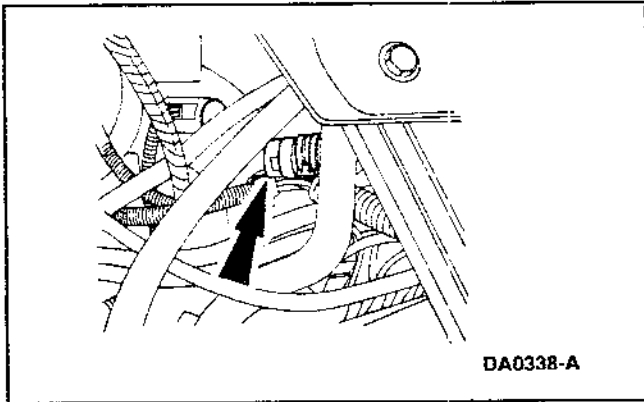

2. Remove the intake manifold (9424); refer to Intake Manifold – Variable Resonance Induction System (VRIS) in this section.
3. Remove the timing chains (6268); refer to Timing Drive Components in this section.
4. Compress and slide the hose clamp back and remove the evaporation water hose (18472) if so equipped.

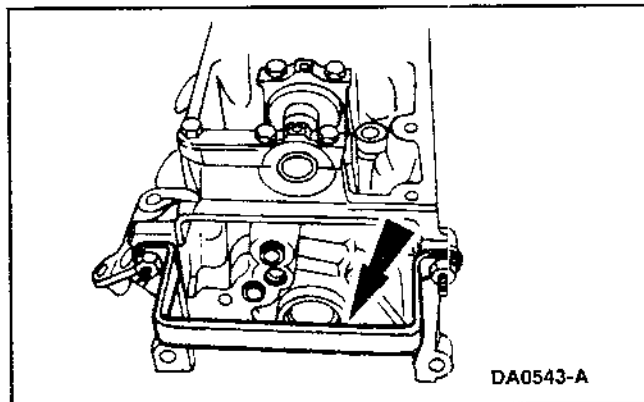

5. Install the Lifting Handles.

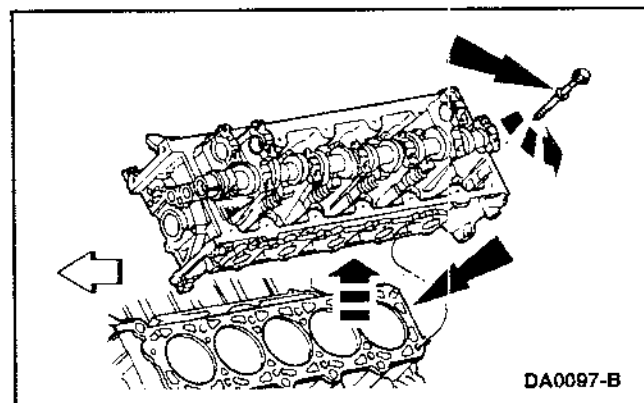

6.  **CAUTION: These bolts must be replaced with new bolts. They are tighten-to-yield designed and cannot be reused.**

Remove the bolts and the cylinder head (6049).

- Discard the head gasket (6051), the cylinder head bolts (6049) and clean the engine block surface.
- The LH is shown. The RH is similar.

7. **NOTE:** Sealant must be removed and area cleaned with solvent.

⚠ CAUTION: Mating parts must make contact to each other within 4 minutes and connecting bolts must be torqued within 15 minutes after applying sealant. Failure to follow this procedure can cause future oil leakage.

- Use silicone gasket and sealant F6AZ-19562-AA or equivalent meeting Ford specification WSE-M4G323-A6.

NOTE: Sealant must be removed and area cleaned with solvent if above instructions are not followed.

- Use metal surface cleaner F4AZ-19A536-RA or equivalent meeting Ford specification WSE-M5B292-A.

Cylinder Head - Installation

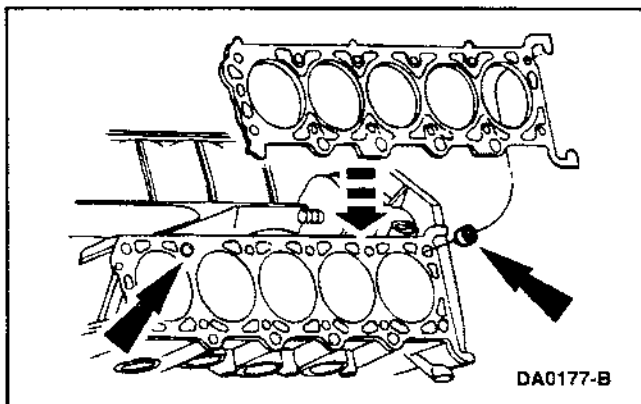
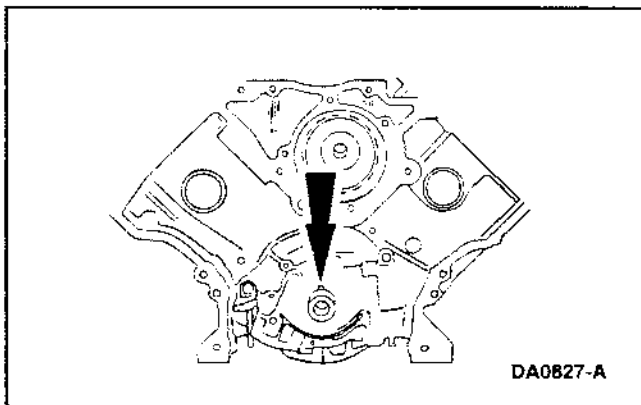

1. Rotate the crankshaft (6303) to position the keyway at 12 o'clock.

2. **NOTE:** Do not turn the crankshaft until otherwise instructed.

Install the head gasket over the dowel pins.

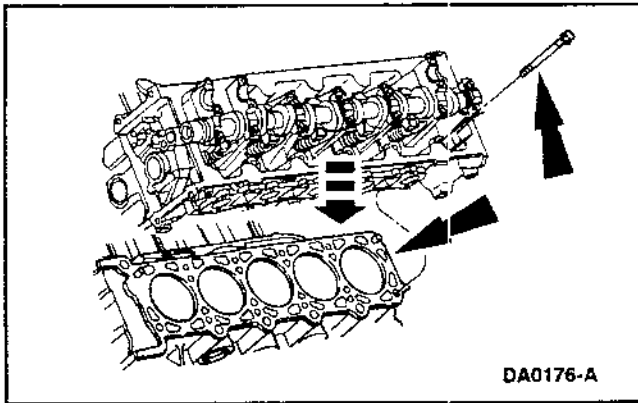

3. **NOTE:** Head bolts are torque to yield and must be replaced whenever cylinder head is removed.

Install the cylinder head on the head gasket and loosely install new bolts.

- The LH is shown; the RH is similar.

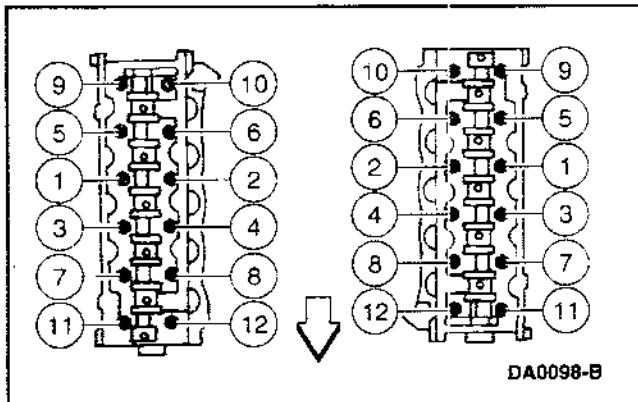

4. **NOTE:** Be sure to tighten the bolts in three stages.

- Stage 1: Tighten to 37-43 Nm (27-32 lb/ft).
- Stage 2: Tighten an additional 85 degrees to 95 degrees.
- Stage 3: Tighten an additional 85 degrees to 95 degrees.

5. Install the timing chains; refer to Drive Components in this section.

6. Install the intake manifold; refer to Intake Manifold – Variable Resonance Induction System (VRIS) in this section.

Oil Level Indicator Tube - Removal

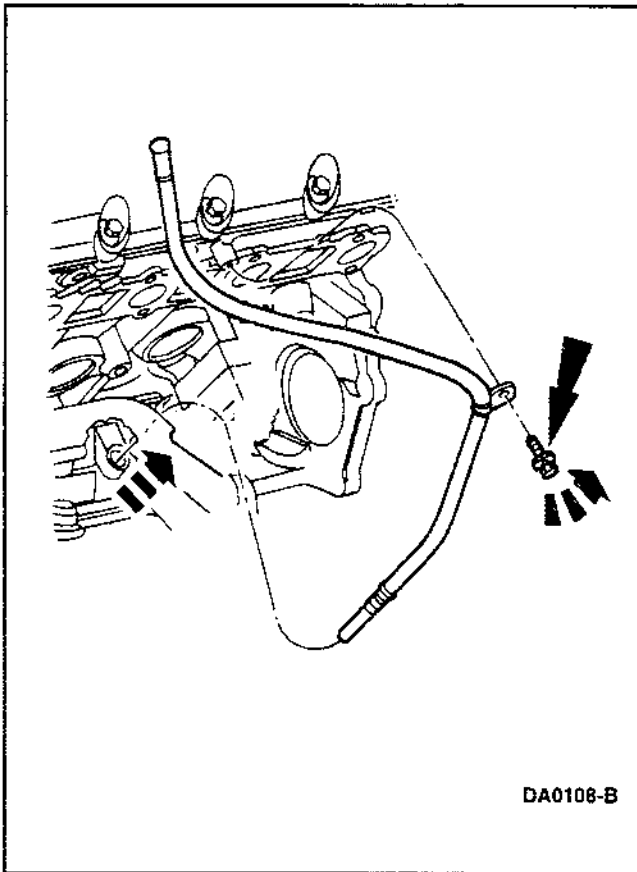

1. Remove the bolt and remove the oil level indicator tube (6754).
2. Inspect the oil level indicator tube for damage.

Oil Level Indicator Tube - Installation

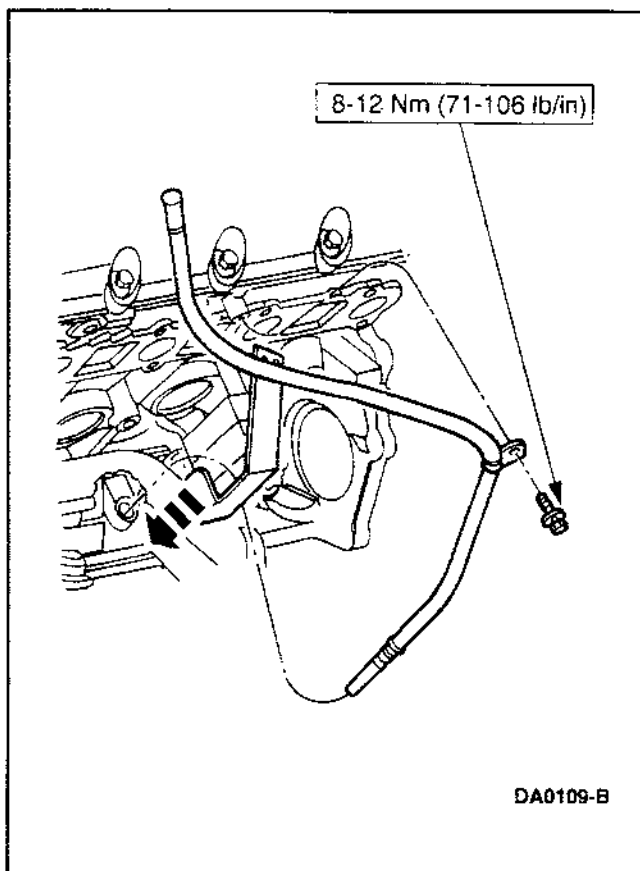

1. Follow the removal procedure in reverse order.
2. Replace and lubricate the O-rings with Super Premium SAE 5W30 Motor Oil D9AZ-19579-A or equivalent meeting Ford specification WSS-M2C153-G.
3. Replace oil level indicator (oil dipstick).

Oil Pan - Removal

1. Disconnect the battery ground cable (14301).
2. Partially drain the radiator (8005) and disconnect the upper radiator hose (8260) at the radiator.
3. Drain the engine oil and remove the oil bypass filter (6714).
4. Remove the nuts retaining the front engine support insulator (6038) to the front engine support bracket (6028). The RH is shown, the LH is typical.

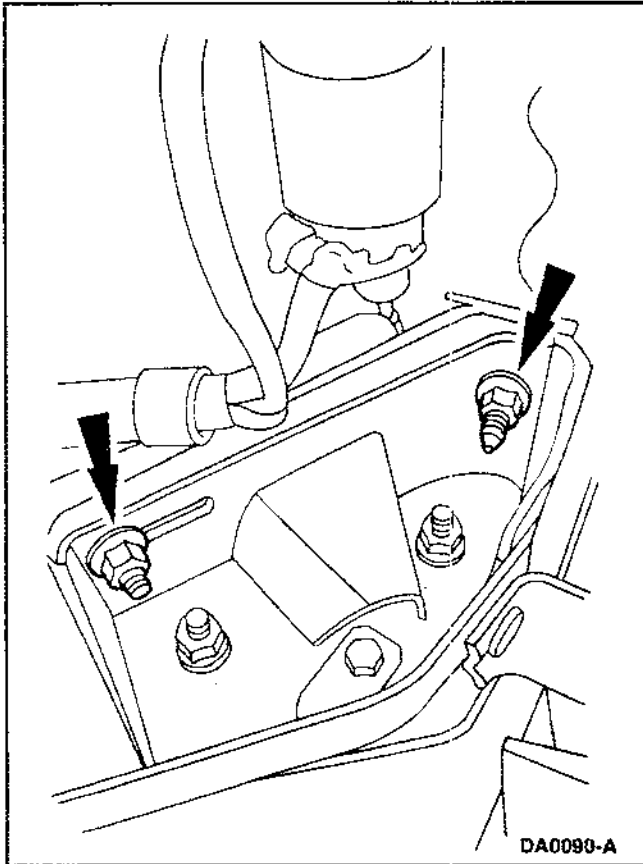

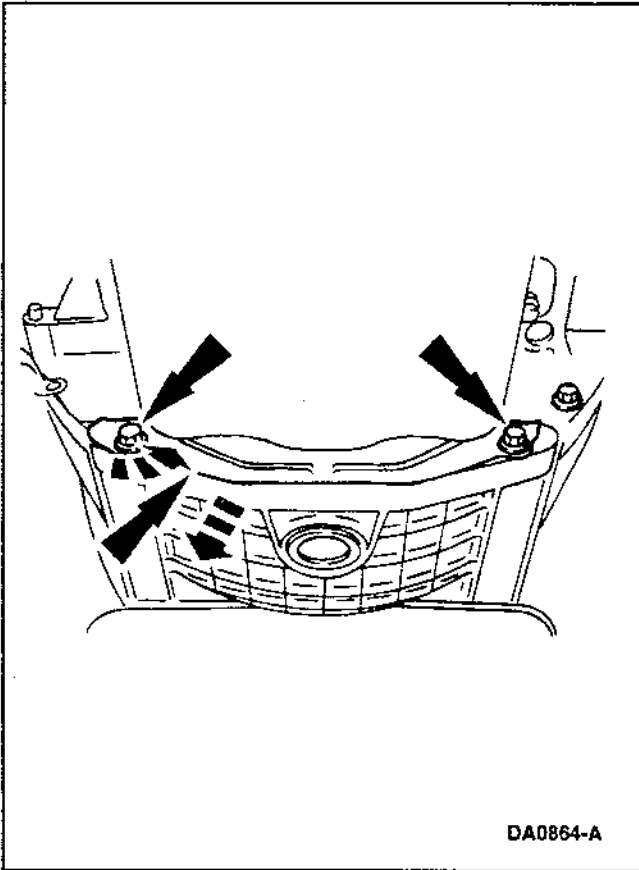

5. Remove the flywheel inspection plate.

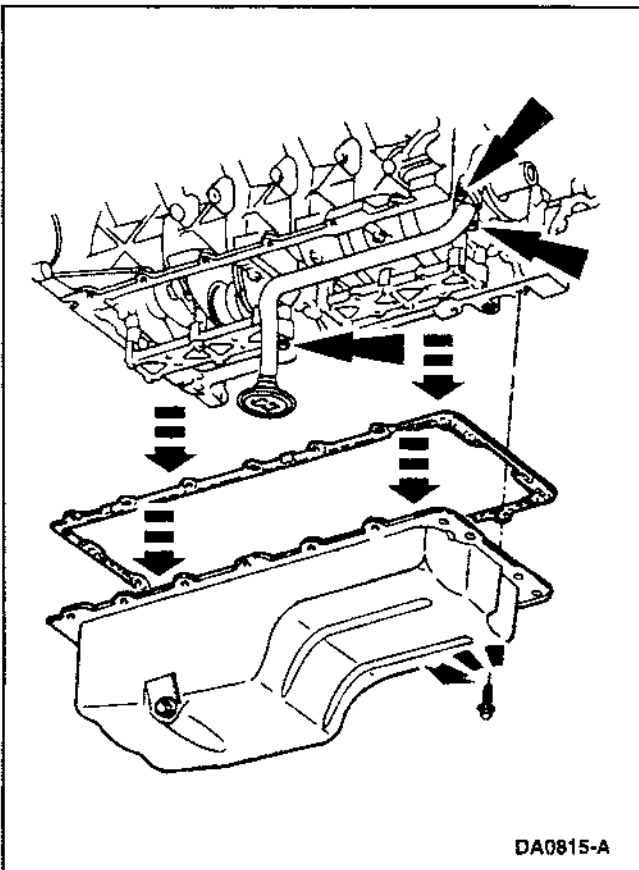

6. Remove the bolts and partially lower the oil pan (6675).

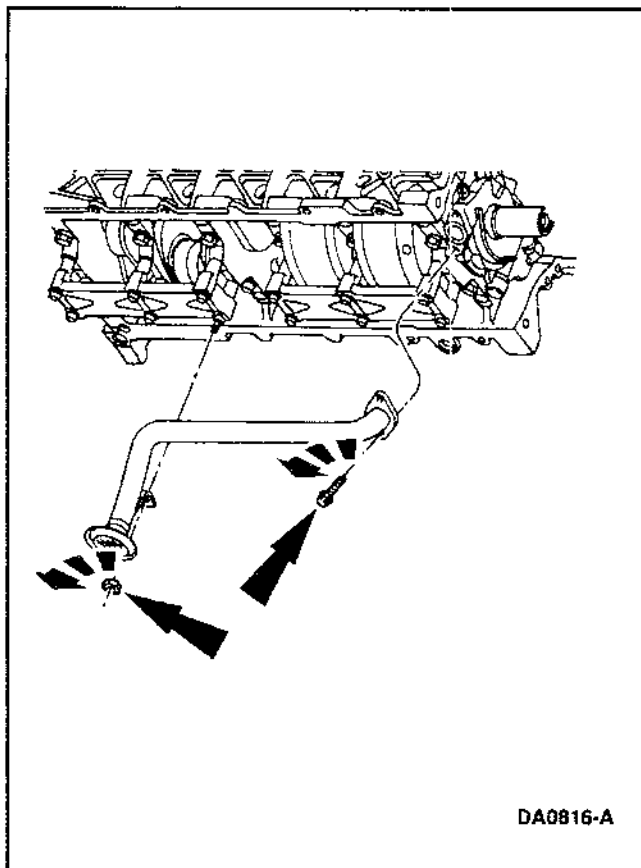

7. Remove the two bolts and the nut retaining the oil pump screen cover and tube (6622) and let them drop into the oil pan.
8. Remove the oil pan and oil pan gasket (6710) from the rear of the engine.
9. Clean the mating surfaces and thoroughly clean the oil pan.

Oil Pan - Installation

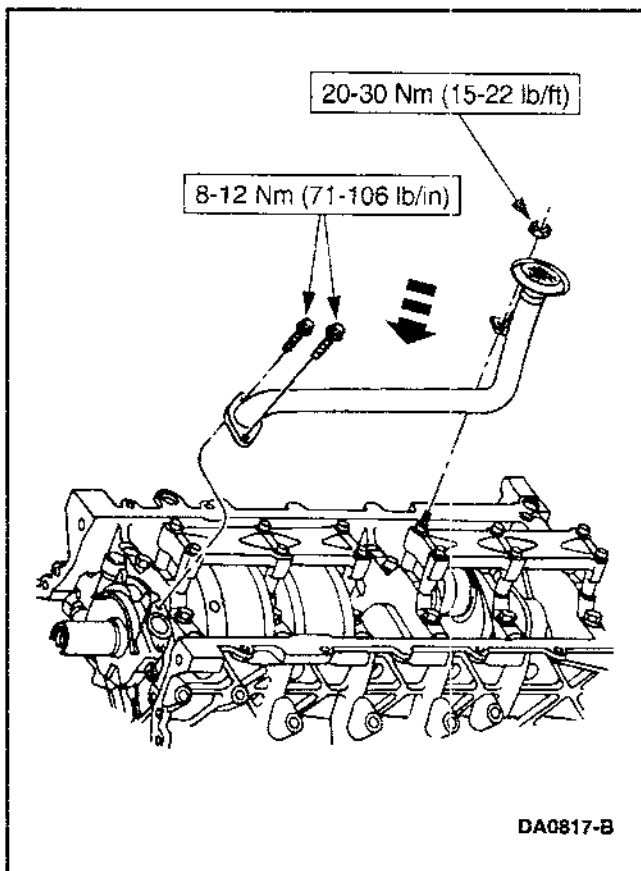

1. Install the oil pump screen cover and tube.
2. **CAUTION:** Mating parts must make contact to each other within 4 minutes and connecting bolts must be torqued within 15 minutes after applying sealant. Failure to follow this procedure can cause future oil leakage.

- Use silicone gasket and sealant F6AZ-19562-AA or equivalent meeting Ford specification WSE-M4G323-A6.

NOTE: Sealant must be removed and area cleaned with solvent if above instructions are not followed.

- Use metal surface cleaner F4AZ-19A536-RA or equivalent meeting Ford specification WSE-M5B292-A.

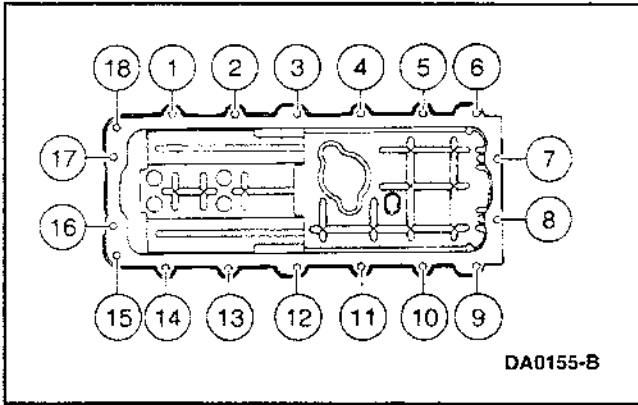

3. **NOTE:** Be sure to tighten the bolts in three stages.

Replace oil pan and bolts.

Tighten the bolts in the sequence shown.

- Stage 1: Tighten to 2 Nm (18 lb/in).
- Stage 2: Tighten to 20 Nm (15 lb/ft).
- Stage 3: Tighten an additional 60 degrees.

4. Install oil drain plug 11-16 Nm (98-143 lb/in).

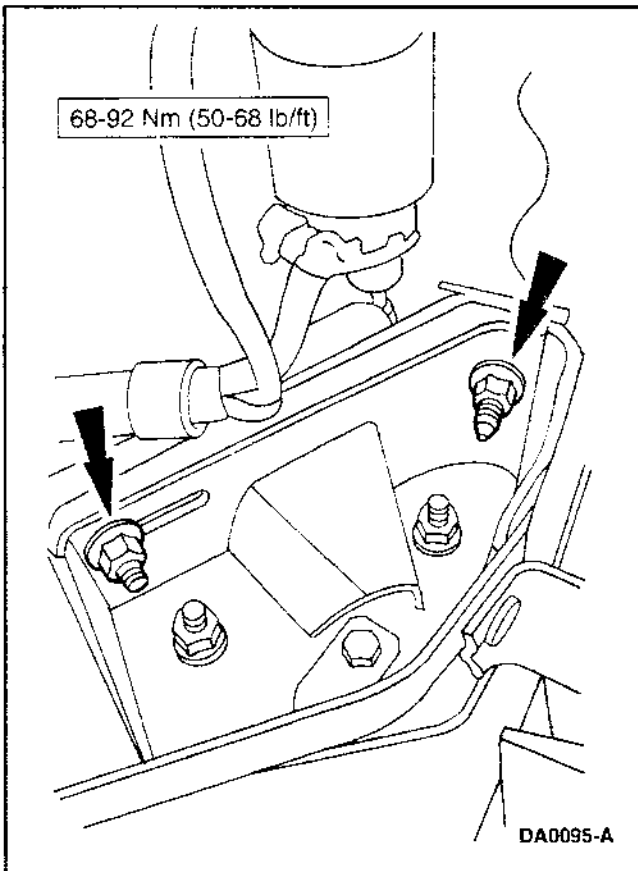

5. Tighten the front engine support insulators.

6. Connect the battery ground cable.

7. Fill the engine with oil.

- Use Motorcraft Engine Oil XO-5W30-QSP or equivalent meeting Ford specification WSS-M2C153-G.

8. Fill the cooling system.

Oil Pump - Removal

1. Disconnect the battery ground cable (14301).
2. Remove the engine front cover (6019) and crankshaft sprockets (6306); refer to Engine Front Cover in this section.
3. Remove the oil pan (6675); refer to Oil Pan in this section.
4. Remove the oil pump (6600).
 - Remove the bolts.
 - Remove the oil pump

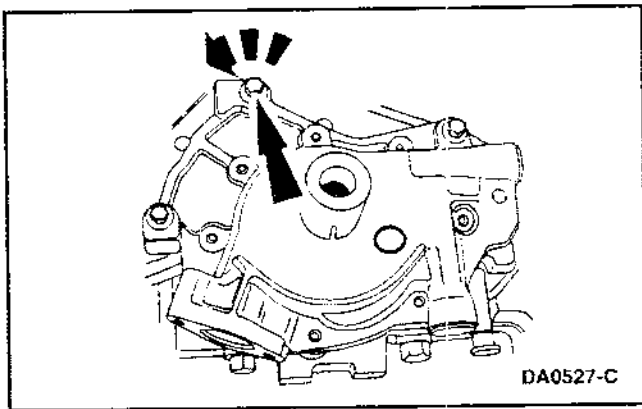

Oil Pump - Installation

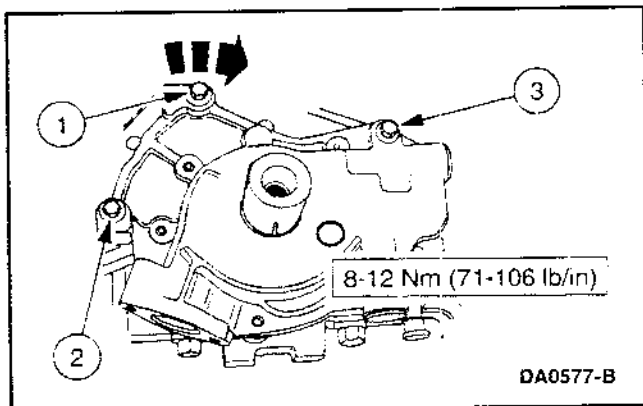

1. Clean and inspect the mating surfaces.
2. Position the oil pump and loosely install the bolts. Tighten the bolts in the sequence shown.
3. Install the oil pan; refer to Oil Pan in this section.
4. Install the timing chain (6268); refer to Timing Drive Components in this section.
5. Connect the battery ground cable.

Flywheel - Removal

1. Disconnect the battery ground cable (14301).
2. Remove generator from bell housing.
3. Remove bell housing.
4. Remove the bolts and the flywheel (6375).

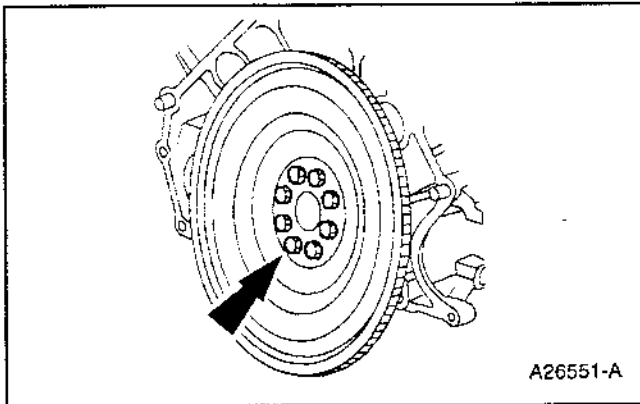

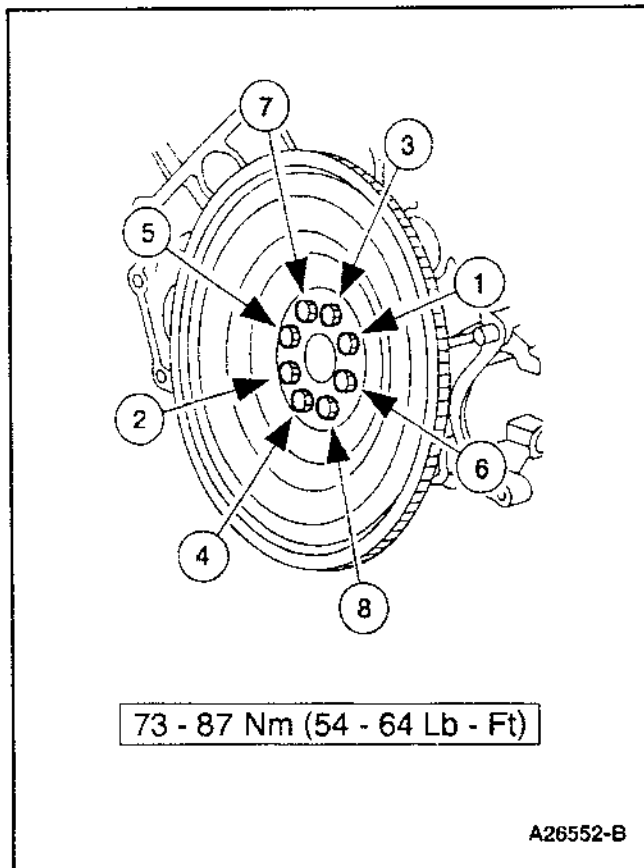

Flywheel - Installation

1. Follow the removal procedure in reverse order.



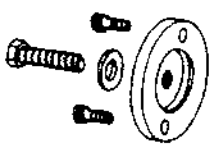
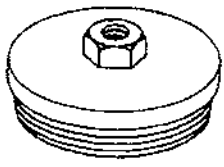

Crankshaft Rear Oil Seal - Removal

Special Tool(s)

 <p>ST1480-A</p>	<p>Rear Crankshaft Seal Adapter 303-518 (T95P-6701-DH)</p>
 <p>ST1382-A</p>	<p>Rear Crankshaft Seal Remover 303-519 (T95P-6701-EH)</p>
 <p>ST1482-A</p>	<p>Rear Crankshaft Slinger Replacer 303-517 (T95P-6701-CH)</p>

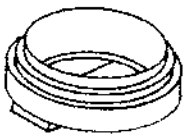
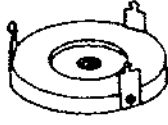
Special Tool(s)

 <p>ST1479-A</p>	<p>Rear Crankshaft Seal Replacer 303-516 (T95P-6701-BH)</p>
 <p>ST1481-A</p>	<p>Rear Crankshaft Slinger Remover 303-514 (T95P-6701-AH)</p>
 <p>ST1185-A</p>	<p>Slide Hammer 100-001 (T50T-100-A)</p>

Special Service Tools called for by the procedures can be obtained by calling:
1-800-ROTUNDA (1-800-768-8632).

1. Disconnect the battery ground cable (14301).
2. Remove the flywheel (6375); refer to Flywheel in this section.
3. Use the Rear Crankshaft Slinger Remover and the Slide Hammer to remove the crankshaft oil slinger (6310).
4. Use the Rear Crankshaft Seal Remover and the Impact Slide Hammer to remove the crankshaft rear oil seal (6701).

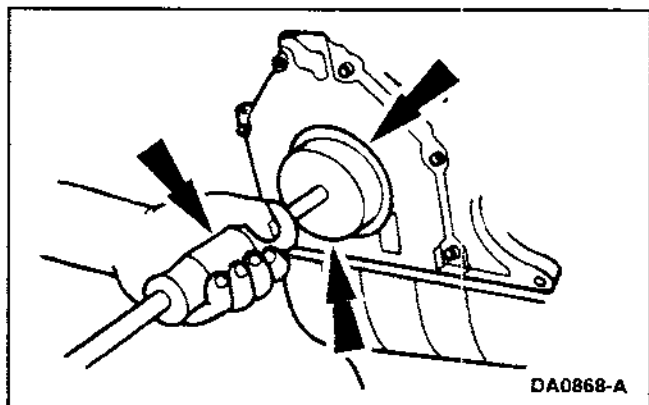

Crankshaft Rear Oil Seal - Installation

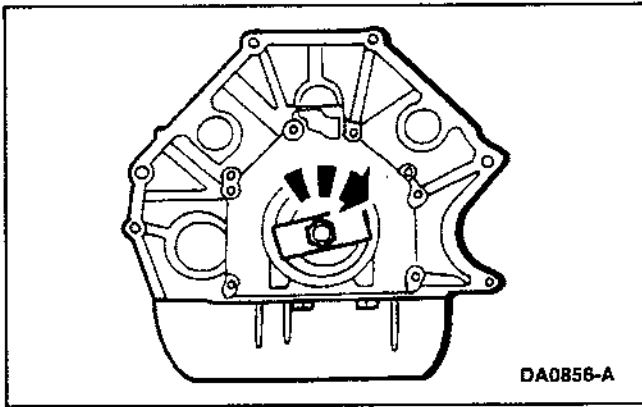

1. **CAUTION:** Mating parts must make contact to each other within 4 minutes and connecting bolts must be torqued within 15 minutes after applying sealant. Failure to follow this procedure can cause future oil leakage.

- Use silicone gasket and sealant F6AZ-19562-AA or equivalent meeting Ford specification WSE-M4G323-A6.

NOTE: Sealant must be removed and area cleaned with solvent if above instructions are not followed.



- Use metal surface cleaner F4AZ-19A536-RA or equivalent meeting Ford specification WSE-M5B292-A.
2. Using the Rear Crankshaft Seal Replacer and the Rear Crankshaft Seal Adapter, install the crankshaft rear oil seal.
 3. With the Rear Crankshaft Seal Adapter still installed, use the Rear Crankshaft Slinger Replacer and the Rear Crankshaft Seal Replacer to install the rear main seal slinger.
 4. Install the flywheel; refer to Flywheel in this section.
 5. Connect the battery ground cable.

Crankshaft Rear Oil Seal (with retainer plate) - Removal

Special Tool(s)

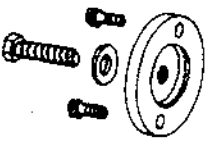
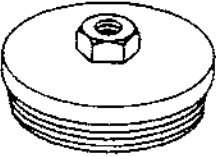
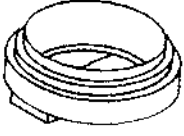
Special Tool(s)

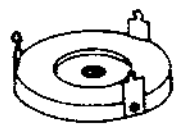
 <p>ST1480-A</p>	<p>Rear Crankshaft Seal Adapter 303-518 (T95P-6701-DH)</p>
 <p>ST1382-A</p>	<p>Rear Crankshaft Seal Remover 303-519 (T95P-6701-EH)</p>
 <p>ST1479-A</p>	<p>Rear Crankshaft Seal Replacer 303-516 (T95P-6701-BH)</p>

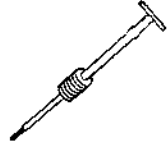
 <p>ST1481-A</p>	<p>Rear Crankshaft Slinger Remover 303-514 (T95P-6701-AH)</p>
 <p>ST1482-A</p>	<p>Rear Crankshaft Slinger Replacer 303-517 (T95P-6701-CH)</p>
 <p>ST1185-A</p>	<p>Slide Hammer 100-001 (T50T-100-A)</p>

Special Service Tools called for by the procedures can be obtained by calling:
1-800-ROTUNDA (1-800-768-8632).

1. Disconnect the battery ground cable (14301).

Remove the flywheel (6375); refer to Flywheel in this section.

2. Use the Rear Crankshaft Slinger Remover and the Impact Slide Hammer to remove the crankshaft oil slinger (6310).

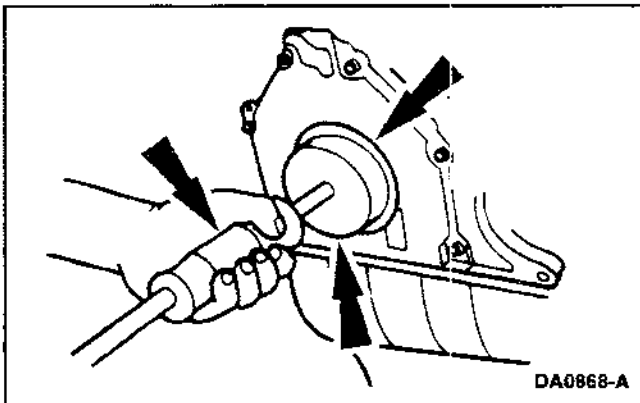

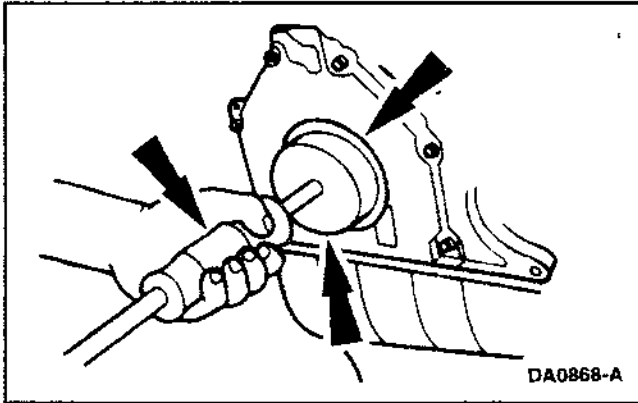

3. Use the Rear Crankshaft Seal Remover and the Impact Slide Hammer to remove the crankshaft rear oil seal (6701).

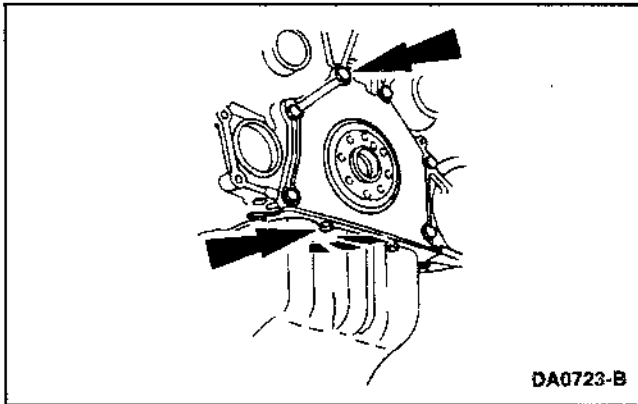

4. Remove the oil pan; refer to Oil Pan in this section.
5. Remove the crankcase bolts and the crankshaft rear oil seal retainer plate.

Crankshaft Rear Oil Seal (with retainer plate) - Installation

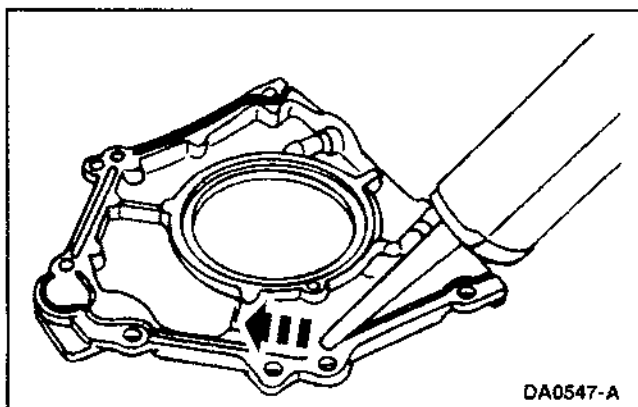

1. **CAUTION:** Mating parts must make contact to each other within 4 minutes and connecting bolts must be torqued within 15 minutes after applying sealant. Failure to follow this procedure can cause future oil leakage.

- Use silicone gasket and sealant F6AZ-19562-AA or equivalent meeting Ford specification WSE-M4G323-A6.

NOTE: Sealant must be removed and area cleaned with solvent if above instructions are not followed.

2. Apply a bead of silicone around the rear oil seal retainer sealing surface.
 - Use Silicone Gasket and Sealant F6AZ-19562-A or equivalent meeting Ford specification WSE-M4G323-A6.

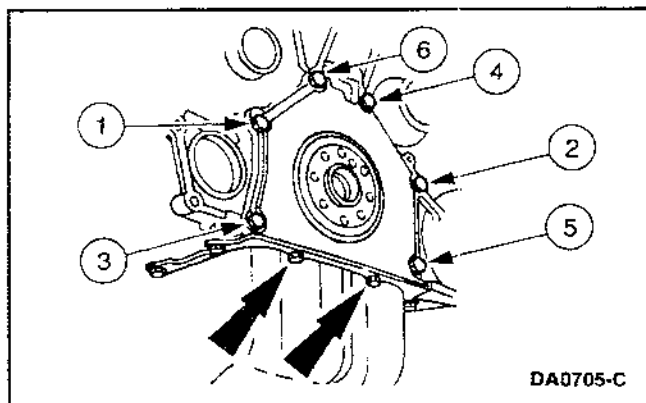

3. **NOTE:** If the rear main oil seal is still in place and being reinstalled, be sure the lip is not folded over or wrinkled during the retainer plate installation. The seal lip must start squarely on the crankshaft journal.

Position the crankshaft rear oil seal and retainer (6K301), install the bolts. Then install the oil pan and the two bolts. Tighten in two stages.

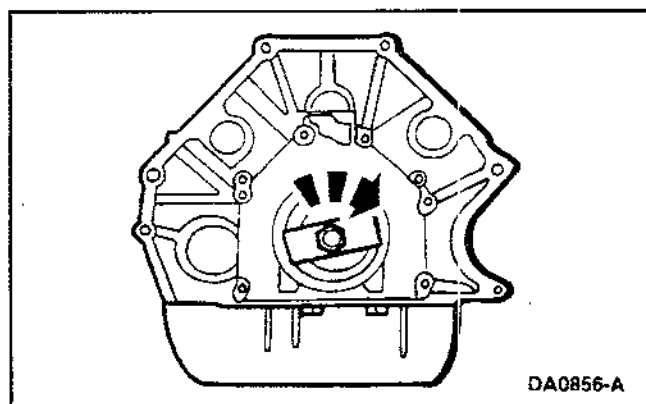

- Stage 1: Tighten retainer plate bolts to 8-12 Nm (71-107 lb/in).
- Stage 2: Tighten oil pan bolts to 14-20 Nm 10-15 lb/ft) then tighten an additional 90°.



4. Use the Rear Crankshaft Seal Replacer and Rear Crankshaft Seal Adapter to install the crankshaft rear oil seal.
5. With the Rear Crankshaft Seal Adapter still installed, use the Rear Crankshaft Slinger Replacer and Rear Crankshaft Seal Replacer to install the crankshaft oil slinger.
6. Install the flywheel; refer to Flywheel in this section.
7. Connect the battery ground cable.

Engine - Removal

Special Tool(s)

 <p>ST1377-A</p>	<p>Modular Lifting Bar 303-F047 (014-00073) or Equivalent</p>
 <p>ST1481-A</p>	<p>Rear Crankshaft Slinger Remover T95P-6701-AA</p>

Special Tool(s)

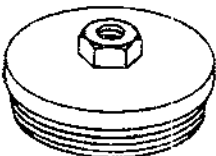
 <p>ST1185-A</p>	<p>Impact Slide Hammer 100-001 (T50T-100-A)</p>
 <p>ST1382-A</p>	<p>Rear Crankshaft Seal Remover 303-519 (T95P-6701-EH)</p>

Special Service Tools called for by the procedures can be obtained by calling:
1-800-ROTUNDA (1-800-768-8632).

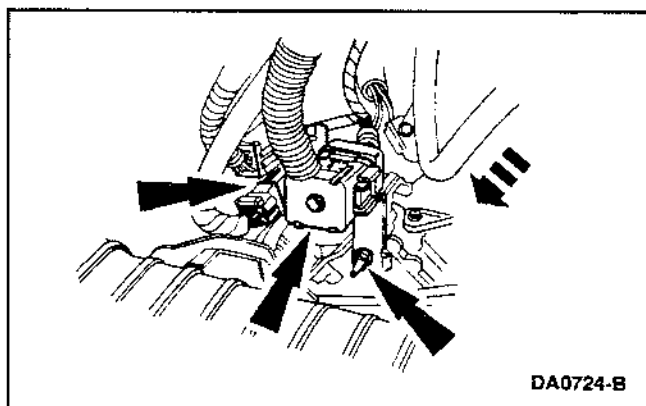

1. Disconnect the battery ground cable (14301).
2. Remove the intake manifold (9424); refer to Intake Manifold – Variable Resonance Induction System (VRIS) in this section.
3. Remove the radiator upper and lower radiator supports (16138).
4. Remove the radiator (8005), fan shroud (8146) and engine cooling fan.
5. Remove the drive belt (8620); refer to Section 05.

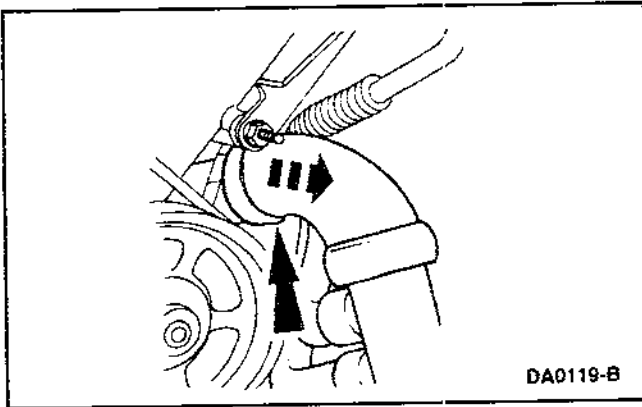

6. At the oil cooler water inlet, disconnect and set aside the lower radiator hose (8286).
7. Disconnect the engine harness.

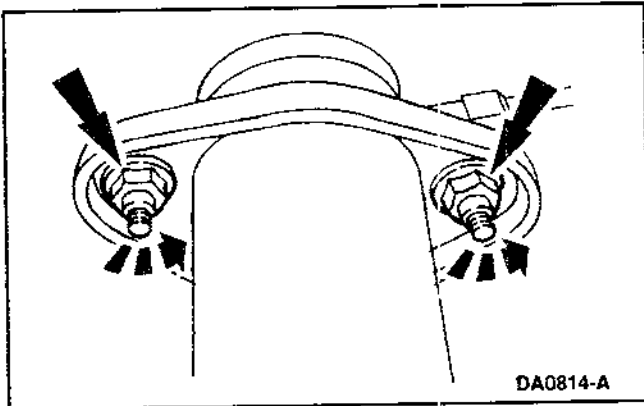

8. Remove exhaust pipe nuts.

9. Drain engine oil and remove the oil bypass filter (6714).
10. Remove the starter motor (11002); refer to Section 07.

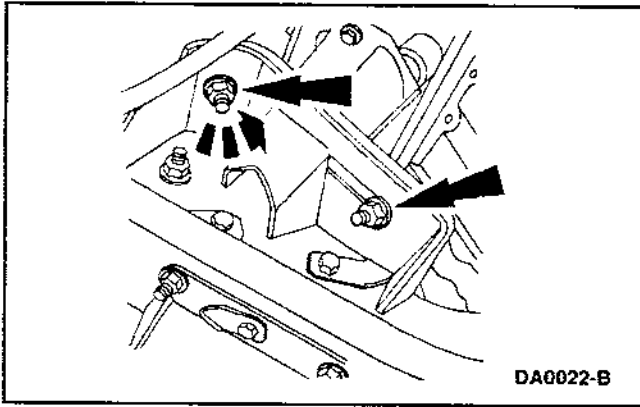

11. Remove the engine support insulator nuts.

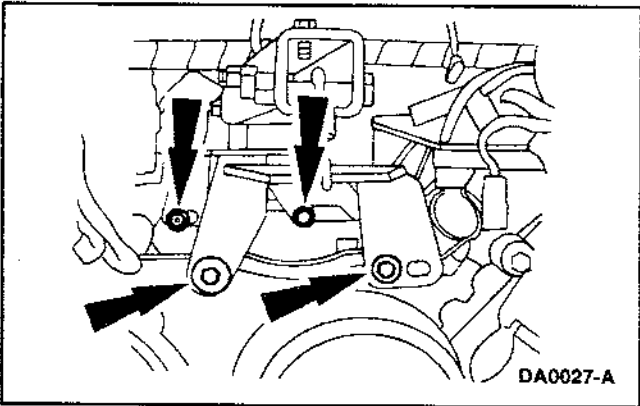

12. Install the Modular Lifting Bar.

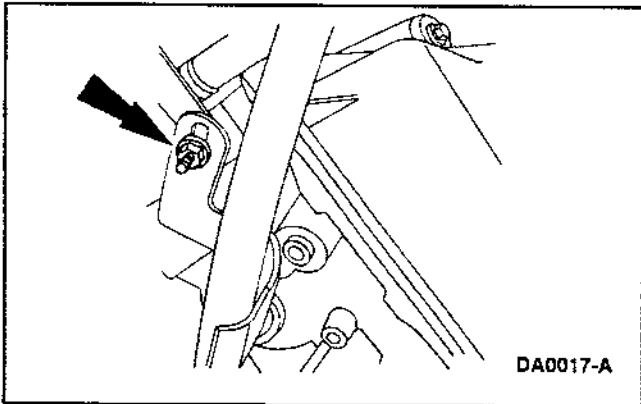

13. Remove the engine from the equipment.

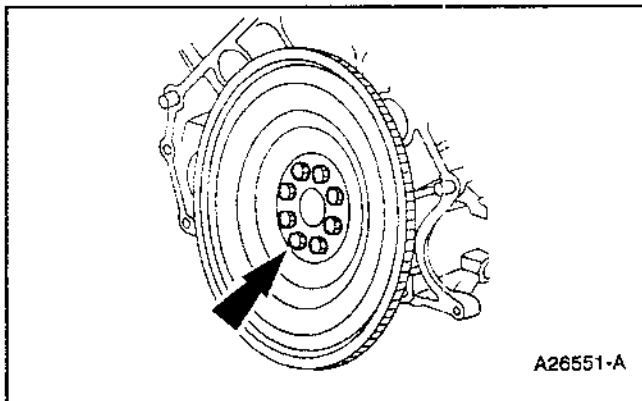

14. Remove the bolts, and remove the flywheel.

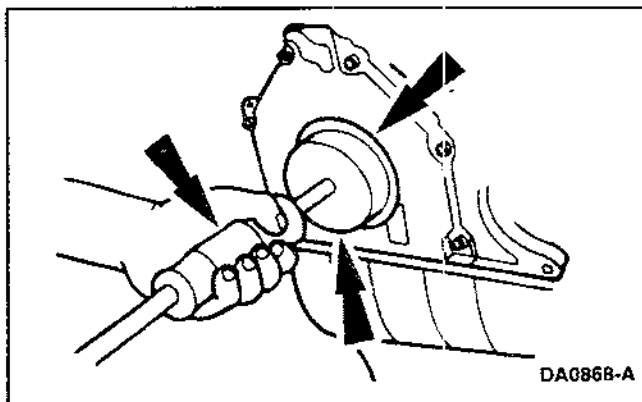

15. Use the Rear Crankshaft Slinger Remover and the Impact Slide Hammer to remove the crankshaft oil slinger (6310).

16. Use the Rear Crankshaft Seal Remover and the Impact Slide Hammer to remove the crankshaft rear oil seal (6701).

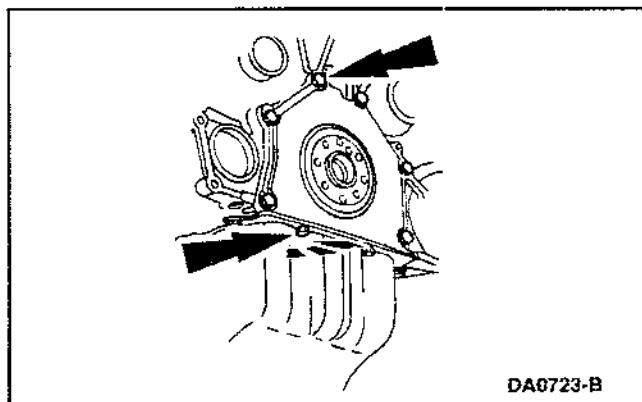

17. Remove the bolts and remove the crankshaft rear oil seal retainer plate.

18. Mount the engine on an engine stand.

19. Remove the Modular Lifting Bar.

Engine - Disassembly

Special Tool(s)

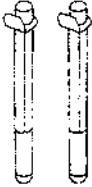
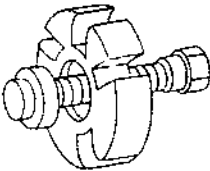
	<p>Camshaft Holding Tool (2 Required) 303-557 (T96T-6256-B)</p>
 <p>ST1337-A</p>	<p>Connecting Rod Guide Tool 303-442 (T93P-6136-A)</p>
 <p>ST1286-A</p>	<p>Crankshaft Damper Remover 303-009 (T58P-6316-D)</p>

Special Tool(s)

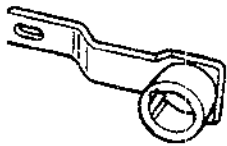
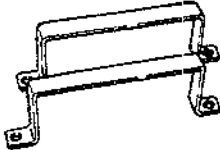
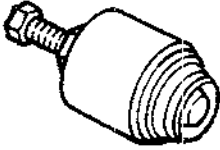
 <p>ST1335-A</p>	<p>Crankshaft Holding Tool 303-448 (T93P-6303-A)</p>
 <p>ST1668-A</p>	<p>Lifting Handles (2 Sets Required) 303-572 (T97T-6000-A)</p>
 <p>ST1730-A</p>	<p>Front Cover Seal Remover 303-107 (T74P-6700-A)</p>

Special Service Tools called for by the procedures can be obtained by calling:
1-800-ROTUNDA (1-800-768-8632).

1. With the engine on the engine stand, remove the engine wiring harness.

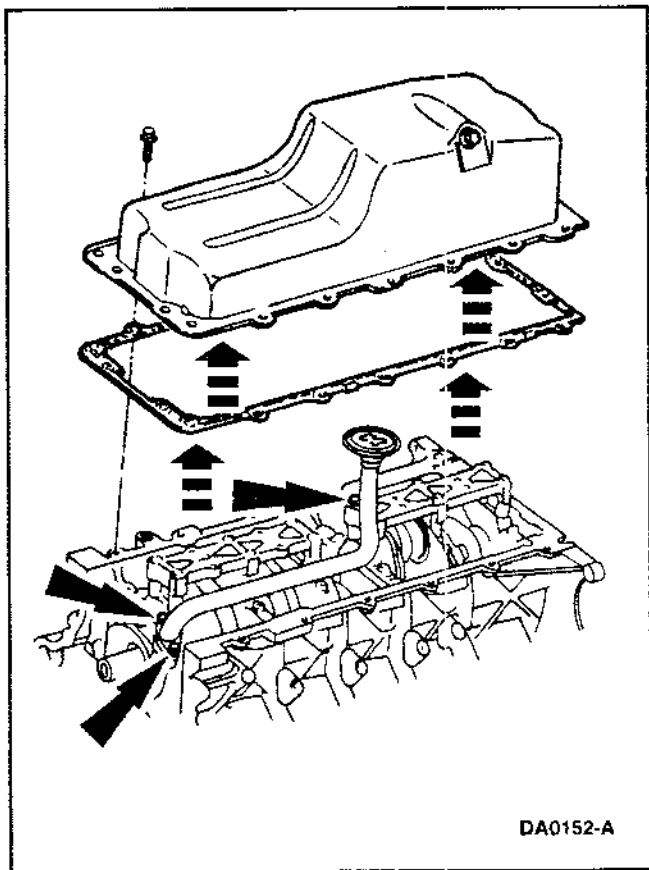

2. Remove the bolts, the oil pan (6675), and the oil pan gasket (6710).

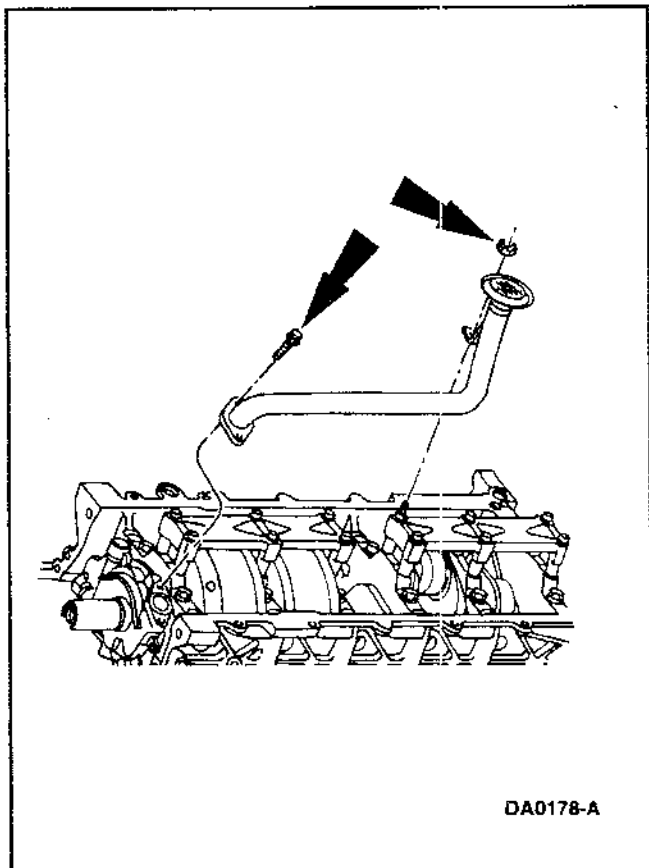

3. Remove the two bolts and nut retaining the oil pump screen cover and tube (6622) and remove the oil pump screen cover and tube.

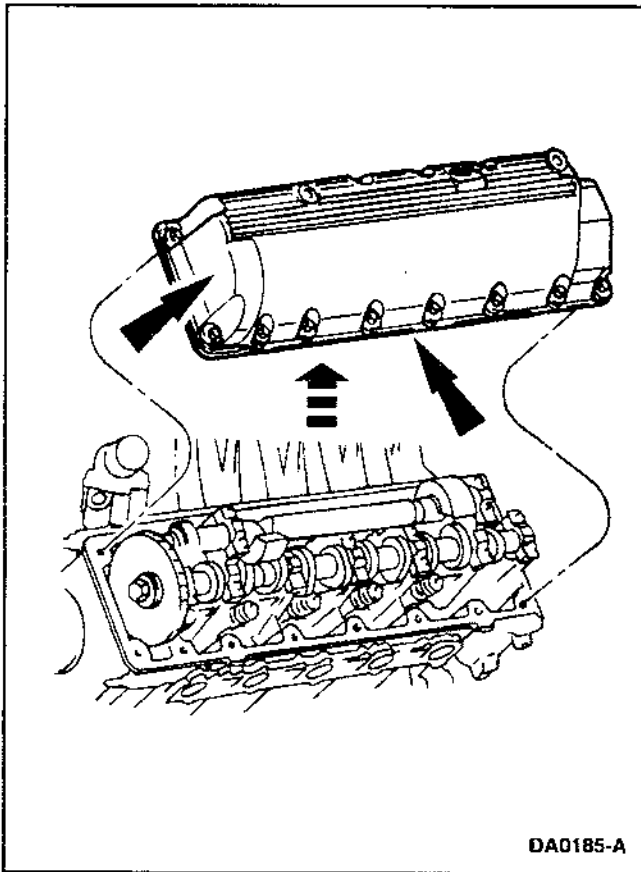

4. **NOTE:** The bolts are a part of the valve cover (6582) and are not to be removed.

LH is shown; RH is similar.

- Fully loosen the sixteen bolts, and remove the valve cover gasket (6584).

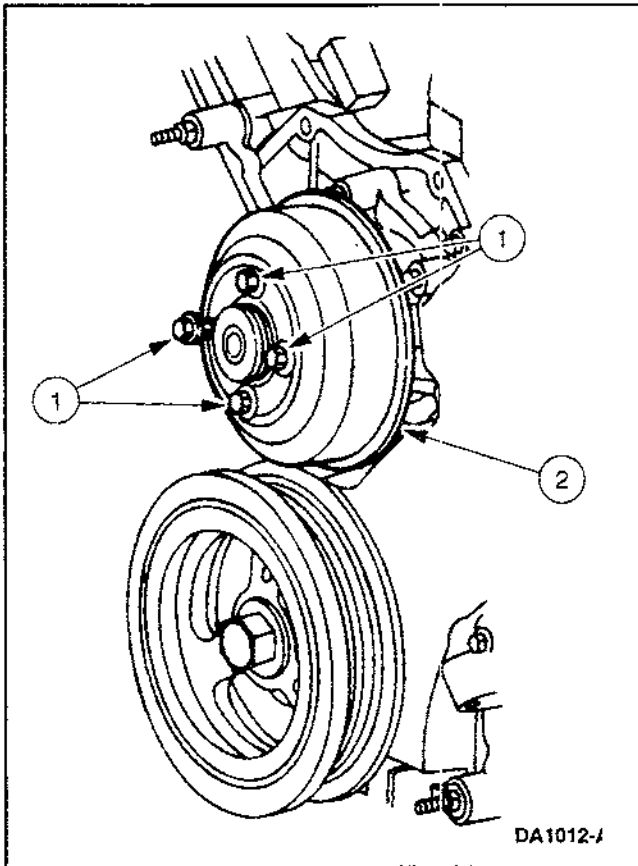

5. Remove the drive belt.
6. Remove the water pump pulley (8509).
 1. Remove the four bolts.
 2. Remove the water pump pulley.

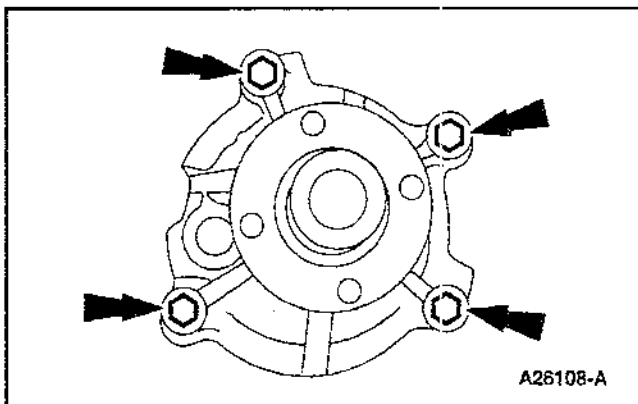

7. Remove the four bolts from the water pump.

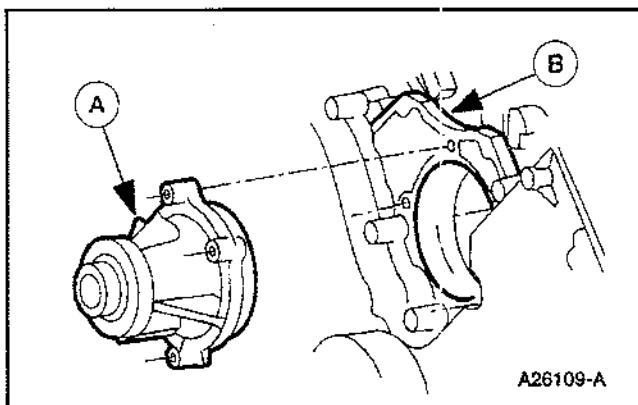

8. Remove the (A) water pump (8501) from the (B) cylinder block (6010).

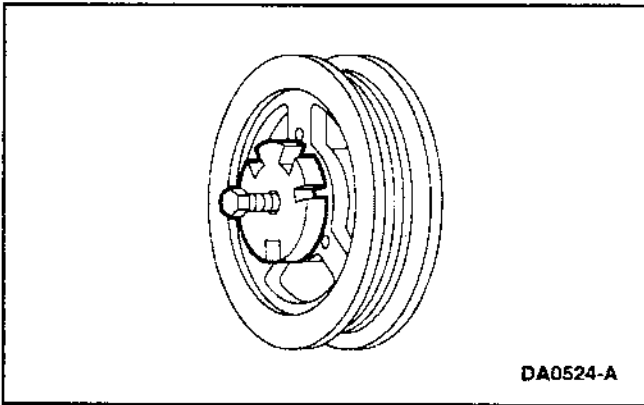

9. Remove the crankshaft pulley bolt (6A340).

Use the Crankshaft Damper Remover to remove the crankshaft pulley (6312).

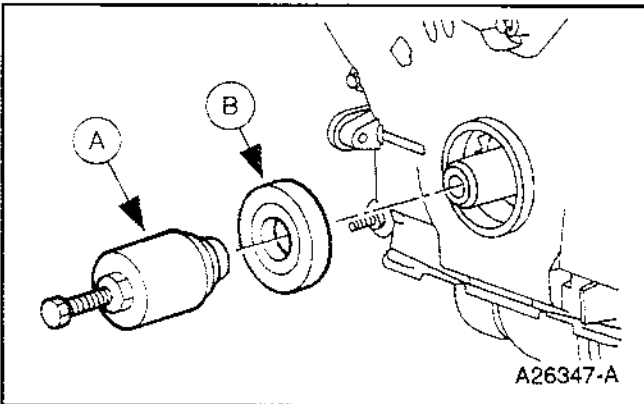

10. Use the (A) Front Cover Seal Remover to remove the (B) crankshaft front seal (6700).

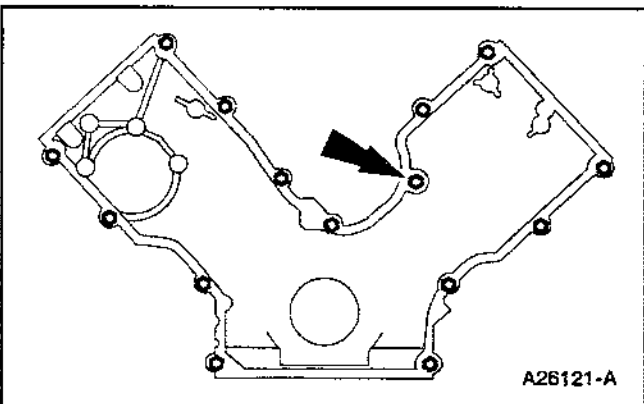

11. Remove the engine front cover fasteners.

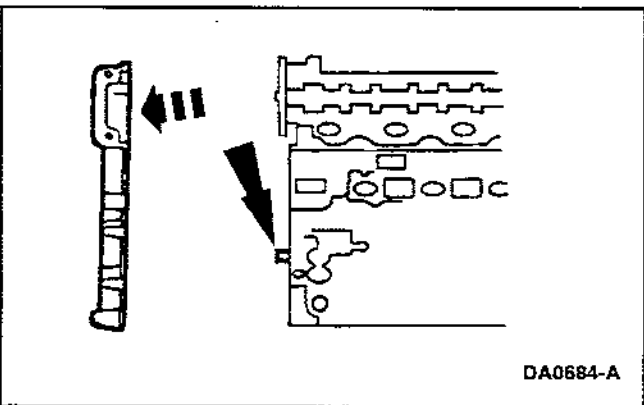

12. Remove the engine front cover (6019) from the front cover to cylinder block dowels (6C002).

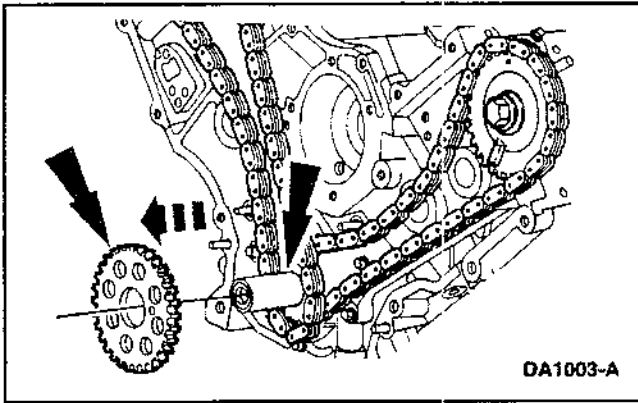

13. Remove the crankshaft sensor ring from the crankshaft (6303).

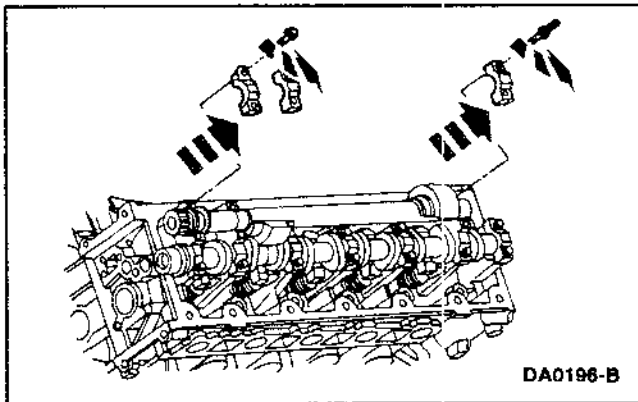

14. Remove the balancing shaft bearing caps.

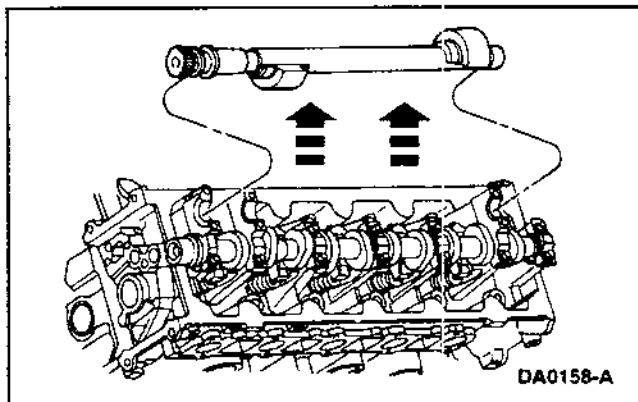

15. Remove balancing shaft.

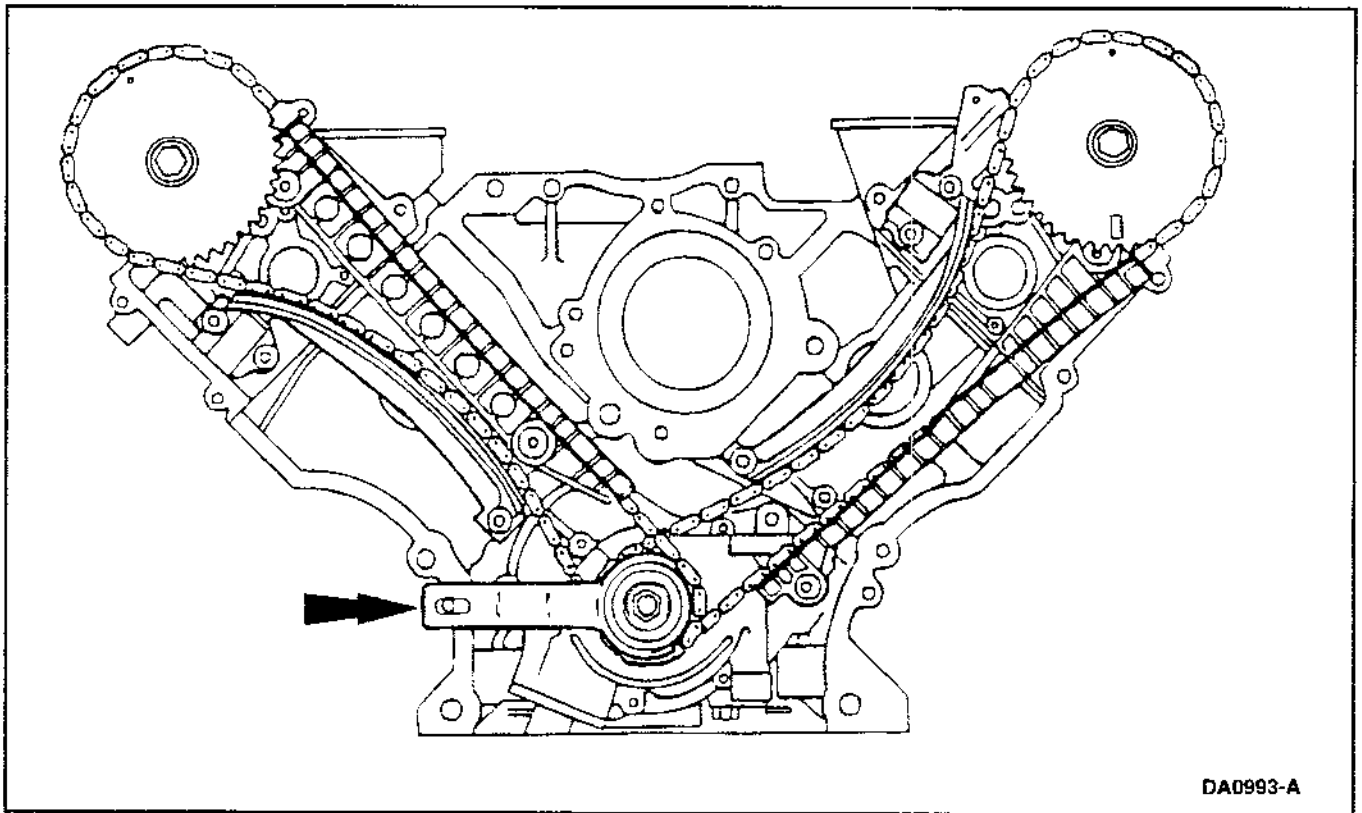

16. **⚠ CAUTION:** Unless otherwise instructed, at no time when the timing chains (6268) are removed and the cylinder heads (6049) are installed is the crankshaft or camshaft (6250) to be rotated. Severe piston (6108) and valve damage will occur.

Position the crankshaft with the Crankshaft Holding Tool as shown.

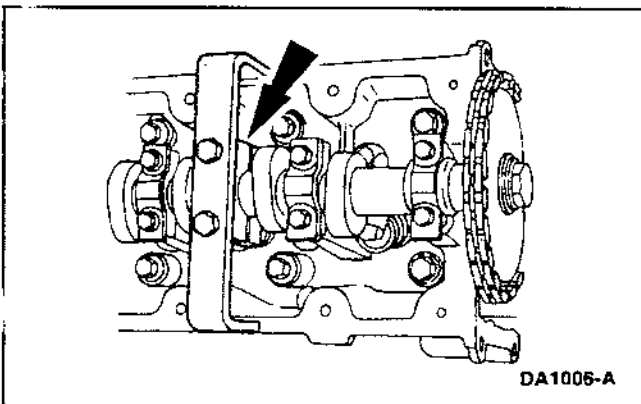

17. Install the Camshaft Holding Tools on the camshafts (2).

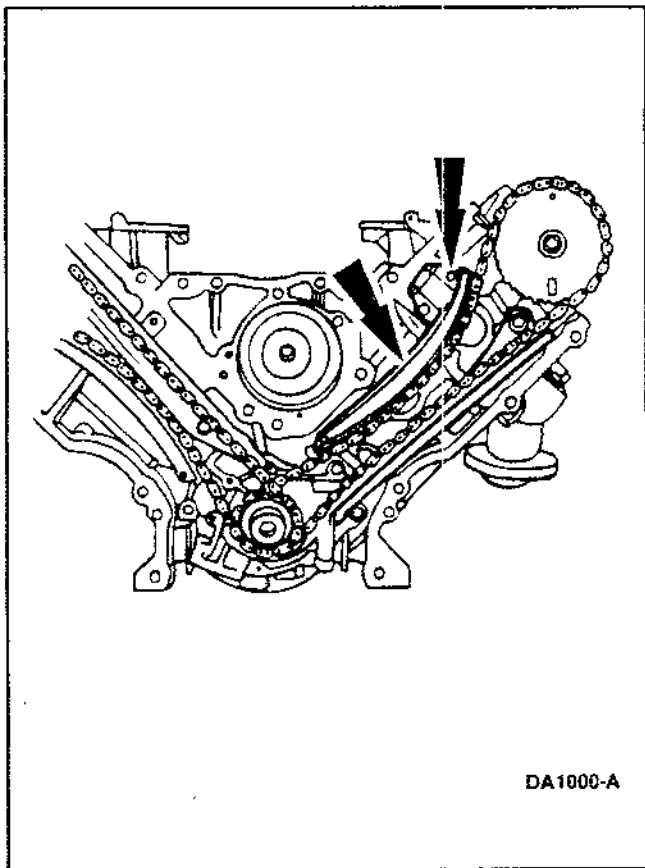

18. Remove the bolts and the timing chain tensioners (6L266). Remove the timing chain tensioner arms (6L253) from the dowel pins.

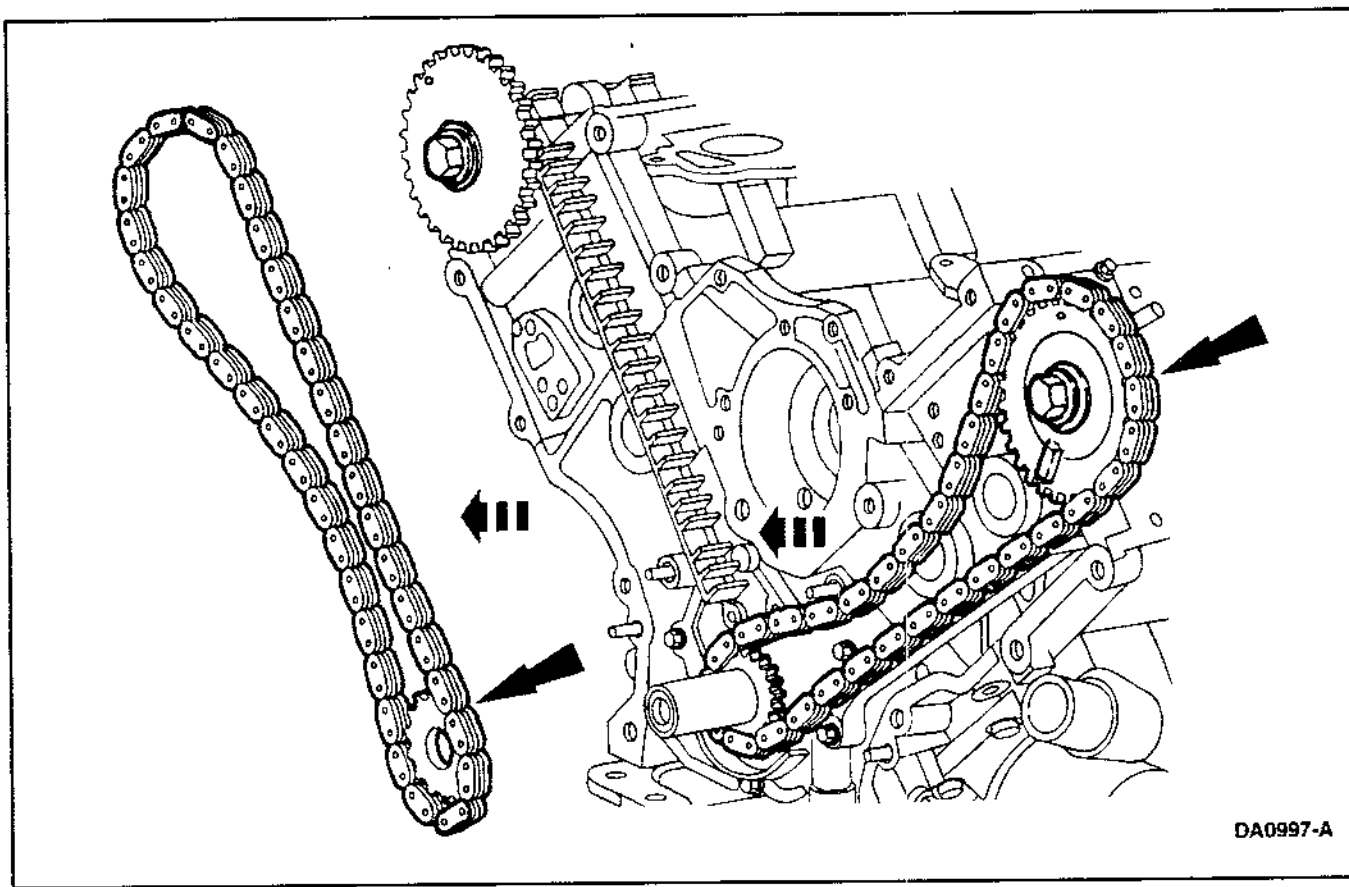

19. **⚠ CAUTION:** Unless otherwise instructed, at no time when the timing chain are removed and the cylinder heads are installed is the crankshaft or camshaft to be rotated. Severe piston and valve damage will occur.

- Remove the Crankshaft Holding Tool.
- Remove the RH timing chain from the camshaft sprocket (6256).
- Remove the RH timing chain and outer crankshaft sprocket from the crankshaft.
- Repeat for the LH timing chain and crankshaft sprocket.

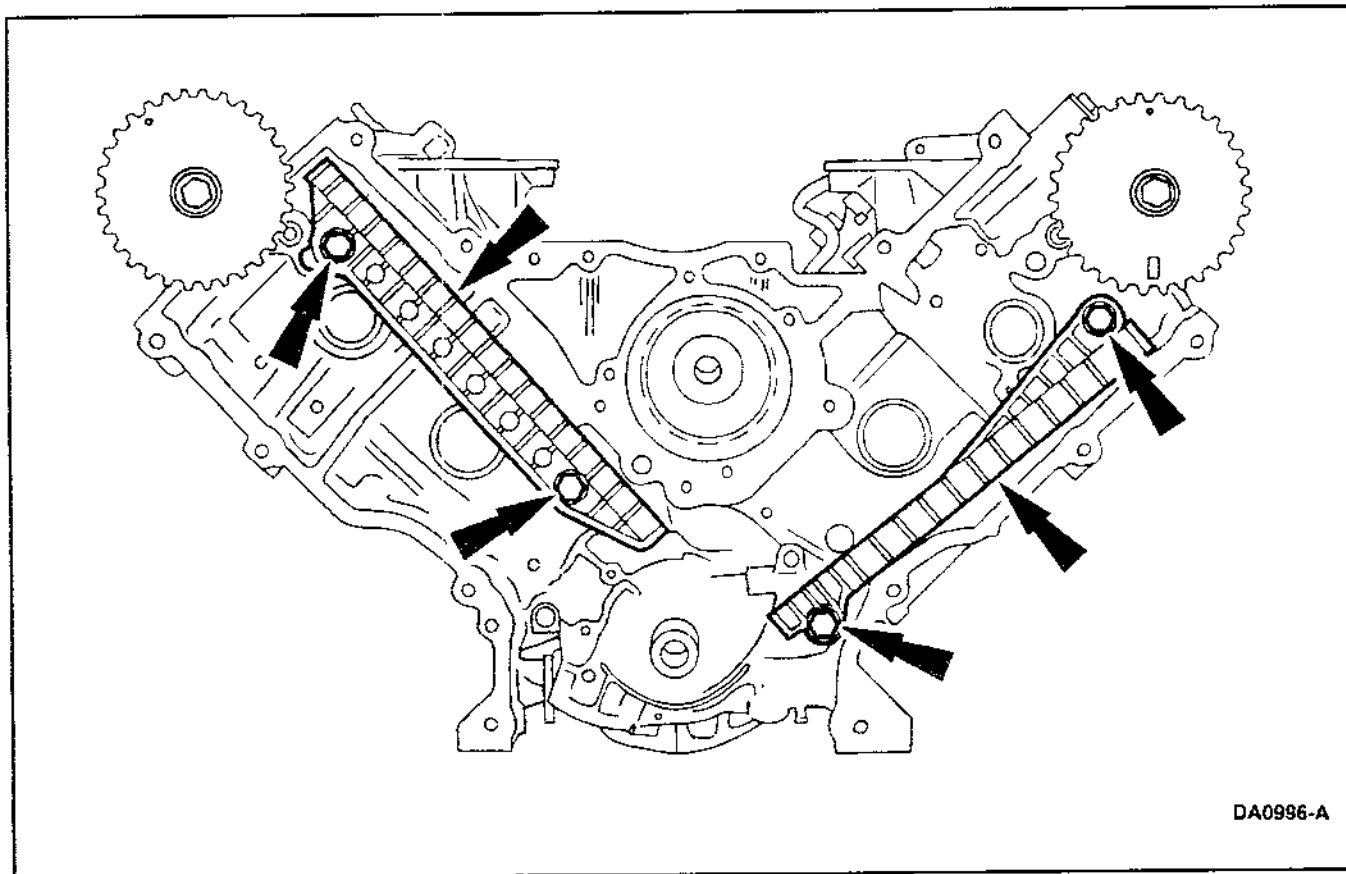

DA0996-A

20. Remove the timing chain guides (6K297).

- Remove the bolts.
- Remove the timing chain guides.

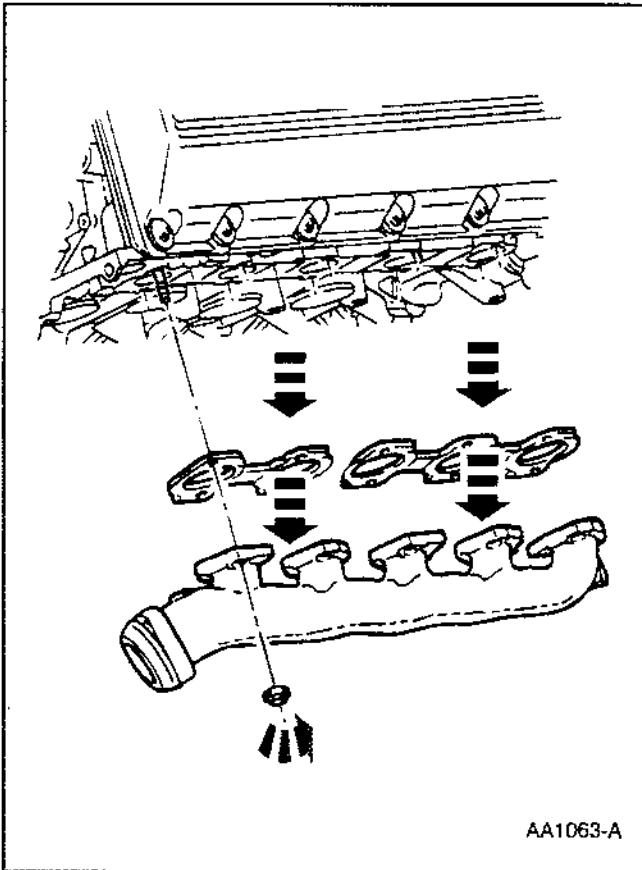

21. Remove the ten nuts and the RH exhaust manifold (9430) and exhaust manifold gasket (9448). Discard the exhaust manifold gasket.

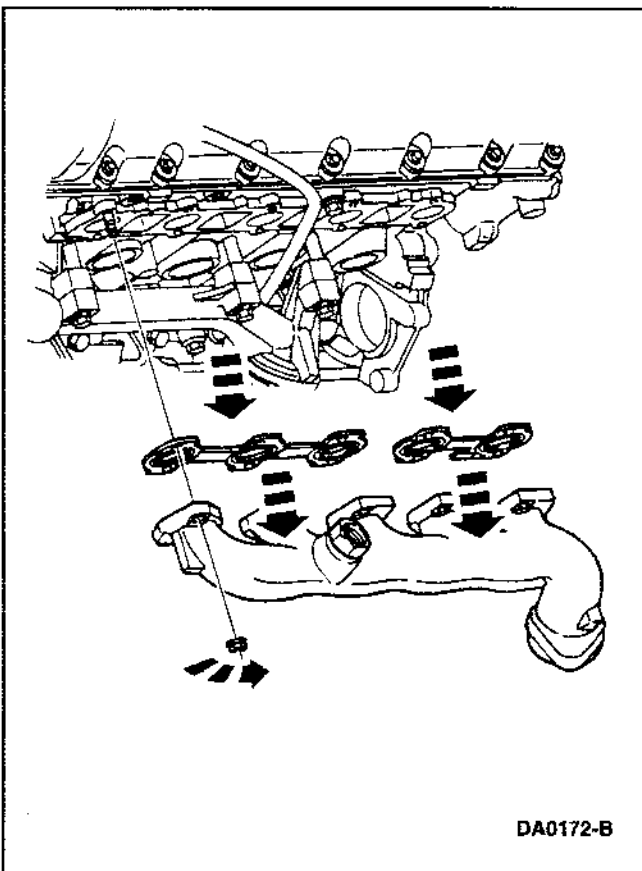

22. Remove the ten nuts, the LH exhaust manifold and the exhaust manifold gaskets. Discard the exhaust manifold gasket.

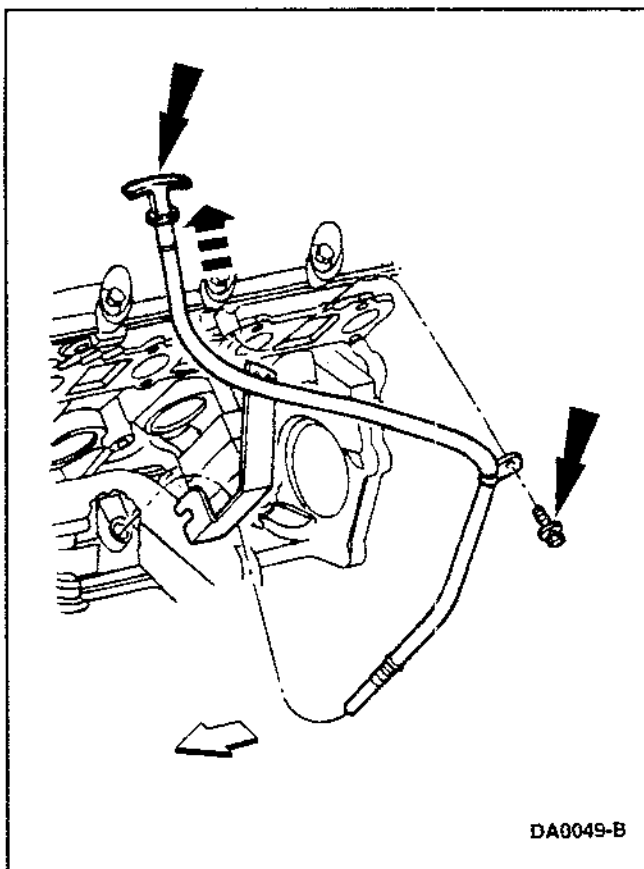

23. Remove the oil level dipstick, the bolt and the oil level indicator tube (6754).

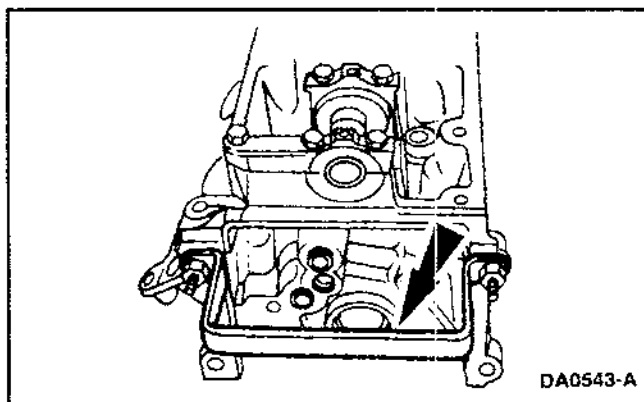

24. Install the Lifting Handles on both ends of the cylinder head.

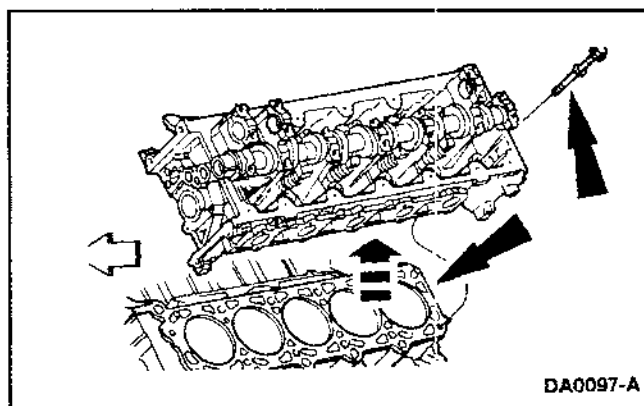

25. **⚠ CAUTION: These bolts must be replaced with new bolts. They are tighten-to-yield designed and cannot be reused.**

Remove the bolts, cylinder head, and head gasket.

- Discard the head gasket (6051), cylinder head bolts and clean the engine block surface.
- LH is shown; RH is similar.

26. Use silicone gasket and sealant F6AZ-19562-AA equivalent meeting Ford specification WSE-M4G323-A6.

NOTE: Sealant must be removed and area cleaned with solvent if above instructions are not followed.

- Use metal surface cleaner F4AZ-19A536-RA or equivalent meeting Ford specification WSE-M5B292-A.

27. Remove the bolts and remove the engine mounts.

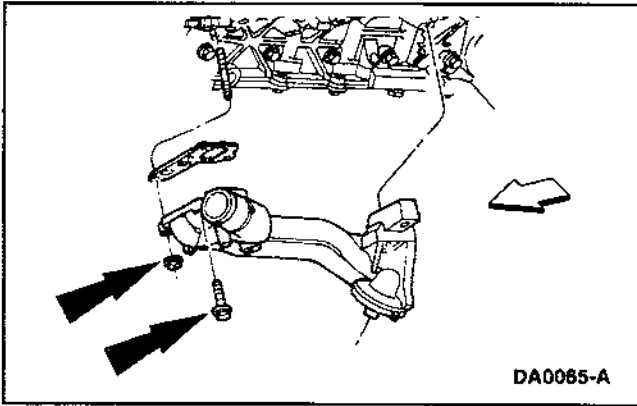

28. Remove the bolts and nut retaining the oil filter adapter (6881) to the cylinder block. Remove the oil filter adapter and clean the gasket surface.

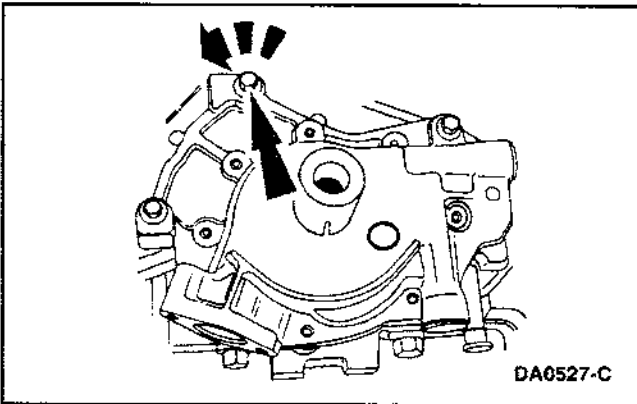

29. Remove the bolts and the oil pump (6600).

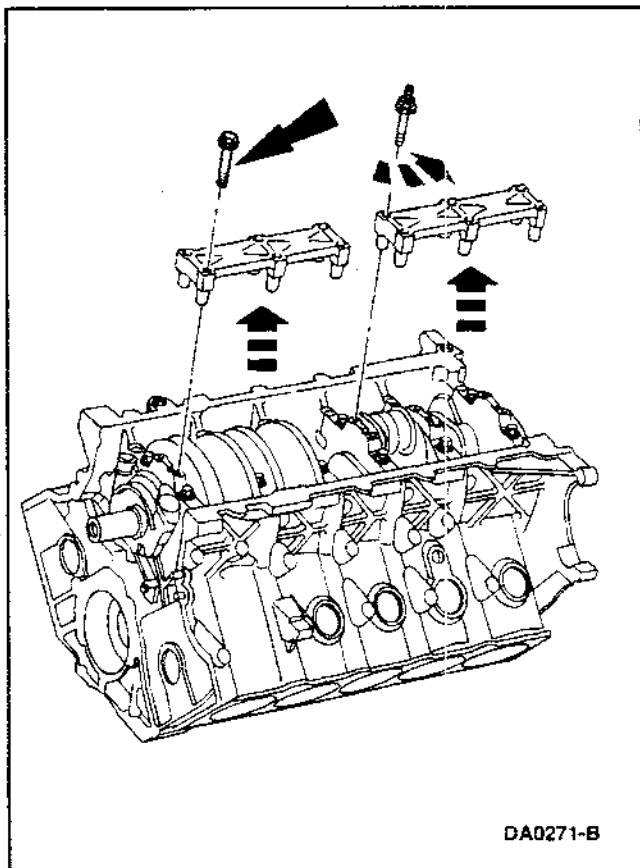

30. Remove the twelve bolts and the two lower crankshaft bearing supports.

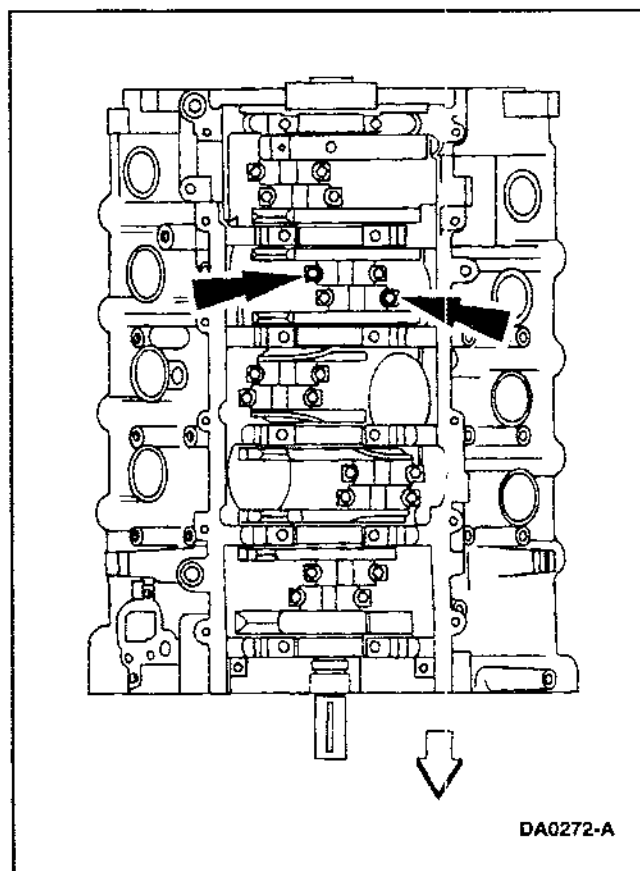

31. **CAUTION:** Make sure connecting rods (6200) and rod caps are numbered, to keep in proper orientation.

Remove the bolts and the connecting rod caps.

- Rotate the crankshaft so that the connecting rod is at bottom dead center.
- Remove the bolts and discard them.

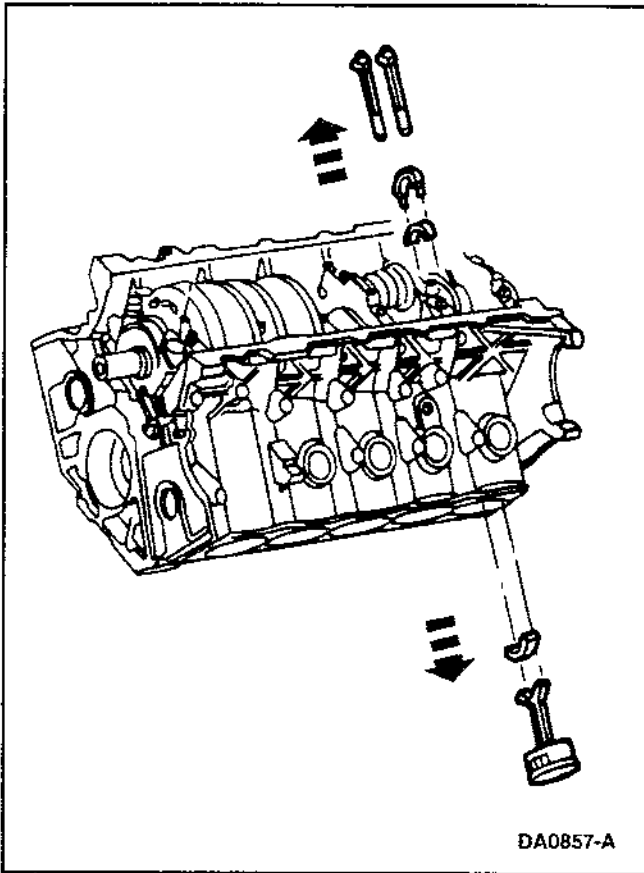

32. **CAUTION:** Do not scratch the cylinder walls or the crankshaft journals with the connecting rod.

Remove the piston and rod assembly.

- Use the Connecting Rod Guide Tools to guide the piston and rod assembly out of the cylinder.
33. Repeat the previous steps until all ten piston and rod assemblies have been removed from the cylinder block.

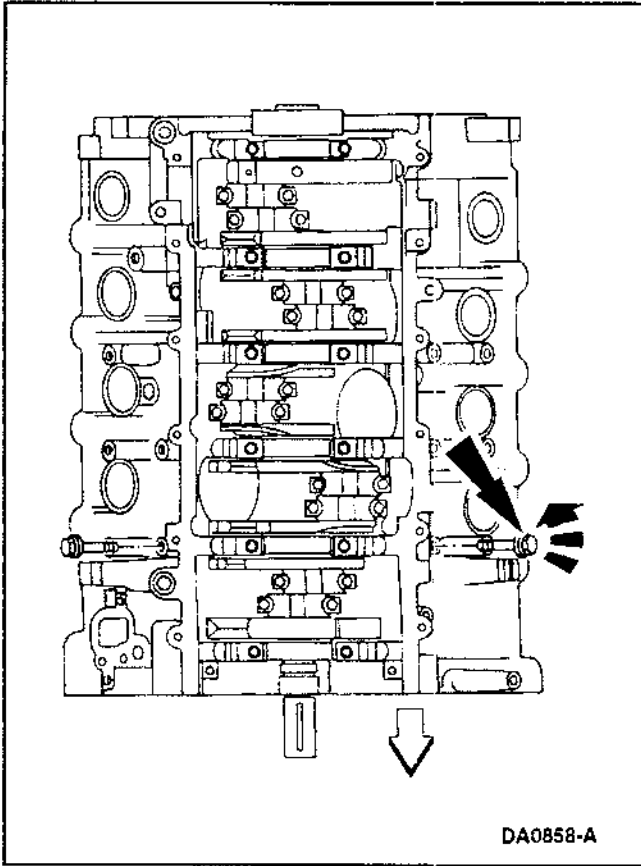

34. Remove and discard the twelve cross-mounted bolts.

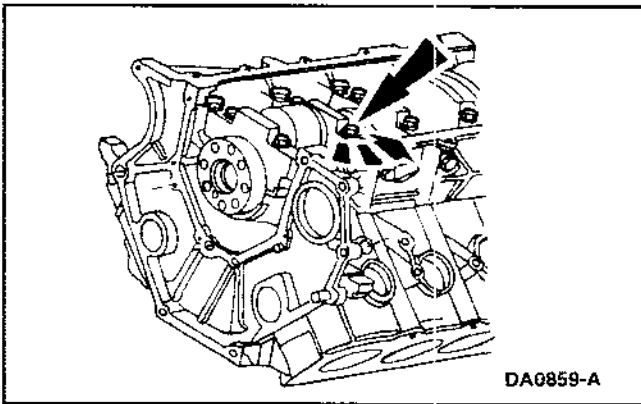

35. Remove the main bearing bolts and discard the bolts.

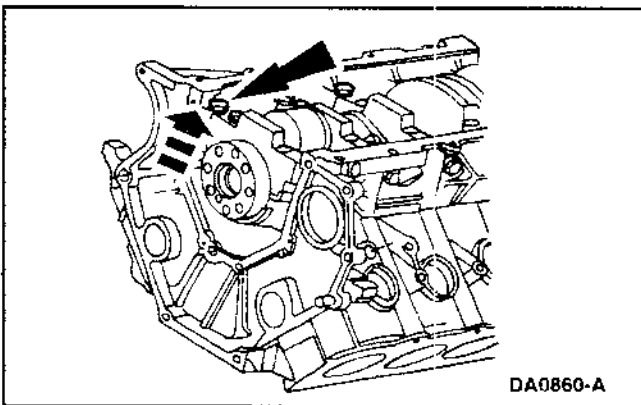

36. Remove the main bearing cap dowel pins.

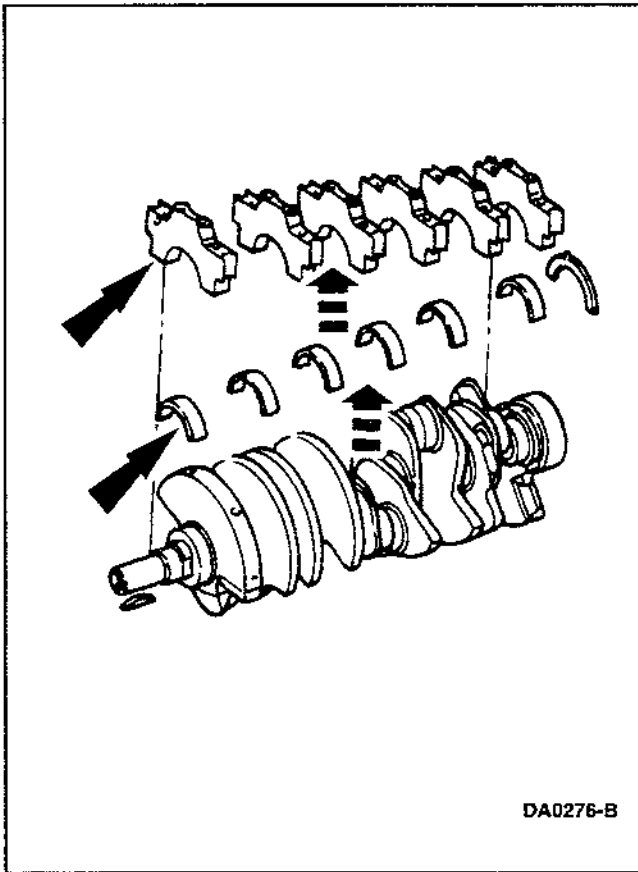

37. Remove the main bearing caps, the lower crankshaft main bearings (6333) and the thrust washer.

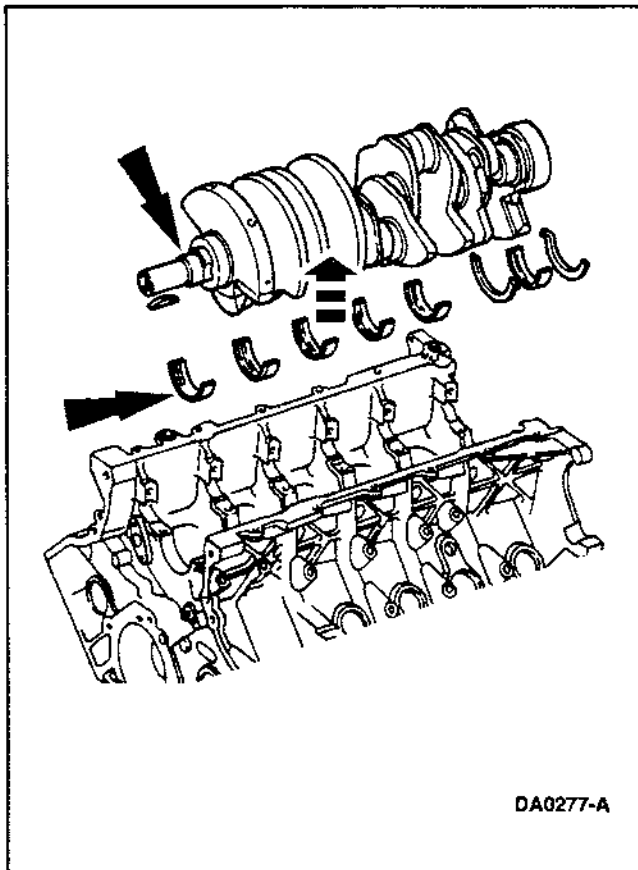

38. Remove the crankshaft and the crankshaft main bearings from the cylinder block.

Cylinder Head - Disassembly

Special Tool(s)

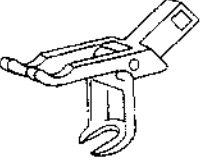
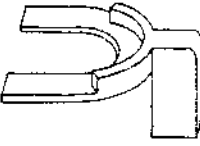
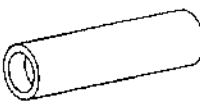
 <p>ST1330-A</p>	<p>Valve Spring Compressor 303-381 (T91P-6565-A)</p>
 <p>ST1331-A</p>	<p>Valve Spring Spacer 303-382 (T91P-6565-AH)</p>
 <p>ST1332-A</p>	<p>Valve Stem Seal Replacer 303-383 (T91P-6571-A)</p>

Special Service Tools called for by the procedures can be obtained by calling:
1-800-ROTUNDA (1-800-768-8632).

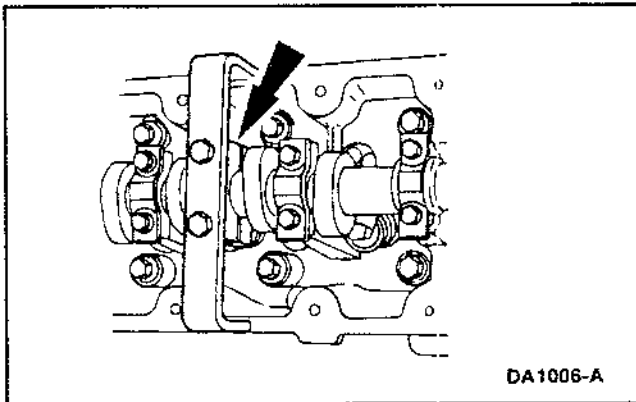

1. Remove the Camshaft Holding Tool from the camshaft (6250).

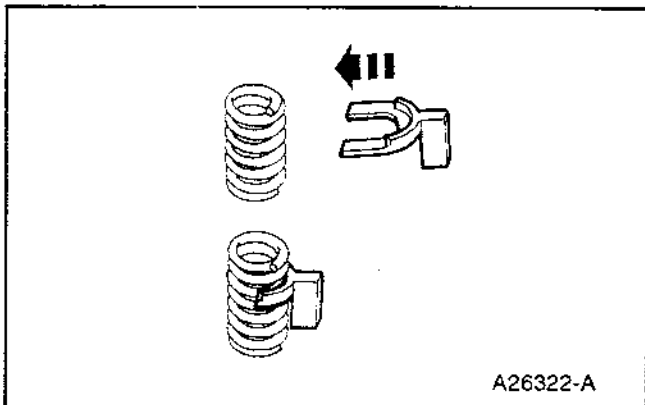

2. **CAUTION:** Do not remove the camshaft before removing the roller followers.

CAUTION: Place the cylinder head on a cardboard or wood surface to prevent damage to the joint face.

Install the Valve Spring Spacer between the valve spring coils to prevent valve stem seal damage.

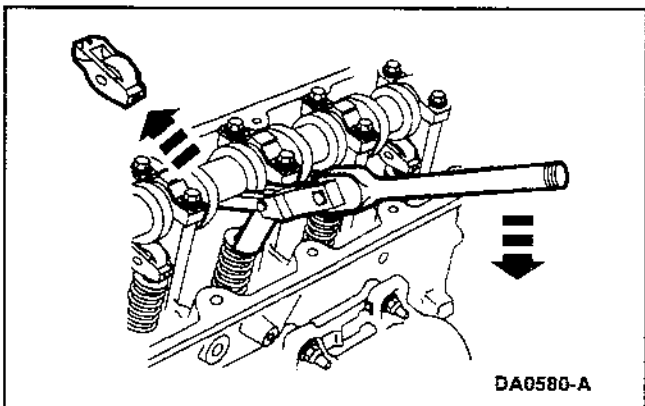

3. Use the Valve Spring Compressor to compress the valve springs (6513), and remove the roller followers.

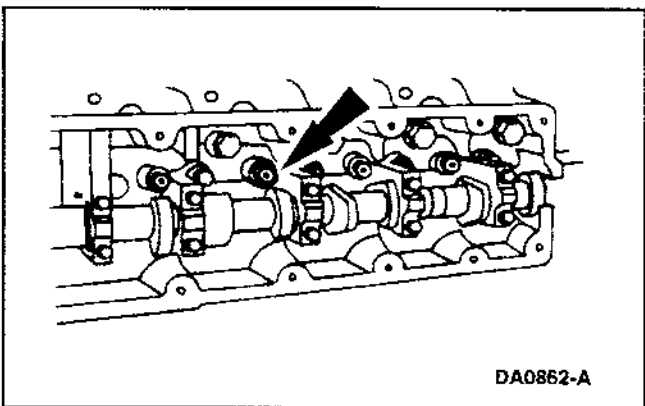

4. Remove the hydraulic lash adjusters.

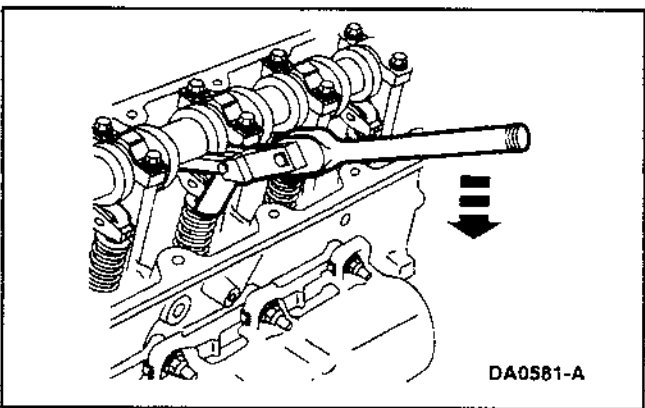

5. Use the Valve Spring Compressor to compress the valve springs.

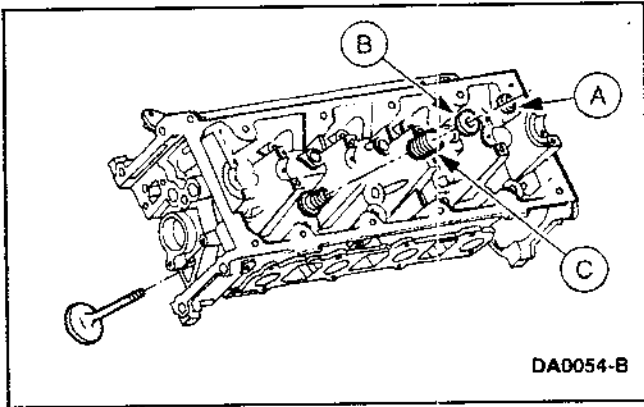

6. **⚠ CAUTION:** Keep the valves and the valve spring retainer keys (6518) in order so they can be installed in the same positions.

NOTE: The 8-cylinder is shown. The 10-cylinder is similar.

NOTE: Shown without camshaft for clarity.

Remove the (A) valve spring retainer keys, the (B) valve spring retainers (6514), the (C) valve springs, and the valves.

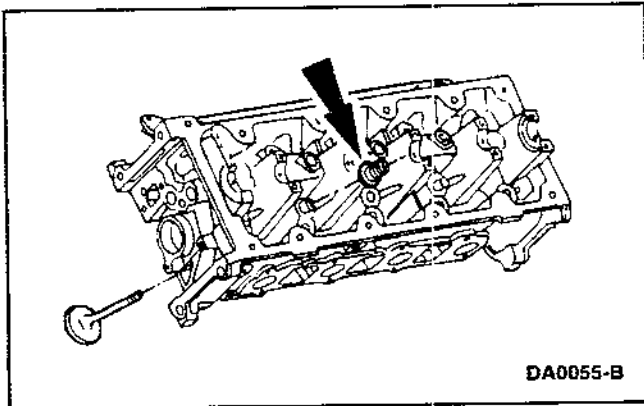

7. Remove the valve stem seals (6571).

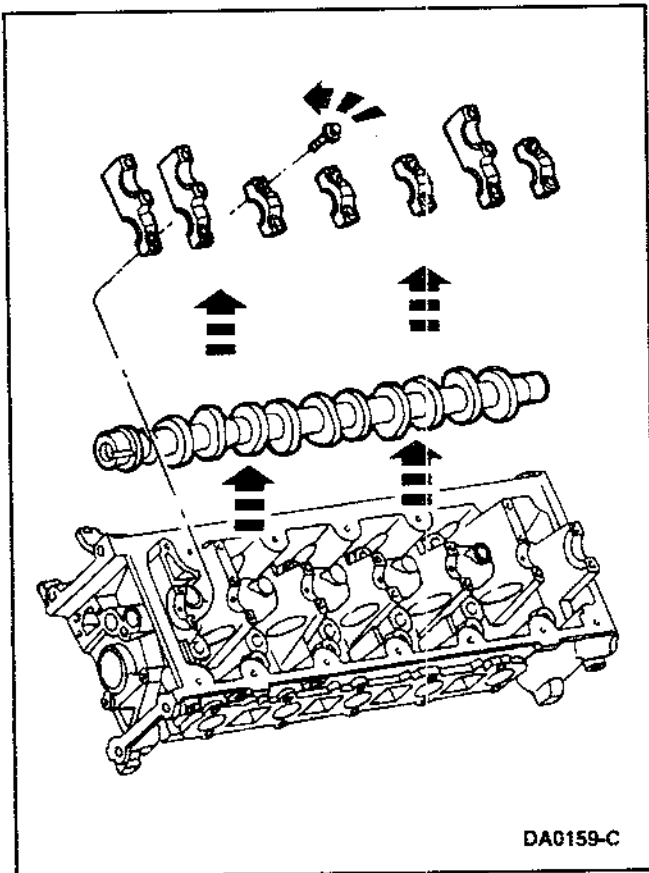

8. **⚠ CAUTION:** The caps must be marked for installation in their original location or damage to the engine may occur.

Remove the bolts, the bearing caps and the camshaft.

Cylinder Head - Assembly

1.  **CAUTION:** Mating parts must make contact to each other within 4 minutes and connecting bolts must be torqued within 15 minutes after applying sealant. Failure to follow this procedure can cause future oil leakage.

- Use silicone gasket and sealant F6AZ-19562-AA or equivalent meeting Ford specification WSE-M4G323-A6.

NOTE: Sealant must be removed and area cleaned with solvent if above instructions are not followed.

- Use metal surface cleaner F4AZ-19A536-RA or equivalent meeting Ford specification WSE-M5B292-A.

2. Lubricate the camshaft journals.

- Use Super Premium SAE 5W30 Motor Oil D9AZ-19579-A or equivalent meeting Ford specification WSS-M2C153-C.

3. Install the camshaft and the camshaft bearing caps in their original location and the bolts.

- Lubricate and position the camshaft bearing caps.
 - Use Super Premium SAE 5W30 Motor Oil D9AZ-19579-A or equivalent meeting Ford specification WSS-M2C153-G.

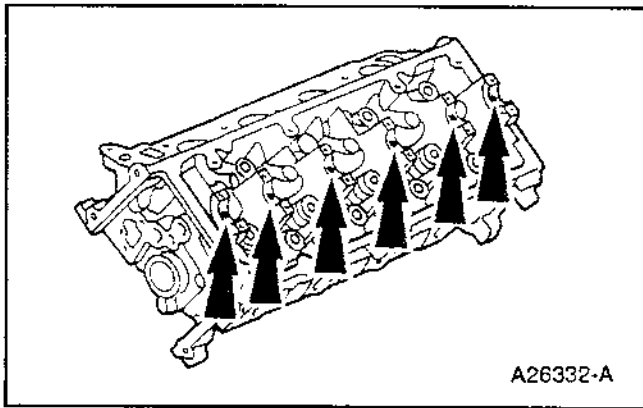

A26332-A

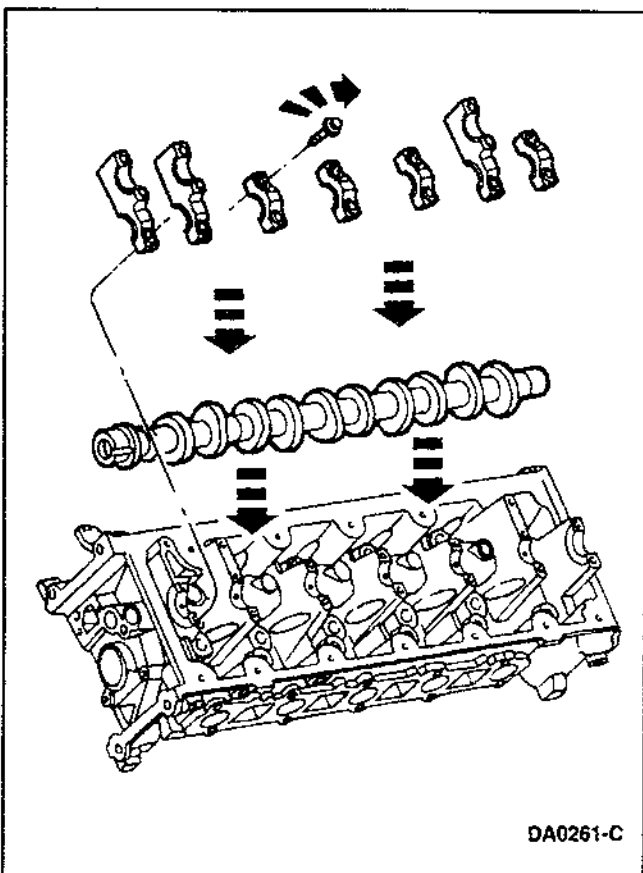

DA0261-C

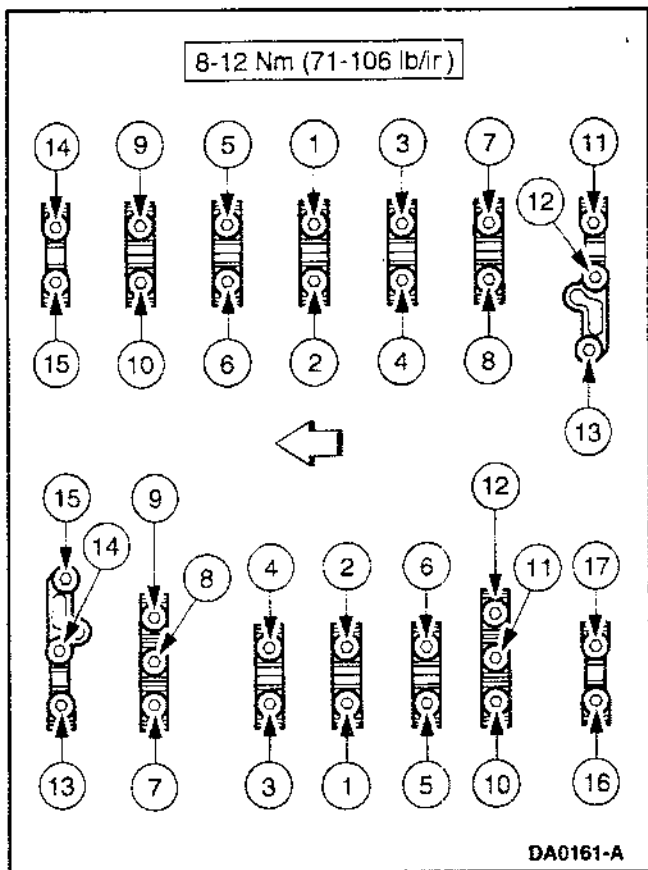

4. Tighten the bolts in the sequence shown.

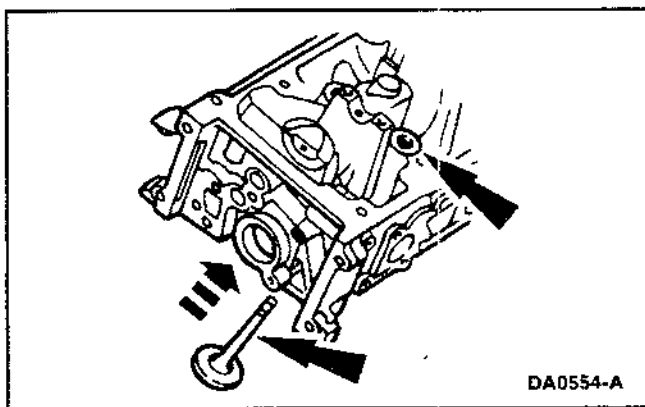

5. Install the valves in the valve guides located in the cylinder block (6010).

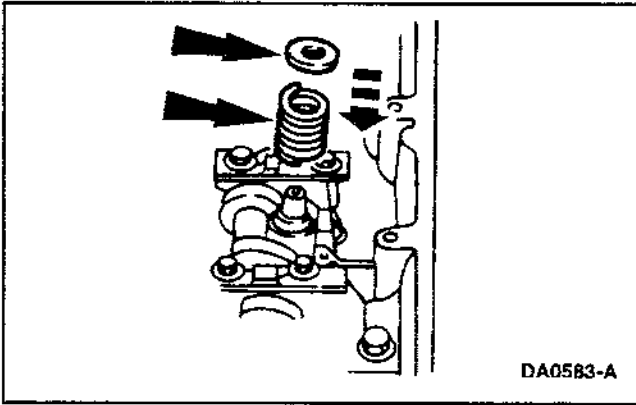

6. Install the valve spring and the valve spring retainer onto the valve.

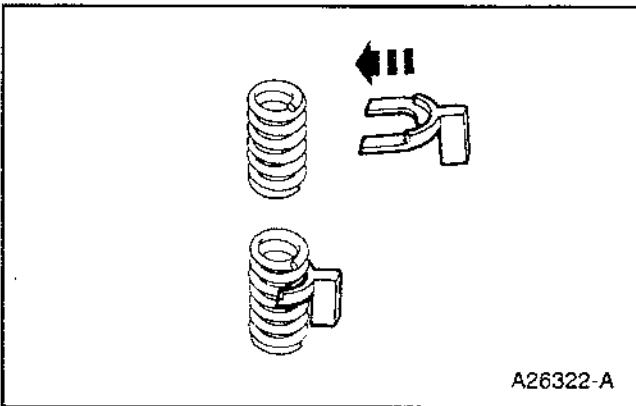

7. Install the valve spring spacer between the valve spring coils to prevent valve stem seal damage.

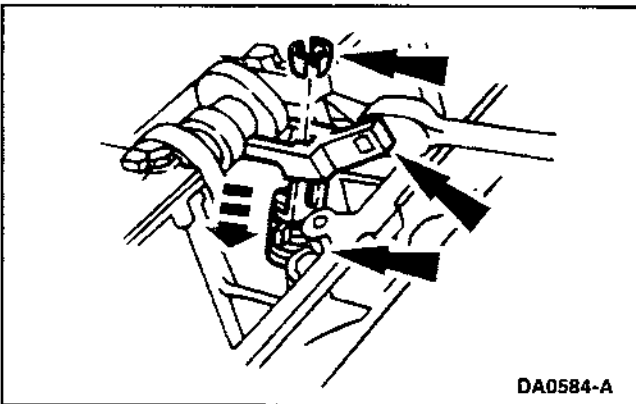

8. Use the Valve Spring Compressor to compress the valve spring, and install the valve spring retainer keys.

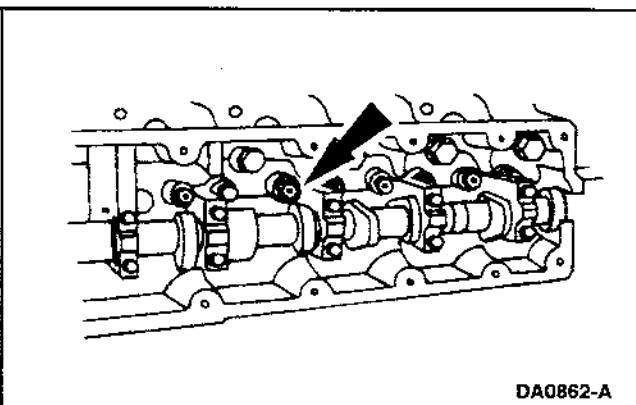

9. Install the hydraulic lash adjusters.

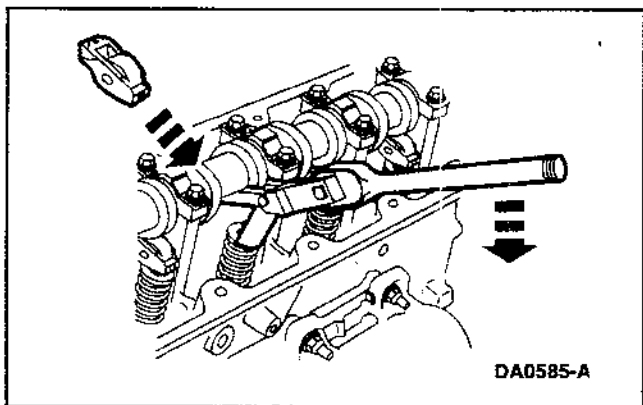

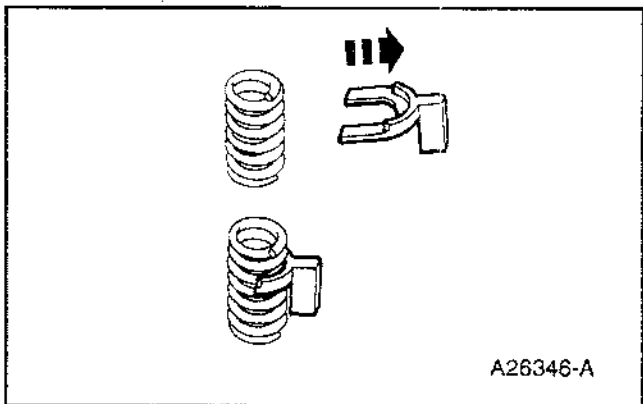

10. Install the roller followers.



11. Remove the Valve Spring Spacer.

Engine - Assembly

Special Tool(s)

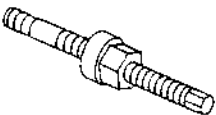
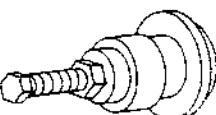
	<p>Camshaft Holding Tool 303-557 (T96T-6256-B) (2 Req'd)</p>
 <p>ST1337-A</p>	<p>Connecting Rod Guide Tool 303-442 (T93P-6136-A)</p>
 <p>ST1287-A</p>	<p>Crankshaft Damper Replacer 303-102 (T74P-6316-B)</p>
 <p>ST1328-A</p>	<p>Crankshaft Seal Replacer/Aligner 303-335 (T88T-6701-A)</p>

Special Tool(s)

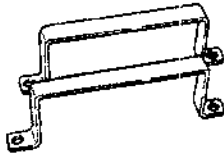
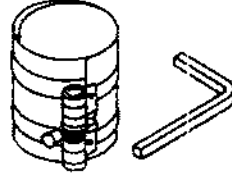
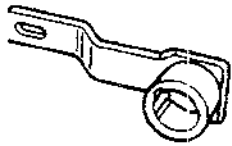
 <p>ST1668-A</p>	<p>Lifting Handles (2 Sets Required) 303-572 (T97T-6000-A)</p>
	<p>Piston Ring Compressor 303-D032 (D81L-6002-C) or Equivalent</p>
 <p>ST1335-A</p>	<p>Crankshaft Holding Tool 303-448 (T93P-6303-A)</p>

Special Service Tools called for by the procedures can be obtained by calling:
1-800-ROTUNDA (1-800-768-8632).

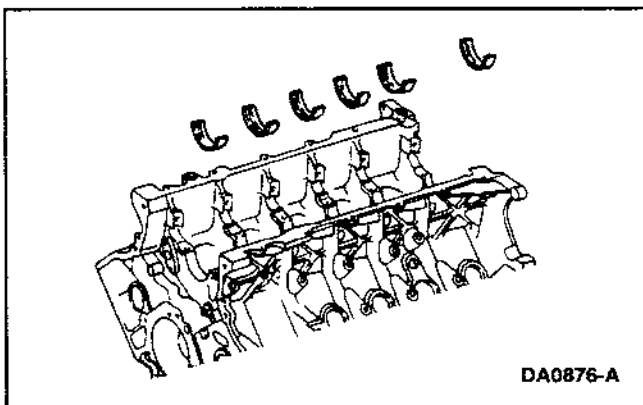

- NOTE:** Before assembling the cylinder block (6010), all seating surfaces must be free of chips, dirt, paint and foreign material. Also, make sure the coolant and oil passages are clear.

Lubricate and install the crankshaft upper main bearings into the cylinder block.

- Use Super Premium SAE 5W30 Motor Oil D9AZ-19579-A or equivalent meeting Ford specification WSS-M2C153-G.

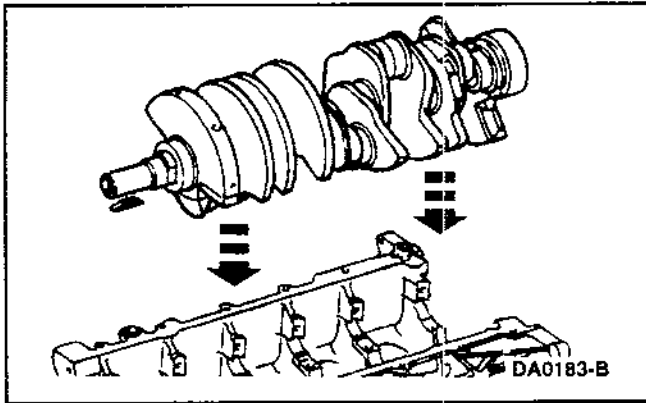

2. Install the crankshaft (6303) into the cylinder block and onto the upper crankshaft main bearings (6333).

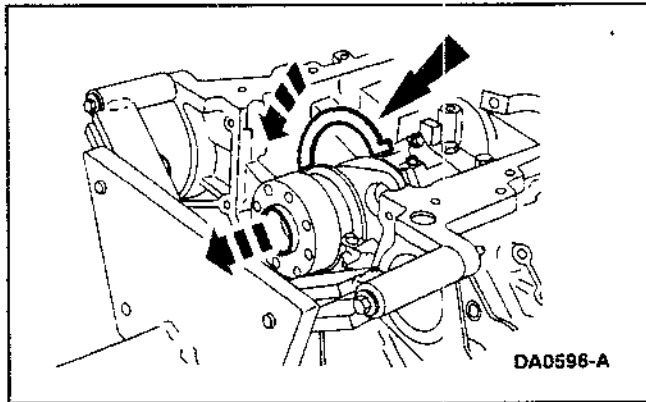

3. Push the crankshaft rearward and install the rear lower crankshaft thrust washer (6334) at the back of the No. 6 main boss.

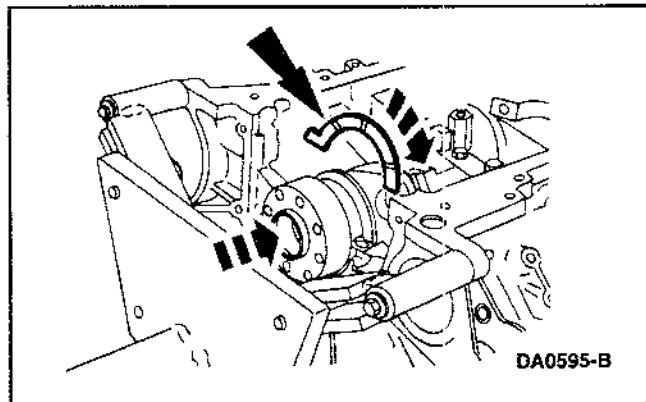

4. Push the crankshaft forward and install the front lower crankshaft thrust washer at the front of the No. 6 main boss.

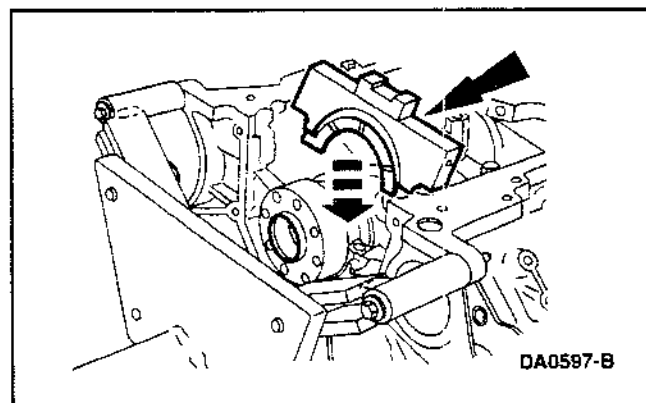

5. **NOTE:** To aid in assembly, apply petroleum jelly to the back of the crankshaft thrust washer.

Install the upper crankshaft thrust washer to the back side of the No. 6 main bearing cap, with oil grooves facing the crankshaft surface, and install the No. 6 rear main bearing cap.

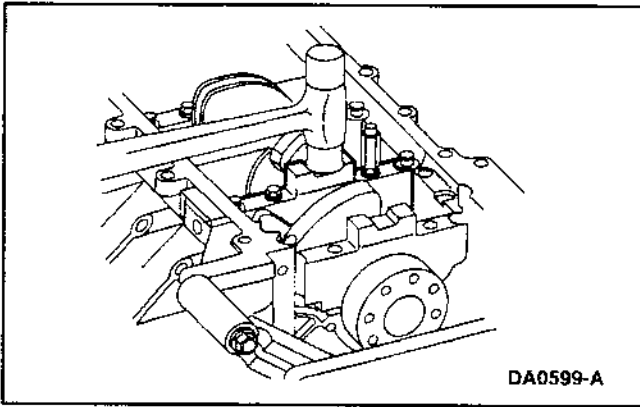

6. Install the No. 1 through No. 5 crankshaft lower main bearings into the main bearing caps. Locate the main bearing caps on the cylinder block and tap into place using a plastic or dead-blow hammer.

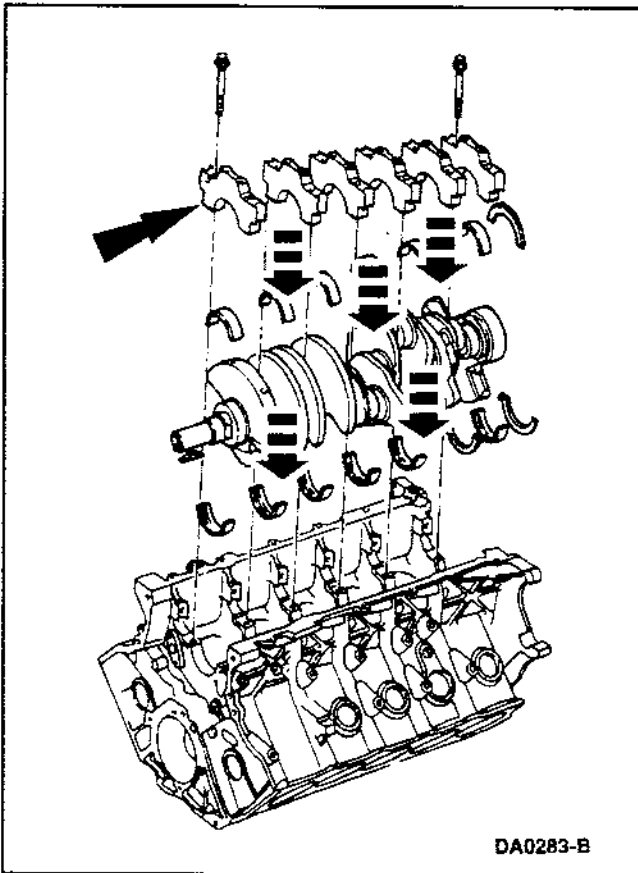

7. Install new main cap bearing bolts.

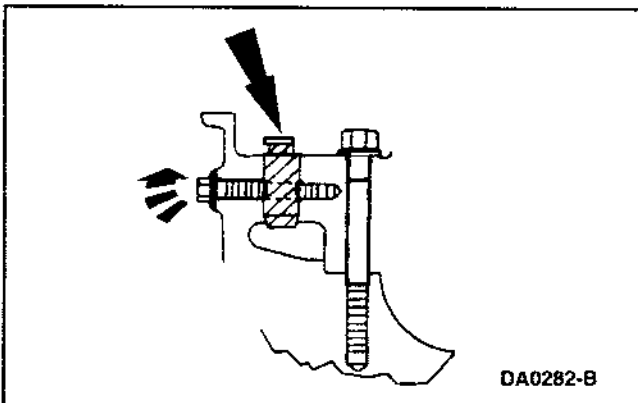

8. Install the ten dowel pins so that the flat sides face the crankshaft. Install the cross-mounted bolts.

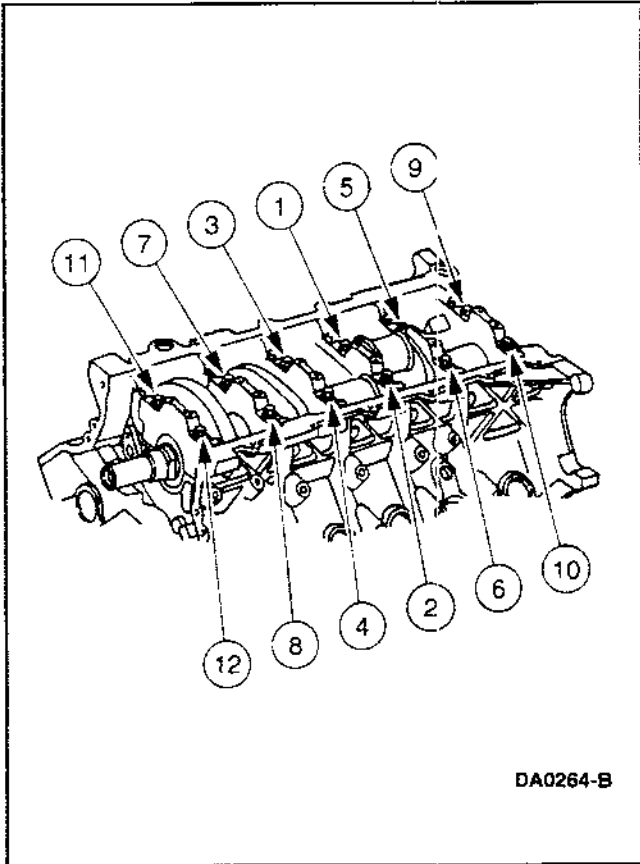

9. Tighten fasteners 1 through 12 in two stages in the sequence shown.

- Stage 1: Tighten to 37-43 Nm (22-32 lb/ft).
- Stage 2: Tighten an additional 85 degrees to 95 degrees.

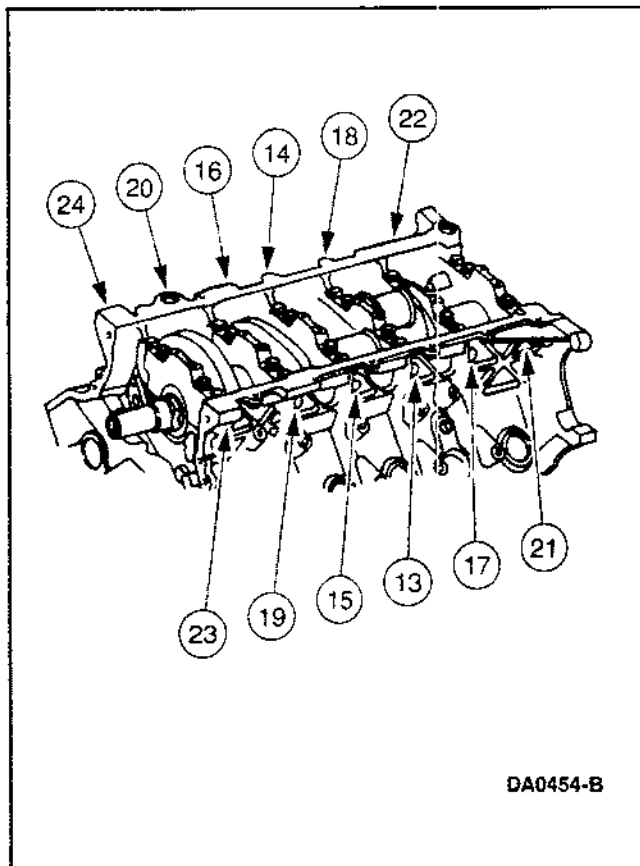

10. Tighten fasteners 13 through 24 in two stages in the sequence shown.

- Stage 1: Tighten to 27-33 Nm (20-26 lb/ft).
- Stage 2: Tighten an additional 85 degrees to 95 degrees.

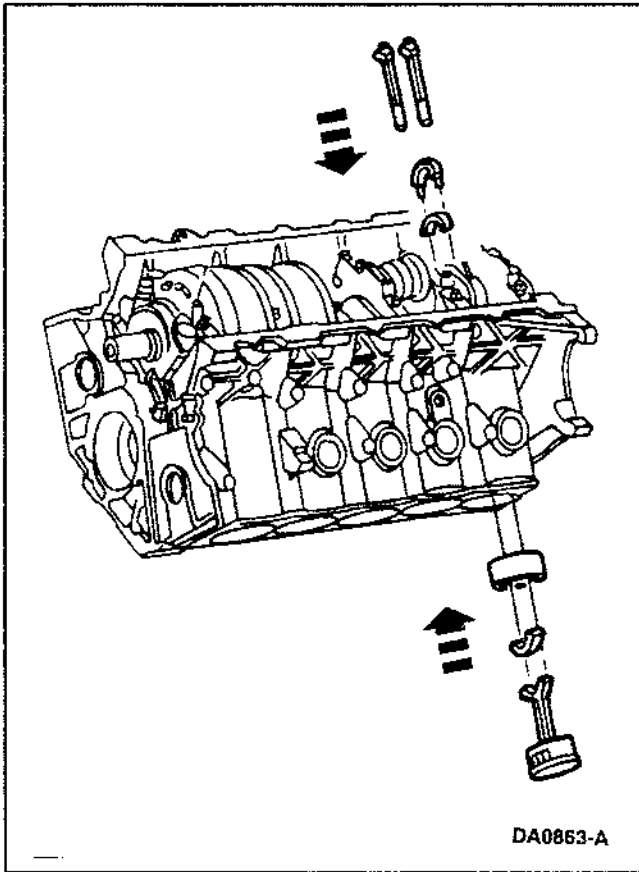

11. Use the Connecting Rod Guide Tool and Piston Ring Compressor to install the piston and connecting rod assembly.

12. **CAUTION:** Do not scratch the cylinder walls or crankshaft journals with the connecting rod (6200).

Once the connecting rod is seated on the crankshaft journal, remove the connecting rod guide tools.

13. **CAUTION:** The rod cap installation must keep the same orientation as marked during disassembly.

NOTE: The connecting rod caps are of the "cracked" design and must mate with the connecting rod ends. Excessive bearing clearance will result if not mated properly.

Install the connecting rod bearings, position the connecting rod cap and loosely install the two new bolts.

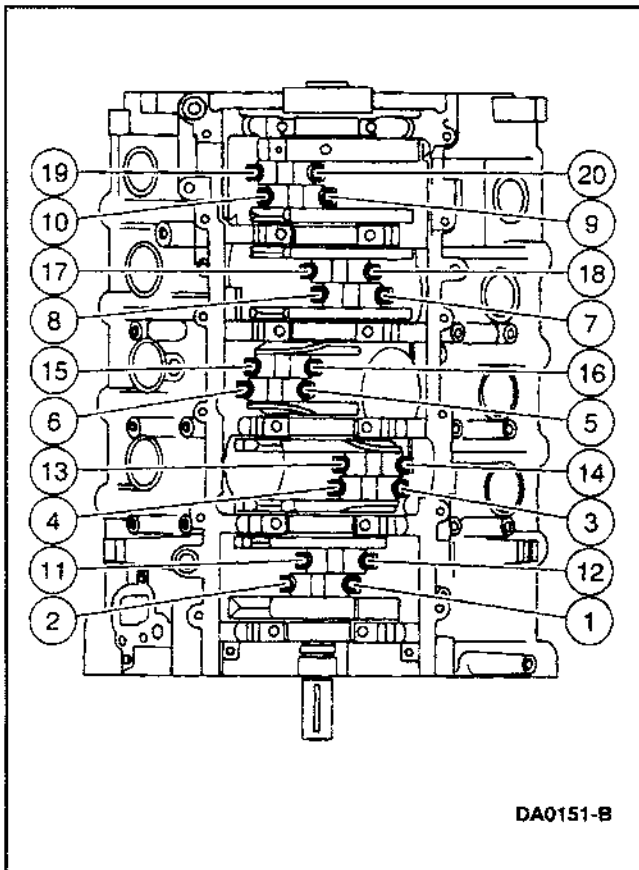

14. **NOTE:** Be sure to tighten the bolts in two stages.

Tighten the connecting rod bolts in the sequence shown.

- Stage 1: Tighten to 40-45 Nm (30-33 lb/ft).
- Stage 2: Tighten an additional 90 degrees to 120 degrees.

15. Rotate the crankshaft and repeat the procedure to position each connecting rod at bottom dead center until all bolts are tightened to specification.

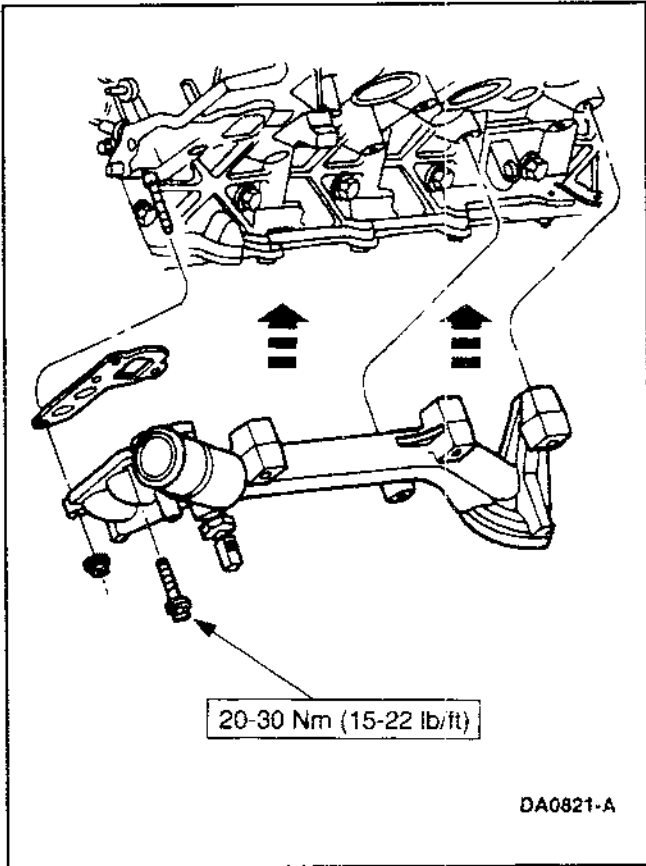

16. Install the oil filter adapter (6881).
17. Install the front engine support insulators (6038).

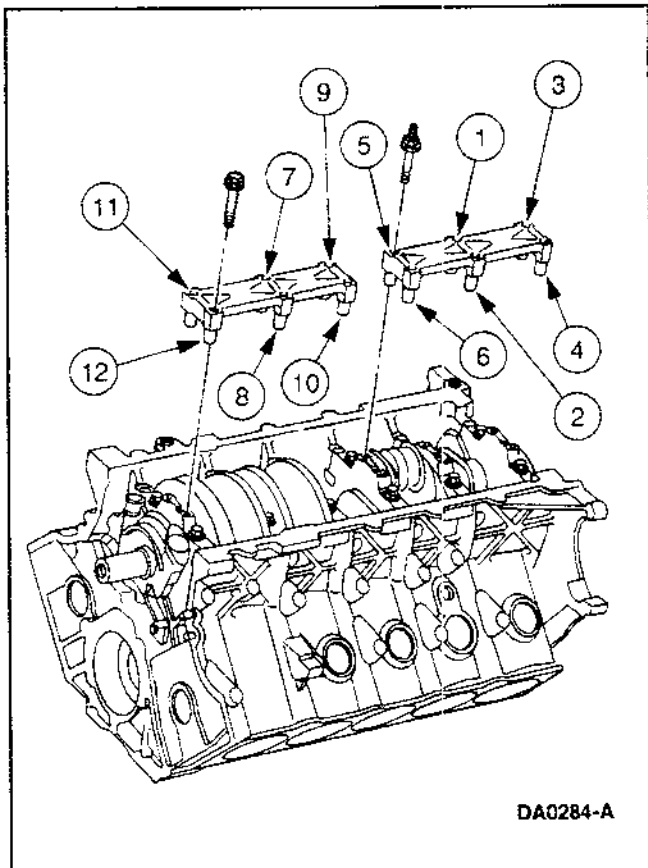

18. Install the lower crankshaft bearing supports and tighten fasteners in the sequence shown.

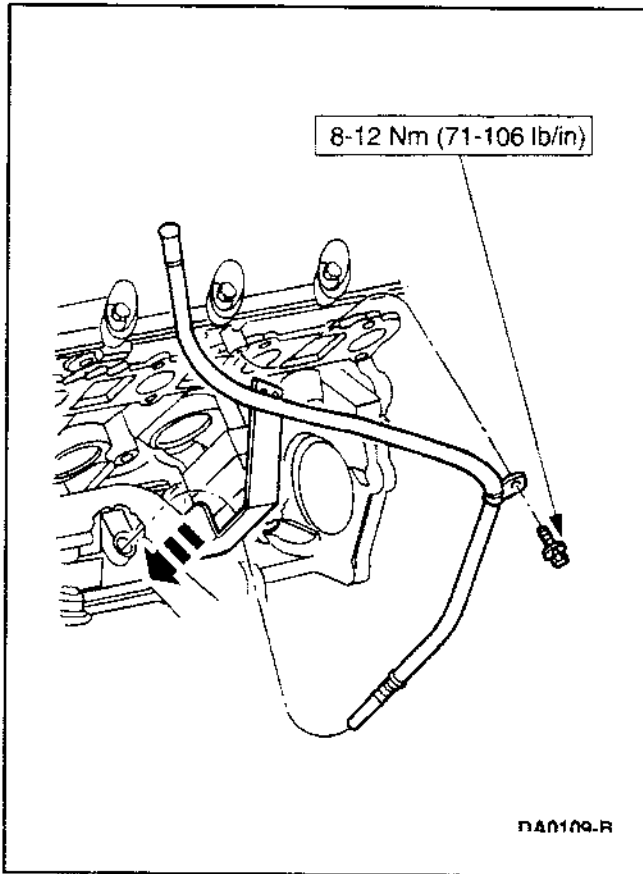

19. Install the oil level indicator tube (6754).

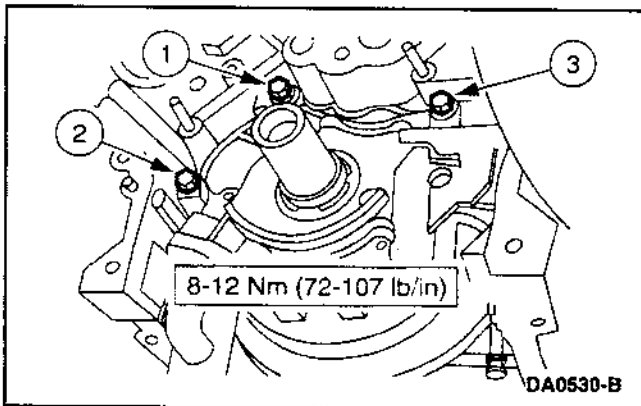

20. Position the oil pump (6600) and install the bolts loosely. Tighten the bolts in the sequence shown.

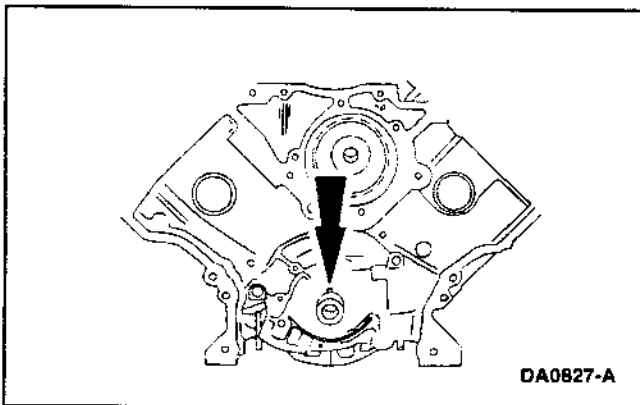

21. Rotate the crankshaft to position the keyway at 12 o'clock.

NOTE: After crankshaft has been positioned, do not turn the crankshaft until instructed to do so.

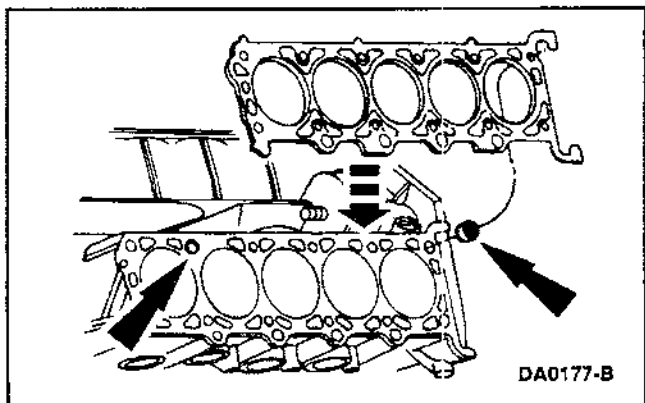

22. Install the head gasket (6051) over the dowel pins.
23. Install the Camshaft Holding Tools.

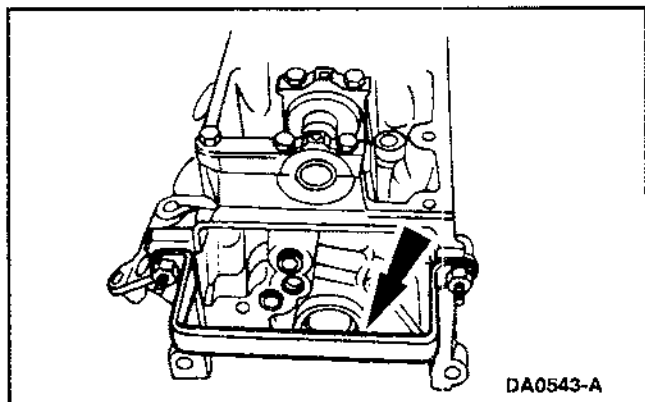

24. Install the Lifting Handles.

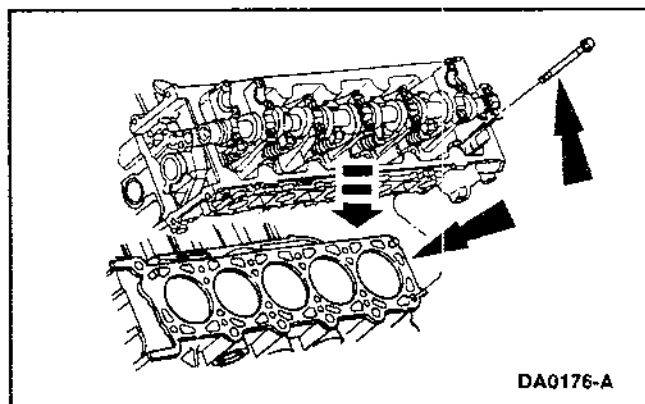

25. Install the cylinder head (6049) on the head gasket and loosely install new bolts.

- The LH is shown; the RH is similar.

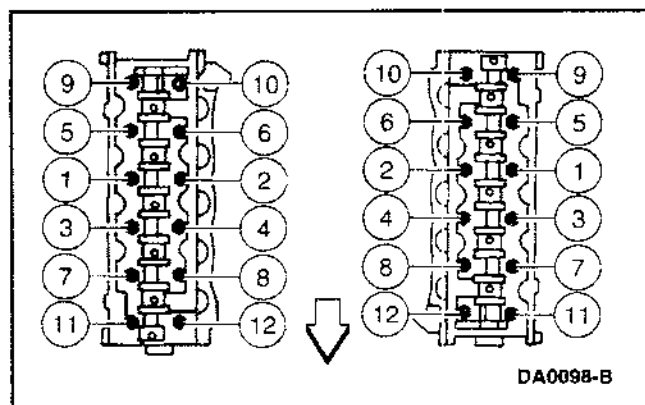

26. **NOTE:** Be sure to tighten the new bolts in three stages.

- Stage 1: Tighten to 37-43 Nm (27-32 lb/ft).
- Stage 2: Tighten an additional 85 degrees to 95 degrees.
- Stage 3: Tighten an additional 85 degrees to 95 degrees.

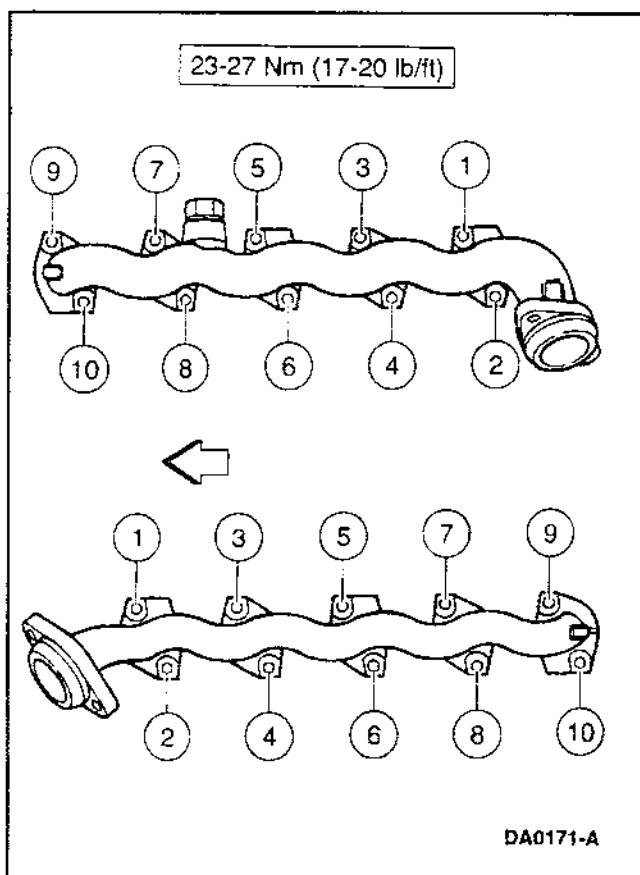

27. Install the left and right exhaust manifold gaskets (9448) and exhaust manifolds (9430). Loosely install the nuts. Tighten the nuts in the sequence shown.

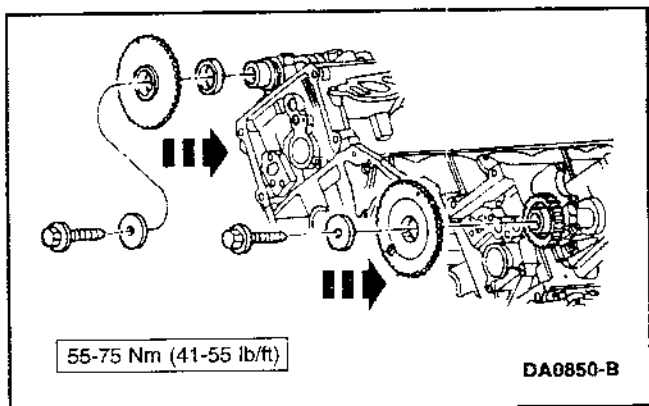

28. **⚠ CAUTION:** Timing chain procedures must be followed exactly or damage to valves and pistons (6108) will result.

If removed, install the left and right camshaft sprockets (6256).

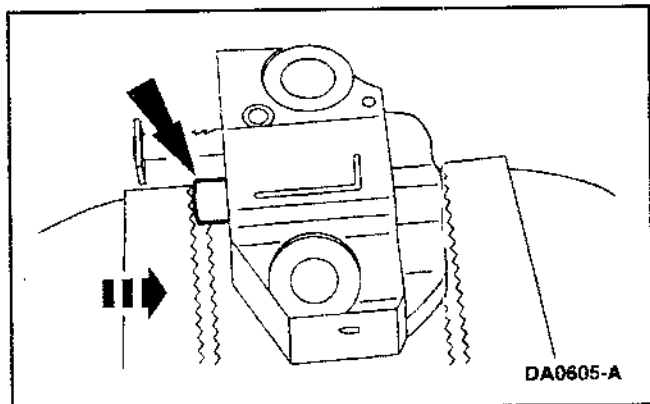

29. **⚠ CAUTION:** Do not compress the ratchet assembly. This will damage the ratchet assembly.

Compress the tensioner plunger, using an edge of a vise.

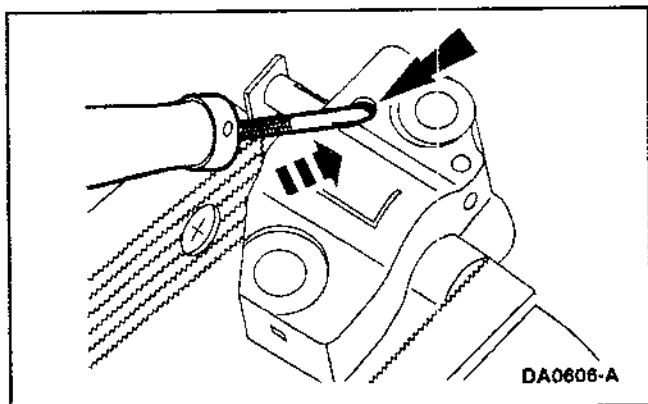

30. Using a small screwdriver or pick, push back and hold the ratchet mechanism.

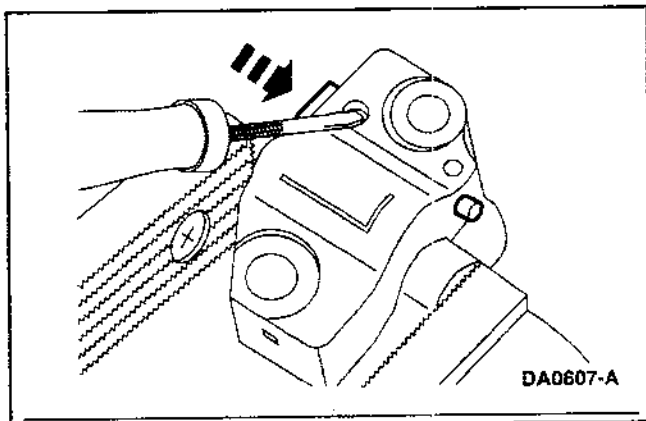

31. While holding the ratchet mechanism, push the ratchet arm back into the tensioner housing.

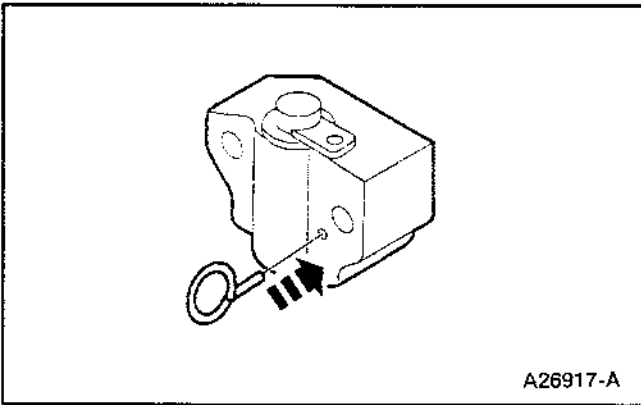

32. Install a paper clip into the hole in the tensiometer housing to hold the ratchet assembly and plunger in during installation.

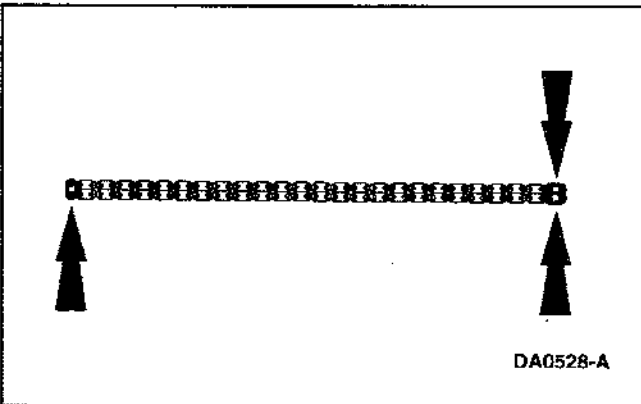

33. If the copper links are not visible, mark two links on one end and one link on the other end to use as timing marks.

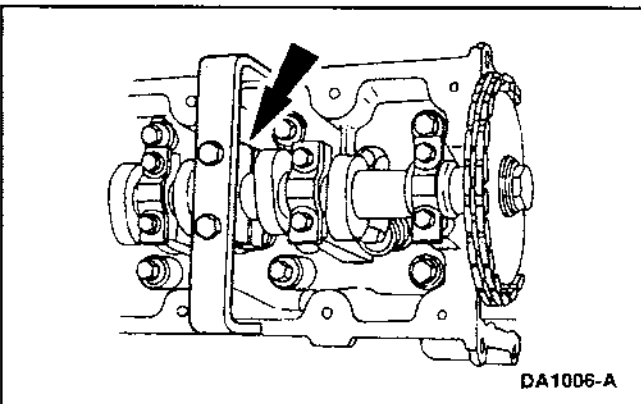

34. Loosen the Camshaft Holding Tools on both camshafts (6250).

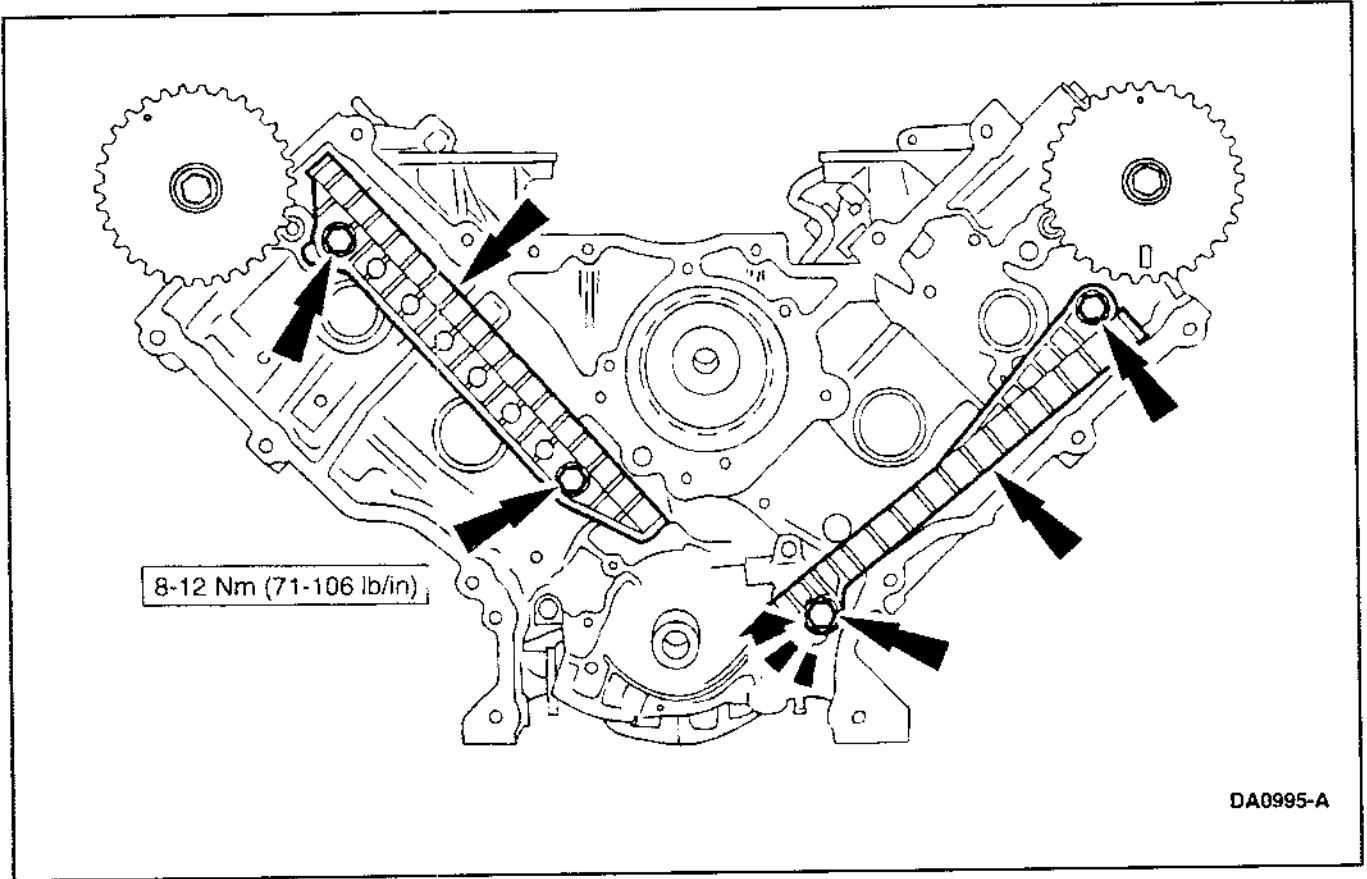

35. Install the timing chain guides (6K297).

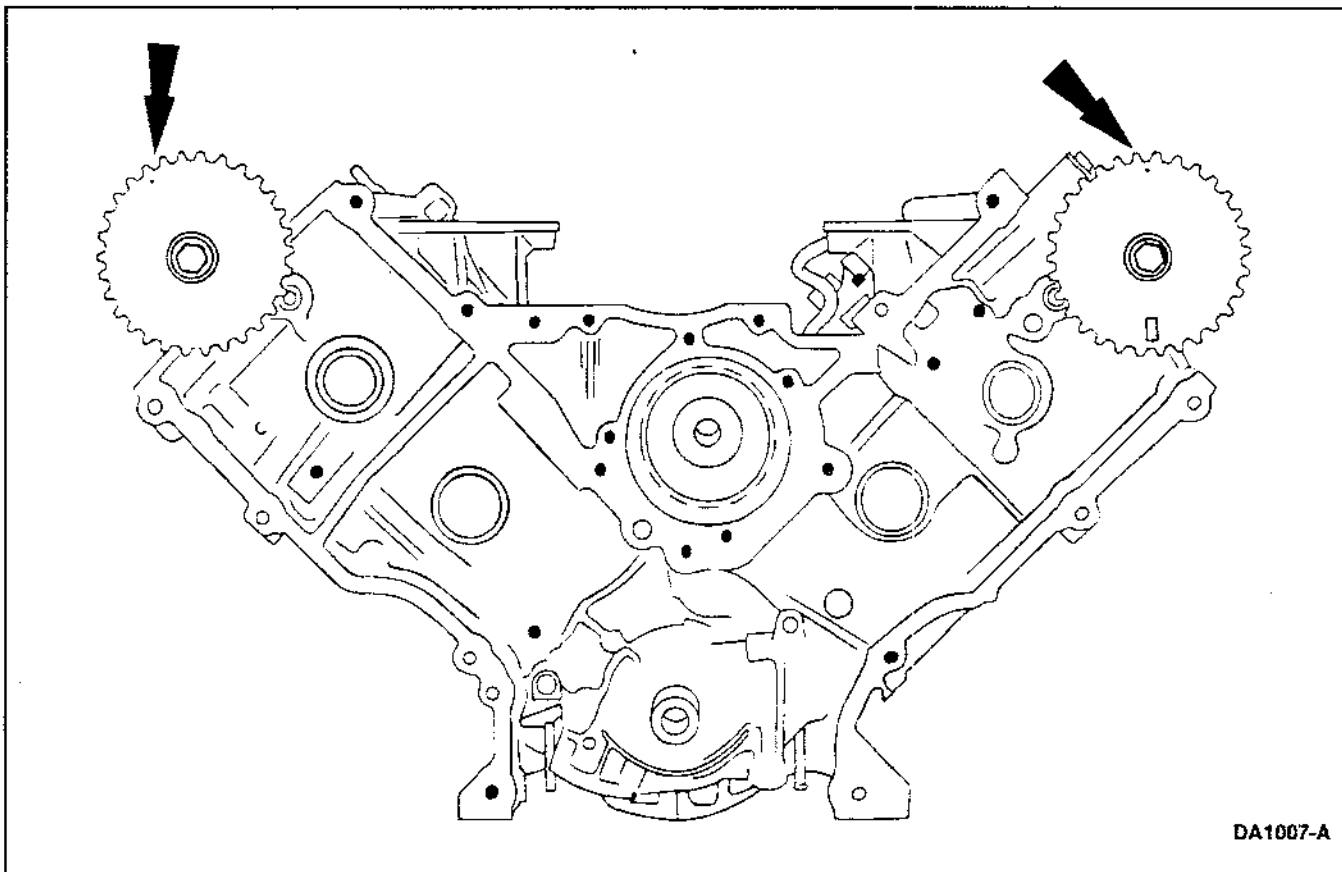

36. Rotate the LH camshaft sprocket until the timing mark is approximately at 12 o'clock.

Rotate the FH camshaft until the timing mark is approximately at 11 o'clock. Tighten the Camshaft Holding Tools to maintain camshaft pre-positioning.

37. **⚠ CAUTION:** Unless otherwise instructed, at no time when the timing chains (6268) are removed and the cylinder heads are installed is the crankshaft or camshaft to be rotated. Severe piston and valve damage will occur.

⚠ CAUTION: Rotate the crankshaft counterclockwise only. Do not rotate past the position shown or severe piston or valve damage can occur.

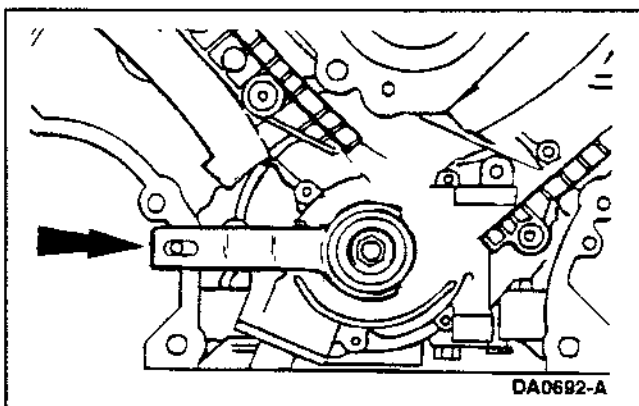

Position the crankshaft with the Crankshaft Holding Tool.

38. Remove the Crankshaft Holding Tool.

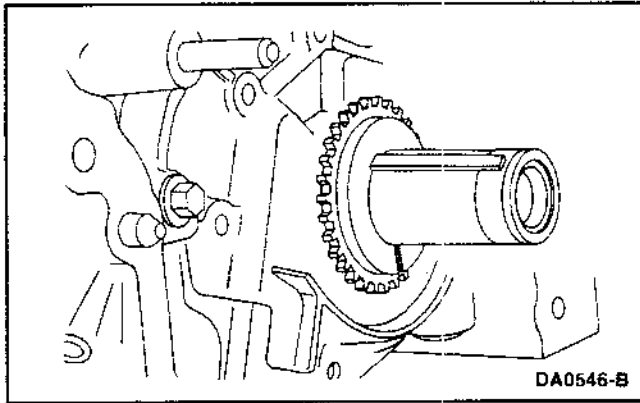

39. Position the inner crankshaft sprocket (6306) with the long hub facing outward.

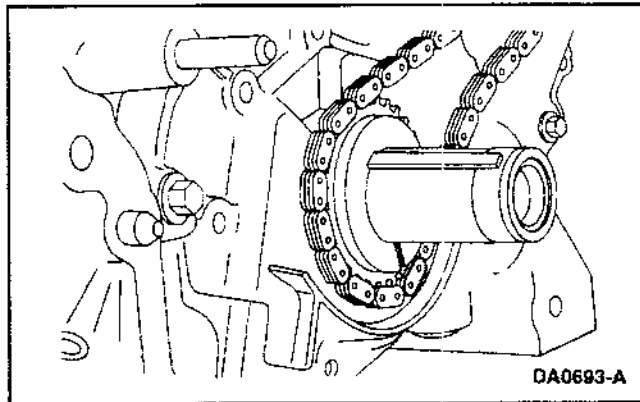

40. Install the LH timing chain/belt onto the crankshaft sprocket, aligning the one copper link on the timing chain with the slot on the crankshaft sprocket.



41. **NOTE:** Make sure the upper half of the timing chain is below the tensioner guide dowel. If necessary, use the Camshaft Holding Tool to adjust.

NOTE: If necessary, adjust the camshaft sprocket slightly to obtain timing mark alignment.

Position the timing chain on the camshaft sprocket with the two copper chain links and the camshaft sprocket timing mark aligned.

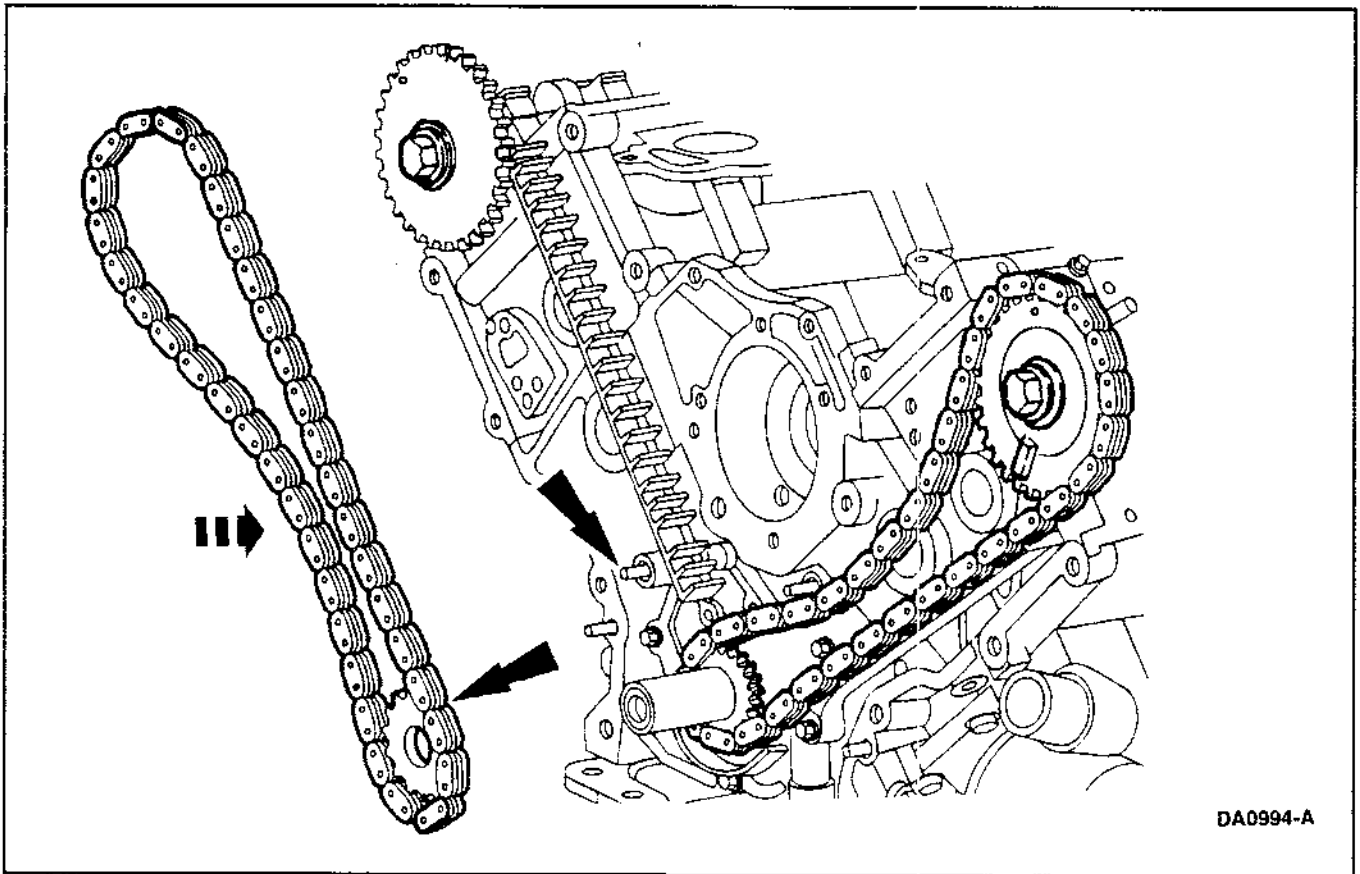

42. **⚠ CAUTION:** The camshaft sprocket can jump time if the Camshaft Holding Tool is not secured.

NOTE: Be sure the copper chain link and the crankshaft sprocket timing mark are aligned.

NOTE: The lower half of the timing chain must be positioned above the dowel.

Position the outer camshaft sprocket and the RH timing chain with the long hub of the camshaft sprocket facing inward.

43. **NOTE:** If necessary, adjust the camshaft sprocket slightly to obtain timing mark alignment.

Position the RH timing chain on the camshaft sprocket. Make sure the two copper-colored links align with the camshaft sprocket timing mark.

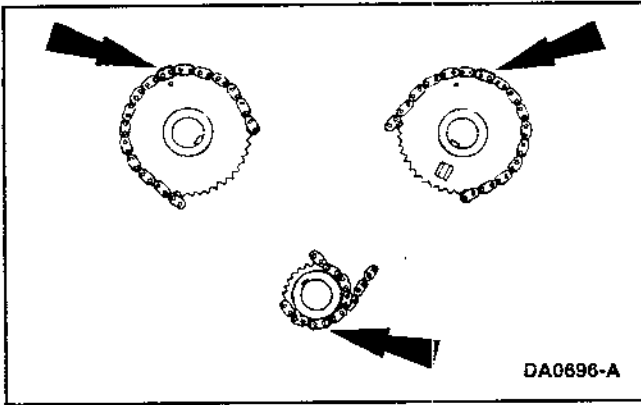

44. As a post-check, verify timing mark alignment.

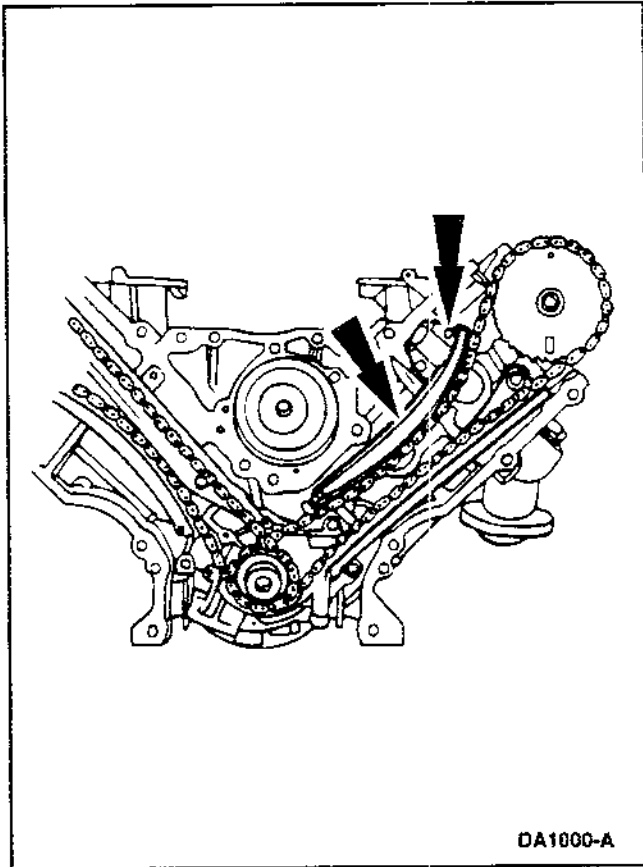

45. Position the LH and RH timing chain tensioner arm (6L253) on the dowel pins. Position the timing chain tensioners (6L266), and install the bolts.

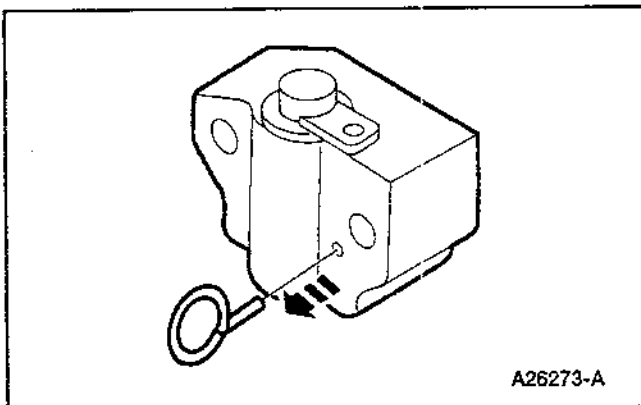

46. Remove both the RH and LH retaining pins from the timing chain tensioner assembly.

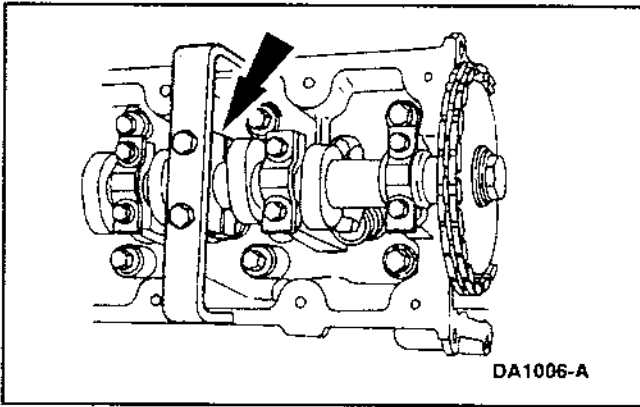

47. Remove the Camshaft Holding Tools from the camshafts.

48. Lubricate the balance shaft journals with engine oil.

- Use Super Premium SAE 5W30 Motor Oil XO-5W30-QSP or equivalent meeting Ford specification WSS-M2C153-G.

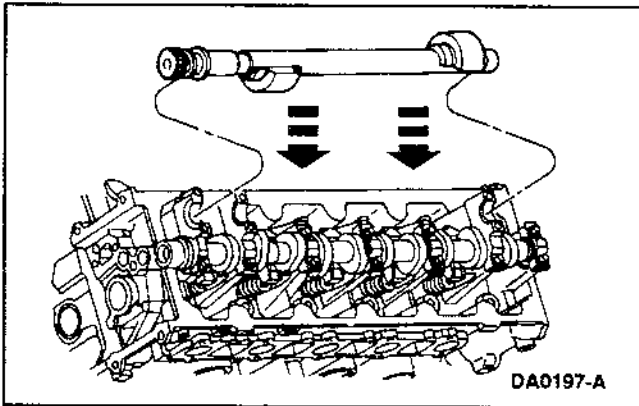

49. Position the balance shaft on the journals.

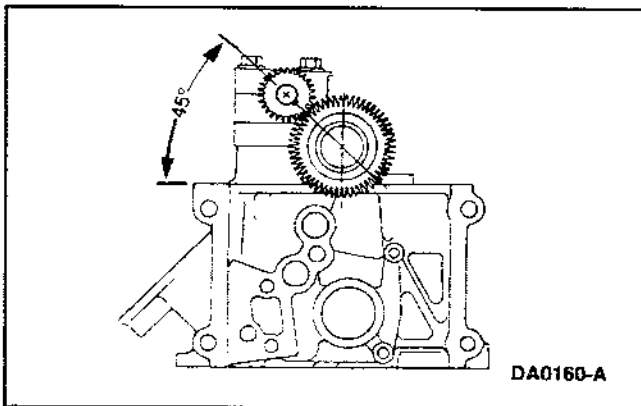

50. Align the balance shaft timing marks as shown.

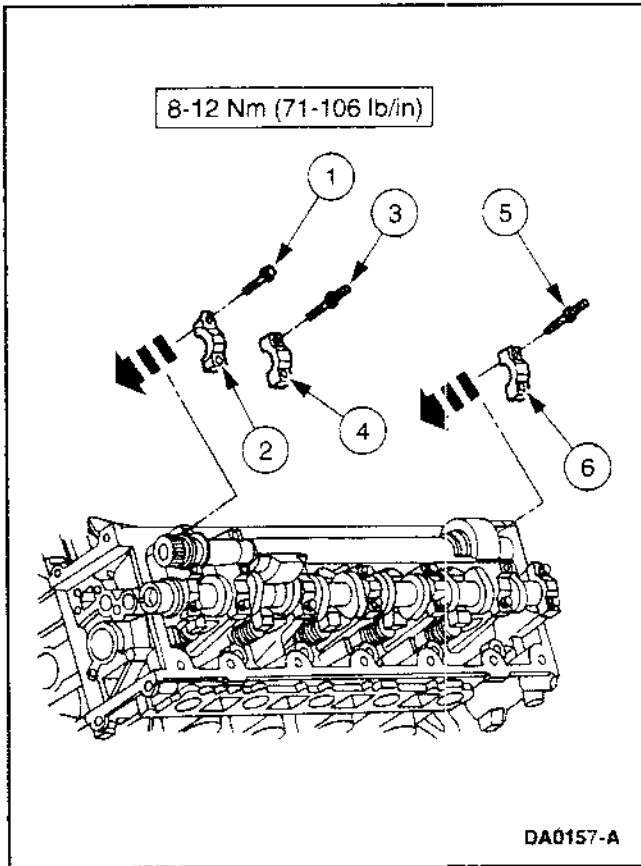

51. Lubricate the balance shaft journals with engine oil.

- Use Super Premium SAE 5W30 Motor Oil XO-5W30-QSP or equivalent meeting Ford specification WSS-M2C153-G.

52. Install the bearing caps and the bolts. Tighten the bolts in the sequence shown.

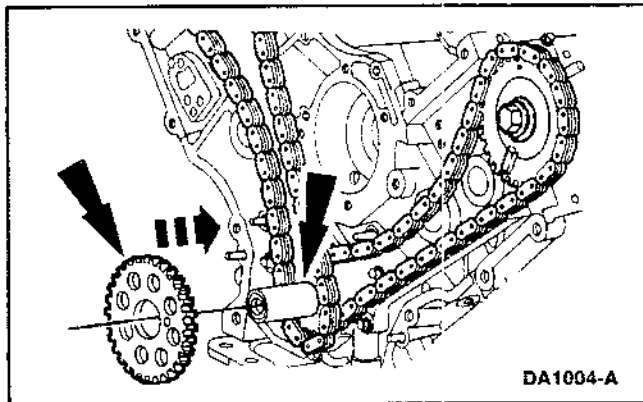

53. Position the crankshaft sensor ring.

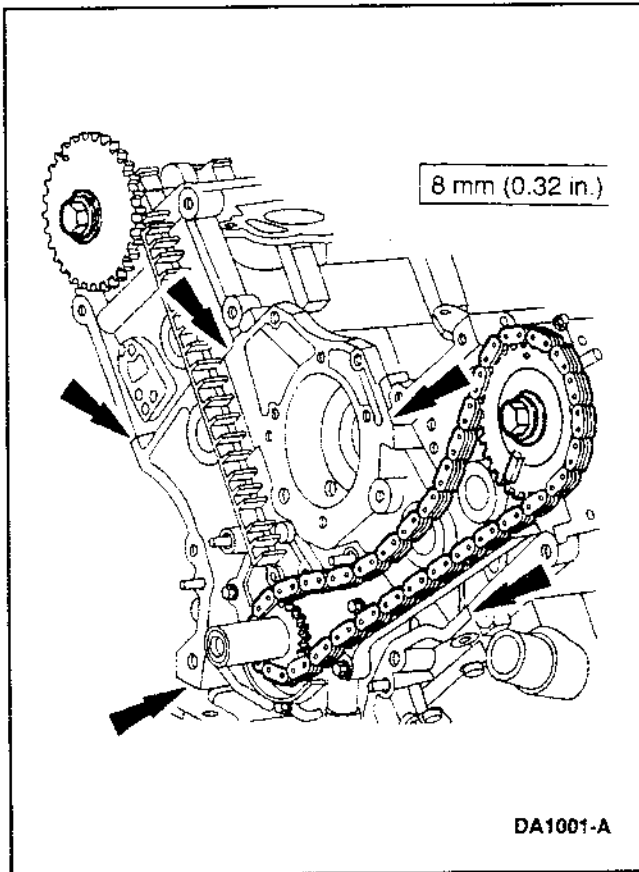

54. **⚠ CAUTION:** Mating parts must make contact to each other within 4 minutes and connecting bolts must be torqued within 15 minutes after applying sealant. Failure to follow this procedure can cause future oil leakage.

- Use silicone gasket and sealant F6AZ-19562-AA or equivalent meeting Ford specification WSE-M4G323-A6.

NOTE: Sealant must be removed and area cleaned with solvent if above instructions are not followed.

- Use metal surface cleaner F4AZ-19A536-RA or equivalent meeting Ford specification WSE-M5B292-A.

NOTE: The RH timing chain is removed for clarity.

- Apply a bead of silicone along the cylinder head-to-block surface and the oil pan-to-cylinder block surface as specified.

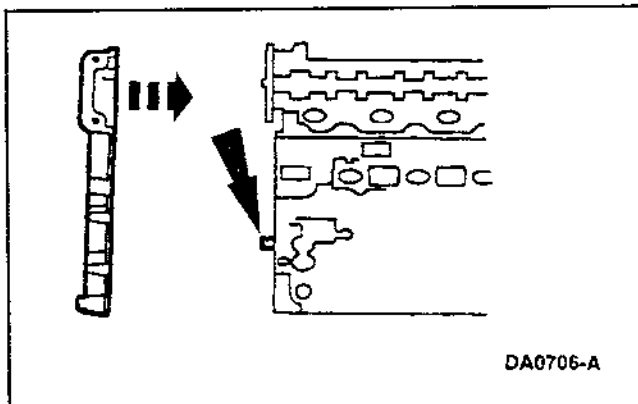

55. Install a new engine front cover gasket (6020) onto the engine front cover (6019), then position the engine front cover on the front cover to cylinder block dowel (6C002).

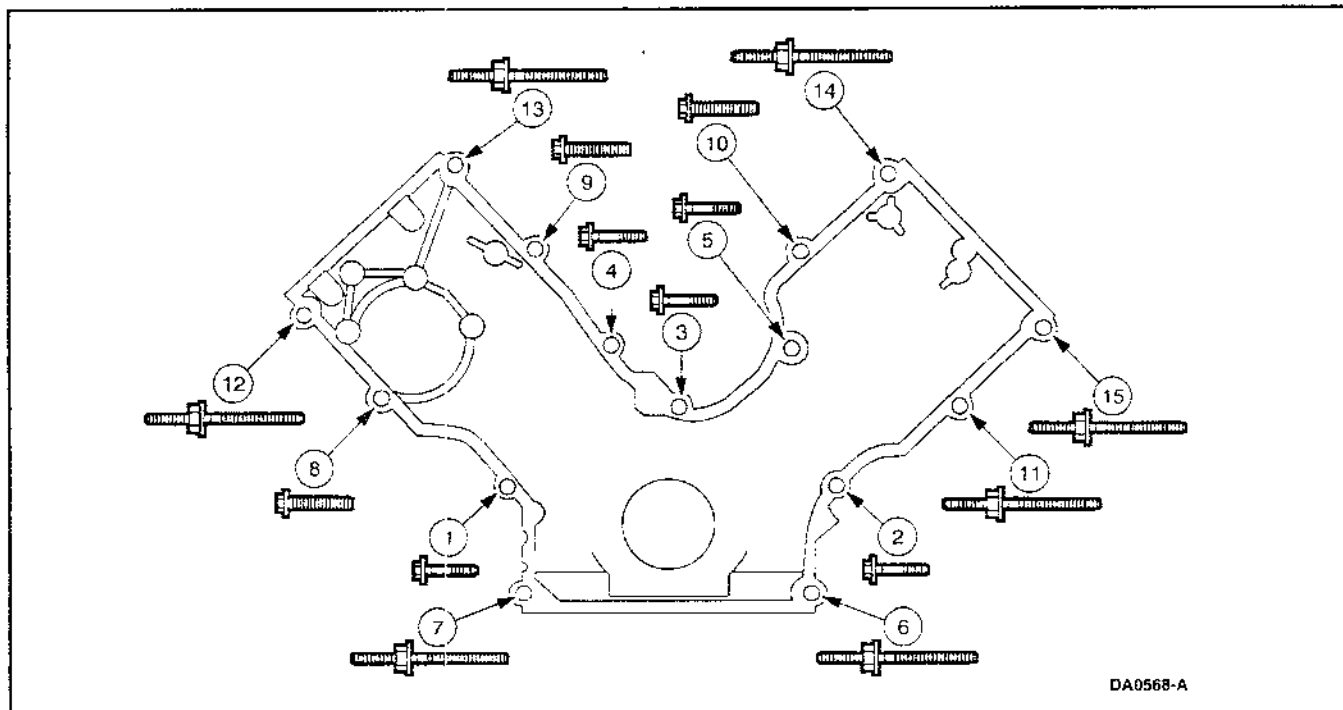

DA0568-A

56. Loosely install the fasteners.

Item	Part Number	Description
1	N806177	Bolt, Hex Flange Head Pilot, M8 x 1.25 x 53
2	N806177	Bolt, Hex Flange Head Pilot, M8 x 1.25 x 53
3	N806177	Bolt, Hex Flange Head Pilot, M8 x 1.25 x 53
4	N806177	Bolt, Hex Flange Head Pilot, M8 x 1.25 x 53
5	N806177	Bolt, Hex Flange Head Pilot, M8 x 1.25 x 53
6	N808529	Stud, Hex-Head Pilot, M10 x 1.5 x 1.5 x 103.1
7	N808529	Stud, Hex-Head Pilot, M10 x 1.5 x 1.5 x 103.1
8	N808142	Screw and Washer, Hex Pilot, M10 x 1.5 x 57.5

Item	Part Number	Description
9	N808142	Screw and Washer, Hex Pilot, M10 x 1.5 x 57.5
10	N808142	Screw and Washer, Hex Pilot, M10 x 1.5 x 57.5
11	N808140	Stud and Washer, Hex-Head Pilot, M10 x 1.5 x M8 x 1.25 x 109.6
12	N808140	Stud and Washer, Hex-Head Pilot, M10 x 1.5 x M8 x 1.25 x 109.6
13	N808140	Stud and Washer, Hex-Head Pilot, M10 x 1.5 x M8 x 1.25 x 109.6
14	N808140	Stud and Washer, Hex-Head Pilot, M10 x 1.5 x M8 x 1.25 x 109.6
15	N808140	Stud and Washer, Hex-Head Pilot, M10 x 1.5 x M8 x 1.25 x 109.6

57. Tighten the fasteners in two stages; refer to the preceding illustration.

- Stage 1: Tighten fasteners 1 through 5 to 20-30 Nm (15-22 lb/ft).
- Stage 2: Tighten fasteners 6 through 15 to 40-55 Nm (30-41 lb/ft).

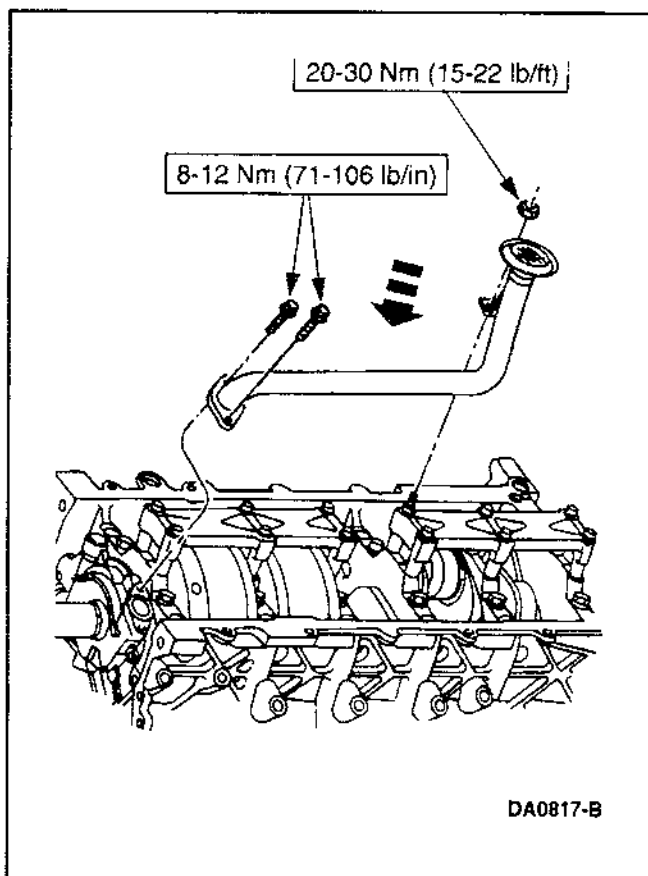

58. Position the oil pump screen cover and tube (6622) and install the bolts and nut.

59. **CAUTION:** Mating parts must make contact to each other within 4 minutes and connecting bolts must be torqued within 15 minutes after applying sealant. Failure to follow this procedure can cause future oil leakage.

- Use silicone gasket and sealant F6AZ-19562-AA or equivalent meeting Ford specification WSE-M4G323-A6.

NOTE: Sealant must be removed and area cleaned with solvent if above instructions are not followed.

- Use metal surface cleaner F4AZ-19A536-RA or equivalent meeting Ford specification WSE-M5B292-A.
- Apply a bead of silicone where the rear crankshaft seal retainer plate and the front cover meets the cylinder block.
- Use Silicone Gasket and Sealant F6AZ-19562-AA or equivalent meeting Ford specification WSE-M4G323-A6.

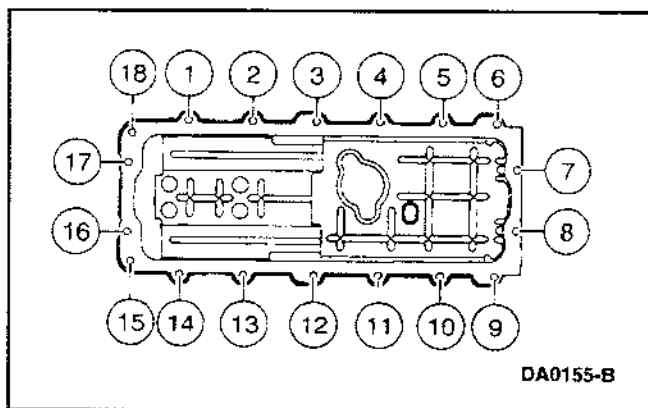

60. **NOTE:** Be sure to tighten the bolts in three stages.

Install the oil pan (6675). Tighten the bolts in the sequence shown.

- Stage 1: Tighten to 2 Nm (18 lb/in).
- Stage 2: Tighten to 20 Nm (15 lb/ft).
- Stage 3: Tighten an additional 60 degrees.

61. Install the oil drain plug. 11-16 Nm (98-143 lb/in).

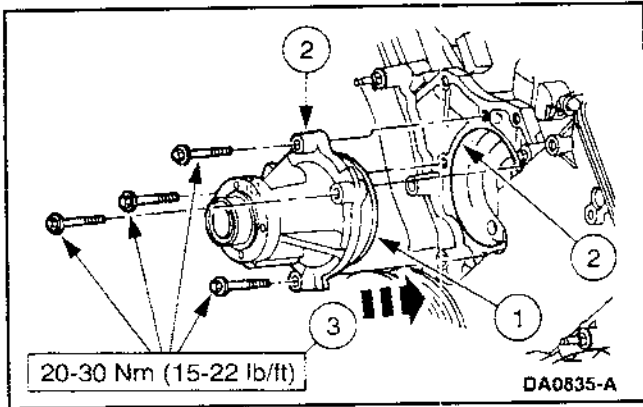

62. **⚠ CAUTION:** Do not rotate the water pump housing once the water pump (8501) has been positioned in the cylinder block. Damage to the O-ring seal will occur.

Install the water pump.

1. Lubricate the new O-ring seal using Premium Cooling Fluid E2FZ-19549-AA or equivalent meeting Ford specification ESE-M97B44-A and install the O-ring seal onto the water pump.

2. Position the water pump into the cylinder block.

3. Install the water pump retaining bolts.

63. Lubricate the (A) engine front cover and the (B) front oil seal inner lip.

- Use Super Premium SAE 5W30 Motor Oil XO-5W30-QSP or equivalent meeting Ford specification WSS-M2C153-G.

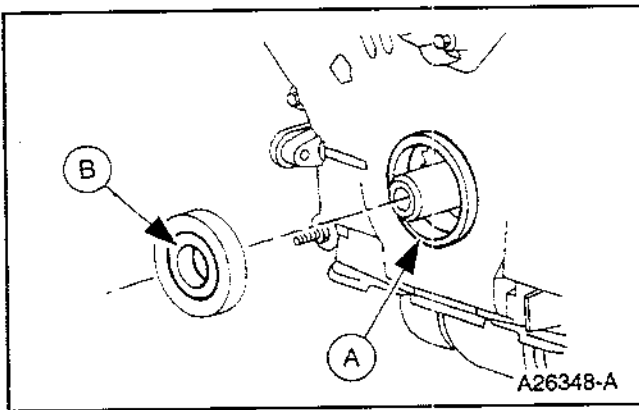

64. Use the (A) Crankshaft Seal Replacer/Aligner to install the (B) crankshaft front seal (6700) into the (C) engine front cover.

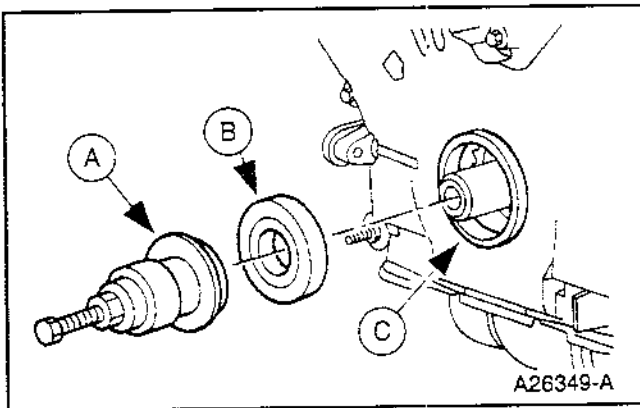

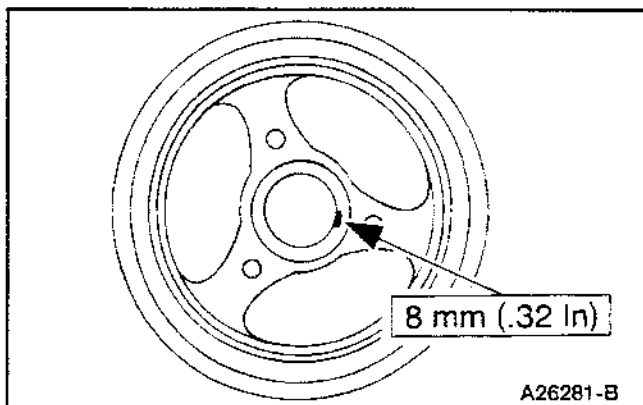

65. **CAUTION:** Mating parts must make contact to each other within 4 minutes and connecting bolts must be torqued within 15 minutes after applying sealant. Failure to follow this procedure can cause future oil leakage.

- Use silicone gasket and sealant F6AZ-19562-AA or equivalent meeting Ford specification WSE-M4G323-A6.

NOTE: Sealant must be removed and area cleaned with solvent if above instructions are not followed.

- Use metal surface cleaner F4AZ-19A536-RA or equivalent meeting Ford specification WSE-M5B292-A.

Apply silicone to the Woodruff key slot on the crankshaft pulley (6312).

- Use Silicone Gasket and Sealant F6AZ-19562-A or equivalent meeting Ford specification WSE-M4G323-A6.

66. Use the Crankshaft Damper Replacer to install the crankshaft pulley.

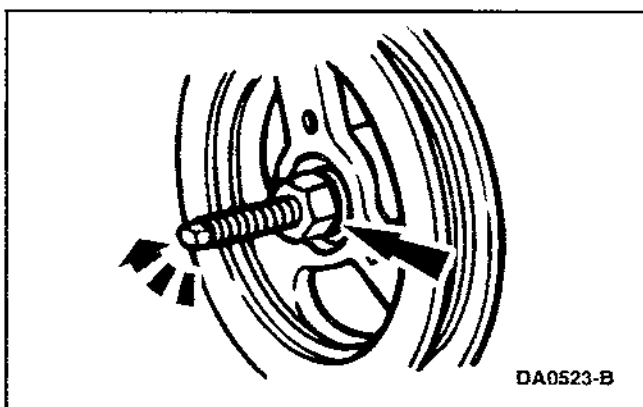

67. Tighten the crankshaft pulley bolt (6A340) in four stages.

- Stage 1: Tighten to 90 Nm (66 lb/ft).
- Stage 2: Loosen 360 degrees.
- Stage 3: Tighten to 47-53 Nm (35-39 lb/ft).
- Stage 4: Tighten an additional 85-90 degrees.

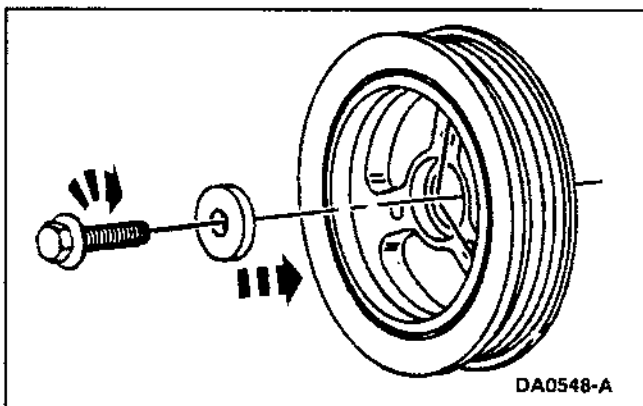

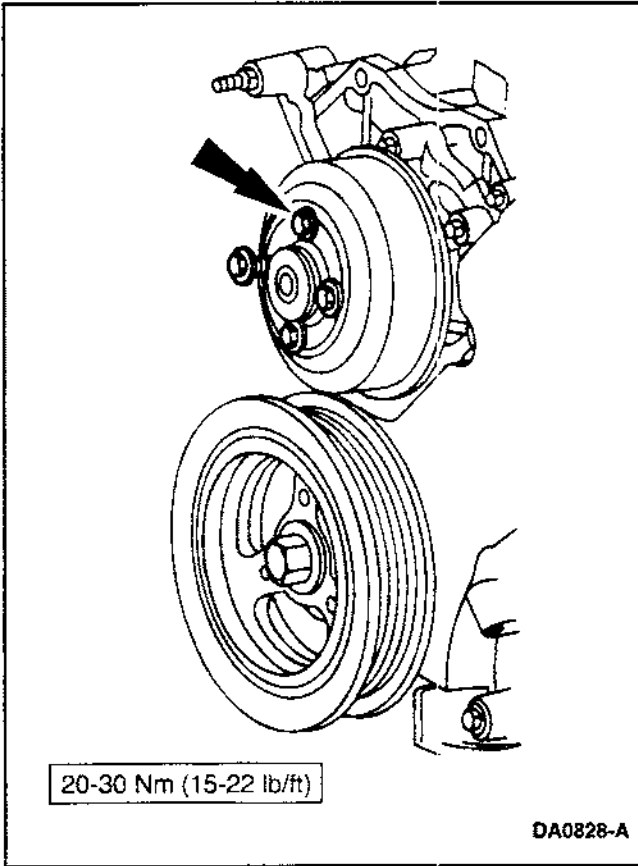

68. Position the water pump pulley (8509) on the water pump and install the bolts.

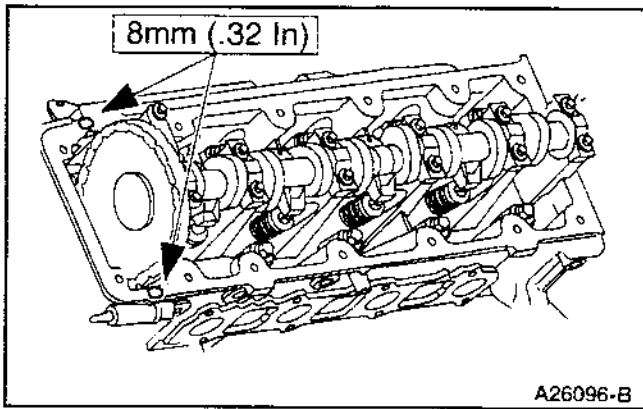

69. **CAUTION:** Mating parts must make contact to each other within 4 minutes and connecting bolts must be torqued within 15 minutes after applying sealant. Failure to follow this procedure can cause future oil leakage.

- Use silicone gasket and sealant F6AZ-19562-AA or equivalent meeting Ford specification WSE-M4G323-A6.

NOTE: Sealant must be removed and area cleaned with solvent if above instructions are not followed.

- Use metal surface cleaner F4AZ-19A536-RA or equivalent meeting Ford specification WSE-M5B292-A.

Apply silicone in two places where the engine front cover meets the cylinder head.

- Use Silicone Gasket and Sealant F6AZ-19562-AA or equivalent meeting Ford specification WSE-M4G323-A6.

70. Position the valve covers (6582).

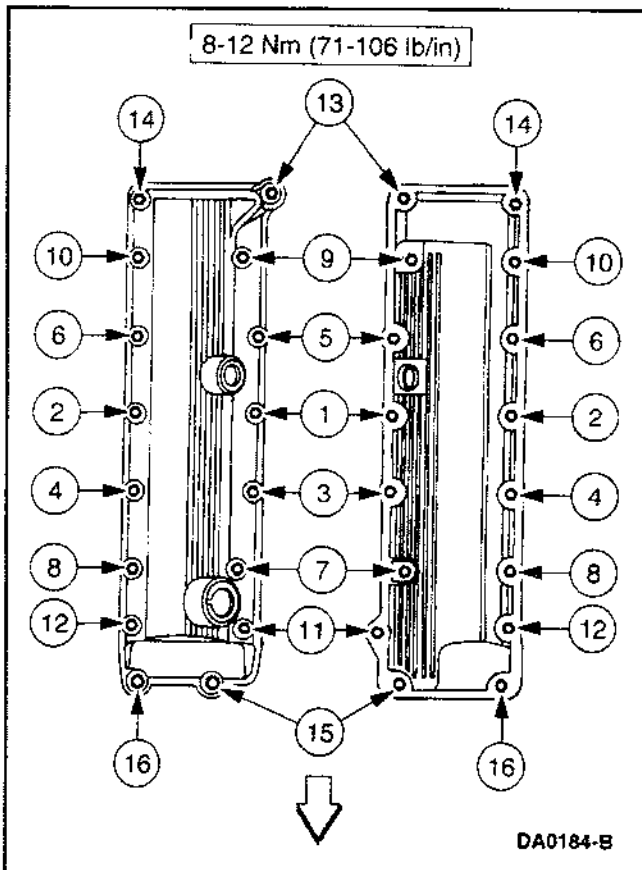

71. Tighten the bolts in the sequence shown.

72. Install the engine control wire harness.





Engine - Installation

Special Tool(s)

 <p>ST1377-A</p>	<p>Modular Lifting Bar 303-F047 (014-00073) or equivalent</p>
 <p>ST1480-A</p>	<p>Rear Crankshaft Seal Adapter 303-518 (T95P-6701-DH)</p>

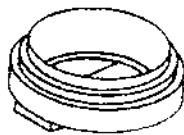
Special Tool(s)

 <p>ST1479-A</p>	<p>Rear Crankshaft Seal Replacer 303-516 (T95P-6701-BH)</p>
 <p>ST1482-A</p>	<p>Rear Crankshaft Slinger Replacer 303-517 (T95P-6701-CH)</p>

Special Service Tools called for by the procedures can be obtained by calling:
1-800-ROTUNDA (1-800-768-8632).

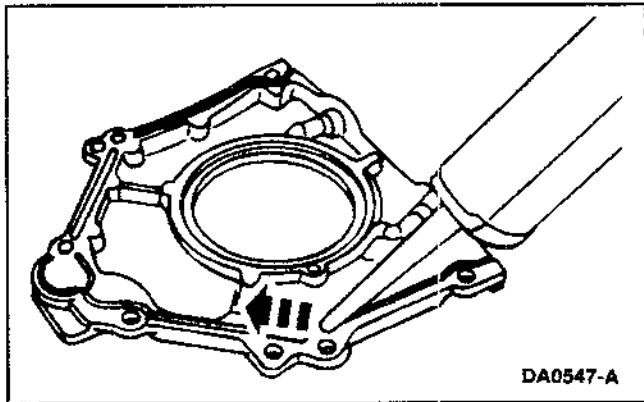

1. Attach the Modular Lifting Bar.
 2. Remove the engine from the engine stand.
 3.  **CAUTION:** Mating parts must make contact to each other within 4 minutes and connecting bolts must be torqued within 15 minutes after applying sealant. Failure to follow this procedure can cause future oil leakage.
 - Use silicone gasket and sealant F6AZ-19562-AA or equivalent meeting Ford specification WSE-M4G323-A6.
- NOTE:** Sealant must be removed and area cleaned with solvent if above instructions are not followed.
- Use metal surface cleaner F4AZ-19A536-RA or equivalent meeting Ford specification WSE-M5B292-A.
4. Apply a bead of silicone around the rear oil seal retainer sealing surface.

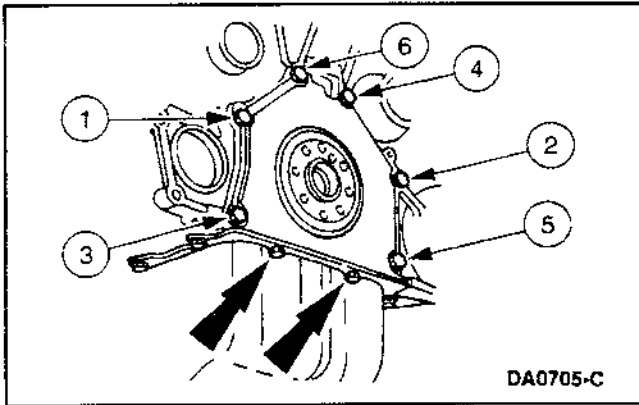

5. Install the retainer plate. Tighten the bolts to 8-12 Nm (71-107 lb/in).

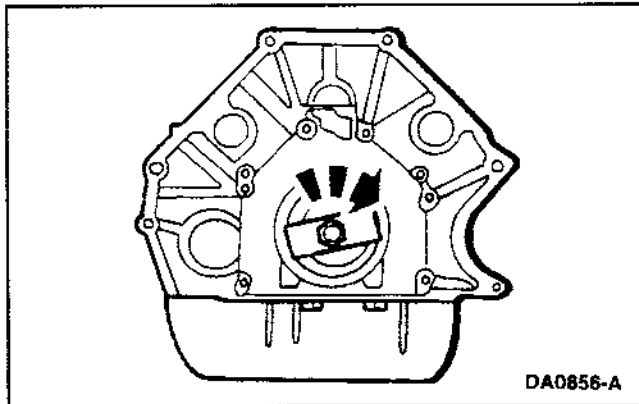

6. Use the Rear Crankshaft Seal Replacer and Rear Crankshaft Seal Adapter to install the crankshaft rear oil seal (6701).
7. With the Rear Crankshaft Seal Adapter still installed, use the Rear Crankshaft Slinger Replacer to install the crankshaft oil slinger.

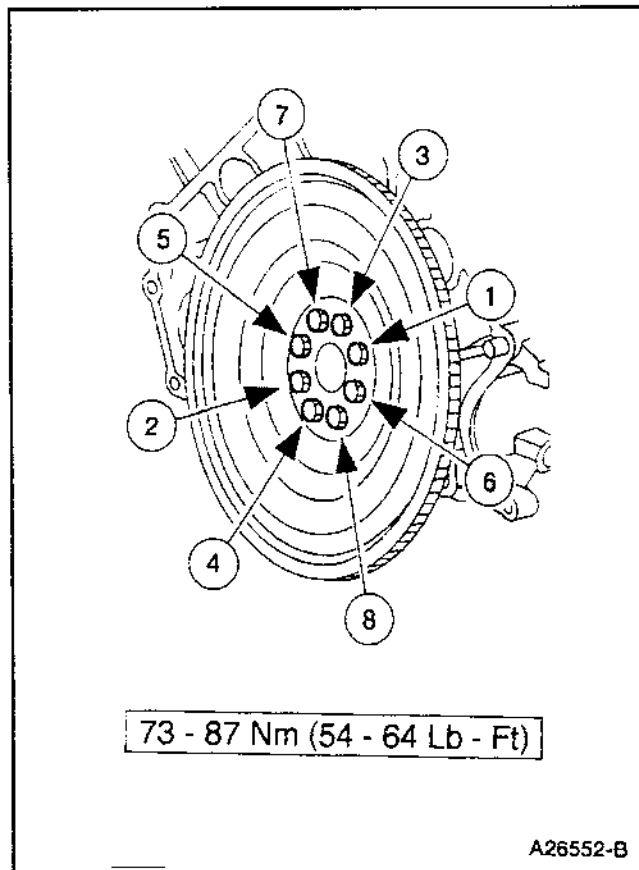

8. Install the flywheel (6375).
9. Install the starter motor (11002).

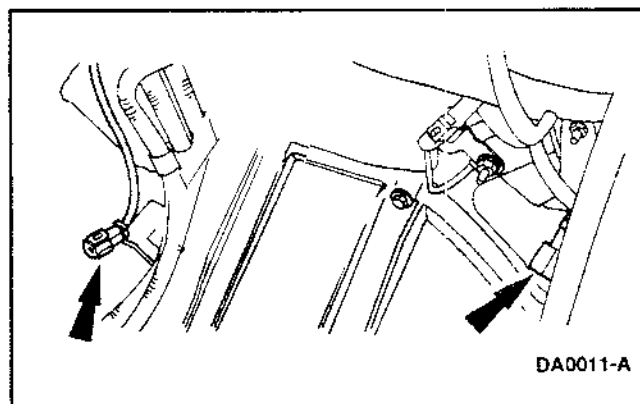
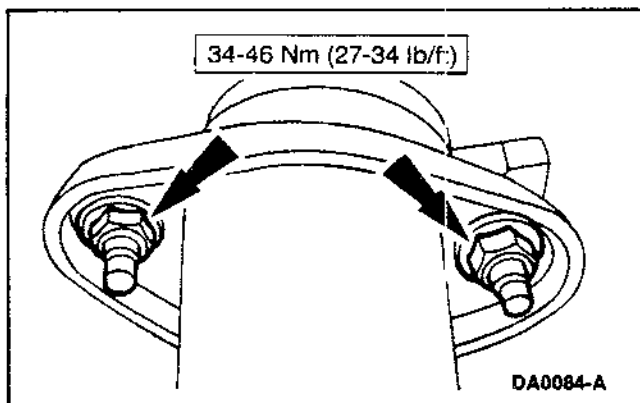

10. Connect the left and right exhaust pipes and install and tighten the nuts.

NOTE: Apply a light coat of anti-sieze compound F6AZ-9L494-AA or equivalent meeting Ford specification ESE-M12A4-A to the threads of the exhaust manifold studs.

11. Connect the LH and RH heated exhaust gas oxygen sensor connector if equipped.

12. Install the intake manifold (9424); refer to Intake Manifold – Variable Resonance Induction System (VRIS) in this section.

13. Install vacuum hoses.

14. Install the drive belt (8620).

15. Install the upper and lower radiator supports (16138).

16. Install the radiator (8005).

17. Install the engine air cleaner (ACL) (9600) and the air cleaner outlet tube (9B659).

18. Fill all fluids to the proper levels.

19. Connect the battery ground cable (14301).

20. Start the engine and check for leaks. Stop the engine and recheck the fluid levels.

SPECIFICATIONS

Torque Specifications

Description	Nm	Lb/Ft	Lb/In
Bolt Hex Flanged (Front of Engine)	20-30	15-22	-
Camshaft Bearing Cap Bolts	8-12	-	71-106
Camshaft Sprocket Bolts	55-75	41-55	-
CKP/CID Bolt	8-12	-	71-106
Coil Pack Bracket Bolts	20-30	15-22	-
Connecting Rod Bolts	(1)(2)	(1)(2)	(1)(2)
Crankshaft Pulley Bolt	(1)	(1)	(1)
Engine Support Insulator Bolts	80	59	-
Engine Support Insulator Nuts	90	66	-
Exhaust Manifold Nuts	23-27	17-20	-
Exhaust System to Exhaust Manifold Nuts	34-46	27-34	-
Flywheel Bolts	73-87	54-64	-
Front Engine Support Insulator	68-92	50-68	-
Head Bolts (LH) (RH) (1)	(1)(2)	(1)(2)	(1)(2)
Heater Water Return Tube Studs	40-55	30-41	-
Idler Pulley Bolt	20-30	15-22	-
Jack Screws	(1)	(1)	(1)
Lower Crankshaft Bearing Bolts and Stud Bolts	20-30	15-22	-
Lower Power Steering Bolts	20-30	15-20	-
Main Bearing Cap Bolts	(1)(2)	(1)(2)	(1)(2)
Main Cap Side Bolts	(1)(2)	(1)(2)	(1)(2)
Motor Mount Pivot Bolt	68-92	50-68	-
Motor Mount to Engine Bolts	52-71	38-52	-
Oil Cooler to Adapter	55-60	-	41-44
Oil Filter	14-17	-	125-151.6
Oil Filter Adapter Assembly Bolts	20-30	15-22	-
Oil Level Indicator Bracket Nut	20-30	15-22	-
Oil Level Indicator Tube Bolt	8-12	-	71-106
Oil Pan Bolts	(1)	(1)	(1)
Oil Pan Drain Plug	11-16	-	98-143
Oil Pump Bolts	8-12	-	71-107
Oil Pump Screen Cover and Tube Bolts	8-12	-	71-106
Oil Pump Screen and Cover Assembly Spacer	20-30	15-22	-
Oil Pump Screen Cover and Tube Nut	20-30	15-22	-
Power Steering Pump Bolts	20-30	15-22	-
Rear Oil Seal Bolts	8-12	-	71-106
Screw and Washer (Front of Engine)	40-55	29-40	-
Stud and Washer (Front of Engine)	40-55	29-40	-
Timing Chain Guide Bolts	8-12	-	71-106
Torque Converter Nuts	34-46	25-34	-

(Continued)

Torque Specifications (Continued)

Description	Nm	Lb/Ft	Lb/In
Flywheel Housing to Engine Bolts	41-54	30-40	-
Upper Intake Manifold Bolts	(1)	(1)	(1)
Upper Intake Manifold to Cylinder Head Bolts	(1)	(1)	(1)
Upper Power Steering Bolts	20-30	15-20	-
Valve Cover Bolts	8-12	-	71-106
Water Pump Bolts	20-30	15-22	-
Water Pump Pulley Bolts	20-30	15-22	-

(1) Refer to this section for tightening procedure and sequence.

(2) Torque to yield bolts must be discarded and replaced with new bolts.

General Specifications

Item	Specification
Displacement (CID)	6.8L (415)
No. Cylinder	10
Bore/Stroke	90.215/105.8 mm
Fire Order	1-6-5-10-2-7-3-8-4-9
Oil Capacity	6.0 qts.
(With oil filter - 6.5)	6.5 qts.
Oil Pressure 93.33°C (200°F) at Cylinder Block	18 psi @ 650 rpm 100 psi @ 4,000 rpm
Cylinder Head/Valve Train	
Combustion Chamber Volume	52.6 - 51.6 cc
Valve Seat Width -- Intake	2.1-1.9 mm
Valve Seat Width -- Exhaust	2.1-1.9 mm
Valve Seat Angle	45.00-44.50 degrees
Valve Seat Runout (T.I.R.)	0.025 mm
Valve Arrangement (Front to Rear)	
Valve Stem Guide Clearance: Intake	0.069-0.020 mm
Exhaust	0.095-0-045 mm
Valve Head Diameter: Intake	44.63-44.37 mm
Exhaust	34.12-33.88 mm
Valve Face Runout (Limit)	0.05 mm
Valve Face Angle	45.75-45.25 degrees
Valve Stem Diameter: Intake	6.995-6.975 mm
Exhaust	6.970-6.949 mm
Valve Stem Diameter (List Oversizes): Intake	N/A
Exhaust	N/A
Valve Spring Compression Pressure: Intake (N @ Spec. Length)	667.3 N @ 28.02 mm
Exhaust (N @ Spec. Length)	667.3 N @ 28.02 mm

(Continued)

General Specifications (Continued)

Item	Specification
Valve Spring Free Length:	
Intake	50.2 mm
Exhaust	50.2 mm
Valve Spring Installed Pressure N @ Spec. Length:	
Intake	289.1 N @ 40.01 mm
Exhaust	289.1 N @ 40.01 mm
Valve Springs Installed Pressure N @ Spec. Length – Service Limit:	
Intake	274.6 n.m @ 40.01 mm
Exhaust	274.6 n.m @ 40.01 mm
Valve Springs – Out of Square Limit:	
Intake	2.5 degrees
Exhaust	2.5 degrees
Valve Guide Inside Diameter	7.044-7.015 mm
Camshaft	
Lobe Lift:	
Intake	6.58077 mm
Exhaust	6.58551 mm
Lobe Lift – Allowable Lift Loss	0
Valve Lift @ Zero Lash:	
Intake	12.00 mm
Exhaust	12.00 mm
Camshaft End Play	0.25-0.188 mm
End Play Service Limit	0.025-0.188 mm
Journal to Bearing Clearance	0.076-0.025 mm
Clearance Service Limit	-
Journal Diameters	26.962-26.936 mm
Journal Inside Diameter (Cap Assembled)	27.012-26.987 mm
Camshaft Runout: Full Indicator Measurement on all journals when supported on front and rear journals Engine	0.09 mm (5 Places)
Cylinder Bore Diameter:	
Grade 1	90.200-90.210 mm
Grade 2	90.210-90.220 mm
Grade 3	90.220-90.230 mm
Piston	
Piston Diameter (Grade 2) at Right Angle to Pin Bore	90.180 ± 0.005 mm
Piston to Bore Clearance	(-0.005) to +0.025 mm
Pin Bore Diameter (Piston)	22.008-22.014 mm
Pin Diameter	22.0005-22.0030 mm
Clearance (Neg. or Pos.)	0.01395-0.005 mm
Pin Bore Diameter (Rod)	22.012-22.024 mm
Clearance	0.009-0.0235 mm
Ring Groove Width:	
Top	1.503-1.505 mm
Intermediate	1.502-1.504 mm

General Specifications (Continued)

Item	Specification
Oil Control	3.030-3.050 mm
Piston Ring Gap:	
Top	0.13-0.28 mm
Intermediate	0.25-0.40 mm
Oil Control	0.15-0.65 mm
Crankshaft	
Main Bearing Journal Diameter	27-482-67.504
Maximum Out-of-Round	0.0075 mm Between Cross Sections
Maximum Taper (Straightness)	0.004 mm
Runout: FIM of center journals when located on front and rear journal	TBD
Clearance – Crankshaft Journal to Main Bearing Clearance	0.048-0.024 mm
Connecting Rod Journal Diameter	53.003-52.983 mm
Maximum Out-of-Round	0.0075 mm Between Cross Sections
Maximum Taper	0.004 mm
Crankshaft End Play	0.075-0.377
Connecting Rod	
Big End Journal Inside Diameter with Assembled Liners	53.049-53.027 mm
Rod Bearing to Journal Clearance	0.064-0.026 mm
Pin Bore Diameter (Rod)	22.024-22.012 mm
Balance Shaft System	
Balance Shaft Journal Diameter	26.962-26.936 mm
Clearance – Balance Shaft Journal to Cylinder Head	0.076-0.025 mm
Cylinder Head B/S Journal Diameter	27.012-26.987 mm
Gear Backlash	0.0076-0.1295 mm
Balance Shaft End Play	0.04-0.18 mm
Rod Length (Centerline Bore-to-Bore)	169.1 mm
Alignment:	
Bore-to-Bore Max. Twist	± 0.05 mm
Bore-to-Bore Max. Bend	± 0.038 mm
Side Play (As Assembled to Crank):	
Standard Play	0.410 ± 0.26 mm
Max Play	0.670 mm

(Continued)

General Specifications (Continued)

Item	Specification
Sealant and Lubricants	
Silicone Gasket and Sealant F6AZ-19562-AA (in Canada CXC-8-B) (in Oregon F5FZ-19549-CC)	ESE-M97B44-A
Super Premium Engine Oil SAE 5W30	D9AZ-19579A
Petroleum Jelly	WSD-M1C226-A
Metal Surface Cleaner F4AZ-19A536-RA	WSE-M5B392-A
Anti-seize Compound F6AZ-9L494-AA	ESE-M12A4-A

INDEX

Subject	Page
General Information	
Color Abbreviations	03 - 3
How to Find Electrical Concerns	03 - 3
Troubleshooting Tools	03 - 3
Switch Circuit Check and Voltage Check	03 - 4
Continuity Check (locating open circuits)	03 - 4
Short Check	03 - 5
Ground Check	03 - 5
Troubleshooting Wiring Harness & Connector Hidden Concerns	03 - 6
Electrical Symbols	03 - 7
Description	03 - 8
Operation	03 - 8
Overview	03 - 9
Electronic Ignition System	03 - 9
Starting RPM	03 - 9
Camshaft Position Sensor	03 - 9
The Fuel Select Switch	03 - 10
Run Mode	03 - 10
Inputs to the ICM Effecting the Ignition	03 - 10
Crankshaft Position Sensor (CKP Sensor)	03 - 10
Coil on Plug	03 - 11
Engine Crank/Engine Running	03 - 11
CMP FMEM	03 - 11
Cranking Mode	03 - 11
Transient Mode	03 - 11
Overspeed Mode	03 - 11
Electronic Engine Controls	03 - 12
ICM Replacement	03 - 12
Cylinder Head Temperature (CHT) Sensor	03 - 12
Starting Mode	03 - 13
CHT Effects	03 - 13
IAT Effects (Not Used)	03 - 13
Overspeed Protection	03 - 13
Engine Protection	03 - 13
Starter Lockout	03 - 13
Tachometer Output	03 - 13
Ignition System - Components Location	03 - 14
Firing Order	03 - 15
Ignition Coil-on Plug - Removal	03 - 16
Ignition Coil-on Plug - Installation	03 - 16
Harness Connector Pinout Description	03 - 17
Octane Select Operation	03 - 18
Diagnosis and Testing	
Service Adjustments and Checks	03 - 19
Diagnostic Equipment	03 - 19
Preliminary Checks	03 - 20
Visual / Physical Check	03 - 20
Intermittent Problems	03 - 20
Electrical Schematics	03 - 21
Pinpoint Test A - Ignition Check	03 - 30



GENERAL INFORMATION

Color Abbreviations

BL	Blue	N	Natural
BK	Black	O	Orange
BR	Brown	PK	Pink
DB	Dark Blue	P	Purple
DG	Dark Green	R	Red
GN	Green	T	Tan
GY	Gray	W	White
LB	Light Blue	Y	Yellow
LG	Light Green		

NOTE: Whenever a wire is labeled with two colors, the first color listed is the basic color of the wire, and the second color listed is the stripe marking of the wire.

How to Find Electrical Concerns

Troubleshooting Steps

These six steps present an orderly method of troubleshooting.

Step 1: Verify the concern.

- Operate the complete system to check the accuracy and completeness of the customer's complaint.

Step 2: Narrow the concern.

- Using a DVOM, narrow down the possible causes and locations of the concern to pinpoint the exact cause.
- Read the description about the components and study the wiring schematic. You should then know enough about the circuit operation to determine where to check for the trouble.

Step 3: Test the cause.

- Use electrical test procedures to find the specific cause of the symptoms.

Step 4: Verify the cause.

- Confirm that you have found the correct cause by connecting jumper wires and/or temporarily installing a known good component and operating the circuit.

Step 5: Make the repair.

- Repair or replace the inoperative component.

Step 6: Verify the repair.

- Operate the system as in Step 1 and check that your repair has removed all symptoms without creating any new symptoms.

Troubleshooting Tools

Jumper Wire

This is a test lead used to connect two points of a circuit. A Jumper Wire can bypass an open in a wire to complete a circuit.

 **WARNING: NEVER USE A JUMPER WIRE ACROSS LOADS (MOTORS, ETC.) CONNECTED BETWEEN HOT AND GROUND. THIS DIRECT BATTERY SHORT MAY CAUSE INJURY OR FIRE.**

Voltmeter

A DC Voltmeter measures circuit voltage. Connect negative (- or black) lead to ground, and positive (+ or red) lead to voltage measuring point.

Ohmmeter

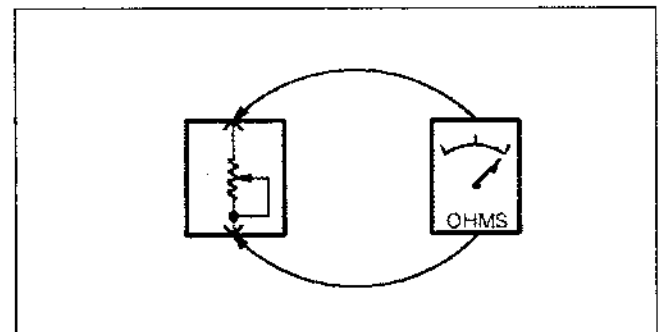

Figure 1 – Resistance Check

An Ohmmeter shows the resistance between two connected points (Figure 1).

Test Lamp

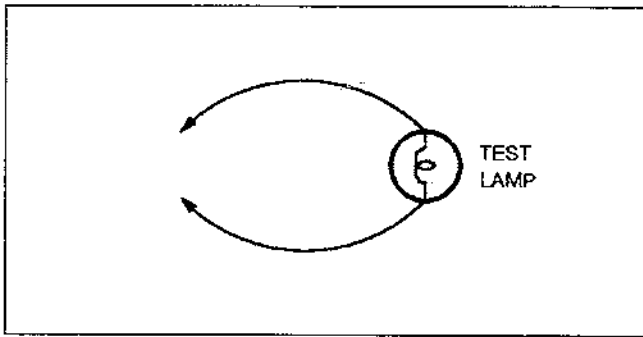

Figure 2 – Test Lamp

A Test Light is a 12-volt bulb with two test leads (Figure 2).

Uses: Voltage Check, Short Check.

Self-Powered Test Lamp

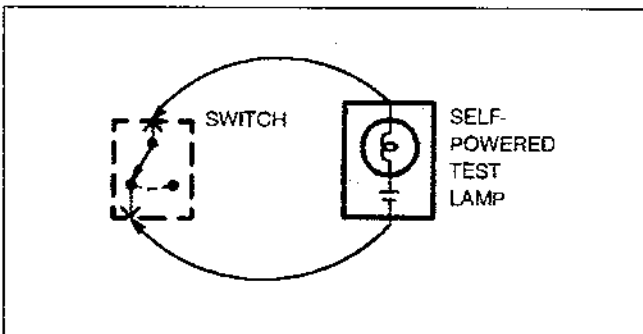

Figure 3 – Continuity Check

The Self-Powered Test Lamp is a bulb, battery and set of test leads wired in series (Figure 3). When connected to two points of a continuous circuit, the bulb glows.

Uses: Continuity Check, Ground Check.



CAUTION: When using a self-powered test lamp or ohmmeter, be sure power is off in circuit during testing. Hot circuits can cause equipment damage and false readings.

Switch Circuit Check & Voltage Check

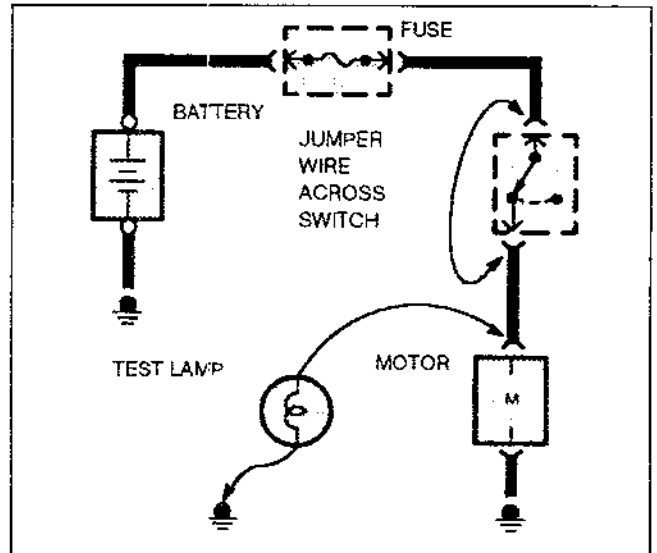

Figure 4 – Switch Circuit Check and Voltage Check

In an inoperative circuit with a switch in series with the load, jumper the terminals of the switch to power the load. If jumpering the terminals powers the circuit, the switch is inoperative (Figure 4).

Continuity Check (Locating open circuits)

Connect one lead of test lamp to a known good ground or the negative (-) battery terminal. Test for voltage by touching the other lead to the test point. The bulb goes on when the test point has voltage (Figure 4).

Short Check

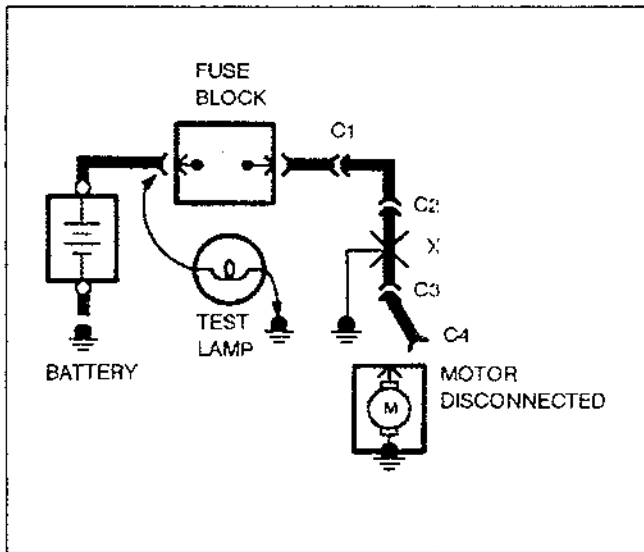

Figure 5 – Short Check

A fuse that repeatedly blows is usually caused by a short to ground. It's important to be able to locate such a short quickly (Figure 5).

1. Turn off everything powered through the fuse.
2. Disconnect other loads powered through the fuse:
 - Motors: disconnect motor connector (Connector C4 in Figure 5).
 - Lights; remove bulbs.
3. Turn the Ignition Switch to RUN (if necessary) to power fuse.
4. Connect one Test Lamp lead to the hot end of the blown fuse. Connect the other lead to ground. The bulb should glow, showing power to fuse. *(This step is just a check to be sure you have power to the circuit).*
5. Disconnect the test lamp lead that is connected to ground, and reconnect it to the load side of the fuse at the connector of the disconnected component. (In Figure 5, connect the test lamp lead to connector C4).
 - If the Test Lamp is off, the short is in the disconnected component.
 - If the Test Lamp goes on, the short is in the wiring. You must find the short by disconnecting the circuit connectors, one at a time, until the Test Lamp goes out. For example, in Figure 5 with a ground at X, the bulb goes out when C1 or C2 is

disconnected, but not after disconnecting C3. This means the short is between C2 and C3.

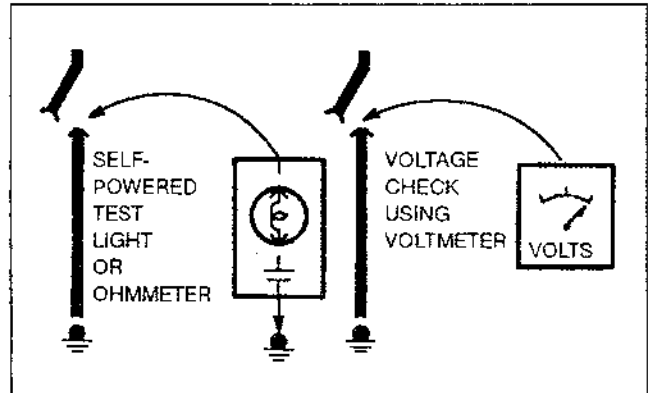

Figure 6 – Ground Check

Ground Check

Turn on power to the circuit. Perform a Voltage Check between the suspected inoperative ground and the frame. Any indicated voltage means that the ground is inoperative (Figure 6).

Turn off power to the circuit. Connect one lead of a Self-Powered Test Lamp or Ohmmeter to the wire in question and the other lead to a known ground. If the bulb glows, the circuit ground is OK (Figure 6).

The circuit schematics in this manual make it easy to identify common points in circuits. This knowledge can help narrow the concern to a specific area. For example, if several circuits fail at the same time, check for a common power or ground connection. If part of a circuit fails, check the connections between the part that works and the part that doesn't work.

For example, if the low beam headlamps work, but the high beams and the indicator lamp don't work, then the power and ground paths must be good. Since the dimmer switch is the component that switches this power to the high beam lights and the indicator, it is most likely the cause of failure.

Troubleshooting Wiring Harness and Connector Hidden Concerns

The following illustrations are known examples of wiring harness, splices and connectors that will create intermittent electrical concerns. The concerns are hidden and can only be discovered by a physical evaluation as shown in each illustration.

NOTE: When servicing gold plated terminals in a connector, only replace with gold plated terminals designed for that connector.

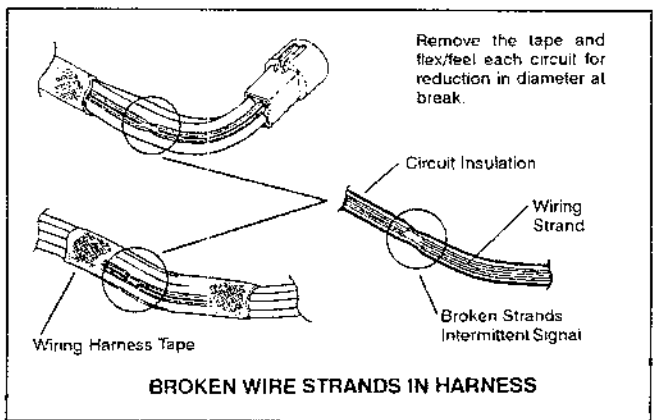
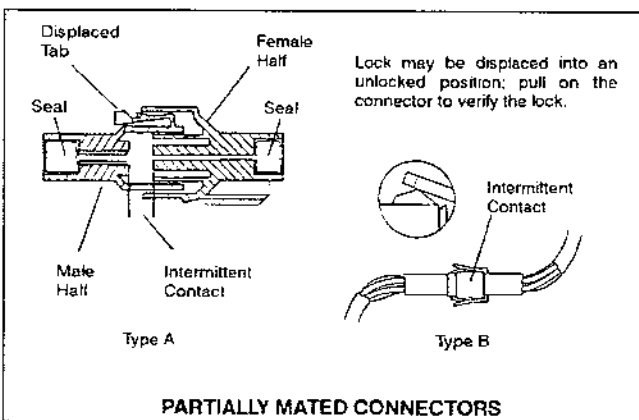
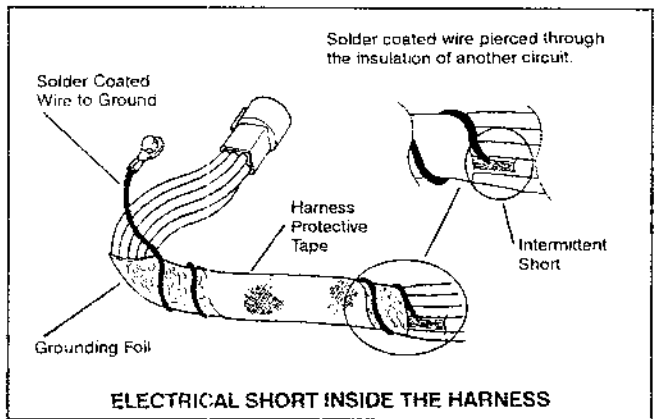
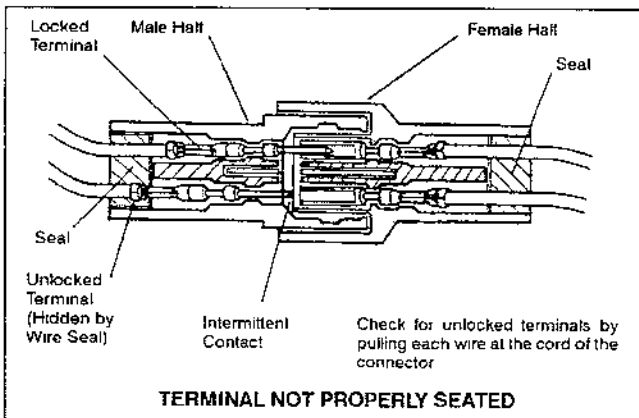
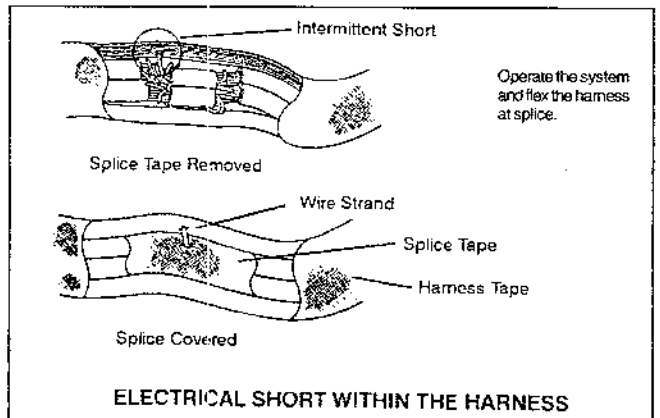
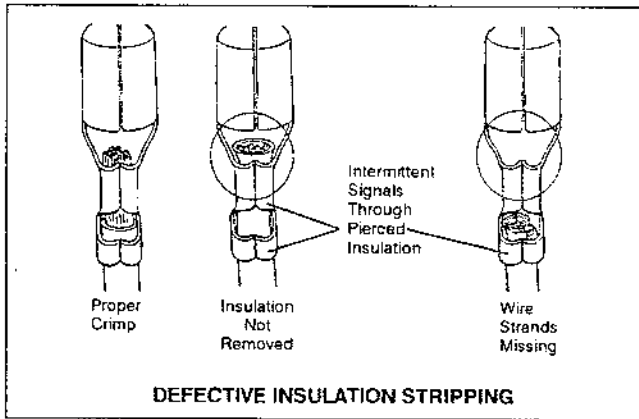
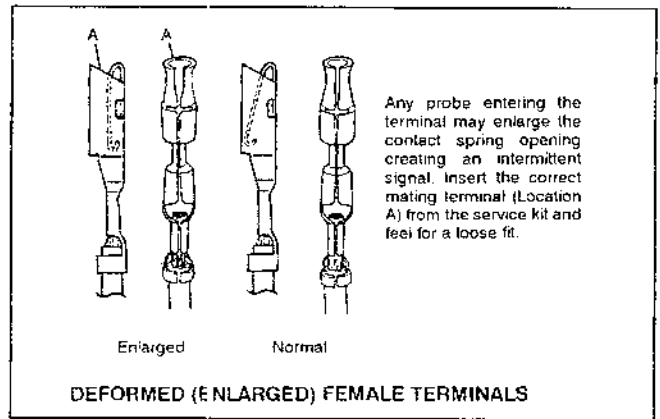

Electrical Symbols

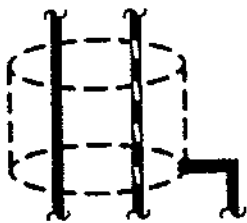

SHIELD
WIRES ARE
COVERED
BY A SHIELD



FIELD COIL



MOTOR



HEATING
ELEMENT



THERMISTOR



RHEOSTAT
OR
POTENTIOMETER



SOLENOID



SWITCH

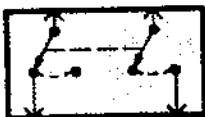

GANGED
SWITCHES
CONTACTS MOVE
AT THE SAME TIME



DIODES
CURRENT FLOWS
IN DIRECTION OF
ARROW ONLY



CAPACITOR

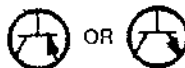

TRANSISTOR



GAUGE



LIGHT
EMITTING
DIODE
(LED)



LIGHT
BULB

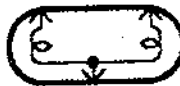

DUAL FILAMENT
LIGHT BULB

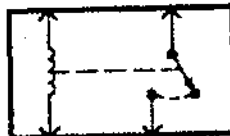

RELAY
CONTACTS
CHANGE POSITION
WITH CURRENT
THROUGH COIL



WARNING: WHEN CARRYING OUT SERVICE OPERATIONS ON AN ENGINE EQUIPPED WITH DISTRIBUTORLESS IGNITION. FOLLOW ALL THE USUAL SAFETY MEASURES TO PREVENT THE POSSIBILITY OF ELECTRIC SHOCKS SHOULD BE FOLLOWED.

NOTE: High tension voltage produced by a distributorless ignition system is higher than for a conventional ignition system. It is in excess of 55,000 Volts.

Description

The WSG-1068 engine uses a Coil On Plug Ignition System to ignite the fuel/air mixture at the correct time and sequence based upon the input it receives. The brain of this system is an Ignition Control Module (ICM). The ICM has the capability at the OEM option to protect the engine from over heating and low oil pressure. Inputs are sensors or switches that feed the ICM information.

- Engine Cylinder Head Temperature Sensor (CHT) Input.
- Camshaft Position Sensor (CMP) Input.
- Crankshaft Position Sensor (CKP) Input.
- Fuel Select Switch.

From these inputs, the ICM computes spark strategy (spark advance) and fuel mixture (air/fuel) to obtain optimum engine performance for correct load conditions.

Operation

The ignition control module needs the following information to calibrate the engine properly:

- Crankshaft position.
- Engine RPM.
- Engine temperature.
- Engine load and altitude.
- Fuel select switch.

The camshaft position sensor (CMP sensor):

- Sends the Ignition Control Module a signal indicating camshaft position used for fuel synchronization.

The crankshaft position sensor (CKP sensor):

- Sends the Ignition Control Module a signal indicating crankshaft position.
- Is essential for calculating spark timing.

The intake air temperature sensor (IAT sensor):

- Sends the ignition control module a signal indicating the temperature of the air entering the engine, but is not used on this engine.
- Resistance decreases as temperature increases.

The cylinder head temperature (CHT sensor):

- Sends a signal to the Ignition Control Module indicating the cylinder head temperature.

Overview

The Ignition System is designed to ignite the compressed air/fuel mixture in an internal combustion engine by a high voltage spark from an ignition coil. The ignition system also provides engine timing information to the ignition control module (ICM) for proper engine operation and misfire detection.

Electronic Ignition System

The Coil On Plug (COP) EI System uses a separate coil per spark plug and each coil is mounted directly onto the plug. The COP EI System eliminates the need for spark plug wires but does require input from the camshaft position (CMP) sensor. Operation of the components are as follows:

1. **Note:** Electronic Ignition engine timing is entirely controlled by the ICM. Electronic Ignition engine timing is NOT adjustable. Do not attempt to check base timing. You will receive false readings.
2. The ICM uses the CMP sensor not shown on COP EI Systems to identify top dead center of compression of cylinder 1 to synchronize the firing of the individual coils.
3. The ICM acts as an electronic switch to ground in the coil primary circuit. When the switch is closed, battery positive voltage (B+) applied to the coil primary circuit builds a magnetic field around the primary coil. When the switch opens, the power is interrupted and the primary field collapses inducing the high voltage in the secondary coil windings and the spark plug is fired. A kickback voltage spike occurs when the primary field collapses.
4. The ICM processes the CKP signal and uses it to drive the tachometer as the Clean Tach Out (CTO) signal.

Starting RPM

The program strategy requires the engine to obtain a minimum of 100-140 RPM before the ICM will allow ignition spark to be generated. Any failure with an auxiliary system can cause excessive engine crank (load) force, which may cause the engine too not reach the required starting RPM. Perform a through inspection of all auxiliary systems and components, inspect for binding hydraulic pumps and misalignment of drive systems.

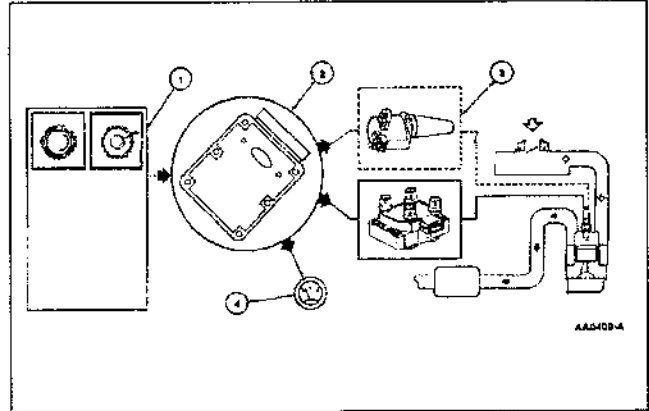

Camshaft Position Sensor

The Camshaft Position (CMP) Sensor detects the position of the camshaft. The CMP Sensor identifies when piston #1 is on its compression stroke.

The CMP Sensor is a magnetic transducer mounted on the engine front cover adjacent to the camshaft. By monitoring a target on the camshaft sprocket, the CMP sensor identifies cylinder one to the ICM. The COP EI system uses this information to synchronize the firing of the individual coils.

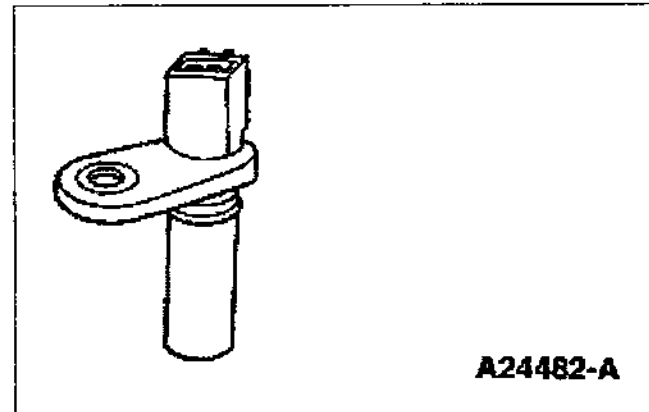

The Fuel Select Switch

In the event that the engine is operated on alternate fuels such as natural gas, compressed natural gas (CNG), or liquefied petroleum gas (LPG), timing can be modified with a Fuel Select Switch.

NOTE: Fuel select switch is supplied by the customer.

- Sends a signal to the ICM to adjust base timing for alternate fuel
- Is manually controlled.

With this system, the ICM monitors the engine load, speed, operating temperature, air intake temperature and decides what degree of spark advance is correct for all of the operating conditions. Because timing is set for life inherently in the design of the engine, and there are no moving parts in the ignition system itself, no maintenance is required except for periodic spark plug checks. The system provides for fixed spark advance at start-up, for cold weather starting, and for "average value" default settings in case of component failure. Particular attention has been given to spark optimization for excellent fuel economy and power in the warm-up mode.

The spark plugs are paired so that one plug fires during the compression stroke and its companion plug fires during the exhaust stroke. The next time that coil is fired, the plug that was on exhaust will be on compression, and the one that was on compression will be on exhaust. The spark in the exhaust cylinder is wasted but little of the coil energy is lost.

Run Mode

The ICM interprets engine speed above 100 RPM as Run Mode.

The Base Spark Advance (BSA) is calculated by the (ICM) module processing the engine speed and load plus sensors mentioned in operation of this section and Fuel Select Switch.

Inputs to the ICM Effecting the Ignition

The spark strategy is based on sensors and manifold vacuum input to the ICM module, which include the following inputs:

Crankshaft Position Sensor (CKP Sensor)

The CKP sensor is a magnetic transducer mounted on the engine block adjacent to a pulse wheel located on the crankshaft. By monitoring the crankshaft mounted pulse wheel **A**, the CKP is the primary sensor for ignition information to the ICM. The pulse wheel located behind the crankshaft pulley **B**, has a total of 39 teeth spaced 9 degrees apart with one empty space **C** for a missing tooth. An A/C voltage signal is generated which increases with engine rpm and provides engine speed and crankshaft position information to the ICM. By monitoring the pulse wheel, the CKP sensor signal indicates crankshaft position and speed information to the ICM. The CKP sensor is also able to identify piston travel in order to synchronize the ignition system and provide a way of tracking the angular position of the crankshaft relative to a fixed reference for the CKP sensor configuration. ICM also uses the CKP signal to determine if a misfire has occurred by measuring rapid decelerations between teeth.

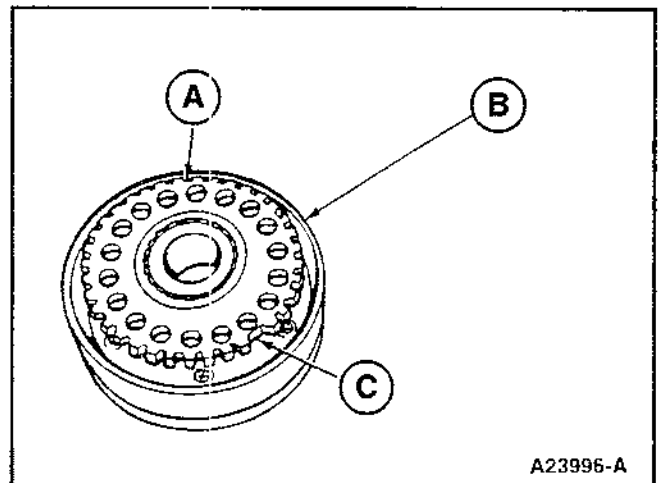

- A** Pulse Wheel (Part Crankshaft Pulley).
- B** Crankshaft Damper (Face Down) 6312.
- C** Gap in Teeth (Provides position reference for number one piston)

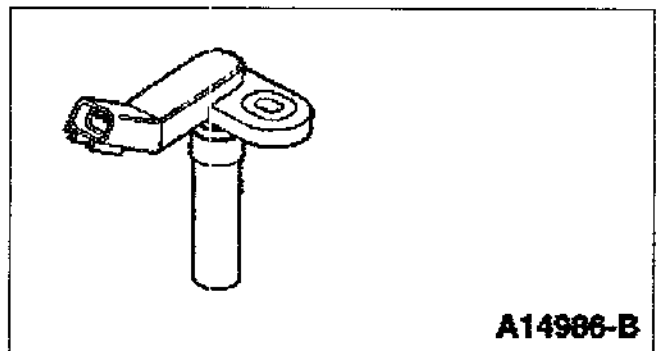

Coil On Plug

The coil on plug (COP) ignition operates similar to standard coil pack ignition except each plug has one coil per plug. COP has three different modes of operation: engine crank, engine running and CMP Failure Mode Effects Management (FMEM).

Engine Crank/Engine Running

During engine crank the ICM will fire two spark plugs simultaneously. Of the two plugs simultaneously fired one will be under compression the other will be on the exhaust stroke. Both plugs will fire until camshaft position is identified by a successful camshaft position sensor signal. Once camshaft position is identified only the cylinder under compression will be fired.

CMP FMEM

During CMP FMEM the COP ignition works the same as during engine crank. This allows the engine to operate without the ICM knowing if cylinder one is under compression or exhaust.

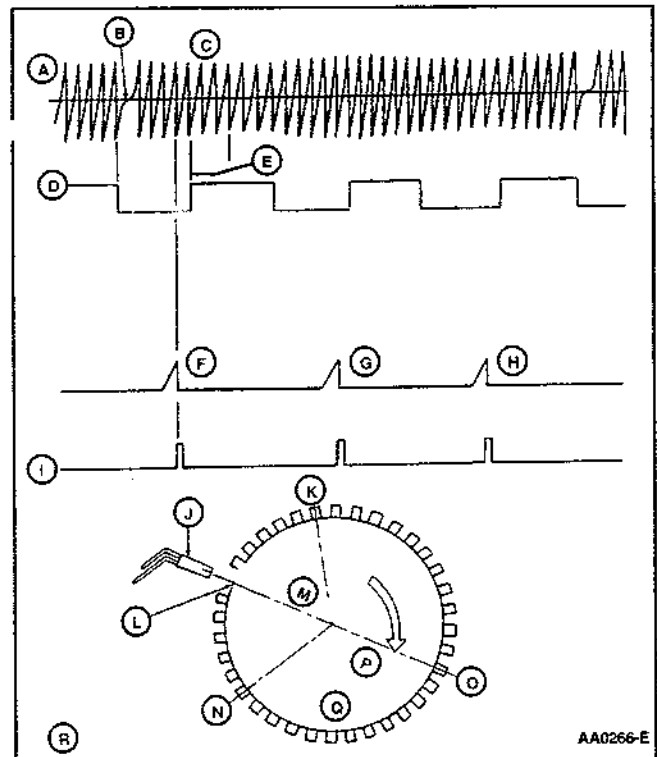
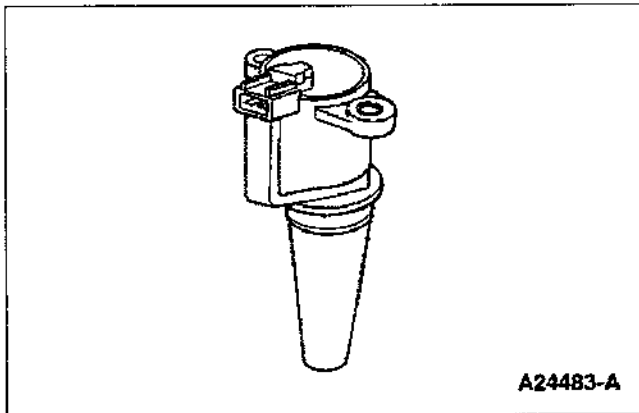

- (A) CKP Sensor
- (B) Missing Tooth 60° BTDC
- (C) TDC
- (D) Spark
- (E) 10° BTDC
- (F) Coil 1
- (G) Coil 2
- (H) Coil 3
- (I) IDM
- (J) CKP Sensor
- (K) TDC 2 and 6
- (L) Missing Tooth
- (M) 60° BTDC
- (N) TDC 1 and 5
- (O) TDC 3 and 4
- (P) 1 and 5
- (Q) Crankshaft Wheel
- (R) **Note:** This diagram does not correlate to any timing marks that may be on the engine front cover or damper.

Cranking Mode

Cranking mode is the area of engine operating speed within which the ignition timing is at a static position. The static spark advance is fixed at 10 degrees BTDC up to 250 RPM.

Transient Mode

This function is to provide a limp in mode whenever certain components fail. The engine will run but at a set timing and batch fuel delivery. This mode will stay in effect until problem is corrected or ignition turned off and back on if an intermittent problem.

Overspeed Mode

Over-speed protection is available on certain ICM modules that have set RPM limits. Refer to the ICM Replacement chart. When the module senses the engine RPM is at the preset limit, grounding of the Coil on Plugs is removed stalling the engine. The ignition must cycle from on to off and to start in order to restart the engine. Note: this strategy must be compatible with governor controllers.

Electronic Engine Controls

Refer to Section 08 of this manual.

ICM Replacement

Make sure the correct ICM part number is being installed for the appropriate engine application.

PART NUMBER	APPLICATION
1U1L-12A297-AA or YU1L-12A297-AA	Turbocharged with 2400 Overspeed Shutdown
XU1L-12A297-AB	Naturally Aspirated with 2250 Overspeed Shutdown
YU1L-12A297-CA	Naturally Aspirated with 4000 Overspeed Shutdown

Cylinder Head Temperature Sensor (CHT Sensor)

The cylinder head temperature (CHT) sensor is a thermistor device in which resistance changes with temperature. The electrical resistance of a thermistor decreases as temperature increases, and increases as temperature decreases. The varying resistance affects the voltage drop across the sensor terminals and provides electrical signals to the ICM corresponding to temperature.

Thermistor-type sensors are considered passive sensors. A passive sensor is connected to a voltage divider network so that varying the resistance of the passive sensor causes a variation in total current flow.

Voltage that is dropped across a fixed resistor in series with the sensor resistor determines the voltage signal at the ICM. This voltage signal is equal to the reference voltage minus the voltage drop across the fixed resistor.

The CHT sensor is installed in the aluminum cylinder head and measures the metal temperature. The CHT sensor communicates an overheating condition to the ICM. The ICM would then initiate a cooling strategy based on information from the CHT sensor. A cooling system failure such as low coolant or coolant loss could cause an overheating condition. As a result, damage to major engine components could occur. Using a CHT sensor and cooling strategy would prevent damage by allowing air cooling of the engine and limp home capability.

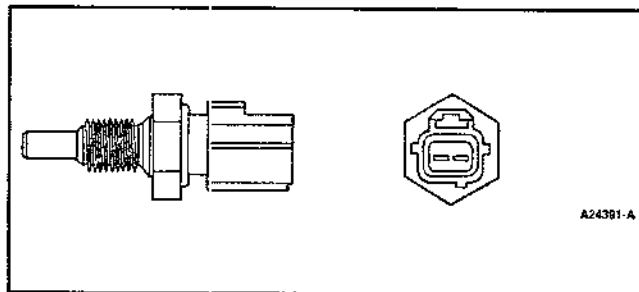

Cylinder Head Temperature (CHT) Sensor.

Starting Mode

Module enters start mode at first application of power. No spark is applied for first turn of crankshaft. Timing is fixed at 10 degrees BTDC. Dwell is fixed at 10 degrees of crankshaft rotation. Start mode remains in effect until 10 turns of the crankshaft @ 500 rpm. If drops below 500 rpm at any time, turn counter is reset. Once 10 turns are made @ 100 rpm or greater, module is set to run mode. In transitioning to run mode, calculated timing values are ramped into system during approximately 3.5 revolutions to ensure transition. Dwell is determined with a base value plus a correction factor based on system voltage.

CHT Effects

Cylinder Head Temperature (CHT) is monitored and a correction factor is applied to engine timing based on one of three 1 X 8 tables. OCT1 selects which timing table will be used for correction.

IAT Effects (Not Used)

Intake Air Temperature (IAT) is monitored and a correction factor is applied to engine timing based on one of three 1 X 8 tables. OCT1 selects which timing table will be used for correction.

Overspeed Protection

The ICM module contains an RPM limit that is set at 4000 RPM. Reaction is the module will be shut off, stalling the engine. Key must cycle from run to off to start in order to restart engine. Note: this strategy must be compatible with governor controllers.

Engine Protection

Reaction for overtemp (based on CHT input) and low oil pressure (based on oil pressure switch input) the module will be shut off, stalling the engine. Key must cycle from run to off to start in order to restart engine. Engine protection becomes active after 240 crankshaft revolutions and when 800 rpm is exceeded. The purpose of having to meet these conditions provides an opportunity for the engine to restart if the failure still exists which caused the engine to stall. Over temperature reaction is experienced when temperature reaches 250°F. Low oil pressure reaction is experienced when oil pressure drops below 6 psi +/- 1.5 psi. Oil pressure switch position is normally open when engine is off.

Starter Lockout

Starter lockout relay control open drain (ICM switch to ground). Activated once engine is in the run mode and has reached 600 RPM. Will not allow start until ignition voltage to ICM module is switched off and back on.

Tachometer Output

Tachometer output will be from auxiliary output #2, which is accessed through the five pin connector terminal E. The pulses per revolution will be determined by the number of cylinders the ICM will control. The four cylinder ICM will output 2 pulses per revolution, the six cylinder ICM output 3 pulses per revolution, the eight cylinder output 4 pulses per revolution, and the ten cylinder 5 pulses per revolution. The intention of this is to allow for use of a conventional tachometer from this output.

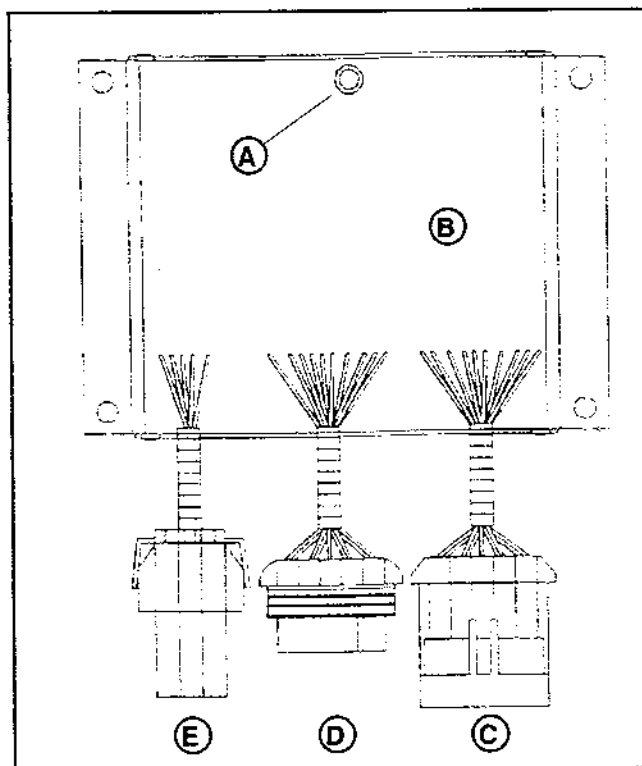

Ignition Control Module (ICM):

- A** Vacuum port (5/32" I.D.) MAP Sensor
- B** Ignition Control Module (ICM)
- C** Connector C4 (10 pin connector)
- D** Connector C2 (10 pin connector)
- E** Connector C3 (5 pin connector)

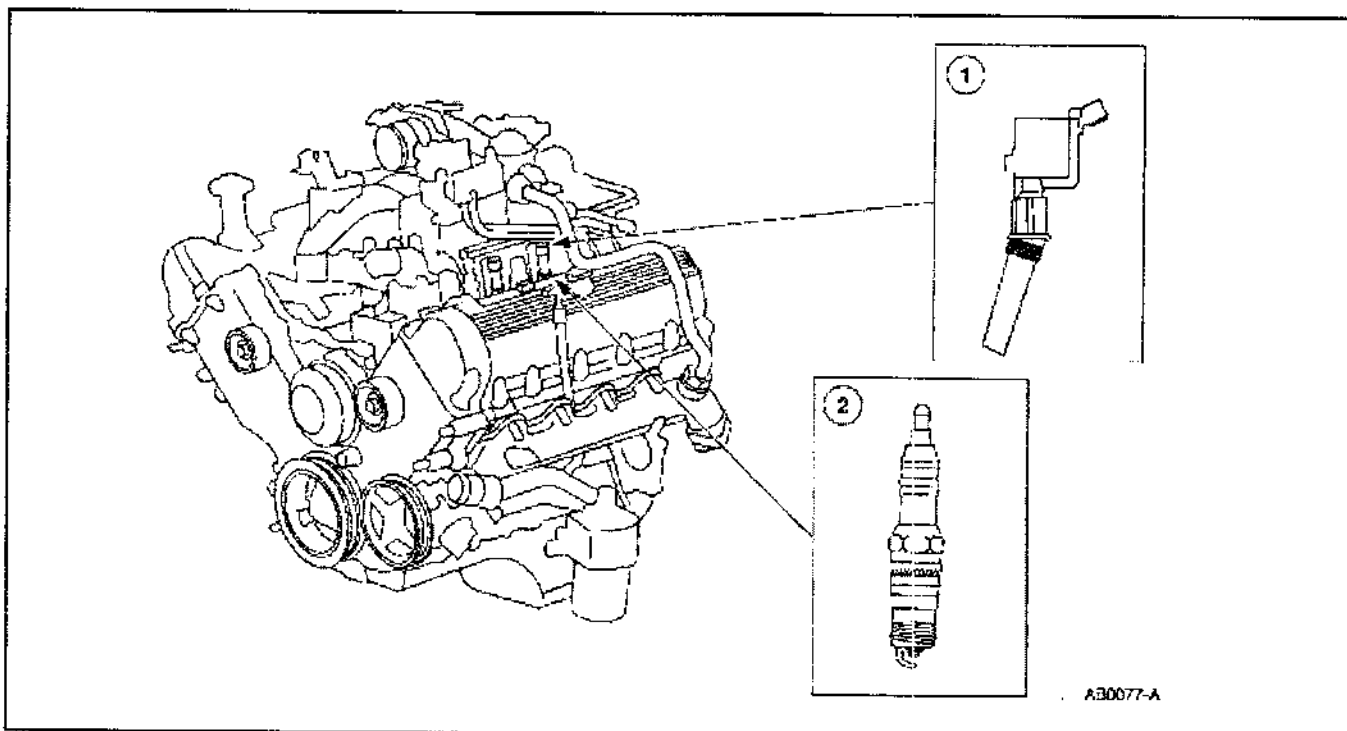
Ignition System - Components Location**1 Ignition Coil (12029)****2 Spark Plug (12405)**

The 6.8L engine is equipped with a coil on plug ignition system. This system has a separate ignition coil mounted on each spark plug. Operation of the coils is controlled by ignition control module (ICM), which computes ignition timing based on inputs from the electronic engine control system sensors. For additional information on sensor inputs related to ignition control; refer to Section 08.

The ignition coils change a supplied low voltage signal into high voltage pulses to the spark plugs. The ignition control module controls the low side of each coil.

The ignition system is set for base timing at 10 degrees before top dead center (BTDC) and is not adjustable.

Refer to Specifications for firing order.

Firing Order

Coil / Cylinder #1 - 5

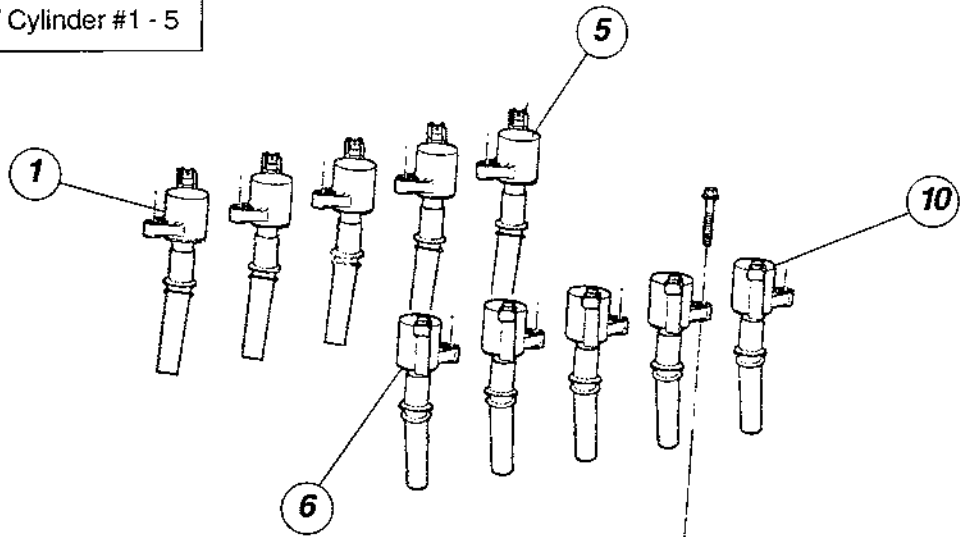

Coil / Cylinder #6 - 10

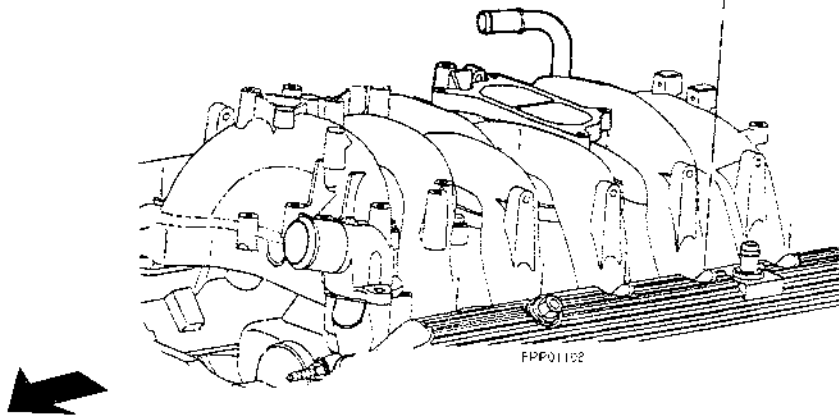

Ignition Coil-On Plug - Removal

1. Disconnect the wiring at the coil.

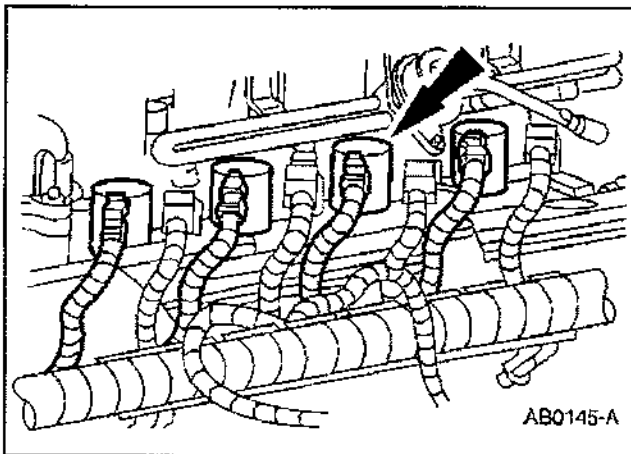

2. Remove the bolt and the coil.

Ignition Coil-On Plug - Installation



WARNING: ALWAYS WEAR SAFETY GLASSES TO PROTECT EYES FROM FLYING FOREIGN MATERIAL.

1. NOTE: Remove any foreign material from spark plug wells with compressed air.
2. Insert a small amount of dielectric grease into each boot using Motorcraft Silicone Brake Caliper Grease and Dielectric Compound XG-3 or equivalent meeting Ford specification ESE-M1C171-A.

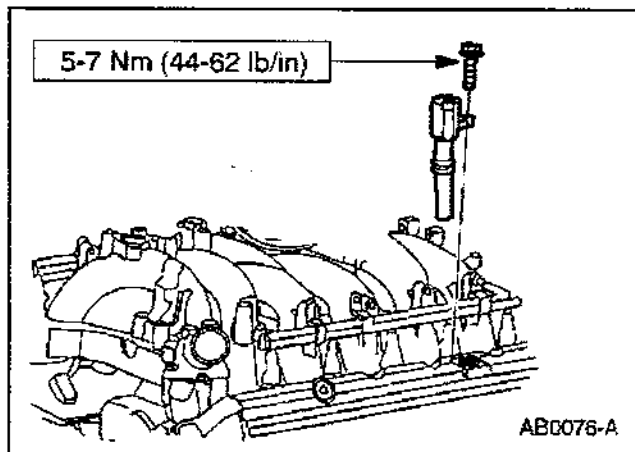

To install, reverse the removal procedure.

Harness Connector Pinout Description

<i>ICM Connector C4 (10 Pin) Terminals</i>			
<i>I/O</i>	<i>Conn</i>	<i>Pin</i>	<i>Description</i>
<i>I</i>	<i>Main</i>	<i>A</i>	<i>Coil #1</i>
<i>I</i>	<i>Main</i>	<i>B</i>	<i>Coil #7</i>
<i>I</i>	<i>Main</i>	<i>C</i>	<i>Coil #6</i>
<i>I</i>	<i>Main</i>	<i>D</i>	<i>Coil #3</i>
<i>I</i>	<i>Main</i>	<i>E</i>	<i>Coil #5</i>
<i>I</i>	<i>Main</i>	<i>F</i>	<i>Coil #3</i>
<i>I</i>	<i>Main</i>	<i>G</i>	<i>Coil #10</i>
<i>I</i>	<i>Main</i>	<i>H</i>	<i>Coil #4</i>
<i>I</i>	<i>Main</i>	<i>J</i>	<i>Coil #2</i>
<i>I</i>	<i>Main</i>	<i>K</i>	<i>Coil #9</i>

I/O = Input / Output

Octane Select Operation

OCT1: Used to select ignition table for fuel type.
Input can be B+. Fuel choices are LPG or Natural Gas.

OCT2: Used to choose constant to add or subtract from selected timing table.

TABLE 3: Operation of ICM

Full Select Operation		
Fuel	OCT1 Circuit 674 (BR-W)	Timing Effect
<i>LPG</i>	<i>Ground</i>	<i>Base LPG</i>
<i>NG</i>	<i>12V</i>	<i>Base NG</i>
<i>NG</i>	<i>Open</i>	<i>Base NG</i>

DIAGNOSIS AND TESTING

Service Adjustments And Checks

1. Each 400 hours of engine operation remove the spark plugs and clean and adjust the electrode.
2. Clean and visually check each coil-on plug connectors, check for secure fit.

Diagnostic Equipment

To accurately diagnose Coil on Plug (COP), certain diagnostic equipment and tools are required. In addition, the suggested diagnostic equipment may make the job easier and more convenient.

Prior to diagnosing COP, obtain the following test equipment or equivalent.

- Spark tester, neon bulb type (Champion CT-436).
- Spark tester, gap type (special service tool D81P-6666-A).

Connect this gap type spark tester between any COP and engine ground to instantly determine if spark is being provided to the plug. A spark plug with a broken side electrode is not sufficient to check for spark and may lead to incorrect results.

- Volt-ohmmeter (Rotunda 73111 Automotive Meter 105-R0057 or equivalent).

A volt-ohmmeter is essential for gathering system operating data during diagnosis, testing, and engine servicing procedures. This digital volt ohmmeter (DVOM) can also be used for general purpose electrical troubleshooting on conventional starting and charging systems.



CAUTION: There should be no wires spliced to the main wire harness for source of power or RPM signal unless pre-approved by Ford Power Products. Otherwise, any alteration will void the warranty. Altering of wire harness may cause lack of power, no start, or erratic running.

NOTE: When using the spark plug firing indicator, place the grooved end as close as possible to the plug boot. Very weak or no flashing may be caused by a fouled plug.

NOTE: Do not use an incandescent test lamp to check CKPS- or CKPS+ circuits. The lamp will prevent the circuit from operating.

Preliminary Checks

Before using this section verify the customer complaint and refer to the appropriate symptom chart. Perform the procedure included in the symptom chart.

Basic Circuit Checks

Basic circuit checks help to minimize pinpoint test steps by providing a procedure to diagnose harness faults associated with the Electronic Engine Control (EC) System. The following techniques provide helpful reminders for diagnosing open circuits (continuity), shorts to ground and shorts to power.

NOTE:

- The suspect circuit must be isolated before testing.
- When disconnecting any harness connector, always inspect for damaged or pushed out pins, corrosion and loose wires. Repair as necessary.
- The digital multimeter must be set to the correct scale.
- The techniques do not apply in all situations, therefore, it is necessary to follow each pinpoint test step accurately and completely.
- General resistance and voltage values are specified below. Always use the pinpoint test values if they differ.
- Always turn the key to the OFF position unless directed otherwise by the pinpoint test.

Each of the following procedures will require the Ignition Control Module (ICM) and component to be disconnected to isolate the harness.

Open Circuit (Continuity)

Disconnect ICM. Measure the harness resistance between the suspect circuit at the harness connector and the appropriate ICM harness connector pin. The resistance must be less than 5.0 ohms.

Shorts to Ground

Measure the harness resistance between the suspect circuit at the harness connector and a reliable ground (B+, chassis ground or PWR GND). The resistance must be greater than 10,000 ohms.

Shorts to Power

Key ON to power up circuit. Measure voltage between the suspect circuit at the harness connector and a reliable ground. The voltage must be less than 1.0 volt.

Visual/Physical Check

Several of the symptom procedures call for a careful visual/physical check. This can often lead to repairing a problem without performing unnecessary steps. Use the following guidelines when performing a visual/physical check:

Inspect unit for modifications or aftermarket equipment that can contribute to symptom, verify that all electrical and mechanical loads or accessory equipment is "OFF" or disconnected before performing diagnosis.

- Inspect engine fluids for correct levels and evidence of leaks.
- Inspect vacuum hoses for damage, leaks, cracks, kinks and improper routing, inspect intake manifold sealing surface for a possible vacuum leak.
- Inspect all wires and harnesses for proper connections and routing, bent or broken connector pins, burned, chafed, or pinched wires, corrosion, and verify harness grounds are clean and tight.
- Inspect ignition control module (ICM), sensors and actuators for physical damage.
- Inspect fuel system for adequate fuel level, and fuel quality (concerns such as proper fuel pressure and contamination).
- Inspect intake air system and air filter for restrictions.

Intermittent Problems

Most intermittent problems are caused by faulty electrical connections or wiring. Perform a careful visual/physical check for the following conditions:

- Poor mating of the connector halves or a terminal not fully seated in the connector (backed out).
- Improperly formed or damaged terminals.
- Improper contact tension. All connector terminals in the problem circuit should be carefully checked.
- Poor terminal-to-wire connections. This requires removing the terminal from the connector body to check.
- Improperly installed aftermarket equipment or accessories.

Operate the engine with accessories "OFF" and a suitable multimeter connected to the suspected circuit. An abnormal voltage when the malfunction occurs is a good indication that there is a fault in the circuit being monitored.

Main Jumper Connector C1-M (XU1L-14324-BB)

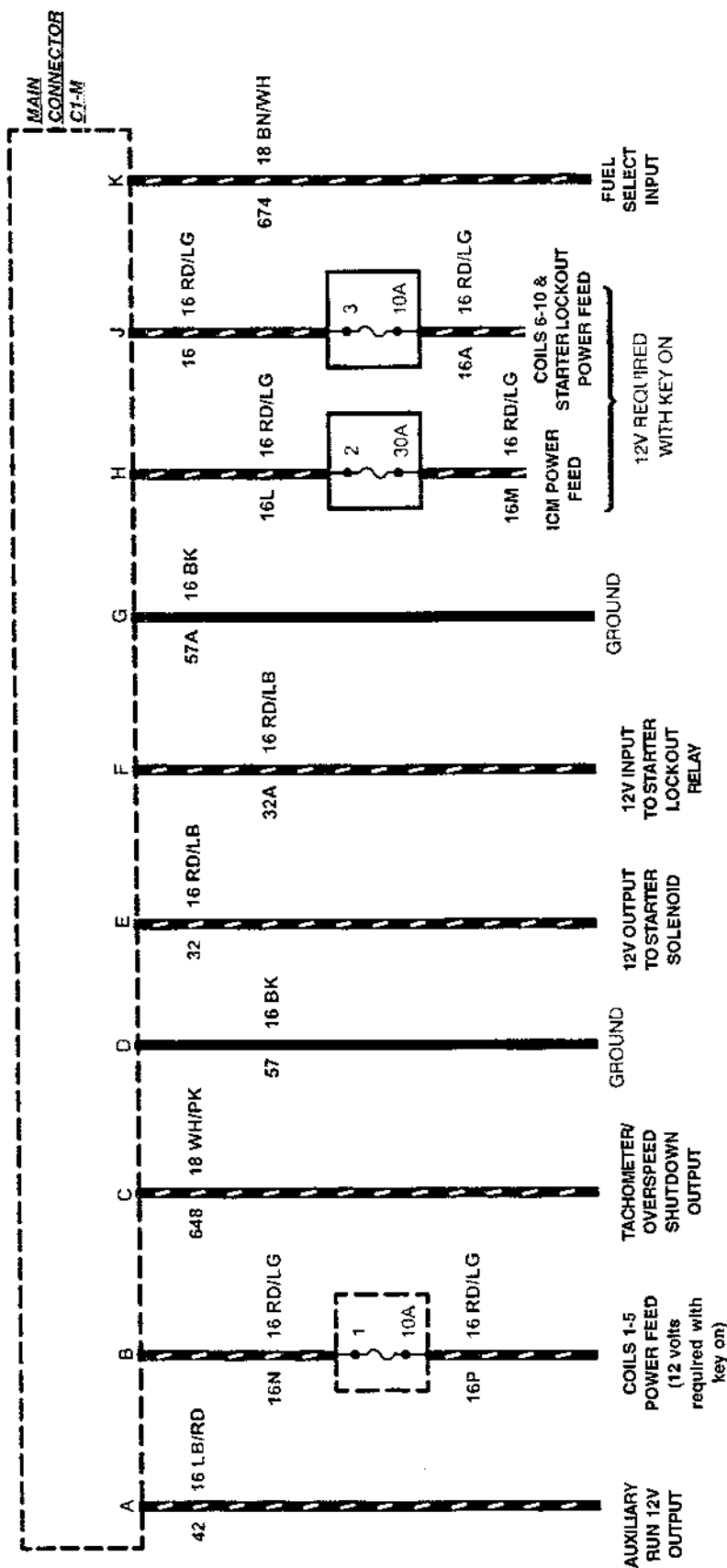

Ignition/Starter Lockout (part of SK2U1L-12A200-BA)

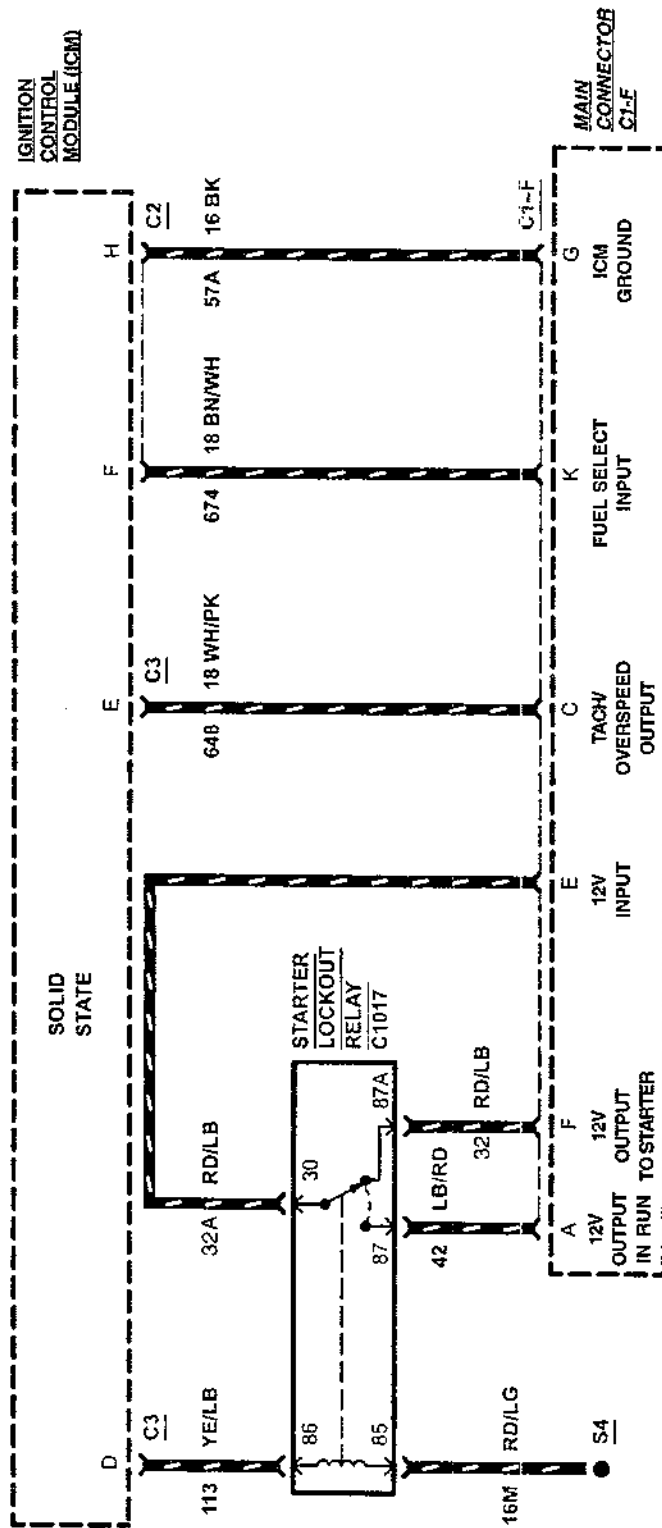

WSG-1068 IGNITION SYSTEM

Engine Controls (part of SK2U1L-12A200-BA)

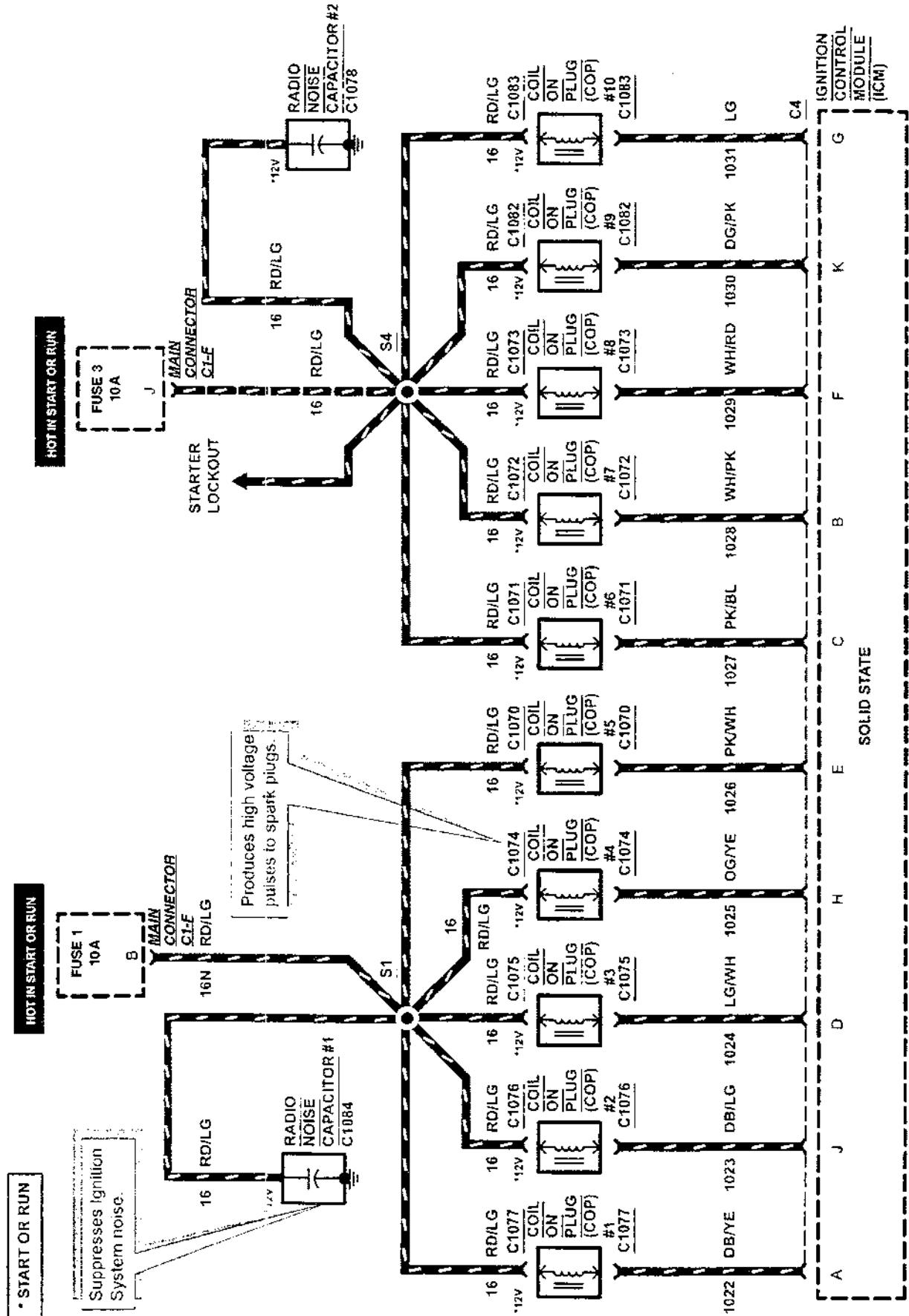

Engine Sensors (part of SK2U1L-12A200-BA)

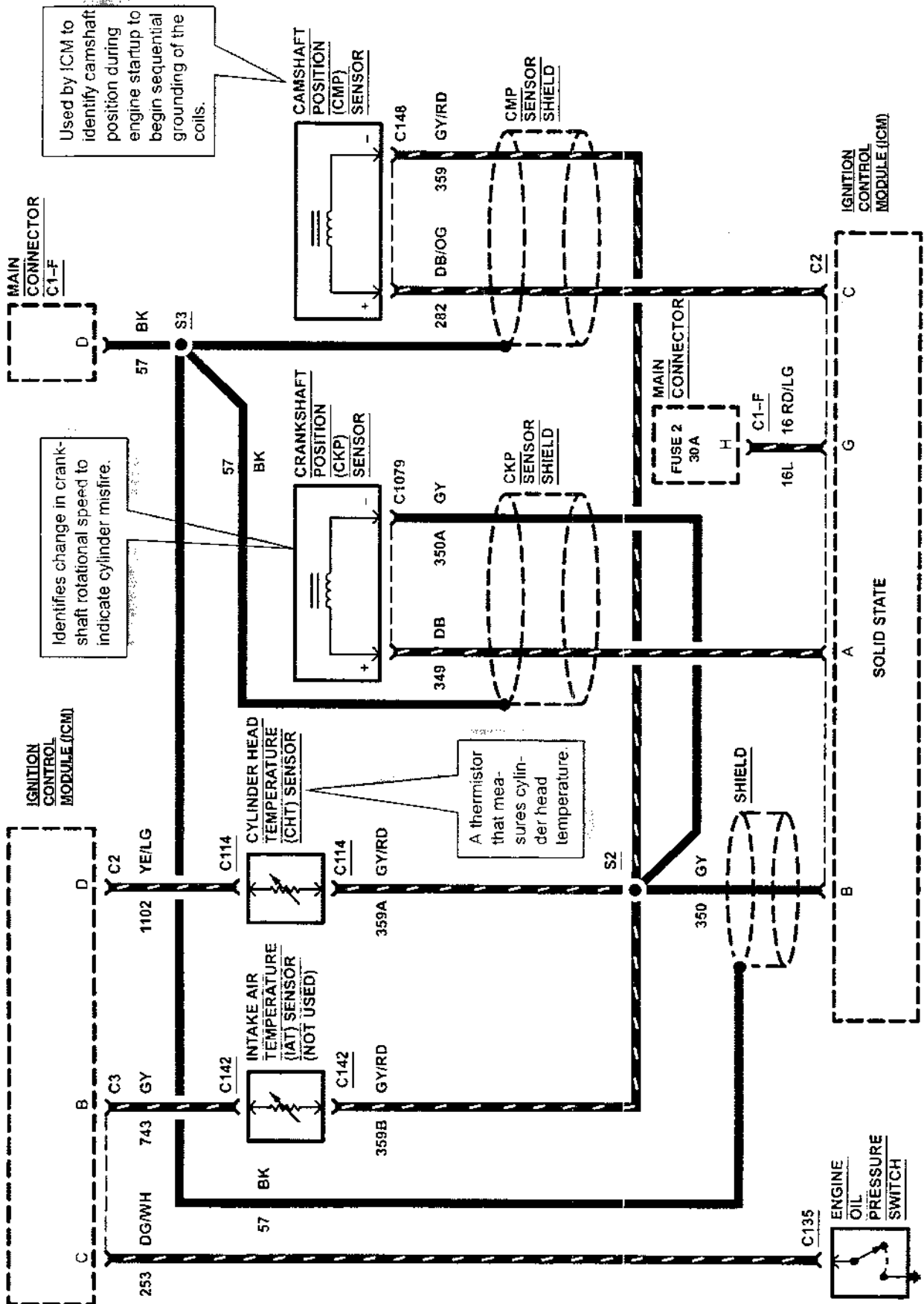

Engine Harness Connectors

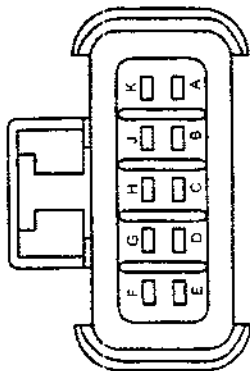

C1-F
Engine Harness 10 Pin Connector
12A200-CG

PIN	CIRCUIT	CIRCUIT FUNCTION
A	42 (LB/RD)	12V Run Output (above 600 RPM)
B	16N (RD/LG)	Coils 6 - 10 and Starter Lockout Power
C	648 (WH/PK)	Tachometer/Overspeed Shutdown Output
D	57 (BK)	Ground
E	32 (RD/LB)	Lockout Relay Power to Starter
F	32A (RD/LB)	12V in Start Position
G	57A (BK)	Ground
H	16L (RD/LG)	12V ICM Power with Key On
J	16 (RD/LG)	12V Coils 1 - 5 Power with Key On
K	674 (BR/WH)	Fuel Select Input

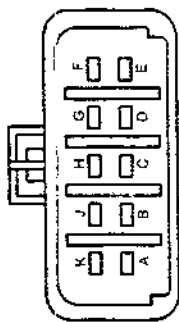

C1-M
Jumper Harness 10 Pin Connector
14324-BB

PIN	CIRCUIT	CIRCUIT FUNCTION
A	42 (LB/RD)	12V Run Output (above 600 RPM)
B	16N (RD/LG)	12V Required with Key On
C	648 (WH/PK)	Tachometer/Shutdown Output
D	57 (BK)	Ground
E	32 (RD/LB)	12V Output to Starter
F	32A (RD/LB)	12V in Start Position
G	57A (BK)	Ground
H	16L (RD/LG)	12V Required with Key On
J	16 (RD/LG)	12V Required with Key On
K	674 (BR/WH)	Fuel Select Input

ICM Connectors

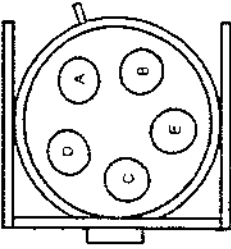
 <p>C3 ICM 5 PIN CONNECTOR</p>		
PIN	CIRCUIT	CIRCUIT FUNCTION
A	-	NOT USED
B	743 (GY)	IAT Sensor (NOT USED)
C	253 (DG/WH)	Oil Pressure Switch Input
D	113 (YE/LB)	Starter Lockout
E	648 (WH/PK)	Aux. Out 2/ Overspeed Ground

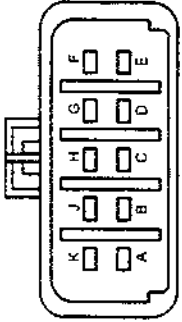
 <p>C2 ICM 10 PIN CONNECTOR</p>		
PIN	CIRCUIT	CIRCUIT FUNCTION
A	349 (DB)	Crank Position Sensor Input
B	350 (GY)	Signal Return (-)
C	282 (DB/OG)	Cam Sensor (+) 5V
D	1102 (YE/LG)	Cylinder Head Temp Sensor (+) 5V
E	-	NOT USED
F	674 (BN/WH)	Fuel Select Input
G	16L (RD/LG)	Power (+) 12V Input
H	57A (BK)	Ground
J	-	NOT USED
K	-	NOT USED

ICM Connectors

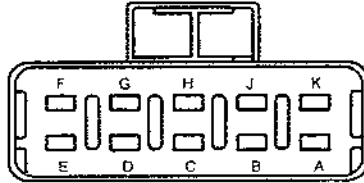

C4
ICM 10 PIN CONNECTOR

PIN	CIRCUIT	CIRCUIT FUNCTION
A	1022 (DB/YE)	Coil #1 Grounding
B	1028 (WH/PK)	Coil #7 Grounding
C	1027 (PK/BU)	Coil #6 Grounding
D	1024 (LG/WH)	Coil #3 Grounding
E	1026 (PK/WH)	Coil #5 Grounding
F	1029 (WH/RD)	Coil #8 Grounding
G	1031 (LG)	Coil #10 Grounding
H	1025 (OG/YE)	Coil #4 Grounding
J	1023 (DB/LG)	Coil #2 Grounding
K	1030 (DG/P)	Coil #9 Grounding

Recommended Wiring - MS-2U1L-3458-BA

NOTE: Finished wire from the CUSTOMER SUPPLIER

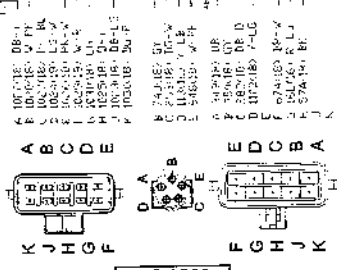
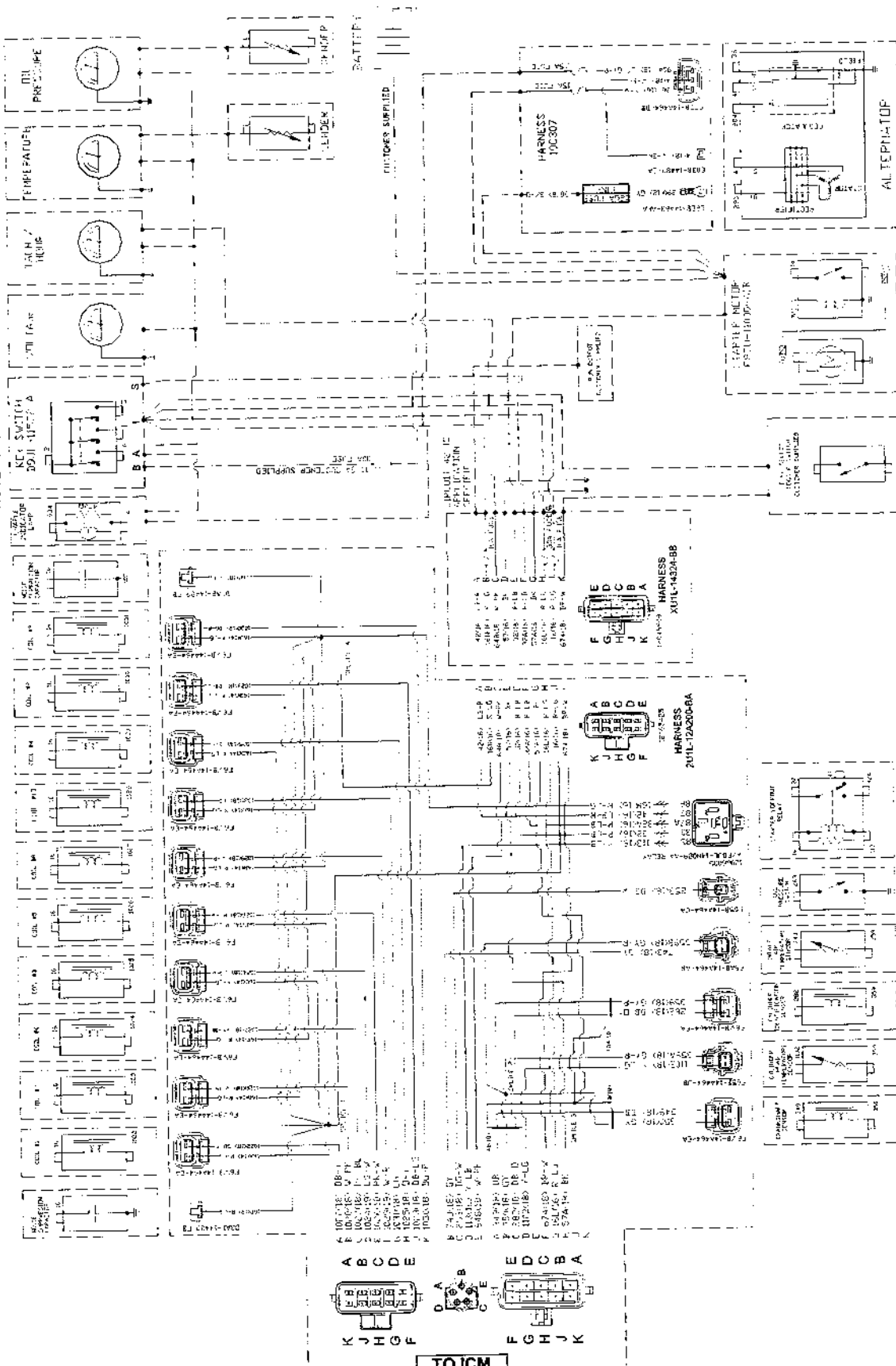

Pinpoint Test A - Ignition Check

The ignition system check will verify the required inputs and outputs recommended by Ford Power Products. Always locate and inspect all power, ground and terminal connections prior to the start of this test, as failures and corrosion associated with these areas can adversely affect the engine to start properly.

Inspection and Verification

1. Visually inspect for obvious signs of mechanical and electrical damage.
2. Visually inspect for and note auxiliary system connections not shown on the **recommended wiring schematic**.

Step	Action	Values	Yes	No
1	<ol style="list-style-type: none"> 1. Key Off, Engine Off. 2. Inspect the battery for clean and tight battery positive and negative connections. 3. Using an ohmmeter, measure the voltage across the battery posts. <p>Is the voltage within the specified value?</p>	12.53 Volts	GO to Step 2	Recharge the battery. TEST the system for normal operation.
2	<ol style="list-style-type: none"> 1. Disconnect the Battery Positive cable from the battery and the starter B+ post. 2. Using an ohmmeter, measure the resistance between the terminal ends of the cable. <p>Is the resistance within the specified value?</p>	Less than 5 Ohms	GO to Step 3	Replace the Battery Positive Cable and RETEST
3	<ol style="list-style-type: none"> 1. Disconnect the Battery Negative cable from the battery. 2. Using an ohmmeter, measure the resistance between the terminal ends of the cable. <p>Is the resistance within the specified value?</p>	Less than 5 Ohms	GO to Step 4	Replace the Battery Negative Cable and RETEST
4	<ol style="list-style-type: none"> 1. Key Off, Engine Off. 2. Inspect the starter B+ terminal for a clean and tight connection. 3. Using an ohmmeter, measure the voltage at the starter B+ terminal <p>Is the voltage within the specified value?</p>	Battery Voltage	GO to Step 5	REPAIR the circuit(s) in question. TEST the system for normal operation.
5	<ol style="list-style-type: none"> 1. KOEO. 2. Using an ohmmeter, measure the voltage at the ignition switch B terminal. <p>Is the voltage within the specified value?</p>	Battery Voltage	GO to Step 6	Inspect or Replace the 30A fuse. REPAIR the circuit(s) in question. TEST the system for normal operation.
6	<ol style="list-style-type: none"> 1. KOEO. 2. Using an ohmmeter, measure the voltage at the ignition switch I terminal. <p>Is the voltage within the specified value?</p>	Battery Voltage	GO to Step 7	Remove and Replace the Ignition Switch And Retest

WSG-1068 IGNITION SYSTEM

Step	Action	Values	Yes	No
7	1. Inspect the throttle plate. 2. Verify that the throttle plate is moving during crank. Is the throttle plate moving?		Return to Symptom Chart	Refer to the Fuel Systems Manufacturing Information and Test

INDEX



Subject	Page
General Information	
System Operation - LPG	04- 3
System Operation - Natural Gas	04- 4
Diagnosis and Testing	
Pinpoint Test A - Fuel Pressure Check	04- 5



NOTE: For further information on Servicing the fuel system, refer to Manufacturer's Service Information.

GENERAL INFORMATION

System Operation – LPG

	WARNING:	
<p>WHEN INSTALLING ANY LIQUID PETROLEUM GAS/FUEL SYSTEMS, FOLLOW ALL COUNTRY AND LOCAL CODES.</p> <p>IN THE USA FOLLOW ALL REGULATIONS AND STANDARDS MANDATED BY THE NATIONAL FIRE PROTECTION ASSOCIATION, INC. INCLUDING NEPA 37, NFPA 52, AND NFPA 58, PLUS ANY OTHER STANDARDS. YOU CAN OBTAIN COPIES FROM YOUR LOCAL FIRE DEPARTMENT.</p> <p>FOR CANADIAN CODES SEE NATIONAL STANDARDS OF CANADA.</p> <p>IN THE UNITED KINGDOM FOLLOW THE CODE OF PRACTICE ELEVEN PRODUCED BY THE LPG/NG ASSOCIATION.</p>		

Since your LPG & NG units are not purchased through Ford Power Products, they are not calibrated specifically to your application. It is a requirement that each of these units are calibrated by the customer within the acceptable limits provided by Ford Power Products Engineering.

Development testing is underway to provide the customer with appropriate guidelines to successfully calibrate their LPG & NG fuel systems. Recommendations may include but are not limited to: air-fuel ratios, exhaust temperatures, and mixer/regulator orientation.



High pressure liquefied Petroleum Gas passes through a solenoid operated fuel shut-off valve into an engine coolant heated vaporizer/regulator unit where it is converted into a low pressure gas. This gas is then fed into the carburetor body/mixer where a vacuum operated gas metering valve ensures that the correct air-to-fuel ratio is maintained.

When the engine is switched off, the electrical supply to the fuel shut-off solenoid is disconnected and the valve closes, cutting off the high pressure fuel supply to the vaporizer/regulator. The electrical supply to fuel shut-off valve passes through a vacuum operated safety switch. Should the engine stall, the vacuum switch opens and cuts off the electrical supply to the fuel shut-off valve. When starting the engine, there is sufficient vacuum present, even at cranking speed, to close the safety switch.

FUEL SYSTEMS – FIELD CALIBRATIONS/GENERAL

When performing field calibrations on LPG & NG systems, it should be noted that improper fuel calibrations and/or improper hardware installation may result in decreased durability/life of the cylinder head valve train. Validation testing on the valve train was conducted in a controlled laboratory environment with proper air-fuel distribution and proper air-fuel ratios which fall within acceptable ranges.

System Operation – Natural Gas

	WARNING:	
<p>WHEN INSTALLING ANY NATURAL GAS/FUEL SYSTEMS, FOLLOW ALL COUNTRY AND LOCAL CODES.</p> <p>IN THE USA FOLLOW ALL REGULATIONS AND STANDARDS MANDATED BY THE NATIONAL FIRE PROTECTION ASSOCIATION, INC. INCLUDING NEPA 37, NFPA 52, AND NFPA 58, PLUS ANY OTHER STANDARDS. YOU CAN OBTAIN COPIES FROM YOUR LOCAL FIRE DEPARTMENT.</p> <p>FOR CANADIAN CODES SEE NATIONAL STANDARDS OF CANADA.</p> <p>IN THE UNITED KINGDOM FOLLOW THE CODE OF PRACTICE ELEVEN PRODUCED BY THE LPG/NG ASSOCIATION.</p>		

sufficient vacuum present, even at cranking speed, to open the fuel shut-off valve.

The system is similar to the LPG system, except a convertor (vaporizer) is not used, and the coolant connections are also not needed. A regulator is required and must be supplied by the OEM to suit the mains gas supply pressure.

Natural gas passes through a vacuum operated fuel shut-off valve into a regulator unit where it is converted into a low pressure gas. This gas is then fed into the mixer where a vacuum operated gas metering valve ensures that the correct air-to-fuel ratio is maintained.

When the engine is switched off, vacuum supply to the fuel shut-off vacuum is disconnected and the valve closes, cutting off the fuel supply to the regulator.

Should the engine stall, the loss of vacuum will close the fuel shut-off valve. When starting the engine, there is

DIAGNOSIS AND TESTING

Pinpoint Test A - Fuel Pressure Check

Inspection and Verification

1. Visually inspect for obvious signs of mechanical and electrical damage.
2. Visually inspect for and note auxiliary system connections not shown on the **Recommended Customer Connections Wiring Schematic**.

Normal Operation

Fuel pressure is customer supplied. The following test is a generalized procedure, which should be completed prior to all test.

Step	Action	Values	Yes	No
1	<ol style="list-style-type: none"> 1. Key Off, Engine Off 2. Check the fuel supply line and shut-off valve for proper operation. <p>Is the fuel supply line in the open position and the shut-off valve operating properly?</p>		GO to Step 2	Repair or replace any inoperative component and Retest
2	<ol style="list-style-type: none"> 1. Check the fuel system pressure. <p>Is the fuel supply pressure within the specified value?</p>	LPG: System Pressure CNG: 120-150 psi NG: 15" of water column	GO to Step 3	Correct fuel pressure and Retest
3	<ol style="list-style-type: none"> 1. Note: This test may require an assistant depending on the application. 2. Key Off. 3. Hold the fuel lockout device. 4. Key On. 5. Vacuum controlled fuel lockout units require the engine to be cranked. <p>Does the fuel lockout unit open?</p>		GO to Step 7	For electric lockout units GO to Step 4 For Vacuum controlled units GO to Step 6
4	<ol style="list-style-type: none"> 1. Disconnect the fuel lockout unit connector. 2. KOEO 3. Check for battery voltage. <p>Is battery voltage present?</p>		GO to Step 5	REPAIR the circuit(s) in question. TEST the system for normal operation.
5	<ol style="list-style-type: none"> 1. Key Off 2. Check the other side of the fuel lockout connector pin for continuity to a known good ground. <p>Is the resistance less than 5 ohms?</p>		Check for fuel line blockage Refer to the Fuel Systems Manufacturing Information and Test	Is the resistance less than 5 Ohms?
6	<ol style="list-style-type: none"> 1. Key Off 2. Inspect all vacuum hoses for damage. 3. Disconnect the vacuum hose to the fuel lockout unit. 4. Using a manual vacuum tester, connect to the lockout unit. 5. While holding the lockout device apply vacuum to the fuel lockout unit. <p>Does the lockout device hold vacuum and is fuel present?</p>		Go to Step 7	Refer to the Fuel Systems Manufacturing Information and Test

Step	Action	Values	Yes	No
7	1. Inspect the throttle plate. 2. Verify that the throttle plate is moving during crank. Is the throttle plate moving?		Return to Symptom Chart	Refer to the Fuel Systems Manufacturing Information and Test

INDEX

Subject	Page
General Information	
Engine Cooling	05 - 3
Coolant Flow	05 - 4
Coolant	05 - 4
Recycled Coolant	05 - 4
Unsatisfactory Coolant Materials	05 - 4
General Service Procedures	
Cooling System Draining	05 - 5
Cooling System Filling	05 - 7
Drive Belt Routing	05 - 9
Cooling System Flushing	05 - 9
Removal and Installation	
Radiator Hose - Removal	05 - 10
Radiator Hose - Installation	05 - 10
Thermostat - Removal	05 - 10
Thermostat - Installation	05 - 10
Removal of Heater Water Inlet Tube	05 - 11
Installation of Water Heater Return Tube Assembly with by-pass Hose	05 - 11
Cylinder Head Temperature (CHT) Sensor - Replacement	05 - 12
Fan Drive Belt - Removal & Installation	05 - 12
Belt Tensioner - Removal	05 - 13
Belt Tensioner - Installation	05 - 13
Belt Idler Pulley - Removal	05 - 14
Belt Idler Pulley - Installation	05 - 14
Water Pump - Removal	05 - 15
Water Pump - Installation	05 - 15
Diagnosis and Testing	
Visual Inspection	05 - 17
Cooling System Visual Test	05 - 18
Thermostat Test - Thermostat Removed	05 - 19
Radiator Leak Test, Removed from Vehicle	05 - 20
Engine Cylinder Head Temperature (CHT) Sensor	05 - 20
V-Ribbed Serpentine Drive Belt	05 - 22
Drive Belt Symptom Chart	05 - 22
Drive Tensioner / Belt Length Indicator	05 - 23
Drive Belt Misalignment	05 - 23
Visual Inspection Chart	05 - 24
Inspection and Verification	05 - 24
Symptom Chart	05 - 24
Pinpoint Test A: Loss of Coolant	05 - 25
Pinpoint Test B: The Engine Overheats	05 - 27
Pinpoint Test C: The Engine Does Not Reach Normal Operating Temperature	05 - 30

INDEX (CONT.)

Subject	Page
Specifications	
General Specifications	05 - 31
Torque Specifications	05 - 31

GENERAL INFORMATION

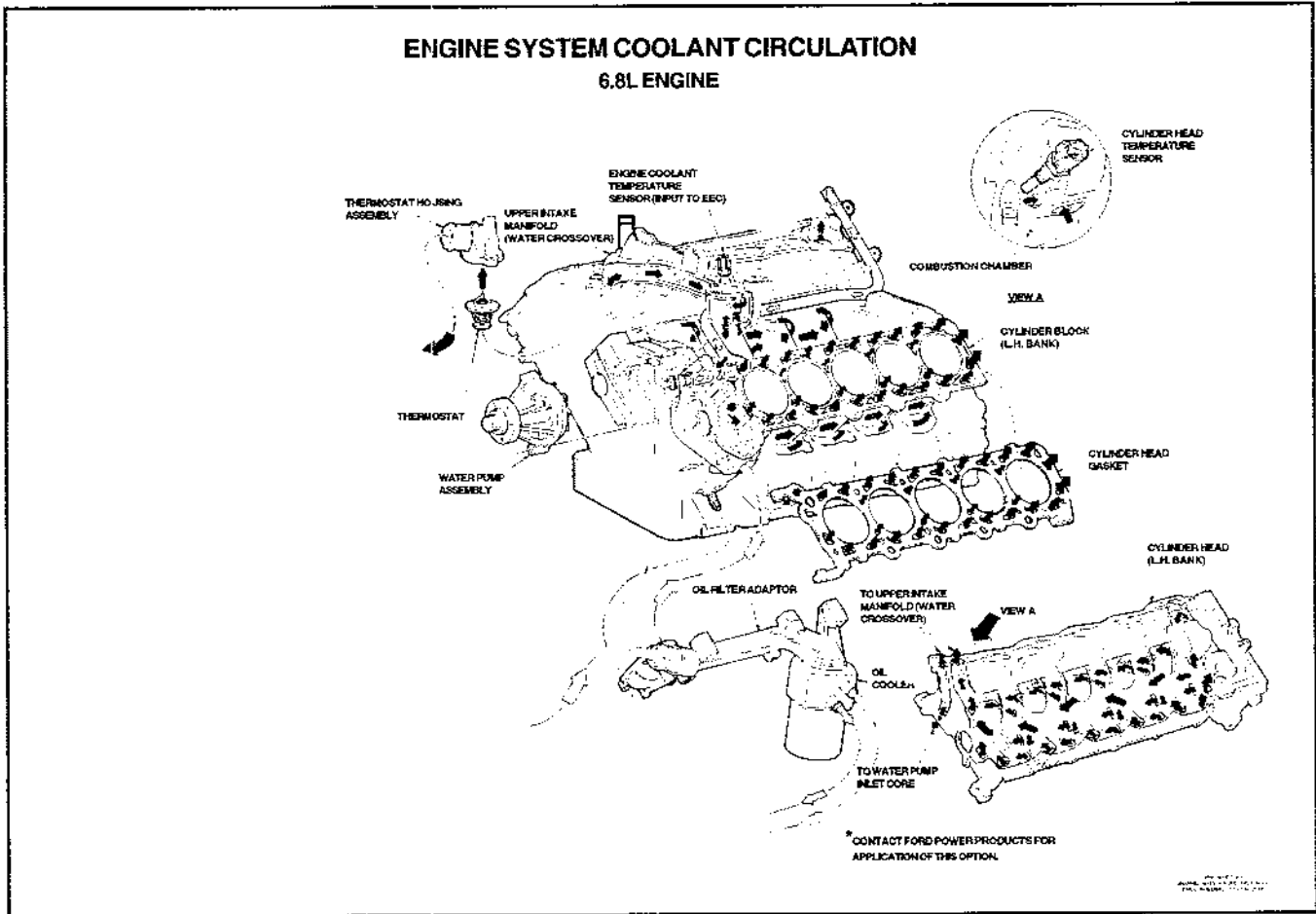

Engine Cooling

Walter C. Avrea, the owner of patents 3,601,181 and RE27,965, has granted Ford Motor Company rights with respect to cooling systems covered by these patents.

The cooling system components are:

- Cylinder head temperature sensor (CHT sensor).
- Water thermostat and gasket assembly.
- Water pump assembly.

Coolant Flow is as follows:

- The water pump (8501) circulates the coolant.
- From the water pump to the engine block and the cylinder heads (6049) to the thermostat.
 - Thermostat closed, the coolant returns to the water pump through bypass hose.
 - Thermostat open, the coolant flows back to the radiator.
 - To the radiator for heat rejection then back to the lower radiator hose.
 - From the lower radiator hose (8286) to the water pump.



CAUTION: Alkaline brine solutions will cause serious engine cooling system damage.



CAUTION: Do not use. 100,000 mile, red in color antifreeze, it is not compatible with copper radiators.

Coolant:

- Use a 50/50 mix of Ethylene Glycol Permanent Antifreeze and water. This mixture is to be used year-round with temperatures above -30°F.

Recycled Coolant:

- Use recycled engine coolant produced by Ford approved processes. Not all coolant recycling processes produce coolant which meets Ford specification ESE-M97B44-A or WSS-M97B44-D, and use of such a coolant may harm engine and cooling system components.

Unsatisfactory Coolant Material:

- Alcohol-type antifreeze does not provide adequate water pump lubrication.
 - Has a lower boiling point.
 - Provides reduced antifreeze protection.

GENERAL SERVICE PROCEDURES

Cooling System Draining

⚠ WARNING: NEVER REMOVE THE PRESSURE RELIEF CAP WHILE THE ENGINE IS OPERATING OR WHEN THE COOLING SYSTEM IS HOT. MAY CAUSE PERSONAL INJURY OR DAMAGE TO COOLING SYSTEM OR ENGINE. TO AVOID HAVING SCALDING HOT COOLANT OR STEAM BLOW OUT OF THE DEGAS BOTTLE WHEN REMOVING THE PRESSURE RELIEF CAP, WAIT UNTIL THE ENGINE HAS COOLED DOWN TO AT LEAST 110°F.

1. Wrap a thick cloth around the pressure relief cap and turn it slowly one-half turn counterclockwise. Stepping back while the pressure is released from the cooling system.
2. When you are sure all the pressure has been released, (still with a cloth) turn the pressure relief cap counterclockwise and remove.

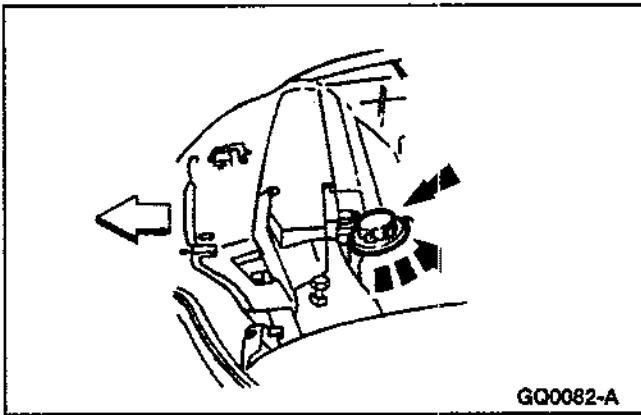

⚠ CAUTION: The coolant must be recovered in a suitable, clean container for reuse. If the coolant is contaminated it must be recycled or disposed of properly.

NOTE: About 80% of coolant capacity can be recovered with the engine in the vehicle. Dirty, rusty or contaminated coolant requires replacement.

3. Place a suitable container below the radiator draincock (8" 15). If equipped, disconnect the coolant return hose at the fluid cooler.
4. Open the radiator draincock.

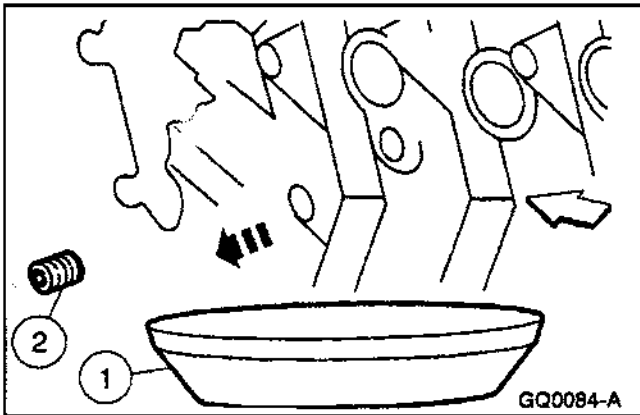

5. Remove the cylinder drain plug, if equipped, to drain the coolant from the cylinder block (6010).
 1. Place a drain pan below the cylinder block.
 2. Remove the drain plugs.

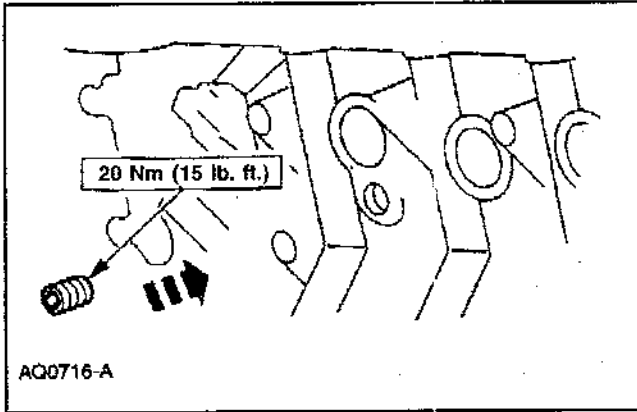

6. When the coolant is drained, make sure drain plugs are installed and tight.

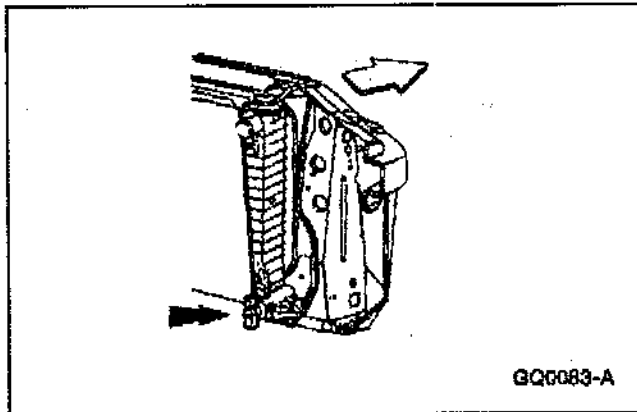

7. Close the radiator draincock when finished.

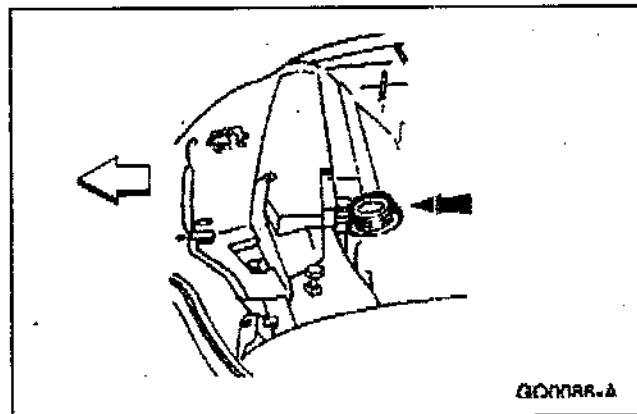

Cooling System Filling

1. Add the proper engine coolant mixture to the degas bottle or radiator.
2. Move the temperature blend selector to the full warm position when equipped.
3. Run the engine until it reaches operating temperature.

4. Add the proper engine coolant mixture to the degas bottle or radiator until the coolant level is between the "COOLANT FILL LEVEL" marks.

NOTE: Systems without degas bottle fill radiator up to 1 inch below the filler neck.

5. Turn off the engine and allow the cooling system to cool.
6. Repeat Steps 1 through 5 until the radiator level is OK.

Drive Belt Routing

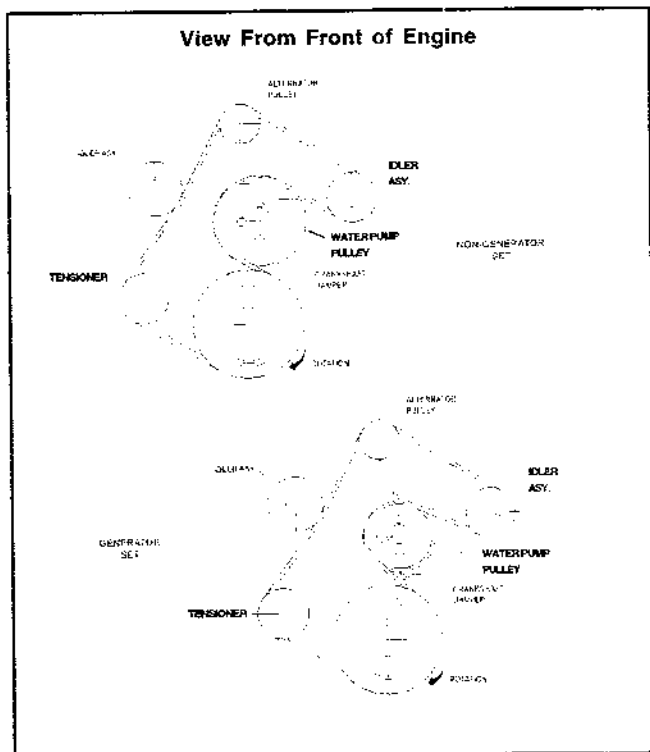

Cooling System Flushing

Special Tool(s)

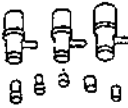
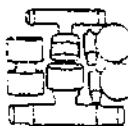
 <p>ST1166-A</p>	<p>Coolant System Drain/Flush/Fill. 164-R3673</p>
 <p>ST1167-A</p>	<p>Flush Kit Hardware Package 164-R3658 or equivalent</p>
 <p>ST1168-A</p>	<p>Drain Kit 164-R3662 or equivalent</p>

Special Service Tools called for by the procedures can be obtained by calling:
1-800-ROTUNDA (1-800-768-8632).

REMOVAL AND INSTALLATION

Radiator Hose - Removal

Radiator hoses should be replaced whenever they become cracked, rotted or have a tendency to collapse.

Drain the radiator into appropriate container then loosen the clamps at each end of the hose to be removed. Slide the hose off the radiator connection and the engine water outlet connection (upper hose) or the water pump connection (lower hose).

Radiator Hose - Installation

Position the clamps at least 1/8 inch from each end of the hose. Coat the connection areas with an approved water-resistant sealer and slide the hose on the connection. Make sure the clamps are beyond the bead and placed in the center of the clamping surface of the connections. Tighten the clamps. Fill the radiator with the recommended permanent antifreeze and water 50/50 mixture. Operate the engine for several minutes, then check the hoses and connections for leaks.

Thermostat - Removal

⚠ WARNING: AVOID INJURY FROM HOT COOLANT WHEN ENGINE IS HOT.

1. Partially drain the cooling system. For additional information, refer to Cooling System Draining, Filling and Flushing in this section.
2. Disconnect the upper radiator hose.
3. Remove the water outlet connection.
 - Remove the bolts.
 - Remove the water outlet connection.
4. Remove the (B) O-ring seal and the (A) water thermostat (8575).
 - Discard the (B) O-ring seal.

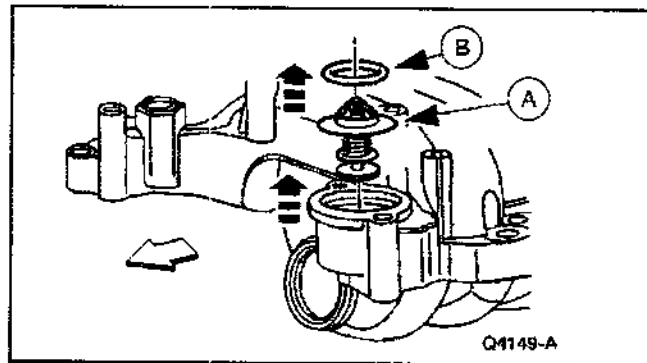

(A) Thermostat (B) O-ring Seal

Thermostat - Installation

NOTE: Thermostat must be installed as illustrated.

1. Install the (B) water thermostat and use a new (A) O-ring seal to position the (B) water thermostat in the (C) upper intake manifold (9424).

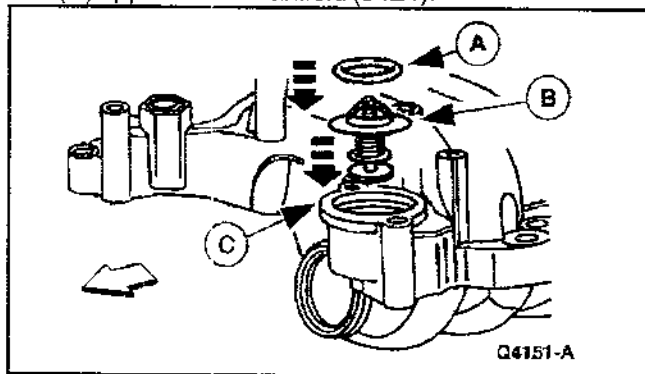

(A) O-ring Seal (B) Thermostat (C) Intake Manifold

2. Install the water outlet connection.
 1. Position the (A) water outlet connection on the (B) upper intake manifold.
 2. Install the bolts.

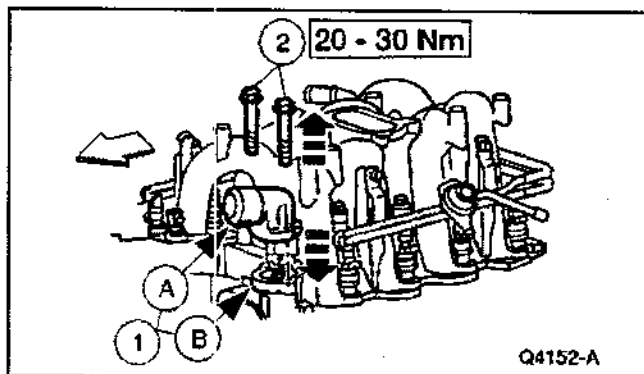

3. Connect the upper radiator hose.
4. Fill the cooling system. For additional information, refer to Cooling System Draining, Filling and Flushing in this section.

With or Without Dry Fuel Evaporator Plumbing

Removal of Heater Water Inlet Tube (18663)

1. Drain the cooling system.
2. Remove the upper and lower intake manifold together. Refer to Section 01 for details.
3. Remove the two studs securing the tube to the rear of the right side cylinder head and remove the tube.
4. Inspect the water pump tube assembly o-rings for damage.

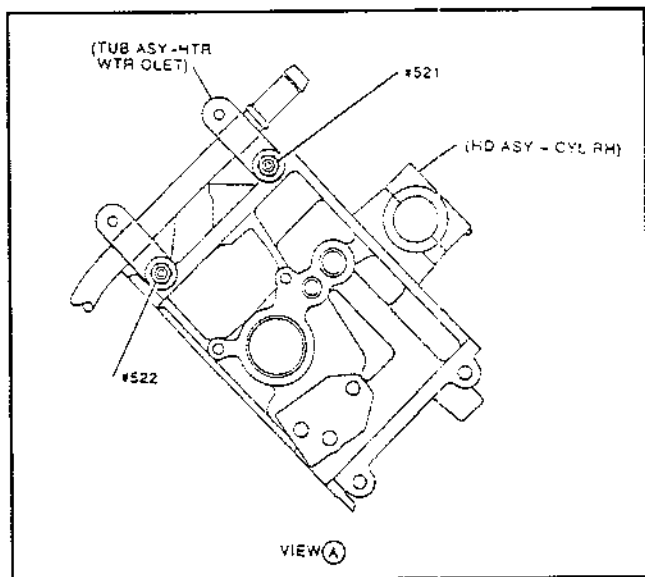

Installation of Water Heater Return Tube Assembly with by-pass Hose

1. Lightly lubricate the o-rings prior to installing the water outlet tube.

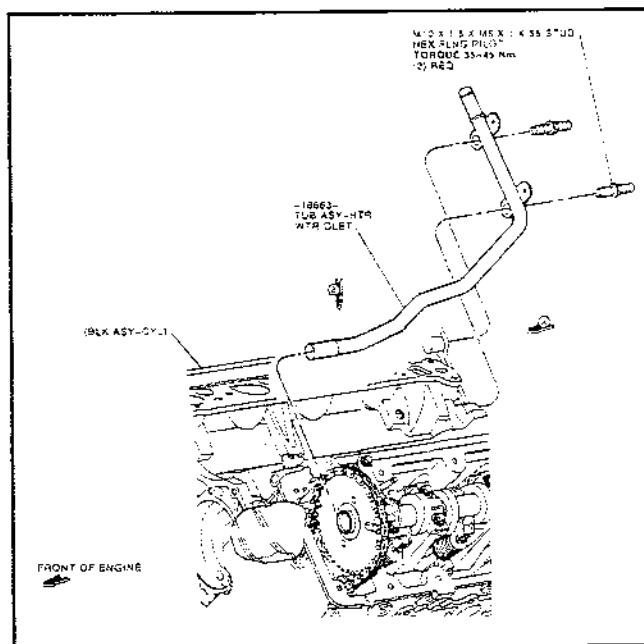
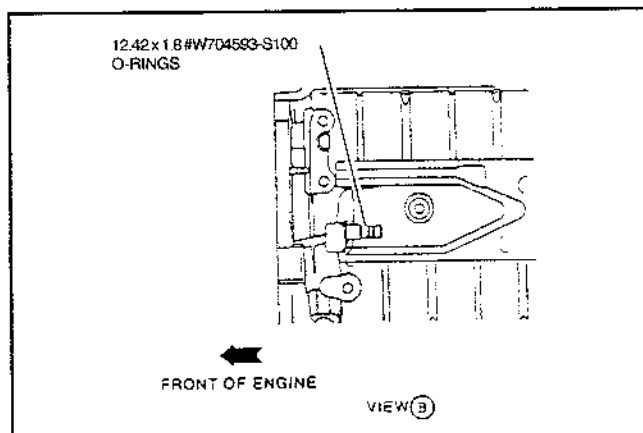

2. Install the heater water outlet tube.
3. Install the water tube-mounting studs.
4. Install the lower and upper intake manifold. (Refer to Section 01).
5. Install rubber cap and clamp on outlet tube if not using LPG or cab heater.
6. Refill the cooling system.

Cylinder Head Temperature (CHT) Sensor - Replacement

1. Remove the upper and lower intake manifold together. For additional information, refer to Section 01.
2. Remove the cylinder head temperature (CHT) sensor.
 1. Disconnect the electrical connector.
 2. Remove the CHT sensor.

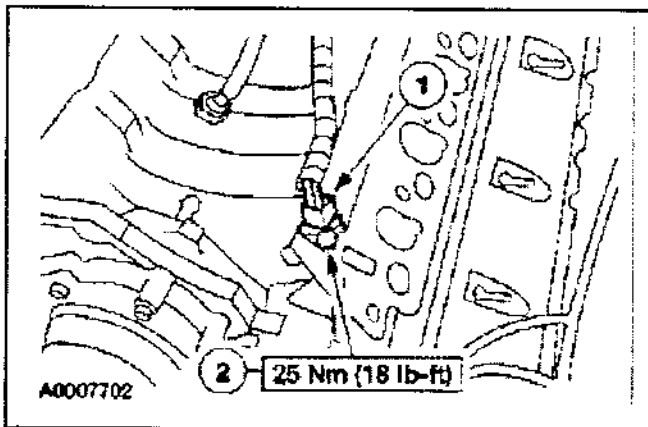

3. To install, reverse the removal procedure.

CAUTION: Do not over torque. May damage sensor.

Fan Drive Belt - Removal and Installation

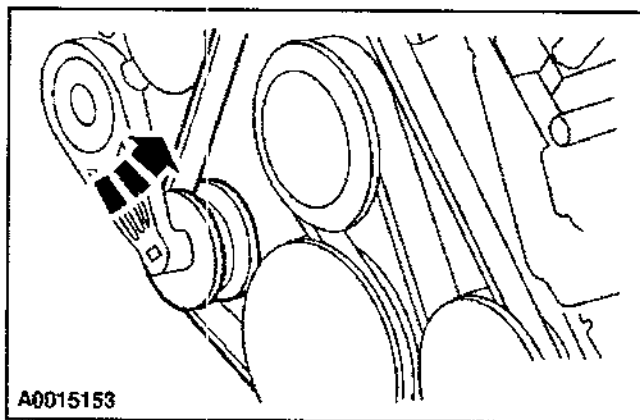

1. Rotate the drive belt tensioner counterclockwise and remove the drive belt.
 2. **NOTE:** Refer to 05-9 for correct drive belt routing.
- To install, reverse the removal procedure.

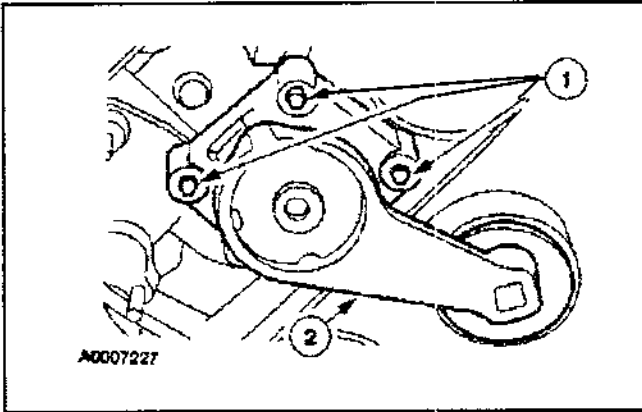

Belt Tensioner - Removal

1. Remove the drive belt (8620). For additional information, refer to Fan Drive Belt page 05-12.
2. Remove the belt tensioner.
 1. Remove the bolts.
 2. Remove the belt tensioner.

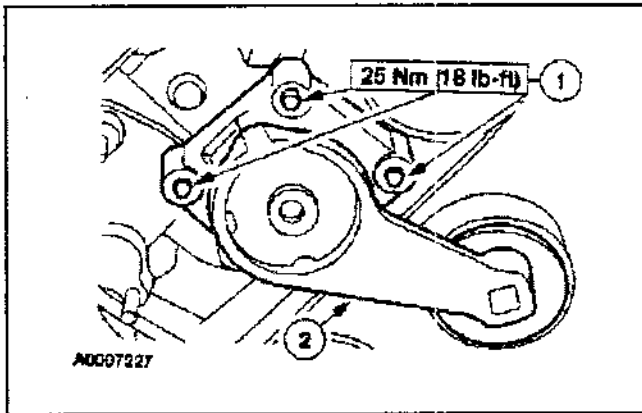

Belt Tensioner - Installation

1. To install, reverse the removal procedure.

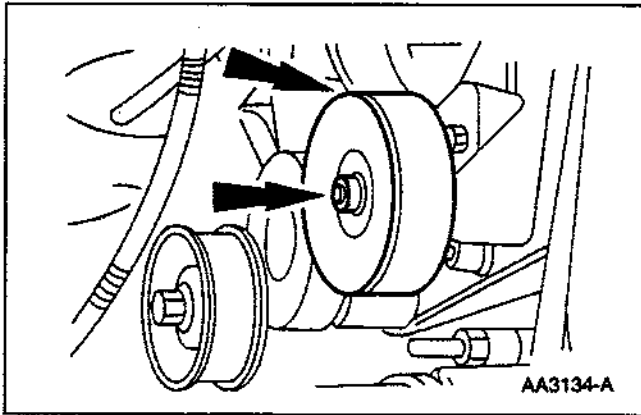

Belt Idler Pulley - Removal

1. Remove the fan drive belt (8620) off of the belt idler pulley (8678). For additional information, refer to Fan Drive Belt page 05-12.
2. Remove the bolt and the belt idler pulley.

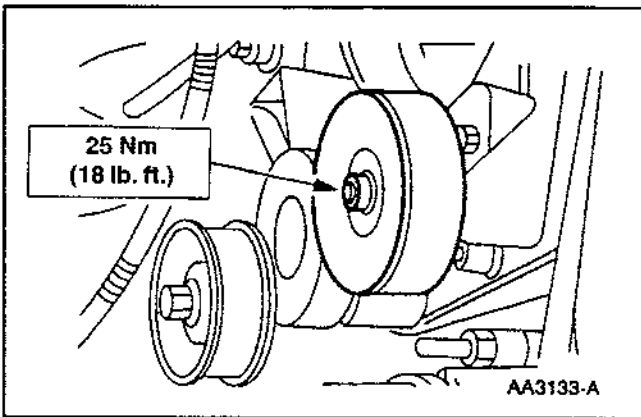

Belt Idler Pulley - Installation

1. To install, reverse the removal procedure.

Water Pump - Removal

Material

Item	Specification
Motorcraft Premium Engine Coolant VC-4-A	ESE-M97B44-A

1. Drain the cooling system. For additional information, refer to Cooling System Draining, Filling and Flushing page 05-05.
2. Remove the engine cooling fan.
3. Remove the drive belt. For additional information, refer to Fan Drive Belt page 05-12.
4. Remove the water pump pulley (8509).
 - Remove the water pump pulley.

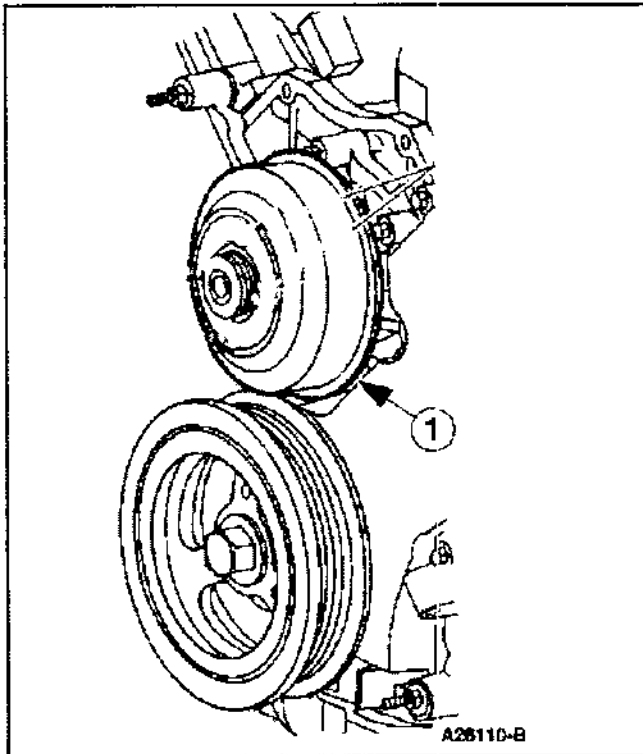

5. Remove the water pump bolts.

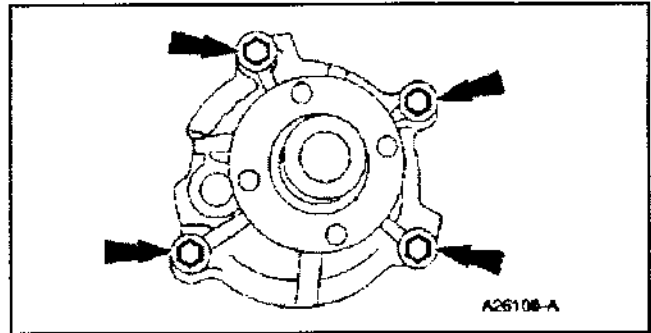

6. Remove the (A) water pump from the (B) cylinder block.

- Clean and inspect the mating surfaces.

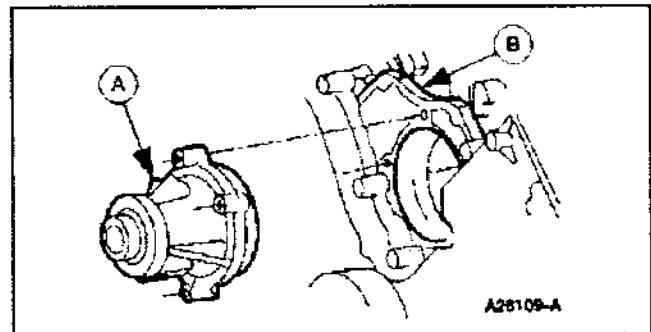

Water Pump - Installation

1. **CAUTION:** Cooling systems are recommended to be filled with Motorcraft Premium Engine Coolant VC-4-A meeting Ford specification ESE-M97B44-A (green color). Do not mix coolant types.

Install the water pump.

1. Lubricate the new O-ring seal using engine coolant and install the O-ring seal onto the water pump.
2. Position the water pump into the engine block and heater water outlet tube.
3. Install the bolts.

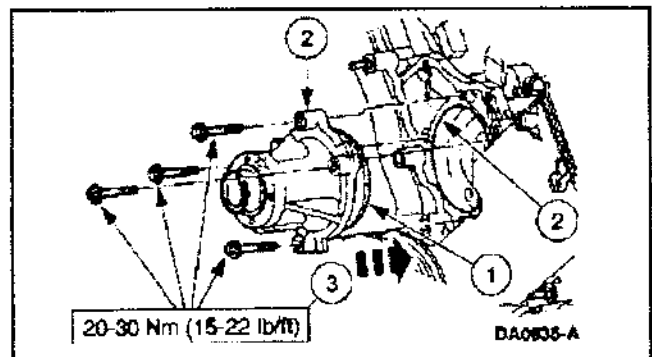

2. Position the pulley onto the water pump.

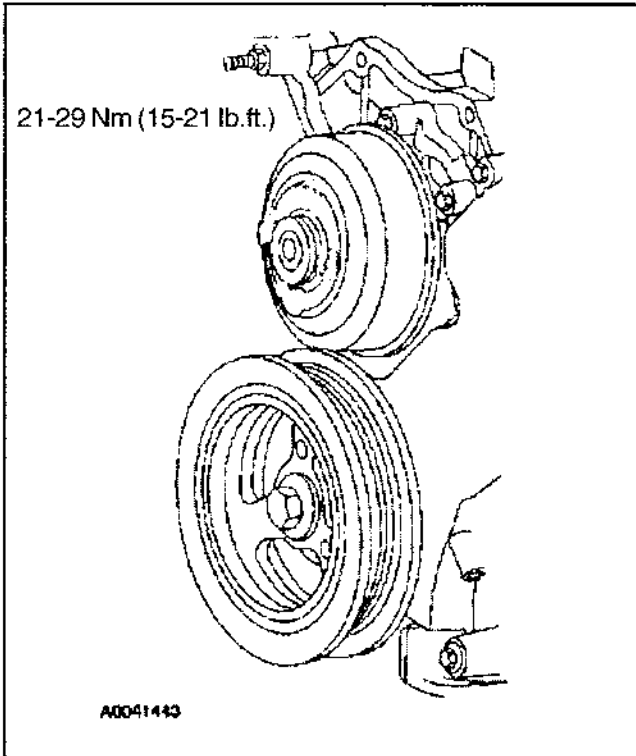

3. Install the fan spacer and fan.
4. Install the drive belt.
5. Refill the cooling system. For additional information, refer to Cooling System Draining, Filling and Flushing in this section.

DIAGNOSING AND TESTING

Refer to the following Diagnosis Chart for cooling system problems, their possible cause and recommended correction. Refer to the pertinent part for testing and repair.

The most frequent cooling system complaints are leakage and overheating. Either of these problems will soon render the vehicle inoperable.

Most vehicles use an ethylene glycol base antifreeze solution to which the manufacturers have added a dye color. The dye color makes the antifreeze solution an excellent leak detector. If this type of solution is not being used in the cooling system, a vegetable dye may be added to aid in locating external leakage.

NOTE: A small amount of antifreeze coming out the water pump weep hole may be normal.

CONDITION	POSSIBLE SOURCE	ACTION
<ul style="list-style-type: none"> Loss of coolant. 	<ul style="list-style-type: none"> Pressure cap and gasket. Leakage. Internal leakage. 	<ul style="list-style-type: none"> Inspect, washer gasket and test. Replace only if cap will not hold pressure to specification Pressure test system. Inspect hose, hose connection, radiator, edges of cooling system gaskets, core plugs and drain plugs, water pump. Repair or replace as required. Disassembly engine as necessary – check for: cracked intake manifold, blown head gaskets, warped head or block gasket surfaces, cracked cylinder head or cylinder block.
<ul style="list-style-type: none"> Engine overheats. 	<ul style="list-style-type: none"> Low coolant level. Faulty drive belt tensioner. Pressure cap. Radiator obstruction. Closed thermostat. Fan. Ignition. Temp. gauge. Engine. Coolant mixture. 	<ul style="list-style-type: none"> Fill as required. Check for coolant loss. Replace belt or tensioner as required. Test, replace if necessary. Remove bugs, leaves, etc. Test, replace if necessary. Test, replace if necessary. Check electrical circuits and repair as required. Check water pump and block for blockage. 1/2 water and 1/2 permanent antifreeze mixture.
<ul style="list-style-type: none"> Engine fails to reach normal operating temperature. 	<ul style="list-style-type: none"> Open thermostat. Temperature gauge. 	<ul style="list-style-type: none"> Test, replace if necessary. Check electrical circuits and repair as required.

Visual Inspection

Check for leakage at:

1. All hoses and hose connections.
2. Radiator seams, radiator core, and radiator drain petcock.
3. All block core plugs and drain plugs.
4. Edges of all cooling system gaskets.
5. Water pump shaft and bushing.

Examine oil dipstick for evidence of coolant contaminated engine oil (white milky appearance).

NOTE: A small amount of antifreeze coming out the water pump weep hole may be normal.

Cooling System Visual Test

Special Tool(s)

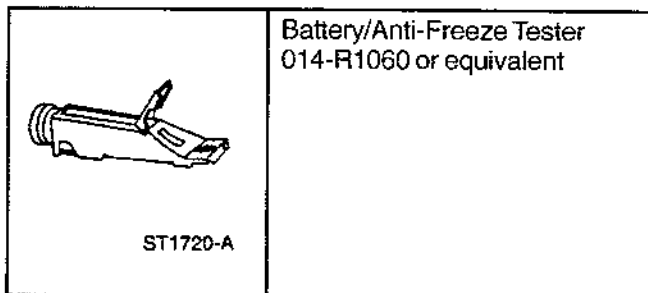

Special Service Tools called for by the procedures can be obtained by calling:

1-800-ROTUNDA (1-800-768-8632).

⚠ WARNING: NEVER REMOVE THE PRESSURE RELIEF CAP WHILE THE ENGINE IS OPERATING OR WHEN THE COOLING SYSTEM IS HOT. MAY CAUSE PERSONAL INJURY OR DAMAGE TO COOLING SYSTEM OR ENGINE. TO AVOID HAVING SCALDING HOT COOLANT OR STEAM BLOW OUT OF THE DEGAS BOTTLE WHEN REMOVING THE PRESSURE RELIEF CAP, WAIT UNTIL THE ENGINE HAS COOLED DOWN TO AT LEAST 110°F.

1. Wrap a thick cloth around the pressure relief cap and turn it slowly one-half turn counterclockwise. Stepping back while the pressure is released from the cooling system.
2. When you are sure all the pressure has been released, (still with a cloth) turn counterclockwise and remove the pressure relief cap.

⚠ CAUTION: If there is engine coolant in the engine oil the cause must be corrected and the oil changed or engine damage may occur.

NOTE: Check the engine coolant in the degas bottle and radiator (8005) when vehicle has been allowed to reach normal operating temperature. This will make sure sufficient engine coolant exchange has occurred.

3. Inspect the coolant in both the radiator and the degas bottle for coolant color:

- Clear, light green or blue indicates higher water content than required
- Dark brown indicates unauthorized stop leak may have been used. Use cooling system Stop Leak Powder E6AZ-19558-A or equivalent meeting Ford specification ESE-M99B170-A only.
- A light or reddish-brown color indicates rust in the cooling system. Flush the system and refill with the correct mixture of water and Premium Engine Coolant (green in color), E2FZ-19549-AA or equivalent meeting Ford specification ESE-M97B44-A
- An iridescent sheen on top of the coolant indicates a trace of oil is entering the cooling system.
- A milky-brown color indicates that oil is entering the cooling system.
- The causes of the leak might be:
 - A blown head gasket (6051).
 - A cracked or warped cylinder head (6049).
 - A crack in the engine oil gallery and the cooling passageways.
- If engine coolant is present in the engine oil, the cause of the leak might be:
 - A blown head gasket.
 - A cracked or warped cylinder head.
 - A crack in the engine oil gallery and cooling passageways.

4. If the engine coolant appearance is good, test the engine coolant range with the battery and antifreeze tester:

- Maximum ratio is 60/40.
- Minimum ratio is 45/55.

5. Check the engine coolant system conditions:

- If the engine cooling fluid is low, add specified coolant mixture only.
- If the engine coolant fluid tests weak, add straight engine coolant until the readings are within acceptable levels.
- If the engine coolant tests strong, remove some of the engine coolant and add water until readings are within acceptable levels.

6. Check for electrical charge in coolant. Using a DVOM, insert the (+) probe into coolant without touching radiator. Hold the (-) probe to radiator shell or a good ground and read the volts.:

- Less than 1.5 volts is good.
- If voltage is above 1.5 volts - drain, flush and replace coolant with a 50/50 mixture.

NOTE: Above 3 volts may indicate a bad head gasket.

Thermostat Test – Thermostat Removed



WARNING: USE CAUTION WORKING WITH HOT BOILING WATER AND WEAR APPROPRIATE PROTECTIVE GEAR. MAY CAUSE BODILY HARM.

Remove the thermostat and immerse it in boiling water. Replace the thermostat if it does not open at least 0.230" after one minute at 212°F.

If the problem being investigated is the inability of the cooling system to reach normal operating temperature, the thermostat should be checked for leakage. This may be done by holding the thermostat up to a lighted background. Leakage of light all around the thermostat valve (thermostat at room temperature) indicates that the thermostat is unacceptable and should be replaced. It is possible, on some thermostats, that a slight leakage of light at one or two locations on the perimeter of the valve may be detected. This should be considered normal.

Radiator Leak Test, Removed From Vehicle

CAUTION: Never leak test an aluminum radiator in the same water that copper/brass radiators are tested in. Flux and caustic cleaners may be present in the cleaning tank and they will damage aluminum radiators.

1. Always install plugs in the oil cooler fittings before leak-testing or cleaning any radiator.
2. Clean the radiator before leak-testing to avoid contamination of the tank.
3. Leak-test the radiator in clean water with 138 kPa (20 psi) air pressure.

Engine Cylinder Head Temp. (CHT) Sensor

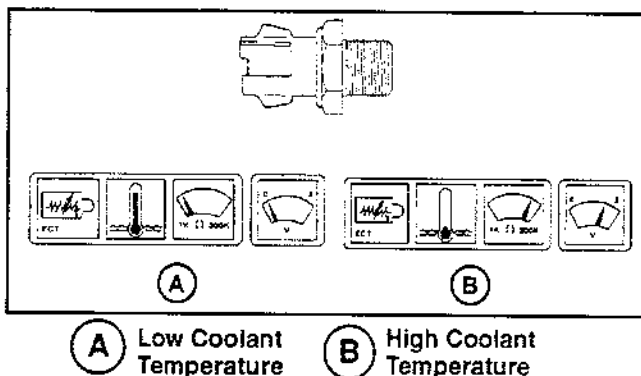

- Output is a variable voltage signal which typically ranges from 0.3 volt to 4.5 volts.
- At -40°F (CHT) resistance is approximately 925K ohms.
- At 77°F (CHT) resistance is approximately 30K ohms.
- At 248°F (CHT) resistance is approximately 1.2K ohms.

NOTE: Complete list of temperature sensor characteristics can be found on page 05-21 of this section.

Diagnostic Aids

The (CHT) sensor shares the same ground with other sensors. Check the ground circuit 359 (Gray) if other shared components.

NOTE: Refer to Section 08 for further diagnostics.

Inspect the harness connectors for backed-out terminals, improper mating, broken locks, improperly formed or damaged terminals, and poor terminal-to-wire connections. Inspect the wiring harness for damage. If the harness appears to be OK, back probe the CHT sensor connector with a digital voltmeter and observe the voltage while moving connectors and wiring harnesses related to the CHT sensor. A change in the voltmeter display will indicate the location of the fault.

Circuit Description

The engine cylinder head temperature (CHT) sensor is a thermistor which measures the temperature of the engine cylinder head. The ICM supplies a ground (circuit 359, Gray/Red) from the sensor and monitors voltage signal (circuit to 1102, Yellow/Lt. Green) to the sensor. When the engine coolant is cold, the sensor resistance is high and the ICM will monitor a high signal voltage at the CHT signal circuit. If the engine cylinder head is warm, the sensor resistance is lower, causing the ICM to monitor a lower voltage.

- Engine cylinder head temperature (CHT) sensor is a type of thermistor that converts engine temperature to an electrical voltage signal.
- The electrical resistance of the (CHT) sensor changes with temperature. As engine coolant temperature increases, the (CHT) resistance decreases.

WSG-1068 COOLING SYSTEM

CHT Sensor Data

Temperature Sensor Characteristics

TEMPERATURE:		NOM R, (OHMS)	NOM E _{OUT} (VOLTS)
(C)	(F)		
-40	-40	925,021	4.54
-35	-31	673,787	4.50
-30	-22	496,051	4.46
-25	-13	368,896	4.41
-20	-4	276,959	4.34
-15	5	209,816	4.25
-10	14	160,313	4.15
-5	23	123,485	4.02
0	32	95,851	3.88
5	41	74,914	3.71
10	50	58,987	3.52
15	59	46,774	3.32
20	68	37,340	3.09
25	77	30,000	2.86
30	86	24,253	2.62
35	95	19,716	2.39
40	104	16,113	2.15
45	113	13,236	1.93
50	122	10,926	1.72
55	131	9,061	1.52
60	140	7,548	1.34
65	149	6,332	1.18
70	158	5,335	1.04
75	167	4,515	.91
80	176	3,837	.79
85	185	3,274	.70
90	194	2,804	.61
95	203	2,411	.53
100	212	2,080	.47
105	221	1,801	.41
110	230	1,564	.36
115	239	1,363	.32
120	248	1,191	.28
125	257	1,044	.25
130	266	918	.22
135	275	809	.19
140	284	715	.17
145	293	633	.15
150	302	563	.14

Voltage values calculated for VREF=5 volts (may vary 15% due to sensor and VREF variations).

V-Ribbed Serpentine Drive Belt

Cracks Across Ribs - Normal

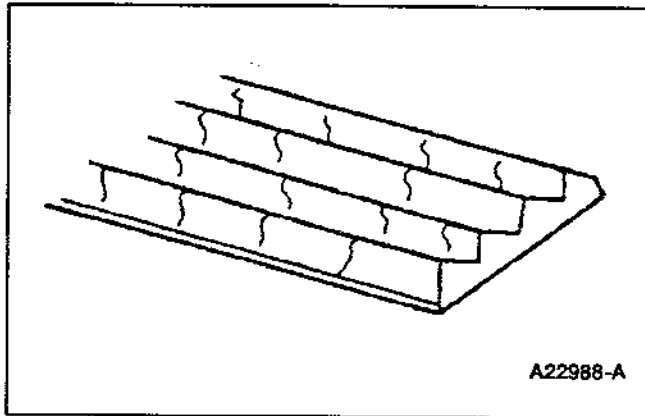

Chunks of Rib Missing - Replace Belt

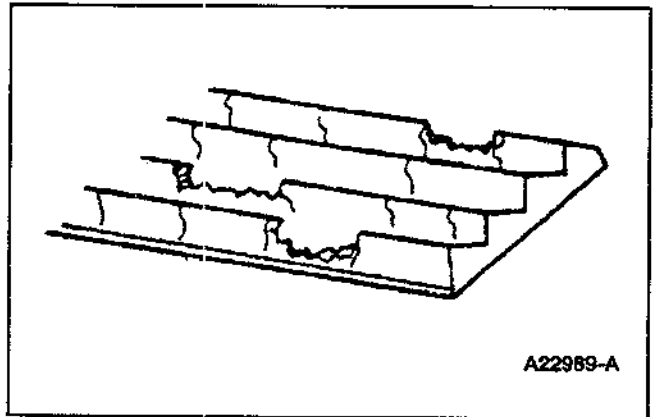

Drive Belt Symptom Chart

Condition	Possible Source	Action
<ul style="list-style-type: none"> • Drive belt cracking • Drive belt chunking. 	<ul style="list-style-type: none"> • Worn out. • Overheated • Chemical or oil spilled on belt. 	<ul style="list-style-type: none"> • REPLACE the drive belt; Refer to Belt in this section.
<ul style="list-style-type: none"> • Drive belt noise or squeal. 	<ul style="list-style-type: none"> • Pulley misalignment. • Excessive pulley groove runout. • Damaged drive belt tensioner (6B209). • Fluid or contamination on the drive belt. 	<ul style="list-style-type: none"> • DETERMINE from which pulley the noise originates. CHECK that area with a straightedge and LOOK for for accessory pulley to be out of position in the fore/aft direction or at an angle to the straightedge. REPLACE the pulley or the component; • Replace belt tensioner. • CLEAN or REPLACE the drive belt; Refer to Fan Drive Belt this section.

Drive Tensioner/Belt Length Indicator

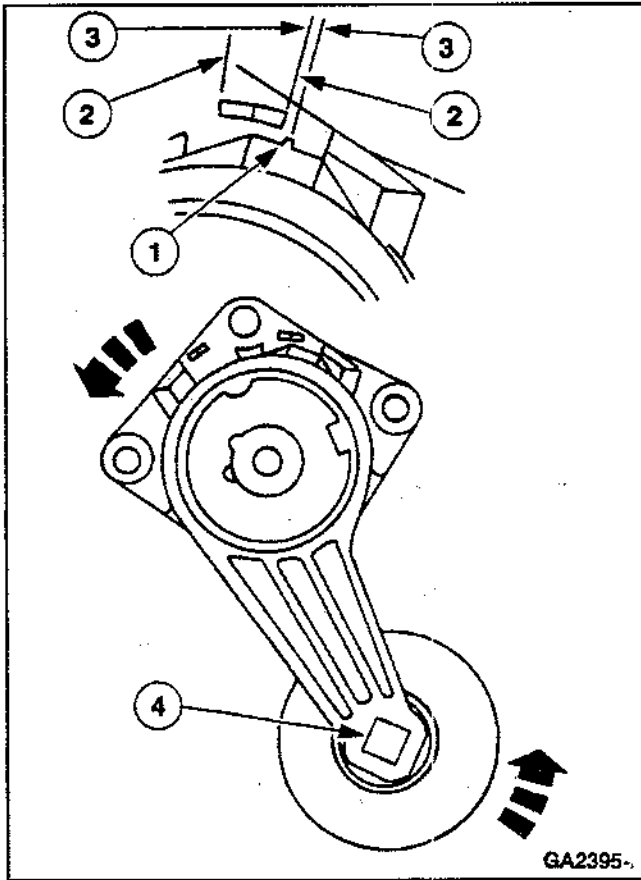

Item	Part Number	Description
1	-	Belt Length Indicator
2	-	Acceptable Belt Installation and Wear Range
3	-	Belt Replacement Range
4	-	Belt Tension Relief Point (Use 1/2 Inch Ratchet)

Automatic tensioners are calibrated at the factory to provide the correct amount of tension to the belt. Unless a spring within the tensioner assembly breaks or some other mechanical part of the tensioner fails, there is no need to check tensioners for proper tension.

The only mechanical check that need be made, if you have any doubt about the tensioner function, would be to remove the belt in the area of the tensioner, to avoid belt contact, then using the proper tool, rotate the tensioner from its relaxed position through its full stroke and back to the relaxed position to assure that there is no "stick, grab, bind," and to assure that there is tension on the spring. It is a normal condition for the tensioner to be moving, under certain conditions, when the engine is

running. If the tensioner meets this criteria, it should be assumed to be a good tensioner.

Drive Belt Misalignment

⚠ CAUTION: Incorrect drive belt installation will cause excessive drive belt wear and may cause the drive belt to come off the drive pulleys.

Non-standard replacement drive belts may track differently or improperly. If a replacement drive belt tracks improperly, replace it with an original equipment drive belt to avoid performance failure or loss of belt.

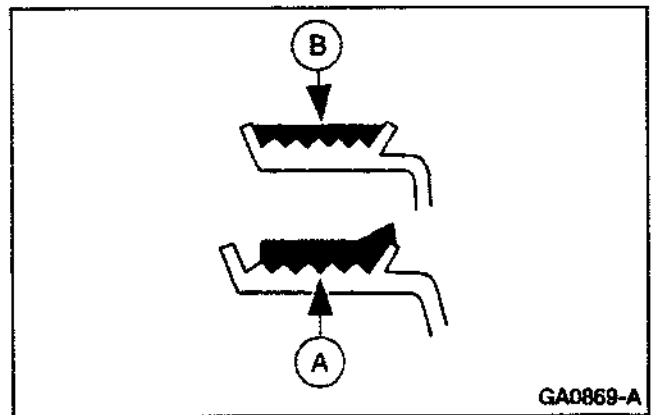



With the engine running, check drive belt tracking. If the **A** edge of the drive belt rides beyond the edge of the pulleys, noise and premature wear may occur. Make sure the **B** drive belt rides correctly on the pulley. If a drive belt tracking condition exists, proceed with the following:

Visually check the drive belt tensioner for damage, especially the mounting pad surface. If the drive belt tensioner is not installed correctly, the mounting surface pad will be out of position. This will result in a chirp or squeal noises.

- With the engine running, visually observe the grooves in the pulleys (not the pulley flanges or pulley front surfaces) for excessive wobble. Replace components as required.
- Check all accessories, mounting brackets and the drive belt tensioner for any interference that would prevent the component from mounting properly. Correct any interference condition and recheck belt tracking.
- Tighten all accessories, mounting brackets, and drive belt tensioner retaining hardware to specification. Recheck the drive belt tracking.

Special Tool(s)

 <p>ST1474-A</p>	<p>Radiator/Heater Core Pressure Tester 014-R1072 or equivalent</p>
 <p>ST1137-A</p>	<p>Rotunda 73 Digital Multimeter 105-R0051 or equivalent</p>

Special Service Tools called for by the procedures can be obtained by calling:
1-800-ROTUNDA (1-800-768-8632).

Visual Inspection Chart

Mechanical	Electrical
<ul style="list-style-type: none"> • Leaks • Damaged hoses • Loose/damaged hose clamps • Damaged water thermostat gasket • Damaged head gaskets • Damaged intake manifold gasket • Damaged water pump • Damaged radiator • Damaged degas bottle • Damaged fan/fan clutch 	<ul style="list-style-type: none"> • Damaged engine coolant temperature sensor • Damaged wiring

Inspection and Verification

1. Verify the customer's concern by operating the engine to duplicate the condition.
2. Inspect to determine if any of the following mechanical or electrical concerns apply.
3. If the inspection reveals an obvious concern that can be readily identified, repair as necessary.
4. If the concern remains after the inspection, determine the symptom(s) and go to the Symptom Chart.

Symptom Chart

Condition	Possible Source	Action
<ul style="list-style-type: none"> • Loss of Coolant 	<ul style="list-style-type: none"> • Radiator. • Water pump seal. • Radiator hoses. • Heater hoses/tubes. • Heater core (if equipped). • Engine gaskets. • Degas bottle. 	<ul style="list-style-type: none"> • GO to Pinpoint Test A.
<ul style="list-style-type: none"> • The Engine Overheats 	<ul style="list-style-type: none"> • Water thermostat. • Water pump. • Internal engine coolant leak. • Radiator. • Cooling fan. • Pressure relief cap. 	<ul style="list-style-type: none"> • GO to Pinpoint Test B.
<ul style="list-style-type: none"> • The Engine Does Not Reach Normal Operating Temperature 	<ul style="list-style-type: none"> • Water thermostat. 	<ul style="list-style-type: none"> • GO to Pinpoint Test C.

PINPOINT TEST A: LOSS OF COOLANT

TEST CONDITIONS	TEST DETAILS/RESULTS/ACTIONS
<p>1 CHECK THE ENGINE COOLANT LEVEL</p>	
<p>NOTE: Allow the engine to cool before checking the engine coolant level.</p>	
	<p>1 Visually check the engine coolant level at the degas bottle (if equipped).</p> <ul style="list-style-type: none"> • Is the engine coolant level within specification? <p>► Yes GO to 2.</p> <p>► No REFILL the engine coolant as necessary. GO to 6.</p>
<p>2 CHECK THE PRESSURE RELIEF CAP</p>	
	<p>1 Perform the Pressure Relief Cap Test. For additional information, refer to Component Tests, Cap-Pressure Relief in this section.</p> <ul style="list-style-type: none"> • Is pressure relief cap OK? <p>► Yes GO to 3.</p> <p>► No INSTALL a new pressure relief cap. TEST the system for normal operation.</p>
<p>3 CHECK THE ENGINE COOLANT FOR INTERNAL LEAK</p>	
	<p>1 Inspect the engine coolant in degas bottle for signs of engine oil.</p> <ul style="list-style-type: none"> • Is oil evident in coolant? <p>► Yes If engine oil is evident, GO to Section 01.</p> <p>► No GO to 4.</p>

(Continued)

PINPOINT TEST A: LOSS OF COOLANT (Continued)

TEST CONDITIONS	TEST DETAILS/RESULTS/ACTIONS
4 CHECK THE ENGINE BLOCK FOR COOLANT	<p>1 Remove the oil level dipsticks (6750) from the engine.</p> <ul style="list-style-type: none"> • Is coolant evident in oil? <p>► Yes If coolant is in engine, GO to Section 01.</p> <p>► No GO to 5.</p>
5 CHECK THE COOLANT RECOVERY SYSTEM	<p>1  WARNING: NEVER REMOVE THE PRESSURE RELIEF CAP WHILE THE ENGINE IS OPERATING OR WHEN THE COOLING SYSTEM IS HOT. MAY CAUSE PERSONAL INJURY OR DAMAGE TO COOLING SYSTEM OR ENGINE. TO AVOID HAVING SCALDING HOT COOLANT OR STEAM BLOW OUT OF THE DEGAS BOTTLE WHEN REMOVING THE PRESSURE RELIEF CAP, WAIT UNTIL THE ENGINE HAS COOLED DOWN TO AT LEAST 110°F.</p> <p>2 Wrap a thick cloth around the pressure relief cap and turn it slowly one-half turn counterclockwise. Stepping back while the pressure is released from the cooling system.</p> <p>3 When you are sure all the pressure has been released, (still with a cloth) turn counterclockwise and remove the pressure relief cap.</p> <p>4 Inspect the pressure relief cap for foreign material between the sealing gasket and the diaphragm.</p> <ul style="list-style-type: none"> • Is the pressure relief cap OK? <p>► Yes GO to 6.</p> <p>► No CLEAN or INSTALL a new pressure relief cap. TEST the system for normal operation. GO to 1.</p>

PINPOINT TEST A: LOSS OF COOLANT (Continued)

TEST CONDITIONS	TEST DETAILS/RESULTS/ACTIONS
6 CHECK THE DEGAS BOTTLE	<p>1 NOTE: The engine must be cool when coolant is added to the degas bottle.</p> <p>Add coolant to the degas bottle until fluid is between the coolant fill level marks.</p> <ul style="list-style-type: none"> • Does the degas bottle leak? <p>▶ Yes INSTALL a new degas bottle. TEST the system for normal operation.</p> <p>▶ No PERFORM the cooling system pressure test. For additional information, refer to Component Tests and Pressure Test in this section. REPAIR as necessary. TEST the system for normal operation.</p>

PINPOINT TEST B: THE ENGINE OVERHEATS

TEST CONDITIONS	TEST DETAILS/RESULTS/ACTIONS
1 CHECK THE ENGINE COOLANT LEVEL	<p>NOTE: If the engine is hot, allow the engine to cool before proceeding.</p> <p>1  WARNING: NEVER REMOVE THE PRESSURE RELIEF CAP WHILE THE ENGINE IS OPERATING OR WHEN THE COOLING SYSTEM IS HOT. MAY CAUSE PERSONAL INJURY OR DAMAGE TO COOLING SYSTEM OR ENGINE. TO AVOID HAVING SCALDING HOT COOLANT OR STEAM BLOW OUT OF THE DEGAS BOTTLE WHEN REMOVING THE PRESSURE RELIEF CAP, WAIT UNTIL THE ENGINE HAS COOLED DOWN TO AT LEAST 110°F.</p> <p>2 Wrap a thick cloth around the pressure relief cap and turn it slowly one-half turn counterclockwise. Stepping back while the pressure is released from the cooling system.</p> <p>3 When you are sure all the pressure has been released, (still with a cloth) turn counterclockwise and remove the pressure relief cap.</p> <p>4 Check the engine coolant level at the degas bottle.</p> <ul style="list-style-type: none"> • Is the engine coolant OK? <p>▶ Yes GO to 2.</p> <p>▶ No REFILL the engine coolant at the degas bottle. GO to Pinpoint Test A.</p>

(Continued)

PINPOINT TEST B: THE ENGINE OVERHEATS (Continued)

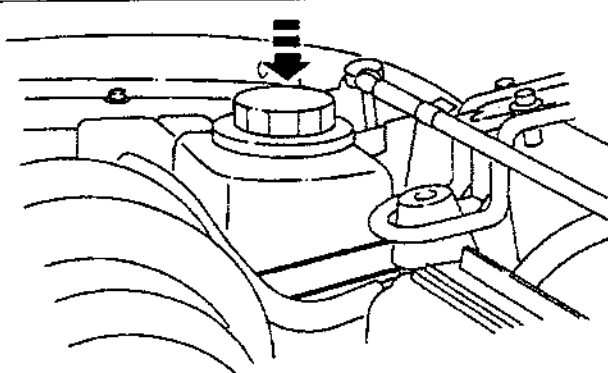
TEST CONDITIONS	TEST DETAILS/RESULTS/ACTIONS
<p>2 CHECK THE COOLANT CONDITION</p>	<p>1 Check the coolant for contaminants such as rust, corrosion, or discoloration.</p> <ul style="list-style-type: none"> • Is the coolant condition OK? <p>▶ Yes GO to 3.</p> <p>▶ No FLUSH the engine cooling system. For additional information, refer to Flushing – Engine and Radiator in this section. TEST the system for normal operation.</p>
<p>3 CHECK FOR AN AIRFLOW OBSTRUCTION</p>	<p>1 Inspect the radiator for obstructions such as leaves or dirt.</p> <ul style="list-style-type: none"> • Is there an obstruction? <p>▶ Yes REMOVE the obstruction. CLEAN the radiator. TEST the system for normal operation.</p> <p>▶ No GO to 4.</p>
<p>4 CHECK THE HEATER CORE (IF EQUIPPED) OPERATION AND/OR LPG EVAPORATOR</p>  <p style="text-align: right;">Q4194-B</p>	<p>1 Install the pressure relief cap.</p>

(Continued)

PINPOINT TEST B: THE ENGINE OVERHEATS (Continued)

TEST CONDITIONS	TEST DETAILS/RESULTS/ACTIONS
<p>4 CHECK THE LPG EVAPORATOR OPERATION (Continued)</p>	<p>2 As the engine starts to heat up, feel the inlet and outlet heater water hoses (18472). They should feel approximately the same after three or four minutes.</p> <ul style="list-style-type: none"> • Is the LPG evaporation hose approximately the same temperature as the inlet heater water hose? <p>▶ Yes GO to 5.</p> <p>▶ No TURN the engine off. REPAIR or INSTALL a new heater core or clear the LPG evaporation coolant passage way. TEST the system for normal operation.</p>
<p>5 CHECK THE WATER THERMOSTAT OPERATION</p>	<p>1 Start the engine and allow the engine to run for ten minutes.</p> <p>2 Feel the inlet and outlet heater water hoses and the underside of the upper radiator hose (8260).</p> <ul style="list-style-type: none"> • Are the upper radiator hose and the heater water hoses cold? <p>▶ Yes INSTALL a new water thermostat. TEST the system for normal operation.</p> <p>▶ No Go to 6.</p>
<p>6 CHECK THE COOLING FAN OPERATION</p>	<p>1 Perform the cooling fan component tests. For additional information, refer to the Component Tests in this section.</p> <ul style="list-style-type: none"> • Is the cooling fan operation OK? <p>▶ Yes GO to Section 01 for diagnosis and testing of the engine.</p> <p>▶ No INSTALL a new component determined to be faulty. For additional information, refer to Fan – Blade, and Shroud in this section. TEST the system for normal operation.</p>

(Continued)

PINPOINT TEST C: THE ENGINE DOES NOT REACH NORMAL OPERATING TEMPERATURE

TEST CONDITIONS	TEST DETAILS/RESULTS/ACTIONS
<p>1 CHECK THE ENGINE TEMPERATURE</p>	<p>1 Start the engine and allow the engine to idle for ten minutes.</p> <p>Feel the inlet and heater water hoses and the underside of the upper radiator hose.</p> <ul style="list-style-type: none"> • Are the upper radiator hose and the heater water hoses cold? <p>▶ Yes INSTALL a new water thermostat.</p> <p>▶ No Test and diagnose the engine coolant temperature gauge.</p>

SPECIFICATIONS

General Specifications

Item	Specification
Drive Belt	6 Ribs
Capacity 4.2L ¹ (qts)	16.4 (17.3)
Coolant Mixture With Water	50% ²
Radiator Pressure Test	138 kPa (20 psi)
Water Pump Pulley Ratio	1.2
Water Thermostat Start To Open Temperature C (F)	83-87°C (181-188.6°F)
Water Thermostat Full Open Temperature C (F)	97.7-100°C (206-213°F)
Lubrication & Sealants	
Ford Premium Cooling System Flush F1AZ-19A503-A	ESR-M14P7-A
Pipe Sealant with Teflon® D8AZ-19554-A	WSK-M2G350-A2
Premium Long Life Grease XG-1-C	ESA-M1C75-B
Stop Leak Powder E6AZ-19558-A	ESE-M99B170

¹ Includes radiator coolant recovery reservoir fluid level between the "COOLANT FILL LEVEL" lines.

² Ford Premium Engine Coolant (green in color) ESE-M97B44-A or -B (Canada: Motorcraft CXC-10-B, Oregon: VC-5) Recycled Coolant or equivalent meeting Ford specification ESE-M97B44-A.

Torque Specifications

Description	Nm	Lb-Ft
Belt Idler Pulley Bolt	55	40
Drive Belt Tensioner Bolt	55	40

Description	Nm	Lb-Ft	Lb-In
Cylinder Head Temperature Sensor	9-11	-	80-95
Pulley to water pump	21-29	15-21	
Fan Assembly To Water Pump	55	41	-
Fan Shroud Bolts	9	-	80
Radiator Draincock	0.7-1.4	-	6-12
Radiator Support Bracket Bolts	30	22	-
Water Inlet and Outlet Connection Clamps	9	-	80
Water Pump Bolts	25	18	-
Water Outlet Tube Mounting Bolt	35-45	26-33	-

NOTE: Bolt information on installation page this section.

INDEX

Subject	Page
General Information	
Generator	06- 3
Circuit Description	06- 3
Diagnosis and Testing	
Recommended Accessory Wiring	06- 4
Recommended Generator Wiring.....	06- 5
Voltage Regulator and Back of Governor.....	06- 5
Visual Inspection	06- 6
Generator Output Test	06- 6
Generator Voltage Test.....	06- 6
Battery - Drain Test	06- 6
Symptom Chart	06- 8
Pinpoint Test A: Generator Output Voltage.....	06- 9
Pinpoint Test B: Voltage Output High.....	06- 11
Pinpoint Test C: Indicator Lamp ON, Engine Running.....	06- 12
Removal and Installation	
Generator - Removal.....	06- 13
Generator - Installation.....	06- 13
Regulator - Removal	06- 13
Regulator - Installation	06- 14
Specifications	
Torque Specifications.....	06- 15
Generator Parts Cross-Reference.....	06- 15
Special Tools.....	06- 15



GENERAL INFORMATION

Generator

With the key in the RUN position, voltage is applied through the charge indicator lamp "I" circuit to the voltage regulator. This turns the voltage regulator on allowing current to flow from the battery sense "A" circuit to the generator field coil. When the engine (6007) is started, the generator (10346) begins to generate alternating (AC) current which is converted to direct (DC) current by the rectifier internal to the generator. This current is then supplied to the electrical system through the Battery Positive voltage (B+) terminal located on the rear of the generator.

Once the generator begins generating current, a voltage signal is taken from the stator and fed back to the voltage regulator "S" circuit, turning off the charge indicator/lamp.

With the system functioning normally, the generator output current is determined by the voltage at the "A" circuit. This voltage is compared to a set voltage internal to the voltage regulator, and the voltage regulator controls the generator field current to maintain proper generator output. The set voltage will vary with temperature and is typically higher in the winter than in the summer, allowing for better battery recharge.

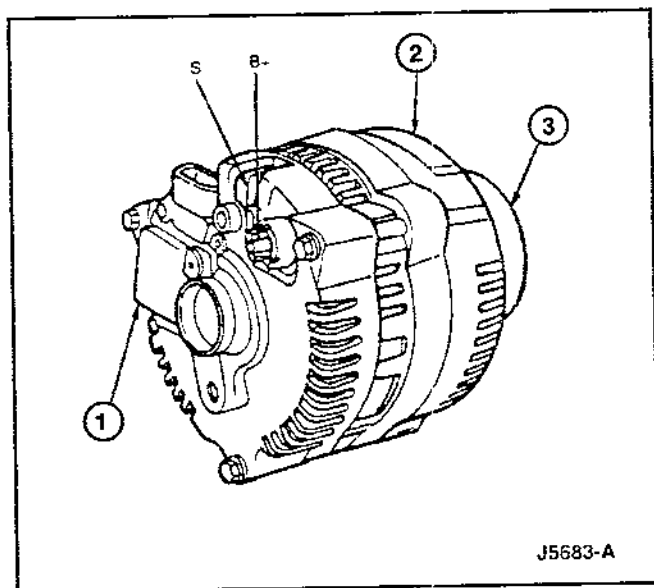

- ① Generator Regulator 10316
- ② Generator 10346
- ③ Generator Pulley 10344

Circuit Description

Battery Positive Voltage (B+) Output

The generator output circuit 38 (BK/O) is supplied through the battery positive voltage (B+) output connection to the battery and electrical system. The B+ circuit is hot at all times. This circuit is protected by a 12 gage fuse link.

"I" Circuit

The "I" circuit, or ignition switch (11572), circuit 904 (LG/R) is used to turn on the voltage regulator. This circuit is closed with the ignition switch in the RUN position. This circuit is also used to turn the charge indicator lamp on if there is a fault in the charging system operation or associated wiring circuits.

"A" Circuit

NOTE: The "A" circuit is electrically hot at all times.

The "A" circuit, or battery sense circuit, circuit 36 (Y/W) is used to sense the battery voltage. This voltage is used by the voltage regulator to determine the output. This circuit is also used to supply power to the field coil. This circuit is recommended to be protected by a 15 amp fuse or a fuse link.

"S" Circuit

The "S" circuit, or stator circuit, circuit 4 (W/BK) is used to feed back a voltage signal from the generator to the voltage regulator. This voltage, typically 1/2 battery voltage when the generator is operating, is used by the voltage regulator to turn off the charge indicator lamp.

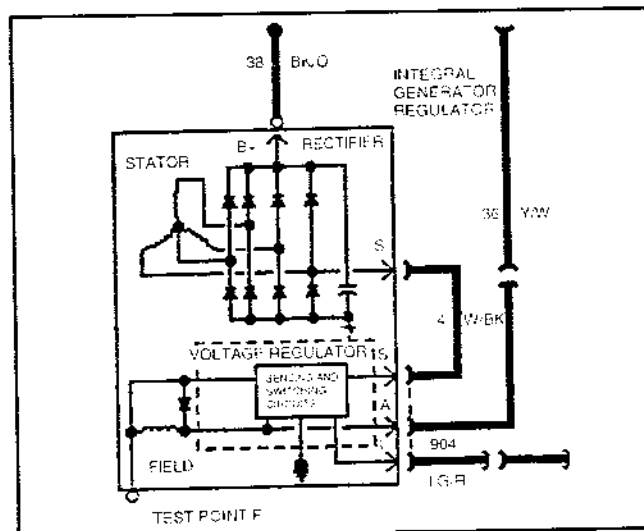

DIAGNOSIS AND TESTING

Recommended Accessory Wiring

NOTE: Dashed wire lines are CUSTOMER SUPPLIED!!

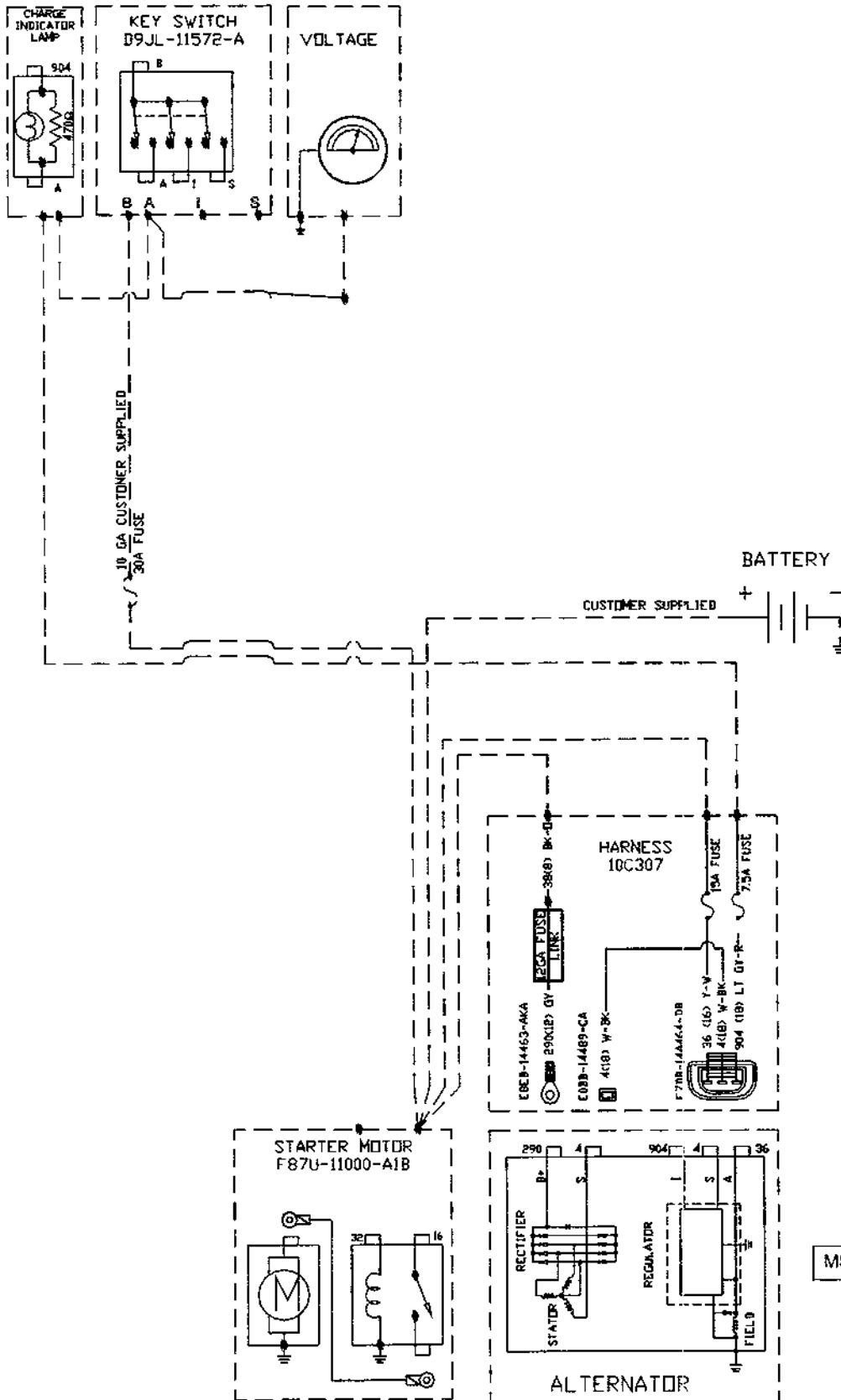

MS-2U1L-3458-BA

Recommended Generator Wiring

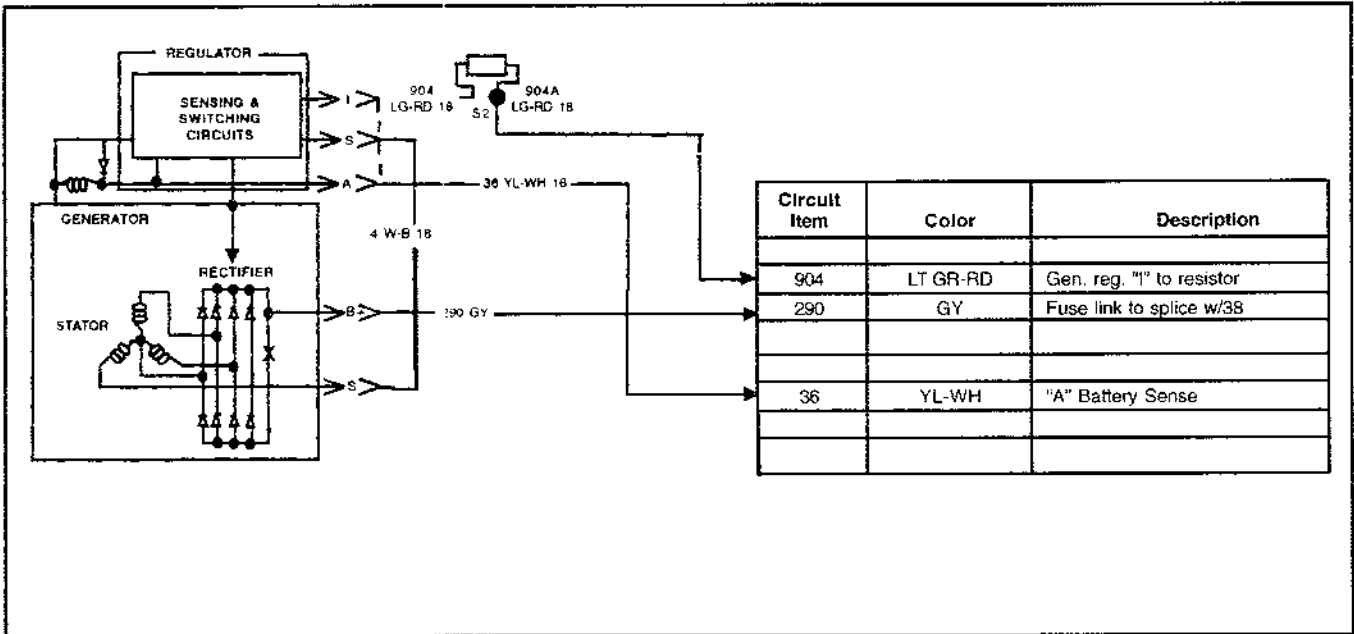

Before performing generator tests on the unit, note conditions such as: slow cranking, dead battery, charge indicator lamp stays on with engine running, etc. This information will aid in isolating the part of the system causing the symptom.

Voltage Regulator and Back of Governor

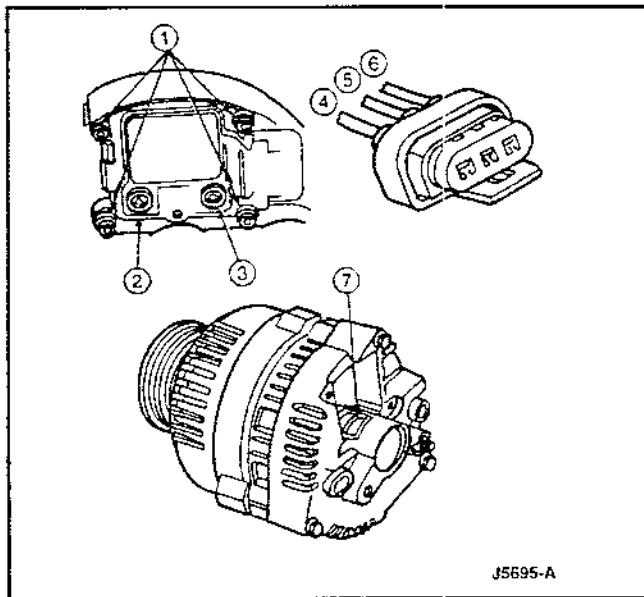

Item	Part Number	Description
1	-	Mounting Screws (Ground Connection) (4 req'd). Tighten to 1.7-2.8 Nm (15-25 In-Lb) (Part of 10316).
2	-	Brush Holder Screw (Test Point "F") (Part of 10316).
3	-	Brush Holder Screw (Test Point "A") (Part of 10316).
4	-	I Circuit 904 (Part of 14305).
5	-	S Circuit 4 (part of 14305).
6	-	A Circuit 36 (Part of 14305).
7	10328	Rotor Slip Ring.

Visual Inspection

Preliminary checks to the charging system should be made regardless of the fault condition. These checks include:

1. Check battery posts and cable terminals for clean and tight connections. Clean the posts and the cables to ensure good electrical contact.
2. Check for secure connections at the generator output, regulator, and engine ground. Also check the connection at the load distribution point (starter relay).
3. Check the fuses/fuse links and wiring to the generator to ensure that they are not burned or damaged. This condition, resulting in an open circuit or high resistance, can cause erratic or intermittent charging system concerns.
4. Check the battery voltage. If the voltage is less than 12.3 volts with the engine and all accessories off, charge battery before proceeding.

In order to check the generator, the use of Rotunda Starting and Charging System Tester 078-00005 (VAT-40) [Rotunda Tools (1-800-578-7375)] or equivalent, is recommended.

Generator Output Test

NOTE: Refer to the test equipment user's manual for complete directions on examining the charging system.

1. Switch the tester to ammeter function.
2. Connect the positive and negative leads of the tester to the battery.
3. Connect current probe to generator B+ output lead Circuit 38 (BK/O) (to measure generator output).
4. With the engine running at 2000 rpm, adjust the VAT-40 or equivalent load bank to determine the output of the generator. Generator output should be greater than values given in graph below. If not, refer to symptom chart in this Section.

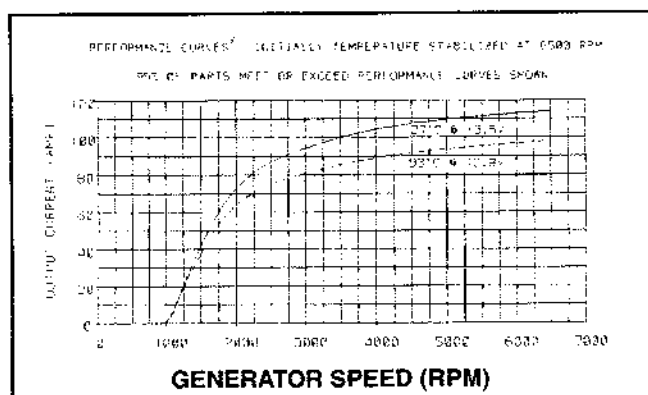

Generator Voltage Test

1. Switch the tester to the voltmeter function.
2. Connect the positive lead to the generator A- terminal connector and the negative lead to ground.
3. Turn off all electrical accessories.
4. With the engine running at 2000 rpm, check the generator voltage.
5. Voltage should be between 13.0-15.5 volts.

NOTE: If voltage is **not** within specifications, refer to symptom chart.

Battery — Drain Test

WARNING: DO NOT ATTEMPT THIS TEST ON A LEAD-ACID BATTERY THAT HAS RECENTLY BEEN RECHARGED. EXPLOSIVE GASES MAY CAUSE PERSONAL INJURY. FAILURE TO FOLLOW THESE INSTRUCTIONS MAY RESULT IN PERSONAL INJURY.

CAUTION: To prevent damage to the meter, do not crank the engine or operate accessories that draw more than 10A.

NOTE: No accessory system should have more than a 50 mA (0.050 amp) draw.

NOTE: Many modules draw 10 mA (0.010 amp) or more continuously.

NOTE: Use an in-line ammeter between the battery positive or negative post and its respective cable.

NOTE: Typically, a drain of approximately one amp can be attributed to a lamp staying on continually. Other component failures or wiring shorts may be located by selectively pulling fuses to pinpoint the location of the current drain. When the current drain is found, the meter reading will fall to an acceptable level. If the drain is still not located after checking all the fuses, it may be due to the generator.

NOTE: To accurately test the drain on a battery, an in-line digital ammeter must be used. Use of a test lamp or voltmeter is not an accurate method.

WSG-1068 CHARGING SYSTEM

Check for current drains on the battery in excess of 50 milliamps (0.050 amp) with all the electrical accessories off and the engine off. Current drains can be tested with the following procedure:

1. Make sure the junction box/fuse panels are accessible without turning on auxiliary components.
2. Operate the engine at least five minutes and exercise systems.
3. Allow the engine to sit with the key OFF for at least 40 minutes to allow modules to time out/power down.
4. Connect a fused jumper wire between the negative battery cable and the negative battery post to prevent modules from resetting and to catch capacitive drains.
5. Disconnect the negative battery cable from the post without breaking the connection of the jumper wire.

NOTE: It is very important that continuity is not broken between the battery and the negative battery cable when connecting the meter. If this happens, the entire procedure must be repeated. Connect the tester between the negative battery cable and the post. The meter must be capable of reading milliamps and should have a 10amp capability.

NOTE: If the meter settings need to be switched or the test leads need to be moved to another jack, the jumper wire must be reinstalled to avoid breaking continuity.

6. Remove the jumper wire.

NOTE: Amperage draw will vary from engine to engine depending on the equipment package. Compare to a similar engine for reference.

NOTE: No engine application should have more than a 50 mA (0.050 amp) draw.

7. If the draw is found to be excessive, pull fuses or disconnect suspected draws one at a time and note the current drop. Do not reinstall the fuses or connections until you are finished testing.
8. Check the wiring for any auxiliary circuits that run from the battery. Disconnect these circuits if the draw is still excessive.

Symptom Chart

SYMPTOM	POSSIBLE CAUSE	ACTION
Batter is discharged (battery voltage less than 8 volts)	<ul style="list-style-type: none"> • Corroded terminal(s). • Loose connection(s). • High key-off current drain(s). • Battery. • Generator. 	Go to Pinpoint Test A
The charge system warning indicator is on with the engine running (the system voltage does not increase)	<ul style="list-style-type: none"> • Circuitry. • Voltage regulator. • Generator. 	Go to Pinpoint Test C
The system overcharges (battery voltage greater than 15 volts)	<ul style="list-style-type: none"> • Circuitry. • Voltage regulator. • Generator. 	Go to Pinpoint Test B
The charging system warning indicator flickers or is intermittent	<ul style="list-style-type: none"> • Corroded terminal(s). • Circuitry. • Voltage regulator. • Generator. • Fuse(s). 	Go to Pinpoint Test A
The generator is noisy	<ul style="list-style-type: none"> • Bolts or brackets. • Drive belt. • Generator or pulley. 	Inspect accessory drive components

Pinpoint Test A: Generator Output Voltage

Inspection and Verification

1. Visually inspect for obvious signs of terminal corrosion and electrical harness damage.
2. Inspect fusible links and generator connector for bent or backed-out connector pins, or damage to wiring.
3. Visually inspect for and note auxiliary system connections not shown on the **Recommended Customer Connections Wiring Schematic**.

Normal Operation

With voltage applied to the generator I circuit, the regulator is activated, allowing current to flow from the sense A circuit to generator field coil. The generator then generates an internal AC current, which is converted to a DC output by the rectifier assembly internal to the generator, and is supplied to the battery through the B+ terminal. The S (stator) circuit is used to feed back a voltage signal from the generator to the regulator. This voltage (typically half battery voltage) is used by the regulator to turn off the charge indicator.

Step	Action	Values	Yes	No
1	1. Determine if the battery can hold a charge and is OK for use. Is the battery OK?	12.53-15.2 volts	GO to Step 2	Install a new battery and RETEST the system for normal operation.
2	1. Measure the voltage at the B+ terminal on the back of the generator. Is the voltage at B+ terminal equal to battery voltage?		GO to Step 3	Check the fusible links and replace if required. If OK inspect for open circuits.
3	1. Measure voltage at test point A on the voltage regulator. Is the voltage at test point A equal to battery voltage?		GO to Step 4	Check the fusible links and replace if required. If OK inspect for open circuits.
4	1. Measure voltage at test point F. Is the voltage at test point A equal to battery voltage?		GO to Step 5	GO to Step 11
5	1. KOEO. 2. Note: Voltage regulator must be connected to wiring harness for this test. Measure the voltage at wiring harness I terminal circuit 904. Is the voltage greater than 1 volt?		GO to Step 6	REPAIR the circuit(s) in question. TEST the system

Step	Action	Values	Yes	No
6	1. Measure the voltage drop between test point A on the voltage regulator and the positive (+) battery post. Is the voltage drop less than 0.25 volts?		Go to Step 7	Inspect auxiliary wiring connections for an excessive current draw. Check the fusible links and replace if required. REPAIR the circuit(s) in question. TEST the system
7	1. Measure the voltage at test point F on the voltage regulator. Is the voltage at test point F less than 2 volts?		Go to Step 8	Refer to the Fuel Systems Manufacturing Information and Test
8	1. Remove the one-pin S connector from the generator. 2. Measure for voltage between the S terminal on the back of the generator and ground. Is the voltage reading greater than 1 volt?		Replace the generator.	Go to Step 9
9	1. Install the S connector. 2. Start the engine. 3. Turn on any accessory. 4. With the engine running at 2000 RPM, measure the voltage drop between the B+ terminal on the back of the generator and the positive (+) battery post. Is the voltage drop greater than 0.5 volts?		Go to Step 10	Inspect wiring for auxiliary connections for an excessive current draw. REPAIR the circuit(s) in question. TEST the system
10	1. Connect a jumper wire from test point A on the voltage regulator to the battery negative post 2. Perform the Generator Output Test. Is generator output greater than the minimum output specified?		Replace the Voltage Regulator	Replace the Generator
11	1. Remove the generator. 2. Remove the voltage regulator. 3. Measure the resistance between the generator slip rings. Is the resistance greater than 10 ohms or less than 1 ohm?		Replace the Generator	Check for worn brushes (less than 8mm long) or open brush leads and replace if required

Pinpoint Test B: Voltage Output High

Inspection and Verification

1. Visually inspect for obvious signs of terminal corrosion and electrical harness damage.
2. Inspect for poor ground connections or backed-out connector pins, or damage to wiring.
3. Visually inspect for and note auxiliary system connections not shown on the **Recommended Customer Connections Wiring Schematic**.

Step	Action	Values	Yes	No
1	<ol style="list-style-type: none"> 1. KOEO. 2. Measure the voltage drop between test point A on the voltage regulator and the positive (+) battery post. <p>Is the voltage drop less than 0.25 volt?</p>		GO to Step 2	Inspect auxiliary wiring connections for an excessive current draw. Check the fusible links and replace if required. REPAIR the circuit(s) in question. TEST the system
2	<ol style="list-style-type: none"> 1. NOTE: Voltage regulator must be connected to wiring harness for this test. 2. Measure the voltage at wiring harness terminal circuit 904 LG/RD. <p>Is the voltage greater than 1volt?</p>		GO to Step 3	Inspect auxiliary wiring connections for an excessive current draw. Check the fusible links and replace if required. REPAIR the circuit(s) in question. TEST the system
3	<ol style="list-style-type: none"> 1. Check for poor ground connections between voltage regulator and the generator. 2. Check for poor ground connection between the engine and battery. <p>Are all ground connections clean and tight?</p>		GO to Step 4	CLEAN or REPAIR grounds as required
4	<ol style="list-style-type: none"> 1. Key OFF 2. Measure voltage at test point F on the voltage regulator. <p>Is the voltage at test point F equal to battery voltage?</p>		Generator is OK, Replace the voltage regulator	GO to Step 5
5	<ol style="list-style-type: none"> 1. Remove the generator. 2. Remove the voltage regulator. 3. Measure the resistance between each generator slip ring to the generator housing. <p>Is the resistance between each ring and the generator housing less than 200 ohms?</p>		If grease or dirt has accumulated near the slip rings, CLEAN the slip rings and RECHECK resistance. If still less than 200 ohms, Replace the generator.	Replace the voltage regulator

Pinpoint Test C: Indicator Lamp ON, Engine Running**Inspection and Verification**

1. Visually inspect for obvious signs of terminal corrosion and electrical harness damage or a bulb failure.
2. Inspect fusible links and generator connector for bent or backed-out connector pins, or damage to wiring.
3. Visually inspect for and note auxiliary system connections not shown on the **Recommended Customer Connections Wiring Schematic**.

Normal Operation

With voltage applied the high side of a charge warning indicator lamp, the generator will momentarily pull the warning lamp to ground and illuminate the indicator until the regulator is activated. The S (stator) circuit is used to feed back a voltage signal from the generator to the regulator. This voltage (typically half battery voltage) is used by the regulator to turn off the charge indicator.

Step	Action	Values	Yes	No
1	<ol style="list-style-type: none"> 1. Disconnect the three-pin generator connector. 2. KOEO <p>Is the charge indicator ON?</p>		<p>Inspect the auxiliary wiring for a short to ground. REPAIR the circuit(s) in question. TEST the system</p>	GO to Step 2
2	<ol style="list-style-type: none"> 1. KOEO 2. Jumper the generator harness connector I terminal, circuit 904 LT GY/RD to ground. <p>Does the charge indicator illuminate?</p>		GO to Step 3	<p>Inspect the warning bulb and circuit 904 for an open circuit. REPAIR the circuit(s) in question. TEST the system</p>
3	<ol style="list-style-type: none"> 1. Reconnect the three-pin generator connector. 2. Remove the one-pin S connector. 3. Jumper the S terminal circuit 4 WH/BK to battery voltage. <p>Is the charge indicator ON?</p>		<p>Remove the jumper wire. GO to Step 4</p>	<p>Remove the jumper wire. GO to Step 5</p>
4	<ol style="list-style-type: none"> 1. Key Off. 2. Disconnect the three-pin generator connector. 3. Measure the resistance between the one-pin S connector and the S (center) pin of the voltage regulator connector. <p>Is the resistance greater than 1 ohm?</p>		<p>Repair open or excess resistance in circuit 4 WH/BK. TEST the system</p>	<p>CHECK for a loose or bent pin in the voltage regulator or connector. If OK, replace the voltage regulator.</p>
5	<ol style="list-style-type: none"> 1. Reconnect the one-pin S connector. 2. Start the engine. 3. Measure the voltage at the one-pin S connector. <p>Is the voltage at least ½ of the battery voltage?</p>		GO to Step 6	<p>GO to Pinpoint Test A to find the cause of low generator output.</p>

REMOVAL AND INSTALLATION

Generator - Removal

1. Disconnect battery ground cable (14301).
2. Remove snow/ice shield.
3. Disconnect the generator voltage regulator wiring (14305) to the voltage regulator.
4. Remove wiring connector bracket.
5. Relieve the tension of the drive belt tensioner (613209) and remove the drive belt.
6. Remove the bolts holding the generator to the generator bracket (10A313).
7. Remove the generator from the generator bracket.

Generator - Installation

1. Position the generator on the generator bracket.
2. Install the bolts and tighten to 40-55 Nm (30 -40 ft-lb).
3. Install the drive belt over the generator pulley.
4. Relieve the tension of the drive belt tensioner and install the drive belt over tensioner.
5. Connect generator voltage regulator wiring to the voltage regulator. Tighten generator Battery Positive Voltage (B+) wire attaching nut to 9-12 Nm (6.5-9 ft-lb).
6. Install wiring connector bracket.
7. Install snow/ice shield.
8. Connect battery ground cable.

Regulator - Removal

1. **NOTE:** for ease of removal and installation of regulator, remove the generator from engine as described above.

Remove the four screws (T20 Torx type head) attaching the voltage regulator to the generator housing. Remove the voltage regulator with generator brush holder (10351) attached, from the generator.

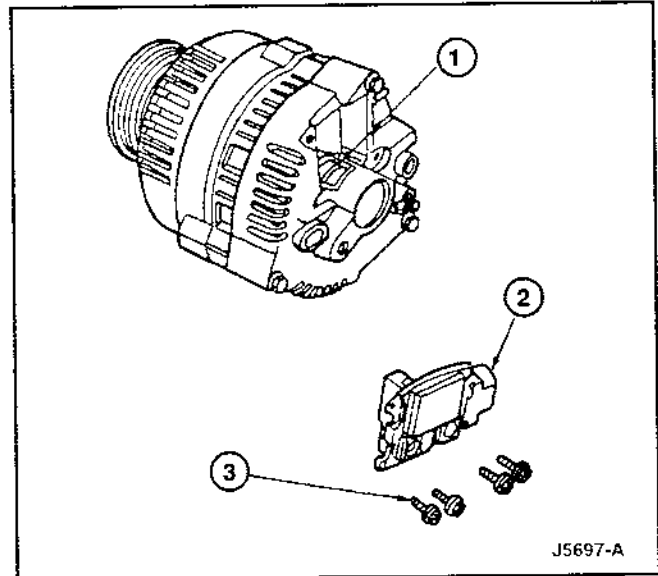

- | | |
|--|---|
| <p>① Slip Rings 10328</p> <p>② Regulator 10316 and Brush Holder Assembly 10347</p> | <p>③ Screw 4 Req'd. Tighten to 2.3-3.4 Nm (20-30 In-Lb)</p> |
|--|---|

2. Hold the voltage regulator in one hand and pry off the cap covering the "A" screw head with a screwdriver.
3. Remove two screws (T20 Torx type head) attaching the regulator to the generator brush holder. Separate the regulator from generator brush holder.

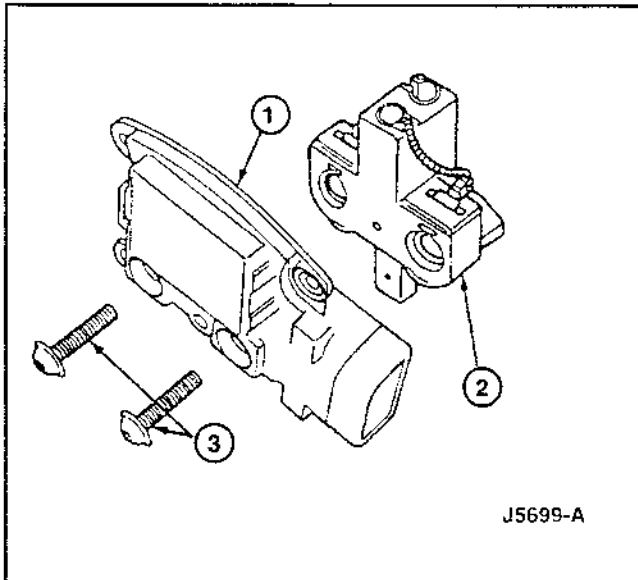

- ① Voltage Regulator 10316
- ② Generator Brush Holder 10347
- ③ Screw (2 Req'd) Tighten to 2.8-4.0 Nm (25-35 In-Lb)

Regulator - Installation

1. Replace generator brush holder to voltage regulator and install attaching screws.
2. Replace cap on the head of the "A" terminal screw.
3. Depress the generator brushes in the generator brush holder.
 - Hold the generator brushes in position by inserting a standard size paper clip (or equivalent) through both the location hole in the voltage regulator and through the holes in the generator brush holders.
4. Install the voltage regulator and generator brush holder to the generator with attaching screws.
 - Remove paper clip (or equivalent) from the regulator.
5. Install generator following installation in this section.

NOTE: Only the regulator, brush holder and generator pulley are serviceable. If the generator needs further service, it must be replaced as an assembly.

SPECIFICATIONS

Torque Specifications

Description	N m	Lb-Ft	Lb-In
Mounting Bracket Bolts	40-55	30-40	
Regulator Ground Screw	1.7-2.8	15.25	
Wire Attaching Nut	9-12	6.5-9	
Voltage Reg. Hold Down Bolts	2.8-4.0		25-35

Generator Parts Cross-Reference

Base Part #	Part Name	Old Part Name
6007	Engine	
6B209	Drive Belt Tensioner	
8620	Drive Belt	
10A313	Generator Bracket	Alternator Mounting Parts
10344	Generator Pulley	Alternator Pulley
10346	Generator	Alternator
10351	Generator Brush Holder	
14305	Generator Voltage Regulator Wiring	

Special Tools

Rotunda Equipment

Tool Number	Description
105-R0057	73111 Automotive Meter

INDEX

Subject	Page
General Information	
Sequence of Operation	07 - 3
Starter Lockout Relay	07 - 3
Jump Starting	07 - 4
Negative Grounded Battery	07 - 4
Diagnosis and Testing	
Starter Load Test	07 - 5
Bench Tests	07 - 5
Starter No-Load Test	07 - 6
Starter Lock-Out Relay	07 - 6
Main Jumper Harness	07 - 7
Starter Lockout Relay Schematic	07 - 8
System Inspection and Verification	07 - 9
Symptom Chart	07 - 9
Pinpoint Test A - Starter Lockout Relay Check	07 - 10
Pinpoint Test B - Starter Does Not Crank	07 - 11
Component Tests	07 - 13
Starter Drive and Flywheel Ring Gear Insection	07 - 15
Removal and Installation	
Starter Motor - Battery Cable Routing	07 - 16
Starter Motor - Removal	07 - 17
Starter Motor - Installation	07 - 18
Specifications	
Torque Specifications	07 - 20
General Specifications	07 - 20
Special Tools	07 - 20
Electronic Specifications	07 - 20



GENERAL INFORMATION

The function of the starting system is to crank the engine at a speed fast enough to permit the engine to start. Heavy cables, connectors, and switches are used in the starting system because of the large current required by the starter while it is cranking the engine. The amount of resistance in the starting circuit must be kept to an absolute minimum to provide maximum current for starter operation. A discharged or damaged battery, loose or corroded connections, or partially broken cables will result in slower than normal cranking speeds, and may even prevent the starter from cranking the engine.

The starting system includes the permanent magnet gear-reduction starter motor with a solenoid-actuated drive, the battery, a remote control starter switch (part of the ignition switch), the starter relay, the heavy circuit wiring, and may include starter lock-out, controlled by the ICM through a starter lockout relay.

6. The current flows to the motor, and the drive pinion gear drives the flywheel and the engine crankshaft.
7. As current flows to the motor, the solenoid pull in coil is bypassed.
8. The hold-in coil keeps the drive pinion gear engaged with the flywheel.
9. The gear remains engaged until the ignition switch is released from the START position.

Field Service

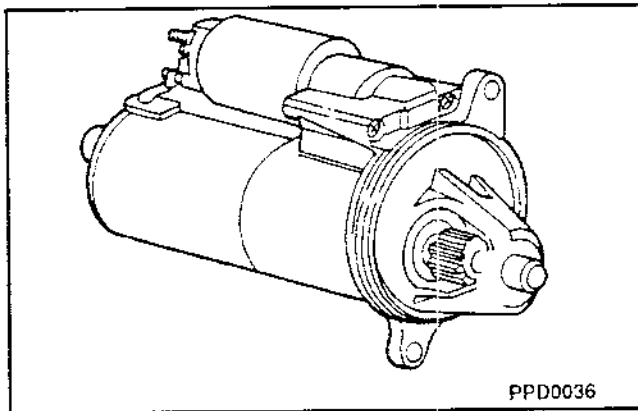

Starter Motor Assy 11001

Sequence Of Operation

1. The ignition switch is turned to the START position.
2. A remote starter relay is energized, which provides voltage to the starter solenoid. The starter solenoid is energized, creating a magnetic field in the solenoid coil.
3. The iron plunger core is drawn into the solenoid coil.
4. A lever connected to the drive assembly engages the drive pinion gear to the flywheel ring rear.
5. When the iron plunger core is all the way into the coil, its contact disc closes the circuit between the battery and the motor terminals.

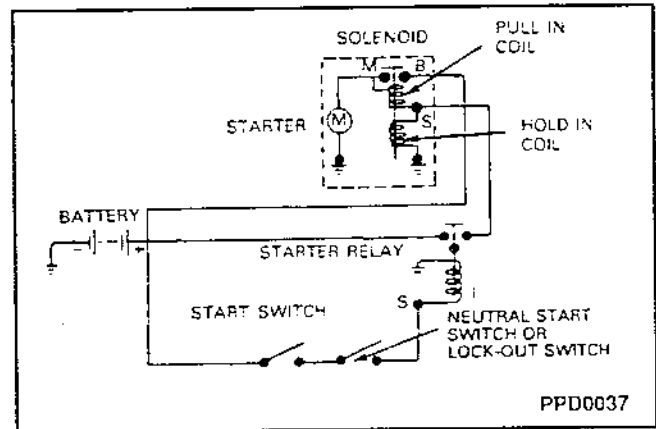

NOTE: The ICM is programmed to lock the starter out when the engine is operating over 600 rpm and the following sequence takes place:

Starter Lockout Relay

See page 07-6 for further details.

1. During start up with key in the on position 12V (B+) is applied to relay through circuit 32A (RD/LB) 16G.
2. With ignition switch turned to the crank position, current flows from ignition switch to relay circuit 32A (RD/LB) 16G through relay and out circuit 32 (RD/LB) 16G to starter solenoid.
3. The starter then should respond as in steps 2 through 9 in sequence of operation circuit 113 (YL/LB) 18G is connected to ICM C3 Pin "D". The ICM keeps circuit 113 open until it reads 400+ engine rpm. Over 600 rpm the ICM grounds circuit 113 causing the relay to open circuits 32A and 32. This will prevent starter engagement while engine is running.

NOTE: An overrunning clutch in the drive assembly protects the starter from the excessive speeds during the brief period before the driver releases the ignition switch from the START position (as the engine starts).

For cases of a starter that cranks the engine very slowly, connect a 12-volt booster battery to the system.

NOTE: Engine may not start if crank sensor reads less than 140 RPM.

Jump Starting

To avoid damage to the vehicle or equipment and battery or the possibility of personal injury, follow these instructions and precautions:



WARNING: HYDROGEN AND OXYGEN GASES ARE PRODUCED DURING NORMAL BATTERY OPERATION. THIS GAS MIXTURE CAN EXPLODE IF FLAMES, SPARKS OR LIGHTED TOBACCO ARE BROUGHT NEAR THE BATTERY. WHEN CHARGING OR USING A BATTERY IN AN ENCLOSED SPACE, ALWAYS PROVIDE VENTILATION AND SHIELD YOUR EYES.



WARNING: KEEP OUT OF REACH OF CHILDREN. BATTERIES CONTAIN SULFURIC ACID. AVOID CONTACT WITH SKIN, EYES OR CLOTHING. ALSO, SHIELD YOUR EYES WHEN WORKING NEAR THE BATTERY TO PROTECT AGAINST POSSIBLE SPLASHING OF THE ACID SOLUTION. IN CASE OF ACID CONTACT WITH SKIN, EYES OR CLOTHING, FLUSH IMMEDIATELY WITH WATER FOR A MINIMUM OF 15 MINUTES. IF ACID IS SWALLOWED, DRINK LARGE QUANTITIES OF MILK OR WATER, FOLLOWED BY MILK OF MAGNESIA, A BEATEN EGG, OR VEGETABLE OIL. CALL A PHYSICIAN IMMEDIATELY.



CAUTION: Do not disconnect the battery of the vehicle to be started. Disconnecting the battery could damage the vehicle's electronic system.

Negative Grounded Battery



WARNING: TO AVOID INJURY, USE PARTICULAR CARE WHEN CONNECTING A BOOSTER BATTERY TO A DISCHARGED BATTERY.

1. Position vehicles or equipment so jumper cables will reach, being careful that vehicles do not touch.



WARNING: MAKING THE FINAL CABLE CONNECTION COULD CAUSE AN ELECTRICAL SPARK NEAR THE BATTERY AND COULD CAUSE AN EXPLOSION. REFER TO WARNING AT THE BEGINNING OF THE JUMP STARTING PROCEDURE.



WARNING: WHEN SERVICING STARTER OR PERFORMING OTHER UNDERHOOD WORK IN THE VICINITY OF THE STARTER, BE AWARE THAT THE HEAVY GAUGE BATTERY INPUT LEAD AT THE STARTER SOLENOID IS "ELECTRICALLY HOT" AT ALL TIMES.

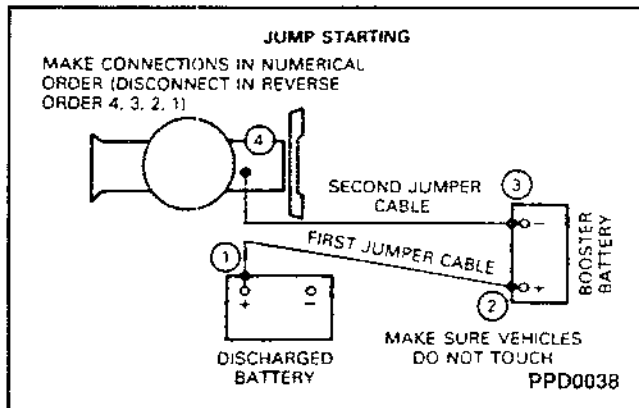

NOTE: Be sure to disconnect battery negative cable before servicing starter.

2. Make jumper cable connections.
 - a. Connect one end of first jumper cable to positive (+) 1 terminal of discharged battery and other end of positive (+) 2 terminal of booster battery.
 - b. Connect one end of second jumper cable to negative (-) 3 terminal of booster battery. Connect other end to an engine bolthead or good metallic contact spot on engine 4 of equipment to be started. NOT TO NEGATIVE (-) BATTERY TERMINAL.
 - c. Make sure jumper cables are not in way of moving engine parts.
 - d. Start engine of vehicle with good battery. Run engine at a moderate speed.
 - e. Start engine of vehicle with discharged battery. Follow starting instructions in the Owner Guide.
3. Completely discharged batteries may require an electrical load to initialize charging.
4. Remove cables in exact REVERSE sequence. Begin by removing negative (-) cable from engine of vehicle 4 that had discharged battery.

If the starter does not turn the engine over, even with the booster battery attached, refer to On Vehicle Testing.

DIAGNOSIS AND TESTING

Starter Load Test

Conduct this test if the starter cranks slowly and it is desired to compare current to specifications.

1. Connect Rotunda Starting and Charging Tester 078-00005 or equivalent. Make sure that current is not flowing through ammeter and heavy-duty carbon pile rheostat portion of circuit (rheostat at maximum counterclockwise position).
2. Disconnect load from engine. Place transmission in NEUTRAL. Crank engine with ignition off, and determine exact reading on voltmeter. This test is

accomplished by disconnecting push-on connector "S" at starter relay and by connecting a remote control starter switch from positive battery terminal to "S" terminal starter relay.

3. Stop cranking engine and reduce resistance of carbon pile until voltmeter indicates same reading as that obtained while starter cranked the engine. The ammeter will indicate starter current draw under load. Check this with value listed in Specifications on page 07-19.

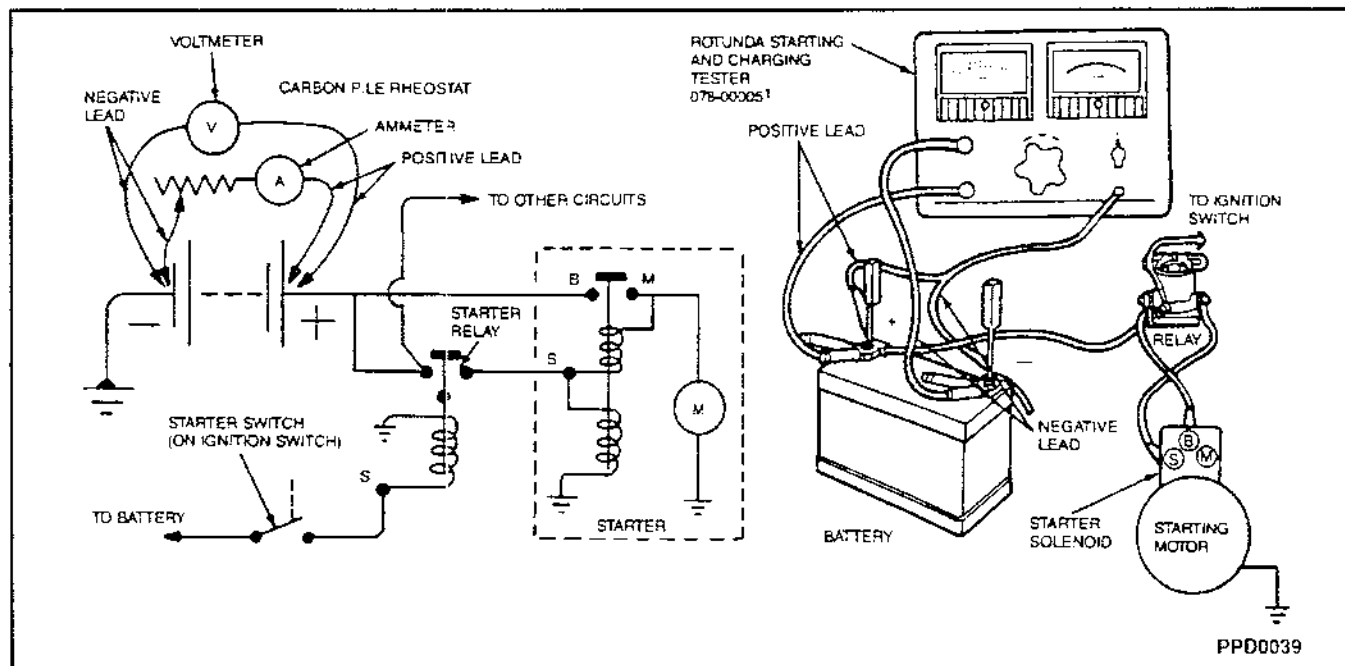

Bench Tests

CAUTION: Make sure that the starter is securely mounted in bench vise while energizing, as starter will move or jump.

1. Connect a fully charged battery, Rotunda Starting and Charging Tester 078-00005, or equivalent. Make sure that the battery and starter motor are grounded.
2. Engage the remote starter switch.
3. The starter motor should eject the starter drive and run smoothly. If the starter motor does not run smoothly, replace it.
4. While the starter motor is running, check the voltmeter and ammeter.

5. If the voltage is lower than the 11.0 volts, or the amperage is higher than 70 amps, replace the starter motor.

NOTE: Service parts for rebuilding permanent magnet starter are not available from Ford Power Products.

Starter No-Load Test

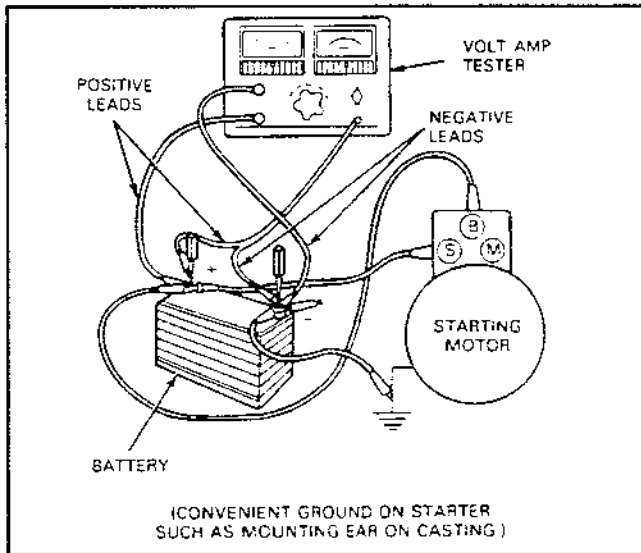

Circuit	Relay Terminal	Circuit Description
32	30	Voltage to Starter
16M	86	Relay Coil Power
113	85	To ICM
32A	87A	Ignition Feed
42	87	Auxiliary Run Output

NOTE: All readings are made with connector attached to relay and back probing connector using a paper clip and fully charged battery.

CAUTION: Make sure that the starter is securely mounted in bench vise while energizing, as starter will move or jump.

Starter Lock-Out Relay

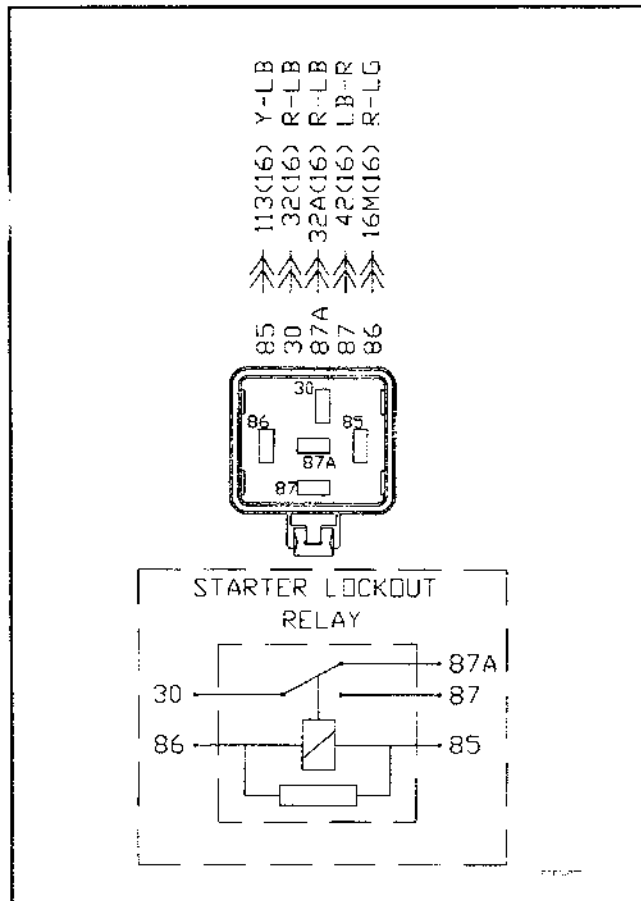

Function	Normal Specs.	Area to Check (Out of Specs.)
Circuit 16M		
K- Off =	0V	Ignition or wiring
KOEO =	12V	Check fuse and wiring
KOER =	12V	Check fuse and wiring
Crank =	12V	Ignition switch or wiring
Circuit 32		
K- Off =	0V	Wiring
KOEO =	12V	Ignition switch & wiring
KOER =	0V	ICM & wiring
Crank =	12V	Ignition switch & wiring
Circuit 32A		
K- Off =	0V	Wiring
KOEO =	12V	Ignition or wiring
KOER =	12V	Ignition or wiring
Crank =	12V	Ignition or wiring
Circuit 42		
K- Off =	0V	Wiring
KOEO =	0V	Ignition or wiring
KOER =	12V	Ignition or wiring
Crank =	0V	Ignition or wiring
Circuit 133		
K- Off =	0V	Ignition or wiring
KOEO =	12V	Relay or wiring
KOER =	12V	Relay or Wiring
Crank =	12V	Relay or wiring

WSG-1068 STARTER SYSTEM

Main Jumper Harness (XU1L-14324-BB)

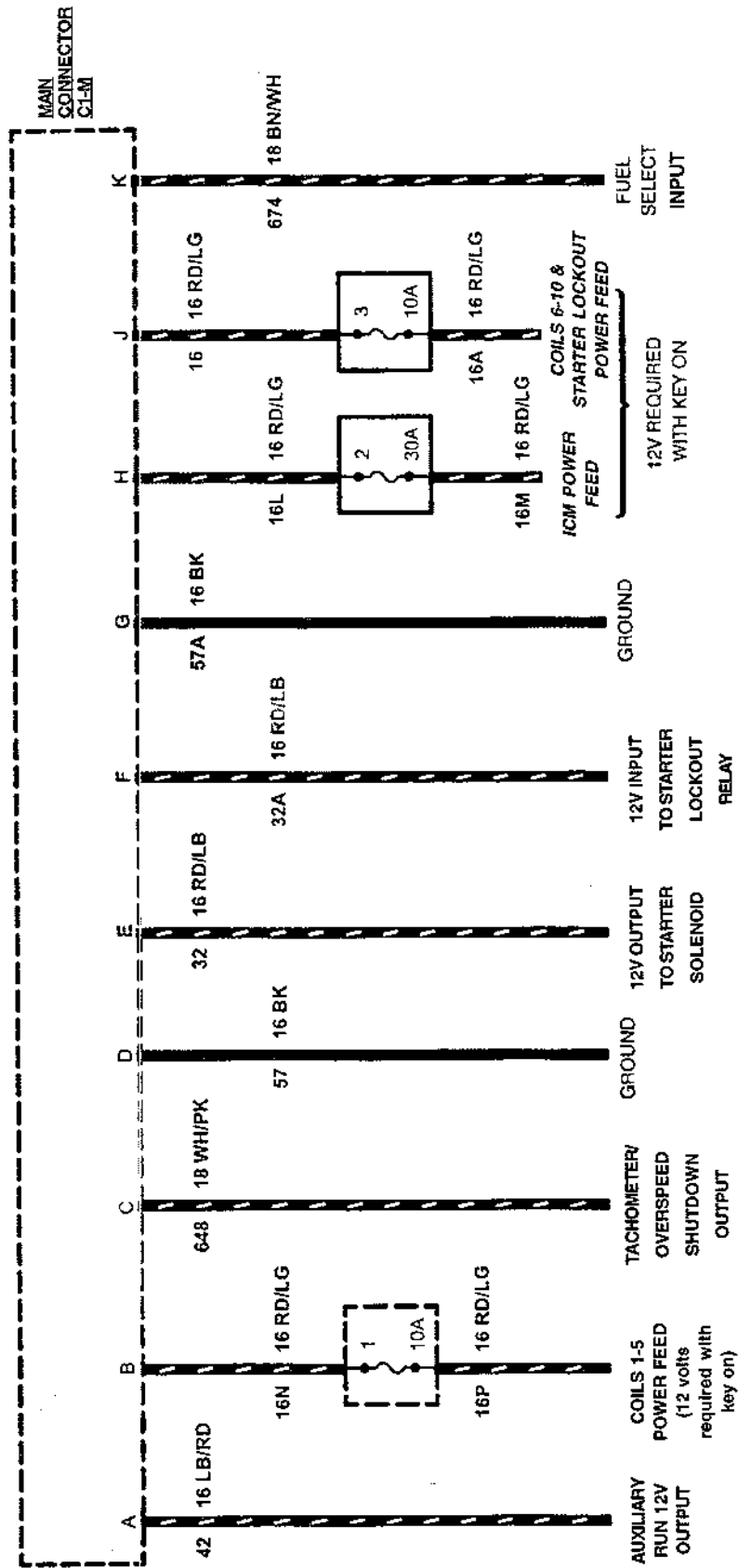

Starter Lockout Relay Schematic (part of SK2U1L-12A200-BA)

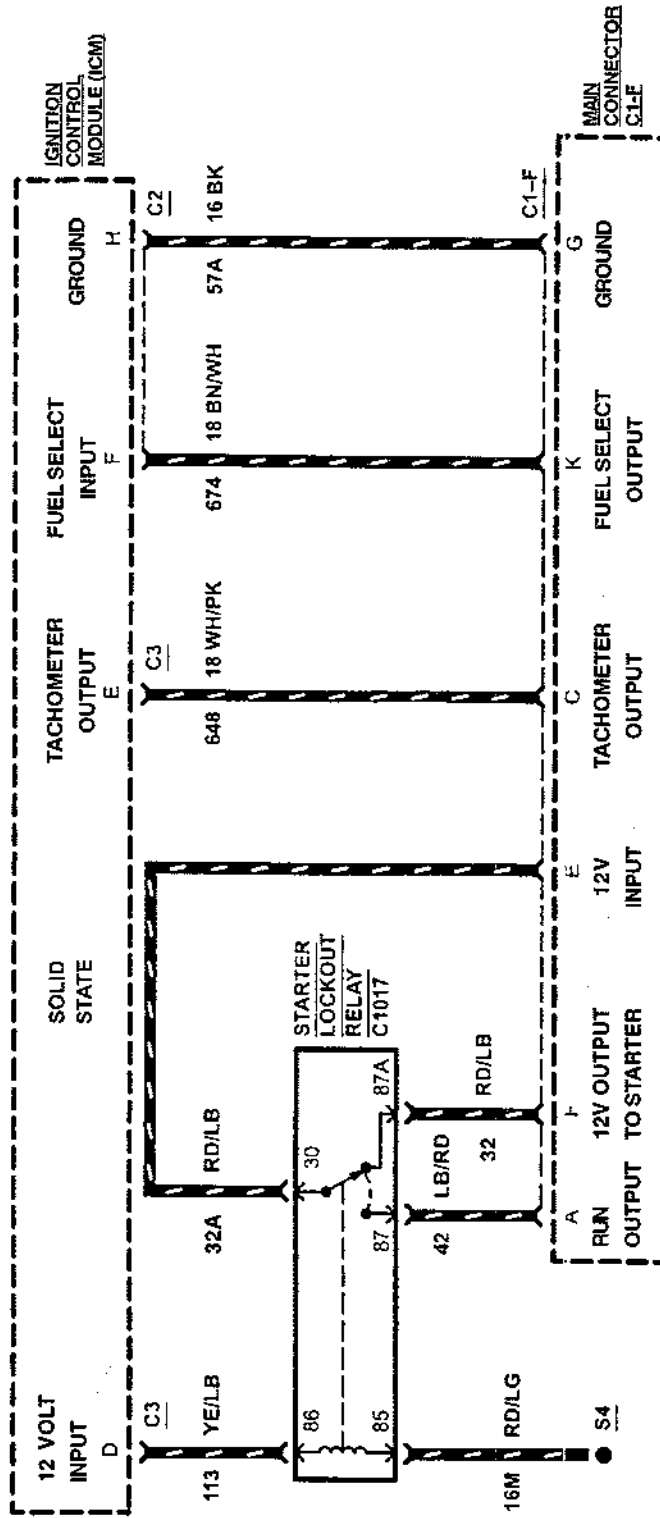

System Inspection and Verification

 **CAUTION:** When disconnecting the plastic hardshell connector at the solenoid "S" terminal, grasp the plastic connector and pull lead off. DO NOT pull separately on lead wire.

 **WARNING:** WHEN SERVICING STARTER OR PERFORMING OTHER WORK IN THE VICINITY OF THE STARTER, BE AWARE THAT THE HEAVY GAUGE BATTERY INPUT LEAD AT THE STARTER SOLENOID IS "ELECTRICALLY HOT" AT ALL TIMES.

NOTE: Be sure to disconnect battery negative cable before servicing starter.

1. Inspect starting system for loose connections.
2. If system does not operate properly, note condition and continue diagnosis using the symptom chart.

 **WARNING:** WHEN WORKING IN AREA OF THE STARTER, BE CAREFUL TO AVOID TOUCHING HOT EXHAUST COMPONENTS.

SYMPTOM CHART

CONDITION	POSSIBLE SOURCE	ACTION
Starter solenoid does not pull in and starter does not crank (audible click may or may not be heard).	<ul style="list-style-type: none"> • Low battery. • Defective remote relay. • Open circuit or high resistance in external feed circuit to starter solenoid. 	<ul style="list-style-type: none"> • Charge battery and retest. • Go to Test A. • Go to Test A.
Unusual starter noise during starter overrun.	<ul style="list-style-type: none"> • Starter not mounted flush (cocked). • Noise from other components. • Ring gear tooth damage or excessive ring gear runout. • Defective Starter. 	<ul style="list-style-type: none"> • Realign starter on transmission bell housing or SAE housing. • Investigate other powertrain accessory noise contributors. • Replace flywheel ring gear. • Replace starter. See removal and installation procedure this section.
Starter cranks but engine does not start.	<ul style="list-style-type: none"> • Problem in fuel delivery system. • Problem in ignition system. • Engine-related problem. • Engine does not exceed 100 RPM. 	<ul style="list-style-type: none"> • Refer to manufacture installed fuel system information. • Refer to ignition system section. • Refer to Section 01, Diagnosis and Testing.
Starter cranks slowly.	<ul style="list-style-type: none"> • Low battery. • High resistance or loose connections in starter solenoid battery feed or ground circuit. • Ring gear runout excessive. • Defective Starter. • Auxiliary Drive binding. 	<ul style="list-style-type: none"> • Charge or replace battery. • Check that all connections are secure. • Replace ring gear. • Check starter load. • Inspect auxiliary drives and components.
Starter remains engaged and runs with engine.	<ul style="list-style-type: none"> • Shorted ignition switch. • Battery cable touching solenoid "S" terminal (defective or mispositioned cable). • Defective Starter. 	<ul style="list-style-type: none"> • Go to Section 03. • Replace or relocate cable. • Replace starter. See removal and installation procedure this section.
Starter clicks and engages but engine will not crank.	<ul style="list-style-type: none"> • Low battery power. • Seized auxiliary component. • Hydrolocked cylinder. • Seized main or rod bearing. 	<ul style="list-style-type: none"> • Check battery. • Inspect auxiliary components. • Remove all plugs one at a time while checking for fluid in cylinders. • Repair as needed. Refer to Section 01.

Pinpoint Test A - Starter Lockout Relay Check

Inspection and Verification

1. Visually inspect for obvious signs of mechanical and electrical damage.
2. Visually inspect for and note auxiliary system connections not shown on the **recommended wiring schematic**.
3. > = Greater than
4. < = Less than

Normal Operation

Terminals 30 and 87A of the starter lockout relay are normally closed while the ignition switch is in the start/crank position and the engine rpm is less than 600. When the engine has reached 600 rpm or greater the ICM will ground the relay terminal 85 and open terminals 30 & 87A which will not allow the starter to be engaged while the engine is operating above 600 rpm.

Step	Action	Values	Yes	No
1	1. Check Fuse 1 for an open 10A fuse Is the fuse open?		Go to Section 03	GO to Step 2
2	1. Disconnect the starter lockout relay. 2. Key Off 3. Using an ohmmeter, measure for battery voltage on Circuit 16M RD/LG at the starter lockout relay connector. 4. KOEO. Is the voltage within the specified value?	Battery Voltage	GO to Step 3	Repair Circuit 16M RD/LG for OPEN and RETEST
3	1. Disconnect the starter lockout relay. 2. Key Off 3. Using an ohmmeter, measure the resistance of circuit 113 YL/LB to ground. 4. KOEO. Is the resistance less than 5.0 ohms?	>5ohms	GO to Step 4	GO to Step 5
4	1. Disconnect the ICM connector C3. 2. Disconnect the starter lockout relay. 3. Using an ohmmeter, measure the resistance of C3 Pin D Circuit 113 YL/LB to ground. Is the resistance less than 5.0 ohms?	>5ohms	Repair Circuit 113 YL/LB for a Short to ground and RETEST.	REPLACE the ICM and retest.
5	1. Key Off. 2. Disconnect the starter lockout relay. 3. Refer to the pin numbers molded on the Starter Lockout Relay. 4. Apply 12 volts to Starter Lockout relay terminal 30. 5. Apply ground to Starter Lockout relay terminal 85. 6. Measure the resistances between pin 30 and 87A. Is the resistance less than 5.0 ohms?		REPLACE the Starter Lockout Relay and retest.	

Pinpoint Test B - Starter Does Not Crank

Inspection and Verification

1. Visually inspect for obvious signs of mechanical and electrical damage.
2. Visually inspect for and note auxiliary system connections not shown on the **Recommended Customer Connections Wiring Schematic**.

Normal Operation

Terminals 30 and 87A of the starter lockout relay are normally closed while the ignition switch is in the start/crank position and the engine rpm is less than 600. Battery voltage flows to the starter solenoid engaging the starter. When the engine has reached 600 rpm or greater the ICM will ground the relay terminal 85 and open terminals 30 & 87A which will not allow the starter to be engaged while the engine is operating above 600 rpm. Once the relay is energized it will not reset until the ICM is turned off and then back on.

Step	Action	Values	Yes	No
1	Have you performed Pin Point Test E Ignition Check?		GO to Step 2	Go to Section 03 Pin Point Test A
2	<ol style="list-style-type: none"> 1. Note: This test may require an assistant depending on the application. 2. Turn and hold the Ignition switch in the START position. 3. Using an ohmmeter, measure for battery voltage at the starter solenoid START terminal. <p>Is the voltage within the specified value?</p>	Battery Voltage	GO to Section 07	GO to Step 3
3	<ol style="list-style-type: none"> 1. Disconnect the starter lockout relay. 2. Turn and hold the Ignition switch in the START position. 3. Using an ohmmeter, measure for battery voltage on Circuit 32A RD/LB at the starter lockout relay connector. <p>Is the voltage within the specified value?</p>	Battery Voltage	GO to Step 4	Repair Circuit 32A RD/LB between the starter lockout relay and the ignition switch S terminal for OPEN circuit and RETEST
4	<ol style="list-style-type: none"> 1. Key OFF 2. Using an ohmmeter, measure resistance between Circuit 32 RD/LB at the starter lockout relay connector and the starter solenoid ignition start terminal. <p>Is the resistance less than 5 Ohms?</p>		GO to Step 5	Repair Circuit 32 RD/LB between the starter lockout relay and the starter solenoid ignition start terminal for OPEN circuit and RETEST
5	<ol style="list-style-type: none"> 1. Disconnect the starter lockout relay. 2. KOEO 3. Turn and hold the Ignition switch in the START position. 4. Using an ohmmeter, measure resistance between Circuit 113 YL/LB at the starter lockout relay connector and known good ground. <p>Is the resistance greater than 5 Ohms?</p>		GO to Step 7	GO to Step 6

Step	Action	Values	Yes	No
6	1. Key Off. 2. Disconnect the starter lockout relay. 5. Using an ohmmeter, measure resistance between the Starter Lockout Relay terminals 30 and 87A. Is the resistance less than 5 Ohms?		GO to Step 7	REPLACE The Starter Relay and RETEST
7	1. Key OFF. 2. Disconnect the ICM connector C4. 3. Disconnect the starter lockout relay. 4. Using an ohmmeter, measure resistance between Circuit 113 YL/LB at the starter lockout relay connector and known good ground. Is the resistance less than 5 Ohms?		REPLACE the ICM and retest.	REPAIR the circuit(s) in question. TEST the system for normal operation.

Component Tests

Starter Motor - Voltage Drop Test



WARNING: WHEN REPAIRING THE STARTER MOTOR OR PERFORMING OTHER UNDERHOOD WORK IN THE VICINITY OF THE STARTER MOTOR, BE AWARE THAT THE HEAVY GAUGE BATTERY INPUT LEAD AT THE STARTER SOLENOID IS "ELECTRICALLY HOT" AT ALL TIMES. WHEN SHORTED TO GROUND, MAY CAUSE PERSONAL INJURY.

CAUTION: A protective cap or boot is provided over the battery input terminal on all vehicle lines and must be replaced after repairing. Failure to replace protective cap could cause electrical short that may damage electrical system. Be sure to disconnect the battery ground cable before repairing the starter motor.

NOTE: Always connect the 73 Digital Multimeter at the component terminal rather than at the wiring end connector. Making a connection at the wiring end connector could result in false readings because the meter will not pick up a high resistance between the wiring connector and the component.

Starter Motor - Motor Feed Circuit

1. Make sure the battery is fully charged.
2. Connect a remote starter switch between the starter motor solenoid S-terminal and the battery positive (+) terminal.
3. Connect the 73 Digital Multimeter positive lead to the battery positive (+) post. Connect negative lead to the starter motor solenoid M-terminal.

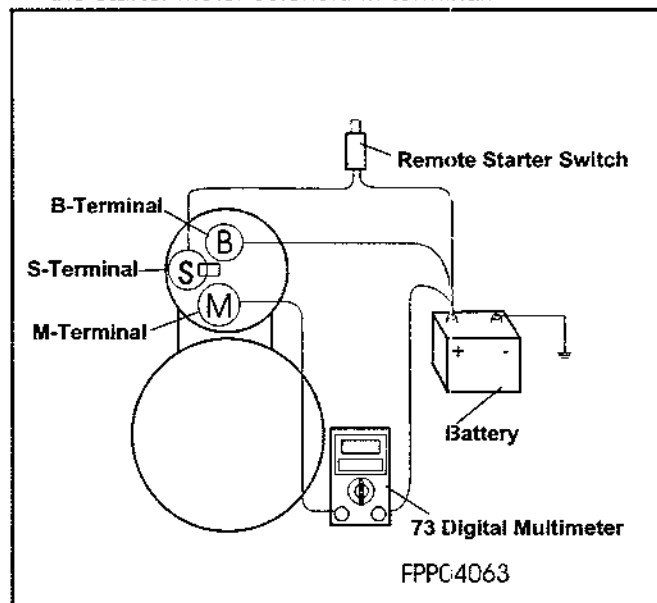

4. Engage the remote starter switch. Read and record the voltage. The voltage reading should be 0.5 volts or less.

5. If the voltage reading is 0.5 volts or less – Refer to "Starter Motor - Motor Ground Circuit" on page 14.
6. If the voltage reading is greater than 0.5 volts, indicating excessive resistance, move the 73 Digital Multimeter negative lead to the starter motor B-terminal and repeat the test. If the voltage reading at the B-terminal is lower than 0.5 volts, the concern is either in the connections at the starter motor solenoid or in the starter motor solenoid contacts.
7. Remove the cables from the starter motor solenoid B-, S- and M-terminals. Clean the cables and connections and reinstall the cables to the proper terminals. Repeat Steps 3 through 6. If the voltage drop reading is still greater than 0.5 volts when checked at the M-terminal or less than 0.5 volts when checked at the B-terminal, the concern is in the solenoid contacts. Replace the starter motor.
8. If the voltage reading taken at the starter motor solenoid B-terminal is still greater than 0.5 volts after cleaning the cables and connections at the solenoid, the concern is either in the positive (+) battery cable connection or in the positive battery cable itself.
9. By moving the 73 Digital Multimeter negative lead toward the battery and checking each mechanical connection point, the excessive voltage drop can be located. When the high reading disappears, the last mechanical point that was checked is the concern. Repair or replace this connection as required.

Starter Motor - Motor Ground Circuit

A slow cranking condition can be caused by resistance in the ground or return portion of the cranking circuit. Check the voltage drop in the ground circuit as follows:

1. Disconnect the inertia fuel shutoff switch (on road vehicle only).
2. Connect a remote starter switch between the starter motor solenoid S-terminal and the battery positive (+) terminal.
3. Connect the 73 Digital Multimeter positive lead to the starter motor housing (the connection must be clean and free of rust or grease). Connect the negative lead to the negative (-) battery terminal.

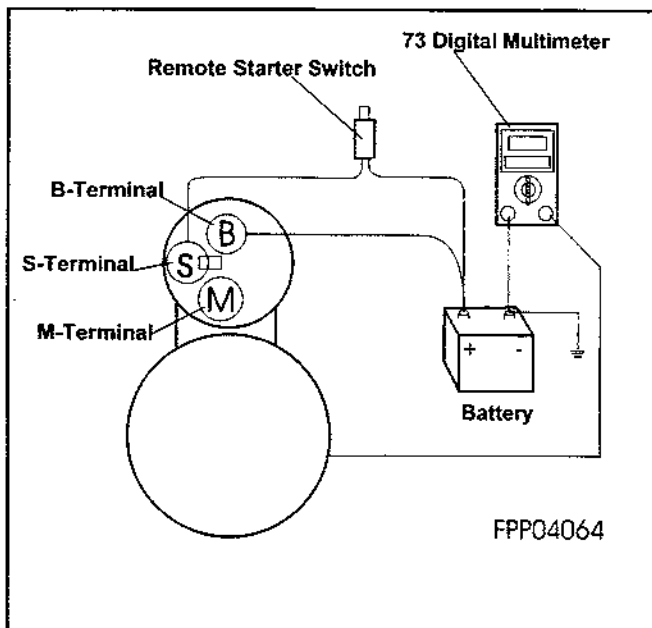

4. Engage the remote starter switch and crank the engine. Read and record the voltage reading. The reading should be 0.5 volts or less.
5. If the voltage drop is more than 0.5 volts, clean the negative cable connections at the battery and body connections, and retest.
6. If the voltage drop is greater than 0.5 volts, determine which way the current is flowing in the cable. Connect the 73 Digital Multimeter positive lead to the end of the cable nearest battery positive.
7. Connect the multimeter negative lead to the terminal at the other end of the cable.
8. Crank the engine and observe the voltage reading. The voltage reading should be 0.5 volts or lower. If the voltage drop is too high, clean the terminal ends. Retest, and if still high, replace the cable. If the voltage reading is less than 0.5 volts and the engine still cranks slowly, replace the starter motor.

Starter Drive and Flywheel Ring Gear Inspection

Pinion and Ring Gear Wear Patterns

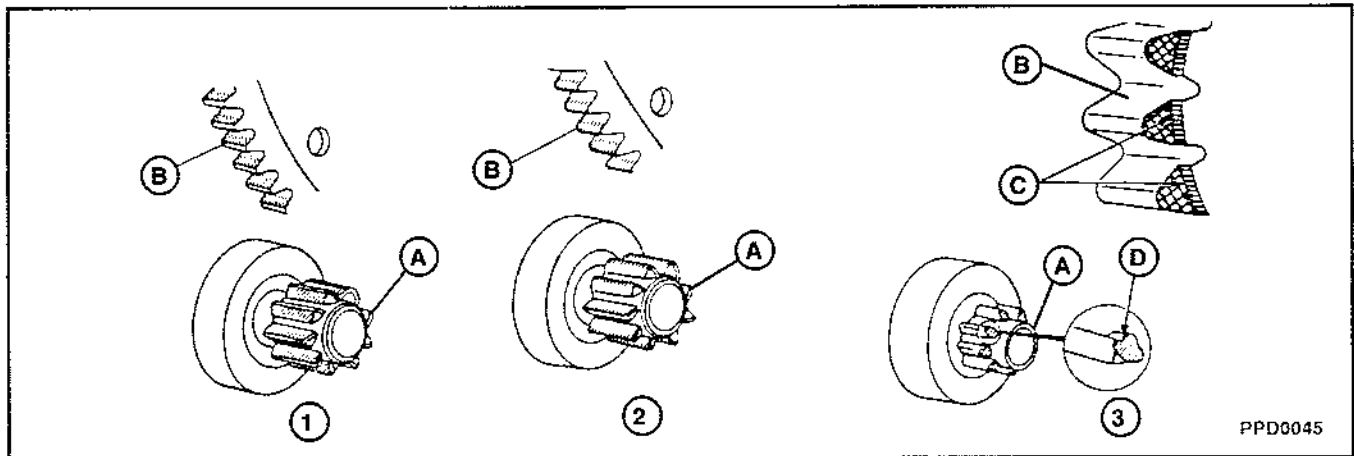

PPD0045

① NORMAL WEAR PATTERN

- Ⓐ Armature Gear
- Ⓑ Flywheel Gear

② SMALL WEAR PATTERN

- Ⓐ Armature Gear
- Ⓑ Flywheel Gear

③ MILLED GEARS

- Ⓐ Armature Gear
- Ⓑ Flywheel Gear
- Ⓒ Milled Condition Excessive Wear on 3 or 3 Teeth
- Ⓓ Milled Tooth Metal Build-up Will Not Permit Engagement

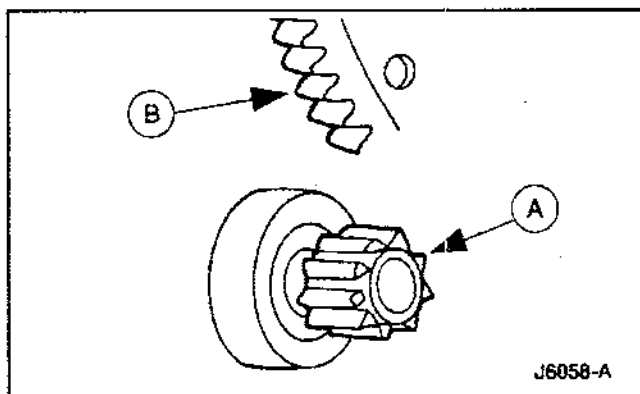

J6058-A

1. Check the wear patterns on the (A) starter drive (11350) and the (B) flywheel ring gear. If the wear pattern is normal, install the starter motor; refer to Starter Motor - Installation on page 07-18.

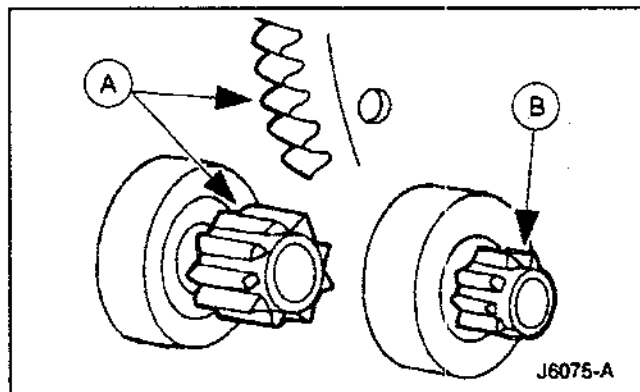

J6075-A

2. If the (A) starter drive gear and the flywheel ring gear are not fully meshing or the gears are (B) milled or damaged, replace the starter motor; refer to Starter Motor - Installation on page 07-18. Replace the flywheel ring gear.

REMOVAL AND INSTALLATION

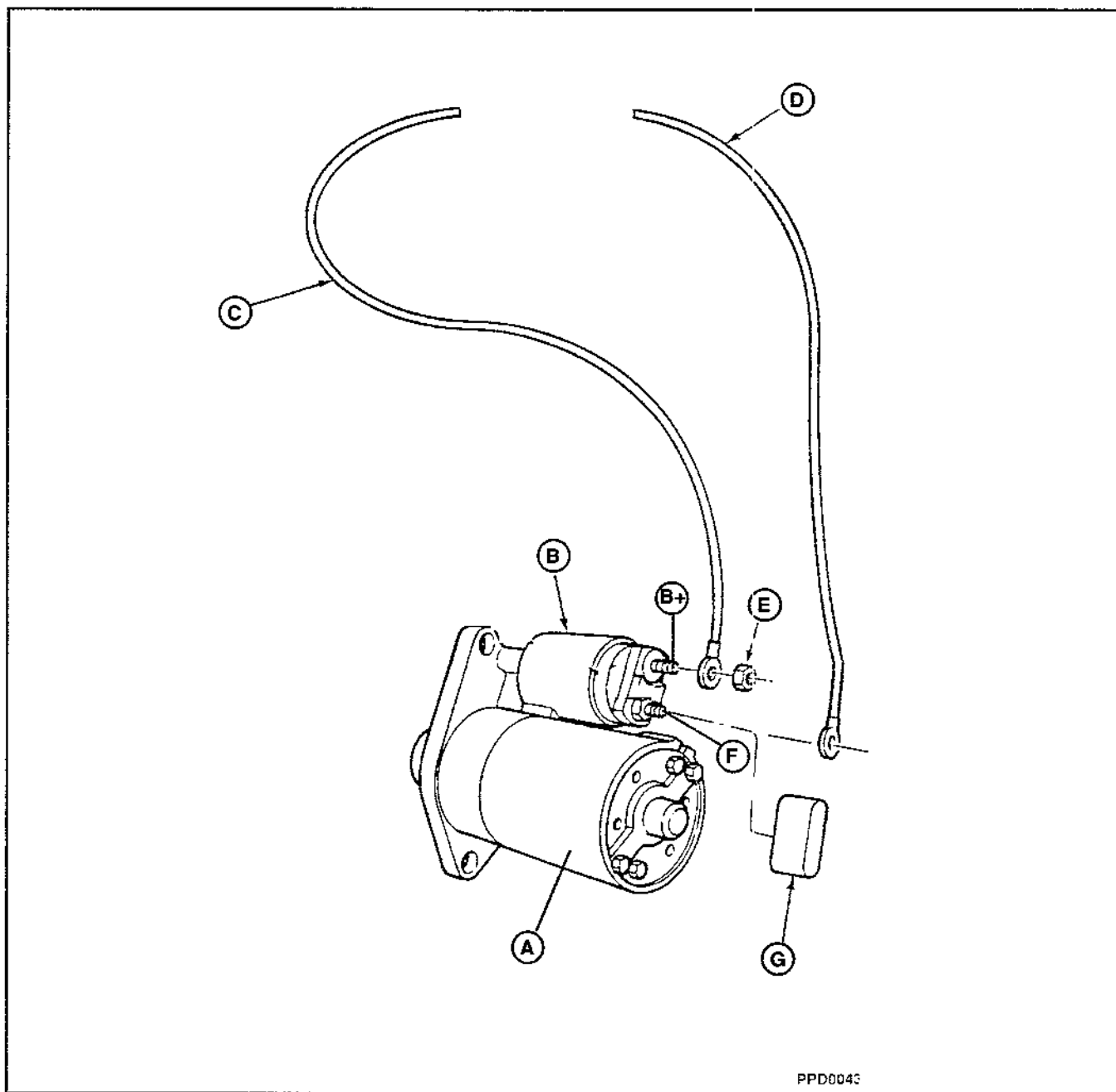

⚠ CAUTION: A jumper wire must not be installed between the large round electrical terminal and the solenoid blade terminal at the starter. If done, voltage is generated to the solenoid by the spinning starter after release of the start key or button, causing the starter to remain engaged, resulting in failure.

- (A) Permanent Magnet Starter
- (B) Starter Motor Solenoid
- (B+) 12 Volt Battery Supply Terminal
- (C) Starter Cable

- (D) B+ when relay is energized from ignition switch in crank position to "3" Terminal
- (E) Nut
- (F) Starter Solenoid Ignition Feed
- (G) Terminal Cover

Starter Motor - Removal

 **WARNING: WHEN CARRYING OUT MAINTENANCE ON THE STARTER SYSTEM BE AWARE THAT HEAVY GAUGE LEADS OR CONNECTED DIRECTLY TO THE BATTERY. MAKE SURE PROTECTIVE CAPS ARE IN PLACE WHEN MAINTENANCE IS COMPLETE. FAILURE TO FOLLOW THESE INSTRUCTIONS MAY RESULT IN PERSONAL INJURY.**

1. Disconnect the battery ground cable.
2. Raise and support the vehicle or equipment.
3. Remove the starter motor solenoid terminal cover (11N087).

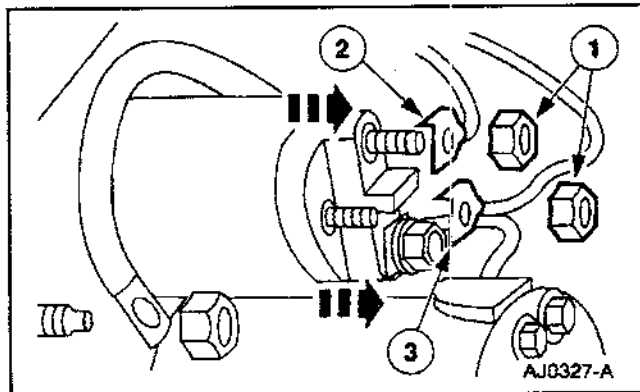
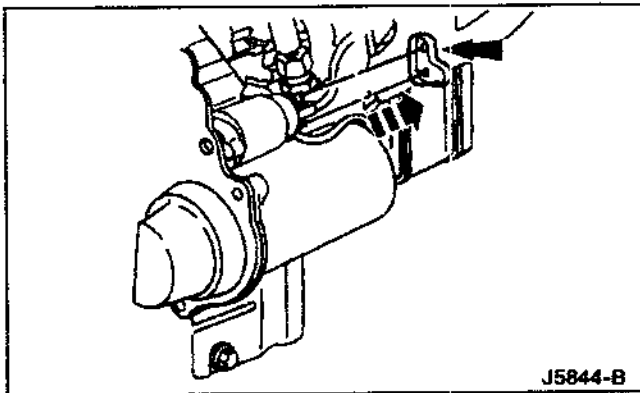

4. Disconnect the starter motor electrical connections.
 1. Remove the two nuts.
 2. Remove the battery cable.
 3. Remove the starter solenoid wire.

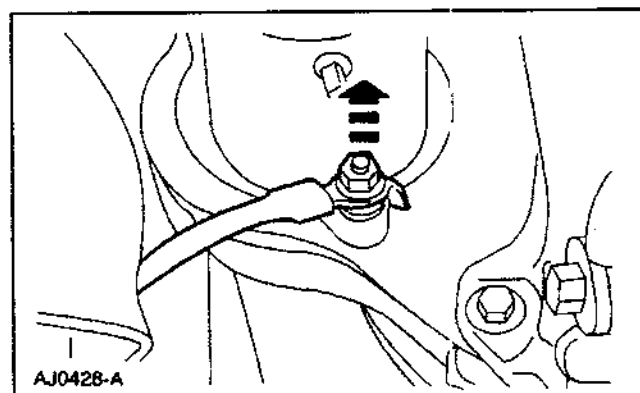

5. Remove the nut and the starter motor ground cable when equipped.

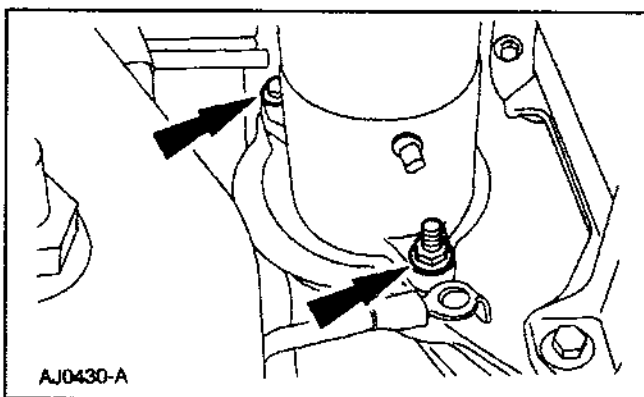

6. Remove the bolt and nut.

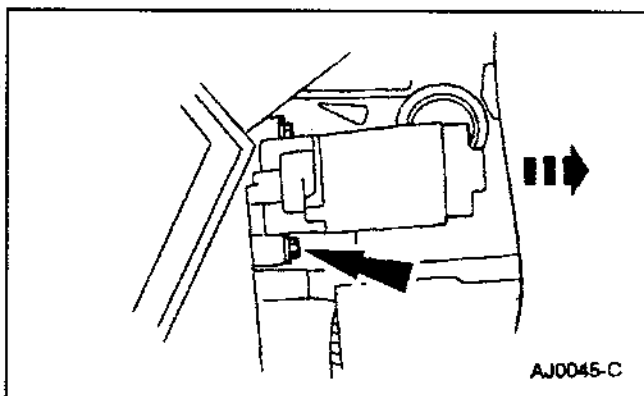

7. Remove the starter motor.

Starter Motor - Installation

 **WARNING: WHEN CARRYING OUT MAINTENANCE ON THE STARTER SYSTEM BE AWARE THAT HEAVY GAUGE LEADS ARE CONNECTED DIRECTLY TO THE BATTERY. MAKE SURE PROTECTIVE CAPS ARE IN PLACE WHEN MAINTENANCE IS COMPLETE. FAILURE TO FOLLOW THESE INSTRUCTIONS MAY RESULT IN PERSONAL INJURY.**

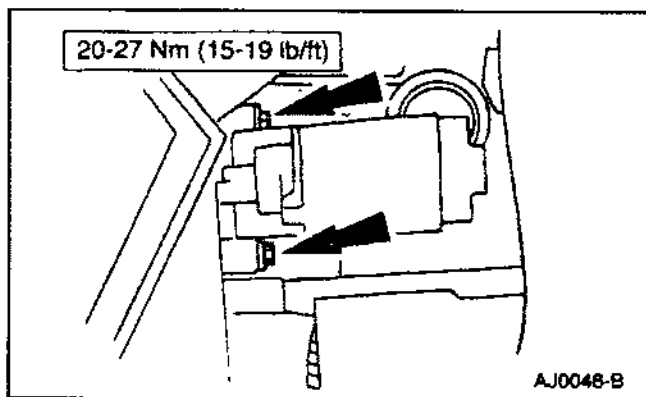

NOTE: It is recommended that wiring service kit F2PZ-11K162-A be used, which includes a 70 inch long #12 gauge wire, a terminal nut, a terminal cover, four tie wraps and insulation instructions.

1. Install the starter motor.
 1. Position the starter motor.
 2. Install the bolts.

WSG-1068 STARTER SYSTEM

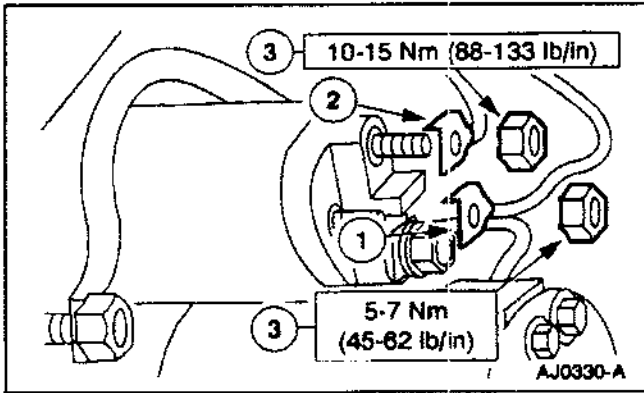

2. Connect the starter motor electrical connections.
 1. Position the starter solenoid wire.
 2. Position the battery cable.
 3. Install the nuts.

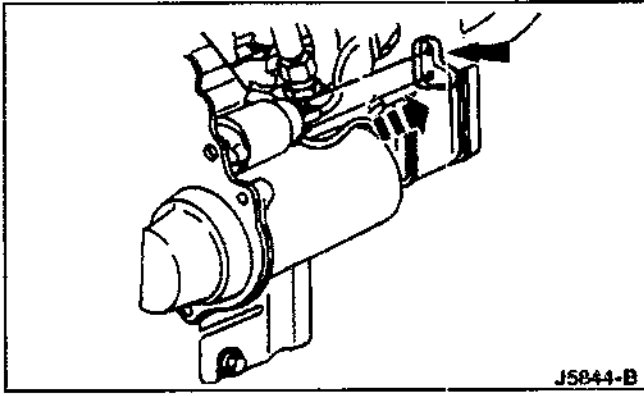

3. Install the starter motor solenoid terminal cover.
4. Connect the battery ground cable.

SPECIFICATIONS

Torque Specifications

Description	Nm	Lb-In
Brush Plate Screw	2.3-3.4	20-30
Mounting Bolt	20.3-27	15-20 (Lb-Ft)
Solenoid Bolt	5.1-9.6	45-85
Starting Circuit Max. Voltage Drop (Engine Temp. Normal) Volts		0.5
Terminal Nut "S"	10-14	84-120
Terminal Nut "B"	10-14	84-120
Through-Bolt	5.0-9.5	45-84

Electrical Specifications

Voltage Drop	
Starting circuit maximum voltage drop (engine temp. normal)	0.5 volts

General Specifications

Starter Motor						Starter Brushes					
Motor Diameter		Current Draw Under Normal Load	Normal Engine Cranking Speed *	Min. Stall Torque @ 5 Volts		Max. Load	No Load	Mfg. Length		Spring Tension	
mm	Inches	Amps	RPM	Nm	Lb-Ft	Amps	Amps	mm	Inches	N	oz.
108	4	130-220	140-220	14.7	11.0	800	70 ± 10	16.8	0.66	18	64

Maximum commutator runout is 0.12mm (0.005 inch). Maximum starting circuit voltage drop (battery positive terminal to starter terminal) at normal engine temperature is 0.5 volt.

*NOTE: Engine may not start if cranking speed is below 140 RPM.

Special Tools

Rotunda Equipment

Tool Number	Description
105-R0057	Digital Volt/Ohm Meter (DVOM)

Special Service Tools called for by the procedures can be obtained by calling:

1-800-ROTUNDA (1-800-768-8632).

INDEX

Subject	Page
General Information	
Camshaft Position Sensor (CMP) (Hall Effect).....	08- 3
Engine Cylinder Head Temperature Sensor (CHT).....	08- 5
Crankshaft Position Sensor (CKP).....	08- 7
Oil Pressure Switch.....	08- 9
Electronic Engine Controls (EEC).....	08- 10
Diagnosis and Testing	
General Procedures for Pinpoint Testing.....	08- 11
CHT Sensor Data.....	08- 12
Main Jumper Connector C1-M.....	08- 13
Starter Lockout.....	08- 14
Sensors.....	08- 15
Engine Controls.....	08- 16
Engine Harness Connectors.....	08- 17
ICM Connectors.....	08- 18
Recommended Wiring.....	08- 19
Main Jumper Harness.....	08- 20
Symptom Chart.....	08- 21
Pinpoint Test A - ICM Check.....	08- 24
Pinpoint Test B - Camshaft Position (CMP) Sensor Check.....	08- 26
Pinpoint Test C - Crankshaft Position (CKP) Sensor Check.....	08- 28
Pinpoint Test D - Coil on Plug Check.....	08- 30
Pinpoint Test E - Oil Pressure Sensor Check.....	08- 32
Pinpoint Test F - Cylinder Head Temperature Sensor Check.....	08- 34
Pinpoint Test G - Ground Shield Check.....	08- 36
Specifications	
Special Tools.....	08- 37



GENERAL INFORMATION

Camshaft Position Sensor (CMP) (HALL EFFECT)

The camshaft position (CMP) sensor detects the position of the camshaft. The CMP sensor identifies when piston No. 1 is on its compression stroke. The Coil On Plug (COP) Ignition application also uses the CMP signal to select the proper ignition coil to fire. The input circuit to the ICM is referred to as the CMP input or circuit.

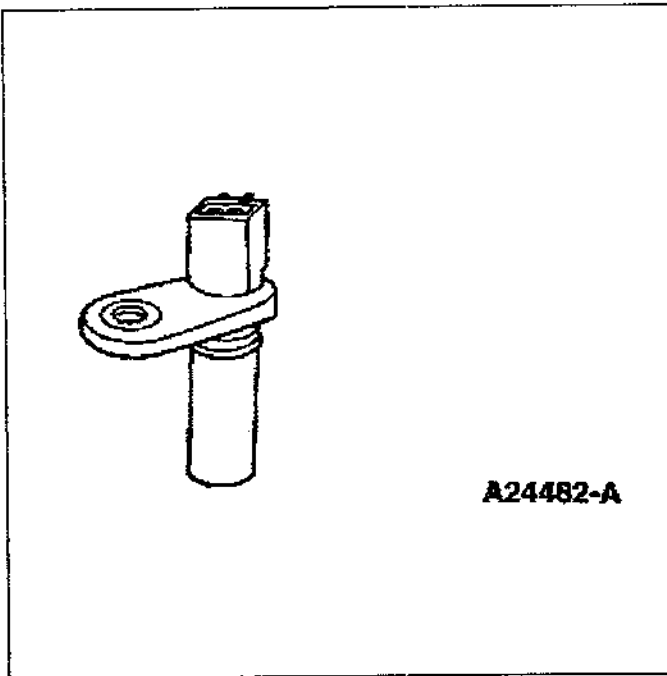

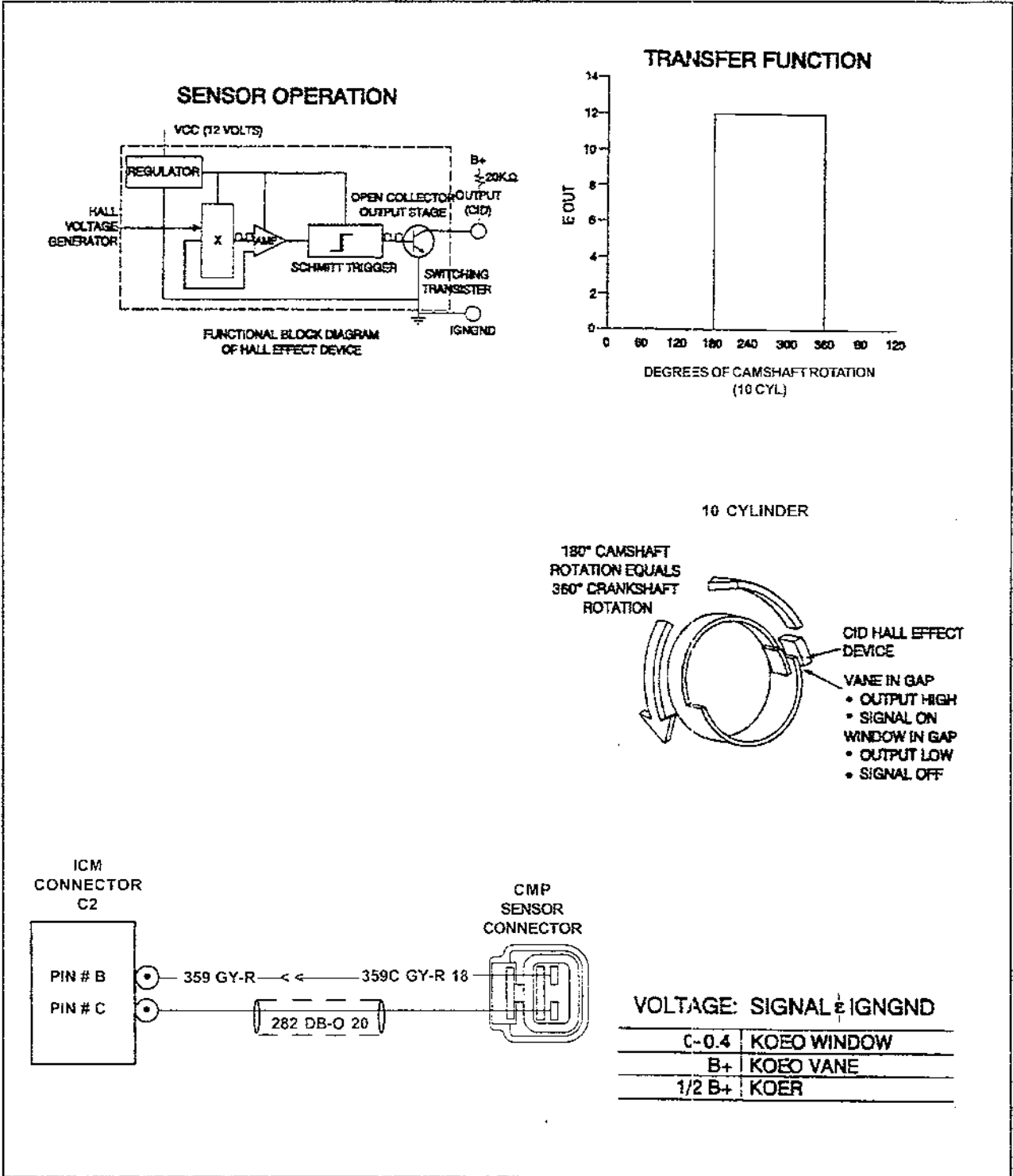

Engine Cylinder Head Temperature (CHT) Sensor

The cylinder head temperature (CHT) sensor is a thermistor device in which resistance changes with temperature. The electrical resistance of a thermistor decreases as temperature increases, and increases as temperature decreases. The varying resistance affects the voltage drop across the sensor terminals and provides electrical signals to the ICM corresponding to temperature.

Thermistor-type sensors are considered passive sensors. A passive sensor is connected to a voltage divider network so that varying the resistance of the passive sensor causes a variation in total current flow.

Voltage that is dropped across a fixed resistor in series with the sensor resistor determines the voltage signal at the ICM. This voltage signal is equal to the reference voltage minus the voltage drop across the fixed resistor.

The cylinder head temperature (CHT) sensor is installed in the aluminum cylinder head and measures the metal temperature. The CHT sensor can provide complete engine temperature information and can be used to infer coolant temperature. If the CHT sensor conveys an overheating condition to the ICM, the ICM would then initiate a fail-safe cooling strategy based on information from the CHT sensor. A cooling system failure such as low coolant or coolant loss could cause an overheating condition. As a result, damage to major engine components could occur. Using both the CHT sensor and fail-safe cooling strategy, the ICM prevents damage by allowing air cooling of the engine and limp home capability.

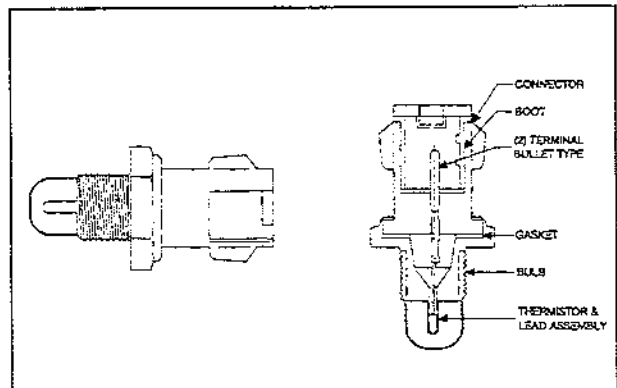

CHT sensor (typical).

Specifications

- Range of Measurement: -40°C / -40°F to 125°C / 257°F
- Measurement Accuracy: $\pm 3^\circ\text{C}$
- Response Time: 10 sec. max. for full range
- Resolution: 0.6°C max.
- Output Range: 4.8% min. to 91% max. of VREF
- Current Draw: < 5 mA from VREF
- Load Impedance: ≥ 100 kohms

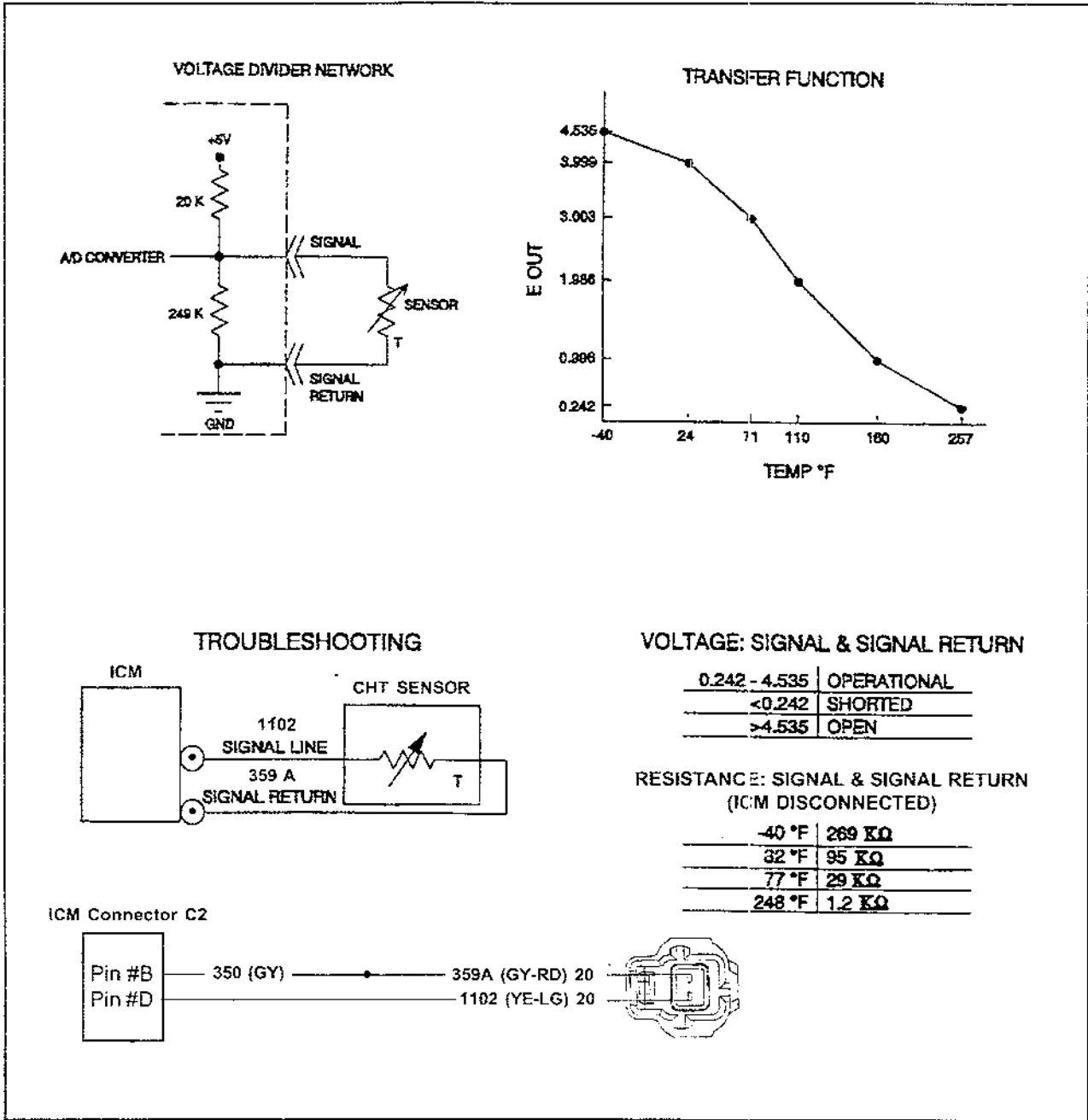

Crankshaft Position Sensor (CKP)

The crankshaft position (CKP) sensor is a magnetic transducer mounted on the engine block adjacent to a pulse wheel located on the crankshaft. By monitoring the crankshaft mounted pulse wheel, the CKP is the primary sensor for ignition information to the ignition control module (ICM). The trigger wheel has a total of 35 teeth spaced 10 degrees apart with one empty space for a missing tooth. The 6.8L ten cylinder pulse wheel has 39 teeth spaced 9 degrees apart and one 9 degree empty space for a missing tooth. By monitoring the trigger wheel, the CKP indicates crankshaft position and speed information to the ICM. By monitoring the missing tooth, the CKP is also able to identify piston travel in order to synchronize the ignition system and provide a way of tracking the angular position of the crankshaft relative to fixed reference.

NOTE: Engine may not start if cranking speed is below 140 RPM.

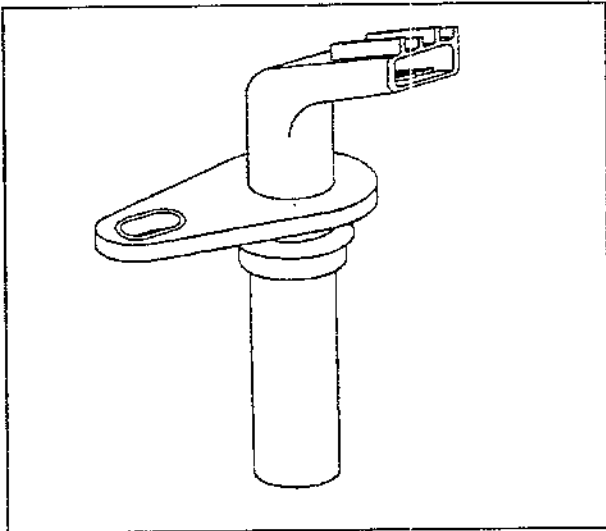

CKP Sensor (typical).

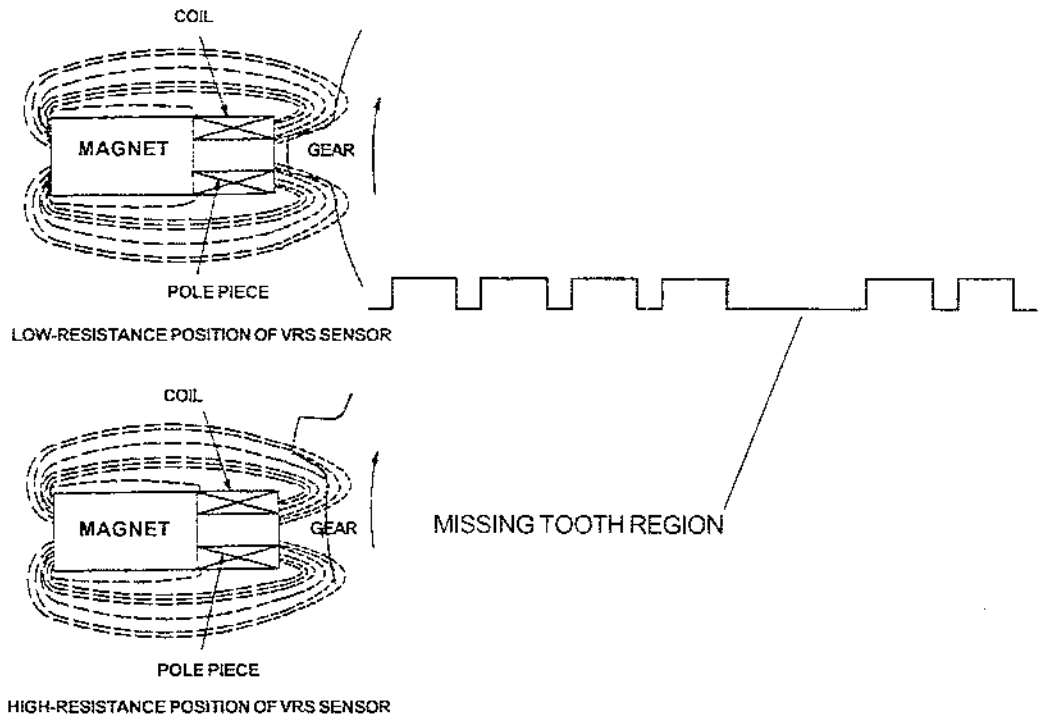

CKP sensor output voltage is 150 millivolts peak-to-peak at a minimum engine speed of 300 RPM.

CKP sensor output voltage is 300 millivolts peak-to-peak at a maximum engine speed of 8000 RPM.

CRANKSHAFT POSITION SENSOR (CKP) 36-1 TOOTH TRIGGER WHEEL

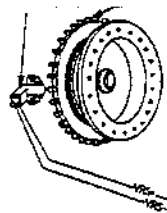

HARD SHELL CONNECTOR

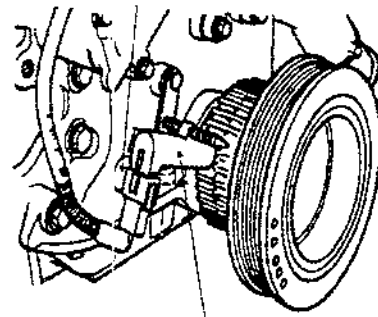

Crankshaft Position Sensor (CKP)

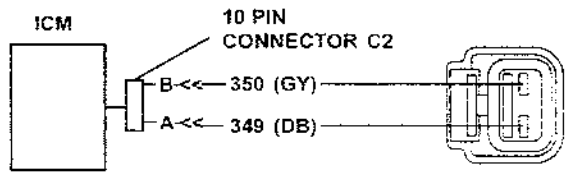

Oil Pressure Switch

It is a normally opened switch. When engine oil pressure falls below 6 psi, the oil pressure switch will close, the ICM will sense ground and immediately remove the ground side of the ignition coils until the ignition has been cycled off and on. The ICM will allow the engine to restart, but will stall again as long as the oil pressure stays below 6 psi.

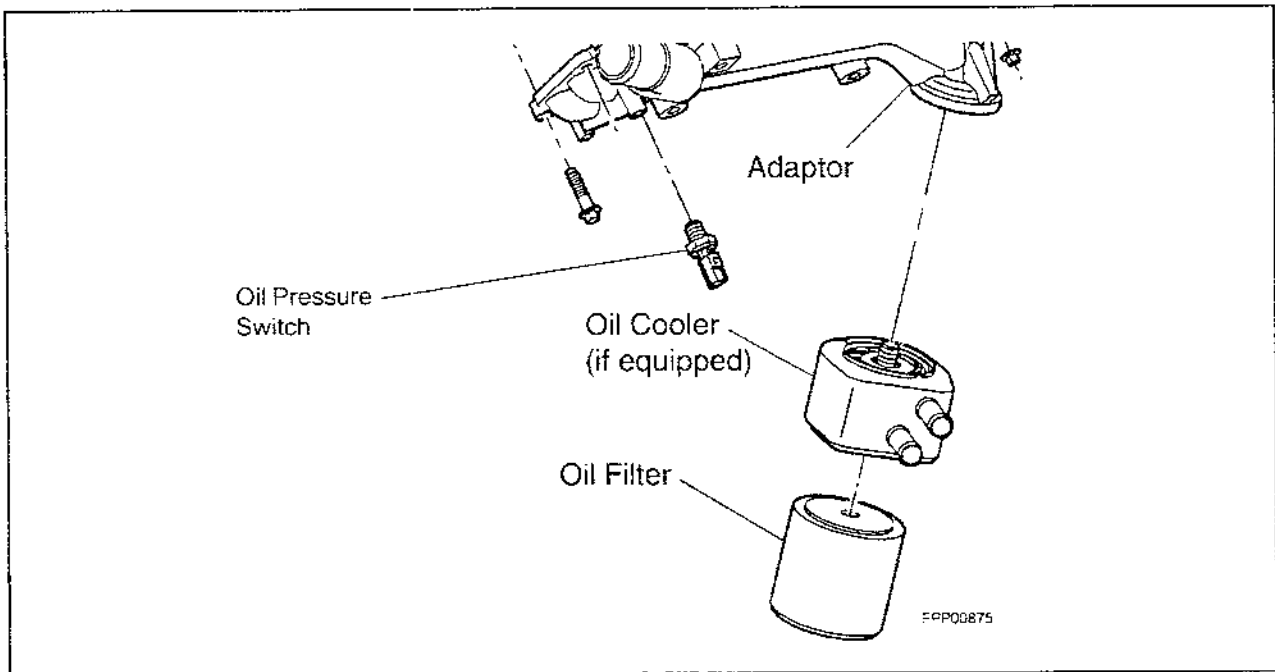

Electronic Engine Controls

The electronic engine controls consist of the:

- Integrated control module (ICM).
- Camshaft position (CMP) sensor.
- Crankshaft position (CKP) sensor.
- Cylinder head temperature (CHT) sensor.
- Coil on plug (COP).
- Oil Pressure Switch.

The ICM needs the following inputs to calibrate the engine properly:

- Camshaft position.
- Engine rpm.
- Crankshaft position.
- Cylinder head temperature.

The CMP sensor:

- Sends the ICM a signal indicating camshaft position used for spark synchronization.

The CKP sensor:

- Sends the ICM a signal indicating crankshaft position.
- Is essential for calculating spark timing.

The cylinder head temperature (CHT) sensor:

- Is mounted into the wall of the cylinder head and is not connected to any coolant passages.
- Sends a signal to the ICM indicating the cylinder head temperature.
 - If the temperature exceeds 126°C (258°F) the ICM disables four coils at a time. The ICM will alternate which four coils are disabled every 32 engine cycles. The four cylinders that are not being powered act as air pumps to aid in cooling the engine.
 - If the temperature exceeds 154°C (310°F) the ICM disables all of the coils until the engine temperature drops below 154°C (310°F).

DIAGNOSIS AND TESTING

General Procedures for Pinpoint Testing

Inspection

The ignition control module (ICM) does not contain internal diagnostics. The symptom based chart will assist in directing the technician in validating component function and operation. The basic diagnostic procedure recommended for most sensor and actuator circuits is to disconnect the harness at the connector and inspect for corrosion, bent pins, spread pins or any condition that could cause a loose or intermittent connection.

Connector Checks to Ground (B-)

Measure the resistance of all wiring harness connectors to ground (preferably the negative battery cable) to determine if a short to ground condition is present. **It is important that during this test all accessories be turned off. Current flow in the system will affect resistance readings. If the reading is fluctuating greatly, disconnect the battery and measure to the negative battery cable.**

- Signal return (marked A on all sensor circuits) should measure less than 5 ohms.
- The VREF and signal lines, with the processor connected, will normally measure greater than 50 k ohms.
- Power ground on an actuator circuit should measure less than 5 ohms. The control side of an actuator circuit will also normally measure greater than 50 k ohms.

Connector Voltage Checks

The next step is to turn the ignition key to the ON position and measure if the expected voltages are present at the connector. On circuits with expected voltages this test will verify the integrity of that circuit. On circuits without an expected voltage this test will determine if that circuit is shorted or miswired to a voltage source.

- Signal return (marked A on all sensor circuits) should measure less than 2.5 volts.
- VREF should measure 4.5-5.5 volts. If this is higher or lower than expected, disconnect sensors one at a time to determine if a sensor is biasing the circuit and refer to VREF pinpoint procedures.

- Signal lines will measure either 0-.25v if the circuit is designed to pull down when disconnected or a higher voltage (normally 4.6-5, or 12v) if it is designed as a pull up circuit. A pull up signal circuit that measures the the expected value normally indicates a good circuit.
- Actuator circuits may be either on/off type circuits (normally 12 volts) or pulse width modulated circuits (12 volts controlled by a % duty cycles).
- Communication circuits are similar to sensor circuits when disconnected in that they will be designed to either pull up or pull down when disconnected. Measuring the expected voltage of a communication circuit when disconnected will often discern its condition.

Harness Resistance Tests

Harness resistance tests are performed when a circuit is suspected of having high resistance or being open. Measure resistance from the sensor connector end to the processor connector. If an open circuit or high resistance is encountered, the problem is most easily isolated by separating the circuit at the interim connectors (normally the 10-pin main connector) and measuring resistance through both halves of the circuit.

WSG-1068 ENGINE CONTROLS

CHT SENSOR DATA

Temperature Sensor Characteristics

TEMPERATURE		NOM R, (OHMS)	NOM E _{OUT} (VOLTS)
(C)	(F)		
-40	-40	925,021	4.54
-35	-31	673,787	4.50
-30	-22	496,051	4.46
-25	-13	368,896	4.41
-20	-4	276,959	4.34
-15	5	209,816	4.25
-10	14	160,313	4.15
-5	23	123,485	4.02
0	32	95,851	3.88
5	41	74,914	3.71
10	50	58,987	3.52
15	59	46,774	3.32
20	68	37,340	3.09
25	77	30,000	2.86
30	86	24,253	2.62
35	95	19,716	2.39
40	104	16,113	2.15
45	113	13,236	1.93
50	122	10,926	1.72
55	131	9,061	1.52
60	140	7,548	1.34
65	149	6,332	1.18
70	158	5,335	1.04
75	167	4,515	.91
80	176	3,837	.79
85	185	3,274	.70
90	194	2,804	.61
95	203	2,411	.53
100	212	2,080	.47
105	221	1,801	.41
110	230	1,564	.36
115	239	1,363	.32
120	248	1,191	.28
125	257	1,044	.25
130	266	918	.22
135	275	809	.19
140	284	715	.17
145	293	633	.15
150	302	563	.14

Voltage values calculated for VREF=5 volts (may vary 15% due to sensor and VREF variations).

WSG-1068 ENGINE CONTROLS

Main Jumper Connector C1-M (XU1L-14324-BB)

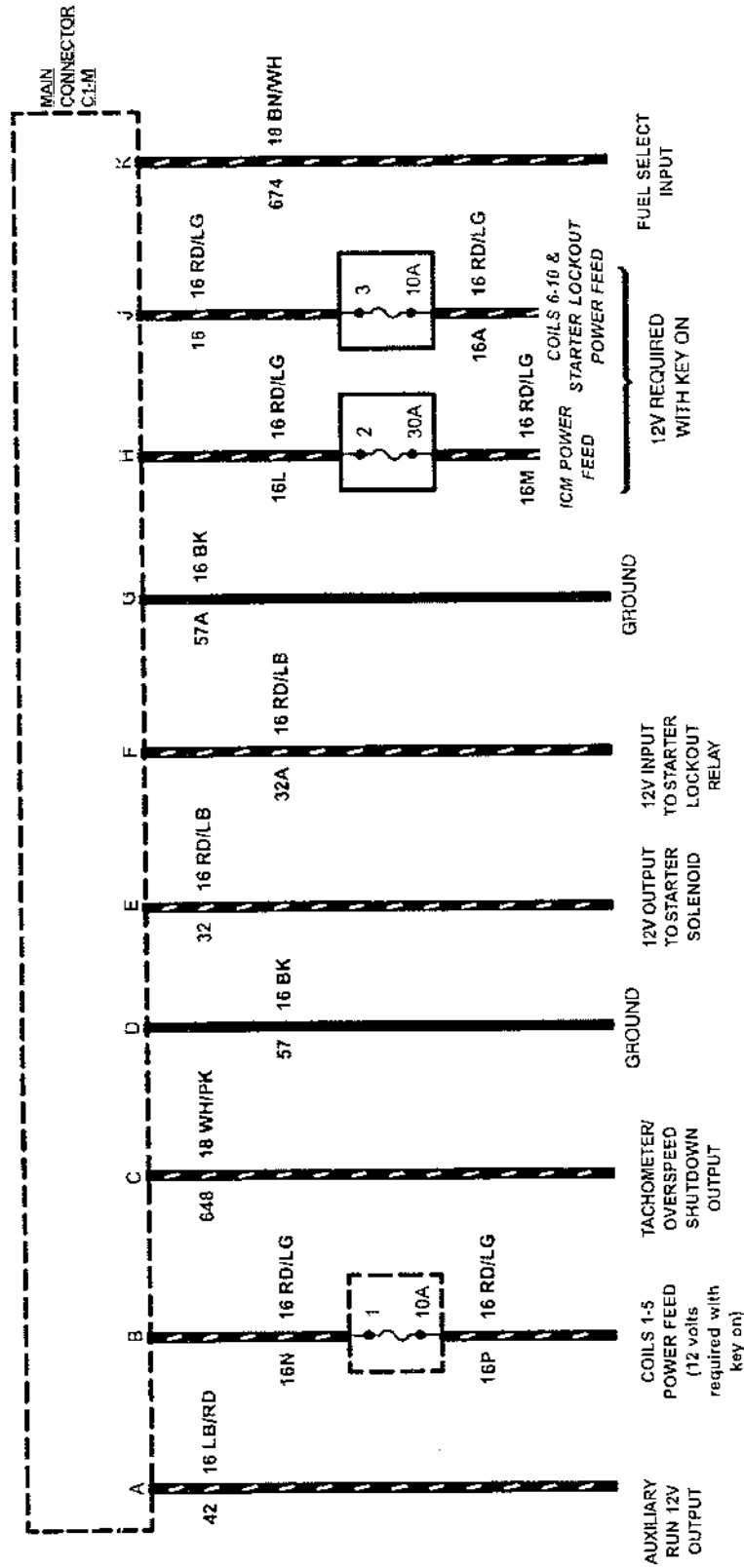

Starter Lockout (part of SK2U1L-12A200-BA)

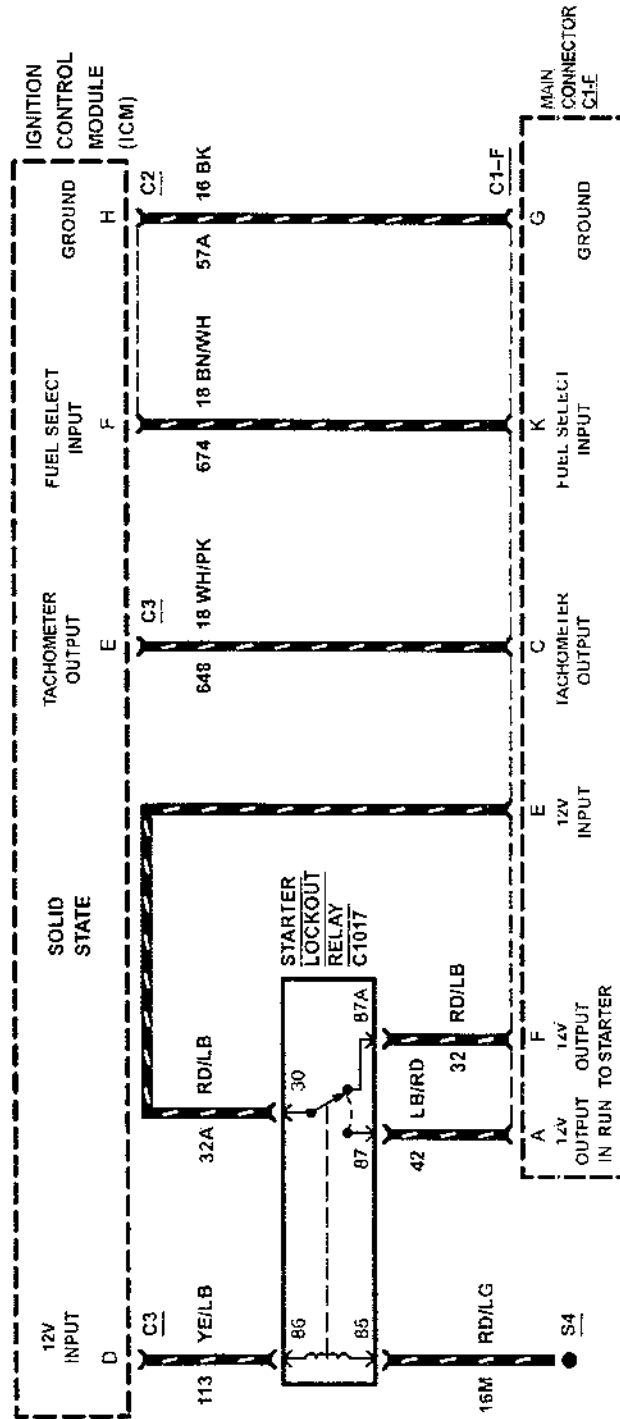

WSG-1068 ENGINE CONTROLS

Sensors (part of SK2U1L-12A200-BA)

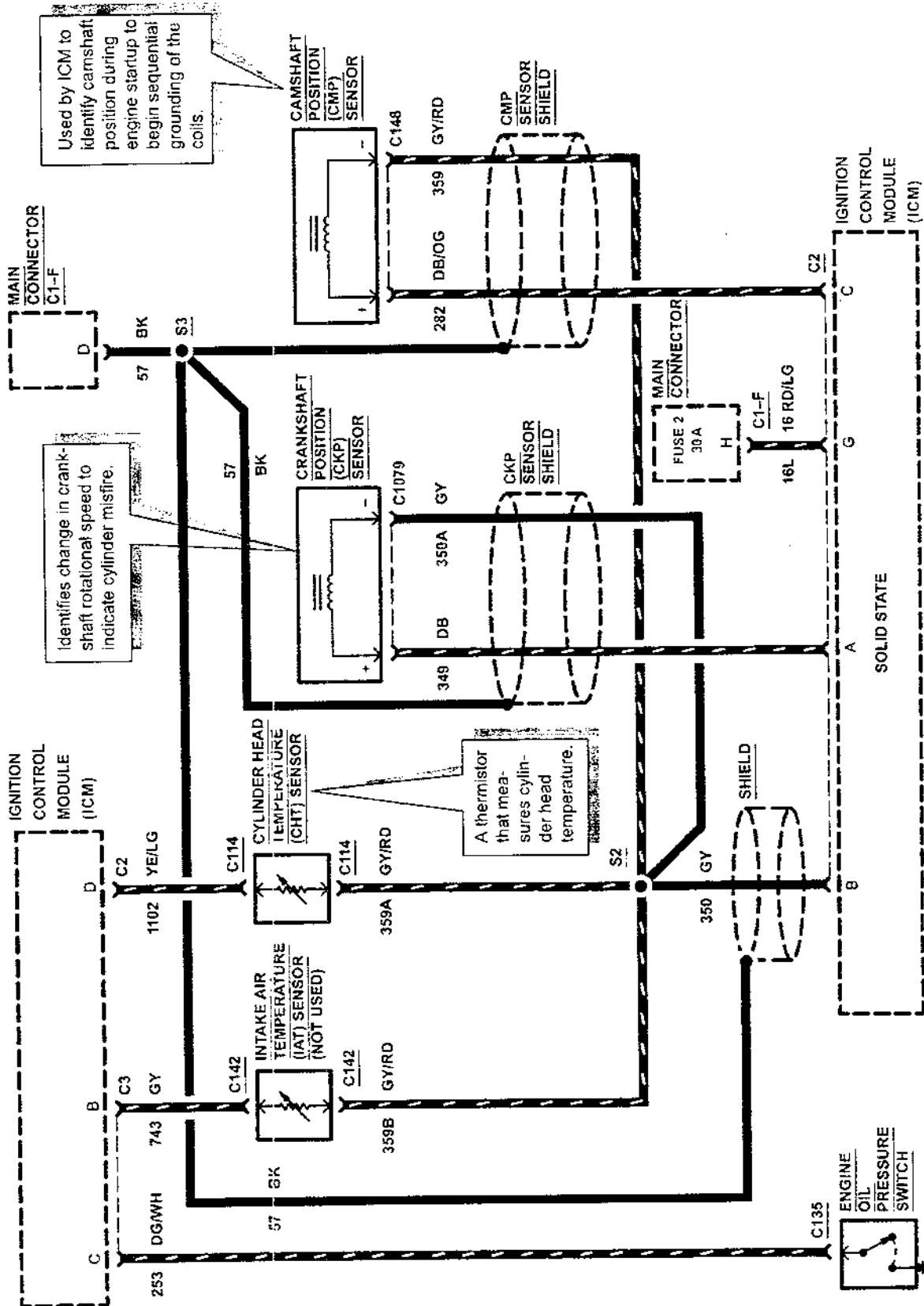

WSG-1068 ENGINE CONTROLS

Engine Controls (part of SK2U1L-12A200-BA)

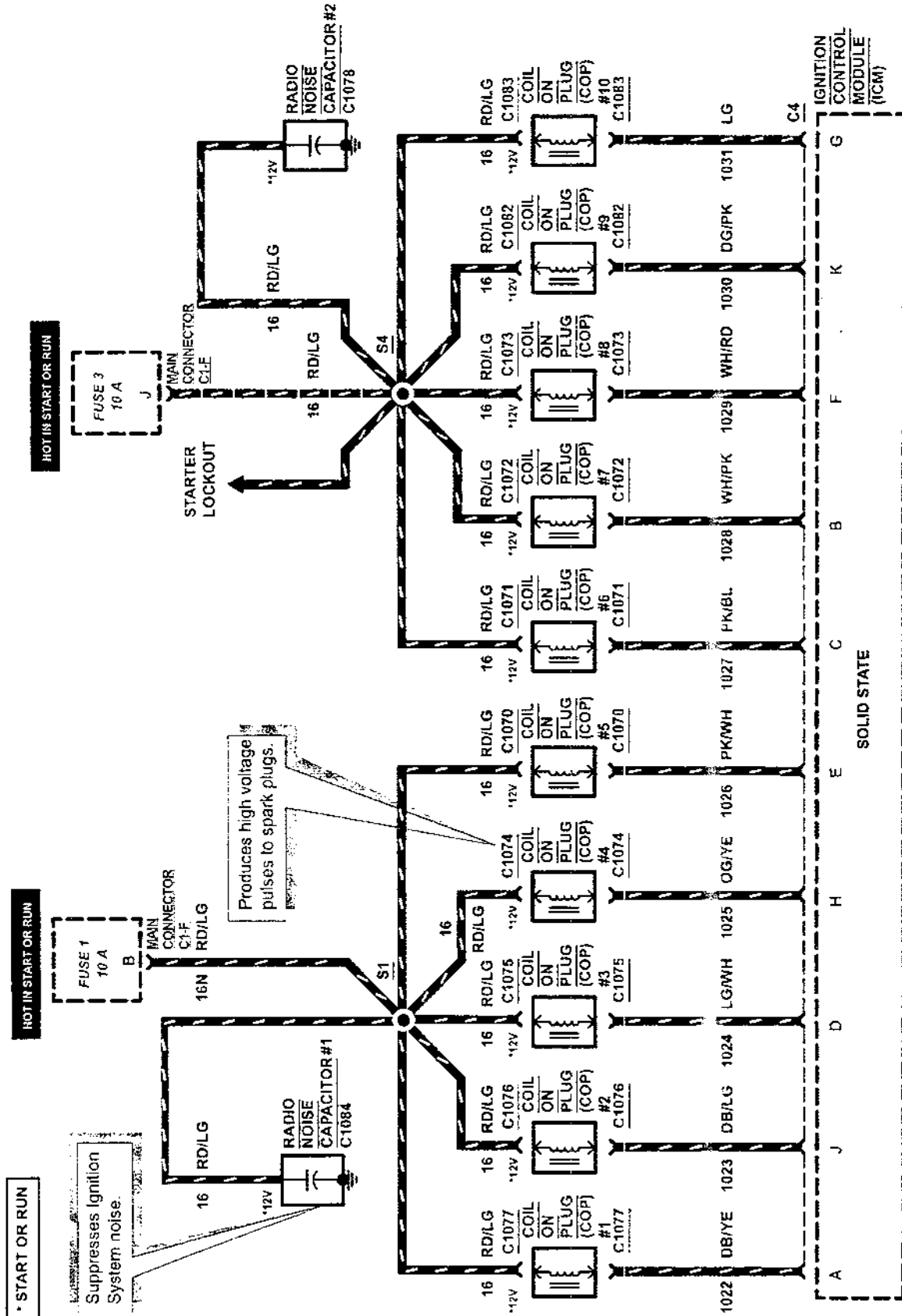

WSG-1068 ENGINE CONTROLS

Engine Harness Connectors

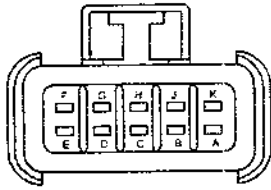

C1-F

**Engine Harness 10 Pin Connector
12A200-CG**

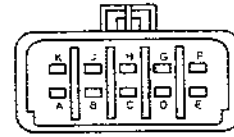

C1-M

**Jumper Harness 10 Pin Connector
14324-BB**

PIN	CIRCUIT	CIRCUIT FUNCTION
A	42 (LB/RD)	12V Run Output (above 600 RPM)
B	16N (RD/LG)	Coils 6 - 10 and Starter Lockout Power
C	648 (WH/PK)	Tachometer/Overspeed Shutdown Output
D	57 (BK)	Ground
E	32 (RD/LB)	Lockout Relay Power to Starter
F	32A (RD/LB)	12V in Start Position
G	57A (BK)	Ground
H	16L (RD/LG)	12V ICM Power with Key On
J	16 (RD/LG)	12V Coils 1 - 5 Power with Key On
K	674 (BR/WH)	Fuel Select Input

PIN	CIRCUIT	CIRCUIT FUNCTION
A	42 (LB/RD)	12V Run Output (above 600 RPM)
B	16N (RD/LG)	12V Required with Key On
C	648 (WH/PK)	Tachometer/Shutdown Output
D	57 (BK)	Ground
E	32 (RD/LB)	12V Output to Starter
F	32A (RD/LB)	12V in Start Position
G	57A (BK)	Ground
H	16L (RD/LG)	12V Required with Key On
J	16 (RD/LG)	12V Required with Key On
K	674 (BR/WH)	Fuel Select Input

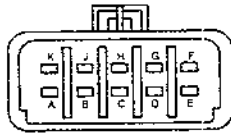

**C2
ICM 10 PIN CONNECTOR**

PIN	CIRCUIT	CIRCUIT FUNCTION
A	349 (DB)	Crank Position Sensor Input
B	350 (GY)	Signal Return (-)
C	282 (DB/OG)	Cam Sensor (+) 5V
D	1102 (YE/LG)	Cylinder Head Temp Sensor (+) 5V
E	-	NOT USED
F	674 (BN/WH)	Fuel Select Input
G	16L (RD/LG)	Power (+) 12V Input
H	57A (BK)	Ground
J	-	NOT USED
K	-	NOT USED

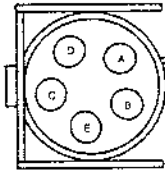

**C3
ICM 5 PIN CONNECTOR**

PIN	CIRCUIT	CIRCUIT FUNCTION
A	-	NOT USED
B	743 (GY)	IAT Sensor (NOT USED)
C	253 (DG/WH)	Oil Pressure Switch Input
D	113 (YE/LB)	Starter Lockout
E	648 (WH/PK)	Aux. Out 2/ Overspeed Ground

ICM Connectors

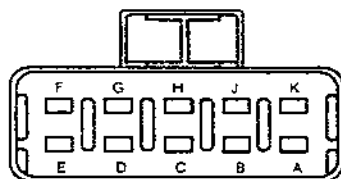

C4
ICM 10 PIN CONNECTOR

PIN	CIRCUIT	CIRCUIT FUNCTION
A	1022 (DB/YE)	Coil #1 Grounding
B	1028 (WH/PK)	Coil #7 Grounding
C	1027 (PK/BU)	Coil #6 Grounding
D	1024 (LG/WH)	Coil #3 Grounding
E	1026 (PK/WH)	Coil #5 Grounding
F	1029 (WH/RD)	Coil #8 Grounding
G	1031 (LG)	Coil #10 Grounding
H	1025 (OG/YE)	Coil #4 Grounding
J	1023 (DB/LG)	Coil #2 Grounding
K	1030 (DG/P)	Coil #9 Grounding

WSG-1068 ENGINE CONTROLS

Symptom Chart

Engine Performance No Load

SYMPTOM	POSSIBLE CAUSE	ACTION
Engine Runs Briefly and Shuts Down	<ul style="list-style-type: none"> • Low Fuel Pressure • Electronic Actuator Instability • Overspeed Shutdown • Low Oil Pressure • Oil Pressure Switch Failure • CHT Switch Failure • Wiring Failure • Engine Overheating • ICM Failure 	<ul style="list-style-type: none"> • Go to Section 04 • Go to Section 04 • Go to Pinpoint Test A • Go to Pinpoint Test E • Go to Pinpoint Test E • Go to Pinpoint Test F • Go to Pinpoint Test A • Go to Section 05 • Go to Pinpoint Test A
Engine Cranks But No Start	<ul style="list-style-type: none"> • Electronic Actuator Not Open • Low Fuel Pressure • Fuel Lockout not operating • Coil on Plug Power Loss • Crankshaft Position Sensor Failure • Camshaft Position Sensor Failure • ICM Ground Loss • Wiring Failure • Engine Overheating 	<ul style="list-style-type: none"> • Go to Section 04 • Go to Section 04 • Go to Section 04 • Go to Pinpoint Test D • Go to Pinpoint Test C • Go to Pinpoint Test B • Go to Pinpoint Test A • Go to Pinpoint Test A • Go to Section 05
Engine Runs Poorly	<ul style="list-style-type: none"> • Actuator or Air Blockage • Fuel Contaminated • Low Fuel Pressure • Incorrect Fuel Select Table Selected • Noise Suppression Capacitor Failure • Harness Ground Shielding Failure • Coil on Plug Failure • New ICM Installed 	<ul style="list-style-type: none"> • Go to Section 04 • Go to Section 04 • Go to Section 04 • Go to Pinpoint Test A • Go to Pinpoint Test D • Go to Pinpoint Test F • Go to Pinpoint Test D • Verify part number.
Engine Cranks Slowly	<ul style="list-style-type: none"> • Low Battery Voltage • Starter Solenoid • Starter Failure • Auxiliary Failure 	<ul style="list-style-type: none"> • Go to Section 07 • Go to Section 07 • Go to Section 07 • Inspect auxiliary drive components
Engine Does Not Crank	<ul style="list-style-type: none"> • OEM Shutdown- Engine Temp Safety • Starter Lockout Relay • ICM Power Fuse Open 	<ul style="list-style-type: none"> • Go to Pinpoint Test F • Go to Section 07 • Go to Pinpoint Test A
Engine Stalls/Quits	<ul style="list-style-type: none"> • Low Fuel Pressure • Low Battery Voltage • OEM Safety Shutdowns 	<ul style="list-style-type: none"> • Go to Section 04 • Go to Section 07 • Go to Pinpoint Test A

WSG-1068 ENGINE CONTROLS

Engine Performance No Load

SYMPTOM	POSSIBLE CAUSE	ACTION
Runs Rough	<ul style="list-style-type: none"> • Low Fuel Pressure • Vacuum Loss • Ground Loss • Spark Plugs Fouled • Coil on Plug Power Loss • Wiring Failure 	<ul style="list-style-type: none"> • Go to Section 04 • Inspect vacuum hose • Go to Pinpoint Test G • Go to Section 04 • Go to Pinpoint Test D • Go to Pinpoint Test A
Misses	<ul style="list-style-type: none"> • Spark Plugs Fouled • Spark Plug Gap to High • Cracked Spark Plug Insulator • Harness Ground Shielding Failure • Coil on Plug Power Loss 	<ul style="list-style-type: none"> • Go to Pinpoint Test A • Inspect Spark Plugs • Inspect Spark Plugs • Go to Pinpoint Test G • Go to Pinpoint Test D
Buck/Jerk	<ul style="list-style-type: none"> • Low Fuel Pressure • Electronic Actuator Sticking • Vacuum Leak • Not All Coils Operational 	<ul style="list-style-type: none"> • Go to Section 04 • Go to Section 04 • Inspect vacuum hose • Go to Pinpoint Test D
Hesitation/Stumble	<ul style="list-style-type: none"> • Low Fuel Pressure 	<ul style="list-style-type: none"> • Go to Section 04
Surge	<ul style="list-style-type: none"> • Low Fuel Pressure • Electronic Actuator Sticking • Not All Coils Operational 	<ul style="list-style-type: none"> • Go to Section 04 • Go to Section 04 • Go to Pinpoint Test D
Backfires	<ul style="list-style-type: none"> • Excess Lean Condition • Fouled Spark Plugs • Cylinder Head Temperature (CHT) Sensor • Coil on Plug Power Loss • Intake Manifold Leak • Dry Fuel Lockout Inoperative 	<ul style="list-style-type: none"> • Go to Section 04 • Inspect Spark Plugs • Go to Pinpoint Test F • Go to Pinpoint Test D • Inspect manifold • Go to Section 04
Lack/Loss of Power	<ul style="list-style-type: none"> • Low Fuel Pressure • Electronic Actuator Sticking • Aux. Component • Camshaft Position (CMP) Sensor Ground Shielding Lost • Crankshaft Position (CRK) Sensor Ground Shielding Lost • Low Cylinder Compression • Engine is in Limp Home Mode • Binding Auxiliary Equipment 	<ul style="list-style-type: none"> • Go to Section 04 • Go to Section 04 • Inspect for auxiliary engine component binding condition • Go to Pinpoint Test B • Go to Pinpoint Test G • Go to Section 02 • Go to Pinpoint Test G • Inspect for auxiliary binding components

WSG-1068 ENGINE CONTROLS

Engine Performance No Load

SYMPTOM	POSSIBLE CAUSE	ACTION
Spark Knock/Detonation	<ul style="list-style-type: none"> • Fuel Delivery System • Fuel Selection Timing • Wrong Spark Plugs (Too High Heat Range) • High Intake Air Temperature • High Engine Temperature 	<ul style="list-style-type: none"> • Go to Section 04 • Go to Section 04 • Inspect spark plugs • Go to Section 04 • Go to Section 05

Performance Concerns

SYMPTOM	POSSIBLE CAUSE	ACTION
Diesels/Runs On	<ul style="list-style-type: none"> • Faulty Fuel Delivery System • Hot Spots In Cylinders <ul style="list-style-type: none"> - Spark Plugs - Carbon Build-up - High Idle Speed • Damaged Ignition System • Improper Sealing of Intake Manifold 	<ul style="list-style-type: none"> • Go to Section 04 • Go to Pinpoint Test A • Go to Section 03 • Go to Section 02
Poor Fuel Economy	<ul style="list-style-type: none"> • Low Fuel Pressure • High Engine Temperature • ICM 	<ul style="list-style-type: none"> • Go to Section 04 • Go to Section 05 • Go to Pinpoint Test A

Engine

SYMPTOM	POSSIBLE CAUSE	ACTION
Oil System Concerns - High Oil Consumption	<ul style="list-style-type: none"> • Oil Viscosity • External Leaks • Improper Oil dipstick • Low Cylinder Compression • Valve Seals • Cylinder Wall Taper Excessive 	<ul style="list-style-type: none"> • Go to Section 02 • Go to Section 02 • Go to Section 02 • Go to Section 02 • Go to Section 02 • Go to Section 02
Poor Fuel Economy	<ul style="list-style-type: none"> • Restricted Air Filter Element 	<ul style="list-style-type: none"> • Inspect for clogged air system
Cooling System Concerns	<ul style="list-style-type: none"> • Trapped Air Pocket • Worn Drivebelt • Worn Waterpump • Stuck Thermostat • Plugged Radiator (Internal & External) 	<ul style="list-style-type: none"> • Go to Section 05 • Go to Section 05 • Go to Section 05 • Go to Section 05 • Go to Section 05
Exhaust System Concerns - Visible Smoke		<ul style="list-style-type: none"> • Go to Section 04
Fuel System Concerns	<ul style="list-style-type: none"> • Leaky Lines 	<ul style="list-style-type: none"> • Go to Section 04
Engine Noise	<ul style="list-style-type: none"> • Coil on Plug Spark 	<ul style="list-style-type: none"> • Go to Pinpoint Test D

Pinpoint Test A - ICM Check

The ICM check will verify the required inputs and outputs of the module. Always inspect the integrity of the systems the engine controls prior to the start of this test as failures and faults associated within these can adversely affect the engine to operate properly.

Inspection and Verification

1. Visually inspect for obvious signs of mechanical and electrical damage.
2. Check the battery is fully charged.
3. Inspect for bent or broken connector terminals.
4. Inspect battery and starter power feed terminals for loose or corroded connections.
5. Inspect all ground connections for loose or corroded connections.
6. Visually inspect for and note auxiliary system connections not shown on the **Recommended Customer Connections Wiring Schematic**.

NOTE: Auxiliary applications may time out and remove voltage to the ICM, cycle key off and on to verify this application is present.

Normal Operation

A constant 12-volt input with the key on, and a good solid ground is required. Under certain equipment applications, the 12-volt input may time out with-in 15 seconds after the ignition switch is placed into the ON position, due to the dry fuel safety shut-off system.

Step	Action	Values	Yes	No								
1	1. KOEO. 2. Disconnect the ICM connector C2. 3. Using a voltmeter, check pin G circuit 16L RD/LG. Is the voltage within the specified value?	Battery Voltage	GO to Step 2	GO to Step 9								
2	1. Disconnect the ICM connector C4. 2. KOEO. 3. Using a voltmeter, check pins A thru K of the harness connector. Is the voltage within the specified value?	Battery Voltage	GO to Step 3	Inspect Fuse 1 and 3 for OPEN and RETEST. If FPP fuses are not present, Go to Pinpoint Test D								
3	1. KOEO. 2. Disconnect the ICM connector C3. 3. Using a voltmeter, check pin D circuit 113 YL/LB. Is the voltage within the specified value?	Battery Voltage	GO to Step 4	Go to Section 07								
4	1. KOEO. 2. Disconnect connector C2. 3. Using a voltmeter/ohmmeter, compare the value of pin F circuit 674 BR/WH to the fuel select table below. <table border="1" style="margin-left: auto; margin-right: auto;"> <thead> <tr> <th>FUEL SELECT</th> <th>CIRCUIT 674 BR/WH VALUE</th> </tr> </thead> <tbody> <tr> <td>LPG</td> <td>GROUND</td> </tr> <tr> <td>NG</td> <td>12 VOLTS</td> </tr> <tr> <td>NG</td> <td>OPEN</td> </tr> </tbody> </table> Does the measured value match the fuel application?	FUEL SELECT	CIRCUIT 674 BR/WH VALUE	LPG	GROUND	NG	12 VOLTS	NG	OPEN		GO to Step 5	REPAIR the circuit(s) in question. TEST the system for normal operation.
FUEL SELECT	CIRCUIT 674 BR/WH VALUE											
LPG	GROUND											
NG	12 VOLTS											
NG	OPEN											

WSG-1068 ENGINE CONTROLS

Step	Action	Values	Yes	No
5	<ol style="list-style-type: none"> 1. Disconnect the ICM connector C2. 2. KOEO 3. Using a voltmeter, check pin H circuit 57A BK. <p>Is the voltage present?</p>	0 volts	GO to Step 6	REPAIR the circuit(s) for a short to power and RETEST the system for normal operation.
6	<ol style="list-style-type: none"> 1. Key Off, Engine Off. 2. Inspect the ICM ground terminal location (s) for clean and tight connections. 3. Disconnect ICM connector C2. 4. Using an ohmmeter, measure the resistance of terminal C2 pin H to a known good ground. <p>Is the resistance within the specified value?</p>	0.00 ohms or Ω	GO to Step 7	REPAIR the circuit(s) for an OPEN and RETEST the system for normal operation.
7	<ol style="list-style-type: none"> 1. Key Off 2. Disconnect ICM Connector C3. 3. Using an ohmmeter, check the resistance of circuit 253 DG/WH between connector C3 pin C and the oil pressure switch connector. <p>Is the resistance less than 5 ohms?</p>		GO Pinpoint Test E	GO to Step 8
8	<ol style="list-style-type: none"> 1. Key Off 2. Reconnect ICM Connector C3. 3. Disconnect the oil pressure switch. 4. Using an ohmmeter, check the resistance of circuit 253 DG/WH to a known ground. <p>Is the resistance less than 5 ohms?</p>		Replace the ICM and RETEST the system.	System OK. Check for a stuck throttle, loose or binding throttle linkage.
9	<ol style="list-style-type: none"> 1. Check the 30A Fuse in the main jumper harness. <p>Is the fuse open?</p>		GO to Step 10	GO to Section 03
10	<ol style="list-style-type: none"> 1. Key Off. 2. Remove the 30A fuse. 3. Using a voltmeter, check both side of the fuse terminal for battery voltage. <p>Is battery voltage present?</p>		REPAIR the circuit(s) for short to power and RETEST the system for normal operation.	GO to Step 11
11	<ol style="list-style-type: none"> 1. Key Off 2. Using an ohmmeter, check both side of the fuse terminal for resistance to ground. <p>Is the resistance less than 5 ohms?</p>		REPAIR the circuit(s) for short to ground and RETEST the system for normal operation.	System OK

Pinpoint Test B - Camshaft Position (CMP) Sensor Check

Inspection and Verification

1. Visually inspect for obvious signs of mechanical and electrical damage.
2. Inspect for bent or broken connector terminals.
3. Inspect for a loose or damaged sensor.
4. Visually inspect for and note auxiliary system connections not shown on the **Recommended Customer Connections Wiring Schematic**.

Normal Operation

The camshaft position (CMP) sensor detects the position of the camshaft. The CMP sensor identifies Piston No. 1 is on its compression stroke. The Coil On Plug (COP) Ignition application also uses the CMP signal to select the proper ignition coil to fire. The ICM monitors the VREF output for current drop.

Step	Action	Values	Yes	No
1	1. Start the engine. Does the engine start and shut down above 400 RPM or after 3 or 4 seconds of operation?		Check for a stuck throttle, loose or binding throttle linkage.	Engine does not start, GO to Step 2
2	1. Key Off. 2. Disconnect the camshaft position CMP sensor. 3. KOEO 4. Using a voltmeter, measure the voltage at the CMP connector circuit 282 DB/OG. NOTE: Auxiliary applications may time out and remove voltage to the ICM, cycle key off and on to verify this application is present. Is the voltage within the specified value?	4.5-5.0v	GO to Step 3	GO to Step 6
3	1. Key ON. 2. Using a voltmeter, check for voltage at the CMP connector circuit 359 GY/RD and ground. Is the voltage within the specified value?	0 volts	GO to Step 4	REPAIR Short to power, and RETEST the system for normal operation.
4	1. Key Off. 2. Using an ohmmeter, check the resistance at the CMP connector circuit 359 GY/RD and ground. Is the resistance less than 5 ohms?	< 5 Ohms	GO to Step 5	REPAIR the circuit(s) in question. TEST the system for normal operation.
5	1. Key Off. 2. Disconnect ICM Connector C2. 3. Using an ohmmeter, measure the resistance between pin B circuit 350 GY and pin C circuit 282 DB/OG. Is resistance between 250 and 1K ohms?		System OK If you have been directed to perform a system check Go to the next test.	Replace the camshaft position sensor. And RETEST
6	1. Key Off. 2. Disconnect ICM Connector C2. 3. Using an ohmmeter, check the resistance between the ICM Connector C2 pin B circuit 350 GY and the CMP connector circuit 282 DB/OG. Is the resistance less than 5 ohms?	< 5 Ohms	If PP Test A ICM Check has been previously preformed, Replace the ICM and Retest the system	REPAIR the circuit(s) for OPEN and RETEST the system for normal operation.

WSG-1068 ENGINE CONTROLS

Step	Action	Values	Yes	No
7	1. Key Off. 2. Disconnect ICM Connector C2. 3. Using an ohmmeter, check the resistance between the ICM Connector C2 pin B circuit 350 GY and the CMP connector circuit 359 GY/RD. Is the resistance less than 5 ohms?	< 5 Ohms	Replace the ICM and Retest the system	REPAIR the circuit(s) for an OPEN and RETEST the system for normal operation.
8	1. Key Off. 2. Disconnect ICM Connector C2. 3. Using an ohmmeter, check the resistance between the ICM Connector C2 pin B circuit 350 GY and the CMP connector circuit 359 GY/RD. Is the resistance less than 5 ohms?	< 5 Ohms	Replace the ICM and Retest the system	REPAIR the circuit(s) for an OPEN and RETEST the system for normal operation.

Pinpoint Test C - Crankshaft Position (CKP) Sensor Check

Inspection and Verification

1. Visually inspect for obvious signs of mechanical and electrical damage.
2. Inspect for bent or broken connector terminals.
3. Inspect for a loose or damaged sensor.
4. Visually inspect for and note auxiliary system connections not shown on the **Recommended Customer Connections Wiring Schematic**.

Normal Operation

The crankshaft position (CKP) sensor is a magnetic transducer mounted on the engine block adjacent to a pulse wheel located on the crankshaft. By monitoring the crankshaft mounted pulse wheel, the CKP is the primary sensor for ignition information to the ignition control module (ICM). The trigger wheel has a total of 39 teeth spaced 9 degrees apart and one 9 degree empty space for a missing tooth. By monitoring the trigger wheel, the CKP indicates crankshaft position and speed information to the ICM. By monitoring the missing tooth, the CKP is also able to identify piston travel in order to synchronize the ignition system and provide a way of tracking the angular position of the crankshaft relative to fixed reference.

Step	Action	Values	Yes	No
1	1. Start the engine. Does the engine start and shut down above 400 RPM or after 3 or 4 seconds of operation?		Check for a stuck throttle, loose or binding throttle linkage.	Engine does not start, GO to Step 2
2	1. Key Off. 2. Disconnect the crankshaft position CKP sensor. 3. KOEO 4. Using a voltmeter, measure the voltage at the CKP connector circuit 349 DB. NOTE: Auxiliary applications may time out and remove voltage to the ICM, cycle key off and on to verify this application is present. Is the voltage within the specified value?	4.5-5.0V	GO to Step 3	GO to Step 6
3	1. KOEO. 2. Using a voltmeter, check for voltage at the CKP connector circuit 350A GY and ground. Is the voltage within the specified value?	0 volts	GO to Step 4	REPAIR Short to power and RETEST the system for normal operation.
4	1. KOEO. 2. Using an ohmmeter, check the resistance at the CKP connector circuit 350A GY and ground. Is the resistance less than 5 ohms?	< 5 Ohms	GO to Step 5	GO to Step 7
5	1. Key Off. 2. Disconnect ICM Connector C2. 3. Using an ohmmeter, measure the resistance between pin B circuit 350A GY and pin A circuit 349 DB. Is resistance between 250 and 1K ohms?		System OK If you have been directed to perform a system check Go to the next test.	Replace the crankshaft position sensor. And RETEST

WSG-1068 ENGINE CONTROLS

Step	Action	Values	Yes	No
6	<ol style="list-style-type: none"> 1. Key Off. 2. Disconnect ICM Connector C2. 3. Using an ohmmeter, check the resistance between the ICM Connector C2 pin A circuit 349 DB and the CKP connector circuit 349 DB. <p>Is the resistance less than 5 ohms?</p>	< 5 Ohms	Replace the ICM and Retest the system	REPAIR the circuit(s) for an OPEN and RETEST the system for normal operation.
7	<ol style="list-style-type: none"> 1. Key Off. 2. Disconnect ICM Connector C2. 3. Using an ohmmeter, check the resistance between the ICM Connector C2 pin B circuit 350 GY and the CKP connector circuit 350A GY. <p>Is the resistance less than 5 ohms?</p>	< 5 Ohms	Replace the ICM and Retest the system	REPAIR the circuit(s) for an OPEN and RETEST the system for normal operation.

Pinpoint Test D - Coil on Plug Check

Inspection and Verification

1. Visually inspect for obvious signs of mechanical and electrical damage.
2. Visually inspect for and note auxiliary system connections not shown on the **recommended wiring schematic**.
3. Visually inspect for and note auxiliary mechanical or hydraulic systems that could be binding which may cause the engine not to reach 100rpm and energize the ignition coils.
4. Inspect for a stuck, loose or binding throttle linkage.

Ω = Infinity or no resistance.

Normal Operation

All coils work as individual units and are mounted on top of each sparkplug. B+ is supplied to all coils when the ignition switch is in the run or crank position. During crank mode the ICM reads the pulse from the Camshaft Position sensor and Crankshaft sensor. When these two inputs are correct and the engine has reached or is above 100 rpm the ICM will start grounding/firing the individual coil. Refer to **Section 03 Ignition System** for the firing order.

Step	Action	Values	Yes	No
1	<ol style="list-style-type: none"> 1. Key OFF Engine OFF. 2. Disconnect connector C1. 3. KOEO. 4. Using a DVOM, check for battery voltage at pins B and H. <p>Is the voltage within the specified value?</p>	Battery Voltage	GO to Step 2	<p>If the FPP jumper harness has fuse protection and either fuse is OPEN, GO to Step 8</p> <p>If the FPP harness has no Fuse protection or both fuses are OK GO to Ignition System Check</p>
2	<ol style="list-style-type: none"> 1. Key OFF 2. Using a DVOM, check the resistance to ground of pins D and G of the jumper harness. <p>Is the resistance within the specified value?</p>	5 ohms or less	GO to Step 3	REPAIR the circuit(s) in question. TEST the system
3	<ol style="list-style-type: none"> 1. Reconnect connector C1. 2. NOTE: Fuse 1 supplies B+ to the right side COP BANK 1 thru 5. Disconnect (right bank) COP connectors 1 thru 5. 3. Key On. 4. Using a DVOM, measure the voltage of circuit 16N RD/LG at each connector. <p>Is the voltage within the specified value?</p>	Battery Voltage	GO to Step 4	REPAIR the circuit(s) in question. TEST the system
4	<ol style="list-style-type: none"> 1. Reconnect connector C1. 2. NOTE: Fuse 3 supplies B+ to the left side COP BANK 6 thru 10. Disconnect (left side) COP connectors 6 thru 10. 3. Key On. 4. Using an ohmmeter, measure the voltage of circuit 16 RD/LG at each connector. <p>Is the voltage within the specified value?</p>	Battery Voltage	GO to Step 5	REPAIR the circuit(s) in question. TEST the system

WSG-1068 ENGINE CONTROLS

Step	Action	Values	Yes	No
5	<ol style="list-style-type: none"> 1. Key Off. 2. COP connectors disconnected. 3. Disconnect noise capacitors 1 and 2. 4. Using a DVOM measure each COP and capacitor connector for resistance to ground. <p>Is the resistance within the specified value?</p>	Ω	GO to Step 6	REPAIR the circuit(s) in question. TEST the system
6	<ol style="list-style-type: none"> 1. Reconnect COP and capacitor connectors. 2. Disconnect ICM connector C2. 3. Using an ohmmeter, check the resistance of circuit 57A BK from connector C2 pin H and a known ground. <p>Is the resistance within the specified value?</p>	5 ohms or less	GO to Step 7	REPAIR the circuit(s) in question. TEST the system
7	<ol style="list-style-type: none"> 1. Reconnect connector C2. 2. Start the engine, run for 30 seconds or less at minimum 800 RPM. <p>Does the engine shut down after running for 4-5 seconds?</p>		Coil On Plug System OK Return to the Symptom Chart	Return to Symptom Chart
8	<ol style="list-style-type: none"> 1. Key OFF 2. Connector C1 disconnected. 3. Replace the OPEN fuse. <p>Does the fuse OPEN?</p>		Inspect the auxiliary wiring for a short to ground. Repair and Retest.	GO to Step 9
9	<ol style="list-style-type: none"> 1. Key OFF 2. Reconnect connector C1. 3. Disconnect all COP connectors. 4. Disconnect the ignition capacitors. 5. KOEO 6. Reconnect each COP connector. 7. Monitor the fuse and reconnect each COP connector. <p>Does the fuse OPEN?</p>		REPAIR the circuit(s) in question for a short to ground. RETEST the system	GO to Step 10
10	<ol style="list-style-type: none"> 1. KOEO 2. Monitor the fuse and reconnect each ignition capacitor connector. <p>Does the fuse OPEN?</p>		Replace the failed capacitor and fuse.	Intermittent condition, carefully inspect the harness, coils and connectors for cracks or damage.

Pinpoint Test E - Oil Pressure Sensor Check

Inspection and Verification

1. Visually inspect for obvious signs of mechanical and electrical damage.
2. Visually inspect for and note auxiliary system connections not shown on the **Recommended Customer Connections Wiring Schematic**.

Normal Operation

The oil pressure is monitored at engine rpm above 800rpm and after the first 100 crankshaft rotations. When the oil switch closes to ground, (pressure drops below 6psi) the ICM will protect the engine by removing the ground-side of the ignition coils. The engine can be restarted, but will stall again as long as the oil pressure stays below 6 psi.

Step	Action	Values	Yes	No
1	<ol style="list-style-type: none"> 1. Check the engine oil level and oil change maintenance records. <p>Is the engine operating at the correct oil level and has not been operating past the specified oil change interval?</p>	300 Hours	GO to Step 2	Top off the engine oil or Replace the oil and filter if the oil change interval is past 300 Hours.
2	<ol style="list-style-type: none"> 1. Start the engine. <p>Does the engine shut down above 400 RPM or 3-4 seconds of operation?</p>		GO to Step 3	System OK
3	<ol style="list-style-type: none"> 1. Key Off, Engine Off. 2. Disconnect the oil pressure switch connector. 3. Key On. 4. Using an ohmmeter, measure the voltage of circuit 253 DG/WH. <p>Is the voltage within the specified value?</p>	Battery Voltage	GO to Step 4	GO to Step 6
4	<ol style="list-style-type: none"> 1. Key Off, Engine Off 2. With the oil pressure switch disconnected. 3. Using an ohmmeter, check the resistance of the oil pressure switch terminal to ground. <p>Is the resistance within the specified value?</p>	Ω	GO to Step 5	Remove and Replace the Oil Pressure Switch And Retest
5	<ol style="list-style-type: none"> 1. Note: This test may require an assistant depending on the application. 2. Disconnect and remove the oil pressure switch. 3. Install an auxiliary analog oil pressure gauge. 4. Note: Do not allow the engine to run for more than 15 seconds 5. Start the engine, run for 30 seconds or less at minimum 800 RPM. <p>Does the engine shut down after running for 4-5 seconds and the oil pressure is within the specified value?</p>	30-80 PSI	Oil Pressure System OK Check for a stuck throttle plate, and loose or binding throttle linkage. If OK, return to the Symptom Chart	0-29 PSI GO to Section 1 Replace the Oil Pump 31-80 PSI GO to Section 1 Check for stuck Oil Pump Relief Valve.

WSG-1068 ENGINE CONTROLS

Step	Action	Values	Yes	No
6	1. Key Off 2. Disconnect ICM Connector C3. 3. Disconnect the oil pressure switch. 4. Using an ohmmeter, check the resistance of circuit 253 DG/WH between connector C3 pin C and the oil pressure switch connector. Is the resistance less than 5 ohms?		GO to Step 7	REPAIR the circuit(s) in question. TEST the system for normal operation.
7	1. Reconnect ICM Connector C3. 2. Disconnect the oil pressure switch. 3. KOEO. 4. Using an ohmmeter, check the resistance of circuit 253 DG/WH from connector C3 pin C and a known ground. Is the resistance less than 5 ohms?		Replace the ICM and Retest the system	System OK

Pinpoint Test F - Cylinder Head Temperature Sensor Check

Inspection and Verification

1. Visually inspect for obvious signs of mechanical and electrical damage
2. Inspect for bent or broken connector terminals.
3. Visually inspect for and note auxiliary system connections not shown on the **Recommended Customer Connections Wiring Schematic**.

Normal Operation

The factory installed thermostat provides engine cooling @ 194 degrees F (90 Celsius) through all operating ranges. In the event the engine temperature rises above 250 degrees F (121 C), the ICM will protect the engine by removing the groundside of the ignition coils. The engine can be restarted, but will stall again as long as the ICM reads the engine temperature is staying below -40 degrees F (-40 C) or above 250 degrees F (121 C).

Step	Action	Values	Yes	No
1	1. Check for an auxiliary temperature gauge. Does the gauge reflect a temperature above 250 degrees F?		Go to Step 2	Go to Step 3
2	1. Check the engine coolant level. Does the engine have the correct coolant level?		GO to Step 3	Top off the engine coolant and check for coolant circulation and RETEST
3	1. Start the engine. Does the engine shut down above 400 RPM or after 3 or 4 seconds of operation?		Check for a stuck throttle, loose or binding throttle linkage. If fuel system is OK, GO to Step 4	System OK
4	1. Key Off. 2. Disconnect ICM Connector C2. 3. Using an ohmmeter, measure the voltage of pin G circuit 16L. 4. KOEO. NOTE: Auxiliary applications will time out and remove voltage to the ICM, cycle key off and on to verify this application is present. Is the voltage within the specified value?	Battery Voltage	GO to Step 5	Inspect 30A Fuse REPAIR the circuit(s) in question. RETEST the system for normal operation.
5	1. Key Off. 2. Disconnect ICM Connector C2. 3. Using an ohmmeter, measure the resistance between pins B circuits 350 GY and D 1102 YE/LG. Is the resistance within the specified value?	Refer to the CHT Sens or Data Chart	System OK If you have been directed to perform a system check Go to the next test.	GO to Step 6

WSG-1068 ENGINE CONTROLS

Step	Action	Values	Yes	No
6	<ol style="list-style-type: none"> 1. Reconnect ICM connector C2. 2. Remove the Generator, Go to Section 06. 3. Disconnect the CHT sensor connector. 4. KOEO. 5. Using a Voltmeter, measure the voltage of CHT connector circuit 359A GY/RD. <p>Is the voltage within the specified value?</p>	5.0 Volts	GO to Step 8	GO to Step 7
7	<ol style="list-style-type: none"> 1. Key Off. 2. Disconnect ICM Connector C2. 3. Using an ohmmeter, check the resistance between the ICM Connector C2 pin B circuit 350 GY and the CHT connector circuit 359A GY/RD. <p>Is the resistance less than 5 ohms?</p>		Replace the ICM and Retest the system	REPAIR the circuit(s) in question. TEST the system for normal operation.
8	<ol style="list-style-type: none"> 1. Key Off. 2. Disconnect ICM Connector C2. 3. Using an ohmmeter, check the resistance between the ICM Connector C2 pin D circuit 1102 YE/LG and ground. <p>Is the resistance less than 5 ohms?</p>		REPAIR the circuit(s) for a short to ground. RETEST the system for normal operation.	Go to Step 9
9	<ol style="list-style-type: none"> 1. Key Off. 2. Disconnect ICM Connector C2. 3. Using an ohmmeter, check the resistance between the ICM Connector C2 pin D circuit 1102 YE/LG and the CHT connector circuit 1102 YE/LG. <p>Is the resistance less than 5 ohms?</p>		GO to Step 10	REPAIR the circuit(s) in question. TEST the system for normal operation.
10	<ol style="list-style-type: none"> 1. Key Off 2. Disconnect the CHT sensor. 3. Using an ohmmeter, check the terminals of the CHT sensor. <p>Is the resistance within the specified value?</p>	Refer to the CHT Sensor Data Chart	Check for a stuck throttle, loose or binding throttle linkage.	Remove and replace the CHT sensor, refer to Section 05

Pinpoint Test G - Ground Shield Check

Inspection and Verification

1. Visually inspect for obvious signs of mechanical and electrical damage.
2. Visually inspect for and note auxiliary system connections not shown on the **recommended wiring schematic**.

Normal Operation

The Camshaft and the Crankshaft Position Sensor harness circuits are wrapped with a grounding shield to eliminate electro magnetic interference.

Step	Action	Values	Yes	No
1	Have you preformed Ignition Check?		GO to Step 2	Go to Section 03 Pin Point Test A
2	<ol style="list-style-type: none"> 1. Key Off, Engine Off. 2. Inspect the ICM ground terminal location (s) for clean and tight connections. 3. Disconnect the Main 10-Pin connector C1. 4. Using an ohmmeter, measure the resistance of terminal C2 pin D of the equipment side of the harness to a known good ground. <p>Is the resistance less than 5 ohms?</p>		Re-tape the harness and GO to Step 3	REPAIR the circuit(s) in question. TEST the system for normal operation.
3	<ol style="list-style-type: none"> 1. Key Off, Engine Off. 2. Disconnect the Camshaft Position (CMP) Sensor. 3. Carefully remove the harness tape 50mm back from the CMP connector. 4. Open the confluent exposing the grounding shield. 5. Using an ohmmeter, gently touch the foil shielding and measure the resistance between the foil and terminal C2 pin D, circuit 57BK of the engine harness to a known good ground. <p>Is the resistance less than 5 ohms?</p>		Re-tape the harness and GO to Step 4	REPAIR the circuit(s) in question. TEST the system for normal operation.
4	<ol style="list-style-type: none"> 1. Key Off, Engine Off. 2. Disconnect the Crankshaft Position (CKP) Sensor. 3. Carefully remove the harness tape 50mm back from the CKP connector. 4. Open the confluent exposing the grounding shield. 5. Using an ohmmeter, gently touch the foil shielding and measure the resistance between the foil and terminal C2 pin D, circuit 57BK of the engine harness to a known good ground. <p>Is the resistance less than 5 ohms?</p>		Return to the Symptom Chart	REPAIR the circuit(s) in question. TEST the system for normal operation.

SPECIFICATIONS

Special Tools

Rotunda Equipment	
105-RO057	73111 Automotive Meter

INDEX

Subject	Page
Introduction	09 - 2
Nomenclature for Bolts	09 - 2
Bolt Strength Identification	09 - 3
Hex Nut Strength Identification	09 - 3
Other Types of Parts	09 - 4
English/Metric conversion	09 - 5
Decimal and Metric Equivalents	09 - 6
Torque Conversion	09 - 6
J1930 Terminology List	09 - 7

INTRODUCTION

Most threaded fasteners are covered by specifications that define required mechanical properties, such as tensile strength, yield strength, proof load and hardness. These specifications are carefully considered in initial selection of fasteners for a given application. To ensure continued satisfactory vehicle performance, replacement fasteners used should be of the correct strength, as well as the correct nominal diameter, thread pitch, length, and finish.

Most original equipment fasteners (English or Metric system) are identified with markings or numbers indicating the strength of the fastener. These markings are described in the pages that follow. Attention to these markings is important to ensure that the proper replacement fasteners are used.

Further, some metric fasteners, especially nuts, are colored blue. This metric blue identification is in most cases a temporary aid for production start-up, and color will generally revert to normal black or bright after start-up.

English or Metric system fasteners are available through your Ford Parts and Service operation.

NOMENCLATURE FOR BOLTS

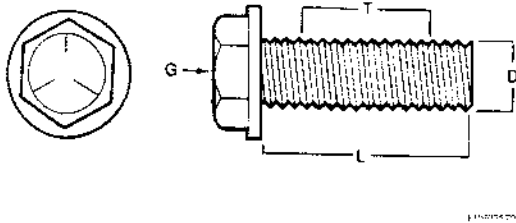
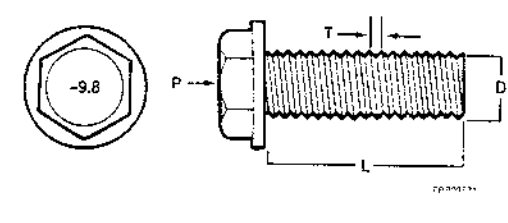
English System Bolt, 1/2 - 13 x 1	Metric System Bolt, M12 - 1.75 x 25
	
<p>G = Grade Marking (bolt strength) L = Length (inches) ** T = Thread Pitch (thread/inch) D = Nominal Diameter (inches)</p>	<p>P = Property Class (bolt strength) * L = Length (millimeters) ** T = Thread Pitch (thread width crest to crest mm) D = Nominal Diameter (millimeters)</p>

* The Property class is an Arabic numeral distinguishable from the slash SAE English grade system.

** The length of all bolts is measured from the underside of the head to the end.

BOLT STRENGTH IDENTIFICATION

English System

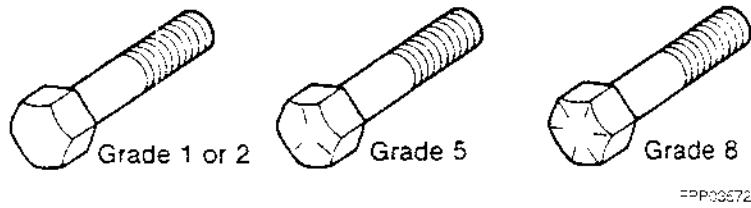

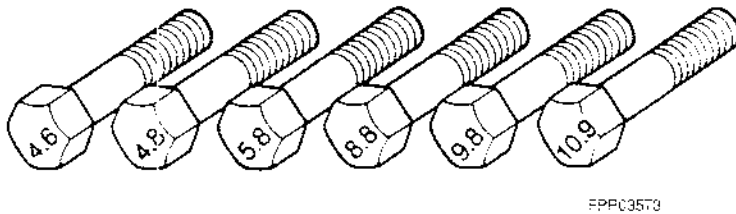

English (inch) bolts: Identification marks correspond to bolt strength, increasing number of slashes represent increasing strength.

Metric System



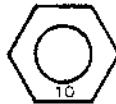

Metric (mm) bolts: Identification class numbers correspond to bolt strength, increasing numbers represent increasing strength. Common metric fastener bolt strength property are 9.8 and 10.9 with the class identification embossed on the bolt head.

HEX NUT STRENGTH IDENTIFICATION

English System - Grade Identification	Metric System - Class Identification
<div style="display: flex; justify-content: space-around; align-items: center;"> <div style="text-align: center;"> <p>HEX NUT Grade 5 (3 dots)</p>  </div> <div style="text-align: center;"> <p>HEX NUT Grade 8 (6 dots)</p>  </div> </div> <p style="text-align: center; font-size: small;">FPP03574</p>	<div style="display: flex; justify-content: space-around; align-items: center;"> <div style="text-align: center;"> <p>HEX NUT Property Class 9 (Arabic 9)</p>  </div> <div style="text-align: center;"> <p>HEX NUT Property Class 10 (Arabic 10)</p>  </div> </div> <p style="text-align: center; font-size: small;">FPP03575</p>
<p>Increasing dots represent increasing strength.</p>	<p>May also have blue finish or paint daub on hex flat. Increasing numbers represent increasing strength.</p>

OTHER TYPES OF PARTS

Metric identification schemes vary by type of part, most often a variation of that used of bolts and nuts. Note that many types of English and Metric fasteners carry no special identification if they are otherwise unique.

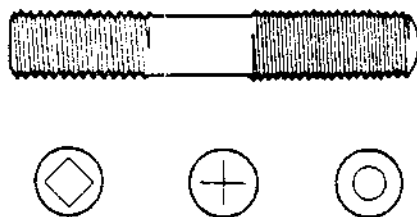
<p>Stamped U-Nuts</p>	 <p>FPP03576</p>
<p>Tapping, thread forming and certain other case hardened screws</p>	 <p>FPP03577</p>
<p>Studs. Large studs may carry the property class number. Smaller studs use a geometric code on the end.</p>	 <p>CLASS 10.9 CLASS 9.8 CLASS 8.8</p> <p>FPP03578</p>

ENGLISH/METRIC CONVERSION

TO CONVERT FROM TO	TO FROM	MULTIPLY BY DIVIDE BY
Distance		
inches	mm	25.4
inches	m	0.0254
feet	mm	304.8
feet	m	0.3048
yards	m	0.9144
mile	km	1.609
Area		
in ²	mm ²	645.16
ft. ²	m ²	0.0929
ft. ²	cm ²	6.45
yds ²	m ²	0.8361
Volume		
in ³	cm ³	16.3871
in ³	mm ³	16387.0
in ³	1 liter	0.016387
yard ³	m ³	0.7646
pint (us)	1 liter	0.47318
pint (uk)	1 liter	0.56826
quart (us)	1 liter	0.94635
gallon (us)	1 liter	3.7854
gallon (uk)	1 liter	4.5461
ft. ³	1 liter	28.3168
ft. ³	m ³	0.02832
Mass		
oz.	g	28.3495
lb.	kg	0.45359
ton	kg	907.18
ton (US)	tonne	0.90718
ton (UK)	tonne	1.01605
Density		
Force		
lbf	Newton (N)	4.44822
kilogram	Newton (N)	9.807
ounce	Newton (N)	0.2780
Pressure & Stress		
1000 kpa	Bar	1000
lbf/in ² (psi)	kPa	6.895
lbf/in ² (psi)	N/M ²	6894.76
lbf/in ² (psi)	Bar	0.0689
lbf/in ² (psi)	N/mm ²	0.00689
lbf/m ² (psi)	mmHg	51.715
"H ₂ O	kPa	0.2491
"H ₂ O	mmH ₂ O	25.4
"Hg	mmHG	25.4
ton (US)/in ²	N/mm ²	13.7894
ton (UK)/in ²	N/mm ²	15.4443
Velocity		
ft./sec.	m/s	0.3048
ft./sec.	km/h	1.09728
miles/h	m/s	0.44694
miles/h	km/h	1.609
Acceleration		
in./sec ²	m/s ²	0.0254
ft./sec ²	m/s ²	0.3048
Light		
foot candle	lumens/sq meter	10.764

TO CONVERT FROM TO	TO FROM	MULTIPLY BY DIVIDE BY
Energy		
kW.h	Joules (J)	3,600,000
lb/ft	Joules (J)	1.3558
Btu	Joules (J)	1055.06
Kcal	Joules (J)	4186.8
HP.h	kW.h	0.7457
PS.h	kW.h	0.7355
Temperature		
degree Farenheit (°F)	degree Celsius (°C)	(°F-32) x 0.556
Torque		
lb./ft.	Nm	1.35582
lb./in.	Nm	0.11298
Power		
HP	kW	0.7457
PS	kW	0.7355
HP	PS	1.01387
Specific Fuel Consumption		
lb./hp.h	g/kW.h	608.277
miles/gal	kilometers/liter (km/L)	0.4251
gal/miles	liters/kilometer (L/km)	2.3527

DECIMAL AND METRIC EQUIVALENTS

TORQUE CONVERSION

FRACTIONS	DECIMAL INCH	METRIC MM
1/64	.015625	.397
1/32	.03125	.794
3/64	.046875	1.191
1/16	.0625	1.588
5/64	.078125	1.984
3/32	.09375	2.381
7/64	.109375	2.778
1/8	.125	3.175
9/64	.140625	3.572
5/32	.15625	3.969
11/64	.171875	4.366
3/16	.1875	4.763
13/64	.203125	5.159
7/32	.21875	5.556
15/64	.234375	5.953
1/4	.250	6.35
17/64	.265625	6.747
9/32	.28125	7.144
19/64	.296875	7.54
5/16	.3125	7.938
21/64	.328125	8.334
11/32	.34375	8.731
23/64	.359375	9.128
3/8	.375	9.525
25/64	.390625	9.922
13/32	.40625	10.319
27/64	.421875	10.716
7/16	.4375	11.113
29/64	.453125	11.509
15/32	.46875	11.906
31/64	.484375	12.303
1/2	.500	12.7
33/64	.515625	13.097
17/32	.53125	13.494
35/64	.546875	13.891
9/16	.5625	14.288
37/64	.578125	14.684
19/32	.59375	15.081
39/64	.609375	15.478
5/8	.625	15.875
41/64	.640625	16.272
21/32	.65625	16.669
43/64	.671875	17.066
11/16	.6875	17.463
45/64	.703125	17.859
23/32	.71875	18.256
47/64	.734375	18.653
3/4	.750	19.05
49/64	.765625	19.447
25/32	.78125	19.844
51/64	.796875	20.241
13/16	.8125	20.638
53/64	.828125	21.034
27/32	.84375	21.431
55/64	.859375	21.828
7/8	.875	22.225
57/64	.890625	22.622
29/32	.90625	23.019
59/64	.921875	23.416
15/16	.9375	23.813
61/64	.953125	24.209
31/32	.96875	24.606
63/64	.984375	25.003
1	1.00	25.4

Newton Meters (Nm)	Pound Feet (lb-ft)
1	0.7376
2	1.5
3	2.2
4	3.0
5	3.7
6	4.4
7	5.2
8	5.9
9	6.6
10	7.4
15	11.1
20	14.8
25	18.4
30	22.1
35	25.8
40	29.5
50	36.9
60	44.3
70	51.6
80	59.0
90	66.4
100	73.8
110	81.1
120	88.5
130	95.9
140	103.3
150	110.6
160	118.0
170	125.4
180	132.8
190	140.1
200	147.5
225	166.0
250	184.4

Newton Meters (Nm)	Pound Feet (lb-ft)
1	1.356
2	2.7
3	4.0
4	5.4
5	6.8
6	8.1
7	9.5
8	10.8
9	12.2
10	13.6
15	20.3
20	27.1
25	33.9
30	40.7
35	47.5
40	54.2
45	61.0
50	67.8
55	74.6
60	81.4
65	88.1
70	94.9
75	101.7
80	108.5
90	122.0
100	135.6
110	149.1
120	162.7
130	176.3
140	189.8
150	203.4
160	216.9
170	230.5
180	244.0

J1930 TERMINOLOGY LIST

Certain Ford Component names have been changed in this Service Manual to conform to Society of Automotive Engineers (SAE) directive J1930.

SAE J1930 standardizes automotive component names for all vehicle manufacturers.

New Term	New Acronym	Old Terms (Acronyms)
Accelerator Pedal	AP	Accelerator
Air Cleaner	ACL	Thermac Air Cleaner
Air Cleaner Element	ACL Element	Air Cleaner Element (ACL Element)
Air Cleaner Housing	ACL Housing	Air Cleaner Housing (ACH)
Air Cleaner Housing Cover	ACL Housing Cover	Air Cleaner Housing Cover (ACL Housing Cover)
Air Conditioning	A/C	Air Conditioning (AC)
Air Conditioning Clutch	A/C Clutch	Air Conditioning Clutch (ACC)
Air Conditioning Cycling Switch	A/C Cycling Switch	Air Conditioning Cycling Switch (ACCS)
Air Conditioning Sensor	A/C Sensor	Air Conditioning Sensor (A/C Sensor)
Air Conditioning System	A/C System	Air Conditioning System (SCS)
Automatic Transaxle	A/T	Electronic Automatic Transaxle (EATX)
Automatic Transmission	A/T	Electronic Automatic Transmission (EATX)
Barometric Pressure	BARO	Barometric Pressure (BARO)
Barometric Pressure Sensor	BARO Sensor	- Absolute Pressure Sensor (APS) - Barometric Pressure Sensor (BP Sensor)
Battery Positive Voltage	B+	Battery Positive Voltage (B+)
Camshaft Position	CMP	Sync Pickup
Camshaft Position Sensor	CMP Sensor	- Camshaft Position Sensor (CPS) - Camshaft Sensor - Cylinder Identification Sensor (Cylinder ID Sensor) (CID)
Canister	Canister	Canister
Carburetor	CARB	Feed Back Carburetor (FBC)
Central Multiport Fuel Injection	Central MFI	- Central Multiport Fuel Injection (CMFI) - Fuel Injection (FI)
Charge Air Cooler	CAC	- After Cooler - Inter Cooler
Closed Loop	CL	Closed Loop System (CLS)
Closed Throttle Position	CTP	Closed Throttle Position (CTP)
Closed Throttle Position Switch	CTP Switch	Closed Throttle Switch
Clutch Pedal Position	CPP	Clutch Pedal Position (CPP)
Clutch Pedal Position Switch	CPP Switch	- Clutch Engage Switch (CES) - Clutch Start Switch - Clutch Switch
Compact Disc Read Only memory	CDROM	Compact Disc Read Only Memory (CDROM)

New Term	New Acronym	Old Terms (Acronyms)
Continuous Fuel Injection	CFI	- Continuous Injection System (CIS) - Continuous Injection System - Electronic (continuous Injection System-E) (CIS-E) - Fuel Injection (FI) - K-Jetronic - KE-Jetronic - KE-Motronic
Continuous Fuel Injection system	CFI System	Continuous Injection System (CIS)
Continuous Trap Oxidizer	CTOX	- Continuous Trap Oxidizer (CTO) - Trap Oxidizer - Continuous (TOC)
Crankshaft Position	CKP	- Crankshaft Position (CP) - Position Indicator Pulse (PIP)
Crankshaft Position Sensor	CKP Sensor	- Crankshaft Position Sensor (CPS) - Crank Angle Sensor
Data Link Connector	DLC	- Assembly Line Communication Link (ALCL) - Assembly Line Diagnostic Link (ALDL) - Self Test Connector - Vehicle in Process Connector (VIP Connector)
Diagnostic Test Mode	DTM	Modes
Diagnostic Trouble Code	DTC	Self Test Codes
Differential Pressure Feedback Gas Recirculation System	Differential Pressure Feedback EGR System	Differential Pressure Feedback EGR System
Direct Fuel Injection	DFI	- Direct Injection (DI) - Direct Injection - Diesel (DID) - Fuel Injection (FI)
Distributor Ignition	DI	- Capacitive Discharge Ignition (CDI) - Closed Bowl Distributor - Electronic Ignition (EI) (with Distributor) - Electronic Spark Advance Control (ESAC) - High Energy Ignition (HEI) - Remote Mount Thick Film Ignition (Remote Mount TFI) - Thick Film Ignition (TFI)
Distributor Ignition Capacitor	DI Capacitor	Condenser
Distributor Ignition Control Module	Distributor ICM	Electronic Distributor Ignition System Module (EDIS Module)
Distributor Ignition System	DI System	Electronic Distributor Ignition System (EDIS)
Early Fuel Evaporation	EFE	Early Fuel Evaporation (EFE)
Electrically Erasable Programmable Read Only Memory	EEPROM	Electrically Erasable Programmable Read Only Memory (E2PROM)
Electronic Continuous Fuel Injection System	Electronic CFI System	Continuous Injection System - Electronic (Continuous Injection System-E) (CIS-E)
Electronic engine Control	Electronic EC	Electronic Engine Control (EEC)
Electronic Ignition	EI	- Computer Controlled Coil Ignition (C3I) - Distributorless Ignition (DLI) - Electronic Ignition (EI) (without distributor) - Integrated Direct Ignition (IDI)
Electronic Ignition System	EI System	- Direct Ignition System (DIS) - Distributorless Ignition System (DIS) - Electronic Distributorless Ignition System (EDIS)
Engine Control	EC	Electronic Engine Control (EEC)
Engine Control Module	ECM	Engine Control Module (ECM)

WSG-1068 METRICS

New Term	New Acronym	Old Terms (Acronyms)
Engine Coolant Level	ECL	Engine Coolant Level (ECL)
Engine Coolant Level Indicator	ECL Indicator	Engine Coolant Level Indicator
Engine Coolant Temperature	ECT	Engine Coolant Temperature (ECT)
Engine Coolant Temperature Sensor	ECT Sensor	- Coolant Temperature Sensor (CTS) - Engine Coolant Temperature Sender (ECT Sender)
Engine Coolant Temperature Switch	ECT Switch	Coolant Temperature Switch (CTS)
Engine Speed	RPM	- Crankshaft Speed - Revolutions Per Minute (RPM)
Engine Speed Sensor	RPM Sensor	Crankshaft Speed Sensor
Erasable Programmable Read Only Memory	EPROM	Erasable Programmable Read Only Memory (EPROM)
Evaporative Emission	EVAP	Evaporative Emission (EVAP)
Evaporative Emission Canister	EVAP Canister	- Canister - Charcoal Canister
Evaporative Emission Canister Purge	EVAP Canister Purge	- EVAP CANP - Canister Purge (CANP)
Evaporative Emission Canister Purge Valve	EVAP Canister Purge Valve	- Canister Purge Valve - Canister Purge Vacuum Switching Valve (Canister Purge VSV) - Duty Solenoid for Purge Valve - Evaporative Emission Purge Valve (EVAP Purge Valve) - Vacuum Solenoid Valve (Canister) (VSV) - Vacuum Solenoid Valve (EVAP) (VSV)
Evaporative Emission System	EVAP System	Evaporation Emission Control System (EECS)
Exhaust Gas Recirculation	EGR	Digital Exhaust Gas Recirculation (Digital EGR)
Exhaust Gas Recirculation Backpressure Transducer	EGR Backpressure Transducer	Backpressure Transducer
Exhaust Gas Recirculation Diagnostic Valve	EGR Diagnostic	EGR Diagnostic Valve
Exhaust Gas Recirculation System	EGR System	EGR System
Exhaust Gas Recirculation Temperature	EGRT	EGR Temperature
Exhaust Gas Recirculation Temperature Sensor	EGRT Sensor	Recirculated Exhaust Gas Temperature Sensor (REGTS)
Exhaust Gas Recirculation Thermal Vacuum Valve	EGR TVV	EGR Thermal Vacuum Valve (EGR TVV)
Exhaust Gas Recirculation Vacuum Regulator Solenoid	EGR Vacuum Regulator Solenoid	EGR Vacuum Regulator Solenoid (EVR Solenoid)
Exhaust Gas Recirculation Vacuum Regulator Valve	EGR Vacuum Regulator Valve	EGR Vacuum Regulator Valve (EVRV)
Exhaust Gas Recirculation Valve	EGR Valve	EGR Valve (EGRV)
Exhaust Gas Recirculation Valve Control	EGR Valve Control	EGR Valve Control (EGRVC)
Exhaust Gas Recirculation Valve Position Sensor	EGR Valve Position Sensor	EGR Valve Position Sensor (EVP Sensor)
Fan Control	FC	- Electro-Drive Fan Control (EDF Control) - Engine Coolant Fan Control - High Electro-Drive Fan Control (HEDF Control) - Radiator Fan Control
Fan Control Module	FC Module	Fan Control Module

New Term	New Acronym	Old Terms (Acronyms)
Fan Control Relay	FC Relay	- Fan Motor Control Relay - Radiator Fan Relay
Feedback Pressure Exhaust Gas Recirculation	Feedback Pressure EGR	Pressure Feedback Exhaust Gas Recirculation
Feedback Pressure Exhaust Gas Recirculation Sensor	Feedback Pressure EGR Sensor	Pressure Feedback Exhaust Gas Recirculation (PFE) Sensor
Flash Electrically Erasable Programmable Read Only Memory	FEEPROM	Flash EEPROM
Flash Erasable Programmable Read Only Memory	FEPRM	Flash EPROM
Flexible Fuel	FF	Flexible Fuel (FF)
Flexible Fuel Sensor	FF Sensor	- Alcohol Concentration Sensor - Fuel Concentration Sensor - Fuel Quality Sensor - Percent Alcohol Sensor - Variable Fuel Sensor
Forth Gear	4GR	Fourth Gear (4GR)
Fuel Level Sensor	Fuel Level Sensor	Fuel Sensor
Fuel Pressure	Fuel Pressure	Fuel Pressure
Fuel Pressure Regulator	Fuel Pressure Regulator	Fuel Regulator
Fuel Pump	FP	Fuel Pump (FP)
Fuel Pump Module	FP Module	- Fuel Module - Fuel Sender - Fuel Tank Unit - In Tank Module
Fuel Pump Relay	FP Relay	Fuel Pump Relay
Fuel Trim	FT	Adaptive Fuel Strategy
Generator	GEN	Alternator (ALT)
Governor	Governor	Governor
Governor Control Module	GCM	Governor Electronic Module (GEM)
Ground	GND	Ground (GRD)
Heated Oxygen Sensor	HO2S	- Heated Exhaust Gas Oxygen Sensor (HEGO Sensor) - Heated Oxygen Sensor (HOS)
High Speed Fan Control Switch	High Speed FC Switch	High speed Fan Control Switch (High Speed FC Switch)
Idle Air Control	IAC	- Idle Air Bypass Control - Idle speed Control (ISC) - Idle Speed Control Bypass air (ISC BPA)
Idle Air Control Thermal Valve	IAC Thermal Valve	Fast Idle Thermo Valve
Idle Air Control Valve	IAC Valve	- Air Valve - Fast Idle Thermo Valve - Idle Air Control Valve (IACV)
Idle Speed Control	ISC	Throttle Opener
Idle Speed Control Actuator	ISC Actuator	Idle Speed Control Actuator (ISC Actuator)
Idle Speed Control Solenoid Vacuum	ISC Solenoid Vacuum Valve	- Throttle Opener Vacuum Switching Valve (Throttle Opener VSV) - Vacuum Solenoid Valve (Throttle) (VSV)

WSG-1068 METRICS

New Term	New Acronym	Old Terms (Acronyms)
Ignition Control	IC	- Electronic Spark Advance (ESA) - Electronic spark Timing (EST)
Ignition Control Module	ICM	- Distributorless Ignition System Module (DIS Module) - Thick Film Ignition Module (TFI Module)
Indirect Fuel Injection	IFI	- Fuel Injection (FI) - Indirect Fuel Injection (IDFI) - Indirect Diesel Injection (IDI)
Inertia Fuel Shutoff	IFS	Inertia Fuel Shutoff (IFS)
Inertia Fuel Shutoff Switch	IFS Switch	- Inertia Switch - Inertia Fuel - Shutoff Switch
Intake Air	IA	Intake Air
Intake Air Duct	IA Duct	Intake Air Duct
Intake Air System	IA System	Air Intake System
Intake Air Temperature	IAT	- Air Charge Temperature (ACT) - Manifold Air Temperature (MAT) - Throttle Body Temperature (TBT) - Vane Air Temperature (VAT)
Intake Air Temperature Sensor	IAT Sensor	- Air Temperature Sensor (ATS) - Intake Air Temperature Sensor (IATS) - Manifold Air Temperature Sensor (MATS)
Keep Alive Random Access Memory	Keep Alive RAM	Keep Alive memory (KAM)
Knock Sensor	KS	Detonation Sensor (DS)
Long Term Fuel Trim	Long Term FT	- Block Learn Matrix (BLM) - Block Learn Memory (BLM) - Block Learn Multiplier (BLM)
Low Speed Fan Control Switch	Low Speed FC Switch	Low Speed Fan Control Switch (Low Speed FC Switch)
Malfunction Indicator Lamp	MIL	- Check Engine - Service Engine Soon
Manifold Absolute Pressure	MAP	Manifold Absolute Pressure (MAP)
Manifold Absolute Pressure Sensor	MAP Sensor	- Intake Manifold Absolute Pressure Sensor - Manifold Absolute Pressure Sensor (MAPS) - Pressure Sensor (P-Sensor)
Manifold Differential Pressure	MDP	Manifold Differential Pressure (MDP)
Manifold Differential Pressure Sensor	MDP Sensor	Vacuum Sensor (VAC Sensor)
Manifold Surface Temperature	MST	Manifold Surface Temperature (MST)
Manifold Vacuum Zone	MVZ	Manifold Vacuum Zone (MVZ)
Manifold Vacuum Zone Switch	MVZ Switch	Vacuum Switches
Mass Air Flow	MAF	- Air Flow Control (AFC) - Air Flow Meter
Mass Air Flow Sensor	MAF Sensor	- Air Flow Meter - Air Flow Sensor (AFS) - Hot Wire Anemometer
Mixture Control	MC	- Feed Back Control (FBC) - Mixture Control (M/C)
Mixture Control Solenoid	MC Solenoid	Mixture Control Solenoid (MCS)

New Term	New Acronym	Old Terms (Acronyms)
Multipoint Fuel Injection	MFI	- D-Jetronic - Digital Fuel Injection (EFI) - Electronic Fuel Injection (EFI) - Fuel Injection (FI) - L-Jetronic - LH-Jetronic - Motronic - Multipoint Injection (MPI) - Multipoint Injection (MPI) - Port Fuel Injection (PFI) - Programmed Fuel Injection (PGM-FI) - Tuned Port Injection (TPI)
Nonvolatile Random Access Memory	NVRAM	- Keep Alive Memory (KAM) - Nonvolatile Memory (NVM)
Oil Pressure Sensor	Oil Pressure Sensor	Oil Pressure Sender
Oil Pressure Switch	Oil Pressure Switch	Oil Pressure Switch
On-Board Diagnostic	OBD	Self Test
Open Loop	OL	Open Loop (OL)
Oxidation Catalytic Converter	OC	- Continuous Oxidation Catalyst (COC) - Oxidation Catalyst (OC)
Oxygen Sensor	O2S	- Exhaust Gas Oxygen Sensor (EGC Sensor, EGOS) - Exhaust Gas Sensor (EGS) - Exhaust Oxygen Sensor (EOS) - Lambda - Oxygen Sensor (O2 Sensor, OS)
Park/Neutral Position	PNP	Park/Neutral (P/N)
Park/Neutral Position Switch	PNP Switch	- Neutral Drive Switch (NDS) - Neutral Gear Switch (NGS) - Neutral Position Switch (NPS) - Neutral Safety Switch
Periodic Trap Oxidizer	PTOX	Trap Oxidizer - Periodic (TOP)
Positive Crankcase Ventilation	PCV	Positive Crankcase Ventilation (PCV)
Positive Crankcase Ventilation (Valve)	PCV Valve	Positive Crankcase Ventilation (PCV valve)
Power Steering Pressure	PSP	Power Steering Pressure (PSP)
Power Steering Pressure Switch	PSP Switch	Power Steering Pressure Switch (P/S Pressure Switch, PSPS)
Powertrain Control Module	PCM	- Electronic Control Assembly (ECA) - Electronic Control Unit 4 (ECU4) - Electronic Engine Control Processor (EEC Processor) - Microprocessor Control Unit (MCU) - Single Board Engine Control (SBEC) - Single Module Engine Control (SMEC)
Pressure Transducer Exhaust Gas Recirculation System	Pressure Transducer EGR System	Pressure Transducer EGR System
Programmable Read Only Memory	PROM	Programmable Read Only memory (PROM)
Pulsed Secondary Air Injection	PAIR	- Air Injection Reactor (AIR) - Air Injection Valve (AIV) - Pulsair - Thermactor II
Pulsed Secondary Air Injection Valve	PAIR Valve	Reed Valve
Random Access Memory	RAM	Random Access Memory (RAM)
Read Only memory	ROM	Read Only Memory (ROM)

WSG-1068 METRICS

New Term	New Acronym	Old Terms (Acronyms)
Relay Module	RM	Integrated Relay Module
Scan Tool	ST	Scan Tool
Secondary Air Injection	AIR	- Air Injection (AI) - Air Injection Reactor (AIR) - Thermac - Thermactor
Secondary Air Injection Bypass	AIR Bypass	- Air Management 1 (AM1) - Secondary Air Injection Bypass (AIRB) - Thermactor Air Bypass (TAB)
Secondary Air Injection Bypass Valve	AIR Bypass Valve	Secondary Air Bypass Valve (SABV)
Secondary Air Injection Check Valve	AIR Check Valve	Secondary Air Check Valve
Secondary Air Injection Control Valve	AIR Control Valve	- Air Control Valve - Secondary Air Check Valve (SACV)
Secondary Air Injection Diverter	AIR Diverter	- Air Management2 (AM2) - Secondary Air Injection Diverter (AIRD) - Thermactor Air Diverter (TAD)
Secondary Air Injection Pump	AIR Pump	Air Injection Pump (AIP)
Secondary Air Injection Switching Valve	AIR Switching Valve	Secondary Air Switching Valve (SASV)
Sequential Multiport Fuel Injection	SFI	- Fuel Injection (FI) - Sequential Electronic Fuel Injection (SEFI) - Sequential Fuel Injection (SFI)
Service Reminder Indicator	SRI	- Check Engine - Engine Maintenance Reminder (EMR) - Oxygen Sensor Indicator (OXS) - Service Engine Soon
Short Term Fuel Trim	Short Term FT	Integrator (INT)
Smoke Puff Limiter	SPL	Smoke Puff Limiter (SPL)
Supercharger	SC	Supercharger (SC)
Supercharger Bypass	SCB	Supercharger Bypass (SCB)
Supercharger Bypass Solenoid	SCB Solenoid	Supercharger Bypass Solenoid (SBS)
System Readiness Test	SRT	System Readiness Test (SRT)
Thermal Vacuum Valve	TVV	Thermal Vacuum Switch (TVS)
Third Gear	3GR	Third Gear (3GR)
Three Way Catalytic Converter	TWC	Three Way Catalytic Converter (TWC)
Three Way + Oxidation Catalytic Converter	TWC + OC	Dual Bed
Throttle Body	TB	Fuel Charging Station
Throttle Body Fuel Injection	TBI	- Central Fuel Injection (CFI) - Electronic Fuel Injection (EFI) - Fuel Injection (FI) - Monotronic - Single Point Injection (SPI)
Throttle Position	TP	Throttle Position (TP)
Throttle Position Sensor	TP Sensor	- Throttle Position Sensor (TP) - Throttle Potentiometer
Throttle Position Switch	TP Switch	Throttle Position Switch (TPS)
Torque Converter Clutch	TCC	- Converter Clutch Control (CCC) - Converter Clutch Override (CCO) - Viscous Converter Clutch (VCC)

New Term	New Acronym	Old Terms (Acronyms)
Torque Converter Clutch Relay	TCC Relay	Lock Up Relay
Torque Converter Clutch Solenoid Valve	TCC Solenoid Valve	Lock Up Solenoid Valve (LUS)
Transmission Control Module	TCM	Transmission Control Module
Transmission Range	TR	- Park, Reverse, Neutral, Drive, Low (PRNDL) - Selection Lever Position (SLP) - Transmission Range Selection (TRS)
Transmission Range Sensor	TR Sensor	Manual Lever Position Sensor (MLP Sensor)
Transmission Range Switch	TR Switch	- Manual Range Position Switch (MRPS) - Transmission Position Switch - Transmission Range Selection Switch (TRSS)
Turbocharger	TC	Turbo
Vehicle Speed Sensor	VSS	- Distance Sensor - Pulse Generator (PG)
Voltage Regulator	VR	voltage Regulator (VR)
Volume Air Flow	VAF	- Air Flow Control (AFC) - Air Flow Meter - Vane Air Flow
Volume Air Flow Sensor	VAF Sensor	- Air Flow Meter - Air Flow Sensor (AFS)
Warm Up Oxidation Catalytic Converter	WU-OC	Light Off Catalyst
Warm Up Three Way Catalytic Converter	WU-TWC	Light Off Catalyst
Wide Open Throttle	WOT	Full Throttle
Wide Open Throttle Switch	WOT Switch	Wide Open Throttle Switch (WOTS)

FORD POWER PRODUCTS SERVICE

Dealers / Distributors

FORD POWER PRODUCTS SERVICE

Ford Service facilities are available in nearly every country of the world.

- Service in Europe is available via a network of Specialist Power Products distributors, or any other Authorized Ford Dealer.
- Dealers outside of Europe are supervised by Ford Affiliates, worldwide. A distributors list is provided below for your information.

Distributors

Australia

IF YOU ARE IN	THEN CALL	ADDRESS	TELEPHONE NUMBERS
AUSTRALIA	Lees Industries Australia PTY Ltd.	1224 Lytton Road Hemmant, Brisbane Wynnum Central Queensland 4178 Australia	Tel: 61-7-3390-5522 Fax: 61-7-3390-7571

Europe

IF YOU ARE IN	THEN CALL	ADDRESS	TELEPHONE NUMBERS
FINLAND	Masino OY	Karkikuja 3, FIN-01740 Vantaa Finland	Tel: 358-9-476-800 Fax: 358-9476-80300
FRANCE	Fornaut S.A.	45, Rue Charles Nodier, 93310 Le-Pre-St.-Gervais France	Tel: 33-148-450-394 Fax: 33-148-457-504
GERMANY	I.M.A -H.-D Groeschler GmbH H.D. Groschler	Westring 41 D-33818 Leopoldshoehe Germany	Tel: 49-5202-987-510 Fax: 49-5202-987-515
	Sauer & Sohn Sauer Mctive Systems	Gross Zimmerer Strasse 51 D-64807 Dieburg Germany	Tel: 49-6071-206-330 Fax: 49-6071-206-219
GREAT BRITAIN	Dalton Power Products Ltd. (Main Office)	Unit 6, Autumn Park Industrial Estate Dysart Road, Grantham Lincolnshire NG31 7DD England	Tel: 44-1476-576-666 Fax: 44-1476-577-127
	Dalton Power Products Ltd.	Industrial Road Hertburn Industrial Estate Washington Tyne & Wear NE37 2SE England	Tel: 44-191-416-1922/47 Fax: 44-191-415-3682
	Dalton Power Products Ltd.	Ellesmere Street Manchester M15 4LP England	Tel: 44-161-833-2932 Fax: 44-161-834-8465
	Hendy Power	School Lane Chandlers Ford Industrial Estate, Eastleigh, Hampshire SO53 4DG England	Tel: 44-2380-579-800 Fax: 44-2380-271-471
	Power Torque Engineering	Unit 6, Upminster Trading Park, Warley Street, Upminster, Essex RM14 3PJ England	Tel: 44-1708-221-070 Fax: 44-1708-226-855
	Power Torque Engineering	Herald Way, Binley, Coventry Warwickshire CV3 2RQ England	Tel: 44-2476-635-757 Fax: 44-2476-635-878

Europe (Continued)

IF YOU ARE IN	THEN CALL	ADDRESS	TELEPHONE NUMBERS
ITALY	CTM S.p.A.	Via C. Colombo 41, I-20090 Trezzano sul Naviglio, (Milano) Italy	Tel: 39-02-445-5141 Fax: 39-02-484-01771
NETHERLANDS	Nedato BV	Rendementsweg 4 NL-3641 SK Mijdrecht Netherlands	Tel: 31-297-293-200 Fax: 31-297-285-930
SWITZERLAND	Minelli AG	Mattenstr. 3, CH-8330 Pfäeffikon (ZH) Switzerland	Tel: 41-1-950-1720 Fax: 41-1-950-1132

New Zealand

IF YOU ARE IN	THEN CALL	ADDRESS	TELEPHONE NUMBERS
NEW ZEALAND	Lees Industries Group Delta Centre	345 Gt. South Road Takanini Papakura, Auckland New Zealand	Tel: 64-9-299-6019 Fax: 64-9-298-9986

North America - Canada

IF YOU ARE IN	THEN CALL	ADDRESS	TELEPHONE NUMBERS
BRITISH COLUMBIA	Industrial Engines Ltd.	1020 Cliveden Ave. Delta, Annacis Island, British Columbia, Canada, V3M 5R5	Tel: 1-604-525-8529 1-877-438-6560 Fax: 1-604-525-0974
ONTARIO, QUEBEC, MONITOBA	M-K Power Products Corp.	5641 McAdam Road Mississauga, Ontario, Canada, L4Z-1N9	Tel: 1-905-890-5323 CAN 1-800-263-5011 Fax: 1-905-890-6660
ALBERTA, SASKATCHEWAN	Industrial Engines, Ltd.	14335 12th Avenue Edmonton, Alberta Canada, T5L 2R8	Tel: 1-780-484-6213 CAN 1-866-484-6213 Fax: 1-780-732-0400
NOVA SCOTIA, NEW BRUNSWICK, NEW FOUNDLAND, PRINCE EDWARD ISLAND	Lunenburg Industrial Foundry & Engineering	53 Falkland Street, PO 1240 Lunenburg, Nova Scotia Canada, B0J 2C0	Tel: 1-902-634-8827 Fax: 1-902-634-8886

North America - United States

IF YOU ARE IN	THEN CALL	ADDRESS	TELEPHONE NUMBERS
ALABAMA	M&I Engine Company, Inc.	30762 State Highway 181 Daphne, AL 36526	Tel: 1-251-626-8080 1-800-633-1834 Fax: 1-251-626-2744
ALASKA	E.C. Power Systems	6051 S. 194th Street Kent, WA 98032	Tel: 1-253-872-7011 1-800-247-5899 Fax: 1-253-872-6947
ARIZONA	E.C. Power Systems	8360 E. Via de Ventura Blvd., Suite L-200 Scottsdale, AZ 85258	Tel: 1-480-905-5585 Fax: 1-503-224-3907

North America - United States (Continued)

IF YOU ARE IN	THEN CALL	ADDRESS	TELEPHONE NUMBERS
ARKANSAS -(Northern) -(Extreme Southern Territory)	Kansas City Power Products, Inc.	80 South James Kansas City, KS 66118	Tel: 1-913-321-7040 1-800-486-5277 Fax: 1-913-321-7341
	Lightbourn Equipment Co.	13649 Beta Road Dallas, TX 75244	Tel: 1-972-233-5151 Fax: 1-972-661-0738
CALIFORNIA	Powertech Engines Inc. (Main Office)	2933 E. Hamilton Avenue Fresno, CA 93721	Tel: 1-559-264-1776 1-800-891-1776 Fax: 1-559-264-2933
	Powertech Engines Inc.	2003 Leghorn Street Mountainview, CA 94043	Tel: 1-650-968-2434 Fax: 1-650-969-1267
	Powertech Engines Inc.	1410 South Acacia Avenue, Suite B Fullerton, CA 92831	Tel: 1-714-635-1774 1-800-784-1776 Fax: 1-714-635-1771
COLORADO	Industrial Power Systems, Inc. Engine Division	3233 Oakland Street Aurora, CO 80010	Tel: 1-303-360-7110 1-800-678-3673 Fax: 1-303-360-7519
CONNECTICUT	Engine Distributors, Inc.	400 University Court Blackwood, NJ 08012	Tel: 1-856-228-7298 1-800-220-2700 Fax: 1-856-228-5657(Parts) 1-856-228-5531(Sales)
DELAWARE	Engine Distributors, Inc.	400 University Court Blackwood, NJ 08012	Tel: 1-856-228-7298 1-800-220-2700 Fax: 1-856-228-5657(Parts) 1-856-228-5531(Sales)
DISTRICT OF COLUMBIA	Engine Distributors, Inc.	400 University Court Blackwood, NJ 08012	Tel: 1-856-228-7298 1-800-220-2700 Fax: 1-856-228-5657(Parts) 1-856-228-5531(Sales)
FLORIDA -(Panhandle)	Highway Equipment & Supply Co. (Main Office)	1016 West Church Street Orlando, FL 32805	Tel: 1-407-843-6310 1-800-827-6495 Fax: 1-407-849-0740
	Highway Equipment & Supply Co.	4850 Collins Rd. Unit 103, Jacksonville, FL 32073	Tel: 1-904-215-6356 1-800-827-3019 Fax: 1-904-215-7109
	Highway Equipment & Supply Co.	6015 U.S. Highway 301 North Tampa, FL 33610	Tel: 1-813-621-9634 1-800-827-9092 Fax: 1-813-621-6873
	M&I Engine Company, Inc.	30762 Highway 181 Daphne, AL 36526	Tel: 1-251-626-8080 1-800-633-1834 Fax: 1-251-626-2744
GEORGIA -(Western) -(Central) -(Southeastern Corner)	Engine Distributors, Inc.	303 Interstate Drive Archdale, NC 27263	Tel: 1-336-434-6616 1-800-220-7080 Fax: 1-336-434-6612
	Highway Equipment & Supply Co.	4850 Collins Road, Unit 103 Jacksonville, FL 32073	Tel: 1-904-215-6356 1-800-827-3019 Fax: 1-904-215-7109
HAWAII	Powertech Engines Inc. (Main Office)	2933 E. Hamilton Avenue Fresno, CA 93721	Tel: 1-559-264-1776 1-800-891-1776 Fax: 1-559-264-2933
IDAHO	E.C. Power Systems	4499 Market Street Boise, ID 83705	Tel: 1-208-342-6541 1-800-354-6767 Fax: 1-208-345-4308

North America - United States (Continued)

IF YOU ARE IN	THEN CALL	ADDRESS	TELEPHONE NUMBERS
ILLINOIS - (Central) - (North Central) - (Northeastern) - (Southern) - (Northwestern)	Engine Power, Inc.	1830 Executive Drive Oconomowoc, WI 53066	Tel: 1-262-567-8575 1-800-242-2289 Fax: 1-262-567-2556
	Kansas City Power Products, Inc.	80 South James Kansas City, KS 66118	Tel: 1-913-321-7040 1-800-486-5277 Fax: 1-913-321-7341
	Anderson Industrial Engines	5532 Center Street Omaha, NE 68106	Tel: 1-402-558-8700 1-800-747-1438 Fax: 1-402-558-8249
INDIANA	Engine Power, Inc.	1830 Executive Drive Oconomowoc, WI 53066	Tel: 1-262-567-8575 1-800-242-2289 Fax: 1-262-567-2556
IOWA	Anderson Industrial Engines	5532 Center Street Omaha, NE 68106	Tel: 1-402-558-8700 1-800-747-1438 Fax: 1-402-558-8249
KANSAS	Kansas City Power Products, Inc.	80 South James Kansas City, KS 66118	Tel: 1-913-321-7040 1-800-486-5277 Fax: 1-913-321-7341
KENTUCKY - (Western) - (Eastern)	Engine Power, Inc.	1830 Executive Drive Oconomowoc, WI 53066	Tel: 1-262-567-8575 1-800-242-2289 Fax: 1-262-567-2556
	Pitt Auto Electric Co. Industrial Engine Division	1241 Freedom Road Cranberry Twp., PA 16066	Tel: 1-724-778-8200 US: 1-800-367-3463 Fax: 1-724-778-8206
LOUISIANA	Lightbourn Equipment Co.	13649 Beta Rd., Dallas, TX 75244	Tel: 1-972-233-5151 Fax: 1-972-661-0738
	Lightbourn Equipment Co.	8272 El Rio, Suite 110, Houston, TX 77054	Tel: 1-713-741-2003 Fax: 1-713-741-1909
MAINE	Engine Distributors, Inc.	400 University Court Blackwood, NJ 08012	Tel: 1-856-228-7298 1-800-220-2700 Fax: 1-856-228-5657(Parts) 1-856-228-5531(Sales)
MARYLAND	Engine Distributors, Inc.	400 University Court Blackwood, NJ 08012	Tel: 1-856-228-7298 1-800-220-2700 Fax: 1-856-228-5657(Parts) 1-856-228-5531(Sales)
MASSACHUSETTS	Engine Distributors, Inc.	400 University Court Blackwood, NJ 08012	Tel: 1-856-228-7298 1-800-220-2700 Fax: 1-856-228-5657(Parts) 1-856-228-5531(Sales)
MICHIGAN - (Lower Peninsula) - (Upper Peninsula)	Engine Center, Inc.	2351 Hilton Road Ferndale, MI 48220	Tel: 1-248-399-0002 1-800-726-8870 Fax: 1-248-399-3142
	Engine Power, Inc.	1830 Executive Drive Oconomowoc, WI 53066	Tel: 1-262-567-8575 1-800-242-2289 Fax: 1-262-567-2556
MINNESOTA	Northern Power Products, Inc.	2859 Lexington Avenue S. Eagan, MN 55121	Tel: 1-651-452-8900 1-800-284-6247 Fax: 1-651-452-9182(Sales) 1-651-452-9047(Parts)

North America - United States (Continued)

IF YOU ARE IN	THEN CALL	ADDRESS	TELEPHONE NUMBERS
MISSISSIPPI - (Northern)	Kansas City Power Products, Inc.	80 South James Kansas City, KS 66118	Tel: 1-913-321-7040 1-800-486-5277 Fax: 1-913-321-7341
	Lightbourn Equipment Co.	8272 El Rio, Suite 110, Houston, TX 77054	Tel: 1-713-741-2003 Fax: 1-713-741-1909
MISSOURI	Kansas City Power Products, Inc.	80 South James Kansas City, KS 66118	Tel: 1-913-321-7040 1-800-486-5277 Fax: 1-913-321-7341
MONTANA - (Eastern) - (Central)	Industrial Power Systems, Inc. Engine Division	3233 Oakland Street Aurora, CO 80010	Tel: 1-303-360-7110 1-800-678-3673 Fax: 1-303-360-7519
	E.C. Power Systems	4499 Market Street Boise, ID 83705	Tel: 1-208-342-6541 1-800-354-6767 Fax: 1-208-345-4308
NEBRASKA	Anderson Industrial Engines	5532 Center Street Omaha, NE 68106	Tel: 1-402-558-8700 1-800-747-1438 Fax: 1-402-558-8249
NEVADA	Powertec Engines Inc.	2933 E. Hamilton Avenue Fresno, CA 93721	Tel: 1-559-264-1776 1-800-891-1776 Fax: 1-559-264-2933
NEW HAMPSHIRE	Engine Distributors, Inc.	400 University Court Blackwood, NJ 08012	Tel: 1-856-228-7298 1-800-220-2700 Fax: 1-856-228-5657(Parts) 1-856-228-5531(Sales)
NEW JERSEY	Engine Distributors, Inc.	400 University Court Blackwood, NJ 08012	Tel: 1-856-228-7298 1-800-220-2700 Fax: 1-856-228-5657(Parts) 1-856-228-5531(Sales)
NEW MEXICO - (Southern)	E.C. Power Systems	8360 E. Via de Ventura Blvd., Suite L-200 Scottsdale, AZ 85258	Tel: 1-480-905-5585 Fax: 1-503-224-3907
	Industrial Power Systems, Inc. Engine Division	3233 Oakland Street Aurora, CO 80010	Tel: 1-303-360-7110 1-800-678-3673 Fax: 1-303-360-7519
NEW YORK - (New York City) - (Nassau Co.) - (Suffolk Co.)	Engine Distributors, Inc.	400 University Court Blackwood, NJ 08012	Tel: 1-856-228-7298 1-800-220-2700 Fax: 1-856-228-5657(Parts) 1-856-228-5531(Sales)
	- (Upstate) - (Hudson Valley)	Pitt Auto Electric Co. Industrial Engine Division	1241 Freedom Road Cranberry Twp., PA 16066
NORTH CAROLINA	Engine Distributors, Inc.	303 Interstate Drive Archdale, NC 27263	Tel: 1-336-434-6616 1-800-220-7080 Fax: 1-336-434-6612
NORTH DAKOTA	Northern Power Products, Inc.	2859 Lexington Avenue S. Eagan, MN 55121	Tel: 1-651-452-8900 1-800-284-6247 Fax: 1-651-452-9182(Sales) 1-651-452-9047(Parts)

North America - United States (Continued)

IF YOU ARE IN	THEN CALL	ADDRESS	TELEPHONE NUMBERS
OHIO - (Central)	Graham Ford, Inc.	707 W. Broad Street Columbus, OH 43216	Tel: 1-614-464-6006 1-800-837-7070 Fax: 1-614-464-6013
	North Coast Ford Industrial, Inc.	11885 Bellaire Road Cleveland, OH 44135	Tel: 1-216-251-5800 1-800-423-1316 Fax: 1-216-251-8675
	Pitt Auto Electric Co. Industrial Engine Division	1241 Freedom Road Cranberry Twp., PA 16066	Tel: 1-724-778-8200 US: 1-800-367-3463 Fax: 1-724-778-8206
OKLAHOMA - (Except Panhandle)	Kansas City Power Products	7714 Meirose Lane Oklahoma City, OK 73127	Tel: 1-405-491-9491 1-800-654-3673 Fax: 1-405-491-9495
	- (Panhandle)	Lightbourn Equipment Co.	13649 Beta Road, Dallas, TX 75244 Tel: 1-972-233-5151 Fax: 1-972-661-0738
OREGON	E.C. Power Systems	1805 N.W. 21st Avenue Portland, OR 97210	Tel: 1-503-224-3623 1-800-452-1511 Fax: 1-503-224-3907
PENNSYLVANIA - (Eastern)	Engine Distributors, Inc.	400 University Court Blackwood, NJ 08012	Tel: 1-856-228-7298 1-800-220-2700 Fax: 1-856-228-5657(Parts) 1-856-228-5531(Sales)
	- (Western)	Pitt Auto Electric Co. Industrial Engine Division	1241 Freedom Road Cranberry Twp., PA 16066 Tel: 1-724-778-8200 US: 1-800-367-3463 Fax: 1-724-778-8206
RHODE ISLAND	Engine Distributors, Inc.	400 University Court Blackwood, NJ 08012	Tel: 1-856-228-7298 1-800-220-2700 Fax: 1-856-228-5657(Parts) 1-856-228-5531(Sales)
SOUTH CAROLINA	Engine Distributors, Inc.	303 Interstate Drive Archdale, NC 27263	Tel: 1-336-434-6616 1-800-220-7080 Fax: 1-336-434-6612
SOUTH DAKOTA	Northern Power Products, Inc.	2859 Lexington Avenue S. Eagan, MN 55121	Tel: 1-651-452-8900 1-800-284-6247 Fax: 1-651-452-9182(Sales) 1-651-452-9047(Parts)
TENNESSEE - (Central) - (Eastern)	M&I Engine Company, Inc.	30762 Highway 181 Daphne, AL 36526	Tel: 1-251-626-8080 1-800-633-1834 Fax: 1-251-626-2744
	- (Western)	Kansas City Power Products, Inc.	80 South James Kansas City, KS 66118 Tel: 1-913-321-7040 1-800-486-5277 Fax: 1-913-321-7341
TEXAS	Lightbourn Equipment Co.	13649 Beta Rd., Dallas, TX 75244	Tel: 1-972-233-5151 Fax: 1-972-661-0738
	Lightbourn Equipment Co.	8272 El Rio, Suite 110, Houston, TX 77054	Tel: 1-713-741-2003 Fax: 1-713-741-1909

North America - United States (Continued)

IF YOU ARE IN	THEN CALL	ADDRESS	TELEPHONE NUMBERS
UTAH - (Northern)	Industrial Power Systems, Inc. Engine Division	2492 W. Custer Road Salt Lake City, UT 84104	Tel: 1-801-908-8099 1-800-678-3673 Fax: 1-303-360-7519
	- (Southern)	E.C. Power Systems 3683 West 2270 South, Suite A, Salt Lake City, UT 84120	Tel: 1-801-886-1424 1-800-462-3370 Fax: 1-801-886-1464
VERMONT	Engine Distributors, Inc.	400 University Court Blackwood, NJ 08012	Tel: 1-856-228-7298 1-800-220-2700 Fax: 1-856-228-5657(Parts) 1-856-228-5531(Sales)
VIRGINIA - (Central) - (Eastern)	Engine Distributors, Inc.	400 University Court Blackwood, NJ 08012	Tel: 1-856-228-7298 1-800-220-2700 Fax: 1-856-228-5657(Parts) 1-856-228-5531(Sales)
	- (Southwestern)	Pitt Auto Electric Co. Industrial Engine Division 1241 Freedom Road Cranberry Twp., PA 16066	Tel: 1-724-778-8200 US: 1-800-367-3463 Fax: 1-724-778-8206
WASHINGTON	E.C. Power Systems	6051 S. 194th Street Kent, WA 98032	Tel: 1-253-872-7011 US: 1-800-247-5899 Fax: 1-253-872-6947
WEST VIRGINIA	Pitt Auto Electric Co. Industrial Engine Division	1241 Freedom Road Cranberry Twp., PA 16066	Tel: 1-724-778-8200 US: 1-800-367-3463 Fax: 1-724-778-8206
WISCONSIN - (Eastern) - (Central)	Engine Power, Inc.	1830 Executive Drive Oconomowoc, WI 53066	Tel: 1-262-567-8575 1-800-242-2289 Fax: 1-262-567-2556
	- (Northwestern)	Northern Power Products, Inc. 2859 Lexington Avenue S. Eagan, MN 55121	Tel: 1-651-452-8900 1-800-284-6247 Fax: 1-651-452-9182(Sales) 1-651-452-9047(Parts)
WYOMING	Industrial Power Systems, Inc. Engine Division	3233 Oakland Street Aurora, CO 80010	Tel: 1-303-360-7110 1-800-678-3673 Fax: 1-303-360-7519

WE WANT TO HEAR FROM YOU!

Your suggestions will help us to improve this manual.

Mail this form or fax your comments to:

Ford Power Products
28333 Telegraph Rd., Suite 300
Southfield, Michigan 48034

Or Fax your comments to:
Ford Power Products Publication
(248) 945-4431

Manual _____ Vehicle _____ Year _____

Are you reporting an error in the procedures or illustrations?

YES	NO
<input type="checkbox"/>	<input type="checkbox"/>

If yes, page _____ please describe in detail: _____

Did the procedures make sense and were they easy to follow?

YES	NO
<input type="checkbox"/>	<input type="checkbox"/>

If no, page _____ please describe: _____

Is the organization of the manual clear and easy to follow?

YES	NO
<input type="checkbox"/>	<input type="checkbox"/>

Please comment: _____

Are there any important procedures not covered in this manual that you would like to see included? YES NO

<input type="checkbox"/>	<input type="checkbox"/>
--------------------------	--------------------------

If yes, please describe: _____

Please enclose a copy of each page marked with your suggestions.

Please tell us who you are:

Name _____

Street _____

City _____ State _____ Zip _____

Company _____ Position _____

Thank You for Your Help – Ford Power Products Publications Department





**The Source for Power...
Worldwide™**

Headquarters

Ford Power Products

15700 Lundy Parkway Dr., Suite 200

Dearborn, MI 48126 USA

313-845-1400

800-833-4773

(Fax) 313-619-2600

European Engineering and Sales Operations

Ford Power Products

20/586 Arisdale Avenue

South Ockendon

Essex, RM 15 5TJ England

44-1708-672-677

(Fax) 44-1708-672-349

European Sales and Marketing Office

Ford Power Products

Stolberger Str. 313

D-50933 Köln, Germany

49-221-94700-552

(Fax) 49-221-94700-560

GENERAC[®]
POWER SYSTEMS, INC.

P.O. BOX 310 EAGLE, WI 53119