

LIQUID-COOLED

DIAGNOSTIC REPAIR MANUAL

1.5L HOME STANDBY GENERATORS

www.guardiangenerators.com

Models: 4721, 4722, 4723, 4724, 4725, 4726

GUARDIAN
by Generac Power Systems, Inc.



Important Safety Notice

Proper service and repair is important to the safe, economical and reliable operation of all standby electric power systems. The troubleshooting, testing and servicing procedures recommended by Generac and described in this manual are effective methods of performing such operations. Some of these operations or procedures may require the use of specialized equipment. Such equipment should be used when and as recommended.

It is important to note that this manual contains various DANGER, CAUTION, and NOTE blocks. These should be read carefully in order to minimize the risk of personal injury or to prevent improper methods or practices from being used. Use of improper or unauthorized practices may damage equipment or render it unsafe. The DANGER, CAUTION and NOTE blocks are not exhaustive. Generac could not possibly know, evaluate and advise the service trade of all conceivable ways in which operations described in this manual might be accomplished or of the possible hazardous consequences of each way. Consequently, Generac has not taken any such broad evaluation. Accordingly, anyone who uses any troubleshooting, testing or service procedure that is not recommended by Generac must first satisfy himself that neither his safety nor the equipment's safety will be jeopardized by the procedure or the method he selects.



SAVE THESE INSTRUCTIONS – *The manufacturer suggests that these rules for safe operation be copied and posted in potential hazard areas. Safety should be stressed to all operators and potential operators of this equipment.*

Study these SAFETY RULES carefully before installing, operating or servicing this equipment. Become familiar with the *Owner's Manual* and with the unit. The generator can operate safely, efficiently and reliably only if it is properly installed, operated and maintained. Many accidents are caused by failing to follow simple and fundamental rules or precautions.

Generac cannot anticipate every possible circumstance that might involve a hazard. The warnings in this manual, and on tags and decals affixed to the unit are, therefore, not all-inclusive. If using a procedure, work method or operating technique that Generac does not specifically recommend, ensure that it is safe for others. Also make sure the procedure, work method or operating technique utilized does not render the generator unsafe.



Despite the safe design of this generator, operating this equipment imprudently, neglecting its maintenance or being careless can cause possible injury or death. Permit only responsible and capable persons to install, operate or maintain this equipment.



Potentially lethal voltages are generated by these machines. Ensure all steps are taken to render the machine safe before attempting to work on the generator.



Parts of the generator are rotating and/or hot during operation. Exercise care near running generators.

GENERAL HAZARDS

- For safety reasons, Generac recommends that this equipment be installed, serviced and repaired by an authorized service dealer or other competent, qualified electrician or installation technician who is familiar with applicable codes, standards and regulations. The operator also must comply with all such codes, standards and regulations.
- Installation, operation, servicing and repair of this (and related) equipment must always comply with applicable codes, standards, laws and regulations. Adhere strictly to local, state and national electrical and building codes. Comply with regulations the Occupational Safety and Health Administration (OSHA) has established. Also, ensure that the generator is installed, operated and serviced in accordance with the manufacturer's instructions and recommendations. Following installation, do nothing that might render the unit unsafe or in noncompliance with the aforementioned codes, standards, laws and regulations.
- The engine exhaust fumes contain carbon monoxide gas, which can be DEADLY. This dangerous gas, if breathed in sufficient concentrations, can cause unconsciousness or even death. For that reason, adequate ventilation must be provided. Exhaust gases must be piped safely away from any building or enclosure that houses the generator to an area where people, animals, etc., will not be harmed. This exhaust system must be installed properly, in strict compliance with applicable codes and standards.
- Keep hands, feet, clothing, etc., away from drive belts, fans, and other moving or hot parts. Never remove any drive belt or fan guard while the unit is operating.
- Adequate, unobstructed flow of cooling and ventilating air is critical to prevent buildup of explosive gases and to ensure correct generator operation. Do not alter the installation or permit even partial blockage of ventilation provisions, as this can seriously affect safe operation of the generator.
- Keep the area around the generator clean and uncluttered. Remove any materials that could become hazardous.
- When working on this equipment, remain alert at all times. Never work on the equipment when physically or mentally fatigued.
- Inspect the generator regularly, and promptly repair or replace all worn, damaged or defective parts using only factory-approved parts.
- Before performing any maintenance on the generator, disconnect its battery cables to prevent accidental start-up. Disconnect the cable from the battery post indicated by a NEGATIVE, NEG or (-) first. Reconnect that cable last.
- Never use the generator or any of its parts as a step. Stepping on the unit can stress and break parts, and may result in dangerous operating conditions from leaking exhaust gases, fuel leakage, oil leakage, etc.

ELECTRICAL HAZARDS

- All generators covered by this manual produce dangerous electrical voltages and can cause fatal electrical shock. Utility power delivers extremely high and dangerous voltages to the transfer switch as well as the standby generator. Avoid contact with bare wires, terminals, connections, etc., on the generator as well as the transfer switch, if applicable. Ensure all appropriate covers, guards and barriers are in place before operating the generator. If work must be done around an operating unit, stand on an insulated, dry surface to reduce shock hazard.
- Do not handle any kind of electrical device while standing in water, while barefoot, or while hands or feet are wet. **DANGEROUS ELECTRICAL SHOCK MAY RESULT.**
- If people must stand on metal or concrete while installing, operating, servicing, adjusting or repairing this equipment, place insulative mats over a dry wooden platform. Work on the equipment only while standing on such insulative mats.

- The National Electrical Code (NEC), Article 250 requires the frame and external electrically conductive parts of the generator to be connected to an approved earth ground and/or grounding rods. This grounding will help prevent dangerous electrical shock that might be caused by a ground fault condition in the generator set or by static electricity. Never disconnect the ground wire.
- Wire gauge sizes of electrical wiring, cables and cord sets must be adequate to handle the maximum electrical current (ampacity) to which they will be subjected.
- Before installing or servicing this (and related) equipment, make sure that all power voltage supplies are positively turned off at their source. Failure to do so will result in hazardous and possibly fatal electrical shock.
- Connecting this unit to an electrical system normally supplied by an electric utility shall be by means of a transfer switch so as to isolate the generator electric system from the electric utility distribution system when the generator is operating. Failure to isolate the two electric system power sources from each other by such means will result in damage to the generator and may also result in injury or death to utility power workers due to backfeed of electrical energy.
- Generators installed with an automatic transfer switch will crank and start automatically when NORMAL (UTILITY) source voltage is removed or is below an acceptable preset level. To prevent such automatic start-up and possible injury to personnel, disable the generator's automatic start circuit (battery cables, etc.) before working on or around the unit. Then, place a "Do Not Operate" tag on the generator control panel and on the transfer switch.
- In case of accident caused by electric shock, immediately shut down the source of electrical power. If this is not possible, attempt to free the victim from the live conductor. **AVOID DIRECT CONTACT WITH THE VICTIM.** Use a nonconducting implement, such as a dry rope or board, to free the victim from the live conductor. If the victim is unconscious, apply first aid and get immediate medical help.
- Never wear jewelry when working on this equipment. Jewelry can conduct electricity resulting in electric shock, or may get caught in moving components causing injury.

FIRE HAZARDS

- Keep a fire extinguisher near the generator at all times. Do NOT use any carbon tetra-chloride type extinguisher. Its fumes are toxic, and the liquid can deteriorate wiring insulation. Keep the extinguisher properly charged and be familiar with its use. If there are any questions pertaining to fire extinguishers, consult the local fire department.

EXPLOSION HAZARDS

- Properly ventilate any room or building housing the generator to prevent build-up of explosive gas.
- Do not smoke around the generator. Wipe up any fuel or oil spills immediately. Ensure that no combustible materials are left in the generator compartment, or on or near the generator, as FIRE or EXPLOSION may result. Keep the area surrounding the generator clean and free from debris.
- Generac generator sets may operate using one of several types of fuels. All fuel types are potentially FLAMMABLE and/or EXPLOSIVE and should be handled with care. Comply with all laws regulating the storage and handling of fuels. Inspect the unit's fuel system frequently and correct any leaks immediately. Fuel supply lines must be properly installed, purged and leak tested according to applicable fuel-gas codes before placing this equipment into service.
- Diesel fuels are highly FLAMMABLE. Gaseous fluids such as natural gas and liquid propane (LP) gas are extremely EXPLOSIVE. Natural gas is lighter than air, and LP gas is heavier than air; install leak detectors accordingly.

DIAGNOSTIC REPAIR MANUAL

1.5 LITER PREPACKAGED HOME STANDBY GENERATORS

TABLE OF CONTENTS		
PART	TITLE	PAGE
	SPECIFICATIONS	2
1	General Information	3
2	Prepackaged Liquid Cooled AC Generators	19
3	V-Type Prepackaged Transfer Switches	39
4	DC Control- Units with Liquid-Cooled Engine	57
5	Operational Tests and Adjustments	95
6	Electrical Data	101

SPECIFICATIONS

GENERATOR SPECIFICATIONS

Phase Single
 Rated Max. Cont. AC Power Output (kW) 15*
 Rated Voltage (volts) 120/240
 No. of Rotor Poles - 15 kW 2
 No. of Rotor Poles - 20/25 kW 4
 Driven Speed of Rotor - 15 kW 1800
 Driven Speed of Rotor - 20/25 kW 3600
 Rotor Excitation System .. Direct excited brush type
 Rotor/Stator Insulation Class F

* Rated power of generator is subject to and limited by such factors as ambient temperature, altitude, engine condition, and other factors. Engine power will decrease about 3% for each 1000 feet above 600 feet and will decrease an additional 1.65% for each 10°F above 77°F. Maximum output power of the generator is limited by maximum engine power.

ENGINE SPECIFICATIONS

MakeMitsubishi
 Displacement.....92 inches
 (1.5 liters)
 Cylinder Arrangement4, in-line
 Valve Arrangement.....Overhead Cam
 Firing Order1-3-4-2
 Number of Main Bearings5
 Compression Ratio9 to 1
 No. of Teeth on Flywheel.....104
 Ignition Timing
 at 1800 rpm35 degrees BTDC
 Spark Plug Gap.....0.020-0.025 inch
 Recommended Spark Plugs
 ChampionRN11YC4
 Oil Pressure30-50 psi
 Crankcase Oil Capacity ...3.0 U.S. quarts (2.8 liters)
 Recommended Engine OilSAE 15W-40
 Type of Cooling SystemPressurized, closed recovery
 Cooling FanPusher Type
 Cooling System Capacity ..2 U.S. gallons (7.6 liters)
 Recommended Coolant.....Use a 50-50 mixture of
 ethylene glycol base.

FUEL CONSUMPTION

25 kW Models

Using Natural Gas 441 cu. ft. per hour
 Using LP Gas..... 175 cubic ft. (4.8 gal.) per hour

20 kW Models

Using Natural Gas 359 cu. ft. per hour
 Using LP Gas 143 cubic ft. (4.0 gal.) per hour

15 kW Models

Using Natural Gas 277 cu. ft. per hour
 Using LP Gas 110 cubic ft.(3.1 gal.) per hour

NOTE: Fuel consumption is given at rated maximum continuous power output when using natural gas rated at 1000 Btu per cubic foot and LP gas rated 2520 Btu per cubic foot. Actual fuel con-

sumption obtained may vary depending on such variables as applied load, ambient temperature, engine conditions and other environmental factors.

Fuel pressure for a natural gas set up should be five inches to 14 inches of water column (0.18 to 0.5 psi) at all load ranges.

Fuel pressure for an LP vapor set up should be 11 inches to 14 inches of water column (0.4 to 0.5 psi) at all load ranges.

ENGINE OIL RECOMMENDATIONS

The unit has been filled with 15W-40 engine oil at the factory. Use a high-quality detergent oil classified "For Service SJ or latest available." Detergent oils keep

Temperature	Oil Grade (Recommended)
Above 80° F (27° C)	SAE 30W or 15W-40
32° to 80° F (-1° to 27° C)	SAE 20W-20 or 15W-40
Below 32° F (0° C)	SAE 10W or 15W-40

the engine cleaner and reduce carbon deposits. Use oil having the following SAE viscosity rating, based on the ambient temperature range anticipated before the next oil change:

NOTE: Synthetic oil is highly recommended when the generator will be operating in ambient temperatures which regularly exceed 90° F and/or fall below 30° F.



ANY ATTEMPT TO CRANK OR START THE ENGINE BEFORE IT HAS BEEN PROPERLY SERVICED WITH THE RECOMMENDED OIL MAY RESULT IN AN ENGINE FAILURE.

COOLANT RECOMMENDATIONS

Use a mixture of half low silicate ethylene glycol base anti-freeze and deionized water. Cooling system capacity is about 8 U.S. quarts (7.6 liters). Use only deionized water and only low silicate anti-freeze. If desired, add a high quality rust inhibitor to the recommended coolant mixture. When adding coolant, always add the recommended 50-50 mixture.



DO NOT USE ANY CHROMATE BASE RUST INHIBITOR WITH ETHYLENE GLYCOL BASE ANTI-FREEZE OR CHROMIUMHYDROXIDE ("GREEN SLIME") FORMS AND WILL CAUSE OVERHEATING. ENGINES THAT HAVE BEEN OPERATED WITH A CHROMATE BASE RUST INHIBITOR MUST BE CHEMICALLY CLEANED BEFORE ADDING ETHYLENE GLYCOL BASE ANTI-FREEZE. USING ANY HIGH SILICATE ANTI-FREEZE BOOSTERS OR ADDITIVES WILL ALSO CAUSE OVERHEATING. IT IS ALSO RECOMMENDED THAT ANY SOLUBLE OIL INHIBITOR IS NOT USED FOR THIS EQUIPMENT.

PART 1 GENERAL INFORMATION

1.5 LITER PREPACKAGED HOME STANDBY GENERATORS

TABLE OF CONTENTS		
PART	TITLE	PAGE
1.1	Generator Identification	4
1.2	Prepackaged Installation Basics	6
1.3	Preparation Before Use	9
1.4	Testing, Cleaning and Drying	10
1.5	Engine-Generator Protective Devices	13
1.6	Operating Instructions	15
1.7	Automatic Operating Parameters	17

SECTION 1.1 GENERATOR IDENTIFICATION

PART 1

GENERAL INFORMATION

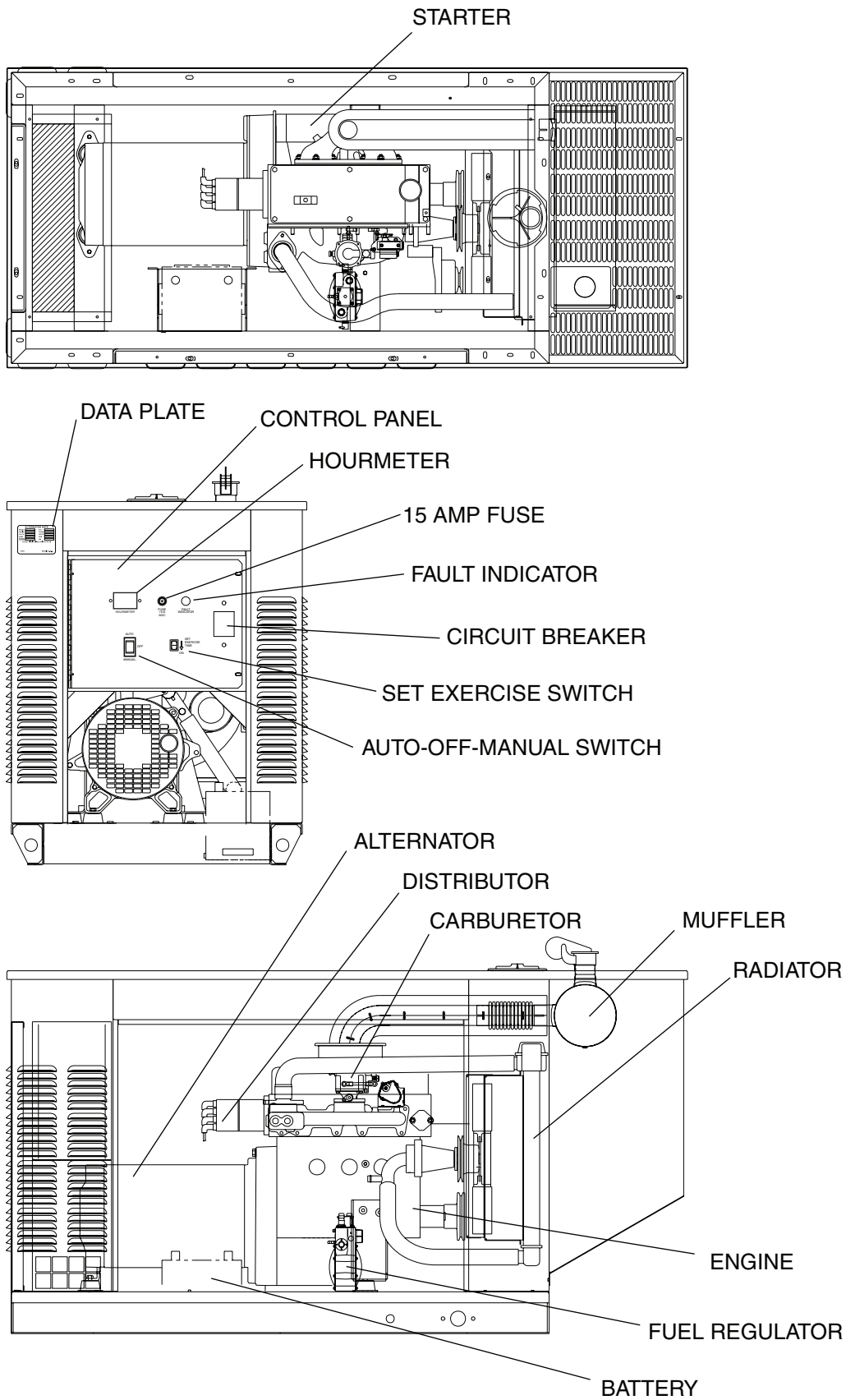

INTRODUCTION

This Diagnostic Repair Manual has been prepared especially for the purpose of familiarizing service personnel with the testing, troubleshooting and repair of prepackaged home standby generator systems. Every effort has been expended to ensure that information and instructions in the manual are both accurate and current. However, the manufacturer reserves the right to change, after or otherwise improve the product at any time without prior notification.

The manual has been divided into several PARTS. Each PART has been divided into SECTIONS. Each SECTION consists of two or more SUBSECTIONS.

It is not the manufacturers intent to provide detailed disassembly and reassembly instructions in this manual. It is the manufacturers intent to (a) provide the service technician with an understanding of how the various assemblies and systems work, (b) assist the technician in finding the cause of malfunctions, and (c) effect the expeditious repair of the equipment.

UNITS WITH LIQUID COOLED ENGINE

A typical prepackaged generator with liquid cooled engine is shown on Page 4 at front of this manual.

A DATA PLATE, affixed to the unit, contains important information pertaining to the unit, including its Model Number, Serial Number, kW rating, rated rpm, rated voltage, etc. The information from this data plate may be required when requesting information, ordering parts, etc.

ALTERNATOR DATA			
MODEL	<input type="text"/>	KVA	<input type="text"/>
SERIAL	<input type="text"/>	PHASE	<input type="text"/>
VOLTS	<input type="text"/>	HERTZ	<input type="text"/>
AMPS	<input type="text"/>	RPM	<input type="text"/>
POWER FACTOR	<input type="text"/>	KW	<input type="text"/>
CLASS F WINDING INSULATION AT 40° C.			
45452		MADE IN U.S.A.	

Figure 1. A Typical Data Plate

INTRODUCTION

Information in this section is provided so that the service technician will have a basic knowledge of installation requirements for prepackaged home standby systems. Problems that arise are often related to poor or unauthorized installation practices.

A typical prepackaged home standby electric system is shown in Figure 1, below. Installation of such a system includes the following:

- Selecting a Location
- Mounting of the generator.
- Grounding the generator.
- Providing a fuel supply.
- Mounting the transfer switch.
- Connecting power source and load lines.
- Connecting system control wiring.
- Post installation tests and adjustments.

SELECTING A LOCATION

Install the generator set as close as possible to the electrical load distribution panel(s) that will be powered by the unit, ensuring that there is proper ventilation for cooling air and exhaust gases. This will reduce wiring and conduit lengths. Wiring and conduit not only add to the cost of the installation, but excessively long wiring runs can result in a voltage drop.

MOUNTING THE GENERATOR

Mount the generator set to a concrete slab. The slab should extend past the generator and to a distance of at least twelve (12) inches on all sides. The unit can be retained to the concrete slab with masonry anchor bolts.

GROUNDING THE GENERATOR

The National Electric Code requires that the frame and external electrically conductive parts of the generator be properly connected to an approved earth ground. Local electrical codes may also require proper grounding of the unit. For that purpose, a grounding lug is attached to the unit. Grounding may be accomplished by attaching a stranded copper wire of the proper size to the generator's grounding lug and to an earth-driven copper or brass grounding-rod (electrode). Consult with a local electrician for grounding requirements in your area.

THE FUEL SUPPLY

Units with liquid cooled engines are shipped from the factory to run on natural gas (Figure 2). Units that will use LP (propane) gas fuel (Figure 3) must be converted in the field per instructions located in the Installation Manual.

LP (propane) gas is usually supplied as a liquid in pressure tanks. Liquid cooled units require a "vapor withdrawal" type of fuel supply system when LP (propane) gas is used. The vapor withdrawal system utilizes the gaseous fuel vapors that form at the top of the supply tank.

The pressure at which LP gas is delivered to the generator's fuel solenoid valve may vary considerably, depending on ambient temperatures. In cold weather, supply pressures may drop to "zero". In warm weather, extremely high gas pressures may be encountered. A primary/secondary supply regulator is required to maintain correct gas supply pressure to the generator demand regulator.

Minimum recommended gaseous fuel pressure at the inlet side of the generator's fuel solenoid valve is

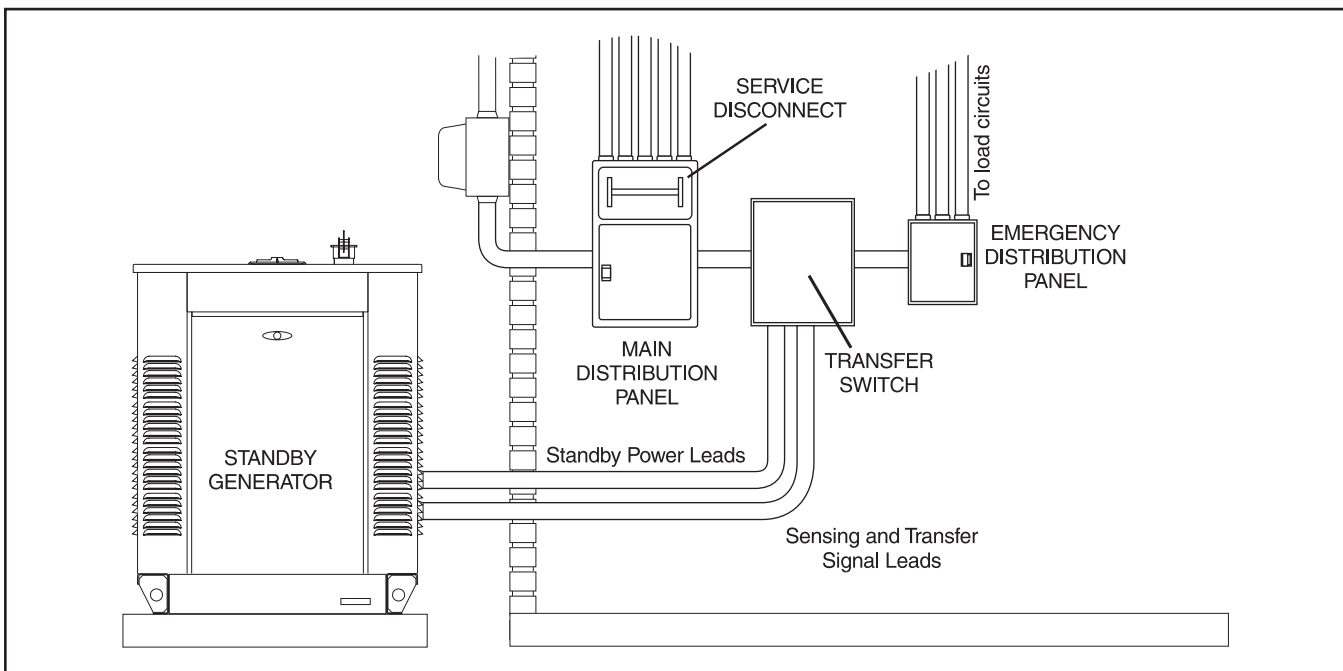

Figure 1. Typical Prepackaged Installation

11 inches water column for LP gas (6.38 ounces per square inch), and 5 inches water column for natural gas (2.89 ounces per square inch). The maximum recommended pressure is 14 inches water column (8.09 ounces per square inch). A primary regulator may be required to ensure that proper fuel supply pressures are maintained.



DANGER: LP AND NATURAL GAS ARE BOTH HIGHLY EXPLOSIVE. GASEOUS FUEL LINES MUST BE PROPERLY PURGED AND TESTED FOR LEAKS BEFORE THIS EQUIPMENT IS PLACED INTO SERVICE AND PERIODICALLY THEREAFTER. PROCEDURES USED IN GASEOUS FUEL LEAKAGE TESTS MUST COMPLY STRICTLY WITH APPLICA-

BLE FUEL GAS CODES. DO NOT USE FLAME OR ANY SOURCE OF HEAT TO TEST FOR GAS LEAKS. NO GAS LEAKAGE IS PERMITTED. LP GAS IS HEAVIER THAN AIR AND TENDS TO SETTLE IN LOW AREAS. NATURAL GAS IS LIGHTER THAN AIR AND TENDS TO SETTLE IN HIGH PLACES. EVEN THE SLIGHTEST SPARK CAN IGNITE THESE FUELS AND CAUSE AN EXPLOSION.

Use of a flexible length of hose between the generator fuel line connection and rigid fuel lines is required. This will help prevent line breakage that might be caused by vibration or if the generator shifts or settles. The flexible fuel line must be approved for use with gaseous fuels.

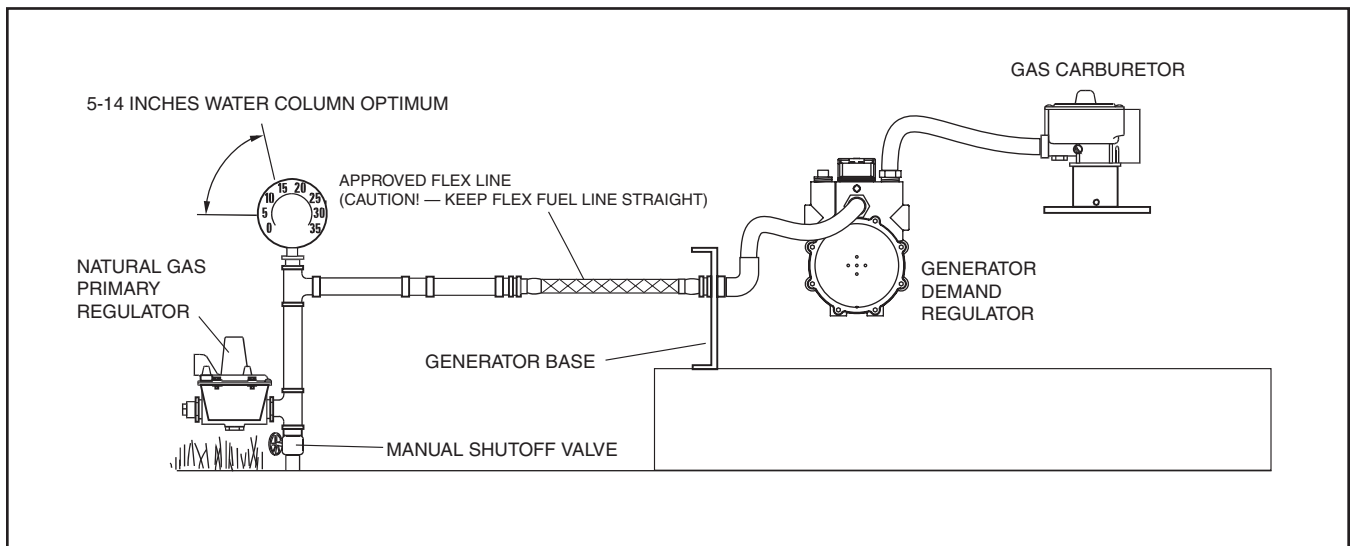

Figure 2. Typical Natural Gas Fuel System (Liquid Cooled Units)

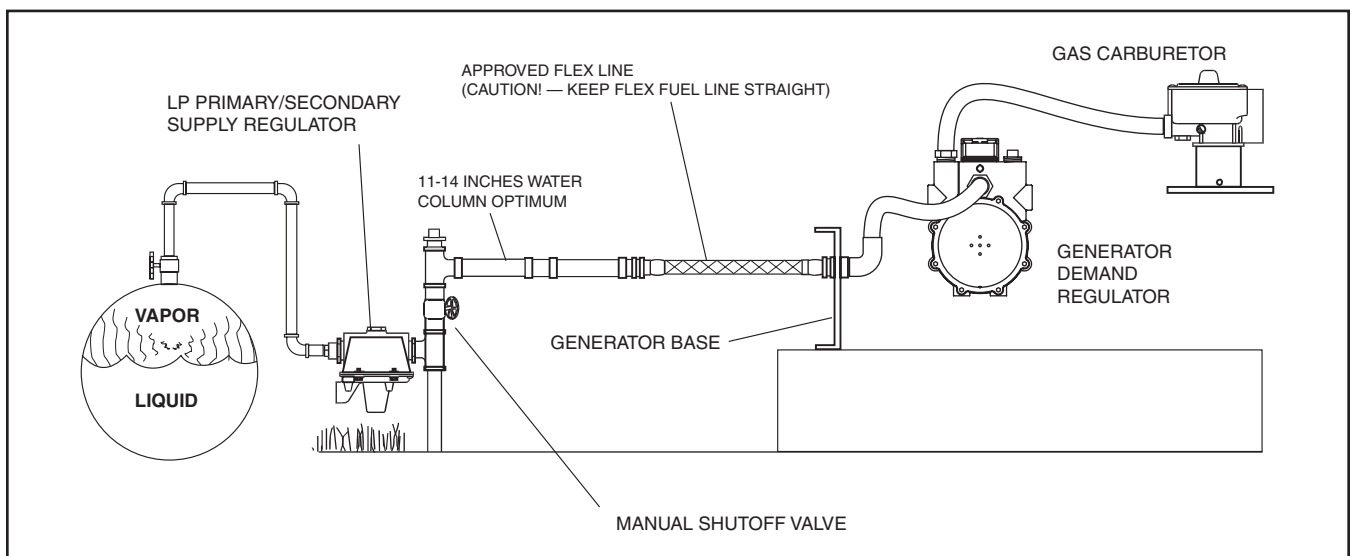

Figure 3. Typical LP Gas Fuel System (Liquid Cooled Units)

THE TRANSFER SWITCH

A transfer switch is required by electrical code, to prevent electrical feedback between the utility and standby power sources, and to transfer electrical loads from one power supply to another safely.

PREPACKAGED TRANSFER SWITCHES:

Instructions and information on prepackaged transfer switches may be found in Part 3 of this manual.

POWER SOURCE AND LOAD LINES

The utility power supply lines, the standby (generator) supply lines, and electrical load lines must all be connected to the proper terminal lugs in the transfer switch. The following rules apply:

In 1-phase systems with a 2-pole transfer switch, connect the two "Utility" source hot lines to transfer switch Terminal Lugs N1 and N2. Connect the "Standby" source hot lines (E1, E2) to transfer switch Terminal Lugs E1 and E2. Connect the load lines from transfer switch Terminal Lugs T1/T2 to the electrical load circuit. Connect "Utility", "Standby" and "Load" neutral lines to the neutral block in the transfer switch.

SYSTEM CONTROL INTERCONNECTIONS

Prepackaged home standby generators are equipped with a terminal board identified with the following ter-

minals: (a) utility 1, (b) utility 2, (c) load 1, (d) load 2, (e) 23, and (f) 194. Prepackaged transfer switches house an identically marked terminal board. Suitable, approved wiring must be interconnected between identically numbered terminals in the generator and transfer switch. When these six terminals are properly interconnected, dropout of utility source voltage below a preset value will result in automatic generator start-up and transfer of electrical loads to the "Standby" source. On restoration of utility source voltage above a preset value will result in retransfer back to that source and generator shutdown. System control wiring must be routed through its own separate conduit.

A control board, mounted on the standby generator set, provides a "7-day exercise" feature. This feature allows the standby generator to start and run once every 7 days, on a day and at a time of day selected. The timer clock that controls this automatic exercise of the unit must be powered by voltage from the transfer switch Load 1/Load 2 terminals. If the exercise function is to be made available, connect suitable wiring from the ATS transfer switch load terminal lugs, to the "Load 1/Load 2" terminals in the generator.

The control board in the generator also provides a battery "trickle charge" circuit. This circuit, when powered by utility source voltage, will deliver a charging voltage to the battery during non-operating periods to keep the battery charged. To use the trickle charge feature, connect suitable wiring to the generator's "Utility 1/Utility 2" terminals and to the appropriate terminals in the "ATS" transfer switch.

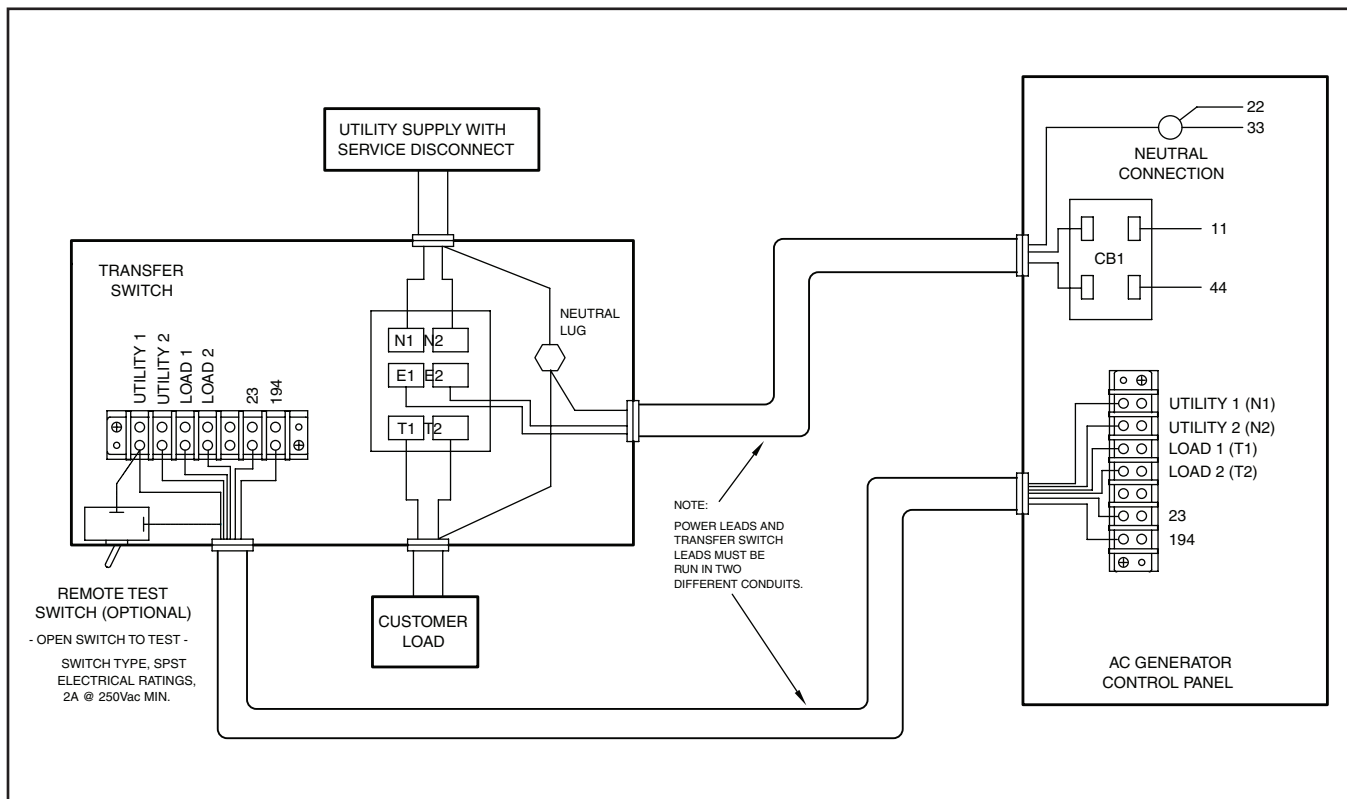

Figure 4. Prepackaged Interconnection Diagram

GENERAL

The installer must ensure that the home standby generator has been properly installed. The system must be inspected carefully following installation. All applicable codes, standards and regulations pertaining to such installations must be strictly complied with. In addition, regulations established by the Occupational Safety and Health Administration (OSHA) must be complied with.

Prior to initial startup of the unit, the installer must ensure that the engine-generator has been properly prepared for use. This includes the following:

- An adequate supply of the correct fuel must be available for generator operation.
- The engine must be properly serviced with the recommended oil.
- The engine cooling system must be properly serviced with the recommended coolant.

FUEL REQUIREMENTS

Liquid cooled engine units are shipped from the factory to run on natural gas. The installer must ensure that the correct fuel supply system has been installed and is compatible with engine-generator requirements. Read "The Fuel Supply" in Section 1.3 carefully.

ALL UNITS:

- When natural gas is used as a fuel, it should be rated at least 1000 BTU's per cubic foot.
- When LP (propane) gas is used as a fuel, it should be rated at 2520 BTU's per cubic foot.

ENGINE OIL RECOMMENDATIONS

For prepackaged generators with liquid cooled engine, use a high quality detergent oil that meets or exceeds API Service SC, SD, SE or SF. Detergent oils keep the engine cleaner and reduce carbon deposits. Use oil having the following SAE viscosity rating, based on the anticipated ambient temperature range before the next oil change:

Engine crankcase oil capacities for the 1.5 Liter engine covered in this manual can be found in the specifications section at the beginning of the book.

AMBIENT TEMPERATURE RANGE	RECOMMENDED OIL
Above 80° F (27° C)	SAE 30W or 15W-40
32° to 80° F (-1° to 27° C)	SAE 20W-20 or 15W-40
Below 32° F (0° C)	SAE 10W or 15W-40

RECOMMENDED ENGINE COOLANT

Use a mixture of 50 percent soft water and 50 percent ethylene glycol base anti-freeze in the engine cooling system. Use only SOFT WATER and LOW SILICATE anti-freeze. If so equipped, a coolant recovery bottle must also be properly serviced with the recommended 50-50 mixture. When adding coolant to the radiator or to the coolant recovery bottle, use only the recommended mixture.

If desired, a high quality rust inhibitor may be added to the recommended coolant mixture.



CAUTION: Do NOT use any chromate base rust inhibitor with ethylene glycol base anti-freeze, or the formation of chromium hydroxide (called "green slime") may result and cause overheating of the engine. The use of high silicate antifreeze boosters or additives may also cause overheating. In addition, use of any soluble oil type rust inhibitor is NOT recommended.

VISUAL INSPECTION

When it becomes necessary to test or troubleshoot a generator, it is a good practice to complete a thorough visual inspection. Remove the access covers and look closely for any obvious problems. Look for the following:

- Burned or broken wires, broken wire connectors, damaged mounting brackets, etc.
- Loose or frayed wiring insulation, loose or dirty connections.
- Check that all wiring is well clear of rotating parts.
- Verify that the Generator properly connected for the correct rated voltage. This is especially important on new installations. See Section 1.2, "AC Connection Systems".
- Look for foreign objects, loose nuts, bolts and other fasteners.
- Clean the area around the Generator. Clear away paper, leaves, snow, and other objects that might blow against the generator and obstruct its air openings.

MEASURING VOLTAGES

When troubleshooting and testing the generator set, the technician will be required to measure both AC and DC voltages. Measurement of voltage requires that the user be thoroughly familiar with the meter being used for such tests. Consult the instruction manual for the meter being used.

When measuring voltage, it is best to connect the meter test leads to the terminals being tested while the generator is shut down or while power to those terminals is turned off.



DANGER: POWER VOLTAGES GENERATED BY THIS EQUIPMENT ARE EXTREMELY HIGH AND DANGEROUS. USE EXTREME CARE WHEN MEASURING POWER VOLTAGES SUCH AS GENERATOR AC OUTPUT VOLTAGE. CONTACT WITH LIVE TERMINALS AND CONDUCTORS MAY RESULT IN HARMFUL AND POSSIBLY LETHAL ELECTRICAL SHOCK. DO NOT ATTEMPT TO READ POWER VOLTAGES WHILE STANDING ON WET OR DAMP GROUND, OR WHILE HANDS OR FEET ARE WET. STAY WELL CLEAR OF HIGH VOLTAGE POWER TERMINALS. CONNECT METER TEST LEADS TO TERMINALS

AND LEADS WHILE THE GENERATOR IS SHUT DOWN OR WHEN THE POWER SUPPLY TO SUCH LEADS AND TERMINALS IS TURNED OFF. THE USE OF INSULATIVE RUBBER MATS IS RECOMMENDED. TAKE POWER VOLTAGE READINGS ONLY WHILE STANDING ON SUCH INSULATIVE MATS.

MEASURING CURRENT

Alternating current (AC) can be measured with a clamp-on ammeter. Most clamp-on ammeters will not measure direct current (DC). Load current readings should never exceed the generator's data plate rating for continuous operation. However, momentary surges in load current may be encountered when starting electric motors.

On 1-phase generators, the data plate generally lists rated line-to-line and line-to-neutral current.

MEASURING RESISTANCE

The resistance (in ohms) of generator stator and rotor windings can be measured using an ohmmeter or an accurate volt-ohm-milliammeter (VOM).

The resistance of some windings is extremely low. Some readings are so low that a meter capable of reading in the "milliohms" range would be required. Many meters will simply read CONTINUITY. However, a standard volt-ohm-milliammeter (VOM) may be used to test for continuity, or for a shorted or grounded condition.

INSULATION RESISTANCE

The insulation resistance of stator and rotor windings is a measurement of the integrity of the insulating materials that separate the electrical windings from the generator's steel core. This resistance can degrade over time or due to such contaminants as dust, dirt, oil, grease and especially moisture. In most cases, failures of stator and rotor windings is due to a breakdown in the insulation. And, in many cases, a low insulation resistance is caused by moisture that collects while the generator is shut down. When problems are caused by moisture buildup on the windings, they can usually be corrected by drying the windings. Cleaning and drying the windings can usually eliminate dirt and moisture built up in the generator windings.

MEGGERs:

The normal resistance of generator winding insulation is on the order of millions of ohms. This high resistance can be measured with a device called a "megger". The megger is a megohm meter ("meg" stands for million) and a power supply. The power supply voltage varies between megger models and is selectable on some models. The most common power supply voltage is 500 volts. Use of power supplies greater than 500 volts are not recommended on prepackaged generators.



CAUTION: Before attempting to measure insulation resistance, first disconnect and isolate all leads of the winding to be tested. Electronic components, diodes, surge protectors, relays, voltage regulators, etc., can be destroyed if subjected to high megger voltages.

HI-POT TESTER:

A "Hi-Pot" tester is shown in Figure 1. The model shown is only one of many that are commercially available. The tester shown is equipped with a voltage selector switch that permits the power supply voltage to be selected. It also mounts a breakdown lamp that will illuminate to indicate an insulation breakdown during the test.

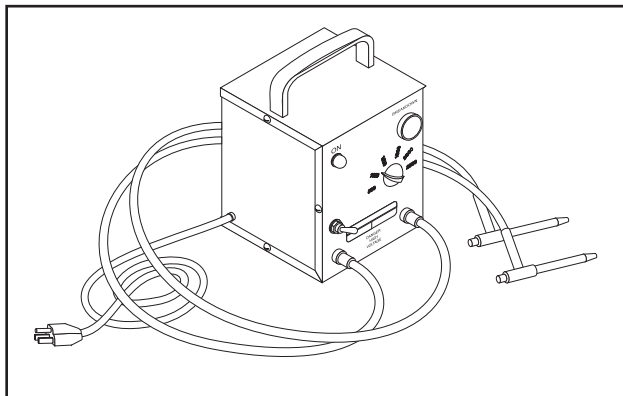

Figure 1. One Type of Hi-Pot Tester

STATOR INSULATION TESTS

GENERAL:

Units with liquid cooled engine and 1 -phase stator windings are equipped with (a) dual stator AC power windings, and (b) an excitation or DPE winding. These units are not equipped with a battery charge winding. Stator winding insulation tests consist of (a) testing all windings to ground, (b) testing between isolated windings, and (c) testing between parallel windings. Figure 3 represents the various stator AC output leads on 1 -phase units with liquid-cooled engine.

TEST ALL WINDINGS TO GROUND:

1. Disconnect and isolate Stator Leads 11, 22, 33, 44, 2 and 6.
2. Connect terminal ends of all stator leads together. Make sure all wire terminal ends are completely isolated from frame ground.
3. Connect the red test probe of the Hi-Pot tester to the terminal ends of all stator leads. Connect the black tester probe to a clean frame ground on the stator can. Then, proceed as follows:
 - a. Turn the Hi- Pot tester switch OFF
 - b. Plug the tester cord into a 120 volts AC wall socket and set its voltage selector switch to "500 volts".
 - c. Turn the tester switch ON and observe the breakdown lamp. After one (1) second, turn the tester switch OFF.

If the breakdown lamp turned on during the one (1) second test, clean and dry the stator. Then, repeat the test. If breakdown lamp comes on during the second test, replace the stator assembly.

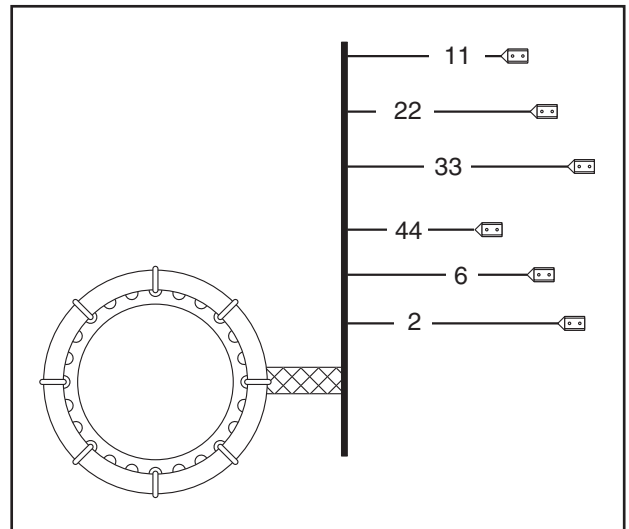

Figure 3. Stator Winding Leads (Liquid Cooled Units)

TEST BETWEEN ISOLATED WINDINGS:

1. Connect the red test probe to stator lead 2, the black probe to stator lead 11.
2. Set the tester switch to "500 volts".
3. Turn the tester switch ON and check that the pilot lamp is lighted.
4. Wait one (1) second while observing the tester breakdown lamp. **DO NOT EXCEED ONE SECOND.** After one (1) second, turn the tester switch OFF.
5. Connect the red test probe to stator lead 2, the black probe to stator lead 33. Then, repeat Steps 2, 3 and 4.

SECTION 1.4 TESTING, CLEANING AND DRYING

PART 1

GENERAL INFORMATION

If the breakdown lamp turned on during any one (1) second test, the stator should be cleaned and dried. After cleaning and drying, repeat the test. If the breakdown lamp turns on during the second test, replace the stator assembly.

TEST BETWEEN PARALLEL WINDINGS:

- 1 Set the tester's voltage switch to "500 volts".
2. Connect the red tester probe to stator lead 11, the black probe to stator lead 33.
3. Turn the tester switch ON and check that the pilot lamp is on.
4. Waft one (1) second while observing the breakdown lamp. Then, turn the tester switch OFF.

If the breakdown lamp came on during the one (1) second test, clean and dry the stator. Then, repeat the test. If breakdown lamp comes on during second test, replace the stator assembly.

TESTING ROTOR INSULATION

Before attempting to test rotor insulation, either the brush leads must be completely removed from the brushes or the brush holders must be completely removed. The rotor must be completely isolated from other components before starting the test.

1. Connect the red tester lead to the positive (+) slip ring (nearest the rotor bearing).
2. Connect the black tester probe to a clean frame ground, such as a clean metal part of the rotor.
3. Turn the tester switch OFF.
4. Plug the tester into a 120 volts AC wall socket and set the voltage switch to "500 volts".
5. Turn the tester switch ON and make sure the pilot light has turned on.
6. Observe the breakdown lamp, then turn the tester switch OFF. **DO NOT APPLY VOLTAGE LONGER THAN ONE (1) SECOND.**

If the breakdown lamp came on during the one (1) second test, cleaning and drying of the rotor may be necessary. After cleaning and drying, repeat the insulation breakdown test. If breakdown lamp comes on during the second test, replace the rotor assembly.

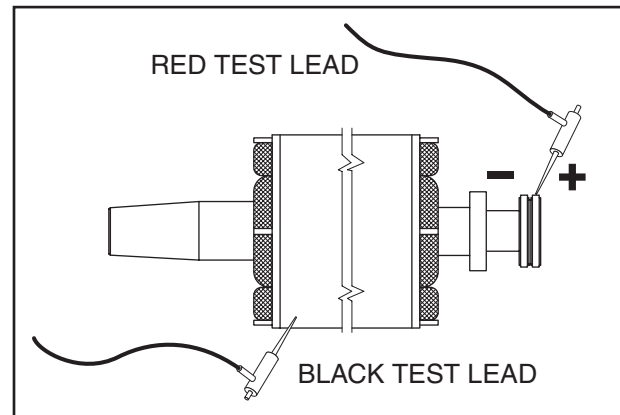

Figure 6. Testing Rotor Insulation

CLEANING THE GENERATOR

Caked or greasy dirt may be loosened with a soft brush or a damp cloth. A vacuum system may be used to clean up loosened dirt. Dust and dirt may also be removed using dry, low-pressure air (25 psi maximum).



CAUTION: Do not use sprayed water to clean the generator. Some of the water will be retained on generator windings and terminals, and may cause very serious problems.

DRYING THE GENERATOR

To dry a generator, proceed as follows:

1. Open the generator main circuit breaker. **NO ELECTRICAL LOADS MUST BE APPLIED TO THE GENERATOR WHILE DRYING.**
2. Disconnect all wires No. 4 from the voltage regulator.
3. Provide an external source to blow warm, dry air through the generator interior (around the rotor and stator windings. **DO NOT EXCEED 185° F. (85° C.).**)
4. Start the generator and let it run for 2 or 3 hours.
5. Shut the generator down and repeat the stator and rotor insulation resistance tests.

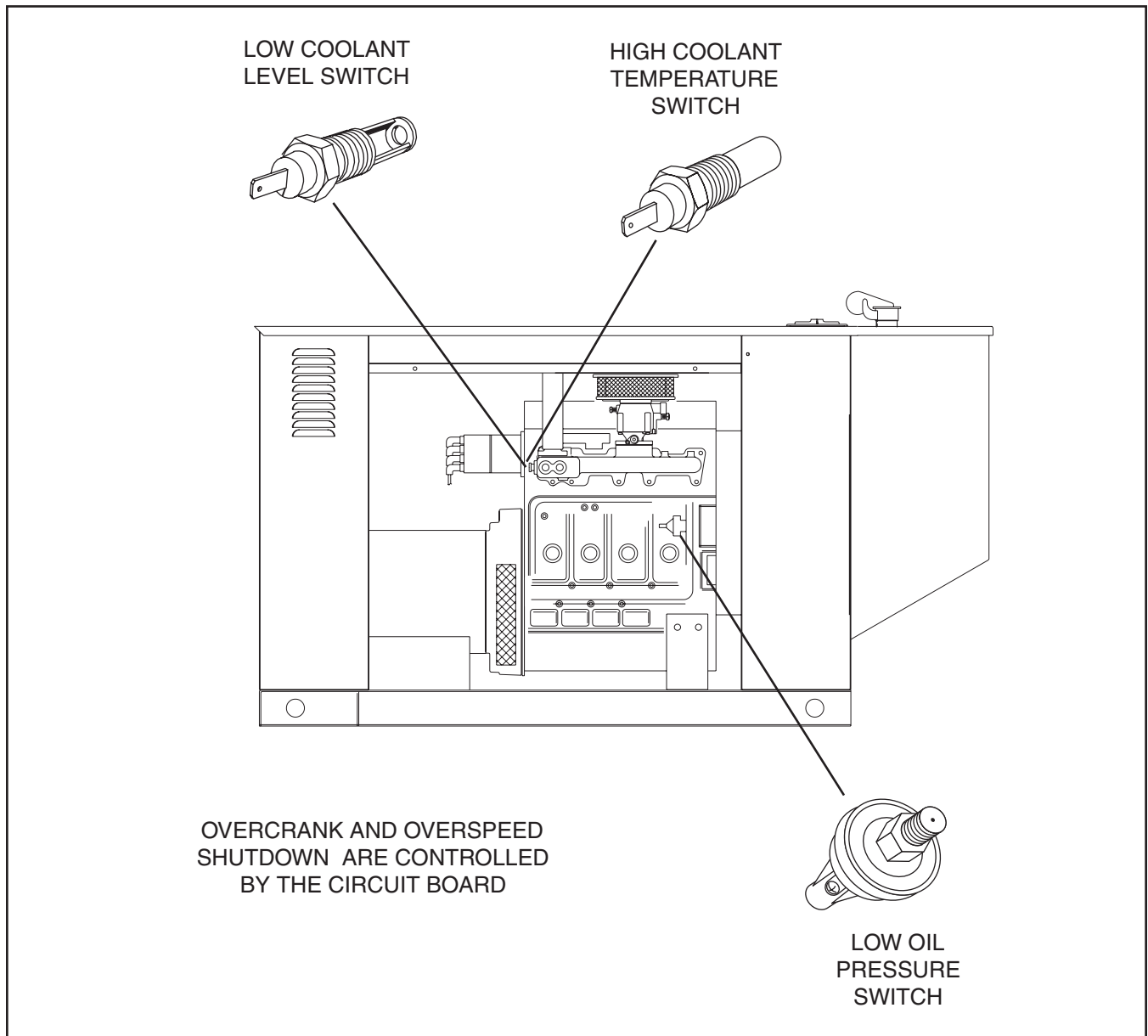

Figure 1. Protective Devices on Liquid Cooled Engine

GENERAL

Standby electric power generators will often run unattended for long periods of time. Such operating parameters as (a) engine oil pressure, (b) engine temperature, (c) engine operating speed, and (d) engine cranking and startup are not monitored by an operator during automatic operation. Because engine operation will not be monitored, the use of engine protective safety devices is required to prevent engine damage in the event of a problem.

Prepackaged generator engines mount several engine protective devices. These devices work in conjunction with a control circuit board, to protect the engine

against such operating faults as (a) low engine oil pressure, (b) high temperature, (c) overspeed, and (d) overcrank. On occurrence of any one or more of those operating faults, control board action will effect an engine shutdown.

LOW OIL PRESSURE SHUTDOWN:

See Figure 1. Prepackaged generators with liquid cooled engine are equipped with an oil pressure switch having a closing pressure of about 10 psi. Should oil pressure drop below that value, an automatic engine shutdown will occur. Circuit operation is similar to that of air-cooled units.

SECTION 1.5 ENGINE-GENERATOR PROTECTIVE DEVICES

PART 1

GENERAL INFORMATION

HIGH COOLANT TEMPERATURE SHUTDOWN:

The engine is equipped with a coolant temperature switch. Should engine coolant temperature exceed approximately 284° F. (140° C.), the engine will be shut down automatically by control board action.

LOW COOLANT LEVEL SENSOR:

It is possible that engine coolant level might drop low enough so that the high temperature switch is no longer immersed in the liquid coolant. If this happens engine temperatures could increase rapidly but the temperature switch would not sense the high temperature condition and the engine would continue to run. To prevent this occurrence, a low coolant level sensor is provided. The sensor is immersed in cooling system liquid. If coolant level drops below the level of the low coolant level sensor, the device will complete a Wire 85 circuit to ground. Engine shutdown will occur.

OVERSPEED SHUTDOWN:

The control board on liquid cooled units receives AC frequency (rpm) signals directly from the stator AC power windings, via sensing leads S15 and S16. Should AC frequency exceed approximately 72 Hz, circuit board action will initiate an automatic engine shutdown.

NOTE: For units rated 1800 rpm, 72 Hz is equal to 2160 rpm.

NOTE: The control board also uses the sensing lead signals (S15, S16) (a) to terminate cranking at about 50% of rated frequency, and (b) as an "engine running" signal. The circuit board will not initiate transfer of electrical loads to the "Standby" source until sensing voltage and frequency is greater than 50 % of the unit's rated values.

OVERCRANK SHUTDOWN:

Automatic engine cranking and startup normally occurs when the control board senses that utility source voltage has dropped below approximately 60 percent of its nominal rated voltage and remains at that low level longer than six (6) seconds. At the end of six (6) seconds, control board action will energize a crank relay and a run relay (both relays are on the control board). On closure of the crank relay contacts, control board action will deliver 12 volts DC to a control contactor (CC). The control contactor will energize and battery power will be delivered across its closed contacts to the starter motor (SM). The engine will then crank.

During a manual startup (AUTO-OFF-MANUAL switch at "Manual"), action is the same as during an automatic start, except that cranking will begin immediately when the switch is set to "Manual".

Control board action (during both a manual and an automatic start) will hold the crank relay energized for about 7-9 seconds. The relay will then de-energize for about 7-9 seconds, and then energize again. In this manner, the engine will be cranked for 7-9 seconds, will rest for 7-9 seconds, and will crank again, and so on until the engine starts.

If the engine has not started after approximately 90 seconds of these crank-rest cycles, cranking will automatically terminate and shutdown will occur. The control board uses AC signals from the stator battery charge windings as an indication that the engine has started.

CONTROL PANELGENERAL:

See Figure 1 (Page 16). A typical prepackaged control panel on units with liquid cooled engine includes: (a) an auto-off-manual switch, (b) a fault indicator lamp, (c) a 15 amp fuse, and (d) a set exercise switch.

AUTO-OFF-MANUAL SWITCH:

Use this switch to (a) select fully automatic operation, (b) to crank and start the engine manually, and (c) to shut the unit down or to prevent automatic startup.

1. AUTO position:
 - a. Select AUTO for fully automatic operation.
 - b. When AUTO is selected, circuit board will monitor utility power source voltage.
 - c. Should utility voltage drop below a preset level and remain at such a low level for a preset time, circuit board action will initiate engine cranking and startup.
 - d. Following engine startup, circuit board action will initiate transfer of electrical loads to the "Standby" source side.
 - e. On restoration of utility source voltage above a preset level, circuit board action will initiate retransfer back to the "Utility Source" side.
 - f. Following retransfer, circuit board will shut the engine down and will then continue to monitor utility source voltage.
2. OFF Position:
 - a. Set the switch to OFF to stop an operating engine.
 - b. To prevent an automatic startup from occurring, set the switch to OFF.
3. MANUAL Position:
 - a. Set switch to MANUAL to crank and start unit manually.
 - b. Engine will crank cyclically and start (same as automatic startup, but without transfer). The unit will transfer if utility voltage is not available.



DANGER: WHEN THE GENERATOR IS INSTALLED IN CONJUNCTION WITH AN AUTOMATIC TRANSFER SWITCH, ENGINE CRANKING AND STARTUP CAN OCCUR AT ANY TIME WITHOUT WARNING (PROVIDING THE AUTO-OFF-MANUAL SWITCH IS SET TO AUTO). TO PREVENT AUTOMATIC STARTUP AND POSSIBLE INJURY THAT MIGHT BE CAUSED BY SUCH STARTUP, ALWAYS SET THE AUTO-OFF-MANUAL SWITCH TO ITS OFF POSITION BEFORE WORKING ON OR AROUND THIS EQUIPMENT.

FAULT INDICATOR LAMP:

The fault indicator lamp will turn on in the event that any one or more of the following engine fault conditions should occur: (a) low oil pressure, (b) high coolant temperature, (c) low coolant level, (d) over-speed, and (e) overcrank.

15 AMP FUSE:

This fuse protects the DC control system, including the control board, against overload. If the fuse has blown, engine cranking and running will not be possible. Should fuse replacement become necessary, use only an identical 15 amp replacement fuse.

THE SET EXERCISE SWITCH:

Use this switch to select the time and day for system exercise.

TO SELECT AUTOMATIC OPERATION

The following procedure applies to those installations in which the prepackaged home standby generator is installed in conjunction with a prepackaged transfer switch. Prepackaged transfer switches do not have an intelligence circuit of their own. Instead, automatic operation on prepackaged transfer switch and generator combinations is controlled by a control circuit board housed in the generator.

To select automatic operation when a prepackaged transfer switch is installed along with a prepackaged home standby generator, proceed as follows:

1. Check that the prepackaged transfer switch main contacts are at their "Utility" position, i.e., the load is connected to the utility power supply. If necessary, manually actuate the switch main contacts to their "Utility" source side. See Part 3 of this manual for instructions.
2. Check that utility source voltage is available to transfer switch Terminal Lugs N1 and N2 (2-pole, 1-phase transfer switches).
3. Set the generator's AUTO-OFF-MANUAL switch to its AUTO position.
4. Actuate the generator's main line circuit breaker to its ON or "Closed" position. With the preceding Steps 1 through 4 completed, a dropout in utility supply voltage below a preset level will result in automatic generator cranking and start-up. Following startup, the prepackaged transfer switch will be actuated to its "Standby" source side, i.e., loads powered by the standby generator.

MANUAL TRANSFER TO "STANDBY" AND MANUAL STARTUP

To transfer electrical loads to the "Standby" (generator) source and start the generator manually, proceed

SECTION 1.6 OPERATING INSTRUCTIONS

PART 1

GENERAL INFORMATION

as follows:

1. On the generator panel, set the AUTO-OFF-MANUAL switch to OFF.
2. On the generator, set the main line circuit breaker to its OFF or "Open" position.
3. Turn OFF the utility power supply to the transfer switch, using whatever means provided (such as a utility-source line circuit breaker).
4. Manually actuate the transfer switch main contacts to their "Standby" position, i.e., loads connected to the "Standby" power source side.
5. On the generator panel, set the AUTO-OFF-MANUAL switch to MANUAL. The engine should crank and start.
6. Let the engine warm up and stabilize for a minute or two at no-load.
7. Set the generator's main line circuit breaker to its ON or "Closed" position. The generator now powers the electrical loads.

MANUAL SHUTDOWN AND RETRANSFER BACK TO "UTILITY"

To shut the generator down and retransfer electrical loads back to the "Utility" position, proceed as follows:

1. Set the generator's main line circuit breaker to its OFF or "Open" position.
2. Let the generator run at no-load for a few minutes, to cool.

3. Set the generator's AUTO-OFF-MANUAL switch to OFF. Wait for the engine to come to a complete stop.
4. Turn OFF the "Utility" power supply to the transfer switch using whatever means provided (such as a "Utility" source main line circuit breaker)
5. Manually actuate the prepackaged transfer switch to its "Utility" power source side, i.e., "Load" connected to the "Utility" source.
6. Turn ON the "Utility" power supply to the transfer switch, using whatever means provided.
7. Set the generator's AUTO-OFF-MANUAL switch to AUTO.

THE SET EXERCISE TIME SWITCH

The prepackaged home standby generator will start and exercise once every seven (7) days, on a day and at a time of day selected by the owner or operator. The set exercise time switch is provided to select the day and time of day for system exercise.

See Part 5, Section 5.2 ("The 7-Day Exercise Cycle") for instructions on how to set exercise time.



DANGER: THE GENERATOR WILL CRANK AND START WHEN THE SET EXERCISE TIME SWITCH IS SET TO "ON". DO NOT ACTUATE THE SWITCH TO "ON" UNTIL AFTER YOU HAVE READ THE INSTRUCTIONS IN SECTION 1.6.

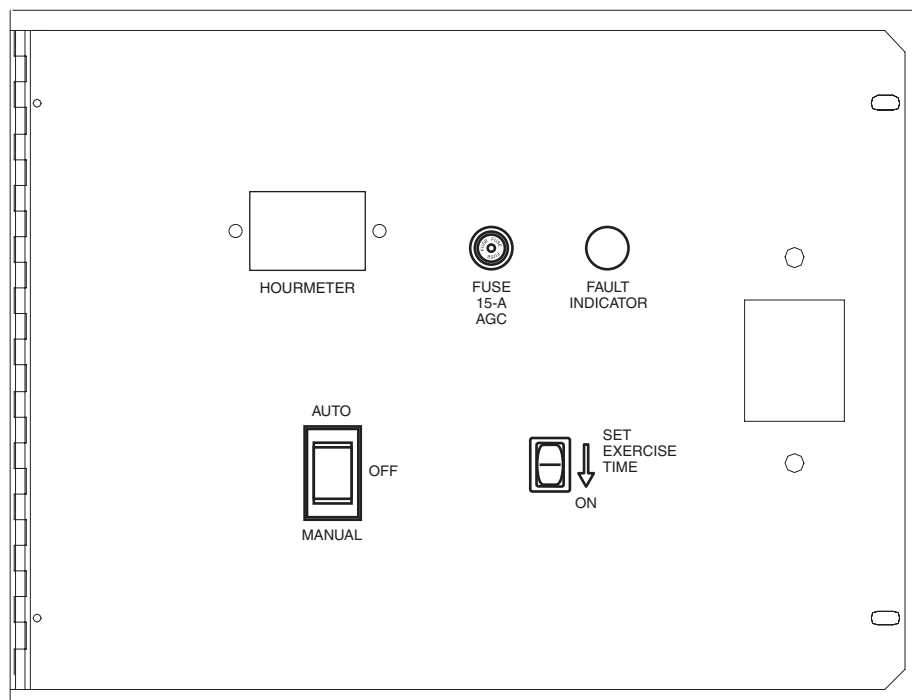

Figure 1. Control Panel

INTRODUCTION

When the prepackaged generator is installed in conjunction with a prepackaged transfer switch, either manual or automatic operation is possible. Manual transfer and engine startup, as well as manual shutdown and retransfer are covered in section 1.7. Selection of fully automatic operation is also discussed in that section. This section will provide a step-by-step description of the sequence of events that will occur during automatic operation of the system.

AUTOMATIC OPERATING SEQUENCES

PHASE 1 - UTILITY VOLTAGE AVAILABLE:

With utility source voltage available to the transfer switch, that source voltage is sensed by a control board in the generator panel and the circuit board takes no action.

Electrical loads are powered by the "Utility" source and the AUTO-OFF-MANUAL switch is set to AUTO.

PHASE 2 - UTILITY VOLTAGE DROPOUT:

If a dropout in utility source voltage should occur below about 60 percent of the nominal utility source voltage, a 12 second timer on the control board will start timing. This timer is required to prevent false generator starts that might be caused by transient utility voltage dips.

PHASE 3 - ENGINE CRANKING:

When the control board's 12 second timer has finished timing and if utility source voltage is still below 60 percent of the nominal source voltage, control board action will energize a crank relay and a run relay. Both of these relays are mounted on the control board.

Control board action will hold the crank relay energized for about 7-9 seconds. The relay will then be de-energized for about 7-9 seconds, energized again for 7-9 seconds, and so on. When the crank relay energizes the engine will crank, when it is de-energized, engine cranking will stop. This cyclic action of crank/rest, crank/rest, etc., will continue until either (a) the engine starts, or (b) until ninety (90) seconds have elapsed.

If the engine has not started within ninety (90) seconds, cranking will terminate and shutdown will occur. On liquid cooled engine units, a fault indicator lamp (LED) on the generator panel will illuminate.

If the engine starts, cranking will terminate when generator AC output frequency reaches approximately 30 Hz.

PHASE 4 - ENGINE STARTUP AND RUNNING:

The control board senses that the engine is running by receiving a voltage/frequency signal from the generator stator windings.

When generator AC frequency reaches approximately 30 Hz, an engine warm-up timer on the control board turns on. That timer will run for about fifteen (15) seconds. At the same time, an engine minimum run timer will turn on.

The engine warm-up timer lets the engine warm-up and stabilize before transfer to the "Standby" source can occur.

The engine minimum run timer prevents a cold engine from being shut down, as might happen if utility source power is restored very quickly. The minimum run timer will run for about 10-12 minutes. That means the engine must run for 10-12 minutes before it can be shut down automatically.

NOTE: The engine can be shut down manually at any time, by setting the AUTO-OFF-MANUAL switch to OFF.

PHASE 5 - TRANSFER TO "STANDBY":

When the control board's engine warm-up timer has timed out, control board action completes a transfer relay circuit to ground. The transfer relay is housed in the prepackaged transfer switch enclosure.

The transfer relay energizes and transfer of loads to the "Standby" power source occurs. Loads are now powered by standby generator AC output.

PHASE 6 - "UTILITY" POWER RESTORED:

When utility source voltage is restored above about 80 percent of the nominal supply voltage, a fifteen (15) second timer on the control board starts timing. If utility voltage remains sufficiently high at the end of fifteen (15) seconds, a "retransfer time delay" will start timing and will time for about six (6) seconds.

PHASE 7 - RETRANSFER BACK TO "UTILITY":

When the retransfer time delay has finished timing, control board action will open a circuit to a transfer relay (housed in the transfer switch). The transfer relay will then de-energize and retransfer back to the "Utility" source will occur. Loads are now powered by "Utility" source power. On retransfer, an "engine cool-down timer" starts timing and will run for about one (1) minute.

PHASE 8 - GENERATOR SHUTDOWN:

When the engine cool-down timer has finished timing, and if the minimum run timer has timed out, engine shutdown will occur.

SECTION 1.7
AUTOMATIC OPERATING PARAMETERS

PART 1

GENERAL INFORMATION

AUTOMATIC OPERATING SEQUENCES CHART

SEQ.	CONDITION	ACTION	SENSOR, TIMER OR OTHER
1	“Utility” source voltage is available.	No action	Voltage Dropout Sensor on control circuit board.
2	“Utility” voltage dropout below 60% of rated voltage occurs.	A 6-second timer on control board turns on.	Voltage Dropout Sensor and 6 second timer on control board.
3	“Utility” voltage is still below 60% of rated voltage.	6-second timer runs for 6 seconds, then stops.	Voltage Dropout Sensor and 6 second timer.
4	“Utility” voltage is still low after 6 seconds.	Control board action energizes a crank relay and a run relay. The engine cranks for 7-9 seconds, rests for 7-9 seconds, and so on until engine starts. See NOTE 1.	Control board crank and run relays.
5	“Utility” voltage still low and the engine has started.	Control board’s “engine warmup timer” and “engine minimum run timer” both turn on.	Engine Warmup Timer (15 seconds) Minimum Run Timer (13 minutes)
6	Engine running and “engine warmup timer” times out.	Control board action energizes a transfer relay in transfer switch and transfer to “Standby” occurs.	Control board transfer relay circuit Transfer switch transfer relay.
7	Engine running and load is powered by “Standby” power.	No further action	Control board’s “voltage pickup sensor” continues to seek an acceptable “Utility voltage.
8	“Utility” source voltage is restored above 80% of rated source voltage.	Control board’s “voltage pickup sensor” reacts and a “return to utility timer” turns on.	Voltage Pickup Sensor (80%) Return to Utility Timer (10 seconds)
9	“Utility voltage still high after 6 seconds.	“Return to utility timer” times out	Return to Utility Timer
10	“Utility” voltage still high.	Control board action opens the transfer relay circuit to ground. Transfer relay de-energizes and retransfer to “Utility” occurs.	Control board transfer relay circuit Transfer switch transfer relay.
11	Engine still running, loads are powered by “Utility” source.	Control board’s “engine cooldown timer” starts running.	control board’s Engine Cooldown Timer (1 minute)
12		After 1 minute, “engine cooldown timer” stops and control board’s run relay de-energizes. Engine shuts down.	Engine Cooldown Timer control board Run Relay.
13	Engine is shut down, loads are powered by “Utility” source. Return to Sequence 1.	No action.	Voltage Dropout Sensor on control circuit board.

Note1: In Sequence 4, if engine has not started in 90 seconds cranking will end and shutdown will occur.

PART 2 PREPACKAGED LIQUID-COOLED AC GENERATORS

1.5 LITER PREPACKAGED HOME STANDBY GENERATORS

TEST	DESCRIPTION	PAGE
1	Check Main Circuit Breaker	30
2	Check AC Output Voltage	31
3	Test Excitation Circuit Breaker	31
4	Test Thermal Protector	32
5	Fixed Excitation Test/Rotor Amp Draw Test	32
6	Wire Continuity	33
7	Check Field Boost	33
8	Testing the Ststor with a VOM	34
9	Resistance Check of Rotor Circuit	35

TABLE OF CONTENTS		
PART	TITLE	PAGE
2.1	Description and Major Components	20
2.2	AC Output Operational Analysis	24
2.3	AC Output Troubleshooting Flow Charts	26
	Problem 1 - Generator Produces Zero Voltage or Residual Voltage	26
	Problem 2 - Generator Produces Low Voltage at No-Load	28
	Problem 3 - Generator Produces High Voltage at No-Load	28
	Problem 4 - Voltage and Frequency Drop Excessively When Loads Are Applied	29
2.4	AC Output Diagnostic Tests	30

TEST	DESCRIPTION	PAGE
10	Check Brushes and Slip Rings	35
11	Test Rotor Assembly	35
12	Check AC Output Frequency	36
13	Check and Adjust Governor Board and Stepper Motor	36
14	Check and Adjust Voltage Regulator	38
15	Check Voltage and Frequency Under Load	38
16	Check for Overload Condition	38
17	Check Engine Condition	38

INTRODUCTION

This section covers the major components of the AC generator proper, i.e., those generator assemblies that provide for the production of AC electrical power.

The single bearing rotor (revolving field) is driven by a 1.5 liter, liquid cooled gas engine. The rotor is coupled to the engine flywheel, by means of a flexible coupling and a fan and ring gear assembly, so the engine crankshaft and rotor operate at the same speed.

Major components of the AC generator are shown in Figure 1 on the next page. These components are (a) a flexible coupling, (b) fan and ring gear, (c) rotor, (d) blower housing, (e) stator assembly, (f) rear bearing carrier, and (g) a rear bearing carrier cover.

BLOWER HOUSING

The blower housing is bolted to the engine and supports the engine end of the AC generator. It houses the fan and ring gear assembly. A cutout area on one side of the housing allows a blower air outlet screen to be mounted.

FLEXIBLE DISK

A flexible disk bolts to the engine flywheel and to the fan and ring gear assembly. The disk maintains proper alignment between the engine and generator parts.

FAN AND RING GEAR ASSEMBLY

The fan and ring gear assembly are retained to the flexible disk which, in turn, is retained to the engine flywheel. The fan draws cooling air into the generator interior through slots in a rear bearing carrier cover, then expels the heated air outward through a screen on the blower housing. The ring gear teeth mate with teeth on a starter motor pinion gear, when the engine is cranked.

ROTOR ASSEMBLY

The rotor assembly on units rated 1800 rpm is a 4-pole type, having two north magnetic poles and two south magnetic poles.

The rear end of the rotor is bolted and keyed to the fan and ring gear. A ball bearing has been pressed onto the rotor's front shaft, which is retained, in a machined bore in the rear bearing carrier.

A positive (+) and a negative (-) slip ring is provided on the rotor shaft that retains the ball bearing. Brushes will ride on these slip rings.

The combination of slip rings and brushes allow rotor excitation current to be transmitted from stationary components into the rotating rotor windings. The positive (+) slip ring is the one nearest the rotor bearing.

REAR BEARING CARRIER

The rear bearing carrier supports the front of the generator. Mounting feet at the carrier bottom permit the carrier to be bolted to the generator's mounting base. A machined bore, in the center of the carrier, accepts the rotor bearing. Bosses allow for the retention of brush holders. Long stator bolts pass through holes in the carrier's outer periphery, to sandwich and retain the stator can between the carrier and the blower housing. A rear bearing carrier gasket helps prevent dust from entering the bearing area.

STATOR ASSEMBLY

The stator can is sandwiched between the blower housing and the rear bearing carrier, and retained in that position by four (4) stator bolts.

A notched cutout has been provided in the rear bearing carrier end of the stator can. A rubber grommet has been placed into that notch, for protection of the stator leads that are brought out of the stator.

REAR BEARING CARRIER PLATE

This plate is retained to the rear bearing carrier by four (4) capscrews, lockwashers and flatwashers. The plate provides slotted air inlet openings for the passage of cooling and ventilating air into the generator.

BRUSH HOLDERS AND BRUSHES

Brushes are retained in a brush holder which is retained to drilled and threaded bosses on the rear bearing carrier. In most cases, two brush holders are used having two brushes per holder. Brush holders are precisely positioned so that one of the two brushes slides on a positive (+) slip ring, the other on a negative (-) slip ring. The positive (+) brush and slip ring are nearest the rotor bearing. The positive (+) side of the DC excitation circuit (Wire No. 4, red) connects to the positive (+) brush; the negative (-) or grounded side (Wire No. 0) to the negative (-) brush. Brushes and brush holders are illustrated in Figure 2, on Page 22.

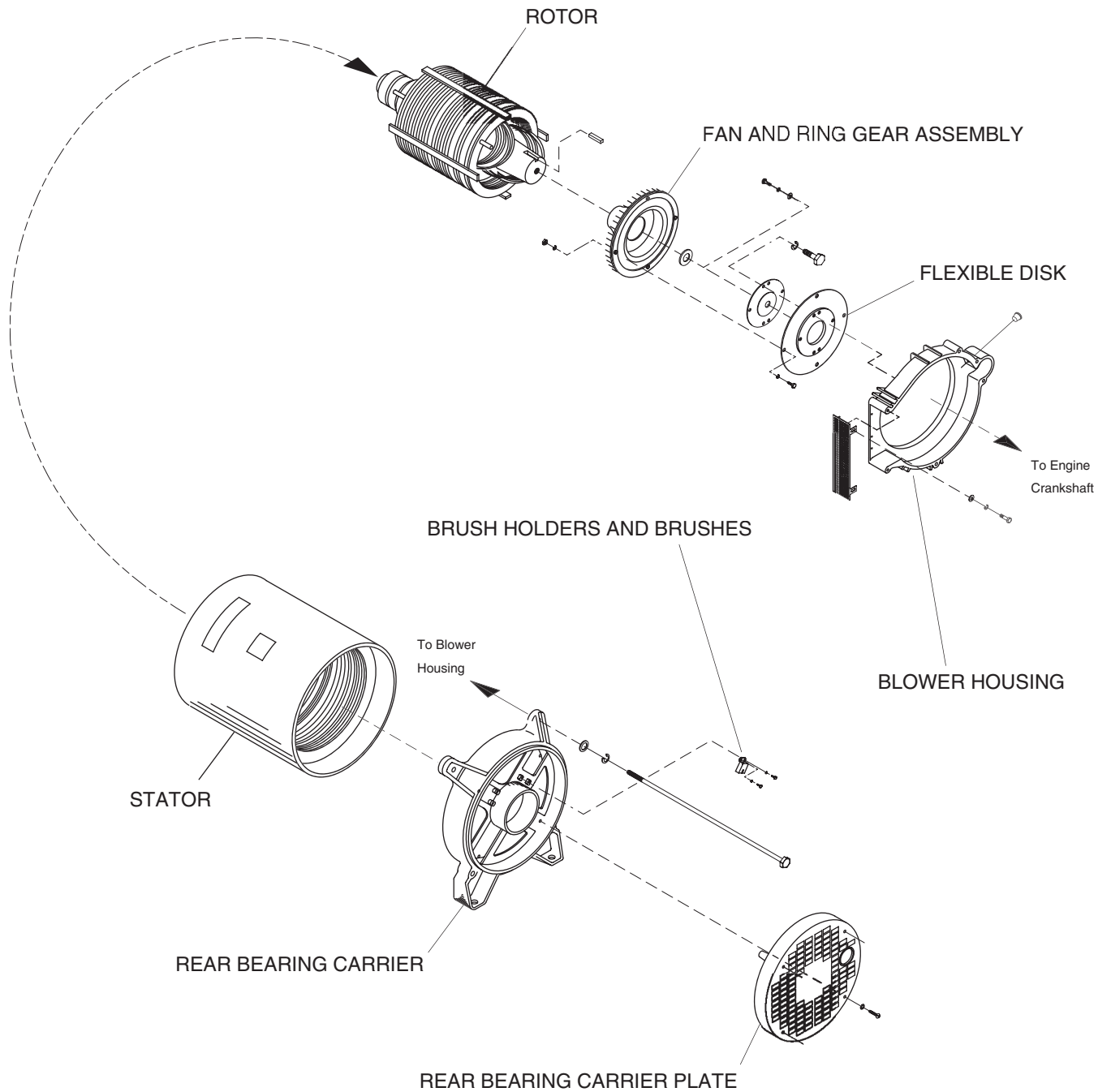

Figure 1. Generator Major Components

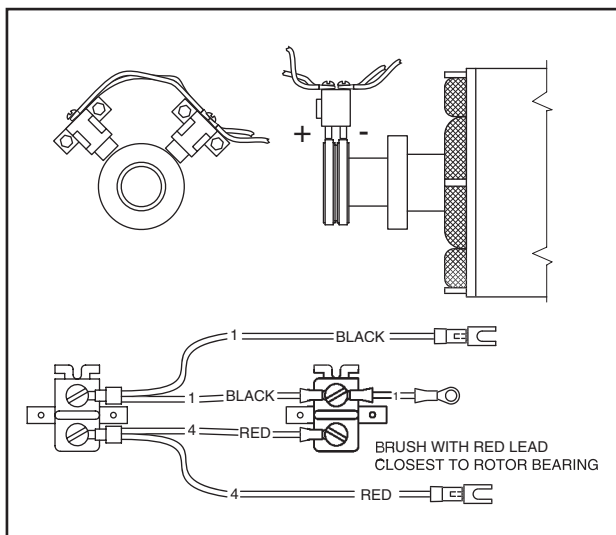

Figure 2. Brush Holders and Brushes

THE EXCITATION CIRCUIT

AC output from the stator excitation (DPE) winding is delivered to the voltage regulator, via a thermal protector (TP), Wire No. 2, an excitation circuit breaker (CB1), Wire No. 162, and Wire No. 6. This is “unregulated” excitation current.

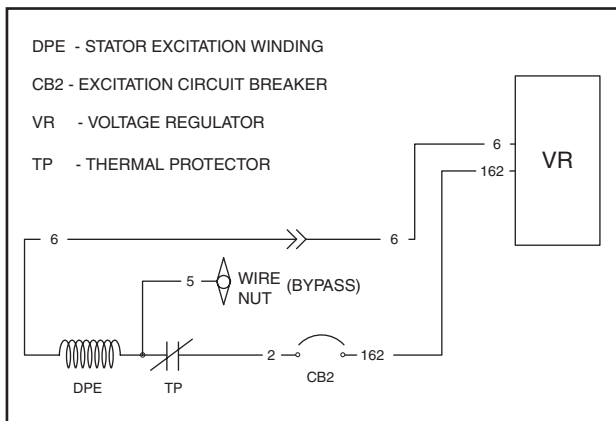

Figure 3. Schematic - Excitation Circuit

THERMAL PROTECTOR:

This normally closed thermal switch protects the stator windings against excessively high internal temperatures. The switch is physically imbedded in the stator windings and electrically connected in series with the DPE winding AC output to the regulator. If internal stator temperatures exceed a safe value, the switch contacts will open and the DPE output to the voltage regulator will be terminated. Without excitation current flow to the rotor, generator AC output voltage will drop to a value commensurate with rotor residual magnetism.

The thermal protector is self-resetting. That is, when internal stator temperatures drop to a safe value, its contacts will re-close and normal DPE output to the regulator will resume.

Wire No. 5 is a thermal protector “bypass” lead. If the thermal switch has failed in its open position, it can be bypassed. The Wire No. 5 bypass lead is brought out of the stator and has a wire nut on its end.

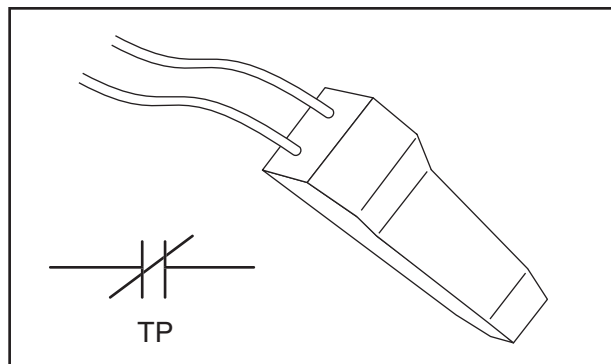

Figure 4. The Thermal Protector

EXCITATION CIRCUIT BREAKER:

This circuit breaker protects the regulator against high voltage surges. If the breaker has tripped open, loss of excitation current will occur. Stator power winding AC output voltage will then drop to a value commensurate with residual magnetism in the rotor. The breaker is self-resetting.

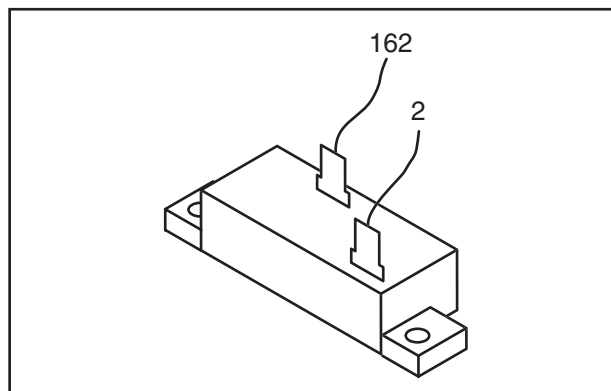

Figure 5. Excitation Circuit Breaker

VOLTAGE REGULATOR:

See Figure 6. Unregulated AC output from the stator DPE winding is delivered to the voltage regulator, via Wires No. 6 and 162. Stator power winding AC voltage and frequency signals are delivered to the regulator, via “sensing” Wires No. S15 and S16. The regulator rectifies the DPE output and, based on the sensing lead signals, regulates the DC current output. An LED (light emitting diode) is incorporated into the regulator. This red light senses the “sensing” (S15/S16) input.

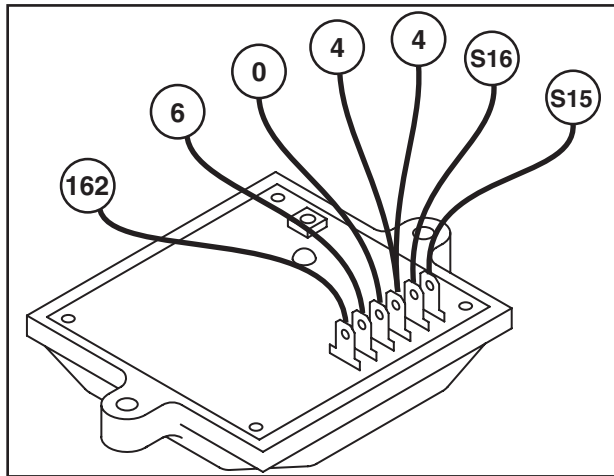

Figure 6. Prepackaged Voltage Regulator

If the red LED goes “out”, sensing signals to the regulator have been lost. The following rules apply:

- Loss of sensing can be caused by an “open” circuit condition in sensing leads S15 and S16. These sensing leads also operate the generator’s panel mounted AC frequency meter. Thus, if the red LED is out, it may be assumed that an open circuit exists in the sensing circuit.
- Loss of sensing to the regulator will usually result in a “full field” condition and resultant high voltage output from stator AC power winding. The maximum voltage that regulator action can deliver is limited by a “clamming” action on the part of the regulator.
- A complete open circuit condition in the stator AC power windings will cause loss of sensing voltage and frequency. However, this will result in a zero voltage output from the stator windings.

Based on the “sensing” signals, the regulator delivers direct current (DC) to the rotor, via Wire No. 4 and the positive (+) brush and slip ring. This regulated current flows through the rotor and to frame ground, via the negative (-) slip ring and brush and Wire No. 1. The following apply:

- The concentration of magnetic flux lines around the rotor will be proportional to the regulated excitation current flow through the rotor plus any residual magnetism.

- An increase in excitation current flow through the rotor windings will increase the concentration of “magnetic flux” lines around the rotor which, in turn, will increase the AC voltage induced into the stator AC power windings.

FIELD BOOST

See Figure 7. The prepackaged system provides a “field boost” feature. Field boost, in effect, “flashes the field” whenever the engine is cranking to ensure an early “pickup voltage” in the stator windings.

A field boost diode and a field boost resistor are installed in a printed circuit board. Field boost DC output to the rotor is reduced to approximately 9-10 volts by the field boost resistor.

Manual and automatic cranking is initiated by PCB board action, when that board energizes a crank relay (K1). When the relay is energized, battery voltage is delivered across its closed contacts and to the rotor, via a field boost resistor, field boost diode, and Wire No. 4. Notice that field boost current flow is available only while the engine is cranking.

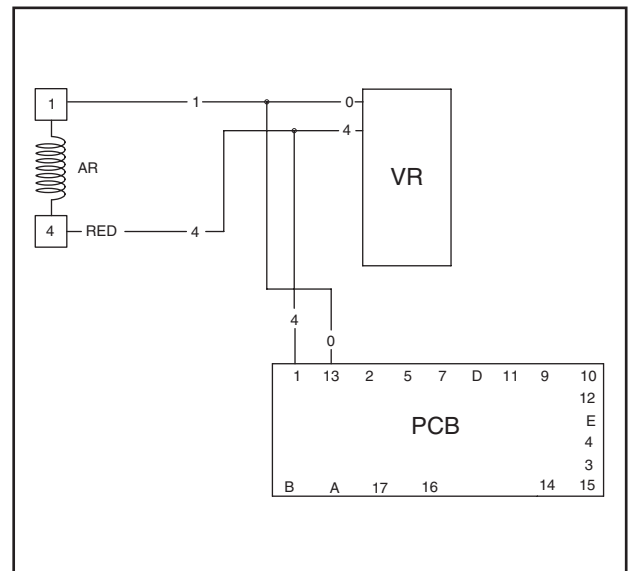

Figure 7. The Field Boost Circuit
(from Schematic Drawing #0F5244)

ROTOR RESIDUAL MAGNETISM

The generator revolving field (rotor) may be considered to be a permanent magnet. Some 'residual' magnetism is always present in the rotor. This residual magnetism is sufficient to induce a voltage into the stator AC power windings that is approximately 2-12 volts AC.

FIELD BOOST

FIELD BOOST CIRCUIT:

When the engine is cranking, direct current flow is delivered from a circuit board to the generator rotor windings, via Wire 4.

The field boost system is shown schematically in Figure 2. Manual and automatic engine cranking is initiated by circuit board action, when that circuit board energizes a crank relay. Battery voltage is then delivered to field boost Wire 4 (and to the rotor), via a field boost resistor and diode. The crank relay, field boost resistor and diode are all located on the circuit board.

Notice that field boost current is available only while the crank relay is energized, i.e., while the engine is cranking.

Field boost voltage is reduced from that of battery voltage by the resistor action and, when read with a DC voltmeter, will be approximately 9 or 10 volts DC.

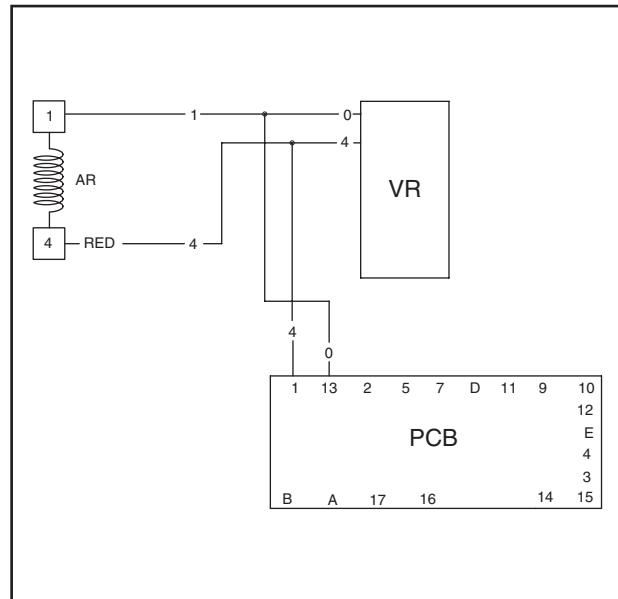

Figure 7. The Field Boost Circuit
(from Schematic Drawing #0F5244)

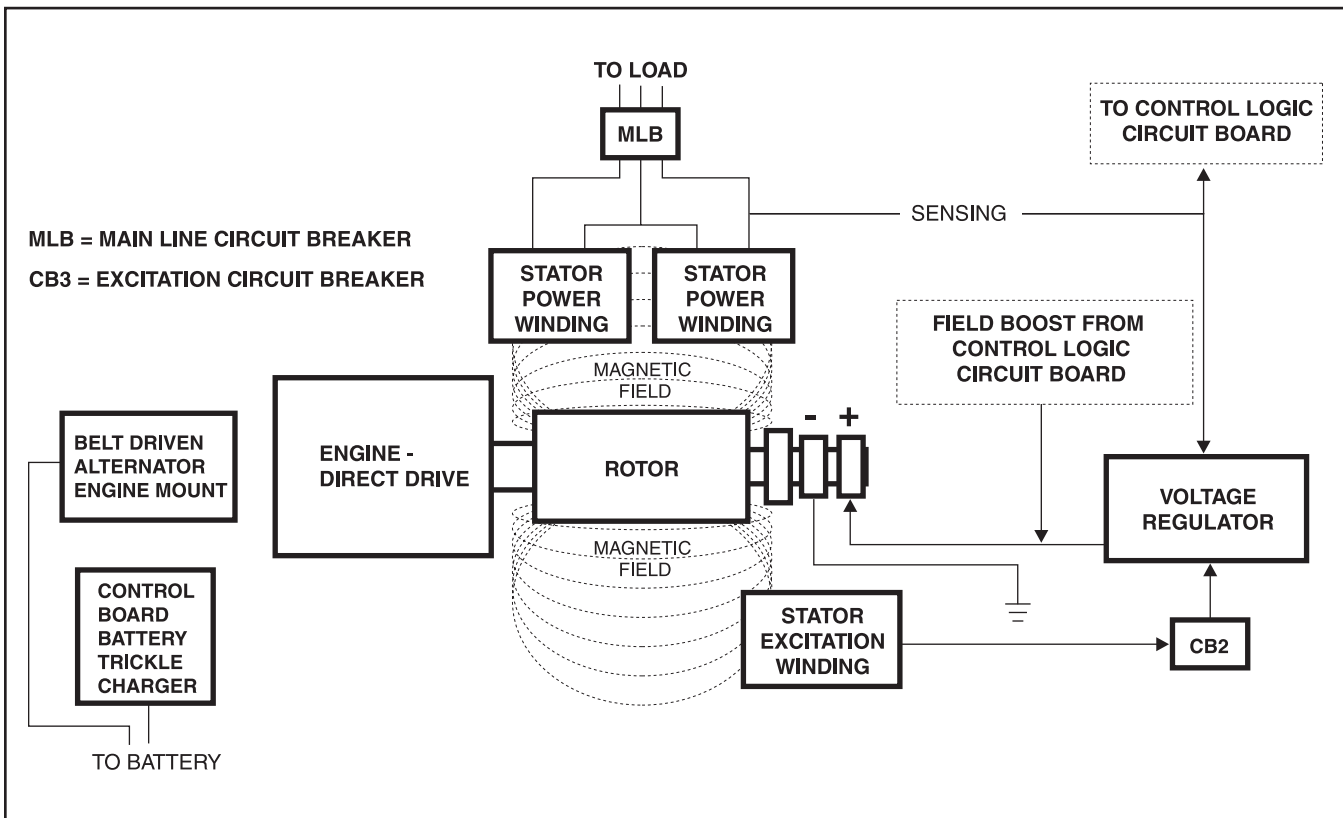

Figure 1. Operating Diagram of AC Generator

OPERATION

STARTUP:

When the engine is started, residual plus field boost magnetism from the rotor induces a voltage into the stator AC power windings and the stator excitation or DPE windings. In an "on-speed" condition, residual plus field boost magnetism are capable of creating approximately one-half the unit's rated voltage.

ON-SPEED OPERATION:

As the engine accelerates, the voltage that is induced into the stator windings increases rapidly, due to the increasing speed at which the rotor operates.

FIELD EXCITATION:

An AC voltage is induced into the stator excitation (DPE) windings. The DPE winding circuit is completed to the voltage regulator, via Wire 2, excitation circuit breaker, Wire 162, and Wire 6. Unregulated alternating current can flow from the winding to the regulator.

The voltage regulator "senses" AC power winding output voltage and frequency via stator Wires S15 and S16.

The regulator changes the AC from the excitation winding to DC. In addition, based on the Wires S15 and S16 sensing signals, it regulates the flow of direct current to the rotor.

The rectified and regulated current flow from the regulator is delivered to the rotor windings, via Wire 4, and the positive brush and slip ring. This excitation current flows through the rotor windings and is directed to ground through the negative (-) slip ring and brush, and Wire 1.

The greater the current flow through the rotor windings, the more concentrated the lines of flux around the rotor become.

The more concentrated the lines of flux around the rotor that cut across the stationary stator windings, the greater the voltage that is induced into the stator windings.

Initially, the AC power winding voltage sensed by the regulator is low. The regulator reacts by increasing the flow of excitation current to the rotor until voltage increases to a desired level. The regulator then maintains the desired voltage. For example, if voltage exceeds the desired level, the regulator will decrease the flow of excitation current. Conversely, if voltage drops below the desired level, the regulator responds by increasing the flow of excitation current.

AC POWER WINDING OUTPUT:

A regulated voltage is induced into the stator AC power windings. When electrical loads are connected across the AC power windings to complete the circuit, current can flow in the circuit. The regulated AC power winding output voltage will be in direct proportion to the AC frequency. For example, on units rated 120/240 volts at 60 Hz, the regulator will try to maintain 240 volts (line-to-line) at 60 Hz. This type of regulation system provides greatly improved motor starting capability over other types of systems.

SECTION 2.3 TROUBLESHOOTING FLOW CHARTS

Use the "Flow Charts" in conjunction with the detailed instructions in Section 2.4. Test numbers used in the flow charts correspond to the numbered tests in Section 2.4.

The first step in using the flow charts is to correctly identify the problem. Once that has been done, locate the problem on the following pages. For best results, perform all tests in the exact sequence shown in the flow charts.

Problem 1 - Generator Produces Zero Voltage or Residual Voltage

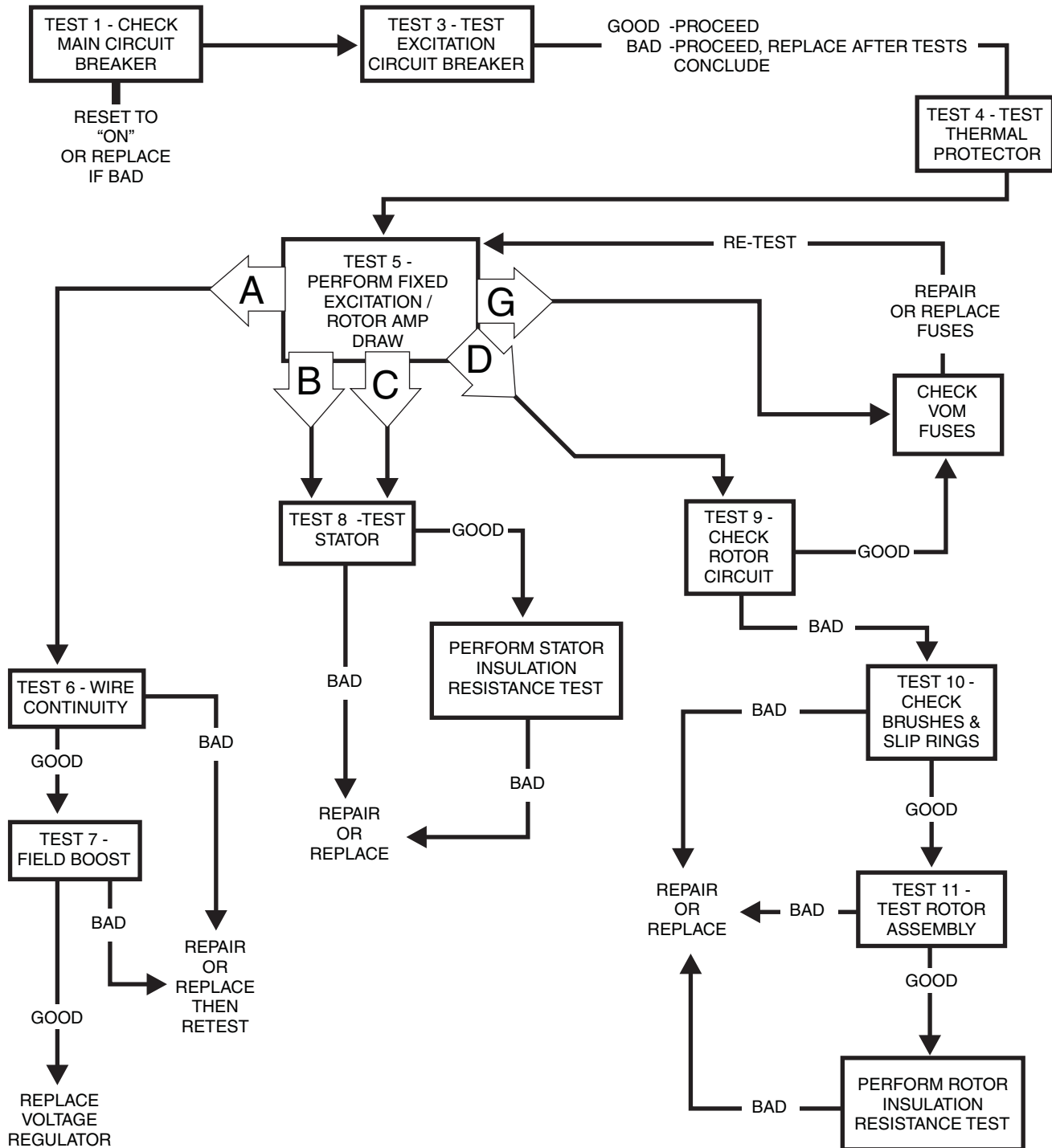

**Problem 1 - Generator Produces Zero Voltage or Residual Voltage
(Continued)**

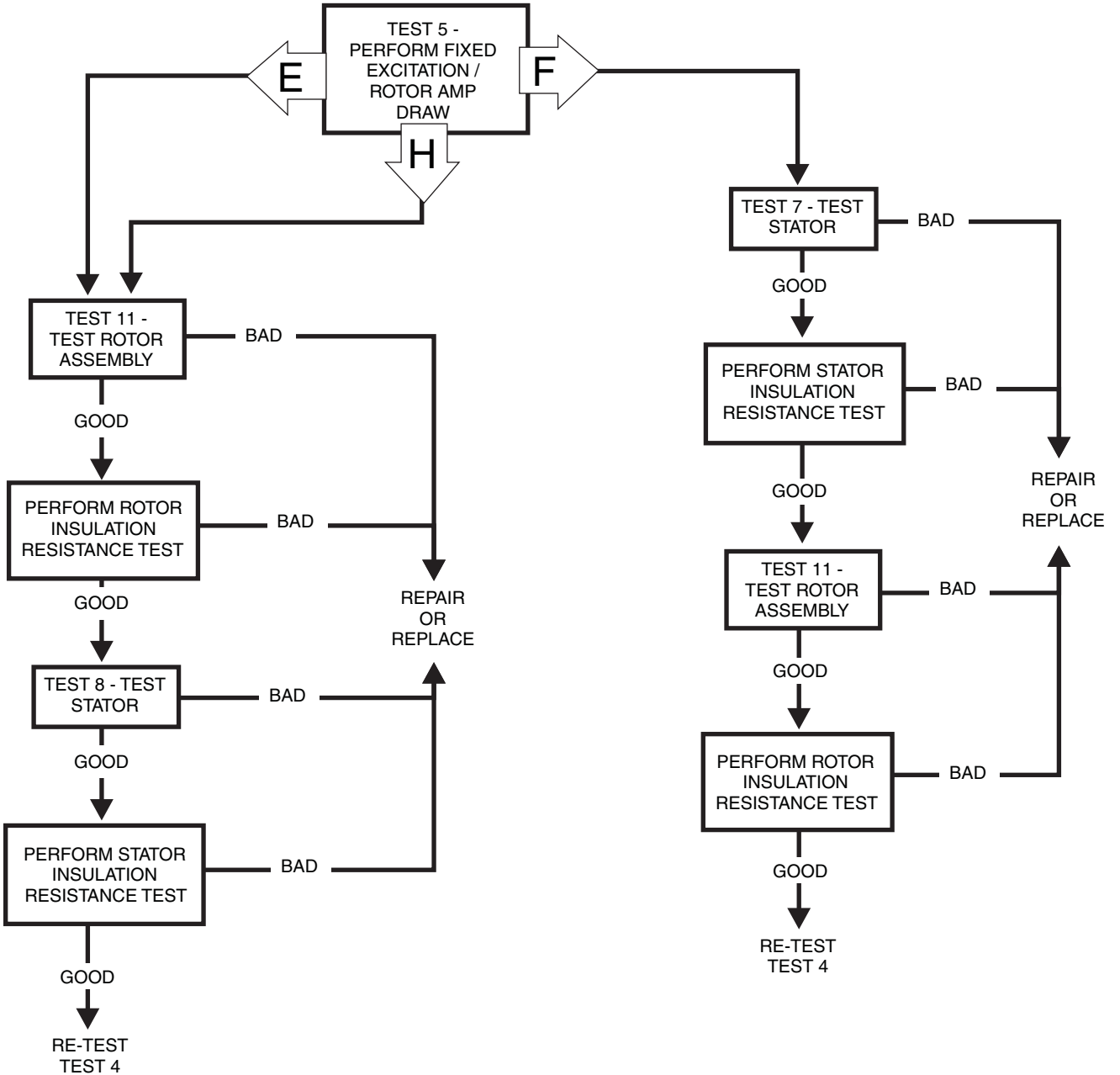

SECTION 2.3
TROUBLESHOOTING FLOW CHARTS

Problem 2 - Generator Produces Low Voltage at No-Load

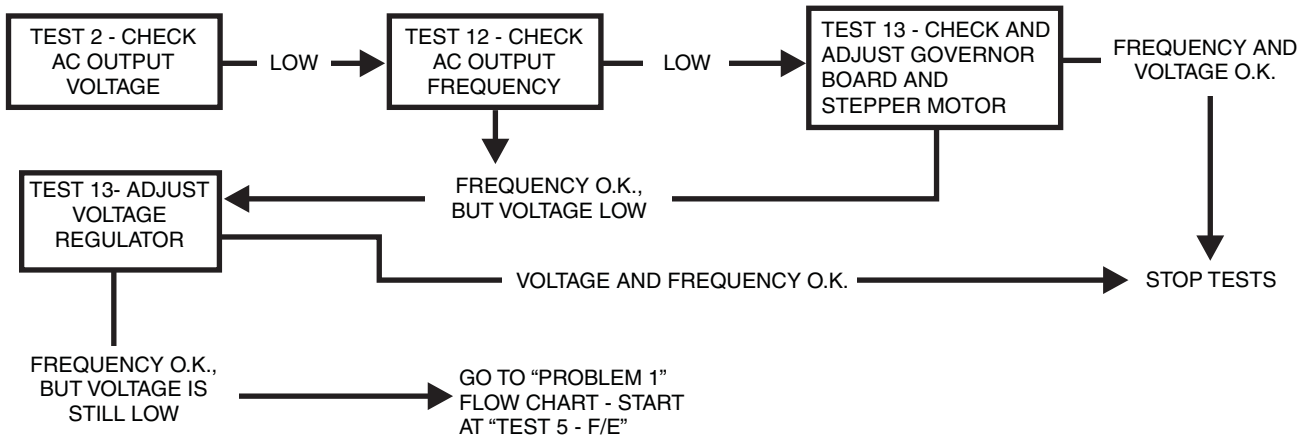

Problem 3 - Generator Produces High Voltage at No-Load

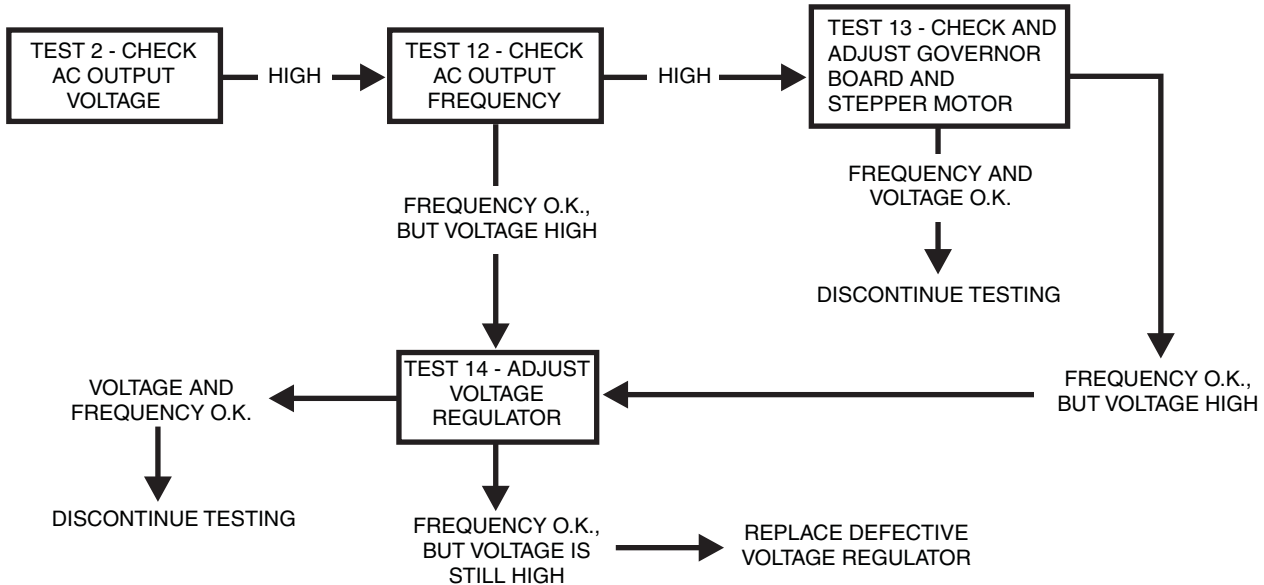

Problem 4 - Voltage and Frequency Drop Excessively When Loads Are Applied

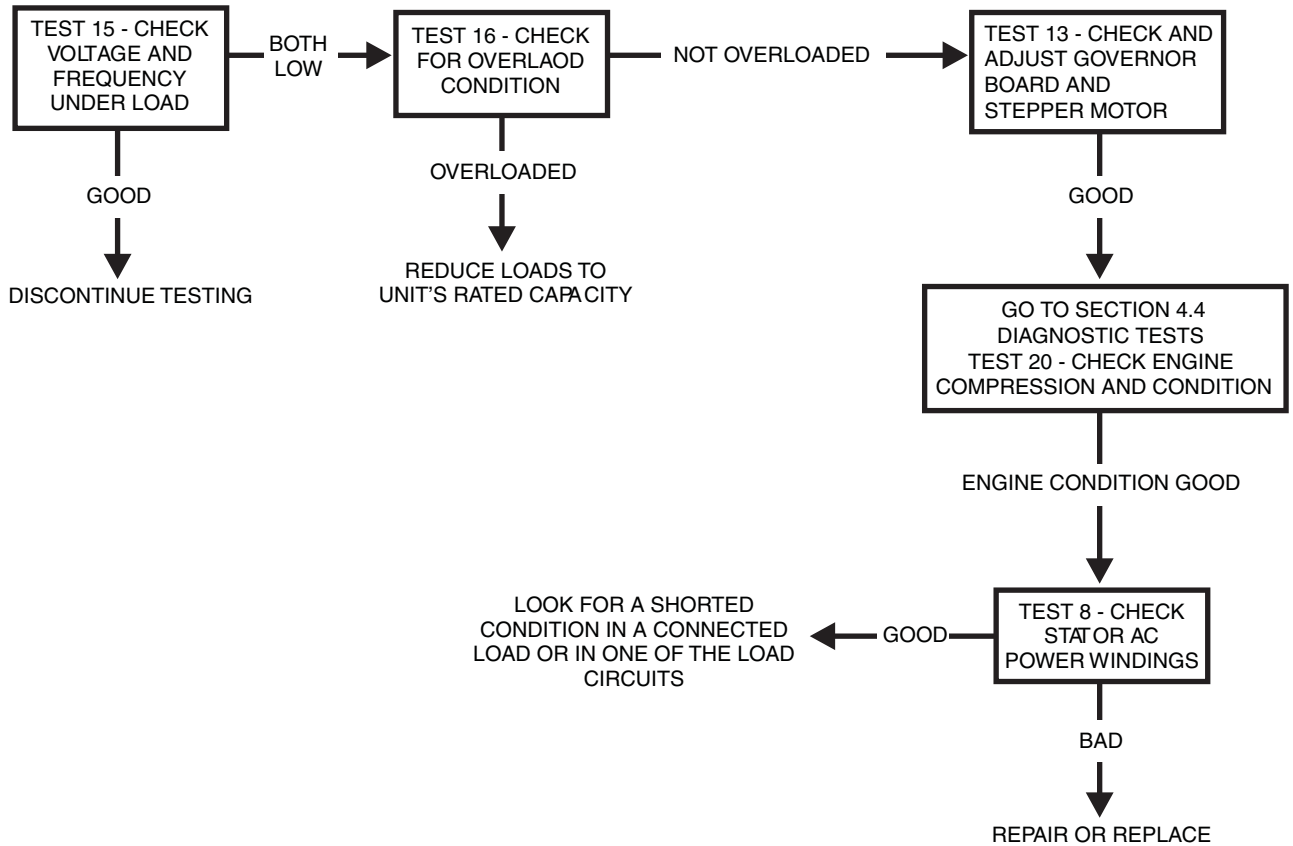

INTRODUCTION

This section is provided to familiarize the service technician with acceptable procedures for the testing and evaluation of various problems that could be encountered on prepackaged standby generators with liquid-cooled engines. Use this section of the manual in conjunction with Section 2.3, "Troubleshooting Flow Charts". The numbered tests in this section correspond with those of Section 2.3.

Test procedures in this section do not require the use of specialized test equipment, meters or tools. Most tests can be performed with an inexpensive volt-ohm-milliammeter (VOM). An AC frequency meter is required, where frequency readings must be taken. A clamp-on ammeter may be used to measure AC loads on the generator.

Testing and troubleshooting methods covered in this section are not exhaustive. We have not attempted to discuss, evaluate and advise the home standby service trade of all conceivable ways in which service and trouble diagnosis might be performed. We have not undertaken any such broad evaluation. Accordingly, anyone who uses a test method not recommended herein must first satisfy himself that the procedure or method he has selected will jeopardize neither his nor the product's safety.

SAFETY

Service personnel who work on this equipment must be made aware of the dangers of such equipment. Extremely high and dangerous voltages are present that can kill or cause serious injury. Gaseous fuels are highly explosive and can be ignited by the slightest spark. Engine exhaust gases contain deadly carbon monoxide gas that can cause unconsciousness or even death. Contact with moving parts can cause serious injury. The list of hazards is seemingly endless.

When working on this equipment, use common sense and remain alert at all times. Never work on this equipment while you are physically or mentally fatigued. If you don't understand a component, device or system, do not work on it.

TEST 1- CHECK MAIN CIRCUIT BREAKER

DISCUSSION:

Often the most obvious cause of a problem is overlooked. If the generator main line circuit breaker is set to OFF or "Open", no electrical power will be supplied to electrical loads. If loads are not receiving power, perhaps the main circuit breaker is open or has failed.

PROCEDURE:

The generator main circuit breaker is located on the control panel. If loads are not receiving power, make sure the breaker is set to ON or "Closed".

If you suspect the breaker may have failed, it can be tested as follows (see Figure 1):

1. Set a volt-ohm-milliammeter (VOM) to its "R x 1" scale and zero the meter.
2. With the generator shut down, disconnect all wires from the main circuit breaker terminals, to prevent interaction.
3. With the generator shut down, connect one VOM test probe to the Wire 11 terminal of the breaker and the other test probe to the Wire E1 terminal.
4. Set the breaker to its ON or "Closed" position. The VOM should read CONTINUITY.
5. Set the breaker to its OFF or "Open" position and the VOM should indicate INFINITY.
6. Repeat Steps 4 and 5 with the VOM test probes connected across the breaker's Wire 44 terminal and the E2 terminal.

RESULTS:

1. If the circuit breaker tests good, go on to Test 2.
2. If the breaker tests bad, it should be replaced.

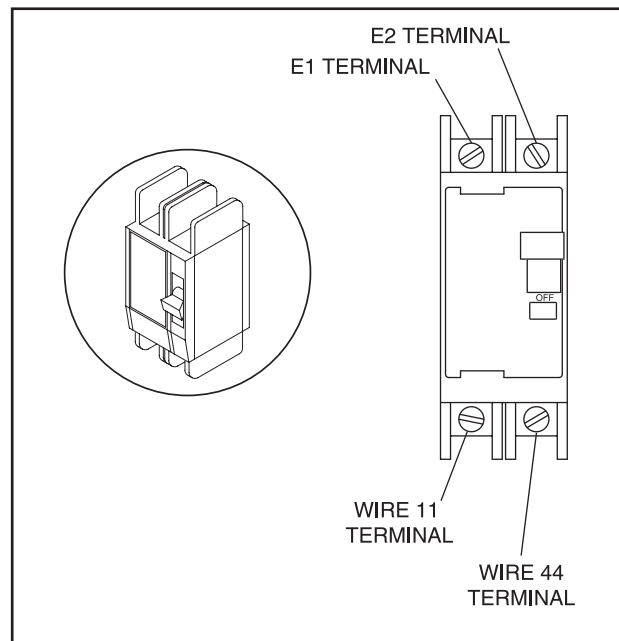

Figure 1. Generator Main Circuit Breaker Test Points

TEST 2- CHECK AC OUTPUT VOLTAGE**DISCUSSION:**

A volt-ohm-milliammeter (VOM) may be used to check the generator output voltage. Output voltage may be checked at the unit's main circuit breaker terminals. Refer to the unit's DATA PLATE for rated line-to-line and line-to-neutral voltages.



DANGER: USE EXTREME CAUTION DURING THIS TEST. THE GENERATOR WILL BE RUNNING. HIGH AND DANGEROUS VOLTAGES WILL BE PRESENT AT THE TEST TERMINALS. CONNECT METER TEST CLAMPS TO THE HIGH VOLTAGE TERMINALS WHILE THE GENERATOR IS SHUT DOWN. STAY CLEAR OF POWER TERMINALS DURING THE TEST. MAKE SURE METER CLAMPS ARE SECURELY ATTACHED AND WILL NOT SHAKE LOOSE.

PROCEDURE:

1. With the engine shut down, connect the AC voltmeter test leads across the Wires 11 and 44 terminals of the generator main circuit breaker (see Figure 1). These connections will permit line-to-line voltages to be read.
2. Set the generator main circuit breaker to its OFF or "Open" position. This test will be conducted with the generator running at no-load.
3. Start the generator, let it stabilize and warm up for a minute or two.
4. Take the meter reading. On unit's having a rated line-to-line voltage of 240 volts, the no-load voltage should be about 242-252 volts AC.
5. Shut the engine down and remove the meter test leads.

RESULTS:

1. If zero volts or residual voltage is indicated, go on to Test 3.
2. If the voltage reading is higher than residual, but is lower than the stated limits, go to Test 11.
3. If a high voltage is indicated, go on to Test 11.

NOTE: "Residual" voltage may be defined as the voltage that is produced by rotor residual magnetism alone. The amount of voltage induced into the stator AC power windings by residual voltage alone will be approximately 2 to 16 volts AC, depending on the characteristics of the specific

generator. If a unit is supplying residual voltage only, either excitation current is not reaching the rotor or the rotor windings are open and the excitation current cannot pass. On current units with liquid-cooled engine, "field boost" current flow is available to the rotor only during engine cranking.

TEST 3- TEST EXCITATION CIRCUIT BREAKER**DISCUSSION:**

Unregulated excitation current is delivered to the voltage regulator from the stator excitation (DPE) winding, via Wire 2, an excitation circuit breaker (CB2), Wire 162, and Wire 6. If the excitation circuit breaker has failed open, excitation current will not be available to the voltage regulator or to the rotor. Stator AC power winding output will then be reduced to a voltage that is the product of residual magnetism alone.

PROCEDURE:

1. With the generator shut down for at least two minutes, locate the excitation circuit breaker in the generator panel. Disconnect wires from the breaker, to prevent interaction.
2. Set a volt-ohm-milliammeter (VOM) to its "R x 1" scale and zero the meter.
3. Connect the VOM test probes across the circuit breaker terminals. The meter should read CONTINUITY.

RESULTS:

1. Replace circuit breaker if defective (meter reads "OPEN"). Then proceed to Test 4.
2. If circuit breaker is good, go on to Test 4.

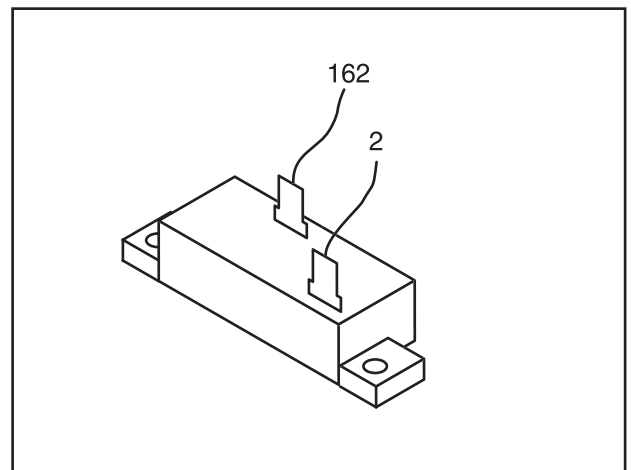

Figure 2. Excitartion Circuit Breaker

TEST 4 - TEST THERMAL PROTECTOR

DISCUSSION:

An open thermal protector will result in loss of excitation. Generator AC output voltage will then drop to a residual voltage.

PROCEDURE:

1. Locate DPE Wire No. 2 where it connects to the excitation circuit breaker. Disconnect the wire from the circuit breaker.
2. Disconnect DPE Wire No. 6 from the voltage regulator.
3. Set a VOM to its "Rx1" scale and zero the meter.
4. Connect the VOM test leads across Wires No. 2 and 6. The meter should indicate the resistance of the stator excitation (DPE) winding.
5. If the meter indicated INFINITY in Step 4, connect the VOM test leads across Wire No. 5 (bypass wire) and Wire No. 6. The meter should indicate the resistance of the stator excitation (DPE) winding.

NOTE: Normal DPE Winding Resistance across Wires No. 2 & 6 is:

15 kW	0.635 ohms.
20 kW	0.056 ohms.
25 kW	0.041 ohms.

RESULTS:

1. If normal DPE winding resistance was indicated in Step 5, but INFINITY is indicated in Step 4, bypass the thermal protector by connecting Wire No. 5 to the excitation circuit breaker (CB1). See Figure 2.
2. If normal resistance is indicated in Step 4, go to Test 5.

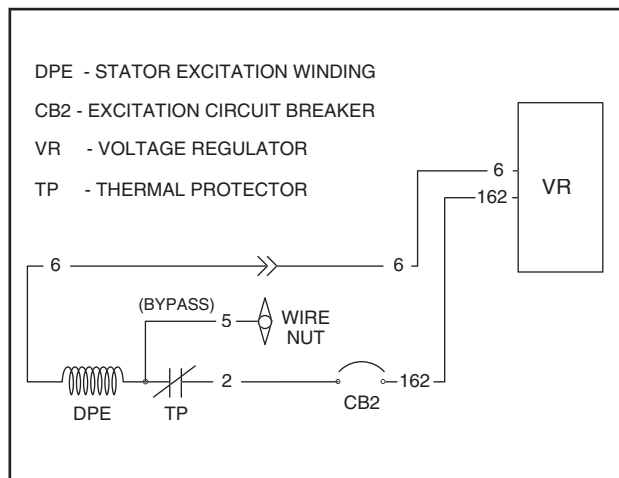

Figure 2. Bypassing the Thermal Protector

TEST 5 - FIXED EXCITATION TEST / ROTOR AMP DRAW TEST

DISCUSSION:

Supplying a fixed DC current to the rotor will induce a magnetic field in the rotor. With the generator running, this should create a proportional voltage output from the stator windings.

PROCEDURE:

1. Disconnect Wire 4 from the voltage regulator, third terminal from the top. See Figure 3.
2. Connect a jumper wire to the disconnected Wire 4 and to the 12 volt fused battery supply Wire 15. (located at 15A fuse).

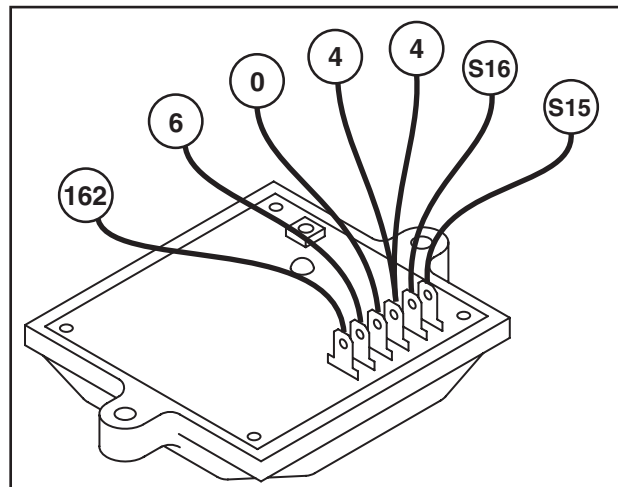

Figure 3. Voltage Regulator

3. Set VOM to AC volts.
4. Disconnect Wire 2 from the excitation circuit breaker (CB2) and connect one meter test lead to that wire. Disconnect Wire 6 from the voltage regulator and connect the other meter test lead to that wire. (5th terminal from top, double check wire number).
5. Set the AUTO-OFF-MANUAL switch to MANUAL. Once the engine starts, record the AC voltage.
6. Set the AUTO-OFF-MANUAL switch to OFF. Reconnect Wire 2 and Wire 6.
7. Disconnect Wire S15 from the voltage regulator and connect one meter test lead to that wire. Disconnect Wire S16 from the voltage regulator and connect the other meter test lead to that wire (both wires are located at the top two terminals of the voltage regulator, see Figure 3).

TEST 5 RESULTS - FIXED EXCITATION TEST/ROTOR AMP DRAW TEST

Results:		A	B	C	D	E	F	G	H
Voltage Results Wire 2 & 6		Above 60 VAC	Above 60 VAC	Below 60 VAC	Zero or Residual Volts	Below 60 VAC	Below 60 VAC	Above 60 VAC	Below 60 VAC
Voltage Results Wire S15 & S16		Above 60 VAC	Below 60 VAC	Above 60 VAC	Zero or Residual Volts	Below 60 VAC	Below 60 VAC	Above 60 VAC	Below 60 VAC
Static Rotor Amp Draw	15kW	2.2A	2.2A	2.2A	Zero	Above 2.2A	2.2A	Zero	2.2A
	20kW	1.5A	1.5A	1.5A	Current	Above 1.5A	1.5A	Zero	1.5A
	25kW	1.3A	1.3A	1.3A	Draw	Above 1.3A	1.3A	Zero	1.3A
Running Rotor Amp Draw	15kW	2.2A	2.2A	2.2A	Zero	Above 2.2A	2.2A	Zero	2.2A
	20kW	1.5A	1.5A	1.5A	Current	Above 1.5A	1.5A	Zero	1.5A
	25kW	1.3A	1.3A	1.3A	Draw	Above 1.3A	1.3A	Zero	1.3A

← MATCH RESULTS WITH LETTER AND REFER TO FLOW CHART IN SECTION 2.3 "Problem 1" →

8. Set the AUTO-OFF-MANUAL switch to MANUAL. Once the engine starts, record the AC voltage.
9. Set the AUTO-OFF-MANUAL switch to OFF. Reconnect Wire S15 and Wire S16.
10. Set VOM to DC amperage.
11. Remove jumper lead connected to Wire 4 and Wire 15.
12. Connect one meter test lead to battery positive twelve-volt supply Wire 15, located at the 15A fuse. Connect the other meter test lead to Wire 4 (still disconnected from previous tests). Measure and record static rotor amp draw.
13. Set the AUTO-OFF-MANUAL switch to the MANUAL position. Once the engine starts, repeat step 12. Measure and record running rotor amp draw with the engine running.
14. Set the AUTO-OFF-MANUAL switch to OFF. Reconnect Wire 4 to the voltage regulator.

RESULTS:

Refer to Chart above : "Test 5 Results - Fixed Excitation Test/Rotor Amp Draw Test."

TEST 6 - WIRE CONTINUITY**DISCUSSION:**

The voltage regulator receives unregulated alternating current from the stator excitation winding, via Wires 2, 6, and 162. It also receives voltage sensing from the stator AC power windings, via Wires S15 and S16. The regulator rectifies the AC from the excitation winding and based on the sensing signals, regulates the DC current flow to the rotor. The rectified and regulated current flow is delivered to the rotor brushes via Wires 4 (positive) and 0 (negative). This test will verify the integrity of Wires 0 and 162.

PROCEDURE:

1. Set VOM to its "R x 1" scale.
2. Remove Wire 0 from the voltage regulator, 4th terminal from the top. Also voltage regulator is labeled (-) next to terminal.
3. Connect one test lead to Wire 0, connect the other test lead to a clean frame ground. The meter should read CONTINUITY.
4. Disconnect Wire 162 from the voltage regulator, 6th terminal from the top. Disconnect the other end of Wire 162 from the excitation circuit breaker. Connect one test lead to one end of Wire 162, and the other test lead to the other end of Wire 162. The meter should read CONTINUITY.

RESULTS:

If CONTINUITY was not measured across each wire, repair or replace the wires as needed.

TEST 7 - CHECK FIELD BOOST**DISCUSSION:**

See "Field Boost Circuit" in Section 2.2. Field boost current (from the circuit board) is available to the rotor only while the engine is cranking. Loss of field boost output to the rotor may or may not affect power winding AC output voltage. The following facts apply:

- A small amount of voltage must be induced into the DPE winding to turn the voltage regulator on.
- If rotor residual magnetism is sufficient to induce a voltage into the DPE winding that is high enough to turn the voltage regulator on, regulator excitation current will be supplied even if field boost has failed. Normal AC output voltage will then be supplied.
- If rotor residual magnetism has been lost or is not sufficient to turn the regulator on, and field boost has also been lost, excitation current will not be supplied to the rotor. Generator AC output voltage will then drop to zero or nearly zero.

SECTION 2.4 DIAGNOSTIC TESTS

PART 2

PREPACKAGED LIQUID
COOLED AC GENERATORS

PROCEDURE:

1. Locate Wire 4 that is routed from the circuit board and connects to the voltage regulator terminal, third from the top (see Figure 3). Disconnect that wire from the voltage regulator terminal.
2. Set a VOM to read DC volts.
3. Connect the positive (+) VOM test probe to the terminal end of disconnected Wire 4.
4. Connect the common (-) VOM test probe to the grounding lug.
5. Crank the engine while observing the VOM reading. While the engine is cranking, the VOM should read approximately 3-4 volts DC. When engine is not cranking, VOM should indicate "zero" volts (see Figure 4).

RESULTS:

1. If normal field boost voltage is indicated in Step 5, replace the voltage regulator.
2. If normal field boost voltage is NOT indicated in Step 5, check Wire 4 (between regulator and circuit board) for open or shorted condition. If wire is good, replace the circuit board.

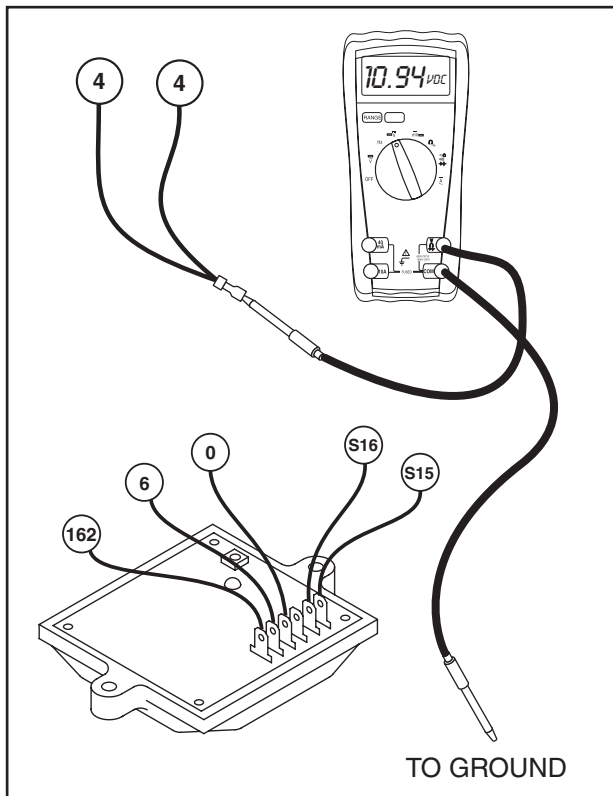

Figure 4. Field Boost Test Points

TEST 8 - TESTING THE STATOR WITH A VOM

DISCUSSION:

A Volt-OHM-Milliammeter (VOM) can be used to test the stator windings for the following faults:

- An open circuit condition
- A "short-to-ground" condition
- A short circuit between windings

Note: The resistance of stator windings is very low. Some meters will not read such a low resistance, and will simply indicate CONTINUITY. Recommended is a high quality, digital type meter capable of reading very low resistances.

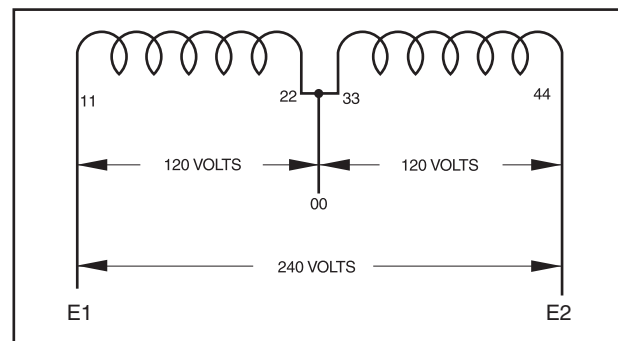

Figure 5. Typical 1-Phase Stator Windings

PROCEDURE:

1. Testing 1-Phase Stators (Figure 5)
 - a. Disconnect Stator Leads 11 and 44 from the generator main circuit breaker terminals.
 - b. Disconnect Stator Leads 22 and 33 from the neutral block (00).
 - c. Complete a resistance test across Stator Leads 11 and 22. The resistance of a single winding should be indicated.
 - d. Test for resistance across Stator Leads 33 and 44. Again, the resistance of that winding should be indicated.

Stator Power Winding Resistance Across Wires No. 11 & 22 and No. 33 & 44 should be:

15 kW	0.063 ohms.
20 kW	0.056 ohms.
25 kW	0.041 ohms.

- e. Set the meter to a high resistance scale. Then, test for a shorted condition as follows:
 - (1) Connect one test probe to stator lead 11, the other test probe to a clean frame ground on the stator can. The meter should read INFINITY.
 - (2) Connect one meter test probe to stator lead 33 and the other to frame ground. The meter should read INFINITY.

f. With the meter still set to a. high resistance scale, check for a shorted condition between parallel windings as follows:

- (1) Connect one meter test probe to stator lead 11.
- (2) Connect the second meter test probe to stator lead 33. The meter should read INFINITY.

NOTE: Read section 1.5, "Testing, Cleaning and Drying" carefully. If the winding tests good, perform an insulation resistance test. If the winding fails the insulation resistance test, clean and dry the stator as outlined in Section 1.5. Then, repeat the insulation resistance test. If the winding fails the second resistance test (after cleaning and drying), replace the stator assembly.

TEST 9 - RESISTANCE CHECK OF ROTOR CIRCUIT

DISCUSSION:

To verify the zero current draw reading and measure the rotor circuit.

PROCEDURE:

1. Disconnect Wire 4 from the voltage regulator. It is located third terminal from the top of the volt regulator.
2. Set VOM to the "Rx1" scale.
3. Connect one test lead to Wire 4. Connect the other test lead to a clean frame ground. Note the resistance reading.

15 kW 5.8 ohms.

20 kW 8.7 ohms.

25 kW 10 ohms.

RESULTS:

1. If the resistance reading is correct, check your VOM meters fuse and repeat Test 4.
2. If INFINITY is measured on your VOM meter, go to Test 10.

TEST 10 - CHECK BRUSHES AND SLIP RINGS

DISCUSSION:

The function of the brushes and slip rings is to provide for passage of excitation current from stationary components to the rotating rotor. Brushes are made of a special long lasting material and seldom wear out or fail. However, slip rings can develop a tarnish or film that can inhibit or offer a resistance to the flow of electricity. Such a non-conducting film usually develops during non-operating periods. Broken or disconnected wiring can also cause loss of excitation cur-

rent to the rotor.

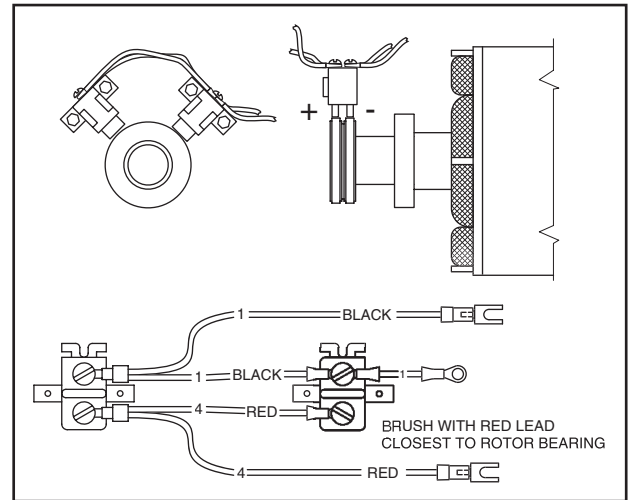

Figure 6. Brushes and Slip Rings

PROCEDURE:

1. Remove the brush holders from the rear bearing carrier. Visually inspect the brushes for cracks, chipping, or other damage. Replace brushes in pairs, if necessary.
2. If the slip rings appear dull or tarnished, they may be cleaned with fine sandpaper. DO NOT USE ANY METALLIC GRIT TO CLEAN SLIP RINGS. After polishing the slip rings, use low pressure air to blow away any sandpaper residue.
3. Test unit operation.

RESULTS:

1. Repair, replace or reconnect wires as necessary.
2. Replace any damaged slip rings or brush holder.
3. Clean and polish slip rings as required.

TEST 11 - TEST ROTOR ASSEMBLY

DISCUSSION:

A rotor having completely open windings will cause loss of excitation current flow and, as a result, generator AC output voltage will drop to "residual" voltage. A "shorted" rotor winding can result in a low voltage condition.

PROCEDURE:

1. Disconnect the brush wires or remove the brush holder, to prevent interaction.
2. Set a VOM to its "R x 1" scale and zero the meter.

3. Connect the positive (+) VOM test lead to the positive (+) rotor slip ring (nearest the rotor bearing); and the common (-) test lead to the negative (-) slip ring. The meter should read (approximately) as follows:

15 kW	5.8 ohms.
20 kW	8.7 ohms.
25 kW	10 ohms.

4. Now, set the VOM to a high resistance scale (such as "R x 10,000" or "R x 1K"). Again, zero the meter.
5. Connect the positive (+) VOM test lead to the positive (+) slip ring and the common (-) test lead to a clean frame ground. The meter should indicate INFINITY.

RESULTS:

1. Replace rotor assembly if it is open or shorted.
2. If rotor tests good, perform "Insulation Resistance Test" in Section 1.4.

NOTE: Be sure to read Section 1.5, "Testing, Cleaning and Drying", carefully. If the rotor tests good, try performing an insulation resistance test. Clean and dry the rotor if it fails that test. Then, repeat the test. If the rotor fails the second insulation resistance test, it should be replaced.

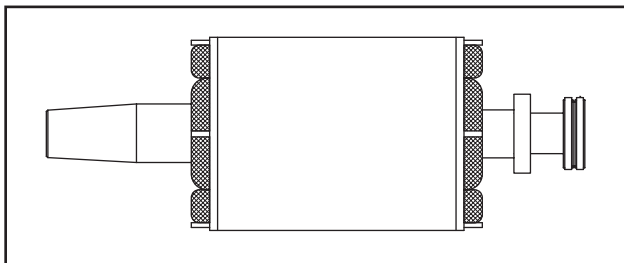

Figure 8. The Rotor Assembly

TEST 12 - CHECK AC OUTPUT FREQUENCY

DISCUSSION:

The generator AC frequency is proportional to the operating speed of the rotor. A 4-pole rotor (having two north and two south magnetic poles) will supply a 60 Hertz AC frequency at 1800 rpm. A 2-pole rotor will supply a 60 Hertz AC frequency at 3600 rpm. The unit's AC output voltage is proportional to the AC frequency. For example, a unit rated 240 volts (line-to-line) will supply that rated voltage (plus or minus 2 percent) at a frequency of 60 Hertz. If, for any reason, the frequency should drop to 30 Hertz, the line-to-line voltage will drop to a matching voltage of 120 volts AC. Thus, if the AC voltage output is high or low and the AC frequency is correspondingly high or low, the engine speed governor may require adjustment.

PROCEDURE:

1. Connect an accurate AC frequency meter across the Wires 11 and 44 terminals of the generator main line circuit breaker (see Figure 1, Section 2.4).
2. Start the engine, let it stabilize and warm up at no-load.
3. When engine has stabilized, read the frequency meter. The no-load frequency should be about 61-63 Hertz.

RESULTS:

1. If the AC frequency is high or low, go on to Test 13.
2. If frequency is good, but voltage is high or low, go to Test 14.
3. If frequency and voltage are both good, tests may be discontinued.

TEST 13 - CHECK AND ADJUST GOVERNOR BOARD AND STEPPER MOTOR

DISCUSSION:

The generator is equipped with a "voltage over frequency" type AC voltage regulator. The units AC output voltage is generally proportional to AC frequency. A low or high governor speed will result in a correspondingly low or high AC frequency and voltage output. The governed speed must be adjusted before any attempt to adjust the voltage regulator is made.

Troubleshooting the stepper motor governor system is generally limited to checking inputs to the control module, adjustments, settings, electrical connections, and testing the stepper motor windings.

NOTE: A fuel supply problem can sometimes be mistaken for a speed control problem. Verify whether a problem is fuel related before attempting to readjust the governor pot / switch settings.

The following is a list of possible problems and tests to perform, followed by descriptions of the tests.

PROBLEM:

- Overspeeding

TEST PROCEDURES:

Check the frequency switch setting, TEST 13A, TEST 13B, TEST 13C, TEST 13D.

PROBLEM:

- Instability, erratic operation

TEST PROCEDURES:

Adjust linkage and check for binding, adjust control module pots, TEST 13C, TEST 13D.

PROBLEM:

- Low speed, no fuel

TEST PROCEDURES:

TEST 13A, TEST 13B, TEST 13C, TEST 13D, check position of the frequency switch.

TEST 13A**(Check DC Voltage Supply to Control Module)**

If the control module loses the 12 volt DC input, it will no longer be able to control or move the stepper motor. If this happens while the unit is under a load, an "overspeed" condition could occur as soon as the load is removed. The stepper motor could remain in a position supplying too much fuel for the "no load" condition.

TEST 13B**(Check AC Frequency Input to Control Module)**

Similar to the control module losing its DC input, the control module will no longer be able to control the stepper motor if the frequency sensing input is lost. The stepper motor's inability to move or react properly could result in an "overspeed" condition.

To check frequency sensing input, run unit while manually controlling speed at a safe level. Ensure that the unit is providing AC output.

Check the condition of the wires and connections on "blue" sensing leads between the main circuit breaker and the control module.

TEST 13C**(Check connections between Control Module and Stepper Motor)**

There are two "Plug-In" connectors housed inside the connection boxes in the harness between the control module and the stepper motor. Remove the covers from the boxes and carefully inspect the connections.

TEST 13D**(Test Stepper Motor)**

A defective stepper motor can cause overspeed, low speed, or no-start, hard start or erratic operation.

NOTE: It is difficult to perform an operational test on the Stepper Motor since the control voltages vary, and motor rotational movement is so small.

If a defective stepper motor is suspected, the windings can be tested for resistance, open circuits, and shorts to ground. (See Figure 9) for schematic and resistance values. Any other readings other than those which are indicated, including continuity to ground, indicates a faulty stepper motor.

CONTROL MODULE

A detailed adjustment procedure for the Control Module begins on Page 99.

If problems still persist after all the previous tests and adjustments have been completed, it is recommended to then replace the Control Module and adjust as necessary

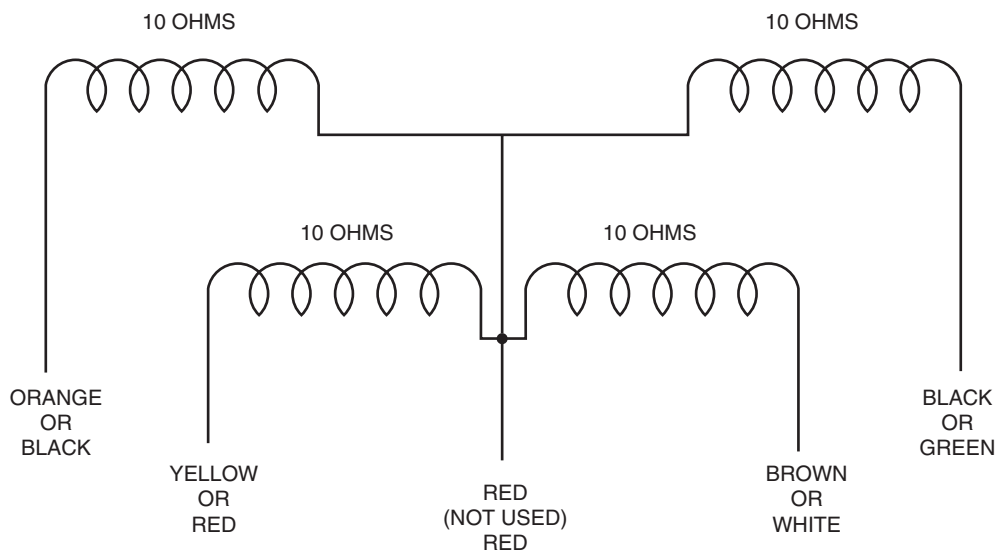

* Measure resistance across any combination of orange, yellow, brown, or black should read approximately 20 OHMS.

* Measure from red to any other lead should read 10 OHMS.

* Testing from any lead to stepper motor case should read INFINITY.

Figure 9. Schematic and Resistance Values

**TEST 14 - CHECK AND ADJUST
VOLTAGE REGULATOR**

DISCUSSION:

For additional information, refer to description and components Section 2.1.

PROCEDURE:

With the frequency between 59.5-60.5 Hertz, slowly turn the slotted potentiometer (Figure 10) until line voltage reads 238-242 volts.

NOTE: You must remove the access panel on top of the control panel to adjust the voltage regulator.

NOTE: The voltage regulator is housed above the generator control panel. The regulator maintains a voltage in direct proportion to frequency at a 2-to-1 ratio. For example, at 62 Hertz, line-to-neutral voltage will be 124 volts.

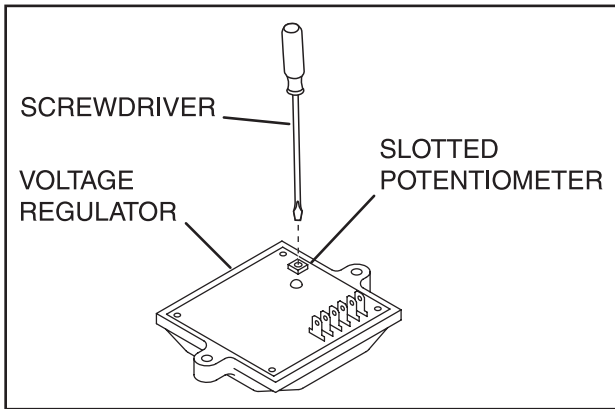

Figure 10. Voltage Adjustment Potentiometer

RESULTS:

1. If the frequency and voltage are now good, discontinue tests.
2. If frequency is now good but voltage is high or low, go to Problem 1, Test 5.

**TEST 15 - CHECK VOLTAGE AND
FREQUENCY UNDER LOAD**

DISCUSSION:

It is possible for the generator AC output frequency and voltage to be good at no-load, but they may drop excessively when electrical loads are applied. This condition, in which voltage and frequency drop excessively when loads are applied, can be caused by (a) overloading the generator, (b) loss of engine power, or (c) a shorted condition in the stator windings or in one or more connected loads.

PROCEDURE:

1. Connect an accurate AC frequency meter and an AC voltmeter across the stator AC power winding leads.
2. Start the engine, let it stabilize and warm-up.
3. Apply electrical loads to the generator equal to the rated capacity of the unit.
4. Check the AC frequency and voltage. Frequency should not drop below approximately 59 Hertz. Voltage should not drop below about 230 volts (plus or minus 2 per cent).

RESULTS:

1. If frequency and voltage drop excessively under load, go to Test 16.
2. If frequency and voltage under load are good, discontinue tests.

**TEST 16 - CHECK FOR OVERLOAD
CONDITION**

DISCUSSION:

An "overload" condition is one in which the generator rated wattage/ampere capacity has been exceeded. To test for an overload condition on an installed unit, the best method is to use an ammeter. See "Measuring Current" in Section 1.4.

PROCEDURE:

Use a clamp-on ammeter to measure load current draw, with the generator running and all normal electrical loads turned on.

RESULTS:

1. If the unit is overloaded, reduce loads to the unit's rated capacity.
2. If unit is not overloaded, but rpm and frequency drop excessively when loads are applied, go to Test 17.

TEST 17 - CHECK ENGINE CONDITION

DISCUSSION:

If engine speed and frequency drop excessively under load, the engine may be under-powered. An under-powered engine can be the result of a dirty air cleaner, loss of engine compression, faulty carburetor settings, incorrect ignition timing, etc.

PROCEDURE:

For engine testing, troubleshooting and repair procedures refer to following manual:

- P/N 0C1947 - Service Manual 1.5 Liter Gas Engine

PART 3 “V-TYPE” PREPACKAGED TRANSFER SWITCHES

1.5 LITER PREPACKAGED HOME STANDBY GENERATORS

TEST	DESCRIPTION	PAGE
1	Check Voltage at Terminal Lugs E1, E2	50
2	Check Voltage at Standby Closing Coil C2	50
3	Test Transfer Relay TR	51
4	Check Manual Transfer Switch Operation	51
5	Test Limit Switch XB1	52
6	Check Wiring and Wiring Connections	53

TEST	DESCRIPTION	PAGE
7	Check Voltage at Terminal Lugs N1, N2	53
8	Check Voltage at Utility 1 and Utility 2 Terminals	53
9	Check Voltage at Utility Closing coil C1	54
10	Check Fuses F1 and F2	54
11	Test Limit Switch XA1	55

TABLE OF CONTENTS		
PART	TITLE	PAGE
3.1	Description and Components	40
3.2	Operational Analysis	44
3.3	Troubleshooting Flow Charts	48
	Problem 1 - In Automatic Mode, No Transfer to Standby	48
	Problem 2 - In Automatic Mode, No Transfer Back to Utility	49
	Problem 3 - In Automatic Mode, Generator Starts and Transfer to Standby Occurs When Utility Source Voltage is Available	49
3.4	Diagnostic Tests	50

GENERAL

The prepackaged, "V-Type" transfer switch is rated 100 amps at 250 volts maximum. It is available in 2-pole configuration only and, for that reason, is useable with 1-phase systems only.

Prepackaged transfer switches do not have an intelligence system of their own. Instead, automatic operation of these transfer switches is controlled by a control board housed in the generator control panel.

In a typical installation, both the utility and standby power source conductors are connected to the transfer switch, as well as load lines. See Part 1, Section 1.2 for prepackaged interconnections.

TRANSFER SWITCH MAJOR COMPONENTS

Figure 1, below, shows the transfer switch components. Major components include the following:

ENCLOSURE

The standard prepackaged, V-Type transfer switch enclosure is a NEMA 3R type ("NEMA" stands for "National Electrical Manufacturer's Association"). Based on NEMA Standards, the NEMA 3R enclosure may be defined as one that is intended for outdoor use primarily to provide a degree of protection against contact with the enclosed equipment and where unusual service conditions do not exist.

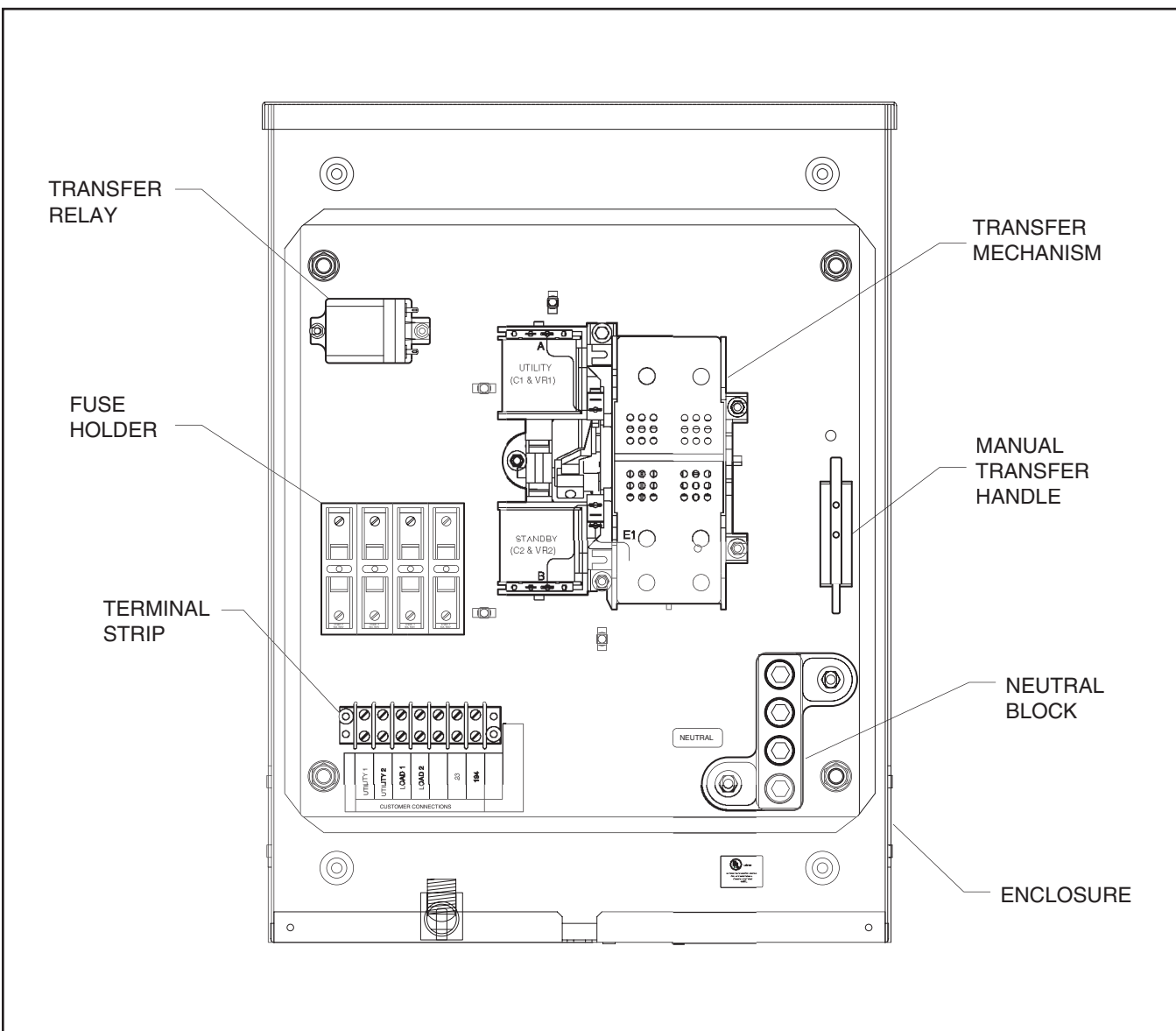

Figure 1. Exploded View of V-Type Prepackaged Transfer Switch

TRANSFER MECHANISM

The 2-pole transfer mechanism consists of a pair of moveable LOAD contacts, a pair of stationary UTILITY contacts, and a pair of stationary STANDBY contacts. The LOAD contacts can be connected to the UTILITY contacts by a utility closing coil; or to the STANDBY contacts by a standby closing coil. In addition, the LOAD contacts can be actuated to either the UTILITY or STANDBY side by means of a manual transfer handle. See Figures 2 and 3.

UTILITY CLOSING COIL C1:

See Figure 4. This coil is energized by rectified utility source power, to actuate the load contacts to the "Utility" power source side. When energized, the coil will move the main contacts to an "overcenter" position. A limit switch will then be actuated to open the circuit and spring force will complete the retransfer to "Standby". A bridge rectifier, which changes the utility source alternating current (AC) to direct current (DC), is sealed in the coil wrappings. If coil or bridge rectifier replacement becomes necessary, the entire coil and bridge assembly should be replaced.

STANDBY CLOSING COIL C2:

Coil C2 is energized by rectified standby source power, to actuate the load contacts to their "Standby" source side. Energizing the coil moves the load contacts to an overcenter position; limit switch action then opens the circuit and spring force will complete the transfer action to "Standby". This coil's bridge rectifier is also sealed in the coil wrappings. Replace the coil and bridge rectifier as a unit.

LIMIT SWITCHES XA1 AND XB1:

Switches are mechanically actuated by load contacts movement. When the load contacts are connected to the utility contacts, limit switch XA1 opens the utility circuit to utility closing coil C1 and limit switch XB1 closes the standby circuit to standby closing coil C2. The limit switches "arm" the system for retransfer back to "Utility" when the load contacts are connected to the "Standby" side. Conversely, when the load contacts are connected to the "Utility" side, the switches "arm" the system for transfer to "Standby". An open condition in limit switch XA1 will prevent retransfer to "Utility". An open switch XB1 will prevent transfer to "Standby".

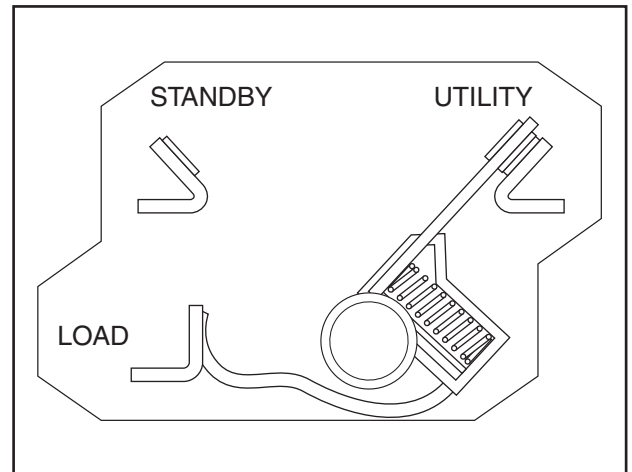

Figure 2. Load Connected to Utility Power Source

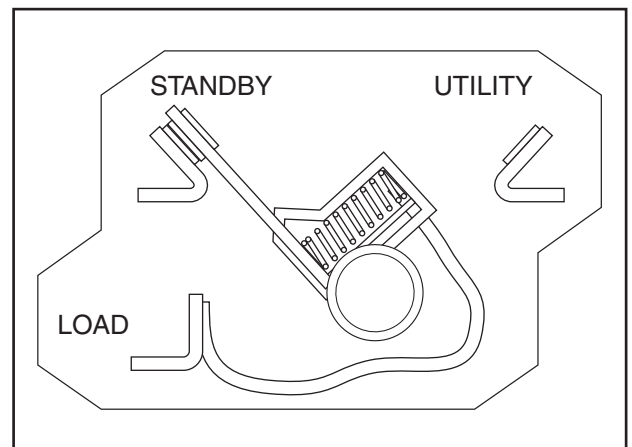

Figure 3. Load Connected to Standby Power Source

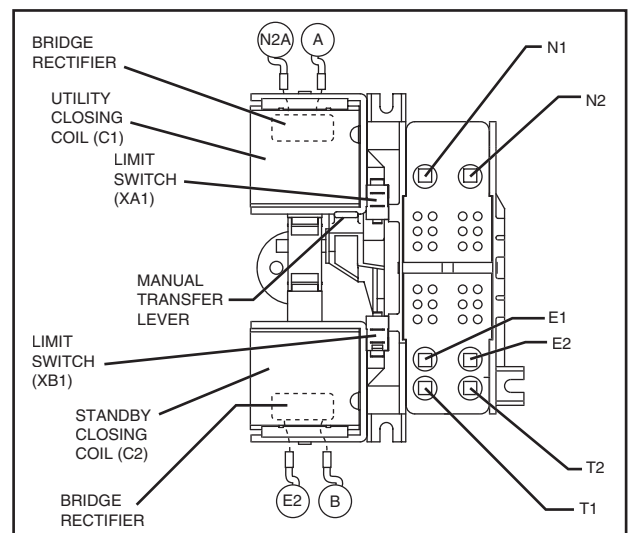

Figure 4. The "V-Type" Transfer Mechanism

TRANSFER RELAY

Transfer relay operation is controlled by a control circuit board mounted on the standby generator set. The standby system installer must interconnect suitable wiring to terminals 23 and 194 of a transfer switch terminal block. He must interconnect that wiring with identically numbered terminals in the generators control board. See Section 1.2, Figure 4.

Figure 5 on this page shows the transfer relay pictorially and schematically. Relay operation may be briefly described as follows:

1. Generator set battery voltage (12 volts DC) is available to the transfer relay coil from the generator's control board, via terminal 194 and relay terminal A.
 - a. The 12 volt DC circuit is completed through the transfer relay coil and back to the generator's control board, via transfer switch terminal 23, customer installed wiring, and control board terminal 23.
 - b. Control board action normally holds the Wire No. 23 circuit open to ground and the relay is de-energized.
 - c. When de-energized, the relay's normally-open contacts are open and its normally-closed contacts are closed.
 - d. The normally-closed relay contacts will deliver utility source power to the utility closing circuit of the transfer mechanism.
 - e. The normally-open relay contacts will deliver standby source power to the transfer mechanism's standby closing circuit.
2. During automatic system operation, when the generator's control board "senses" that utility source voltage has dropped out, the circuit board will initiate engine cranking and startup.
3. When the control board "senses" that the engine has started, an "engine warm-up timer" on the circuit board starts timing.
4. When the "engine warm-up timer" has timed out, control board action completes the Wire No. 23 circuit to ground.
 - a. The transfer relay then energizes.
 - b. The relay's normally-closed contacts open and its normally-open contacts close.
 - c. When the normally-open contacts close, standby source power is delivered to the standby closing coil and transfer to "Standby" occurs.
5. When the generator's control board "senses" that utility source voltage has been restored above a preset level, the board will open the Wire No. 23 circuit to ground.

- a. The transfer relay will de-energize, its normally-closed contacts will close and its normally-open contacts will open.
- b. When the normally-closed relay contacts close, utility source voltage is delivered to the utility closing coil to energize that coil.
- c. Retransfer back to "Utility" occurs.

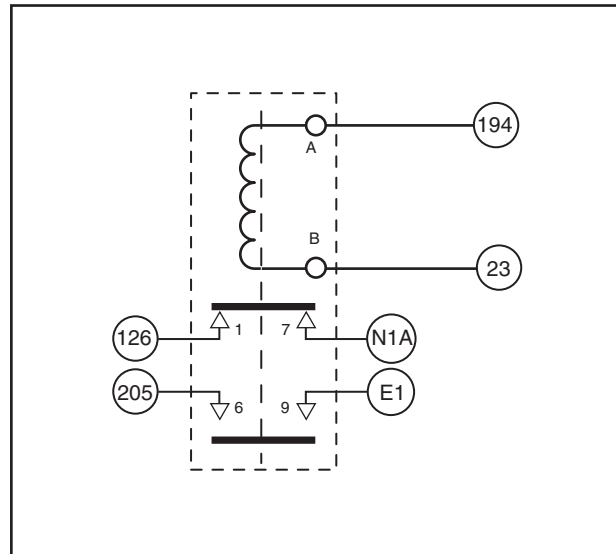

Figure 5. Transfer Relay Schematic

NEUTRAL LUG

See Figure 1. The standby generator is equipped with an UNGROUNDED neutral. The neutral lug in the transfer switch is isolated from the switch enclosure, since its base is of plastic. Load, Utility and Standby neutral lines all should be attached to the neutral lug's 3/8 inch stud and securely retained with the 3/8"-16 hex nut.

MANUAL TRANSFER HANDLE

The manual transfer handle (Figure 1) is retained in the transfer switch enclosure by means of a wing stud. Use the handle to manually actuate the transfer mechanism load contacts to either the "Utility" or "Standby" source side.

Instructions on use of the manual transfer handle may be found in Part 5, "Operational Tests and Adjustments".

TERMINAL BLOCK

During system installation, this 7-point terminal block must be properly interconnected with an identically labeled terminal block in the generator's control module assembly.

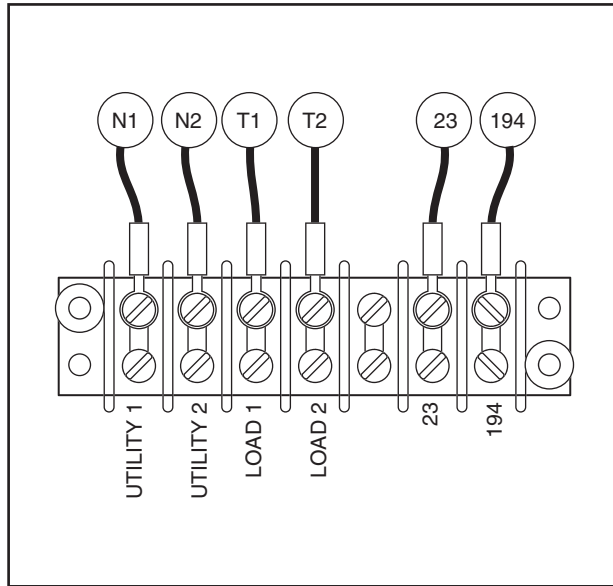

Figure 6. Transfer Switch Terminal Block

Terminals used on the terminal block are identified as Utility 1 and 2; Load 1 and 2; 23 and 194.

UTILITY 1 AND 2:

Interconnect with identically labeled terminals in the generator's control board. This is the "Utility Voltage" signal to the control board. The signal is delivered to a "step-down" transformer in the control module assembly and the resultant reduced voltage is then delivered to the circuit board. Utility 1 and 2 power is used by the control board as follows:

- If utility source voltage should drop below a preset level, control board action will initiate automatic cranking and startup, followed by automatic Transfer to the "Standby" source.
- Utility source voltage is used by the control board to operate a battery "trickle charge" circuit which helps to maintain battery state of charge during non-operating periods.

LOAD 1 AND 2:

The control board is equipped with a "7-Day Exerciser" circuit which will start the generator and let it "exercise" once every seven (7) days on a preselected day and at a preselected time of day. The "Load 1 and 2" terminals provide power to operate the exerciser timer clock.

TERMINALS 23 AND 194:

These terminals connect the transfer relay to the generator's control board. See Section 3.1, "Transfer Relay".

FUSE HOLDER

The fuse holder holds four (4) fuses, designated as fuses F1, F2, F3 and F4. Each fuse is rated 2 amperes.

FUSES F1 AND F2:

These two fuses protect the terminal boards "Utility 1 and 2" circuit against overload.

FUSES F3 AND F4:

These two fuses protect the "Load 1 and 2" circuit against overload.

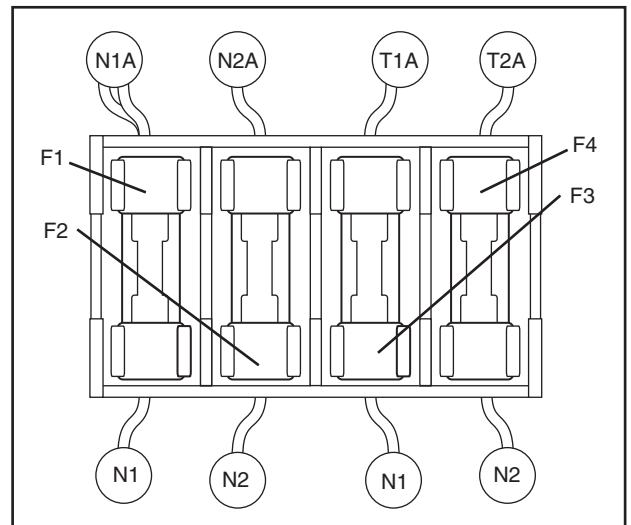

Figure 7. The Fuse Holder

UTILITY SOURCE VOLTAGE AVAILABLE

Figure 1 is a schematic representation of the transfer switch with utility source power available. The circuit condition may be briefly described as follows:

- Utility source voltage is available to Terminal Lugs N1 and N2 of the transfer mechanism.
- Line N2A is closed to the utility closing coil (C1), via a bridge rectifier.
- Utility source voltage is available to limit switch (XA1) via the normally-closed transfer relay contacts (1 and 7) and Wire No. 126. However, XA1 is open and the Circuit to the utility closing coil is open.
- Utility voltage "sensing" signals are delivered to a control board on the generator, via Wire No. N1A, a 5 amp fuse (F1), transfer switch terminal N1, to the sensing transformer. The second line of the utility voltage "sensing" circuit is via Wire No. N2A, a 5 amp Fuse (F2), transfer switch terminal N2, to the sensing transformer.

NOTE: Transfer switch terminals N1 and N2 (Utility 1 and 2) must be properly connected to generator terminals N1 and N2 (Utility 1 and 2) by the installer.

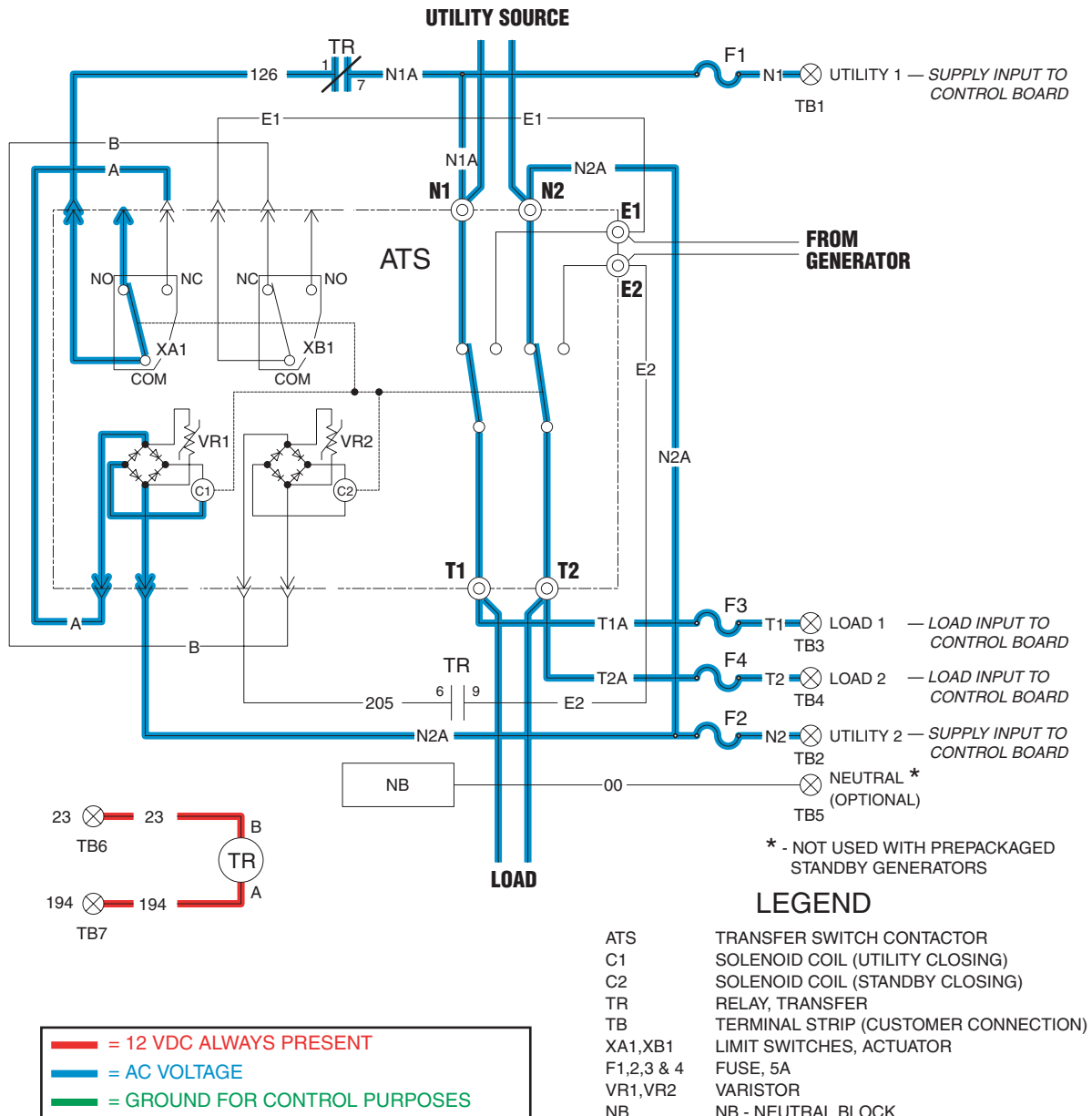

Figure 1. Circuit Condition- Utility Source Voltage Available

UTILITY SOURCE VOLTAGE DROPOUT

If utility source voltage should drop below a preset value, the generator's control board will sense the dropout. That circuit board will then initiate generator cranking and startup after a time delay circuit times out.

TRANSFER TO STANDBY

The generator's control board delivers 12 volts DC to the transfer relay, via terminal 194 and back to the circuit board via terminal 23. However, circuit board action holds the Wire No. 23 circuit open and the transfer relay remains de-energized. On generator startup, an "engine warm-up timer" on the generator's control board starts timing. When that timer has timed out, control board action completes the Wire No. 23 circuit to ground. The transfer relay then energizes, its normally-open contacts close, and standby source voltage is delivered to the standby closing coil via Wires No. E1 and E2, the transfer relay (TR) contacts, limit switch (XB1), Wire "B". and a bridge rectifier. The standby closing coil energizes and the main contacts actuate to their "Standby" side.

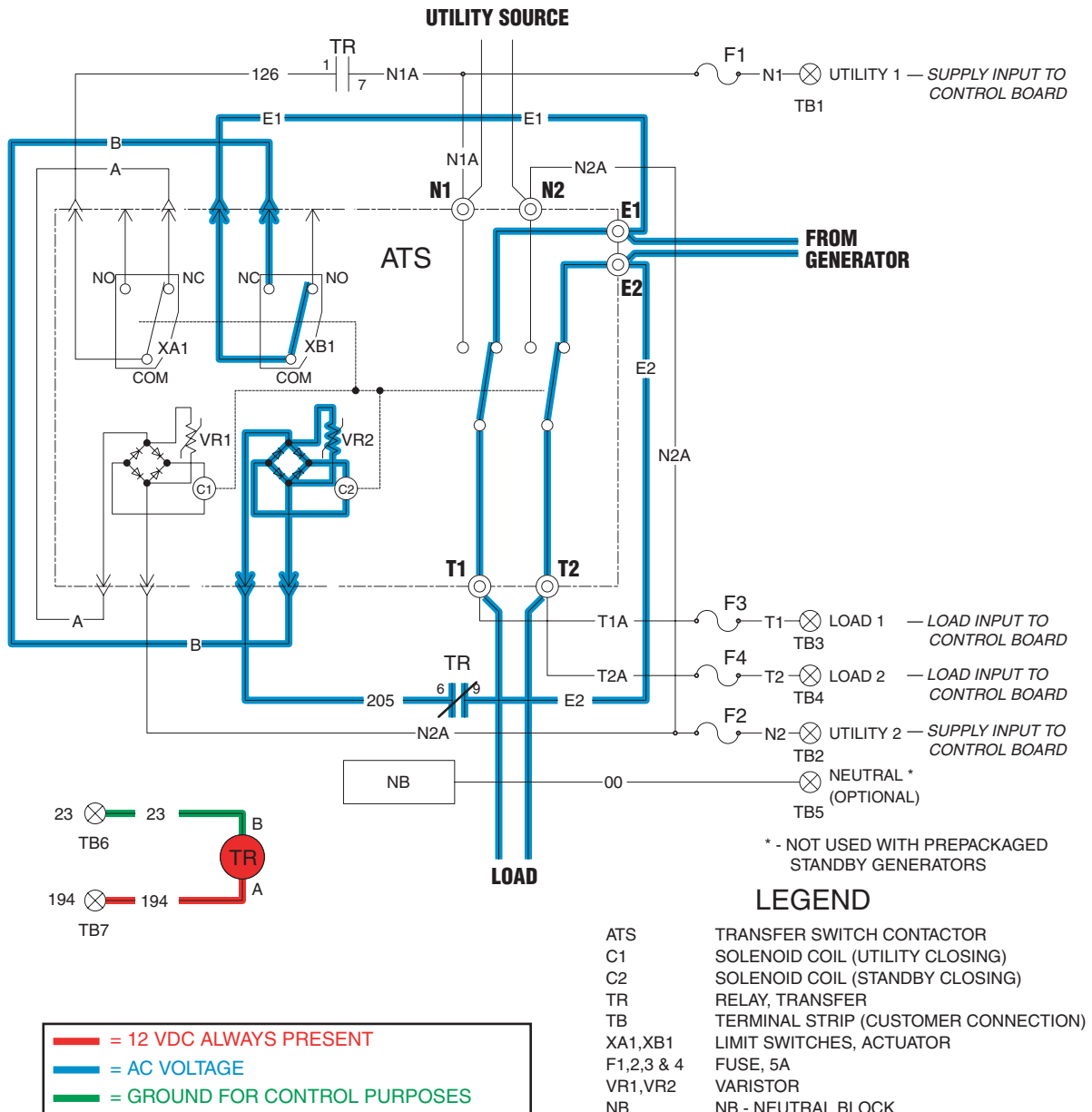

Figure 2. Circuit Condition - Transfer to Standby

RETRANSFER BACK TO UTILITY

On restoration of utility source voltage above a preset value, the generator's control board "senses" that voltage via terminals N1 and N2.

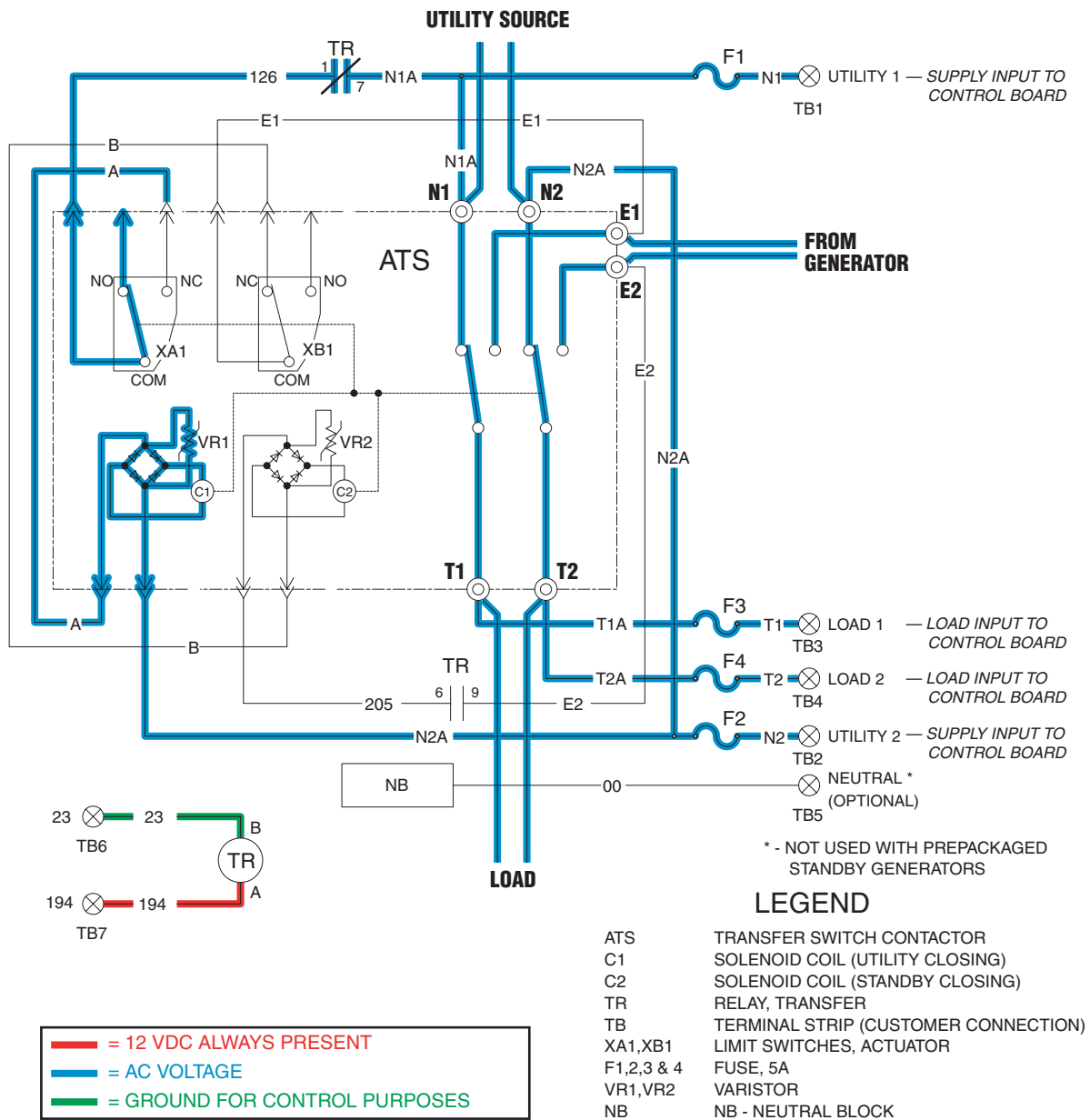

Figure 3. Initial Retransfer to Utility

TRANSFER TO UTILITY COMPLETE

After a preset time interval, that circuit board opens the terminal 23 circuit to ground. The transfer relay de-energizes, it's normally-closed contacts close, and utility source voltage is delivered to utility closing coil (C1), via Wires N1A and N2A, closed transfer relay (TR) contacts, limit switch XA1, and a bridge rectifier.

On closure of the main contacts to the utility power source side, limit switches XA1 and XB1 are mechanically actuated to "arm" the circuit for transfer to standby.

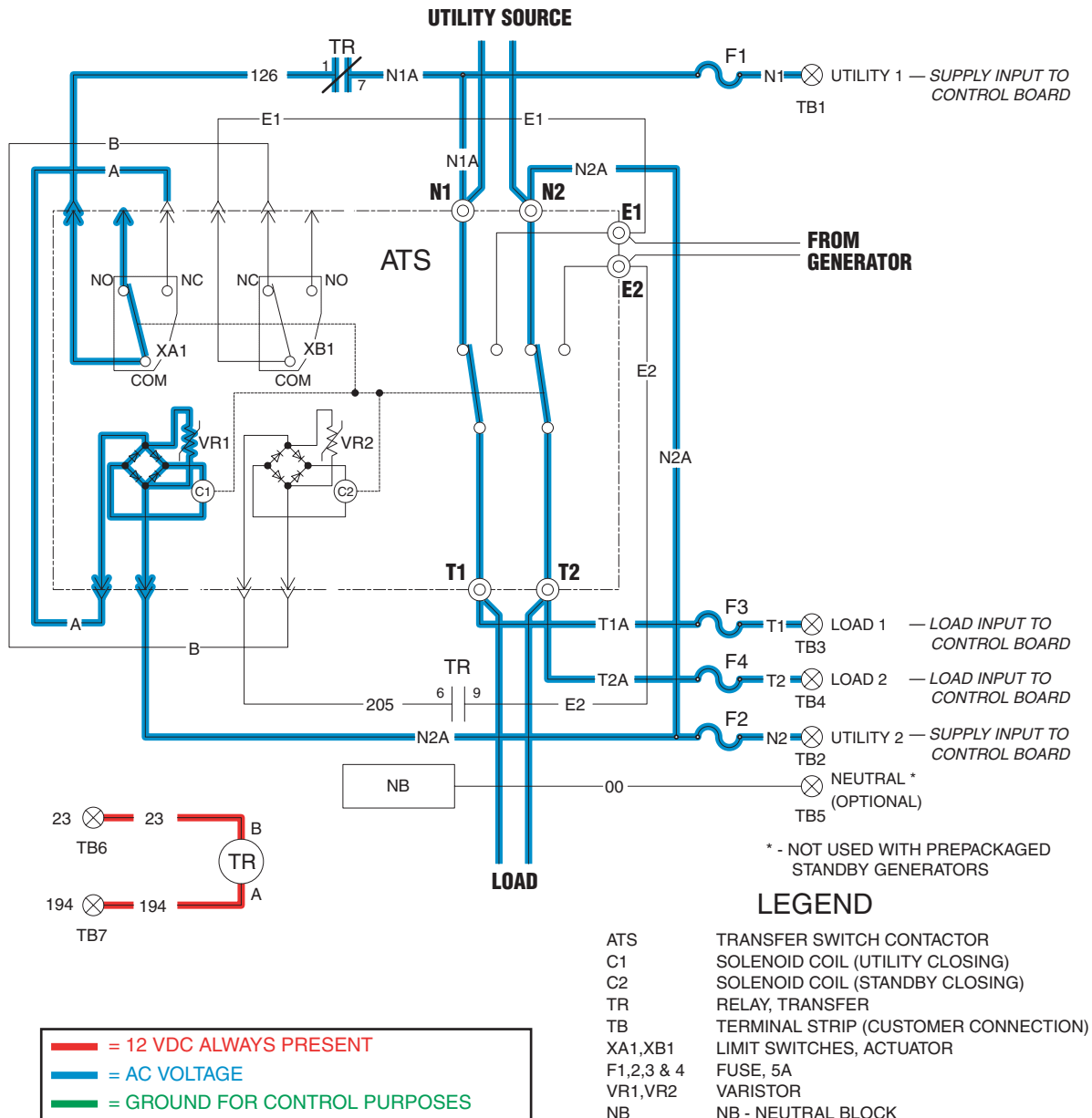

Figure 4. Final Retransfer to Utility

INTRODUCTION TO TROUBLESHOOTING

The first step in troubleshooting is to correctly identify the problem. Once that is done, the cause of the problem can be found by performing the tests in the appropriate flow chart.

Test numbers assigned in the flow charts are identical to test numbers in Section 3.4, "Diagnostic Tests." Section 3.4 provides detailed instructions for performance of each test.

Problem 1 - In Automatic Mode, No Transfer to Standby

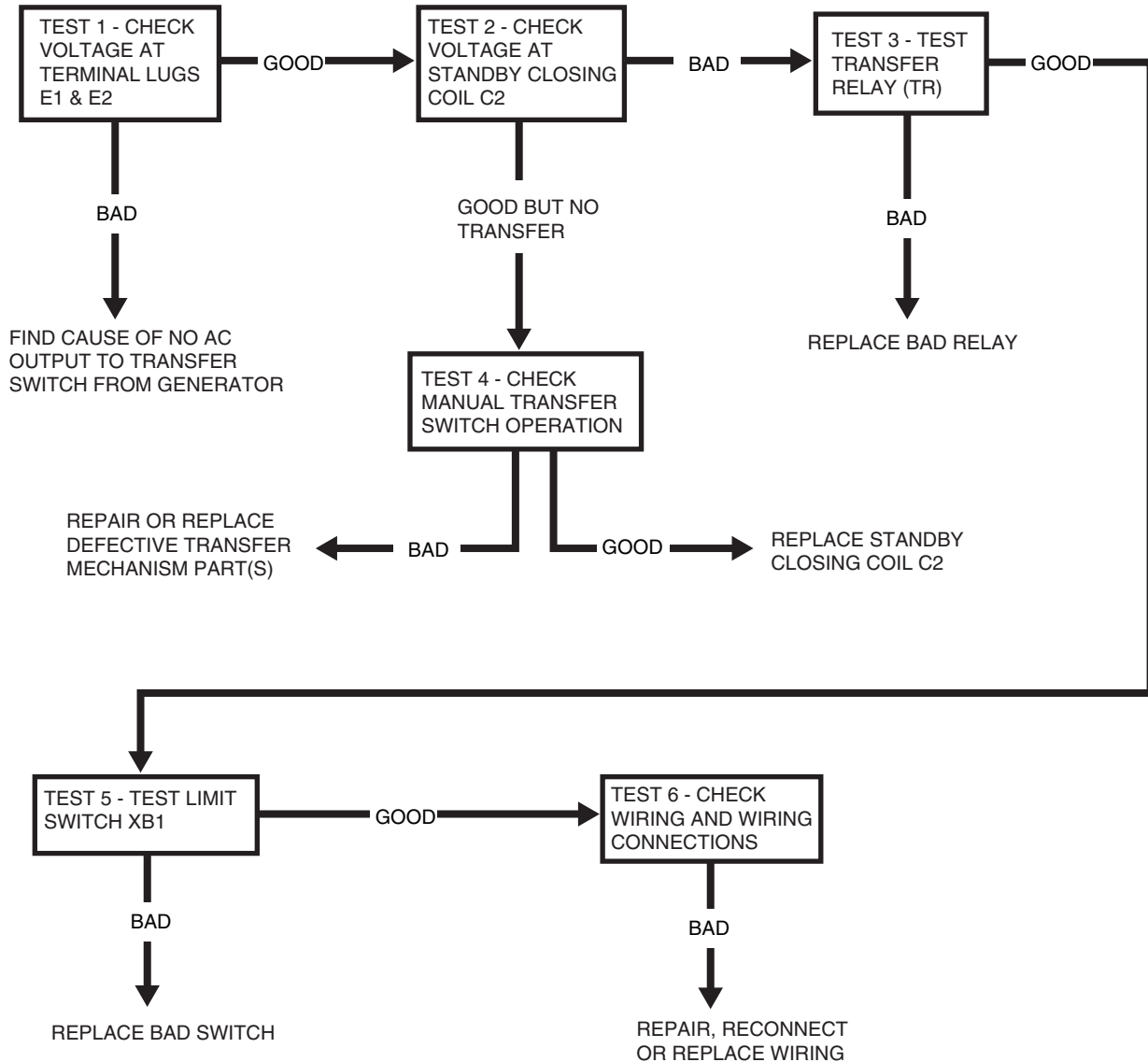

GENERAL

Test numbers in this section correspond to the numbered tests in Section 3.3, "Troubleshooting Flow Charts". When troubleshooting, first identify the problem. Then, perform the diagnostic tests in the sequence given in the flow charts.

TEST 1 - CHECK VOLTAGE AT TERMINAL LUGS E1, E2

DISCUSSION:

In automatic mode, the standby closing coil (C2) must be energized by standby generator output if transfer to the "Standby" source is to occur. Transfer to "Standby" cannot occur unless that power supply is available to the transfer switch.



DANGER: BE CAREFUL! HIGH AND DANGEROUS VOLTAGES ARE PRESENT AT TERMINAL LUGS E1 AND E2 WHEN THE GENERATOR IS RUNNING. AVOID CONTACT WITH HIGH VOLTAGE TERMINALS OR DANGEROUS AND POSSIBLY LETHAL ELECTRICAL SHOCK MAY RESULT. DO NOT PERFORM THIS VOLTAGE TEST WHILE STANDING ON WET OR DAMP GROUND, WHILE BAREFOOT, OR WHILE HANDS OR FEET ARE WET.

PROCEDURE:

1. If the generator engine has started automatically (due to a utility power source outage) and is running, check the position of the generator's main circuit breaker. The circuit breaker must be set to its ON or "Closed" position. When you are sure the generator's main circuit breaker is set to ON or "Closed", check the voltage at transfer mechanism Terminal Lugs E1 and E2 with an accurate AC voltmeter or with an accurate volt-ohm-milliammeter (VOM). The generator's line-to-line voltage should be indicated.
2. If the generator has been shut down, proceed as follows:
 - a. On the generator control panel, set the AUTO-OFF-MANUAL switch to OFF.
 - b. Turn OFF all power voltage supplies to the transfer switch. Both the "Utility" and "Standby" power supplies must be positively turned off before proceeding.
 - c. Check the position of the transfer mechanism main contacts. The moveable LOAD contacts must be connected to the stationary "Utility" source contacts. If necessary, manually actuate the main contacts to the "Utility" power source side. See Part 5 for manual operating procedures.

- d. Actuate the generator's main line circuit breaker to its ON or "Closed" position. The "Utility" power supply to the transfer switch must be turned OFF.
- e. Set the generator's AUTO-OFF-MANUAL switch to AUTO.
 - (1) The generator should crank and start.
 - (2) When the generator starts, an "engine warm-up timer" should start timing. After about 15 seconds, the transfer relay should energize and transfer to the "Standby" source should occur.
- f. If transfer to "Standby" does NOT occur, check the voltage across transfer switch Terminal Lugs E1 and E2. The generator's line-to-line voltage should be indicated.

RESULTS:

1. If normal transfer to "Standby" occurs, discontinue tests.
2. If transfer to "Standby" does NOT occur and no voltage is indicated across Terminal Lugs E1/E2, determine why generator AC output has failed.
3. If transfer to "Standby" does NOT occur and voltage reading across Terminal Lugs E1/E2 is good, go on to Test 2.

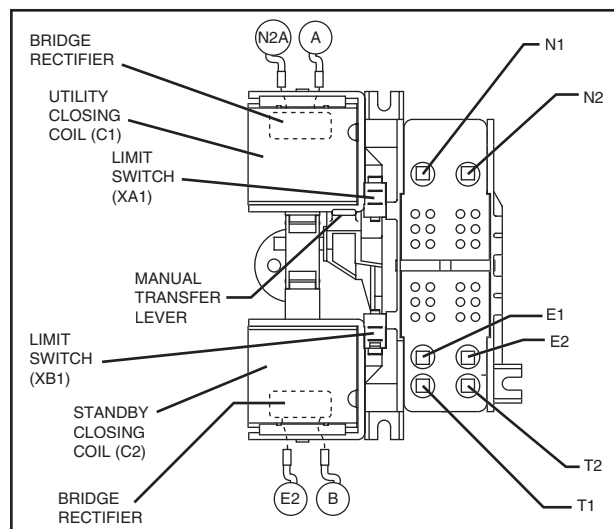

Figure 1. The "V-Type" Transfer Mechanism

TEST 2- CHECK VOLTAGE AT STANDBY CLOSING COIL C2

DISCUSSION:

Standby source voltage is used to energize the standby closing coil and actuate the main contacts to their "Standby" source side. Standby source alternating

current (AC) is changed to direct current (DC) by a bridge rectifier before reaching the closing coil. This test will determine if standby voltage is available to the closing coil.

If normal standby source voltage is available to the terminals of the standby closing coil but transfer to "Standby" does not occur, look for (a) binding or sticking in the transfer mechanism, (b) a defective coil, or (c) a bad bridge rectifier. The coil and the bridge rectifier must be replaced as a unit.

PROCEDURE:

1. If necessary, repeat Step 2 under "Procedure" of Test 1. The system must be in automatic operating mode, with engine running, and standby source voltage available to Terminal Lugs E1 and E2.
2. On the standby closing coil, locate the two terminals to which Wires E1 and E2 connect (Figure 1). Use an accurate AC voltmeter (or a VOM) to check the voltage across these two terminals. Generator line-to-line voltage must be indicated.

RESULTS:

1. If generator line-to-line voltage is indicated and transfer to "Standby" occurs, discontinue tests.
2. If generator line-to-line voltage is indicated but transfer does NOT occur, go to Test 4.
3. If generator line-to-line voltage is NOT indicated, go to Test 3.

TEST 3- TEST TRANSFER RELAY TR

DISCUSSION:

In automatic operating mode, the transfer relay must be energized by control board action or standby source power will not be available to the standby closing coil. Without standby source power, the closing coil will remain de-energized and transfer to "Standby" will not occur. This test will determine if the transfer relay is functioning normally.

PROCEDURE:

1. See Figure 2. Disconnect all wires from the transfer relay, to prevent interaction.
2. Set a VOM to its "Rx1" scale and zero the meter.
3. Connect the VOM test leads across relay terminals 6 and 9 with the relay de-energized. The VOM should read INFINITY.
4. Connect the positive (+) post of a 12 volt battery to Relay Terminal "A" and the negative (-) battery post to Relay Terminal "B". The relay should energize and the VOM should read CONTINUITY.

5. Now, connect the VOM test leads across Relay Terminals 1 and 7.

- a. Energize the relay and the meter should indicate INFINITY.
- b. De-energize the relay and the VOM should read CONTINUITY.

CONNECT VOM TEST LEADS ACROSS	DESIRED METER READING	
	ENERGIZED	DE-ENERGIZED
Terminals 6 and 9	Continuity	Infinity
Terminals 1 and 7	Infinity	Continuity

RESULTS:

1. Replace transfer relay if it is defective.
2. If transfer relay checks good go to Test 5.

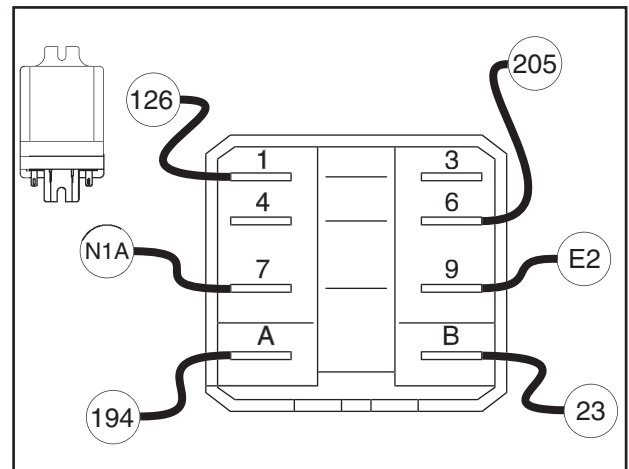

Figure 2. Transfer Relay Test Points

TEST 4- CHECK MANUAL TRANSFER SWITCH OPERATION

DISCUSSION:

In automatic operating mode, when utility source voltage drops below a preset level, the engine should crank and start. On engine startup, an "engine warm-up timer" on the generator's control board should start timing. When that timer has timed out (about 15 seconds), the transfer relay should energize to deliver utility source power to the standby closing coil terminals. If normal utility source voltage is available to the standby closing coil terminals, but transfer to "Standby" does not occur, the cause of the failure may be (a) a failed standby closing coil and/or bridge rectifier, or (b) a seized or sticking actuating coil or load contact. This test will help you evaluate whether any sticking or binding is present in the transfer mechanism.

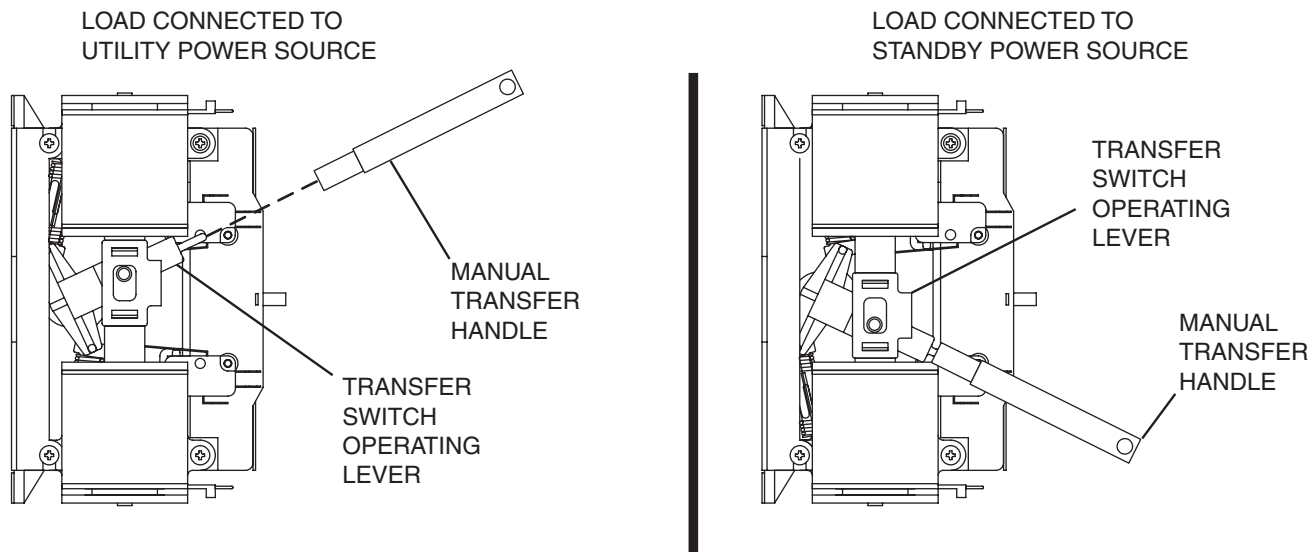

Figure 3. Manual Transfer Switch Operation

PROCEDURE:

1. With the generator shut down, set the generator's AUTO-OFF-MANUAL switch to OFF.
2. Set the generator's main circuit breaker to OFF or "Open".
3. Turn off the "Utility" power supply to the transfer switch, using whatever means provided (such as a utility source main line breaker).



DANGER: DO NOT ATTEMPT MANUAL TRANSFER SWITCH OPERATION UNTIL ALL POWER VOLTAGE SUPPLIES TO THE SWITCH HAVE BEEN POSITIVELY TURNED OFF. FAILURE TO TURN OFF ALL POWER VOLTAGE SUPPLIES MAY RESULT IN EXTREMELY HAZARDOUS AND POSSIBLY LETHAL ELECTRICAL SHOCK.

4. In the transfer switch enclosure, locate the manual transfer handle. Handle is retained in the enclosure with a wing stud. Remove the wing stud and handle.
5. See Figure 3. Insert the un-insulated end of the handle over the transfer switch operating lever.
 - a. Move the transfer switch operating lever up to actuate the load contacts to the "Utility" position, i.e., load connected to the "utility" source.
 - b. Actuate the operating lever down to move the load contacts against the "Standby" contacts, i.e., load connected to the "Standby" source.

6. Repeat Step 5 several times. As the transfer switch operating lever is moved slight force should be needed until the lever reaches its center position. As the lever moves past its center position, an over-center spring should snap the moveable load contacts against the stationary "Standby" or "Utility" contacts.
7. Finally, actuate the main contacts to their "Utility" power source side, i.e., load contacts against the "Utility" contacts (upward movement of the operating lever).

RESULTS:

1. If there is no evidence of binding, sticking, excessive force required, replace the standby closing coil (C2).
2. If evidence of sticking, binding, excessive force required to move main contacts, find cause of binding or sticking and repair or replace damaged part(s).

TEST 5- TEST LIMIT SWITCH XB1

DISCUSSION:

Standby power source voltage must be available to the standby closing coil in order for a "transfer to standby" action to occur. To deliver that source voltage to the coil, limit switch XB1 must be closed to the "Standby" power source side. If the limit switch did not get actuated or has failed open, the source voltage will not be available to the closing coil and transfer to "Standby" will not occur.

PROCEDURE:

With the generator shut down and with the "Utility" power supply to the transfer switch turned OFF, test limit switch XB1 as follows:

1. To prevent interaction, disconnect Wire No. 205 and Wire "B" from the limit switch terminals.
2. Set a VOM to its "Rx1" scale and zero the meter.
3. See Figure 1. Connect the VOM test probes across the two terminals from which the wires were disconnected.
4. Manually actuate the main contacts to their "Standby" position. The meter should read INFINITY.
5. Manually actuate the main contacts to their "Utility" position. The meter should read CONTINUITY.
6. Repeat Steps 4 and 5 several times and verify the VOM reading at each switch position.

RESULTS:

1. If limit switch XB1 fails the test, remove and replace the switch or adjust switch until it is actuated properly.
2. If limit switch is good, go on to Test 6.

TEST 6- CHECK WIRING AND WIRING CONNECTIONS

DISCUSSION:

An open circuit in transfer switch wiring can prevent a transfer action from occurring.

PROCEDURE:

See Figure 1. Inspect transfer switch wiring carefully. Make sure all wires are property and securely attached to the correct terminals. Test wiring for an open or shorted condition.

RESULTS:

Repair, reconnect or replace any damaged, disconnected, incorrectly connected, open or shorted wire(s).

TEST 7- CHECK VOLTAGE AT TERMINAL LUGS N1, N2

DISCUSSION:

If retransfer to the "Utility" power source side is to occur, utility source voltage must be available to Terminal Lugs N1 and N2 of the transfer mechanism. In addition, if that source voltage is not available to N1/N2 terminals, automatic startup and transfer to "Standby" will occur when the generator's AUTO-OFF-MANUAL switch is set to AUTO. This test will prove that "Utility" voltage is available to those termi-

nals, or is not available. It is the first test in a series of tests that should be accomplished when (a) retransfer back to "Utility" does not occur, or (b) startup and transfer occurs unnecessarily.



DANGER: PROCEED WITH CAUTION! HIGH AND DANGEROUS VOLTAGES ARE PRESENT AT TERMINAL LUGS N1/N2. CONTACT WITH HIGH VOLTAGE TERMINALS WILL RESULT IN DANGEROUS AND POSSIBLY LETHAL ELECTRICAL SHOCK. DO NOT ATTEMPT THIS TEST WHILE STANDING ON WET OR DAMP GROUND, WHILE BAREFOOT, OR WHILE HANDS OR FEET ARE WET.

PROCEDURE:

1. Make sure that all main line circuit breakers in the utility line to the transfer switch are ON or "Closed."
2. Test for utility source line-to-line voltage across Terminal Lugs N1 and N2 (see Figure 1). Normal utility source voltage should be indicated.

RESULTS:

1. If low or no voltage is indicated, find the cause of the problem and correct.
2. If normal utility source voltage is indicated, go on to Test 8.

TEST 8 - CHECK VOLTAGE AT UTILITY 1 AND UTILITY 2 TERMINALS

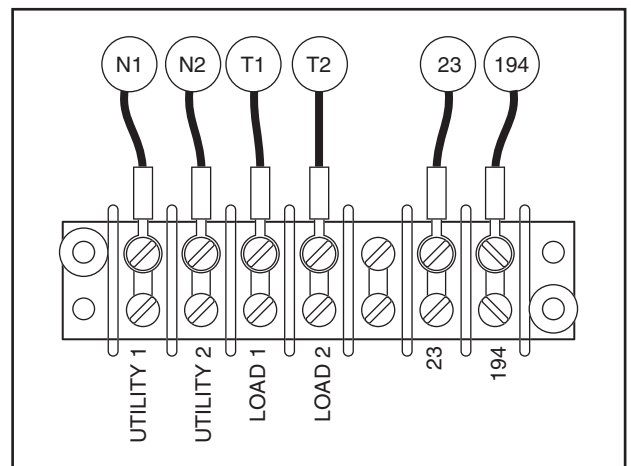

Figure 4. Transfer Switch Terminal Block

During installation the installer should have connected the "Utility 1" and "Utility 2" terminals in the transfer switch with identically labeled terminals on a terminal block on the generators control board. These terminals deliver utility voltage "sensing" to a control

SECTION 3.4 DIAGNOSTIC TESTS

PART 3

"V-TYPE" PREPACKAGED TRANSFER SWITCHES

board. If voltage at the terminals is zero or low, standby generator startup and transfer to the "Standby" source will occur automatically as controlled by the control board. A zero or low voltage at these terminals will also prevent retransfer back to the "Utility" source.

PROCEDURE:

With utility source voltage available to Terminal Lugs N1 and N2, use an AC voltmeter or a VOM to test for utility source line-to-line voltage across terminal block "Utility 1" and "Utility 2" terminals. Normal line-to-line utility source voltage should be indicated.

RESULTS:

1. If voltage reading across the "Utility 1" and "Utility 2" terminals is zero, go to Test 10.
2. If voltage reading is good, go to Test 9.

TEST 9 - CHECK VOLTAGE AT UTILITY CLOSING COIL C1

DISCUSSION:

Utility source voltage is required to energize utility closing coil C1 and effect retransfer back to the "Utility" source. This voltage is delivered to the utility closing coil via Wires No. N1A and N2A, the transfer relay's normally-closed contacts (relay de-energized), Wire No. 126, limit switch XA1, and a bridge rectifier.

PROCEDURE:

1. On the generator control panel, set the AUTO-OFF-MANUAL switch to OFF.
2. Turn OFF the utility power supply to the transfer switch, using whatever means provided (such as a utility source main line circuit breaker).
3. Set the generator's main line circuit breaker to its OFF or "Open" position.
4. Check the position of the transfer mechanism main contacts. The moveable load contacts must be connected to the stationary utility contacts. If necessary, manually actuate the main contacts to their "Utility source side (load connected to the "Utility" source).
5. Set the generator's main line circuit breaker to its ON or "Closed" position.
6. Set the generator's AUTO-OFF-MANUAL switch to AUTO.
 - a. The generator should crank and start.
 - b. About 15 seconds after engine startup, the transfer relay should energize and transfer to the "Standby" source should occur.

7. When you are certain that transfer to "Standby" has occurred, turn ON the utility power supply to the transfer switch. After a short wait, retransfer back to the "Utility" source should occur.

8. If retransfer back to "Utility" does not occur, use an AC voltmeter (or a VOM) to test the voltage across the two terminals of the utility closing coil. Normal utility source line-to-line voltage should be indicated.

RESULTS:

1. In Step 6, if the generator does not crank or start, refer to Part 4, "DC Control - Units with Liquid Cooled Engine".
2. In Step 6, if transfer to the "Standby" source does not occur, go to Problem 1.
3. In Step 8, if normal utility source line-to-line voltage is NOT indicated, go to Test 3.
4. In Step 8, if normal utility source line-to-line voltage is indicated but retransfer back to "Utility" does not occur, go to Test 4.

TEST 10 - CHECK FUSES F1 AND F2

DISCUSSION:

Fuses F1 and F2 are connected in series with the Utility 1 and Utility 2 circuits, respectively. A blown fuse will open the applicable circuit and will result in (a) generator startup and transfer to "Standby", or (b) failure to retransfer back to the "utility" source.

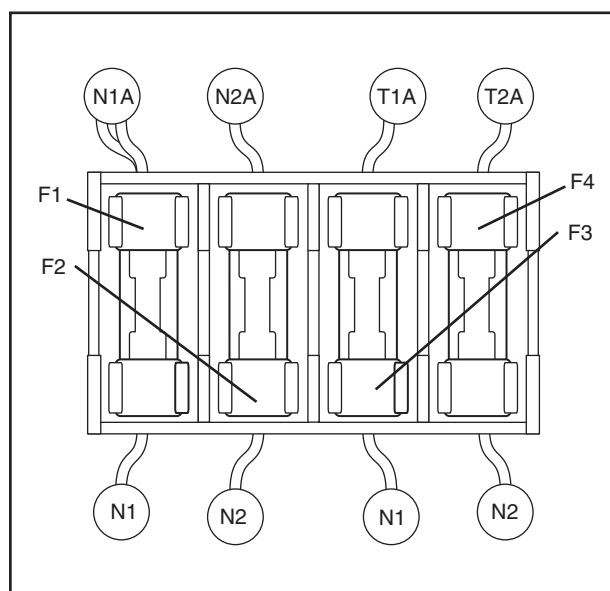

Figure 5. Fuse Holder and Fuses

PROCEDURE:

1. On the generator panel, set the AUTO-OFF-MANUAL switch to OFF.
2. Turn OFF the utility power supply to the transfer switch, using whatever means provided.
3. See Figure 5. Remove fuses F1 and F2 from the fuse holder.
4. Inspect and test fuses for blown condition.

RESULTS:

1. Replace blown fuse(s).

TEST 11- TEST LIMIT SWITCH XA1

DISCUSSION:

When the transfer switch main contacts are actuated to their "Utility" position, limit switch XA1 should be mechanically actuated to its open position. On transfer to the "Standby" position, the limit switch should actuate to its "Closed" position. If the switch does not actuate to its "Closed" position, retransfer back to "Utility" will not occur.

PROCEDURE:

1. With the standby generator shut down, set the AUTO-OFF-MANUAL switch to OFF.
2. Turn OFF the utility power supply to the transfer switch, using whatever means provided.
3. To prevent interaction, disconnect Wire No. 126 and Wire "A" from the limit switch terminals.
4. Set a VOM to its "Rx1" scale and zero the meter.
5. Connect the VOM test leads across the two limit switch terminals from which Wires "A" and 126 were removed.
6. Manually actuate the main contacts to their "Standby" position. The VOM should indicate CONTINUITY.
7. Manually actuate the main contacts to their "Utility" position. The VOM should read INFINITY.

RESULTS:

Replace limit switch XA1 if it checks bad.

NOTE: Problems with transfer switch operation can also be caused by (a) defective wiring between the generator and transfer switch, or (b) a defective component in the generator's control board. See Part 4, "DC Control - Units with Liquid Cooled Engine".

SECTION 3.4
DIAGNOSTIC TESTS

PART 3

"V-TYPE" PREPACKAGED
TRANSFER SWITCHES

PART 4 DC CONTROL LIQUID COOLED ENGINE UNITS

1.5 LITER PREPACKAGED HOME STANDBY GENERATORS

TABLE OF CONTENTS		
PART	TITLE	PAGE
4.1	Description and Components	58
4.2	Operational Analysis	62
4.3	Troubleshooting Flow Charts	80
	Problem 1 - Engine Will Not Crank When Utility Power Failure Occurs	80
	Problem 2 - Engine Will Not Crank When AUTO-OFF-MANUAL Switch is Set to "MANUAL"	80
	Problem 3 - Engine Cranks but Won't Start	81
	Problem 4 - Engine Cranks and Starts but Won't Transfer to Standby	81
	Problem 5 - Engine Starts and Transfer Occurs When Utility Power is Available	81
4.4	Diagnostic Tests	82

TEST	DESCRIPTION	PAGE
1	Check AUTO-OFF-MANUAL Switch Position	82
2	Try to Start Engine Manually	82
3	Test AUTO-OFF-MANUAL Switch	82
4	Inspect AUTO-OFF-MANUAL Switch to control Board Wiring	83
5	Check 15 Amp Fuse (F1)	83
6	Check battery	83
7	Test Control Contactor CC	84
8	Test Starter Motor (SM)	85
9	Check control Board Power and Wire 56 Output	85
10	Check for Mechanical Damage	86
11	Check Fuel Supply	86
12	Check Wire 14 Output to Distributor	87
13	Benchmark Testing, Distributor Internal Components	88

TEST	DESCRIPTION	PAGE
14	Inspect Distributor Cap and Rotor	88
15	Check Spark Plugs	89
16	Check Ignition Wires	89
17	Check Ignition Timing	89
18	Check DC Volts at Terminal 14 of TB1	90
19	Test Fuel Solenoid (FS)	90
20	Check Engine Compression and Condition	90
21	Check Generator Main Line Circuit Breaker	91
22	Check Sensing to control Board	91
23	Ground control Board Terminal 23	91
24	Check Voltage at Terminal Lugs E1 & E2	92
25	Check Voltage at Terminal Lugs N1 & N2	92
26	Check Voltage at control Board Terminals N1A and N2	92
27	Test Sensing Transformer	93

GENERAL

Information in this section is provided to familiarize the reader with the various components that make up the DC control system on prepackaged units having a liquid cooled engine. These components may be divided into two (2) broad categories as follows:

- Components in the generator control console.
- Engine mounted components.

CONTROL CONSOLE COMPONENTS

LOCATION AND DESCRIPTION:

The control console includes (a) three terminal boards, (b) a sensing transformer, and (c) a control board.

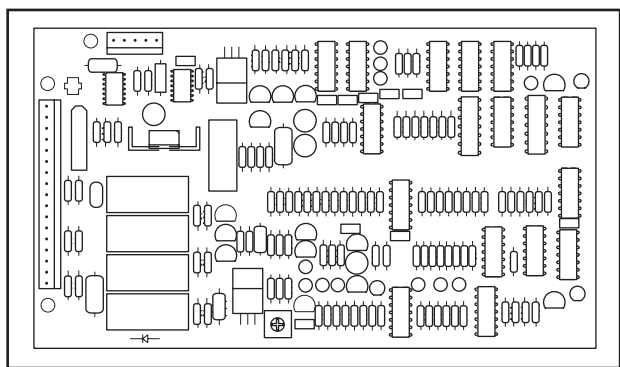

Figure 1. Control Board

CONTROL WIRE TERMINAL BOARD:

The terminal board provides convenient attachment points for control system wiring that must be interconnected between the prepackaged transfer switch and generator during system installation. This wiring must be installed and interconnected between the control console terminal board and an identically marked terminal board in the prepackaged transfer switch. The following terminals are identified:

A. N1 and N2 (Utility 1 and Utility 2)

1. These terminals deliver “Utility” power source line-to-line voltage from the prepackaged transfer switch and to the primary coil of a sensing transformer.
2. Dropout of the “Utility” sensing voltage below a preset value will result in generator startup due to control board action.
3. This line-to-line “Utility” voltage is also used by the control board to operate a battery “trickle charge” circuit. That circuit helps maintain battery state of charge when the engine is not running.

B. T1 and T2 (Load 1 and Load 2):

1. This line-to-line power is taken from transfer switch “Load” Terminal Lugs T1 and T2.

2. This “Load” voltage power is used by the control board to operate a “7-day exercise” clock or timer circuit. This circuit starts and exercises the generator once every seven days, on a day and at a time of day selected by the installer.

C. Terminals 23 and 194:

1. The control board delivers a +12 volt DC signal to a transfer relay coil in the transfer switch, via Terminal and Wire 194. The 12 volt DC circuit is completed through the transfer relay coil and back to the control board, via Wire 23.
2. The control board normally holds the Terminal 23 circuit open to ground and the transfer relay is de-energized.
3. During a “Utility” power source outage, control board action will crank and start the generator. Following generator startup, control board action will complete the Terminal 23 circuit to ground. The transfer relay will then energize to initiate transfer of “Load” circuits to the “Standby” power source.
4. When “Utility” source voltage is restored, control board action will again open the Terminal 23 circuit to ground. The transfer relay will then de-energize to initiate retransfer back to the “Utility” source.

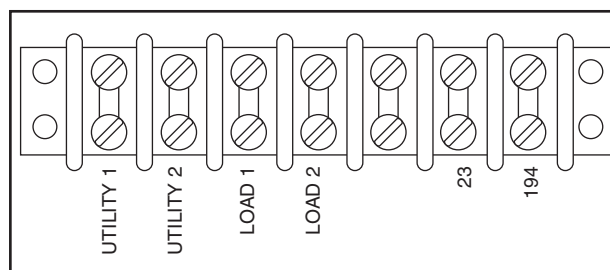

Figure 2. Terminal Board TS3

TRANSFORMER T1:

The line-to-line voltage from the “Utility 1/Utility 2” terminals is delivered to the primary coil of this step-down transformer. A voltage of about 14 volts AC is induced into the transformer’s secondary coil and is delivered to the control board as sensing voltage.

The reduced secondary coil output from the transformer is used by the control board not only as “Utility” source sensing voltage, but also to operate a battery trickle charge circuit. The latter helps maintain the battery at a high state of charge during non-operating periods.

CONTROL BOARD:

This solid state circuit board controls all standby electric system operations, including engine cranking, startup, running, automatic transfer and shutdown. Other operations controlled by the circuit board include the following:

- The board delivers “field boost” current to the generator rotor via Connector Pin 1 and Wire 4. Also see Section 2.2, “Field Boost”.
- The circuit board provides automatic engine shutdown in the event of (a) low engine Oil pressure, (b) high engine coolant temperature, (c) low coolant level, (d) overspeed and (e) overcrank. See Section 1.6, “Engine-Generator Protective Devices”. On occurrence of any one or more of these engine faults, the circuit board will turn on a fault indicator lamp.

The various functions handled by the control board are listed in the following chart, along with appropriate circuit board connector pin numbers and wire numbers.

PIN	WIRE	FUNCTION (Wiring Dia. #0F5243)
2	4	Field boost to rotor (9-10 volts DC)
3	85	Engine shutdown fault line (low oil pressure, high coolant temperature)
4	23	Grounded (-) side of transfer relay circuit
5	194	Positive (+) DC side of transfer relay circuit
6	56	+12 volts DC to control contactor for cranking
7	---	Not used
8	14	+12 volts DC to ignition coil and hourmeter
9	---	Not used
10	178	Manual start line to AUTO-OFF-MANUAL switch
11	15A	+12 volts DC with AUTO-OFF-MANUAL switch at AUTO or MANUAL
12	239	+12 volts DC to AUTO-OFF-MANUAL switch
13	15	+12 volts DC (battery trickle charge)
14	0	Common ground
15	224	14 volts AC from control board sensing transformer
16	225	14 volts AC from control board sensing transformer
17	T2	Line-to-line AC voltage from “Load” terminal lugs of transfer switch
18	T1	Line-to-line AC voltage from “Load” terminal lugs of transfer switch
2	S15	Frequency (rpm) sensing from AC power winding
3	S16	Frequency (rpm) sensing from AC power winding
4	150	Engine preheat (only on diesel engine units)
5	229	Negative (-) side of optional alarm relay connection. Circuit board action will complete this circuit to ground on occurrence of a fault shutdown.
6	176	Negative (-) side of fault indicator lamp circuit. Circuit board action will complete this circuit to ground on occurrence of a fault shutdown.

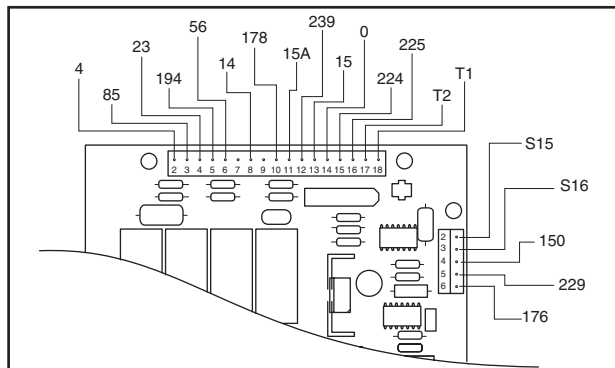

Figure 3. Control Board Connector Terminals

CONTROL CONSOLE COMPONENTS

TERMINAL BOARD TB1:

This 20-position terminal board (Figure 4) provides a convenient connection point for DC control system wiring. Terminals, associated wires and their functions are listed in the following chart.

TERM.	WIRE	FUNCTION
0	0	Common ground
79	--	Not used on prepackaged units
13	13	Unfused battery volts (12 volts DC)
14	14	12 volts DC with engine running only- used to turn on ignition, open a fuel solenoid and turn on an hourmeter.
15	--	No factory connected wires (fused 12 volts DC)- see Terminal 229.
4	4	Regulated excitation and field boost current to rotor
229	---	Connection for remote alarm
56	56	12 volts DC when cranking only
68	68	Oil pressure sender to panel gauge
69	69	coolant temperature sender to panel gauge
85	85	Low oil pressure switch connection
86	86	High coolant temperature switch connection
150	---	For preheat on diesel engine units only
218	---	Not used on prepackaged units
219	---	Not used on prepackaged units

NOTE: For additional information on Terminal 229 see “Remote Alarm Connection” in this section.

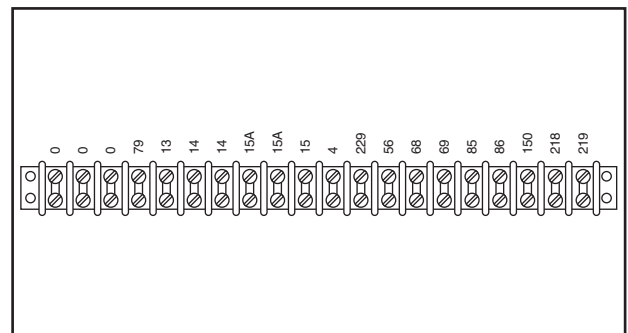

Figure 4. Terminal Board TB1

REMOTE ALARM CONNECTION:

Terminal 229 on terminal board TB1 is a connection point for an alarm system (not supplied). The terminal will support any relay requiring up to a maximum of 100 milli-amps of current draw. A relay coil is connected across terminals 15 and 229. A remote alarm device is connected across the relay contacts so that, on contacts closure, a separate power supply will turn the alarm device on. Terminal 15 is fused battery voltage (12 volts DC). On occurrence of any monitored engine fault, control board action will complete the terminal 229 circuit to ground, to energize the relay and turn the alarm on.

SECTION 4.1 DESCRIPTION AND COMPONENTS

PART 4

DC CONTROL
LIQUID COOLED
ENGINE UNITS

TERMINAL BOARD TS2:

This 2-position terminal board (terminals 178 and 183) must be used when the standby generator is installed in conjunction with a standard "ATS" type automatic transfer switch. See Section 1.3.

AUTO-OFF-MANUAL SWITCH:

The AUTO-OFF-MANUAL is shown in Figure 6. Also see Section 1.7, "Operating Instructions".

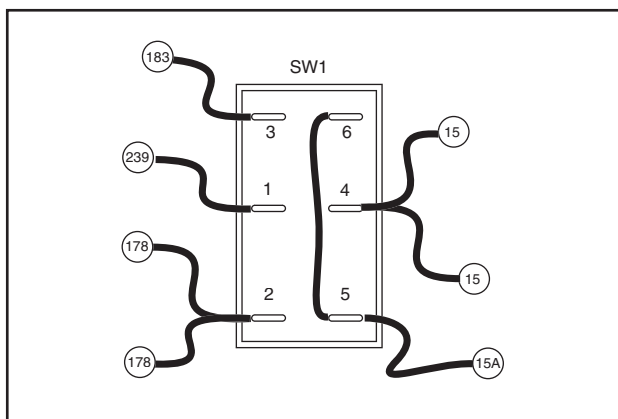

Figure 6. AUTO-OFF-MANUAL Switch

FUSE F1:

Fuse F1 is connected in series with Wires 13 and 15 and is rated 15 DC amperes. If fuse replacement becomes necessary, use only an identical 15 amp replacement fuse.

FAULT INDICATOR LAMP L1:

Lamp L1 is powered by the Wire 15 circuit (fused battery voltage). The lamp circuit is completed to the control board, via Wire 176. On occurrence of a monitored engine fault, circuit board action will complete the Wire 176 circuit to ground and the lamp will turn ON. Engine faults that will cause the lamp to turn on are discussed in Section 1.6, "Engine-Generator Protective Devices".

ENGINE MOUNTED COMPONENTS

Engine mounted DC control system components include the following:

- A 12 volts battery and battery charge components.
- A starter motor (SM).
- A control contactor (CC).
- Low Oil Switch (LOS) and high water temperature switch (HWT).
- Engine ignition system parts.

BATTERY AND BATTERY CHARGE SYSTEM:

See Figure 7. An alternator delivers a charging voltage to the battery during engine operation. The charging voltage is regulated and rectified by the DC regulator.

The belt driven alternator is a permanent magnet type. Alternator maintenance is limited to replacement of defective parts.

The DC voltage regulator is housed in an aluminum heat sink. All components are covered with epoxy resin. The regulator is NOT repairable. Regulator connector pins are numbered from left to right, as follows:

PIN	FUNCTION
1	Charging output to battery (12.5-14.5 volts DC)
2	Charging input from alternator (AC)
3	Charging input from alternator (AC)
4	Charge indicating lamp connection (not used)
5	Sensing voltage from battery (Wire #15)

NOTE. The alternator supplies alternating current (AC) which is changed to direct current (DC) by the regulator.

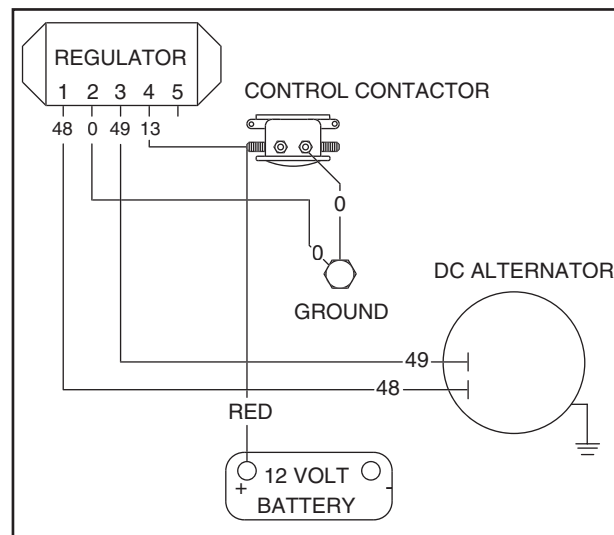

Figure 7. Battery Charging System

STARTER MOTOR AND CONTROL CONTACTOR:

During manual or automatic startup, control board action delivers 12 volts DC to a control contactor (CC) coil. The coil energizes, its contacts close, and battery power is delivered to the starter motor (SM). The starter motor then energizes and the engine is cranked.

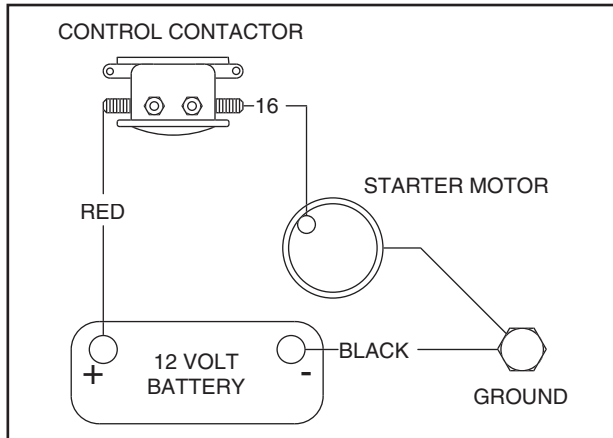

Figure 8. Engine Cranking Circuit

LOW OIL PRESSURE SWITCH:

The low oil pressure (LOP) switch has normally-closed contacts which are held open by engine oil pressure during cranking and running conditions. Should engine oil pressure drop below approximately 8-12 psi, the switch contacts will close. Control board action will then effect an automatic engine shutdown and the fault indicator lamp (L1) will turn on.

HIGH COOLANT TEMPERATURE SWITCH:

The high coolant temperature switch (HWT) has normally-open contacts. Contacts are thermally actuated. If engine coolant temperature should exceed approximately 284° F. (140° C.), control board action will shut the engine down. The fault indicator lamp (L1) will then illuminate.

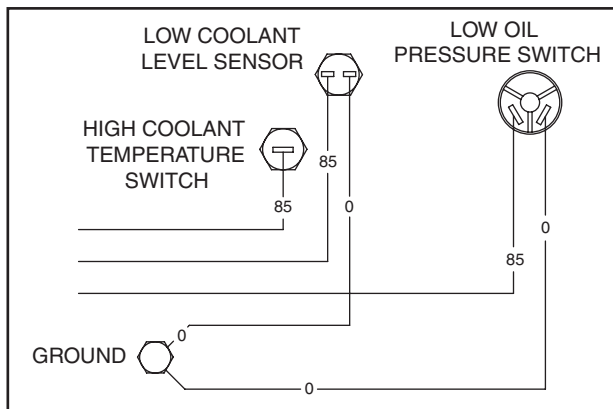

Figure 9. Oil Pressure & Coolant Temperature Circuit

LOW COOLANT LEVEL SENSOR:

It is possible that engine coolant level might drop low enough so that the high temperature switch is no longer immersed in the liquid coolant. If this happens engine temperatures could increase rapidly but the temperature switch would not sense the high temper-

ature condition and the engine would continue to run. To prevent this occurrence, a low coolant level sensor is provided. The sensor is immersed in cooling system liquid. If coolant level drops below the level of the low coolant level sensor, the device will complete a Wire 85 circuit to ground. Engine shutdown will occur.

FUEL SOLENOID:

The fuel solenoid (FS) provides a positive shutoff of fuel when the engine is not running. The solenoid is energized open by 12 volts DC (Wire 14); it is de-energized closed.

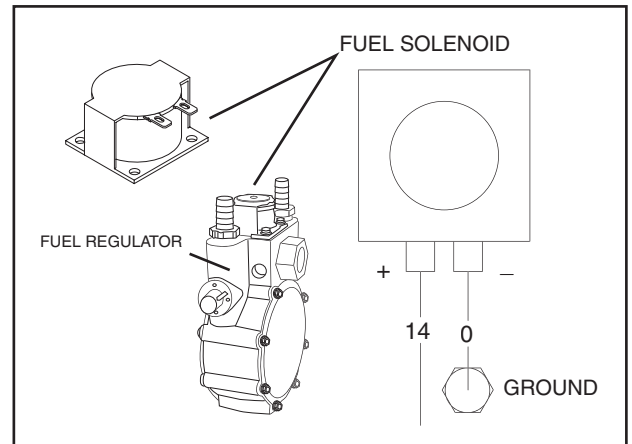

Figure 10. Fuel Solenoid (FS)

ENGINE IGNITION SYSTEM:

The control board acts as the "ignition switch", i.e., it turns the ignition system on for startup and turns the system off for shutdown. During startup, a crank relay (K1) on the control board energizes, its contacts close, and 12 volts DC is delivered to the ignition coil via Wire 14. The ignition system consists of (a) electronic ignition distributor, (b) spark plug wires, and (c) spark plugs.

See Figure 11. Battery voltage is available to the control board, via Wire 15A. During cranking and running conditions, circuit board action delivers the battery voltage to the electronic ignition distributor. High voltage output from the distributor is delivered through the rotor and cap to the individual spark plugs in a timed sequence.

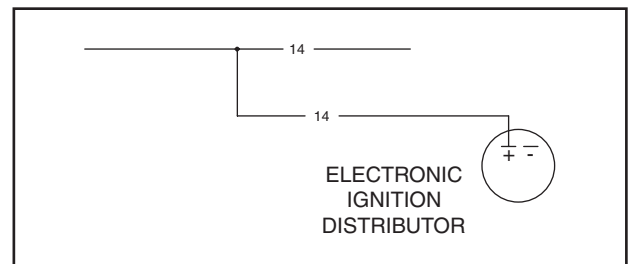

Figure 11. Engine Ignition Distributor Schematic

INTRODUCTION

The schematic diagram on this and the following pages shows the DC control system in three (3) major areas, i.e., the standby generator area, the engine, and the prepackaged transfer switch.

CIRCUIT CONDITION - UTILITY SOURCE VOLTAGE AVAILABLE

- Utility source voltage is available to transfer mechanism Terminal Lugs N1, N2, via installer attached utility source lines.
- Transfer mechanism main contacts are at their “Utility” source side, i.e., “Utility” voltage is across the closed main contacts and to transfer mechanism Terminal Lugs T1 and T2. Loads connected to lugs T1 and T2 are powered by the “Utility” supply.
- Utility source voltage is available to transfer mechanism terminals A1/A2, via Wires N1 and N2, normally-closed transfer relay (TR) contacts, and Wire 194.
- Limit switches XA1 and XB1 in the transfer mechanism are closed to their terminals B1/B2 side. Thus, the A1/A2 circuit to the main contacts actuating coil (C) is open and the actuating coil (c) is de-energized.
- Transformer (T1) action induces a reduced voltage (about 14 volts AC) into the transformer (T1) secondary coil. This reduced sensing voltage is delivered to the control board. As long as the sensing voltage remains above 60 percent of nominal rated line-to-line voltage, the control board takes no action.
- The transformer reduced sensing voltage is used to operate a “trickle charge” circuit to the unit battery. This trickle charge output is delivered to the battery from the control board via Wire 15, a 15 amp fuse (F1), and Wire 13.
- Battery power is available to the AUTO-OFF-MANUAL switch (SW1) via Wire 13, terminal 13 of terminal board TB1, Wire 13, 15 amp fuse (F1), and Wire 15. With the AUTO-OFF-MANUAL switch set to AUTO, battery power is available to the control board via Wire 15A.
- Line-to-line load voltage from transfer mechanism Terminal Lugs T1/T2 is delivered to the control board via Wires T1 FT2, transfer switch terminals T1/T2, installer connected wires, and terminals T1/T2 of the control board’s terminal board. This power is used by the circuit board to operate a 7-day exerciser circuit. Circuit Condition- Initial Utility Voltage Dropout

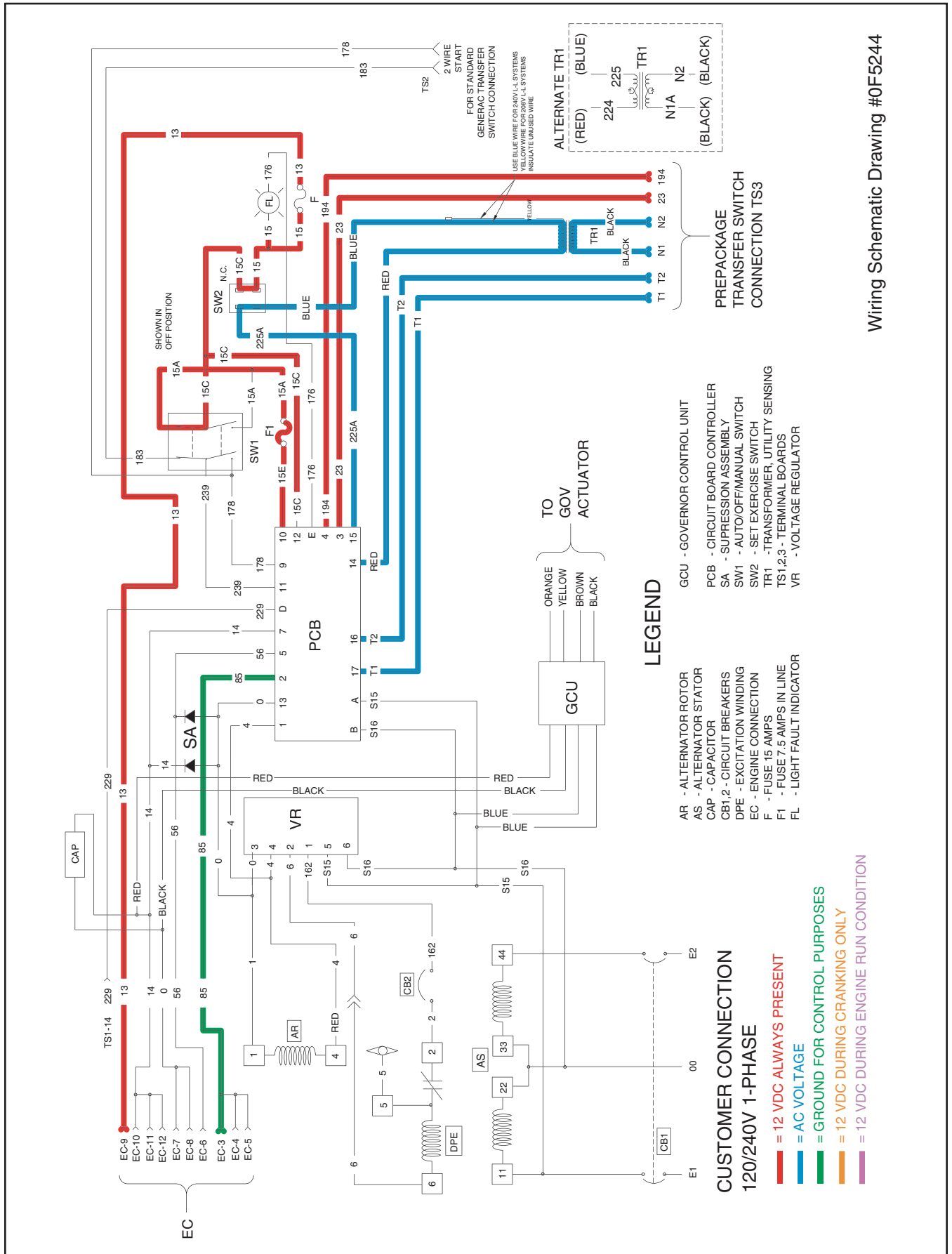

Wiring Schematic Drawing #0F5244

CIRCUIT CONDITION- INITIAL UTILITY VOLTAGE DROPOUT

- Line-to-line “Utility” current is delivered to the sensing transformer. Transformer action reduces the line-to-line voltage to approximately 14 volts AC. The reduced voltage is delivered to the control board as “Utility” sensing voltage. If “Utility” source voltage drops below about 60 percent of rated voltage, control board action will turn on a “15-second timer”.
- Voltage is unavailable from both power sources to load terminals T1/T2. Some timing loss may occur on the control board’s 7-day exerciser clock.

CIRCUIT CONDITION- CRANKING AND INITIAL STARTUP

- The control board's 15-second timer will time for 15 seconds. If "Utility" source voltage is still low after 15 seconds, a crank relay (K1) and a run relay (K2) on the circuit board will energize simultaneously.
- When the crank relay (K1) energizes, its contacts will close to deliver 12 volts DC to a control contactor (CC) coil via Wire 56. The contactor energizes and its contacts close to deliver battery power to the engine starter motor (SM). Starter motor (SM) energizes and the engine is cranked.
- On the first crank cycle circuit board action will hold crank relay (K1) energized for about 7-9 seconds, will de-energize the relay for 7-9 seconds, energize it again for 7-9 seconds, and so on. Thus, the engine will crank for 7-9 seconds, rest for 7-9 seconds, and so on. This cyclic crank/rest action will continue until either the engine starts, or has cycled through six (6) crank cycles. If the engine has not started in approximately 90 seconds, cranking will end and the fault indicator lamp will light ("overcrank" condition).
- When the engine is cranking, a DC output is delivered to the generator rotor. This is "field boost" current, which is delivered cyclically (during cranking only). See "Field Boost Circuit" on Page 2.1-4.
- When the engine run relay (K2) is energized by circuit board action, 12 volts DC is delivered to a fuel solenoid, and to the engine ignition system. The fuel solenoid (FS) is energized open, to allow fuel flow to the fuel system. Ignition occurs.
- With fuel available to the carburetor and with engine ignition occurring, the engine will start.
- Generator AC output voltage and frequency signals are available to the control board, via Wires S15 and S16.
- When generator AC output frequency reaches approximately 50% of the rated AC frequency, an "engine warm-up timer" and an "engine minimum run timer" on the control board are both turned on.

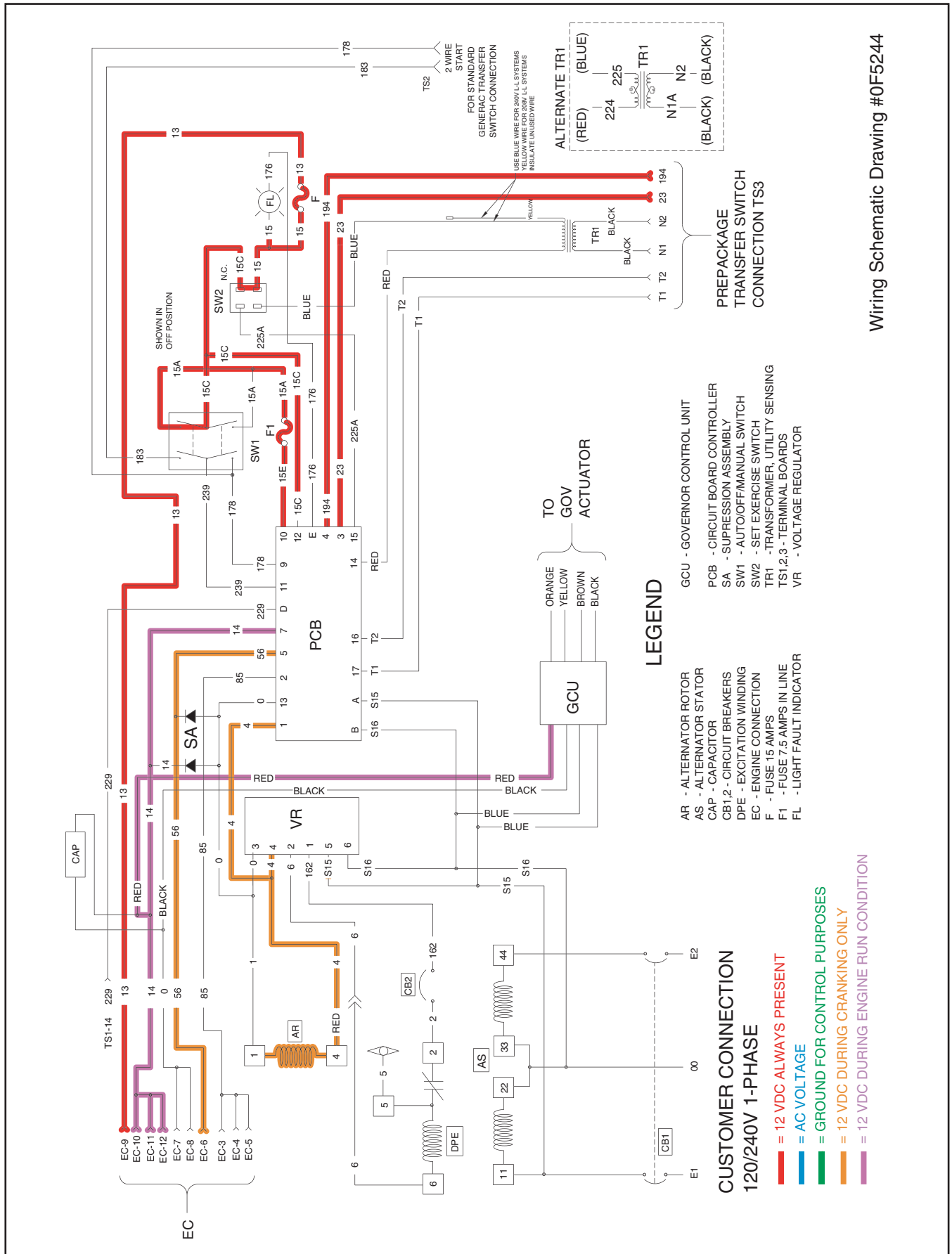

Wiring Schematic Drawing #0F5244

CIRCUIT CONDITION- INITIAL TRANSFER TO STANDBY

- The “engine warm-up timer” will run for approximately 15 seconds. The “minimum run timer” will run for about 13 minutes. Engine cannot be shut down in automatic mode until the “minimum run timer” has finished timing (prevents shutdown of a cold engine).
- At approximately 30 Hz, engine cranking terminates. The circuit board’s run relay (K2), however, remains energized.
- A DC (battery) voltage is delivered to the transfer switch’s transfer relay (TR) coil, via Wire 194. This voltage is available through the relay coil and back to the circuit board, via Wire 23. However, control board action holds the Wire 23 circuit open.
- When the “engine warm-up timer” has timed out, control board action closes the Wire 23 circuit to ground. The transfer relay (TR) energizes, its normally-closed contacts (1 & 7) open; its normally-open contacts (6 & 9) close.
- With TR normally-open contacts closed, “Standby” source power is available to the main contacts actuating coil (C), via Wires E1/E2, transfer mechanism terminals B1/B2, limit switches XA1 and XB1, and a bridge rectifier. Actuating coil (C) energizes.
- When actuating coil (C) energizes, the main current carrying contacts of the transfer mechanism are actuated to their “Neutral” position (“Load” terminals disconnected from both power supplies). The main contacts will remain at “Neutral” as long as actuating coil (C) remains energized.

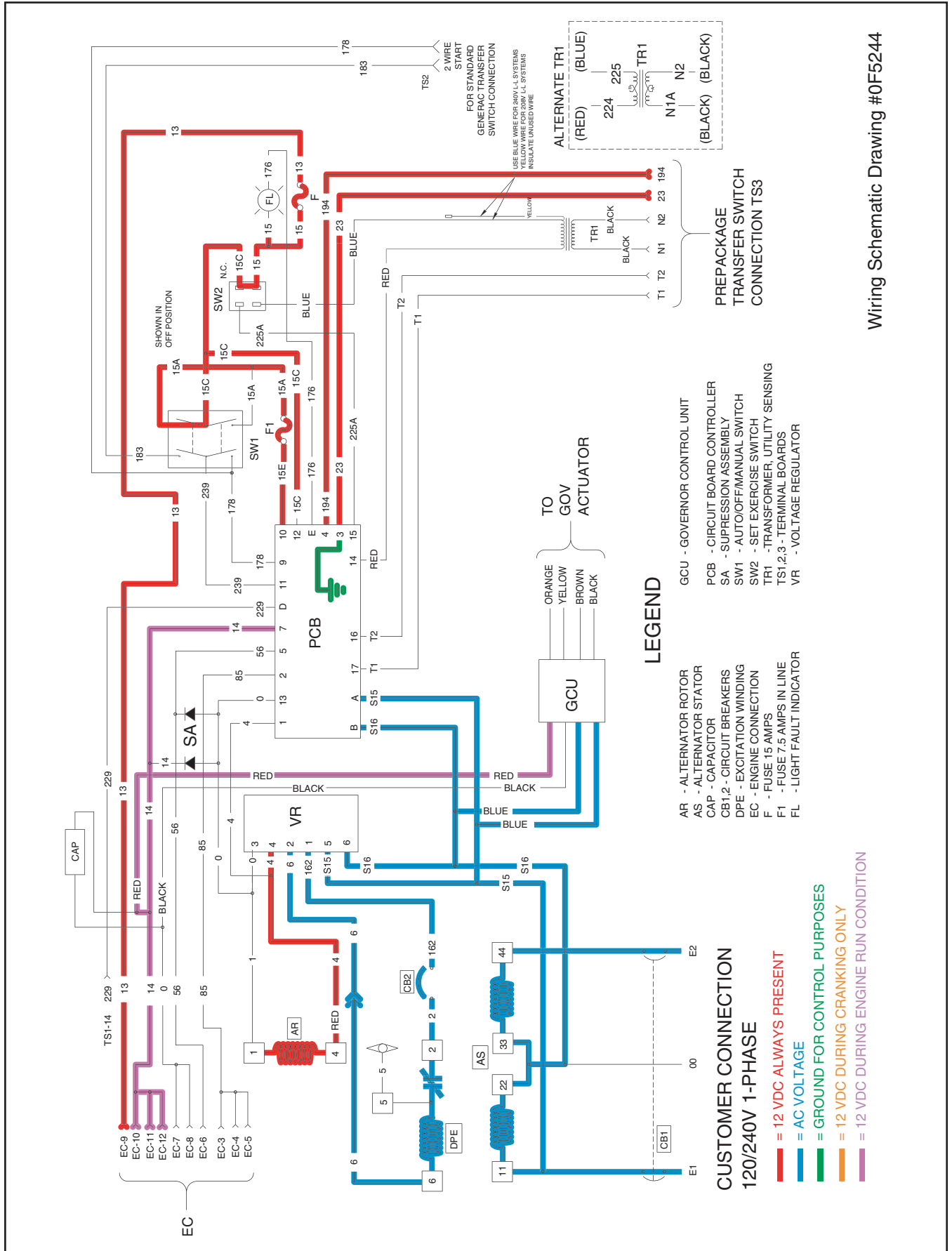

Wiring Schematic Drawing #0F5244

CIRCUIT CONDITION- FINAL TRANSFER TO STANDBY

- When the transfer mechanism's main load carrying contacts reach "Neutral" position (disconnected from both power sources), a mechanical interlock opens limit switch LS3. This opens the circuit to actuating coil (C) and the coil de-energizes.
- With coil (C) de-energized, spring force closes the main contacts to their "Standby" power source side ("Load" connected to the "Standby" source).
- As the main contacts close to the "Standby" side, a mechanical interlock actuates limit switches XA1/XB1 to their terminals A1/A2 side. This action "prepares" the circuit for retransfer back to "Utility".
- Electrical load circuits (T1/T2) are now powered by generator AC output.

CIRCUIT CONDITION- UTILITY VOLTAGE RESTORED

- Utility source line-to-line voltage is delivered directly to the sensing transformer's primary winding. A resultant sensing voltage is then delivered from the transformer's secondary winding to the control board. If the "Utility" sensing voltage is above about 80 percent of the nominal rated voltage, the control board will react.
- On restoration of "Utility" source voltage, control board action will turn on a "return to utility timer."

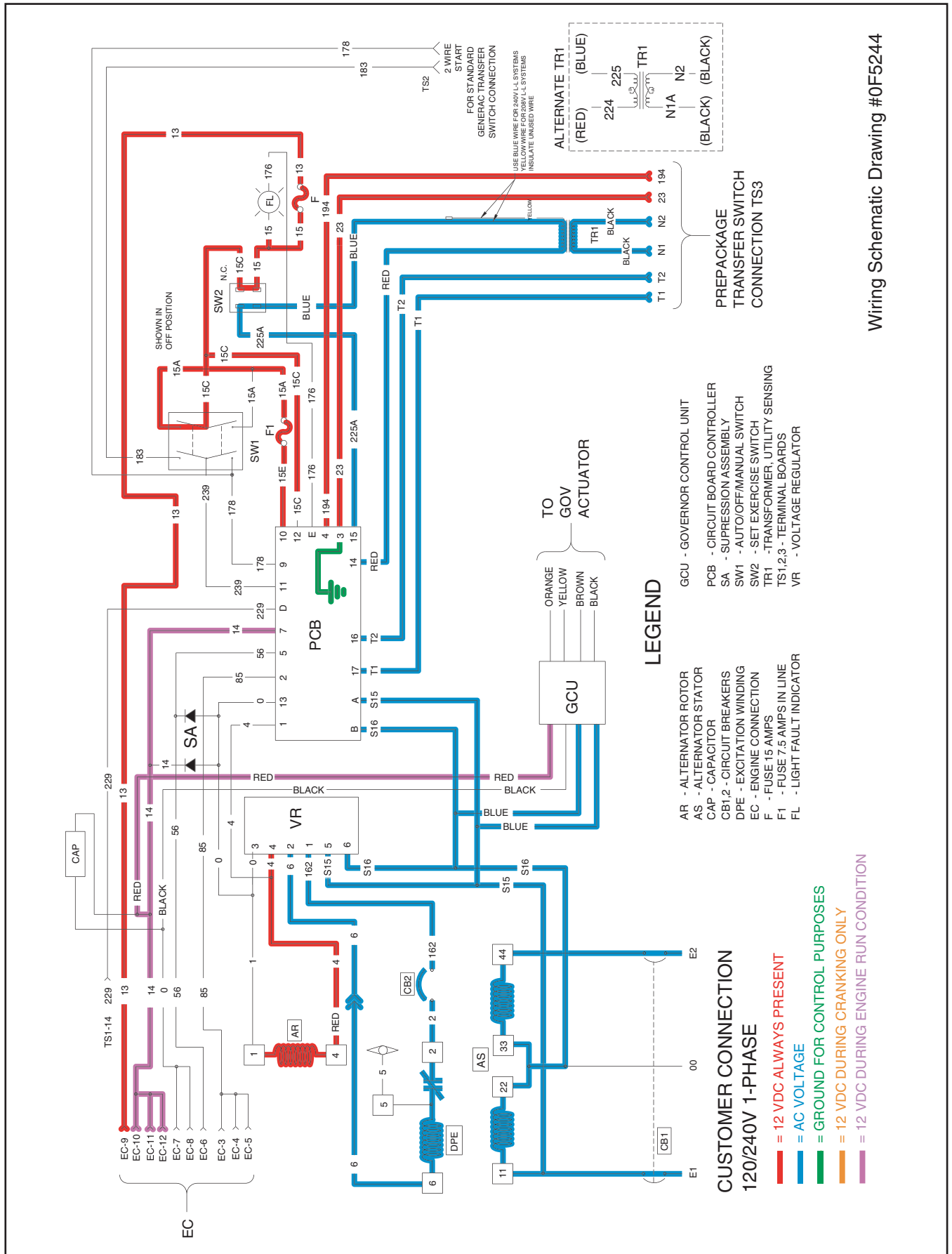

CIRCUIT CONDITION- INITIAL RETRANSFER BACK TO UTILITY

- When the “return to utility timer” times out (about 10 seconds), control board action will open the Wire 23 circuit to ground.
- With Wire 23 circuit open, the transfer relay (TR) will de-energize. The relay’s normally-closed contacts will close.
- Utility source power is now delivered to the main contacts actuating coil (C), via Wires N1/N2, the closed TR contacts, transfer mechanism terminals A1/A2, limit switches XA1/XB1, and the bridge rectifier.
- Actuating coil (C) energizes and the main contacts are pulled to their “Neutral” position. The main contacts will remain at “Neutral” (“Load” disconnect from both power supplies) as long as actuating coil (C) remains energized.

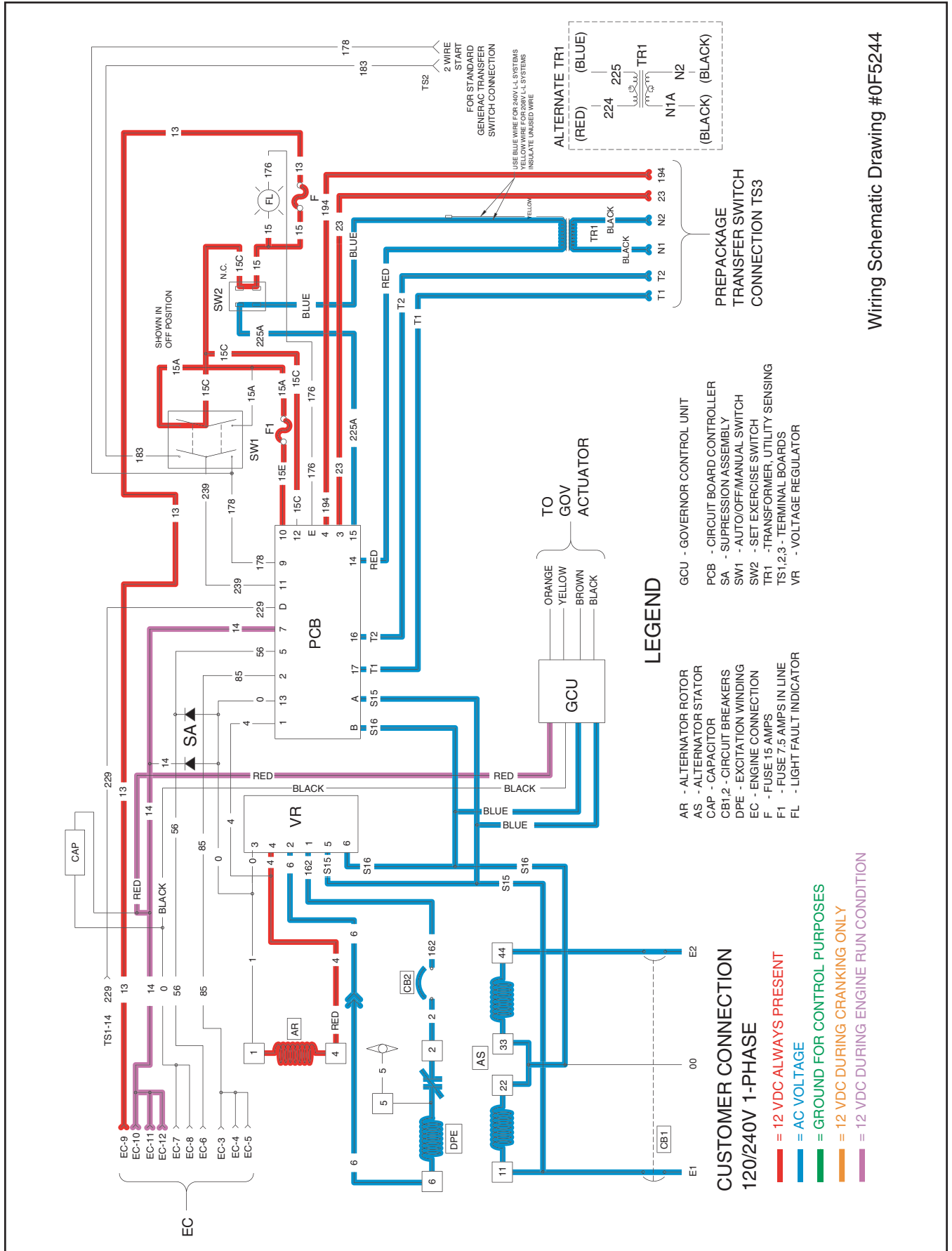

Wiring Schematic Drawing #0F5244

CIRCUIT CONDITION- FINAL RETRANSFER TO UTILITY

- When the transfer mechanism's main contacts reach "Neutral" position ("Load" disconnected from both power sources), limit switch XA1 is opened by a mechanical interlock. This opens the circuit to actuating coil (C). Coil (C) de-energizes.
- With coil (C) de-energized, spring force completes the transfer action back to the "Utility" side ("Load" connected to the "Utility" supply).
- Loads are now powered by the "Utility" power source.
- The standby generator is still running and generator AC output voltage is still available to transfer mechanism Terminal Lugs E1 and E2.
- Following retransfer back to the "Standby" source, an "engine cool down timer" starts timing. This timer will time for about 1 minute. Purpose of this timer is to allow the engine to run at no-load for about one (1) minute to stabilize internal engine-generator temperatures.

CIRCUIT CONDITION- GENERATOR SHUTDOWN

- When the “engine cool down timer” has finished timing (about 1 minute) and providing the “minimum run timer” (about 13 minutes) has also timed out, control board action will de-energize the board’s run relay.
- With the run relay de-energized, its contacts open and the 12 volts DC power supply to Wire 14 is terminated.
- The Wire 14 circuit is now “dead”. The fuel solenoid (FS) is de-energized closed, and engine ignition is terminated.
- The engine shuts down.

SECTION 4.3
TROUBLESHOOTING FLOW CHARTS

PART 4

DC CONTROL
LIQUID COOLED
ENGINE UNITS

Problem 1 - Engine Will Not Crank When Utility Power Failure Occurs

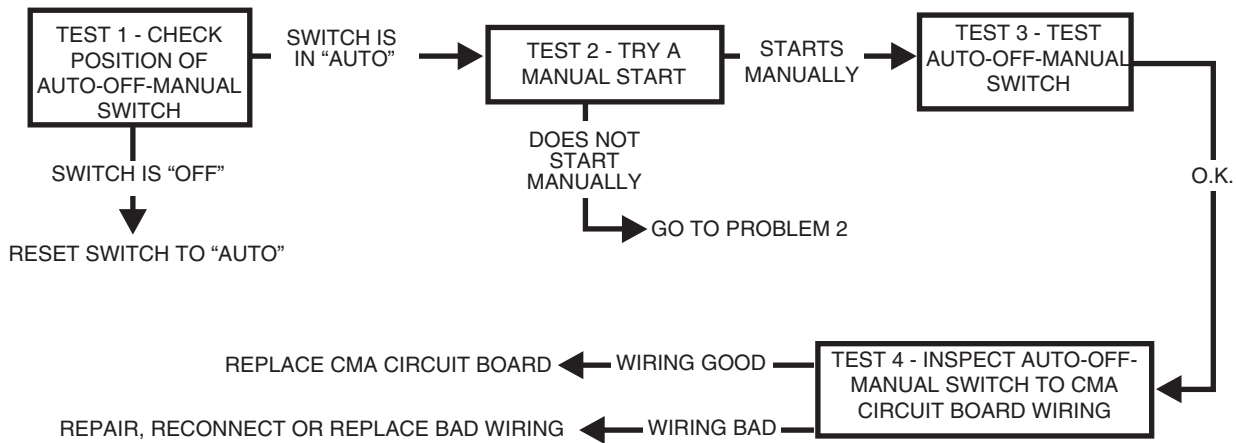

Problem 2 - Engine Will Not Crank When AUTO-OFF-MANUAL Switch is Set to "MANUAL"

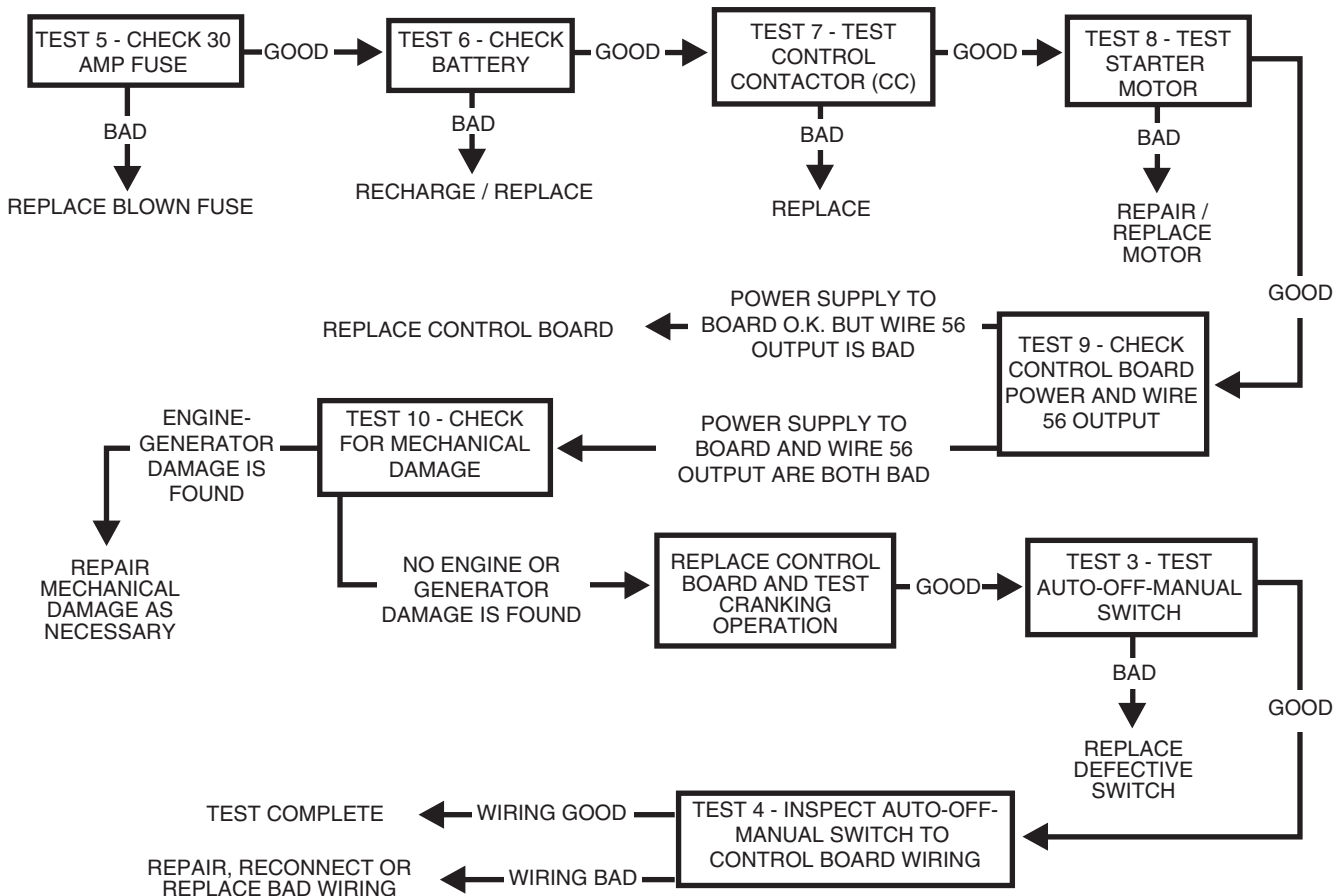

Problem 3 - Engine Cranks but Won't Start

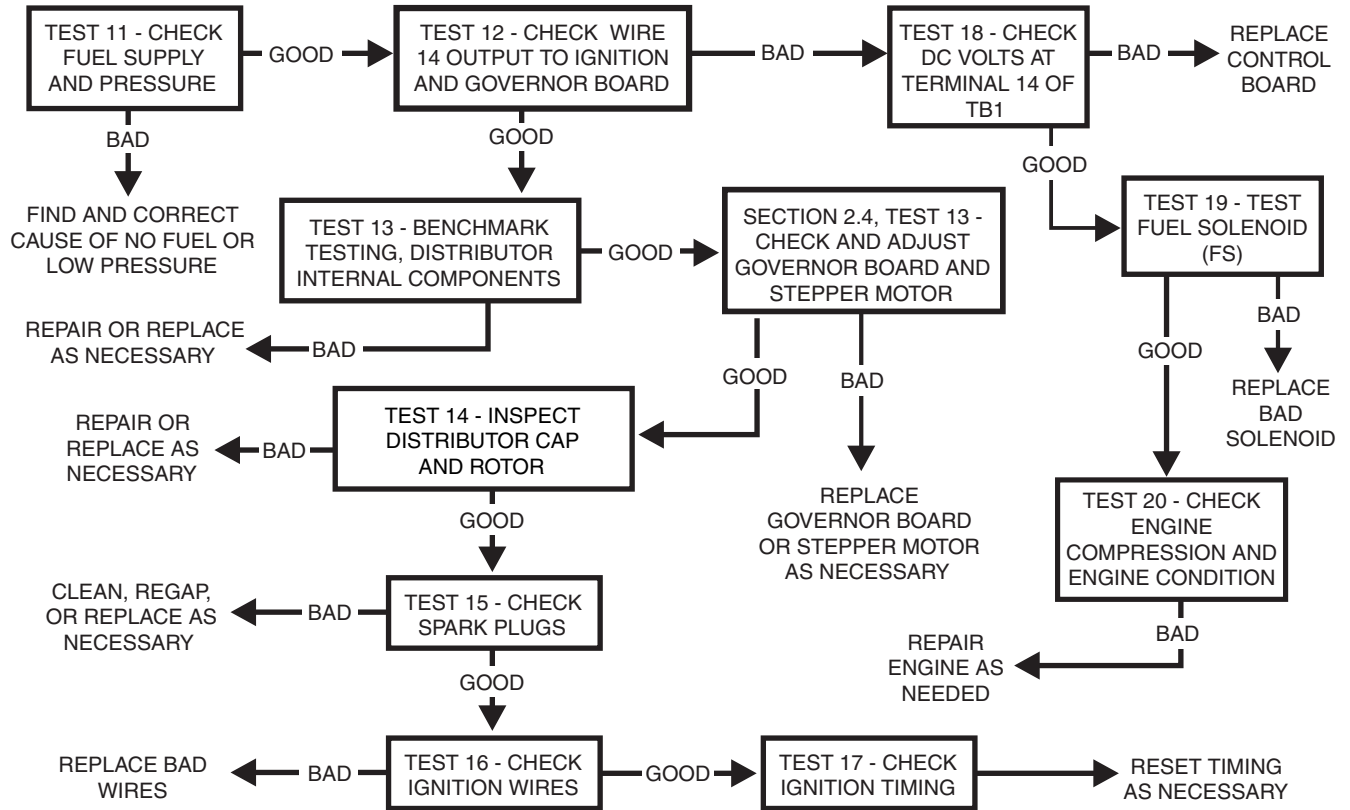

Problem 4 - Engine Cranks and Starts but Won't Transfer to Standby

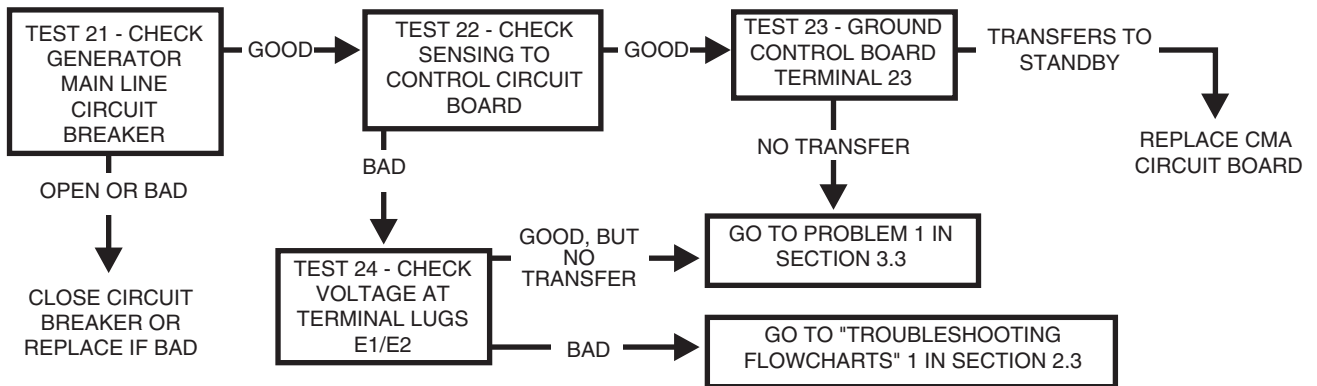

Problem 5 - Engine Starts and Transfer Occurs When Utility Power is Available

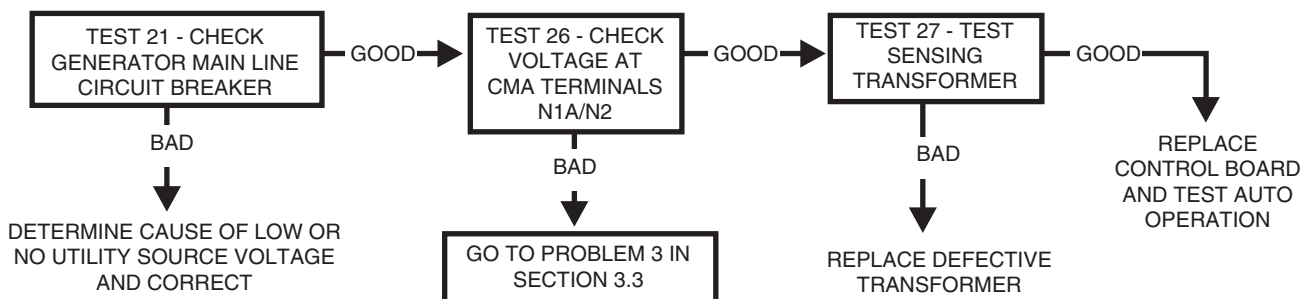

GENERAL

Perform the tests in this section in conjunction with the "Troubleshooting Flow Charts" of Section 4.3. Test numbers in this section correspond with the numbered tests in Section 4.3.

TEST 1 - CHECK AUTO-OFF-MANUAL SWITCH POSITION

DISCUSSION:

If the standby system is to operate automatically, the generator's AUTO-OFF-MANUAL switch must be set to AUTO. That is, the generator will not crank and start on occurrence of a "Utility" power outage unless that switch is at AUTO. In addition, the generator will not exercise every seven (7) days as programmed unless the switch is at AUTO.

PROCEDURE:

With the AUTO-OFF-MANUAL switch set to AUTO, test automatic operation. Testing of automatic operation can be accomplished by turning OFF the "Utility" power supply to the transfer switch. When the "Utility" power is turned OFF, the standby generator should crank and start. Following startup, transfer to the "Standby" source should occur. Refer to Section 1.8 in this manual for an "Automatic Operating Sequences Chart". Use the chart as a guide in evaluating automatic operation.

Following generator startup and transfer to the "Standby" source, turn ON the "Utility" power supply to the transfer switch. Retransfer back to the "Utility" source should occur. After a "minimum run timer" and an "engine cooldown timer" have timed out, generator shutdown should occur.

RESULTS:

1. If normal automatic operation is obtained, discontinue tests.
2. If engine does not crank when "Utility" power is turned off, go on to Test 2 of Problem 1 in Section 4.3.
3. If engine cranks but won't start, go to Problem 3 in Section 4.3.
4. If engine cranks and starts, but transfer to "Standby" does not occur, go to Problem 4 in Section 4.3.
5. If transfer to "Standby" occurs, but retransfer back to "Utility" does not occur when that source voltage is restored, go to Problem 5 in Section 4.3.

TEST 2 - TRY TO START ENGINE MANUALLY

DISCUSSION:

With the AUTO-OFF-MANUAL switch set to AUTO, a

"Utility" power source outage should result in engine cranking and startup. If that power source fails and the engine does not crank, the first step in troubleshooting should be to see if a manual startup can be accomplished.

PROCEDURE:

1. On the generator panel, set the AUTO-OFF-MANUAL switch to OFF.
2. Set the generator's main line circuit breaker to its OFF or "Open" position.
3. Set the AUTO-OFF-MANUAL switch to MANUAL. The engine should crank and start.

RESULTS:

1. If the engine will not start manually either, go to Problem 2 in the "Troubleshooting Flow Charts".
2. If the engine cranks and starts manually, but will not crank in automatic mode, go to Test 3.

TEST 3 - TEST AUTO-OFF-MANUAL SWITCH

DISCUSSION:

Power for control board operation is taken from the Wire 15 circuit (fused 12 volts DC) and delivered to the circuit board through AUTO-OFF-MANUAL switch contacts when the switch is set to AUTO or MANUAL. A defective switch can produce the same results as setting the switch to OFF (engine will not crank).

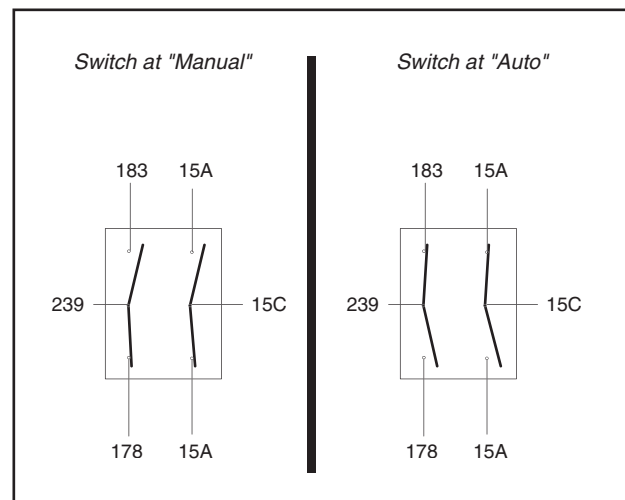

Figure 1. Schematic of AUTO-OFF-MANUAL Switch

PROCEDURE:

Disconnect all wires from switch terminals, to prevent interaction. Use a volt-ohm-milliammeter (VOM) to test for continuity across switch terminals as follows:

CONNECT ACROSS TERMINALS	SWITCH POSITION	METER READING
1 and 2	AUTO MANUAL OFF	Continuity Infinity Infinity
1 and 3	AUTO MANUAL OFF	Infinity Continuity Infinity
4 and 5	AUTO MANUAL OFF	Continuity Infinity Infinity
4 and 6	AUTO MANUAL OFF	Infinity Continuity Infinity

RESULTS:

1. Replace switch is defective.
2. If switch is good, go to Test 4.

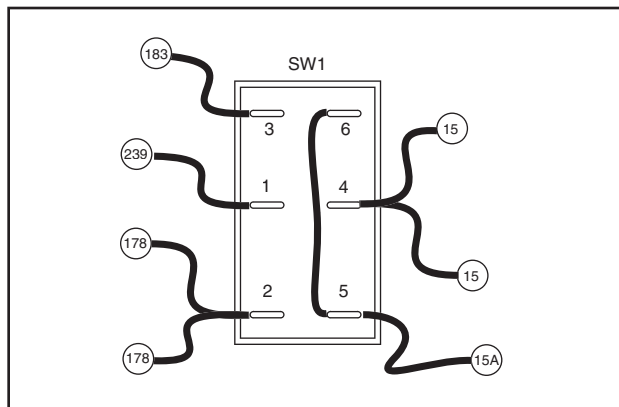

Figure 2. AUTO-OFF-MANUAL Switch Test Points

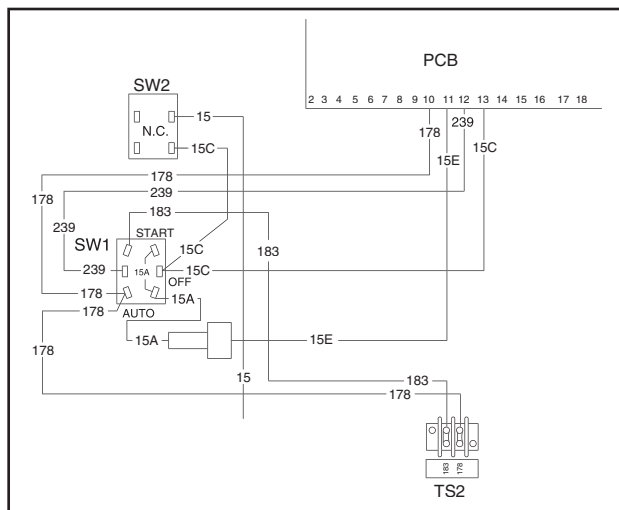

Figure 3. AUTO-OFF-MANUAL Switch Wiring

TEST 4 - INSPECT AUTO-OFF-MANUAL SWITCH TO CONTROL BOARD WIRING

DISCUSSION:

Any open or disconnected wiring between the switch and the control board, or between the switch and other components, can have the same effect as an open or defective switch. See Figure 3.

PROCEDURE:

Inspect and test all wires connected to the switch terminals for open, disconnected or shorted condition. This includes (a) Jumper Wire 15A between Switch Terminals 5 and 6; (b) Wire 15 between Terminal 4 and the circuit board; (c) Wire 15A between switch and circuit board; (d) Wire 183 between Terminal 2 and TB3; (e) Wire 239 between Terminal 1 and the circuit board; Wire 178 between Terminal 3 and TB3; (f) Wire 178 between Terminal 3 and the circuit board.

RESULTS:

Repair, reconnect or replace any bad wiring.

TEST 5 - CHECK 15 AMP FUSE (F1)

DISCUSSION:

A blown fuse F1 will open the DC power supply to the AUTO-OFF-MANUAL switch and to the control board. This will render the circuit board incapable of cranking or starting the engine, since its power supply is gone.

PROCEDURE:

Push in on fuse holder cap and turn counterclockwise to remove cap and fuse. Check the fuse with a VOM for open condition indicating that fuse is blown.

RESULTS:

1. Replace fuse if blown.
2. If fuse is good but engine won't crank, go on to Test 6.

TEST 6 - CHECK BATTERY

DISCUSSION:

Battery power is used to (a) crank the engine and (b) to power the control board. Low or no battery voltage can result in failure of the engine to crank, either manually or during automatic operation.

PROCEDURE:

A. Inspect battery Cables:

1. Visually inspect battery cables and battery posts.
2. If cable clamps or terminals are corroded, clean away all corrosion.

SECTION 4.4 DIAGNOSTIC TESTS

PART 4

DC CONTROL
LIQUID COOLED
ENGINE UNITS

3. Install battery cables, making sure all cable clamps are tight. The red battery cable (from control contactor (CC) must be securely attached to the positive (+) battery post; the black cable (from the frame ground stud) must be tightly attached to the negative (-) battery post.

B. Test Battery State of Charge:

1. Use an automotive type battery hydrometer to test battery state of charge.
2. Follow the hydrometer manufacturer's instructions carefully. Read the specific gravity of the electrolyte fluid in all battery cells.
3. If the hydrometer does not have a "percentage of charge" scale, compare the reading obtained to the following:
 - a. An average reading of 1.260 indicates the battery is 100% charged.
 - b. An average reading of 1.230 means the battery is 75% charged.
 - c. An average reading of 1.200 means the battery is 50% charged.
 - d. An average reading of 1.170 indicates the battery is 25% charged.

C. Test Battery Condition:

1. If the difference between the highest and lowest reading cells is greater than 0.050 (50 points), battery condition has deteriorated and the battery should be replaced.
2. However, if the highest reading cell has a specific gravity of less than 1.230, the test for condition is questionable. Recharge the battery to a 100 percent state of charge, then repeat the test for condition.

RESULTS:

1. Remove the battery and recharge with an automotive battery charger, if necessary.
2. If battery condition is bad, replace the battery with a new one.

TEST 7- TEST CONTROL CONTACTOR CC

DISCUSSION:

During any startup, control board action delivers 12 volts DC to the coil of a control contactor. The control contactor energizes, its contacts close, and battery power is delivered to the starter motor (SM) to crank the engine. A defective control contactor (CC) can prevent the engine from being cranked in both the automatic and manual modes of operation.

PROCEDURE:

Use a DC voltmeter (or VOM) to test control contactor (CC) operation, as follows:

1. Connect the positive (+) test lead to the control contactor's Wire 56 terminal, the common (-) test lead to a clean frame ground.
2. Set the AUTO-OFF-MANUAL switch to MANUAL. The meter should indicate battery voltage (about 12 volts DC).

RESULTS:

1. If battery voltage is not indicated, go to Step 3.
2. If battery voltage is indicated but engine does not crank, go to Step 4.
3. Connect the meter test leads across terminals 0 and 56 of terminal board TB1 (in the control console). Set the AUTO-OFF-MANUAL switch to MANUAL. The meter should read battery voltage.

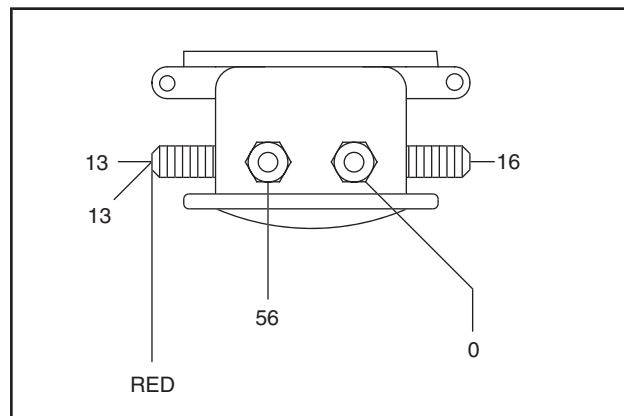

Figure 4. Control Contactor Test Points

RESULTS:

1. If battery voltage is indicated in Step 3 but not in Step 2, Wire 56 between the control contactor and terminal board TS1 is open. Repair, reconnect or replace Wire 56 as necessary.
2. If battery voltage is not indicated in either Step 2 or Step 3, replace the control board.
3. If battery voltage is indicated in both Steps 2 and 3, but the engine does not crank, go on to Step 4.
4. Connect the meter test leads across the large terminal stud on the control contactor to which the battery cable (Wire 13) attaches and frame ground. The meter should read battery voltage.
5. Now, connect the positive (+) meter test lead to the starter motor (SM) terminal stud and the common (-) test

lead to frame ground. Set the AUTO-OFF-MANUAL switch to MANUAL. The meter should read battery voltage and engine should crank.

RESULTS:

1. If battery voltage is indicated in Step 5, but engine does not crank, go on to Test 8.
2. If battery voltage is not indicated in Step 5, replace the control contactor (CC).

TEST 8 - TEST STARTER MOTOR (SM)**DISCUSSION:**

The starter motor must develop adequate torque to crank the engine efficiently at sufficient rpm for start-up to occur.

PROCEDURE:

1. Repeat Step 5 of Test 7. If battery voltage is indicated during the test, but engine does not crank, the starter is probably defective and should be replaced or repaired.
2. If desired, starter performance can be tested as follows:
 - a. Remove the starter.
 - b. See Figure 5. Connect the starter motor, a fully charged 12 volts battery, a tachometer and an ampmeter as shown.
 - c. Operate the starter motor and note the ammeter and tachometer readings. A starter motor in good condition will be within the test specifications shown below:

MAXIMUM MOTOR RPM	6000-7200
MAXIMUM AMPERES	17

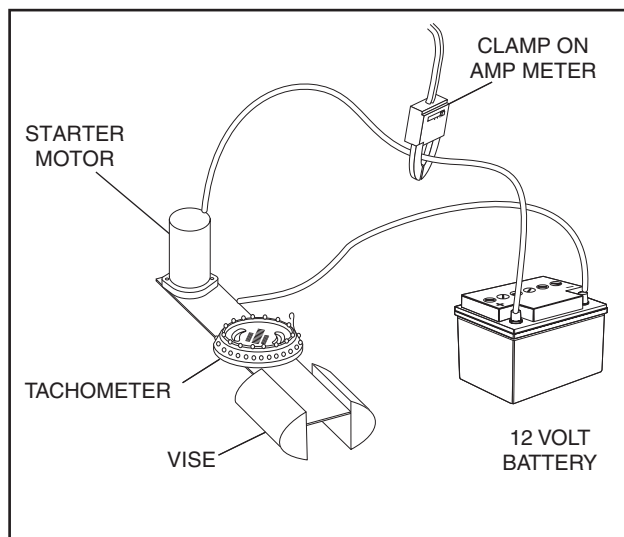

Figure 5. Starter Motor Performance Test

RESULTS:

1. Repair or replace bad starter motor.
2. If motor is good, go to Test 9.

TEST 9 - CHECK CONTROL BOARD POWER AND WIRE 56 OUTPUT**DISCUSSION:**

A 12 volt DC power supply must be available to the control board or the board will not operate. A 2 volt DC output must be delivered from the circuit board to Wire 56 or engine cranking cannot occur. In this test, you will check the DC power supply to the board and you will also check for a DC output to Wire 56.

PROCEDURE:

To check for a 12 volt DC power supply to the control board, proceed as follows:

1. See Figure 6. Connect the positive (+) test lead of a DC voltmeter (or a VOM) to terminal 4 of the AUTO-OFF-MANUAL switch.
2. Connect the common (-) meter test lead to frame ground. The meter should read 12 volts DC.
3. Now, set the AUTO-OFF-MANUAL switch to OFF.
 - a. Connect the positive (+) meter test lead to switch terminal 6; the common (-) test lead to frame ground. The meter should indicate "zero" volts.
 - b. Set the switch to MANUAL. The meter should read battery voltage.
4. Locate Pin 10 of the control board connector, to which Wire 15A attaches.
 - a. Connect the positive (+) meter test lead to Pin 10 (Wire 15A), the common (-) test lead to frame ground. Zero volts should be indicated.
 - b. Set the AUTO-OFF-MANUAL switch to MANUAL. The meter should read battery voltage.
5. Locate Pin 5 of the control board connector, to which Wire 56 attaches.
 - a. Connect the positive meter test lead to Connector Pin 5.
 - b. Connect the common meter test lead to frame ground. The meter should indicate "zero" volts.
 - c. Set the AUTO-OFF-MANUAL switch to MANUAL.

Crank relay K1 on the control board should energize and the meter should read battery voltage.

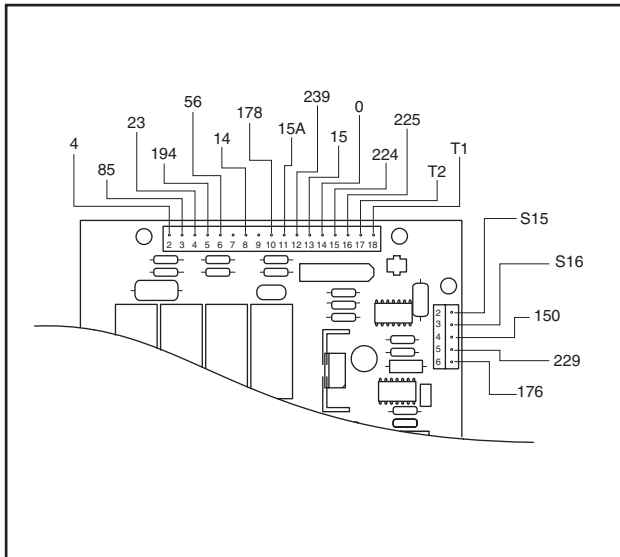

Figure 6. Check Circuit Board Power Input and Output

RESULTS:

1. In Step 2, if the meter does not indicate battery voltage, repeat Test 5. Also check the Wire 15 circuit for an open condition.
2. In Step 3, if battery voltage is not indicated when MANUAL is selected, the AUTO-OFF-MANUAL switch is suspect. Repeat Test 3 and replace the switch, if bad.
3. In Step 4(b), if battery voltage is not indicated, Wire 15A (between the AUTO-OFF-MANUAL switch and circuit board) is suspect. Reconnect, repair or replace Wire 15A as needed.
4. In Step 5, if battery voltage is not indicated, the control board is bad, Replace the circuit board and test manual and automatic operation.

TEST 10- CHECK FOR MECHANICAL DAMAGE

DISCUSSION:

If the engine will not crank when MANUAL position is selected, the problem is most likely to be an electrical fault. However, the possibility that engine or generator damage is preventing the unit from cranking cannot be overlooked.

PROCEDURE:

Examine the engine and generator carefully for evidence of seizure.

RESULTS:

If engine-generator is seized due to mechanical damage, repair the unit as necessary.

TEST 11- CHECK FUEL SUPPLY

DISCUSSION:

Often the most obvious cause of a problem is overlooked. If the engine cranks, but will not start, perhaps the fuel supply is exhausted or fuel pressure is too low. The following facts apply:

- For propane (LP) gas fuel systems, only a "vapor withdrawal" type supply system should be used on prepackaged units. The vapor pressure must be high enough to sustain engine operation.
- Minimum recommended gas pressure at the generator's fuel inlet connection is 11-14 inches water column for LP units, and 5-14 inches water column for NG units.
- The gaseous fuel system must be tested for leaks following installation and periodically thereafter. No leakage is permitted. Leak test methods and procedures must comply strictly with applicable fuel-gas codes.
- A schematic diagram of a simple propane (LP) gas vapor withdrawal system is shown in Figure 7. A typical natural gas fuel system is shown in Figure 8.

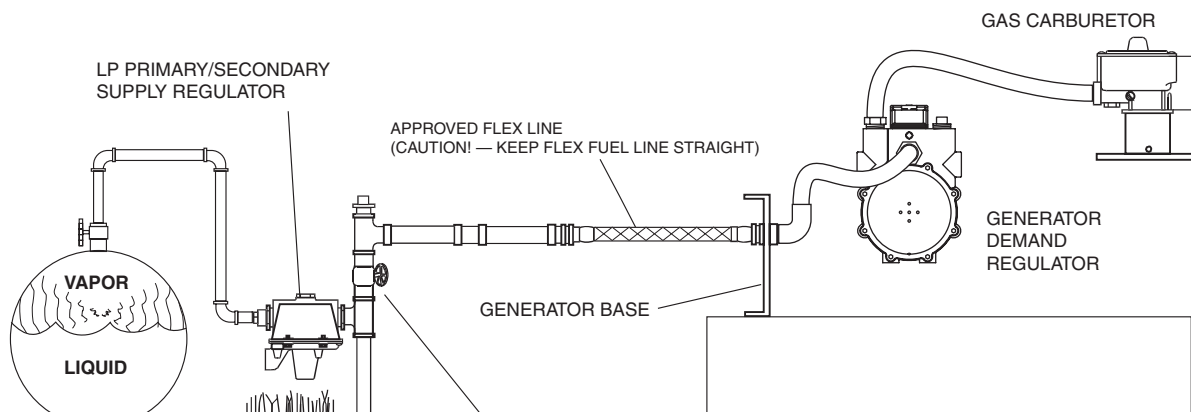

Figure 7. Typical LP Gas Fuel System

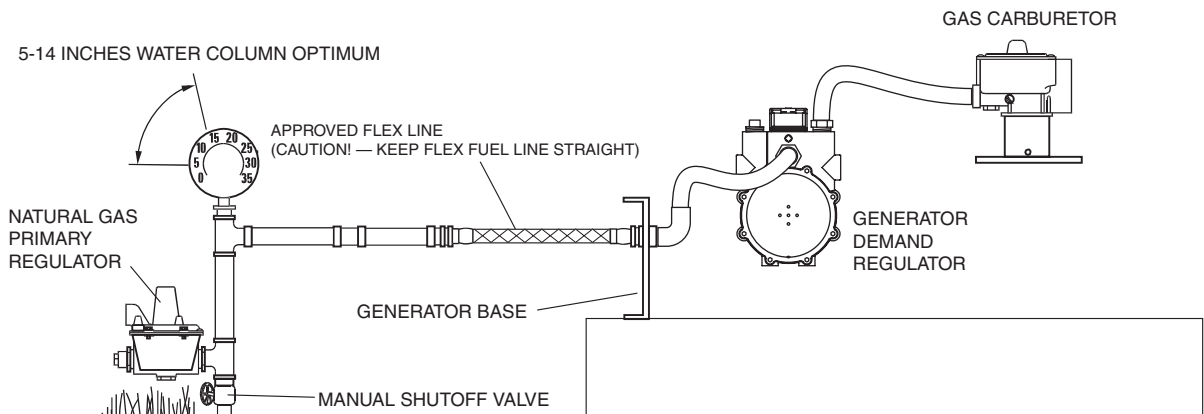

Figure 8. Typical Natural Gas Fuel System

PROCEDURE:

In the case of LP (propane) gas, some supply tanks will be equipped with a gauge that indicates when the tank is low on fuel.

For natural gas systems, the gas distribution company will usually provide piping from the main transmission line to the generator site. The primary regulator may or may not be furnished and adjusted by the supplier. It is the responsibility of the supplier to ensure that adequate gas pressure is available to operate the primary regulator.

Where the primary regulator is furnished and is to be maintained by the gas supplier, the supplier may adjust the primary regulator outlet pressure. In any event, a gas service technician should accomplish adjustment of the primary regulator pressure. Gaseous fuel pressures are usually measured with a water manometer or with a pressure gauge that reads “ounces per square inch”.

RESULTS:

If fuel supply and pressure are adequate, but engine will not start, go to Test 12.

TEST 12 - CHECK WIRE 14 OUTPUT TO DISTRIBUTOR

DISCUSSION:

When the engine is cranked either automatically or manually, a crank relay and a run relay on the control board are energized simultaneously. See Figure 9. When the engine is cranking, battery voltage is delivered to the positive (+) terminal of the distributor via Wire 14.

On startup, the crank relay de-energizes while the run relay remains energized. Battery voltage is delivered to the distributor via Wire 14.

PROCEDURE:

1. On the distributor, locate the terminal to which Wire 14 attaches.

2. Connect the positive (+) test lead of a DC voltmeter (or VOM) to the Wire 14 terminal. Connect the other test lead to a clean frame ground.
3. Set the AUTO-OFF-MANUAL switch to MANUAL. The engine should crank and the meter should indicate battery voltage.
4. On startup and when the crank relay de-energizes, the meter voltage reading should remain about the same as when cranking.

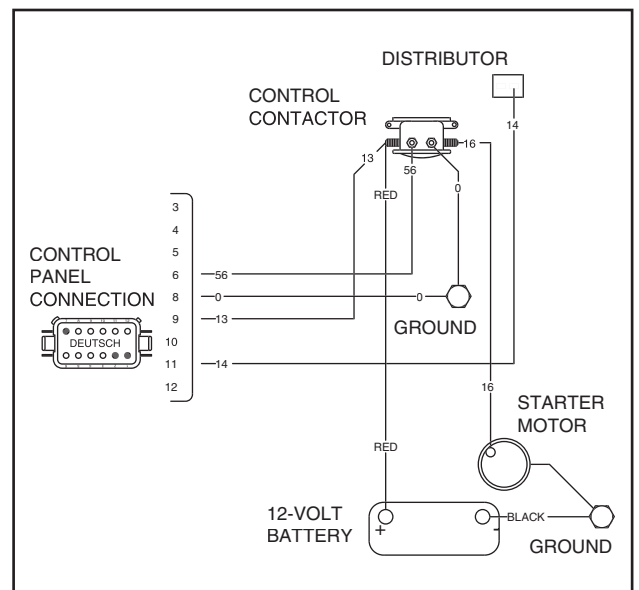

Figure 9. Typical Prepackaged Ignition Circuit

RESULTS:

1. If meter indicates battery voltage while cranking, it may be assumed that Wire 14 output to the distributor is normal. Go to Test 13.

SECTION 4.4 DIAGNOSTIC TESTS

PART 4

DC CONTROL
LIQUID COOLED
ENGINE UNITS

- If meter indicates battery voltage while cranking, but voltage drops to zero and shutdown occurs when cranking terminates, go to Test 21.

TEST 13 - BENCHMARK TESTING, DISTRIBUTOR INTERNAL COMPONENTS

DISCUSSION:

The engine distributor can be tested quickly and easily by checking the benchmark resistances across component terminals.

PROCEDURE:

- To test the coil primary winding, connect the test probes of an ohmmeter (or VOM) across the terminals of the coil and read the resistance (see Figure 10). A reading of approximately 1.3 ohms ($\pm 10\%$) should be measured at 68°F (20°C).

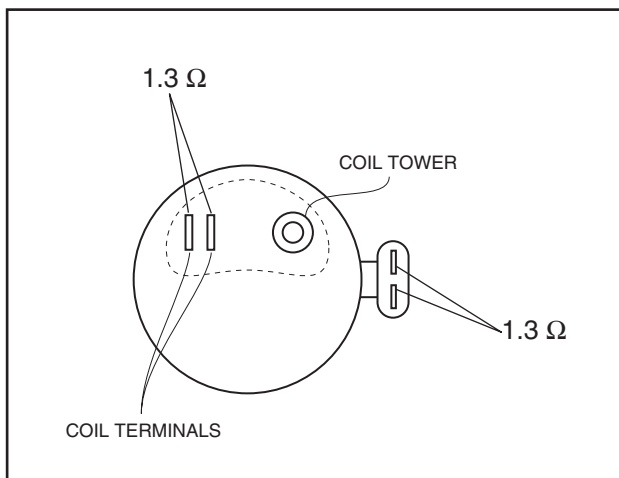

Figure 10. Testing Primary Winding Resistance

- To test secondary coil resistance, measure resistance from each coil terminal to the contact in the bottom of the coil tower (see Figure 11). The reading from each terminal to the coil tower contact should be approximately 24 kilohms ($\pm 10\%$) at 68°F (20°C).
- To test power input terminals, measure across the external power connection terminals with an ohmmeter. The reading across the two internal connector terminals should be 1.3 ohms ($\pm 10\%$) at 68°F (20°C). The reading from each terminal to ground should be 30 kilohms ($\pm 10\%$) at 68°F (20°C).

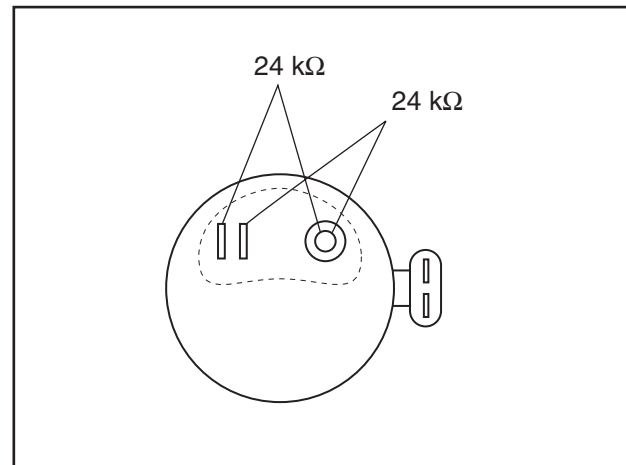

Figure 11. Testing Secondary Coil Resistance

RESULTS:

Resistances other than those indicated in Steps 1 and 2 require coil replacement. Verify that the spring is in place in the coil tower and has sufficient tension to mate with the contact in the distributor cap.

Resistance values other than indicated in Step 3 would warrant replacement of the internal ignitor and pick-up components.

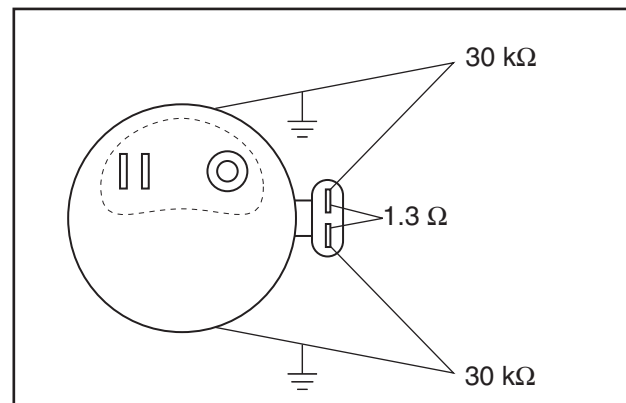

Figure 12. Testing Power Input Terminals

TEST 14 - INSPECT DISTRIBUTOR CAP AND ROTOR

DISCUSSION:

This test continues the testing of engine ignition system components.

PROCEDURE:

Inspect the distributor cap and rotor for dust, carbon deposits, cracks.

RESULTS:

1. Replace distributor cap and rotor, if defective.
2. If inspection reveals the cap and rotor are good, go on to Test 15.

TEST 15 - CHECK SPARK PLUGS**DISCUSSION:**

This test is a continuation of the tests on the engine ignition system.

PROCEDURE:

1. Disconnect spark plug wires by grasping the boot. Do NOT pull on the wires.
2. Use a spark plug wrench to remove the spark plugs.
3. Spark plugs may be cleaned in a sandblast cleaner.
4. Inspect the plug insulators for cracks and chipping. Inspect the gaskets for damage, deterioration. Check electrodes for wear, burring, or pitting. Check spark plug gap and set to 0.031-0.035 inch.
5. Replace spark plugs, if bad.
6. Install spark plugs and tighten to 14-22 foot-pounds of torque (20-29 N-m).

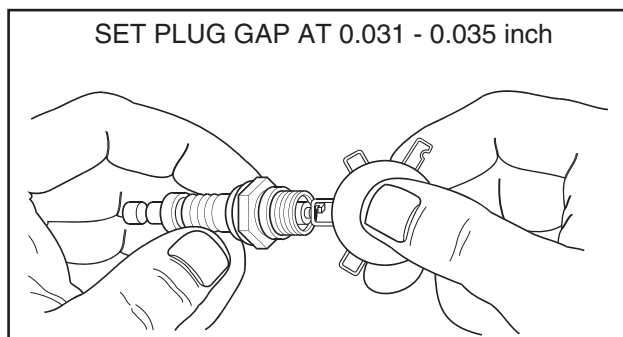

Figure 13. Checking Spark Plug Gap

NOTE: Use Champion RN11YC4 replacement spark plugs.

RESULTS:

1. Replace bad spark plugs.
2. If spark plugs are good, go to Test 19.

TEST 16 - CHECK IGNITION WIRES**DISCUSSION:**

This is a continuation of tests on the engine ignition system.

PROCEDURE:

Check high tension ignition wires for damage, cracks, burned terminals, proper fit. Measure the resistance of each wire. Shake each wire as the resistance reading is taken. Resistance should be less than 30,000 ohms.

RESULTS:

1. Replace any defective ignition wire.
2. If wires test good, go on to Test 20.

TEST 17 - CHECK IGNITION TIMING**DISCUSSION:**

If engine starts hard and runs rough, or if it does not start, it may be out of time. If badly out of time, back-firing may result.

PROCEDURE:

1. Loosen distributor hold down bolt.
2. Run engine and rotate distributor for maximum rpm.
3. Retighten distributor hold down bolt.

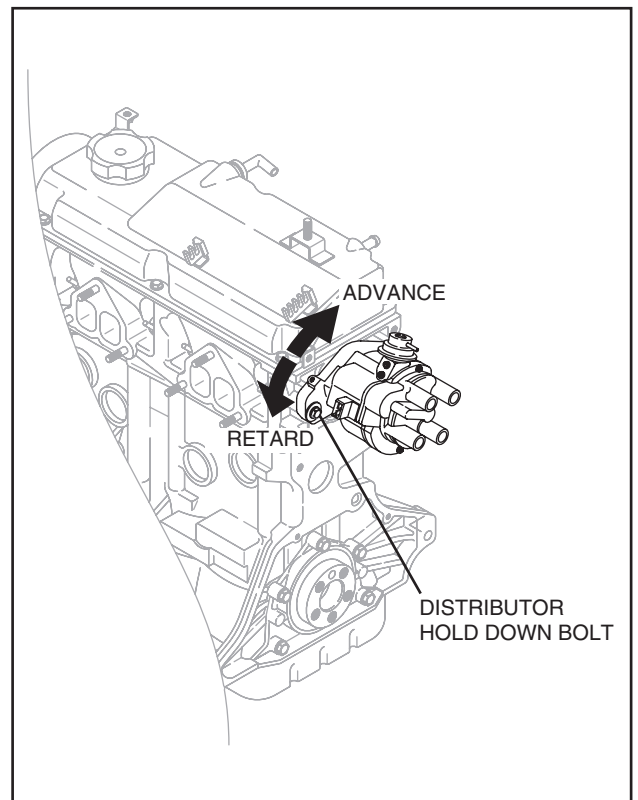

Figure 14. Distributor Hold Down Bolt

TEST 18 - CHECK DC VOLTS AT TERMINAL 14 OF TB1

DISCUSSION:

This test will determine if control board action is delivering battery voltage to the Wire 14 circuit. Wire 14 circuit voltage is required to (a) power the engine ignition system and (b) open the fuel solenoid. Terminal board TB1 is housed in the generator control console. See "Control Console Components" in Section 4.1).

PROCEDURE:

1. Use a DC voltmeter (or VOM) to check for battery voltage at Terminal 14 of terminal board TB1.
2. Connect the positive (+) meter test lead to Terminal 14, the common (-) test lead to Terminal 0 (ground).
3. Set the AUTO-OFF-MANUAL switch to MANUAL. The meter should indicate battery voltage.

RESULTS:

1. If battery voltage is not indicated, test Wire 14 between terminal board TB1 and the control board for an open condition.
 - a. If Wire 14 is good, replace the control board.
 - b. If Wire 14 is bad, repair, reconnect or replace as necessary.
2. If battery voltage is indicated, go to Test 22.

TEST 19 - TEST FUEL SOLENOID (FS)

DISCUSSION:

The fuel solenoid is opened by 12 volt DC power from Wire 14 and from the control board.

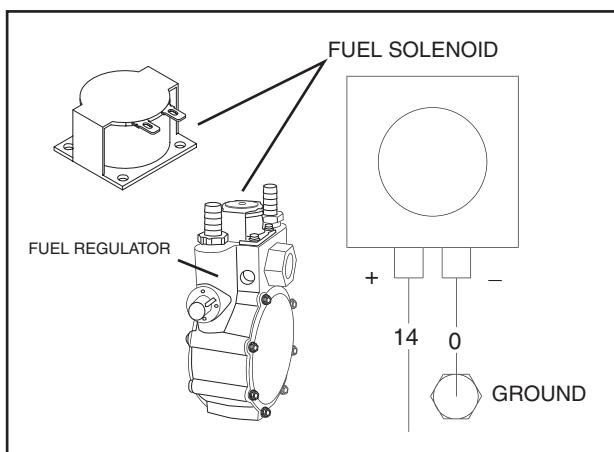

Figure 15. Fuel Solenoid (FS)

PROCEDURE:

1. Connect a DC voltmeter (or VOM) across Wire 14 at the fuel solenoid and frame ground.
2. Set the AUTO-OFF-MANUAL switch to MANUAL. The engine should crank and start. The meter should indicate battery voltage. The fuel solenoid should energize.

RESULTS:

1. If battery voltage is indicated but the fuel solenoid does not energize, replace the solenoid.
2. If the fuel solenoid is good, go on to Test 23.

TEST 20 - CHECK ENGINE COMPRESSION AND CONDITION

DISCUSSION:

If the engine cranks but will not start, or if it starts hard and runs rough, one possible cause of the problem is a mechanical failure in the engine.

PROCEDURE:

1. Warm up the engine.
2. Shut engine down and remove all spark plugs.
3. Use an automotive type compression tester to check engine compression.

NOTE: When checking compression, hold the carburetor throttle wide open. Then, crank engine and read the compression pressure.

4. Compression pressure should be as follows:

Standard = 160 psi (12.1 kg/cm²) at 350 rpm

Minimum = 120 psi (8.4 kg/cm²) at 350 rpm

Difference between cylinders should not exceed 15 psi (1.1 kg/cm²)

If compression is low in any cylinder, pour a small amount of clean engine oil into the spark plug opening. Then, retest compression and evaluate as follows:

- If compression pressure increases after adding the oil, check for worn or damaged piston rings.
- If compression pressure did NOT increase after adding the oil, check for sticking or improperly seated valves.
- If compression in any two adjacent cylinders is low and adding oil did NOT increase the compression pressure, check for a leaking head gasket

**TEST 21 - CHECK GENERATOR MAIN LINE
CIRCUIT BREAKER****DISCUSSION:**

Transfer to the "Standby" power source cannot occur unless that power supply is available to the transfer switch. If automatic startup occurs while the generator's main line circuit breaker is open, transfer to "Standby" will not occur.

PROCEDURE:

1. Check that the generator's main line circuit breaker is ON or "Closed".
2. Use an AC voltmeter (or a VOM) to check for proper generator AC output to the circuit breaker.
3. With the breaker set to ON or "Closed", check for correct AC output to the circuit breaker output terminals.

RESULTS:

1. If necessary, set the main circuit breaker to its ON or "Closed" position.
2. If normal rated AC power is available to the breaker input terminals, but not to the output terminals, replace the circuit breaker.
3. If normal rated AC power is not available to the breaker AC input terminals, refer to Part 2 of this manual.

**TEST 22 - CHECK SENSING TO CONTROL
BOARD****DISCUSSION:**

In automatic mode and when a "Utility" power source dropout occurs, the control board will initiate engine cranking and startup. A line-to-neutral voltage/frequency-sensing signal is delivered to the control board from the generator's AC power windings, via Wires S15 and S16. This sensing signal "tells" the circuit board that the engine has started and is running. Starter cutout occurs when the sensing signal voltage reaches approximately 50 volts AC. The board's minimum run and engine warm-up timers will then turn on.

Transfer of loads to the "Standby" power supply cannot occur until after the board's engine warm-up timer has timed out. Thus, if the Wires S15/S16 signal is lost, transfer will not occur. This test will determine if the line-to-neutral sensing signal is available to the control board.

PROCEDURE:

1. Set the AUTO-OFF-MANUAL switch to OFF.

2. Turn OFF both the "Utility" and "Standby" power supplies to the transfer switch.
3. If necessary, manually actuate the transfer switch main contacts to their "Utility" position ("Load" terminals connected to the "Utility" terminals).
4. Insert the test probes of an AC voltmeter across Pins A and B of the control board, to which Wires S15 and S16 attach.
5. Turn ON the "Utility" power supply to the transfer switch.
6. Set the generator's main line circuit breaker to its ON or "Closed" position.
7. Set the generator's AUTO-OFF-MANUAL switch to AUTO.
8. While observing the AC voltmeter, turn OFF the "Utility" power supply to the transfer switch.
 - a. The engine should crank and start in automatic mode.
 - b. Starter cutout should occur at approximately 30 Hertz.
 - c. With engine running at rated speed, the voltmeter should read about 122-126 volts AC.

RESULTS:

1. If correct voltage is indicated in Step 8, but transfer to "Standby" did not occur, go on to Test 26.
2. If low or no voltage is indicated in Step 8, repeat Test 24.
 - a. If correct AC voltage is indicated in Test 24, but not in Step 8 of this test, check sensing leads S15 and S16 for an open or disconnected condition.
 - b. If low or no voltage was indicated in Test 24, refer to Part 2 of this manual.

**TEST 23 - GROUND CONTROL BOARD
TERMINAL 23****DISCUSSION:**

Following automatic startup and when the control board's engine warm-up timer has timed out (15 seconds), circuit board action should connect Wire 23 circuit to ground. The transfer relay (in transfer switch) should then energize and transfer to the "Standby" source should occur. This test will determine if the control board is working properly and is grounding the Wire 23 circuit.

PROCEDURE:

1. Set the AUTO-OFF-MANUAL switch to OFF.

SECTION 4.4 DIAGNOSTIC TESTS

PART 4

DC CONTROL
LIQUID COOLED
ENGINE UNITS

2. Turn OFF both the "Utility" and "Standby" power supplies to the transfer switch using whatever means provided.
3. If necessary, manually actuate the transfer switch main contacts to their "Utility" position, i.e., "Load" connected to the "Utility" power supply.
4. Turn ON the "Utility" power supply to the transfer switch.
5. Set the generator's main line circuit breaker to its ON or "Closed" position.
6. Set the AUTO-OFF-MANUAL switch to AUTO.
7. Turn OFF the "Utility" power supply to the transfer switch.
 - a. Engine should crank and start in automatic mode.
 - b. After the control board's engine warm-up timer has timed out, the transfer relay (in transfer switch) should energize and transfer to "Standby" should occur.
8. If the engine starts and runs but transfer does NOT occur, proceed as follows:
 - a. With the engine running, connect a jumper wire across Terminal 23 of terminal board TB2 and Terminal 0 of terminal board TB1.
 - (1) The transfer relay should energize.
 - (2) Transfer to "Standby" should occur.

RESULTS:

1. In Step 8, if transfer to "Standby" occurs when the jumper wire is connected across Terminals 23 and 0, proceed as follows:
 - a. Test Wire 23 (between terminal board TB2 and the control board connector) for an open condition.
 - b. If Wire 23 is good, replace the control board.
2. In Step 8, if transfer to "Standby" does NOT occur when the jumper wire is connected, refer to Section 3.3.

TEST 24 - CHECK VOLTAGE AT TERMINAL LUGS E1 & E2

DISCUSSION:

Transfer to the "Standby" source cannot occur unless that power supply is available to the transfer switch. This test will determine if "Standby" power is available to the transfer switch terminal lugs.



DANGER: PROCEED WITH CAUTION. HIGH AND DANGEROUS VOLTAGES ARE NORMALLY PRESENT AT THE TRANSFER SWITCH TERMINAL LUGS. CONTACT WITH THESE HIGH VOLTAGE TERMINALS WILL RESULT IN EXTREMELY DANGEROUS AND POSSIBLY DEADLY ELECTRICAL SHOCK.

PROCEDURE:

1. Start the generator engine manually, let it stabilize and warm-up.
2. Set the generator's main line circuit breaker to ON or "Closed".
3. Use an AC voltmeter to test generator line-to-line voltage across transfer switch Terminal Lugs E1 and E2. Normal rated generator AC output voltage should be indicated.

RESULTS:

1. If normal "Standby" source voltage is indicated, but transfer to "Standby" does not occur, go to Section 3.3.
2. If normal "Standby" source voltage is NOT indicated, refer to "Troubleshooting Flow Charts" in Section 2.3.

TEST 25 - CHECK VOLTAGE AT TERMINAL LUGS N1 & N2

DISCUSSION:

Automatic startup of the generator engine will occur if the voltage delivered to transfer switch Terminal Lugs N1/N2 is below a preset value.

PROCEDURE:

Use an AC voltmeter to check line-to-line voltage across Terminal Lugs N1/N2. Normal rated "Utility" power source voltage should be indicated.

RESULTS:

1. If normal "Utility" voltage is read, but generator startup and transfer to "Standby" occurs in automatic mode, go to Test 29.
2. If normal "Utility" voltage is NOT indicated automatic startup and transfer is a normal condition.

TEST 26 - CHECK VOLTAGE AT CONTROL BOARD TERMINALS N1A AND N2

DISCUSSION:

"Utility" power source voltage is delivered to control board Terminals N1 and N2 (Utility 1 and 2), and from there to the control board transformer. The step-down transformer reduces this sensing voltage. The reduced sensing voltage is then delivered to the control board. If, for any reason, the reduced sensing voltage to the control board is lost, the circuit board will initiate engine startup and transfer to "Standby". This test will determine if "Utility" source voltage is available to the control board.

PROCEDURE:

With "Utility" source power available to the transfer switch, connect the test leads of an AC voltmeter across Terminals N1 and N2 of the control board terminal board. Normal rated "Utility" source voltage should be indicated.

RESULTS:

1. If voltage reading in Test 28 was good, but reading in this test is bad, go to Section 3.3.
2. If voltage reading in both Tests 28 and 29 are good, go on to Test 30.

TEST 27 - TEST SENSING TRANSFORMER**DISCUSSION:**

Normal line-to-line "Utility" source voltage is delivered to the primary winding of the control board transformer. Transformer action reduces this voltage to approximately 14 volts AC. The reduced sensing voltage is then delivered to the control board. This is a test of the control board transformer.

PROCEDURE:

1. See Figure 16. Connect an AC voltmeter across Primary Input Leads N1 and N2 (two Black Wires). Normal "Utility" power source voltage should be indicated.
2. Now, connect the meter test leads across the Red and Blue leads to check the Secondary Output.. Approximately 18 volts AC should be indicated.

RESULTS:

1. If normal "Utility" source voltage is indicated in Step 1, but not in Step 2, replace the control board transformer.
2. If the transformer checks good, but startup and transfer still occur when "Utility" power is available, replace the control board and test automatic operation.

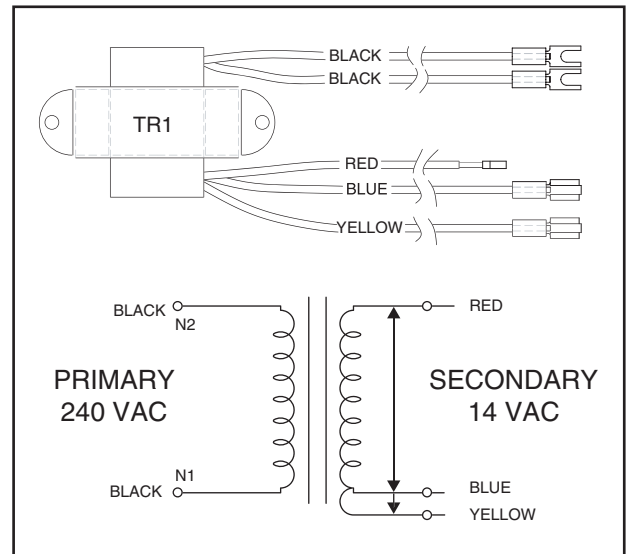

Figure 16. The Sensing Transformer

SECTION 4.4
DIAGNOSTIC TESTS

PART 4

DC CONTROL
LIQUID COOLED
ENGINE UNITS

**PART 5
OPERATIONAL
TESTS
AND
ADJUSTMENTS**

**1.5 LITER PREPACKAGED
HOME STANDBY
GENERATORS**

TABLE OF CONTENTS		
PART	TITLE	PAGE
5.1	System Functional Tests	96
5.2	Adjustments — Liquid Cooled Units	99

INTRODUCTION

Following standby electric system installation and periodically thereafter, the system should be tested. Functional tests of the system include the following:

- Manual transfer switch operation.
- System voltage tests.
- Generator Tests Under Load.
- Testing automatic operation.

Before proceeding with functional tests, read instructions and information on tags or decals affixed to the generator and transfer switch. Perform all tests in the exact order given in this section.

MANUAL TRANSFER SWITCH OPERATION

“V-TYPE” TRANSFER SWITCHES:

1. On the generator panel, set the AUTO-OFF-MANUAL switch to OFF.
2. Turn OFF the “Utility” power supply to the transfer switch using whatever means provided (such as a “Utility” main line circuit breaker).
3. Set the generator’s main line circuit breaker to OFF or “Open”.



DANGER: BE SURE TO TURN OFF ALL POWER VOLTAGE SUPPLIES TO THE TRANSFER SWITCH BEFORE ATTEMPTING MANUAL OPERATION. FAILURE TO TURN OFF POWER VOLTAGE SUPPLIES TO THE TRANSFER SWITCH MAY RESULT IN DANGEROUS AND POSSIBLY LETHAL ELECTRICAL SHOCK.

4. Remove the manual transfer handle from the enclosure.
5. Place open end of the manual transfer handle over transfer switch operating lever.
6. To connect “Load” terminal lugs to the “Standby” power source, move, the handle upward.
7. To connect “Load” terminals to the “Utility” power source, move the handle downward.
8. Actuate the switch to UTILITY and to MANUAL several times. Make sure no evidence of binding or interference is felt.
9. When satisfied that manual transfer switch operation is correct, actuate the main contacts to their “Utility” position (“Load” connected to the “Utility” power supply).

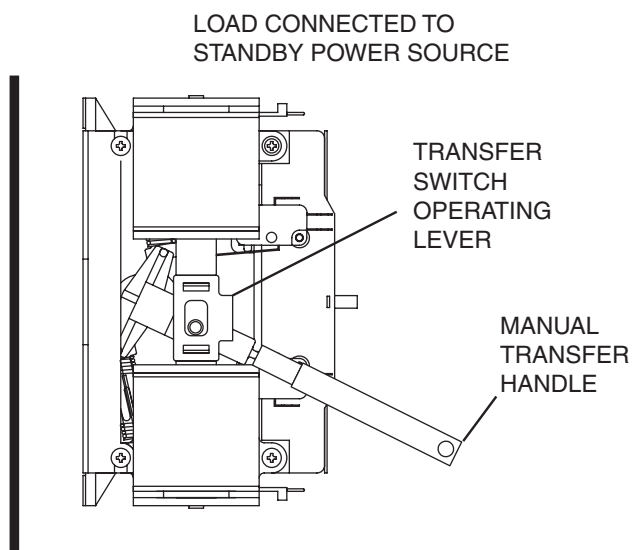
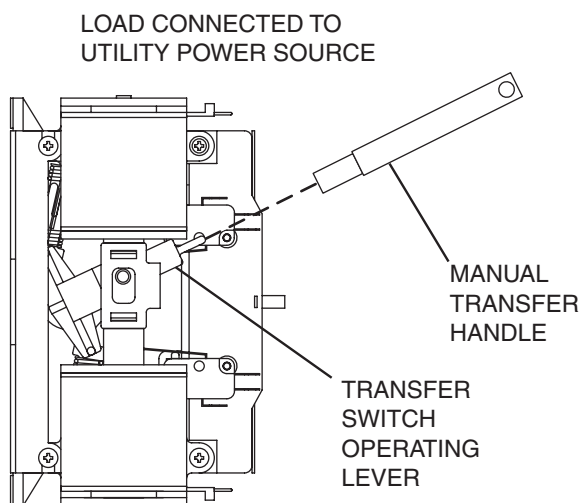

Figure 1. Manual Operation “V-Type” Switch

SYSTEM VOLTAGE TESTS

1. Turn ON the "Utility" power supply to the transfer switch using whatever means provided (such as a "Utility" main line circuit breaker).



DANGER: PROCEED WITH CAUTION. THE TRANSFER SWITCH IS ELECTRICALLY HOT. CONTACT WITH LIVE TERMINALS OR WIRES WILL CAUSE HAZARDOUS AND POSSIBLY DEADLY ELECTRICAL SHOCK.

2. Use an accurate AC voltmeter to check line-to-line voltage. On 2-pole switches, check across terminals N1 and N2. The voltage must be correct and compatible with rated transfer switch voltage, as listed on the transfer switch DATA PLATE.
3. When certain that "Utility" source voltage is correct and compatible, set the generator's AUTO-OFF-MANUAL switch to OFF.
4. Turn OFF the "Utility" power supply to the transfer switch.
5. Check that the generator's main line circuit breaker is set to ON or "Closed".
6. On the generator panel, set the AUTO-OFF-MANUAL switch to MANUAL. The engine should crank and start.
7. Let the generator engine stabilize and warm up for a few minutes.



DANGER: PROCEED WITH CAUTION. THE TRANSFER SWITCH IS ELECTRICALLY HOT. CONTACT WITH LIVE TERMINALS OR WIRES WILL CAUSE DANGEROUS AND POSSIBLY DEADLY ELECTRICAL SHOCK.

8. Use an accurate AC voltmeter to check line-to-line voltage across Terminal Lugs E1 and E2. Rated generator voltage should be indicated and must be compatible with the transfer switch rated voltage.
9. Use an accurate AC frequency meter to check for proper frequency. Connect the frequency meter test leads across Terminal E1 and the "Neutral" block. Frequency at no-load should be about 60 Hertz.
10. After all voltage and frequency measurements have been completed, set the generator's main circuit breaker to its OFF or "Open" position.

NOTE: Do NOT proceed until generator AC output voltage and frequency are correct. If no-load voltage and frequency are both correspondingly high or low, the engine governor may require adjustment. If AC frequency is good, but AC voltage is

high or low, the AC voltage regulator may require adjustment.

GENERATOR TESTS UNDER LOAD

1. Set the generator's main line circuit breaker to OFF or "Open".
2. Set the AUTO-OFF-MANUAL switch to OFF.
3. Turn OFF the "Utility" power supply to the transfer switch using whatever means provided (such as a "Utility" main line circuit breaker).
4. Manually actuate the transfer switch main contacts to their STANDBY position, i.e., "Load" connected to the "Standby" source.
5. Set the AUTO-OFF-MANUAL switch to MANUAL. The engine should crank and start. When it starts, let it stabilize and warm up for a few minutes.
6. Actuate the generator's main circuit breaker to its ON or "Closed" position.
7. Turn ON electrical loads equal to the full rated wattage/ampere capacity of the generator. DO NOT OVERLOAD THE UNIT.
8. With maximum rated load applied, check AC voltage and frequency across Transfer Switch Terminals E1/E2 (1-phase). Voltage should be greater than 230 volts AC. Frequency should be greater than 58 Hz.
9. Let the generator run at its maximum rated load for 30 minutes. Listen for unusual noises, evidence of vibration, overheating, oil and coolant leaks, etc.
10. When checkout under load is completed, set the generator's main line circuit breaker to OFF or "Open".
11. Let the generator run at no-load for a few minutes. Then, set the AUTO-OFF-MANUAL switch to OFF to stop the engine.
12. Make sure all power supplies to the transfer switch are turned OFF. Then, actuate the transfer switch back to its UTILITY position ("Load" connected to "Utility, power source").
13. Turn ON the "Utility" power supply to the transfer switch.
14. Set the AUTO-OFF-MANUAL switch to AUTO. The system is now set for fully automatic operation.

TESTING AUTOMATIC OPERATION

1. Set the generator's AUTO-OFF-MANUAL switch to OFF.

SECTION 5.1

SYSTEM FUNCTIONAL TESTS

PART 5

OPERATIONAL TESTS AND ADJUSTMENTS

2. Turn OFF both the "Utility" and "Standby" power supplies to the transfer switch.
3. If necessary, manually actuate the transfer switch main contacts to their UTILITY position, i.e., "Load" connected to the "Utility" source.
4. Turn ON the "Utility" power supply to the transfer switch.
5. Set the generator's main line circuit breaker to its ON or "Closed" position.
6. Set the generator's AUTO-OFF-MANUAL switch to its AUTO position.
7. Turn OFF the "Utility" power supply to the transfer switch.
 - a. The generator engine should crank and start.
 - b. After the control board's "engine warm-up timer" has timed out, transfer of "Load" circuits to the "Standby" power supply should occur.
8. Wait about 10-15 minutes, then turn ON the "Utility" power supply to the transfer switch.
 - a. After about six (6) seconds, retransfer back to the "Utility" source should occur.
 - b. After an "engine cool down timer" (one minute) has timed out and after any time remaining on an "engine minimum run timer" has elapsed, the engine should shut down.

NOTE. The "engine minimum run timer" comes on during startup in automatic mode. Engine must run for about 13 minutes before it can be shut down automatically. The timer prevents shutdown of a cold engine. Engine can be shut down manually at any time.

SETTING WEEKLY EXERCISE CYCLE

The generator will start and exercise once every seven (7) days, on a day and at a time of day selected by the installer or operator. The unit will run for approximately 13-15 minutes during this “exercise” cycle, and will then shut down. Transfer of electrical loads to the “standby” power source will not occur during the exercise.

A switch located on the generator control console permits the day and time of exercise to be selected. To select the day and time of day for the system to exercise, proceed as follows:

- Place the AUTO-OFF-MANUAL switch to its OFF position.
- Hold the set exercise time switch at its ON position for about five (5) seconds.
- After five seconds, release the set exercise time switch to its OFF position. Wait 30 seconds, then place the AUTO-OFF-MANUAL switch at AUTO. The generator will exercise every seven (7) days at the selected time.

NOTE: Failure to wait 30 seconds before placing the AUTO-OFF-MANUAL switch to AUTO may result in engine cranking and startup. If the engine does crank and start, it will shut-down automatically within about two (2) minutes.

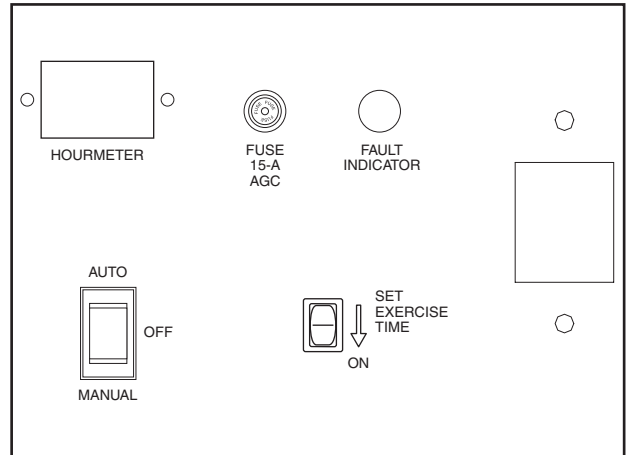

Figure 1. The “Set Exercise Time” Switch

ENGINE STEPPER MOTOR ELECTRONIC GOVERNOR

INTRODUCTION:

The governor system consists of a governor module mounted inside the generator control panel, a stepper motor mounted near the carburetor, and interconnecting wires and connection boxes. (See Figure 2)

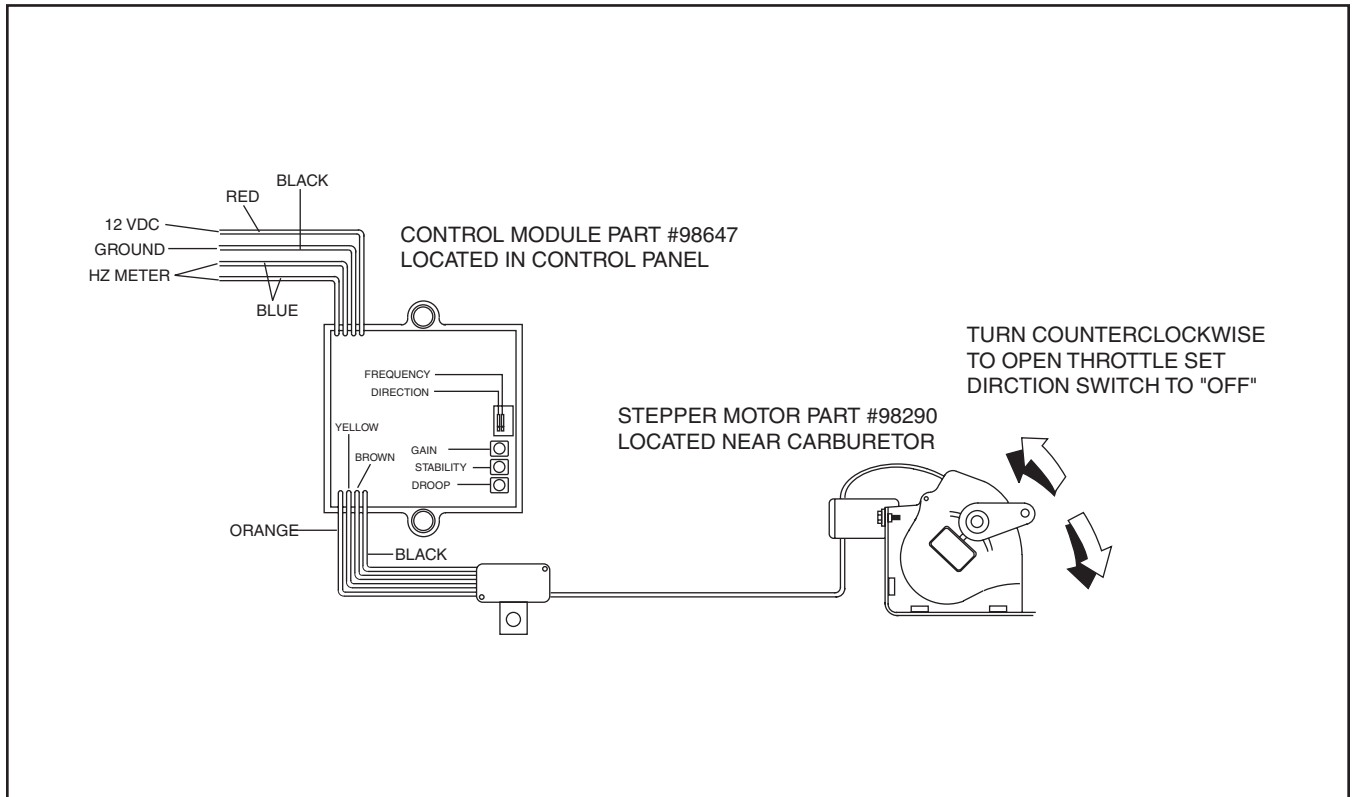

Figure 2. Stepper Motor and Control Module

OPERATIONAL ANALYSIS

During the engine start-up and run, +12 volts DC is applied to the control module via the red (+ positive) and black (- negative) wires. The voltage from the main engine control latch/crank PCB Wire 14 (run circuit) powers up the control module for governor system operation. The control module receives a speed “sensing” signal from AC output frequency via the two (2) blue wires.

The control module sends variable signals to the stepper motor via the orange, yellow, brown and black wires to position the stepper motor and throttle linkage to obtain a steady 50 or 60 Hz. (selectable on the control module frequency switch)

SET-UP AND ROD LENGTH ADJUSTMENT PROCEDURE

STEPPER MOTOR/THROTTLE LINKAGE

Determine which direction the stepper motor must rotate to open the throttle to “full fuel”. Adjust the rod length so when the throttle is wide open, the stepper motor is at it’s full rotation, then tighten the jam nuts. Ensure linkage moves freely and does not bind in any way.

CONTROL MODULE POTS AND SWITCHES

The following is description of the adjustment procedure for the electronic governor control module and stepper motor. (See Figure 2)

POT SETTINGS:

Set GAIN, DROOP, and STABILITY pots to midpoint.

SWITCH SETTINGS:

Set frequency switch to the OFF position (60 Hz). Frequency switch set to ON is for 50 Hz operation.

SET DIRECTION SWITCH:

The lever arm opens the throttle by rotating in the counterclockwise direction. The direction switch should be set in the OFF position.

When the switches and pots are set correctly, start the engine. Adjust the gain pot if necessary to stabilize engine speed.

- Apply a 25-50% load to system. If system is unstable, reduce gain until it stabilizes.
- Adjust droop pot so that the engine speed recovers to the pre-selected speed. (50 or 60 Hz based on unit).
- Observe performance of system when loads are applied and removed.
- Increasing stability will decrease recovery time, but may result in damped oscillations (decreasing hertz around preset speed). Decreasing stability will soften the recovery and reduce the transient hertz.

Frequency and direction switches are integrated only at engine start. Changing switch settings while engine is running will have no effect until the engine is stopped and restarted.

VOLTAGE REGULATOR ADJUSTMENT

GENERAL:

For additional information on the prepackaged AC voltage regulator, see “The Excitation Circuit” in Section 2.1 of this manual.

Before adjusting the voltage regulator for correct AC voltage output, make sure engine governed speed is correct.

ADJUSTMENT PROCEDURE:

1. Connect an accurate AC voltmeter and frequency meter across the generator’s AC output leads. Readings of line-to-line voltage may be used.
2. Start the engine, let it stabilize and warm up at no-load.
3. Check the AC frequency reading. Frequency should be as close as possible to 60 Hertz at no-load. Adjust the engine governor, if necessary.
4. With engine running at correct speed (frequency), slowly turn the slotted potentiometer on the regulator to obtain the proper AC voltage as follows:
 - a. For units rated 120/240 volts AC, the no-load line-to-line voltage should be as close as possible to 242 volts (240-244 volts).
 - b. For units rated 120/208 volts AC, the no-load line-to-line voltage should be as close as possible to 210 volts (208-212 volts).

NOTE: The no-load voltage is generally proportional to AC frequency. For units rated 240 volts, the no-load (line-to-line) voltage at 62 Hertz will be approximately 248 volts. For units rated 120/208 volts, the no-load (line-to-line) voltage will be about 215 volts.

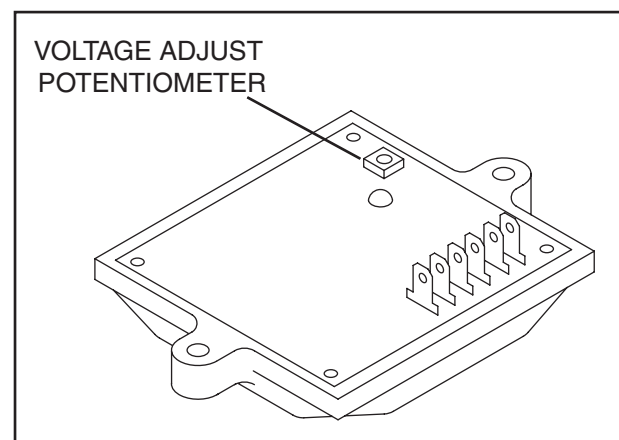

Figure 5. Voltage Regulator

**PART 6
ELECTRICAL
DATA**

**1.5 LITER PREPACKAGED
HOME STANDBY
GENERATORS**

TABLE OF CONTENTS		
DWG #	TITLE	PAGE
0E6093-B	"V-Type" Transfer Switch 100 Amp, 2-Pole	102
0F0015-A	"V-Type" Transfer Switch 100/200 Amp, 2-Pole	104
0E0345	Wiring Diagram 1-Phase Liquid Cooled Generator	106
0E1525	Schematic 1-Phase Liquid Cooled Generator	107
0E0343-B	Wiring Diagram 1.5 Liter Liquid Cooled Engine	108
0A7182-C	Schematic 1.5 Liter Liquid Cooled Engine	109
	Electrical Formulas	110

"V-TYPE" TRANSFER SWITCH 100 AMP, 2-POLE

PART 9

ELECTRICAL DATA

DRAWING #0E6093-B

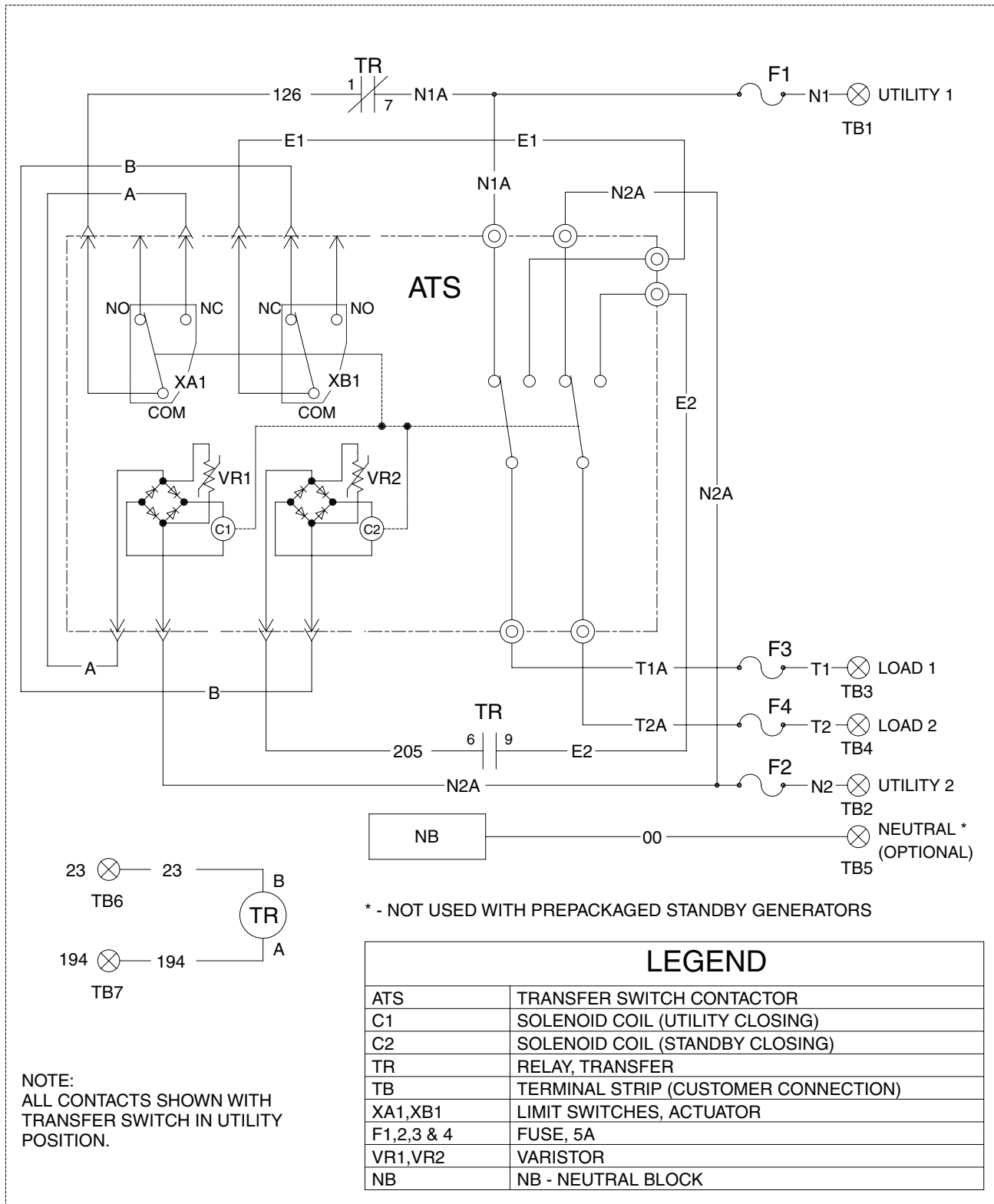

NOTE:
ALL CONTACTS SHOWN WITH
TRANSFER SWITCH IN UTILITY
POSITION.

* - NOT USED WITH PREPACKAGED STANDBY GENERATORS

LEGEND	
ATS	TRANSFER SWITCH CONTACTOR
C1	SOLENOID COIL (UTILITY CLOSING)
C2	SOLENOID COIL (STANDBY CLOSING)
TR	RELAY, TRANSFER
TB	TERMINAL STRIP (CUSTOMER CONNECTION)
XA1, XB1	LIMIT SWITCHES, ACTUATOR
F1, 2, 3 & 4	FUSE, 5A
VR1, VR2	VARISTOR
NB	NB - NEUTRAL BLOCK

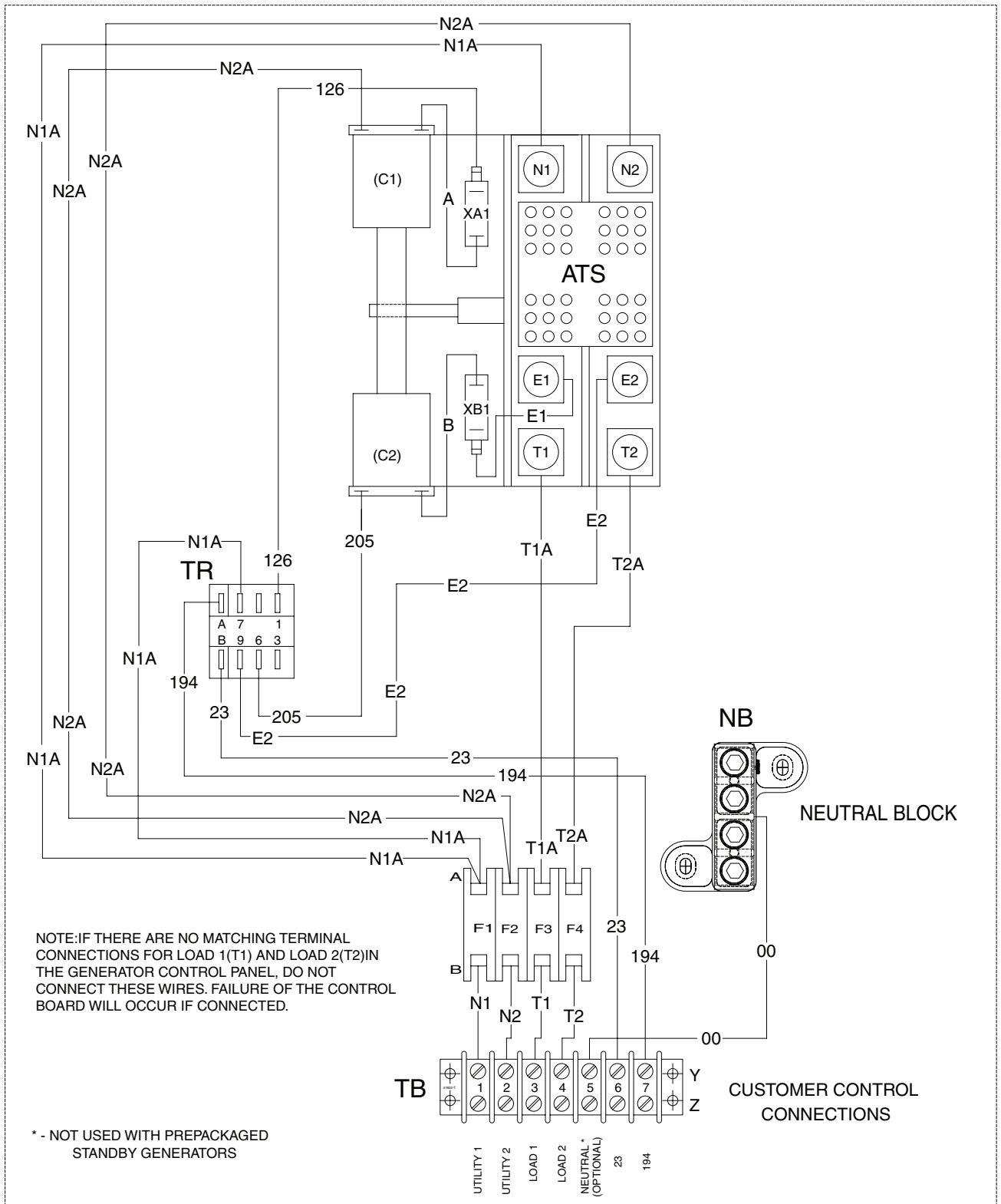

"V-TYPE" TRANSFER SWITCH 100/200 AMP, 2-POLE

PART 9

ELECTRICAL DATA

DRAWING #0F0015-A 1 of 2

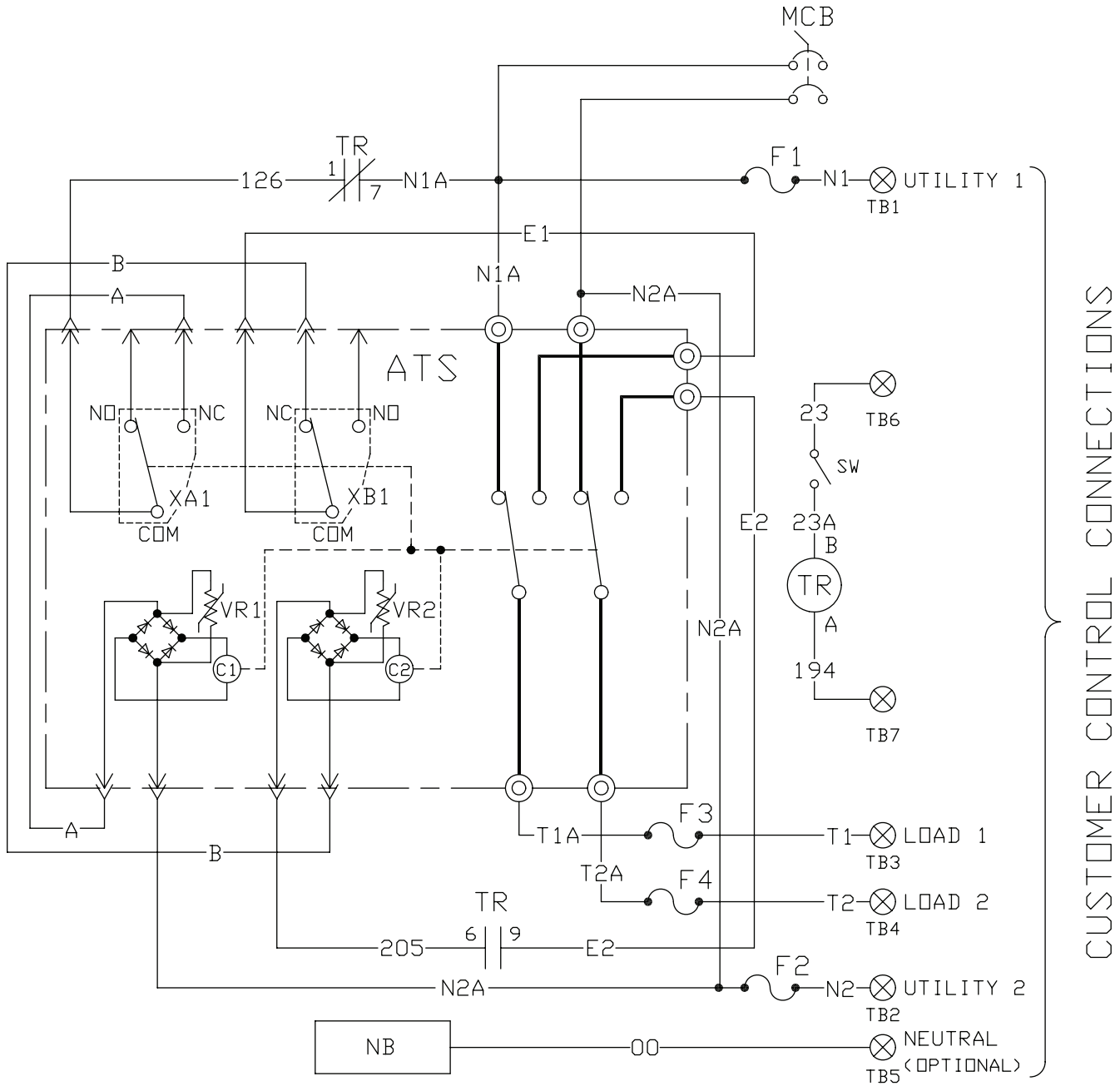

CUSTOMER CONTROL CONNECTIONS

NOTE:
ALL CONTACTS SHOWN WITH
TRANSFER SWITCH IN UTILITY
POSITION.

LEGEND	
ATS	TRANSFER SWITCH CONTACTOR
C1	SOLENOID COIL (UTILITY CLOSING)
C2	SOLENOID COIL (STANDBY CLOSING)
F1, F2, F3, F4	FUSE, 5A
MCB	MASTER CIRCUIT BREAKER
NB	NB - NEUTRAL BLOCK
SW	SWITCH, GENERATOR DISCONNECT
TB	TERMINAL STRIP (CUSTOMER CONNECTION)
TR	RELAY, TRANSFER
VR1, VR2	VARISTOR
XA1, XB1	LIMIT SWITCHES, ACTUATOR

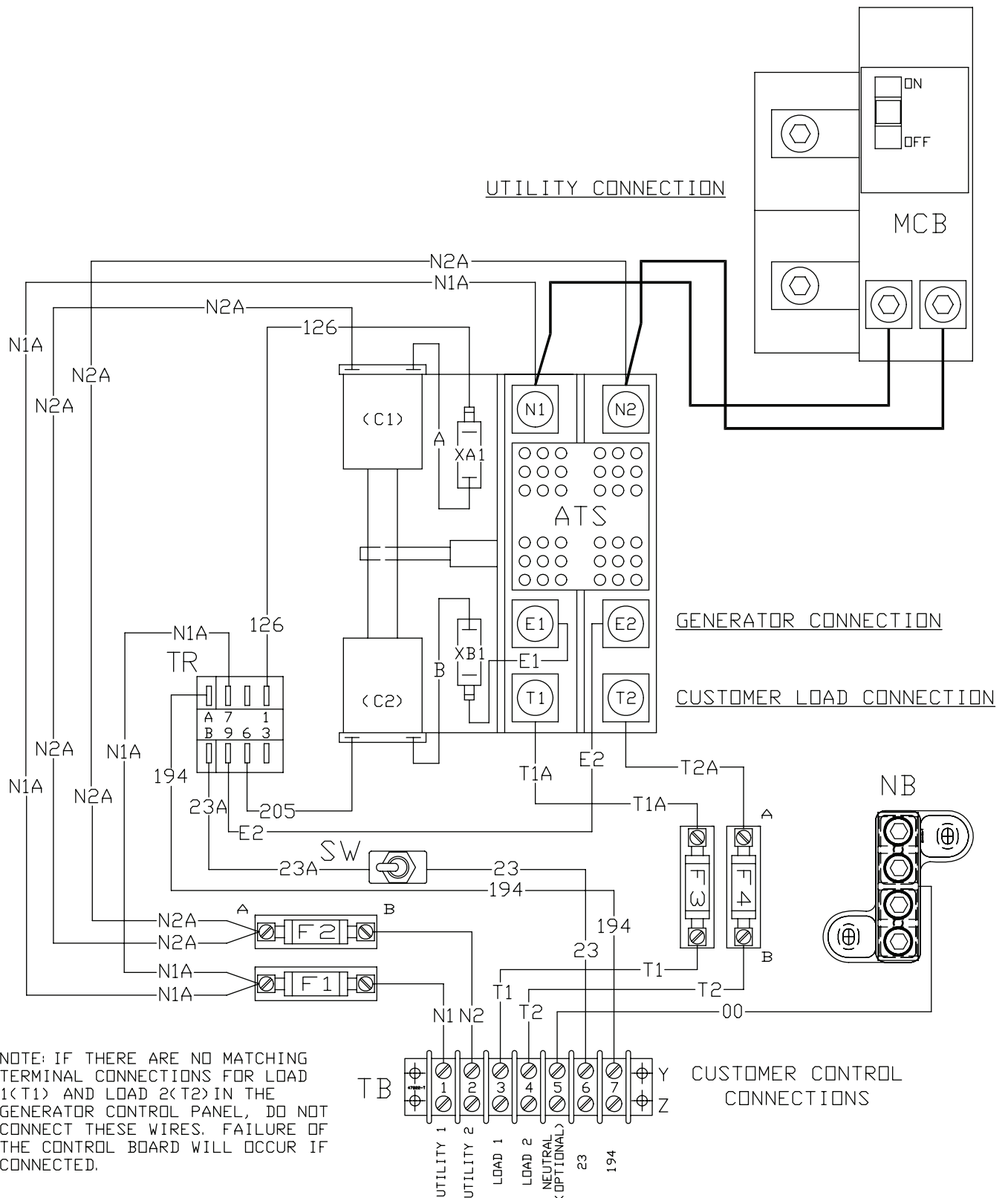

NOTE: IF THERE ARE NO MATCHING TERMINAL CONNECTIONS FOR LOAD 1 (T1) AND LOAD 2 (T2) IN THE GENERATOR CONTROL PANEL, DO NOT CONNECT THESE WIRES. FAILURE OF THE CONTROL BOARD WILL OCCUR IF CONNECTED.

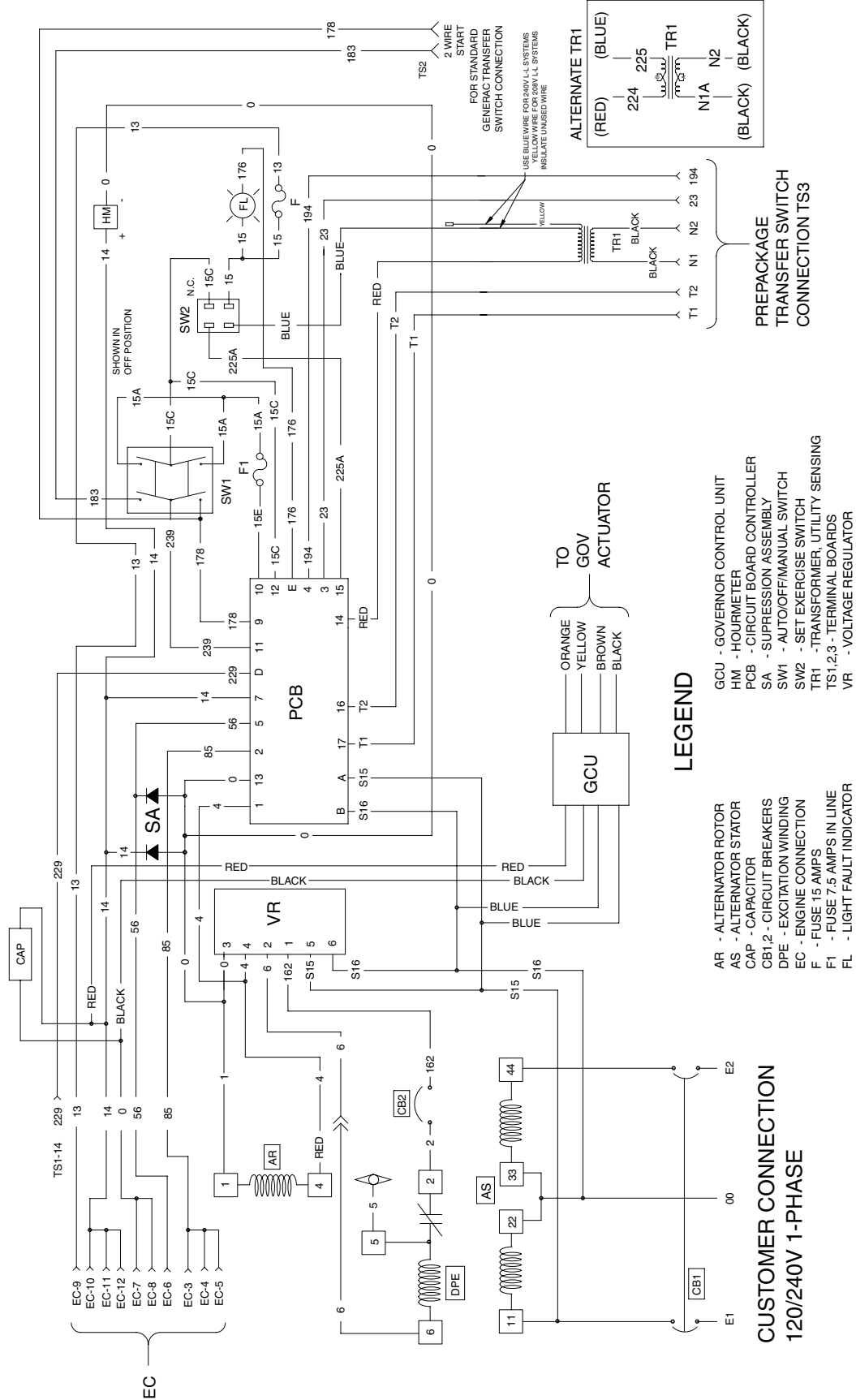

LEGEND

- AR - ALTERNATOR ROTOR
- AS - ALTERNATOR STATOR
- CAP - CAPACITOR
- CB1,2 - CIRCUIT BREAKERS
- DPE - EXCITATION WINDING
- EC - ENGINE CONNECTION
- F - FUSE 15 AMPS
- F1 - FUSE 7.5 AMPS IN LINE
- FL - LIGHT FAULT INDICATOR
- GCU - GOVERNOR CONTROL UNIT
- HM - HOURMETER
- PCB - CIRCUIT BOARD CONTROLLER
- SA - SUPPRESSION ASSEMBLY
- SW1 - AUTO/OFF/MANUAL SWITCH
- SW2 - SET EXERCISE SWITCH
- TR1 - TRANSFORMER, UTILITY SENSING
- TS1,2,3 - TERMINAL BOARDS
- VR - VOLTAGE REGULATOR

**CUSTOMER CONNECTION
120/240V 1-PHASE**

WIRING DIAGRAM 1.5 LITER LIQUID COOLED ENGINE

PART 9

ELECTRICAL DATA

DRAWING #0E0343-B

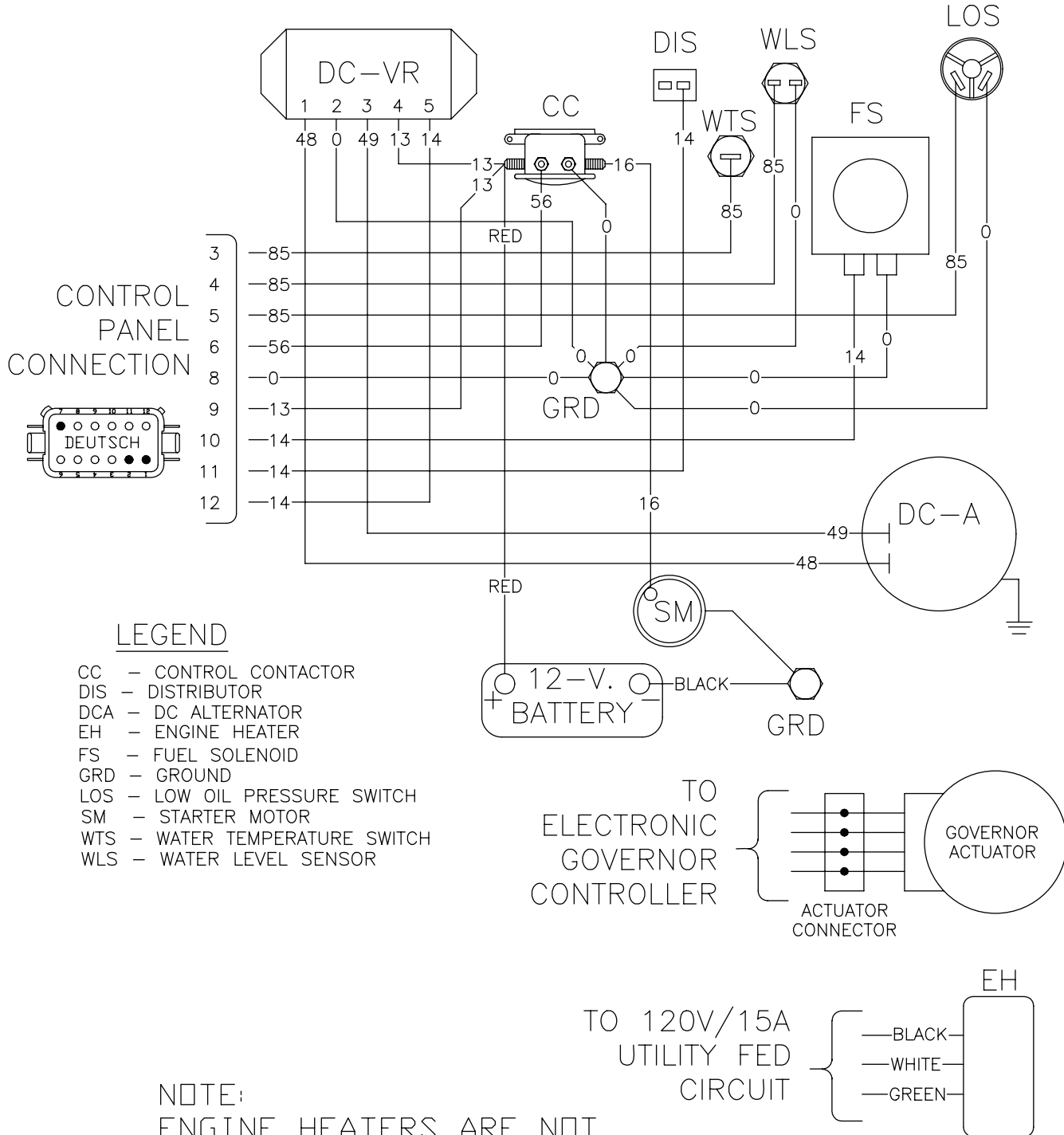

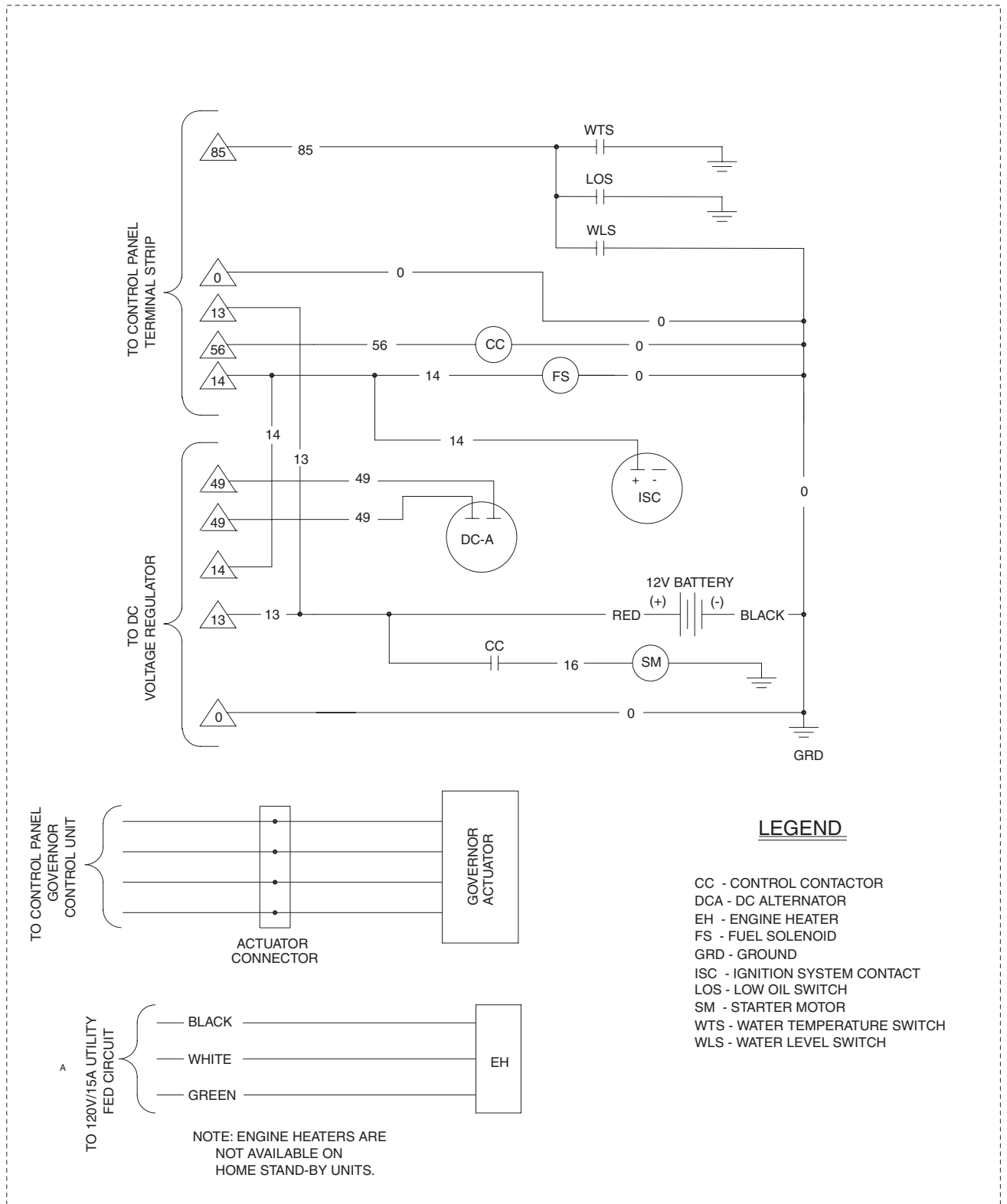

ELECTRICAL FORMULAS

PART 9

ELECTRICAL DATA

TO FIND	KNOWN VALUES	1-PHASE	3-PHASE
KILOWATTS (kW)	Volts, Current, Power Factor	$\frac{E \times I}{1000}$	$\frac{E \times I \times 1.73 \times PF}{1000}$
KVA	Volts, Current	$\frac{E \times I}{1000}$	$\frac{E \times I \times 1.73}{1000}$
AMPERES	kW, Volts, Power Factor	$\frac{kW \times 1000}{E}$	$\frac{kW \times 1000}{E \times 1.73 \times PF}$
WATTS	Volts, Amps, Power Factor	Volts x Amps	$E \times I \times 1.73 \times PF$
NO. OF ROTOR POLES	Frequency, RPM	$\frac{2 \times 60 \times \text{Frequency}}{\text{RPM}}$	$\frac{2 \times 60 \times \text{frequency}}{\text{RPM}}$
FREQUENCY	RPM, No. of Rotor Poles	$\frac{\text{RPM} \times \text{Poles}}{2 \times 60}$	$\frac{\text{RPM} \times \text{Poles}}{2 \times 60}$
RPM	Frequency, No. of Rotor Poles	$\frac{2 \times 60 \times \text{Frequency}}{\text{Rotor Poles}}$	$\frac{2 \times 60 \times \text{Frequency}}{\text{Rotor Poles}}$
kW (required for Motor)	Motor Horsepower, Efficiency	$\frac{HP \times 0.746}{\text{Efficiency}}$	$\frac{HP \times 0.746}{\text{Efficiency}}$
RESISTANCE	Volts, Amperes	$\frac{E}{I}$	$\frac{E}{I}$
VOLTS	Ohm, Amperes	$I \times R$	$I \times R$
AMPERES	Ohms, Volts	$\frac{E}{R}$	$\frac{E}{R}$

E = VOLTS

I = AMPERES

R = RESISTANCE (OHMS)

PF = POWER FACTOR

PO BOX 297
WHITEWATER, WI 53190
www.guardiangenerators.com

P/N 0F7698 Rev. 0 / Printed in the USA / 8.05

