

DIAGNOSTIC REPAIR Manual

**STANDBY/PRIME
ELECTRIC
POWER
SYSTEMS**
All Series

GENERAC

C O R P O R A T I O N

*P. O. Box 8
Phone: (414) 544-4811*

*Waukesha, WI 53187
FAX: (414) 544-4851*

IMPORTANT SAFETY NOTICE

Proper service and repair is important to the safe, economical and reliable operation of all standby electric power systems. The troubleshooting, testing and servicing procedures recommended by Generac and described in this manual are effective methods of performing such operations. Some of these operations or procedures may require the use of specialized equipment. Such equipment should be used when and as recommended.

It is important to note that this manual contains various DANGER, CAUTION, and NOTE blocks. These should be read carefully in order to minimise the risk of personal injury or to prevent improper methods or practices from being used. Use of improper or unauthorised practices may damage equipment or render it unsafe. The DANGER, CAUTION and NOTE blocks are not exhaustive. Generac could not possibly know, evaluate and advise the service trade of all conceivable ways in which operations described in this manual might be accomplished or of the possible hazardous consequences of each way. Consequently, Generac has not taken any such broad evaluation. Accordingly, anyone who uses any troubleshooting, testing or service procedure that is not recommended by Generac must first satisfy himself that neither his safety nor the equipment's safety will be jeopardised by the procedure or the method he selects.

LIST OF CHANGES

This manual has been revised, corrected or changed as listed below. The manual's current revision date is located on the lower left corner of the front cover.

- Revision 1 (10/31/92): Added section 1.5, "Mechanical Engine Governors"; Section 1.6, "Electronic Engine Governors"; and Section 1.7, "Diesel Engine Governors".
- Revision 2 (05/08/93): Revised Section 1.2, "Types of Stator Connection Systems" to reflect new Voltage codes.
- Revision 3 (10/02/93): Added Sections 3.6, "Permenant Magnet Generators", and 3.7 "Testing PMG Units". Also added Section 11.7, "Inphase Monitor Control".
- Revision 4 (11/07/96): Added "Stepper Motor Governor" to Section 1.6, updated Section 3.6 "PMG's", added Section 7.6 "18 Lamp Annunciator", and updated Section 11.7 "Inphase Monitor Control".

NOTICE:

A "Technical Publications Catalog" P/N 91021 is available which lists other Diagnostic, Repair, and Parts manuals, including Engine Repair and Generator Installation information. This catalog and any other manuals can be ordered through your regular source of Generac Parts.

DIAGNOSTIC REPAIR MANUAL

STANDBY ELECTRIC POWER SYSTEMS All Series

TABLE OF CONTENTS	
PART	TITLE
1	Introduction to Standby Electric Power Systems
2	Direct Excited AC Generators
3	Brushless AC Generators
4	"Marathon®" AC Generators
5	Options A & B Control Consoles
6	Option C Control Console
7	Generator Options & Accessories
8	"Y-Type" Automatic Transfer Switches
9	"Wn" Type Automatic Transfer Switches
10	The "CPU" Type Intelligence System
11	The "Logic" Type Intelligence System
12	Transfer Switch Options

NOTICE

A "WIRING DIAGRAMS & ELECTRICAL SCHEMATICS" manual for standby electric power systems is available from Generac. To order, specify Manual Part No. 87691.

NOTES

**PART 1
INTRODUCTION
TO STANDBY
ELECTRIC
POWER
SYSTEMS**

**STANDBY
ELECTRIC
POWER
SYSTEMS**

All Series

TABLE OF CONTENTS	
SECTION	TITLE
1.1	Standby Generator Identification
1.2	Types of Stator Connection Systems
1.3	Standby Electric System Familiarization
1.4	Generator Maintenance and Testing
1.5	Mechanical Engine Governors
1.6	Electronic Engine Governors
1.7	Diesel Engine Governors

Section 1.1 STANDBY GENERATOR IDENTIFICATION

Introduction

Generac standby generators are often unique products which have been engineered and designed to the specifications of a specific buyer. Differences in design, ratings, attached options and accessories, etc., may exist between units.

To aid in the proper identification of each generator set, the following have been provided at the factory:

- A DATA PLATE has been prominently affixed to the generator.
- One or more DATA CARDS have been shipped with each unit.

Data Plate

See Figure 1. The typical data plate shown lists valuable information pertaining to the standby generator, including Model Number, Serial Number, rated voltage, rated maximum continuous current (amperes), Kva rating, phase, rated AC frequency, rpm, and kilowatts.

ALTERNATOR DATA

MODEL	<input type="text"/>	KVA	<input type="text"/>
SERIAL	<input type="text"/>	PHASE	<input type="text"/>
VOLTS	<input type="text"/>	HERTZ	<input type="text"/>
AMPS	<input type="text"/>	RPM	<input type="text"/>
POWER FACTOR	<input type="text"/>	KW	<input type="text"/>

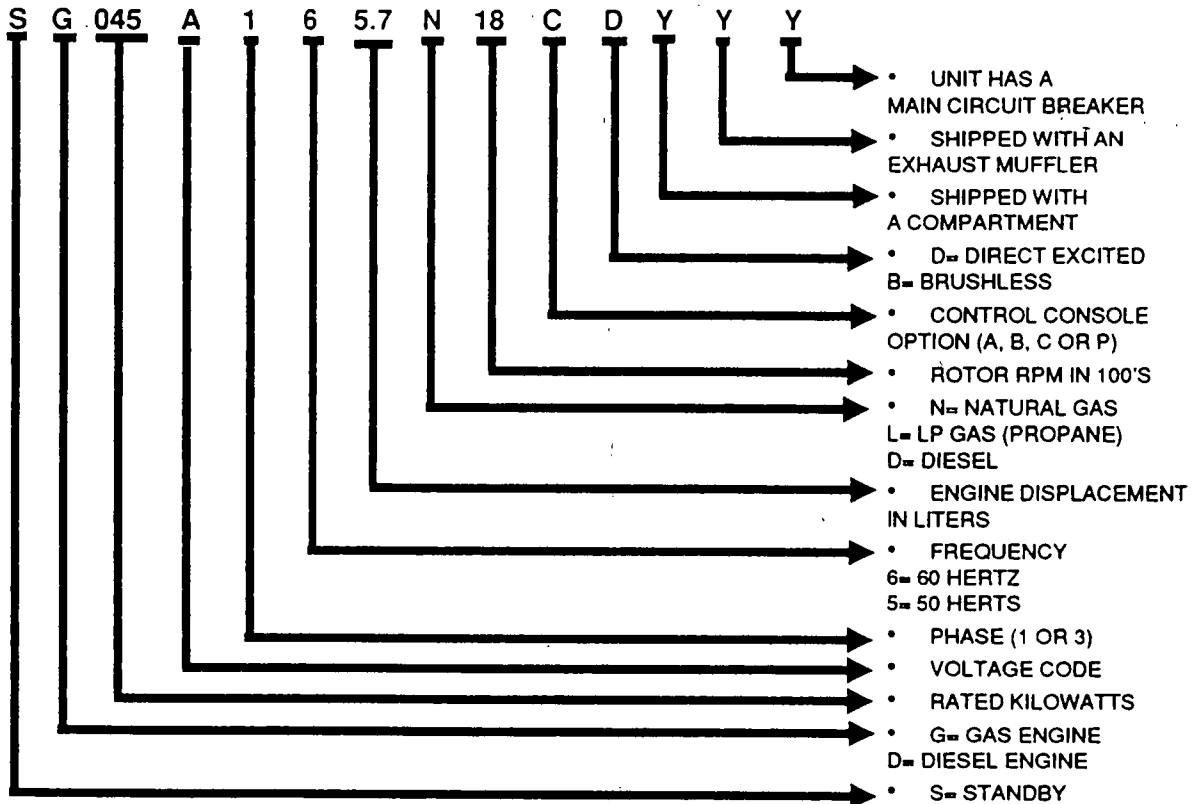
CLASS F WINDING INSULATION AT 40° C.

GENERAC CORP.
WAUKESHA, WI

45452
MADE IN U.S.A.

Figure 1. A Typical Data Plate

GENERATOR IDENTIFICATION CODE



The Data Card

One or more DATA CARDS are shipped with each standby generator set. When ordering parts or requesting information, you may be asked to provide information from this card.

The card provides important information peculiar to each unit. Included on the card are the following:

- The unit's MODEL NUMBER.
- The date of manufacture.
- A "Generator Identification Code"- This code is explained by means of a diagram on Page 1.1-1.
- A "Group-Description-Assembly Number" listing which includes all major assemblies that make up the generator set. The "assembly numbers" refer to the various exploded views that make up each major assembly.

GENERAC CORP				
MODEL NO. 91A01256S		DATE 5/09/91		
		SG012-A161.2N18CDYNY		
GROUP	DESCRIPTION	ASSEMBLY NUMBERS		
A	Generator	00000	00000	
B	Control Panel	00000	00000	00000
C	Mounting Base	00000	00000	
D	Engine & Accy.	00000		
E	Fuel System	00000		
G	Wiring Diagram	00000	00000	00000

Figure 2. A Typical Data Card

Section 1.2 TYPES OF STATOR CONNECTION SYSTEMS

General

Generac standby generators may be equipped with any one of several different stator configurations. The electrician who installs a standby generator, as well as generator service technicians, must be familiar with these different stator configurations and the various stator connection systems.

You may wish to review the "Generator Identification Code" in Section 1.1. A "Voltage Code", which identifies the generator's rated AC output voltage, is part of that identification code. Also included in the Code are a "Phase" and a "Frequency" designator.

NOTE: Stator connection system information in this section applies to standby generators rated at up to 125 kW. For units rated 125 kW and higher, refer to Part 4, "MARATHON AC GENERATORS".

The Generator AC Connection Panel

Typically, the generator's AC connection panel (Figure 1) is that enclosure directly below the control panel. It is often called the "lower panel". All of the stator's AC output leads are routed into this panel. Electrical connections in the panel should be made in accordance with the appropriate "connection diagram". Use the diagram that is appropriate for the number of leads and the voltage range required.

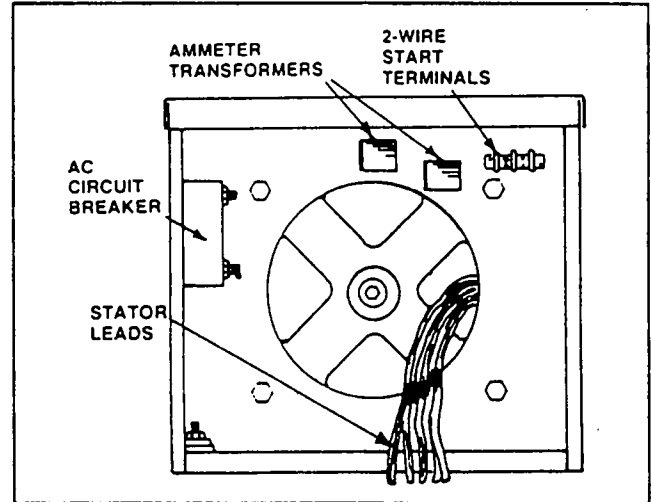


Figure 1. Generator AC Connection Panel (Typical)

NOTE: The final voltage setting is established within the desired range by adjustment of the voltage regulator. Some generators may have multiple, identically marked cables for each lead. Connect all identically marked cables together.

Types of AC Connection Systems

VOLTAGE CODE	RATED VOLTS	PHASE	HERTZ	NO. OF WINDINGS	NO. OF LEADS	TYPE OF STATOR CONNECTION SYSTEM
A	120/240	1	60	2	4	Dual voltage, 3-wire, 1-phase
B*	120/208	3	60	6	12	Low (Parallel) Wye
C*	240/416	3	60	6	12	High (Series) Wye
D**	120/240	1 & 3	60	6	12	Delta
G	120/208	3	60	6	12	Low (Parallel) Wye
H	240/416	3	60	6	12	High (Series) Wye
J	120/240	3	60	6	12	Delta
K	277/480	3	60	6	12	High (Series) Wye
L	600	3	60	6	4	Wye Connected
M	110/220	1	50	2	4	Dual voltage, 3-wire, 1-phase
N	115/200	3	50	6	12	Low (Parallel) Wye
P	100/200	3	50	6	12	Delta
R	231/400	3	50	6	12	High (Series) Wye
S	480	3	50	6	12	Wye Connected

* Voltage Codes "B" and "C" are obsolete but were used prior to 1988.

** Stators with Voltage Code "D" can supply 1-phase output at up the full rated capacity of the generator, but cannot be reconnected to 277/480 volts (High Wye).

Dual Winding 1-Phase Stators

See Figure 2. Units with Voltage Codes "A" and "M" are equipped with stators having dual windings. Two leads are brought out of each winding and routed into the AC connection (lower) panel, for a total of four (4) leads. The leads are numbered 11, 22, 33 and 44. Leads 11 and 44 become the two "Hot" leads (E1 and E3). The junction of leads 22 and 33 forms the "Neutral" connection (00).

Each stator winding can supply a 120 volts AC output at 60 Hertz (or a 110 volts AC output at 50 Hertz). When the two windings are connected in series, a 240 volts, 60 Hertz (or 220 volts, 50 Hertz) AC output results.

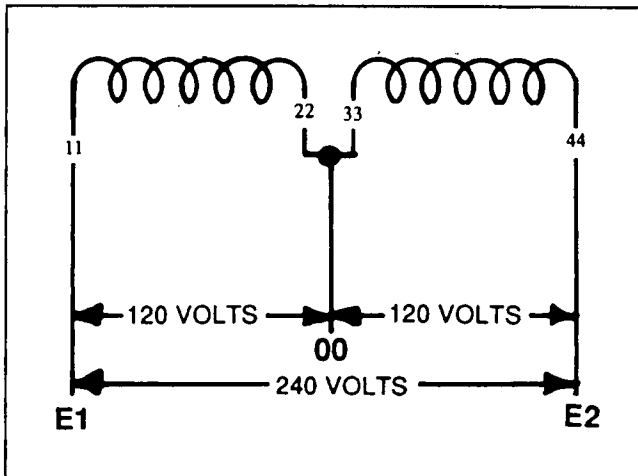


Figure 2. Dual Winding, 1-Phase Stator System

Parallel Wye or Low Wye Stator

Low Wye or Parallel Wye type stators (Figure 3) have six windings and twelve (12) leads coming out into the AC connection (lower) panel. This type of stator can be used to supply the 3-phase voltages indicated in the following CHART.

VOLTAGE		CONNECT	L1	L2	L3	NEUTRAL
L-L	L-N					
60 HZ	190	S10-S11-S12 S4-S5-S6	E1	E2	E3	S10-S11-S12 S4-S5-S6
	208					
	220	S1-S7				
	230					
50 HZ	190	S2-S8				
	200					
	208	S3-S9				

High Wye or Series Wye Stator

See Figure 4. This type of stator has six (6) windings and twelve (12) leads brought out into the AC connection (lower) panel. This configuration is used in units with Voltage Codes "C", "H", "K" and "R" (see CHART on previous page). The following CHART indicates how the 12 leads are connected to form L1, L2, L3 and Neutral.

VOLTAGE		CONNECT	L1	L2	L3	NEUTRAL
L-L	L-N					
60 HZ	380	S10-S11-S12	E1	E2	E3	S10-S11-S12
	416					
	440					
	480	S5-S8				
50 HZ	380	S4-S7				
	400					
	416					

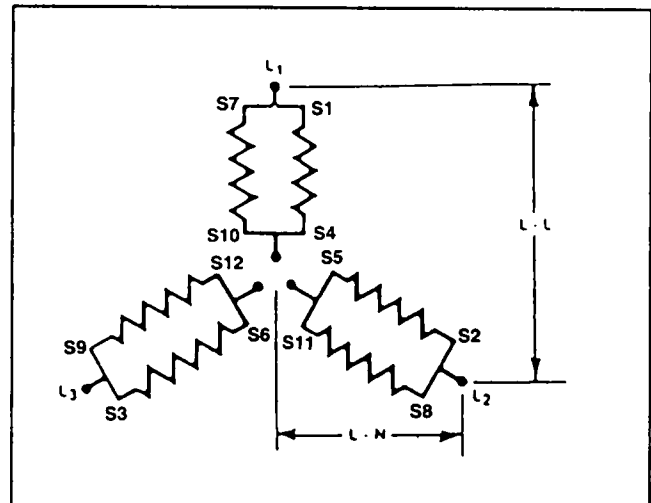


Figure 3. Parallel Wye (Low Wye) Stator

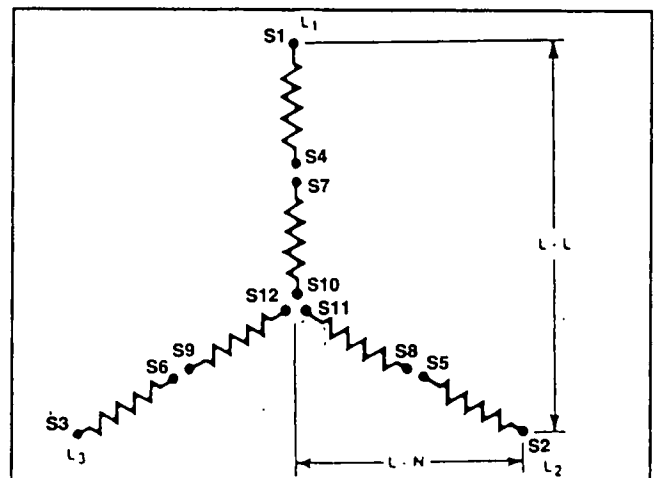


Figure 4. Series Wye (High Wye) Stator

Delta Stators

This type of stator has six (6) windings and twelve (12) leads coming out. See Figure 5. The stator can be used to supply the voltages indicated in the following CHART.

VOLTAGE		CONNECT	L1	L2	L3	NEUTRAL
L-L	L-N					
60 HZ	240	S4-S7	E1	E2	E3	S5-S8
	120	S5-S8				
	277	S6-S9				
50 HZ	200	S1-S11				
	220	S2-S12				
	110	S3-S10				

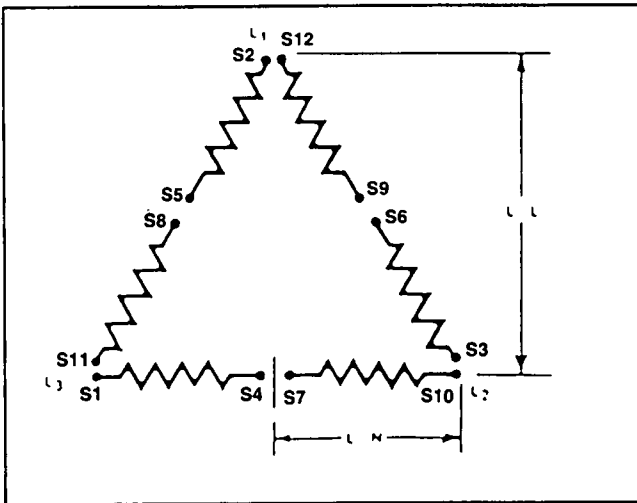


Figure 5. High Delta Connection System

NOTE: Units with Voltage Code "D" are equipped with a High Delta stator configuration, but are specially wound to supply the unit's full rated capacity when connected for a 120/240 volts, 1-phase AC output.

Low Delta Connection System

The 12-lead generators can be reconnected to form a "Low Delta" connection system, shown in Figure 6.

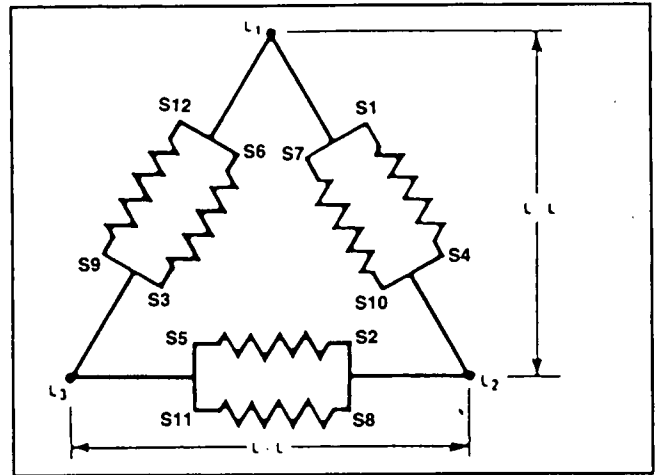


Figure 6. Low Delta Connection System

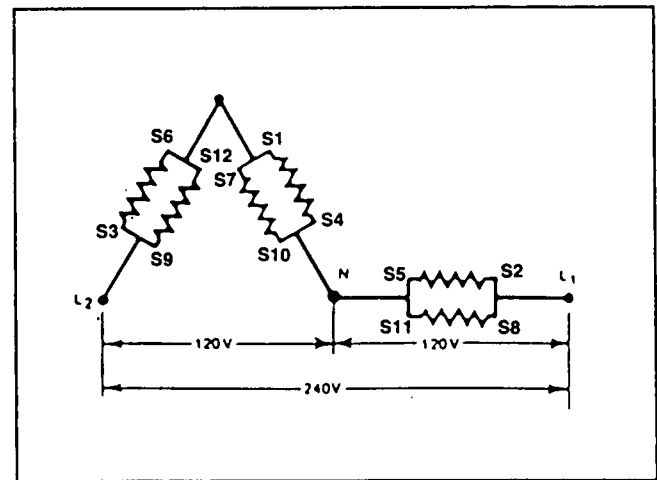


Figure 7. Zig Zag Connection System

VOLTAGE		CONNECT	L1	L2	L3	
L-L	L-N					
60 HZ	120	S1-S7-S6-S12	E1	E2	E3	
	139	S2-S8-S4-S10				
50 HZ	100	S3-S9-S5-S11				
120						

The Zig Zag Connection System

Units with twelve lead, reconnectable stators can be reconnected to form a "Zig Zag" system, shown in Figure 7.

VOLTAGE		CONNECT	L1	L2	NEUTRAL
L-L	L-N				
60 HZ	120/240	S3-S9	E2	E3	S4
		S1-S6-S7-S12			
		S2-S8			
		S4-S10-S5-S11			

Multi-Voltage Changeover Boards

On some generator models, multi-voltage changeover boards are used for quicker changeover from one connection system to another. Refer to Part 7, "GENERATOR OPTIONS & ACCESSORIES".

Section 1.3

STANDBY ELECTRIC SYSTEM FAMILIARIZATION

Introduction

The purpose of a standby electric power system is to supply electrical power for the operation of critical electrical loads in the event of a utility power failure or dropout of that power source below an acceptable level.

Standby electric power systems have long been used as sources of emergency electrical power in hospitals, schools, airports and other public buildings. Use of such systems is spreading rapidly, making it an absolute necessity that all who are involved with such systems be thoroughly familiar with standby system products and their application.

The rapid increase in the use of such systems is primarily due to three factors. First, the increase in dependence on electricity (coupled with costly electrical blackouts and brownouts) has dramatically increased the need for such systems. Second, the trend toward automation in manufacturing facilities has increased steadily. Any down time in such facilities means very expensive loss of production. And third, such systems are being used more frequently in less critical applications as building and safety codes become stricter (for example, the requirement that elevators in high rise buildings remain operable in the event of a fire).

New developments in the design and application of standby electric systems are constantly surfacing. In addition, new problems are being created by the more sophisticated electrical systems of today. As standby generators, transfer switches, and other standby system components are called upon to do more and more, and as accessories and components become more and more varied, selection of the proper components for any particular application becomes more difficult.

Installation Manual

An "Installation Manual for Standby Electric Power Systems" is available from Generac Corporation. To order, specify Manual Part No. 46622.

A Simple Standby Electric Power System

A simple standby electric power system is shown schematically in Figure 1. The UTILITY and STANDBY power supplies are both connected to a transfer switch, as well as the LOAD circuits. Use of an approved transfer switch is required by electrical code. The transfer switch serves the following purposes:

- When UTILITY source power is available, the switch must connect that source to the electrical LOAD circuits to be powered. When UTILITY power is not available, the switch must connect the STANDBY power supply to critical electrical LOADS.

- The transfer switch must positively prevent the UTILITY and STANDBY power supplies from feeding the LOAD simultaneously.
- The transfer switch must positively isolate the building electrical circuits from the UTILITY power lines while LOAD circuits are being powered by the STANDBY source.

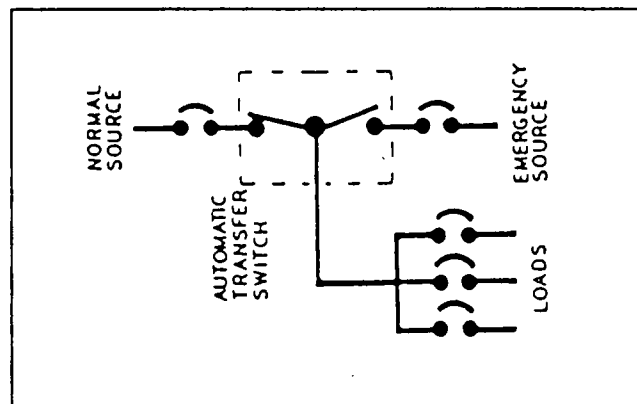


Figure 1. Schematic- Simple Standby Electric System

Methods of Isolation

Either of two different isolation methods may be used in a standby electric system. These may be called (a) the emergency circuit isolation method, or (b) the total circuit isolation methods.

EMERGENCY CIRCUIT ISOLATION METHOD:

See Figure 2. This method of isolation employs both a MAIN and an EMERGENCY distribution panel. Critical, essential electrical loads within the wattage/ampere capacity of the generator are grouped together and wired into the emergency distribution panel. Only those electrical loads that are fed by the emergency panel are supplied when the standby generator is running. Use of this type of isolation method will help avoid overloading the standby generator. The installed transfer switch must meet the following requirements:

- The transfer switch must have an ampere rating equal to or greater than the total ampere rating of the emergency distribution panel load circuits.
- The transfer switch must be installed between the building's main distribution panel and the emergency distribution panel.

TOTAL CIRCUIT ISOLATION METHOD:

Only one electrical distribution panel is used in this type of installation. To prevent overloading the standby generator, non-essential electrical loads must be turned off. The following rules apply:

- The ampere rating of the installed transfer switch must equal or exceed the ampere rating of the normal incoming utility service.
- Switch must be installed between the utility power supply service entrance and distribution panel.

Methods of Isolation (Continued)

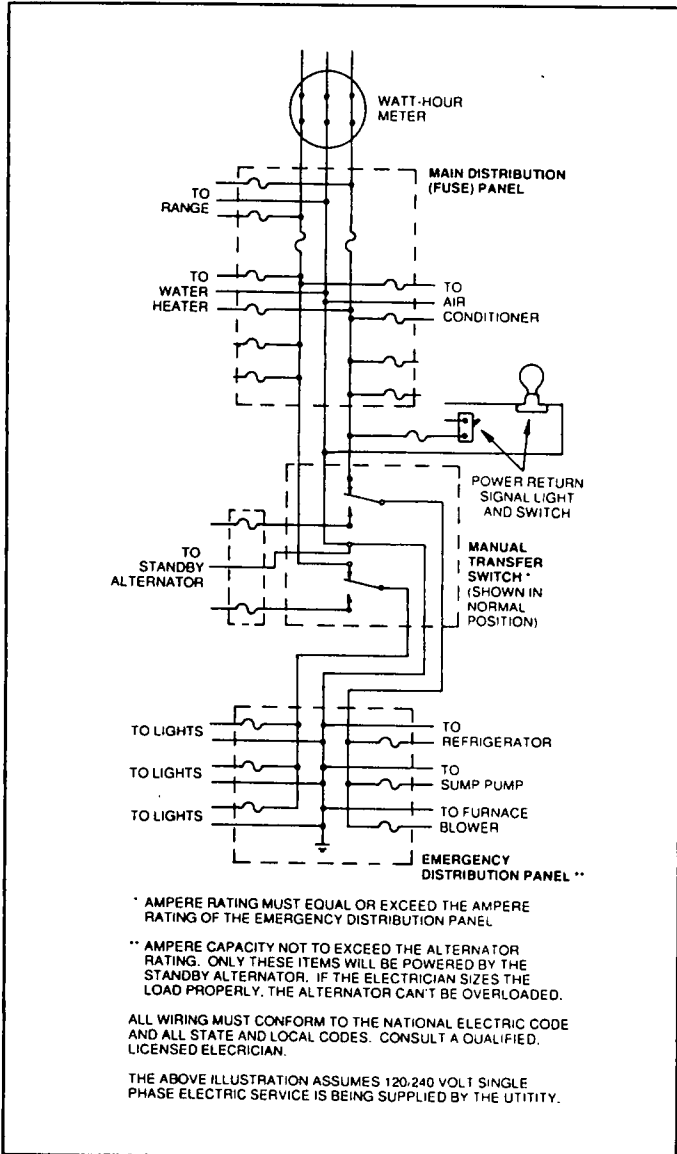


Figure 2. Schematic- Emergency Circuit Isolation

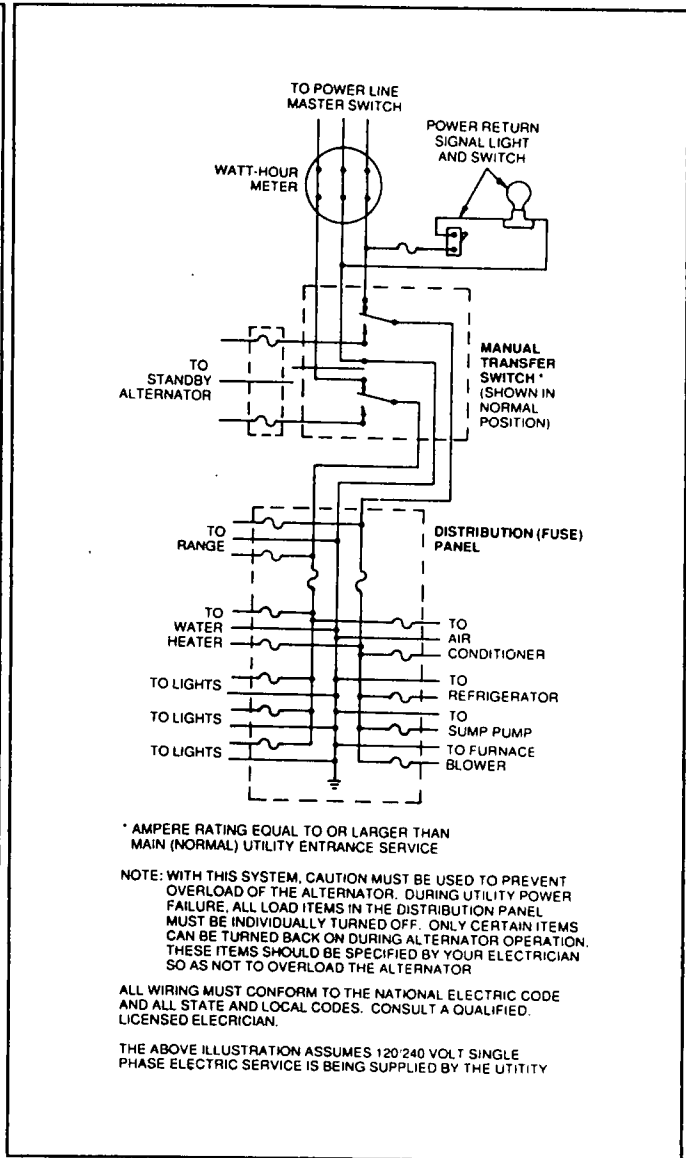


Figure 3. Schematic- Total Circuit Isolation

DANGER: CONNECTION OF ANY GENERATOR SET TO AN ELECTRICAL SYSTEM NORMALLY SUPPLIED BY AN ELECTRIC UTILITY MUST BE DONE BY MEANS OF A DOUBLE THROW TRANSFER SWITCH, SO AS TO ISOLATE THE ELECTRIC SYSTEM FROM THE UTILITY DISTRIBUTION SYSTEM WHILE THE GENERATOR IS OPERATING (NEC 701). FAILURE TO ISOLATE THE ELECTRIC SYSTEM BY SUCH MEANS WILL RESULT IN DAMAGE TO THE GENERATOR OR POSSIBLE INJURY OR DEATH TO UTILITY POWER WORKERS DUE TO BACKFEED OF ELECTRICAL ENERGY.

Section 1.4 GENERATOR MAINTENANCE AND TESTING

Effects of Dirt and Moisture

If dust or dirt particles are allowed to accumulate on generator parts, they will conduct electrical energy between points of different electrical potential. If moisture is allowed to accumulate with the dirt and dust, the problem will be worsened. The combination of dust, dirt and moisture on generator windings can result in a breakdown of the winding insulation.

Normally, moisture buildup on windings is not a problem since internal heat tends to dry the windings. However, moisture may accumulate while the unit is idle. Problems with moisture will become worse in very humid environments, or where rapid temperature changes can cause condensation.

In addition to causing insulation breakdown, dirt and moisture can increase internal generator temperatures by restricting air flow through the unit or by blocking the dissipation of heat. Such materials as talc, lint, rock dust, and cement dust will seriously obstruct ventilation openings in an operating unit. Such materials as carbon black, metallic dust, metal chips, and similar materials are probably the most harmful. The latter materials will not only impede ventilation, but will form a conductive film over the insulation.

Generators that operate in very dusty or dirty areas should be disassembled and cleaned periodically. In addition, the condition of the insulation should be tested by measuring the insulation resistance.

Drying the Generator

If tests indicate that the insulation resistance of stator and rotor windings is below a safe value, such electrical components should be dried before operating the unit. Some recommended drying methods include the use of (a) heating units, and (b) forced air.

HEATING UNITS:

The generator can be enclosed in a covering and heating units can be installed to raise the temperature about 15°-18° F. (8°-10° C.) above the temperature outside the covering.

FORCED AIR:

Portable forced air heaters can be used to dry the generator. Direct the heat into the generator's air inlet openings and run the unit at no-load and with the voltage regulator removed. The heat at the point of entry should not exceed 150° F. (66° C.).

Cleaning the Generator

The generator can be cleaned properly only when it is disassembled. The methods used for cleaning should be determined by the kind of dirt.

Be sure to dry the generator after it has been cleaned. A shop that repairs electric motors in your area may be able to assist you with proper cleaning of generator windings. Such shops are often experienced in special problems that may be peculiar to a certain area (such as a sea coast, marine applications, mining, oil rigs, etc.).

USING SOLVENTS FOR CLEANING:

A solvent is usually required when dirt contains oil or grease. Only petroleum distillates should be used to clean electrical components. Recommended are safety type petroleum solvents having a flash point greater than 100° F. (38° C.).

Use a soft brush or cloth to apply solvent. Be careful to avoid damaging magnet wire or insulation on windings. After cleaning, be sure to dry all components thoroughly with moisture free, low pressure, compressed air.

DANGER: WHEN USING SOLVENTS, ALWAYS PROVIDE ADEQUATE VENTILATION. IF SUFFICIENT VENTILATION IS NOT PROVIDED, FIRE, EXPLOSION OR HEALTH HAZARDS MAY EXIST. WEAR EYE PROTECTION. ALSO WEAR RUBBER GLOVES OR OTHER SUITABLE PROTECTION FOR THE HANDS WHEN USING SOLVENTS.

CAUTION: Many generators use epoxy or polyester base winding varnishes. Use only solvents that do not attack such materials.

CLOTH AND COMPRESSED AIR FOR CLEANING:

When cleaning small components or if only dry dirt is to be removed, cleaning with a dry cloth may prove satisfactory. After wiping such components clean with the cloth, use low pressure air at 30 psi (206 Kpa) to blow the dirt away.

BRUSHING AND VACUUM CLEANING:

Brushing with a bristle brush followed by vacuuming may be used to remove dry dust and dirt. Loosen the dust first, then remove it with the vacuum.

Checking Insulation Resistance

Insulation resistance is a measurement of the integrity of the insulating materials that separate the electrical windings from the generator's steel core. This resistance can degrade over time, due to contaminants such as dust, dirt, grease and especially moisture. Tests of insulation resistance are usually done with a "megohmmeter" or a "hi-pot" tester.

Checking Insulation Resistance (Continued)

Most failures of generator windings are caused by a breakdown in the insulation system. In some cases, a reduced insulation resistance can be caused by moisture that has collected on the windings while the unit is shut down. This problem can usually be corrected by drying the generator windings.

The normal insulation resistance for generator windings is on the order of "millions of ohms". It can be measured using a device called a "megohmmeter", or with a "hi-pot tester". One type of hi-pot tester is shown in Figure 1 below.

CAUTION: When using Insulation resistance testers, follow the manufacturer's instructions carefully. Improper use of such testers can result in serious damage to generator components. DO NOT APPLY VOLTAGES IN EXCESS OF THOSE RECOMMENDED FOR GENERATOR WINDINGS. Apply voltage for a maximum time limit of one (1) second only. When applying voltage, terminal ends of winding leads must NOT be in contact with any part of the generator.

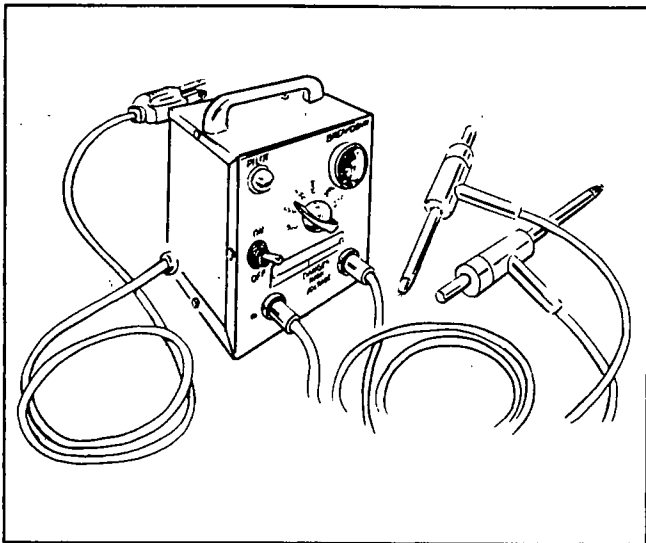


Figure 1. One Kind of Hi-Pot Tester

Testing Stator Insulation

GENERAL:

Stator winding leads are routed out of the stator can and into the generator's AC connection (lower) panel. The following procedure utilizes the hi-pot tester shown in Figure 1 to test the insulation resistance. If using another type of insulation resistance tester, be sure to follow the manufacturer's instructions carefully. Follow the instructions carefully when performing tests. You may wish to review the information in Section 1.2, "Types of Stator Connection Systems".

CAUTION: Connect the tester probes only to the stator leads. DO NOT connect the test probes to any leads that are routed into the generator control console.

TESTING STATOR INSULATION TO GROUND:

1. Disconnect and isolate all stator output leads in the AC connection (lower) panel.
2. Connect the terminal ends of all stator output leads together.
 - a. On 1-phase units with dual stator windings, connect leads 11, 22, 33, 44, 2 and 6A (or 6B) together.
 - b. On "broad range" units with 12-lead reconnectable stator, connect leads S1 through S12 and leads 2 and 6 together.
 - c. Make sure none of the lead terminal ends are in contact with the generator frame.
3. Connect the red test probe of the hi-pot tester to the joined stator lead terminal ends.
4. Connect the black tester probe to a clean frame ground on the stator can.
5. Turn the hi-pot tester switch to "Off".
6. Set the tester's voltage selector switch to "500 volts".
7. Turn the tester switch "On" and check that the pilot lamp is lighted.
8. Observe the breakdown lamp on the tester, wait one second, then turn the hi-pot tester switch to "Off".

If the tester breakdown lamp illuminates during the 1 second test, clean and dry the stator. After cleaning and drying, repeat the test. If the breakdown lamp comes on during the second test (after cleaning and drying), replace the stator assembly.

TEST BETWEEN ISOLATED STATOR WINDINGS:

On 1-Phase Units: Test between isolated windings as follows:

1. Connect the red hi-pot tester probe to terminal end of stator lead 11, the black tester probe to terminal end of Wire #2.
2. Turn the tester switch "On" and check that the tester pilot lamp is lighted.
3. Set the tester's voltage selector switch to 1500 volts. APPLY VOLTAGE FOR ONE SECOND ONLY. Observe the tester breakdown lamp, then turn the tester switch to "Off".
4. Reset the tester voltage selector switch to "500 volts". Connect the red tester probe to terminal end of stator lead 33, the black test probe to terminal end of Wire #2.
5. Turn the tester switch "On" and make sure the tester pilot lamp is lighted.
6. Set the tester's voltage selector switch to "1500 volts". APPLY VOLTAGE FOR ONE SECOND ONLY. Observe the tester breakdown lamp, then set the tester switch to "Off".
7. Reset the tester's voltage selector switch to "500 volts".

NOTE: Figures 2, 3 and 4 are schematic illustrations of a 1-phase stator, a 3-phase Wye connected stator and a 3-phase Delta connected stator, respectively.

Testing Stator Insulation (Continued)

On 3-Phase Units: To test the insulation resistance between isolated windings on 3-phase stators, proceed as follows:

1. Make sure all twelve stator leads are completed isolated from one another.
2. Connect the red tester probe to terminal end of stator lead S3; the black tester probe to terminal end of stator lead 5.
3. Turn the tester switch "On" and check that the pilot lamp is lighted.
4. Set the voltage selector switch to "1500 volts". APPLY VOLTAGE FOR ONE SECOND ONLY. Observe the tester breakdown lamp, then turn the tester switch to "Off".
5. Reset the voltage selector switch to "500 volts".
6. Repeat Steps 1 through 5, with the black tester probe connected to stator lead 5 and the red tester probe connected to each of the following stator leads, one at a time:
 - a. Lead S9.
 - b. Lead S7.
 - c. Lead S1.
 - d. Lead S2.
 - e. Lead S8.

If the tester breakdown lamp comes on during any of the one second tests, clean and dry the stator, then repeat the tests. If (after cleaning and drying), stator fails the second test, replace the stator assembly.

TEST BETWEEN PARALLEL WINDINGS:

1-Phase Stators: To test for insulation breakdown between parallel windings on 1-phase stators, proceed as follows:

1. Connect the red tester probe to terminal end of stator lead 11; the black probe to terminal end of stator lead 33.
2. Set the tester's voltage selector switch to "500 volts".
3. Turn the tester switch "On" and check that the pilot lamp is lighted. APPLY VOLTAGE FOR ONE SECOND ONLY.
4. Observe the breakdown lamp, then turn the tester switch to "Off".

3-Phase Stators: To test insulation resistance between parallel windings on 3-phase stators, proceed as follows:

1. Connect red tester probe to terminal end of stator lead S3; black tester probe to terminal end of stator lead S9.
2. Set the voltage selector switch to "500 volts".
3. Turn the tester switch "On" and check that the pilot lamp is lighted. APPLY VOLTAGE FOR ONE SECOND ONLY. Observe the breakdown lamp, then turn the tester switch "Off".
4. Repeat Steps 1 through 3 with the red tester probe connected to stator lead S3; the black probe connected to the following leads one at a time: S9- S11- S5- S1- S7.
5. Repeat Steps 1 through 3 with red probe connected to stator lead S9 and with black probe connected to

the following stator leads, one at a time: S11- S5- S1- S7.

5. Repeat Steps 1 through 3 with red probe connected to stator lead 11 and black probe connected to the following leads, one at a time: S5- S1- S7.

6. Repeat Steps 1 through 3 with red tester probe connected to stator lead S1; black probe connected to stator lead S7.

If the breakdown lamp comes on during any one second test, clean and dry the stator. Then, retest stator insulation resistance. If stator fails the second test (after cleaning and drying), replace the stator assembly.

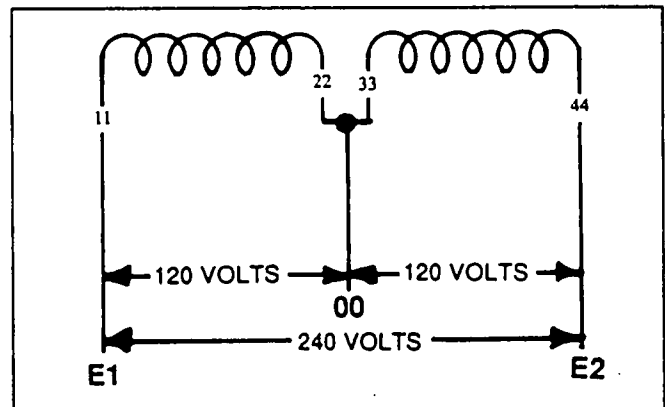


Figure 2. Schematic- 1-Phase Stator

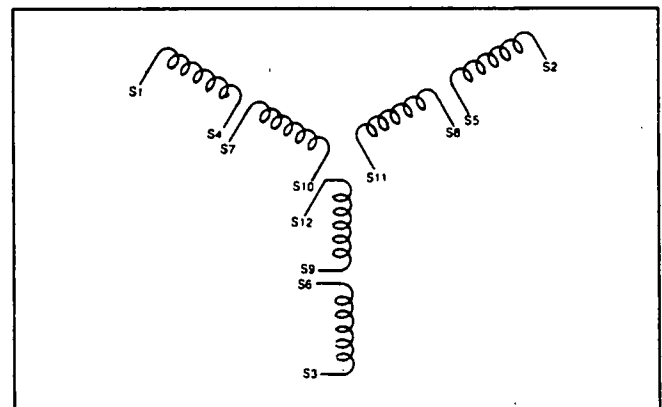


Figure 3. Schematic- 3-Phase Wye Connected Stator

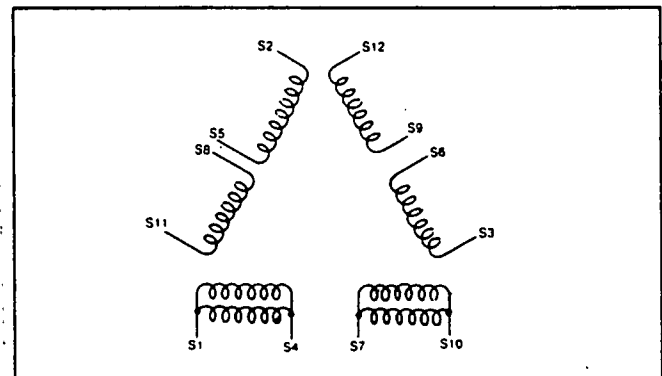


Figure 4- Schematic- 3-Phase Delta Connected

Testing Stator Insulation with a Megohmmeter

GENERAL:

A megohmmeter, often called a "megger", consists of a meter calibrated in megohms and a power supply. The most common power supply is 500 volts. Use of any megger voltage in excess of 500 volts is not recommended.

TESTING STATOR INSULATION:

All parts that might be damaged by high megger voltages must be disconnected from the circuit before starting the test. Isolate all of the stator leads from ground and connect all stator lead terminal ends together. Connect one megger test lead to the stator leads; the other to frame ground. Follow the megger manufacturer's instructions carefully. Take the megger reading. The minimum acceptable value can be calculated using the following formula:

$$\begin{array}{l} \text{Minimum Insulation} \\ \text{Resistance} \\ \text{(In Megohms)} \end{array} = \frac{\text{Generator Rated Volts}}{1000} + 1$$

Example: For a generator rated 240 volts, divide "240" by "1000" to obtain "0.24". Then, add "1" to obtain "1.24" megohms. In this case the minimum allowable insulation resistance for the stator is 1.24 megohms.

Testing Rotor Insulation on Direct Excited Units

Direct excited generators are those which utilize brushes and slip rings to deliver excitation current from the stationary voltage regulator to the rotating rotor assembly. Test the rotor insulation for breakdown with a hi-pot tester, as follows:

1. Gain access to the rotor's brushes and slip rings.
2. Disconnect all wires from the brushes, or remove the brush holders with brushes.
3. Connect the red hi-pot tester probe to the positive (+) slip ring (nearest the rotor bearing).
4. Connect the black tester probe to a clean frame ground.
5. Turn the hi-pot tester switch to "Off".
6. Plug the tester into a 120 volts AC wall socket.
7. Set the tester's voltage selector switch to "500 volts".
8. Turn the tester switch "On" and check that the pilot lamp is lighted.
9. Set the voltage selector switch to "1250 volts" and observe the tester breakdown lamp. Then, turn the tester switch "Off".

If the breakdown lamp comes on in Step 9, drying of the generator may be necessary. After cleaning and drying, repeat the test. If rotor fails the second test (after cleaning and drying), it should be replaced.

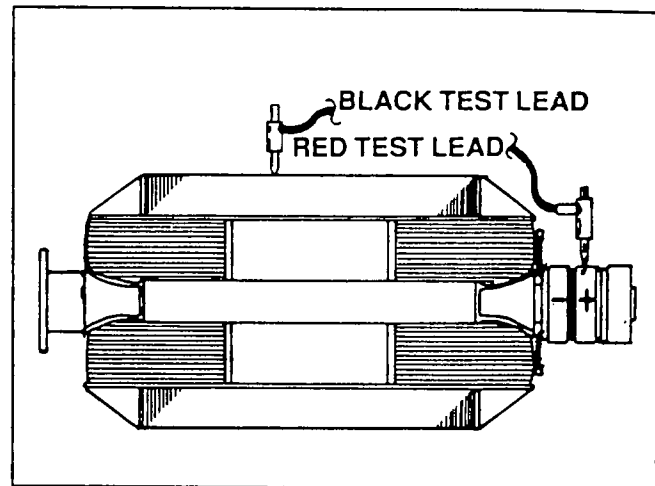


Figure 5. Testing Rotor Resistance (Typical)

Insulation Resistance Tests on Brushless Generators

GENERAL:

Stator windings on brushless generators are identical to those used on direct excited units and may be tested in the same manner. However, as the name implies, brushless units do not have brushes and slip rings. Instead, excitation current is supplied to the main rotor windings by means of (a) an exciter stator, (b) an exciter rotor, and (c) the main rotor itself. Each of these windings can be tested separately for insulation breakdown.

TESTING WITH A HI-POT TESTER:

Disconnect the appropriate winding leads (main rotor, exciter stator, or exciter rotor) and isolate them from ground. Connect all of the winding leads together. Then, connect the red tester probe to the winding leads; the black probe to frame ground. Set the voltage selector switch to "500 volts". DO NOT EXCEED 500 VOLTS. Turn the tester switch "On", observe the breakdown lamp, then turn the tester switch "Off".

If the breakdown lamp comes on during the test, clean and dry the winding(s) and retest. If a winding fails the second test (after cleaning and drying), replace the defective winding.

TESTING WITH A MEGOHMMETER:

Use a megger having a rated voltage of 500 volts. DO NOT EXCEED 500 VOLTS. Disconnect the appropriate leads (main rotor, exciter stator or exciter rotor) and isolate them from ground. Connect the leads of the winding to be tested together. Connect the megger test probes across the junction of all winding leads and frame ground. Read the meter, then disconnect the meter quickly. The minimum allowable resistance reading is 1.5 megohms.

Insulation Resistance Tests on Brushless Generators (Continued)

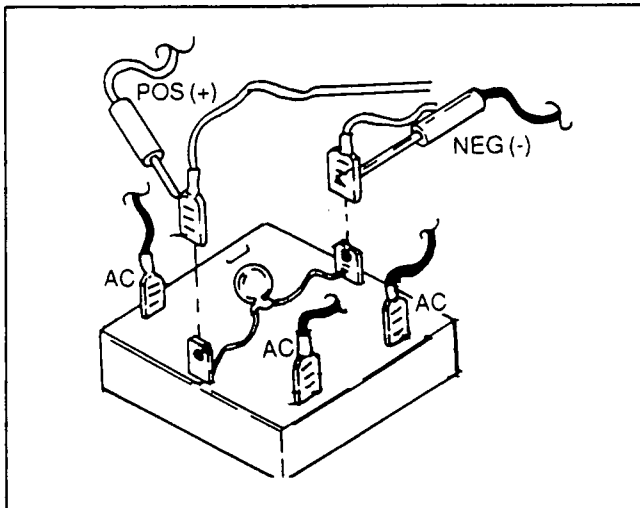


Figure 6. Main Rotor Testing (Typical Brushless)

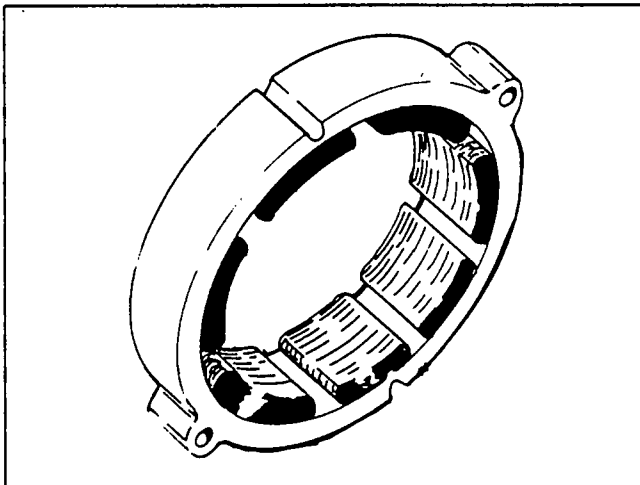


Figure 7. Exciter Stator (Typical Brushless Unit)

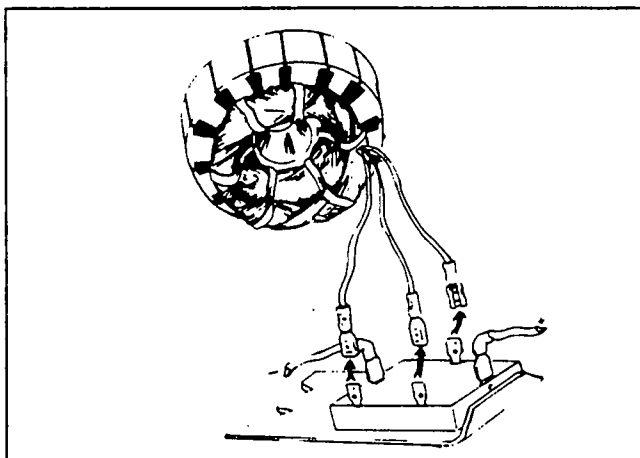


Figure 8. Exciter Rotor (Typical Brushless Unit)

Measuring Voltages

AC VOLTAGES:

When reading generator AC output voltage, the generator must be running at its rated operating speed. In addition, some of its protective guards and covers may be removed. **PROCEED WITH CAUTION.** Keep yourself and the meter test leads well clear of moving parts. Stay clear of power voltage terminals and wire terminal ends.

DANGER: STANDBY GENERATORS PRODUCE EXTREMELY HIGH AND DANGEROUS VOLTAGE. CONTACT WITH HIGH VOLTAGE TERMINALS MAY RESULT IN HAZARDOUS AND EVEN DEADLY ELECTRICAL SHOCK. USE EXTREME CARE WHEN CHECKING ELECTRICAL VOLTAGES.

The generator's AC output voltage can be read at the unit's main circuit breaker or (on installed units) at the transfer switch terminal lugs. The following rules apply:

- On 1-phase generators, line-to-line voltage may be read across generator lines E1 to E3; line-to-neutral voltage across line E1 to 00 or across line E3 to 00.
- One 3-phase units, line-to-line voltage can be read across line E1 to E2; E2 to E3; and E3 to E1. Line-to-neutral voltage can be read across line E1 to 00; line E2 to 00; or line E3 to 00.

Some standby generators will have an AC voltmeter mounted on their control console, along with a voltage-phase selector switch that allows the operator to select the line being read on the meter. These console mounted voltmeters are generally very reliable and accurate.

Most Generac standby generators are equipped with a solid state "voltage over frequency" type voltage regulator. This type of regulation maintains an AC output voltage that is proportional to the unit's operating speed and AC frequency. Thus, if operating speed and frequency are high or low, generator AC output voltage will be correspondingly high or low. For that reason, when checking AC voltage it is a good idea to check AC frequency as well. The voltage regulator can be adjusted to maintain the correct rated AC output voltage, but such adjustment should be accomplished only when AC frequency is correct.

DC VOLTAGES:

Use an accurate DC voltmeter to measure these voltages. Always observe correct DC polarity. Some meters will be equipped with a polarity switch; on other meters, polarity is reversed by reversing the meter test leads. The meter must be set to a higher scale than the anticipated voltage reading. When in doubt, start with the highest available voltage scale and adjust the scale downward until the correct reading is observed. Some DC voltmeters are designed with a positive (+) to negative (-) current flow; some with a negative (-) to positive (+) current flow.

Measuring Current

The generator's AC output current can usually be taken with a "clamp-on" type ammeter. Most clamp-on ammeters will not measure direct current (DC). When measuring current, the following rules apply:

- Some generators may have more than one lead for each line or phase. When checking current (amperes), make sure the clamp-on meter is around all cables for each line or phase.
- If the physical size of the conductors or the capacity of the ammeter will not allow all lines or cables to be measured simultaneously, measure the current flow in each line or cable individually. Then, add the individual readings together to obtain the total.
- Compare the readings obtained to the unit's DATA PLATE values. When running electrical loads, the DATA PLATE amperage should never be exceeded.

Measuring Resistance

MAIN STATOR WINDINGS RESISTANCE:

The resistance of stator AC power windings is typically very low. Some meters will not be capable of reading such a low resistance and will simply indicate "continuity". However, a standard volt-ohm-milliammeter (VOM) can be used to test the stator windings for (a) continuity, (b) shorts, or (c) grounded condition.

STATOR EXCITATION WINDINGS:

Stator excitation windings can be tested for either a shorted or grounded condition. "Marathon®" generators are not equipped with an excitation winding.

ROTOR WINDING RESISTANCE:

On direct excited units, the rotor can be tested with a volt-ohm-milliammeter (VOM) to determine if it is grounded or shorted. Always connect the meter's positive (+) test lead to the positive (+) slip ring; the common (-) test lead to the negative (-) slip ring. The positive (+) slip ring is usually the slip ring nearest the rotor bearing.

On brushless generators, the exciter stator, exciter rotor and main rotor can all be tested for an open or shorted condition, using a volt-ohm-milliammeter.

Measuring AC Frequency

The operating speed and AC frequency of a generator are directly proportional. The following rules apply:

- Units having a 4-pole rotor will supply a 60 Hertz AC output frequency at 1800 rpm; a 50 Hertz AC frequency at 1500 rpm.
- Units with 2-pole rotor will deliver a 60 Hertz AC frequency at 3600 rpm; a 50 Hertz frequency at 3000 rpm.

Generac standby generators are typically equipped with a solid state voltage regulator, often called a "voltage-over-frequency" or "V/F" type regulator. These voltage regulators maintain a voltage that is proportional to AC frequency. For example, a unit rated 240 volts, 60 Hertz will supply that voltage at 60 Hertz. If frequency (and rpm) decrease, output voltage will decrease proportionally.

When testing for proper AC voltage, both voltage and frequency readings should be taken. The voltage regulator should never be adjusted for correct voltage until AC frequency is correct. Frequency and rpm are adjusted at the engine speed governor.

Section 1.5 MECHANICAL ENGINE GOVERNORS

Introduction

Governor AC output frequency is directly proportional to the driven speed of the rotor. In order to maintain a specific AC output frequency, rotor speed must be precisely controlled. Rotor speed can be maintained by governing the operating speed of the driving engine.

Many spark ignited (gas fueled) engines employ a fixed speed, mechanical engine governor. Because proper generator operation is so dependent on a correctly adjusted and maintained governor, some of the adjustment procedures for mechanical governors will be discussed in this section.

How a Mechanical Governor Works

See Figure 1. Engine and governor speed will decrease if the load on the engine is increased even slightly. In response to the decrease in engine speed, governor flyweights (2) are forced inward by governor spring force. Flyweight (2) movement is transmitted through a sleeve (3) and a shaft (4) to a governor lever (5). The governor lever (5) then moves a link (6) which actuates the carburetor throttle valve to a more open position. Engine speed then increases.

As engine speed increases, flyweight (2) centrifugal force overcomes governor spring force and the flyweights move outward. Flyweight movement is then transmitted through a sleeve (3), a shaft (4) and to a governor lever (5). This actuates a link (6) to a reduced fuel flow position and engine speed decreases.

An equilibrium will be reached when flyweight centrifugal force becomes equal to governor spring force. This type of governor actually never reaches a state of equilibrium. That is, governing action consists of a series of very small and brief accelerations and decelerations.

Sudden dumping of a load will cause a rapid increase in engine speed. The governor must be able to recover very quickly, to prevent an overspeed condition.

Some Typical Mechanical Governors

Governors currently in use on spark ignited (gas) engines include (a) Part No. 65934 and (b) Part No. 68985. The latter (68985) is used on 1.0 and 1.2 liter gas/gasoline engines. Governor 65934 is used on most other spark ignited engines.

NOTE: Starting in September 1991, Generac began to replace the mechanical governor (65934) with the new Generac electronic governor. The 1.0, 1.2 and 2.3 liter engines will continue to use a mechanical governor. For information and instructions on the new electronic governor, refer to Section 1.6. Adjustment procedures on diesel engine governors are discussed in Section 1.7.

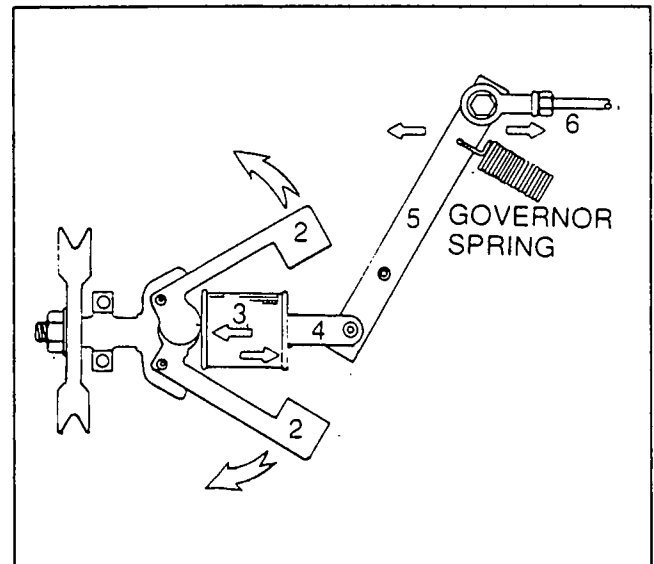


Figure 1. Governor Operating Diagram

Adjustment of 65934 Governor

GENERAL:

The following adjustment procedure applies to engines that are NOT equipped with a vacuum operated dashpot system.

Some 2.6 liter, 5.7 liter and 7.4 liter engines are equipped with a vacuum operated dashpot system. These systems were installed to alleviate rpm surges that might occur at mid-power ranges on the applicable engines. Kits were made available for field installation of the dashpot system on early production units. Adjustment procedures for units with dashpot system are not included in this manual, but may be found in the following manuals which are available from Generac:

- Instructions and Parts, "Vacuum Operated Governor Dashpot Kits for 5.7 & 7.4 Liter Gas Engines". Order Manual Part No. 78915.
- Instructions and Parts, "Vacuum Operated Governor Dashpot Kits for 2.6 Liter Gas Engines". Order Manual Part No. 78916.

INITIAL (PRESTART) ADJUSTMENTS:

1. Find the length of the throttle linkage rod by observing the position of the governor arm and the throttle plate arm.
 - a. The governor arm should be in alignment with the spring tension arm.
 - b. The throttle arm should be between one and two o'clock.
 - c. With the relationship between (a) and (b) above established, no drag or binding should be present and full travel of the entire linkage assembly should be obtained.

Adjustment of 65934 Governor (Continued)

2. Adjust the DROOP ADJUSTMENT SCREW so that approximately 3/4 inch of thread is showing above the upper lock nut. Then, tighten the upper and lower DROOP ADJUSTMENT SCREW lock nuts.
3. Turn the BUMPER SCREW out (counterclockwise) until approximately 3 or 4 threads are engaged. Then, tighten the BUMPER SCREW lock nut.

CAUTION: The bumper screw locknut must be tightened before startup or oil will leak from the governor.

4. Turn the SPEED ADJUSTING SCREW in (clockwise) until a slight tension is felt on the governor spring. This should provide low speed operation on initial startup.

FINAL ADJUSTMENT (ENGINE RUNNING):

1. Connect an accurate AC frequency meter to the generator's AC output leads.
2. Start the engine and let it warm up at no-load.
3. Turn the SPEED ADJUSTING SCREW clockwise to increase speed and AC frequency. Slowly increase engine speed until the frequency meter reads 62 Hertz at no-load.

NOTE: At this point governing action may be somewhat unstable. You may wish to stabilize the governor by placing your hand on the GOVERNOR ARM as a dampener. This will help stabilize rpm and frequency and allow you to complete adjustments.

4. Loosen the lock nut on the BUMPER SCREW.
 - a. Tap the governor arm to make it go into an unstable condition.
 - b. Turn the BUMPER SCREW clockwise until the governor begins to stabilize.
 - c. Continue to turn the BUMPER SCREW clockwise until frequency starts to increase. Then, turn the BUMPER SCREW counterclockwise until frequency reads 62 Hertz at no-load.
 - d. Tighten the BUMPER SCREW lock nut.

CAUTION: If the BUMPER SCREW is turned clockwise too far, speed adjustment may be adversely affected. If any governor setting (speed, bumper, droop) is changed, the other settings must be rechecked.

5. When settings are complete, tighten all locknuts. Then, check to make sure settings have not changed.
6. Apply an electrical load equal to the unit's rated wattage/ampere capacity. Frequency should not droop more than four (4) Hertz.
 - a. If excessive rpm and frequency droop occurs, increase tension on the DROOP SPRING.
 - b. After changing DROOP SPRING tension, reset the SPEED ADJUSTING SCREW to 62 Hertz at no-load.

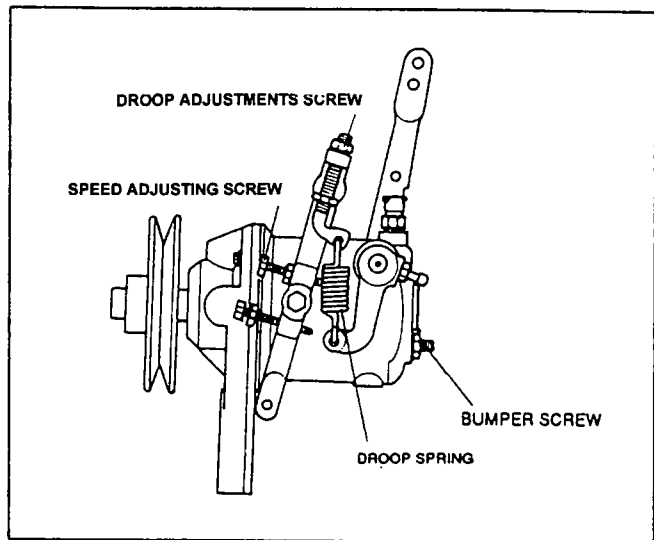


Figure 2. Governor Part No. 65934

Adjusting Governor 68985

GENERAL:

This governor is used on some 1.0 and 1.2 liter spark ignited, gas engines. It consists of (a) a fixed speed mechanical governor, and (b) a battery charge alternator. See Figure 4.

ADJUSTMENT PROCEDURE:

1. The length of the governor lever to carburetor link, as measured between ball joint centerlines, should be 4-3/8 inches.

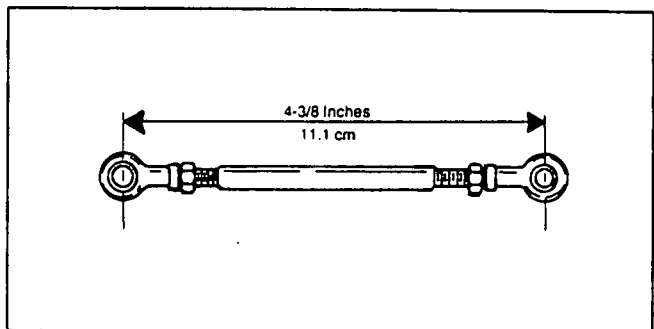


Figure 3. Governor Lever to Carburetor Link

2. Connect an accurate AC frequency meter to the generator's AC output leads.
3. Start the engine, let it warm up at no-load.
4. Adjust the NO-LOAD SPEED ADJUST SCREW to obtain a frequency reading as close as possible to 61.5 Hertz for 60 Hertz units; or 50 Hertz for 50 Hertz units.
5. Adjust the NO-LOAD BUMPER SCREW to obtain a no-load speed of 62 Hertz for 60 Hertz units (51 Hertz for 50 Hertz units).
6. Apply an electrical load to the generator as close as possible to the unit's rated wattage/ampere capacity.

Adjusting Governor 68985

- a. Check the AC frequency with load applied.
- b. If frequency droops below about 58 Hertz (60 Hertz units) or 49 Hertz (50 Hertz units), adjust the DROOP ADJUSTMENT downward.
- c. Adjust the DROOP ADJUSTMENT until application of the load results in the smallest possible AC frequency droop.

NOTE: If surging occurs when electrical loads are removed, adjust the NO-LOAD BUMPER SCREW inward. If BUMPER SCREW adjustment changes the AC frequency, back the BUMPER SCREW out until no-load frequency returns to 62 Hertz (60 Hertz units) or to 51 Hertz (50 Hertz units).

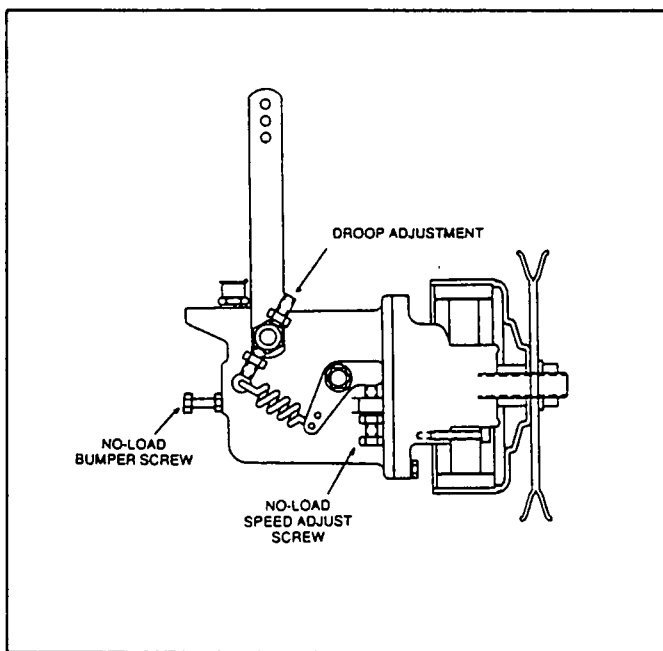


Figure 4. Governor Part No. 68985

Section 1.6 ELECTRONIC ENGINE GOVERNORS

Introduction

This section provides information on the components and adjustment of electronic engine governor systems used with Generac standby generators. The standby generator engine may be equipped with either (a) a Barber-Colman governor or (b) a Generac electronic governor.

BARBER-COLMAN GOVERNORS:

These governor systems are manufactured by the Precision Dynamics Division of the Barber-Colman Company, headquartered at 1354 Clifford Avenue, P. O. Box 2940, Loves Park, Illinois 61132-2940. The following governors may be used:

- The "DYNA-MASTER" governor system.
- The "DYNA-8000" governor system.

GENERAC ELECTRONIC GOVERNOR:

Operation and adjustment of Generac's electronic governor system will be discussed in this section.

The "DYNA 8000" Governor

GENERAL:

The "DYNA 8000" system is an all electric governor which provides precise isochronous or droop speed control of medium size engines, depending on the type of fuel system used. The basic system consists of (a) a controller, (b) an actuator and (c) a magnetic pickup.

THE ACTUATOR:

The actuator is basically a simple, proportional, electric solenoid with a sliding armature. The solenoid's magnetic force is proportional to the input coil current. Balanced between the force of its return spring and the magnetic force, the armature slides on anti-friction bearings, providing a hysteresis-free linear movement. The linear motion is converted to output shaft rotation by a bell crank. The following differences may exist between actuators (see ELECTRONIC GOVERNOR APPLICATION CHART in this section).

- Direction of shaft rotation (CW or CCW).
- System voltage (12 or 24 volts DC).
- Available torque (Dyna 8000 actuator is rated at about 1.0 foot-pound).

THE CONTROLLER:

The controller receives engine speed (frequency) signals from a magnetic pickup. It is powered by DC voltage from the generator battery (12 or 24 volts DC). Adjustment pots are provided on the controller for the adjustment of (a) governed speed, (b) gain, and (c) droop. DYNA 8000 specifications are as follows:

Output Current @ 12 VDC	Nominal Quiescent Current Maximum Amperes @ Stall	80 mA 13 amps
Output Current @ 24 VDC	Nominal Quiescent Current Maximum Amperes @ Stall	80 mA 13 amps

MAGNETIC PICKUP:

The magnetic pickup is installed so that its magnetic tip is directly over the engine flywheel's ring gear teeth. The device will emit a pulse or cycle of electricity each time a gear tooth passes the magnetic tip. The pulse is delivered to the governor controller as an indication of actual engine speed.

The input signal frequency delivered from the magnetic pickup to the controller can be calculated using the following formula, where "A" is the input signal frequency in Hertz, "RPM" is engine speed, and "N" is the number of gear teeth on the flywheel. :

$$A = \frac{RPM \times N}{60}$$

ISOCHRONOUS OPERATION:

Isochronous operation is obtained by setting the DROOP potentiometer fully counterclockwise. The governor is all electric and is normally operated in the isochronous mode. That is, engine speed is constant (plus or minus 0.25%) under steady state load conditions, up to the engine's maximum capability, regardless of load on the engine.

DROOP OPERATION:

Droop operation is obtained by setting the DROOP potentiometer clockwise to increase droop. The amount of droop for a given setting depends on the magnetic pickup frequency and the no-load to full-load actuator shaft rotation. A droop potentiometer setting of 10 o'clock will give about 4% droop, no-load to full-load, when pickup frequency is 4260 Hz and actuator shaft rotation is approximately 30 degrees from no-load to full-load. A lower pickup frequency or a smaller shaft rotation results in less droop for the system.

MAGNETIC PICKUP INSTALLATION:

If the magnetic pickup is removed for any reason, it must be installed properly. Rotate the ring gear until a gear tooth face is directly in the center of the pickup tapped hole. See Figure 1, on next page. Gently turn the magnetic pickup clockwise into the tapped hole until it just bottoms on the gear tooth. Then, back off 1/4 turn and tighten the jam nut securely.

CAUTION: DO NOT rotate ring gear until after the magnetic pickup has been properly installed or damage to equipment will result.

The "DYNA-8000" Governor (Continued)

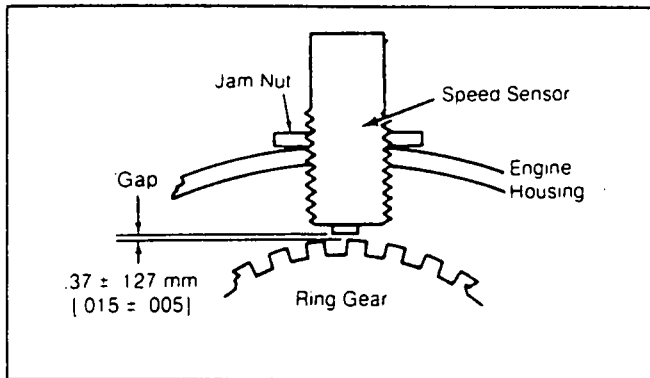


Figure 1. Magnetic Pickup Installation

DYNA 8000 CALIBRATION AND ADJUSTMENTS:

A: Initial Settings: With engine shut down, complete initial potentiometer adjustments as follows:

1. Set the "I" adjustment one division from zero and the "GAIN" at the third division from zero.
2. Select either isochronous or droop operation as follows:
 - a. For isochronous operation, set DROOP counterclockwise to its minimum position as shown in Figure 2.
 - b. For droop operation, set the DROOP potentiometer clockwise to obtain desired amount of droop from no-load to full-load. Turn the adjustment clockwise to increase droop.

OPTIONAL REMOTE SPEED ADJUSTMENT:

An optional remote speed selector is available for adjusting engine speed from up to 300 feet (90 meters) from the unit. See terminals 6, 7 and 9 in Figure 2.

NOTE: If the full 35° rotation of the actuator shaft is used and the linkage adjusted to use only the active fuel range, maximum obtainable droop would be approximately 12% at full load.

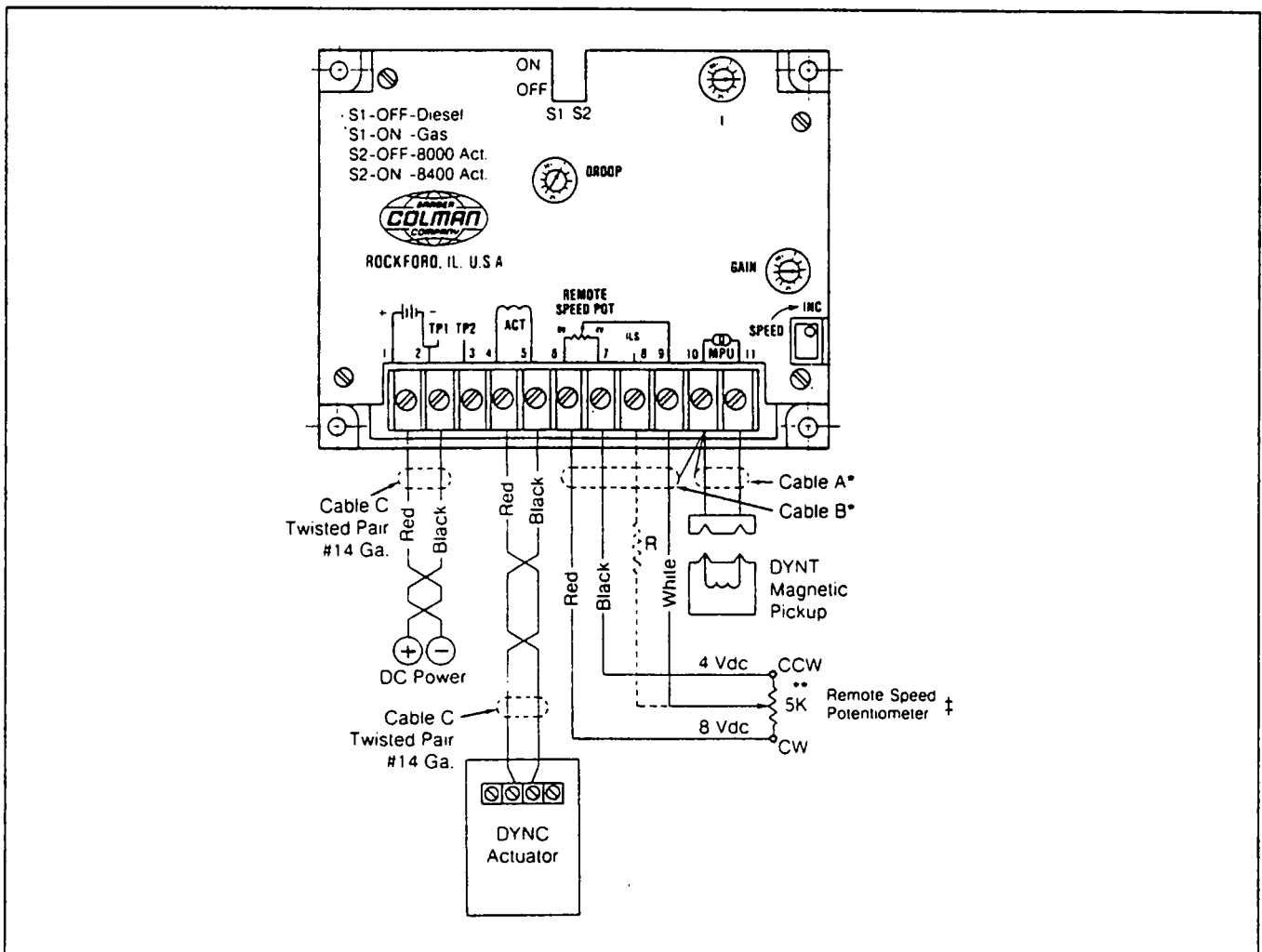


Figure 2. DYNA 8000 Governor System

The "DYNA 8000 Governor (Continued)

3. Set switches S1 and S2 as follows:
 - a. Switch S1 selects one of two integrating rate ranges. The diesel version integrates at twice the rate of the gas version.
 - b. Switch S2 selects the point at which actuator coil current level causes the intergator limit to be actuated. This level is normally 6.3 amperes for the DYNA 8000.
 - c. Set switches S1 and S2 as follows:
 - (1) Set Switch S1 to OFF for diesel engines; to ON for gas engines.
 - (2) Set switch S2 to OFF for the "8000" actuator.

NOTE: Figure 3 below should clarify any confusion about switch settings. The easiest way to set the switches is to apply downward pressure with a small pointed object (as shown) until the switch clicks into position.

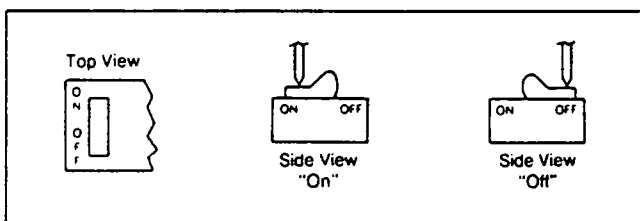


Figure 3. Setting Switches S1 and S2

4. If a remote speed potentiometer is used, set it to mid-range.

NOTE: If the remote speed potentiometer is connected to terminals 6, 7 and 9, the resistor "R" in the wire is not required. This will provide approximately a plus or minus 5% adjustable speed range.

B. Adjustment with Engine Running: After all initial settings are completed, start the engine. Let it stabilize and warm up for a few minutes. Then, proceed as follows:

1. Adjust the controller "SPEED" potentiometer until the engine is running at the desired speed. Turn the adjustment clockwise to increase rpm and AC frequency.
2. If the governor system is unstable, slightly reduce the "I" and "GAIN" settings.

NOTE: Except for the "SPEED" adjustment, the potentiometers have internal stops at their 0 and 100% positions.

3. With the generator running at no-load, finalize the settings of "I" and "GAIN" as follows:
 - a. Turn the GAIN adjustment slowly clockwise until the actuator lever oscillates. This will be a faster oscillation than was observed when "I" was adjusted. When oscillation occurs, turn GAIN slowly counterclockwise until the lever stabilizes. Upset the lever with your hand. If the lever oscillates 3 to 5 diminishing oscillations and stops, the setting is correct.

b. If system performance to load changes is satisfactory, omit Step 4.

4. Reduce the GAIN setting counterclockwise one division. Next, turn the "I" adjustment fully clockwise while observing the actuator lever. If the lever does not become unstable, upset it by hand. When the lever slowly oscillates, turn the GAIN adjustment slowly counterclockwise until the lever is stable. Upset the lever again; it should oscillate 3 to 5 times and then become stable for optimum response.

NOTE: Use the settings of Step 3 or Step 4, whichever provides the best performance.

The unit is now calibrated.

The "DYNA-MASTER" Governor

GENERAL:

Engine speed is controlled by an all-electric governor assembly consisting of an actuator and a controller. The actuator output is connected to the fuel control lever via a linkage rod. The speed signal from the engine is obtained from a magnetic pickup in the engine flywheel housing.

ACTUATOR:

The actuator consists of an electro-magnet with an iron armature rotating on a center shaft. The actuator is provided with a return spring which balances the magnetic forces of the armature. When DC current is flowing in the coil, the magnetic force tends to rotate the armature in the stator.

CONTROLLER:

The electronic controller is the information processing unit of the governor assembly. It contains electronic components which process the input signal from the magnetic pickup. External adjustments are available on the controller for field adjustment of the unit, if necessary.

POWER SOURCE:

The governor system is energized by the generator battery which supplies either 12 volts DC or 24 volts DC, depending on the specific unit. Average operating current is about 2 to 3 amperes. Highest current flow is about 10 amperes, during startup or during a large load change.

ISOCHRONOUS OPERATION:

Droop operation is normally available only on DYN1 10614 series units only. In isochronous operation, engine speed is constant (plus 0.35%) under steady state load conditions, up to the engine's maximum capabilities, regardless of load on engine.

The "DYNA-MASTER" Governor (Continued)

DROOP OPERATION:

The amount of droop for a given setting depends on magnetic pickup frequency and the no-load to full-load actuator shaft rotation. A DROOP potentiometer setting of 9 o'clock will give about 3% droop, no-load to full-load, when the pickup frequency is 4260 Hz and actuator shaft rotation is 33° from no-load to full-load. Lower pickup frequency or a smaller shaft rotation results in less droop.

NOTE: Droop operation is not available on systems equipped with the controller shown in Figure 4 (no droop adjustment). The controller shown in Figure 5, however, will provide droop operation.

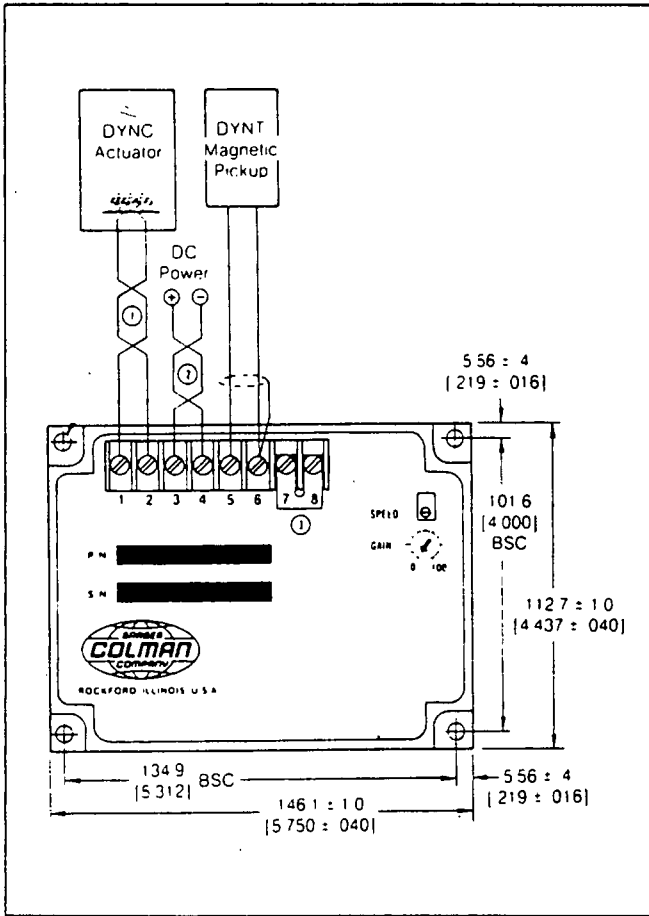


Figure 4. Typical System Without Droop Adjustment

DYNA-MASTER CALIBRATION & ADJUSTMENT:

(Isochronous Only, No Droop Adjustment)

- A. See Figure 4. Prior to starting the engine, complete the following adjustments:
1. Set "GAIN" full counterclockwise.

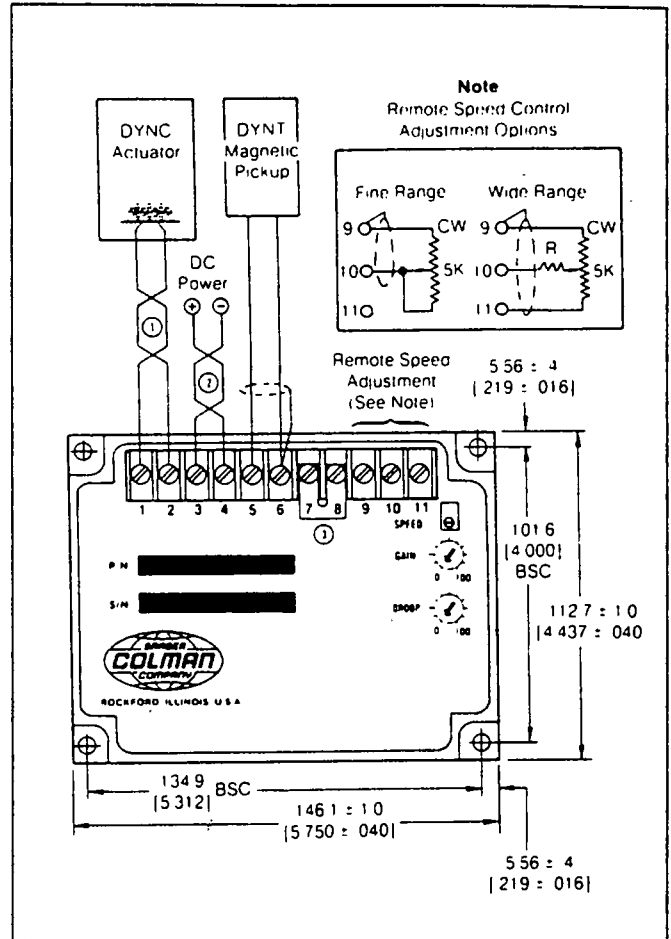


Figure 5. System with Droop Adjustment

2. "SPEED" is factory set for an idle speed. It may be necessary to turn it clockwise before the engine will start. This is a multi-turn potentiometer, 20 turns plus or minus 20%.
- B. Start the engine. Then, adjust as follows:
 1. Adjust the "SPEED" potentiometer until engine is operating at the correct speed. Clockwise increases engine speed.
 2. Adjust the "GAIN" pot slowly clockwise until the governor starts to hunt (unstable). Then, turn the "GAIN" slowly counterclockwise until governor is stable. Upset the governor by tapping actuator lever. Engine should return quickly to its commanded speed without hunting.

NOTE: An "integral gain" jumper is installed across controller terminals 7 and 8. For most engines, best operation will be obtained with the jumper in place. For some engines, where engine response is slow or when engine lag times are long, improved performance may be achieved with the jumper removed from terminals 7 and 8.

The "DYNA-MASTER" Governor (Continued)

DYNA-MASTER CALIBRATION & ADJUSTMENT:

(System with Droop Adjustment)

A. See Figure 5. Prior to starting the engine, set the controller potentiometers as follows:

1. Set "GAIN" fully counterclockwise.
2. "SPEED" adjustment was factory set for a reduced (idle) speed. It may be necessary to turn "SPEED" clockwise before the engine will start. This is a multi-turn potentiometer (20 turns plus or minus 20%).
3. Determine whether you wish to have isochronous or droop operation. Refer to "Isochronous Operation" and "Droop Operation" on Page 1.6-1.
 - a. If droop operation is desired, adjust the "DROOP" potentiometer clockwise to obtain the desired amount of droop for your application.
 - b. If isochronous operation is desired, turn the "DROOP" adjustment fully counterclockwise.

NOTE: The amount of droop for a given setting depends on the magnetic pickup frequency and the no-load to full-load actuator shaft rotation. Lower pickup frequency or smaller actuator output shaft rotation results in less droop.

4. If a remote speed potentiometer is used, set it to its mid-range.

B. Start the engine, then perform the following adjustments:

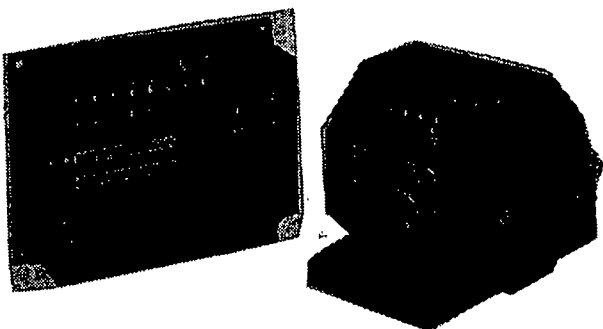
1. Adjust the "SPEED" potentiometer until engine is running at the desired speed. Turn the adjustment clockwise to increase rpm.
2. Adjust the "GAIN" potentiometer **slowly clockwise** until the governor starts to hunt (unstable). Then, turn "GAIN" **slowly counterclockwise** until the governor is stable.
3. Upset the governor by tapping actuator lever. Engine should return quickly to its commanded speed without hunting.

NOTE: An "Integral Gain" jumper may be installed across controller terminals 7 and 8. For most engines, best operation will be obtained with the jumper installed across terminals 7 and 8. On some applications, where engine response is slow or when engine lag times are long, improved performance may be obtained by removing the jumper.

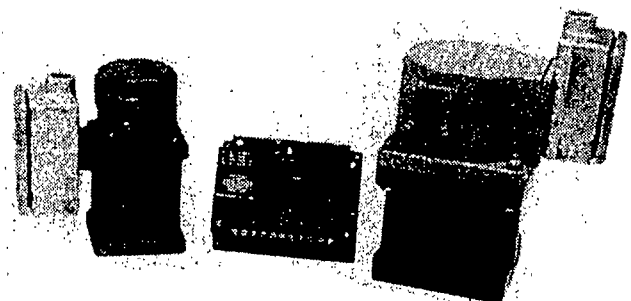
Electronic Governor Application Chart

ENGINE SIZE	TYPE OF ENGINE	GOVERNOR TYPE	RATED VOLTS	GOVERNOR ACTUATOR		CONTROLLER PART NO.
				PART NO.	ROTATION	
1.3 liter	Gas	DYNA-MASTER	12 VDC	59161		59449
2.6 liter	Gas	DYNA-MASTER	12 VDC	59161		59449
5.7 liter	Gas	DYNA-MASTER	12 VDC	59161		59162
5.7 liter (GB)	Gas	DYNA-MASTER	12 VDC	59161		59162
2.2 liter	Diesel	DYNA 8000	12 VDC			
3.0 liter	Diesel	DYNA 8000	12 VDC	67705	Clockwise	67709
7.4 liter	Gas	DYNA 8000	12 VDC	67707	Counterclockwise	67711
7.4 liter (GB)	Gas	DYNA 8000	12 VDC	67707	Counterclockwise	67711
4.0 liter	Diesel	DYNA 8000	24 VDC	67706	Clockwise	67710
6.4 liter	Diesel	DYNA 8000	24 VDC	67708	Counterclockwise	67710
13.3 liter	Diesel	DYNA 8000	24 VDC	67708	Counterclockwise	67710
5.0 liter		DYNA 8000	12 VDC	67707	Counterclockwise	67711

"Dyna-Master" (Typical)



"Dyna 8000" (Typical)



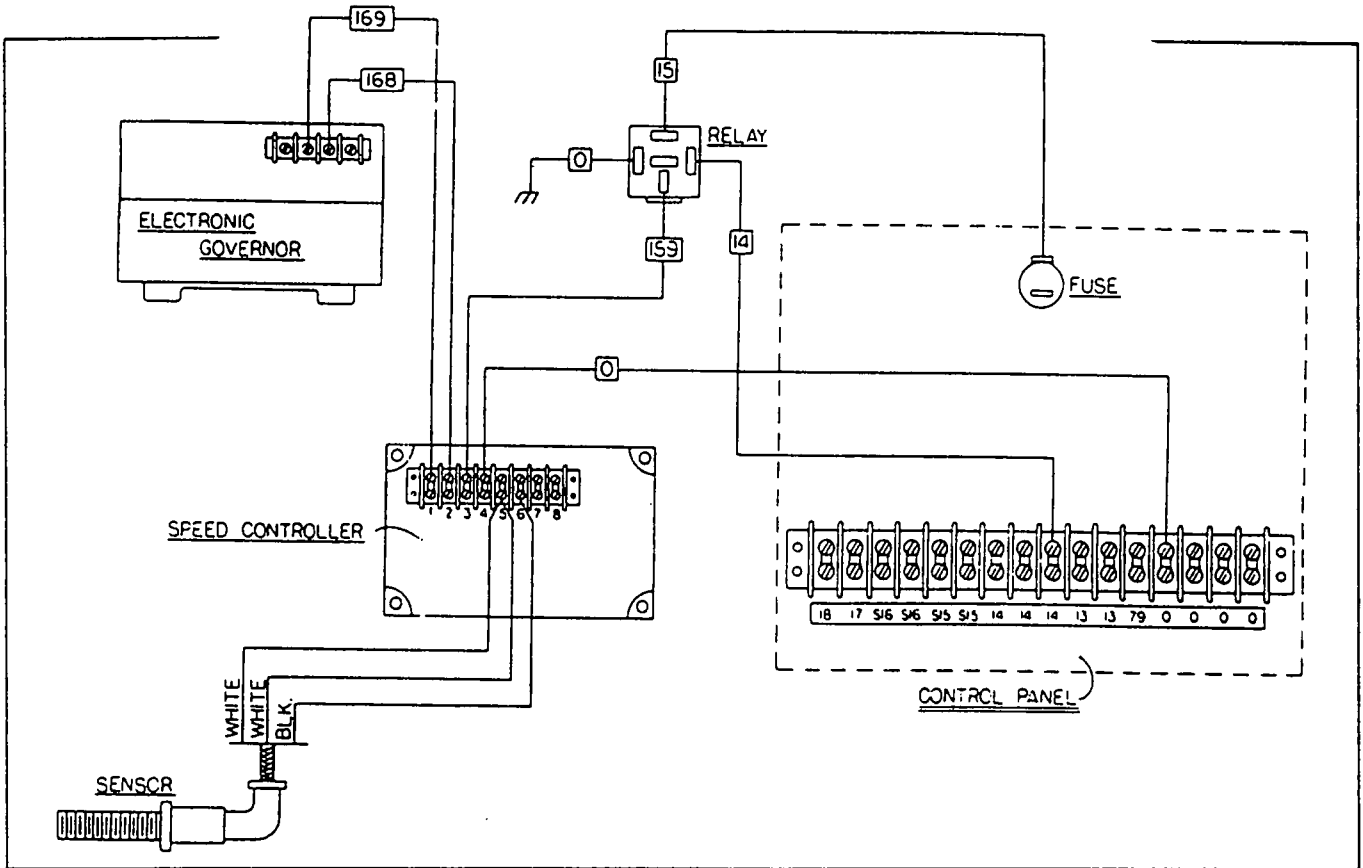


Figure 6. Wiring Diagram - "DYNA-MASTER" Electronic Governor System (Drawing No. 60720)

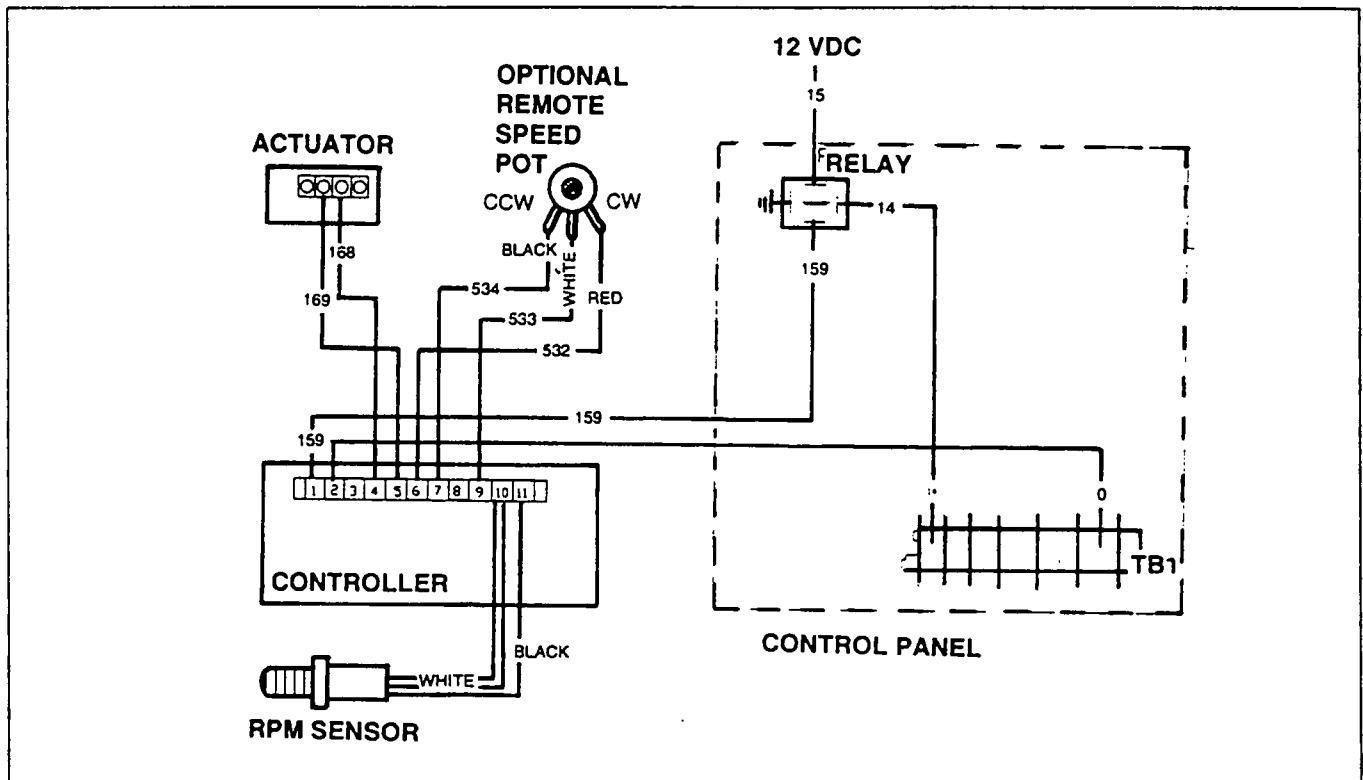


Figure 7. Wiring Diagram - "DYNA 8000" Electronic Governor System (Drawing No. 67713)

Generac's Electronic Governor

GENERAL INFORMATION:

The Generac electronic governor system consists of (a) a circuit board, (b) an actuator, (c) an rpm sensor, (d) a governor relay, and (e) interconnecting wires. See Figure 8. During engine startup, a DC control/latch-crank circuit board delivers battery voltage to the GOVERNOR RELAY coil via Wire 14. The GOVERNOR RELAY then energizes, its normally-open contacts close, and 12 volts DC is delivered to the GOVERNOR CIRCUIT BOARD via Wire 168. The governor system is then turned on. Engine speed information is delivered to the GOVERNOR CIRCUIT BOARD from an RPM SENSOR via Wire 79. The GOVERNOR CIRCUIT BOARD delivers speed correction signals to the GOVERNOR ACTUATOR via Wire 169.

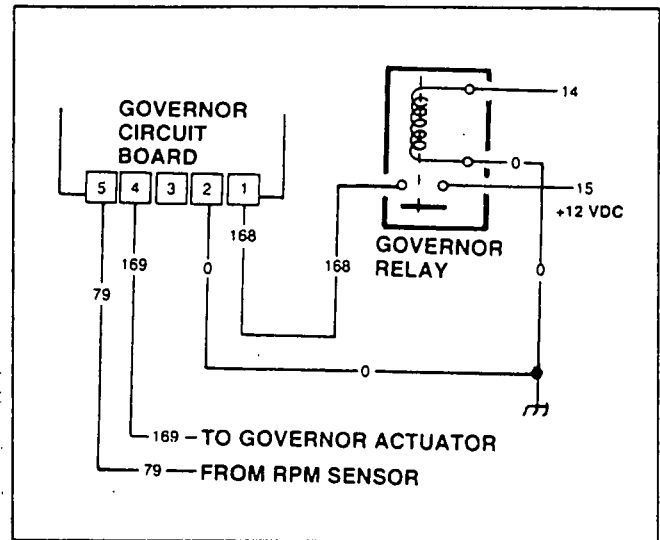


Figure 8. Governor System Schematic

GOVERNOR ACTUATOR ADJUSTMENT:

Adjust the length of the governor actuator with engine shut down. With the throttle valve closed, adjust so that approximately 0.40-0.78 inch (1-2mm) of clearance exists between the actuator stop washer and the actuator body.

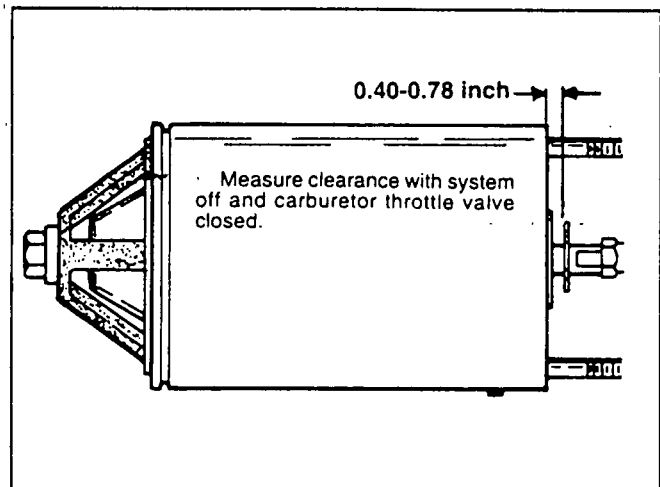


Figure 9. Governor Actuator

ELECTRONIC GOVERNOR SETUP:

The GOVERNOR CIRCUIT BOARD (Figure 10) is housed in the generator control console. All circuit board adjustments for new generators have been completed at the factory. No readjustment should be required. If the circuit board must be replaced adjust governing parameters as follows:

- Set the speed pot (R5) fully counterclockwise.
- Set all other potentiometers (R12, R13, R22, R26) to their mid-point.
- Set Jumper J2 to "FAST" position.
- Adjust speed pot (R5) clockwise to obtain the correct AC frequency.

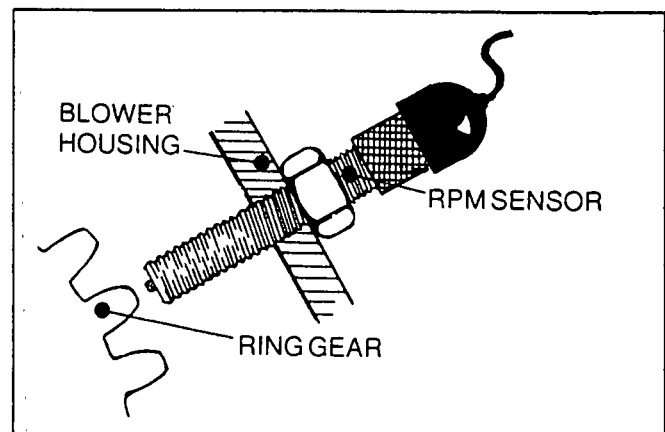


Figure 10. RPM Sensor

Generac's Electronic Governor (Continued)

- Check no-load stability. System stability can be improved by adjusting R12 and R13 clockwise.
- Apply 25% of the unit's rated load. Then, check stability. If undesirable oscillations are observed when the 25% load is applied, adjust R22 clockwise. Adjusting R22 clockwise will dampen undesirable oscillations that occur when the load is applied.
- Shut engine down. Then, restart it and observe startup characteristics. If the overshoot during start is higher than desired, adjust R26 clockwise to reduce startup overshoot.
- Apply rated block load to the generator. Observe the recovery from block load application and from load dump.
 1. Adjusting R12 and R13 counterclockwise will improve recovery from block load application, but will tend to make the system less stable.
 2. Adjusting R26 counterclockwise will improve recovery from load dump, but will allow more overshoot at startup.

Complete the preceding adjustments as required to obtain the best balance of all parameters. Basic guidelines for system operation are as follows:

1. The system should reach stability at all load points with not more than four (4) oscillations.
2. The system should recover to within one (1) Hz of steady state in less than two (2) seconds for all load transients. No-load to full-load droop should be less than 0.5 Hz steady state.

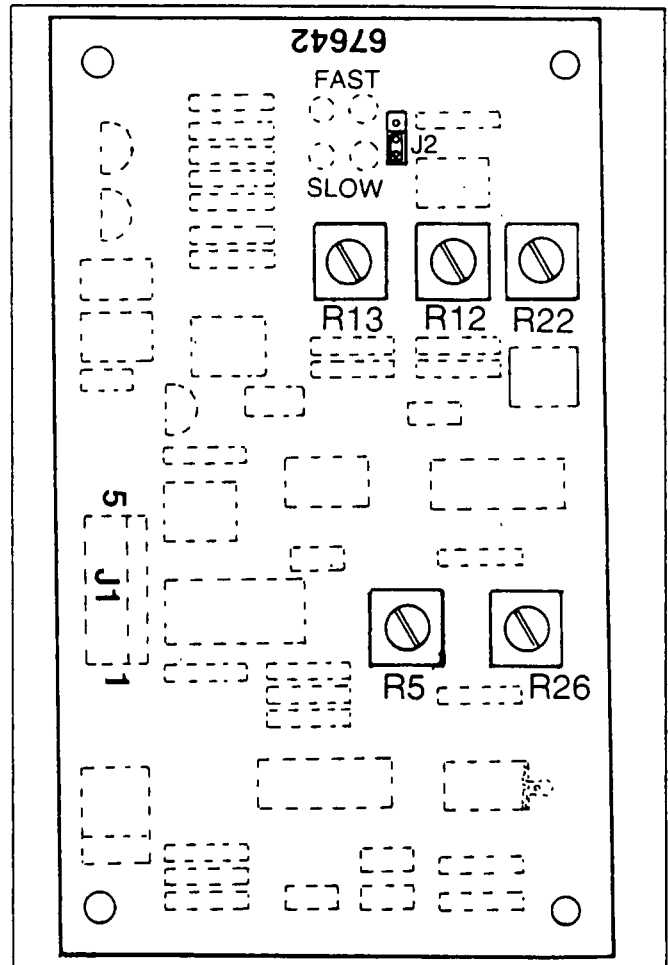


Figure 11. Governor Circuit Board

GENERAC STEPPER MOTOR ELECTRONIC GOVERNOR

Introduction

The Generac Stepper Motor Electronic Governor system is used on some small diesel and gas engines with 12 volt DC electrical systems. The governor system consists of a governor module mounted inside the generator control panel, a stepper motor mounted near the injection pump or carburetor, and interconnecting wires and connection boxes. (See Figure 1)

Operational Analysis

During the engine start-up and run, a +12 volt DC is applied to the control module via the red (+ positive) and black (- negative) wires. The voltage from the main engine control latch/crank PCB wire #14 (run circuit) powers up the control module for governor system operation. The control module receives a speed "sensing" signal from AC output frequency via the two (2) blue wires.

The control module sends variable signals to the stepper motor via the orange, yellow, brown and black wires to position the stepper motor and throttle linkage to obtain a steady 50 or 60 Hz. (selectable on the control module frequency switch)

Control Module Pots and Switches

the following is description of the adjustment procedure for the new electronic governor control module and stepper motor. (See Figure 1)

POT SETTINGS:

Set GAIN, DROOP, and STABILITY pots to midpoint.

SWITCH SETTINGS:

Set frequency switch to either 50 or 60 Hz.

* Frequency switch set to "OFF" = 60 Hz.

* Frequency switch set to "ON" = 50 Hz.

SET DIRECTION SWITCH:

Determine which direction the stepper motor lever needs to be set to open the throttle. Some units are set to open at the clockwise position, and some are set to open at the counterclockwise position.

If the lever is set to open at the counterclockwise position, then the direction switch should be set in the "OFF" position. If the lever is set to open at the clockwise position, the direction switch should be set to the "ON" position.

When the switches and pots are set correctly, start the engine. Adjust the gain pot if necessary to stabilize engine speed.

* Apply load to system-25-50% is best. If system is unstable, reduce gain until it stabilizes.

* Adjust droop pot so that the engine speed recovers to the pre-selected speed. (50 or 60 Hz based on unit).

* Observe performance of system when loads are applied and removed.

* Increasing stability will decrease recovery time, but may result in damped oscillations (decreasing hertz around preset speed). Decreasing stability will soften the recovery and reduce the transient hertz.

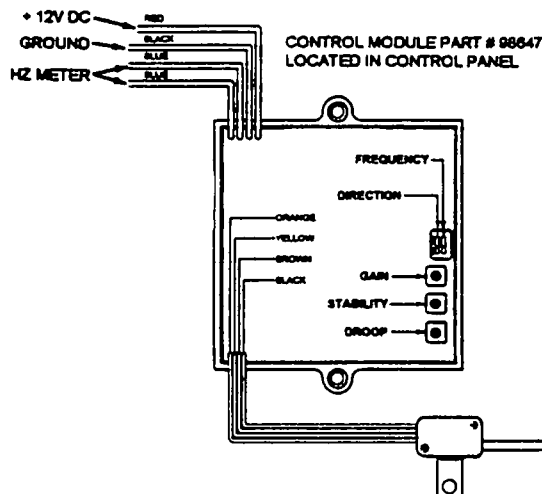
Set-up and Adjustment Procedure

(Stepper Motor/Throttle Linkage : Gas & Diesel)

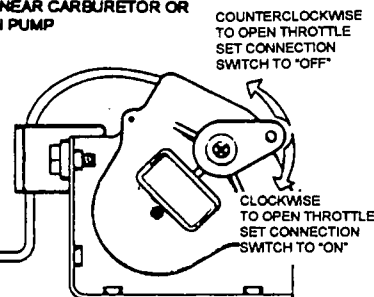
Determine which direction the stepper motor must rotate to open the throttle to "full fuel". Adjust the rod length so when the throttle is wide open, the stepper motor is at it's full rotation, then tighten the jam nuts. Ensure linkage moves freely and does not bind in any way.

Frequency and direction switches are integrated only at engine start. Changing switch settings while engine is running will have no effect until the engine is stopped and restarted.

Figure 1. Stepper Motor and Control Module



STEPPER MOTOR PART #08290
LOCATED NEAR CARBURETOR OR
INJECTION PUMP



TROUBLESHOOTING

Troubleshooting Stepper Motor Governor System

Troubleshooting the stepper motor governor system is generally limited to checking inputs to the control module, adjustments, settings, electrical connections, and testing the stepper motor windings.

NOTE: A fuel supply problem can sometimes be mistaken for a speed control problem. Verify whether a problem is fuel related before attempting to readjust the governor pot / switch settings.

The following is a list of possible problems and tests to perform, followed by descriptions of the tests.

PROBLEM: "Overspeeding"

TEST PROCEDURES: Check the Hz switch setting, TEST #1, TEST #2, TEST #3, TEST #4.

PROBLEM: "Instability, erratic operation"

TEST PROCEDURES: Adjust linkage and check for binding, adjust control module pots, TEST #3, TEST #4.

PROBLEM: "Low speed, no fuel"

TEST PROCEDURES: TEST #1, TEST #2, TEST #3, TEST #4, check position of the Hz switch.

Test #1

(Check DC Voltage Supply to Control Module)

If the control module loses its 12 volt input, it will no longer be able to control or move the stepper motor. If this happens while the unit is under a load, an "overspeed" condition could occur as soon as the load is removed. The stepper motor could remain in a position supplying too much fuel for the "no load" condition.

Test #2

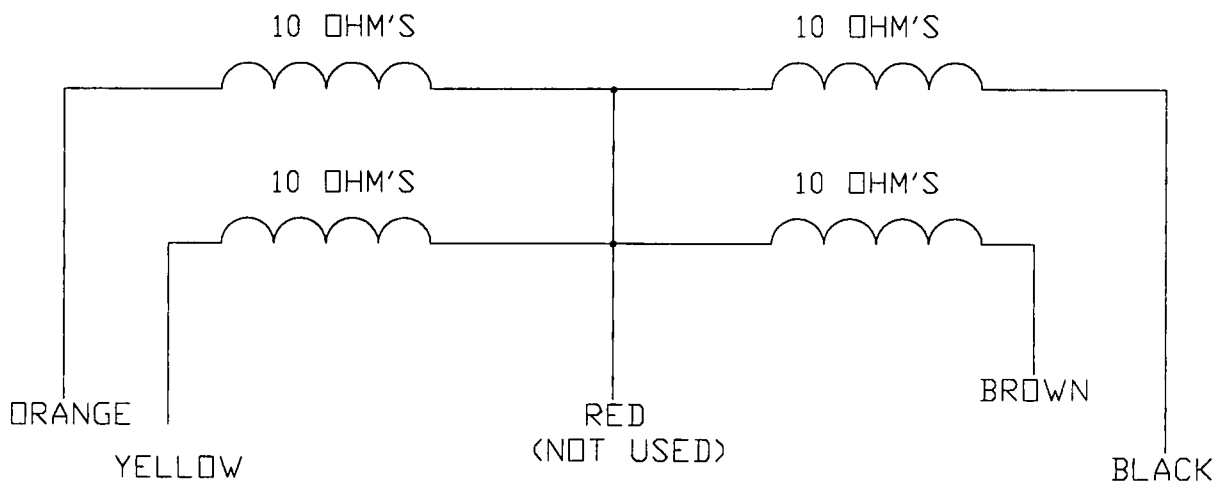
(Check AC Frequency Input to Control Module)

Similar to the control module losing its DC input, the control module will no longer be able to control the stepper motor if the Hz sensing input is lost. The stepper motor's inability to move or react properly could result in an "overspeed" condition.

To check Hz sensing input, run unit while manually controlling speed at a safe level. Ensure that the unit is providing AC output and that the hertz meter is indicating properly (the Hz meter is the connection point for the control module sensing leads).

Check the condition of the wires and connections on "blue" sensing leads between the Hz meter and the control module.

Figure 2. Schematic and Resistance Values



*Measure resistance across any combination of orange, yellow, brown, or black should read approximately 20 OHMS.

*Measure from red to any other lead should read 10 OHMS.

*Testing from any lead to stepper motor case should read "infinity".

TROUBLESHOOTING (continued)

Test #3

(Check connections between Control Module and Stepper Motor)

There are two "Plug-In" connectors housed inside the connection boxes in the harness between the control module and the stepper motor. Remove the covers from the boxes and carefully inspect the connections.

Test #4

(Test Stepper Motor)

A defective stepper motor can cause overspeed, low speed, or no-start, hard start or erratic operation.

NOTE: *It is difficult to perform an operational test on the Stepper Motor since the control voltages vary, and motor rotational movement is so small.*

If a defective stepper motor is suspected, the windings can be tested for resistance, open circuits, and shorts to the case. (See Figure 2) for schematic and resistance values. Any other readings other than those which are indicated, including continuity to case, indicates a faulty stepper motor.

Control Module

If problems still persist after all the previous tests and adjustments have been completed, it is recommended to then replace the Control Module and adjust as necessary.

Section 1.7 DIESEL ENGINE GOVERNORS

Introduction

Unlike automotive engines and many industrial engines, the operating speed of AC generator engines must be held constant. Operation at a constant speed is required to ensure correct AC voltage and frequency output from the generator.

Diesel engines are equipped with a mechanical engine governor which is usually part of the fuel injection pump. The governor must (a) maintain a fairly constant speed when the engine is running at no-load, and (b) must not permit excessive rpm droop when heavy loads are applied.

The following general rules apply to generators that utilize a mechanical engine governor:

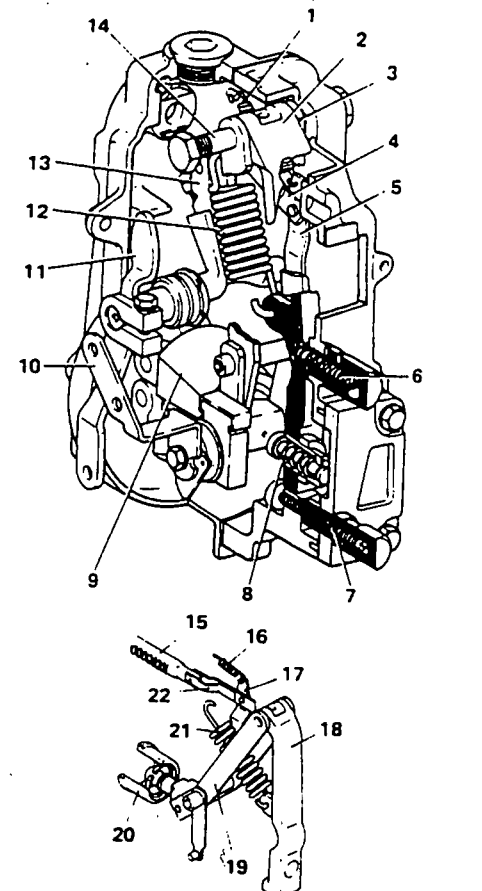
- On units rated 60 Hertz, the mechanical governor is generally factory adjusted to maintain a 62 Hertz AC frequency at no-load. When electrical loads equal to the unit's full rated wattage/amperage capacity are applied, engine speed should not droop below about 58 Hertz.

- On units rated 50 Hertz, the governor is factory set to maintain approximately 51 Hertz at no-load. When electrical loads equal to the unit's full rated wattage/amperage capacity are applied, engine speed should not droop below about 49 Hertz.

A Typical Injection Pump Governor

See Figure 1 below. The governor assembly shown is used on Generac's 4.0 liter diesel engine. The Generac 6.4 and 13.3 liter diesel engines are equipped with governors that are very similar. Governor operation is based on spring tension (Item 12 and 21) versus centrifugal force acting on a flyweight (Item 9).

Governor movement acts on a control rod (Item 15) which, in turn, adjusts a control sleeve in the injection pump. Control sleeve movement increases or decreases fuel flow to the fuel injection nozzles and to the engine combustion chambers.



Governor shown is for the 4.0 liter diesel engine. Governors on 6.4 and 13.3 liter engines are similar.

ITEM	NOMENCLATURE
1	Start Spring
2	Tension Lever
3	Guide Lever
4	Shackle Assembly
5	Control Lever
6	Idle Spring
7	Full Load Adjustment
8	Adapter Spring
9	Flyweight Assembly
10	Stop Lever
11	Adjusting Lever
12	Speed Control Spring
13	Swivelling Lever
14	Lever Support Shaft
15	Control Rod
16	Start Spring
17	Control Lever
18	Tension Lever
19	Guide Lever
20	Governor Sleeve
21	Speed Control Spring
22	Shackle

Figure 1. Typical Injection Pump Governor

A Typical Injection Pump Governor (Continued)

Governor action may be briefly described as follows:

- Spring force acts on the control rod (Item 15) which moves axially to impart a radial motion to the control sleeve (Item 20). Fuel flow and engine speed increase.
- As engine speed increases, centrifugal force acts on the flyweight assembly (Item 9) tending to move the flyweights outward in opposition to spring force.
- When centrifugal force acting on the flyweights is sufficient to overcome spring force, the control rod is moved in the opposite direction. Fuel flow and engine speed will then decrease.
- As engine speed decreases a point is reached where spring force is greater than centrifugal force. The control rod will then move to increase fuel flow and engine speed.
- The governing action is a series of very small cyclic increases and decreases in engine speed as the system attempts to reach a point where centrifugal and spring force are balanced.

From the above, it is apparent that governed speed can be established by adjusting the tension of the spring (Item 12). Some other adjustment parameters are also provided.

Adjustments Familiarization

See Figure 2. A typical diesel governor provides the following adjustments:

1. Full load adjust screw.
2. Stop adjust screw.
3. Maximum speed screw.
4. Governor adjust screw.
5. Idling subspring.
6. Stop lever.

FULL LOAD ADJUST SCREW:

Use the full load adjust screw (Item 1) to eliminate excessive rpm and frequency droop when electrical loads are applied to the generator. If generator AC frequency drops too low when the unit's rated maximum load is applied, remove the cap and turn the adjust screw in (clockwise) to increase control rod travel. The following apply:

1. With unit running at its correct no-load frequency, apply electrical load to the unit's rated capacity.
2. With the load applied, turn the adjust screw in (clockwise) to increase frequency. Then, turn the adjust screw out (counterclockwise) until frequency starts to drop off. Finally, turn the adjust screw in (clockwise) to recover frequency. Full-load frequency should be 59-60 Hz (never below 58 Hz).

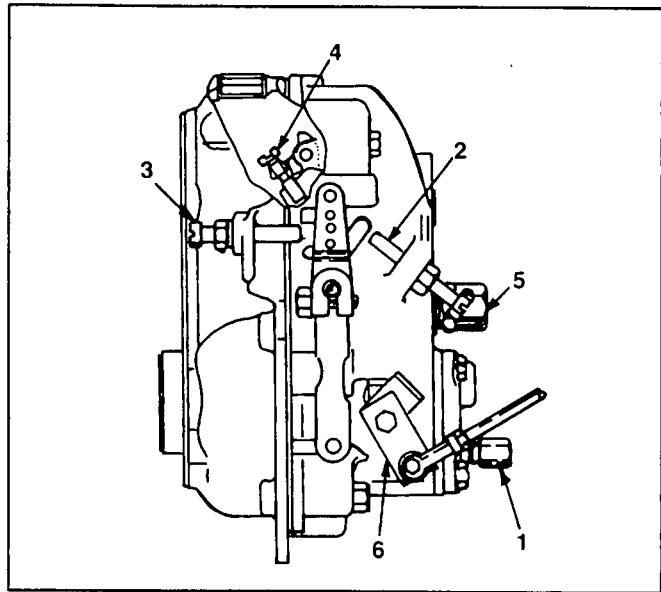


Figure 2. Adjustments on a Typical Governor

STOP ADJUST SCREW:

Use this adjust screw to establish a governed no-load speed equal to the rated no-load speed and AC frequency of the unit. Other times the stop adjust screw will be turned are:

- Prior to adjusting the governor adjust screw (Item 4).
- When setting the speed/frequency at which overspeed shutdown will occur.

MAXIMUM SPEED SCREW:

Adjustment of the maximum speed screw (Item 3) should not be required. One exception to this rule is when the screw must be backed out during adjustment of overspeed shutdown.

GOVERNOR ADJUST SCREW:

Adjustment of this adjust screw (Item 4) is normally required only on new replacement fuel injection pumps.

Adjust the screw with the engine shut down, as follows:

1. Remove plug at top of governor housing.
2. Back the full load adjust screw (Item 1) all the way out (counterclockwise).
3. Move the stop lever (Item 6) to the right (shutdown position) to allow adjustment of the governor adjust screw. Turn the governor adjust screw in (clockwise) for better and more stable governing.

NOTE: On the Generac 4.0 liter diesel engine, it will be necessary to remove the engine intake adapter to gain access to the governor adjust screw.

Adjustments Familiarization (Continued)

NOTE: The GOVERNOR ADJUST SCREW (Item 4) is adjusted by counting the number of "clicks" as the screw is turned. There is no hard and fast rule as to the number of clicks that will provide optimum, stable governing. After adjustment, start the engine and let it run at the unit's rated no-load speed. If governing is unstable, shut engine down and adjust the governor adjust screw (Item 4) in (clockwise) one or two clicks. Restart the engine, let it run at rated speed and check again for unstable governing. If governing is unstable, shut down and adjust screw in (clockwise) one or two more clicks. Continue this process until stable governing is obtained. If governing is stable at no-load, but instability occurs when partial load is applied, turn the screw out (counterclockwise) to eliminate the problem.

IDLING SUBSPRING:

Idle speed is increased by turning the idling sub-spring screw (Item 5) in (clockwise). Adjustment of the screw should never be required in the field. If the screw is turned in (clockwise) too far, maximum governed rpm will be changed.

STOP LEVER:

An electrically actuated fuel solenoid (FS) is connected to the stop lever (Item 6). When the stop lever is moved to its right, fuel flow is terminated and shut-down will occur.

Proper adjustment of the fuel solenoid linkage to the stop lever is critical since positive fuel shutoff must occur when the electrical solenoid is de-energized. Conversely, when the fuel solenoid energizes, fuel flow must be positively turned on.

Governor Adjustment

GENERAL:

The following covers governor adjustment procedures for 4.0, 6.4 and 13.3 liter diesel engines. All of the procedures may or may not be required when adjusting the governor.

BLEEDING THE FUEL SYSTEM:

If engine fuel system parts have been removed and replaced, or removed and reinstalled, bleeding of air from the system may be required. Air in the fuel system will result in hard starting and rough, unstable operation.

GOVERNOR ADJUSTMENT PROCEDURES:

1. Start the engine, let it warm up for a few minutes at no-load.
2. See Figure 2. With engine running at no-load, turn the STOP ADJUST SCREW (Item 2) to obtain correct no-load AC frequency (62 Hz on units rated 60 Hz).

IF ENGINE SPEED IS ERRATIC OR HUNTING OCCURS, GO TO STEP 3; IF NOT ERRATIC, STEP 4.

3. If hunting or erratic operation occur at no-load governed speed, adjust the GOVERNOR ADJUST SCREW (Item 4) as follows:

- a. Stop the engine.
- b. Turn the STOP ADJUST SCREW (Item 2) all the way out.
- c. At top of governor housing, remove the plug to gain access to the GOVERNOR ADJUST SCREW (Item 4).

NOTE: On the Generac 4.0 liter engine, removal of the engine air intake adapter may be required to allow room for adjustment.

- d. Hold the STOP LEVER (Item 6) all the way to its right. Then, insert a screwdriver into the access hole and turn the GOVERNOR ADJUST SCREW (Item 4) in about four (4) clicks.
- e. Install and tighten the plug into the access hole.
- f. Turn the STOP ADJUST SCREW (Item 2) back to its original setting.
- g. Restart the engine and let it warm up. If hunting or erratic operation is still present, repeat Steps 4(a) through 4(f). Then, restart engine and check for hunting and erratic operation at no-load.

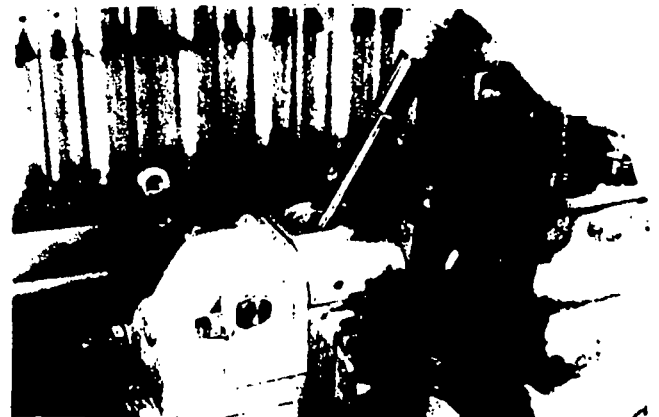


Figure 3. Adjustment of Governor Adjust Screw

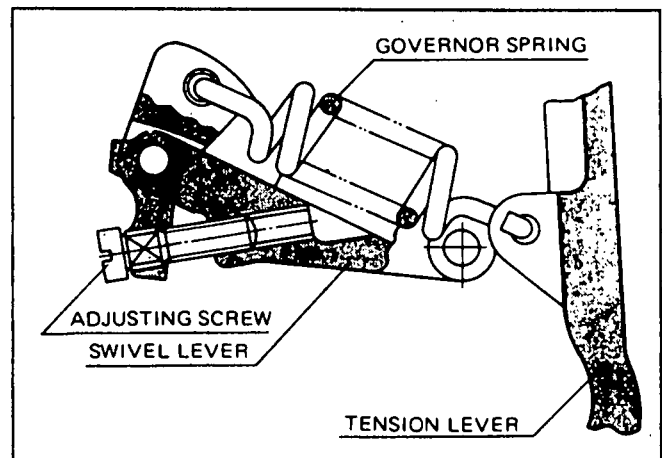


Figure 4. The Governor Adjust Screw

Governor Adjustment (Continued)

- h. Repeat Steps 3(a) through 3(h) until no further hunting or erratic operation is noted. Then, rereadjust the STOP ADJUST SCREW (Item 2) to correct no-load AC frequency and go on to Step 4.
4. With engine running at correct rated no-load speed (frequency), apply a light electrical load in increments. Start at about 10% of rated wattage/amperage capacity. Then, increase to 20%, 30%, 40% and 50% of rated load, one increment at a time. If hunting or erratic operation occurs under light electrical loading, it will be necessary to readjust the GOVERNOR ADJUST SCREW (Item 4) as follows:
- Shut the engine down.
 - Turn the STOP ADJUST SCREW (Item 2) all the way out.
 - Remove the plug at top of governor housing to gain access to the GOVERNOR ADJUST SCREW (Item 4).
 - Hold the STOP LEVER (Item 6) all the way to its right. Then, turn the GOVERNOR ADJUST SCREW (Item 4) out one (1) click.
 - Install and tighten plug into access hole.
 - Turn the STOP ADJUST SCREW (Item 2) back to its original setting.
 - Restart the engine, let it run at no-load.
 - If necessary, reset the STOP ADJUST SCREW (Item 2) to obtain correct governed no-load speed.
 - Apply light electrical loads in increments as stated in Step 4 above. If hunting or erratic operation still occur under light loading, repeat Steps 4(a) through 4(f).
 - Continue the above process until no further hunting or erratic operation is noted under light electrical loading.
5. With engine running at correct rated no-load frequency, apply electrical loads equal to 100% of the unit's rated wattage/amperage capacity.
- With unit running at full rated load, check the AC frequency reading. Reading should not be less than about 59-60 Hertz.
 - If reading is about 59-60 Hertz at full rated load, no further adjustment is required.
 - If the reading is less than 58 Hertz at full rated load, go on to Step 6.
6. If AC frequency at full rated load is low, adjust the FULL LOAD ADJUST SCREW (Item 1) as follows:
- Remove the cap from the ADJUST SCREW.
 - With engine running and full rated load applied, turn the FULL LOAD ADJUST SCREW (Item 1) in (clockwise) until speed increases as close to 60 Hertz as possible. Then, back the SCREW out until frequency starts to drop off. Finally, turn the SCREW (Item 1) back in until frequency recovers.
 - When the engine is running at its best frequency under full rated load, install the cap over the FULL LOAD ADJUST SCREW.

NOTE: The frequency obtained at full rated load should be as close as possible to the unit's rated frequency (50 or 60 Hertz). However, the maximum frequency obtainable will depend on the specific engine. It is desirable to operate as close as possible to rated frequency (50 or 60 Hertz). Frequency under full rated load should not be less than 58 Hertz (units rated 60 Hertz) or 49 Hertz (units rated 50 Hertz).

**PART 2
DIRECT
EXCITED
AC
GENERATORS**

**STANDBY
ELECTRIC
POWER
SYSTEMS**

All Series

TABLE OF CONTENTS

SECTION	TITLE
2.1	Description and Components
2.2	Operational Analysis
2.3	Troubleshooting Flow Charts
2.4	Diagnostic Tests

Section 2.1 DESCRIPTION AND COMPONENTS

Introduction

Direct excited generators are equipped with brushes which are spring loaded against slip rings on the rotor assembly. The brushes and slip rings transfer excitation current flow from stationary parts to the rotating rotor assembly.

This section is intended to familiarize the reader with the basic construction and major components of direct excited standby generators manufactured by Generac.

Major Generator Components

See Figure 1 on next page. A typical direct excited unit is shown, having the following major parts:

AC CONNECTION PANEL:

The large connection panel (Item 13) is constructed of formed sheet steel and is retained to the rear bearing carrier (Item 12) by means of four stator studs (Item 14). It is sometimes called the "lower panel" since the generator control console is mounted just above it.

Cooling air is drawn into the generator through air openings in the panel by the action of a cooling fan (Item 5).

A typical panel provides mounting holes for a main line circuit breaker, which may or may not be factory installed.

Stator AC power winding and excitation winding output leads are brought out of the stator and routed into the connection panel.

A "2-wire start" terminal strip is mounted in the connection panel, with terminals 178 and 183 identified. These two numbered terminals must be properly interconnected with identically numbered terminals in a "GTS" type automatic transfer switch during standby system installation. When these terminals are properly interconnected, a dropout in utility power source voltage below a preset level will result in generator cranking and startup, followed by transfer of electrical loads to the standby power source side.

REAR BEARING CARRIER:

The cast and machined rear bearing carrier (Item 12) supports (a) the AC connection panel, (b) the front end of the stator can, and (c) the front of the rotor assembly. A machined bore in the center of the rear bearing carrier accepts the rotor bearing. Mounting pads are provided on the carrier for retention of one or more brush holders, which are positioned to allow the brushes to slide on the rotor slip rings. Mounting feet on the carrier are retained to the unit mounting base, with vibration dampeners separating the feet from the mounting base (to absorb vibration).

STATOR ASSEMBLY:

The stator assembly (Item 11) is sandwiched between the rear bearing carrier (Item 12) and the blower housing (Item 1). It is retained in this "sandwiched" position by means of four stator studs (Item 14), along with appropriate nuts and lockwashers.

Also see Section 1.2, "Types of Stator Connection Systems".

BLOWER HOUSING:

The blower housing (Item 1) houses a drive hub and fan (Item 5). Cooling air that enters the cooling air slots of the AC connection (lower) panel is ducted out of the blower housing through an air outlet screen. The rear end of the four stator studs are retained in the blower housing. On units equipped with an Option "C" control console, an rpm sensor (Item 29) threads into the blower housing side.

NOTE: The rpm sensor is essentially a magnetic pickup device which is installed directly over the teeth of the engine ring gear. During operation, the sensor delivers an electrical pulse at the passage of each ring gear tooth. These electrical pulses are delivered to a DC control/latch-crank circuit board in the generator control console. The circuit board uses these pulses as an rpm indicator, for establishing such important parameters as starter cutout speed, overspeed shutdown, etc.

DRIVE HUB:

The drive hub and cooling fan assembly (Item 5) is bolted to the engine flywheel and rotate with the flywheel. The rear end of the rotor assembly is retained in the drive hub bore, by means of a bearing lock nut and washer (Items 6 and 7).

Some generators may use flexible drive discs to connect the rotor to the engine flywheel. Some units may utilize such flexible drive discs, in conjunction with a drive hub assembly, to connect the rotor to the flywheel.

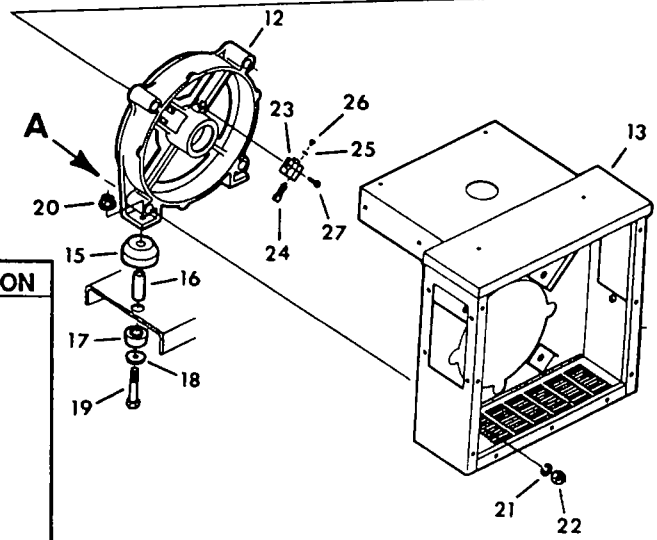
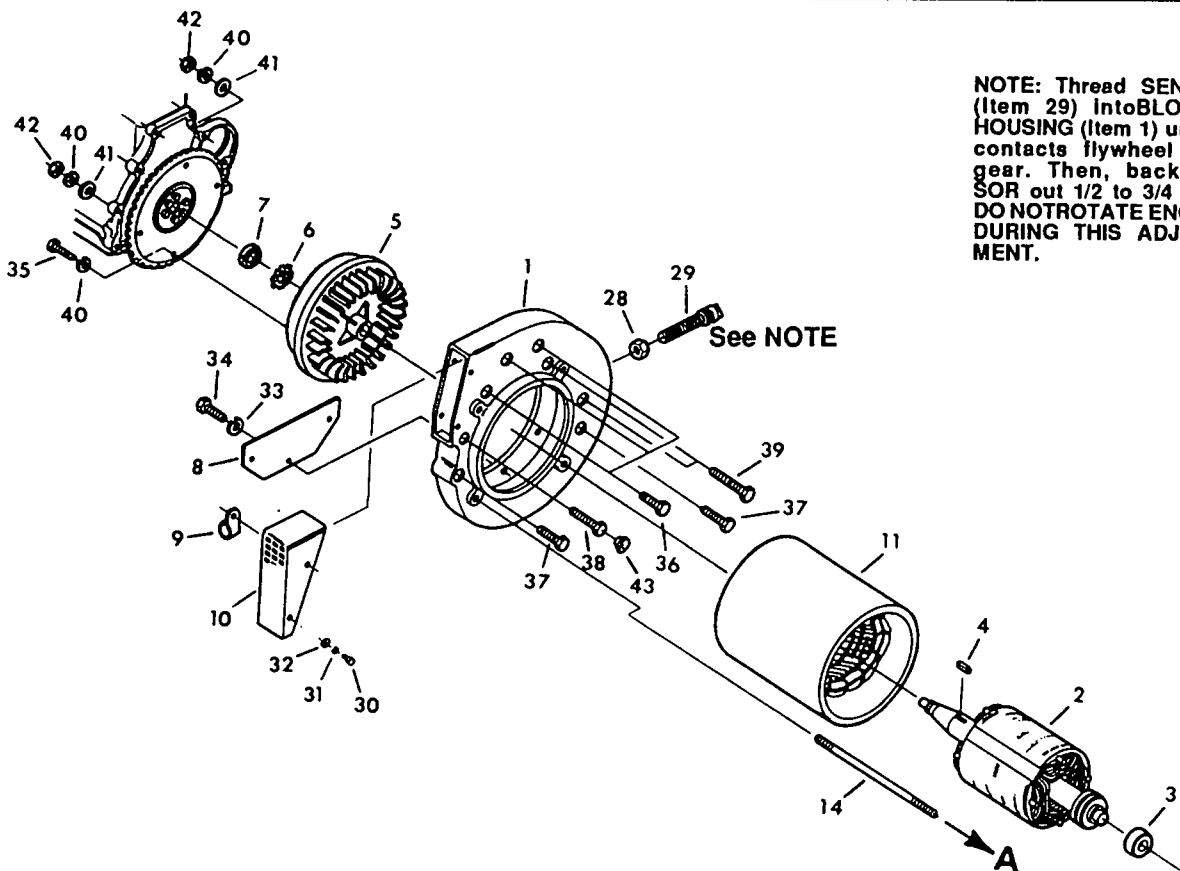
ROTOR ASSEMBLY:

The tapered rotor shaft is keyed and fits into the tapered and keyed bore provided in the drive hub. The front shaft of the rotor mounts a rotor bearing, which is pressed onto the shaft. The rotor bearing outer diameter fits into the machined bore of the rear bearing carrier. Rotors may be either a 2-pole or a 4-pole type (see "Measuring AC Frequency" on Page 1.4-6).

BRUSH ASSEMBLIES:

Brushes are retained in a brush holder which, in turn, are retained to bosses on the rear bearing carrier. Some units may have only one brush holder, others

NOTE: Thread SENSOR (Item 29) into BLOWER HOUSING (Item 1) until it contacts flywheel ring gear. Then, back SENSOR out 1/2 to 3/4 turn. DO NOT ROTATE ENGINE DURING THIS ADJUSTMENT.



ITEM	DESCRIPTION	ITEM	DESCRIPTION
1	Blower Housing	22	Hex Nut
2	Rotor assembly	23	Brush Holder
3	Rotor Bearing	24	Brush
4	Drive Key	25	Lockwasher
5	Drive Hub and Fan	26	Screw
6	Bearing Lock Washer	27	Screw
7	Bearing Lock Nut	28	Hex Nut
8	Flywheel Cover	29	RPM Sensor
9	Clamp	30	Capscrew
10	Air Outlet Screen	31	Lockwasher
11	Stator assembly	32	Flatwasher
12	Rear Bearing Carrier	33	Lockwasher
13	A-c connection Panel	34	Capscrew
14	Stud	35	Capscrew
15	Vibration Dampener	36	Capscrew
16	Spacer	37	Capscrew
17	Vibration Dampener	38	Capscrew
18	Flatwasher	39	Capscrew
19	Capscrew	40	Lockwasher
20	Lock Nut	41	Flatwasher
21	Lockwasher	42	Hex Nut

Figure 1. Exploded View- Typical Direct Excited Unit

Major Generator Components (Continued)

may have two. Each brush holder has two individual brushes. One of the two brushes slides on the rotor's positive (+) slip ring, the other on the negative (-) slip ring. Brushes are spring-loaded in their holder, to allow slight lateral movement of the rotor shaft and slip rings during operation.

When properly and carefully installed, very little brush wear should occur. During extended non-operating periods, a thin film may form on the slip rings. Such a film may inhibit current flow between the brushes and slip rings. The slip rings should have a shiny appearance. If they appear dull or tarnished, they may be cleaned with fine sandpaper. **DO NOT USE ANY METALLIC GRIT TO CLEAN SLIP RINGS.**

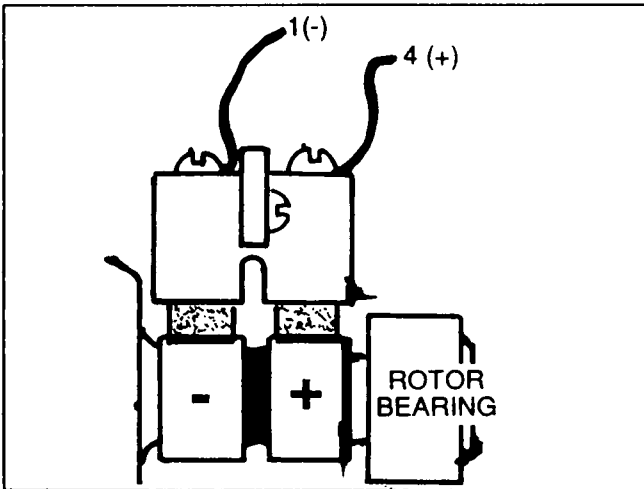


Figure 2. Brushes and Slip Rings (Typical)

Other AC Generator Components

GENERAL:

Several generator components are housed inside the generator control console. These are (a) an excitation circuit breaker, (b) the voltage regulator, (c) a field boost resistor, and (d) a field boost diode.

EXCITATION CIRCUIT BREAKER:

See Figure 3. The excitation circuit breaker is electrically connected in series, between the stator excitation (DPE) winding and the voltage regulator. The breaker will trip open to protect the regulator against overcurrent conditions. The breaker is self-resetting. Thus, when voltage drops to normal, the breaker will automatically reset to its closed position.

VOLTAGE REGULATOR:

See Figure 4. Unregulated excitation (DPE) winding output is delivered to the regulator. The regulator rectifies this output (changes it to direct current). The regulator then delivers a regulated excitation current to the rotor, based on sensing signals from the stator AC power windings.

FIELD BOOST RESISTOR AND DIODE:

During startup and operation, a DC control/latch-crank circuit board delivers a "field boost" current to the rotor windings via Wire 14, the field boost resistor, Wire 29, the field boost diode, and Wire 4. The field boost current increases the strength of the rotor's magnetic field above that of residual magnetism alone. In effect, field boost "flashes the field" on every startup to ensure an adequate pickup voltage in the stator windings.

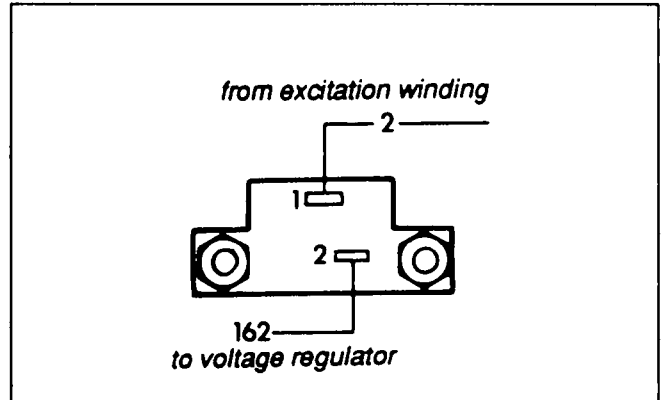


Figure 3. The Excitation Circuit Breaker

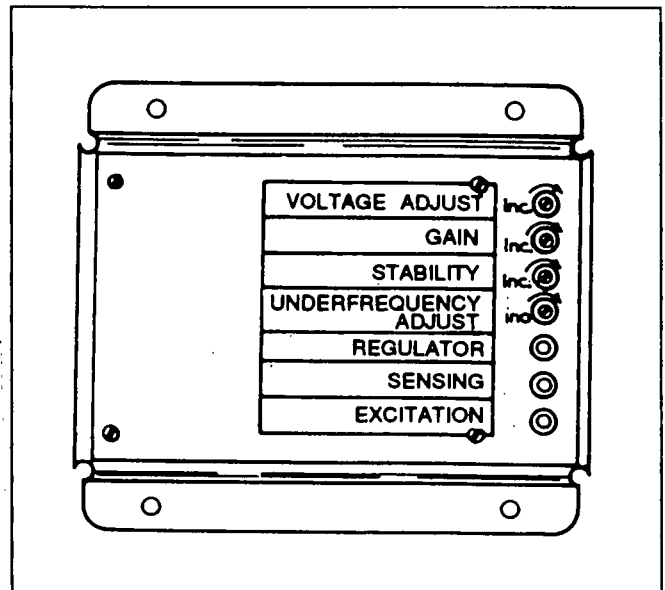


Figure 4. The AC Voltage Regulator

Other AC Generator Components (Continued)

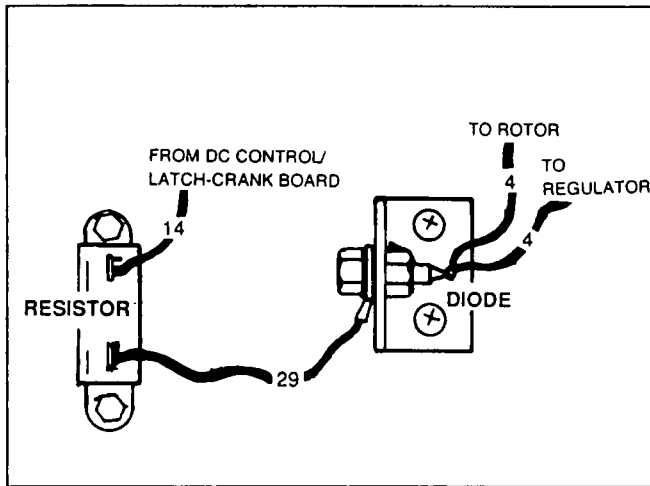


Figure 5. Field Boost Circuit Components

More About the Stator Assembly

GENERAL:

A typical stator assembly includes (a) the stator AC power windings and (b) the excitation or DPE windings.

STATOR AC POWER WINDINGS:

Stator AC power windings may be either a 1-phase type or a 3-phase type. Refer to Section 1.2, "Types of Stator AC Connection Systems".

STATOR EXCITATION (DPE) WINDINGS:

These stator windings are often called "DPE" windings, which stands for "displaced phase excitation". The DPE windings deliver an unregulated AC current to the voltage regulator. The regulator (a) rectifies that current, and (b) regulates the current.

See Figure 6. Excitation winding unregulated AC output is delivered to the voltage regulator via Wire No. 2 and, depending on the generator model, Wire No. 6, 6A or 6B. The following general rules apply:

Wire No. 6 is used on brushless type generators. Wires 6A and 6B may or not be provided on those units.

Wire No. 6A is used on direct excited (brush type) generators that are rated 120/208, 120/240 and 240/416 volts.

Wire No. 6B is used on direct excited (brush type) generators that are rated 139/240 volts or 277/480 volts AC.

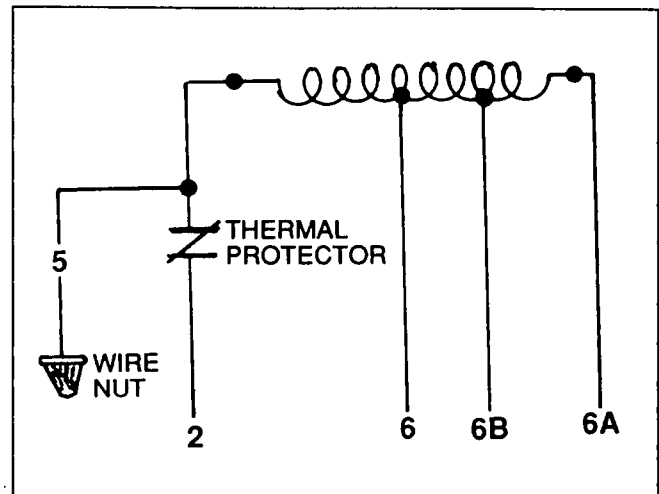


Figure 6. Excitation (DPE) Winding Leads

THERMAL PROTECTOR:

A thermal protector is physically imbedded in the stator windings and electrically connected in series with the excitation windings unregulated AC output to the voltage regulator. The device (Figure 7) is a temperature sensitive switch having normally-closed contacts.

The switch contacts will open in the event of a high temperature condition in the stator. On contacts opening, excitation winding output to the regulator and regulated excitation current to the rotor will be lost. Stator winding AC output voltage will then drop to a value that is commensurate with the rotor's residual magnetism plus field boost magnetism. The following general rules apply:

- Rotor residual magnetism alone (without field boost current and without excitation current) will produce a stator AC output voltage that is equal to approximately 2 to 7 percent of the unit's rated voltage.
- Rotor residual magnetism plus field boost current (without excitation winding output) will produce approximately one-half (1/2) the unit's rated voltage.

NOTE: The preceding facts are valuable troubleshooting aids. For example, a very low AC output voltage (about 2 to 7 percent of rated volts) probably means that both field boost and excitation winding output have been lost. If generator AC output voltage is about one-half the unit's rated voltage, only excitation winding output has been lost.

A thermal protector "bypass lead" has been provided. If testing reveals that the thermal protector has failed open, simply connect Wire No. 5 to Wire No. 2. This

More About the Stator Assembly (Continued)

will bypass the thermal protector and restore normal excitation winding output to the regulator. However, it should be mentioned (when the thermal protector is bypassed), stator overtemperature protection will not be available.

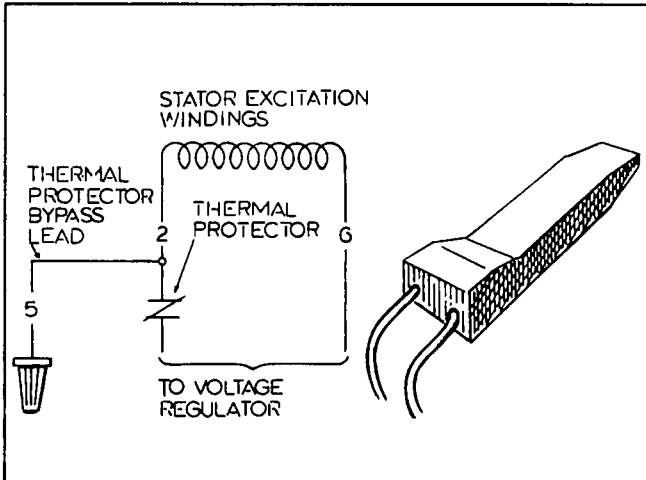


Figure 7. The Thermal Protector

More About the Voltage Regulator

The voltage regulator is equipped with three lamps (LED's). These lamps are (a) a red "Regulator" lamp, (b) a yellow "Sensing" lamp, and (c) a green "Excitation" lamp. During normal operation with no faults in the system, all three lamps should be ON.

The voltage regulator is powered by stator excitation (DPE) winding output, with approximately 4 to 8 volts required to turn the regulator on.

The green "Excitation" lamp and the red "Regulator" lamp are both powered by excitation winding output. If excitation winding output is gradually reduced, these two lamps will begin to dim until, at some midpoint voltage and current, the lamps will no longer glow visibly. Depending on the specific generator model, excitation (DPE) voltage may be about 40-240 volts RMS.

The yellow "Sensing" lamp is powered by sensing input to the regulator from the stator AC power windings. The brightness of this lamp will depend on the available sensing voltage. Sensing input to the regulator is approximately 190-240 volts RMS, depending on the specific generator.

The following factors apply to voltage regulator operation:

1. The voltage regulator will shut down on occurrence of any one or more of the following conditions:
 - a. Loss of sensing voltage (Leads S15, S16) to the regulator.
 - b. Loss of excitation (DPE) voltage input to the regulator.
 - c. Loss of circuit reference.

NOTE: The term "circuit reference" refers to voltage regulator settings. The regulator "regulates" excitation (DPE) winding current flow to the rotor (field) in order to maintain a sensing voltage that is commensurate with a preset "reference" voltage. That is, the regulator seeks to maintain a sensing (actual) voltage that is the same as a "reference" voltage. Regulator "reference" voltage is adjustable within a 20 percent range at the regulator. In addition, regulated output current to the rotor can be varied by changing the "sensing" voltage input to the regulator. The latter is accomplished by means of a voltage adjust knob on the generator console.

2. During generator operation, all three lamps (LED's) should be ON.
 - a. "Regulator" lamp ON indicates the regulator is operating normally.
 - b. "Sensing" lamp ON indicates that sensing voltage is available to the regulator.
 - c. "Excitation" lamp ON indicates that unregulated excitation (DPE) current is available to the regulator.
3. If the red "Regulator" lamp goes OUT, a voltage regulator fault exists or the regulator has shut down due to occurrence of one or more shutdown conditions.
 - a. Expect to see a generator AC output voltage that is commensurate with rotor residual magnetism plus the magnetism produced by field boost.
 - b. Residual plus field boost magnetism will provide approximately one-half the unit's rated voltage.
4. If the green "Excitation" lamp goes out, loss of excitation (DPE) winding output to the regulator has occurred.
 - a. Loss of excitation (DPE) output to the regulator will result in regulator shutdown and the red "Regulator" lamp will also turn on.
 - b. If the red "Regulator" and the green "Excitation" lamps are both OUT, look for an AC output voltage that is commensurate with residual plus field boost magnetism.
5. If the yellow "Sensing" lamp goes out, loss of sensing to the regulator has occurred (Wires S15, S16).
 - a. Loss of sensing may cause the regulator to shut down.
 - b. On regulator shutdown, both the "Regulator" and the "Sensing" lamps will be OUT.
 - c. Look for a generator output voltage that is the result of residual plus field boost magnetism.
6. If all three of the lamps go out, look for a fault that can cause both sensing and excitation to fail.
 - a. Look for faulty slip rings, brushes, rotor, etc.
 - b. Look for a fault in the regulator to rotor circuit.
7. If the red "Regulator" lamp is flashing, "Stability" probably requires adjustment.

An open condition in the sensing leads to the regulator (S15, S16) tends to create a "full field" condition. This occurs because the regulator tries to bring the sensing voltage up to an equal value with the "reference" voltage setting, by increasing regulated excitation current to the rotor. However, regulator shutdown occurs on loss of sensing voltage. This, in turn, causes loss of excitation current to the rotor. The generator's AC output voltage will then become commensurate with rotor residual magnetism plus field boost magnetism, about one-half rated voltage.

Voltage Regulator Specifications

Response	Less than one (1) cycle
Temperature tracking (32°-120° F.)	0.41 percent
Temperature drift	Less than 1% for each 40° C. change
Steady state regulation	0.75% RMS conditionally
Droop (voltage over frequency)	0-4 volts per Hertz Selectable start 52-62 Hz (underfrequency pot) Rate 4/8 volts per Hz (jumper select)
Maximum output current to field	100 amps @ 1 cycle peak 10 amps at 50° C. continuous 20 amp one minute forcing
Regulator turn on	4 volts RMS from DPE windings
SCR control	Pulse with modulation
Maximum DPE energy	93%
Startup overshoot	10% conditionally
Startup voltage time	1 second
Stability (100 amp, 0.8 PF)	0% oscillation
LED indicators	Excitation ON (green) lamp SCR firing signal (red lamp) Sensing voltage present (yellow) lamp
Excitation voltage	40-240 volts RMS
Sensing input to regulator	1-Phase, 190-240 volts RMS
Field flash (field boost)	On continuously
Regulator shutdown conditions	Loss of sensing voltage Loss of excitation voltage Loss of circuit reference

Section 2.2 OPERATIONAL ANALYSIS- DIRECT EXCITED UNITS

Magnetism

Although magnetism is invisible, some of the effects it produces can be clearly seen. The behavior patterns of magnetism have been studied. It is the application of these behavior patterns that has led to the development of generators, motors, relays, transformers, coils, etc.

Magnetism can be used to produce electricity. Conversely, electricity can produce magnetism. Because of the relationship between magnetism and electricity, a study of one should include a study of the other. The following facts are known about magnetism:

- Lines of magnetic force, called "flux", are directed away from the north pole of a magnet, travel in a loop, and re-enter the magnet at its south pole.
- Lines of flux form definite patterns which vary in density according to the strength of the magnet.
- Lines of flux never cross one another.
- The area surrounding a magnet in which its lines of magnetic flux can be felt is called a "magnetic field".

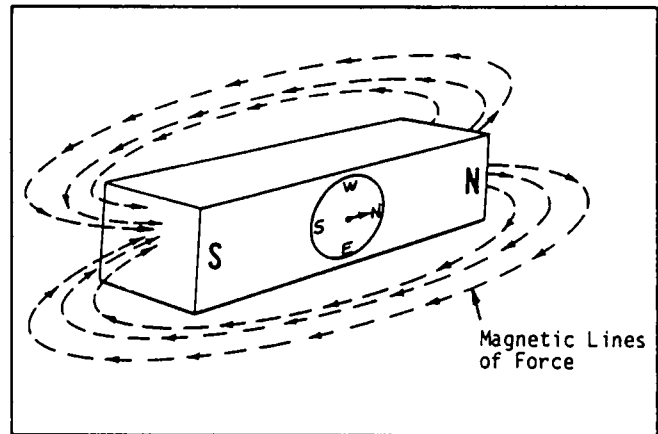


Figure 1. Magnetic Lines of Flux

Electromagnetism

Current carrying electrical conductors are surrounded by a magnetic field which is at right angles to the conductor. When current flow through the conductor increases, the number of lines of flux increase proportionally. That is, the strength of the magnetic field increases when current flow increases. The magnetic field is distributed along the entire length of the conductor.

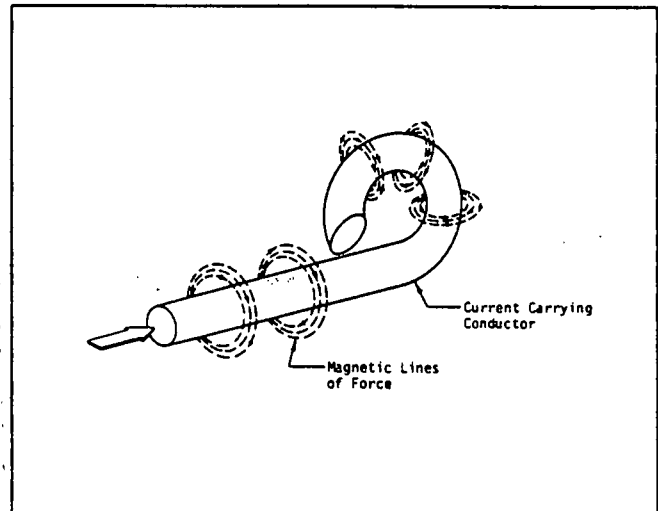


Figure 2. Magnetism Around a Conductor

Electromagnetic Induction

When a conductor is moved so that it passes through a magnetic field, an electromotive force (EMF or voltage) is created in the conductor. If the magnetic field is moved so that it cuts across the conductor, an EMF or voltage will also be created in the conductor. This is the basic principle that allows a generator to produce electricity.

Figure 3 shows a simple revolving field generator. A permanent magnet rotates so that its lines of flux cut across a coil of wires called a stator. As the north pole of the magnet passes the stator windings, a voltage is induced into the stator and current will flow in one direction through the light bulb (called the "load"). As the north pole passes the stator, voltage and current will drop to zero. When the magnet's south pole pass the stator, current flow increases in the opposite direction. Magnet rotation causes this cycle to continue, with current flow reversing direction at the passage of each north and south pole. This constant reversal of current is called "alternating current" or "AC".

The flow of electrical current through a conductor in one direction followed by its reversal and flow in the opposite direction is called a "cycle" or "1 Hertz".

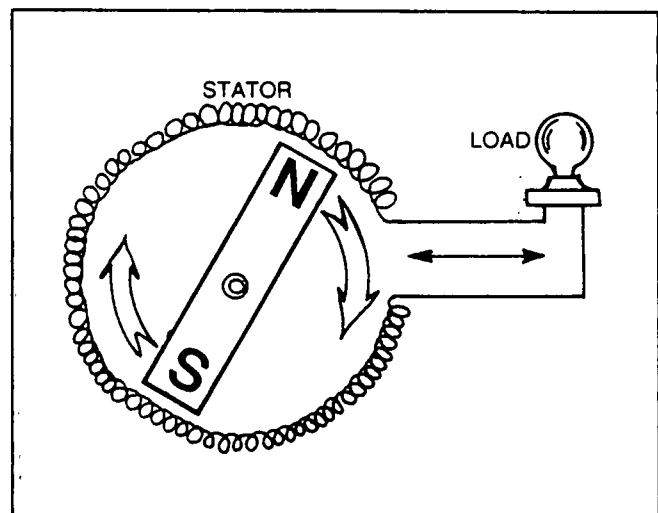


Figure 3. A Simple Revolving Field Generator

Generator Operation

1. The rotor is driven at a pre-determined speed by an engine, so that the rotor's magnetic field cuts across the stationary stator windings.
 - a. Some residual or permanent magnetism is always present in the rotor.
 - b. Direct current flow from a field boost circuit is delivered to the rotor windings, to create a magnetic field that is added to the residual magnetism.
2. As the rotor's magnetic lines of flux cut across the stator's AC power windings, a voltage is induced into those windings. Light bulbs, called a "load", are connected across the windings. The voltage flows through the load, turning the light bulbs on.
3. As the lines of flux from the rotor cross the stator excitation winding, a voltage and current flow is induced into that winding.
 - a. Excitation winding AC current is delivered to the voltage regulator, via a thermal protector and an excitation circuit breaker.
 - b. The voltage regulator rectifies the excitation winding current, i.e., changes it to direct current (DC).
 - c. Sensing leads from the AC power windings are connected to the voltage regulator.
 - d. Based on the sensing signals from the AC power windings, the regulator regulates the direct current flow delivered to the brushes, slip rings and rotor.
4. The regulated and rectified direct current flow through the rotor windings creates a magnetic field around the rotor that is "regulated" in strength.

5. The regulated magnetic field induces a regulated AC voltage into the stator AC power windings. This regulated voltage is delivered to the load.

A generator's excitation circuit is that circuit that delivers a regulated current flow to the rotor windings, to create a regulated magnetic field around the rotor. In turn, the regulated magnetic field will induce a regulated voltage into the AC power windings.

It is evident that the rotor's magnetic field strength is the result of (a) residual magnetism, (b) field boost current flow, and (c) regulated direct current from the voltage regulator.

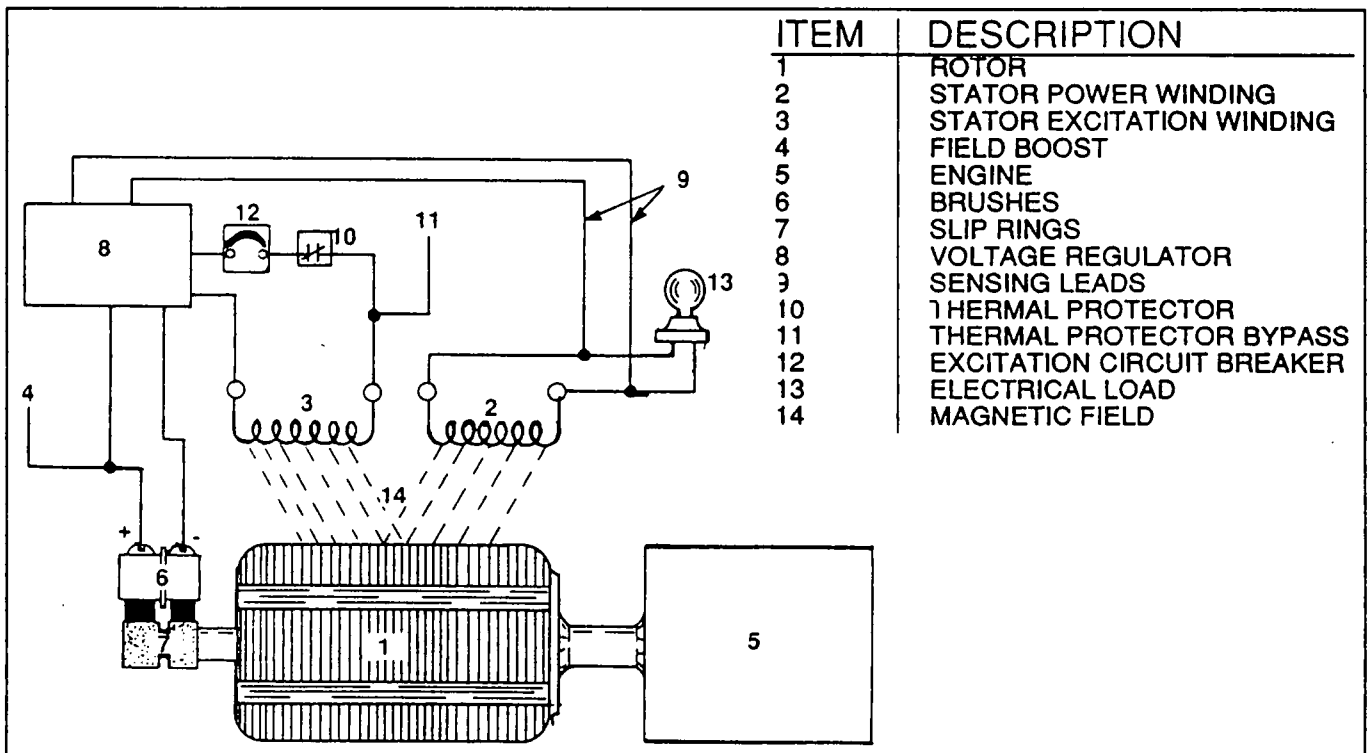


Figure 4. Operating Diagram- Typical Direct Excited Generator

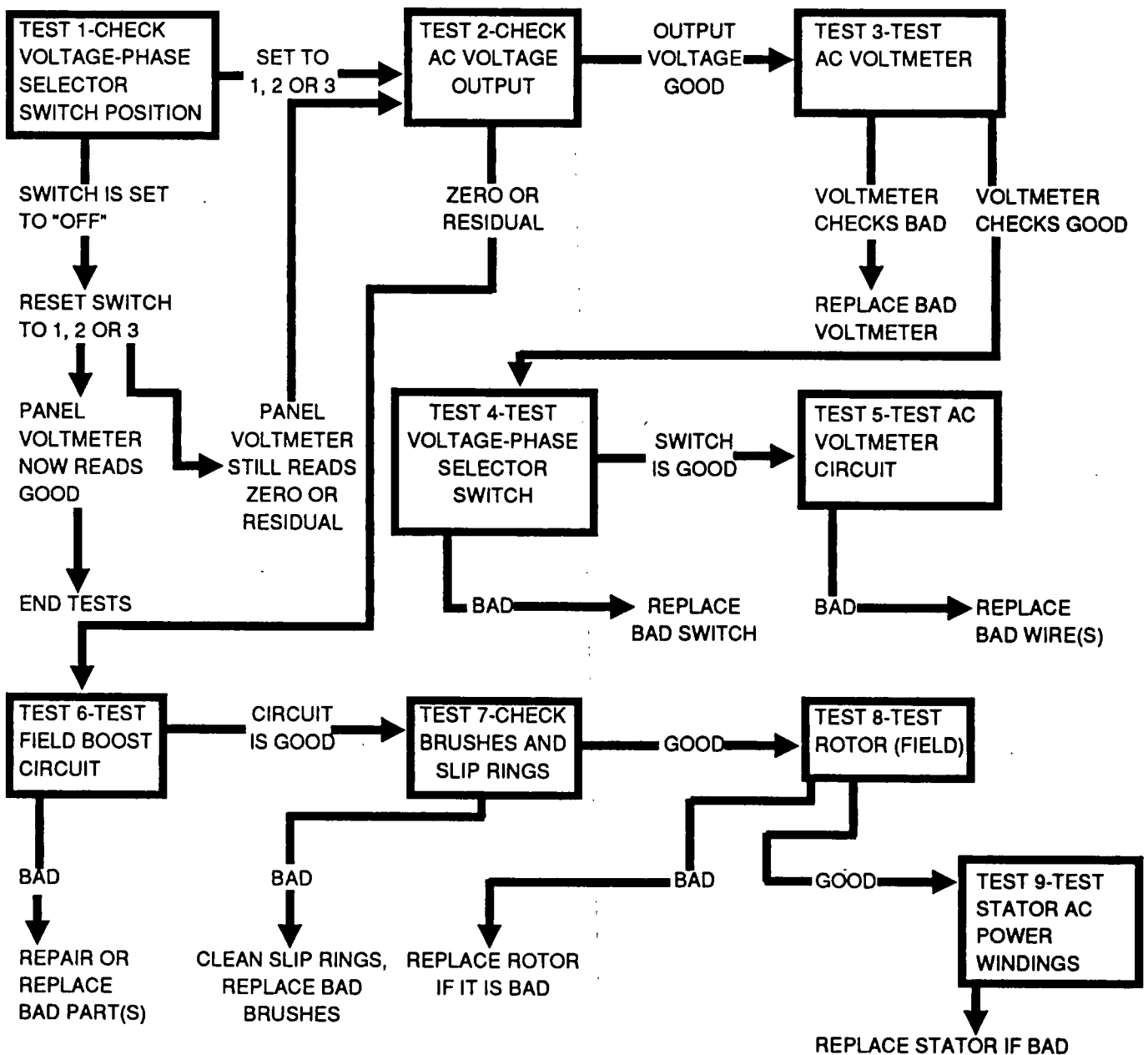
Section 2.3 TROUBLESHOOTING FLOW CHARTS

A generator does not have a large number of parts. However, these parts are expensive. For that reason, use of "guesswork" when troubleshooting and diagnosing problems is not cost effective and must be avoided.

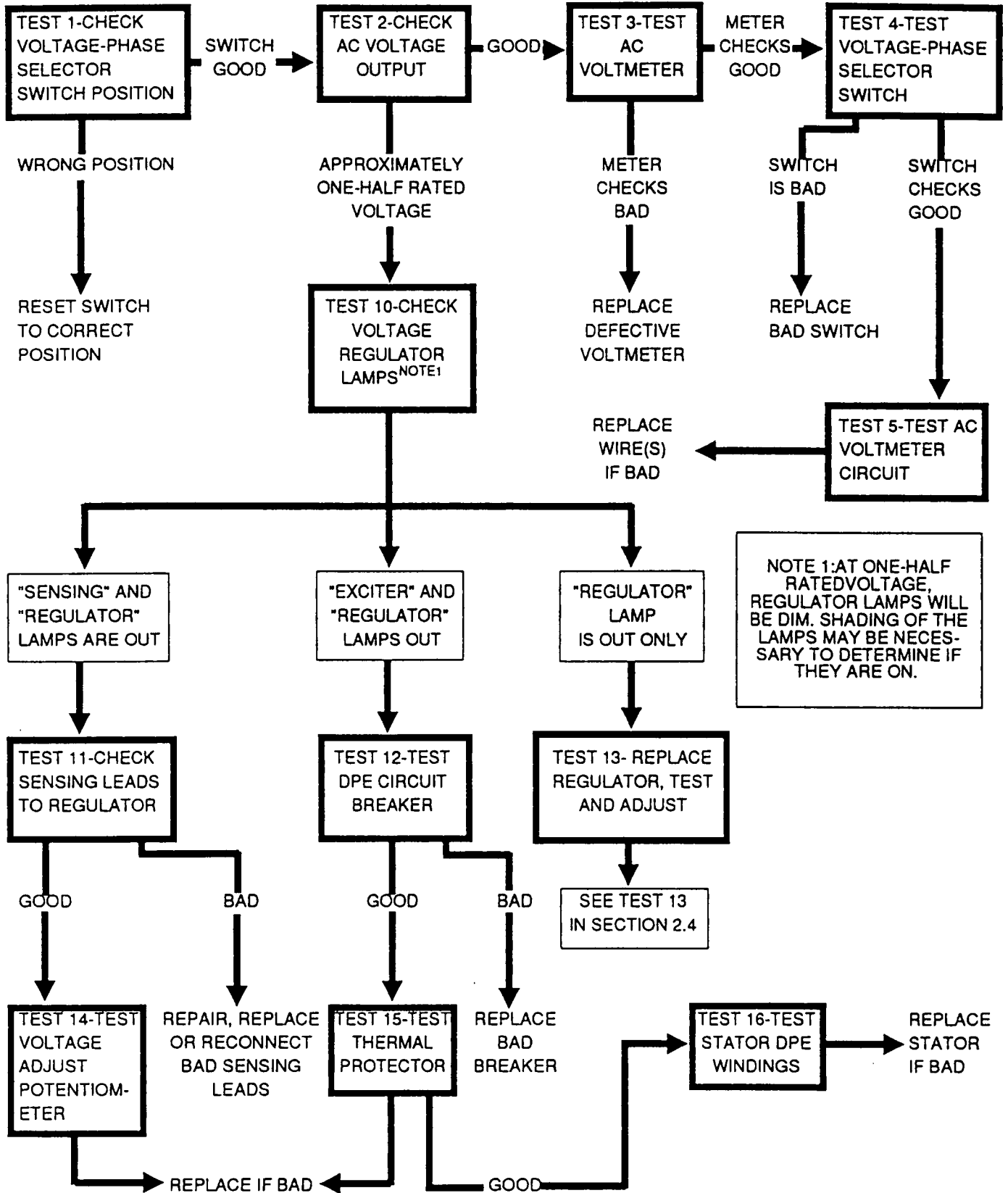
The following "Troubleshooting Flow Charts" have been carefully formulated in logical sequence. They should cover most of the problems and remedies that might be encountered. Follow the flow charts carefully. If you are uncertain of how to perform any test in the chart, refer to "Diagnostic Tests" in Section 2.4.

Problem 1- Panel AC Voltmeter Reads No. Voltage or Residual Voltage at No-Load

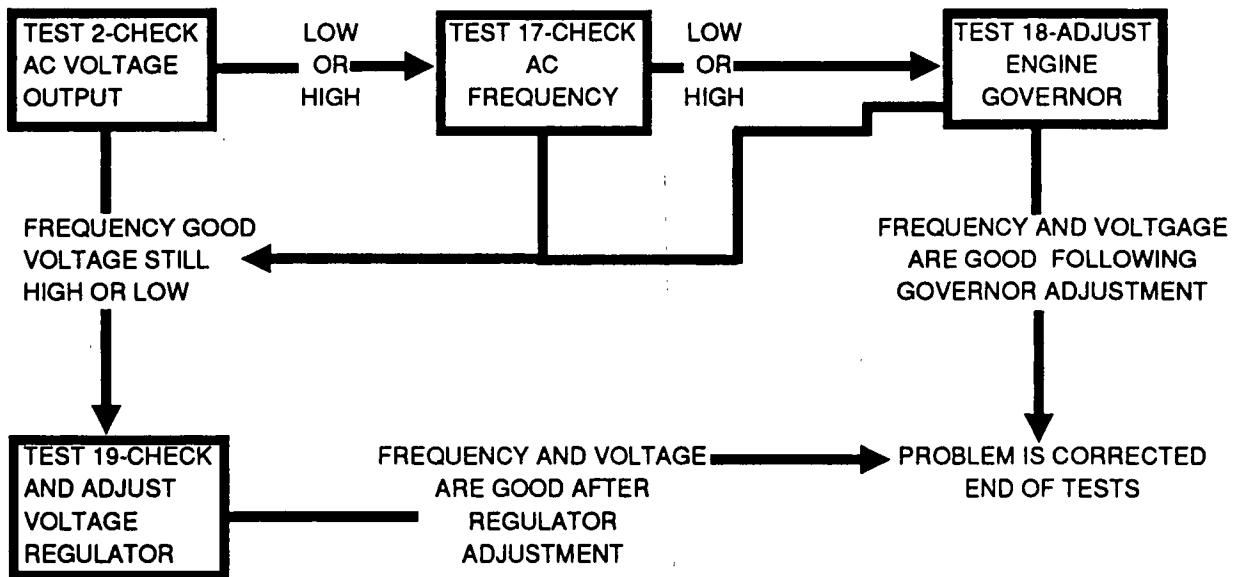
NOTE: Residual voltage is that generator AC output voltage produced by rotor residual magnetism alone. It is generally equal to approximately 2 to 7 percent of the unit's rated AC voltage.



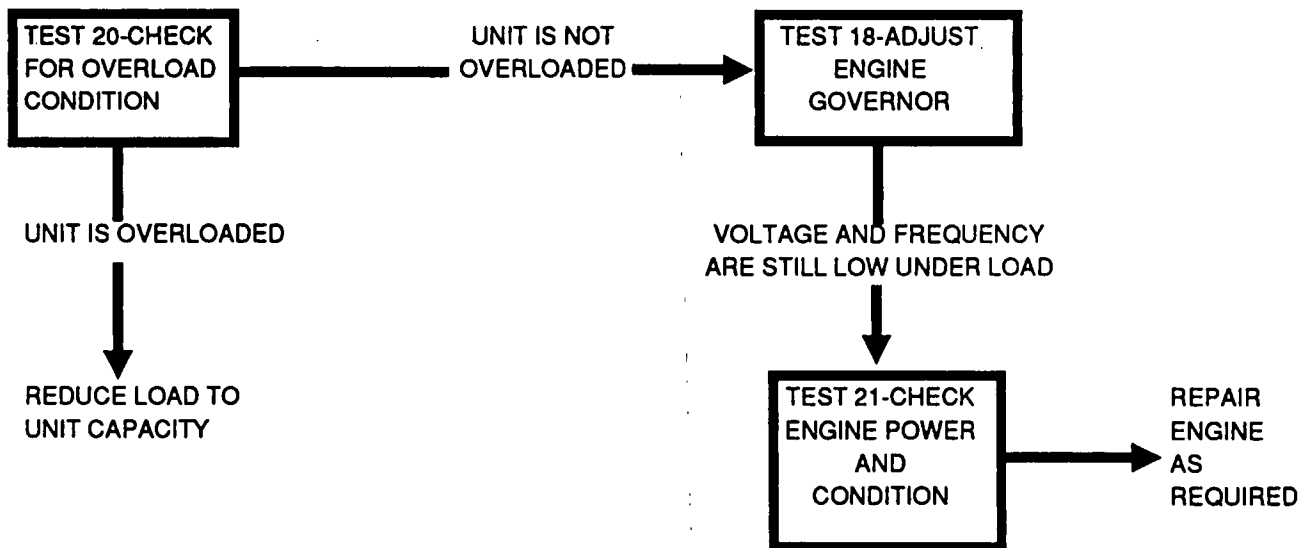
Problem 2- Panel AC Voltmeter Reads Approximately One-Half Rated Voltage



Problem 3- Generator Produces Low or High Voltage at No-Load



Problem 4- Voltage and Frequency Drop Low When Loads Are Applied



Section 2.4
DIAGNOSTIC TESTS

Test 1- Check Voltage-Phase Selector Switch Position

DISCUSSION:

If so equipped, this 4-position switch will be found on the front face of the generator control console. Switch positions and meter readings are as follows:

SWITCH POSITION	VOLTAGE/AMPERAGE READING	
	1-PHASE UNITS	3-PHASE UNITS
1	Line E1 to Neutral	Line E1 to E2
2	Line E3 to Neutral	Line E2 to E3
3	Line E1 to Line E3	Line E3 to E1
OFF	No Reading	No Reading

PROCEDURE:

If both the panel AC voltmeter and ammeter read "zero", check the position of the voltage-phase selector switch. It is normal for these meters to read "zero" when the switch is set to "Off". Set the switch to read either line-to-line or line-to-neutral voltage as desired.

RESULTS:

If switch is positioned correctly but AC voltmeter still reads incorrectly, go on to Test 2.

Test 2- Check AC Voltage Output

DISCUSSION:

What appears to be an undesirable AC voltage may be caused by a defective panel voltmeter. The accuracy of the panel voltmeter can be checked by using an external AC voltmeter to measure generator output voltage.

DANGER: USE EXTREME CAUTION WHEN CHECKING AC VOLTAGE OUTPUT. STANDBY GENERATORS PRODUCE EXTREMELY HIGH AND DANGEROUS VOLTAGES WHICH CAN CAUSE SERIOUS INJURY OR EVEN DEATH. WHEN READING AC VOLTAGE OUTPUT THE GENERATOR SHOULD BE RUNNING AT ITS RATED SPEED AND MAY HAVE SOME OF ITS PROTECTIVE GUARDS AND COVERS REMOVED. IT IS BEST TO SHUT THE GENERATOR DOWN BEFORE ATTACHING METER TEST LEADS TO AC POWER TERMINALS. WHEN USING ALLIGATOR CLIPS OR PUSH-ON TERMINALS, MAKE SURE THE LEADS ARE PROPERLY SUPPORTED SO VIBRATION WILL NOT SHAKE THEM LOOSE.

PROCEDURE:

Generator AC output voltage may be read at (a) the generator's main line circuit breaker, (b) at transfer switch terminal lugs on installed units, or (c) at generator AC power leads E1, E3 and 00 (neutral) for 1-phase units, or (d) at generator AC power leads E1, E2, E3 and 00 (neutral) for 3-phase units.

1-Phase Units: To read line-to-line voltage, connect the meter test leads across lines E1 and E3. To read line-to-neutral voltage, connect the meter test leads across line E1 and 00; or across Line E3 and 00.

3-Phase Units: To read line-to-line voltage, connect the meter test leads first across lines E1 to E2; then, across Lines E2 to E3; finally, across Lines E3 to E1. To read line-to-neutral voltage, connect the meter across any line (E1, E2, E3) and 00 (neutral).

RESULTS:

1. If the voltage reading is the same as the panel AC voltmeter reading, go to Test 6.
2. If meter indicates normal voltage but panel voltmeter reads incorrectly, go to Test 3.

Test 3- Test AC Voltmeter

DISCUSSION:

If the voltage reading taken in Test 2 was correct, but the panel voltmeter reads incorrectly, either the panel voltmeter is defective, or the voltage-phase selector switch is bad, or voltmeter circuit wiring is bad.

PROCEDURE:

Gain access to the back of the panel AC voltmeter. Connect the test leads of an external AC voltmeter across the panel voltmeter terminals. With the engine running, read the external meter and compare its reading with that of the panel meter.

RESULTS:

1. If the external meter and panel voltmeter readings are the same, the panel voltmeter is good. Go to Test 4.
2. If the external meter reads correct voltage but the panel meter reads incorrectly, replace the panel AC voltmeter.

Test 4- Test Voltage-Phase Selector Switch

DISCUSSION:

A defective voltage-phase selector switch may result in erroneous panel voltmeter readings. The following procedure may be used to test the switch.

Test 4- Test Voltage-Phase Selector Switch (Continued)

PROCEDURE:

With the engine shut down, gain access to the rear of the voltage-phase selector switch (in generator console). Test the switch as follows:

1. Set a volt-ohm-milliammeter (VOM) to its "Rx1" scale and zero the meter.
2. Refer to the chart that follows. Connect the VOM test leads across the switch terminals as shown in the chart.
 - a. Note the VOM reading with the voltage-phase selector switch at each of its positions.
 - b. Readings should be as indicated in the chart.

CONNECT VOM ACROSS CONTACTS	SWITCH POSITION			
	1	2	3	OFF
14 to 13	Continuity	Infinity	Continuity	Infinity
16 to 15	Infinity	Continuity	Infinity	Infinity
20 to 19	Continuity	Infinity	Infinity	Infinity
18 to 17	Infinity	Continuity	Continuity	Infinity
1 to 2	Infinity	Continuity	Continuity	Continuity
3 to 4	Continuity	Infinity	Infinity	Infinity
5 to 6	Continuity	Infinity	Continuity	Continuity
7 to 8	Infinity	Continuity	Infinity	Infinity
9 to 10	Continuity	Continuity	Infinity	Continuity
11 to 12	Infinity	Infinity	Continuity	Infinity

RESULTS:

1. Replace the voltage-phase selector switch if it is defective.
2. If voltage-phase selector switch is good, go to Test 5.

Test 5- Test AC Voltmeter Circuit

DISCUSSION:

An open or shorted wire in the voltmeter circuit will produce the same results as a defective voltage-phase selector switch.

PROCEDURE:

See Figure 2 or the appropriate wiring diagram for the unit being tested. Inspect and test all wiring between the generator AC output leads (E1, E2, E3), the voltage-phase selector switch, and the AC voltmeter.

RESULTS:

Repair, reconnect or replace any damaged or defective wiring.

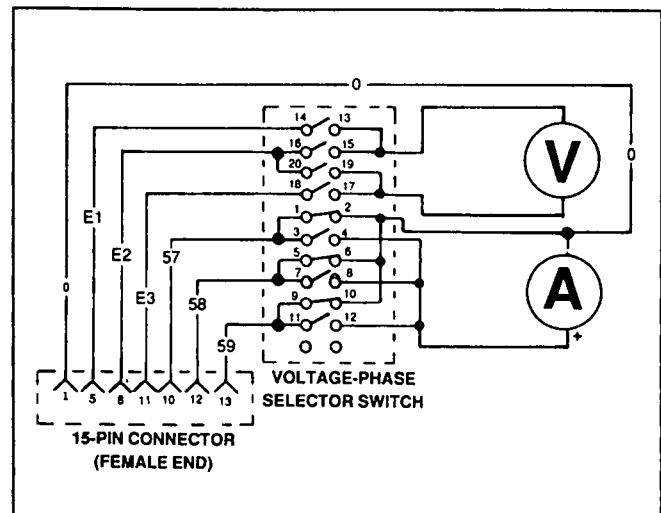


Figure 1. AC Voltmeter and Ammeter Circuit

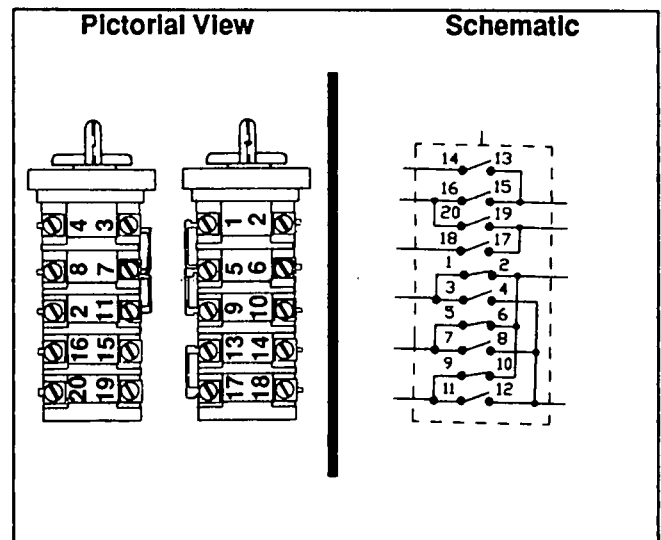


Figure 2. Voltage-Phase Selector Switch

Test 6- Test Field Boost Circuit

DISCUSSION:

See Figure 3. During startup and running operations, the DC control/latch-crank circuit board (in the generator control console) delivers 12 volts DC to the rotor windings, via Wire No. 14, a field boost resistor (R2), Wire No. 29, a field boost diode (D1), Wire No. 4, and the brushes and slip rings.

The rotor circuit is completed to ground through the negative (-) slip ring and brush, Wire No. 1, and terminal 0 of a terminal board in the control console.

The field boost feature acts to "flash the field" on every start. This helps ensure that an adequate "pick-up" voltage is induced into the stator windings early on every start. The following facts apply to the field boost function:

Test 6- Test Field Boost Circuit (Continued)

- The ability of the generator to develop a pickup voltage in its stator windings depends on the characteristics of the individual unit. On some units, failure of the field boost system may never be noticed.
- In some cases when field boost has failed, the excitation windings may not produce sufficient voltage to turn the regulator on.
- Rotor residual magnetism alone (without excitation current and without field boost) will provide a generator AC output voltage equal to approximately 2 to 7 percent of the unit's rated voltage.
- Rotor residual magnetism plus the magnetism produced by field boost (without excitation current) will provide a generator AC output voltage of approximately 40 to 50 percent of the unit's rated voltage.

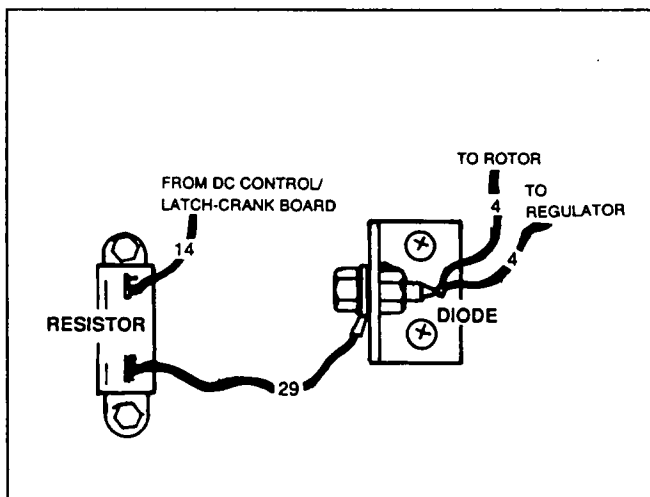


Figure 3. The Field Boost Circuit

PROCEDURE:

1. Set a volt-ohm-milliammeter (VOM) to "+DC" and to a voltage scale greater than 12 volts.
2. Gain access to the interior of the generator control console. On the interior floor of the console, locate the field boost resistor (R2) and the field boost diode (D1). See Figure 3.
3. Disconnect the connector plug from the voltage regulator, to prevent excitation current from affecting the meter reading.
4. Connect the VOM positive (+) test lead to the Wire 4 diode terminal. Connect the common (-) VOM test lead to terminal 0 of terminal board TB1 (ground).
5. Start the engine, let it stabilize.

6. Read the VOM. The meter should read approximately 7-10 volts DC.
7. Leave the common (-) VOM test lead connected to terminal 0 of TB1. Connect the positive (+) VOM test lead to the Wire 29 terminal of field boost diode D1. The meter should read approximately 7-10 volts DC.
8. With the common (-) test lead still connected to terminal 0, connect the positive (+) test lead to the Wire 29 terminal of resistor R2. The VOM should read 7-10 volts DC.
9. With the common (-) test lead still attached to terminal 0 of TB1, connect the positive (+) test lead to the Wire 14 terminal of resistor R2. The meter should read approximately 12 volts DC.
10. Shut the engine down and test the following wires for an open condition:
 - a. Wire 14 to the resistor (R2).
 - b. Wire 29 between resistor (R2) and diode (D1).

RESULTS:

1. If field boost voltage was indicated in Step 6, but not in Step 7, replace the field boost diode (D2).
2. If field boost voltage was indicated in Step 9, but not in Step 8, replace the resistor (R2).
3. Repair, reconnect or replace any open wire(s).

NOTE: The DC output to Wire 14 is controlled by a DC control/latch-crank circuit board, housed in the control console. Wire 14 voltage also turns on engine fuel flow, engine ignition, etc. Thus, if the engine starts and runs, circuit board output to Wire 14 must be normal.

Test 7- Check Brushes and Slip Rings

DISCUSSION:

Direct excited generators are equipped with brushes and slip rings which transmit excitation and field boost current from stationary components into the rotating rotor windings. These brushes and slip rings are extremely durable. However, generators that have been idle for a period of time may develop a coating on the slip rings. This coating causes a dull or tarnished appearance on the slip rings and tends to impede the flow of electrical current.

PROCEDURE:

Remove Wire 4 (red) from the positive brush and Wire 0 (black) from the negative brush. Then, remove the brush holders from the bearing carrier. Carefully inspect brush holders, brushes and slip rings. Look for cracked or damaged brush holders, worn or damaged brushes, dull or tarnished slip rings.

Test 7- Check Brushes and Slip Rings (Continued)

RESULTS:

1. Replace any damaged or defective brush holder.
2. Replace any damaged, cracked or worn brushes.
3. If slip rings appear dull or tarnished, they may be cleaned with fine sandpaper. DO NOT USE ANY METALLIC GRIT TO CLEAN SLIP RINGS. Clean slip rings to a bright, shiny appearance. After cleaning, vacuum or blow away any sandpaper residue.
4. If problems still persist, go to Test 8.

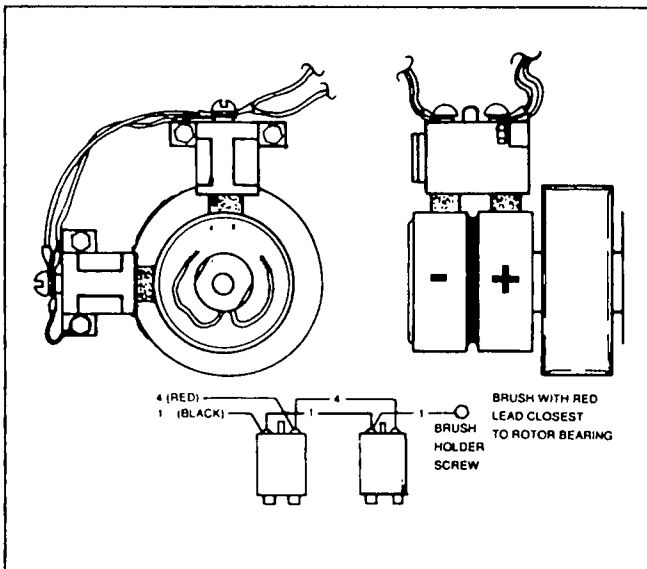


Figure 4. Brushes and Slip Rings (Typical)

Test 8- Test Rotor (Field)

DISCUSSION:

The rotor can be tested for an open or grounded condition using a VOM.

PROCEDURE:

Remove brushes and brush holders to prevent interaction. Set a VOM to its "Rx1" scale and zero the meter. Connect the VOM positive (+) test probe to the positive (+) slip ring, nearest the rotor bearing. Connect the common (-) test probe to the negative (-) slip ring. The meter should indicate the resistance of the rotor windings. Depending on the specific generator model, rotor resistance may vary from 5 to 17 ohms.

To test for a grounded condition, first make sure the brushes and brush holders are removed. Set the VOM to a high resistance scale and zero the meter. Connect the positive VOM test probe to the positive (+) slip ring, nearest the rotor bearing. Connect the common (-) test probe to a clean frame ground. "Infinity" should be read.

RESULTS:

1. If the rotor windings are open, replace the rotor assembly.
2. If a grounded condition is indicated, test rotor insulation resistance (Section 1.4, "Generator Maintenance and Testing").

Test 9- Test Stator AC Power Windings

DISCUSSION:

You may wish to review the information in Section 1.2 of this manual. Stator AC output leads are routed out of the stator can and into the generator's AC connection (lower) panel. Remember, some stators have six coils with twelve leads coming out. Some 1-phase units have only two coils with four leads coming out.

An accurate volt-ohm-milliammeter (VOM) may be used to perform preliminary tests of the stator AC power windings. Windings may be tested for (a) an open condition, (b) a grounded condition, and (c) a shorted condition. When testing for an open condition, the resistance of the power windings is very low, often in the "milliohm" range. Many VOM's will simply indicate "continuity".

PROCEDURE:

General Inspection: Make sure the stator leads are properly connected for correct voltage and phase as outlined in Section 1.2 (especially important on new installations). Also look for obvious problems, such as burned wires, broken or disconnected connectors, loose connections, frayed or worn insulation, etc.

Test for Open Condition: Set a VOM to its "Rx1" scale and zero the meter. Test all stator coils for continuity, one coil at a time. Test each coil separately. In each case, the VOM should read the resistance of the individual stator coil.

Test for Grounded Condition: Set the VOM to its highest resistance scale (such as "Rx10,000" or "Rx1K"). Zero the meter. Connect one VOM test probe to a lead of one stator coil, the other test probe to a clean frame ground on the stator can. Then, test the remaining stator coils in the same manner, one at a time. In each case, the VOM should read "infinity".

Test for Shorted Condition: This test will determine if one stator coil is shorted to another coil. Set the VOM to its highest resistance scale. Zero the meter. Connect one VOM test probe to one lead of a stator coil, the other test probe to one lead of a second stator coil. Continue until all stator coils have been tested for shorted condition. In each case, the VOM should read "infinity".

Test 9- Test Stator AC Power Windings (Continued)

RESULTS:

If testing reveals a defective stator, you may wish to remove the stator assembly and test further with an insulation resistance tester. See Section 1.4, "Generator Maintenance and Testing". Replace any stator with open, grounded or shorted windings.

Test 10- Check Voltage Regulator Lamps

DISCUSSION:

Review the information on Page 2.1-5, "More About the Voltage Regulator". All three regulator lamps (LED's) are normally ON during generator operation. Become familiar with the following facts:

- If the yellow "Sensing" lamp is out, loss of sensing voltage to the regulator is indicated (Wires S15 and S16).
- If the green "Excitation" lamp is out, loss of un-regulated excitation current from the stator excitation (DPE) windings is indicated.
- If the red "Regulator" lamp is out, the regulator's SCR's are not firing (regulator is not functioning).
- On loss of "Sensing", the regulator normally shuts down. Both the "Sensing" lamp and the "Regulator" lamp will then go out.
- On loss of "Excitation", the regulator will normally shut down. Both the "Excitation" lamp and the "Regulator" lamp will then go out.
- It is possible for a regulator failure to occur while both "Sensing" and "Excitation" are available. In this case, only the red "Regulator" lamp will go out.
- Under low or reduced voltage conditions, the regulator lamps (LED's) will glow dimly. It may be necessary to shield the lamps from light in order to see them.

PROCEDURE:

With the generator running, observe the lamps. All lamps should be ON.

RESULTS:

1. If the yellow "Sensing" lamp and the red "Regulator" lamp are both OUT, go to Test 11 (problem is in the sensing circuit to regulator).
2. If the green "Exciter" and the red "Regulator" lamp are both out, go to Test 12. The problem must be in the excitation circuit to the regulator.
3. If only the red "Regulator" lamp is out, go to Test 13 (a regulator problem exists).

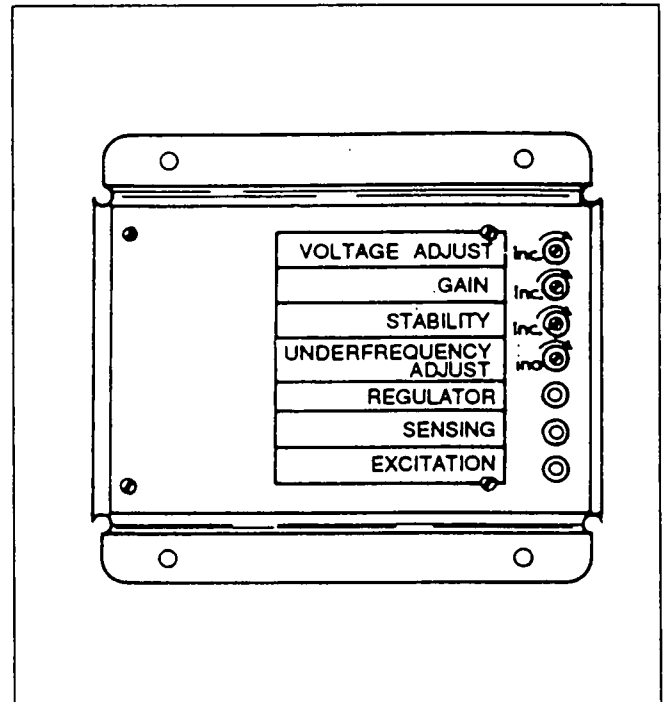


Figure 5. Voltage Regulator Lamps (LED's)

Test 11- Check Sensing Leads to Regulator

DISCUSSION:

The sensing leads provide a signal of actual voltage to the regulator. The regulator "compares" this "actual voltage" signal to a preset "reference" voltage.

If actual voltage is lower than the "reference" voltage, regulator action will increase regulated DC excitation current to the rotor in an attempt to build up the rotor's magnetic field and increase the voltage induced into the stator windings.

If actual voltage is higher than the "reference" voltage, the reverse action will occur. Regulated DC excitation current to the rotor will decrease in an attempt to reduce the induced stator voltage.

In the event of an open circuit condition in the sensing circuit, complete loss of the sensing signal to the regulator will occur. The regulator will then shut down to prevent a "full field" and accompanying high voltage condition.

PROCEDURE:

Carefully inspect Wires S15, S16 and 89 between the regulator and the main circuit breaker. See Figure 6. Test all wires with a VOM.

Test 11- Check Sensing Leads to Regulator (Continued)

RESULTS:

1. Reconnect, repair or replace any damaged or defective Wires S15, S16, 89.
2. If all sensing leads are good and problem persists, go to Test 14, "Test Voltage Adjust Potentiometer".

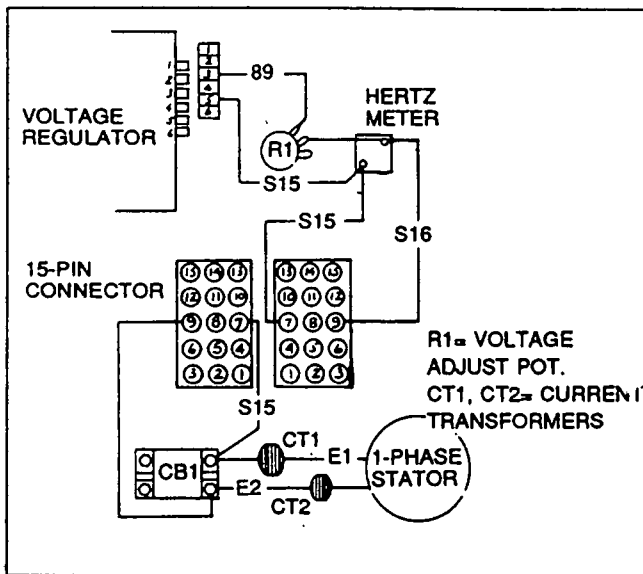


Figure 6. Typical Sensing Circuit

Test 12- Test DPE Circuit Breaker

DISCUSSION:

If the green "Excitation" and the red "Regulator" lamp are both OUT, an open circuit probably exists between the stator excitation (DPE) windings and the voltage regulator. One of the components in this circuit that might be open is the DPE circuit breaker. This circuit breaker is self resetting and cannot be reset manually.

PROCEDURE:

Disconnect Wires 2 and 162 from the circuit breaker. Set a VOM to its "Rx1" scale and zero the meter. Connect the VOM test leads across the two circuit breaker terminals (Figure 7). The meter should read "continuity". If the meter reads "infinity", the breaker has failed open and should be replaced.

RESULTS:

1. Replace the excitation (DPE) circuit breaker if it fails the test.
2. If the DPE breaker checks good, go on to Test 15, "Test Thermal Protector".

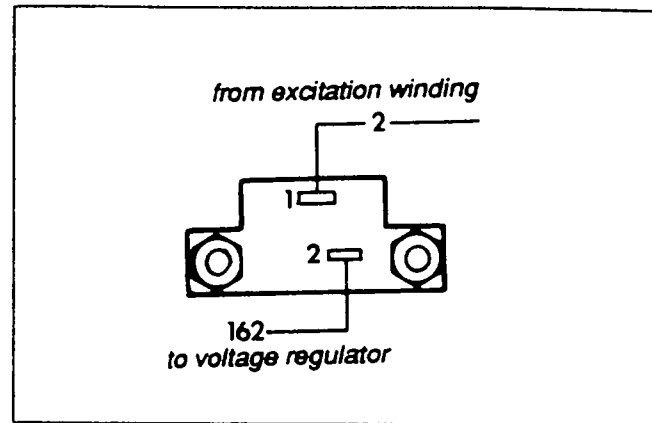


Figure 7. Excitation (DPE) Circuit Breaker

Test 13- Replace Regulator, Test and Adjust

DISCUSSION:

If the yellow "Sensing" lamp and the green "excitation" lamp are both ON, but the red "Regulator lamp is OUT, a voltage regulator failure is indicated.

PROCEDURE:

The voltage regulator is housed inside the generator control console. Unplug the regulator connector plug, then remove the regulator. Install a new replacement regulator as follows:

1. On the new replacement regulator, locate the miniature switch on the regulator circuit board identified as "SW1". Set the switch to "1" if installing it on a direct excited (brush type) unit; set it to "2" for brushless generators. See Figure 8.

NOTE: On early production voltage regulators, set the switch to Position "E" for brushless generators; to "B" for units with brushes.

2. Install the new regulator.
3. Plug the regulator connector plug into the regulator receptacle.
4. Set the following potentiometers on the regulator to their centered or mid-position:
 - a. Voltage Adjust.
 - b. Gain.
 - c. Stability.
 - d. Underfrequency Adjust.
5. On the generator console, set the voltage adjust potentiometer to its centered or mid-position.
6. Adjust the voltage regulator as outlined in Test 19.

Test 13- Replace Regulator, Test and Adjust (Continued)

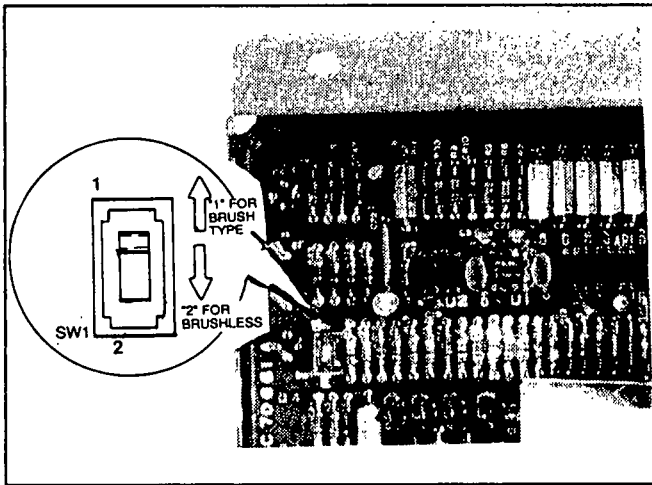


Figure 8. Switch SW1 on Regulator Circuit Board

Test 14- Test Voltage Adjust Potentiometer

DISCUSSION:

The voltage adjust potentiometer, housed in the control console, is electrically connected in series with sensing leads S16 and 89 to the regulator. The device permits the operator to bias the sensing voltage signal in order to adjust AC output voltage within a range of plus or minus 10 percent. Thus, if a generator's AC output voltage is within plus or minus 10 percent of the unit's rated voltage, it can be adjusted to nominal rated voltage using the potentiometer. The device is rated 10 k-ohm, 2 watts (plus or minus 10%). If the device fails open, loss of regulator sensing will result.

PROCEDURE:

1. See Figure 9. Connect an accurate ohmmeter across the potentiometer terminals to which Wires No. S16 and 89 attach.
 - a. Slowly rotate the potentiometer knob clockwise and counterclockwise while observing the meter.
 - b. As the knob is slowly rotated clockwise from its minimum stop, resistance reading should increase smoothly. Erratic readings or dropoff to zero at any point is cause for replacement.
2. Start the generator, let engine stabilize and warm up at no-load.
 - a. Set the voltage adjust pot to its mid (centered) position and check the generator AC output voltage reading.
 - b. Turn the pot all the way counterclockwise and, again, note the AC output voltage.
 - c. Turn the pot all the way clockwise and note the AC voltage reading.
 - d. Calculate the percentage of voltage adjustment provided by the potentiometer. Adjustment range should be plus or minus 10 percent (20% total).

RESULTS:

Replace the voltage adjustment potentiometer if it is open at any point along its travel, if its total voltage adjustment range is less than plus or minus 10 percent, or if readings are erratic.

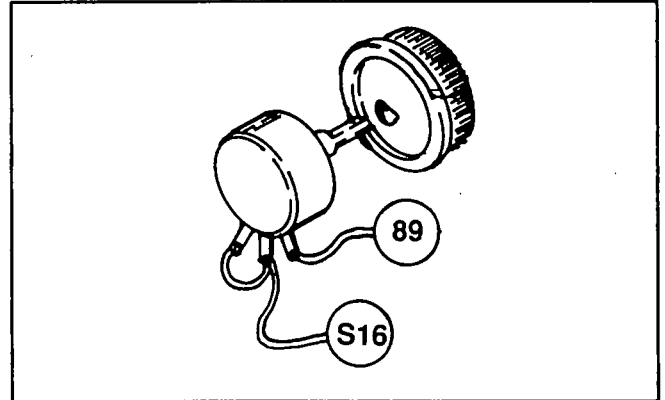


Figure 9. Voltage Adjust Potentiometer Test Points

Test 15- Test Thermal Protector

DISCUSSION:

If the thermal protector has failed open, loss of excitation (DPE) winding output current to the voltage regulator will occur. The regulator's "Excitation" lamp will then go out. In addition, the regulator cannot operate without excitation power and the "Regulator" lamp will also illuminate. Without excitation current flow to the rotor windings, generator AC output voltage will drop to a value that is commensurate with (a) field boost current plus (b) residual rotor magnetism (approximately one-half rated voltage).

NOTE: You may wish to review thermal protector information in Section 2.1. See "More About the Stator Assembly" on Page 2.1-4.

PROCEDURE:

1. In the AC connection (lower) panel, unplug the mating halves of the 15-pin connector plug.
2. Set a VOM to its "Rx1" scale and zero the meter.
3. See Figure 10. Connect one VOM test probe to Pin 3 of the 15-pin connector plug (Wire No. 2 attaches to Pin 3.)
4. Connect the remaining VOM test lead to Pin 6 of the 15-pin plug, to which Wire No. 6 (or 6A) attaches. The VOM should read excitation winding resistance.
5. Now, connect the VOM test leads across Pin 6 of the 15-pin connector (Wire 6 or 6A) and the stripped end of Wire 5 in the AC connection (lower) panel. The meter should indicate excitation winding resistance.

RESULTS:

If a very high resistance or "infinity" is indicated in Step 4, but DPE winding resistance is indicated in Step 5, the thermal protector has failed open and should be bypassed.

Test 15- Test Thermal Protector (Continued)

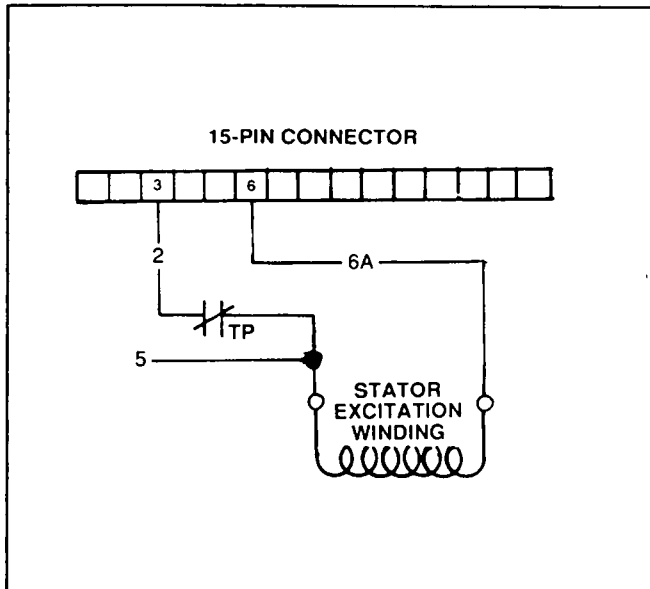


Figure 10. Thermal Protector Test Points

TO BYPASS THE THERMAL PROTECTOR:

See Figure 11. To bypass the thermal protector, locate Wire No. 2 and No. 5 in the AC connection (lower) panel. Wire No. 5 is brought out of the stator and into the lower panel. A wire nut covers the stripped end of Wire No. 5. Cut Wire No. 2 at a convenient place and strip the end of the wire that goes to the 15-pin connector plug. Remove the wire nut from Wire No. 5. Use the wire nut to join the stripped end of Wire No. 5 to the stripped end of Wire No. 2.

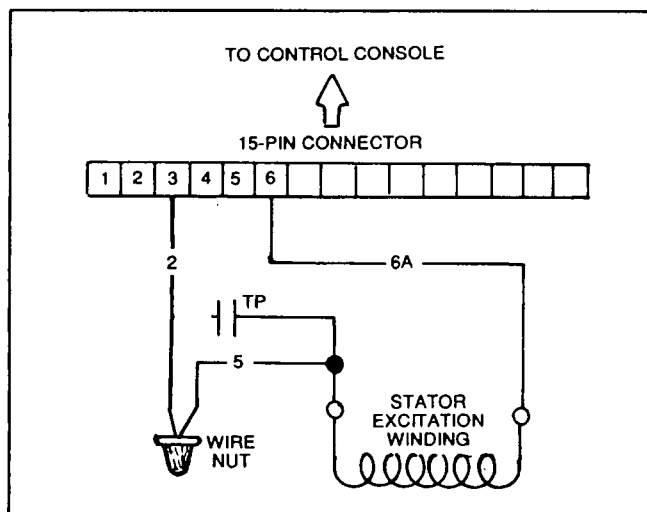


Figure 11. Bypassing the Thermal Protector

Test 16- Test Stator DPE Windings

DISCUSSION:

The excitation (DPE) winding leads are brought out of the stator assembly and into the AC connection (lower) panel. The leads are numbered 2 and 6, or 2 and 6A. Both leads are then routed to the 15-pin connector plug and then into the control console.

PROCEDURE:

1. In the AC connection panel, unplug the mating halves of the 15-pin connector plug.
2. Set a VOM to its "Rx1" scale and zero the meter.
3. Connect one VOM test probe into Pin No. 3 of the 15-pin connector, to which Wire No. 2 attaches.
4. Connect the remaining VOM test probe to the stripped end of Wire No. 5, in the AC connection panel.

NOTE: Wire No. 5 is unattached and has a wire nut covering its stripped end.

5. The VOM should read the resistance of the stator excitation (DPE) windings. Depending on the specific model and stator used, the winding resistance may be approximately 0.25 to 1.15 ohms.
6. Now, set the VOM to a high resistance scale (such as "Rx10,000" or "Rx1K"). Zero the meter.
7. Connect one VOM test lead to Pin 3 of the 15-pin connector plug, the other test lead to a clean frame ground on the stator. The meter should read "infinity".

RESULTS:

1. If an open condition or a very high resistance is indicated in Step 5, replace the stator assembly.
2. If the meter reads other than "infinity" in Step 7, remove the stator and test its insulation resistance. See Section 1.4, "Generator Maintenance and Testing".

Test 17- Check AC Frequency

DISCUSSION:

Rotor speed, voltage and AC frequency are all proportional. If engine speed is low, expect to see a reduction in voltage and frequency.

PROCEDURE:

Start the generator, let it stabilize and warm up at no-load. Observe the console frequency meter reading. For units rated 60 Hertz, no-load speed should be close to 62 Hertz. On 50 Hertz units, the no-load frequency should be as close to 51 Hertz as possible.

If you suspect the panel frequency meter might be in error, use an external frequency meter. Connect the meter across the generator's AC output leads.

RESULTS:

1. If AC frequency is high or low, go to Test 18, "Adjust Engine Governor".
2. If frequency is good, but voltage is high or low, go to Test 19, "Check and Adjust Voltage Regulator".

Test 18- Adjust Engine Governor

DISCUSSION:

If the generator's AC output frequency is not correct, the engine governor requires adjustment. The governor may be a mechanical, fixed speed type. Or an electronic isochronous type.

PROCEDURE:

Gasoline or gaseous fueled engines may be equipped with a belt driven mechanical governor. See Section 1.5.

Later production units may be equipped with Generac's electronic governor. Refer to Section 1.6.

For adjustment procedures on diesel engine governors, refer to Section 1.7.

Test 19- Check and Adjust Voltage Regulator

DISCUSSION:

Four adjustment potentiometers are provided on the standby voltage regulator. These are (a) voltage adjust, (b) gain, (c) stability, and (d) underfrequency adjust.

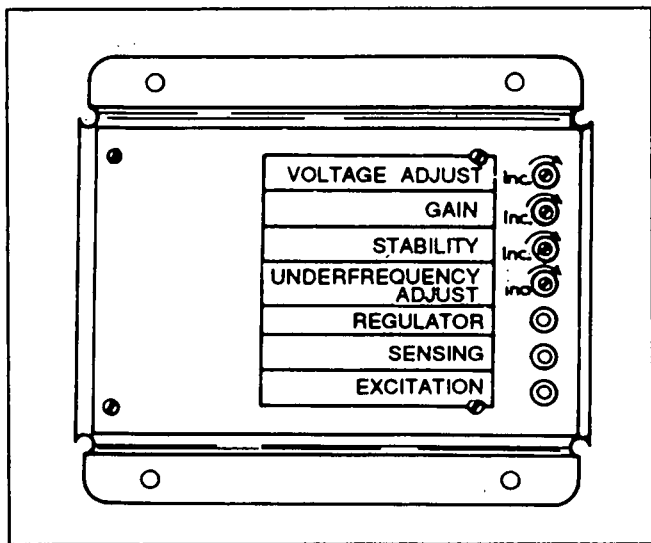


Figure 12. The Voltage Regulator

PROCEDURE:

1. Connect an accurate AC voltmeter and AC frequency meter to the generator's AC output leads.
2. On the regulator, set the potentiometers as follows:
 - a. Turn the "Voltage Adjust" pot fully counterclockwise.
 - b. Set "Gain" to its centered (mid) position.
 - c. Set "Stability" to its centered (mid) position.
 - d. Do NOT adjust "Underfrequency Adjust".
3. On the generator console, set the voltage adjust potentiometer to its centered or mid-position.
4. Turn OFF all electrical loads. Startup and initial adjustment will be done under a "no-load" condition.

5. Start the engine. Let it stabilize and warm up at no-load.

6. Check the reading on the frequency meter. If necessary, adjust the engine governor to obtain a frequency as close as possible to 62 Hertz at no-load (60 Hertz units); or 51 Hertz at no-load for 50 Hertz units.

7. With the unit running at correct no-load frequency, observe the lamps (LED's) on the voltage regulator. All lamps should be ON. See Test 10 in this section. Also see "More About the Voltage Regulator" on Page 2.1-5.

8. Turn the regulator's "Voltage Adjust" pot to obtain a line-to-line voltage output as shown in the following chart.

VOLTAGE CODE	RATED VOLTAGE	DESIRED LINE-TO-LINE VOLTAGE
A	240 Volts	248 Volts at 62 Hertz
B	208 Volts	215 Volts at 62 Hertz
C	416 Volts	430 Volts at 62 Hertz
D	240 Volts	248 Volts at 62 Hertz
G	208 Volts	215 Volts at 62 Hertz
H	416 Volts	430 Volts at 62 Hertz
J	240 Volts	248 Volts at 62 Hertz
K	480 Volts	496 Volts at 62 Hertz
M	220 Volts	224 Volts at 51 Hertz
N	380 Volts	388 Volts at 51 Hertz
O	416 Volts	424 Volts at 51 Hertz

9. If the red "Regulator" lamp (LED) is flashing, turn the "Stability" potentiometer either direction until the flashing stops.

10. Apply an electrical load and check engine speed recovery.

- a. Adjust the "Underfrequency Adjust" pot counterclockwise to unload the unit and reduce load voltage while the engine recovers.
- b. For flat regulation (no voltage decrease as frequency drops), set the "Underfrequency Adjust" potentiometer fully clockwise.
- c. To obtain a constant voltage reduction as frequency decreases, set the "Underfrequency Adjust" pot fully counterclockwise. Set point for this adjustment is 62 Hertz (counterclockwise) to 52 Hertz (clockwise).

11. With electrical load still applied, check the "Regulator" lamp for flashing. If lamp is flashing, adjust the "Stability" pot until the flashing stops.

12. If better response is needed, adjust the "Gain" pot clockwise as needed. Then (if needed), correct for instability by adjusting the "Stability" pot.

13. Turn off electrical loads. Then, recheck the regulator lamps (LED's) at no-load.

When all adjustments have been completed, let the engine run at no-load for a few minutes to stabilize internal engine-generator temperatures. Then, shut the generator down.

Test 20- Check for Overload Condition**DISCUSSION:**

The generator's rated wattage/amperage capacity should not be exceeded for continuous operation. The Options B and C control consoles incorporate an AC ammeter which provides an accurate amperage (load current) reading. If the generator panel does not include an ammeter, or if you suspect the panel ammeter is defective, a "clamp-on" ammeter may be used to measure load current flow.

In many cases, the maximum wattage/amperage capacity of a generator is limited by available engine power. As load current demands increase, a point will be reached at which the engine begins to "bog down" under load. Engine speed, frequency and voltage will then start to drop off.

PROCEDURE:

Start the generator and turn on electrical loads that will normally be operated by the unit. Select line-to-line amperage reading, using the voltage-phase selector switch on the console. Read the load current on the panel AC ammeter. If the unit does not have a panel ammeter, use a clamp-on ammeter.

RESULTS:

1. If the unit's wattage/amperage capacity are exceeded, reduce the electrical load until current and wattage are within the unit's rated limits.
2. If unit is not overloaded but frequency and voltage are low, try adjusting the engine governor. You may also want to check engine condition and available engine power (Test 21).

Test 21- Check Engine Power and Condition**DISCUSSION:**

If the load is within the generator's wattage/amperage capacity, but engine speed drops sharply when a load is applied, perhaps the engine has lost power. In many cases, a good "engine tuneup" will correct the problem.

PROCEDURE:

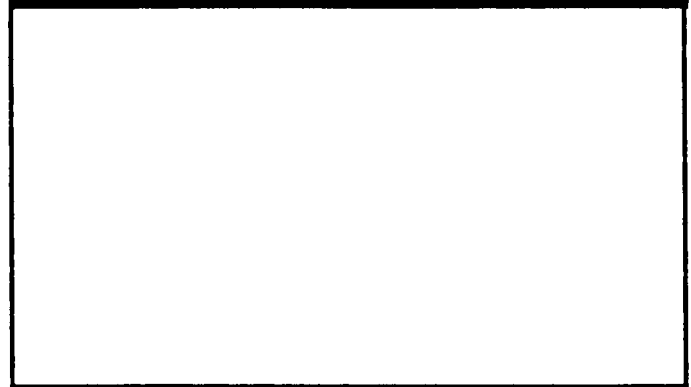
Check engine power and performance. Refer to the appropriate engine service manual. The engine may need a tuneup, or it may require other mechanical repairs.

**PART 3
BRUSHLESS
AC
GENERATORS**

**STANDBY
ELECTRIC
POWER
SYSTEMS**
All Series

TABLE OF CONTENTS

SECTION	TITLE
3.1	Description and Components
3.2	Operational Analysis
3.3	Troubleshooting Flow Charts
3.4	Diagnostic Tests
3.5	Insulation Resistance Tests
3.6	Permanent Magnet Generators
3.7	Testing PMG Units



Section 3.1 DESCRIPTION AND COMPONENTS

General

Brushless AC generators do not utilize brushes and slip rings to deliver excitation current to the revolving field (rotor). Instead, the principle of "electromagnetic induction" is used to induce a voltage and current into the rotor windings.

Generac brushless standby generators are single bearing units with cast bearing carriers and blower housings. Flexible drive discs and engine to rotor adapters are machined to SAE (Society of Automotive Engineers) standards. The single rotor bearing is prelubricated and sealed, thus requiring no additional lubrication for the life of the bearing.

Major Components

See Figure 1 on next page. A typical brushless generator consists of the following major components:

AC CONNECTION (LOWER) PANEL:

The large AC connection (lower) panel is constructed of formed sheet steel. It supports the generator control console. Openings in the lower panel allow air to be drawn into the generator interior by the action of a cooling fan which is attached to flexible couplings and rotates with the engine flywheel. A typical lower panel provides for mounting a main circuit breaker which may or may not be shipped with the unit. Stator AC power leads are routed into and are accessible in the lower panel. Also located in the lower panel is a "2-wire" start terminal strip, with terminals 178 and 183. Customer supplied wiring must be attached to these terminals and to an identically numbered terminal strip in Generac's "GTS" transfer switch.

REAR BEARING CARRIER:

The cast and machined rear bearing carrier supports the AC connection (lower) panel as well as the front of the stator can. A machined bore in the carrier accepts the rotor bearing. Mounting feet on the carrier are retained to the unit mounting base by means of vibration dampeners, capscrews, washers and hex lock nuts. Four (4) dowels on the carrier position a stationary exciter field and prevent the field from turning. Four holes around the bearing carrier's outer periphery provide for passage of the four stator can studs.

STATOR ASSEMBLY:

The stator assembly is sandwiched between the rear bearing carrier and a blower housing. It is aligned by means of flanges on the bearing carrier and blower housing. Four stator studs retain the stator in its sandwiched position between the bearing carrier and blower housing. (NOTE: Also see Section 1.2, "Types of Stator Connection Systems".)

BLOWER HOUSING:

The blower housing houses a blower fan, flexible drive discs, and the engine flywheel. Cooling and ventilating air that entered the generator through the AC connection (lower) panel is ducted out of the blower housing through a screened air outlet duct. One end of the four stator studs are retained in threaded holes of the blower housing.

FLEX DRIVE DISCS:

Rotating members of the generator are retained to the engine flywheel by a set of flexible drive discs. A blower fan is bolted to the outer periphery of the drive discs. The outer ring of bolts also retains the flex discs to the engine flywheel. A drive hub is bolted to the discs' inner periphery. The tapered revolving field (main rotor) shaft is retained in the inner bore of the drive hub by a drive key, a capscrew, a lockwasher and a spacer.

MAIN ROTOR:

The main rotor may be either a 2 or a 4-pole type. A tapered main rotor shaft is keyed to the drive hub and retained by means of a capscrew, lockwasher and spacer. A prelubricated and sealed ball bearing is pressed onto one main rotor shaft. The outer race of that bearing is retained in the center bore of the rear bearing carrier.

A 2-pole main rotor must be operated at 3600 rpm to supply an AC frequency of 60 Hertz; or 3000 rpm to supply 50 Hertz.

A 4-pole main rotor must be operated at 1800 rpm to deliver 60 Hertz; or at 1500 rpm to deliver 50 Hertz.

EXCITER FIELD:

The stationary exciter field is retained to the rear bearing carrier and positioned by dowels. Regulated direct current from the AC voltage regulator is delivered to the exciter field windings, to create a magnetic field around the exciter field.

EXCITER ASSEMBLY:

The exciter assembly is keyed to a rotor end cap which, in turn, is retained to the main rotor shaft. Thus, the exciter assembly rotates with the main rotor during operation. The exciter field's magnetic field induces a current flow into the exciter assembly.

DIODE BRIDGE:

A diode bridge is retained to a support which, in turn, is bolted to the rotor end cap. The diode bridge changes the regulated alternating current output of the exciter assembly to direct current. The direct current is then delivered to the main rotor.

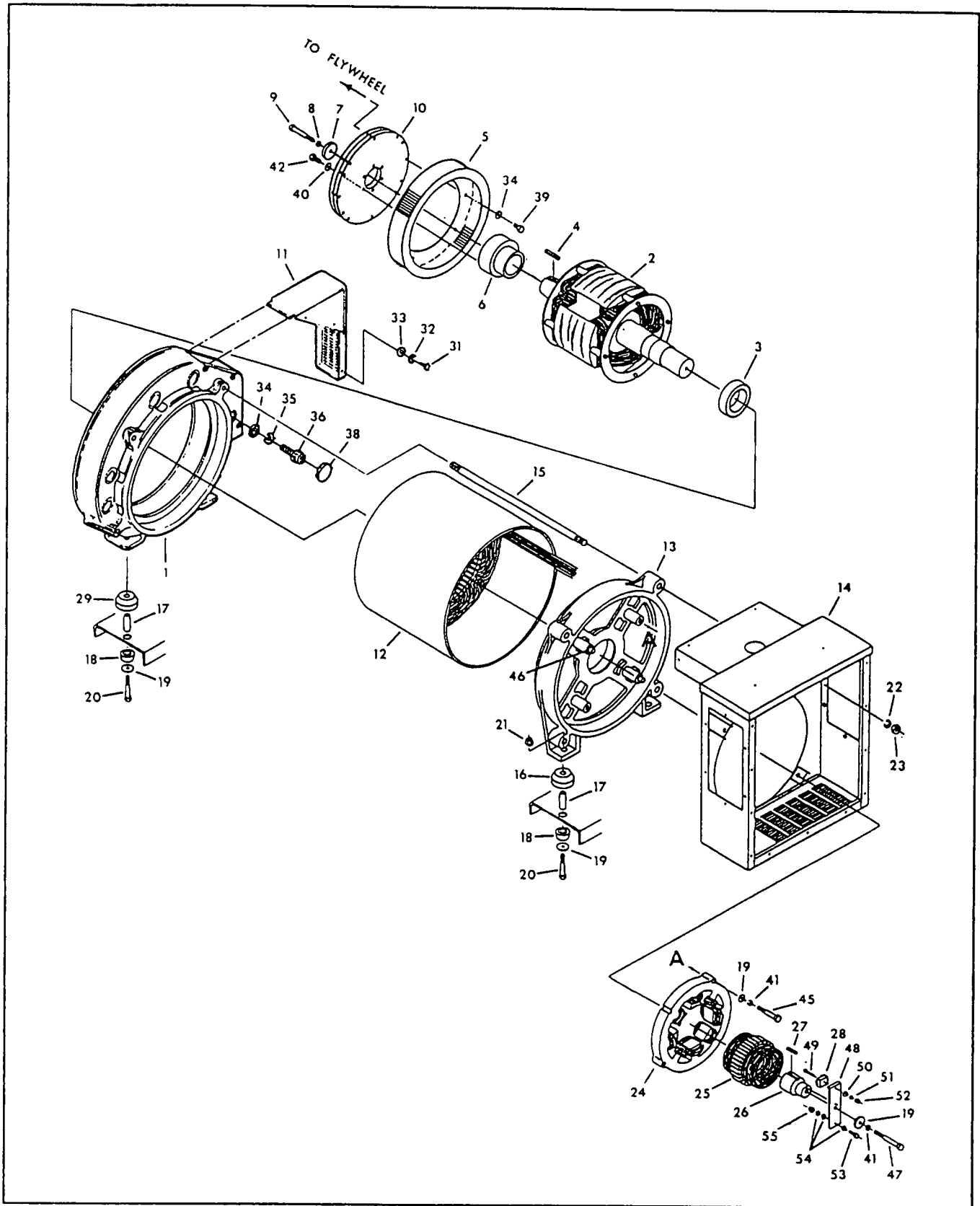


Figure 1. Exploded View of a Typical Brushless Generator

Parts List for Figure 1

ITEM	DESCRIPTION	ITEM	DESCRIPTION
1	Blower Housing	29	Vibration Dampener
2	Main Rotor	31	Capscrew
3	Rotor Bearing	32	Lockwasher
4	Key	33	Flatwasher
5	Fan	34	Flatwasher
6	Drive Hub	35	Lockwasher
7	Spacer	36	Capscrew
8	Lockwasher	38	Snap Bushing
9	Capscrew	39	Capscrew
10	Flexible Disc	40	Flatwasher
11	Air Outlet Screen	41	Lockwasher
12	Stator Assembly	42	Capscrew
13	Rear Bearing Carrier	45	Capscrew
14	AC Connection (Lower) Panel	46	Dowel
15	Stator Studs	47	Capscrew
16	Vibration Dampener	48	Diode Bridge Support
17	Spacer	49	Capscrew
18	Vibration Dampener	50	Flatwasher
19	Washer	51	Lockwasher
20	Capscrew	52	Hex Nut
21	Hex Lock Nut	53	Capscrew
22	Lockwasher	54	Flatwasher
23	Hex Nut	55	Hex Lock Nut
24	Exciter Field		
25	Exciter Assembly		
26	Rotor End Cap		
27	Key		

Some Other AC Generator Parts

Several AC generator components are housed in the unit's control console which rests on top of the AC connection (lower) panel. These are (a) a DPE circuit breaker, (b) electronic voltage regulator, (c) field boost diode, and (d) field boost resistor. Functions of these components will be discussed in Section 3.2.

Section 3.2 OPERATIONAL ANALYSIS

Introduction

Operation of all AC generators is basically the same. However, brushless units are not equipped with brushes and slip rings. Instead, excitation current is delivered to the main rotor by means of electromagnetic induction.

Figure 1, below, is an operating diagram of a typical brushless generator. The rotating portion of the generator includes (a) an exciter, (b) a diode bridge, and (c) the main rotor.

Non-rotating components of the generator include (a) stator AC power windings, (b) stator DPE windings, (c) voltage regulator, (d) DPE circuit breaker, (e) exciter field, (f) voltage adjust potentiometer, (g) a field boost resistor, and (h) a field boost diode.

RESIDUAL MAGNETISM:

The exciter field and main rotor may be thought of as permanent magnets. That is, some "residual" magnetism is always present in these windings.

Residual magnetism alone is capable of inducing a low voltage into the stator power windings (equal to approximately 2 to 7 percent of the unit's rated AC output voltage).

FIELD BOOST:

During engine startup and operation, a DC control/latch-crank circuit board (housed in the control console) delivers 12 volts DC to Wire No. 14. This direct current flows through a field boost resistor, a field boost diode, the exciter field, and to frame ground. Field boost resistor and diode action reduces the field boost voltage to approximately 9-10 volts DC. As field boost current flows through the exciter field, a magnetic field is created around the exciter field that is proportional in strength to the current flow.

Residual magnetism plus the magnetic field created by "field boost" current is capable of inducing a mid-range voltage into the stator power windings (about one-half rated voltage).

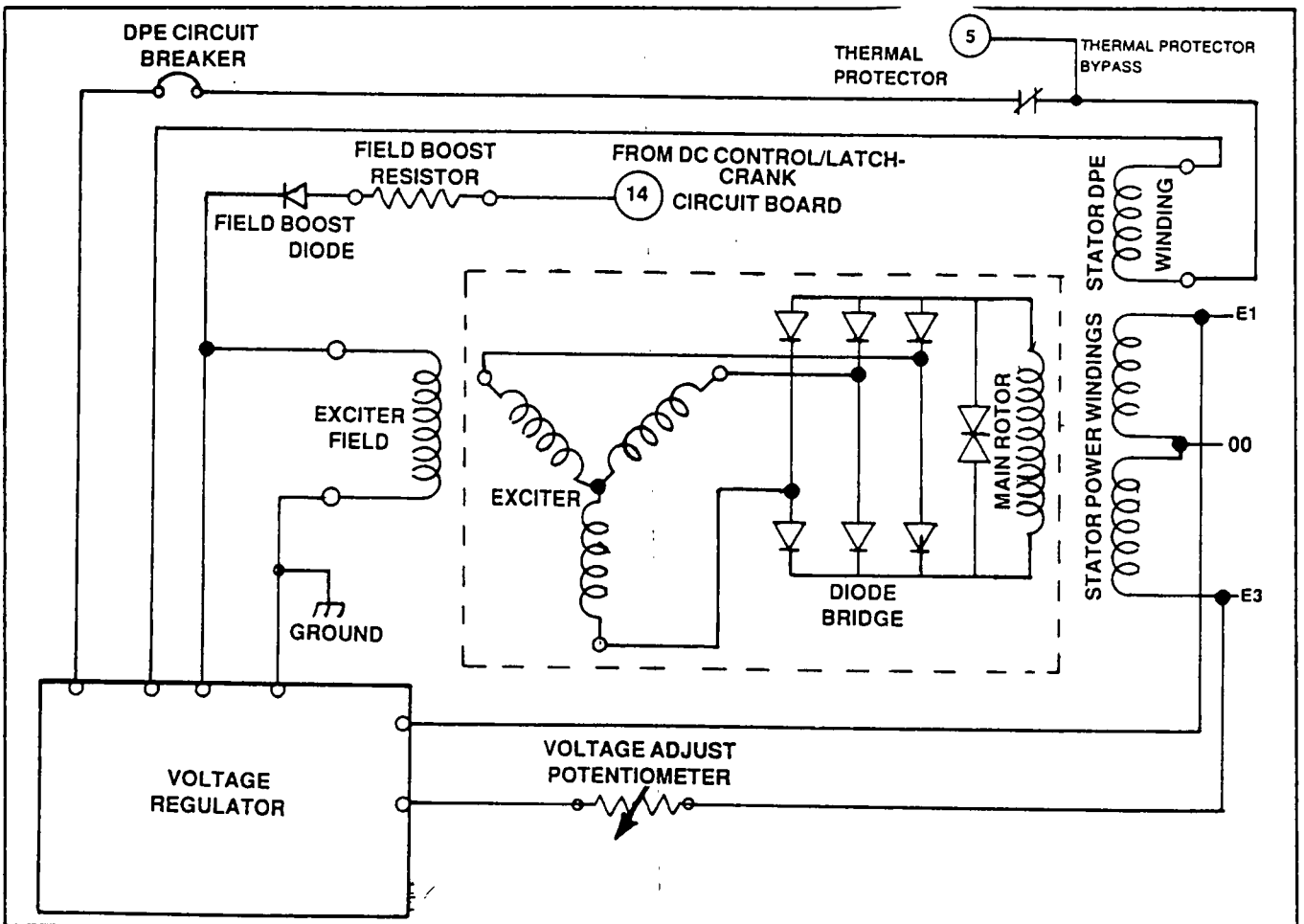


Figure 1. Brushless Generator Operating Diagram (Typical)

Theory of Operation

1. During initial engine startup, a DC control/latch-crank circuit board delivers a direct current to the exciter field, via a field boost resistor and a field boost diode.
 - a. Resistor and diode action reduce this field boost voltage to approximately 9-10 volts DC.
 - b. A magnetic field is created around the exciter field that is proportional in strength to the field boost current flow through the exciter field plus any "residual" magnetism in the exciter field.
2. A revolving exciter rotates so that its 3-phase windings cut across the magnetic lines of flux around the exciter field.
 - a. An alternating current (AC) is induced into the revolving exciter.
 - b. Exciter output current is rectified by a diode bridge (changed to direct current).
 - c. The direct current is delivered to the main rotor windings.
3. A magnetic field is created around the main rotor that is proportional in strength to the current flow through the main rotor windings (plus any "residual" magnetism in the main rotor).
 - a. The main rotor's magnetic lines of flux cut across the stator AC power windings and the stator DPE (excitation) windings.
 - b. A voltage is induced into the stator power windings that is proportional to the strength or concentration of the main rotor's magnetic field.
 - c. If the stator power winding circuit is completed by connecting electrical load(s) across Wires E1, E3 and 00 (neutral), current will flow in the circuit.
 - d. A voltage is induced into the stator DPE windings and current can flow in this circuit.
4. Stator DPE winding AC output current flows to a voltage regulator, via a DPE circuit breaker.
 - a. A "sensing" voltage signal is also delivered to the voltage regulator from the stator power winding AC output leads, via a voltage adjust potentiometer.
 - b. The voltage regulator has been adjusted to establish a "reference" voltage.
 - c. The regulator electronically compares the "sensing" (actual) voltage to the preset "reference" voltage.
 - (1) The regulator changes the DPE winding's alternating current to direct current (rectifies it).
 - (2) The regulator "regulates" the rectified DPE winding current as follows:
 - (a) If the "sensing" voltage is higher than the preset "reference" voltage, the regulator will decrease current flow to the exciter field.
 - (b) If the "sensing" voltage is lower than the preset "reference" voltage, the regulator will increase current flow to the exciter field.
5. The rectified and regulated DPE (excitation) current flows through the exciter field.
 - a. Magnetic lines of flux are created around the exciter field. The strength or concentration of these magnetic lines is proportional to the current flow through the exciter field.

- b. A voltage and current flow is induced into the revolving exciter windings that is proportional to the strength or concentration of the magnetic lines of flux around the exciter field.
6. Exciter AC output current is rectified by action of a diode bridge. The resultant direct current is delivered to the main rotor windings.
 - a. A magnetic field is created around the main rotor windings that is proportional to the current flow through those windings.
 - b. The main rotor's magnetic field cuts across the stator power windings and DPE windings, to induce a voltage into those windings that is proportional to the strength of the magnetic field.
 7. The voltage induced into the stator power and DPE windings is equal to (a) main rotor residual magnetism, plus (b) the magnetic field created by field boost current flow through the exciter field, plus (c) the magnetic field created by regulated excitation current flow from the voltage regulator.

Stator Power Windings

Figure 1 on Page 3.2-1 shows a single phase, 3-wire stator power winding. Refer to Section 1.2, "Types of Stator Connection Systems" for other possible stator power winding configurations.

Stator DPE Winding

"DPE" means "displaced phase excitation". The term refers to an excitation winding that is physically located in the stator so that it is "out of phase" with the stator power windings.

Unregulated AC output from the stator DPE winding is delivered to the voltage regulator, via a 15-pin connector plug, Wires No. 2 and 6, and a DPE circuit breaker. A minimum DPE output of approximately 4 volts AC is required to turn the regulator on.

See Figure 2. Depending on the type of generator, unregulated AC output from the DPE winding may be delivered to the regulator via Wire No. 2 and Wire No. 6, 6A or 6B as follows:

- Wire No. 6 is used on brushless generators. Wires 6A and 6B may or may not be provided on brushless units.
- Wire No. 6A is used on direct excited (brush type) units rated 120/208, 120/240 or 240/416 volts.
- Wire No. 6B is used on direct excited (brush type) units rated 139/240 volts or 277/480 volts.

Thermal Protector

A thermal protector is physically imbedded in the wire windings of the stator and electrically connected in series with the DPE winding output to the regulator. The device is a normally-closed, temperature sensitive switch which will open on occurrence of an over-temperature condition in the stator. Should the device open, DPE winding output will be lost and the voltage regulator will shut down.

Thermal Protector (Continued)

When the voltage regulator shuts down, excitation current to the exciter field will be lost. Stator power winding output voltage will then drop to a value that is commensurate with residual plus field boost magnetism.

The thermal protector is self-resetting and, when internal stator temperatures return to normal, will close to restore DPE winding output to the regulator. Stator power winding output voltage will then return to normal.

A thermal protector bypass lead (Wire No. 5) has been provided. Should the device fail open, it can be bypassed by connecting Wire No. 5 to excitation Wire No. 2.

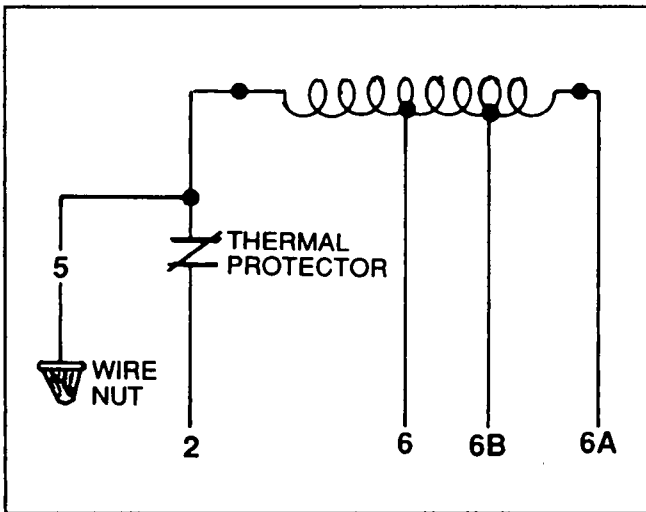


Figure 2. Stator DPE Winding Configurations

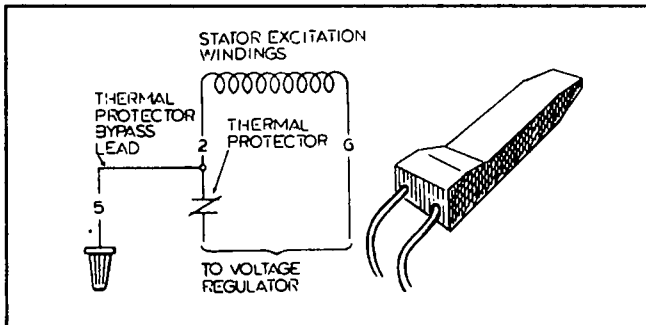


Figure 3. Thermal Protector

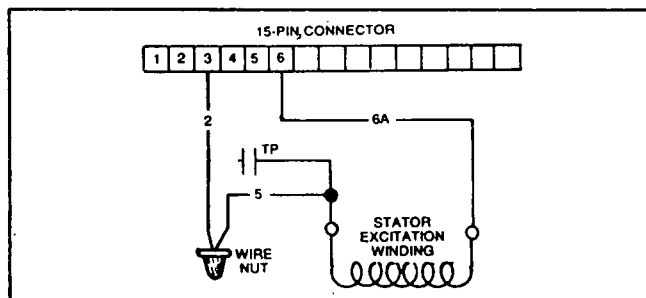


Figure 4. Bypassing the Thermal Protector

The DPE Circuit Breaker

This circuit breaker protects the solid state voltage regulator against overcurrent conditions. Should the breaker trip open due to an overload, loss of unregulated AC current flow to the regulator will occur. The regulator will then shut down. The results will then be the same as when a thermal protector opens.

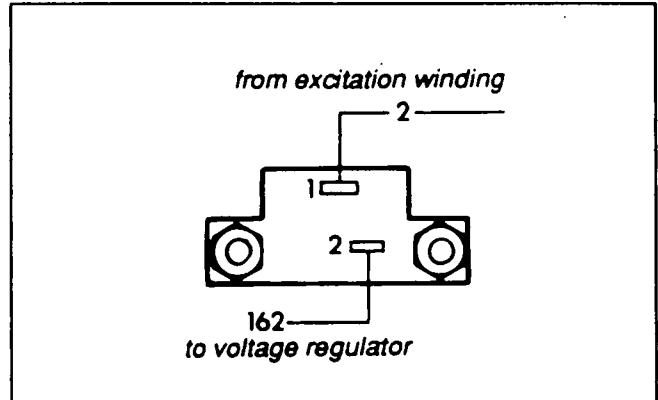


Figure 5. DPE Circuit Breaker

Exciter Field

The stationary exciter field is retained to the rear bearing carrier. It is positioned and prevented from turning by dowels in the rear bearing carrier. Regulated direct current from the voltage regulator is delivered to the exciter field windings. The exciter field then induces a voltage and current flow into the rotating exciter that is commensurate with the strength of the exciter field's magnetic field.

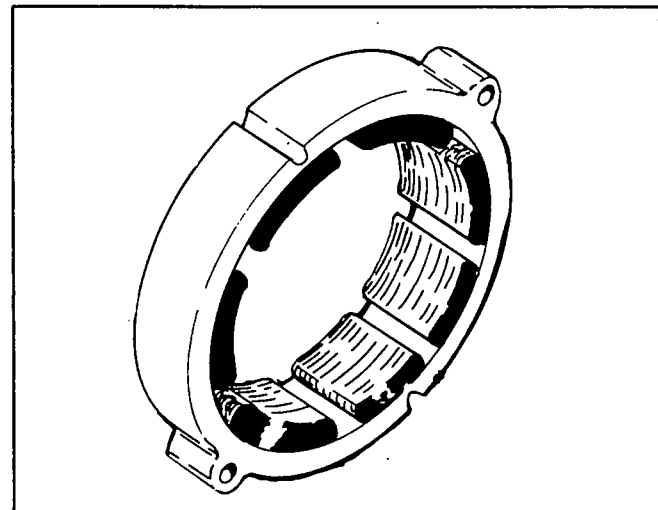


Figure 6. Exciter Field

Rotating Portion of Generator

An AC voltage and current flow are induced into the 3-phase exciter windings by the action of the exciter field's magnetic flux lines. From the exciter, the altern-

Rotating Portion of Generator (Continued)

ating current is changed to direct current (DC) by a diode bridge. The direct current is then delivered to the main rotor. Flow of current through the main rotor windings creates a magnetic field which induces a voltage into the stator power and DPE windings.

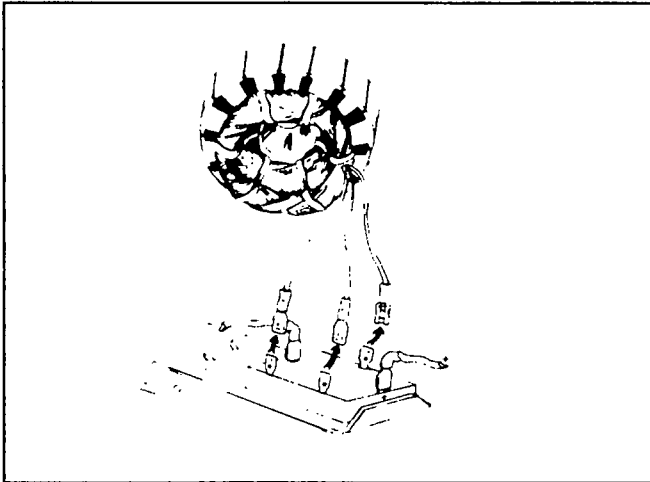


Figure 7. Exciter and Diode Bridge

Voltage Regulator

Excitation (DPE) winding AC output is delivered to the voltage regulator. The regulator rectifies this AC output and, based on "sensing" signals, regulates it. The regulated DC output is then delivered to the exciter field. A minimum of 4 volts AC from the DPE winding is required for regulator operation. Without DPE output, the regulator will shut down and regulated DC output to the exciter field will be lost.

"Sensing" or actual voltage signals are delivered to the voltage regulator via Wires No. S15, S16 and 89, which connect to the stator power winding output leads. The regulator compares these actual voltage signals with a preset (adjusted) reference voltage.

A voltage adjust potentiometer is connected in series with the sensing leads to the regulator. The potentiometer permits the operator to adjust stator power winding AC output voltage within a range of plus or minus 10 percent.

NOTE: The voltage adjust potentiometer actually permits sensing or actual voltage signals to the regulator to be changed. The regulator compares the sensing voltage to a reference voltage in an attempt to maintain a stator power winding output that is identical to the reference voltage. Regulated DC output to the exciter field is then changed as the regulator attempts to match the reference and sensing voltages.

The regulator (Figure 8) is equipped with three lamps (LED's). These are (a) a red "Regulator" lamp, (b) a yellow "Sensing" lamp, and (c) a green "Excitation" lamp. During normal operation all lamps should be on.

The green "Excitation" lamp is powered by DPE winding output, as well as the red "Regulator" lamp. Approximately 4 to 8 volts AC from the DPE winding is required for regulator operation. If DPE winding output voltage is gradually reduced, both lamps will dim until, at some reduced voltage, they no longer glow visibly.

NOTE: Depending on the specific generator and stator assembly, DPE (excitation) voltage may be about 40-240 volts RMS.

The yellow "Sensing" lamp is powered by sensing voltage. Lamp brightness will depend on the available sensing voltage.

NOTE: Also see "More About the Voltage Regulator" on Page 2.1-5.

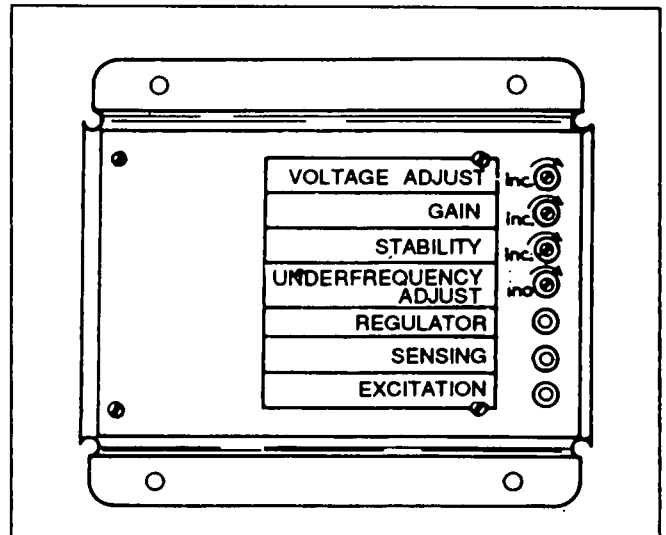


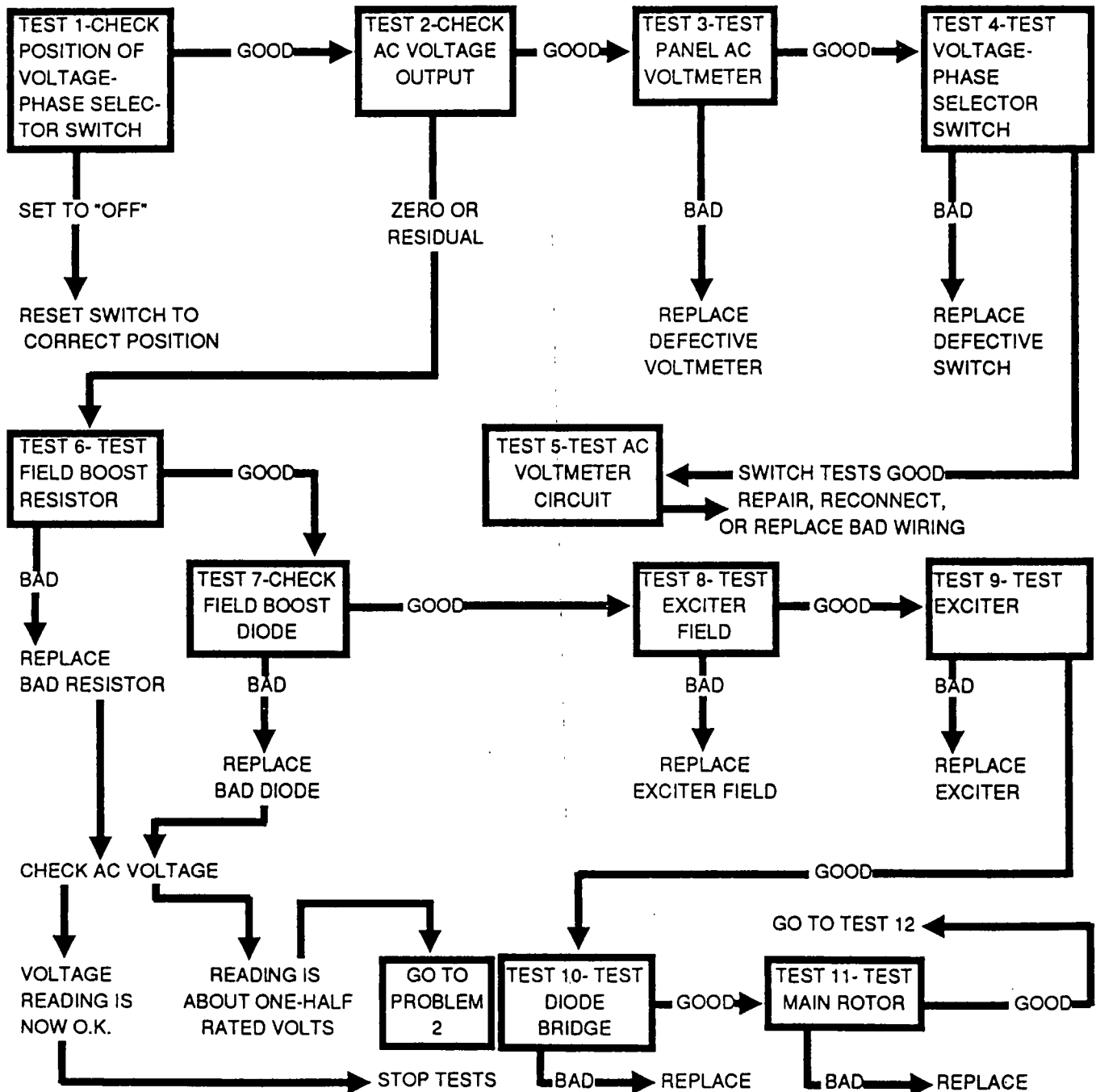
Figure 8. The Electronic Voltage Regulator

Section 3.3 TROUBLESHOOTING FLOW CHARTS

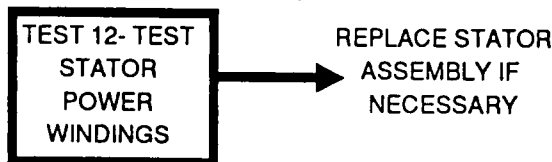
A generator does not have a large number of parts. However, these parts are expensive. For that reason, use of "guesswork" when troubleshooting and diagnosing problems is not cost effective and must be avoided.

The following "Troubleshooting Flow Charts" have been carefully formulated in logical sequence. They should cover most of the problems and remedies that might be encountered. Follow the flow charts carefully. If you are uncertain of how to perform any test in the chart, refer to "Diagnostic Tests" in Section 2.4.

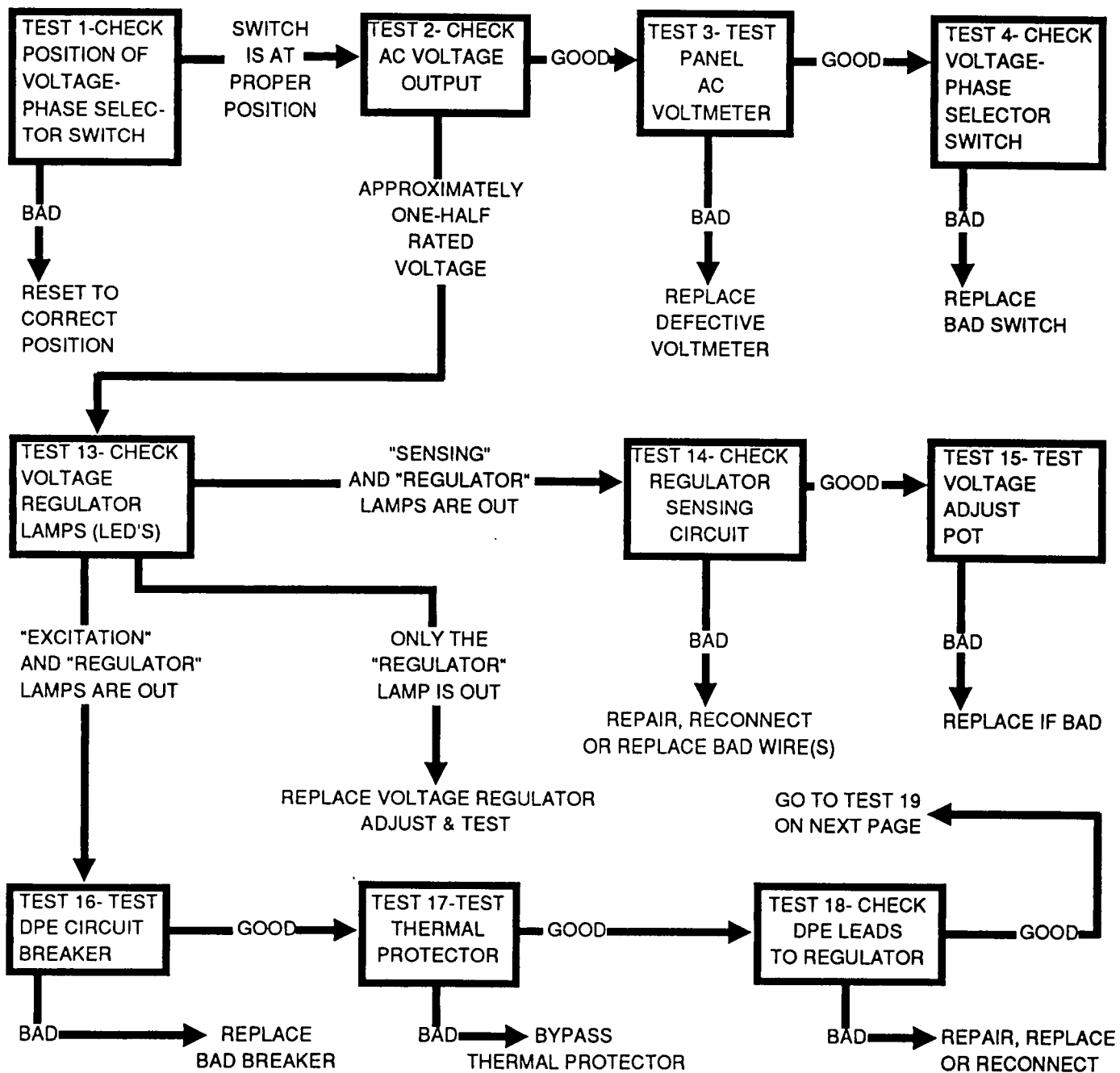
Problem 1- Panel AC Voltmeter Reads Zero or Residual Voltage at No-Load



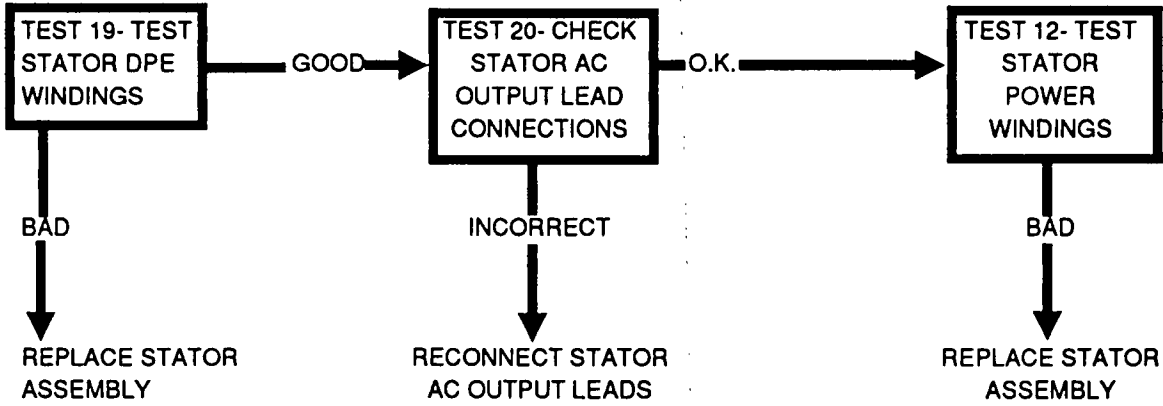
Problem 1- Panel AC Voltmeter Reads Zero or Residual Voltage at No-Load (Continued)



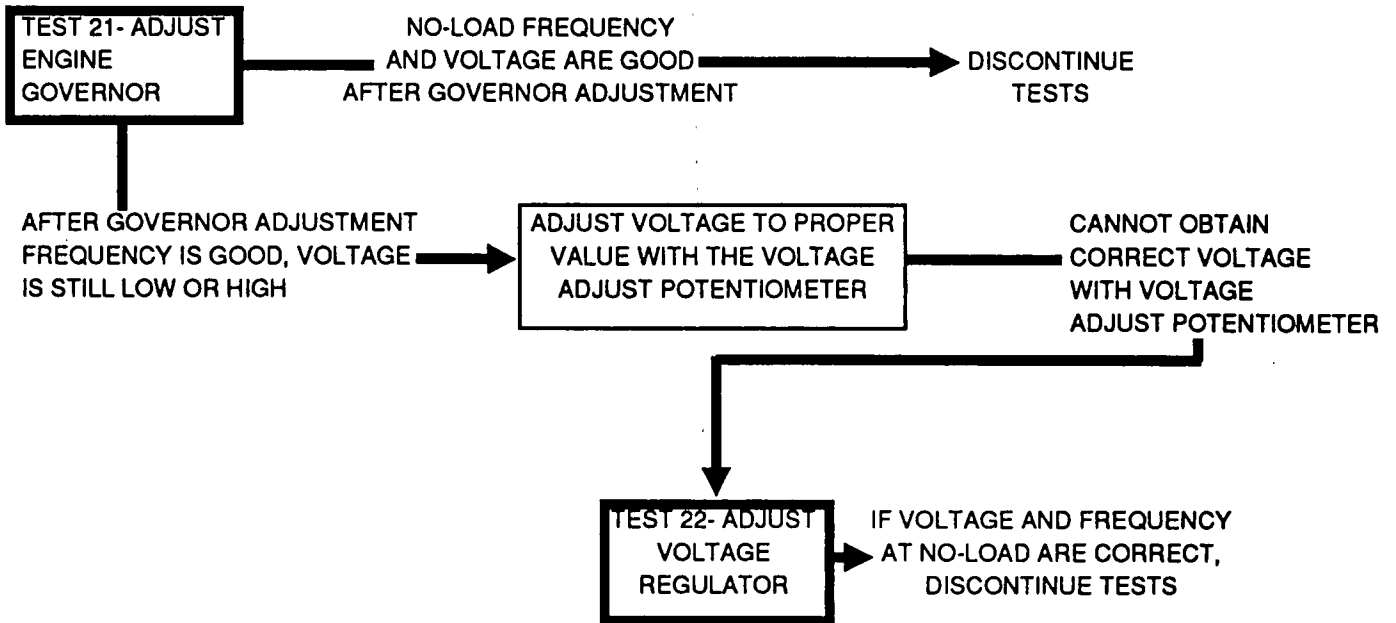
Problem 2- Generator Produces Approximately One-Half Rated Voltage



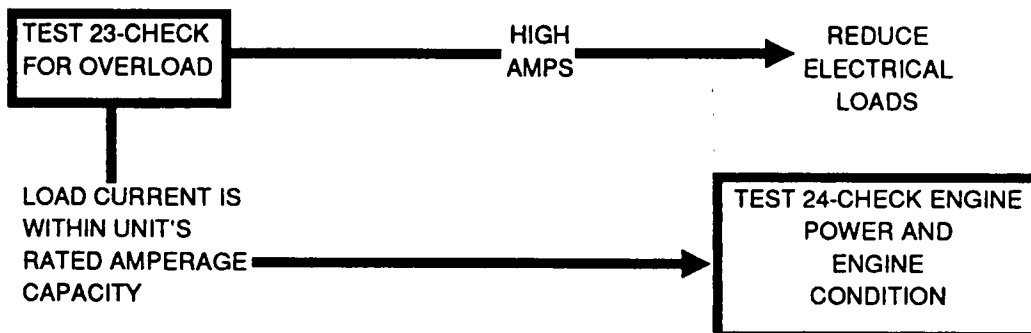
Problem 2- Generator Produces Approximately One-Half Rated Voltage (Continued)



Problem 3- Low or High Frequency and Voltage at No-Load



Problem 4- Voltage and Frequency Reading Drops Low When Load Is Applied



Section 3.4 DIAGNOSTIC TESTS

Introduction to Diagnostic Tests

Perform the "Diagnostic Tests" in this section in conjunction with Section 3.3, "Troubleshooting Flow Charts". Test numbers in Section 3.3 are identical to the test numbers in this section.

Test 1- Check Position of Voltage-Phase Selector Switch

DISCUSSION:

Readings displayed on the control console AC voltmeter and ammeter depend on the position of the voltage-phase selector switch. Depending on that switch position, the voltmeter and ammeter will display (a) line-to-line voltage and amperage, (b) line-to-neutral voltage and amperage, or (c) no reading at all. This is shown in the following chart:

SWITCH POSITION	VOLTAGE-AMPERAGE READING	
	1-PHASE UNITS	3-PHASE UNITS
1	Line E1 to Neutral	Line E1 to E2
2	Line E3 to Neutral	Line E2 to E3
3	Line E1 to Line E3	Line E3 to E1
Off	No Reading	No Reading

PROCEDURE:

Check the position of the voltage-phase selector switch. Reset the switch to its correct position, if necessary.

RESULTS:

If voltage reading is still "zero" or one-half rated voltage after selecting the correct switch position, go to Test 2.

Test 2- Check AC Output Voltage

DISCUSSION:

The panel AC voltmeter is generally very accurate. However, if incorrect voltage readings are displayed on the meter, you should verify that panel readings are correct before proceeding. By verifying panel meter readings, you will determine whether a generator fault actually exists or if the problem is in the voltmeter circuit.

DANGER: USE EXTREME CAUTION WHEN MEASURING GENERATOR AC OUTPUT VOLTAGES. THESE VOLTAGES ARE EXTREMELY HIGH AND DANGEROUS. IT IS BEST TO CONNECT TEST LEADS WITH THE GENERATOR SHUT DOWN. CONTACT WITH HIGH VOLTAGE WIRES OR TERMINALS CAN RESULT IN DANGEROUS SHOCK.

PROCEDURE:

1. With the generator shut down, connect the test leads of an AC voltmeter across the proper generator leads or terminals as follows:
 - a. On 1-phase units, connect across line E1 to E3 for line-to-line readings; across line E1 to 00 and/or E3 to 00 for line-to-neutral readings.
 - b. On 3-phase units, read all three line-to-line voltages one at a time (line E1 to E2; line E2 to E3; line E3 to E1).
2. With the external AC voltmeter properly connected, start the generator. Let it stabilize and warm up.
3. Read the line-to-line and line-to-neutral voltages.

RESULTS:

1. If the panel voltmeter reading was bad, but readings in Test 2 are good, go on to Test 3.
2. If the voltage reading in Step 3 above is "zero" or "residual" voltage, go to Test 6. See Section 3.3, "Troubleshooting Flow Charts" (Problem 1).
3. If the voltage reading in Step 3 above is approximately one-half rated voltage, go to Test 13. See Problem 2 in Section 3.3.

Test 3- Test Panel AC Voltmeter

DISCUSSION:

This test will isolate the panel AC voltmeter as the cause of an incorrect voltage reading.

PROCEDURE:

See Figure 1. Connect the test leads of an accurate AC voltmeter across the panel AC voltmeter terminals. With the generator running, set the voltage-phase selector switch to Position 1, 2 and 3. Read the external voltmeter at each switch position and compare its reading to the panel voltmeter reading. Readings should be the same on the external meter and on the panel meter.

RESULTS:

1. If a comparison of the readings indicate that the panel voltmeter is defective, replace the panel voltmeter.
2. If external and panel voltmeter readings are the same, but readings are incorrect, go to Test 4.

Test 4- Test Voltage-Phase Selector Switch

DISCUSSION:

If Test 3 indicated that the panel AC voltmeter is reading correctly, but those readings are not the actual voltage output of the unit, the voltage-phase selector switch may be defective. Figure 1 on the next page shows the switch pictorially and schematically

Switch positions and resultant voltage readings (line-to-line or line-to-neutral) are discussed in Test 1.

Test 4- Test Voltage-Phase Selector Switch (Continued)

PROCEDURE:

With the generator engine shut down, gain access to the rear of the voltage-phase selector switch (in the generator control console). Test the switch as follows:
 1. Set a volt-ohm-milliammeter (VOM) to its "Rx1" scale and zero the meter.
 2. Refer to the following chart. Connect the VOM test leads across pairs of switch contacts as listed in the chart.

- a. Note the VOM reading with the switch set at each of its positions.
- b. Readings should be as indicated in the chart.

CONNECT TEST LEADS ACROSS CONTACTS	SWITCH POSITION			
	1	2	3	OFF
14 to 13	Continuity	Infinity	Continuity	Infinity
16 to 15	Infinity	Continuity	Infinity	Infinity
20 to 19	Continuity	Infinity	Infinity	Infinity
18 to 17	Infinity	Continuity	Continuity	Infinity
1 to 2	Infinity	Continuity	Continuity	Continuity
3 to 4	Continuity	Infinity	Infinity	Infinity
5 to 6	Continuity	Infinity	Continuity	Continuity
7 to 8	Infinity	Continuity	Infinity	Infinity
9 to 10	Continuity	Continuity	Infinity	Continuity
11 to 12	Infinity	Infinity	Continuity	Infinity

RESULTS:

- 1. Replace switch if defective.
- 2. If switch tests good, and panel voltmeter is reading incorrectly, go on to Test 5.

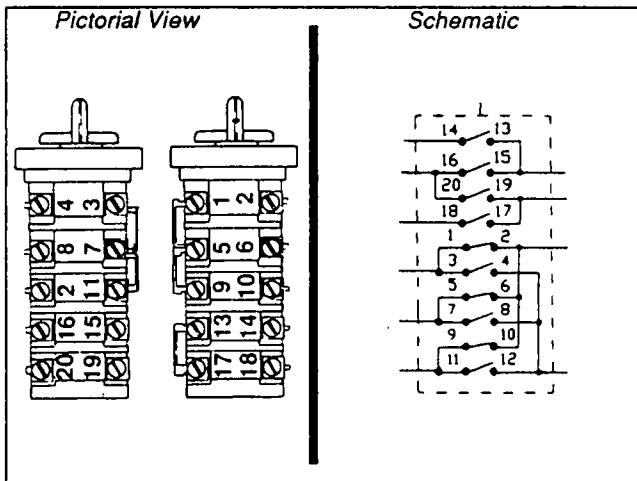


Figure 1. Voltage-Phase Selector Switch

Test 5- Test AC Voltmeter Circuit

DISCUSSION:

If the console AC voltmeter (or ammeter) is reading incorrectly, one possible cause of the problem might be an open, grounded or shorted wire in the voltmeter (or ammeter) circuit. Figure 2 is a schematic representation of the voltmeter/ammeter circuit from the 15-pin connector plug in the AC connection (lower) panel to the panel meters.

PROCEDURE:

Carefully inspect all wiring in the circuit for damage, disconnected terminal ends, etc. Make sure wires are connected to the proper switch terminals. Use a VOM to test wires for an open or shorted condition.

RESULTS:

Repair, reconnect or replace circuit wires as needed.

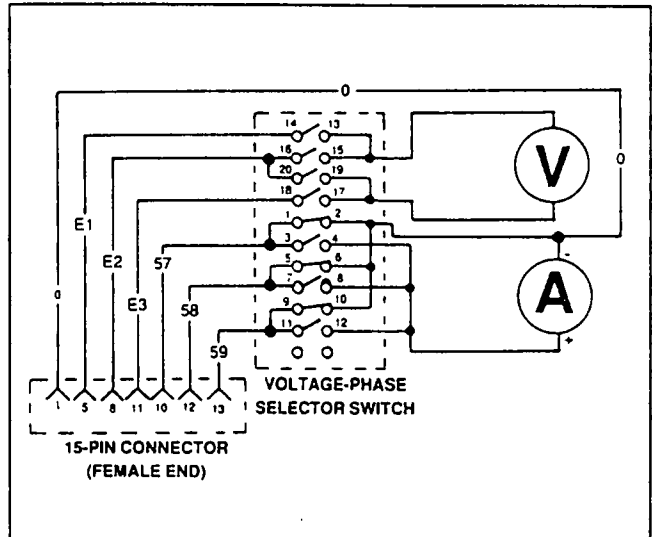


Figure 2. Console Voltmeter/Ammeter Circuit

Test 6- Test Field Boost Resistor

DISCUSSION:

During startup and running, a DC control/latch-crank circuit board (in the generator control console) delivers a DC voltage to the exciter field, via Wire No. 14, the field boost resistor (R2), the field boost diode (D1), and Wire No. 4. The DC circuit is completed through the exciter field and to frame ground.

The field boost circuit should "flash the field" on every startup. This helps ensure that an adequate "pickup" voltage is induced into the stator windings on every start and that the required 4 to 8 volts DPE winding output is available to turn the voltage regulator on.

Failure of the voltage regulator to turn on will result in loss of regulated excitation current flow to the exciter field. The following facts apply to such a loss of regulated DPE current to the exciter field:

Test 6- Test Field Boost Resistor (Continued)

- If only excitation (DPE) current flow to the exciter field is lost, with field boost current still available, stator AC power winding output voltage will be the result of (a) the magnetic field created by field boost current, plus (b) "residual" magnetism always present in the exciter field and main rotor.
- The stator power winding output voltage produced as a result of field boost current plus residual magnetism is equal to approximately one-half the unit's rated voltage (in the neighborhood of about 40-60 percent of rated voltage).
- If, for any reason, both excitation and field boost current flow are lost, stator power winding output voltage will be approximately 2 to 7 percent of rated voltage. This is the result of residual magnetism only.
- Residual magnetism alone (without field boost) may or may not generate sufficient DPE voltage to turn the voltage regulator on, depending on the characteristics of the individual generator set.

PROCEDURE:

1. Set a VOM to "+DC" and to a voltage scale high enough to read battery voltage.

NOTE: Be sure to read the instructions for the VOM being used. Some meters are based on current flow theory, in which direct current flows from positive (+) to negative (-). Other meters function on the electron flow theory, with direct current flowing from negative (-) to positive (+).

2. Gain access to the control console interior and locate the field boost resistor (Figure 3).
3. Start the engine, let it run at rated speed and at no-load.
4. Connect the positive (+) VOM test probe to the Wire 14 terminal of the resistor and the common (-) test probe to terminal 0 of the large terminal board (TB1). The VOM should indicate battery voltage.
5. Now, connect the VOM positive (+) test probe to the Wire 29 terminal of the resistor; the common (-) test probe to terminal 0 of TB1. A somewhat reduced voltage should be indicated (approximately 9-10 volts DC).

RESULTS:

1. If the meter reads battery voltage in Step 4 and a slightly reduced battery voltage in Step 5, the field boost resistor is good. Go on to Test 7.
2. If the meter indicates battery voltage in Step 4, but reads zero volts in Step 5, the field boost resistor should be replaced.
3. If the meter reads zero volts in Step 4, check Wire No. 14 (between the resistor and terminal board) for an open condition.

NOTE: The DC control/latch-crank board must be working since the engine cranked and started normally. Wire 14 voltage also turns on engine ignition and fuel flow functions.

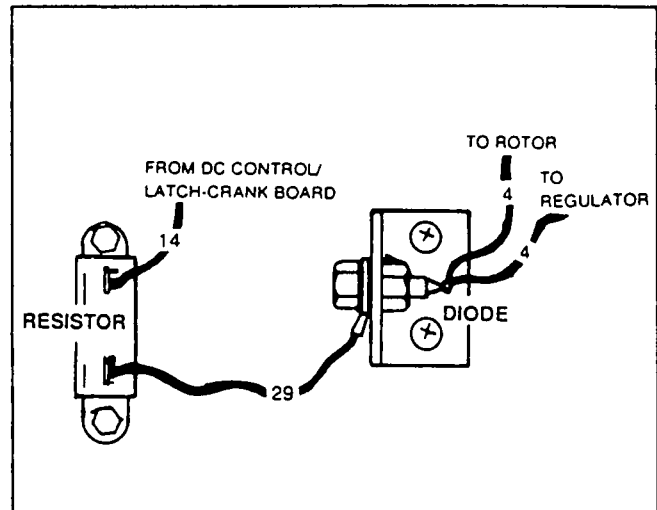


Figure 3. The Field Boost Circuit

NOTE: When replacing a field boost resistor, be sure to use one that is identical to the original resistor. The most common field boost resistor ratings are (a) 5 ohms, (b) 10 ohms, or (c) 25 ohms.

Test 7- Check Field Boost Diode

DISCUSSION:

See "Discussion" under Test 6. The field boost diode is rated 12 amps, 600 volts. Its anode is connected to the case.

PROCEDURE:

With the generator engine shut down, test the field boost diode as follows (Figure 3):

1. Set a VOM to its "Rx1" scale and zero the meter.
2. Connect the VOM test leads across the diode stud and the Wire No. 4 terminal. Watch the meter for any upscale movement.
3. Now reverse the polarity of the meter test leads and, again, observe the meter reading. The meter should swing upscale and read the forward resistance of the diode at one polarity only. At the opposite polarity, the VOM should read "infinity".

RESULTS:

1. Replace the diode, if it fails the test.
2. If field boost diode checks good, go to Test 8.

Test 8- Test Exciter Field

DISCUSSION:

An open condition in the exciter field coil means that neither field boost nor regulated DPE current can flow through the exciter field. The AC voltage induced into the stator power windings will then be commensurate with "residual" magnetism in the main rotor (about 2 to 7 percent of the unit's rated voltage). This test will check the exciter field for (a) an open condition, and (b) a grounded condition. The exciter field (Figure 4) is accessible in the AC connection (lower) panel.

Test 8- Test Exciter Field (Continued)**PROCEDURE:**

In the AC connection (lower) panel, locate the 15-pin connector plug (Figure 4). Disconnect the connector plug halves and test the exciter field as follows:

1. On the lower half of the connector plug, locate Pins 2 and 4. Wires No. 1 and 4, respectively, attach to these pins.
2. Set a VOM to its "Rx1" scale and zero the meter.
3. Connect the positive (+) VOM test lead to Pin 4 (Wire No. 4); connect the common (-) test lead to Pin 2 (Wire No. 1).
4. Read the meter. The resistance of the exciter field should be indicated (about 4.5 to 6.5 ohms). A very high reading or a reading of "infinity" indicates an open circuit.
5. Now, set the VOM to a very high resistance scale, such as "Rx10,000" or "Rx1K". Zero the meter again.
6. Connect the positive VOM test lead to Pin 4 (Wire No. 4). Connect the common (-) test lead to a clean frame ground. The meter should read "infinity". Any upscale movement of the meter needle indicates a grounded condition.

RESULTS:

1. If test results indicate an open or grounded exciter field, first check Wires 1 and 4 (between the exciter field and the 15-pin connector). Replace any damaged, defective, open or grounded Wires 1 and 4. Then, retest the exciter field.
2. If exciter field coil is open or grounded, replace the exciter field.
3. If the exciter field checks good, go to Test 9.

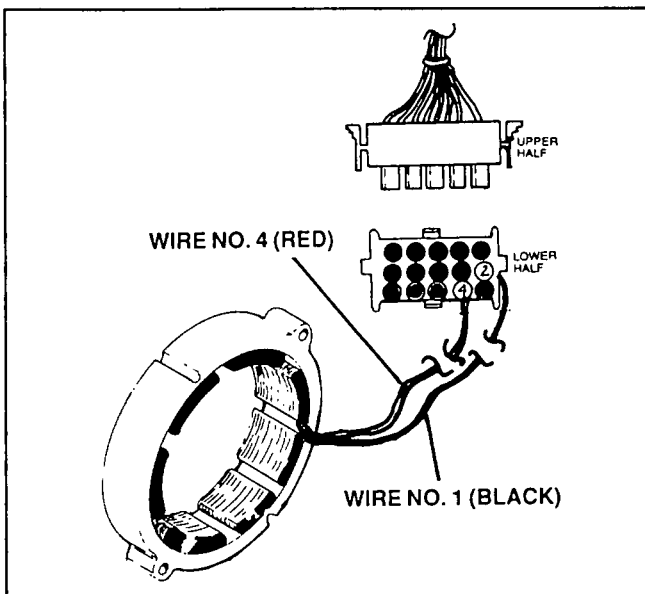


Figure 4. Exciter Field and 15-Pin Connector

Test 9- Test Exciter**DISCUSSION:**

The exciter is keyed to a rotor end cap and rotates with the main rotor during operation. It consists of three (3) wye connected coils, with three (3) leads coming out. The three leads connect to "AC" terminals on the diode bridge. See Figure 5.

PROCEDURE:

1. Disconnect the three exciter leads from the diode bridge, to prevent interaction.
2. Set a VOM to its "Rx1" scale and zero the meter.
3. Connect the VOM test leads across any two of the exciter leads and note the reading. Then, test across the third lead and any other lead. In each case, exciter coil resistance should be indicated (about 3 to 5 ohms). A very high resistance or a reading of "infinity" indicates an open circuit.
4. Now set the VOM to a very high resistance scale (such as "Rx10,000" or "Rx1K") and zero the meter. Then, check for a grounded condition as follows:
 - a. Connect a VOM test lead to one exciter lead, the other test lead to a clean frame ground (such as the rotor end cap). The VOM should read "Infinity".
 - b. Repeat Step (a) above with VOM test leads across a second exciter lead and ground. "Infinity" should be read.
 - c. Repeat Step (a) with VOM test leads across the third test lead and ground. Again, the VOM should read "infinity".

RESULTS:

1. If the test reveals an open or grounded exciter, replace the exciter.
2. If the exciter tests good, go to Test 10.

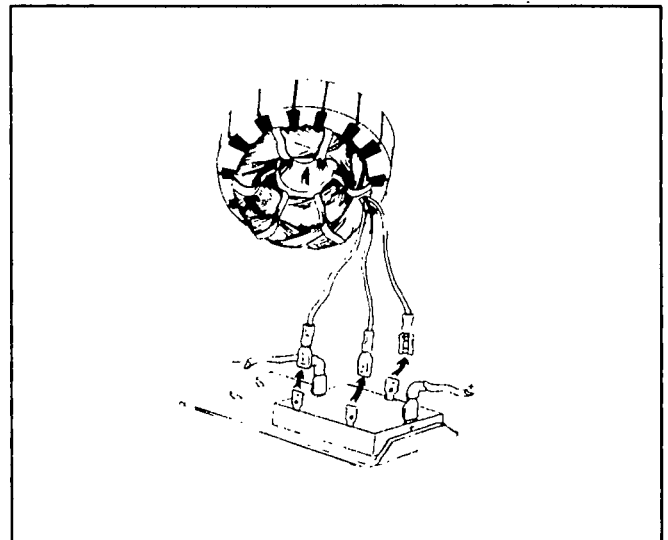


Figure 5. Exciter and Diode Bridge

Test 10- Test Diode Bridge

DISCUSSION:

The diode bridge changes the alternating current (AC) output of the exciter to direct current (DC). That is, it rectifies exciter output. The bridge consists of six (6) diodes, i.e., two diodes for each phase of the exciter. The function of a diode is to permit current flow at one polarity (in one direction) only.

If Diodes Fail Open: One type of diode failure is an "open" condition. Current cannot flow in either direction through an open diode. What happens to stator power winding AC output voltage will depend on the number of diodes in the diode bridge that have failed open.

1. Each pair of diodes passes excitation current to the main rotor from a single exciter phase winding.

2. If a single diode fails open, the output from a single exciter phase winding will be lost.

a. Voltage regulator action will increase excitation current through the remaining two exciter coils in an attempt to maintain a preset reference voltage.

b. In some cases, a voltage dropoff may be observed as applied loads approach the generator's rated maximum capacity.

c. In some cases, the output of two exciter coils will be adequate to provide normal voltage at full rated load.

3. If two or more diodes have failed open, current cannot flow in the exciter windings.

a. Loss of current flow in the exciter must occur since one diode is needed to pass current to the main rotor; the other diode must provide a return path for the current.

b. If two diodes fail open, loss of excitation current through the main rotor will result. Stator power winding output voltage will then drop to a value that is commensurate with field boost plus residual magnetism (approximately one-half rated voltage).

If Diodes Short Circuit: If a shorted condition occurs in the diode bridge, alternating current (AC) will begin to flow through the main rotor windings. This will probably result in collapse of the magnetic field. A voltage dropoff to zero will be the end result.

PROCEDURE:

1. Carefully inspect the diode bridge. Evidence of overheating, heat bubbles, melting or burning may indicate that the surge protector in the diode bridge has failed.

2. Inspect wiring connections at the diode bridge. See Figure 6.

3. Disconnect the three exciter leads from diode bridge terminals, to prevent interaction.

4. Set a VOM to its "Rx1" scale and zero the meter. If the VOM has a polarity switch, set it to "+DC".

5. Connect the positive (+) VOM test leads to the diode bridge terminal indicated by a "+". Then, connect the common (-) test leads to each "AC" terminal, one at a time. As you connect each common (-) test lead, note the meter reading.

6. Now reverse the test leads. That is, connect the common (-) VOM test lead to the diode bridge terminal indicated by a "+". Then, connect the positive (+) VOM test leads to each of the "AC" terminals, one at a time, and note the meter reading.

The VOM should read "infinity" at one polarity only. At the opposite polarity, the forward resistance of a diode should be indicated.

RESULTS:

1. If the VOM reads "infinity" at both polarities, replace the diode bridge.

2. If the VOM reads the forward resistance of any diode at both polarities, replace the diode bridge.

3. If the VOM reads "continuity" at both polarities, replace the diode bridge.

4. If the diode bridge tests good, go on to Test 11.

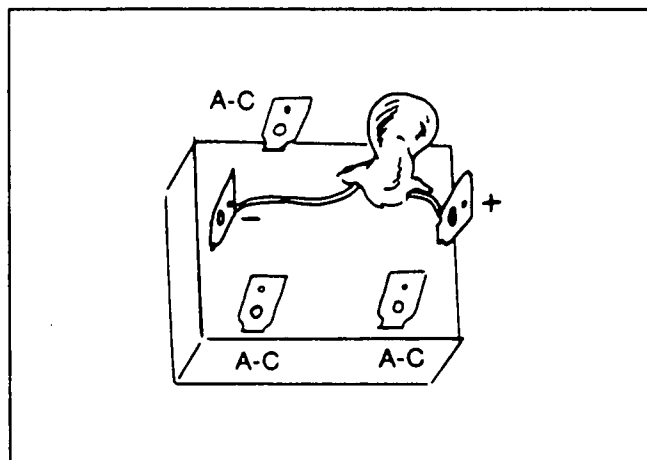


Figure 6. The Diode Bridge

Test 11- Test Main Rotor

DISCUSSION:

You may wish to review the information pertaining to the main rotor in Sections 3.1 and 3.2. The main rotor leads connect to the diode bridge terminals indicated by a "+" and a "-". See Figure 7.

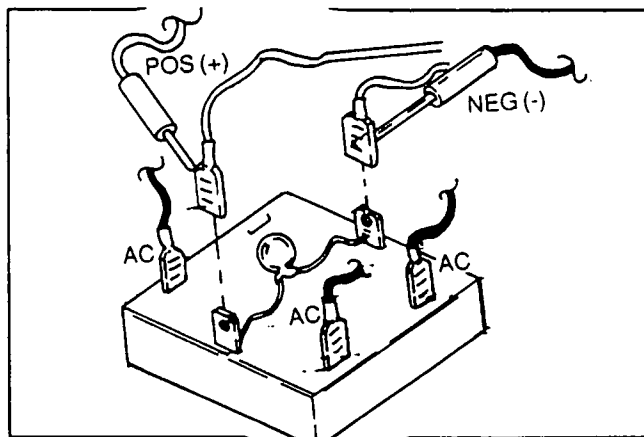


Figure 7. Main Rotor Test Points

Test 11- Test Main Rotor (Continued)

PROCEDURE:

1. Disconnect the main rotor leads from the diode bridge terminals indicated by a "+" and a "-".
2. Set a VOM to its "Rx1" scale and zero the meter.
3. If the VOM has a polarity switch, set it to "+DC".
4. Connect the positive VOM test lead to the rotor lead just disconnected from the diode bridge "+" terminal.
5. Connect the VOM common (-) test lead to the rotor lead just disconnected from the diode bridge "-" terminal.
 - a. The resistance of the main rotor windings should be indicated (approximately 4 to 12 ohms, depending on the generator rated capacity).
 - b. A reading of "infinity" indicates an open circuit condition in the main rotor.
6. Now, set the VOM to a high resistance scale, such as "Rx10,000" or "Rx1K". Zero the meter.
 - a. Connect the positive (+) VOM test lead to the main rotor lead previously disconnected from the diode bridge "+" terminal.
 - b. Connect the common (-) VOM test lead to a clean frame ground. The meter should read "infinity". Any upscale movement of the meter needle indicates a grounded condition.

RESULTS:

1. Replace the main rotor if it is open or grounded.
2. If main rotor tests good, go on to Test 12.

Test 12- Test Stator Power Windings

DISCUSSION:

The stator power winding's AC output leads are accessible in the AC connection (lower) panel. Stator windings generally have a very low resistance, in the neighborhood of about 0.1 to 1.0 ohm. Some meters will not read such a small resistance, but will simply read continuity.

PROCEDURE:

Refer to Test 9 in Section 2.4 of this manual.

RESULTS:

Remove and replace any stator assembly that is open, grounded or shorted.

Test 13- Check Voltage Regulator Lamps

DISCUSSION:

The electronic voltage regulator (Figure 8) is equipped with three advisory lamps (LED's) which can prove helpful when troubleshooting the generator set. See "Voltage Regulator" on Page 3.2-4. These lamps are normally on, will go out if the appropriate fault occurs. The lamps are identified by the words "Regulator" (red lamp); "Sensing" (yellow lamp); and "Excitation" (green lamp).

PROCEDURE:

1. Gain access to the voltage regulator, inside the generator control console.
2. Start the generator engine, let it stabilize and warm up at no-load and at rated operating speed.
3. Check the condition of the regulator lamps (LED's).
 - a. All three lamps should be ON.
 - (1) "Regulator" lamp ON indicates that the voltage regulator is operating.
 - (2) "Sensing" lamp ON indicates that sensing or actual voltage signals from the stator power windings are available to the regulator (Leads S15, S16 and 89).
 - (3) "Excitation" lamp ON indicates that stator DPE winding AC output is available to the regulator. About 4 to 8 volts AC is required from the DPE winding for regulator operation.

NOTE: The regulator lamps tend to become dimmer as their power supply decreases. For example, if sensing voltage and current start to decrease, the "sensing" lamp will become correspondingly dimmer. If the DPE winding output voltage and current decrease, the "Excitation" lamp will become correspondingly dimmer. Under some conditions it may be necessary to shade the lamps to improve visibility.

- b. If the "Excitation" lamp goes out, unregulated DPE winding AC output to the regulator has been lost.
 - (1) Without DPE winding output to the regulator, the regulator will shut down.
 - (2) When the regulator shuts down, both the "Excitation" and the "Regulator" lamps will go out.
- c. If the "Sensing" lamp goes out, loss of power winding sensing signals to the regulator has occurred.
 - (1) On loss of sensing signals, the regulator will shut down.
 - (2) With the regulator shut down, both the "Sensing" and the "Regulator" lamps will go out.
- d. If only the "Regulator" lamp is out, the regulator has probably failed.

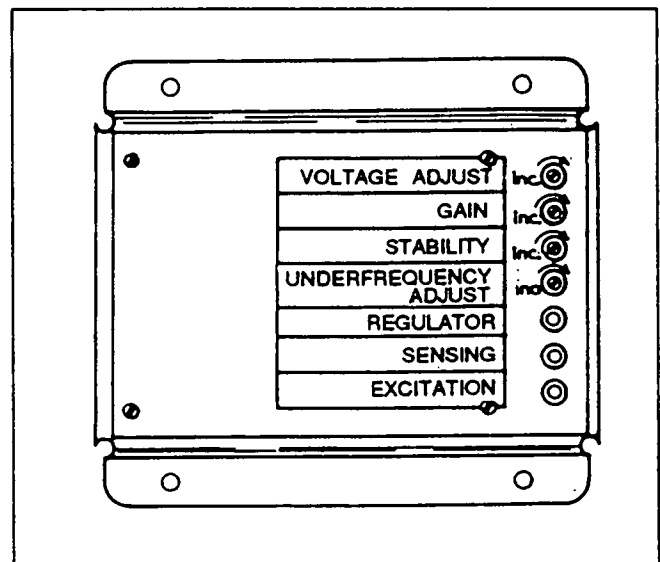


Figure 8. The Voltage Regulator

Test 13- Check Voltage Regulator Lamps (Continued)

RESULTS:

1. If the "Sensing" and "Regulator" lamps are out, go to Tests 14 and 15. The problem appears to be in the sensing circuit.
2. If the "Excitation" and the "Regulator" lamps are out, go to Test 16. The problem is probably in the DPE circuit to the regulator.
3. If only the "Regulator" lamp is out, replace the voltage regulator. Test and adjust as necessary.

Test 14- Check Regulator Sensing Circuit

DISCUSSION:

The voltage regulator receives "sensing" signals from the stator power winding output leads. These signals of "actual" voltage are compared with a "reference" voltage that has been preset in the regulator.

- If "actual" voltage is lower than "reference" voltage, regulator action will increase regulated direct current flow to the exciter field. Current from the exciter to the main rotor is then increased, and the voltage induced into the stator power windings is increased. The increase in exciter field and main rotor current will continue until the "actual" voltage matches the "reference" voltage.
- If "actual" (sensing) voltage is greater than "reference" voltage, regulator action will decrease the regulated current flow to the exciter field. The decrease in current flow will continue until sensing voltage matches the "reference" voltage.
- On loss of "sensing" voltage signals to the regulator, the "Sensing" lamp will go out. Without sensing voltage, the regulator will shut down and the "Regulator" lamp will also go out.

PROCEDURE:

1. Carefully inspect Wires S15 and S16 which connect to Pins 7 and 9 of the 15-pin connector plug. The 15-pin connector plug is accessible in the AC connection (lower) panel.
2. Inspect Wires S15 and S16 between the 15-pin connector plug and the control console's frequency meter.
3. Inspect Wire S15 between the frequency meter and the voltage regulator. Check all wire connections.
4. Inspect Wire S16 between the frequency meter and the voltage adjust potentiometer.
5. Inspect Wire 89 between the voltage adjust potentiometer and the voltage regulator.
6. Inspect the voltage regulator connector plug.

RESULTS:

1. Repair, reconnect or replace wire(s) as needed.
2. If all wires are good, but the "Sensing" and "Regulator" lamps are still out during operation, go to Test 15.

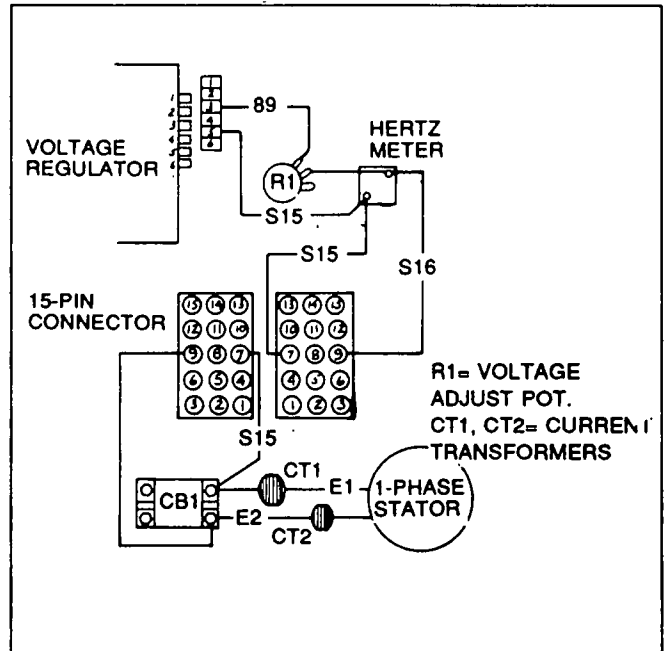


Figure 9. Voltage Regulator Sensing Circuit

Test 15- Test Voltage Adjust Pot

DISCUSSION:

The voltage adjust potentiometer is connected in series with sensing leads S16 and 89 to the voltage regulator. The device biases the sensing (actual) voltage signal to the regulator, thus allowing generator AC output voltage to be changed (within a range of approximately plus or minus 10 percent). An open condition in the potentiometer will result in loss of sensing voltage and regulator shutdown.

If a generator's AC output voltage is within plus or minus 10 percent of the unit's rated voltage, it can be adjusted to nominal rated voltage using the potentiometer. The pot is rated 10 k-ohm, 2 watts (plus or minus 10 percent).

PROCEDURE:

1. Gain access to the voltage adjust potentiometer terminal ends, inside the control console. See Figure 10.
2. Set an accurate VOM to its "Rx10" scale and zero the meter.
3. Connect the meter test leads across the potentiometer terminals to which Wires S16 and 89 attach. Then, test the potentiometer as follows:

Test 15- Test Voltage Adjust Pot (Continued)

- a. Slowly rotate the potentiometer knob clockwise and counterclockwise while observing the meter.
 - b. As the knob is turned in either direction, the resistance reading should increase or decrease smoothly. Erratic readings or dropoff to zero at any point is cause for replacement of the potentiometer.
2. Start the generator, let the engine stabilize and warm up at no-load.
- a. Set the voltage adjust pot to its centered or mid-position. Check the AC voltage reading.
 - b. Turn the pot all the way clockwise and, again, note the voltage reading.
 - c. Turn the pot all the way counterclockwise and note the voltage reading.
 - d. Calculate the percentage of voltage adjustment provided by the potentiometer. Adjustment range should be plus or minus 10 percent, or a total of 20 percent.

RESULTS:

If the voltage adjust potentiometer fails any part of the test, it should be replaced.

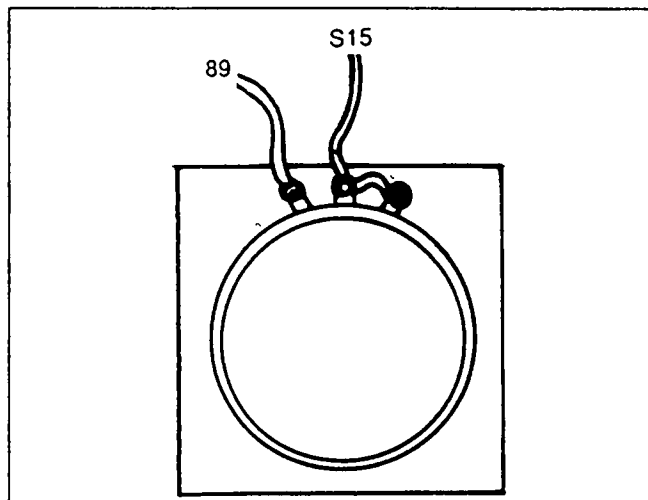


Figure 10. Voltage Adjust Potentiometer

Test 16- Test DPE Circuit Breaker**DISCUSSION:**

This circuit breaker is connected in series with the stator DPE winding output leads to the voltage regulator. The breaker will open to protect the regulator against high current output from the stator DPE (excitation) windings. It is self resetting. If the breaker is open, unregulated DPE winding output to the regulator will be

lost. Approximately 4 to 8 volts DPE output is required for regulator operation. Thus, if the breaker opens, the regulator's "Excitation" lamp will go out as well as the "Regulator" lamp.

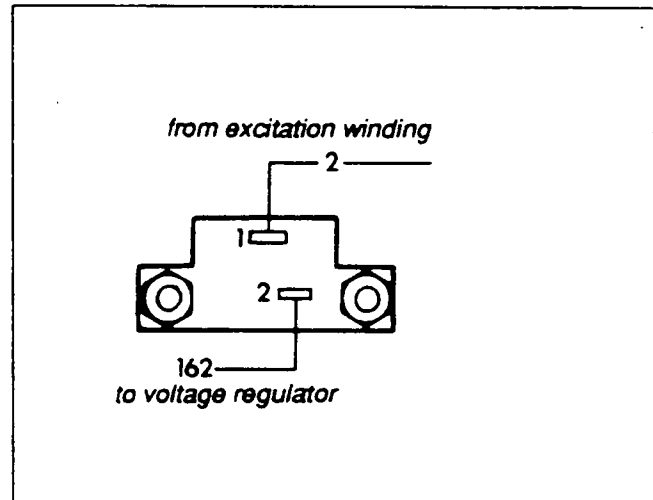


Figure 11. The DPE Circuit Breaker

PROCEDURE:

Disconnect Wires No. 2 and 162 from the circuit breaker terminals. Set a VOM to its "Rx1" scale and zero the meter. Connect the meter test leads across its two terminals. The meter should read "continuity". If the meter indicates "infinity", the breaker is open and should be replaced.

RESULTS:

1. Replace DPE breaker if defective.
2. If the breaker checks good, go on to Test 17.

Test 17- Test Thermal Protector**DISCUSSION:**

For information on the thermal protector, refer to Pages 3.2-2 and 3.2-3.

PROCEDURE:

1. In the upper part of the AC connection (lower) panel, unplug the mating halves of the 15-pin connector plug.
2. Set a VOM to its "Rx1" scale and zero the meter.
3. See Figure 12. Connect one VOM test probe to Pin 3 of the 15-pin connector (Wire No. 2 attaches to this pin).
4. Connect the remaining test probe to Pin 6 of the 15-pin connector, to which Wire No. 6 (or 6A) attaches. The meter should read excitation (DPE) winding resistance.

Test 17- Test Thermal Protector (Continued)

5. Now, connect the VOM test leads across Pin 6 of the 15-pin plug (Wire 6 or 6A) and the stripped end of Wire No. 5 in the AC connection panel. Again, the meter should indicate excitation (DPE) winding resistance (approximately 0.5 to 1 ohm).

RESULTS:

1. If a very high resistance or "infinity" is indicated in Step 4, but DPE winding resistance (about 0.5-1 ohm) is indicated in Step 5, the thermal protector has failed open and should be bypassed.
2. If DPE winding resistance is read in both Steps 4 and 5, the thermal protector is good. Go on to Test 18.

NOTE: Before replacing the stator assembly due to an incorrect resistance reading, consult the factory.

NOTE: For information on bypassing the thermal protector, see Pages 3.2-2 and 3.2-3.

Test 18- Check DPE Leads to Regulator

DISCUSSION:

All stator winding leads, including the excitation (DPE) windings, are brought out of the stator can and into the AC connection (lower) panel. See "Stator DPE Winding" on Page 3.2-2.

PROCEDURE:

See Figure 12. Carefully inspect Wires No. 2, 6 and 162 for damage, proper connections. Use a VOM to check the leads for an open or grounded condition.

RESULTS:

1. Repair, reconnect or replace any damaged, disconnected or otherwise defective wires.
2. If all DPE wires are good, go to Test 19.

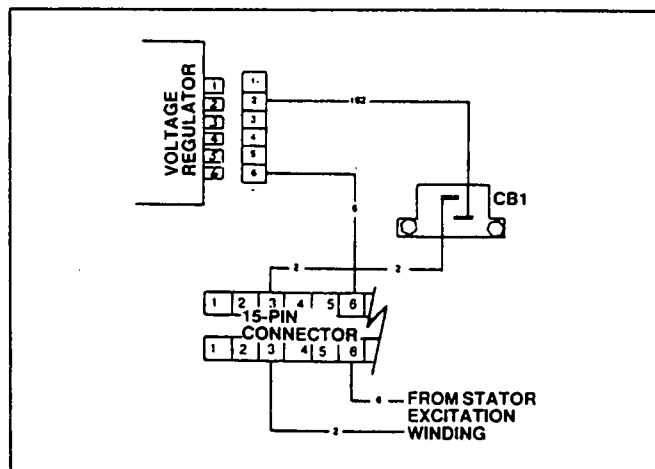


Figure 12. DPE Winding AC Output Leads

Test 19- Test Stator DPE Windings

DISCUSSION:

The stator DPE (excitation) windings were previously tested as part of the thermal protector test (Test 17).

PROCEDURE:

1. In the upper part of the AC connection (lower) panel, unplug the mating halves of the 15-pin connector plug.
2. Set a VOM to its "Rx1" scale and zero the meter.
3. Connect the VOM test probes across Pin 6 of the 15-pin connector plug (Wire No. 6 or 6A) and the stripped end of Wire No. 5. The meter should indicate DPE winding resistance (about 0.5 to 1 ohm).
4. Now, set the VOM to a high resistance scale, such as "Rx10,000" or "Rx1K". Again, zero the meter.
5. Connect one VOM test probe to the stripped end of Wire No. 5, the other test probe to a clean frame ground on the stator can.
 - a. The meter should read "infinity".
 - b. Any upscale movement of the meter needle indicates a grounded condition.

RESULTS:

1. If a high resistance or "infinity" is indicated in Step 3, replace the stator assembly.
2. If the meter reads other than "infinity" in Step 5, replace the stator assembly.
3. If the DPE winding checks good, go to Test 20.

Test 20- Check Stator AC Output Lead Connections

DISCUSSION:

Be sure to review the information in Section 1.2, "Types of Stator Connection Systems". If stator power winding output voltage is incorrect, it is possible that the power winding's AC output leads have been improperly connected. This test is especially relevant on new installations.

PROCEDURE:

In the AC connection (lower) panel, carefully inspect all bolted junctions. On 12-wire reconnectable stators, all connections must be correct for the desired voltage. If the unit is equipped with a voltage changeover board, make sure it is properly positioned for the desired phase and voltage.

RESULTS:

1. If necessary, reconnect wiring to obtain proper voltage.
2. If leads are properly connected but voltage output is bad, complete Test 12.

Test 21- Adjust Engine Governor**DISCUSSION:**

Generators with 2-pole main rotor supply a 60 Hertz AC frequency at 3600 rpm; a 50 Hertz frequency at 3000 rpm.

Units having a 4-pole main rotor deliver 60 Hertz at 1800 rpm; or 50 Hertz at 1500 rpm.

Depending on the setting of the voltage regulator's "Underfrequency Adjust" potentiometer, the AC output voltage will be more or less proportional to the AC frequency. That is, as rpm and frequency decrease, voltage output will also decrease. If both frequency and voltage are proportionally low or high, engine governed speed may be set too low or too high. This test will determine if engine governed speed is correct.

PROCEDURE:

In most cases, the frequency meter on the generator console may be used to provide an accurate frequency reading. If the console is not equipped with a frequency meter or if you suspect the frequency reading is incorrect, use an accurate external AC frequency meter to check engine speed and frequency. Connect the meter to the stator power winding output leads.

- Check frequency with the unit running at no-load. For units rated 60 Hertz, no-load frequency should be as close as possible to 62 Hertz at no-load.
- For units rated 50 Hertz, no-load frequency should be as close as possible to 51 Hertz at no-load.
- When electrical loads are applied equal to the generator's rated wattage/ampere capacity, the frequency should not drop below about 58 Hertz.

NOTE: For additional information on engine governors, refer to Sections 1.5, 1.6 and 1.7 in this manual. Governors and governor adjustment procedures will also be discussed in the appropriate Engine Service Manual.

RESULTS:

1. If frequency and voltage checks are good following governor adjustment, discontinue tests.
2. If frequency is good, but voltage is high or low, try adjusting to the correct voltage using the console's voltage adjust potentiometer.
3. If correct voltage cannot be obtained with the console's voltage adjust potentiometer, try adjusting the voltage regulator (Test 22).

Test 22- Adjust Voltage Regulator**DISCUSSION:**

See "Voltage Regulator" on Page 3.2-4.

PROCEDURE:

1. Gain access to the voltage regulator, in the generator control console.

NOTE: If a new regulator is being installed, the three (3) switches on the regulator circuit board must be set properly before installation. Refer to "Voltage Regulator Switches" in section 3.6.

2. If necessary, connect an accurate AC voltmeter and frequency meter to the generator's AC output leads.
3. On the voltage regulator, set the potentiometers as follows:
 - a. Turn the "Voltage Adjust" pot fully counterclockwise.
 - b. Set "Gain" to its centered (mid) position.
 - c. Set "Stability" to its centered (mid) position.
 - d. Do NOT adjust "Underfrequency Adjust".
4. On the control console, set the voltage adjust potentiometer to its centered (mid) position.
5. Turn OFF all electrical loads. Startup and initial adjustments will be accomplished under a "no-load" condition.
6. Start the engine, let it stabilize and warm up at no-load.
7. Check the reading on the frequency meter.
 - a. If necessary, adjust the engine governor to obtain a no-load frequency of 62 Hertz at no-load on units rated 60 Hertz.
 - b. For units rated 50 Hertz, adjust engine governor as close as possible to 51 Hertz at no-load.
8. With the unit running at its correct no-load speed and frequency, check the lamps (LED's) on the regulator. All lamps should be ON.
9. Turn the regulator's "Voltage Adjust" pot to obtain a line-to-line voltage as shown in the chart on next page.
10. If the red "Regulator" lamp is flashing, turn the "Stability" potentiometer either direction until the flashing stops.
11. Apply an electrical load and check engine speed recovery.
 - a. Adjust "Underfrequency Adjust" counterclockwise to unload the unit and reduce load voltage while the engine recovers.

Test 22- Adjust Voltage Regulator (Continued)

b. For flat regulation (no voltage decrease as frequency drops), set the "Underfrequency Adjust" pot fully clockwise (CW). Set point for this adjustment is 62 Hertz (counterclockwise) to 52 Hertz (clockwise).

c. To obtain a constant voltage reduction as frequency drops, set the "Underfrequency Adjust" pot fully counterclockwise (CCW)

12. With electrical loads still applied, check the "Regulator" lamp for flashing. If lamp is flashing, adjust the "Stability" pot until the flashing stops.

13. If better response is needed, adjust the "Gain" pot clockwise as needed. Then (if needed), correct for instability by adjusting the "Stability" pot.

14. Turn off all electrical loads and check regulator lamps at no-load.

15. When all adjustments have been completed, let the engine run at no-load for a few minutes to stabilize internal engine-generator temperatures.

16. Shut the engine down.

VOLT CODE	RATED VOLTAGE	DESIRED LINE-TO-LINE VOLTAGE
A	240 Volts	248 Volts at 62 Hertz
B	208 Volts	215 Volts at 62 Hertz
C	416 Volts	430 Volts at 62 Hertz
D	240 Volts	248 Volts at 62 Hertz
G	208 Volts	215 Volts at 62 Hertz
H	416 Volts	430 Volts at 62 Hertz
J	240 Volts	248 Volts at 62 Hertz
K	480 Volts	496 Volts at 62 Hertz
M	220 Volts	224 Volts at 51 Hertz
N	380 Volts	388 Volts at 51 Hertz
O	416 Volts	424 Volts at 51 Hertz

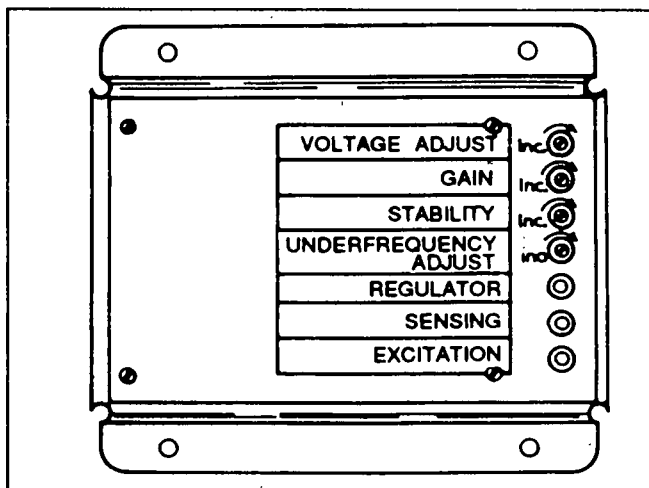


Figure 13. Voltage Regulator

RESULTS:

1. If voltage and frequency are correct, discontinue tests.
2. If voltage and frequency are incorrect, go to appropriate Problem 1, 2 or 3.

Test 23- Check For Overload

DISCUSSION:

If frequency and voltage are alright when the unit is running at no-load, but drop excessively when electrical loads are turned on, the generator may be overloaded. That is, applied loads may be greater than the unit's rated wattage/ampere capacity.

- Voltage and frequency are generally set slightly high at no-load. This helps prevent excessive rpm, frequency and voltage droop under heavy electrical loading. For example, a unit rated 60 Hertz is usually set to about 62 Hertz at no-load; units rated 50 Hertz are usually set to about 51 Hertz at no-load.
- As a general rule, AC frequency should not drop below about 58-59 Hertz at the unit's rated wattage/ampere capacity (60 Hertz units).

PROCEDURE:

The console AC ammeter can usually be used as a reliable indicator of current flow to the load. If you suspect that the ammeter is wrong or if the console does not have an AC ammeter, a clamp-on ammeter may be used to measure load current. See "Measuring Current" in Section 1.4 (Page 1.4-6). Load current should not be greater than the rated current stated on the unit's DATA PLATE.

RESULTS:

1. If load current is excessive, reduce the load by turning off non-essential loads.
2. If current flow is within the unit's rated capacity, but excessive rpm and frequency droop occurs when loads are applied, go to Test 24.

Test 24- Check Engine Power and Engine Condition

DISCUSSION:

An underpowered engine can cause excessive frequency and rpm dropoff when electrical loads are applied. In some cases, maximum generator output is limited by available engine power. Thus, if a generator's rated AC output power cannot be obtained, it is a good idea to check engine condition and power.

**Test 24- Check Engine Power and Condi-
tion**

PROCEDURE:

Refer to the appropriate Engine Service Manual. Determine why the engine has lost power and correct the problem as necessary.

Section 3.5 INSULATION RESISTANCE TESTS

General

Also see Section 1.4, "Generator Maintenance and Testing".

Insulation breakdown tests on brushless generators are similar to those on direct excited (brush type) units. However, brushless generators are equipped with several components not found on direct excited generators.

This section will provide instructions on the use of a Hi-Pot tester to test brushless generator components for insulation breakdown.

DANGER: WHEN USING A HI-POT TESTER, FOLLOW THE MANUFACTURER'S INSTRUCTIONS CAREFULLY. IMPROPER OR CARELESS USE OF SUCH TESTERS MAY RESULT IN ELECTRICAL SHOCK TO THE USER OR DAMAGE TO COMPONENTS BEING TESTED. DO NOT APPLY VOLTAGES IN EXCESS OF THE RECOMMENDED VALUES. APPLY VOLTAGE FOR A MAXIMUM TIME LIMIT OF ONE SECOND ONLY.

Testing Stator Insulation

See "Testing Stator Insulation" on Pages 1.4-2 and 1.4-3.

Testing Main Rotor Insulation

1. In the AC connection (lower) panel, locate the diode bridge (Figure 1).
2. Disconnect the main rotor leads from the diode bridge terminals indicated by a "+" and "-".
3. Turn the Hi-Pot Tester switch to "Off".
4. Connect the main rotor leads together, along with the red tester probe.
5. Connect the black tester probe to a clean frame ground.
6. Plug the tester into a 120 volts AC wall outlet.
7. Set the tester's voltage selector switch to "500 Volts".
8. Turn the tester switch to "On" and check that the tester's pilot lamp is lighted.
9. Wait one second, observe the breakdown lamp, then turn the tester switch to "Off".

If the tester breakdown lamp illuminates during the one second test, the main rotor winding should be cleaned and dried. Then, the insulation breakdown test should be repeated. If the breakdown lamp comes on during the second test (after cleaning and drying), replace the main rotor.

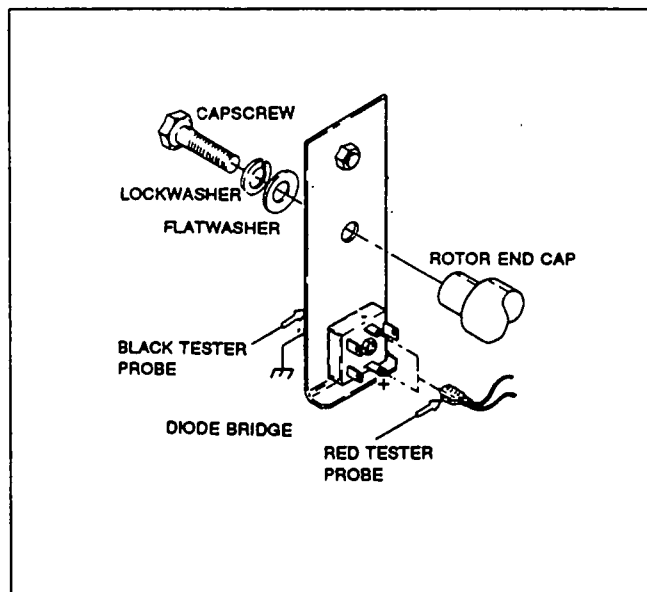


Figure 1. Testing Main Rotor Insulation

Testing Exciter Field Insulation

1. In the AC connection (lower) panel, locate the 15-pin connector plug. Disconnect the mating halves of the connector plug.
2. On the connector plug, locate male pins No. 2 and 4, to which Wires No. 1 and 4 (respectively) attach.
3. Connect male pins No. 2 and 4 (or Wires No. 1 and 4) together by means of alligator clips or other suitable means.
4. Turn the Hi-Pot Tester switch "Off".
5. Connect the red tester probe to the junction of Pins 2 and 4 (or to the junction of Wires 1 and 4).
6. Connect the black tester probe to a clean frame ground.
7. Plug the tester into a 120 volts AC wall socket.
8. Set the tester's voltage selector switch to "500 Volts".
9. Turn the tester switch "On" and check that the pilot lamp is lighted.
10. Wait one second, observe the breakdown lamp, and turn the tester switch to "Off".

Testing Exciter Field Insulation (Continued)

If, during the one second test, the tester breakdown lamp comes on, clean and dry the exciter field. Then, repeat the insulation breakdown test. If the exciter field fails the second test (after cleaning and drying), it should be replaced.

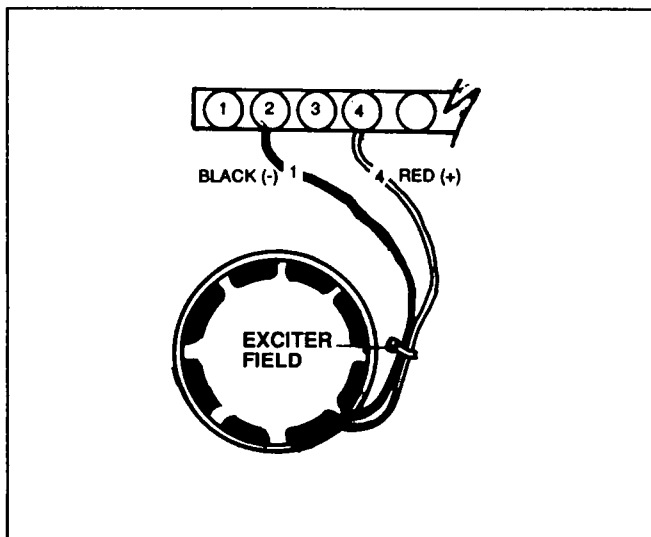


Figure 2. The Exciter Field

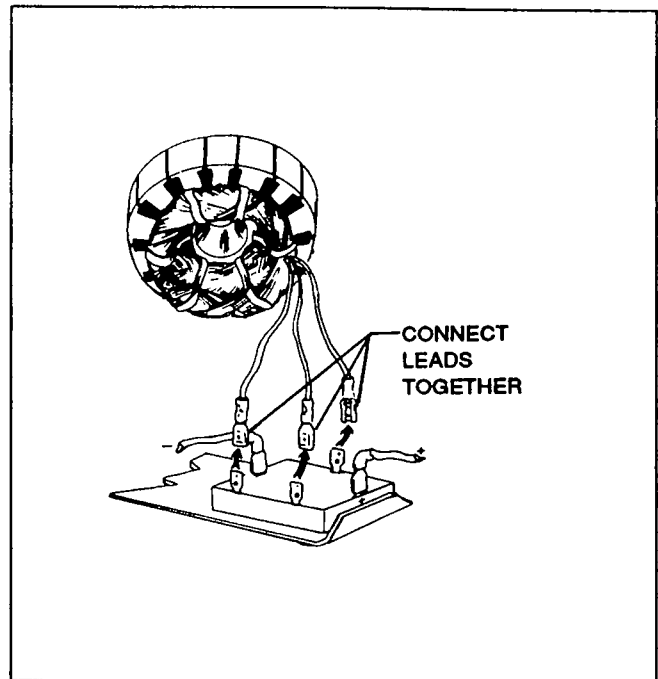


Figure 3. Testing Exciter Insulation

Testing Exciter Insulation

1. Disconnect the three exciter leads from the diode bridge terminals indicated by "AC".
2. Turn the HI-Pot Tester switch to "Off".
3. Connect the three exciter leads together, along with the red tester probe.
4. Connect the black tester probe to a clean frame ground.
5. Plug the HI-Pot Tester into a 120 volts AC wall socket.
6. Set the tester's voltage selector switch to "500 Volts".
7. Set the tester switch to "On" and check that the pilot lamp is lighted.
8. Wait one second, observe the breakdown lamp, then turn the tester switch to "Off".

If the tester breakdown lamp came on during the one second test, clean and dry the exciter. Then, repeat the breakdown test. If the exciter fails the second test (after cleaning and drying), it should be replaced.

Section 3.6

PERMANENT MAGNET GENERATORS

General

"PMG" stands for "permanent magnet generator". In a PMG unit, a permanent magnet exciter replaces the stator excitation (DPE) winding that is used in non-PMG units. That is, the permanent magnet exciter (PME) delivers unregulated excitation current to the electronic voltage regulator. The voltage regulator rectifies and regulates the current. The regulated excitation current is then delivered to the brushless field excitation system.

PMG units are exactly like any other Generac brushless generator, except that the PMG units are not equipped with a stator excitation (DPE) winding.

PMG Applicability

The PMG system is not generally used in conjunction with a brush type excitation system. It is used in conjunction with a brushless system.

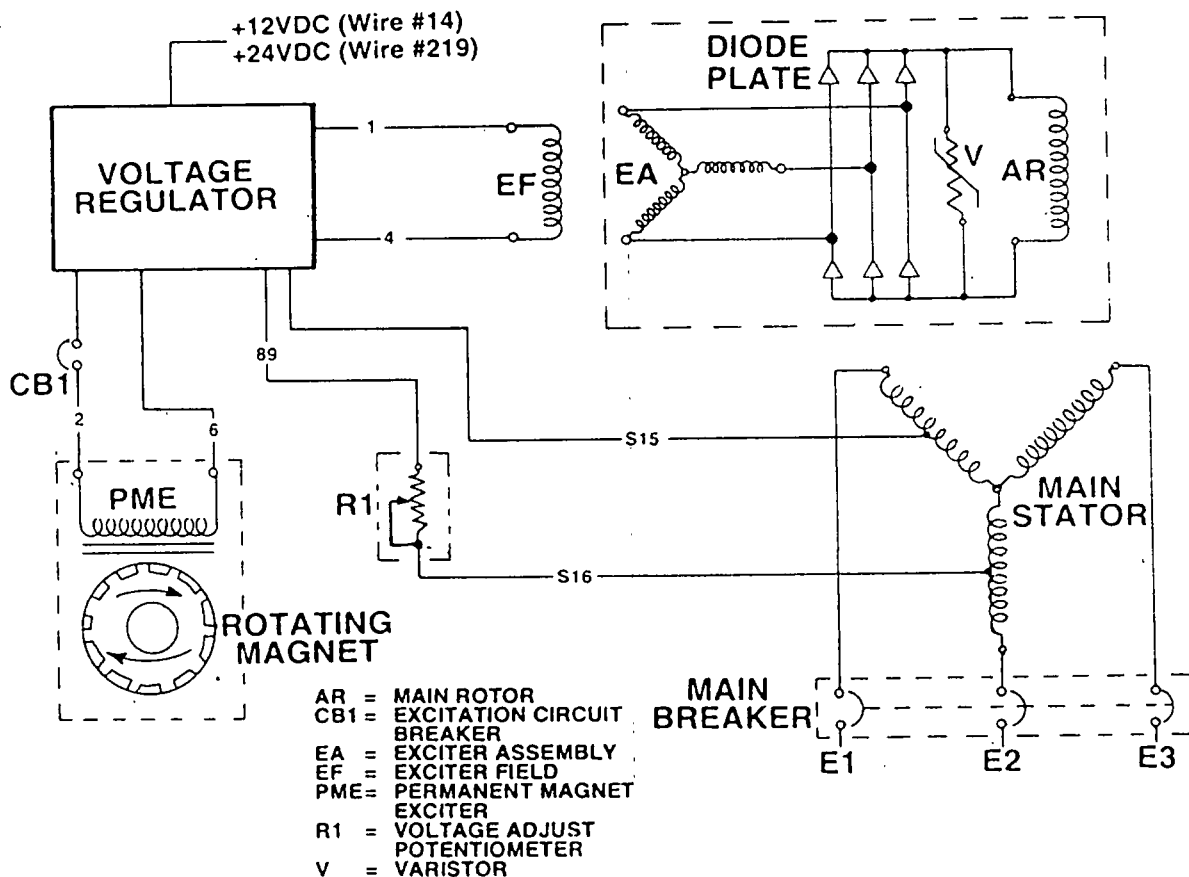
The PMG system is used on Generac generators rated 25 kW and larger. Started in 1993, PMG's were used on units rated 125 kW and larger (520mm stator laminations). In late 1996 PMG's became an option on units rated 25 kW through 100 kW. (390 mm stator laminations).

Operational Analysis

Figure 1, below is an operating diagram for Generac PMG units. Generator operation may be briefly described as follows:

1. A ROTATING MAGNET (part of the PMG) induces a voltage into the PERMANENT MAGNET EXCITER (PME). The PME output (unregulated excitation current) is delivered to the VOLTAGE REGULATOR, via Wires No. 2 and 6 and an excitation circuit breaker (CB1).
2. The VOLTAGE REGULATOR rectifies and regulates the PME excitation current and the regulated direct current is delivered across the windings of an EXCITER FIELD (EF). A magnetic field is created around the EXCITER FIELD having a magnetic field strength proportional to the regulated direct current flowing through it's windings.
3. The magnetic field of the EXCITER FIELD (EF) induces a voltage and current flow into the rotating EXCITER ASSEMBLY (EA). This alternating current flow is rectified by six (6) diodes and delivered to the generators MAIN ROTOR (AR).
4. A magnetic field is created around the MAIN ROTOR (AR) having a magnetic field strength proportional to the current flow through the MAIN ROTOR (AR) windings. This magnetic field cuts across the MAIN STATOR windings to induce a voltage into those windings that is proportional to the strength of the MAIN ROTORS (AR) magnetic field.

Figure 1. Operating Diagram- Units with PMG



Operational Analysis (Continued)

5. Voltage is available from the MAIN STATOR to customer load connections E1, E2, and E3.

6. Voltage signals are delivered to the VOLTAGE REGULATOR via "SENSING" leads S15 and S16, a VOLTAGE ADJUSTMENT POTENTIOMETER (R1), and wire #89.

7. Based on the "sensing" voltage it reads from wires S15, and S16, the VOLTAGE REGULATOR will either increase or decrease the excitation current flow it sends to the EXCITER FIELD (EF). The REGULATOR does this by electronically "comparing" the actual (sensing) voltage with a pre-set (reference) voltage.

a. If the "sensing" voltage is higher than the "reference" voltage, the REGULATOR will decrease current flow to the EXCITER FIELD (EF). This will reduce the strength of EF's magnetic field and will reduce the voltage and current delivered from the EXCITER ASSEMBLY (EA) to the MAIN ROTOR (AR). With current flow through the MAIN ROTOR windings reduced, the strength of the MAIN ROTOR's magnetic field will be reduced, and the voltage induced into the MAIN STATOR will be reduced correspondingly.

b. If "sensing" voltage is lower than the "Reference" voltage, REGULATOR action will increase current flow to the EXCITER FIELD (EF). EF's magnetic field strength will then increase, to increase the current flow delivered to the MAIN ROTOR (AR). The MAIN ROTOR magnetic field strength will then be increased and the voltage induced into the MAIN STATOR will increase correspondingly.

Short Circuit Operation

In the event of a short circuit in the generator's AC output leads, the generator should be able to deliver up to 300 percent of it's rated current for up to 30 seconds before any loss of AC output occurs. The time limit of 30 seconds should be adequate time for a downstream breaker to trip (open).

This current boost feature is provided by adding a seventh wire to the voltage regulator, as follows.

- For 12 volts DC engine electrical systems, the seventh wire will be Wire #14.
- For 24 volts DC engine electrical systems, the seventh wire will be Wire #219.

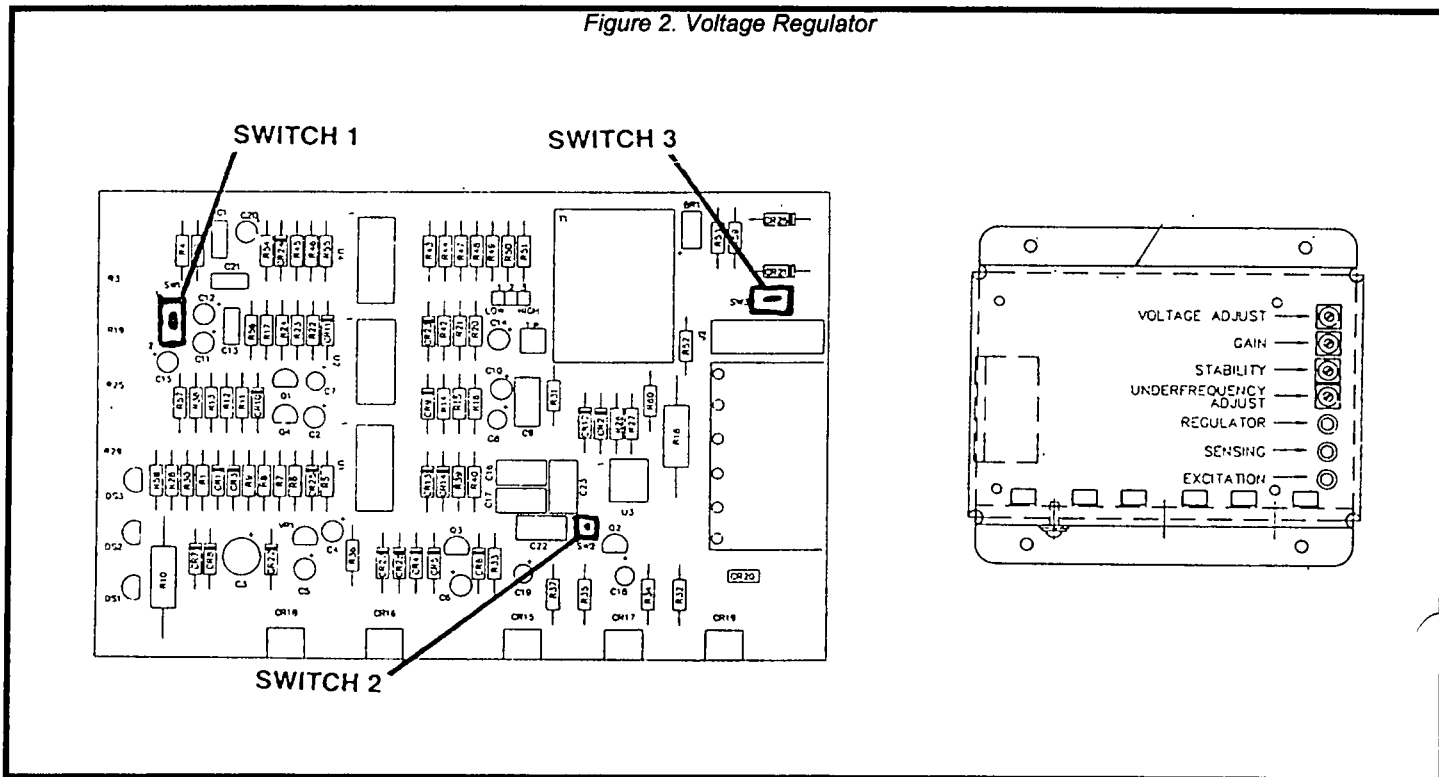
The purpose of the seventh wire is to continue firing the voltage regulator's SCR's during short circuit operation (when the AC output and "sensing" voltage decrease to zero or nearly zero). If a short circuit condition should occur without the seventh wire attached to the voltage regulator, the sensing voltage will decrease and the voltage regulator will shut down.

NOTE: With the seventh wire attached to the regulator, and SW3 on the back of the regulator turned "ON", a loss of "sensing" (wires S15 and 89) will no longer turn the regulator off. Loss of sensing signals to the regulator (such as an open voltage adjustment potentiometer, loose wire S15 / S16, etc.) would result in a "FULL FIELD" condition and a resultant high output voltage. To protect the genset and loads from damage, an overvoltage shutdown option should be installed. (See Figure 8 for schematic)

Voltage Regulator Switches

With the introduction of generac's new line of permanent magnet generators (PMG), the solid state Voltage Regulator had to be updated as well. New Voltage Regulator circuit boards now have three (3) miniature switches, identified on the board as Switch 1, Switch 2, and Switch 3. In the event that a voltage Regulator must be replaced, the technician must make sure all switches are properly positioned as follows:

Figure 2. Voltage Regulator



SWITCH 1:

- If the generator is a direct excited unit with brushes, set the switch to "1".
- For all brushless units, set the switch to "2".

SWITCH 2:

- For all standard (non-PMG) units, set this switch to "STD".
- For all PMG (permanent magnet generator) units, set the switch to "PM".

SWITCH 3:

- If a seventh wire has been attached to the Voltage Regulator, set this switch to "On". See "Short Circuit Operation" on Page 3.6-2.
- If a seventh wire has NOT been added to the Voltage Regulator, set the switch to "Off".

PMG Unit Identification

Figure 3, below, shows a typical permanent magnet generator (PMG) as it appears completely assembled.

An Exploded View of a typical PMG unit is provided on Page 3.6-4, with corresponding Parts List on Page 3.6-5.

Major PMG Components

INTRODUCTION:

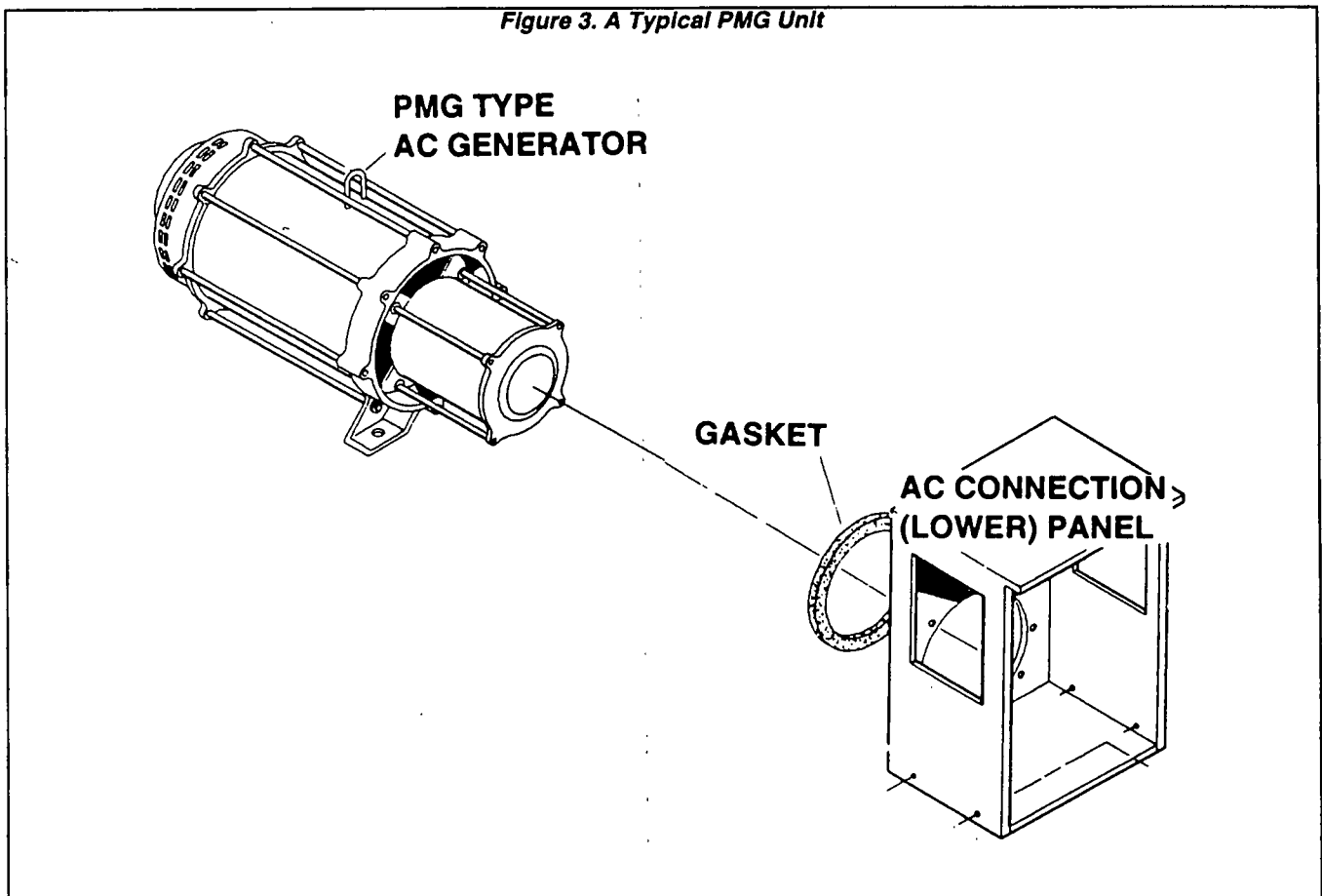
See Figure 4 and accompanying Parts List on next page. Major components of a PMG stator unit may be listed as follows:

- Flexible Coupling Plates (Item 1).
- Drive Hub and Fan (Item 2).
- Blower Housing (Item 8).
- Main Rotor Assembly (Item 5).
- Main Stator Assembly (Item 10).
- Rear Bearing Carrier (Item 12).
- Permanent Magnet Exciter (Item 18).
- Permanent Magnet (Item 19).
- Permanent Magnet Cooling Fan (Item 20).
- Exciter Field (Item 37).
- Exciter Assembly (Item 40).
- Exciter Cooling Fan (Item 41).
- Diode Plate Assembly (Item 45).

FLEXIBLE COUPLING PLATES:

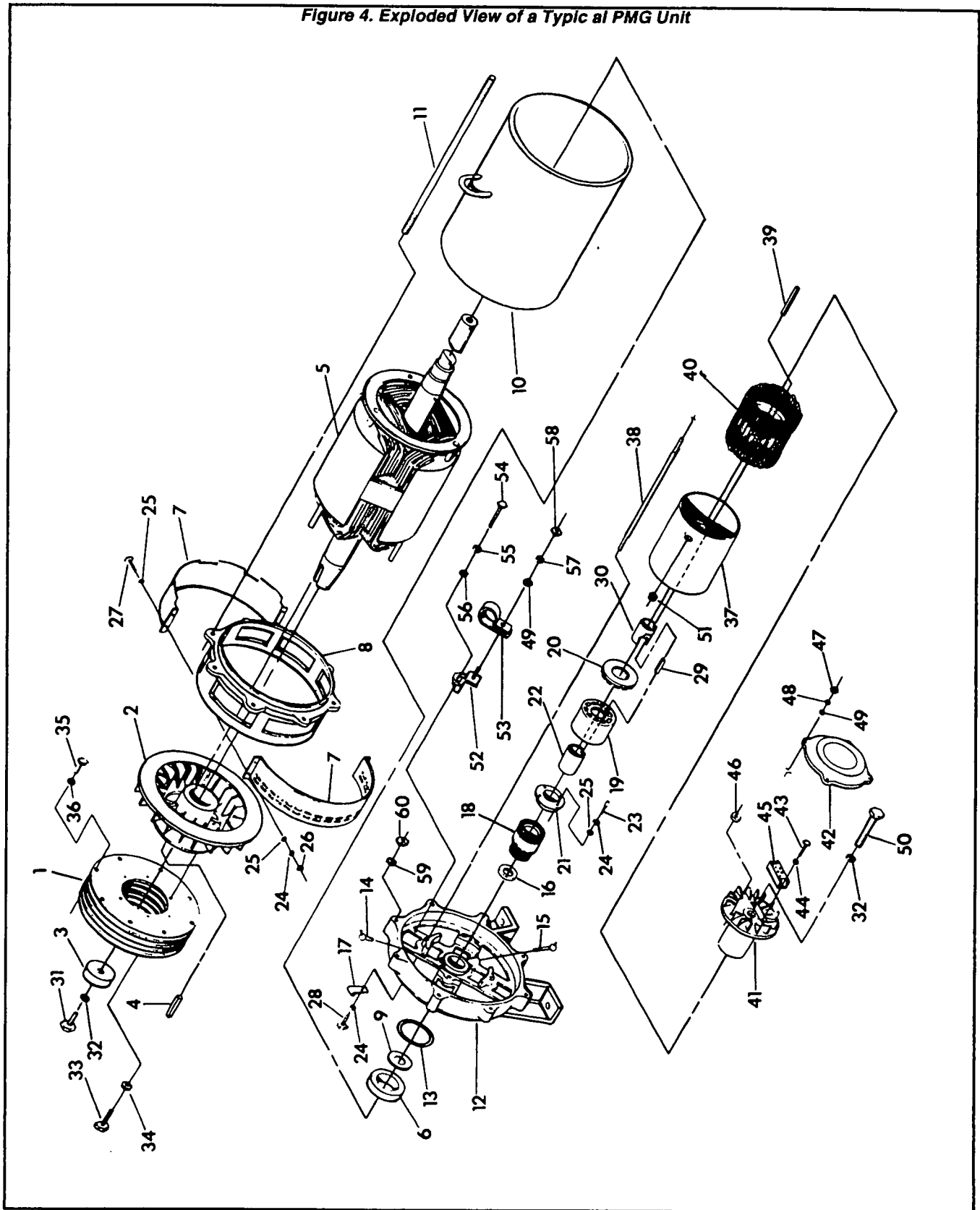
A stack of flex coupling plates is retained to the engine flywheel by eight (8) capscrews and flatwashers around the outer periphery of the plates. The plates are retained to the drive hub and fan by means of six (6) capscrews and flatwashers through the plates' inner circle of holes.

Figure 3. A Typical PMG Unit



Major PMG Components (Continued)

Figure 4. Exploded View of a Typical PMG Unit



Parts List for Figure 4		
ITEM	QTY	DESCRIPTION
1	5	Flexible Coupling Plate
2	1	Drive Hub and Fan
3	1	Hub and Fan Spacer
4	1	Square Drive Key
5	1	Main Rotor Assembly
6	1	Main Rotor Assembly Bearing
7	2	Blower Air Outlet Screen
8	1	Blower Housing
9	1	Bearing Spacer
10	1	Main Stator Assembly
11	8	Stator Stud
12	1	Rear Bearing Carrier
13	1	O-Ring Seal
14	1	Pressure Relief Fitting
15	1	Grease Fitting
16	1	Grease Seal
17	1	Cable Clamp
18	1	Permanent Magnet Exciter (PME)
19	1	Permanent Magnet
20	1	Permanent Magnet Cooling Fan
21	1	Retaining Ring
22	1	Slip Fit Collar
23	4	Socket Head Capscrew
24	9	Lockwasher
25	12	Flatwasher
26	4	Hex Nut
27	4	Hex Head Capscrew
28	1	Hex Head Capscrew
29	1	Drive Key
30	1	Slip Fit Collar
31	1	Hex Head Capscrew
32	2	Lockwasher
33	6	Hex Head Capscrew
34	6	Flatwasher
35	8	Hex Head Capscrew
36	8	Flatwasher
37	1	Exciter Field (EF)
38	4	Exciter Field Stud
39	1	Drive Key
40	1	Exciter Assembly (EA)
41	1	Exciter Cooling Fan
42	1	Exciter Rear Cover
43	2	Capscrew
44	2	Lockwasher
45	1	Diode Plate Assembly
46	1	Grommet
47	4	Hex Nut
48	4	Lockwasher
49	8	Flatwasher
50	1	Hex Head Capscrew
51	1	Grommet
52	4	Wire Support Bracket
53	4	Cable Clamp
54	4	Hex Head Capscrew
55	4	Lockwasher
56	4	Flatwasher
57	4	Lockwasher
58	4	Hex Nut
59	8	Lockwasher
60	8	Hex Nut

DRIVE HUB AND FAN:

The drive hub and fan (Item 2) is keyed to the tapered shaft of the main rotor assembly. It is also retained to the main rotor assembly by means of a hex head capscrew (Item 31), lockwasher (Item 32), and a hub and fan spacer (Item 3).

The drive sequence is apparent. The engine flywheel drives the flexible coupling plates, which drive the drive hub and fan, which drives the main rotor assembly.

BLOWER HOUSING:

The blower housing (Item 8) gets its name because it does house the drive hub and fan, often called the blower fan. Eight retaining ears are located around the outer periphery of the housing to accept one end of the main stator studs (Item 11).

MAIN ROTOR ASSEMBLY:

The main rotor assembly creates the magnetic field which induces a voltage into the main stator assembly windings. It is keyed and bolted to the drive hub and fan. It is supported at the other end in the rear bearing carrier by the main rotor bearing.

A 4-pole main rotor assembly is one that has two North magnetic poles and two South magnetic poles. Units with 4-pole main rotor will deliver an AC output frequency of 60 Hertz at 1800 rpm, or 50 Hertz at 1500 rpm.

A 2-pole main rotor has a single North magnetic pole and a single South magnetic pole. This type will deliver an AC output frequency of 60 Hertz at 3600 rpm, or 50 Hertz at 3000 rpm.

MAIN STATOR ASSEMBLY:

The main stator assembly is "sandwiched" between the blower housing (Item 8) and the rear bearing carrier (Item 12). It is retained in this sandwiched position by eight studs (Item 11).

The various winding configurations of the main stator assembly are discussed in Part 1, Section 1.2 of this Manual. Main stator AC output leads are brought out of the stator and into the AC connection (lower) panel.

REAR BEARING CARRIER:

The rear bearing carrier supports the main rotor assembly bearing. A grease fitting is provided for lubricating the bearing and a pressure relief fitting prevents excessive pressure buildup in the grease chamber.

The main stator assembly is "sandwiched" between the blower housing and the rear bearing carrier and retained in that position by the eight stator studs (Item 11).

PERMANENT MAGNET EXCITER (PME):

The stationary (non-rotating) PME delivers its excitation current to the voltage regulator via its output leads No. 2 and 6. The PME is equipped with not only an excitation winding, but with battery charge windings as well.

WINDING NAME	WIRES	RESISTANCE
Excitation	2 and 6	1.0
Battery Charge	66 & 77	0.063
Battery Charge	66A & 77A	0.063

Major PMG Components (Continued)

PERMANENT MAGNET:

The rotating permanent magnet is keyed to the rotor assembly shaft. The magnet assembly consists of two (2) rows of sixteen (16) magnets equally spaced inside a magnet housing. The magnets are attached by means of a 2-part epoxy adhesive. The finished assembly is balanced to prevent vibration.

The magnet assembly induces a voltage into the permanent magnet exciter (PME). PME output current is then delivered to the electronic voltage regulator, via Wires #2 and #6.

A cooling fan (Item 37) rotates with the permanent magnet.

EXCITER FIELD (EF):

The regulated and rectified output of the voltage regulator is delivered to the stationary exciter field, via Wires #1 (Negative) and #4 (positive). Nominal resistance of the exciter field is given below.

NOMINAL RESISTANCE AT 68° F. (20° C.)	
ACROSS LEADS	NOMINAL RESISTANCE
1 and 4	5.22 to 5.78 ohms

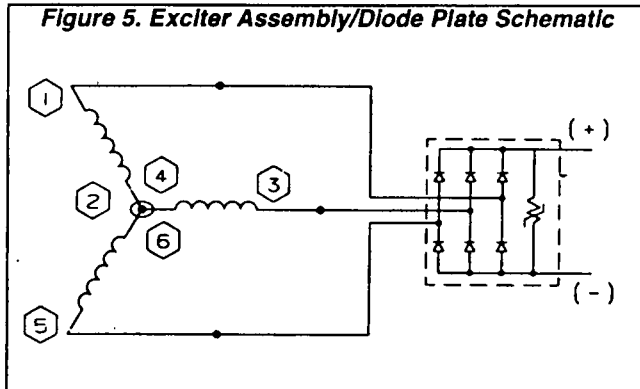
EXCITER ASSEMBLY (EA):

Regulated and rectified excitation current from the voltage regulator creates a magnetic field around the rotating exciter field (EF). This magnetic field cuts across the windings of the exciter assembly (EA) to induce a voltage into the EA windings that is proportional to the strength of the EF magnetic field.

The exciter assembly (EA) is a 3-phase, wye connected winding with three (3) leads coming out. The three (3) output leads connect to the diode plate assembly.

NOMINAL RESISTANCE AT 68° F. (20° F.)	
ACROSS LEADS	NOMINAL RESISTANCE
1 and 5	0.12 to 0.20 Ohm
1 and 3	0.12 to 0.20 Ohm
3 and 5	0.12 to 0.20 Ohm

Figure 5. Exciter Assembly/Diode Plate Schematic



DIODE PLATE ASSEMBLY:

The diode plate assembly is bolted to the exciter cooling fan and rotates with the main rotor. It consists of a bridge rectifier assembly with six (6) diodes and a varistor. The DIODES rectify the exciter assembly (EA) output current to the main rotor (AR). The VARISTOR protects the diodes against high voltage spikes.

NOTE: Varistors are unique types of resistors that present a high resistance to normal voltages and a low resistance to high voltages that might occur in a circuit. They are also called "voltage sensitive, non-linear resistors". The varistor permits normal voltages to flow through the diodes, but will shunt excessively high voltages to ground.

Figure 6. The Diode Plate Assembly

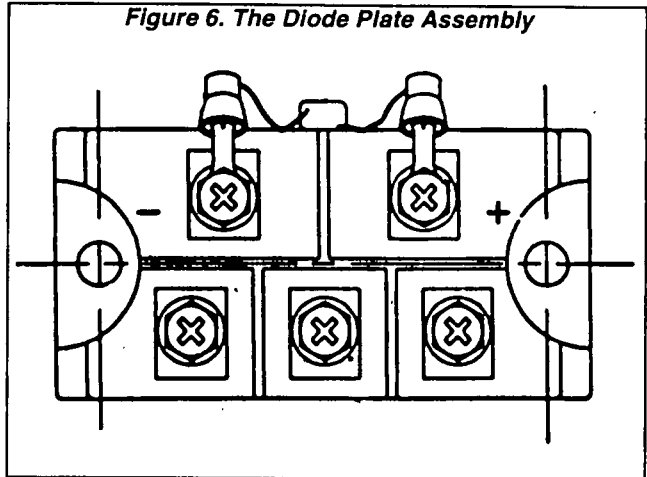


Figure 7. Diode Plate Assembly Schematic

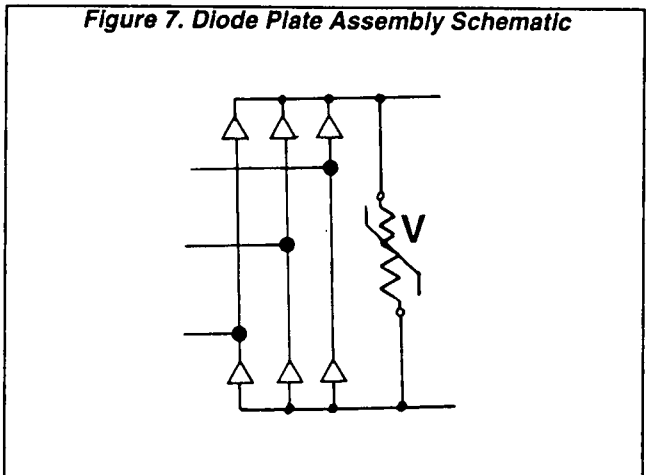
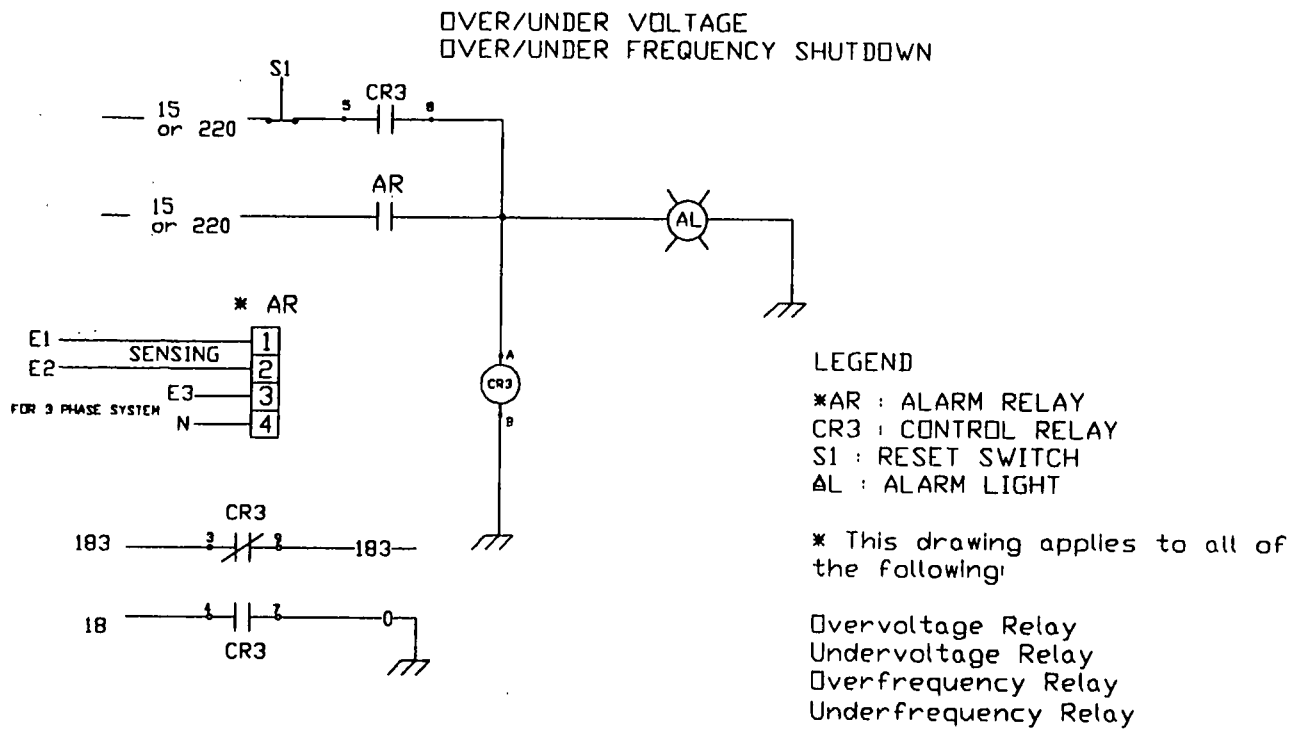


Figure 8. Schematic of Over-Voltage Shutdown



Section 3.7 TESTING PMG UNITS

Introduction

Be sure to read Section 3.6 carefully, in order to understand how PMG units work.

Operationally, PMG units are very similar to the non-PMG BRUSHLESS generators covered in Sections 3.1 through 3.5. What makes the PMG units different is that they do not have a stator excitation (DPE) winding. Instead, the PMG units are equipped with a PMG assembly.

The PMG assembly consists of a rotating permanent magnet and a permanent magnet exciter (PME). PME output current is delivered to the electronic voltage regulator as excitation current.

Troubleshooting Flow Charts

Use the "Troubleshooting Flow Charts" in Section 3.3 to analyze PMG unit problems. These charts can be applied to PMG units, with the following exceptions:

- If a test applies to the DPE or Excitation windings, test the permanent magnet exciter (PME) circuit instead.
- Short circuit operation for PMG units will be different than for non-PMG units. See "Short Circuit Operation" on Page 3.6-2.
- If sensing signals to the voltage regulator are lost on PMG units having a seventh wire attached to the regulator, a "full field" condition and high AC output voltage may result.
- When testing or troubleshooting any generator, be sure to consult the appropriate wiring diagram/electrical schematic.

Insulation Resistance Tests

INTRODUCTION:

You may wish to review "Checking Insulation Resistance" on Page 1.4-2 of this manual.

Complete insulation resistance tests on most PMG unit windings as outlined in Section 3.5.

The PMG units are equipped with a Permanent Magnet Exciter (PME), which standard brushless units do not have. The PME replaces the stator excitation (DPE) winding. Stators used on PMG units will not have an excitation (DPE) winding.

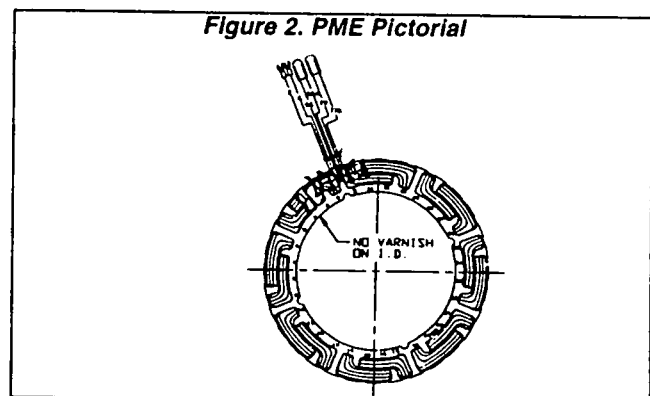
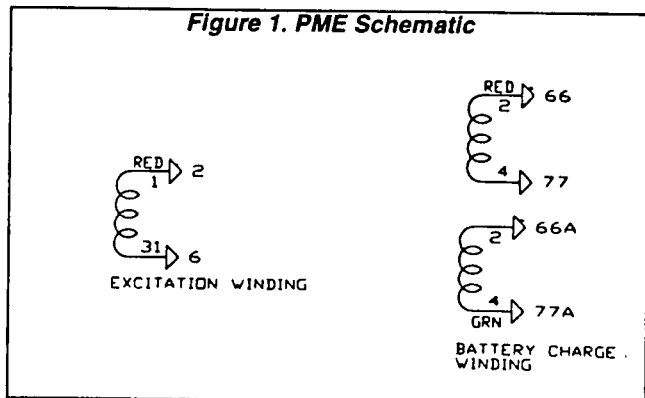
PME INSULATION RESISTANCE:

To test the insulation resistance of the permanent magnet exciter (PME) used on PMG units, use a Hi-Pot Tester. Test between (a) isolated windings, and (b) all windings to ground as follows:

1. Disconnect and isolate all PME output leads (see Figure 1).

2. Connect the terminal ends and/or stripped ends of all output leads together (Wires #2, #6, #66, #77, #66A, #77A). Make sure none of the leads are in contact with the generator frame.
3. Connect the red probe of the Hi-Pot Tester to the joined terminal ends. Connect the black Tester probe to a clean frame ground.
4. Turn the Hi-Pot Tester switch to "Off".
5. Set the Tester's voltage selector switch to "2000" volts.
6. Turn the Tester switch "On" and check that the pilot lamp is lighted.
7. Observe the breakdown lamp on the Tester, wait one (1) second, then turn the Tester switch to "Off".
8. Connect the red Tester probe to Wire #2, the black probe to Wire #66. Turn the Tester switch to "Off". Set the Tester's voltage selector switch to "1500" volts, then turn the Tester switch to "On" and check that the pilot lamp is lighted. Finally, observe the Tester breakdown lamp, wait one (1) second, and turn the Tester switch to "Off".
9. Repeat Step 8 with the red Tester probe connected to Wire #2 and the black probe attached to Wire #66A.
10. Repeat Step 8 with the red Tester probe attached to Wire #66 and the black probe to Wire #66A.

If the Tester breakdown lamp illuminates during the one second test, clean and dry the PME. After cleaning and drying, repeat the test. If the breakdown lamp comes on during the second test (after cleaning and drying), replace the PME.



PART 4
"MARATHON®"
AC
GENERATORS

STANDBY
ELECTRIC
POWER
SYSTEMS

All Series

TABLE OF CONTENTS	
SECTION	TITLE
4.1	Description and Components
4.2	Operational Analysis
4.3	Generator Lead Connections
4.4	Maintenance, Cleaning and Drying
4.5	Disassembly
4.6	Inspection
4.7	Reassembly
4.8	Troubleshooting Flow Charts
4.9	Generator Testing
4.10	Specifications

Section 4.1 DESCRIPTION AND COMPONENTS

General

At the time of this writing, "Marathon®" generators were being used on standby generators rated 100 to 350 kW (100,000-350,000 watts). Units are manufactured with cast iron end brackets and adapters, as well as fabricated steel frames. Flexible drive discs and SAE adapters are machined to SAE (Society of Automotive Engineers) standards.

An aluminum die cast main rotor core provides high mechanical integrity and low vibration at operating speeds. Amortisseur winding and coil supports are die cast as an integral part of the main rotor. Laminations are 4-pole, one-piece type which are shrunk fit and keyed to the main rotor shaft. No dovetails, cross bolts or other pole to shaft connecting devices are used.

Units are available with several adapter and drive disc arrangements. When changing flexible drive discs, spacers are required between the discs and the cast iron hub to maintain SAE standard dimensions.

The rotating portion of the generator includes (a) the main rotor, (b) cooling fan, (c) drive hub, (d) drive disc spacers, (e) a rectifier mounting hub, (f) rotating rectifier, and (g) an exciter rotor.

Voltage Regulator

A solid state electronic voltage regulator is housed in the generator control console. This is the same regulator used on Generac direct excited and brushless units.

These generators are not equipped with a stator excitation (DPE) winding. Instead, excitation current is taken from the main stator power windings. This excitation current and voltage is reduced by a step-down transformer before it is delivered to the regulator. Transformer output passes through an excitation circuit breaker, which protects the regulator against voltage surges. That breaker is self resetting and cannot be reset manually.

A sensing voltage (actual voltage signal) is delivered to the regulator from the main stator, via Wires S15 and S16. A "reference" voltage is preset into the regulator. The regulator regulates excitation current flow to an exciter stator in order to maintain a sensing voltage that is the same as the reference voltage.

"Marathon®" units are not equipped with field boost. A voltage is induced into the main stator windings as the result of excitation current and residual magnetism only.

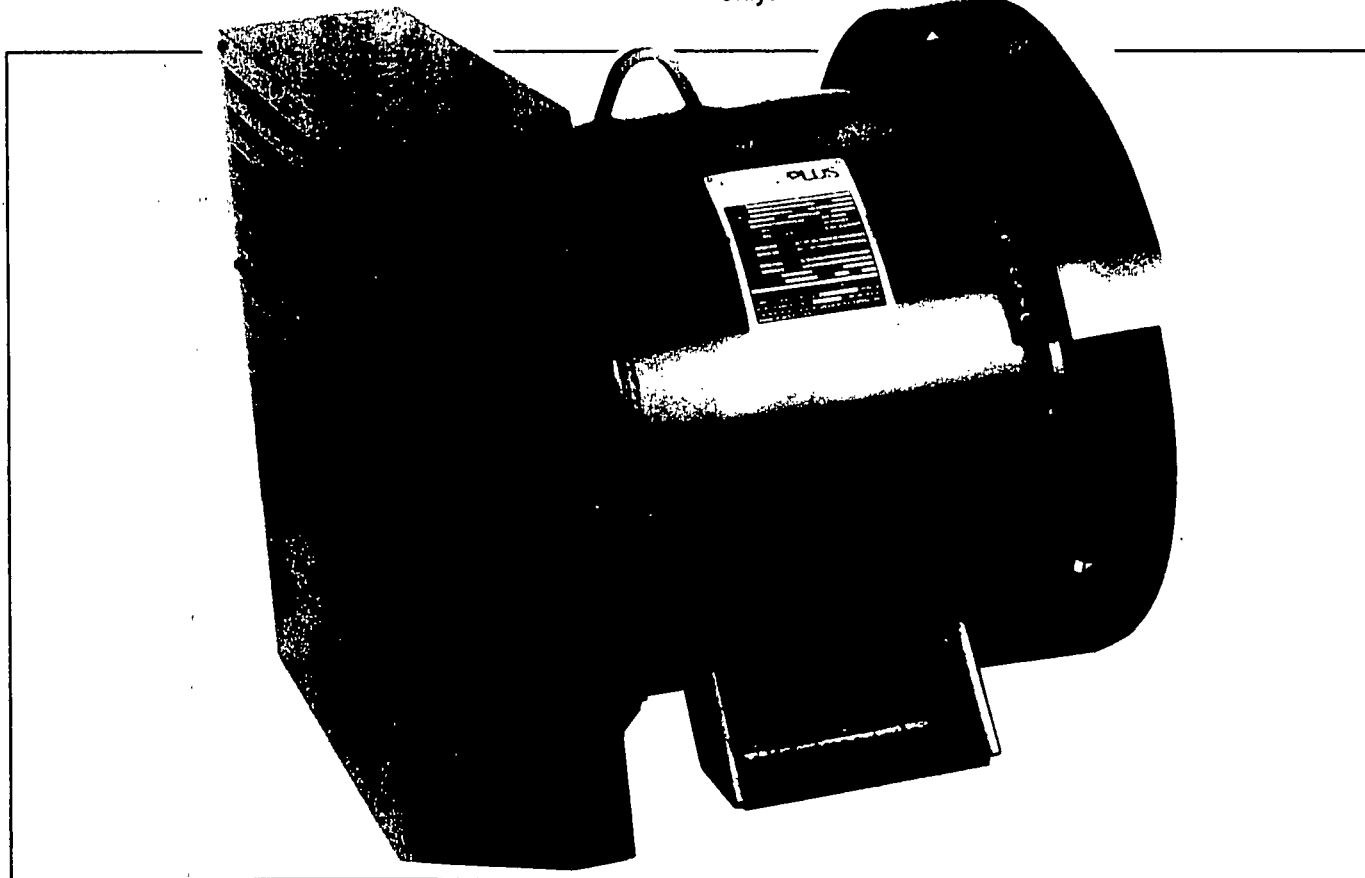


Figure 1. A Typical "Marathon" Generator ("MagnaPlus™" Shown)

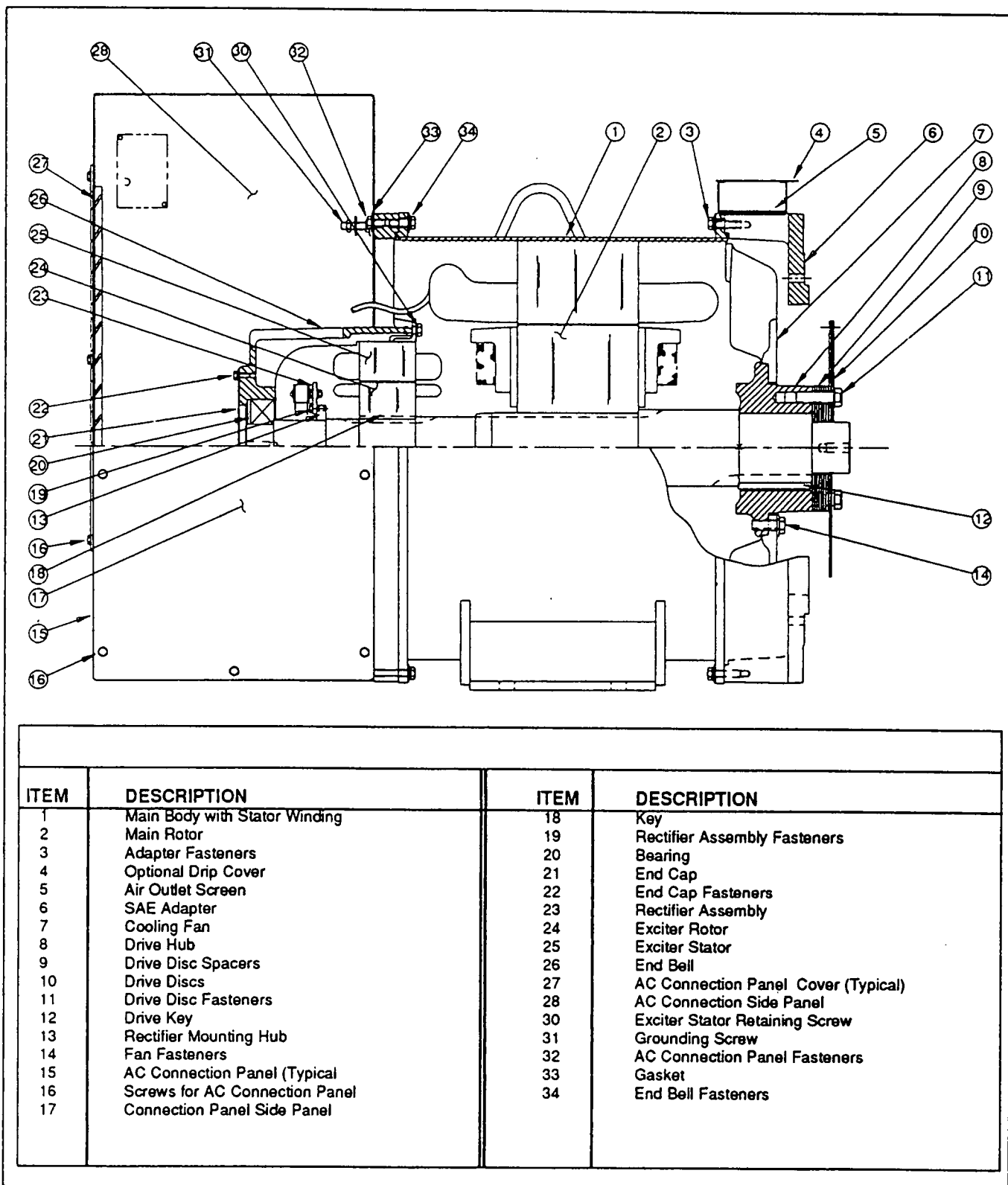


Figure 2. Sectional View of "Marathon®" Generator (Typical)

Section 4.2 OPERATIONAL ANALYSIS

General

"Marathon®" generators are similar to other brushless units in that all utilize the principles of electromagnetic induction to produce electricity. However, the following differences should be noted:

- All "Marathon®" models are equipped with a 3-phase stator assembly which can be connected in a variety of ways to deliver the desired voltage and phase output.
- "Marathon®" units do not have a separate stator excitation (DPE) winding. Instead, unregulated excitation current is delivered to the voltage regulator from the main stator's AC power windings.
- A step-down transformer is used on "Marathon®" generators, to reduce the excitation voltage before it reaches the voltage regulator.
- "Marathon®" generators do not use the field boost feature that is used on Generac direct excited and brushless units.

Operation

See Figure 1, below. Operation of the generator set may be briefly described as follows:

1. The ROTATING PORTION of the generator is attached to and rotates with the driving engine.
2. Some residual magnetism is always present in the MAIN ROTOR windings.
3. As the MAIN ROTOR turns, its magnetic field cuts across the MAIN STATOR windings, to induce a voltage into the MAIN STATOR.
 - a. If MAIN STATOR leads E1, E2, E3 are connected to an electrical load to complete the circuit, current will flow through the circuit and to the load.
 - b. The "sensing" circuit (S15, S16) is completed from the MAIN STATOR and through the VOLTAGE REGULATOR, to tell the REGULATOR what the actual voltage is.
 - c. An "excitation" circuit is completed to the VOLTAGE REGULATOR, via a step-down TRANSFORMER and an EXCITATION CIRCUIT BREAKER. Unregulated excitation current from the MAIN STATOR flows through this circuit and to the REGULATOR.
4. The VOLTAGE REGULATOR rectifies the excitation current and, based on the "sensing" voltage of S15 and S16, delivers a regulated excitation current to an EXCITER STATOR.
 - a. The REGULATOR compares a preset "reference" voltage with the "sensing" (actual) voltage.

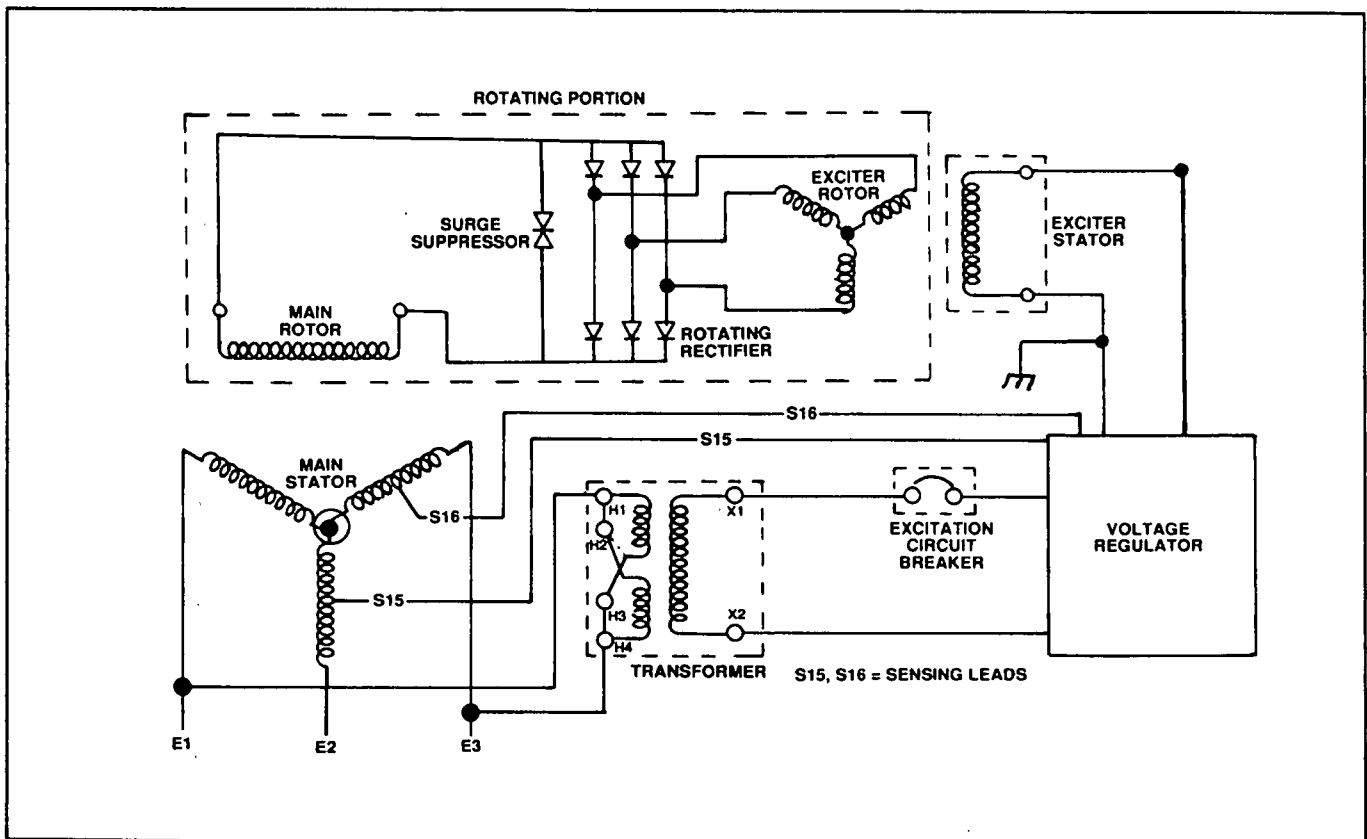


Figure 1. "Marathon®" Generators Operating Diagram (Typical)

Operation (Continued)

- b. If the "sensing" voltage is less than the "reference" voltage, the REGULATOR increases excitation current flow to the EXCITER STATOR.
 - c. If "sensing" voltage is greater than "reference" voltage, the REGULATOR reduces excitation current to the EXCITER STATOR.
5. Current flow through the EXCITER STATOR creates a magnetic field having a strength or concentration that is proportional to the current flow.
 6. The magnetic field around the EXCITER STATOR induces a voltage and current flow into the EXCITER ROTOR that is proportional to the magnetic field strength.
 7. A ROTATING RECTIFIER changes the alternating current of the EXCITER ROTOR to direct current.
 8. The direct current (DC) output is delivered through the MAIN ROTOR windings, to create a magnetic field around those windings that is proportional to the current flow through the windings.
 9. The MAIN ROTOR's magnetic field cuts across the MAIN STATOR WINDINGS, to induce a voltage into those windings that is proportional to the strength of the MAIN ROTOR's magnetic field.
 10. MAIN STATOR voltage continues to build until the "sensing" voltage (S15, S16) is equal to the "reference" voltage that is preset into the REGULATOR.

Section 4.3 GENERATOR LEAD CONNECTIONS

Introduction

The AC connection (lower) panel is also called a "conduit box". Panel construction permits conduit to enter at almost any location.

To minimize the transmission of vibration, use flexible conduit between any rigid conduit and the standby generator.

Refer to the connection diagram supplied with the generator and/or the correct diagram shown in this section. Wiring and wiring connections must be in

stalled in strict compliance with applicable electrical codes. The following rules apply:

- Clean all contact surfaces to assure good electrical bonding with generator lugs or bus bars.
- A main line circuit breaker may or may not be included in the AC connection (lower) panel. In most cases, where a circuit breaker is included, external wiring may be connected to the breaker.
- Make sure the generator frame and all other components in the standby system are properly grounded, in accordance with local regulations.

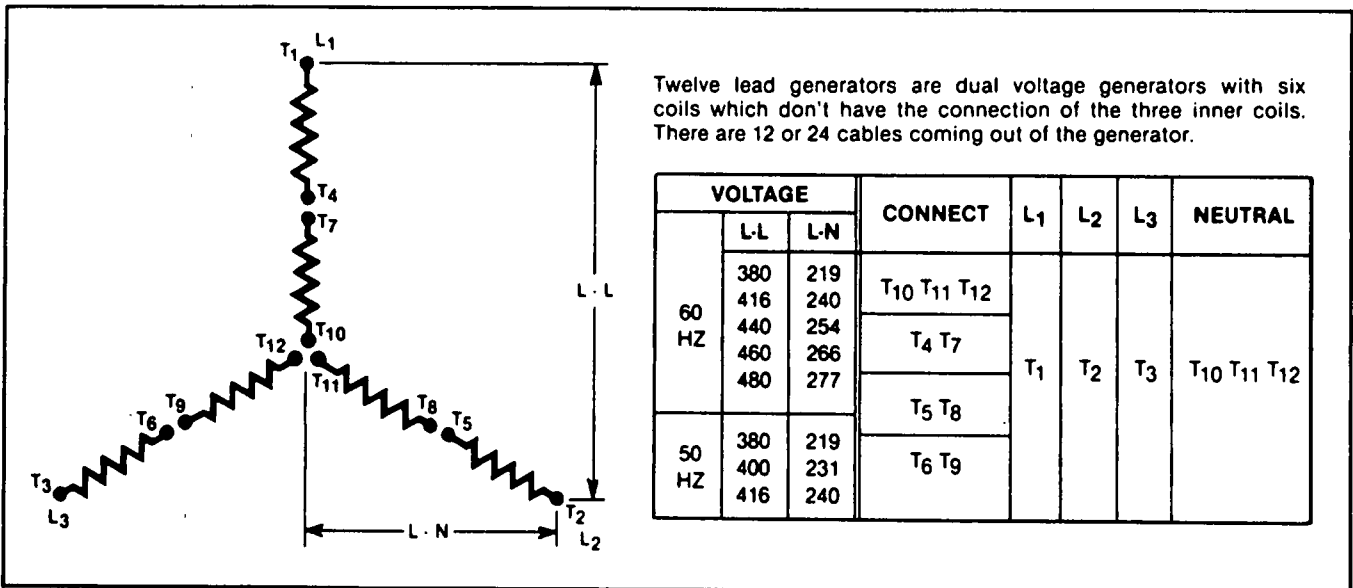


Figure 1. The 12-Lead Hi Wye Connection System

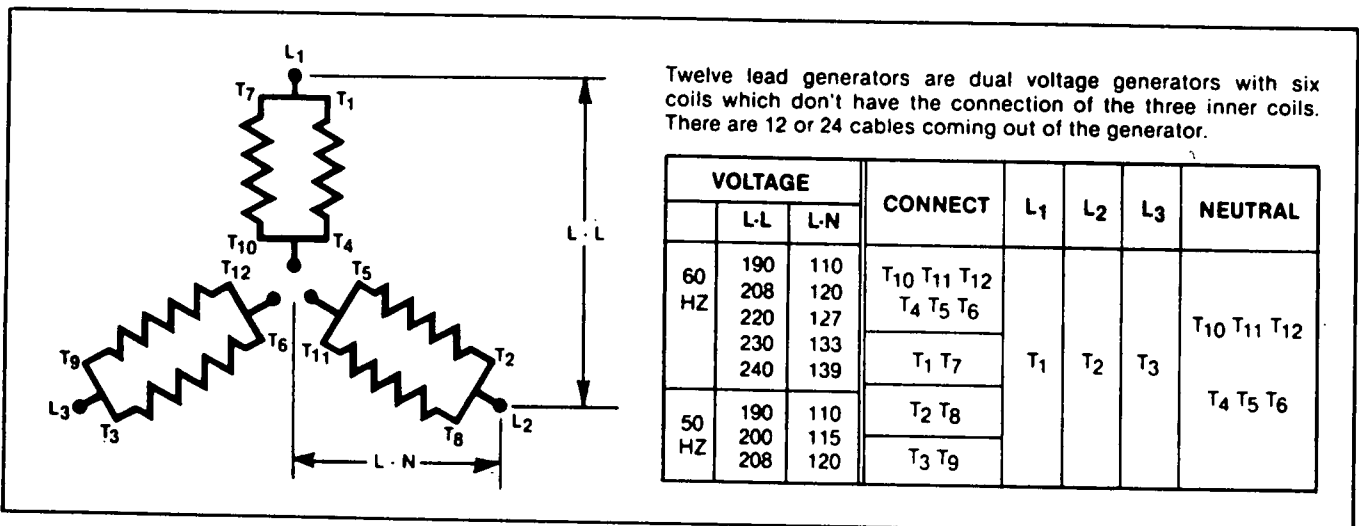


Figure 2. The 12 Lead Low Wye Connection System

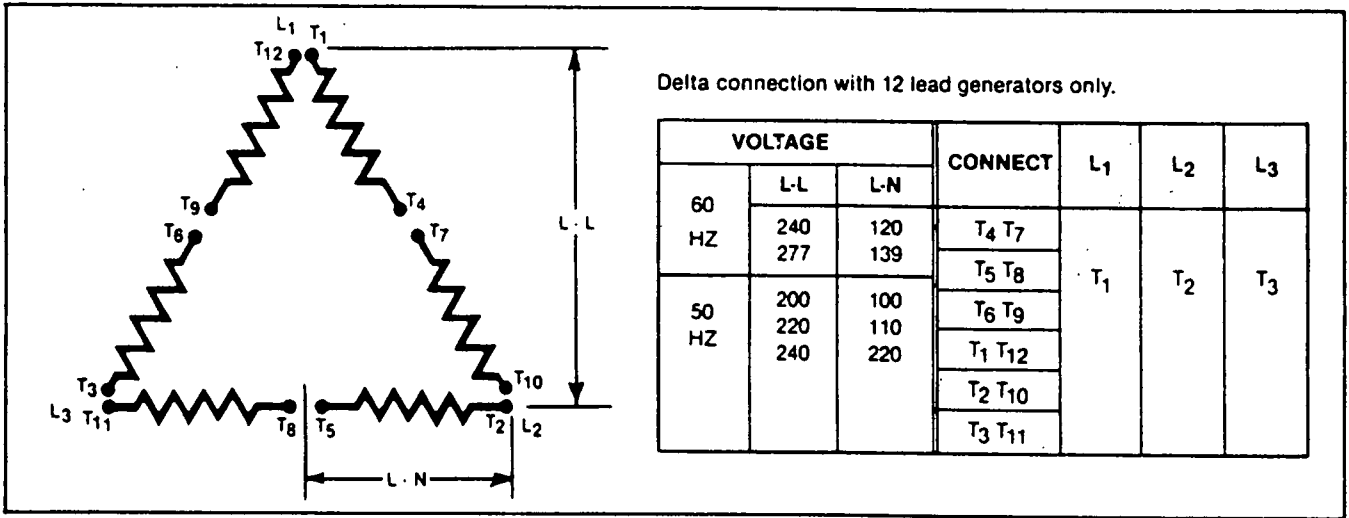


Figure 3. The 12 Lead Hi-Delta Connection System

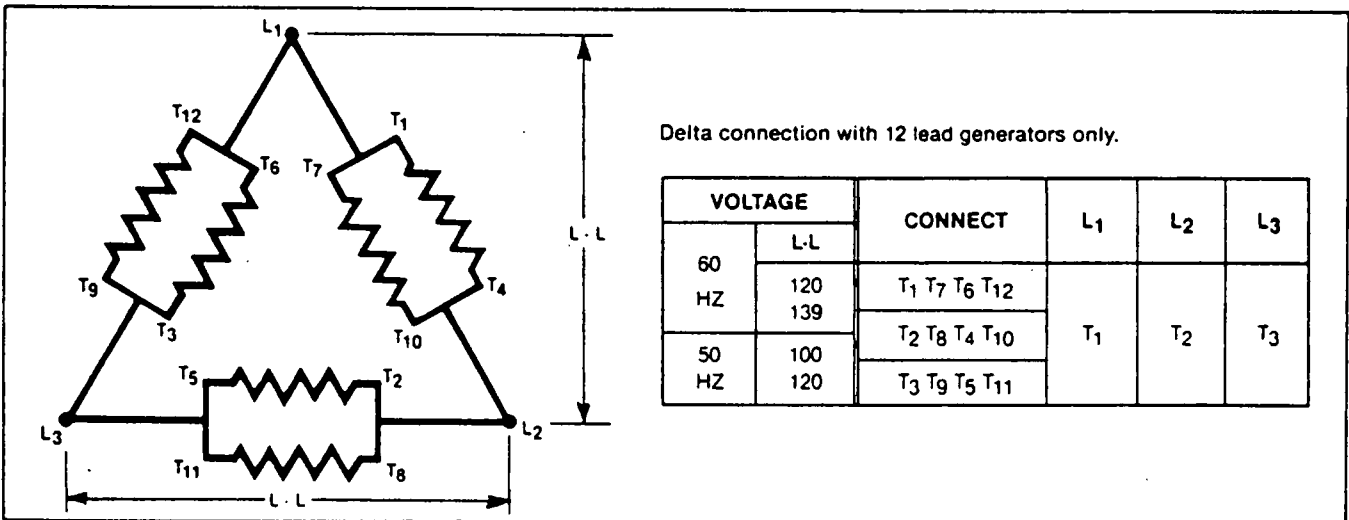


Figure 4. The 12 Lead Low-Delta Connection System

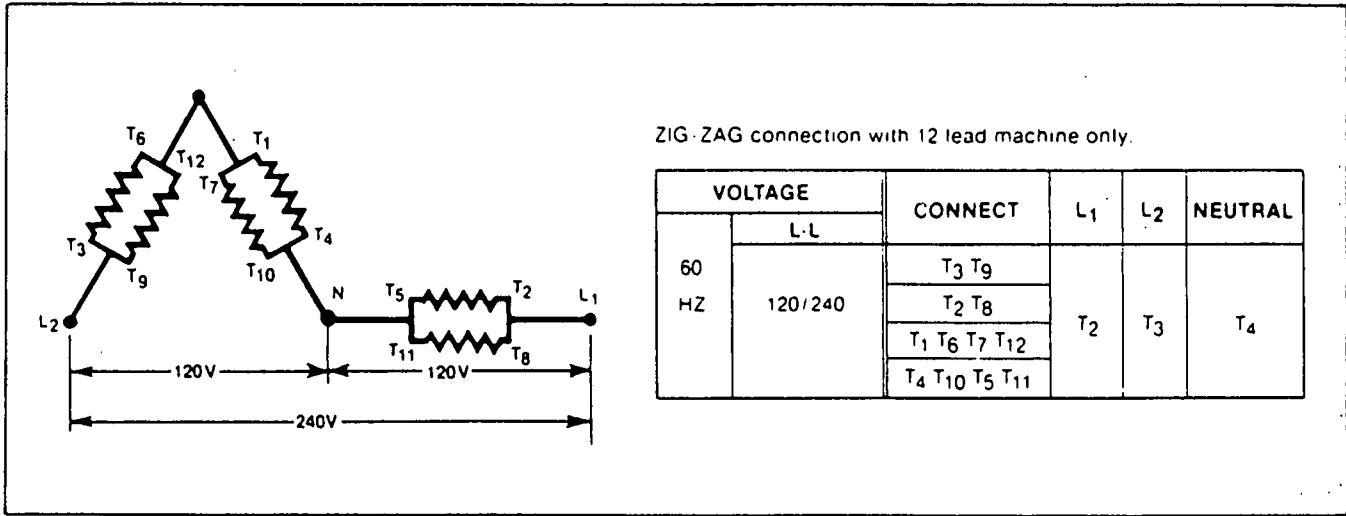


Figure 5. The 12 Lead Zig Zag Connection System

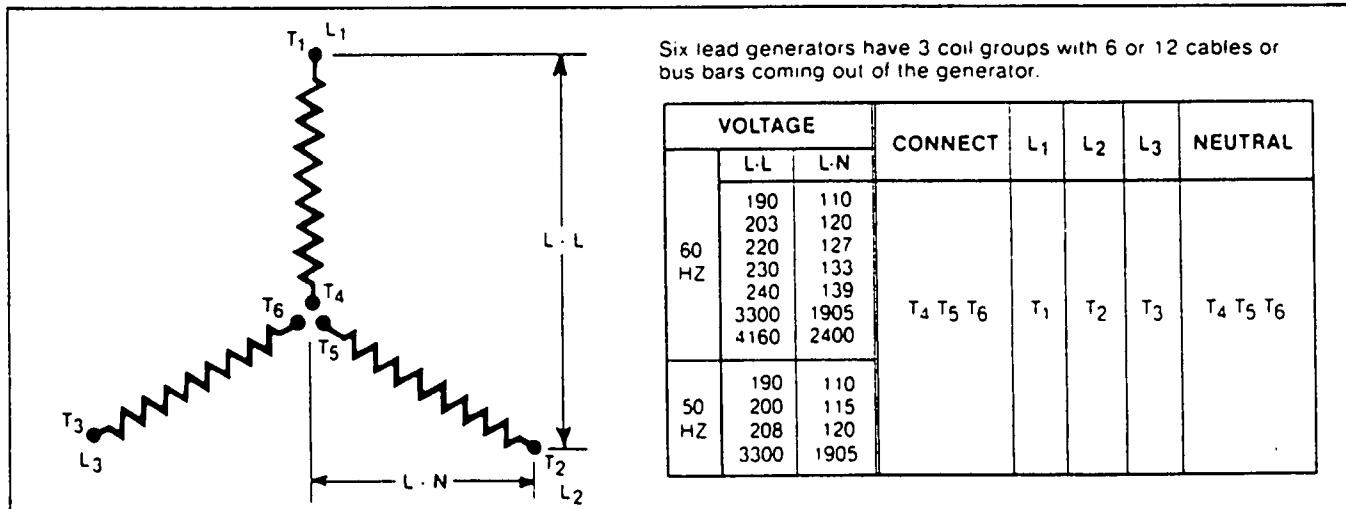


Figure 6. The 6 Lead Wye Connected System

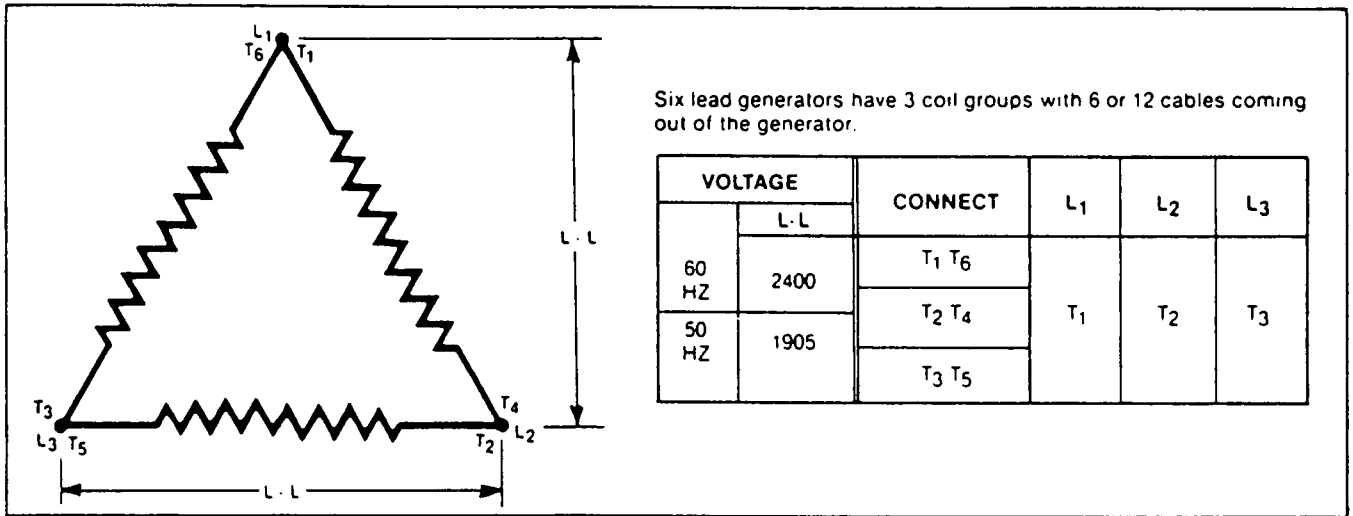


Figure 7. The 6 Lead Delta Connected System

Section 4.4 MAINTENANCE, CLEANING AND DRYING

General

Dirt, heat, moisture and vibration are common enemies of the generator.

- Keep the generator clean and dry.
- Maintain proper alignment of the generator and engine.
- Prevent overloads.
- If the generator is installed outdoors, protect it from the elements by means of suitable shelters or enclosures.

Dirt and dust will conduct electricity between points of different electrical potential. Moisture will worsen the problem. Failure of the insulation system can result if dust, dirt and moisture are allowed to accumulate on generator windings. The condition of the insulation system can be tested by measuring insulation resistance (see Section 4.9, "Generator Testing").

Insulation resistance should be checked (a) when placing the generator into service, (b) after it has been in storage, and (c) if moisture and dirt contamination is suspected. Normally, moisture buildup does not become a problem when the unit is running since heat produced internally will keep it dry. However, moisture can become a problem when the unit is shut down. The problem will worsen in humid environments or in areas where extreme temperature changes cause condensation to form on windings. Space heaters, air filters and premium insulation systems should be considered in difficult environments.

Accumulations of dust and dirt contribute to insulation breakdown and can also increase internal temperatures by restricting ventilation and blocking the dissipation of heat. If a generator is exposed to such materials as talc, lint, rock dust, cement dust, etc., ventilation may become obstructed. The most harmful foreign materials include carbon black, metallic dust, metallic chips, and similar substances. Such materials will impede ventilation and form a conductive film over the insulation, thus increasing the possibility of insulation failure. Generators that are operated in dusty or dirty areas should be disassembled and cleaned periodically.

Drying Electrical Insulation

If tests of insulation resistance indicate that such resistance is below a safe value, electrical components must be dried. The following methods may be used to dry generator components.

SPACER HEATERS:

Electric space heaters can be installed in the generator. When energized, from a power source other than the generator, they will heat and dry the generator interior. If an alternate source of electricity is not available, enclose the generator with a covering and insert

heating units to raise the temperature 15°-18° F. (8°-10° C.) above the temperature outside the enclosure. Leave a hole at top of the enclosure to allow moisture to escape.

OVEN:

Place the generator inside an oven and bake it at a temperature not to exceed 194° F. (90° C.). The voltage regulator and any electronic components or accessories must be removed from the unit when using this method.

FORCED AIR:

If desired, a portable forced air heater may be used to direct heat into the generator air inlet openings. Run the generator at no-load and without excitation. Removal of excitation can be accomplished by unplugging the voltage regulator. Heat at any point of entry should not exceed 150° F. (66° C.).

SHORT CIRCUIT METHOD:

The generator can be dried quickly and thoroughly using this method.

DANGER: ALL OF THE FOLLOWING STEPS MUST BE PERFORMED. ALL NECESSARY PRECAUTIONS MUST BE TAKEN. FAILURE TO COMPLY STRICTLY WITH INSTRUCTIONS CAN RESULT IN PERSONAL INJURY AND/OR DAMAGE TO THE GENERATOR.

1. Disconnect leads 1 and 4, between the voltage regulator and exciter stator.
2. Connect a battery or other DC power source of approximately 20-35 volts to exciter stator leads 1 and 4. An adjustable voltage source is desirable. However, a rheostat rated about 2 amps and connected in series with the DC power source will work.
3. Short circuit the generator AC output leads to each other (E1 to E2 to E3). If using jumpers, make sure they are large enough to carry full load current (amperes).
4. Start the generator and measure current flow through the generator's AC output leads with a clamp-on ammeter.
5. Adjust the voltage source to produce approximately 80% of the rated nameplate current. In no case should nameplate amperage be exceeded. If an adjustable source of voltage is not available and current is excessive, use a lower DC source voltage or a larger resistor in series with the source.

NOTE: Running time will vary depending on the amount of moisture present in the unit. Test insulation resistance every one to four hours until a fairly constant value is obtained.

Drying Electrical Insulation (Continued)

6. When the generator is dry and insulation resistance is within limits, remove the short circuit from the line leads, disconnect the DC voltage source, and reconnect leads 1 and 4 to the exciter stator. Make sure all connections are tight and correct before attempting to operate the generator.

Cleaning Methods

A number of acceptable methods for cleaning the generator are available. Each method will require that the unit be disassembled. The cleaning method used will be determined by the kind of dirt and when the unit must be returned to service. After cleaning, drying is required.

When the generator is disassembled, inspect the windings and clean the insulation. Verify that windings are connected properly, that insulation is in good condition, and that varnish coverage is adequate. Check winding ties and coil supports. Look for signs of coil movement or looseness, repair as required.

An electric motor repair shop in your area can assist you with proper cleaning of generator windings. Such shops may be experienced in special problems (such as sea coast, marine, oil rig, mining, etc.) that are peculiar to a certain area.

SOLVENTS:

A solvent is usually required to remove accumulated soil containing oil or grease. Only petroleum distillates should be used to clean electrical components. Petroleum solvents of the safety type and with a flash point greater than 100° F. (38° C.) are recommended.

CAUTION: Winding varnishes are epoxy or polyester based. Use only solvents that will not attack such materials.

DANGER: WHEN USING SOLVENTS, PROVIDE ADEQUATE VENTILATION. FIRE, EXPLOSION AND HEALTH HAZARDS ARE PRESENT. AVOID BREATHING SOLVENT VAPORS. WEAR EYE PROTECTION. WEAR RUBBER GLOVES OR OTHER SUITABLE PROTECTION FOR THE HANDS.

Apply solvent with a soft brush or cloth. Use care to avoid damage to magnet wire or insulation on the windings. After cleaning, dry all components thoroughly with moisture-free, low pressure compressed air.

CLOTH AND COMPRESSED AIR:

Use of a dry cloth may be satisfactory when cleaning small components, when surfaces are accessible, and when only dry dirt is to be removed. Where dirt cannot be reached with a cloth, blow dirt out with clean, dry air at 20 psi (206 KPA).

BRUSHING AND VACUUM CLEANING:

Dry dust and dirt can be removed with bristle brushes, followed by vacuum cleaning. Do NOT use wire brushes.

SHELL BLASTING:

Removal of hard dirt deposits from insulation can be accomplished by air blasting with ground nut shells. Use mild abrasives, such as 12-20 mesh ground walnut shells.

STEAM CLEANING:

Steam cleaning can be used, providing the generator is completely disassembled (including bearings and electronic components). However, all windings must be thoroughly dried in an oven after cleaning. All moisture must be removed before the unit is placed into service.

Section 4.5 DISASSEMBLY

Removal of Generator From Engine

DANGER: MAKE SURE ALL POWER IS TURNED OFF BEFORE SERVICING. FAILURE TO COMPLY WITH ALL SAFETY INSTRUCTIONS CAN RESULT IN SERIOUS PERSONAL INJURY OR DEATH.

NOTE: Before disconnecting electrical wiring, mark it so it can be identified for reinstallation.

1. Remove cover(s) from AC connection (lower) panel or from conduit box.
2. Disconnect all external wiring from the generator set.
3. Remove all conduit or ducting from the AC connection (lower) panel.
4. Attach a suitable hoist to the generator's lifting lugs.
5. Remove bolts that retain the screen assembly to the SAE adapter. Then, remove the screen. See Figure 1.

DANGER: DO NOT APPLY ANY FORCE TO THE GENERATOR FAN FOR LIFTING OR ROTATING THE GENERATOR ROTOR. IF THIS INSTRUCTION IS DISREGARDED, PERSONAL INJURY OR DAMAGE TO EQUIPMENT MAY RESULT.

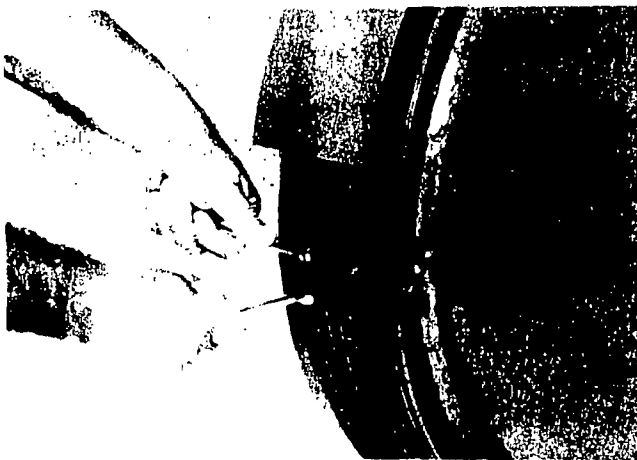


Figure 1. Removal of Screen Assembly

Remove the bolts that retain the drive discs to the engine flywheel. Also remove the capscrews that retain the SAE adapter to the flywheel housing.

6. Remove the mounting bolts that retain the generator to the base. For easier reassembly, note the position of and save any shims that were used under the feet for alignment.

7. Raise the generator slightly and move the unit away from the engine. Raise or lower the generator, to remove pressure from the drive discs and allow them to slide easily out of the flywheel.

NOTE: If the generator is to be shipped, the rotor must be properly supported. See "Shipping Instructions" below.

Shipping Instructions

Installed rotors are supported at their drive end by drive discs which are bolted to the engine flywheel. When the generator is removed from the engine, the rotor must be supported by an appropriate fixture. If the rotor is not properly supported, damage to the main rotor, main stator or exciter may result.

Shipping and handling will be simplified if the generator is fastened to a suitable skid that will permit handling by a forklift. The skid should extend beyond the generator in all directions.

Overseas shipping may require special export crating. Check with your freight carrier.

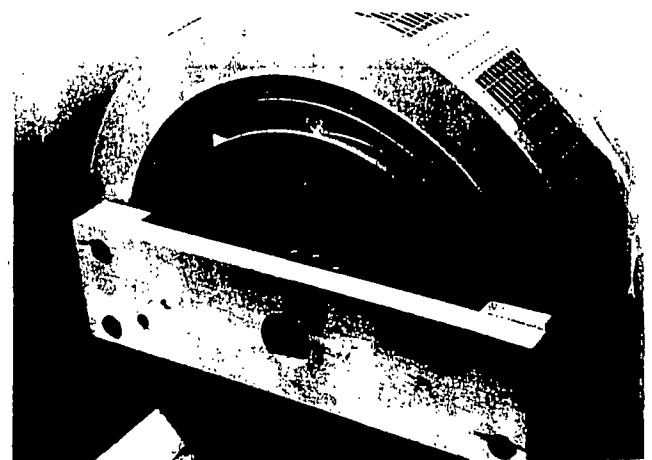


Figure 2. Supporting the Rotor for Shipment

AC Connection Panel Removal

Disconnect any wiring that will prevent the AC connection (lower) panel from being removed. Then, remove fasteners that retain the panel and remove the panel.



Figure 3. AC Connection Panel Removal (Typical)

PMG Stator Removal

NOTE: The generator may or may not be equipped with a permanent magnet generator. If your generator is not equipped with a PMG, disregard instructions pertaining to it.

1. Remove PMG leads and loosen all cable ties so that leads will be removed along with the PMG stator.
2. Note the position of the PMG stator leads which exit at the left outboard side, or mark the stator so it can be reinstalled in the same position.
3. Remove the four mounting screws (Figure 4).



Figure 4. Removal of PMG Stator Screws

4. Use two screwdrivers to gently pry the PMG stator from the mounting pad. Slide the stator over the PMG rotor. Magnets used in the PMG are very strong and will resist PMG stator removal. See Figure 5.

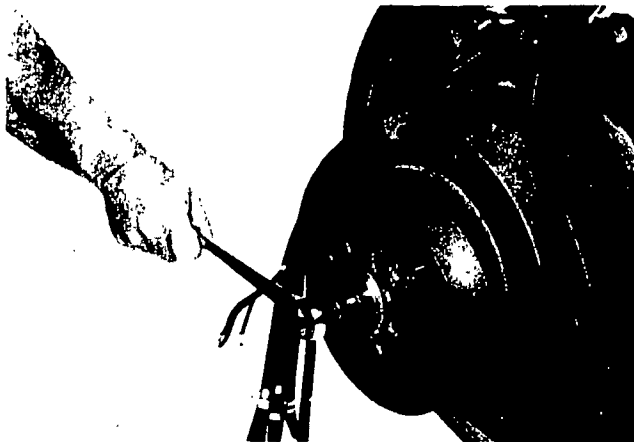


Figure 5. PMG Stator Removal

PMG Rotor Removal (If So Equipped)

1. The PMG rotor is mounted to the generator shaft with a stud shaft extension. Remove center cap screw and pull assembly off its locating pin.

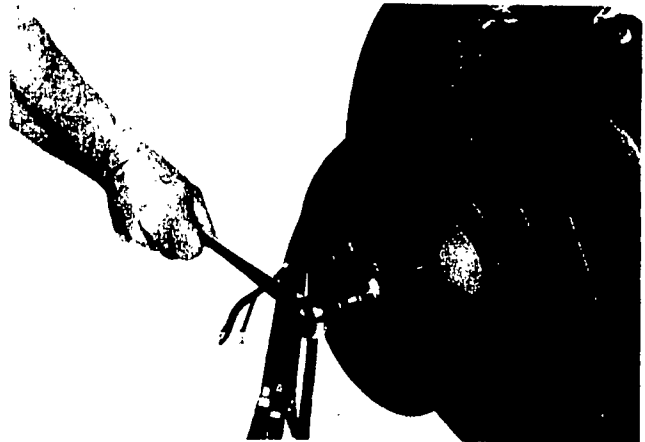


Figure 6. PMG Rotor Removal



Figure 7. PMG Rotor Removal

2. Use snap ring pliers to remove the PMG rotor from the stub shaft. Remove the snap ring; then slide the PMG rotor off its shaft. A loading spring behind the PMG rotor keeps tension on the snap ring. See Figure 8.

Main Rotor Removal

1. See Figure 9. Remove the capscrews and hardened washers that retain the drive discs to the drive hub. Remove all drive discs (and spacers, if any).

Main Rotor Removal Continued)

2. Remove the capscrews that retain the SAE adapter to the generator, then remove the adapter. See Figure 10.

CAUTION: On large generators, a hoist and lifting strap should be used to assist in drive end bracket or SAE adapter removal.

3. If the generator fan (Figure 11) requires service, it can be removed at this time. See Section 4.6, "Inspection" for details.

NOTE: The fan does not have to be removed in order to remove the rotor assembly from the generator.

4. Use a suitable lifting fixture and hoist to remove the rotor (Figure 12). Carefully remove the rotor from the main stator through the drive end.

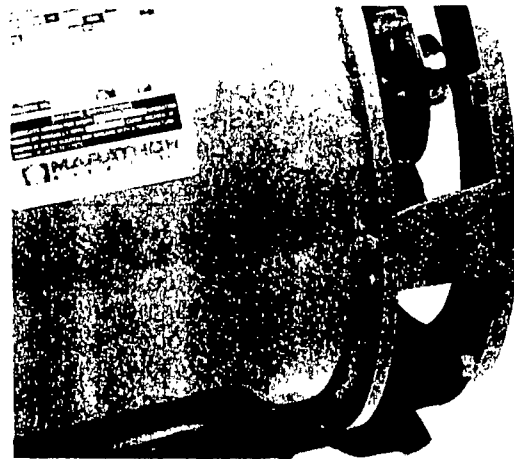


Figure 10. SAE Adapter Removal



Figure 8. Removing PMG Rotor Snap Ring

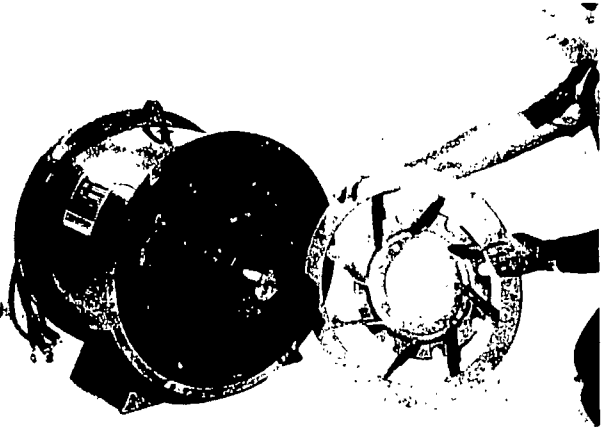


Figure 11. Generator Fan Removal

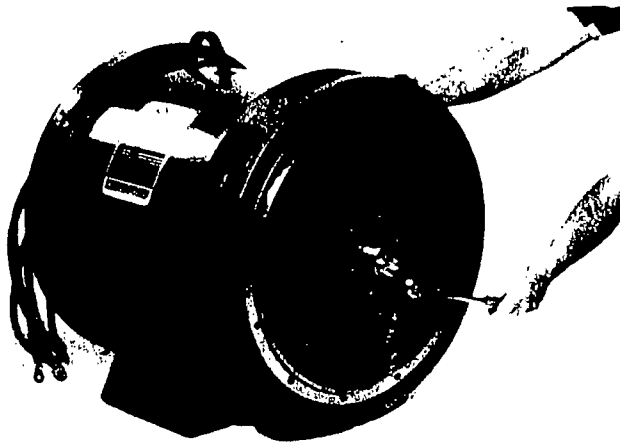


Figure 9. Removing Drive Discs from Drive Hub

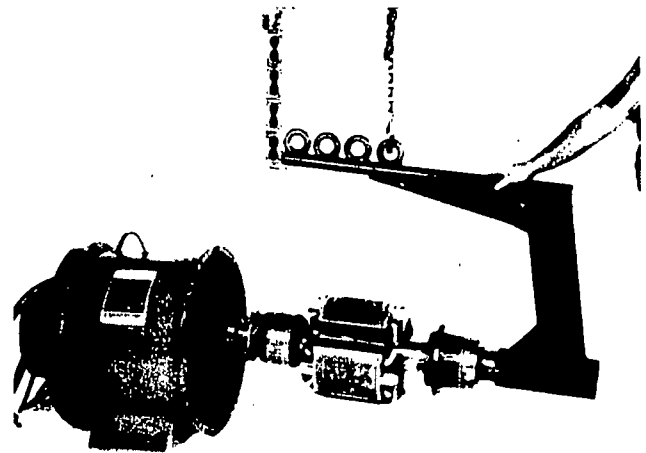


Figure 12. Rotor Removal

Front End Bracket Removal

Remove the front end bracket mounting screws. Then, remove the front end bracket from the stator assembly.



Figure 13. Front End Bracket Removal

Exciter Stator (Field) Removal

See Figure 14. Remove the exciter stator retaining screw. Note the position of the exciter stator in the housing, then remove.

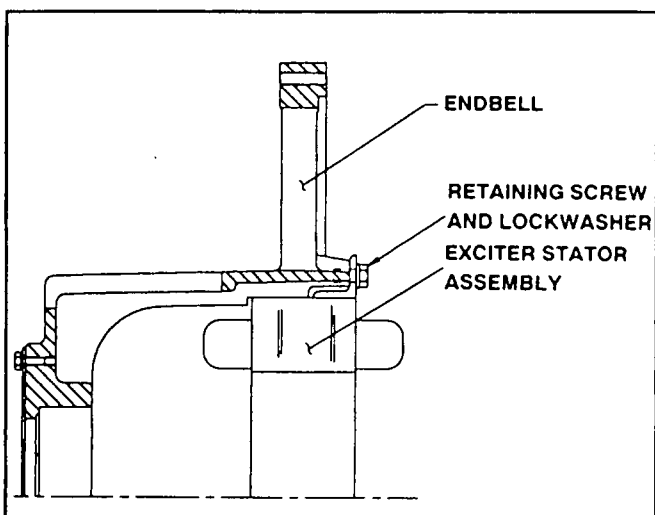


Figure 14. Exciter Stator Removal

Exciter Rotor Removal

The exciter rotor is shrunk fit to the shaft. If the winding is intact, do not remove it. If the winding is damaged or defective, use a bearing puller to remove it from the shaft.

Section 4.6 INSPECTION

Exciter Inspection

EXCITER STATOR:

1. Clean dust and dirt from the stator winding.
2. Check the exciter stator for loose, burned or frayed winding.
3. Measure winding resistance and insulation resistance. See Section 4.9, "Generator Testing".
4. Look for score marks in the bore of the exciter core that might be caused by rubbing. This could indicate bearing or assembly problems and should be investigated.

EXCITER ROTOR:

1. Clean dust and dirt from the exciter rotor and from the rectifier assembly.
2. Check the rectifiers and surge protector for proper operation (Section 4.9). Replace any defective parts.

CAUTION: Three forward polarity and three reverse polarity diodes are used. Make sure the correct diode is installed in the proper location. The surge suppressor is polarized. Observe polarity markings when changing the surge suppressor.

NOTE: Tighten diode mounting nuts to 25 inch-pounds. Use a heat sink when soldering diode leads.

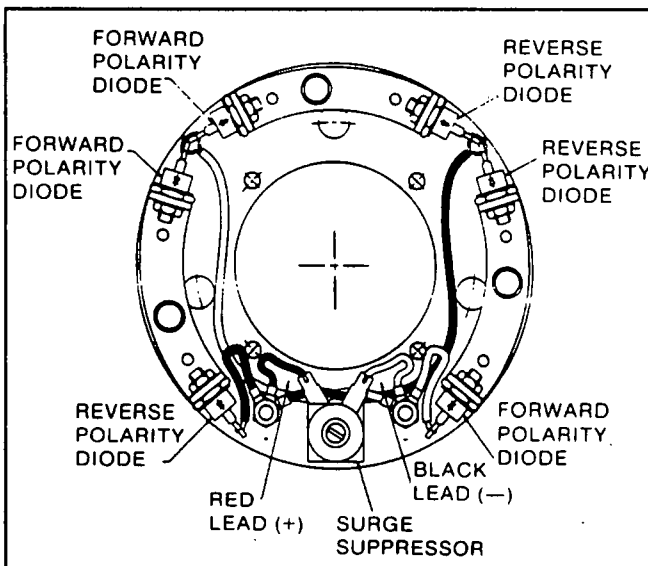


Figure 1. Rectifier Assembly

3. Check the exciter rotor (armature) and rectifier assembly for loose, frayed or burned windings or loose connections.
4. Measure winding resistance and insulation resistance (Section 4.9). DO NOT MEGGER DIODES OR SURGE SUPPRESSOR. Repair or replace as necessary.

5. Check for score marks on the outside diameter of the rotor core that might be caused by rubbing. This could indicate bearing or assembly problems and should be investigated.

PMG Inspection

GENERAL:

Some units may be equipped with a permanent magnet generator (PMG). If so equipped, inspect the PMG components as outlined below.

PMG STATOR:

1. Clean dust and dirt from the PMG stator winding.
2. Inspect PMG stator for loose, burned, frayed winding.
3. Measure winding resistance and insulation resistance (Section 4.9).
4. Look for score marks in the stator bore caused by rubbing.

PMG ROTOR:

CAUTION: The PMG rotor uses extremely strong magnets. Keep away from iron and steel parts that could be attracted by the magnets. Keep away from other generator components that could be damaged by strong magnetic fields.

1. Clean dust and dirt from the PMG rotor.
2. Make sure all magnets are securely bonded to the PMG rotor.
3. Check for burrs or corrosion in the bore and keyway where the rotor mounts to the shaft.
4. Look for score marks on the outer diameter caused by rubbing.
5. Inspect snap ring and loading spring, replace as necessary.

Main Rotor Inspection

BEARING:

1. Inspect bearing for damage or wear. Clean old grease from the bearing cap and fill the bearing cap grease cavity 1/3 to 1/2 full with CHEVRON SR1 (or equivalent) grease.

CAUTION: If the bearing has to be removed for any reason, always install a new bearing.

2. If the bearing must be replaced, remove the existing bearing with a suitable puller and install the new bearing as follows:
 - a. Heat the new bearing in an oven to a maximum temperature of 212° F. (100° C.).

Main Rotor Inspection (Continued)

- b. Apply a thin coat of clean lubricating oil to the press-fit area of the rotor shaft.
- c. Using suitable heat resistant gloves, install the bearing over the end of the shaft until it seats against the shaft shoulder. The bearing should slide onto the shaft and seat without excessive force. If the bearing binds on the shaft before it is fully seated against the shoulder, use a length of pipe slightly larger than the press-fit area to drive the bearing into place. Use light taps with a soft mallet and apply force to the inner race of the bearing only.

CAUTION: Never apply force on the bearing outer race as this could result in permanent damage to the bearing.

- d. Let the bearing cool for one hour before attempting to assemble the generator.

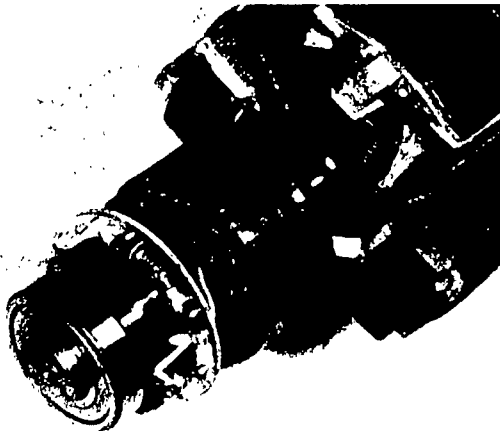


Figure 2. Main Rotor Assembly

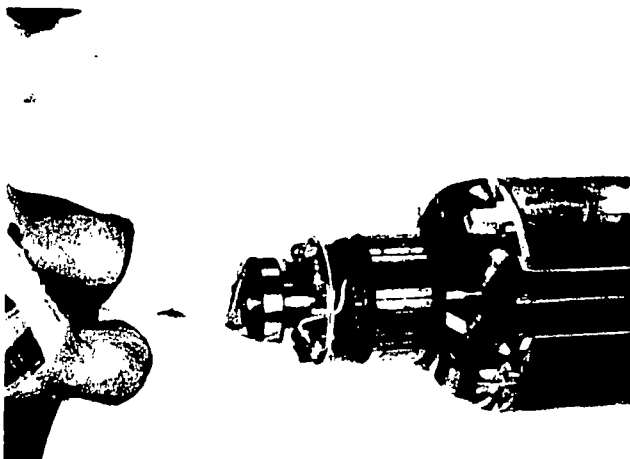


Figure 3. Rotor Bearing Installation

FAN:

1. Inspect the fan for cracks or broken blades. Replace the fan if defective.
2. Mark the hub and fan for alignment. This is necessary to ensure that balance weights will be in the same position when the fan is installed.
3. Remove the fan mounting capscrews. Then, slide the fan off the shaft.

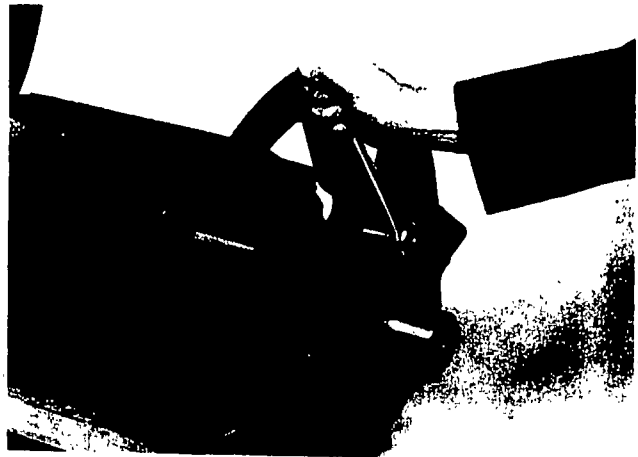


Figure 4. Fan Removal

4. To reinstall fan, slide fan onto shaft. Make sure the fan mounting surface is toward the drive hub. Align reference marks and mount the fan to the drive hub with capscrews and belleville washers (Figure 5). Tighten capscrews to 60 foot-pounds (81 N-m).

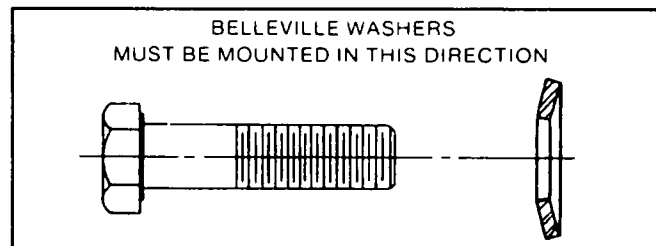


Figure 5. Fan Capscrew and Belleville Washer

NOTE: Fan balance weights are for balancing the complete rotor assembly. If a new fan has been installed, the rotor assembly should be rebalanced.

DRIVE HUB:

1. Inspect drive hub for cracks and for stripped mounting holes. Replace hub if damaged or defective.
2. If the hub is to be replaced, remove the fan as previously discussed. Then, remove the hub as follows:
 - a. Remove the setscrew (if so equipped) in the hub over the key.
 - b. Use a torch to rapidly heat the hub at its outer diameter while tightening a puller. Do this rapidly before heat can expand the shaft. Remove the hub

Main Rotor Inspection (Continued)

3. To ensure proper fan location, mark the new hub in the same place as the old relative to the keyway. Install key in shaft. Heat the new hub to 500°-600° F. (260°-316° C.). Use suitable heat resistant gloves to slide the hub over the key in the shaft until it seats against the shaft shoulder.



Figure 6. Hub Removal



Figure 7. Hub Installation

4. Let the hub cool for one hour. Then, tighten the setscrews in the hub to 50 foot-pounds (68 N-m). Match the alignment marks on the fan and hub and mount the fan.

NOTE: Rebalancing of the rotor assembly is not required when only the hub has been replaced and the fan is mounted in the same location relative to the hub and shaft.

MAIN ROTOR:

1. Clean all parts. Remove dust and dirt from the rotor windings. To remove dirt from winding air passages, a length of wire or low pressure, dry air may be used.

CAUTION: If a length of wire is used for cleaning, use care to avoid scratching the winding. If winding is scratched, an insulation breakdown may occur.

2. Inspect the rotor for loose, frayed or burned windings.
3. Measure winding resistance and insulation resistance (see Section 4.9).
4. Test for shorted turns using an impedance tester (Section 4.9).

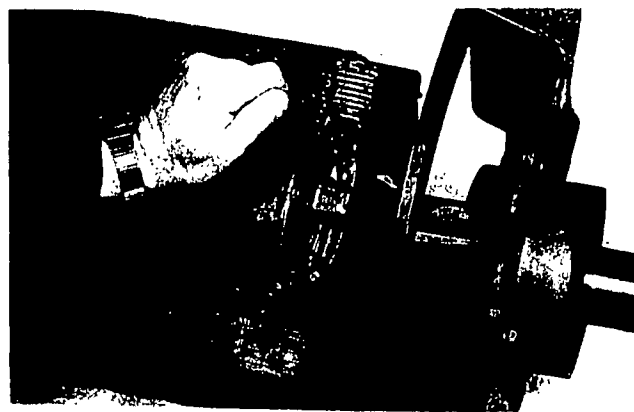


Figure 8. Cleaning Rotor Winding Air Passages

DRIVE DISCS:

1. Inspect drive discs for distorted or worn edges. Also check for worn mounting holes. Replace any defective discs.
2. Inspect the drive disc capscrews for damaged threads, replace any defective capscrews.

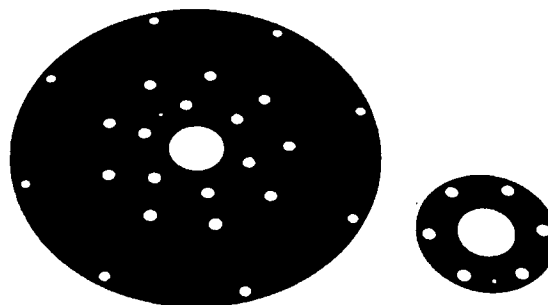
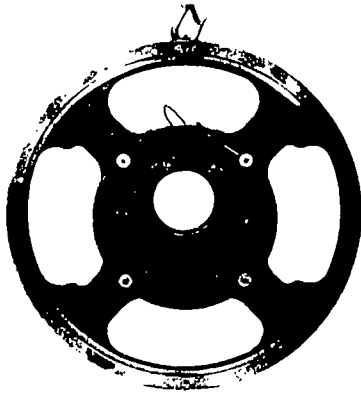


Figure 9. Drive Discs

Front End Bracket Inspection

1. Clean the front end bracket, its bearing bore, and capscrews. Remove all dust, dirt and grease.
2. Inspect bracket for stripped threads, cracks, burred or rough mating surfaces. Check bearing bore for burrs, wear.

Front End Bracket Inspection (Continued)*Figure 10. Front End Bracket*

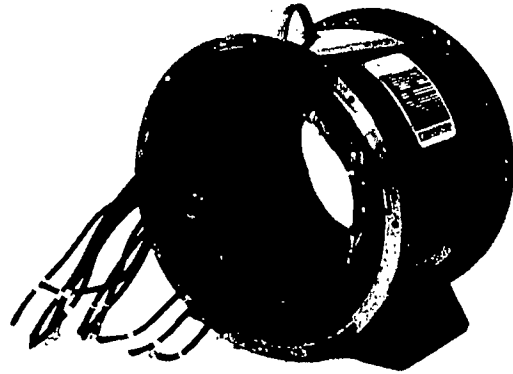
3. Inspect the mounting area for the PMG stator (if so equipped) and exciter stator. These areas must be smooth, clean, free of any burrs or rust.

Drive End Bracket or SAE Adapter Inspection

1. Clean the bracket or adapter, capscrews and screen assembly. Remove all dust, dirt and grease.
2. Inspect all capscrews for stripped threads, replace if defective.
3. Inspect the bracket or adapter for stripped threads, cracks, burred or rough mating surfaces.
4. Inspect the bearing bore for burrs or wear.

Main Stator Inspection

1. Clean all dust and dirt from the stator frame and windings.
2. Inspect the frame for stripped threads, cracks, burred mating surfaces, or for other damage.
3. Inspect stator for loose, frayed or burned windings.
4. Measure winding resistance and insulation resistance. See Section 4.9.

*Figure 11. Main Stator*

Section 4.7 REASSEMBLY

Front End Bracket Installation

1. See Figure 1. Install two guide pins (threaded rod may be used) into the generator side of the end bracket mounting holes. Align the guide pins with the holes in the generator frame and slide the bracket onto the frame. Install bracket mounting capscrews.

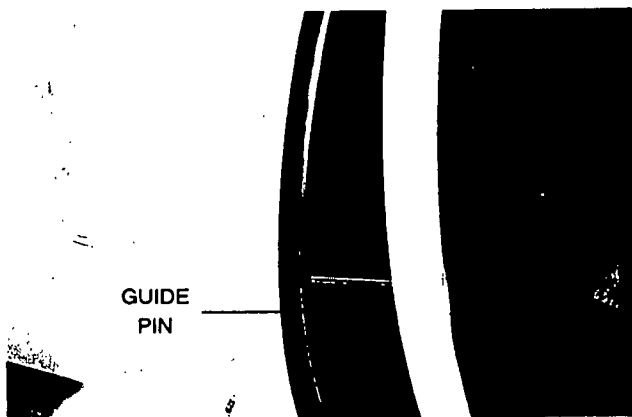


Figure 1. Front End Bracket Installation

CAUTION: On larger generators, use a hoist and lifting strap to assist in front end bracket installation.

2. Remove the two guide pins, insert the remaining capscrews.

Main Rotor Installation

1. Grease the bearing cavity with Chevron SR1 grease (or equivalent). The cavity should be about 1/3 full.
2. Use a suitable lifting fixture and hoist (Figure 2) and carefully install the rotor assembly into the main stator assembly, through the drive end.

CAUTION: Use care when installing the rotor. Damage to windings could result if the rotor is permitted to strike the main stator.

DANGER: DO NOT APPLY FORCE TO GENERATOR FAN FOR LIFTING OR ROTATING THE ROTOR. IF THIS PRECAUTION IS DISREGARDED, PERSONAL INJURY OR DAMAGE TO EQUIPMENT MAY RESULT.

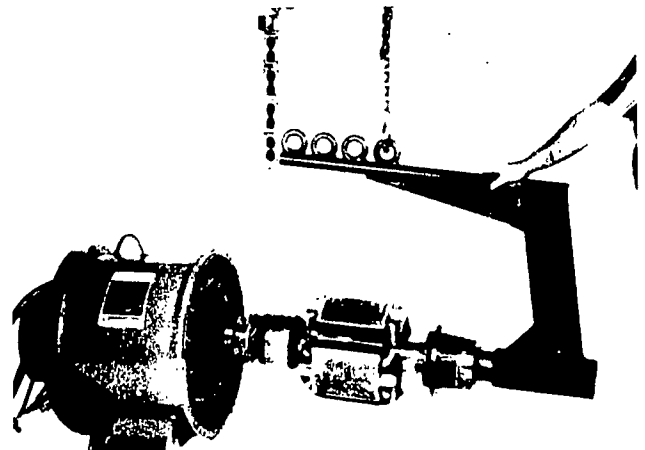


Figure 2. Main Rotor Installation

3. Slide the SAE adapter over the fan, making sure the locating mark is at the bottom. See Figures 3 and 4. Retain the adapter to the main stator with capscrews. It may be necessary to raise the rotor assembly slightly to allow the SAE adapter to be mounted.



Figure 3. SAE Adapter Installation

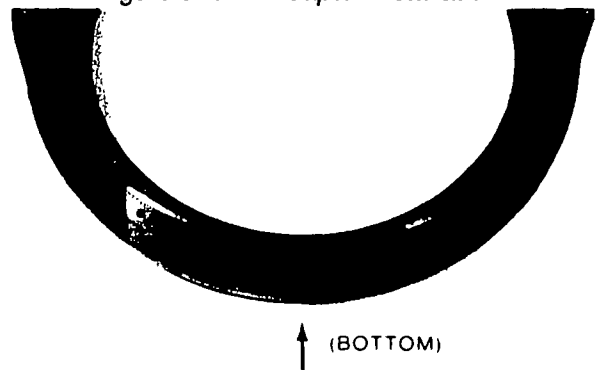


Figure 4. SAE Adapter Locating Mark

Main Rotor Installation (Continued)

4. Insert a guide stud into the drive hub. Position all spacers (if any), then all drive discs (one at a time) until all discs are installed. Make sure all disc mounting holes are properly aligned at their inner and outer diameters. Secure the discs with the Grade 8 (5/8"-18) capscrews and hardened washers. Tighten to 192 foot-pounds (260 N-m). See Figure 5 for tightening sequences.

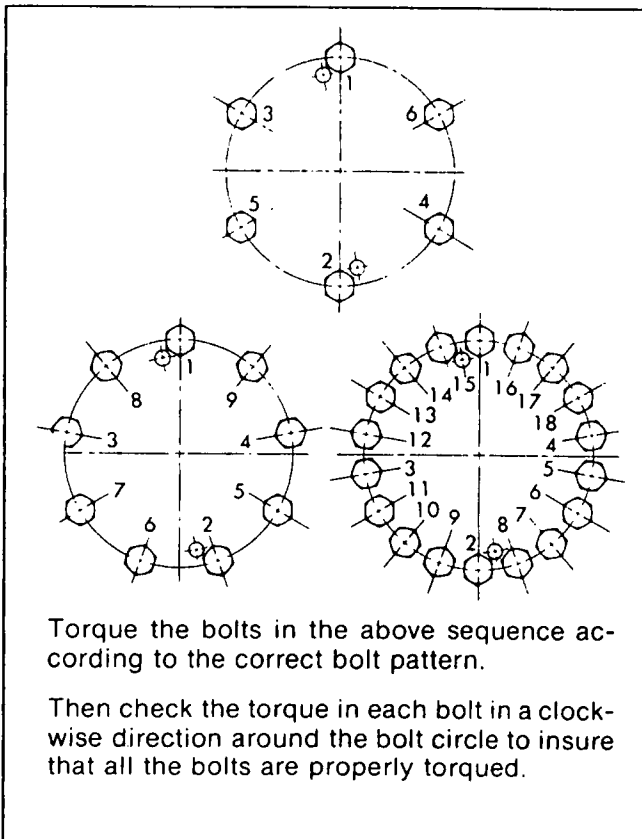


Figure 5. Tightening Sequences

PMG Installation (Optional)

If the unit is equipped with the optional PMG, install as follows:

1. Install the stub shaft and tighten mounting bolt to 84 foot-pounds (Figure 6).
2. Temporarily hang the mounting ring for the PMG stator over the stub shaft.
3. Install the loading spring and the PMG rotor on the stub shaft and retain with snap ring. The loading spring will push outward on the PMG rotor. A length of pipe slightly larger than the shaft may be used to push the snap ring back until it engages in its slot (Figure 6).
4. Install the PMG stator on the mounting pad and retain with four capscrews. Tighten four capscrews to 4 foot-pounds. See Figure 7.



Figure 6. Installing PMG Rotor Snap Ring

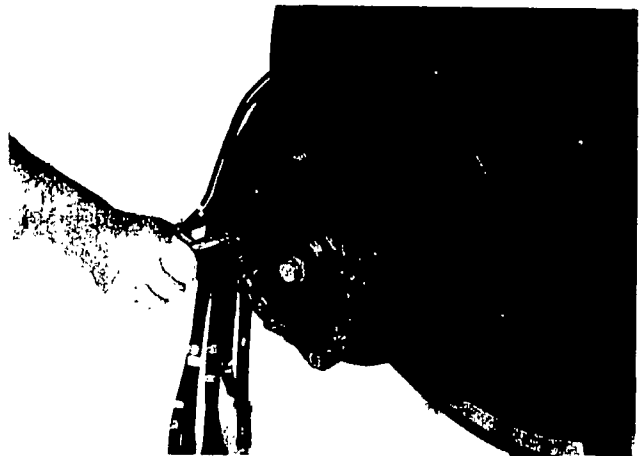


Figure 7. Installing the PMG Stator

Install AC Connection Panel

1. Install the lower panel over the main stator leads and retain with bolts and lockwashers (Figure 8).
2. Reconnect all wiring. Refer to appropriate wiring diagram(s).

Installing the Generator

1. Attach a suitable hoist to the generator lifting lugs. Move the generator until its mounting feet holes are aligned with the base and slightly above.

Installing the Generator (Continued)

2. If the screen assembly is installed on the adapter, remove mounting bolts and remove the screen. If so equipped, do NOT remove the drip cover from the screen. Insert two guide pins in the flywheel and two in the flywheel housing. Adjust generator position until the drive discs are piloted in the flywheel. Then, remove the guide pins and retain the discs with Grade 8 bolts and hardened washers or Grade 8 capscrews and heavy series lockwashers.
3. Position the generator so that the SAE adapter mates with the flywheel housing. **DO NOT FORCE ALIGNMENT OF THE UNITS.**
4. If shims were used under the mounting feet, install the same shims that were removed during disassembly to obtain proper alignment.
5. Install the screen assembly and tighten the mounting bolts.
6. Install mounting hardware that retains the mounting feet to the generator base.
7. Attach existing conduit to the AC connection panel.
8. Finish connecting all wiring, as necessary.

Section 4.8 TROUBLESHOOTING FLOW CHARTS

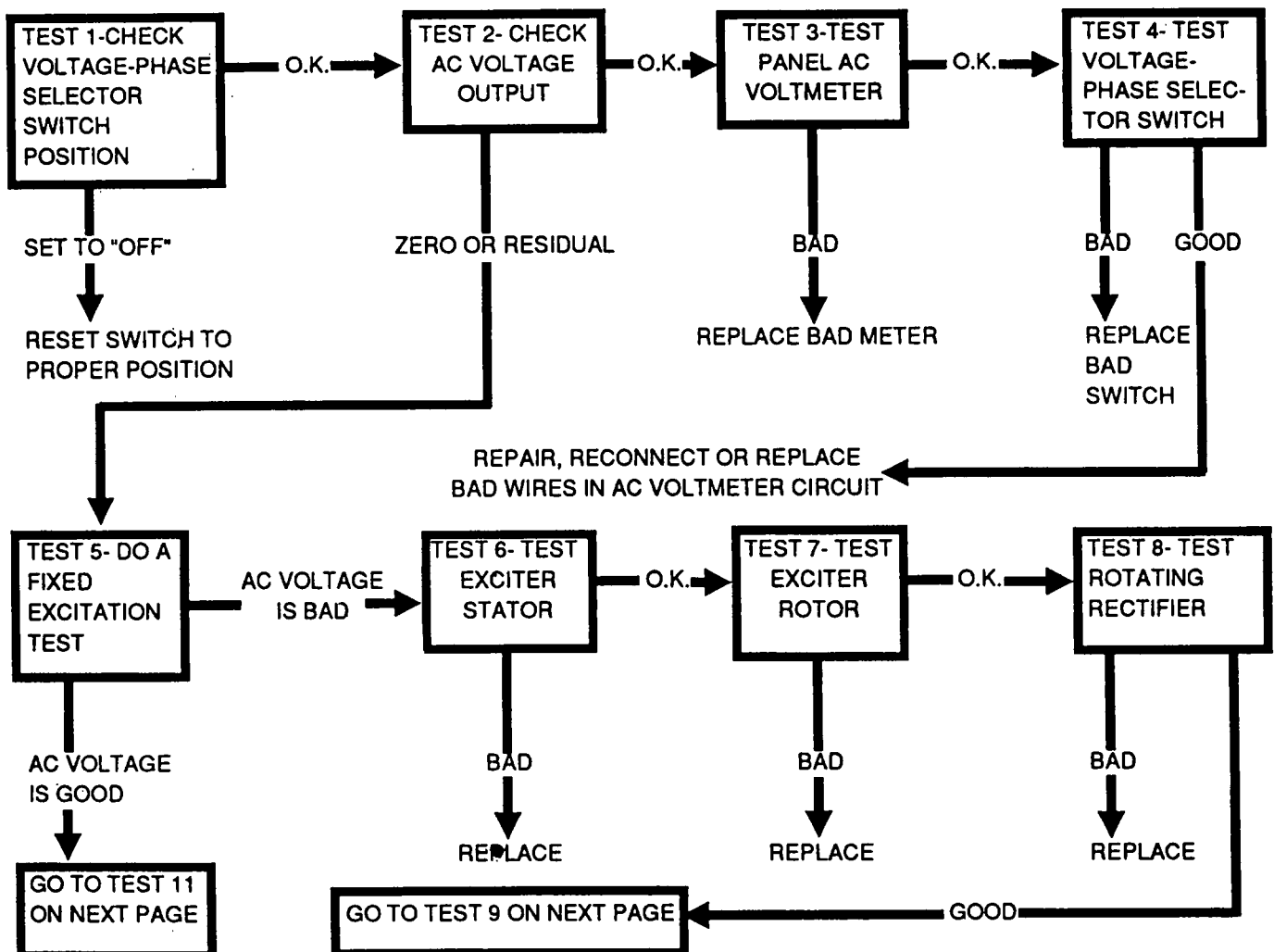
DANGER: EXTREMELY HIGH AND DANGEROUS VOLTAGES ARE PRESENT AT GENERATOR AC TERMINALS WHEN THE UNIT IS RUNNING. HIGH RESIDUAL VOLTAGES MAY BE PRESENT EVEN WHEN THE VOLTAGE REGULATOR IS DISCONNECTED. SOME OPTIONAL EQUIPMENT MAY BE ENERGIZED EVEN WHEN THE GENERATOR IS SHUT DOWN. KEEP TOOLS, EQUIPMENT, CLOTHING AND BODY PARTS WELL CLEAR OF MOVING PARTS AND ELECTRICAL TERMINALS. SPECIAL CARE MUST BE TAKEN WHILE TROUBLESHOOTING, SINCE PROTECTIVE COVERS AND OTHER SAFETY DEVICES MAY BE DISABLED. SERIOUS INJURIES OR DEATH CAN RESULT FROM THESE HAZARDS. IF QUESTIONS ARISE, CONSULT WITH QUALIFIED PERSONNEL.

Introduction

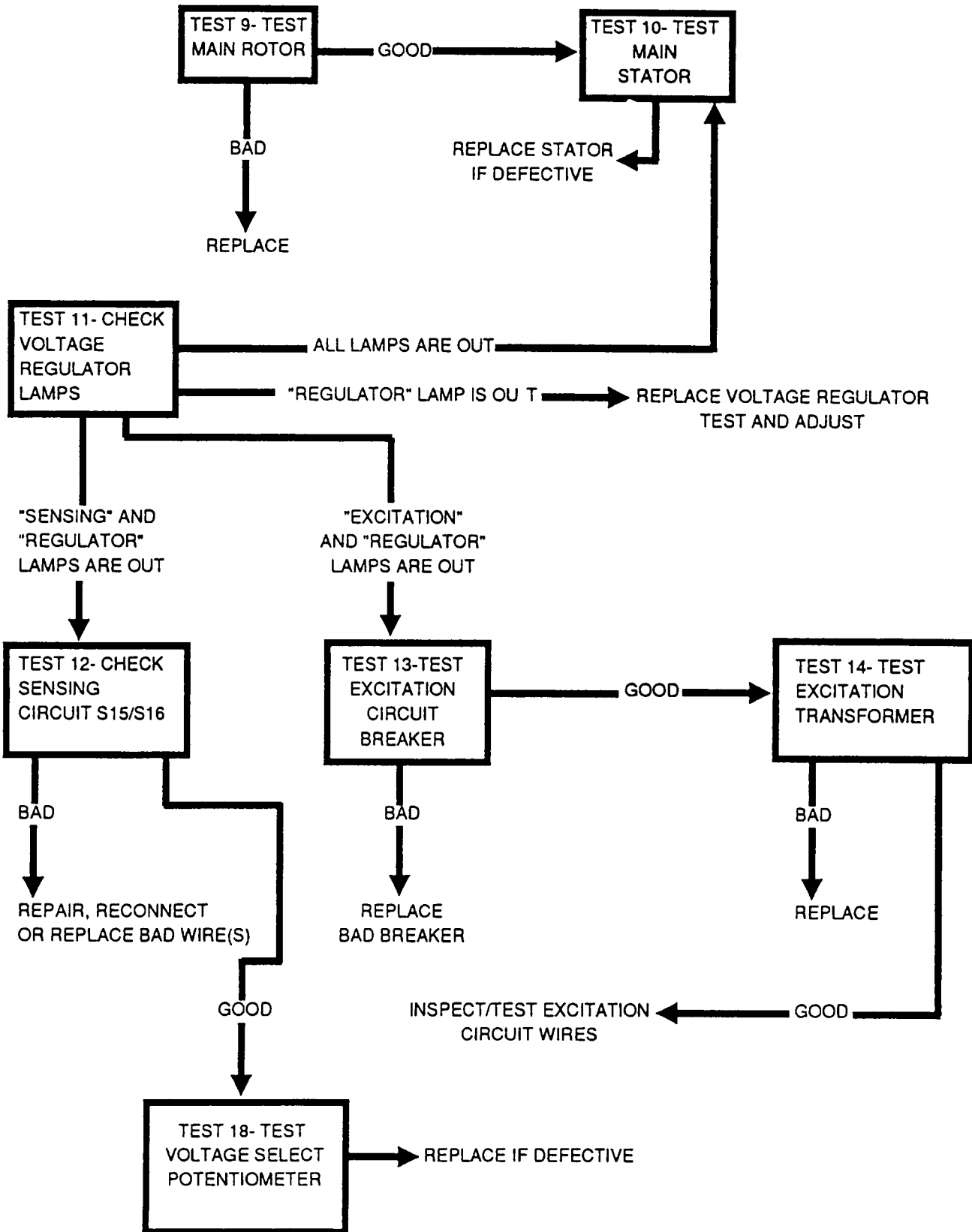
The information in this section is provided to suggest a systematic approach to locating and correcting generator malfunctions. The section consists of several problems or symptoms, with each problem or symptom followed by tests that can be performed to isolate the cause of the problem or symptom.

The various charts are arranged in "flow chart" format under each problem. Tests are arranged in orderly fashion to (a) perform the easiest tests first, (b) check the most probable cause first, and (c) prevent damage to system components while testing.

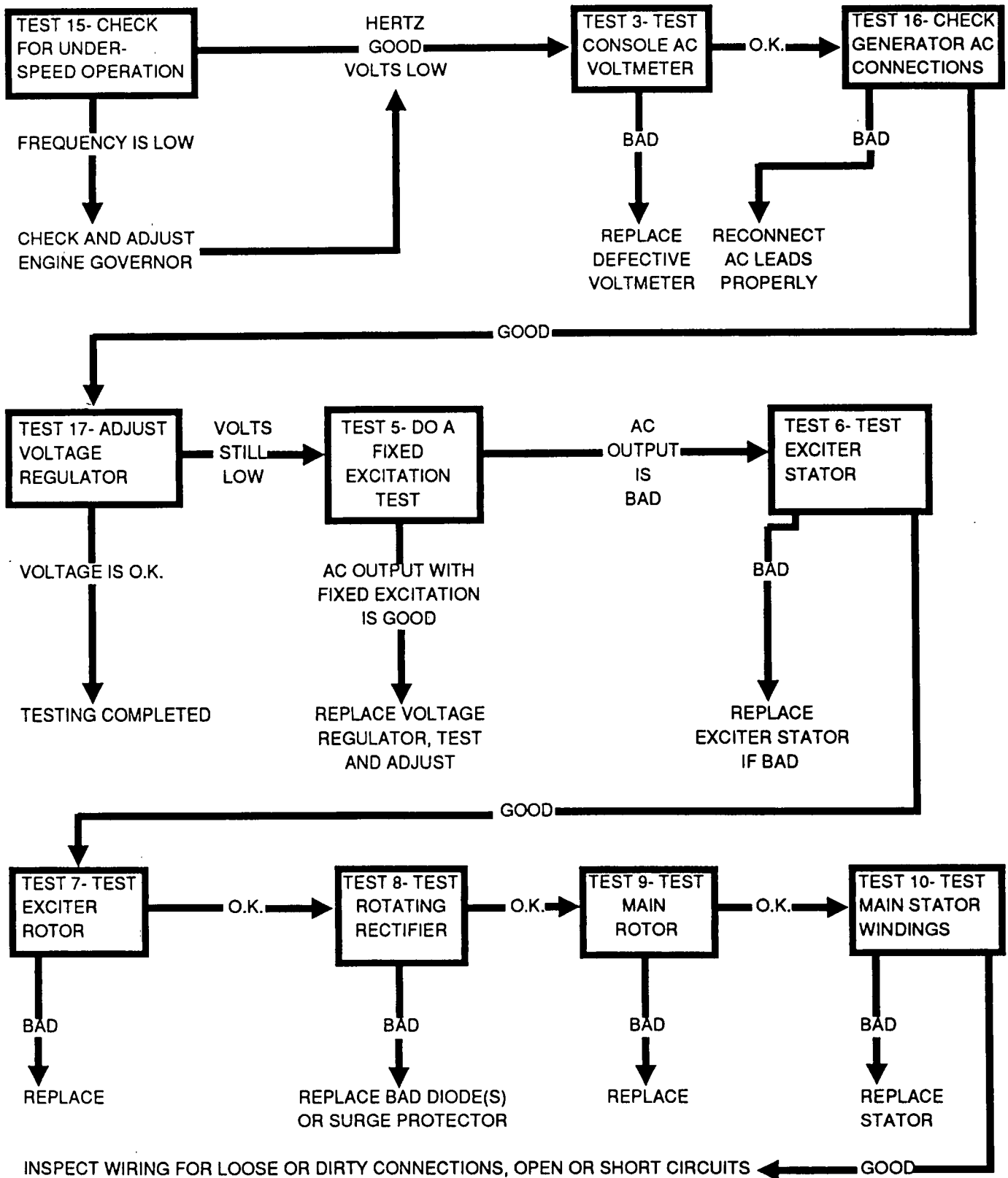
Problem 1- Generator Produces Zero or Residual Voltage at No-Load



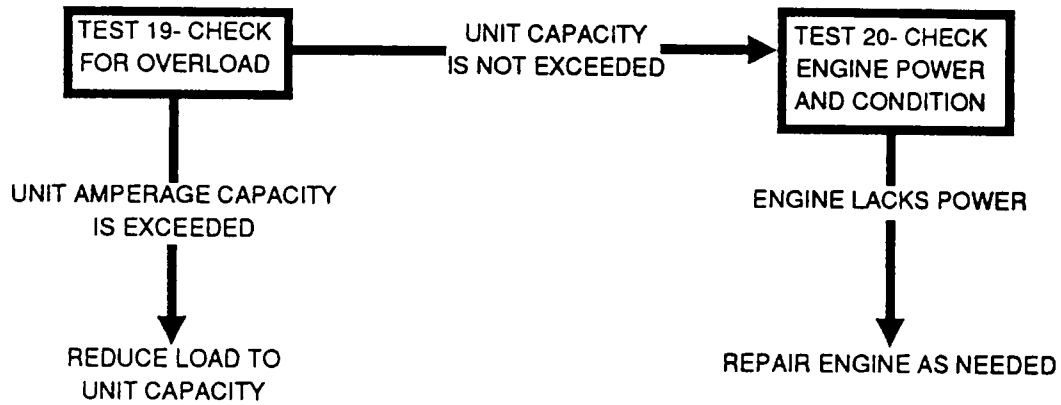
Problem 1- Generator Produces Zero or Residual Voltage at No Load (Continued)



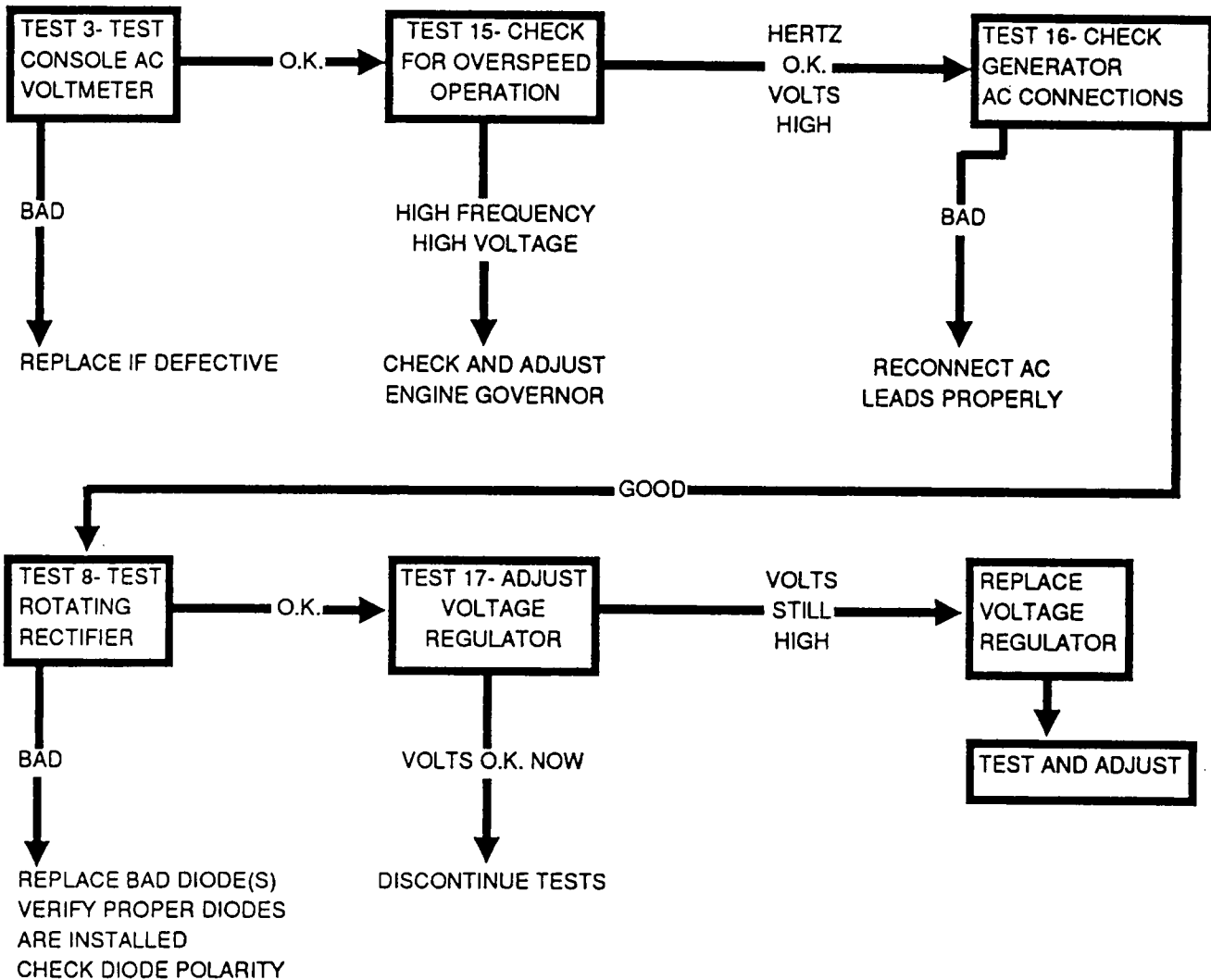
Problem 2- Generator Produces Low Voltage at No-Load



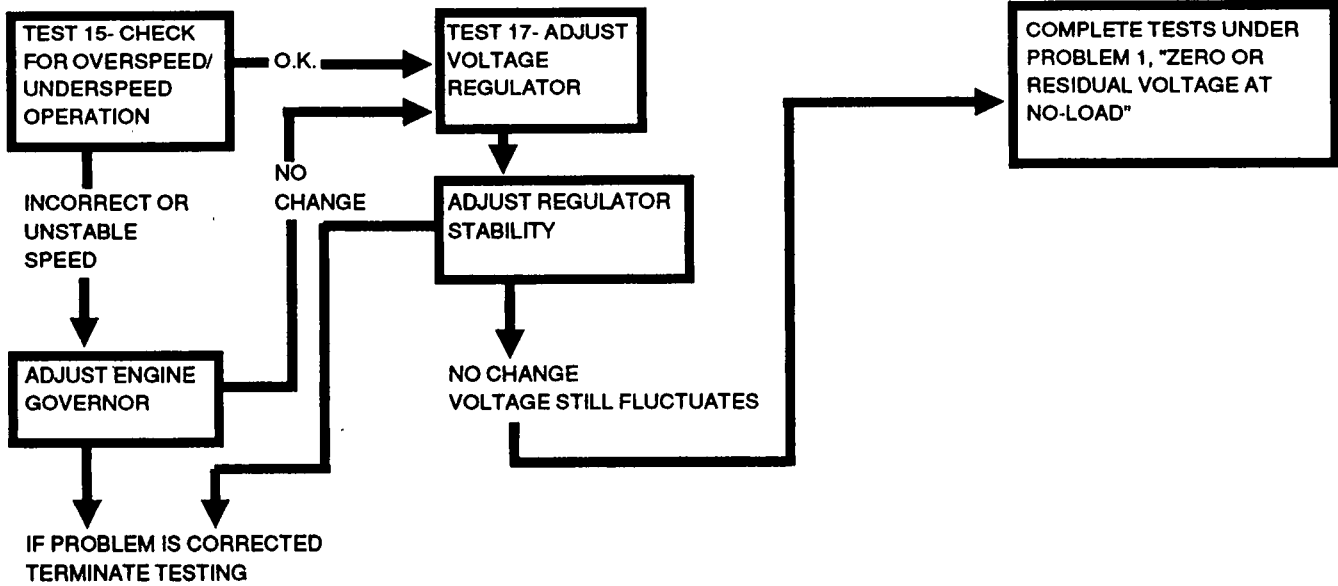
Problem 3- AC Voltage & Frequency Drop Excessively When Load is Applied



Problem 4- Generator Produces High Voltage



Problem 5- Generator Output Voltage Fluctuates



Section 4.9 GENERATOR TESTING

Introduction

The various tests in this section should be performed in conjunction with the "Troubleshooting Flow Charts" of Section 4.8. Test numbers in this section are identical to the numbered tests in the flow charts.

Test 1- Check Voltage-Phase Selector Switch Position

DISCUSSION:

The voltage-phase selector switch is physically mounted on the generator control console and electrically connected in series with "sensing" lead S16 to the voltage regulator. The switch provides operator selection of either line-to-line or line-to-neutral readings on the control console AC voltmeter and ammeter. Switch positions and voltmeter-ammeter readings are as follows:

SWITCH POSITION	1-PHASE UNITS	3-PHASE UNITS
"1"	Line E1 to Neutral	Line E1 to E2
"2"	Line E3 to Neutral	Line E2 to E3
"3"	Line E1 to Line E3	Line E3 to E1
"Off"	No Reading	No Reading

Notice that, if the switch is set to "Off", both the panel AC voltmeter and ammeter will read "zero".

PROCEDURE:

If the panel voltmeter reads "zero" volts, check the position of the voltage-phase selector switch. Reset the switch to the desired position, if necessary.

RESULTS:

1. If switch is set to correct position and the panel AC voltmeter reads "zero" volts, go to Test 2.
2. If the panel AC voltmeter now reads correct rated no-load voltage, discontinue tests.

Test 2- Check AC Voltage Output

DISCUSSION:

If the panel AC voltmeter reads low voltage, high voltage, or no voltage at all, the first logical step in troubleshooting should be to determine (a) if the meter itself is at fault, or (b) if voltage output is actually low, high or zero. This test will utilize an external meter to read the actual AC voltage output of the generator.

Check line-to-line voltage across lines E1 to E2, E2 to E3, E3 to E1.

PROCEDURE:

Connect an accurate AC voltmeter or VOM across lines E1 to E2, E2 to E3, E3 to E1. Operate the generator at its normal operating speed and at no-load. Read the line-to-line voltage and compare it to the console voltmeter reading.

RESULTS:

1. If the line-to-line readings indicate that the control console meter readings are incorrect, go to Test 3.
2. If the actual line-to-line readings indicate that generator AC output voltage is zero or residual, go to Test 5.

Test 3- Test Panel AC Voltmeter

DISCUSSION:

If, in Test 2, you determined that the control console's AC voltmeter was reading incorrectly, the next step is to determine whether the voltmeter itself is at fault or whether the problem lies in other meter circuit components.

PROCEDURE:

1. Gain access to the rear of the AC voltmeter inside the generator control console.
2. Connect an accurate AC voltmeter across the terminals of the AC voltmeter.
3. Read the voltage with the unit running at rated speed and at no-load.
4. Compare the external voltmeter reading with the console voltmeter reading.

RESULTS:

1. If the external meter reads the same as the console meter, go to Test 4.
2. If the external meter reads a different voltage than the console meter, remove and replace the console meter.

Test 4- Test Voltage-Phase Selector Switch

DISCUSSION:

In Test 3, you used an external meter to check the accuracy of the console AC voltmeter. If the console voltmeter checks good, the next step is to test the voltage-phase selector switch. A defective switch can cause the reading on the console meter to be in error. The voltage-phase selector switch is shown pictorially and schematically in Figure 1 on the next page.

Test 4- Test Voltage-Phase Selector Switch (Continued)

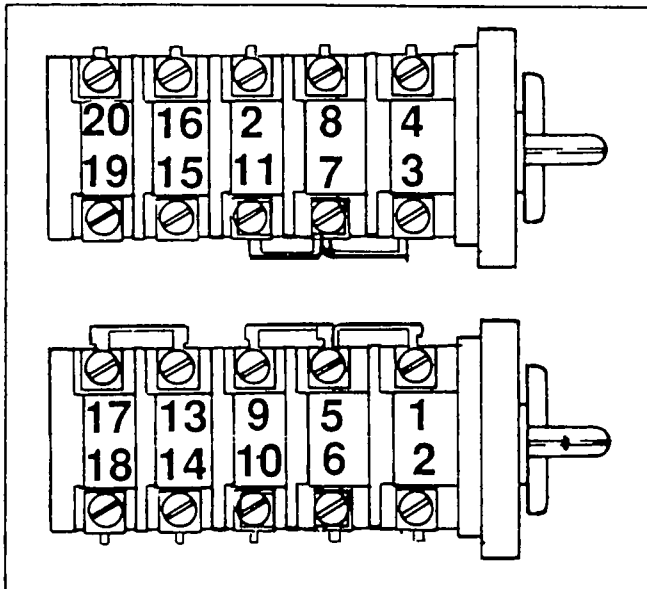


Figure 1. Voltage-Phase Selector Switch

2. If switch tests good, inspect and test voltmeter circuit wires.

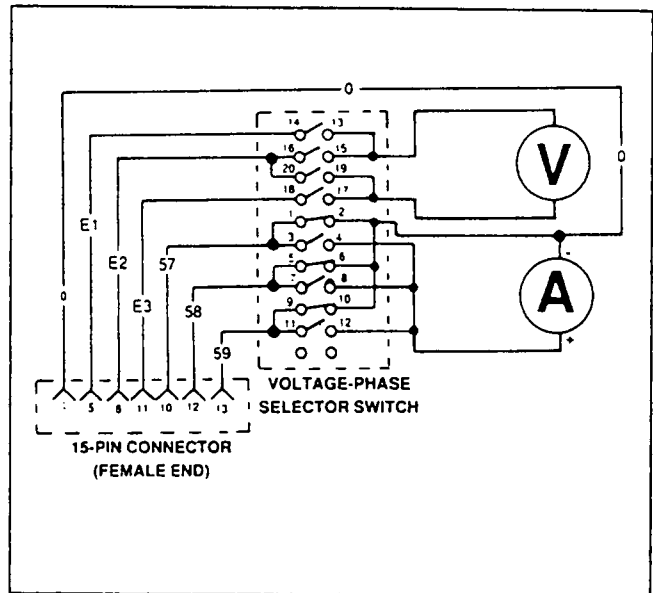


Figure 2. AC Voltmeter and Ammeter Circuits

PROCEDURE:

With the generator shut down, gain access to the voltage-phase selector switch terminals inside the control console. Then, test the switch as follows:

1. Set a volt-ohm-milliammeter (VOM) to its "Rx1" scale and zero the meter.
2. Connect the VOM test probes across the pairs of switch terminals as listed in the chart that follows.
3. Actuate the switch to positions "1", "2", "3" and "Off". At each position, note the meter reading. Readings should match those indicated in the chart.

CONNECT VOM ACROSS CONTACTS	SWITCH POSITION			
	1	2	3	OFF
14 to 13	Continuity	Infinity	Continuity	Infinity
16 to 15	Infinity	Continuity	Infinity	Infinity
20 to 19	Continuity	Infinity	Infinity	Infinity
18 to 17	Infinity	Continuity	Continuity	Infinity
1 to 2	Infinity	Continuity	Continuity	Continuity
3 to 4	Continuity	Infinity	Infinity	Infinity
5 to 6	Continuity	Infinity	Continuity	Continuity
7 to 8	Infinity	Continuity	Infinity	Infinity
9 to 10	Continuity	Continuity	Infinity	Continuity
11 to 12	Infinity	Infinity	Continuity	Infinity

RESULTS:

1. Replace switch if it fails the test.

Test 5- Do a Fixed Excitation Test

DISCUSSION:

The generator's AC output voltage depends on the following factors:

- Design of the generator.
- The applied electrical load.
- Generator speed (rpm).
- Current flow through the exciter stator.

If the unit speed and the current flow through the exciter stator are known, the no-load AC voltage output can be measured and compared to a design value. Problems can then be isolated to either (a) the voltage regulator side of the circuit, or (b) the exciter stator and rotating portion of the unit.

"Excitation Data" charts are provided in Section 4.10 which give the design value for no-load output voltage when either 12 or 24 volts DC is applied to the exciter stator.

NOTE: Fixed excitation voltages listed in the charts on Page 4.10-2 are for "High Wye" connected stators. For "Low Wye" connected stators, divide the values given in the chart by 2. For "High Delta" connection systems, divide the listed value by 1.732.

Test 5- Do a Fixed Excitation Test (Continued)

PROCEDURE:

1. With the generator shut down, connect an AC voltmeter across the generator's AC output leads.
2. Unplug the connector plug from the voltage regulator (inside the generator console).
3. Turn off all electrical loads. The unit must be started and operated at no-load for this test.
4. Start the generator engine, let it run at rated speed.
5. Connect a jumper wire from terminal 13 of the control console terminal strip (TB1) and to Pin 4 (Wire No. 4) of the voltage regulator's connector plug.
6. Read the line-to-line AC output voltage on the voltmeter connected in Step 1.
7. Disconnect the jumper wire and shut the engine down.
8. Reconnect the voltage regulator connector plug.
9. Compare the voltage reading of Step 6 to the values listed in the "Excitation Data" charts on Page 4.10-2.

NOTE: Voltages listed in the "Excitation Data" charts on Page 4.10-2 are for a High Wye connection system. For Low Wye systems, divide the listed value by 2. For High Delta systems, divide the listed value by 1.732.

RESULTS:

1. If AC voltage output is not as listed in the charts on Page 4.10-2, go to Test 6. The problem is in the exciter stator or in the rotating components of the generator.
2. If the AC voltage is approximately the same as listed in the charts on Page 4.10-2, go to Test 11. The problem is in the voltage regulator side of the excitation system.

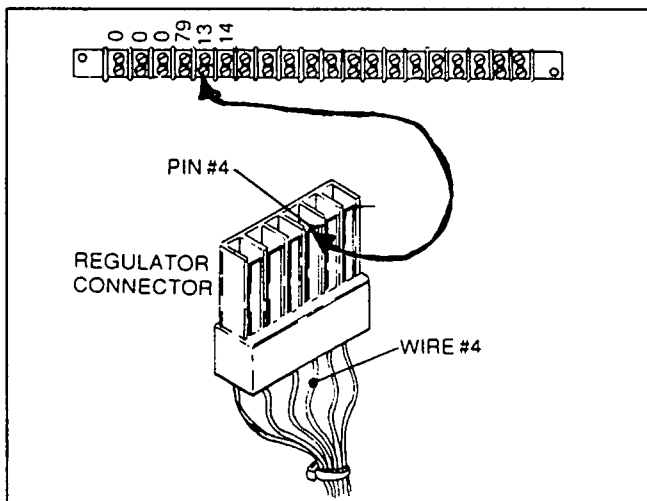


Figure 3. Doing a Fixed Excitation Test

Test 6- Test Exciter Stator

DISCUSSION:

This test will determine if the exciter stator windings are open, or grounded.

NOTE: Exciter stator (exciter field) nominal resistance can be found in the charts on Page 4.10-2. The charts also list regulator DC output voltage to the exciter stator at no-load.

PROCEDURE:

In the AC connection panel, locate the 15-pin connector plug. Unplug the mating halves of the connector plug. In the lower half of the connector plug, locate Pin 2 to which Wire No. 1 attaches. Also, locate Pin 4 to which Wire No. 4 attaches. See Figure 4. Test the exciter stator as follows:

1. Set a VOM to its "Rx1" scale and zero the meter.
2. Connect the VOM positive (+) test probe to Pin 4 of the 15-pin connector plug. Wire No. 4 to the exciter stator must be connected to this pin (NOT Wire No. 4 to the regulator).
3. Connect the VOM negative (-) test probe to Pin 1 of the 15-pin connector plug. Wire No. 1 to the exciter stator must connect to this pin (NOT Wire No. 1 to the control console).
4. Read the exciter stator resistance. Correct nominal resistance is approximately 18.6 ohms at 25° C.
5. Now, set the VOM to a high resistance scale (such as "Rx10,000" or "Rx1K"). Again, zero the meter.
6. Connect the positive (+) VOM test probe to Pin 4 (Wire 4) that goes to the exciter stator.
7. Connect the common (-) test probe to a clean frame ground.
8. Read the resistance. The VOM should read "infinity". Any upscale movement of the meter indicates a grounded condition.

RESULTS:

1. If the VOM reading in Step 4 is less than 16.7 ohms or greater than 20.5 ohms, remove the exciter stator and test further.
 - a. A reading of "infinity" indicates the exciter stator windings are open. Replace the exciter stator.
 - b. A very low resistance indicates a shorted condition. Test exciter stator insulation resistance.
2. If a reading other than "infinity" is obtained in Step 8, remove the exciter stator and test further. A grounded condition is indicated. Test exciter stator insulation resistance.

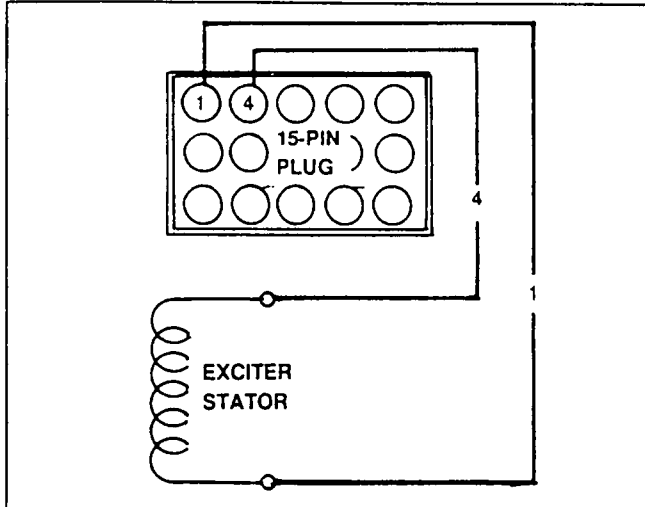
Test 6- Test Exciter Stator (Continued)

Figure 4. Testing the Exciter Stator

Test 7- Test Exciter Rotor**DISCUSSION:**

The following will test the exciter rotor for an open or grounded condition.

PROCEDURE:

Disconnect the three exciter rotor leads at the diodes. Measure the resistance between all three leads. Compare the readings obtained with the values listed in Section 4.10.

To test the exciter rotor for a grounded condition, measure from the three leads to the exciter mounting bolt. Any reading other than "Infinity" indicates a grounded condition.

RESULTS:

1. Replace exciter rotor if it fails the tests.
2. If exciter rotor tests good, go on to Test 8.

Test 8- Test Rotating Rectifier**DISCUSSION:**

Diodes perform the functions of an electrical check valve. That is, they conduct current in one direction only. It is said that diodes "rectify" current. That is, they change alternating current (AC) to direct current (DC). The diode plate (Figure 5) mounts three forward polarity diodes, three reverse polarity diodes, and a surge suppressor.

PROCEDURE:

To test the diodes, measure across each diode, first at one polarity and then at the opposite polarity. The resistance reading should be very high at one polarity and very low at the opposite polarity. Make sure the correct diodes are installed at their proper location as shown in the illustration. The surge suppressor is polarized. Observe polarity markings when installing a surge suppressor.

- A shorted diode will read a low resistance at both polarities.
- An open diode will read high resistance at both polarities.

NOTE: Some meters may not have enough voltage output from their internal batteries to turn a diode on (about 0.6 volt is needed). The meter voltage can change with different range settings. In addition, polarities supplied by some meters may not always correspond to the "+" and "-" markings on the meter. Consult the instruction manual for your meter.

RESULTS:

1. Replace any defective diode(s).
2. If diodes are good, go to Test 9.

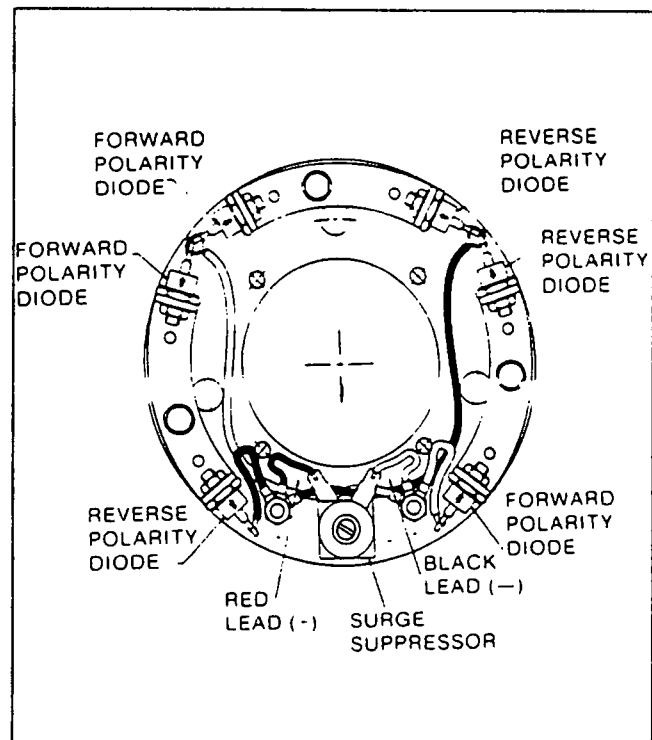


Figure 5. Rotating Rectifier Assembly

Test 9- Test Main Rotor

DISCUSSION:

This test will determine if the main rotor is open or grounded.

PROCEDURE:

Mark the main rotor leads for reconnection. Then, disconnect the leads from the rectifier assembly. Measure the resistance across the main rotor winding. Compare the resistance with the value listed in Section 4.10.

To test for a grounded condition, connect the meter test leads across the main rotor leads and the exciter mounting bolt.

RESULTS:

1. Replace the main rotor if it fails the test.
2. If main rotor tests good, go to Test 10.

Test 10- Test Main Stator

DISCUSSION:

This test will determine if the main stator windings are open or grounded. You may wish to review the information in Section 4.3, "Generator Lead Connections".

PROCEDURE:

Measure the line-to-line resistance across the main stator windings. Compare the readings obtained with the values listed in Section 4.10.

To test for a grounded condition, connect the meter test leads across the main stator leads and a clean frame ground on the stator can.

RESULTS:

Replace the stator if it fails the test.

Test 11- Check Voltage Regulator Lamps

DISCUSSION:

In most cases, "Marathon®" generators are equipped with a Generac electronic voltage regulator. The regulator is equipped with three advisory lamps (LED's), i.e., a "Sensing" lamp, an "Excitation" lamp, and a "Regulator" lamp. These lamps are normally ON when the system is functioning normally. The lamps become a valuable aid when troubleshooting, as follows:

- If "sensing" (actual voltage signals) to the regulator are lost, the "Sensing" lamp will go out.

- If unregulated excitation current from the main stator windings is lost, the "Excitation" lamp will go out.
- If a voltage regulator fault exists (regulator failure), the "Regulator" lamp will go out.
- When sensing signals to the regulator are lost, the regulator will shut down. Thus, on loss of sensing voltage, both the "Sensing" and the "Regulator" lamp will go out.
- The regulator requires approximately 4 to 8 volts AC of unregulated excitation voltage for its operation. Thus, if unregulated excitation current to the regulator is lost, the "Excitation" and "Regulator" lamps will both go out.

PROCEDURE:

Gain access to the voltage regulator which is housed in the generator control console. Start the generator engine and operate the unit at no-load and at its rated speed. Observe the generator lamps.

RESULTS:

1. If all lamps are OUT, test the main stator (Test 10).
2. If the "Regulator" lamp is OUT, replace the voltage regulator, test and adjust it. For regulator adjustment procedures, see Test 17.
3. If the "Sensing" and "Regulator" lamps are OUT, go to Test 12.
4. If the "Excitation" and "Regulator" lamps are OUT, go to Test 13.

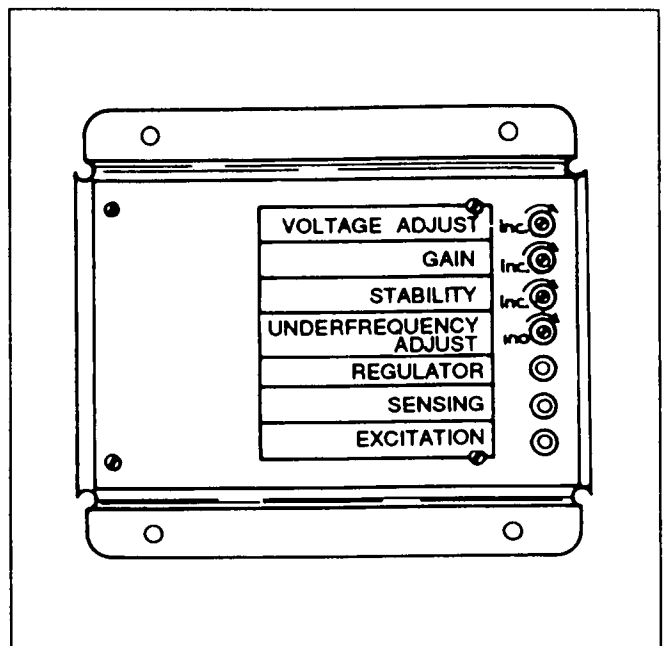


Figure 6. Electronic Voltage Regulator

Test 12- Check Sensing Circuit S15/S16**DISCUSSION:**

The sensing circuit delivers a signal of "actual" generator AC output voltage to the regulator. The regulator "compares" this sensing voltage with a preset "reference" voltage and regulates current flow to the exciter stator to match the sensing voltage with the reference voltage.

Should an open circuit occur in the sensing circuit, the regulator will sense "zero" volts. The regulator will then attempt to go to a "full field" condition in an attempt to increase AC output and sensing voltage. However, Generac's electronic regulator is equipped with a protective circuit. In the event that sensing input to the regulator should become lost, the regulator will shut down. Regulated excitation current to the exciter stator will then drop to "zero". The generator's AC output voltage will drop to a value commensurate with residual magnetism in the main rotor.

Since the voltage regulator will shut down on loss of sensing voltage, both the "Regulator" lamp and the "Sensing" lamp will normally go out on loss of sensing.

PROCEDURE:

Inspect and test Wires S15 and S16 between the main stator and the voltage regulator. This circuit is illustrated in Figure 7.

RESULTS:

1. Repair, reconnect or replace any defective wire(s).
2. If all wires check good, go on to Test 18, "Test Voltage Adjust Potentiometer".

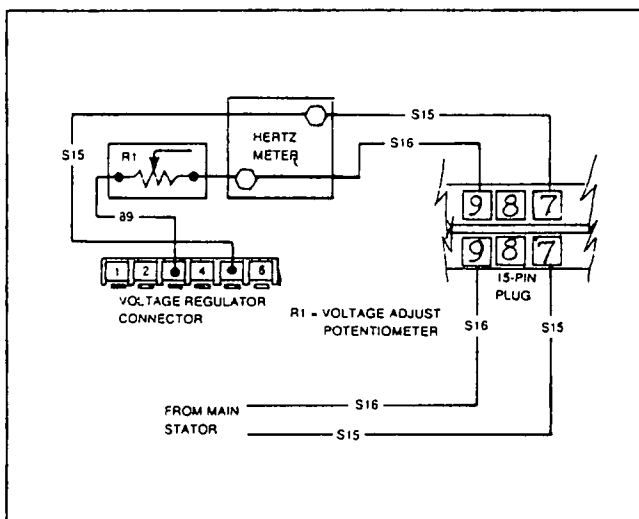


Figure 7. The Regulator Sensing Circuit (Typical)

Test 13- Test Excitation Circuit Breaker**DISCUSSION:**

Unregulated excitation current is taken from the main stator leads and delivered to a step-down transformer. The transformer's secondary winding output is then delivered to the voltage regulator, via Wires 2 and 6, an excitation circuit breaker, and Wire 162. See Figure 8.

The excitation circuit breaker protects the regulator against high current. The breaker is self resetting and cannot be reset manually. Should the breaker fail open, loss of excitation current will occur, the regulator will shut down, and generator AC output voltage will drop to a value commensurate with main rotor residual magnetism. The regulator's "Excitation" and "Regulator" lamps will both go out on loss of unregulated excitation current.

PROCEDURE:

1. Set a VOM to its "Rx1" scale and zero the meter.
2. With the generator shut down, connect the meter leads across the two breaker terminals to which Wires No. 2 and 162 attach.
3. Read the resistance. The meter should indicate "continuity".

RESULTS:

1. If "continuity" is indicated, go to Test 14.
2. If any reading other than "continuity" is indicated, replace the excitation circuit breaker.

NOTE: On most wiring diagrams and electrical schematics, the excitation circuit breaker is identified as "CB1". Some diagrams and schematics erroneously identify the breaker (CB1) as a "field boost" circuit breaker. Any circuit breaker to which Wires 2 and 162 attach is NOT a field boost breaker but IS an excitation circuit breaker.

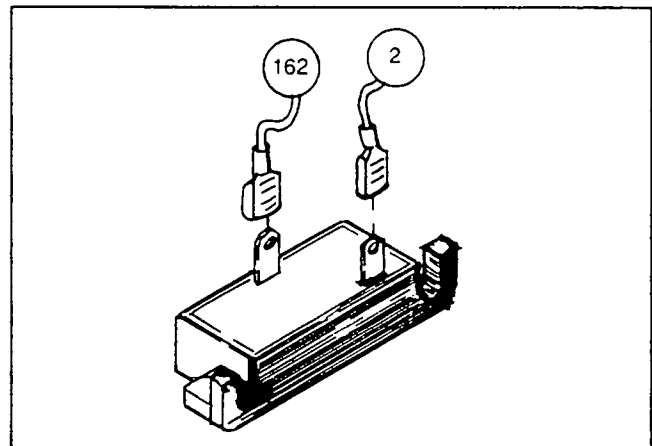


Figure 8. The Excitation Circuit Breaker

Test 14- Test Excitation Transformer

DISCUSSION:

"Marathon®" generators are not equipped with a stator excitation winding. Instead, unregulated excitation current is taken from the main stator windings. Main stator winding output voltage is too high for the voltage regulator and must be reduced to a compatible value. For that reason, an excitation transformer is used on these units.

The excitation transformer is a "step-down" type which can be used in conjunction with a high voltage main stator output (416 or 480 volts), or with a low voltage main stator output (208 or 240 volts). Transformer secondary winding output of approximately 120 volts AC is delivered to the regulator as excitation voltage.

See Figure 9. The transformer's primary coils are connected in series for high voltage stators. For low voltage stators, the primary coils must be connected in parallel (Figure 10).

PROCEDURE:

Gain access to the excitation transformer in the generator AC connection (lower) panel. Inspect and test the transformer as follows:

1. Carefully inspect wiring connections at the transformer terminals. Make sure that Wires E1 and E3 are properly and securely attached to transformer terminals H4 and H1, respectively. Also make sure that Wires 2 and 6 are properly attached to transformer terminals X1 and X2, respectively.
2. Inspect the transformer's jumper strips.
 - a. For high voltage line-to-line input from the main stator (416 or 480 volts), a single jumper should be connected across transformer terminals H2 and H3.
 - b. For low voltage line-to-line input from the main stator (208 or 240 volts), two jumper strips must be used. One jumper should interconnect terminals H2 and H4; the other should interconnect terminals H1 and H3.

DANGER: BEFORE PROCEEDING TO STEP 3, THE GENERATOR ENGINE MUST BE SHUT DOWN. DO NOT ATTEMPT THIS TEST WITH THE ENGINE RUNNING. HIGH AND DANGEROUS VOLTAGES ARE PRESENT AT TRANSFORMER TERMINALS DURING OPERATION.

3. To prevent interaction while testing, disconnect all wires from transformer terminals and remove terminal jumpers. Set a VOM to its "Rx1" scale and zero the meter. Then, test the transformer as follows:

- a. Connect the test leads of a VOM across transformer terminals H1 and H3. The meter should indicate approximately 3.0 ohms (plus or minus 20%).
- b. Connect the meter test leads across transformer terminals H2 and H4. Meter should read about 3.0 ohms (plus or minus 20%).
- c. Connect the VOM test leads across transformer terminals X1 and X2. Meter should indicate approximately 0.7 ohms (plus or minus 20%).
- d. Set the VOM to a high resistance scale (such as "Rx10,000" or "Rx1K") and again zero the meter. Test the transformer for a grounded condition as follows:

- (1) Connect one VOM test lead to terminal H2, the other to the transformer body (ground). The VOM should read "infinity".
- (2) Connect VOM test leads across terminal H1 and ground. A reading of "infinity" should be obtained.
- (3) Connect VOM test leads across terminal X1 and ground. VOM should read "infinity".

RESULTS:

1. Replace the excitation transformer if it fails any part of the test.
2. If the transformer tests good, inspect and test excitation circuit wires E1/E3 to the transformer, and Wires 2 and 6 to the 15-pin connector and regulator. Repair, reconnect or replace any defective wire(s) in the circuit.

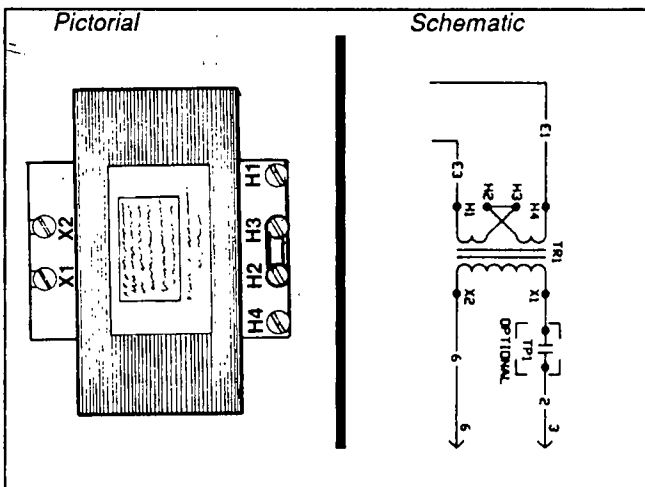


Figure 9. High Voltage Transformer Connections

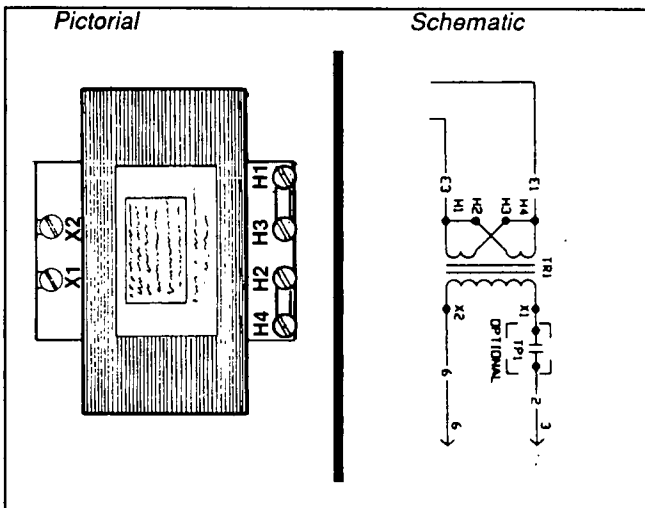


Figure 10. Low Voltage Transformer Connections

Test 15- Check for Underspeed/Over-speed Operation**DISCUSSION:**

"Marathon®" generators are generally equipped with a 4-pole main rotor which delivers an AC frequency of 60 Hertz at 1800 rpm; or 50 Hertz at 1500 rpm. Depending on the setting of an "Underfrequency Adjust" pot on the voltage regulator, AC frequency and voltage will be more or less proportional. That is, as rpm and frequency drop off, voltage will drop off proportionally. For that reason, if a low voltage, high voltage, or fluctuating voltage condition exists, it is a good idea to check for correct rpm and AC frequency.

PROCEDURE:

The console frequency meter is generally very reliable and accurate. Check that meter reading and compare it with the voltage reading. If the console is not equipped with AC meters, connect an accurate external frequency meter across the main stator output leads.

RESULTS:

1. If frequency is low, high or fluctuating, check and adjust the engine governor.
2. If frequency is good, but voltage is low, high or fluctuating, go to the appropriate problem in Section 4.8, "Troubleshooting Flow Charts".

Test 16- Check Generator AC Connections**DISCUSSION:**

You may wish to review the information in Section 4.3, "Generator Lead Connections". If the main stator AC output leads are connected improperly, a low or high voltage condition can result. This test is particularly applicable to new installations.

PROCEDURE:

Inspect the generator AC output lead connections. Make sure the leads are properly connected for the correct rated voltage.

RESULTS:

1. Reconnect main stator output leads as required to supply the correct phase and voltage.
2. If generator leads are properly connected, but the unit voltage is low, high or fluctuating, go to Test 17.

Test 17- Adjust Voltage Regulator**DISCUSSION:**

A defective or misadjusted voltage regulator can cause low, high or fluctuating voltage output.

NOTE: Adjust the voltage regulator only when the generator's no-load AC frequency is correct. If necessary, adjust the engine governor before attempting to adjust the regulator.

PROCEDURE:

- Gain access to the regulator in the control console. See Figure 12. Adjust the voltage regulator as follows:
1. Prior to installing a new replacement voltage regulator, locate the miniature switch on its circuit board identified as "SW1". Set the switch as follows:
 - a. On early production units, set the switch to "E" for brushless type or to "B" for units with brushes.
 - b. On later production units, set the switch to "1" for units with brushes or to "2" for brushless units.

NOTE: All "Marathon®" units are of the brushless type.

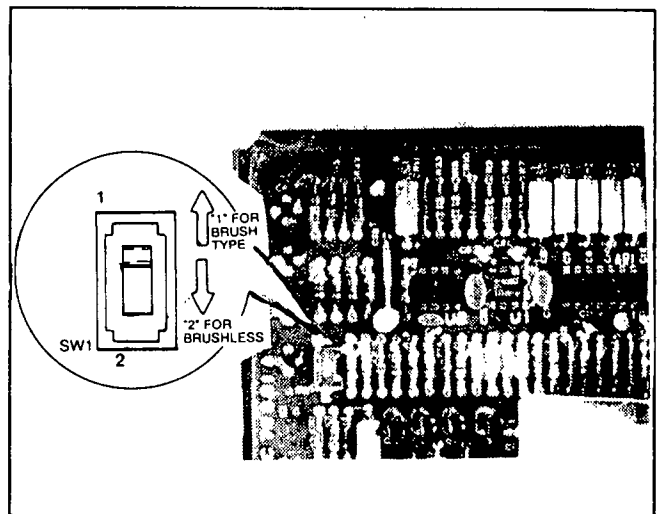


Figure 11. Selector Switch on Voltage Regulator

2. Connect an accurate AC frequency meter and voltmeter to the units AC output leads.
3. On the regulator (Figure 10), set the adjustment potentiometers as follows:
 - a. Set "Voltage Adjust" pot fully counterclockwise.
 - b. Set "Gain" to its centered (mid) position.
 - c. Set "Stability" to its centered (mid) position.
 - d. Do NOT adjust "Underfrequency Adjust".
4. On the generator console, set the voltage adjust potentiometer to its centered (mid) position.
5. Turn OFF all electrical loads. Initial setup and adjustment will be accomplished at no-load condition.
6. Start the generator engine, let it stabilize and warm up.
7. Check the frequency meter reading. If necessary, adjust the engine governor to obtain a frequency as close as possible to 62 Hertz (60 Hertz units); or 51 Hertz (50 Hertz units).
8. With the unit running at its correct frequency, analyze the system condition by observing the voltage regulator lamps (LED's).
 - a. With conditions normal, all lamps should be ON.
 - b. If the "Regulator" lamp is out, a voltage regulator fault exists with accompanying zero or residual voltage.

Test 17- Adjust Voltage Regulator (Continued)

- c. If the "Sensing" and "Regulator" lamps are both out, loss of sensing signals to the regulator has occurred with resultant regulator shutdown.
- d. If the "Excitation" and "Regulator" lamps are out, loss of excitation current to the regulator has occurred with resultant regulator shutdown.
- 9. Turn the "Voltage Adjust" pot on the regulator to obtain a line voltage as follows:

VOLTAGE CODE	RATED VOLTAGE	DESIRED LINE-TO-LINE VOLTS
A	240 volts	248 volts at 62 Hz
B	208 volts	215 volts at 62 Hz
C	416 volts	430 volts at 62 Hz
D	240 volts	248 volts at 62 Hz
G	208 volts	215 volts at 62 Hz
H	416 volts	430 volts at 62 Hz
J	240 volts	248 volts at 62 Hz
K	480 volts	496 volts at 62 Hz
M	220 volts	224 volts at 51 Hz
N	380 volts	388 volts at 51 Hz
O	416 volts	424 volts at 51 Hz

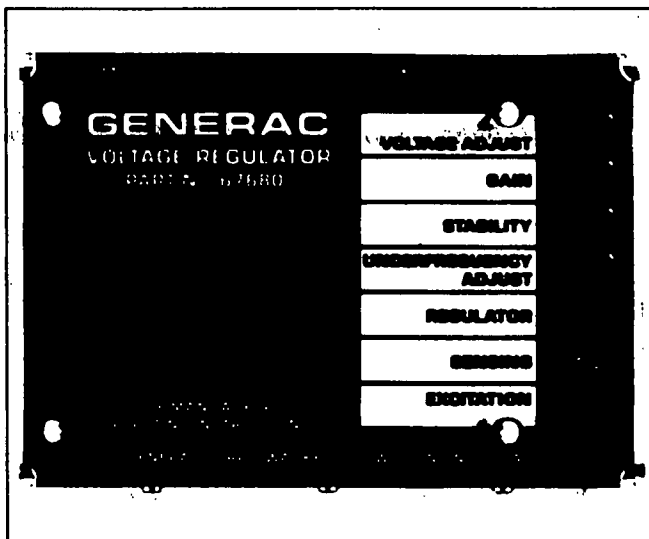


Figure 12. Voltage Regulator

- 10. If the red "Regulator" lamp is flashing, "Stability" probably needs to be adjusted. Turn the pot either direction until the flashing stops.
- 11. Apply an electrical load and check engine speed recovery.
 - a. Adjust the "Underfrequency Adjust" pot counterclockwise to unload the unit and reduce load voltage while the unit recovers.
 - b. For "flat regulation" (no voltage decrease as frequency drops), set the "Underfrequency Adjust" pot fully clockwise (CW). Set point for this adjustment is 62 Hertz (counterclockwise) to 52 Hertz (clockwise).
 - c. To obtain a constant voltage reduction as frequency drops, set the "Underfrequency Adjust" pot fully counterclockwise.

- 12. With electrical loads still applied, check the "Regulator" lamp for flashing. If lamp is flashing, adjust the "Stability" pot until the flashing stops.
- 13. If better response is needed, adjust the "Gain" pot clockwise as needed. Then, if necessary, correct for instability by adjusting the "Stability" pot.
- 14. Turn off all electrical loads and check the regulator lamps at no-load.
- 15. When all adjustments have been completed, let the unit run at no-load for a few minutes to stabilize internal engine-generator temperatures.
- 16. Shut the engine down.

Test 18- Test Voltage Adjust Potentiometer

DISCUSSION:

The voltage adjust pot, located on the control console, permits the operator to "fine adjust" output voltage within a range of plus or minus 10 percent. The device is connected in series with the sensing circuit to the regulator. Changing the sensing voltage "tells" the regulator to change the regulated excitation output current proportionately.

An open circuit in the voltage adjust pot will open the sensing circuit to the regulator. The regulator's "Sensing" lamp will go out. Without a sensing signal, the regulator will shut down and the "Regulator" lamp will also go out.

The voltage adjust pot is rated 10 k-ohm, 2 watts (plus or minus 10 percent).

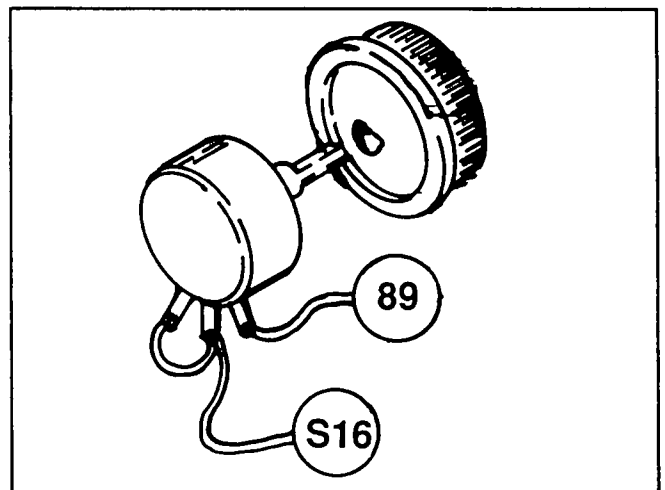


Figure 13. Voltage Adjust Pot Test Points

PROCEDURE:

- 1. Gain access to the voltage adjust pot terminal ends, inside the control console.
- 2. Set a VOM to its "Rx10" scale and zero the meter.
- 3. Connect the VOM test leads across the potentiometer terminals to which Wires S16 and 89 attach. Then, test the potentiometer as follows:

Test 18- Test Voltage Adjust Potentiometer (Continued)

- a. Slowly rotate the potentiometer knob clockwise and counterclockwise while observing the meter.
 - b. As the knob is turned in either direction, the resistance reading should increase and decrease smoothly. Erratic readings or dropoff to "infinity" at any point is cause for pot replacement.
4. Start the engine, let it stabilize and warm up at no-load.
- a. Set the voltage adjust pot to its centered or mid-position. Note the AC voltage reading on the console voltmeter.
 - b. Turn the pot all the way counterclockwise and note the AC voltmeter reading.
 - c. Turn the pot all the way clockwise and note the voltmeter reading.
 - d. Calculate the percentage of voltage adjustment provided by the potentiometer. Adjustment range should be plus or minus 10 percent, a total of 20 percent.

RESULTS:

Replace the voltage adjust potentiometer if defective.

Test 19- Check for Overload**DISCUSSION:**

Quite often, a generator's rated maximum wattage/amperage capacity is a function of available engine power. If the unit is overloaded, the engine will "bog down" under the excessive load. As a result, AC frequency will drop and AC voltage output will decrease. Thus, if the unit operates normally at no-load but rpm, frequency and voltage droop excessively when electrical loads are applied, perhaps the unit has been overloaded.

PROCEDURE:

Start the generator, let it warm up. Then, turn on electrical loads while observing voltage, frequency and current. If voltage and frequency droop excessively when the loads are applied, check the console ammeter reading. The ammeter reading should not be greater than the generator's rated capacity.

If the unit is not equipped with a console ammeter, or if voltage and frequency droop excessively while electrical loads are within unit capacity, a clamp-on ammeter may be used to verify load current.

RESULTS:

1. If unit is overloaded, reduce loads to unit capacity.
2. If unit is not overloaded, but voltage and frequency droop excessively when loads are applied, go to Test 20.

Test 20- Check Engine Power and Condition**DISCUSSION:**

As previously stated, generator output capacity is often a function of available engine power. Thus, if engine power has become reduced for any reason, the maximum output of the generator will be decreased.

PROCEDURE:

Test operation under load. If engine rpm, frequency and voltage all droop excessively when electrical loads are applied, first check the load current. If load current is within the unit's rated capacity, check the engine. Refer to the service manual for the specific engine model.

RESULTS:

Repair engine as needed to restore its power.

Section 4.10 SPECIFICATIONS

Cross Reference Chart "MagnaPLUS™" Generators

MARATHON MODEL NO.	GENERAC PART NO.	DIESEL ENGINE	RATED KW
430S1262	76831-G	6.4 Liter	100
430S1263	73395	6.4 Liter	125
430S1264	76548	6.4 Liter*	150
430S1265	76830-G	6.4 Liter*	175
430S1266	76832-G	6.4 Liter*	200
430S1268	76738	6.4 Liter*	270+
430S1262	76831	13.3 Liter	100
430S1263	76828	13.3 Liter	130
430S1264	76829	13.3 Liter	150
430S1265	76830	13.3 Liter	175
432S1266	76832	13.3 Liter	200
431S1268	76833	13.3 Liter	275

* Indicates engines equipped with a gearbox.

+ This generator is standard on the 175 kW, 6.4 liter engine unit due to efficiency requirements.

Cross Reference Chart "MagnaMAX™" Generators

MARATHON MODEL NO.	GENERAC PART NO.	DIESEL ENGINE	RATED KW
431RSL2004	76469-A	6.4 Liter	100
431RSL2006	76469-B	6.4 Liter	125
431RSL2008	76469-C	6.4 Liter*	150
431RSL2010	76469-D	6.4 Liter*	175
431RSL2012	76469-E	6.4 Liter*	200
431RSL2016	76469-F	6.4 Liter*	270+
431RSL2004	76470-A	13.3 Liter	100
431RSL2006	76470-B	13.3 Liter	130
431RSL2008	76470-C	13.3 Liter	150
431RSL2010	76470-D	13.3 Liter	175
431RSL2012	76470-E	13.3 Liter	200
431RSL2016	76470-F	13.3 Liter	275
433RSL2023	76470-G	13.3 Liter	350

* Indicates engines equipped with a gearbox.

+ This generator is standard on the 175 kW, 6.4 liter engine unit due to efficiency requirements.

Resistance Values- Main Stator Windings In OHMS at 25° C.

MODEL NO.	MAIN STATOR ¹	MAIN ROTOR
430S1260	0.204	0.482
430S1261	0.181	0.504
430S1262	0.123	0.520
430S1263	0.0935	0.558
430S1264	0.0721	0.594
430S1265	0.0541	0.636
432S1266	0.0415	0.704
432S1267	0.0373	0.711
432S1268	0.0264	0.825

¹ Main stator values shown are line to line on the high wye connection. For low wye connections divide the value shown by 4.

Resistance Values- Exciter Windings In OHMS at 25° C.

EXCITER STATOR*	EXCITER ROTOR	PMG STATOR**
18.6/28.7	0.105	2.00

* Leads F1 to F2= 18.6 ohms

Leads F1 to F3 = 28.7 ohms

** Unit may or may not have a PMG.

Excitation Data- 60 Hz- 1800 RPM

Model Number	Exciter Field Resistance- Ohms @25° C.	Exciter Field Volts 1 and 4 at Regulator No-Load ¹ 240/480 Volts	No-Load Output Voltage With Fixed Excitation ² High Wye Connection ²	
			12 VDC	24 VDC
430S1260	18.6	8.9	530	530
430S1261	18.6	10.4	510	600
430S1262	18.6	10.0	510	600
430S1263	18.6	10.2	510	600
430S1264	18.6	9.7	520	610
430S1265	18.6	11.0	500	590
430S1266	18.6	12.1	480	570
432S1267	18.6	11.7	490	580
432S1268	18.6	14.9	440	550

- 1 For rated load exciter field volts, see generator nameplate.
 2 For low wye connections, divide the value shown in table by 2.
 For high delta connection, divide value shown in table by 1.732.

Excitation Data- 50 Hz - 1500 RPM

Model Number	Exciter Field Resistance- Ohms @25° C.	Exciter Field Volts 1 and 4 at Regulator No-Load ¹ 240/480 Volts	No-Load Output Voltage With Fixed Excitation ² High Wye Connection ²	
			12VDC	24VDC
430S1260	18.6	11.0	430	510
430S1261	18.6	12.5	410	490
430S1262	18.6	12.1	410	490
430S1263	18.6	12.1	410	490
430S1264	18.6	11.9	420	500
430S1265	18.6	13.8	400	480
430S1266	18.6	14.9	380	470
432S1267	18.6	13.8	400	480
432S1268	18.6	17.5	360	450

- 1 For rated load exciter volts, see generator nameplate.
 2 For low wye connection, divide the value shown in table by 2.
 For high delta connection, divide the value shown in table by 1.732.
 For delta connection, divide the value shown in table by 1.732.

**PART 5
OPTIONS
A AND B
CONTROL
CONSOLES**

**STANDBY
ELECTRIC
POWER
SYSTEMS**
All Series

TABLE OF CONTENTS

SECTION	TITLE
5.1	Meters, Gauges and Controls
5.2	Internal Console Components
5.3	AC Circuits Operation
5.4	DC Control- 12 Volts Gas Units
5.5	DC Control- 12 Volts Diesel Units
5.6	DC Control- 24 Volts Diesel Units
5.7	Troubleshooting Charts
5.8	Diagnostic Tests
5.9	Dual 12 or 24 Volts DC Control

Section 5.1 METERS, GAUGES AND CONTROLS

The Option "B" Console

STANDARD FEATURES:

The Option "B" control console offers the following standard features, shown in Figure 1 below:

- The engine can be started manually using a start/stop switch.
- The engine can be started automatically when installed in conjunction with an automatic transfer switch. Such automatic startup and stopping is done by means of a 2-wire start/stop circuit, interconnected between the console and the automatic transfer switch.
- A single fault indicator lamp will turn on in the event of an automatic shutdown caused by (a) high coolant temperature, (b) low coolant level, (c) low engine oil pressure, (d) overspeed or (e) overcrank.
- Full engine instrumentation includes an oil pressure gauge, coolant temperature gauge, and a DC ammeter.

OPTIONAL ACCESSORIES:

The following optional accessories are available for use with Option "B" control consoles:

- A 3-lamp remote annunciator panel.
- A horn alarm that will sound in the event of an engine-generator failure.

See Part 7, "Generator Options and Accessories" for additional information.

The Option "A" Control Console

The Option "A" console is similar to the Option "B" console, with the following differences:

- The Option "A" Console is not equipped with AC meters (voltmeter, ammeter and frequency meter).
- The Option "A" console does not have a line-phase selector switch.

Because of the similarity between the two consoles, only the Option "B" console is illustrated here.

AC Voltmeter

On Option "B" units, the AC voltmeter indicates generator AC output voltage during operation. Nominal line-to-line (no-load) AC voltage readings for generators will depend on the unit's rated voltage as follows:

VOLTAGE CODE	RATED VOLTAGE	NOMINAL LINE-TO-LINE VOLTS
A, D, J	120/240	248 Volts at 62 Hz
B, G	120/208	215 Volts at 62 Hz
C, H	240/416	430 Volts at 62 Hz
K	277/480	496 Volts at 62 Hz
M	110/220	224 Volts at 51 Hz
N	220/380	388 Volts at 51 Hz
O	240/416	424 Volts at 51 Hz

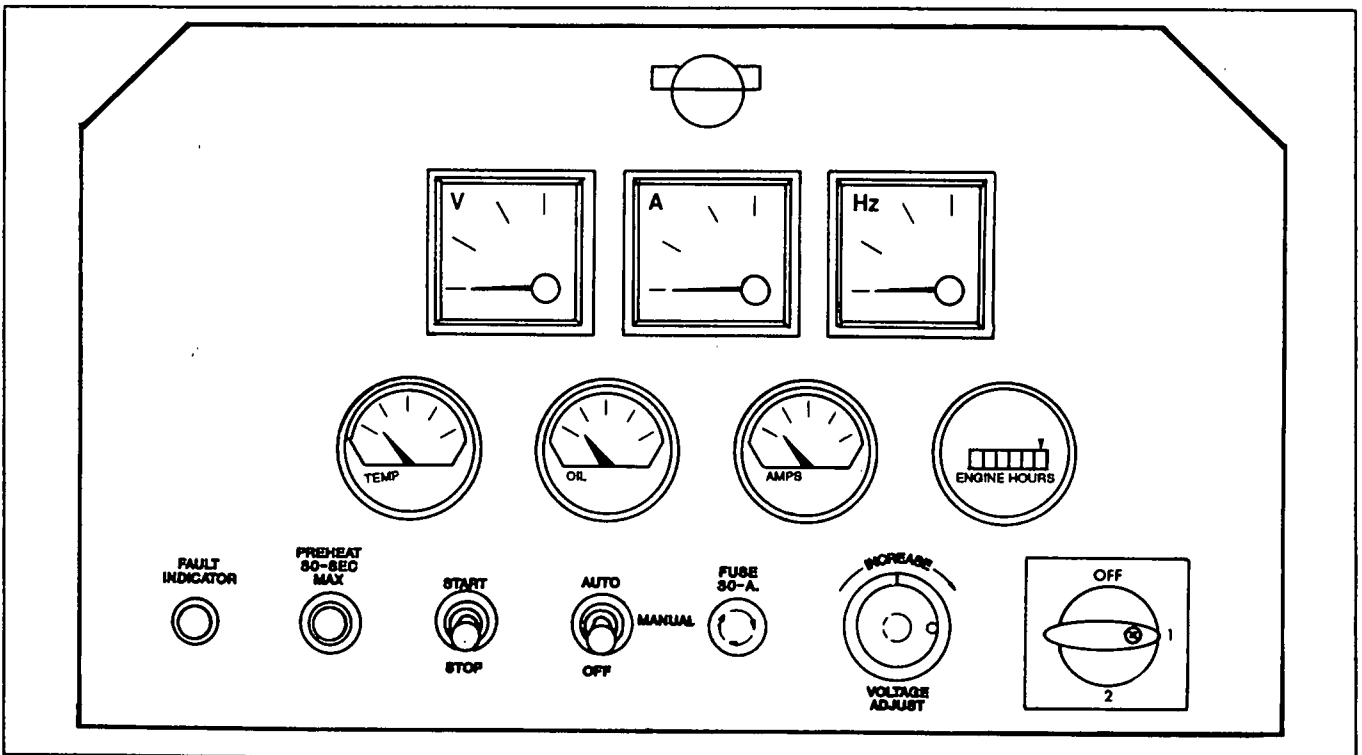


Figure 1. Typical Control Console (Option "B" Shown)

AC Ammeter

The AC ammeter indicates the current draw of connected electrical loads during generator operation. The ammeter will indicate either line-to-line or line-to-neutral amperes, as selected with a line-phase selector switch.

The total amperage of all connected loads should not be greater than the unit's rated amperage.

AC Frequency Meter

This meter indicates the generator's AC output frequency in "Hertz" or "cycles per second". On Option "A" and "B" units, the frequency meter receives frequency signals from the voltage regulator's sensing leads (S15 and S16).

Frequency and the driven speed of the rotor are proportional. A 2-pole rotor must be operated at 3600 rpm to supply 60 Hertz; at 3000 rpm to produce 50 Hertz. A 4-pole rotor will deliver 60 Hertz at 1800 rpm; or 50 Hertz at 1500 rpm.

Coolant Temperature Gauge

Gauge indicates the temperature of the engine coolant. The gauge is powered by Wire No. 14, which is electrically hot only when the generator is running. A sending unit on the engine provides temperature signals for gauge operation.

Oil Pressure Gauge

Indicates engine oil pressure during operation. A sending unit on the engine delivers oil pressure signals to the gauge. Gauge is turned on by 12 volts DC from Wire 14 (same as coolant temperature gauge).

DC Ammeter

During engine operation, the generator battery is charged by a belt driven DC alternator on the engine. The DC ammeter indicates rate of charge to the battery from that DC alternator, in amperes.

Hourmeter

The hourmeter provides a continuous indication of engine-generator operating time in hours and tenths of hours. Use the hourmeter in conjunction with the periodic maintenance schedule for the generator set. The hourmeter is powered by DC voltage from Wire No. 14. That wire is electrically hot only when the unit is running.

Preheat Switch (Diesel Units Only)

Diesel engines are equipped with either glow plugs or a preheat unit. These devices are turned on by actuating the preheat switch, to preheat the engine combustion chambers prior to startup.

Prior to manual startup, use the preheat switch to warm the engine combustion chambers. During automatic startup, the preheat function will occur automatically.

Fault Indicator Lamp

This lamp will turn on in the event of an automatic shutdown caused by (a) high coolant temperature, (b) low coolant level, (c) low oil pressure, (d) overspeed, or (e) overcrank during automatic startup. The lamp will also turn on when the start/stop switch is set to "Run".

Start/Stop Switch

This 3-position switch permits the engine to be started and stopped manually (electrically). To crank and start the engine manually, first set the auto-off-manual switch to "Manual". To crank and start the engine, hold the start/stop switch at "Start". Release the switch to its centered (Run) position when the engine starts. To shut down an operating engine, set the switch to its "Stop" position.

Auto-Manual-Off Switch

This 3-position safety switch can be used to prevent automatic startup while the unit is being serviced or repaired. Switch positions are as follows:

1. "Auto" Position: Set the switch to "Auto" for normal automatic operation.
 - a. With "Auto" selected, loss or dropout of utility power source voltage below a preset level will result in engine cranking and startup.
 - b. Following engine startup, transfer of electrical loads to the "Standby" source will occur.
 - c. On restoration of utility source voltage above a preset level, retransfer of electrical loads back to the utility source and generator shutdown will occur.
2. "Manual" Position: Set the switch to "Manual" before using the start/stop switch to crank and start the engine manually.
3. "Off" Position: When switch is set to "Off", neither automatic or manual cranking and startup will be possible.

DANGER: WHEN THE GENERATOR IS INSTALLED IN CONJUNCTION WITH AN AUTOMATIC TRANSFER SWITCH (SUCH AS THE "GTS" TYPE TRANSFER SWITCH), THE ENGINE CAN CRANK AND START SUDDENLY WITHOUT WARNING. SUCH SUDDEN STARTUP NORMALLY OCCURS WHEN UTILITY SOURCE VOLTAGE HAS DROPPED BELOW AN ACCEPTABLE LEVEL. TO PREVENT SUCH SUDDEN STARTUP AND POSSIBLE INJURY, ALWAYS SET THE AUTO-MANUAL-OFF SWITCH TO ITS "OFF" POSITION BEFORE WORKING ON THE GENERATOR. THEN, PLACE A "DO NOT OPERATE" TAG ON THE GENERATOR AND ON THE AUTOMATIC TRANSFER SWITCH.

30 Amp Fuse

The 30 amp fuse protects the control console's DC control circuit against electrical overload. If the fuse element has melted open due to an overload, engine cranking cannot occur either manually or automatically. If the fuse must be replaced, use only an identical 30 amp replacement fuse.

NOTE: A second in-line fuse is located inside the control console. This second fuse is rated 14 DC amperes.

Line-Phase Selector Switch

This switch permits operator selection of either line-to-line or line-to-neutral readings on the console's AC voltmeter and ammeter. Switch positions, along with corresponding voltage and amperage readings, are listed below.

SWITCH POSITION	VOLTAGE/AMPERAGE READING	
	1-PHASE UNITS	3-PHASE UNITS
1	Line E1 to Neutral	Line E1 to E2
2	Line E3 to Neutral	Line E2 to E3
3	Line E1 to Line E3	Line E3 to E1
Off	No Reading	No Reading

Voltage Adjust Potentiometer

Use this adjustment to "fine adjust" the generator's AC output voltage. An adjustment range of about plus or minus 10 percent is available.

Section 5.2 INTERNAL CONSOLE COMPONENTS

General

Components housed inside the generator control console are shown in Figure 1, below. Components mounted on the console floor are as follows:

- Terminal Board TB1.
- Engine Run Relay (Diesel engines only).
- Excitation circuit breaker.
- Resistor.
- Field Boost Resistor.
- Field Boost Diode.
- Preheat Relay (Diesel engines only).
- Preheat Relay (Diesel engines only).

Mounted on the rear console panel is the AC voltage regulator. A DC control/latch-crank circuit board is mounted on a console side panel.

Terminal Board TB1

This 20-position terminal board provides a convenient connection point for wiring that is routed between the engine components and the control console components. A decal is provided to identify the numbered terminals. See Figure 2 below.

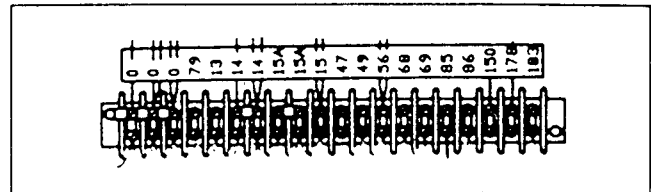


Figure 2. Terminal Board TB1

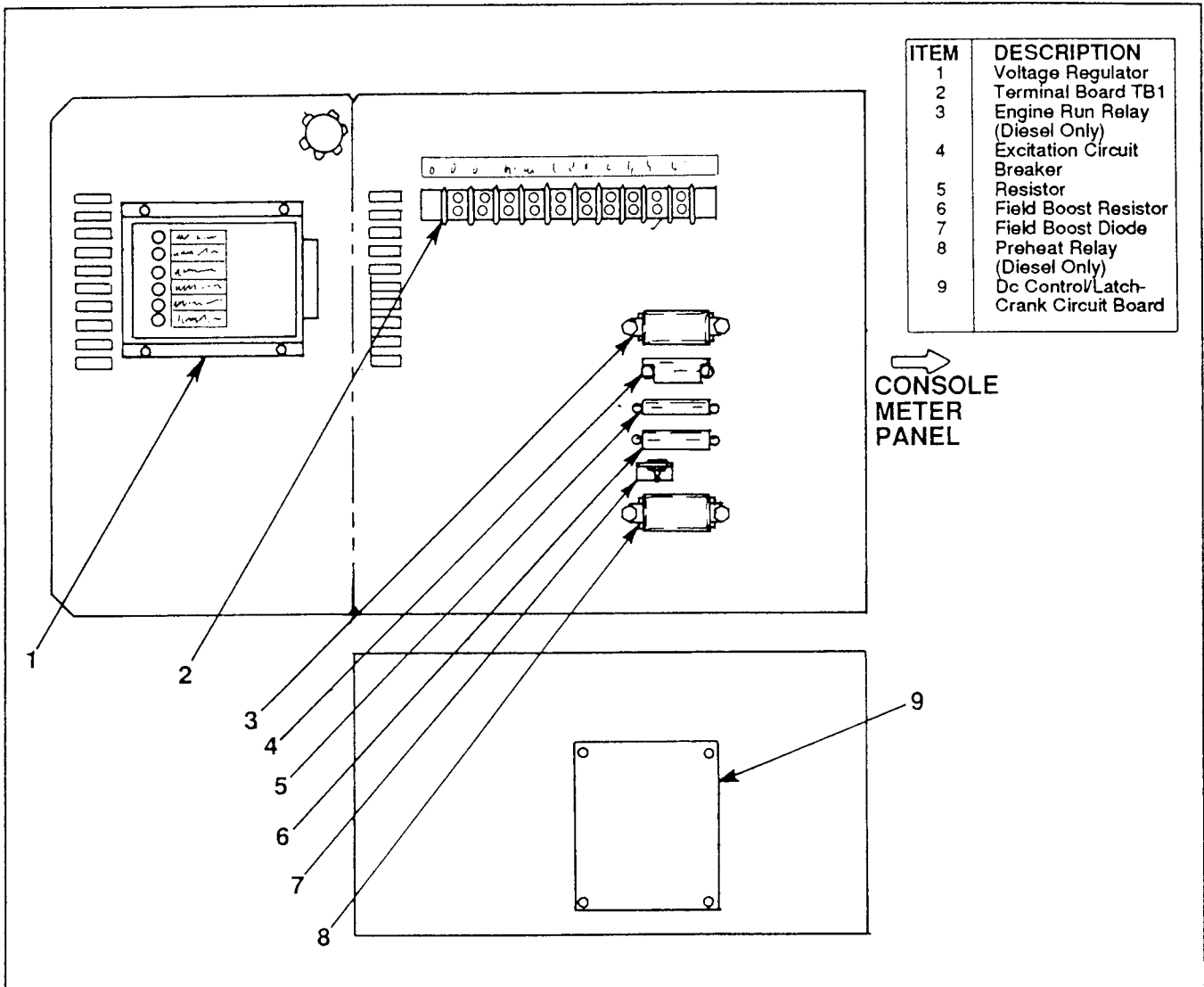


Figure 1. Internal Console Components

Terminal Board TB1 (Continued)

Terminals on the terminal board may be identified as follows.

TERMINAL	WIRE	CIRCUIT FUNCTION
0	0	Common ground.
79	-	Not used on Options A and B control consoles.
13	13	Unfused battery voltage (Always hot).
14	14	Fused battery voltage. Hot with engine running only.
15	15	Fused battery voltage Always hot (12 volts DC).
47	47	Field flash for DC alternator.
49	--	Not Used.
56	56	Engine starter contactor circuit. Hot when cranking only.
68	68	Engine coolant temperature sender to coolant temperature gauge.
69	69	Engine oil pressure sender to oil pressure gauge.
85	85	High coolant temperature and low coolant level shutdown circuit.
86	86	Common to Wire 85.
150	150	Engine preheat circuit (on diesel engines only).
218	218	Engine run circuit.
219	219	Engine run circuit.

Engine Run Relay

The engine run relay is used only on diesel engine units that are equipped with a 24 volts DC engine electrical system. When energized by 12 volts DC from Wire No. 14, closure of the relay's normally open contacts will deliver 24 volts DC battery power to engine components required for startup and operation.

NOTE: The engine run relay is required on 24 volts DC engine systems since a 24 to 12 volts converter is used on such units. The converter changes the 24 volts from the engine battery to 12 volts for operation of control console circuits. Although control console components are operated by 12 volts DC, some engine electrical components require 24 volts DC for their operation.

Excitation Circuit Breaker

Refer to Part 2 for information on the excitation circuit breaker used in direct excited generators.

Refer to Part 3 for information on the excitation circuit breaker used in brushless generators.

See Part 4 for information on the excitation circuit breaker in "Marathon®" generators.

Field Boost Resistor and Diode

This resistor and diode are part of the AC generator excitation system. Refer to Part 2, 3 or 4 as appropriate for information on these components.

DC Control/Latch-Crank Circuit Board

This solid state circuit board controls automatic and manual engine cranking, startup, running and shut-down operations. A 15-pin connector is attached to the circuit board. Functions and related wires of this connector are listed in the following chart:

TERMINAL	WIRE	CIRCUIT FUNCTION
1	S16	Frequency (rpm) signal for starter cutout, overspeed shut-down, calibration.
2	183	Automatic crank-startup circuit.
3	S15	Same as Terminal 1.
4	172	12 volts DC RUN circuit.
5	178	Same as Terminal 2.
6	174	12 volts DC in "Auto".
7	17	Crank circuit for manual start.
8	15	Fused 12 volts DC power.
9	56	Engine starter contactor circuit.
10	0	Common ground.
11	14	Engine run circuit is hot only with engine running.
12	15	Same as Terminal 8.
13	221	Preheat relay circuit on diesel units only.
14	86	Engine fault signal.
15	176	Fault indicator lamp circuit.

Section 5.3 AC CIRCUITS OPERATION

General

AC Circuits that will be discussed in this section include the following:

- The AC voltmeter circuit.
- The AC ammeter circuit.
- The AC frequency meter circuit.
- Voltage regulator and field boost circuits.

All components of these circuits may not be housed in the control console. Units with Option "A" control console are not equipped with an AC voltmeter, ammeter and frequency meter circuit.

AC Voltmeter Circuit

See Figure 1, below. Voltage signals are taken from the stator's AC power winding leads (E1, E2, E3). The voltmeter leads are routed to Pins 5, 8 and 11 of a 15-pin connector plug. From the connector plug, the leads are routed to a line-phase selector switch, and then to the panel-mounted AC voltmeter.

15-PIN CONNECTOR PLUG:

See Figure 2. The connector provides a "quick disconnect" between control console and AC connection (lower) panel components.

Pin numbers, associated wires and functions of each circuit are shown in the chart below:

PIN NO.	WIRE NO.	FUNCTION
1	0	Common Ground.
2	1	Negative (-) side of regulated DC field excitation circuit.
3	2	Unregulated AC field excitation.
4	4	Positive (+) side of regulated DC field excitation circuit.
5	E1	To line-phase selector switch and AC voltmeter.
6	6	Unregulated AC field excitation.
7	S15	AC frequency sensing lead to panel frequency meter and circuit board.
8	E2	To line-phase selector switch and AC voltmeter.
9	S16	AC frequency sensing lead to panel frequency meter and circuit board.
10	57	Line E1 current flow from transformer to line-phase selector switch and AC ammeter.
11	E3	To line-phase selector switch and AC voltmeter.
12	58	Line E2 current flow from transformer to line-phase selector switch and AC ammeter.
13	59	Line E3 current flow from transformer to line-phase selector switch and AC ammeter.
14	178	Auto. start circuit (see NOTE below).
15	183	Auto. start circuit (see NOTE below).

NOTE: Closure of the Wires 178/183 circuit by automatic transfer switch will initiate automatic cranking and startup.

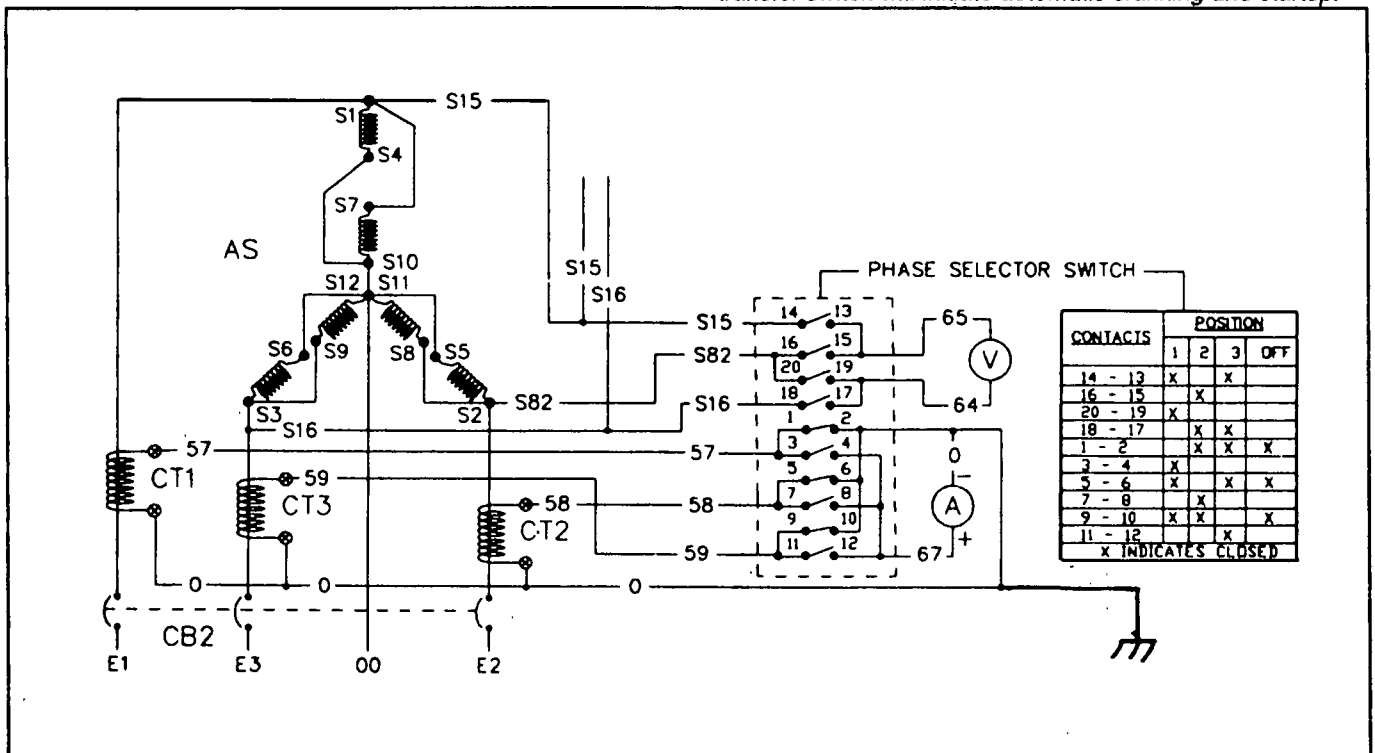


Figure 1. Panel AC Voltmeter and Ammeter Circuits

AC Voltmeter Circuit (Continued)

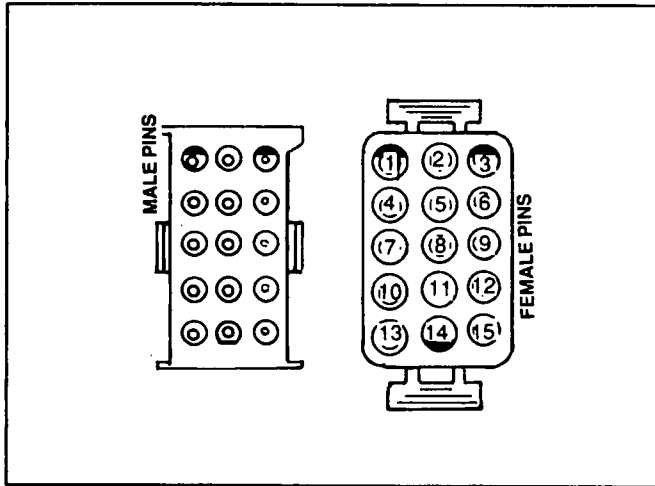


Figure 2. 15-Pin Connector Plug

LINE-PHASE SELECTOR SWITCH:

This 4-position switch permits operator selection of either line-to-line or line-to-neutral voltmeter/ammeter readings. Also see "Line-Phase Selector Switch" on Page 5.1-3. Switch contacts positions at the various switch positions are shown in the following chart ("X" indicates contacts are closed).

CONTACTS	SWITCH POSITION			
	1	2	3	OFF
14-13	X		X	
16-15		X		
20-19	X			
18-17		X	X	
1-2		X	X	X
3-4	X		X	
5-6	X		X	X
7-8		X		
9-10	X	X		X
11-12			X	

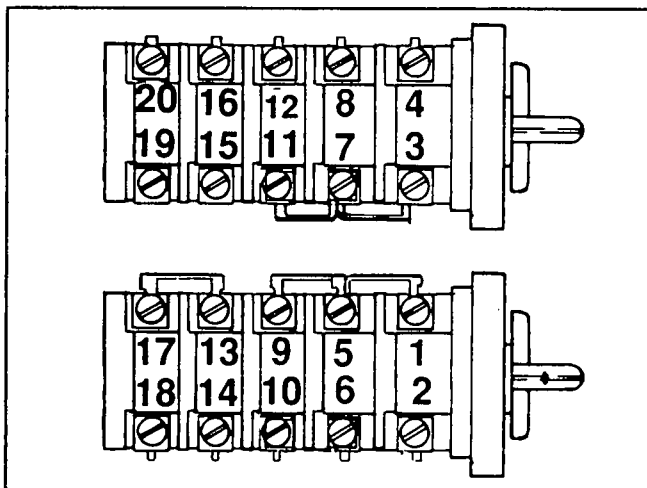


Figure 3. Line-Phase Selector Switch

AC VOLTMETER:

The AC voltmeter used on any generator set depends on the unit's rated voltage and the voltage range of the voltmeter. Also see "AC Voltmeter" on Page 5.1-1.

AC Ammeter Circuit

On a 1-phase generator set, lines E1 and E3 pass through a current transformer. On 3-phase units, lines E1, E2 and E3 pass through a current transformer. Two transformers are required for 1-phase units; three for 3-phase units.

See Figure 1. Current flow through lines E1/E2/E3 induce a voltage and current flow into the transformers. Transformer AC output current is then delivered to the control console ammeter, via Wires 57, 58 and 58; the line-phase selector switch; and Wires 67 and 0.

AC Frequency Meter Circuit

The frequency meter is operated by sensing leads S15 and S16. See Figure 4.

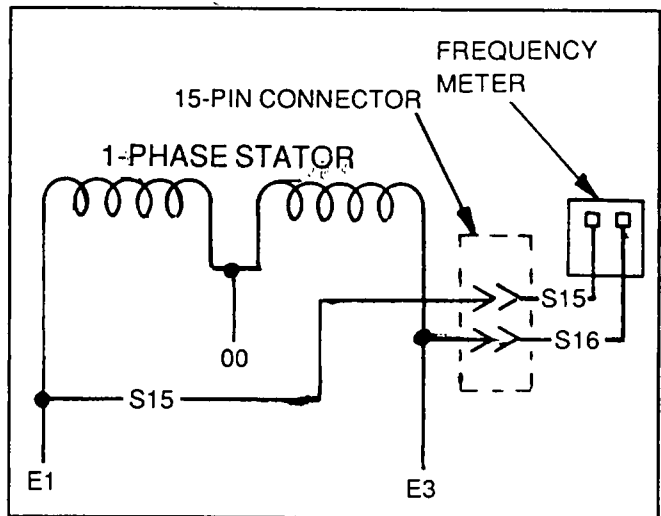


Figure 4. The AC Frequency Meter Circuit

Section 5.4 DC CONTROL- 12 VOLTS GAS UNITS

Introduction

Also refer to "DC Control/Latch-Crank Circuit Board" on Page 5.2-2. That circuit board is the "heart" of the DC control system. The circuit board controls engine cranking, starting, running and shutdown operations.

DC Control/Latch-Crank Circuit Board

See Figure 1, below. The circuit board is equipped with a 15-pin connector. For identification of terminals, associated wires and circuit functions, refer to Page 5.2-2.

The circuit board also mounts two relays. A "crank" relay (K1) is energized by circuit board action to initiate engine cranking. A "run" relay (K2) is energized by circuit board action to activate a Wire No. 14 circuit. That circuit energizes engine components required to keep the engine running (such as a fuel solenoid).

Circuit Condition- Engine Shut Down

Battery voltage (12 volts DC) is available to terminal board TB1, via Wire No. 13. Battery power is then delivered to a 30 amp fuse on the console front face.

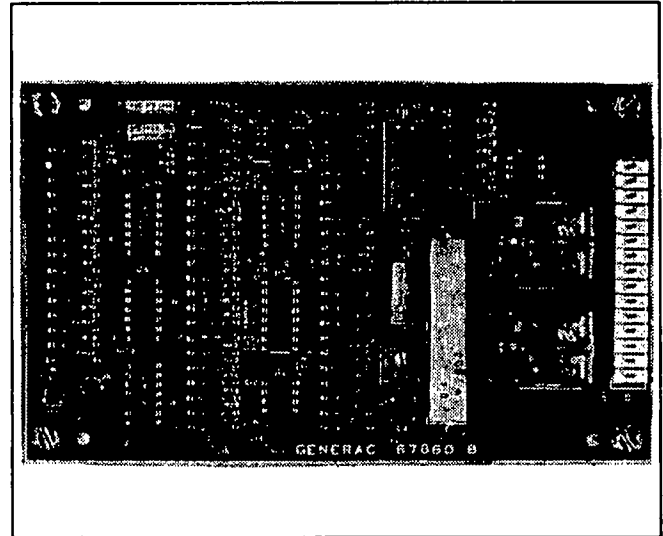


Figure 1. DC Control/Latch-Crank Circuit Board

The fused battery voltage then splits into three separate paths or circuits as follows:

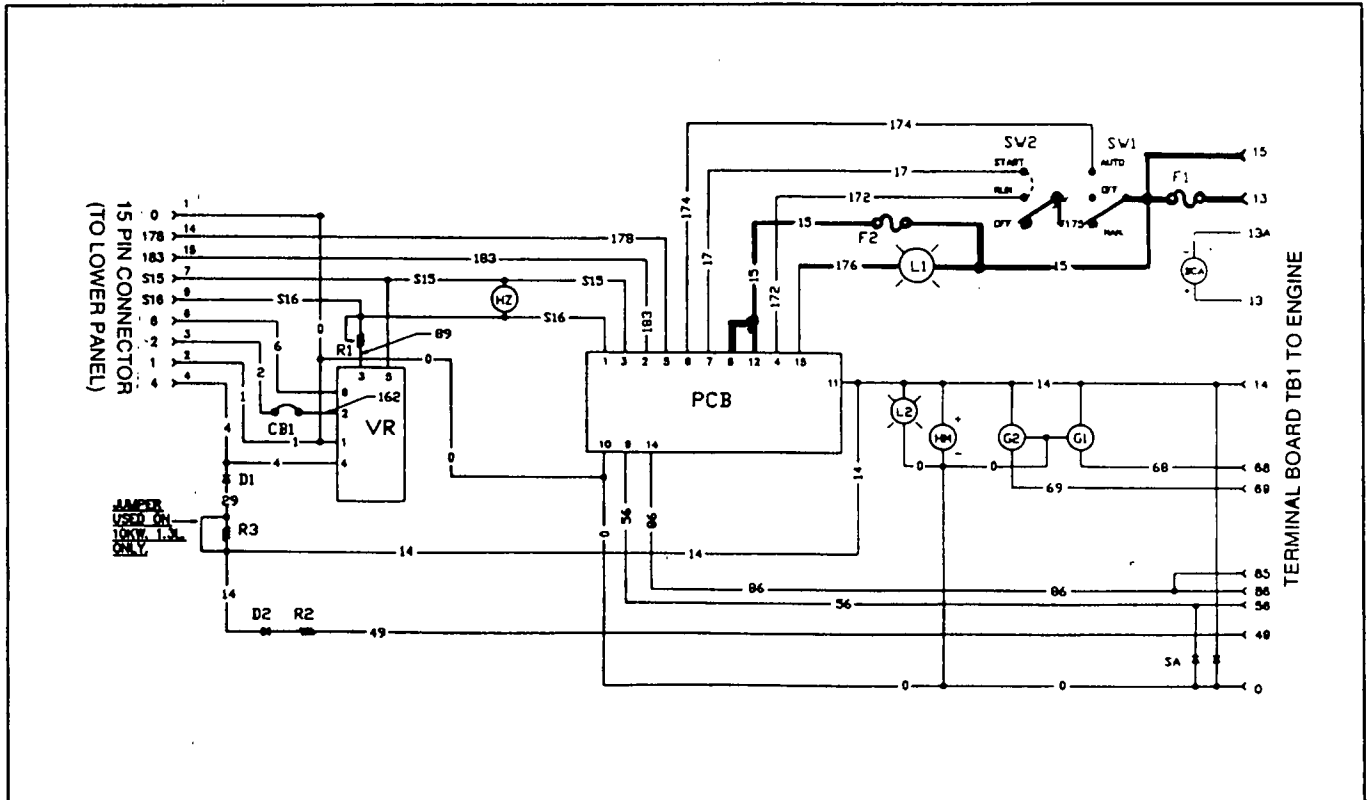


Figure 2. Circuit Condition- Engine Shut Down

**Circuit Condition- Engine Shut Down
(Continued)**

a. Wire No. 15 to the terminal board TB1. The customer may use terminal No. 15 as a source of fused battery voltage for a variety of purposes (such as a power source for a remote annunciator device, a remote lamp, etc.).

b. Wire No. 15 to the console's fault indicator lamp and to the DC control/latch-crank circuit board. The Wire 15 circuit to the circuit board is protected by a 14 amp in-line fuse.

(1) The fault indicator lamp circuit is completed to the circuit board, via Wire No. 176. Circuit board action normally holds the Wire 176 circuit open to ground. However, in the event of an engine fault (high coolant temperature, low coolant level, low oil pressure, overspeed), circuit board action will complete the Wire 176 circuit to ground and the fault indicator lamp will illuminate.

(2) Wire No. 15 to the circuit board provides 12 volts DC power for board operation.

c. Wire No. 15 to the control console's auto-manual-off switch (SW1).

(1) With the auto-manual-off switch set to "Manual", battery voltage is available to the common terminal of the start/stop switch (SW2), via Wire 175.

(2) With "Auto" selected, battery voltage is available to the DC control/latch-crank board, via Wire No. 174.

Circuit Condition- Manual Cranking

See Figure 3, below. When the auto-manual-off switch is set to "Manual" and the start/stop switch is held at "Start", the following action occurs:

- Battery voltage is delivered to Pin No. 7 of the DC control/latch-crank circuit board, via the auto-manual-off switch, Wire No. 175, start/stop switch, and Wire No. 17.
- The circuit board's crank (K1) and run (K2) relays are energized simultaneously.
- When Relay K1 energizes, battery voltage is delivered to the coil of an engine starter contactor, via Wire No. 56. The starter contactor energizes, battery voltage is delivered to the engine starter motor, and the engine cranks.
- When relay K2 energizes, battery voltage is delivered to the Wire No. 14 circuit. This circuit, when energized, turns on (a) a control console lamp L2, (b) hourmeter HM, (c) oil pressure gauge G1, (d) coolant temperature gauge G2, and a fuel solenoid FS. With FS energized open, the engine can start and run.

NOTE: Automatic cranking action is similar to manual cranking. However, during automatic cranking, crank relay K1 will energize cyclically and the engine will crank cyclically in 5.4 second intervals until it starts. See "Circuit Condition- Automatic Cranking".

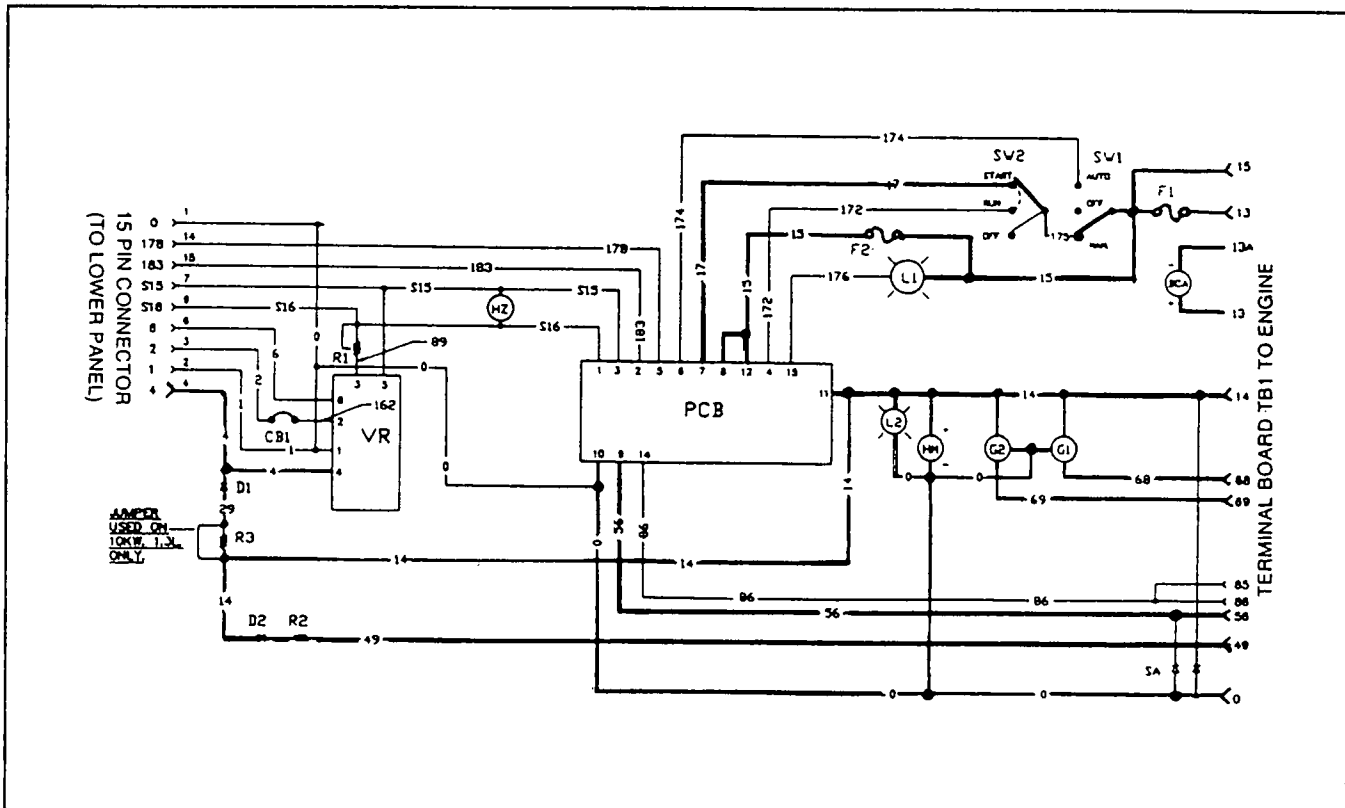


Figure 3. Circuit Condition- Manual Cranking

Circuit Condition- Startup and Running

When run relay K2 is energized by circuit board action, 12 volts DC power is delivered to the Wire No. 14 circuit. The Wire No. 14 circuit turns on (a) the console light, (b) the hourmeter, (c) oil pressure gauge, (d) coolant temperature gauge. The DC power from Wire No. 14 is also delivered to the engine fuel solenoid valve, ignition components, etc. With fuel flow and ignition available, the engine should start and run. Wire No. 14 also delivers 12 volts DC power to (a) the generator's field boost circuit and (b) the engine DC alternator field.

NOTE: Wire No. 14 delivers field boost power to the generator rotor windings via a field boost resistor (R3), Wire No. 29, field boost diode (D1), and Wire No. 4. On 10 kW units with 1.3 liter engine a jumper may be used to bypass the field boost resistor. Wire No. 14 delivers 12 volts DC to the engine driven DC alternator, via (a) diode D2, (b) resistor R2, and (c) Wire No. 49.

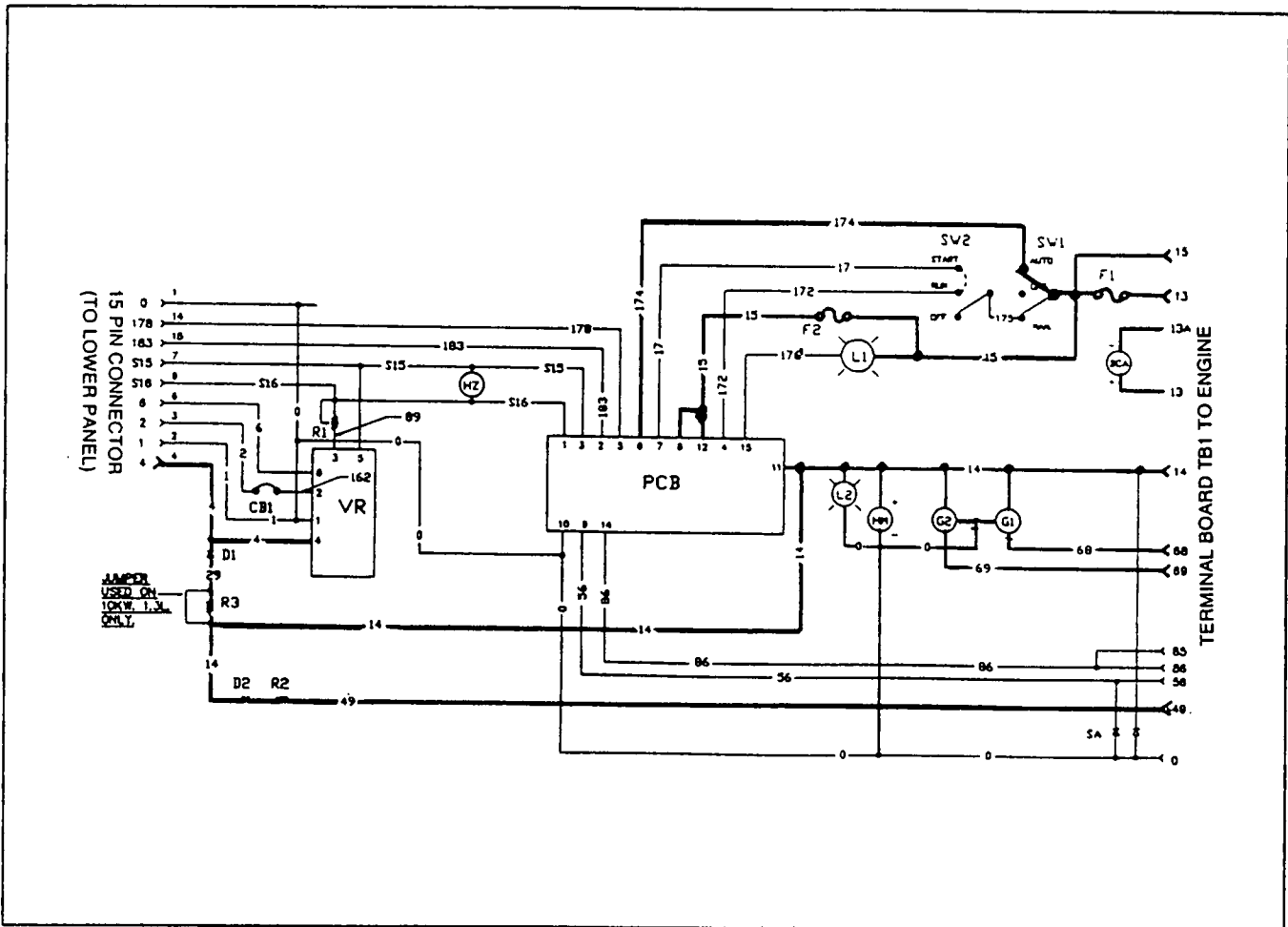


Figure 5. Circuit Condition- Startup and Running

Section 5.5 DC CONTROL- 12 VOLTS DIESEL UNITS

Circuit Condition- Manual Preheat

Units powered by a diesel engine having a 12 volts DC electrical system have a DC control system that is similar to the control system on units with gas engine (Section 5.4). However, diesel engines are equipped with a "preheat" function which utilizes glow plugs or a heater unit to warm the engine combustion chamber for cold weather starts. The control console mounts a preheat switch (SW3) and a preheat relay (PHR) is housed in the console.

See Figure 1. Battery voltage is available to the preheat relay (PHR) and preheat switch (SW3), via Wire No. 13, a 30 amp fuse (F1), Wire No. 15, preheat relay (PHR) and Wire No. 221. Battery voltage is also available to the normally open contacts of the preheat relay (PHR). When the preheat switch is held closed, the preheat relay (PHR) circuit is completed to ground. PHR then energizes, its normally-open contacts close, and battery voltage is delivered to the engine glow plugs or heater via Wire No. 150. The glow plugs or heater will remain on as long as the preheat switch is held closed.

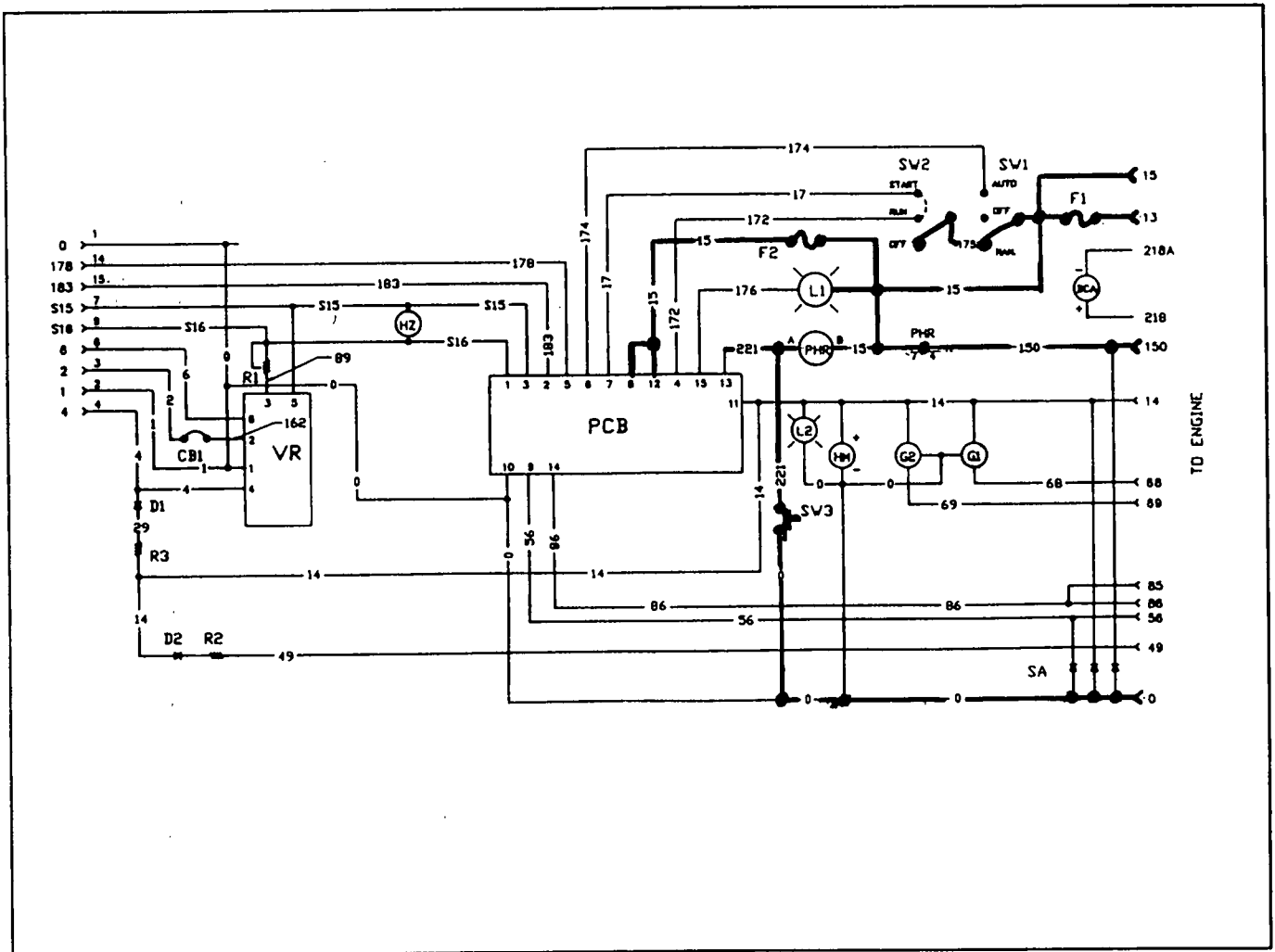


Figure 1. Circuit Condition- Manual Preheat

DC Control Circuit- 12 Volts Diesel Engine Units

The DC control circuit on 12 volts diesel engine units is shown in Figure 2, below. Its operation for cranking, startup, running and shutdown is the same as for gas engine units (Section 5.4). Operation during manual preheat was discussed on the previous page. During automatic startup, preheat occurs automatically when the preheat relay is energized by circuit board action.

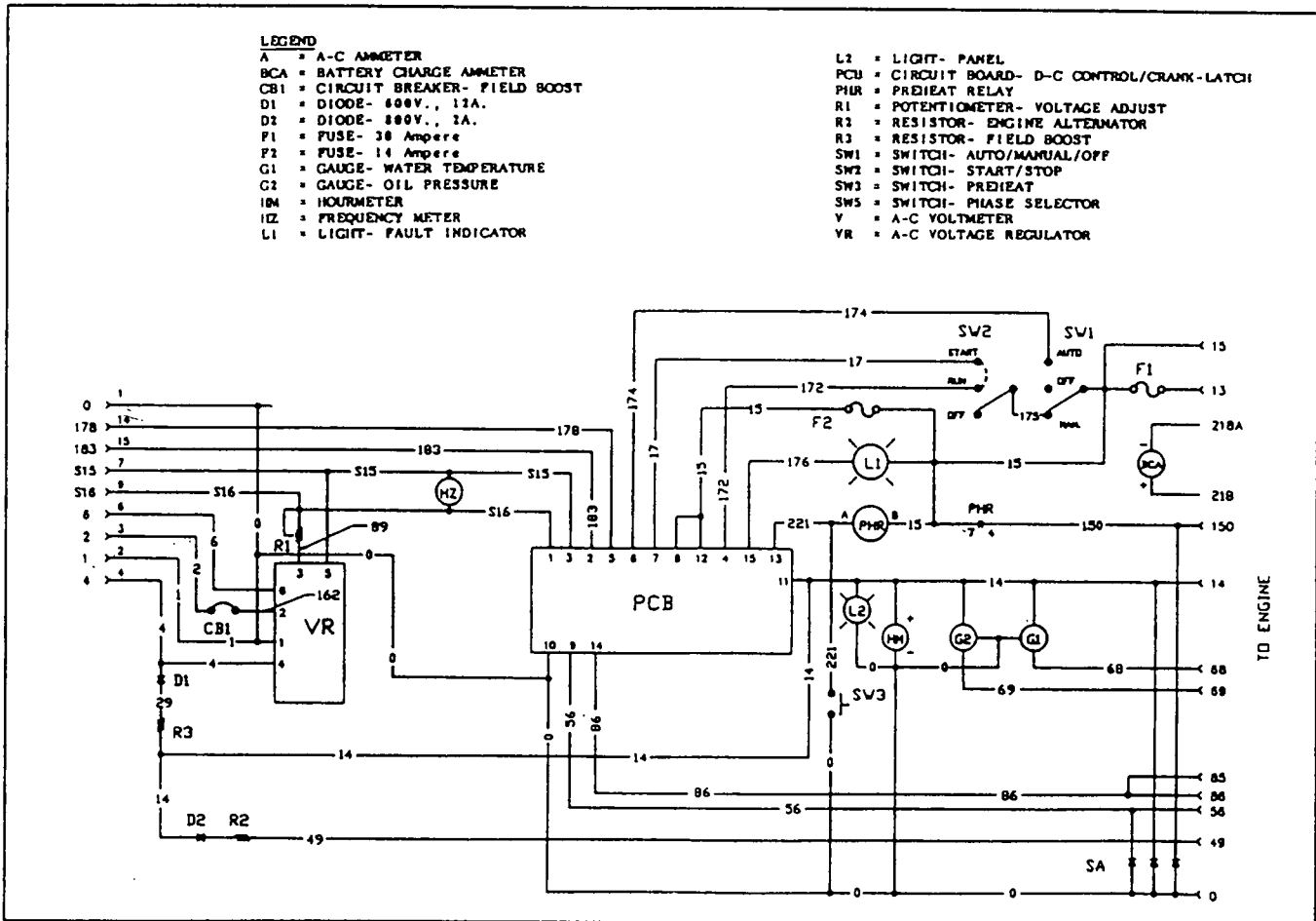


Figure 2. DC Control Circuit- 12 Volts Diesel Engine Units

Section 5.6 DC CONTROL- 24 VOLTS DIESEL UNITS

Introduction

The DC control system on units with diesel engine and with a 24 volts engine electrical system is similar to systems discussed in Sections 5.4 and 5.5. However, because the engine electrical system parts are rated 24 volts DC and control console parts are rated 12 volts DC, a 24 to 12 volts DC converter is required. Figure 1 below is a pictorial representation of the converter.

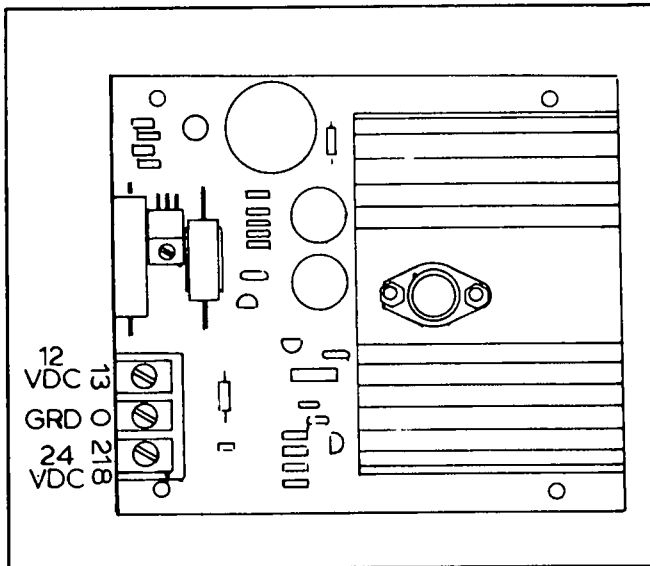


Figure 1. The 24 to 12 Volts Converter

Figure 2 is a schematic representation of the converter circuit. Battery voltage (24 volts DC) is available to the converter, via Wire No. 218. A reduced battery voltage (12 volts DC) is then delivered to the control console, via Wire No. 13.

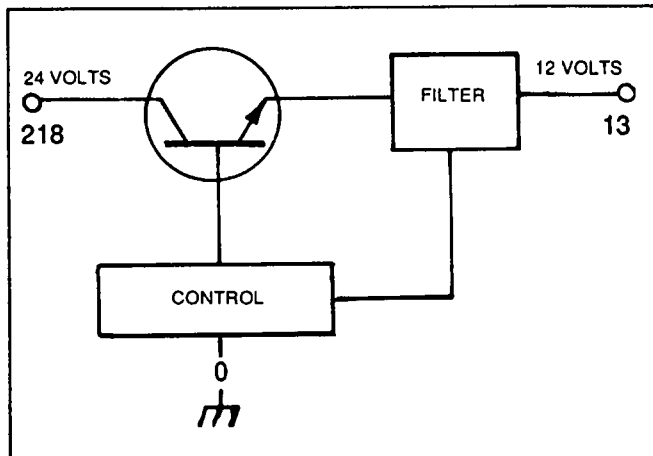


Figure 2. Converter System Schematic

Engine Run Relay

Because the engine electrical system is rated 24 volts DC and the control console voltage is 12 volts DC, an engine run relay is required. When energized by control console voltage (12 volts DC), the relay contacts can pass 24 volts DC to engine components.

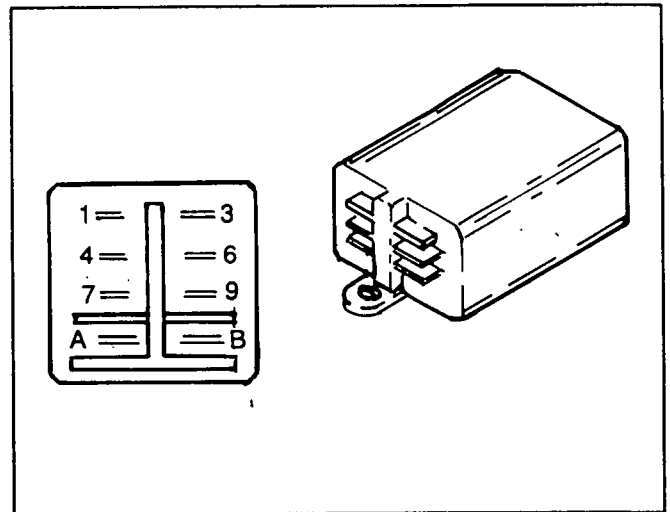


Figure 3. Engine Run Relay

Preheat Circuit

See Figure 4. When a preheat relay (PHR) is energized by preheat switch action or by circuit board action, its contacts (PHR) close to deliver 12 Volts DC to a preheat contactor (PHC). The contactor contacts then close to deliver 24 volts DC to an air intake heater (AIH). The heater turns on to warm the air entering the engine combustion chambers.

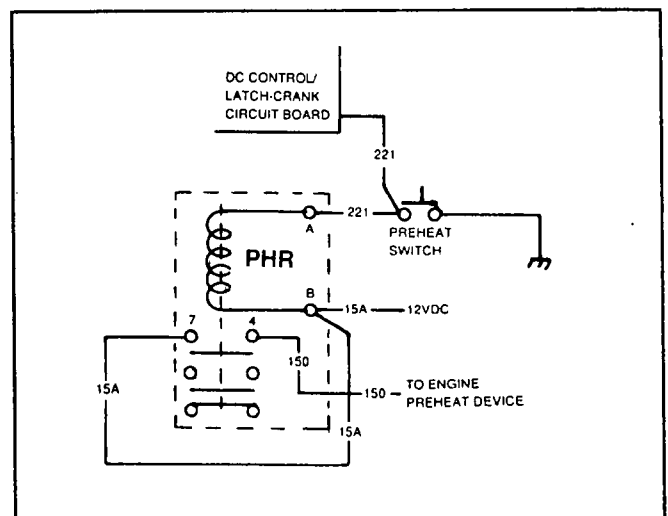


Figure 4. Preheat Circuit Diagram

DC Control- 24 Volts Diesel Engine Units

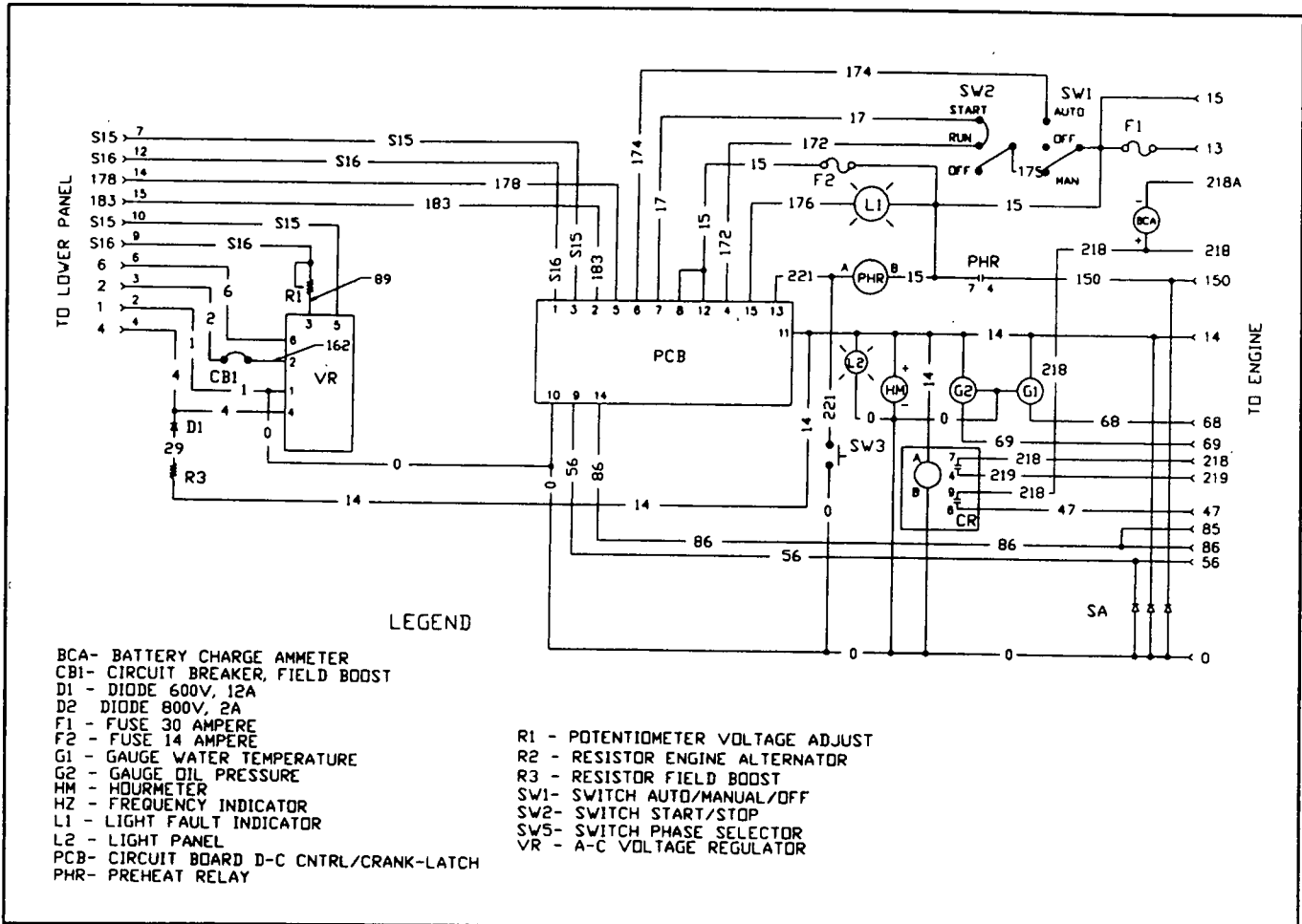


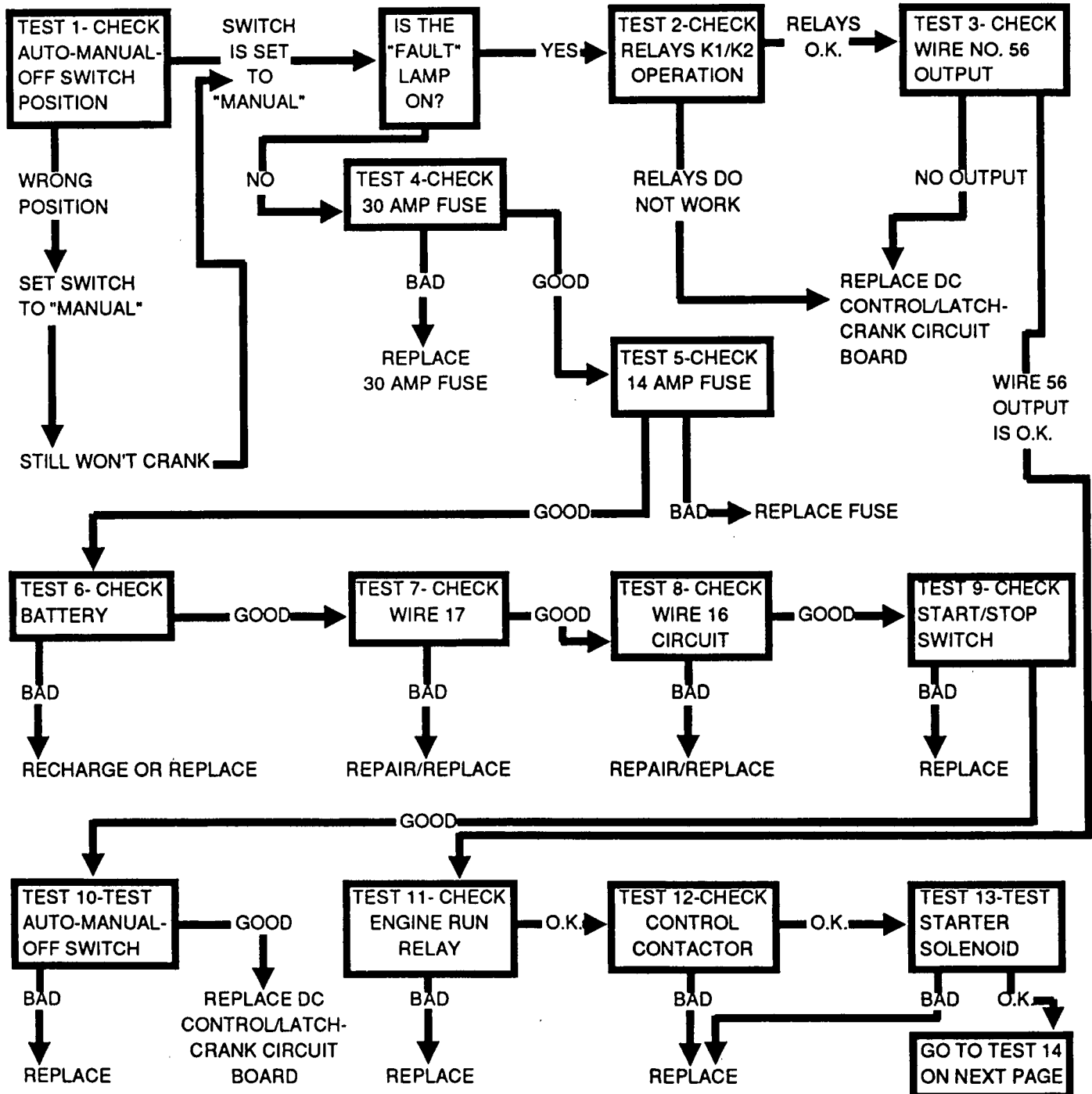
Figure 5. Schematic Diagram- DC Control System

Section 5.7 TROUBLESHOOTING CHARTS

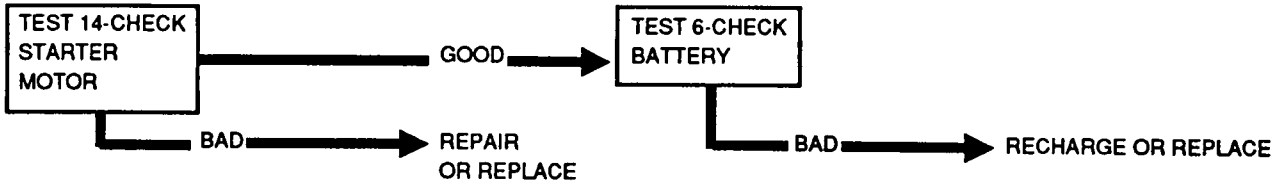
Introduction

The flow charts on this and on following pages can be used in conjunction with Section 5.8, "Diagnostic Tests". To use the charts, first identify the specific problem. Locate that problem in the flow charts, then proceed with the numbered tests that follow. If you do not know how to perform a test, refer to Section 5.8. The numbered tests in that section correspond with test numbers in this section.

Problem 1 - Engine Won't Crank Manually

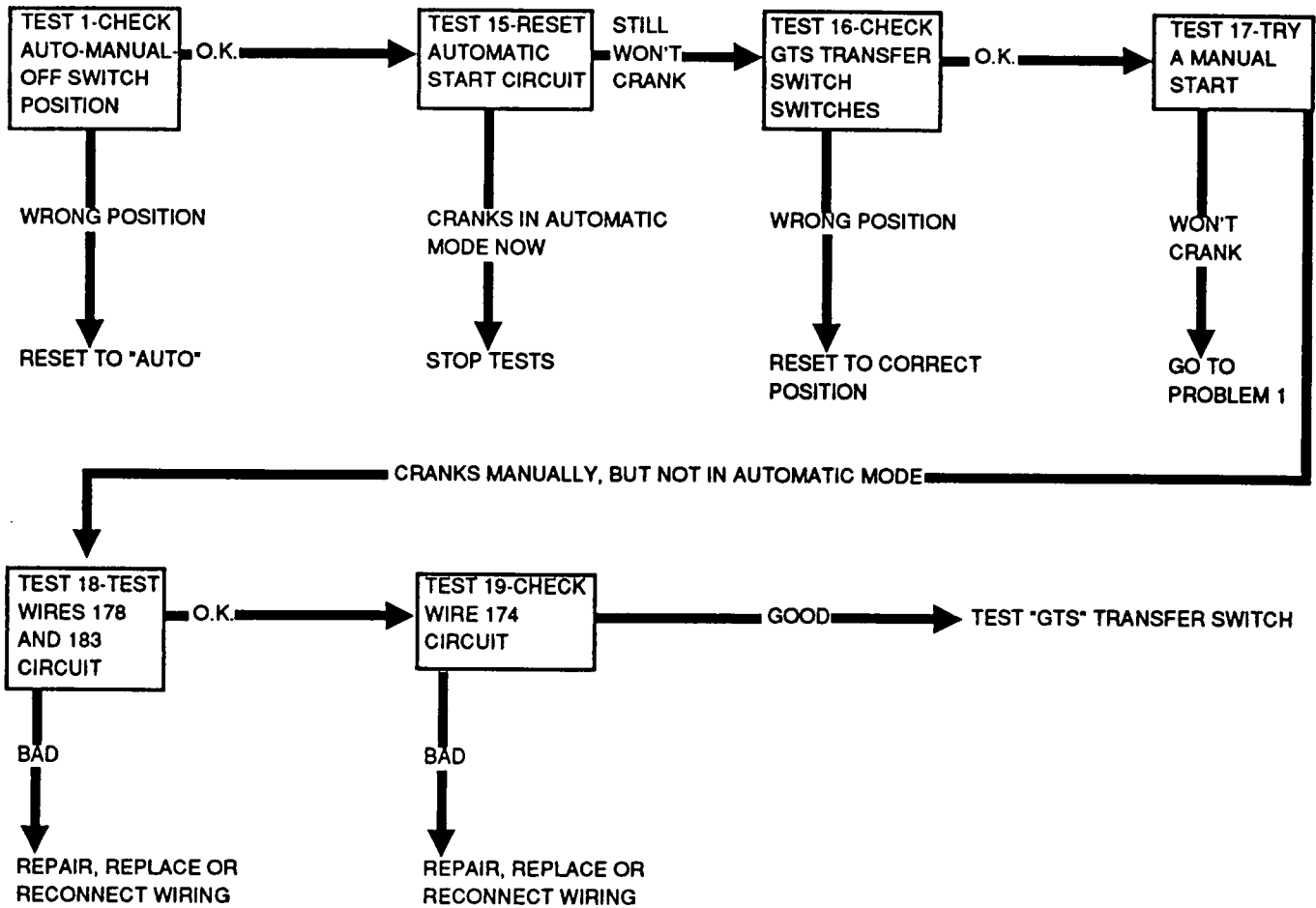


Problem 1- Engine Won't Crank Manually (Continued)

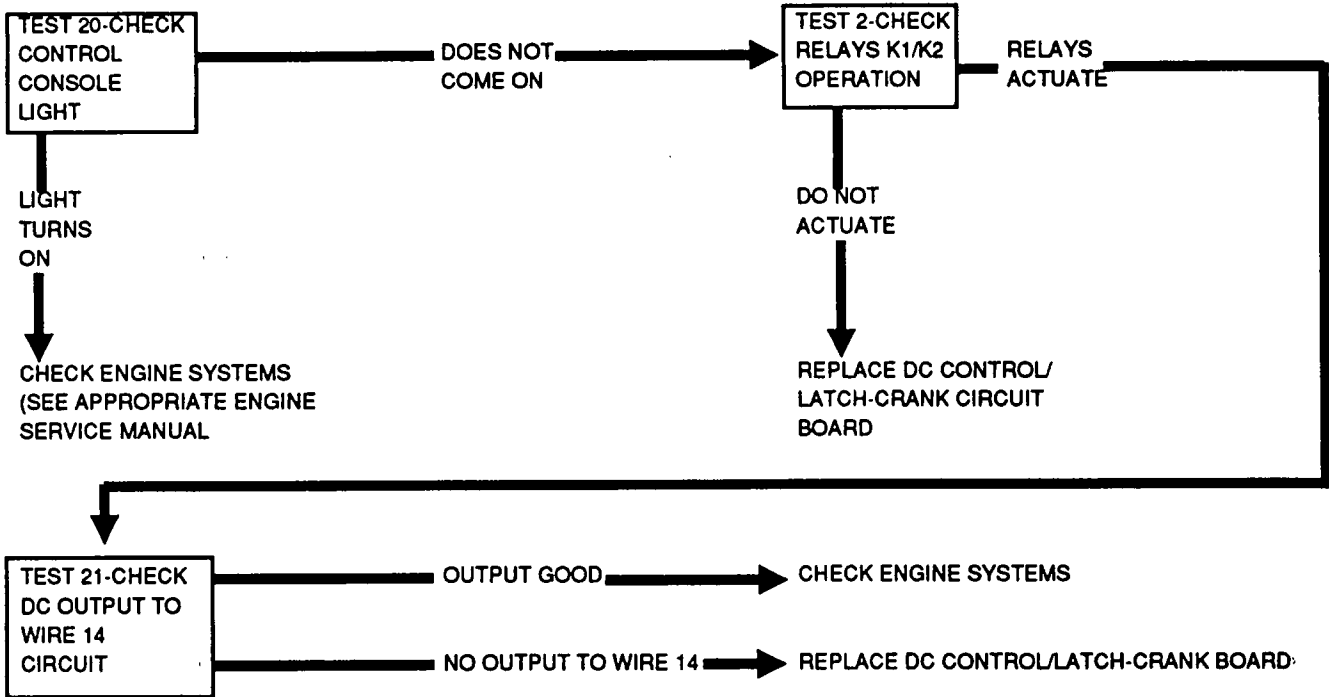


NOTE: Test 11 (Check Engine Run Relay) applies only to diesel engine units with a 24 volts DC engine electrical system.

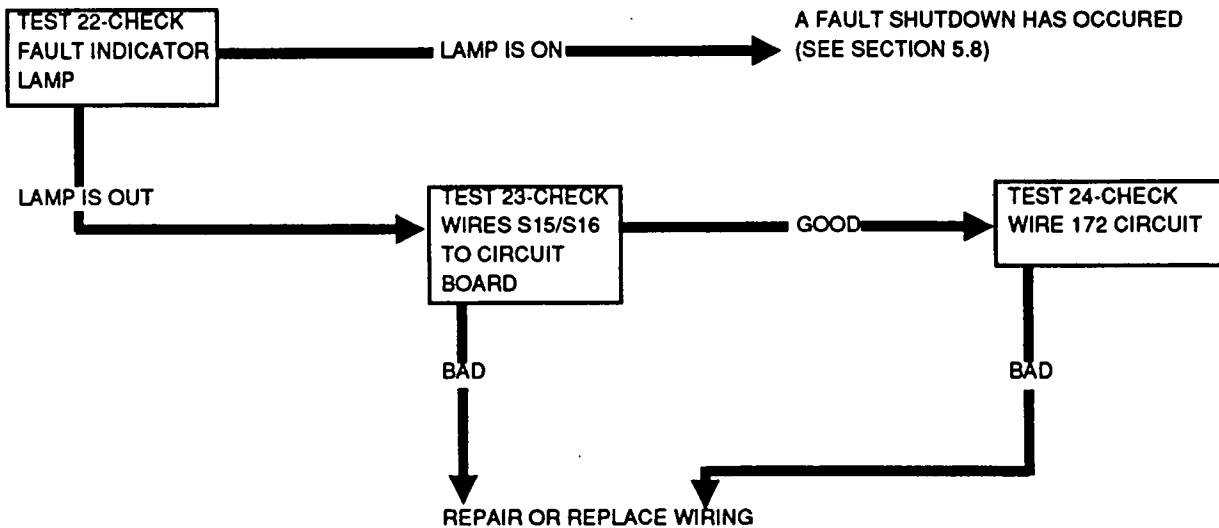
**Problem 2- Engine Won't Crank in Automatic Mode
(Won't Crank on Utility Power Outage or System Test)**



Problem 3- Engine Cranks But Won't Start



Problem 4- Engine Cranks, Starts and Then Shuts Down



Section 5.8 DIAGNOSTIC TESTS

Introduction

Perform the diagnostic tests in this section in conjunction with the "Troubleshooting Charts" of Section 5.7.

Test 1- Check Auto-Manual-Off Switch Position

DISCUSSION:

This 3-position, console mounted switch must be properly positioned or manual/automatic cranking will not occur. The following rules apply:

- Before attempting to crank and start the engine manually, set the switch to "Manual". Engine will not crank if switch is set to either "Auto" or "Off".
- Set the switch to "Auto" for automatic operations. With switch set to "Auto" closure of the 2-wire start circuit (by transfer switch circuit board action) will initiate engine cranking and startup, followed by transfer of electrical loads to the "Standby" power source.
- When it becomes desirable to prevent both manual and automatic startup, set the switch to "Off".

DANGER: WHEN THE GENERATOR IS INSTALLED IN CONJUNCTION WITH AN AUTOMATIC TRANSFER SWITCH, THE ENGINE CAN CRANK AND START SUDDENLY WITHOUT WARNING. SUCH AUTOMATIC STARTUP NORMALLY OCCURS WHEN UTILITY SOURCE VOLTAGE HAS DROPPED BELOW A PRESET LEVEL. TO PREVENT SUCH SUDDEN STARTUP AND POSSIBLE INJURY ALWAYS SET THE AUTO-MANUAL-OFF SWITCH TO "OFF" POSITION BEFORE ATTEMPTING TO SERVICE OR REPAIR THE GENERATOR SET.

PROCEDURE:

Check the switch position. Switch must be set to "Manual" before attempting manual startup, or to "Auto" for automatic startup.

RESULTS:

1. If switch is set to the correct position but engine will not crank and start, go to Test 2.
2. If necessary, reset switch to "Manual" for manual startup; to "Auto" for automatic startup.

Test 2- Check Relays K1/K2 Operation

DISCUSSION:

Relays K1 and K2 are an integral part of the DC Control/latch-crank circuit board. Relay K1 is the "crank" relay and is energized by circuit board action to crank the engine. When the relay is energized, it

normally-open contacts close and a DC voltage is delivered to circuit board terminal No. 9 and to Wire No. 56. Current flow through Wire No. 56 energizes a control contactor which, in turn, energizes a starter contactor. When the contacts of the energized starter contactor close, battery voltage is delivered to the engine starter and the engine cranks.

NOTE: Units with diesel engine and with a 24 volts DC engine electrical system also include an "engine run" relay. See Section 5.6.

Relay K2 is the "run" relay. It is energized by circuit board action at the same time as relay K1. When relay K2 energizes, 12 volts DC is delivered to circuit board terminal 11 and to the Wire 14 circuit.

PROCEDURE:

Hold the start/stop switch at "Start" while observing the two circuit board relays for movement of their contacts. Both relays should actuate simultaneously.

RESULTS:

1. If the relays actuate, go on to Test 3.
2. If the relays do NOT actuate, go to Test 4.

Test 3- Check Wire #56 Output

DISCUSSION:

On closure of the crank relay (K1) contacts, battery voltage should be delivered to terminal 9 of the circuit board and to Wire No. 56.

PROCEDURE:

1. Set a VOM to a DC voltage scale great enough to read battery voltage (12 volts DC).
2. Connect the positive (+) VOM test lead to terminal 9 of the DC control/latch-crank board (Wire No. 56).
3. Connect the VOM common (-) test lead to terminal 0 of terminal board TB1 (common ground).
4. Crank the engine by holding the start/stop switch at "Start". The VOM should read approximately 12 volts DC (battery voltage).

RESULTS:

1. If the relays actuated in Test 2 but the VOM does not read battery voltage, replace the circuit board.
2. If relay K1 actuated in Test 2 and the VOM indicates a DC voltage but engine won't crank, go to Test 11.

Test 4- Check 30 Amp Fuse

DISCUSSION:

If the 30 amp fuse has blown, engine cranking will not be possible since the power supply to the circuit board has been interrupted.

Test 4- Check 30 Amp Fuse (Continued)

PROCEDURE:

To check the fuses, set the auto-manual-off switch to its "Manual" position. The fault indicator lamp should turn on, indicating the fuses are good.

If the lamp does not turn on, remove the 30 amp fuse from the fuse holder. Use a VOM to check the fuse for an open condition.

RESULTS:

1. Replace fuse if open (blown).
2. If 30 amp fuse is good, go to Test 5.

Test 5- Check 14 Amp Fuse

DISCUSSION:

The 14 amp inline fuse is housed inside the generator console. It is connected in series with Wire 15 (fused DC voltage) to the dc control/latch-crank board.

PROCEDURE:

When the auto-manual-off switch is set to "Manual", the fault indicator lamp should turn on. If the lamp does NOT turn on, remove the 14 amp fuse from its inline fuse holder. Use a VOM to test the fuse for an open condition.

RESULTS:

1. Replace the fuse if it is open.
2. If the fuse is good, go to Test 6.

Test 6- Check Battery

DISCUSSION:

The generator battery supplies the required power for operation of the DC control system and engine electrical system components. A dead or discharged battery will result in a failure of the engine to crank. Battery power is delivered to the engine control console via Wire 13. Fused battery power is delivered to the DC control/latch-crank circuit board via Wire 15.

Some units with diesel engine are equipped with a 24 volts DC engine electrical system. Two 12 volts batteries are usually connected in series to supply the needed 24 volts DC on such units. Because the control console components require a 12 volts DC power supply, a 24 to 12 volts converter is installed on these generators. In addition, such units require an engine run relay. The relay is energized by 12 volts DC from the DC control/latch-crank board but delivers 24 volts DC power to engine components requiring the higher voltage.

NOTE: Generators may be equipped with either a 2 or 10 amp battery charger. These chargers are powered by utility source voltage. Always turn off utility source voltage to the charger before connecting or disconnecting battery cables. See Part 7, "Generator Options and Accessories".

DANGER: STORAGE BATTERIES GIVE OFF EXPLOSIVE HYDROGEN GAS. DO NOT ALLOW FLAME, SPARKS OR ANY SOURCE OF HEAT NEAR THE BATTERY. THE SLIGHTEST SPARK CAN CAUSE AN EXPLOSION.

DANGER: BATTERY ELECTROLYTE FLUID IS AN EXTREMELY CAUSTIC SULFURIC ACID SOLUTION THAT CAN CAUSE SEVERE BURNS. DO NOT PERMIT FLUID TO CONTACT EYES, SKIN, CLOTHING, PAINTED SURFACES, WIRING INSULATION, ETC. IF SPILLAGE OCCURS, FLUSH THE AFFECTED AREA WITH CLEAR WATER IMMEDIATELY.

PROCEDURE:

Use an automotive type battery hydrometer to test the battery (or batteries) for (a) state of charge and (b) condition. Follow the hydrometer manufacturer's instructions carefully.

State of Charge: Use the hydrometer to test the specific gravity of the fluid in all battery cells. Return all fluid to the cell from which it was taken. If the hydrometer used does not have a "percentage of charge" scale, compare the readings obtained with the following:

SPECIFIC GRAVITY	PERCENTAGE OF CHARGE
1.260	100%
1.230	75%
1.200	50%
1.170	25%

If necessary, remove the battery and charge it to a 100 percent state of charge using an automotive battery charger.

Battery Condition: If the difference in specific gravity between the highest and lowest reading cell is greater than 0.050 (50 points), the battery is nearing the end of its useful life and should be replaced. However, if the battery is discharged, recharge it and then repeat the test for condition. If, after charging, the difference between the highest and lowest reading cell is still more than 0.050 (50 points), replace the battery.

NOTE: Install only a fully charged battery. Generator battery chargers will maintain a state of charge but should not be relied on to recharge a battery.

Battery Cables: Inspect battery cables and posts for cleanliness and corrosion. Clean away all corrosion from cable clamps and from battery posts. When installing cables, make sure they are clean and tight. Replace any defective cables. A damaged, defective or corroded cable can prevent the engine from starting and may also result in other serious problems with the standby electric system.

Test 6- Check Battery (Continued)

RESULTS:

1. Recharge or replace battery as required.
2. If battery tests good, go on to Test 7.

Test 7- Check Wire 17

DISCUSSION:

Battery voltage is available to the console start/stop switch via terminal 13 of terminal board TB1, 30 amp fuse F1, Wire 15, "Manual" position of the auto-manual-off switch, and Wire 175. When the start/stop switch is set to "Start" position, the battery voltage is delivered to Pin 7 of the DC control/latch-crank board via Wire 17. If, for any reason, the battery voltage is not available to the circuit board, manual cranking will not occur.

PROCEDURE:

Inspect Wire 17, between the start/stop switch and the circuit board. Look for damage, proper connection. Test the wire for an open or shorted condition.

RESULTS:

1. Repair, reconnect or replace Wire 17 if necessary.
2. If Wire 17 is good, go on to Test 8.

Test 8- Check Wire 15 Circuit

DISCUSSION:

If Wire 15 is open, battery voltage will not be available to the auto-manual-off switch and engine cranking/startup will not occur.

PROCEDURE:

1. Set a VOM to a DC voltage scale high enough to read battery voltage.
2. Connect the VOM positive (+) test lead to the Wire 15 terminal of the auto-manual-off switch.
3. Connect the VOM common (-) test lead to terminal 0 of terminal board TB1. The meter should read battery voltage.
4. Now, connect the VOM positive (+) test lead to terminal 15 of terminal board TB1, the common test lead to TB1 terminal 0. Again, the meter should indicate battery voltage.

RESULTS:

1. If battery voltage is indicated in Step 4, but not in Step 3, Wire 15 between the terminal board and auto-manual-off switch must be open. Repair, replace or reconnect the wire as required.
2. If battery voltage is indicated in both Steps 3 and 4, go on to Test 9.

Test 9- Check Start/Stop Switch

DISCUSSION:

A defective start/stop switch can prevent manual startup.

PROCEDURE:

1. Disconnect all wires from the start/stop switch (Figure 1), to prevent interaction.
2. Set a VOM to its "Rx1" scale and zero the meter.
3. Connect one VOM test lead to switch terminal 4, to which Wire 175 was attached.
4. Connect the second VOM test lead to switch terminal 3, to which Wire 17 was attached.
5. Set the switch to its "Start" position. The VOM should read "continuity".
6. Now, connect one VOM test lead to switch terminal 4, the other test lead to switch terminal 2.
7. Set the switch to its "Run" (centered) position. The meter should read "continuity".

RESULTS:

1. Replace switch if defective.
2. If switch tests good, go on to Test 10.

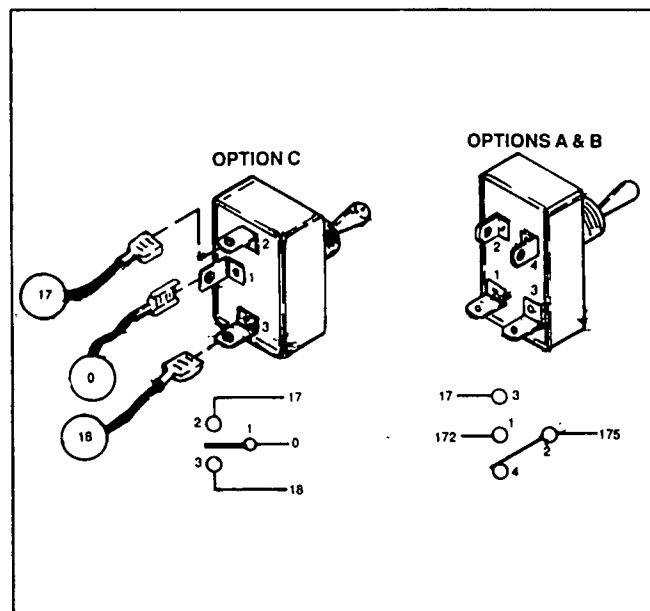


Figure 1. Start/Stop Switch Test Points

Test 10- Check Auto-Manual-Off Switch

DISCUSSION:

The auto-manual-off switch must be set to "Manual" for manual starts, to "Auto" for automatic startup. It is apparent that a defective switch can prevent cranking and startup from occurring. This is a test of the auto-manual-off switch.

Test 10- Check Auto-Manual-Off Switch (Continued)

PROCEDURE:

1. Disconnect wires from switch terminals (Figure 2) to prevent interaction.
2. Set a VOM to its "Rx1" scale and zero the meter.
3. Connect one VOM test lead to switch terminal 1, the other to switch terminal 2.
 - a. Set switch to "Auto"- the meter should read "continuity".
 - b. Set the switch to "Off"- VOM should indicate "infinity".
 - c. Set the switch to "Manual"- meter should read "infinity".
4. Now, connect the VOM test leads across switch terminals 2 and 3.
 - a. Set the switch to "Manual"- VOM should read "continuity".
 - b. Set switch to "Auto"- meter should indicate "infinity".
 - c. Set the switch to "Off"- VOM should read "infinity".

RESULTS:

Replace the switch if it fails the test.

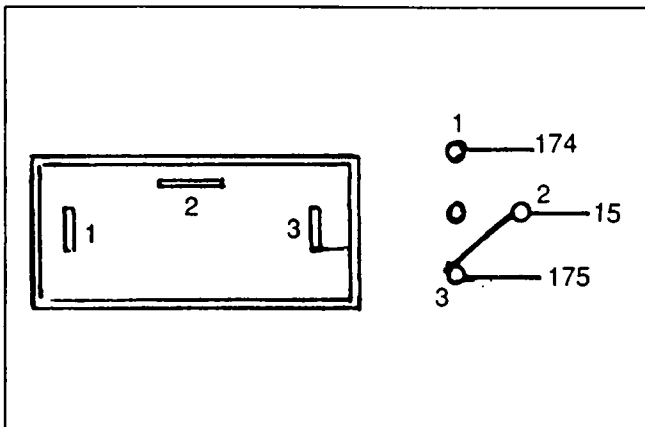


Figure 2. Auto-Manual-Off Switch Terminals

Test 11- Test Engine Run Relay

DISCUSSION:

Diesel engine generators having a 24 volts DC engine electrical system are equipped with an engine run relay. The relay functions to permit 24 volts DC engine components to be energized by the control console's 12 volts DC system.

PROCEDURE:

- Disconnect all wires from relay terminals, to prevent interaction. Then, test the relay as follows:
1. With relay de-energized, connect VOM test leads across relay terminals 4 and 7. The meter should read "infinity".
 2. Connect relay terminal B to terminal 0 of terminal board TB1 (ground).

3. Connect relay terminal A to terminal 13 of terminal board TB1. The relay should energize and the meter should read "continuity" across relay terminals 4 and 7.
4. Now, connect the VOM test leads across relay terminals 6 and 9.
5. Ground terminal B as in Step 2.
6. Connect relay terminal A to terminal 13 of TB1. The relay should energize and the meter should read "continuity".
7. Disconnect relay terminal A from TB1 terminal 13. The relay should de-energize and the VOM should indicate "infinity".

RESULTS:

1. Replace relay if defective.
2. If relay tests good, go on to Test 12.

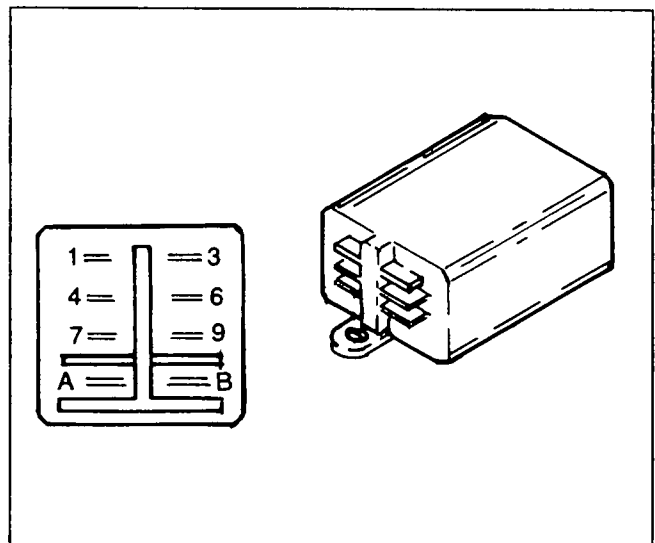


Figure 3. Engine Run Relay Terminals

Test 12. Check Control Contactor

DISCUSSION:

The control contactor (CC) is energized by DC control/latch-crank board action when that circuit board's crank relay (K1) energizes to deliver 12 volts DC to Wire 56. When the contactor energizes, its normally-open contacts close to deliver cranking power to the engine starter.

On units with 24 volts DC engine electrical system, energizing the contactor with 12 volts DC power delivers 24 volts battery power to a starter solenoid. The starter solenoid contacts then close to deliver 24 volts DC to the starter motor. The engine then cranks.

Cranking system operation on units with 12 volts DC engine electrical systems is similar to 24 volts DC operation. On these units, the contactor is energized by 12 volts DC to deliver 12 volts DC to the starter solenoid.

Test 12- Check Control Contactor (Continued)

PROCEDURE:

Refer to the appropriate engine service manual for starter contactor information.

RESULTS:

1. Replace control contactor if defective.
2. If contactor tests good, go to Test 13.

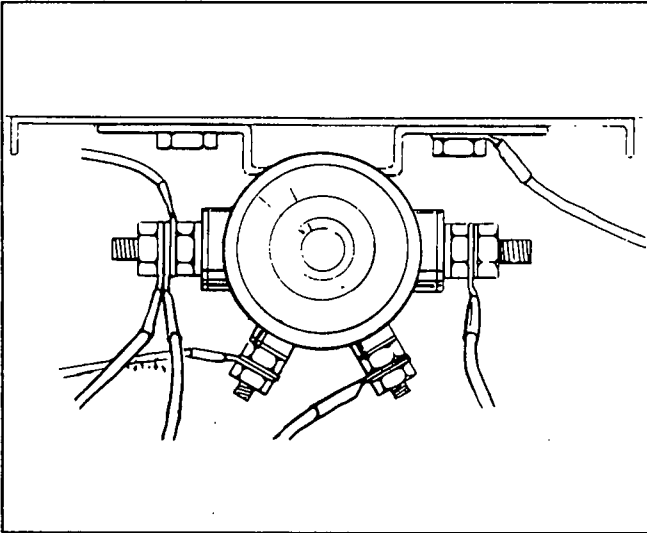


Figure 4. Typical Control Contactor

Test 13- Check Starter Contactor

DISCUSSION:

Refer to the appropriate engine wiring diagram/schematic for the specific generator unit.

PROCEDURE:

See appropriate engine service manual for starter contactor test procedures.

RESULTS:

Replace starter contactor if defective.

Test 14- Check Starter Motor

Refer to the appropriate engine service manual for starter motor information and testing instructions.

Test 15- Reset Automatic Start Control Circuit

DISCUSSION:

Engine cranking is disabled after any fault shutdown (low oil pressure, high coolant temperature, low coolant level, overspeed, overcrank). To enable cranking, the automatic start circuit must be reset following such a fault shutdown.

PROCEDURE:

Set the auto-manual-off switch to "Off" and then back to either "Auto" or "Manual".

Test 16- Check "GTS" Control Switches

DISCUSSION:

When the standby generator is installed in conjunction with a "GTS" type automatic transfer switch, automatic cranking will not occur unless the control switches on the transfer switch are properly positioned. For example, if the transfer switch is equipped with a safety disconnect switch, that switch must be set to "Automatic" for automatic operation.

PROCEDURE:

Refer to the appropriate transfer switch instructions. Make sure all transfer switch control switches are properly positioned.

Test 17- Try a Manual Start

DISCUSSION:

During normal automatic operation, engine cranking and startup will occur when circuit boards in the "GTS" type automatic transfer switch sense a dropout in utility source voltage below a preset level. Such a dropout in utility source voltage will cause a transfer switch intelligence circuit to close the automatic start circuit (Wires 178 and 183).

If automatic cranking and startup do not occur, it is a good idea to try a manual start.

PROCEDURE:

1. On the generator control console, set the auto-manual-off switch to "Manual".
2. Use the console mounted start/stop switch to crank the engine manually.

RESULTS:

1. If engine cranks and starts manually but will not crank in automatic mode, go to Test 18.
2. If engine will not crank manually, go to Problem 1 in Section 5.7.
3. If engine cranks but will not start, go to Problem 3 in Section 5.7.

Test 18- Check Wires 178/183 Circuit

DISCUSSION:

Wires 178/183 form the 2-wire circuit for automatic startup and shutdown. When this circuit is closed by "GTS" transfer switch action, a complete circuit is formed.

Test 18- Check Wires 178/183 Circuit (Continued)

ed back to the DC control/latch-crank circuit board in the generator console. The DC control/latch-crank board then controls engine cranking and startup by energizing a crank relay (K1) and a run relay (K2) mounted on the circuit board.

Figure 5, below, shows a 2-wire start circuit. A 2-position terminal strip is provided in the generator's AC connection (lower) panel. For automatic operation, appropriate wiring must be connected to that terminal strip and to an identically numbered terminal strip in the "GTS" transfer switch.

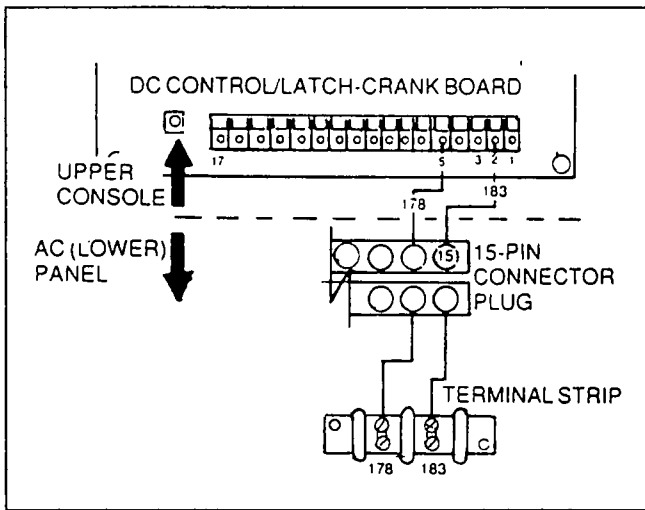


Figure 5. The 2-Wire Start Circuit

If engine cranking will not occur during a utility power outage or during a test of automatic operation, check the 2-wire start circuit as outlined under "Procedure".

PROCEDURE:

1. In the generator's AC connection (lower) panel, locate the 2-position terminal strip identified with the numbers 178 and 183.

- a. Connect a jumper wire across terminals 178 and 183. The engine should crank and start.
- b. Disconnect the jumper wire and the engine should shut down.

RESULTS:

- 1. If the engine would not crank on occurrence of a utility power outage, but cranks when the jumper wire is connected, the problem must be in the "GTS" transfer switch or in the customer-supplied wiring between the generator and transfer switch.
- 2. If engine did not crank when jumper wire was connected, go on to Step 2 of the test.

PROCEDURE:

2. Disconnect the mating halves of the 15-pin connector plug in the AC connection (lower) panel. Wire No. 178 connects to Pin 14 of this plug and Wire No. 183 to Pin 15. See Figure 6.

- a. Connect a jumper wire across Pins 14 and 15 of the upper plug. Engine should crank and start.
- b. Remove the jumper wire. Cranking should terminate or engine should shut down.

RESULTS:

- 1. If engine did not crank in Step 1 but cranks now, look for an open circuit between the 178/183 terminal strip and the 15-pin connector plug.
- 2. If engine still does not crank, go on to Step 3.

PROCEDURE:

3. Inside the control console, locate the DC control/latch-crank board and its connector. Insert a thin probe into Pins 5 and 2 (to which Wires 178 and 183 attach). Do not unplug the circuit board connector. Connect a jumper wire across Pins 5 and 2. The engine should crank and start. Disconnect jumper wire and remove probes before proceeding.

RESULTS:

- 1. If engine cranks in Step 3 but did not crank in Step 2, look for an open condition in Wires 178/183 between the 15-pin connector and the circuit board.
- 2. If engine does not crank in Step 3, remove and replace the DC control/latch-crank circuit board.

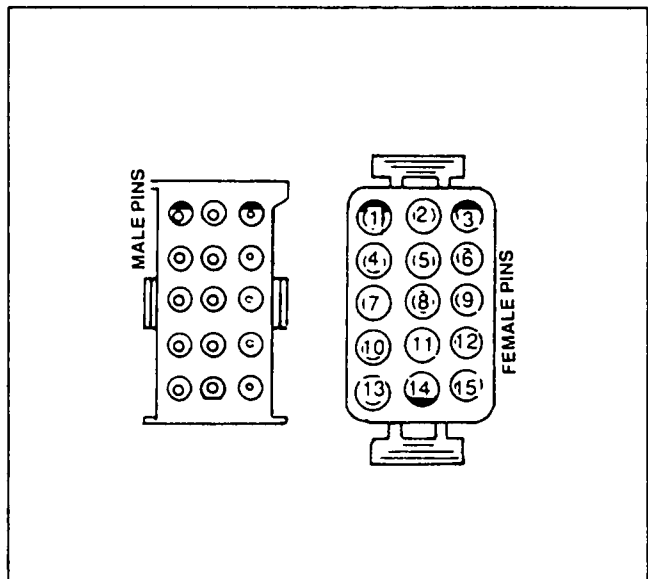


Figure 6. The 15-Pin Connector Plug

**Test 18- Check Wires 178/183 Circuit
(Continued)**

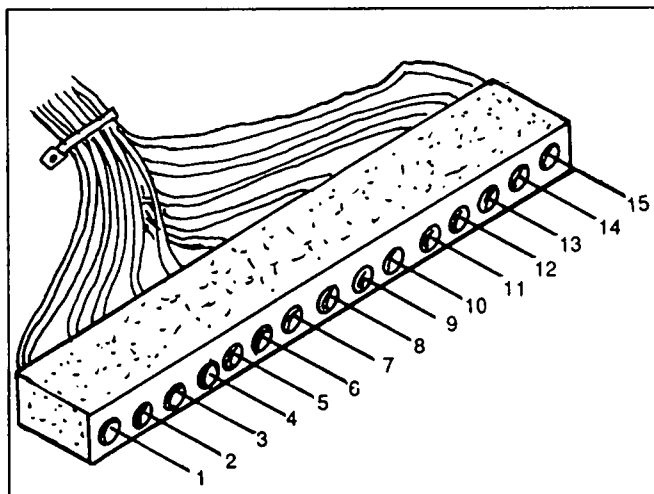


Figure 7. DC Control/Latch-Crank Board Connector

Test 19- Check Wire 174 Circuit

DISCUSSION:

Wire No. 174 is routed between terminal 1 of the auto-manual-off switch and pin 6 of the DC Control/latch-crank board connector. This wire is the "Auto" circuit between the switch and circuit board, i.e., it delivers a DC voltage to the circuit board only when the switch is set to "Auto". An open condition in this wire will produce the same effect as setting the switch to "Off" or "Manual". That is, the open circuit will prevent automatic cranking.

PROCEDURE:

1. Unplug the circuit board connector.
2. Connect the VOM test leads across Pin 6 of the board connector (to which Wire No. 174 attaches) and terminal 0 of terminal board TB1.
3. Set the auto-manual-off switch to "Auto". The meter should read battery voltage.
4. Now, connect one VOM test lead to terminal 1 of the auto-manual-off switch and the other test lead to terminal 0 of TB1.
5. Set the auto-manual-off switch to "Auto". The meter should read battery voltage.

RESULTS:

1. If battery voltage is indicated in Step 3, continue troubleshooting as outlined in Problem 2 of Section 5.7.
2. If battery voltage is indicated in Step 5, but not in Step 3, Wire 174 must be open. Repair, replace or reconnect Wire 174 as required.

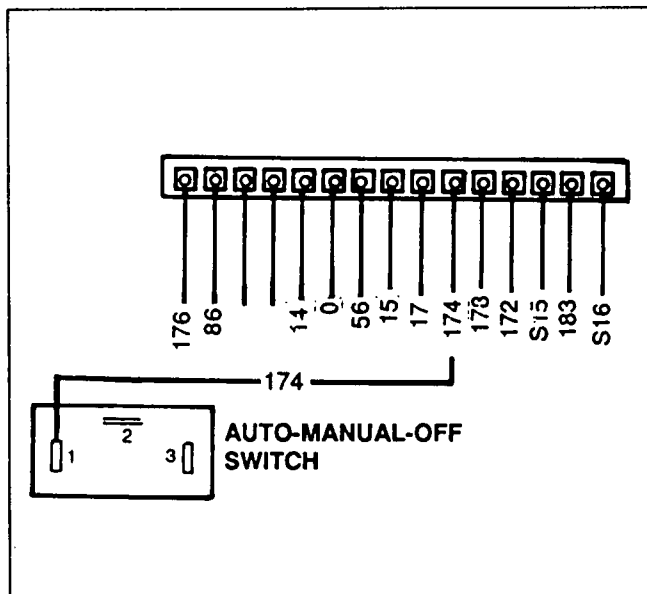


Figure 8. The Wire 174 Circuit

**Test 20- Check Control Console Lamp
Operation**

DISCUSSION:

During engine cranking (automatic or manual), circuit board action energizes a crank relay (K1) and a run relay (K2) simultaneously. When energized, the crank relay delivers battery voltage to the Wire No. 56 circuit to initiate engine cranking. The run relay, when energized, delivers battery voltage to the Wire No. 14 circuit to turn on components required for engine operation (fuel flow, ignition, etc.). When battery voltage is delivered to the Wire 14 circuit, that circuit turns on the control console lamp. Thus, if the lamp comes on you may assume that the circuit board is functioning properly and the relays are energized.

NOTE: Operation of the crank and run relays can be observed. See Test 2.

PROCEDURE:

Crank engine while observing the control console lamp. If the engine cranks and lamp comes on, the DC control/latch-crank board is functioning properly.

RESULTS:

1. If engine cranks and lamp illuminates, but engine will not start, the engine system(s) must be at fault. See appropriate engine service manual.
2. If engine cranks but console lamp does not turn on, go to Test 2, "Check Relays K1/K2 Operation".

Test 21- Check DC Output to Wire 14**DISCUSSION:**

In Test 20, illumination of the control console lamp indicated that DC control/latch-crank board action was delivering battery voltage to the Wire 14 circuit. This can be proved by actually measuring the circuit board output to Wire No. 14.

PROCEDURE:

Connect the positive (+) test probe of a VOM to terminal 14 of terminal board TB1. Connect the VOM common test probe to terminal 0 of that terminal board. Crank the engine and the VOM should read about 12 volts DC.

RESULTS:

1. If DC voltage is not indicated, replace the DC control/latch-crank circuit board.
2. If DC output is good but engine will not start, check the engine systems (see appropriate engine service manual).

Test 22- Check Console Fault Indicator Lamp**DISCUSSION:**

If the engine cranks and starts, then shuts down, check the fault indicator lamp. If lamp is on, a shutdown fault has occurred (low oil pressure, high coolant temperature, low coolant level, overspeed, overcrank).

PROCEDURE:

Observe the fault indicator lamp. If lamp is on, a fault condition has caused shutdown.

RESULTS:

If lamp is on, determine the cause of the fault shutdown.

Test 23- Check Wires S15/S16**DISCUSSION:**

Wires S15 and S16 are AC sensing leads that deliver a voltage/frequency signal to (a) the solid state AC voltage regulator, (b) the panel frequency meter, and (c) the DC control/latch-crank board. The circuit board uses the signal as an indicator of engine/rotor speed in order to establish (a) starter cutout speed and (b) overspeed shutdown.

If an open circuit should exist in the sensing leads to the voltage regulator, sensing to the regulator will be lost. The regulator "Sensing" lamp will then turn off and possibly the "Regulator" lamp as well (regulator shuts down when sensing is lost).

If sensing lead output to the DC control/latch-crank board is lost, a dangerous situation would exist since automatic shutdown due to overspeed would be impossible. To prevent this, circuit board action will shut the engine down on loss of sensing signals from the leads.

PROCEDURE:

Check the reading on the panel frequency meter (Option B consoles). If the frequency meter indicates normal frequency, the sensing leads to the meter are good.

Inspect S15 and S16 leads between the panel frequency meter and the circuit board. Test the leads for an open or shorted condition.

RESULTS:

Repair, replace or reconnect any damaged or defective wiring as necessary.

Test 24- Check Wire 172 Circuit**DISCUSSION:**

Wire No. 172 is routed from the start/stop switch "Run" (centered) position to the DC control/latch-crank circuit board. When the switch is set to "Run", 12 volts DC is delivered to terminal 4 of the circuit board connector. If the Wire 172 circuit is open, the engine will not start. If the wire is shorted, the fuse will blow.

PROCEDURE:

Set the start/stop switch to its "Run" (centered) position. The fault indicator lamp should come on, indicating that the switch and Wire 172 are normal.

RESULTS:

1. If fault indicator lamp does NOT turn on with switch set to "Run", test Wire 172 and the start/stop switch.
2. If fault indicator lamp turns on with switch at "Run", you may assume that Wire 172 and the switch are normal.

Section 5.9 DUAL 12 OR 24 VOLTS DC CONTROL

Introduction

Sections 5.4, 5.5 and 5.6 provide information on DC control systems that are now obsolete. Those older control consoles housed a DC control/latch-crank circuit board that required 12 volts DC only for its operation. Other control console components were also rated 12 volts DC. This meant that diesel engine units with a 24 VDC engine system required that 24 volts be reduced to 12 volts DC for control console operation. A 24-to-12 volts DC converter was used for this purpose.

Beginning in the last quarter of 1991, the following changes were incorporated into Generac standby generators:

- All control console components, including the DC control/latch-crank board, were changed to dual voltage type. That is, all console components can now be operated on either 12 or 24 volts DC.
- On units with 24 volts DC engine systems, the DC converter is no longer required.
- Units with 24 VDC engine system no longer require an engine run relay.
- Generators manufactured more recently and having Option A or B control consoles will be equipped with engine control circuit board Part No. 82495. This is a dual voltage (12 or 24 volts) board.
- Units manufactured more recently and equipped with an Option C control console are equipped with engine control circuit board Part No. 83089. This is a dual voltage (12 or 24 volts) circuit board.

NOTE: When the old style (12 volts only) circuit board has failed, the new style, dual voltage board will be shipped as a replacement part. The new board will work with any old or new style system, since it will operate on either 12 or 24 volts DC.

Meters, Gauges and Controls

For Options A and B control consoles, refer to Section 5.1.

AC Circuits Operation

Refer to Section 5.3 (Part 5, Section 5.3, Page 5.3-1).

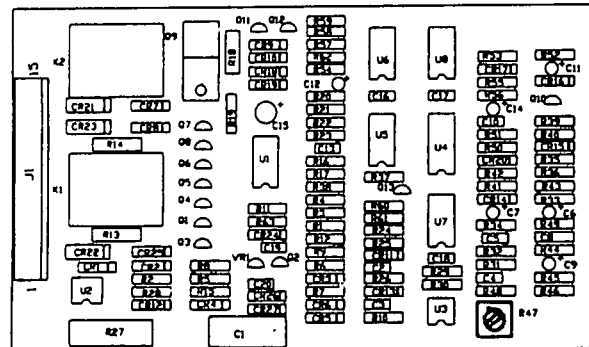
DC Control- 12 Volts Units

Operation of the dual voltage DC control system is the same as for earlier production units. Figure 2 (next page) is a schematic representation of a late production Option B control console for a 12 volts diesel engine unit.

See Section 5.4 for an operational description of 12 volts gas units.

See Section 5.5 for an operational description of 12 volts diesel units.

Figure 1. Engine Control Circuit Board- Options A and B



DC Control- 24 Volts Diesel Units INTRODUCTION:

Figure 3 (next page) is a schematic representation of an Option "B" control console for a 24 volts diesel engine unit.

NOTE: Wiring diagrams and electrical schematics for many Generac standby generators and transfer switches are available in book form. To order, specify Manual Part No. 87691.

Circuit Board Calibration

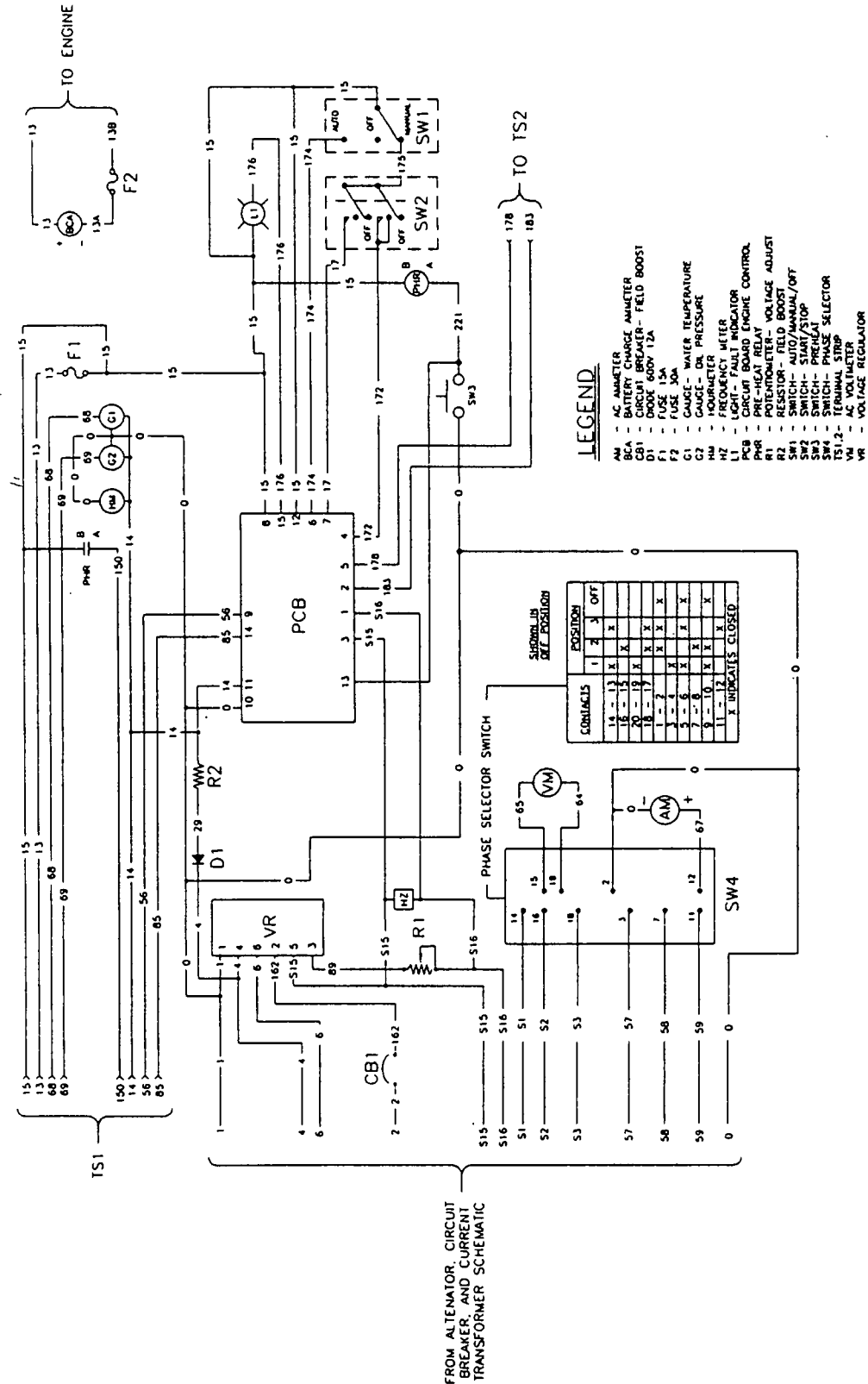
The engine control circuit board for units with Options A and B control console is factory set to initiate an overspeed shutdown at about 68-70 Hertz. The board requires no additional calibration.

If you wish to test the overspeed shutdown function, proceed as follows:

1. Start the engine, let it warm up at no-load.
2. Still at no-load, slowly advance the engine throttle to approximately 68-70 Hertz. Shutdown should occur and the "Overspeed" lamp (LED) on the console should illuminate.

CAUTION: Be careful. Do not overspeed engine excessively. Do NOT exceed 68-70 Hertz. Advance the throttle SLOWLY. Make sure the generator is at no-load.

Figure 2. Schematic Diagram- Oplton B Console for 12 VDC Diesel Engine Unit (Typical)



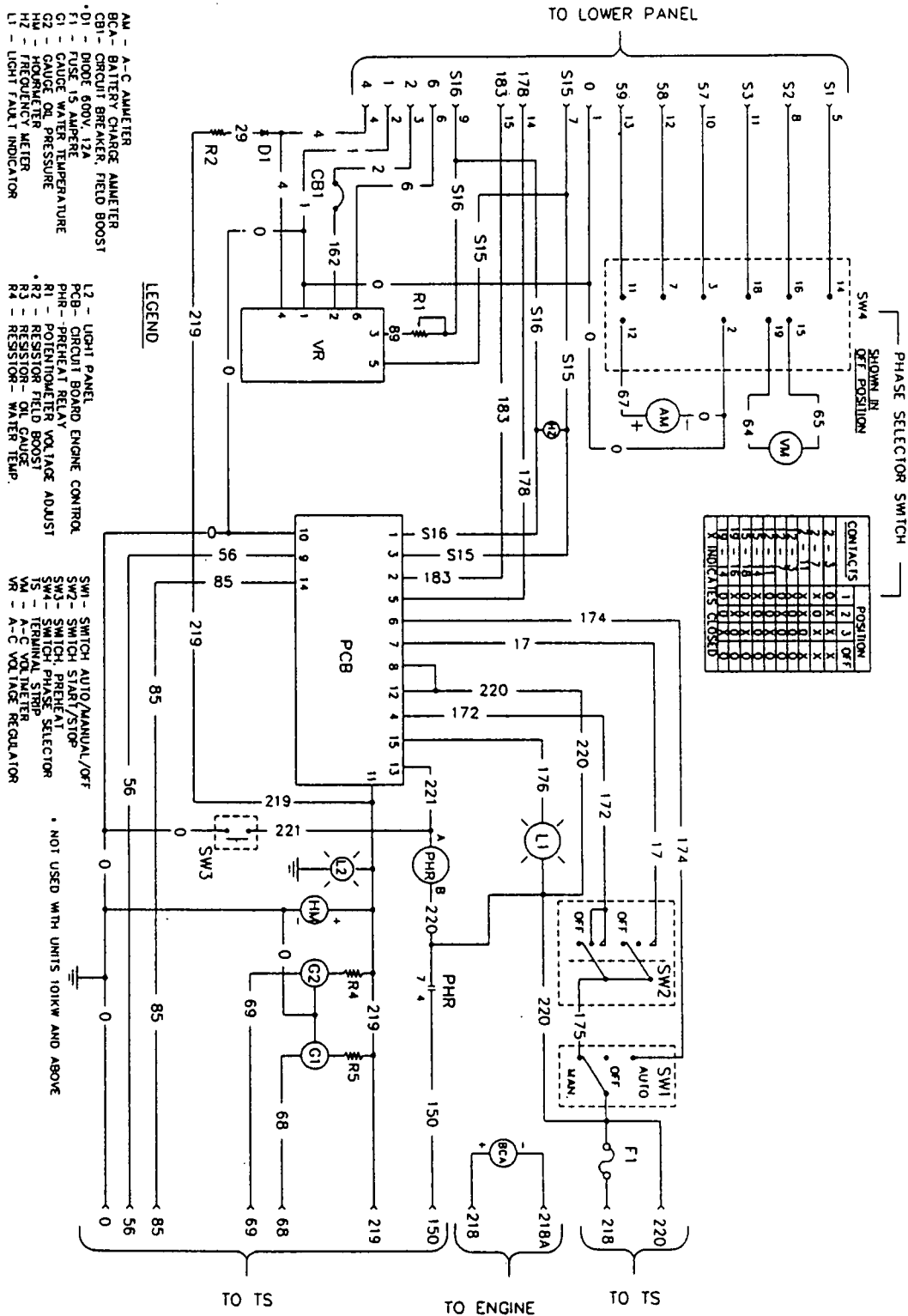
LEGEND

- AM - AC AMMETER
- BCA - BATTERY CHARGE AMMETER
- CB1 - CIRCUIT BREAKER - FIELD BOOST
- D1 - DIODE 600V 12A
- F1 - FUSE 15A
- F2 - FUSE 15A
- G1 - GAUGE - WATER TEMPERATURE
- G2 - GAUGE - OIL PRESSURE
- HZ - HOURMETER
- L1 - LIGHT - FAULT INDICATOR
- PCB - CIRCUIT BOARD, ENGINE CONTROL
- P - POTENTIOMETER - VOLTAGE ADJUST
- R1 - POTENTIOMETER - FIELD BOOST
- R2 - RESISTOR - FIELD BOOST
- SW1 - SWITCH - AUTO/MANUAL/OFF
- SW2 - SWITCH - START/STOP
- SW3 - SWITCH - PREHEAT
- SW4 - PHASE SELECTOR
- TS1.2 - TERMINAL STRIP
- VA - AC VOLT/METER
- VR - VOLTAGE REGULATOR

CONTACTS	POSITION		
	1	2	3
14 - 13	X	X	
15 - 14	X	X	
16 - 15	X	X	
17 - 16	X	X	
18 - 17	X	X	
19 - 18	X	X	
20 - 19	X	X	
21 - 20	X	X	
22 - 21	X	X	
23 - 22	X	X	
24 - 23	X	X	
25 - 24	X	X	
26 - 25	X	X	
27 - 26	X	X	
28 - 27	X	X	
29 - 28	X	X	
30 - 29	X	X	
31 - 30	X	X	
32 - 31	X	X	
33 - 32	X	X	
34 - 33	X	X	
35 - 34	X	X	
36 - 35	X	X	
37 - 36	X	X	
38 - 37	X	X	
39 - 38	X	X	
40 - 39	X	X	
41 - 40	X	X	
42 - 41	X	X	
43 - 42	X	X	
44 - 43	X	X	
45 - 44	X	X	
46 - 45	X	X	
47 - 46	X	X	
48 - 47	X	X	
49 - 48	X	X	
50 - 49	X	X	
51 - 50	X	X	
52 - 51	X	X	
53 - 52	X	X	
54 - 53	X	X	
55 - 54	X	X	
56 - 55	X	X	
57 - 56	X	X	
58 - 57	X	X	
59 - 58	X	X	
60 - 59	X	X	
61 - 60	X	X	
62 - 61	X	X	
63 - 62	X	X	
64 - 63	X	X	
65 - 64	X	X	
66 - 65	X	X	
67 - 66	X	X	
68 - 67	X	X	
69 - 68	X	X	
70 - 69	X	X	
71 - 70	X	X	
72 - 71	X	X	
73 - 72	X	X	
74 - 73	X	X	
75 - 74	X	X	
76 - 75	X	X	
77 - 76	X	X	
78 - 77	X	X	
79 - 78	X	X	
80 - 79	X	X	
81 - 80	X	X	
82 - 81	X	X	
83 - 82	X	X	
84 - 83	X	X	
85 - 84	X	X	
86 - 85	X	X	
87 - 86	X	X	
88 - 87	X	X	
89 - 88	X	X	
90 - 89	X	X	
91 - 90	X	X	
92 - 91	X	X	
93 - 92	X	X	
94 - 93	X	X	
95 - 94	X	X	
96 - 95	X	X	
97 - 96	X	X	
98 - 97	X	X	
99 - 98	X	X	
100 - 99	X	X	
101 - 100	X	X	
102 - 101	X	X	
103 - 102	X	X	
104 - 103	X	X	
105 - 104	X	X	
106 - 105	X	X	
107 - 106	X	X	
108 - 107	X	X	
109 - 108	X	X	
110 - 109	X	X	
111 - 110	X	X	
112 - 111	X	X	
113 - 112	X	X	
114 - 113	X	X	
115 - 114	X	X	
116 - 115	X	X	
117 - 116	X	X	
118 - 117	X	X	
119 - 118	X	X	
120 - 119	X	X	
121 - 120	X	X	
122 - 121	X	X	
123 - 122	X	X	
124 - 123	X	X	
125 - 124	X	X	
126 - 125	X	X	
127 - 126	X	X	
128 - 127	X	X	
129 - 128	X	X	
130 - 129	X	X	
131 - 130	X	X	
132 - 131	X	X	
133 - 132	X	X	
134 - 133	X	X	
135 - 134	X	X	
136 - 135	X	X	
137 - 136	X	X	
138 - 137	X	X	
139 - 138	X	X	
140 - 139	X	X	
141 - 140	X	X	
142 - 141	X	X	
143 - 142	X	X	
144 - 143	X	X	
145 - 144	X	X	
146 - 145	X	X	
147 - 146	X	X	
148 - 147	X	X	
149 - 148	X	X	
150 - 149	X	X	
151 - 150	X	X	
152 - 151	X	X	
153 - 152	X	X	
154 - 153	X	X	
155 - 154	X	X	
156 - 155	X	X	
157 - 156	X	X	
158 - 157	X	X	
159 - 158	X	X	
160 - 159	X	X	
161 - 160	X	X	
162 - 161	X	X	
163 - 162	X	X	
164 - 163	X	X	
165 - 164	X	X	
166 - 165	X	X	
167 - 166	X	X	
168 - 167	X	X	
169 - 168	X	X	
170 - 169	X	X	
171 - 170	X	X	
172 - 171	X	X	
173 - 172	X	X	
174 - 173	X	X	
175 - 174	X	X	
176 - 175	X	X	
177 - 176	X	X	
178 - 177	X	X	
179 - 178	X	X	
180 - 179	X	X	
181 - 180	X	X	
182 - 181	X	X	
183 - 182	X	X	
184 - 183	X	X	
185 - 184	X	X	
186 - 185	X	X	
187 - 186	X	X	
188 - 187	X	X	
189 - 188	X	X	
190 - 189	X	X	
191 - 190	X	X	
192 - 191	X	X	
193 - 192	X	X	
194 - 193	X	X	
195 - 194	X	X	
196 - 195	X	X	
197 - 196	X	X	
198 - 197	X	X	
199 - 198	X	X	
200 - 199	X	X	

X INDICATES CLOSED

Figure 3. Schematic Diagram- Option B Console for 24 VDC Engine Unit



**PART 6
OPTION C
CONTROL
CONSOLE**

**STANDBY
ELECTRIC
POWER
SYSTEMS**
All Series

TABLE OF CONTENTS	
SECTION	TITLE
6.1	Meters, Gauges and Controls
6.2	Engine Monitor Panel
6.3	Internal Console Components
6.4	AC Circuits Operation
6.5	DC Control- 12 Volts Gas Units
6.6	DC Control- 12 Volts Diesel Units
6.7	DC Control- 24 Volts Diesel Units
6.8	Troubleshooting Charts
6.9	Diagnostic Tests
6.10	Dual 12 or 24 Volts DC Control

Section 6.1 METERS, GAUGES AND CONTROLS

Standard Features

The Option "C" control console (Figure 1) incorporates the following features as standard equipment:

- Provides either manual or automatic start capability.
- Mounts an AC voltmeter, ammeter and frequency meter.
- Includes an oil pressure gauge, coolant temperature gauge, DC ammeter and hourmeter.
- Includes an auto-manual-off switch to prevent automatic startup during maintenance and servicing.
- Provides a "Not in Automatic Start Mode" advisory lamp which illuminates when the auto-manual-off switch is not set to "Auto".
- Includes an engine monitor panel with advisory lamps that turn on in the event of (a) overcrank, (b) overspeed, (c) high coolant temperature, (d) low oil pressure, and (e) rpm sensor loss.

Available Options

Some of the options available for use with the Option "C" console include the following:

- An 18 lamp remote annunciator panel
- An annunciator panel, mounted on the control console, which provides up to nine (9) annunciator and pre-alarm lamps.
- A 3-lamp remote mounted annunciator panel.
- A 5-lamp remote mounted annunciator panel.
- A 14-lamp remote mounted annunciator panel.
- A horn alarm.

For more information on available options, refer to Part 7, "Generator Options and Accessories".

Meters, Gauges, Lamps and Switches

ENGINE MONITOR PANEL:

See Part 6.2, "Engine Monitor Panel".

AC VOLTMETER:

The panel AC voltmeter provides an indication of the generator's AC voltage output. The meter may indicate selected line-to-line or line-to-neutral voltage (see "Line-Phase Selector Switch"). The nominal rated AC voltage of each generator model is listed on the unit data plate.

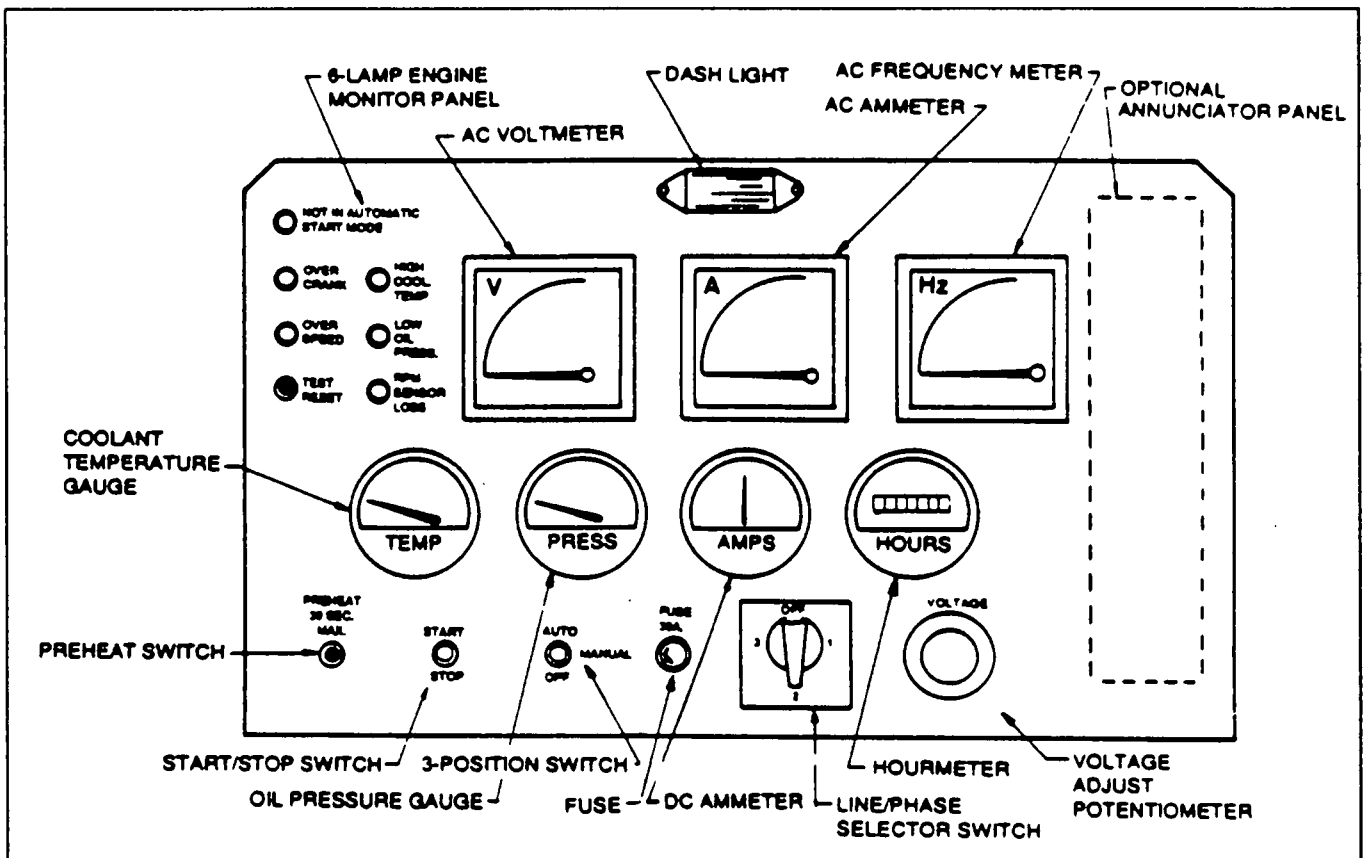


Figure 1. The Option "C" Control Console

Meters, Gauges, Lamps and Switches (Continued)**AC AMMETER:**

The AC ammeter indicates the current draw of connected electrical loads, in "amperes". A line-phase selector switch permits operator selection of line-to-line or line-to-neutral amperage readings.

Generator AC output leads E1 and E3 (1-phase units) or E1, E2 and E3 (3-phase units) pass through current transformers in the AC connection panel. Current flow through E1, E2 and E3 induce a voltage and current flow into the transformers. Transformer output current is delivered to the AC ammeter via the line-phase selector switch.

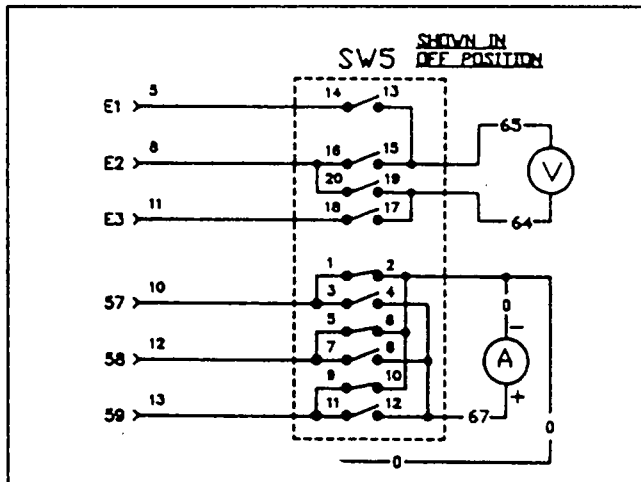


Figure 2. Typical AC Voltmeter and Ammeter Circuit

AC FREQUENCY METER:

Indicates generator AC output frequency, in "Hertz" or "cycles per second". The following facts apply:

- Units rated 60 Hertz and having a 2-pole rotor deliver a 60 Hertz AC output at 3600 rpm.
- Units rated 50 Hertz and with 2-pole rotor deliver a 50 Hertz output at 3000 rpm.
- Units rated 60 Hertz and with 4-pole rotor provide a 60 Hertz output at 1800 rpm.
- Units rated 50 Hertz and with 4-pole rotor supply 50 Hertz at 1500 rpm.
- Correct rotor speed and frequency is maintained by an engine governor which must be adjusted to maintain the desired AC frequency.
- Governed speed at no-load is usually adjusted to about 62 Hertz (1860 rpm for 4-pole rotors, 3720 rpm for 2-pole rotors). This slightly high no-load speed helps prevent excessive rpm, frequency and voltage droop under heavy electrical loading.
- Under heavy electrical loading, frequency may droop to about 59 Hertz but should never droop below about 58 Hertz.
- The frequency meter is operated by AC generator sensing leads S15 and S16.

NOTE: On some early production standby generators, the frequency meter was operated by the output of an rpm sensor. See Section 6.2, "Engine Monitor Panel".

COOLANT TEMPERATURE GAUGE:

The coolant temperature gauge provides a reading of engine coolant temperature. The gauge is operated by the Wire 14 circuit where that circuit's DC output is controlled by a coolant temperature sending unit on the engine. See Figure 3 below.

On a typical engine, normal operating temperature may be between 185°-200° F. (85°-94° C.). Actual coolant temperature may vary, depending on such variables as ambient temperature, applied load, cooling system condition, etc.

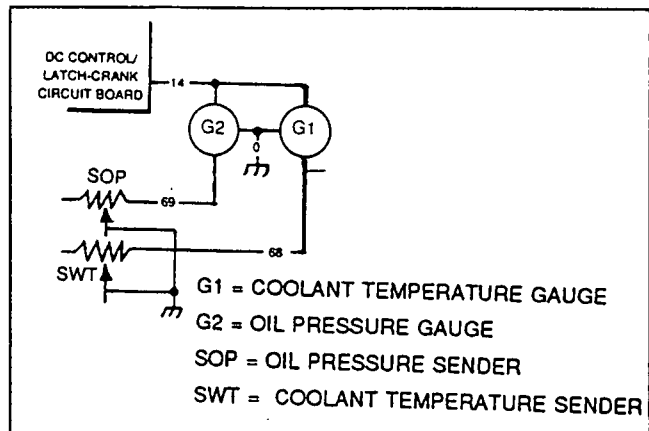


Figure 3. Coolant Temperature/Oil Pressure Circuits

OIL PRESSURE GAUGE:

The oil pressure gauge indicates engine oil pressure during operation. Oil pressure may vary depending on the specific engine, oil viscosity, oil temperature, engine speed, ambient temperature, etc.

The oil pressure gauge is powered by the Wire No. 14 circuit with the DC voltage controlled by an oil pressure sending unit on the engine. See Figure 3.

DC AMMETER:

The DC ammeter indicates rate of charge during operation from an engine-driven DC alternator.

HOURMETER:

Provides a continuous indication of engine-generator operating time, in hours and tenths of hours. A typical hourmeter will record operating times up to 99,999.9 hours. The meter will then start over again at "zero". Use the hourmeter in conjunction with the recommended periodic maintenance schedule on the generator.

START/STOP SWITCH:

Use this 3-position switch to crank and start the engine manually or to shut down manually, as follows:

Meters, Gauges, Lamps and Switches (Continued)

- To crank and start the engine manually, hold the switch at its "Start" position. When the engine starts, release the switch to its "Run" (centered) position.
- To shut down an operating engine, set the switch to its "Stop" position.

NOTE: When starting the engine manually, the auto-manual-off switch may be set to either "Auto" or "Manual". If that switch is set to "Off", neither manual or automatic startup will be possible.

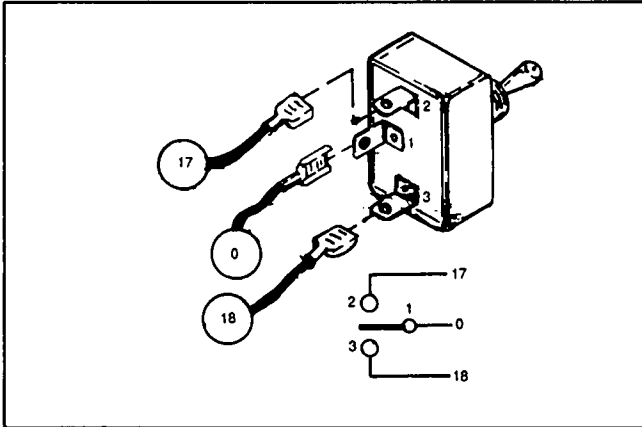


Figure 4. Schematic of Start/Stop Switch

AUTO-MANUAL-OFF SWITCH:

Use this safety switch to prevent automatic startup while servicing the generator set. Switch positions are as follows:

"Auto": Select this switch position for all automatic operations. When "Auto" is selected, closure of the Wires 178/183 circuit by "GTS" transfer switch action will result in automatic engine cranking and startup. Closure of the Wires 178/183 circuit is normally accomplished by transfer switch circuit board action when utility source voltage drops below a preset level. The circuit will also be closed when either "Fast Test" or "Normal Test" are selected on the transfer switch controls.

"Manual": When "Manual" is selected, automatic cranking and startup will not occur. This position is useful when testing or troubleshooting the unit where cranking and startup is necessary, but where automatic startup is undesirable.

"Off": When switch is set to "Off", neither automatic or manual engine cranking can occur.

Figure 5 is a schematic representation of the auto-manual-off switch.

30 AMP FUSE:

A 12 volts DC power supply is delivered to the control console from the generator battery. Units equipped with a 24 volts DC battery system use a DC converter to reduce the console voltage down to 12 volts.

The 12 volts DC power from the battery (or converter) is delivered to the control console via Wire No. 13, and

to the 30 amp fuse. The fuse protects DC control system components against overload. If the fuse has blown due to an overload, use only an identical 30 amp replacement fuse.

NOTE: A 14 amp inline fuse is housed inside the control console, in series with Wire No. 15 to the DC control/latch-crank circuit board. This inline fuse protects the circuit board. Either a blown 30 amp fuse or a blown 14 amp fuse will prevent engine cranking and startup.

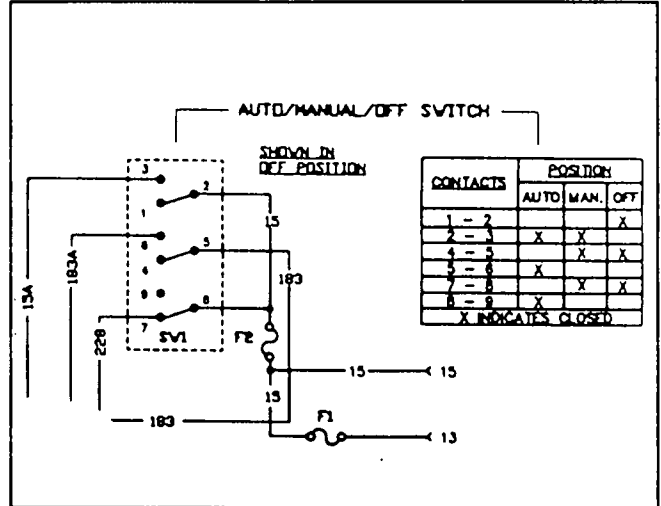


Figure 5. Schematic of Auto-Manual-Off Switch

LINE-PHASE SELECTOR SWITCH:

Use this 4-position switch to select either line-to-line or line-to-neutral AC voltmeter and ammeter readings. Switch positions and readings are listed in the chart below.

SWITCH POSITION	1-PHASE UNITS	3-PHASE UNITS
1	Line E1 to Neutral	Line E1 to E2
2	Line E3 to Neutral	Line E2 to E3
3	Line E1 to E3	Line E3 to E1
OFF	No Reading	No Reading

VOLTAGE ADJUST POTENTIOMETER:

This adjustable potentiometer permits the operator to "fine adjust" generator AC output voltage, within a range of plus or minus 5 percent. The potentiometer is connected in series with sensing lead S16 to the voltage regulator and acts to "bias" the sensing signal to the regulator. Turn the knob clockwise to increase AC output voltage, counterclockwise to decrease it.

NOTE: When adjusting the voltage regulator, do so with the voltage adjust potentiometer centered at its mid-position.

Section 6.2 ENGINE MONITOR PANEL

General

The engine monitor panel (Figure 1) mounts five (5) engine fault advisory lamps, a test/reset switch, and a "Not in Automatic Start Mode" advisory lamp. The panel mounts the following engine fault advisory lamps:

- Overcrank.
- High Coolant Temperature/Low Coolant Level.
- Overspeed.
- Low Oil Pressure.
- RPM Sensor loss.

If one or more of the above fault conditions should occur, the engine will shut down and the appropriate lamp(s) will illuminate. The following rules apply:

- The engine cannot be cranked or started while any fault lamp is on.
- To turn all lamps off and allow the engine to be cranked, push the test/reset switch in.

NOTE: On units option "C" control consoles manufactured after June of 1996 pressing the Test / Reset switch will result in the fault lights turning on momentarily and automatically turning off, even if the switch is held in continuously.

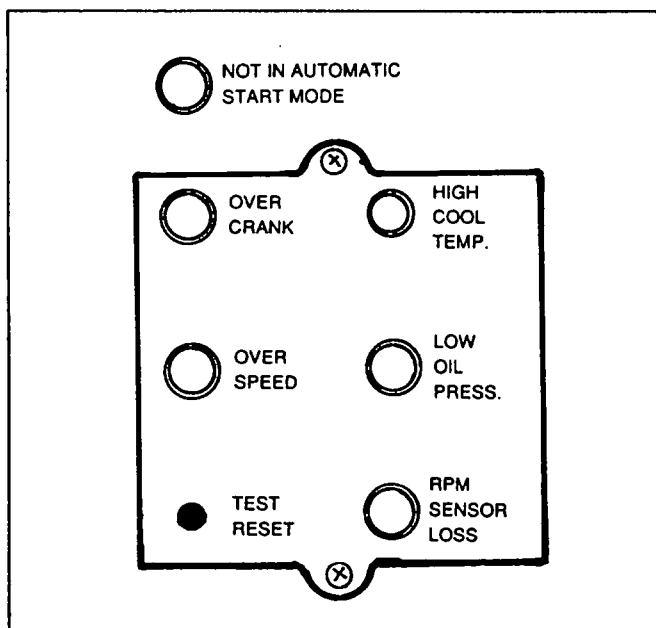


Figure 1. The Option "C" Engine Monitor Panel

Overcrank Condition

The generator console houses a DC control/latch-crank circuit board. The circuit board controls automatic and manual engine cranking, startup, running and shut-down operations.

Automatic cranking and startup normally occurs when a circuit board in the "GTS" automatic transfer switch closes the Wires 178/183 circuit. Closure of that circuit energizes a crank relay (K1) and a run relay (K2) on the control console's DC control/latch-crank board. Circuit board action will energize the crank relay (K1) for about eight (8) seconds, de-energize it for about eight (8) seconds, energize it again for eight (8) seconds, and so on. Each time the crank relay is energized, its normally-closed contacts close. On contacts closure, the engine cranks. The resultant cyclic cranking action will continue during automatic startup until either (a) the engine starts, or (b) until eight (8) crank/no-crank cycles have been used up. That is, if the engine has not started in eight cranking cycles, cranking will end and the "overcrank" lamp will turn on.

Neither manual or automatic cranking can be initiated while the lamp is on. If additional cranking is desired, push in the test/reset switch to turn the lamp out, then crank the engine.

High Coolant Temperature/Low Coolant Level

The engine mounts both a high coolant temperature switch and a low coolant level sensor. Both of these devices have normally-open contacts. Should engine coolant temperature exceed a safe level (above about 245° F.), the switch contacts will close. Should coolant level drop below a safe level, the sensor contacts will close. DC control/latch-crank circuit board action will then (a) shut the engine down, and (b) turn on the high coolant temperature lamp. Shutdown and lamp on condition will occur subject to the following conditions:

- If the engine is started with an existing high temperature or low coolant level, shutdown and lamp on will occur when the engine reaches starter cutout speed (about 1000 rpm).
- If engine starts normally but high temperature or low coolant level occur later, shutdown and lamp on will occur immediately.

Overspeed Condition

Units with Option "C" console mount an rpm sensor. This sensor is essentially a magnetic pickup which is installed so that its magnetic tip is directly over the engine flywheel gear teeth. As the flywheel gear rotates, an electrical pulse is emitted each time a flywheel gear passes the magnetic tip. These pulses are used by the DC control/latch-crank circuit board as a speed indicator to (a) establish starter cutout speed, (b) establish an overspeed shutdown point, and (c) calibrate the DC control/latch crank circuit board.

In the event of an overspeed condition, circuit board action will initiate engine shutdown and a lamp on condition, subject to the following:

- Automatic shutdown and lamp on condition will result if frequency exceeds 69-78 Hertz, providing the overspeed lasts longer than about four (4) seconds.
- If the overspeed exceeds approximately 78 Hertz, shutdown and lamp on condition will occur immediately.

NOTE: On units rated 1800 rpm, 69-78 Hertz is equal to 2070-2340 rpm. On 3600 rpm units, 69-78 Hertz equals 4140-4680 rpm.

Low Oil Pressure Condition

The engine mounts an oil pressure switch having normally-closed contacts. The contacts will be held open by engine oil pressure during cranking and running operations. Should engine oil pressure drop below a preset value (about 10 psi), automatic engine shutdown and illumination of the advisory lamp will occur. Operation of the low oil pressure fault system can be described briefly as follows:

- When the engine is cranking and after speed has reached approximately 800-1000 rpm, the DC control/latch-crank board allows about four (4) seconds for oil pressure to build before it takes any action.
- Above 800-1000 rpm, with oil pressure still low, and if longer than four (4) seconds have elapsed, engine shutdown will occur but the fault will not "latch". That is, the lamp will not turn on. Since the lamp is not on (condition is not latched), the circuit board will allow the engine to crank until all eight (8) of the allotted crank cycles have been

used up. If oil pressure is still low after eight (8) crank cycles, shutdown will occur and the LOW OIL PRESSURE light will turn on.

- If engine cranks and starts normally, but oil pressure drops later, the circuit board will wait about four (4) seconds for oil pressure to be restored. If oil pressure is still low after four (4) seconds, shutdown and lamp on will occur.

RPM Sensor Loss Lamp

Also see "Overspeed Condition" on this page. Loss of signals to the DC control/latch-crank circuit board from the rpm sensor means that (a) the board has no signal for starter cutout, and (b) no signal is present for overspeed shutdown. This is a potentially damaging situation. For that reason, the circuit board will effect an automatic shutdown and a lamp on condition if sensor signals to the board are lost. Operation of the rpm sensor loss circuit may be briefly described as follows:

- **During Manual Startup:** If the engine starts within two (2) seconds after cranking is initiated and the board senses no rpm sensor signals, engine shutdown will occur as soon as the start/stop switch is released. However, the condition will not latch, i.e., the rpm sensor loss lamp will not turn on. If engine startup occurs more than two (2) seconds after cranking is initiated, engine cranking will end and the advisory lamp will illuminate.
- **During Automatic Startup:** On loss of rpm sensor output, the engine will shut down. About one (1) second after engine stoppage, it will crank again. If rpm sensor loss persists longer than two (2) seconds after cranking has resumed, shutdown and lamp on condition will occur. If the engine started within two (2) seconds after re crank was initiated, the starter will remain engaged until after the two (2) second delay has elapsed.

NOTE: The rpm sensor loss lamp will turn on only while cranking and only if the cranking period exceeds two (2) seconds. During startup, the circuit board will allow the rpm sensor about two (2) seconds to provide an output signal. If an output signal is not received, the run relay (K2) will de-energize to stop the engine.

RPM Sensor Loss Lamp (Continued)

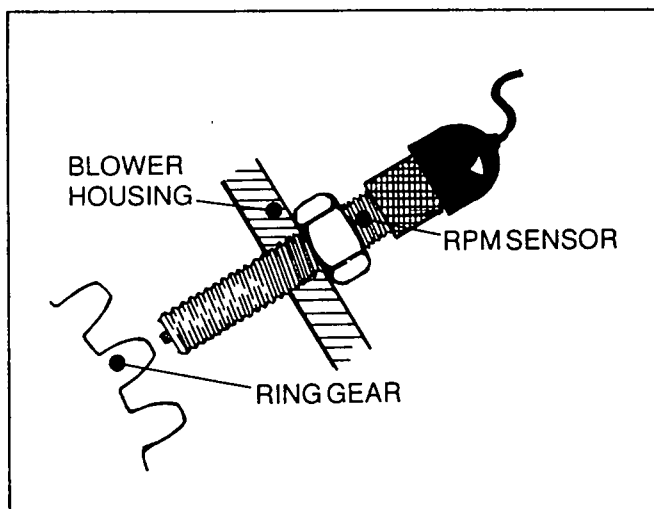


Figure 2. A Typical RPM Sensor

Test-Reset Switch

Use this switch to (a) test all engine monitor panel lamps, and (b) to reset a monitored engine fault and permit further cranking.

- To test all lamps, push the switch in. All lamps should turn on.
- If any lamp is on, cranking is inhibited. To turn the lamp(s) off, push the switch in.
- If the switch is actuated while the engine is running, only the lamps will be tested (engine will not shut down).

Occurrence of an Unmonitored Fault

Should engine shutdown occur due to some unmonitored fault (out of gas, faulty ignition, etc.), none of the advisory lamps will light. If the auto-manual-off switch is set to "Auto" when such an unmonitored fault occurs, the engine will re crank and attempt to start until all eight (8) of the allotted crank cycles have been used up. Cranking will then terminate and the "Overcrank" lamp will illuminate.

Section 6.3 INTERNAL CONSOLE COMPONENTS

General

Components housed in the generator control console are shown in Figure 1, below. Option "C" control consoles may be arbitrarily divided into three general types, as follows:

- Units with a gas engine and having a 12 volts DC engine electrical system.
- Units with diesel engine and a 12 volts DC engine electrical system.
- Units with diesel engine and a 24 volts DC engine electrical system.

DC components housed in the control console require 12 volts DC power for their operation. This DC power is taken from the generator battery. If the engine has a 24 volts DC electrical system, a 24 to 12 volts DC converter is used to reduce battery output down to 12 volts for console operation.

NOTE: 24 VDC systems manufactured after the last quarter of 1991. DO NOT use a 24 to 12 volt converter. Refer to Section 6.10.

ITEM	DESCRIPTION	ITEM	DESCRIPTION	ITEM	DESCRIPTION
1	AC Voltage Regulator	9	Start/Stop Switch	17	Panel Lamp
2	Excitation Circuit Breaker	10	Auto-Manual-Off Switch	18	Hourmeter
3	Terminal Board TB1	11	30 Amp Fuse	19	DC Ammeter
4	DC Alternator Resistor	12	Line-Phase Selector Switch	20	Oil Pressure Gauge
5	Field Boost Diode	13	Voltage Adjust Potentiometer	21	Coolant Temperature Gauge
6	DC Control/Latch-Crank Board	14	Frequency Meter	22	Engine Monitor Panel Circuit Board
7	Wiring Harness	15	AC Ammeter	23	Engine Run Relay (24 volts diesel only)
8	Preheat Switch (Diesel Only)	16	AC Voltmeter	24	Preheat Relay (diesel engine units only)

Item 25= Diode
Item 26= Field Boost Resistor

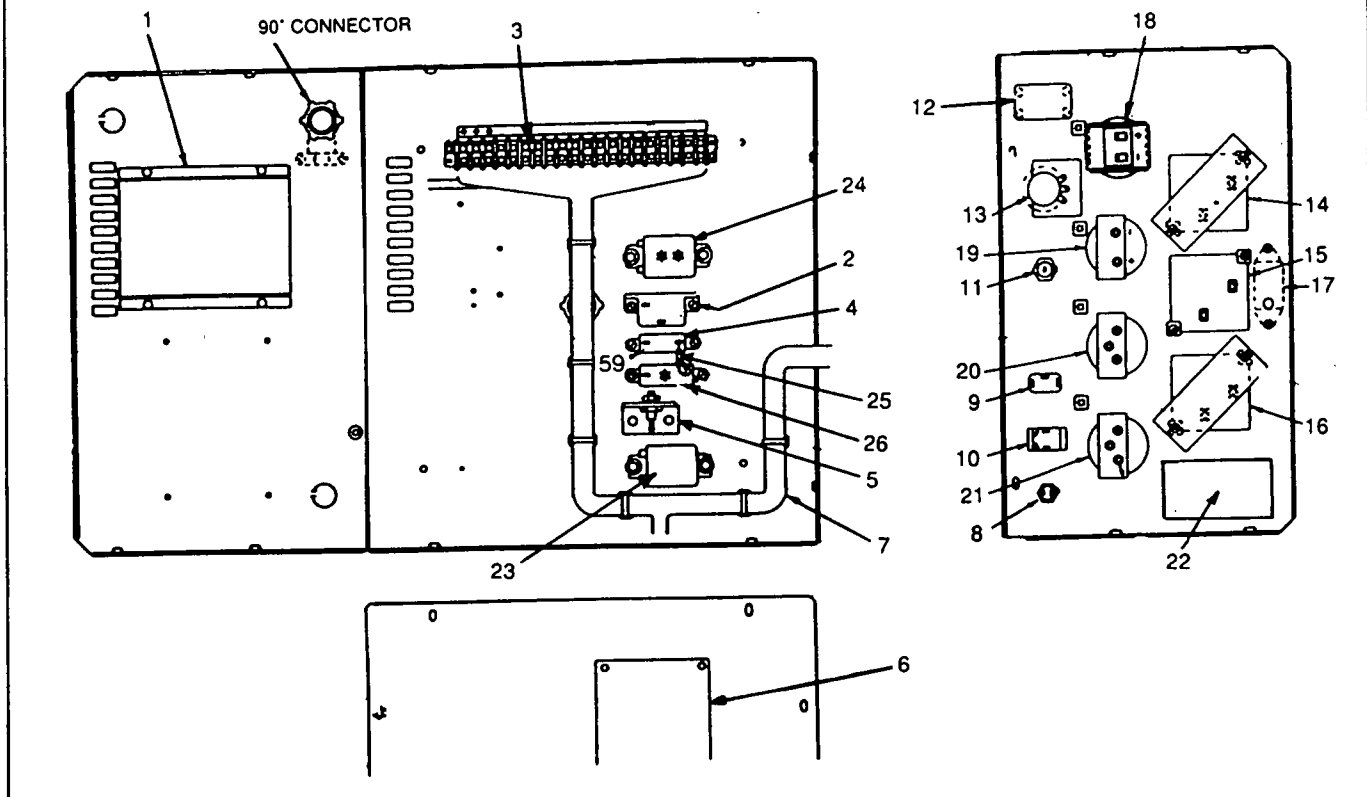


Figure 1. Internal Control Console Components (24 Volts Diesel Unit Shown)

AC Generator Components

Some components housed in the control console are part of the AC generator system. Refer to the Part 2, 3 or 4 as appropriate for information on these components.

- AC voltage regulator (Item 1).
- Excitation circuit breaker (Item 2).
- Field boost resistor (Item 4).
- Field boost diode (Item 5).

NOTE: Operation of the AC voltmeter, ammeter and frequency meter circuits will be discussed in Section 6.4, "AC Circuits Operation".

Terminal Board TB1

This 20-position terminal board provides a convenient method of interconnecting engine electrical components with control console circuits. Terminal numbers and functions are listed in the chart that follows.

TERMINAL & WIRE NO.	CIRCUIT FUNCTION
0	Common ground.
79	RPM Sensor output signal to DC control/latch-crank circuit board.
13	Unfused battery voltage (12 volts DC).
14	"Engine run" circuit, electrically hot only with engine running. Circuit turns on engine ignition, fuel flow, etc.
15	Fused battery voltage (12 volts DC).
47	Used only on units with 24 volts DC engine electrical system. DC alternator output to an engine run relay.
49	Field excitation to engine DC alternator.
56	Engine cranking circuit.
68	From coolant temperature sender to gauge.
69	From oil pressure sender to gauge.
85, 86	Low oil pressure and high coolant temperature
150	Engine preheat circuit (diesel only)
218, 219	24 volts DC circuits on diesel only.

DC Control/Latch-Crank Circuit Board

The DC control/latch-crank board is the "control center" for engine cranking, startup, running and shutdown operations.

- The board is powered by fused 12 volts DC power from Wire 15.
- The circuit board mounts two relays, a crank relay (K1) and a run relay (K2).
- Circuit board action energizes crank relay (K1) to deliver 12 volts DC to the Wire 56 circuit, which initiates engine cranking.
- Board action energizes the run relay (K2) to energize engine components required for operation (fuel solenoid, engine ignition, etc.).
- When energized, relay K2 delivers 12 volts DC to a Wire 14 circuit (the "engine run" circuit).

A 13-pin connector plug interconnects the DC control/latch-crank board with the various wiring circuits. Connector plug pin numbers, associated wires and functions of each circuit are listed in the chart below.

PIN NO.	WIRE NO.	FUNCTION
1	15A	Fused battery voltage (12 volts DC).
2	0	Common Ground.
3	86	Low oil pressure switch circuit. When grounded by switch contacts closure, engine shutdown occurs.
4	85	High coolant temperature and low coolant level circuit.
5	79	RPM sensor signals to circuit board.
6	183A	Automatic start circuit.
7	17	Manual crank circuit from start/stop switch.
8	18	Manual stop circuit from start/stop circuit.
9	228	Fused 12 volts DC to board when auto-manual-off switch is set to "Manual" or "Off".
10	221	Preheat circuit (diesel only).
11	14	12 volts DC when running only.
12	56	12 volts DC cranking signal.
13	229	12 volts DC output to optional alarm relay on occurrence of a monitored fault shutdown.

A second 8-pin connector interconnects the DC control circuit board with an engine monitor panel board. Connector pins, associated wire numbers and functions of each circuit are listed in the chart that follows.

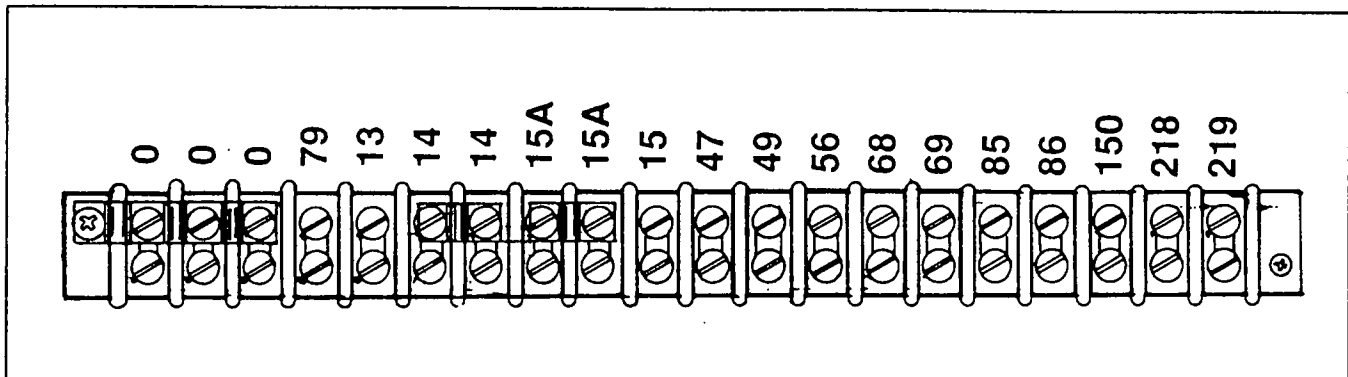


Figure 2. Terminal Board TB1 (Typical)

DC Control / Latch-Crank Circuit Board (Continued)

PIN	WIRE	FUNCTION
1	137	12 VDC from board to engine monitor panel's test/reset switch. Common ground.
2	0	12 VDC output to "low oil press" lamp on closure of oil pressure switch contacts.
3	94	12 VDC to "overspeed" lamp on on closure of "high coolant" temperature switch or low coolant level sensor contacts.
4	95	12 VDC to "overspeed" lamp on occurrence of engine overspeed.
5	97	12 VDC to "overcrank" lamp following occurrence of an overspeed condition.
6	96	12 VDC to "rpm sensor loss" lamp on loss of sensor output to circuit board.
7	98	12 VDC to "not in automatic start mode" lamp when the manual-auto-off switch is set to either "Manual" or "Off".
8	503	

CIRCUIT BOARD OVERSPEED ADJUSTMENT:

The DC control / latch-crank board must be calibrated each time it is replaced, for the following reasons:

- The board must be matched to the specific engine fly-wheel or engine speed sensing errors will result.
 - The board must be calibrated to establish an overspeed shutdown setting that is about 10 hertz above the normal operating speed.
- When overspeed setting is correct, starter cutout will also be correct.

To calibrate the circuit board, (See Figure 3) proceed as follows:

1. On the circuit board, locate the "Fine" and "Coarse" potentiometers. Also, locate the red LED (light emitting diode).
2. Turn the "Coarse" all the way "counterclockwise (CCW).
3. Turn the "FINE" pot all the way clockwise (CW).

CAUTION:

Steps 2 and 3 above MUST be completed before the engine is started following circuit board replacement. If the engine is started before Steps 2 and 3 are completed, an overspeed shutdown may occur at normal rated operating speed.

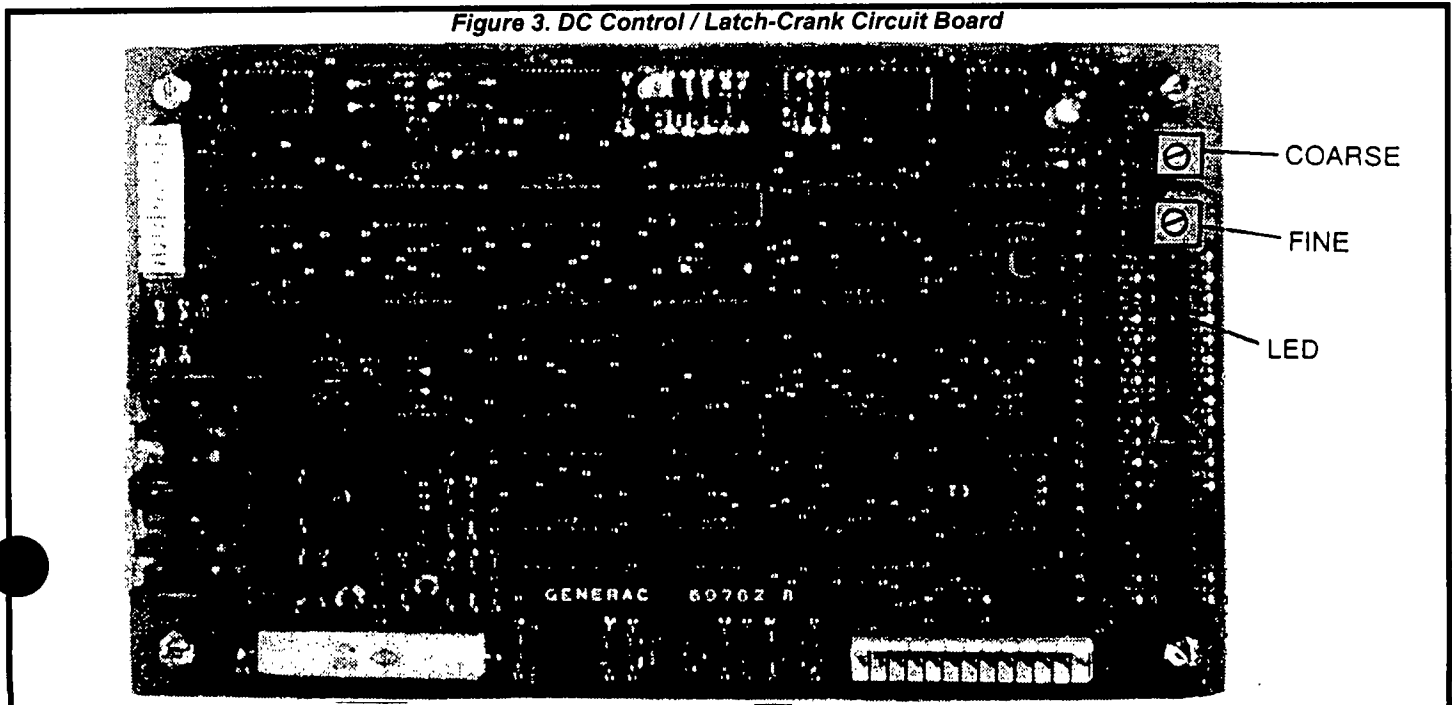
4. Start the engine manually. Let it stabilize and warm up at normal rated no-load speed. If necessary, adjust the engine governor to obtain the no-load frequency reading.

NOTE: If "OVERSPEED" shutdown occurs upon engine start in step four (4), reverse initial pot settings in steps two (2) and three (3).

5. Slowly turn the "Coarse" adjustment pot clockwise (CW) until the red LED just turns on.
6. Slowly turn the "Fine" adjustment pot counterclockwise until the red LED just goes out.
7. Slowly turn the "Fine" adjustment pot clockwise (CW) until the red LED just turns on.

With the above calibration completed, overspeed shutdown will occur about 10 Hertz above the no-load speed. For example, if the unit was running at 62 Hertz during calibration, overspeed shutdown will occur at about 72 Hertz.

Figure 3. DC Control / Latch-Crank Circuit Board



Wiring Harness

The control console wiring harness interconnects control console electrical components. Harnesses for gas and diesel engine units are NOT interchangeable.

Preheat Switch (Diesel Only)

The preheat switch permits the operator to warm the combustion chambers of a cold engine prior to a manual startup. During automatic startup, the preheat function is controlled by the DC control/latch-crank board.

Fused 12 volts DC power is always available to the preheat switch, via Wire 15A, the preheat relay coil, and Wire 221. When the switch contacts are closed by the operator, Wire 221 is connected to ground. The preheat relay then energizes, its contacts close, and DC power is delivered to the diesel engine glow plugs or air intake heater.

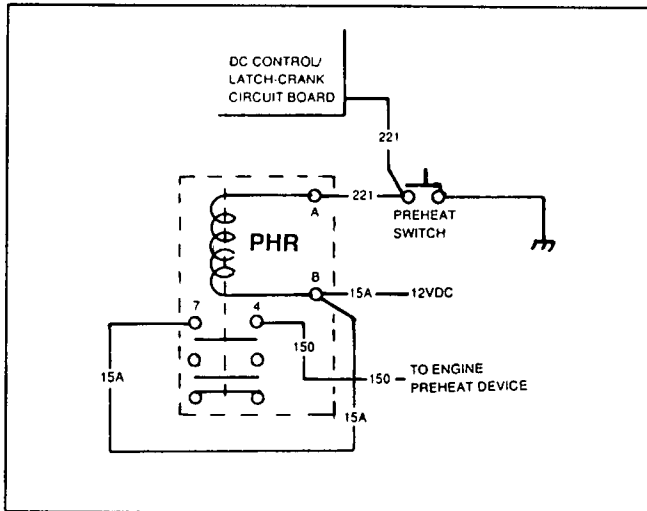


Figure 4. Preheat Circuit (Typical)

Start/Stop Switch

The 3-position start/stop switch connects Wire 17 to ground when set to "Start" position. Circuit board action will then energize a crank and a run relay to crank and start the engine.

When the switch is set to "Stop", Wire 18 is connected to ground. Circuit board action will then de-energize the run relay and shutdown will occur.

When set to its "Run" (centered) position, Wires 17 and 18 circuits are both open.

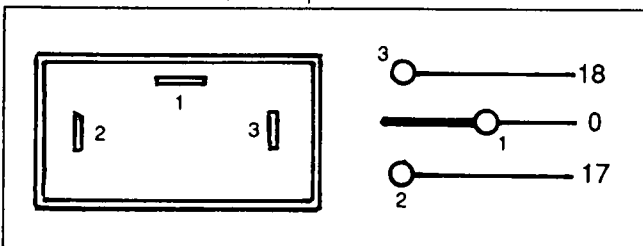


Figure 5. Start/Stop Switch Circuit (Typical)

Auto-Manual-Off Switch

Also see "Auto-Manual-Off Switch" in Section 6.1. The switch is shown pictorially and schematically in Figure 6. The schematic shows the switch in its "Off" position. Switch contacts positions with the switch set to "Auto", "Manual" and "Off" are given in the following chart.

TERMINAL NUMBERS	CONTACTS POSITION		
	AUTO	MANUAL	OFF
1 and 2	Open	Open	Closed
2 and 3	Open	Closed	Open
4 and 5	Open	Closed	Closed
5 and 6	Closed	Open	Open
7 and 8	Open	Closed	Closed
8 and 9	Closed	Open	Open

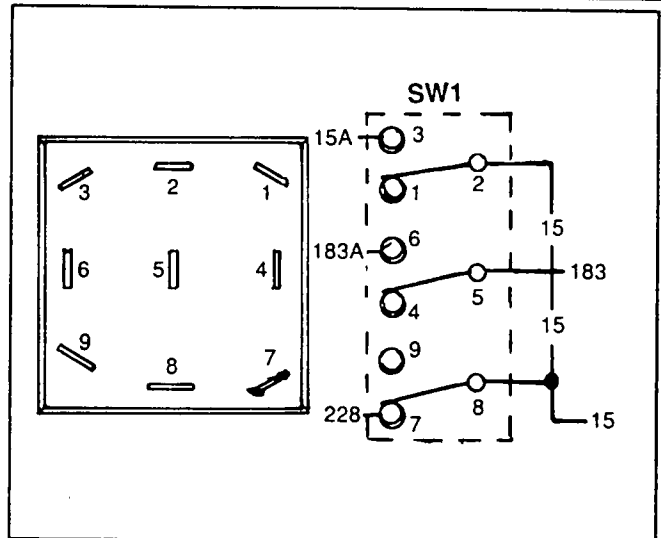


Figure 6. Auto-Manual-Off Switch

Voltage Adjust Potentiometer

This adjustable potentiometer permits the operator to "fine adjust" generator AC output voltage, within a range of approximately plus or minus 10 percent. The potentiometer is electrically connected in series with one of the sensing leads to the voltage regulator.

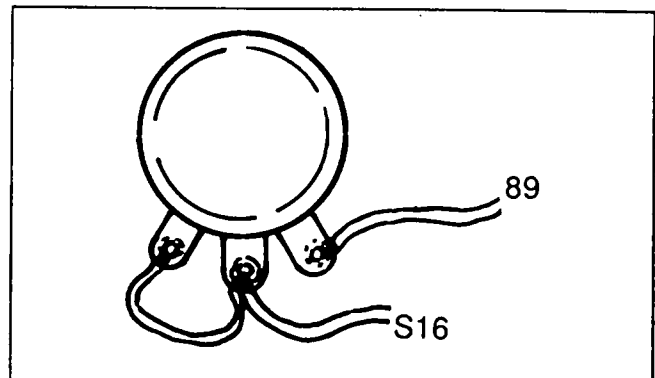


Figure 7. Voltage Adjust Potentiometer Terminals

Line-Phase Selector Switch

Also see "Line-Phase Selector Switch" in Section 6.1. A schematic representation of the switch is shown in Figure 8, with the switch shown in its "Off" position. The condition of the switch contacts at each position of the switch are shown in the following chart.

CONTACT NUMBERS	SWITCH POSITION			
	1	2	3	4
1 and 2	Open	Closed	Closed	Closed
3 and 4	Closed	Open	Open	Open
5 and 6	Closed	Open	Closed	Closed
7 and 8	Open	Closed	Open	Open
9 and 10	Closed	Closed	Open	Closed
11 and 12	Open	Open	Closed	Open
13 and 14	Closed	Open	Closed	Open
15 and 16	Open	Closed	Open	Open
17 and 18	Open	Closed	Closed	Open
19 and 20	Closed	Open	Open	Open

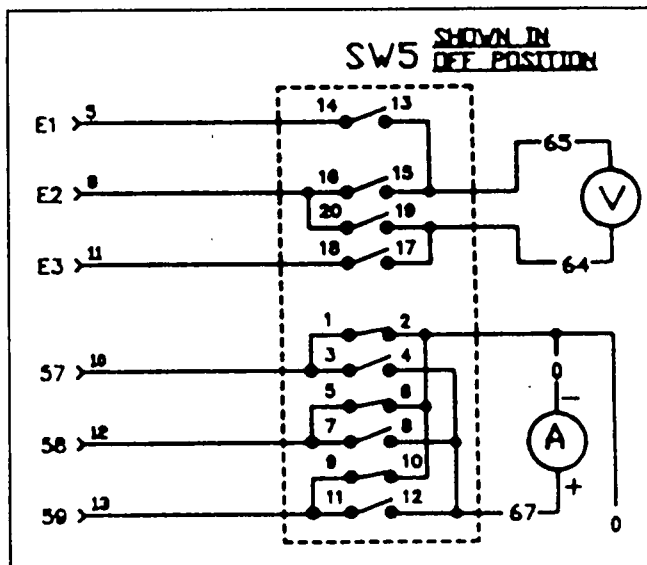


Figure 8. Schematic- Line-Phase Selector Switch

Engine Monitor Circuit Board

This "display" circuit board mounts six (6) advisory lamps, which are really LED's or light emitting diodes. A connector plug and wire set interconnects the circuit board with the DC control/latch-crank board.

Engine Run Relay (24 Volts Diesel Units Only)

Generator models having engines with 24 volts DC electrical systems use the standard Option "C" console. This console requires 12 volts DC for its operation. Engine starters, DC alternators, fuel solenoids, glow plugs or air intake heaters, etc., may require 24 volts DC power for their operation. Some method of energizing these 24 volts components with 12 volts console power must be provided. This is the engine run relay.

The engine run relay is energized by a 12 volts DC output from the DC control/latch-crank circuit board. When the relay is energized, its normally-open contacts close. On closure of those contacts, 24 volts DC can be delivered to those engine components requiring the higher voltage.

In Figure 9, 24 volts DC is available to the normally-open relay contacts via Wire No. 218. When the DC control circuit board's run relay (K2) energizes, 12 volts DC is delivered to relay terminal "A" via Wire 14. The relay then energizes, its contacts close and 24 volts DC is delivered to an engine fuel solenoid via Wire 219, and to the engine DC alternator via Wire 47.

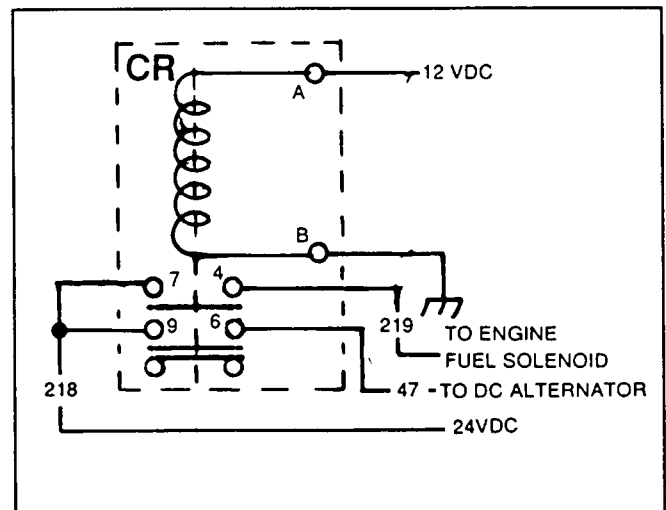


Figure 9. Schematic- Engine Run Relay

Preheat Relay (Diesel Engines Only)

The preheat relay (Figure 10) can be energized by (a) actuating the console mounted preheat switch, or (b) circuit board action during automatic startup. When energized, the relay contacts close to deliver 12 volts DC to an engine preheat contactor via Wire No. 150. Energizing the preheat contactor delivers 24 or 12 volts DC to an air intake heater or to engine glow plugs.

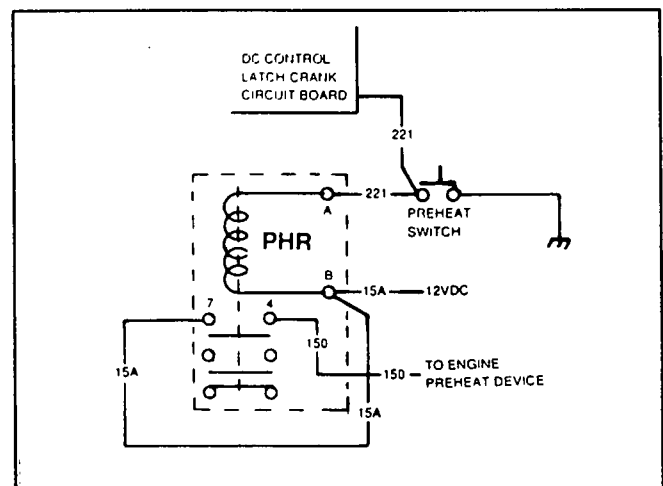


Figure 10. Schematic- Typical Preheat Circuit

Optional Alarm Relay

Some Option "C" consoles may be equipped with an optional alarm relay. The alarm relay can be used to turn on a remote mounted alarm device in the event of a monitored engine shutdown (see Section 6.2, "Engine Monitor Panel").

See Figure 11. Fused 12 volts DC is always available to the relay coil via Wire 15A, and to the circuit board via Wire 229. On occurrence of any monitored shutdown fault, circuit board action will complete the Wire 229 circuit to ground. The alarm relay will then energize, its normally-open contacts will close and its normally-closed contacts will open. Note that the connected remote alarm device must have its own power supply.

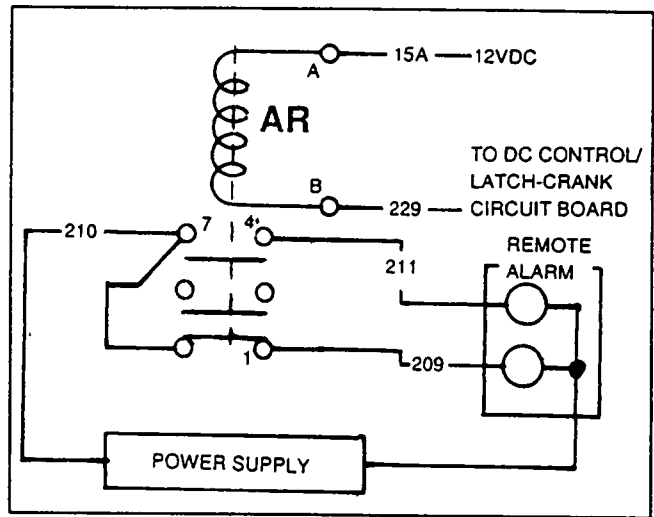


Figure 11. Optional Alarm Relay Circuit

Section 6.4 AC CIRCUITS OPERATION

General

A schematic diagram of the control console's AC circuits is shown in Figure 1, below. The console's AC circuits include (a) AC voltmeter circuit, (b) AC ammeter circuit, and (c) the frequency meter circuit.

In addition to the meter circuits, some field (rotor) excitation circuits are housed in the control console.

The AC Voltmeter Circuit

CIRCUIT DESCRIPTION:

Generator AC output voltage signals are delivered to the console AC voltmeter, via Wires No. E1, E2 and E3 (for 3-phase generators), and a line-phase selector switch. A 15-pin connector plug, located in the AC connection (lower) panel, connects the control console wiring to lower panel wiring.

LINE-PHASE SELECTOR SWITCH:

See "Line-Phase Selector Switch" on Page 6.3-4.

The AC Ammeter Circuit

In the AC connection (lower) panel, generator AC output leads E1, E2 and E3 are routed through three current transformers. Current flow through leads E1/E2/E3 induce a current flow into the transformers. Transformer output current is then delivered to the console AC ammeter, via Wires 57, 58 and 59.

NOTE: The above is true of 3-phase units. On 1-phase units, generator AC output leads E1 and E3 are routed through transformers and only two transformers are required.

The AC Frequency Meter Circuit

The console's AC frequency meter is powered by sensing leads S15 and S16. Leads S15/S16 also deliver voltage/frequency sensing signals to the voltage regulator.

The Field Excitation Circuit

Refer to Part 2, Part 3 or Part 4 as appropriate for excitation circuit instructions and information.

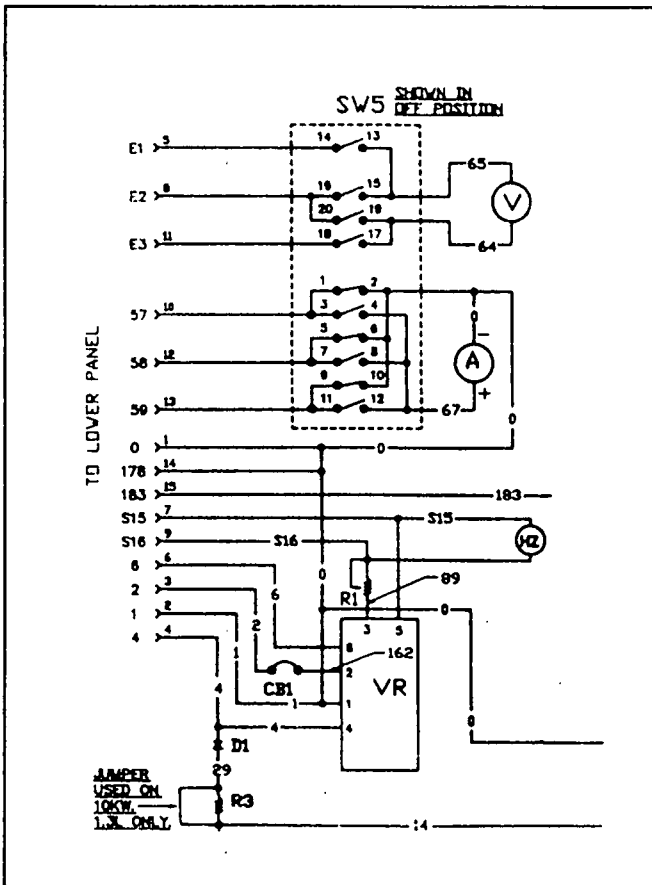
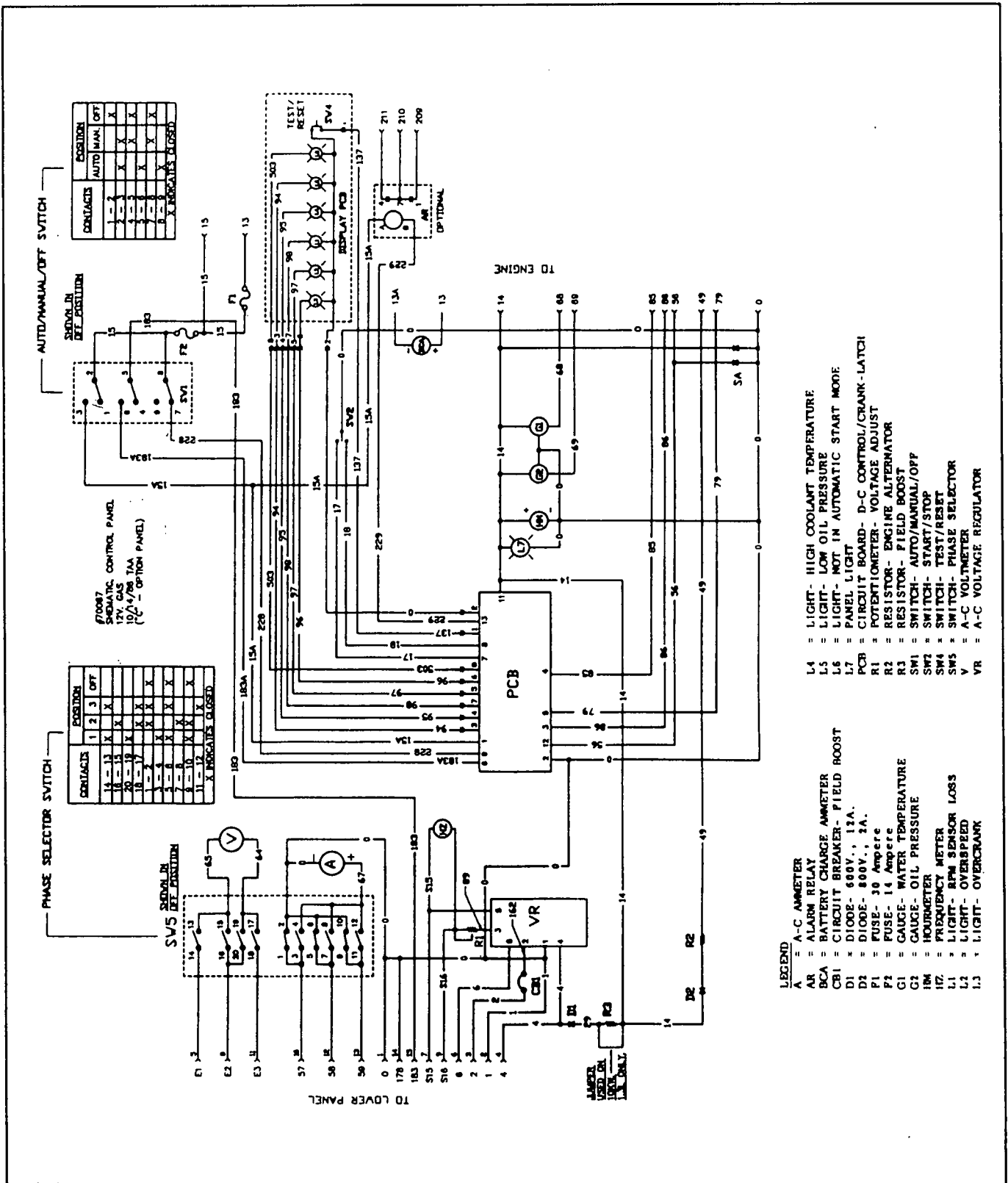
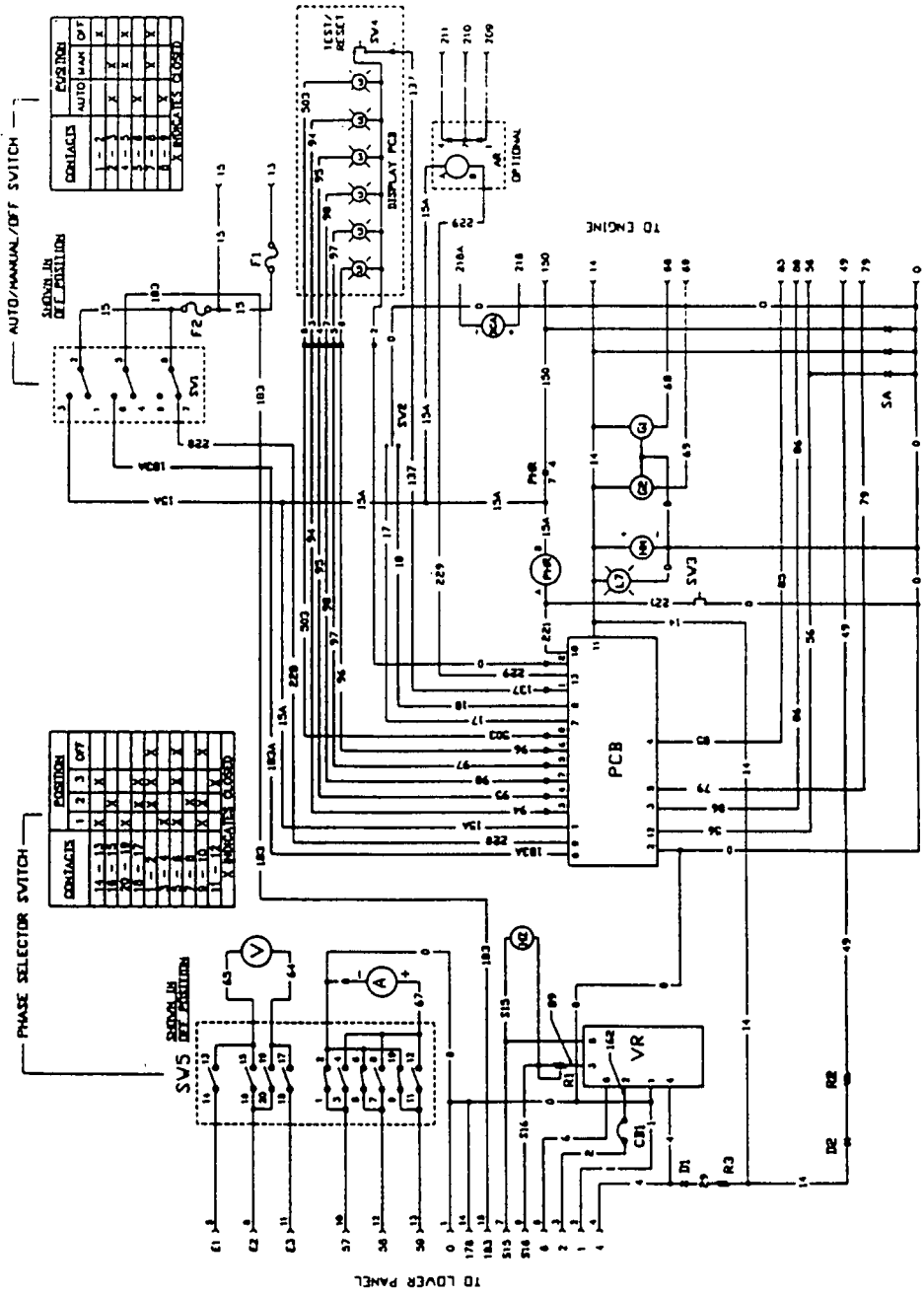


Figure 1. Control Console AC Circuits Schematic

Section 6.5 DC CONTROL- 12 VOLTS GAS UNITS



Section 6.6 DC CONTROL - 12 VOLTS DIESEL UNITS

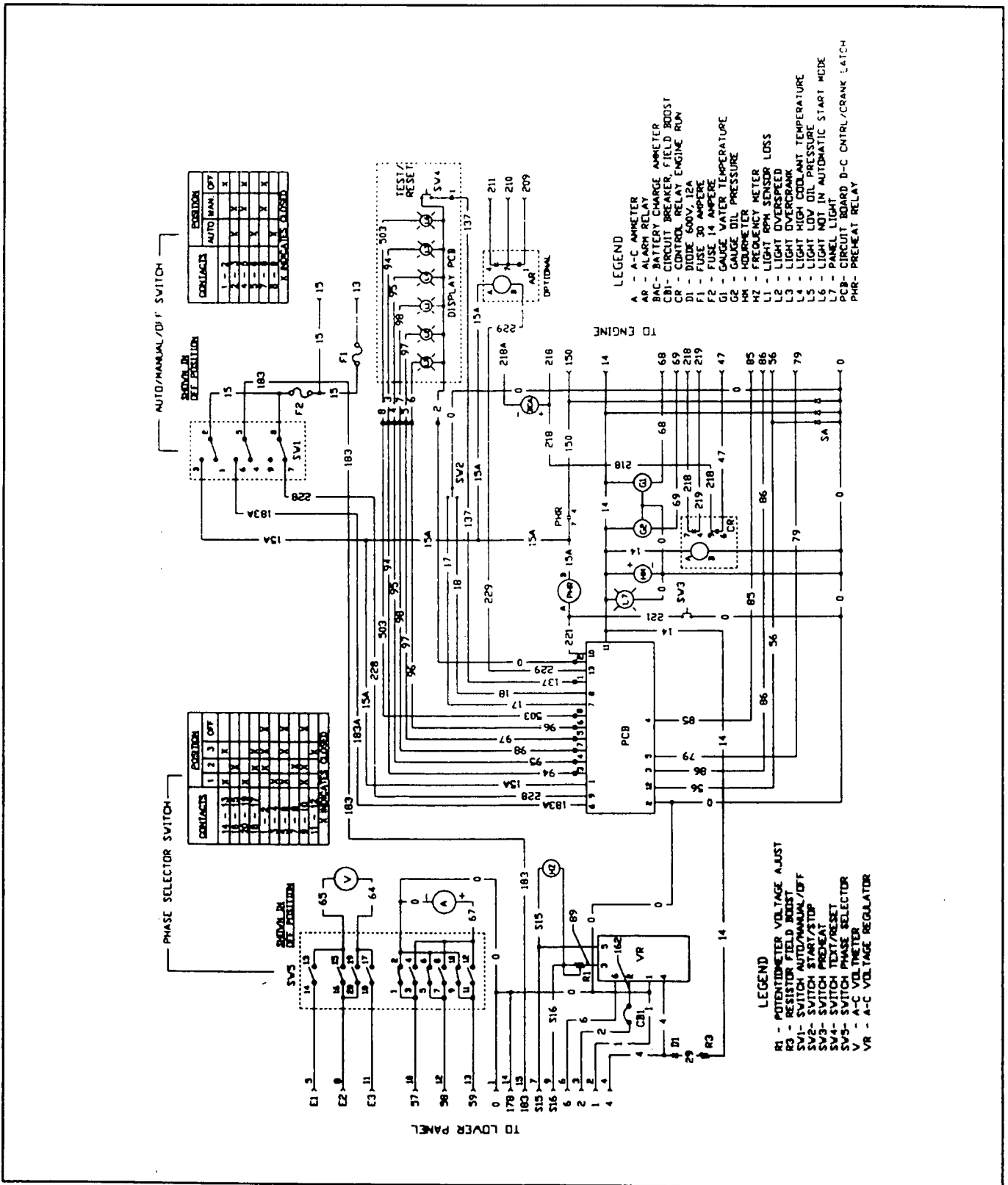


CONTACTS		POSITION	
		AUTO	MAN OFF
1	2	X	X
3	4	X	X
5	6	X	X
7	8	X	X
9	10	X	X
11	12	X	X
13	14	X	X
15	16	X	X
17	18	X	X
19	20	X	X
21	22	X	X
23	24	X	X
25	26	X	X
27	28	X	X
29	30	X	X
31	32	X	X
33	34	X	X
35	36	X	X
37	38	X	X
39	40	X	X
41	42	X	X
43	44	X	X
45	46	X	X
47	48	X	X
49	50	X	X
51	52	X	X
53	54	X	X
55	56	X	X
57	58	X	X
59	60	X	X
61	62	X	X
63	64	X	X
65	66	X	X
67	68	X	X
69	70	X	X
71	72	X	X
73	74	X	X
75	76	X	X
77	78	X	X
79	80	X	X
81	82	X	X
83	84	X	X
85	86	X	X
87	88	X	X
89	90	X	X
91	92	X	X
93	94	X	X
95	96	X	X
97	98	X	X
99	100	X	X

CONTACTS		POSITION	
		1	2
1	2	X	X
3	4	X	X
5	6	X	X
7	8	X	X
9	10	X	X
11	12	X	X
13	14	X	X
15	16	X	X
17	18	X	X
19	20	X	X
21	22	X	X
23	24	X	X
25	26	X	X
27	28	X	X
29	30	X	X
31	32	X	X
33	34	X	X
35	36	X	X
37	38	X	X
39	40	X	X
41	42	X	X
43	44	X	X
45	46	X	X
47	48	X	X
49	50	X	X
51	52	X	X
53	54	X	X
55	56	X	X
57	58	X	X
59	60	X	X
61	62	X	X
63	64	X	X
65	66	X	X
67	68	X	X
69	70	X	X
71	72	X	X
73	74	X	X
75	76	X	X
77	78	X	X
79	80	X	X
81	82	X	X
83	84	X	X
85	86	X	X
87	88	X	X
89	90	X	X
91	92	X	X
93	94	X	X
95	96	X	X
97	98	X	X
99	100	X	X

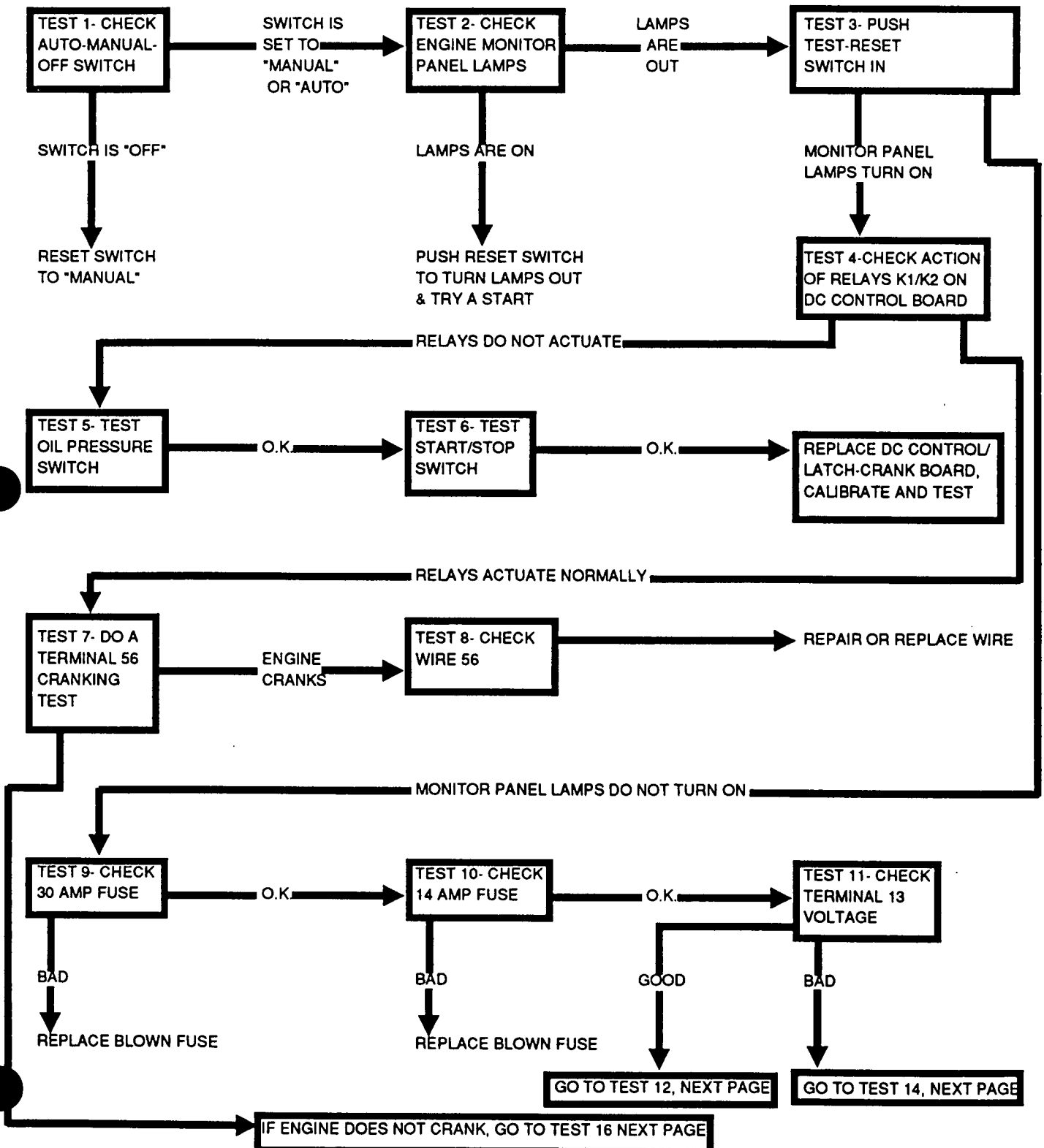
- LEGEND**
- A = A-C AMMETER
 - AR = ALARM RELAY
 - BCA = BATTERY CHARGE AMMETER
 - CB1 = CIRCUIT BREAKER - FIELD BOOST
 - D1 = DIODE - 600V., 12A.
 - D3 = DIODE - 600V., 2A.
 - F1 = FUSE - 10 Ampere
 - F2 = FUSE - 14 Ampere
 - G1 = GAUGE - WATER TEMPERATURE
 - G2 = GAUGE - OIL PRESSURE
 - IM = HOURMETER
 - IMZ = FREQUENCY METER
 - L1 = LIGHT - RPM SENSOR LOSS
 - L2 = LIGHT - OVSPEED
 - L3 = LIGHT - OVSURBANK
 - L4 = LIGHT - HIGH COOLANT TEMPERATURE
 - L5 = LIGHT - LOW OIL PRESSURE
 - L6 = LIGHT - NOT IN AUTOMATIC START MENU
 - L7 = PANEL LIGHT
 - PCB = CIRCUIT BOARD - D-C CONTROL/CRANK-LATTI
 - PIR = PREHEAT RELAY
 - R1 = POTENTIOMETER - VOLTAGE ADJUST
 - R2 = RESISTOR - ENGINE ALTERNATOR
 - R3 = RESISTOR - FIELD BOOST
 - SV1 = SWITCH - AUTO/MANUAL/OFF
 - SV2 = SWITCH - START/STOP
 - SV3 = SWITCH - TEST/RESET
 - SV4 = SWITCH - PHASE SELECTOR
 - V = A-C VOLTMEETER
 - VR = A-C VOLTAGE REGULATOR

Section 6.7 DC CONTROL- 24 VOLTS DIESEL UNITS

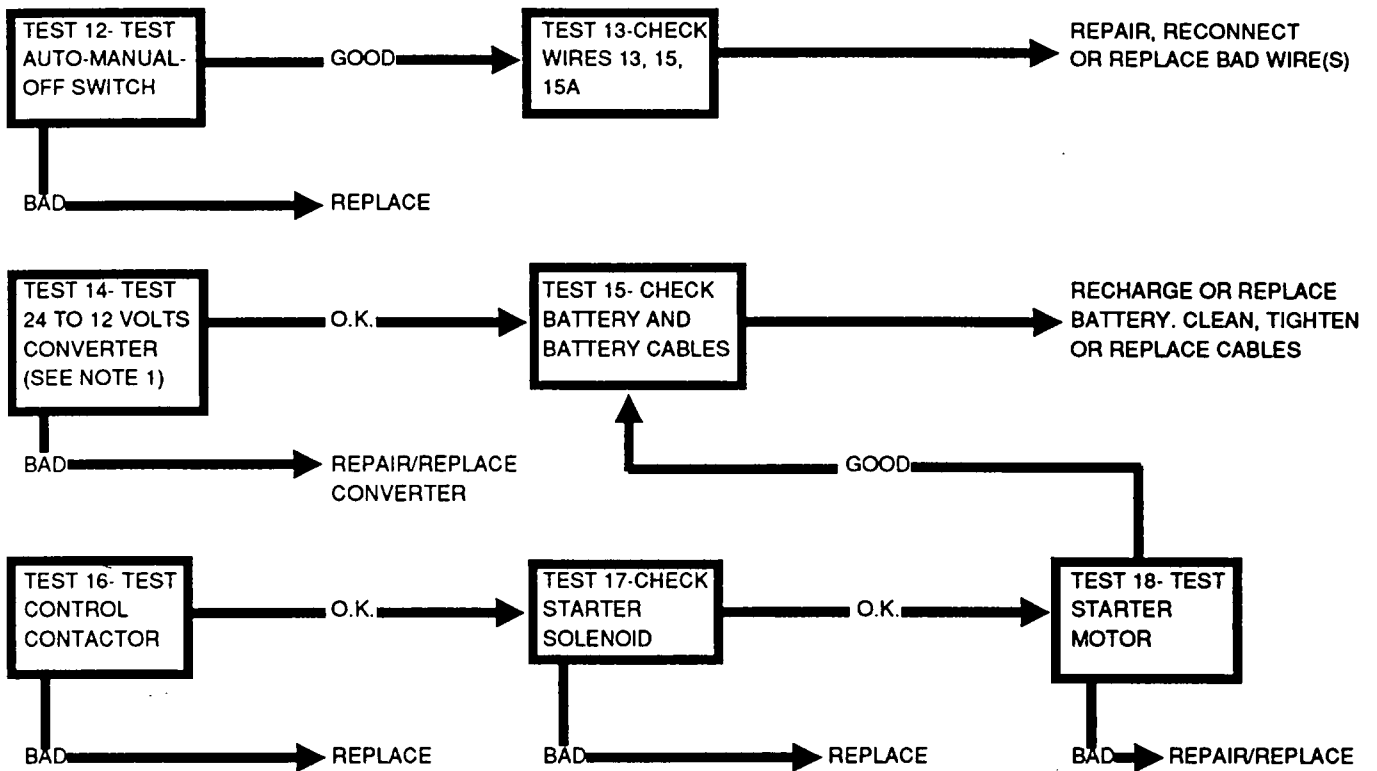


Section 6.8
TROUBLESHOOTING CHARTS

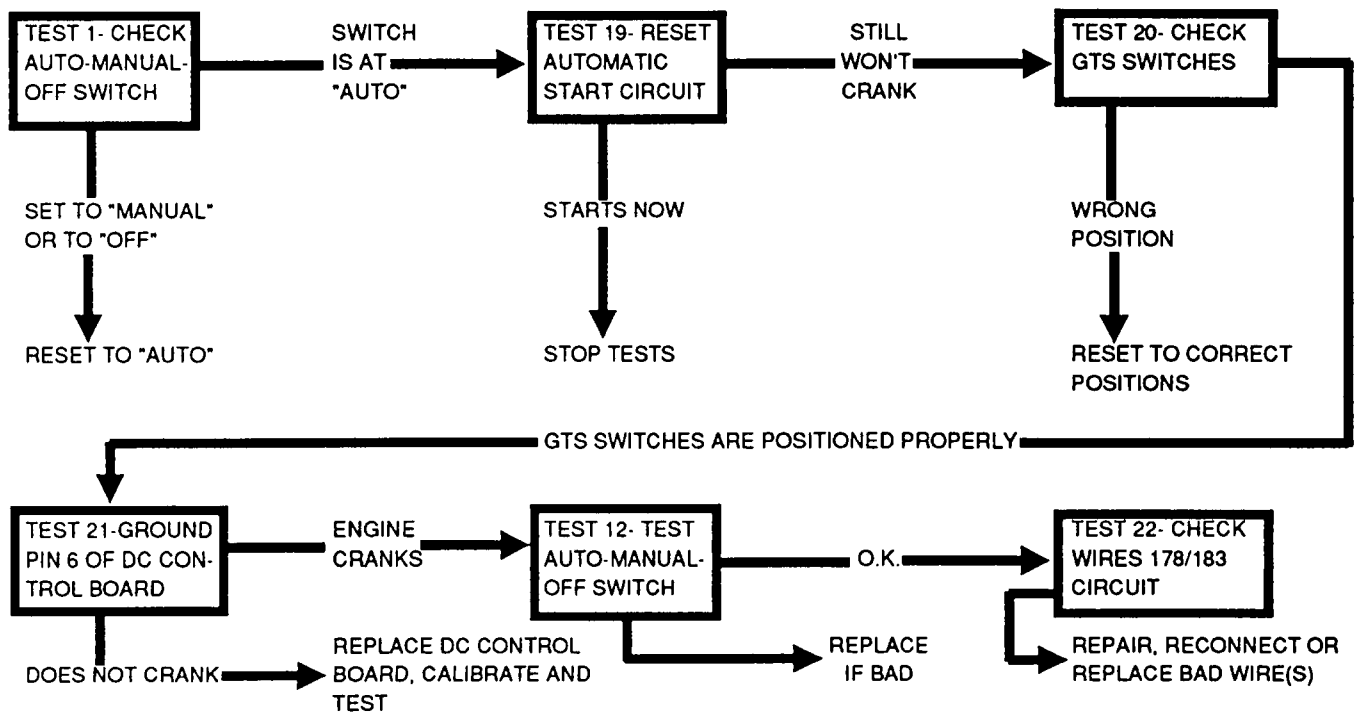
Problem 1- Engine Won't Crank Manually



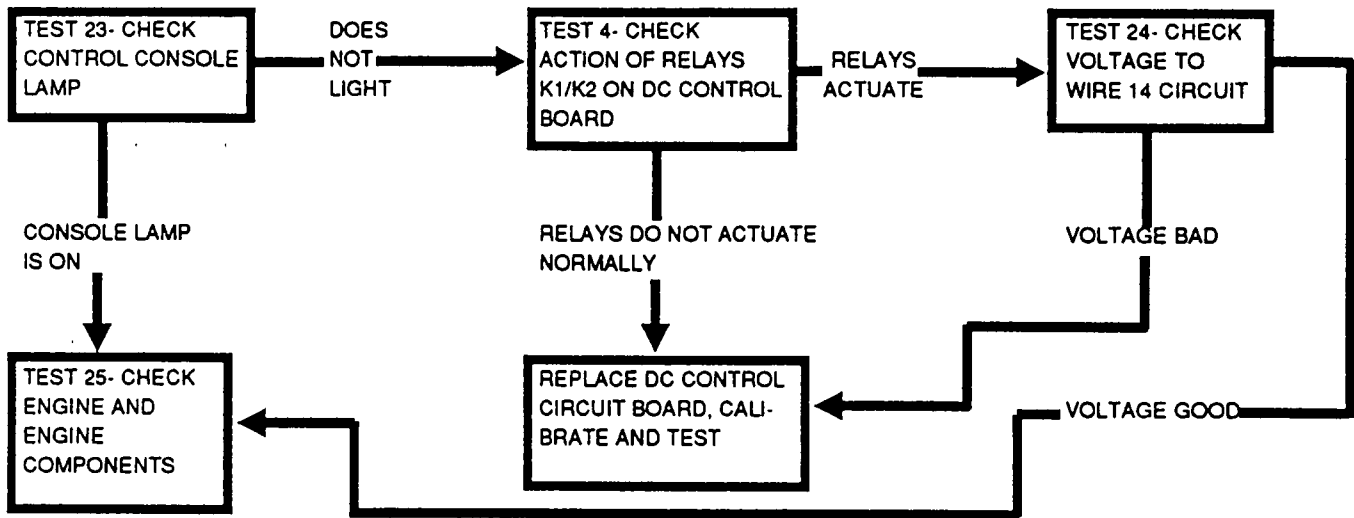
Problem 1- Engine Won't Crank Manually (Continued)



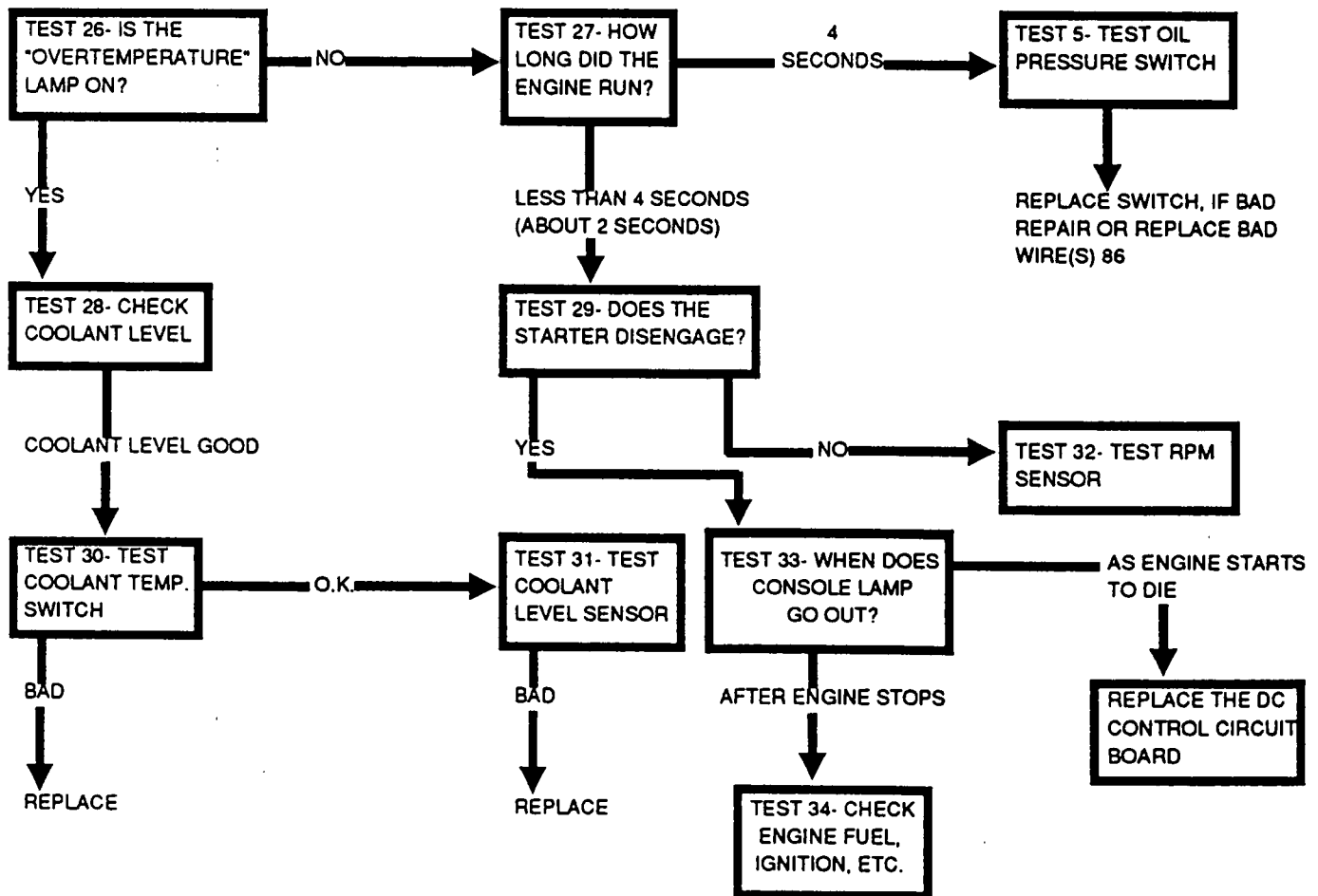
Problem 2- Engine Won't Crank in Automatic Mode



Problem 3- Engine Cranks But Won't Start



Problem 4- Engine Cranks, Starts, Then Shuts Down



Section 6.9 DIAGNOSTIC TESTS

NOTE: The numbered tests in this section coincide with test numbers in Section 6.8, "Troubleshooting Charts".

Test 1- Check Auto-Manual-Off Switch

DISCUSSION:

The generator engine will not crank either manually or in automatic mode if the console auto-manual-off switch is set to "Off". When the switch is set to "Manual", the engine can be cranked manually but not automatically. With "Auto" selected, the engine can be cranked manually or automatically.

If the switch is set to either "Manual" or "Off", the "Not in Automatic Start Mode" lamp will be on.

PROCEDURE:

Note the position of the Auto-Manual-Off switch. For manual operation, the switch should be set to "Manual". For automatic operation, set the switch to "Auto".

RESULTS:

1. Reset the switch to "Manual" or "Auto" as required.
2. If switch position is correct but engine will not crank, go to Test 2.

Test 2- Check Engine Monitor Panel Lamps

DISCUSSION:

If any one of the advisory lamps on the engine monitor panel is on, the engine will not crank automatically and cannot be cranked manually.

PROCEDURE:

Observe the engine monitor panel. If any lamp is on, push the test-reset switch in to reset the system. The lamp(s) should go out and further cranking should be possible.

RESULTS:

If all engine monitor panel lamps are out but engine will not crank, go to Test 3.

Test 3- Push Test-Reset Switch In

DISCUSSION:

If the engine will not crank manually or automatically, one possible cause of the problem is loss of power to the DC control/latch-crank circuit board. Such a power loss may be caused by (a) an open 30 amp fuse, or (b) an open 14 amp fuse, or (c) an open circuit in the power supply circuit (i.e., Wires 13, 15, 15A). Instead of testing fuses and wiring, we shall use a faster method to test the circuit board's power supply circuit.

PROCEDURE:

On the engine monitor panel, push the test-reset in. All lamps should light, indicating that DC power is available for circuit board operation.

RESULTS:

1. If all panel lamps turn on, go to Test 4.
2. If panel lamps do NOT turn on, go to Test 9.

Test 4- Check Action of Relays K1/K2 on DC Control Board

DISCUSSION:

During either a manual or automatic startup, DC control circuit board action will energize a crank relay (K1) and a run relay (K2). These two relays are mounted on the DC control/latch-crank circuit board. When crank relay (K1) energizes, its contacts close to deliver 12 volts DC to a Wire 56 circuit. This energizes a control contactor which, in turn, energizes a starter solenoid. The energized starter solenoid, in turn, energizes the starter motor and the engine cranks.

When run relay (K2) energizes, its contacts close to deliver 12 volts DC to a Wire 14 circuit. Wire 14 (a) turns on the console lamp, and (b) delivers DC power to the engine ignition system, to a fuel solenoid, etc. The engine can now start and run.

PROCEDURE:

Gain access to the control console interior where the DC control/latch-crank circuit board relays can be observed. Then, proceed as follows:

1. Set a VOM to a DC voltage scale greater than 12 volts.
2. Connect the positive (+) VOM test lead to terminal 56 of terminal board TB1. Connect the common (-) VOM test lead to terminal 0 (ground).
3. Try to crank the engine by holding the start/stop switch at "Start". Crank relay (K1) should energize, the VOM should indicate 12 volts DC, and the engine should crank.
4. Try to crank the engine. Run relay (K2) should energize, engine should start and run.

RESULTS (IF ENGINE DOES NOT CRANK):

1. If crank relay K1 does NOT actuate, go to Test 5.
2. If relay K1 actuates, but VOM does NOT read 12 volts in Step 3, replace the DC control/latch-crank circuit board. Calibrate the new board and test operation.
3. If crank relay K1 actuates, 12 volts DC is read in Step 3, but engine does not crank, go to Test 7.

Test 4- Check Action of Relays K1/K2 on DC Control Board (Continued)**RESULTS (ENGINE CRANKS BUT WON'T START):**

1. If the run relay (K2) energizes in Step 5 and if the engine cranks but won't start, go to Test 24 ("Check Output Voltage to Wire 14 Circuit").
2. If the run relay does NOT actuate in Step 4, replace the DC control/latch-crank circuit board. Calibrate and test the new board.

Test 5- Test Oil Pressure Switch**DISCUSSION:**

The oil pressure switch has normally-closed contacts which are held open by oil pressure during cranking and running (approximately 10 psi and higher). With the engine shut down, the switch contacts should be closed and its Wire 86 circuit should be closed to frame ground. The DC control/latch-crank board will initiate engine cranking only if the oil pressure switch circuit is closed to ground, i.e., when zero volts is read in the circuit. During a cranking and startup operation and after the switch contacts have opened, the circuit to ground will be broken and circuit voltage will build to approximately 11 volts DC.

PROCEDURE:

1. Set a VOM to read DC voltage and to a voltage scale greater than 12 volts DC.
2. Connect the positive (+) VOM test lead to Terminal 86 of terminal board TB1 and the common (-) test lead to terminal 0 (ground). With the engine shut down, voltage reading should be zero.

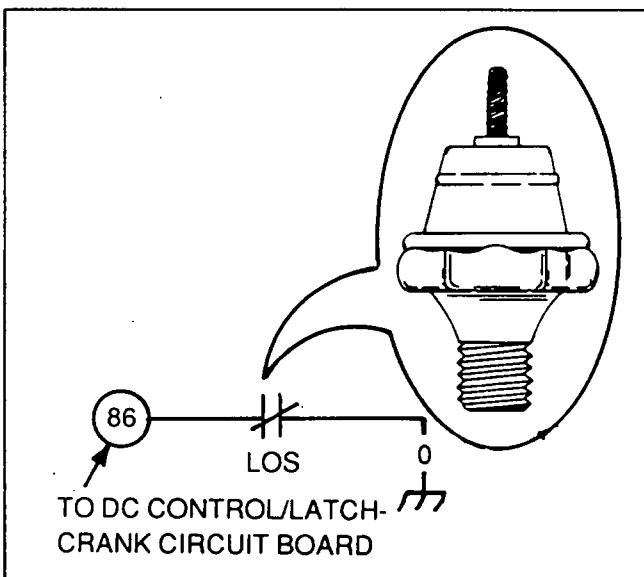


Figure 1. Low Oil Pressure Switch Circuit

RESULTS:

1. If the VOM reads about 11 volts, either the switch contacts or the Wire 86 circuit is open.
 - a. Replace the oil pressure switch if its contacts are open.
 - b. If switch contacts are closed, check the Wire 86 circuit for an open condition. Repair, reconnect or replace wiring as necessary.
2. If the VOM read zero volts, go on to Test 6.

Test 6- Test Start/Stop Switch**DISCUSSION:**

Failure of the engine to crank manually can be caused by a defective start/stop switch. When the switch is set to its "Run" (centered) position, approximately 11 volts DC should be read across the switch Wire 17 terminal to ground. Set the switch to its "Start" position and the voltage reading should drop to "zero".

PROCEDURE A:

1. Set the VOM to read DC volts and to a scale greater than 12 volts.
2. Connect the positive (+) VOM test probe to the Wire 17 terminal of the start/stop switch and the common (-) test probe to terminal 0 of terminal board TB1.
 - a. Set the start/stop switch to "Run" (centered) position. The VOM should read approximately 11 volts DC.
 - b. Now, set the switch to "Start". The VOM should read "zero" volts.

RESULTS:

1. If the VOM reads about 11 volts DC in Step 2(a) and the voltage drops to "zero" in Step 2(b), but engine will not crank, replace the DC control/latch-crank circuit board. Calibrate the board and test operation.
2. If the VOM reads 11 volts DC in Step 2(a) but voltage does NOT drop to zero in Step 2(b), either the switch is defective or Wire 0 (switch terminal to ground) is open. Go to Step 3 of this test (under PROCEDURE B, below).
3. If the VOM does NOT read about 11 volts DC in Step 2(a), check Wire 17 between the switch and the DC control/latch-crank board.
 - a. Repair, reconnect or replace Wire 17, if defective.
 - b. If Wire 17 is good but the VOM does not read 11 volts in Step 2(a), replace the DC control/latch-crank board. Calibrate the board and test operation.

PROCEDURE B:

3. Inspect and test Wire 0 from the start/stop switch to its grounded connection. If Wire 0 is bad, it must be repaired, reconnected or replaced.
4. Test the start/stop switch as follows:

Test 6- Test Start/Stop Switch (Continued)

- a. Set a VOM to its "Rx1" scale and zero the meter.
- b. To prevent interaction, disconnect Wires 17, 18 and 0 from the start/stop switch.
- c. Connect the VOM test leads across the switch Wire 17 and Wire 0 terminal. Set the switch to "Start", "Run" and "Off" while observing the meter readings. Readings at each switch position should be as indicated in the chart below.
- d. Now, connect the meter test leads across the switch Wire 18 and Wire 0 terminals. Observe the meter reading with the switch set to "Start", "Run" and "Off". Readings should be as indicated in the chart below.

VOM TEST LEADS ACROSS TERMINALS	DESIRED METER READING		
	START	RUN	STOP
17 and 0 18 and 0	Continuity Infinity	Infinity Infinity	Infinity Continuity

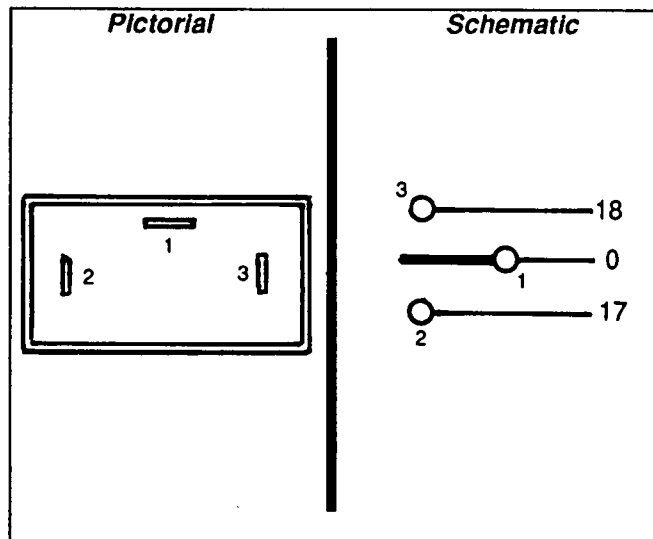


Figure 2. The Start/Stop Switch (Option "C" Units)

RESULTS:

1. Repair, reconnect or replace Wire 0 as necessary.
2. Replace the start/stop switch if it fails the test.

Test 7- Do a Terminal 56 Cranking Test

DISCUSSION:

During startup, a crank relay (K1) on the DC control/latch-crank board must be energized by circuit board action. When the K1 relay is energized, its contacts close to deliver a DC voltage to the Wire 56 circuit. Wire 56 circuit then energizes a control contactor (CC) to initiate engine cranking.

When the engine will not crank, this test will tell you the following:

- If the problem is in the Wire 56 circuit between terminal board TB1 and the circuit board, or in the circuit board itself.
- If the problem is in the Wire 56 circuit to the control contactor or in the engine cranking system.

PROCEDURE:

Connect a jumper wire from terminal 13 of terminal board TB1 to terminal 56. The engine should crank.

RESULTS:

1. If the circuit board crank relay K1 actuated in Test 4 and the engine did not crank, but the engine cranks now, go to Test 8. The problem must be in Wire 56 between terminal board TB1 and the DC control circuit board.
2. If the engine does not crank during this test, go to Test 16. The problem must be in the engine cranking circuit.

Test 8- Check Wire 56

DISCUSSION:

During startup, the DC control/latch-crank board must deliver a DC voltage to the Wire 56 circuit to initiate engine cranking. This test will determine if there is a DC output to terminal 56 of TB1 and, if there is no DC output to that terminal, if Wire 56 or the circuit board is/are at fault.

PROCEDURE:

1. Set a VOM to read DC volts and to a scale greater than 12 volts.
2. Connect the positive (+) VOM test probe to terminal 56 of terminal board TB1. Connect the common (-) test lead to terminal 0 of TB1.
3. Hold the start/stop switch at "Start". Crank relay K1 on the circuit board should actuate and the VOM should read approximately 11-12 volts DC.

RESULTS:

1. If the crank relay K1 actuates but the VOM does not indicate a DC voltage, proceed as follows:
 - a. Inspect and test Wire 56 between terminal board TB1 and the DC control board. Repair, reconnect or replace Wire 56 as required.
 - b. If DC voltage was NOT indicated during the test and Wire 56, between terminal 56 and the circuit board, checks good replace the DC control/latch-crank circuit board. Calibrate the new board and test operation.
2. If voltage reads good in Step 3 but engine did not crank, go to Test 16.

Test 9- Check 30 Amp Fuse**DISCUSSION:**

In Test 3, if the test-reset switch was actuated and the engine monitor panel lamps did not light, one possible cause is a blown fuse.

PROCEDURE:

Remove the 30 amp fuse from the fuse holder. Use a VOM to test the fuse for "continuity".

RESULTS:

1. If fuse has blown, it must be replaced.
2. If the 30 amp fuse checks good, go to Test 10.

Test 10- Check 14 Amp Fuse**DISCUSSION:**

Failure of the engine monitor panel lamps to turn on when the test-reset switch is pushed in can be caused by a blown 14 amp fuse.

PROCEDURE:

Gain access to the control console interior. Remove the 14 amp fuse from its in-line fuse holder. Test and inspect the fuse.

RESULTS:

1. Replace the 14 amp fuse, if it has blown.
2. If the 14 amp fuse checks good, go to Test 11.

Test 11- Check Terminal 13 Voltage**DISCUSSION:**

Terminal 13 is unfused battery voltage from the generator battery. This terminal is always electrically hot. If, for any reason, battery voltage is not available to terminal 13, the engine will not crank and start (either in automatic or manual mode). This test will determine if battery voltage is available to terminal 13.

PROCEDURE:

1. If so equipped, turn off the power supply to the utility powered battery charger to prevent the charger from affecting the battery voltage reading.
2. Set a VOM to read DC volts and to a scale greater than 12 volts.

3. Connect the positive (+) VOM test probe to terminal 13 of TB1; the common (-) test probe to terminal 0. The meter should read normal battery voltage (between 12-13 volts DC).

NOTE: Units with a 24 volts engine electrical system will be equipped with a 24-to-12 volts DC converter. The converter will reduce the 24 volts DC output of the unit batteries to approximately 12 volts DC. It is the converter output of 12 volts DC that is available to terminal 13.

RESULTS:

1. If battery voltage is good, go on to Test 12.
2. If battery voltage is zero or low, go to Test 14.

Test 12- Test Auto-Manual-Off Switch**DISCUSSION:**

The power for DC control/latch-crank board operation is delivered to the board through the auto-manual-off switch contacts. Thus, failure of the engine to crank in either manual or automatic mode may be caused by a defective switch. The switch is shown in Figure 3.

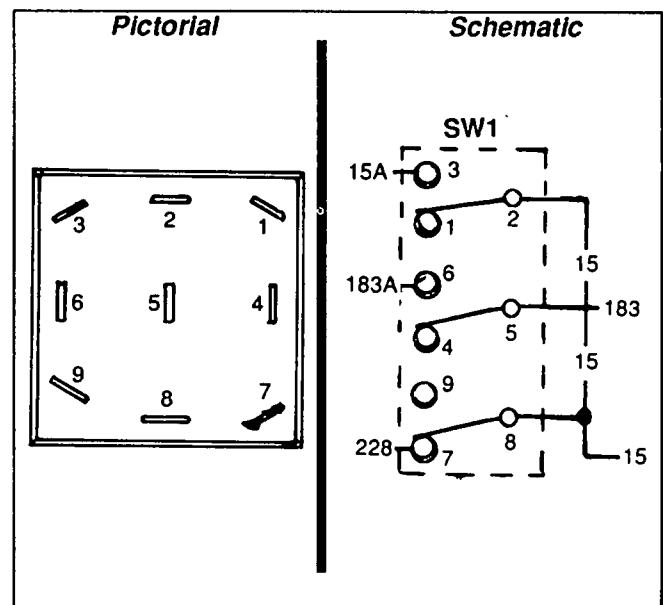


Figure 3. Auto-Manual-Off Switch

PROCEDURE:

1. Disconnect wires from the switch terminals to prevent interaction.
2. Set a VOM to its "Rx1" scale and zero the meter.
3. Connect VOM test probes across switch terminals as listed in the following chart. Actuate switch to "Auto", "Man" and "Off" and note the VOM readings.

**Test 12- Test Auto-Manual-Off Switch
(Continued)**

VOM readings at each switch position should be as stated in the chart for the appropriate switch contacts.

TEST ACROSS CONTACTS	SWITCH POSITION		
	AUTO	MAN	OFF
1 & 2	Infinity	Infinity	Continuity
2 & 3	Continuity	Continuity	Infinity
4 & 5	Infinity	Continuity	Continuity
5 & 6	Continuity	Infinity	Infinity
7 & 8	Infinity	Continuity	Continuity
8 & 9	Continuity	Infinity	Infinity

Reconnect all wires to the correct switch terminals before proceeding.

RESULTS:

1. Replace the auto-manual-off switch, if defective.
2. If the switch checks good, go to Test 13.

Test 13- Check Wires 13, 15 and 15A

DISCUSSION:

Wires 13, 15 and 15A deliver battery voltage to the DC control/latch-crank board via the auto-manual-off switch, the 30 amp fuse and the 14 amp fuse. An open condition in these circuits can be the cause of a "no-crank" condition. A shorted condition will probably result in a blown fuse. You should have already tested the fuses and the auto-manual-off switch. If those components tested good and the engine still won't crank, the Wires 13, 15 and 15A circuits should be inspected and tested.

PROCEDURE:

Inspect the Wires 13, 15, 15A circuits between terminal board TB1 and the auto-manual-off switch. Also inspect and test those wires between the auto-manual-off switch and the DC control/latch-crank board.

RESULTS:

Repair, reconnect or replace any open or shorted wire(s).

Test 14- Test 24 to 12 Volts Converter

DISCUSSION:

Units equipped with engines having a 24 volts DC engine electrical system require a DC converter to reduce the battery voltage down to the 12 volts DC required by control console components. If a check of the voltage at terminal 13 of terminal board TB1 indicates that voltage is extremely low or zero, perhaps the DC converter is defective. Figure 4 below shows the DC converter circuit board, located in the AC connection (lower) panel.

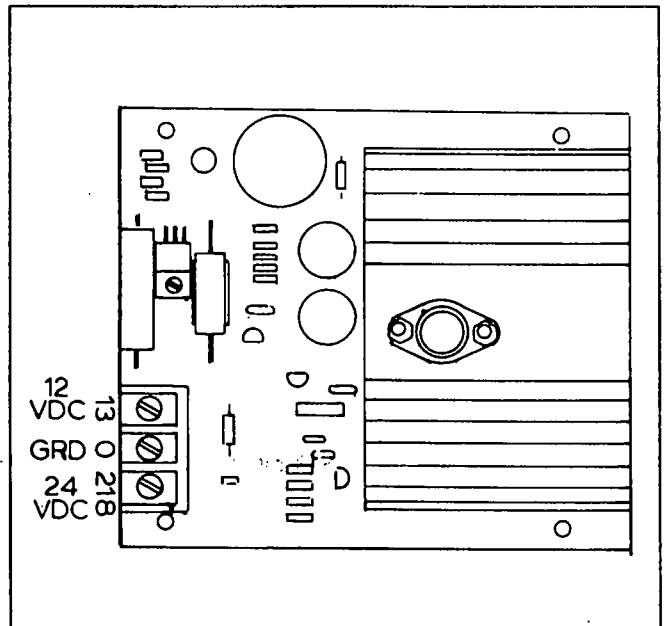


Figure 4. DC Converter Circuit Board

PROCEDURE:

1. Locate the DC converter in the AC connection (lower) panel.
2. Connect the VOM positive (+) test probe to the converter's terminal 13, the common (-) test probe to terminal 0. The meter should read approximately 12 volts DC (control console voltage).
3. Connect the positive (+) VOM test probe to converter terminal 218 and the common (-) test probe to terminal 0. The meter should read approximately 24 volts DC (engine system voltage).

RESULTS:

1. If 24 volts DC was indicated in Step 3, but 12 volts was NOT read in Step 2, replace the DC converter.
2. If normal DC voltage was indicated in both Steps 2 and 3, go to Test 15.

Test 15- Check Battery and Battery Cables

DISCUSSION:

A discharged battery or defective battery cables can result in failure of the engine to crank.

NOTE: A "quick test" of the battery system is to set the start/stop switch to "Start". If the engine monitor panel lamps flash dimly when the switch is released, the battery may be weak, the DC converter (24 volts units) may be bad, or battery cable(s) may be defective.

PROCEDURE:

Inspect the battery cables and cable connections carefully. Battery posts and cables must be clean, tight and free of corrosion. Clean cables and connections as required. Replace any damaged or defective cable(s).

Use an automotive type battery hydrometer to test the battery (or batteries) for (a) state of charge and (b) condition. Follow the hydrometer manufacturer's instructions carefully.

State of Charge: If the hydrometer does not have a percentage of charge scale, compare the specific gravity reading obtained with the following chart.

SPECIFIC GRAVITY	PERCENTAGE OF CHARGE
1.260	100%
1.230	75%
1.200	50%
1.170	25%

Condition: Charge the battery to a 100 percent state of charge. Then, test the specific gravity of fluid in all battery cells. If the difference in specific gravity between the highest and lowest reading cell is greater than 0.050 (50 points), the battery is nearing the end of its useful life and should be replaced.

RESULTS:

1. Recharge or replace battery as needed. Replace any defective battery cable(s).
2. If battery and battery cables are good, go to Test 16.

Test 16- Test Control Contactor

DISCUSSION:

See "Troubleshooting Charts" in Section 6.8. If Test 7 was completed and the engine did not crank, it is likely that one or more of the engine cranking system components has failed. Engine cranking system components include (a) a control contactor, (b) a starter solenoid, and (c) a starter motor.

12 Volts Engine Electrical Systems: See Figure 5. Battery voltage is available to one of the large terminal studs via Wire 13. When the DC control/latch-crank board's crank relay (K1) is energized, a DC voltage is delivered to the Wire 56 terminal stud to energize the control contactor. The contactor's normally-open con-

tacts then close to deliver battery voltage to the starter solenoid (SC) via Wire 16.

24 Volts Engine Electrical Systems: See Figure 6. Battery voltage (24 volts DC) is available to one of the large terminal studs via Wire 218. When the DC control board's crank relay (K1) is energized, 12 volts DC is delivered to the contactor via Wire 56. The contactor's normally-open contacts close to deliver 24 volts DC to the starter solenoid (SC) via Wire 16.

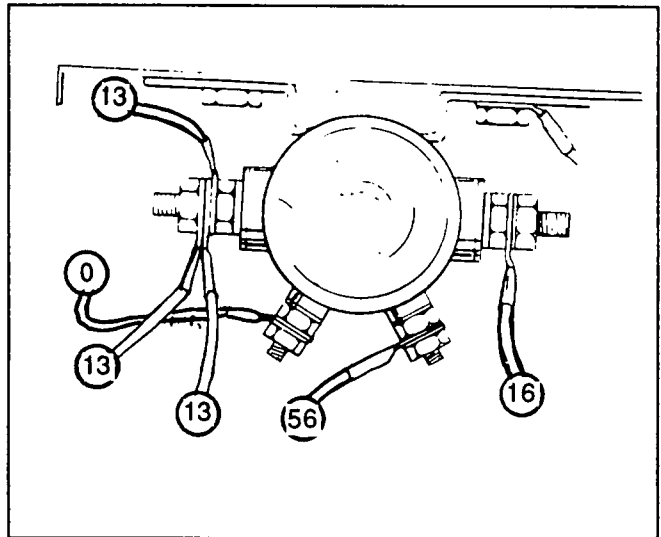


Figure 5. Control Contactor on 12 Volts DC Systems

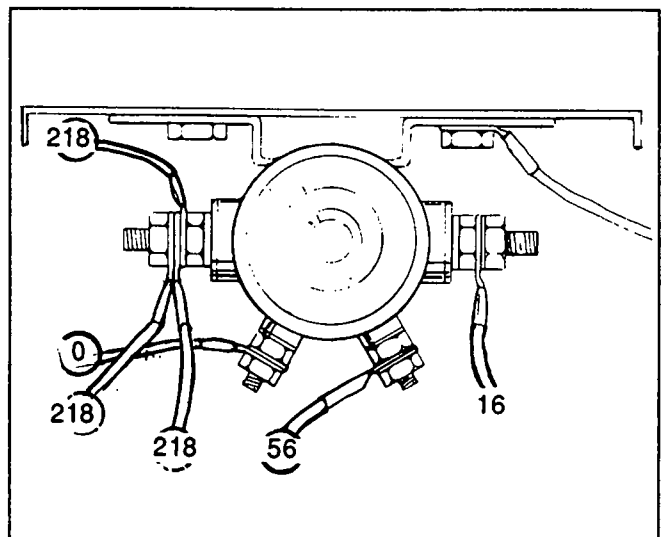


Figure 6. Control Contactor- 24 Volts DC Systems

PROCEDURE:

1. Set a VOM to read DC voltage.
2. Connect one VOM test probe to the Wire 56 terminal stud of the control contactor, the other test probe to the Wire 0 (grounded) terminal.
3. Set the start/stop switch at "Start". The VOM should read approximately 11-12 volts DC. Release the switch and VOM reading should drop to zero.

Test 16- Test Control Contactor (Continued)

4. Now, connect the VOM test probes to the control contactor terminal studs as follows:
 - a. On units with 12 volts DC engine electrical system, connect the positive (+) VOM test probe to the large Wire 13 terminal stud. Connect the the common (-) VOM test probe to frame ground. The VOM should read battery voltage (about 12 volts DC).
 - b. On units with 24 volts DC engine electrical system, connect the positive (+) VOM test probe to the large Wire 218 terminal stud and the common (-) test probe to frame ground. The VOM should read read battery voltage (about 24 volts DC).
5. Finally, connect the positive (+) VOM test probe to the Wire 16 terminal stud and the common (-) test probe to frame ground. Set the start/stop switch to "Start" and the VOM should read battery voltage. Release the switch and the VOM reading should drop to zero.

RESULTS:

1. If the VOM does not read normal battery voltage in Step 4, inspect and test the positive battery cable. Clean or replace the cable as necessary.
2. If the VOM reads normal battery voltage in Step 4 but not in Step 5, replace the control contactor.
3. If the VOM reads normal battery voltage in both Steps 4 and 5, but the engine does not crank, go to Test 17.

Test 17- Check Starter Solenoid

DISCUSSION:

On most standby engines, the starter solenoid is a part of the starter motor (see Figure 7). When energized by DC battery voltage from Wire 16, the starter solenoid (SC) should energize to (a) move the starter pinion gear into mesh with the engine ring gear, and (b) close a set of contacts to energize the starter motor itself.

NOTE: Complete Test 16 first before performing this test or the test results may not be valid.

PROCEDURE:

Connect the positive (+) VOM test probe to the Wire 16 terminal of the starter solenoid and the common (-) test probe to frame ground. Check for the following results:

- Battery voltage should be indicated when the start/stop switch is set to "Start". The reading should drop to zero when the start/stop switch is released.
- The starter pinion gear should throw out to engage the engine ring gear.
- The starter motor should energize and operate.

For additional tests of the starter solenoid and starter motor, refer to the appropriate engine service manual. Follow the instructions in the engine service manual for testing, servicing and repair of starter motors.

RESULTS:

1. If battery voltage is NOT indicated at the Wire 16 terminal when the start/stop switch is set to "Start", inspect and test the Wire 16 cable between the control contactor and the starter solenoid. Replace the cable if it is defective.
2. If battery voltage is indicated at the Wire 16 terminal, but the starter solenoid does not throw out or the starter does not operate, test the starter solenoid and the starter motor as outlined in the appropriate engine service manual.

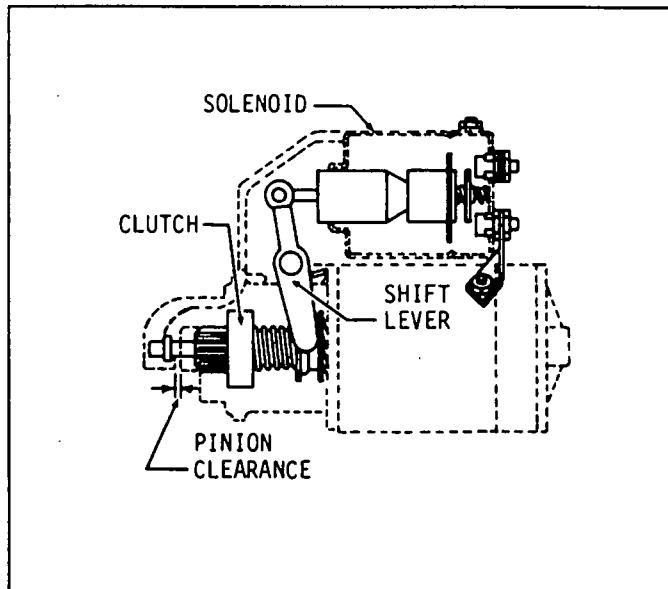


Figure 7. A Typical Starter Solenoid (SC)

Test 18- Test Starter Motor

DISCUSSION:

Read "Discussion" under Test 17.

PROCEDURE:

Test the starter motor as outlined in the appropriate engine service manual.

RESULTS:

Repair or replace the starter motor, if necessary.

Test 19- Reset Automatic Start Circuit

DISCUSSION:

If the engine will not crank in automatic operating mode, it is possible that the automatic start circuit needs to be reset. Automatic cranking and startup normally occur when solid state circuit boards in a "GTS" automatic transfer switch detect a utility power source dropout below a pre-set voltage. Transfer switch action will then close the automatic start circuit (Wires 178/183) to initiate engine cranking and startup. After an automatic start attempt that has failed, the automatic start circuit may have to be reset.

**Test 19- Reset Automatic Start Circuit
(Continued)**PROCEDURE:

If any fault lamp on the engine monitor panel is on, reset the automatic start circuit as follows:

Method 1: On the engine monitor panel, push the test-reset switch in. All panel fault lamps must go out.

Method 2: Set the auto-manual-off switch to "Off" and then back to "Auto".

RESULTS:

1. If, after resetting the auto start circuit, the engine cranks in automatic mode, discontinue tests.
2. If, after resetting the auto start circuit, engine still won't crank in automatic mode, go to Test 20.

Test 20- Check GTS SwitchesDISCUSSION:

Cranking and startup in automatic mode cannot occur unless transfer switch action closes the automatic start circuit. The GTS transfer switch is equipped with (a) a system test switch on the switch enclosure door, and (b) a maintenance disconnect switch housed in the GTS enclosure. Both switches must be properly positioned in order for automatic operation to occur. Refer to Part 8 or 9 of this manual as appropriate.

PROCEDURE:

1. On the GTS transfer switch enclosure door, set the system test switch to "Automatic" position.
2. In the GTS enclosure, set the maintenance disconnect switch to "Automatic".

RESULTS:

If GTS switches are positioned correctly but automatic startup will not occur, go to Test 21.

Test 21- Ground Pin 6 of DC Control BoardDISCUSSION:

Normal automatic cranking and startup are initiated when solid state circuits in the GTS transfer switch sense that a utility power source dropout has occurred. On occurrence of a utility power source dropout, GTS circuit board action closes the automatic start circuit (Wires 178 and 183) to ground. With that circuit closed to ground, the generator's DC control/latch-crank board initiates engine cranking. This test will determine if the DC control/latch-crank circuit board will respond properly when the auto start circuit is grounded.

PROCEDURE:

Connect a jumper wire from Pin 6 (Wire 183A) of the DC control/latch-crank board and to terminal 0 (ground) of terminal board TB1. The engine should crank as in automatic operation.

RESULTS:

1. If automatic cranking occurs now but does not occur normally, complete Test 12, "Test Auto-Manual-Off Switch".

a. If auto-manual-off switch is good, go to Test 22, "Check Wires 178/183 Circuit".

b. Replace auto-manual-off switch if it is bad.

2. If engine did NOT crank when Pin 6 of the circuit board was grounded, replace the DC control/latch-crank board. Calibrate the board and test operation.

NOTE: Wire 183 (Pin 6) is the "high side" of the 2-wire start circuit, while Wire 178 is the "grounded" side of the circuit. Automatic startup is normally initiated when GTS circuit board action closes the 183 circuit to the grounded side.

Test 22- Check Wires 178/183 CircuitDISCUSSION:

An open condition in the Wires 178/183 circuit will result in failure of the engine to crank in automatic mode.

PROCEDURE:

1. Start at the GTS transfer switch terminal board, as follows:

a. Connect a jumper wire across terminals 178/183 in the transfer switch enclosure. The generator engine should crank in automatic mode.

b. Disconnect the jumper wire and the engine should shut down.

2. Now, do the same thing across the 178/183 terminals in the generator's AC connection (lower) panel. The engine should crank. Disconnect the jumper and engine should shut down.

3. In the generator control console, connect a jumper wire to the Wire 183 terminal of the auto-manual-off switch and to terminal 0 (ground) of terminal board TB1. The engine should crank in automatic mode.

RESULTS:

1. If the engine cranks and starts in Step 1 but will not crank on occurrence of a utility power outage, the problem is in the GTS transfer switch.

2. If engine cranked in Step 2 but did not crank in Step 1, look for an open condition in Wires 178/183 between the generator and the transfer switch.

3. If engine cranks in Step 3 but did not crank in Step 2, look for an open condition in Wires 178/183 between the control console and the AC connection (lower) panel.

Test 23- Check Control Console LampDISCUSSION:

If the engine cranks normally but will not start, the generator's control console lamp can be a valuable troubleshooting aid. During manual or automatic startup, the DC control board's run relay (K2) should energize to deliver 12 volts DC to a Wire 14 circuit. The Wire 14 circuit then energizes engine components needed for engine startup and running operations. That circuit

**Test 23- Check Control Console Lamp
(Continued)**

also turns on the control console lamp. Thus, if the lamp turns on while cranking, it is evident that the Wire 14 circuit has been energized. If the Wire 14 circuit is energized but the engine will not start, look for a problem in the engine itself (fuel flow, ignition, etc.).

PROCEDURE:

Crank the engine while observing the control console lamp (the "dash light"). The lamp should illuminate, indicating the DC control board is functioning properly and the Wire 14 circuit is energized.

RESULTS:

1. If the lamp (dash light) comes on but engine will not start, go to Test 25.
2. If the console lamp does NOT turn on, perform Test 4 to check the DC control circuit board and relays.
 - a. If relay K2 actuates normally during Test 4, but engine will not start, go to Test 24.
 - b. If relay K2 does NOT actuate normally during Test 4, replace the DC control/latch-crank board. Calibrate and test the circuit board.

Test 24- Check Voltage to Wire 14 Circuit

DISCUSSION:

It is remotely possible for the relay K2 to actuate normally during cranking and startup but fail to deliver a voltage to the Wire 14 circuit. This could happen if the relay contacts were defective or if the contacts remain open. Before performing this test, you should have completed Test 23 and observed that the console lamp did not light. Secondly, you should have completed Test 4 and noted that the relay K2 actuated but engine startup did not occur. This test will verify whether or not a DC voltage is actually being delivered to Wire 14.

PROCEDURE:

1. Set a VOM to read DC volts and to a scale greater than 12 volts.
2. Connect the positive (+) VOM test probe to terminal 14 of terminal board TB1; the common (-) test probe to terminal 0 of TB1.
3. Set the start/stop switch to "Start". The VOM should read approximately 12 volts DC.
4. Release the start/stop switch to its "Run" position. The VOM should read zero volts.

RESULTS:

1. If normal battery voltage is indicated in Step 3, but engine will not start, go to Test 25.
2. If normal battery voltage is NOT indicated in Step 3, replace the DC control/latch-crank board. Calibrate the board and test operation.

Test 25- Check Engine and Engine Components

DISCUSSION:

If the Wire 14 circuit was electrically hot in Test 24, and if engine cranks but will not start, the problem must be in one of the engine systems (fuel, ignition, compression, mechanical damage, etc.). In some engines, the Wire 14 circuit energizes a fuel solenoid to turn on fuel flow. In other engines, Wire 14 may open a fuel shutoff valve and turn on the engine ignition system.

PROCEDURE:

Refer to the specific engine service manual for the engine involved. Test and troubleshoot the engine fuel system, ignition system, and mechanical systems as outlined in that manual.

RESULTS:

Repair or replace defective engine components as required.

NOTE: Tests 26 through 34 are tests that should be performed if the engine cranks, starts and then shuts down. Refer to Problem 4 in Section 6.8.

Test 26- Is the "Overtemperature" Lamp On?

DISCUSSION:

If the engine cranks, starts and then shuts down, it is possible that an overtemperature condition exists. If the engine is started with an existing high coolant temperature or low coolant level, shutdown will occur when the engine reaches starter cutout speed (about 1000 rpm).

PROCEDURE:

On the engine monitor panel, observe the "High Cool. Temp." lamp. If that lamp is on, it is normal for the engine to crank, start and then shut down.

RESULTS:

1. If the lamp is on, go to Test 28, "Check Coolant Level".
2. If the lamp is NOT on, but engine started and then shut down, go to Test 27, "How Long Did the Engine Run?".

Test 27- How Long Did the Engine Run?

DISCUSSION:

Review the information in Section 6.2, "Engine Monitor Panel". The following are repeated here:

- If a low oil pressure condition exists, the DC control board will allow about four (4) seconds after starter cutout speed for oil pressure to build. If oil pressure has not built in the allotted four (4) seconds, shutdown will occur.

**Test 27- How Long Did the Engine Run?
(Continued)**

■ Once the engine speed reaches approximately 800-1000 rpm, the DC control/latch-crank board will wait about two (2) seconds to receive rpm signals from the rpm sensor. If, at the end of two seconds, rpm signals are not detected, engine shutdown will occur.

PROCEDURE:

Crank the engine and let it start. Time the wait between initial startup and shutdown.

RESULTS:

1. If the engine started and ran for about four (4) seconds before shutdown occurred, go to Test 5, "Test Oil Pressure Switch".
2. If the engine started and ran for less than four (4) seconds and then shut down, go to Test 29, "Does the Starter Disengage?".

Test 28- Check Coolant Level

DISCUSSION:

If the engine started, then shut down and the high coolant temperature lamp is on, the next step in correcting the problem is to check engine coolant level.

PROCEDURE:

Check coolant level in the coolant recovery bottle. Fill the recovery bottle about half full with a 50-50 mixture of the recommended coolant.

DANGER: Wait for engine to cool before removing the radiator pressure cap. Remove the radiator cap slowly. Be careful. The coolant mixture in the radiator is under pressure. Removal of the radiator cap while coolant is hot may result in serious burns from boiling liquid or steam.

Check coolant level in the radiator. If necessary, fill the radiator to the proper level with the recommended coolant mixture.

RESULTS:

If coolant level is good, but overtemperature lamp is on, go to Test 30.

Test 29- Does the Starter Disengage?

DISCUSSION:

If the engine runs less than four (4) seconds (about 2 seconds) and then shuts down, try to determine if the engine starter has disengaged. If the starter does NOT disengage, rpm sensor output may be lost.

PROCEDURE:

Crank the engine while listening for the sound of the starter motor. There is a distinct difference in the sound of the starter while it is engaged and when it disengages. Note whether the starter disengages before the engine shuts down.

RESULTS:

1. If the starter does NOT disengage, and engine shuts down in less than four (4) seconds, go to Test 32, "Test RPM Sensor".
2. If the starter disengages, go to Test 33, "When Does the Console Lamp Go Out?".

Test 30- Test Coolant Temperature Switch

DISCUSSION:

If the coolant temperature lamp is on, the radiator and coolant recovery bottle are properly filled, and engine cranks, starts and shuts down, a defective coolant temperature switch or coolant level sensor may be the problem. This test will provide instructions on testing the coolant temperature switch.

PROCEDURE:

Testing with Switch Installed: To test the temperature switch while it is installed, proceed as follows:

1. Disconnect Wire 85 from the high coolant temperature switch terminal.
2. Set a VOM to its "Rx1" scale and zero the meter.
3. Connect one VOM test lead to the switch terminal from which Wire 85 was just removed. Connect the remaining test lead to a clean frame ground. The meter should read "infinity".
4. Check that no electrical loads are connected to the generator, then crank and attempt to start the generator.
5. If the generator starts, hold the terminal end of Wire 85 firmly against a clean frame ground. After a short delay, the engine should shut down.

RESULTS:

1. If the VOM reads other than "infinity" in Step 3, the switch has failed closed and should be replaced.
2. If the engine starts in Step 4, but will not start when Wire 85 is connected to the switch terminal, replace the high coolant temperature switch.
3. If the engine will not shut down in Step 5 when Wire 85 is grounded, check Wire 85 (along its entire length between the switch and the DC control/latch-crank board) for an open condition. Repair, reconnect or replace Wire(s) as needed. If all of Wire 85 checks good, replace the DC control/latch-crank circuit board. Calibrate the board and test operation.

Testing with the Switch Removed: Remove Wire 85 from the switch terminal. Remove the switch and test as follows:

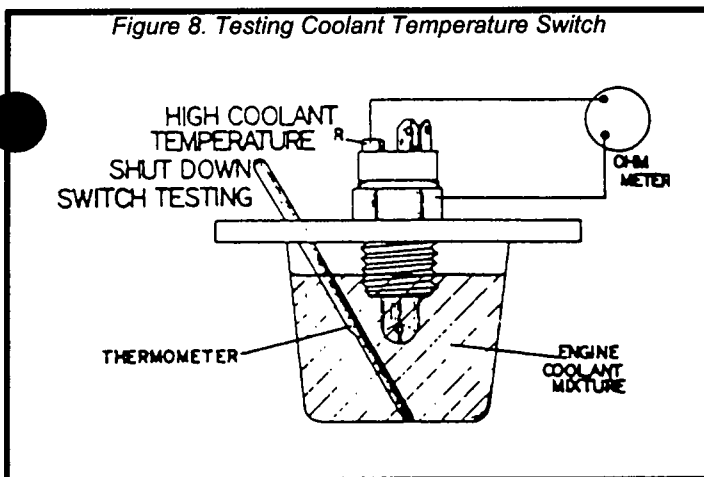
1. See Figure 8. Immerse the switch in a 50-50 mixture of ethylene glycol base anti-freeze and water.

Test 30- Test Coolant Temperature Switch (continued)

2. Set a VOM to its Rx1 scale and zero the meter.
3. Connect one VOM test probe to the terminal from which Wire 85 was disconnected. Connect the remaining test probe to the switch housing. The meter should read "Infinity".
4. Place an actuate the thermometer into the fluid mixture (See Figure 8).
5. Heat the fluid, at approximately 245° - 266° F., the switch contacts should close and the VOM should read "continuity".
6. Remove the fluid mixture from its source for heat and allow it to cool. As the temperature drops below about 245° - 266° F., the switch contacts should open and the VOM should read "infinity".

RESULTS:

Replace the coolant temperature switch if it fails any part of the test. If the switch checks good, go to Test 31, "Test Coolant Level Sensor".



Test 31- Test Coolant Level Sensor

DISCUSSION:

A defective low coolant level sensor will produce the same effects as a failed high coolant temperature switch.

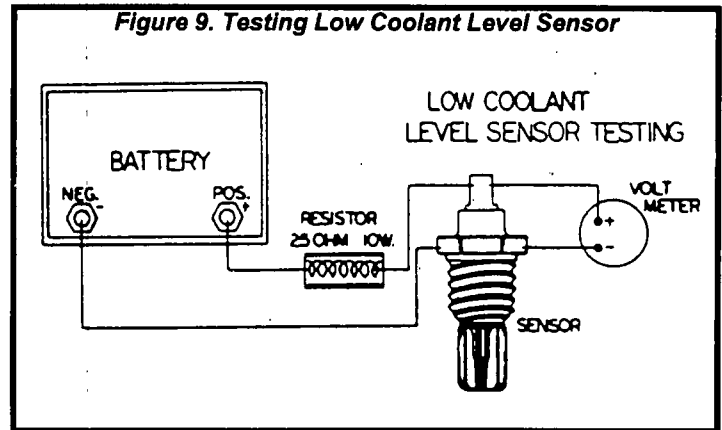
PROCEDURE:

See Figure 9. Connect a test harness as shown to the sensor terminals and to a fully charged 12 volt battery. Then, set a VOM to read DC volts. Connect the VOM across the sensor terminals. Initially, the VOM should read approximately 7-11 volts DC. After about 15 seconds, as the sensor becomes hot, the voltage reading should drop off to less than 5 volts.

RESULTS:

Replace the sensor if it fails the test.

Figure 9. Testing Low Coolant Level Sensor



Test 32- Test RPM Sensor

DISCUSSION:

The rpm sensor is installed in a threaded hole on the engine flywheel housing. To install the rpm sensor, thread it into the flywheel housing until the sensor tip just contacts the flywheel gear. Then, turn the sensor counterclockwise about 3/4 to 1 turn. Hold that setting and tighten the sensor locknut.

PROCEDURE:

1. Gain access to the control console interior. Connect an accurate AC voltmeter across terminals 79 and 0. At engine cranking speed, the meter should read approximately 0.4 to 0.6 volt.
2. Use a VOM to test sensor resistance.
 - Older sensors (with cable connector plug) should measure about 130 ohms ± 10%.
 - Newer sensors (with cable molded into sensor) should measure about 1,000 ohms ± 10%.

NOTE: If the resistance is within limits but voltage reading is slightly low, voltage can be increased by adjusting the rpm sensor closer to the flywheel. **DO NOT LOCATE THE SENSOR TIP CLOSER THAN 1/2 TURN FROM THE FLYWHEEL.**

RESULTS:

Replace the rpm sensor if it fails the tests.

Test 33- When Does the Console Lamp Go Out?

DISCUSSION:

Remember, the control console lamp is turned on by a DC voltage from the DC control/latch-crank board. This DC voltage is delivered to the lamp via the Wire 14 circuit. If the engine cranks, starts, then shuts down, this test will help you determine is (a) the DC control/latch-crank board or (b) engine system component is bad. If the console lamp goes out and then the engine dies, the DC control/latch-crank board is suspect. On the other hand, if the engine comes to a stop and the the lamp goes out, check the engine fuel system, ignition system, etc.

***Test 33- When Does the Console Lamp
Go Out? (Continued)***

PROCEDURE:

Crank the engine while observing the control console "dash light". If the engine starts and then shuts down note when the lamp went out.

RESULTS:

1. If the lamp goes out as the engine starts to die, replace the DC control/latch-crank circuit board. Calibrate the new board and test operation.
2. If the lamp goes out after the engine stops, go to Test 34.

Test 34- Check Engine Fuel, Ignition, etc.

DISCUSSION:

In test 33, the console lamp stayed on until the engine came to a stop. This indicates that the Wire 14 circuit is energized and power should be available to the engine fuel solenoid, ignition system, etc. Thus, if the engine shuts down, a problem must exist in the engine electrical system.

PROCEDURE:

Refer to the appropriate engine service manual for the specific engine involved. Troubleshoot the engine systems as outlined in the service manual.

RESULTS:

Repair or replace defective engine part(s), as necessary.

Section 6.10 DUAL 12 OR 24 VOLTS DC CONTROL

Introduction

Sections 6.5, 6.6 and 6.7 provide information on DC control systems that are no longer being manufactured. Those older control consoles housed a DC control/latch-crank circuit board that required 12 volts DC for its operation. Other console components were also rated 12 volts DC.

On those older units, engines with a 24 volts DC electrical system required that a DC converter be installed to reduce the 24 volts DC battery voltage to 12 volts DC. Later production units have been equipped with a dual (12 or 24 volts) control system and do not require this DC converter.

In the last quarter of 1991, the following changes were incorporated:

- All control console components, including the DC control/latch-crank circuit board, were changed to dual voltage type. That is, all control console components can now be operated on either 12 or 24 volts DC.
- These later production control consoles can be installed on units with 24 volts DC engine electrical system without requiring a 24-to-12 volts DC converter.
- Units with a 24 volts DC engine system no longer require an engine run relay.
- Later production units with Option A or B control consoles are equipped with a dual voltage (12 or 24 volts) engine control circuit board (Part No. 82495).
- Later production units with Option C control console are equipped with a dual voltage engine control circuit board Part No. 83089.

NOTE: The new style dual voltage engine control circuit board will be shipped as a replacement part. This new board will work with any old or new style system, since it will operate on either 12 or 24 volts DC.

Schematic Diagrams

Figure 2 is a schematic diagram for a typical Option C console when the engine electrical system is rated 12 volts DC.

Figure 3 is a schematic diagram for a typical Option C control console when the engine is equipped with a 24 volts DC system.

Adjusting Overspeed Shutdown

The dual voltage circuit board (Figure 1) must be calibrated each time it is replaced, for the following reasons:

The circuit board must be matched to the specific engine flywheel or speed sensing errors will result.

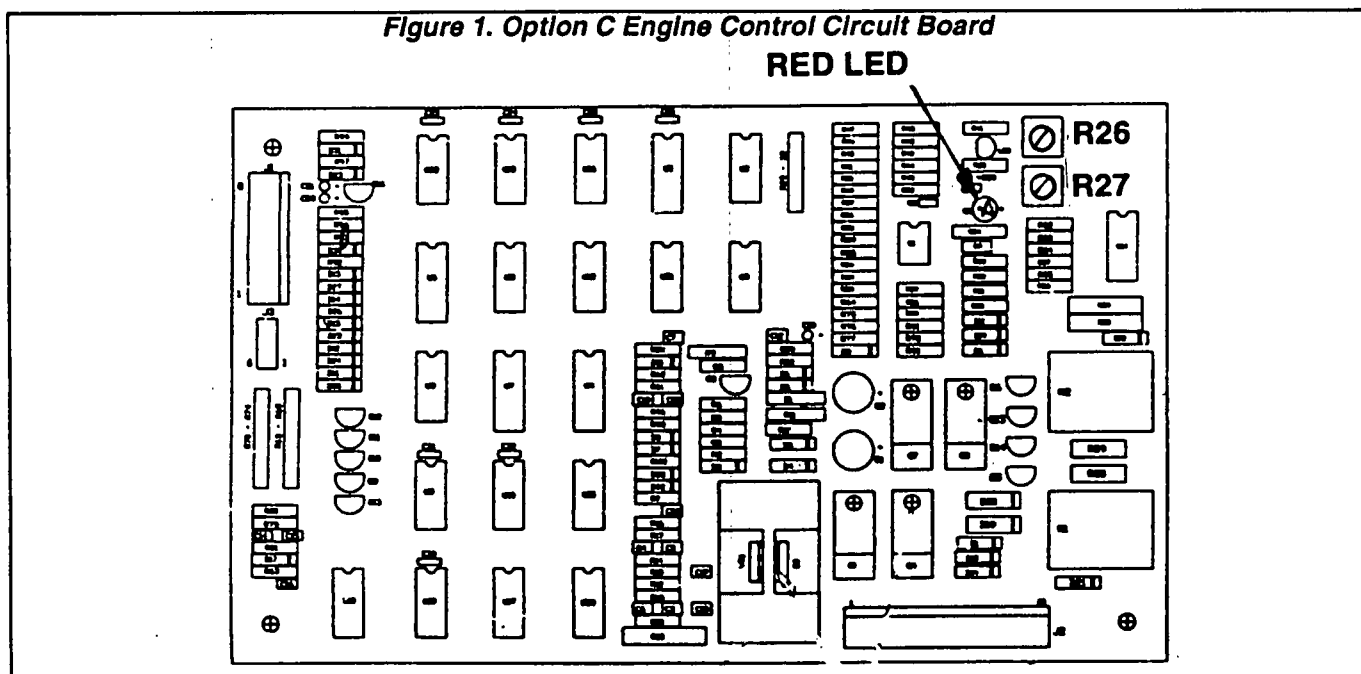
The board must be calibrated to establish an overspeed shutdown setting that is about 10 Hertz above the unit's normal operating speed.

When the overspeed shutdown setting is correct, starter cutout speed during automatic startup will also be correct.

To calibrate the engine control circuit board, proceed as follows:

1. On the circuit board, locate potentiometers R26 and R27. See Figure 1. Also, locate the red LED.

Figure 1. Option C Engine Control Circuit Board



Adjusting Overspeed Shutdown (Continued)

2. Turn the COARSE (R26) pot all the way clockwise (CW).
3. Turn the FINE (R27) pot all the way counterclockwise (CCW).

CAUTION: Steps 2 and 3 MUST be completed BEFORE THE ENGINE IS STARTED. If the engine is started before the steps are completed, an overspeed shutdown may occur at normal rated operating speed.

4. Start the generator engine manually, using the Start/Stop switch. Let the engine stabilize and warm up at no-load. If necessary, adjust the engine governor to obtain normal rated operating speed.
5. With the unit running at no-load and at its normal rated speed, slowly turn the COARSE (R26) pot counterclockwise (CCW) until the red LED just turns on.
6. Slowly turn the FINE (R27) pot clockwise (CW) until the red LED just goes out.
7. Slowly, turn the FINE (R27) pot counterclockwise (CCW) until the red LED just turns on.

With the board properly calibrated, overspeed shutdown will occur at approximately 10 Hertz above the unit's normal operating frequency. For example, if the engine no-load speed is 62 Hertz, overspeed shutdown will occur at approximately 72 Hertz.

Terminal Strip J1 on Engine Control Circuit Board

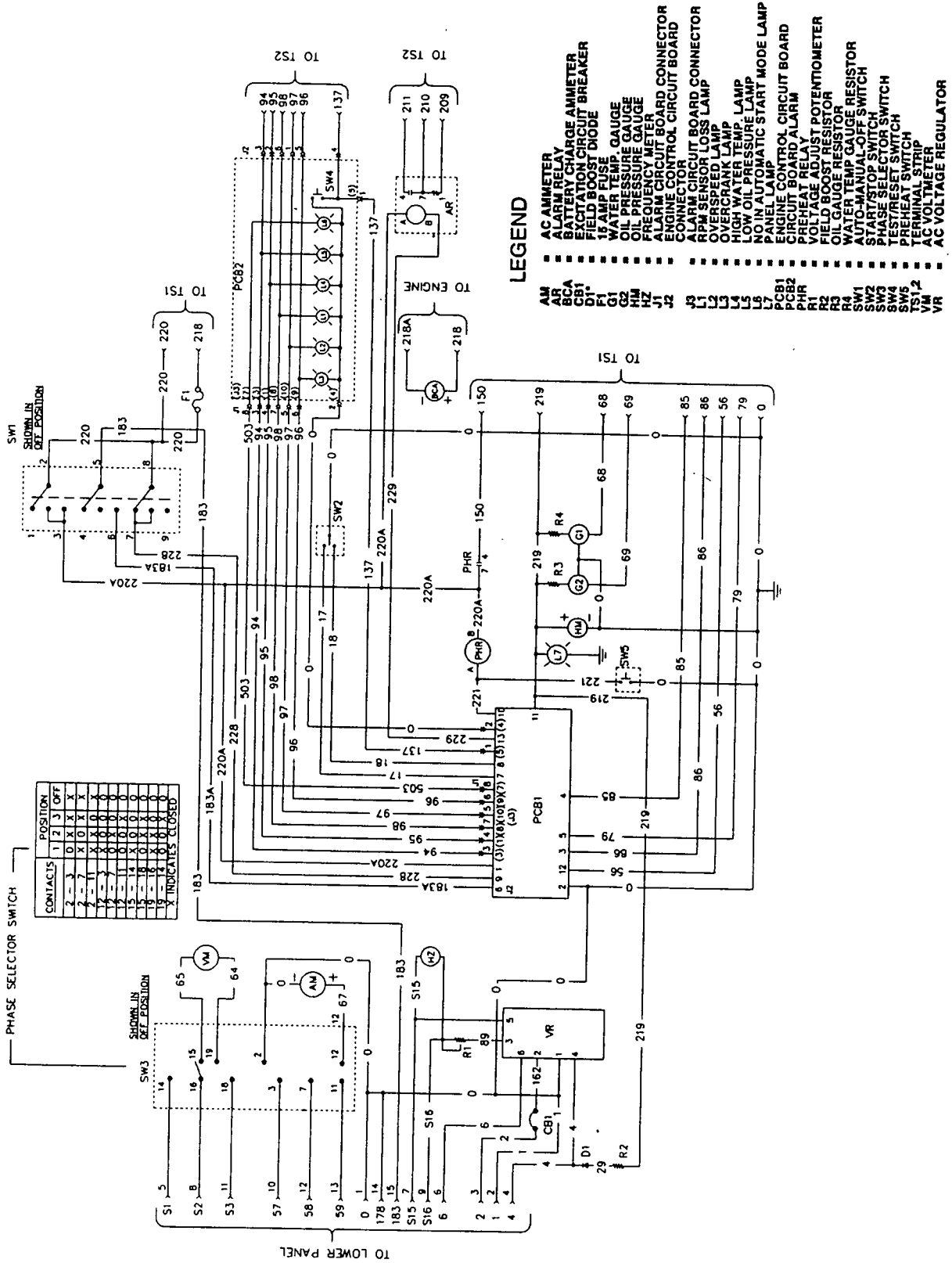
UNITS WITH 12 VDC ENGINE SYSTEM:

PIN NO.	WIRE NO.	FUNCTION(S)
1	15A	Fused battery voltage to circuit board (12 Volts DC)
2	0	Common Ground
3	86	From engine high coolant temperature & low coolant level shutdown switch
4	85	From engine low oil pressure shutdown switch
5	79	From engine RPM sensor
6	183A	Automatic start/stop circuit
7	17	Manual start signal from start/stop switch
8	18	Manual stop circuit
9	228	Auto enable- circuit is hot when Auto-Off- Manual switch is set to "Auto"
10	221	Engine preheat circuit (diesel only)
11	14	Engine run circuit
12	56	Starter circuit

UNITS WITH 24 VDC ENGINE SYSTEM:

PIN NO.	WIRE NO.	FUNCTION(S)
1	220A	Fused battery voltage to circuit board
2	0	Common Ground
3	86	From engine low coolant level/high coolant temperature switches
4	85	From engine low oil pressure switch
5	79	From engine RPM sensor
6	183A	Automatic start/stop circuit
7	17	Manual cranking circuit
8	18	Manual stop circuit
9	228	Auto enable- circuit is hot when Manual-Off-Auto switch is at "Auto"
10	221	Engine preheat circuit (diesel only)
11	219	Engine run circuit
12	56	Engine starter circuit

Figure 3. Electrical Schematic- Option C Console with 24 VDC Engine System (Typical)



PART 7 GENERATOR OPTIONS AND ACCESSORIES

STANDBY ELECTRIC POWER SYSTEMS

All Series

TABLE OF CONTENTS	
SECTION	TITLE
7.1	Generator Strip Heaters
7.2	Voltage Changeover Boards
7.3	The 3- Lamp Remote Annunciator
7.4	The 5- Lamp Remote Annunciator
7.5	The 14- Lamp Remote Annunciator
7.6	The 18- Lamp Remote Annunciator

Section 7.1 GENERATOR STRIP HEATERS

Introduction

Stator and rotor windings have a very large mass. When the unit is not operating, temperatures of such windings can drop below the dew point. For that reason and because of the large mass, water droplets could form on the windings during startup. This could result in a breakdown of winding insulation.

To help prevent temperatures from dropping below the dew point, optional strip heaters are available. The heaters include controls to turn the heater off during generator operation.

Strip Heater Components

See Figure 1, below. The typical strip heater kit shown includes a RELAY to turn the heater off and on. The RELAY and a TERMINAL STRIP are housed in a covered enclosure.

Customer Connections

A 120 volts AC utility source power supply connects to the terminal strip. The heater is on until Wire 14 energizes the relay (startup), then turns off.

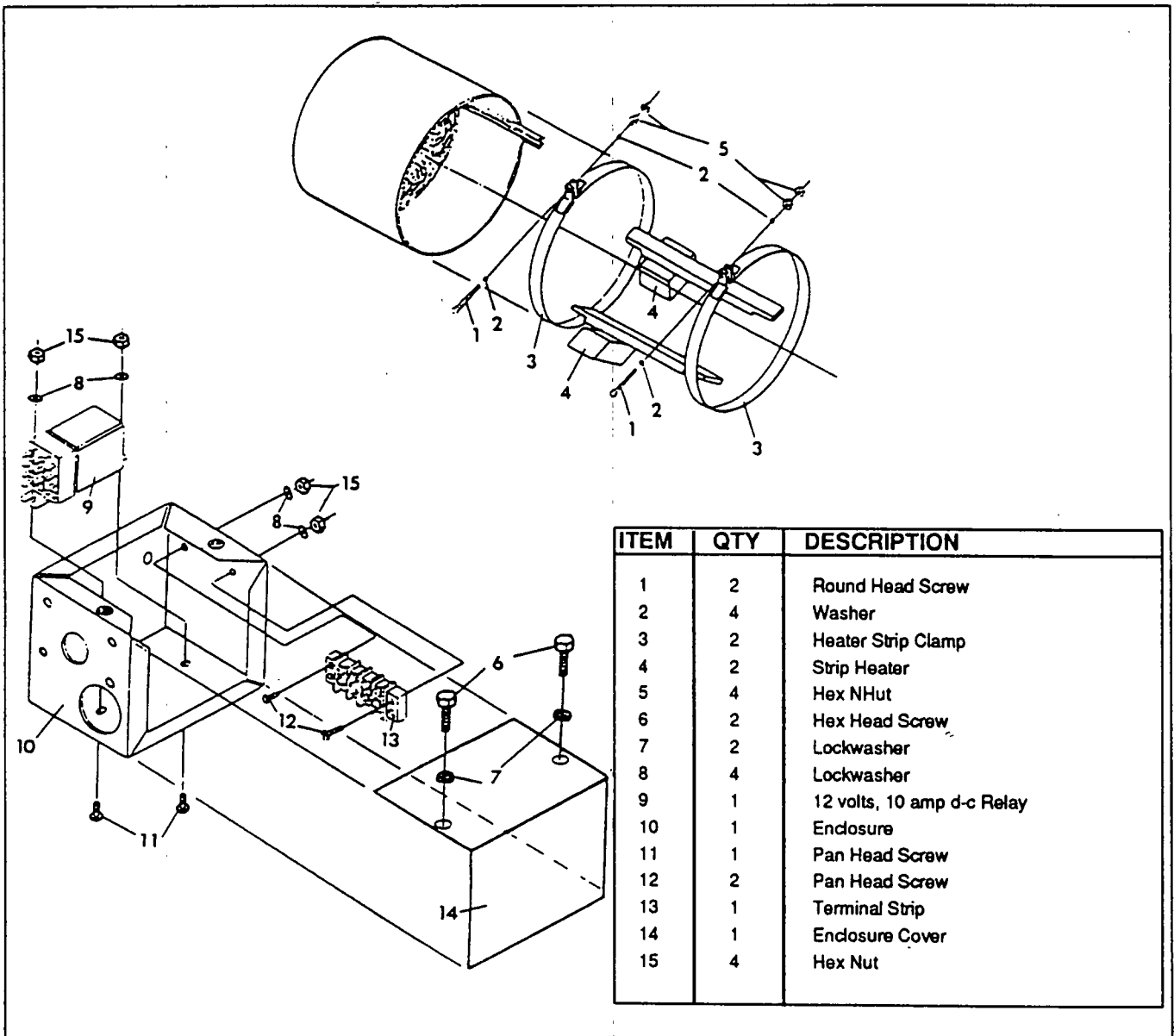


Figure 1. Typical Strip Heater Kit (Drawing No. 73835)

Section 7.1 GENERATOR STRIP HEATERS

Introduction

Stator and rotor windings have a very large mass. When the unit is not operating, temperatures of such windings can drop below the dew point. For that reason and because of the large mass, water droplets could form on the windings during startup. This could result in a breakdown of winding insulation.

To help prevent temperatures from dropping below the dew point, optional strip heaters are available. The heaters include controls to turn the heater off during generator operation.

Strip Heater Components

See Figure 1, below. The typical strip heater kit shown includes a RELAY to turn the heater off and on. The RELAY and a TERMINAL STRIP are housed in a covered enclosure.

Customer Connections

A 120 volts AC utility source power supply connects to the terminal strip. The heater is on until Wire 14 energizes the relay (startup), then turns off.

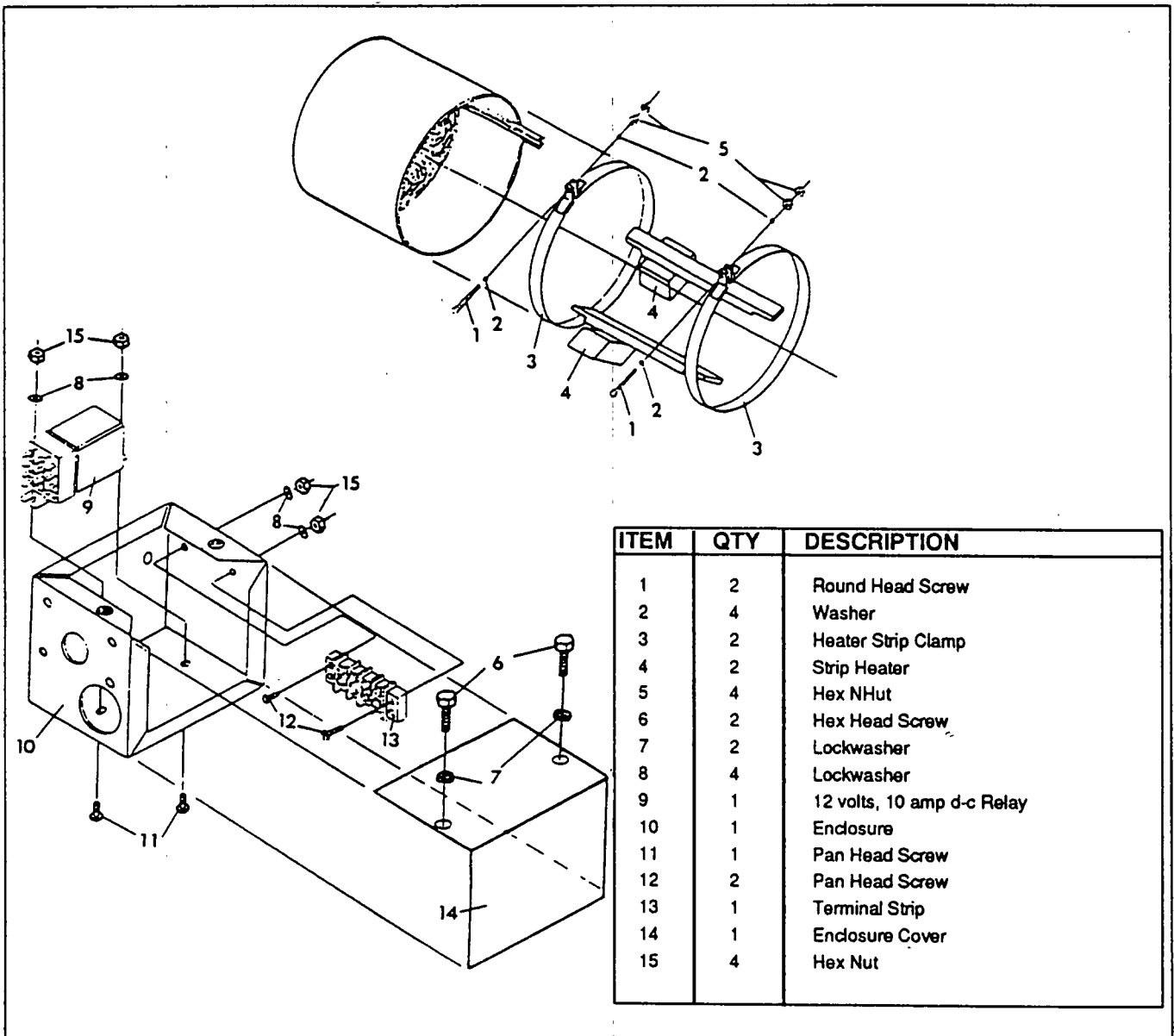


Figure 1. Typical Strip Heater Kit (Drawing No. 73835)

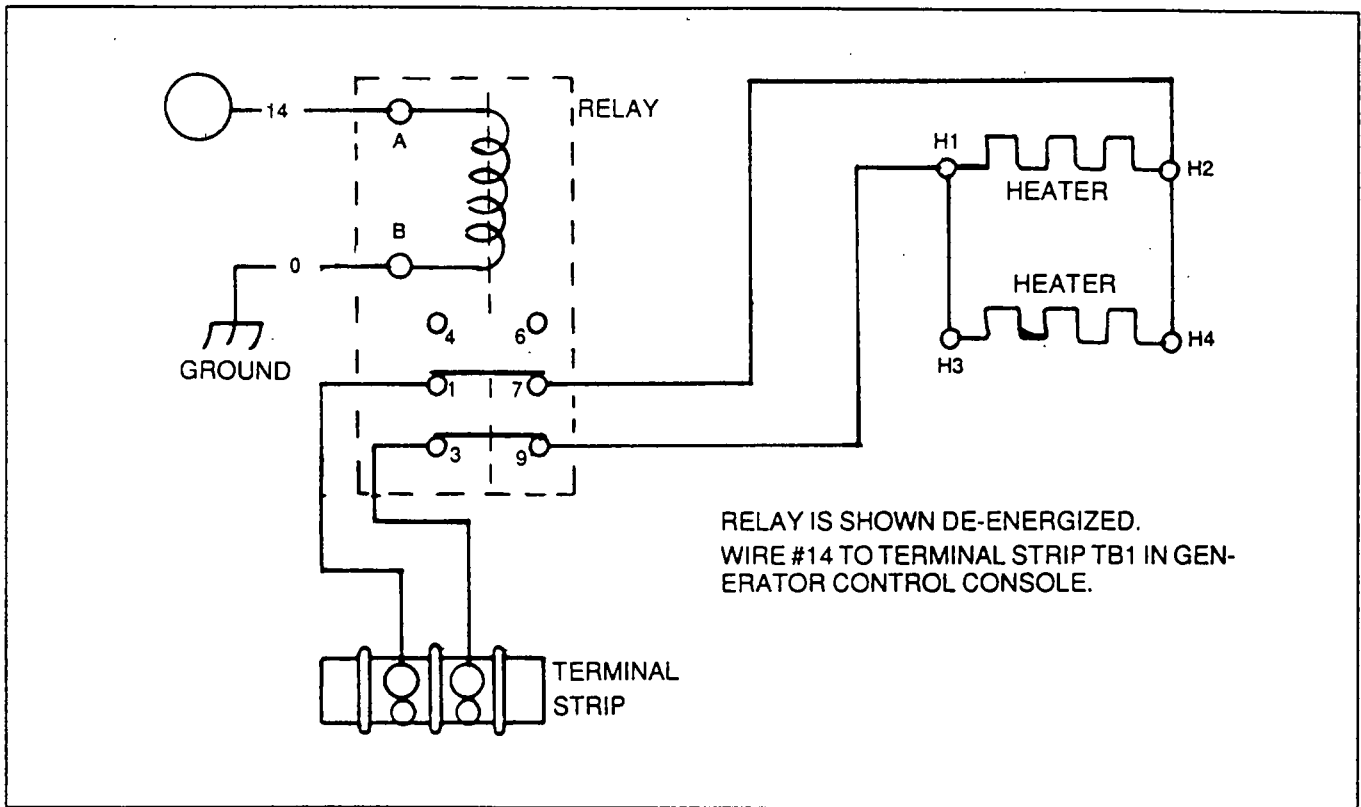


Figure 2. Electrical Schematic- Strip Heaters

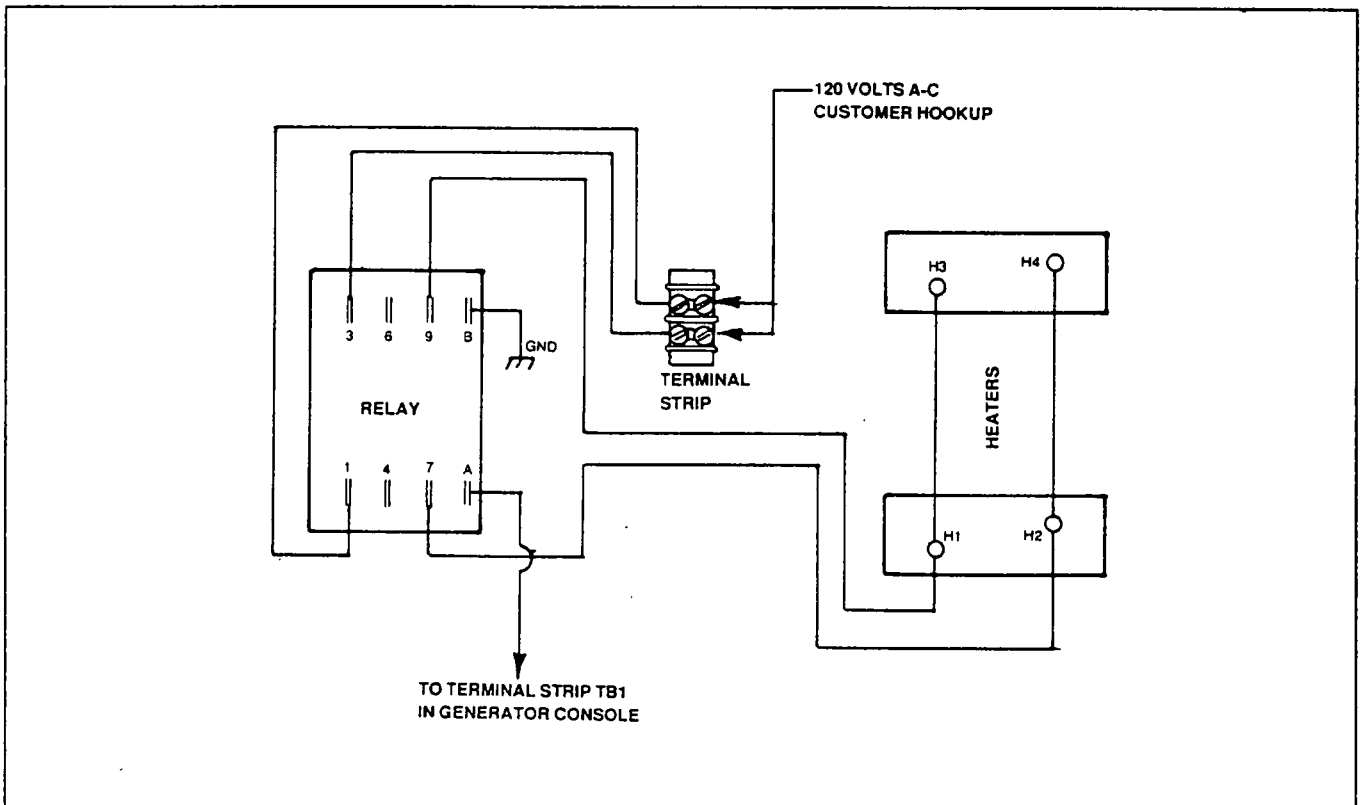


Figure 3. Wiring Diagram- Strip Heaters

Section 7.2 VOLTAGE CHANGEOVER BOARDS

General

The use of voltage changeover boards allow the generator set to be quickly converted from one rated voltage to another rated voltage. This rapid changeover capability is especially useful on rental units since it permits a single generator to supply several different voltage outputs.

Voltage changeover boards provide a more convenient method of reconnecting stator AC output leads on 12-wire (reconnectable) type stators. You may wish to review Section 1.2, "Types of Stator Connection Systems".

Two different types of voltage changeover boards have been used. For purposes of this discussion, they shall be arbitrarily called "Type 1" and "Type 2".

Type 1 Voltage Changeover Boards

DESCRIPTION:

A typical voltage changeover board consists of (a) a stud board, and (b) a strapping board as shown in Figure 1 below. To select a certain voltage/phase, the strapping board is installed over the stud board so that the desired voltage is visible through a "window" in the strapping board. When the strapping board is properly positioned over the stud board, the 12-lead stator will be reconnected to deliver the indicated voltage.

Both a LOW VOLTAGE and a HIGH VOLTAGE changeover board are available. The low voltage board allows selection of (a) 120/240 volts, 1 or 3-phase, or (b) 120/208 volts, 3-phase output. The HIGH VOLTAGE board provides selection of (a) 120/240 volts, 1 or 3-phase, (b) 120/208 volts, 3-phase, or (c) 277/480 volts, 3-phase.

The various positions of both the high and low voltage boards are shown in Figures 2 through 6 as follows. Notice that the selected voltage is displayed in the window in each case.

- Figure 2 shows the low voltage board with 120/208 volts, 3-phase selected.
- Figure 3 shows the low voltage board with 120/240 volts, 1 or 3-phase selected.
- Figure 4 shows the high voltage board with 120/240 volts, 1 or 3-phase selected.
- Figure 5 shows the high voltage board with 120/208 volts, 3-phase selected.
- Figure 6 shows the high voltage board with 277/480 volts, 3-phase selected.

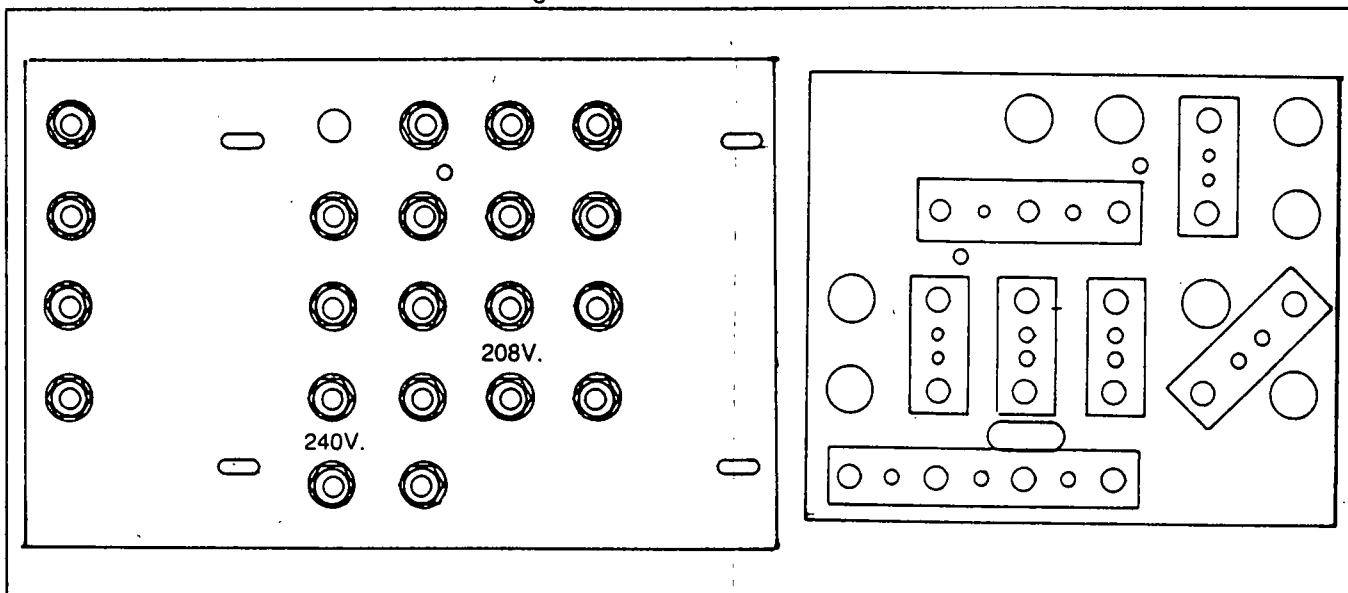


Figure 1. Low Voltage Stud Board and Strapping Board

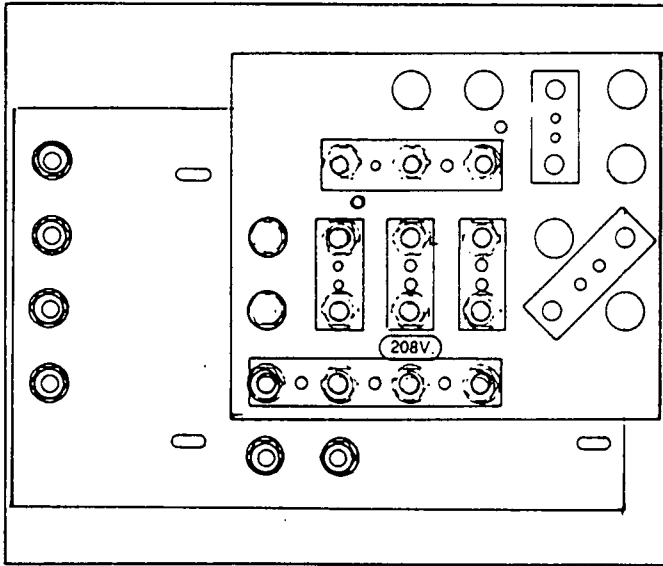


Figure 2. Low Voltage Board-120/208 Volts Selected

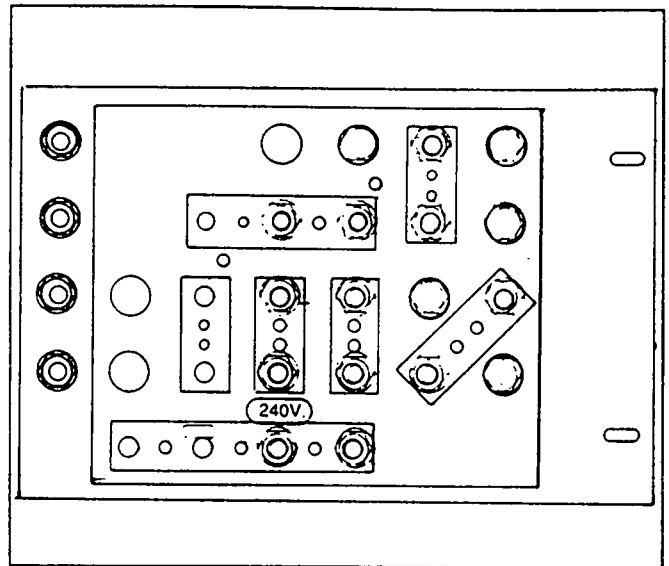


Figure 3. Low Voltage Board-120/240 Volts Selected

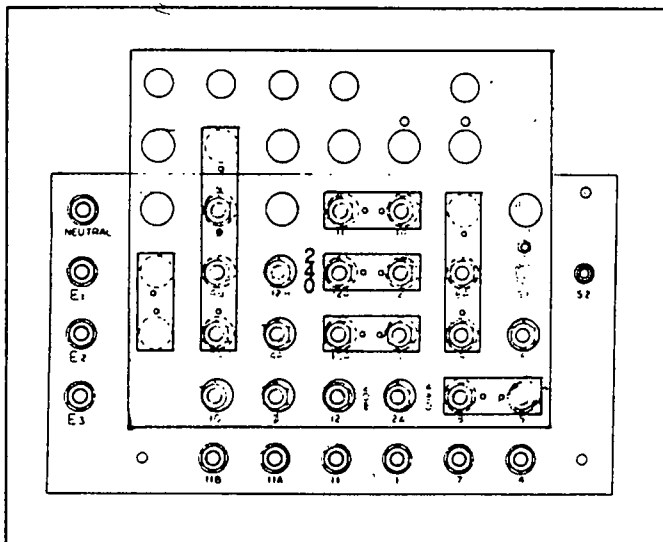


Figure 4. High Voltage Board-120/240 Volts Selected

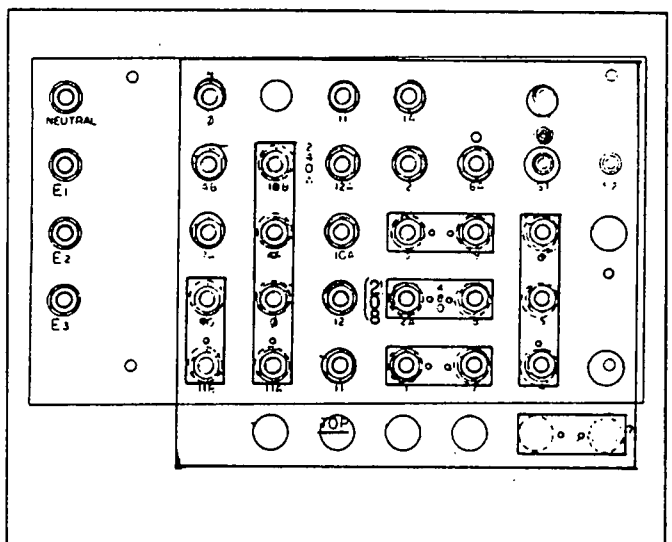


Figure 5. High Voltage Board-120/208 Volts

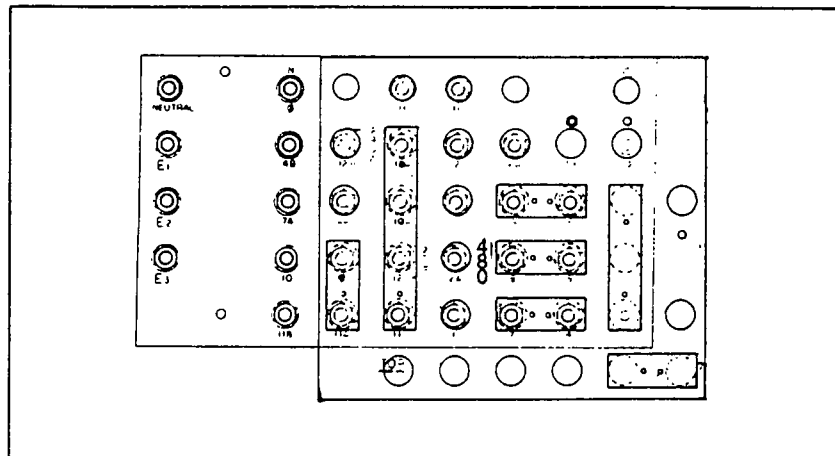


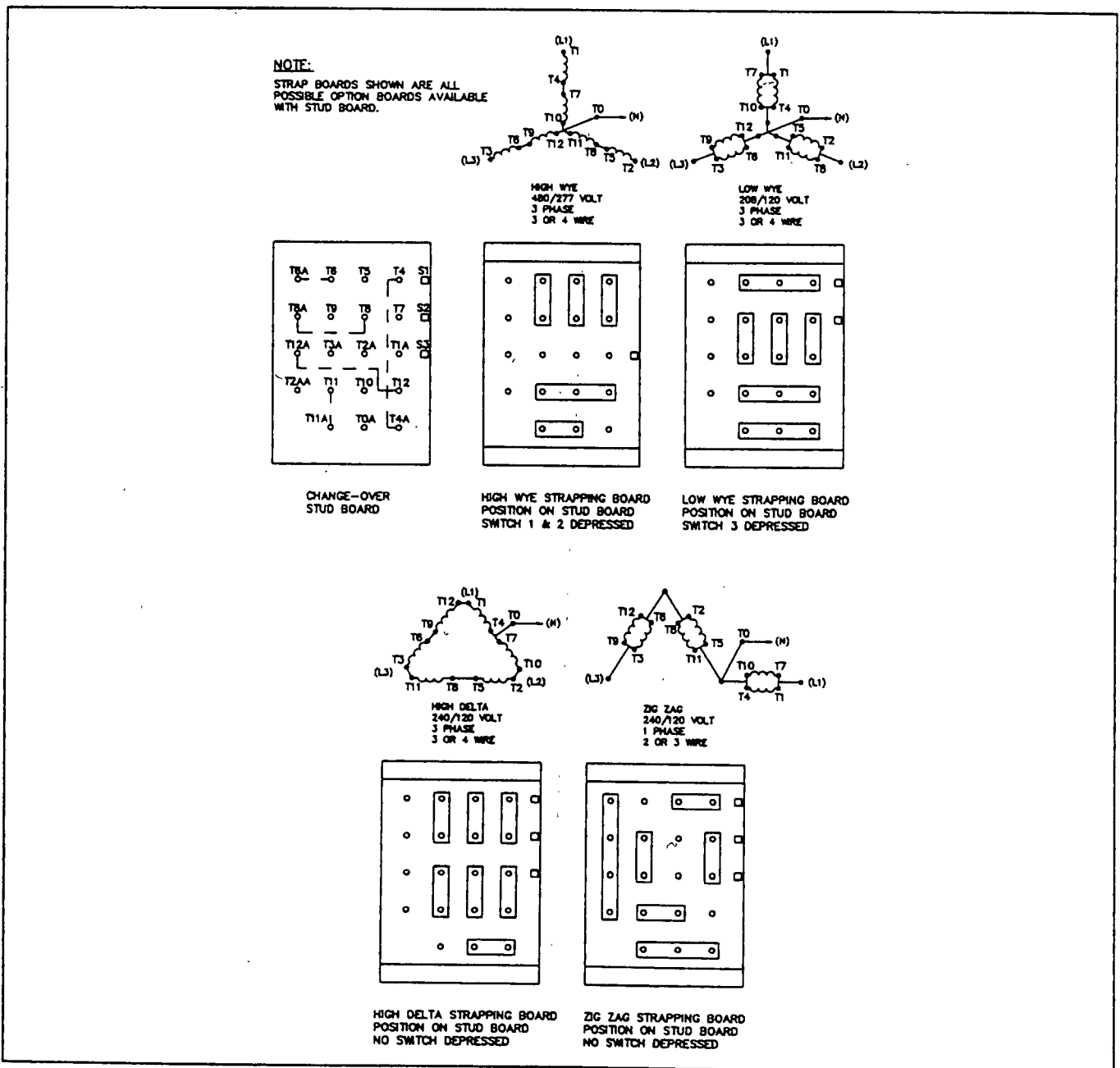
Figure 6. High Voltage Board-277/480 Volts Selected

Type 2 Voltage Changeover Boards

Type 2 voltage changeover boards, like the Type 1, consist of a stud board and a strapping board. However, Type 2 uses a single stud board onto which any one of several different strapping board options may be installed. Several switches are mounted on the stud board. These switches may or may not be actuated by strapping board installation, as shown in Figure 7 below.

The following strapping boards are available:

- High Wye Strapping Board for 277/480 volts, 3-phase, 3 or 4 wire.
- Low Wye strapping board for 120/208 volts, 3-phase, 3 or 4-wire.
- High Delta strapping board for 120/240 volts, 3-phase, 3 or 4-wire.
- Zig Zag strapping board for 120/240 volts, 1-phase, 2 or 3-wire.



Type 2 Changeover Boards with "Marathon®" Units

When the Type 2 voltage changeover board is used in conjunction with a "Marathon®" generator, some reconnecting is required. See Figure 9, below. The following facts apply:

- Sensing leads S15 and S16 are disconnected from leads E1 and E3.
- A "sensing voltage selector switch" must be properly positioned. This rotary switch is located on the stud board. Terminals 12 and 13 of the switch are "common" terminals. For 480 volts sensing, switch contacts 14 and 10 must be closed to the common contacts

- For 208 and 240 volts sensing, switch contacts 11 and 15 must be closed to the common contacts.
- The stud board switch (SW3) is closed when a low wye strapping board (120/208 volts) is installed and open when any other strapping board is installed.
- The stud board potentiometer (R1) must be adjusted as stated in Figure 8. The potentiometer is mounted under switch SW3 on the stud board.
- Leads from terminals X1 and X2 of the sensing transformer are excitation leads 2 and 6. Route these leads to the voltage regulator.

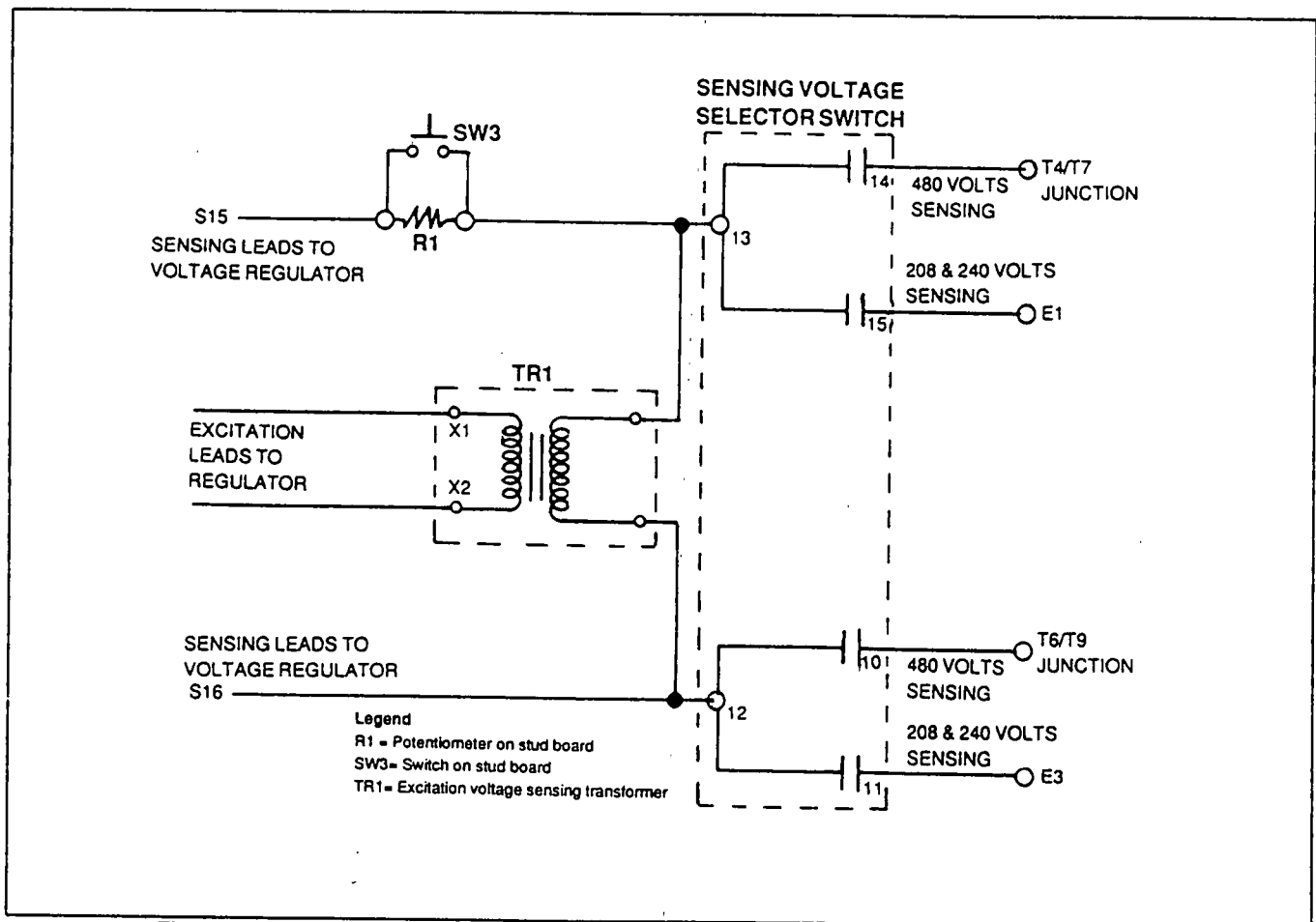


Figure 9. Reconnections when Type 2 Changeover Board is Used on "Marathon®" UNits

Section 7.3 THE 3-LAMP REMOTE ANNUNCIATOR

Introduction

Generac's 3-lamp remote annunciator panel, Model No. 8848, is shown in Figure 1. The annunciator can be located inside a monitoring station that is remote from the standby generator.

The 3-lamp annunciator may be used in conjunction with any standby installation that includes a Generac automatic transfer switch and a generator with Option "C" control console.

Annunciator Panel Lamps

The remote panel is equipped with three (3) lamps as follows:

1. "Utility Power Supply"- Lamp illuminates when the utility power supply is delivering electrical power to the loads.
2. "Emergency Power Supply"- Turns on when the standby generator is powering the electrical loads.
3. "Generator Fault"- Turns on when a monitored engine shutdown fault has occurred (low oil pressure, high coolant temperature, low coolant level, overspeed, overcrank, rpm sensor loss).

Installation and Description

The annunciator enclosure is a surface mount type measuring 9.03 inches wide by 4 inches high by 3.59 inches deep. Panel lamps (LED's) are operated by a 12 volts DC power supply. Four 0.875 inch (2.2cm) holes are provided in the enclosure, for routing wires into the panel. Wiring interconnections between the generator, transfer switch and annunciator are shown in Figure 2.

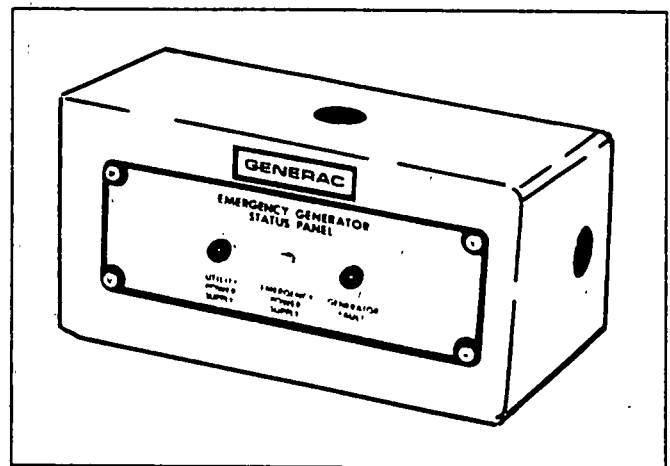


Figure 1. The Model 8848 Annunciator

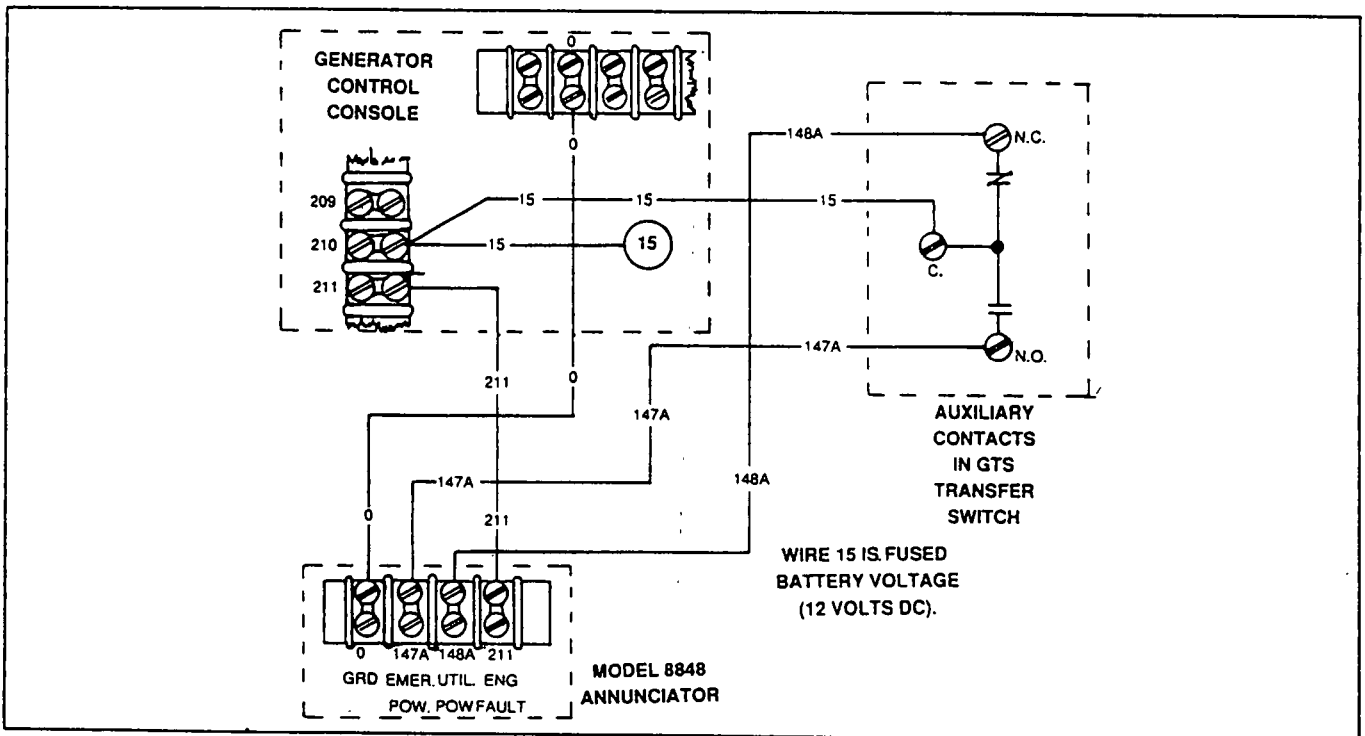
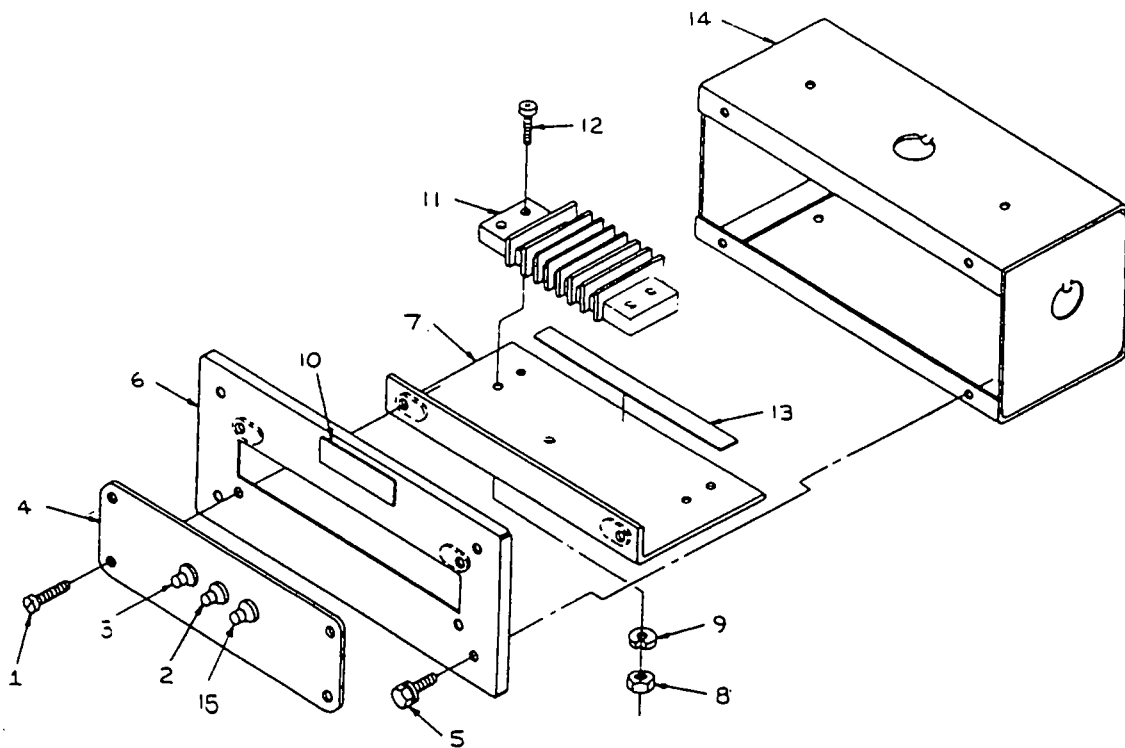


Figure 2. Interconnection Diagram and Schematic



ITEM	QTY	DESCRIPTION
1	4	Round Head Machine Screw
2	1	Yellow Lamp
3	1	Green Lamp
4	1	Annunciator Panel
5	4	Screw
6	1	Front Panel
7	1	Panel Support Bracket
8	2	Hex Nut
9	2	Lockwasher
10	1	"Generac" Decal
11	1	Terminal Block
12	2	Pan Head Machine Screw
13	1	Terminal Block Decal
14	1	Enclosure
15	1	Red Lamp

Figure 3. Exploded View of 3-Lamp Annunciator

THE 5-LAMP REMOTE ANNUNCIATOR

Introduction

The Model 8617 remote annunciator is compatible with any Generac generator having a "C" option control console. The annunciator provides both visual and audible indications of five monitored engine faults. A 12 volt DC input is required to operate the panel.

NOTE: Also see Section 6.2, "Engine Monitor Panel" and "Optional Alarm Relay" on Page 6.3-5.

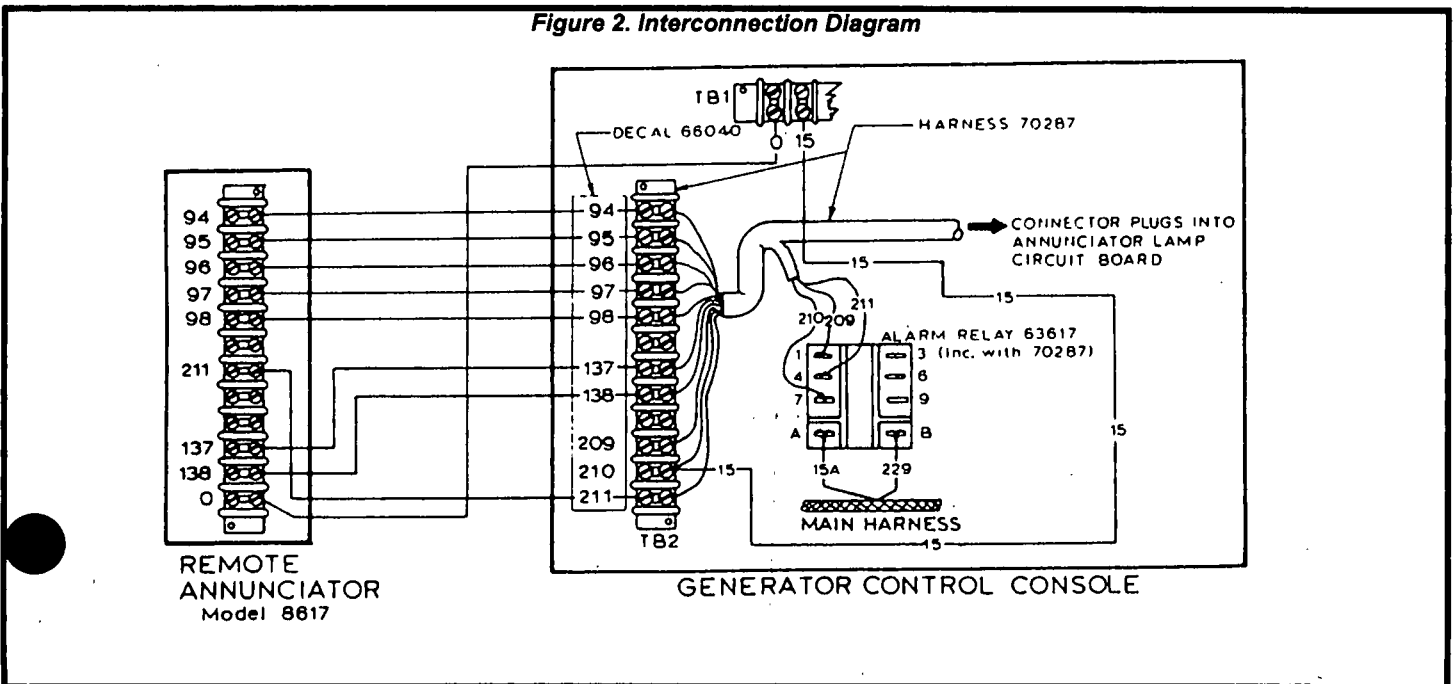
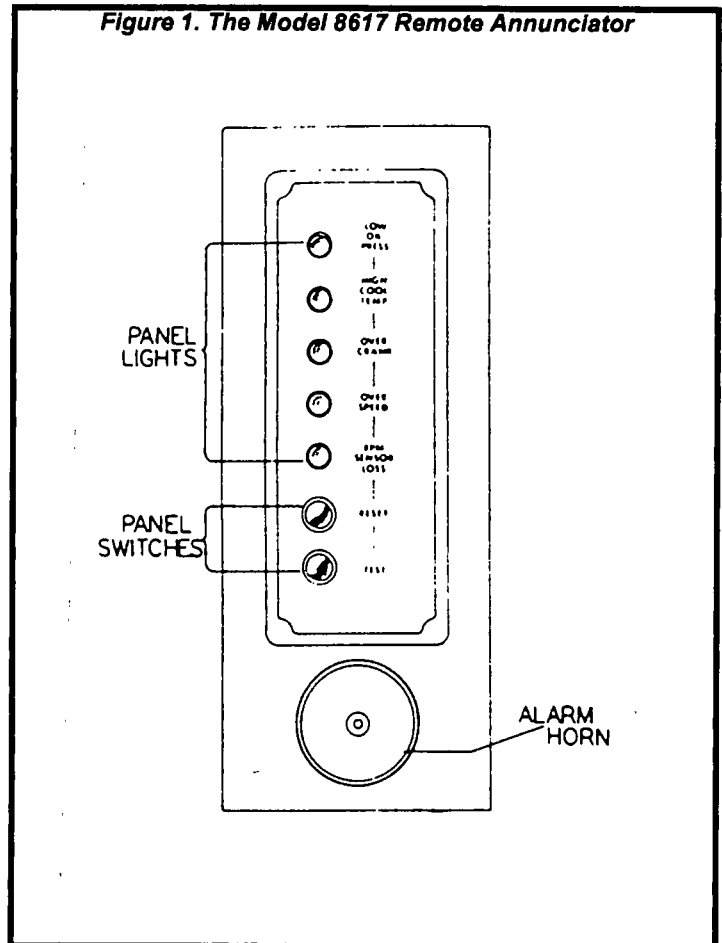
The following engine fault shutdown conditions will be indicated on the annunciator panel:

- Low engine oil pressure.
- High engine coolant temperature/low coolant level.
- Overcrank condition.
- Overspeed condition.
- RPM sensor loss condition.

A TEST switch allows all panel lamps to be tested. A RESET switch turns the lamp(s) off and reactivates the generator's DC control/latch- crank circuit board after any monitored shutdown. Engine will not crank while any lamp is on. An ALARM HORN will sound on occurrence of any monitored shutdown.

NOTE: Post 1987 units do not use Wire 138 (Reset Switch). Both test and reset functions are controlled by the test switch (Wire 137).

The Panel is a surface mount type measuring 10.47 inches high by 3.97 inches deep. Wiring interconnections are shown in Figure 2, below.



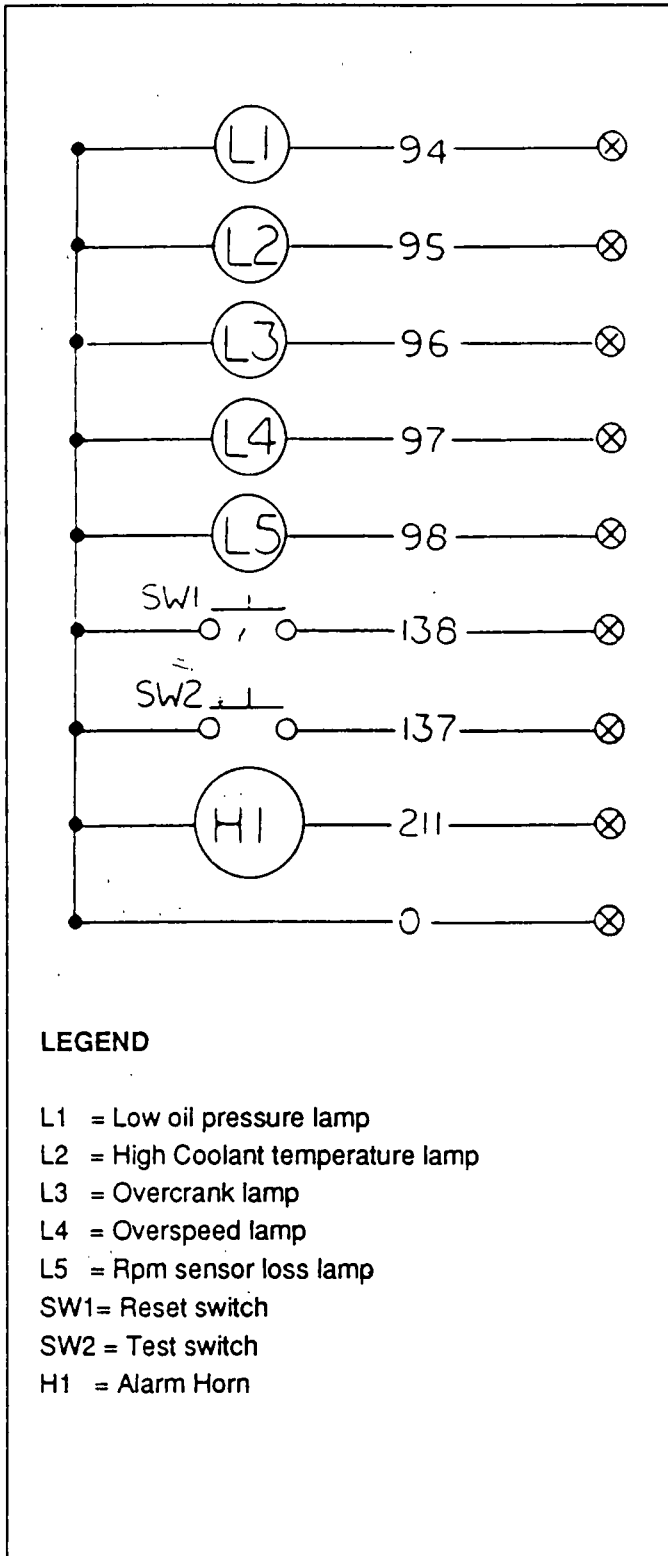


Figure 3. Annunciator Electrical Schematic

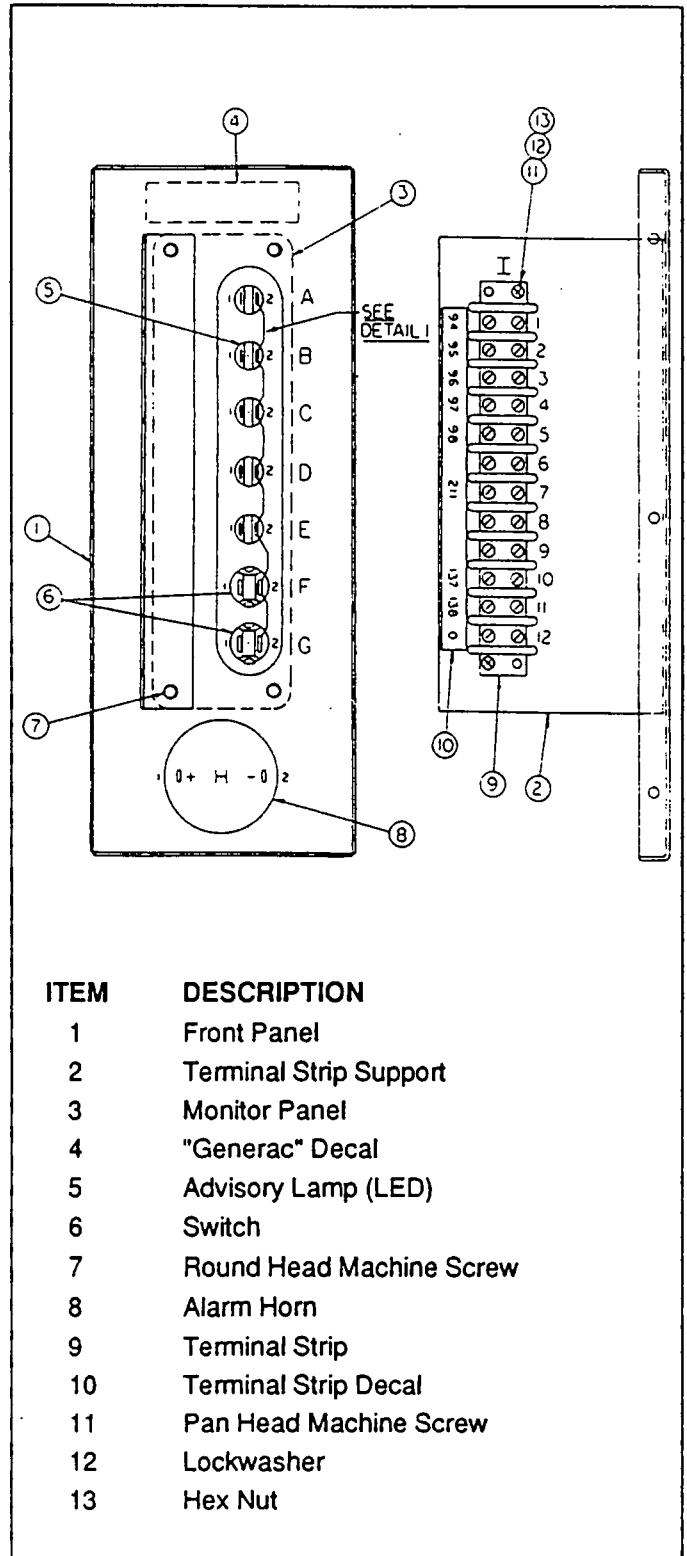


Figure 4. Annunciator Assembly

Section 7.5 THE 14-LAMP REMOTE ANNUNCIATOR

Introduction

Figure 1 shows the front panel of a typical 14-lamp annunciator. Two models are available, as follows:

- Model No. 8702 is a surface mount type.
- Model No. 8815 is a flush mount type.

Annunciator lamps on the panel are listed in the following chart. The chart lists lamp color and whether the alarm horn sounds on lamp illumination.

NAME OF LAMP	COLOR	DOES ALARM HORN SOUND
Prealarm-High Water Temp.	Yellow	Yes
High Water Temperature	Red	Yes
Low Water Temperature	Red	Yes
High Battery Voltage	Red	No
Low Battery Voltage	Red	No
Generator Power	Yellow	No
System Ready	Green	No
Prealarm- Low Oil Pressure	Yellow	Yes
Low Oil Pressure	Red	Yes
Low Fuel	Red	Yes
Overspeed	Red	Yes
Overcrank	Red	Yes
Line Power	Green	No
Alarm Switch Off	Red	No

Annunciator Description

The Models 8702/8815 remote annunciator panels are a self-contained system utilizing solid state circuits to annunciate up to twelve engine-driven generator operating parameters. The system meets National Fire Protection Association (NFPA) requirements for standby electric power systems. The remote panel may be used with any Generac standby generator having an Option "C" console and an alarm relay.

The annunciator system will monitor any sensing device having normally-open contacts which delivers a DC voltage to the appropriate panel lamp on contacts closure. On contacts closure, both an alarm lamp and an alarm horn are activated and latched in to manual reset. The horn can be silenced without disturbing the visual indication, with any subsequent alarm re-activating the horn. The system also includes a test circuit.

NOTE: The one exception to the "normally-open" contacts rule is the low battery voltage lamp. That lamp must be connected to normally-closed contacts in Generac's 10 amp battery charger.

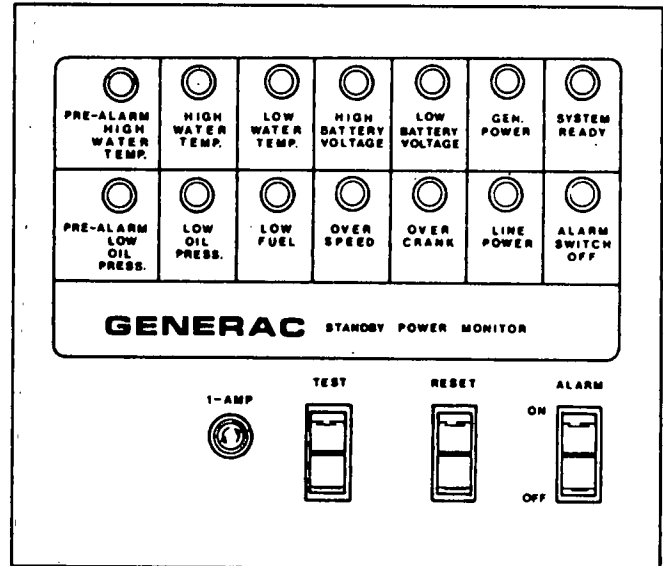


Figure 1. Typical 14-Lamp Annunciator Panel

Wiring Interconnections

See Figure 2 on next page. All input signal connections are made at a 21 point terminal block, located on the remote panel's monitor circuit board. Use purchased No. 14 AWG wire for interconnections.

NOTE: Terminal board TB3, shown in Figure 2, is factory installed in the generator control console when the optional prealarms have been factory installed.

Items 1 through 5 in Figure 2 may be identified as follows:

ITEM	DESCRIPTION
1	Wiring Harness
2	Alarm Relay
3	Tie Wrap
4	Terminal Board TB2 (see Note 1 below)
5	Terminal Board TB3 (see Note 2 below)

NOTE 1: Terminal board TB2 is included on all Option "C" control consoles.

NOTE 2: Terminal board TB3 included in control console when prealarms have been factory installed.

18 LIGHT REMOTE ANNUNCIATOR

Description

The 18 lamp REMOTE ANNUNCIATOR PANEL is a self contained system,utilizing solid state circuits to annunciate up to sixteen (16) engine driven generator operating parameters. The system meets NFPA (National Fire Protection Association) specifications for standby electric power systems.

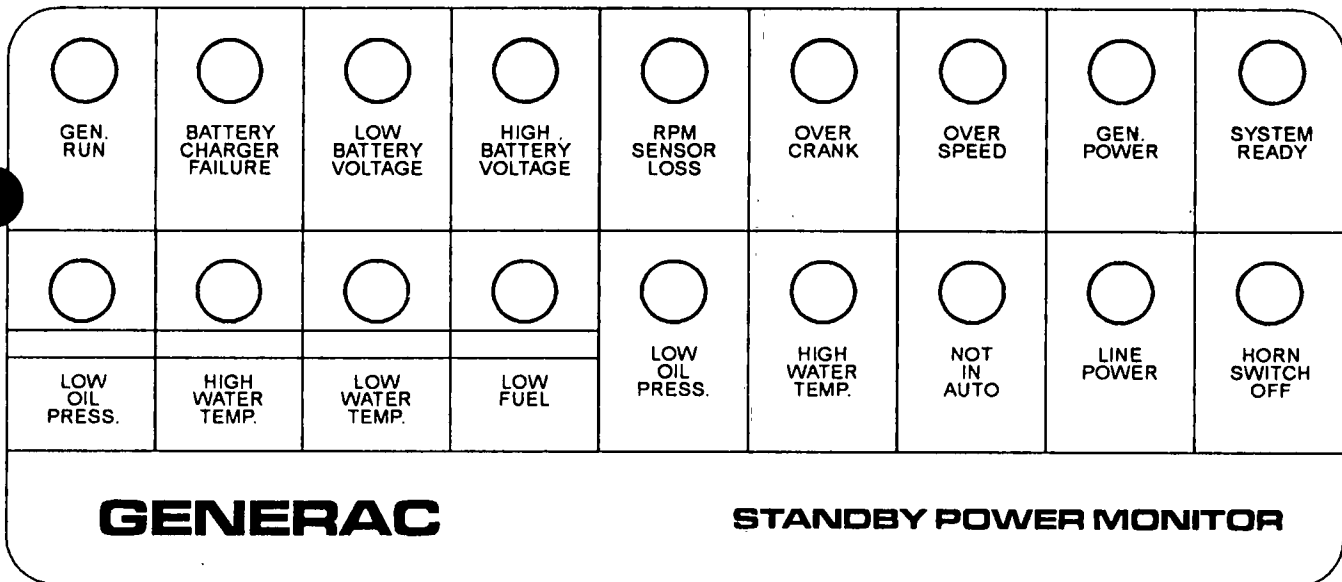
The system will monitor any sensing device having normally open (N.O.) contacts which provide a +DC signal to the appropriate panel lamps on contact closure. On contacts closure, both an alarm lamp and an alarm horn are activated and latched in to manual reset. The alarm horn may be silenced without disturbing the visual indication and any subsequent alarm will re-activate the horn. The system includes a test circuit.

NOTE: The one exception to the normally open contacts rule is the LOW BATTERY VOLTAGE lamp. That lamp must be connected to the normally closed (N.C.) contacts of a battery monitor circuit board (in the generator panel).

Panel Wiring Interconnections

All signal wiring connections are made at a 24 screw terminal block, located on the remote panel's MONITOR CIRCUIT BOARD. Use purchased No. 14 AWG wiring for all interconnections. Maximum recommended distance between the annunciator panel and the standby generator should not exceed 1000 feet. (305 meters). See Figure 3 for wiring interconnections.

Figure 1. Annunciator Front Panel

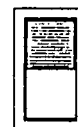
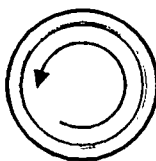
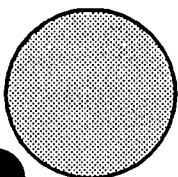


1 AMP

TEST / RESET

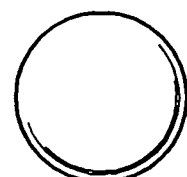
RE- ARM HORN

HORN



ON

OFF



PANEL LAMPS

Generac Stop Signals

All signals occur when generator shutdown occurs as a result of failure indicated by the illuminated lamp (s).

1. **High Water Temperature/Low Water Level:** Lamp turns ON on horn sounds when the generator set's high temperature alarm is on.
2. **Low Oil Pressure:** Lamp illuminates and the alarm horn sounds when the generator set's low oil pressure alarm is on.
3. **Overspeed:** Lamp turns ON and alarm sounds when the generator's overspeed alarm is on.
4. **Overcrank:** Lamp turns On and alarm horn sounds when the generator set's overcrank alarm is on.
5. **Sensor Loss:** Lamp illuminates and alarm horn sounds when the generator's rpm sensor loss alarm is on.

Latchable Signals

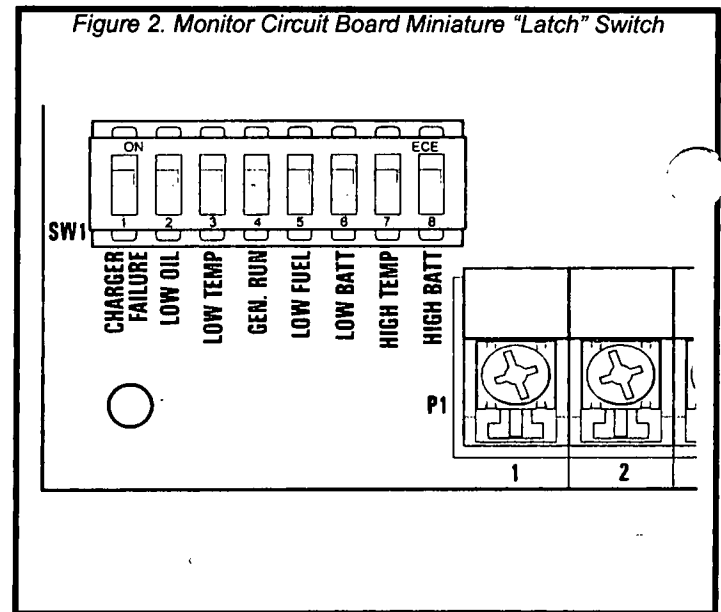
The following signals can be individually selected by means of a miniature switch on the remote panel's monitor board (See Figure 2). The available switch positions are "Latch On", and "Latch Off". "Latch Off" indicates that the lamp will turn ON only when the signal is present. "Latch On" indicates the lamp will be ON until the monitor "Reset" switch is pressed. The alarm horn sounds when "Latch" is selected. The horn will stay ON until either the "Rearm Horn" or the "Reset" switch is pressed.

1. **Low Battery Voltage:** Lamp illuminates when the generator's battery voltage drops low, indicating a discharge condition.
2. **High Battery Voltage:** Lamp will turn ON when generator battery voltage is high, indicating an over charge condition.
3. **Battery Charger Failure:** Lamp will illuminate on failure of the generator's battery charge system.
4. **Low Fuel:** Lamp comes ON on occurrence of a low fuel level in the generator's fuel tank.
5. **Prealarm- High Temp:** Lamp illuminates to warn of an approaching or imminent high coolant temperature shut-down.
6. **Prealarm- Low Temp:** Lamp will turn ON when coolant temperature has decreased, indicating an engine coolant heater failure.
7. **Prealarm- Low Oil Pressure:** Lamp will illuminate in advance of a low oil pressure shutdown, indicating engine oil pressure has decreased to near the point of automatic shutdown.
8. **Generator Run:** Lamp illuminates to advise that the generator has started and / or is running. Lamp On indicates the generator "run" circuit is active (wire #14 on units with 12 volts DC engine control system. Wire #219 on units with 24 volts DC engine control system).

Other Lamps

1. **System Ready:** Lamp will be ON to indicate the generator set is able to run. If the lamp is OUT, a "stop" signal is present.
2. **Not in Auto:** Lamp will turn ON to indicate the generator's Auto-Off-Manual switch is NOT set to "Auto" (that is, the switch is set to either "Manual or Off" and automatic operation is not possible).
3. **Horn Switch Off:** Lamp will turn ON to indicate the horn switch annunciator panel is turned OFF. With the horn switch set to OFF, lamps will not be affected. However, the alarm horn will not sound.
4. **Line Power:** Lamp will be ON when the automatic transfer switch main contacts are in their "Utility" position, (load connected to the power supply).
5. **Generator Power:** Lamp will turn ON when the transfer switch main contacts are in their "Standby" position, i.e., load is connected to the generator power supply.

Figure 2. Monitor Circuit Board Miniature "Latch" Switch



Troubleshooting

Troubleshooting the 18 lamp annunciator is limited to checking wire connections at the generator panel, transfer switch and annunciator, and checking for proper DC inputs to annunciator terminal strip. If all connections and input DC voltage signals are good but a problem still exists with the annunciator operation, replace annunciator circuit board.

ANNUNCIATED SIGNALS

Signal	Source	Lamp	Response	Latched	Rearm
High Temp	Control Board*	Red	Lamp & Horn	Yes	Yes
Low Oil	Control Board*	Red	Lamp & Horn	Yes	Yes
Overspeed	Control Board*	Red	Lamp & Horn	Yes	Yes
Overcrank	Control Board*	Red	Lamp & Horn	Yes	Yes
Sensor Loss	Control Board*	Red	Lamp & Horn	Yes	Yes
System Ready	Annunciator	Green	Lamp	No	N/A
Line Power	Transfer Switch	Green	Lamp	No	N/A
Generator Power	Transfer Switch	Yellow	Lamp & Horn	No	Yes
High Battery	Battery Monitor	Yellow	Lamp & Horn	Select	Yes
Low Battery	Battery Monitor	Yellow	Lamp & Horn	Select	Yes
Not in Auto	Control Board	Red	Lamp & Horn	No	No
Horn Switch Off	Annunciator	Red	Lamp	No	N/A

PREALARMS

Signal	Source	Lamp	Response	Latched	Rearm
Low Fuel	Float Switch	Yellow	Lamp & Horn	Select	Yes
High Temperature	Temperature Switch	Yellow	Lamp & Horn	Select	Yes
Low Temperature	Temperature Switch	Yellow	Lamp & Horn	Select	Yes
Low Oil	Pressure Switch	Yellow	Lamp & Horn	Select	Yes
Generator Run	Control Board	Yellow	Lamp & Horn	Select	Yes
Battery Charge Fail	Battery Monitor	Yellow	Lamp & Horn	Select	Yes

* Automatic generator stop occurs on these signals.

NOTES

1. **Automatic Generator Stop Signals:** Horn and lamp are always latched if one of these signals occurs. Generator stop lamps and horn can be reset by either test / reset switch at the annunciator or reset of fault lamps at the generator.

2. **Test / Reset:** Depressing the test / reset switch energizes all lamps except "horn switch off" lamp plus the horn. Release of switch resets lamps and horn. T/R switch has no effect on fault indicators at the genset.

3. **Latch Select:** Lamps and horn can be chosen to be latched by on-board switch. Unlatched signals activate lamp only; the lamp is de-energized if the fault signal is cleared. Latching provides an audible signal plus keeps the lamp energized as an indicator even if the prealarm fault has been cleared.

4. **Rearm:** Clears horn but not lamps. Lamps are held active by either latch or fault signal. After rearm, horn is enabled to sound if another fault occurs.

5. **"System Ready" Lamp:** Lamp indicates genset is operational. Lamp is energized whenever power is applied to the annunciator circuit and no generator stop signals are present.

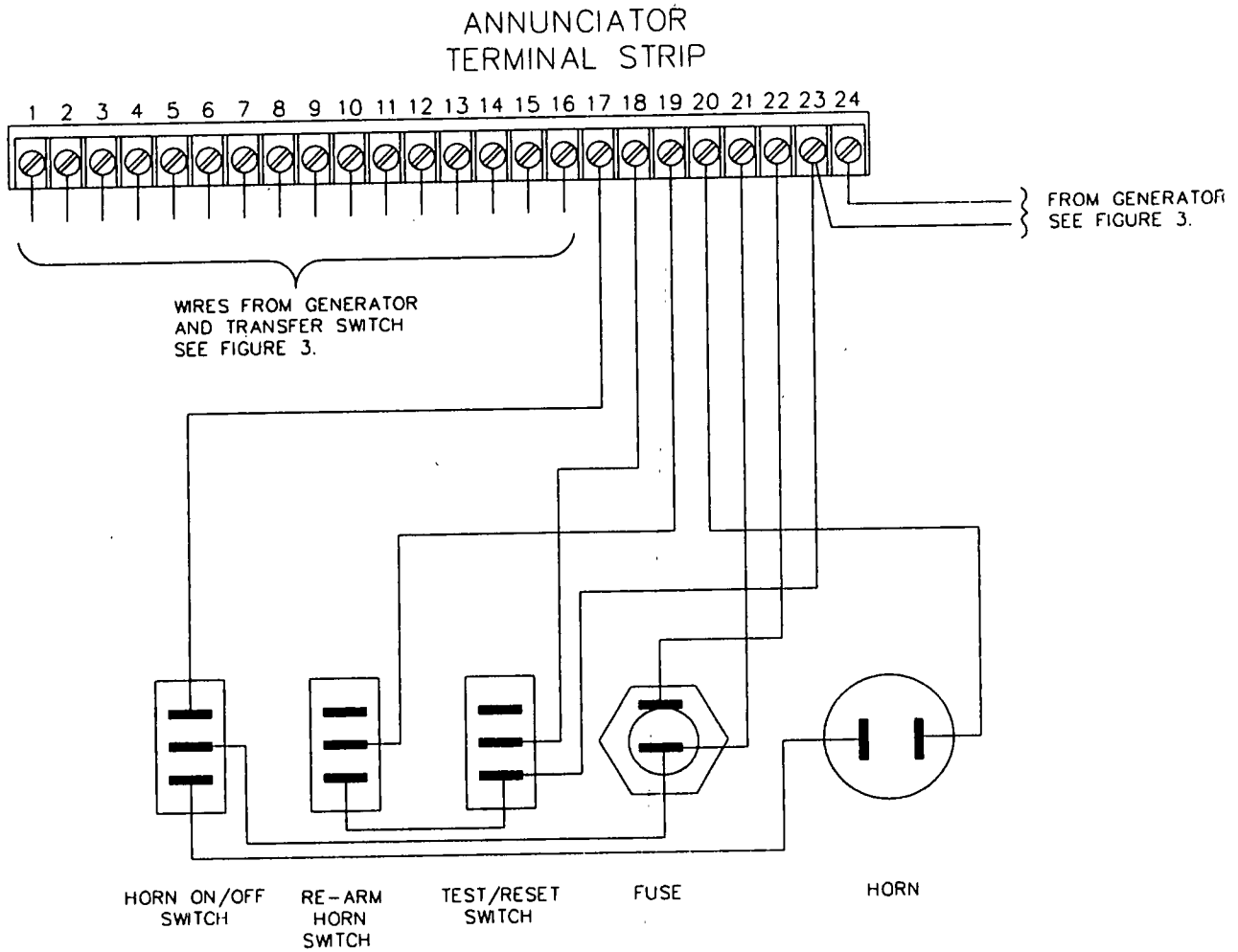
6. **"Line Power- Gen Power" Lamps:** Indicate the position of transfer switch. When load is transferred to the genset, the "Generator Power" lamp is lit and the horn sounds.

8. **"Horn Switch Off" Lamp:** Indicates power to horn has been disconnected by horn disable switch.

9. **Annunciator Delays:** Signals will be annunciated if they exist for the following minimum times:

- Not in Auto, Horn Off, 100 msec.
- Prealarm Low Oil Pressure, 10 seconds.
- All Others, 1 second.

Figure 4. Annunciator Internal Wiring



**PART 8
"Y-TYPE"
AUTOMATIC
TRANSFER
SWITCHES**

**STANDBY
ELECTRIC
POWER
SYSTEMS**
All Series

TABLE OF CONTENTS	
SECTION	TITLE
8.1	Transfer Switch Major Components
8.2	"Y-Type" Transfer Mechanism
8.3	Transfer Mechanism Disassembly
8.4	Transfer Switch Installation
8.5	Operating Instructions
8.6	Functional Tests
8.7	Operational Analysis
8.8	Multi-Voltage Transfer Switches
8.9	Troubleshooting Flow Charts
8.10	Diagnostic Tests

Section 8.1 TRANSFER SWITCH MAJOR COMPONENTS

Introduction

The purpose of a transfer switch is to transfer critical electrical loads to a "Standby" power source when the "Utility" power supply has failed or dropped below a preset level. A transfer switch is required in all standby electric power systems, to prevent electrical feedback between the two power supplies.

The "Y-Type" automatic transfer switches are rated 250 AC volts and are available in 105 to 420 ampere sizes. Figure 1, below, shows a typical transfer switch with its NEMA 12 enclosure door opened to reveal major components.

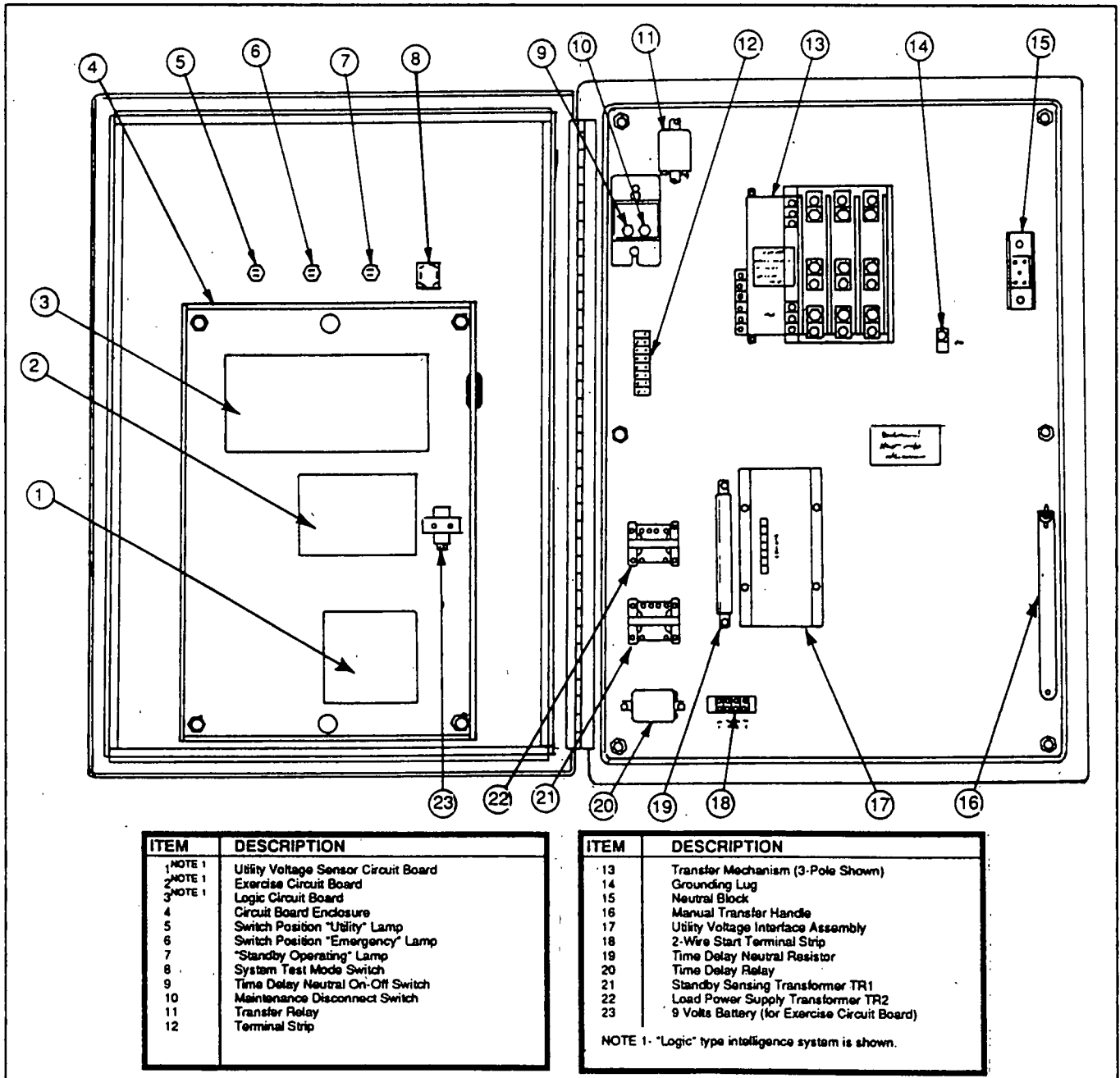


Figure 1. Major Transfer Switch Components

System Test Switch

INTRODUCTION:

The system test switch provides selection of (a) Automatic Mode, (b) Normal Test Mode, and (c) Fast Test Mode. See Figure 2 below.

AUTOMATIC MODE:

With "Automatic Mode" selected, a utility voltage sensor circuit board will constantly monitor utility power source voltage. Should that source voltage drop below a preset level and remain at such low level for a preset time, circuit board action will initiate generator cranking and startup. Following engine warmup and when generator AC output voltage and frequency have reached a preset level, transfer of electrical loads to the "Standby" power source will occur. The circuit board will continue to monitor utility source voltage and, on restoration of that supply voltage, will initiate retransfer back to "Utility" and generator shutdown.

NORMAL TEST MODE:

This switch position simulates a utility power outage. Generator startup and transfer to "Standby" will occur just as though an actual utility source failure has occurred. When the switch is reset back to "Automatic Mode", retransfer and shutdown will occur in the same manner as during automatic operation.

FAST TEST MODE:

When "Fast Test" is selected, the generator engine will crank and start and transfer to "Standby" will occur, with all circuit board timers reduced to a total time of less than five (5) seconds. The switch is spring-loaded out of the "Fast Test" position, must be held there.

"Standby Operating" Advisory Lamp

Lamp turns on when the generator is running. Power for lamp operation is reduced generator output volts.

Switch Position Advisory Lamps

Two lamps indicate the position of the main current carrying contacts in the transfer mechanism. A set of auxiliary contacts in the transfer mechanism will turn one or the other of the lamps on, as follows:

- When the load circuit is connected to the "Utility" source side, the "Utility" lamp will turn on.
- When the load is connected to the "Standby" source side, the "Emergency" lamp will turn on.

NOTE: Utility source power must be available or transfer to that source cannot occur. Standby source power must be available or transfer to that source cannot occur.

Intelligence Circuit Boards

A circuit board compartment is provided in the switch enclosure door. The compartment will house either two or three circuit boards.

- For LOGIC type intelligence systems, the compartment houses three (3) circuit boards. See Part 11.
- For CPU type systems, the compartment houses two (2) circuit boards. See Part 10.

Maintenance Disconnect Switch

When set to its "Manual" position, this switch effectively opens the standby system's 2-wire start circuit (Wires 178/183), as well as the automatic transfer circuit. Thus, when "Manual" is selected, automatic startup and transfer will not be possible.

When set to "Automatic", automatic startup and transfer will occur as programmed in the intelligence circuit.

DANGER: WITH "AUTOMATIC" SELECTED, GENERATOR CAN CRANK AND START WITHOUT WARNING. TO PREVENT INJURY, SET THE SWITCH TO "MANUAL" BEFORE WORKING ON OR AROUND THE GENERATOR.

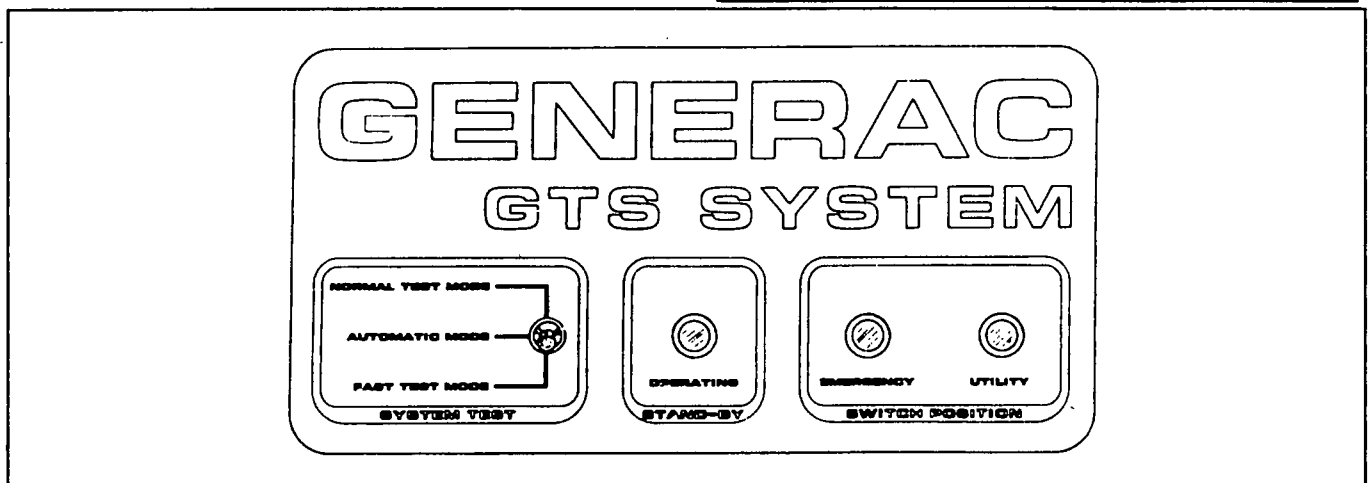


Figure 2. Switch and Lamps on Enclosure Door (Typical)

Optional Time Delay Neutral Switch

Some units may be equipped with an optional time delay neutral switch, usually located adjacent to the maintenance disconnect switch. Setting the switch to "On" activates a "time delay at neutral" function. Also see "Time Delay Relay" in this section.

The time delay neutral feature is a preset time interval during which the transfer switch main contacts will remain disconnected from both the utility and standby source sides.

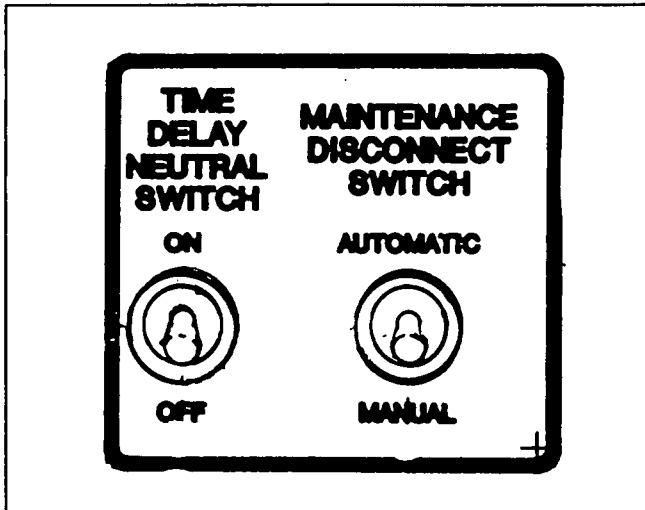


Figure 3. Maintenance Disconnect/Time Delay Neutral Switches

Transfer Relay

When energized by circuit board action, this relay delivers standby source power to the transfer mechanism, to initiate transfer of the main contacts to the "Standby" source side.

When de-energized by circuit board action, the relay actuates to deliver utility source voltage to the transfer mechanism. This initiates re-transfer back to the "Utility" source.

Transfer Mechanism

The transfer mechanism houses the main current carrying contacts. It also houses other electrical and mechanical components needed for switch operation. See Section 8.2.

Neutral Block

Utility, standby and load neutral lines must be connected to the neutral block. Neutral blocks rated 120/150 amps, 200/300 amps, and 420 amps are available.

NOTE: Most standby generators have an "ungrounded" or "floating" neutral. Ground such neutral lines at the main electrical service entrance only. Be sure to comply with appropriate electrical codes:

Grounding Lug

This lug provides a convenient point for connecting the transfer switch to an earth ground.

When conduit is attached to the transfer switch enclosure and such conduit is grounded, the enclosure may be assumed to be grounded. Some installers will simply attach a bare copper wire to the grounding lug and to the conduit.

Manual Transfer Handle

Use this handle for maintenance and testing purposes, to actuate the transfer mechanism main contacts manually.

Terminal Strips TS1 and TS2

Terminal strip TS1 provides a convenient method of interconnecting transfer switch wiring circuits.

Terminal strip TS2 is the "2-wire start" terminal strip, with terminals 178 and 183 identified. Suitable wiring must be connected between these two terminals and an identically numbered terminal strip in the generator's AC connection (lower) panel.

Time Delay Relay

Some transfer switches may be equipped with a "time delay at neutral" feature. This feature extends the disconnect time of the main current carrying contacts beyond the normal disconnect time.

The "neutral" position of the main contacts is that position where the load is disconnected from both power sources. By extending the time at "neutral", residual voltages generated by heavy inductive loads can decay to a safe level before the main contacts are reconnected. The "time delay at neutral" feature provides a measure of protection against blowing of fuses or tripping of circuit breakers that often occurs during rapid transfer of motor and other heavy inductive loads.

Transformer TR1

This step-down transformer may be called the "Standby" transformer, since its primary coil is connected to that power supply. The transformer works as follows:

- Line-to-line standby generator output flows through the transformer's primary winding.
- A reduced voltage is induced into the transformer secondary winding at about 24 volts AC.
- The reduced secondary winding output is delivered to (a) a "Standby Operating" lamp, and to (b) a logic (or CPU) circuit board. The lamp turns on and the logic (or CPU) board begins to operate.

Transformer TR2

This step-down transformer may be called the "Load-Side" transformer since its primary coil connects to the

Transformer TR2 (Continued)

transfer mechanism's load terminals. Load current, flowing through the transformer's primary windings, induces a voltage into the secondary windings at about 24 volts AC. Secondary winding output is used to operate a timing circuit which starts and exercises the generator once every seven (7) days.

On units with CPU type control system (only two circuit boards), secondary winding output is delivered to the CPU circuit board. The 7-day exercise timing circuit is included in that circuit board.

On units with "logic" type control system (three circuit boards) secondary winding output is delivered to a 7-day exercise circuit board.

NOTE: Reduced load terminal voltage is available to the CPU or exercise board at all times, except during the brief period when the transfer mechanism main contacts are at "Neutral". During this brief period, when the load is disconnected from both power sources, the exercise circuit is powered by a 9 volts battery.

Utility Sensing Interface

This device houses either two or three "step-down" transformers. That is, 1-phase systems use two transformers while 3-phase system require three.

The interface allows several different rated voltages and 1 or 3-phase to "interface" properly with a single utility voltage sensor circuit board.

Utility power source voltage is delivered to terminals N1/N2/N3 of the interface. Reduced secondary winding output is delivered to terminals 224 through 227 and then to the utility voltage sensor board as "sensing" voltage. The voltage step-down ratio is fixed and sensing voltage delivered to the utility voltage sensor circuit board will vary as the utility power supply voltage varies. Figures 4 and 5 at right are schematic representations of (a) a 240 volts, 1-phase interface, and (b) a 208/240 volts, 3-phase interface.

NOTE: Some transfer switches may be equipped with a "multi-voltage" utility sensing interface. The multi-voltage interface allows one transfer switch to be used with several different system voltages and phases. Refer to Section 8.8.

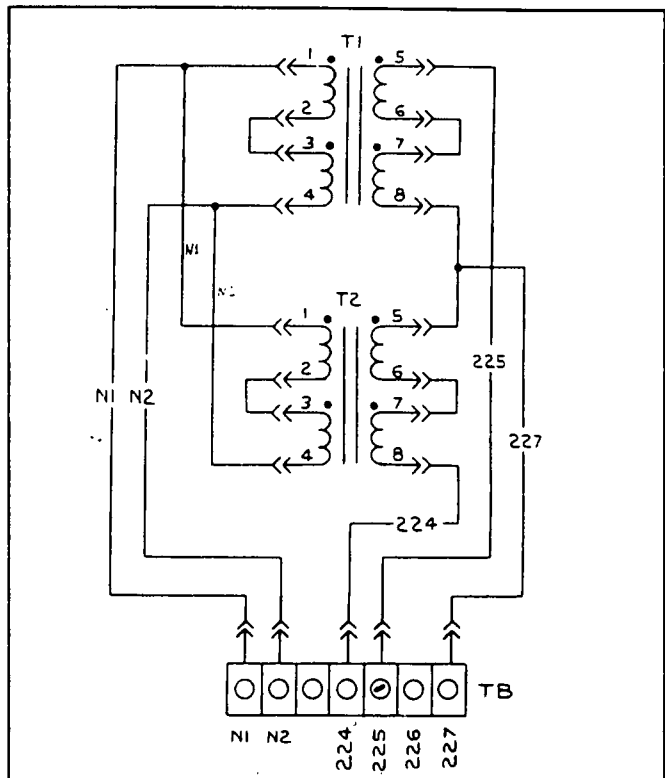


Figure 4. Utility Sensing Interface- 240 Volts, 1-Phase

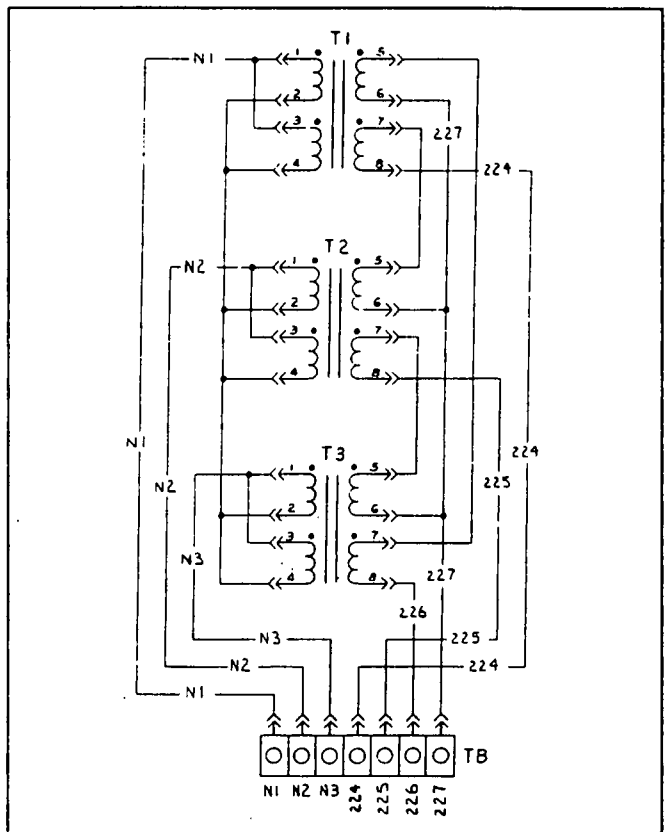


Figure 5. Utility Sensing Interface- 208/240 Volts, 3-Phase

Section 8.2 "Y-TYPE" TRANSFER MECHANISM

General

"Y-Type" automatic transfer switches are rated at not more than 250 volts AC. The mechanisms are available as 2-pole, 3-pole or 4-pole type as shown in Figures 1, 2 and 3.

- The 2-pole unit is for 1-phase applications only.
- The 3-pole units may be used with 3-phase applications or with 1-phase applications in which the "Neutral" line is to be switched during transfer.
- The 4-pole units may be used with 3-phase applications where the 3-phase "Neutral" line is to be switched during transfer.

NOTE: On 1-phase, 3-pole switches where "Neutral" is to be switched, a neutral block may not be provided. On 3-phase, 4-pole switches where "Neutral" is to be switched, a neutral block may not be provided.

Each single pole of the transfer mechanism consists of stationary main contacts and moveable main contacts. The stationary main contacts are retained in the pole assembly, with each pole assembly sandwiched together and retained by two thru-bolts. A single piece moveable contact carrier pivots on a single shaft. Contacts are retained in the moveable contact carrier by a spring.

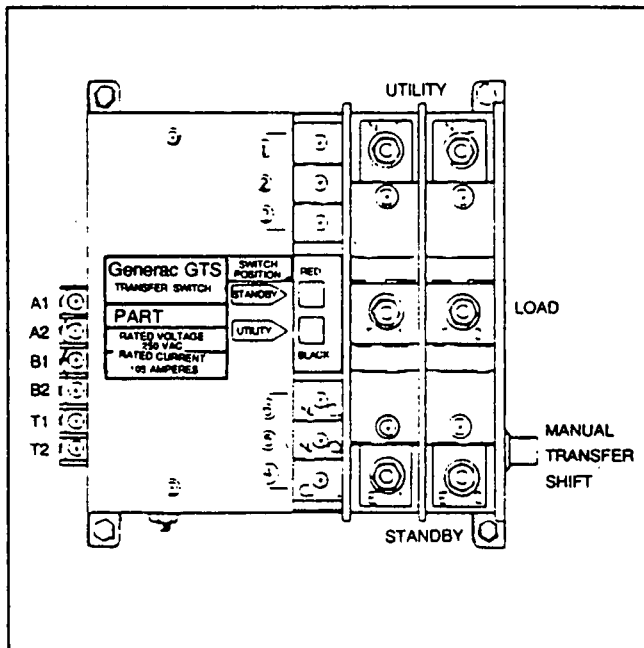


Figure 1. Typical 2-Pole Transfer Mechanism

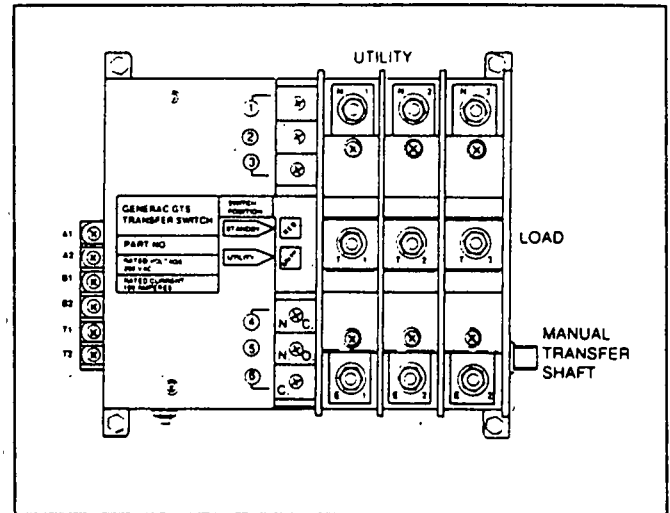


Figure 2. Typical 3-Pole Transfer Mechanism

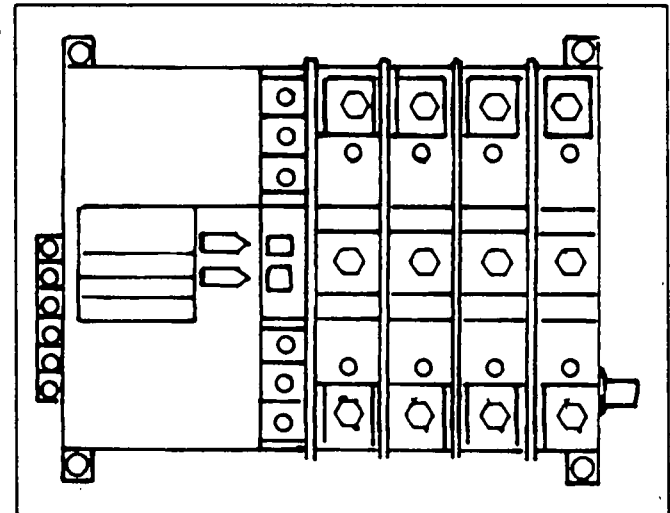


Figure 3. Typical 4-Pole Transfer Mechanism



Figure 4. Stationary and Moveable Main Contacts

Main Contacts Operation

The moveable main contacts provide the interconnection between the load and power source terminals. The moveable main contacts are spring-loaded, to ensure proper alignment between the contact surfaces. Figure 5 shows the moveable main contacts at the "Utility" side, i.e., load terminals connected to the utility terminals.

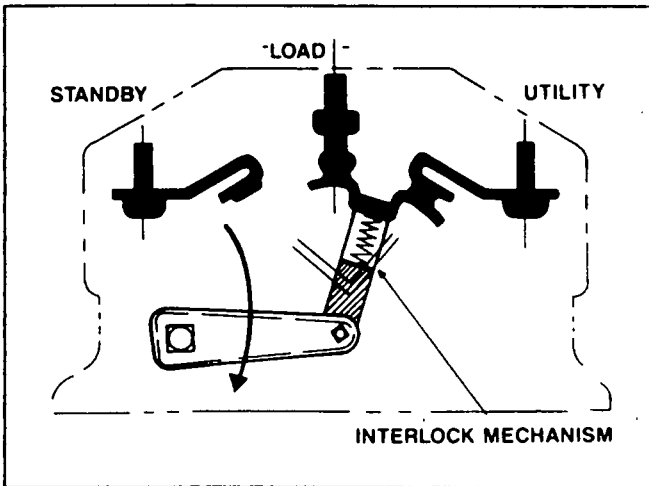


Figure 5. Main Contacts at "Utility" Position

Figure 6 shows the moveable main contacts at their "Neutral" position, with the load terminals disconnected from both power supplies. During automatic operation, the main contacts will remain at "Neutral" as long as the actuating coil remains energized.

NOTE: Some units may be equipped with a "time delay at neutral" feature. See "Time Delay Relay" on Page 8.1-3. This feature holds the main contacts actuating coil energized for a preset time interval during any transfer action. The main contacts remain at "Neutral" as long as that coil stays energized.

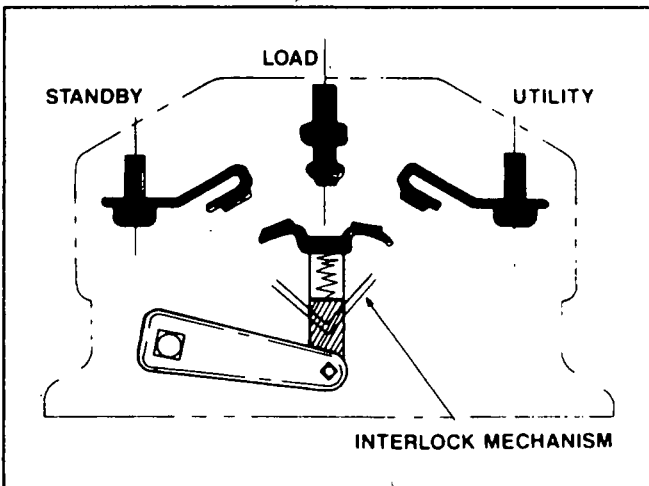


Figure 6. Main Contacts at "Neutral"

Figure 7 shows the main contacts at their "Standby" position, i.e., load terminals are connected to the standby terminals.

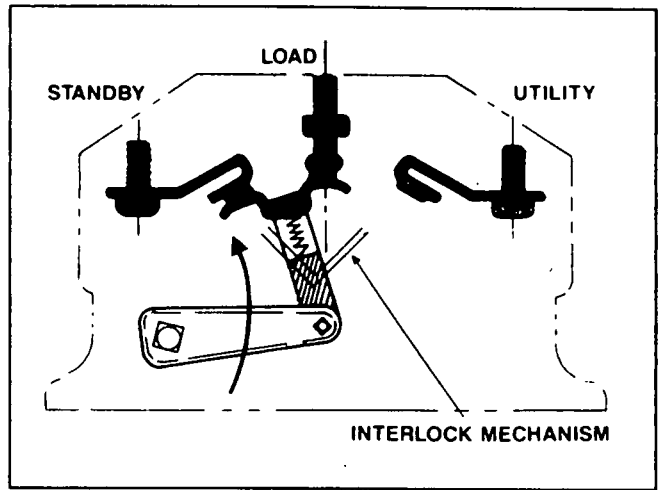


Figure 7. Main Contacts at "Standby"

Auxiliary Contacts

The transfer mechanism mounts two sets of auxiliary contacts. One set, numbered 1-2-3, is already in use for operation of switch position lamps on the enclosure door. The second set of contacts (4-5-6) are available for use by the customer. One possible use of the auxiliary contacts might be to turn remote-mounted switch position advisory lamps off and on.

The auxiliary contacts are rated 15 amps at 125, 250 or 480 volts; or 1/2 amp at 125 volts DC; or 1/4 amp at 250 volts DC. DO NOT EXCEED THE RATED AMPS OF THE CONTACTS.

Contacts consist of a common, normally-closed and normally-open contacts as listed in the following chart.

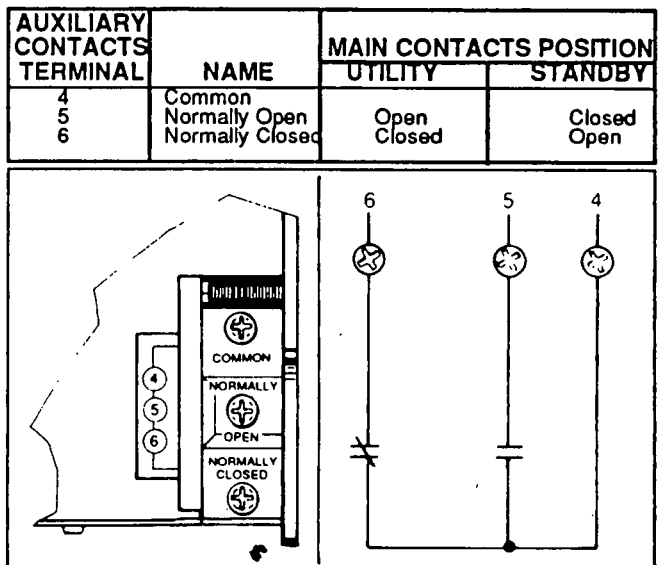


Figure 8. Auxiliary Contacts

Electrical Components

Transfer mechanism electrical components are shown in Figure 9. Included in the illustration are (a) a solenoid coil, (b) a terminal strip, (c) a bridge rectifier, (d) limit switches LS1 and LS2, and (e) limit switch LS3.

SOLENOID COIL:

Flow of electrical current through this coil creates a magnetic field which actuates a plunger. Plunger movement then actuates the main contacts to either their "Utility" or "Standby" side. The coil is energized by rectified DC power from the power source to which the load terminals are being connected. The following facts apply to actuating coil operation:

- The solenoid coil is operated by direct current from either the "Utility" or the "Standby" power source.
- Rectified "Standby" source power is used to actuate the plunger and main contacts to their "Standby" source side.
- Rectified "Utility" source power is used to actuate the plunger and main contacts to their "Utility" source side.
- With the solenoid coil energized, plunger movement will actuate the main contacts to their "Neutral" position. They will remain at "Neutral" as long as the solenoid coil remains energized.
- The coil is normally de-energized by the action of a "Neutral" limit switch (LS3), to allow the main contacts to complete the transfer action.

TERMINAL STRIP:

Terminal numbers and their functions are listed in the following chart:

TERMINALS	FUNCTION
A1, A2	Actuating command to the "Utility" power source side from the utility power supply.
B1, B2	Actuating command to the "Standby" power source side from standby power supply.
T1, T2	Time delay at neutral circuit.

BRIDGE RECTIFIER:

The solenoid coil requires direct current (DC) for its operation. The bridge rectifier changes the power source alternating current (AC) to direct current (DC).

LIMIT SWITCHES LS1/LS2:

During transfer to either power source side, a mechanical interlock actuates these limit switches. The two limit switches function to ensure that the solenoid coil can be energized only by the active power source side.

On transfer to "Standby", LS1 and LS2 will actuate to close the terminals A1/A2 circuit and open the B1/B2

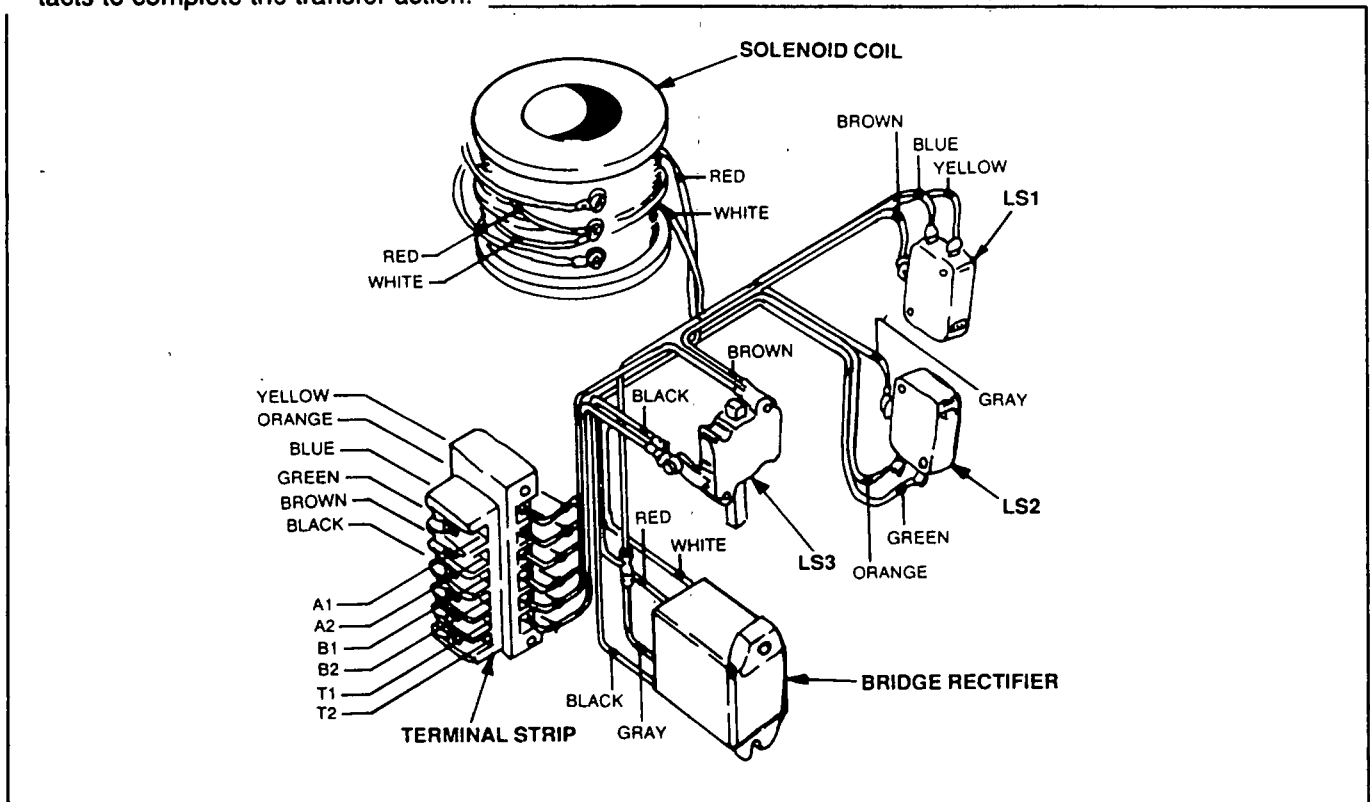


Figure 9. Transfer Mechanism Electrical Components

Electrical Components (Continued)

circuit. Thus, with the load connected to the standby source, the A1/A2 circuit is "armed" and ready for retransfer back to "Utility".

On re-transfer back to "Utility", limit switch action will open the terminals A1/A2 circuit and close the B1/B2 circuit. With circuit B1/B2 closed, the transfer mechanism is ready for transfer to the "Standby" source.

NEUTRAL LIMIT SWITCH LS3:

This switch is opened by a mechanical interlock when the main contacts reach their "Neutral" position. Opening of LS3 opens the circuit to the solenoid coil. The coil will then de-energize and the transfer action will be completed.

NOTE: The main contacts will remain at "Neutral" as long as the solenoid coil is energized. Opening of LS3 de-energizes the solenoid coil and spring force, acting on an "over-center" mechanism, will complete the transfer action.

NOTE: On units equipped with the optional "time delay at neutral" feature, LS3 is bypassed during a transfer action by the T1/T2 circuit. The T1/T2 circuit will hold the solenoid coil energized for a pre-set time interval. The main contacts will then remain at "Neutral" for that pre-set time.

Section 8.3 TRANSFER MECHANISM DISASSEMBLY

Transfer Mechanism Removal

To remove the transfer mechanism from the transfer switch enclosure, proceed as follows:

1. On the generator control console, set the auto-manual-off switch to "Off". Then, place a "DO NOT OPERATE" tag on or near the console.
2. As a safety measure, to prevent generator startup, disconnect the cables from the generator battery.
3. Turn OFF all power voltage supplies to the transfer switch using whatever means provided (such as the "Utility" and "Standby" main line circuit breakers).

DANGER: DO NOT PROCEED UNTIL ALL POWER VOLTAGE SUPPLIES TO THE TRANSFER SWITCH HAVE BEEN POSITIVELY TURNED OFF. FAILURE TO TURN OFF POWER VOLTAGE SUPPLIES WILL RESULT IN HAZARDOUS AND POSSIBLY LETHAL ELECTRICAL SHOCK. BOTH THE "UTILITY" AND "STANDBY" POWER SUPPLIES TO THE TRANSFER SWITCH MUST BE DISCONNECTED OR TURNED OFF.

4. Disconnect all wires from transfer mechanism terminal lugs N1, N2, N3. Also disconnect wires T1, T2, T3 and E1, E2, E3 from their terminal lugs on the transfer mechanism.
5. Disconnect wiring from transfer mechanism terminal strip (A1, A2, B1, B2, T1, T2).
6. Remove the capscrews, lockwashers and flatwashers that retain the transfer mechanism in the transfer switch enclosure.
7. Remove the transfer mechanism.

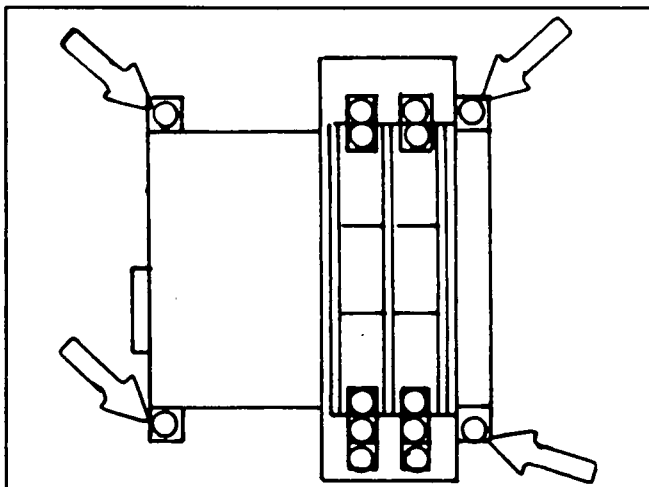


Figure 1. Transfer Mechanism Removal

Electrical Section Disassembly

1. See Figure 2. Remove two (2) screws that retain the outer cover to the transfer mechanism.

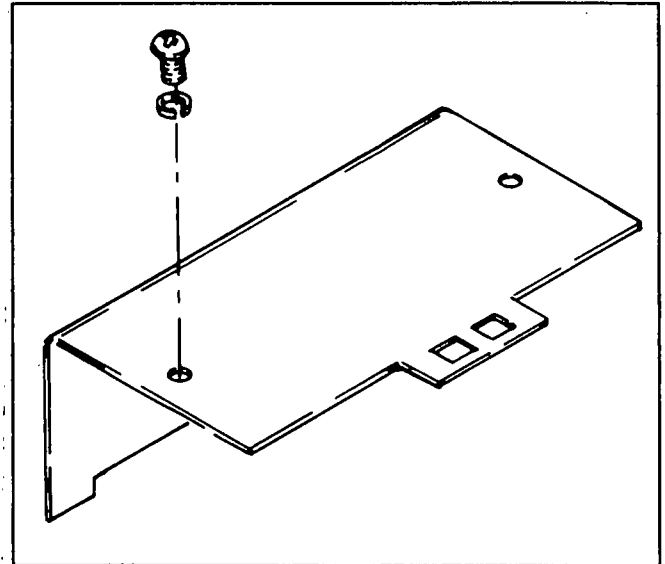


Figure 2. Outer Cover Removal

2. See Figure 3. Remove four (4) screws that retain the inner cover.

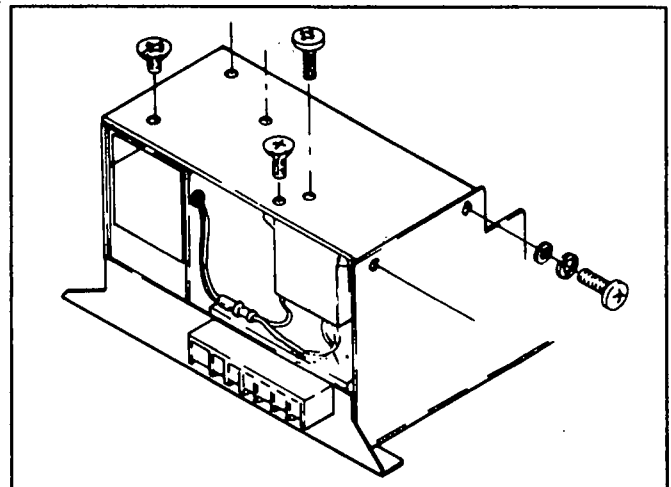


Figure 3. Removal of Inner Cover Screws

3. Limit switch LS3 is retained to the inner cover by two long screws with countersunk head (see Figure 4) and a retaining bar with threaded holes. Lift up on the cover slightly and remove the two long screws.
4. Remove the inner cover and the limit switch retaining bar. Also remove limit switch actuating lever bracket, limit switch actuating lever, and an actuating lever spring.

NOTE: Keep all limit switch parts together in a safe place, such as a container. These parts are small and are easily lost.

Electrical Section Disassembly (Continued)

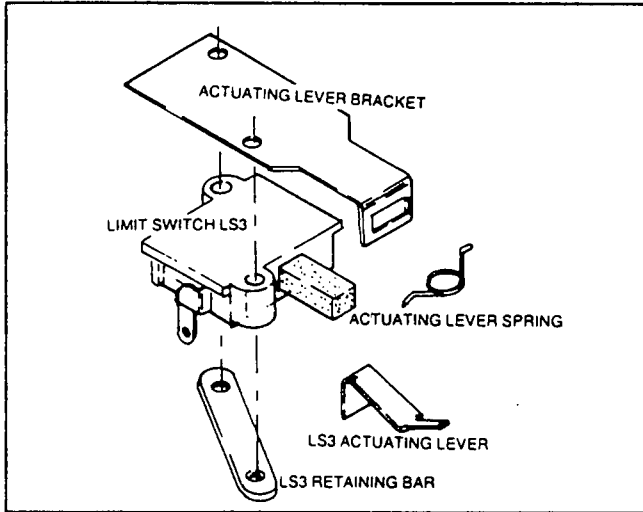


Figure 4. Limit Switch LS3 Actuating Parts

LIMIT SWITCH LS3 REMOVAL:

1. The limit switch retaining screws and bar were previously removed during removal of the inner cover.
2. Disconnect all wires from limit switch LS3 and completely remove the switch from the transfer mechanism.

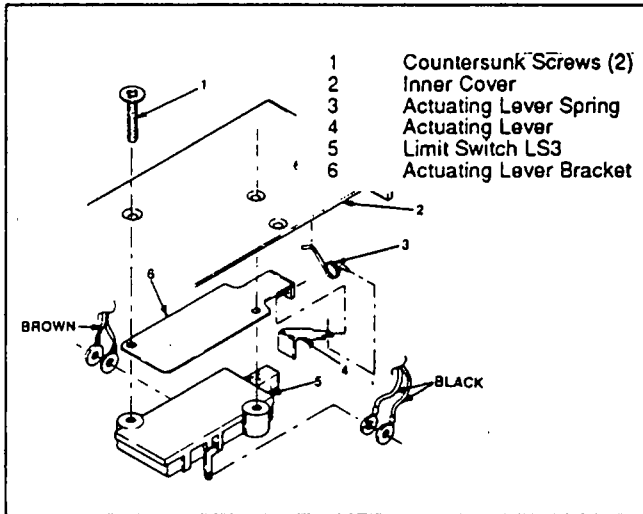


Figure 5. Exploded View of Limit Switch LS3

TERMINAL STRIP REMOVAL:

1. See Figure 6. Remove two (2) screws that retain the terminal strip to the transfer mechanism.
2. Loosen- do not remove- the wire retaining screws at back of terminal strip. Remove all wires and remove the terminal strip.

SOLENOID COIL REMOVAL:

1. See Figure 7. Remove four capscrews that retain the coil backing plate.

2. Remove the capscrew that retains the solenoid coil to the backing plate.
3. Rotate the coil slightly to allow access to the coil terminal screws. Remove the terminal screws and disconnect the coil's red and white wires.
4. Remove the solenoid coil along with the coil cylinder.

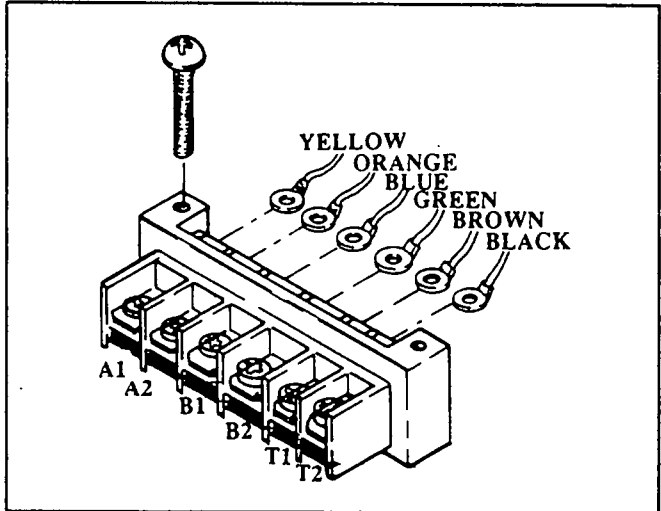


Figure 6. Terminal Strip Removal

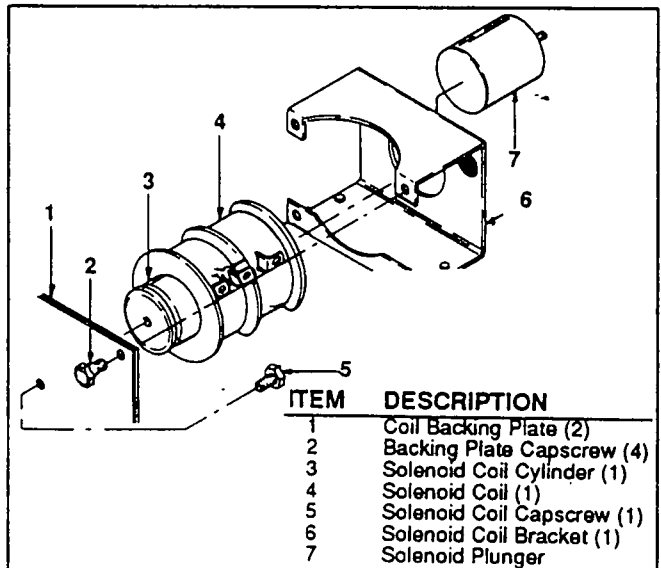


Figure 7. Solenoid Coil Removal

BRIDGE RECTIFIER REMOVAL:

Guide the bridge rectifier wires out through the protective rubber grommet. Remove the bridge rectifier. See Figure 8.

SOLENOID COIL BRACKET REMOVAL:

Remove two screws that retain the bracket to the base. Then, remove the coil bracket. See Figure 9.

Electrical Section Disassembly (Continued)

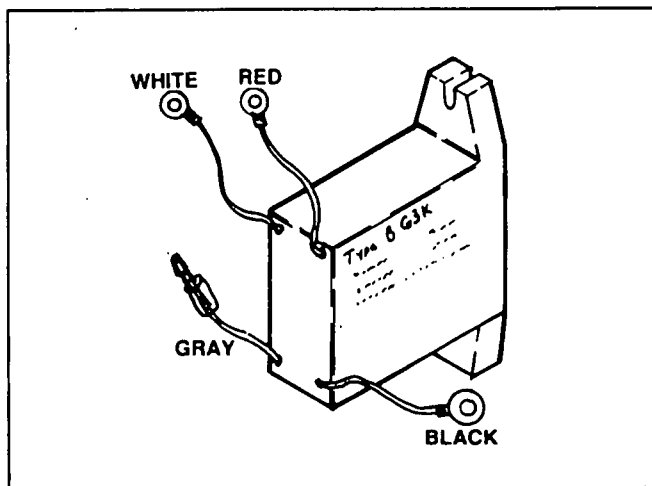


Figure 8. Bridge Rectifier Assembly

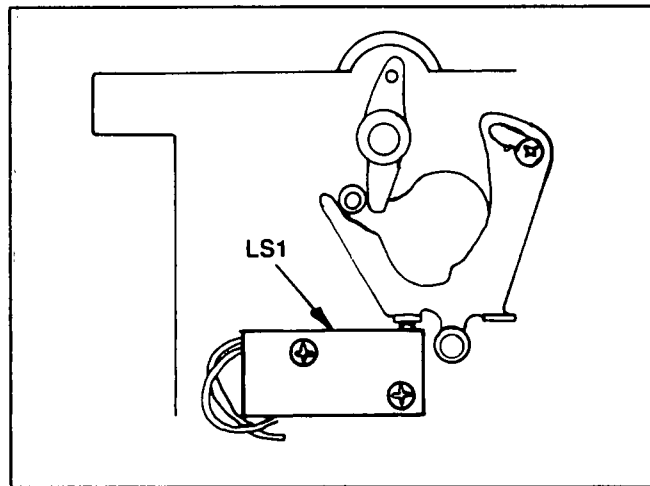


Figure 10. Limit Switch LS1 Removal

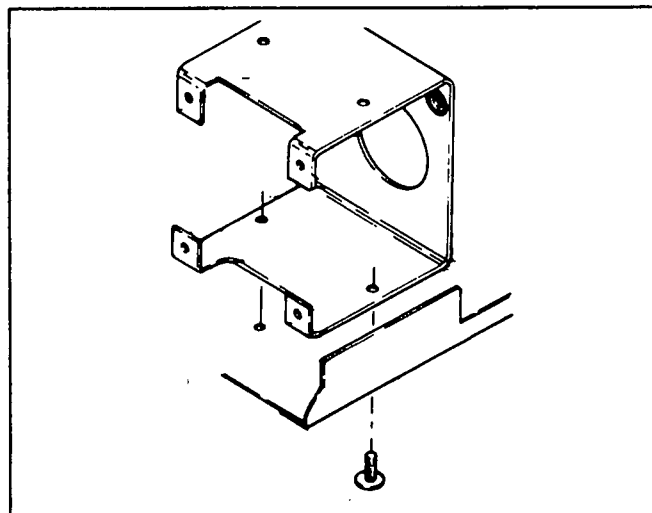


Figure 9. Solenoid Coil Bracket Removal

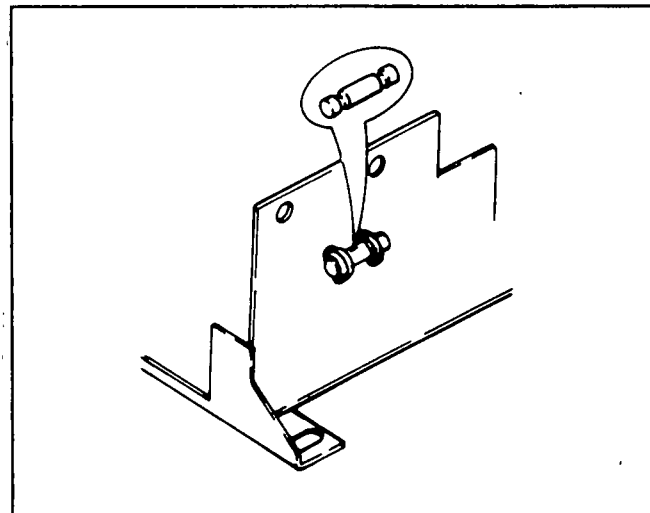


Figure 11. Spring Retaining Pin Removal

LIMIT SWITCH LS1 REMOVAL:

See Figure 10. With the solenoid coil removed, limit switch LS1 is accessible. Remove two (2) screws, then remove LS1 along with two insulator strips. Wires on switch LS1 are soldered connections.

LIMIT SWITCH LS2 REMOVAL:

1. See Figure 11. Remove the spring retaining pin.
2. See Figure 12. Remove two (2) screws that retain the actuating link assembly to the transfer mechanism base.
3. You should be able to lift the actuating link assembly high enough to remove two (2) screws that retain limit switch LS2 to its support. Remove the two screws.
4. Remove limit switch LS2 along with two insulator strips. Switch wires have soldered connections.

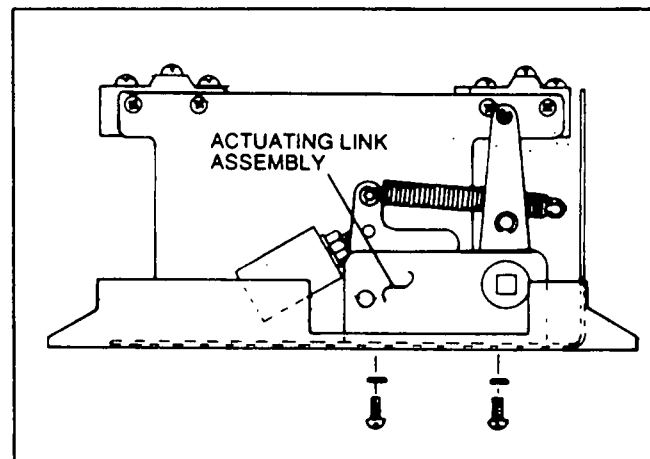


Figure 12. Actuating Link Assembly Screws

Electrical Section Disassembly (Continued)

AUXILIARY CONTACTS REMOVAL:

Refer to Figure 13. Remove two screws that retain one set of auxiliary contacts and remove the contacts. The second set of auxiliary contacts can be removed in the same manner.

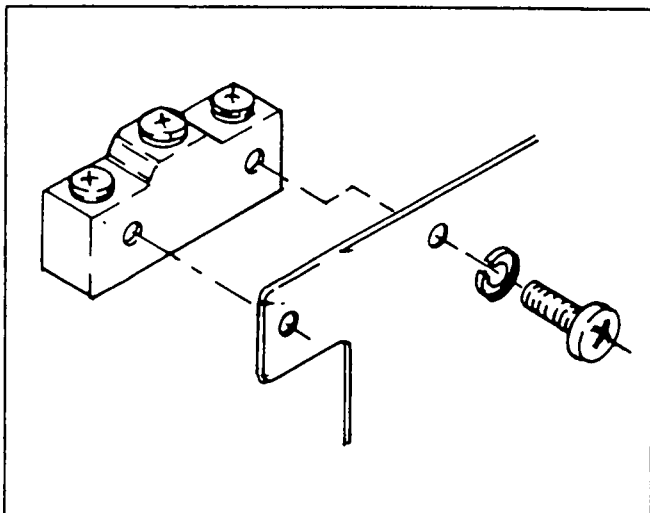


Figure 13. Auxiliary Contacts Removal

Stationary Main Contacts Removal

Remove the two long thru-bolts that retain the stationary main contacts assembly. Carefully remove the stationary main contacts.

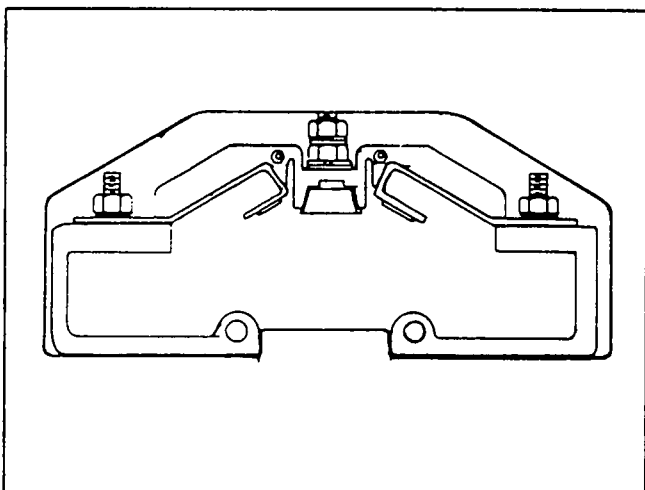


Figure 14. Stationary Main Contacts Assembly

Moveable Main Contacts

The moveable main contacts are now exposed and may be inspected, removed or replaced as necessary. The main contacts assembly consists of (a) a moveable contact carrier, (b) contact spring, and (c) contact.

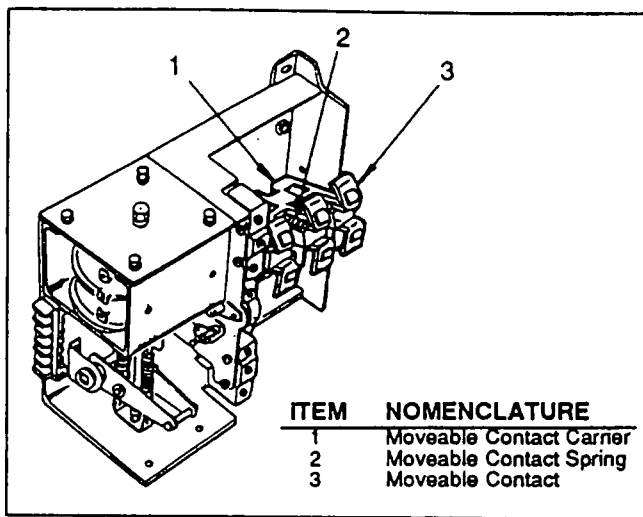


Figure 15. Moveable Main Contacts

Testing and Inspection

Inspect the stationary and moveable main contacts closely. Inspect springs, linkage, retaining pins, etc., for damage, wear. Replace any damaged or defective parts.

Switches may be tested using a volt-ohm-milliammeter (VOM). Replace any defective switch.

NOTE: Test procedures for most switches, the bridge rectifier and the solenoid coil are discussed in Section 8.10, "Diagnostic Tests".

Reassembly

Reassemble the transfer mechanism in the reverse order of disassembly.

Following reassembly, the transfer mechanism should be tested thoroughly before it is placed into service. Before applying electrical power, actuate the main contacts manually several times (using the manual transfer handle). When you are certain that manual operation is correct, electrical power may be applied. Test electrical operation of the transfer switch.

Section 8.4 TRANSFER SWITCH INSTALLATION

Introduction

Generac "GTS" transfer switches have been factory wired and tested. Installation at the standby electric system site consists of the following:

- Mounting the transfer switch.
- Connection of power source and load lines.
- Connection of the 2-wire start circuit.
- Installation of any options and accessories.
- Functional tests and adjustments.

Mounting the Transfer Switch

For enclosure mounting dimensions, refer to the appropriate Owner's Manual. Typically, the transfer switch enclosures are wall mounted. However, some units with higher amperage ratings may be self-supporting, floor-mounted units.

The enclosure should be mounted vertically to a strong, rigid supporting structure. All mounting points should be level. If necessary, install flatwashers behind the mounting holes to prevent distortion.

CAUTION: Handle the transfer switch assembly carefully. Protect the unit against impact. Also protect the unit against construction grit, metal chips, lint, dust, dirt, etc. Never install a transfer switch that has been damaged.

CAUTION: The transfer switch will respond only to its correct rated voltage and phase. Transfer switch rated voltage and phase must be compatible with the voltage and phase of the "Utility" and "Standby" power supplies. Also see Section 8.8. "Multi-Voltage Transfer Switches".

Power Source and Load Line Connections

DANGER: TURN OFF ALL POWER VOLTAGE SUPPLIES BEFORE ATTEMPTING TO CONNECT POWER SOURCE AND LOAD LINES TO THE TRANSFER SWITCH TERMINAL LUGS. EXTREMELY HIGH AND DANGEROUS VOLTAGES ARE PRESENT IN POWER SOURCE LINES. FAILURE TO TURN OFF OR DISCONNECT POWER VOLTAGE SUPPLIES MAY RESULT IN HAZARDOUS AND POSSIBLY FATAL ELECTRICAL SHOCK.

Power source and load line connections are made at solderless, screw-type terminal lugs on the transfer mechanism. See Section 8.2. "Y-Type Transfer

Mechanism". In most cases, the switch enclosure will include a neutral block for attachment of power source and load neutral lines.

All power cables should enter the switch enclosure adjacent to the appropriate terminal lugs. Conductors must be (a) properly supported, (b) protected by approved conduit, (c) of approved insulative qualities, and (d) of the correct wire gauge size to handle the maximum current load that will be applied. All applicable electrical codes and regulations must be strictly complied with. Maintain proper electrical clearance between live metal parts and grounded metal, as follows:

- Allow at least one-half inch of clearance for 100-400 amp circuits.
- Allow at least one inch of clearance for circuits over 400 amps.

Remove surface oxides from stripped ends of power source and load conductors with a wire brush. If aluminum conductors are used, apply joint compound to the conductor's stripped end. Insert stripped end of conductor into the correct terminal lug, then tighten the terminal to its specified torque. Finally, wipe away excess joint compound.

Recommended torques of terminal lugs are as follows:

Units rated 100 amps = 50 Inch-pounds (6 N-m)
All Other Units = 250 Inch-pounds (26 N-m)

Connecting 2-Wire Start Circuit Leads

Connect suitable, approved wiring to terminals 178 and 183 in the transfer switch enclosure. These wires must be routed to and interconnected with identically numbered terminals in the generator's AC connection (lower) panel.

The 2-wire start wiring must be routed through conduit that is separate from circuits of any other source. Closure of the Wires 178/183 circuit must result in engine cranking and startup.

NOTE: A "3-wire" start system is also available as an option. If a generator having a 3-wire start system is to be installed, use a transfer switch equipped with a 3-wire start system.

NOTE: Some very early production standby generators were equipped with a "9-wire" start system. The optional "3-wire" transfer switch system can be used with the "9-wire" generator system by installing a Model 8815 "Start Control Interface".

Connection of 2-Wire Start Leads (Continued)

Recommended wire gauge sizes for the 2-wire start circuit are given in the following chart:

WIRE LENGTH	WIRE GAUGE SIZE
Up to 460 feet (140m)	No. 18 AWG
461-730 feet (223m)	No. 16 AWG
731-1160 feet (354m)	No. 14 AWG
1161-1850 feet (565m)	No. 12 AWG

Auxiliary Contacts

The transfer mechanism includes a set of auxiliary contacts. See Figure 1. Contacts identified as 1, 2 and 3 have been factory connected to switch position advisory lamps on the transfer switch enclosure door. Contacts 4, 5 and 6 are available for customer use, if desired. Refer to "Auxiliary Contacts" on Page 8.2-2.

Post Installation Tests and Adjustments

Following installation, the transfer switch and other parts of the standby electric system must be tested and adjusted. See Section 8.6, "Functional Tests". Never place a standby system into operation until all operational tests and adjustments have been properly completed.

Section 8.5 OPERATING INSTRUCTIONS

Normal Automatic Operation

To select normal automatic operation, proceed as follows:

1. On the transfer switch enclosure door, check that the "Switch Position-Utility" lamp is ON.

NOTE: The "Switch Position-Utility" lamp MUST be lighted before proceeding. The lamp indicates that (a) utility power source voltage is available to the transfer switch, and (b) the transfer mechanism main contacts are at their "Utility" position (loads are connected to the utility power supply). If necessary, manually actuate the main contacts to their "Utility" side and turn on the utility power supply to the transfer switch.

2. Inside the transfer switch enclosure, set the maintenance disconnect switch to "Automatic" position.
3. If so equipped, set the generator's auto-manual-off switch to "Auto".
4. On the transfer switch enclosure door, set the system test switch to its "Automatic Mode" position.

The system is now set for fully automatic operation. Should utility source voltage drop below a preset level, the generator engine will crank and start. Following generator startup, an "engine warmup timer" on the logic (or CPU) circuit board will start timing. When that timer has timed out and when generator AC output voltage and frequency have reached preset levels, transfer of loads to the "Standby" source will occur. On restoration of utility source voltage above a preset level, retransfer back to "Utility" and generator shut-down will occur.

NOTE: Timers and sensors which control automatic operation are located on circuit boards in the transfer switch enclosure door. Two different types of circuit board systems are currently in use. The "CPU" type system utilizes two circuit boards. The "logic" system has three circuit boards. For more detailed information on automatic operating parameters, sequences and times, see Part 10, "The CPU Type Intelligence System" and Part 11, "The Logic Type Intelligence System".

Manual Transfer to "Standby"

To manually transfer loads to the "Standby" source and to start the generator manually, proceed as follows:

1. Inside the transfer switch enclosure, set the maintenance disconnect switch to "Manual".
2. If so equipped, set the generator's auto-manual-off switch to "Manual".
3. Turn OFF all power voltage supplies to the transfer switch.

DANGER: DO NOT ATTEMPT MANUAL TRANSFER SWITCH OPERATION UNTIL ALL POWER VOLTAGE SUPPLIES HAVE BEEN POSITIVELY TURNED OFF. FAILURE TO TURN POWER OFF MAY RESULT IN DANGEROUS OR DEADLY ELECTRICAL SHOCK.

4. Remove the manual transfer handle from its storage place in the transfer switch enclosure.
5. Place open end of manual transfer handle over the square shaft on the transfer mechanism. See Figure 1. Then, actuate the handle as follows:
 - a. Move the handle upward. Movement will stop when the main contacts reach their "Neutral" position (load disconnected from both power supplies).
 - b. When handle movement stops at "Neutral", return the handle to its original position and actuate again.
6. Observe the changeover display on the transfer mechanism.
 - a. If "Utility" arrow is aligned with the green band, load is connected to the "Utility" power supply.
 - b. If the "Standby" arrow is aligned with the green band, load is connected to the "Standby" power supply.
7. If necessary, repeat Steps 5 and 6 until the "Standby" arrow points to the green band, i.e., loads are connected to the "Standby" source.
8. Remove the manual transfer handle from the square shaft and store the handle in the place provided.
9. Crank and start the generator manually, using the start/stop switch on the generator console. Refer to appropriate Owner's Manual.
10. Let the engine stabilize and warm up. Then, turn ON the "Standby" power supply to the transfer switch using whatever means provided.
 - a. The "Standby Operating" lamp on switch enclosure door should illuminate.
 - b. The "Switch Position-Emergency" lamp on switch enclosure door should turn on.

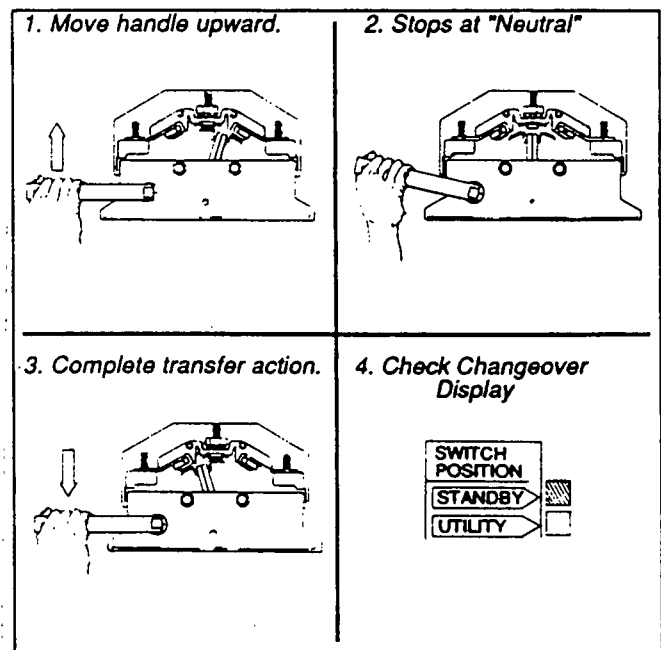


Figure 1. Manual Transfer Switch Operation

Manual Retransfer Back to "Utility"

To retransfer loads back to the "Utility" power source and shut the generator down, proceed as follows:

1. Turn OFF all power voltage supplies to the transfer switch, using whatever means provided (such as the utility and standby main line circuit breakers).

DANGER: DO NOT PROCEED UNTIL ALL POWER VOLTAGE SUPPLIES TO THE TRANSFER SWITCH ARE POSITIVELY TURNED OFF. FAILURE TO TURN OFF POWER VOLTAGE SUPPLIES MAY RESULT IN EXTREMELY HAZARDOUS AND POSSIBLY FATAL ELECTRICAL SHOCK.

2. Remove the manual transfer handle from its place of storage.
3. Place open end of manual handle over the square shaft on transfer mechanism. Actuate the handle as follows:
 - a. Move the handle upward. Movement will stop when the main contacts reach their "Neutral" position.
 - b. When movement stops at "Neutral", return the handle to its original position and actuate again.
4. Observe the "Changeover Display" on the transfer mechanism.
 - a. If the "Utility" arrow is aligned with the green band, load is connected to the "Utility" power supply.
 - b. If the "Standby" arrow is aligned with the green band, load is connected to the "Standby" power supply.
 - c. If necessary, repeat Steps 3 and 4 until the "Utility" arrow is aligned with the green band (load connected to "Utility" source).
5. Turn ON the "Utility" power supply to the transfer switch using whatever means provided.
 - a. Check that the "Switch Position-Utility" lamp is lighted, indicating that utility power is available and the main contacts are at their "Utility" position.
 - b. The "Standby Operating" lamp will still be on since the generator is running.
6. In the transfer switch enclosure, set the maintenance disconnect switch to its "Automatic" position.
7. If so equipped, set the generator's auto-manual-off switch to "Auto".
8. Shut the generator engine down.

Section 8.6 FUNCTIONAL TESTS

Introduction

Following installation of a standby electric power system and before placing the system into service, the entire system should be thoroughly inspected and tested. All applicable codes, standards and regulations must be strictly complied with.

When the installer is absolutely certain that the installation is correct and complete, a "functional test" of the system should be performed. Perform these functional tests in the exact order they are presented here or damage to the transfer switch might result.

Manual Transfer Switch Operation

Use the manual transfer handle to actuate the main contacts to "Standby" and to "Utility" several times. When certain that the switch is operating normally, return the main contacts to their "Utility" position (load connected to the "Utility" source). See Section 8.5, "Operating Instructions".

Remove the manual handle from the square shaft and store in the place provided.

IMPORTANT; THE LOAD MUST BE CONNECTED TO THE "UTILITY" SOURCE BEFORE PROCEEDING.

Voltage Checks

Check the transfer switch DATA PLATE for rated voltage and phase. The DATA PLATE voltage and phase must be fully compatible with the rated voltage and phase of both power sources.

NOTE: Also see Section 8.8, "Multi-Voltage Transfer Switches".

DANGER: DURING THE FOLLOWING VOLTAGE CHECKS, THE TRANSFER SWITCH WILL BE ELECTRICALLY HOT. PROCEED WITH CAUTION. AVOID CONTACT WITH LIVE WIRES, TERMINALS, ETC.

Perform voltage checks as follows:

1. In the transfer switch enclosure, check that the maintenance disconnect switch is set to "Manual".
2. Check that the load is connected to the "Utility" power supply.
 - a. Observe "Changeover Display" on transfer mechanism. The "Utility" arrow should point to the green band.
 - b. The "Switch Position-Utility" lamp on enclosure door should be ON. Light on indicates that (a) utility power is available and (b) load is connected to "Utility" source.
3. On the utility voltage sensor circuit board, check that the "Utility On" lamp is lighted. LAMP MUST BE ON BEFORE PROCEEDING.

4. Use an AC voltmeter to check line-to-line (phase-to-phase) and line-to-neutral (phase-to-neutral) voltages across transfer mechanism terminal lugs N1, N2, N3 and the "Neutral" block. Supplied voltages must be compatible with transfer switch rated voltage.

NOTE: If the transfer switch is a "multi-voltage" type, installer selection of a compatible voltage and phase is possible. Refer to Section 8.8, "Multi-Voltage Transfer Switches".

NOTE: The "sensing" voltage that is delivered to the utility voltage sensor circuit board will vary as the utility source voltage varies. It may be necessary to calibrate the utility voltage sensor board to match the "Utility" voltage. See Part 10 or Part 11 as appropriate.

5. Refer to the appropriate generator Owner's Manual. Make sure the generator engine has been properly serviced and is ready for use.
6. When certain that it is ready for use, start the engine manually. Let the engine stabilize and warm up for a few minutes.
7. Use an AC voltmeter to test line-to-line (phase-to-phase) and line-to-neutral (phase-to-neutral) voltage across transfer mechanism terminal lugs E1, E2, E3 and the neutral block. Supplied voltages must be compatible with transfer switch rated voltage.
8. Shut the generator engine down.

Normal Test

Perform a "Normal Test" of the standby system as follows:

1. On the transfer switch enclosure door, check that the "Switch Position-Utility" lamp is lighted.
2. In the transfer switch enclosure, set the maintenance disconnect switch to "Automatic".
3. If so equipped, set the generator's auto-manual-off switch to "Auto".
4. On the transfer switch enclosure door, set the system test switch to "Normal Test Mode". The generator should crank and start and transfer to "Standby" should occur, just as though an actual utility source outage has occurred.
5. When test is complete, return the switch to "Automatic Mode". Retransfer back to the "Utility" source followed by generator shutdown should occur.

NOTE: The sequence of events that occur during "Normal Test" are exactly the same as the sequences during an actual utility power failure. Sequences and times are controlled by timers and sensors on transfer switch circuit boards. See Parts 10 or 11 of this manual, as appropriate.

Fast Test

Hold the system test switch at "Fast Test Mode". Generator startup and transfer to "Utility" should occur very quickly, with all timers reduced to less than five (5) seconds. Switch is spring loaded, must be held at "Fast Test Mode".

Circuit Board Sensor and Timer Adjustments

The installer or customer may wish to change the timer and sensor settings on the transfer switch circuit boards. This can be done quickly and easily. Lamps (LED's) are provided on the circuit boards which will turn on during the operation of each sensor and/or timer.

For transfer switches with "CPU" type intelligence systems, see Part 10, "The CPU Type Intelligence System".

For units equipped with a "Logic" type intelligence system, refer to Part 11, "The Logic Type Intelligence System".

Section 8.7 OPERATIONAL ANALYSIS

Introduction

This section will familiarize the reader with the electrical operation of a typical "Y-Type" transfer switch having a "Logic" type intelligence system. The "Logic" system uses three circuit boards (utility voltage sensor, 7-day exercise, and logic boards).

"CPU" type intelligence systems feature only two circuit boards (utility voltage sensor and CPU board). Except for the number and functions of the circuit boards, operation of the two systems is nearly identical. On the CPU type system, the CPU circuit board handles the functions of both the logic board and the 7-day exerciser board.

Transfer Mechanism Operation

Figure 1 is a schematic representation of A 3-pole "Y-Type" transfer mechanism, shown with the LOAD connected to the STANDBY power supply. Operation of the transfer mechanism may be briefly described as follows:

LOAD POWERED BY STANDBY SOURCE:

1. Generator AC output is delivered to transfer mechanism terminal lugs E1/E2/E3, across the main contacts, to load terminals T1/T2/T3, and to the load circuits.
2. Limit switches LS1 and LS2 are closed to the terminals A1/A2 side (utility power source side).
3. Limit switch LS3 is closed.
4. A transfer relay has been energized by logic (or CPU) board action and standby source AC voltage is available to terminals B1/B2. However, that circuit is held open by LS1/LS2 action and the solenoid coil (C) is de-energized.
5. Auxiliary contacts terminal 1 is connected to terminal 3; terminal 4 to terminal 5.

RETRANSFER BACK TO UTILITY:

1. When utility power is restored, the action of a logic (or CPU) circuit board de-energizes a transfer relay. That relay's normally-closed contacts then deliver utility source voltage to terminals A1/A2.
2. The utility source voltage is delivered to solenoid coil (C), via terminals A1/A2, limit switches LS1/LS2/LS3, and a bridge rectifier (B).
3. Solenoid coil (C) energizes to actuate the main contacts to their "Neutral" position (load is disconnected from both power sources). Main contacts will remain at "Neutral" as long as solenoid coil (C) remains energized.
4. When the main contacts reach "Neutral", interlock action opens limit switch LS3 and solenoid coil (C) de-energizes. Spring force then completes the movement to the "Utility" source side (load connected to the "Utility" power supply).

LEGEND

- B = Bridge Rectifier
- C = Solenoid Coil
- LS1, LS2= Limit Switch (Switch Operation)
- LS3= Limit Switch (Neutral Position)
- VR = Varistor

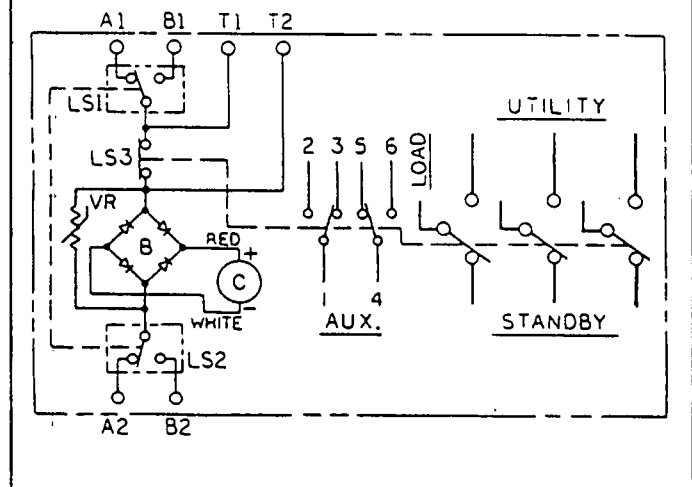


Figure 1. Transfer Mechanism Electrical Schematic

5. Limit switches LS1/LS2 actuate to the terminals B1/B2 side. The auxiliary contacts are repositioned.

TRANSFER TO STANDBY:

1. When utility source voltage drops below a preset level and remains at such low level for a preset time, utility voltage sensor circuit board action will close the 2-wire start circuit (178/183). Generator will crank and start.
2. Logic (or CPU) board action will energize a transfer relay. Standby source power will then be delivered to terminals B1/B2 and to the solenoid coil (C) via LS1/LS2/LS3 and a bridge rectifier (B). The solenoid coil (C) energizes and actuates the main contacts to "Neutral".
3. When main contacts reach "Neutral", LS3 opens. Solenoid coil (C) de-energizes and main contacts complete the transfer action to the "Standby" source side.
4. Limit switches LS1/LS2 are actuated to the terminals A1/A2 terminals side, to "prepare" the circuit for retransfer back to "Utility".
4. The auxiliary contacts (AUX) are repositioned by a mechanical interlock mechanism.

Circuit Condition- Utility Power Available

Refer to Figure 2 on facing page. The dark and heavy lines indicate circuits that are electrically hot while normal "Utility" power is available to the transfer switch. Circuit condition may be briefly described as follows:

1. Utility source voltage is available to transfer mechanism terminal lugs N1/N2/N3, through the closed main contacts, and to load terminals T1/T2/T3.
2. Utility source voltage is available to transfer mechanism terminals A1 and A2. However, limit switches LS1 and LS2 have actuated to the terminals B1/B2 side and this circuit is open.
3. From load terminals T1/T2, utility source voltage is delivered to the primary winding of a load side transformer (TR2). This is a "step-down" transformer, which will provide a voltage reduction of approximately 10 to 1. The reduced voltage is delivered to a 7-day exercise circuit board, via Wires 185 and 0. The step-down voltage is used to operate the timing circuit (clock) that starts and exercises the generator at regular weekly intervals.
4. From terminal lugs N1/N2/N3, utility source power is delivered to a utility sensing interface. Step-down transformers in that interface reduce the utility voltage to a value that is compatible with a utility voltage sensor circuit board.
5. As long as the utility voltage sensor board reads a normal utility source voltage, the system takes no action.

Circuit Condition- Utility Power Source Dropout

1. A "voltage dropout sensor" on the utility voltage sensor circuit board constantly monitors utility power source voltage. Should that source voltage drop below a preset level, a "line interrupt delay timer" will start timing. If utility voltage is still low when that timer has timed out, the circuit board will (a) close the 2-wire start circuit which consists of terminals and wires 178 and 183, and (b) open the wires 199 and 202 circuit between the utility voltage sensor board and the system control (logic) board.
2. Closure of the 178/183 circuit energizes components in the generator's DC control/latch-crank circuit board and the engine cranks cyclically. That is, the engine will crank for about eight (8) seconds, rest for about eight (8) seconds, crank for eight (8) seconds, and so on.
3. When the generator starts, standby source power is delivered to the transfer mechanism terminals E1/E2/E3, and to a sensing transformer (TR1). The transformer's secondary coil delivers a "step-down" voltage to (a) a "Standby Operating" lamp and (b) to the system control (Logic) circuit board. The "Standby Operating" lamp illuminates. The System Control (Logic) board starts operating.
4. A "minimum run timer" and an "engine warmup timer" on the system control (logic) board both start timing.

NOTE: During the time that power is not available to the 7-Day Exercise board, the board is operated by a 9 volts battery. On units with a CPU type system (only two circuit boards), secondary winding output from transformer TR2 is delivered to the CPU circuit board. When power to TR2 is lost, the CPU board is powered by a 9 volts battery.

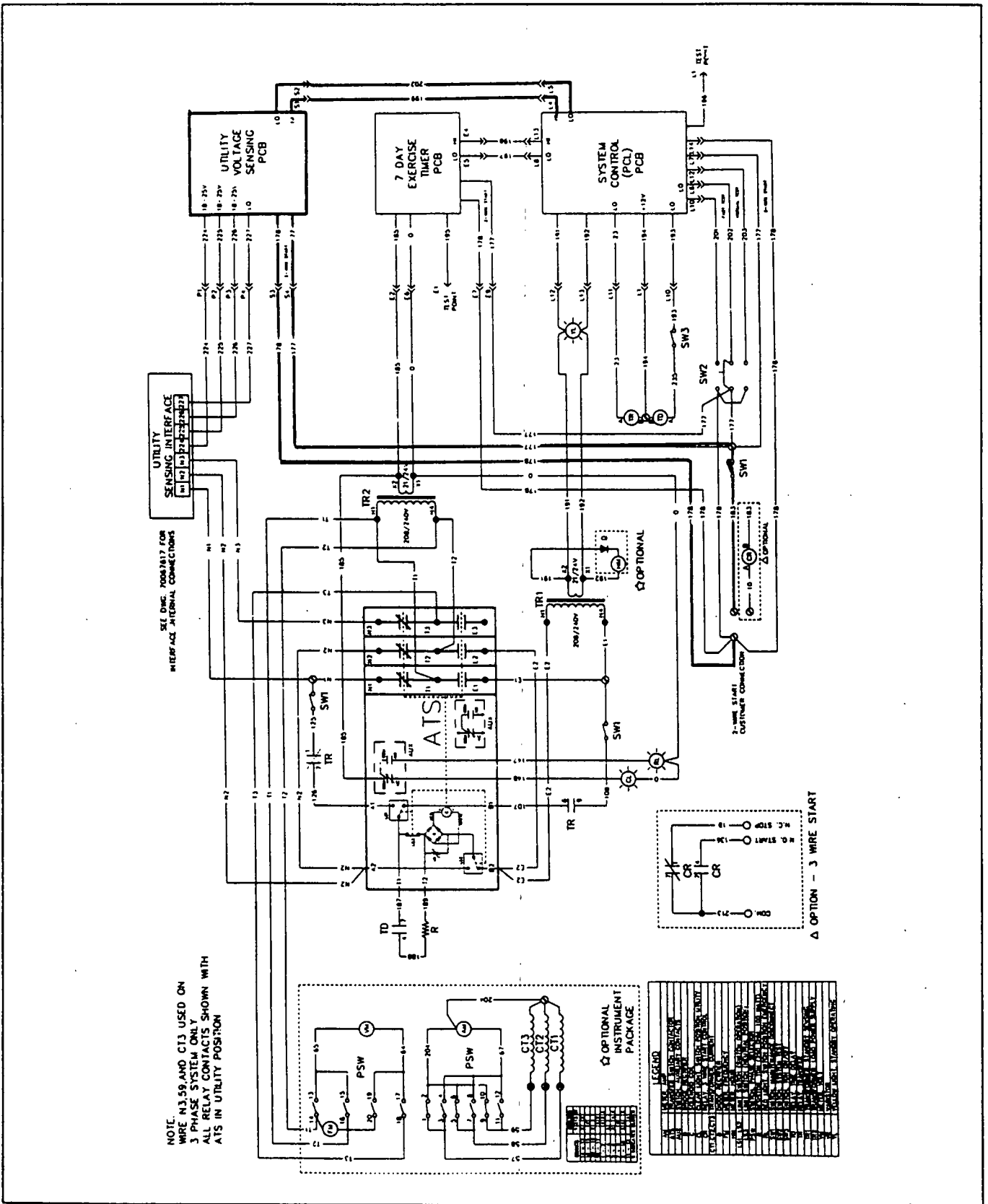


Figure 3. Circuit Condition- Utility Power Source Dropout

Circuit Condition- Standby Generator Running

1. Standby generator AC output is delivered to transfer mechanism terminal lugs E1/E2/E3 via customer supplied conductors.
2. From terminals E1/E2/E3, generator AC output is delivered to the primary winding of step-down transformer TR1. A reduced voltage is induced into the transformer's secondary coil, at about a 10 to 1 ratio. Secondary coil output is then delivered to (a) a "Standby Operating" lamp, and to (b) the system control (logic) circuit board.
 - a. The "Standby Operating" lamp turns on.
 - b. The system control (logic) board turns on. A "minimum run timer" and an "engine warmup timer" on the logic board start timing. The circuit board delivers a 12 volts DC output to the transfer relay (TR) coil, via Wire 194 and back to the circuit board via Wire 23. However, circuit board action holds the Wire 23 circuit open and the transfer relay (TR) is de-energized.
 - c. If so equipped, the DC output from the circuit board is delivered to the actuating coil of a time delay relay (TD) and back to the circuit board via Wire 193. However, circuit board action holds the time delay relay de-energized at this time.
3. Standby source power is available to transfer mechanism terminal B2 and to the normally-open contacts of the transfer relay (TR). However, TR is de-energized and the circuit is held open.

Circuit Condition- Transfer to Standby

When an "engine warmup timer" on the system control (logic) board has timed out, and when standby frequency and voltage have reached the settings of a "standby frequency sensor" and a "standby voltage sensor" on that board, circuit board action will complete the Wires 23 and 193 circuits to ground. The transfer relay will energize and (if so equipped) a time delay relay will also energize.

1. The transfer relay's normally-open contacts close to deliver standby power to transfer mechanism terminals B1 and B2.

2. From the B1/B2 terminals standby power is delivered to a bridge rectifier and to the solenoid coil (C). The solenoid coil energizes to actuate the main contacts to their "Neutral" position.

3. **Units without Time Delay Neutral:** As the main contacts reach "Neutral", limit switch LS3 opens. On units without the time delay neutral feature, the main contacts will then complete their movement to the standby power source side.

Units with Time Delay Neutral: Limit switch LS3 is bypassed by the time delay circuit which consists of the time delay relay (TD), a resistor (R), and Wires 187 and 189. The solenoid coil (C) will then remain energized as long as the time delay relay (TD) remains energized. When TD is de-energized by system control board action, solenoid coil (C) will de-energize and main contacts will complete their movement to the standby side.

Circuit Condition- Utility Source Voltage Restored

On restoration of utility source voltage, that source voltage is delivered to the utility sensing interface via terminals and wires N1, N2, N3. Reduced utility sensing interface voltage is then available to the utility voltage sensor circuit board via Wires 224-227.

If the utility voltage is above the setting of a "voltage pickup sensor" on the utility voltage sensor board, circuit board action will close the Wires 199/202 circuit. Closure of the 199/202 circuit will signal the system control (logic) board that utility voltage is now restored. A "return to utility timer" on the system control board then starts timing. When the timer has timed out, retransfer back to the utility source will be initiated.

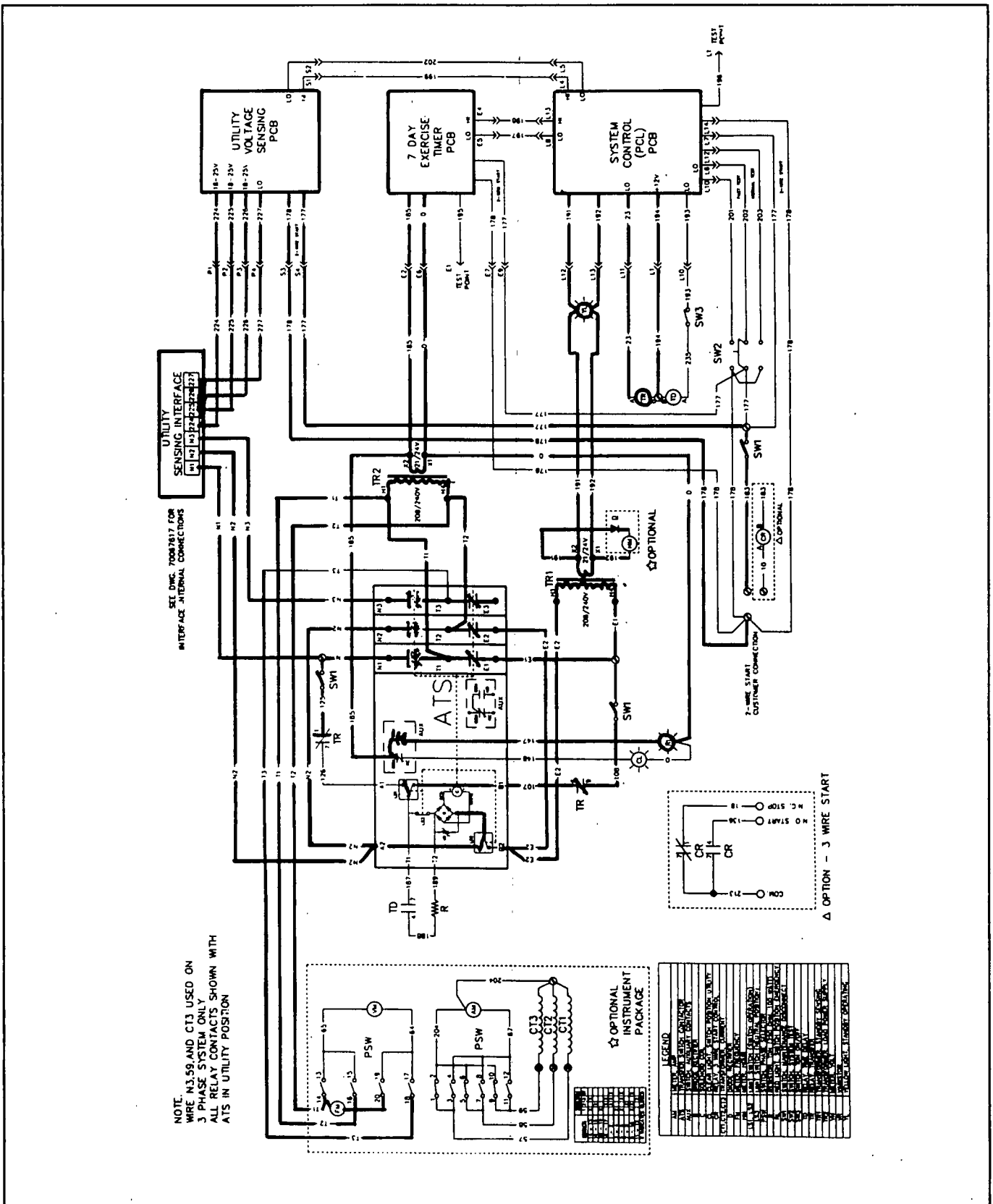


Figure 6. Circuit Condition- Utility Source Voltage Restored

Circuit Condition- Retransfer to Utility

When the system control (logic) board's "return to utility timer" has timed out, circuit board action opens the Wire 23 circuit. The transfer relay (TR) de-energizes. Circuit board action also closes the Wire 193 circuit and time delay relay (TD) energizes. If so equipped, a "time delay neutral timer" on the circuit board starts timing. The following actions then occur:

1. Utility source voltage is delivered to transfer mechanism terminals A1/A2 and to the solenoid coil (C).
2. Solenoid coil (C) energizes to actuate the main contacts to their "Neutral" position.
3. When the main contacts reach "Neutral", limit switch LS3 opens. On units without the time delay neutral feature, solenoid coil (C) will then de-energize and spring force will complete the main contacts movement back to the utility side.
4. On units with the time delay neutral feature, solenoid coil (C) will remain energized as long as the time delay relay (TD) stays energized. Main contacts will remain at "Neutral" as long as the solenoid coil (C) is energized.
5. Following retransfer, an "engine cooldown timer" on the system control (logic) board will start timing. When that timer has timed out, circuit board action will open the 178/183 circuit and the generator will shut down.

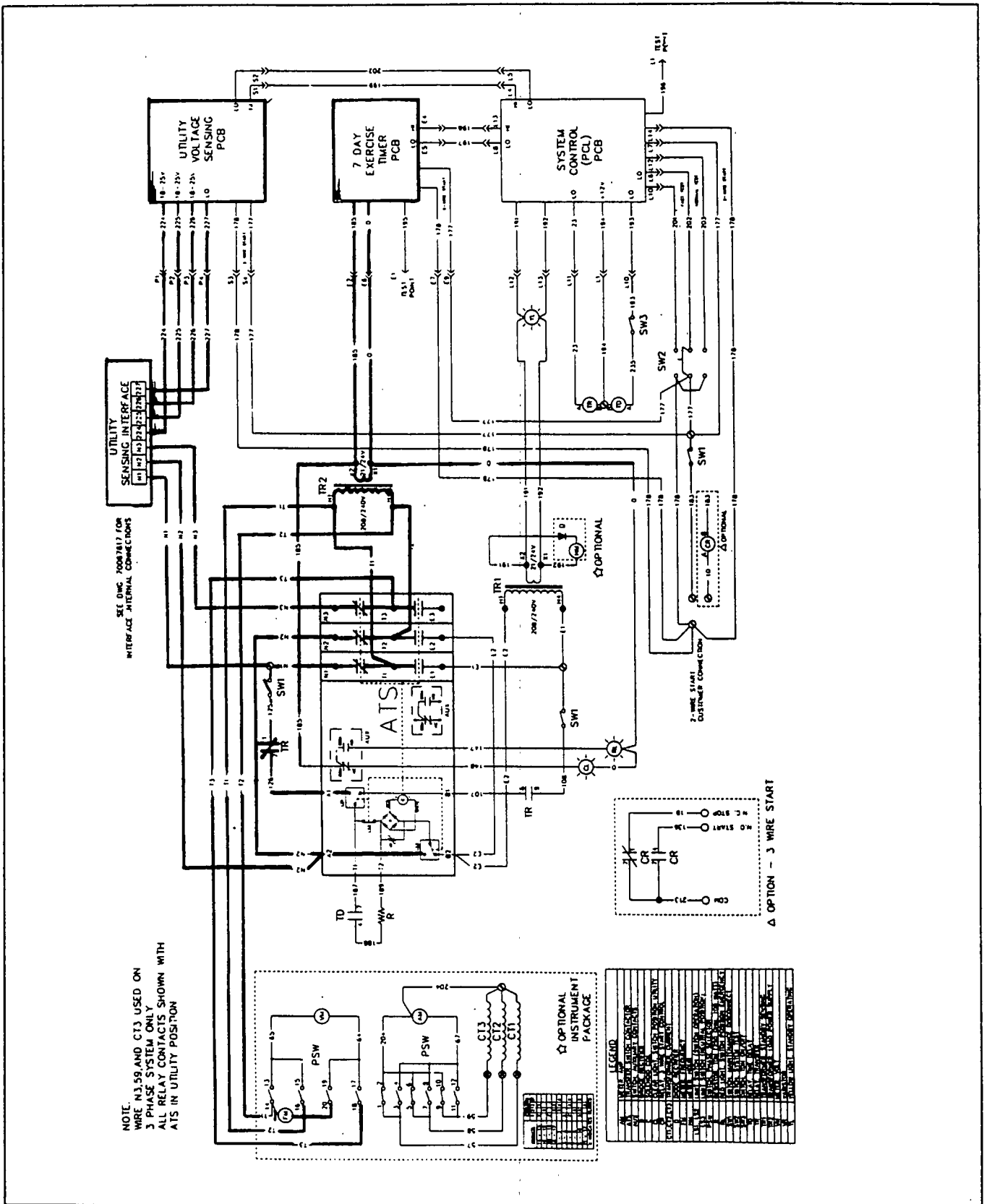


Figure 7. Circuit Condition- Retransfer to Utility

Section 8.8 MULTI-VOLTAGE TRANSFER SWITCHES

General

Standard "Y-Type" transfer switches must be installed and used in conjunction with power source voltages that are compatible with the rated voltage and phase of the specific transfer switch and as stated on the transfer switch data plate.

Use of a multi-voltage type transfer switch allows greater flexibility since it permits several different voltage/phase selections to be made by the installer. Thus, a single transfer switch may be installed in any one of several applications having different power source voltages.

Voltage selections are made by means of a "multi-voltage interface panel" and a "voltage selector switch" on the utility voltage sensor circuit board. **VOLTAGE SELECTIONS ON THE INTERFACE PANEL MUST MATCH THE RATED UTILITY POWER SOURCE PHASE AND VOLTAGE.**

Voltage Selections

See Figure 1. The multi-voltage interface panel shown permits the installer to match the transfer switch phase and voltage to the utility power source phase and voltage. Simply plug the interface connector into the interface panel receptacle identified with the correct phase and voltage. Then, set the selector switch on the utility voltage sensor circuit board to match the interface voltage and phase.

Using 3-Pole Transfer Mechanisms in 1-Phase Applications

A special procedure may be required when connecting a 1-phase power source to a 3-pole transfer mechanism (in multi-voltage applications). The procedure used will vary depending on whether the neutral block is to be used or whether the 1-phase neutral line will be switched.

If the Neutral Block Is to Be Used: When utility, standby and load "Neutral" lines are to be connected to the transfer switch neutral block ("Neutral" is not to be switched), connect lines as follows:

1. Connect utility hot line 1 to terminal lug N1; utility hot line 2 to terminal lug N3. Connect the utility service neutral line to the neutral block.
2. Connect generator line E1 to terminal lug E1; generator line E3 to terminal lug E3. Connect the generator neutral line (00) to the neutral block.
3. Connect the load hot lines 1 and 2 to terminal lugs T1 and T3, respectively. Connect the load neutral line to the transfer switch terminal block.

This concludes 1-phase connections where the "Neutral" block is to be used, i.e., "Neutral" will NOT be switched during transfer.

If the 1-Phase Neutral Line Will Be Switched: If a 3-pole transfer switch is to be used in a 1-phase system and it is desirable to switch the "Neutral" during a transfer action, comply with the following instructions:

1. Disconnect Wire N2 from terminal lug N2 of the transfer mechanism and from terminal A2 of the transfer mechanism terminal strip. Completely remove the disconnected Wire N2.

CAUTION: Wire N2 that must be removed is a factory installed wire that is usually routed from transfer mechanism terminal N2 to terminal A2 of the transfer mechanism terminal strip. If Wire N2 is not removed, the switched "Neutral" line will be connected to hot line E3 in the multi-voltage interface panel. This will result in serious problems and possible damage to the system.

2. Connect utility power source line 1 to transfer mechanism terminal N1. Connect utility line 2 to transfer mechanism terminal lug N3. Connect the utility source "Neutral" line to transfer mechanism terminal lug N2.
3. Connect generator line E1 to transfer mechanism terminal lug E1. Connect 1-phase generator lead E3 to terminal lug E3. Connect the generator "Neutral" line to transfer mechanism terminal lug E2.
4. Connect load line 1 to transfer mechanism terminal lug T1; load line 2 to terminal lug T3. Connect the load "Neutral" line to terminal lug T2.

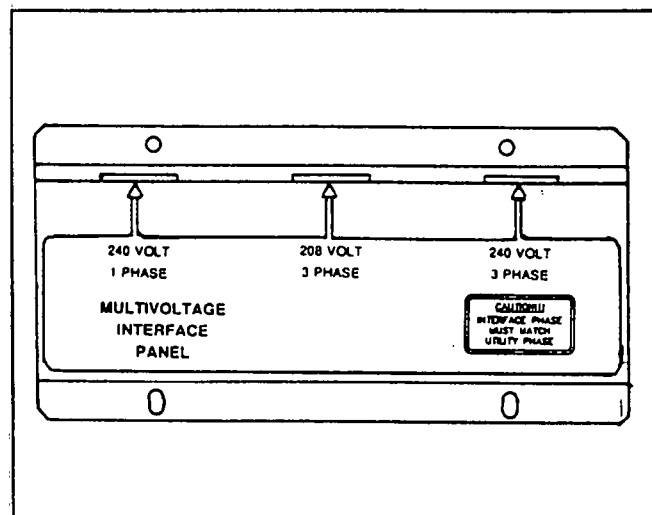


Figure 1. Multi-Voltage Interface Panel (Typical)

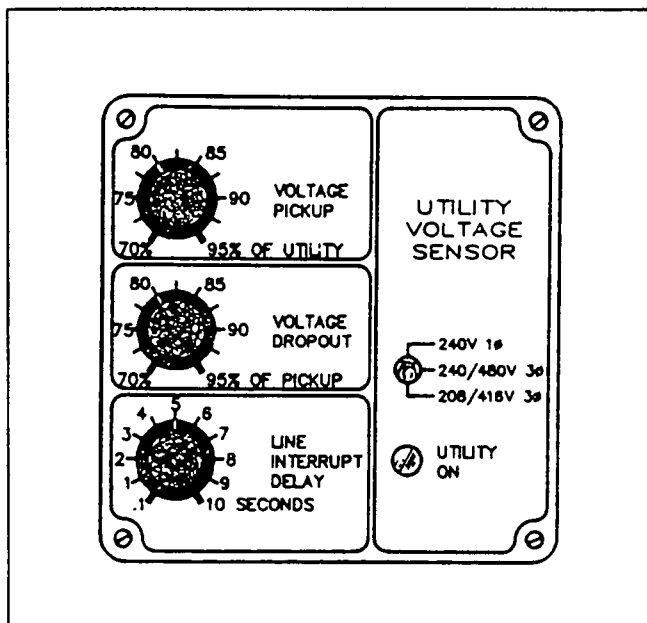


Figure 2. Utility Voltage Sensor Board

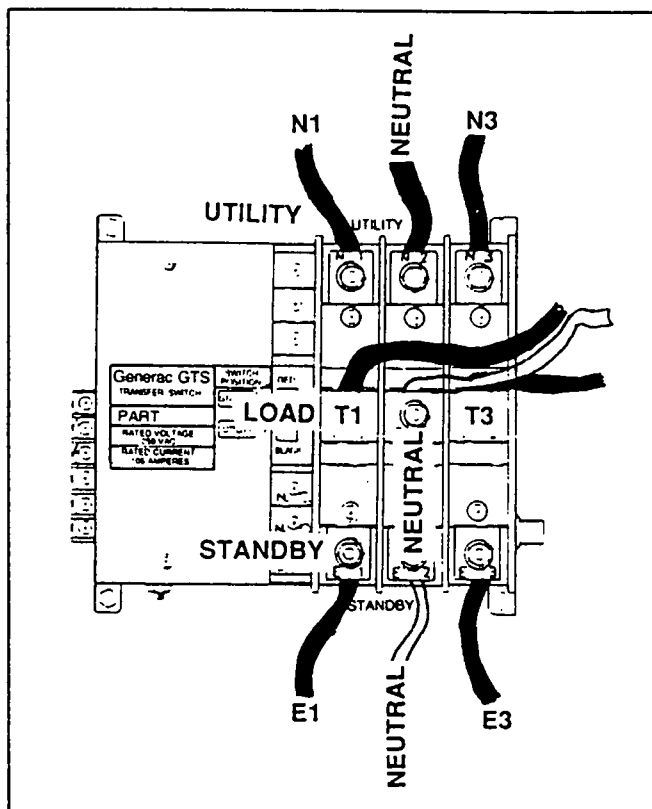


Figure 4. 1-Phase Connections if Neutral is to be Switched

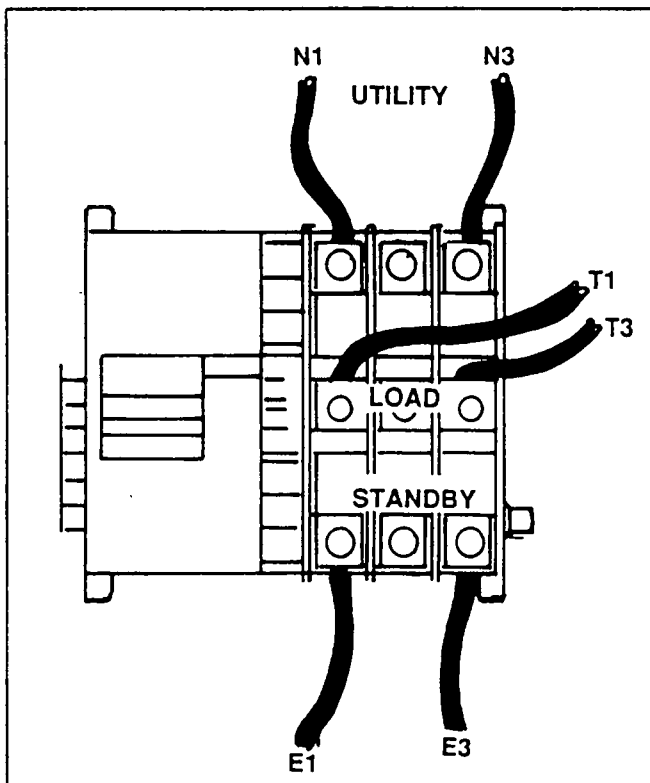


Figure 3. 1-Phase Connections if Neutral will Not be Switched

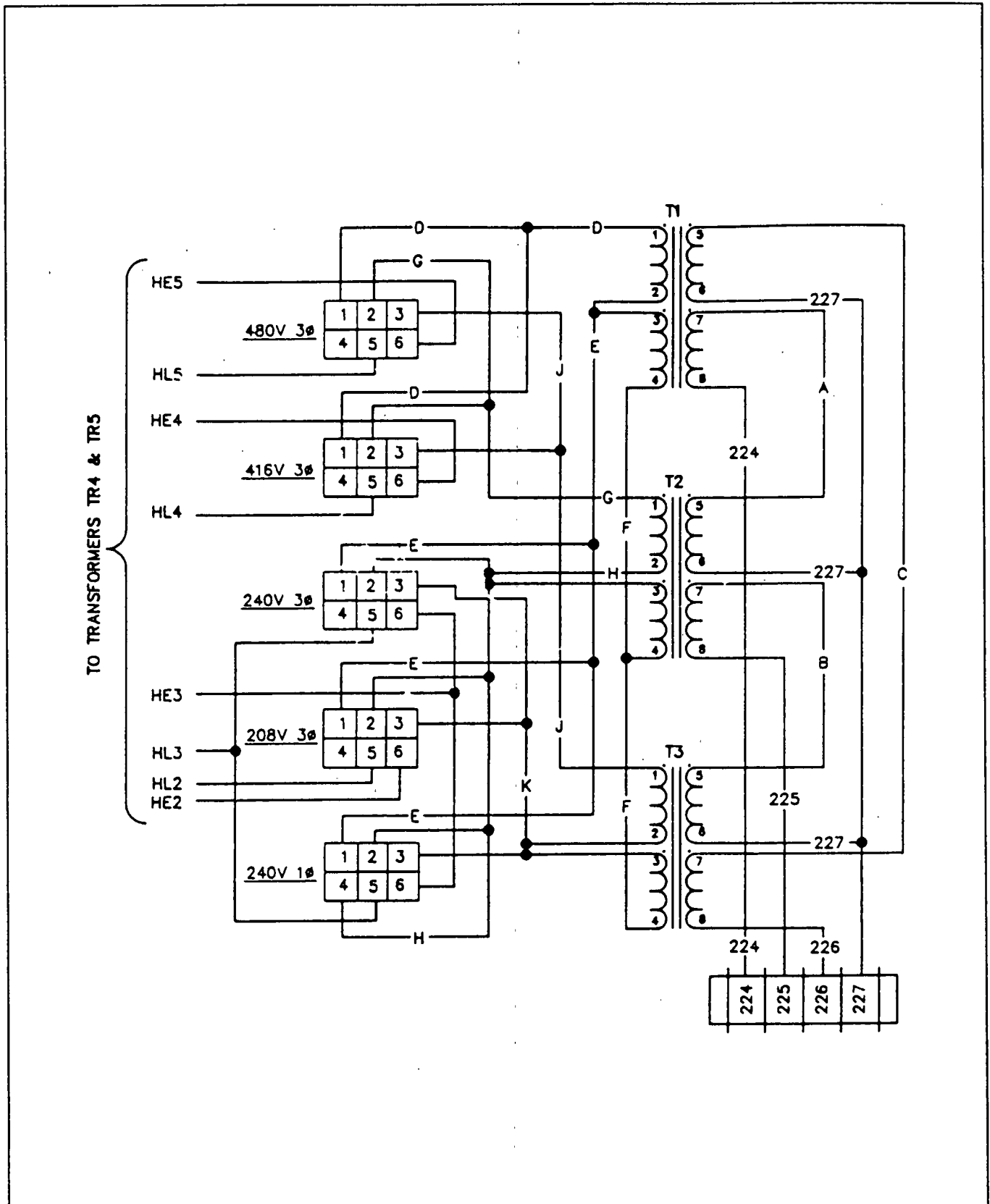


Figure 5. Schematic Diagram- Typical Multi-Voltage Interface Panel

Section 8.9 TROUBLESHOOTING FLOW CHARTS

Introduction

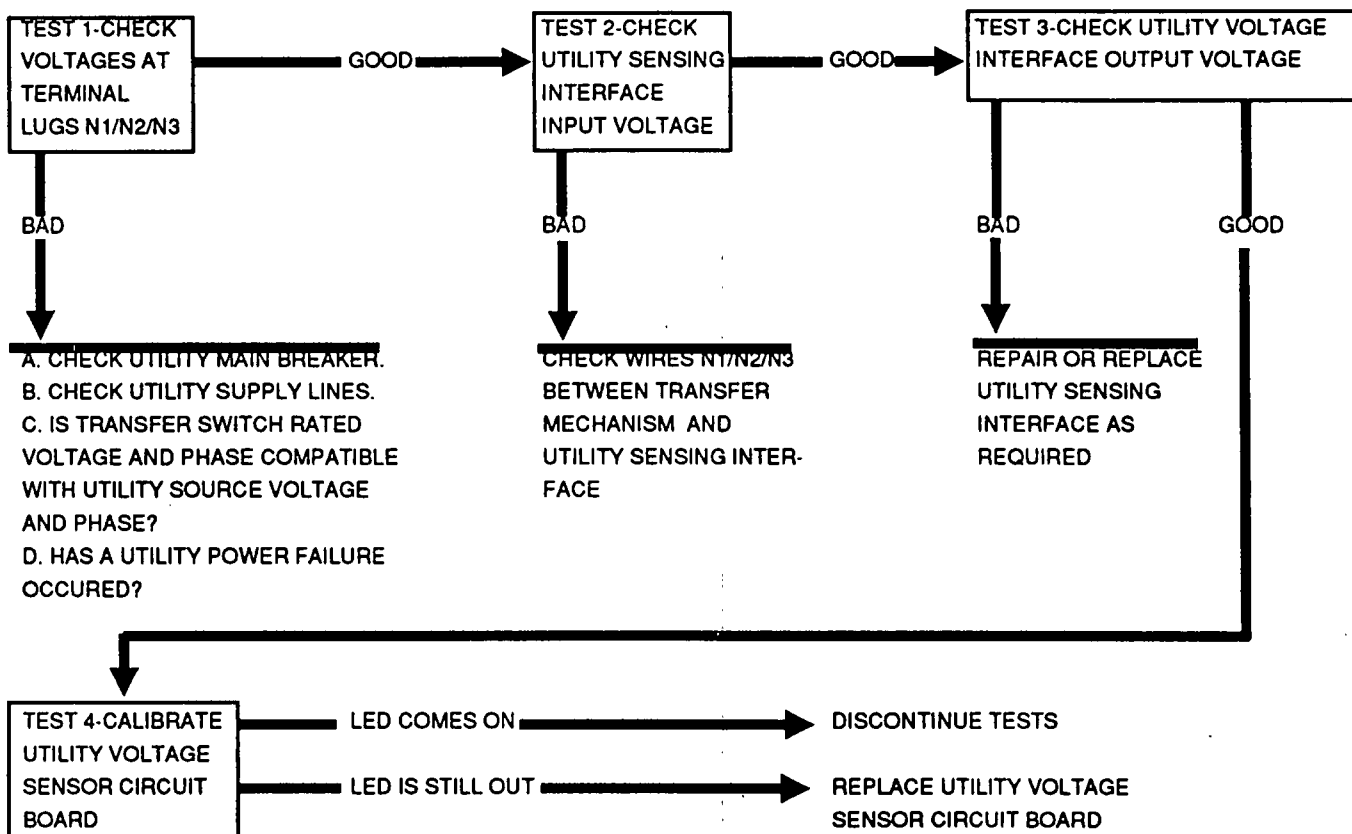
The "Flow Charts" in this section are sequenced in logical order. To use the flow charts, first identify the specific problem you have encountered. Once that is done, locate the description of that problem on the following pages. Then, accomplish each test under that problem in the exact order the tests are presented.

DANGER: USE EXTREME CARE WHEN PERFORMING TESTS ON THE TRANSFER SWITCH. SOME TESTS MAY BE PERFORMED WHILE HIGH AND DANGEROUS VOLTAGES ARE PRESENT AT TRANSFER SWITCH TERMINALS. CONTACT WITH LIVE TERMINALS WILL RESULT IN EXTREMELY DANGEROUS AND POSSIBLY LETHAL ELECTRICAL SHOCK. BE ALERT AT ALL TIMES. IF A TEST CAN BE PERFORMED WITH POWER VOLTAGE SUPPLIES TURNED OFF, THEN TURN VOLTAGE SUPPLIES OFF BEFORE PERFORMING THE TEST.

Problem 1- Circuit Board "Utility On" Lamp Does Not Turn On

The "Utility On" lamp (LED) is located on the utility voltage sensor circuit board. Following installation, the LED should illuminate within 10 seconds after the utility power supply to the transfer switch is turned on. A "lamp out" condition generally means that (a) utility sensing voltage is not available to the circuit board, or (b) utility sensing voltage is below the setting of a "voltage dropout sensor" on the circuit board. When the maintenance disconnect switch is set to "Automatic", a "lamp out" condition will usually result in generator startup and transfer of loads to the "Standby" power supply. However, if the maintenance disconnect switch is set to "Manual", the system will take no action.

NOTE: Early production utility voltage sensor boards were "phase sensitive". These early production boards had a green "Utility On" lamp. Later production boards have a red lamp and are NOT phase sensitive.



Problem 2- Loss of Timing on 7-Day Exercise (or CPU) Circuit Board

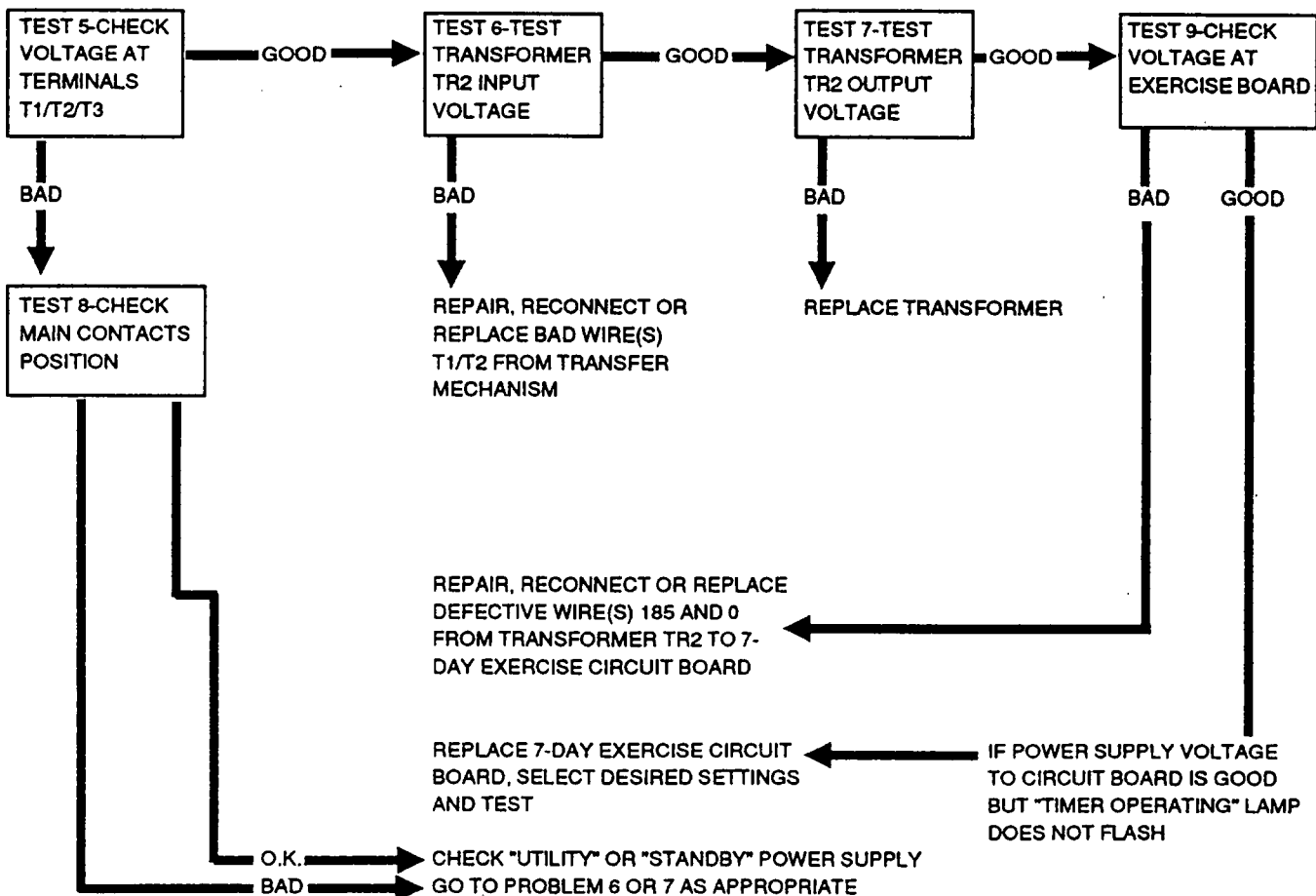
The 7-day exercise circuit board is operated by transformer reduced voltage from the transfer switch load terminals. Load terminal voltage is delivered to the primary winding of step-down transformer TR2. A reduced voltage is then induced into the transformer's secondary winding, at a 10-to-1 ratio. Transformer secondary winding output is delivered to the 7-day exercise board via Wires 185 and 0.

When the 7-day exercise board's timer is operating, a "timer operating" lamp on the circuit board should be flashing. Loss of power to the board or a timer failure will cause the LED to stop flashing.

During any transfer action, the load terminals will be disconnected from a power source while the transfer mechanism's main contacts are at "Neutral", i.e., load disconnected from both power supplies. During this brief period, the "Timer Operating" lamp will stop flashing and a 9 volts transistor battery will prevent the pre-set exercise time and day from becoming "scrambled". The standard 7-day exercise board will lose the amount of timing count that power is disconnected and, if power is lost indefinitely, the battery will eventually discharge. The exercise time and day will then become scrambled.

NOTE: The optional DELUXE EXERCISE BOARD also uses a 9 volts battery to prevent the preset time and day of exercise from becoming "scrambled". Timing count on this board will also be lost during the time the main contacts are at "Neutral". However, on restoration of the board's power supply, the deluxe board will automatically reset itself to the proper time.

If the "Timer Operating" lamp on the exercise circuit board is not flashing, troubleshoot the system as follows:

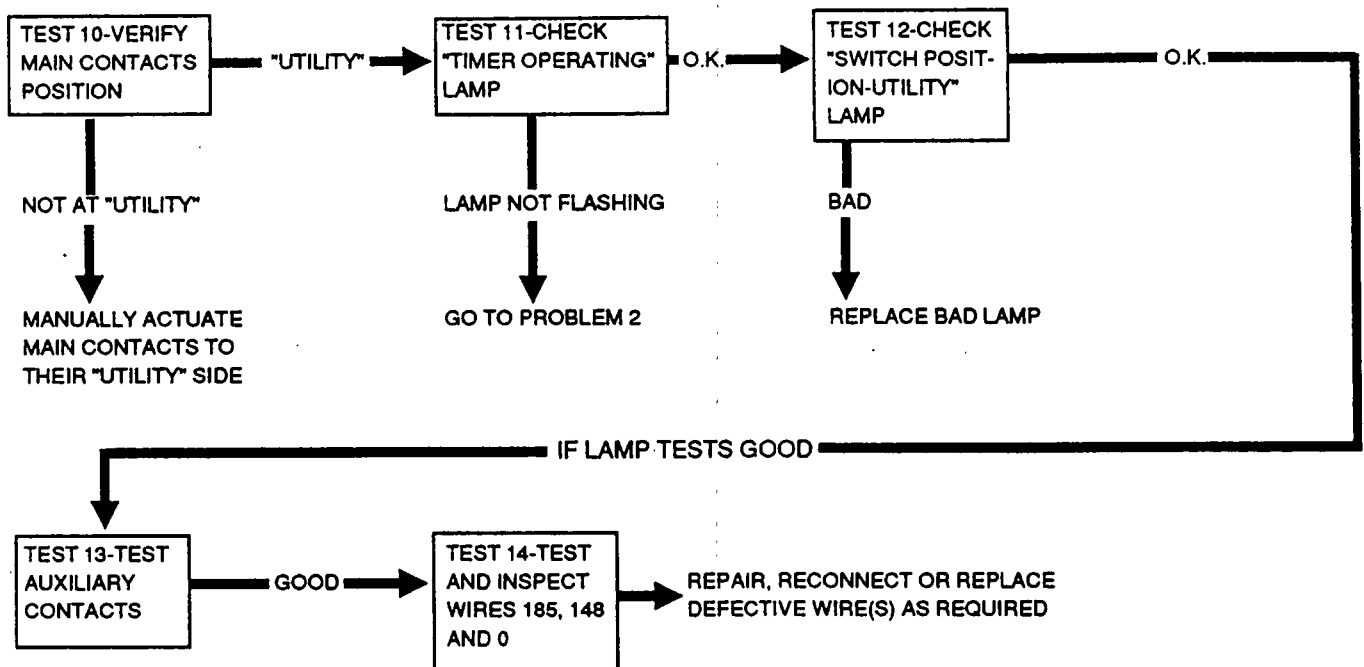


Problem 3- "Switch Position Utility" Lamp Does Not Come On

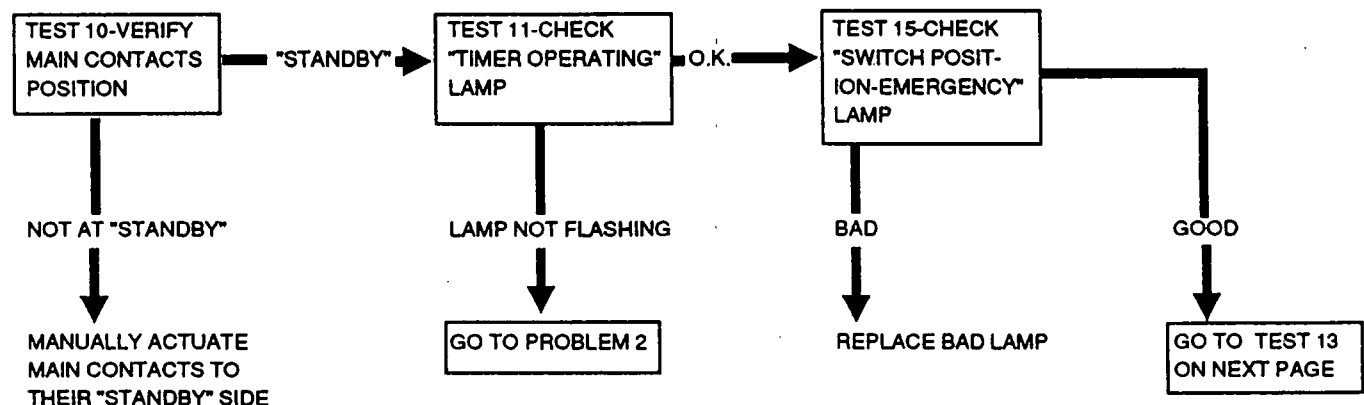
Following installation and before placing the system into service, the installer should verify that the transfer mechanism main contacts have been actuated to their "Utility" position (load connected to the utility power source side). Similarly, before the system is set for normal automatic operation, the operator should verify that the main contacts are at their "Utility" position. When the main contacts have been actuated to their "Utility" power source side and the "Utility" power supply to the transfer switch has been turned on, a "Switch Position-Utility" lamp on the switch enclosure door should illuminate.

The same transformer reduced voltage that operates the 7-day exercise board is used to operate the "Switch Position-Utility" lamp. That voltage is delivered to the lamp via a set of auxiliary contacts only when the main contacts have been actuated to their "Utility" power source side.

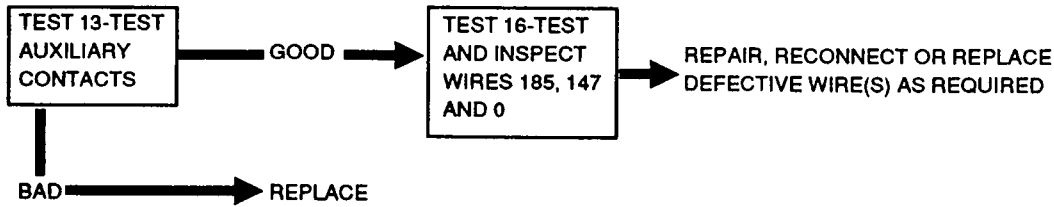
If the main contacts have been positioned to their "Utility" side, "Utility" power to the transfer switch is turned on, and the "Switch Position-Utility" lamp does not turn on, test the system as follows:



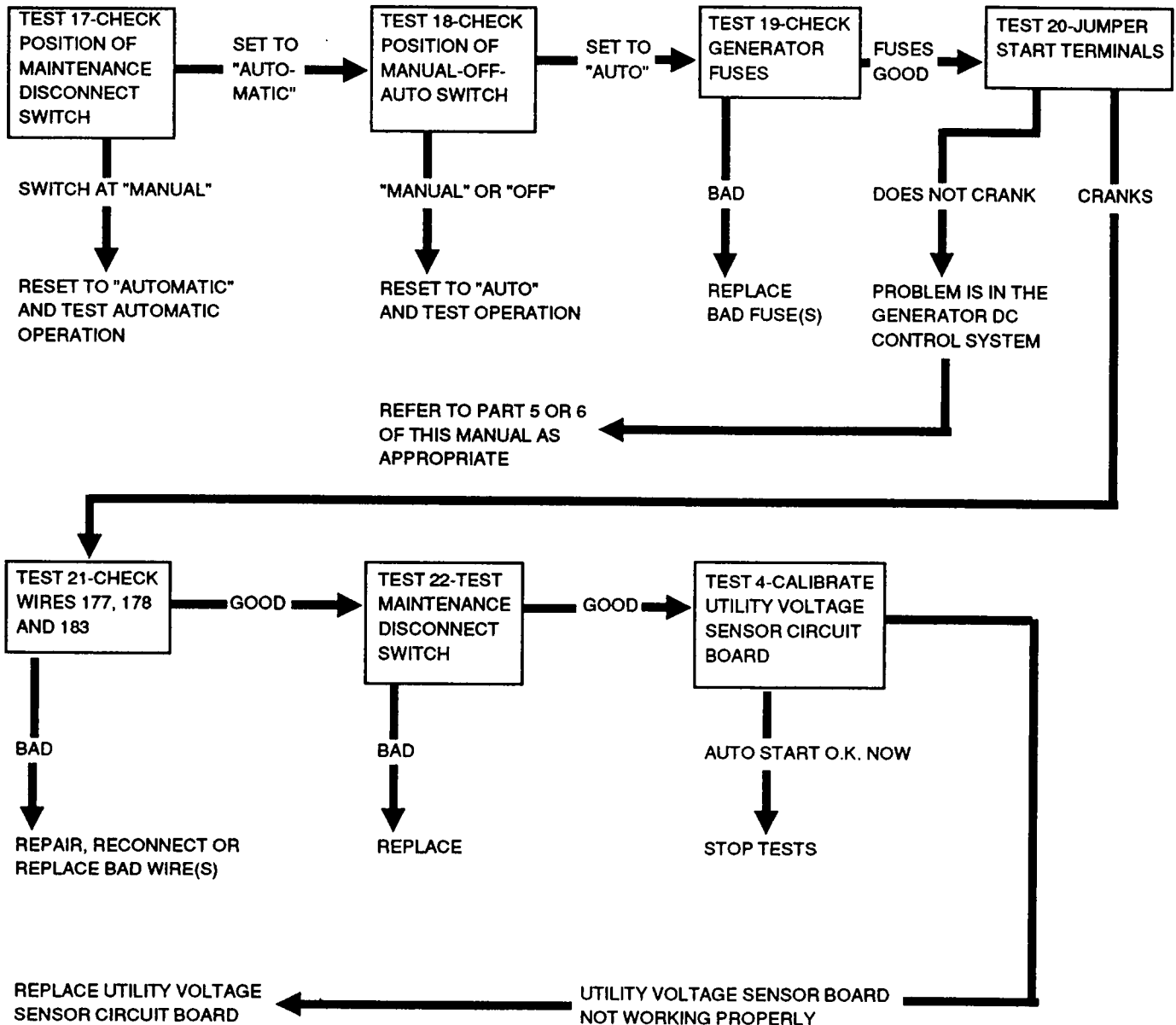
Problem 4- "Switch Position-Emergency" Lamp Does Not Come On



Problem 4- "Switch Position-Emergency" Lamp Does Not Come On (Continued)



Problem 5- Generator Engine Does Not Crank in Automatic Mode

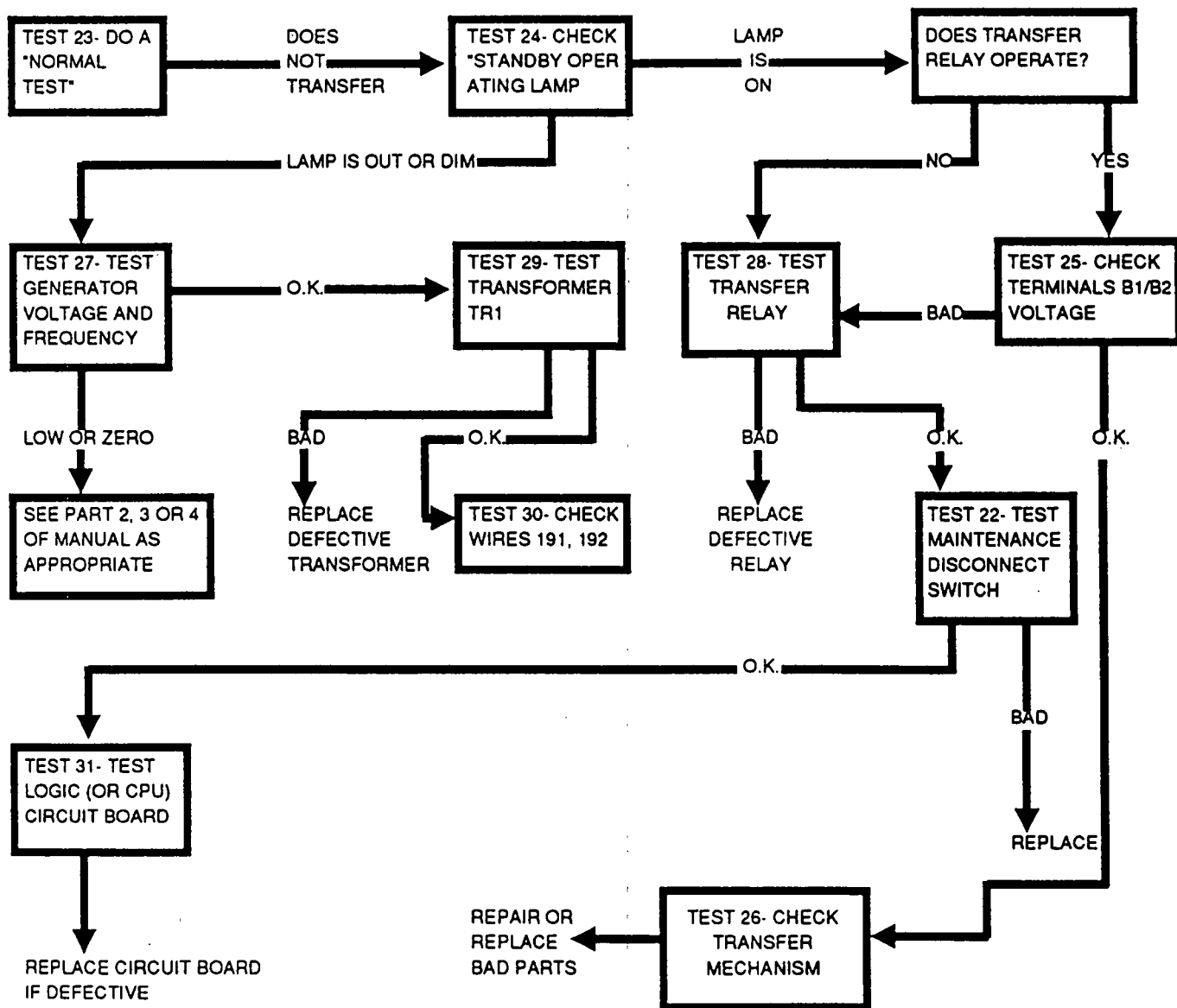


NOTE: If engine does not crank in automatic mode, try testing the system as outlined in Part 5, "Options A and B Control Consoles"; or in Part 6, "Option C Control Consoles".

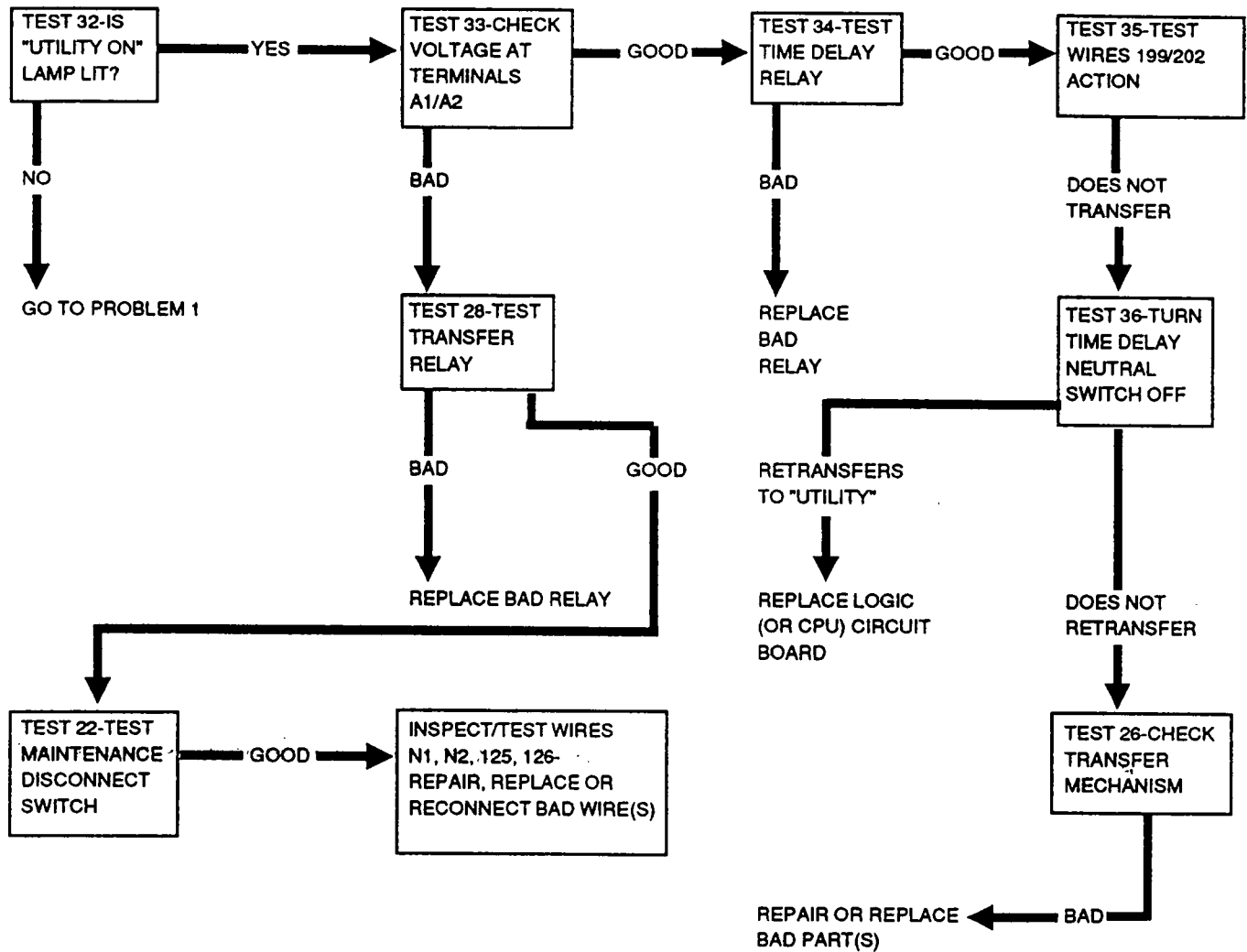
Problem 6- No Transfer to "Standby" in Automatic Mode

During operation in automatic mode, the utility voltage sensor board monitors transformer reduced "Utility" power source voltage. Should that source voltage drop below the setting of a "voltage dropout sensor" on the circuit board, closure of the 2-wire start circuit (178/183) will occur. On closure of that circuit, the generator's DC control/latch-crank board initiates engine cranking and startup. At the same time, the utility voltage sensor board opens a Wire 199/202 circuit between itself and the system control (Logic) board. With the generator running, transformer reduced "Standby" source voltage is delivered to the system control board and to a "Standby Operating" lamp on the transfer switch enclosure door. An "engine warmup timer" on the system control board starts timing. When that timer has timed out and if "Standby" source voltage and frequency have reached the settings of voltage and frequency sensors on the system control board, the system control board will complete a Wire 23 circuit to ground. A transfer relay will then energize and, on closure of the relay's normally-open contacts, power will be delivered to transfer mechanism terminals B1/B2. The transfer mechanism's solenoid coil should then energize and transfer to "Standby" should occur.

If the generator engine starts normally in automatic mode, but transfer to "Standby" does not occur, troubleshoot the system as follows:



Problem 7- In Automatic Mode, No Retransfer Back to "Utility"



Section 8.10
DIAGNOSTIC TESTS

Introduction

Use the "Diagnostic Tests" in conjunction with the "Troubleshooting Flow Charts" of Section 8.9. Test numbers in this section correspond to the numbered tests in the "Flow Charts".

To find the cause of a problem, first define the problem. Then, locate the defined problem in Section 8.9. Perform the tests under that problem in the exact order indicated by the flow chart.

**Test 1- Check Voltages at Terminals
N1/N2/N3**

DISCUSSION:

Utility power source voltage must be available to terminal lugs N1 and N2 (2-pole units) or N1, N2 and N3 (3-pole units). In addition, the applied voltage must be compatible with the rated voltage and phase of the transfer switch. If correct rated voltage is not available to the transfer switch, the following will result:

- The "Switch Position-Utility" lamp on the transfer switch enclosure door will not turn on.
- The "Utility On" lamp (LED) on the utility voltage sensor circuit board will not illuminate.
- If the utility voltage is lower than the setting of the utility voltage sensor board's "voltage dropout sensor", generator startup and transfer to the standby power source will occur.
- Retransfer back to the utility power supply will not occur.

DANGER: THE POWER VOLTAGES DELIVERED TO TRANSFER MECHANISM TERMINALS N1/N2/N3 IS EXTREMELY HIGH AND DANGEROUS. CONTACT WITH POWER VOLTAGE TERMINALS WILL RESULT IN EXTREMELY HAZARDOUS AND POSSIBLY DEADLY ELECTRICAL SHOCK.

PROCEDURE:

1. Turn on the utility power supply to the transfer switch using whatever means available (such as the utility power source main line circuit breaker).
2. Use an AC voltmeter to check the line-to-line and line-to-neutral voltages applied to terminal lugs N1, N2, N3 and the neutral block in the transfer switch. The meter must indicate correct rated voltage and must be compatible with transfer switch rated voltage.

RESULTS:

1. If utility supply voltage is not available, check the utility main line circuit breaker. Also make sure that a utility power source outage has not occurred.
2. If the utility voltage supply to transfer mechanism terminal lugs is good, go on to Test 2.

**Test 2- Check Utility Sensing Interface
Input Voltage**

DISCUSSION:

Utility power source voltage is not delivered directly to the utility voltage sensor board. Instead, utility source voltage is delivered to a utility voltage sensing interface. Transformers in the interface reduce the voltage. It is this reduced voltage that is delivered to the utility voltage sensor circuit board.

PROCEDURE:

Use an AC voltmeter to measure the utility source voltage across terminals N1, N2 and N3 of the utility voltage sensing interface. Correct rated utility source voltage (line-to-line) should be indicated.

RESULTS:

1. If voltage readings are good, go on to Test 3.
2. If voltage readings are bad but readings in Test 1 were good, inspect and test Wires N1/N2/N3 (between the transfer mechanism and the utility sensing interface). Repair, reconnect or replace any bad wire(s).

**Test 3- Check Utility Voltage Interface
Output Voltage**

DISCUSSION:

The utility voltage sensing interface will reduce the utility source voltage at a fixed ratio. This test, in conjunction with Test 2, will indicate whether a fault exists in the utility sensing interface.

PROCEDURE:

Use an AC voltmeter to test for correct interface output voltage across interface terminals 224 through 227. Test connections and acceptable interface output voltages are listed in the following chart.

Test 3- Check Utility Voltage Interface Output Voltage (Continued)

TEST ACROSS TERMINALS	224-225	224-227
	225-226	225-227
	224-226	226-227
LINE-TO-LINE RATED VOLTS	OUTPUT VOLTS	
600 Volts AC	40-43 VAC	22.5-25 VAC
480 Volts AC	40-43 VAC	22.5-25 VAC
400 Volts AC	40-43 VAC	22.5-25 VAC
240 Volts AC	40-43 VAC	22.5-25 VAC
208 Volts AC	36.5-39 VAC	20.5-23 VAC

RESULTS:

1. If voltage readings in Test 3 are bad, but readings taken in Test 2 were good, replace the utility sensing interface.
2. If readings taken in both Test 2 and Test 3 were good, go on to Test 4.

Test 4- Calibrate Utility Voltage Sensor Circuit Board

DISCUSSION:

The utility sensing interface reduces utility source voltage at a fixed ratio. Thus, if utility voltage varies from the nominal, sensing voltage to the circuit board will also vary. For that reason, calibration of the circuit board to match system voltage may be required.

CAUTION: The installed transfer switch must be rated at a voltage and phase that is compatible with the utility and standby power supplies. DO NOT attempt to calibrate any utility voltage sensor board on a non-compatible unit in an attempt to make the unit compatible.

Once the circuit board has been properly calibrated, the voltage that was present during calibration establishes 100 percent utility voltage for "pickup" and "dropout" settings. Utility source voltage must be available to the transfer switch during calibration.

PROCEDURE:

1. In the transfer switch enclosure, set the maintenance disconnect switch to "Manual".

2. On the utility voltage sensor circuit board, locate Test Points "TP3" and "TP4" (Figure 1). Connect a jumper wire across these two test points.
3. Locate the small potentiometer "R10". Turn the potentiometer fully counterclockwise.
4. Now, turn the "R10" potentiometer SLOWLY clockwise until the "Utility On" lamp (LED) just turns on.
5. Remove the jumper wire from "TP3" and "TP4".
6. Reset the maintenance disconnect switch to "Automatic".

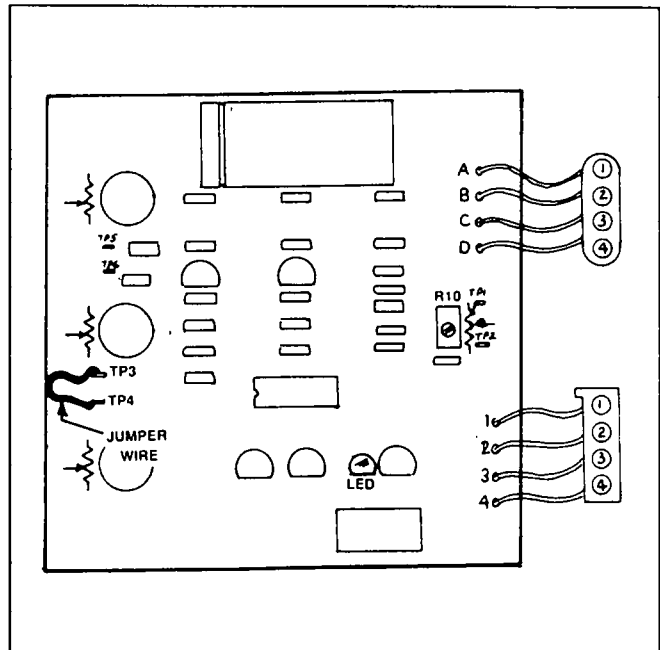


Figure 1. Utility Voltage Sensor Circuit Board

RESULTS:

1. If the "Utility On" lamp (LED) does NOT turn on as described under "Procedure", replace the utility voltage sensor board. Calibrate the new board and perform a "Normal Test" of the system.
2. If the "Utility On" lamp turns on, discontinue tests.

Test 5- Check Voltage at Terminals T1/T2/T3

DISCUSSION:

Terminals T1, T2 and T3 are the "load side" terminals of the transfer mechanism. Either "Utility" or "Standby" voltage is always available to the "Load" terminals, unless (a) the main contacts are at their "Neutral" position, or (b) one or both of the supply voltage sources has failed. If power is not available to the load terminals, the 7-day exercise timer will not function. In addition, neither of the "Switch Position" lamps on the switch enclosure door will operate.

Test 5- Check Voltage at Terminals T1/T2/T3 (Continued)

PROCEDURE:

Use an AC voltmeter to test for correct rated AC voltage across terminal lugs T1, T2 and T3 and across each terminal lug and the neutral block.

RESULTS:

1. If correct rated line-to-line and line-to-neutral AC voltages are indicated, go on to Test 6.
2. If correct rated voltages are not indicated, go on to Test 8.

Test 6- Test Transformer TR2 Input Voltage

DISCUSSION:

Transformer TR2 is the "load side" transformer. Its function is to reduce the Line 1 (T1) to Line 2 (T2) load voltage at a ratio of about 10 to 1. Thus, a line-to-line AC input voltage of 240 volts will be reduced to about 24 volts AC by transformer action. This transformer reduced voltage is delivered to the 7-day exercise circuit board for operation of the exercise timer. As long as the reduced voltage is available to the board and the timer is operating, a "Timer Operating" lamp on the board will flash.

PROCEDURE:

Use an AC voltmeter to test for correct rated line-to-line voltage across transformer TR2 terminals H1 and H4 (see Figure 2). Normal rated line to line load terminal voltage should be indicated.

RESULTS:

1. If normal rated line to line load voltage is not indicated, but normal volts was indicated in Test 5, inspect and test Wires T1 and T2 between the transformer and the transfer mechanism. Repair, reconnect or replace any defective wire(s) as required.
2. If normal rated line to line load voltage is indicated, go on to Test 7.

Test 7- Check Transformer TR2 Output Voltage

DISCUSSION:

In Test 6, input voltage to the primary winding of transformer TR2 was checked. To determine if the transformer is functioning properly, the output voltage from the transformer's secondary winding must be checked.

PROCEDURE:

Use an AC voltmeter to check the voltage across terminals X1 and X2 of transformer TR2. The indicated voltage should be about 21 volts AC for a 208 volts system; about 24 volts AC for a 240 volts system.

RESULTS:

1. If correct line to line voltage was indicated in Test 6, but correct step-down voltage was not indicated in Test 7, replace transformer TR2.
2. If the reduced voltage reading across transformer terminals X1 and X2 is correct, go on to Test 8.

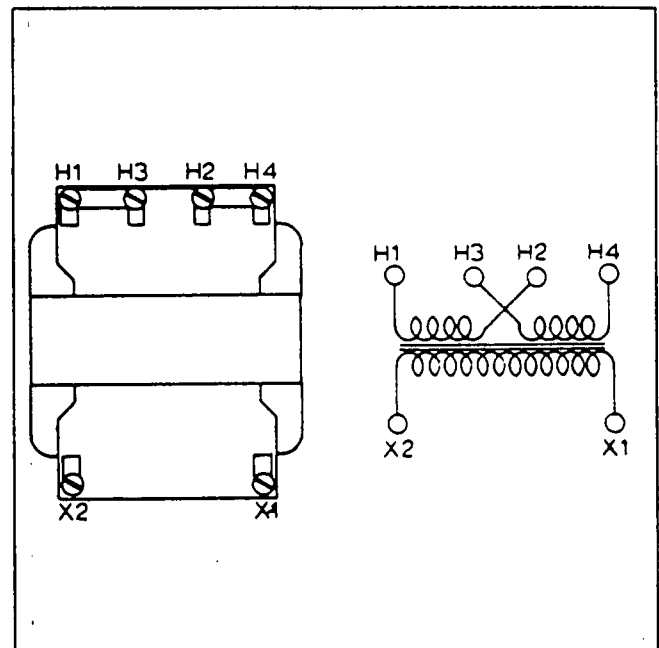


Figure 2. Transformer TR2 Test Points

Test 8- Check Main Contacts Position

DISCUSSION:

During operation in automatic (electrical) mode, the transfer mechanism main contacts will remain at "Neutral" as long as the solenoid coil remains energized. Normally, limit switch LS3 will be opened to de-energize the solenoid coil and allow spring force to complete the transfer action. On units with the "time delay at neutral" feature, a time delay relay will be de-energized by circuit board action to de-energize the solenoid coil.

While the main contacts are at "Neutral", the load terminals (T1, T2, T3) are disconnected from both power sources and the 7-day exerciser circuit will not operate.

**Test 8- Check Main Contacts Position
(Continued)****PROCEDURE:**

1. Observe the "Switch Position" advisory lamps on the transfer switch enclosure door. Either the "Utility" or "Emergency" lamp should be on.
2. Visually observe the main contacts through the clear plastic cover on side of transfer mechanism. The switch position can be seen (Figure 3).

NOTE: The "Changeover Display" on front of transfer mechanism will indicate whether the main contacts are at "Utility" or "Standby". It does not provide a valid indication should the main contacts be held at "Neutral".

RESULTS:

1. If main contacts are at "Utility" and the "Switch Position-Utility" lamp is not on, check the "Utility" power supply to the transfer switch (Test 1).
2. If the main contacts are at "Standby" and the "Switch Position-Emergency" lamp is not on, check the "Standby" power supply to the transfer switch.

Test 9- Check Voltage at Exercise Board**DISCUSSION:**

You should have already determined that transformer TR2 output voltage is good. That voltage must be available to the 7-day exercise board, for operation of the exercise timer circuit. This test (Test 9) will determine (a) if an open or shorted condition exists between transformer TR2 and the exercise (or CPU) board, and (b) if the exercise (or CPU) board is defective.

You may wish to review Part 10, "The CPU Type Intelligence System" and/or Part 11, "The Logic Type Intelligence System".

PROCEDURE:

Units with System Control (Logic) Board: Locate Pins 2 and 6 of the 7-day exercise board's connector plug, to which Wires 185 and 0 connect. Use an AC voltmeter to check the voltage reading across these two pins and wires. The meter should read about 21 volts for a 208 volts system; about 24 volts for a 240 volts system.

Units with CPU Circuit Board: Locate Pins 14 and 15 of the CPU board connector, to which Wires 185 and 0 connect. Use an AC voltmeter to check the voltage across these two pins and wires. Readings should be about 21 volts for a 208 volts system; about 24 volts for a 240 volts system.

RESULTS:

1. If voltage reading is bad, repair, reconnect or replace Wires 185 or 0, between transformer TR2 and the circuit board.
2. If the voltage reading is good but the "Timer Operating" lamp (LED) on the circuit board does not flash, replace the 7-day exercise board. (Lamp on CPU board does not flash.)

Test 10- Verify Main Contacts Position**DISCUSSION:**

If the "Switch Position-Emergency" lamp on the transfer switch enclosure door does not come on, the first step in troubleshooting is to verify the position of the main contacts. That lamp will illuminate only if (a) the main contacts are at "Standby" and (b) if generator AC output power is available to the transfer switch.

PROCEDURE:

Refer to Test 8.

RESULTS:

1. If the main contacts are at "Standby" but lamp is not on, go to Test 11.
2. If the main contacts are NOT at "Standby", manually actuate them to the "Standby" position. Then, recheck the "Switch Position-Emergency" lamp.

Test 11- Check "Timer Operating" Lamp**DISCUSSION:**

The "Timer Operating" lamp on the 7-day exercise board is powered by the same voltage source that operates the two "Switch Position" lamps. If either of the "Switch Position" lamps do not turn on, a check of the "Timer Operating" lamp will indicate whether the required step-down voltage is available for lamp operation.

PROCEDURE:

Visually check the "Timer Operating" lamp (LED) on the circuit board. The lamp should be flashing.

RESULTS:

1. If the lamp is NOT flashing, go to Problem 2.
2. If the lamp IS flashing and the "Switch Position-Utility" lamp does not come on, go to Test 12.
3. If the lamp IS flashing and the "Switch Position-Emergency" lamp does not light, go to Test 15.

Test 12- Check "Switch Position-Utility" Lamp

DISCUSSION:

With "Utility" source power available to the transfer switch and the main contacts at their "Utility" position, the "Switch Position-Utility" lamp should be ON.

Test 10 verified the position of the main contacts. Test 11 verified that power is available to operate the "Timer Operating" lamp (LED) on the 7-day exercise board. You will now want to check the "Switch Position-Utility" lamp itself.

PROCEDURE:

1. Make sure the main contacts are at "Utility" and that "Utility" source power is available to the transfer switch.
2. Connect an AC voltmeter across the two terminals of the "Switch Position-Utility" lamp, inside the transfer switch enclosure door. The meter should read about 24 volts for 240 volts systems; or 21 volts for 208 volts systems.

RESULTS:

1. If the meter reads normal step-down voltage but the lamp is out, replace the lamp.
2. If voltage is not indicated, go to Test 13.

Test 13- Test Auxiliary Contacts

DISCUSSION:

Two sets of auxiliary contacts are provided on the transfer mechanism. See "Auxiliary Contacts" on Page 8.2-2. The contacts with terminals numbered 4, 5 and 6 are for customer use. Contacts numbered 1, 2 and 3 operate the "Switch Position" lamps on the transfer switch enclosure door. Thus, a defective auxiliary contacts switch can mean that the "Switch Position" lamp(s) will not turn on.

PROCEDURE:

Before attempting to test the auxiliary contacts, first turn OFF all power voltage supplies to the transfer switch. Then, test the auxiliary contacts as follows:

DANGER: DO NOT PROCEED UNTIL BOTH THE "UTILITY" AND "STANDBY" POWER SUPPLIES TO THE TRANSFER SWITCH HAVE BEEN TURNED OFF. FAILURE TO TURN OFF ALL POWER VOLTAGE SUPPLIES MAY RESULT IN DANGEROUS AND POSSIBLE FATAL ELECTRICAL SHOCK.

1. Turn OFF all power voltage supplies to the transfer switch, using whatever means provided (such as the "Utility" or "Standby" main line circuit breakers.

2. Use the manual transfer handle to actuate the main contacts to their "Standby" position, i.e., load connected to the "Standby" source. See Section 8.5 for manual operating instructions.

a. Set a VOM to its "Rx1" scale and zero the meter. Connect the VOM test leads across auxiliary contacts terminals 1 (common) and 3 (normally-open). Meter should read as indicated in chart below.

b. Now, connect the VOM test leads across auxiliary contacts terminals 1 (common) and 2 (normally-closed). The VOM should read as indicated in chart below.

3. Use the manual transfer handle to actuate the main contacts to their "Utility" position. See Section 8.5 for manual transfer procedures.

a. Connect the VOM test leads across terminal 1 (common) and 3 (normally-open). See chart below for correct reading.

b. Connect the VOM test leads across terminal 1 (common) and 2 (normally-closed). See chart for correct reading.

AUXILIARY CONTACTS TERMINALS	MAIN CONTACT POSITION	METER READING
1 and 3	Standby	Continuity
1 and 2	Standby	Infinity
1 and 3	Utility	Infinity
1 and 2	Utility	Continuity

RESULTS:

1. Replace auxiliary contacts, if bad.
2. If auxiliary contacts are good, go to Test 14.

Test 14- Test and Inspect Wires 185, 148 and 0

DISCUSSION:

An open condition in Wires 185, 148 or 0 will result in a failure of the "Switch Position-Utility" lamp to light.

PROCEDURE:

Refer to appropriate wiring diagram. Inspect and test Wires 185, 148 and 0 for an open, shorted or grounded condition.

RESULTS:

Repair, reconnect or replace defective wire(s) as necessary.

Test 15- Check "Switch Position-Emergency" Lamp**DISCUSSION:**

When the main contacts are at "Standby" and the generator is running, the "Switch Position-Emergency" lamp should be on. You should have already checked the "Timer Operating" lamp on the exercise board (Test 11) and that lamp should be flashing. This test (Test 15) will determine if the "Switch Position-Emergency" lamp is out.

PROCEDURE:

1. With the main contacts at "Standby" and with "Standby" power available to the transfer switch (generator running), use an AC voltmeter to check voltage across the two lamp terminals. Wires 147 and 0 connect to the two terminals.
2. The meter should read about 24 volts for a 240 volts system; about 21 volts for a 208 volts system.

RESULTS:

1. If meter indicates normal step-down voltage but lamp does not light, replace the lamp.
2. If normal step-down voltage is not available to the lamp, go on to Test 13.

Test 16- Test and Inspect Wires 185, 147 and 0**DISCUSSION:**

If any of these wires are open, shorted or grounded, the "Switch Position-Emergency" lamp will not function.

PROCEDURE:

Carefully inspect Wires 185, 147 and 0. Use a VOM to test wires for an open or grounded condition.

RESULTS:

Repair, reconnect or replace any defective wire(s).

Test 17- Check Position of Maintenance Disconnect Switch**DISCUSSION:**

On dropout of "Utility" source voltage below a preset level and if that source voltage remains at such a low level for a preset time, closure of the 2-wire start circuit should result. Closure of the 2-wire start circuit should also result during a "Normal Test". When the 2-wire start circuit closes, engine cranking and startup should occur. If the engine does not crank in automatic mode, perhaps the maintenance disconnect switch is set to "Manual". The switch must be at "Automatic" or cranking will not occur.

PROCEDURE:

Inside the transfer switch enclosure, check that the maintenance disconnect switch is set to "Automatic".

RESULTS:

1. If the switch is at "Automatic" but engine does not crank in automatic mode, go to Test 18.
2. If switch is at "Manual", reset it to "QAutomatic" then test automatic operation.

Test 18- Check Position of Auto-Manual-Off Switch**DISCUSSION:**

An auto-manual-off switch is located on the generator control console (if so equipped). The switch must be set to "Auto" position for normal automatic operations.

PROCEDURE:

On the generator control console, check that the auto-manual-off switch is set to "Auto" (if so equipped).

RESULTS:

1. If the switch is set to "Auto" but engine will not crank in automatic mode or during a "Normal Test", go to Test 19.
2. If the switch is set to "Manual" or "Off", reset it to "Auto". Then test automatic operation.

Test 19- Check Generator Fuses**DISCUSSION:**

A 30 amp fuse is mounted on the generator console. A 14 amp in-line fuse is located inside the control console housing. If either of these fuses has blown, neither automatic or manual engine cranking will be possible.

PROCEDURE:

Refer to Part 5 or 6 of this manual as appropriate.

RESULTS:

1. If both fuses are good but engine will not crank, go to Test 20.
2. Replace any blown fuse(s). Then, test automatic operation.

Test 20- Jumper Start Terminals**DISCUSSION:**

Automatic engine cranking normally begins when transfer switch circuit board action closes the 2-wire start circuit (Wires 178/183). This action can be simulated by using a jumper to physically close that circuit. If engine will not crank in automatic mode, this test will isolate the problem to either the generator or the transfer switch.

Test 20- Jumper Start Terminals (Continued)

PROCEDURE:

Test the system's 2-wire start capability as follows:

DANGER: THE GENERATOR ENGINE WILL CRANK AND START DURING THIS PROCEDURE. MAKE SURE ALL PERSONNEL ARE CLEAR OF THE GENERATOR BEFORE PERFORMING THIS TEST.

CAUTION: The generator must have been properly serviced and ready for use before this test is performed. Failure to properly prepare the engine-generator for use will result in damage to the unit.

1. On the generator console, set the auto-manual-off switch to "Auto".
2. On the transfer switch enclosure door, set the system test mode switch to "Automatic Mode".
3. In the transfer switch enclosure, set the maintenance disconnect switch to "Automatic".
4. In the transfer switch enclosure, locate the terminal strip with terminals 178 and 183 identified.
5. Connect a jumper wire across terminals 178 and 183. The engine should crank and start.
6. Disconnect the jumper wire. The engine should shut down.

RESULTS:

1. If the engine does not crank when the jumper wire is connected across terminals 178/183, the problem is in the generator's DC control system. Refer to Part 5 or 6 as appropriate.
2. If the engine cranks when the jumper wire is connected across terminals 178/183, but does not crank during normal automatic operation, go to Test 21.

Test 21- Check Wires 177, 178 and 183

DISCUSSION:

Refer to appropriate transfer switch wiring diagram. An open condition in the Wires 177/178/183 circuit will prevent closure of the 2-wire start circuit. If that circuit cannot close, automatic startup will not be possible.

PROCEDURE:

Inspect and test Wires 177, 178 and 183 for an open or grounded condition.

RESULTS:

1. Repair, reconnect or replace any defective wire(s).
2. If all wires are good, go to Test 22.

Test 22- Test Maintenance Disconnect Switch

DISCUSSION:

An internal failure in the maintenance disconnect switch can result in a permanently open condition in the 2-wire start circuit. Such an open condition will result in failure of the engine to crank in automatic mode.

PROCEDURE:

1. On the generator console, set the auto-manual-off switch to "Off" (if so equipped).
2. In the transfer switch enclosure, set the maintenance disconnect switch to "Manual".
3. Turn OFF all power voltage supplies to the transfer switch using whatever means provided (such as the "Utility" and "Standby" main line circuit breakers).
4. Disconnect all wires from the maintenance disconnect switch, to prevent interaction.
5. Use an ohmmeter to test the switch. The meter should read either "infinity" or "continuity" as listed in the chart below.

RESULTS:

1. Replace the maintenance disconnect switch, if defective.
2. If switch tests good but engine will not crank in automatic mode, go to Test 4.

SWITCH POSITION	METER TEST POINTS	READING	
"AUTOMATIC"	Terminals 1 and 2	Continuity	
	Terminals 2 and 3	Infinity	
	Terminals 4 and 5	Continuity	
	Terminals 5 and 6	Infinity	
	Terminals 7 and 8	Continuity	
	Terminals 8 and 9	Infinity	
	Terminals 10 and 11	Continuity	
	Terminals 11 and 12	Infinity	
	"MANUAL"	Terminals 1 and 2	Infinity
		Terminals 2 and 3	Continuity
Terminals 4 and 5		Infinity	
Terminals 5 and 6		Continuity	
Terminals 7 and 8		Infinity	
Terminals 8 and 9		Continuity	
Terminals 10 and 11		Infinity	
Terminals 11 and 12		Continuity	

Test 23- Do a "Normal Test"

DISCUSSION:

Performing a "Normal Test" simulates automatic operation. When the system test mode switch is set to "Normal Test", engine will crank and start followed by transfer to the "Standby" source, just as though an actual "Utility" source failure has occurred. Thus, if you

Test 23- Do a "Normal Test" (Continued)

wish to test normal automatic operation (including cranking, startup, running, transfer, etc.), the "Normal Test" method is a good way to do just that.

PROCEDURE:

Perform a "Normal Test" as outlined in Section 8.6, "Functional Tests". The generator engine should crank and start just as though a "Utility" power outage has occurred. On system control (Logic) type circuit boards, LED's can be monitored during the test. These LED's turn on to indicate that various timers are operating.

When the "Normal Test" is completed, reset the switch back to "Automatic Mode". Retransfer back to the "Utility" source and generator shutdown should occur as programmed.

NOTE: For a description of automatic operating sequences and times, see Part 10 ("The CPU Type Intelligence System") or Part 11 ("The Logic Type Intelligence System"). These sequences and times can be monitored by observing LED's on the CPU or system control (logic) board.

RESULTS:

1. If generator startup and transfer to standby occurs as programmed, system operation is good.
2. If the engine does not crank, go to Problem 5.
3. If the engine cranks and starts but no transfer to "Standby" occurs, go to Test 24.
4. If startup and transfer to "Standby" are normal, but when switch is reset to "Automatic Mode", retransfer back to "Utility" does not occur, go to Problem 7.

Test 24- Check "Standby Operating" Lamp**DISCUSSION:**

Transfer to either power source cannot occur unless that power supply is available to the transfer switch. For example, transfer to "Standby" cannot occur unless that power supply is available. One quick way of checking for "Standby" power is to observe the "Standby Operating" lamp on the transfer switch door. If the lamp is ON, you may assume that generator power is available.

PROCEDURE:

Perform a "Normal Test" (Test 23, above). If transfer to "Standby" does not occur, check the "Standby Operating" lamp.

RESULTS:

1. If the "Standby Operating" lamp is ON, but transfer to "Standby" did not occur, go to Test 25.
2. If the "Standby Operating" lamp is OUT or DIM, go to Test 27.

NOTE: During an actual "Utility" power outage, utility sensor board action will open the Wires 199/202 circuit to the system control or CPU circuit board. Opening of that circuit "tells" the system control (or CPU) board that utility voltage has dropped out. The system control (or CPU) board will then initiate transfer to the "Standby" source side. If an acceptable preset voltage is available, the 199/202 circuit will not be opened and transfer to "Standby" will not occur. During a "Normal Test", the 199/202 circuit is bypassed and transfer to "Standby" will occur even if "Utility" voltage is available. If transfer to "Standby" occurs during a "Normal Test" but not during an actual "Utility" source outage, try replacing the utility voltage sensor circuit board. On new installations with this problem, first verify that the transfer relay has been wired correctly.

Test 25- Check Terminals B1/B2 Voltage**DISCUSSION:**

Following engine startup in "Automatic" or "Normal Test" mode, an engine warmup timer on the system control (or CPU) circuit board will start timing. A "Standby Voltage" and a "Standby Frequency" sensor on that circuit board will check for an acceptable (preset) generator AC output voltage and frequency. After the engine warmup timer has timed out and providing standby voltage and frequency are above a preset level, system control (or CPU) board action will energize a transfer relay. When the transfer relay energizes, its normally-open contacts will close to deliver generator output voltage to transfer mechanism terminals B1 and B2. With standby voltage available to B1/B2, transfer to the "Standby" source should occur. This test will determine if the transfer relay has energized and if generator AC output is available to terminals B1/B2.

NOTE: On units equipped with the optional time delay at neutral feature, a time delay relay will be energized at the same time as the transfer relay.

PROCEDURE:

1. Perform a "Normal Test".
2. After the engine has started, wait for the "engine warmup timer" to time out. Transfer to "Standby" should then occur.
3. If transfer does not occur, use an AC voltmeter to check for "Utility" voltage across terminals B1 and B2. Generator rated AC voltage should be indicated.

**Test 25- Check Terminals B1/B2 Voltage
(Continued)**

RESULTS:

1. If generator rated voltage is indicated at terminals B1/B2, but transfer to "Standby" did not occur, the problem is in the transfer mechanism. Go to Test 26.
2. If generator rated voltage is NOT indicated at terminals B1/B2, go to Test 28.

Test 26- Check Transfer Mechanism

DISCUSSION:

If generator AC output voltage is available to transfer mechanism terminals B1/B2, but transfer to "Standby" does not occur, the most obvious cause of the problem is a defective transfer mechanism.

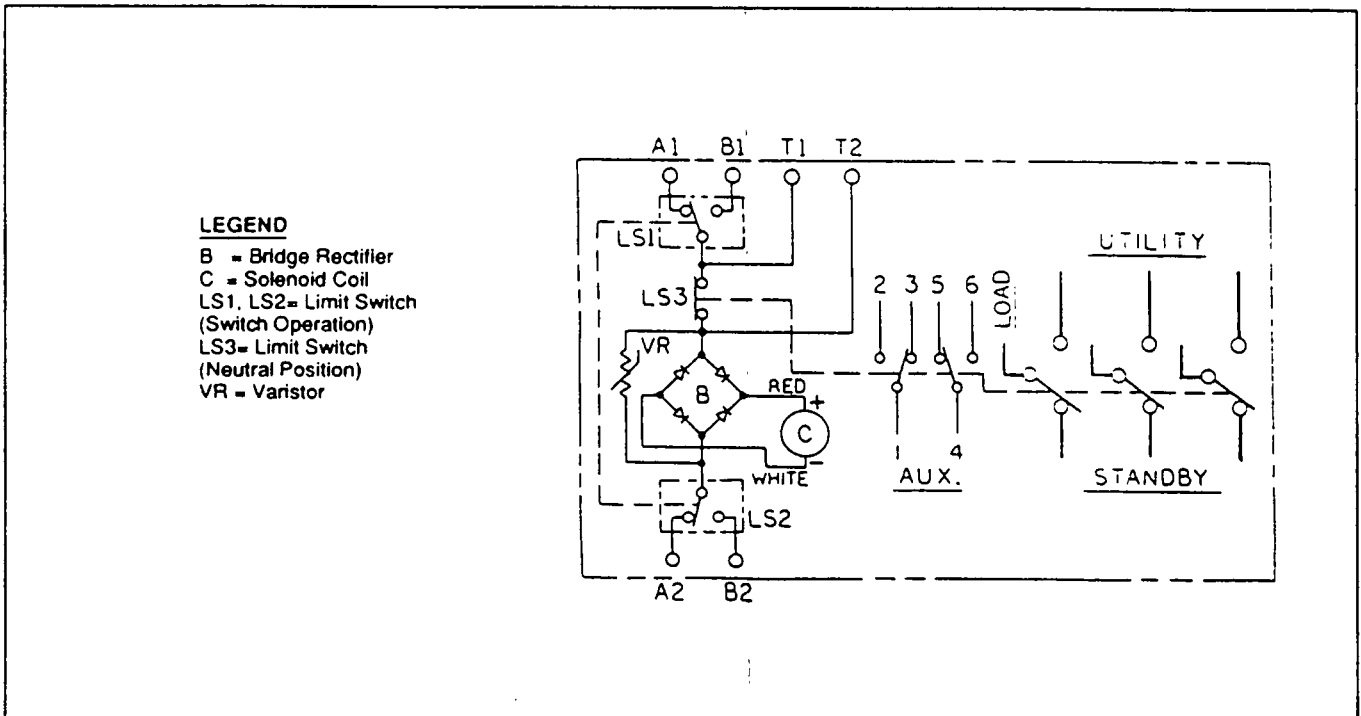
This test will outline procedures for completion of "preliminary tests" of the transfer mechanism. These tests are those that can be performed with little or no disassembly of the mechanism. If the tests indicate a defective component, further disassembly and testing may be required.

DANGER: BEFORE PERFORMING PRELIMINARY TESTS, TURN OFF ALL POWER VOLTAGE SUPPLIES TO THE TRANSFER SWITCH. FAILURE TO TURN OFF ALL POWER VOLTAGE SUPPLIES MAY RESULT IN EXTREMELY HAZARDOUS AND POSSIBLY FATAL ELECTRICAL SHOCK.

PROCEDURE:

A. Test Limit Switch LS1: Test limit switch LS1 in the transfer mechanism as follows:

1. Set the maintenance disconnect switch to "Manual". This will prevent automatic operation when the "Utility" power supply is turned off.
2. Turn OFF all power voltage supplies to the transfer switch. Both the "Utility" and "Standby" power supplies must be turned off.
3. Use the manual transfer handle to actuate the main contacts to their "Standby" position.
 - a. Check the changeover display on the transfer mechanism.
 - b. The "Standby" arrow should point to the green band; the "Utility" arrow to the red band.
4. Set a volt-ohm-milliammeter (VOM) to its "Rx1" scale and zero the meter.
5. Connect one VOM test lead to terminal A1; the other to terminal T1. The meter should read "continuity".
6. Connect the VOM test leads across terminals B1 and T1. The meter should read "infinity".
7. Manually actuate the main contacts to their "Utility" power source side.
 - a. Check the changeover display on transfer mechanism.
 - b. The "Utility" arrow should point to the green band; the "Standby" arrow to the red band.
8. Connect the VOM test leads across terminals A1 and T1. The meter should read "Infinity".
9. Connect the VOM test leads across terminals B1 and T1. The meter should read "Continuity".



LEGEND

- B = Bridge Rectifier
- C = Solenoid Coil
- LS1, LS2= Limit Switch (Switch Operation)
- LS3= Limit Switch (Neutral Position)
- VR = Varistor

Figure 3. Transfer Mechanism Schematic Diagram

Test 26- Check Transfer Mechanism (Continued)

B. Testing Limit Switch LS2:

1. Turn OFF all power voltage supplies to the transfer switch.
2. Set the maintenance disconnect switch to "Manual" and main contacts at their "Utility" side.
3. **IMPORTANT:** Use a digital meter and set the meter to its "diode test" position.
4. Read across transfer mechanism terminals A2 and T2- meter should read "infinity".
5. Read across B2 and T2- some resistance should be read, i.e., the resistance of the varistor.
6. Manually actuate the main contacts to "Standby" and then read across A2 and T2- varistor resistance should be read.
7. Read across B2 and T2- meter should read "infinity".

C. Testing Limit Switch LS3:

1. Set the maintenance disconnect switch to "Manual".
2. Turn off all power voltage supplies to the transfer switch.
3. Set a VOM to its "Rx1" scale and zero the meter.
4. Connect the VOM test leads across transfer mechanism terminals T1 and T2.
5. Manually actuate the main contacts to "Standby" and to "Utility" several times. Check the VOM reading with the contacts at "Utility", with the contacts at "Standby", and with the contacts at "Neutral".
 - a. With main contacts at "Neutral", VOM should read "Infinity".
 - b. At "Utility", the VOM should read "Continuity".
 - c. At "Standby", the VOM should indicate "Continuity".

D. Testing the Bridge Rectifier:

1. Set the maintenance disconnect switch to "Manual".
2. Turn OFF all power voltage supplies to the transfer switch.
3. On the transfer mechanism, locate the solenoid coil cover. Remove the cover to expose the coil terminals. Cover may display a "Tap Change of Coil" diagram.
 - a. A RED wire indicates the positive (+) side of coil.
 - b. A WHITE wire indicates negative (-) side of coil.
4. To prevent interaction, disconnect the red and white wires from the far left and far right coil terminals (red wire at left, white wire at right).
5. Manually actuate the main contacts to their "Standby" position ("Standby" arrow next to the green color band).
6. Set a VOM to its "Rx1" scale and zero the meter.
7. Connect the VOM positive (+) test lead to the terminal end of red wire at far left.
8. Connect the common (-) VOM test lead to transfer mechanism terminal A2. Observe the meter reading.
9. Now, reverse the test leads. That is, connect the common (-) test lead to terminal end of red wire and the positive (+) test lead to terminal A2. Observe the meter reading.
 - a. The forward resistance of a bridge rectifier diode should be indicated at one polarity only.
 - b. At opposite polarity, VOM should read "Infinity".

10. Now, connect the VOM positive (+) test lead to terminal end of white wire and the common (-) test lead to terminal A2. Observe the meter reading.

11. Reverse the test leads. Again, observe the meter reading.

a. At one polarity, the meter should indicate the forward resistance of a bridge rectifier diode.

b. At the opposite polarity, the VOM should read "Infinity".

12. Connect the positive (+) VOM test lead to terminal A1; the common (-) test lead to the red wire. Note the meter reading. Reverse the test leads and again note the meter reading.

a. At one polarity, the VOM should read the forward resistance of a diode.

b. At the opposite resistance, the meter should read "Infinity".

13. Finally, connect the positive (+) VOM test lead to terminal A1; the common (-) test lead to the white wire. Note the reading. Then, reverse the test leads and again note the reading.

a. At one polarity, the VOM should read diode resistance.

b. At the opposite polarity, the meter should read "Infinity".

NOTE: When reconnecting the red and white wires to the actuating coil, be sure to follow the "Tap Change of Coil" diagram.

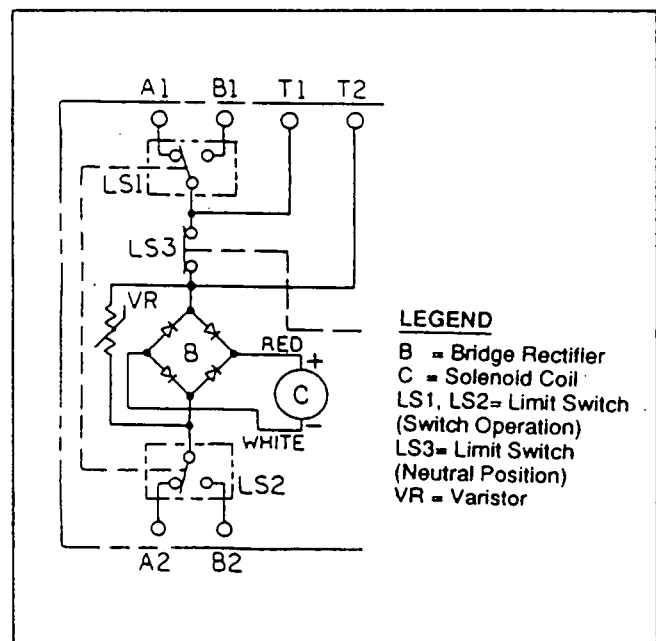


Figure 4. Bridge Rectifier Testing

E. Testing the Actuating Coil: Test the transfer mechanism's actuating coil as follows:

1. Set the maintenance disconnect switch to "Manual".
2. Turn OFF power voltage supplies to transfer switch.

Test 26- Check Transfer Mechanism (Continued)

3. Remove outer cover and plastic actuating coil cover.
4. Disconnect the red and white wires from the actuating coil.
5. Use a VOM to measure actuating coil resistance as follows:
 - a. From the red wire to outer terminal, about 34-36 ohms.
 - b. From the white wire to the outer terminal, about 34-36 ohms.

Test 27- Test Generator Voltage and Frequency

DISCUSSION:

Transfer to the "Standby" source will not occur in automatic mode until after (a) the engine has started, (b) an engine warmup timer has timed out, and (c) generator AC output frequency and voltage have reached preset minimum values. This test will determine if generator AC output voltage and frequency are high enough to permit a "transfer to standby" operation.

PROCEDURE:

1. Refer to Test 1 in this section. Check voltage at terminals N1/N2/N3 as outlined in that test. Normal rated voltage of the system should be indicated.
2. Use an AC frequency meter to test the frequency at the "Utility" terminal lugs (N1/N2). Normal rated AC frequency should be indicated.

RESULTS:

1. If voltage and frequency check good, go to Test 29.
2. If voltage/frequency are low or zero, troubleshoot the AC generator systems as outlined in Part 2, 3 or 4 of this manual as appropriate.

Test 28- Test Transfer Relay

DISCUSSION:

During automatic operation, system control (or CPU) circuit board action should energize the transfer relay to initiate automatic transfer to the "Standby" power source

(providing utility voltage sensor board action has opened the Wires 199/202 circuit).

When "Utility" power has been restored, utility voltage sensor board action will open the Wires 199/202 circuit. System control (or CPU) board action will then open the transfer relay circuit. The transfer relay will de-energize, its normally-closed contacts will close, and retransfer back to "Utility" will be initiated.

Failure of the transfer relay can mean (a) no transfer to "Standby", or (b) no retransfer back to "Utility".

PROCEDURE:

Test the transfer relay as follows:

1. Set the maintenance disconnect switch to "Manual", to prevent automatic startup when power voltage supplies are turned off.
2. Turn OFF all power voltage supplies to the transfer switch, using whatever means provided (such as the "Utility" and "Standby" main line circuit breakers).
3. Disconnect all wires from the transfer relay terminals (see Figure 5). Note wire numbers and the relay terminals to which they connect.
4. Connect the positive (+) post of a 12 volts battery to relay terminal B. Connect the battery negative (-) post to relay terminal A. The relay should energize.
5. With the relay energized, connect the test leads of a VOM across relay terminals 6 and 9, then across terminals 1 and 7. In each case, note the meter resistance readings.
6. Disconnect the battery posts from relay terminals A and B. The relay should de-energize.
7. With the relay de-energized, connect the VOM test leads across relay terminals 1 and 7; also across terminals 6 and 9. Again, note the meter readings.

Correct readings in each case are listed in the chart below.

Be sure to reconnect all wires to the relay terminals before proceeding.

TRANSFER RELAY CONDITION	ACROSS TERMINALS	DESIRED READING
ENERGIZED	1 and 7	Infinity
ENERGIZED	6 and 9	Continuity
ENERGIZED	4 and 7	Continuity
DE-ENERGIZED	1 and 7	Continuity
DE-ENERGIZED	6 and 9	Infinity
DE-ENERGIZED	4 and 7	Infinity

Test 28- Test Transfer Relay (Continued)

RESULTS:

1. Replace transfer relay if it is defective.
2. If transfer relay is good, perform Test 22, "Test Maintenance Disconnect Switch". If maintenance disconnect switch is good, complete Test 31.

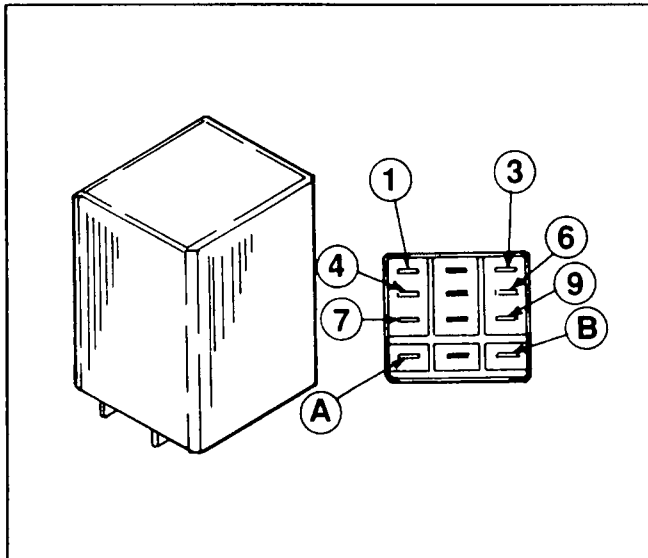


Figure 5. Transfer Relay Test Points

Test 29- Test Transformer TR1

DISCUSSION:

Power for system control (or CPU) circuit board operation is taken from the secondary winding of transformer TR1. Secondary winding output from that transformer also operates the "Standby Operating" lamp on the transfer switch enclosure door. Without the reduced output of transformer TR1, the system control (or CPU) circuit board will not operate and transfer to "Standby" will not occur.

PROCEDURE:

A. Check TR1 Primary Winding Input

1. With the standby generator running and its main line circuit breaker closed, use an AC voltmeter to check for correct voltage across transformer terminals H1 and H4.
2. Normal rated generator AC output voltage should be indicated.

B. Check TR1 Secondary Winding Output

1. With the generator still running, check for correct step-down voltage across transformer terminals X1 and X2.
2. For a system rated 208 volts, reading should be 21 volts.
3. For a 240 volts system, reading should be about 24 volts.

NOTE: The step-down ratio of transformer TR1 is fixed at a ratio of approximately 10-to-1. For that reason, the secondary winding output voltage will vary as the standby generator voltage varies.

RESULTS:

1. If primary winding input voltage is zero or low, but generator voltage and frequency reading in Test 27 was good, test Wires E1 and E2 between the transfer mechanism and the transformer. Repair, reconnect or replace any bad wire(s).
2. If primary winding input voltage is good, but secondary winding output voltage is bad, replace the transformer TR1.
3. If input voltage to primary winding is good and output from secondary winding is also good, go to Test 30.

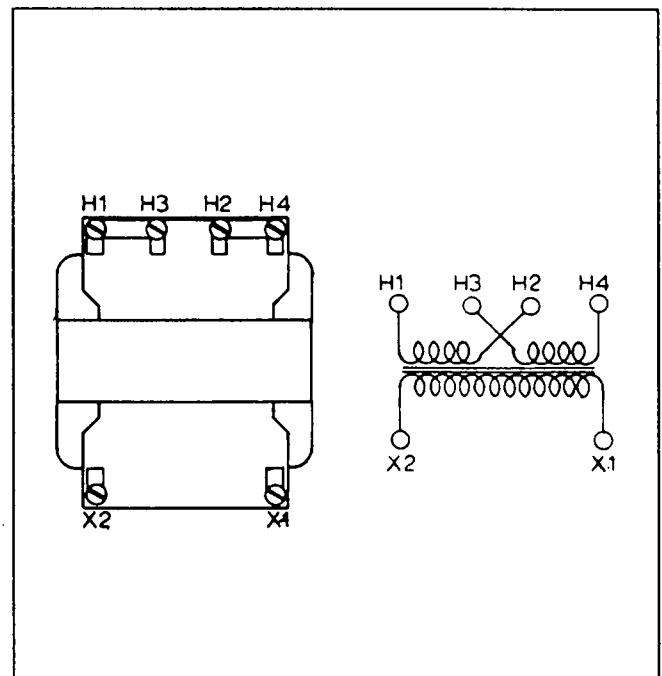


Figure 6. Transformer TR1 Test Points

Test 30- Check Wires 191, 192

DISCUSSION:

The step-down voltage from transformer TR1 secondary windings is delivered to (a) the "Standby Operating" lamp, and (b) the system control (or CPU) circuit board, via Wires 191 and 192.

PROCEDURE:

Inspect and test Wires 191/192, between transformer TR1 and the "Standby Operating" lamp and between the "Standby Operating" lamp and the system control (or CPU) circuit board.

Test 30- Check Wires 191, 192 (Continued)

RESULTS:

Repair, reconnect or replace defective wire(s), as necessary.

Test 31- Test Logic (or CPU) Circuit Board DISCUSSION:

During operation in automatic mode, system control (or CPU) circuit board action may be briefly described as follows:

1. The circuit board is turned on by step-down voltage from the secondary winding of transformer TR1. This is transformer reduced "Standby" source voltage.
2. When turned on, an "engine warmup timer" starts timing.
3. The board delivers 12 volts to a transfer relay coil via Wire 194. From the relay coil, the circuit is completed back to the circuit board via Wire 23. However, circuit board action will hold the Wire 23 circuit open until the following requirements are met:
 - a. Utility voltage sensor board action must have opened the Wires 199/202 circuit due to a "Utility" voltage dropout below a preset level.
 - b. The "engine warmup timer" must have finished timing.
 - c. "Standby" voltage must be at or above the setting of a "standby voltage" sensor on the circuit board.
 - d. "Standby" frequency must be at or above the setting of a "standby frequency" sensor on the circuit board.
4. When all of the above conditions have been met, circuit board action will complete the Wire 23 circuit to ground.
 - a. The transfer relay will then energize.
 - b. Transfer to "Standby" will be initiated as the normally-open contacts of the transfer relay close to deliver "Standby" source power to transfer mechanism terminals B1/B2.

PROCEDURE:

1. Perform a "Normal Test" of the system. See Section 8.6, "Functional Tests".
2. During the "Normal Test", observe lamps on the transfer switch door and on the system control board (not on the CPU board) as follows:
 - a. Check that the "Standby Operating" lamp on the transfer switch enclosure door is lit.
 - b. Check that the "Engine Warmup Timer" lamp (LED) on the circuit board turns on and goes out when the timer has finished timing.
 - c. Check that the "Standby Voltage Sensor" lamp (LED) on the circuit board turns on.
 - d. Check that the "Standby Frequency Sensor" lamp (LED) on the circuit board turns on.

3. If transfer to "Standby" does not occur, proceed as follows with the generator running.

- a. Locate Pin 11 of the system control (or CPU) circuit board connector, to which Wire No. 23 connects. Also locate Pin 2 of the circuit board connector, to which Wire 202 connects.
- b. Connect a jumper wire from Pin 11 (Wire No. 23) and to Pin 2 (Wire No. 202).
- c. When the jumper wire is connected across Pins 11 and 2 (Wires 23 and 202), the transfer relay should energize and transfer to "Standby" should occur.

RESULTS:

If transfer to "Standby" occurs when the jumper wire is connected, but does not occur normally, replace the system control (or CPU) circuit board. Then, retest automatic operation.

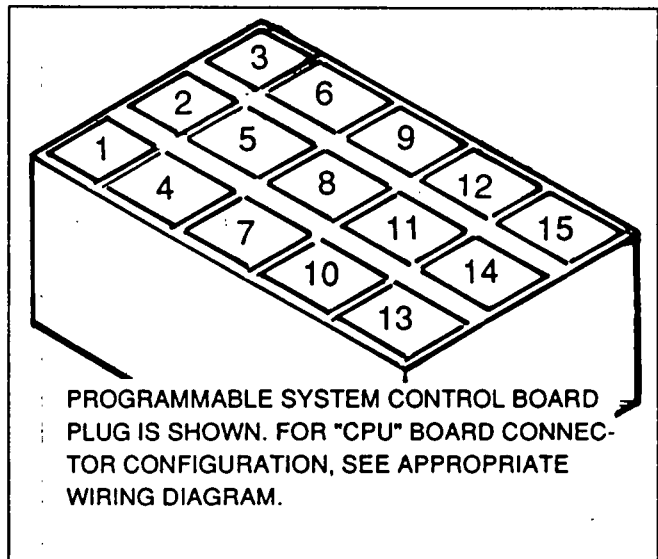


Figure 7. System Control (CPU) Board Connector

Test 32- Is "Utility On" Lamp Lit?

DISCUSSION:

The "Utility On" lamp is located on the utility voltage sensor circuit board. The lamp (LED) should illuminate when "Utility" source voltage is above the setting of a "voltage dropout sensor". Check condition of this lamp if retransfer back to the "Utility" source does not occur in automatic mode.

PROCEDURE:

Simply observe the lamp (LED). If the LED is lighted, "Utility" source sensing voltage is available to the utility voltage sensor board.

RESULTS:

1. If lamp is ON, but retransfer does not occur, go to Test 33.
2. If lamp is OUT, go to Problem 1.

Test 33- Check Voltage at Terminals A1/A2

DISCUSSION:

Transfer mechanism terminals A1/A2 are the "retransfer back to utility" terminals. These two terminals are powered by "Utility" source voltage when the transfer relay de-energizes, to initiate the retransfer action. This test will determine if the transfer relay has de-energized to deliver "Utility" source voltage to terminals A1 and A2.

PROCEDURE:

Perform a "Normal Test". Wait for the generator engine to start and wait for transfer to "Standby" to occur. Then, set the system test mode switch back to its "Automatic Mode" position. Let the circuit board timers time out and then determine if retransfer back to the "Utility" source has occurred ("Switch Position-Utility" lamp comes on). If retransfer back to "Utility" does not occur, use an AC voltmeter to check voltage across terminals A1 and A2. Normal rated "Utility" voltage should be indicated.

RESULTS:

1. If "Utility" source voltage is NOT indicated, go to Test 28 (see Problem 7 on Page 8.9-6).
2. If voltage reading at A1/A2 is good but retransfer back to "Utility" does not occur, go to Test 34.

Test 34- Test Time Delay Relay

DISCUSSION:

Some transfer switches may be equipped with the "time delay at neutral" feature. That feature functions to hold the transfer mechanism's solenoid coil energized for a preset time period. The main contacts will remain at "Neutral" as long as the solenoid coil is energized.

The time delay relay is normally energized by system control (or CPU) circuit board action during any transfer operation. When the relay is energized, its normally-open contacts will close to bypass limit switch LS3 and allow the solenoid coil to remain energized for a preset time. A time delay resistor limits current flow to the coil. After a "time delay neutral timer" on the system control (or CPU) board has finished timing, circuit board action will de-energize the time delay relay. The relay's contacts will then open and the solenoid coil will de-energize. Spring force will then complete the transfer action.

A defective time delay relay can (a) prevent transfer by keeping the main contacts at "Neutral", or (b) result in immediate transfer without occurrence of the "time delay at neutral" function.

PROCEDURE:

See Test 28. Test the time delay relay in the same manner as the transfer relay.

RESULTS:

1. Replace time delay relay if defective.
2. If time delay relay tests good, go to Test 35.

Test 35- Test Wires 199/202 Action

DISCUSSION:

During a utility power source dropout, utility voltage sensor board action should open the Wires 199/202 circuit, to "tell" the system control (or CPU) board that a utility power source failure has occurred. If the circuit is not closed, the system control (or CPU) board will not initiate transfer to the "Standby" side.

When utility source voltage has been restored, the utility voltage sensor board must re-close the Wires 199/202 circuit. If the circuit is not re-closed, retransfer back to "Utility" will not occur.

PROCEDURE:

Perform a "Normal Test". Wait for the standby generator to start and wait for transfer to the "Standby" side. Then, proceed as follows:

1. System Control (Logic) Circuit Boards Only: Reset the system test mode switch back to "Automatic Mode" and observe the "return to utility timer" lamp (LED) on the circuit board. That lamp should turn on as soon as the system test mode switch is reset back to "Automatic Mode". Retransfer should occur when the timer has timed out.

CPU Circuit Boards: This circuit board is not equipped with a "return to utility timer" lamp. The board's "return to utility timer" has a fixed (non-adjustable) setting of 30 seconds. Reset the system test mode switch back to "Automatic Mode" and wait for 30 seconds. Retransfer back to "Utility" should occur when the timer has timed out.

2. If retransfer back to "Utility" does not occur, test the Wires 199/202 action as follows (see Figure 8):

- a. Insert a jumper wire into Pins 1 and 2 of the utility voltage sensor board's connector plug. Wires 199 and 202 attach to these pins.
- b. Wait about a minute to see if retransfer back to "Utility" occurs.

RESULTS:

1. If retransfer occurs when Wires 199/202 are jumpered, but does not occur otherwise, replace the utility voltage sensor board. Calibrate the new board (Test 4) and perform a "Normal Test".

Test 35- Test Wires 199/202 Action

2. If retransfer does not occur when the wires are jumpered, go to Test 36.

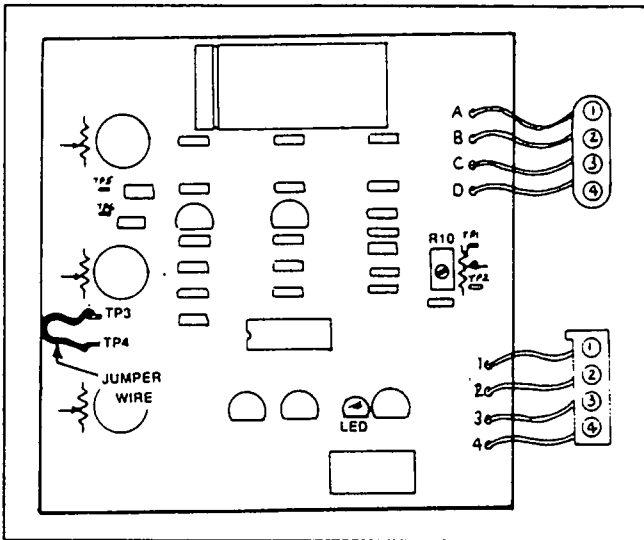


Figure 8. Utility Voltage Sensor Board Connectors

Test 36- Turn Time Delay Neutral Switch Off

DISCUSSION:

This test is a continuation of Test 35. If system control (or CPU) board has failed to de-energize the time delay relay, transfer will not occur. By turning the time delay neutral switch "Off", the relay circuit is broken and the relay must de-energize.

PROCEDURE:

Turn the time delay neutral switch to "Off" and observe transfer switch action.

RESULTS:

1. If retransfer back to "Utility" occurs when the switch is reset to "Off", replace the system control (or CPU) circuit board.
2. If retransfer back to "Utility" does not occur, perform Test 26.

PART 9 "WN" TYPE AUTOMATIC TRANSFER SWITCHES

STANDBY ELECTRIC POWER SYSTEMS

All Series

TABLE OF CONTENTS	
SECTION	TITLE
9.1	Major Components
9.2	The Transfer Mechanism
9.3	Installation
9.4	Operating Instructions
9.5	Functional Tests
9.6	Operational Analysis
9.7	Multi-Voltage Transfer Switches
9.8	Troubleshooting Flow Charts
9.9	Diagnostic Tests
9.10	Transfer Mechanism Disassembly

Section 9.1 MAJOR COMPONENTS

Introduction

The "Wn" type automatic transfer switch is so named because of the actuating configuration of its main contacts (W) and because it offers a time delay with the main contacts at "Neutral" (n). The transfer switch is rated 600 volts and is available in 100 to 2600 ampere sizes. Components may be housed in a standard NEMA 12 enclosure or in an optional NEMA 3R enclosure.

ITEM	DESCRIPTION
1	Transfer Mechanism ("Wn" Type)
2	Transfer Relay (TR)
3	Time Delay Neutral Relay
4	Grounding Lug
5	Maintenance Disconnect Switch
6	Time Delay Neutral On-Off Switch
7	Neutral Lug
8	Manual Transfer Handle
9	Utility Voltage Sensing Interface
10	Transformer TR4 (480 volts units only)
11	Transformer TR3 (480 volts units only)
12	2-Wire Start Terminal Strip
13	Transformer TR1
14	Transformer TR2
15	Terminal Strip
16	Circuit Board Compartment

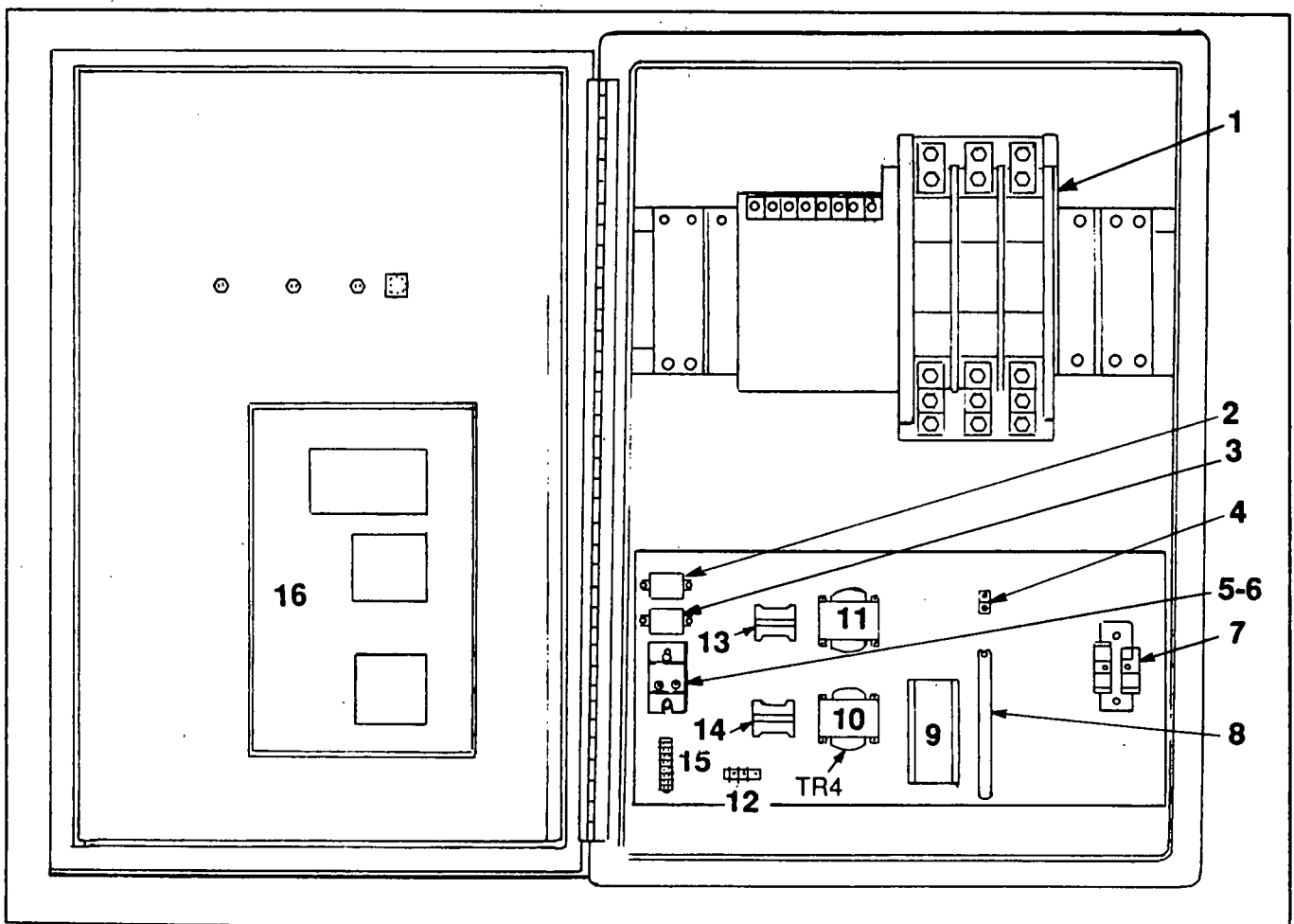


Figure 1. Typical "Wn" Type Transfer Switch

Transfer Mechanism

The transfer mechanism contains the main load-carrying contacts of the transfer switch, as well as other mechanical and electrical components. Additional information on the transfer mechanism can be found in Section 9.2.

Transfer Relay

When energized by system control (or CPU) circuit board action, the transfer relay's normally-open contacts close. On closure of those contacts, "Standby" source voltage is delivered to transfer mechanism terminals AT1/AT2 (see Section 9.2). The transfer mechanism main contacts will then actuate to their "Standby" power source side, i.e., loads connected to "Standby" source.

When de-energized by system control (or CPU) board action, the relay's normally-closed contacts close. "Utility" source power is then delivered across the closed contacts to transfer mechanism terminals BT1 and BT2. Transfer mechanism main contacts will then actuate to their "Utility" source side. See "Transfer Mechanism Operational Analysis" in Section 9.2.

Neutral Lug

"Neutral" lines from the utility, standby and load circuits must be properly connected to the neutral block. The neutral block used must have the same (or greater) amperage rating as the transfer mechanism.

Maintenance Disconnect Switch

This safety switch should always be set to its "Manual" position before working on the standby system. When set to "Manual", the switch (a) opens the 2-wire start circuit, and (b) opens the transfer signal circuits to the transfer mechanism. Thus, with "Manual" selected, the generator cannot be started in automatic mode and automatic transfer to either power source side will not occur.

The switch should be set to "Automatic" for normal automatic operations, for a "Normal Test" and for a "Fast Test".

Grounding Lug

The grounding lug provides a convenient way of connecting the transfer switch enclosure to earth ground. In many cases, the enclosure is connected to ground when wiring conduit is installed and grounded. Some installers will simply attach a bare copper wire to the grounding lug and to a bolted junction at the wiring conduit.

NOTE: Most standby generators have an ungrounded or "floating" neutral line. Be sure to comply with applicable codes pertaining to the grounding of neutral lines in such applications. In most cases, the neutral block can be grounded only at main electrical service entrance.

Terminal Strip

This terminal strip provides a convenient method of interconnecting transfer switch components. Most units are equipped with a 7-position terminal strip as shown in Figure 2. However, units rated 480 volts use a 6-position strip.

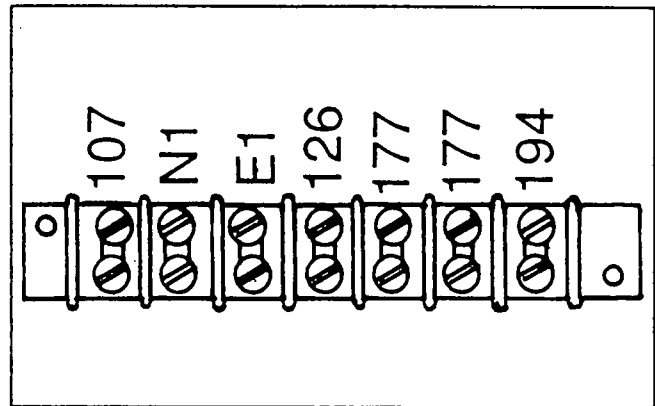


Figure 2. The 7-Position Terminal Strip

Time Delay Neutral Switch

Some transfer switches may be equipped with an optional "time delay at neutral" feature. The time delay neutral switch (if so equipped) permits that feature to be turned off or on. When the switch is set to "On", the main contacts will be held at "Neutral" for a preset time during transfer to either power source.

The "Neutral" position of the main contacts is that position where the load is disconnected from both power supplies. By allowing the time at "Neutral" to be extended, residual voltages generated by heavy inductive loads can decay to a safe level before the main contacts are reconnected. The feature provides some protection against nuisance tripping of circuit breakers or blowing of fuses that can occur during rapid transfer of motor and other heavy inductive loads.

Transformer TR1

When the generator is running, generator AC output is delivered to the primary winding of this step-down transformer. A reduced voltage is induced into the transformer secondary winding. The reduced secondary winding output is delivered to (a) a "Standby Operating" lamp on the switch enclosure door, and to (b) the system control (or CPU) circuit board. Transformer nominal input/output voltages are listed below:

PRIMARY WINDING INPUT VOLTAGE	SECONDARY WINDING OUTPUT VOLTAGE
208 volts AC	21 volts AC
240 volts AC	24 volts AC
416 volts AC	21 volts AC
480 volts AC	24 volts AC

The system control (or CPU) circuit board is turned on and starts to operate at the same time the "Standby Operating" lamp turns on.

Transformer TR2

Load terminal voltage from transfer mechanism terminal lugs T1/T2 is delivered to the primary winding of this step-down transformer. This induces a reduced voltage into the transformer's secondary winding. Secondary winding output is delivered to the 7-day exercise circuit board for operation of the 7-day exercise timer. Input and output voltages are the same as for transformer TR1.

NOTE: On units with only two circuit boards, the 7-day exercise circuit is incorporated into the CPU circuit board.

Transformer TR3

This step-down transformer is employed only on transfer switches rated at 480 volts. The transformer reduces the standby source voltage used for transfer mechanism main contacts operation to a voltage that is compatible with the transfer mechanism's operating voltage. This must be done since the transfer mechanism's actuating coil will respond only to its rated voltage.

A standby source voltage input of 480 volts to the primary winding will result in a 240 volts AC output from the transformer secondary winding.

Transformer TR4

This step-down transformer is used only on systems rated 480 volts. The transformer reduces utility power source voltage to a voltage that is compatible with that required by the transfer mechanism actuating coil.

2-Wire Start Terminal Strip

Terminals 178 and 183 on this terminal strip must be interconnected with identically numbered terminals in the generator's AC connection (lower) panel. Closure of this circuit by transfer switch circuit board action will initiate generator cranking and startup. Opening of the circuit by circuit board action will result in generator shutdown.

NOTE: Automatic cranking is initiated by closure of the 2-wire start circuit. However, cranking, running and stopping operations are controlled by a DC control/latch-crank board in the generator control console. See Part 5 or 6 as appropriate.

Manual Transfer Handle

Use this handle to actuate the transfer mechanism main contacts manually. See Section 9.4, "Operating Instructions".

Circuit Board Compartment

This compartment, in the transfer switch enclosure door, houses either two or three circuit boards as follows:

- Units with the "Logic" type intelligence system have three circuit boards, i.e., a utility voltage sensor board, a system control board, and a 7-day exercise board.
- Units with "CPU" type intelligence system have only two circuit boards, a utility voltage sensor board and a CPU board. The "exercise" function is controlled by the CPU circuit board.

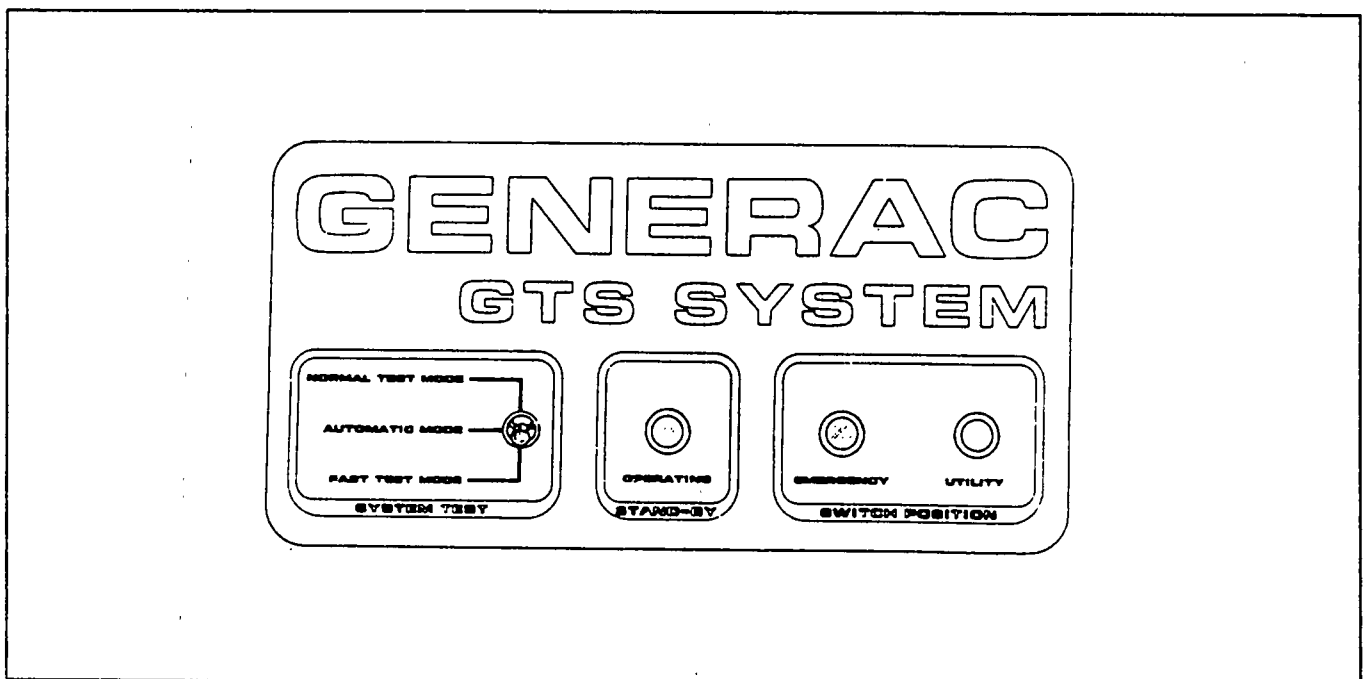


Figure 3. Switches and Lamps on Enclosure Door (Typical)

Utility Voltage Sensing Interface

Refer to "Utility Sensing Interface" on Page 8.1-4 (Part 8, Section 8.1).

Transfer Switch Enclosure

Either a NEMA 12 or a NEMA 3R type enclosure may be used.

The NEMA 12 enclosure is intended for INDOOR installation only.

The NEMA 3R enclosure is intended for OUTDOOR installation.

Switches and Lamps on Enclosure Door

See Figure 3 on previous page. The transfer switch enclosure door mounts the following switches and lamps:

- System Test Switch.
- "Standby Operating" Lamp.
- "Switch Position" Lamps

SYSTEM TEST SWITCH:

Automatic Mode: Set this switch to its "Automatic Mode" position for all normal automatic operations. When "Automatic Mode" is selected, operation will be as follows:

1. A utility voltage sensor circuit board will constantly monitor "Utility" source voltage.
 - a. As long as "Utility" voltage is above the setting of a "voltage dropout sensor", a "Utility On" lamp (LED) on the circuit board will be on.
 - b. Should "Utility" voltage drop below the "voltage dropout sensor" setting, a timer on the circuit board will start timing.
 - c. When the timer has timed out and if "Utility" voltage is still below the "voltage dropout sensor" setting, circuit board action will effect closure of the 2-wire start circuit. The generator will crank and start.
2. On generator startup, an "engine warmup timer" starts timing.
3. When the "engine warmup timer" has timed out and providing generator voltage and frequency are acceptable, transfer to the "Standby" power supply will occur. Load circuits are now powered by generator AC output.
4. On restoration of "Utility" voltage above a preset level, a "return to utility timer" starts timing.
5. When the timer has timed out and if "Utility" voltage is still good, retransfer back to the "Utility" source will occur.
6. Following retransfer, circuit board action will open the 2-wire start circuit. Engine shutdown will then occur.

Normal Test Mode: This switch position, when selected, will simulate a "Utility" power source dropout. The generator will crank and start followed by transfer to "Standby" just as though an actual "Utility" source dropout has occurred.

Fast Test Mode: Generator starts and transfer to "Standby" occurs in less than five seconds.

SWITCH POSITION LAMPS:

Switch Position Utility: Lamp will turn on when (a) "Utility" source power is available, and (b) when the main contacts are at "Utility" (load connected to the "Utility" side).

Switch Position-Emergency: Will turn on when (a) "Standby" power is available to the transfer switch and (b) when the main contacts are at "Standby" (load connected to the "Standby" side).

STANDBY OPERATING LAMP:

Lamp should turn ON as soon as the standby generator is running.

Section 9.2 THE TRANSFER MECHANISM

General

The transfer mechanism houses the main current carrying contacts, along with other components required for switch operation. The main contacts are electrically actuated and mechanically held. They are of silver alloy or silver alloy composition, to resist welding or sticking.

A typical 3-pole transfer mechanism is shown in Figure 1 below. Also available are 4-pole transfer mechanisms.

NOTE: At the time of this writing, "Wn" type transfer switches were not available with a 2-pole transfer mechanism. When a transfer switch is ordered, the purchaser must specify (a) the rated voltage, (b) rated phase, and (c) rated current. Units rated 1-phase will include a 3-pole transfer mechanism. However, since the unit is rated "1-phase", factory wiring connections to the third pole (N3, E3, T3) are omitted and a 1-phase utility sensing interface is used.

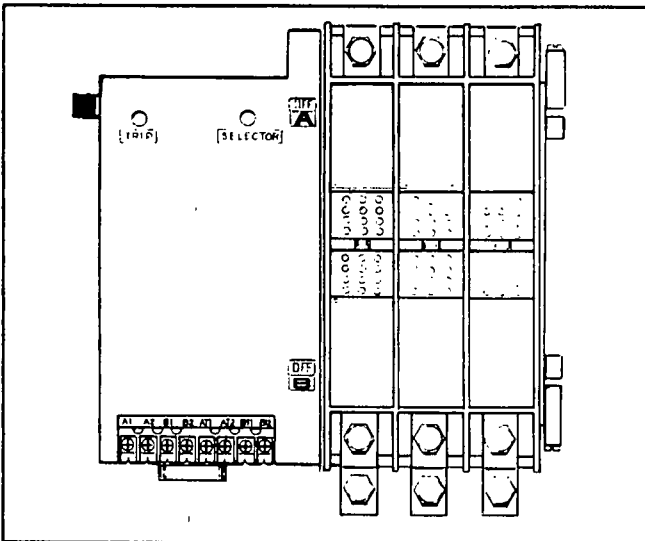


Figure 1. A Typical 3-Pole Transfer Mechanism

Transfer Mechanism Construction

Figure 6 on next page shows the major components of a typical "Wn" type transfer mechanism.

The LOAD CONTACTS are stationary and are retained to a PLASTIC POLE PIECE. The UTILITY and EMERGENCY CONTACTS are moveable and are actuated by means of a closing coil (in the CONTROL ASSEMBLY) and mechanical linkage. Three or four plastic pole pieces, along with stationary and moveable main contacts, are sandwiched together to form a 3 or a 4-pole mechanism.

Main Contacts Operation

LOAD CONNECTED TO "UTILITY" SOURCE:

Figure 2 shows a set of moveable "Utility" contacts connected to the stationary "Load" contact. The LOAD is connected to the UTILITY power source. On the transfer mechanism cover, window "A" will display the word "ON" and window "B" will display the word "OFF".

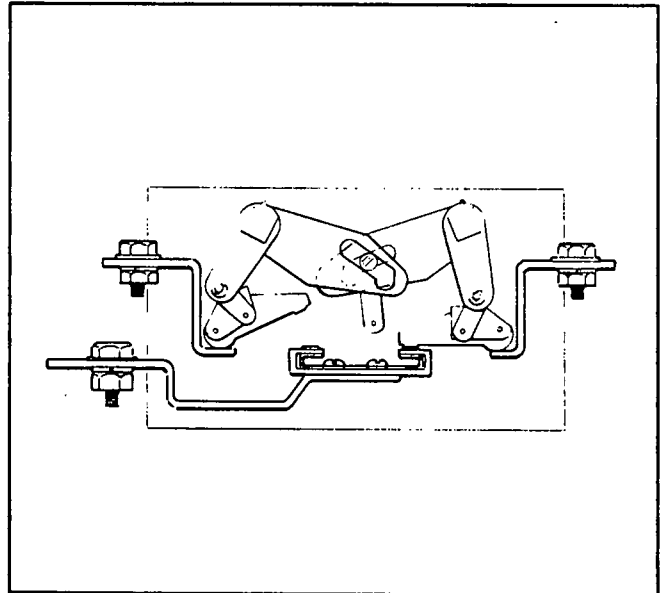


Figure 2. Load Connected to Utility Source

NEUTRAL OR "TRIPPED" POSITION:

See Figure 3. The LOAD contacts are disconnected from both the "Utility" and "Standby" power supplies. Windows "A" and "B" will both display the word "OFF".

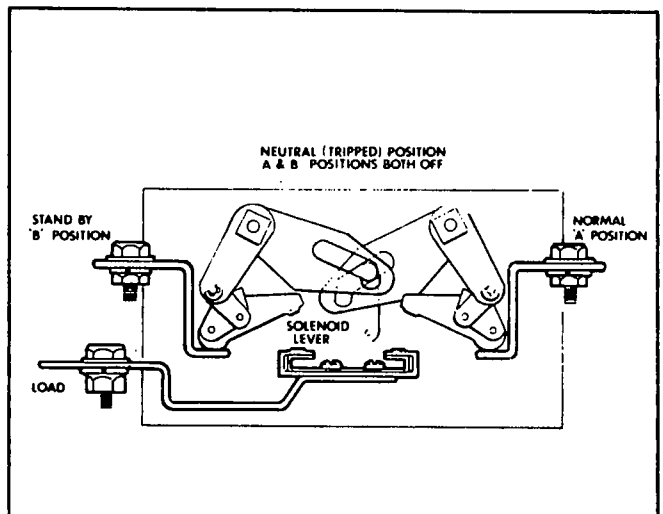


Figure 3. "Neutral" or "Tripped" Position

Main Contacts Operation (Continued)

LOAD CONNECTED TO "STANDBY" SOURCE:

See Figure 4. The moveable standby contact is connected to the load contact. Window "A" will display the word "OFF"; window "B" the word "ON".

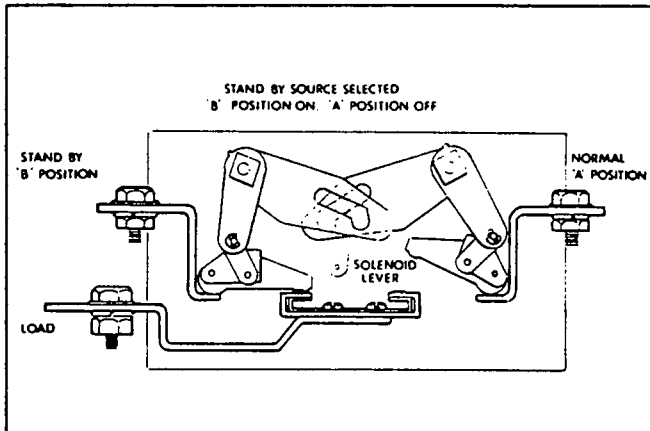


Figure 4. Load Connected to "Standby" Source

Auxiliary Contacts

A set of auxiliary contacts may be provided on the transfer mechanism. One auxiliary contacts switch is used to operate "Switch Position" lamps on the door. The second switch may be used by the customer, if desired. A suitable power supply must be connected across the "common" terminal, for operation of customer device(s) such as remote advisory lamps, remote annunciator, etc.

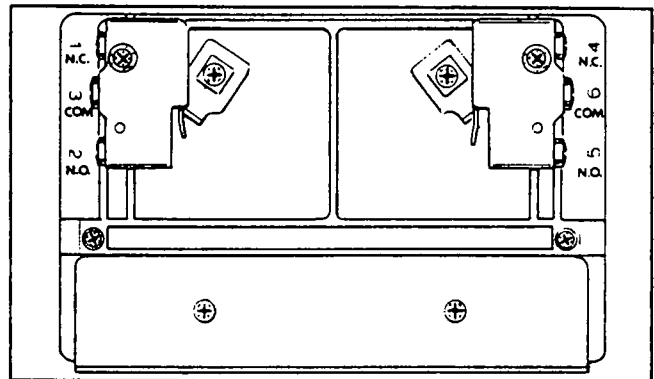


Figure 5. Auxiliary Contacts

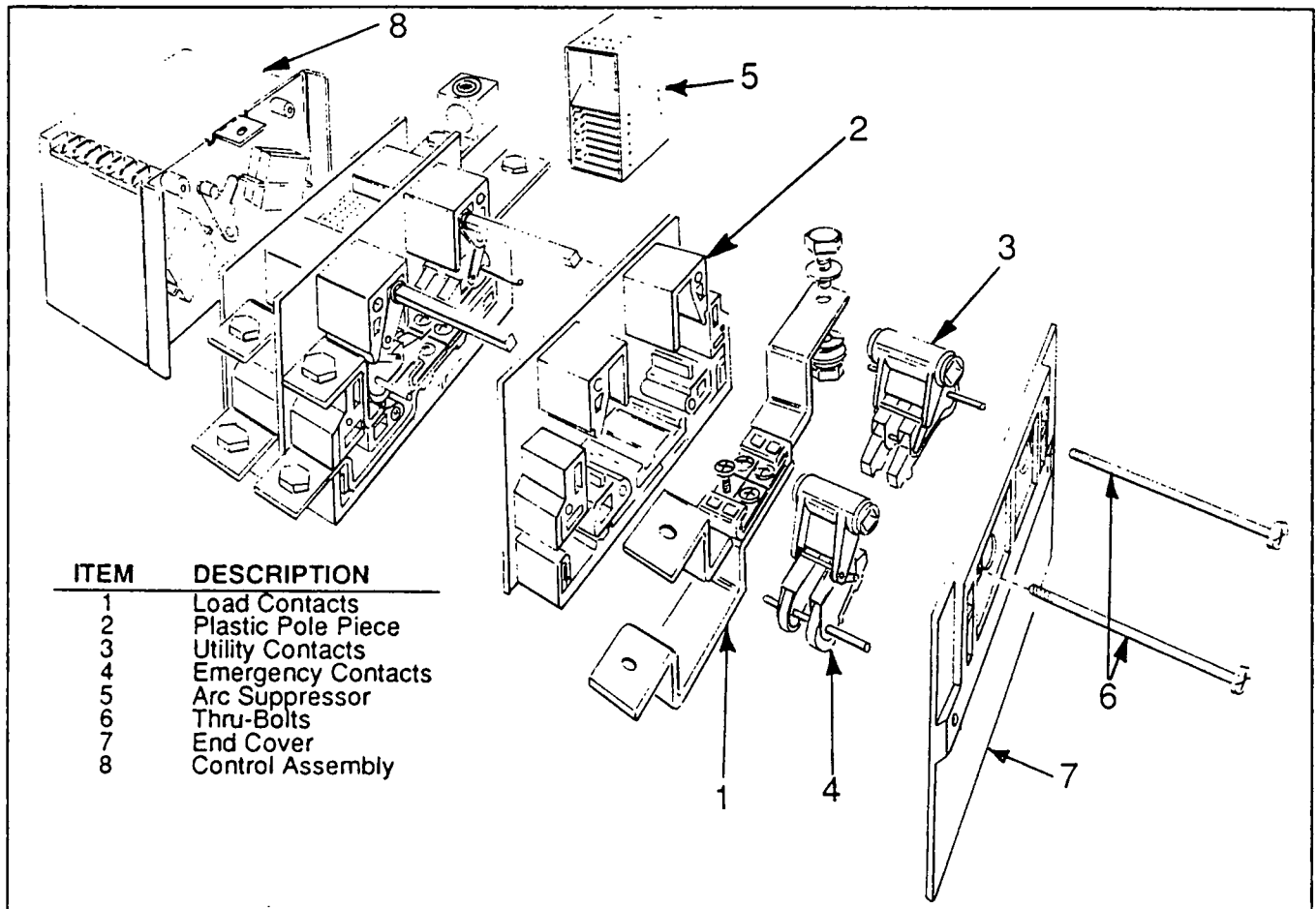


Figure 6. Transfer Mechanism Major Components

Control Assembly

GENERAL:

See Figure 7. The control assembly houses the following components:

- A terminal strip.
- A trip coil.
- A selective coil.
- A closing coil.
- A selective switch.
- Control switches.
- Trip control switches.

TERMINAL STRIP:

The terminal strip (Figure 8) includes the following terminals:

Terminals A1, A2: Actuating command to the "Utility" power source side. Transfer to "Utility" cannot occur unless that power source is available.

Terminals B1, B2: Actuating command to the "Standby" power source side. Transfer to "Standby" cannot occur unless that power source is available.

Terminals AT1, AT2: Power from the "Standby" source is applied here, to provide a "trip to neutral" command from the "Utility" position.

Terminals BT1, BT2: Power from the "Utility" source is applied here, to provide a "trip to neutral" command from the "Standby" position.

TRIP COIL:

During automatic operation, the trip coil (TC) actuates the main contacts to their "tripped" or "neutral" position.

The trip coil is energized by applying "Standby" source power to terminals AT1/AT2, for a "trip to neutral" action from the "Utility" position.

The trip coil is energized by applying "Utility" source power to terminals BT1/BT2, for a "trip to neutral" action from the "Standby" position.

SELECTIVE COIL:

When energized by rectified (and reduced on 480 volts units) "Utility" or "Standby" voltage, the selective coil acts to reset selective switches (LS).

CLOSING COIL:

When energized by "Utility" or "Standby" source power, the closing coil actuates the main contacts from their "tripped" (Neutral) position to closed position (closed to either the "Utility" or "Standby" source side).

SELECTIVE SWITCH:

Actuated by the selective coil (SC), to prepare the circuit for transfer to "Standby" or for retransfer back to "Utility".

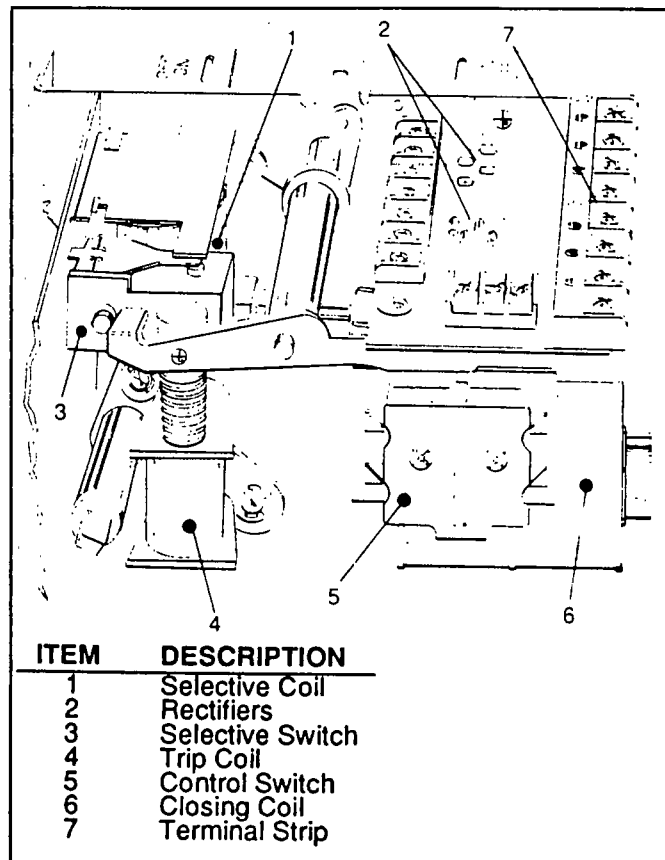


Figure 7. The Control Assembly

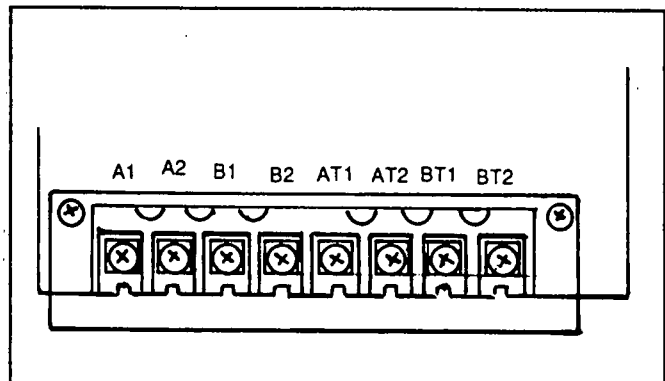


Figure 8. Terminal Strip

CONTROL SWITCHES:

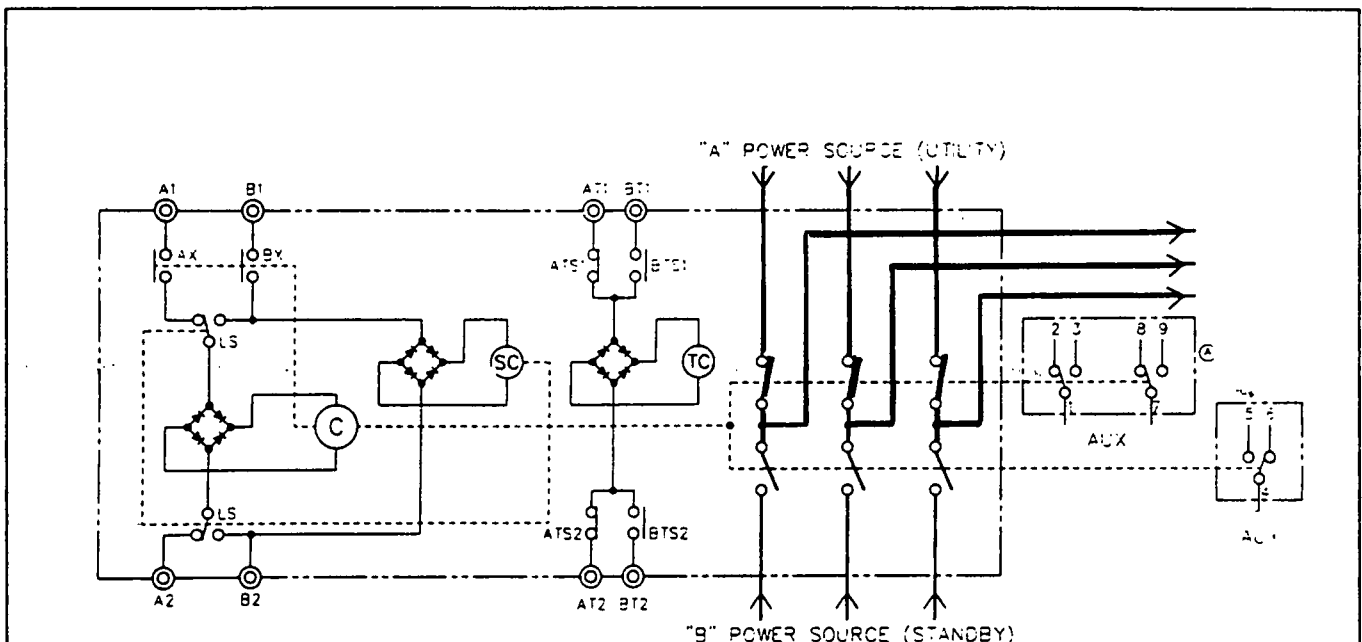
Control switches Ax/Bx are actuated by closing coil action. The following facts apply:

- The control switches will open when the main contacts reach their "Utility" or "Standby" position.
- The control switches will close when "trip to neutral" occurs.

Transfer Mechanism Operational Analysis

PHASE 1- MAIN CONTACTS AT "UTILITY":

- The LOAD is connected to the UTILITY power source side, i.e., LOAD is powered by the UTILITY source ("A" power source).
- Auxiliary contacts (AUX) are positioned as shown.
- Control switches Ax/Bx are open.
- Selective switches (LS) are closed to the terminals A1/A2 side.
- Trip control switches ATS1/ATS2 are closed.
- Trip control switches BTS1/BTS2 are open.



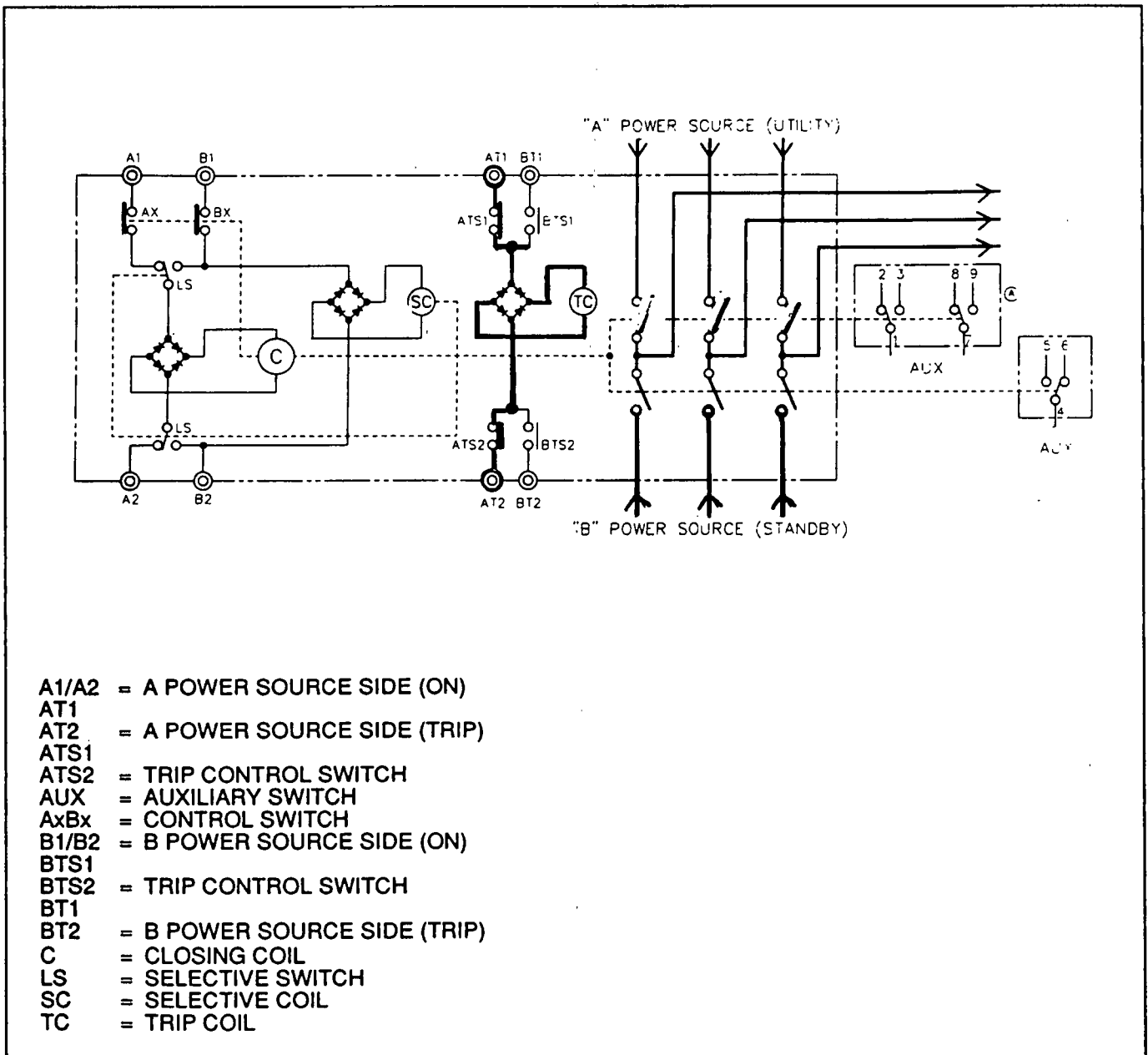
- A1/A2 = A POWER SOURCE SIDE (ON)
- AT1
- AT2 = A POWER SOURCE SIDE (TRIP)
- ATS1
- ATS2 = TRIP CONTROL SWITCH
- AUX = AUXILIARY SWITCH
- AxBx = CONTROL SWITCH
- B1/B2 = B POWER SOURCE SIDE (ON)
- BTS1
- BTS2 = TRIP CONTROL SWITCH
- BT1
- BT2 = B POWER SOURCE SIDE (TRIP)
- C = CLOSING COIL
- LS = SELECTIVE SWITCH
- SC = SELECTIVE COIL
- TC = TRIP COIL

Transfer Mechanism Operational Analysis (Continued)

PHASE 2- TRIP TO "NEUTRAL" FROM "UTILITY":

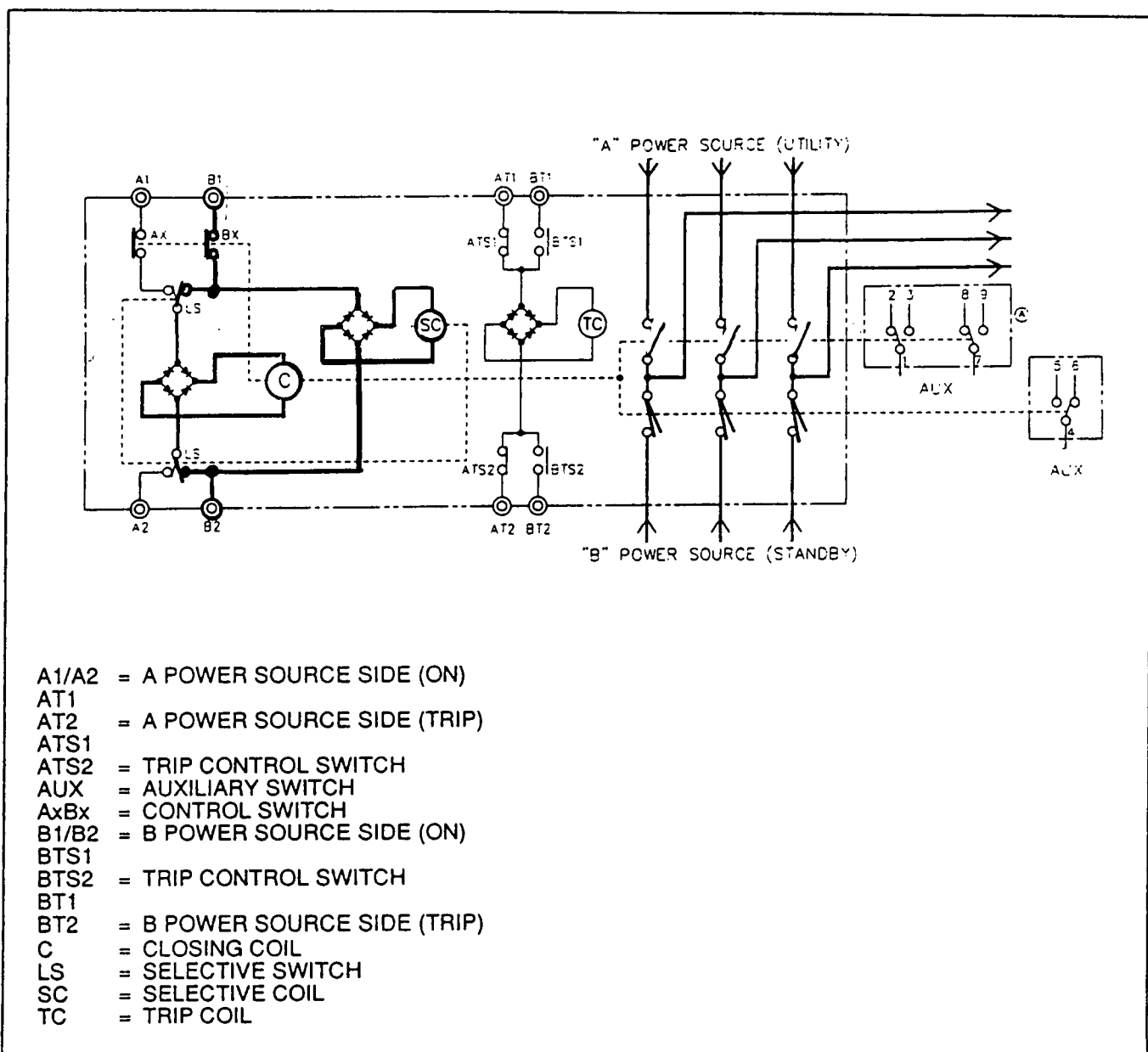
On "Utility" failure, the generator engine will crank and start. The following will then take place:

- Generator voltage is applied across terminals AT1/AT2.
- With trip control switches ATS1/ATS2 closed, standby power is delivered to the trip coil (TC), via a bridge rectifier.
- The trip coil energizes to open a mechanical latch on the main contacts, which then actuate to their "tripped" or "neutral" position (customer load disconnected from both power supplies).
- As the main contacts reach "neutral", control switches Ax and Bx close.



Transfer Mechanism Operational Analysis (Continued)**PHASE 3- TRANSFER TO "STANDBY":**

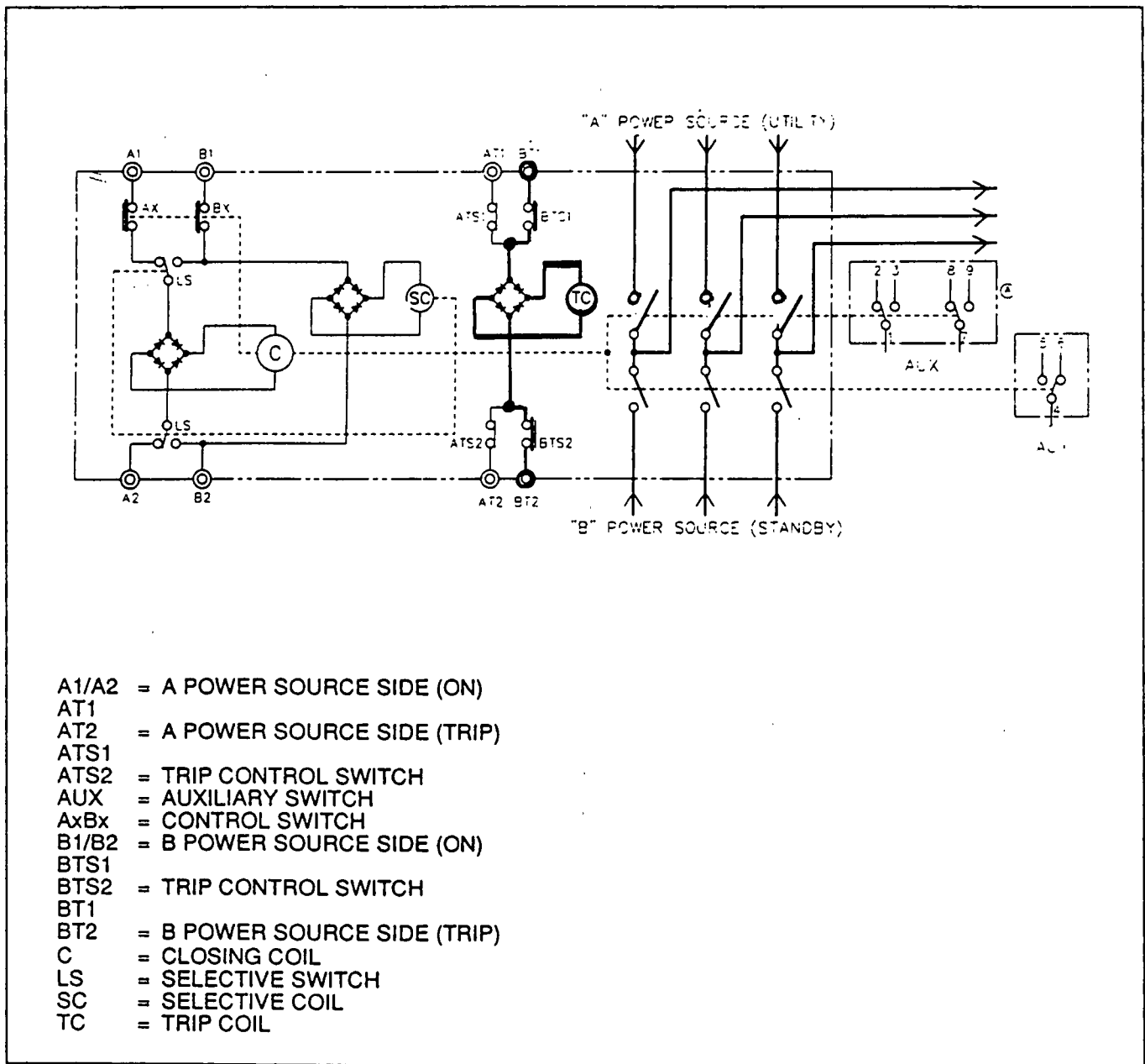
- Standby operating voltage is applied to terminals B1/B2.
- With control switch Bx closed, selective coil SC energizes, causing both selective switches LS to close to the terminals B1/B2 side.
- Closing coil (C) now energizes and the main contacts are actuated to their "Standby" power source side (loads connected to the "B" power source).
- As the main contacts reach their "Standby" position, control switches Ax/Bx open and control switches BTS1/BTS2 close. This prepares the circuit for "return to utility" operations.



Transfer Mechanism Operational Analysis (Continued)

PHASE 4- TRIP TO "NEUTRAL" FROM "STANDBY":

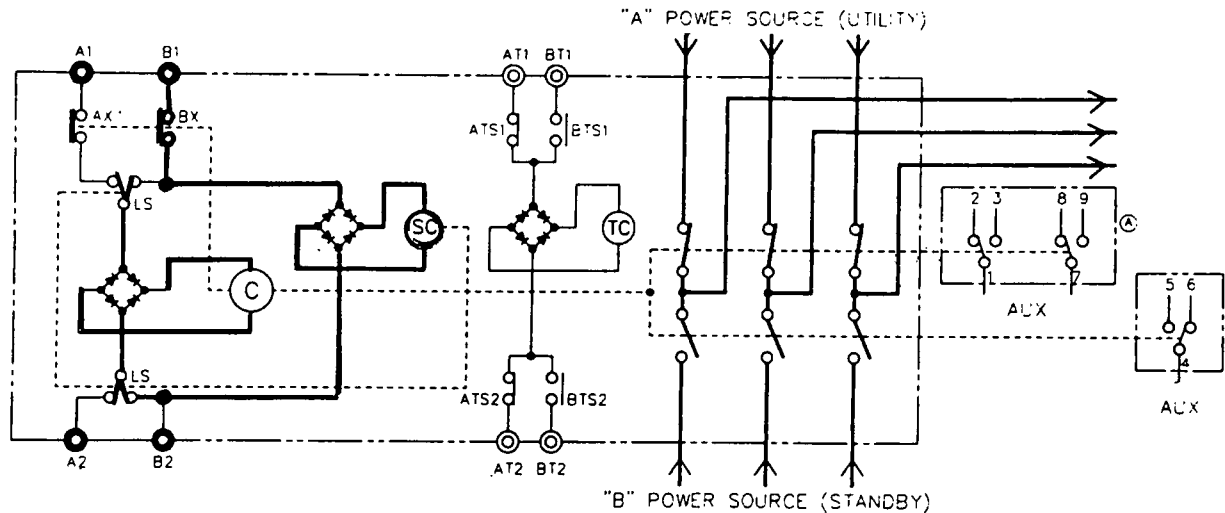
- On restoration of "Utility" source voltage ("B" power source), that voltage is applied across terminals BT1/BT2.
- Since control switches BTS1/BTS2 are closed, trip coil TC energizes.
- With trip coil TC energized, the mechanical latch on the main contacts opens. The main contacts move to their "tripped" or "neutral" position.
- As the main contacts reach "neutral", control switches Ax/Bx close.



Transfer Mechanism Operational Analysis (Continued)

PHASE 5- RETRANSFER BACK TO "UTILITY":

- "Utility" source voltage is applied across terminals A1/A2.
- With control switches Ax/Bx closed, selective coil SC energizes to reset selective switches LS to the A1/A2 side.
- Closing coil (C) is now energized by "Utility" source voltage. The main contacts actuate to their "Utility" position (load connected to "A" power source).
- As the main contacts close to the "Utility" side, control switches Ax/Bx open and ATS1/ATS2 close (to prepare the circuit for the next "trip to neutral" action).



- A1/A2 = A POWER SOURCE SIDE (ON)
- AT1
- AT2 = A POWER SOURCE SIDE (TRIP)
- ATS1
- ATS2 = TRIP CONTROL SWITCH
- AUX = AUXILIARY SWITCH
- AxBx = CONTROL SWITCH
- B1/B2 = B POWER SOURCE SIDE (ON)
- BTS1
- BTS2 = TRIP CONTROL SWITCH
- BT1
- BT2 = B POWER SOURCE SIDE (TRIP)
- C = CLOSING COIL
- LS = SELECTIVE SWITCH
- SC = SELECTIVE COIL
- TC = TRIP COIL

Section 9.3 INSTALLATION

Transfer Switch Selection

Because automatic transfer switches are an integral part of a unified, coordinated electrical distribution system, five factors should be considered when selecting the transfer switch to be used. These factors are:

- Distribution system parameters.
- Functional circuit demands.
- System coordination.
- Environmental or unusual operating conditions.
- Safety.

DISTRIBUTION SYSTEM PARAMETERS:

Figure 1, below, is a simplified guide for selecting a transfer switch. The "Selection Chart" includes a list of operating system parameters, switch ratings, available enclosures and required options.

FUNCTIONAL CIRCUIT DEMANDS:

Automatic transfer switches that monitor all phases of the utility power source are said to offer complete protection, others may offer partial protection.

SYSTEM COORDINATION:

The automatic transfer switch must be properly coordinated with the rest of an electrical distribution system. That is, the switch must be carefully selected on the basis of the distribution system's voltage, continuous current, frequency, short circuit capabilities, etc. The continuous current rating of the transfer switch should be determined based on both the "Utility" and "Standby" loads being supplied. Two factors are especially important when coordinating the transfer switch with the rest of the system:

- The switch must be capable of carrying full load currents and must also be able to withstand the thermal and electro-magnetic effects of short circuit currents.
- Transfer equipment and associated wiring must be provided with suitable protective devices (circuit breakers or fuses). These protective devices must be able to clear a fault without extensive damage.

Under abnormal operating conditions where a fault exists between the transfer switch and the load, the switch may be subjected to (a) withstand, (b) closing, and (c) interrupting conditions as follows:

Transfer Switch Selection Chart			
1. SYSTEM DATA	UTILITY	STANDBY	3. TYPE OF ENCLOSURE (CHECK ONE)
Voltage	_____	_____	<input type="checkbox"/> Open
Frequency	_____	_____	<input type="checkbox"/> NEMA 1 General Purpose
Phase	_____	_____	<input type="checkbox"/> NEMA 3R Outdoors
No. of Wires	_____	_____	<input type="checkbox"/> NEMA 12 Industrial
Current Rating	_____	_____	<input type="checkbox"/> Other (Specify)
Available short circuit current at point where transfer switch is to be installed _____			
Interrupting rating of the upstream protective device _____			
2. AUTOMATIC TRANSFER SWITCH RATINGS			
Voltage _____			
Continuous Current _____			
Withstand _____			
Closing _____			
Interrupting _____			
4. OPTIONS OR SPECIAL EQUIPMENT (LIST)			

Figure 1. Transfer Switch Selection Chart

Transfer Switch Selection (Continued)

- With the switch closed to the "Utility" power source side, it must be able to WITHSTAND the energy let-through of the utility service protective device while that device interrupts the fault.
- When the "Standby" power supply is available, the transfer switch could transfer the load before the utility system's protective device clears the fault. This requires that the transfer switch be capable of INTERRUPTING the protective device's let-through current.
- The transfer switch might "close in" on a fault and, for that reason, it requires a CLOSING rating.

NOTE: Special circuitry may be required to ensure the transfer switch operates safely under interrupting, closing and withstand conditions. Publications that outline the safe use of automatic transfer switches are (a) The National Electric Code, and (b) UL 1008, "Standard for Safety, Automatic Transfer Switches".

Installation Requirements

Generac automatic transfer switches have been factory wired and tested. Transfer switch components have been housed in a sturdy, steel, lockable enclosure. Installation of the transfer switch includes the following:

- Mounting the enclosure.
- Connection of generator start circuit wiring.
- Connection of power source and load lines.
- Installation and connection of any options or accessories.
- Completion of Functional tests and adjustments.

Mounting the Enclosure

Refer to the appropriate Owner's Manual for the transfer switch to be installed. Comply with mounting instructions in that manual. Some enclosures are designed for wall mounting and should be mounted vertically to a rigid supporting structure. Some larger enclosures require floor mounting.

CAUTION: Handle the transfer switch carefully. Protect it against impact at all times. Also protect the unit against metal chips, construction grit, lint, fillings, dust, dirt, etc. Never attempt to use a transfer switch that has been damaged.

Connection of Start Circuit Wiring

Suitable, approved wiring must be properly connected to the 2-wire start terminal strip in the transfer switch enclosure and to an identically numbered terminal strip in the generator's AC connection (lower) panel. Closure of the Wires 178/183 circuit by transfer switch circuit board action must result in generator engine cranking and startup. Route the start circuit wiring through its own separate conduit. Never run start wiring through the same conduit as any power source or load leads. Recommended wire gauge sizes for this wiring depends on wire run length, as follows:

MAXIMUM WIRE LENGTH	RECOMMENDED WIRE SIZE
460 feet (140m)	No. 18 AWG
730 feet (223m)	No. 16 AWG
1160 feet (354m)	No. 14 AWG
1850 feet (565m)	No. 12 AWG

NOTE: The preceding procedure applies to connection of a 2-wire start circuit only. An optional 3-wire start circuit is also available. See Part 12, "Transfer Switch Options".

Power Source and Load Lines

Power source and load line conductors must be properly supported, of approved insulative qualities, and of the correct wire gauge size.

When connecting power source and load lines, remove surface oxides with a wire brush. Apply joint compound to the stripped end of the conductors. Tighten terminals to the specified torque value, then wipe away excess joint compound. Tighten power source and load terminal lugs on the transfer mechanism as follows:

For units rated 100 amps, tighten to 50 inch-pounds (6 N-m).
For all other units, tighten to 250 inch-pounds (28 N-m).

DANGER: ALWAYS TURN OFF ALL POWER VOLTAGE SUPPLIES TO THE TRANSFER SWITCH BEFORE ATTEMPTING TO CONNECT POWER SOURCE AND LOAD LINES. BOTH THE "UTILITY" AND "STANDBY" POWER SUPPLIES TO THE TRANSFER SWITCH MUST BE POSITIVELY TURNED OFF. FAILURE TO TURN OFF ALL POWER VOLTAGE SUPPLIES MAY RESULT IN DANGEROUS AND POSSIBLY LETHAL ELECTRICAL SHOCK.

CAUTION: Be sure to maintain correct electrical clearance between live metal parts and grounded metal. Allow at least one-half inch of clearance for 100-400 amp circuits; or one inch for circuits over 400 amps.

NOTE: The transfer switch rated voltage and phase must match the rated voltage and phase of the power sources. Multi-voltage transfer switches (Section 9.7) are available which permit installer selection of transfer switch rated voltage and phase.

3-POLE TRANSFER SWITCH CONNECTIONS:

For 3-Phase Applications: Before connecting any 3-phase power supply to the transfer switch, make sure the transfer switch is rated for 3-phase use. To connect a 3-phase system to a 3-pole transfer mechanism, proceed as follows:

1. Connect "Utility" source lines 1, 2 and 3 (A, B and C) to transfer mechanism terminal lugs N1, N2 and N3 respectively.
2. Connect "Standby" source lines E1, E2 and E3 to transfer mechanism terminal lugs E1, E2 and E3.
3. Connect load lines 1, 2 and 3 (A, B and C) to terminal lugs T1, T2 and T3 respectively.

Power Source and Load Lines (Continued)

4. Connect "Utility", "Standby" and "Load" NEUTRAL lines to the transfer switch neutral block.

For 1-Phase Applications: At the time of this writing, "Wn" type transfer switches were available with 3 or 4-pole transfer mechanisms only. Transfer switches rated for 1-phase use are 3-pole type with factory wiring connections to terminal lugs N3, E3 and T3 omitted. The installer must ensure that the switch to be installed is rated for 1-phase use or a multi-voltage transfer switch must be used. Connect the 1-phase power source and load lines to the transfer switch as follows:

1. Connect "Utility" source lines 1 and 2 to transfer mechanism terminal lugs N1 and N2, respectively.
2. Connect "Standby" source lines E1 and E3 to transfer mechanism terminal lugs E1 and E2, respectively.
3. Connect "Load" lines 1 and 2 to terminal lugs T1 and T2.
4. If the "Neutral" line is not to be switched, connect utility, standby and load "Neutral" lines to the transfer switch neutral block.
5. If the "Neutral" line is to be switched during transfer, connect the "Utility" neutral line to terminal N3; the "Standby" source neutral line to terminal E3; and the "Load" neutral line to terminal T3.

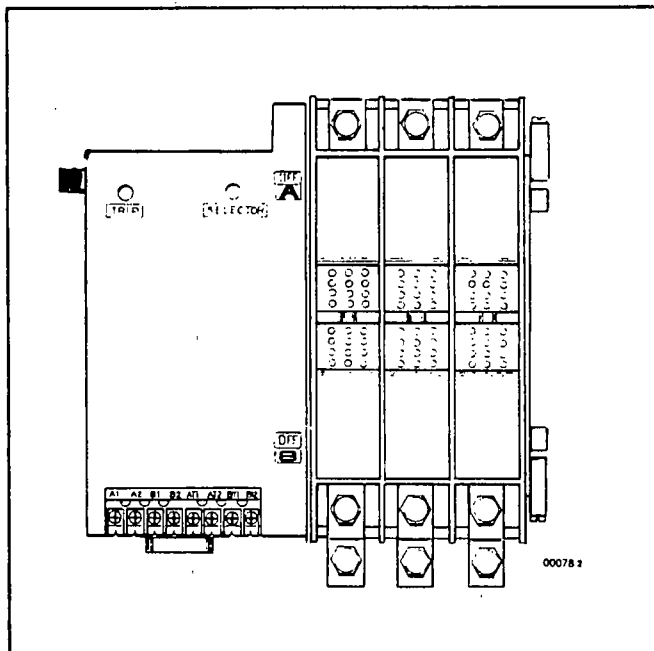


Figure 2. A 3-Pole Transfer Mechanism

4-POLE TRANSFER SWITCH CONNECTIONS:

Typically, a 4-pole transfer mechanism is used in conjunction with a 3-phase system when it is desirable to switch the "Neutral" during a transfer action. Generally, a 4-pole unit is not equipped with a neutral block since "Neutral" will be connected at the transfer mechanism terminal lugs.

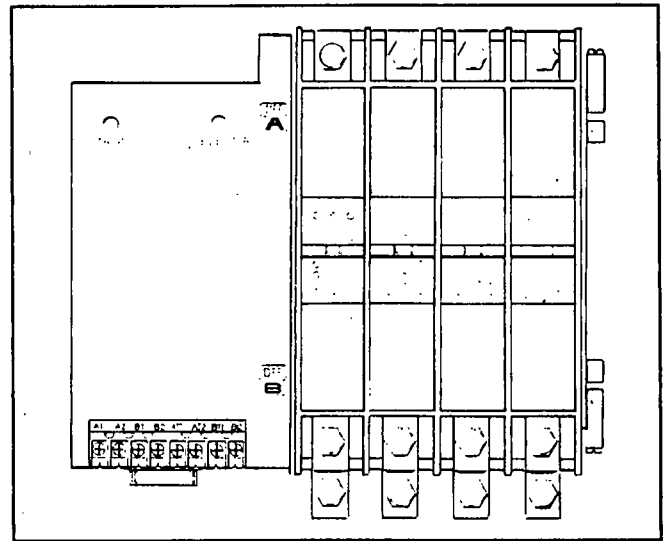


Figure 3. A 4-Pole Transfer Mechanism

Connect a 3-phase system to a 4-pole transfer mechanism as follows, when the "Neutral" is to be switched during transfer:

1. Connect "Utility" lines 1, 2 and 3 (A, B and C) to terminals N1, N2, N3.
2. Connect "Standby" lines E1, E2, E3 to terminal lugs E1, E2, E3 respectively.
3. Connect "Load" lines 1, 2 and 3 (A, B and C) to terminals T1, T2, T3 respectively.
4. Connect the "Utility" source NEUTRAL to terminal lug N4.
5. Connect the "Standby" source NEUTRAL to terminal lug E4.
6. Connect the "Load" NEUTRAL line to terminal lug T4.

Options and Accessories

Install, connect and test any accessories or options that are to be used. For generator set options and accessories, see Part 7. Transfer switch options and accessories are discussed in Part 12.

Functional Tests

Before placing the system into service all necessary adjustments and all functional tests should be completed. Refer to Section 9.5, "Functional Tests".

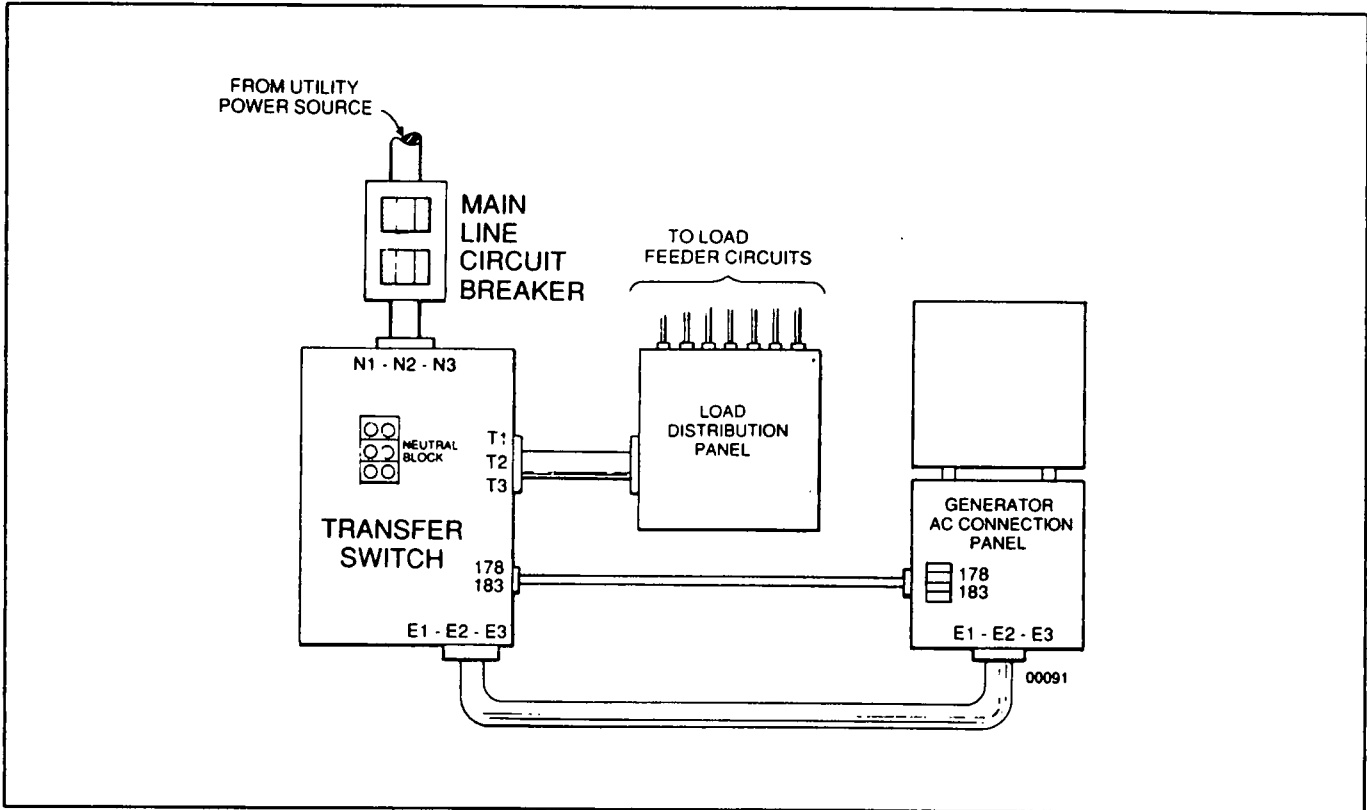


Figure 4. Standby Electric System Interconnections (Typical)

Section 9.4 OPERATING INSTRUCTIONS

Normal Automatic Operation

To set the system for normal automatic operation, proceed as follows:

1. On the transfer switch enclosure door, check the switch position advisory lamps. The "Switch Position-Utility" lamp should be on, indicating that "Utility" power is available and the main contacts are at their "Utility" position (load connected to the "Utility" supply).

NOTE: If necessary, manually actuate the main contacts to their "Utility" power source side. See "Manual Operation" in this section. Also, turn on the "Utility" power supply to the transfer switch, if necessary. The main contacts must be at "Utility" and that power supply must be available to the transfer switch before proceeding.

NOTE: On newly installed systems, check the "Utility On" lamp on the utility voltage sensor circuit board. That lamp should be ON, indicating that "Utility" source sensing voltage is available to the board and is above the setting of the board's "voltage dropout sensor". Calibration of the utility voltage sensor board may be necessary, to match the board sensors to actual "Utility" source voltage (see Part 10 or Part 11 as appropriate).

2. On the transfer switch enclosure door, set the system test switch to its "Automatic Mode".
3. In the transfer switch enclosure, set the maintenance disconnect switch to its "Automatic" position.
4. On the generator control console, set the auto-manual-off switch to "Auto" (if so equipped).
5. Set the generator ("Standby") main line circuit breaker to its "On" or "Closed" position.

When the preceding Steps 1 through 5 are completed, a "Utility" source voltage dropout will result in automatic generator cranking and startup. Following generator startup, transfer of the load to the "Standby" source will occur. See Part 10 or 11 as appropriate for automatic operating sequences and parameters.

DANGER: WHEN SET FOR AUTOMATIC OPERATION, THE STANDBY GENERATOR CAN CRANK AND START SUDDENLY AT ANY TIME WITHOUT WARNING. TO PREVENT SUCH AUTOMATIC STARTUP AND POSSIBLE INJURY THAT MIGHT BE CAUSED BY SUCH A STARTUP, ALWAYS DISABLE THE 2-WIRE START SYSTEM BEFORE WORKING ON OR AROUND THE SYSTEM. AUTOMATIC STARTUP CAN BE PREVENTED BY SETTING THE MAINTENANCE DISCONNECT SWITCH TO "MANUAL". IF SO EQUIPPED, ALSO SET THE GENERATOR'S AUTO-MANUAL-OFF SWITCH TO "OFF". FINALLY, PLACE A "DO NOT OPERATE" TAG ON THE GENERATOR AND ON THE TRANSFER SWITCH.

Manual Operation

TRANSFER TO "STANDBY":

To transfer loads to the "Standby" power source and start the generator manually, proceed as follows:

1. In the transfer switch enclosure, set the maintenance disconnect switch to "Manual".
2. On the generator console, set the auto-manual-off switch to "Manual".
3. Turn OFF both the "Utility" and "Standby" power supplies to the transfer switch, using whatever means provided.

DANGER: DO NOT ATTEMPT MANUAL TRANSFER SWITCH OPERATION UNTIL AFTER ALL POWER VOLTAGE SUPPLIES TO THE SWITCH HAVE BEEN POSITIVELY TURNED OFF. FAILURE TO TURN OFF ALL POWER VOLTAGE SUPPLIES MAY RESULT IN HAZARDOUS AND POSSIBLY DEADLY ELECTRICAL SHOCK.

4. Use the manual transfer handle to manually actuate the main contacts to their "Standby" source side (LOAD connected to the "Standby" supply). The word "ON" must be visible in window B of the transfer mechanism; the word "OFF" in window A. Refer to Section 9.5, "Functional Tests" for manual operating procedures.
5. Start the generator engine manually, using the start/stop switch on the generator control console. Let the engine stabilize and warm up.
6. Set the generator's main line circuit breaker to "On" or "Closed". Loads are now powered by the standby generator.

RETRANSFER TO "UTILITY" AND SHUTDOWN:

To retransfer loads back to the "Utility" source and shut the generator down, proceed as follows:

1. Check that the maintenance disconnect switch (in transfer switch enclosure) is set to "Manual".
2. If so equipped, set the auto-manual-off switch (on generator console) to "Manual".
3. Turn OFF both the "Utility" and "Standby" power supplies to the transfer switch, using whatever means available (such as the "Utility" and "Standby" main line circuit breakers).
4. Use the engine-start/stop switch on generator console to shut down the generator engine.
5. See Section 9.5, "Functional Tests". Use the manual transfer handle to manually actuate the main contacts back to their "Utility" position (load connected to the utility power supply). On the transfer mechanism, window A should display the word "On" and window B the word "Off".
5. Turn ON the "Utility" power supply to the transfer switch. Then, set the system for normal automatic operation (see "Normal Automatic Operation").

Normal Test

To perform a "Normal Test" of the system, refer to Section 9.5, "Functional Tests".

Fast Test

To conduct a "Fast Test" of the system, refer to Section 9.5, "Functional Tests".

System Exercise

Once every seven days, on a day and at a time of day selected by the owner, the standby generator will start and run for a preset time period. During this exercise, transfer to the "Standby" source may or may not occur as selected by means of a circuit board switch.

NOTE: On units equipped with three circuit boards, system exercise is controlled by a 7-day exercise circuit board. An optional programmable exercise board is also available which provides an exercise runup on selected day or days of the week. On transfer switches having only two circuit boards, the exercise feature is part of the CPU circuit board.

Section 9.5 FUNCTIONAL TESTS

General

Following installation, the standby electric system should be inspected and tested. All required adjustments should be completed.

Functional testing of the system includes (a) manual operation, (b) voltage checks, (c) electrical operation, and (d) completing required adjustments.

Read and make sure you understand all instructions before proceeding. Also read instructions on tags and labels that might be affixed to the transfer switch. Note any options or accessories that might be installed and review their operation.

DANGER: DO NOT ATTEMPT MANUAL TRANSFER SWITCH OPERATION UNTIL ALL POWER VOLTAGE SUPPLIES TO THE TRANSFER SWITCH HAVE BEEN POSITIVELY TURNED OFF. FAILURE TO TURN OFF ALL POWER VOLTAGE SUPPLIES MAY RESULT IN EXTREMELY HAZARDOUS AND POSSIBLY LETHAL ELECTRICAL SHOCK.

Manual Operation

Both a manual transfer handle and an actuating pin are included with the "Wn" type automatic transfer switch. Following installation, manual operation should be checked before the switch is operated electrically. To operate the transfer switch manually, proceed as follows:

CAUTION: Do NOT apply excessive force when operating the main contacts manually, or the manual transfer handle may be damaged. Always set the contacts to their "tripped" or "neutral" position before selecting either "Utility" or "Standby". The main contacts are at "tripped" or "neutral" when the word "Off" appears in both windows A and B.

1. In the transfer switch enclosure, set the maintenance disconnect switch to its "Manual" position.
2. Turn off both the "Utility" and "Standby" power supplies to the transfer switch, using whatever means provided.
3. Note the position of the transfer mechanism main contacts by observing the display in windows A and B.
 - a. When window A reads "ON" and window B reads "OFF", load is connected to the "Utility" power source.
 - b. When window B reads "ON" and window A reads "OFF", the load is connected to the "Standby" power source.
 - c. When windows A and B both read "OFF", the load is disconnected from both power sources ("tripped" or "neutral").

4. If window A or B reads "ON": Go to Step 6. The switch must be "tripped" to "Neutral" before it is reset to "Manual" or "Utility".
5. If windows A and B Both Read "OFF": Switch is already "tripped" to "Neutral". Go to Step 7.
6. To "trip" the contacts (set them to "Neutral"), proceed as follows:
 - a. Insert the actuating pin (shipped with unit) into Hole "T" (see Figure 1 below). Push the trip lever in.
 - b. The main contacts should "trip" to "Neutral" and the word "OFF" should appear in windows A and B.

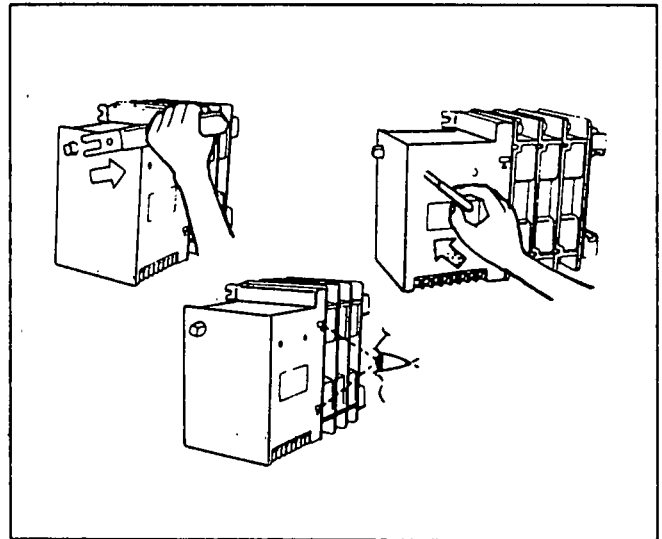


Figure 1. Trip to "Neutral"

7. To close the main contacts to the "Utility" power source side, proceed as follows:
 - a. Attach the manual transfer handle to the square shaft at upper corner of transfer mechanism (Figure 2).
 - b. Move the handle upward. The word "ON" should appear in window A, the word "OFF" in window B. This indicates the "Load" is connected to the "Utility" power source side.
8. To close the main contacts to their "Standby" power source side, proceed as follows:
 - a. Attach manual transfer handle to square shaft.
 - b. Operate the handle upward and, at the same time, use the actuating pin to push in on trip lever through Hole "S". The main contacts should actuate.
 - c. The word "ON" should appear in window B; the word "OFF" in window A. This indicates the "Load" is connected to the "Utility" source side.
9. Repeat Steps 6, 7 and 8 several times, until you are certain that manual operation is correct.

NOTE: Before proceeding to "Voltage Checks", "LOad" must be connected to the "Utility" source. Window A must display the word "ON", window B must display the word "OFF".

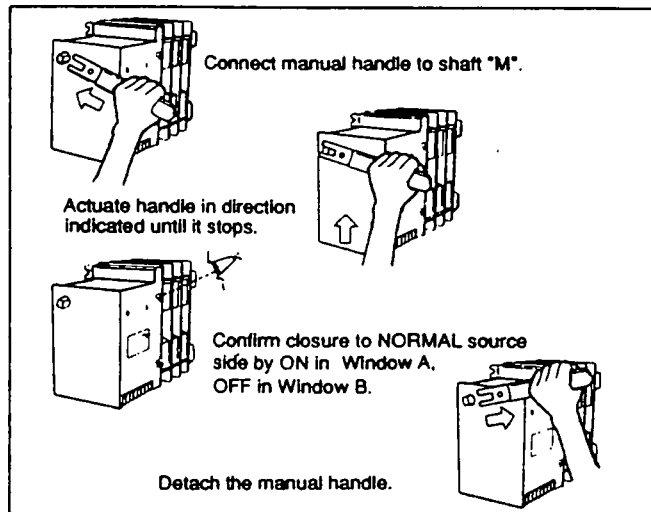
Manual Operation (Continued)

Figure 2. Closing to "Utility" Source Side

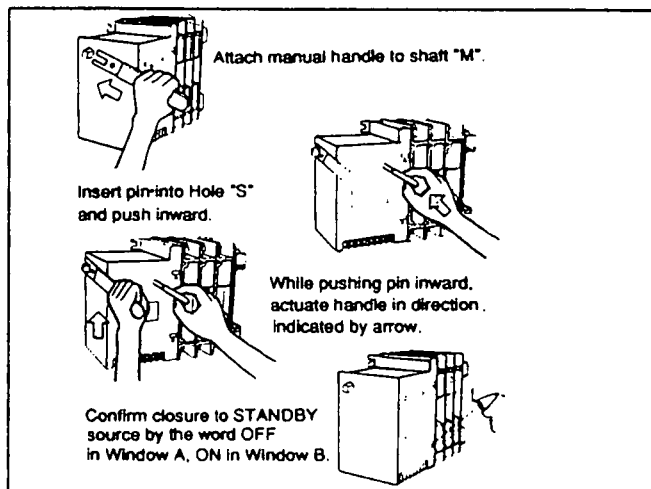


Figure 3. Closing to "Standby" Source Side

Voltage Checks

Before proceeding, check the transfer switch data plate for rated voltage. Both "Utility" and "Standby" voltage must be compatible with the data plate voltage.

DANGER: FOR SAFETY, SET THE MAINTENANCE DISCONNECT SWITCH TO "MANUAL" BEFORE PERFORMING VOLTAGE CHECKS.

DANGER: USE EXTREME CAUTION WHEN PERFORMING VOLTAGE CHECKS. POWER TERMINALS AND WIRES ARE ELECTRICALLY HOT. DO NOT TOUCH LIVE ELECTRICAL PARTS. DO NOT PERFORM VOLTAGE CHECKS WHILE BAREFOOT, WHILE HANDS OR FEET ARE WET, OR WHILE STANDING IN WATER. IF POSSIBLE STAND ON INSULATIVE MATS WHILE PERFORMING THE VOLTAGE CHECKS.

Perform voltage checks as follows:

1. In the transfer switch enclosure, set the maintenance disconnect switch to "Manual".
2. If so equipped, set the generator's auto-manual-off switch to "Off" position.
3. On the switch enclosure door, set the system test switch to "Automatic Mode".
4. Check that the main contacts are actuated to their "Utility" position, i.e., "Load" connected to the "Utility" source. Window A should display the word "ON"; window B the word "OFF".

CAUTION: DO NOT proceed until the preceding Steps 1 through 4 have been completed.

5. Turn ON the "Utility" power supply to the transfer switch using whatever means provided (such as the "Utility" main line circuit breaker).
 - a. Check that the "Switch Position-Utility" lamp is ON. "Lamp ON" condition indicates that (a) "Utility" voltage is available to the transfer switch and (b) the "Load" is connected to the "Utility" side.
 - b. Inside the transfer switch enclosure door, locate the utility voltage sensor circuit board. The board's "Utility On" lamp (LED) should be ON. Lamp illuminates to indicate that (a) "Utility" sensing voltage is available to the circuit board, and (b) the "Utility" sensing voltage is above the setting of a "voltage dropout sensor".

NOTE: It is recommended that the utility voltage sensor circuit board be calibrated to match the local "Utility" power source voltage. Refer to Part 10 or 11 as appropriate for circuit board calibration procedures.

6. Use an AC voltmeter to check line-to-line (phase-to-phase) voltages across transfer switch terminal lugs N1, N2, N3. Also check line-to-neutral voltage across terminal lug N1 and neutral; N2 and neutral; N3 and neutral. Supplied voltage must be compatible with transfer switch rated voltage and phase.

NOTE: For MULTI-VOLTAGE transfer switches, see Section 9.7.

7. Refer to the appropriate Owner's Manual for the specific standby generator set.
 - a. Make sure the generator and its engine have been properly serviced and are completely ready for use.
 - b. On the generator control console, set the auto-manual-off switch to "Manual".
 - c. Use the start/stop switch on generator console to crank and start the generator engine. Let the engine stabilize and warm up.
 - d. Turn on the "Standby" power supply to the transfer switch, using whatever means provided (such as the generator main line circuit breaker).
8. On the transfer switch enclosure door, check that the "Standby Operating" lamp is lighted.
9. Use an AC voltmeter to check voltage across terminal lugs E1, E2, E3 (line-to-line), and across each terminal lug and the neutral block (line-to-neutral).

Voltage Checks (Continued)

10. Use an AC frequency meter to check generator AC frequency. If necessary, adjust the engine speed governor to supply correct frequency.
11. When all tests and adjustments have been completed, shut the generator down.

Electrical Operation

PERFORM A "NORMAL TEST":

1. On the utility voltage sensor circuit board, check that the "Utility On" lamp is ON.
2. On the switch enclosure door, check that the "Switch Position-Utility" lamp is ON.
3. In the transfer switch enclosure, set the maintenance disconnect switch to "Automatic".
4. If so equipped, set the generator's auto-manual-off switch to "Auto".
5. Make sure the standby generator and its engine have been properly serviced and are completely ready for use.
6. Set the "Standby" main line circuit breaker to "On" or "Closed".
7. Set the system test switch to its "Normal Test Mode" position.
 - a. The standby generator engine should crank and start. The "Standby Operating" lamp on transfer switch door should illuminate.
 - b. Following generator startup, transfer to the "Standby" source should occur. The "Switch Position-Emergency" lamp should illuminate.
8. With the generator running and with loads powered by generator output, reset the system test switch back to "Automatic Mode".
 - a. After a brief pause, retransfer back to the "Utility" power source should occur.
 - b. Following retransfer, an "engine cooldown timer" and an "engine minimum run timer" will time out. When those timers have finished timing, the generator should shut down.

NOTE: On units equipped with a "logic type" intelligence system (3 circuit boards), advisory lamps on the system control (logic) circuit board will turn on to indicate operation of the various sensors and timers that control automatic operation. By observing these lamps (LED's), automatic operation sequences and times can be verified. See Part 11, "The Logic Type Intelligence System".

Section 9.6 OPERATIONAL ANALYSIS

NOTE: The transfer switch used in this operational analysis is a 3-pole, 1-phase, 240 volts unit equipped with (a) a "Logic" type intelligence system having 3 circuit boards, and (b) with the time delay neutral feature.

Circuit Condition- Utility Power Available

"Utility" source voltage is delivered to transfer mechanism (GTS) terminals N1, N2, N3 via customer supplied wiring. From the transfer mechanism (GTS), "Utility" voltage is delivered to terminals N1, N2 and N3 of a utility sensing interface. Step-down transformers in the interface reduce the voltage signal to about 18-25 volts, depending on the actual "Utility" source voltage. The reduced voltage is then delivered to a utility voltage sensor circuit board via Wires 224-227. A "Utility On" lamp (LED) on that circuit board should be ON.

From terminal lug N1, "Utility" source power is delivered to transfer mechanism terminal A1, via Wire N1, the safety disconnect switch ("Automatic" selected), Wire 125, the normally-closed transfer relay (TR) contacts, Wire 126, normally-closed time delay relay (TD) contacts. From terminal lug N2, "Utility" power is available to transfer mechanism terminal A2, via wire N2. With the main contacts at "Utility", the A1/A2 circuit to the closing coil (C) is held open by control switch Ax action.

Power from terminal lugs N1/N2 is also available to transfer mechanism terminals BT1 and BT2. However, trip control switches BTS1/BTS2 are held open by transfer mechanism action and trip coil (TC) is de-energized.

From load terminals T1/T2, "Utility" source voltage is delivered to the primary coil of transformer TR2. A reduced voltage is induced into the TR2 secondary coil. This reduced (step-down) voltage is available to the 7 day exerciser board via wires 185 and 0. The step-down voltage is also delivered to a "Switch Position-Utility" lamp (CL), via the normally-closed auxiliary contacts and the lamp is ON.

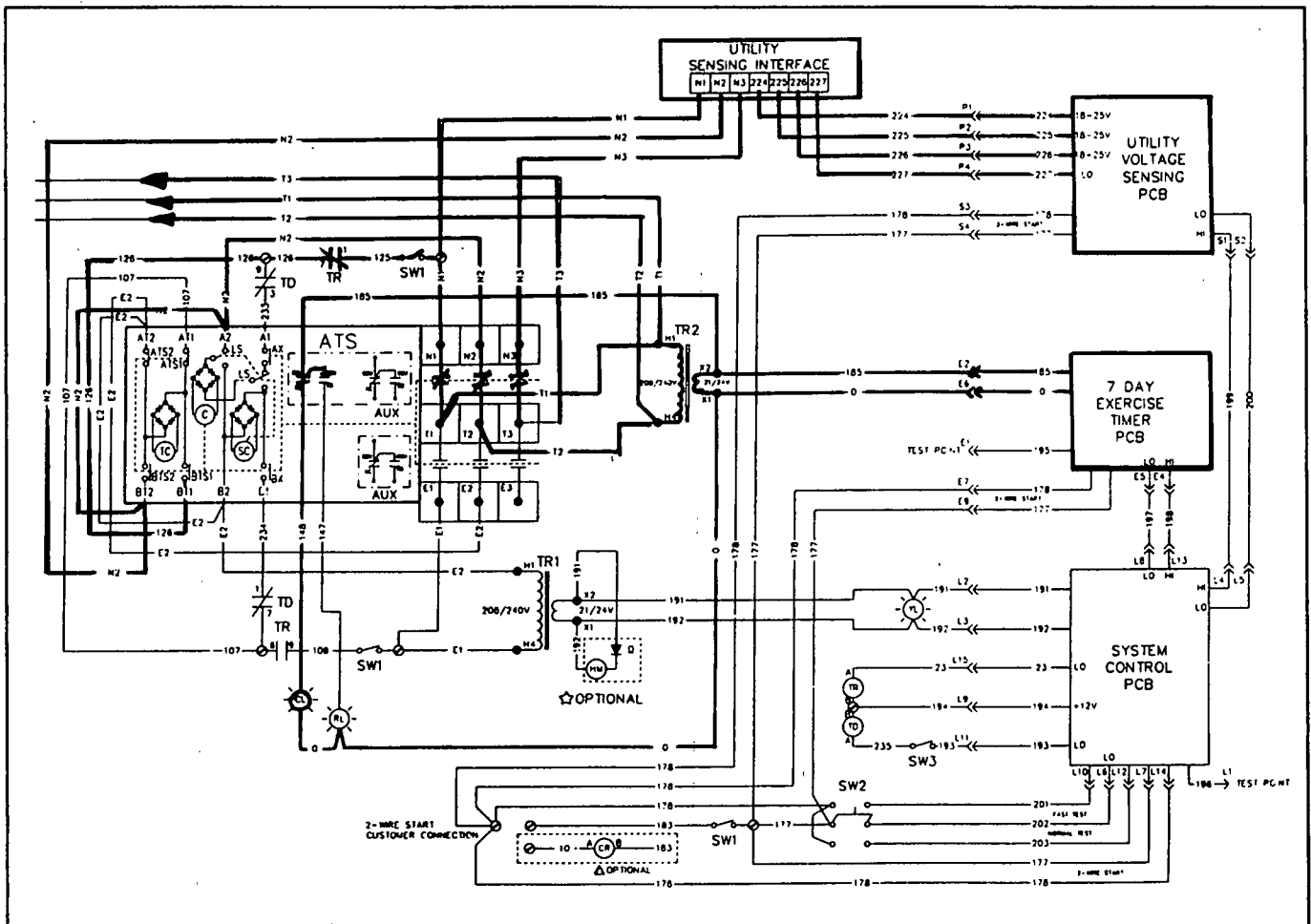


Figure 1. Circuit Condition- Utility Source Power Available

Circuit Condition- Utility Power Source Dropout

The utility voltage sensor monitors the "Utility" power source voltage from the utility sensing interface, via Wires 224-227. Should that source voltage drop below the setting of a "voltage dropout sensor" on the circuit board, a timer on the circuit board will start. Should the sensing voltage remain low after the timer has finished timing, circuit board action will close the wires 178/183 circuit. The generator will then crank and start as controlled by a dc control/latch-crank board in the generator console.

The utility voltage sensor board will also open the wires 199/202 circuit between its connector and the system control (logic or CPU) circuit board, to "tell" the system control board that "Utility" voltage is low. If the circuit is not opened by circuit board action when in automatic mode, transfer to "Standby" will not occur.

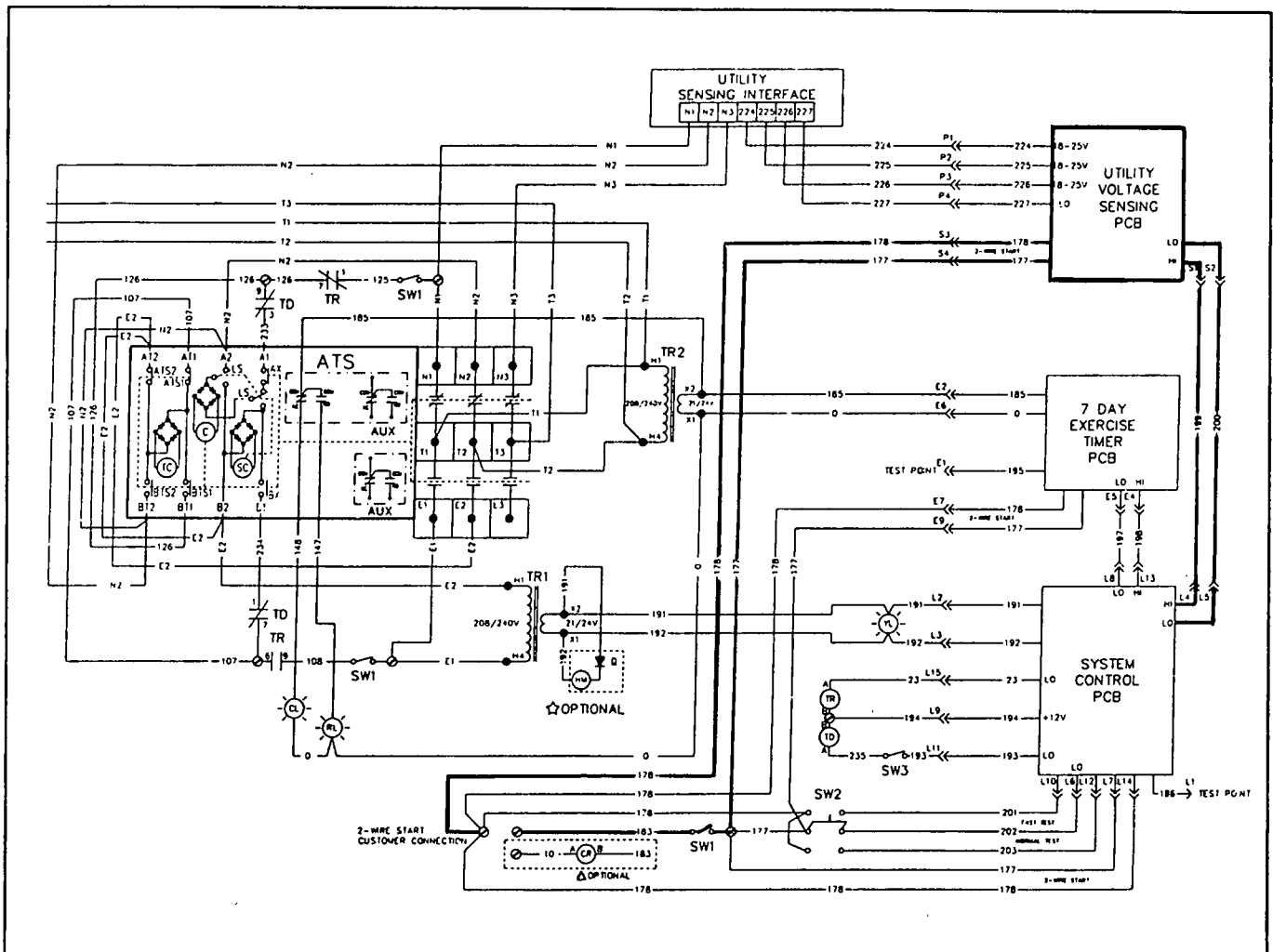


Figure 2. Circuit Condition- Utility Power Source Dropout

Circuit Condition- Standby Generator Running

With the standby generator running, generator AC output voltage is delivered to transfer mechanism terminal lugs E1, E2, E3. Standby current flows through the primary coil of transformer TR1, to induce a step-down voltage into the transformer secondary coil. Secondary coil output is then delivered to a "Standby Operating" lamp and to the system control circuit board.

The "Standby Operating" lamp turns on.

The system control circuit board turns on and delivers 12 volts DC to (a) a transfer relay (TR) coil and (b) a time delay relay (TD) coil. The TR coil circuit is completed back to the system control board via Wire 23; the TD coil circuit via Wire 193. Circuit board action holds these circuits open and both relays remain de-energized.

An "engine warmup timer" and a "minimum run timer" on the system control board start timing.

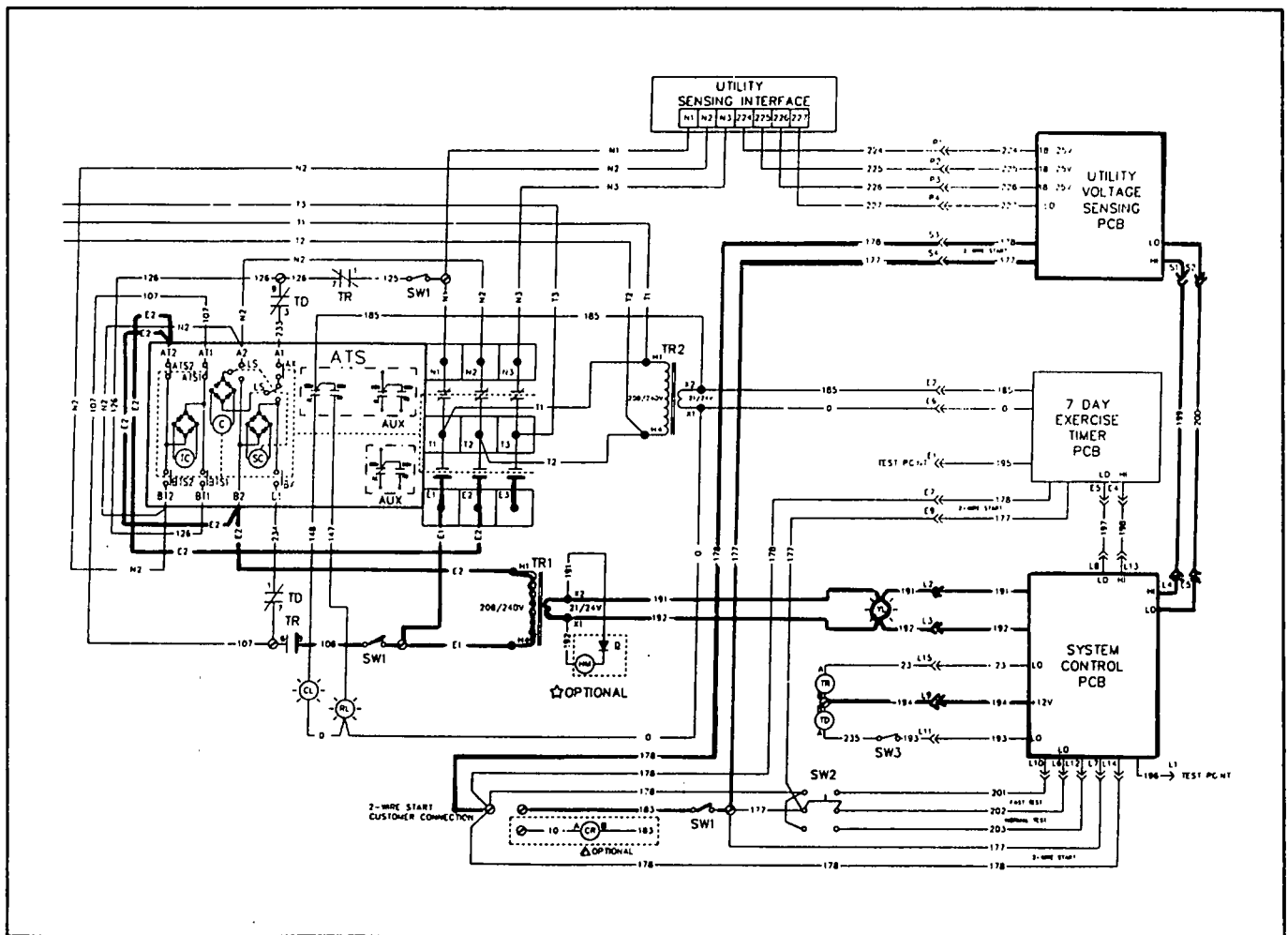


Figure 3. Circuit Condition- Generator Running

Circuit Condition- Transfer to Standby

When the "engine warmup timer" has timed out and providing standby source voltage and frequency are at an acceptable (preset) level, the system control board will complete the transfer relay (TR) circuit and the time delay neutral relay (TD) circuits to ground. Both relays will then energize simultaneously. Standby power will then be delivered across the closed transfer relay (TR) contacts and to transfer mechanism terminals AT1/AT2. The time delay relay (TD) normally-closed contacts have opened and no power is available to transfer mechanism terminals B1/B2.

Power from terminals AT1/AT2 is delivered to a trip contactor (TC). TC energizes to unlatch the main contacts. The main contacts then actuate to their "tripped" or "neutral" position.

Main contacts movement to the "tripped" position closes control switches Ax and Bx.

When a time delay timer on the system control board times out, the circuit board opens the Wire 193 circuit and the time delay relay (TD) de-energizes. That relay's normally-closed contacts close to deliver power to terminals A1/A2. This energizes a selective coil (SC) which, in turn, closes selective switches (LS) to the B1/B2 side.

Closure of the selective switches (LS) delivers power to the closing coil (C). The closing coil energizes to complete the transfer action to the "Standby" power source side.

As the main contacts actuate to their "Standby" side, control switches Ax and Bx are opened.

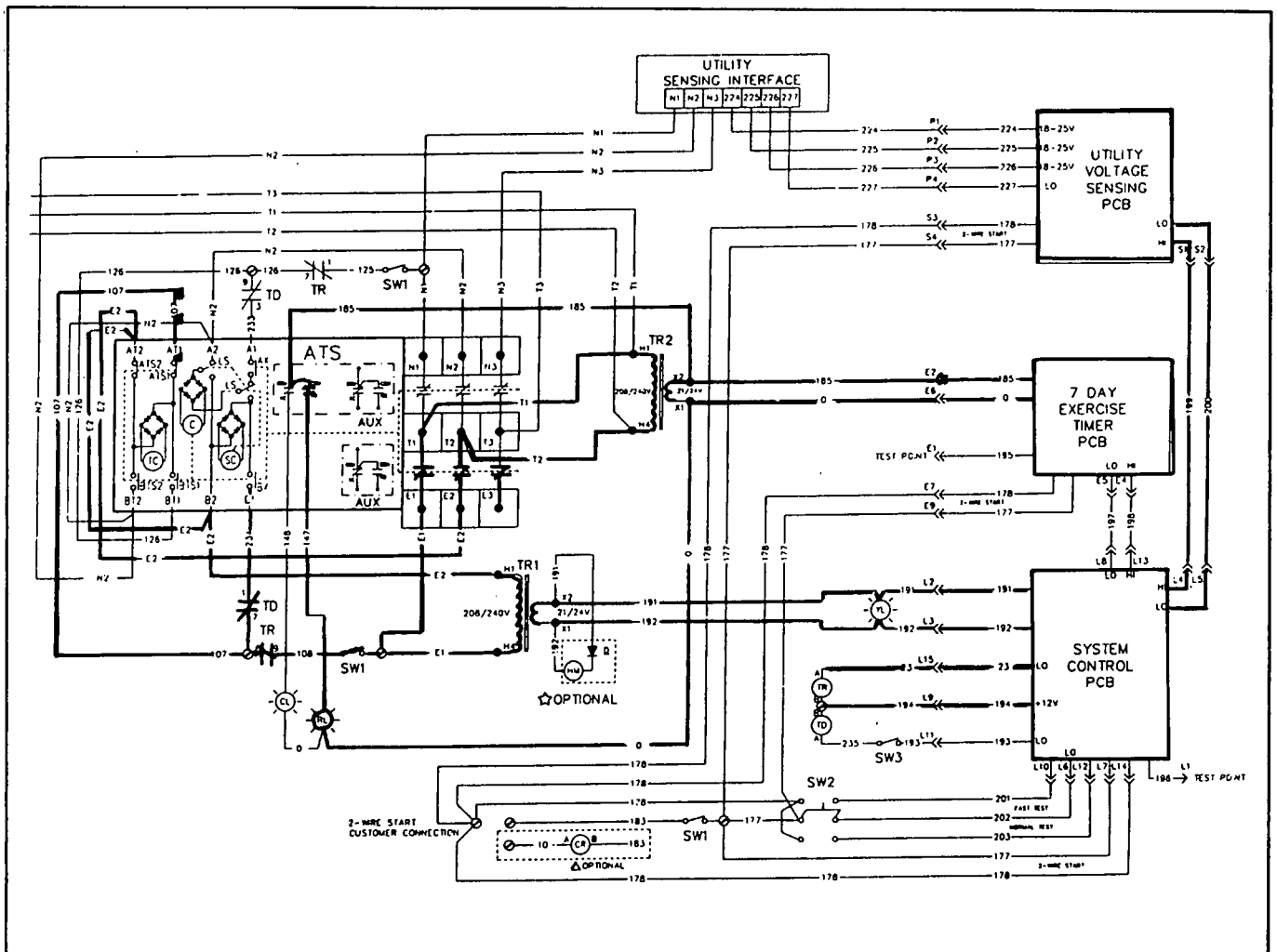


Figure 4. System Condition- Transfer to Standby

Circuit Condition- Utility Source Voltage Restored

On restoration of utility power source voltage, that source is delivered to transfer mechanism terminals N1, N2, N3. The utility voltage is available to step-down transformers in the utility sensing interface. A reduced voltage is delivered to the utility voltage sensor board, via wires 224-227. The utility voltage sensor board's "voltage pickup sensor" reacts to the restored voltage and a "return to utility timer" turns on. If the utility voltage remains high after that timer has timed out, the utility voltage sensor board will close the wires 199/202 circuit to the system control board.

Utility source voltage is available to the normally-closed contacts of transfer relay (TR). However, because TR is energized these contacts are open and the circuit is incomplete.

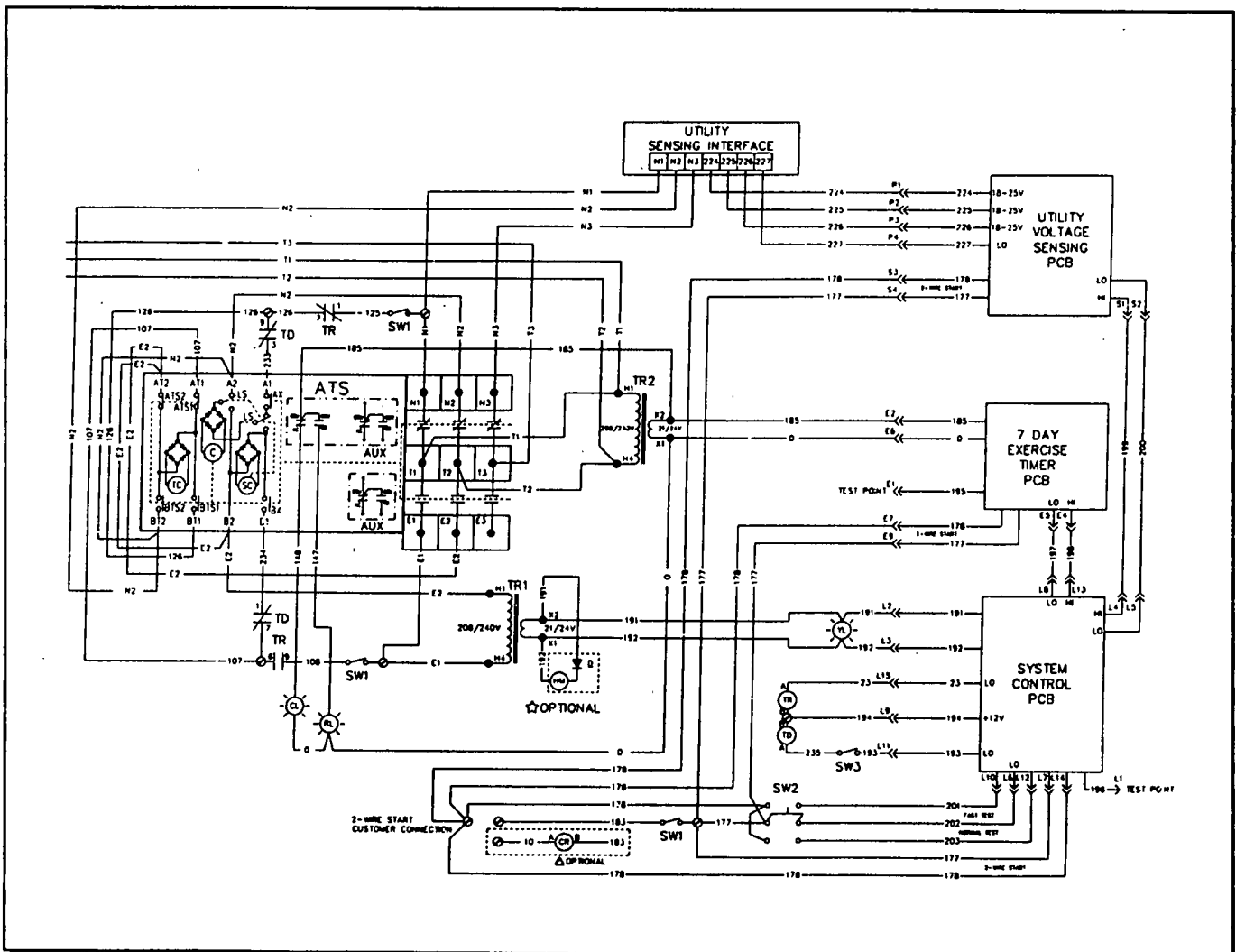


Figure 5. Circuit Condition- Utility Source Voltage Restored

Circuit Condition- Retransfer Back to Utility Source

With a preset utility sensing voltage available to the utility voltage sensor board, that board closes the 199/200 circuit to "tell" the system control board that utility voltage is now available. A "return to utility timer" on the system control board starts timing. After a preset time interval, the system control board opens the transfer relay's wire 23 circuit and closes the time delay relay (TD) circuit to ground. The transfer relay (TR) de-energizes and its normally-closed contacts close. The time delay relay energizes and its normally-closed contacts open.

Utility source voltage is now available to transfer mechanism terminals BT1/BT2. A trip coil (TC) energizes to unlatch the main contacts and allow them to move to their "tripped" or "neutral" position. Main contacts movement to "neutral" closes control switches Ax/Bx in the transfer mechanism. Utility power is then delivered to a selective coil (SC). The selective coil (SC) energizes and closes selective switches (LS) to their A1/A2 side.

When a "time delay neutral timer" on the system control board has timed out, circuit board action de-energizes the time delay relay (TD). The relay's normally-closed contacts then close to deliver utility source power to closing coil (C). Closing coil (C) then energizes to actuate the main contacts to their utility power source side.

Main contacts movement to the utility power source side opens control switches Ax/Bx.

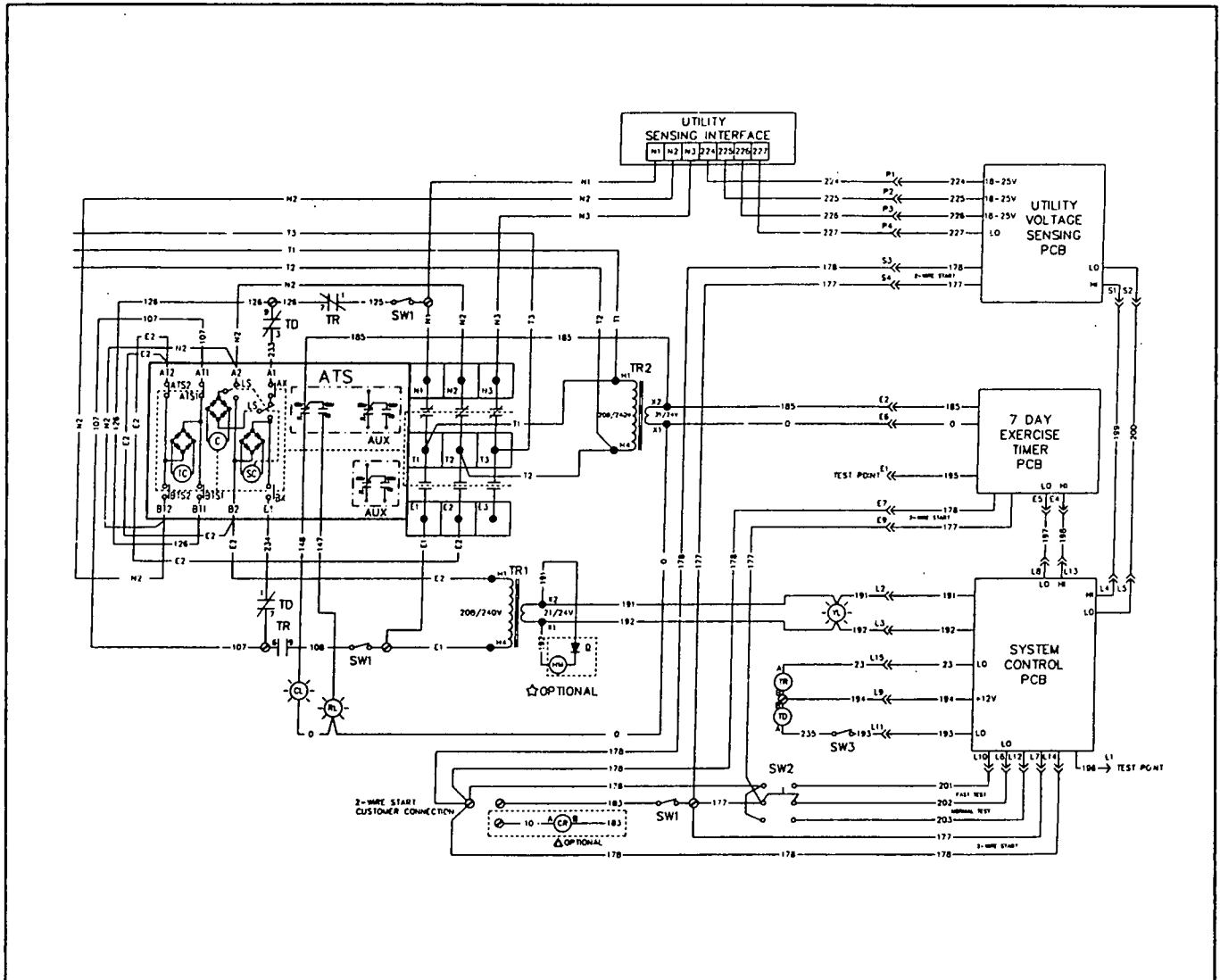


Figure 6. Circuit Condition- Retransfer Back to Utility Source

Section 9.7 MULTI-VOLTAGE TRANSFER SWITCHES

General

Standard GTS transfer switches must be installed and used with a power source voltage and phase that is compatible with the transfer switch rated voltage and phase (as stated on the transfer switch data plate).

The "multi-voltage" type transfer switch permits greater flexibility of use since it permits several different voltage and phase selections to be made by the installer. The installer must make sure the selected voltage and phase is compatible with the power source voltage and phase.

Voltage Selections

A multi-voltage interface panel is shown in Figure 1 at right. A typical multi-voltage interface panel will permit selection of the following:

- 240 volts, 1-phase.
- 208 volts, 3-phase.
- 240 volts, 3-phase.
- 416 volts, 3-phase.
- 480 volts, 3-phase.

To select a voltage and phase, simply plug the connector into the interface panel receptacle indicated by the correct voltage and phase.

NOTE: The utility voltage sensor circuit board should be calibrated to match the actual utility power source voltage. See Part 10 or 11 of this manual as appropriate.

Using 3-pole Transfer Mechanisms in 1-Phase Applications

A special procedure may be required when connecting a 1-phase power supply to a 3-pole transfer mechanism on multi-voltage units. See Section 8.8, "Multi-Voltage Transfer Switches".

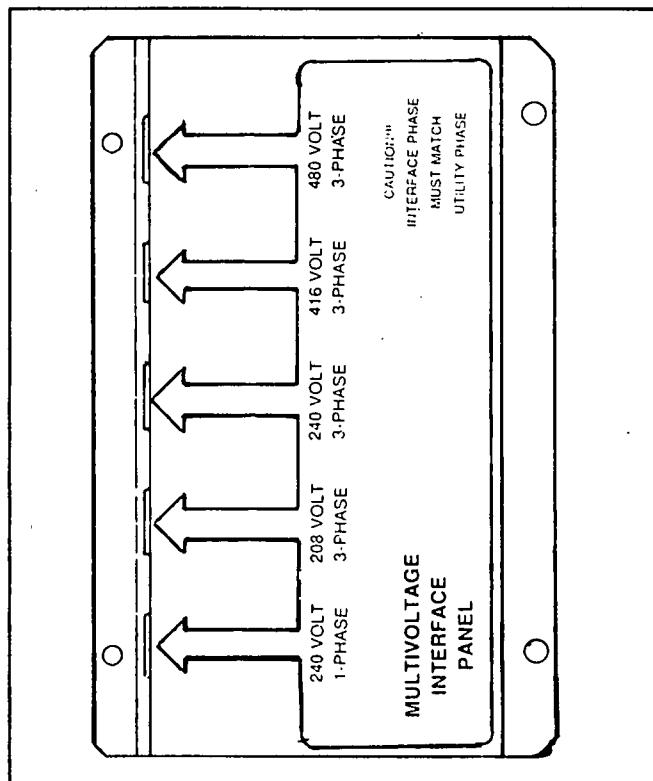


Figure 1. Multi-Voltage Interface Panel (Typical)

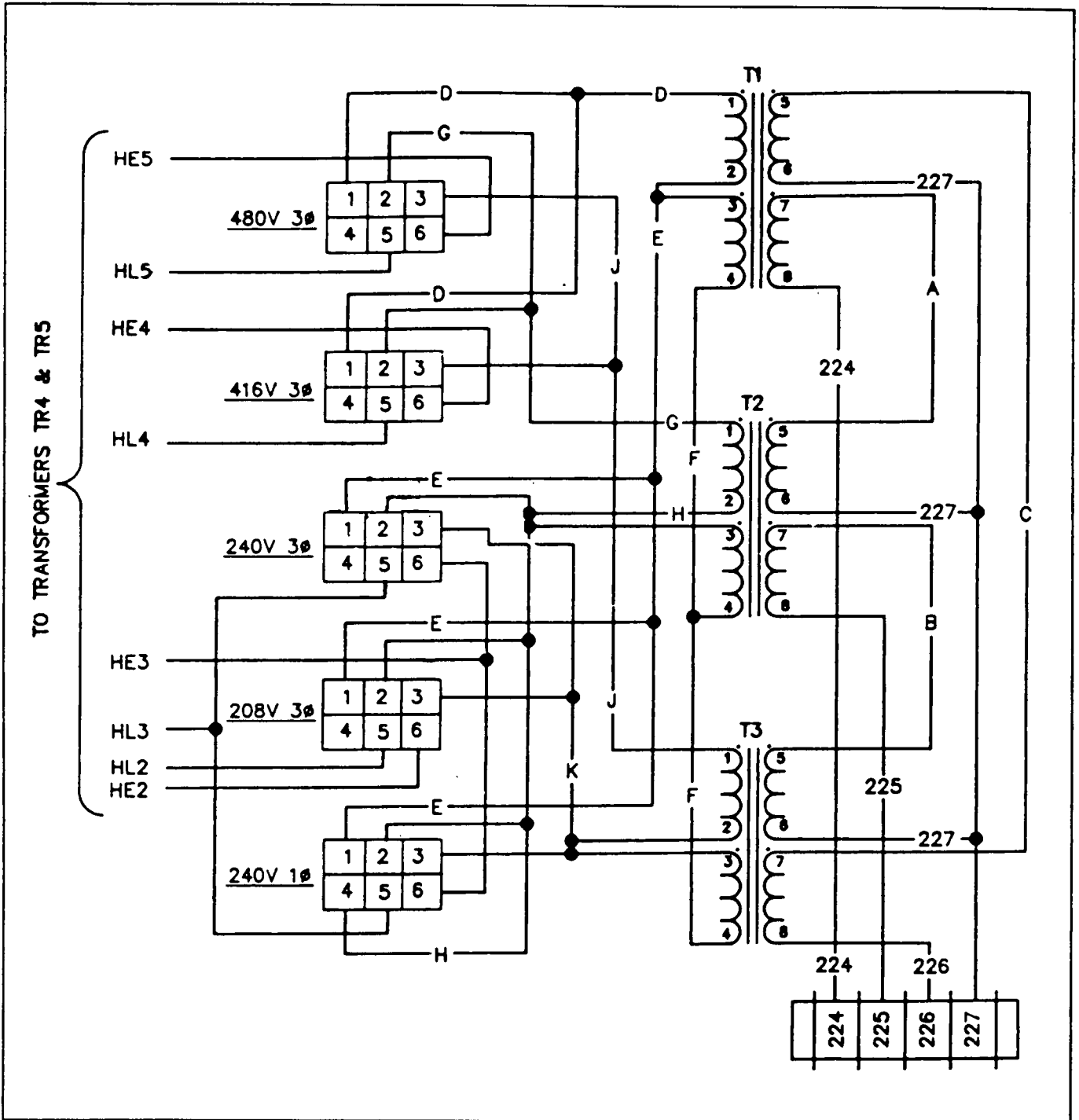
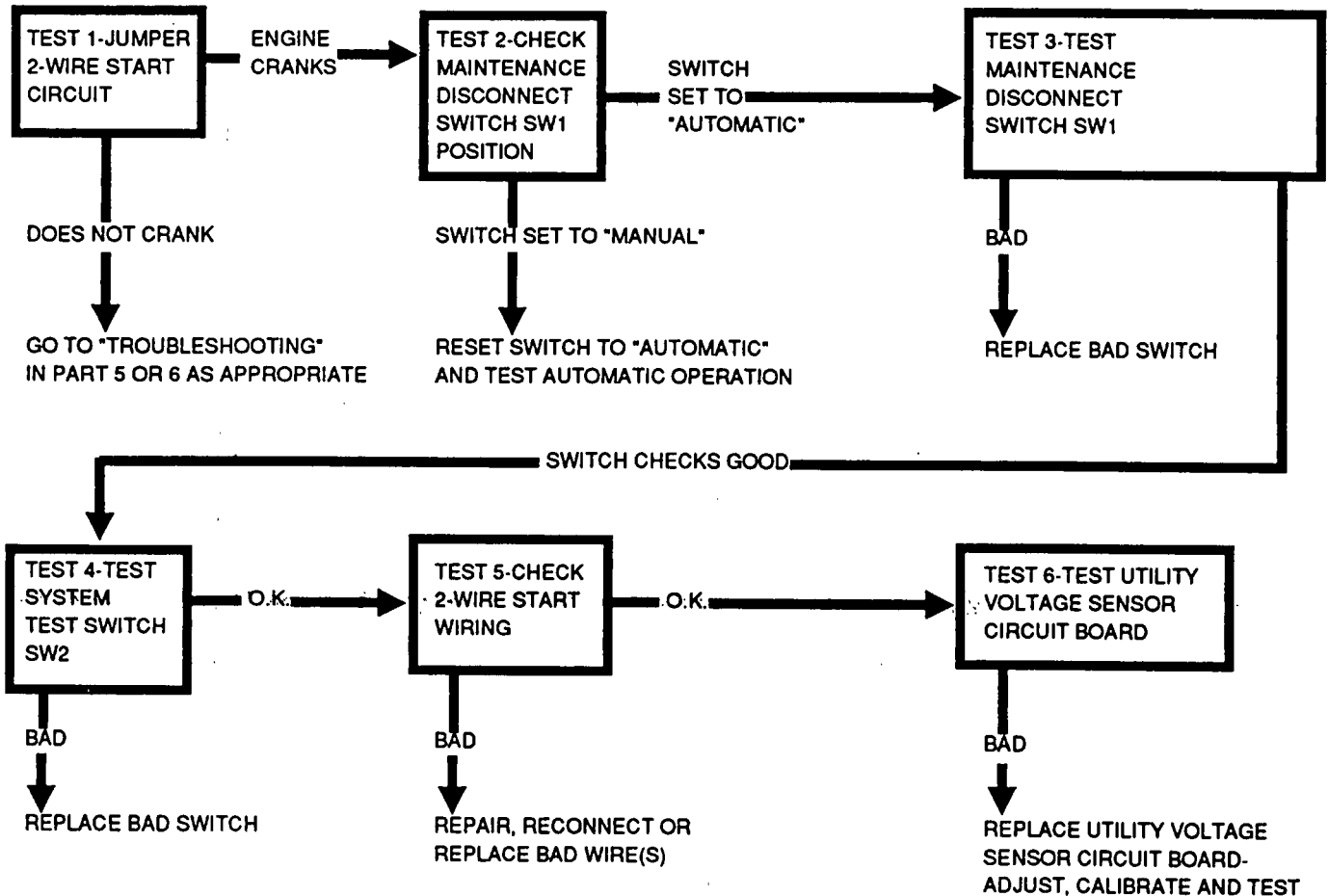


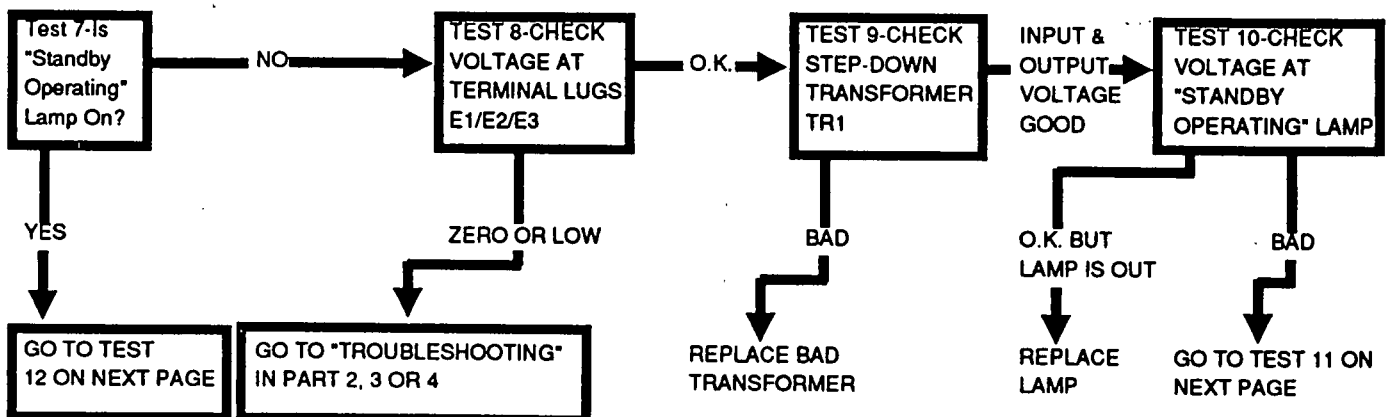
Figure 2. Schematic Diagram- Multivoltage Interface

Section 9.8 TROUBLESHOOTING FLOW CHARTS

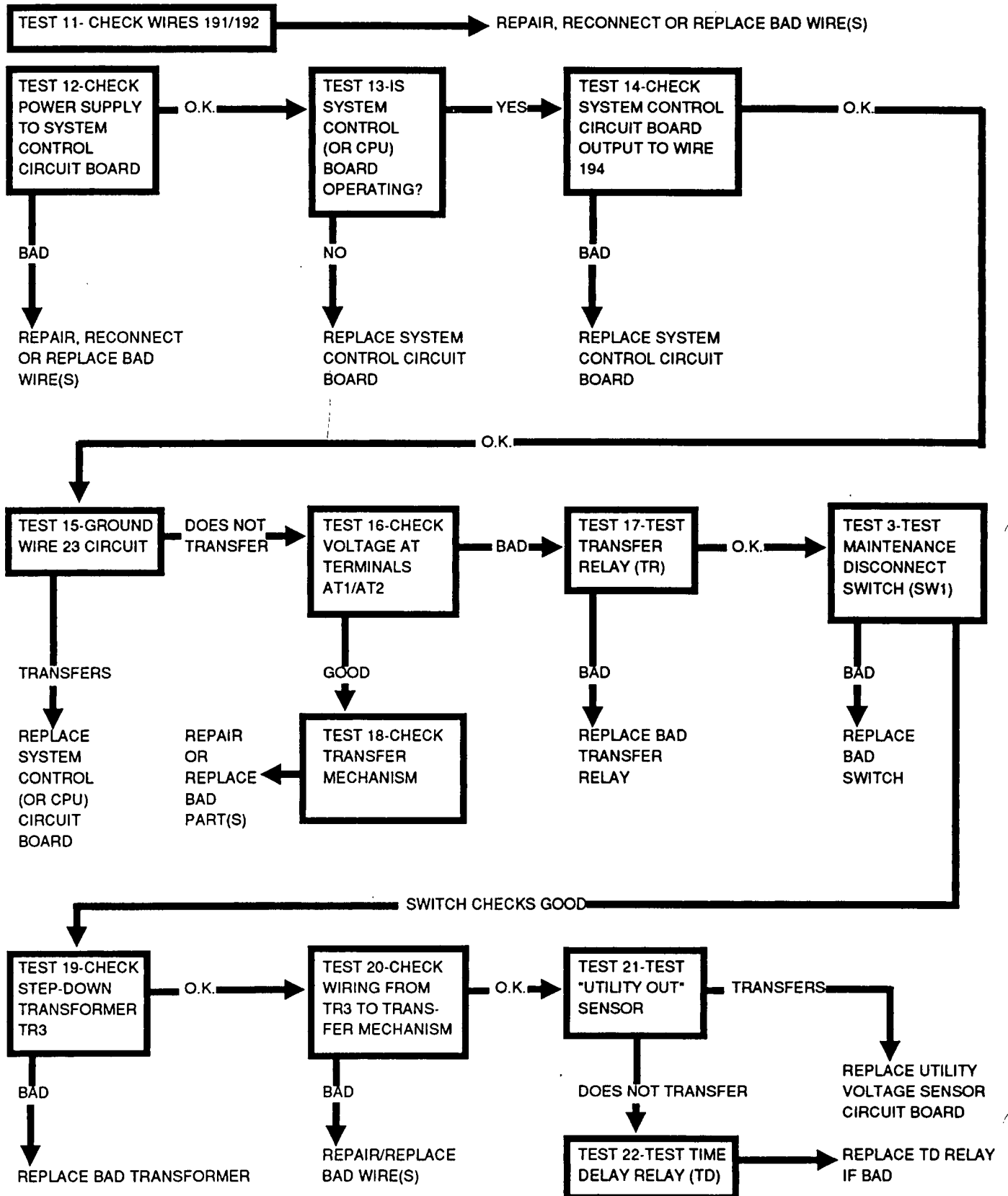
Problem 1- Generator Engine Does Not Crank in Automatic Mode (On Utility Failure or "Normal Test")



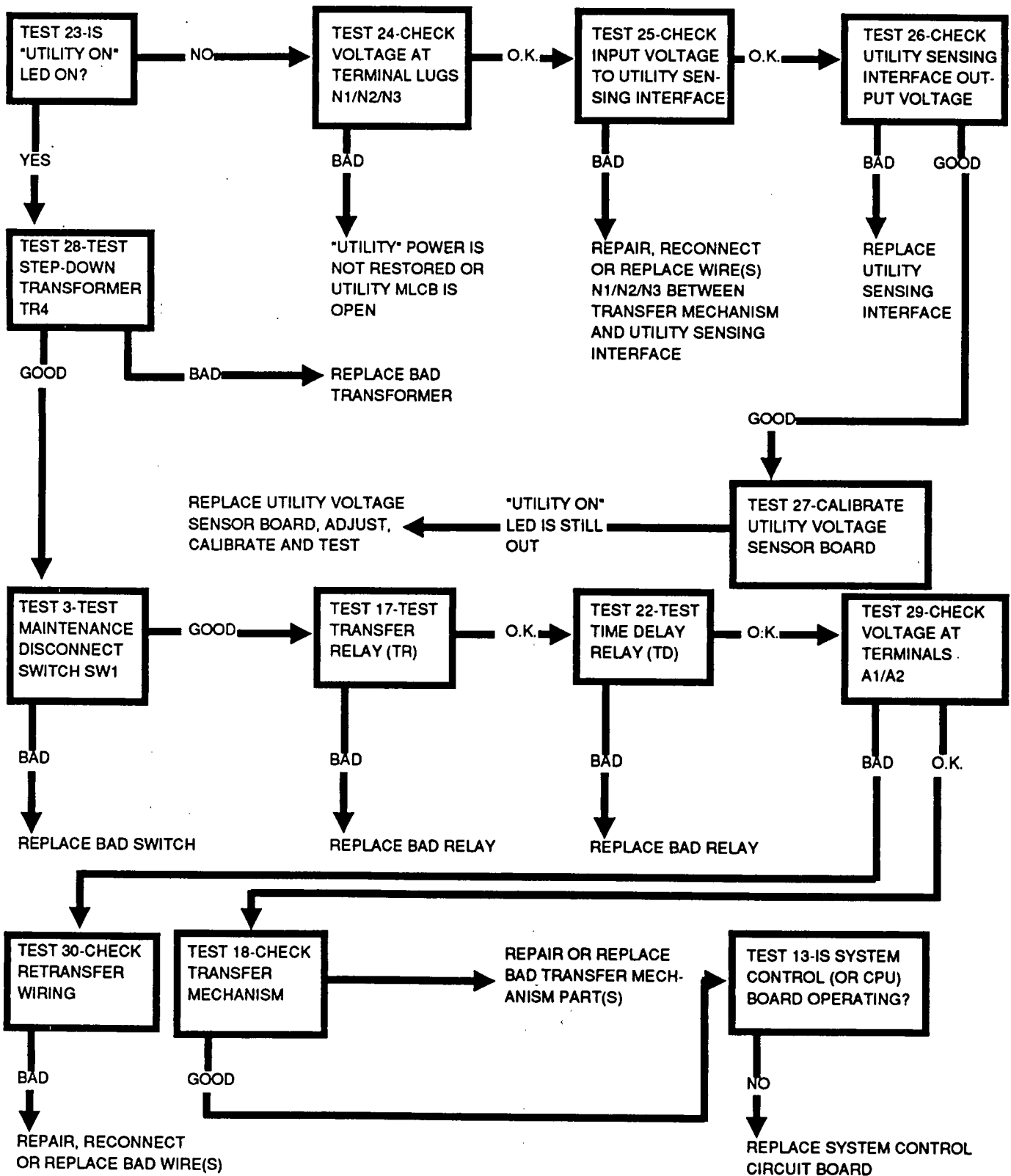
Problem 2- Does Not Transfer to "Standby" in Automatic Mode



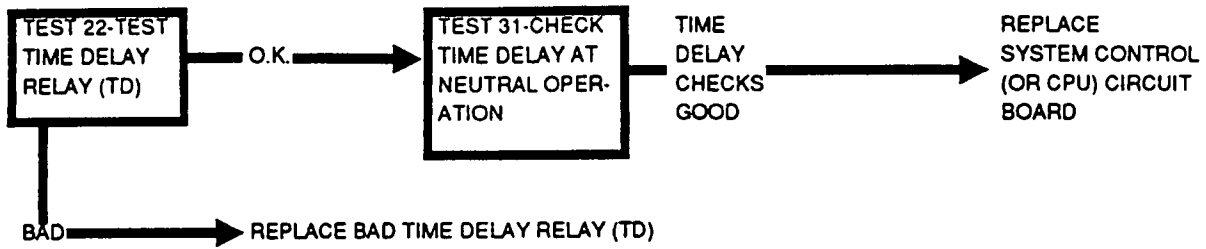
Problem 2- Does Not Transfer to "Standby" in Automatic Mode (Continued)



**Problem 3- Does Not Retransfer Back to "Utility" When That Power Supply is Restored
(In Automatic Mode or During "Normal Test")**



**Problem 4- Transfer and Retransfer Occurs But No Time Delay at Neutral Function
(If So Equipped)**



Section 9.9 DIAGNOSTIC TESTS

Introduction

Perform the diagnostic tests in this section in conjunction with the "Troubleshooting Flow Charts" of Section 9.8. The numbered tests in Section 9.8 correspond to test numbers in this section.

Test 1- Jumper 2-Wire Start Circuit

DISCUSSION:

Following a "Utility" power outage, utility voltage sensor board action should close the 2-wire start circuit (Wires 178/183). On closure of that circuit, a DC control/latch-crank circuit board in the generator console should crank and start the engine. The same events should take place during performance of a "Normal Test". If engine does not crank during a "Normal Test" or on "Utility" power failure, this test will determine if the problem is in the automatic transfer switch or in the standby generator.

PROCEDURE:

Connect a jumper wire across terminals 178 and 183 in the transfer switch enclosure (Figure 1). The engine should crank and start, as controlled by a DC control/latch-crank board in the generator control console.

RESULTS:

1. If engine does NOT crank, a problem exists in the 2-wire start leads to the generator or in the generator DC control system. Refer to troubleshooting in Part 5 or 6 as appropriate.
2. If engine cranks when jumper wire is attached but not during automatic operation, go on to Test 2. The problem is in the transfer switch.

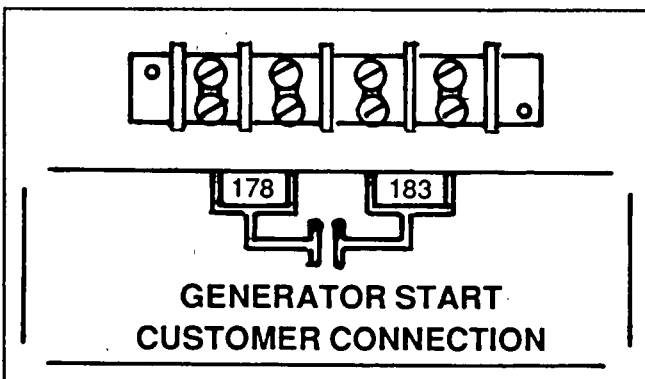


Figure 1. The 2-Wire Start Terminals

Test 2- Check Maintenance Disconnect Switch Position

DISCUSSION:

This switch must be set to its "Automatic" position for all operations in the automatic mode. When the switch is set to "Manual", neither automatic engine startup or automatic transfer will occur.

PROCEDURE:

Check that the maintenance disconnect switch (in transfer switch) is set to its "Automatic" position.

RESULTS:

1. If necessary, reset switch to "Automatic" and test automatic operation.
2. If automatic cranking and operation cannot be obtained with switch set to "Automatic", go to Test 3.

Test 3- Test Maintenance Disconnect Switch

DISCUSSION:

A defective maintenance disconnect switch can prevent (a) engine cranking in automatic mode, (b) transfer to the "Standby" source side, and (c) retransfer to the "Utility" side.

PROCEDURE:

Test the maintenance disconnect switch as follows (see Figure 2):

- Turn OFF all power voltage supplies to the transfer switch.
- Set the switch to "Automatic". Use an ohmmeter to test the switch as indicated in the following chart.
- Set the switch to "Manual". Again test the switch as indicated in the following chart.

SWITCH POSITION	TEST POINTS	METER READING
"Automatic"	Terminals 1 and 2	Continuity
	Terminals 2 and 3	Infinity
	Terminals 4 and 5	Continuity
	Terminals 5 and 6	Infinity
	Terminals 7 and 8	Continuity
	Terminals 8 and 9	Infinity
	Terminals 10 and 11	Continuity
"Manual"	Terminals 11 and 12	Infinity
	Terminals 1 and 2	Infinity
	Terminals 2 and 3	Continuity
	Terminals 4 and 5	Infinity
	Terminals 5 and 6	Continuity
	Terminals 7 and 8	Infinity
	Terminals 8 and 9	Continuity
"Manual"	Terminals 10 and 11	Infinity
	Terminals 11 and 12	Continuity

Test 3- Test Maintenance Disconnect Switch (Continued)

RESULTS:

1. If the switch checks good, go to Test 4.
2. Replace switch if defective.

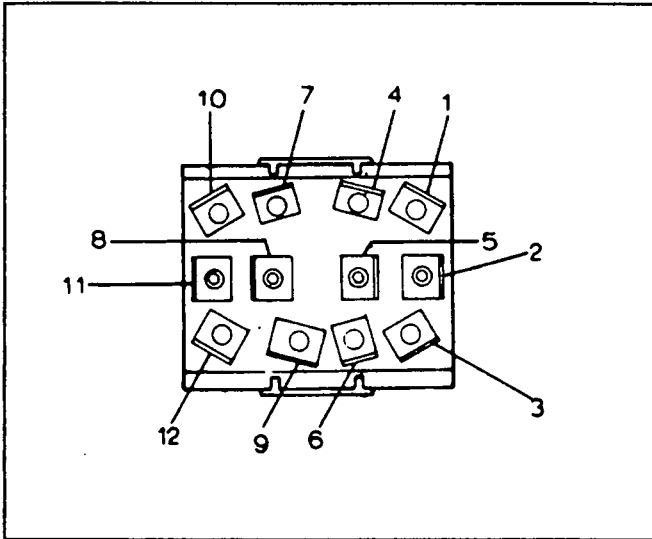


Figure 2. Maintenance Disconnect Switch Test Points

Test 4- Test System Test Switch SW2

DISCUSSION:

This switch is used to select either (a) automatic operation, (b) a "Normal Test", or (c) a "Fast Test".

PROCEDURE:

Test the system test switch with a VOM as follows (Figure 3):

- Set the VOM to its "Rx1" scale and zero the meter. Disconnect leads from the switch, to prevent interaction.
- Connect the VOM test leads across switch terminals as indicated in the chart that follows.

RESULTS:

1. If switch checks good, go to Test 5.
2. Replace switch if defective.

SWITCH POSITION	TEST POINT	METER READING
"AUTOMATIC"	Terminals 3 & 5	"Infinity"
	Terminals 1 & 3	"Infinity"
	Terminals 4 & 6	"Infinity"
	Terminals 2 & 4	"Infinity"
"FAST TEST"	Terminals 2 & 4	"Continuity"
	Terminals 1 & 3	"Continuity"
	Terminals 3 & 5	"Infinity"
	Terminals 4 & 6	"Infinity"
"NORMAL TEST"	Terminals 2 & 4	"Infinity"
	Terminals 1 & 3	"Infinity"
	Terminals 3 & 5	"Continuity"
	Terminals 4 & 6	"Continuity"

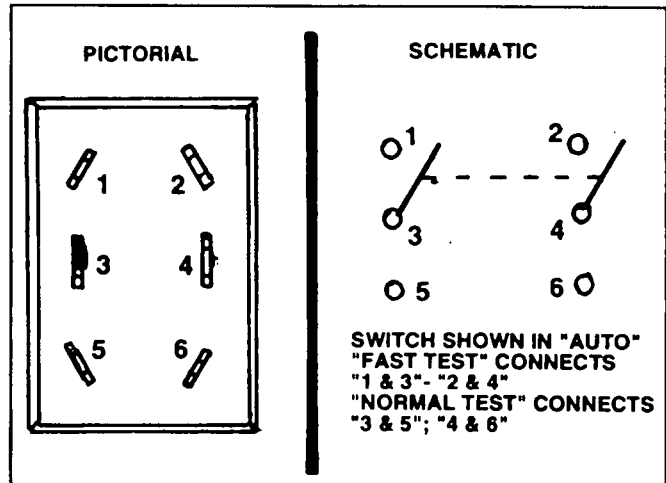


Figure 3. System Test Switch Test Points

Test 5- Check 2-Wire Start Wiring

DISCUSSION:

Any open condition in the 2-wire start wiring will prevent automatic cranking following a "Utility" power outage or during a "Normal Test" or "Fast Test".

PROCEDURE:

Carefully inspect Wires 177, 178 and 183 in the transfer switch. Look for damaged or disconnected wires. Refer to appropriate wiring diagram. Also check wires 201, 202 and 203 (between the system test switch and the system control board).

RESULTS:

1. Repair, reconnect or replace and bad wire(s).
2. If all wiring checks good, go to Test 6.

Test 6- Test Utility Voltage Sensor Circuit Board

DISCUSSION:

If automatic engine cranking does not occur following a "Utility" power source loss, the utility voltage sensor circuit board could be the cause.

PROCEDURE:

Unplug the connector plug from the utility voltage sensor board to which Wires 177, 178, 199 and 200 attach. Connect a jumper wire across connector plug Pins No. 3 and 4 to which Wires 178 and 177 connect. The generator engine should crank.

RESULTS:

If engine cranks now but did not on "Utility" outage, replace the utility voltage sensor circuit board. Calibrate and adjust the new board as necessary.

Test 7- Is "Standby Operating" Lamp On?

DISCUSSION:

Transfer to the "Standby" power source cannot occur until that power supply is available to the transfer switch. One quick method of determining whether "Standby" power is available is to observe the "Standby Operating" lamp on the transfer switch door. The lamp is powered by transformer reduced "Standby" source voltage. Perform this test when transfer of the load to "Standby" does not occur in automatic mode.

PROCEDURE:

Perform a "Normal Test". The generator should crank and start. On generator startup, the "Standby Operating" lamp should illuminate. After a short engine warmup period, transfer to the "Standby" side should occur and the "Switch Position-Emergency" lamp should light, indicating that transfer to the "Standby" side has occurred.

RESULTS:

1. If the "Standby Operating" lamp comes on but the "Switch Position-Emergency" lamp does not, transfer to "Standby" has NOT occurred. Go to Test 12.
2. If the "Standby Operating" lamp does NOT come on, go to Test 8.

Test 8- Check Voltage at Terminal Lugs E1/E2/E3

DISCUSSION:

As previously stated, transfer to "Standby" cannot occur unless that power supply is available to the transfer switch. This test is a positive method of determining whether "Standby" source voltage is available to the transfer switch.

The system control (or CPU) circuit board incorporates a standby voltage and a standby frequency sensor. Transfer to the "Standby" source side cannot occur unless generator AC output voltage is above the setting of the voltage sensor and unless frequency is above the setting of the frequency sensor.

PROCEDURE:

Perform a "Normal Test". With the generator running, use an AC voltmeter to test line-to-line voltage across terminal lugs E1/E2/E3. Normal rated generator AC output voltage should be indicated.

Now, use an AC frequency meter to test AC frequency across terminal lugs. Normal rated AC frequency should be indicated.

RESULTS:

1. If voltage/frequency is zero or low, go to "Troubleshooting" in Part 2, 3 or 4 as appropriate.
2. If volts and frequency are good, go to Test 9.

Test 9- Check Step-Down Transformer TR1

DISCUSSION:

"Standby" source power is delivered to the primary winding of transformer TR1. As alternating current flows through the primary winding, a step-down voltage is induced into the transformer's secondary winding. This reduced voltage is delivered to (a) a "Standby Operating" lamp and (b) the system control (or CPU) circuit board for the operation of that board. If reduced "Standby" voltage is not available to turn the "Standby On" lamp on, one possible cause is a defective transformer TR1.

PROCEDURE:

1. Perform a "Normal Test".
2. With the generator running, use an AC voltmeter to test the line-to-line voltage across terminals H1 and H4 of transformer TR1, to which wires E1 and E2 connect. Normal rated generator AC output voltage should be indicated.
3. Now, check the step-down voltage across terminals X1 and X2 of transformer TR1. Transformer reduced voltage (about 24 volts) should be indicated.

RESULTS:

1. If voltage readings across terminal lugs E1/E2/E3 were good, but readings in Step 2 of this test are bad, check wires E1 and E2 between the transfer mechanism and transformer TR1. Repair, reconnect or replace defective wire(s).
2. If voltage readings in Step 2 are good, but readings in Step 3 are bad, replace transformer TR1.
3. If transformer TR1 input and output voltages are both good, go to Test 10.

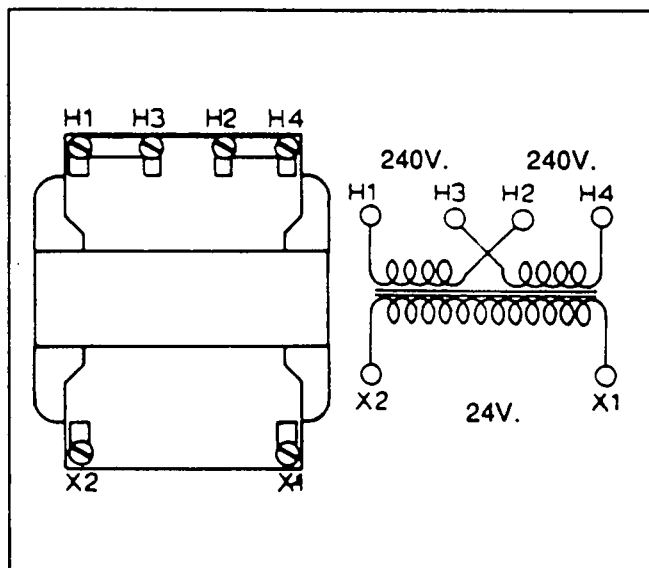


Figure 4. Transformer TR1 Test Points

Test 10- Check Voltage at "Standby Operating" Lamp**DISCUSSION:**

This test will determine if (a) the "Standby Operating" lamp is out, or (b) if wires 191/192 are good.

PROCEDURE:

On the transfer switch door interior, locate the "Standby Operating" lamp. With the generator running, connect the test leads of an AC voltmeter across the lamp terminals. The meter should indicate transformer reduced voltage.

RESULTS:

1. If voltage reading is good, but lamp is out, replace the lamp.
2. If voltage reading is bad, go to Test 11.

Test 11- Check Wires 191/192**DISCUSSION:**

Since the "Standby Operating" lamp is not illuminated, wires 191 and 192 are suspect.

PROCEDURE:

If voltage reading at terminals X1/X2 of transformer TR1 was good, but reading was bad in Test 10, Wires 191/192 are suspect. Test the wires for an open or grounded condition.

RESULTS:

Repair, replace or reconnect wire(s) 191/192 as necessary.

Test 12- Check Power Supply to System Control Circuit Board**DISCUSSION:**

If transfer to "Standby" does not occur during automatic operation, but the generator starts and the "Standby Operating" lamp is ON, this test should be performed. The system control (or CPU) circuit board is powered by the same transformer reduced power supply that operates the "Standby Operating" lamp.

PROCEDURE:

Check AC voltage supply to the system control (or CPU) circuit board (wires 191/192). Refer to appropriate wiring diagram/schematic.

RESULTS:

1. If operating voltage is not available to the system control (or CPU) board, check wires 191/192 between the "Standby Operating" lamp and the circuit board connector.

2. If normal operating voltage is available to the system control (or CPU) circuit board, go to Test 13.

Test 13- Is System Control (or CPU) Board Operating?**DISCUSSION:**

You should have already verified that normal operating voltage is available to the system control board. During automatic operation (or "Normal Test"), various LED's on the circuit board should turn on to indicate that circuit board timers and sensors are functioning.

PROCEDURE:

Perform a "Normal Test" and observe lamps on system control board. See Part 10 or 11 of manual for operating sequences and times. If unit has a CPU board, red LED will flash a few times and go out (if CPU is normal).

RESULTS:

1. If the system control (or CPU) board is not functioning, replace the circuit board.
2. If the circuit board sensors and timers appear to be functioning normally, go to Test 14.

Test 14- Check System Control Circuit Board Output to Wire 194**DISCUSSION:**

During automatic operation and with an operating voltage available to the system control (or CPU) board, a 12 volts DC output should be delivered from the circuit board to a transfer relay and to a time delay relay, via wire 194. If this voltage is not available, neither the transfer relay or the time delay relay can become energized and transfer to "Standby" cannot occur. This test will verify that a 12 volts DC output is available to energize the transfer relay and initiate transfer to "Standby".

PROCEDURE:

Connect the positive (+) test lead of a DC voltmeter to the transfer relay's wire 194 terminal. Connect the meter's common (-) test lead to ground. With the generator running, the meter should read approximately 12 volts DC.

RESULTS:

1. If 12 volts DC is NOT indicated, replace the system control (or CPU) circuit board.
2. If 12 volts DC is indicated, go to Test 15.

Test 15- Ground Wire 23 Circuit**DISCUSSION:**

During automatic operation and following generator startup, system control circuit board action should deliver 12 volts DC to the transfer relay via wire 194.

Test 15- Ground Wire 23 Circuit (Continued)

You should have already verified that 12 volts DC is available to the transfer relay, in Test 14. That circuit is completed back to the system control (or CPU) board via wire 23. Circuit board action will hold the circuit open until (a) an engine warmup timer has timed out, (b) standby voltage is above the setting of a "standby voltage sensor", and (c) standby frequency is above the setting of a "standby frequency sensor". When the three requirements are met, circuit board action will complete the wire 23 circuit to ground. The transfer relay should then energize and transfer to "Standby" should occur.

PROCEDURE:

Locate the circuit board connector pin to which Wire 23 connects (Pin 15). Perform a "Normal Test". If the unit starts and runs but transfer to "Standby" does not occur, connect Wire No. 23 (Pin 15) to terminal 177 of the terminal strip (terminal 177 is grounded). The transfer relay should energize and transfer to "Standby" should occur.

RESULTS:

1. If transfer to "Standby" occurs when wire 23 is grounded but does not otherwise occur, replace the system control (or CPU) circuit board.
2. If transfer to "Standby" does NOT occur, go to Test 16.

Test 16- Check Voltage at Terminals AT1/AT2

DISCUSSION:

When the transfer relay is energized, its normally open contacts close to deliver "Standby" source voltage to transfer mechanism terminals AT1 and AT2. If that voltage is available to those terminals, but transfer to "Standby" does not occur, a transfer mechanism failure is suspect.

PROCEDURE:

Connect the test leads of an AC voltmeter across transfer mechanism terminals AT1 and AT2. Repeat Test 15 and note the voltage reading across AT1/AT2. The meter should read rated generator voltage.

NOTE: On 480 volts units, generator system voltage is reduced to approximately 240 volts AC by a step-down transformer (TR3). It is this reduced voltage that is delivered to terminals AT1/AT2 of the transfer mechanism.

RESULTS:

1. If voltage reading is good but transfer to "Standby" does not occur, go to Test 18.
2. If voltage reading is bad, go to Test 17.

Test 17- Test Transfer Relay

DISCUSSION:

This is a test of the transfer relay itself, to determine if it is functioning properly. If transfer to "Standby" is to occur, the relay must energize and its normally-open contacts must close. For retransfer to "Utility", the relay must de-energize and its normally-closed contacts must close.

PROCEDURE:

See Figure 5. Test the transfer relay (TR) for proper operation as follows:

- In the transfer switch enclosure, set the maintenance disconnect switch to "Manual". This must be done to prevent standby generator startup when the "Utility" power supply is turned off.
- Turn OFF all power voltage supplies to the transfer switch, using whatever means available (such as the "Utility" and "Standby" main line circuit breakers).
- Disconnect all wires from the transfer relay terminals, to prevent interaction. Note wire numbers and the terminals to which they connect.
- Connect the positive (+) side of a 12 volts DC power source to relay terminal B and the negative (-) side to relay terminal A. The relay should energize.
- Set a volt-ohm-milliammeter (VOM) to its "Rx1" scale and zero the meter.
- With the relay energized, connect the VOM test leads across relay terminals 6 and 9; then across relay terminals 1 and 7. In each case, note the resistance reading.
- Disconnect the 12 volts DC power source from the relay. The relay should de-energize.
- With the relay de-energized, connect the VOM test leads across relay terminals 1 and 7; and across terminals 6 and 9. In each case, note the reading.

Correct readings are shown in the following chart. Be sure to reconnect all wires to the relay terminals before proceeding.

TRANSFER RELAY CONDITION	TEST ACROSS TERMINAL	DESIRED READING
ENERGIZED	1 AND 7	INFINITY
	6 AND 9	CONTINUITY
	4 AND 7	CONTINUITY
DE-ENERGIZED	1 AND 7	CONTINUITY
	6 AND 9	INFINITY
	4 AND 7	INFINITY

RESULTS:

1. If transfer relay tests bad, replace it.
2. If transfer relay tests good, and automatic transfer to "Standby" does not occur, perform Test 3, "Test Maintenance Disconnect Switch". See "Problem 2" in Section 9.8.
3. If transfer relay tests good and automatic retransfer back to "Utility" does not occur, perform Test 22, "Test Time Delay Relay". See "Problem 3" in Section 9.8.

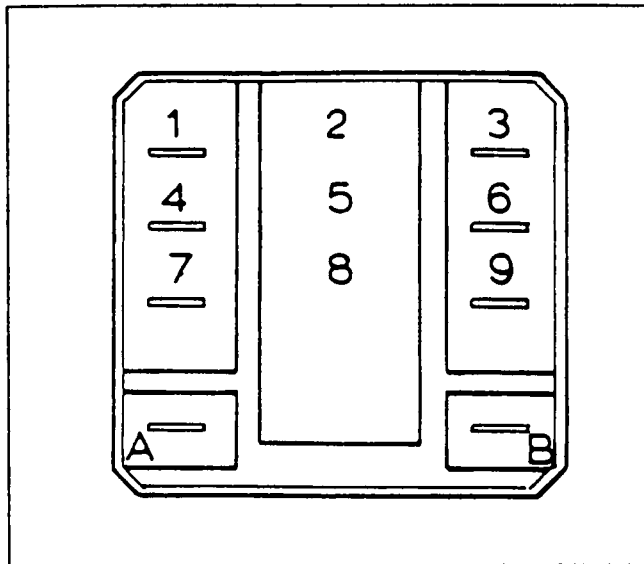
Test 17- Test Transfer Relay (Continued)

Figure 5. Transfer Relay Test Points

Test 18- Check Transfer Mechanism**DISCUSSION:**

For additional information on the transfer mechanism, refer to Section 9.2, "The Transfer Mechanism". Also see Section 9.10, "Transfer Mechanism Disassembly".

DANGER: BEFORE ATTEMPTING TO WORK ON THE TRANSFER MECHANISM, TURN OFF ALL POWER VOLTAGE SUPPLIES TO THE TRANSFER SWITCH. EXTREMELY HIGH AND DANGEROUS VOLTAGES ARE DELIVERED TO TRANSFER MECHANISM TERMINALS. FAILURE TO TURN OFF POWER VOLTAGE SUPPLIES MAY RESULT IN HAZARDOUS AND POSSIBLY LETHAL ELECTRICAL SHOCK.

PROCEDURE:

A. Visual Inspection: In many cases, transfer mechanism problems can be detected by conducting a close visual inspection of the unit.

1. Remove the transfer mechanism cover.
2. Inspect the transfer mechanism carefully. Look for burning, charring, hot spots, evidence of arcing, etc.
3. Remove arc suppressors and inspect main contacts for burning, scoring, pitting, evidence of arcing, etc. Check arc suppressors for damage caused by arcing.

B. Check Manual Operation: See Section 9.5, "Functional Tests". Check manual operation as outlined in that section.

C. Preliminary Electrical Tests: The following "preliminary" tests will help determine if all transfer

mechanism electrical components are functioning properly.

1. Refer to the "Transfer Mechanism Test Chart" on next page.
2. Manually trip the main contacts to "Neutral" first ("OFF" appears in both window A and B). Then, perform resistance tests across the terminals indicated in the chart. Meter readings should be as indicated in the chart.
3. Actuate the main contacts to their "Utility" position and perform tests indicated in the chart.
4. Actuate the contacts to "Standby" and complete tests indicated in the chart.

RESULTS:

If any meter reading is not as indicated in the chart on next page, a fault exists in the transfer mechanism. Further testing of individual transfer mechanism electrical components will be necessary. Refer to Section 9.10, "Transfer Mechanism Disassembly".

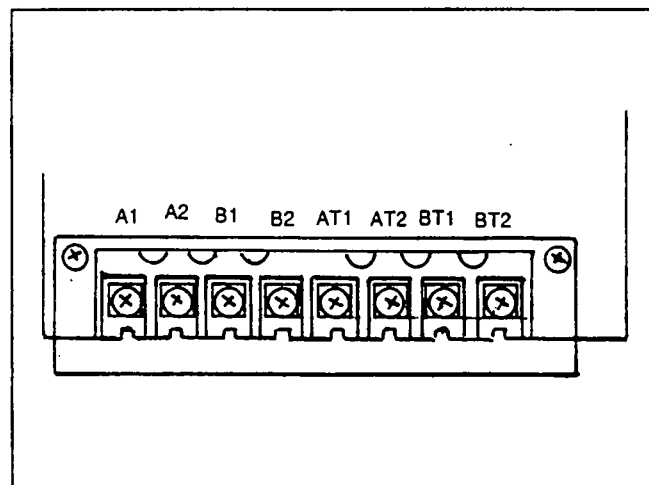


Figure 6. Transfer Mechanism Terminal Strip







Test 19- Check Step-Down Transformer TR3**DISCUSSION:**

Step-down transformer TR3 is used only on 480 volts transfer switches. The transformer reduces line E1 to line E2 voltage to about 240 volts AC. The reduced voltage is then delivered to the transfer mechanism terminals. Use of transformer TR3 allows a transfer mechanism rated 240 volts to be used in 480 volts system applications. A defective transformer TR3 will prevent "Standby" source voltage from reaching the transfer mechanism terminals and transfer to the "Standby" side will not occur in automatic mode.

PROCEDURE:

1. With the standby generator running, check for correct AC voltage across terminals H1 and H4 of the transformer. The meter should indicate normal rated generator voltage (about 480 volts AC).

Transfer Mechanism Test Chart

MAIN CONTACTS POSITION	WINDOWS INDICATIONS	TEST CONNECTIONS	DESIRED METER READING
<p>Tripped to "Neutral"</p> 	<p>Windows A and B both read "OFF"</p> 	<p>Positive test lead at "A1" Common (-) test lead at "A2"</p> <p>Positive test lead at "A2" Common (-) test lead at "A1"</p> <p>Positive test lead at "B1" Common (-) test lead at "B2"</p> <p>Positive test lead at "B2" Common (-) test lead at "B1"</p> <p>Positive test lead at "AT1" Common (-) test lead at "AT2"</p> <p>Positive test lead at "AT2" Common (-) test lead at "AT1"</p> <p>Positive test lead at "BT1" Common (-) test lead at "BT2"</p> <p>Positive test lead at "BT2" Common (-) test lead at "BT1"</p>	<p>A small resistance (About 1-1/2 ohms)</p> <p>A small resistance (About 1-1/2 ohms)</p> <p>Infinity</p> <p>Infinity</p> <p>Infinity</p> <p>Infinity</p> <p>Infinity</p> <p>Infinity</p>
<p>"Utility" Power Source Side</p> 	<p>Window A reads "ON" Window B reads "OFF"</p> 	<p>Positive test lead at "A1" Common (-) test lead at "A2"</p> <p>Positive test lead at "A2" Common (-) test lead at "A1"</p> <p>Positive test lead at "B1" Common (-) test lead at "B2"</p> <p>Positive test lead at "B2" Common (-) test lead at "B1"</p> <p>Positive test lead at "AT1" Common (-) test lead at "AT2"</p> <p>Positive test lead at "AT2" Common (-) test lead at "AT1"</p> <p>Positive test lead at "BT1" Common test lead at "BT2"</p> <p>Positive test lead at "BT2" Common (-) test lead at "BT1"</p>	<p>Infinity</p> <p>Infinity</p> <p>Infinity</p> <p>Infinity</p> <p>Small resistance (about 1.8-2.0 ohms)</p> <p>Small resistance (About 1.8-2.0 ohms)</p> <p>Infinity</p> <p>Infinity</p>
<p>"Standby" Power Source Side</p> 	<p>Window A reads "OFF" Window B reads "ON"</p> 	<p>Positive test lead at "A1" Common (-) test lead at "A2"</p> <p>Positive test lead at "A2" Common test lead at "A1"</p> <p>Positive test lead at "B1" Common test lead at "B2"</p> <p>Positive test lead at "B2" Common (-) test lead at "B1"</p> <p>Positive test lead at "AT1" Common (-) test lead at "AT2"</p> <p>Positive test lead at "AT2" Common (-) test lead at "AT1"</p> <p>Positive test lead at "BT1" Common (-) test lead at "BT2"</p> <p>Positive test lead at "BT2" Common (-) test lead at "BT1"</p>	<p>Infinity</p> <p>Infinity</p> <p>Infinity</p> <p>Infinity</p> <p>Infinity</p> <p>Infinity</p> <p>Small resistance (About 1.8-2.0 ohms)</p> <p>Small resistance (About 1.8-2.0 ohms)</p>

Test 19- Check Step-Down Transformer TR3 (Continued)

2. Now, check the transformer AC output voltage at terminals X1 and X4. Meter should indicate about 240 volts AC.

RESULTS:

1. If voltage reading across terminals H1 and H4 is bad, check wires E1/E2 between the transformer and the transfer mechanism (Test 20).

2. If voltage reading across terminals H1/H4 is good but reading across X1/X4 is bad, replace sensing transformer TR3.

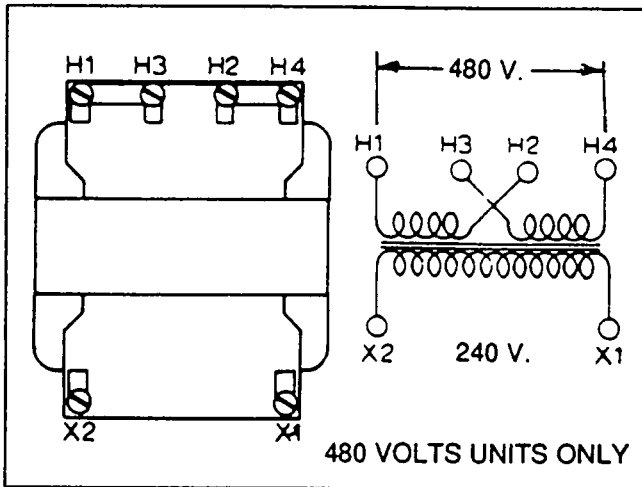


Figure 7. Transformer TR3 and TR4

Test 20- Check Wiring From TR3 to Transfer Mechanism

DISCUSSION:

"Standby" source power from the transfer mechanism is delivered to the transformer's primary winding via Wires E1 and E2. If the voltage reading at transformer terminals H1/H4 was bad, wires E1/E2 may be open or grounded.

PROCEDURE:

Inspect Wires E1 and E2 carefully. Turn OFF all power voltage supplies to the transfer switch and use a VOM to test the wires for an open or grounded condition.

RESULTS:

Repair, reconnect or replace wires E1 and/or E2 as necessary.

Test 21- Test "Utility Out" Sensor

DISCUSSION:

Wires 199 and 200 are routed from the utility voltage sensor circuit board to the system control (or CPU) circuit board. Wire 199 connects a transistor in the utility voltage sensor board to the transfer circuit in the system control (or CPU) board. Wire 200 is a grounded connection, i.e., grounded in the system control (or CPU) board. When "Utility" source sensing voltage is available to the utility voltage sensor board, that circuit board applies a small voltage to the base of a transistor. This causes the transistor to act much like a "switch". The transistor becomes a conductor and closes the wire 199 circuit to ground. As long as the circuit is closed to ground, the system control board will not initiate transfer to the "Standby" source side. That is, transfer to "Standby" cannot occur while "Utility" source power is available.

On dropout of "Utility" source voltage, the voltage signal to the transistor base is removed. Transistor action then opens the 199/200 circuit. Transfer to "Standby" can now occur.

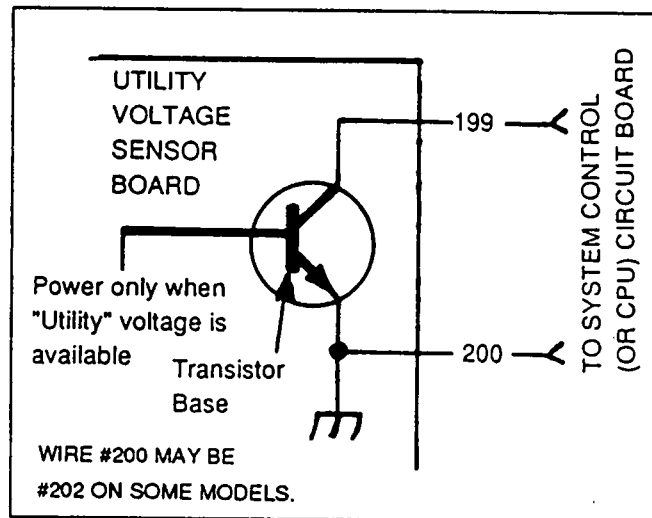


Figure 8. Wires 199/200 (or 199/202) Circuit

If transfer to the "Standby" source does not occur in automatic mode, the "Utility Loss Sensor" circuit may be tested as follows:

PROCEDURE:

1. At the utility voltage sensor circuit board, disconnect the connector to which wires 177, 178, 199 and 200 attach.
2. Set the maintenance disconnect switch (in transfer switch enclosure) to "Automatic".
3. Start the engine manually, using the start/stop switch on the generator console.

Test 21- Test "Utility Out" Sensor (Continued)

NOTE: If the transfer switch is equipped with three circuit boards, LED's on the system control circuit board should turn on when the generator has started. LED's that will turn on include (a) a "Standby On" lamp, (b) an "Engine Minimum Run" lamp, (c) an "engine warmup timer" lamp, and finally (d) a "transfer to standby" lamp. When the "transfer to standby" lamp illuminates, transfer to that power source should occur. On units with two circuit boards, the CPU board is not equipped with advisory lamps (LED's).

4. Following generators startup, transfer to "Standby" should occur.

RESULTS:

1. If transfer to "Standby" occurs with the utility voltage sensor board connector unplugged, but does not occur in normal automatic operating modes, replace the utility voltage sensor board. Calibrate, adjust and test the new circuit board.
2. If transfer to "Standby" does not occur, go to Test 22.

NOTE: On 3 circuit board units having a "programmable" system control board, illumination of that board's "transfer to standby" lamp indicates the "Utility Out Sensor" on the utility voltage sensor board is functioning properly. If the "transfer to standby" lamp turns on but transfer to "Standby" does not occur, repeat all tests under Problem 2 in Section 9.8.

Test 22- Test Time Delay Relay

DISCUSSION:

In order for a "transfer to standby" operation to occur, "Standby" source power must be available to transfer mechanism terminals B1 and B2. That power source will not be available to those terminals unless the time delay relay's normally-closed contacts (1 and 7) are closed.

For a "retransfer to utility" operation, "Utility" source power must be available to transfer mechanism terminals A1 and A2. That power supply will not be available to those terminals unless the time delay relay's normally-closed contacts (3 and 9) are closed.

Failure of the time delay relay's normally-closed contacts to close can result in a failure to transfer loads to either power source side while in automatic mode.

PROCEDURE:

The time delay relay is identical to the transfer relay. Refer to Test 17 (Pages 9.9-5 and 9.9-6).

RESULTS:

Replace the time delay relay (TD) if it fails the test.

Test 23- Is "Utility On" LED On?

DISCUSSION:

Perform this test if retransfer back to "Utility" does not occur in automatic mode or during "Normal Test". The "Utility On" lamp is located on the utility voltage sensor circuit board. The lamp should illuminate when "Utility" power source voltage is above the setting of that circuit board's "voltage dropout sensor".

PROCEDURE:

Observe the "Utility On" lamp (LED). If the lamp is ON, "Utility" source voltage sensing is available to the utility voltage sensor board and is above the setting of the "voltage dropout sensor". If the lamp is OUT, "Utility" sensing voltage is not available to the board or is below the setting of a "voltage pickup sensor".

RESULTS:

1. If the LED is ON, go to Test 28.
2. If the LED is OUT, go to Test 24.

Test 24- Check Voltage at Terminal Lugs N1/N2/N3

DISCUSSION:

This test should be performed if the "Utility On" lamp on the utility voltage sensor board is not lighted. The purpose of the test is to determine if "Utility" voltage is actually available to the transfer switch.

DANGER: USE EXTREME CARE DURING THE TEST. POWER VOLTAGE SUPPLIES TO THE TRANSFER SWITCH ARE HIGH AND DANGEROUS.

PROCEDURE:

Use an AC voltmeter to test line-to-line voltage across transfer mechanism terminal lugs N1, N2 and N3. Normal rated "Utility" source voltage should be indicated.

RESULTS:

1. If voltage readings are bad, check the "Utility" source main line circuit breaker. Perhaps that power source has not been restored.
2. If voltage readings are good, go to Test 25.

Test 25- Check Input Voltage to Utility Sensing Interface

DISCUSSION:

If the utility voltage sensor board's "Utility On" lamp does not light and you have determined that "Utility" source voltage is available to the transfer mechanism terminal lugs, the next step is to determine if that source voltage is available to the utility sensing interface.

Test 25- Check Input Voltage to Utility Sensing Interface (Continued)

PROCEDURE:

- In the transfer switch, set the maintenance disconnect switch to "Manual".
- Use an AC voltmeter to check line-to-line voltage across terminals N1, N2 and N3 of the utility sensing interface. See Figure 9.
- Normal rated "Utility" source voltage should be indicated.

RESULTS:

1. If voltage reading is bad, but readings in Test 24 were good, repair, reconnect or replace wires N1, N2, or N3 between the transfer mechanism and the utility sensing interface.
2. If voltage readings are good, go to Test 26.

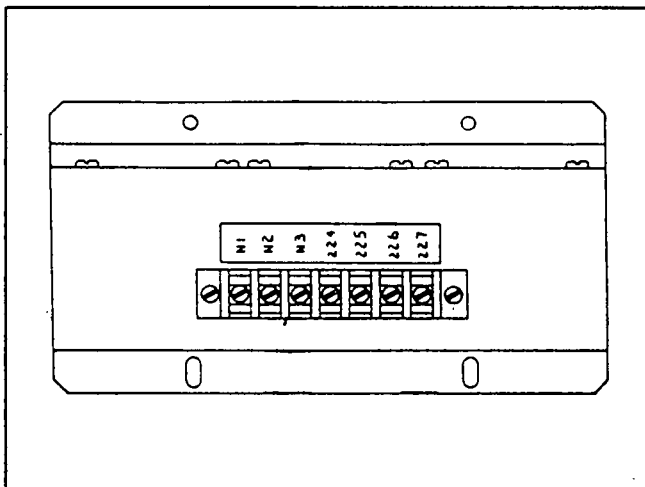


Figure 9. Utility Sensing Interface Test Points

Test 26- Check Utility Sensing Interface Output Voltage

DISCUSSION:

Step-down transformers in the utility sensing interface are used to reduce the actual "Utility" source voltage to a proportional sensing voltage that is delivered to the utility voltage sensor circuit board. The interface transformers provide a fixed ratio reduction in voltage. This test, in conjunction with Test 25, will determine if the utility sensing interface is in good condition.

You may also wish to review the information on multi-voltage utility sensing interface systems. Refer to Section 9.7, "Multi-Voltage Transfer Switches".

PROCEDURE:

Use an AC voltmeter to test for correct voltage across interface terminals 224 through 227. Test connections and acceptable interface output voltages are listed in the following chart.

TEST ACROSS TERMINALS	224-225	224-227
	225-226	225-227
LINE TO LINE RATED VOLTS	OUTPUT VOLTS	
600 volts AC	40-43 VAC	22.5-25.0 VAC
480 volts AC	40-43 VAC	22.5-25.0 VAC
400 volts AC	40-43 VAC	22.5-25.0 VAC
240 volts AC	40-43 VAC	22.5-25.0 VAC
208 volts AC	36.5-39.0 VAC	20.5-23.0 VAC
240 volts, 1-Phase	41-46 VAC	20.5-23.0 VAC*

* 226 not used on 1-phase units.

RESULTS:

1. If voltage readings in Test 25 were good, but readings taken in Test 26 were bad, replace the utility sensing interface.
2. If voltage readings are good, go to Test 27.

Test 27- Calibrate Utility Voltage Sensor Board

DISCUSSION:

The utility sensing interface transformers reduce utility power source voltage at a fixed ratio. For that reason, if the "Utility" voltage varies from the nominal rated voltage, the sensing voltage to the utility voltage sensor board will also vary a proportional amount. In some cases, calibration of the circuit board may be required.

CAUTION: The installed transfer switch must be rated at a voltage and phase that is compatible with the "Utility" and "Standby" power supplies. Do NOT attempt to calibrate a utility voltage sensor board on a non-compatible unit in an attempt to make the unit compatible with supplied voltages.

Once the circuit board has been properly calibrated, the voltage that was present during calibration establishes 100 percent "Utility" voltage for "dropout" and "pickup" settings. "Utility" source power must be available during calibration.

PROCEDURE:

1. In the transfer switch enclosure, set the maintenance disconnect switch to "Manual". Make sure rated "Utility" source voltage is available to the unit.
2. On the utility voltage sensor board, locate Test Points "TP3" and "TP4" (Figure 10). Connect a jumper wire across these two test points.
3. Locate the small potentiometer "R10". Turn the potentiometer fully counterclockwise (CCW).
4. Now, turn the potentiometer SLOWLY clockwise until the circuit board's "Utility On" lamp (LED) just turns on.
5. Remove the jumper wire from "TP3" and "TP4".
6. Reset the maintenance disconnect switch to "Automatic".

RESULTS:

If "Utility On" lamp is still out even though the sensing voltage to the board is good, replace the utility voltage sensor circuit board.

Test 27- Calibrate Utility Voltage Sensor Board (Continued)

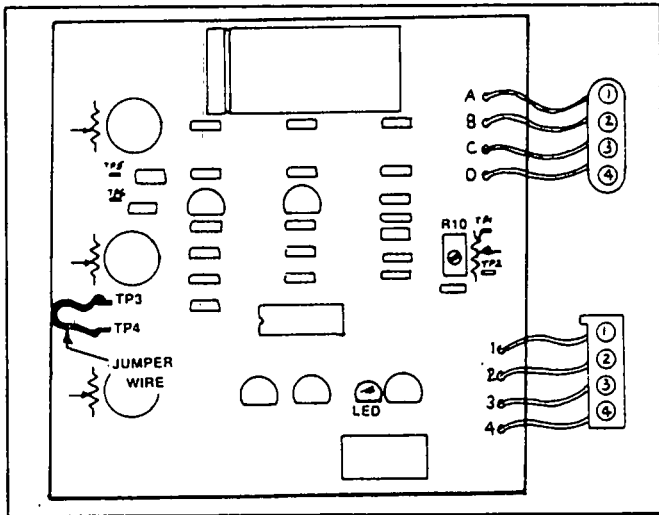


Figure 10. Utility Voltage Sensor Board Calibration

Test 28- Test Step-Down Transformer TR4

DISCUSSION:

Transformers TR3 and TR4 are used only on transfer switches rated 480 volts. The two transformers act to reduce the 480 volts power supply to a voltage that is compatible with transfer mechanism requirements (about 240 volts). Transformer TR3 reduces "Standby" source voltage; transformer TR4 reduces "Utility" source voltage.

An open or shorted condition in transformer TR4 can prevent retransfer back to the "Utility" side.

PROCEDURE:

1. See Figure 11. Turn ON the "Utility" power supply to the transfer switch.
2. Use an AC voltmeter to check voltage across transformer terminals H1 and H4. Approximately 480 volts AC should be indicated.
3. Now, check the voltage across terminals X1 and X2 of the transformer. About 240 volts should be read.

NOTE: The transformer provides a fixed step-down ratio. For that reason, voltage reading across terminals X1 and X2 may not read exactly 240 volts.

RESULTS:

1. If voltage reading in Step 2 is bad, check wires N1/N2 between transformer and transfer mechanism.
2. If reading in Step 2 is good, but Step 3 reading is bad, replace transformer TR4.
3. If readings in both Step 2 and Step 3 are good, go to Test 3.

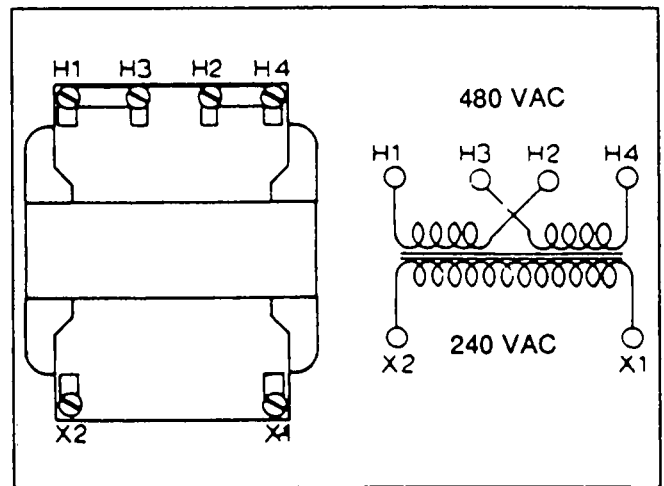


Figure 11. Transformer TR4 Test Points

Test 29- Check Voltage at Terminals A1/A2

DISCUSSION:

If retransfer back to the "Utility" power source is to occur, that power source voltage must be delivered to transfer mechanism terminals A1 and A2. The following requirements must be met to deliver "Utility" voltage to those terminals:

- "Utility" voltage must be available to transfer mechanism terminal lugs N1 and N2.
- A transfer relay (TR) must be energized by system control (or CPU) circuit board action and the relay's normally-open contacts must close.
- If so equipped, a time delay relay (TD) must be de-energized by system control (or CPU) circuit board action and the relay's normally-closed contacts must be closed.

This test will determine if "Utility" source voltage is available to terminals A1/A2 of the transfer mechanism during a retransfer action. You should have already tested the transfer relay (Test 17) and the time delay relay (Test 22). If the unit is a 480 volts unit, you should have tested transformer TR4 (Test 28). If "Utility" power is still not available to terminals A1/A2, the wiring between terminal lugs N1/N2 and terminals A1/A2 must be bad.

PROCEDURE:

1. Connect the test leads of an AC voltmeter across transfer mechanism terminals A1 and A2.
2. Perform a "Normal Test". Carefully monitor automatic operation during the test.
3. When the generator has started, wait for the system to transfer loads to the "Standby" power source side.
 - a. Check that the utility voltage sensor board's "Utility On" lamp is lighted.
 - b. On the transfer switch door, check that the "Standby Operating" lamp is lighted and that the "Switch Position-Emergency" lamp is on.
4. Set the system test switch back to "Automatic Mode" and monitor the AC voltmeter.

**Test 29- Check Voltage at Terminals
A1/A2 (Continued)**

5. After an "engine cooldown timer" on the system control (or CPU) board has timed out, the following should be observed:

- a. On the system control board, a time delay neutral timer lamp (LED) should illuminate (if the unit is equipped with the time delay neutral feature).
- b. When the time delay neutral timer has timed out, the AC voltmeter previously connected across A1/A2 should indicate "Utility" voltage. Retransfer back to "Utility" should then occur.

RESULTS:

1. If normal rated "Utility" source voltage is indicated at A1/A2, but retransfer back to "Utility" does not occur, go to Test 18. The problem appears to be in the transfer mechanism.
2. If normal rated "Utility" voltage is NOT indicated at A1/A2, go to Test 30.

Test 30- Check Retransfer Wiring**DISCUSSION:**

An open or grounded condition in the retransfer circuit can prevent retransfer back to "Utility" from occurring.

PROCEDURE:

Carefully inspect and test wires between terminal lugs N1/N2 and transfer mechanism terminals A1/A2. Trace the circuit on an appropriate wiring diagram and inspect and test all wires.

RESULTS:

Repair, reconnect or replace any defective wire(s).

**Test 31- Check Time Delay at Neutral
Operation****DISCUSSION:**

During automatic operation and after the standby generator has started the following timers on the system control (or CPU) board will start timing: (a) engine minimum run timer, (b) engine warmup timer.

NOTE: On units with programmable system control board, LED's on the circuit board will turn on to indicate the timers or sensors are operating.

Also on the system control (or CPU) circuit board, a standby voltage and a standby frequency sensor will be activated when generator voltage and frequency have reached a preset level. LED's are provided on the programmable system control board to indicate that standby voltage and frequency are acceptable.

When the engine warmup timer has timed out, and when standby voltage and frequency have reached a

preset level, system control (or CPU) board action will energize both the transfer relay and the time delay relay simultaneously. When the transfer relay energizes, its normally-open contacts close. However, when the time delay relay energizes its normally-closed contacts open. This opens the circuit to transfer mechanism terminals B1/B2 and transfer to "Standby" cannot occur.

The time delay relay will remain energized until a "time delay neutral timer" on the system control board has timed out. When that timer has timed out, circuit board action will de-energize the relay, its normally-closed contacts will close, and transfer to "Standby" will occur.

This test will determine if the system control (or CPU) circuit board is (a) energizing the time delay relay and (b) de-energizing the relay as programmed.

PROCEDURE:

1. Connect an AC voltmeter across transfer mechanism terminals B1/B2.
2. Perform a "Normal Test" with the time delay switch set to "On".
3. When the generator has started and after a preset time interval, the AC voltmeter should indicate "Standby" source voltage. At the same time, transfer to "Standby" should occur.
4. If voltage is not indicated at terminals B1/B2 after a preset time, turn the time delay neutral switch "Off" and observe the voltmeter.

RESULTS:

1. If the AC voltmeter indicates "Standby" voltage, but transfer does not occur, a problem exists in the transfer mechanism.
2. If the voltmeter does not read "Standby" voltage with the time delay neutral switch at "On", but does when the switch is set to "Off", replace the system control (or CPU) circuit board.

NOTE: In Result 2 above, transfer should occur when the time delay neutral switch is turned "Off" since power is available to transfer mechanism terminals B1/B2.

Section 9.10

TRANSFER MECHANISM DISASSEMBLY

Introduction

The transfer mechanism houses the main current carrying contacts, along with other mechanical and electrical components required for switch operation. The main contacts are actuated by a single solenoid and are electrically operated and mechanically held. The contacts are silver plated or silver alloy, to provide resistance against welding or sticking. Contacts shape provides concentrated contact pressure for positive circuit continuity.

The main contacts assembly consists of three or four pole assemblies. Each pole assembly houses and supports a dual set of moveable contactis (utility and emergency contactis) and a stationary load contactis assembly. The pole assemblies are sandwiched together and retained to the control assembly by means of thru-bolts. Arc suppressors are retained in each pole assembly.

NOTE: You may wish to review main contacts operation in Section 9.2, "The Transfer Mechanism".

Main Contacts Assembly

Figure 1, below, shows the transfer mechanism with the main contacts assembly separated from the control assembly.

DANGER: DO NOT ATTEMPT TO REMOVE THE TRANSFER MECHANISM FROM THE TRANSFER SWITCH ENCLOSURE UNTIL ALL POWER VOLTAGE SUPPLIES TO THE TRANSFER SWITCH SWITCH HAVE BEEN TURNED OFF.

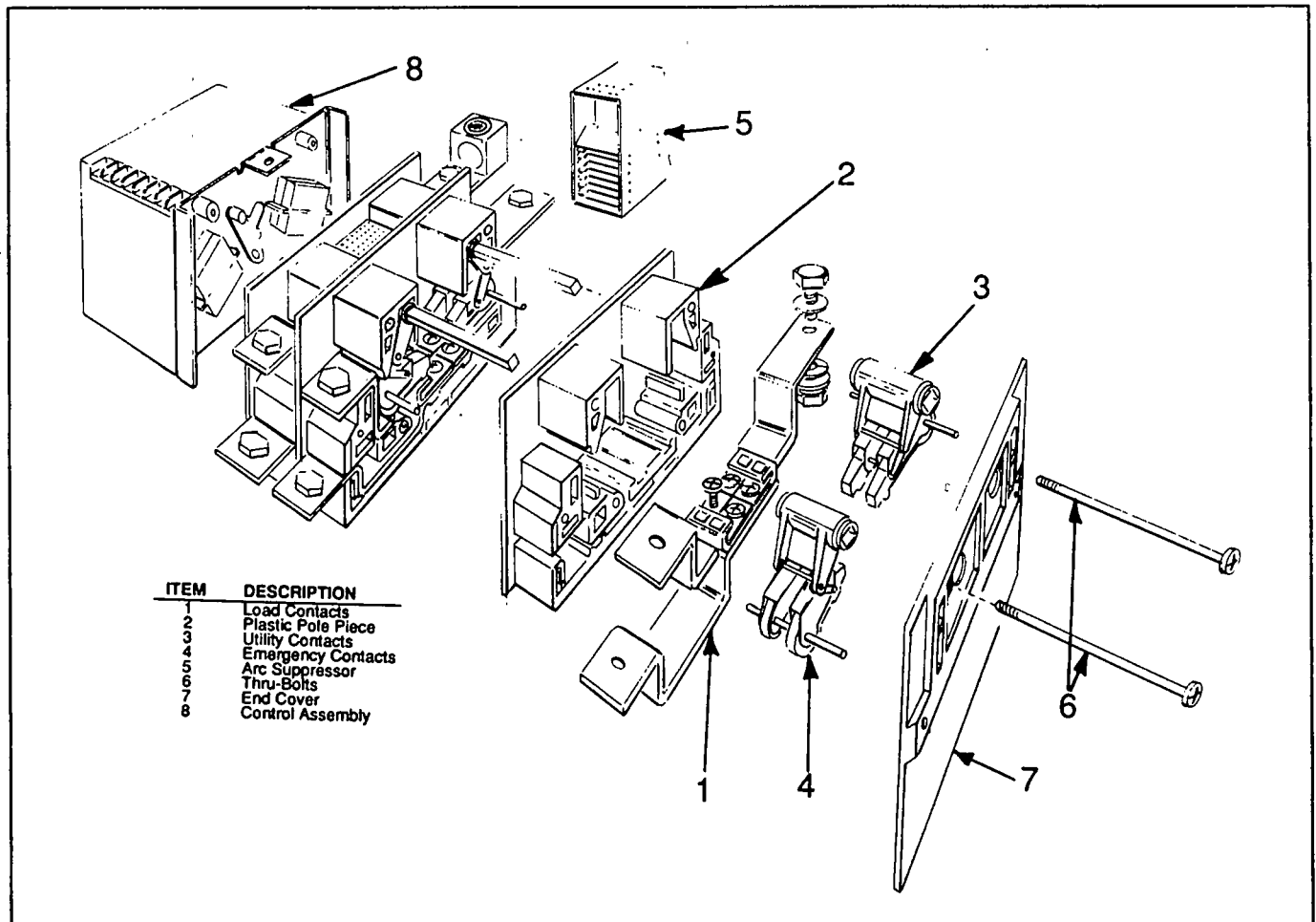


Figure 1. Transfer Mechanism Major Components

Auxiliary Contacts Removal

Each set of auxiliary contacts (Figure 2) is retained to the main contacts assembly side cover by means of a single screw. The auxiliary contacts are rated 10 amps at 125 or 250 volts AC.

Main Contacts Assembly Removal

The main contacts assembly can be removed from the control assembly by first removing the thru-bolts which retain the pole pieces to the control assembly. The side cover can then be removed, followed by the utility, emergency and load contacts in one plastic pole piece.

After removing the side cover, slide the utility and emergency contacts off their square shafts. Then remove the first plastic pole piece, along with the stationary load contacts. The second and third (and fourth, if required) pole piece components can then be removed in similar fashion.

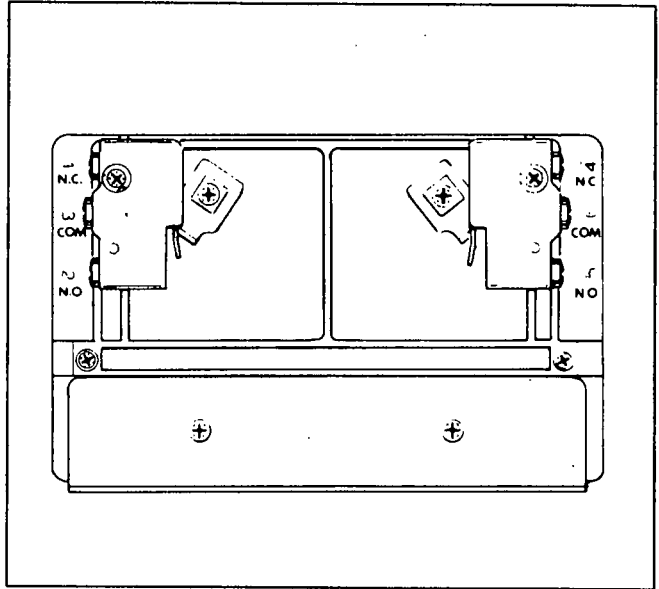


Figure 2. Auxiliary Contacts

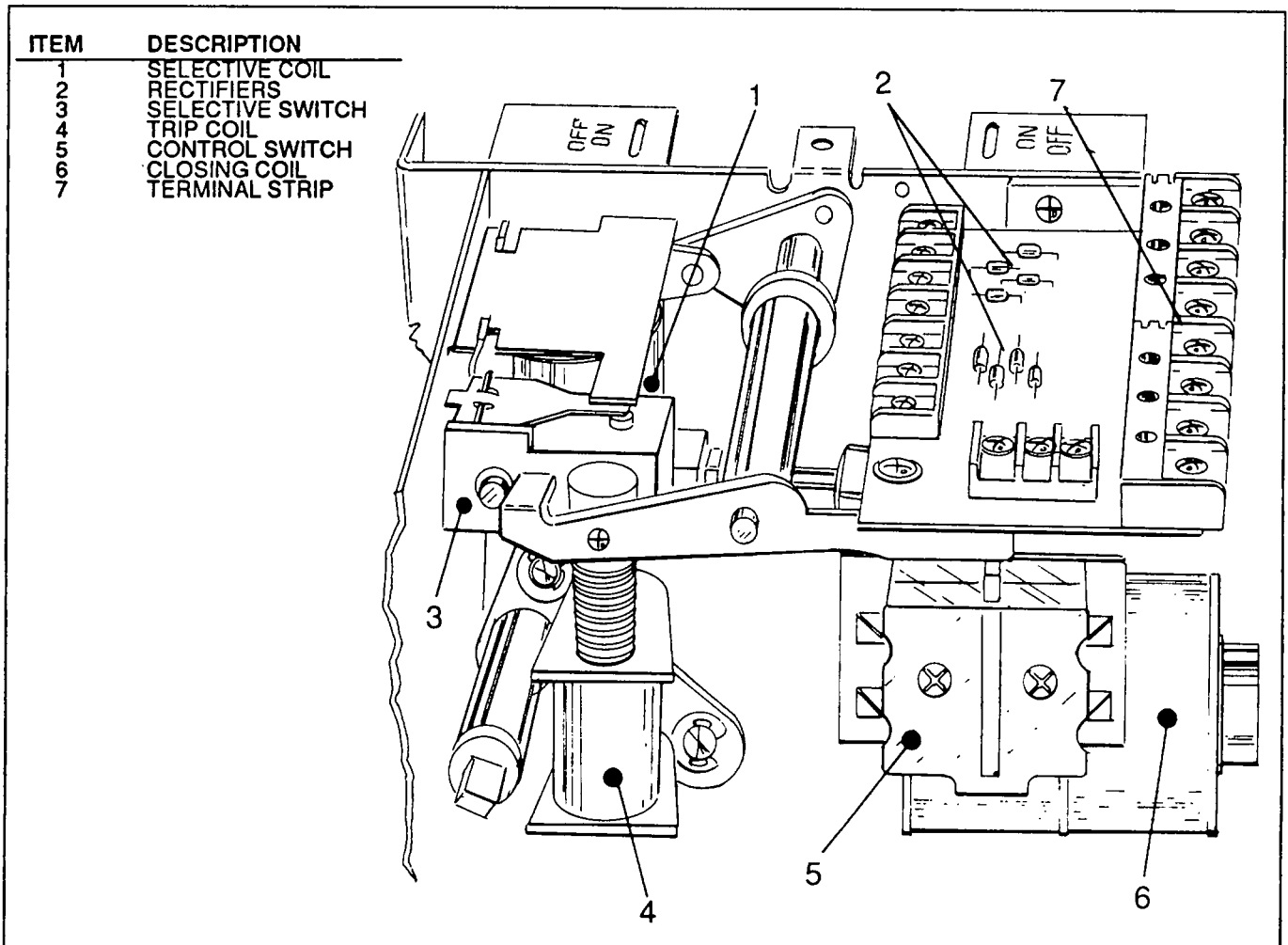


Figure 3. Control Assembly Components

**PART 10
THE "CPU"
TYPE
INTELLIGENCE
SYSTEM**

**STANDBY
ELECTRIC
POWER
SYSTEMS**

All Series

TABLE OF CONTENTS	
SECTION	TITLE
10.1	System Familiarization
10.2	Automatic Operating Sequences
10.3	Utility Voltage Sensor Circuit Board
10.4	The CPU Circuit Board
10.5	Sensor and Timer Settings

Section 10.1 SYSTEM FAMILIARIZATION

General

The CPU type intelligence system consists of two solid state circuit boards called (a) a utility voltage sensor board and (b) the CPU board. Both circuit boards are housed in a circuit board compartment in the transfer switch enclosure door.

This system differs from the "Logic" type intelligence system in several ways. The most obvious difference is that the CPU system utilizes only two circuit boards, while the Logic system has three boards. This was accomplished by having the CPU circuit board assume the dual tasks of (a) controlling the 7-day exercise timer and (b) performing the tasks of the system control circuit board.

Another major difference between the two systems is that the "Logic" system's system control circuit board is fully programmable. The CPU circuit board does not offer this advantage but, instead, relies on fixed sensors and timers.

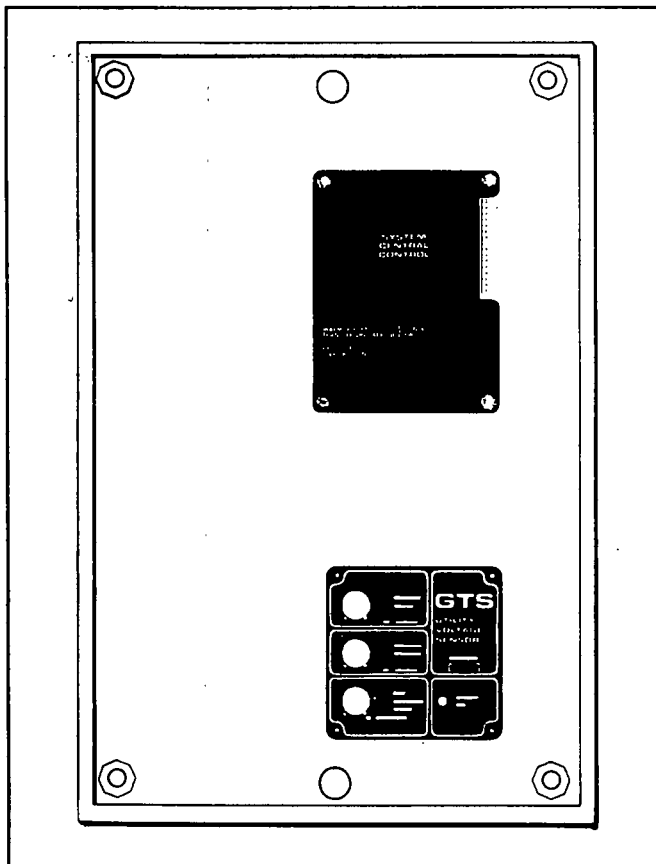


Figure 1. The Two Circuit Board (CPU) System

What the System Does

The utility voltage sensor board constantly monitors "Utility" power source voltage. Should that source voltage drop below a preset level, the utility voltage sensor board will initiate closure of the 2-wire start circuit (wires 178/183). On closure of that circuit, a DC control/latch-crank circuit board (housed in the generator console) will crank and start the engine. The sensor circuit board will also open a "utility loss sensor" circuit to the CPU board, to "tell" that board that "Utility" power has failed.

With standby generator AC output available to the transfer switch, the CPU circuit board will be turned on. The CPU board incorporates sensors and timers to control automatic operation, as follows:

- An "engine minimum run timer" on the CPU board will start timing. This timer establishes the minimum length of time the engine must run before it can be shut down in automatic mode. The timer prevents shutdown of a cold engine.
- An "engine warmup timer" starts timing. This timer provides an engine warmup period before electrical loads are transferred to the "Standby" source.
- A "standby voltage sensor" looks for an acceptable (preset) "Standby" source voltage. Transfer of loads to the "Standby" source cannot occur until that source voltage is above a preset level.
- A "standby frequency sensor" prevents transfer to the "Standby" source until that source frequency is above a preset level.
- When (a) the engine has warmed up and (b) standby voltage and frequency have reached preset levels, the CPU circuit board will energize a transfer relay. Transfer of loads to the "Standby" power supply will then occur.

NOTE: If so equipped, a time delay at neutral relay will be energized at the same time as the transfer relay. With the time delay neutral relay energized, the main contacts will trip to neutral. The main contacts will remain at "Neutral" (load disconnected from both power source sides) as long as the time delay neutral relay remains energized. A "time delay neutral timer" on the CPU board establishes the length of time the time delay neutral relay remains energized. When that timer has timed out, transfer of loads to the "Standby" side will occur.

The utility voltage sensor board continues to seek an acceptable (preset) "Utility" source voltage. On restoration of that source voltage above a preset level and for a preset time, the sensor board closes the "utility loss sensor" circuit to the CPU board. This "tells" the CPU

What the System Does (Continued)

circuit board that "Utility" source voltage has been restored.

NOTE: A "line interrupt delay timer" on the utility sensor board delays closure of the "utility loss sensor" circuit for a preset time interval. This time interval is required, to prevent retransfer that might otherwise occur as a result of transient voltages.

When the "line interrupt delay timer" times out, CPU board action will (a) de-energize the transfer relay, and (b) energize the time delay neutral relay (if so equipped). The following events will then take place:

- **Units Without Time Delay Neutral:** When the transfer relay de-energizes, "Utility" source voltage is delivered to transfer mechanism terminals and retransfer back to the "Utility" source occurs.
- **Units with Time Delay Neutral:** When the transfer relay de-energizes, the main contacts will trip to "Neutral". A "time delay neutral timer" on the CPU board will time. When that timer has timed out, the time delay neutral relay will de-energize and the main contacts will complete their travel to the "Utility" source side.

Following retransfer back to the "Utility" source, an "engine cooldown timer" on the CPU board will start timing. When that timer has timed out, circuit board action will open the 2-wire start circuit (178/183) and the generator will shut down.

The 7-Day Exercise Feature

The CPU circuit board incorporates a "7-day exercise" circuit. This feature will start the generator once every seven days (at a preset time and on a preset day). The generator will run (exercise) for a preset time interval and then shut down. During the exercise runup, transfer to the "Standby" source may or may not occur, as selected by means of a "bypass transfer on exercise" switch. The "bypass" switch is located on the CPU board.

Section 10.2

AUTOMATIC OPERATING SEQUENCES

Introduction

Timers and sensors on the CPU circuit board, used to regulate automatic operation, are fixed and non-adjustable. That is, the CPU circuit board is non-programmable.

The utility voltage sensor circuit board provides three adjustable settings as follows:

1. Voltage Pickup setting
 - a. Establishes the "Utility" source voltage required before retransfer back to that power source can occur.
 - b. Adjustment settings are given in "percent of utility" voltage.
2. Voltage Dropout setting
 - a. Establishes the voltage dropout point at which standby generator startup and transfer to "Standby" will occur.
 - b. Adjustment settings are given in "percent of pickup voltage".
3. Line Interrupt Delay Timer
 - a. Establishes the time delay between "Utility" voltage dropout below the "voltage dropout" setting and generator startup.
 - b. The time delay is required to prevent false generator starts that might otherwise be caused by transient voltage dips.
 - c. Adjustment settings are given in "seconds".

NOTE: A special utility voltage sensor board is used on multi-voltage type transfer switches. The "multi-voltage" circuit board includes a voltage selector switch. Refer to Section 8.8.

Sequence of Automatic Operation

1. With an acceptable "Utility" source voltage sensing signal available to the utility voltage sensor board, the following conditions exist:
 - a. A "voltage dropout sensor" on the utility voltage sensor circuit board monitors the "Utility" source voltage.
 - b. A "Utility On" lamp (LED) on the utility voltage sensor board is ON.
 - c. A "Switch Position-Utility" lamp on the transfer switch enclosure door is ON.
 - d. Transformer reduced "Load" terminal voltage is delivered to the CPU circuit board, for operation of the 7-day exercise timer.
 - e. A "Standby Operating" lamp on the switch enclosure door is OUT and operating voltage for the CPU circuit board is not available.
2. If "Utility" source voltage drops below the setting of the utility voltage sensor board's "voltage dropout sensor", the following events will occur:
 - a. The circuit board's "Utility On" lamp (LED) goes out and the "utility loss sensor" circuit to the CPU board is opened.
 - b. The utility voltage sensor board's "line interrupt delay timer" starts timing. The timer can be set at any point between 0.1 and 10 seconds.
 - c. If voltage is still low when the timer has finished timing, the following events will occur:
 - (1) Utility voltage sensor board action will close the 2-wire start circuit (178/183).
 - (2) The generator engine will crank and start as controlled by a DC control/latch-crank circuit board in the generator console.
3. On engine startup, the following events will occur:
 - a. A "Standby Operating" lamp on the transfer switch enclosure door illuminates.
 - b. Transformer reduced "Standby" source voltage is delivered to the CPU circuit board, which now becomes operational.
 - c. An "engine minimum run timer" on the CPU board starts timing.
 - (1) The timer is fixed at 10 minutes. That is, the engine must run for at least 10 minutes before it can be shut down in automatic mode.
 - (2) The "engine minimum run timer" prevents shut-down of a cold engine.
 - d. An "engine warmup timer", also on the CPU board, starts timing.
 - (1) "Engine warmup timer" setting is fixed at 30 seconds.
 - (2) Transfer of loads to the "Standby" power supply cannot occur until the timer has timed out.
 - e. A "standby voltage sensor" and a "standby frequency sensor" on the CPU board look for a preset, acceptable "Standby" source voltage and frequency.
 - (1) The "standby voltage" and "standby frequency" sensors are set at a fixed 80 percent of rated "Standby" source voltage and frequency.
 - (2) Transfer of the load to the "Standby" source can occur only if standby voltage and frequency are above the sensor settings.

Sequence of Automatic Operation (Continued)

4. The CPU circuit board will initiate transfer to the "Standby" power supply, providing the following conditions have been met:

- a. Utility voltage sensor board must still hold the "utility loss sensor" circuit to the CPU board open. This "tells" the CPU board that "Utility" source voltage is still low.
- b. The "engine warmup timer" must have timed out.
- c. "Standby" AC voltage and frequency must be greater than 80 percent of system rated voltage and frequency.

NOTE: It must be emphasized that a transfer to "Standby" action cannot occur unless the utility voltage sensor board has opened the "utility loss sensor" circuit. That is, transfer to "Standby" cannot occur while "Utility" voltage is above the setting of the "voltage dropout sensor".

5. When all of the conditions in Sequence 4 above have been met, CPU board action will complete the transfer relay and (if so equipped) time delay relay circuits to ground.

- a. The transfer relay will energize, its normally-open contacts will close, and "Standby" source voltage will be delivered to the transfer mechanism terminals. Transfer to the "Standby" source will then occur.
- b. If so equipped, the time delay relay will energize at the same time as the transfer relay.
 - (1) Time delay relay's normally-closed contacts will open. This action will open the "Standby" voltage circuit to the transfer mechanism's "B power source side on" terminals, to prevent transfer to the "Standby" power source side.
 - (2) The transfer mechanism's main contacts will trip to "Neutral" and remain at that position as long as the time delay relay is energized.
 - (3) After five seconds, CPU board action will de-energize the time delay relay. The main contacts will then complete their movement to the "Standby" power source side.
- c. Electrical loads are now powered by the "Standby" power source.

6. The utility voltage sensor circuit board's "voltage pickup sensor" continues to seek an acceptable preset "Utility" source voltage.

- a. On restoration of "Utility" source voltage above the setting of the "voltage pickup sensor", utility voltage sensor board action closes the "utility loss sensor" circuit to the CPU board to "tell" the CPU board that "Utility" voltage has been restored.

b. A "return to utility timer" on the CPU board starts timing, will time for 30 seconds.

c. If the "utility loss sensor" circuit is still closed when the "return to utility timer" has finished timing, CPU board action will initiate the following:

(1) Circuit board action will de-energize a transfer relay. The relay's normally-closed contacts will close, to deliver "Utility" voltage to the transfer mechanism and retransfer back to the "Utility" power source will occur.

(2) If so equipped, CPU board action will energize a time delay neutral relay. The main contacts will then trip to "Neutral" and remain at "Neutral" as long as the time delay relay is energized. After five seconds, CPU board de-energizes the time delay relay and re-transfer back to the "Utility" source occurs.

7. On re-transfer back to the "Utility" side, an "engine cooldown timer" on the CPU circuit board starts timing.

- a. When the "engine cooldown timer" has finished timing, circuit board action will open the 2-wire start circuit (178/183) and engine shutdown will occur.
- b. The "engine minimum run timer" must also have timed out before engine shutdown can occur.

8. Following re-transfer back to the "Utility" source side and generator shutdown, the utility voltage sensor board continues to monitor "Utility" source voltage.

Section 10.3

UTILITY VOLTAGE SENSOR CIRCUIT BOARD

Introduction

See Figure 1. A standard utility voltage sensor board cover is shown. Note the voltage block just below the words "utility voltage sensor" on the cover. The circuit board's rated voltage must match the rated voltage of the system in which the board is used.

NOTE: Multi-voltage transfer switches use a utility voltage sensor board cover which mounts a "voltage selector switch". The switch permits a single circuit board to be used for several different rated voltage applications.

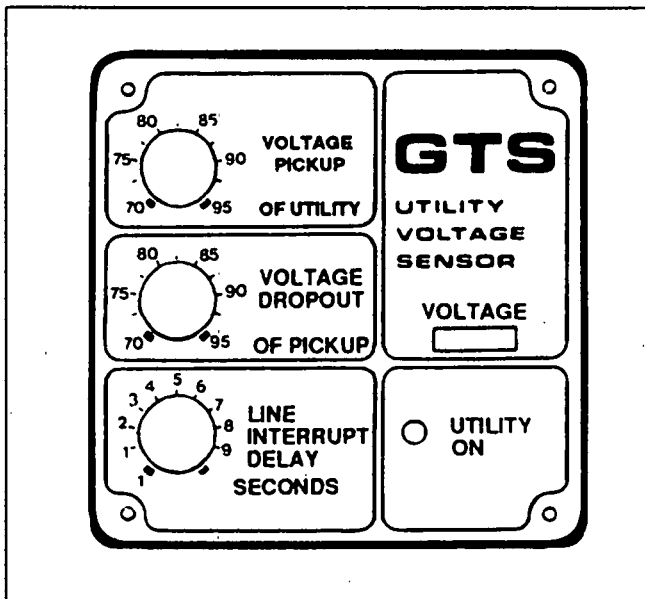


Figure 1. Utility Voltage Sensor Board Cover

Utility Voltage Sensing Connector

This 4-pin connector (Figure 2) connects the utility voltage sensor board to the utility sensing interface. Wires 224 through 227 attach to the connector. The utility sensing interface delivers a transformer reduced "Utility" sensing voltage to the circuit board via this connector. For sensing voltage inputs to the circuit board, see Test 3 on Page 8.10-2 or Test 26 on Page 9.9-10.

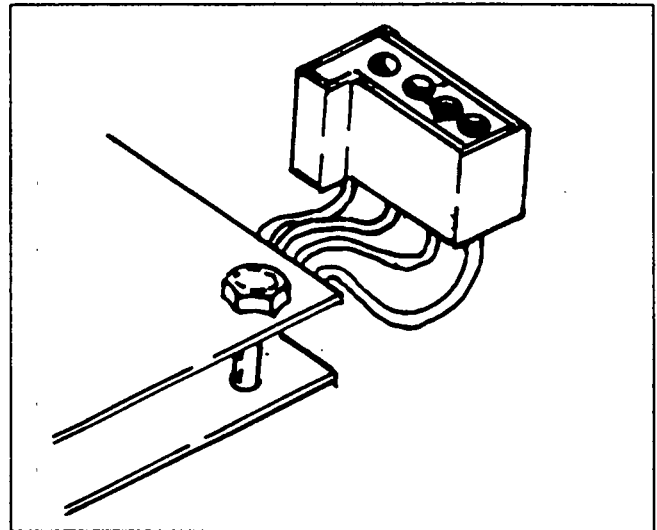


Figure 2. Utility Voltage Sensing Connector

Control System Connector

See Figure 3. Wires 177, 178, 199 and 202 attach to this connector.

Wires 177 and 178 form the 2-wire auto-start circuit. Closure of this circuit by circuit board action will occur during a "Utility" power outage, to initiate generator cranking and startup as controlled by a DC control/match-crank circuit board in the generator console.

Wires 199 and 202 (sometimes 199 and 200) are part of the "utility loss sensor" circuit which connects the utility voltage sensor board to the CPU circuit board. When "Utility" source voltage is available and above the setting of the "voltage dropout sensor", utility voltage sensor board action holds the circuit closed. However, should "Utility" voltage drop below the setting of the "voltage dropout sensor", utility voltage sensor board action will open the circuit to "tell" the CPU circuit board that "Utility" power has failed.

NOTE: Transfer to "Standby" cannot occur while the "utility loss sensor" circuit is closed.

Control System Connector (Continued)

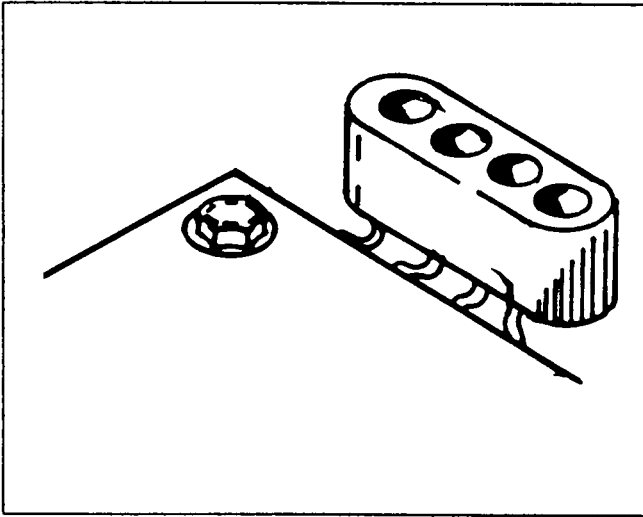


Figure 3. Control System Connector

The "Utility Loss Sensor" Circuit

Figure 4 is a simplified schematic of the "utility loss sensor" circuit. A transistor is used as a "switch", to open and close the circuit. The transistor holds the circuit closed as long as a voltage is applied to the base of the transistor. Remove the voltage that is applied to the transistor base and the circuit opens.

A voltage is applied to the transistor base as long as "Utility" source voltage is available and is above the setting of the "voltage dropout sensor". During this time, transistor action holds the "sensor" circuit closed. Wire 199 is the "high" side of the circuit, while wire 202 is the "low" (grounded) side.

When "Utility" voltage drops below the setting of the "voltage dropout sensor", circuit board action removes the voltage from the transistor base. The transistor then becomes an effective open circuit.

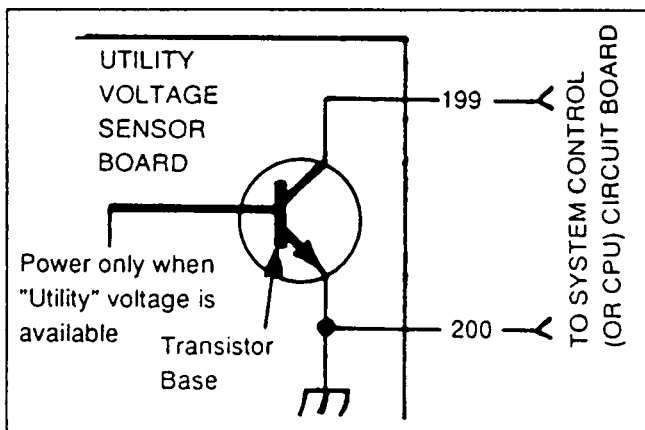


Figure 4. Schematic- Utility Loss Sensor Circuit

Circuit Board Calibration

The utility sensing interface transformers reduce the "Utility" power source voltage at a fixed ratio. Any variation in the actual "Utility" voltage supplied to the transfer switch will also result in a corresponding variation of the sensing voltage supplied to the utility voltage sensor board. For that reason, calibration of the circuit board to match the actual "Utility" source voltage may be required.

The correct procedure for calibrating the utility voltage sensor board can be found on Page 8.10-2 (Part 8, Section 8.10).

Proper calibration of the circuit board will establish the actual voltage present at the time of calibration as 100 percent, for "pickup" and "dropout" settings.

CAUTION: The installed transfer switch and the utility voltage sensor board must be rated at a voltage and phase that is compatible with the rated "Utility" and "Standby" system voltages. Do NOT attempt to calibrate a non-compatible circuit board in an attempt to make a non-compatible unit match the system voltages.

Section 10.4 THE CPU CIRCUIT BOARD

Introduction

Called the CPU or "central processing unit", this circuit board incorporates the various timers and sensors needed for automatic operation as well as the 7-day exercise timer. Timer and sensor settings are fixed and non-adjustable, except for the 7-day exercise timer's day and time selection.

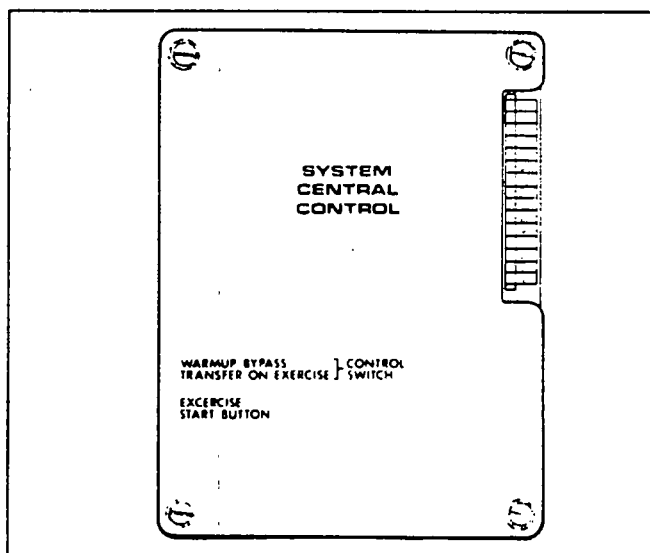


Figure 1. CPU Circuit Board Cover

Circuit Board Connector

A 15-pin connector is provided, to interconnect the CPU circuit board with other transfer switch components and circuits. The connector is shown in Figure 2. Pin numbers, associated wire numbers and circuit functions are listed in the chart that follows:

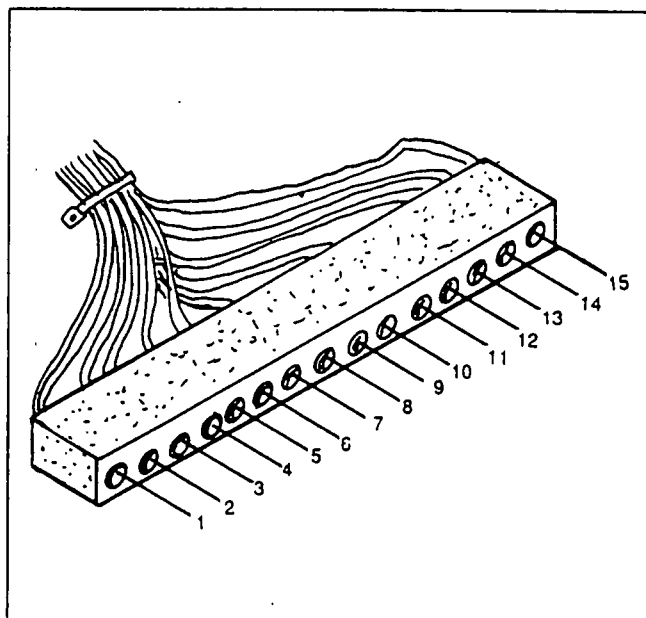


Figure 2. CPU Board Connector

Circuit Board Sensors and Timers

As previously mentioned, CPU board sensors and timers are fixed and non-adjustable. These include the following:

- An ENGINE MINIMUM RUN TIMER, fixed at 10 minutes.
- An ENGINE WARMUP TIMER, fixed at 30 seconds.
- A STANDBY VOLTAGE SENSOR, fixed at 80 percent of rated voltage.
- A STANDBY FREQUENCY SENSOR, fixed at 80 percent of rated frequency.
- A RETURN TO UTILITY TIMER, fixed at 30 seconds.
- An ENGINE COOLDOWN TIMER, fixed at 10 minutes.

The CPU board also provides (a) an engine warmup timer bypass switch, (b) a "set exercise time" switch, and (c) a "transfer on exercise" selector switch. See Section 10.5.

PIN NO.	WIRE NO.	CIRCUIT FUNCTION & DESCRIPTION
1	194	Delivers 12 volts DC to transfer relay coil with engine running.
2	202	Common ground
3	201	High (+) side of "Fast Test" signal circuit.
4	203	High (+) side of "Normal Test" signal circuit.
5	199	High (+) side of "utility voltage loss" sensor circuit.
6	177	Part of the 2-wire start circuit.
7	178	Part of 2-wire start circuit.
8	—	Not Used.
9	—	Not Used.
10	193	Low (grounded) side of time delay neutral relay coil circuit.
11	23	Low (grounded) side of transfer relay coil circuit.
12	191	Circuit board power supply from transformer TR1 (step-down "Standby" source voltage [about 21-24 volts AC] is delivered to this terminal and terminal 13).
13	192	Same as Pin No. 12.
14	185	Power supply for 7-day exercise timer. Reduced load terminal voltage from transformer TR2 is delivered here.
15	0	Same as Pin No. 14.

Section 10.5
SENSOR AND TIMER SETTINGS

Utility Voltage Sensor Circuit Board

VOLTAGE PICKUP SENSOR:

The voltage pickup sensor establishes the "Utility" power source voltage level at which retransfer back to that power source can occur. Easily adjustable to any setting between 70-95 percent of the nominal "Utility" power source voltage. The sensor was factory set to about 90 percent of "Utility" voltage.

VOLTAGE DROPOUT SENSOR:

Sensor establishes the "Utility" power source voltage level at which generator startup and transfer to "Standby" will be initiated. Sensor can be adjusted between 70-95 percent of the voltage pickup setting, is factory set to about 80 percent of that value.

LINE INTERRUPT DELAY TIMER:

This timer establishes a time delay interval between "Utility" voltage dropout below the voltage dropout sensor setting and generator startup. Such a time interval is required to prevent false starts that might otherwise occur because of transient voltage dips. Timer is adjustable from 0.1 to 10 seconds; it is factory set to about five (5) seconds.

NOTE: Wide differences can exist between "Utility" source supply voltages. It may be necessary to "calibrate" the utility voltage sensor circuit board to match "Utility" supply voltage. See "Circuit Board Calibration" on Page 10.3-2.

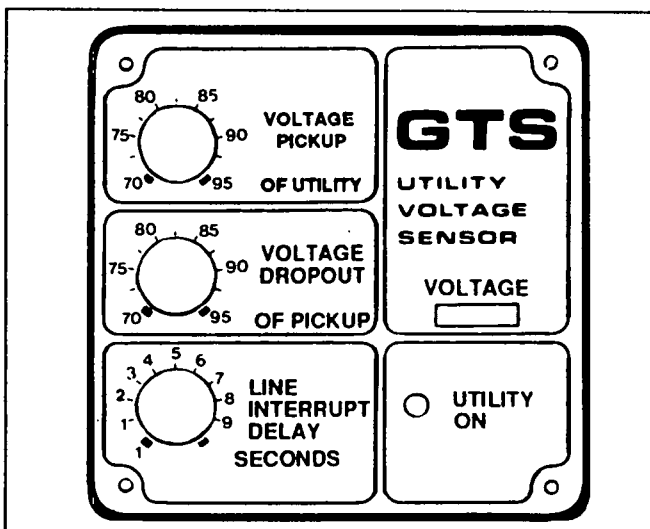


Figure 1. Utility Voltage Sensor Board Cover

CPU Circuit Board Selections

Sensors and timers on the CPU board are fixed and non-adjustable. However, several miniature switches are provided as follows.

ENGINE WARMUP TIMER BYPASS SWITCH:

Following engine startup, transfer of loads to the "Standby" source cannot occur until (a) the engine warmup timer has timed for about 30 seconds, (b) generator voltage has reached 80 percent of rated voltage, and (c) generator frequency has reached 80 percent of rated frequency.

If desired, the engine warmup timer can be bypassed. Transfer to "Standby" will then occur as soon as "Standby" voltage and frequency have reached 80 percent of rated voltage.

To bypass the engine warmup timer, actuate Switch "1" away from its "Off" position and toward the number "1". To place the engine warmup timer back into operation, actuate Switch 1 to its "Off" position.

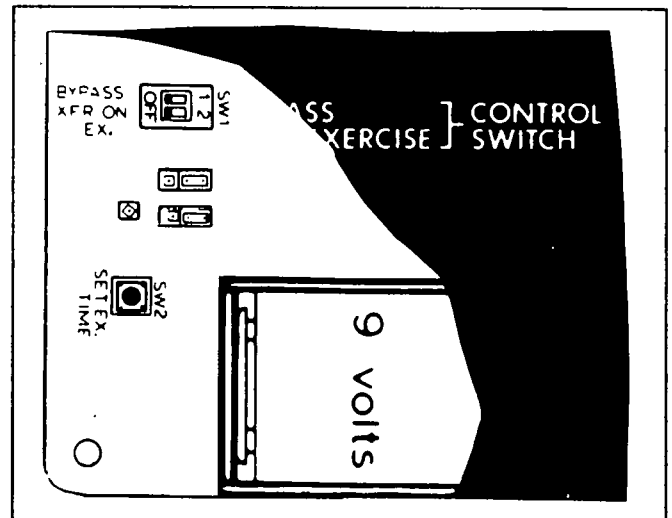


Figure 2. CPU Circuit Board Switches

TRANSFER ON EXERCISE SWITCH:

To transfer loads to the "Standby" power source during the 7-day exercise runup, actuate Switch 2 away from its "Off" position and toward the number "2". If no transfer is desired during exercise, set Switch 2 to "Off".

CPU Circuit Board Selections (Continued)

SELECTING EXERCISE DAY AND TIME OF DAY:

On the day and at the time of day you wish the system to start and exercise, push the "SET EX. TIME" switch in and hold for about 15 seconds. The generator will start and exercise every seven (7) days thereafter at the selected time of day.

**PART 11
THE "LOGIC"
TYPE
INTELLIGENCE
SYSTEM**

**STANDBY
ELECTRIC
POWER
SYSTEMS**
All Series

TABLE OF CONTENTS

SECTION	TITLE
11.1	System Familiarization
11.2	Automatic Operating Sequences
11.3	Utility Voltage Sensor Circuit Board
11.4	System Control Circuit Board
11.5	Exercise Circuit Board
11.6	Sensor and Timer Settings
11.7	Inphase Monitor Control

NOTES

Section 11.1

SYSTEM FAMILIARIZATION

General

The "Logic" type intelligence system consists of three (3) solid state circuit boards called (a) a utility voltage sensor board, (b) a system control board, and (c) an exercise board. All three circuit boards are housed in a circuit board compartment located in the transfer switch enclosure door.

This system differs from the CPU type intelligence system in several ways. The most obvious difference is that the "Logic" system utilizes three (3) circuit boards, including an exercise circuit board.

Another difference is that the "Logic" system incorporates a system control circuit board that is fully programmable.

What the System Does

The utility voltage sensor board constantly monitors "Utility" power source voltage. Should that source voltage drop below a preset level, the utility voltage sensor board will close the 2-wire start circuit (wires 178 and 183). On closure of that circuit, a DC control/latch-crank circuit board (housed in the generator console) will crank and start the engine. The utility voltage sensor board will also open a "utility loss sensor circuit" to the system control board, to "tell" the system control board that "Utility" power has dropped low.

With the generator engine running and "Standby" source power available to the transfer switch, the system control circuit board will be turned on. That circuit board incorporates sensors and timers for the control of automatic operation as follows:

- A "Standby On" lamp (LED) on the circuit board turns on, to indicate that (a) the generator is running, (b) the system control board is powered, and (c) 12 volts DC power is available to the transfer relay (and to a "time delay neutral relay, if so equipped). Because circuit board action holds the grounded side of the relay circuits open, the relays do not energize at this time.
- An "engine minimum run timer" on the circuit board starts timing (an LED comes on), to establish the minimum length of time the engine must run before it can be shut down. This prevents shutdown of a cold engine.
- An "engine warmup timer" starts timing and its lamp (LED) turns on at the same time the "minimum run timer" comes on. The timer establishes a preset engine warmup period before the load can be transferred to the "Standby" source.
- When generator AC output voltage and frequency have reached the settings of a "standby voltage sensor" and a "standby frequency sensor", these two lamps (LED's) turn on.
- When the "engine warmup timer" has timed out and when standby voltage and frequency have reached preset levels, system control board action will close the grounded side of the transfer relay (and the time delay neutral relay, if so equipped) to ground. These relays will now energize.
- As the transfer relay energizes, its normally-open contacts close and "Standby" source voltage trips the main contacts to "Neutral".

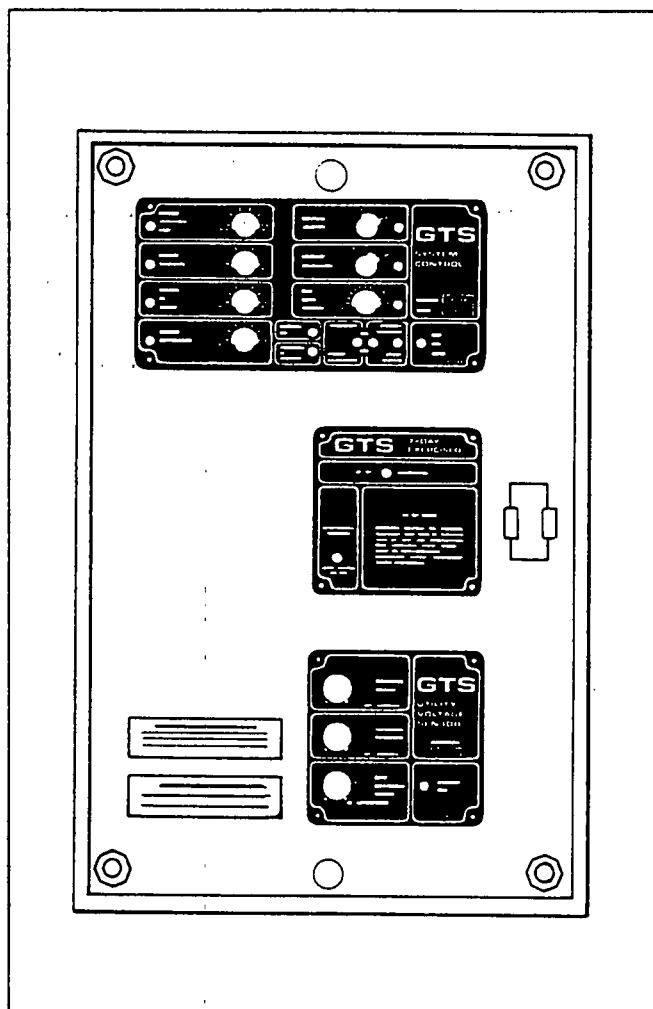


Figure 1. The "Logic" Intelligence System

What the System Does (Continued)

NOTE: If so equipped, as the time delay neutral relay energizes its normally-closed contacts open to open the transfer mechanism's "transfer to Standby" circuit. The main contacts will remain at "Neutral" as long as the relay remains energized. A "time delay neutral timer" on the circuit board establishes the length of time the time delay neutral relay will remain energized and thus the length of time the main contacts remain at "Neutral".

- Transfer to "Standby" occurs when the transfer relay energizes and when the time delay neutral relay de-energizes.

The utility voltage sensor board continues to seek an acceptable preset "Utility" source voltage. When that source voltage is restored above the preset level of a "voltage pickup sensor", utility voltage sensor board action closes the "utility loss sensor circuit". Closure of that circuit to ground "tells" the system control board that "Utility" voltage has been restored. An "engine cool-down timer" on the system control board then starts timing and, when it has timed out, system control board action opens the transfer relay circuit to ground and (if so equipped) closes the time delay neutral relay circuit to ground.

The transfer relay de-energizes, its normally-closed contacts close, and "Utility" source power trips the main contacts to "Neutral". When a "time delay neutral timer" on the system control board has timed out, circuit board action will open the time delay neutral relay circuit to ground. That relay will then de-energize and the main contacts will complete the transfer action back to the "Utility" power supply.

Following retransfer, an "engine cooldown timer" on the system control board will start timing. When that timer has timed out, circuit board action will open the 2-wire start circuit. Generator engine shutdown will then occur.

The 7-Day Exercise Feature

The 7-day exercise circuit board is powered by transformer reduced (step-down) voltage from the transfer mechanism's LOAD terminal lugs. This circuit board establishes an automatic startup and "exercise" cycle that occurs once every seven (7) days, on a day and at a time of day selected.

Loss of operating voltage will normally result in loss of timer count and the day and time of exercise would become scrambled. To prevent this, a 9 volts transistor battery has been provided to supply minimum operating power during the time the main contacts are at "Neutral" during as transfer action. The battery does not prevent loss of timing count during periods at "Neutral", but will prevent the preset day and time of exercise from becoming scrambled.

NOTE: A deluxe programmable exercise circuit board is also available. See Part 12, "Transfer Switch Options".

Section 11.2
AUTOMATIC OPERATING SEQUENCES

SEQ.	CIRCUIT BOARD	TIMER/SENSOR	ACTION
1	Utility voltage sensor	Voltage dropout sensor	"Utility" source voltage drops below 70-95% of the voltage pickup sensor setting (factory set to about 80%).
2	Utility voltage sensor	Line interrupt delay timer	Line interrupt delay timer times for 0.1 to 10 seconds (factory setting is about 5 seconds).
3	Utility voltage sensor		Circuit board action closes 2-wire start circuit, generator cranks and starts.
4	System control System control System control	"Standby On" lamp ON Engine minimum run timer Engine warmup timer	Lamp ON indicates generator is running and system control board is powered. Timer can be set for 5 to 30 minutes, is factory set for 10 minutes. Engine cannot be shut down in automatic mode until timer has timed out. Timer can be set for 5 seconds to 30 minutes, or turned off. Transfer to "Standby" cannot occur until timer has finished timing.
5	System control System control	Standby voltage sensor Standby frequency sensor	Can be set to 70-90% of generator rated voltage. Can be set for 80-90% of rated generator frequency. Transfer to "Standby" cannot occur until generator AC voltage and frequency have reached the setting of these sensors.
6	System control	"Transfer to Standby" LED turns ON Time delay neutral timer's LED turns ON (if so equipped)	Transfer relay is energized and transfer to "Standby" occurs. Main contacts trip to "Neutral" and remain at "Neutral" for 0.1 to 10 seconds (adjustable). When time delay neutral timer has timed out, transfer to "Standby" occurs.
7			Loads are powered by "Standby" power supply.
8	Utility voltage sensor	Voltage pickup sensor	Sensor is adjustable from 70-95% of rated "Utility" voltage. On restoration of "Utility" voltage above the sensor setting, circuit board closes a "utility loss sensor circuit" to the system control board and Sequence 8 begins.
9	System control	Return to "Utility" timer	Return to "Utility" timer is adjustable from 1-30 minutes.
10	System control	Return to "Utility" timer Time delay neutral timer's LED turns ON (if so equipped)	When timer times out, circuit board action de-energizes the transfer relay and re-transfer back to "Utility" occurs. When return to "Utility" timer times out, circuit board action will energize time delay neutral relay. That relay will stay energized for 0.1-10 seconds to hold main contacts at "Neutral" for the pre-selected time length.
11	System control	Engine cooldown timer	Following retransfer, engine cooldown timer turns on. When timer finishes timing, generator shutdown will occur (providing the "engine minimum run timer" has also finished timing).
12	Utility voltage sensor	Voltage dropout sensor	Circuit board continues to monitor "Utility" power source voltage.

Section 11.3

UTILITY VOLTAGE SENSOR CIRCUIT BOARD

The utility voltage sensor circuit board is discussed in Part 10, Section 10.3. Also see Part 8, Section 8.8, "Multi-Voltage Transfer Switches".

Section 11.4
SYSTEM CONTROL CIRCUIT BOARD

General

The system control circuit board is powered by transformer reduced (step-down) "Standby" source voltage. The board is "programmable", in that its sensors and timers are adjustable (unlike the CPU board which has "fixed" sensors and timers). The circuit board mounts sensor and timer lamps (LED's) which turn on to indicate sensor/timer operation. Thus, automatic operation can be monitored by simply observing the LED's.

A system control board cover (Figure 1) is mounted to the circuit board by screws and separated from the board by "standoffs". A second set of screws and standoffs retain the board to the transfer switch enclosure. Holes in the circuit board cover permit the sensor/timer LED's to be seen.

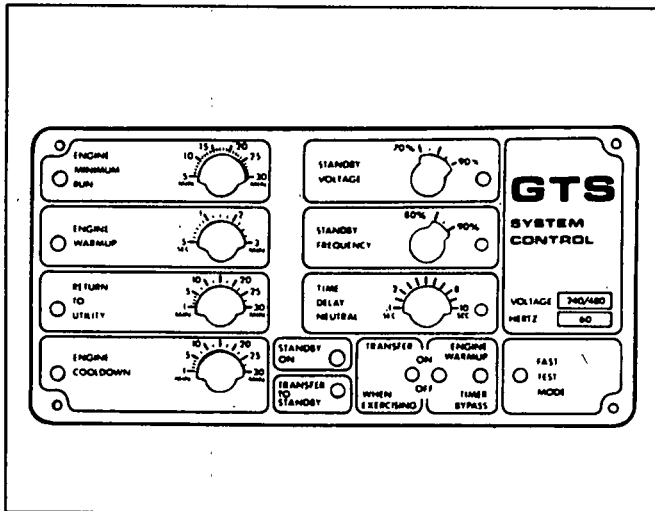


Figure 1. System Control Circuit Board Cover

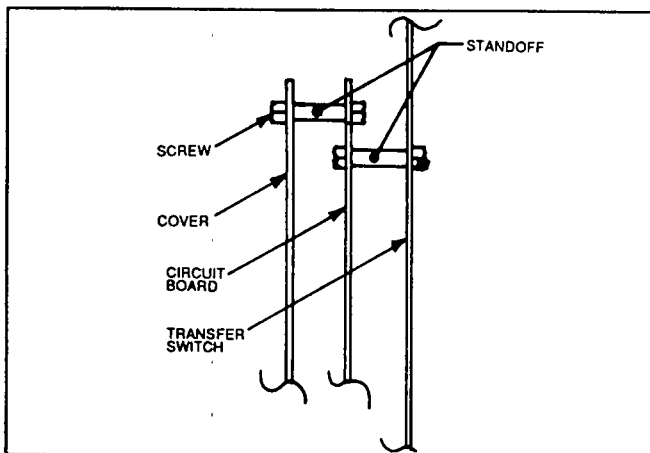


Figure 2. Circuit Board Mounting Details

Circuit Board Connections

A 15-pin connector is provided on the circuit board (Figure 3). Connector pin numbers, associated wire numbers and functions of each circuit are listed in the following chart:

PIN NO.	WIRE NO.	FUNCTION AND DESCRIPTION
1	196	Not Used (Test Point).
2	191	Transformer reduced (step-down) "Standby" source power supply to circuit board.
3	192	Same as Pin No. 2.
4	199	High (+DC) side of "utility loss sensor circuit" from utility voltage sensor board. "Tells" the system control board that "Utility" voltage is low or out.
5	200	Low (grounded) side of "utility loss sensor circuit". Function is same as Pin No. 4.
6	202	Low (grounded) side of "Fast Test" and "Normal Test" circuits to system test switch.
7	177	Part of 2-wire start circuit (becomes Wire 183).
8	197	Low (grounded) side of exercise signal circuit from exercise circuit board. Exercise board grounds this circuit to initiate system exercise.
9	194	High side (+12 volts DC) of transfer relay and time delay neutral relay coils circuit.
10	201	High side of "Fast Test" circuit. Pin No. 6 is the low (grounded) side of this circuit.
11	193	Low (grounded) side of time delay neutral relay circuit. Pin No. 9 is the high side of circuit.
12	203	High (+DC) side of "Normal Test" circuit. Pin No. 6 is the low (grounded) side of circuit.
13	198	High (+DC) side of exercise signal circuit from exercise circuit board. Pin No. 8 (Wire No. 197) is the low (grounded) side of circuit.
14	178	Part of 2-wire start circuit (see Pin No. 7).
15	23	Low (grounded) side of transfer relay circuit. Pin No. 9 is the high side of this circuit.

2

Section 11.5
EXERCISE CIRCUIT BOARD

Introduction

The 7-day exercise circuit board is powered by transformer reduced (step-down) voltage from the transfer mechanism LOAD terminals (T1, T2, T3). The circuit board function is to start and exercise the standby generator once every seven (7) days, on a pre-selected day and at a pre-selected time. A "Timer Operating lamp (LED) is provided. The lamp will flash to indicate that power is available and the timer is operating.

This voltage supply operates a timer (clock) Once every seven (7) days on a pre-selected day and at a pre-selected time of day, circuit board action will close the 2-wire start circuit. At the same time, circuit board action will complete a Wires 197/198 circuit to the system control board. The standby generator will start. Transfer to the "Standby" side may or may not occur, depending on the pre-selected position of a "transfer on exercise" switch on the system control board.

Generator "exercise" will last for approximately 20-30 minutes.

Circuit Board Connector

A 9-pin connector is provided to interconnect the exercise board with other transfer switch components. Connector pin numbers, associated wires and functions of each circuit are identified in the following chart.

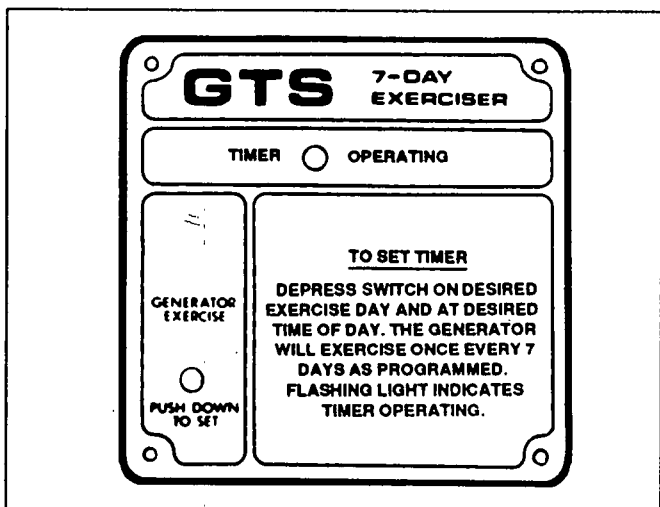


Figure 1. Exercise Circuit Board Cover

NOTE: An optional programmable exercise circuit board is also available. See Part 12, "Transfer Switch Options".

9 Volts Transistor Battery

During a transfer action (when transferring to either power source side), the transfer mechanism's LOAD terminals will be disconnected from both power source sides for a brief period. Power for operation of the exercise board is not available for this short time span. For that reason, a 9 volts battery has been provided to prevent the timer setting from becoming scrambled during transfer.

It is recommended that the 9 volts battery be removed and replaced at least once annually.

Circuit Board Operation

Transformer reduced (step-down) voltage is delivered to the circuit board from the transfer mechanism LOAD terminals.

PIN NO.	WIRE NO.	FUNCTIONS AND DESCRIPTION
1	195	Not Used (Test Point)
2	185	Transformer reduced power supply from LOAD terminal lugs.
3	---	Not Used
4	198	High (+DC) side of exercise signal to system control circuit board.
5	197	Low (grounded) side of exercise signal to system control circuit board.
6	0	Same as Pin No. 2
7	178	Part of 2-wire start circuit.
8	---	Not Used
9	177	Part of 2-wire start circuit (becomes Wire 183).

Section 11.6
SENSOR AND TIMER SETTINGS

Utility Voltage Sensor Circuit Board

Sensor and timer settings on this board are identical to those on the CPU type intelligence system. See Section 10.5.

NOTE: For multi-voltage transfer switches, also see Sections 8.8 and 9.7. Utility voltage sensor boards used on multi-voltage units mount a "voltage selector" switch.

NOTE: The utility voltage sensor board may require calibration to match actual system voltage. For calibration procedure, see Test 4 in Section 8.10 or Test 27 in Section 9.9.

System Control Circuit Board

ENGINE MINIMUM RUN TIMER:

Establishes the minimum length of time the generator must run before it can be shut down in automatic mode, to prevent shutdown of a cold engine. Timer is adjustable from 5 to 30 minutes and is usually factory set to about 10 minutes.

ENGINE WARMUP TIMER:

Provides for an engine warmup time before automatic transfer of loads to the "Standby" side can occur. Timer is adjustable from 5 seconds to 30 minutes and is usually factory set to about 1 minute.

NOTE: The circuit board provides an "Engine Warmup Timer Bypass Switch".

RETURN TO UTILITY TIMER:

Establishes a time interval between restoration of "Utility" voltage above the setting of a "voltage pickup sensor" and re-transfer back to that source. This time interval is required to prevent re-transfer that might otherwise occur as the result of transient voltages. Timer is adjustable between 1 and 30 minutes, is usually factory set to about 5 minutes.

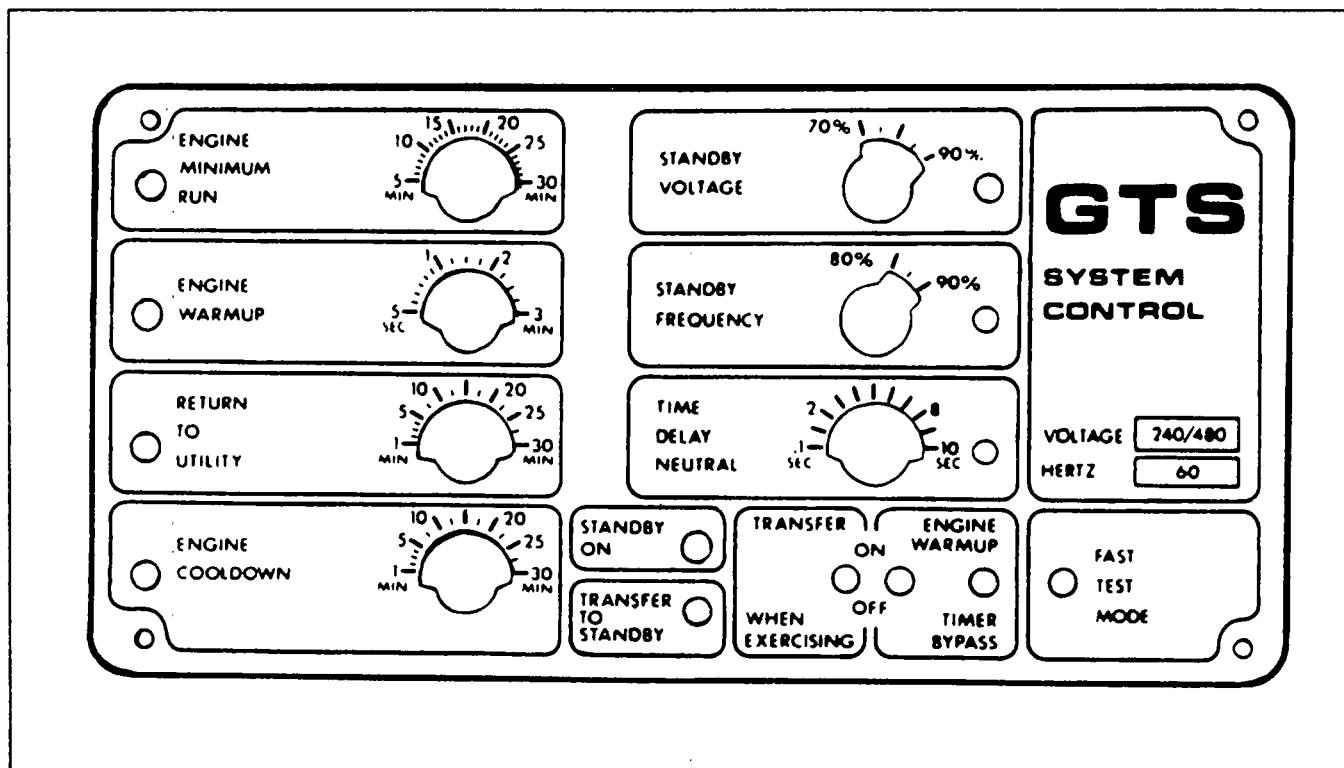


Figure 1. System Control Circuit Board Cover

System Control Circuit Board (Continued)
ENGINE COOLDOWN TIMER:

Provides a time delay between re-transfer back to the "Utility" source and generator engine shutdown. This time delay is necessary, to prevent shutdown of a hot engine (allows internal engine-generator temperatures to stabilize at no-load before shutdown). Timer is adjustable from 1 to 30 minutes. It is usually factory set to about 10 minutes.

STANDBY VOLTAGE SENSOR:

Establishes the minimum generator AC output voltage that must be available before the system can transfer to the "Standby" source side. The sensor is adjustable from 70 to 90 percent of system rated voltage. It is usually factory set to about 80 percent of system voltage.

STANDBY FREQUENCY SENSOR:

Establishes the minimum generator AC output frequency that must be available before system can transfer to the "Standby" source side. Sensor is adjustable from 80-90 percent of rated frequency and is usually set at the factory to about 80 percent.

TIME DELAY NEUTRAL TIMER:

This timer establishes the length of time that the time delay neutral relay will remain energized during a transfer or re-transfer action. That is, it will establish the time delay with the main contacts at "Neutral" (LOAD disconnected from both power supplies). Timer is adjustable from 0.1 to 10 seconds and factory set to about 5 seconds.

STANDBY ON LAMP (LED):

Although not an adjustment, this lamp is mentioned for informational purposes. The LED illuminates to indicate that the standby generator is running and transformer reduced "Standby" voltage is available for system control board operation.

TRANSFER TO STANDBY LAMP:

Not an adjustment. Lamp will turn on when the transfer relay has been energized by circuit board action, i.e., as soon as transfer to "Standby" has occurred.

TRANSFER WHEN EXERCISING SWITCH:

Permits the owner/operator to decide whether loads will be transferred to the "Standby" source side during the 7-day exercise. Use the switch as follows:

- If you wish loads to be transferred to "Standby" during exercise, set the switch upward to "On".
- If you do not wish loads to be transferred during exercise, set the switch down to "Off".

ENGINE WARMUP TIMER BYPASS SWITCH:

Permits the time delay between engine startup and transfer to "Standby" to be eliminated. If the switch is set to "On", transfer will occur as soon as generator AC output voltage and frequency have reached the settings of the standby voltage and frequency sensors (with no engine warmup).

- To bypass the engine warmup timer, set the switch to "On".
- To provide an engine warmup time before transfer, set the switch to "Off".

FAST TEST MODE LAMP (LED):

Not an adjustment. Lamp (LED) will turn on whenever a "Fast Test" operation is in progress.

7-Day Exercise Timer Setting

See Figure 2. A "Generator Exercise" switch has been provided. On the desired day of exercise and at the desired time of day, push the switch in and hold for about 15 seconds. The system will automatically start and exercise every seven (7) days thereafter, on the day and at the time of day selected.

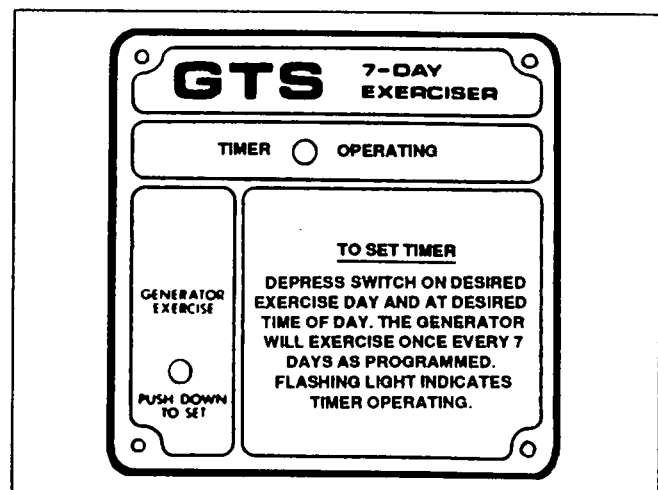


Figure 2. Exercise Circuit Board Cover

Section 11.7 INPHASE MONITOR CONTROL

Introduction

A new Inphase Monitor Control circuit board will soon be used on GTS type transfer switches having the LOGIC type control system. The Inphase Monitor Control circuit board cover is shown in Figure 1, below.

The new Inphase Monitor Control was a new system as of September 1993. The feature will become standard on all GTS systems.

Description

The Inphase Monitor Control provides instantaneous transfer of the load to either of two live voltage sources. Transfer time is less than one (1) second (the time it takes the transfer mechanism to actuate). Operators can select between instant transfer and "Time Delay Neutral". The latter is already standard equipment on Generac GTS type transfer switches.

Operation

The system operator selects his own operating parameters. In a generator startup and transfer situation, the system will respond automatically to the operator's pre-set instructions. For example, load circuits will not be transferred from the Utility power supply to the Generator set power supply until after the genset has attained a preset minimum voltage and frequency output. Another requirement for transfer to the Genset is the generator engine must warm up.

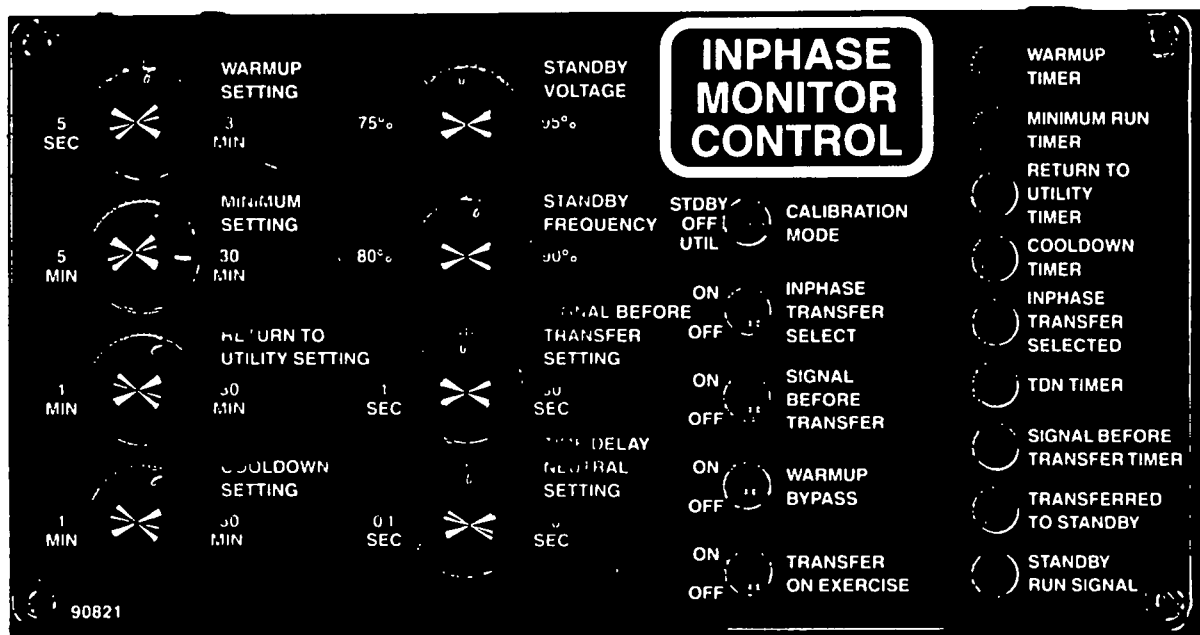
Inphase Transfer Specifications

The Inphase Monitor Control circuit board is operational only when the generator set is running. Transfer will occur when Utility and Generator voltage and phase are comparatively equal, with a maximum difference of 20° between the power sources. To assure precision matching control, minimum voltage and frequency ranges are specified by the operator. In addition, each inphase control is programmed with the use of an onboard DIP switch, to match the actuation time of the corresponding switch. Inphase transfer is utilized only between two live power sources, and NOT during a Utility source failure. The Inphase Monitor Control is designed to transfer loads under the following conditions:

- When Genset frequency is between 58-62 Hz (48-52 Hz for 50 Hz systems).
- When the Genset and Utility power source frequencies are within 2 Hz.
- When the Genset and Utility source voltages are within 85-110 percent of normal voltage.
- When both power sources are able to come into phase within 10 seconds.
- When less than 10 seconds has elapsed since the engine warmup timer has indicated a "go ahead".

If any one of the preceding conditions are not met, the system will automatically revert to Time Delay Neutral.

Figure 1. Inphase Monitor Control Circuit Board



Inphase Transfer Specifications (continued)

Timers and Sensors

WARMUP SETTING: This establishes the length of time the Genset must warm up before the transfer to the generator can occur. The Warmup timer starts after the the generator's voltage and frequency thresholds have been reached. Adjustable from 5 seconds to 3 minutes.

MINIMUM SETTING: Once the generator has been started, it must run for a minimum length of time before it can be shut down. The timer is adjustable from 5 to 30 minutes.

RETURN TO UTILITY SETTING: The "Return to Utility Timer" starts running when the utility power has returned to the value established by the Utility Voltage Sensor circuit board settings. The Timer can be adjusted from 5 to 30 seconds.

COOL DOWN SETTING: After re-transfer back to the Utility source has occurred, this timer allows the Genset engine to cool down before engine shutdown can occur. Timer is adjustable from 1 to 30 minutes.

STANDBY VOLTAGE: This sensor establishes the minimum Genset voltage that must be available before transfer to generator AC output can occur. transfer to Genset output can occur only when the generator's voltage and frequency exceed this setting. Sensor is adjustable from 75%-95% of the Genset's output voltage.

STANDBY FREQUENCY: Establishes the minimum Genset frequency that must be available before the transfer to the Genset can occur. Sensor is adjustable from 80%-90% of generator's normal AC frequency.

SIGNAL BEFORE TRANSFER SETTING: If the "Signal Before Transfer" function is selected, this timer will control the amount of time the signal remains active. Timer is adjustable from 1 to 30 seconds.

NOTE: The "Signal Before Transfer" feature provides a time delay that allows elevators to continue operating before transfer to another power supply occurs. (See Section 12.5)

TIME DELAY NEUTRAL SETTING: This timer holds the transfer mechanism's main contacts in their neutral position for the length of time the timer is setfor. "Neutral" is the main contacts position where the LOAD is disconnected from both the UTILITY and GENSET power supplies. Timer is adjustable from 0.1 to 10 seconds.

Selector Switches

CALIBRATION MODE SWITCH: This switch has three positions, identified as "STDBY", "OFF", and "UTIL". The switch allows the installer to calibrate the circuit board to the existing Genset output voltage and to the existing Utility power source voltage. The board must be calibrated to both power source voltages in order to initiate transfer and re-transfer at the correct voltages. To calibrate the circuit board to the correct voltage, see "Calibrating the Circuit Board" in this section.

NOTE: Loads cannot be transferred unless the generator and Utility source voltage are within 85% to 110% of the nominal (calibrated) voltage.

INPHASE TRANSFER SELECT SWITCH: This switch allows the operator or installer to select either "Inphase Transfer" or "Time Delay Neutral" operation. The switch may be positioned as follows:

Switch at "ON": Inphase transfer operation is selected. See "Inphase Transfer Specifications" on Page 11.7-1.

Switch at "OFF": Time delay neutral operation is selected.

SIGNAL BEFORE TRANSFER SWITCH: This switch allows the operator to activate or bypass the "Signal Before Transfer" feature. To activate, place switch on the "ON" position. To eliminate, place the switch in the "OFF" position. Timer is adjustable from 1 to 30 seconds.

NOTE: See Section 12.5 for information on the "Signal Before Transfer" feature. Certain relays and some other components are required to make the "Signal Before Transfer" option operational.

WARM-UP BYPASS SWITCH: This switch allows the operator to eliminate the engine "Warm-up Timer", allowing the Transfer Switch to activate as soon as voltage and frequency parameters are met. The "Warm-up Timer" will be bypassed when the switch is in the "ON" position. (See "Warm-up Setting" under "Timers and Sensors").

TRANSFER ON EXERCISE SWITCH: The Genset will start and exercise weekly as programmed by the installer or operator. To transfer load circuits during the weekly exercise cycle, set this switch to "ON". If loads are NOT to be transferred during the exercise, set the switch to "OFF"

Inphase Transfer Specifications (continued)

Advisory Lamps

GENERAL: The advisory lamps on the Inphase Monitor Control consist of nine (9) LED's (light emitting diodes) as follows:

- Six (6) timer LED's are green.
- A red "Inphase Transfer Selected" LED.
- A red "Transferred to Standby" lamp.
- A red "Standby Run Signal" lamp.
- The four (4) red timer lamps will turn on when their respective timers are activated.
- The "Inphase Transfer Selected" lamp will illuminate when the Inphase Transfer Select switch is set to "ON", indicating the system will operate in its "inphase" mode, and NOT in the Time Delay Mode.

- The "Transferred to Standby" lamp indicates the Generator is supplying power to the load circuits.
- The "Standby Run Signal" lamp indicates that the generator is running and that the Inphase Monitor Board is operational and controlling the generator.

NOTE: The Inphase Monitor circuit board is operational only when the generator is running.

PIN#	WIRE#	FUNCTION
1	266	Source AC input for Power Board 40 VAC to wire 191 from TR1 on both lines.
2	191	Source AC Input for Board Power 40 VAC to wire 266. from TR1 on both lines.
3	202	Utility voltage from TR3 20 VAC to wire 264 used to determine Inphase Transfer Timing.
4	264	Utility voltage from TR3, 20 VAC to wire 202 used to determine Inphase Transfer Timing.
6	194	12 VDC positive output when Genset is operating. Used for TR and TD relay coil.
7	178	Ground side of normally open contacts for 2 wire start circuit, circuit will close contacts to keep the engine running.
8	177	12 VDC positive of side of normally open contacts of 2 wire start circuit, replaces wire 183 in transfer switch.
9	23	Switched ground for the "Transfer Relay", when grounded, the Transfer Relay energizes and the contactor will move.
10	193	Switched Ground for the "Time Delay" relay to hold to ground as long as time delay timer is active.
11	267	Switched ground for optional Signal Before Transfer relay.
12	199	This signal is normally pulled low internally when utility is present. When utility loss occurs, this signal is allowed to float up to positive 12 VDC. The Inphase Monitor Board then senses that there is a utility failure.
13	198	When this board input goes to positive 12 VDC the Inphase Monitor functions in the exercise mode.
14	201	Positive 12 VDC signal when pulled low (to ground) the Inphase Monitor goes to fast test mode.
15	203	Positive 12 VDC signal, when pulled low (to ground) the "Inphase Monitor" goes into "Normal Test Mode".
16	265	12 VDC positive input for optional "Return to Normal Bypass feature.

Inphase Transfer Specifications (continued)

Calibrating the Circuit Board

(Also see "Calibration Mode Switch" on Page 11.7-2)

The Inphase Monitor Circuit Board must be calibrated to the existing Utility and Standby source voltages, if the system is to operate properly. To calibrate the board, two (2) adjustment potentiometers (R102, R107) are provided in the lower left corner of the circuit board (Figure 2 below). R102 is the generator adjustment, and R107 is used for utility calibration. The circuit board may be calibrated as follows:

1. Check that Utility supply voltage is available to system.
2. Start the generator, let it stabilize and warm up. The "Standby Run Signal" lamp should be on.
3. Set the Calibration Mode Switch to "STDBY" and observe the four (4) top LED's on the circuit board (Warm-up Timer, Minimum Run Timer, Return to Utility Timer and Cool down Timer). These are the red LED lamps.
 - a. If the two upper LED's are flashing, calibration is set too low.
 - b. If the two bottom LED's are flashing, calibration is set too high.

4. On the circuit board, adjust potentiometer R102 until the two center LED's are flashing (minimum Run and Return to Utility).

5. Now, set the Calibration Mode Switch to "UTIL" and observe the four upper LED's on the circuit board.

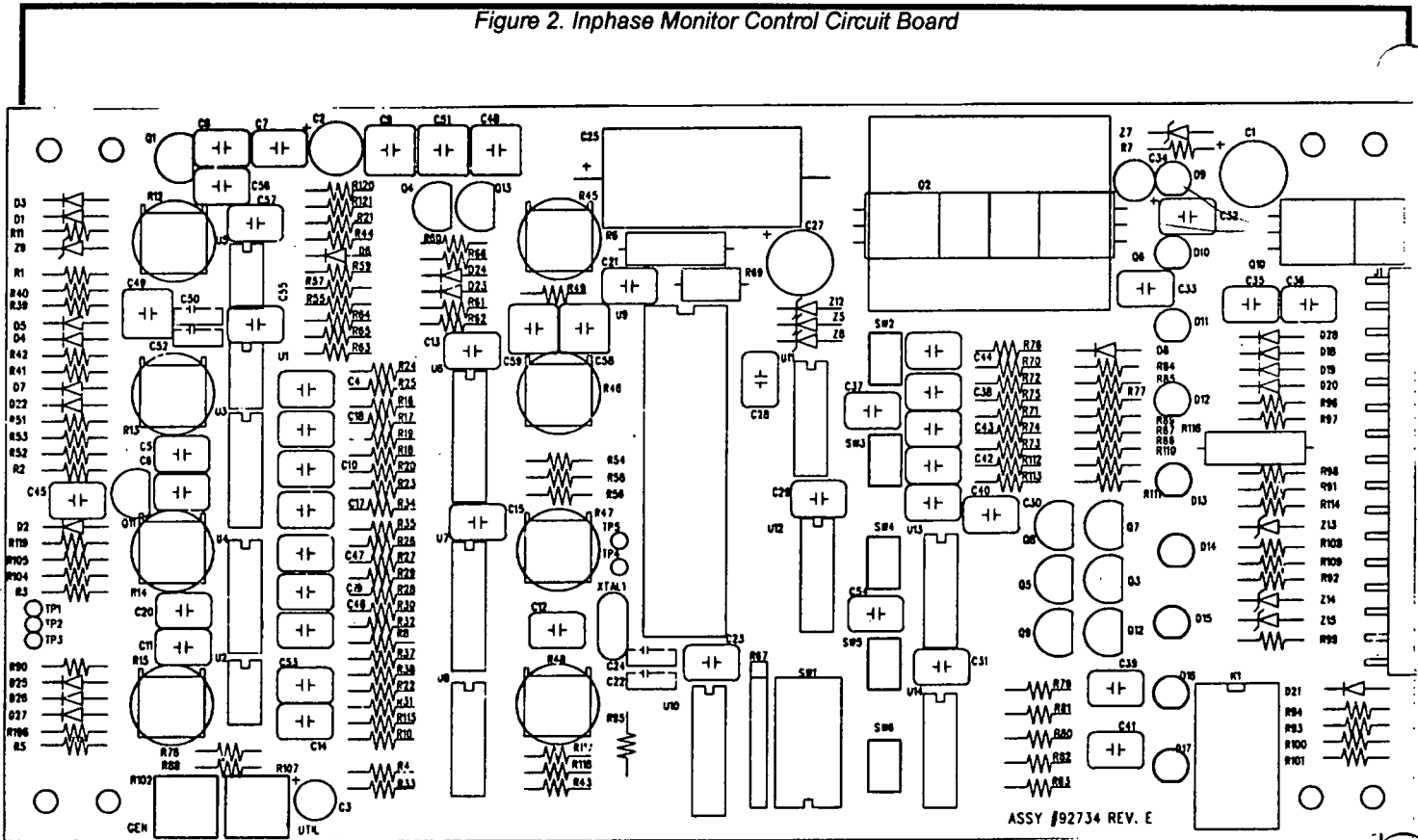
6. Adjust potentiometer R107 until the two center LED's are flashing (Minimum Run and Return to Utility).

7. Set the Calibration Mode Switch to "OFF". The Inphase Monitor Board is calibrated.

NOTE: With the Calibration Mode switch set to "STDBY" or "UTIL", the four top LED's should turn "ON" in sequence. That is, the lights should sweep on and off, from one light to the next. Calibration is obtained when the two center lamps of the four (Minimum Run and Return to Utility) are flashing.

NOTE: The Inphase Monitor Control Circuit Board should be calibrated when the transfer switch has been installed as part of an operating system. In addition, new replacement circuit boards should be calibrated.

Figure 2. Inphase Monitor Control Circuit Board



ASSY #92734 REV. E

Inphase Transfer Specifications (continued)

Circuit Board Switch 1 (Continued)

If the Inphase Monitor Control Circuit Board is replaced, switch SW1 on the new replacement MUST be reset to match system requirements. The individual switches that make up SW1 are numbered from "1" (bottom) through "8" (top), as shown in Figure 3 at right. To "marry" the Circuit Board to the specific transfer switch assembly, set the switches as indicated in the chart below.

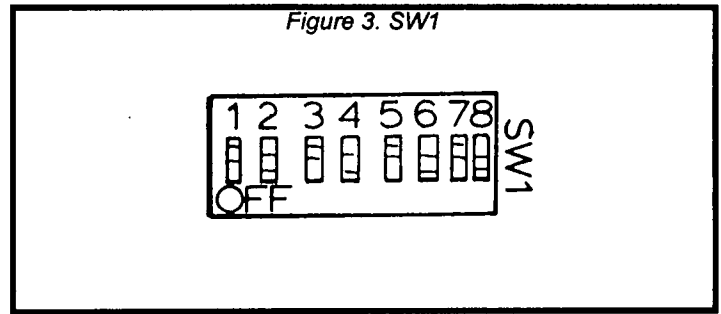
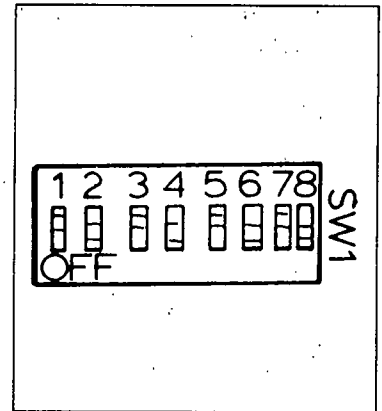


TABLE A. SW1 SETTINGS- "Y" TYPE SWITCHES

TRANSFER SWITCH	SWITCH RATED 208/416 VOLTS								SWITCH RATED 240/480 VOLT							
	1	2	3	4	5	6	7	8	1	2	3	4	5	6	7	8
105 AMPS, 2-POLE "Y" TYPE (63302)	*	ON	OFF	ON	ON	OFF	ON	OFF	*	ON	OFF	ON	ON	ON	ON	OFF
105 AMPS, 3-POLE "Y" TYPE (62642)	*	ON	OFF	ON	OFF	ON	ON	ON	*	ON	OFF	ON	ON	OFF	ON	ON
105 AMPS, 4-POLE "Y" TYPE (63597)	*	ON	OFF	ON	OFF	OFF	ON	OFF	*	ON	OFF	ON	OFF	ON	ON	OFF
150 AMPS, 2-POLE "Y" TYPE 63312)	*	ON	OFF	ON	ON	OFF	OFF	ON	*	ON	OFF	ON	ON	ON	OFF	OFF
150 AMPS, 3-POLE "Y" TYPE(62643)	*	ON	OFF	ON	OFF	ON	OFF	ON	*	ON	OFF	ON	ON	OFF	ON	OFF
150 AMPS, 4-POLE "Y" TYPE (63599)	*	ON	OFF	ON	OFF	OFF	OFF	OFF	*	ON	OFF	ON	OFF	ON	OFF	OFF
200 AMPS, 2-POLE "Y" TYPE (62677)	*	ON	OFF	ON	OFF	OFF	ON	OFF	*	ON	OFF	ON	OFF	ON	ON	OFF
200 AMPS, 3-POLE "Y" TYPE (64198)	*	ON	OFF	OFF	ON	ON	OFF	ON	*	ON	OFF	ON	OFF	OFF	ON	ON
200 AMPS, 4-POLE "Y" TYPE (63598)	*	ON	OFF	ON	OFF	OFF	ON	ON	*	ON	OFF	ON	ON	OFF	OFF	ON
300 AMPS, 2-POLE "Y" TYPE (62645)	*	ON	OFF	ON	OFF	ON	OFF	OFF	*	ON	OFF	ON	OFF	ON	ON	ON
300 AMPS, 3-POLE "Y" TYPE (62646)	*	ON	OFF	ON	OFF	ON	ON	ON	*	ON	OFF	ON	ON	ON	OFF	OFF
300 AMPS, 4-POLE "Y" TYPE (64100)	*	ON	OFF	ON	OFF	ON	ON	ON	*	ON	OFF	ON	ON	ON	OFF	OFF
420 AMPS, 2-POLE "Y" TYPE (62647)	*	ON	OFF	ON	OFF	ON	OFF	OFF	*	ON	OFF	ON	OFF	ON	ON	ON
420 AMPS, 3-POLE "Y" TYPE (62648)	*	ON	OFF	ON	OFF	OFF	ON	OFF	*	ON	OFF	ON	ON	OFF	OFF	ON

NOTE: On boards not installed at the factory, SW1 must be set by the installer. SW1 must be set to match the type of transfer switch in which the board is installed.

The individual switches on SW1 are numbered from "1" (bottom) through "8" (top), as shown in the figure to the right. To make the circuit board compatible to the specific transfer switch assembly, set the switches as indicated in the chart below. Improper settings may cause transfer outside the 20-degree specification.



DIP Switch Settings — WN type Transfer Switches

TRANSFER SWITCH	SWITCH RATED 208 VOLTS								SWITCH RATED 240/416/480/600 VOLTS							
	1	2	3	4	5	6	7	8	1	2	3	4	5	6	7	8
100 amps, 3-pole (64787)	*	ON	ON	OFF	ON	OFF	ON	OFF	*	ON	ON	OFF	ON	ON	ON	ON
100 amps, 4-pole (64788)	*	ON	ON	OFF	ON	ON	OFF	OFF	*	ON	ON	ON	OFF	OFF	OFF	OFF
150 amps, 2-pole (64789)	*	ON	ON	OFF	ON	ON	OFF	ON	*	ON	ON	ON	OFF	OFF	OFF	OFF
150 amps, 3-pole (64790)	*	ON	ON	OFF	ON	ON	OFF	ON	*	ON	ON	ON	OFF	OFF	OFF	ON
150 amps, 4-pole (64791)	*	ON	ON	OFF	ON	ON	OFF	OFF	*	ON	ON	ON	OFF	OFF	ON	OFF
200 amps, 2-pole (64789)	*	ON	ON	OFF	ON	ON	OFF	ON	*	ON	ON	ON	OFF	OFF	OFF	OFF
200 amps, 3-pole (64790)	*	ON	ON	OFF	ON	ON	OFF	ON	*	ON	ON	ON	OFF	OFF	OFF	ON
200 amps, 4-pole (64791)	*	ON	ON	OFF	ON	ON	OFF	OFF	*	ON	ON	ON	OFF	OFF	ON	OFF
300 amps, 2-pole (64795)	*	ON	ON	OFF	OFF	ON	ON	OFF	*	ON	ON	OFF	ON	OFF	OFF	ON
300 amps, 3-pole (64796)	*	ON	ON	OFF	OFF	ON	OFF	ON	*	ON	ON	OFF	ON	OFF	OFF	ON
300 amps, 4-pole (64797)	*	ON	ON	OFF	OFF	ON	ON	ON	*	ON	ON	OFF	ON	ON	OFF	OFF
400 amps, 2-pole (64795)	*	ON	ON	OFF	OFF	ON	ON	OFF	*	ON	ON	OFF	ON	OFF	OFF	ON
400 amps, 3-pole (64796)	*	ON	ON	OFF	OFF	ON	OFF	ON	*	ON	ON	OFF	ON	OFF	OFF	ON
400 amps, 4-pole (64797)	*	ON	ON	OFF	OFF	ON	ON	ON	*	ON	ON	OFF	ON	ON	OFF	OFF
600 amps, 3-pole (72111)	*	ON	OFF	OFF	ON	ON	ON	ON	*	ON	OFF	ON	OFF	ON	ON	OFF
600 amps, 4-pole (72117)	*	ON	OFF	OFF	ON	ON	OFF	ON	*	ON	OFF	ON	OFF	ON	OFF	OFF
800 amps, 3-pole (72113)	*	ON	OFF	OFF	ON	ON	OFF	OFF	*	ON	OFF	ON	OFF	OFF	ON	OFF
800 amps, 4-pole (72119)	*	ON	OFF	OFF	ON	ON	ON	OFF	*	ON	OFF	ON	OFF	OFF	ON	ON
1000 amps, 3-pole (72113)	*	ON	OFF	OFF	ON	ON	OFF	OFF	*	ON	OFF	ON	OFF	OFF	ON	OFF
1000 amps, 4-pole (72119)	*	ON	OFF	OFF	ON	ON	ON	OFF	*	ON	OFF	ON	OFF	OFF	ON	ON
1200 amps, 3-pole (72114)	*	ON	OFF	OFF	ON	OFF	ON	ON	*	ON	OFF	ON	OFF	OFF	OFF	ON
1200 amps, 4-pole (72120)	*	ON	OFF	ON	OFF	ON	OFF	OFF	*	ON	OFF	OFF	ON	ON	OFF	OFF
1600 amps, 3-pole (72114)	*	ON	OFF	OFF	ON	OFF	ON	ON	*	ON	OFF	ON	OFF	OFF	OFF	ON
1600 amps, 4-pole (72120)	*	ON	OFF	ON	OFF	ON	OFF	OFF	*	ON	OFF	OFF	ON	ON	OFF	OFF
2000 amps, 3-pole (72115)	*	OFF	ON	ON	OFF	OFF	ON	ON	*	OFF	ON	ON	ON	ON	ON	ON
2000 amps, 4-pole (72121)	*	OFF	ON	ON	OFF	OFF	OFF	ON	*	OFF	ON	ON	ON	ON	ON	OFF
2600 amps, 3-pole (72116)	CONSULT THE FACTORY								*	OFF	OFF	ON	OFF	OFF	ON	OFF
2600 amps, 4-pole (72122)	CONSULT THE FACTORY								CONSULT THE FACTORY							

* Set Switch 1 to OFF for 60 Hz systems; set Switch 1 to ON for 50 Hz systems.

PART 12 TRANSFER SWITCH OPTIONS

DIAGNOSTIC REPAIR MANUAL

All Series

TABLE OF CONTENTS	
SECTION	TITLE
12.1	Programmable Exercise Circuit Board
12.2	Preferred Source Selector Switch
12.3	Return to Normal Bypass
12.4	Remote Automatic Control
12.5	Signal Before Transfer Contacts

Section 12.1

PROGRAMMABLE EXERCISE CIRCUIT BOARD

Introduction

The optional programmable exercise circuit board is shown in Figure 1, below. The circuit board permits selection of the exercise function on one day of the week, two days of the week, three days each week, and so on, up to as many as seven days each week. The day(s) of the week and the time of day that exercise will occur can be selected, with a visible digital chronograph used to indicate time.

The deluxe programmable board can be used on any transfer switch equipped with the "Logic" type intelligence system described in Part 11 of this manual.

The 9 Volts Battery

Like the standard exercise circuit board, the programmable board uses a battery to prevent the timing count from becoming scrambled while the transfer switch main contacts are at "Neutral". It is recommended that this battery be replaced once each year.

NOTE: In the case of the standard exercise board, timing count will be lost during the brief period the main contacts are at "Neutral". The programmable exercise board, however, will reset its timing count as soon as the transfer action is completed.

Adjustment

To select the day (or days) of exercise and the time of day for exercise to occur, perform the following steps in the exact order they are given.

A. SET THE ACTUAL DAY OF THE WEEK:

Locate the push button switch above which appears the words "Advance Day". Actuate this switch while observing the lighted "Day of Week" indicator. The indicator will advance one day each time the switch is depressed. When the correct (actual) day of the week is indicated, this setting is complete.

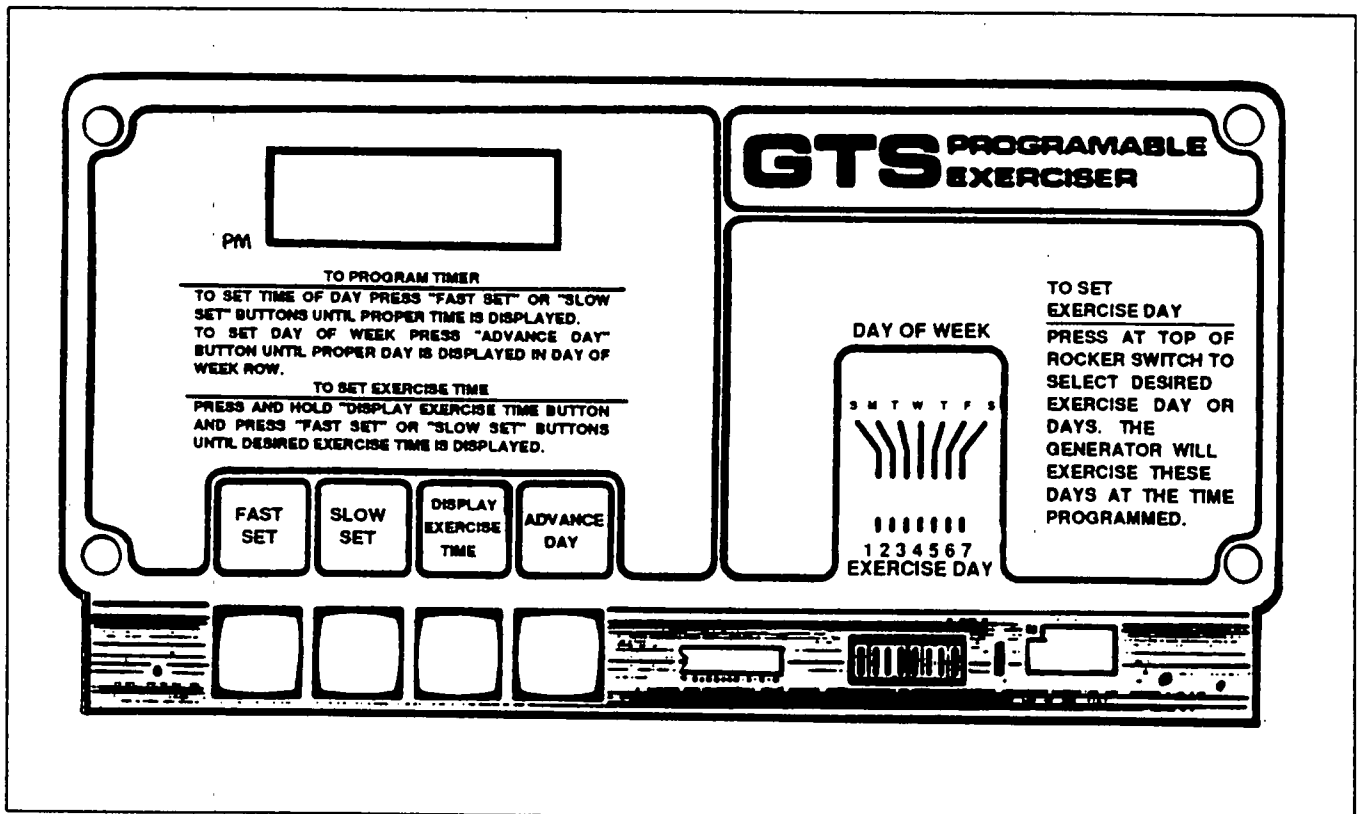


Figure 1. Programmable Exercise Circuit Board

Adjustment (Continued)**B. SET ACTUAL TIME OF DAY:**

Hold the "Fast Set" switch down while observing the lighted chronograph at left side of board. When close to the actual time of day, release the "Fast Set" switch. Then, use the "Slow Set" switch to complete the adjustment to the actual time of day.

C. SELECT DAY (OR DAYS) OF EXERCISE:

A bank of eight (8) miniature rocker switches is provided at lower right side of the circuit board. Switches "1" through "7" correspond to the days of the week, with switch "1" representing "Sunday", Switch "2" for "Monday", and so on, with Switch "7" for "Saturday". Switch "8" is NOT used.

To select a day of the week for the system to start and exercise, actuate the correct numbered switch to its "On" position (opposite of "Open"). A lighted band will then appear next to that day. In this manner, the system can be set to start and exercise one, two or more days each week.

D. SELECT EXERCISE TIME OF DAY:

Depress the switch below the words "Display Exercise Time". Hold that switch down, then actuate the "Fast Set" and "Slow Set" switches until the desired time of day for system exercise is displayed.

A red dot, adjacent to the letters "PM", indicate afternoon times.

Circuit Board Maintenance

Circuit board maintenance is limited to the following:

- Board removal and replacement.
- Board cover removal and replacement.
- Adjustment (selection) of exercise day(s) and time of day.
- Replacement of the 9 volts battery.

Section 12.2

PREFERRED SOURCE SELECTOR SWITCH

Introduction

The optional preferred source switch permits the operator select which power source will be the preferred one and which one will be the "Standby" or "backvup" source. If "Source 1" is selected as the preferred source, then "Source 2" will provide the backup function. Typically, this option would be used when both power sources are generators and it is desirable to divide the runing time between the two units.

The option consists of a door-mounted, 3-pole, double throw, rotary switch.

Operation

SWITCH POSITION AT "SOURCE 1":

See Figure 1, below. When the switch is set to its "Source 1" position, generator set No. 1 is selected as the "preferred source".

The transfer switch functions normally. However, a 2-wire start connection has been added for Source 1. The selector switch terminals 9 and 10 are closed, to connect the wires 253 and 254 circuits. Shorting these two wires provides the 2-wire start signal for generator set No. 1, and that generator starts and runs as the

"preferred source." If generator set No. 1 should fail, the "Source 2" generator set will start and loads will be transferred to "Source 2" until the "Source 1" power returns.

SWITCH POSITION "SOURCE 2":

When the switch is set to "Source 2", generator No. 2 becomes the preferred source. This is accomplished by opening the "utility sensor loss" signal line between the utility voltage sensor board and the system control board. Wire No. 199 is opened by terminals 1 and 2 of the preferred source selector switch, to make the system control board "think" that power source is not available. Terminals 6 and 7 of the preferred source selector switch connect the wires 177/178 circuit and the "Source 2" generator cranks and starts. When operating conditions are met, the load will transfer to the "Source 2" generator.

Terminals 10 and 11 if the selector switch are also closed, to connect a set of normally-open transfer relay contacts across the "Source 1" start circuit. If generator 1 fails, transfer relay will de-energize, its contacts 2 and 8 will close the start circuit of the "Source 1" generator. On startup, load will transfer to "Source 1".

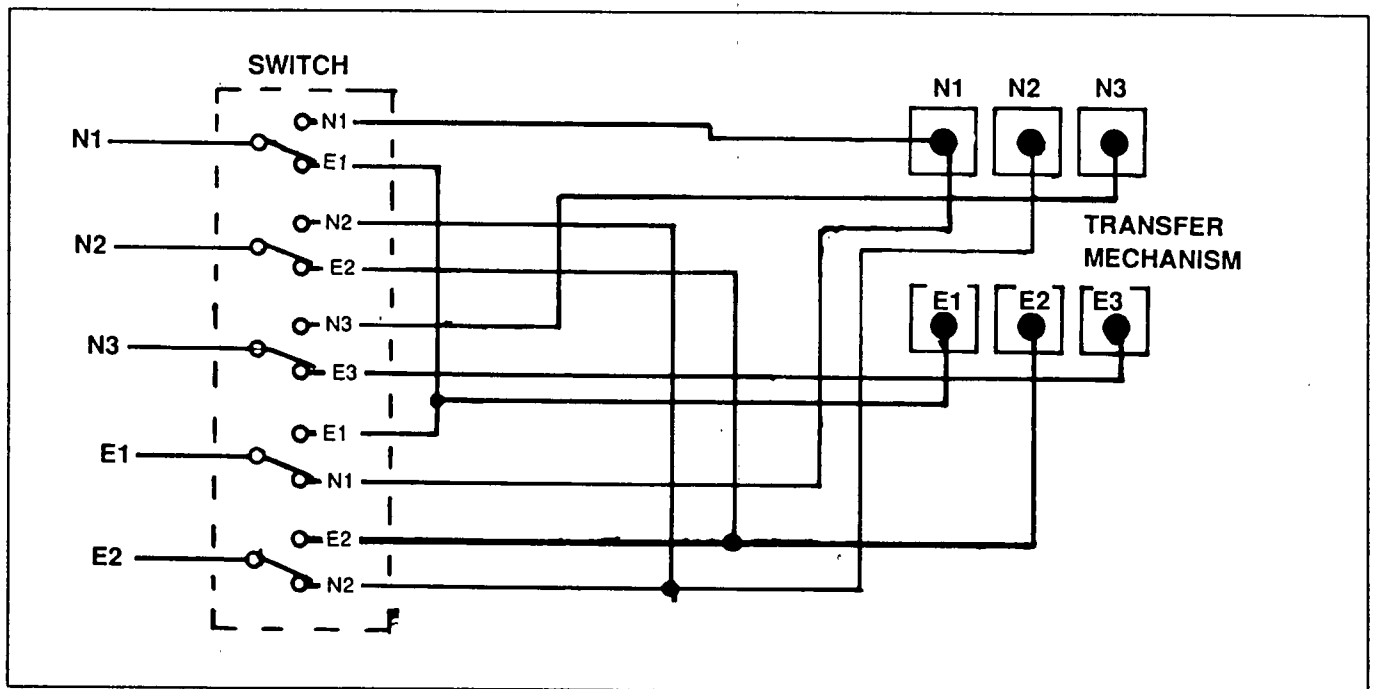


Figure 1. Schematic- Preferred Source Selector Switch

Section 12.3
RETURN TO NORMAL BYPASS

Introduction

During normal automatic operation, the utility voltage sensor board will monitor "Utility:" source voltage. On dropout of that source voltage, generator startup and transfer of loads to the "Standby" source will then occur. On restoration of "Utility" source voltage, retransfer back to that power source can occur at any time.

In certain applications, it may not be desirable to retransfer loads back to the "Utility" source. That is, it may be best to continue powering loads with "Standby" power, even though "Utility" power has been restored.

The optional "return to normal bypass" feature will permit the operator to select when retransfer back to "Utility" will occur and when the generator will shut down. He can do this by simply actuating a push-button switch.

Description

The "return to normal bypass" option consists of two relays (K1 and K2), along with a push button switch. Wiring is also installed, to interconnect the switch and relays with transfer mechanism terminals B1 and B2.

Operational Analysis:

"UTILITY" POWER AVAILABLE:

With an acceptable (preset) "Utility" voltage available, the generator is shut down and "Standby" voltage is not available to transfer mechanism terminals B1 and B2. The circuit condition may then be briefly described as follows:

- Relays K1 and K2 are de-energized, their normally-open contacts are open and their normally-closed contacts are closed.
- With relay K2 de-energized, the wires 199/199A circuit (between the utility voltage sensor and system control boards) is closed. This "tells" the system control (or CPU) board that "Utility" voltage is available.

NOTE: The transfer relay and transfer mechanism are included as standard equipment on all GTS type automatic transfer switches. They are not a part of the optional "return to normal bypass system", but are shown in the circuit diagrams for reference.

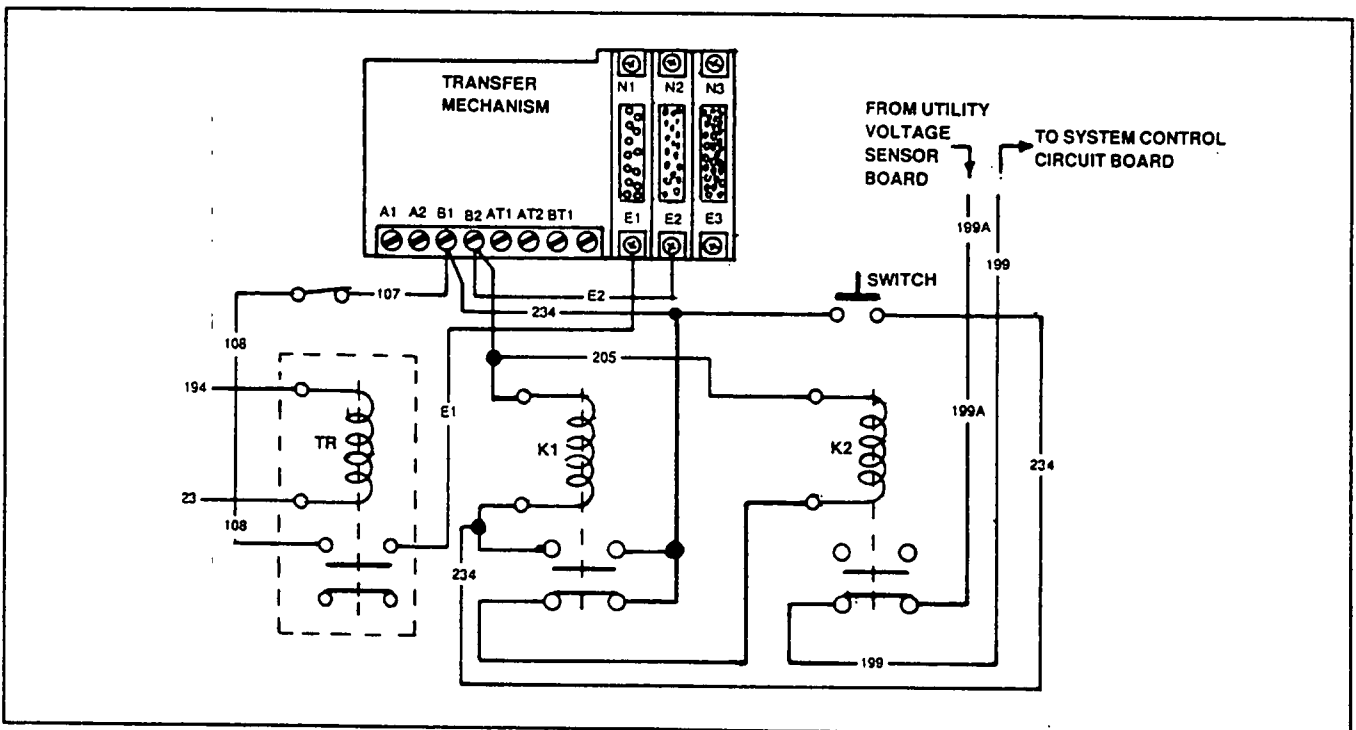


Figure 1. Schematic Diagram- Return to Normal Bypass Circuit

Operational Analysis (Continued)**UTILITY SOURCE FAILURE & STANDBY ON:**

With the generator running, system control (or CPU) circuit board action will energize a transfer relay (TR). On closure of that relay's normally-open contacts, "Standby" source voltage will be delivered to transfer mechanism terminals B1/B2. The transfer mechanism's main contacts will then actuate to their "Standby" source side. From terminals B1/BN2, "Standby" source voltage is also available to the relay K2 actuating coil and that relay will energize. The relay K2 normally-closed contacts open, to open the Wires 199/199A circuit between the utility voltage sensor and the system control (or CPU) circuit boards. This action "tells" the system control (or CPU) board that "Utility" source voltage has failed.

UTILITY SOURCE VOLTAGE RESTORED:

With "Standby" source power still available to transfer mechanism terminals B1/B2, relay K2 remains energized and its normally-closed contacts remain open. This holds the "utility loss" circuit open. The system control board "thinks" that "Utility" voltage is still low and the board takes no action to retransfer loads back to that source.

RETURN TO UTILITY:

When the operator closes the switch, relay K1 becomes energized by "Standby" source voltage. The normally-closed K1 contacts open to de-energize relay K2. The normally-open K1 contacts close to form a holding circuit for the K1 relay to keep K1 energized as long as "Standby" source power is available.

With K2 de-energized, its normally-closed contacts close. The "utility loss sensor circuit" (between the utility voltage sensor and system control boards) closes. This action "tells" the system control (CPU) board that "Utility" source voltage is available. The board then initiates retransfer back to the "Utility" side.

Section 12.4
REMOTE AUTOMATIC CONTROL

Introduction

Under some circumstances, it might be desirable to perform a "Normal Test" of the standby power system from a remote location. This can be done by using a remote automatic control system.

Description

A double pole, single throw switch is required for the remote automatic control. Use stranded copper wire to connect the remote switch to the transfer switch. Recommended wire gauge size of the interconnecting wires depends on the distance between the switch and the transfer switch (length of wire) and is shown in the following chart.

MAXIMUM WIRE LENGTH	WIRE SIZE
460 feet (140m)	No. 18AWG
730 feet (223m)	No. 16 AWG
1160 feet (354m)	No. 14 AWG
1850 feet (565m)	No. 12 AWG)

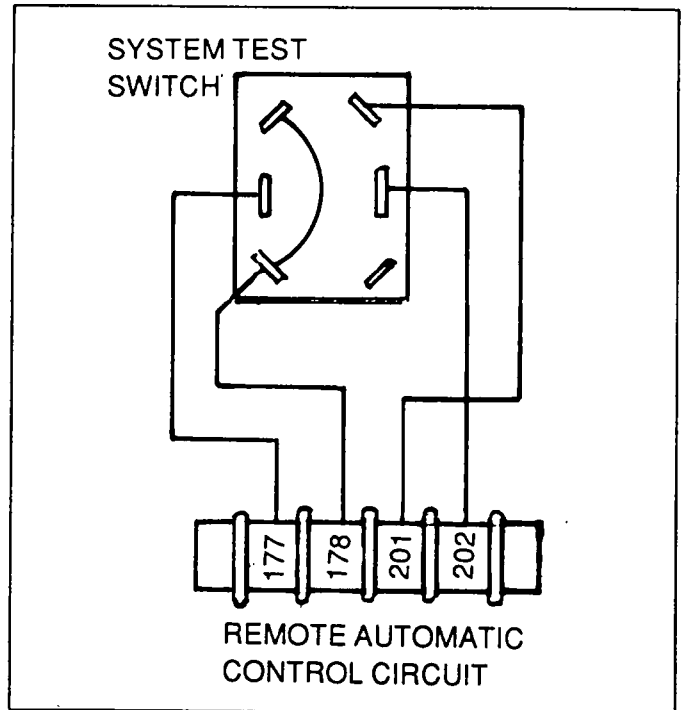


Figure 1. Schematic- Remote Automatic Control

Section 12.5 SIGNAL BEFORE TRANSFER CONTACTS

Introduction

A standby electric system might be installed for back-up power in a high rise building equipped with elevators. Safety codes for high rise buildings might include the requirement that elevators be operational in the event of a "Utility" power outage. The optional "Signal Before Transfer Contacts" provide a time delay that allows elevators to continue operating before transfer to another power source occurs.

The time delay will keep the elevators running long enough to reach the next floor, and will open the elevator doors prior to transfer. Without this optional time delay, the loss of power that occurs during any transfer action (while the main contacts are at "Neutral") could result in elevator stoppage between floors.

The time delay will function prior to a "transfer to Standby" action, as well as before a "retransfer to Utility" action.

Components

Components included with the "Signal Before Transfer Contacts" include the following:

- Relays SR2 and TD2 which are energized by "Standby" source voltage.
- Relays SR1 and TD1 which are energized by "Utility" source voltage.
- Interconnecting wires (see "Wiring Diagram" in this section).

Operational Analysis

The following operational analysis pertains to operation of the optional "Signal Before Transfer Contacts" when (a) the transfer mechanism is a "Wn" type and (b) when the transfer switch is rated 480 volts AC. Transformers TR3 and TR4 are not used on transfer switches rated less than 480 volts.

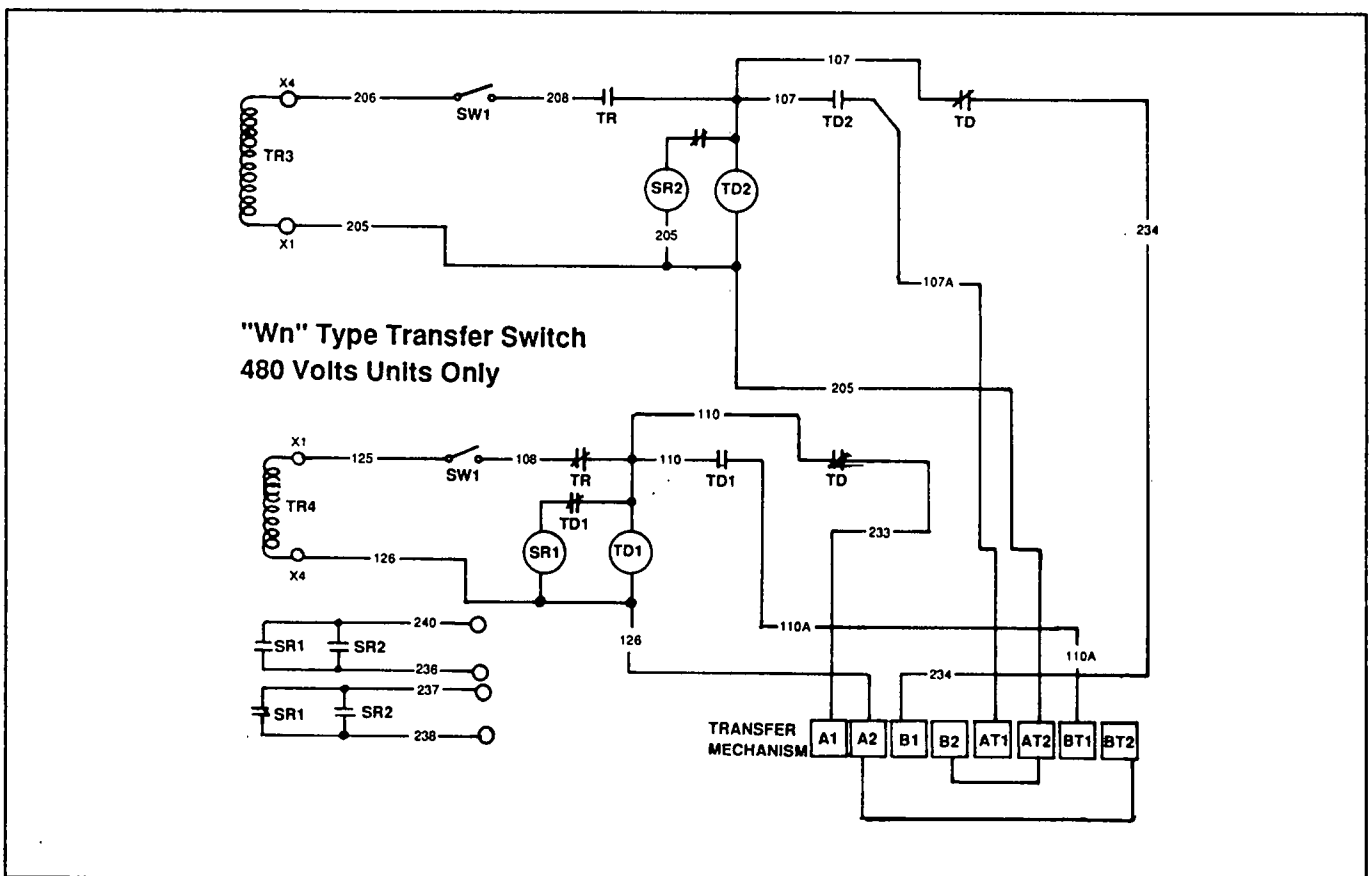


Figure 1. Schematic Diagram- Signal Before Transfer Option

GENERAC CORPORATION P.O. BOX 8 WAUKESHA, WISCONSIN 53187