



GENERAC® GUARDIAN® SERIES

STANDBY GENERATORS - PREPACKAGED

8 kW - 10 kW - 14 kW

Air-Cooled Gas Engine Generator Sets

Standby Power Rating

Model 005870-0 (Steel - Bisque) - 8 kW 60Hz

Model 005871-0 (Steel - Bisque) - 10 kW 60Hz

Model 005872-0 (Steel - Bisque) - 14 kW 60Hz

INCLUDES:

- True Power® Electrical Technology
- Two Line LCD Tri-lingual Digital Nexus™ Controller
- 10, 12 or 14 Circuit Automatic Transfer Switch with Built-In Priority Load Center
- Electronic Governor
- Pre-wired External Connection Box
- External Main Circuit Breaker & System Status LED Indicators
- Flexible Fuel Line Connector
- Composite Mounting Pad
- Pre-wired conduits
- Natural Gas or LP Gas Operation
- UL 2200 Listed



FEATURES

- **INNOVATIVE DESIGN & PROTOTYPE TESTING** are key components of GENERAC'S success in "IMPROVING POWER BY DESIGN." But it doesn't stop there. Total commitment to component testing, reliability testing, environmental testing, destruction and life testing, plus testing to applicable CSA, NEMA, EGSA, and other standards, allows you to choose GENERAC POWER SYSTEMS with the confidence that these systems will provide superior performance.
- **TRUE POWER® ELECTRICAL TECHNOLOGY:** Superior harmonics and sine wave form produce less than 5% Total Harmonic Distortion for utility quality power. This allows confident operation of sensitive electronic equipment and micro-chip based appliances, such as variable speed HVAC.
- **TEST CRITERIA:**
 - ✓ **PROTOTYPE TESTED**
 - ✓ **SYSTEM TORSIONAL TESTED**
 - ✓ **NEMA MG1-22 EVALUATION**
 - ✓ **MOTOR STARTING ABILITY**
- **SOLID-STATE, FREQUENCY COMPENSATED VOLTAGE REGULATION.** This state-of-the-art power maximizing regulation system is standard on all Generac models. It provides optimized FAST RESPONSE to changing load conditions and MAXIMUM MOTOR STARTING CAPABILITY by electronically torque-matching the surge loads to the engine. An unequalled ±1% voltage regulation.
- **SINGLE SOURCE SERVICE RESPONSE** from Generac's extensive dealer network provides parts and service know-how for the entire unit, from the engine to the smallest electronic component.
- **GENERAC TRANSFER SWITCHES.** Long life and reliability are synonymous with GENERAC POWER SYSTEMS. One reason for this confidence is that the GENERAC product line includes its own transfer systems and controls for total system compatibility.

GENERAC®

FEATURES

Generac® Guardian® Series Standby Generator - 8 kW - 10 kW - 14 kW

ENGINE	<ul style="list-style-type: none"> •Generac (OHVI) Design 	Maximizes engine “breathing” for increased fuel efficiency. Plateau honed cylinder walls and plasma moly rings help engine run cooler, reducing oil consumption. Because heat is the primary cause of engine wear, the OHVI has a significantly longer life than competitive engines.
	<ul style="list-style-type: none"> •“Spiny-lok” cast iron cylinder walls 	Rigid construction and added durability provide long engine life.
	<ul style="list-style-type: none"> •Electronic ignition/spark advance 	These features combine to assure smooth, quick starting every time.
	<ul style="list-style-type: none"> •Full pressure lubrication system 	Superior lubrication to all vital bearings means better performance, less maintenance and significantly longer engine life. Now featuring a 2 year/200 hour oil change interval.
	<ul style="list-style-type: none"> •Low oil pressure shutdown system •High temperature shutdown 	Superior shutdown protection prevents catastrophic engine damage due to low oil. Prevents damage due to overheating.
GENERATOR	<ul style="list-style-type: none"> •Revolving field 	Allows for smaller, light weight unit that operates 25% more efficiently than a revolving armature generator.
	<ul style="list-style-type: none"> •Skewed rotor (8 & 10 kW) Skewed stator (14 kW) 	Produces a smooth output waveform for compatibility with electronic equipment.
	<ul style="list-style-type: none"> •Displaced phase excitation 	Maximizes motor starting capability.
	<ul style="list-style-type: none"> •Automatic voltage regulation 	Regulates the output voltage to $\pm 1\%$ prevents damaging voltage spikes.
	<ul style="list-style-type: none"> •UL 2200 Listed 	For your safety
TRANSFER SWITCH	<ul style="list-style-type: none"> •Fully Automatic 	Transfers your vital electrical loads to the energized source of power.
	<ul style="list-style-type: none"> •Pre-wired, color coded conduits 	Ensures the easiest, trouble free installation.
	<ul style="list-style-type: none"> •Remote Mounting 	Mounts near your existing distribution panel for simple, low cost installation.
	<ul style="list-style-type: none"> •UL Listed 	For your safety
NEXUS™ CONTROLS	<ul style="list-style-type: none"> •Manual/Auto/Off switch 	Selects the operating mode.
	<ul style="list-style-type: none"> •Utility voltage sensing 	Constantly monitors utility voltage, setpoints 60% dropout, 80% pick-up, of standard voltage.
	<ul style="list-style-type: none"> •Generator voltage sensing 	Constantly monitors generator voltage to ensure the cleanest power delivered to the home.
	<ul style="list-style-type: none"> •Utility interrupt delay 	Prevents nuisance start-ups of the engine, adjustable 10-30 seconds.
	<ul style="list-style-type: none"> •Engine warm-up 	Ensures engine is ready to assume the load, setpoint approximately 5 seconds.
	<ul style="list-style-type: none"> •Engine cool-down 	Allows engine to cool prior to shutdown, setpoint approximately 1 minute.
	<ul style="list-style-type: none"> •Programmable seven day exerciser 	Operates engine to prevent oil seal drying and damage between power outages by running the generator for 12 minutes every week.
	<ul style="list-style-type: none"> •Smart battery charger 	Delivers charge to the battery only when needed at varying rates depending on outdoor air temperature.
	<ul style="list-style-type: none"> •Main Line Circuit Breaker 	Protects generator from overload.
	<ul style="list-style-type: none"> •Electronic governor 	Maintains constant 60 Hz frequency.
UNIT	<ul style="list-style-type: none"> •Weather protective enclosure 	Ensures protection against mother nature. Hinged key locking roof panel for security. Lift-out front for easy access to all routine maintenance items. Electrostatically applied textured epoxy paint for added durability.
	<ul style="list-style-type: none"> •Enclosed critical grade muffler 	Quiet, critical grade muffler is mounted inside the unit to prevent injuries.
	<ul style="list-style-type: none"> •Small, compact, attractive 	Makes for an easy, eye appealing installation.
INSTALLATION SYSTEM	<ul style="list-style-type: none"> •Pre-wired External Connection Box •1' Flexible Fuel Line Connector •Composite Mounting Pad •Pre-wired conduits •UL Listed wire nuts 	Easy Installation - Virtually all hardware included, plus step-by-step photographed Installation Guide.

SPECIFICATIONS

GENERAC®

GENERATOR		Model 005870-0 (8 kW)	Model 005871-0 (10 kW)	Model 005872-0 (14 kW)
Rated Maximum Continuous Power Capacity (LP)		8,000 Watts*	10,000 Watts*	14,000 Watts*
Rated Maximum Continuous Power Capacity (NG)		7,000 Watts*	9,000 Watts*	13,000 Watts*
Rated Voltage		120/240	120/240	120/240
Rated Maximum Continuous Load Current – 240 Volts		33.3 LP/29.2 NG	41.6 LP/37.5 NG	58.3 LP/54.2 NG
Total Harmonic Distortion		Less than 5%	Less than 5%	Less than 5%
Main Line Circuit Breaker		35 Amp	45 Amp	60 Amp
Phase		1	1	1
Number of Rotor Poles		2	2	2
Rated AC Frequency		60Hz	60Hz	60Hz
Power Factor		1	1	1
Battery Requirement (not included)		Group 26R 12 Volts and 350 Cold-cranking Amperes Minimum	Group 26R 12 Volts and 525 Cold-cranking Amperes Minimum	Group 26R 12 Volts and 525 Cold-cranking Amperes Minimum
Unit Weight		340 Pounds	387 Pounds	439 Pounds
Dimensions (L" x W" x H")		48 x 25 x 29	48 x 25 x 29	48 x 25 x 29
Sound output in dB(A) at 23 ft. with generator operating at normal load		62	63	66
ENGINE		Model 005870-0 (8 kW)	Model 005871-0 (10 kW)	Model 005872-0 (14 kW)
Type of Engine		GENERAC OHVI	GENERAC OHVI V-TWIN	GENERAC OHVI V-TWIN
Number of Cylinders		1	2	2
Displacement		410cc	530cc	992cc
Cylinder Block		Aluminum w/Cast Iron Sleeve	Aluminum w/Cast Iron Sleeve	Aluminum w/Cast Iron Sleeve
Valve Arrangement		Overhead Valve	Overhead Valve	Overhead Valve
Ignition System		Solid-state w/Magneto	Solid-state w/Magneto	Solid-state w/Magneto
Governor System		Electronic	Electronic	Electronic
Compression Ratio		9.4:1	9.5:1	9.5:1
Starter		12 Vdc	12 Vdc	12 Vdc
Oil Capacity Including Filter		Approx. 1.5 Qts./1.5L	Approx. 1.7 Qts./1.7L	Approx. 1.9 Qts./1.8L
Operating RPM		3,600	3,600	3,600
Fuel Consumption				
Natural Gas	cu.ft./hr.			
	1/2 Load	77	102	156
	Full Load	139	156	220
Liquid Propane	ft ³ /hr (gal/hr)			
	1/2 Load	34 (0.94)	46 (1.25)	58 (1.56)
	Full Load	62 (1.68)	70 (1.93)	84 (2.30)
Required fuel pressure to generator fuel inlet at all load ranges - 5 to 7 inches of water column for natural gas, 10 to 12 inches of water column for LP gas				
CONTROLS				
2-Line Plain Text LCD Display		Simple user interface for ease of operation		
Mode Switch				
-Auto		Automatic Start on Utility failure. 7 day exerciser		
-Off		Stops unit. Power is removed. Control and charger still operate.		
-Manual/Test (start)		Start with starter control, unit stays on. If utility fails, transfer to load takes place.		
Programmable start delay between 10-30 seconds		Standard		
Engine Start Sequence		Cyclic cranking: 16 sec. on, 7 rest (90 sec. maximum duration)		
Engine Warm-up		5 seconds		
Engine Cool-Down		1 minute		
Starter Lock-out		Starter cannot re-engage until 5 sec. after engine has stopped.		
Smart Battery Charger		Standard		
Automatic Voltage Regulation with Over and Under Voltage Protection		Standard		
Automatic Low Oil Pressure Shutdown		Standard		
Overspeed Shutdown		Standard, 72Hz		
High Temperature Shutdown		Standard		
Overcrank Protection		Standard		
Safety Fused		Standard		
Failure to Transfer Protection		Standard		
Low Battery Protection		Standard		
50 Event Run Log		Standard		
Future Set Capable Exerciser		Standard		
Incorrect Wiring Protection		Standard		
Internal Fault Protection		Standard		
Common External Fault Capability		Standard		

Rating definitions - Standby: Applicable for supplying emergency power for the duration of the utility power outage. No overload capability is available for this rating. (All ratings in accordance with BS5514, ISO3046 and DIN6271). * Maximum wattage and current are subject to and limited by such factors as fuel Btu content, ambient temperature, altitude, engine power and condition, etc. Maximum power decreases about 3.5 percent for each 1,000 feet above sea level; and also will decrease about 1 percent for each 12° C (10° F) above 15.5° C (60°F).

Generac® Guardian® Series Standby Generator - 8 kW - 10 kW - 14 kW

EZ SWITCH™ & LOAD CENTER	Model 005870-0 (8 kW)	Model 005871-0 (10 kW)	Model 005872-0 (14 kW)
No. of Poles	2	2	2
Current Rating (amps)	100	100	100
Voltage Rating (VAC)	250	250	250
Utility Voltage Monitor (fixed)			
-Pick-up	80%	80%	80%
-Dropout	60%	60%	60%
Return to Utility	approx. 15 sec.	approx. 15 sec.	approx. 15 sec.
Exerciser weekly for 12 minutes	Standard	Standard	Standard
UL Listed	Standard	Standard	Standard
Dimensions (H" x W" x D")	26.5 x 12.5 x 7	26.5 x 12.5 x 7	26.5 x 12.5 x 7
Total of Pre-wired Circuits	10	12	14
No. 15A 120V	3	5	4
No. 20A 120V	3	3	6
No. 20A 240V	1	-	1
No. 30A 240V	1	1	-
No. 40A 240V	-	1	1
No. 50A 240V	-	-	-
Circuit Breaker Protected			
Available RMS Symmetrical			
Fault Current @ 250 Volts	10,000	10,000	10,000

EZ Switch™ Features

- Electrically operated, mechanically-held contacts for fast, positive connections.
- Rated for all classes of load, 100% equipment rated, both inductive and resistive.
- 2 pole, 250 VAC contactors.
- 160 millisecond transfer time.
- Dual coil design.
- Main contacts are silver plated or silver alloy to resist welding and sticking.
- NEMA 1 (indoor rated) enclosure is standard on the 100 amp switch.
- Pre-wired 30 foot whip to connect to the pre-wired external connection box.
- Pre-wired 2 foot whip, color coded to connect into the existing electrical panel.

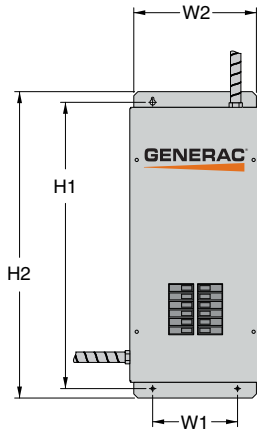

Mechanical Dimensions (in inches)						
Current Rating	No. of Poles	Height		Width		Depth
		H1	H2	W1	W2	
100 UL Listed	2	26.5	29.25	8.14	12.5	7

Terminal Wire Ranges			
ATS Rated Amps	Switch Terminal	Neutral Lug/Stud	Ground Lug
100A 2-Pole UL	1 x 1/0-12	1 x 3/8-16 Stud	1 x 2/0-14

Design and specifications subject to change without notice. Dimensions shown are approximate. Contact your Generac dealer for certified drawings. DO NOT USE THESE DIMENSIONS FOR INSTALLATION PURPOSES.

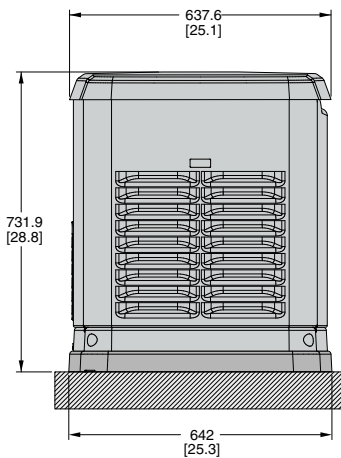

LEFT SIDE VIEW

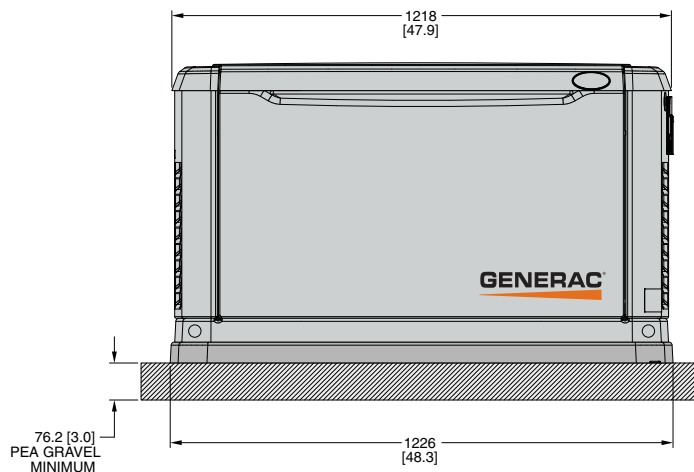

FRONT VIEW



Generac Power Systems, Inc. • S45 W29290 HWY. 59, Waukesha, WI 53189 • generac.com