

# **DIAGNOSTIC REPAIR MANUAL**

---

## **3.9 LITER PRE-PACKAGED HOME STANDBY GENERATORS**

**WITH R-100 CONTROL PANEL**

**MODEL 5221-0  
MODEL 5222-0**

## Important Safety Notice

**Proper service and repair is important to the safe, economical and reliable operation of all standby electric power systems. The troubleshooting, testing and servicing procedures recommended by Generac and described in this manual are effective methods of performing such operations. Some of these operations or procedures may require the use of specialized equipment. Such equipment should be used when and as recommended.**

**It is important to note that this manual contains various DANGER, CAUTION, and NOTE blocks. These should be read carefully in order to minimize the risk of personal injury or to prevent improper methods or practices from being used. Use of improper or unauthorized practices may damage equipment or render it unsafe. The DANGER, CAUTION and NOTE blocks are not exhaustive. Generac could not possibly know, evaluate and advise the service trade of all conceivable ways in which operations described in this manual might be accomplished or of the possible hazardous consequences of each way. Consequently, Generac has not taken any such broad evaluation. Accordingly, anyone who uses any troubleshooting, testing or service procedure that is not recommended by Generac must first satisfy himself that neither his safety nor the equipment's safety will be jeopardized by the procedure or the method he selects.**



**SAVE THESE INSTRUCTIONS – The manufacturer suggests that these rules for safe operation be copied and posted in potential hazard areas. Safety should be stressed to all operators and potential operators of this equipment.**

Study these SAFETY RULES carefully before installing, operating or servicing this equipment. Become familiar with the *Owner's Manual* and with the unit. The generator can operate safely, efficiently and reliably only if it is properly installed, operated and maintained. Many accidents are caused by failing to follow simple and fundamental rules or precautions.

Generac cannot anticipate every possible circumstance that might involve a hazard. The warnings in this manual, and on tags and decals affixed to the unit are, therefore, not all inclusive. If using a procedure, work method or operating technique that Generac does not specifically recommend, ensure that it is safe for others. Also make sure the procedure, work method or operating technique utilized does not render the generator unsafe.



**Despite the safe design of this generator, operating this equipment imprudently, neglecting its maintenance or being careless can cause possible injury or death. Permit only responsible and capable persons to install, operate or maintain this equipment.**



**Potentially lethal voltages are generated by these machines. Ensure all steps are taken to render the machine safe before attempting to work on the generator.**



**Parts of the generator are rotating and/or hot during operation. Exercise care near running generators.**

## **GENERAL HAZARDS**

- For safety reasons, Generac recommends that this equipment be installed, serviced and repaired by an authorized service dealer or other competent, qualified electrician or installation technician who is familiar with applicable codes, standards and regulations. The operator also must comply with all such codes, standards and regulations.
- Installation, operation, servicing and repair of this (and related) equipment must always comply with applicable codes, standards, laws and regulations. Adhere strictly to local, state and national electrical and building codes. Comply with regulations the Occupational Safety and Health Administration (OSHA) has established. Also, ensure that the generator is installed, operated and serviced in accordance with the manufacturer's instructions and recommendations. Following installation, do nothing that might render the unit unsafe or in noncompliance with the aforementioned codes, standards, laws and regulations.
- The engine exhaust fumes contain carbon monoxide gas, which can be DEADLY. This dangerous gas, if breathed in sufficient concentrations, can cause unconsciousness or even death. For that reason, adequate ventilation must be provided. Exhaust gases must be piped safely away from any building or enclosure that houses the generator to an area where people, animals, etc., will not be harmed. This exhaust system must be installed properly, in strict compliance with applicable codes and standards.
- Keep hands, feet, clothing, etc., away from drive belts, fans, and other moving or hot parts. Never remove any drive belt or fan guard while the unit is operating.
- Adequate, unobstructed flow of cooling and ventilating air is critical to prevent buildup of explosive gases and to ensure correct generator operation. Do not alter the installation or permit even partial blockage of ventilation provisions, as this can seriously affect safe operation of the generator.
- Keep the area around the generator clean and uncluttered. Remove any materials that could become hazardous.
- When working on this equipment, remain alert at all times. Never work on the equipment when physically or mentally fatigued.
- Inspect the generator regularly, and promptly repair or replace all worn, damaged or defective parts using only factory-approved parts.
- Before performing any maintenance on the generator, disconnect its battery cables to prevent accidental start-up. Disconnect the cable from the battery post indicated by a NEGATIVE, NEG or (-) first. Reconnect that cable last.
- Never use the generator or any of its parts as a step. Stepping on the unit can stress and break parts, and may result in dangerous operating conditions from leaking exhaust gases, fuel leakage, oil leakage, etc.

## **ELECTRICAL HAZARDS**

- All generators covered by this manual produce dangerous electrical voltages and can cause fatal electrical shock. Utility power delivers extremely high and dangerous voltages to the transfer switch as well as the standby generator. Avoid contact with bare wires, terminals, connections, etc., on the generator as well as the transfer switch, if applicable. Ensure all appropriate covers, guards and barriers are in place before operating the generator. If work must be done around an operating unit, stand on an insulated, dry surface to reduce shock hazard.
- Do not handle any kind of electrical device while standing in water, while barefoot, or while hands or feet are wet. **DANGEROUS ELECTRICAL SHOCK MAY RESULT.**
- If people must stand on metal or concrete while installing, operating, servicing, adjusting or repairing this equipment, place insulating mats over a dry wooden platform. Work on the equipment only while standing on such insulating mats.

- The National Electrical Code (NEC), Article 250 requires the frame and external electrically conductive parts of the generator to be connected to an approved earth ground and/or grounding rods. This grounding will help prevent dangerous electrical shock that might be caused by a ground fault condition in the generator set or by static electricity. Never disconnect the ground wire.
- Wire gauge sizes of electrical wiring, cables and cord sets must be adequate to handle the maximum electrical current (ampacity) to which they will be subjected.
- Before installing or servicing this (and related) equipment, make sure that all power voltage supplies are positively turned off at their source. Failure to do so will result in hazardous and possibly fatal electrical shock.
- Connecting this unit to an electrical system normally supplied by an electric utility shall be by means of a transfer switch so as to isolate the generator electric system from the electric utility distribution system when the generator is operating. Failure to isolate the two electric system power sources from each other by such means will result in damage to the generator and may also result in injury or death to utility power workers due to backfeed of electrical energy.
- Generators installed with an automatic transfer switch will crank and start automatically when NORMAL (UTILITY) source voltage is removed or is below an acceptable preset level. To prevent such automatic start-up and possible injury to personnel, disable the generator's automatic start circuit (battery cables, etc.) before working on or around the unit. Then, place a "Do Not Operate" tag on the generator control panel and on the transfer switch.
- In case of accident caused by electric shock, immediately shut down the source of electrical power. If this is not possible, attempt to free the victim from the live conductor. **AVOID DIRECT CONTACT WITH THE VICTIM.** Use a nonconducting implement, such as a dry rope or board, to free the victim from the live conductor. If the victim is unconscious, apply first aid and get immediate medical help.
- Never wear jewelry when working on this equipment. Jewelry can conduct electricity resulting in electric shock, or may get caught in moving components causing injury.

### **FIRE HAZARDS**

- Keep a fire extinguisher near the generator at all times. Do NOT use any carbon tetra-chloride type extinguisher. Its fumes are toxic, and the liquid can deteriorate wiring insulation. Keep the extinguisher properly charged and be familiar with its use. If there are any questions pertaining to fire extinguishers, consult the local fire department.

### **EXPLOSION HAZARDS**

- Properly ventilate any room or building housing the generator to prevent build-up of explosive gas.
- Do not smoke around the generator. Wipe up any fuel or oil spills immediately. Ensure that no combustible materials are left in the generator compartment, or on or near the generator, as FIRE or EXPLOSION may result. Keep the area surrounding the generator clean and free from debris.
- Generac generator sets may operate using one of several types of fuels. All fuel types are potentially FLAMMABLE and/or EXPLOSIVE and should be handled with care. Comply with all laws regulating the storage and handling of fuels. Inspect the unit's fuel system frequently and correct any leaks immediately. Fuel supply lines must be properly installed, purged and leak tested according to applicable fuel-gas codes before placing this equipment into service.
- Diesel fuels are highly FLAMMABLE. Gaseous fluids such as natural gas and liquid propane (LP) gas are extremely EXPLOSIVE. Natural gas is lighter than air, and LP gas is heavier than air; install leak detectors accordingly.

# DIAGNOSTIC REPAIR MANUAL

## 3.9 LITER PREPACKAGED HOME STANDBY GENERATORS

<b>TABLE OF CONTENTS</b>		
<b>PART</b>	<b>TITLE</b>	<b>PAGE</b>
	<b>SPECIFICATIONS</b>	<b>2</b>
<b>1</b>	<b>General Information</b>	<b>3</b>
<b>2</b>	<b>Prepackaged Liquid Cooled AC Generators</b>	<b>19</b>
<b>3</b>	<b>DC Control- Units with Liquid-Cooled Engine</b>	<b>41</b>
<b>4</b>	<b>Electrical Data</b>	<b>87</b>

# SPECIFICATIONS

## GENERATOR SPECIFICATIONS

Model	4991-1
Rated Max. Cont. AC Power Output (kW)	37 (NG), 40 (LP)
Rated voltage (volts)	120/240
No. of Rotor Poles	4
Driven Speed of Rotor	1800
Rotor Excitation System	Direct excited brush type
Type of Stator	4 Wire
Rotor/Stator Insulation	Class F/H

## ENGINE SPECIFICATIONS

Make Chrysler  
 Displacement ..... 92 inches (3.9 liters)  
 Cylinder Arrangement ..... V-6  
 Valve Arrangement ..... Overhead Cam  
 Firing Order ..... 1-6-5-4-3-2  
 Number of Main Bearings ..... 4  
 Compression Ratio ..... 9.1 to 1  
 No. of Teeth on Flywheel ..... 164  
 Ignition Timing at 1800 rpm ..... 30 degrees BTDC  
 Spark Plug Gap ..... 1.01mm (0.040 in.)  
 Recommended Spark Plugs  
 Champion ..... RC12LC4  
 Oil Pressure ..... 30-80 psi  
 Crankcase Oil Capacity ..... 4.0 U.S. quarts (3.8 liters)  
 Recommended Engine Oil ..... SAE 15W-40  
 Type of Cooling System ..... Pressurized, closed recovery  
 Cooling Fan ..... Pusher Type  
 Cooling System Capacity ..... 5.0 U.S. gal. (19.3 liters)  
 Recommended Coolant ..... Use a 50-50 mixture of ethylene glycol base and de-ionized water.

## FUEL CONSUMPTION

### NATURAL GAS:

% of Load	25%	50%	75%	100%
m3/hr	4.1	7.7	11.0	14.2
ft3/hr	143.1	271.1	388.5	502.0

### LP VAPOR:

% of Load	25%	50%	75%	100%
m3/hr	1.7	3.3	4.7	6.0
ft3/hr	60.7	115.0	164.9	213.0

**NOTE: Fuel consumption is given at rated maximum continuous power output when using natural gas rated at 1000 Btu per cubic foot and LP gas rated 2520 Btu per cubic foot. Actual fuel consumption obtained may vary depending on such variables as applied load, ambient temperature, engine conditions and other environmental factors.**

Fuel pressure for a natural gas set up should be five inches to 14 inches of water column (0.18 to 0.5 psi)

at all load ranges, however optimal performance is achieved between 11 to 14 inches of water column.

Fuel pressure for an LP vapor set up should be 11 inches to 14 inches of water column (0.4 to 0.5 psi) at all load ranges.

## ENGINE OIL RECOMMENDATIONS

The unit has been filled with 15W-40 engine oil at the factory. Use a high-quality detergent oil classified "For Service SJ or latest available." Detergent oils keep the engine cleaner and reduce carbon deposits. Use oil having the following SAE viscosity rating, based on the ambient temperature range anticipated before the next oil change:

Temperature	Oil Grade (Recommended)
Above 80° F (27° C)	SAE 30W or 15W-40
32° to 80° F (-1° to 27° C)	SAE 20W-20 or 15W-40
Below 32° F (0° C)	SAE 10W or 15W-40

**NOTE: Synthetic oil is highly recommended when the generator will be operating in ambient temperatures which regularly exceed 90° F and/or fall below 30° F.**



**ANY ATTEMPT TO CRANK OR START THE ENGINE BEFORE IT HAS BEEN PROPERLY SERVICED WITH THE RECOMMENDED OIL MAY RESULT IN AN ENGINE FAILURE.**

## COOLANT RECOMMENDATIONS

Use a mixture of half low silicate ethylene glycol base anti-freeze and deionized water. Cooling system capacity is about 5.6 U.S. gallons. Use only deionized water and only low silicate anti-freeze. If desired, add a high quality rust inhibitor to the recommended coolant mixture. When adding coolant, always add the recommended 50-50 mixture.



**DO NOT USE ANY CHROMATE BASE RUST INHIBITOR WITH ETHYLENE GLYCOL BASE ANTI-FREEZE OR CHROMIUM HYDROXIDE ("GREEN SLIME") FORMS AND WILL CAUSE OVERHEATING. ENGINES THAT HAVE BEEN OPERATED WITH A CHROMATE BASE RUST INHIBITOR MUST BE CHEMICALLY CLEANED BEFORE ADDING ETHYLENE GLYCOL BASE ANTI-FREEZE. USING ANY HIGH SILICATE ANTI-FREEZE BOOSTERS OR ADDITIVES WILL ALSO CAUSE OVERHEATING. IT IS ALSO RECOMMENDED THAT ANY SOLUBLE OIL INHIBITOR IS NOT USED FOR THIS EQUIPMENT.**

# **PART 1 GENERAL INFORMATION**

## **3.9 LITER PREPACKAGED HOME STANDBY GENERATORS**

<b>TABLE OF CONTENTS</b>		
<b>PART</b>	<b>TITLE</b>	<b>PAGE</b>
<b>1.1</b>	<b>Generator Identification</b>	<b>4</b>
<b>1.2</b>	<b>Prepackaged Installation Basics</b>	<b>5</b>
<b>1.3</b>	<b>Preparation Before Use</b>	<b>9</b>
<b>1.4</b>	<b>Testing, Cleaning and Drying</b>	<b>10</b>
<b>1.5</b>	<b>Engine-Generator Protective Devices</b>	<b>13</b>
<b>1.6</b>	<b>Operating Instructions</b>	<b>15</b>
<b>1.7</b>	<b>Automatic Operating Parameters</b>	<b>17</b>

# SECTION 1.1 GENERATOR IDENTIFICATION

SERVICE ITEM ACCESSIBILITY CHART

SERVICE ITEM	3.0L 30KW	3.9L 40KW
OIL FILL CAP	LOCATED ON LEFT VALVE COVER, ACCESSIBLE THRU LEFT DOOR	THRU RIGHT DOOR
OIL DIP STICK	THRU LEFT DOOR	THRU RIGHT DOOR
OIL FILTER	THRU LEFT DOOR	THRU LEFT DOOR
OIL DRAIN HOSE	THRU LEFT DOOR	THRU LEFT DOOR
RADIATOR DRAIN HOSE	THRU RIGHT DOOR	THRU LEFT DOOR
AIR CLEANER ELEMENT	EITHER DOOR	EITHER DOOR
SPARK PLUGS	BOTH DOORS	BOTH DOORS
MUFFLERS	SEE NOTE 6	SEE NOTE 6
FAN BELT	EITHER DOOR	EITHER DOOR
BATTERY	THRU RIGHT DOOR	THRU RIGHT DOOR

REFERENCE OWNERS MANUAL FOR PERIODIC REPLACEMENT PART LISTINGS

BATTERY  
12 VOLT 24F  
625 COLD  
CRANKING  
AMPS

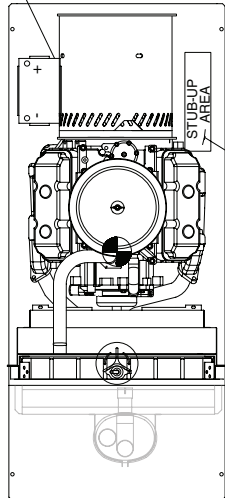

TOP VIEW

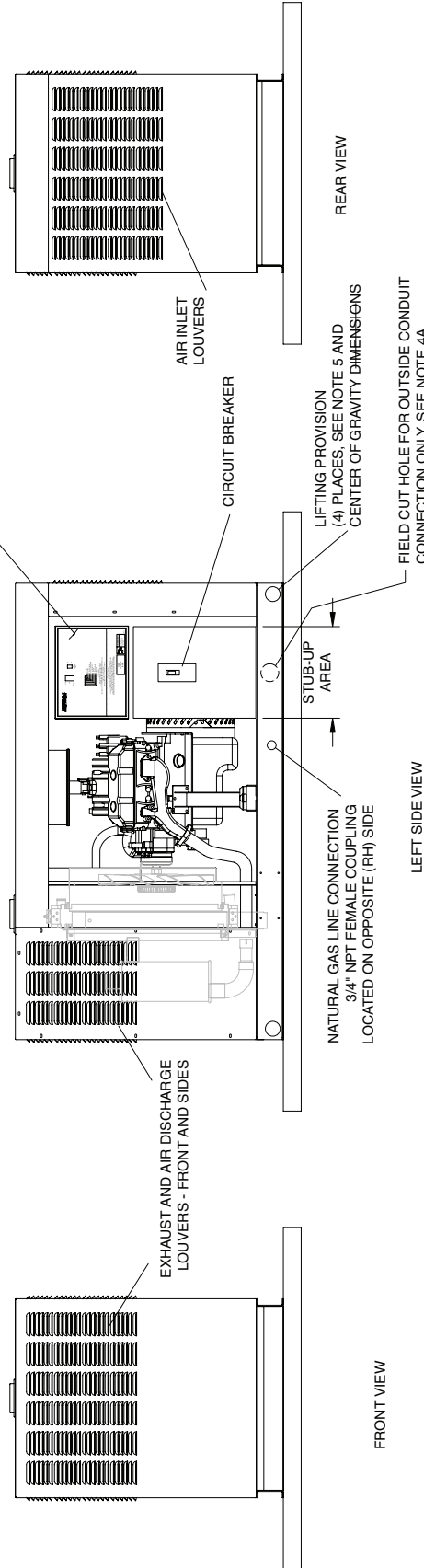

**INTRODUCTION**

This Diagnostic Repair Manual has been prepared especially for the purpose of familiarizing service personnel with the testing, troubleshooting and repair of 3.9 Liter home standby generator systems. Every effort has been expended to ensure that information and instructions in the manual are both accurate and current. However, the manufacturer reserves the right to change, after or otherwise improve the product at any time without prior notification.

The manual has been divided into several PARTS. Each PART has been divided into SECTIONS. Each SECTION consists of two or more SUBSECTIONS.

It is not the manufacturers intent to provide detailed disassembly and reassembly instructions in this manual. It is the manufacturers intent to (a) provide the service technician with an understanding of how the various assemblies and systems work, (b) assist the technician in finding the cause of malfunctions, and (c) effect the expeditious repair of the equipment.

**UNITS WITH LIQUID COOLED ENGINE**

A typical 3.9 Liter generator with liquid cooled engine is shown on Page 4 at front of this manual.

A DATA PLATE, affixed to the unit, contains important information pertaining to the unit, including its Model Number, Serial Number, kW rating, rated rpm, rated voltage, etc. The information from this data plate may be required when requesting information, ordering parts, etc.

<b>ALTERNATOR DATA</b>			
MODEL	<input type="text"/>	KVA	<input type="text"/>
SERIAL	<input type="text"/>	PHASE	<input type="text"/>
VOLTS	<input type="text"/>	HERTZ	<input type="text"/>
AMPS	<input type="text"/>	RPM	<input type="text"/>
POWER FACTOR	<input type="text"/>	KW	<input type="text"/>
CLASS F WINDING INSULATION AT 40° C.			
45452		MADE IN U.S.A.	

Figure 1. A Typical Data Plate

**INTRODUCTION**

Information in this section is provided so that the service technician will have a basic knowledge of installation requirements for prepackaged home standby systems. Problems that arise are often related to poor or unauthorized installation practices.

A typical prepackaged home standby electric system is shown in Figure 1, below. Installation of such a system includes the following:

- Selecting a Location
- Mounting of the generator.
- Grounding the generator.
- Providing a fuel supply.
- Mounting the transfer switch.
- Connecting power source and load lines.
- Connecting system control wiring.
- Post installation tests and adjustments.

**SELECTING A LOCATION**

Install the generator set as close as possible to the electrical load distribution panel(s) that will be powered by the unit, ensuring that there is proper ventilation for cooling air and exhaust gases. This will reduce wiring and conduit lengths. Wiring and conduit not only add to the cost of the installation, but excessively long wiring runs can result in a voltage drop. Consult NFPA 37 and 70.

**MOUNTING THE GENERATOR**

Mount the generator set to a concrete slab. The slab should extend past the generator and to a distance of at least twelve (12) inches on all sides. The unit can be retained to the concrete slab with masonry anchor bolts.

**GROUNDING THE GENERATOR**

The National Electric Code requires that the frame and external electrically conductive parts of the generator be properly connected to an approved earth ground. Local electrical codes may also require proper grounding of the unit. For that purpose, a grounding lug is attached to the unit. Grounding may be accomplished by attaching a stranded copper wire of the proper size to the generator's grounding lug and to an earth-driven copper or brass grounding-rod (electrode). Consult with a local electrician for grounding requirements in your area.

**THE FUEL SUPPLY**

Units with liquid cooled engines are shipped from the factory to run on natural gas (Figure 2). Units that will use LP (propane) gas fuel (Figure 3) must be converted in the field per instructions located in the Installation Manual.

LP (propane) gas is usually supplied as a liquid in pressure tanks. Liquid cooled units require a "vapor withdrawal" type of fuel supply system when LP (propane) gas is used. The vapor withdrawal system utilizes the gaseous fuel vapors that form at the top of the supply tank.

The pressure at which LP gas is delivered to the generator's fuel solenoid valve may vary considerably, depending on ambient temperatures. In cold weather, supply pressures may drop to "zero". In warm weather, extremely high gas pressures may be encountered. A primary/secondary supply regulator is required to maintain correct gas supply pressure to the generator demand regulator.

Minimum recommended gaseous fuel pressure at the inlet side of the generator's fuel solenoid valve is 11 inches water column for LP gas (6.38 ounces per square inch), and 5 inches water column for natural

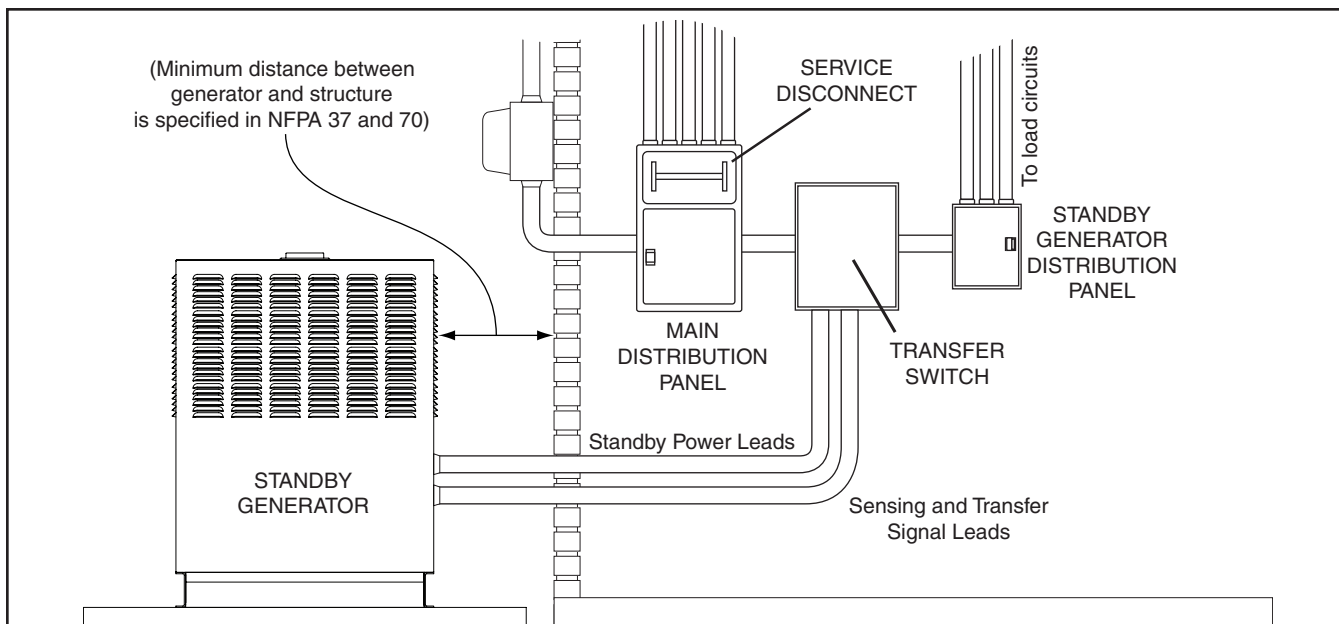

Figure 1. Typical Prepackaged Installation

gas (2.89 ounces per square inch). The maximum recommended pressure is 14 inches water column (8.09 ounces per square inch). A primary regulator may be required to ensure that proper fuel supply pressures are maintained.



**DANGER: LP AND NATURAL GAS ARE BOTH HIGHLY EXPLOSIVE. GASEOUS FUEL LINES MUST BE PROPERLY PURGED AND TESTED FOR LEAKS BEFORE THIS EQUIPMENT IS PLACED INTO SERVICE AND PERIODICALLY THEREAFTER. PROCEDURES USED IN GASEOUS FUEL LEAKAGE TESTS MUST COMPLY STRICTLY WITH APPLICABLE FUEL GAS CODES. DO NOT USE FLAME OR ANY SOURCE OF HEAT TO TEST FOR GAS LEAKS.**

**NO GAS LEAKAGE IS PERMITTED. LP GAS IS HEAVIER THAN AIR AND TENDS TO SETTLE IN LOW AREAS. NATURAL GAS IS LIGHTER THAN AIR AND TENDS TO SETTLE IN HIGH PLACES. EVEN THE SLIGHTEST SPARK CAN IGNITE THESE FUELS AND CAUSE AN EXPLOSION.**

Use of a flexible length of hose between the generator fuel line connection and rigid fuel lines is required. This will help prevent line breakage that might be caused by vibration or if the generator shifts or settles. The flexible fuel line must be approved for use with gaseous fuels. Flexible fuel line must be straight. Any bends can cause restrictions in gas flow.

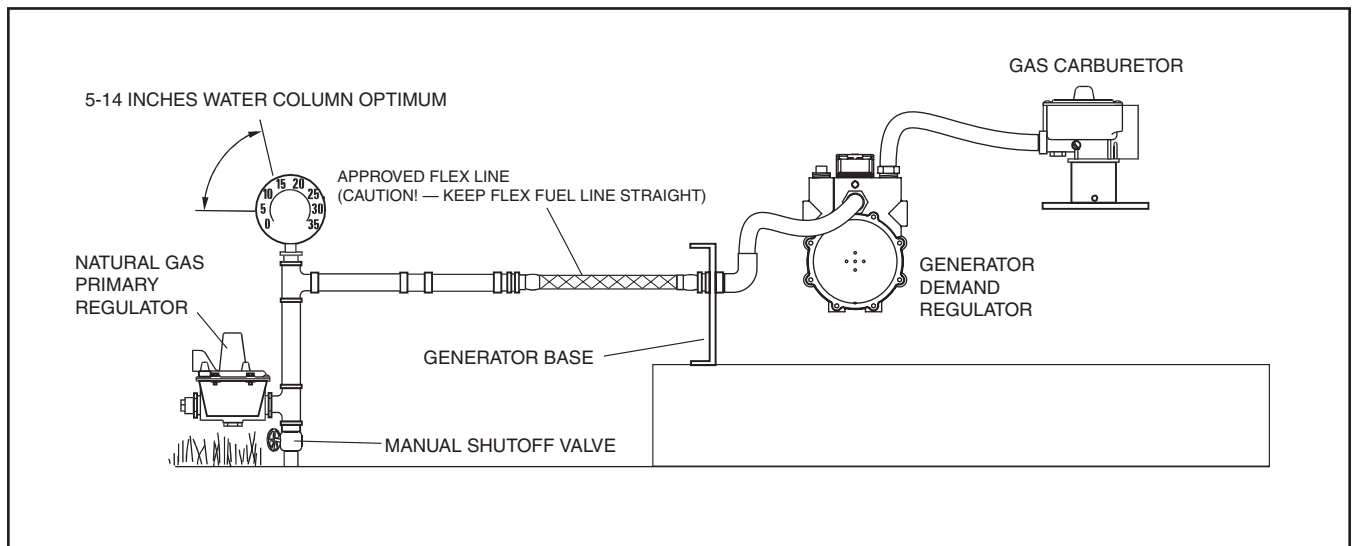

Figure 2. Typical Natural Gas Fuel System (Liquid Cooled Units)

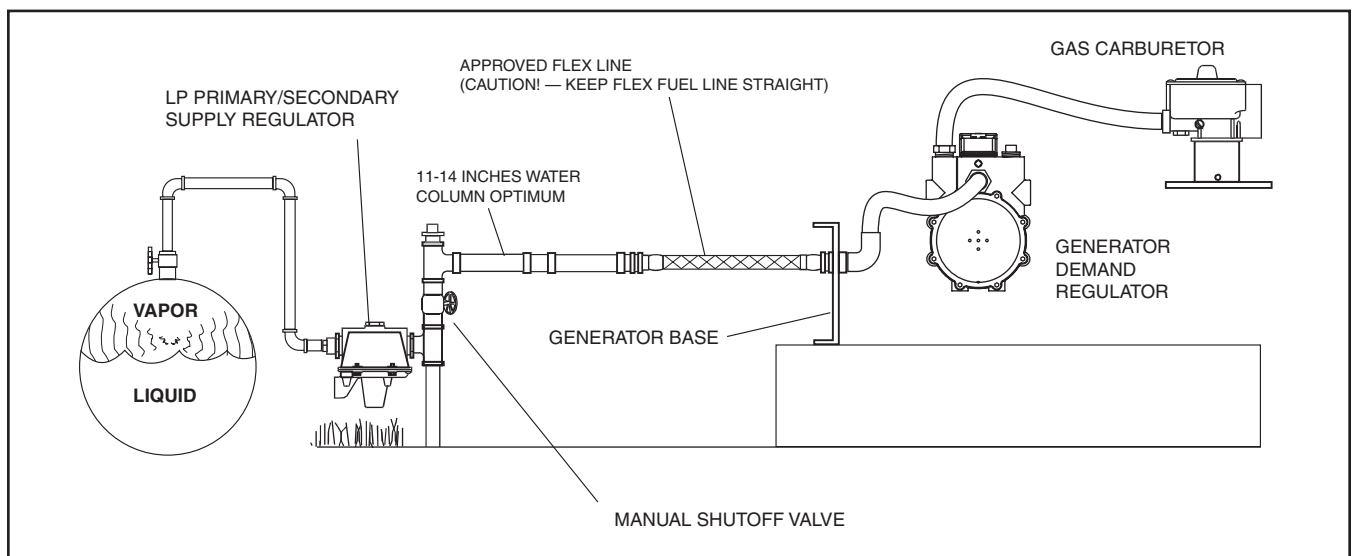

Figure 3. Typical LP Gas Fuel System (Liquid Cooled Units)

**THE TRANSFER SWITCH**

A transfer switch is required by electrical code, to prevent electrical feedback between the utility and standby power sources, and to transfer electrical loads from one power supply to another safely.

**TRANSFER SWITCHES:**

Instructions and information on transfer switches may be found in Part 3 of this manual.

**POWER SOURCE AND LOAD LINES**

The utility power supply lines, the standby (generator) supply lines, and electrical load lines must all be connected to the proper terminal lugs in the transfer switch. The following rules apply:

In 1-phase systems with a 2-pole transfer switch, connect the two "Utility" source hot lines to transfer switch Terminal Lugs N1 and N2. Connect the "Standby" source hot lines (E1, E2) to transfer switch Terminal Lugs E1 and E2. Connect "Utility", "Standby" and "Load" neutral lines to the neutral block in the transfer switch.

**SYSTEM CONTROL INTERCONNECTIONS**

Home standby generators are equipped with a terminal board identified with the following terminals: (a) utility 1, (b) utility 2, (c) 23, (d) 194, (e) 178, and (f) 183. Suitable, approved wiring must be interconnected between identically numbered terminals in the generator and transfer switch. When these four terminals are properly interconnected, dropout of utility source voltage below a preset value will result in automatic generator startup and transfer of electrical loads to the "Standby" source. On restoration of utility source voltage above a preset value will result in retransfer back to that source and generator shutdown. System control wiring must be routed through its own separate conduit.

On units with an RTS type transfer switch, a control board mounted on the standby generator set provides a "7-day exercise" feature. This feature allows the standby generator to start and run once every 7 days, on a day and at a time of day selected. On units with a GTS type switch exercise is controlled via the GTS switch.

The R-type control panel comes with a standard 2 Amp charger. This charger, when powered by 120 VAC from the utility distribution panel, will deliver a charging voltage to the battery during non-operating periods to keep the battery charged.

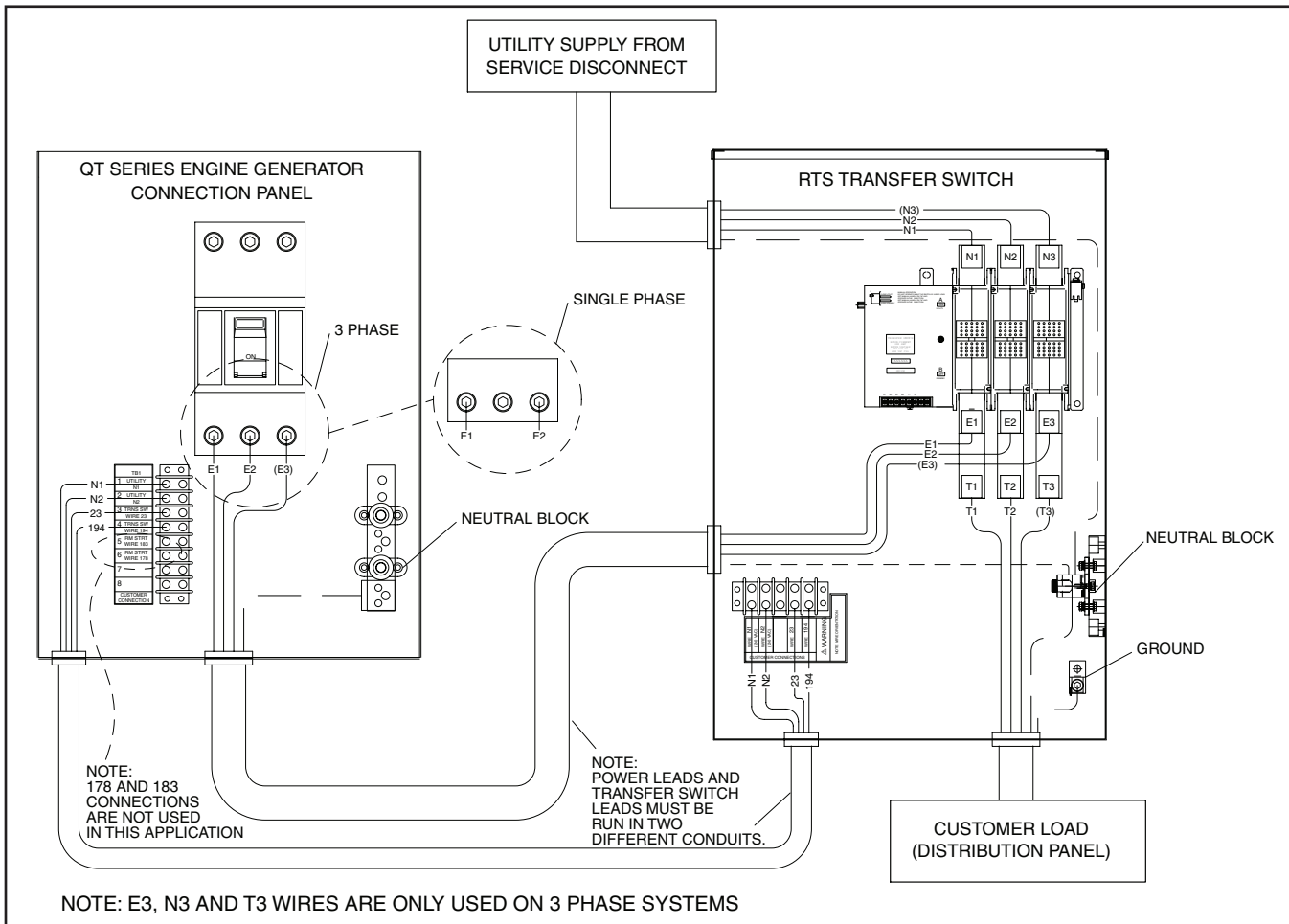

Figure 4. Prepackaged Interconnection Diagram

**GENERAL**

The installer must ensure that the home standby generator has been properly installed. The system must be inspected carefully following installation. All applicable codes, standards and regulations pertaining to such installations must be strictly complied with. In addition, regulations established by the Occupational Safety and Health Administration (OSHA) must be complied with.

Prior to initial startup of the unit, the installer must ensure that the engine-generator has been properly prepared for use. This includes the following:

- An adequate supply of the correct fuel must be available for generator operation.
- The engine must be properly serviced with the recommended oil.
- The engine cooling system must be properly serviced with the recommended coolant.

**FUEL REQUIREMENTS**

Liquid cooled engine units are shipped from the factory to run on natural gas. The installer must ensure that the correct fuel supply system has been installed and is compatible with engine-generator requirements. Read "The Fuel Supply" in Section 1.2 carefully.

**ALL UNITS:**

- When natural gas is used as a fuel, it should be rated at least 1000 BTU's per cubic foot.
- When LP (propane) gas is used as a fuel, it should be rated at 2520 BTU's per cubic foot.

**ENGINE OIL RECOMMENDATIONS**

For prepackaged generators with liquid cooled engine, use a high quality detergent oil that meets or exceeds API Service SJ or higher. Detergent oils keep the engine cleaner and reduce carbon deposits. Use oil having the following SAE viscosity rating, based on the anticipated ambient temperature range before the next oil change:

Engine crankcase oil capacities for the 3.9 Liter engine covered in this manual can be found in the specifications section at the beginning of the book.

AMBIENT TEMPERATURE RANGE	RECOMMENDED OIL
Above 80° F (27° C)	SAE 30W or 15W-40
32° to 80° F (-1° to 27° C)	SAE 20W-20 or 15W-40
Below 32° F (0° C)	SAE 10W or 15W-40

**RECOMMENDED ENGINE COOLANT**

Use a mixture of 50 percent soft water and 50 percent ethylene glycol base anti-freeze in the engine cooling system. Use only SOFT WATER and LOW SILICATE anti-freeze. If so equipped, a coolant recovery bottle must also be properly serviced with the recommended 50-50 mixture. When adding coolant to the radiator or to the coolant recovery bottle, use only the recommended mixture.

If desired, a high quality rust inhibitor may be added to the recommended coolant mixture.



**CAUTION: Do NOT use any chromate base rust inhibitor with ethylene glycol base anti-freeze, or the formation of chromium hydroxide (called "green slime") may result and cause overheating of the engine. The use of high silicate antifreeze boosters or additives may also cause overheating. In addition, use of any soluble oil type rust inhibitor is NOT recommended.**

### ***VISUAL INSPECTION***

When it becomes necessary to test or troubleshoot a generator, it is a good practice to complete a thorough visual inspection. Remove the access covers and look closely for any obvious problems. Look for the following:

- Burned or broken wires, broken wire connectors, damaged mounting brackets, etc.
- Loose or frayed wiring insulation, loose or dirty connections.
- Check that all wiring is well clear of rotating parts.
- Verify that the Generator is properly connected for the correct rated voltage. This is especially important on new installations. See Section 1.2, "AC Connection Systems".
- Look for foreign objects, loose nuts, bolts and other fasteners.
- Clean the area around the Generator. Clear away paper, leaves, snow, and other objects that might blow against the generator and obstruct its air openings.

### ***MEASURING VOLTAGES***

When troubleshooting and testing the generator set, the technician will be required to measure both AC and DC voltages. Measurement of voltage requires that the user be thoroughly familiar with the meter being used for such tests. Consult the instruction manual for the meter being used.

When measuring voltage, it is best to connect the meter test leads to the terminals being tested while the generator is shut down or while power to those terminals is turned off.



**DANGER: POWER VOLTAGES GENERATED BY THIS EQUIPMENT ARE EXTREMELY HIGH AND DANGEROUS. USE EXTREME CARE WHEN MEASURING POWER VOLTAGES SUCH AS GENERATOR AC OUTPUT VOLTAGE. CONTACT WITH LIVE TERMINALS AND CONDUCTORS MAY RESULT IN HARMFUL AND POSSIBLY LETHAL ELECTRICAL SHOCK. DO NOT ATTEMPT TO READ POWER VOLTAGES WHILE STANDING ON WET OR DAMP GROUND, OR WHILE HANDS OR FEET ARE WET. STAY WELL CLEAR OF HIGH VOLTAGE POWER TERMINALS. CONNECT METER TEST LEADS TO TERMINALS AND LEADS WHILE THE GENERATOR IS SHUT DOWN OR WHEN THE POWER SUPPLY TO SUCH LEADS AND TERMINALS IS TURNED OFF. THE USE OF INSULATING RUBBER MATS IS RECOMMENDED. TAKE POWER VOLTAGE READINGS ONLY WHILE STANDING ON SUCH INSULATING MATS.**

### ***MEASURING CURRENT***

Alternating current (AC) can be measured with a clamp-on ammeter. Most clamp-on ammeters will not measure direct current (DC). Load current readings should never exceed the generator's data plate rating for continuous operation. However, momentary surges in load current may be encountered when starting electric motors.

On 1-phase generators, the data plate generally lists rated line-to-line and line-to-neutral current.

### ***MEASURING RESISTANCE***

The resistance (in ohms) of generator stator and rotor windings can be measured using an ohmmeter or an accurate volt-ohm-milliammeter (VOM).

The resistance of some windings is extremely low. Some readings are so low that a meter capable of reading in the "milliohms" range would be required. Many meters will simply read CONTINUITY. However, a standard volt-ohm-milliammeter (VOM) may be used to test for continuity, or for a shorted or grounded condition.

### ***INSULATION RESISTANCE***

The insulation resistance of stator and rotor windings is a measurement of the integrity of the insulating materials that separate the electrical windings from the generator's steel core. This resistance can degrade over time or due to such contaminants as dust, dirt, oil, grease and especially moisture. In most cases, failures of stator and rotor windings is due to a breakdown in the insulation. And, in many cases, a low insulation resistance is caused by moisture that collects while the generator is shut down. When problems are caused by moisture buildup on the windings, they can usually be corrected by drying the windings. Cleaning and drying the windings can usually eliminate dirt and moisture built up in the generator windings.

#### **MEGGERS:**

The normal resistance of generator winding insulation is on the order of millions of ohms. This high resistance can be measured with a device called a "megger". The megger is a megohm meter ("meg" stands for million) and a power supply. The power supply voltage varies between megger models and is selectable on some models. The most common power supply voltage is 500 volts. Use of power supplies greater than 500 volts are not recommended on prepackaged generators.



**CAUTION: BEFORE ATTEMPTING TO MEASURE INSULATION RESISTANCE, FIRST DISCONNECT AND ISOLATE ALL LEADS OF THE WINDING TO BE TESTED. ELECTRONIC COMPONENTS, DIODES, SURGE PROTECTORS, RELAYS, VOLTAGE REGULATORS, ETC., CAN BE DESTROYED IF SUBJECTED TO HIGH MEGGER VOLTAGES.**

**HI-POT TESTER:**

A "Hi-Pot" tester is shown in Figure 1. The model shown is only one of many that are commercially available. The tester shown is equipped with a voltage selector switch that permits the power supply voltage to be selected. It also mounts a breakdown lamp that will illuminate to indicate an insulation breakdown during the test.

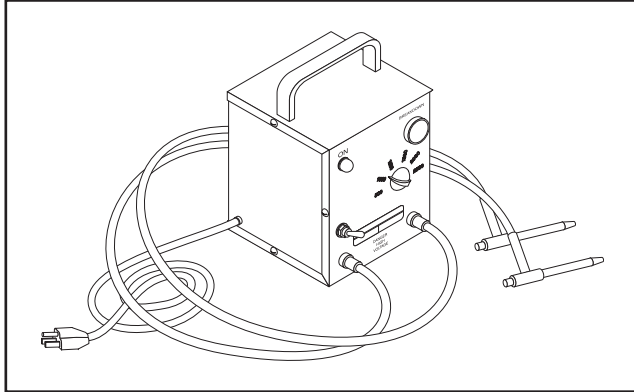

Figure 1. One Type of Hi-Pot Tester

**STATOR INSULATION TESTS****GENERAL:**

Units with liquid cooled engine and 1 -phase stator windings are equipped with (a) dual stator AC power windings, and (b) an excitation or DPE winding. These units are not equipped with a battery charge winding. Stator winding insulation tests consist of (a) testing all windings to ground, (b) testing between isolated windings, and (c) testing between parallel windings. Figure 3 represents the various stator AC output leads on 1 -phase units with liquid-cooled engine.

**TEST ALL WINDINGS TO GROUND:**

1. Disconnect and isolate all stator leads.
2. Make sure all wire terminal ends are completely isolated from frame ground.
3. Connect the black tester probe to a clean frame ground on the stator can. Test each stator lead by connecting the red test probe of the Hi-Pot tester to the terminal end of each stator lead. Then, proceed as follows:
  - a. Turn the Hi- Pot tester switch OFF
  - b. Plug the tester cord into a 120 volts AC wall socket and set its voltage selector switch to "500 volts".
  - c. Turn the tester switch ON and observe the breakdown lamp. After one (1) second, turn the tester switch OFF.
  - d. Repeat a, b and c for each lead.

If the breakdown lamp turned on during the one (1) second test, clean and dry the stator. Then, repeat the test. If breakdown lamp comes on during the second test, replace the stator assembly.

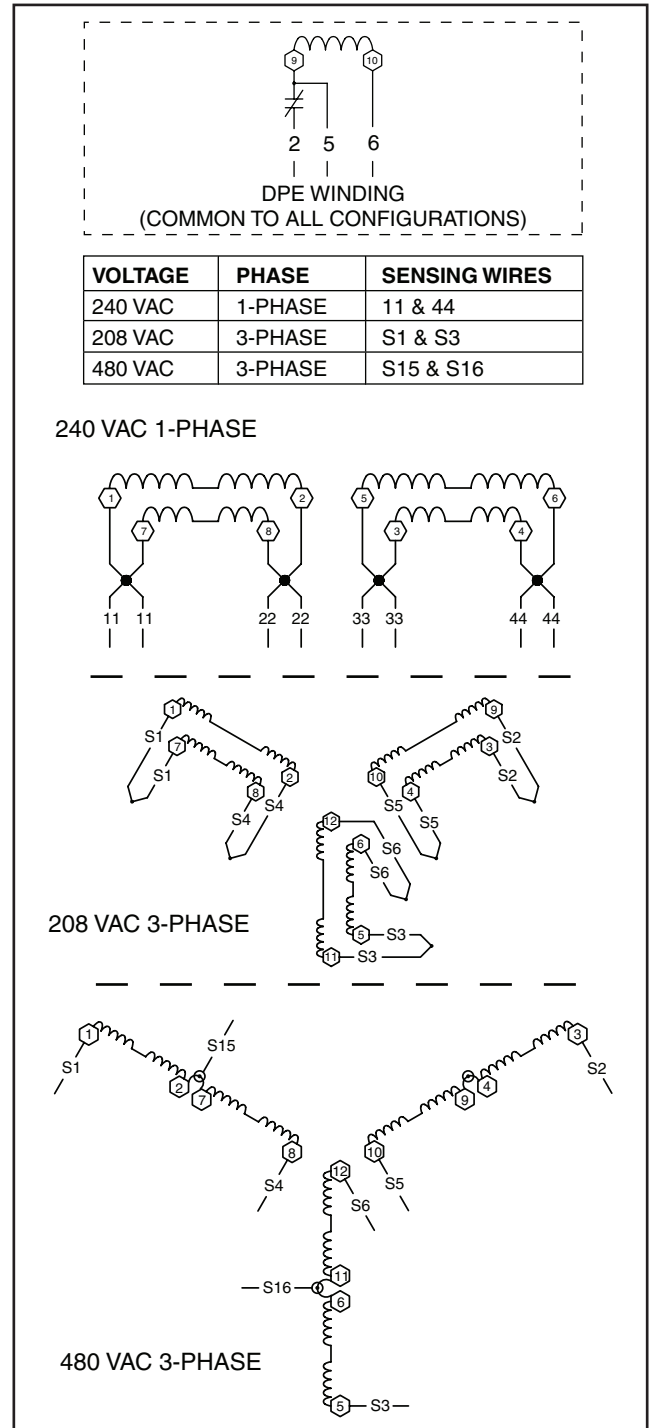

Figure 3. Stator Winding Leads

**TEST BETWEEN ISOLATED WINDINGS:**

Each winding consists of 2 leads. Use the matrix below as an aid in connecting and testing all windings.

1. Connect red and black probes of the hi-pot according to the matrix.
2. Isolate all lead ends from each other. Be sure that the leads at the other ends of the winding being tested do not touch each other or ground.

## SECTION 1.4 TESTING, CLEANING AND DRYING

PART 1

GENERAL INFORMATION

3. Set the tester switch to "500 volts".
4. Turn the tester switch ON and check that the pilot lamp is lighted.
5. Wait one (1) second while observing the tester breakdown lamp. DO NOT EXCEED ONE SECOND. After one (1) second, turn the tester switch OFF.

**Example: Connect the red test probe to stator lead 2, the black probe to stator lead 33. Then, repeat Steps 2, 3 and 4. Repeat for each pair of leads as shown in the matrix.**

	1-PHASE	3-PHASE
RED LEAD	2	2
BLACK LEAD	11	S1
RED LEAD	2	2
BLACK LEAD	33	S3
RED LEAD	11	2
BLACK LEAD	33	S5
RED LEAD		S1
BLACK LEAD		S3
RED LEAD		S1
BLACK LEAD		S5
RED LEAD		S3
BLACK LEAD		S5

If the breakdown lamp turned on during any one (1) second test, the stator should be cleaned and dried. After cleaning and drying, repeat the test. If the breakdown lamp turns on during the second test, replace the stator assembly.

### TESTING ROTOR INSULATION

Before attempting to test rotor insulation, either the brush leads must be completely removed from the brushes or the brush holders must be completely removed. The rotor must be completely isolated from other components before starting the test.

1. Connect the red tester lead to the positive (+) slip ring (nearest the rotor bearing).
2. Connect the black tester probe to a clean frame ground, such as a clean metal part of the rotor.
3. Turn the tester switch OFF.
4. Plug the tester into a 120 volts AC wall socket and set the voltage switch to "500 volts".
5. Turn the tester switch ON and make sure the pilot light has turned on.
6. Observe the breakdown lamp, then turn the tester switch OFF. DO NOT APPLY VOLTAGE LONGER THAN ONE (1) SECOND.

If the breakdown lamp came on during the one (1) second test, cleaning and drying of the rotor may be necessary. After cleaning and drying, repeat the insulation breakdown test. If breakdown lamp comes on during the second test, replace the rotor assembly.

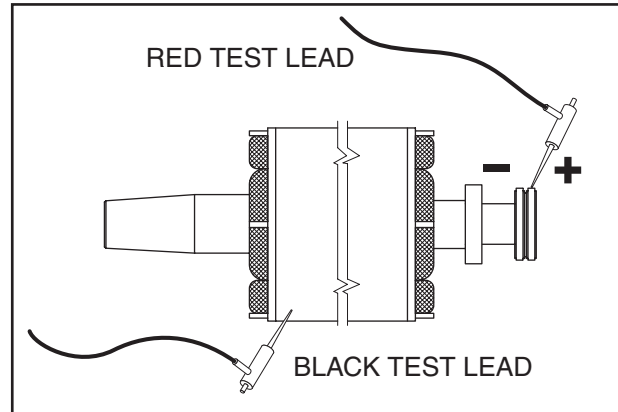

Figure 6. Testing Rotor Insulation

### CLEANING THE GENERATOR

Caked or greasy dirt may be loosened with a soft brush or a damp cloth. A vacuum system may be used to clean up loosened dirt. Dust and dirt may also be removed using dry, low-pressure air (25 psi maximum).



**CAUTION: Do not use sprayed water to clean the generator. Some of the water will be retained on generator windings and terminals, and may cause very serious problems.**

### DRYING THE GENERATOR

To dry a generator, proceed as follows:

1. Open the generator main circuit breaker. NO ELECTRICAL LOADS MUST BE APPLIED TO THE GENERATOR WHILE DRYING.
2. Disconnect all wires No. 4 from the voltage regulator.
3. Provide an external source to blow warm, dry air through the generator interior (around the rotor and stator windings. DO NOT EXCEED 185° F. (85° C.).
4. Start the generator and let it run for 2 or 3 hours.
5. Shut the generator down and repeat the stator and rotor insulation resistance tests.

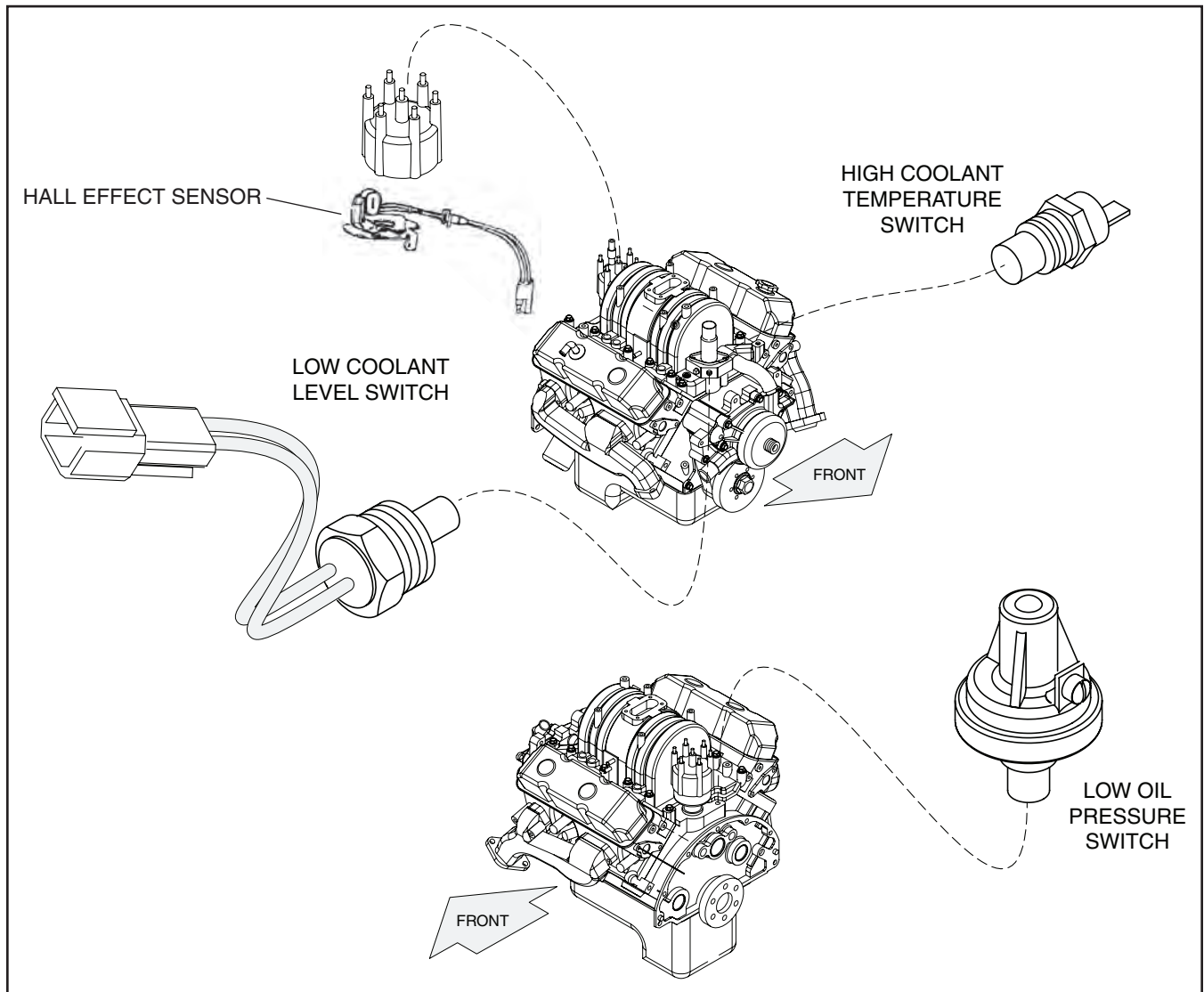

Figure 1. Protective Devices on Liquid Cooled Engine

### GENERAL

Standby electric power generators will often run unattended for long periods of time. Such operating parameters as (a) engine oil pressure, (b) engine temperature, (c) engine operating speed, and (d) engine cranking and startup are not monitored by an operator during automatic operation. Because engine operation will not be monitored, the use of engine protective safety devices is required to prevent engine damage in the event of a problem.

Prepackaged generator engines mount several engine protective devices. These devices work in conjunction with a control circuit board, to protect the engine against such operating faults as (a) low engine oil pressure, (b) high temperature, (c) overspeed, and (d) overcrank. On occurrence of any one or more of those operating faults, control board action will effect an engine shutdown.

### LOW OIL PRESSURE SHUTDOWN

See Figure 1. Prepackaged generators with liquid cooled engine are equipped with an oil pressure switch having a closing pressure of about 10 psi. Should oil pressure drop below that value, an automatic engine shutdown will occur. Circuit operation is similar to that of air-cooled units.

### LOW FUEL PRESSURE (YELLOW LED INDICATOR)

The yellow low fuel pressure LED will turn ON if the fuel supply pressure drops below approximately five inches water column (i.e. occurs when the low fuel pressure sensing switch on the fuel regulator opens).

This is a non-latched fault (visual LED warning only) and does not trigger the controller alarm output. Low fuel pressure sensing is active in all generator operating modes (i.e. MANUAL, OFF and AUTO).

***LOW BATTERY***  
***(RED LED INDICATOR)***

The R-100 Controller continually monitors the battery voltage and turns on the low battery LED if the battery voltage falls below approximately 12 VDC for one minute. A low battery voltage is a non-latching alarm and will not shut down the engine, however, it is a possible indication of a potential issue with the battery or battery charger and should be investigated.

The low battery LED will automatically turn off if the battery voltage rises above approximately 12.5 VDC.

If the engine is running when the low battery condition occurs, the engine will continue to run as long as possible.

If the battery voltage drops below 6 VDC at any time during cranking, the crank cycle will be terminated and the low battery LED will remain lit. This is a latched fault and will shut down the engine.

***LOW OIL PRESSURE***  
***(RED LED INDICATOR)***

Occurs if the oil pressure switch closes while the engine is running after the 10 second hold off timer expires. This is a latched fault and will shutdown the engine.

***HIGH COOLANT TEMP/LOW COOLANT LEVEL***  
***(RED LED INDICATOR)***

Occurs if either the high coolant temp switch closes, or the low coolant level switch is in air. The two sensors are wired in parallel on the engine. Checks are made after the 10 second hold off timer expires. This is a latched fault and will shutdown the engine.

***OVERSPEED***  
***(RED LED INDICATOR):***

An overspeed shutdown will occur if the engine speed is greater than 4320 rpm for 3 seconds with a 3600 rpm engine or greater than 2160 rpm with an 1800 rpm engine. An Overspeed condition will shutdown the engine and activate the over speed LED. An immediate overspeed shutdown will occur if the engine speed is greater than 4500 rpm with a 3600 rpm engine or greater than 2250 rpm with an 1800 rpm engine.

***RPM SIGNAL FAILURE***  
***(FLASHING RED OVERSPEED INDICATOR)***

If the R-100 controller does not receive a signal from the engine crank or flywheel sensor, the R-100 controller cannot maintain the generator output frequency or monitor for an overspeed condition. If this signal is lost the R-100 controller will shut down the engine as follows:

***RPM SIGNAL FAILURE DURING CRANKING:***

The engine control board (R-100 controller) will monitor the engine speed signal during engine cranking.

If the control board does not see a valid signal within the first four seconds of each crank cycle it will stop the crank cycle, lock out on a shut down fault and flash the overspeed LED.

***RPM SIGNAL FAILURE DURING RUNNING:***

Running mode is handled differently because there is always the possibility the engine could slow down or stop running do to a temporary overload. To avoid shutting down and latching out on a temporary problem the following is done. If the engine is up and running, and the control board stops receiving a valid engine speed input signal it will respond as follows:

1. It will close the throttle.
2. It will shut down the engine by turning off the fuel supply.
3. It will wait for 15 seconds to ensure the engine has stopped.
4. It will then energize the starter and monitor the engine speed signal.
  - a. If the control board does not see the engine speed signal it will stop the crank cycle, lock out on fault, and flash the overspeed LED.
  - b. If the control board does see the engine speed input signal during cranking it will start and run the engine normally. If the engine speed signal is again lost while running it will repeat the above procedure one more time.
  - c. If the failure should repeat a third time, the control board will shut down the engine, lock out on fault, and flash the over speed LED.

***OVERCRANK***  
***(RED LED INDICATOR)***

Occurs if the engine has not started within the total 90 second crank cycle. This is a latched fault and will shutdown the engine.

***INVALID BOSCH ACTUATOR POSITION***  
***FEEDBACK (ALL RED LED'S ON SOLID)***

All five RED LED's on the front panel will be ON all the time if the Bosch Actuator is not in the CLOSED position when the unit is set to AUTO or MANUAL.

***ALARM CANCEL***

When the generator is shut down on a latched fault or latching alarm, the AUTO/OFF/MANUAL switch must be set to the OFF position to turn off the corresponding fault LED. Prior to moving the switch to the OFF position, record which LEDs are ON or FLASHING and the date on the back cover of this manual.

**CONTROL PANEL****GENERAL:**

See Figure 1 (Page 16). A typical prepackaged control panel on units with liquid cooled engine includes: (a) an auto-off-manual switch, (b) seven LED indicators, (c) a 15 amp fuse, and (d) a set exercise switch.

**AUTO-OFF-MANUAL SWITCH:**

Use this switch to (a) select fully automatic operation, (b) to crank and start the engine manually, and (c) to shut the unit down or to prevent automatic startup.

**1. AUTO position:**

- a. Select AUTO for fully automatic operation.
- b. When AUTO is selected, circuit board will monitor utility power source voltage.
- c. Should utility voltage drop below a preset level and remain at such a low level for a preset time, circuit board action will initiate engine cranking and startup.
- d. Following engine startup, circuit board action will initiate transfer of electrical loads to the "Standby" source side.
- e. On restoration of utility source voltage above a preset level, circuit board action will initiate retransfer back to the "Utility Source" side.
- f. Following retransfer, circuit board will shut the engine down and will then continue to monitor utility source voltage.

**2. OFF Position:**

- a. Set the switch to OFF to stop an operating engine.
- b. To prevent an automatic startup from occurring, set the switch to OFF.

**3. MANUAL Position:**

- a. Set switch to MANUAL to crank and start unit manually.
- b. Engine will crank cyclically and start (same as automatic startup, but without transfer). The unit will not transfer if utility voltage is not available.



**DANGER: WHEN THE GENERATOR IS INSTALLED IN CONJUNCTION WITH AN AUTOMATIC TRANSFER SWITCH, ENGINE CRANKING AND STARTUP CAN OCCUR AT ANY TIME WITHOUT WARNING (PROVIDING THE AUTO-OFF-MANUAL SWITCH IS SET TO AUTO). TO PREVENT AUTOMATIC STARTUP AND POSSIBLE INJURY THAT MIGHT BE CAUSED BY SUCH STARTUP, ALWAYS SET THE AUTO-OFF-MANUAL SWITCH TO ITS OFF POSITION BEFORE WORKING ON OR AROUND THIS EQUIPMENT.**

**LED INDICATORS:**

The seven LED indicators are labelled as follows (see Figure 1, next page):

System Ready	Green LED
Low Fuel Pressure	Yellow LED
Low Battery	Red LED
Low Oil Pressure	Red LED
Hi Coolant Temp/Low Coolant Level	Red LED
Over Speed/RPM Sensor Loss	Red LED
Over Crank	Red LED

**15 AMP FUSE:**

This fuse protects the DC control system, including the control board, against overload. If the fuse has blown, engine cranking and running will not be possible. Should fuse replacement become necessary, use only an identical 15 amp replacement fuse.

**THE SET EXERCISE SWITCH:**

Use this switch to select the time and day for system exercise.

**TO SELECT AUTOMATIC OPERATION**

The following procedure applies to those installations in which the prepackaged home standby generator is installed in conjunction with a prepackaged transfer switch. Prepackaged transfer switches do not have an intelligence circuit of their own. Instead, automatic operation on prepackaged transfer switch and generator combinations is controlled by a control circuit board housed in the generator.

To select automatic operation when a prepackaged transfer switch is installed along with a prepackaged home standby generator, proceed as follows:

1. Check that the prepackaged transfer switch main contacts are at their "Utility" position, i.e., the load is connected to the utility power supply. If necessary, manually actuate the switch main contacts to their "Utility" source side. See Part 3 of this manual for instructions.
2. Check that utility source voltage is available to transfer switch Terminal Lugs N1 and N2 (2-pole, 1-phase transfer switches).
3. Set the generator's AUTO-OFF-MANUAL switch to its AUTO position.
4. Actuate the generator's main line circuit breaker to its ON or "Closed" position. With the preceding Steps 1 through 4 completed, a dropout in utility supply voltage below a preset level will result in automatic generator cranking and start-up. Following startup, the prepackaged transfer switch will be actuated to its "Standby" source side, i.e., loads powered by the standby generator.

**MANUAL TRANSFER TO "STANDBY" AND  
MANUAL STARTUP**

To transfer electrical loads to the "Standby" (generator) source and start the generator manually, proceed as follows:

1. On the generator panel, set the AUTO-OFF-MANUAL switch to OFF.
2. On the generator, set the main line circuit breaker to its OFF or "Open" position.
3. Turn OFF the utility power supply to the transfer switch, using whatever means provided (such as a utility-source line circuit breaker).
4. Manually actuate the transfer switch main contacts to their "Standby" position, i.e., loads connected to the "Standby" power source side.
5. On the generator panel, set the AUTO-OFF-MANUAL switch to MANUAL. The engine should crank and start.
6. Let the engine warm up and stabilize for a minute or two at no-load.
7. Set the generator's main line circuit breaker to its ON or "Closed" position. The generator now powers the electrical loads.

**MANUAL SHUTDOWN AND RETRANSFER  
BACK TO "UTILITY"**

To shut the generator down and retransfer electrical loads back to the "Utility" position, proceed as follows:

1. Set the generator's main line circuit breaker to its OFF or "Open" position.
2. Let the generator run at no-load for a few minutes,

to cool.

3. Set the generator's AUTO-OFF-MANUAL switch to OFF. Wait for the engine to come to a complete stop.
4. Turn OFF the "Utility" power supply to the transfer switch using whatever means provided (such as a "Utility" source main line circuit breaker)
5. Manually actuate the prepackaged transfer switch to its "Utility" power source side, i.e., "Load" connected to the "Utility" source.
6. Turn ON the "Utility" power supply to the transfer switch, using whatever means provided.
7. Set the generator's AUTO-OFF-MANUAL switch to AUTO.

**THE SET EXERCISE TIME SWITCH**

The 3.9 liter home standby generator with an R-100 control panel will start and exercise once every seven (7) days, on a day and at a time of day selected by the owner or operator. The set exercise time switch is provided to select the day and time of day for system exercise. On units with a GTS type switch exercise is controlled via the GTS switch.

See Part 5, Section 5.2 ("The 7-Day Exercise Cycle") for instructions on how to set exercise time.



**DANGER: THE GENERATOR WILL CRANK AND START WHEN THE SET EXERCISE TIME SWITCH IS SET TO "ON". DO NOT ACTUATE THE SWITCH TO "ON" UNTIL AFTER YOU HAVE READ THE INSTRUCTIONS IN SECTION 1.6.**

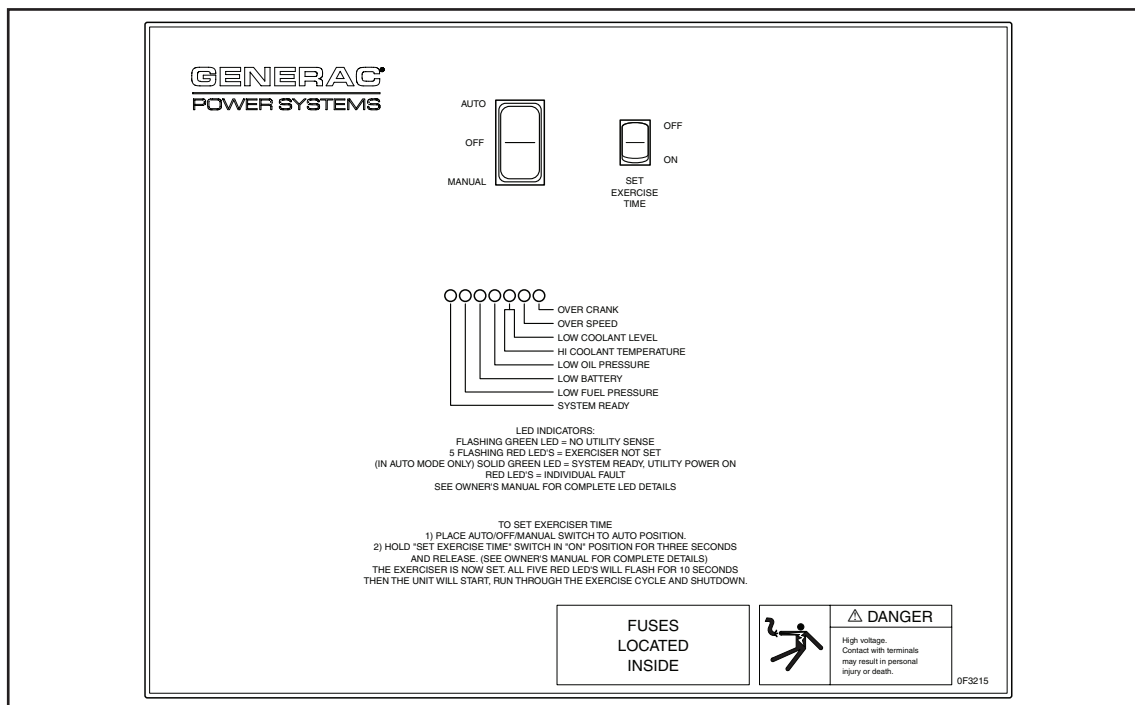

Figure 1. Control Panel

## INTRODUCTION

When the R-100 control panel is installed in conjunction with an RTS transfer switch, either manual or automatic operation is possible. Manual transfer and engine startup, as well as manual shutdown and retransfer are covered in section 1.7. Selection of fully automatic operation is also discussed in that section. This section will provide a step-by-step description of the sequence of events that will occur during automatic operation of the system.

On units with a GTS type switch sensing and exercise are performed at the transfer switch.

## AUTOMATIC OPERATING SEQUENCES (FOR RTS)

### PHASE 1 - UTILITY VOLTAGE AVAILABLE:

With utility source voltage available to the transfer switch, that source voltage is sensed by a control board in the generator panel and the circuit board takes no action.

Electrical loads are powered by the "Utility" source and the AUTO-OFF-MANUAL switch is set to AUTO.

### PHASE 2 - UTILITY VOLTAGE DROPOUT:

If a dropout in utility source voltage should occur below about 60 percent of the nominal utility source voltage, a 15 second timer on the control board will start timing. This timer is required to prevent false generator starts that might be caused by transient utility voltage dips.

### PHASE 3 - ENGINE CRANKING:

When the control board's 15 second timer has finished timing and if utility source voltage is still below 60 percent of the nominal source voltage, control board action will energize a crank relay and a run relay. Both of these relays are mounted in the control panel.

Control board action will hold the crank relay energized for about 7-9 seconds. The relay will then be de-energized for about 7-9 seconds, energized again for 7-9 seconds, and so on. When the crank relay energizes the engine will crank, when it is de-energized, engine cranking will stop. This cyclic action of crank/rest, crank/rest, etc., will continue until either (a) the engine starts, or (b) until ninety (90) seconds have elapsed.

If the engine has not started within ninety (90) seconds, cranking will terminate and shutdown will occur. On liquid cooled engine units, LED indicators on the generator panel will illuminate.

If the engine starts, cranking will terminate when generator AC output frequency reaches approximately 30 Hz.

### PHASE 4 - ENGINE STARTUP AND RUNNING:

The control board senses that the engine is running by receiving a speed frequency signal from the generator magnetic pickup.

When generator AC frequency reaches approximately 30 Hz, an engine warm-up timer on the control board turns on. That timer will run for about fifteen (15) seconds. At the same time, an engine minimum run timer will turn on.

The engine warm-up timer lets the engine warm-up and stabilize before transfer to the "Standby" source can occur.

The engine minimum run timer prevents a cold engine from being shut down, as might happen if utility source power is restored very quickly. The minimum run timer will run for about 10-12 minutes. That means the engine must run for 10-12 minutes before it can be shut down automatically.

***NOTE: The engine can be shut down manually at any time, by setting the AUTO-OFF-MANUAL switch to OFF.***

### PHASE 5 - TRANSFER TO "STANDBY":

When the control board's engine warm-up timer has timed out, control board action completes a transfer relay circuit to ground. The transfer relay is housed in the prepackaged transfer switch enclosure.

The transfer relay energizes and transfer of loads to the "Standby" power source occurs. Loads are now powered by standby generator AC output.

### PHASE 6 - "UTILITY" POWER RESTORED:

When utility source voltage is restored above about 80 percent of the nominal supply voltage, a fifteen (15) second timer on the control board starts timing. If utility voltage remains sufficiently high at the end of fifteen (15) seconds, a "retransfer time delay" will start timing and will time for about six (6) seconds.

### PHASE 7 - RETRANSFER BACK TO "UTILITY":

When the retransfer time delay has finished timing, control board action will open a circuit to a transfer relay (housed in the transfer switch). The transfer relay will then de-energize and retransfer back to the "Utility" source will occur. Loads are now powered by "Utility" source power. On retransfer, an "engine cool-down timer" starts timing and will run for about one (1) minute.

### PHASE 8 - GENERATOR SHUTDOWN:

When the engine cool-down timer has finished timing, and if the minimum run timer has timed out, engine shutdown will occur.

**SECTION 1.7**  
**AUTOMATIC OPERATING PARAMETERS**

**PART 1**

GENERAL INFORMATION

***AUTOMATIC OPERATING SEQUENCES CHART***

SEQ.	CONDITION	ACTION	SENSOR, TIMER OR OTHER
1	“Utility” source voltage is available.	No action	Voltage Dropout Sensor on control circuit board.
2	“Utility” voltage dropout below 60% of rated voltage occurs.	A 6-second timer on control board turns on.	Voltage Dropout Sensor and 6 second timer on control board.
3	“Utility” voltage is still below 60% of rated voltage.	6-second timer runs for 6 seconds, then stops.	Voltage Dropout Sensor and 6 second timer.
4	“Utility” voltage is still low after 6 seconds.	Control board action energizes a crank relay and a run relay. The engine cranks for 7-9 seconds, rests for 7-9 seconds, and so on until engine starts. See NOTE 1.	Control board crank and run relays.
5	“Utility” voltage still low and the engine has started.	Control board’s “engine warmup timer” and “engine minimum run timer” both turn on.	Engine Warmup Timer (15 seconds) Minimum Run Timer (13 minutes)
6	Engine running and “engine warmup timer” times out.	Control board action energizes a transfer relay in transfer switch and transfer to “Standby” occurs.	Control board transfer relay circuit Transfer switch transfer relay.
7	Engine running and load is powered by “Standby” power.	No further action	Control board’s “voltage pickup sensor” continues to seek an acceptable “Utility voltage.
8	“Utility” source voltage is restored above 80% of rated source voltage.	Control board’s “voltage pickup sensor” reacts and a “return to utility timer” turns on.	Voltage Pickup Sensor (80%) Return to Utility Timer (10 seconds)
9	“Utility voltage still high after 6 seconds.	“Return to utility timer” times out	Return to Utility Timer
10	“Utility” voltage still high.	Control board action opens the transfer relay circuit to ground. Transfer relay de-energizes and retransfer to “Utility” occurs.	Control board transfer relay circuit Transfer switch transfer relay.
11	Engine still running, loads are powered by “Utility” source.	Control board’s “engine cooldown timer” starts running.	control board’s Engine Cooldown Timer (1 minute)
12		After 1 minute, “engine cooldown timer” stops and control board’s run relay de-energizes. Engine shuts down.	Engine Cooldown Timer control board Run Relay.
13	Engine is shut down, loads are powered by “Utility” source. Return to Sequence 1.	No action.	Voltage Dropout Sensor on control circuit board.

**Note 1: In Sequence 4, if engine has not started in 90 seconds cranking will end and shutdown will occur.**

# PART 2 PREPACKAGED LIQUID-COOLED AC GENERATORS

## 3.9 LITER PREPACKAGED HOME STANDBY GENERATORS

TEST	DESCRIPTION .....	PAGE
1	Check Voltage Regulator Lamps .....	31
2	Measure Resistance of Sensing Circuit .....	31
3	Test Insulation Resistance of Sensing Circuit ....	32
4	Measure Stator Sensing Wire Resistance .....	32
5	Measure Stator Winding Resistance .....	32
6	Test Continuity of Sensing Wires to Voltage Regulator (AVR) .....	32
7	Check Position of AVR STD/PM Switch .....	33
8	Check Main Circuit Breaker .....	33
9	Measure Resistance of Field Circuit at AVR .....	33
11	Measure Resistance of Field Circuit at Terminal Strip (TB1) .....	33
12	Check Resistance of Field at Slip Rings .....	34

<b>TABLE OF CONTENTS</b>		
PART	TITLE	PAGE
<b>2.1</b>	<b>Description and Major Components</b>	<b>20</b>
<b>2.2</b>	<b>AC Output Operational Analysis</b>	<b>26</b>
<b>2.3</b>	<b>AC Output Troubleshooting Flow Charts</b>	<b>28</b>
	Problem 1 - Generator Produces Zero Voltage or Residual Voltage	28
	Problem 2 - Loss of Excitation	29
<b>2.2</b>	<b>AC Output Diagnostic Tests</b>	<b>31</b>
<b>2.5</b>	<b>Automatic Voltage Regulator</b>	<b>37</b>

TEST	DESCRIPTION .....	PAGE
13	Check Resistance of Field at Brushes .....	34
14	Check Field Flash Diode Condition .....	34
15	Check Field Flash Diode in Bridge Rectifier (BR1) .....	34
16	Check Resistance of Wire 4 .....	34
17	Check Resistance of Wire 1 .....	34
18	Check Resistance of Excitation Circuit at AVR ..	35
19	Check Resistance of Excitation Circuit at TB1 ...	35
20	Check Resistance of Wire 162 .....	35
21	Check Resistance of DPE Breaker .....	35
22	Check Insulation Resistance of Field Circuit .....	35
23	Check Insulation Resistance of Excitation Circuit .....	35

### ***INTRODUCTION***

This section covers the major components of the AC generator proper, i.e., those generator assemblies that provide for the production of AC electrical power.

The single bearing rotor (revolving field) is driven by a 3.9 liter, liquid cooled gas engine. The rotor is coupled to the engine flywheel, by means of a flexible coupling and a fan and ring gear assembly, so the engine crankshaft and rotor operate at the same speed.

Major components of the AC generator are shown in Figure 1 on the next page. These components are (a) a flexible coupling, (b) fan and ring gear, (c) rotor, (d) engine adaptor, (e) stator assembly, (f) rear bearing carrier, and (g) a rear bearing carrier cover.

### ***ENGINE ADAPTOR***

The engine adaptor is bolted to the engine and supports the engine end of the AC generator.

### ***FLEXIBLE DISK***

A flexible disk bolts to the engine flywheel and to the fan and ring gear assembly. The disk maintains proper alignment between the engine and generator parts.

### ***FAN AND RING GEAR ASSEMBLY***

The fan and ring gear assembly are retained to the flexible disk which, in turn, is retained to the engine flywheel. The fan draws cooling air into the generator interior through slots in a rear bearing carrier cover, then expels the heated air outward through a screen on the engine adaptor. The ring gear teeth mate with teeth on a starter motor pinion gear, when the engine is cranked.

### ***ROTOR ASSEMBLY***

The rotor assembly on units rated 1800 rpm is a 4-pole type, having two north magnetic poles and two south magnetic poles.

The rear end of the rotor is bolted and keyed to the fan and ring gear. A ball bearing has been pressed onto the rotor's front shaft, which is retained, in a machined bore in the rear bearing carrier.

A positive (+) and a negative (-) slip ring is provided on the rotor shaft that retains the ball bearing. Brushes will ride on these slip rings.

The combination of slip rings and brushes allow rotor excitation current to be transmitted from stationary components into the rotating rotor windings. The positive (+) slip ring is the one nearest the rotor bearing.

### ***REAR BEARING CARRIER***

The rear bearing carrier supports the front of the generator. Mounting feet at the carrier bottom permit the carrier to be bolted to the generator's mounting base. A machined bore, in the center of the carrier, accepts the rotor bearing. Bosses allow for the retention of brush holders. Long stator bolts pass through holes in the carrier's outer periphery, to sandwich and retain the stator can between the carrier and the engine adaptor. A rear bearing carrier gasket helps prevent dust from entering the bearing area.

### ***STATOR ASSEMBLY***

The stator can is sandwiched between the engine adaptor and the rear bearing carrier, and retained in that position by four (4) stator bolts.

A notched cutout has been provided in the rear bearing carrier end of the stator can.

### ***REAR BEARING CARRIER PLATE***

This plate is retained to the rear bearing carrier by four (4) capscrews, lockwashers and flatwashers. The plate provides slotted air inlet openings for the passage of cooling and ventilating air into the generator.

### ***BRUSH HOLDERS AND BRUSHES***

Brushes are retained in a brush holder which is retained to drilled and threaded bosses on the rear bearing carrier. In most cases, two brush holders are used having two brushes per holder. Brush holders are precisely positioned so that one of the two brushes slides on a positive (+) slip ring, the other on a negative (-) slip ring. The positive (+) side of the DC excitation circuit (Wire No. 4, red) connects to the positive (+) brush; the negative (-) or grounded side (Wire No. 0) to the negative (-) brush. Brushes and brush holders are illustrated in Figure 2, on Page 22.

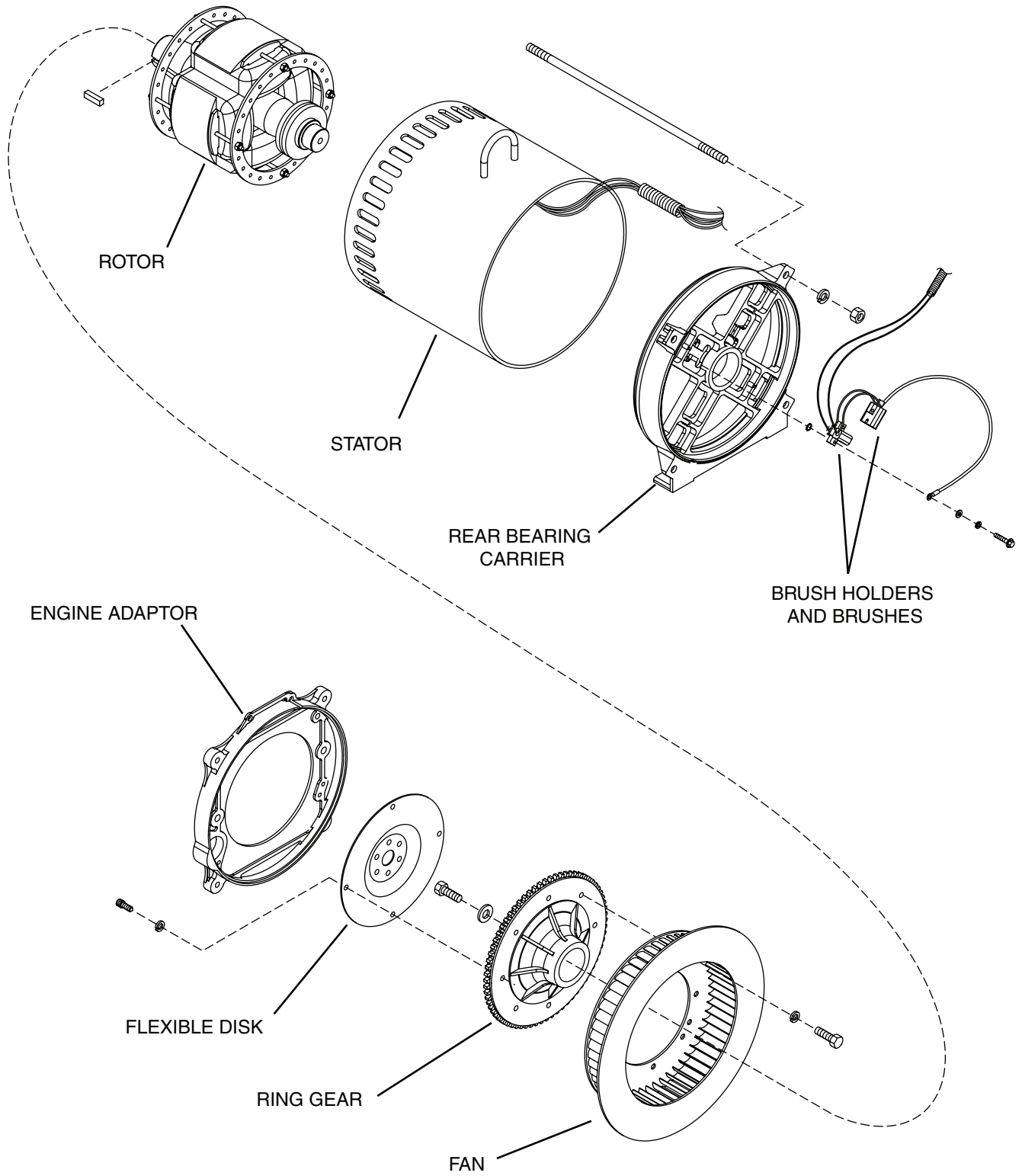

Figure 1. Generator Major Components

## SECTION 2.1 DESCRIPTION AND MAJOR COMPONENTS

### PART 2

PREPACKAGED LIQUID  
COOLED AC GENERATORS

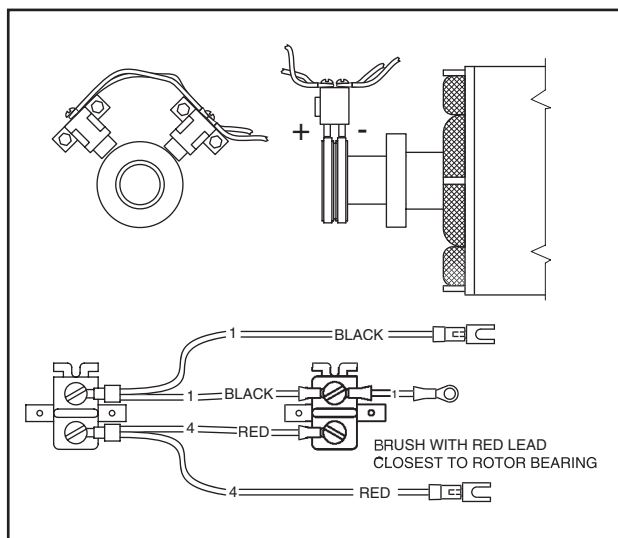

Figure 2. Brush Holders and Brushes

### THE EXCITATION CIRCUIT

AC output from the stator excitation (DPE) winding is delivered to the voltage regulator, via a thermal protector (TP), Wire No. 2, an excitation circuit breaker (CB1), Wire No. 162, and Wire No. 6. This is "unregulated" excitation current.

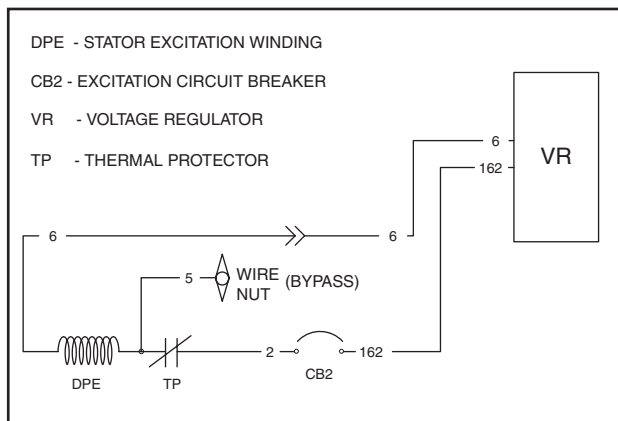

Figure 3. Schematic - Excitation Circuit

### THERMAL PROTECTOR:

This normally closed thermal switch protects the stator windings against excessively high internal temperatures. The switch is physically imbedded in the stator windings and electrically connected in series with the DPE winding AC output to the regulator. If internal stator temperatures exceed a safe value, the switch contacts will open and the DPE output to the voltage regulator will be terminated. Without excitation current flow to the rotor, generator AC output voltage will drop to a value commensurate with rotor residual magnetism.

The thermal protector is self-resetting. That is, when internal stator temperatures drop to a safe value, its contacts will re-close and normal DPE output to the regulator will resume.

Wire No. 5 is a thermal protector "bypass" lead. If the thermal switch has failed in its open position, it can be bypassed. The Wire No. 5 bypass lead is brought out of the stator and has a wire nut on its end.

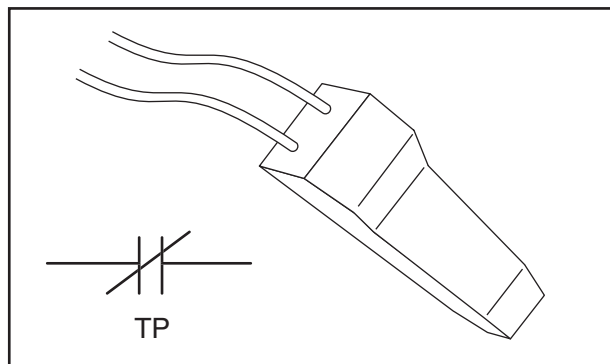

Figure 4. The Thermal Protector

### EXCITATION CIRCUIT BREAKER:

This circuit breaker protects the regulator against high voltage surges. If the breaker has tripped open, loss of excitation current will occur. Stator power winding AC output voltage will then drop to a value commensurate with residual magnetism in the rotor. The breaker is self-resetting.

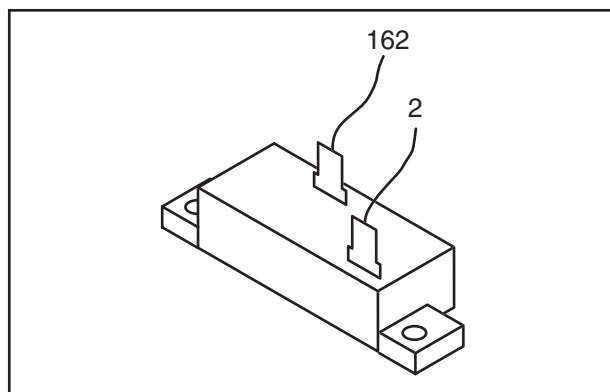

Figure 5. Excitation Circuit Breaker

### SENSING WIRES

These wires deliver stator power winding AC voltage and frequency signals to the voltage regulator. Depending on the voltage and phase of the unit, these wires can be numbered in different ways. In order to properly identify the wires on the unit being serviced, it is essential to know the phase and voltage of the unit. Refer to Figure 6 for proper identification.

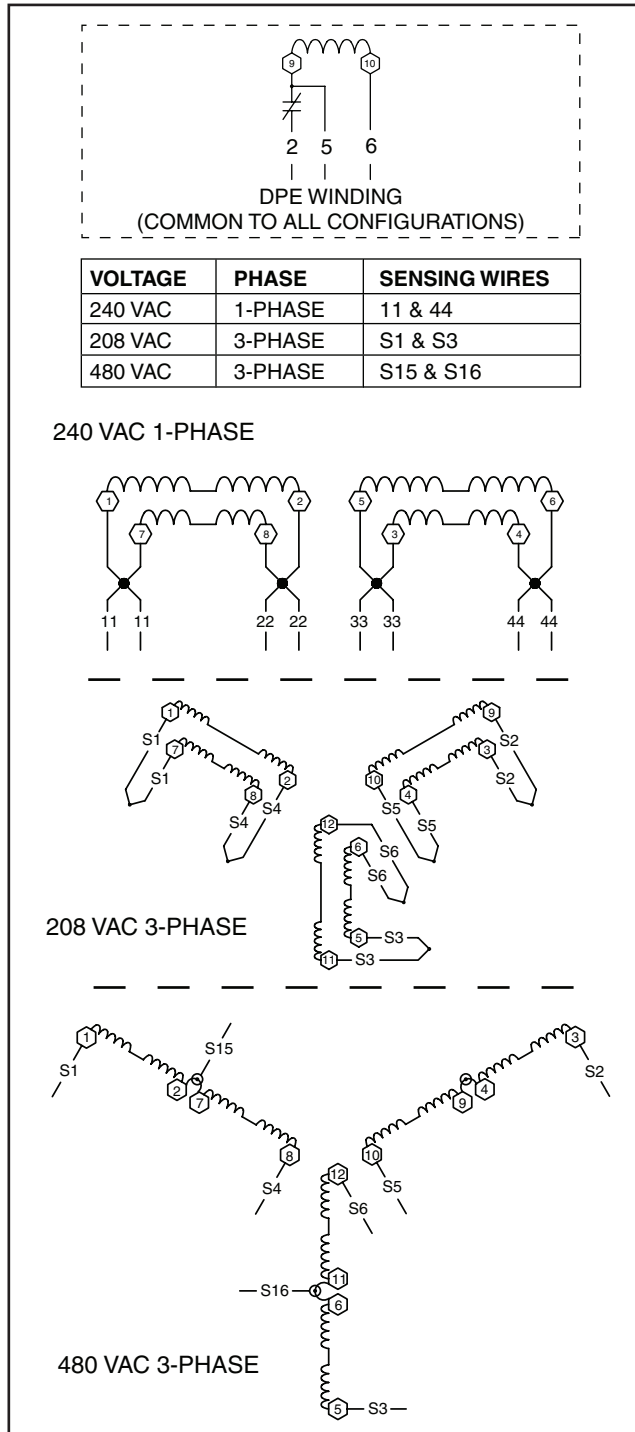

Figure 6. Sensing Wire Identification

**VOLTAGE REGULATOR**

See Figure 7. Unregulated AC output from the stator DPE winding is delivered to the voltage regulator, via Wires No. 6 and 162. Stator power winding AC voltage and frequency signals are delivered to the regulator, via the sensing wires. The regulator rectifies the DPE output and, based on the sensing lead signals, regulates the DC current output. An LED (light emitting

diode) is incorporated on the regulator. This yellow light senses the "sensing" input.

The voltage regulator is equipped with three lamps (LED's). These lamps are (a) a red "Regulator" lamp, (b) a yellow "Sensing" lamp, and (c) a green "Excitation" lamp. During normal operation with no faults in the system, all three lamps should be ON.

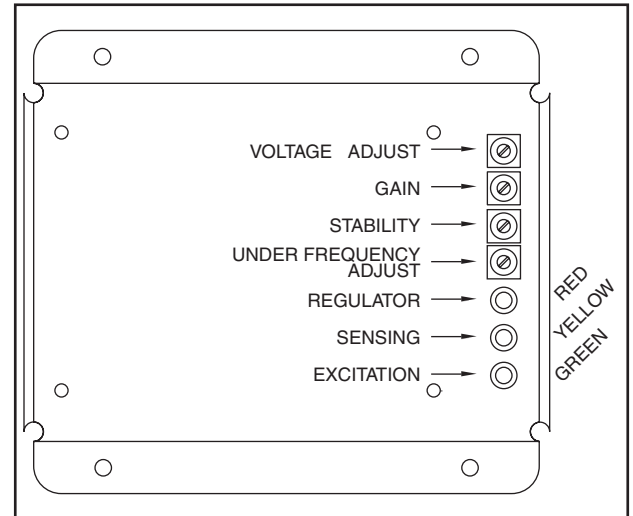

Figure 7. The AC Voltage Regulator

The voltage regulator is powered by stator excitation (DPE) winding output, with approximately 4 to 8 volts required to turn the regulator on.

The green "Excitation" lamp and the red "Regulator" lamp are both powered by excitation winding output. If excitation winding output is gradually reduced, these two lamps will begin to dim until, at some midpoint voltage and current, the lamps will no longer glow visibly. Depending on the specific generator model, excitation (DPE) voltage may be about 40-240 volts RMS.

The yellow "Sensing" lamp is powered by sensing input to the regulator from the stator AC power windings. The brightness of this lamp will depend on the available sensing voltage. Sensing input to the regulator is approximately 190-240 volts RMS, depending on the specific generator.

The following factors apply to voltage regulator operation:

1. The voltage regulator will shut down on occurrence of any one or more of the following conditions:
  - a. Loss of sensing voltage to the regulator.
  - b. Loss of excitation (DPE) voltage input to the regulator.
  - c. Loss of circuit reference.

**NOTE:** The term "circuit reference" refers to voltage regulator settings. The regulator "regulates" excitation (DPE) winding current flow to the rotor (field) in order to maintain a sensing voltage that is commensurate with a preset "reference" voltage. That is, the regulator seeks to maintain a sensing (actual) voltage that is the same as a "reference" voltage. Regulator "reference" volt-

## SECTION 2.1

### DESCRIPTION AND MAJOR COMPONENTS

## PART 2

PREPACKAGED LIQUID  
COOLED AC GENERATORS

*age is adjustable within a 20 percent range at the regulator.*

2. During generator operation, all three lamps (LED's) should be ON.
  - a. "Regulator" lamp ON indicates the regulator is operating normally.
  - b. "Sensing" lamp ON indicates that sensing voltage is available to the regulator.
  - c. "Excitation" lamp ON indicates that unregulated excitation (DPE) current is available to the regulator.
3. If the red "Regulator" lamp goes OUT, a voltage regulator fault exists or the regulator has shut down due to occurrence of one or more shutdown conditions.
  - a. Expect to see a generator AC output voltage that is commensurate with rotor residual magnetism plus the magnetism produced by field boost.
  - b. Residual plus field boost magnetism will provide approximately one-half the unit's rated voltage.
4. If the green "Excitation" lamp goes out, loss of excitation (DPE) winding output to the regulator has occurred.
  - a. Loss of excitation (DPE) output to the regulator will result in regulator shutdown and the red "Regulator" lamp will also turn on.
  - b. If the red "Regulator" and the green "Excitation" lamps are both OUT, look for an AC output voltage that is commensurate with residual plus field boost magnetism.
5. If the yellow "Sensing" lamp goes out, loss of sensing to the regulator has occurred.
  - a. Loss of sensing may cause the regulator to shut down.
  - b. On regulator shutdown, both the "Regulator" and the "Sensing" lamps will be OUT.
  - c. Look for a generator output voltage that is the result of residual plus field boost magnetism.
6. If all three of the lamps go out, look for a fault that can cause both sensing and excitation to fail.
  - a. Look for faulty slip rings, brushes, rotor, etc.
  - b. Look for a fault in the regulator to rotor circuit.
7. If the red "Regulator" lamp is flashing, "Stability" probably requires adjustment.

An open condition in the sensing leads to the regulator (see Sensing Wires in this section) tends to create a "full field" condition. This occurs because the regulator tries to bring the sensing voltage up to an equal value with the "reference" voltage setting, by increasing regulated excitation current to the rotor. However, regulator shutdown occurs on loss of sensing voltage. This, in turn, causes loss of excitation current to the rotor. The generator's AC output voltage will then become commensurate with rotor residual magnetism plus field boost magnetism, about one-half rated voltage.

If the yellow LED goes "out", sensing signals to the regulator have been lost. The following rules apply:

- Loss of sensing can be caused by an "open" circuit condition in sensing the leads. Thus, if the yellow LED is out, it may be assumed that an open circuit exists in the sensing circuit.
- Loss of sensing to the regulator will usually result in a "full field" condition and resultant high voltage output from stator AC power winding. The maximum voltage that regulator action can deliver is limited by a "clamming" action on the part of the regulator.
- A complete open circuit condition in the stator AC power windings will cause loss of sensing voltage and frequency. However, this will result in a zero voltage output from the stator windings.

Based on the "sensing" signals, the regulator delivers direct current (DC) to the rotor, via Wire No. 4 and the positive (+) brush and slip ring. This regulated current flows through the rotor and to frame ground, via the negative (-) slip ring and brush and Wire No. 1. The following apply:

- The concentration of magnetic flux lines around the rotor will be proportional to the regulated excitation current flow through the rotor plus any residual magnetism.
- An increase in excitation current flow through the rotor windings will increase the concentration of "magnetic flux" lines around the rotor which, in turn, will increase the AC voltage induced into the stator AC power windings.

**FIELD BOOST**

See Figure 8. The prepackaged system provides a “field boost” feature. Field boost, in effect, “flashes the field” whenever the engine is running to ensure an early “pickup voltage” in the stator windings.

A field boost diode and a field boost resistor are installed in the control panel. Field boost DC output to the rotor is reduced by the field boost resistor.

Manual and automatic cranking is initiated by PCB board action, when that board energizes the run relay (RL2). When the relay is energized, battery voltage is delivered across its closed contacts and to the rotor, via a field boost resistor (R0), field boost diode (BR1), and Wire No. 4.

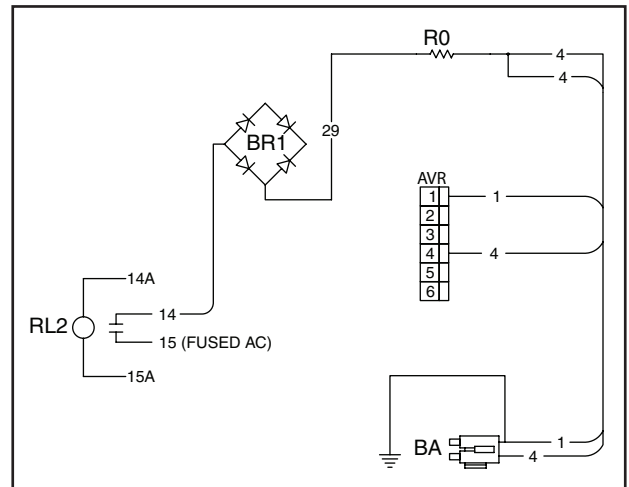

Figure 8. The Field Boost Circuit  
(from Schematic Drawing #0F4277)

Voltage Regulator Design Specifications	
Response	Less than one (1) cycle
Temperature tracking (32°-120° F)	0.41 percent
Temperature drift	Less than 1% for each 40° C change
Steady state regulation	0.75% RMS conditionally
Droop (voltage over frequency)	0-4 volts per Hertz Selectable start 52-62 Hz (underfrequency pot) Rate 4/8 volts per Hz (jumper select)
Maximum output current to field	100 amps @ 1 cycle peal 10 amps at 50° C continuous 20 amp one minute forcing
Regulator turn on	4 volts RMS from DPE windings
SCR control	Pulse with modulation
Maximum DPE energy	93%
Startup overshoot	10% conditionally
Startup voltage time	1 second
Stability (100 amp, 0.8 PF)	0% oscillation
LED indicators	Excitation ON (green) lamp SCR firing signal (red) lamp Sensing voltage present (yellow) lamp
Excitation voltage	40-420 volts RMS
Sensing input to regulator	1-Phase, 190-240 volts RMS
Field flash (field boost)	On continuously
Regulator shutdown conditions	Loss of sensing voltage Loss of excitation voltage Loss of circuit reference

**MAGNETISM**

Although magnetism is invisible, some of the effects it produces can be clearly seen. The behavior patterns of magnetism have been studied. It is the application of these behavior patterns that has led to the development of generators, motors, relays, transformers, coils, etc.

Magnetism can be used to produce electricity. Conversely, electricity can produce magnetism. Because of the relationship between magnetism and electricity, a study of one should include a study of the other. The following facts are known about magnetism:

- Lines of magnetic force called "flux", are directed away from the north pole of a magnet, travel in a loop, and re-enter the magnet at its south pole.
- Lines of flux form definite patterns which vary in density according to the strength of the magnet.
- Lines of flux never cross one another.
- The area surrounding a magnet in which its lines of magnetic flux can be felt is called a "magnetic field".

**ELECTROMAGNETISM**

Current carrying electrical conductors are surrounded by a magnetic field which is at right angles to the conductor. When current flow through the conductor increases, the number of lines of flux increase proportionally. That is, the strength of the magnetic field increases when current flow increases. The magnetic field is distributed along the entire length of the conductor.

**ELECTROMAGNETIC INDUCTION**

When a conductor is moved so that it passes through a magnetic field, an electromotive force (EMF or voltage) is created in the conductor. If the magnetic field is moved so that it cuts across the conductor, an EMF or voltage will also be created in the conductor. This is the basic principle that allows a generator to produce electricity.

Figure 3 shows a simple revolving field generator. A permanent magnet rotates so that its lines of flux cut across a coil of wires called a stator. As the north pole of the magnet passes the stator windings, a voltage is induced into the stator and current will flow in one direction through the light bulb (called the "load"). As the north pole passes the stator, voltage and current will drop to zero. When the magnet's south pole pass the stator, current flow increases in the opposite direction. Magnet rotation causes this cycle to continue, with current flow reversing direction at the passage of each north and south pole. This constant reversal of current is called "alternating current" or "AC".

The flow of electrical current through a conductor in one direction followed by its reversal and flow in the opposite direction is called a "cycle" or "1 Hertz".

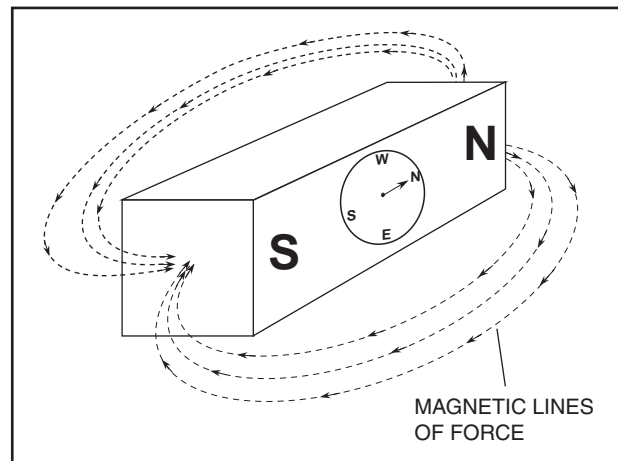

Figure 1. Magnetic Lines of Flux

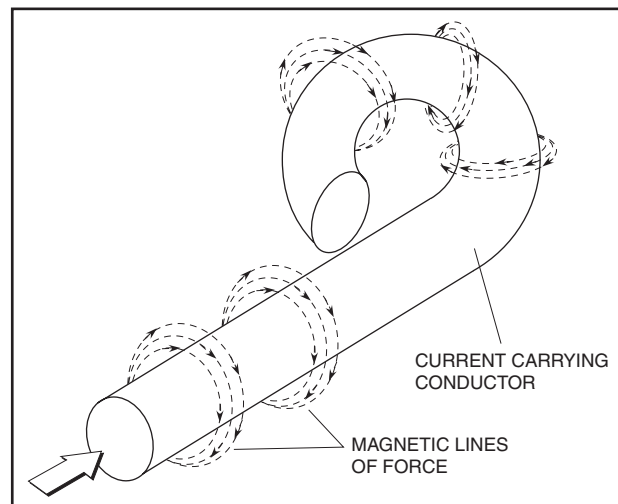

Figure 2 - Magnetism Around a Conductor

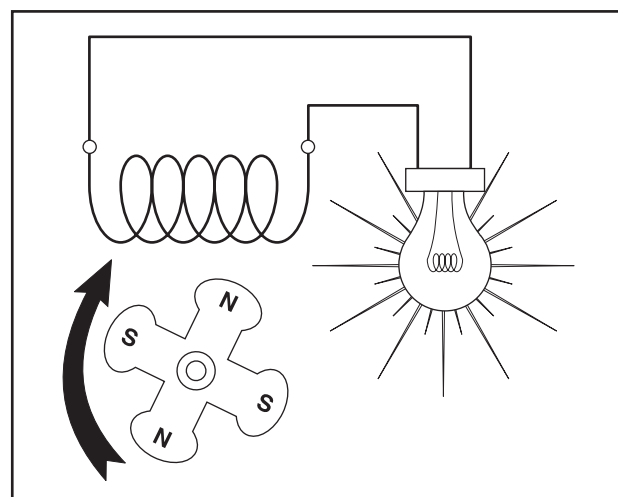

Figure 3 - A Simple Revolving Field Generator

**GENERATOR OPERATION**

**STARTUP:**

When the engine is started, residual plus field boost magnetism from the rotor induces a voltage into the stator AC power windings and the stator excitation or DPE windings. In an "on-speed" condition, residual plus field boost magnetism are capable of creating approximately one-half the unit's rated voltage.

**ON-SPEED OPERATION:**

As the engine accelerates, the voltage that is induced into the stator windings increases rapidly, due to the increasing speed at which the rotor operates.

**FIELD EXCITATION:**

An AC voltage is induced into the stator excitation (DPE) windings. The DPE winding circuit is completed to the voltage regulator, via Wire 2, excitation circuit breaker, Wire 162, and Wire 6. Unregulated alternating current can flow from the winding to the regulator. If excitation voltage is present at the voltage regulator, the green excitation LED will be lit.

The voltage regulator "senses" AC power winding output voltage and frequency via the stator sensing wires.

The regulator changes the AC from the excitation winding to DC. In addition, based on the sensing signals, it regulates the flow of direct current to the rotor.

The rectified and regulated current flow from the regulator is delivered to the rotor windings, via Wire 4, and the positive brush and slip ring. This excitation current

flows through the rotor windings and is directed to ground through the negative (-) slip ring and brush, and Wire 1.

The greater the current flow through the rotor windings, the more concentrated the lines of flux around the rotor become.

The more concentrated the lines of flux around the rotor that cut across the stationary stator windings, the greater the voltage that is induced into the stator windings.

Initially, the AC power winding voltage sensed by the regulator is low. The regulator reacts by increasing the flow of excitation current to the rotor until voltage increases to a desired level. The regulator then maintains the desired voltage. For example, if voltage exceeds the desired level, the regulator will decrease the flow of excitation current. Conversely, if voltage drops below the desired level, the regulator responds by increasing the flow of excitation current.

**AC POWER WINDING OUTPUT:**

A regulated voltage is induced into the stator AC power windings. When electrical loads are connected across the AC power windings to complete the circuit, current can flow in the circuit. The regulated AC power winding output voltage will be in direct proportion to the AC frequency. For example, on units rated 120/240 volts at 60 Hz, the regulator will try to maintain 240 volts (line-to-line) at 60 Hz. This type of regulation system provides greatly improved motor starting capability over other types of systems.

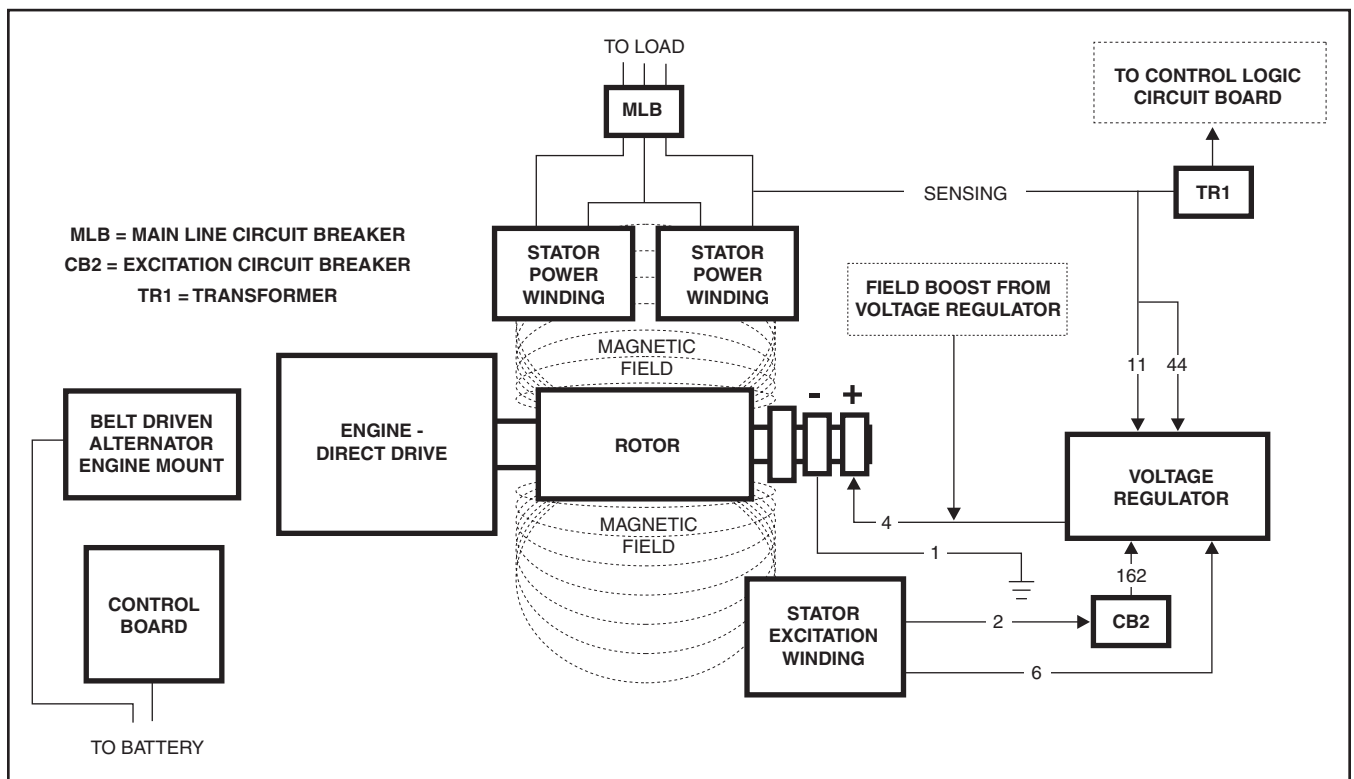

Figure 4. Operating Diagram of AC Generator

# SECTION 2.3 TROUBLESHOOTING FLOW CHARTS

Use the "Flow Charts" in conjunction with the detailed instructions in Section 2.4. Test numbers used in the flow charts correspond to the numbered tests in Section 2.4.

The first step in using the flow charts is to correctly identify the problem. Once that has been done, locate the problem on the following pages. For best results, perform all tests in the exact sequence shown in the flow charts.

## Problem 1 - Generator Produces Zero Voltage or Residual Voltage

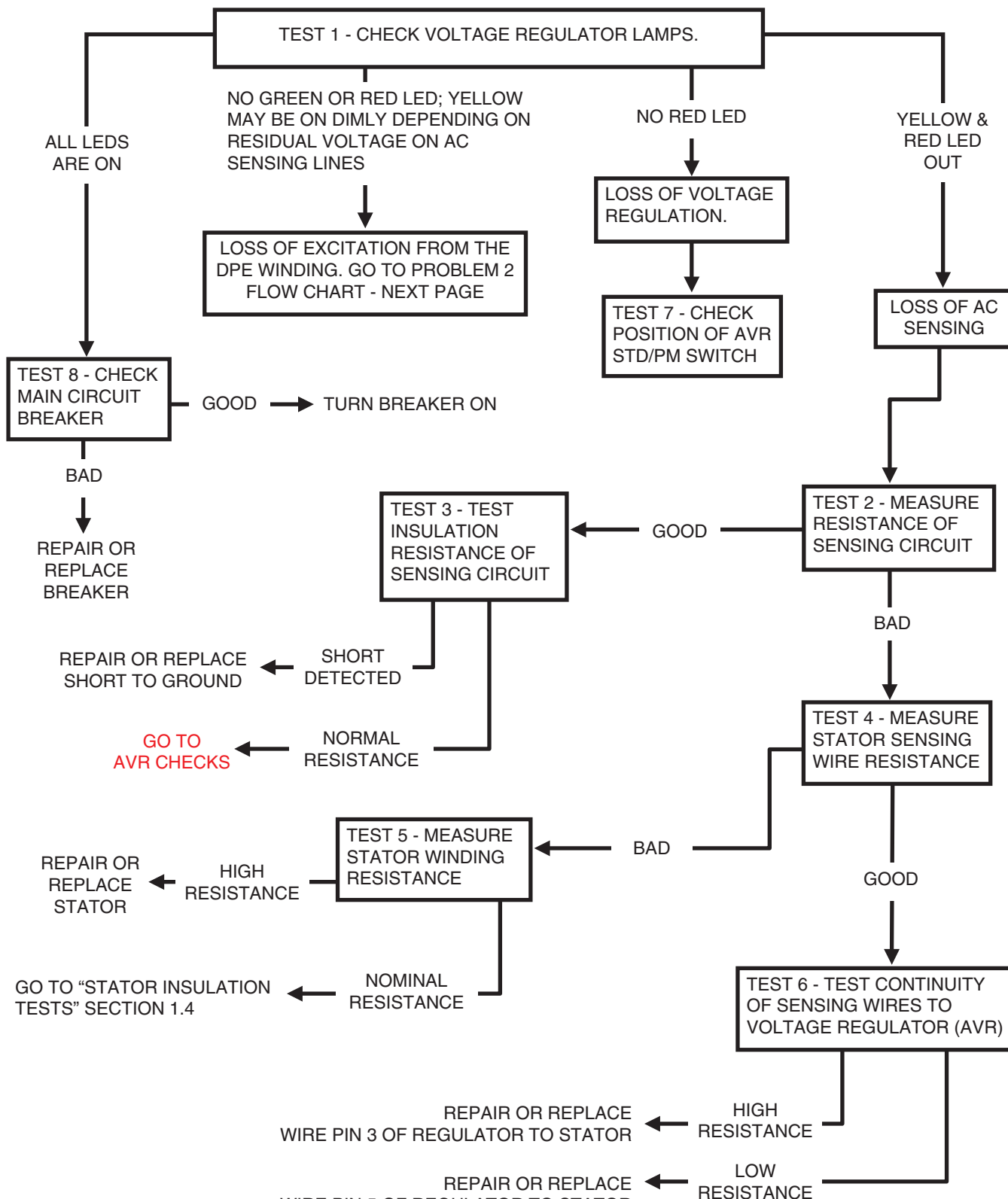

**Problem 2 - Loss of Excitation**

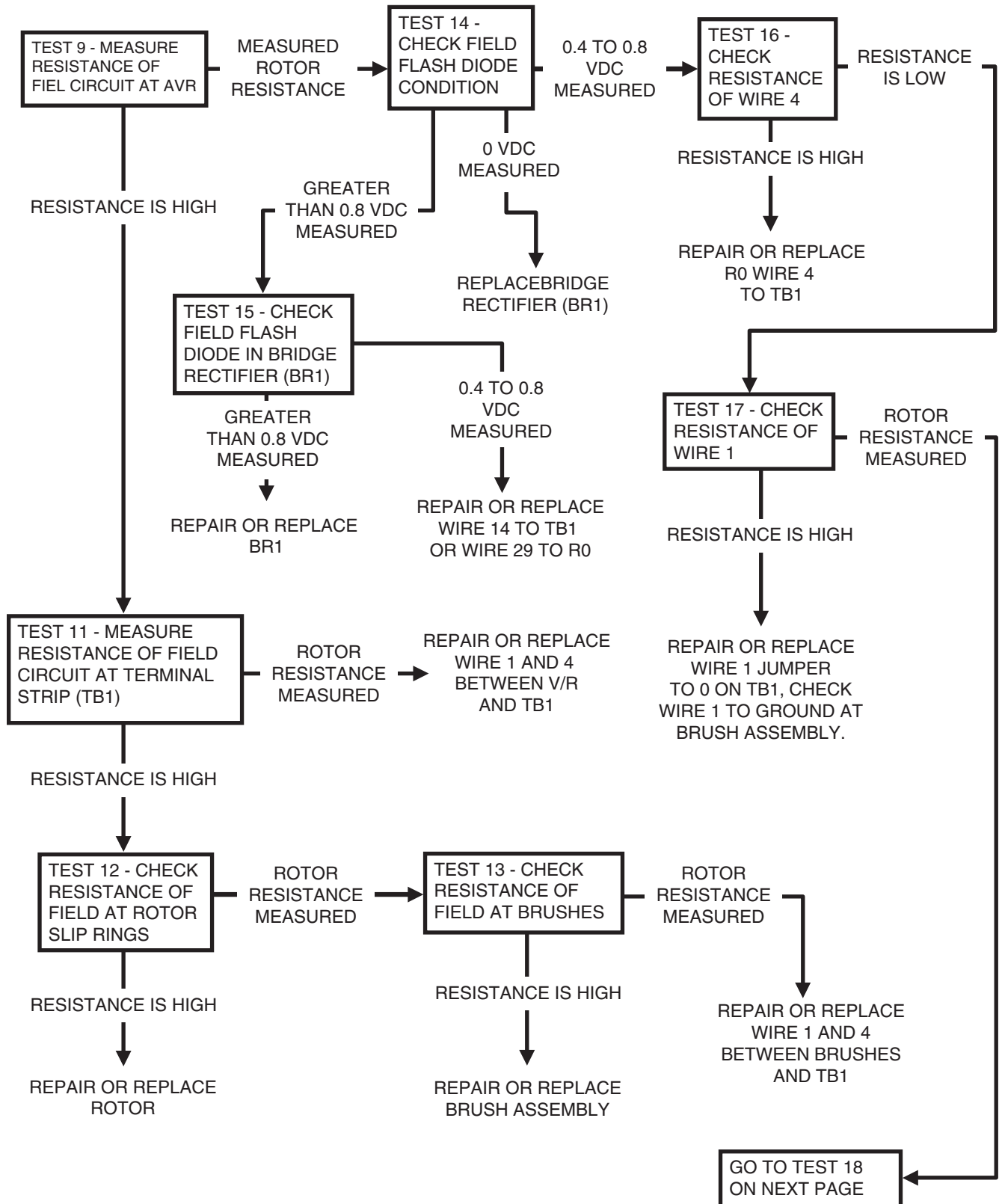

**Problem 2 - Loss of Excitation (Continued)**

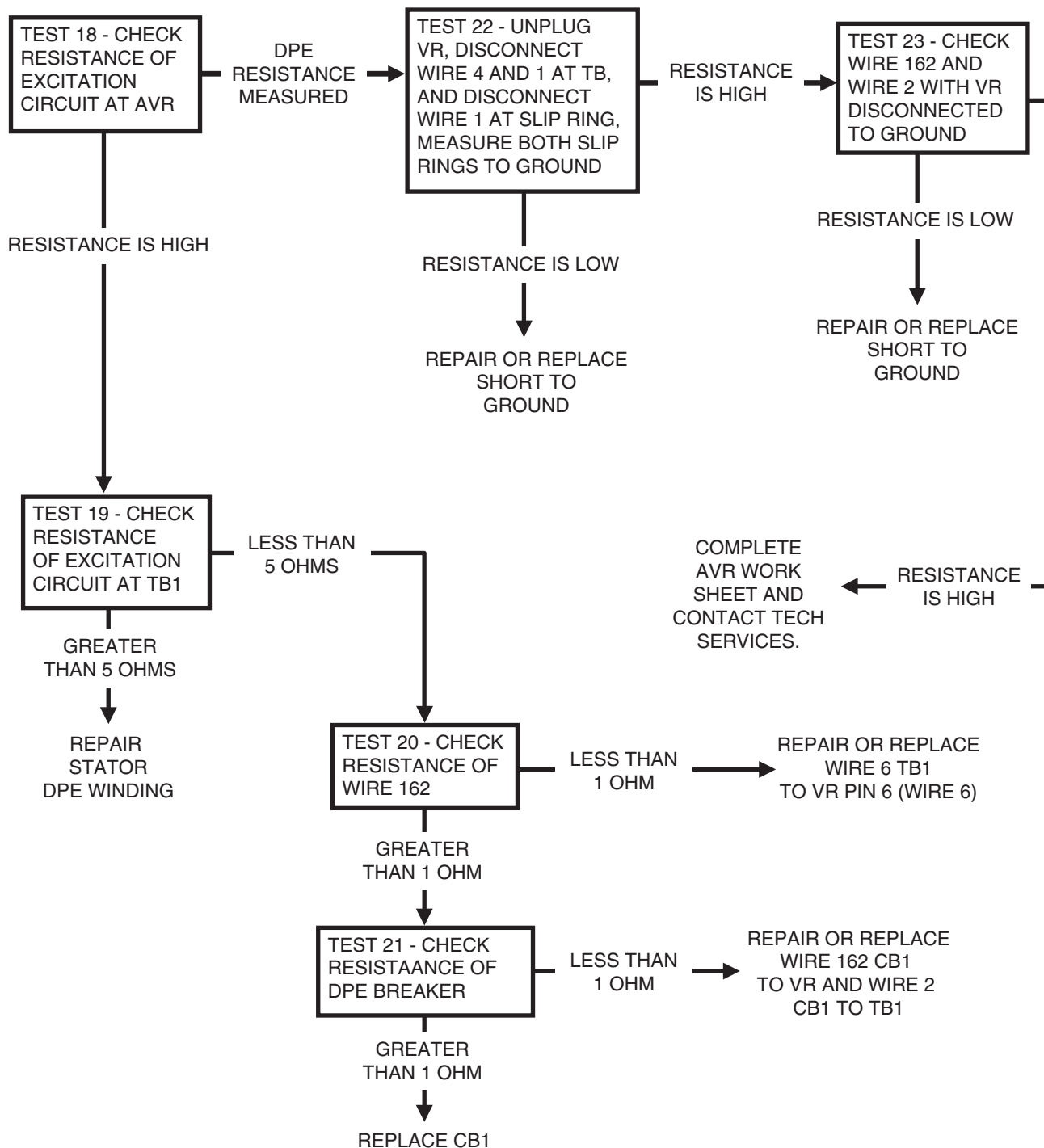

**INTRODUCTION**

This section is provided to familiarize the service technician with acceptable procedures for the testing and evaluation of various problems that could be encountered on prepackaged standby generators with liquid-cooled engines. Use this section of the manual in conjunction with Section 2.3, "Troubleshooting Flow Charts". The numbered tests in this section correspond with those of Section 2.3.

Test procedures in this section do not require the use of specialized test equipment, meters or tools. Most tests can be performed with an inexpensive volt-ohm-milliammeter (VOM). An AC frequency meter is required, where frequency readings must be taken. A clamp-on ammeter may be used to measure AC loads on the generator.

Testing and troubleshooting methods covered in this section are not exhaustive. We have not attempted to discuss, evaluate and advise the home standby service trade of all conceivable ways in which service and trouble diagnosis might be performed. We have not undertaken any such broad evaluation. Accordingly, anyone who uses a test method not recommended herein must first satisfy himself that the procedure or method he has selected will jeopardize neither his nor the product's safety.

**SAFETY**

Service personnel who work on this equipment must be made aware of the dangers of such equipment. Extremely high and dangerous voltages are present that can kill or cause serious injury. Gaseous fuels are highly explosive and can be ignited by the slightest spark. Engine exhaust gases contain deadly carbon monoxide gas that can cause unconsciousness or even death. Contact with moving parts can cause serious injury. The list of hazards is seemingly endless.

When working on this equipment, use common sense and remain alert at all times. Never work on this equipment while you are physically or mentally fatigued. If you don't understand a component, device or system, do not work on it.

**TEST 1 - CHECK VOLTAGE REGULATOR  
(AVR) LAMPS****DISCUSSION:**

During generator operation, all three voltage regulator lamps (LED's) should be on.

- REGULATOR lamp ON indicates regulator is operating normally.
- SENSING lamp ON indicates that sensing voltage is available to the regulator.
- EXCITATION lamp ON indicates that unregulated excitation (DPE) current is available to the regulator.

**PROCEDURE:**

- Open the control panel cover so that the voltage regulator is visible.

- Start the generator and observe the voltage regulator LED's.

**RESULTS:**

- If all LED's are illuminated, go to Test 8.
- If the Red LED is not ON, go to Test 7.
- If the Yellow and Red LED's are not ON, go to Test 2.
- If the Green and Red LED's are not ON, and the Yellow LED is ON or only dimly lit, go to Problem 2 Flow Chart. The brightness of the Yellow LED will depend upon the residual voltage of the AC sensing lines.

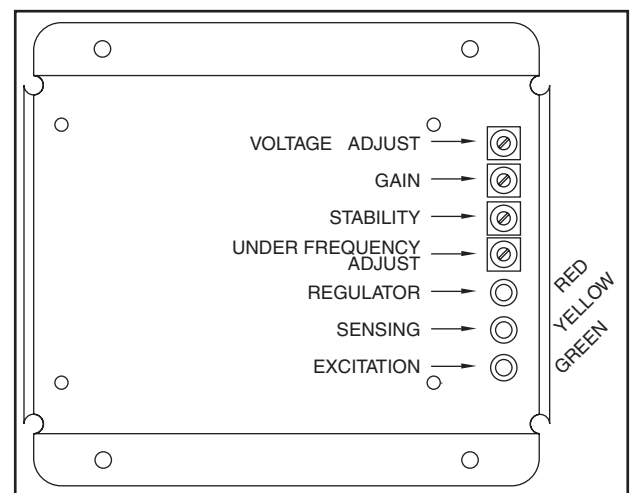

Figure 1. Voltage Regulator Lamp's (LED's)

**TEST 2 - MEASURE RESISTANCE OF  
SENSING CIRCUIT****DISCUSSION:**

A rotor having completely open windings will cause loss of excitation current flow and, as a result, generator AC output voltage will drop to "residual" voltage. A "shorted" rotor winding can result in a low voltage condition.

**PROCEDURE:**

- Disconnect the battery.
- Carefully remove the 6 position orange connector plugged into the voltage regulator (AVR).
- Set a VOM to measure Hertz.
- Measure the resistance between Pin 3 (Wire 11, S1 or S15) and Pin 5 (Wire 44, S3 or S16) of the harness.

**RESULTS:**

- A resistance measurement of less than 10 ohms would indicate that the circuit is complete through the stator. Go to Test 3.

2. A resistance measurement above 10 ohms would indicate that the circuit through the stator is open or has a bad connection. Proceed to Test 4.

**TEST 3 - TEST INSULATION RESISTANCE OF SENSING CIRCUIT**

PROCEDURE:

1. Disconnect the battery.
2. Carefully remove the 6 position orange connector plugged into the AVR.
3. Test resistance to ground. The best method is to test with a hi-pot meter (megger), but can be done with a VOM.
  - a. Using a VOM: Set the meter to "Ohms" and measure resistance of Pin 3 to engine ground, and Pin 5 to engine ground.
  - b. Using a hi-pot meter: Set the meter to 500 volts, 5 mA, and the duration to one (1) second. Test leakage of Pin 3 to ground and Pin 5 to ground.

RESULTS:

1. Measurement with a VOM should be greater than 100 ohms resistance. Using a hi-pot tester, leakage should be less than 5 milliamps. This would indicate that the stator is not shorted to ground. Go to AVR test, Section 2.5.
2. If Measurement with a VOM is less than 100 ohms resistance, or using a hi-pot indicated a greater amp draw than 5 milliamps, there is a short to ground somewhere in the circuit. Locate the short to ground and repair it.

**TEST 4 - MEASURE STATOR SENSING WIRE RESISTANCE**

PROCEDURE:

1. Disconnect the battery.
2. Carefully remove the 6 position orange connector plugged into the AVR.
3. Set a VOM to measure resistance.
4. Measure the resistance between the sensing wires at the stator (see Sensing Wires, Section 2.1).
  - a. For 1-phase 240 volt and 3-phase 208 volt units, these wires are wired to the main line circuit breaker (MLCB) in the customer connection box.
  - b. For 3-phase 480 volt units these wires are wired directly from the stator.

RESULTS:

1. If resistance measurement is greater than stator resistance, go to Test 5.
2. If resistance measurement is equal to stator resistance, go to Test 6.

**TEST 5 - MEASURE STATOR WINDING RESISTANCE**

PROCEDURE:

1. Disconnect the battery.
2. Carefully remove the 6 position orange connector plugged into the AVR.
3. Set a VOM to measure resistance.
4. Measure the resistance between the stator wires. Figure 6, Section 2.1 shows the stator wires for all configurations.

RESULTS:

1. If resistance on any stator winding is greater than nominal stator resistance, the stator will need to be repaired or replaced.
2. If nominal stator resistance is measured on all windings, go to "Stator Insulation Tests", Section 1.4 to test for short to ground.

**TEST 6 - TEST CONTINUITY OF SENSING WIRES TO VOLTAGE REGULATOR (AVR)**

PROCEDURE:

1. Disconnect the battery.
2. Carefully remove the 6 position orange connector plugged into the AVR.
3. Set a VOM to measure resistance.
4. For 1-phase and 3-phase 208 volt units, measure the resistance between AVR Pin 3 and the terminal opposite E1 at the main line circuit breaker (MLCB). For 3-phase 480 volt units, measure between AVR Pin 3 and Wire S15 from the stator.

RESULTS:

1. If resistance measures less than 1 ohm,
  - a. For 1-phase and 3-phase 208 volt units, look for a break or bad connection of the wire between AVR Pin 5 and the MLCB.
  - b. For 3-phase 480 volt units, look for a break or bad connection of the wire between AVR Pin 5 and the stator.
2. If resistance measures greater than 1 ohm,
  - a. For 1-phase and 3-phase 208 volt units, look for a break or bad connection of the wire between AVR Pin 3 and the MLCB.
  - b. For 3-phase 480 volt units, look for a break or bad connection of the wire between AVR Pin 3 and the stator.

**TEST 7 - CHECK POSITION OF AVR STD/PM  
SWITCH****PROCEDURE:**

1. Disconnect the battery.
2. Carefully remove the 6 position orange connector plugged into the AVR.
3. Remove the four (4) mounting screws from the AVR.
4. Check the position of the STD/PM switch.

**RESULTS:**

1. If switch is in PM, switch it to STD.
2. If switch is in STD go to AVR tests, Section 2.5.

**TEST 8 - CHECK MAIN CIRCUIT BREAKER****DISCUSSION:**

Often the most obvious cause of a problem is overlooked. If the generator main line circuit breaker is set to OFF or "Open", no electrical power will be supplied to electrical loads. If loads are not receiving power, perhaps the main circuit breaker is open or has failed.

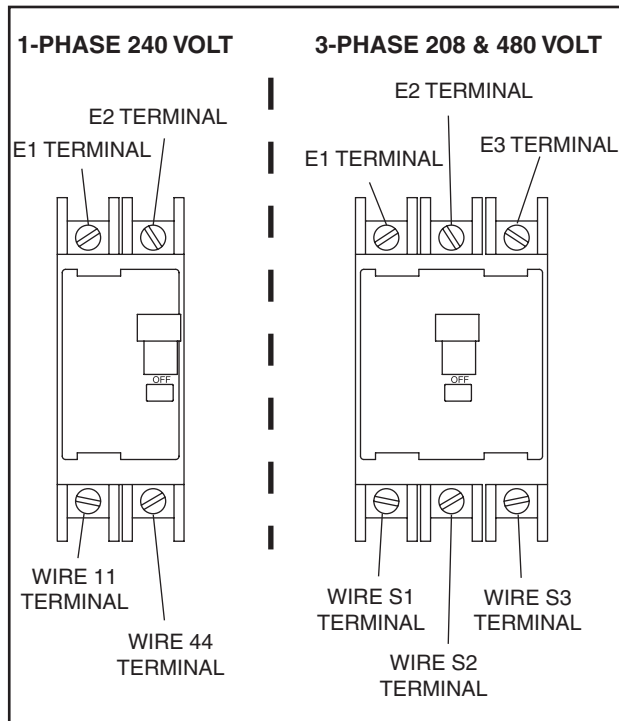

Figure 1. Generator Main Circuit Breaker Test Points

**PROCEDURE:**

The generator main circuit breaker is located on the control panel. If loads are not receiving power, make sure the breaker is set to ON or "Closed".

If you suspect the breaker may have failed, it can be tested as follows (see Figure 1):

1. Set a volt-ohm-milliammeter (VOM) to its "R x 1" scale and zero the meter.
2. With the generator shut down, disconnect all wires from the main circuit breaker terminals, to prevent interaction.
3. With the generator shut down, connect one VOM test probe to the Wire 11 or Wire S1 Terminal of the breaker and the other test probe to the Wire E1 terminal.
4. Set the breaker to its ON or "Closed" position. The VOM should read CONTINUITY.
5. Set the breaker to its OFF or "Open" position and the VOM should indicate infinity.
6. Repeat Steps 4 and 5 with the VOM test probes connected across the breaker's Wire 44 or Wire S2 terminal and the E2 terminal.
7. For 3-phase repeat Steps 4 and 5 with the VOM test probes connected across the breaker's Wire S3 terminal and the E3 terminal.

**RESULTS:**

If the breaker tests bad, it should be replaced.

**TEST 9 - MEASURE RESISTANCE OF FIELD  
CIRCUIT AT AVR****PROCEDURE:**

1. Disconnect the battery.
2. Carefully remove the 6 position orange connector plugged into the voltage regulator (AVR).
3. Set a VOM to measure resistance.
4. Measure the resistance between Pin 1 (Wire 1) and Pin 4 (Wire 4) of the harness at AVR plug

**RESULTS:**

1. If resistance measures less than 10 ohms, at this point it can be assumed that the rotor, brushes and slip rings are good. Go to Test 14.
2. If resistance measures more than 10 and less than 30, rotor may be good but slip ring is probably dirty and will need to be cleaned, if the slip rings are clean and smooth at this point and problem persists go to Test 11.
3. If resistance measures more than 30 ohms, go to Test 11.

**TEST 11 - MEASURE RESISTANCE OF FIELD  
CIRCUIT AT TERMINAL STRIP (TB1)****PROCEDURE:**

1. Disconnect the battery.
2. Carefully remove the 6 position orange connector plugged into the voltage regulator (AVR).
3. Set a VOM to measure resistance.

## SECTION 2.4 DIAGNOSTIC TESTS

### PART 2

PREPACKAGED LIQUID  
COOLED AC GENERATORS

4. Measure the resistance between Pin 1 (Wire 1) and Pin 4 (Wire 4) at TB1.

#### RESULTS:

1. If resistance measures less than 20 ohms, the problem is in the connection of Wire 1 and Wire 4 between the AVR and the Regulator. Repair wires as necessary.
2. If resistance is higher than 30 ohms proceed to Test 12.

### **TEST 12 - CHECK RESISTANCE OF FIELD AT ROTOR SLIP RINGS**

#### PROCEDURE:

1. Disconnect the battery.
2. Carefully remove the 6 position orange connector plugged into the AVR.
3. Set a VOM to measure resistance.
4. Measure the resistance between the positive and negative slip rings of the rotor.

#### RESULTS:

1. If resistance is over 20 ohms, repair or replace the rotor.
2. If resistance is under 20 ohms, go to Test 13.

### **TEST 13 - CHECK RESISTANCE OF FIELD AT BRUSHES**

#### PROCEDURE:

1. Disconnect the battery.
2. Carefully remove the 6 position orange connector plugged into the AVR.
3. Set a VOM to measure resistance.
4. Measure the resistance between Wire 1 and Wire 4 at the brush holders.

#### RESULTS:

1. If resistance measures over 20 ohms, clean slip rings, check brushes for wear and check wire connections.
2. If resistance is under 20 ohms, repair Wires 1 and 4 between the brushes and Terminal Block 1 (TB1).

### **TEST 14 - CHECK FIELD FLASH DIODE CONDITION**

#### PROCEDURE:

1. Disconnect the battery.
2. Place a VOM in diode check mode.

3. Connect the positive lead (red) of the VOM on Wire 14 of TB1 and the negative lead (black) on Wire 29 of R0.

#### RESULTS:

1. Typical diode drop will read 0.400 VDC to 0.800 VDC. If this is what is measured go to Test 16.
2. If 0 VDC is measured, replace the Bridge Rectifier (BR1).
3. If the diode check reads higher than 0.800 VDC, go to Test 15.

### **TEST 15 - CHECK FIELD FLASH DIODE IN BRIDGE RECTIFIER (BR1)**

#### PROCEDURE:

1. Disconnect the battery.
2. Set a VOM to diode check mode.
3. Connect the positive test lead (red) of VOM on the negative (-) terminal of BR1 and the negative test lead (black) on the AC terminal connected to Wire 29.

#### RESULTS:

1. A typical diode drop will read 0.400 VDC to 0.800 VDC. If this is what is measured, check continuity (should be less than 1 ohm) and repair Wire 29 to R0, or Wire 14 to TB1 as necessary.
2. If diode check reads higher than 0.800 VDC, replace the Bridge Rectifier (BR1).

### **TEST 16 - CHECK RESISTANCE OF WIRE 4**

#### PROCEDURE:

1. Disconnect the battery.
2. Set a VOM to measure resistance.
3. Check the resistance of Wire 4 on TB1 to R0.

#### RESULTS:

1. If resistance is high, repair Wire 4 TB1 to R0.
2. If resistance is less than 1 ohm, go to Test 17.

### **TEST 17 - CHECK RESISTANCE OF WIRE 1**

#### PROCEDURE:

1. Disconnect the battery.
2. Set a VOM to measure resistance.
3. Check the resistance of Wire 1 at TB1 to engine ground.

RESULTS:

1. If resistance is greater than 1 ohm, repair jumper Wire 1 to 0 on TB1, Wire 1 from brush holder to bearing carrier or Wire 0 to engine ground.
2. If resistance is less than 1 ohm, go to Test 18.

**TEST 18 - CHECK RESISTANCE OF  
EXCITATION CIRCUIT AT AVR**PROCEDURE:

1. Disconnect the battery.
2. Carefully remove the 6 position orange connector plugged into the AVR.
3. Set a VOM to measure resistance.
4. Measure resistance between Pin 2 (Wire 162) and Pin 6 (Wire 6) of the AVR.

RESULTS:

1. If the measurement is less than 5 ohms, go to Test 22.
2. If the measurement is more than 5 ohms, go to Test 19.

**TEST 19 - CHECK RESISTANCE OF  
EXCITATION CIRCUIT AT TB1**PROCEDURE:

1. Disconnect the battery.
2. Set a VOM to measure resistance.
3. Measure the resistance between Wire 2 and Wire 6 of TB1.

RESULTS:

1. If less than 5 ohms is measured, go to Test 20.
2. If the resistance measured is greater than 5 ohms, repair the stator DPE winding. The thermal protector may be bad.

**TEST 20 - CHECK RESISTANCE OF WIRE 162**PROCEDURE:

1. Disconnect the battery.
2. Carefully remove the 6 position orange connector plugged into the AVR.
3. Set a VOM to measure resistance.
4. Measure the resistance of Pin 2 (Wire 162) of the AVR to Wire 2 on TB1.

RESULTS:

1. If the resistance measured is less than 1 ohm, repair Wire 6 between TB1 and Pin 6 of the AVR.

2. If greater than 1 ohm is measured, go to Test 21.

**TEST 21 - CHECK RESISTANCE OF DPE  
BREAKER**PROCEDURE:

1. Disconnect the battery.
2. Set a VOM to measure resistance.
3. Measure the resistance of the DPE breaker (CB1).

RESULTS:

1. If the resistance measured is less than 1 ohm, repair Wire 162 of CB1 to AVR, or Wire 2 of CB1 to TB1.
2. If greater than 1 ohm is measured, replace CB1.

**TEST 22 - CHECK INSULATION RESISTANCE  
OF FIELD CIRCUIT**PROCEDURE:

1. Disconnect the battery.
2. Carefully remove the 6 position orange connector plugged into the AVR.
3. Disconnect Wire 1 at the bearing carrier.
4. Remove jumper connecting Wire 1 to Wire 0 on TB1.
5. Test resistance to ground. The best test is with a hi-pot tester (megger), but it can be done with a VOM.
  - a. Using a VOM: Set meter to "Ohms" and measure the resistance of Pin 1 to engine ground, and Pin 4 of the AVR to engine ground.
  - b. Using hi-pot tester: Set tester to 500 volts, 5 mA, and duration to 1 second. Test leakage of Pin 1 to engine ground and Pin 4 to engine ground.

RESULTS:

1. Measurement with a VOM should be greater than 100 ohms resistance. Using a hi-pot tester leakage should be less than 5 milliamps. This would indicate that the rotor is not shorted to ground. Reconnect all wires and go to Test 23.
2. If Measurement with a VOM is less than 100 ohms resistance, or using a hi-pot tester indicated a greater amp draw than 5 milliamps, there is a short to ground somewhere in the circuit. Find and repair short to ground.

**TEST 23 - CHECK INSULATION RESISTANCE  
OF EXCITATION CIRCUIT**PROCEDURE:

1. Disconnect the battery.

## SECTION 2.4

### DIAGNOSTIC TESTS

## PART 2

PREPACKAGED LIQUID  
COOLED AC GENERATORS

2. Carefully remove the 6 position orange connector plugged into the AVR.
3. Test resistance to ground. The best test is with a hi-pot tester (megger), but it can be done with a VOM.
  - a. Using a VOM: Set meter to "Ohms" and measure resistance of Pin 2 to engine ground, and Pin 6 of AVR to engine ground.
  - b. Using hi-pot tester: Set to 500 volts, 5 mA, and duration to 1 second. Test leakage of Pin 1 to engine ground and Pin 4 to engine ground.

#### RESULTS:

1. Measurement with a VOM should be greater than 100 ohms resistance. Using a hi-pot tester, leakage should be less than 5 milliamps. This would indicate that the stator is not shorted to ground. Reconnect all wires and go to AVR test.
2. If Measurement with a VOM is less than 100 ohms resistance, or using a hi-pot indicated a greater amp draw than 5 milliamps there is a short to ground somewhere in the circuit. Find and repair short to ground.

**067680 VOLTAGE REGULATOR**

The 067680 Voltage Regulator is used on all Generac Alternators from 10 kW through 350 kW, including the PTO lineup. **The only exceptions are the Guardian Line which use the smaller 83048 regulator.**

The 067680 Regulator is a single phase sensing regulator, meaning that it senses single phase from the alternator.

Some competitive regulators will sense all three phases on a 3-phase machine rather than just one phase. 3-phase sensing is not necessarily an advantage especially with single phase loading, where the regulator would average the voltage for the three phases rather than maintain the correct voltage on the single phase load.

**VOLTAGE REGULATOR CONTROLS AND INDICATORS**

Four adjustment pots and three lights are visible on the front face of the voltage regulator. In addition, there are three miniature switches located on the circuit board within the voltage regulator. They are described as follows.

VOLTAGE ADJUST GAIN:

This pot adjusts the line to line voltage of the alternator. Gain determines how sensitive the regulator is and how fast the regulator will respond to a voltage change. If the gain is too low, the alternator voltage will take a long time to recover from a load and will overshoot. If the gain is too high, the voltage will recover too fast and overshoot and then undershoot and become unstable. Different alternator sizes have different characteristics and the the gain pot allows the regulator to be matched to the given alternator.

STABILITY:

Stability looks at the type of load and how the quickly the measurement samples are taken to adjust the voltage. The red light is an indication of stability. If it is blinking or unsteady the stability control is not correctly set.

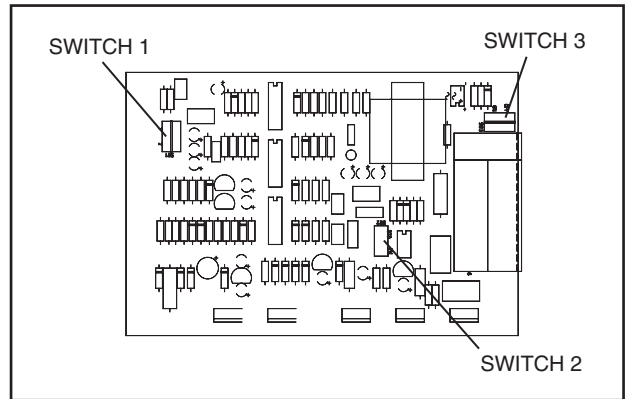

Figure 1. Automatic Voltage Regulator Circuit Board

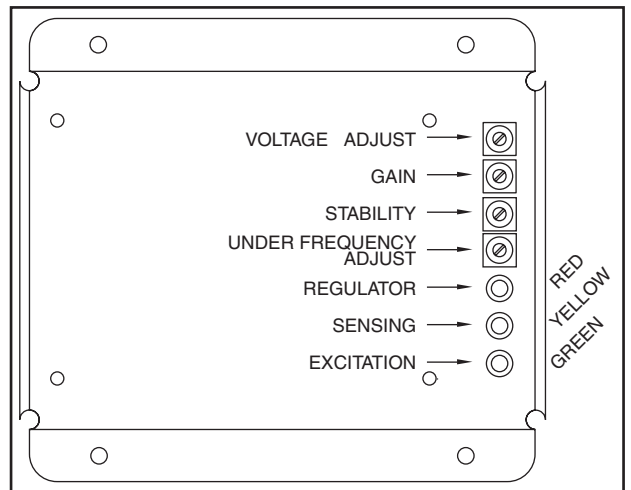
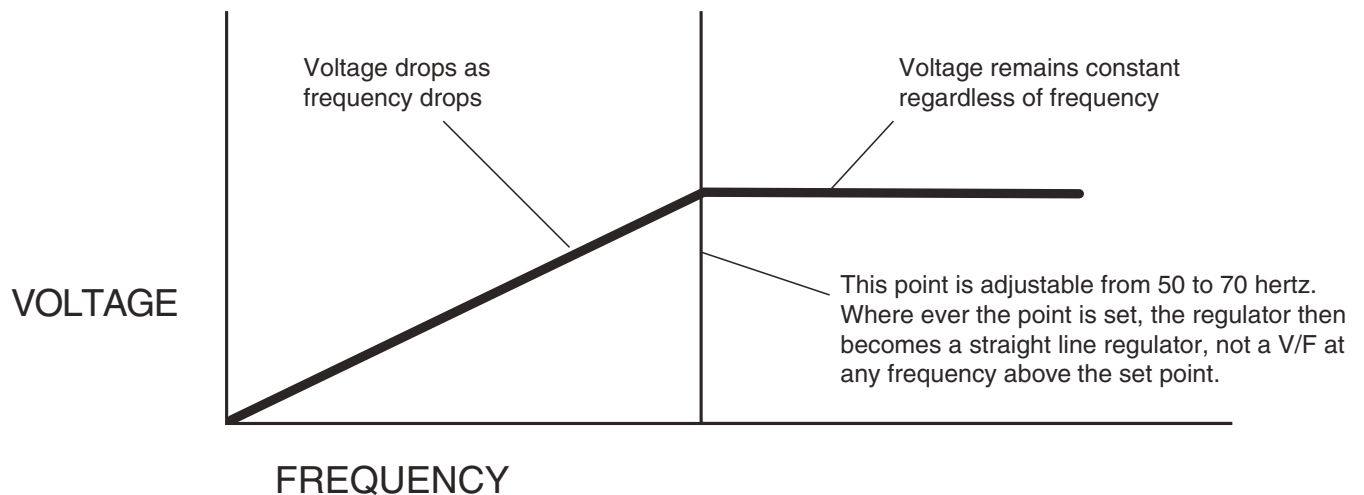

Figure 2. Automatic Voltage Regulator Front Face

UNDERFREQUENCY ADJUST:

The voltage regulator is an adjustable V/F which means that the voltage will vary directly with the frequency. If the frequency drops the voltage will drop. If the frequency rises the voltage will rise. The point



## SECTION 2.5

### AUTOMATIC VOLTAGE REGULATOR

PART 2

PREPACKAGED LIQUID  
COOLED AC GENERATORS

at which the regulator becomes V/F is adjustable. Turning the pot fully counterclockwise makes the regulator totally v/f regulated. Full clockwise makes the regulator a constant voltage device.

There are three lights under the adjustable pots, which indicate if the regulator is receiving the correct signals and is working.

#### REGULATOR (RED LIGHT):

If this light is on, the regulator is working. A signal is being sent to the gate circuits at the DC output side and the output to the rotor field is being regulated.

#### SENSING (YELLOW LIGHT):

The regulator is receiving voltage output from the stator terminals. The sensing voltage for this regulator is 200 - 250 volts. For 277/480 volt units, the sensing is obtained at the midpoints of the series wye connection which is 240 volts.

Whenever sensing is available the yellow light is on.

#### EXCITATION (GREEN LIGHT):

This light monitors the incoming excitation winding. It is this winding that provides the ac power which is later converted to DC and directed to the rotor field. If excitation power is available the green light is on.

#### SWITCH 1 (SW1):

Position 1 ( 1 ) is for brush type units

Position 2 ( 2 ) is for PME and brushless units

#### SWITCH S(W2):

For brush type or brushless excitation, the switch is toward the transformer or tap of the regulator.

For permanent magnet (PMG) the switch is down toward the bottom or SCR side of the regulator.

#### SWITCH (SW3):

This switch must be turned to the ON position when the seventh plug on the input side is connected to 12 or 24 volts. This prevents the regulator from shutting down during short circuit or very low voltage conditions. It is used when the alternator is setup for 250% short circuit output. This can only be done with PMG **exaltation**. Brush or brushless excitation systems will collapse the output voltage under short circuit conditions.

#### JUMPER 1 (JMP1):

This jumper determines the rate of V/F droop.

Position 1 is 4 volts per hertz

Position 2 is 8 volts per hertz

The standard setup is 8 volts per hertz. This allows the voltage to drop off faster and helps the engine recover after a heavy load is applied. If the voltage drops 10%, from ohms law the current will also drop 10%. Since power is volt x amps,  $90\% \times 90\% = 81\%$  of the power at full voltage. A small voltage drop can reduce power requirements significantly.

### **SET-UP AND ADJUSTMENT FOR VOLTAGE REGULATOR SWITCHES:**

With the introduction of Generac's new line of permanent magnet Generators (PMG), the solid state Voltage Regulator had to be updated as well. New Voltage Regulator circuit boards mount three (3) miniature switches, identified on the board as Switch 1, Switch 2, and Switch 3. In the event that a Voltage Regulator must be replaced, the technician must make sure that all switches are properly positioned as follows:

**Switch 1:** If the generator is a direct excited unit with brushes, set the switch to "1".

For all brushless units, set the switch to "2".

**NOTE: On early production voltage regulators, set the switch to Position "E" for brushless generators; to "B" for units with brushes.**

**Switch 2:** For all standard (non-PMG) units, set this switch to "STD".

For all PMG (permanent magnet generator) units, set the switch to "PM".

**Switch 3:** If a seventh wire has been attached to the Voltage Regulator, set this switch to "ON".

If a seventh wire has NOT been added to the Voltage Regulator, set the switch to "OFF".

### **CHECK AND ADJUST VOLTAGE REGULATOR**

#### DISCUSSION:

Four adjustment potentiometers are provided on the standby voltage regulator. These are (a) voltage adjust, (b) gain, (c) stability, and (d) underfrequency adjust.

#### PROCEDURE:

1. Connect an accurate AC voltmeter and AC frequency meter to the generator's AC output leads.
2. On the regulator, set the potentiometers as follows:
  - a. Set the "Voltage Adjust" pot at midpoint.
  - b. Set "Gain" to its centered (mid) position.
  - c. Set "Stability" to its centered (mid) position.
  - d. Turn the "Underfrequency Adjust" pot fully clockwise.
3. On the generator console, set the voltage adjust potentiometer to its centered or mid-position.
4. Turn OFF all electrical loads. Startup and initial adjustment will be done under a "no-load" condition.
5. Start the engine. Let it stabilize and warm up at no-load.
6. Check the reading on the frequency meter with a multimeter. Ensure the unit is running at rated speed (60 Hz electronic governor, 62 Hz mechanical governor).
7. With the unit running at correct no-load frequency, observe the lamps (LED's) on the voltage regulator. All lamps should be ON.

8. Turn the regulators "Voltage Adjust" pot to obtain a line-to-line voltage output as shown in the following chart.

Voltage Code	Rated Voltage
A	240 Volts
B	208 Volts
C	416 Volts
D	240 Volts
G	208 Volts
H	416 Volts
J	240 Volts
K	480 Volts
M	220 Volts
N	380 Volts
O	416 Volts

9. If the red "Regulator" lamp (LED) is flashing, turn the "Stability" potentiometer either direction until the flashing stops.
10. Apply an electrical load slowly, and check engine speed recovery.
- With full load, place multimeter leads on S15 and S16.
  - Slowly turn under frequency counterclockwise.
  - When voltage starts to drop, turn pot back to the point where the voltage was just before it started to drop. For example, if voltage is at 239 while adjusting the under frequency, once the voltage starts to drop, slowly reverse the adjustment until it reaches 239 volts again.
11. With electrical load still applied, check the "Regulator" lamp for flashing. If lamp is flashing, adjust the "Stability" pot until flashing stops.
12. If better response is needed, adjust the "Gain" pot clockwise as needed. Then (if needed), correct for instability by adjusting the "Stability" pot.
13. Turn off electrical loads. Then, recheck the regulator lamps (LED's) at no-load.

When all adjustments have been completed, let the engine run at no-load for a few minutes to stabilize internal engine-generator temperatures. Then, shut the generator down.

### AUTOMATIC VOLTAGE REGULATOR BYPASS TEST

If the Automatic Voltage Regulator (AVR) should have a light out (Regulator [Red], Sensing [Yellow] or Excitation [Green]), the following test can be performed to determine if the AVR is at fault or the AC Alternator is at fault.

#### PROCEDURE:

1. With the engine in the off mode, remove the Orange Plug from the AVR.

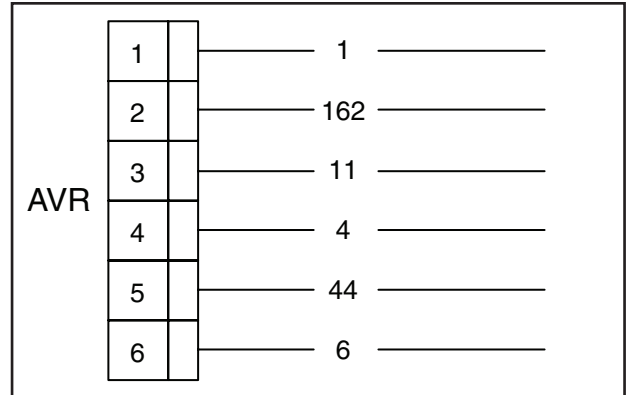

Figure x. Automatic Voltage Regulator 6-pin Connector Wiring.

**NOTE: Guardian units utilizing the 067680 AVR, substitute Wire 11 for Wire 89 and Wire 44 for S15. Also, if wires cannot be identified, remove the AVR and look at where the plug mates with the AVR. There will be a number 1 and 6 on each side of the PCB.**

2. Locate Wires 162 and 6 (positions 2 and 6 on the plug). Put VOM leads (with meter set to AC) into these locations. Turn on the generator at this point. The minimum voltage that should be read is 40 VAC

(If the unit is equipped with a Permanent Magnetic Excitation (P.M.G) set up, the reading will range from 170 to 190 VAC).

3. Repeat the same process for Wires 89 and S15 (positions 3 and 5 on the plug). The minimum voltage across these wires should be 60 VAC.

4. Locate Wires 1 (negative) and 4 (positive). Put the VOM leads (with meter set to DC) into these locations. Brushless type excitation will have a DC reading of two (2) to three (3) VDC and brushed type excitation will have a DC reading of eight (8) to nine (9).

**NOTE: If there is no voltage at these points, check to see if the field boost system is grounding out or is open at the diode or resistor. Also check to see if wire 14 (on the resistor) is not open or grounding out.**

#### RESULTS:

If these minimums are not met, the problem is in the A/C Alternator (rotor, stator, exciter field, exciter armature, or brushes, rotating bridge rectifier). If these minimums are met, replace the AVR.



# PART 3 DC CONTROL LIQUID COOLED ENGINE UNITS

TEST DESCRIPTION .....	PAGE
1 - Check AUTO-OFF-MANUAL Switch Position.....	69
2 - Try to Start Engine Manually.....	69
3 - Check MDS Switch on Transfer Switch .....	70
4 - Identify System Transfer Switch Type .....	70
5 - Check Position 2 of 8-position Dip Switch (OFF).....	70
6 - Check Position 2 of 8-position Dip Switch (ON).....	70
7 -Check for Proper Voltage at J2 Connector Pin 8 to Pin 12 .....	70
8 -Check for Battery Voltage at J2 Connector Pin 11 and Pin 14 .....	70
9 -Check for Voltage at Auto-Off-Manual Switch (SW1) Position 4.....	71
10 -Check for Voltage at Auto-Off-Manual Switch (SW1) Position 3.....	71
11 -Check for Voltage at Auto-Off-Manual Switch (SW1) Position 5.....	71
12 - Attempt a 2-Wire Start.....	69
13 -Check for Voltage at Customer Connect Wire 183 .....	71
14 - Check for Voltage at J2 Connector Pin 4 from PCB..	71
15 -Check for Continuity Between Wire 178 and Engine Ground .....	72
16 -Check for Continuity From J2 Pin 6 to J2 Pin 14 Through the PCB.....	72
20 - Check Ground to PCB.....	72
21 - Check Battery Voltage to PCB.....	72
22 - Check Battery Voltage at SW1.....	72
23 - Check PCB Start Output.....	73
24 - Check Voltage at TB1.....	73
25 - Check Battery Voltage at SW1.....	73
26 - Check Battery Voltage at SW2.....	73
27 - Check Battery Voltage at SW2.....	73
28 - Check Battery Voltage at TB1.....	73
29 - Check 15A Fuse (F1).....	74
30 - Check Battery Voltage at Fuse (F1).....	74
31 - Check Battery Voltage At Tb1.....	74
32 - Check Battery Voltage at SW1.....	74
33 - Check Battery Voltage at Control Contactor (CC) .....	74
34 - Check Battery Voltage at Starter Motor (SM) .....	74
35 - Check Control Contactor (CC) Wiring .....	74
36 - Check Ground at Control Contactor (CC) .....	74
37 - Check Battery Voltage Engine Start Relay (RL1).....	75
38 - Check Engine Start Relay (RL1) Wiring.....	75
39 - Check Wire 56A at PCB.....	75
40 - Check Wire 56 from RL1 to TB1.....	75
50 - Observe Low Fuel pressure LED on Front Panel.....	75
51 - Examine Choke.....	75
52 - Examine Choke with SW1 in "MANUAL" Position.....	76
53 - Check Ignition for Spark .....	76
54 - Check Distributor Output Frequency .....	76

<b>TABLE OF CONTENTS</b>		
PART	TITLE	PAGE
<b>3.1</b>	<b>Description and Components</b>	<b>42</b>
<b>3.2</b>	<b>Operational Analysis</b>	<b>46</b>
<b>3.3</b>	<b>Troubleshooting Flow Charts</b>	<b>58</b>
	Problem 1 - Engine Will Not Crank When Utility Power Failure Occurs	58
	Problem 2 - Engine Will Not Crank When SW1 is Set to "MANUAL"	60
	Problem 3 - Engine Cranks but Will Not Start	62
	Problem 4 - Low Battery Alarm	67
	Problem 5 - Low Coolant Alarm	68
	Problem 5 - Low Oil Pressure	68
<b>3.4</b>	<b>Diagnostic Tests</b>	<b>69</b>

TEST DESCRIPTION .....	PAGE
55 - Check Distributor Input Voltage .....	77
56 - Check Output Voltage of PCB to Distributor .....	77
57 - Check Battery Voltage at Ignition Coil (IC) .....	78
58 - Check Battery Voltage at PCB.....	78
59 - Check Ground at Ignition Coil .....	78
60 - Check Signal to Ignition Coil (IC) .....	78
61 -Check Continuity Wire 25 Between PCB and Ignition Coil (IC) .....	78
62 - Check Fuel System Voltage at TB1.....	78
63 - Check Battery Voltage at PCB .....	79
64 -Check Resistance of Wire 14A From PCB to Engine Run Relay (RL2) .....	79
65 -Check Resistance of Wire 15A From TB1 to Engine Run Relay (RL2) .....	80
66 - Check PCB Output.....	80
67 - Check Engine Run Relay (RL2) Output.....	80
68 - Check Engine Run Relay (RL2).....	80
70 - Check Electric Governor Driver (DEG).....	80
71 - Check Wires from DEG to PCB.....	80
73 - Check PWM Output of Driver to Governor .....	81
74 - Check PWM From PCB to DEG .....	81
75 - Check Driver Enable From PCB to DEG .....	81
76 - Check Continuity of Wire 768 from PCB to DEG.....	81
77 - Test Bosch Governor .....	82
80 - Test Fuel Solenoid (FS) Wiring from TB1.....	82
81 - Check Fuel Solenoid (FS) Operation.....	82
83 - Check Fuel Supply to Demand Regulator .....	82
85 - Check Engine Vacuum .....	82
86 - Check Vacuum to Demand Regulator .....	82
87 - Check Voltage At Battery.....	83
88 - Check Battery Voltage At PCB .....	83
89 - Check Low Battery Sensing at PCB.....	83
90 - Check Battery Condition.....	83
91 - Check Battery Charger Input.....	83
92 - Check Battery Charger Connections.....	83
93 - Check Battery Charger Input Fuse.....	84
94 - Check Battery Voltage at Battery Charger .....	84
95 - Check Battery Charger Current Output.....	84
96 - Check Battery Charger Output Fuse .....	84
97 - Check Float Voltage .....	84
98 - Check Coolant Temperature at Thermal Adapter .....	85
99 - Check Coolant Level .....	85
100 - Check Coolant Hoses.....	85
101 - Check Coolant Level.....	85
102 - Check Coolant Level Switch.....	85
Test 103 - Check for Coolant in Thermal Adapter.....	85
Test 104 - Check Oil Level.....	86
Test 105 - Check Oil Pressure.....	86
Test 106 - Check LOP Signal at PCB.....	86
Test 107 - Check Low Oil Pressure Switch (LOP).....	86

# SECTION 3.1 DESCRIPTION AND COMPONENTS

## GENERAL

Information in this section is provided to familiarize the reader with the various components that make up the DC control system on prepackaged units having a liquid cooled engine. These components may be divided into two (2) broad categories as follows:

- Components in the generator control console.
- Engine mounted components.

## CONTROL CONSOLE COMPONENTS

### LOCATION AND DESCRIPTION:

The control console includes (a) a terminal board, (b) a control board, (c) a driver board, (d) a 15 amp fuse, (e) an automatic voltage regulator, (f) an engine run relay, and (g) an engine start relay.

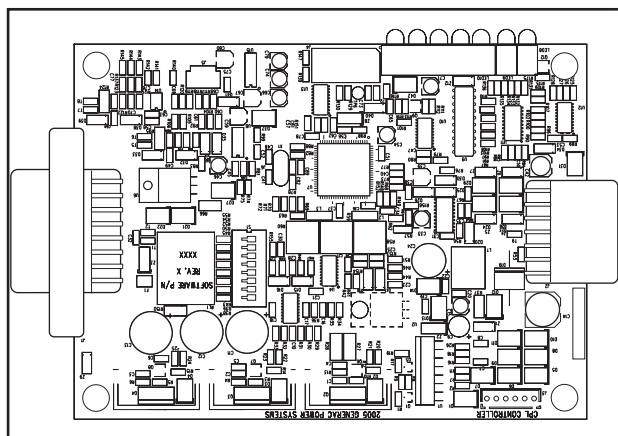

Figure 1. Control Board

### CONTROL BOARD:

This solid state circuit board controls all standby electric system operations, including engine cranking, startup, running, automatic transfer and shut-down. Other operations controlled by the circuit board include the following:

- The circuit board provides automatic engine shut-down in the event of (a) low engine Oil pressure, (b) high engine coolant temperature, (c) low coolant level, (d) overspeed, (e) overcrank and rpm sensor loss. See Section 1.6, "Engine-Generator Protective Devices". On occurrence of any one or more of these engine faults, the circuit board will turn on a fault indicator lamp.

LED Indicators visible through Front Panel (see Table 1 and Figure 2).

System Ready	Green LED
Low Fuel Pressure	Yellow LED
Low Battery	Red LED
Low Oil Pressure	Red LED
Hi Coolant Temp/Low Coolant Level	Red LED

Over Speed/RPM Sensor Loss	Red LED
Over Crank	Red LED

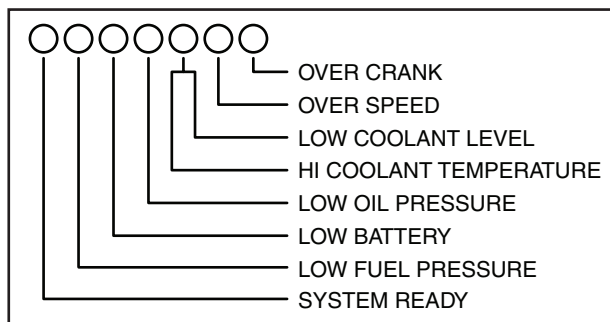

Figure 2 — LED Indicators on Front Panel

The various functions handled by the control board are listed in the following charts, along with appropriate circuit board connector pin numbers and wire numbers.

Pin #	Wire #	Function
1	14	Bosch 12 VDC Supply
2	805	Reserved (Do not connect any wires to this pin)
3	0	GND-B to Bosch Driver
4	85	Hi-Coolant Temp/Lo Coolant Level Input
5	767	0 VDC to Bosch Driver
6	765	5 VDC Supply to Bosch Driver
7	194	Distributor (Hall Sensor) 12 VDC Sensor Supply
8	808	Reserved (Do not connect any wires to this pin)
9	79	2.5L/3.0L Crank Signal Input or 3.9L Flywheel Sensor Input
10	0	2.5L/3.0L Crank Signal Return or 3.9L Flywheel Sensor Return
11	601	Low Fuel Pressure Input
12	766	Bosch Position Feedback Input
13	804	Reserved (Do not connect any wires to this pin)
14	9A	Coil + (Supply voltage to engine coil pack)
15	25	Coil A Driver
16	0	3.9L Distributor Sensor Return
17	402	3.9L Distributor Sensor Input
18	769	Bosch PWM Output
19	768	Bosch Enable Output
20	86	Lo Oil Pressure Input
21	SHLD	3.9L Flywheel Sensor Screen or 3.0L Crank Sensor Screen
22	-	Coil C Driver
23	-	Coil B Driver

R-100 J2 CONNECTOR (14 PIN WHITE)		
Pin #	Wire #	Function
1	–	Reserved (Do not connect any wires to this pin)
2	56A	Start (Crank) Relay Driver Output (minimum coil resistance is 90 ohms)
3	14A	Fuel (Run) Relay Driver Output (minimum coil resistance is 90 ohms)
4	183	2-Wire Start Input (from relay contact in 'W Type' Transfer Switch)
5	15E	Momentary Open Switch Input (B+)
6	178	2-Wire Start Return (from relay contact in 'W Type' Transfer Switch)
7	15A	Manual/Auto Input (+BS)
8	224	19.5 VAC Utility Sense Input
9	–	Alarm Relay Driver Output (minimum coil resistance is 90 ohms)
10	23	Transfer Relay Driver Output (minimum coil resistance is 90 ohms)
11	239	Manual Input
12	225	19.5 VAC Utility Sense Return
13	–	Reserved (Do not connect any wires to this pin)
14	0	GND-B (Battery Ground)

**CONTROL BOARD DIP SWITCH SETTINGS:**

The Switch "ON" position location is marked on the DIP Switch housing (see Figure 3). To activate the DIP Switch settings place the AUTO-OFF-MANUAL Switch in the OFF Mode, make the DIP Switch changes and then push and hold the Set Exercise Switch for five seconds.

**DIP Switch Position 1:** Selects the Generator main alternator output frequency. The ability to select the Generator output frequency (i.e. 60Hz or 50Hz) is only available on the 2.5L Generators.

**DIP Switch Position 2:** Selects the type of transfer switch to be used with the Generator. When an "HS" or "RTS" type transfer switch is used (ATS Mode) this DIP Switch should be in the OFF Position. When a "W" or "HTS" type transfer switch is used (GTS Mode) the Generator 2-Wire start inputs can be used to control the Generator operation. The 2-Wire start inputs are labeled as 178 and 183 on the wiring terminals inside the R-Panel.

**DIP Switch Position 3:** Selects the engine operating speed in exercise mode.

**DIP Switch Position 4:** Selects the type of Fuel used by the Generator. The Fuel Regulator must also be configured for the correct Fuel type.

**DIP Switch Position 5:** Selects the engine displacement.

**DIP Switch Position 6:** Selects the number of engine cylinders.

**DIP Switch Position 7:** Selects the direction of rota-

tion of the Stepper motor Governor and should be set for CCW Stepper rotation (DIP Switch OFF) for the 2.5L Generator. Rotation is observed looking at the stepper shaft as it moves from closed throttle to open throttle.

**DIP Switch Position 8:** The position of this DIP switch (ON or OFF) does not affect Generator operation.

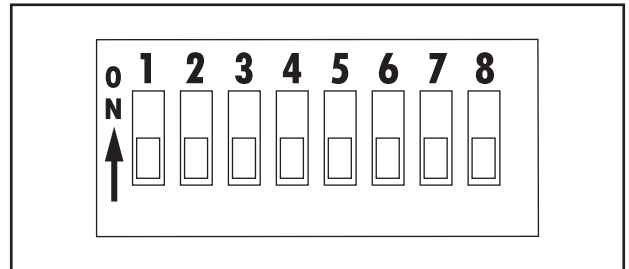

Figure 3. 8-position Dip Switch

**CONTROL CONSOLE COMPONENTS**

**TERMINAL BOARD TB1:**

This 12-position terminal board (Figure 4) provides a convenient connection point for DC control system wiring. Terminals, associated wires and their functions are listed in the following chart.

TERM.	WIRE	FUNCTION
1	0	Common ground
2	1	Ground for (-) brush. (-) side of DC to rotor
3	4	(+) side of DC to rotor from AVR
4	2	Excitation voltage to AVR through DPE breaker
5	6	Excitation voltage to AVR
6	11, S1 or S15	AC Sensing voltage to AVR (referenced to Wire 44, S3 or S16)
7	44, S3 or S16	AC Sensing voltage to AVR (referenced to Wire 11, S1 or S15)
8	13	Unfused (+) battery
9	14	(+) battery when engine is running
10	15A	Fused (+) battery, only available when SW1 set to MANUAL or AUTO
11	15	Fused (+) battery
12	15	Fused (+) battery

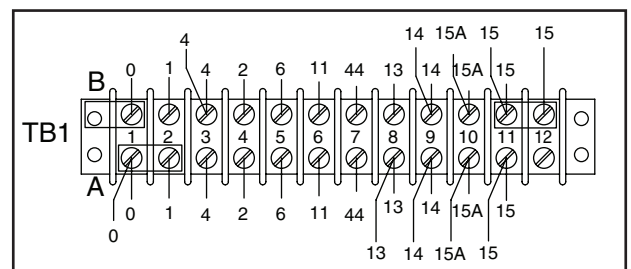

Figure 4. Terminal Board TB1

## SECTION 3.1 DESCRIPTION AND COMPONENTS

**PART 3**

DC CONTROL  
LIQUID COOLED  
ENGINE UNITS

### BOSCH DRIVER BOARD (DEG):

A solid state circuit board that provides current output to drive the Bosch actuator.

Position	Wire	Function
1	0	Ground for driver from PCB J1
2		
3		
4	14	(+) 12 VDC from PCB J1
5		
6		
7		
8	770	DC current output to GOV
9	771	DC current output to GOV
10	768	Driver enable from PCB J1
11		
12	769	5 volt PWM input referenced to 0

### ENGINE RUN RELAY (RL2):

An automotive dry contact relay that energizes and closes Wire 15 [fused (+) battery voltage] to Wire 14 when the engine is running. Provides (+) battery voltage to the fuel solenoid and field boost through BR1 to the rotor.

### START RELAY (RL1):

An automotive dry contact relay that energizes and closes Wire 15 [fused (+) battery voltage] to Wire 56 when the engine is cranking. Provides (+) battery voltage to operate the starter contactor.

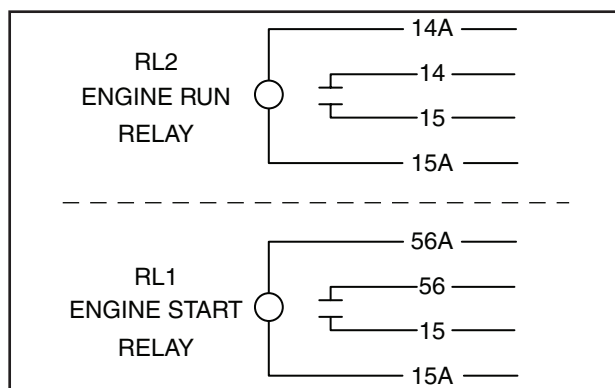

Figure 4. Engine Run and Start Relays

### BRIDGE RECTIFIER (BR1):

Used as blocking diodes to prevent back feeding of alternator and rotor voltages. While engine is running (+) battery voltage is allowed to flow into the rotor and alternator to “flash the field” as necessary.

### EXCITATION CIRCUIT BREAKER (CB2):

Sometimes called DPE breaker. Will open when DPE current exceeds rated current. After cooling it will self reset.

### SET EXERCISE SWITCH (SW2):

When depressed this switch breaks power to the control board. When the switch is released the control board wakes up. If the control board sees good utility voltage and SW3 is in AUTO, the exercise time is set.

### BATTERY CHARGER (BCH):

Provides battery charge voltage during non-operational periods. Power is supplied through 120 VAC utility supply from the distribution panel. The BCH has two indicator LEDs: green on means that utility is available. Yellow is on only when the charger is charging the battery. The battery will stop charging if battery voltage drops below 11 VDC.

### REMOTE ALARM CONNECTION:

The R-100 panel has an optional remote alarm. Pin 9 is an open collector output that may be wired to a 12 VDC relay. The relay is required to have a minimum coil resistance of 90 ohms. It is recommended that the same relay configuration that is used on the engine run and start relays be used. This would be one side of the coil to fused battery and the other to the Pin 9 open collector output. During alarm conditions the alarm output Pin 9 will be pulled to ground, and the relay will operate.

### AUTO-OFF-MANUAL SWITCH:

The AUTO-OFF-MANUAL is shown in Figure 6. Also see Section 1.7, “Operating Instructions”.

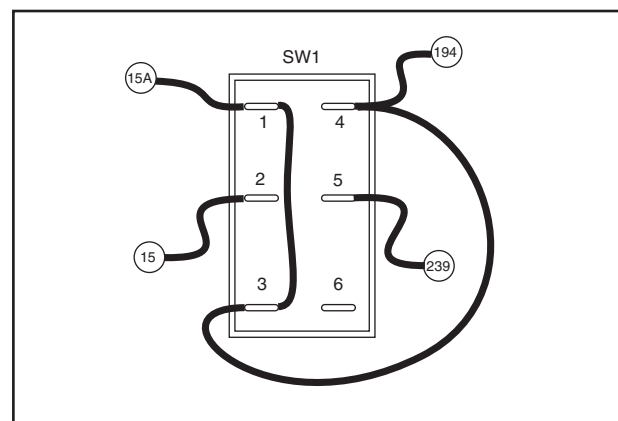

Figure 6. AUTO-OFF-MANUAL Switch

### FUSE F1:

Fuse F1 is connected in series with Wires 13 and 15 and is rated 15 DC amperes. If fuse replacement becomes necessary, use only an identical 15 amp replacement fuse.

## **ENGINE MOUNTED COMPONENTS**

Engine mounted DC control system components include the following:

- A 12 volts battery and battery charge components.
- A starter motor (SM).
- A control contactor (CC).

- Low Oil Switch (LOS) and High Water Temperature switch (HWT).
- Engine ignition system parts.

**BATTERY AND BATTERY CHARGE SYSTEM:**

An alternator delivers a charging voltage to the battery during engine operation. The charging voltage is regulated and rectified by the DC regulator.

The belt driven alternator is a permanent magnet type. Alternator maintenance is limited to replacement of defective parts.

**STARTER MOTOR AND CONTROL CONTACTOR:**

During manual or automatic startup, control board action actuates Engine Start Relay (RL1) which delivers 12 VDC to a control contactor (CC) coil. The coil energizes, its contacts close, and battery power is delivered to the starter motor (SM). The starter motor then energizes and the engine is cranked.

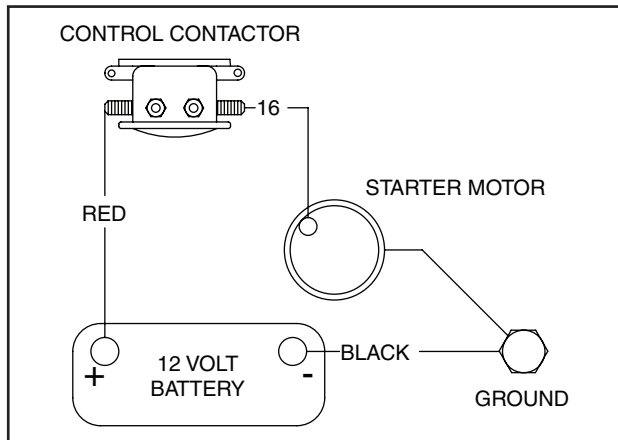

Figure 8. Engine Cranking Circuit

**LOW OIL PRESSURE SWITCH:**

The low oil pressure (LOP) switch has normally-closed contacts which are held open by engine oil pressure during cranking and running conditions. Should engine oil pressure drop below approximately 8-12 psi, the switch contacts will close. Control board action will then effect an automatic engine shutdown and the low oil pressure LED will turn on.

**HIGH COOLANT TEMPERATURE SWITCH:**

The high coolant temperature switch (HWT) has normally-open contacts. Contacts are thermally actuated. If engine coolant temperature should exceed approximately 284° F. (140° C.), control board action will shut the engine down. The high coolant temperature indicator LED will then illuminate.

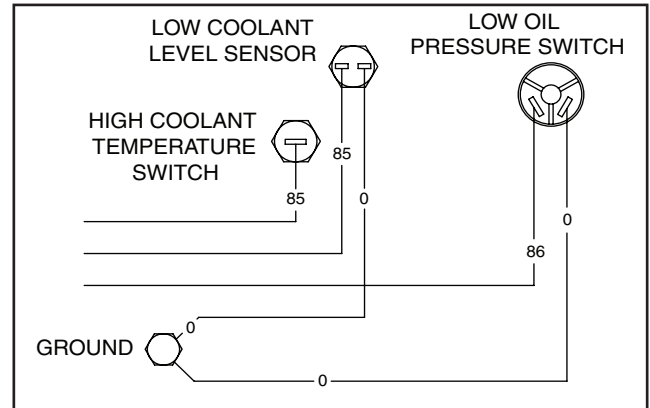

Figure 9. Oil Pressure & Coolant Temperature Circuit

**LOW COOLANT LEVEL SENSOR:**

It is possible that engine coolant level might drop low enough so that the high temperature switch is no longer immersed in the liquid coolant. If this happens engine temperatures could increase rapidly but the temperature switch would not sense the high temperature condition and the engine would continue to run. To prevent this occurrence, a low coolant level sensor is provided. The sensor is immersed in cooling system liquid. If coolant level drops below the level of the low coolant level sensor, the device will complete a Wire 85 circuit to ground. Engine shutdown will occur and the low coolant level LED will illuminate.

**FUEL SOLENOID:**

The fuel solenoid (FS) provides a positive shutoff of fuel when the engine is not running. The solenoid is energized open by 12 volts DC (Wire 14); it is de-energized closed.

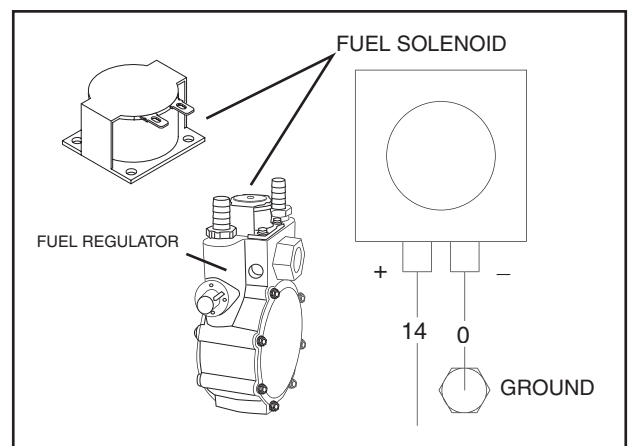

Figure 10. Fuel Solenoid (FS)

**INTRODUCTION**

The schematic diagram on this and the following pages shows the DC control system in three (3) major areas, i.e., the standby generator area, the engine, and the prepackaged transfer switch.

**CIRCUIT CONDITION - UTILITY SOURCE VOLTAGE AVAILABLE**

- (+) Battery is supplied from battery via Wire 13 to the control contactor (CC), alternator (ALT), Fuse (F1), and Battery charger (BCH). The alternator and control contactor are not active at this point. The (+) battery to the battery charger provides battery sensing and a battery charge when necessary to keep the battery level up during none operating periods. At the fuse the (+) Battery it is switched to the Wire 15.
- Wire 15 supplies fused (+) battery to AUTO-OFF-MANUAL switch (SW1), momentary switch (SW2), start relay (RL1), and engine run relay (RL2). At SW1 the (+) battery is switched onto Wires 15A and 194. SW2 is a normally closed switch that shunts the fused (+) battery to the Wire 15E. The fused (+) battery is applied to the start relay and engine run relay coils that are currently not active.

- = 12 VDC ALWAYS PRESENT
- = AC VOLTAGE
- = GROUND
- = 12 VDC DURING CRANKING ONLY

- = 12 VDC DURING ENGINE RUN CONDITION
- = 5 VDC FOR 2-WIRE
- - - = FLASH VOLTS
- - - = 5 VDC PWM

- CONTROL PANEL LEGEND**
- AVR - AUTOMATIC VOLTAGE REGULATOR
  - BCH - BATTERY CHARGER
  - BR1 - BRIDGE RECTIFIER
  - CB2 - CIRCUIT BREAKER (EXCITATION)
  - F1 - FUSE, BAT POWER (15A ATO TYPE)
  - J2 - CONNECTOR 2 (ON PCB)
  - R0 - ZERO OHM JUMPER
  - RL1 - RELAY 1 (START RELAY)
  - RL2 - RELAY 2 (ENGINE RUN)
  - SW1 - AUTO/OFF/MANUAL SWITCH
  - SW2 - SET EXERCISER SWITCH
  - TR\_ - TRANSFORMER (6VA UTIL/16 VAC)

ADD FOR 277/480V UNITS

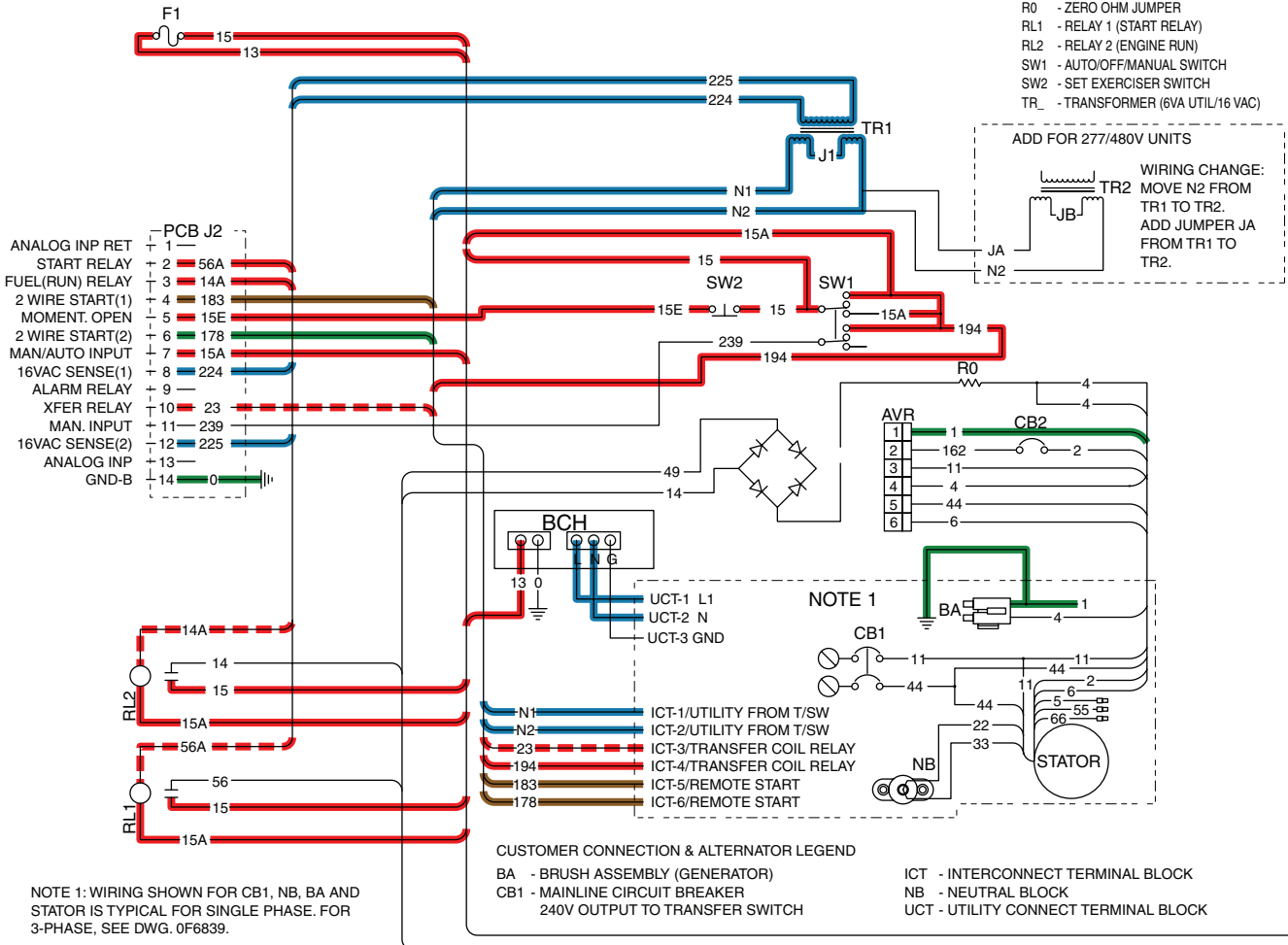
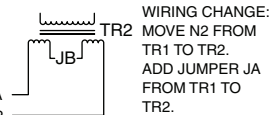

- Wire 15A supplies fused battery to engine run relay and the start relay contacts, the relay contacts are both open at this point. Wire 15A also places fused (+) battery to PCB J2 Pin 7 (MAN/AUTO input). This tells the control board that the unit is in AUTO or MANUAL.
- Wire 15E from the momentary switch supplies fused (+) battery to PCB J2 Pin 5. This is the power supply to the control board (PCB) and allows it to function. The control board also senses battery level on Wire 15E.
- For configured transfer switches (GTS) the control board looks for a two-wire start and ignores inputs of Wires 225 and 224 utility sensing. The control board supplies a 5 Volt signal output from J2 Pin 4 to Wire 183.
- For RTS and HS transfer switches the control board monitors Wires 225 and 224 input at J2 Pin 8 and J2 Pin 12. This is approximately 16 VAC stepped down from the N1 and N2 utility supplied to sensing transformer (TR1). Two-wire start is ignored.

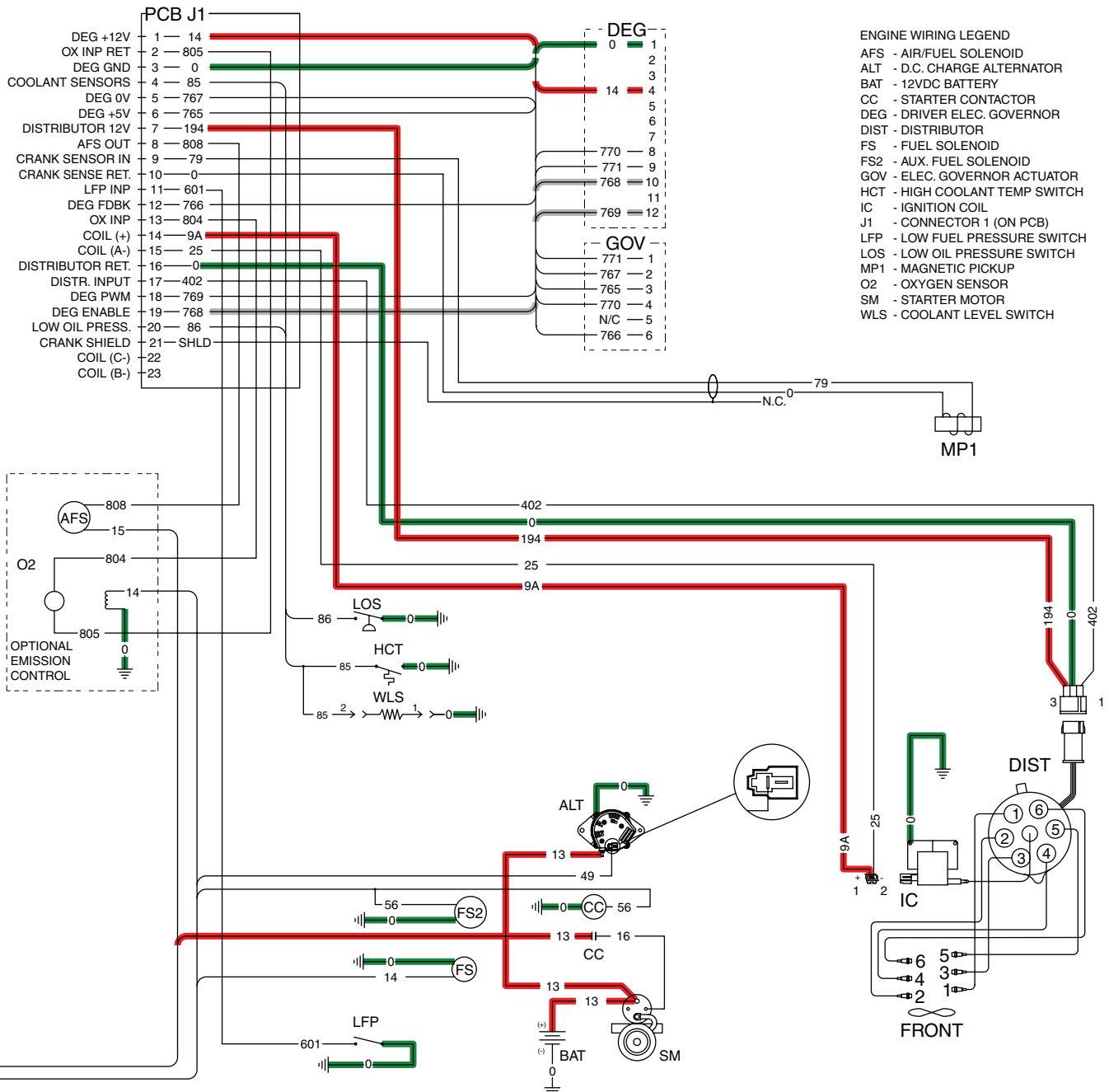

**CIRCUIT CONDITION – INITIAL POWER LOSS.**

- For RTS or HS switch, Line to line voltage is sensed at TR1 and reduced to about 16 VAC and sensed at the PCB at J2 Pin 8 and Pin 12. If this voltage drops below 60 percent of operating voltage, the board will start a 15 second timer. If the utility voltage is still below 60 percent of operating voltage the engine will begin the cranking cycle.
- For GTS configured units utility sensing is done at the transfer switch, nothing will happen at the generator until the transfer switch signals the generator for a start.

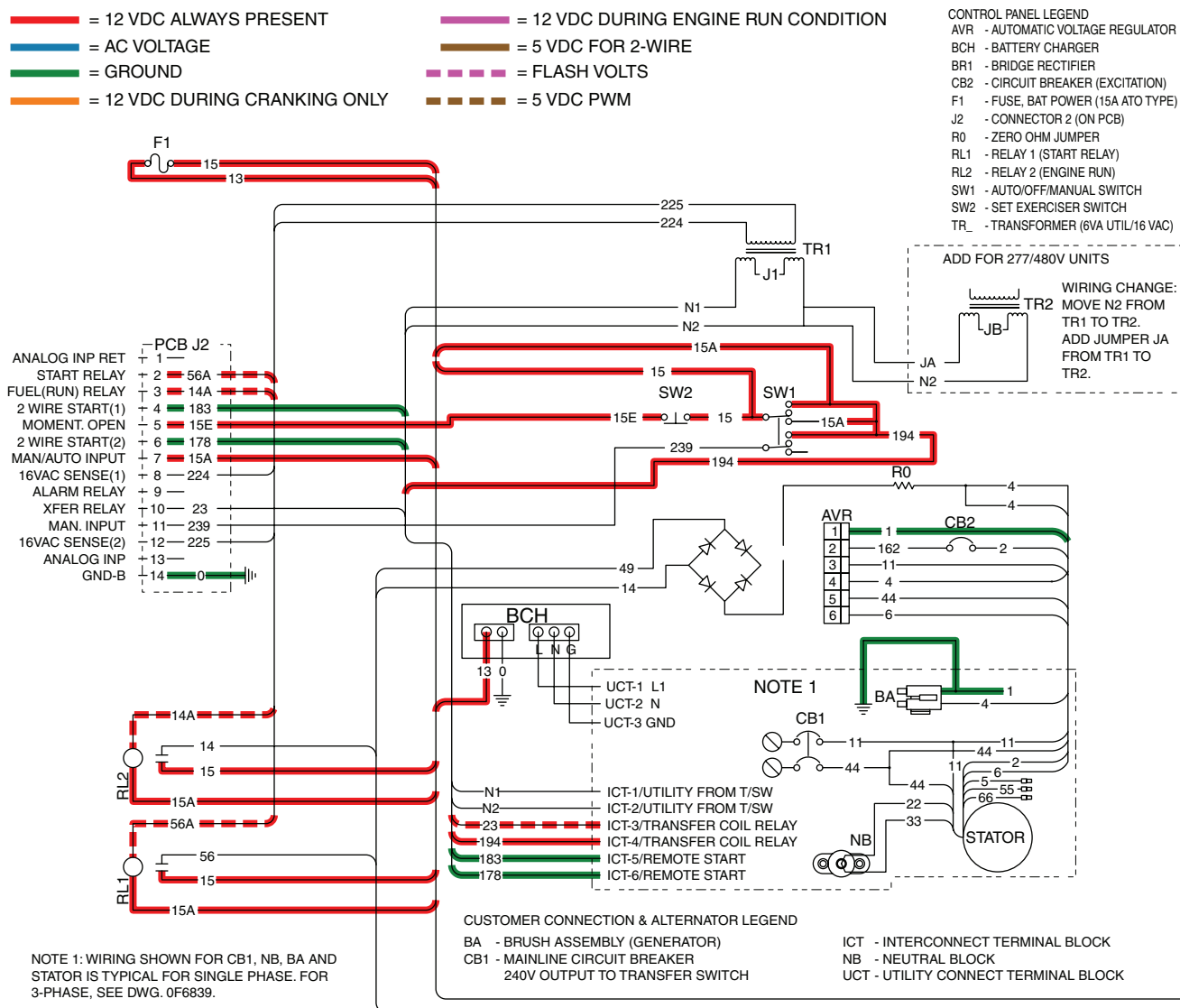

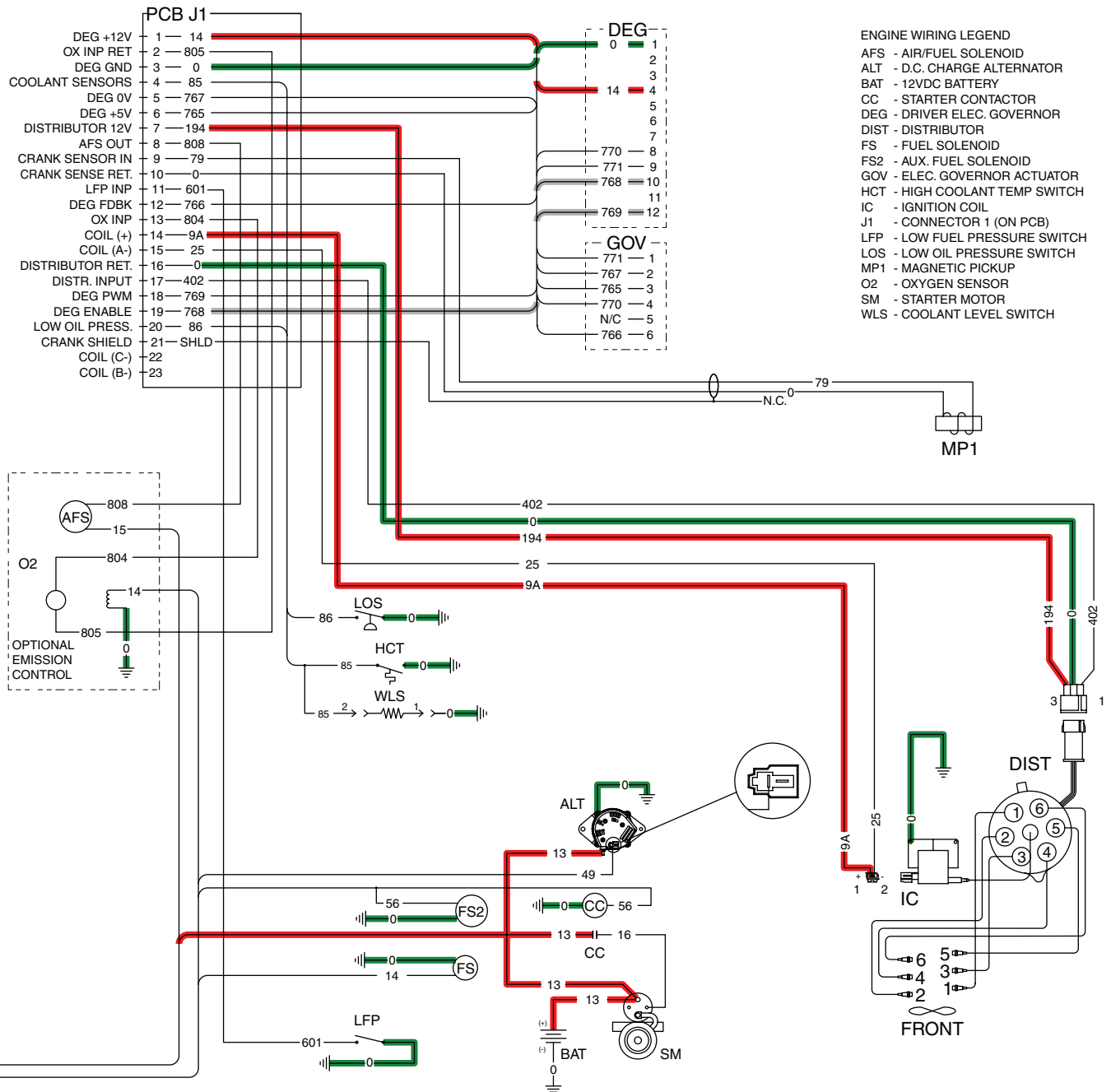

**CIRCUIT CONDITION – CRANKING AND INITIAL STARTUP**

- For RTS and HS transfer switches, after voltage is not sensed for 15 seconds the engine will begin to crank.
- For GTS configured switches, after voltage is not sensed at the transfer switch utility sensing board for a pre-determined amount of time, a contact will close in the switch completing a current path for Two-wire start. Two-wire start is sensed by the unit as a low on Wire 183 at J2 Pin 4. Two-wire start consists of a current limited ground source on J2 Pin 6 going out on Wire 178 at the customer connection, through a normally open contact in the GTS and returning on Wire 183 to J2 Pin 4.
- The starter is now activated. Wire 56A is brought low to ground by control board (PCB) J2 Pin 2; this creates a difference of potential across the coil of start relay (RL1). The start relay closes the contact connecting fused (+) battery to Wire 56. Fused (+) battery is brought by the Wire 56 to the control contactor (CC) creating a difference of potential across its coil, energizing the control contactor. The control contactor closes its contact connecting (+) battery Wire 13 to Wire 16. The Wire 16 connects (+) battery to the starter solenoid creating a difference of potential across the starter solenoid's coil. Starter solenoid closes (+) battery to the starter motor causing the motor to spin, cranking the engine over. The initial crank cycle will be a 15-second crank followed by a 7-second rest. This will be followed by 5 additional cycles of 7 second cranks followed by 7 second rests. If the engine fails to start after a total of 90 seconds, the overcrank LED will illuminate.
- The fuel circuit is activated. Wire 14A is brought low to ground by control board (PCB) J2 Pin 3; this creates a difference of potential across the coil of the engine run relay (RL2). Engine run relay closes fused (+) battery Wire 15 to Wire 14. Wire 14 carries voltage to the fuel solenoid (FS), this creates a difference of potential across the coil and opens the demand regulator. Wire 14 also is wired to BR1 (-). This provides (+) battery for the field flash of the alternator (Wire 49) and rotor (Wire 29). Wire 29 is jumped to Wire 4 through R0.

- = 12 VDC ALWAYS PRESENT
- = AC VOLTAGE
- = GROUND
- = 12 VDC DURING CRANKING ONLY
- = 12 VDC DURING ENGINE RUN CONDITION
- = 5 VDC FOR 2-WIRE
- - - = FLASH VOLTS
- - - = 5 VDC PWM

- CONTROL PANEL LEGEND**
- AVR - AUTOMATIC VOLTAGE REGULATOR
  - BCH - BATTERY CHARGER
  - BR1 - BRIDGE RECTIFIER
  - CB2 - CIRCUIT BREAKER (EXCITATION)
  - F1 - FUSE, BAT POWER (15A ATO TYPE)
  - J2 - CONNECTOR 2 (ON PCB)
  - R0 - ZERO OHM JUMPER
  - RL1 - RELAY 1 (START RELAY)
  - RL2 - RELAY 2 (ENGINE RUN)
  - SW1 - AUTO/OFF/MANUAL SWITCH
  - SW2 - SET EXERCISER SWITCH
  - TR\_ - TRANSFORMER (6VA UTIL/16 VAC)

ADD FOR 277/480V UNITS

**WIRING CHANGE:**  
MOVE N2 FROM TR1 TO TR2.  
ADD JUMPER JA FROM TR1 TO TR2.

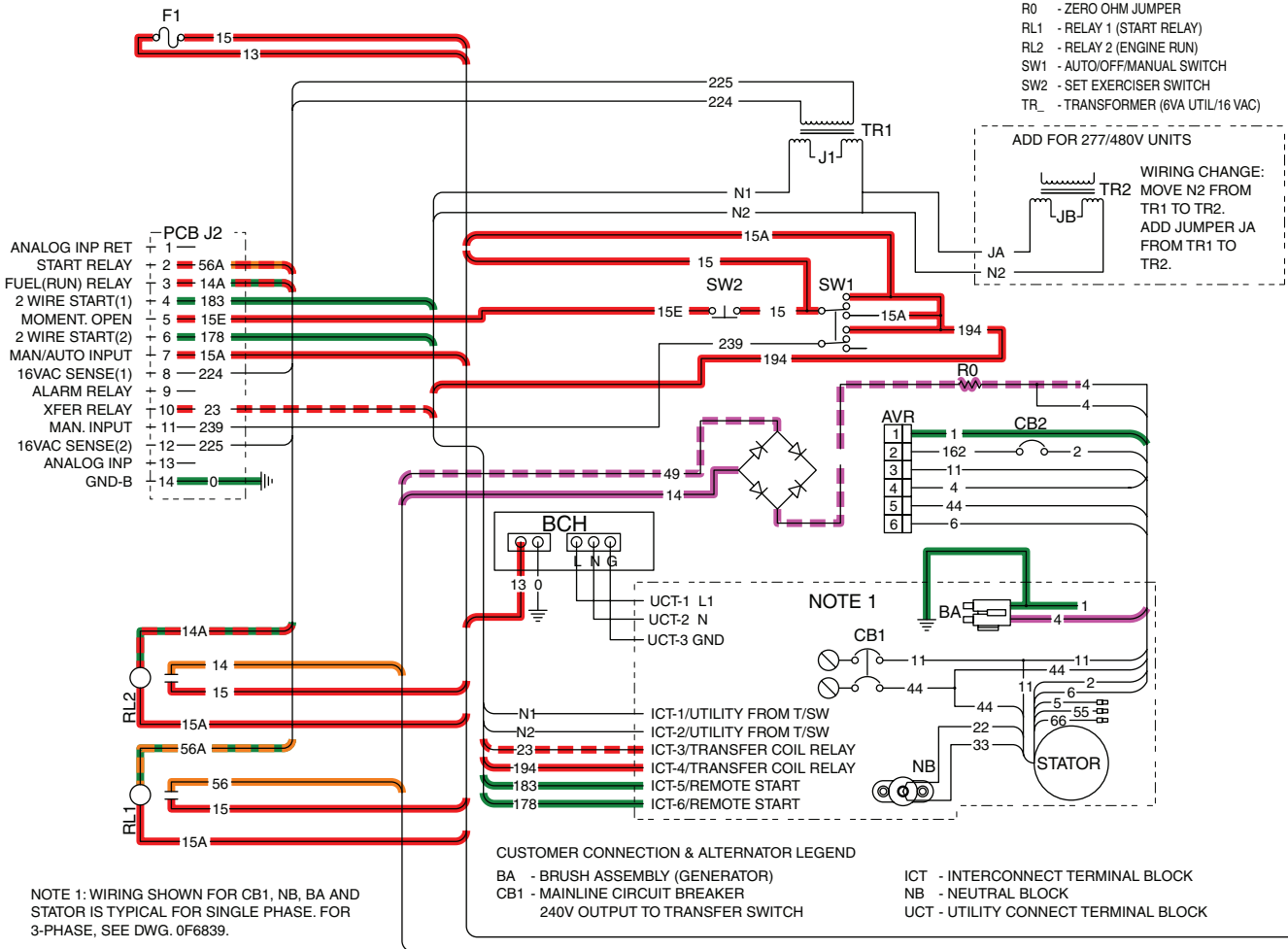

NOTE 1: WIRING SHOWN FOR CB1, NB, BA AND STATOR IS TYPICAL FOR SINGLE PHASE. FOR 3-PHASE, SEE DWG. 0F6839.

**CUSTOMER CONNECTION & ALTERNATOR LEGEND**

- BA - BRUSH ASSEMBLY (GENERATOR)
- CB1 - MAINLINE CIRCUIT BREAKER
- ICT - INTERCONNECT TERMINAL BLOCK
- NB - NEUTRAL BLOCK
- UCT - UTILITY CONNECT TERMINAL BLOCK
- 240V OUTPUT TO TRANSFER SWITCH

- Electronic governor driver (DEG) is activated. Control board (PCB) J1 Pin 1 supplies 12 VDC to DEG Pin 4. PCB J1 Pin 19 takes Wire 768 low to DEG Pin 10, this enables the driver output to governor. From PCB Pin 18 a 5 VDC PWM signal is sent on Wire 769 to DEG Pin 12. The 5 VDC PWM signal is converted to a high current output and sent to drive the governor. DEG Pin 8 (Wire 770) is the (-) to Bosch governor actuator (GOV) Pin 4, DEG Pin 9 (Wire 771) is the (+) to GOV Pin 1.
- Electronic governor actuator activated. Power is received from the electronic driver on Pins 1 and 4. PCB J1 Pin 6 (Wire 765) supplies 5 VDC power supply to governor Pin 3 for the actuator position feedback circuit. PCB J1 Pin 5 (Wire 767) is the 0 VDC to governor Pin 2 for the actuator position feedback circuit. Pin 6 of governor feeds a 0 to 5 VDC feedback to PCB J1 Pin 12 via Wire 766.
- Ignition system activated. The distributor has a Hall effect sensor in it, which sends a frequency back to PCB J1 Pin 17 via Wire 402. This information is used to activate a ground out of PCB J1 Pin 15 via Wire 25 to Pin 2 of the (-) ignition coil (IC). This pulsed ground signal fires the coil as necessary.
- Speed sensor activates. At time of crank the starter will turn the engine. This turning of the engine is picked up by the magnetic pick up (MPU). The MPU sends a frequency back to PCB J1 Pin 9. Cranking will develop a frequency of about 400 Hz.

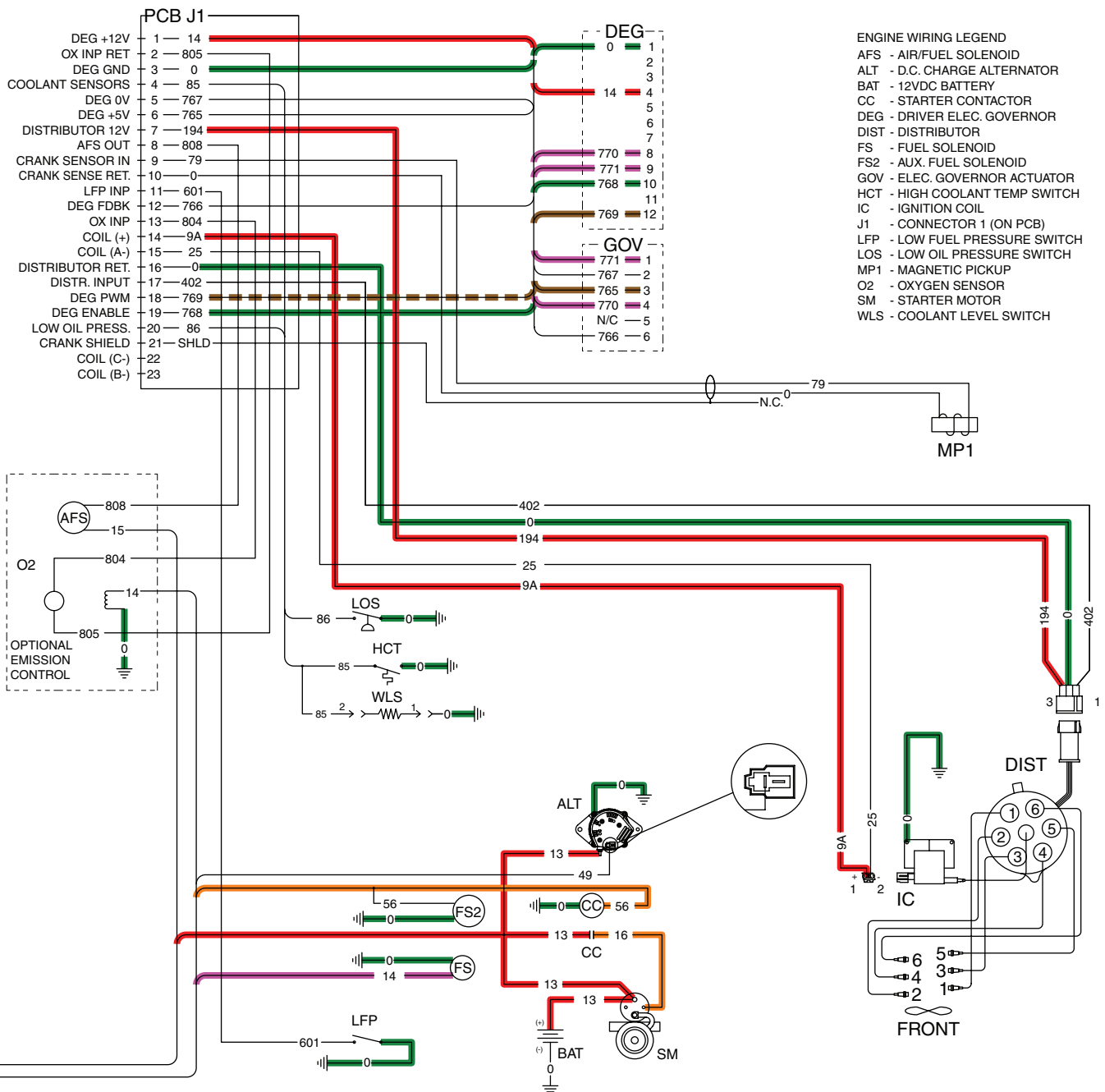

**ENGINE RUNNING.**

- When engine reaches between 600 and 800 RPM the control board will turn off the starter. Ground will be removed from PCB pin 2 disengaging the starter.
- Using (+) battery field boost on Wire 4 the rotor begins to create a magnetic field. The magnetic field will induce a voltage on the stator windings as the rotor spins. Wires 11 and 44 are the sensing voltage leads connecting to Pin 3 and Pin 4 of the automatic voltage regulator (AVR). The stator also produces an excitation voltage on Wires 2 and 6 of the AVR. The AVR rectifies the excitation voltage to produce the field voltage. The AVR uses the sensing voltage to know how much field voltage to supply into the rotor.
- When system is equipped with RTS and HS switches the control board will start a 10-second warm up timer after engine comes up to speed. After approximately 10 seconds, the control board will initiate a transfer by grounding PCB J2 Pin 10. At the transfer switch, the grounding of Wire 23 will produce a difference of potential across the transfer relay coil, forcing transfer of the load from utility to standby generator voltage.
- When equipped with a GTS configured switch all transfer control is controlled at the transfer switch.

- = 12 VDC ALWAYS PRESENT
- = AC VOLTAGE
- = GROUND
- = 12 VDC DURING CRANKING ONLY

- = 12 VDC DURING ENGINE RUN CONDITION
- = 5 VDC FOR 2-WIRE
- - - = FLASH VOLTS
- - - = 5 VDC PWM

- CONTROL PANEL LEGEND
- AVR - AUTOMATIC VOLTAGE REGULATOR
  - BCH - BATTERY CHARGER
  - BR1 - BRIDGE RECTIFIER
  - CB2 - CIRCUIT BREAKER (EXCITATION)
  - F1 - FUSE, BAT POWER (15A ATO TYPE)
  - J2 - CONNECTOR 2 (ON PCB)
  - R0 - ZERO OHM JUMPER
  - RL1 - RELAY 1 (START RELAY)
  - RL2 - RELAY 2 (ENGINE RUN)
  - SW1 - AUTO/OFF/MANUAL SWITCH
  - SW2 - SET EXERCISER SWITCH
  - TR\_ - TRANSFORMER (6VA UTIL/16 VAC)

ADD FOR 277/480V UNITS

WIRING CHANGE:  
MOVE N2 FROM  
TR1 TO TR2.  
ADD JUMPER JA  
FROM TR1 TO  
TR2.

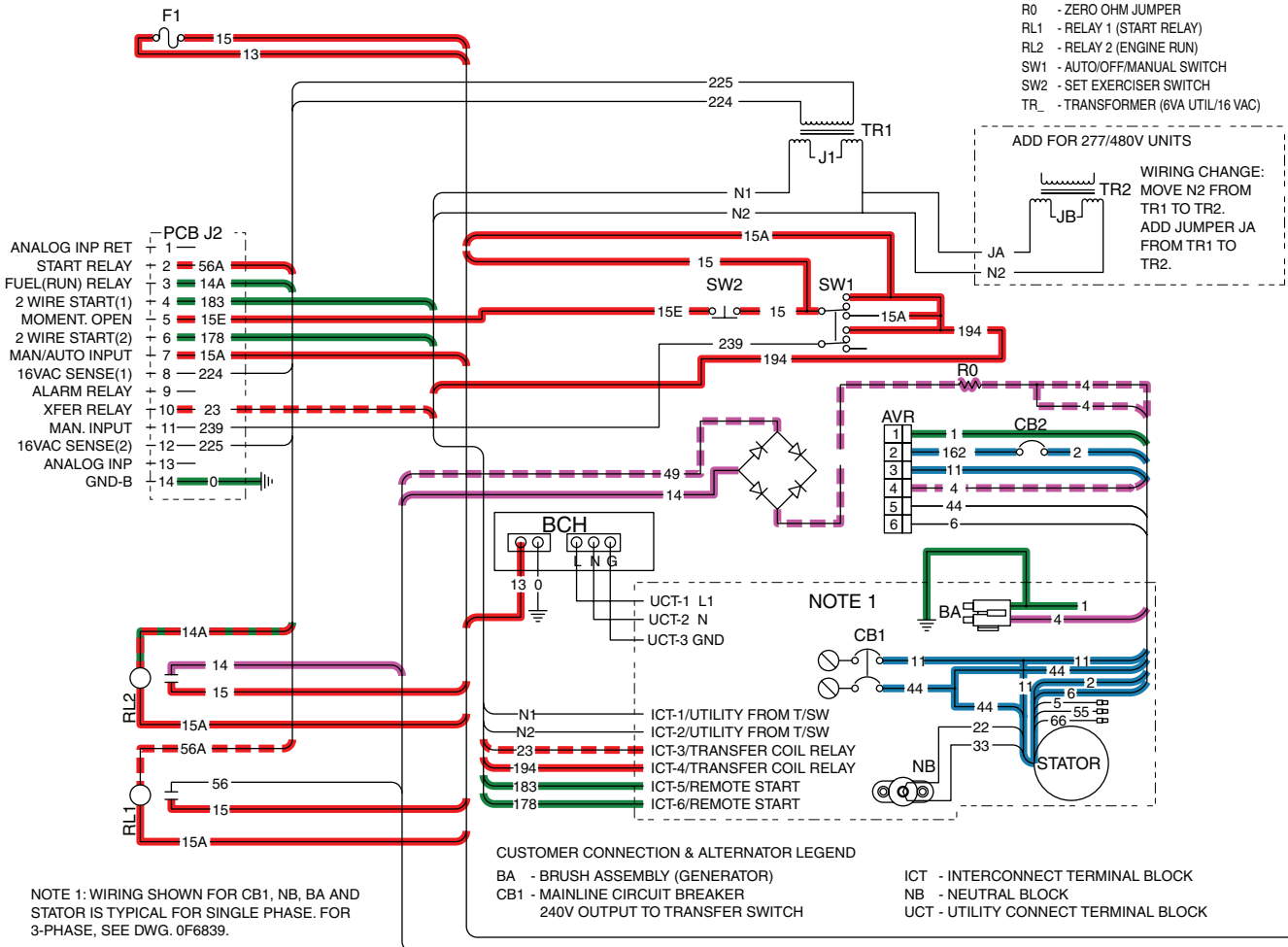

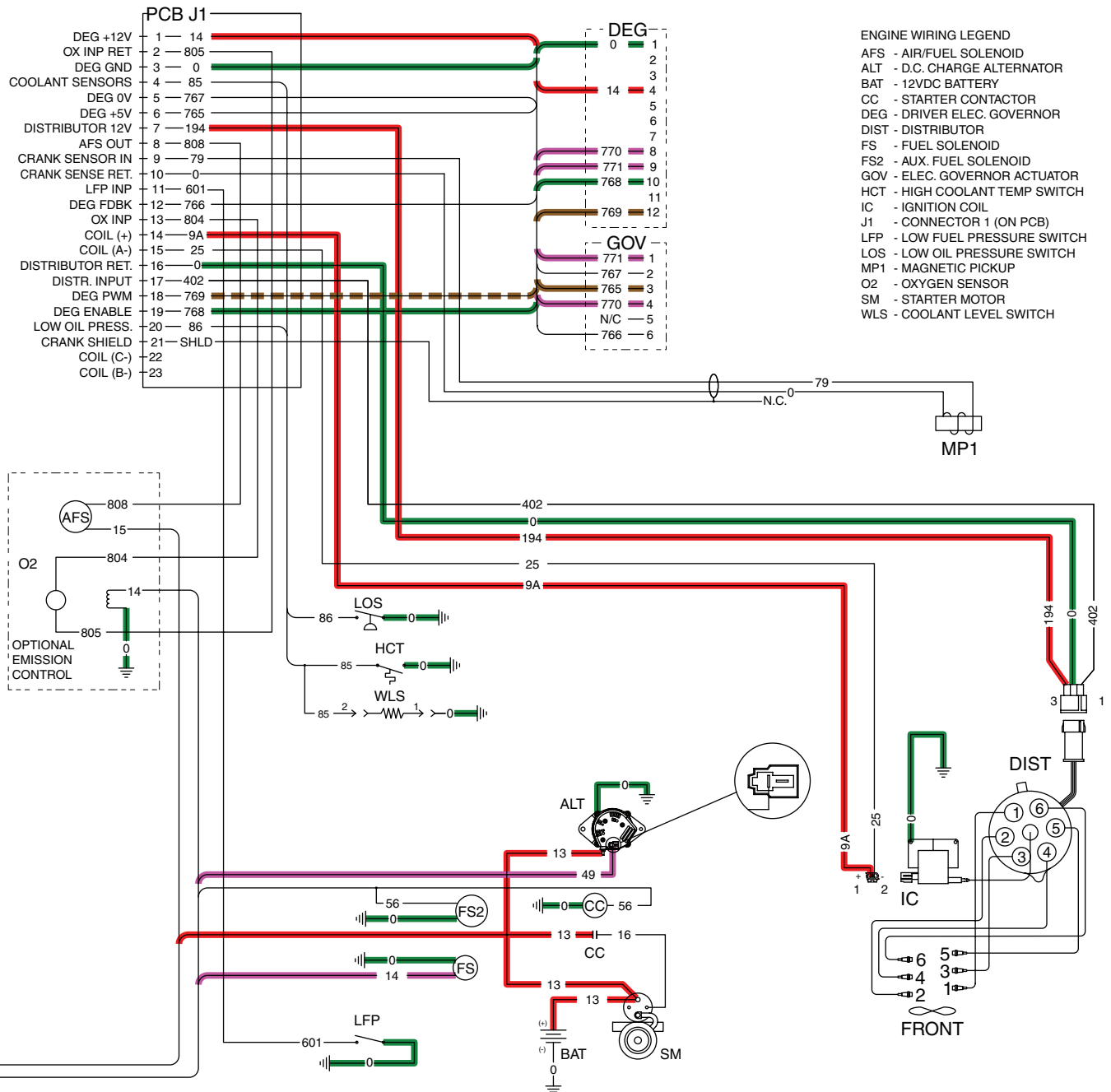

**RETURN OF UTILITY**

- For RTS and HS transfer switches, Utility will return and be sensed via N1 and N2. Transformer TR1 steps down this voltage. The stepped down sensing voltage is inputted to the control board (PCB) at J2 Pin 8 (Wire 224 and Pin 12 (Wire 225). After 80% utility voltage is sensed for a period of about 15 seconds the control board will remove ground off of PCB J2 Pin 10 (Wire 23). The difference of potential is removed from transfer relay of transfer switch, forcing the load to be transferred from generator to utility source. After transfer the control board will initiate a one minute cool down timer.
- For GTS configured units no change will occur at the generator.

- = 12 VDC ALWAYS PRESENT
- = AC VOLTAGE
- = GROUND
- = 12 VDC DURING CRANKING ONLY

- = 12 VDC DURING ENGINE RUN CONDITION
- = 5 VDC FOR 2-WIRE
- - - = FLASH VOLTS
- - - = 5 VDC PWM

- CONTROL PANEL LEGEND
- AVR - AUTOMATIC VOLTAGE REGULATOR
  - BCH - BATTERY CHARGER
  - BR1 - BRIDGE RECTIFIER
  - CB2 - CIRCUIT BREAKER (EXCITATION)
  - F1 - FUSE, BAT POWER (15A ATO TYPE)
  - J2 - CONNECTOR 2 (ON PCB)
  - R0 - ZERO OHM JUMPER
  - RL1 - RELAY 1 (START RELAY)
  - RL2 - RELAY 2 (ENGINE RUN)
  - SW1 - AUTO/OFF/MANUAL SWITCH
  - SW2 - SET EXERCISER SWITCH
  - TR\_ - TRANSFORMER (6VA UTIL/16 VAC)

ADD FOR 277/480V UNITS

WIRING CHANGE:  
MOVE N2 FROM  
TR1 TO TR2.  
ADD JUMPER JA  
FROM TR1 TO  
TR2.

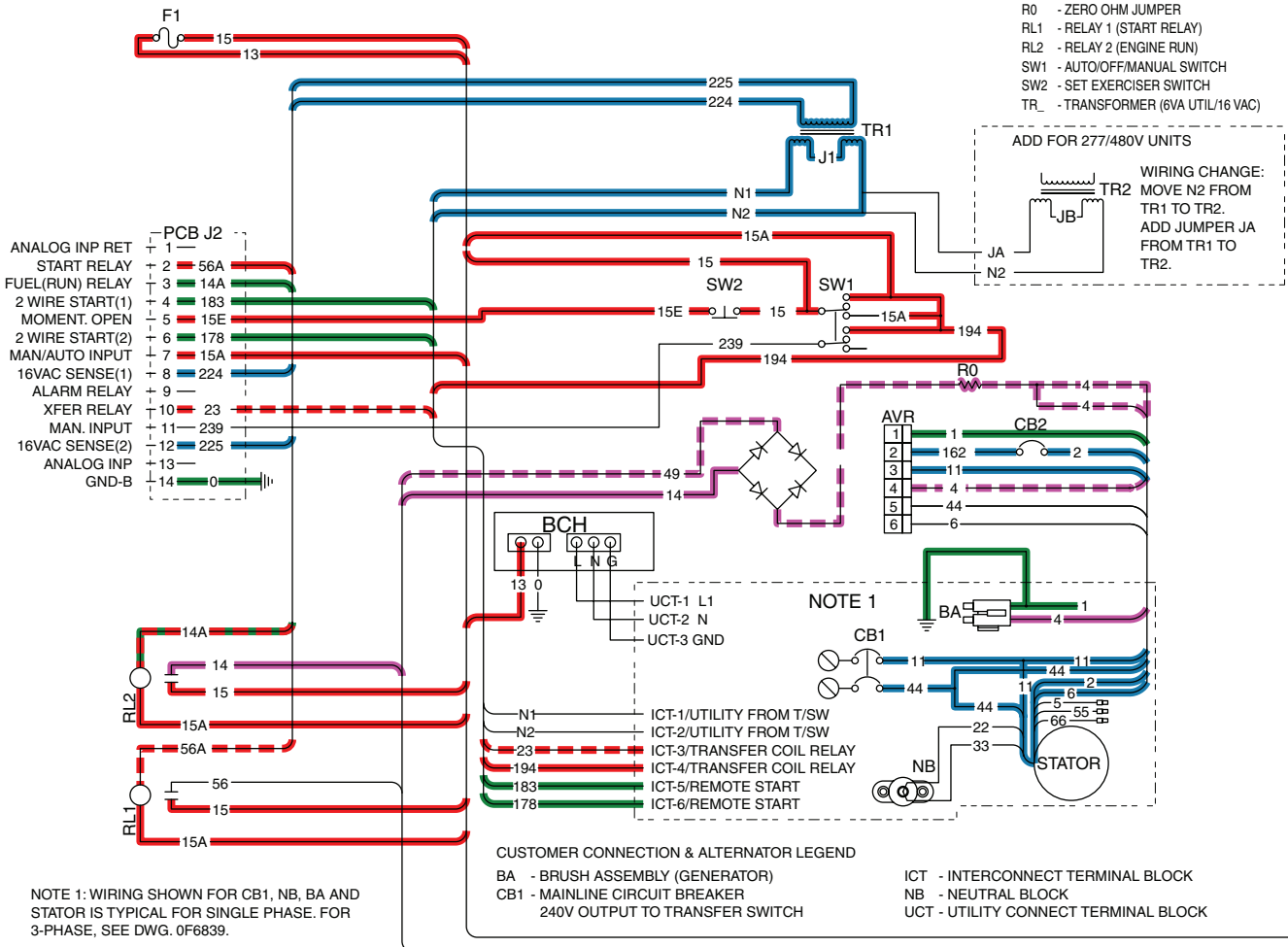

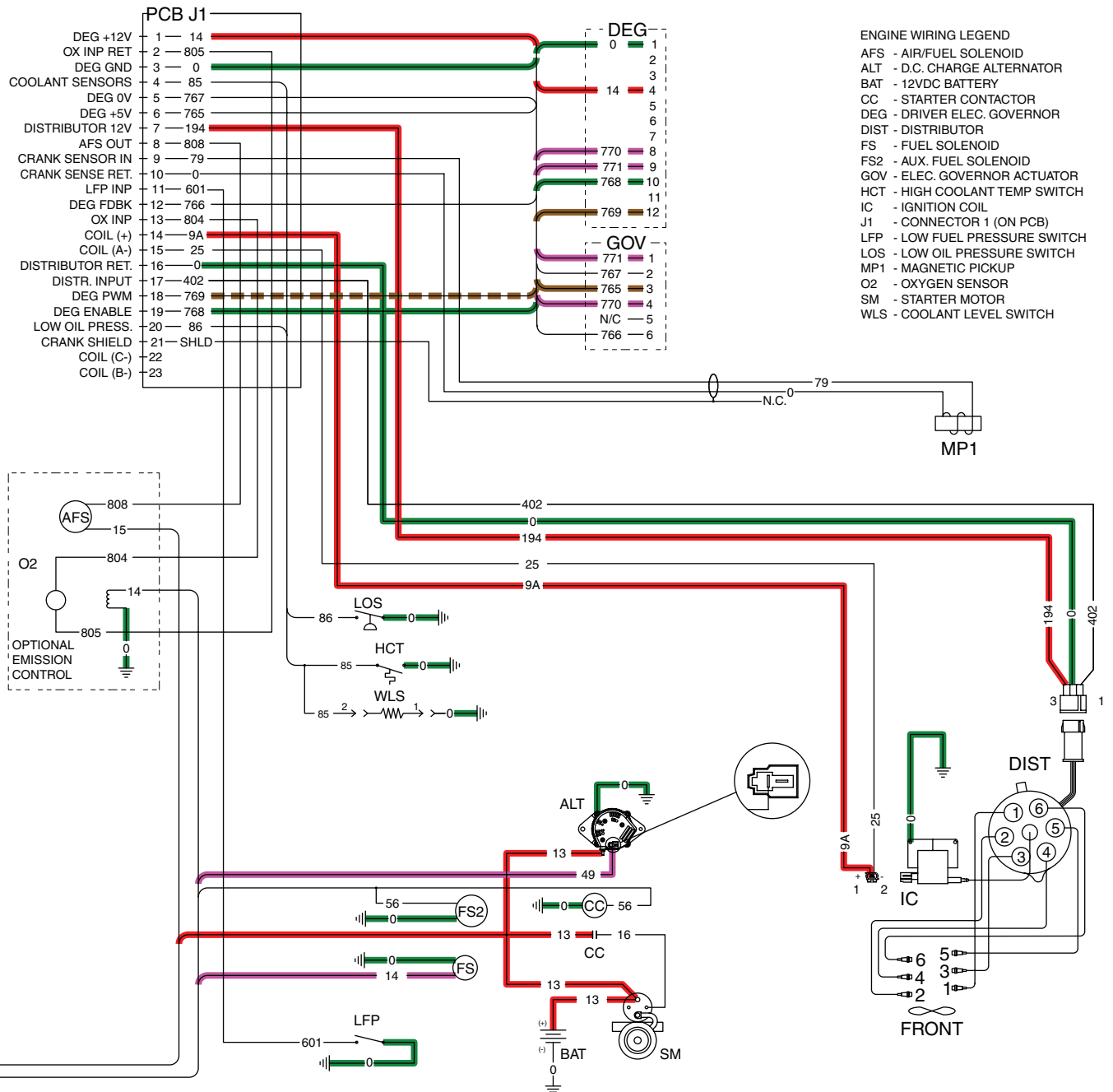

**SHUTDOWN**

- For RTS or HS transfer switches unit will shut down after cool down timer has completed its time out.
- For GTS configured transfer switches the two-wire start circuit opens, this is seen at the control board as a return of 5 VDC on J2 Pin 4
- In both cases the control board will remove ground from J2 Pin 3, removing power to the fuel system. The control board will also remove the ground from the driver enable line at J1 Pin 19 (Wire 768), allowing the actuator to close. Ignition will continue to fire coil until speed is no longer sensed.

- = 12 VDC ALWAYS PRESENT
- = AC VOLTAGE
- = GROUND
- = 12 VDC DURING CRANKING ONLY

- = 12 VDC DURING ENGINE RUN CONDITION
- = 5 VDC FOR 2-WIRE
- - - = FLASH VOLTS
- - - = 5 VDC PWM

- CONTROL PANEL LEGEND
- AVR - AUTOMATIC VOLTAGE REGULATOR
  - BCH - BATTERY CHARGER
  - BR1 - BRIDGE RECTIFIER
  - CB2 - CIRCUIT BREAKER (EXCITATION)
  - F1 - FUSE, BAT POWER (15A ATO TYPE)
  - J2 - CONNECTOR 2 (ON PCB)
  - R0 - ZERO OHM JUMPER
  - RL1 - RELAY 1 (START RELAY)
  - RL2 - RELAY 2 (ENGINE RUN)
  - SW1 - AUTO/OFF/MANUAL SWITCH
  - SW2 - SET EXERCISER SWITCH
  - TR\_ - TRANSFORMER (6VA UTIL/16 VAC)

ADD FOR 277/480V UNITS

WIRING CHANGE:  
MOVE N2 FROM  
TR1 TO TR2.  
ADD JUMPER JA  
FROM TR1 TO  
TR2.

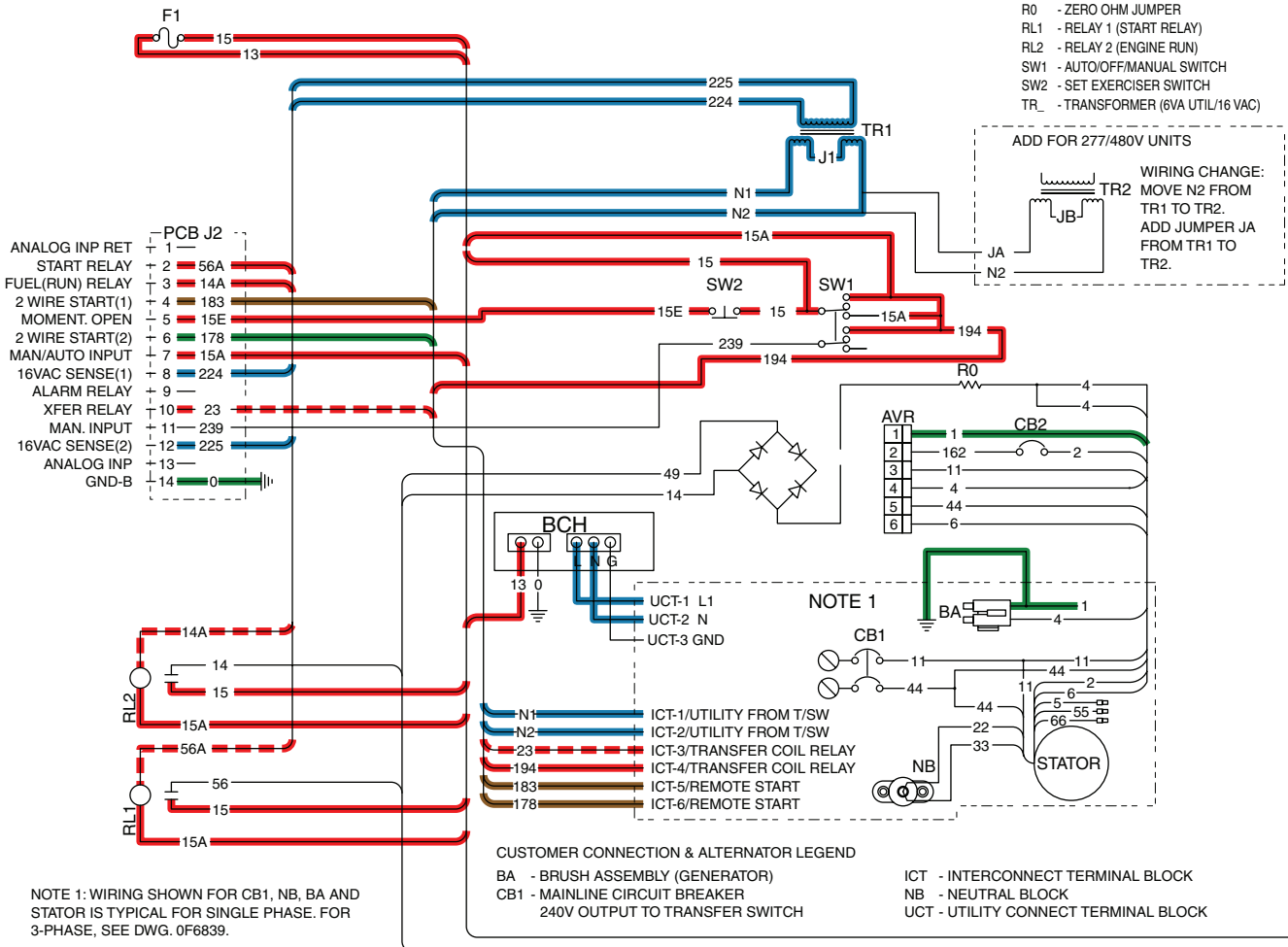

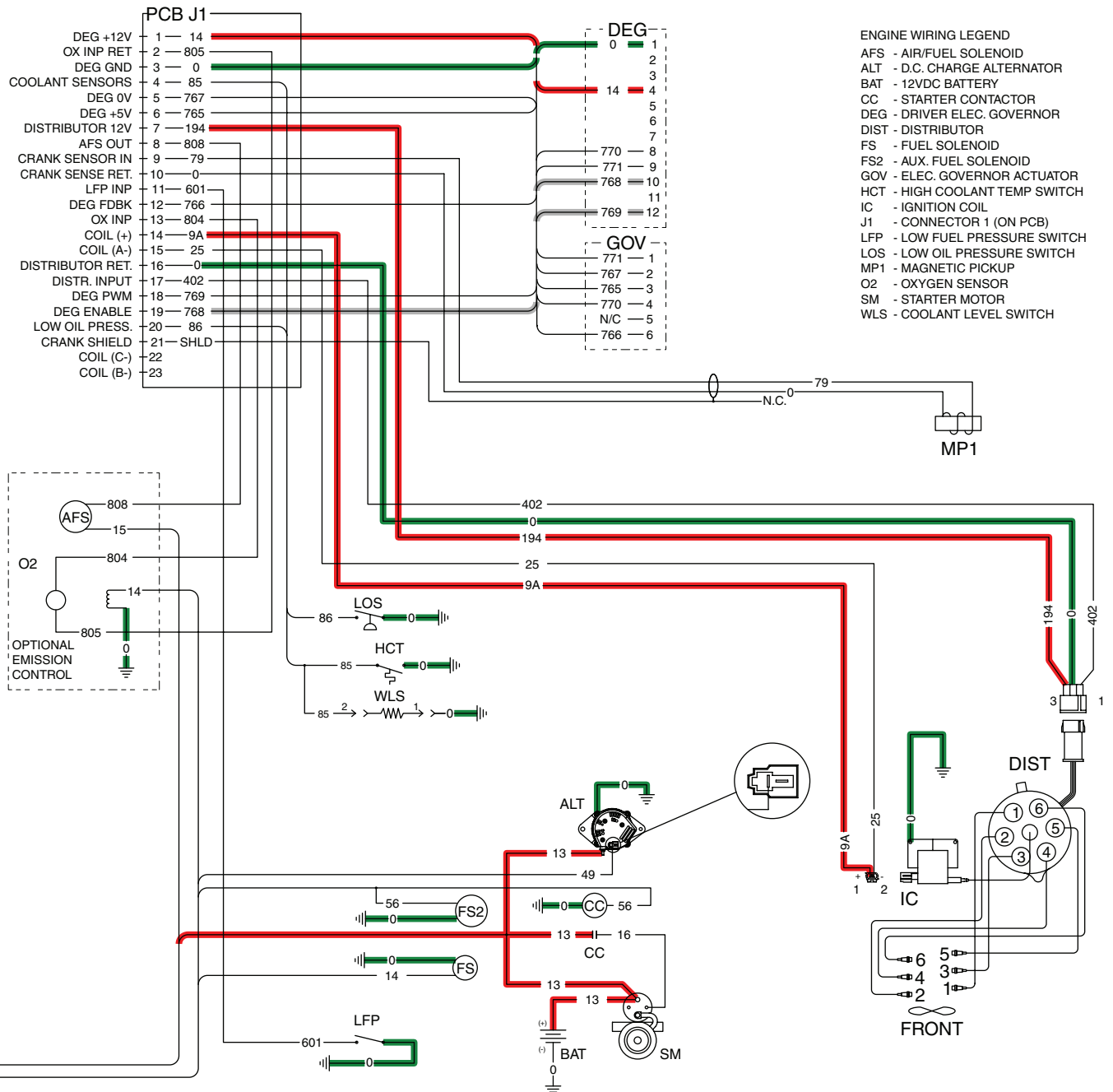

**SECTION 3.3**  
**TROUBLESHOOTING FLOW CHARTS**

**Problem 1 - Engine Will Not Crank When Utility Power Failure Occurs**

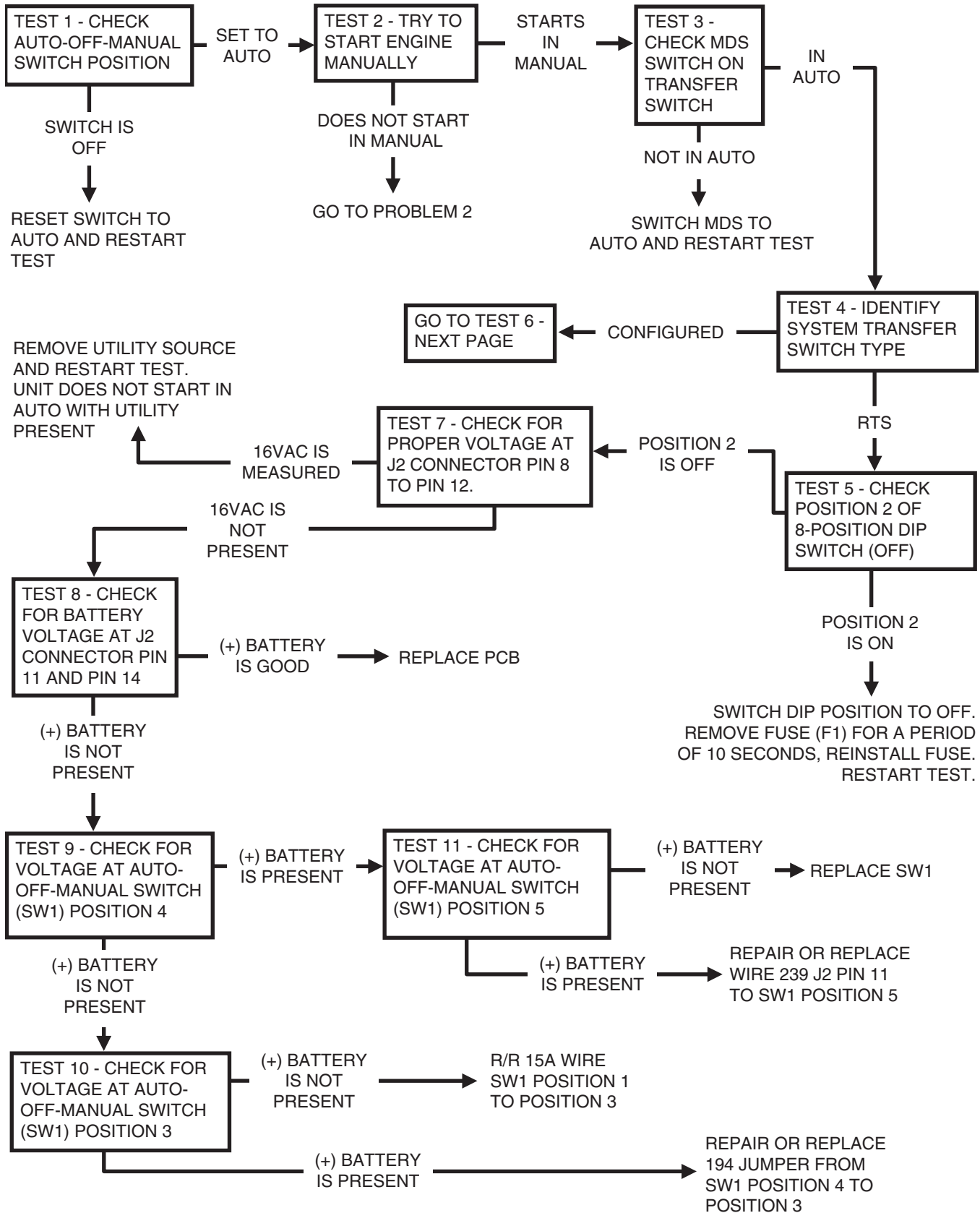

**Problem 1 - Engine Will Not Crank When Utility Power Failure Occurs (continued)**

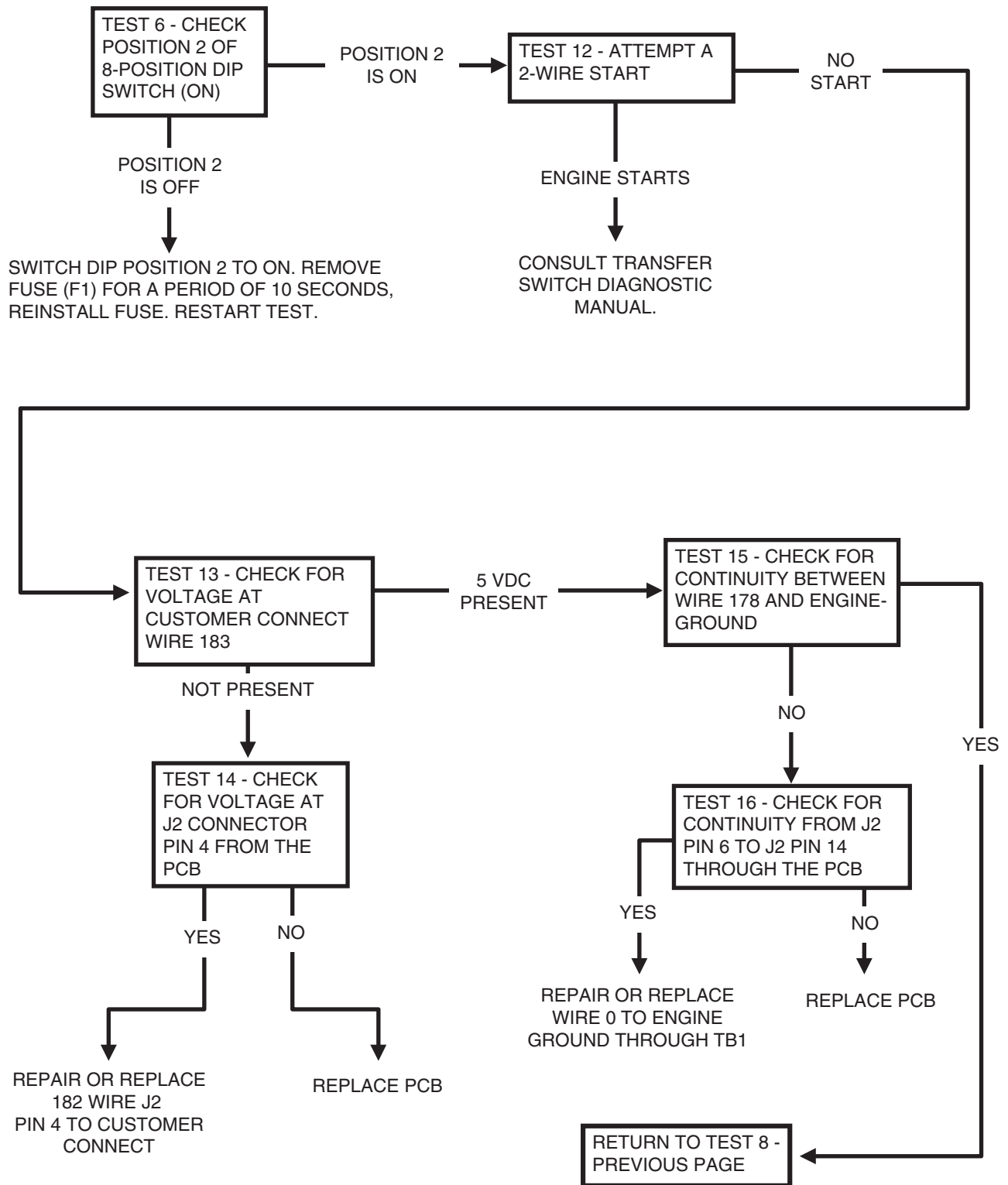

**SECTION 3.3**  
**TROUBLESHOOTING FLOW CHARTS**

**PART 3**

DC CONTROL  
 LIQUID COOLED  
 ENGINE UNITS

**Problem 2 - Engine Will Not Crank When SW1 is Set to MANUAL**

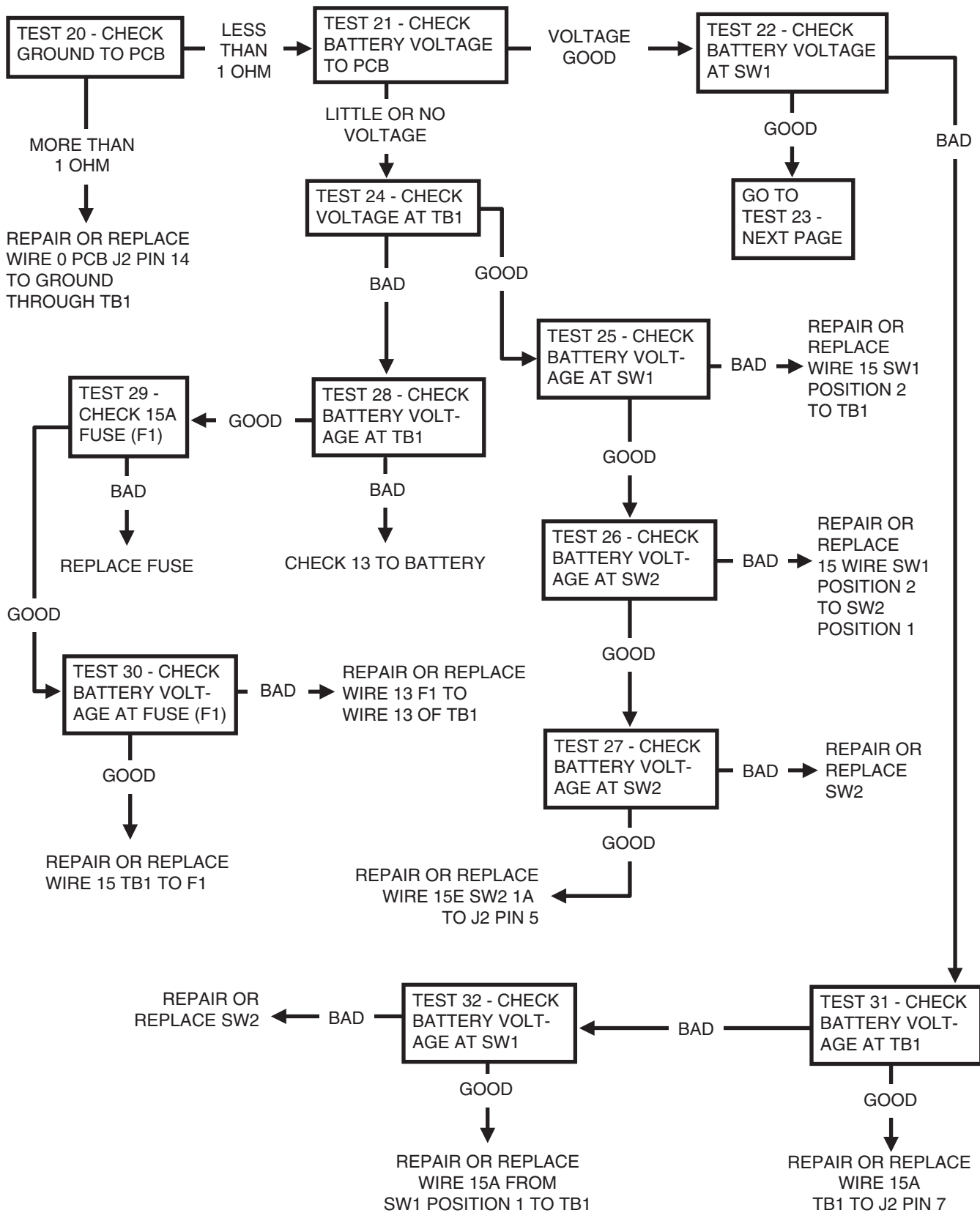

**Problem 2 - Engine Will Not Crank When SW1 is Set to MANUAL (continued)**

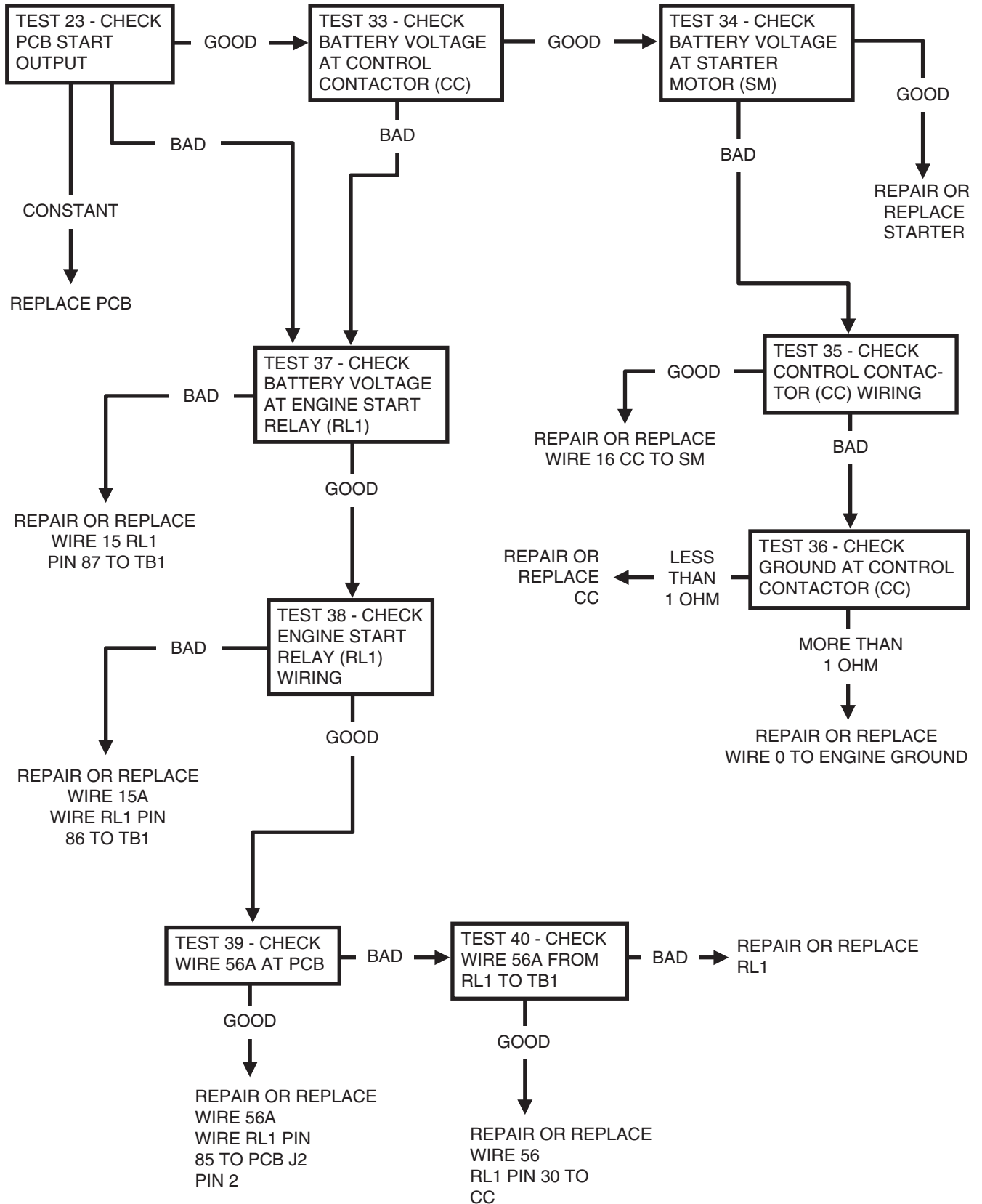

***Problem 3 - Engine Cranks But Will Not Start***

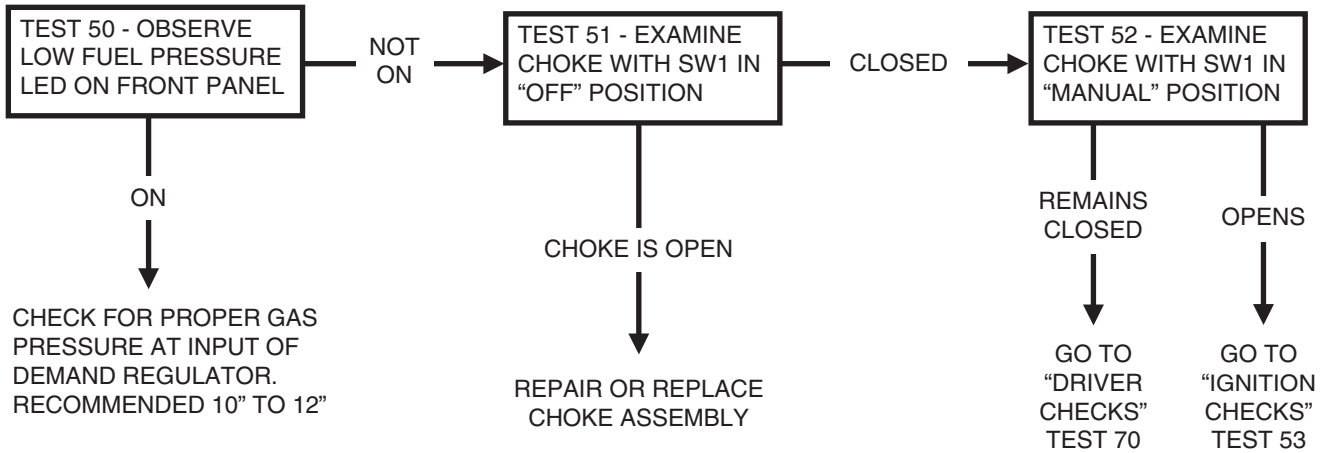

***Problem 3 - Engine Cranks But Will Not Start  
Ignition Checks***

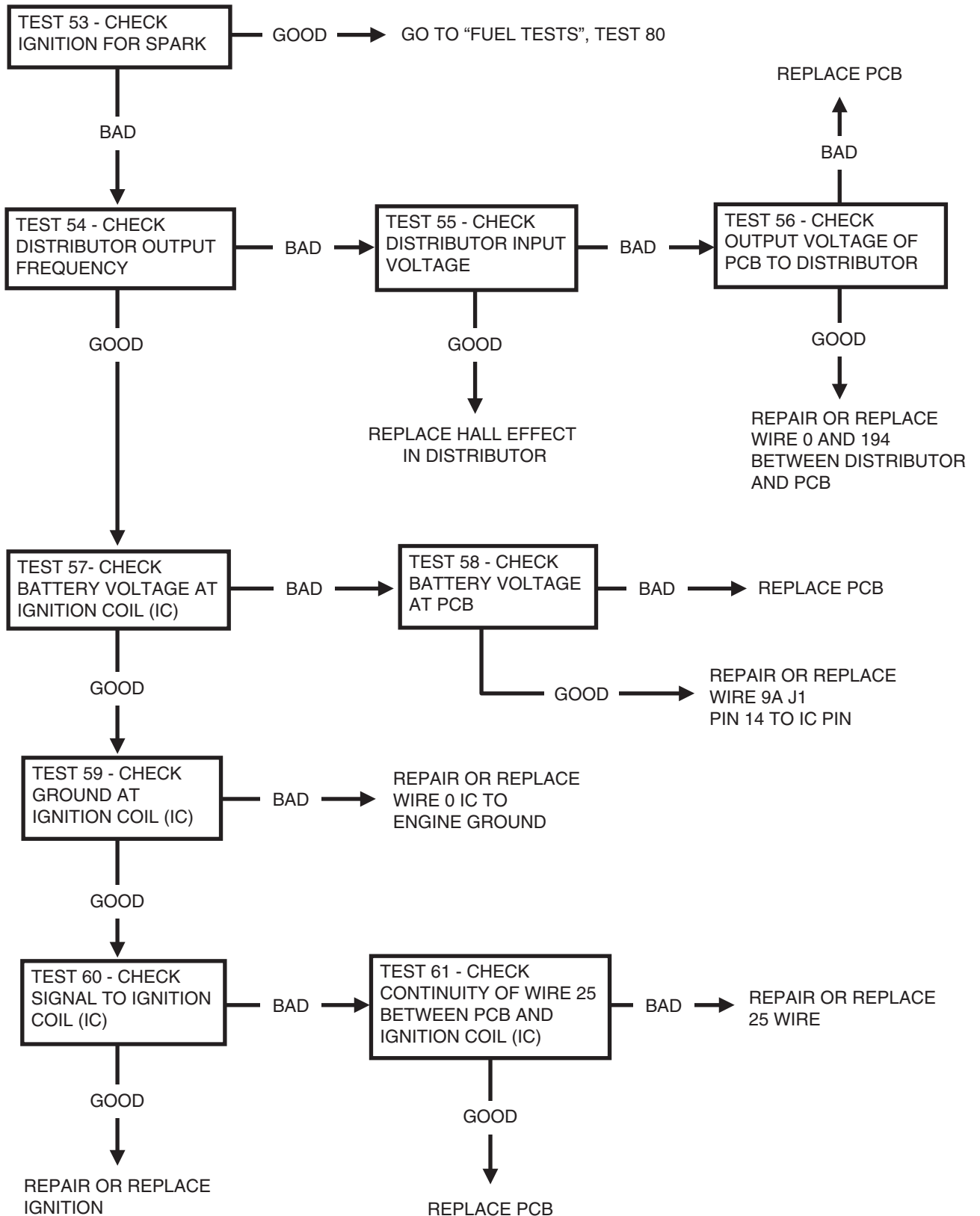

**Problem 3 - Engine Cranks But Will Not Start**  
**Relay Checks**

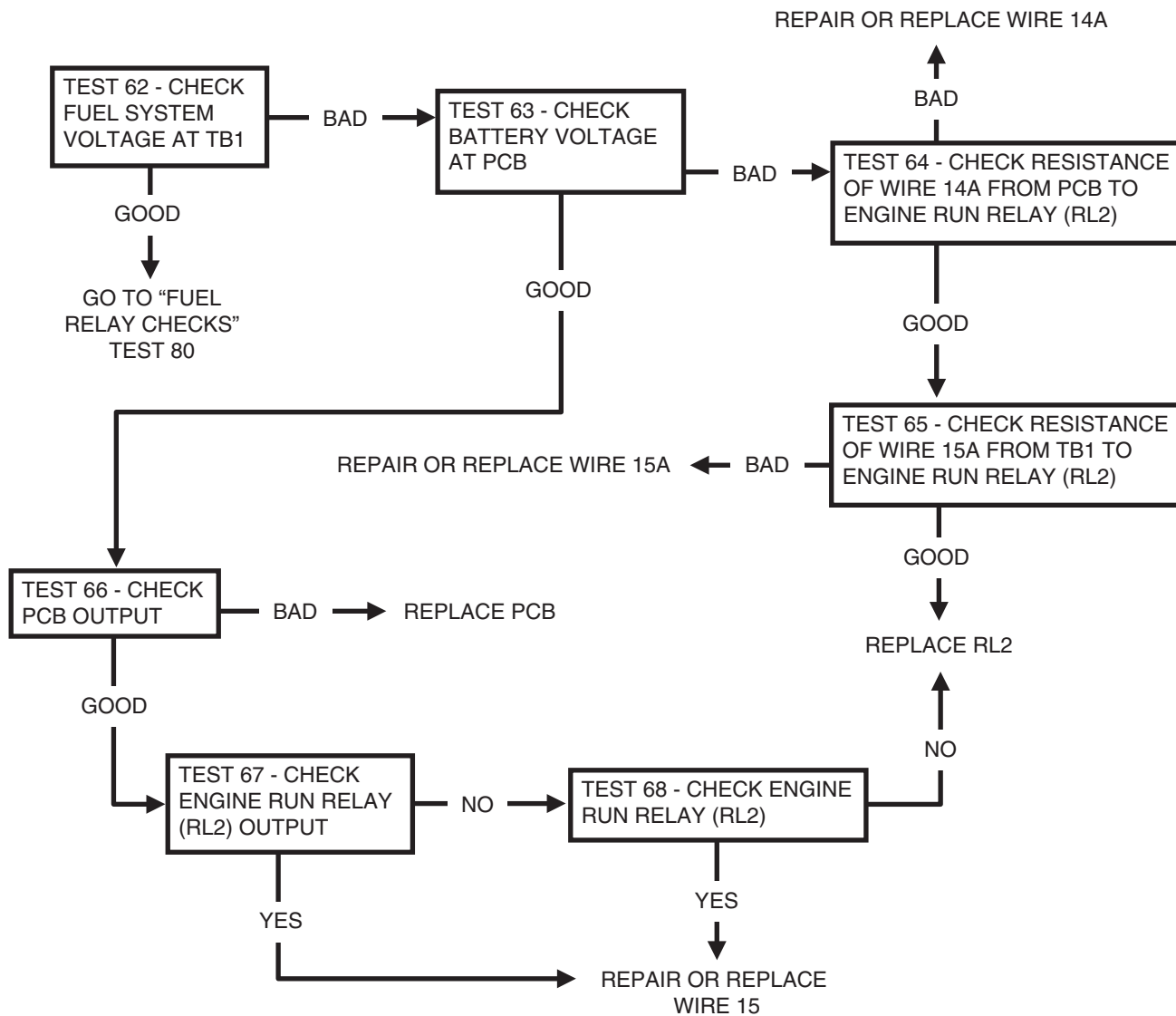

**Problem 3 - Engine Cranks But Will Not Start  
Driver Checks**

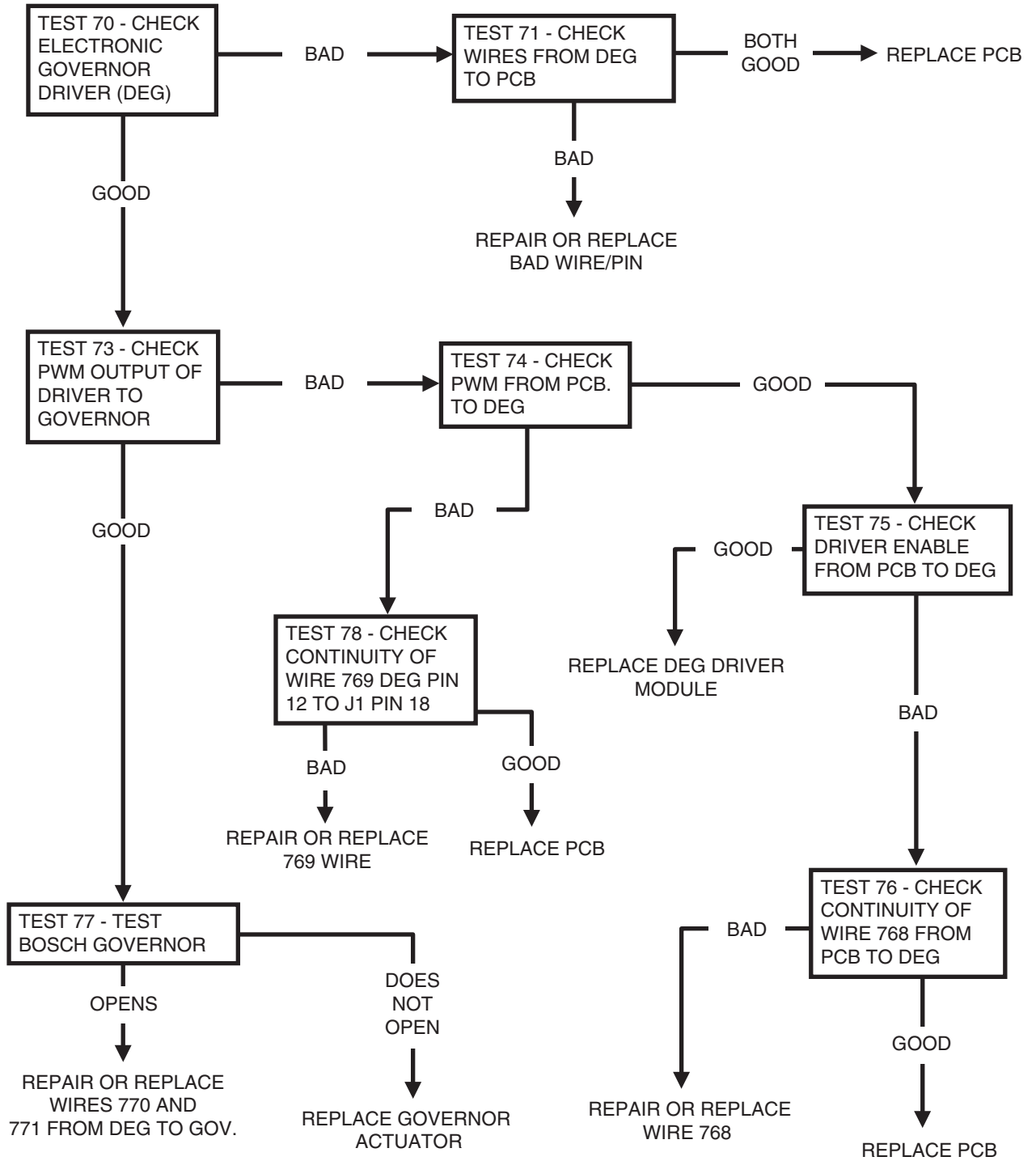

**Problem 3 - Engine Cranks But Will Not Start**  
**Fuel Checks**

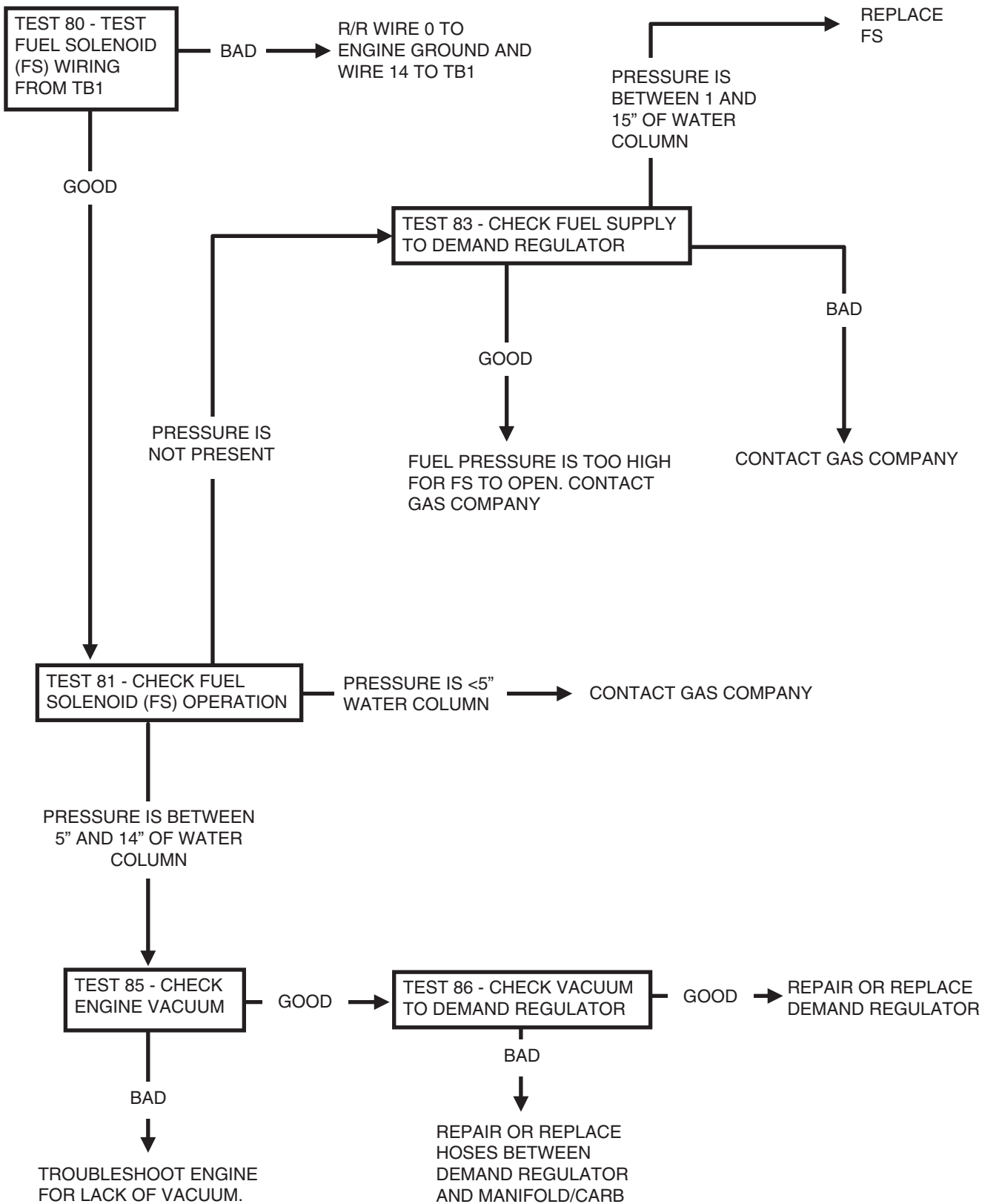

**Problem 4 - Low Battery Alarm**

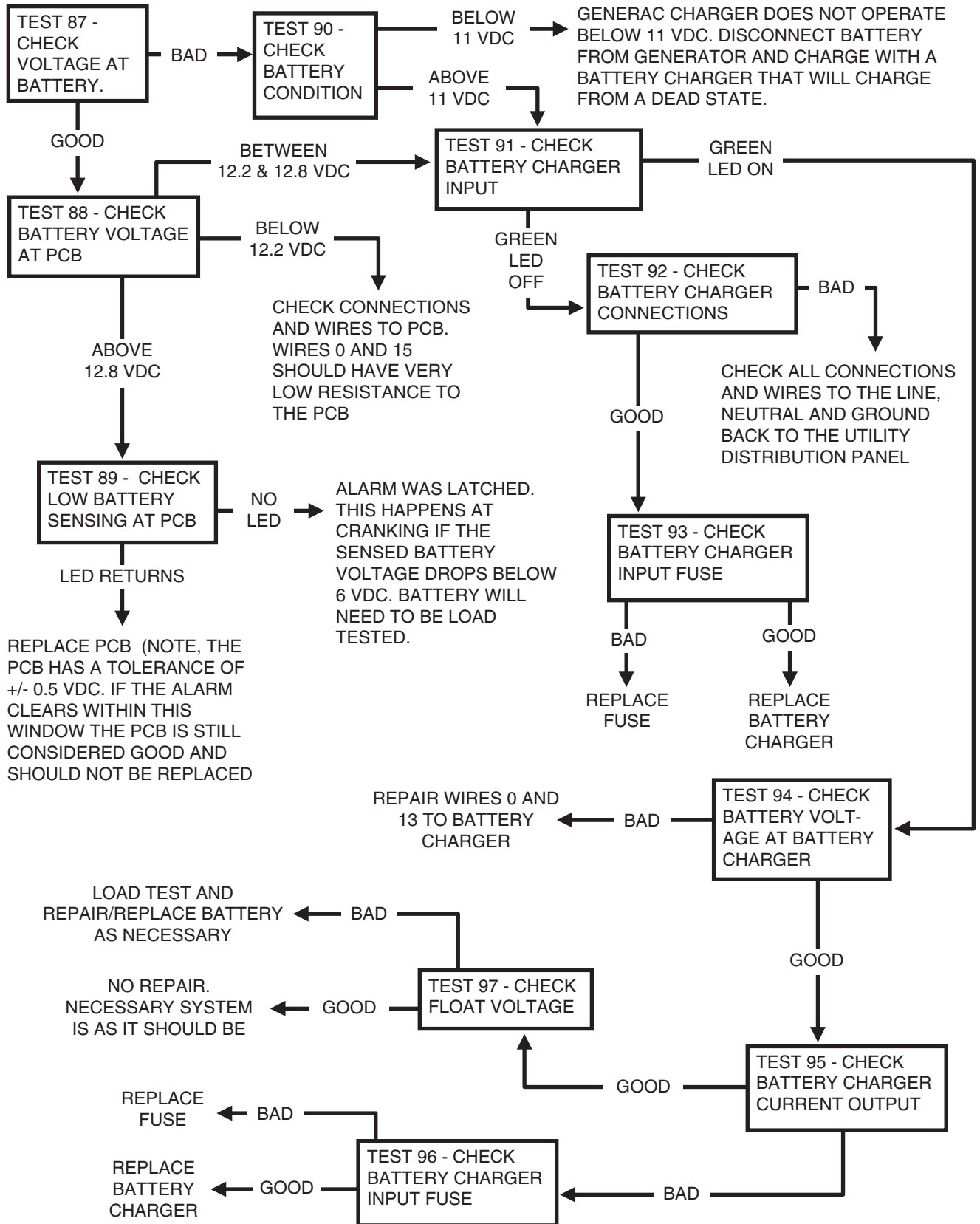

**Problem 5 - Low Coolant Alarm**

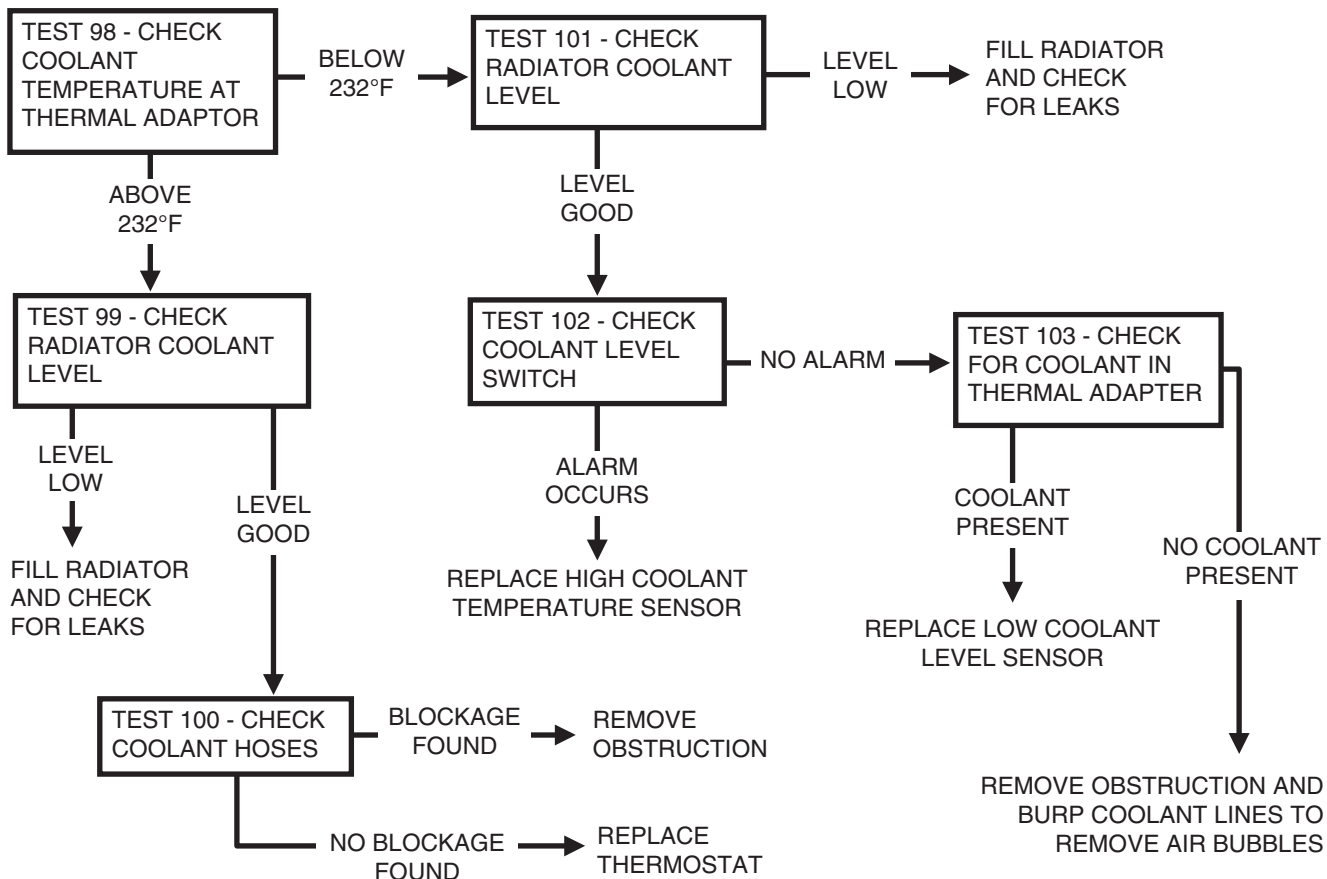

**Problem 6 - Low Oil Pressure**

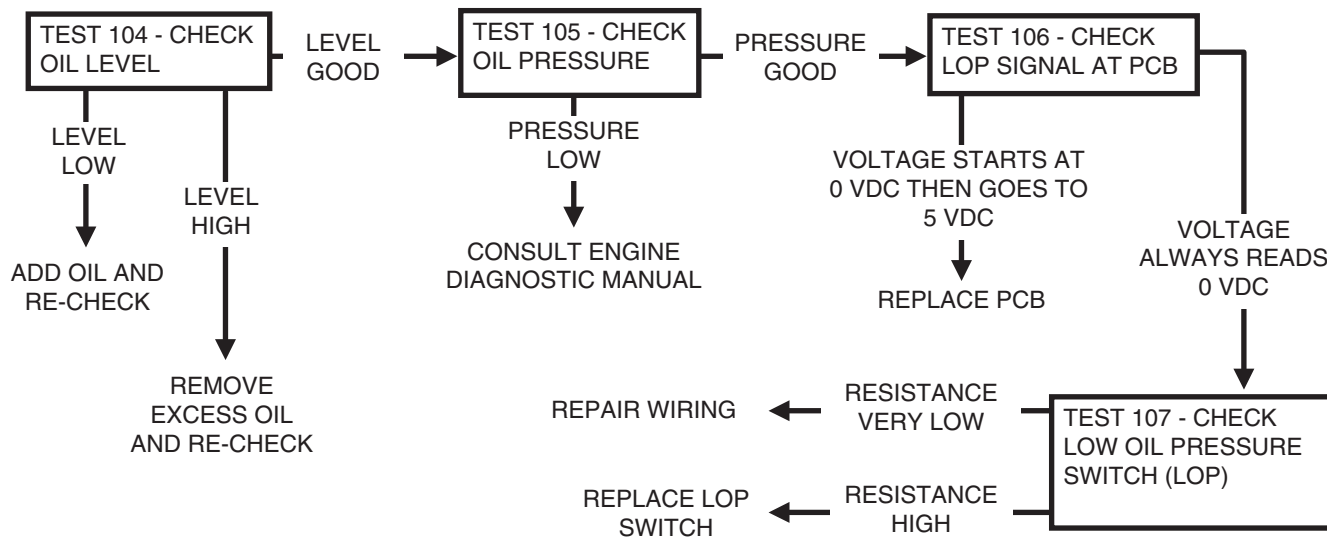

**GENERAL**

Perform the tests in this section in conjunction with the "Troubleshooting Flow Charts" of Section 4.3. Test numbers in this section correspond with the numbered tests in Section 4.3.

DISCUSSION:

In order for unit to start and transfer when in auto, the following requirements must be met.

1. Battery must be connected.
2. Generator Auto-off-manual must be set to Auto.
3. Maintenance disconnect switch (MDS) in transfer switch must be set to ON.
4. Utility source must be removed.
  - a. For RTS switches the sensing for the utility is in the generator control. When the utility sensed drops below a preset level (usually below 60% rated utility voltage), the control board will sense this, start generator and transfer load.
  - b. For configured GTS switches; utility sensing, warm-up, and cool-down timers are all controlled by the switch.

**TEST 1 - CHECK AUTO-OFF-MANUAL SWITCH POSITION**

DISCUSSION:

If the standby system is to operate automatically, the generator's AUTO-OFF-MANUAL switch must be set to AUTO. That is, the generator will not crank and start on occurrence of a "Utility" power outage unless that switch is at AUTO. In addition, the generator will not exercise every seven (7) days as programmed unless the switch is at AUTO.

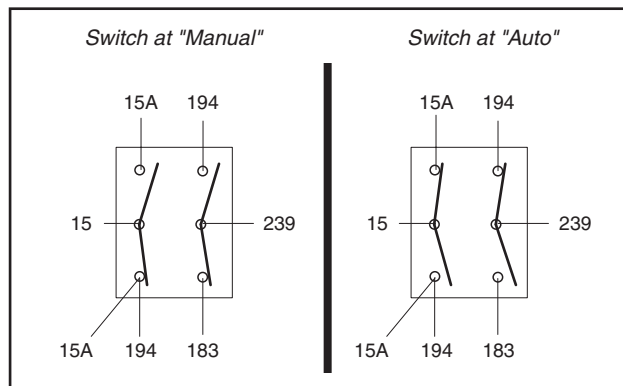

Figure 1. Schematic of AUTO-OFF-MANUAL Switch

PROCEDURE:

With the AUTO-OFF-MANUAL switch set to AUTO, test automatic operation. Testing of automatic operation can be accomplished by turning OFF the "Utility" power supply to the transfer switch. When the "Utility"

power is turned OFF, the standby generator should crank and start. Following startup, transfer to the "Standby" source should occur. Refer to Section 1.8 in this manual for an "Automatic Operating Sequences Chart". Use the chart as a guide in evaluating automatic operation.

Following generator startup and transfer to the "Standby" source, turn ON the "Utility" power supply to the transfer switch. Retransfer back to the "Utility" source should occur. After a "minimum run timer" and an "engine cool down timer" have timed out, generator shutdown should occur.

1. Check AUTO-OFF-MANUAL switch position.

RESULTS:

1. Switch is set to AUTO, go to Test 2
2. Switch is set to other than AUTO, place switch in AUTO and restart utility loss test.

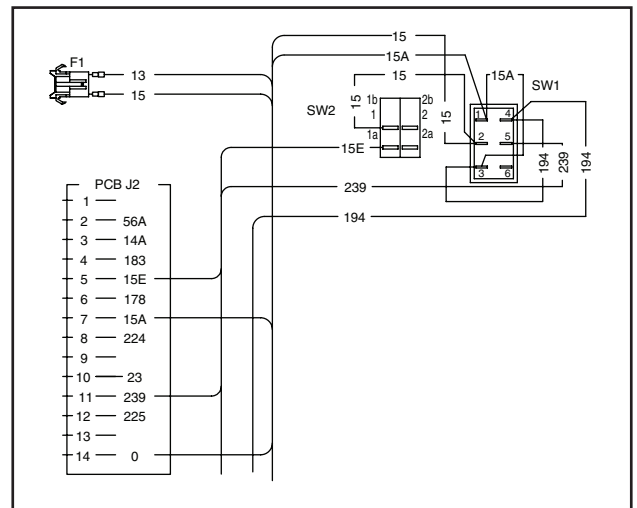

Figure 2. AUTO-OFF-MANUAL Switch Wiring

**TEST 2 - TRY TO START ENGINE MANUALLY**

DISCUSSION:

With the AUTO-OFF-MANUAL switch set to AUTO, a "Utility" power source outage should result in engine cranking and startup. If that power source fails and the engine does not crank, the first step in troubleshooting should be to see if a manual startup can be accomplished.

PROCEDURE:

1. When AUTO-OFF-MANUAL switch is moved to the manual position, does unit start?

RESULTS:

1. If unit starts, go to Test 3
2. If unit does not start, go to unit will not crank tests.

**TEST 3 - CHECK MDS SWITCH ON  
TRANSFER SWITCH**

1. Is the MDS switch on transfer switch ON?

RESULTS:

1. Switch is ON, go to Test 4.
2. For RTS and HS applications, go to Test 4. (MDS will not stop a unit from starting, it will only stop the switch from transferring).
3. For GTS configured MDS being off will stop the 2-wire start circuit from closing, place MDS on and restart test.

**TEST 4 - IDENTIFY SYSTEM TRANSFER  
SWITCH TYPE**

PROCEDURE:

1. What type of transfer switch does the system have?

RESULT:

1. If the system has an RTS or HS (Home Standby), go to Test 5.
2. If the unit is configured, and has a GTS, go to Test 6.

**TEST 5 - CHECK POSITION 2 OF 8-POSITION  
DIP SWITCH (OFF)**

PROCEDURE:

1. Open the control panel to expose the backside of the control board.
2. Check Position 2 of the 8-position Dip switch.

RESULTS:

1. If Position 2 is OFF, go to Test 7
2. If Position 2 is ON, switch it to the OFF position, place AUTO-OFF-MANUAL switch to OFF, then press and hold the Set Exercise switch for 10 seconds. This should reset the power to the control board so the control board recognizes the new setting.

**TEST 6 - CHECK POSITION 2 OF 8-POSITION  
DIP SWITCH (ON)**

PROCEDURE:

1. Open the control panel to expose the backside of the control board.
2. Check Position 2 of the 8-position Dipswitch.

RESULTS:

1. If Position 2 is OFF, go to Test 12
2. If Position 2 is OFF, switch it to the ON position, place AUTO-OFF-MANUAL switch to OFF, then press and hold the Set Exercise switch for 10 seconds. This should reset the power to the control board so the control board recognizes the new setting.

**TEST 7 - CHECK FOR PROPER VOLTAGE AT  
J2 CONNECTOR PIN 8 TO PIN 12**

PROCEDURE:

1. Disconnect the battery.
2. Open the control panel.
3. Carefully remove the J2 connector plug.
4. Place a VOM on AC Volts.
5. Locate Pin 8 and Pin 12. Connect one meter test lead to each pin.

**Caution: Do not force meter leads into connector pins, as the leads will spread the pins and cause future bad connections!**

RESULTS:

1. If less than 9 VAC is measured, go to Test 8
2. If more than 9 VAC is measured, utility is not low enough for generator to start and transfer. Completely remove utility source and restart test.

**TEST 8 - CHECK FOR BATTERY VOLTAGE AT  
J2 CONNECTOR PIN 11 AND PIN 14**

PROCEDURE:

1. Open the control panel.
2. Carefully remove the J2 connector plug.
3. Place AUTO-OFF-MANUAL switch to AUTO.
4. Place a VOM on DC volts.
5. Place the black (-) test lead on J2 Pin 14, and the red (+) test lead on J2 Pin 11.

**Caution: Do not force meter leads into connector pins, as the leads will spread the pins and cause future bad connections!**

RESULTS:

1. If (+) battery voltage is measured, replace the PCB.
2. If little or no voltage is measured, go to Test 9

**TEST 9 - CHECK FOR VOLTAGE AT AUTO-OFF-MANUAL SWITCH (SW1) POSITION 4**PROCEDURE:

1. Open the control panel.
2. Place a VOM on DC volts
3. Place the black (-) test lead on Terminal 0 of TB1. Place the red (+) test lead on SW1 Position 4 (Wire 194).

RESULTS:

1. If (+) battery voltage is measured, go to Test 11.
2. If little or no voltage is measured, go to Test 10

**TEST 10 - CHECK FOR VOLTAGE AT AUTO-OFF-MANUAL SWITCH (SW1) POSITION 3**PROCEDURE:

1. Open the control panel.
2. Place a VOM on DC volts
3. Place the black (-) test lead on Terminal 0 of TB1. Place the red (+) test lead on SW1 Position 3 (Wire 15A and Wire 194).

RESULTS:

1. If (+) battery voltage is measured, repair jumper Wire 194 from SW1 Position 4 to Position 3.
2. If little or no voltage is measured, repair jumper Wire 15A from SW1 Position 1 to Position 3.

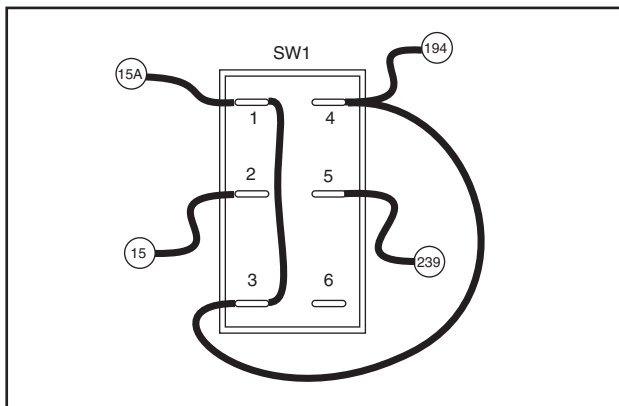

Figure 3. AUTO-OFF-MANUAL Switch Test Points

**TEST 11 - CHECK FOR VOLTAGE AT AUTO-OFF-MANUAL SWITCH (SW1) POSITION 5**PROCEDURE:

1. Open the control panel.

2. Place a VOM on DC volts
3. Place the black (-) test lead on Terminal 0 of TB1. Place the red (+) test lead on SW1 Position 5 (Wire 239).

RESULTS:

1. If (+) battery voltage is measured, repair Wire 239 from SW1 Position 5 to PCB J2 Connector Pin 11.
2. If little or no voltage is measured, repair or replace SW1.

**TEST 12 - ATTEMPT A 2-WIRE START**PROCEDURE:

1. Place AUTO-OFF-MANUAL switch in OFF.
2. Remove the customer connect access cover.
3. Place jumper across Wire 183 to Wire 178. This will complete a 2-wire start circuit.
4. Place AUTO-OFF-MANUAL switch to AUTO.

RESULTS:

1. If the engine starts, consult transfer switch diagnostic manual. Problem is with the transfer switch or connecting wires.
2. If engine does not start, go to Test 13.

**TEST 13 - CHECK FOR VOLTAGE AT CUSTOMER CONNECT WIRE 183**PROCEDURE:

1. Place AUTO-OFF-MANUAL switch in OFF.
2. Remove the customer connect access cover.
3. Open the control panel.
4. Remove Wire 183 coming from the transfer switch to the customer connect.
5. Place a VOM on DC volts
6. Place the black (-) test lead on Terminal 0 of TB1. Place the red (+) test lead on Wire 183 at the customer connect.

RESULTS:

1. If 5 VDC is measured, go to Test 15.
2. If little or no voltage is measured, go to Test 14.

**TEST 14 - CHECK FOR VOLTAGE AT J2 CONNECTOR PIN 4 FROM PCB**

1. Disconnect the battery.
2. Remove the customer connect access cover.
3. Open the control panel.

4. Remove Wire 183 coming from transfer switch to the customer connect.
5. Carefully remove the PCB J2 connector plug.
6. Set a VOM to measure resistance.
7. Connect one test lead to Wire 183 of customer connect. Connect the other test lead to PCB J2 Connector Pin 4. Measure the resistance.

RESULTS:

1. If resistance measures less than 1 ohm, replace the PCB.
2. If resistance is greater than 1 ohm, repair Wire 183 from the customer connect to PCB J2 Connector Pin 4.

**TEST 15 - CHECK FOR CONTINUITY  
BETWEEN WIRE 178 AND ENGINE GROUND**

1. Disconnect the battery.
2. Remove the customer connect access cover.
3. Remove Wire 178 coming from transfer switch to the customer connect.
4. Set a VOM to measure resistance.
5. Connect one test lead to Wire 178 of the customer connect. Connect the other test lead to engine ground.

RESULTS:

1. If the resistance measured is greater than 10 ohms, go to Test 16.
2. If the resistance measured is less than 10 ohms, go to Test 8.

**TEST 16 - CHECK FOR CONTINUITY FROM  
J2 PIN 6 TO J2 PIN 14 THROUGH THE PCB**

PROCEDURE:

1. Disconnect the battery.
2. Open the control panel.
3. Carefully remove the PCB J2 connector plug.
4. Set a VOM to measure resistance.
5. Connect one test lead to PCB J2 Pin 14 and the other test lead to PCB J2 Pin 6.

RESULTS:

1. If resistance measures less than 5 ohms, repair Wire 178 from PCB J2 Pin 6 to the customer connect.
2. If resistance measures greater than 5 ohms replace the PCB.

**TEST 20 - CHECK GROUND TO PCB**

PROCEDURE:

1. Disconnect the battery.
2. Open the control panel.
3. Carefully remove PCB J2 connector.
4. Set a VOM to measure resistance.
5. Measure resistance from PCB J2 Pin 14 to engine ground.



**Do not force meter leads into pins, leads will spread pins and cause future bad connections!!**

RESULTS:

1. If resistance measures more than 1 ohm, repair Wire 0 from engine ground through TB1 to PCB J2 Pin 14.
2. Resistance measures less than 1 ohm, reconnect battery and go to Test 21.

**TEST 21 - CHECK BATTERY VOLTAGE TO PCB**

PROCEDURE:

1. Open the control panel.
2. Carefully remove PCB J2 connector.
3. Set AUTO-OFF-MANUAL switch to MANUAL.
4. Set a VOM to measure DC volts.
5. Connect the black (-) test lead to Position 0 of TB1. Connect the red (+) test lead to PCB J2 Pin 5.



**Do not force meter leads into pins, leads will spread pins and cause future bad connections!!**

RESULTS:

1. If little or no voltage is measured, go to Test 24.
2. If (+) battery voltage is measured, go to Test 22.

**TEST 22 - CHECK BATTERY VOLTAGE AT PCB**

PROCEDURE:

1. Open the control panel.
2. Carefully remove PCB J2 connector.
3. Set AUTO-OFF-MANUAL switch to MANUAL.
4. Set a VOM to measure DC volts.
5. Connect the black (-) test lead to Position 0 of TB1. Connect the red (+) test lead to PCB J2 Pin 7.



**Do not force meter leads into pins, leads will spread pins and cause future bad connections!**

RESULTS:

1. If little or no voltage is measured, go to Test 31.
2. If (+) battery voltage is measured, reconnect PCB J2 Connector and go to Test 23.

**TEST 23 - CHECK PCB START OUTPUT**

PROCEDURE:

1. Open the control panel.
2. Set a VOM to measure DC volts.
3. Connect the black (-) test lead to Position 0 of TB1. Connect the red (+) test lead to PCB J2 Pin 2 (Wire 56A). To connect to Pin 2 it is best to use a J-hook and connect to the metal bar that connects the pin to the PCB solder point, or use a wire piercing probe. Shorting to another lead on the PCB will cause damage to PCB components.
4. Set the AUTO-OFF-MANUAL switch to MANUAL. Watch the meter for several crank cycles. Crank cycle will consist of an initial crank time of 15 seconds. During this time Line 56A is pulled low. A measurement of 0.2 to 0.7 VDC is expected. After the initial crank, the control board will go to a 7-second period of rest. Expected voltage during rest time is (+) battery.

RESULTS:

1. If (+) battery voltage is constant, the board is not pulling low during the cranking cycle. Replace the PCB.
2. A measurement of consistently low or no voltage (0 to 0.7 VDC) is an indication that the engine start relay is not operating. Therefore it can be assumed that (+) battery is not available. Go to Test 37.
3. If voltage is cycling low, then high as expected, go to Test 33.

**TEST 24 - CHECK VOLTAGE AT TB1**

PROCEDURE:

1. Open the control panel.
2. Set a VOM to measure DC volts.
3. Connect the black (-) test lead to Position 0 of TB1. Connect the red (+) test lead to Position 15 of TB1.

RESULTS:

1. If (+) battery voltage is measured, go to Test 25.
2. If little or no voltage is measured, go to Test 28.

**TEST 25 - CHECK BATTERY VOLTAGE AT SW1**

1. Open the control panel.
2. Set a VOM to measure DC volts.
3. Connect the black (-) test lead to Position 0 of TB1. Connect the red (+) test lead to Position 2 of SW1.

RESULTS:

1. If (+) battery voltage is measured, go to Test 26.
2. If little or no voltage is measured, repair Wire 15 from TB1 to Position 2 of SW1.

**TEST 26 - CHECK BATTERY VOLTAGE AT SW2**

PROCEDURE:

1. Open the control panel.
2. Set a VOM to measure DC volts.
3. Connect the black (-) test lead to Position 0 of TB1. Connect the red (+) test lead to Position 1 of SW2.

RESULTS:

1. If (+) battery voltage is measured, go to Test 27.
2. If little or no voltage is measured, repair Wire 15 from SW1 Position 2 to SW1 Position 1 of SW2.

**TEST 27 - CHECK BATTERY VOLTAGE AT SW2**

1. Open the control panel.
2. Set a VOM to measure DC volts.
3. Connect the black (-) test lead to Position 0 of TB1. Connect the red (+) test lead to Position 1A of SW2.

RESULTS:

1. If (+) battery voltage is measured, repair Wire 15E SW2 Position 1A to PCB J2 Pin 5.
2. If little or no voltage is measured, repair SW2.

**TEST 28 - CHECK BATTERY VOLTAGE AT TB1**

PROCEDURE:

1. Open the control panel.
2. Set a VOM to measure DC volts.
3. Connect the black (-) test lead to Position 0 of TB1. Connect the red (+) test lead to Position 13 of TB1.

RESULTS:

1. If (+) battery voltage is measured, go to Test 29.
2. If little or no voltage is measured, repair Wire 13 from TB1 to battery.

**TEST 29 - CHECK 15A FUSE (F1)**

1. Open the control panel.
2. Pull the 15 amp fuse (F1) in lower left of control panel and inspect.

RESULTS:

1. If fuse is open/blown, look for short and replace fuse.
2. If fuse is good, go to Test 30.

**TEST 30 - CHECK BATTERY VOLTAGE AT FUSE (F1)**

1. Open the control panel.
2. Set a VOM to measure DC volts.
3. Connect the black (-) test lead to Position 0 of TB1. Connect the red (+) test lead to Wire 13 of F1.

RESULTS:

1. If (+) battery voltage is measured, repair Wire 15 F1 to TB1.
2. If little or no voltage is measured, repair Wire 13 F1 to TB1.

**TEST 31 - CHECK BATTERY VOLTAGE AT TB1**

1. Open the control panel.
2. Set the AUTO-OFF-MANUAL to MANUAL.
3. Set a VOM to measure DC volts.
4. Connect the black (-) test lead to Position 0 of TB1. Connect the red (+) test lead to 15A of TB1.

RESULTS:

1. If (+) battery voltage is measured, repair Wire 15A from TB1 to J2 Pin 7.
2. If little or no voltage is measured, go to Test 32.

**TEST 32 - CHECK BATTERY VOLTAGE AT SW1**

1. Open the control panel.
2. Set the AUTO-OFF-MANUAL to MANUAL.
3. Set a VOM to measure DC volts.
4. Connect the black (-) test lead to Position 0 of TB1. Connect the red (+) test lead Position 1 (Wire 15A) of SW1.

RESULTS:

1. If (+) battery voltage is measured, repair Wire 15A from TB1 to SW1 Position 1.

2. If little or no voltage is measured, repair SW2.

**TEST 33 - CHECK BATTERY VOLTAGE AT CONTROL CONTACTOR (CC)**

PROCEDURE:

1. Set the AUTO-OFF-MANUAL to MANUAL.
2. Set a VOM to measure DC volts.
3. Connect the black (-) test lead to engine ground. Connect the red (+) test lead to the Control Contactor (CC).

RESULTS:

1. If (+) battery voltage is measured, go to Test 34.
2. If little or no voltage is measured, go to Test 37.

**TEST 34 - CHECK BATTERY VOLTAGE AT STARTER MOTOR (SM)**

PROCEDURE:

1. Set the AUTO-OFF-MANUAL to MANUAL.
2. Set a VOM to measure DC volts.
3. Connect the black (-) test lead to engine ground. Connect the red (+) test lead to the starter motor (Wire 16).

RESULTS:

1. If (+) battery voltage is measured, repair starter motor.
2. If little or no voltage is measured, go to Test 35.

**TEST 35 - CHECK CONTROL CONTACTOR (CC) WIRING**

PROCEDURE:

1. Set the AUTO-OFF-MANUAL to MANUAL.
2. Set a VOM to measure DC volts.
3. Connect the black (-) test lead to engine ground. Connect the red (+) test lead to the Control Contactor (Wire 16).

RESULTS:

1. If (+) Battery voltage is measured, repair Wire 16 to the Control Contactor.
2. If little or no voltage is measured, go to Test 35.

**TEST 36 - CHECK GROUND AT CONTROL CONTACTOR (CC)**

PROCEDURE:

1. Disconnect the battery.

2. Set a VOM to measure ohms.
3. Connect one meter lead to engine ground and the other lead to Wire 0 on the Control Contactor.

**RESULTS:**

1. If less than 1 ohm is measured, repair Control Contactor.
2. If greater than 1 ohm is measured, repair Wire 0 to engine ground.

**TEST 37 - CHECK BATTERY VOLTAGE ENGINE START RELAY (RL1)**

1. Open the control panel.
2. Set a VOM to measure DC volts.
3. Connect the black (-) test lead to Position 0 of TB1. Connect the red (+) test lead to Pin 87 (Wire 15) of the engine start relay.

**RESULTS:**

1. If (+) battery is measured, go to Test 38.
2. If little or no voltage is present, repair Wire 15 from TB1 to Pin 87 of the engine start relay.

**TEST 38 - CHECK ENGINE START RELAY (RL1) WIRING****PROCEDURE:**

1. Open the control panel.
2. Set the AUTO-OFF-MANUAL switch to MANUAL.
3. Set a VOM to measure DC volts.
4. Connect the black (-) test lead to Position 0 of TB1. Connect the red (+) test lead to Pin 87 (Wire 15) of the engine start relay.

**RESULTS:**

1. If (+) battery voltage is measured, go to Test 39.
2. If little or no voltage measured, repair Wire 15A from TB1 to engine start relay Pin 85.

**TEST 39 - CHECK WIRE 56A AT PCB****PROCEDURE:**

1. Open the control panel.
2. Set the AUTO-OFF-MANUAL switch to MANUAL.
3. Set a VOM to measure DC volts.
4. Connect the black (-) test lead to Position 0 of TB1. Connect the red (+) test lead to Pin 85 (Wire 56A) of the engine start relay.

**RESULTS:**

1. If (+) battery voltage is measured, repair Wire 56A from PCB J2 Pin 2.
2. If little or no voltage measured, go to Test 40.

**TEST 40 - CHECK WIRE 56 FROM RL1 TO TB1****PROCEDURE:**

1. Open the control panel.
2. Set the AUTO-OFF-MANUAL switch to MANUAL.
3. Set a VOM to measure DC volts.
4. Connect the black (-) test lead to Position 0 of TB1. Connect the red (+) test lead to Pin 30 (Wire 56) of the engine start relay.

**RESULTS:**

1. If (+) battery voltage is measured, repair Wire 56 from the engine start relay to the control contactor.
2. If little or no voltage is measured, repair the engine start relay.

**TEST 50 - OBSERVE LOW FUEL PRESSURE LED ON FRONT PANEL****PROCEDURE:**

1. Visually inspect the front panel low fuel pressure LED.

**RESULT:**

1. If the yellow low fuel pressure LED is on, go to fuel pressure checks.
2. If the low fuel pressure LED remains off, go to Test 51.

**TEST 51 - EXAMINE CHOKE WITH SW1 IN "OFF" POSITION**

1. Set the AUTO-OFF-MANUAL switch to the OFF position.
  2. Remove the air cleaner.
  3. Look into the carburetor assembly.
-  **Caution! A face shield must be worn when looking into an open carburetor when the unit is running to protect against backfire!**
4. Look at the position of the choke flap inside the throttle venturi.

**RESULTS:**

1. If the choke flap is open, repair the choke assembly. The choke flap should snap shut when the unit is shut down.
2. If there is no choke flap, the generator is a high speed unit and uses a secondary fuel solenoid to put fuel directly into the intake.

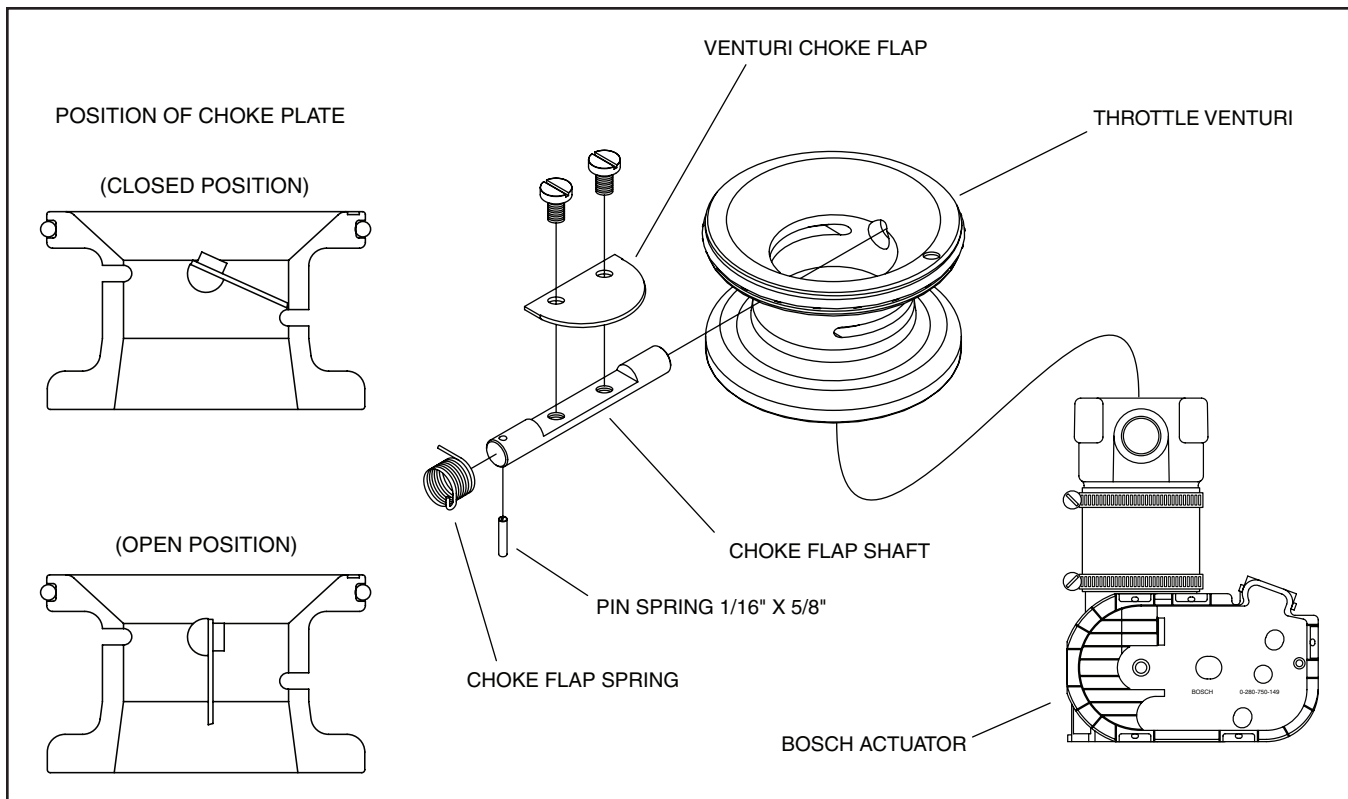

Figure x. Choke Components

3. If the choke flap is closed, go to Test 52.

**TEST 52 - EXAMINE CHOKE WITH SW1 IN "MANUAL" POSITION**

PROCEDURE:

1. Set the AUTO-OFF-MANUAL switch to the OFF position.
2. Remove the air cleaner.

**Caution!** With the air cleaner off, be sure no parts or foreign material fall into the intake!

3. Look into the carburetor assembly.

**Caution!** A face shield must be worn when looking into an open carburetor when the unit is running to protect against backfire!

4. Place the AUTO-OFF-MANUAL to the MANUAL position.
5. Watch the position of the Bosch actuator flap.

RESULTS:

1. If the flap remains closed, go to driver checks, Test 70.
2. If the flap opens, reinstall the air cleaner and proceed to Test 53.

**TEST 53 - CHECK IGNITION FOR SPARK**

PROCEDURE:

1. Set the AUTO-OFF-MANUAL switch to the OFF position.
2. Place a spark tester in line between a spark plug and the ignition wire.
3. Set the AUTO-OFF-MANUAL switch to the MANUAL position.

RESULTS:

1. If spark is present, go to fuel tests, Test 80.
2. If spark is not present, go to Test 54.

**TEST 54 - CHECK DISTRIBUTOR OUTPUT FREQUENCY**

DISCUSSION:

When operating, the distributor will send a pulse every two (2) revolutions. Starter speed will give 150 RPM, which will convert to 2 to 3 Hertz. Running at 1800 RPM, this will convert to 30 Hertz. Running at 3600 RPM, this will convert to 60 Hertz.

PROCEDURE:

1. Set the AUTO-OFF-MANUAL switch to the OFF position.
2. Set a VOM to measure DC hertz.

3. Connect the black (-) test lead to Pin 2 of the distributor, Connect the red (+) test lead to Pin 1 of the distributor.
4. Set the AUTO-OFF-MANUAL switch to the MANUAL position.

**RESULTS:**

1. If there is no output, go to Test 55.
2. If output is 2 to 3 Hertz, go to Test 57.

**TEST 55 - CHECK DISTRIBUTOR INPUT VOLTAGE**

**PROCEDURE:**

1. Set the AUTO-OFF-MANUAL switch to the OFF position.
2. Set a VOM to measure DC volts.
3. Connect the black (-) test lead to Pin 2 of the distributor, Connect the red (+) test lead to Pin 3 of the distributor.
4. Set the AUTO-OFF-MANUAL switch to the MANUAL position.

**RESULTS:**

1. If 12 Volts DC is measured, replace the Hall effect (pick-up switch) in the distributor.
2. If little or no voltage is measured, go to Test 56.

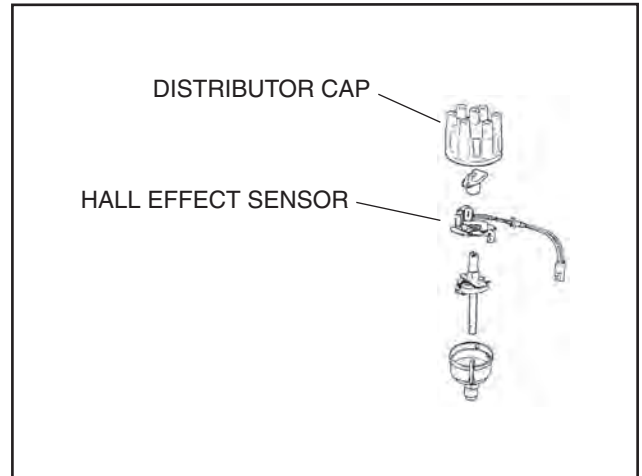

Figure x. Distributor Hall Effect Sensor

**TEST 56 - CHECK OUTPUT VOLTAGE OF PCB TO DISTRIBUTOR**

**PROCEDURE:**

1. Set the AUTO-OFF-MANUAL to switch the OFF position.
2. Open the control panel
3. Remove the J1 connector from the PCB.

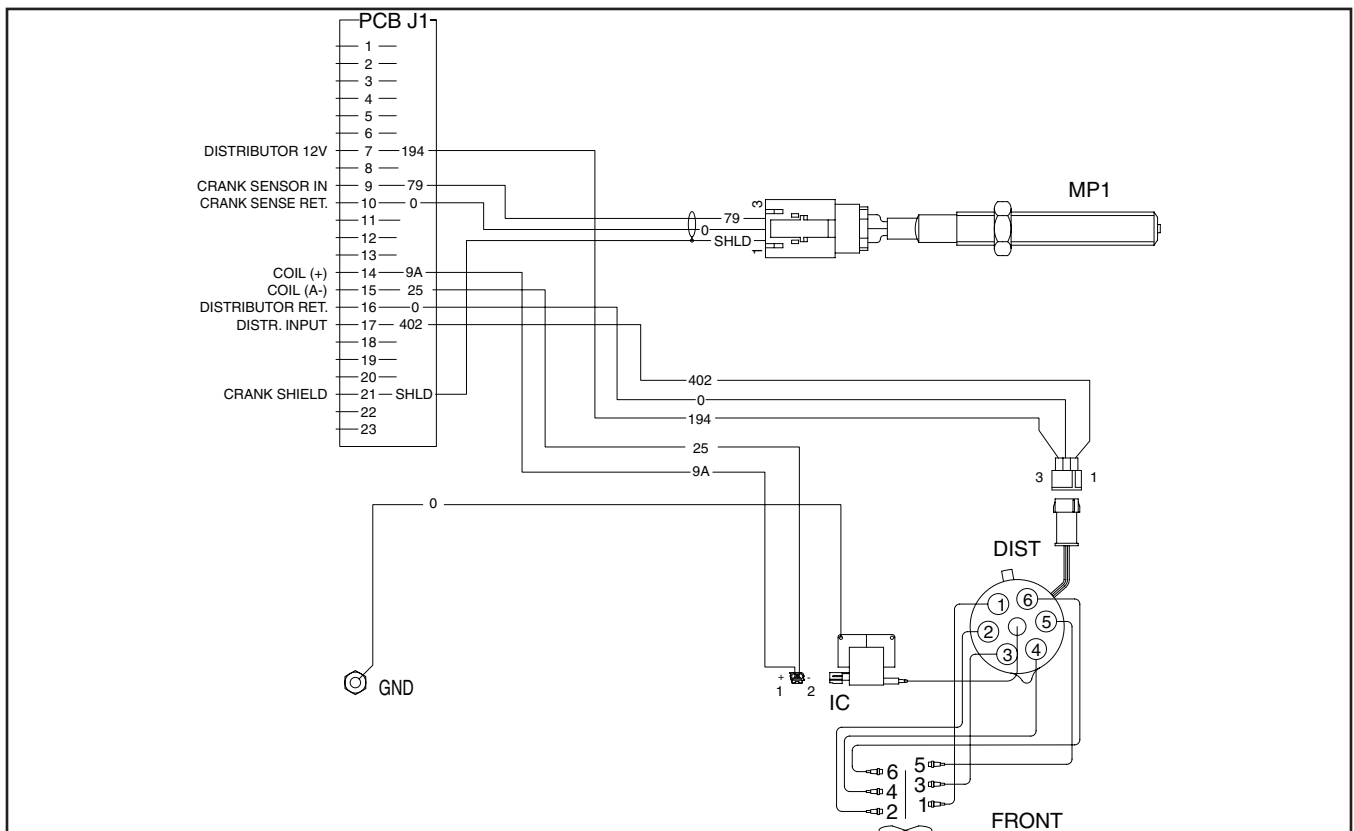

Figure x. Ignition System Wiring

## SECTION 3.4 DIAGNOSTIC TESTS

### PART 3

DC CONTROL  
LIQUID COOLED  
ENGINE UNITS

4. Set a VOM to measure DC volts.
5. Connect the black (-) test lead to PCB J1 Pin 16. Connect the red (+) test lead to PCB J1 Pin 7.
6. Set the AUTO-OFF-MANUAL to the MANUAL position.

#### RESULTS:

1. If 12 VDC is measured, repair Wire 0 and Wire 194 from the PCB to the distributor.
2. If little or no voltage is measured, replace the PCB.

### **TEST 57 - CHECK BATTERY VOLTAGE AT IGNITION COIL (IC)**

#### PROCEDURE:

1. Set the AUTO-OFF-MANUAL to switch the OFF position.
2. Set a VOM to measure DC volts.
3. Connect the black (-) test lead to engine ground. Connect the red (+) test lead to Pin 1 (+) (Wire 9A) of the ignition coil.
4. Set the AUTO-OFF-MANUAL to the MANUAL position.

#### RESULTS:

1. If (+) battery voltage is measured, go to Test 59
2. If little or no voltage is measured, go to Test 58.

### **TEST 58 - CHECK BATTERY VOLTAGE AT PCB**

#### PROCEDURE:

1. Set the AUTO-OFF-MANUAL to switch the OFF position.
2. Set a VOM to measure DC volts.
3. Connect the black (-) test lead to engine ground. Connect the red (+) test lead to PCB J1 Pin 14 (Wire 9A).
4. Set the AUTO-OFF-MANUAL to the MANUAL position.

#### RESULTS:

1. If (+) battery voltage is measured, repair or replace Wire 9A from PCB J1 Pin 14 to Ignition Coil (IC) Pin 1.
2. If little or no voltage is measured, replace PCB.

### **TEST 59 - CHECK GROUND AT IGNITION COIL**

#### PROCEDURE:

1. Disconnect the battery.
2. Set a VOM to measure resistance.
3. Connect the black (-) test lead to engine ground. Connect the red (+) test lead to Wire 0 of the ignition coil (IC).

#### RESULTS:

1. If less than 1 ohm is measured, reconnect the battery and go to Test 60.
2. If more than 1 ohm is measured, repair Wire 0 to engine ground.

### **TEST 60 - CHECK SIGNAL TO IGNITION COIL (IC)**

#### PROCEDURE:

1. Set the AUTO-OFF-MANUAL to switch the OFF position.
2. Set a VOM to measure DC Volts or Hertz.
3. Connect the black (-) test lead to engine ground. Connect the red (+) test lead to Pin 2 (-) (Wire 25) of the ignition coil.
4. Set the AUTO-OFF-MANUAL switch to the MANUAL position.

#### RESULTS:

1. Proper signal will be 12 VDC pulled to ground when ever the PCB signals the coil to fire. If signal is present, replace ignition coil.
2. If signal is not present, a DC level of 12 VDC will be measured. Go to Test 61.

### **TEST 61 - CHECK CONTINUITY WIRE 25 BETWEEN PCB AND IGNITION COIL (IC)**

#### PROCEDURE:

1. Disconnect the battery.
2. Set a VOM to measure resistance.
3. Connect the black (-) test lead to IC Pin 2 (Wire 25). Connect the red (+) test lead to PCB J1 Pin 15.

#### RESULTS:

1. If measurement is less than 1 ohm, replace PCB.
2. If measurement is greater than 1 ohm, repair Wire 25 from ignition coil to PCB J1 Pin 15.

### **TEST 62 - CHECK FUEL SYSTEM VOLTAGE AT TB1**

#### PROCEDURE:

1. Set the AUTO-OFF-MANUAL to switch the OFF position.
2. Open the control panel.
3. Set a VOM to measure DC volts.

4. Connect black (-) test lead to 0 of TB1, Connect red (+) test lead to 14 of TB1.
5. Set AUTO-OFF-MANUAL switch to manual

**RESULTS:**

1. If (+) battery voltage is measured, go to Fuel Relay Checks, Test 80.
2. Little or no voltage is measured, Go to Test 63.

**TEST 63 - CHECK BATTERY VOLTAGE AT PCB**

**PROCEDURE:**

1. Set AUTO-OFF-MANUAL switch to OFF.
2. Open the control panel.
3. Unplug PCB J2 connector.
4. Set a VOM to measure DC volts.
5. Connect black (-) test lead to 0 of TB1, Connect red (+) test lead to PCB J2 Pin 3 (wire 14A).



**Do not force meter leads into pins, leads will spread pins and cause future bad connections!!**

6. Set AUTO-OFF-MANUAL switch to MANUAL.

**RESULTS:**

1. If (+) battery voltage is measured, go to Test 66.
2. If little or no voltage measured, go to Test 64.

**TEST 64 - CHECK RESISTANCE OF WIRE 14A FROM PCB TO ENGINE RUN RELAY (RL2)**

**PROCEDURE:**

1. Disconnect battery.
2. Open the control panel.
3. Unplug PCB J2 connector.
4. Set a VOM to measure resistance.
5. Connect one lead to PCB J2 Pin 3 (Wire 14A) and other lead to Pin 85 (Wire 14A) of engine run relay (RL2).

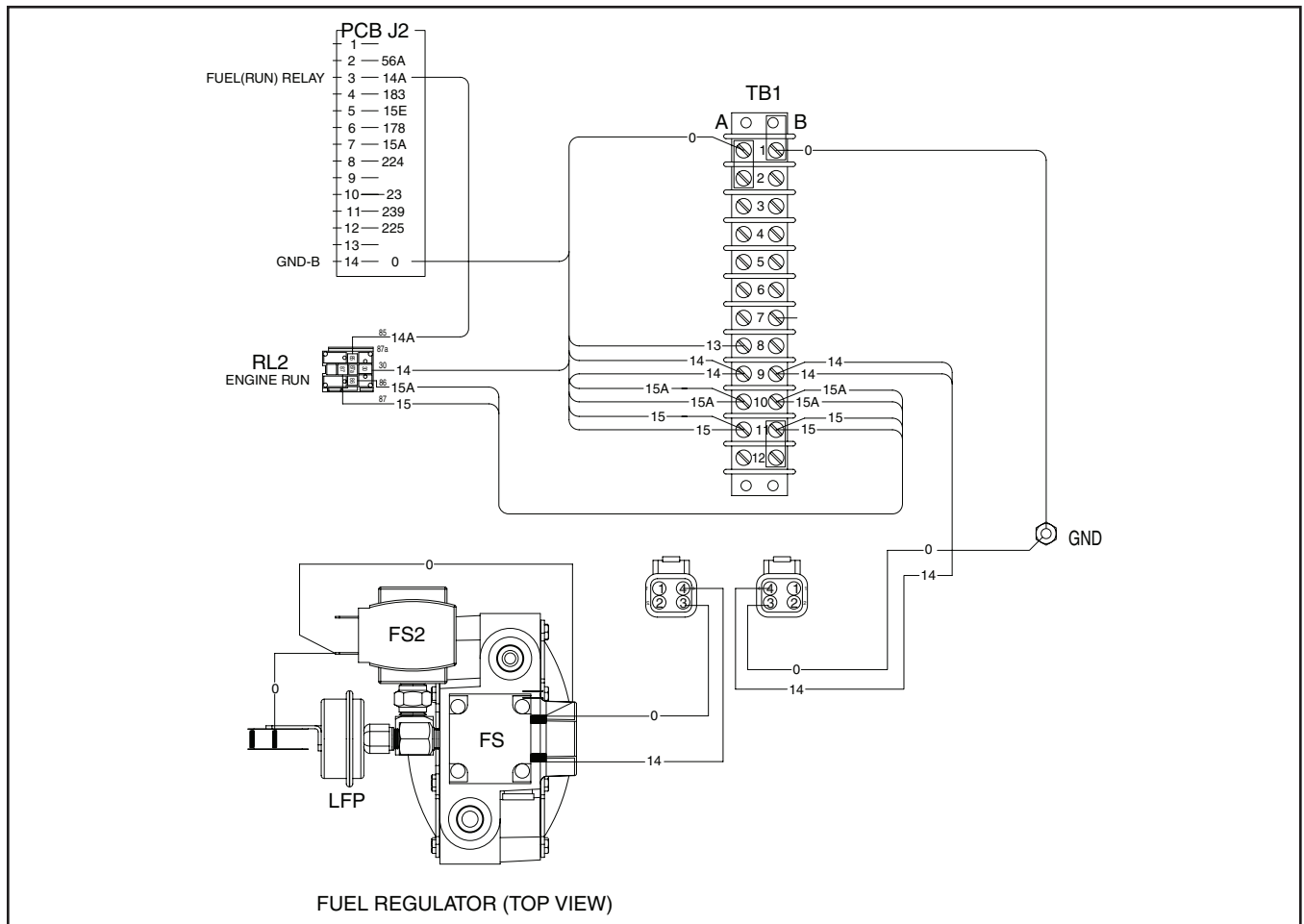

Figure x. Fuel System Wiring



**Do not force meter leads into pins, leads will spread pins and cause future bad connections!!**

RESULTS:

1. If measurement is less than 1 ohm, go to Test 65.
2. If measurement is greater than 1 ohm, repair Wire 14A from RL2 Pin 85 to PCB J2 Pin 3.

**TEST 65 - CHECK RESISTANCE OF WIRE 15A FROM TB1 TO ENGINE RUN RELAY (RL2)**

PROCEDURE:

1. Disconnect battery.
2. Open the control panel.
3. Set a VOM to measure resistance.
4. Connect one lead to Pin 86 (Wire 15A) of engine run relay to Wire 15A at TB1.

RESULTS:

1. If measurement is less than 1 ohm, repair engine run relay (RL2)
2. If measurement is greater than 1 ohm, repair Wire 15A from engine run relay Pin 85 to 15A of TB1.

**TEST 66 - CHECK PCB OUTPUT**

PROCEDURE:

1. Set AUTO-OFF-MANUAL switch to OFF.
2. Open the control panel.
3. Set a VOM to measure DC volts.
4. Connect black (-) test lead to Wire 0 at TB1. Connect red (+) test lead to engine run relay Pin 85 (Wire 14A).
5. Set AUTO-OFF-MANUAL switch to MANUAL.

RESULTS:

1. If little or no voltage is measured, go to Test 67.
2. If (+) battery voltage is measured, replace PCB.

**TEST 67 - CHECK ENGINE RUN RELAY (RL2) OUTPUT**

PROCEDURE:

1. Set AUTO-OFF-MANUAL switch to OFF.
2. Open the control panel.
3. Set a VOM to measure DC volts.

4. Connect the black (-) test lead to Wire 0 at TB1. Connect the red (+) test lead to engine run relay Pin 30 (Wire 14).
5. Set AUTO-OFF-MANUAL switch to MANUAL.
1. If little or no voltage is measured, go to Test 68.
2. If (+) battery voltage is measured, repair Wire 14 from RL2 Pin 30 to TB1.

**TEST 68 - CHECK ENGINE RUN RELAY (RL2)**

PROCEDURE:

1. Set AUTO-OFF-MANUAL switch to OFF.
2. Open the control panel.
3. Set a VOM to measure DC volts.
4. Connect the black (-) test lead to Wire 0 at TB1, Connect the red (+) test lead to engine run relay Pin 87 (Wire 15).
5. Set AUTO-OFF-MANUAL switch to MANUAL.

RESULTS:

1. If little or no voltage is measured, repair Wire 15 RL2 Pin 87 to TB1.
2. If (+) battery voltage is measured, replace engine run relay (RL2).

**TEST 70 - CHECK ELECTRONIC GOVERNOR DRIVER (DEG)**

PROCEDURE:

1. Open the control panel.
2. Unplug the electronic governor driver (DEG) connector.
3. Set a VOM to measure DC volts.
4. Connect the black (-) test lead to Pin 1 of DEG (Wire 0). Connect the red (+) test lead to Pin 4 of DEG (Wire 4).



**Do not force meter leads into pins, leads will spread pins and cause future bad connections!!**

5. Set AUTO-OFF-MANUAL switch to MANUAL.

RESULT:

1. If (+) battery voltage is measured, go to Test 73.
2. If little or no voltage is measured, go to Test 71.

**TEST 71 - CHECK WIRES FROM DEG TO PCB**

PROCEDURE:

1. Open the control panel.
2. Disconnect PCB J1 and DEG connector.

3. Set meter to measure resistance.
4. Connect one test lead to PCB J1 Pin 1. Connect the other test lead to DEG Pin 4 (Wire 14).
5. Record the measurement.



**Do not force meter leads into pins, leads will spread pins and cause future bad connections!!**

6. Connect one test lead to PCB J1 Pin 3. Connect the other test lead to DEG Pin 1 (Wire 0).
7. Record the measurement.

#### RESULTS:

1. If resistance of Wire 14 reads more than 1 ohm, repair Wire 14.
2. If resistance of Wire 0 reads more than 1 ohm, repair Wire 0.
3. If both wires read less than 1 ohm, replace the PCB.

### ***TEST 73 - CHECK PWM OUTPUT OF DRIVER TO GOVERNOR***

#### PROCEDURE:

1. Set the AUTO-OFF-MANUAL switch to the OFF position.
2. Unplug the connector at the Bosch governor (GOV).
3. Set a VOM to measure DC volts.
4. Connect the black (-) test lead to GOV Pin 1 (Wire 771). Connect the red (+) test lead to GOV Pin 4 (Wire 770).



**Do not force meter leads into pins, leads will spread pins and cause future bad connections!!**

5. Set AUTO-OFF-MANUAL to MANUAL.

#### RESULTS:

1. If measurement is between 10 and 12 VDC, go to Test 77.
2. If measurement is approximately 0 VDC, Go to Test 74.

### ***TEST 74 - CHECK PWM FROM PCB TO DEG***

#### PROCEDURE:

1. Set the AUTO-OFF-MANUAL switch to the OFF position.
3. Set a VOM to measure DC volts.
3. Connect the black (-) test lead to DEG Pin 1 (Wire 0), Connect the red (+) test lead to DEG Pin 12 (Wire 769).
4. Set AUTO-OFF-MANUAL to MANUAL.

#### EXPECTED:

PWM (pulse width modulated) signal should be switching between 0 and 5 VDC. When the actuator needs to be wide open, signal will be 90% duty cycle, which will look to be around 4 VDC. When the actuator is closed the PWM signal will have a 10 % duty cycle witch will look to be around a 1 VDC.

#### RESULTS:

1. If measurement is above 1 VDC when cranking, go to Test 75.
2. If measurement is below 1 VDC when cranking, go to Test 78.

### ***TEST 75 - CHECK DRIVER ENABLE FROM PCB TO DEG***

#### PROCEDURE:

1. Set the AUTO-OFF-MANUAL switch to the OFF position.
2. Set a VOM to measure DC volts.
3. Connect the black (-) test lead to DEG Pin 1 (Wire 0). Connect the red (+) test lead to DEG Pin 10 (Wire 768).
4. Set AUTO-OFF-MANUAL to MANUAL.

#### EXPECTED:

PCB should pull voltage to 0 VDC to allow the driver to operate. Initial state should be 5 VDC, then pulled down to 0 VDC.

#### RESULTS:

1. If less than 1 VDC is measured, replace DEG driver module.
2. If greater than 1 VDC is measured, go to Test 76.

### ***TEST 76 - CHECK CONTINUITY OF WIRE 768 FROM PCB TO DEG***

#### PROCEDURE:

1. Disconnect J1 Connector from the PCB, and DEG connector.
2. Set a VOM to measure resistance.
3. Connect the black (-) test lead to PCB Pin 19 (Wire 768). Connect the red (+) test lead to DEG Pin 10 (Wire 768).

#### RESULTS:

1. If less than 1 ohm is measured, replace the PCB.
2. If greater than 1 ohm is measured, repair Wire 768.

**TEST 77 - TEST BOSCH GOVERNOR**

PROCEDURE:

1. Disconnect the connector to the Bosch governor actuator (GOV).
2. Remove the air cleaner to view actuator valve position.
3. Connect negative (-) side of a 9-volt battery to actuator Pin 1, and positive (+) side of 9-volt battery to actuator Pin 4.

RESULTS:

1. If there is no actuator valve movement, replace actuator.
2. If actuator opens a little, repair Wire 770 and Wire 771 to actuator.

**TEST 78 - CHECK CONTINUITY OF WIRE 769 FROM PCB TO DEG**

1. Disconnect J1 Connector from the PCB, and DEG connector.
2. Set a VOM to measure resistance.
3. Connect the black (-) test lead to PCB Pin 18 (Wire 769). Connect the red (+) test lead to DEG Pin 12 (Wire 769).

RESULTS:

1. If less than 1 ohm is measured, replace the PCB.
2. If greater than 1 ohm is measured, repair Wire 769.

**TEST 80 - TEST FUEL SOLENOID (FS) WIRING FROM TB1**

PROCEDURE:

1. Set a VOM to measure DC volts.
2. Connect the black (-) test lead to fuel solenoid (FS) Wire 0. Connect the red (+) test lead to fuel solenoid (FS) Wire 14.
3. Set the AUTO-OFF-MANUAL to MANUAL.

RESULTS:

1. If less than 1 VDC is measured, repair Wire 0 FS to engine ground or Wire 14 FS to TB1.
2. If (+) battery voltage is measured, go to Test 81.

**TEST 81 - CHECK FUEL SOLENOID (FS) OPERATION**

1. Set the AUTO-OFF-MANUAL switch to the OFF position.
2. Remove lower pressure tap plug from demand regulator.

3. Connect pressure tester to lower pressure tap.
4. Set AUTO-OFF-MANUAL to MANUAL.

RESULT:

1. If measurement is between 5" to 7" of water column pressure, go to Test 85.
2. If no pressure is measured, go to Test 83.

**TEST 83 - CHECK FUEL SUPPLY TO DEMAND REGULATOR**

1. Disconnect gas supply.
2. Remove low fuel pressure switch assembly from upper pressure tap of demand regulator.
3. Connect pressure tester to upper pressure tap.
4. Reconnect gas supply.

RESULTS:

1. If measurement is above 14" of water column pressure, contact gas supplier.
2. If measurement is less than 5" of water column pressure, contact gas supplier.
3. If measurement is between 5" and 14" of water column pressure, repair fuel solenoid.

**TEST 85 CHECK ENGINE VACUUM**

PROCEDURE:

Check that engine has adequate vacuum at the input to the venturi holder located under the air cleaner while engine is cranking.

RESULT:

1. If there is no vacuum, troubleshoot engine for lack of vacuum.
2. If vacuum is good, go to Test 86.

**TEST 86 - CHECK VACUUM TO DEMAND REGULATOR**

Check that engine has adequate vacuum at demand regulator while engine is cranking.

RESULTS:

1. If vacuum is less than what was at venturi, check hoses for leak.
2. If vacuum is good, repair the demand regulator.

## LOW BATTERY

### DISCUSSION:

Typical float voltage is about 13.4 VDC when generator is just sitting, with a good battery charger. Low Battery alarm will operate for two reasons: if the voltage sensed at main PCB is below about 12.2 VDC for one minute or if battery voltage sensed at main PCB drops below 6 VDC during a crank cycle. If either of these things occur it is a good indication of a bad battery. If the low battery alarm is on and it is not a latched alarm, the unit will still attempt to crank and run when needed.

- Green LED – signifies that utility voltage of 120 VAC is at the battery charger.
- Orange LED – turns on when charge current from the battery is over ½ amp, all other times it is off.

All tests are to be performed with utility present and the unit in AUTO, not running unless otherwise specified.

### TEST 87 - CHECK VOLTAGE AT BATTERY

#### PROCEDURE:

1. Set a VOM to measure DC volts.
2. Set positive lead of meter on the positive terminal of the battery and negative lead to negative lead of terminal.

#### RESULTS:

1. If voltage is above 12.2 VDC, go to Test 88.
2. If voltage is below 12.2 VDC, go to Test 91.

**Note: If battery voltage continues to increase from 12.2 VDC to over 12.5 VDC (at which point the low battery LED should go out) this is an indication that the battery charger is operating as it should. Allow time for the unit to charge and stabilize before continuing to troubleshoot.**

### TEST 88 - CHECK BATTERY VOLTAGE AT PCB

#### PROCEDURE:

1. Open the control panel to gain access to the J2 connector on the main PCB.
2. Set a VOM to measure DC volts.
3. Connect the positive test lead to J2 Pin 5 (Wire 15E) and the negative test lead to J2 Pin 14 (Wire 0).

#### RESULTS:

1. If voltage is below 12.2 VDC and voltage measured at the battery in Test 87 is significantly higher, check all connections of Wires 15E, 15, 13, and 0 between the main PCB and the battery.
2. If voltage is between 12.2 and 12.8 VDC, this is an indication that the battery or the battery charger is bad, go to Test 91.

3. If voltage is over 12.8 VDC and the LED is still on, go to Test 89.

### TEST 89 - CHECK LOW BATTERY SENSING AT PCB

#### PROCEDURE:

1. Be sure battery voltage is being maintained at a steady voltage.
2. Switch AUTO-OFF-MANUAL switch to OFF, then back to AUTO.
3. Wait one (1) minute and observe.

#### Results:

1. If low battery LED returns replace PCB.
2. If low battery LED does not return, most likely this was a "latched alarm". The low battery alarm is latched if the battery voltage drops below 6 volts during engine crank. Load test battery and replace battery if necessary.

### TEST 90 - CHECK BATTERY CONDITION

#### PROCEDURE:

1. Is battery voltage measured in Test 87 below 11 VDC?

#### RESULTS:

1. If voltage was below 11 VDC, remove battery from unit and charge with an external battery charger. The installed battery charger does not operate when the voltage is below 11 VDC. This is to prevent damage to the battery charger from a battery failure.
2. If voltage is above 11 VDC, go to Test 91.

### TEST 91 - CHECK BATTERY CHARGER INPUT

#### PROCEDURE:

1. Open the control panel and observe the green LED of the battery charger.

#### RESULTS:

1. If green LED is off, go to Test 92.
2. If green LED is on, go to Test 94.

### TEST 92 - CHECK BATTERY CHARGER CONNECTIONS

#### PROCEDURE:

1. Open the control panel.
2. Set a VOM to measure AC volts.
3. Place one meter lead on Wire N going into the battery

charger. Place the other lead on Wire L1 going into battery charger. Voltage should measure about 120 VAC.

**RESULTS:**

1. If no voltage is measured, check all connections back to the customer utility distribution panel looking for open or shorted wire, or an open breaker.
2. If 120 VAC is present, go to Test 93

**TEST 93 - CHECK BATTERY CHARGER  
INPUT FUSE**

**PROCEDURE:**

1. Open the control panel.
2. Remove the 2 amp glass fuse from the battery charger.
3. With a VOM set to measure ohms, check the fuse.

**RESULTS:**

1. If fuse is good, replace battery charger.
2. If fuse is bad, replace fuse.

**TEST 94 - CHECK BATTERY VOLTAGE AT  
BATTERY CHARGER**

**PROCEDURE:**

1. Open control panel to gain access to the battery charger.
2. Set a VOM to measure DC Volts.
3. Place positive lead of VOM on Wire 13 input to battery charger and negative lead on Wire 0 into battery charger.
4. Record voltage reading.

**RESULTS:**

1. If battery voltage is about the same as battery voltage measured in test 87, go to Test 95.
2. If battery voltage is significantly lower than battery voltage measured in test 87, repair Wires 13 and 0 between battery charger and battery.

**TEST 95 - CHECK BATTERY CHARGER  
CURRENT OUTPUT**

**PROCEDURE:**

1. Open control panel to gain access to the battery charger.
2. Use a DC clamp-on ammeter, or an in line ammeter to measure current on the Wire 13 connected to the battery charger.
3. Record value. At 11 through 13 VDC the battery charger should be putting out about 2 amps to the battery. As the

battery voltage level approaches float voltage the charger will begin reducing current slowly.

**RESULTS:**

1. No output current, go to Test 96.
2. Output current is as expected, go to Test 97.

**TEST 96 - CHECK BATTERY CHARGER  
OUTPUT FUSE**

**PROCEDURE:**

1. Open control panel to gain access to the battery charger.
2. Pull the blade fuse from the battery charger.
3. Use an ohmmeter to check continuity.

**RESULTS:**

1. If fuse is good, replace battery charger.
2. If the fuse is bad, replace fuse.

**TEST 97 - CHECK FLOAT VOLTAGE**

**PROCEDURE:**

1. Set a VOM to measure DC Volts.
2. Set positive lead of meter on the positive terminal of the battery and negative lead to negative lead of terminal.

**RESULTS:**

1. Battery voltage should rise when the battery charger is on. Voltage should eventually reach float voltage of about 13.4 VDC. If it does the system is most likely good, if it does not the battery will need to be replaced.

**HIGH COOLANT TEMPERATURE /  
LOW COOLANT LEVEL.**

**DISCUSSION:**

Low coolant level and high coolant temperature sensors are both mounted on the thermal adapter of the engine. The two sensors are wired in parallel and operate essentially the same way, when a failure occurs Wire 85 is taken to a low level (shorted to ground).

The high coolant temperature switch will fail when the temperature of the coolant flowing by reaches a temperature of 248 degrees, plus or minus 16 degrees. The failure mode will close an internal switch connecting the wire tab to the case of the switch which is at ground potential.

The low coolant level switch will fail when the tip of the coolant sensor has no liquid on it. This sensor is a current device and will have variable resistance depending on temperature. The failure mode will be a

near short to ground when no coolant is present.

### **TEST 98 - CHECK COOLANT TEMPERATURE AT THERMAL ADAPTER**

#### PROCEDURE:

1. Access the thermal adapter.
2. Use heat gun pointed at thermal adapter or thermal coupler attached to thermal adapter.
3. Record the reading.

#### RESULTS:

1. If coolant temperature reading is over 232°F, go to Test 99.
2. If coolant temp is under 232°F, go to Test 101.

### **TEST 99 - CHECK RADIATOR COOLANT LEVEL**

#### PROCEDURE:

1. Carefully remove the radiator cap.



**Caution! Coolant is under pressure and at high temperature. Exercise extreme caution when removing cap!**

2. Check the coolant level. Coolant should be up to the valve stem of radiator cap.

#### RESULT:

1. If coolant level is low, fill radiator with coolant prescribed by owners manual. Check for leaks. Check oil for a milky color (this may be a sign of a leak internal to the engine).
2. If coolant level is normal, go to Test 100.

### **TEST 100 - CHECK COOLANT HOSES**

#### PROCEDURE:

1. Check hoses for blockages, pinch points, and anything that would constrict the flow of coolant through the engine.

#### RESULTS:

1. If no blockages are found, replace the thermostat. Check engine water pump for correct operation. Thermostat should operate around 195°F.
2. If a blockage is found, repair the blockage and retest unit.

### **TEST 101 - CHECK RADIATOR COOLANT LEVEL**

1. Carefully remove the radiator cap.



**Caution! Coolant is under pressure and at high temperature. Exercise extreme caution when removing cap!**

2. Check the coolant level. Coolant should be up to the valve stem of radiator cap.

#### RESULT:

1. If coolant level is low, fill radiator with coolant prescribed by owners manual. Check for leaks. Check oil for a milky color (this may be a sign of a leak internal to the engine).
2. If coolant level is normal, go to Test 102.

### **TEST 102 - CHECK COOLANT LEVEL SWITCH**

#### PROCEDURE:

1. Access the coolant level switch.
2. Carefully remove the Wire 85 attached to coolant level switch. Tape up the end of the wire to keep it from touching engine ground.
3. Start the unit and run for an amount of time that a fault would normally occur.
4. Shut down unit after the point of failure is past.
5. Reattach Wire 85.

#### RESULTS:

1. If alarm occurred again as before, replace coolant temperature switch.
2. If alarm did not occur, go to Test 103.

### **TEST 103 - CHECK FOR COOLANT IN THERMAL ADAPTER**

#### PROCEDURE:

1. Access the low coolant level switch.
2. Begin removing low coolant level switch, turning slowly until coolant begins seeping out slowly.
3. Verify that coolant is present in thermal adapter.
4. Tighten low coolant level switch.

#### RESULTS:

1. If coolant is present, replace low coolant level switch.
2. If coolant is not present, look for obstructions and burp the lines to remove any air bubbles.

### **LOW OIL PRESSURE**

#### DISCUSSION:

Low oil pressure is indicated as a shutdown anytime

## SECTION 3.4 DIAGNOSTIC TESTS

### PART 3

DC CONTROL  
LIQUID COOLED  
ENGINE UNITS

the engine oil pressure drops below 10 PSI after 10 seconds of running. Many things could cause this that are not engine related. Loss of fuel, ignition, or air will cause the unit to stop running, and the only fault that will be displayed is LOP.

### **TEST 104 - CHECK OIL LEVEL**

#### PROCEDURE:

1. Remove the oil dipstick and observe the oil level.

#### RESULTS:

1. If oil level is low, add oil and retest.
2. If oil level is correct, go to Test 105.
3. If oil level is too high, remove excess oil and retest.

### **TEST 105 - CHECK OIL PRESSURE**

#### PROCEDURE:

1. Access the low oil pressure switch and remove switch.
2. Install a mechanical oil pressure gage.
3. Start engine and monitor engine oil pressure when unit is starting/running.
4. After taking readings reinstall low oil pressure switch.

#### RESULTS:

1. If oil pressure moves above and remains above 10 PSI, go to Test 106.
2. If oil pressure is below 10 PSI while running, consult engine diagnostic manual. Possible problem may be low oil viscosity or pressure relief valve stuck open inside engine.

### **TEST 106 - CHECK LOP SIGNAL AT PCB**

#### PROCEDURE:

1. Open control panel to access J2 Connector of main PCB.
2. Set VOM to measure DC volts.
3. Connect negative lead of VOM to Wire 0 at TB1 and positive lead to J2 Pin 20 (Wire 86) of main PCB.
4. Observe the VOM during start condition. VOM should read 0 VDC when switch is closed (engine not running and oil pressure low). VOM should read 5 VDC when engine is running and pressure is over 10 psi.

#### RESULTS:

1. If voltage always reads 0 VDC, go to Test 107.
2. If voltage starts at 0 VDC then goes to 5 VDC, sender is operating as it should. Replace the PCB.

### **TEST 107 - CHECK LOW OIL PRESSURE SWITCH (LOP)**

#### PROCEDURE:

1. Open the control panel and remove J2 Connector from main PCB.
2. Access low oil pressure switch.
3. Remove Wire 86 from low oil pressure switch.
4. Set a VOM to measure resistance.
5. Connect one lead of VOM to Wire 86. Connect the other lead to Wire 0.
6. The VOM should read OPEN.
7. Reconnect J2 Connector and Wire 86 to low oil pressure switch.

#### RESULTS:

1. If measurement reads very low resistance to ground, repair wire.
2. If resistance is high, wire is not shorted. Replace defective low oil pressure switch.

**PART 4  
ELECTRICAL  
DATA**

**3.9 LITER PREPACKAGED  
HOME STANDBY  
GENERATORS**

<b>TABLE OF CONTENTS</b>		
<b>DWG #</b>	<b>TITLE</b>	<b>PAGE</b>
0F3864-F	Wiring Diagram 1-Phase Liquid Cooled Generator	88
0F4277-D	Schematic 1-Phase Liquid Cooled Generator	90
0F6839-B	R-Series Control Panel	92
	Electrical Formulas	96



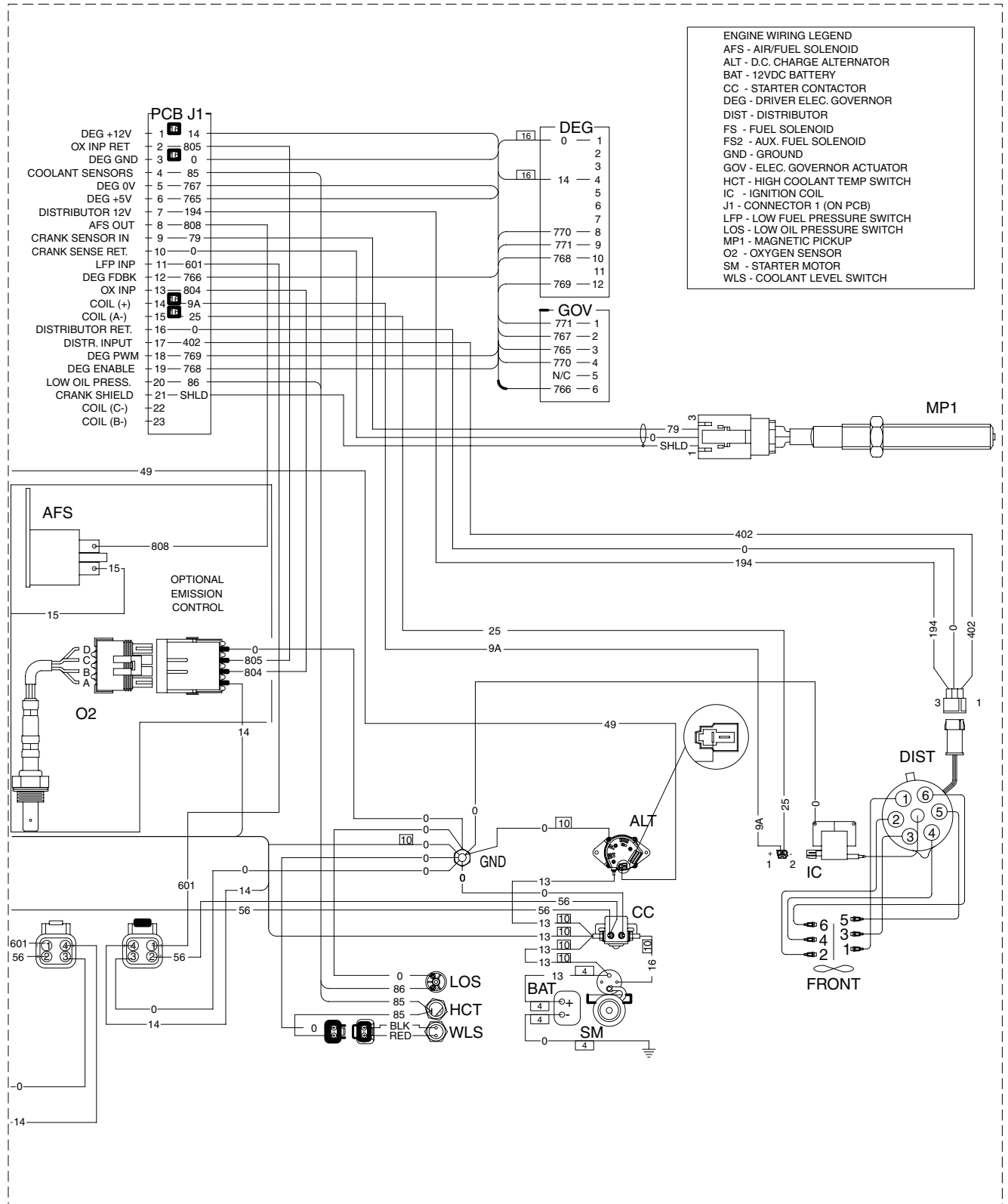

# SCHEMATIC 1-PHASE LIQUID COOLED GENERATOR

PART 4

ELECTRICAL DATA

DRAWING #0F4277-D (1 OF 2)

### CONTROL PANEL LEGEND

- AVR - AUTOMATIC VOLTAGE REGULATOR
- BCH - BATTERY CHARGER
- BR1 - BRIDGE RECTIFIER
- CB2 - CIRCUIT BREAKER (EXCITATION)
- F1 - FUSE, BAT POWER (15A ATO TYPE)
- J2 - CONNECTOR 2 (ON PCB)
- R0 - ZERO OHM JUMPER
- RL1 - RELAY 1 (START RELAY)
- RL2 - RELAY 2 (ENGINE RUN)
- SW1 - AUTO/OFF/MANUAL SWITCH
- SW2 - SET EXERCISER SWITCH
- TR1 - TRANSFORMER (6VA UTIL/16 VAC)

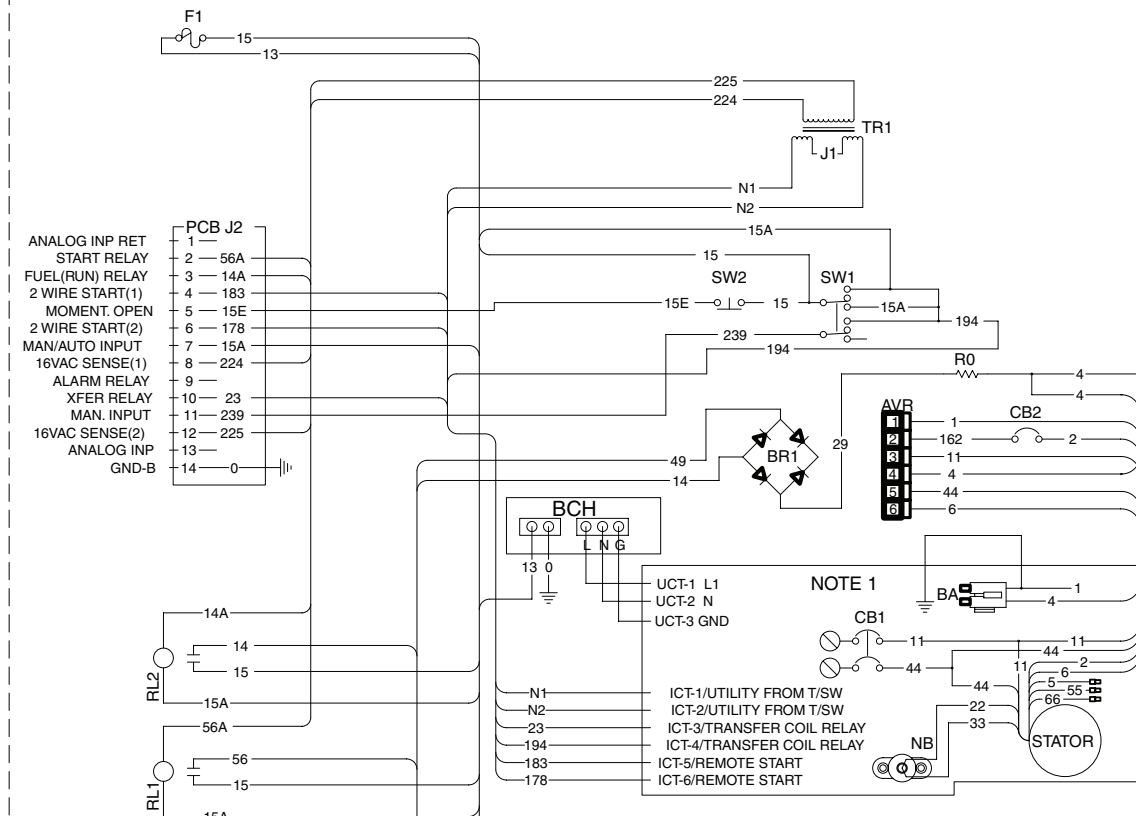

NOTE 1: WIRING SHOWN FOR CB1, NB, BA AND STATOR IS TYPICAL FOR SINGLE PHASE. FOR 3-PHASE, SEE DWG. 0F6839.

### NOTE 1

- UCT-1 L1
- UCT-2 N
- UCT-3 GND
- ICT-1/UTILITY FROM T/SW
- ICT-2/UTILITY FROM T/SW
- ICT-3/TRANSFER COIL RELAY
- ICT-4/TRANSFER COIL RELAY
- ICT-5/REMOTE START
- ICT-6/REMOTE START

### CUSTOMER CONNECTION & ALTERNATOR LEGEND

- BA - BRUSH ASSEMBLY (GENERATOR)
- CB1 - MAINLINE CIRCUIT BREAKER
- 240V OUTPUT TO TRANSFER SWITCH
- ICT - INTERCONNECT TERMINAL BLOCK
- NB - NEUTRAL BLOCK
- UCT - UTILITY CONNECT TERMINAL BLOCK

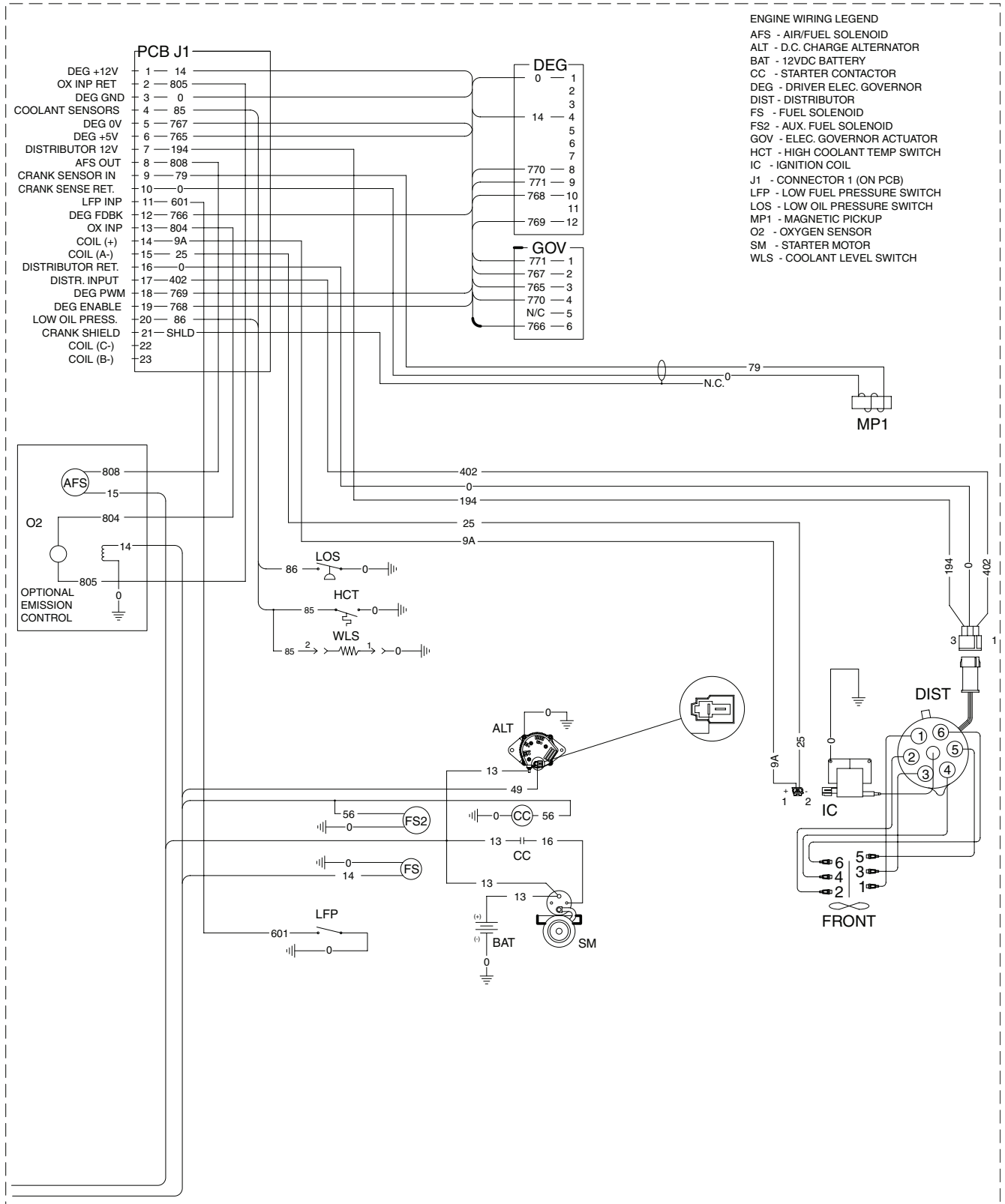

# WIRING DIAGRAM R-SERIES CONTROL PANEL

**PART 4**

ELECTRICAL DATA

**DRAWING #0F6839-B (1 OF 4)**

OPTION 1 - SINGLE PHASE, R-SERIES CONTROL PANEL, 240V

LEGEND

- AR = ALTERNATOR ROTOR
- AS = ALTERNATOR STATOR
- MLCB = MAIN CIRCUIT BREAKER
- NB = NEUTRAL BLOCK

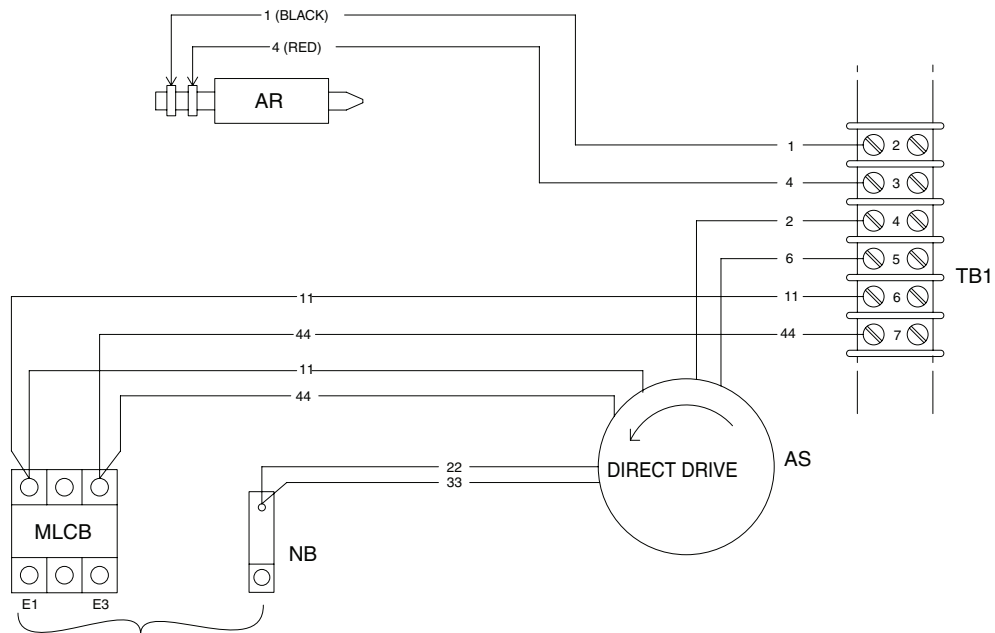

GENERATOR OUTPUT  
CUSTOMER CONNECTION

- E1 - E3 = 240VAC
- E1 - NB = 120VAC
- E3 - NB = 120VAC

OPTION 2 - THREE PHASE, R-SERIES CONTROL PANEL, 6-WIRE 120/208V

LEGEND

- AR = ALTERNATOR ROTOR
- AS = ALTERNATOR STATOR
- MLCB = MAIN CIRCUIT BREAKER
- NB = NEUTRAL BLOCK

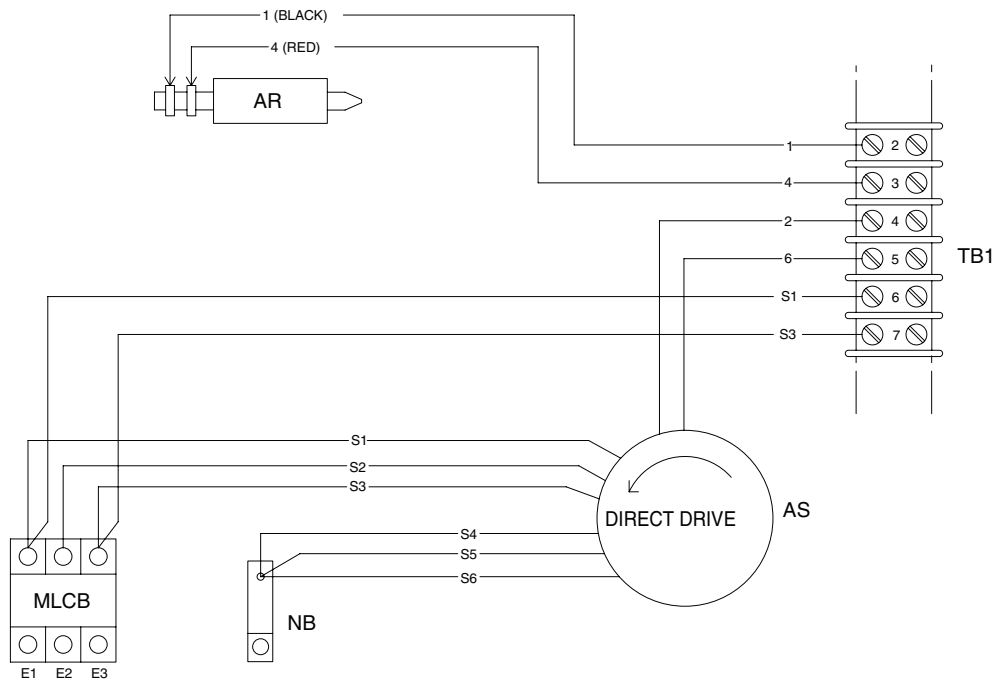

GENERATOR OUTPUT  
CUSTOMER CONNECTION  
E1 TO E2  
E2 TO E3 \*208VAC }  
E1 TO E3

E1, E2, OR E3 TO NB = \* 120VAC

\*NOTE: THE 8th DIGIT OF THE MODEL NUMBER SPECIFIES OUTPUT VOLTAGE

"G" = 120/208VAC

# WIRING DIAGRAM R-SERIES CONTROL PANEL

**PART 4**

ELECTRICAL DATA

**DRAWING #0F6839-B (3 OF 4)**

OPTION 3 - THREE PHASE, R-SERIES CONTROL PANEL, 6-WIRE 277/480V

LEGEND

- AR = ALTERNATOR ROTOR
- AS = ALTERNATOR STATOR
- MLCB = MAIN CIRCUIT BREAKER
- NB = NEUTRAL BLOCK

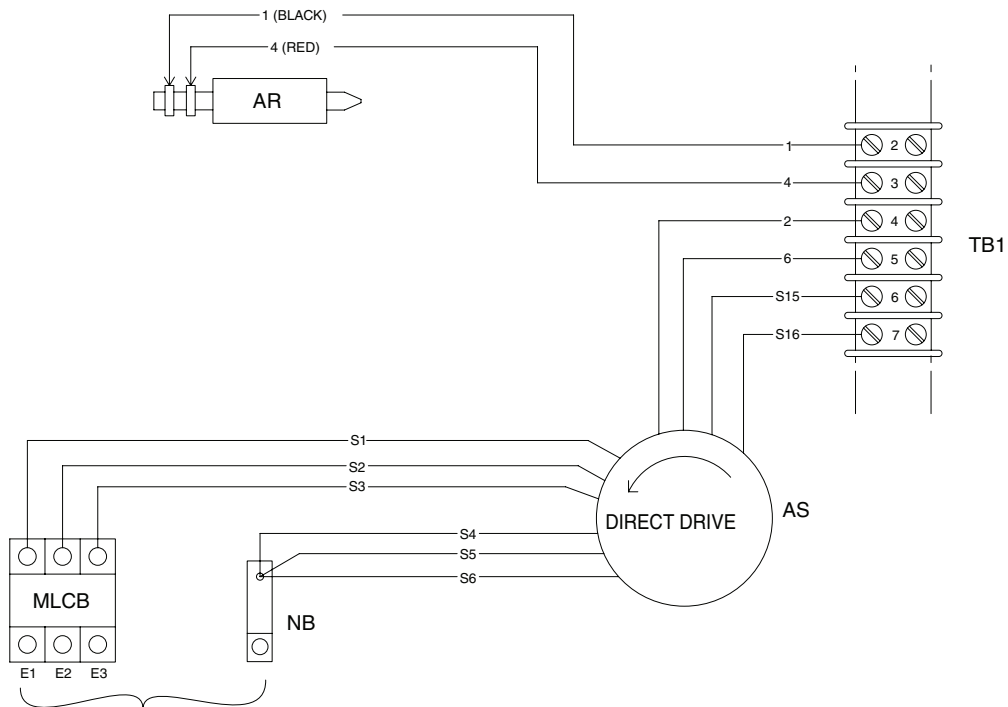

GENERATOR OUTPUT  
CUSTOMER CONNECTION

- E1 TO E2
- E2 TO E3 \*480VAC
- E1 TO E3

E1, E2, OR E3 TO NB = \* 277VAC

\*NOTE: THE 8th DIGIT OF THE MODEL NUMBER SPECIFIES OUTPUT VOLTAGE

"K" = 227/480VAC

OPTION 4 - THREE PHASE, R-SERIES CONTROL PANEL, 12-WIRE 120/208

LEGEND

- AR = ALTERNATOR ROTOR
- AS = ALTERNATOR STATOR
- MLCB = MAIN CIRCUIT BREAKER
- NB = NEUTRAL BLOCK

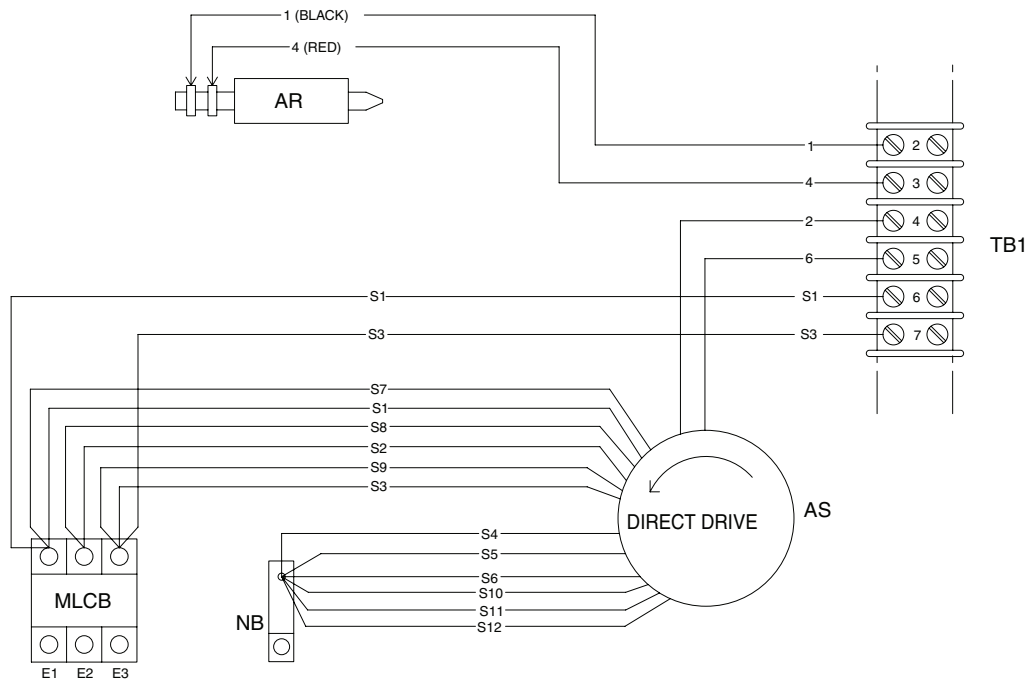

GENERATOR OUTPUT  
CUSTOMER CONNECTION

E1 TO E2  
E2 TO E3   \*208VAC }  
E1 TO E3

E1, E2, OR E3 TO NB = \* 120VAC

\*NOTE: THE 8th DIGIT OF THE MODEL NUMBER SPECIFIES OUTPUT VOLTAGE  
"G" = 120/208VAC

# ELECTRICAL FORMULAS

## PART 4

### ELECTRICAL DATA

TO FIND	KNOWN VALUES	1-PHASE	3-PHASE
KILOWATTS (kW)	Volts, Current, Power Factor	$\frac{E \times I}{1000}$	$\frac{E \times I \times 1.73 \times PF}{1000}$
KVA	Volts, Current	$\frac{E \times I}{1000}$	$\frac{E \times I \times 1.73}{1000}$
AMPERES	kW, Volts, Power Factor	$\frac{kW \times 1000}{E}$	$\frac{kW \times 1000}{E \times 1.73 \times PF}$
WATTS	Volts, Amps, Power Factor	Volts x Amps	$E \times I \times 1.73 \times PF$
NO. OF ROTOR POLES	Frequency, RPM	$\frac{2 \times 60 \times \text{Frequency}}{\text{RPM}}$	$\frac{2 \times 60 \times \text{frequency}}{\text{RPM}}$
FREQUENCY	RPM, No. of Rotor Poles	$\frac{\text{RPM} \times \text{Poles}}{2 \times 60}$	$\frac{\text{RPM} \times \text{Poles}}{2 \times 60}$
RPM	Frequency, No. of Rotor Poles	$\frac{2 \times 60 \times \text{Frequency}}{\text{Rotor Poles}}$	$\frac{2 \times 60 \times \text{Frequency}}{\text{Rotor Poles}}$
kW (required for Motor)	Motor Horsepower, Efficiency	$\frac{HP \times 0.746}{\text{Efficiency}}$	$\frac{HP \times 0.746}{\text{Efficiency}}$
RESISTANCE	Volts, Amperes	$\frac{E}{I}$	$\frac{E}{I}$
VOLTS	Ohms, Amperes	$I \times R$	$I \times R$
AMPERES	Ohms, Volts	$\frac{E}{R}$	$\frac{E}{R}$

E = VOLTS

I = AMPERES

R = RESISTANCE (OHMS)

PF = POWER FACTOR