

# **DIAGNOSTIC REPAIR MANUAL**

---

**Air-Cooled**

**Recreational Vehicle**

**Generators**

---

**GENERAC**

## **FOREWORD**

**This DIAGNOSTIC REPAIR MANUAL has been prepared especially for the purpose of familiarizing service personnel with the operational analysis, troubleshooting, testing, disassembly and repair of the Series NP45G, NP55G and NP65G recreational vehicle generators.**

**Keep the Manual in a safe place and refer to it as often as necessary. The Manual contains important technical data and should be referred to whenever the need for such information arises.**

**Every effort has been expended to ensure the information in the Manual is both accurate and current. However, the manufacturer reserves the right to change, alter, or otherwise improve his product at any time without prior notice.**

# TABLE OF CONTENTS

	Page		Page
Wiring Diagram and Electrical Schematic.....	11	<b>Troubleshooting the RV Generator</b>	
Exploded View of Sheet Metal.....	26	Introduction.....	12
Exploded View of Base and Pulley.....	28	Problem No. 1- Engine Won't Crank.....	13
Exploded View of Generator and Panel.....	30	Problem No. 2- Engine Cranks, Won't Start.....	15
Electrical Formulas.....	32	Problem No. 3- Engine Cranks and Starts, Shuts Down When Start/Stop Switch Is Released.....	17
Specifications.....	33	Problem No. 4- Engine Starts Hard, Runs Rough.....	18
 		Problem No. 5- Engine Won't Shut Down.....	18
<b>Generator Fundamentals</b>		Problem No. 6- Loss of Generator a-c Output.....	19
Introduction.....	2	 	
Electro-Magnetic Induction.....	2	<b>Engine Troubleshooting</b>	
A Simple a-c Generator.....	2	General.....	23
A More Sophisticated a-c Generator.....	2	Checking Engine Compression.....	23
Generator Block Diagram.....	3	Check Engine Ignition.....	23
 		Check Carburetion.....	23
<b>Introduction to Troubleshooting</b>		Other Problems that Might Affect Engine Operation..	23
Introduction.....	4	 	
Tools and Test Equipment.....	4	<b>Adjustments</b>	
Rotor Rotational Speed.....	4	General.....	24
Relationship of Voltage and Frequency.....	5	Engine Governor Adjustments.....	24
Generator a-c Connection System.....	5	Voltage Regulator Adjustment.....	24
Effects of Engine Power.....	5	Automatic Choke Adjustment.....	25
Effects of Dirt and Moisture on RV Generators.....	5	 	
<b>Operational Analysis of D-C Control System</b>			
Introduction.....	6		
Circuit Condition- Engine Shut Down.....	6		
Circuit Condition- Engine Cranking.....	6		
Circuit Condition- Startup and Running.....	7		
Circuit Condition- Normal Shutdown.....	8		
<b>Insulation Resistance Tests</b>			
General.....	9		
The Hi-Pot Tester.....	9		
Testing Stator Insulation.....	9		
Testing Rotor Insulation for Breakdown.....	10		
Cleaning the Generator.....	10		
Drying the Generator.....	10		

# GENERATOR FUNDAMENTALS

## Introduction

It has long been known that a relationship exists between magnetism and electricity. Revolving field a-c generators depend on this relationship for their operation. The service technician must understand that relationship. This section of your DIAGNOSTIC REPAIR MANUAL will familiarize you with the basic fundamentals of generator operation.

## Electro-Magnetic Induction

**A Magnetism Creates Electricity:** - When a wire or coil of wire is moved through a magnetic field, an electrical voltage is created in that wire. If the ends of the wire are joined to complete a circuit, electrical current will flow in the wire. The direction that current flows in the wire depends on the polarity of the magnetic field.

**B Current Flow Creates a Magnetic Field:** - Whenever electrical current flows through a wire or coil of wire, a magnetic field is created around that wire. The strength of the field depends on the amount of current flow and the number of coils or loops in the wire.

**C** A simple a-c generator consists of a spinning magnetic field called a ROTOR and stationary coil of wire called a STATOR. As the Rotor spins, its lines of magnetic force cut across the stationary Stator. When the ends of the Stator winding are connected across a load (such as a light bulb) to complete the circuit, current will flow through the circuit. In this simple generator, the Rotor is a permanent magnet. The amount of voltage and current flow induced into the Stator windings depends on (a) the Rotor's magnetic field strength, (b) Rotor rotational speed, and (c) the number of turns of wire in the Stator.

## A More Sophisticated a-c Generator

**D** A more sophisticated generator is equipped with a Stator a-c power winding and a Stator excitation winding. Regulated direct current from the excitation winding flows through carbon brushes which slide on metallic slip rings and then through the Rotor windings. Regulated current flow through the Rotor creates a regulated magnetic field strength. In turn, the regulated magnetic field strength induces a regulated voltage into the stationary Stator winding.

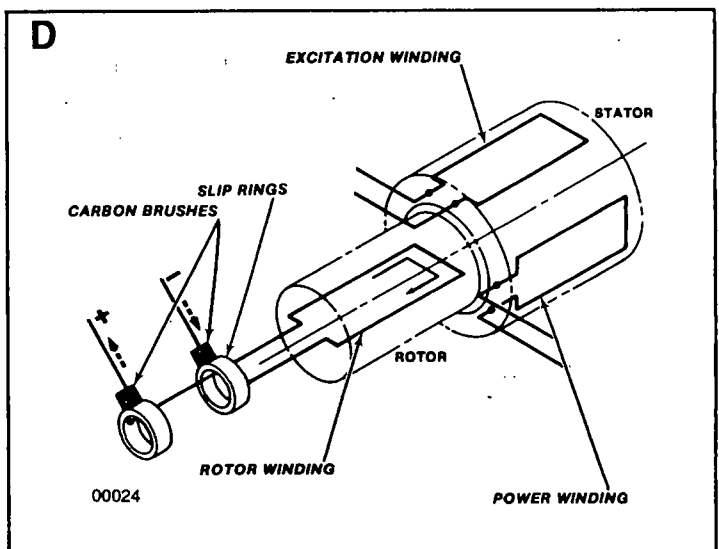
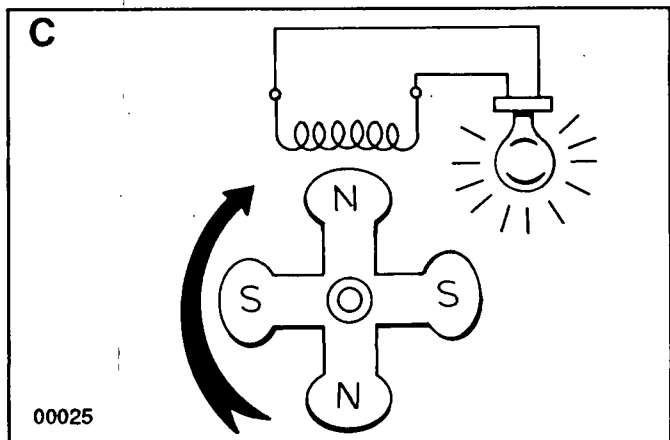
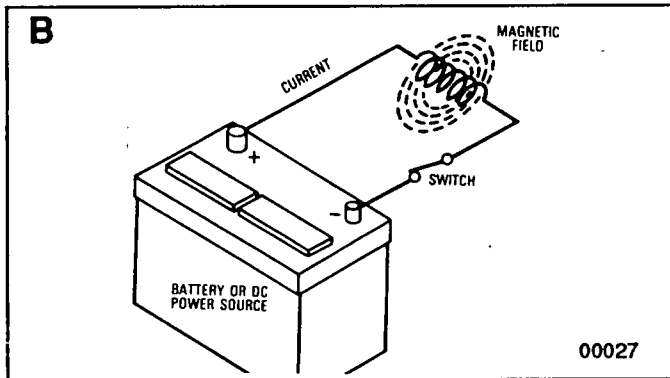
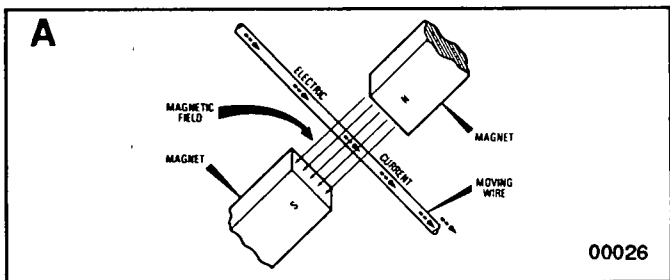

## Generator Block Diagram

**E** The Rotor (spinning field) is driven by the engine, through a belt and pulley arrangement to maintain a fixed operating speed. The Rotor's magnetic field cuts across (a) a Stator a-c power winding, (b) a Stator excitation winding, and (c) a Stator battery charge winding, to induce a voltage into those windings.

1. **Stator Battery Charge Winding:** Rectified direct current output from this winding is delivered to the generator's 12-volts battery, to maintain battery state-of-charge.

2. **Stator a-c Power Winding:-** The a-c output from this winding is used to supply electrical power to connected electrical loads.

3. **Excitation Winding:-** Output from this winding is delivered to an Electronic Voltage Regulator, where it is rectified and, based on a-c power winding sensing signals, regulated. The regulated, rectified current flows through the brushes and slip rings and into the Rotor windings. Because the current flow is regulated, the Rotor's magnetic field strength is regulated. In turn, because the field strength is regulated, the voltage induced into the Stator windings is regulated.

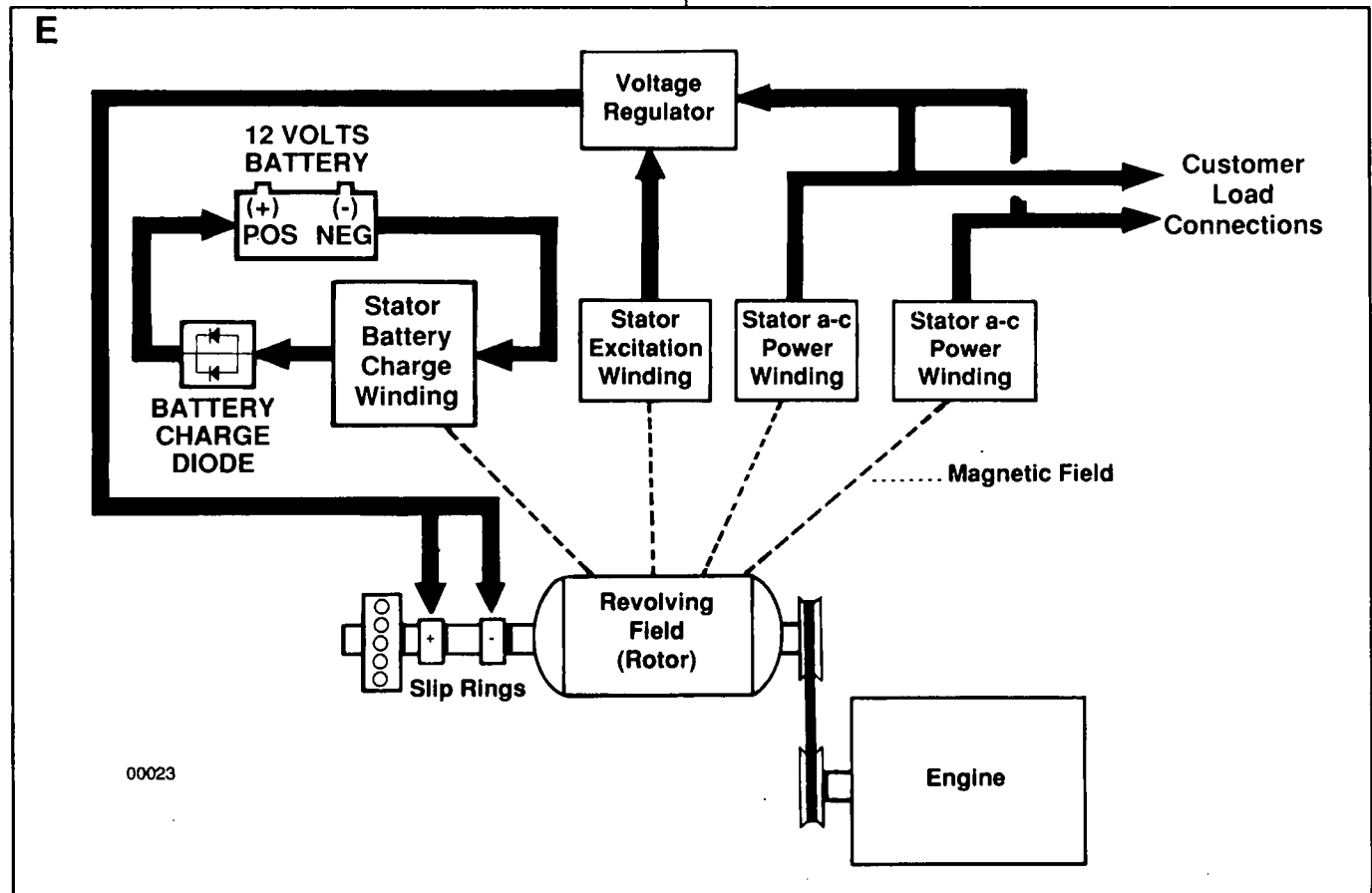

# INTRODUCTION TO TROUBLESHOOTING

## Introduction

A typical RV generator set does not have a large number of parts. However, the parts are expensive. For that reason, a parts replacement method of troubleshooting is not cost effective. A basic understanding of generators is essential to good troubleshooting, i.e., why they behave or don't behave as they should. This section will introduce the technician to some of the fundamentals of troubleshooting.

**DANGER!** Recreational vehicle generators produce extremely high and dangerous voltages. Use extreme care when working on or around the generator. Contact with live wires and terminals will cause extremely hazardous and possibly lethal electrical shock. Only personnel who have been thoroughly trained in the maintenance of RV generators should attempt to troubleshoot, test, repair or service a generator.

## Tools and Test Equipment

The generator service technician should have a well stocked tool box having a good selection of common hand tools. Such a tool box should contain wrenches in both metric and english sizes. Also recommended is a good nut driver set.

**A Volt-Ohm-Milliammeter:**- An accurate volt-ohm-milliammeter (VOM) is essential for the troubleshooting and testing of generators. Simply having a VOM is not enough. The technician must understand electricity, must be familiar with electrical circuits, must be able to read wiring diagrams/electrical schematics, and must know how to use the VOM.

**B Frequency Meter:**- This test device permits the generator's a-c output frequency, in HERTZ or CYCLES PER SECOND, to be read. Measurement of frequency is required for precise adjustment of engine-generator speed. Also see ROTOR ROTATIONAL SPEED.

**C Insulation Resistance Tester:**- Also called a "HI-POT", this device permits generator Stator and Rotor winding insulation to be tested for breakdown. Use the Hi-Pot tester to test resistance between parallel stator windings, between isolated windings, and the resistance of all windings to ground. See also EFFECTS OF DIRT AND MOISTURE ON GENERATORS.

**NOTE:** An electrical LOAD BANK is also recommended for generator testing and adjustment. The Load Bank permits a known electrical load to be applied to the generator, for the purpose of testing/adjusting unit operation under load.

## Rotor Rotational Speed

The generator's revolving field on Series NP45G, NP55G and NP65G generators is a 2-pole type, having a single north and a single south magnetic pole. The Rotor is en-

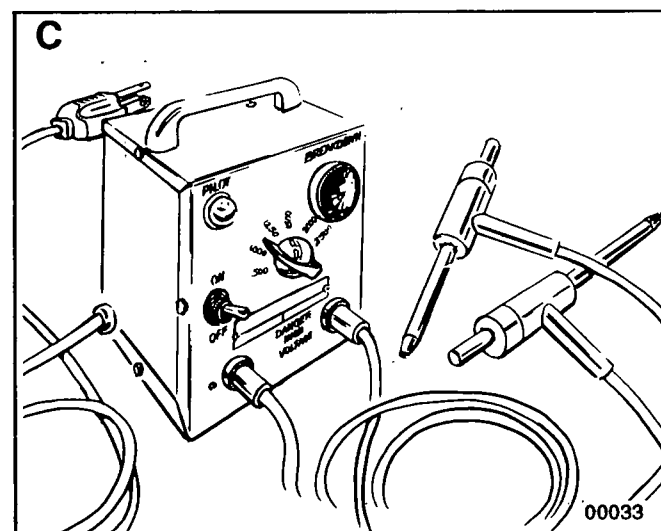
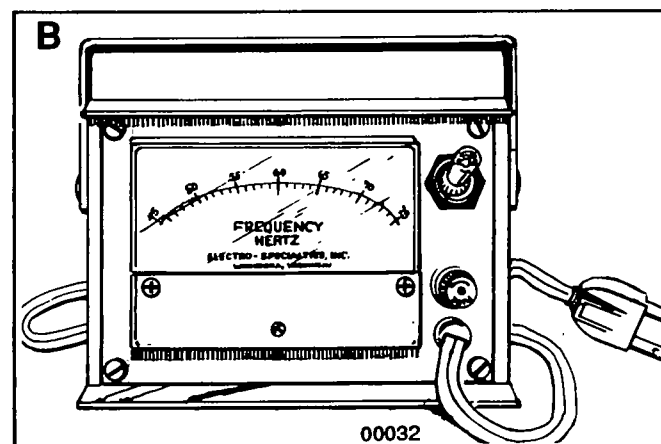
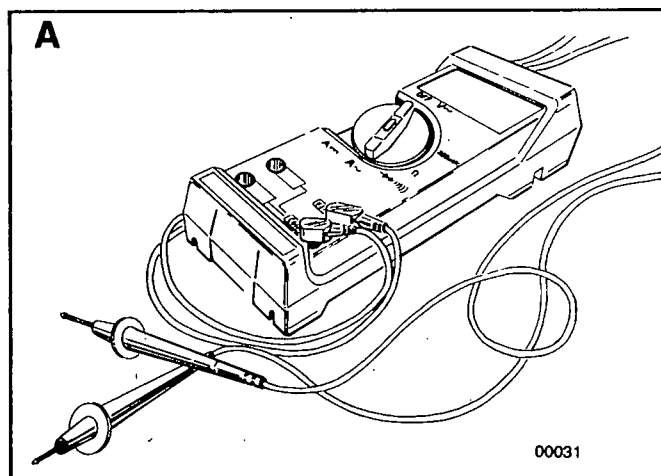

gine driven through a belt and pulley arrangement. Such a 2-pole Rotor must be operated at 3600 rpm to supply an a-c frequency output of 60 Hz. The belt and pulley arrangement provides a speed reduction, so that engine speed can be reduced while driving the Rotor at its required operating speed. The following formulae apply

when determining a-c frequency, Rotor rpm and number of Rotor poles.

$$\text{Frequency} = \frac{\text{rpm} \times \text{No. of Rotor Poles}}{2 \times 60}$$

$$\text{RPM} = \frac{2 \times 60 \times \text{Frequency}}{\text{No. of Rotor Poles}}$$

$$\text{Rotor Poles} = \frac{2 \times 60 \times \text{Frequency}}{\text{rpm}}$$

### Relationship of Voltage and Frequency

Engine governed speed and a-c voltage are adjusted with no electrical loads applied to the generator (no-load). That is, the a-c voltage is set at a fixed ratio to a-c frequency. Recommended frequency and voltage settings are as follows:

Set Frequency to: 60.5 to 63.5 Hz  
 Set Voltage to: 121 to 127 volts\*

\*Line-to-Neutral Voltage

### Generator a-c Connection System

**D** Series NP45G, NP55G and NP65G RV generators are equipped with dual Stator a-c power windings. These windings may be connected in parallel to provide a 120-volts a-c output as shown. Note that customer loads of up to 30 a-c amperes may be connected across Wires T1 (red) and T2 (white); loads up to 20 a-c amperes across wires T2 (white) and T3 (black).

**E** The generator's a-c output leads may be reconnected in series, to supply a dual voltage (120 and/or 240 volts) a-c output. When this is done, connect 240 volts a-c loads across T1 (red) and T3 (black); 120 volts across T1 (red) and T2 (white) or T3 (black) and T2 (white). T2 is the neutral wire.

### Effects of Engine Power

The generator engine must develop sufficient power to operate the generator under varying electrical loads. The greater the wattage (amperage) demands of connected electrical loads, the greater the engine power needs. As a general rule, approximately 2 engine horsepower is needed for each 1000 watts (1.0 kW) of generator power output.

If the generator's wattage/amperage capacity is exceeded, engine power may not be adequate to handle the increased load. The result will be a decrease in engine rpm, a corresponding decrease in generator a-c output voltage and frequency, and internal generator overheating.

A badly worn engine, one that has lost compression, or one with defective fuel, ignition or air intake system may

not be able to handle loads within the generator's rated capacity. Problems with generator a-c output are often caused by an engine problem.

**NOTE:** A shorted condition in one or more connected electrical loads or in generator windings can dramatically increase the power demands on the driving engine. Such shorted conditions may present the same symptoms as an underpowered engine.

### Effects of Dirt and Moisture on RV Generators

If moisture is permitted to remain in contact with generator windings, some of that moisture may be retained in cracks and voids of the winding insulation. This will cause a reduced insulation resistance. However, prolonged exposure to moisture resistance of stator and rotor winding insulation. Dirt can make the problem worse, since it tends to hold moisture into contact with windings. Salt (as from sea air) also makes the problem worse, since salt will absorb moisture from the air. When salt and moisture combine, they form a good electrical conductor.

Because of the detrimental effects of dirt and moisture, the generator should be kept as clean and as dry as possible. Stator and rotor windings should be tested periodically, using an insulation resistance tester (Hi-Pot or megohmmeter). If insulation resistance is excessively low, drying may be required to remove moisture. After drying, a second test of insulation resistance is still low after drying, replacement of defective windings may be necessary.

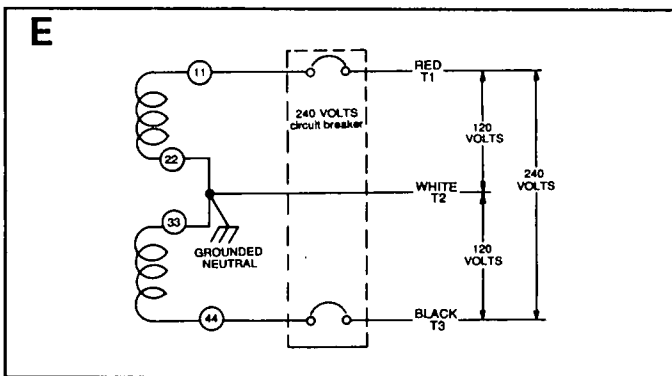
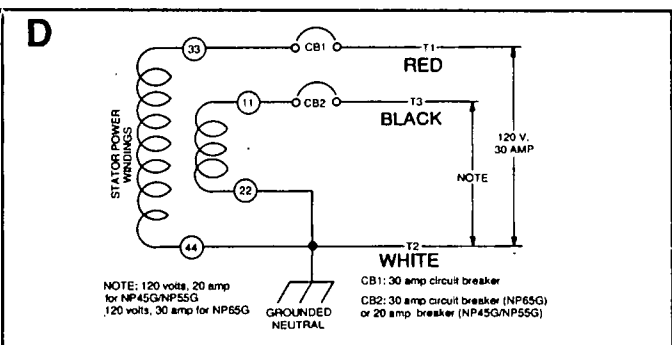

# OPERATIONAL ANALYSIS OF D-C CONTROL SYSTEM

## Introduction

This section of your Manual is intended to familiarize the reader with how the RV generator's d-c control system functions. The d-c control system provides the means to obtain engine cranking, engine ignition and fuel flow, carburetor choking, field boost and battery charging. If problems with any of these functions are encountered, the technician must have a working knowledge of how the system operates.

## Circuit Condition- Engine Shut Down

**A** With engine stopped, the circuit condition may be described as follows:

1. Battery voltage is available to the normally-open Starter Contactor (SC) contacts. The contacts are open and the circuit is incomplete.
2. Battery voltage is available through a 15 amp Fuse (F1) and to the normally open contacts of Control Relay (CR1). These contacts are open and the circuit is incomplete.
3. Battery voltage is available through Fuse (F1), through the normally-closed contacts of Control Relay (CR1), through the Starter Contactor (SC) coil, and to the Start/Stop Switch (SW1). However, the Switch contacts are open and the circuit is incomplete.
4. Battery voltage is available through Fuse (F1), through the Control Relay (CR2) actuating coil, and to the Start/Stop Switch (SW1). However, the Switch contacts are open and the circuit is incomplete.

5. Battery voltage is available to the Battery Charge Rectifier (BCR), via Wire #13, 15 amp Fuse (F1), Wire #15, and to a Battery Charge Rectifier (BCR). However, BCR diode action inhibits current flow.

## Circuit Condition- Engine Cranking

**B** When the Start/Stop Switch is held at its START position, the following sequence of events occurs:-

1. Start/Stop Switch closure connects the Control Relay (CR2) and the Starter Contactor (SC) actuating coils to frame ground.
2. The Starter Contactor (SC) energizes and its contacts close to deliver battery voltage to (a) Starter Motor (SM) and (b) a Choke Solenoid (CS) and (c) a Choke Module (CM). The following events then occur:
  - a. Starter Motor (SM) energizes and the engine cranks.
  - b. Battery voltage is delivered to the Choke Module (CM), via Wire 16, the Choke Solenoid coil, and Wire 90. Choke Module (CM) action opens and closes this circuit to ground at a rate dependent on ambient temperature, to energize and de-energize the Choke Solenoid. Choke Solenoid (CS) opens and closes the carburetor choke.
  - c. Battery voltage delivered to the Choke Module (CM) is delivered to the generator Rotor windings via a Field Boost Resistor and Diode (housed in the Choke Module), Wire 4 and the Rotor brushes and slip rings. This is field boost.

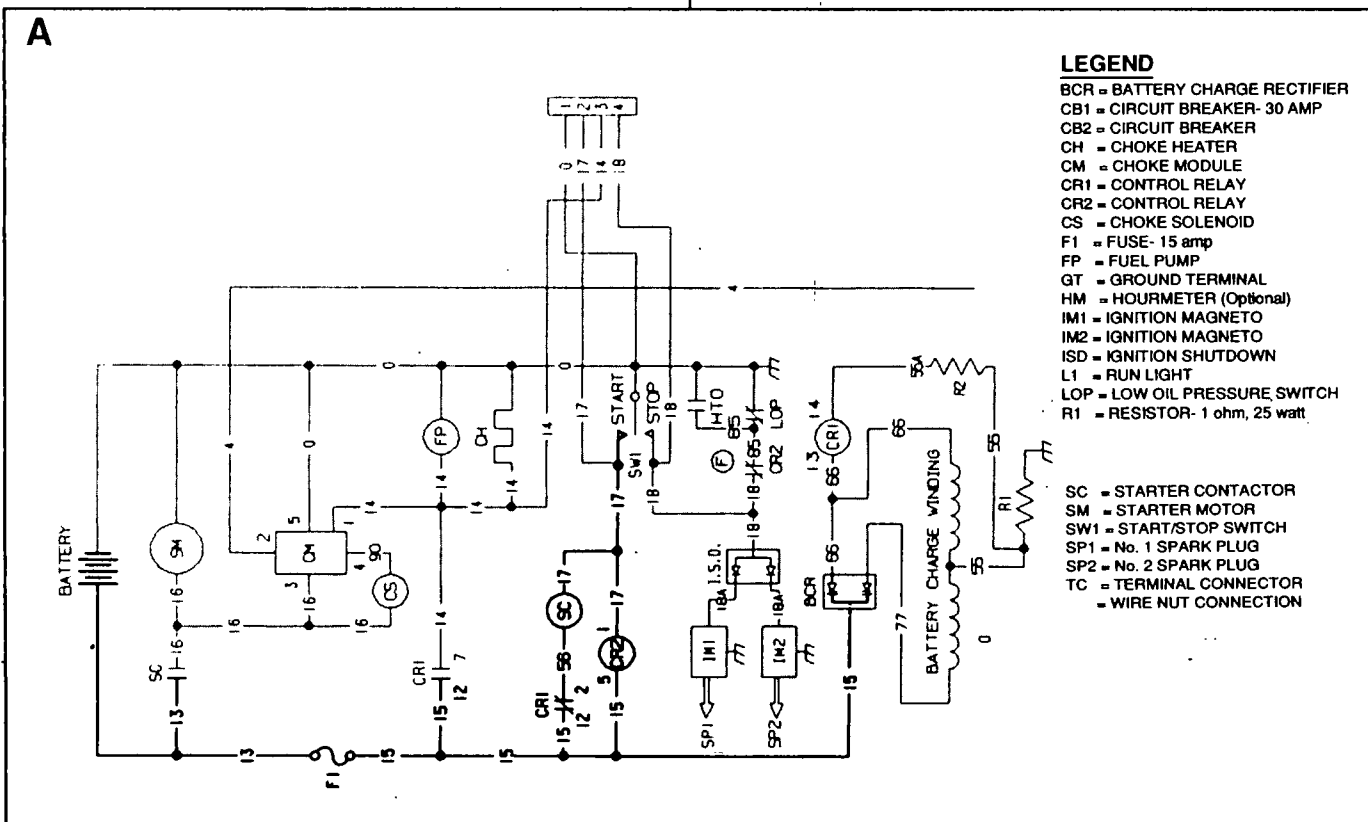

d. Battery voltage is delivered through a diode (housed in the Choke Module) and to the Wire 14 circuit. Wire 14 is now electrically hot, to operate (a) a Fuel Pump (FP), (b) a Choke Heater (CH), and (c) an "Engine Run" lamp on the optional remote panel.

3. Control Relay (CR2) energizes, its normally-closed contacts open and the Wire 18 circuit is effectively isolated from frame ground. Ignition can now occur, since that circuit is now open to ground.

4. With automatic choking, and with fuel flow and ignition available, the engine will start.

5. Engine oil pressure buildup opens the Low Oil Pressure Switch (LOP).

## Circuit Condition- Startup and Running

**C** When engine fires and starts, the operator will release the Start/Stop Switch. Circuit condition may then be described as follows:

1. When a-c output from the generator's Battery Charge Winding reaches approximately 9-12 volts a-c, Control Relay (CR1) energizes and its normally open contacts close, to deliver battery voltage to the Wire 14 circuit (Fuel Pump and Choke Heater actions continue).

2. The Starter Contactor (SC) and Control Relay (CR2) circuits to ground are opened.

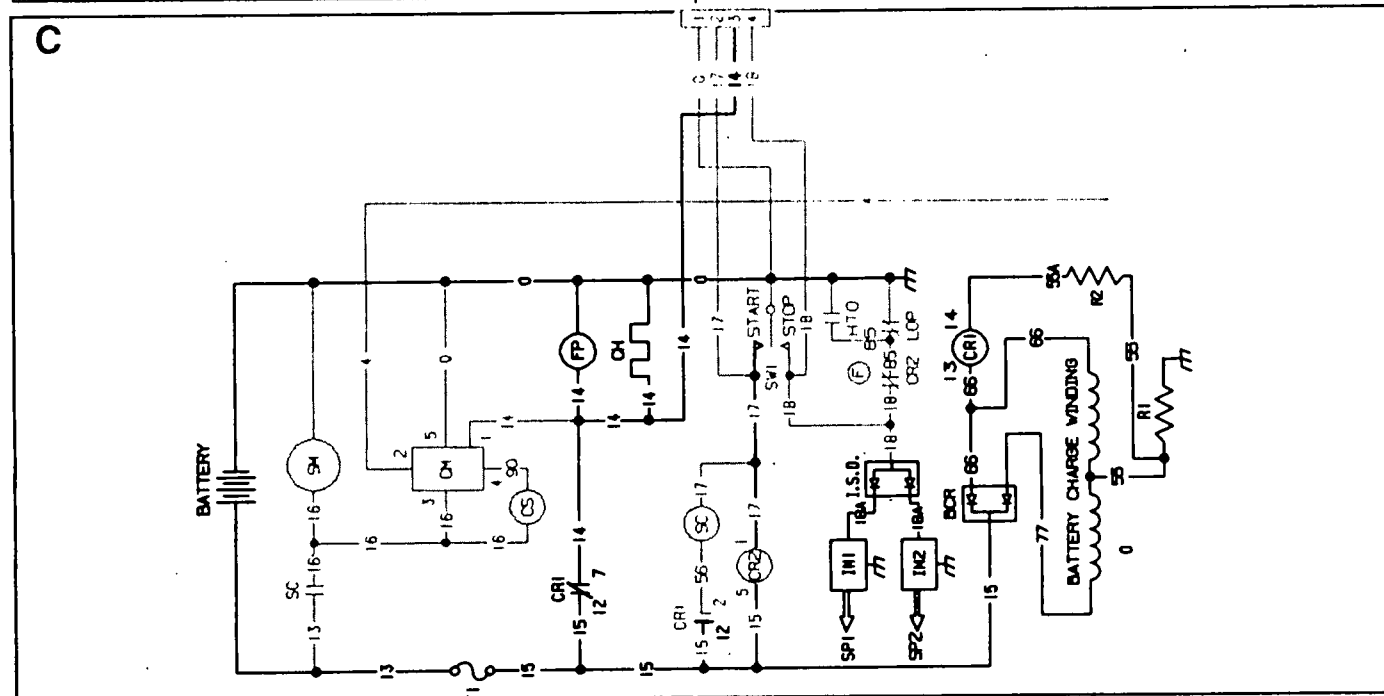
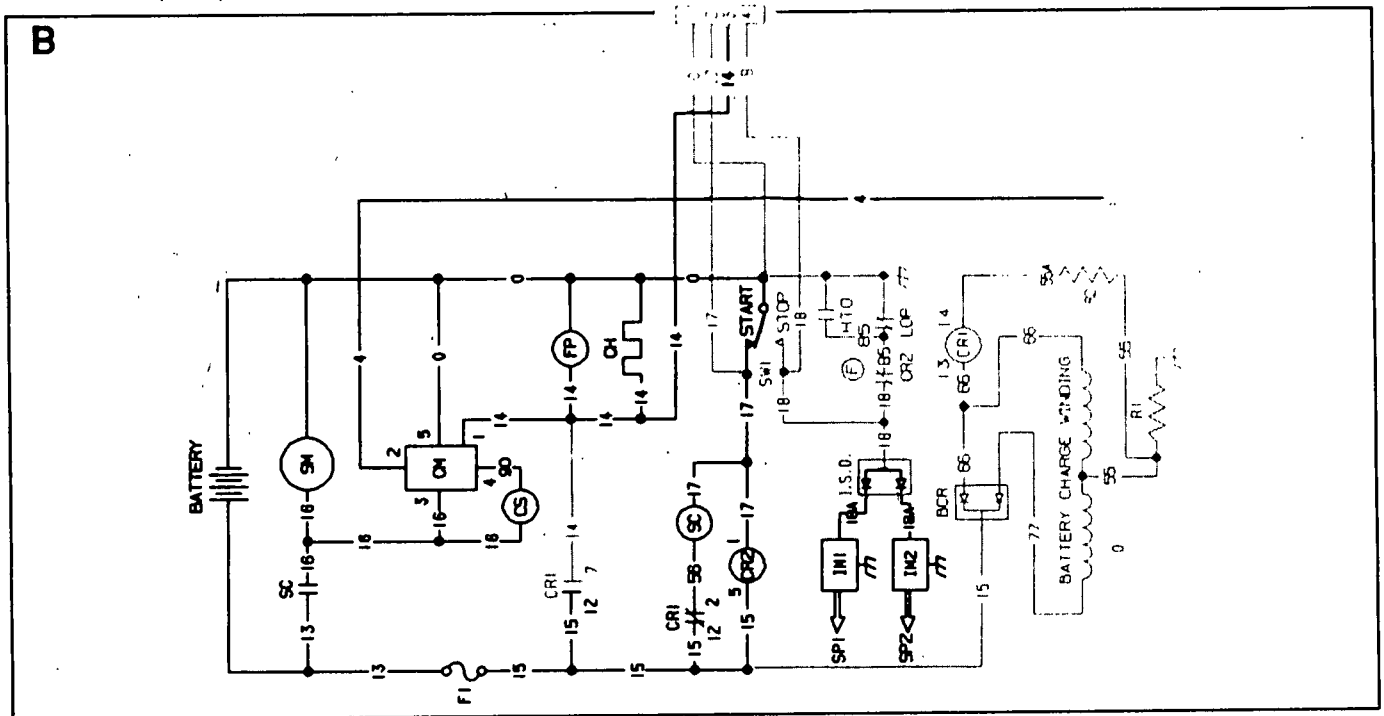



# INSULATION RESISTANCE TESTS

## General

Refer to EFFECTS OF DIRT AND MOISTURE ON RV GENERATORS (Page 5). The resistance of rotor and stator windings should be tested periodically, using a "Hi-Pot" resistance tester.

**CAUTION!:** When using the HI-Pot (Insulation Resistance) tester, follow the tester manufacturer's instructions carefully. Improper use of the tester can result in serious damage to the generator. Do not apply voltage in excess to those recommended in this Manual to Stator or Rotor windings.

## The Hi-Pot Tester

**A** The HI-Pot tester shown is only one of many brands available. It is equipped with an On/Off switch. The pilot Lamp glows to indicate tester power is available. The breakdown lamp will light to indicate failure of the winding being tested.

## Testing Stator Insulation

**B** Gain Access to Stator Leads: Remove screws that retain the front panel to the panel housing. Remove the generator cover. Inside the panel housing, locate the Electronic Voltage Regulator and the 30-amp Circuit Breaker (CB1).

**C** Disconnect Stator Leads: Disconnect Stator a-c output wires 11 and 22 from the Electronic Voltage Regulator terminals. Disconnect Stator Wire 33 from the 30-amp Breaker (CB1). Separate wires 22 and 44 at their junction. Finally, disconnect Stator Excitation Winding Wires 2 and 6 from the Electronic Voltage Regulator terminals.

**DANGER!:** Follow the instructions carefully. Wire terminal ends must not be touching any part of the generator when HI-Pot voltage is applied. Do not exceed the recommended voltages. Apply voltage to windings for a maximum of 1 second only.

**Test All Stator Windings to Ground:** Connect terminal ends of Stator a-c output Wires 11, 22, 33, 44, 2 and 6 tightly together. Make sure no terminal end is in contact with the generator frame. Then proceed as follows:

1. Connect RED test lead of Hi-Pot tester to joined terminal ends of Wires 11, 22, 33, 44, 2 and 6.
2. Connect the BLACK test lead to a clean, painted frame ground (on generator Stator can).
3. Turn HI-Pot tester switch OFF. Then plug tester into a 120 volts wall socket and set its Voltage Selector Switch to 500 volts.

**CAUTION!:** IN STEP 4, DO NOT APPLY VOLTAGE LONGER THAN ONE MINUTE.

4. Turn tester switch ON and check that Pilot Lamp is ON. Then, set Voltage Selector Switch to 2000 volts. Observe the BREAKDOWN lamp, wait one second, then turn tester switch OFF.

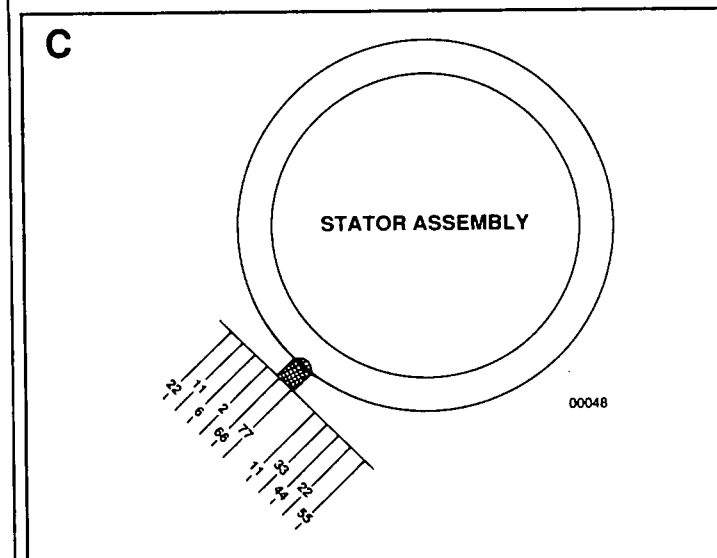
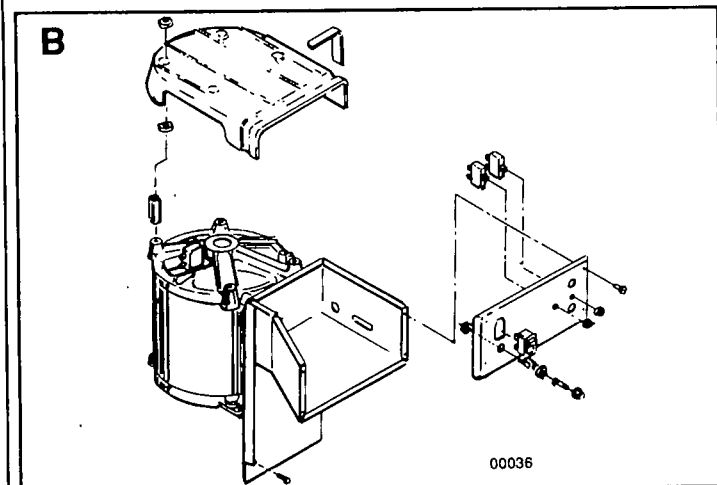
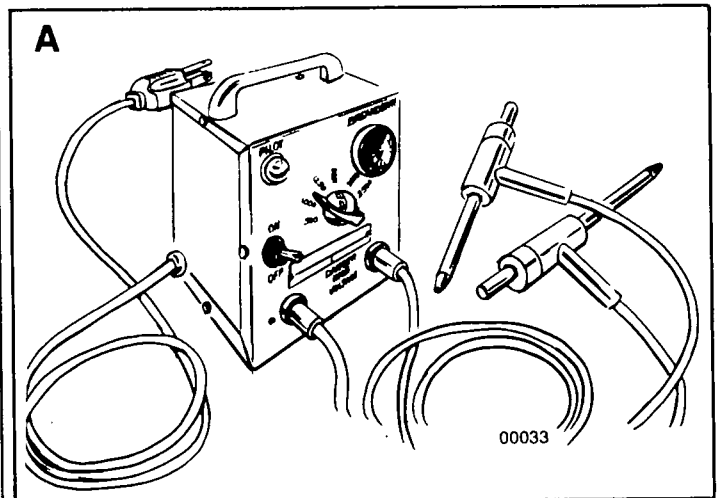

**Test Between Isolated Windings:-** To test between isolated Stator windings, proceed as follows:

1. Connect RED lead of Hi-Pot tester to terminal end of Wire 11, BLACK test lead to Wire 2 terminal end.
2. Turn tester switch ON and check that Pilot Light is ON.
3. Set Voltage Selector Switch to 1500 volts- **APPLY VOLTAGE FOR ONE SECOND ONLY.** Observe tester Breakdown lamp. Turn tester switch OFF and reset Voltage Selector Switch to 500 volts.

**Test Between Parallel Windings:-** Test between parallel Stator windings as follows:

1. Set tester Voltage Selector Switch to 500 volts.
2. Connect tester RED test lead to Wire #11, BLACK test lead to Wire 33.
3. Turn tester switch ON and check that Pilot Light is ON.
4. Apply voltage for one second while observing the Breakdown lamp. Then, turn tester switch OFF.

**RESULTS:** If tester Breakdown lamp comes ON during any one second test, clean and dry the stator. Then, repeat the breakdown test. If Breakdown lamp illuminates after drying, replace the Stator Assembly.

### Testing Rotor Insulation for Breakdown

**D** Remove generator cover to gain access to the Rotor slip rings and brushes.

**E** Remove all wires that connect to the Brushes. Then, test Rotor insulation as follows:

1. Connect tester RED test lead to the positive (+) Rotor slip ring (nearest the Rotor bearing).
2. Connect BLACK test lead to a clean frame ground.
3. Turn tester switch OFF.
4. Plug tester into a 120 volts wall socket.
5. Set Voltage Selector Switch on tester to 500 volts.
6. Turn tester switch ON and check that Pilot Light is ON.
7. Set Voltage Selector Switch to 1250 volts and observe the tester breakdown lamp. Then, turn tester switch OFF.

**RESULTS:-** If tester breakdown lamp illuminates during the 1 second test, drying of the generator may be necessary. After drying, repeat the Hi-Pot test. If Rotor windings fail the second test (after drying), replace the Rotor assembly.

### Cleaning the Generator

Removed caked on or greasy dirt with a soft brush or a clean, damp cloth. A vacuum system may be used to pick up loosened dirt. Loose dust and dirt may also be removed using low pressure, dried air (25 psi maximum).

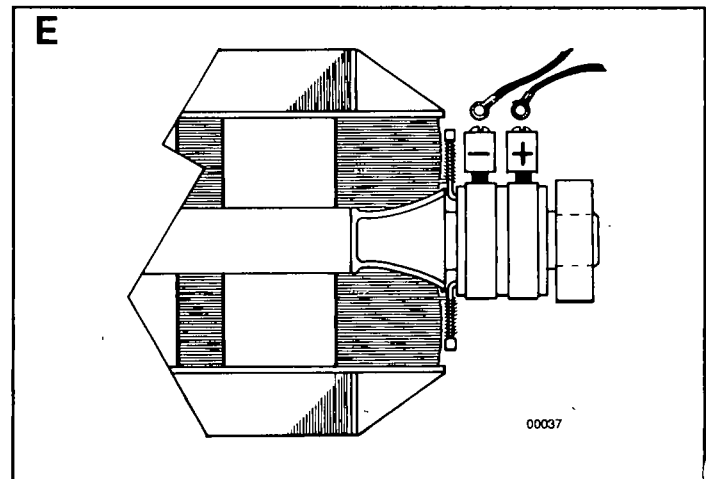
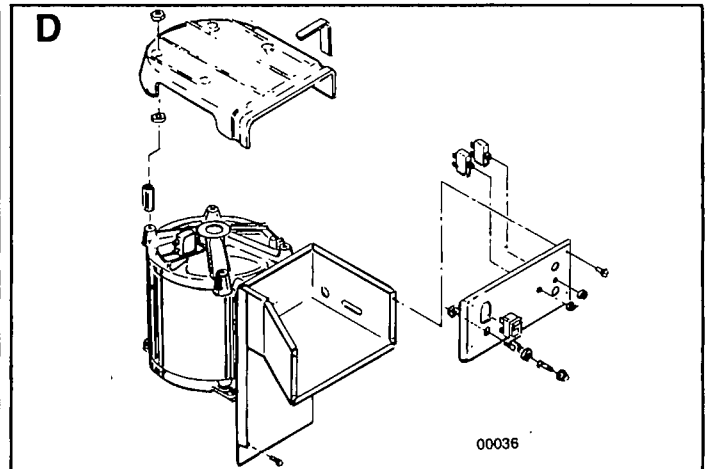

**CAUTION!:** Do NOT use a forceful spray of water to clean generator. Some of the water will be retained on generator windings and will cause serious problems.

### Drying the Generator

1. Open the main circuit breaker or main line switch. **NO ELECTRICAL LOADS MUST BE CONNECTED TO GENERATOR WHILE DRYING.**
2. Remove the generator cover (see illustration "B" on previous page).
3. Disconnect Wire #4 from the Electronic Voltage Regulator.
4. Provide an external source to blow warm, dry air through the generator. Do NOT exceed 185° F. (85° C.).
5. Start the engine, let it run for 2 to 3 hours.
6. Stop the engine and retest Stator and Rotor windings.

# WIRING DIAGRAM & ELECTRICAL SCHEMATIC

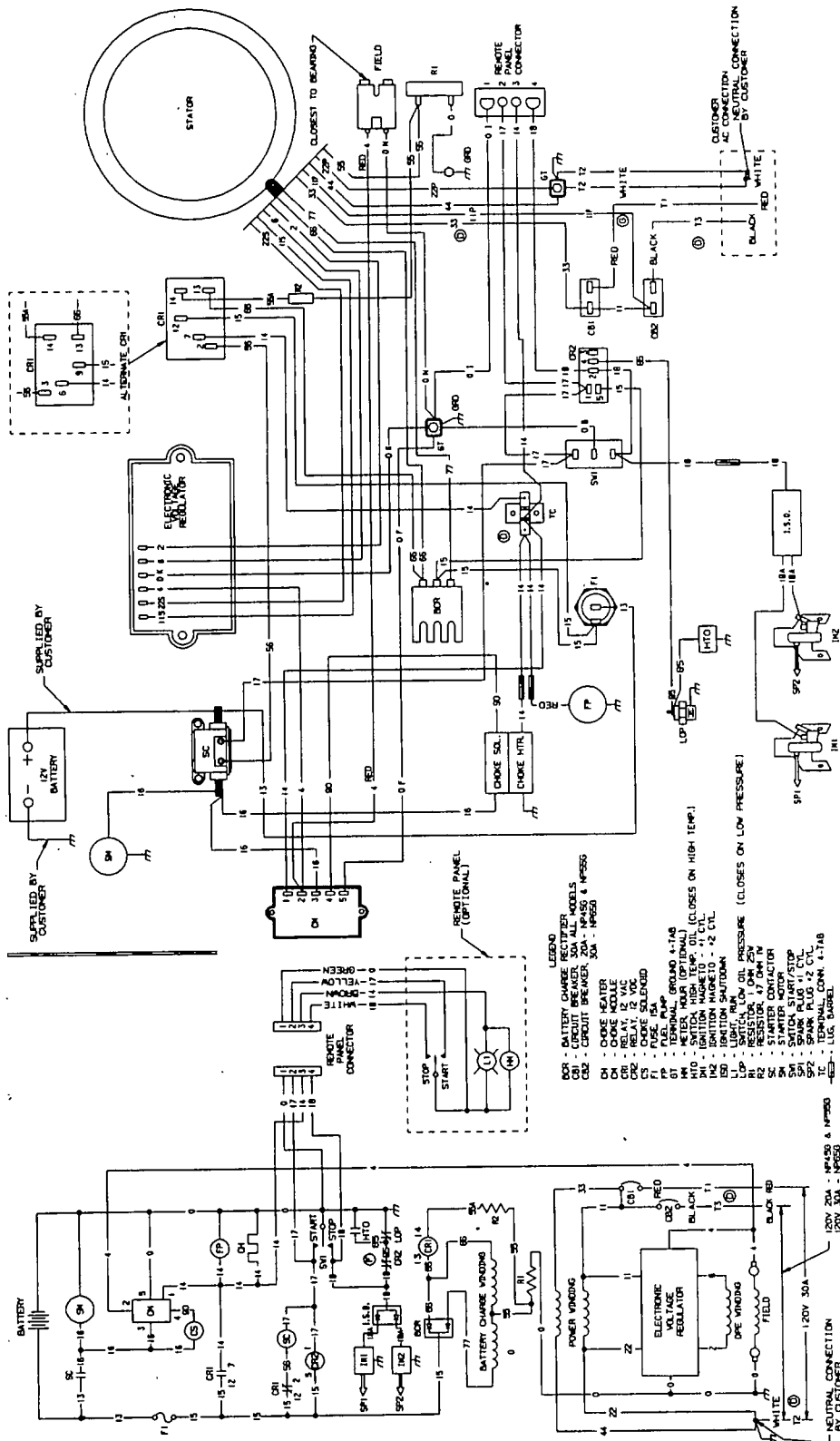

# TROUBLESHOOTING THE RV GENERATOR

## Introduction

The service technician can use this troubleshooting guide to determine the cause of existing problems. Six common problems are covered in this section. Problems are not arranged in any particular sequence.

The first step in troubleshooting is to identify your particular problem. When you have identified your problem, locate that problem in the troubleshooting guide on this page. When working your way through the step-by-step procedure for that problem, start at Step 1 and follow through the step-by-step procedure. Each step is arranged in a definite sequence, from the more probable/easiest to check to the less probable/more complex to check. When the cause of the problem is found and corrected, stop the test.

Follow the step-by-step procedures carefully. After completing each test, read the TEST RESULTS. Some test results may instruct you to skip certain steps and proceed to a new step number.

## Problem No. 1- Engine Won't Crank

Step 1- Check 15 amp Fuse F1

Step 2- Check Battery

Step 3- Check Starter Contactor SC

Step 4- Check Starter Motor SM

Step 5- Check Start/Stop Switch SW1

Step 6- Check Control Relay CR1

## Problem No. 2- Engine Cranks, Won't Start

Step 1- Check Fuel Quantity

Step 2- Check Fuel Shutoff Valves

Step 3- Check Fuel Flow

Step 4- Check Fuel Filter

Step 5- Check Fuel Pump

Step 6- Check Engine Ignition System

Step 7- Test Choke Module

Step 8- Check Automatic Choke Operation

Step 9- Check Engine Compression/Condition

Step 10- Test Control Relay CR2

## Problem No. 3- Engine Cranks and Starts, Shuts Down When Start/Stop Switch is Released

Step 1- Check Engine Oil Level

Step 2- Check Oil Pressure Switch

Step 3- Check Control Relay CR1

Step 4- Check Stator Battery Charge Windings

Step 5- Check Resistor R1

## Problem No. 4- Engine Starts Hard, Runs Rough

Step 1- Check Engine Ignition System

Step 2- Check Carburetion

Step 3- Check Engine Compression

Step 4- Test Automatic Choke

## Problem No. 5- Engine Won't Shut Down

Step 1- Check Start/Stop Switch

Step 2- Check Wire #18 & #0

Step 3- Check Engine Ignition System (I.S.D.)

## Problem No. 6- Loss of Generator a-c Output

Step 1- Check Circuit Breakers CB1/CB2

Step 2- Check Vehicle Wiring

Step 3- Check a-c Voltage and Frequency

Step 4- Check Load Voltage and Frequency

Step 5- Check/Adjust Engine Governor

Step 6- Check Field Boost Circuit

Step 7- Check Stator Excitation Windings

Step 8- Check Stator a-c Power Windings

Step 9- Check Rotor (Field) Circuit

Step 10- Check Voltage Regulator Sensing

Step 11- Check/Adjust Voltage Regulator

# TROUBLESHOOTING GUIDELINES

## Problem No. 1- Engine Won't Crank

### Step 1- Check 15 amp Fuse F1

**Test Procedure:** Remove Fuse F1 from generator panel and inspect fuse element. If necessary, use a Volt-Ohm-Milliammeter (VOM) to check fuse for continuity.

#### Test Results:-

- A. Fuse F1 checks GOOD: Go to Step 2
- B. Fuse F1 is open: Replace Fuse F1. If engine cranks normally STOP.

### Step 2- Check Battery

**Test Procedure:-** Perform the following checks/tests on the generator battery:

1. Inspect battery terminals (posts) and cables. Cable clamps and connections must be clean and tight. Clean and/or tighten cable clamps and connections as necessary. Replace any defective cables.
2. Use an automotive type battery hydrometer to test battery STATE OF CHARGE. Follow the hydrometer manufacturer's instructions carefully. Write down the specific gravity of the electrolyte fluid in each battery cell. Write down the specific gravity reading of each cell as the reading is taken. Return the electrolyte fluid to the cell from which it was removed. If the hydrometer used does not have a percentage of charge scale, compare the readings obtained with the following:

SPECIFIC GRAVITY	PERCENT OF CHARGE
1.260	100%
1.230	75%
1.200	50%
1.170	25%

If necessary, use an automotive type battery charger to recharge the battery to a 100% state of charge.

**DANGER!:** Storage batteries give off EXPLOSIVE hydrogen gas while charging. Completely remove the battery from the vehicle before attempting to recharge it. Charge the battery only in a well ventilated space where explosive gases cannot accumulate and present the danger of explosion. Do not permit smoking, open flame or sparks in the vicinity while charging a battery.

3. If the difference in specific gravity between the highest and lowest reading cell is 0.050 (50 points) or greater, the battery is nearing the end of its useful life and should be replaced. However, if the lowest reading cell has a specific gravity of less than 1.200, recharge the battery and then repeat the specific gravity test. If, after charging, the difference between the highest and lowest reading cell is still 0.050 (50 points), replace the battery.

#### Test Results:-

- A. Normal engine cranking occurs: STOP tests
- B. Battery checks GOOD, no cranking: Go to Step 3.

### Step 3- Check Starter Contactor SC

**Test Procedure:-** Starter Contactor operation may be tested as follows:

1. See Figure 1. Connect the positive (+) test lead of a d-c voltmeter to the Wire 56 terminal of the Starter Contactor. Connect the meter negative (-) test lead to a clean frame ground. The voltmeter should indicate battery voltage (12 volts d-c).

#### Test Results:

- A. Battery voltage NOT indicated: Go to Step 6
  - B. Battery voltage was indicated: Continue test
2. Connect the positive (+) test lead of a d-c voltmeter to the Wire 16 terminal stud of the Starter Contactor; connect negative (-) test lead to a clean frame ground. Zero volts should be indicated.
  3. With d-c voltmeter still connected to the Wire 16 terminal stud and frame ground, disconnect Wire 17 from its terminal stud on Starter Contactor. Connect a jumper wire from the Wire 17 terminal stud (on Starter Contactor) to a clean frame ground. The d-c voltmeter should indicate battery voltage and engine should crank.

#### Test Results:

- A. Battery voltage GOOD and engine cranks, but will not crank with Start/Stop Switch: Go to Step 5
- B. Battery voltage GOOD, engine does NOT crank: Go to Step 4
- C. Zero battery voltage with jumper wire connected and engine does not crank: Replace Starter Contactor SC.

Figure 1. Starter Contactor SC

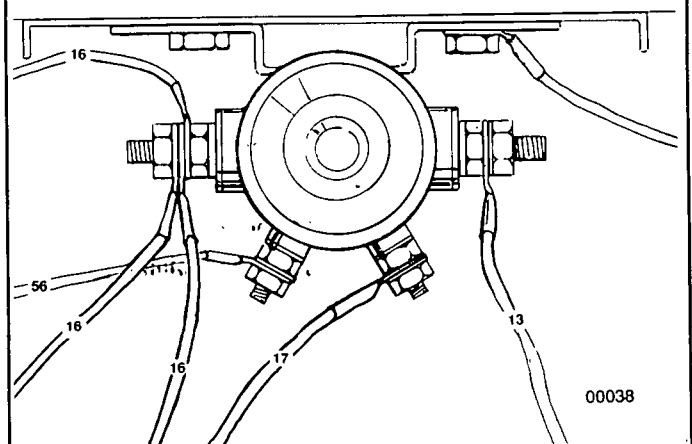

### Step 4- Check Starter Motor SM

**Test Procedure:-** Connect a jumper cable to the large battery cable terminal stud (Wire 13) of the Starter Con-

tactor and to the cable terminal on Starter Motor. Engine should crank.

**Test Results:**

- A. Engine cranks normally but does not crank when using the Start/Stop Switch: Go to Step 5.
- B. Engine does NOT crank: Replace Starter Motor SM
- C. Engine cranks normally with jumper cable and with Start/Stop Switch: STOP tests.

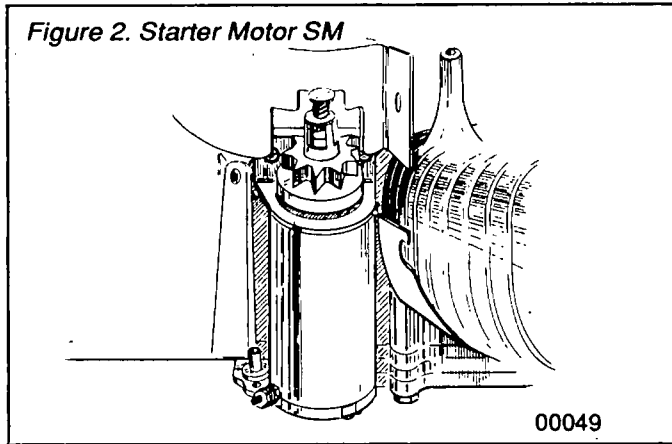

**NOTE: For Starter Motor SM testing and repair instructions, refer to ENGINE SERVICE MANUAL.**

**Step 5- Check Start/Stop Switch SW1**

**Test Procedure:-** See Figure 3. Test the Start/Stop Switch as follows:

1, Set a Volt-Ohm-Milliammeter (VOM) to its "Rx1" scale and zero the meter. Connect one VOM test lead to the Wire 0 terminal of Start/Stop Switch; connect second meter test lead to a clean frame ground. The VOM should indicate continuity.

**Test Results:**

- A. VOM does NOT indicate continuity: Repair or replace Wire 0 between Switch and frame ground connection, as necessary.
- B. VOM indicates continuity: Continue test.

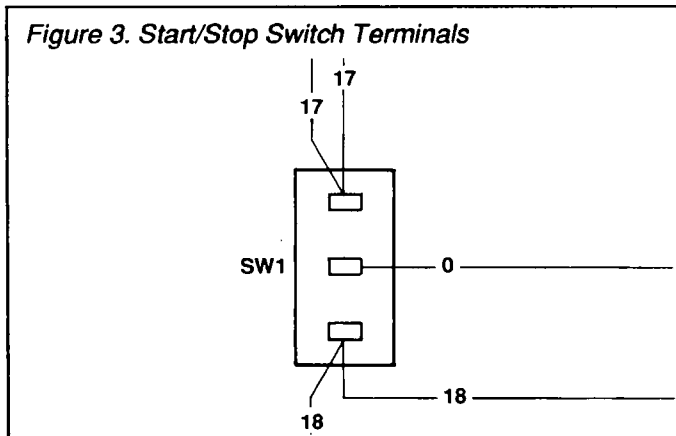

2. Connect a jumper wire between the Start/Stop Switch Wire 17 terminal and a clean frame ground connection. Engine should crank and start. Disconnect jumper wire to terminate cranking when engine starts. To stop the engine, connect jumper wire to Wire 18 terminal of Start/Stop Switch and to frame ground.

**Test Results:**

- A. Engine cranks, starts and shuts down normally when using jumper wire, but not when using Start/Stop Switch: Replace Start/Stop Switch.
- B. Engine will not crank when using jumper wire: Go to Step 6.
- C. Engine cranks and stops normally when using jumper wire and with Start/Stop Switch: STOP tests.

**Step 6- Check Control Relay CR1**

**NOTE: See WIRING DIAGRAM & ELECTRICAL SCHEMATIC on Page 11. Two different types of Control Relay CR1 are used on the NP series generators, Identified in the Wiring Diagram as "CR1" and "Alternate CR1". Also see Figures 4 and 5.**

**Test Procedure:-** See Figure 4 or 5. Test the Relay as follows:

1. Connect the positive (+) test lead of a d-c voltmeter to CR1 terminal 12 (Wire 15 terminal); connect the negative (-) test lead to a clean frame ground. Meter should indicate battery voltage. If alternate CR1 is installed, connect meter positive (+) test lead to Relay terminal 9 (Wire 15 terminal).

**Test Results:**

- A. Battery voltage is indicated: Continue test
- B. Battery voltage is NOT indicated:- Repeat Step 1. Also check Wire 15 between Relay CR1 and Fuse F1 for open or disconnected condition; Wire 13 between Fuse F1 and Starter Contactor SC for open; and positive (+) battery cable to Starter Contactor SC.

2. Connect the positive (+) test lead of a d-c voltmeter to CR1 terminal 2 (Wire 56 terminal); negative (-) test lead to frame ground. If alternate CR1 is installed, connect meter positive (+) test lead to Relay terminal 3 (Wire 56 terminal). Battery voltage should be indicated.

**Test Results:**

- A. Battery voltage NOT indicated: Replace Control Relay CR1
- B. Battery voltage was indicated: Repeat Steps 1 through 5. Refer to WIRING DIAGRAM (Page 11) and test wires for open or shorted condition.

Figure 4. Control Relay CR1

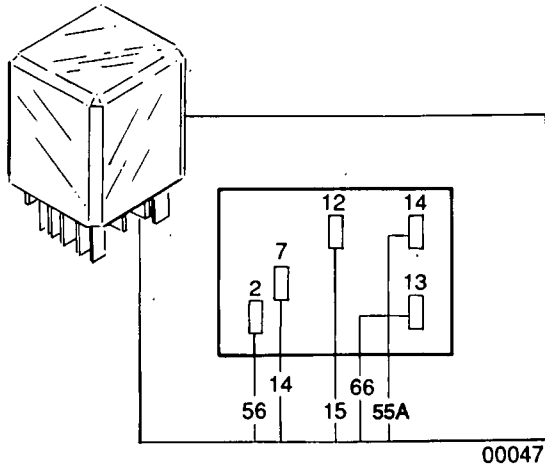
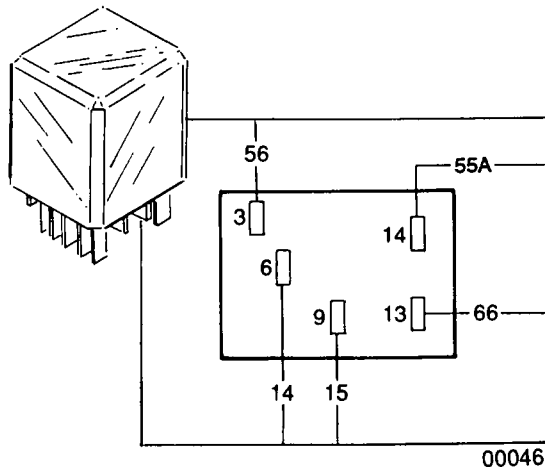

Figure 5. Alternate Control Relay CR1



## Problem No. 2 - Engine Cranks, Won't Start

### Step 1 - Check Fuel Quantity

**Test Procedure:** When troubleshooting a problem, the most simple causes are often overlooked. If engine cranks normally but won't start, check that adequate supply of the proper fuel is available. Many RV generator installations with shared fuel tank utilize a generator fuel pickup tube that is shorter than the vehicle engine's fuel pickup tube. For that reason, the generator will "run out of gas" while fuel is still available for the vehicle engine.

#### Test Results:

- A. Fuel quantity is adequate: Go to Step 2.
- B. Inadequate fuel in tank: Fill fuel tank.

### Step 2 - Check Fuel Shutoff Valves

**Test Procedure:** The fuel supply line in the vehicle may be equipped with one or more fuel shutoff valves. If engine will not start, check that all fuel supply valves are open.

#### Test Results:

- A. Fuel Shutoff Valve(s) are closed: Open all valves
- B. Shutoff valves are open, engine will not start: Go to Step 3

### Step 3- Check Fuel Flow (Gasoline System Only)

**Test Procedure:-** Disconnect fuel line at engine carburetor inlet. Crank engine and check fuel flow from open end of disconnected line.

#### Test Results:

- A. Fuel Flow is inadequate: Go to Step 4
- B. Fuel flow checks GOOD: Go to Step 6

### Step 4- Check Fuel Filter (Gasoline System Only)

**Test Procedure:-** See Figure 6. If fuel flow to carburetor is low, try a new fuel filter. Make sure arrow on filter body points in direction of flow toward carburetor. With new filter installed, recheck fuel flow as outlined in Step 3.

#### Test Results:

- A. Fuel flow is normal: STOP tests
- B. Fuel flow still inadequate: Go to Step 5

Figure 6. Engine Fuel System

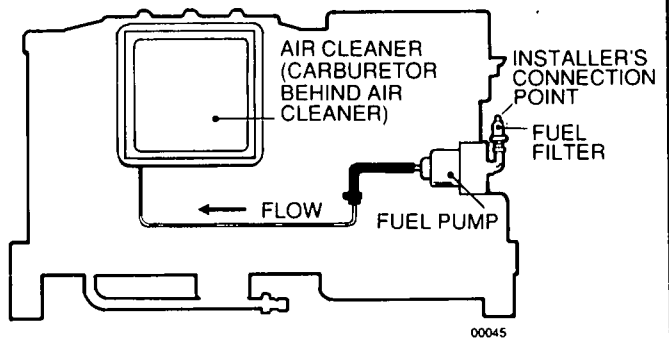

### Step 5- Check Fuel Pump (Gasoline System Only)

**Test Procedure:-** Locate the 4-tab terminal connector to which Wires 14 connects. Locate Wire 14 from Fuel Pump on the terminal connector. Connect the positive (+) test lead of a d-c voltmeter to the Fuel Pump's Wire 14 terminal; connect negative (-) test lead to a clean frame ground. Crank engine- the voltmeter should indicate battery voltage and the Fuel Pump should operate.

#### Test Results:

- A. Battery voltage is indicated and Fuel Pump operates, but still no start: Go to Step 6
- B. No battery voltage indicated and Fuel Pump does not operate: Go to Step 7

### Step 6- Check Engine Ignition System

**Test Procedure:-** Refer to section in this Manual entitled ENGINE TROUBLESHOOTING. Also refer to the ENGINE SERVICE MANUAL, if necessary.

#### Test Results:

- A. Ignition System checks GOOD: Go to Step 7
- B. Ignition System checks BAD: Repair or replace defective component(s) as necessary

### Step 7- Test Choke Module

**NOTE:** The following procedure will test the Wire 14 diode, the field boost diode, and the field boost resistor. To test these components, it is recommended that a Volt-Ohm-Milliammeter having a DIODE TEST capability be used. The solid state circuit that regulates automatic choke opening and closing cannot be tested in the field. That circuit will be tested in Step 8 by observing choke operation.

**Test Procedure:-** See Figure 7. Disconnect all wires from Choke Module terminals to prevent interaction. Then, proceed as follows:

1. To test the Wire 14 diode, connect one VOM test lead to Terminal 3 of the Choke Module; connect second test lead to Terminal 1. Observe the meter reading. Then, reverse the test leads (reverse the d-c polarity) across those Choke Module terminals and again observe the reading. At one polarity, the VOM should read infinity. At the opposite polarity, the VOM should indicate the forward resistance of the 6 amp, 100 volts diode in the Wire 14 circuit. If using a VOM having the diode test feature, allowable voltage drop across the diode is 0.6 to 0.8 volt.
2. To test the Field Boost diode and resistor, connect one VOM test lead to Choke Module Terminal 3, the second test lead to Terminal 2. Note the meter reading. Then, reverse the test leads (reverse polarity) and again observe the VOM reading. At one polarity, the meter should indicate infinity. At the opposite polarity, the meter should read the forward resistance of the diode plus the resistance of the Field Boost Resistor. If a VOM having the diode test feature is used, allowable voltage drop will be 0.6 to 0.8 volts PLUS the voltage drop across the resistor.

**NOTE:** The Field Boost Resistor is rated 47 ohms at 2 watts (plus or minus 10%). The Field Boost diode is rated 1 amp at 600 volts.

3. The Choke Module circuit includes a metal oxide Varistor, rated 22 volts, 0.6-0.8 Joule. There is no good method of testing a Varistor in the field. Typically, when a Varistor fails it will overheat and melt. Inspect the Choke Module- if evidence of overheating and melting is observed, replace the Choke Module.

#### Test Results:

- A. All Choke Module tests are GOOD: Go to Step 8
- B. Choke Module tests BAD: Replace Choke Module

Figure 7. Choke Module

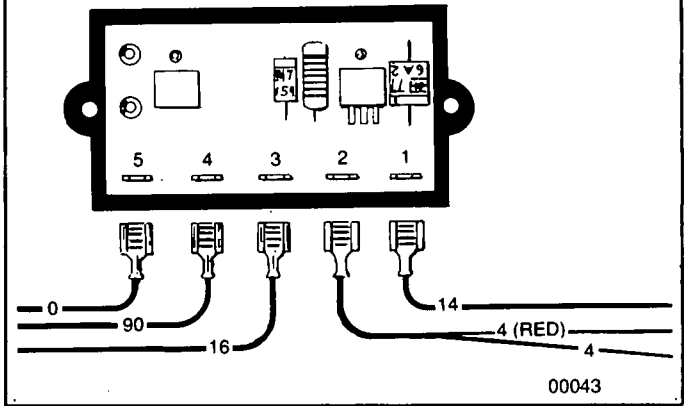

### Step 8- Check Automatic Choke Operation

**Test Procedure:-** See Figure 8. Crank engine while observing choke operation. The Choke Solenoid CS should pull in to close choke for about 0.2-0.4 seconds, should then de-energize to open choke for about 2 seconds. This cyclic action should occur while the engine is cranking. If Choke Solenoid does not actuate, check for binding. Also check for proper choke adjustment (see ADJUSTMENTS section).

#### Test Results:

- A. Choke operation checks GOOD, engine still won't start: Go to Step 9
- B. Choke operation checks BAD: Try adjusting choke- if it still does not operate, replace Choke Module

Figure 8. Automatic Choke

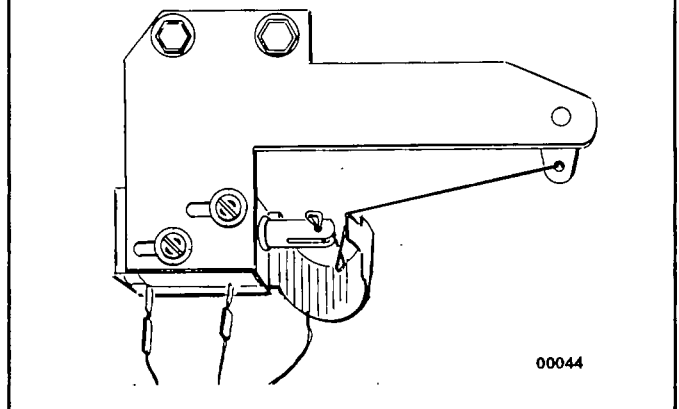

### Step 9- Check Engine Compression/Condition

**Test Procedure:-** Refer to section entitled ENGINE TROUBLESHOOTING. If necessary, also refer to the ENGINE SERVICE MANUAL.

#### Test Results:

- A. Engine Checks GOOD: Go to Step 10
- B. Engine checks BAD: Repair/replace engine as necessary

### Step 10- Test Control Relay CR2

**Test Procedure:-** See Figure 9. Disconnect Wire 18 from Relay Terminal 2 and Wire 85 from Terminal 4, to prevent interaction. Set a VOM to its "Rx1" scale and zero the meter. Then, connect the VOM test leads across Relay Terminals 2 and 4- the meter needle should swing upscale (continuity). Hold Start/Stop Switch at START to crank engine- the VOM needle should drop all the way downscale (infinity).

#### Test Results:

A. Control Relay CR2 checks GOOD: Repeat Steps 1 through 9

B. Control Relay CR2 checks BAD: Replace Relay CR2

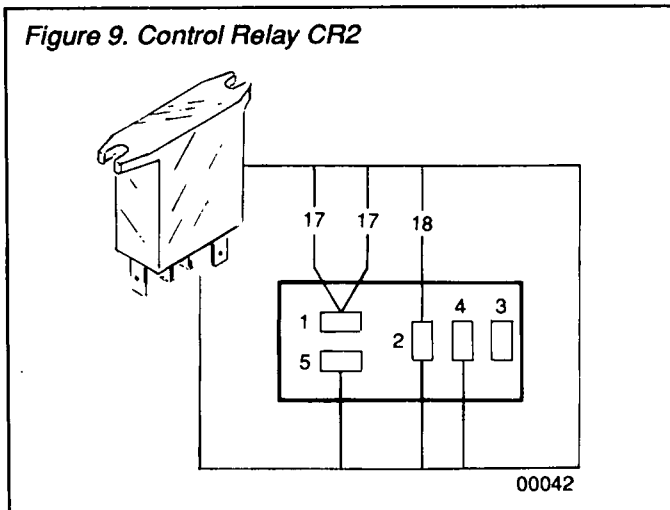

### Problem No. 3- Engine Cranks and Starts, Shuts Down When Start/Stop Switch is Released

#### Step 1- Check Engine Oil Level

**Test Procedure:-** Check engine oil level as outlined in Owner's Manual. If oil level is low, sufficient oil pressure to open the Low Oil Pressure Switch contacts will not be developed. With Start/Stop Switch at START, Control Relay CR2 action will open the engine ignition circuit to ground. However, as soon as the Start/Stop Switch is released, CR2 contacts will close and closure of the Low Oil Pressure Switch contacts will close the ignition circuit to ground and ignition will terminate. The result will be an engine shutdown as soon as the Start/Stop Switch is released.

#### Test Results:-

A. Oil level is LOW: Add oil as required (don't forget Oil Makeup Tank)

B. Oil level is GOOD: Go to Step 2

**NOTE:** You may wish to check engine oil pressure. See ENGINE SERVICE MANUAL for oil pressure check procedures and specifications.

### Step 2 - Check Oil Pressure Switch

**Test Procedure:** Set a VOM to its "Rx1" scale and zero the meter. Disconnect Wire 85 from the Switch terminal, then test the Low Oil Pressure Switch (Fig. 10) as follows:

1. Connect one VOM test lead to the switch terminal, the remaining test lead to a clean frame ground. Meter should indicate continuity.

2. Crank engine. The VOM needle should drop all the way downscale (infinity) as oil pressure increases.

3. If the engine starts and runs, hold terminal end of Wire 85 into firm contact with a clean frame ground. Engine should shut down.

#### Test Results:

A. Oil Pressure Switch checks GOOD: Go to Step 3.

B. Oil Pressure Switch checks BAD: Replace switch.

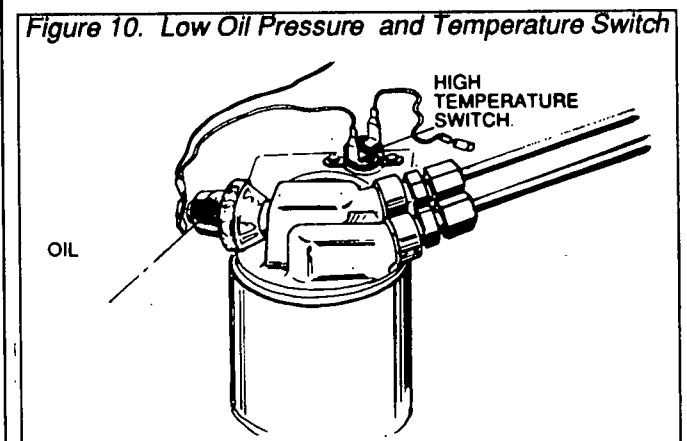

### Step 3- Check Oil Temperature Switch

**Test Procedure:** Set a VOM to its "Rx1" scale and zero the meter. Disconnect Wire 85 from the Switch terminal, then test the Oil Temperature Switch (Fig. 10) as follows:

1. Connect one VOM test lead to the switch terminal, the remaining test lead to a clean frame ground. Meter should indicate continuity.

2. If the engine starts and runs, hold terminal end of Wire 85 into firm contact with a clean frame ground. Engine should shut down.

#### Test Results:

A. Oil Temperature Switch contacts check GOOD: Go to Step 4.

B. Oil Temperature Switch contacts check BAD: Check wiring.

#### Step 4 - Check Control Relay CR1

**Test Procedure:** Refer to Step 6 under Problem No. 1.

**Test Results:**

- A. Control Relay CR1 checks GOOD: Go to Step 5.
- B. Control Relay CR1 checks BAD: Replace Control Relay CR1.

#### Step 5 - Check Stator Battery Charge Windings

**NOTE:** The Volt-Ohm-Milliammeter (VOM) used to test Stator windings must be accurate. Recommended is a digital meter of high accuracy.

**Test Procedure:** Disconnect Wires 66 and 77 (Fig. 11) from the Battery Charge Rectifier BCR terminals. Set a VOM to its "Rx1" scale and zero the meter. Connect the meter test leads across the terminal ends of Wires 66 and 77, just removed from Battery Charge Rectifier BCR. The VOM should indicate Stator Battery Charge Winding resistance, as follows:

Series NP45G = 0.12 ohm

Series NP55G = 0.09 ohm

Series NP65G = 0.07 ohm

All test readings are plus or minus 10%.

Now, set the VOM to its "Rx10,000" scale and zero the meter. Connect one VOM test lead to terminal end of Wire 66, remaining test lead to a clean frame ground. No upscale movement of the meter should be noted (infinity).

**Test Results:**

- A. Battery Charge Winding checks GOOD: Go to Step 6
- B. Battery Charge Winding checks BAD: Replace Stator Assembly.

Figure 11. Checking Stator Battery Charge Windings

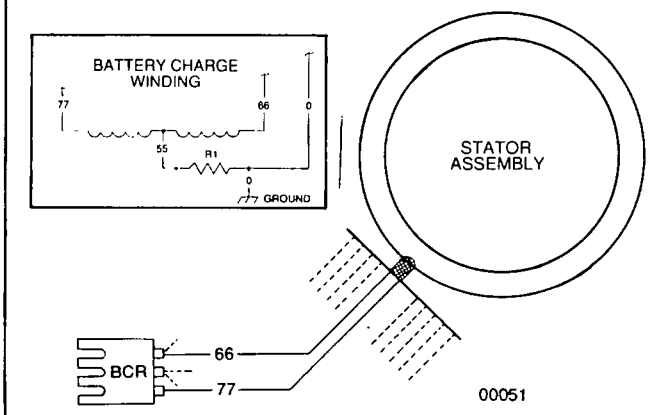

#### Step 6 - Check Resistor R1

**Test Procedure:** Inside the generator panel, locate Resistor R1 (Fig. 12). Test wire 0 (between Resistor R1 and frame ground connection) for an open condition. Correct open condition, if necessary, before proceeding. Disconnect Wire 55 from the Resistor to prevent interac-

tion. Set a VOM to its "Rx1" scale and zero the meter. Connect the first meter test probe to the Wire 55 terminal of Resistor. Connect second test probe to a clean frame ground. Meter should indicate about 1 ohm (plus or minus 5%).

**Test Results:**

- A. Resistor R1 checks GOOD: Repeat Steps 1 through 4 under Problem No. 3.
- B. Resistor R1 checks BAD: Replace Resistor R1.

Figure 12. Resistor R1

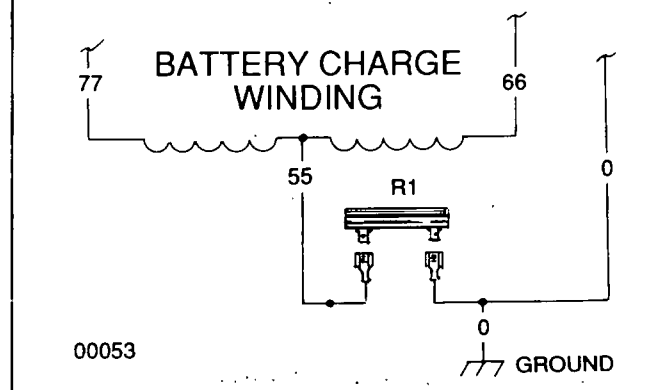

#### Problem No. 4 - Engine Starts Hard, Runs Rough

##### Step 1 - Check Engine Ignition System

**Test Procedure:** Refer to ENGINE TROUBLESHOOTING section. Also see ENGINE SERVICE MANUAL.

**Test Results:**

- A. Ignition system checks GOOD: Go to Step 2.
- B. Ignition system checks BAD: Repair or replace defective component(s).

##### Step 2 - Check Carburetion

**Test Procedure:** See ENGINE TROUBLESHOOTING section. Also see ENGINE SERVICE MANUAL.

**Test Results:**

- A. Checks GOOD: Go to Step 3.
- B. Checks BAD: Adjust, repair or replace as necessary.

##### Step 3 - Check Engine Compression

**Test Procedure:** Refer to ENGINE TROUBLESHOOTING section. Also see ENGINE SERVICE MANUAL.

**Test Results:**

- A. Engine checks GOOD: Go to Step 4.
- B. Engine checks BAD: Repair as required.

#### Step 4 - Test Automatic Choke

**Test Procedure:** Refer to Steps 7 and 8 of Problem No. 2 for automatic choke system test procedures. See ADJUSTMENTS section as well.

#### Test Results:

- A. Choke tests GOOD: Repeat Steps 1 thru 3.
- B. Choke tests BAD: Repair, adjust or replace defective component(s) as necessary.

#### Problem No. 5 - Engine Won't Shut Down

##### Step 1 - Check Start/Stop Switch.

**Test Procedure:** Test the Start/Stop Switch (Fig. 13) as follows:

1. Check Wire 0 (between Start/Stop Switch and ground terminal GT) for open condition. Ground connection must be good before proceeding.
2. Disconnect Wires 17 and 18 from Switch terminals, to prevent interaction.
3. Set VOM "Rx1" scale and zero the meter.
4. Connect one meter probe to the Wire 17 terminal, and connect the remaining test probe to Wire 0 (ground) terminal. Meter should indicate infinity.
5. Actuate the Switch to its START position. Meter should read continuity.
6. Release Switch. Meter should indicate Infinity.
7. Set Switch to STOP. Meter should indicate infinity.
8. Connect one meter probe to the Wire 18 terminal of Switch, and connect the remaining test probe to Wire 0 (ground) terminal. With Switch at START, VOM should indicate infinity. Hold Switch at STOP and meter should read continuity.

#### Test Results:

- A. Start/Stop Switch SW1 checks GOOD: Go to Step 2.
- B. Start/Stop Switch SW1 checks BAD: Replace Switch.

Figure 13. Start/Stop Switch

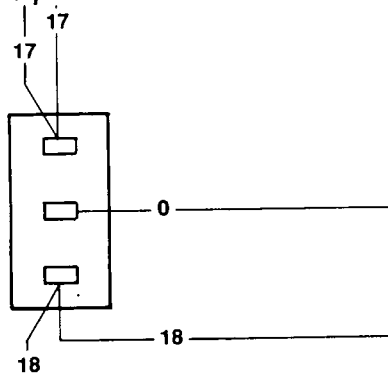

#### Step 2 - Check Wire 18

**Test Procedure:** Refer to WIRING DIAGRAM, Page 11. Test Wire 18 between Ignition Shutdown Module ISD and Start/Stop Switch for open or shorted condition. Also check Wire 18 between Start/Stop Switch and Control Relay CR2 for open or shorted condition.

#### Test Results:

- A. Wire 18 checks GOOD: Go to Step 3.
- B. Wire 18 checks BAD: Repair or replace.

##### Step 3 - Check Engine Ignition System

**Test Procedure:** See ENGINE TROUBLESHOOTING section in this Manual. Also see ENGINE SERVICE MANUAL.

#### Test Results:

Repair or replace defective ignition components as necessary.

#### Problem No. 6 - Loss of Generator a-c Output

##### Step 1 - Check Circuit Breakers CB1/CB2

**Test Procedure:** Try resetting applicable circuit breaker. If this does not correct the problem, use a VOM to test the circuit breakers.

#### Test Results:

- A. Problem is corrected by resetting Breaker: STOP test.
- B. Circuit Breaker tests GOOD, still little or no a-c output: Go to Step 2.
- C. Circuit Breaker tests BAD: Replace Circuit Breaker(s).

##### Step 2 - Check Vehicle Wiring

**Test Procedure:** Check vehicle a-c wiring and a-c distribution components.

#### Test Results:

- A. Vehicle wiring checks GOOD: Go to Step 3
- B. Vehicle wiring checks BAD: Repair or replace as needed.

##### Step 3 - Check a-c Voltage and Frequency

**Test Procedures:** Check generator a-c output voltage frequency (Fig. 14) as follows:

1. Disconnect generator a-c output leads T1 (red), T2 (white) and T3 (black) in the junction box where they connect to vehicle wiring.
2. Connect an accurate a-c voltmeter and frequency meter across generator a-c output leads T1 (red) and T2 (white).

3. Start the generator engine, let it stabilize and warm up at NO-LOAD.

Figure 14. Test Points for a-c Voltage/Frequency

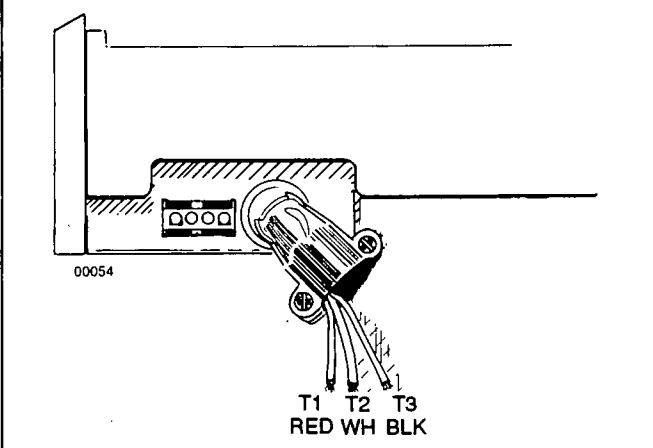

4. Read the no-load a-c voltage and frequency. Indicated readings should be 124 volts at 62 Hz.

**Test Results:**

- A. Voltage and Frequency check GOOD: Go to Step 4.
- B. Voltage and Frequency are both high or low: Go to Step 5.
- C. Low or no a-c voltage: Go to Step 6.
- D. Frequency GOOD, Volts HIGH: Go to Step 10.

**Step 4 - Check Load Voltage and Frequency**

**NOTE:** If the no-load voltage and frequency were within specified limits but operational problems occur when electrical loads are applied, check the a-c voltage and frequency under load.

**Test Procedure:** Proceed as follows:

1. Check that load leads are properly connected to a-c output terminals T1 (red), T2 (white) and T3 (black).
  2. Connect an accurate a-c voltmeter and frequency meter to a-c output leads. Connect meters across leads T1 (red) and T2 (white).
  3. Start the generator engine, let it stabilize and warm up. Then, turn ON electrical loads by whatever means provided (such as double throw switch or circuit breaker). Apply loads as close as possible to the unit's rated maximum continuous wattage/amperage capacity.
  4. With rated loads applied, check the a-c voltage and frequency readings. Voltage should be at least 116 volts; frequency should be at least 58 Hz (or higher).
- Test Results:** If voltage and frequency are good at no-load but drop excessively when electrical loads are applied, check the following.

A. Generator may be overloaded. Add up the wattage or amperage of all electrical loads being operated at one

time. This total should be less than the generator's rated wattage/amperage capacity. Reduce electrical loading as necessary.

B. A ground fault condition may exist in the generator or on one or more connected electrical loads. This can increase current flow dramatically and may cause circuit breakers to trip. See INSULATION RESISTANCE TESTS on Page 9.

C. Loss of engine power may have occurred. Check engine for adequate air flow, clogged air cleaner, incorrect ignition timing, mechanical failure, incorrectly adjusted carburetor, etc. Complete repairs to engine as necessary.

**Step 5 - Check/Adjust Engine Governor**

**Test Procedure:** If the no-load voltage and frequency are both correspondingly high or low, adjustment of the engine governor may be required. See ADJUSTMENTS section. Following governor adjustment to the correct a-c frequency, the a-c voltage must be checked. If engine speed (frequency) is correct but a-c voltage is not, adjustment of the Electronic Voltage Regulator may be required.

**Test Results:**

- A. Voltage and Frequency are correct: STOP tests.
- B. Voltage/Frequency still incorrect. Go to Step 6.

**Step 6 - Check Field Boost Circuit**

**NOTE:** Some "residual" magnetism is normally present in the Rotor (revolving field). This residual magnetism should be adequate to create the necessary "pickup" voltage in the Stator windings. For that reason, failure of the Field Boost function will not usually cause a problem unless the Rotor's residual magnetism is also lost.

**Test Procedure:** Test the Field Boost circuit as follows (Figure 15):

1. Disconnect Wires 4 from Pin 2 of the Choke Module CM.

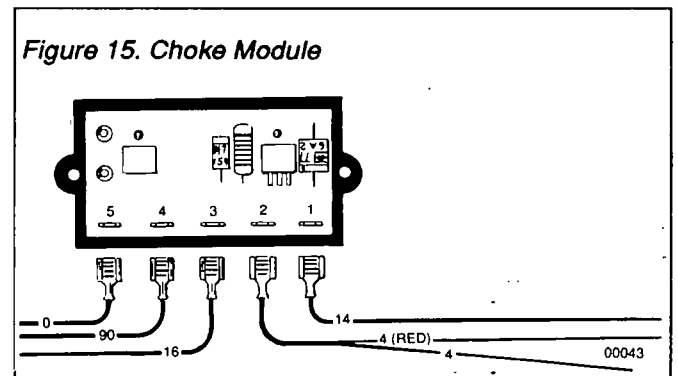

2. Connect the positive (+) test lead of the a d-c voltmeter to Pin 2 of Choke Module CM. Connect negative (-) test lead to a clean frame ground.

3. Crank the engine. The voltmeter should indicate about 7-10 volts d-c with engine cranking.

**Test Results:**

A. Engine won't crank: Go to Problem No. 1.

B. Engine cranks but no d-c voltage is indicated: Replace Choke Module CM and recheck for proper voltage. If voltage is good, STOP test.

C. Engine cranks and normal voltage is indicated: Continue test.

4. Gain access to Brushes and Slip Rings (Fig. 16).

5. Connect the positive lead of a d-c voltmeter to the terminal of the positive (+) brush (RED lead connection). Connect voltmeter test lead to a clean frame ground.

6. Crank engine. The voltmeter should indicate about 7-10 volts d-c with engine cranking.

Figure 16. Brushes and Slip Rings

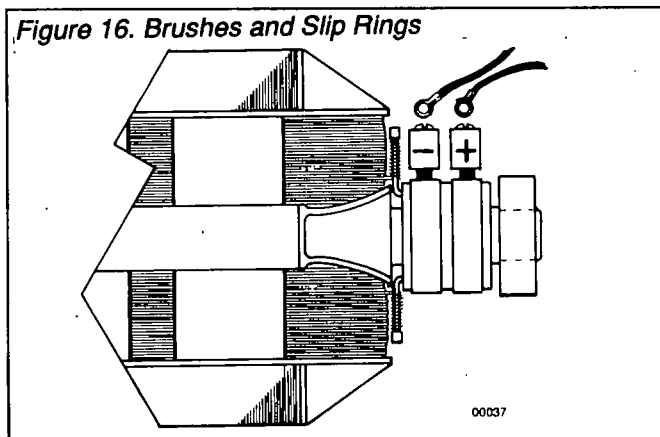

**Test Results:**

A. Engine won't crank: Go to Problem No. 1

B. Engine cranks and no d-c voltage indicated, but voltage was indicated in Item 3 of test: Repair or replace Wire 4 between Choke Module CM and the positive (+) brush.

C. Engine cranks and normal voltage indicated: Go to Step 7.

**Step 7 - Check Stator Excitation Windings**

**Test Procedure:** Disconnect Stator Excitation Winding output leads 2 and 6 (Fig. 17) from the Electronic Voltage Regulator. Set a VOM to its "Rx1" scale and zero the meter. Connect VOM test leads across terminal ends of Wires 2 and 6. The VOM needle should swing upscale and indicate the following resistance:

NP45G Units = 2.2 ohms

NP55G Units = 1.8 ohms

NP65G Units = 1.6 ohms

\*All resistance values are plus or minus 10%.

Now, set the VOM to its "Rx10,000" scale and again zero the meter. Connect one VOM test lead to Wire 2, and the remaining test lead to a clean frame ground. You should not detect any upscale movement (infinity) of the VOM needle.

Figure 17. Stator Excitation Winding Test Points

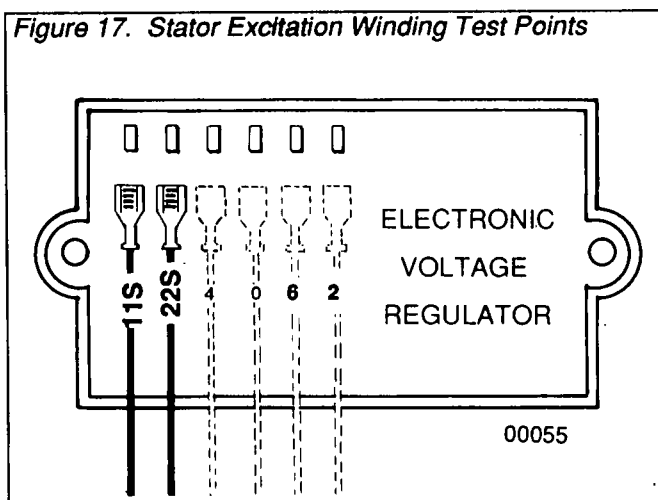

**Test Results:**

A. Excitation windings check GOOD: Go to Step 8.

B. Excitation windings check BAD: Replace Stator Assembly.

**NOTE:** Also see INSULATION RESISTANCE TESTS on Page 9. Typically, in the above test, a low resistance indicates a shorted condition; a high resistance indicates an open condition.

**Test 8 - Check Stator a-c Power Warnings**

**Test Procedure:** Test the Stator (Fig. 18) a-c power windings as follows:

1. Disconnect a-c power winding output leads 11 and 22 from the Electronic Voltage Regulator.

2. Disconnect a-c power winding output lead 33 from Circuit Breaker CB1.

3. At the wire nut junction of a-c output leads 22 and 44, separate the two wires.

4. Set a VOM to its "Rx1" scale and zero the meter. Connect VOM test leads across wire ends of Wires 11 and 22 and note the resistance reading, in ohms. Resistance should be as follows (plus or minus 10%):

NP45G Units = 0.4 ohms

NP55G Units = 0.3 ohms

NP65G Units = 0.2 ohms

5. Connect VOM test leads across wire ends of Wires 33 and 44. Again, note the resistance. Resistance should be the same as in Item 4 above.

6. Set VOM to its "Rx10,000" scale and zero the meter. Connect one VOM test lead to Wire 11 and the second test lead to frame ground. The VOM needle should not move upscale (infinity). Now, connect one test lead to Wire 33 and the second lead to frame ground. Meter should indicate infinity.

**Test Results:**

A. Power Windings check GOOD: Go to Step 9.

B. Power Windings check BAD: Replace Stator Assembly.

Figure 18. Stator a-c Power Windings Test Points

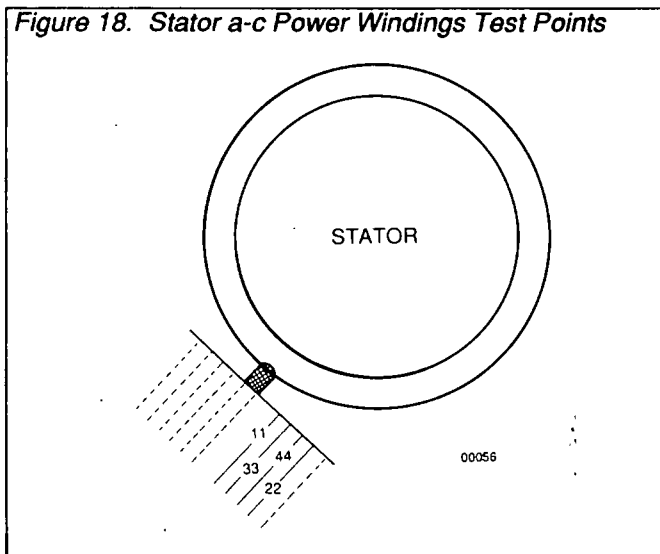

**Step 9 - Check Rotor (Field) Circuit**

**Test Procedure:** Use a VOM to test Wire 4, between Electronic Voltage Regulator and Choke Module for open or shorted condition. Wire 4 between Choke Module and Brushes was previously tested in Step 6. Then, inspect brushes and slip rings and test Rotor as follows:

1. Remove Wires 4 and 0 from Brushes, then remove Brush Holder. Inspect Brushes and Brush Holder. Replace if cracked, damaged, worn excessively, etc. Inspect Slip Rings. If they are dull or tarnished, polish with fine sandpaper. **DO NOT USE ANY METALLIC GRIT TO CLEAN SLIP RINGS.** Use low pressure air (25 psi or less) to blow away cleaning residue.

2. Set a VOM to its "Rx1" scale and zero the meter. Connect VOM positive (+) test lead to the positive (+) Slip Ring (nearest the Rotor bearing). Connect negative (-) VOM test lead to the negative (-) Slip Ring. Meter should indicate the following resistance (plus or minus 10%) at 20°C (68°F).

NP45G Units = 13.9 ohms

NP55G Units = 15.5 ohms

NP65G Units = 11.1 ohms

3. Reassemble Brushes and Brush Holder, retain Brush Holder and Wires. Make sure Brushes are properly seated in Brush Holder and are contacting the Slip Rings properly. Rotate Rotor several times to seat Brushes against Slip Rings.

**Test Results:**

A. Rotor circuit checks GOOD: Go to Step 10.

B. Rotor circuit tests BAD: Repair or replace defective wire(s) or brushes. Replace defective Rotor Assembly.

**Step 10 - Check Voltage Regulator Sensing**

**NOTE:** Sensing signals to the Electronic Voltage Regulator are delivered via Wires 11 and 22. Loss of these sensing signals to the Regulator due to an open or shorted condition (in a non-compensated Regulator) normally means a "Full Field" condition and resultant high a-c voltage output. However, the NP series generators are equipped with a Voltage Regulator that provides automatic protection against an open sensing circuit and the resultant high voltage condition. Should sensing wires 11 or 22 open, Voltage Regulator action will automatically open the Excitation circuit to the Rotor and a-c output voltage will drop dramatically. Total a-c voltage output from the Stator a-c power windings will be a result of residual Rotor magnetism only.

**Test Procedure:** Recheck Wires 11 and 22, between the Electronic Voltage Regulator and the Stator, as outlined in Step 8.

**Test Results:**

A. Wires 11 and/or 22 indicate open or shorted condition: Repair or replace wires as necessary.

B. Wires 11 and 22 check GOOD: Go to Step 11.

**Step 11- Check/Adjust Voltage Regulator**

**Test Procedure:** Refer to ADJUSTMENTS section. With correct a-c frequency indicated, try adjusting the Voltage Regulator. Frequency and voltage must both be within the specified limits.

**Test Results:**

A. Frequency GOOD, cannot adjust in the correct voltage: Replace the Voltage Regulator, adjust and test unit.

B. Frequency and Voltage both GOOD: STOP tests.

# ENGINE TROUBLESHOOTING

## General

Most problems pertinent to engine operation may be classified as one (or a combination) of the following:

1. Will not start
2. Hard Starting
3. Lack of power
4. Vibration
5. Overheating
6. High oil consumption

When the cause of a problem is not readily apparent, perform a check of the engine's Compression, Ignition and Carburetion systems. Checkout of these systems, if performed in a systematic manner, can usually be done in a few minutes. It is the fastest and surest method of finding the cause of a problem.

What appears to be an engine problem may sometimes be caused by the system that the engine is driving. For example, overloading the generator (exceeding its wattage capacity) can cause the same indications as an underpowered engine. A shorted condition in the generator or in electrical loads connected to the generator can also appear to be an underpowered engine.

## Checking Engine Compression

For instructions and information on checking engine compression, refer to the ENGINE SERVICE MANUAL. If compression is poor, look for:

1. Loose spark plug(s)
2. Loose cylinder head bolts
3. Blown head gasket(s)
4. Burned valves or valve seats
5. Insufficient valve tappet clearance
6. Warped cylinder head(s)
7. Warped valve stems
8. Worn cylinder bore and/or rings
9. Broke connecting rod(s)

## Check Engine Ignition

Checkout and servicing of the engine ignition system is discussed in detail, in the ENGINE SERVICE MANUAL. To check ignition system operation, connect a SPARK TESTER to the end of a the Spark Plug wires. Then, crank the engine with both spark plugs removed. If a hot blue spark jumps the Spark Tester gap, you may assume the Ignition System is working properly. If spark jumps the Tester gap, you may wish to try new spark plugs. If spark does NOT jump the Tester gap, look for:

1. Defective Ignition Module(s) IM1 and IM2
2. Defective Ignition Shutdown Module ISD
3. Defective Control Relay CR2

**NOTE: If engine runs but misses during operation, check to see if Ignition System is at fault by connecting the Spark Tester between the high tension Spark Plug wire and the Spark Plugs. A spark miss will be readily apparent.**

## Check Carburetion

See TROUBLESHOOTING GUIDELINES. Before making a carburetion check, make sure (a) an adequate supply of fuel is available, (b) all fuel shutoff valve(s) are open, and (c) fuel flow is adequate. Try adjusting the engine carburetor. Check automatic choke operation and make sure the choke is adjusted properly. If engine will not start, remove and inspect the Spark Plug.

If Spark Plug is WET, look for:

1. Overchoking
2. Excessively rich fuel mixture
3. Water in fuel
4. Intake valve stuck open

If Spark Plug is DRY, look for:

1. Leaking carburetor gasket(s)
2. Dirty or gummy carburetor
3. Intake valve stuck closed
4. Inoperative fuel pump

A simple check to determine if fuel is reaching the combustion chamber is to remove the spark plugs and pour a small amount of gasoline through the Spark Plug hole. Install and tighten Spark Plugs. Crank engine. If engine fires a few times and then stops, look for the same conditions as a dry plug.

## Other Problems that Might Affect Engine Operation

1. Hard Starting or Will Not Start
  - a. Loose drive belts or pulleys- these can cause a "backlash" effect that will counteract engine cranking effort.
  - b. Starting under load- attempting to start with heavy electrical loads applied can often cause problems.
  - c. Shorted condition in the generator or in connected electrical loads can impose a heavy load on the engine, thus preventing start.
2. Vibration
  - a. Check for defective or damaged pulleys, drive belts, or Rotor.
  - b. Check for loose mounting bolts and tighten.
3. Power Loss
  - a. Check for binding or drag in drive train (pulleys and belts)
  - b. Check for defective Rotor bearing.
  - c. Check for Rotor contact with Stator windings.
  - d. Check for excessive drive belt tension.
4. Noise
  - a. Check for a damaged Rotor and/or Stator
  - b. Check for loose or damaged pulleys and drive belts.

# ADJUSTMENTS

## General

This section is included with other a-c generator information, because the covered information is so important to proper generator operation and correct a-c output. The engine governor adjustment may belong in the ENGINE SERVICE MANUAL. However, that adjustment is so important to correct a-c output frequency and voltage that it is included here.

Adjustments included in this section include the following:

1. Engine governor adjustment.
2. Voltage Regulator adjustment
3. Automatic Choke adjustment.

**NOTE:** An optional LP gas (propane) fuel system is available for use with the NP series generators. Instructions for the installation and adjustment of the LP gas conversion kit are included with the kit.

## Engine Governor Adjustment

**A** Also see ROTOR ROTATIONAL SPEED on Page 4 of this Manual. The engine governor is generally adjusted to deliver a generator a-c output frequency of 61-62 Hz, with no electrical loads connected to the generator. Following the no-load adjustment of engine speed, unit operation should be checked with a load applied. Adjust the engine governor as follows:

1. Visually inspect ANTI-LASH SPRING, make sure it is not broken or disengaged. Spring ends must be hooked into GOVERNOR LEVER at bottom end and into carburetor THROTTLE LEVER at top.
2. Loosen GOVERNOR CLAMP NUT.
3. Push spring end of GOVERNOR LEVER all the way up, to wide open throttle position. While holding the LEVER down, insert a screwdriver into slotted end of GOVERNOR SHAFT and rotate SHAFT fully counterclockwise. Then, tighten the GOVERNOR CLAMP NUT to 100 inch-pounds of torque.

**CAUTION!:** Governor shaft **MUST** be rotated fully counterclockwise with throttle wide open or full governor travel will not be reached. Governor clamp nut must be tight or full governor travel may be lost due to vibration.

4. Connect an accurate a-c frequency meter and voltmeter across generator a-c output leads T2 (white) and T3 (black) for Series NP45G/NP55G; or across leads T1 (red) and T2 (white) for Series NP65G. See Step 3 under Problem No. 6 on Page 19. (Check A-C VOLTAGE AND FREQUENCY).

5. Start the engine. Let it stabilize and warm up for a few minutes with **NO ELECTRICAL LOADS APPLIED TO GENERATOR.**

6. Check a-c frequency; it should be 61-63 Hz. If not, turn ADJUSTER NUT until frequency is correct.

7. With governed speed at 61-63 Hz (no-load), check voltage reading. Voltage should be 122-126 volts. If not, adjustment of the Voltage Regulator is required.

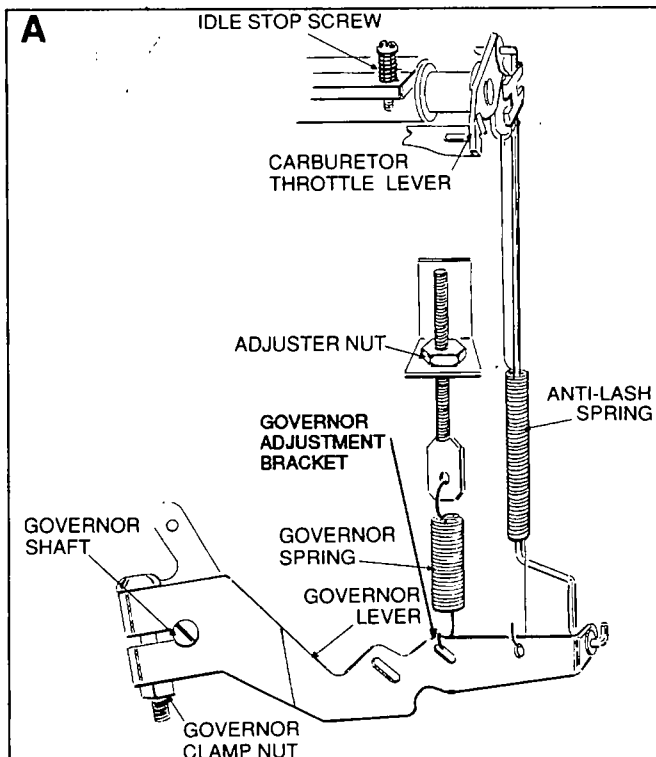

## Voltage Regulator Adjustment

**CAUTION:** DO NOT adjust the Voltage Regulator until a-c output frequency is correct. See ENGINE GOVERNOR ADJUSTMENT.

**B** Check that a-c frequency is correct, as outlined in ENGINE GOVERNOR ADJUSTMENT. If frequency is within stated limit (61-63 Hz), a-c voltage output should be 122-126 volts. If voltage is not correct, adjust the Voltage Regulator by turning the VOLTAGE ADJUST potentiometer slowly until a-c voltage is within the stated limits. Voltage regulator is mounted in the generator control panel interior.

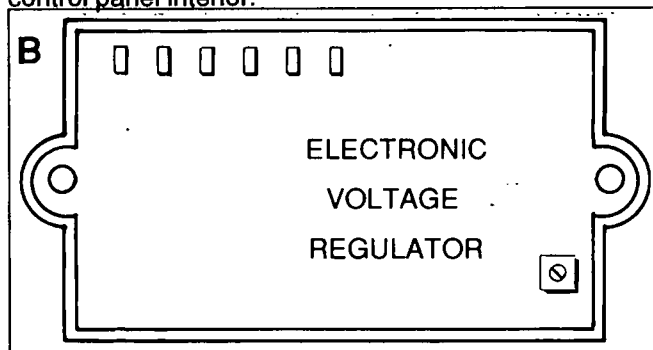

## Automatic Choke Adjustment

**C** Check automatic choke operation and (if necessary) adjust the choke as follows:-

a. **Check Choke Operation:-** Crank the engine while observing automatic choke operation. Initially, the Choke Solenoid should energize to close choke for about 0.2 to 0.4 seconds and then de-energize for about 2 seconds to open the choke. This open/close cycle should repeat itself until the engine starts and cranking is terminated.

b. **Pre-Choke Adjustment:-** With engine cold and Choke Solenoid NOT actuated, check that carburetor choke plate is about 1/8 inch away from its full open position. If necessary to obtain the desired setting, use needle nose pliers to bend tip of BI-METAL.

c. **Choke Solenoid Adjustment:-** Loosen screws that retain the CHOKE SOLENOID to its retaining bracket. Slide the CHOKE SOLENOID in the slotted holes to adjust axial movement of the SOLENOID plunger. Adjust the axial movement so that, with the carburetor choke plate closed, the CHOKE SOLENOID plunger is just bottomed in the solenoid coil (plunger at full actuated position). With choke plate closed and plunger bottomed in the coil, tighten the two screws. Then, crank engine and check choke operation.

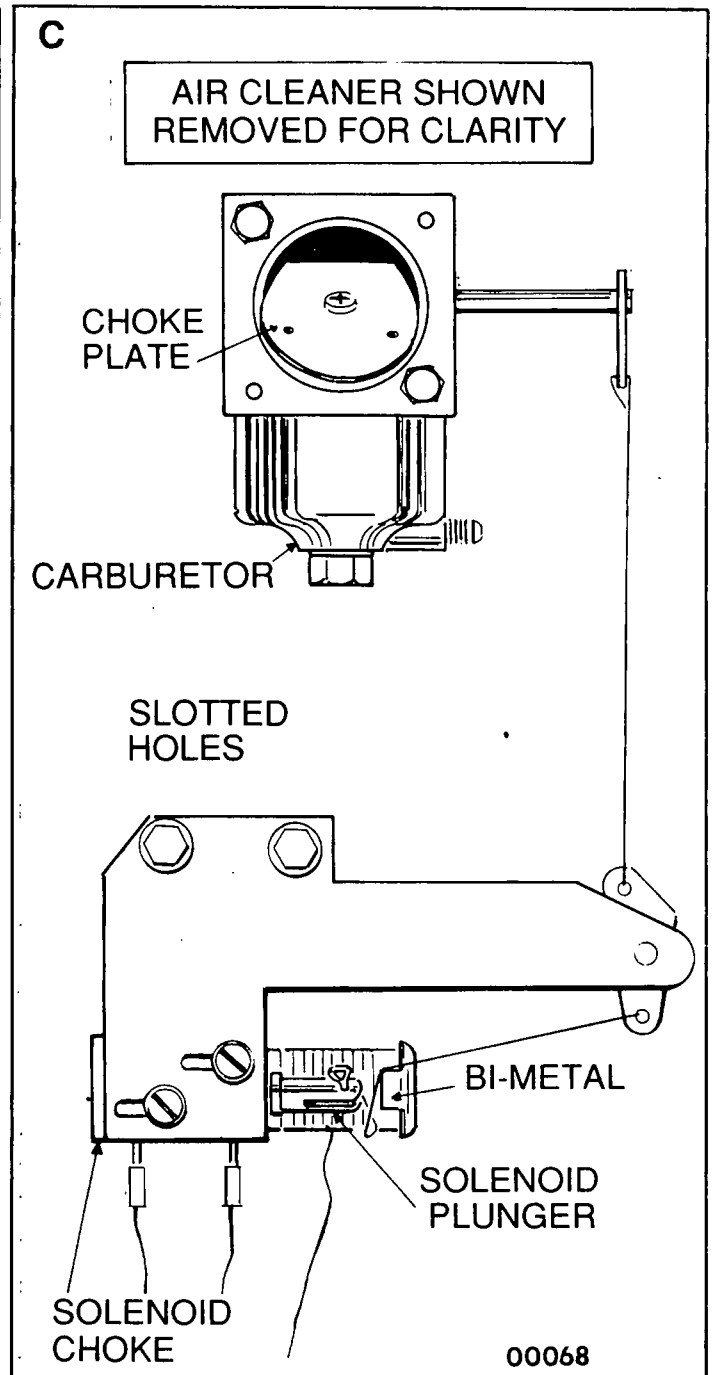

# EXPLODED VIEW OF ENGINE ENCLOSURE

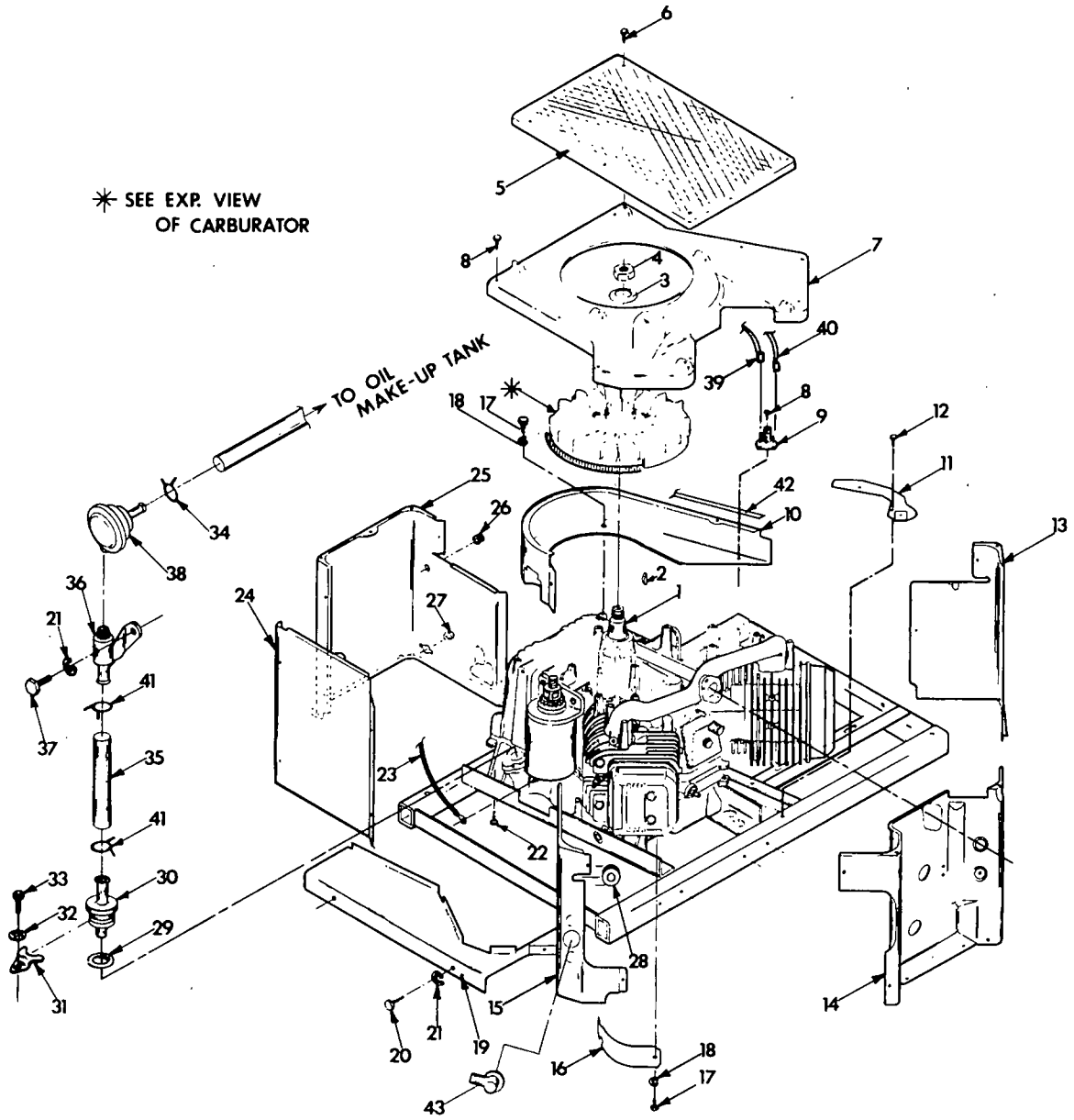

# Exploded View of Sheet Metal

Drawing No. 75464

ITEM	PART NO.	REQ'D	DESCRIPTION
1		1	ENGINE ASSY (See EXPLODED VIEW OF V-TWIN ENGINE)
2	67877	1	KEY, Woodruff- 6 x 25
3	67198-N	1	WASHER, Belleville
4	67890	1	NUT, Hex - M20-1.50
5	74915	1	SCREEN, Air Inlet
6	63036	6	SCREW (Crimptite)- No. 8-32 x 1/4"
7	74904	1	HOUSING, Engine Top
8	56892	22	SCREW (Crimptite)- No. 10-32 x 3/8"
9	70520	1	MODULE, Shorting
10	74903	1	SCROLL, Flywheel
11	74916	1	COVER, Base #2
12	74908	8	SCREW (Taptite)- M5 x 10mm
13	73190	1	WRAPPER- No. 2 Cylinder
14	73189	1	COVER, Valley
15	73188	1	WRAPPER- No. 1 Cylinder
16	74902	2	WRAPPER, Barrel
17	43146	4	CAPSCREW, Hex Head- M6-1.00 x 10mm
18	22097	4	LOCKWASHER- M6
19	73191	1	COVER, Base- No. 1 Cylinder
20	48571	2	CAPSCREW, Hex Head- M8-1.25 x 10mm
21	22129	2	LOCKWASHER- M8
22	75246	4	SCREW (Taptite)- 3/8"-16 x 1/4"
23	11-74260	1	WIRE ASSY- No. 16
24	74900	1	COVER, Starter
25	73186	1	WRAPPER, Crankcase
26	23484-D	1	BUSHING, Snap
27	22717-B	1	GROMMET, Rubber
28	22717-A	2	GROMMET, Rubber
29	67866	1	O-RING
30	74955	1	PROBE, Oil Makeup
31	74965	1	RETAINER, Oil Makeup Probe
32	22447	1	WASHER (Shakeproof)- M6
33	40936	1	SCREW, Socket Head- M6-1.00 x 8mm
34	48031-E	1	CLAMP, Hose
35	47662-BB	1	HOSE- 5/16" ID
36	74956	1	BRACKET, Oil Makeup Pump
37	42907	1	CAPSCREW, Hex Head- M8-1.25 x 16mm
38	46509	1	PUMP, Oil Makeup
39	08-74260	1	WIRE ASSY (Ground)- 5.5" long
40	09-74260	1	WIRE ASSY (Ground)- 15" long
41	48031-D	2	CLAMP, Hose
42	29289	2	TAPE, Foam
43	73132	2	BOOT, Spark Plug

# EXPLODED VIEW OF BASE & PULLEY

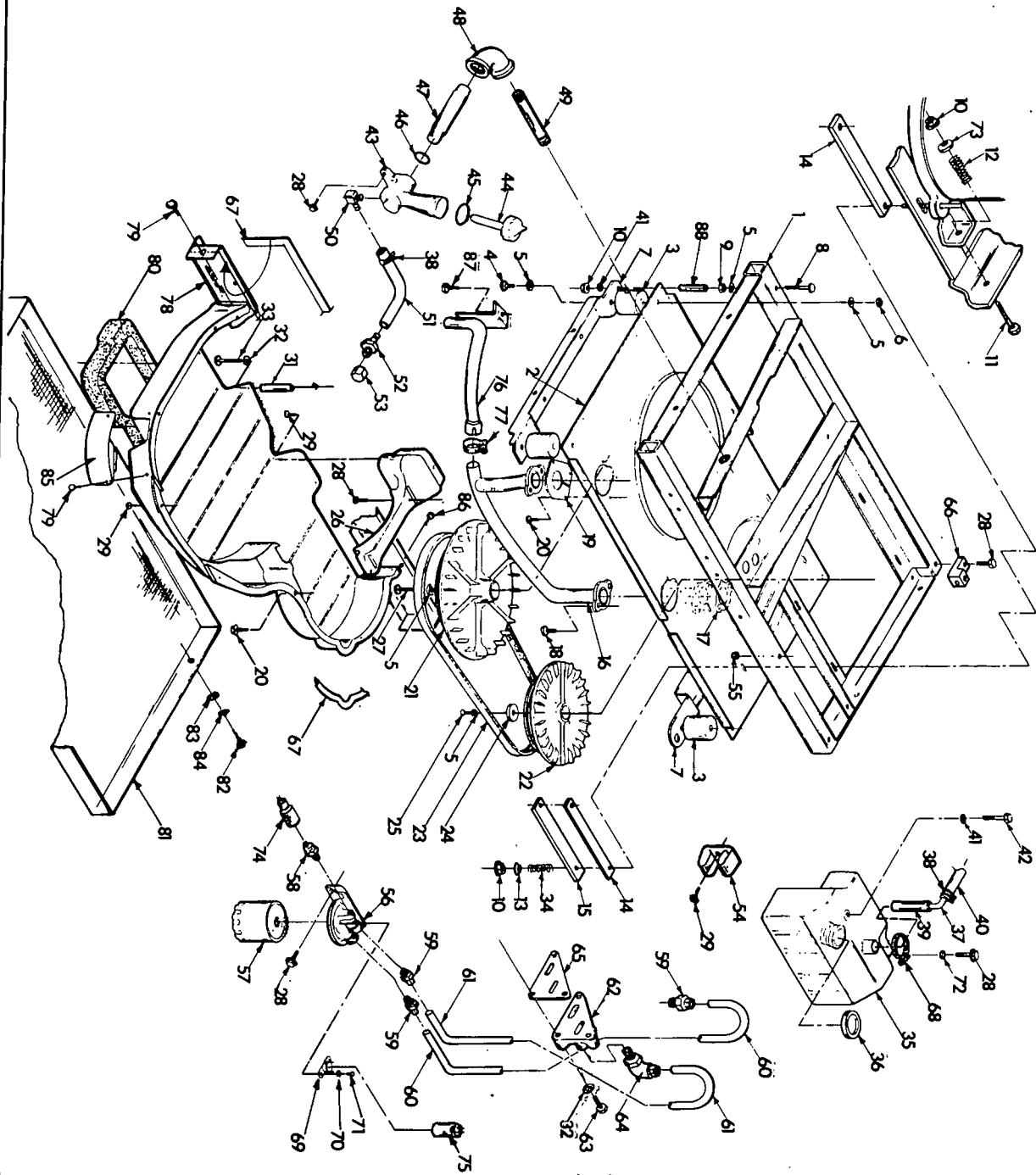

# Exploded View of Base & Pulleys

Drawing No. 75218

ITEM	PART NO.	REQ'D	DESCRIPTION
1	72372	1	BASE, Mounting
2	72382	1	PAN, Collector
3	38353	4	MOUNT (Rubber)
4	25017	4	CAPSCREW, Hex Head 3/8"-16 x 1/2"
5	22237	12	LOCKWASHER- M10
6	22241	4	NUT, Hex - 3/8"-16
7	72391	2	SKID, Rubber Mount
8	73147	2	BOLT, Safety
9	45771	2	NUT, Hex - M8-1.25
10	52858	8	NUT, Flanged Lock- M8-1.25
11	51730	2	CAPSCREW, Hex Head M8-1.25 x 60mm
12	29459	2	SPRING, Belt Tensioner
13	75215	2	WASHER, Spring Center
14	73146	4	SLIDE (Nylon)
15	75209	2	SUPPORT, Nylon Slide
16	73174	1	MANIFOLD, Exhaust
17	67897	1	GASKET, Exhaust Manifold
18	55173	4	CAPSCREW, Hex Head M8-1.25 x 20mm (Grade 10.9)
19	72383	2	GASKET, Collector Pan
20	56892	32	SCREW (Crimptite)- No. 10-24
21	75224-A	1	PULLEY, Engine Fan (NP45G)
	75224-B	1	PULLEY, Engine Fan (NP55G)
	75224-C	1	PULLEY, Engine Fan (NP65G)
22	73106-A	1	PULLEY, Generator Fan (NP45G)
	73106-B	1	PULLEY, Fan (NP55G Only)
	73106-C	1	PULLEY, Fan (NP65G Only)
23	75216	1	BELT (Poly V 4L)- 40"
24	49451	5	WASHER, Pulley Retainer
25	42633	1	CAPSCREW, Socket Head 3/8"-24 x 1" (Grade 5)
26	72381	1	GUIDE, Blower Housing
27	73118	1	CAPSCREW, Hex Head 3/8"-24 x 2-1/2"
28	74906	12	SCREW (Taptite)- M6-1.00 x 20
29	74908	9	SCREW (Taptite)- M5-0.80 x 10
30	72375	1	HOUSING, Blower
31	73185	1	SPACER, Blower Housing
32	22097	1	LOCKWASHER- M6
33	74909	1	CAPSCREW, Hex Head M5-0.80 x 70mm
34	75242	4	SPRING, Generator Set Mount
35	74910	1	TANK, Oil Makeup
36	73156	1	CAP, Oil Makeup Tank
37	49099	1	ELBOW- 90° Barbed
38	48031-E	4	CLAMP, Hose- 3/8"
39	47662-U	1	HOSE- 3/8" x 6" long
40	47662-BG	1	HOSE- 3/8" ID x 25" long
41	50190	5	WASHER, Tank Retainer
	74913	1	CAPSCREW, Hex Head M6-1.00 x 110mm
43	73181	1	TUBE, Oil Fill and Drain

ITEM	PART NO.	REQ'D	DESCRIPTION
44	74958	1	CAP & DIPSTICK ASSY
45	67871	1	O-RING, Cap
46	67866	1	O-RING, Drain
47	73135	1	PIPE, Oil Drain Adapter
48	73138	1	ELBOW, 90° - 3/8" NPT
49	74936	1	NIPPLE- 3/8" NPT x 2-1/4"
50	43790	1	ELBOW- 3/8" NPT x 3/8"
51	47662-BC	1	HOSE- 3/8" x 10-1/2"
52	35461	1	FITTING, Barbed- 1/4" NPT x 3/8"
53	69811	1	CAP, Hex - 1/4" NPT
54	65852	1	CLIP, Hose Retainer
55	52857	1	NUT, Flanged Lock- M6-1.00
56	73179	1	SUPPORT, Oil Filter
57	70185	1	FILTER, Oil (FRAM #PH3614)
58	60108	1	SWITCH, Oil Pressure
59	74948	3	FITTING- 5/16"
60	74950	1	TUBE, Outer Oil
61	74951	1	TUBE, Inner Oil
62	73134	1	ADAPTER, Oil Pad
63	38750	3	CAPSCREW, Hex Head M6-1.00 x 30mm
64	74949	1	FITTING, Barbed 90° - 5/16"
65	69547	1	GASKET, oil Pad
66	46453	1	LUG, Grounding
67	29289	-	TAPE, Foam- 1/16" thick x 8 ft.
68	35472	1	CLAMP
69	75281	1	SWITCH, High Temperature
70	43181	2	SCREW, Pan Head- M3-0.50
71	43182	2	LOCKWASHER- M3
72	22473	1	FLATWASHER- M6
73	75237	4	WASHER, Spring Retainer
74	61274	1	SWITCH, High Water Temp.
75	75474	1	CAP, Vynyl- 17D x 42L x 2H
76	73176	1	ELBOW, Exhaust
77	74907	1	CLAMP, Exhaust- 1-1/8"
78	75226	1	COVER, Air
79	56892	4	SCREW (Crimptite)- No. 10-32
80	75229	1	GASKET, Slide Pan
81	75227	1	SLIDE PAN
82	43116	4	CAPSCREW, Hex Head M6-1.00 x 12mm
83	22473	4	FLATWASHER- M6
84	22097	4	LOCKWASHER- M6
85	72384-B	1	COVER, Exhaust Outlet
86	74908	3	SCREW (Taptite)- M5 x 10mm
87	74906	1	SCREW (Taptite)- M6-1.00 x 20
88	76267	2	SPACER (Plastic)

# EXPLODED VIEW OF GENERATOR & PANEL

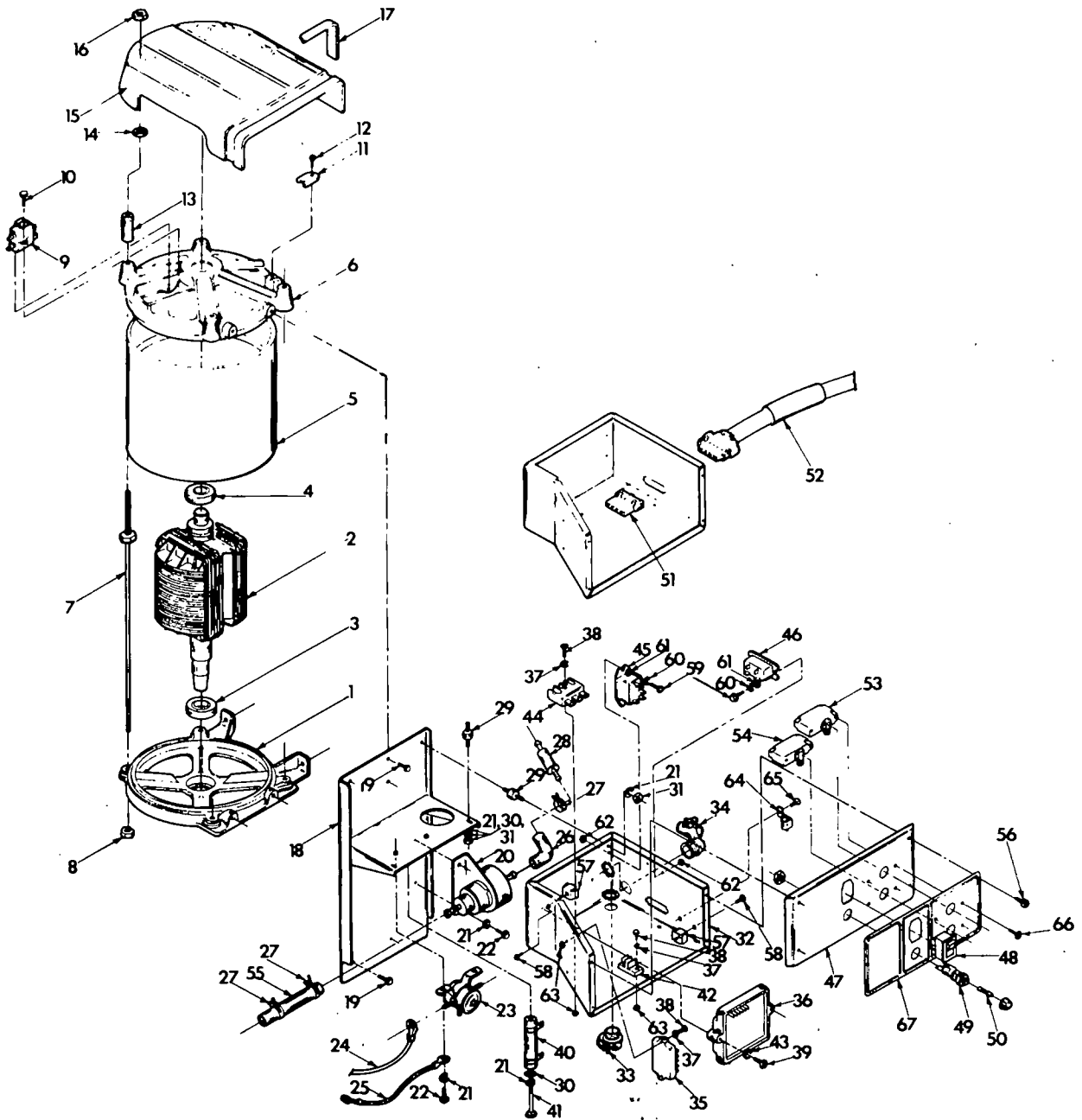

# Exploded View of Alternator and Panel

Drawing No. 75231

ITEM	PART NO.	REQ'D	DESCRIPTION	ITEM	PART NO.	REQ'D	DESCRIPTION
1	72376	1	CARRIER, Lower Bearing	33	34616	1	CONNECTOR- 3/4"
	73160	1	ROTOR ASSY- NP45G	34	39271	1	CONNECTOR, 90° - 3/4"
	73161	1	ROTOR ASSY- NP55G	35	73601	1	MODULE ASSY- Choke
	73162	1	ROTOR ASSY- NP65G	36	74074	1	REGULATOR, Voltage
3	31971	1	BEARING, Ball	37	22264	5	LOCKWASHER- M4
4	73159	1	BEARING, Ball	38	51787	5	SCREW, Hex Head- M4-0.70
5	73164	1	STATOR ASSY- NP45G	39	75235	2	SCREW- M5-0.80 x 30mm
	73165	1	STATOR ASSY- NP55G	40	75234	1	RESISTOR
	73166	1	STATOR ASSY- NP65G	41	74095	1	CAPSCREW, Hex Head M6-1.00 x 60mm
6	72379	1	CARRIER, Upper Bearing	42	75210-A	1	BLOCK, Terminal
7	73145	4	STUD, Stator	43	49226	2	LOCKWASHER- M5
8	45771	4	NUT, Hex - M8-1.25	44	65795	1	RECTIFIER, Battery Charge
9	66386	1	HOLDER, Brush	45	75205	1	RELAY- 12 volts a-c
10	66849	2	SCREW- M5-0.80 x 15mm	46	75204	1	RELAY- 12 volts d-c
11	75203	1	CLAMP, Stator Wire	47	75200	1	PANEL, Control
12	74908	1	SCREW- M5-0.80 x 10mm	48	75208	1	SWITCH, Start/Stop
13	75214	4	SPACER, Cover	49	32300	1	HOLDER, Fuse
14	27756	4	WASHER- Nylon	50	22676	1	FUSE- 15 amp
15	74905	1	HOUSING, Top	51	53650	1	CONNECTOR
16	52858	4	NUT, Flanged Lock- M8-1.25	52	75244	1	CABLE ASSY- Remote
17	29451	-	TAPE, Foam Rubber- 3 feet long	53*	75471	1	BREAKER, Circuit- 30 amp
18	75201	1	BRACKET, Panel	54**	75470	1	BREAKER, Circuit- 20 amp
19	74906	4	SCREW- M6-1.00 x 20mm	55	47662-AW	1	HOSE- 5/16" ID x 4-1/2"
20	74939	1	PUMP, Fuel	56	73513	4	SCREW- No. 10-32 x 1/2"
21	22097	11	LOCKWASHER- M6	57	57345	2	LUG
22	43116	4	CAPSCREW, Hex Head M6-1.00 x 12mm	58	63036	2	SCREW- No. 8-18 x 1/4"
	56739	1	CONTACTOR, Starter	59	33136	4	SCREW, Hex Head Machine No. 6-32 x 5/8"
	74260-10	1	CABLE, Starter	60	22155	4	LOCKWASHER- No. 6
25	53407	2	CABLE, Panel Ground	61	22985	4	FLATWASHER- No. 6
26	74911	1	ELBOW, Pump Inlet	62	22188	4	NUT, Hex - No. 6-32
27	48031-D	4	CLAMP, Hose- 5/16"	63	51715	5	NUT, Hex- M4-0.70
28	75213	1	FILTER, Fuel	64	25433	1	LUG, Ground
29	71908	4	MOUNT, Rubber	65	56893	1	SCREW (Crimptite)- No. 10-24
30	22473	4	FLATWASHER- M6	66	36900	4	SCREW, Pan Head Machine No. 6-32 x 1/4"
31	49813	7	NUT, Hex - M6	67	73129	1	DECAL- Control Panel
32	75202	1	HOUSING, Panel				

\* Used on NP65G Series

\*\* Used on NP45G & NP55G Series

# ELECTRICAL FORMULAS

<b><i>Alternating Current</i></b>		
<b>DESIRED DATA</b>	<b>1-PHASE</b>	<b>3-PHASE</b>
Kilowatts*	$\frac{\text{Volts} \times \text{Amps} \times \text{Power Factor}}{1000}$	$\frac{1.73 \times \text{Volts} \times \text{Amps} \times \text{Power Factor}}{1000}$
KVA*	$\frac{\text{Volts} \times \text{Amps}}{1000}$	$\frac{1.73 \times \text{Volts} \times \text{Amps}}{1000}$
Horsepower*****	$\frac{\text{Volts} \times \text{Amps} \times 100 \times \text{P.F.}}{746 \times \text{Efficiency}}$	$\frac{1.73 \times \text{Volts} \times \text{Amps} \times 100 \times \text{P.F.}}{746 \times \text{Efficiency}}$
Amperes**	$\frac{\text{H.P.} \times 746 \times \text{Efficiency}}{\text{Volts} \times 100 \times \text{P.F.}}$	$\frac{\text{H.P.} \times 746 \times \text{Efficiency}}{1.73 \times \text{Volts} \times 100 \times \text{P.F.}}$
Amperes***	$\frac{\text{Kilowatts} \times 1000}{\text{Volts} \times \text{P.F.}}$	$\frac{\text{Kilowatts} \times 1000}{1.73 \times \text{Volts} \times \text{P.F.}}$
Amperes****	$\frac{\text{kVA} \times 1000}{\text{Volts}}$	$\frac{\text{kVA} \times 1000}{1.73 \times \text{Volts}}$
Frequency	$\frac{\text{RPM} \times \text{Rotor Poles}}{2 \times 60}$	$\frac{\text{RPM} \times \text{Rotor Poles}}{2 \times 60}$
No. of Rotor Poles	$\frac{2 \times 60 \times \text{Frequency}}{\text{RPM}}$	$\frac{2 \times 60 \times \text{Frequency}}{\text{RPM}}$
RPM	$\frac{2 \times 60 \times \text{Frequency}}{\text{No. of Rotor Poles}}$	$\frac{2 \times 60 \times \text{Frequency}}{\text{No. of Rotor Poles}}$

\* Generator output or load input

\*\* When Horsepower is known

\*\*\* When Kilowatts is known

\*\*\*\* When kVA is known

\*\*\*\*\* Engine output

# SPECIFICATIONS

## Series NP45G

Model Number .....	9009-0
Rated Maximum Power.....	4500 watts
Rated a-c Voltage .....	120 volts*
Rated Maximum Current	
At 120 volts a-c .....	37.5 amps
At 240 volts a-c .....	18.75 amps
Rated Frequency .....	60 Hz
Phase.....	1-Phase
No. of Rotor Poles.....	2
Governed Rotor Speed at No-Load .....	3720 rpm
Rotor & Stator Winding Nominal Resistance	
Battery Charge Windings .....	0.12 ohm
Excitation Winding .....	2.21 ohms
Stator a-c Power Windings .....	0.42 ohm
Rotor Windings .....	13.9 ohms

## Series NP55G

Model Number .....	9010-0
Rated Maximum Power.....	5500 watts
Rated a-c Voltage .....	120 volts*
Rated Maximum Current	
At 120 volts a-c .....	45.8 amps
At 240 volts a-c .....	22.9 amps
Rated Frequency .....	60 Hz
Phase.....	1-Phase
No. of Rotor Poles.....	2
Governed Rotor Speed at No-Load .....	3720 rpm
Rotor & Stator Winding Nominal Resistance	
Battery Charge Windings .....	0.09 ohm
Excitation Winding .....	1.84 ohms
Stator a-c Power Windings .....	0.29 ohm
Rotor Windings .....	15.5 ohms

## Series NP65G

Model Number.....	9011-0
Rated Maximum Power.....	6500 watts
Rated a-c Voltage.....	120 volts*
Rated Maximum Current	
At 120 volts a-c.....	54.2 amps
At 240 volts.....	27.1 amps
Rated Frequency.....	60 Hz
Phase .....	1-Phase
No. of Rotor Poles.....	2
Governed Rotor Speed at No-Load.....	3720 rpm
Rotor & Stator Winding Nominal Resistance	
Battery Charge Windings .....	0.07 ohm
Excitation Winding.....	1.67 ohms
Stator a-c Power Windings.....	0.23 ohm
Rotor Windings.....	11.1 ohms

\* All units can be reconnected to 120/240 volts, 1 phase, 60 Hz, a-c output. See GENERATOR A-C CONNECTION SYSTEM on Page 5.

**"NP" Series generators are designed and manufactured by**

---

**GENERAC CORPORATION • P.O. BOX 8 • WAUKESHA, WI 53187**

---

**(414) 544-4811 • FAX 414/544-4851**

---

**Revision 4 (08/31/91)**