

**QUIETPACT® 55/65/75**

# DIAGNOSTIC REPAIR MANUAL

**RECREATIONAL VEHICLE GENERATOR**



**MODELS 4702, 4703, 4705,  
4706 & 4707**



## ***SAFETY***

Throughout this publication, "DANGER!" and "CAUTION!" blocks are used to alert the mechanic to special instructions concerning a particular service or operation that might be hazardous if performed incorrectly or carelessly. PAY CLOSE ATTENTION TO THEM.



**DANGER! UNDER THIS HEADING WILL BE FOUND SPECIAL INSTRUCTIONS WHICH, IF NOT COMPLIED WITH, COULD RESULT IN PERSONAL INJURY OR DEATH.**



**CAUTION! Under this heading will be found special instructions which, if not complied with, could result in damage to equipment and/or property.**

These "Safety Alerts" alone cannot eliminate the hazards that they signal. Strict compliance with these special instructions plus "common sense" are major accident prevention measures.

## ***NOTICE TO USERS OF THIS MANUAL***

This SERVICE MANUAL has been written and published by Generac to aid our dealers' mechanics and company service personnel when servicing the products described herein.

It is assumed that these personnel are familiar with the servicing procedures for these products, or like or similar products manufactured and marketed by Generac. That they have been trained in the recommended servicing procedures for these products, including the use of common hand tools and any special Generac tools or tools from other suppliers.

Generac could not possibly know of and advise the service trade of all conceivable procedures by which a service might be performed and of the possible hazards and/or results of each method. We have not undertaken any such wide evaluation. Therefore, anyone who uses a procedure or tool not recommended by Generac must first satisfy himself that neither his nor the products safety will be endangered by the service procedure selected.

All information, illustrations and specifications in this manual are based on the latest product information available at the time of publication.

When working on these products, remember that the electrical system and engine ignition system are capable of violent and damaging short circuits or severe electrical shocks. If you intend to perform work where electrical terminals could be grounded or touched, the battery cables should be disconnected at the battery.

Any time the intake or exhaust openings of the engine are exposed during service, they should be covered to prevent accidental entry of foreign material. Entry of such materials will result in extensive damage when the engine is started.

During any maintenance procedure, replacement fasteners must have the same measurements and strength as the fasteners that were removed. Metric bolts and nuts have numbers that indicate their strength. Customary bolts use radial lines to indicate strength while most customary nuts do not have strength markings. Mismatched or incorrect fasteners can cause damage, malfunction and possible injury.

## ***REPLACEMENT PARTS***

Components on Generac recreational vehicle generators are designed and manufactured to comply with Recreational Vehicle Industry Association (RVIA) Rules and Regulations to minimize the risk of fire or explosion. The use of replacement parts that are not in compliance with such Rules and Regulations could result in a fire or explosion hazard. When servicing this equipment, it is extremely important that all components be properly installed and tightened. If improperly installed and tightened, sparks could ignite fuel vapors from fuel system leaks.

**SAFETY ..... INSIDE FRONT COVER**

**SECTION 1:  
GENERATOR FUNDAMENTALS ..... 3-7**

MAGNETISM ..... 3  
 ELECTROMAGNETIC FIELDS ..... 3  
 ELECTROMAGNETIC INDUCTION ..... 3  
 A SIMPLE AC GENERATOR ..... 4  
 A MORE SOPHISTICATED AC GENERATOR ..... 4  
 FIELD BOOST ..... 6  
 GENERATOR AC CONNECTION SYSTEM ..... 6

**SECTION 2:  
MAJOR GENERATOR COMPONENTS ..... 8-11**

ROTOR ASSEMBLY ..... 8  
 STATOR ASSEMBLY ..... 8  
 BRUSH HOLDER ..... 9  
 BATTERY CHARGE COMPONENTS ..... 9  
 EXCITATION CIRCUIT COMPONENTS ..... 9  
 CRANKCASE BREATHER ..... 10

**SECTION 3:  
INSULATION RESISTANCE TESTS ..... 12-14**

EFFECTS OF DIRT AND MOISTURE ..... 12  
 INSULATION RESISTANCE TESTERS ..... 12  
 DRYING THE GENERATOR ..... 12  
 CLEANING THE GENERATOR ..... 12  
 STATOR INSULATION RESISTANCE ..... 13  
 TESTING ROTOR INSULATION ..... 14  
 THE MEGOHMMETER ..... 14

**SECTION 4:  
MEASURING ELECTRICITY ..... 15-17**

METERS ..... 15  
 THE VOM ..... 15  
 MEASURING AC VOLTAGE ..... 15  
 MEASURING DC VOLTAGE ..... 15  
 MEASURING AC FREQUENCY ..... 16  
 MEASURING CURRENT ..... 16  
 MEASURING RESISTANCE ..... 16  
 ELECTRICAL UNITS ..... 17  
 OHM'S LAW ..... 17

**SECTION 5:  
ENGINE DC CONTROL SYSTEM ..... 18-26**

INTRODUCTION ..... 18  
 OPERATIONAL ANALYSIS ..... 18-23  
 ENGINE CONTROLLER CIRCUIT BOARD ..... 24  
 BATTERY ..... 24  
 7.5 AMP FUSE ..... 25  
 FUEL PRIMER SWITCH ..... 25  
 START-STOP SWITCH ..... 25  
 STARTER CONTACTOR RELAY  
 & STARTER MOTOR ..... 26

**SECTION 6:  
TROUBLESHOOTING FLOWCHARTS ..... 27-37**

IF PROBLEM INVOLVES AC OUTPUT ..... 27  
 PROBLEM 1 -  
 VOLTAGE & FREQUENCY ARE BOTH  
 HIGH OR LOW ..... 27  
 PROBLEM 2 -  
 GENERATOR PRODUCES ZERO VOLTAGE OR  
 RESIDUAL VOLTAGE (5-12 VAC) ..... 28-29  
 PROBLEM 3 -  
 NO BATTERY CHARGE OUTPUT ..... 29  
 PROBLEM 4 -  
 EXCESSIVE VOLTAGE/FREQUENCY DROOP  
 WHEN LOAD IS APPLIED ..... 30  
 PROBLEM 5 -  
 PRIMING FUNCTION DOES NOT WORK  
 (GASOLINE MODELS) ..... 30  
 PROBLEM 6 -  
 ENGINE WILL NOT CRANK ..... 31  
 PROBLEM 7 -  
 ENGINE CRANKS BUT WILL NOT START  
 (GASOLINE UNITS) ..... 32  
 PROBLEM 7 -  
 ENGINE CRANKS BUT WILL NOT START  
 (LP UNITS) ..... 33  
 PROBLEM 8 -  
 ENGINE STARTS HARD AND RUNS ROUGH  
 (GASOLINE UNITS) ..... 34  
 PROBLEM 8 -  
 ENGINE STARTS HARD AND RUNS ROUGH  
 (LP UNITS) ..... 34  
 PROBLEM 9 -  
 ENGINE STARTS THEN SHUTS DOWN ..... 36  
 PROBLEM 10 -  
 7.5 AMP (F1) FUSE BLOWING ..... 37

**SECTION 7:  
DIAGNOSTIC TESTS..... 38-67**

INTRODUCTION ..... 38  
 TEST 1 -  
 Check No-Load Voltage And Frequency ..... 38  
 TEST 2 -  
 Check Engine Governor ..... 38  
 TEST 3 -  
 Test Excitation Circuit Breaker ..... 39  
 TEST 4 -  
 Fixed Excitation Test/Rotor Amp Draw ..... 39  
 TEST 5 -  
 Wire Continuity ..... 40  
 TEST 6 -  
 Check Field Boost ..... 41  
 TEST 7 -  
 Test Stator DPE Winding..... 41  
 TEST 8 -  
 Check Sensing Leads/Power Windings ..... 42

## Table of Contents

TEST 9 - Check Brush Leads .....	43	TEST 35 - Check Valve Adjustment .....	61
TEST 10 - Check Brushes & Slip Rings .....	43	TEST 36 - Check Carburetion .....	62
TEST 11 - Check Rotor Assembly .....	44	TEST 37 - Check Choke Solenoid .....	62
TEST 12 - Check Main Circuit Breaker .....	44	TEST 38 - Check Engine / Cylinder Leak Down Test / Compression Test .....	64
TEST 13 - Check Load Voltage & Frequency .....	45	TEST 39 - Check Oil Pressure Switch .....	65
TEST 14 - Check Load Watts & Amperage .....	45	TEST 40 - Test Oil Temperature Switch .....	65
TEST 15 - Check Battery Charge Output .....	45	TEST 41 - Test Choke Heater .....	66
TEST 16 - Check Battery Charge Rectifier .....	45	TEST 42 - Check LPG Fuel Solenoid .....	66
TEST 17 - Check Battery Charge Windings/ Battery Charge Resistor .....	46	<b>SECTION 8: ASSEMBLY .....</b>	<b>68-70</b>
TEST 18 - Try Cranking the Engine .....	47	MAJOR DISASSEMBLY .....	68
TEST 19 - Test Primer Switch.....	47	Enclosure/Panel Removal .....	68
TEST 20 - Check Fuel Pump .....	48	Stator Removal .....	68
TEST 21 - Check 7.5 Amp Fuse .....	49	Rotor Removal .....	68
TEST 22 - Check Battery & Cables.....	49	Belt Tensioning .....	69
TEST 23 - Check Power Supply to Circuit Board .....	49	Engine Removal .....	69
TEST 24 - Check Start-Stop Switch .....	50	Starter Removal .....	69
TEST 25 - Check Power Supply to Wire 56 .....	51	Flywheel/Magneto Removal .....	70
TEST 26 - Check Starter Contactor Relay .....	51	<b>SECTION 9: EXPLODED VIEWS / PART NUMBERS .....</b>	<b>72-83</b>
TEST 26A - Check Starter Contactor .....	52	BASE & PULLEY DRAWING .....	72
TEST 27 - Check Starter Motor .....	52	ENCLOSURE DRAWING .....	74
TEST 28 - Check Fuel Supply.....	54	SHEET METAL DRAWING .....	76
TEST 29 - Check Wire 14 Power Supply .....	56	CONTROL PANEL DRAWING .....	78
TEST 30 - Check Wire 18 .....	56	760 V-TWIN ENGINE DRAWING .....	80
TEST 31 - Check Fuel Solenoid (Gasoline Models) .....	57	LP REGULATOR DRAWING .....	82
TEST 32 - Check Ignition Spark .....	57	<b>SECTION 10: SPECIFICATIONS &amp; CHARTS .....</b>	<b>84-86</b>
TEST 33 - Check Spark Plugs .....	59	MAJOR FEATURES AND DIMENSIONS .....	84
TEST 34 - Check and Adjust Ignition Magnets .....	59	GENERATOR SPECIFICATIONS .....	85
		NOMINAL RESISTANCES OF GENERATOR WINDINGS AT 68°F .....	85
		ENGINE SPEEDS AND VOLTAGE SPECIFICATIONS .....	86
		TORQUE SPECIFICATIONS .....	86
		<b>SECTION 11: ELECTRICAL DATA .....</b>	<b>88-89</b>
		ELECTRICAL SCHEMATIC AND WIRING DIAGRAM .....	88

### MAGNETISM

Magnetism can be used to produce electricity and electricity can be used to produce magnetism.

Much about magnetism cannot be explained by our present knowledge. However, there are certain patterns of behavior that are known. Application of these behavior patterns has led to the development of generators, motors and numerous other devices that utilize magnetism to produce and use electrical energy.

See Figure 1-1. The space surrounding a magnet is permeated by magnetic lines of force called "flux". These lines of force are concentrated at the magnet's north and south poles. They are directed away from the magnet at its north pole, travel in a loop and re-enter the magnet at its south pole. The lines of force form definite patterns which vary in intensity depending on the strength of the magnet. The lines of force never cross one another. The area surrounding a magnet in which its lines of force are effective is called a "magnetic field".

Like poles of a magnet repel each other, while unlike poles attract each other.

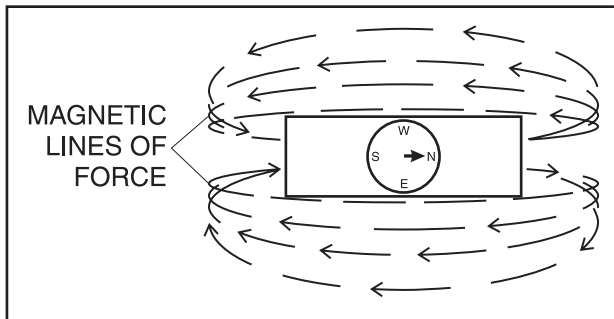

Figure 1-1. – Magnetic Lines of Force

### ELECTROMAGNETIC FIELDS

All conductors through which an electric current is flowing have a magnetic field surrounding them. This field is always at right angles to the conductor. If a compass is placed near the conductor, the compass needle will move to a right angle with the conductor. The following rules apply:

- The greater the current flow through the conductor, the stronger the magnetic field around the conductor.
- The increase in the number of lines of force is directly proportional to the increase in current flow and the field is distributed along the full length of the conductor.
- The direction of the lines of force around a conductor can be determined by what is called the "right hand rule". To apply this rule, place your right hand around the conductor with the thumb pointing in the direction of current flow. The fingers will then be pointing in the direction of the lines of force.

**NOTE:** The "right hand rule" is based on the "current flow" theory which assumes that current flows from positive to negative. This is opposite the "electron" theory, which states that current flows from negative to positive.

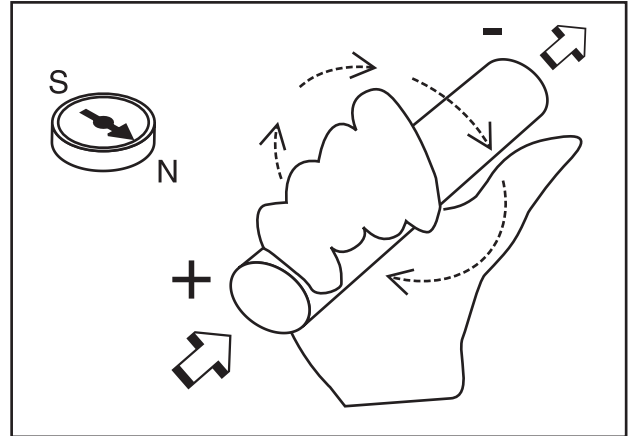

Figure 1-2. – The Right Hand Rule

### ELECTROMAGNETIC INDUCTION

An electromotive force (EMF) or voltage can be produced in a conductor by moving the conductor so that it cuts across the lines of force of a magnetic field.

Similarly, if the magnetic lines of force are moved so that they cut across a conductor, an EMF (voltage) will be produced in the conductor. This is the basic principal of the revolving field generator.

Figure 1-3, below, illustrates a simple revolving field generator. The permanent magnet (Rotor) is rotated so that its lines of magnetic force cut across a coil of wires called a Stator. A voltage is then induced into the Stator windings. If the Stator circuit is completed by connecting a load (such as a light bulb), current will flow in the circuit and the bulb will light.

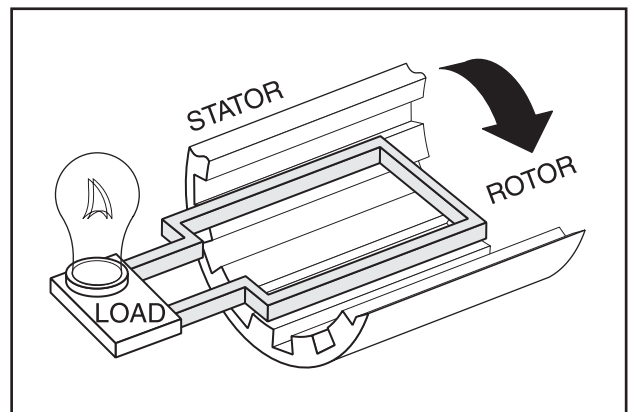

Figure 1-3. – A Simple Revolving Field Generator

# Section 1 GENERATOR FUNDAMENTALS

## A SIMPLE AC GENERATOR

Figure 1-4 shows a very simple AC Generator. The generator consists of a rotating magnetic field called a ROTOR and a stationary coil of wire called a STATOR. The ROTOR is a permanent magnet which consists of a SOUTH magnetic pole and a NORTH magnetic pole.

As the ROTOR turns, its magnetic field cuts across the stationary STATOR. A voltage is induced into the STATOR windings. When the magnet's NORTH pole passes the STATOR, current flows in one direction. Current flows in the opposite direction when the magnet's SOUTH pole passes the STATOR. This constant reversal of current flow results in an alternating current (AC) waveform that can be diagrammed as shown in Figure 1-5.

The ROTOR may be a 2-pole type having a single NORTH and a single SOUTH magnetic pole. Some ROTORS are 4-pole type with two SOUTH and two NORTH magnetic poles. The following apply:

1. The 2-pole ROTOR must be turned at 3600 rpm to produce an AC frequency of 60 Hertz, or at 3000 rpm to deliver an AC frequency of 50 Hertz.
2. The 4-pole ROTOR must operate at 1800 rpm to deliver a 60 Hertz AC frequency or at 1500 rpm to deliver a 50 Hertz AC frequency.

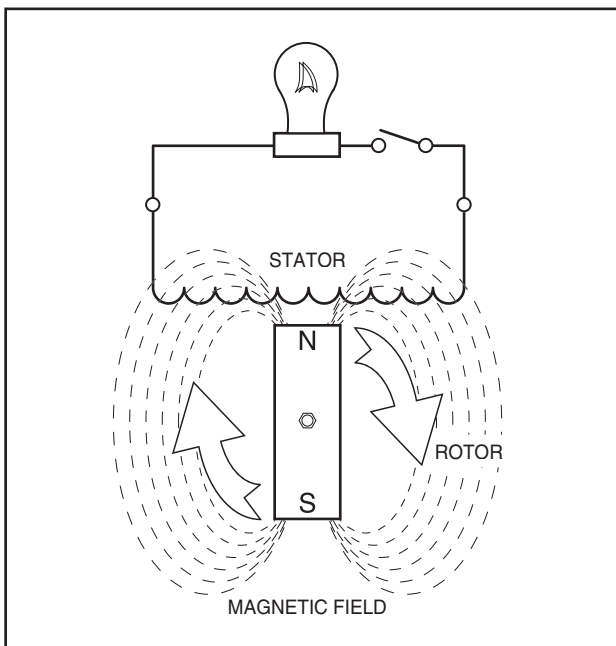

Figure 1-4. – A Simple AC Generator

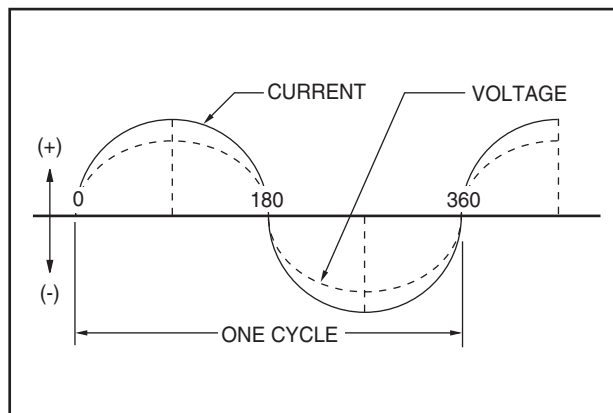

Figure 1-5. – Alternating Current Sine Wave

## A MORE SOPHISTICATED AC GENERATOR

Figure 1-6 represents a more sophisticated generator. A regulated direct current is delivered into the ROTOR windings via carbon BRUSHES AND SLIP RINGS. This results in the creation of a regulated magnetic field around the ROTOR. As a result, a regulated voltage is induced into the STATOR. Regulated current delivered to the ROTOR is called "EXCITATION" current.

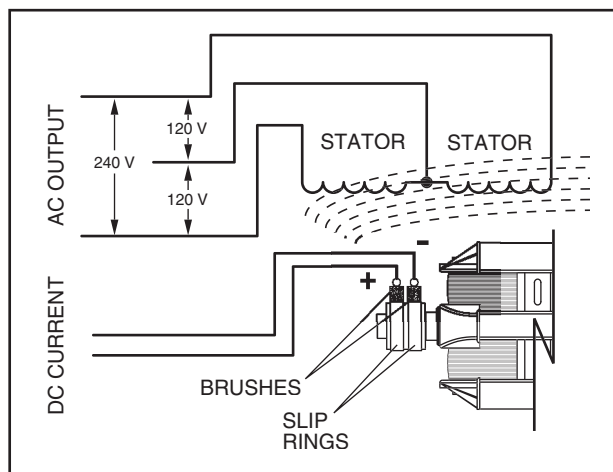

Figure 1-6. – A More Sophisticated Generator

See Figure 1-7 (next page). The revolving magnetic field (ROTOR) is driven by the engine at a constant speed. This constant speed is maintained by a mechanical engine governor. Units with a 2-pole rotor require an operating speed of 3600 rpm to deliver a 60 Hertz AC output. Engine governors are set to maintain approximately 3720 rpm when no electrical loads are connected to the generator.

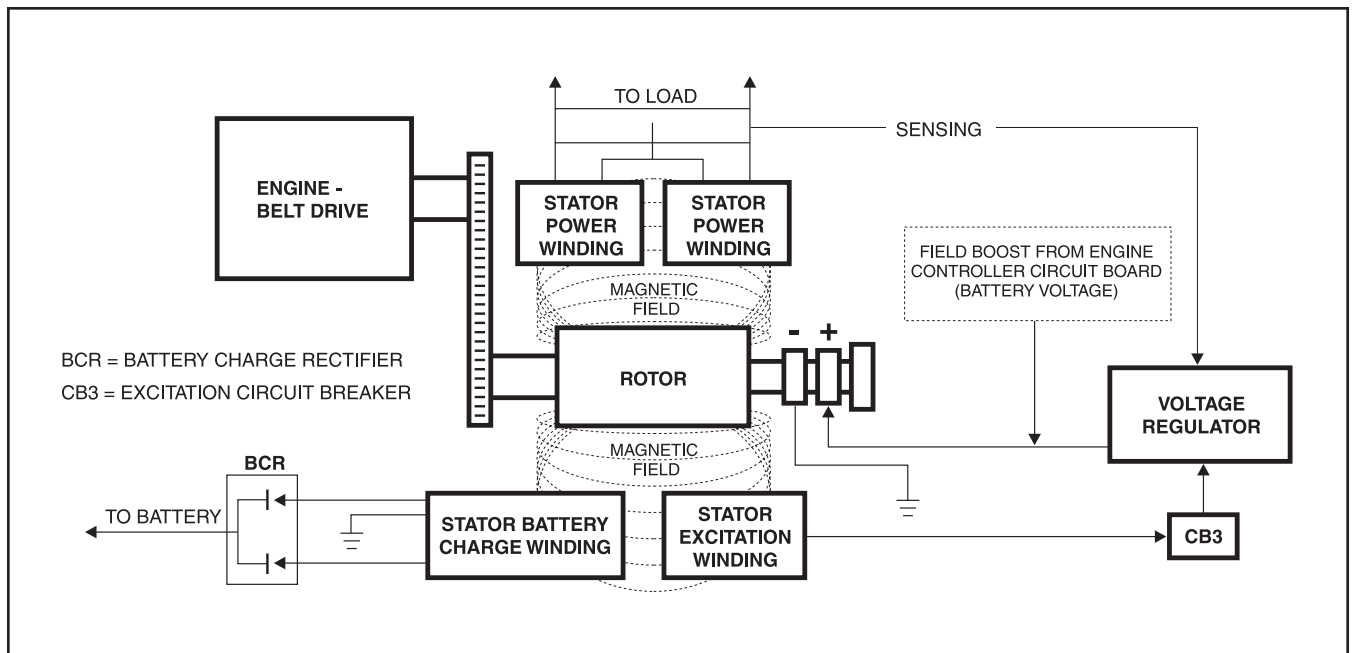

Figure 1-7. – Generator Operating Diagram

**NOTE: AC output frequency at 3720 rpm will be about 62 Hertz. The “No-Load” is set slightly high to prevent excessive rpm, frequency and voltage droop under heavy electrical loading.**

Generator operation may be described briefly as follows:

1. Some “residual” magnetism is normally present in the Rotor and is sufficient to induce approximately 7 to 12 volts AC into the STATOR’s AC power windings.
2. During startup, an engine controller circuit board delivers battery voltage to the ROTOR, via the brushes and slip rings.
  - a. The battery voltage is called “Field Boost”.
  - b. Flow of direct current through the ROTOR increases the strength of the magnetic field above that of “residual” magnetism alone.
3. “Residual” plus “Field Boost” magnetism induces a voltage into the Stator excitation (DPE), battery charge and AC Power windings.
4. Excitation winding unregulated AC output is delivered to an electronic voltage regulator, via an excitation circuit breaker.
  - a. A “Reference” voltage has been preset into the Voltage Regulator.
  - b. An “Actual” (“sensing”) voltage is delivered to the Voltage Regulator via sensing leads from the Stator AC power windings.
  - c. The Regulator “compares” the actual (sensing) voltage to its pre-set reference voltage.

(1) If the actual (sensing) voltage is greater than the pre-set reference voltage, the Regulator will decrease the regulated current flow to the Rotor.

(2) If the actual (sensing) voltage is less than the pre-set reference voltage, the Regulator will increase the regulated current flow to the Rotor.

(3) In the manner described, the Regulator maintains an actual (sensing) voltage that is equal to the pre-set reference voltage.

**NOTE: The Voltage Regulator also changes the Stator excitation windings alternating current (AC) output to direct current (DC).**

5. When an electrical load is connected across the Stator power windings, the circuit is completed and an electrical current will flow.
6. The Rotor’s magnetic field also induces a voltage into the Stator battery charge windings.
  - a. Battery charge winding AC output is delivered to a battery charge rectifier (BCR) which changes the AC to direct current (DC).
  - b. The rectified DC is then delivered to the unit battery, to maintain the battery in a charged state.
  - c. A 1 ohm, 25 watt Resistor is installed in series with the grounded side of the battery charge circuit.

## Section 1 GENERATOR FUNDAMENTALS

### FIELD BOOST

When the engine is cranked during startup, the engine's starter contactor is energized closed. Battery current is then delivered to the starter motor and the engine cranks.

Closure of the starter contactor contacts also delivers battery voltage to Pin 13 of an Engine Controller circuit board. The battery current flows through a 47 ohm, 2 watt resistor and a field boost diode, then to the Rotor via brushes and slip rings. This is called "Field Boost" current.

Field boost current is delivered to the Rotor only while the engine is cranking. The effect is to "flash the field" every time the engine is cranked. Field boost current helps ensure that sufficient "pickup" voltage is available on every startup to turn the Voltage Regulator on and build AC output voltage.

**NOTE: Loss of the Field Boost function may or may not result in loss of AC power winding output. If Rotor residual magnetism alone is sufficient to turn the Regulator on loss of Field Boost may go unnoticed. However, If residual magnetism alone is not enough to turn the Regulator on, loss of the Field Boost function will result in loss of AC power winding output to the load. The AC output voltage will then drop to a value commensurate with the Rotor's residual magnetism (about 7-12 VAC).**

### GENERATOR AC CONNECTION SYSTEM

These air-cooled generator sets are equipped with dual stator AC power windings. These two stator windings supply electrical power to customer electrical loads by means of a dual 2-wire connection system.

Generators may be installed to provide the following outputs:

1. 120 VAC loads only — one load with a maximum total wattage requirement equal to the generator's rated power output (in watts), and 120V across the generator output terminals. Figure 1.8, page 7, shows the generator lead wire connections for 120VAC ONLY.
2. 120/240 VAC loads — one load with a maximum total wattage requirement equal to the generator's rated power output, and 240V across the generator output terminals; or two separate loads, each with a maximum total wattage requirement equal to half of the generator's rated power output (in watts), and 120V across the generator output terminals. Figure 1.9 on page 7, shows the generator lead wire connections for 120/240 VAC loads.

You can use your generator set to supply electrical power for operating one of the following electrical loads:

- QUIETPACT 55G & LP: 120 and/or 240 volts, single phase, 60 Hz electrical loads. These loads can require up to 5500 watts (5.5 kW) of total power, but cannot exceed 45.8 AC amperes of current at 120 volts or exceed 22.9 AC amperes at 240 volts.
- QUIETPACT 65G & LP: 120 and/or 240 volts, single phase, 60 Hz electrical loads. These loads can require up to 6500 watts (6.5 kW) of total power, but cannot exceed 54.1 AC amperes of current at 120 volts or exceed 27 AC amperes at 240 volts.
- QUIETPACT 75G & LP: 120 and/or 240 volts, single phase, 60 Hz electrical loads. These loads can require up to 7500 watts (7.5 kW) of total power, but cannot exceed 62.5 AC amperes of current at 120 volts or exceed 31.2 AC amperes at 240 volts.



**CAUTION! Do not overload the generator.**

Some installations may require that electrical loads be alternated to avoid overloading. Applying excessively high electrical loads may damage the generator and may shorten its life. Add up the rated watts of all electrical lighting, appliance, tool and motor loads the generator will power at one time. This total should not be greater than the wattage capacity of the generator. If an electrical device nameplate gives only volts and amps, multiply volts times amps to obtain watts (volts x amps = watts). Some electric motors require more watts of power (or amps of current) for starting than for continuous operation.

#### LINE BREAKERS (120 VOLTS ONLY):

Protects generator's AC output circuit against overload, i.e., prevents unit from exceeding wattage/ampere capacity. The circuit breaker ratings are as follows:

Model	Circuit Breaker 1	Circuit Breaker 2
QuietPact 55	30A	20A
QuietPact 65	30A	30A
QuietPact 75	35A	35A

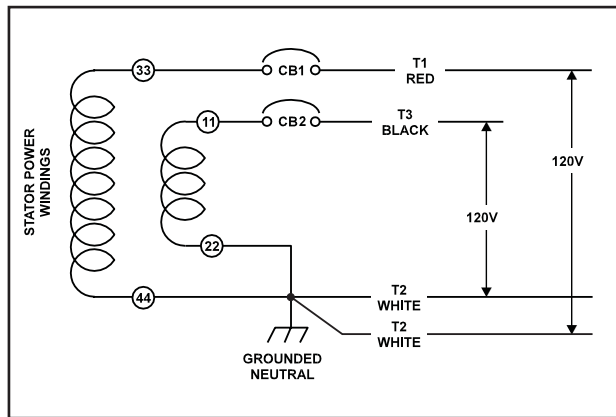

Figure 1-8. – Connection for 120 Volts Only

**RECONNECTION FOR DUAL VOLTAGE OUTPUT:**

When connected for dual voltage output, Stator output leads 11P and 44 form two “hot” leads (T1- Red and T3- Black). The junction of leads 22P and 33 form the “Neutral” line (T2- White).

For dual voltage output, the “Neutral” line remains grounded.

**NOTE:** For units with two 30 amp or two 35 amp main breakers, the existing breakers may be re-used when reconnecting for dual voltage output. However, on units with a 30 amp and a 20 amp main breaker, you may wish to install a 2-pole breaker that is rated closer to the unit’s rated capacity (use two 25 amp main breakers).

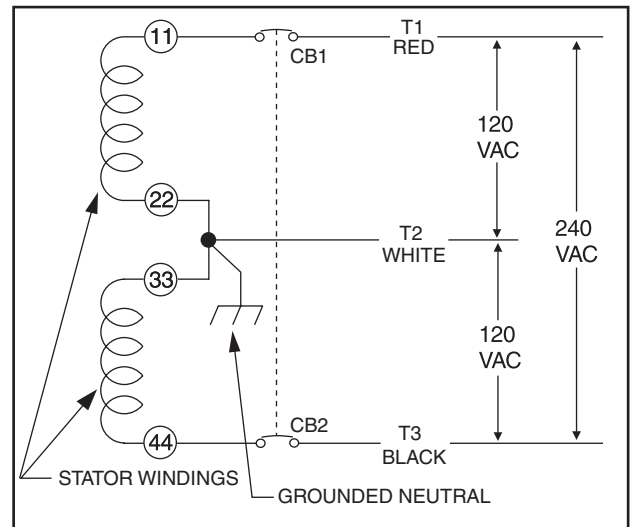
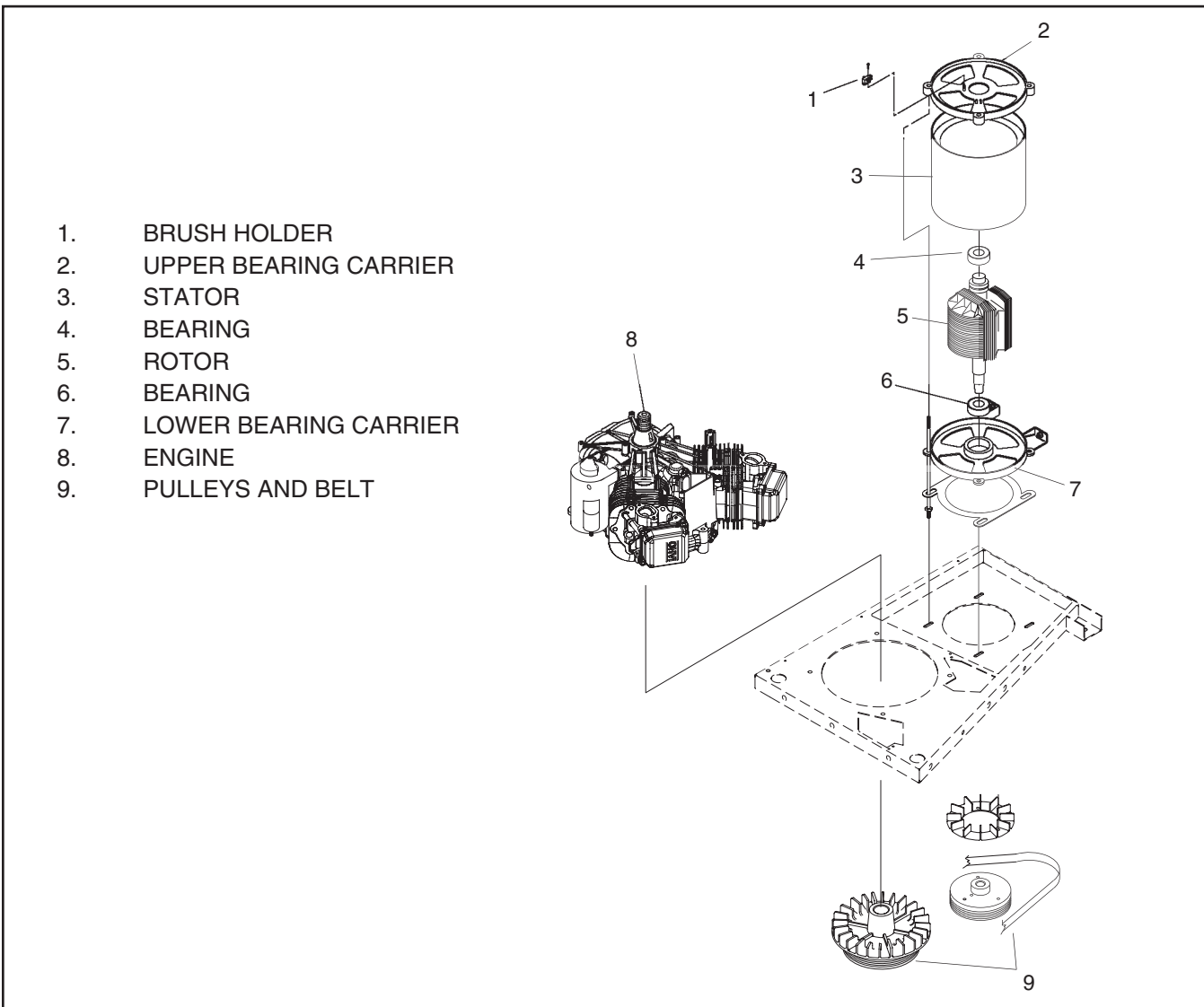

Figure 1-9 - Connection for 120/240 Volts

**NOTE:** If this generator has been reconnected for dual voltage AC output (120/240 volts), the replacement line breakers should consist of two separate breakers with a connecting piece between the breaker handles (so that both breakers operate at the same time). If the unit is reconnected for dual voltage, it is no longer RVIA listed.

## Section 2 MAJOR GENERATOR COMPONENTS



1. BRUSH HOLDER
2. UPPER BEARING CARRIER
3. STATOR
4. BEARING
5. ROTOR
6. BEARING
7. LOWER BEARING CARRIER
8. ENGINE
9. PULLEYS AND BELT

Figure 2-1. Exploded View of Generator

### ROTOR ASSEMBLY

The Rotor is sometimes called the “revolving field”, since it provides the magnetic field that induces a voltage into the stationary Stator windings. Slip rings on the Rotor shaft allow excitation current from the voltage regulator to be delivered to the Rotor windings. The Rotor is driven by the engine at a constant speed through a pulley and belt arrangement.

All generator models in this manual utilize a 2-pole Rotor, i.e., one having a single north and a single south pole. This type of Rotor must be driven at 3600 rpm for a 60 Hertz AC output, or at 3000 rpm for a 50 Hertz output.

Slip rings may be cleaned. If dull or tarnished, clean them with fine sandpaper (a 400 grit wet sandpaper is recommended). **DO NOT USE ANY METALLIC GRIT OR ABRASIVE TO CLEAN SLIP RINGS.**

### STATOR ASSEMBLY

The Stator is “sandwiched” between the upper and lower bearing carriers and retained in that position by four Stator studs. Windings Included in the Stator assembly are (a) dual AC power windings, (b) an excitation or DPE winding, and (c) a battery charge winding. A total of eleven (11) leads are brought out of the Stator as follows:

1. Four (4) Stator power winding output leads (Wires No. 11P, 22P, 33 and 44). These leads deliver power to connected electrical loads.
2. Stator Power winding “sensing” leads (11S and 22S). These leads deliver an “actual voltage signal to the electronic Voltage Regulator.

## Section 2 MAJOR GENERATOR COMPONENTS

3. Two excitation winding output leads (No. 2 and 6). These leads deliver unregulated excitation current to the voltage regulator.
4. Three (3) battery charge output leads (No. 55, 66 and 77).

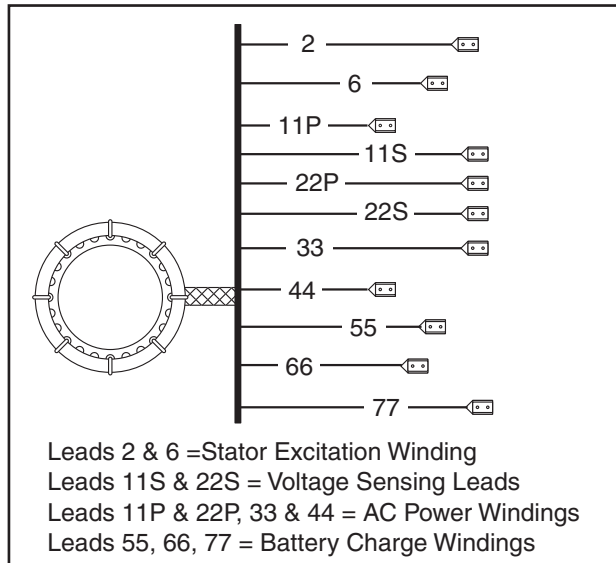

Figure 2-2. – Stator Output Leads

### BRUSH HOLDER

The brush holder is retained in the rear bearing carrier by two M5 screws. It retains two brushes, which contact the Rotor slip rings and allow current flow from stationary parts to the revolving Rotor. The positive (+) brush is located nearest the Rotor bearing.

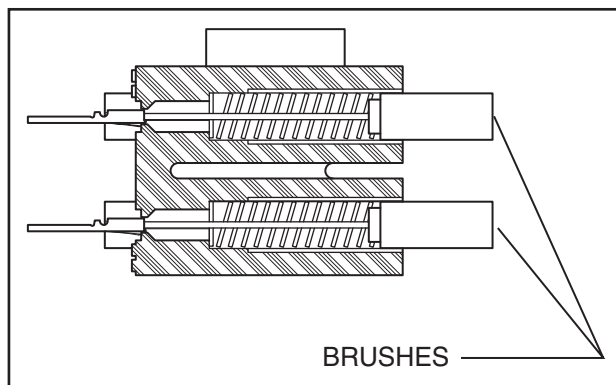

Figure 2-3. – Brush Holder

### BATTERY CHARGE COMPONENTS

The Stator incorporates dual battery charge windings. A battery charge rectifier (BCR) changes the AC output of these windings to direct current (DC). Battery charge winding output is delivered to the unit battery

via the rectifier, a 7.5 amp fuse and Wire No. 13. A 1 ohm, 25 watt resistor is connected in series with the grounded side of the circuit.

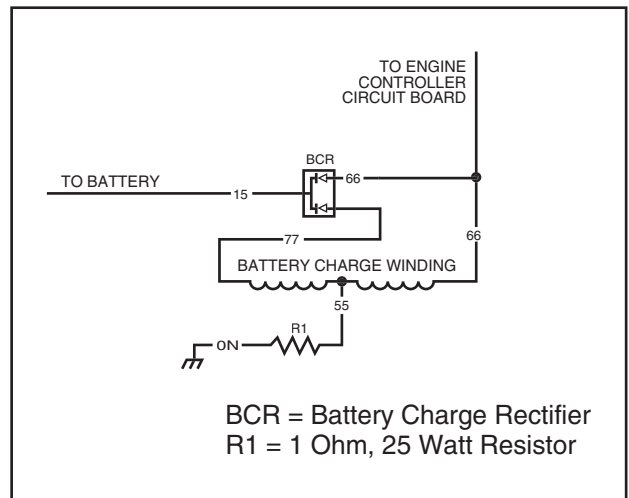

Figure 2-4. – Battery Charge Circuit

### EXCITATION CIRCUIT COMPONENTS

#### GENERAL:

During operation, the Rotor's magnetic field induces a voltage and current flow into the Stator excitation winding. The resultant AC output is delivered to a voltage regulator via an excitation circuit breaker (CB3).

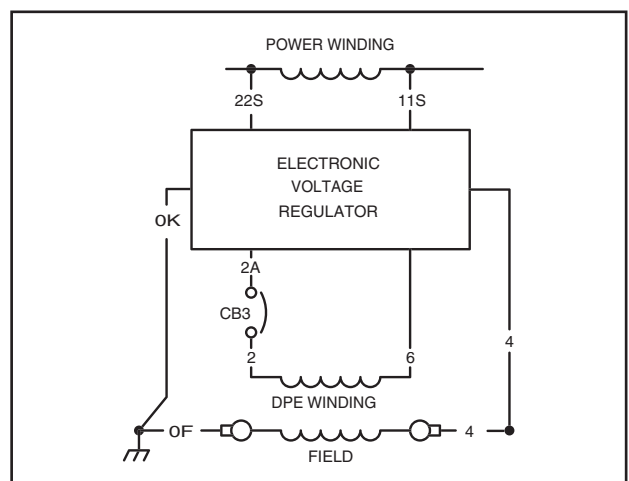

Figure 2-5. – Schematic: Excitation Circuit

#### EXCITATION CIRCUIT BREAKER:

The excitation circuit breaker (CB3) is self-resetting and cannot be reset manually. Should the breaker open for any reason, excitation current flow to the

## Section 2 MAJOR GENERATOR COMPONENTS

Rotor will be lost. The unit's AC output voltage will then drop to a value commensurate with the Rotor's residual magnetism (about 7-12 VAC).

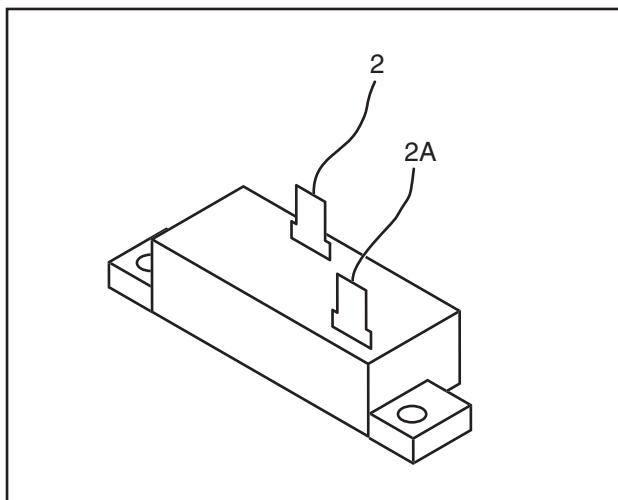

Figure 2-6. – Excitation Circuit Breaker

### VOLTAGE REGULATOR:

Six (6) leads are connected to the voltage regulator as follows:

- Two (2) SENSING leads deliver ACTUAL AC output voltage signals to the regulator. These are Wires No. 11S and 22S.
- Two (2) leads (4 and 0K) deliver the regulated direct current to the Rotor, via brushes and slip rings.
- Two (2) leads (No. 6 and 2A) deliver Stator excitation winding AC output to the regulator.

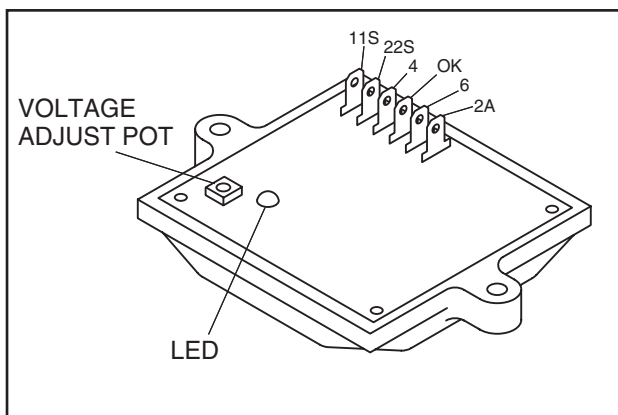

Figure 2-7. – Voltage Regulator

The regulator mounts a "VOLTAGE ADJUST" potentiometer, used for adjustment of the pre-set REFERENCE voltage. A lamp (LED) will turn on to indicate that SENSING voltage is available to the regulator and the regulator is turned on.

### ADJUSTMENT PROCEDURE:

With the frequency set at 62.5 Hertz and no load on the generator, slowly turn the voltage adjust pot on the voltage regulator until 124 VAC is measured. If voltage is not adjustable, proceed to Section 6 - Troubleshooting; Problem 2.

**NOTE:** If, for any reason, sensing voltage to the regulator is lost, the regulator will shut down and excitation output to the Rotor will be lost. The AC output voltage will then drop to a value that is commensurate with Rotor residual magnetism (about 7-12 VAC). Without this automatic shut-down feature, loss of sensing (actual) voltage to the regulator would result in a "full field" or "full excitation" condition and an extremely high AC output voltage.

**NOTE:** Adjustment of the regulator's "VOLTAGE ADJUST" potentiometer must be done only when the unit is running at its correct governed no-load speed. Speed is correct when the unit's no-load AC output frequency is about 62.5 Hertz. At the stated frequency, AC output voltage should be about 124 volts.

### CRANKCASE BREATHER

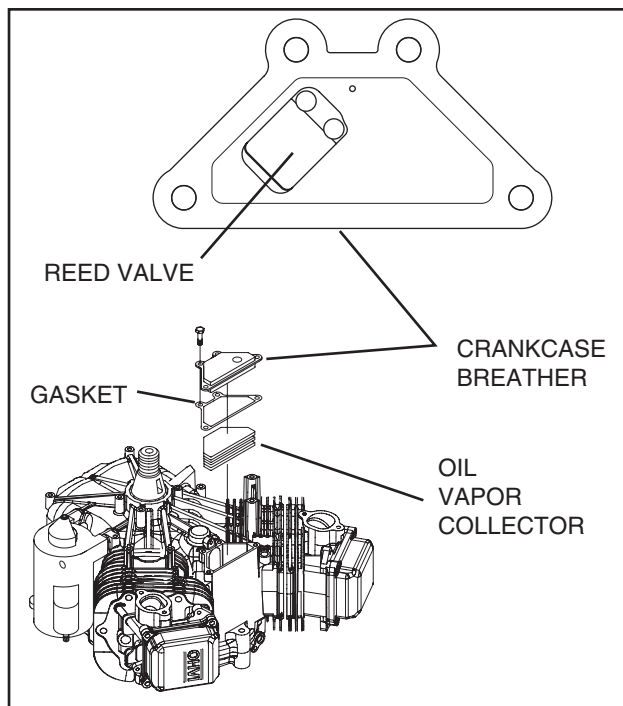

Figure 2-8. – Crankcase Breather

### DESCRIPTION:

The crankcase breather is equipped with a reed valve to control and maintain a partial vacuum in the crankcase. The breather is vented to the intake

elbow. The breather chamber contains a removable oil vapor collector. Oil vapor is condensed on the collector material and drains back into the crankcase, which minimizes the amount of oil vapor entering the breather.

**CHECK BREATHER:**

1. Disconnect breather tube and remove four screws and breather. Discard gasket.
2. Check to see that reed valve is not deformed (Figure 2-8).

**Note: Reed valve must form a complete seal around vent hole.**

3. Remove oil vapor collector and retainer.
4. Check collector for deterioration and replace if necessary.

**INSTALL BREATHER:**

1. Install oil vapor collector and retainer.

**Note: Push oil vapor collector and retainer in until it bottoms.**

2. Install breather with new gasket (Figure 2-8).
  - a. Torque screws to 5-8 ft-lbs.
3. Assemble breather tube to intake elbow.

**CONTROL PANEL COMPONENT IDENTIFICATION**

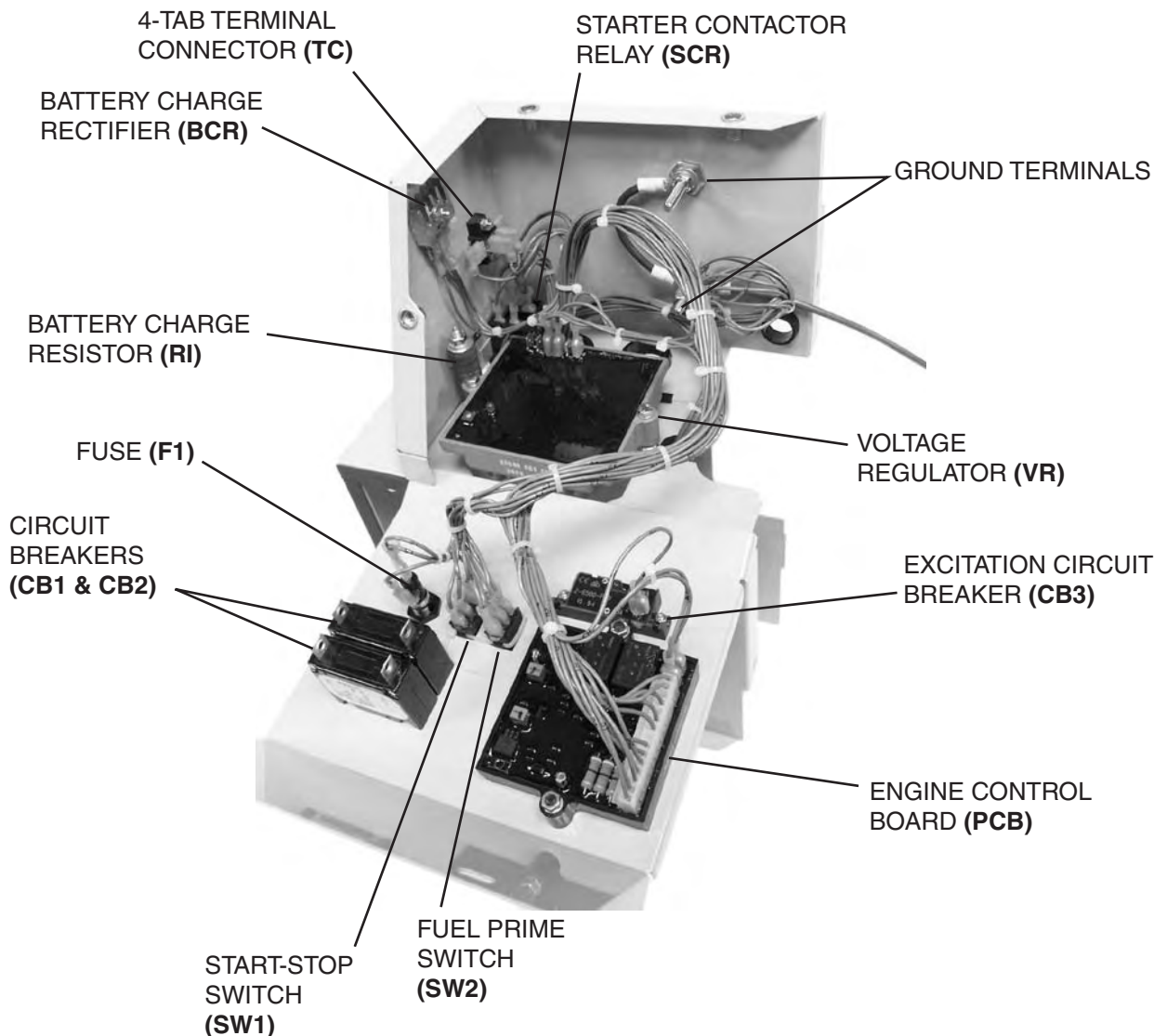

Figure 2-9. – Control Panel Components

## Section 3

### INSULATION RESISTANCE TESTS

#### EFFECTS OF DIRT AND MOISTURE

Moisture and dirt are detrimental to the continued good operation of any generator set.

If moisture is allowed to remain in contact with the Stator and Rotor windings, some of the moisture will be retained in voids and cracks of the winding Insulation. This will result in a reduced Insulation resistance and, eventually, the unit's AC output will be affected.

Insulation used in the generator is moisture resistant. However, prolonged exposure to moisture will gradually reduce the resistance of the winding insulation.

Dirt can make the problem worse, since it tends to hold moisture into contact with the windings. Salt, as from sea air, contributes to the problem since salt can absorb moisture from the air. When salt and moisture combine, they make a good electrical conductor.

Because of the detrimental affects of dirt and moisture, the generator should be kept as clean and as dry as possible. Rotor and Stator windings should be tested periodically with an insulation resistance tester (such as a megohmmeter or hi-pot tester).

If the Insulation resistance is excessively low, drying may be required to remove accumulated moisture. After drying, perform a second insulation resistance test. If resistance is still low after drying, replacement of the defective Rotor or Stator may be required.

#### INSULATION RESISTANCE TESTERS

Figure 3-1 shows one kind of hi-pot tester. The tester shown has a "Breakdown" lamp that will glow during the test procedure to indicate an insulation breakdown in the winding being tested.

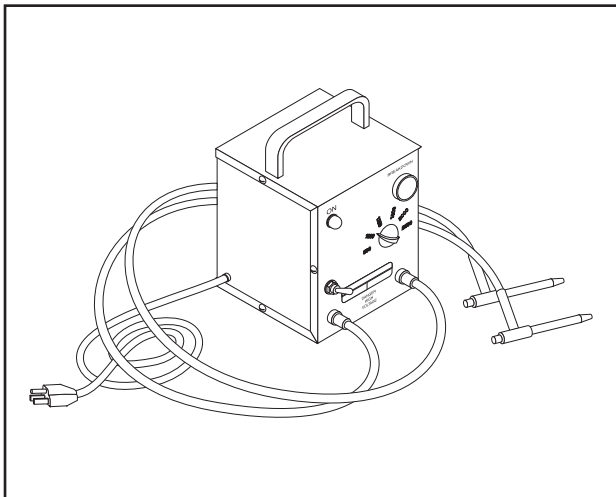

Figure 3-1. – One Type of Hi-Pot Tester



**DANGER! INSULATION RESISTANCE TESTERS SUCH AS HI-POT TESTERS AND MEGOHMMETERS ARE A SOURCE OF HIGH AND DANGEROUS ELECTRICAL VOLTAGE. FOLLOW THE TESTER MANUFACTURER'S INSTRUCTIONS CAREFULLY. USE COMMON SENSE TO AVOID DANGEROUS ELECTRICAL SHOCK**

#### DRYING THE GENERATOR

##### GENERAL:

If tests indicate the insulation resistance of a winding is below a safe value, the winding should be dried before operating the generator. Some recommended drying procedures include (a) heating units and (b) forced air.

##### HEATING UNITS:

If drying is needed, the generator can be enclosed in a covering. Heating units can then be installed to raise the temperature about 15°-18° F. (8°-10° C.) above ambient temperature.

##### FORCED AIR:

Portable forced air heaters can be used to dry the generator. Direct the heated air into the generator's air intake openings. Remove the voltage regulator and run the unit at no-load. Air temperature at the point of entry into the generator should not exceed 150° F. (66° C.).

#### CLEANING THE GENERATOR

##### GENERAL:

The generator can be cleaned properly only while it is disassembled. The cleaning method used should be determined by the type of dirt to be removed. Be sure to dry the unit after it has been cleaned.

**NOTE: A shop that repairs electric motors may be able to assist you with the proper cleaning of generator windings. Such shops are often experienced in special problems such as a sea coast environment, marine or wetland applications, mining, etc.**

##### USING SOLVENTS FOR CLEANING:

If dirt contains oil or grease a solvent is generally required. Only petroleum distillates should be used to clean electrical components. Recommended are safety type petroleum solvents having a flash point greater than 100° F. (38° C.).

 **CAUTION!:** Some generators may use epoxy or polyester base winding varnishes. Use solvents that will not attack such materials.

Use a soft brush or cloth to apply the solvent. Be careful to avoid damage to wire or winding insulation. After cleaning, dry all components thoroughly using moisture-free, low-pressure compressed air.

 **DANGER!:** DO NOT ATTEMPT TO WORK WITH SOLVENTS IN ANY ENCLOSED AREA. PROVIDE ADEQUATE VENTILATION WHEN WORKING WITH SOLVENTS. WITHOUT ADEQUATE VENTILATION, FIRE, EXPLOSION OR HEALTH HAZARDS MAY EXIST. WEAR EYE PROTECTION. WEAR RUBBER GLOVES TO PROTECT THE HANDS.

CLOTH OR COMPRESSED AIR:

For small parts or when dry dirt is to be removed, a dry cloth may be satisfactory. Wipe the parts clean, then use low pressure air at 30 psi (206 Kpa) to blow dust away.

BRUSHING AND VACUUM CLEANING:

Brushing with a soft bristle brush followed by vacuum cleaning is a good method of removing dust and dirt. Use the soft brush to loosen the dirt, then remove it with the vacuum.

### **STATOR INSULATION RESISTANCE**

GENERAL:

Insulation resistance is a measure of the Integrity of the insulating materials that separate electrical windings from the generator's steel core. This resistance can degrade over time due to the presence of contaminants, dust, dirt, grease and especially moisture).

The normal Insulation resistance for generator windings is on the order of "millions of ohms" or "megohms".

When checking the insulation resistance, follow the tester manufacturer's Instructions carefully. Do NOT exceed the applied voltages recommended in this manual. Do NOT apply the voltage longer than one (1) second.

 **CAUTION!:** DO NOT connect the Hi-Pot Tester or Megohmmeter test leads to any leads that are routed into the generator control panel. Connect the tester leads to the Stator or Rotor leads only.

STATOR SHORT-TO-GROUND TESTS:

See Figure 3-2. To test the Stator for a short-to-ground condition, proceed as follows:

1. Disconnect and Isolate all Stator leads as follows:
  - a. Disconnect sensing leads 11S and 22S from the voltage regulator.
  - b. Disconnect excitation winding lead No. 6 from the voltage regulator.
  - c. Disconnect excitation lead No. 2 from the excitation circuit breaker (CB3).
  - d. Disconnect battery charge winding leads No. 66 and 77 from the battery charge rectifier (BCR).
  - e. Disconnect battery charge winding lead No. 55 from the battery charge resistor (R1).
  - f. At the main circuit breakers, disconnect AC power leads No. 11P and 33.
  - g. At the 4-tab ground terminal (GT), disconnect Stator power leads No. 22P and 44.
2. When all leads have been disconnected as outlined in Step 1 above, test for a short-to-ground condition as follows:
  - a. Connect the terminal ends of all Stator leads together (11S, 22S, 11P, 22P, 33, 44, 2,6, 55, 66, 77).
  - b. Follow the tester manufacturer's instructions carefully. Connect the tester leads across all Stator leads and to frame ground on the Stator can. Apply a voltage of 1500 volts. Do NOT apply voltage longer than one (1) second.

If the test Indicates a breakdown in Insulation, the Stator should be cleaned, dried and re-tested. If the winding fails the second test (after cleaning and drying), replace the Stator assembly.

TEST BETWEEN ISOLATED WINDINGS:

1. Follow the tester manufacturer's instructions carefully. Connect the tester test leads across Stator leads No. 11P and 2. Apply a voltage of 1500 volts- DO NOT EXCEED 1 SECOND.
2. Repeat Step 1 with the tester leads connected across the following Stator leads:
  - a. Across Wires No. 33 and 2.
  - b. Across Wires No. 11P and 66.
  - c. Across Wires No. 33 and 66.
  - d. Across Wires No. 2 and 66.

If a breakdown in the insulation between isolated windings is indicated, clean and dry the Stator. Then, repeat the test. If the Stator fails the second test, replace the Stator assembly.

## Section 3 INSULATION RESISTANCE TESTS

### TEST BETWEEN PARALLEL WINDINGS:

Connect the tester leads across Stator leads No. 11P and 33. Apply a voltage of 1500 volts. If an insulation breakdown is indicated, clean and dry the Stator. Then, repeat the test between parallel windings. If the Stator fails the second test, replace it.

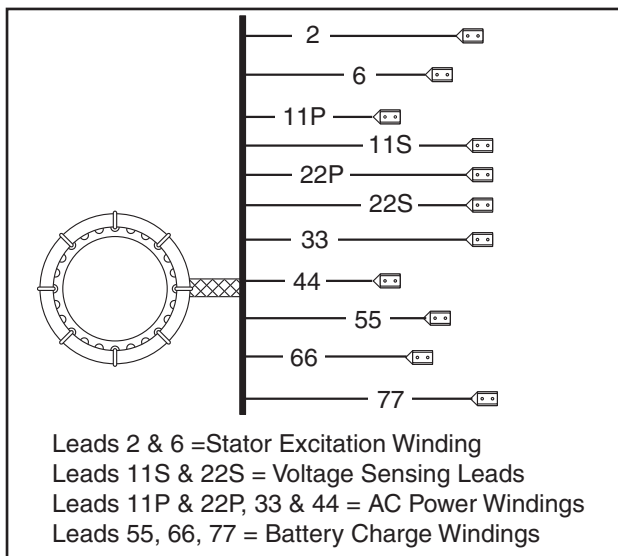

Figure 3-2. – Stator Leads

### TESTING ROTOR INSULATION

To test the Rotor for insulation breakdown, proceed as follows:

1. Disconnect wires from the Rotor brushes or remove the brush holders with brushes.
2. Connect the tester positive (+) test lead to the positive (+) slip ring (nearest the Rotor bearing). Connect the tester negative (-) test lead to a clean frame ground (like the Rotor shaft).

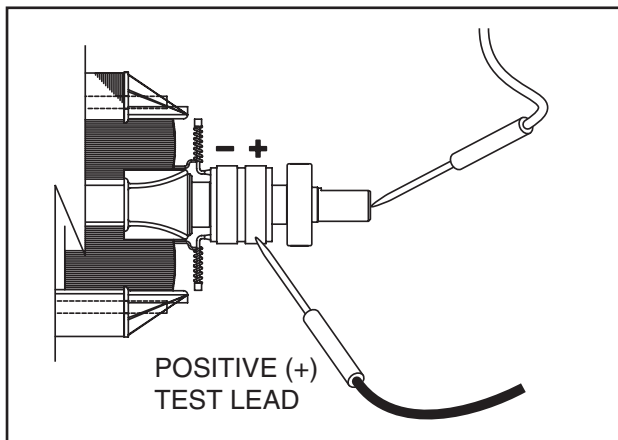

Figure 3-3. – Rotor Test Points

3. Apply 1000 volts. DO NOT APPLY VOLTAGE LONGER THAN 1 SECOND.

If an insulation breakdown is indicated, clean and dry the Rotor then repeat the test. Replace the Rotor if it fails the second test (after cleaning and drying).

### THE MEGOHMMETER

#### GENERAL:

A megohmmeter, often called a “megger”, consists of a meter calibrated in megohms and a power supply. Use a power supply of 1500 volts when testing Stators; or 1000 volts when testing the Rotor. DO NOT APPLY VOLTAGE LONGER THAN ONE (1) SECOND.

#### TESTING STATOR INSULATION:

All parts that might be damaged by the high megger voltages must be disconnected before testing. Isolate all Stator leads (Figure 3-2) and connect all of the Stator leads together. FOLLOW THE MEGGER MANUFACTURER'S INSTRUCTIONS CAREFULLY.

Use a megger power setting of 1500 volts. Connect one megger test lead to the junction of all Stator leads, the other test lead to frame ground on the Stator can. Read the number of megohms on the meter.

$$\begin{array}{l} \text{MINIMUM INSULATION} \\ \text{RESISTANCE} \\ \text{(in "Megohms")} \end{array} = \frac{\text{GENERATOR RATED VOLTS}}{1000} + 1$$

The MINIMUM acceptable megger reading for Stators may be calculated using the following formula:

**EXAMPLE: Generator is rated at 120 volts AC. Divide “120” by “1000” to obtain “0.12”. Then add “1” to obtain “1.12” megohms. Minimum Insulation resistance for a 120 VAC Stator is 1.12 megohms.**

If the Stator insulation resistance is less than the calculated minimum resistance, clean and dry the Stator. Then, repeat the test. If resistance is still low, replace the Stator.

Use the Megger to test for shorts between isolated windings as outlined “Stator Insulation Resistance”.

Also test between parallel windings. See “Test Between Parallel Windings” on this page.

#### TESTING ROTOR INSULATION:

Apply a voltage of 1000 volts across the Rotor positive (+) slip ring (nearest the rotor bearing), and a clean frame ground (i.e. the Rotor Shaft). DO NOT EXCEED 1000 VOLTS AND DO NOT APPLY VOLTAGE LONGER THAN 1 SECOND. FOLLOW THE MEGGER MANUFACTURER'S INSTRUCTIONS CAREFULLY.

#### ROTOR MINIMUM INSULATION RESISTANCE:

1.5 megohms

## METERS

Devices used to measure electrical properties are called meters. Meters are available that allow one to measure (a) AC voltage, (b) DC voltage, (c) AC frequency, and (d) resistance in ohms. The following apply:

- ❑ To measure AC voltage, use an AC voltmeter.
- ❑ To measure DC voltage, use a DC voltmeter.
- ❑ Use a frequency meter to measure AC frequency in “Hertz” or “cycles per second”.
- ❑ Use an ohmmeter to read circuit resistance, in “ohms”.

## THE VOM

A meter that will permit both voltage and resistance to be read is the “volt-ohm-milliammeter” or “VOM”.

Some VOM's are of the “analog” type (not shown). These meters display the value being measured by physically deflecting a needle across a graduated scale. The scale used must be interpreted by the user.

“Digital” VOM's (Figure 4-1) are also available and are generally very accurate. Digital meters display the measured values directly by converting the values to numbers.

**NOTE: Standard AC voltmeters react to the AVERAGE value of alternating current. When working with AC, the effective value is used. For that reason a different scale is used on an AC voltmeter. The scale is marked with the effective or “rms” value even though the meter actually reacts to the average value. That is why the AC voltmeter will give an incorrect reading if used to measure direct current (DC).**

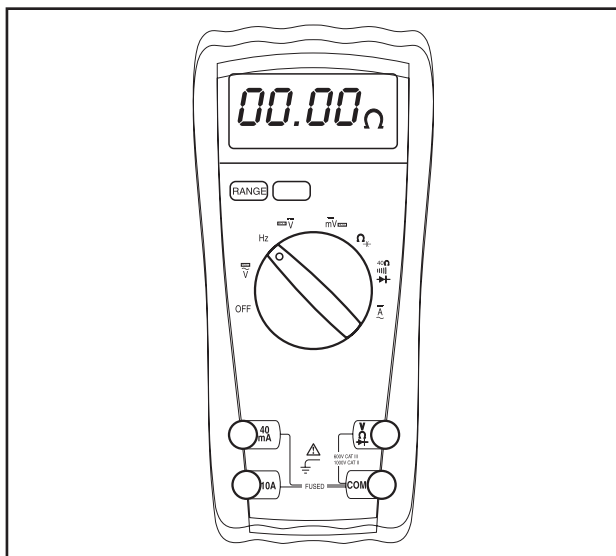

Figure 4-1. – Digital VOM

## MEASURING AC VOLTAGE

An accurate AC voltmeter or a VOM may be used to read the generator's AC output voltage. The following apply:

1. Always read the generator's AC output voltage only at the unit's rated operating speed and AC frequency.
2. The generator's voltage regulator can be adjusted for correct output voltage only while the unit is operating at its correct rated speed and frequency.
3. Only an AC voltmeter may be used to measure AC voltage. DO NOT USE A DC VOLTMETER FOR THIS PURPOSE.



**DANGER!: RV GENERATORS PRODUCE HIGH AND DANGEROUS VOLTAGES. CONTACT WITH HIGH VOLTAGE TERMINALS WILL RESULT IN DANGEROUS AND POSSIBLY LETHAL ELECTRICAL SHOCK.**

## MEASURING DC VOLTAGE

A DC voltmeter or a VOM may be used to measure DC voltages. Always observe the following rules:

1. Always observe correct DC polarity.
  - a. Some VOM's may be equipped with a polarity switch.
  - b. On meters that do not have a polarity switch, DC polarity must be reversed by reversing the test leads.
2. Before reading a DC voltage, always set the meter to a higher voltage scale than the anticipated reading. If in doubt, start at the highest scale and adjust the scale downward until correct readings are obtained.
3. The design of some meters is based on the “current flow” theory while others are based on the “electron flow” theory.
  - a. The “current flow” theory assumes that direct current flows from the positive (+) to the negative (-).
  - b. The “electron flow” theory assumes that current flows from negative (-) to positive (+).

**NOTE: When testing generators, the “current flow” theory is applied. That is, current is assumed to flow from positive (+) to negative (-).**

## Section 4 MEASURING ELECTRICITY

### MEASURING AC FREQUENCY

The generator's AC output frequency is proportional to Rotor speed. Generators equipped with a 2-pole Rotor must operate at 3600 rpm to supply a frequency of 60 Hertz. Units with 4-pole Rotor must run at 1800 rpm to deliver 60 Hertz.

Correct engine and Rotor speed is maintained by an engine speed governor. For models rated 60 Hertz, the governor is generally set to maintain a no-load frequency of about 62 Hertz with a corresponding output voltage of about 124 volts AC line-to-neutral. Engine speed and frequency at no-load are set slightly high to prevent excessive rpm and frequency droop under heavy electrical loading.

### MEASURING CURRENT

To read the current flow, in AMPERES, a clamp-on ammeter may be used. This type of meter indicates current flow through a conductor by measuring the strength of the magnetic field around that conductor. The meter consists essentially of a current transformer with a split core and a rectifier type instrument connected to the secondary. The primary of the current transformer is the conductor through which the current to be measured flows. The split core allows the Instrument to be clamped around the conductor without disconnecting it.

Current flowing through a conductor may be measured safely and easily. A line-splitter can be used to measure current in a cord without separating the conductors.

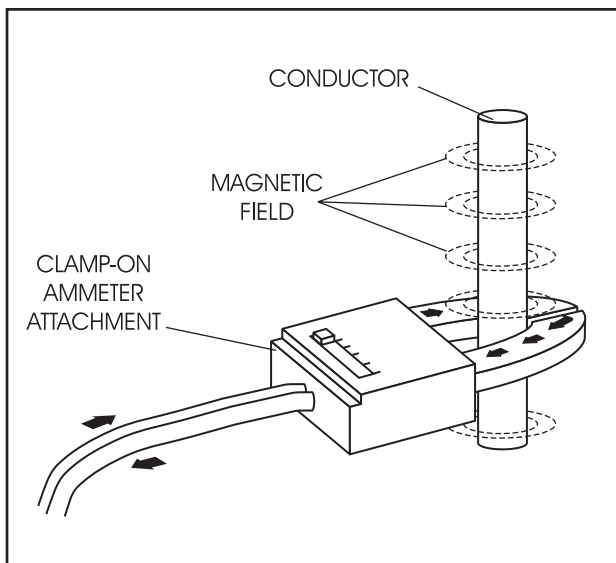

Figure 4-2. – Clamp-On Ammeter

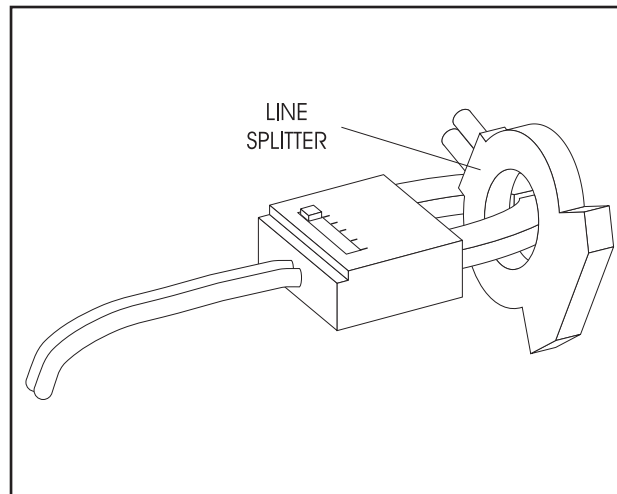

Figure 4-3. – A Line-Splitter

**NOTE:** If the physical size of the conductor or ammeter capacity does not permit all lines to be measured simultaneously, measure current flow in each individual line. Then, add the Individual readings.

### MEASURING RESISTANCE

The volt-ohm-milliammeter may be used to measure the resistance in a circuit. Resistance values can be very valuable when testing coils or windings, such as the Stator and Rotor windings.

When testing Stator windings, keep in mind that the resistance of these windings is very low. Some meters are not capable of reading such a low resistance and will simply read "continuity".

If proper procedures are used, the following conditions can be detected using a VOM:

- A "short-to-ground" condition in any Stator or Rotor winding.
- Shorting together of any two parallel Stator windings.
- Shorting together of any two isolated Stator windings.
- An open condition in any Stator or Rotor winding.

Component testing may require a specific resistance value or a test for "infinity" or "continuity." Infinity is an OPEN condition between two electrical points, which would read as no resistance on a VOM. Continuity is a closed condition between two electrical points, which would be indicated as very low resistance or "ZERO" on a VOM.

**ELECTRICAL UNITS**

**AMPERE:**

The rate of electron flow in a circuit is represented by the AMPERE. The ampere is the number of electrons flowing past a given point at a given time. One AMPERE is equal to just slightly more than six thousand million billion electrons per second.

With alternating current (AC), the electrons flow first in one direction, then reverse and move in the opposite direction. They will repeat this cycle at regular intervals. A wave diagram, called a "sine wave" shows that current goes from zero to maximum positive value, then reverses and goes from zero to maximum negative value. Two reversals of current flow is called a cycle. The number of cycles per second is called frequency and is usually stated in "Hertz".

**VOLT:**

The VOLT is the unit used to measure electrical PRESSURE, or the difference in electrical potential that causes electrons to flow. Very few electrons will flow when voltage is weak. More electrons will flow as voltage becomes stronger. VOLTAGE may be considered to be a state of unbalance and current flow as an attempt to regain balance. One volt is the amount of EMF that will cause a current of 1 ampere to flow through 1 ohm of resistance.

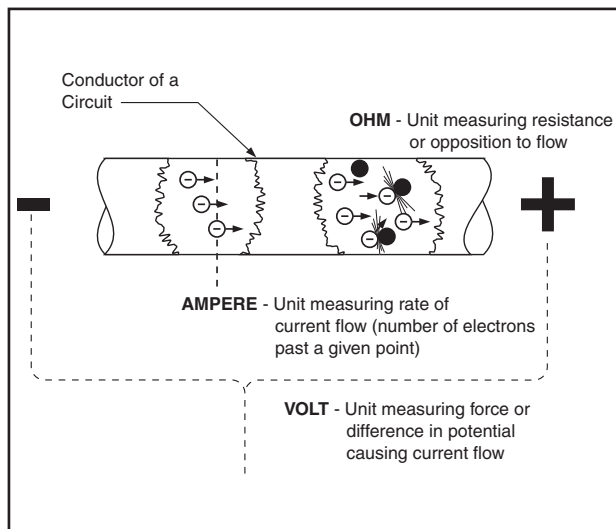

Figure 4-4. – Electrical Units

**OHM:**

The OHM is the unit of RESISTANCE. In every circuit there is a natural resistance or opposition to the flow of electrons. When an EMF is applied to a complete circuit, the electrons are forced to flow in a single direction rather than their free or orbiting pattern. The resistance of a conductor depends on (a) its physical makeup, (b) its cross-sectional area, (c) its length, and (d) its temperature. As the conductor's temperature increases, its resistance increases in direct proportion. One (1) ohm of resistance will permit one (1) ampere of current to flow when one (1) volt of electro-motive force (EMF) is applied.

**OHM'S LAW**

A definite and exact relationship exists between VOLTS, OHMS and AMPERES. The value of one can be calculated when the value of the other two are known. Ohm's Law states that in any circuit the current will increase when voltage increases but resistance remains the same, and current will decrease when resistance increases and voltage remains the same.

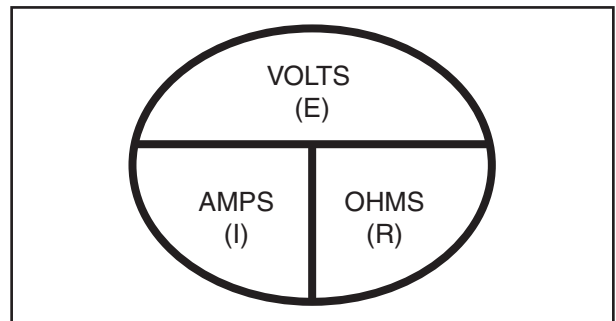

Figure 4-5.

If AMPERES is unknown while VOLTS and OHMS are known, use the following formula:

$$\text{AMPERES} = \frac{\text{VOLTS}}{\text{OHMS}}$$

If VOLTS is unknown while AMPERES and OHMS are known, use the following formula:

$$\text{VOLTS} = \text{AMPERES} \times \text{OHMS}$$

If OHMS is unknown but VOLTS and AMPERES are known, use the following:

$$\text{OHMS} = \frac{\text{VOLTS}}{\text{AMPERES}}$$

# Section 5 ENGINE DC CONTROL SYSTEM

## INTRODUCTION

The engine DC control system includes all components necessary for the operation of the engine. Operation includes rest, priming, cranking, starting, running and shutdown. The system is shown schematically.

## OPERATIONAL ANALYSIS

### CIRCUIT CONDITION - REST:

Battery voltage is available to the engine controller circuit board (PCB) from the unit BATTERY and via (a) the RED battery cable, Wire 13, a 7.5 amp FUSE (F1), Wire 15 and circuit board Terminal J3. However, circuit board action is holding the circuit open and no action can occur.

Battery output is available to the contacts of a STARTER CONTACTOR (SC) and STARTER CONTACTOR RELAY (SCR), but the contacts are open.

Battery voltage is also delivered to the FUEL PRIMER SWITCH (SW2). The switch is open and the circuit is incomplete.

Battery voltage is also available to the REMOTE FUEL PRIMER SWITCH. The switch is open and the circuit is incomplete.

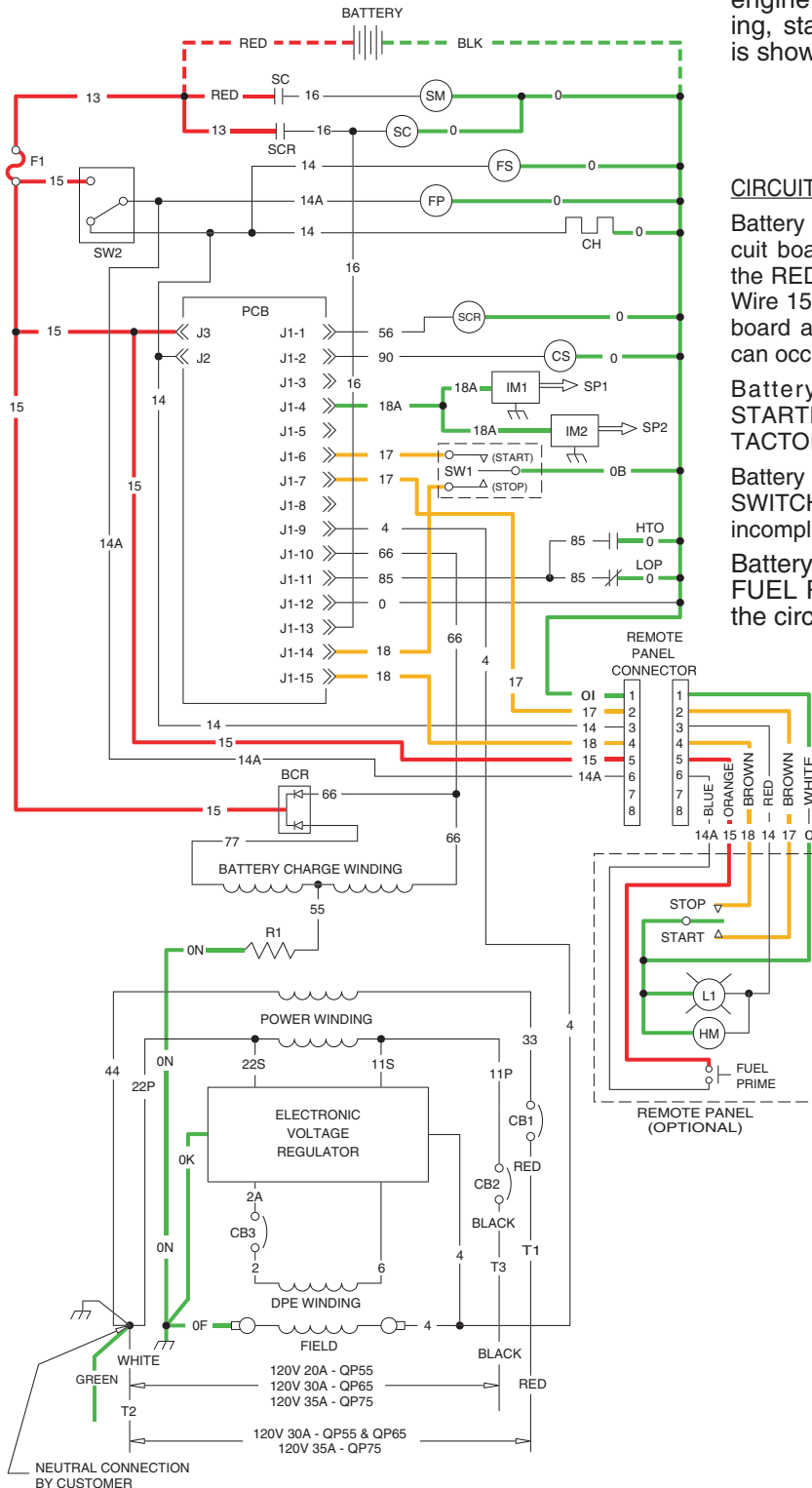

— = 12VDC SUPPLY  
— = 12VDC CONTROL  
— = GROUND

### LEGEND

- BCR - BATTERY CHARGE RECTIFIER
- CB1 - CIRCUIT BREAKER, 30A (QP55 & QP65 MODELS)
- CB2 - CIRCUIT BREAKER, 35A (QP75 MODEL)
- CB3 - CIRCUIT BREAKER, 20A (QP65 MODEL)
- CB3 - CIRCUIT BREAKER, 30A (QP65 MODEL)
- CB3 - CIRCUIT BREAKER, 35A (QP75 MODEL)
- CB3 - CIRCUIT BREAKER, 2.5A (QP55 MODEL)
- CB3 - CIRCUIT BREAKER, 3.0A (QP65 & QP75 MODELS)
- CH - CHOKE HEATER (GASOLINE MODELS ONLY)
- CS - CHOKE SOLENOID (GASOLINE MODELS ONLY)
- F1 - FUSE, 7.5A
- FP - FUEL PUMP-OR-LPG SHUT OFF VALVE
- FS - FUEL SOLENOID
- GT - TERMINAL, GROUND
- HM - METER, HOUR (OPTIONAL)
- HTO - SWITCH, HIGH TEMP. OIL (CLOSES ON HIGH TEMP.)
- IM1 - IGNITION MAGNETO - #1 CYL.
- IM2 - IGNITION MAGNETO - #2 CYL.
- L1 - LIGHT, RUN (OPTIONAL)
- LOP - SWITCH, LOW OIL PRESSURE (CLOSES ON LOW PRESSURE)
- PCB - ENGINE CONTROLLER
- R1 - RESISTOR, 1 OHM 25W
- SC - STARTER CONTACTOR
- SCR - STARTER CONTACTOR RELAY
- SM - STARTER MOTOR
- SW1 - SWITCH, START/STOP
- SW2 - SWITCH FUEL PRIMER
- SP1 - SPARK PLUG #1 CYL.
- SP2 - SPARK PLUG #2 CYL.
- TC - TERMINAL, CONN. 4-TAB
- CONNECTOR

# Section 5 ENGINE DC CONTROL SYSTEM

## CIRCUIT CONDITION- PRIMING:

When the FUEL PRIMER SWITCH (SW2) or the REMOTE PANEL FUEL PRIMER is closed by the operator, battery voltage is delivered across the closed switch contacts and to the FUEL PUMP (FP) via Wire 14A. The FUEL SOLENOID (FS) will be energized via Wire 14 during cranking and running.

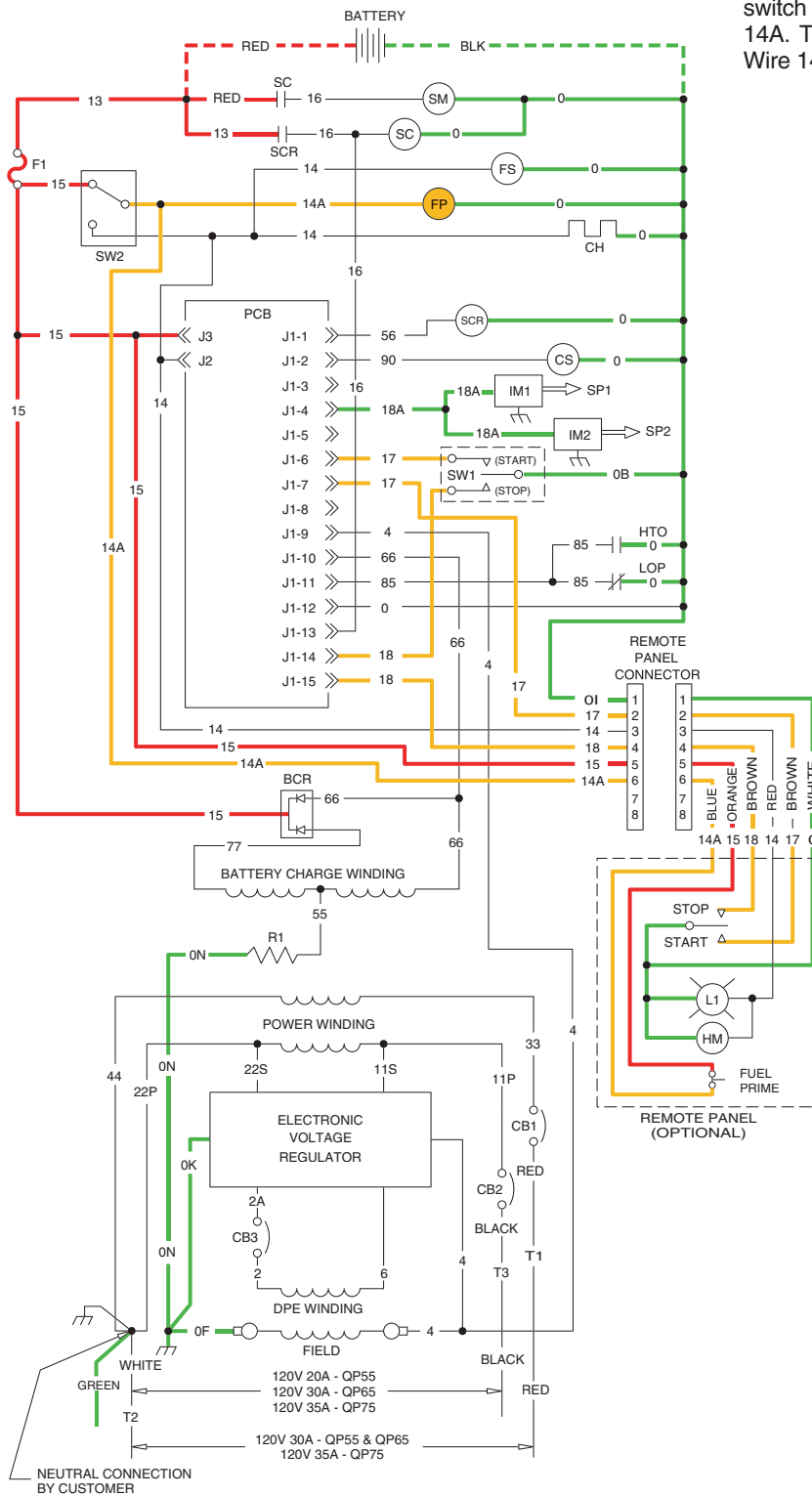

— = 12VDC SUPPLY  
— = 12VDC CONTROL  
— = GROUND

### LEGEND

- BCR - BATTERY CHARGE RECTIFIER
- CB1 - CIRCUIT BREAKER, 30A (QP55 & QP65 MODELS)  
CIRCUIT BREAKER, 35A (QP75 MODEL)
- CB2 - CIRCUIT BREAKER, 20A (QP55 MODEL)  
CIRCUIT BREAKER, 30A (QP65 MODEL)  
CIRCUIT BREAKER, 35A (QP75 MODEL)
- CB3 - CIRCUIT BREAKER, 2.5A (QP55 MODEL)  
CIRCUIT BREAKER, 3.0A (QP65 & QP75 MODELS)
- CH - CHOKE HEATER (GASOLINE MODELS ONLY)
- CS - CHOKE SOLENOID (GASOLINE MODELS ONLY)
- F1 - FUSE, 7.5A
- FP - FUEL PUMP-OR-LPG SHUT OFF VALVE
- FS - FUEL SOLENOID
- GT - TERMINAL, GROUND
- HM - METER, HOUR (OPTIONAL)
- HTO - SWITCH, HIGH TEMP. OIL (CLOSES ON HIGH TEMP.)
- IM1 - IGNITION MAGNETO - #1 CYL.
- IM2 - IGNITION MAGNETO - #2 CYL.
- L1 - LIGHT, RUN (OPTIONAL)
- LOP - SWITCH, LOW OIL PRESSURE (CLOSES ON LOW PRESSURE)
- PCB - ENGINE CONTROLLER
- R1 - RESISTOR, 1 OHM 25W
- SCR - STARTER CONTACTOR RELAY
- SM - STARTER MOTOR
- SW1 - SWITCH, START/STOP
- SW2 - SWITCH, FUEL PRIMER
- SP1 - SPARK PLUG #1 CYL.
- SP2 - SPARK PLUG #2 CYL.
- TC - TERMINAL, CONN. 4-TAB
- — — — — CONNECTOR

# Section 5 ENGINE DC CONTROL SYSTEM

## CIRCUIT CONDITION- CRANKING:

When the START-STOP-SWITCH (SW1) or REMOTE PANEL START SWITCH is held at "START" position, Wire 17 from the Engine controller circuit board is connected to frame Ground. Circuit board action will then deliver battery voltage to a STARTER CONTACTOR RELAY (SCR) via wire 56, and to a automatic CHOKE SOLENOID (CS) via Wire 90.

When battery voltage energizes the STARTER CONTACTOR RELAY (SCR), Its contacts close and battery output is delivered to the STARTER CONTACTOR (SC) via Wire 16. The STARTER CONTACTOR (SC) energizes and its contacts close, battery output is delivered to the STARTER MOTOR (SM) via Wire 16. The STARTER MOTOR energizes and the engine cranks.

When the STARTER CONTACTOR RELAY (SCR) closes, Battery voltage is also delivered to the circuit board pin location J1-13 via Wire 16. This voltage is reduced and used for field boost and is outputted from pin location J1-9.

While cranking, the CHOKE SOLENOID (CS) is energized cyclically by circuit board action (two seconds on, two seconds off).

Also while cranking, circuit board action energizes CIRCUIT BOARD TERMINAL J2 and delivers battery voltage to the Wire 14/14A circuit. This energizes the FUEL PUMP (FP), FUEL SOLENOID (FS) and CHOKE HEATER (CH) and optional light or hourmeter in remote panel.

Circuit board action holds open Wire 18A to common ground. The Magneto will induce a spark during cranking.

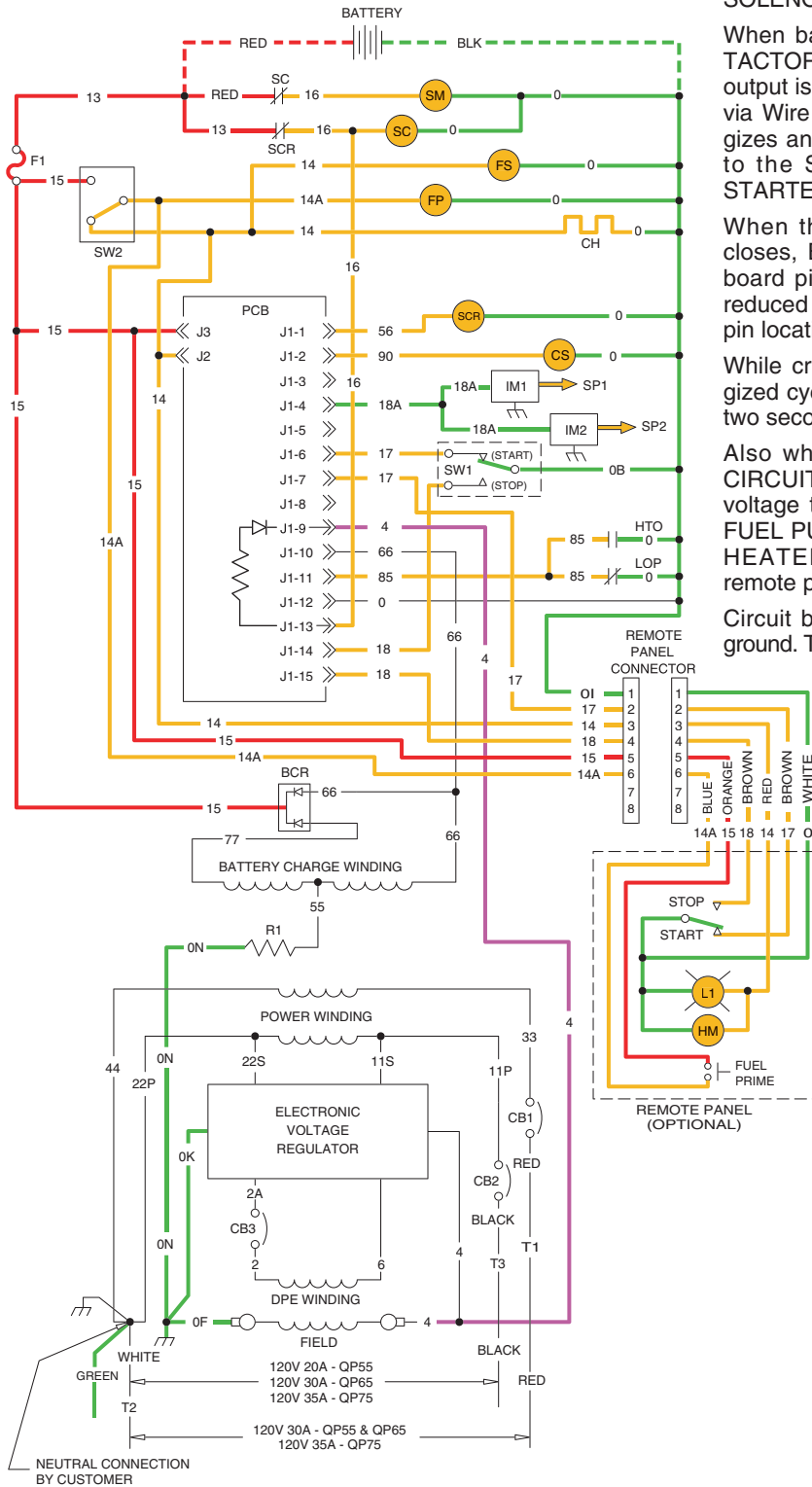

- = 12VDC SUPPLY
- = 12VDC CONTROL
- = 3-5 VDC FIELD BOOST
- = GROUND

- LEGEND
- BCR - BATTERY CHARGE RECTIFIER
  - CB1 - CIRCUIT BREAKER, 30A (QP55 & QP65 MODELS)
  - CIRCUIT BREAKER, 35A (QP75 MODEL)
  - CB2 - CIRCUIT BREAKER, 20A (QP55 MODEL)
  - CIRCUIT BREAKER, 30A (QP65 MODEL)
  - CIRCUIT BREAKER, 35A (QP75 MODEL)
  - CB3 - CIRCUIT BREAKER, 2.5A (QP55 MODEL)
  - CIRCUIT BREAKER, 3.0A (QP65 & QP75 MODELS)
  - CH - CHOKE HEATER (GASOLINE MODELS ONLY)
  - CS - CHOKE SOLENOID (GASOLINE MODELS ONLY)
  - F1 - FUSE, 7.5A
  - FP - FUEL PUMP-OR-LPG SHUT OFF VALVE
  - FS - FUEL SOLENOID
  - GT - TERMINAL, GROUND
  - HM - METER, HOUR (OPTIONAL)
  - HTO - SWITCH, HIGH TEMP. OIL (CLOSES ON HIGH TEMP.)
  - IM1 - IGNITION MAGNETO - #1 CYL.
  - IM2 - IGNITION MAGNETO - #2 CYL.
  - L1 - LIGHT, RUN (OPTIONAL)
  - LOP - SWITCH, LOW OIL PRESSURE (CLOSES ON LOW PRESSURE)
  - PCB - ENGINE CONTROLLER
  - R1 - RESISTOR, 1 OHM 25W
  - SC - STARTER CONTACTOR
  - SCR - STARTER CONTACTOR RELAY
  - SM - STARTER MOTOR
  - SW1 - SWITCH, START/STOP
  - SW2 - SWITCH FUEL PRIMER
  - SP1 - SPARK PLUG #1 CYL.
  - SP2 - SPARK PLUG #2 CYL.
  - TC - TERMINAL, CONN. 4-TAB
  - CONNECTOR

# Section 5 ENGINE DC CONTROL SYSTEM

## CIRCUIT CONDITION-RUNNING:

With the FUEL PUMP (FP) and FUEL SOLENOID (FS) operating and ignition occurring, the engine should start, and the START-STOP SWITCH (SW1) is released.

A voltage is induced into the Stator's BATTERY CHARGE WINDING. This voltage is delivered to the ENGINE CONTROLLER BOARD (PCB) via Wire 66 to prevent STARTER MOTOR engagement above a certain rpm.

Circuit board action terminates DC output to the STARTER CONTACTOR RELAY (SCR), which then de-energizes to end cranking. Circuit board action terminates DC output to the CHOKE SOLENOID (CS). The choke will go to a position determined by the CHOKE HEATER (CH).

The LOW OIL PRESSURE SWITCH (LOP) is normally closed. After start-up, engine oil pressure will open the LOP.

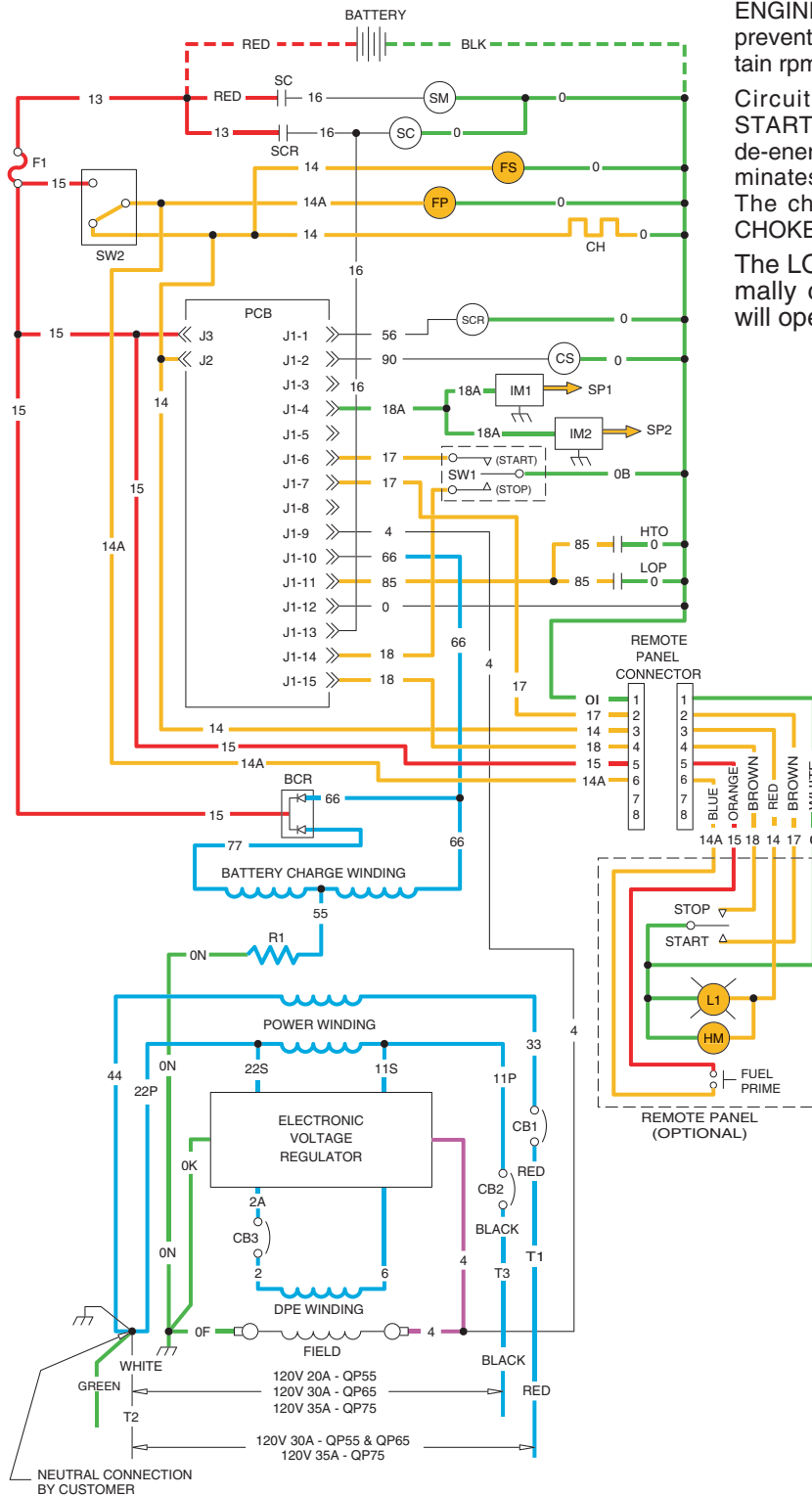

- = 12VDC SUPPLY
- = 12VDC CONTROL
- = VOLTAGE REGULATOR DC OUTPUT
- = AC POWER
- = GROUND

- LEGEND**
- BCR - BATTERY CHARGE RECTIFIER
  - CB1 - CIRCUIT BREAKER, 30A (QP55 & QP65 MODELS)
  - CB2 - CIRCUIT BREAKER, 35A (QP75 MODEL)
  - CB3 - CIRCUIT BREAKER, 20A (QP55 MODEL)
  - CB4 - CIRCUIT BREAKER, 30A (QP65 MODEL)
  - CB5 - CIRCUIT BREAKER, 35A (QP75 MODEL)
  - CB6 - CIRCUIT BREAKER, 2.5A (QP55 MODEL)
  - CB7 - CIRCUIT BREAKER, 3.0A (QP65 & QP75 MODELS)
  - CH - CHOKE HEATER (GASOLINE MODELS ONLY)
  - CS - CHOKE SOLENOID (GASOLINE MODELS ONLY)
  - F1 - FUSE, 7.5A
  - FP - FUEL PUMP-OR-LPG SHUT OFF VALVE
  - FS - FUEL SOLENOID
  - GT - TERMINAL, GROUND
  - HM - METER, HOUR (OPTIONAL)
  - HTO - SWITCH, HIGH TEMP. OIL (CLOSES ON HIGH TEMP.)
  - IM1 - IGNITION MAGNETO - #1 CYL.
  - IM2 - IGNITION MAGNETO - #2 CYL.
  - L1 - LIGHT, RUN (OPTIONAL)
  - LOP - SWITCH, LOW OIL PRESSURE (CLOSES ON LOW PRESSURE)
  - PCB - ENGINE CONTROLLER BOARD
  - R1 - RESISTOR, 1 OHM 25W
  - SC - STARTER CONTACTOR
  - SCR - STARTER CONTACTOR RELAY
  - SM - STARTER MOTOR
  - SW1 - SWITCH, START/STOP
  - SW2 - SWITCH FUEL PRIMER
  - SP1 - SPARK PLUG #1 CYL.
  - SP2 - SPARK PLUG #2 CYL.
  - TC - TERMINAL, CONN. 4-TAB
  - — — — — CONNECTOR

# Section 5 ENGINE DC CONTROL SYSTEM

## CIRCUIT CONDITION- SHUTDOWN:

Setting the START-STOP SWITCH (SW1) or the REMOTE PANEL START-STOP SWITCH to its "STOP" position connects the Wire 18 circuit to frame ground. Circuit board action then closes the circuit to Wire 18A, grounding the ignition magneto. Circuit board action de-energizes DC output to Terminal J2. The FUEL PUMP (FP), FUEL SOLENOID (FS) and CHOKE HEATER (CH) are de-energized by the loss of DC to Wire 14. Ignition and fuel flow terminate and the engine shuts down.

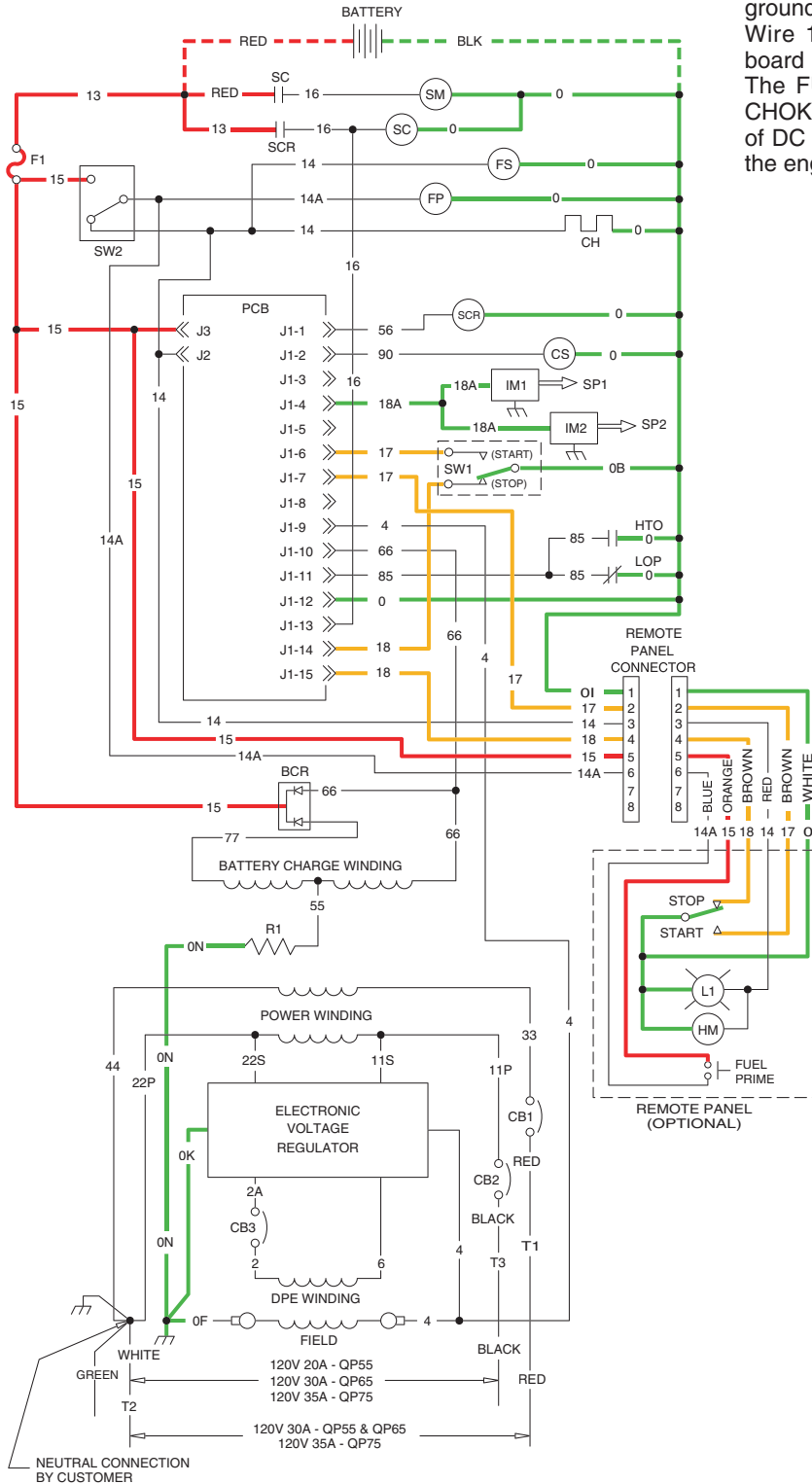

— = 12VDC SUPPLY  
— = 12VDC CONTROL  
— = GROUND

### LEGEND

- BCR - BATTERY CHARGE RECTIFIER
- CB1 - CIRCUIT BREAKER, 30A (QP55 & QP65 MODELS)
- CB2 - CIRCUIT BREAKER, 35A (QP75 MODEL)
- CB3 - CIRCUIT BREAKER, 20A (QP55 MODEL)
- CIRCUIT BREAKER, 30A (QP65 MODEL)
- CIRCUIT BREAKER, 35A (QP75 MODEL)
- CIRCUIT BREAKER, 2.5A (QP65 MODEL)
- CIRCUIT BREAKER, 3.0A (QP65 & QP75 MODELS)
- CH - CHOKE HEATER (GASOLINE MODELS ONLY)
- CS - CHOKE SOLENOID (GASOLINE MODELS ONLY)
- F1 - FUSE, 7.5A
- FP - FUEL PUMP-OR-LPG SHUT OFF VALVE
- FS - FUEL SOLENOID
- GT - TERMINAL, GROUND
- HM - METER, HOUR (OPTIONAL)
- HTO - SWITCH, HIGH TEMP. OIL (CLOSES ON HIGH TEMP.)
- IM1 - IGNITION MAGNETO - #1 CYL.
- IM2 - IGNITION MAGNETO - #2 CYL.
- L1 - LIGHT, RUN (OPTIONAL)
- LOP - SWITCH, LOW OIL PRESSURE (CLOSES ON LOW PRESSURE)
- PCB - ENGINE CONTROLLER
- R1 - RESISTOR, 1 OHM 25W
- SC - STARTER CONTACTOR
- SCR - STARTER CONTACTOR RELAY
- SM - STARTER MOTOR
- SW1 - SWITCH, START/STOP
- SW2 - SWITCH FUEL PRIMER
- SP1 - SPARK PLUG #1 CYL.
- SP2 - SPARK PLUG #2 CYL.
- TC - TERMINAL, CONN. 4-TAB
- CONNECTOR

## Section 5 ENGINE DC CONTROL SYSTEM

### CIRCUIT CONDITION- FAULT SHUTDOWN:

The engine mounts a HIGH OIL TEMPERATURE SWITCH (HTO) and a LOW OIL PRESSURE SWITCH (LOP).

Should engine oil temperature exceed a pre-set value, the switch contacts will close. Wire 85 from the circuit board will connect to frame ground. Circuit board action will then initiate a shutdown.

Should engine oil pressure drop below a safe pre-set value, the switch contacts will close. On contact closure, Wire 85 will be connected to frame ground and circuit board action will initiate an engine shutdown.

The circuit board has a time delay built into it for the Wire 85 fault shutdowns. At STARTUP ONLY the circuit board will wait approximately 6 seconds before looking at the Wire 85 fault shutdowns. Once running after the 6 second time delay, grounding Wire 85 thru either switch will cause an immediate shutdown.

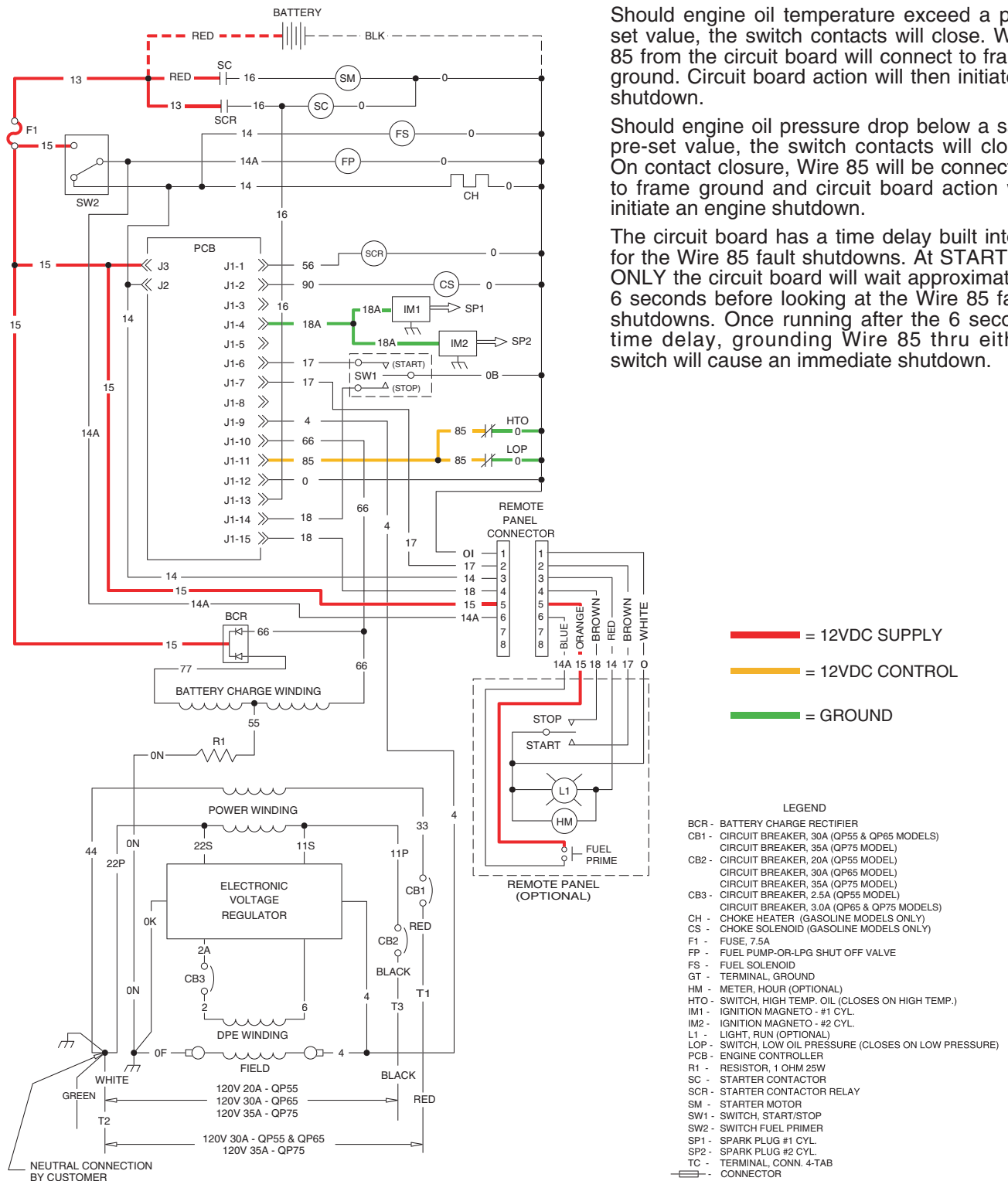

— = 12VDC SUPPLY  
— = 12VDC CONTROL  
— = GROUND

- LEGEND**
- BCR - BATTERY CHARGE RECTIFIER
  - CB1 - CIRCUIT BREAKER, 30A (QP55 & QP65 MODELS)
  - CIRCUIT BREAKER, 35A (QP75 MODEL)
  - CB2 - CIRCUIT BREAKER, 20A (QP55 MODEL)
  - CIRCUIT BREAKER, 30A (QP65 MODEL)
  - CIRCUIT BREAKER, 35A (QP75 MODEL)
  - CB3 - CIRCUIT BREAKER, 2.5A (QP55 MODEL)
  - CIRCUIT BREAKER, 3.0A (QP65 & QP75 MODELS)
  - CH - CHOKE HEATER (GASOLINE MODELS ONLY)
  - CS - CHOKE SOLENOID (GASOLINE MODELS ONLY)
  - F1 - FUSE, 7.5A
  - FP - FUEL PUMP-OR-LPG SHUT OFF VALVE
  - FS - FUEL SOLENOID
  - GT - TERMINAL, GROUND
  - HM - METER, HOUR (OPTIONAL)
  - HTO - SWITCH, HIGH TEMP. OIL (CLOSES ON HIGH TEMP.)
  - IM1 - IGNITION MAGNETO - #1 CYL.
  - IM2 - IGNITION MAGNETO - #2 CYL.
  - L1 - LIGHT, RUN (OPTIONAL)
  - LOP - SWITCH, LOW OIL PRESSURE (CLOSES ON LOW PRESSURE)
  - PCB - ENGINE CONTROLLER
  - R1 - RESISTOR, 1 OHM 25W
  - SC - STARTER CONTACTOR
  - SCR - STARTER CONTACTOR RELAY
  - SM - STARTER MOTOR
  - SW1 - SWITCH, START/STOP
  - SW2 - SWITCH FUEL PRIMER
  - SP1 - SPARK PLUG #1 CYL.
  - SP2 - SPARK PLUG #2 CYL.
  - TC - TERMINAL, CONN. 4-TAB
  - CONNECTOR

## Section 5 ENGINE DC CONTROL SYSTEM

### ENGINE CONTROLLER CIRCUIT BOARD

#### GENERAL:

The engine controller board is responsible for cranking, startup, running and shutdown operations. The board interconnects with other components of the DC control system to turn them on and off at the proper times. It is powered by fused 12 VDC power from the unit battery.

#### CIRCUIT BOARD CONNECTIONS:

The circuit board mounts a 15-pin receptacle (J1) and two single pin terminals (J2 and J3, see Figure 5.3). Figure 5-2 shows the 15-pin receptacle (J1), the associated wires and the function(s) of each pin and wire.

PIN	WIRE	FUNCTION
1	56	Delivers 12 VDC to Starter Contactor (SC) while cranking only.
2	90	Delivers 12 VDC to Choke Solenoid coil while cranking only. (Two seconds ON, Two seconds OFF)
3	—	Not used.
4	18A	Grounds Magneto for Shutdown.
5	—	Not used.
6	17	To Start-Stop switch. When wire is grounded by setting Start-Stop switch to "START", engine will crank.
7	17	To Start-Stop switch on optional Remote Panel.
8	—	Not used.
9	4	Field Boost DC to Voltage Regulator and to Rotor windings.
10	66	Starter Lockout. Prevents cranking while engine is running.
11	85	Fault shutdown circuit. When grounded by closure of High Oil Temperature or Low Oil Pressure Switch engine will shut down.
12	0	Common Ground.
13	16	12 VDC Input to Field Boost circuit while cranking only.
14	18	To Start-Stop switch. When grounded by setting Switch to "STOP" engine shuts down.
15	18	To Start-Stop Switch on optional Remote Panel.

Figure 5-2. – Receptacle J1

In addition to the 15-pin receptacle (J1), the circuit board is equipped with two single pin terminals (J2 and J3). These terminals may be identified as follows:

1. Wire 14 connects to Terminal J2. During cranking and running, the circuit board delivers battery voltage to the Wire 14 circuit for the following functions:

- To operate the electric Fuel Pump (FP).
- To energize the Fuel Solenoid.
- To operate the Choke Heater.
- To the Remote Wire Harness to operate an hourmeter or a light.

2. Wire 15 connects to Terminal J3. This is the power supply (12 VDC) for the circuit board and the DC control system.

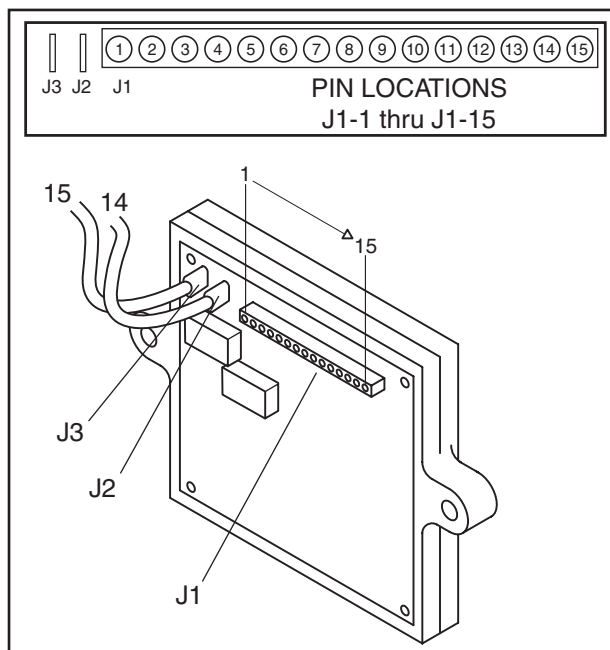

Figure 5-3. – Engine Controller Circuit Board

### BATTERY

#### RECOMMENDED BATTERY:

When anticipated ambient temperatures will be consistently above 32° F. (0° C.), use a 12 volts automotive type storage battery rated 70 amp-hours and capable of delivering at least 400 cold cranking amperes.

If ambient temperatures will be below 32° (0° C.), use a 12 volt battery rated 95 amp-hours and having a cold cranking capacity of 400 amperes.

#### BATTERY CABLES:

Use of battery cables that are too long or too small in diameter will result in excessive voltage drop. For best cold weather starting, voltage drop between the battery and starter should not exceed 0.12 volt per 100 amperes of cranking current.

Select the battery cables based on total cable length and prevailing ambient temperature. Generally, the longer the cable and the colder the weather, the larger the required cable diameter.

The following chart applies:

CABLE LENGTH (IN FEET)	RECOMMENDED CABLE SIZE
0-10	No. 2
11-15	No. 0
16-20	No. 000

**EFFECTS OF TEMPERATURE:**

Battery efficiency is greatly reduced by a decreased electrolyte temperature. Such low temperatures have a decided numbing effect on the electrochemical action. Under high discharge rates (such as cranking), battery voltage will drop to much lower values in cold temperatures than in warmer temperatures. The freezing point of battery electrolyte fluid is affected by the state of charge of the electrolyte as indicated below:

SPECIFIC GRAVITY	FREEZING POINT
1.220	-35° F. (-37° C.)
1.200	--20° F. (-29° C.)
1.160	0° F. (-18° C.)

**ADDING WATER:**

Water is lost from a battery as a result of charging and discharging and must be replaced. If the water is not replaced and the plates become exposed, they may become permanently sulfated. In addition, the plates cannot take full part in the battery action unless they are completely immersed in electrolyte. Add only **DISTILLED WATER** to the battery. **DO NOT USE TAP WATER.**

**NOTE: Water cannot be added to some "maintenance-free" batteries.**

**CHECKING BATTERY STATE OF CHARGE:**

Use an automotive type battery hydrometer to test the battery state of charge. Follow the hydrometer manufacturer's instructions carefully. Generally, a battery may be considered fully charged when the specific gravity of its electrolyte is 1.260. If the hydrometer used does not have a "Percentage of Charge" scale, compare the readings obtained with the following:

SPECIFIC GRAVITY	PERCENTAGE OF CHARGE
1.260	100%
1.230	75%
1.200	50%
1.170	25%

**CHARGING A BATTERY:**

Use an automotive type battery charger to recharge a battery. Battery fluid is an extremely corrosive, sulfuric acid solution that can cause severe burns. For that reason, the following precautions must be observed:

- ❑ The area in which the battery is being charged must be well ventilated. When charging a battery, an explosive gas mixture forms in each cell.

- ❑ Do not smoke or break a live circuit near the top of the battery. Sparking could cause an explosion.
- ❑ Avoid spillage of battery fluid. If spillage occurs, flush the affected area with clear water immediately.
- ❑ Wear eye protection when handling a battery.

**7.5 AMP FUSE**

This panel-mounted Fuse protects the DC control circuit against overload and possible damage. If the Fuse has melted open due to an overload, neither the priming function nor the cranking function will be available.

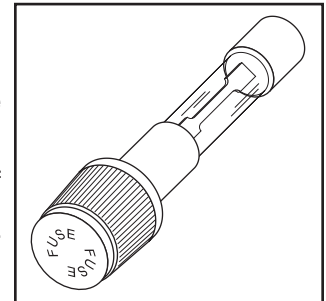

Figure5-4

**FUEL PRIMER SWITCH**

Following generator installation and after the unit has been idle for some time, the fuel supply line may be empty. This condition will require a long cranking period before fuel can reach the carburetor. The Fuel Primer Switch, when actuated to its "PRIME" position will deliver battery voltage across the closed switch contacts to the Fuel Pump (FP) to turn the Pump on. Pump action will then draw fuel from the supply tank to prime the fuel lines and carburetor.

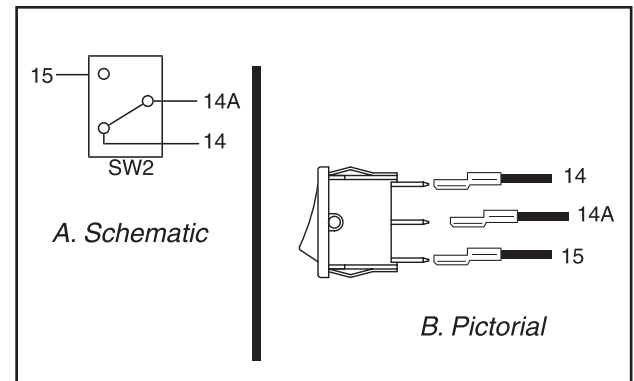

Figure 5-5. – Primer Switch

**START-STOP SWITCH**

The Start-Stop Switch allows the operator to control cranking, startup and shutdown. The following wires connect to the Start-Stop Switch:

1. Wire No. 17 from the Engine Controller circuit board. This is the CRANK and START circuit. When the Switch is set to 'START', Wire 17 is connected to frame ground via Wire OB.
  - a. With wire 17 grounded, a Crank Relay on the circuit board energizes and battery volt-

## Section 5 ENGINE DC CONTROL SYSTEM

age is delivered to the Starter Contactor Relay via Wire 56. The Starter Contactor Relay energizes, its contacts close and the Starter Contactor is energized via wire 16. Its contacts close and the engine cranks.

- b. With Wire 17 grounded, a Run Relay on the circuit board energizes and battery voltage is delivered to the Wire 14 circuit. Battery voltage is delivered to the Fuel Pump, Fuel Solenoid, Choke Heater and the Remote Harness.

2. Wire 18 from the Engine Controller board. This is the ENGINE STOP circuit. When the Start-Stop Switch is set to "STOP", Wire 18 is connected to frame ground via Wire No. 0B. Circuit board action then opens the circuit to Wire 14, and grounds Wire 18A. Fuel flow to the carburetor and ignition are terminated.

3. Wire 0B connects the Switch to frame ground.

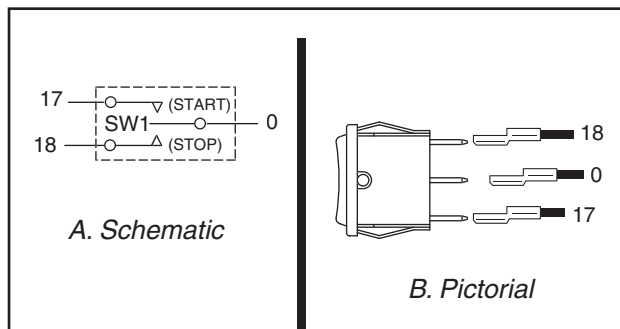

Figure 5-6. – Start-Stop Switch

### STARTER CONTACTOR RELAY & STARTER MOTOR

The positive (+) battery cable attaches to the large lug on the STARTER CONTACTOR. Wire 13 then attaches to one side of the STARTER CONTACTOR RELAY contact, from this point Wire 13 attaches to the fuse F1 to supply battery voltage to the DC control system. The opposite side of the starter contactor relay contact is connected to Wire 16.

Wire 16 will supply battery power to the starter contactor and to the engine controller board for field flash when the starter contactor relay is energized. Attached to the starter contactor relay coil is wire 56 (positive supply during cranking) and wire 0 (ground).

When the Start-Stop switch is set to "START", the circuit board delivers battery voltage to the Starter Contactor Relay via Wire 56. The Starter Contactor Relay energizes, its contacts close and the Starter Contactor is energized via wire 16. Its contacts close and battery voltage is available to the starter motor, and the engine cranks.

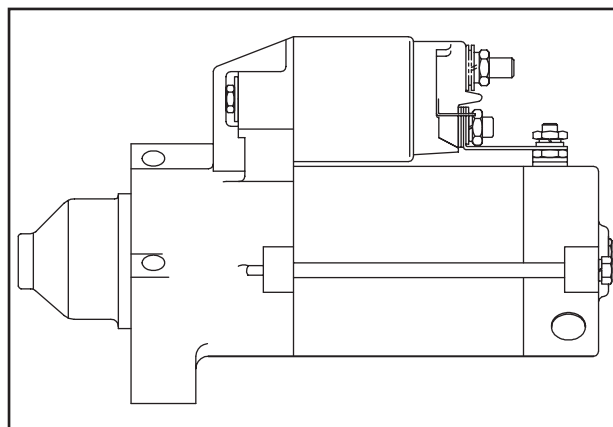

Figure 5-7. – Starter Motor

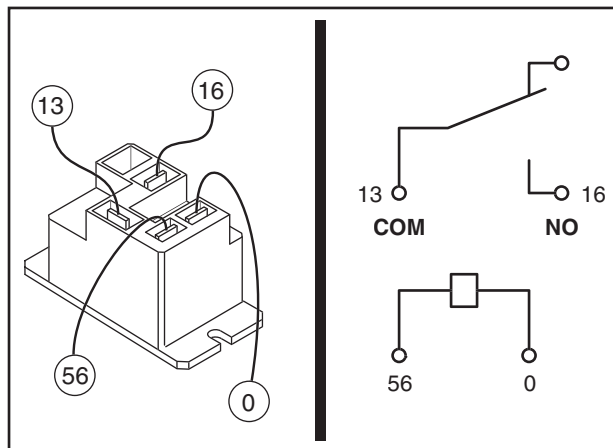

Figure 5-8. – Starter Contactor Relay

**INTRODUCTION**

The "Flow Charts" in this section may be used in conjunction with the "Diagnostic Tests" of Section 7. Numbered tests in the Flow Charts correspond to identically numbered tests of Section 7.

Problems 1 through 4 apply to the AC generator only. Beginning with Problem 5, the engine DC control system is dealt with.

***If Problem Involves AC Output***

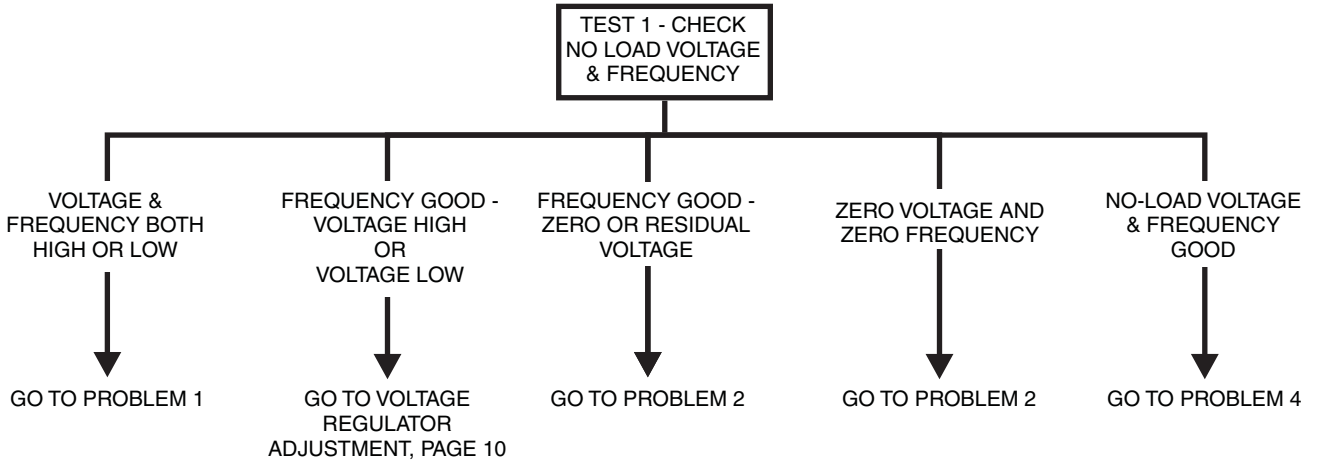

***Problem 1 - Voltage & Frequency Are Both High or Low***

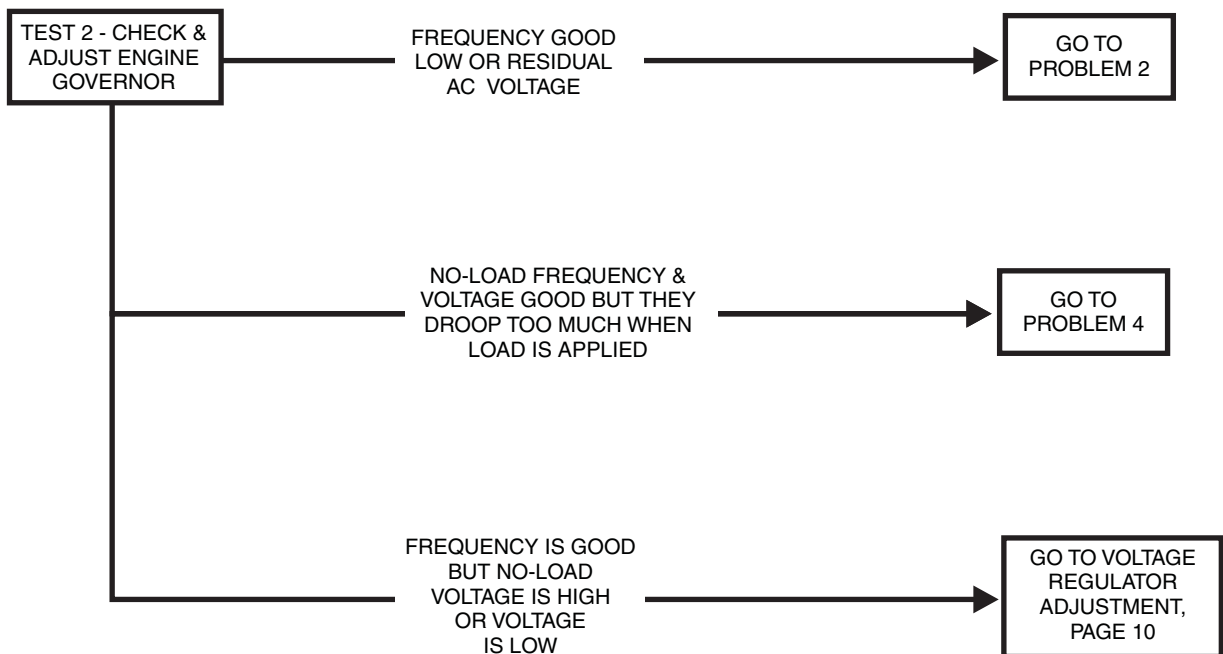

**Section 6  
TROUBLESHOOTING FLOWCHARTS**

**Problem 2 - Generator Produces Zero Voltage or Residual Voltage (5-12 VAC)**

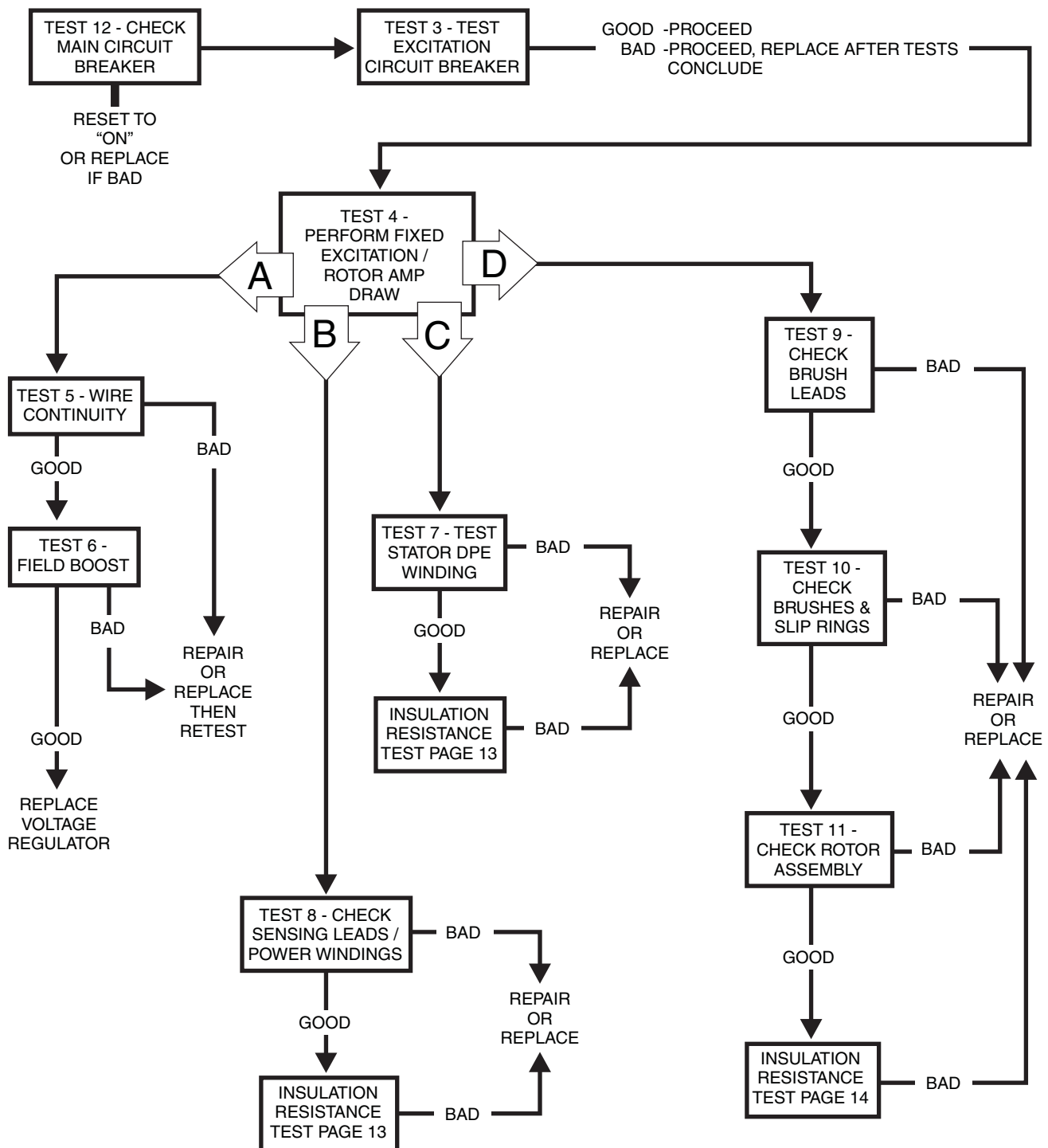

**Problem 2 - Generator Produces Zero Voltage or Residual Voltage (5-12 VAC)  
(continued)**

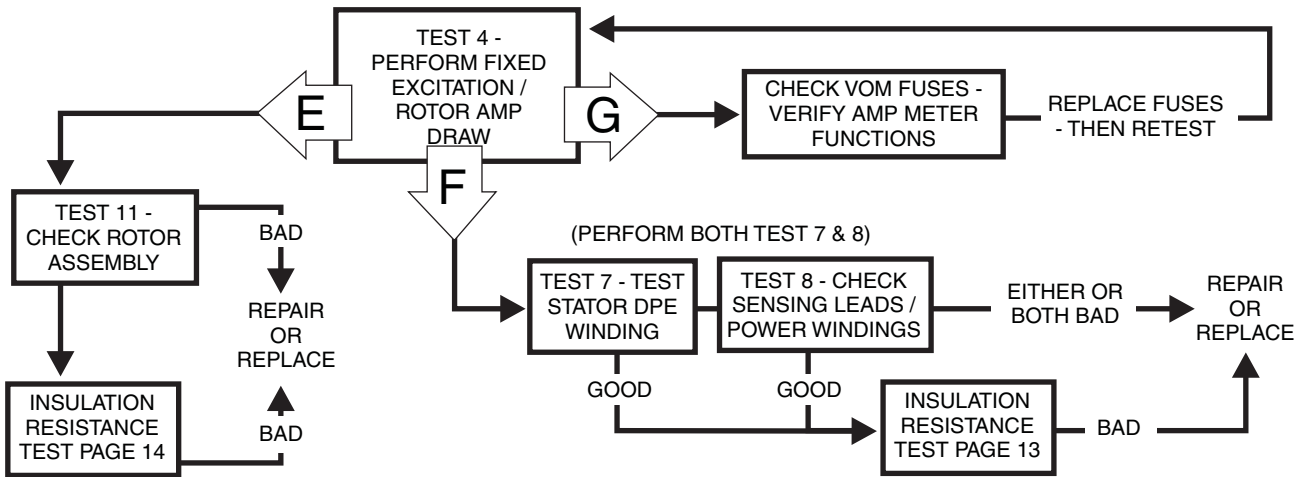

**Problem 3 - No Battery Charge Output**

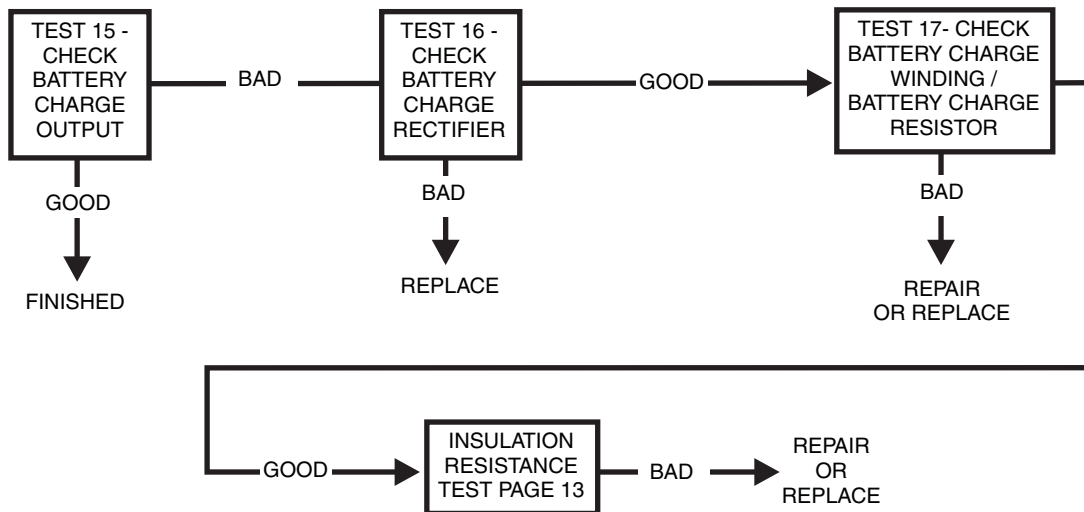

**Section 6**  
**TROUBLESHOOTING FLOWCHARTS**

---

**Problem 4 - Excessive Voltage/Frequency Droop When Load is Applied**

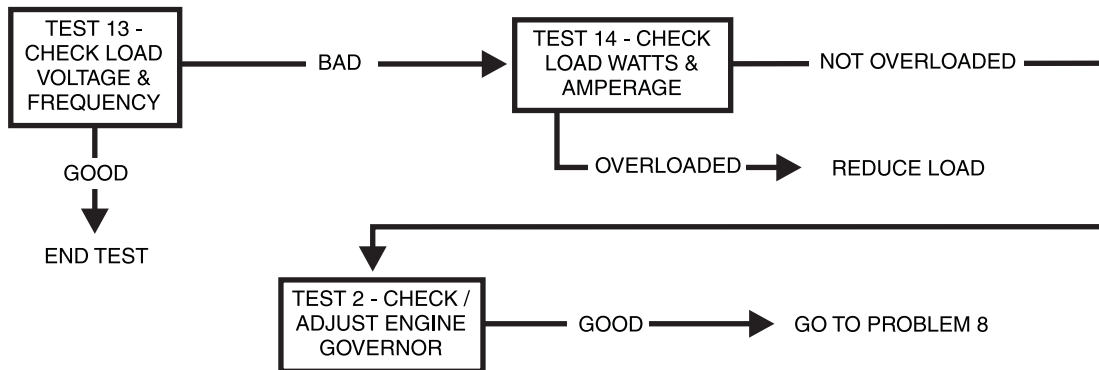

**Problem 5 - Priming Function Does Not Work (Gasoline Models)**

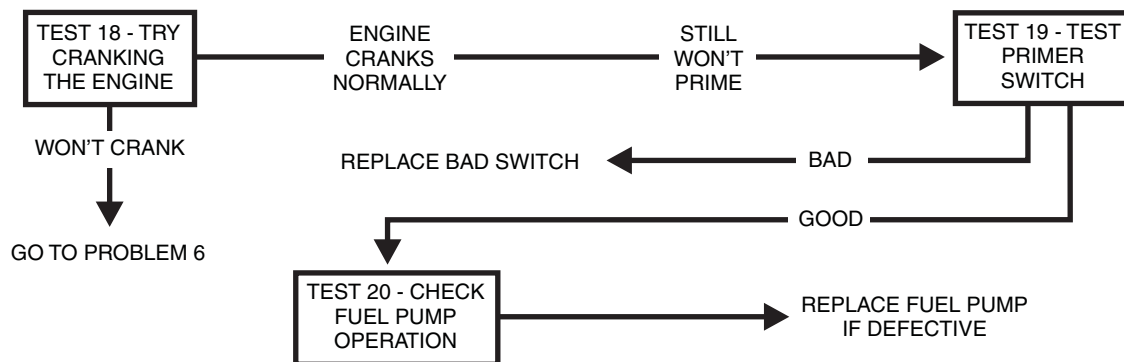

**Problem 6 - Engine Will Not Crank**

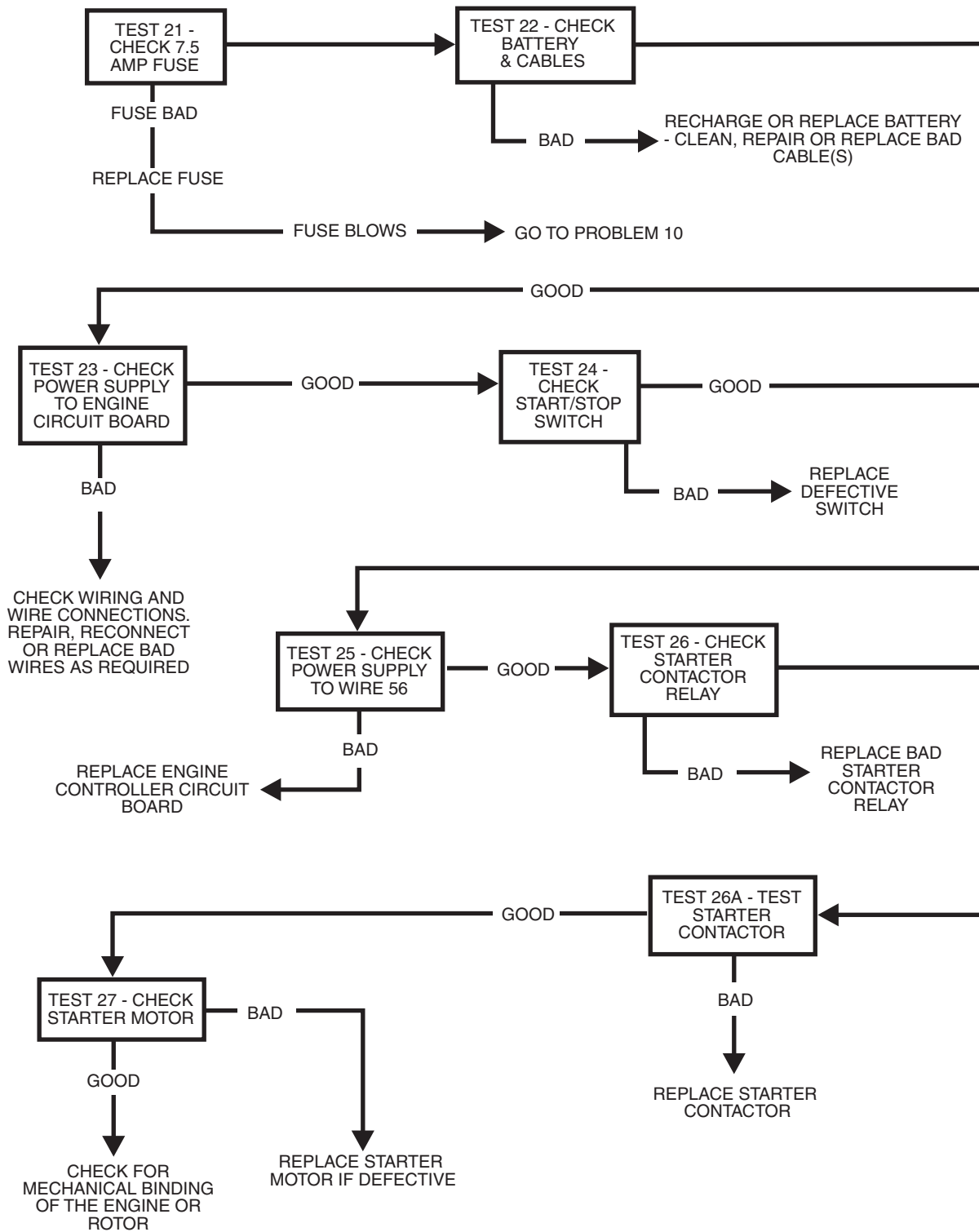

**Section 6**  
**TROUBLESHOOTING FLOWCHARTS**

**Problem 7 - Engine Cranks But Will Not Start (Gasoline Units)**

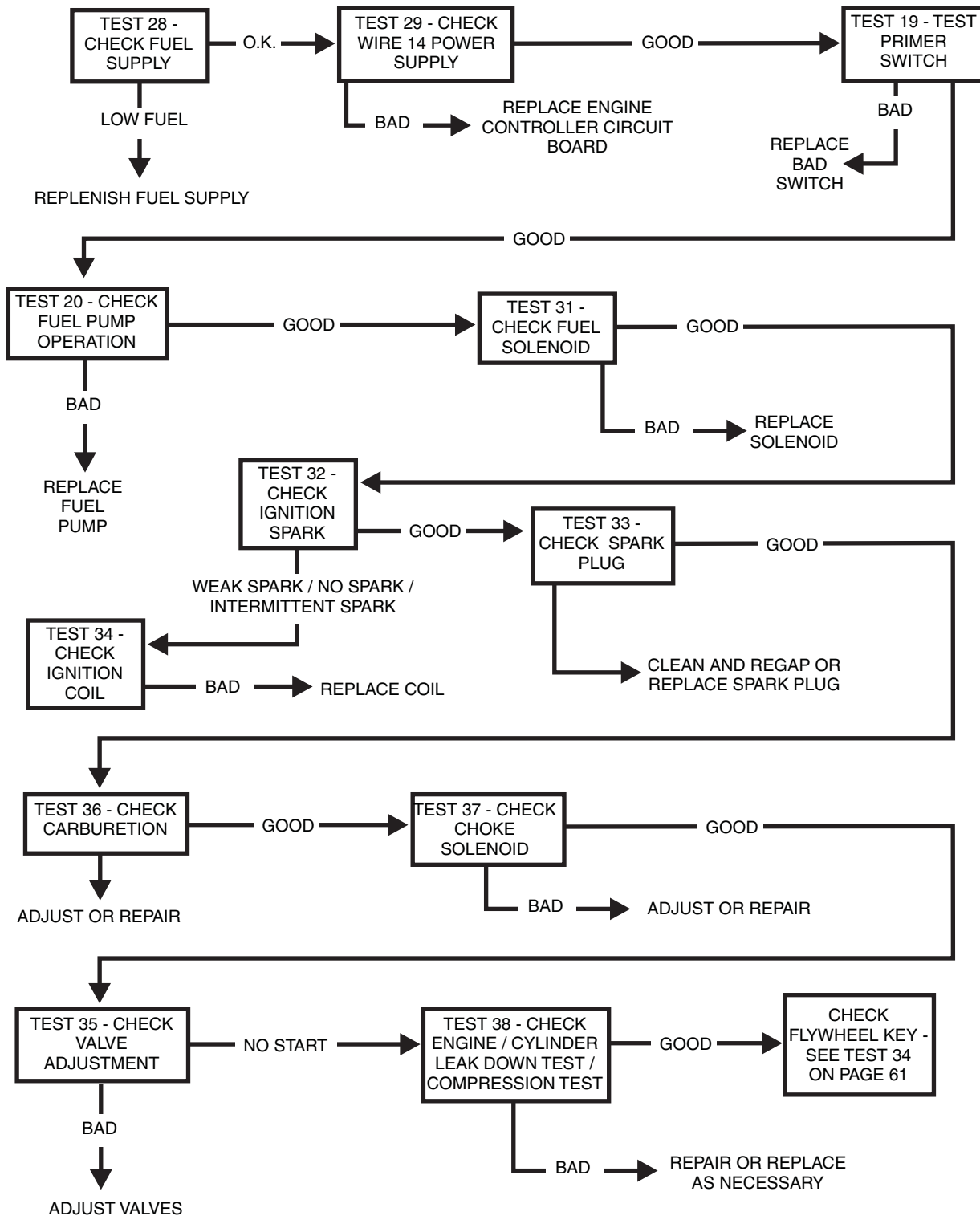

**Problem 7 - Engine Cranks But Will Not Start (LP Units)**

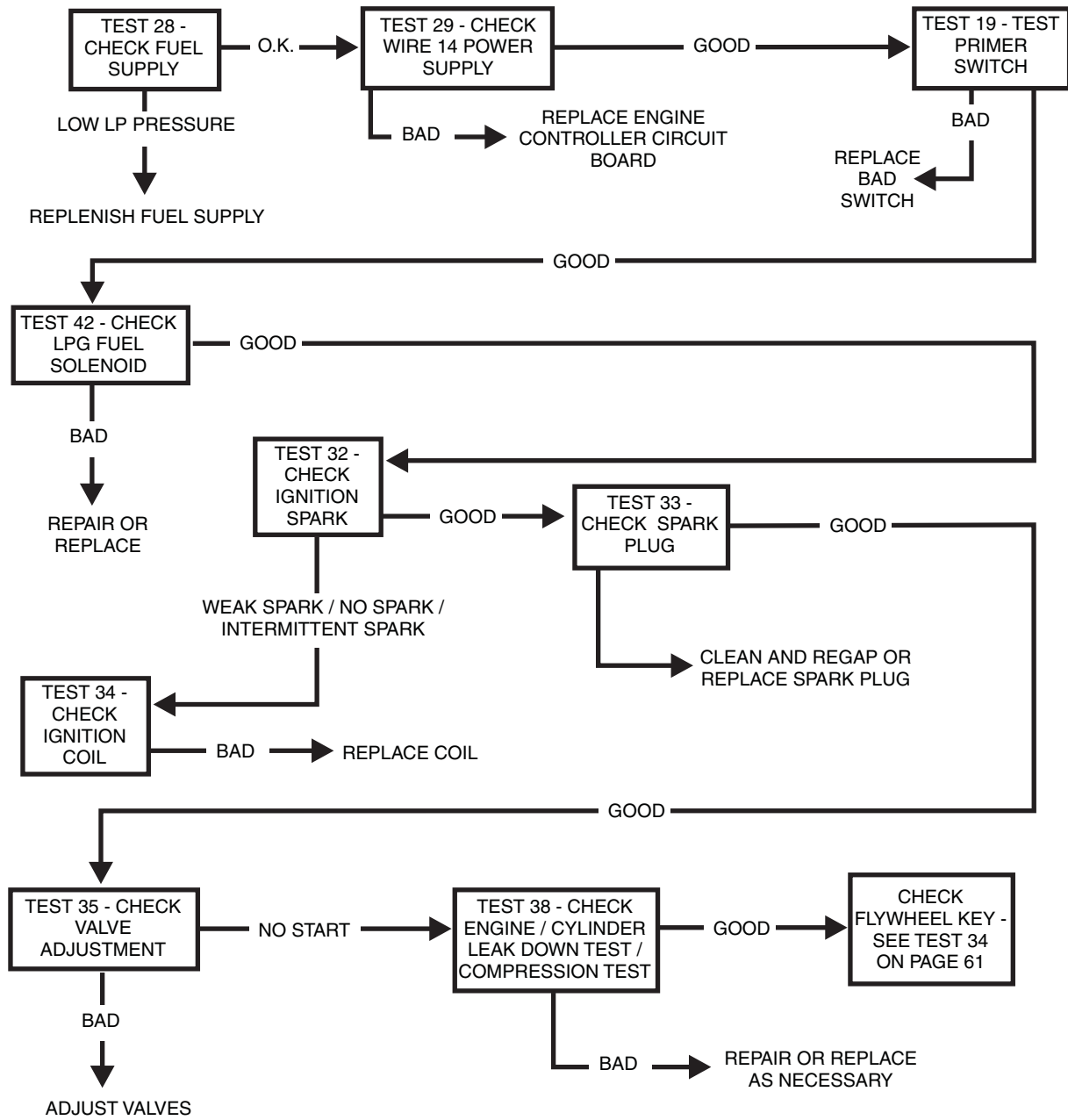

**Section 6**  
**TROUBLESHOOTING FLOWCHARTS**

***Problem 8 - Engine Starts Hard and Runs Rough (Gasoline Units)***

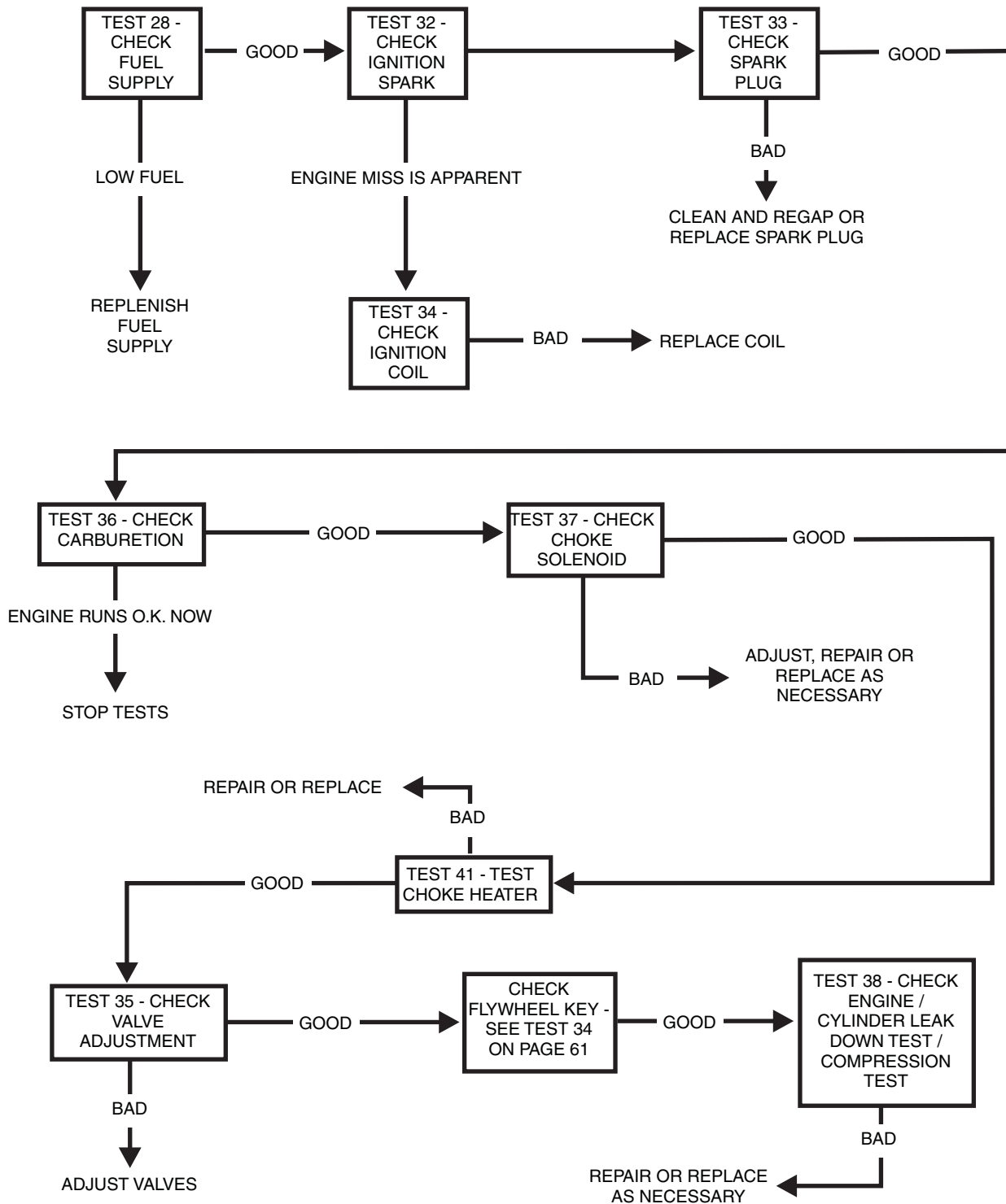

**Problem 8 - Engine Starts Hard and Runs Rough (LP Units)**

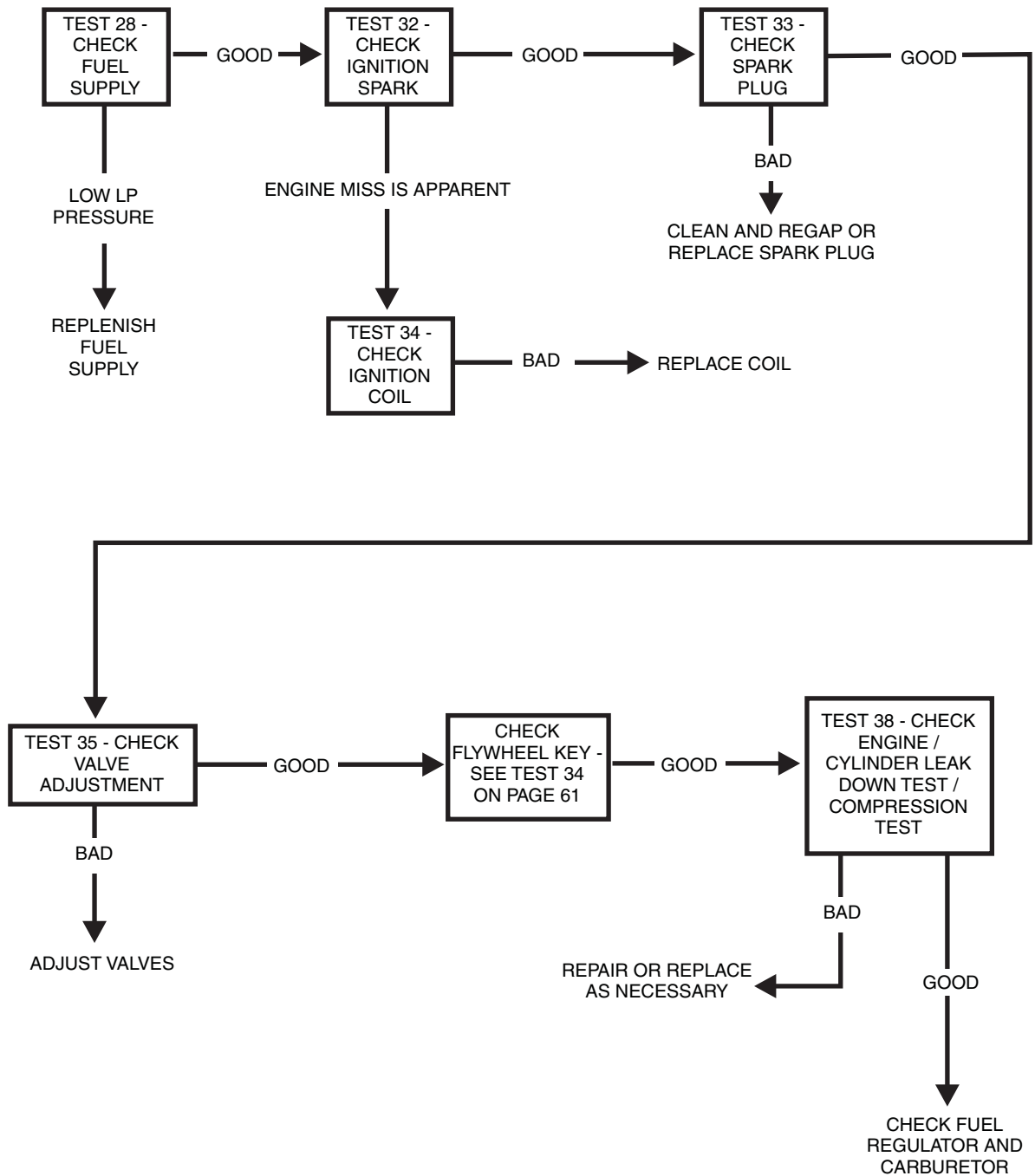

**Section 6**  
**TROUBLESHOOTING FLOWCHARTS**

***Problem 9 - Engine Starts Then Shuts Down***

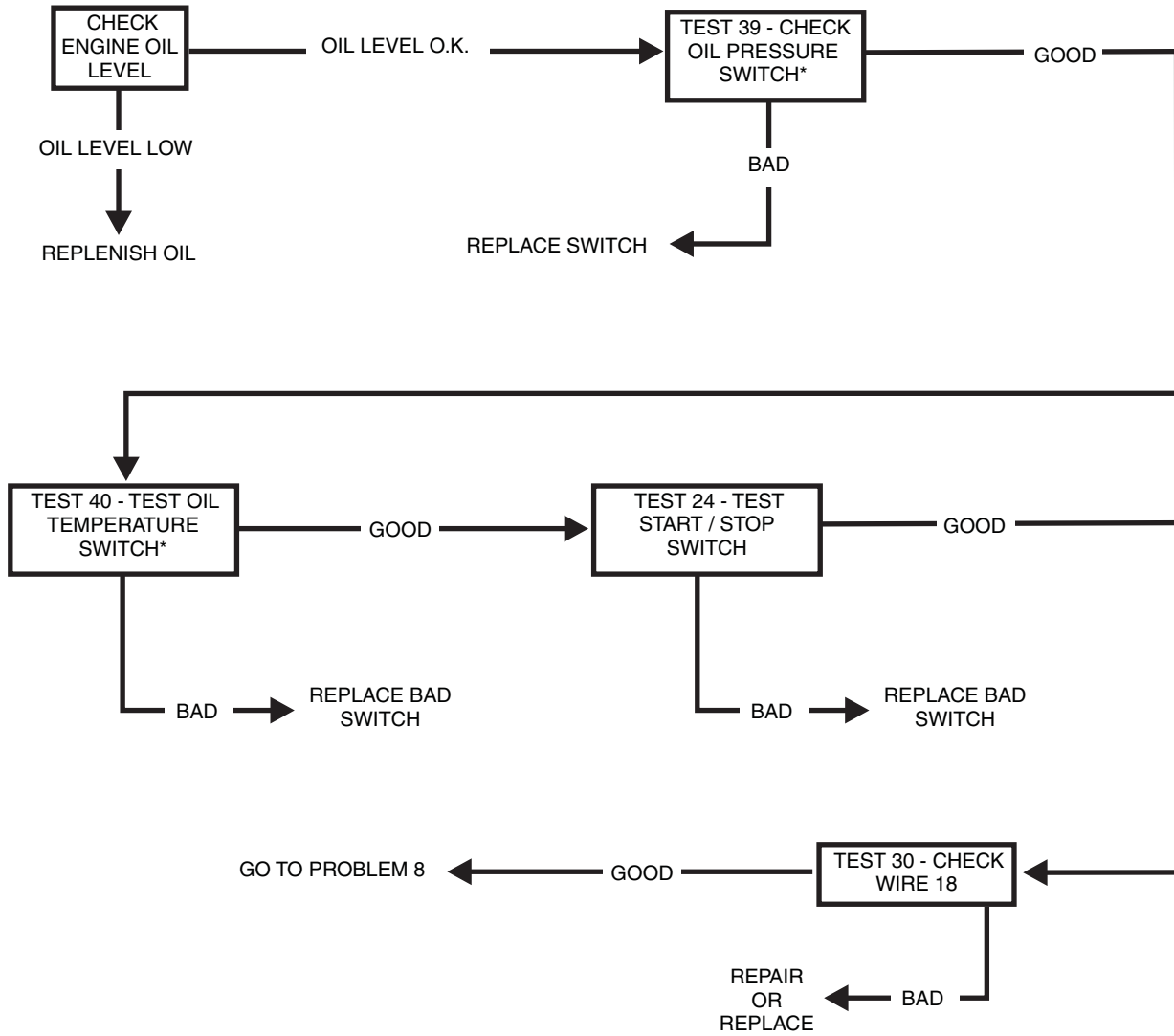

\*NOTE: IF OIL PRESSURE IS LOW, FIND THE CAUSE AND CORRECT.  
 IF OIL TEMPERATURE IS HIGH, DETERMINE THE CAUSE AND CORRECT.

**Problem 10 - 7.5A (F1) Fuse Blowing**

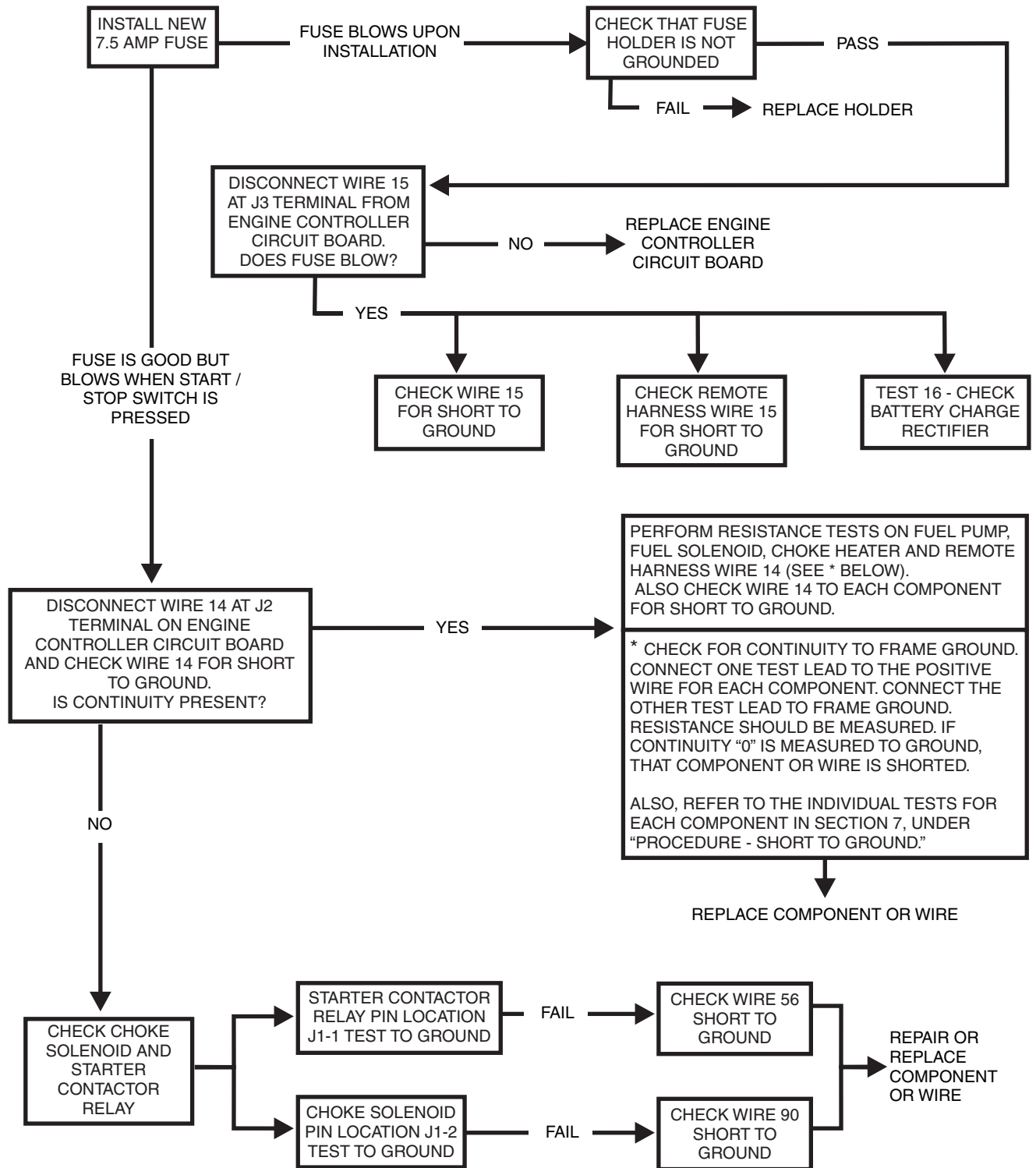

## Section 7 DIAGNOSTIC TESTS

### INTRODUCTION

The "Diagnostic Tests" in this chapter may be performed in conjunction with the "Flow Charts" of Section 6. Test numbers in this chapter correspond to the numbered tests in the "Flow Charts".

Tests 1 through 17 are procedures involving problems with the generator's AC output voltage and frequency (Problems 1 through 4 in the "Flow Charts").

Tests 18 through 42 are procedures involving problems with engine operation (Problems 5 through 9 in the "Troubleshooting Flow Charts").

You may wish to read Section 4, "Measuring Electricity".

**NOTE: Test procedures in this Manual are not necessarily the only acceptable methods for diagnosing the condition of components and circuits. All possible methods that might be used for system diagnosis have not been evaluated. If you use any diagnostic method other than the method presented in this Manual, you must ensure that neither your safety nor the product's safety will be endangered by the procedure or method you have selected.**

### TEST 1- CHECK NO-LOAD VOLTAGE AND FREQUENCY

#### DISCUSSION:

The first step in analyzing any problem with the AC generator is to determine the unit's AC output voltage and frequency. Once that has been done, you will know how to proceed with specific diagnostic tests.

#### PROCEDURE:

1. Set a volt-ohm-milliammeter (VOM) to read AC voltage. Connect the meter test leads across customer connection leads T1 (Red) and T2 (White).
2. Disconnect or turn OFF all electrical loads. Initial checks and adjustments are accomplished at no-load.
3. Start the engine, let it stabilize and warm up.
4. Read the AC voltage.
5. Connect an AC frequency meter across AC output leads T1 (Red) and T2 (White). Repeat the above procedure.

#### RESULTS:

For units rated 60 Hertz, no-load voltage and frequency should be approximately 122-126 VAC and 61-63 Hertz respectively.

1. If AC voltage and frequency are BOTH correspondingly high or low, go to Test 2.
2. If AC frequency is good but low or residual voltage is indicated, go to Test 3.

3. If AC output voltage and frequency are both "zero", go to Test 12.
4. If the no-load voltage and frequency are within the stated limits, go to Test 13.

**NOTE: The term "low voltage" refers to any voltage reading that is lower than the unit's rated voltage. The term "residual voltage" refers to the output voltage supplied as a result of Rotor residual magnetism (approximately 5-12 VAC).**

### TEST 2- CHECK ENGINE GOVERNOR

#### DISCUSSION:

Rotor operating speed and AC output frequency are proportional. The generator will deliver a frequency of 60 Hertz at 3600 Rotor rpm or 62 Hertz at 3720 Rotor rpm.

The Voltage Regulator should be adjusted to deliver 120 VAC (line-to-neutral) at a frequency of 60 Hertz or 124 VAC (line-to-neutral at 62 Hertz. It is apparent that, if governed speed is high or low, AC frequency and voltage will be correspondingly high or low. Governed speed at no-load is usually set slightly above the rated speed of 60 Hertz (to 62 Hertz), to prevent excessive rpm, frequency and voltage droop under heavy electrical loading.

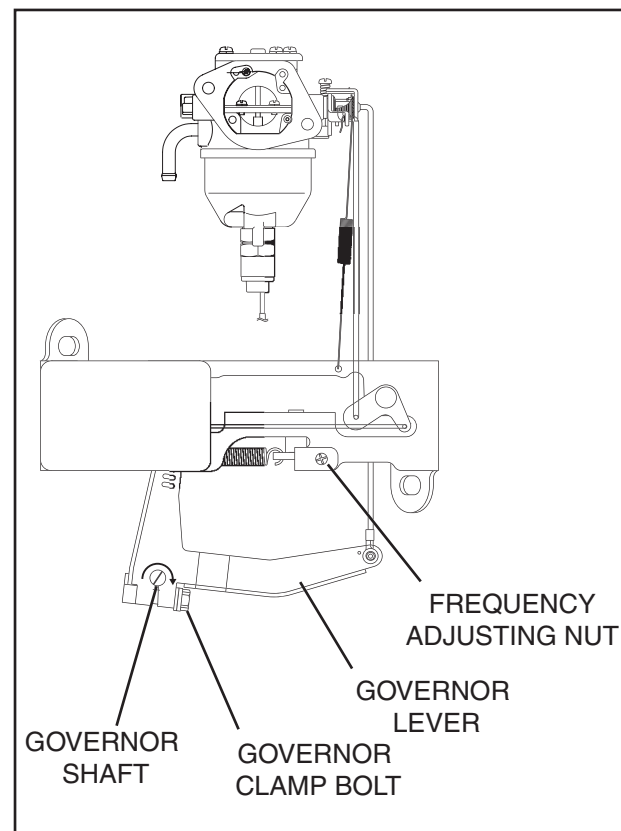

Figure 7-1. – Governor Adjustment Points

**GOVERNOR ADJUSTMENT**

1. Loosen the GOVERNOR CLAMP BOLT.
2. Push Spring end of GOVERNOR LEVER clockwise to wide open throttle position of lever.
  - a. Hold the GOVERNOR LEVER at wide open throttle and, with a pair of pliers, rotate the GOVERNOR SHAFT fully clockwise (CW). Use a minimum amount of force against the governor shaft.
  - b. While holding the GOVERNOR SHAFT fully clockwise and the GOVERNOR LEVER at wide open throttle, tighten the GOVERNOR CLAMP BOLT to 70 inch-pounds (8 N-m).
3. Start engine and let it stabilize.
4. Turn the ADJUSTER NUT to obtain a frequency reading of 62 Hertz.
5. When frequency is correct at no-load, check the AC voltage reading. If voltage is incorrect, the voltage regulator may require adjustment. See "VOLTAGE ADJUSTMENT," Page 10.

**TEST 3- TEST EXCITATION CIRCUIT BREAKER**

**DISCUSSION:**

This circuit breaker (CB3) is normally closed and self-resetting. It will open in the event of excessive current from the Stator excitation (DPE) winding. The circuit breaker should re-close or reset automatically after it cools down (takes approximately two minutes).

When the breaker (CB3) is open, excitation current to the Regulator (and to the Rotor) will be lost. The unit's AC output voltage will then drop to a value that is commensurate with the Rotor's residual magnetism (about 5-12 volts AC). This test will determine if the breaker has failed in its open position.

**PROCEDURE:**

**Note: After running the unit, allow two minutes for the breaker to reset.**

1. Set a volt-ohm-milliammeter (VOM) to its "Rx1" scale and zero the meter.
2. In the generator panel, locate the excitation circuit breaker. Disconnect Wire 2 and Wire 2A from the breaker terminals.
3. Connect the meter test leads across the two circuit breaker (CB3) terminals. The meter should indicate "continuity".

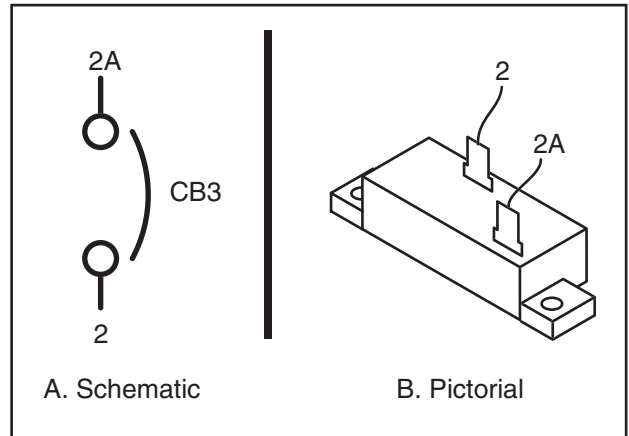

*Figure 7-2. – Excitation "DPE" Circuit Breaker*

**RESULTS:**

1. If the meter did NOT read "continuity", replace the excitation (DPE) circuit breaker (CB3), and go to Test 4.
2. If "continuity" was indicated, go to Test 4.

**TEST 4- FIXED EXCITATION TEST/ROTOR AMP DRAW**

**DISCUSSION:**

The fixed excitation test consists of applying battery voltage (12 VDC) to the Rotor windings. This allows that portion of the excitation circuit between the Voltage Regulator and the Rotor (including the Rotor itself) to be checked as a possible cause of the problem. When battery voltage is applied to the Rotor, the resulting magnetic field around the Rotor should induce a Stator power winding voltage equal to about one-half the unit's rated output voltage.

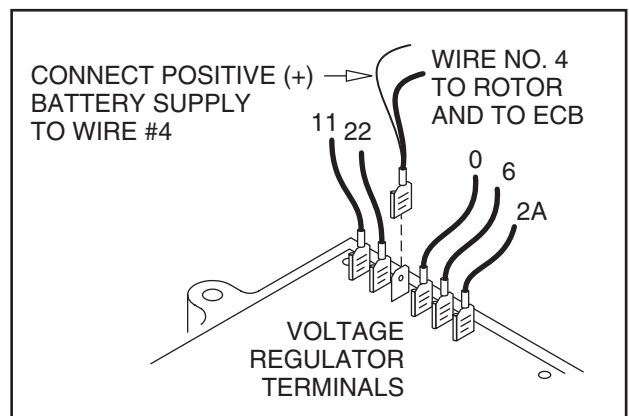

*Figure 7-3. – Fixed Excitation Test*

## Section 7 DIAGNOSTIC TESTS

	TEST 4 RESULTS						
	A	B	C	D	E	F	G
VOLTAGE RESULTS WIRE 2 & 6 EXCITATION WINDING	ABOVE 60 VAC	ABOVE 60 VAC	BELOW 60 VAC	ZERO OR RESIDUAL VOLTAGE (5-12 VAC)	BELOW 60 VAC	BELOW 60 VAC	ABOVE 60 VAC
VOLTAGE RESULTS WIRE 11 & 22 POWER WINDING SENSE LEADS	ABOVE 60 VAC	BELOW 60 VAC	ABOVE 60 VAC	ZERO OR RESIDUAL VOLTAGE (5-12 VAC)	BELOW 60 VAC	BELOW 60 VAC	ABOVE 60 VAC
ROTOR AMP DRAW QP55 (MODEL 4702/4703)	.85 A ± 20%	.85 A ± 20%	.85 A ± 20%	ZERO CURRENT DRAW	≥ 1.2 A	.85 A ± 20%	ZERO CURRENT DRAW
ROTOR AMP DRAW QP65 (MODEL 4704/4705)	1.2 A ± 20%	1.2 A ± 20%	1.2 A ± 20%	ZERO CURRENT DRAW	≥ 1.5 A	1.2 A ± 20%	ZERO CURRENT DRAW
ROTOR AMP DRAW QP75 (MODEL 4706/4707)	.87-.79 A ± 20%	.87-.79 A ± 20%	.87-.79 A ± 20%	ZERO CURRENT DRAW	≥ 1.2 A	.87-.79 A ± 20%	ZERO CURRENT DRAW
<b>(MATCH RESULTS WITH LETTER AND REFER TO FLOW CHART – Problem 2 on Pages 28 &amp; 29)</b>							

### PROCEDURE:

1. Disconnect Wire 4 from the Voltage Regulator (VR). (Third terminal from the top of VR).
2. Connect a jumper wire to Wire 4 and to the 12 volt fused battery positive supply Wire 15 (Wire 15 located at fuse (F1) holder).
3. Set the VOM to measure AC voltage.
4. Disconnect Wire 2 from the DPE breaker (CB3) and connect one test lead to that wire. Disconnect Wire 6 from the Voltage Regulator and connect the other test lead to that wire. Start the generator and measure the AC voltage. It should be above 60 volts. Record the results and stop the generator.
5. Re-connect Wire 2 to the DPE Circuit Breaker (CB3) and re-connect Wire 6 to the Voltage Regulator.
6. Disconnect Wire 11 from the Voltage Regulator (VR) and connect one test lead to that wire. Disconnect Wire 22 from the Voltage Regulator and connect the other test lead to that wire. Start the generator and measure the AC voltage. It should be above 60 volts. Record the results and stop the generator.
7. Re-connect Wire 11 and Wire 22 to the Voltage Regulator.
8. Remove the jumper wire between Wire 4 and 12 volt supply.
9. Set the VOM to measure DC amps.
10. Connect one test lead to the 12 volt fused battery supply Wire 15, and connect the other test lead to Wire 4 (should still be disconnected from the VR).
11. Start the generator. Measure the DC current. Record the rotor amp draw.

12. Stop the generator. Re-connect Wire 4 to the Voltage Regulator.

### RESULTS:

Proceed to “TEST 4 RESULTS” (top of page 40). Match all results to corresponding column in the chart. The column letter refers to the Problem 4 flow charts on pages 28 and 29.

## TEST 5- WIRE CONTINUITY

### DISCUSSION:

The Voltage Regulator receives unregulated alternating current from the Stator Excitation Winding via Wires 2, 6 and 2A. It also receives voltage sensing from the Stator AC Power Windings via Wires 11 and 22. The regulator rectifies the AC from the Excitation Winding and, based on the sensing signals, regulates that DC current flow to the Rotor. The rectified and regulated current flow is delivered to the Rotor Brushes via Wires 4 (+) and 0 (-). This test will verify the integrity of Wires 0 and 2A.

### PROCEDURE:

1. Set a VOM to its “Rx1” scale.
2. Remove Wire 0 from the Voltage Regulator, fourth terminal from the top (identified by a negative (-) sign next to terminal).
3. Connect one test lead to Wire 0 and the other test lead to a clean frame ground. The meter should read continuity.
4. Disconnect Wire 2A from the Voltage Regulator, sixth terminal from the top. Disconnect the other end of this wire from the

Excitation Circuit Breaker (CB3). Connect one test lead to one end of Wire 2A and the other test lead to the other end of the same wire. The meter should read continuity.

### RESULTS:

If continuity was NOT measured across each wire, repair or replace the wires as needed.

If continuity WAS measured, proceed to Test 6.

### TEST 6- CHECK FIELD BOOST

#### DISCUSSION:

Field boost current is delivered to the Rotor only while the engine is being cranked. This current helps ensure that adequate “pickup” voltage is available to turn the Voltage Regulator on and build AC output voltage.

Loss of the field boost function may or may not result in a problem with AC output voltage. If the Rotor’s residual magnetism is sufficient to turn the Regulator on, loss of the function may go unnoticed. However, if the Rotor’s residual magnetism is not enough to turn the Regulator on, loss of field boost can result in failure of the unit to generate an output voltage.

#### PROCEDURE:

1. Set VOM to measure DC voltage.
2. Disconnect Wire 4 from the Voltage Regulator and connect the positive (+) test lead to it. Connect the negative (-) test lead to a clean frame ground.
3. Set the Start-Stop Switch to “START.” During cranking only, measure DC voltage. It should read 3-5 VDC. Reconnect Wire 4 to the Voltage Regulator. If voltage is measured, it can be assumed that the Field Boost is working. Stop testing. If voltage is not measured, proceed to Step 4.
4. Connect the positive (+) test lead to Wire 16 at pin location J1-13 on the PCB (see Figure 7-4) (J1, J2 & J3 connectors remain connected to PCB). Connect the negative(-) test lead to a clean frame ground.
5. Set the Start-Stop Switch to “START.” During cranking only, battery voltage should measure 11-12 VDC.
6. Connect the positive (+) test lead to Wire 4 at pin location J1-9 on the PCB (see Figure 7-4) (J1, J2 & J3 connectors remain connected to PCB). Connect the negative(-) test lead to a clean frame ground.
7. Set the Start-Stop Switch to “START.” During cranking only measure the DC voltage. It should measure 3-5 VDC.

### RESULTS:

1. If battery voltage was not measured in Step 5, repair or replace

Wire 16 between the Starter Contactor Relay and PCB.

2. If field boost voltage was measured in Step 7 but not measured in Step 3, repair or replace Wire 4 between PCB and Voltage Regulator.
3. If battery voltage was measured in Step 5 but field boost voltage was not measured in Step 7, replace PCB.
4. If field boost checks good, replace the Voltage Regulator.

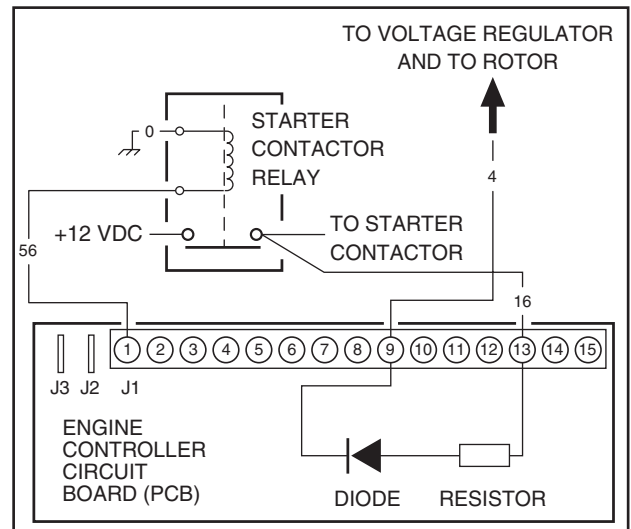

Figure 7-4. – The Field Boost Circuit

### TEST 7 - TEST STATOR DPE WINDING

#### DISCUSSION:

An open circuit in the Stator excitation windings will result in a loss of unregulated excitation current to the Voltage Regulator. The flow of regulated excitation current to the Rotor will then terminate and the unit’s AC output voltage will drop to a value that is commensurate with the rotor’s residual magnetism (about 5 - 12 VAC).

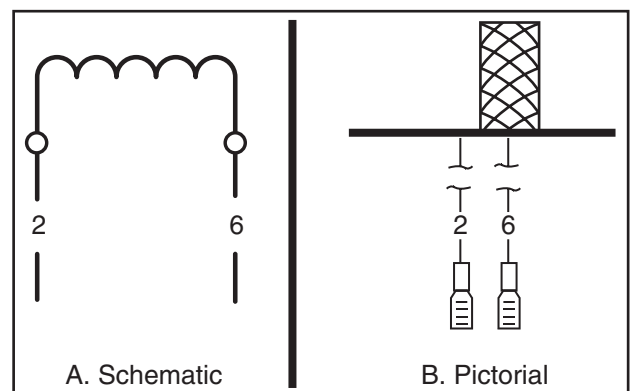

Figure 7-5. – Stator Excitation Winding

## Section 7 DIAGNOSTIC TESTS

### PROCEDURE:

1. Disconnect Wire 2 from the Excitation Circuit Breaker.
2. Disconnect Wire 6 from the Voltage Regulator.
3. Set a VOM to its "Rx1" scale and zero the meter.
4. Connect the VOM test leads across the terminal ends of Wires 2 and 6. The VOM should indicate the resistance of the Stator Excitation (DPE) Windings.

EXCITATION "DPE" WINDING RESISTANCE * (Measured Across Wires 2 & 6)	
MODEL	OHMS
QP55 (4702/4703)	1.41Ω – 1.63Ω
QP65 (4704/4705)	1.59Ω – 1.84Ω
QP75 (4706/4707)	1.12Ω – 1.30Ω

\* Resistance values In ohms at 20° C. (68° F.). Actual readings may vary depending on ambient temperature. A tolerance of plus or minus 5% is allowed.

5. Now, set the meter to its "Rx1 K" or "Rx10,000" scale and zero the meter. Test for a "short-to-ground" condition as follows:
  - a. Connect one meter test lead to Stator lead No. 2, the other test lead to a clean frame ground.
  - b. The meter should read "Infinity". Any other reading indicates a "short-to-ground" condition and the Stator should be replaced.
6. Test for a short between windings as follows:
  - a. Meter should be set to its "Rx1 K" or "Rx10,000" scale.
  - b. Connect one meter test lead to Stator Wire 2, the other test lead to Stator lead No. 11. The meter should read "Infinity".
  - c. Connect one VOM test lead to Stator lead No. 2 the other test lead to Stator lead No. 33. "Infinity" should be indicated.
  - d. Connect one VOM test lead to Stator lead No. 2 and connect the other test lead to Stator lead No. 66. "Infinity" should be indicated.

### RESULTS:

1. If the Stator excitation (DPE) windings are open or shorted, replace the Stator assembly.
2. If the excitation windings are good, perform "Insulation Resistance Test", page 13.

### TEST 8- CHECK SENSING LEADS / POWER WINDINGS

### DISCUSSION:

The Voltage Regulator "regulates" excitation current flow to the Rotor by electronically comparing sensing

voltage to a pre-set reference voltage. The sensing voltage is delivered to the Voltage Regulator via Wires 11S and 22S.

If an open circuit exists in sensing leads 11S or 22S, the normal reaction of an unprotected Regulator would be to increase the excitation current to the Rotor in an effort to increase the actual AC output voltage. This would result in a "full field" condition and an extremely high AC output voltage.

To protect the system against such a high AC output voltage, the Voltage Regulator will shut down if sensing voltage signals are lost.

If the regulator shuts down, the generator's AC output voltage will decrease to a value that is commensurate with the Rotor's residual magnetism (about 5-12 VAC).

### PROCEDURE:

Gain access to the generator control panel interior. Test the Stator power windings, as follows:

1. From main breaker, disconnect Wires 11 P and 33.
2. Also disconnect Wires 22P and 44 from the ground terminal.
3. Disconnect Wires 11S and 22S from the Voltage Regulator.
4. Set a VOM to its "Rx1" scale and zero the meter.
5. Connect the meter test leads across Stator leads 11P and 22P. Normal power winding resistance should be read.
6. Connect the meter test leads across Stator leads 33 and 44. Normal power winding resistance should be read.
7. Connect the meter test leads across Stator leads 11S and 22S. Normal Power Winding resistance should be read.

AC POWER WINDING RESISTANCE * QP55 (Model 4702/4703)	
ACROSS WIRES:	OHMS
11P & 22P	0.28Ω – 0.32Ω
11S & 22S	0.28Ω – 0.32Ω
33 & 44	0.28Ω – 0.32Ω

AC POWER WINDING RESISTANCE * QP65 (Model 4704/4705)	
ACROSS WIRES:	OHMS
11P & 22P	0.209Ω – 0.242Ω
11S & 22S	0.209Ω – 0.242Ω
33 & 44	0.209Ω – 0.242Ω

AC POWER WINDING RESISTANCE * QP75 (Model 4706/4707)	
ACROSS WIRES:	OHMS
11P & 22P	0.157Ω – 0.182Ω
11S & 22S	0.157Ω – 0.182Ω
33 & 44	0.157Ω – 0.182Ω

\* Resistance values In ohms at 20° C. (68° F.). Actual readings may vary depending on ambient temperature. A tolerance of plus or minus 5% is allowed.

8. Now, set the VOM to its "Rx1 K" or "Rx10,000" scale and zero the meter.

9. Connect the meter test leads across Stator lead 11P and frame ground. "Infinity" should be read.
10. Connect the meter test leads across Stator lead 33 and frame ground. The reading should be "Infinity".
11. Connect the meter test leads across Stator leads Wire 11P and Wire 33. The reading should be "Infinity".
12. Connect the meter test leads across Stator leads Wire 11P and Wire 66. The reading should be "Infinity".
13. Connect the meter test leads across Stator leads Wire 33 and Wire 66. The reading should be "Infinity".
14. Connect the meter test leads across Stator leads Wire 11P and Wire 2. The reading should be "Infinity".
15. Connect the meter test leads across Stator leads Wire 33 and Wire 2. The reading should be "Infinity".

**RESULTS:**

1. If the Stator passes all steps except Step 7, repair, re-connect or replace Sensing leads 11S and 22S.
2. Replace the Stator if it's power windings fail the test. (Note Result No. 1).
3. If the Power Windings test good, perform the "Insulation Resistance Test" on Page 13.

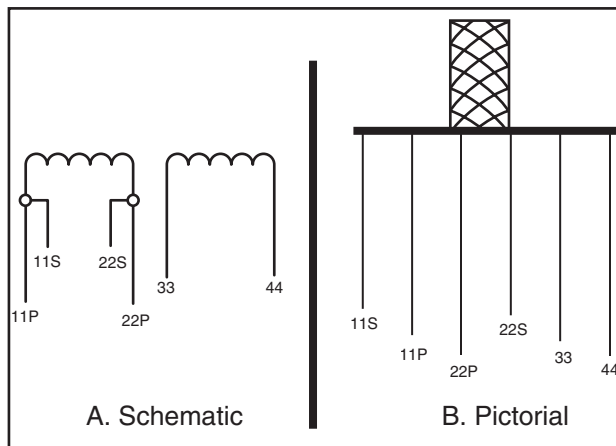

*Figure 7-6. – Stator Power Winding Leads*

**TEST 9- CHECK BRUSH LEADS**

**DISCUSSION:**

In Test 4, if application of battery voltage to the Rotor did NOT result in an output of about one-half rated voltage, the brush leads could be one possible cause of the problem. This test will check Wires 4 and OK for an open circuit condition.

**PROCEDURE:**

1. Set a VOM to its "Rx1" scale and zero the meter.
2. Disconnect Wire 4 from the Voltage Regulator and from the Rotor brush terminal.
3. Connect the VOM test leads across each end of the wire. The meter should read "Continuity".
4. Disconnect Wire OF from the Rotor Brush Terminal. Connect one meter test lead to Wire OF. Connect the other test lead to a clean frame ground. The meter should read "Continuity".

**RESULTS:**

1. Repair, reconnect or replace any defective wire(s).
2. If wires check good, go to Test 10.

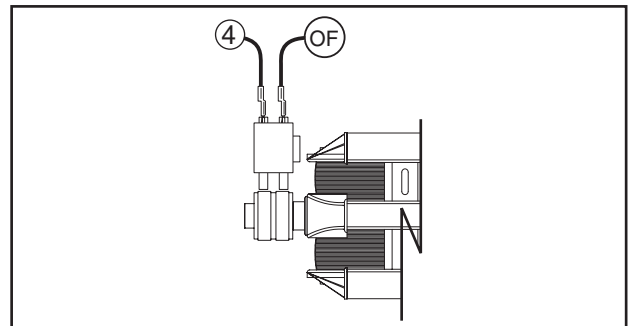

*Figure 7-7. – Brush Leads*

**TEST 10 - CHECK BRUSHES & SLIP RINGS**

**DISCUSSION:**

Brushes and slip rings are made of special materials that will provide hundreds of hours of service with little wear. However, when the generator has been idle for some time, an oxide film can develop on the slip rings. This film acts as an insulator and impedes the flow of excitation current to the Rotor.

If Test 4 resulted in less than one-half rated output voltage, it is possible that the brushes and slip rings are at fault.

**PROCEDURE:**

1. Gain access to the brushes and slip rings.
2. Remove Wire 4 from the positive (+) brush terminal.
3. Remove the ground wire (0F) from the negative (-) brush.
4. Remove the brush holder, with brushes.
5. Inspect the brushes for excessive wear, damage, cracks, chipping, etc.
6. Inspect the brush holder, replace if damaged.

## Section 7 DIAGNOSTIC TESTS

7. Inspect the slip rings.
  - a. If slip rings appear dull or tarnished they may be cleaned and polished with fine sandpaper. **DO NOT USE ANY METALLIC GRIT TO CLEAN SLIP RINGS.** (A 400 grit wet sandpaper is recommended).
  - b. After cleaning slip rings, blow away any sandpaper residue.

### RESULTS:

1. Replace bad brushes. Clean slip rings, if necessary.
2. If brushes and rings are good, go to Test 11.

### TEST 11- CHECK ROTOR ASSEMBLY

#### DISCUSSION:

During the "Fixed Excitation Test" (Test 4), if AC output voltage did not come up to about one-half rated volts, one possible cause might be a defective Rotor. The Rotor can be tested for an open or shorted condition using a volt-ohm-milliammeter (VOM).

Also see Chapter Three, "INSULATION RESISTANCE TESTS".

#### PROCEDURE:

Gain access to the brushes and slip rings. Disconnect Wire 4 and Wire OF from their respective brushes and remove the brush holder. Then, test the Rotor as follows:

1. Set a VOM to its "Rx1" scale and zero the meter.
2. Connect the positive (+) meter test lead to the positive (+) slip ring (nearest the Rotor bearing). Connect the common (-) test lead to the negative (-) slip ring. Read the resistance of the Rotor windings, in OHMS.

ROTOR RESISTANCE *	
MODEL:	OHMS
QP55 4702/4703	14.88Ω
QP65 4704/4705	10.81Ω
QP75 4706/4707	14.50Ω – 16.0Ω

\* Resistance values in ohms at 20° C. (68° F.). Actual readings may vary depending on ambient temperature. A tolerance of plus or minus 5% is allowed.

3. Set the VOM to its "Rx1 K" or "Rx10,000" scale and zero the meter.
4. Connect the positive (+) meter test lead to the positive (+) slip ring, the common (-) test lead to a clean frame ground (such as the Rotor shaft). The meter should read "Infinity".

### RESULTS:

1. Replace the Rotor if it fails the test.

2. If Rotor checks good, perform "Insulation Resistance Test," on Page 14.

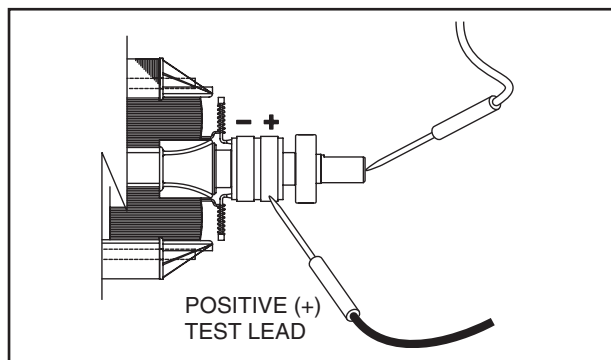

Figure 7-8. – Rotor Assembly

### TEST 12 - CHECK MAIN CIRCUIT BREAKER

#### DISCUSSION:

The main circuit breaker on the generator panel must be closed or no output to the load will be available. A defective breaker may not be able to pass current even though it is in the "ON" position.

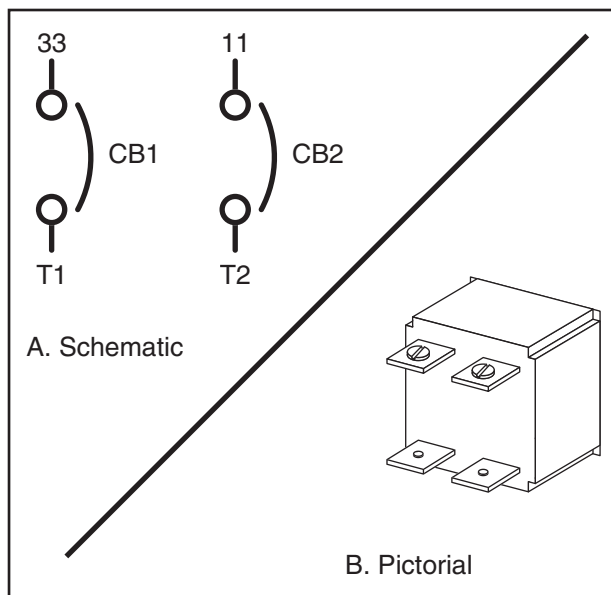

Figure 7-9. – Main Breaker (Typical)

#### PROCEDURE:

Set the coach main breaker to its "OFF" position. Check that the appropriate main breaker on the generator panel is set to its "ON" (closed) position. Set a VOM to measure resistance and use it to check for continuity across the breaker terminals.

**RESULTS:**

1. If breaker is "ON" and "Continuity" is measured, go to Test 3.
2. If breaker is "OFF", reset to the "ON" position and check for AC output.
3. If breaker is "ON" and "Continuity" is not measured, replace the defective circuit breaker.

**TEST 13- CHECK LOAD VOLTAGE &  
FREQUENCY**

**DISCUSSION:**

If engine speed appears to drop off excessively when electrical loads are applied to the generator, the load voltage and frequency should be checked.

**PROCEDURE:**

Perform this test in the same manner as Test 1, but apply a load to the generator equal to its rated capacity. With load applied check voltage and frequency.

Frequency should not drop below about 58 Hertz with the load applied.

Voltage should not drop below about 115 VAC with load applied.

**RESULTS:**

1. If voltage and/or frequency drop excessively when the load is applied, go to Test 14.
2. If load voltage and frequency are within limits, end tests.

**TEST 14- CHECK LOAD WATTS & AMPERAGE**

**DISCUSSION:**

This test will determine if the generator's rated wattage/ampere capacity has been exceeded.

Continuous electrical loading should not be greater than the unit's rated capacity.

**PROCEDURE:**

Add up the wattages or amperages of all loads powered by the generator at one time. If desired, a clamp-on ammeter may be used to measure current flow. See "Measuring Current" on Page 16.

**RESULTS:**

1. If the unit is overloaded, reduce the load.
2. If load is within limits, but frequency and voltage still drop excessively, complete Test 2, "Check/Adjust Engine Governor". If governor adjustment does not correct the problem, go to Problem 8 (Flow Chart, Pages 34 and 35).

**TEST 15 - CHECK BATTERY CHARGE  
OUTPUT**

**DISCUSSION:**

The Battery Charge system consists of a center tap Battery Charge Winding, a Battery Charge Rectifier, and a Battery Charge Resistor. During normal operation the battery charge output will vary between 1 to 2 amps, depending on the load applied to the generator. Battery Charge Winding Stator Lead Wire 66 is tapped at the Battery Charge Rectifier and connected to the Engine Control Circuit Board at Pin location J1-10, and is used as a signal for Starter lockout.

**PROCEDURE:**

1. Disconnect Wire 15 from the Battery Charge Rectifier (center terminal). Wire 15 is the fused battery supply.
2. Set a VOM to measure DC Amps. Connect the positive (+) test lead to the center terminal of the Battery Charge Rectifier. Connect the negative (-) test lead to Wire 15 previously disconnected.
3. Start the generator. The amp reading on the VOM should be approximately 0.8 Amps. Apply full load to the generator. The amp reading should increase to approximately 2 Amps.

**RESULTS:**

1. If amperage was measured between 0.8 to 2 Amps in Step 2 and Step 3, the charging system is working.
2. If no amperage was measured, check the VOM fuses and verify the functioning of the Amp Meter. If DC Amp Meter is good and no current is measured, go to Test 16

**TEST 16 - CHECK BATTERY CHARGE  
RECTIFIER**

**DISCUSSION:**

The Battery Charge Rectifier (BCR) is a full wave rectifier.

**PROCEDURE:**

1. Disconnect Wire 66, Wire 15 and Wire 77 from the Battery Charge Rectifier.
2. Set the VOM to the Diode Test range. Connect the negative (-) test lead to the center terminal of the BCR. Connect the positive (+) test lead to an outer terminal. The meter should measure approximately 0.5 volts. Now connect the positive test lead to the other outer terminal. Again, the meter should measure approximately 0.5 volts.
3. Connect the positive (+) test lead to the center terminal of the BCR. Connect the negative (-) test lead to an outer terminal. The meter should measure "Infinity." Connect the negative test lead to the other outer terminal. "Infinity" should once again be measured.

## Section 7 DIAGNOSTIC TESTS

Short to Ground:

- Set the VOM to measure resistance. Connect the positive (+) test lead to the case housing of the BCR. Connect the negative (-) test lead to an outer terminal. "Infinity" should be measured. Now connect the negative test lead to the BCR center terminal. "Infinity" should be measured. Next, connect the negative test lead to the remaining outer BCR terminal. Once again "Infinity" should be measured.

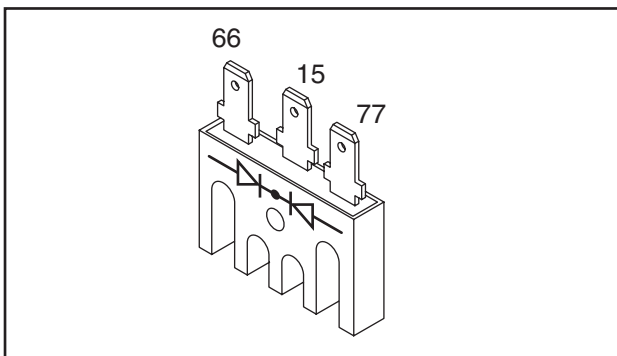

Figure 7-10. – Battery Charge Rectifier

### RESULTS:

- If any of the previous steps has failed, replace the Battery Charge Rectifier.
- If the BCR tests good, go to Test 17.

### TEST 17 - CHECK BATTERY CHARGE WINDINGS / BATTERY CHARGE RESISTOR

### DISCUSSION:

The Battery Charge Winding (BCW) produces AC voltage that is delivered to the Battery Charge Rectifier. The Battery Charge Winding is a center tapped winding consisting of the following Stator Leads: Wire 66, Wire 77 and Wire 55. The Battery Charge Resistor is used as a current limiting resistor.

### PROCEDURE:

- Disconnect the Stator Leads (Wire 66 and Wire 77) from the Battery Charge Rectifier. (Be sure to disconnect Stator Lead Wire 66 "Black" from Wire 66 "Blue" connector for this test). Disconnect the Stator Lead Wire 55 from the Battery Charge Resistor.
- Set the VOM to measure resistance at the "R x 1" scale. Connect one test lead to Stator Lead Wire 66. Connect the other test lead to Stator Lead Wire 55. Normal Battery Charge Winding resistance should be measured.

- Connect one test lead to Stator Lead Wire 77. Connect the other test lead to Stator Lead Wire 55. Normal Battery Charge Winding resistance should be measured.
- Connect one test lead to Stator Lead Wire 55. Connect the other test lead to Stator Leads Wire 11 & 33 at the back of CB1. "Infinity" should be measured.
- Connect one test lead to Stator Lead Wire 55. Disconnect Stator Lead Wire 2 from the DPE circuit breaker (CB3) and connect the other test lead to Wire 2. "Infinity" should be measured.
- Connect one test lead to Stator Lead Wire 55. Connect the other test lead to frame ground. "Infinity" should be measured.
- Connect one test lead to the Battery Charge Resistor terminal that Wire 55 was removed from. Connect the other test lead to frame ground. One (1) ohm should be measured. If 1 ohm was not measured, remove Wire 0 from the Battery Charge Resistor. Connect one test lead to Wire 0 and the other test lead to frame ground. "Continuity" should be measured. Repair or replace Wire 0 if defective and retest the Battery Charge Resistor.

BATTERY CHARGE WINDING RESISTANCE *	
QP55 (Model 4702/4703)	
ACROSS WIRES:	OHMS
55 & 66	0.100Ω – 0.116Ω
55 & 77	0.100Ω – 0.116Ω

BATTERY CHARGE WINDING RESISTANCE *	
QP65 (Model 4704/4705)	
ACROSS WIRES:	OHMS
55 & 66	0.104Ω – 0.120Ω
55 & 77	0.087Ω – 0.101Ω

BATTERY CHARGE WINDING RESISTANCE *	
QP75 (Model 4706/4707)	
ACROSS WIRES:	OHMS
55 & 66	0.092Ω – 0.107Ω
55 & 77	0.076Ω – 0.088Ω

\* Resistance values in ohms at 20° C. (68° F.). Actual readings may vary depending on ambient temperature. A tolerance of plus or minus 5% is allowed.

### RESULTS:

- For Steps 2 & 3, keep in mind that the resistance values are very low. Depending upon the quality of the VOM, it may read "Continuity" across these windings. Exercise good judgement with these values.
- If Steps 2, 3, 4, 5 & 6 fail any test, replace the Stator.

3. In Step 7, if Wire 0 reads "Continuity", but resistor does not measure 1 ohm, replace the Battery Charge Resistor.
4. If all of the Steps in this test pass, perform "Insulation Resistance Test" on page 13.

### **TEST 18 - TRY CRANKING THE ENGINE**

**DISCUSSION:**

If the Fuel Primer Switch on the generator panel is actuated, but the Fuel Pump does not run (priming function doesn't work), perhaps battery voltage is not available.

**PROCEDURE:**

Hold the Start-Stop Switch at "START". The engine should crank and start.

**RESULTS:**

1. If the engine cranks normally, but the priming function still doesn't work, go to Test 19.
2. If engine will not crank, go to Test 21. Refer to Problem 6 of Section 6.
3. If engine cranks but won't start, go to Problem 7 of Section 6.
4. If engine starts hard and runs rough, go to Problem 8 of Section 6.

### **TEST 19- TEST PRIMER SWITCH**

**DISCUSSION:**

A defective primer switch can prevent the priming function from occurring.

Switch failure can also prevent the engine from starting, since the switch is in series with the Wire14 circuit. (Also see "Fuel Primer Switch," page 25).

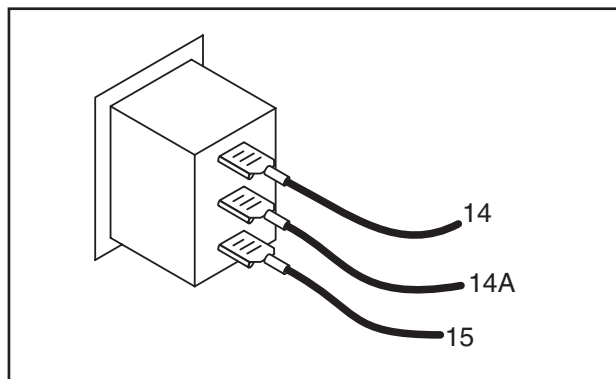

*Figure 7-11. – Primer Switch*

**PROCEDURE:**

1. Set a VOM to read battery voltage (12 VDC).
2. Connect the positive (+) meter test lead to the Wire 15 terminal of the Primer Switch (leave Wire 15 connected to the switch). Connect the negative (-) meter test lead to frame ground. The meter should indicate battery voltage.
3. Connect the positive (+) meter test lead to the Wire 14 terminal of the Primer Switch (leave Wire 14 connected to the switch). Connect the negative (-) meter test lead to a clean frame ground. Set the Start-Stop switch to "START". The engine should crank and battery voltage should be measured.
4. Connect the positive (+) meter test lead to the Wire 14A terminal of the Primer Switch, the negative (-) meter test lead to frame ground.
  - a. With the Primer Switch NOT actuated, no voltage should be indicated.
  - b. Actuate the switch to its "PRIME" position and the meter should read battery voltage.
5. For gasoline models, disconnect Connector 2 at the Fuel Pump. Connect the VOM positive (+) test lead to Wire 14A, (Pin 2 of Connector 2) going up to the Control Panel (see Figure 7-12). Connect the VOM negative(-) test lead to frame ground. Repeat Steps 4a and 4b. Battery Voltage should be measured when the Primer Switch is activated.

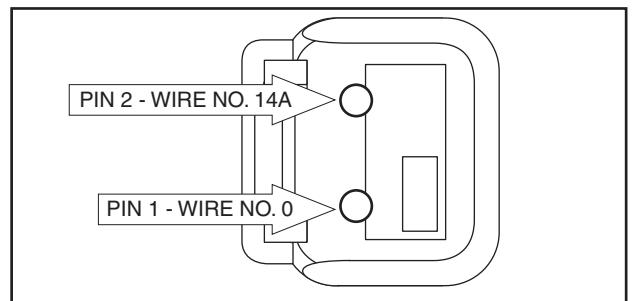

*Figure 7-12. – Harness End of Connector 2*

6. For LPG models, disconnect Wire 14A from the LPG Fuel Solenoid (FS)(see Figure 7-13). Connect the VOM positive (+) test lead to Wire 14A. Connect the VOM negative(-) test lead to frame ground. Repeat Steps 4a and 4b. Battery Voltage should be measured when the Primer Switch is activated.
7. Set the VOM to measure resistance at the "Rx1" scale and zero the meter.
  - a. Disconnect Wire 14 from the Primer Switch.
  - b. Connect the meter test leads across the Wires 14 and 14A terminals of the switch.
  - c. With the switch NOT actuated, the meter should read "Continuity".

## Section 7 DIAGNOSTIC TESTS

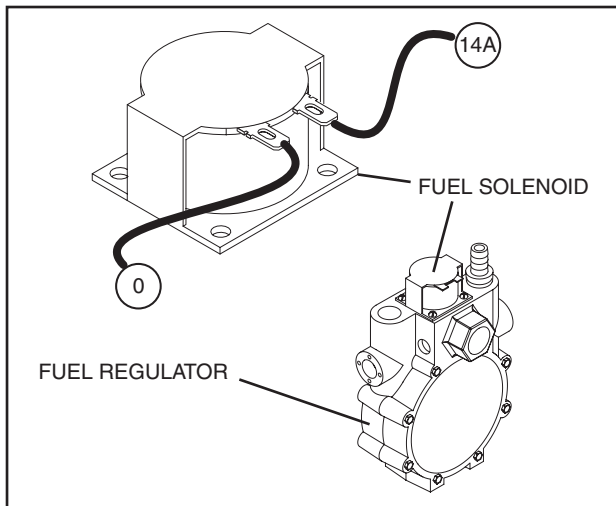

Figure 7-13. – The LPG Fuel Solenoid (FS)

### RESULTS:

1. If battery voltage is not indicated in Step 2, check Wire 15 between the Primer Switch and the 7.5 amp fuse for an open condition.
2. If battery voltage is indicated in Step 2 but not in Step 4, replace the Primer Switch. If battery voltage is NOT indicated in Step 3 repair or replace Wire 14 between the 4-tab Terminal Connector (TC) and the Fuel Primer Switch (SW2).
3. If battery voltage was indicated in Step 4 but not in Step 5:
  - a. For gasoline models repair or replace Wire 14A between the Primer Switch (SW2) and Fuel Pump Connector 2.
  - b. For LPG models repair or replace Wire 14A between the Fuel Prime Switch (SW2) and the LPG Fuel Solenoid (FS).
4. If the meter reads anything other than “Continuity” in Step 7, replace the Primer Switch.
5. If the Primer Switch checks good, go to Test 20 for Gasoline models. For LPG models, go to Test 42.

### TEST 20- CHECK FUEL PUMP

#### DISCUSSION:

An inoperative Fuel Pump will (a) prevent the priming function from working and (b) prevent the engine from starting.

#### PROCEDURE:

1. Remove Fuel Filter and verify that filter is not clogged. Replace filter if necessary.
2. Verify that fuel is available to Fuel Filter inlet. Use an alternative fuel supply if questionable.

3. Remove air filter access panel and air filter. Remove fuel hose from pump. Place a suitable container to catch fuel from fuel pump line. Activate fuel primer switch. Pump should operate and fuel should flow. If pump does not operate, proceed to Step 4.

4. In Test 19, Battery Voltage was checked at Connector 2. This step will test the ground wire. Disconnect Connector 2 at the Fuel Pump. Set the VOM to measure resistance. Connect one test lead to Wire 0, (Pin 1 of Connector 2) that goes to the Control Panel (see Figure 7-12). Connect the other test lead to a clean frame ground. “Continuity” should be measured.

5. To test for an open fuel pump coil, connect one test lead to the Red Wire (Pin 2 of Connector 2) going to the fuel pump. Connect the other test lead to the Black Wire (Pin 1 of Connector 2) going to the Fuel Pump (see Figure 7-15). The VOM should indicate Fuel Pump coil resistance of about 29.5 kW. (Current draw of the pump at nominal voltage is approximately 1.4 amperes MAXIMUM).

Short to Ground:

6. To test for a shorted fuel pump coil, connect one test lead to the Red Wire (Pin 2 of Connector 2, see Figure 7-15). Connect the other test lead to the fuel pump housing. “Infinity” should be measured.

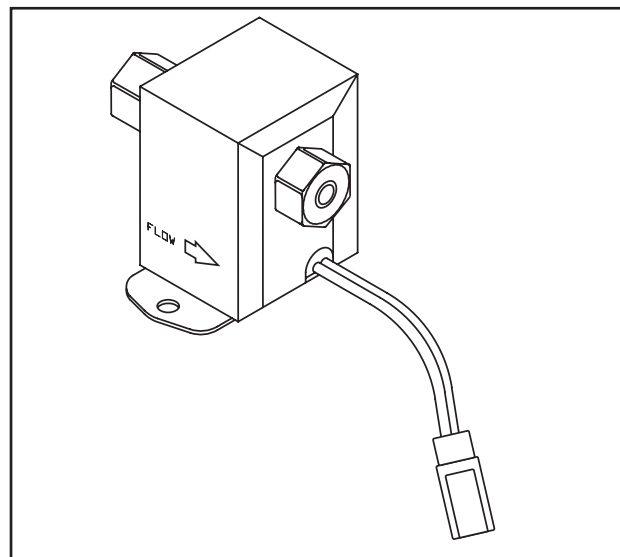

Figure 7-14. – Electric Fuel Pump

#### RESULTS:

1. If “Continuity” was not measured in Step 4, repair or replace Wire 0 between Connector 2 and the ground terminal.
2. If “Continuity” is measured in Step 4, but pump does not operate in Step 3, replace the Fuel Pump.

3. If the pump fails Step 5 or Step 6, replace the Fuel Pump.

**Note: If desired, a pressure gauge can be attached to the pumps outlet side. Pump outlet pressure should be 2.0 to 3.5 psi.**

4. If the pump operates normally, go to Test 31.

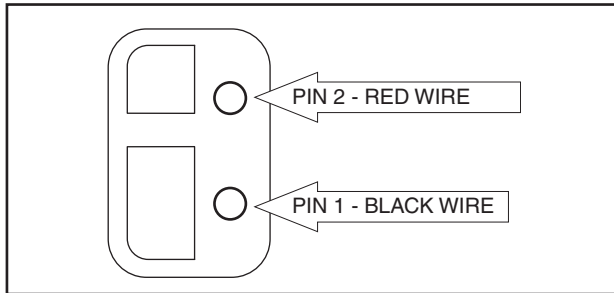

Figure 7-15. – Harness to Fuel Pump

### **TEST 21- CHECK 7.5 AMP FUSE**

**DISCUSSION:**

If the panel-mounted 7.5 amp fuse (F1) has blown, engine cranking will not be possible.

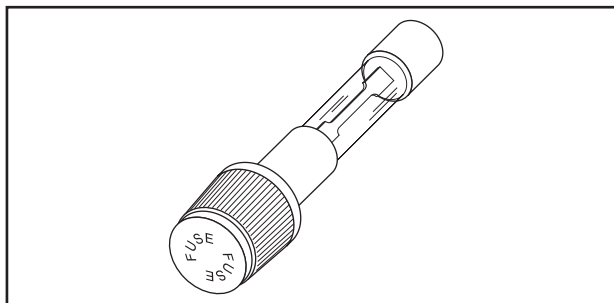

Figure 7-16. – 7.5 Amp Fuse

**PROCEDURE:**

Push In on fuse holder cap and turn counterclockwise. Then, remove the cap with fuse. Inspect the Fuse.

**RESULTS:**

If the Fuse element has melted open, replace the Fuse with an identical size fuse. If Fuse is good, go to Test 22.

### **TEST 22- CHECK BATTERY & CABLES**

**DISCUSSION:**

If the engine won't crank or cranks too slowly, the battery may be weak or discharged. See "Battery" on Page 24.

**PROCEDURE:**

1. Inspect the battery cables and battery posts or terminals for corrosion or tightness. Measure the voltage at the terminal of the starter contactor and verify 11-12 volts DC is available to the generator during cranking. If voltage is below 11 volts DC, measure at the battery terminals during cranking. If battery voltage is below 11 volts DC, recharge/replace battery. If battery voltage is above 11 volts DC, check for proper battery cable sizing (see "BATTERY CABLES" on Page 24). If battery or cables are still suspected, connect an alternate battery and cables to the generator and retest.
2. Use a battery hydrometer to test the battery for (a) state of charge and (b) condition. Follow the hydrometer manufacturer's instructions carefully.

**RESULTS:**

1. Clean battery posts and cables as necessary. Make sure battery cables are tight.
2. Recharge the battery, if necessary.
3. Replace the battery, if necessary.
4. If battery is good, but engine will not crank, go to Test 23.

### **TEST 23- CHECK POWER SUPPLY TO CIRCUIT BOARD**

**DISCUSSION:**

If battery voltage is not available to the circuit board, engine cranking and running will not be possible.

If battery voltage is available to the board, but no DC output is delivered to the board's Wire 56 terminal while attempting to crank, either the circuit board is defective or the Start-Stop Switch has failed.

This test will determine if battery voltage is available to the Engine Controller circuit board. Test 24 will check the Start-Stop Switch. Test 25 will check the DC power supply to the circuit board's Wire 56 terminal (Receptacle J1, Pin 1).

**PROCEDURE:**

1. On the Engine Controller Circuit Board, locate Terminal J3 to which Wire 15 connects (see Figure 5-3 on Page 24).
2. Set a VOM to read battery voltage. Connect the meter test leads across circuit board Terminal J3 and frame ground. The meter should read battery voltage.
3. Set the VOM to measure resistance ("Rx1" scale). Connect one meter test lead to Wire 0, Pin location J1-12 on the Engine Controller Circuit Board. Connect the other test lead to a clean frame ground. "Continuity" should be measured.

## Section 7 DIAGNOSTIC TESTS

### RESULTS:

1. If battery voltage is NOT indicated in Step 1, check continuity of:
  - a. Wire 13 between Starter Contactor and Starter Contactor Relay.
  - b. Wire 13 between Starter Contactor Relay and 7.5 Amp Fuse (F1).
  - c. Wire 15 between the 7.5 Amp fuse (F1) and the Battery Charge Rectifier.
  - d. Wire 15 between the Battery Charge Rectifier and the Engine Controller Board.

Repair, reconnect or Replace bad wiring as necessary.
2. If battery voltage is indicated but engine will not crank, go to Test 24.
3. If "Continuity" was not measured in Step 3, repair or replace Wire 0 between the Engine Controller Circuit Board and the Ground Terminal.

### TEST 24 - CHECK START-STOP SWITCH

#### DISCUSSION:

Engine cranking and startup is initiated when Wire 17 from the Engine Controller board is connected to frame ground by setting the Start-Stop Switch to "START".

Engine shutdown occurs when circuit board Wire 18 is connected to frame ground by the Start-Stop Switch.

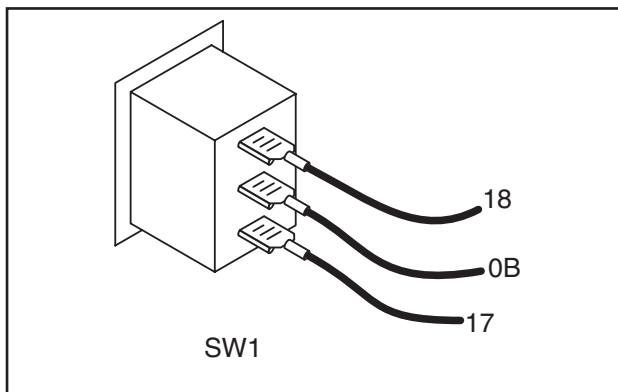

Figure 7-17. – Start-Stop Switch

A defective Start-Stop Switch can result in (a) failure to crank when the switch is set to "START", and/or (b) failure to shut down when the switch is set to "STOP".

#### PROCEDURE:

For Problem 6 (Section 6), perform all steps. For Problem 9, perform Step 1 and Step 5 ONLY.

1. Set a VOM to its "Rx1" scale and zero the meter.

2. Inspect the ground Wire 0B, between the Start-Stop Switch and the grounding terminal. Connect one meter test lead to Wire 0B on SW1. Connect the other test lead to a clean frame ground. "Continuity" should be measured.
3. Disconnect Wire 17 from its Switch terminal and connect it to frame ground. The engine should crank.
4. Remove the 7.5 amp fuse. Disconnect Wire 18, Wire 0B and Wire 17 from the Start-Stop Switch (SW1).
5. Connect one test lead to the center terminal of SW1. Connect the other test lead to an outer terminal of SW1. "Infinity" should be measured. Remove the test lead from the outer terminal of SW1 and connect it to the opposite outer terminal. "Infinity" should be measured.
6. Leave the test lead connected to the center terminal of SW1 from Step 5. Connect the other test lead to an outer terminal. Depress the switch away from the terminal being tested (see Figure 7-18). "Continuity" should be measured. Repeat the procedure with the test lead connected to the other outer terminal. "Continuity" should be measured.

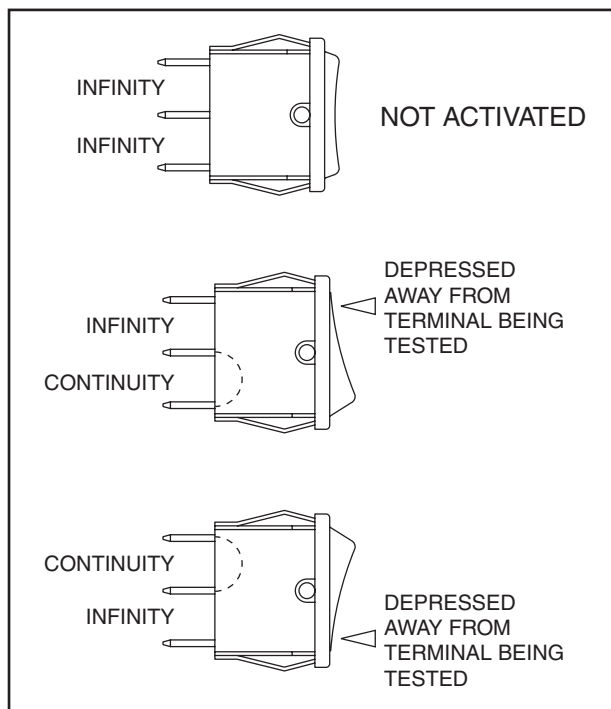

Figure 7-18. – Test 24, Step 6

### RESULTS:

1. If "Continuity" is not measured in Step 2, repair, reconnect or replace Wire 0B (between Start-Stop Switch and ground terminal) as necessary.

2. If engine cranks in Step 3 when Wire 17 is grounded, but will not crank when the Switch is set to "START", replace the Start-Stop Switch.
3. If the Start-Stop Switch (SW1) failed any part of Steps 5 or 6, replace the switch.
4. If engine will not crank when Wire 17 is grounded, proceed as follows:
  - a. Use a jumper wire to connect the circuit board's Wire 17 (pin location J1-6) to ground. If engine does NOT crank, proceed to Test 25.
  - b. If engine cranks now, but would not crank in Step 3 of the procedure, check Wire 17 for continuity between the circuit board and Start-Stop Switch. If "Continuity" is not measured, repair or replace Wire 17 between the engine control board and the Start-Stop Switch.
5. For Problem 9 (Section 6), if switch tests GOOD, go to Test 30.

### **TEST 25 - CHECK POWER SUPPLY TO WIRE 56**

#### DISCUSSION:

If battery voltage is available to the Engine Controller board in Test 23, then DC voltage should be delivered to Wire 56 when the Start-Stop Switch is set to "START" (Test 24). This test will check to see if the circuit board is delivering battery voltage to the Wire 56 terminal.

#### PROCEDURE:

1. Set a VOM to measure DC voltage (12 VDC).
2. Disconnect Wire 56 from its Starter Contactor Relay terminal.
3. Connect the meter positive (+) test lead to Wire 56, just disconnected. Connect the other test lead to frame ground. No voltage should be indicated.
4. Actuate the Start-Stop Switch to its "START" position. The meter should indicate battery voltage. If battery voltage is present, stop the procedure.
5. Connect the VOM positive (+) test lead to Wire 56 (Pin Location J1-1) at the Engine Controller Circuit Board. Connect the other test lead to frame ground.
6. Actuate the Start-Stop Switch to the "START" position. The meter should indicate battery voltage.

#### RESULTS:

1. If battery voltage was measured in Step 6, but not in Step 4, repair or replace Wire 56 between the Engine Controller Circuit Board and Starter Contactor Relay.
2. If battery voltage was not available in Step 6, replace the Engine Controller Circuit Board.

3. If battery voltage is available in Step 4 but engine does not crank, go to Test 26.

### **TEST 26- CHECK STARTER CONTACTOR RELAY**

#### DISCUSSION:

If battery voltage is available to Wire 56 but the engine won't crank, the possible cause could be a failed Starter Contactor Relay.

#### PROCEDURE:

1. Set the VOM to measure resistance ("R x 1" scale). Remove Wire 0 from the Starter Contactor Relay (SCR). Connect one meter test lead to Wire 0, and connect the other meter test lead to frame ground. "Continuity" should be measured. Reconnect Wire 0.
2. Set the VOM to measure resistance ("R x 1" scale). Disconnect Wire 16 and Wire 13 (Wire 13 is 12VDC isolate from ground) from the Starter Contactor Relay (SCR). Connect one meter test lead to an SCR terminal, and connect the other meter test lead to the remaining SCR terminal. "Infinity" should be measured. Set the Start-Stop Switch to "START". The meter should now read "Continuity".

Short to Ground:

3. Set the VOM to measure resistance ("R x 1" scale). Disconnect Wire 56 from the Starter Contactor Relay (SCR). Connect one meter test lead to the SCR terminal from which Wire 56 was just removed. Connect the other meter test lead to a clean frame ground. Starter Contactor Relay coil resistance of 155 ohms should be measured. If "Continuity" is measured a short to ground exists.

**Note: Current draw of the Starter Contactor Relay coil at nominal voltage is approximately 80ma.**

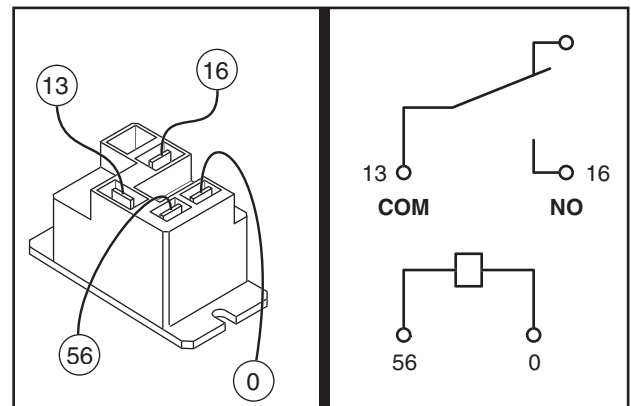

Figure 7-19. – Starter Contactor Relay

## Section 7 DIAGNOSTIC TESTS

### RESULTS:

1. If "Continuity" is not measured in Step 1, repair or replace Wire 0 between the Starter Contactor Relay and the ground terminal.
2. If "Continuity" was not measured in Step 2 when the Start-Stop switch was activated to "START", replace the Starter Contactor Relay.
3. If "Continuity" is measured in Step 2, go to Test 26A.

### TEST 26A - CHECK STARTER CONTACTOR

#### DISCUSSION:

The Starter Contactor (SC) must energize and its heavy duty contacts must close or the engine will not crank. This test will determine if the Starter Contactor is in working order. The Starter Contactor is connected to the Starter Motor (see Figure 7-20).

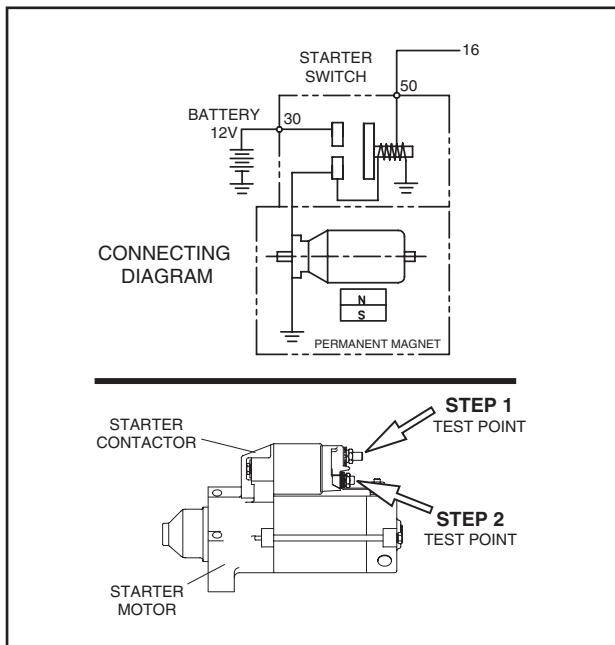

Figure 7-20. – The Starter Contactor (SC)

#### PROCEDURE:

1. Carefully inspect the starter motor cable that runs from the Battery to the Starter Motor. Cable connections should be clean and tight. If connections are dirty or corroded, remove cable and clean cable terminals and studs. Replace any cable that is defective or badly corroded. Set the VOM to measure DC voltage. Connect the positive (+) meter test lead to the Starter Contactor stud that the battery cable is connected to. Connect the negative (-) meter test lead to a clean frame ground. Battery voltage should be measured (see Figure 7-20, **STEP 1 TEST POINT**).

2. Set the VOM to measure DC voltage. Disconnect Wire 16 from the Starter Contactor. Connect the positive (+) meter test lead to Wire 16. Connect the negative (-) meter test lead to a clean frame ground. Set the Start-Stop Switch to "START". Battery voltage should be indicated. Reconnect Wire 16 to the Starter Contactor.
3. Set the VOM to measure DC voltage. Connect the positive (+) meter test lead to the Starter Contactor stud that has the small jumper wire connected to the Starter. Connect the negative (-) meter test lead to a clean frame ground. Set the Start-Stop Switch to "START". Battery voltage should be measured (see Figure 7-20, **STEP 2 TEST POINT**).

#### RESULTS:

1. If battery voltage was not measured in Step 1, repeat Test 22.
2. If battery voltage was not measured in Step 2, repair or replace Wire 16 between the Starter Contactor Relay (SCR) and the Starter Contactor (SC).
3. If battery voltage was measured in Step 1, but not in Step 3, replace the Starter Contactor.
4. If battery voltage was measured in Step 3 but the engine still does not crank, go to test 27.

### TEST 27 - CHECK STARTER MOTOR

#### CONDITIONS AFFECTING STARTER MOTOR PERFORMANCE:

1. A binding or seizing condition in the Starter Motor bearings.
2. A shorted, open or grounded armature.
  - a. Shorted, armature (wire insulation worn and wires touching one another). Will be indicated by low or no RPM.
  - b. Open armature (wire broken) will be indicated by low or no RPM and excessive current draw.
  - c. Grounded armature (wire insulation worn and wire touching armature lamination or shaft). Will be indicated by excessive current draw or no RPM.
3. A defective Starter Motor switch.
4. Broken, damaged or weak magnets.
5. Starter drive dirty or binding.

#### DISCUSSION:

Test 25 verified that circuit board action is delivering DC voltage to the Starter Contactor Relay (SCR). Test 26 verified the operation of the SCR. Test 26A verified the operation of the Starter Contactor (SC). Another possible cause of an "engine won't crank" problem is a failure of the Starter Motor.

**PROCEDURE:**

The battery should have been checked prior to this test and should be fully charged.

Set a VOM to measure DC voltage (12 VDC). Connect the meter positive (+) test lead to the Starter Contactor stud which has the small jumper wire connected to the Starter. Connect the common (-) test lead to the Starter Motor frame.

Set the Start-Stop Switch to its "START" position and observe the meter. Meter should indicate battery voltage, Starter Motor should operate and engine should crank.

**RESULTS:**

1. If battery voltage is indicated on the meter but Starter Motor did not operate, remove and bench test the Starter Motor (see following test).

2. If battery voltage was indicated and the Starter Motor tried to engage (pinion engaged), but engine did not crank, check for mechanical binding of the engine or rotor.

If engine turns over slightly, go to Test 35 "Check and Adjust Valves."

**NOTE: If a starting problem is encountered, the engine itself should be thoroughly checked to eliminate it as the cause of starting difficulty. It is a good practice to check the engine for freedom of rotation by removing the spark plugs and turning the crankshaft over slowly by hand, to be sure it rotates freely.**



**WARNING!: DO NOT ROTATE ENGINE WITH ELECTRIC STARTER WITH SPARK PLUGS REMOVED. ARCING AT THE SPARK PLUG ENDS MAY IGNITE THE GASOLINE VAPOR EXITING THE SPARK PLUG HOLE.**

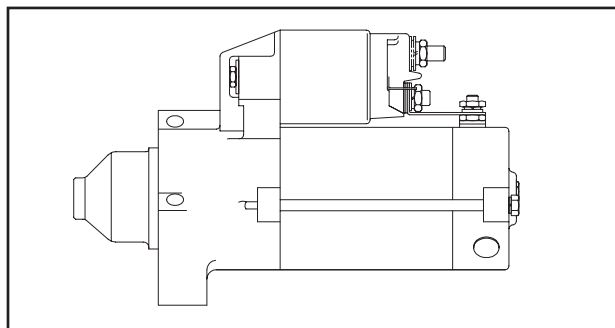

Figure 7-21. – Starter Motor (SM)

**CHECKING THE PINION:**

When the Starter Motor is activated, the pinion gear should move and engage the flywheel ring gear. If the pinion does not move normally, inspect the pinion for binding or sticking.

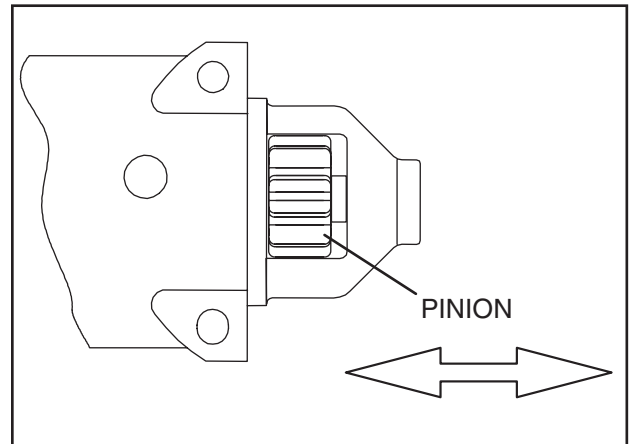

Figure 7-22. – Check Pinion Gear Operation

**TOOLS FOR STARTER PERFORMANCE TEST:**

The following equipment may be used to complete a performance test of the Starter Motor:

- ☐ A clamp-on ammeter.
- ☐ A tachometer capable of reading up to 10,000 rpm.
- ☐ A fully charged 12-volt battery.

**MEASURING CURRENT:**

To read the current flow, in AMPERES, a clamp-on ammeter may be used. This type of meter indicates current flow through a conductor by measuring the strength of the magnetic field around that conductor.

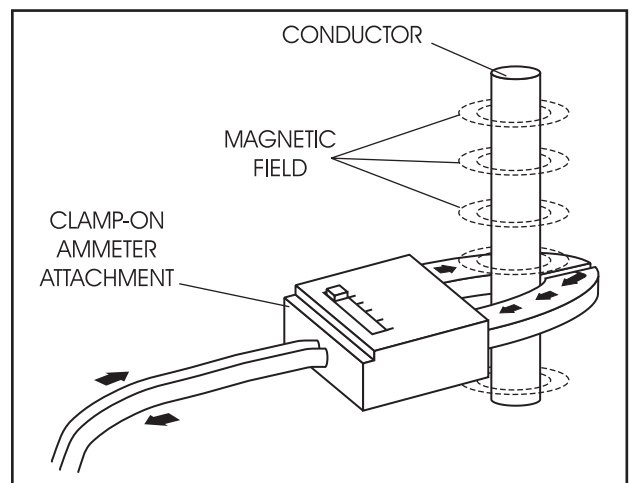

Figure 7-23. – Clamp-On Ammeter

**TACHOMETER:**

A tachometer is available from your Generac Power Systems source of supply. Order as P/N 042223. The tachometer measures from 800 to 50,000 RPM (see Figure 7-24).

## Section 7 DIAGNOSTIC TESTS

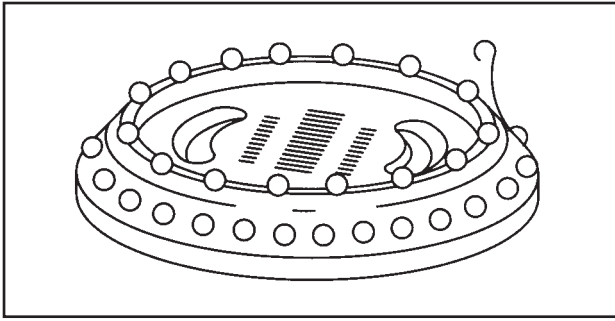

Figure 7-24. – Tachometer

### TEST BRACKET:

A starter motor test bracket may be made as shown in Figure 7-25.

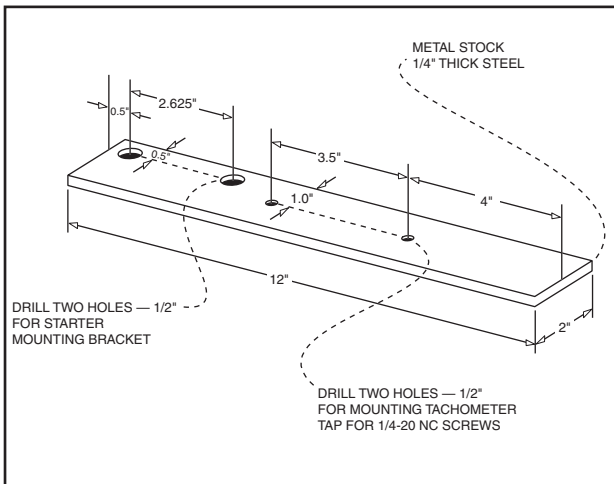

Figure 7-25. – Test Bracket

### REMOVE STARTER MOTOR:

It is recommended that the Starter Motor be removed from the engine when testing Starter Motor performance. Assemble starter to test bracket and clamp test bracket in vise (Figure 7-26).

### TESTING STARTER MOTOR:

1. A fully charged 12 volt battery is required.
2. Connect jumper cables and clamp-on ammeter as shown in Figure 7-26.
3. With the Starter Motor activated (jump the terminal on the Starter Contactor to battery voltage), note the reading on the clamp-on ammeter and on the tachometer (rpm).

**Note: Take the reading after the ammeter and tachometer are stabilized, approximately 2-4 seconds.**

4. A starter motor in good condition will be within the following specifications:

Minimum rpm	4500
Maximum Amps	50

**Note: Nominal amp draw of starter in generator is 60 amps.**

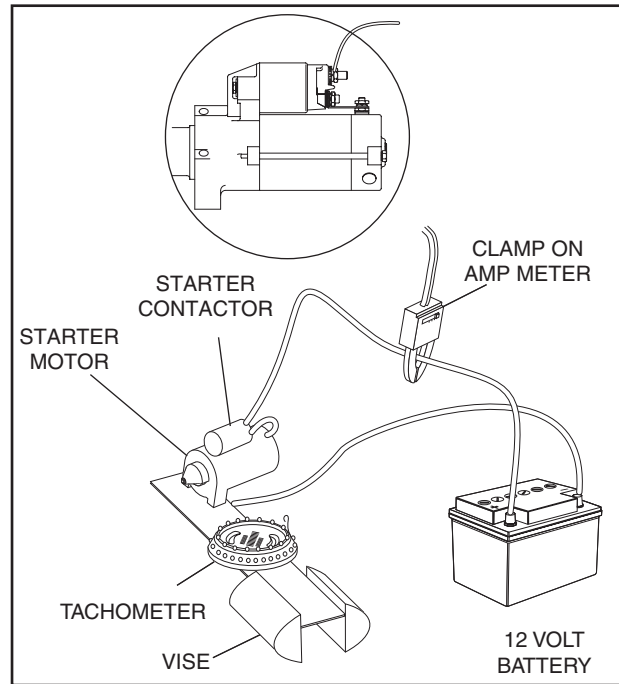

Figure 7-26. – Testing Starter Motor Performance

## TEST 28- CHECK FUEL SUPPLY

### DISCUSSION (GASOLINE MODELS):

If the engine cranks but won't start, don't overlook the obvious. The fuel supply may be low. Many RV generator installations "share" the fuel tank with the vehicle engine. When such is the case, the Installer may have used a generator fuel pickup tube that is shorter than the vehicle engine's pickup tube. Thus, the generator will run out of gas before the vehicle engine.

### PROCEDURE:

Check fuel level in the supply tank. Attach a fresh fuel supply if necessary and restart. Fuel may be stale, causing a hard start.

### RESULTS:

1. If necessary, replenish fuel supply.
2. If fuel is good, go to Test 29 (for Problem 7, Section 6).  
Go to Test 32 for Problem 8 (Section 6).

DISCUSSION (LPG MODELS):

LP gas is stored in pressure tanks as a liquid. The gas systems used with these generators were designed only for vapor withdrawal type systems. Vapor withdrawal systems use the gas vapors that form above the liquid fuel in the tank. Do NOT attempt to use the generator with any liquid withdrawal type system.

Gas pressure delivered to the solenoid valve must be properly regulated by means of a primary gas regulator. Mount the primary regulator at the gas tank outlet or in the supply line from the gas tank. The following rules apply:

- For best results, the primary regulator supplies gaseous fuel to the secondary regulator at 11 inches water column. Do NOT exceed 14 inches water column.
- The installer must be sure the primary regulator is rated at sufficient gas flow to operate the generator plus all other gas appliances in the circuit.

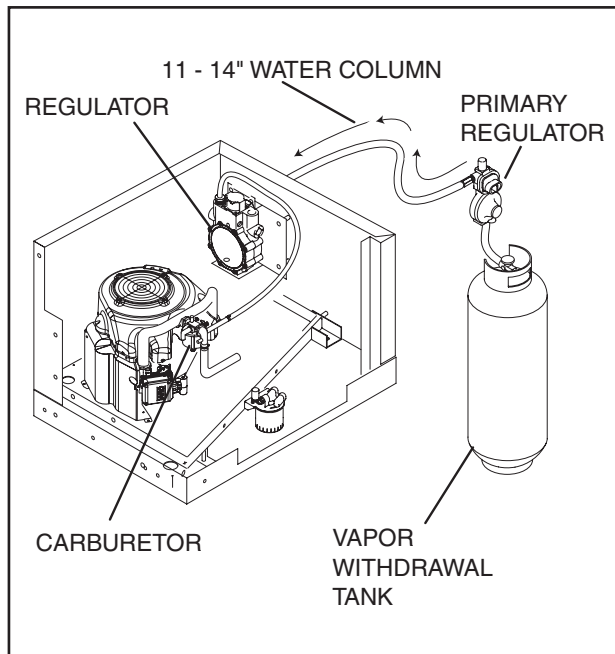

Figure 7-27 – Typical Propane Gas Fuel System

**NOTE: Recommended MINIMUM gas flow rate for all air-cooled QUIETPACT series generators is 67 cubic feet per hour.**

**If an existing primary gas regulator does not have a sufficient flow capacity for the generator and other gas appliances in the circuit, (a) install a primary regulator with adequate flow rate, or (b) install a separate regulator only and rated at least 67 cubic feet per hour. The inlet side of any primary regulator that supplies the generator must connect directly to a gas pressure tank. Do NOT tee the generator line into a gas circuit feeding other areas.**

**CAUTION!** Use only approved components in the fuel supply system. All components must be properly installed in accordance with applicable codes. Improper installation or use of unauthorized components may result in fire or an explosion. Follow approved methods to test the system for leaks. No leakage is permitted. Do not allow fuel vapors to enter the vehicle interior.

LP gas vapors should be supplied to the secondary regulator inlet at about 11 inches water column (positive pressure). The engine pistons draw air in during the intake stroke (Figure 7-28). This air passes through a carburetor venturi, which creates a low pressure that is proportional to the quantity of air being pumped. The low pressure from the carburetor venturi acts on the regulator diaphragm to pull the diaphragm toward the source of low pressure. A lever attached to the diaphragm opens a valve to permit gas flow through the carburetor.

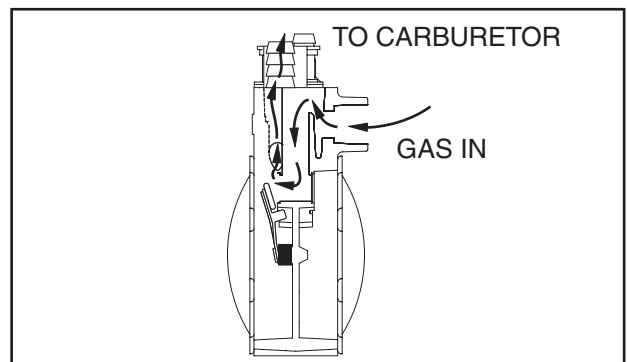

Figure 7-28 – LP Gas Carburetion Diagram

The greater the airflow through the carburetor venturi, the lower the pressure at the venturi throat. The lower the pressure at the venturi throat, the greater the diaphragm movement, and the greater the movement of the regulator valve. The more the regulator valve opens, the greater the gas flow that is proportional to airflow through the generator.

The following facts about the secondary regulator must be emphasized:

- The regulator must be sensitive to venturi throat pressure changes throughout the operating range.
- The regulator must be properly adjusted so it will stop the flow of gas when the engine is not running (no air flow through the carburetor).
- The slightest airflow (and vacuum in the venturi throat) should move the regulator valve off its seat and permit gas to flow.

PROCEDURE:

A water manometer or a gauge that is calibrated in “ounces per square inch” may be used to measure the fuel pressure. Fuel pressure at the inlet side of the

## Section 7 DIAGNOSTIC TESTS

LPG Shut Off Valve should be between 11-14 inches water column as measured with a manometer. The LP system must be able to maintain 11-14 inches water column under all load requirements.

1. Turn LP supply to generator off.
2. Remove the Gas Pressure Tap from the fuel regulator and install manometer to this port.
3. Turn LP supply to generator on, the gauge should read 11-14 inches water column.
4. For Problem 8 only (Section 6), start the engine and the gauge should read 11-14 inches water column.

### RESULTS:

1. If the LP gas pressure is less than 11-14 inches water column the fuel supply system must be corrected in order to maintain 11-14 inches water column.
2. If the LP gas pressure is between 11-14 inches water Column, proceed to Test 29 for Problem 7 (Section 6). Proceed to Test 32 for Problem 8 (Section 6).

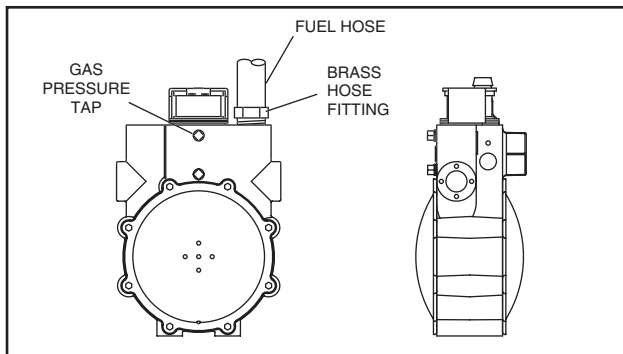

Figure 7-29. – Fuel Regulator

### TEST 29 - CHECK WIRE 14 POWER SUPPLY

#### DISCUSSION:

When the engine is cranked, Engine Controller Circuit Board action must deliver battery voltage to the Wire 14 circuit, or the engine will not start. This is because the Wire 14 circuit will operate the Fuel Pump and Fuel Solenoid on Gasoline models. On LP models it operates the LPG Shut-off valve.

#### PROCEDURE:

Inside the generator panel, locate the 4-tab terminal connector (Figure 7-30). Then, proceed as follows:

1. Set a VOM to read battery voltage (12 VDC).
2. Connect the meter positive (+) test lead to the 4-tab terminal connector, the common (-) test lead to frame ground.

3. Crank the engine and the meter should read battery voltage. If battery voltage is not measured, proceed to Step 4.
4. Connect the positive (+) meter test lead to Terminal J2 on the Engine Controller Circuit Board. Connect the negative (-) test lead to a clean frame ground (see Figure 5-3, Page 24).
5. Crank the engine. The meter should indicate battery voltage.

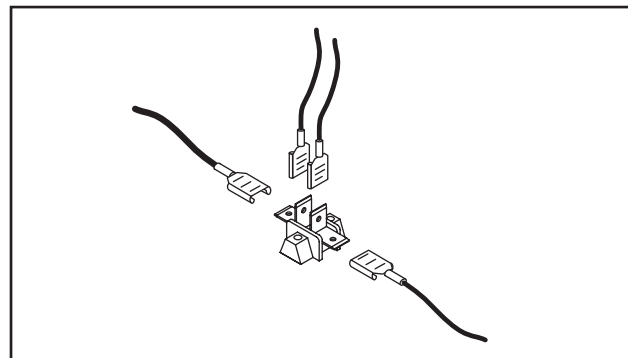

Figure 7-30. – The 4-tab Connector

### RESULTS:

1. If the meter indicated battery voltage, go to Test 19.
2. If battery voltage was NOT indicated in Step 3 but is indicated in Step 5, check Wire 14 between the 4-tab connector and the Engine Controller circuit board.
  - a. Repair, reconnect or replace Wire 14 as necessary.
3. If battery voltage was not indicated in Step 5, replace the Engine Controller Circuit Board.

### TEST 30 - CHECK WIRE 18

#### DISCUSSION:

Wire 18 controls sending the STOP signal to the Engine Controller Circuit Board. If Wire 18 contacts ground it will initiate a shutdown. Coach manufacturers sometimes install a 15 to 30 foot remote harness. A ground on Wire 18 in a remote harness can also cause a shutdown.

#### PROCEDURE:

1. Remove the remote harness connector from the generator and re-test. If generator continues to run, a short is present in the remote harness. Repair or replace the remote harness.
2. Remove the J1 connector from the Engine Controller Circuit Board. Set the VOM to measure resistance. Connect one test lead to Pin Location J1-14. Connect the other test lead to a clean frame ground. "Infinity" should be measured.

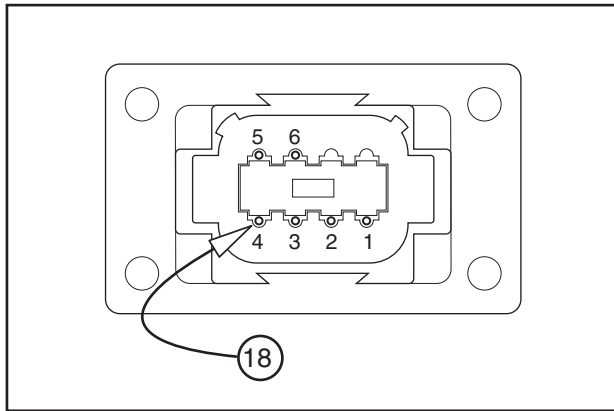

*Figure 7-31. – Remote Harness Connector*

3. Connect one test lead to Pin Location J1-15. Connect the other test lead to a clean frame ground. “Infinity” should be measured.

**RESULTS:**

1. If “Continuity” is measured in Step 2, repair or replace shorted Wire 18 between J1 Connector and Start-Stop Switch.
2. If “Continuity” was measured in Step 3, repair or replace shorted Wire 18 between J1 Connector and remote panel connector.
3. If Wire 18 checks GOOD, proceed to Problem 8 (Section 6).

**TEST 31 - CHECK FUEL SOLENOID  
(GASOLINE MODELS)**

**DISCUSSION:**

If the Fuel Solenoid fails to open, the engine will not start.

**PROCEDURE:**

1. Remove Control Panel cover. Remove Wire 56 from the Starter Contactor Relay. This will prevent the unit from cranking during test (see Figure 7-19, Page 51).
2. Remove air filter cover. Disconnect Connector 2 which connects to the fuel pump.
3. Activate the Start-Stop Switch (SW1) to the START position and hold. This will activate the fuel solenoid. The fuel solenoid should energize and produce an audible click. If the fuel solenoid does not operate, proceed to Step 4. Reconnect Connector 2 back to the fuel pump.
4. Set the VOM to measure DC voltage. Disconnect Wire 14 from the Fuel Solenoid. Connect the positive (+) meter test lead to Wire 14 that goes to the control panel. Connect the negative (-) test lead to a clean frame ground. Activate the Start-Stop Switch (SW1) to the START position and hold. Battery voltage should be measured.

5. Set the VOM to measure resistance. Disconnect Wire 0 from the Carburetor at the bullet connector. Connect one test lead to Wire 0 that goes to the control panel. Connect the other test lead to a clean frame ground. “Continuity” should be measured.

6. Connect one test lead to the Green Wire going to the carburetor. Connect the other test lead to the carburetor body. “Continuity” should be measured.

**Short to Ground:**

7. Set the VOM to measure resistance. Disconnect the bullet connector going to the Fuel Solenoid. Connect one meter test lead to the Red Wire going to the Fuel Solenoid. Connect the other meter test lead to the Fuel Solenoid housing. A reading of 38.0 ohms should be measured. If very low resistance is measured, a short to ground exists. (Fuel Solenoid coil resistance is approximately 38.0 ohms. Current draw of the Fuel Solenoid at nominal voltage is approximately 331 milliamps or 0.331 amps).

**RESULTS:**

1. If the Fuel Solenoid passes Steps 4 & 5 but does NOT operate in Step 3, replace or repair Fuel Solenoid.
2. If battery voltage is not measured in Step 4, repair or replace Wire 14 between the 4-Tab Terminal Connector (TC) and the Fuel Solenoid.
3. If “Continuity” is not measured in Step 5, repair or replace Wire 0 between the Fuel Solenoid and ground terminal.
4. If “Continuity” is not measured in Step 6, repair or replace Carburetor ground wire.
5. If the Fuel Solenoid operates, proceed to Test 32.

**TEST 32 - CHECK IGNITION SPARK**

**DISCUSSION:**

A problem in the engine ignition system can cause any of the following:

- Engine will not start.
- Engine starts hard, runs rough.

A commercially available spark tester may be used to test the engine ignition system. One can also be purchased from Generac Power Systems (Part No. 0C5969).

**PROCEDURE:**

1. Disconnect a high tension lead from a spark plug.
2. Attach the high tension lead to the spark tester terminal.
3. Ground the spark tester clamp by attaching to the cylinder head (see Figure 7-32).

## Section 7 DIAGNOSTIC TESTS

4. Crank the engine rapidly. Engine must be cranking at 350 rpm or more. If spark jumps the tester gap, you may assume the ignition system is working properly. Repeat on remaining cylinder spark plug.
5. To determine if an engine miss is ignition related, connect the spark tester in series with the high tension lead and the spark plug. Then, start the engine. If spark jumps the tester gap at regular intervals, but the engine miss continues, the problem may be in the spark plug or fuel system. Repeat on remaining cylinder spark plug. Proceed to Test 33.
6. If spark jumps the tester gap intermittently, the problem may be in the Ignition Magneto. Proceed to Test 34.

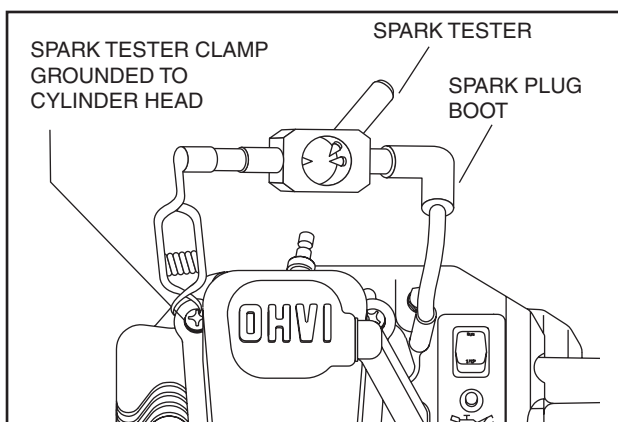

Figure 7-32. – Testing Ignition System

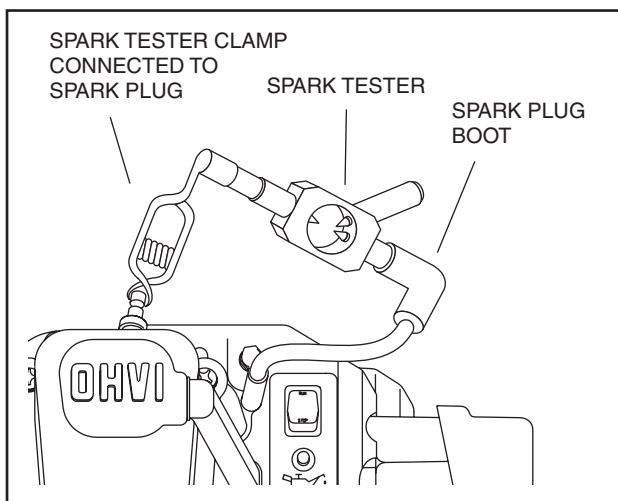

Figure 7-33. – Checking Engine Miss

### RESULTS:

1. If no spark or if engine miss is apparent, go to Test 34.
2. If ignition spark is good, go to Test 33.

### CYLINDER BALANCE TEST:

If the engine is hard starting, runs rough, misses or lacks power, perform a cylinder balance test to determine whether both cylinders are operating to their full potential.

Tools Required:

1. Two Ignition Testers (Generac P/N 0C5969)

Attach an ignition tester between the spark plug lead and each spark plug (Figure 7-33).

Start and run engine running at top no load speed and note spark at ignition testers. If the spark is equal at both ignition testers, the problem is not ignition related. A spark miss will be readily apparent. Now note RPM of engine. Ground out one cylinder by contacting ignition tester and a good ground on engine (Figure 7-34). Note RPM loss. Then ground out the other spark plug and note the RPM loss. If the difference between the two cylinders does not exceed 75 RPM, the amount of work the two cylinders are doing should be considered equal.

If the RPM loss is greater than 75 RPM this indicates that the grounded cylinder with the least RPM loss is the weakest of the two cylinders. Look to that cylinder for a problem.

Example:

Engine RPM - Both Cylinders = 2570 RPM

Engine RPM - No. 1 Cylinder Grounded = 2500 RPM

Engine RPM - No. 2 Cylinder Grounded = 2300 RPM

Conclusion: No. 1 cylinder is weakest of the two cylinders.

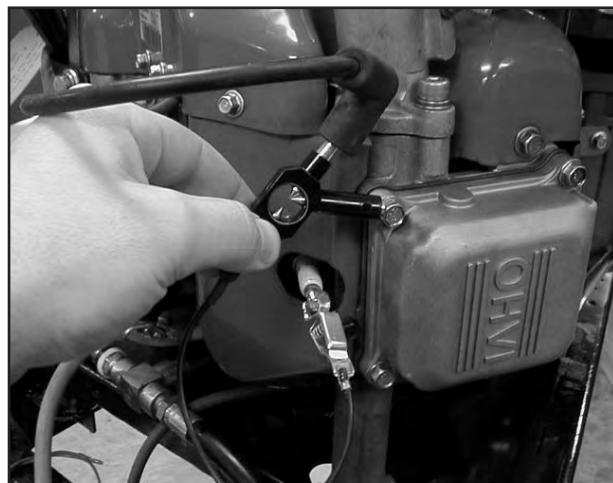

Figure 7-34. – Cylinder Balance Test

The cylinder balance test will also detect a cylinder that is not functioning. When grounding out one cylinder there will be no RPM loss. When the other cylinder is grounded out the engine will stop.

### **TEST 33 - CHECK SPARK PLUGS**

**DISCUSSION:**

During Test 32, if spark jumped the tester gap, the ignition system must be functioning properly. However, if the engine misses the spark plug itself may be fouled.

**PROCEDURE:**

Remove spark plugs. Clean with a commercial solvent. **DO NOT BLAST CLEAN SPARK PLUGS.** Replace spark plugs if badly fouled, if ceramic is cracked, or if badly worn or damaged. Set gap to 0.030 inch (0.76mm). Use a Champion RC14YC (or equivalent) replacement spark plug.

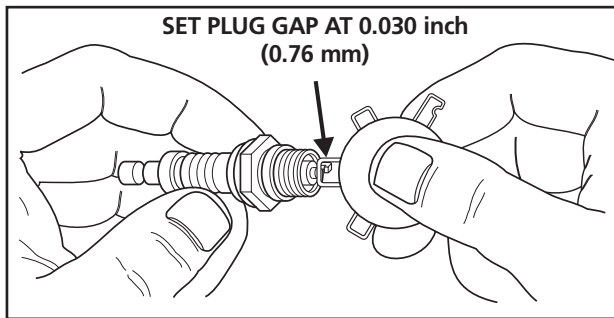

*Figure 7-35 – Setting Spark Plug Gap*

**RESULTS:**

1. Clean and regap or replace spark plug as necessary.
2. If spark plugs are good for gasoline models, go to Test 36. For LPG models, go to Test 35.

### **TEST 34 - CHECK AND ADJUST IGNITION MAGNETOS**

**DISCUSSION:**

The ignition system used on GTV-760 engines is a solid-state (breakerless) type. The system utilizes a magnet on the engine flywheel to induce a relatively low voltage into an ignition magneto assembly. Ignition magneto internal components increase the voltage and deliver the resulting high voltage across the spark plug gap.

The ignition magneto houses a solid state-circuit board that controls ignition timing. Timing is fixed and spark advance is automatic.

Major components of the ignition system include (a) two ignition magneto assemblies, (b) the spark plugs, (c) the engine control board and (d) the engine flywheel.

Solid-state components encapsulated in the ignition magneto are not accessible and cannot be serviced.

If the magneto is defective, the entire assembly must be replaced. The air gap between the magneto and the flywheel magnet is between 0.012" to 0.015".

The ignition magneto assembly (Figure 7-36) consists of (a) ignition magneto, (b) spark plug high tension lead and (c) spark plug boot.

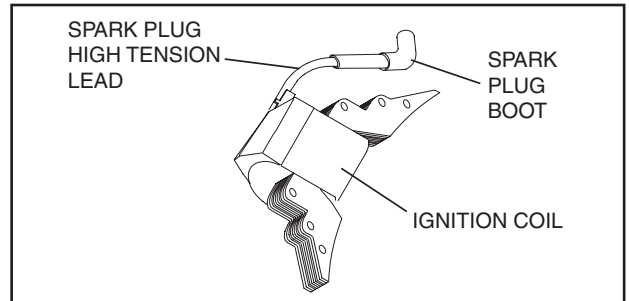

*Figure 7-36. – Ignition Magneto Assembly*

In Test 32, a spark tester was used to check for engine ignition. If sparking or weak spark occurred, one possible cause might be the ignition magneto(s). This test consists of adjusting the air gap between the ignition magneto(s) and the flywheel. The flywheel and flywheel key will also be checked during this test. If no sparking occurs, the ground harness may be at fault.

**PROCEDURE:**

1. Disconnect the J1 connector from the Engine Control Board. Carefully remove Wire 18A from Pin Location J1-4. Connect the J1 connector back to the engine control board. Repeat Test 32 "Check Ignition Spark". If the unit now produces spark go to Step 2. If the unit does not produce spark or has weak spark go to Step 4.
2. Do the following:
  - a. Set a VOM to measure resistance. Connect the positive (+) meter test lead to Wire No.18A (Wire 18A still removed from the J1 connector) Connect the negative (-) meter test lead to a clean frame ground. "Infinity" should be measured, or 0.5 to 1M ohms, depending upon the type of VOM used. If "Continuity" is measured proceed to Step12.
  - b. Set a VOM to the diode test range. Attach the negative (-) meter test lead to Pin Location J1-4 on the Engine Control Board. (Wire 18A still removed from the J1 connector) Attach the positive (+) meter test lead to frame ground. Set the Start-Stop Switch to START. "Infinity" should be measure during cranking and running. If the VOM does not have a diode test range, set VOM to measure resistance again. "Infinity" should be measured.

## Section 7 DIAGNOSTIC TESTS

- If Step 1 produced spark and Step 2 tested good, set the VOM to measure DC voltage. Connect one test lead to Wire 15 (J3 Terminal) on ECB. Connect the other test lead to frame ground. Battery voltage should be measured. Verify that Wire 15 is connected to J3 and that Wire 14 is connected to J2; if reversed the unit will produce no spark.
- Rotate the flywheel until the magnet is under the module (armature) laminations (see Figure 7-37).
- Place a 0.012-0.015 inch thickness gauge between the flywheel magnet and the module laminations.
- Loosen the mounting screws and let the magnet pull the magneto down against the thickness gauge.
- Tighten both mounting screws.
- To remove the thickness gauge, rotate the flywheel.
- Repeat the above procedure for the second magneto.

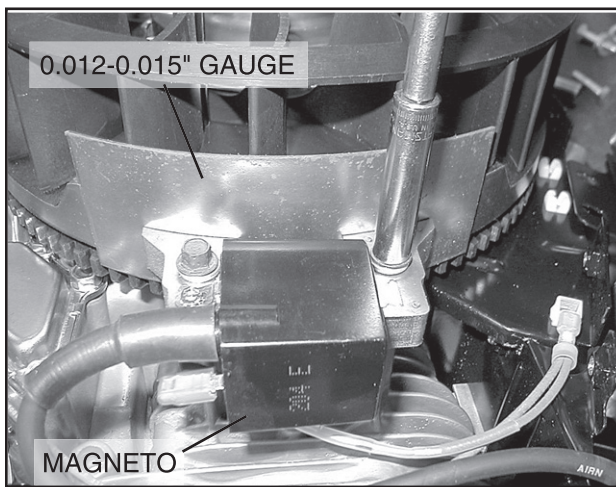

Figure 7-37. – Setting Ignition Magneto (Armature) Air Gap

- Repeat Test 55 and check for spark across the spark tester gap.
- If air gap was not out of adjustment, test ground wires.
- Set the VOM to the diode test position. The meter will display forward voltage drop across the diode. If the voltage drop is less than 0.7 volts, the meter will “Beep” once as well as display the voltage drop. A continuous tone indicates “Continuity” (shorted diode). An incomplete circuit (open diode) will be displayed as “OL.”
- Disconnect the engine ground harness from the ignition magnetos and stud connector (see Figure 7-38).

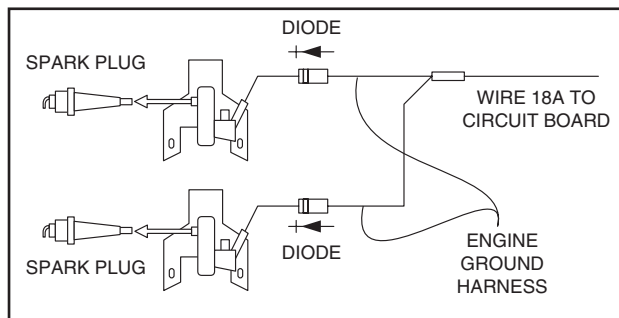

Figure 7-38. – Engine Ground Harness

SWITCH ON	TURNED OFF	CAUSE
Engine Runs On One Cylinder	Shuts Off OK	1 Closed Diode
Engine Runs (Both Cylinders)	Only One Cylinder Shuts Off	1 Open Diode
Won't Run (No Spark)		2 Closed Diodes
Engine Runs (Both Cylinders)	Engine Won't Shut Off	2 Open Diodes

Figure 7-39. – Diode Failure Diagnosis

- Connect the positive (+) test lead to Connector “A” (as shown in Figure 7-40). Connect the negative (-) test lead to Connector “B.”
  - If meter “Beeps” once and displays voltage drop, then the diode is good.
  - If the meter makes a continuous tone, the diode is bad (shorted) and the harness must be replaced.
  - If the meter displays “OL,” the diode is defective (open) and the harness must be replaced.
  - Now repeat Steps 14a through 14c with the negative meter test lead connected to Connector “C” (Figure 7-40).
- If the ground harness tested good, check Wire 18A between the insulated terminal stud and the J1 Connector for a short to ground. Set a VOM to measure resistance. The ground harness should still be disconnected from the ignition magnetos. Connect one meter test lead to Wire 18A which is still removed from the J1 Connector. Connect the other meter test lead to frame ground. “Infinity” should be measured.

### RESULTS:

- If “Infinity” was not measured in Step 2b, replace the Engine Control Board.

**Note: If VOM was set to Diode test, a reading of 0.5 volts would be observed when the Start-Stop Switch is set to STOP. If the VOM was set to resistance, a reading of 0.5 to 1.5M ohms would be**

*measured. During cranking and running this reading should go to "Infinity". Verify that the meter leads were properly connected as per Step 2 instructions.*

- If battery voltage was not measured in Step 3, reconnect Wire 15 and Wire 14 to their correct terminal locations.

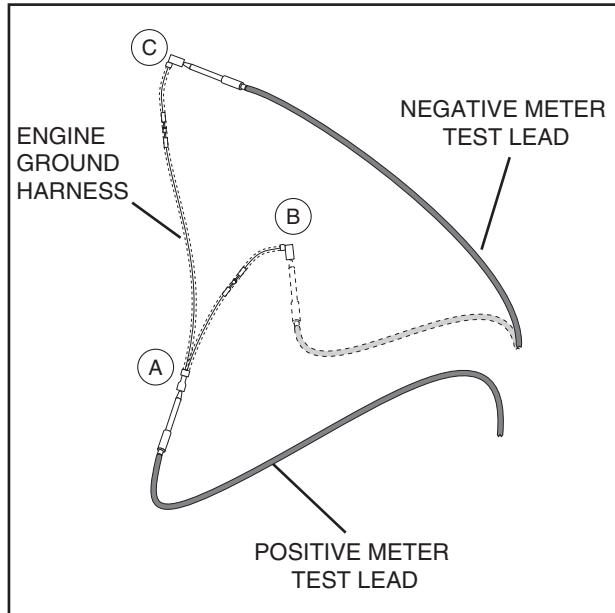

Figure 7-40. – Engine Ground Harness Test Points

- If "Infinity" was not measured in Step 15, repair or replace grounded Wire 18A between the J1 Connector and the insulated terminal stud or defective insulated terminal stud.
- If sparking still does not occur after adjusting the armature air gap, testing the ground wires and performing the basic flywheel test, replace the ignition magneto(s).

**Note: Before replacing the Ignition Magneto, check the Flywheel Magnet.**

**CHECKING FLYWHEEL MAGNET:**

The flywheel magnet rarely loses its magnetism. If you suspect a magnet might be defective, a rough test can be performed as follows:

- Place the flywheel on a wooden surface.
- Hold a screwdriver at the extreme end of its handle and with its point down.
- Move the tip of the screwdriver to about 3/4 inch (19mm) from the magnet. The screwdriver blade should be pulled in against the magnet.

**FLYWHEEL KEY:**

In all cases, the flywheel taper is locked on the crankshaft taper by the torque of the flywheel nut. A key-

way is provided for alignment only and theoretically carries no load.

If the flywheel key becomes sheared or even partially sheared, ignition timing can change. Incorrect timing can result in hard starting or failure to start.

Remove and inspect flywheel key for damage.

**TEST 35 - CHECK VALVE ADJUSTMENT**

**DISCUSSION:**

The valve lash must be adjusted correctly in order to provide the proper air/fuel mixture to the combustion chamber.

**ADJUSTING VALVE CLEARANCE:**

Adjust valve clearance with the engine at room temperature. The piston should be at top dead center (TDC) of its compression stroke (both valves closed).

An alternative method is to turn the engine over and position the intake valve fully open (intake valve spring compressed) and adjust the exhaust valve clearance. Turn the engine over and position the exhaust valve fully open (exhaust valve spring compressed) and adjust the intake valve clearance.

Correct valve clearance is given below, in INCHES (MILLIMETERS).

<b>Intake Valve</b>	<b>0.002-0.004 (0.05-0.1)</b>
<b>Exhaust Valve</b>	<b>0.002-0.004 (0.05-0.1)</b>

- Loosen the rocker arm jam nut. Use a 10mm allen wrench to turn the pivot ball stud while checking the clearance between the rocker arm and valve stem with a feeler gauge (see Figure 7-41).

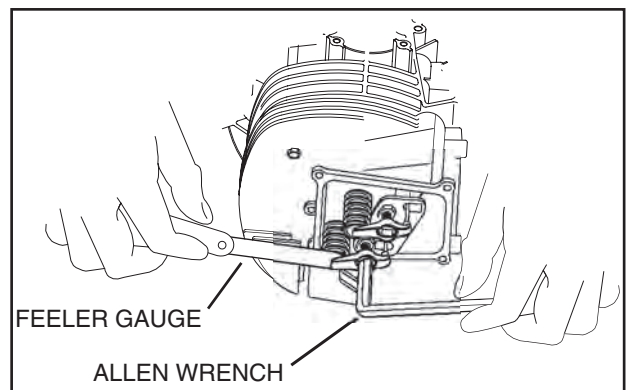

Figure 7-41 – Adjusting Valve Clearance

- When clearance is correct, hold the pivot ball stud with the allen wrench and tighten the rocker arm jam nut to the specified torque with a crow's foot. After tightening the jam nut, recheck valve clearance to make sure it did not change.

**TORQUE SPECIFICATION**  
**ROCKER ARM JAM NUT**  
**174 inch-pounds**

## Section 7

### DIAGNOSTIC TESTS

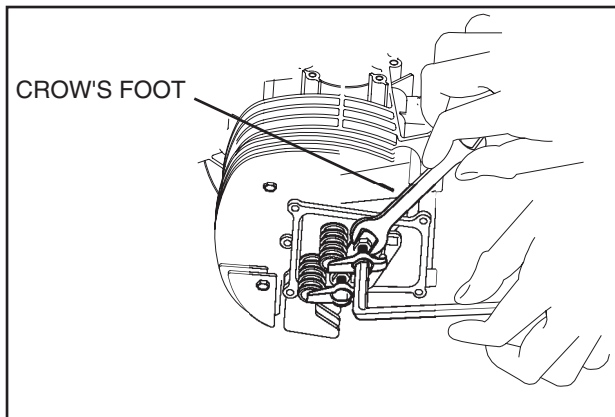

Figure 7-42 – Tightening the Jam Nut

#### INSTALL ROCKER ARM COVER

1. Use a new rocker arm cover gasket. Install the rocker arm cover and retain with four screws.

#### RESULTS:

Adjust valves to specification and retest. If problem continues, go to Test 38.

### **TEST 36 - CHECK CARBURETION**

#### DISCUSSION:

If the engine cranks but will not start, one possible cause of the problem might be the carburetion system.

#### PROCEDURE:

Before making a carburetion check, be sure the fuel supply tank has an ample supply of fresh, clean gasoline.

Check that all shutoff valves are open and fuel flows freely through the fuel line.

Make sure the automatic choke operates properly.

If the engine will not start, remove and inspect the spark plug. If the spark plug is wet, look for the following:

- Overchoking.
- Excessively rich fuel mixture.
- Water in fuel.
- Intake valve stuck open.
- Needle/float stuck open.

If the spark plug is dry look for the following:

- Leaking carburetor mounting gaskets.
- Intake valve stuck closed.
- Inoperative fuel pump.
- Plugged fuel filter(s).
- Varnished carburetor

If the engine starts hard or will not start, look for the following:

- Physical damage to the AC generator. Check the Rotor for contact with the Stator.

- Starting under load. Make sure all loads are disconnected or turned off before attempting to crank and start the engine.

- Check that the automatic choke is working properly.

#### RESULTS:

If problem has not been solved, go to Test 37. If carburetor is varnished, clean or replace.

1. Remove fuel line at carburetor and ensure that there is an adequate amount of fuel entering the carburetor.
2. Remove the float bowl and check to see if there is any foreign matter in bottom of carburetor bowl.
3. The float is plastic and can be removed for access to the needle so it can be cleaned.
4. With all of this removed carburetor cleaner can be used to clean the rest of the carburetor before reassembly.
5. After cleaning carburetor with an approved carburetor cleaner, blow dry with compressed air and reassemble.

Shelf life on gasoline is 30 days. Proper procedures need to be taken for carburetors so that the fuel doesn't varnish over time. A fuel stabilizer must be used at all times in order to ensure that the fuel is fresh at all times.

### **TEST 37 - CHECK CHOKE SOLENOID**

#### DISCUSSION:

The automatic choke is active only during cranking. When the Start-Stop Switch is held at "START", a crank relay on the Engine Controller circuit board is energized closed to (a) crank the engine and (b) deliver a cyclic voltage to the Choke Solenoid via Wire 90. The Choke Solenoid will be pulled in for about two seconds, then deactivate for about two seconds. This cyclic choking action will continue as long as the engine is being cranked.

#### PROCEDURE:

1. Operational Check: Crank the engine. While cranking, the choke solenoid should pull in about every 2 seconds (2 seconds ON, 2 seconds OFF). If the choke solenoid does not pull in, try adjusting the choke as follows.
2. Pre-Choke Adjustment: With the CHOKE SOLENOID not actuated, the carburetor CHOKE PLATE should be approximately 1/8 Inch from its full open position. Verify choke is completely open once engine is warmed up. If not, power will be down and emissions will be up. Adjust position of BI-METAL HEATER ASSEMBLY by loosening screws until unit starts when cold and the choke closes when engine is up to temperature. Tighten the screws to complete the adjustment.
3. Choke Solenoid Adjustment: Loosen the screws that retain the CHOKE SOLENOID to its bracket. Slide the CHOKE SOLENOID in the slotted holes of the bracket to adjust axial move-

ment of the SOLENOID PLUNGER. Adjust SOLENOID PLUNGER movement until, with the carburetor CHOKE PLATE closed, the CHOKE SOLENOID is bottomed in its coil (plunger at full actuated position). With the CHOKE PLATE closed and the plunger bottomed in its coil, tighten the two screws. Verify that the choke solenoid plunger and linkage move freely without any drag or resistance that may restrict movement.

4. Disconnect Connector 1: Set the VOM to measure DC voltage. Connect the positive (+) test lead to Wire 90 (Pin 2) of Connector 1 going to the control panel. Connect the negative (-) test lead to frame ground. Activate the Start-Stop Switch to "START." During cranking, battery voltage should be measured cyclically every two seconds.

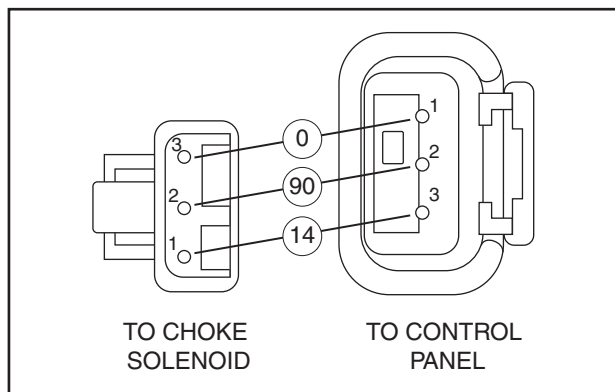

Figure 7-43. – Connector 1

5. If battery voltage was not measured in Step 4, check at J1 Connector: Connect positive (+) test lead to Pin Location J1-2 at the engine control board. Connect the negative (-) test lead to frame ground. Activate the Start-Stop Switch to "START." During cranking, battery voltage should be measured cyclically every two seconds.
6. Set the VOM to measure resistance. Disconnect Connector 1 from the Choke Solenoid. Connect one test lead to Wire 0 (Pin 1) of Connector 1, going to the control panel. Connect the other test lead to frame ground. "Continuity" should be measured.
7. Set the VOM to measure resistance. Disconnect Connector 1. Connect one meter test lead to Wire 90 (Connector 1, Pin 2) going to the Choke Solenoid. Connect the other meter test lead to Wire 0 (Connector 1, Pin 1). Approximately 3.7 ohms should be measured. (Current draw of Choke Solenoid at nominal voltage is 3.4 amps).

Short to Ground:

8. Set the VOM to measure resistance. Disconnect Connector 1. Connect one meter test lead to Wire 90 (Connector 1, Pin 2). Connect the other meter test lead to the metal Choke Solenoid housing. "Infinity" should be measured. If "Continuity" is measured, a short to ground exists.

### RESULTS:

1. If Choke operation is good, go to Test 35 for Problem 7, "Engine Cranks but Won't Start" (Section 6). Go to Test 41 for Problem 8, "Engine Starts Hard and Runs Rough".
2. If battery voltage was measured in Step 5 but not measured in Step 4, repair or replace Wire 90 between Engine Control Board (ECB) and Connector 1.
3. If battery voltage is not measured in Step 5 during engine cranking, replace Engine Control Board.
4. If "Continuity" is not measured in Step 6, repair or replace Wire 0 between the ground terminal and Connector 1.
5. If Choke Solenoid coil resistance is not measured or is incorrect in Step 7, replace the Choke Solenoid.

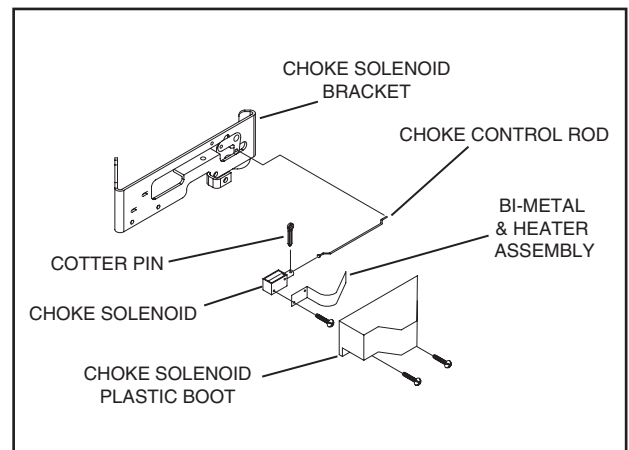

Figure 7-44. – Exploded View of Choke Assembly

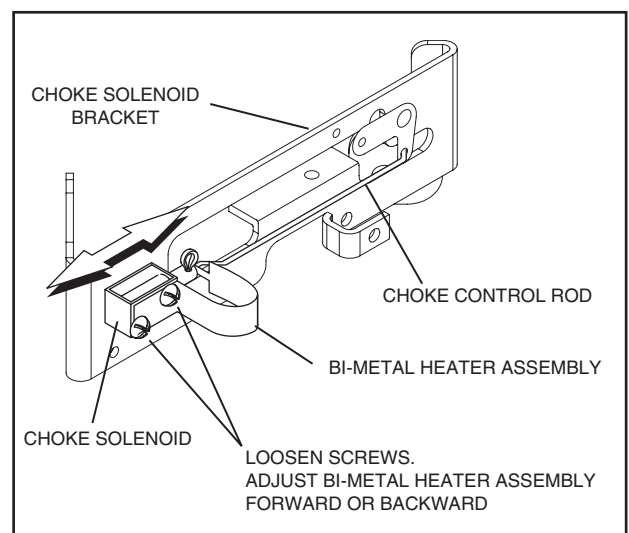

Figure 7-45. – Automatic Choke Assembly

## Section 7

### DIAGNOSTIC TESTS

#### **TEST 38 - CHECK ENGINE / CYLINDER LEAK DOWN TEST / COMPRESSION TEST**

##### GENERAL:

Most engine problems may be classified as one or a combination of the following:

- Will not start.
- Starts hard.
- Lack of power.
- Runs rough.
- Vibration.
- Overheating.
- High oil consumption.

##### DISCUSSION:

The Cylinder Leak Down Tester checks the sealing (compression) ability of the engine by measuring air leakage from the combustion chamber. Compression loss can present many different symptoms. This test is designed to detect the section of the engine where the fault lies before disassembling the engine.

##### PROCEDURE:

1. Remove a spark plug.
2. Gain access to the flywheel. Remove the valve cover.
3. Rotate the engine crankshaft until the piston reaches top dead center (TDC). Both valves should be closed.
4. Lock the flywheel at top dead center.
5. Attach cylinder leak down tester adapter to spark plug hole.
6. Connect an air source of at least 90 psi to the leak down tester.
7. Adjust the regulated pressure on the gauge to 80 psi.
8. Read the right hand gauge on the tester for cylinder pressure. 20 percent leakage is normally acceptable. Use good judgement, and listen for air escaping at the carburetor, the exhaust, and the crankcase breather. This will determine where the fault lies.
9. Repeat Steps 1 through 8 on remaining cylinder.

##### RESULTS:

- Air escapes at the carburetor – check intake valve.
- Air escapes through the exhaust – check exhaust valve.
- Air escapes through the breather – check piston rings.
- Air escapes from the cylinder head – the head gasket should be replaced.

##### CHECK COMPRESSION:

Lost or reduced engine compression can result in (a) failure of the engine to start, or (b) rough operation.

One or more of the following will usually cause loss of compression:

- Blown or leaking cylinder head gasket.
- Improperly seated or sticking-valves.
- Worn Piston rings or cylinder. (This will also result in high oil consumption).

**NOTE: It is extremely difficult to obtain an accurate compression reading without special equipment. For that reason, compression values are not published for the V-Twin engine. Testing has proven that an accurate compression indication can be obtained using the following method.**

##### PROCEDURE:

1. Remove both spark plugs.
2. Insert a compression gauge into either cylinder.
3. Crank the engine until there is no further increase in pressure.
4. Record the highest reading obtained.
5. Repeat the procedure for the remaining cylinder and record the highest reading.

##### RESULTS:

The difference in pressure between the two cylinders should not exceed 25 percent. If the difference is greater than 25 percent, loss of compression in the lowest reading cylinder is indicated.

**Example 1:** If the pressure reading of cylinder #1 is 165 psi and of cylinder #2, 160 psi, the difference is 5 psi. Divide "5" by the highest reading (165) to obtain the percentage of 3.0 percent.

**Example 2:** No. 1 cylinder reads 160 psi; No. 2 cylinder reads 100 psi. The difference is 60 psi. Divide "60" by "160" to obtain "37.5" percent. Loss of compression in No. 2 cylinder is indicated.

If compression is poor, look for one or more of the following causes:

- Loose cylinder head bolts.
- Failed cylinder head gasket.
- Burned valves or valve seats.
- Insufficient valve clearance.
- Warped cylinder head.
- Warped valve stem.
- Worn or broken piston ring(s).
- Worn or damaged cylinder bore.
- Broken connecting rod.
- Worn valve seats or valves.
- Worn valve guides.

**NOTE: Refer to Engine Service manual No. OE2081 for further engine service information.**

### **TEST 39 - CHECK OIL PRESSURE SWITCH**

**DISCUSSION:**

Also see “Operational Analysis” on Pages 18-23. The Low Oil Pressure Switch is normally-closed, but is held open by engine oil pressure during cranking and startup. Should oil pressure drop below a safe level, the switch contacts will close to ground the Wire 85 circuit. Engine controller board action will then initiate an automatic shutdown.

If the switch fails CLOSED, the engine will crank and start, but will then shut down after a few seconds.

If the switch fails OPEN, low oil pressure will not result in automatic shutdown.

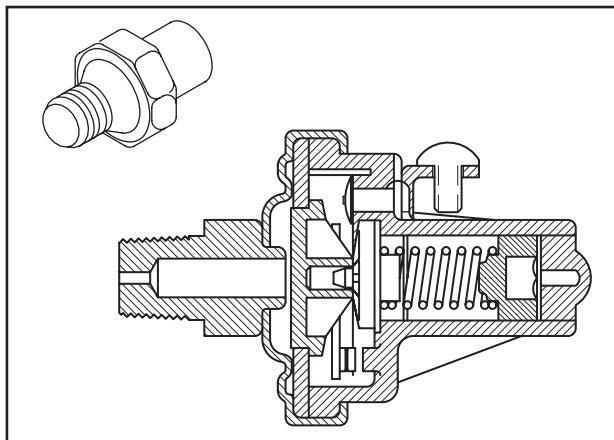

*Figure 7-46. – Oil Pressure Switch*

**PROCEDURE:**

1. Check engine oil level. If necessary, replenish oil level to the dipstick “FULL” mark.
2. Set a VOM to its “Rx1” scale and zero the meter.
3. Connect the meter test leads across the switch terminals, with engine shut down. The meter should read “Continuity”. A small amount of resistance is acceptable.
4. Crank the engine. Oil pressure should open the switch contacts at some point while cranking and starting. Meter should then indicate “Infinity”.
5. If the contacts did not open in Step 5, remove the low oil pressure switch and connect an oil pressure gauge in its place. Start the engine and measure oil pressure. Pressure should be above 10 psi.

**RESULTS:**

1. In Step 3, if “Continuity” is not indicated, replace the switch.
2. If oil pressure checked good in Step 5, but Step 4 measured “Infinity,” replace the low oil pressure switch.

3. If oil pressure is below 10 psi, determine cause of low oil pressure. Refer to Engine Service manual No. 0E2081 for further engine service information. Verify that the oil is the proper viscosity for the climate and season.

4. If all steps check GOOD, go to Test 40.

### **TEST 40 - TEST OIL TEMPERATURE SWITCH**

**DISCUSSION:**

If the engine cranks, starts and then shuts down, one possible cause of the problem may be a high oil temperature condition. Protective shutdown is a normal occurrence if the oil temperature switch exceeds approximately 270°F for gasoline units, or 284°F for LP units.

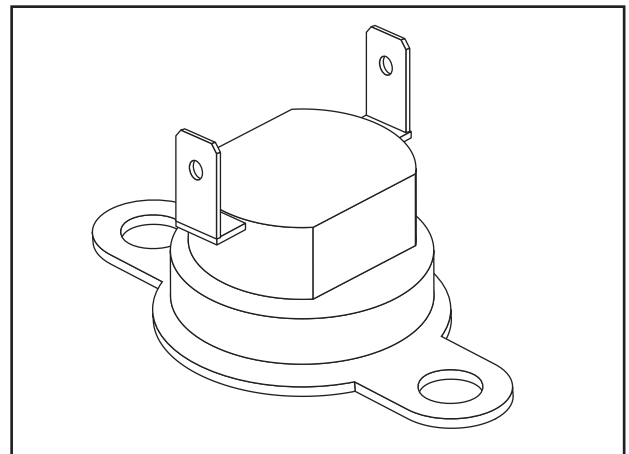

*Figure 7-47. – Oil Temperature Switch*

**PROCEDURE:**

1. Remove Wire 85 from Oil Temperature Switch terminal and start the generator. If engine starts and runs now, but shuts down when Wire 85 is connected to the switch terminal, the following possibilities exist:
  - a. Oil temperature is too high.
  - b. The oil temperature switch has failed closed or is shorted to ground.
2. Remove the switch and place its sensing tip into oil (Figure 7-48). Place a thermometer into the oil.
3. Connect the test leads of a VOM across the switch terminals. The meter should read “Infinity”.
4. Heat the oil. When oil temperature reaches approximately 270-284°F., the switch contacts should close and the meter should read “Continuity”.

## Section 7 DIAGNOSTIC TESTS

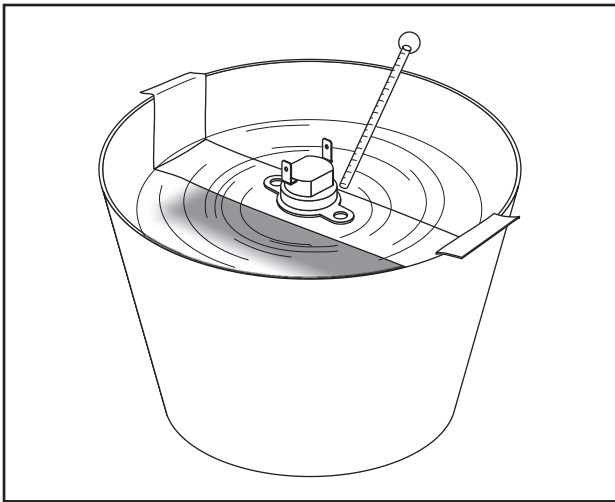

Figure 7-48. – Testing Oil Temperature Switch

### RESULTS:

1. If the Oil Temperature Switch fails Step 3 or Step 4, replace the Oil Temperature Switch.
2. If the Oil Temperature Switch is good, an overheat condition may be occurring. Verify that the installation of the generator is within specified tolerances. The generator must receive the proper amount of incoming air, and also be able to exhaust the cooling air with NO RESTRICTIONS. Check to be sure that the exhaust pipe is not under the air intake. Refer to the Owner's and Installation Manual for proper installation specifications. If installation is correct, go to Test 24.

### **TEST 41 - TEST CHOKE HEATER**

#### DISCUSSION:

The Choke Heater is a sensitive heating element wrapped around a temperature sensitive Bi-Metal strip. The BI-METAL HEATER ASSEMBLY positions the Choke Plate during startup. Once running, the Bi-Metal Heater Assembly will also allow the Choke Plate to fully open. Power for the heater element is supplied from Wire 14 to assist the Bi-Metal Heater Assembly in opening the Choke Plate after starting. Failure of the Choke Plate to open will cause an excessively rich fuel-air mixture and engine performance will suffer.

#### PROCEDURE:

1. Verify that the Choke Plate on the carburetor is mechanically free to move and is not binding. If the engine runs rough, check the operation of the BI-METAL HEATER ASSEMBLY. Allow the engine to run for five minutes, then inspect the choke position. The Bi-Metal strip should have been heated by the Choke Heater and should have expanded to allow the Choke Plate to open fully.

2. If the Choke Plate did not open in Step 1, check the Choke Heater. Set the VOM to measure DC voltage. Disconnect Connector 1 at the Choke Assembly. Connect the positive (+) meter test lead to Wire 14 (Connector 1, Pin 3) going to the control panel. Connect the negative (-) meter test lead to a clean frame ground. Set the Start-Stop Switch to "START." Battery voltage should be measured (see Figure 7-43 on Page 63).
3. If battery voltage was not measured in Step 2, set the VOM to measure resistance. Disconnect Connector 1 at the Choke Assembly. Connect one meter test lead to Wire 14 (Connector 1, Pin 3) going to the control panel. Connect the other meter test lead to the 4-tab Terminal for Wire 14 in the control panel. "Continuity" should be measured.

#### SHORT TO GROUND:

Set the VOM to measure resistance. Connect one meter test lead to Wire 14 (Connector 1, Pin 3) going to the Bi-Metal Heater Assembly. Connect the other meter test lead to the exposed steel portion of the Bi-Metal Heater Assembly. Approximately 37 ohms ( $\pm 20\%$ ) should be measured. (Current draw of the Bi-Metal Heater Assembly at nominal voltage is approximately 340 milliamps or 0.340 amps). If "Continuity" is present the Bi-Metal Heater Assembly has a short to ground.

#### RESULTS:

1. If Choke Plate is binding in Step 1, repair or replace binding Choke Plate. If Bi-Metal Heater Assembly tests good, go to Test 35.
2. If continuity was not measured in Step 3, repair or replace Wire 14 between the 4-tab Terminal and Connector 1.
3. If the resistance value is incorrect in the Short to Ground step, or the Bi-Metal Heater Assembly does not function with voltage present, replace the Bi-Metal Heater Assembly.

### **TEST 42 - CHECK LPG FUEL SOLENOID**

#### DISCUSSION:

If the LPG Fuel Solenoid (FS) fails to open, fuel will not be available to the engine and it will not start.

#### PROCEDURE:

1. Place one hand on the top of the LPG Fuel Solenoid. Activate the Fuel Prime Switch. You should be able to feel as well as hear the solenoid energize. If solenoid energizes discontinue testing.
2. Set VOM to measure resistance. Disconnect Wire 0 from the LPG Fuel Solenoid. Connect one meter test lead to Wire 0. Connect the other test lead to a clean frame ground. "Continuity" should be measured. Reconnect Wire 0 to LPG shut off valve.

SHORT TO GROUND:

Set VOM to measure resistance. Disconnect Wire 14A from the LPG Fuel Solenoid. Connect one meter test lead to LPG Fuel Solenoid terminal that Wire 14A was just removed from. Connect the other meter test lead to a clean frame ground. LPG Fuel Solenoid coil resistance of approximately 30-32 ohms Should be measured. Current draw of the LPG Fuel Solenoid at nominal voltage is approximately 380 milliamps or 0.380 amps.

RESULTS:

1. If the solenoid energized in Step 1, proceed to Test 32.
2. If "Continuity" was not measured in Step 2 repair or replace Wire 0 between the LPG Fuel Solenoid (FS) and the Ground Terminal (GT) in the control panel.
3. If "Continuity" was measured in Step 2, repair or replace the Fuel Solenoid (FS).

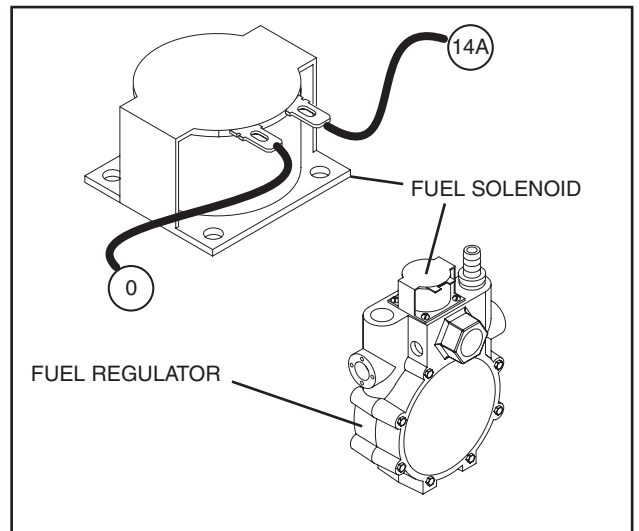

Figure 7-49. – Fuel Solenoid

## Section 8

### ASSEMBLY

#### **MAJOR DISASSEMBLY**

##### ENCLOSURE/PANEL REMOVAL:

1. Remove enclosure door.
2. Remove the nine (9) enclosure roof bolts from the perimeter of the enclosure roof (a 10mm socket is required).
3. Remove six (6) enclosure side panel bolts from the outside perimeter. Remove two (2) front & side enclosure panel bolts from the outside perimeter. Remove three (3) enclosure side panel bolts, located on the inside. Remove three (3) enclosure side panel nuts, two (2) on the top and one (1) on the side. Remove enclosure side panel (a 10mm socket is required).
4. Remove one (1) front & side panel enclosure nut located in the inside corner. Remove front & side enclosure panel (a 10mm socket is required).
5. Remove four (4) muffler bolts (a 13mm socket is required).
6. Loosen muffler clamp. Remove muffler (a 15mm wrench is required).
7. Remove three (3) side mounted muffler shield bolts. Remove two (2) muffler shield nuts located on the inside. Remove muffler shield (a 10mm socket is required).
8. Remove five (5) side and back enclosure panel bolts. Remove wing nut for control panel access. Remove three (3) upper control panel bolts. Remove one (1) upper control panel nut (a 10mm socket is required). Move control panel down-cut tie wraps on red and black wires to the circuit breaker.
9. Remove red and black wires from the circuit breaker. Remove two (2) white and one (1) green wire from the ground lug (using a 10mm deep well socket).
10. Remove customer-wiring conduit.
11. Remove one (1) upper control panel nut. Remove one (1) lower panel nut in corner. Remove two (2) nuts behind upper control panel.
12. Remove six (6) air in duct base bolts from top of stator. Remove air in duct base (a 10mm socket is required).

##### STATOR REMOVAL:

1. Perform enclosure/panel removal steps 1-12.
2. Remove six (6) air in duct base panel bolts from top of stator. Remove air in duct base (using a 10mm socket).
3. Remove four (4) standoff bolts from top of stator (a 13mm wrench is required).

4. Disconnect Wire 4 and Wire 0 from the brush holder assembly.
5. Remove two (2) brush holder assembly screws. Remove the brush holder assembly (a 7mm socket is required).
6. Remove Wire 11 and Wire 33 from the circuit breaker.
7. Remove Wire 66 and Wire 77 from the Battery Charge Rectifier (BCR).
8. Remove Wire 55 from the R1 resistor.
9. Remove Wire 11, Wire 22, and Wire 6 from the Voltage Regulator (VR).
10. Remove Wire 2 from the DPE circuit breaker (CB2).
11. Remove Wire 22 and Wire 44 from the ground lug.
12. Remove upper bearing carrier.
13. Remove stator.

##### ROTOR REMOVAL:

1. Perform Stator removal procedure steps 1-13.
2. Remove carburetor air tube.
3. Remove fuel line.
4. Remove two (2) lower control panel nuts (a 10mm socket is required).
5. Unplug choke solenoid connector.
6. Disconnect Wire 0 and Wire 14 from bullet connectors to fuel solenoid. Disconnect Wire 0 and Wire 85 from Low Oil Pressure (LOS) and High Temperature (HT) switches. Remove positive and negative battery cables from remote box. Unplug Wires 13,16 & 18 from bullet connectors. Remove control panel.
7. Remove four (4) vibration mount nuts (using a 13mm socket).
8. Remove two safety nuts (using a 15 mm socket).
9. Lift generator out of bottom tray.
10. Remove seven (7) blower housing screws. Remove blower housing (using a 1/4" socket).
11. Remove two (2) side belt tensioner bolts. Remove belt (a 13mm socket is required).
12. Remove rotor pulley bolt. (14 mm socket) Use steering wheel puller to remove pulley (use M6 x 1 bolts for puller).
13. Lift rotor and bottom bearing carrier out. Press rotor/bearing from bottom bearing carrier.

### BELT TENSIONING:

Tighten all four stator stud nuts to compress the spring to one half inch (1/2") between the washer and support slide.

Tighten the two side bolts to compress the spring to 5/8 of an inch between the washer and bearing carrier (see Figure 8-1).

### ENGINE REMOVAL:

1. Perform rotor removal steps 1-17.
2. Drain engine oil.
3. Remove engine pulley bolt (using a 14mm socket).
4. Remove engine pulley using steering wheel puller (using 5/16"-18 bolts for puller).
5. Remove 5 of 6 screws holding exhaust gaskets to tray (an 8mm socket is required).
6. Remove four (4) exhaust manifold bolts (using a 6mm allen wrench).
7. Remove last screw holding exhaust gasket to tray (an 8mm socket is required).

8. Remove four (4) engine mounting bolts (using a 14mm socket).
9. Remove oil fill line mounting clamp.
10. Remove two (2) oil lines to oil filter adapter.
11. Remove engine.

### STARTER REMOVAL:

1. Perform enclosure/panel removal steps 1-7.
2. Remove spark plug boot from spark plug left side/cylinder 1.
3. Remove nine (9) bolts from cylinder 1 wrap. Remove cylinder 1 wrap (using an 8mm socket).
4. Remove five (5) bolts from crankcase wrap (using an 8mm socket).
5. Remove four (4) bolts from oil cooler oil duct. Remove oil duct (both a 10mm socket and an 8mm socket are required).
6. Remove crankcase wrap.
7. Remove five (5) bolts holding blower housing (using an 8mm socket).

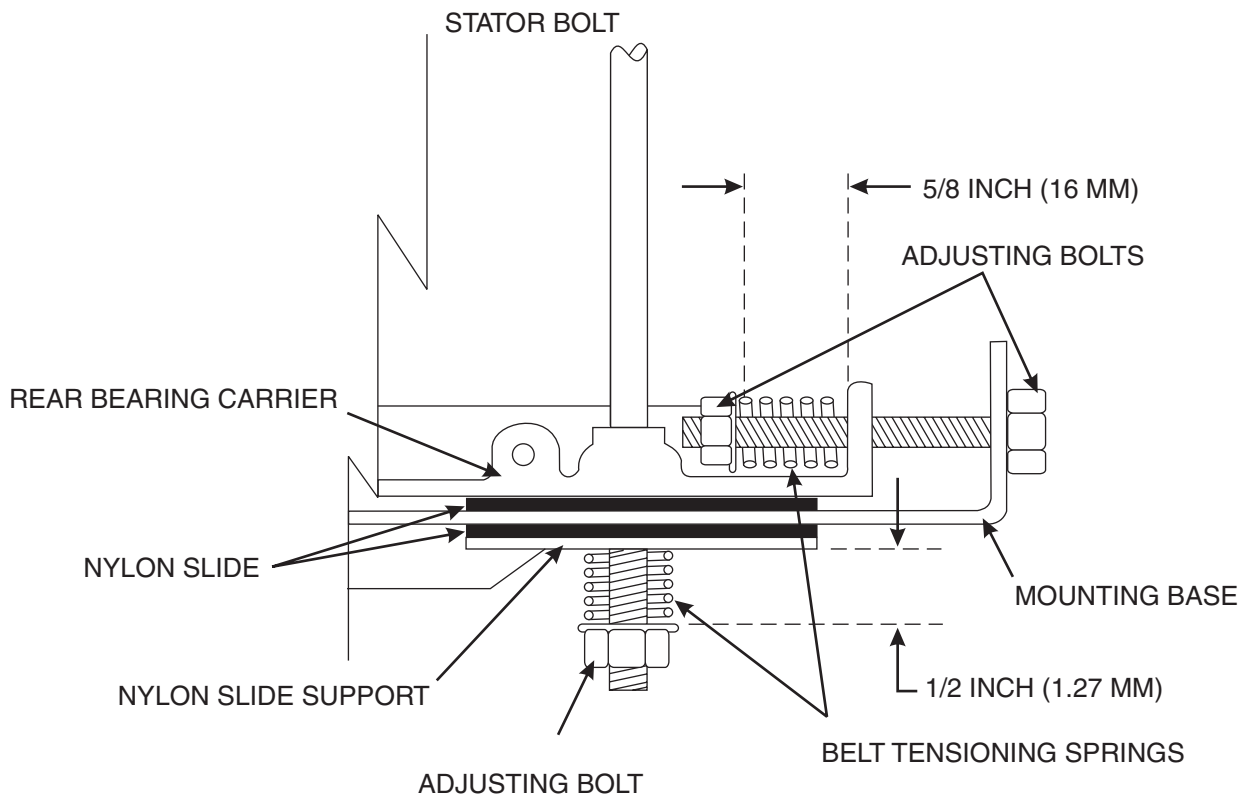

*Figure 8-1. – Drive Belt Tension*

## Section 8

### ASSEMBLY

---

8. Remove two (2) bolts holding blower housing on each cylinder head (a 10mm socket is required).
  9. Loosen four (4) allen head bolts for intake manifold. Tilt manifold forward to gain clearance (using a 6mm allen wrench).
  10. Remove blower housing.
  11. Remove negative cable from starter motor (using 13mm socket).
  12. Remove positive cable and Wire 13 from starter contactor on starter motor (using 13mm socket).
  13. Remove Wire 16 from spade terminal on starter contactor.
  14. Remove two (2) starter bolts (using 13mm socket).
  15. Remove starter motor, watch for possible shim washer on right side mounting bolt.
- FLYWHEEL/MAGNETO REMOVAL:
1. Perform enclosure/panel removal steps 1-7.
  2. Remove spark plug boot from spark plug on left side (Cylinder 1).
  3. Remove nine (9) bolts from cylinder 1 wrap. Remove Cylinder 1 wrap (using an 8mm socket).
  4. Remove five (5) bolts from crankcase wrap (using an 8mm socket).
  5. Remove four (4) bolts from oil cooler oil duct. Remove oil duct (both a 10mm socket and an 8mm socket are required).
  6. Remove crankcase wrap.
  7. Remove five (5) bolts holding blower housing (using an 8mm socket).
  8. Remove two (2) bolts holding blower housing on each cylinder head (a 10mm socket is required).
  9. Loosen four (4) allen head bolts for intake manifold. Tilt manifold forward to gain clearance (using a 6mm allen wrench).
  10. Remove blower housing. Adjust or replace magnetos as needed.
  11. Remove two (2) bolts from plastic fan on flywheel (using a 13mm socket).
  12. Remove flywheel nut.(36mm socket) Use steering wheel puller to remove flywheel (using M8 x 1.25 bolts for puller).



# Section 9 Exploded Views / Part Numbers

Base & Pulley – Drawing No. 0E1323-C

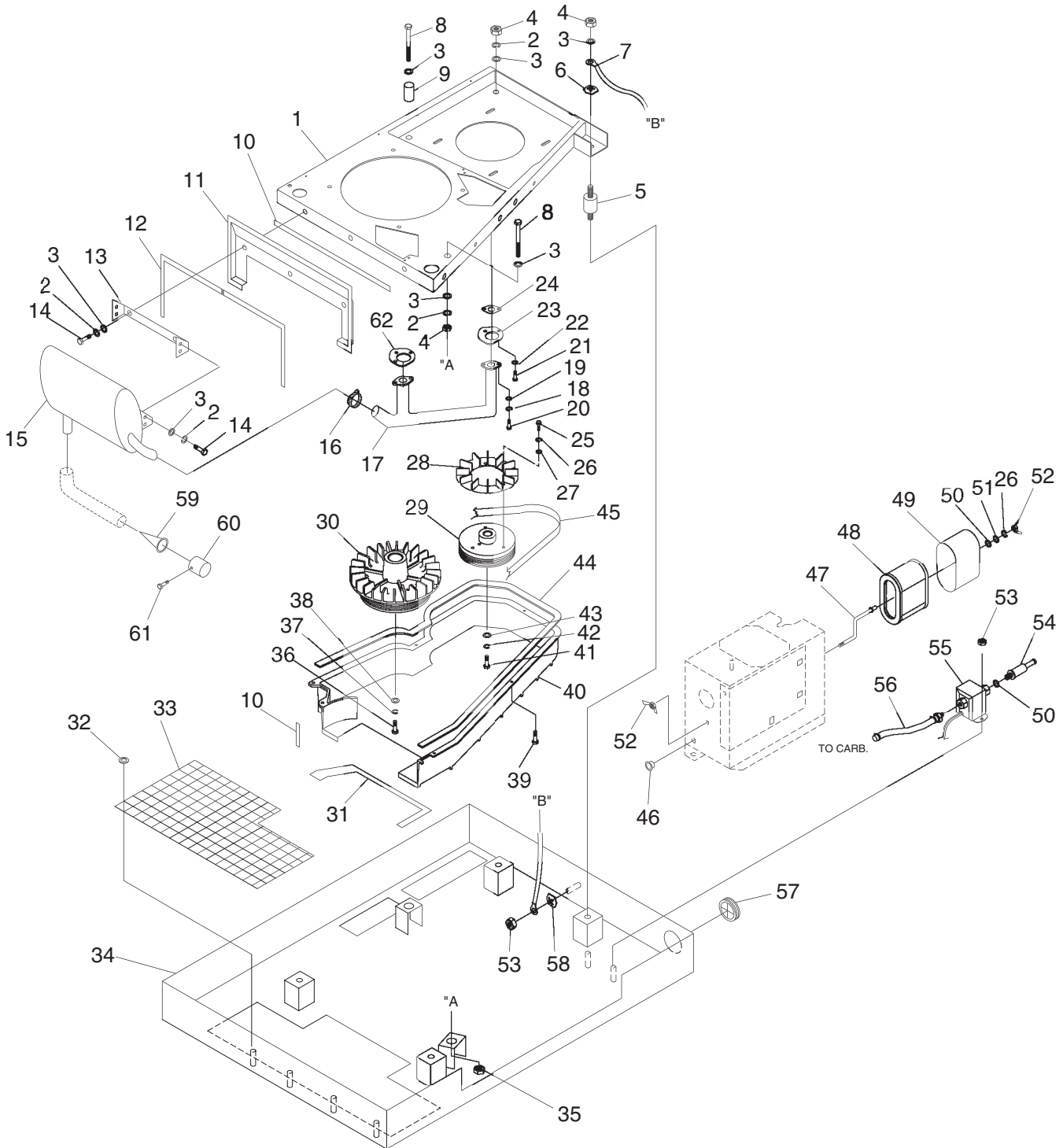

**Section 9**  
**Exploded Views / Part Numbers**

ITEM	QTY.	DESCRIPTION	ITEM	QTY.	DESCRIPTION
1	1	FRAME, 760 ENGINE	31	1	GASKET, BOTTOM AIR OUT QPRV
2	12	WASHER LOCK M8-5/16	32	4	WASHER SELF LOCKING 1"DIA 12GA
3	15	WASHER FLAT 5/16-M8 ZINC	33	1	SCREEN, BOTTOM AIR OUT
4	6	NUT HEX 5/16-18 STEEL	34	1	TRAY, V-TWIN RV
5	4	VIB MNT 1.5 X 1.38 X 5/16-18	35	2	NUT FLG 5/16-18 LOCK
6	1	WASHER LOCK SPECIAL 5/16	36	1	SCREW HHC 3/8-24 X 2-1/4 G8
7	1	EARTH STRAP	37	1	WASHER LOCK M10
8	2	SCREW HHC 5/16-18 X 3.5 SPC	38	1	WASHER FLAT 3/8-M10 ZINC
9	1	SPACER, SAFETY BOLT .375 I.D.	39	7	SCREW TAP-R #10-32 X 9/1
10	1.5 FT.	TAPE ELEC UL FOAM 1/8 X 1/2	40	1	BLOWER HOUSING GTV760 RV
11	1	DUCT, AIR OUT	41	1	SCREW HHC 3/8-24 X 1 G5
12	2	GASKET, AIR OUT DUCT	42	1	WASHER LOCK 3/8
13	1	BRACKET, MUFFLER SUPPORT	43	1	WASHER FLAT .406ID X 1.62OD
14	7	SCREW HHC M8-1.25 X 25 G8.8	44	1	SET, BLOWER HOUSING GASKET
15	1	MUFFLER, GTV760 RV	45	1	BELT, V-RIB 4LX42.5"
16	1	CLAMP, EXHAUST 1.25"	46	1	BUSHING SNAP (GASOLINE ONLY)
17	1	MANIFOLD, EXHAUST		1	PLUG PLASTIC 0.687" (LP ONLY)
18	4	WASHER LOCK M8 SS	47	1	STUD, M6-1.0 OFFSET
19	4	WASHER FLAT M8 SS	48	1	ELEMENT AIR FILTER
20	4	SCREW SHC M8-1.25 X 20 G12.9	49	1	PRECLEANER, AIR GTH990 GASOLINE
21	5	SCREW CRIMPTITE 10-24 X 1/2	50	2	FILTER GASKET RV (GASOLINE ONLY)
22	5	WASHER FLAT #10 ZINC		1	FILTER GASKET RV (LP ONLY)
23	1	GASKET, EXH BASE, GTV760 RV	51	1	WASHER FLAT .281"ID X 1.25"OD
24	2	GASKET, EXHAUST PORT	52	2	NUT WING M6-1.0
25	3	SCREW HHC M6-1.0 X 12 G8.8	53	3	NUT FLANGE M6-1.0 NYLOK (GASOLINE ONLY)
26	4	WASHER LOCK M6-1/4 (5.5 KW ONLY)		1	NUT FLANGE M6-1.0 NYLOK (LP ONLY)
	1	WASHER LOCK M6-1/4 (6.5 & 7.5 KW ONLY)	54	1	FILTER FUEL (GASOLINE ONLY)
27	3	WASHER FLAT 1/4-M6 ZINC (5.5 KW ONLY)	55	1	ASSEMBLY, NON SHUTOFF FUEL PUMP (GASOLINE ONLY)
28	1	FAN NYLON 7" DIA (5.5 KW ONLY)	56	1	ASSEMBLY, RV V-TWIN FUEL LINE (GASOLINE ONLY)
29	1	PULLEY, ALTERNATOR 2200 RPM (5.5 KW ONLY)	57	1	GROMMET, 38.1 DIA. CROSS SLIT (GASOLINE ONLY)
	1	PULLEY, ALTERNATOR 2500 RPM (6.5 & 7.5 KW ONLY)		1	PLUG PLASTIC 1.50" (LP ONLY)
30	1	PULLEY, ENGINE 2100 RPM (5.5 KW ONLY)	58	1	WASHER LOCK SPECIAL 1/4"
	1	PULLEY, ENGINE 2500 RPM (6.5 & 7.5 KW ONLY)	59	1	SCREEN, SPARK ARRESTOR
			60	1	RETAINER, SPARK ARREST SCREEN
			61	1	SCREW HHTT M4-0.7 X 8 BP
			62	1	GASKET, EXHAUST BASE

# Section 9 Exploded Views / Part Numbers

Enclosure – Drawing No. 0E1011-C

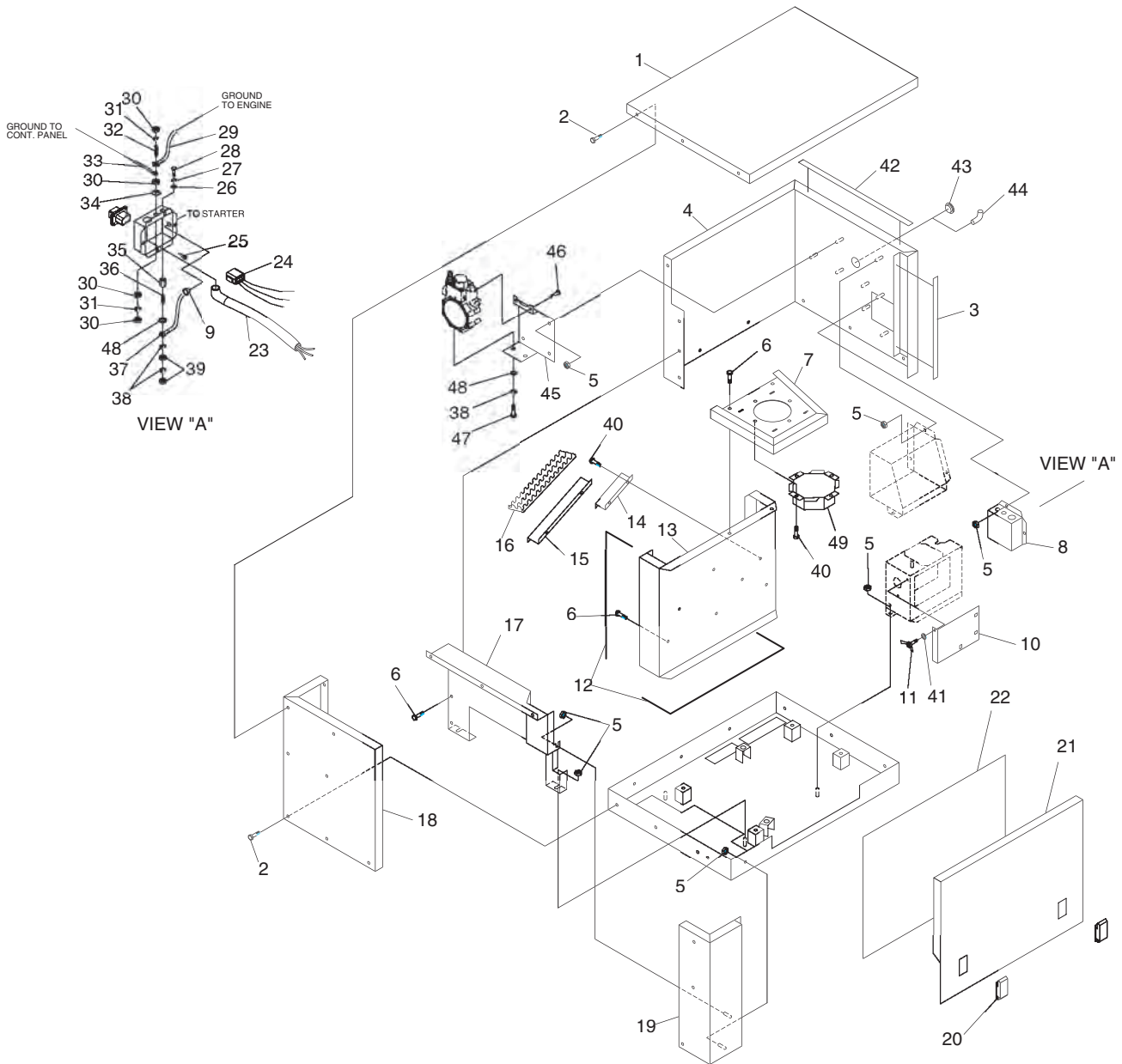

**Section 9**  
**Exploded Views / Part Numbers**

ITEM	QTY.	DESCRIPTION
1	1	PANEL, ENCLOSURE ROOF
2	22	SCREW SW 1/4-20X5/8 N WA JS500
3	11.5 FT.	TAPE ELEC UL FOAM 1/8 X 1/2"
4	1	PANEL, SIDE AND BACK ENCLOSURE
5	14	NUT FLANGE M6-1.0 NYLOK (GASOLINE ONLY)
	17	NUT FLANGE M6-1.0 NYLOK (LP ONLY)
6	8	SCREW HHTT M6-1.0 X 12 YC
7	1	PANEL, AIR IN DUCT BASE
8	1	PANEL, CUSTOMER CONNECTION
9	1	BUSHING SNAP SB-875-11
10	1	COVER, RV AIR CLEANER BOX
11	1	STUD WINGNUT M6-1.0 X 20MM NY
12	1	FOAM SEALING STRIP 1" X 12FT
13	1	PANEL, AIR IN DUCT BACK
14	1	BAFFLE, V-TWIN RV SHORT
15	1	BAFFLE, V-TWIN RV LONG
16	3.5	FOAM, AIR OUT COMPARTMENT
17	1	PANEL, MUFFLER SHIELD
18	1	PANEL, ENCLOSURE SIDE
19	1	PANEL, FRONT & SIDE ENCLOSURE
20	2	SLIDE LATCH, FLUSH
21	1	PANEL, ENCLOSURE DOOR
22	1	FOAM PANEL, DOOR 1/2" THK QP RV
23	1	HARNESS, AC OUTPUT (5.5, 6.5, & 7.5 KW ONLY)
	1	HARNESS, AC OUTPUT (5.0 & 7.0 KW-50 Hz ONLY)
24	1	CUST. CONN. 4KW RV REMOTE
25	4	SCREW HHTT M5-0.8 X 10 BP
26	1	WASHER FLAT 1/4-M6 ZINC
27	1	WASHER LOCK M6-1/4
28	1	SCREW HHC 1/4-20 X 1/2 G5
29	1	WIRE ASM. BATT. (NEG.) QP RV
30	4	NUT HEX JAM 3/8-16 BRASS
31	2	WASHER LOCK 3/8
32	1	STUD 3/8-16 X 2-1/4 BRASS
33	1	GND WIRE C/PNL TO STUD V-T RV
34	1	WASHER LOCK SPECIAL 3/8
35	1	NEUTRAL CONNETCTOR UL
36	1	STUD, 1/4-20 TO 5/16-18
37	1	WIRE ASM BATT. (POS.) QP RV
38	2	WASHER LOCK M8-5/16 (GASOLINE ONLY)
	4	WASHER LOCK M8-5/16 (LP ONLY)
39	2	NUT HEX 5/16-18 STEEL
40	8	SCREW HHTT M6-1.0 X 10 YC
41	1	WASHER NYLON .250
42	6.5 FT.	TAPE, 1/2" X 1/16" CLOSED CELL
43	1	PLUG PLASTIC 1.50" (GASOLINE ONLY)
44	1	ELBOW 90DEG 3/8X3/4 (LP ONLY)
45	1	BRACKET, LP REGULATOR MOUNTING (LP ONLY)
46	2	SCREW HHTT M4-0.7 X 10 BP (LP ONLY)
47	2	SCREW HHC M8-1.25 X 20 G8.8 (LP ONLY)
48	1	WASHER FLAT 5/16-M8 ZINC (GASOLINE ONLY)
	3	WASHER FLAT 5/16-M8 ZINC (LP ONLY)
49	1	PANEL, AIR IN DUCT

# Section 9 Exploded Views / Part Numbers

Sheet Metal – Drawing No. 0F1996-A

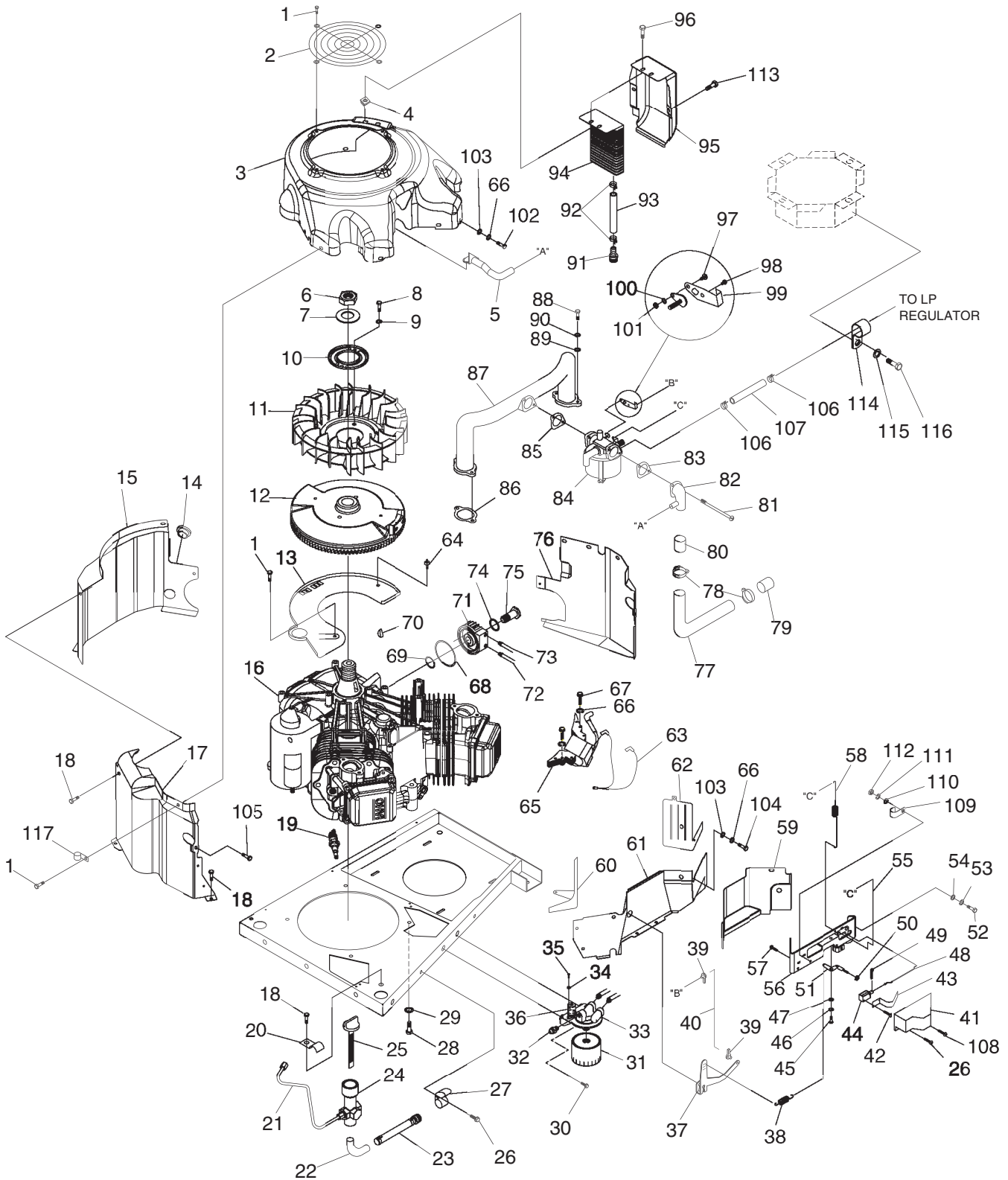

**Section 9**  
**Exploded Views / Part Numbers**

ITEM	QTY.	DESCRIPTION	ITEM	QTY.	DESCRIPTION
1	15	SCREW HHTT M6-1.0 X 10 YC	58	1	SPRING, CHOKE RETURN
2	1	GUARD,FAN 12KW HSB	59	1	WRAP, VALLEY UPPER SPCC
3	1	HOUSING, BLOWER V-TWIN RV	60	1	WRAPPER,UPR #1 W/ M8 WELD NUT
4	4	NUT,GROMMET 1/4 PLUG	61	1	WRAP, VALLEY RV SPCC
5	1	HOSE, BREATHER	62	1	WRAPPER,UPR #2 W/ M8 WELD NUT
6	1	NUT HEX M24-2.0 G8 YEL CHR	63	1	ASSY, GROUNDING WIRE
7	1	WASHER,BELLEVILLE 25MM BOLT	64	1	ASSY,GROUND WIRE CONNECTOR
8	2	SCREW HHC M8-1.25 X 12 G8.8	65	2	ASSY, IGN COIL W/DIODE NO ADV
9	2	WASHER SHAKEPROOF INT M8 SS	66	8	WASHER LOCK M6-1/4
10	1	PLATE, FAN	67	4	SCREW HHTT M6-1.0 X 25 BP
11	1	FAN NYLON	68	1	O-RING 59.92 X 66.98 X 3.53MM
12	1	FLYWHEEL ASSY	69	1	O-RING 21.89 X 27.13 X 2.62MM
13	1	PLATE,BACKING WITH OIL COOL	70	1	KEY, WOODRFF 4 X 19D
14	1	BUSHING SNAP	71	1	ADPTR OIL PAD, FLARE
15	1	WRAP, CRANKCASE RV SPCC	72	1	TUBE, ENGINE OIL RETURN
16	1	VERTICAL SHAFT RV ENGINE	73	1	TUBE, ENGINE OIL OUT
17	1	WRAP, CYL 1 RV SPCC	74	1	O-RING 20.35 X 23.91 X 1.78MM
18	13	SCREW CRIMPTITE 10-24 X 1/2	75	1	BOLT, OIL ADAPTOR
19	2	SPARK PLUG	76	1	WRAP, CYL 2 GTV760 RV SPCC
20	1	CLAMP VINYL 9.5 O.D. TUBE	77	1	INTAKE TUBE 1.25" X 20 GA
21	1	TUBE, OIL DRAIN & CHECK	78	2	HOSE CLMP-BAND 1 5/8
22	1	BARBED EL 90 3/8NPT X 3/8	79	1	BOOT, INTAKE AIRBOX
23	1	ASSEMBLY, OIL DRAIN HOSE	80	1	BOOT, CARB ADAPTOR
24	1	OIL DRAIN / DIPSTICK TUBE VTW	81	2	BOLT,CARB MOUNT M6 X 1.0 -85LG
25	1	ASSEMBLY, CAP & DIP STICK	82	1	ADAPTER, AIR INTAKE CARB
26	2	SCREW TAP-R #10-32 X 9/16 (GASOLINE ONLY)	83	1	GASKET,CARB TO ADAPTOR
	1	SCREW TAP-R #10-32 X 9/16 (LP ONLY)	84	1	CARBURETOR, (GASOLINE ONLY)
27	1	SPRING CLIP HOLDER .37-.62		1	CARBURETOR, (LP ONLY)
28	4	SCREW HHTT 3/8-16 X 1-1/4 CZ	85	1	GASKET,CARB TO INTAKE MANIFOLD
29	1	WASHER LOCK SPECIAL 3/8	86	2	GASKET INTAKE PORT
30	2	SCREW SWAGE 1/4-20 X 1 Z/YC	87	1	MANIFOLD, INTAKE RV
31	1	OIL FILTER	88	4	SCREW SHC M8-1.25 X 30 G12.9
32	1	SWITCH OIL PRESSURE HOBBS	89	4	WASHER FLAT M8 SS
33	1	SUPPORT OIL FLTR,FLARE	90	4	WASHER LOCK M8 SS
34	2	WASHER LOCK M3	91	2	BARBED STR 1/4NPT X 3/8
35	2	SCREW PPHM M3-0.5 X 8	92	4	CLAMP HOSE 0.38" - 0.87"
36	1	SWITCH, OIL HIGH TEMP (GASOLINE ONLY)	93	2	HOSE,3/8"IDX6"L 300F
	1	SWITCH, OIL HIGH TEMP (LP ONLY)	94	1	COOLER, OIL
37	1	ASSEMBLY, GOVERNOR LEVER	95	1	DUCT, OIL CLR RV SPCC
38	1	SPRING, GOV.(5.5 KW & 5.0 KW-50HZ ONLY)	96	4	PLASTITE,1/4-15 X 3/4
	1	SPRING, GOV.(6.5/7.5 KW & 7.0 KW-50HZ ONLY)	97	1	SCREW PPHM #10-32 X 3/8
39	2	BUSHING, GOVERNOR ROD	98	1	SCREW HHTT #4-40 X 1/4
40	1	ROD, GOVERNOR	99	1	PLATE, THROTTLE
41	1	BOOT CHOKE SOLENOID (GASOLINE ONLY)	100	1	WASHER LOCK #10
42	2	RHMS 4-40 X 1/4 SEMS (GASOLINE ONLY)	101	1	NUT HEX #10-32 STEEL
43	1	ASSY, BI-METAL/HEATER (GASOLINE ONLY)	102	2	SCREW HHC M6-1.0 X 12 G8.8
44	1	SOLENOID, CHOKE (GASOLINE ONLY)	103	4	WASHER FLAT M6
45	1	SCREW HHC M5-0.8 X 10 G8.8	104	2	SCREW HHC M6-1.0 X 16 G8.8
46	1	WASHER LOCK M5	105	2	SCREW HHTT M5-0.8 X 8 BP
47	1	WASHER FLAT M5	106	2	CLAMP HOSE #8 .53 - 1.00 (LP ONLY)
48	1	LINKAGE, CHOKE (GASOLINE ONLY)	107	2.25 FT.	HOSE 1/2 ID (LP ONLY)
49	1	COTTER PIN (GASOLINE ONLY)	108	1	SCREW PPHM M4-0.7 X 16 (GASOLINE ONLY)
50	1	NUT LOCK HEX M5-0.8 SS NYL INS	109	1	CLIP-J VINYL COAT .375 ID (GASOLINE ONLY)
51	1	ASSEMBLY, GOV. ADJUSTMENT	110	1	WASHER FLAT #8 (GASOLINE ONLY)
52	2	SCREW HHC M8-1.25 X 20 G10.9	111	1	WASHER LOCK #8 (GASOLINE ONLY)
53	2	WASHER LOCK M8-5/16	112	1	NUT HEX M4-0.7 G8 YC (GASOLINE ONLY)
54	2	WASHER FLAT 5/16-M8 ZINC	113	2	SCREW HHTT M6-1.0 X 16 YC
55	1	LINKAGE CHOKE BELLCRANK/CARB	114	1	CLAMP VINYL 1.06 X .406 (LP ONLY)
56	1	ASSEM., CHOKE BRACKET (GASOLINE ONLY)	115	1	WASHER FLAT 1/4-M6 (LP ONLY)
	1	BRACKET, CHOKE (LP ONLY)	116	1	SCREW HHTT M6-1.0 X 12 (LP ONLY)
57	2	RHMS 4-40 X 5/16SEMS	117	1	CLAMP VINYL .437" X .281"

# Section 9 Exploded Views / Part Numbers

Control Panel – Drawing No. 0E1013-A

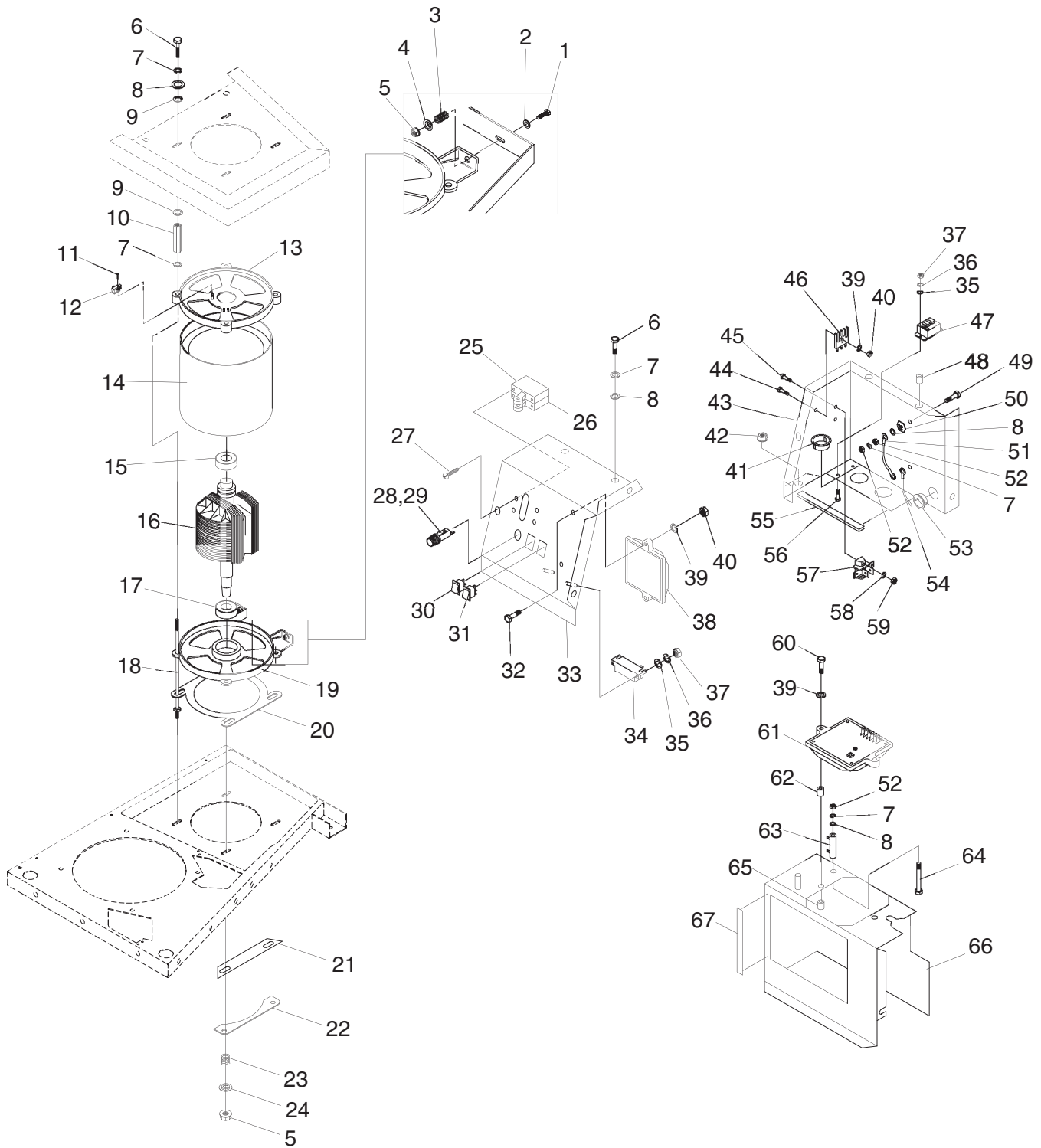

**Section 9**  
**Exploded Views / Part Numbers**

ITEM	QTY.	DESCRIPTION	ITEM	QTY.	DESCRIPTION
1	2	SCREW HHC M8-1.25 X 90 G8.8	32	2	SCREW HHC M5-0.8 X 25 G8.8
2	2	WASHER FLAT 5/16-M8 ZINC	33	1	PANEL, TOP CONTROL
3	2	TENSION SPRING	34	1	CIRCUIT BREAKER 3 X 1
4	2	WASHER, SPRING CENTER	35	4	WASHER FLAT #4 ZINC
5	6	NUT LOCK FL M8-1.25	36	4	WASHER LOCK M3
6	7	SCREW HHC M6-1.0 X 16 G8.8	37	4	NUT HEX M3-0.5 G8 YEL CHR
7	13	WASHER LOCK M6-1/4	38	1	ASSY POTTED RV CNTL
8	10	WASHER FLAT 1/4-M6 ZINC	39	5	WASHER LOCK M5
9	8	WASHER NYLON .404	40	3	NUT HEX M5-0.8 G8 YEL CHR
10	4	STANDOFF, 1/2" HEX	41	2	BUSHING SNAP
11	2	SCREW HHTT M5-0.8 X 16	42	1	NUT FLANGE M6-1.0 NYLOK
12	1	ASSY, BRUSH HOLDER	43	1	PANEL, BOTTOM CONTROL
13	1	BEARING CARRIER, UP	44	1	SCREW HHC M5-0.8 X 20 G8.8
14	1	STATOR ASSEMBLY (5.5 KW ONLY)	45	2	SCREW PPHM M4-0.7 X 16
	1	STATOR ASSEMBLY (6.5 KW ONLY)	46	1	RECTIFIER-BATTERY CHARGE
	1	STATOR ASSEMBLY (7.5 KW ONLY)	47	1	RELAY 12V 25A SPST
15	1	BEARING BALL	48	4	NUT LOCK TRIC M6 X 1.0 Y/ZNC
16	1	ROTOR ASSEMBLY (5.5 KW ONLY)	49	2	SCREW HHC M6-1.0 X 35 G8.8 BLK
	1	ROTOR ASSEMBLY (6.5 KW ONLY)	50	2	WASHER LOCK SPECIAL 1/4"
	1	ROTOR ASSEMBLY (7.5 KW ONLY)	51	1	WIRE ASM GRD STD CONN.
17	1	BEARING	52	4	NUT HEX M6 X 1.0 G8 YEL CHR
18	4	STUD, RV STATOR D/C	53	1	BUSHING SNAP
19	1	BEARING CARRIER, LOW	54	1	GROUND WIRE C/PNL TO STUD V-T RV
20	1	NYLON SLIDE	55	1	RUBBER U-CHANNEL
21	2	SLIDE, NYLON	56	2	SCREW PHM M3-0.5 X 10MM
22	2	SUPPORT, SLIDE	57	1	BLOCK 1 POSITION
23	4	SPRING, GEN. MOUNT	58	2	WASHER LOCK #8-M4
24	4	WASHER, SPRING CENTER	59	2	NUT HEX M4-0.7 G8 YEL CHR
25	1	CIRCUIT BREAKER 30 X 1 (5.5 & 6.5 KW ONLY)	60	2	SCREW HHC M5-0.8 X 60 G8.8
	1	CIRCUIT BREAKER 35 X 1 (7.5 KW ONLY)	61	1	ASY POTTED REG W/FIN
26	1	CIRCUIT BREAKER 20 X 1 (5.5 KW ONLY)	62	2	SPACER .25 X .43 X .55 ST/ZNC
	1	CIRCUIT BREAKER 30 X 1 (6.5 KW ONLY)	63	1	RESISTOR WW LUG 1R 5% 25W
	1	CIRCUIT BREAKER 35 X 1 (7.5 KW ONLY)	64	1	SCREW HHC M6-1.0 X 65 G8.8
27	4	SCREW RHM 6-32 X 1/4 SIMS	65	2	NUT TRIC M5 X .8
28	1	FUSE 7.5 AMP	66	1	COMPARTMENT, AIR BOX
29	1	HOLDER FUSE	67	2.3 FT.	TAPE, 1/2" X 1/16" CLOSED CELL
30	1	SWITCH SPDT ON-MOM-ON	68	1	WIRE HARNESS, QP RV (GASOLINE ONLY)(NOT SHOWN)
31	1	SWITCH 6A SPDT		1	WIRE HARNESS, QP RV (LP ONLY) (NOT SHOWN)
			69	1	WIRE ASS'Y STARTER TO C/PNL (NOT SHOWN)

# Section 9 Exploded Views / Part Numbers

760 V-Twin Engine – Drawing No. 0F1997

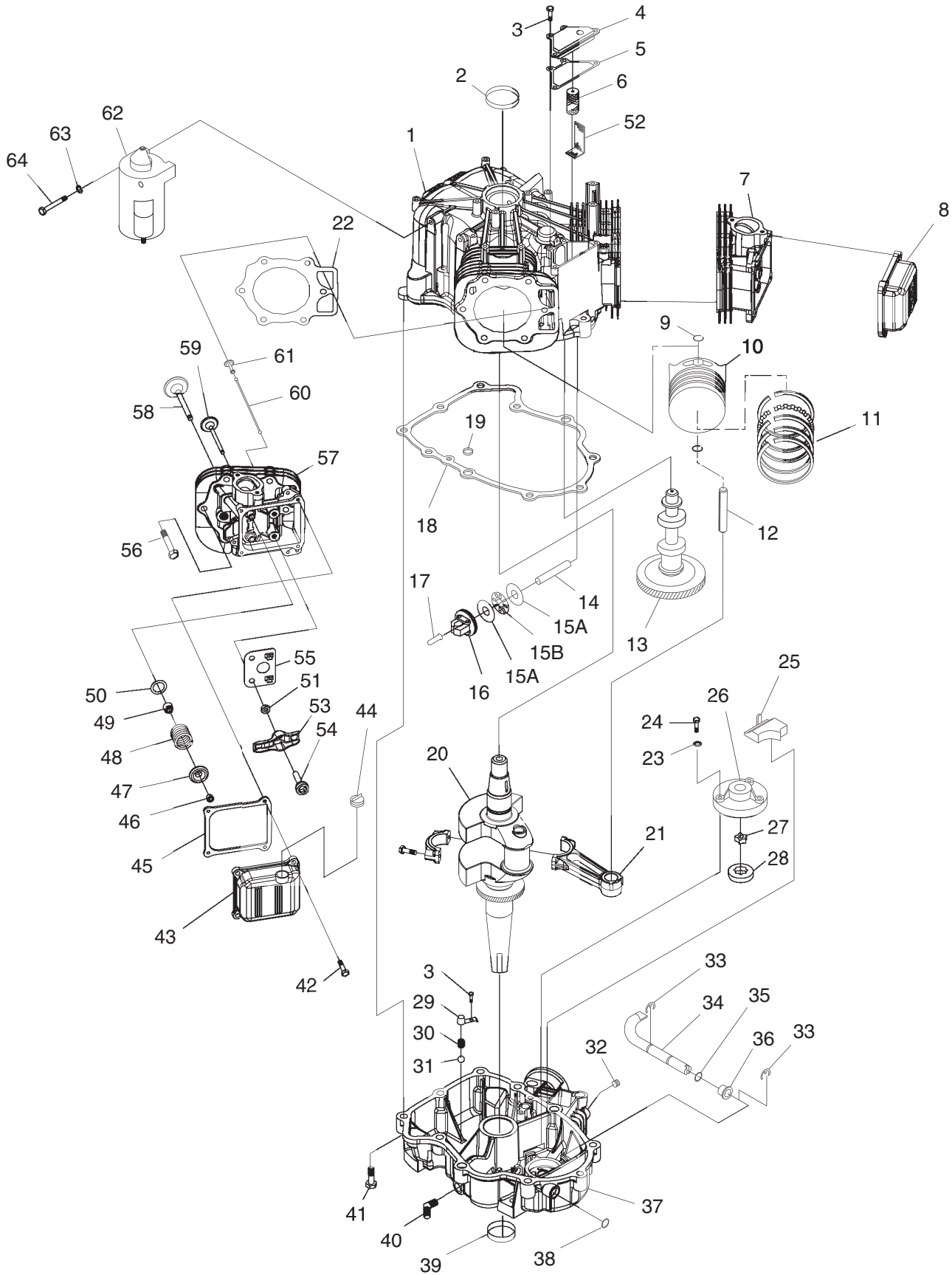

**Section 9**  
**Exploded Views / Part Numbers**

ITEM	QTY.	DESCRIPTION	ITEM	QTY.	DESCRIPTION
1	1	ASSEMBLY, CRANKCASE RV	33	2	E-RING, GOVERNOR ARM
2	1	SEAL, 38 I.D. CRANKCASE	34	1	ARM, GOVERNOR
3	6	SCREW, HHTT M6-1.0 X 12mm	35	1	THRUST WASHER, GOVERNOR
4	1	ASSEMBLY, BREATHER	36	1	BUSHING, GOVERNOR LOWER
5	1	GASKET, BREATHER COVER	37	1	ASSEMBLY, SUMP WITH SLEEVE
6	1	SEPARATOR, OIL BREATHER	38	1	SEAL, GOVERNOR SHAFT
7	1	ASSEMBLY, HEAD #1	39	1	SEAL, 42 I.D. CRANKSHAFT
8	1	COVER, ROCKER	40	1	CONNECTOR, 3/8NPT TO INVTD FLR 3/8OD
9	4	RETAINER, PISTON PIN 20	41	10	SCREW, HHFC M10-1.5 X 55mm
10	2	PISTON, HC	42	8	SCREW HHFC M6-1.0 X 25mm
11	2	SET, PISTON RING 90mm	43	1	COVER, ROCKER WITH OIL FILL
12	2	PIN , PISTON	44	1	ASSEMBLY, OIL FILL CAP
13	1	ASSEMBLY, CAMSHAFT & GEAR	45	2	GASKET, VALVE COVER
14	1	SHAFT, GOVERNOR	46	8	KEEPER, VALVE SPRING
15A	2	ROLLER BEARING, GOVERNOR PLATE	47	4	RETAINER, VALVE SPRING
15B	1	ROLLER BEARING, GOVERNOR	48	4	SPRING, VALVE
16	1	ASSEMBLY, GOVERNOR GEAR	49	2	SEAL, VALVE STEM D7
17	1	SPOOL, GOVERNOR MACHINED	50	4	WASHER, VALVE SPRING
18	1	GASKET, CRANK CASE	51	4	NUT HEX M8-1.0 G8
19	1	SEAL, OIL PASSAGE	52	1	SCREEN CRANKCASE BREATHER
20	1	ASSEMBLY, CRANKSHAFT	53	4	ROCKER ARM
21	2	ASSEMBLY, CONNECTING ROD	54	4	STUD, ROCKER ARM PIVOT
22	2	GASKET, HEAD	55	2	PLATE, PUSH ROD GUIDE
23	3	WASHER, LOCK RIB M6	56	12	SCREW HHFC M8-1.25 X 65mm
24	3	SCREW, SHC M6-1.0 X 30mm	57	1	ASSEMBLY, HEAD #2
25	1	SCREEN, OIL PICKUP	58	2	VALVE, INTAKE
26	1	COVER, GEROTOR	59	2	VALVE, EXHAUST
27	1	GEROTOR, INNER	60	4	PUSHROD 147
28	1	GEROTOR, OUTER	61	4	TAPPET, SOLID
29	2	COVER, OIL RELIEF	62	1	STARTER
30	2	SPRING, OIL RELIEF	63	2	WASHER LOCK M8
31	2	BALL, 1/2D OIL RELIEF	64	2	SCREW, HHC M8-1.25 X 85mm
32	1	1/4" NPT PIPE PLUG			

# Section 9 Exploded Views / Part Numbers

LP Regulator – Drawing No. 0E1530-C

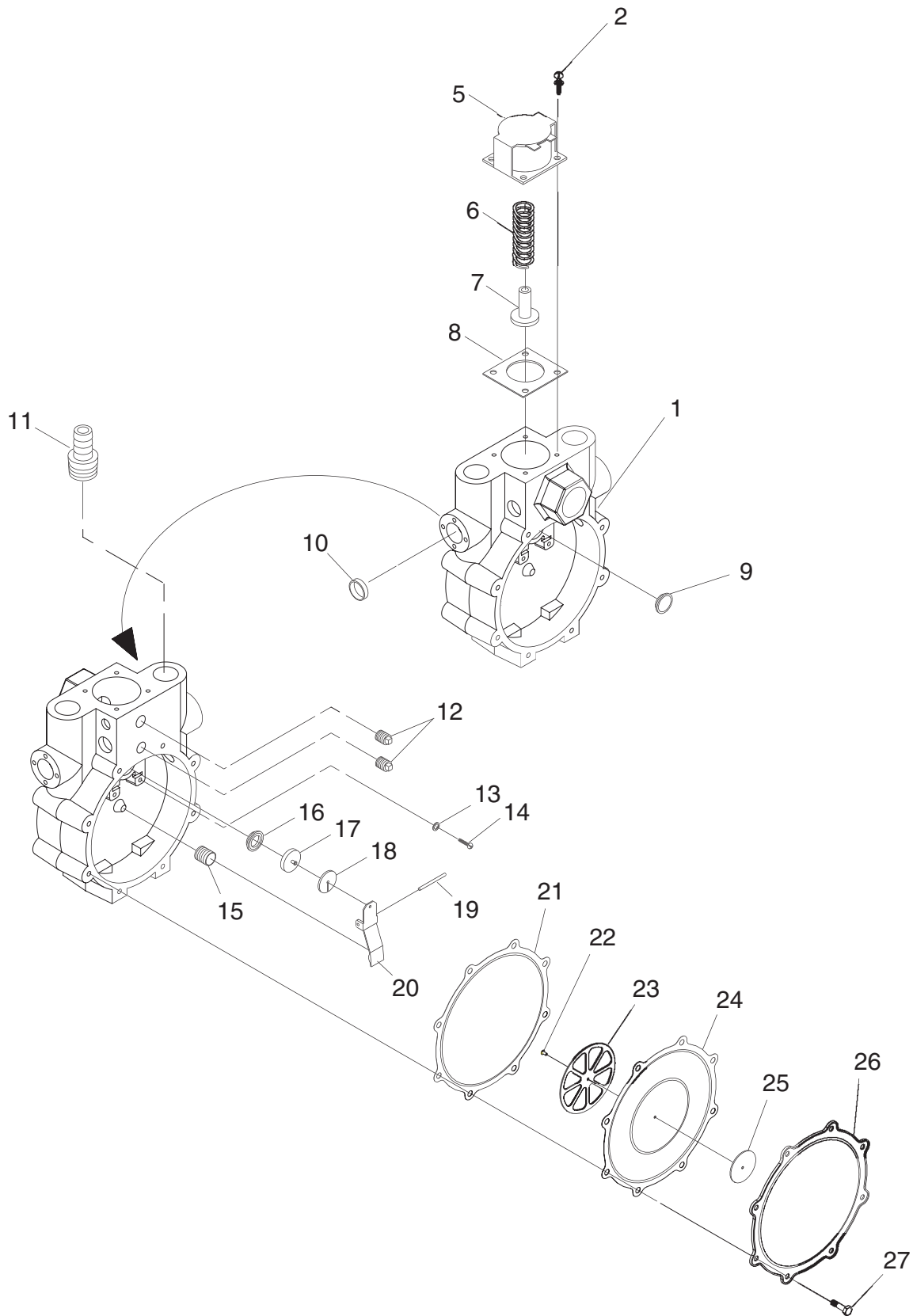

**Section 9**  
**Exploded Views / Part Numbers**

ITEM	QTY.	DESCRIPTION
1	1	CASTING, TWIN REGULATOR HOUSING
2	4	SCREW PPHM SEMS M4-0.7 X 10
5	1	SOLENOID COIL, 12VDC
6	1	SPRING-SOLENOID PLUNGER
7	1	PLUNGER LP REG. ASSY
8	1	GASKET, SOLENOID
9	1	INLET, TWIN REGULATOR NO HOLE
10	1	PLUG, EXPANSION 16MM TWINREG
11	1	BARBED STR 1/2 X 1/2NPT W/VS
12	2	PLUG STD PIPE 1/8 STEEL SQ HD
13	2	WASHER FLAT 3.2MM ID X 10MM OD
14	2	SCREW PFILHM M3-0.5 X 5
15	1	SPRING, REGULATOR 45N/M 32MM
16	1	INLET, TWIN REG 11.11 DIA.
17	1	SEAL, INLET REGULATOR
18	1	SUPPORT, INLET SEAL
19	1	PIN, PIVOT ARM
20	1	LEVER, REGULATOR
21	1	GASKET, DIAPHRAGM
22	1	RIVET .118 X .125 ALUMINUM
23	1	SUPPORT, DIAPHRAGM
24	1	DIAPHRAGM, TWIN REGULATOR
25	1	CAP, DIAPHRAGM SUPPORT
26	1	COVER, TWIN REGULATOR 270457648 SCREW HHTT M4-0.7 X 8 BP

# Section 10 SPECIFICATIONS & CHARTS

## Major Features and Dimensions – Drawing No. 0E1058-E

**NOTE:** ALL AIR INTAKES AND EXHAUST OUTLETS MUST BE KEPT CLEAR OF ANY OBSTRUCTIONS. ALL OPEN AREA IS REQUIRED FOR COOLING.

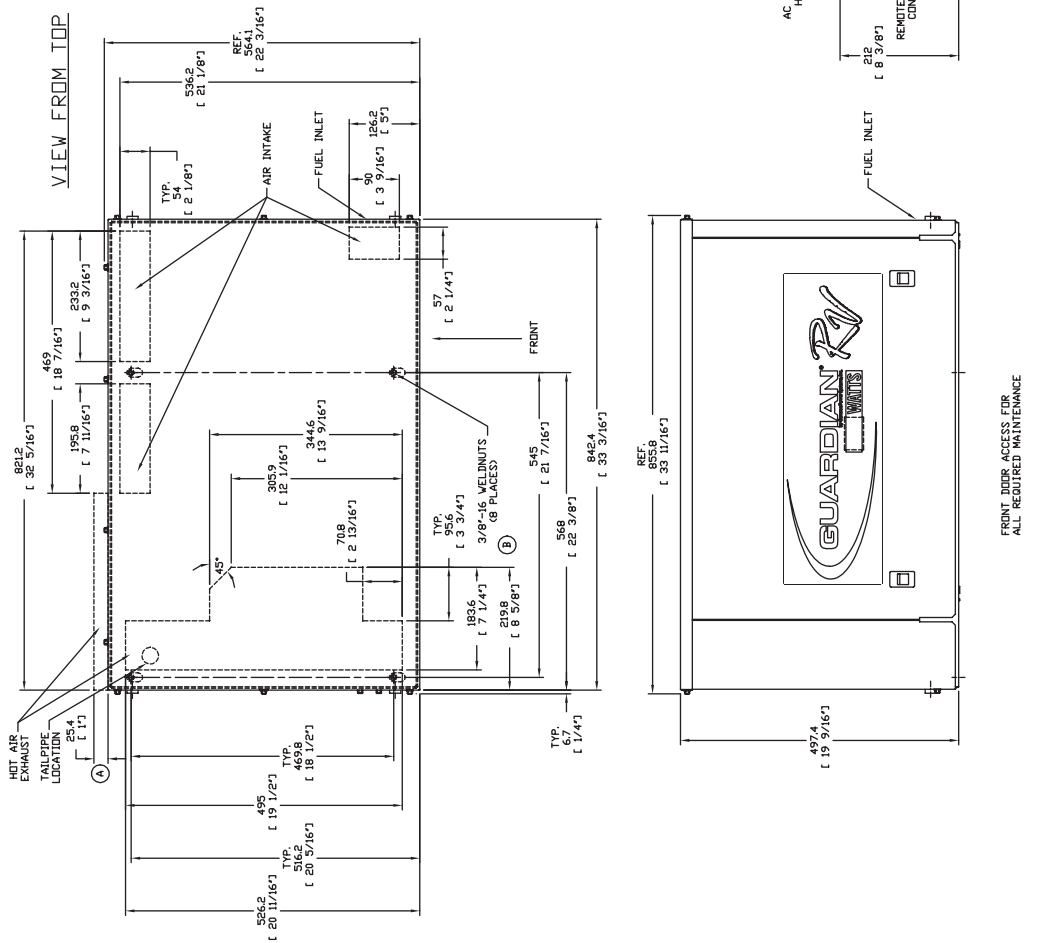

**GENERATOR SPECIFICATIONS**

TYPE	QUIETPACT 55	QUIETPACT 65	QUIETPACT 75
MODEL	4702/4703	4704/4705	4706/4707
WEIGHT	326/329 pounds	328/331 pounds	330/333 pounds
TYPE OF ROTOR	Two-pole	Two-pole	Two-pole
RATED WATTS	5500	6500	7500
RATED VOLTS	120	120	120
PHASE	1-Phase	1-Phase	1-Phase
RATED MAXIMUM LOAD AMPERES	45.8	54.2	62.5
RATED FREQUENCY	60 Hz	60 Hz	60 Hz
OPERATING SPEED	2200 rpm	2571 rpm	2571 rpm
ENGINE MODEL	GTV-760	GTV-760	GTV-760
TYPE OF ENGINE	Vertical Shaft	Vertical Shaft	Vertical Shaft
FUEL SYSTEM	Gasoline/LP	Gasoline/LP	Gasoline/LP
COOLING SYSTEM	Air-Cooled	Air-Cooled	Air-Cooled
OIL SYSTEM	Pressurized with Filter	Pressurized with Filter	Pressurized with Filter
OIL PUMP	Trochoid Type	Trochoid Type	Trochoid Type
AIR CLEANER	Paper element w/foam pre-cleaner	Paper element w/foam pre-cleaner	Paper element w/foam pre-cleaner
STARTER	12 VDC electric	12 VDC electric	12 VDC electric
IGNITION SYSTEM	Solid State	Solid State	Solid State
SPARK PLUG	Champion RC14YC (or equivalent)	Champion RC14YC (or equivalent)	Champion RC14YC (or equivalent)
SPARK PLUG GAP	0.030 inch (0.76mm)	0.030 inch (0.76mm)	0.030 inch (0.76mm)

**NOMINAL RESISTANCES OF GENERATOR WINDINGS AT 68°F**

TYPE	QUIETPACT 55	QUIETPACT 65	QUIETPACT 75
MODEL	4702/4703	4704/4705	4706/4707
Power Windings Lead 11 to 22 Lead 11S to 22S Lead 33 to 44	0.280 - 0.320 ohms	0.209 - 0.242 ohms	0.157 - 0.182 ohms
Excitation "DPE" Winding Lead 2 to 6	1.41 - 1.63 ohms	1.59 - 1.84 ohms	1.12 - 1.30 ohms
Battery Charge Windings Lead 55 to 66 Lead 55 to 77	0.100 - 0.116 ohms 0.100 - 0.116 ohms	0.104 - 0.107 ohms 0.087 - 0.101 ohms	0.092 - 0.107 ohms 0.076 - 0.088 ohms
Rotor Winding Slip Ring to Slip Ring	14.88 ohms	10.81 ohms	14.50 - 16.0 ohms

## Section 10 SPECIFICATIONS & CHARTS

### ENGINE SPEEDS AND VOLTAGE SPECIFICATIONS

Listed below are normal running voltages, load voltages and frequency ranges.

LOAD %	VOLTAGE (VAC)	FREQUENCY (Hz)
0	123-126	62-63
50	118-122	62-59
100	112-118	57-61

### TORQUE SPECIFICATIONS

LONG BLOCK TORQUE REQUIREMENTS	
HEAD BOLTS	22 ft-lbs (±5%)
SUMP COVER BOLTS	36 ft-lbs
CONNECTING ROD CAP BOLTS	16.2 - 19.8 ft-lbs
VALVE COVER BOLTS	4.8 - 5.5 ft-lbs
ROCKER ARM JAM NUTS	156.6 - 191.4 in-lbs
OIL PRESSURE RELIEF COVER BOLT	7.4 ft-lbs
OIL FILTER ADAPTER	9 ft-lbs
IGNITION COILS	6.7 - 8.1 ft-lbs
INTAKE MANIFOLD	12.6 - 15.4 ft-lbs
FAN RETAINER	16 - 20 ft-lbs
LARGE AND SMALL PULLEY	34.2 - 41.8 ft-lbs
TRIM TORQUE REQUIREMENTS	
M3-5 PHILLIPS PAN HEAD SCREW INTO ALUMINUM	50 in-lbs
M6-1 TAPTITE SCREW INTO ALUMINUM	96 in-lbs
M6-1 TAPTITE SCREW INTO WELDNUT	96 in-lbs
M8-1.25 TAPTITE SCREW INTO ALUMINUM	18 ft-lbs
STARTER BRACKET TO BLOCK	18 ft-lbs
GOVERNOR LEVER PINCH BOLT	120 in-lbs
FLYWHEEL NUT	135 - 165 ft-lbs
SPARK PLUG	15 ft-lbs
RV TORQUE REQUIREMENTS	
EXHAUST OUTLET BOLTS	18 ft-lbs
STATOR BOLTS	7.2 - 8.8 ft-lbs
M6-1 TAPTITE SCREW INTO PIERCED HOLE	96 in-lbs

Refer to Engine Service Manual No. 0E2081 for complete GTV-760/990 V-Twin OHVI engine service information.



# Section 11 ELECTRICAL DATA

## Electrical Schematic and Wiring Diagram – Drawing No. 0E1057-E

### SCHEMATIC – DIAGRAM

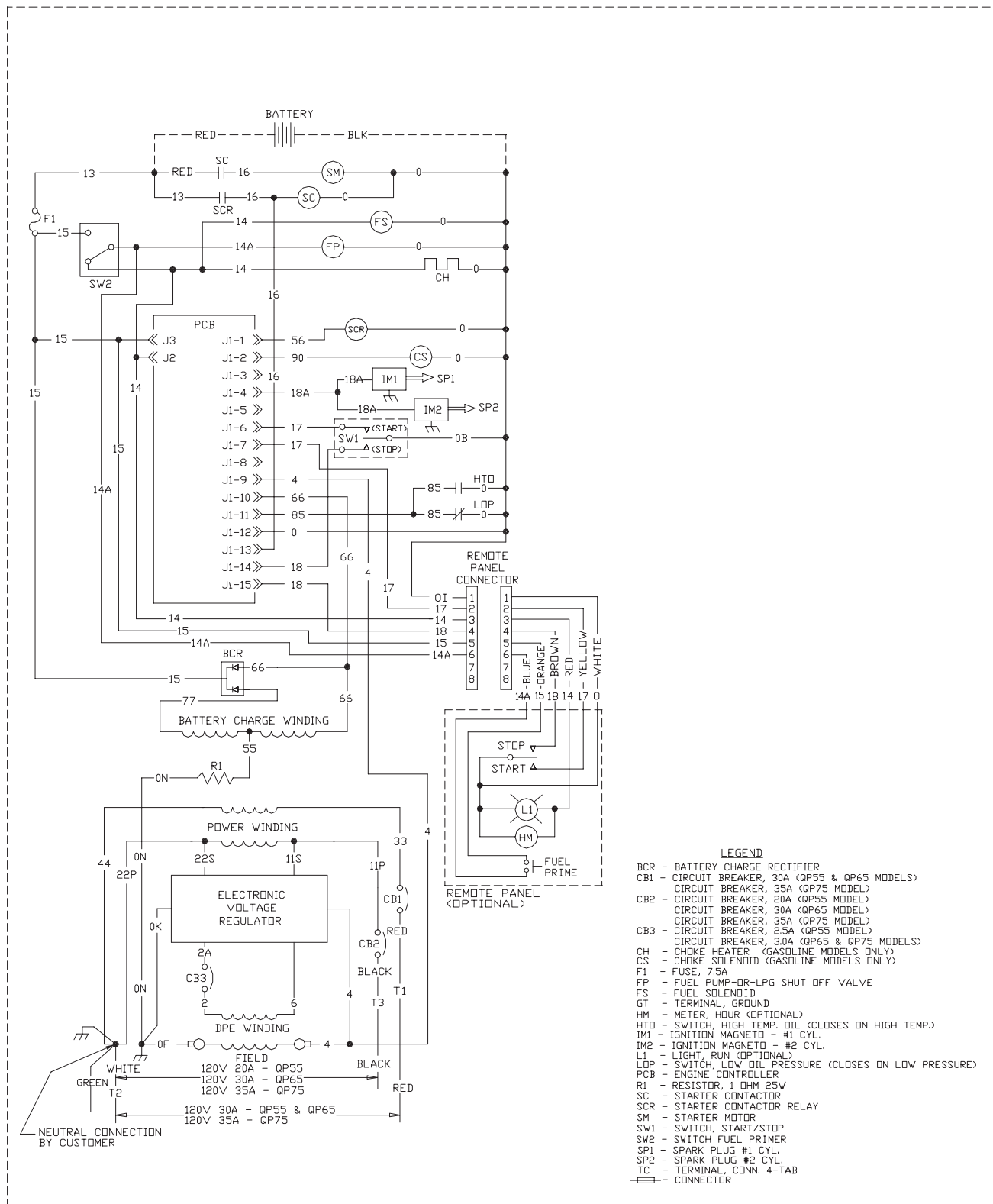

Electrical Schematic and Wiring Diagram – Drawing No. 0E1057-E

SCHEMATIC – DIAGRAM

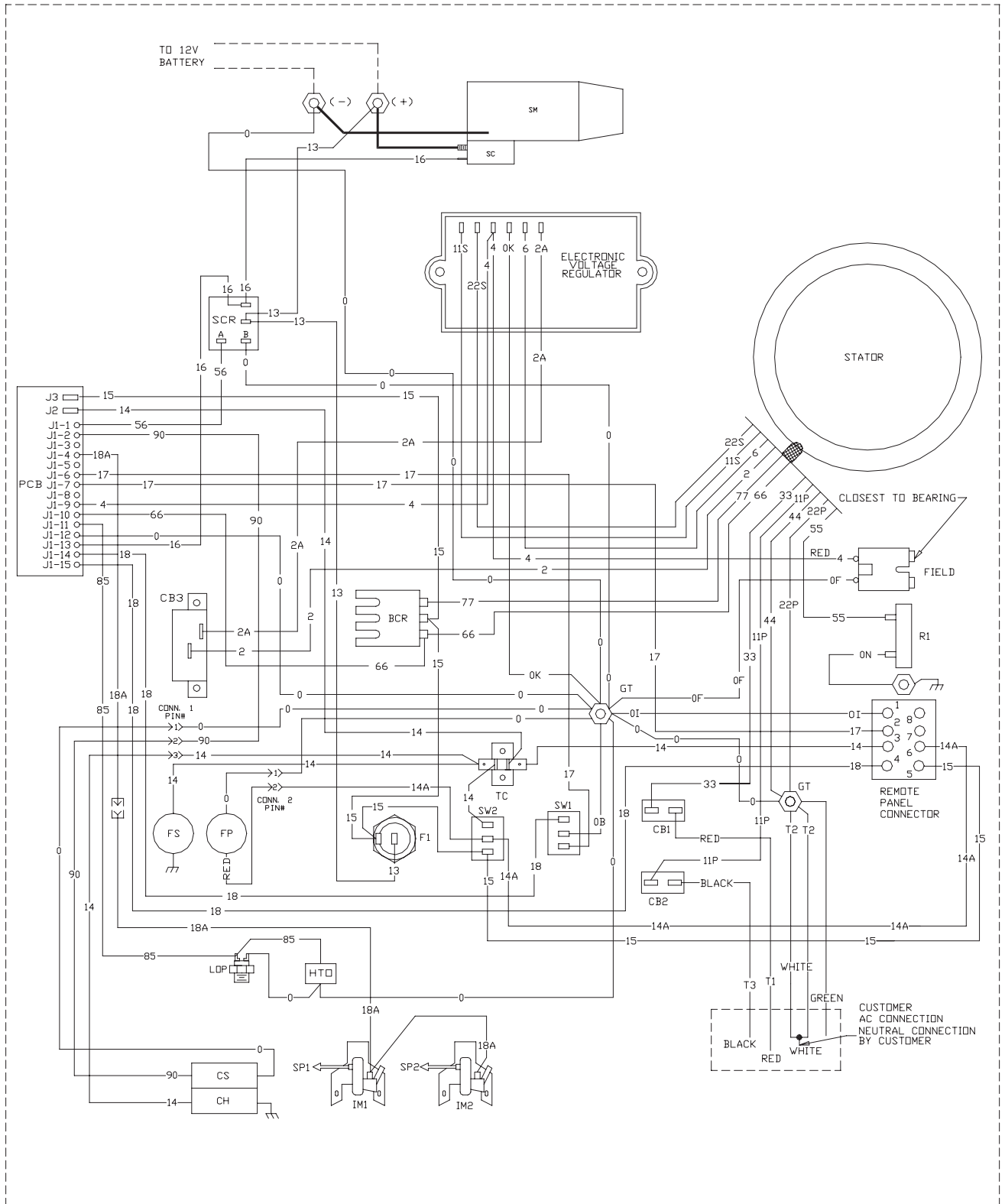



PO BOX 297 • WHITEWATER, WI 53190  
[www.guardiangenerators.com](http://www.guardiangenerators.com)