

DIAGNOSTIC REPAIR MANUAL

GENERAC®

GP Series and UltraSource Portable Generators



MODELS:

Model 4451, 4986 (12.5 kW)

5734, 4582, 4987 (15 kW)

5735, 4583, 5308 (17.5 kW)

PORTABLE GENERATORS

Safety

Throughout this publication and on tags and decals affixed to the generator, DANGER, WARNING, and CAUTION blocks are used to alert personnel to special instructions about a particular operation that may be hazardous if performed incorrectly or carelessly. Observe them carefully. Their definitions are as follows:

 **DANGER**

Indicates a hazardous situation which, if not avoided, will result in death or serious injury.

(000001)

 **WARNING**

Indicates a hazardous situation which, if not avoided, could result in death or serious injury.

(000002)

 **CAUTION**

Indicates a hazardous situation which, if not avoided, could result in minor or moderate injury.

(000003)

NOTE: Notes provide additional information important to a procedure or component.

These safety alerts cannot eliminate the hazards they indicate. Observing safety precautions and strict compliance with the special instructions while performing the action or service are essential to preventing accidents.

 **WARNING**

California Proposition 65. Engine exhaust and some of its constituents are known to the state of California to cause cancer, birth defects, and other reproductive harm.

(000004)

 **WARNING**

California Proposition 65. This product contains or emits chemicals known to the state of California to cause cancer, birth defects, and other reproductive harm.

(000005)

Read This Manual Thoroughly

This diagnostic manual has been written and published by Generac to aid dealer technicians and company service personnel when servicing the products described herein.

It is assumed that these personnel are familiar with the servicing procedures for these products, or like or similar products manufactured and marketed by Generac, and that they have been trained in the recommended servicing procedures for these products, including the use of common hand tools and any special Generac tools or tools from other suppliers.

Generac could not possibly know of and advise the service trade of all conceivable procedures by which a service might be performed and of the possible hazards and/or results of each method. We have not undertaken any such wide evaluation. Therefore, anyone who uses a procedure or tool not recommended by Generac must first satisfy themselves that neither his nor the products safety will be endangered by the service procedure selected.

All information, illustrations and specifications in this manual are based on the latest product information available at the time of publication.

When working on these products, remember that the electrical system and engine ignition system are capable of violent and damaging short circuits or severe electrical shocks. If you intend to perform work where electrical terminals could be grounded or touched, the battery cables should be disconnected at the battery.

Any time the intake or exhaust openings of the engine are exposed during service, they should be covered to prevent accidental entry of foreign material. Entry of such materials will result in extensive damage when the engine is started.

During any maintenance procedure, replacement fasteners must have the same measurements and strength as the fasteners that were removed. Metric bolts and nuts have numbers that indicate their strength. Customary bolts use radial lines to indicate strength while most customary nuts do not have strength markings. Mismatched or incorrect fasteners can cause damage, malfunction and possible injury.

Replacement Parts

When servicing this equipment, it is extremely important that all components be properly installed and tightened. If improperly installed and tightened, sparks could ignite fuel vapors from fuel system leaks.

Table of Contents

Safety	ii	Section 3 Troubleshooting Flowcharts	27
Read This Manual Thoroughly	ii	Introduction	27
Replacement Parts	ii	Section 4 AC Diagnostic Tests	35
Section 1 Description and Components	1	Introduction	35
Introduction	1	Safety	35
Engine-Generator Drive System	1	Important Note Concerning Connectors	35
The AC Generator	1	Test 1 – Check No-Load Voltage and Frequency	35
Rotor Assembly	1	Test 2 – Check Main Circuit Breaker	36
Stator Assembly	1	Test 3 – Test Excitation Circuit Breaker	36
Brush Holder and Brushes	2	Test 4 – Fixed Excitation Test/Rotor Amp Draw Test	36
Other AC Generator Components	2	Test 5 – Check Stepper Motor Control	38
Excitation Circuit Breaker	2	Test 6 – Wire Continuity	39
Voltage Regulator	2	Test 7 – Check Field Boost	40
Adjustment Procedure (12.5 kW and Older 15 kW Units)	3	Test 8 – Diode/Resistor	40
Adjustment Procedure (Newer 15 kW and All 17.5 kW Units)	3	Test 9 – Test Stator	41
Circuit Breakers	3	Test 10 – Sensing Leads	42
Rotor Residual Magnetism	3	Test 11 – Excitation Wiring	43
Field Boost Circuit	3	Test 12 – Check Brush Leads	43
Operation	4	Test 13 – Check Brushes & Slip Rings	44
Startup	4	Test 14 – Check Rotor Assembly	44
On-Speed Operation	4	Test 15 – Check Load Voltage & Frequency	45
Field Excitation	4	Test 16 – Check Load Watts and Amperage	45
AC Power Winding Output	4	Test 17 – Check Battery Charge Output	45
Battery Charge Winding Output	4	Test 18 – Check 10 Amp Battery Charge Output	45
10 Amp Battery Charge Winding Output	4	Test 19 – Check Battery Charge Rectifier (BCR2) ...	46
Specifications	5	Test 20 – Check 10 Amp Circuit Breaker	46
Section 2 Engine DC Control System	7	Test 21 – Check 10 Amp Fuse	47
Printed Circuit Board	7	Test 22 – Check Battery and Cables	47
General Theory	7	Test 23 – Check Voltage At Starter Contactor (SC) .	48
Circuit Board Connections	7	Test 24 – Check Starter Contactor (SC)	48
Dip Switch Positions	7	Test 25 – Check Starter Motor	48
Battery	7	Test 26 – Test Starter Contactor Relay (SCR)	49
Recommended Battery	7	Test 27 – Check Start-Run-Stop Switch (SW1)	50
Control Panel Component Identification	8	Test 28 – Check Start-Run-Stop Switch (SW1) Wiring	50
Operational Analysis (Older Units)	10	Test 29 – Check Ignition Spark	50
Circuit Condition - Rest	10	Test 30 – Check Spark Plugs	51
Circuit Condition - Start	12	Test 31 – Remove Wire 18 / Shutdown Lead	51
Circuit Condition - Run	14	Test 32 – Test Start Stop Relay (SSR)	51
Circuit Condition - Stop	16	Test 33 – Test Wire 167	52
Fault Shutdown	17	Test 34 – Test Start Stop Relay Wiring	53
Operational Analysis (Newer Units)	18	Test 35 – Check and Adjust Ignition Magnetos	54
Circuit Condition - Rest	18	Test 36 – Test Fuel Shutoff Solenoid (FSS)	55
Circuit Condition - Start	20	Test 37 – Test Fuel Shutoff Solenoid Voltage	55
Circuit Condition - Run	22	Test 38 – Check Fuel Pump	55
Circuit Condition - Stop	24	Test 39 – Check Carburetion	55
Fault Shutdown	24	Test 40 – Valve Adjustment	56
		Test 41 – Check Engine / Cylinder Leak Down Test / Compression Test	57
		Test 42 – Check Oil Pressure Switch and Wire 86 ...	58

Table of Contents

Test 43 - Check Start Stop Relay (SSR)	58	Section 6 Electrical Data	75
Test 44 – Test Starter Contactor Relay (SCR)	59	Introduction	75
Test 45 – Check Wire 15 Circuit	59	Wiring Diagram 12.5 & 15 kW	
Test 46 – Check Wire 14 Circuit	59	(Units Without Hourmeter) –	
Test 47 – Check Fuel Shutoff Solenoid (FSS)	59	Drawing No. 0E0228	76
Test 48 – Check Hour Meter	60	Wiring Diagram 12.5 & 15 kW	
Test 49 – Check Wire 15B	60	(Units Without Hourmeter) –	
Test 50 – Check Wire 167	60	Drawing No. 0E0228	77
Test 51 – Check Wires 11S & 44S or 11S & 22S	60	Electrical Schematic 12.5 & 15 kW	
Test 52 – Check Idle Control Switch (SW2)	61	(Units Without Hourmeter) –	
Test 53 – Check Idle Control Wiring	61	Drawing No. 0E0229-A	78
Test 54 – Check Idle Control Transformers (ICT)	62	Electrical Schematic 12.5 & 15 kW	
Test 55 – Check TR1 & TR2 Wiring	62	(Units Without Hourmeter) –	
Test 56 – Choke Test	63	Drawing No. 0E0229-A	79
Insulation Resistance	63	Wiring Diagram 12.5 & 15 kW	
The Megohmmeter	63	(Units With Hourmeter) –	
Introduction	63	Drawing No. 0D4609-D	80
Testing Stator Insulation	63	Wiring Diagram 12.5 & 15 kW	
Testing Rotor Insulation	63	(Units With Hourmeter) –	
Hi-Pot Tester	64	Drawing No. 0D4609-D	81
Stator Insulation Resistance Test	64	Electrical Schematic 12.5 & 15 kW	
Testing All Stator Windings To Ground	64	(Units With Hourmeter) –	
Test Between Windings	65	Drawing No. 0D6297-A	82
Rotor Insulation Resistance Test	65	Electrical Schematic 12.5 & 15 kW	
Cleaning the Generator	65	(Units With Hourmeter) –	
Drying the Generator	65	Drawing No. 0D6297-A	83
Wattage Reference Guide	66	Wiring Diagram 17.5 kW –	
Section 5 Disassembly	67	Drawing No. 0G0731	84
Major Disassembly	67	Wiring Diagram 17.5 kW –	
		Drawing No. 0G0731	85
		Electrical Schematic 17.5 kW –	
		Drawing No. 0G0733	86
		Electrical Schematic 17.5 kW –	
		Drawing No. 0H0729	87
		Wiring Diagram 17.5 kW –	
		Drawing No. 0H0730	88
		Wiring Diagram 17.5 kW –	
		Drawing No. 0H0730	89
		Wiring Diagram, 17.5 kW Manual Transfer	
		Switch – Drawing No. 0G1065	90
		Interconnection Drawing – 17.5 kW generator	
		connected to the external connection box, manual	
		transfer switch and home's main electrical	
		distribution panel	91

Section 1 Description and Components

Introduction

The generator revolving field (rotor) is driven by an air-cooled engine at 3600 rpm.

The generator may be used to supply electrical power for the operation of 120 and, or 240 volts, single-phase, 60 Hz, AC loads.

Engine-Generator Drive System

See [Figure 1-1](#). The generator revolving field is driven by an air-cooled, horizontal crankshaft engine. The generator is directly coupled to the engine crankshaft. Both the engine and generator rotor are driven at approximately 3600 rpm, to provide a 60 Hz AC output.

The AC Generator

[Figure 1-1](#) shows major components of the AC generator.

- A. Brush Holder Assembly
- B. Rotor
- C. Stator
- D. Rear Bearing Carrier
- E. Engine Adapter
- F. Engine

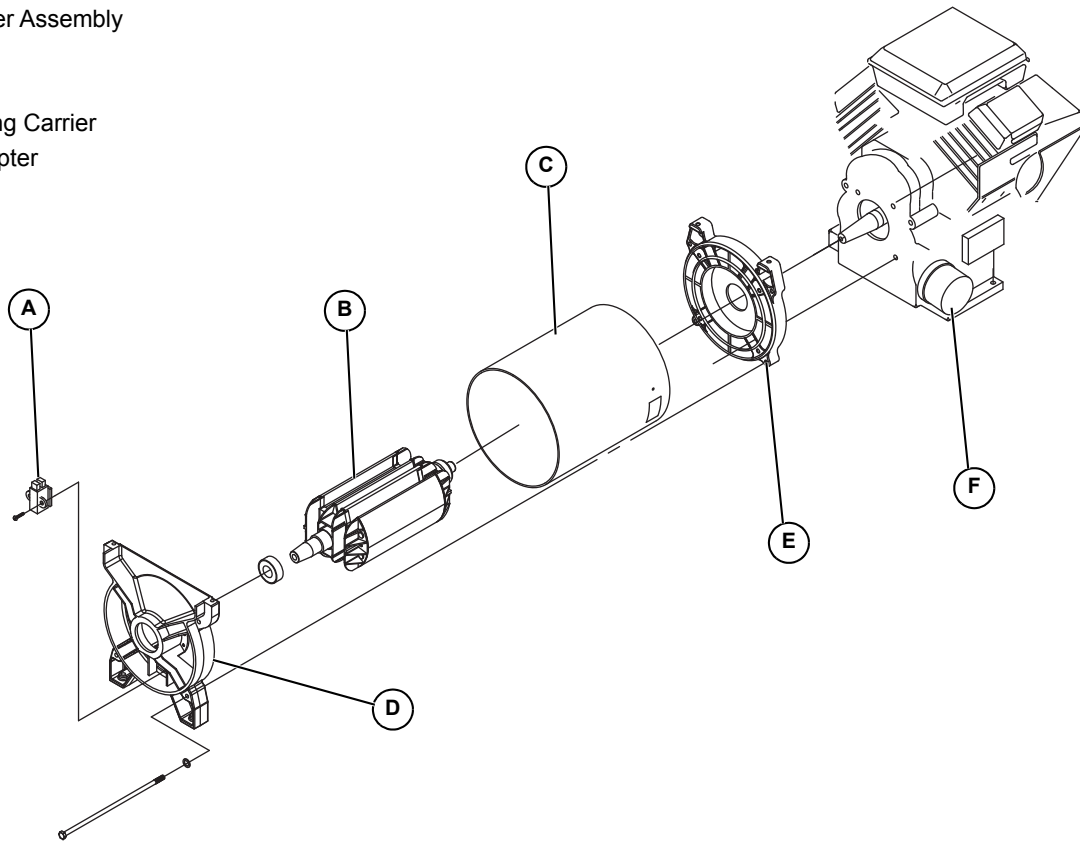

Figure 1-1. AC Generator Major Components

004715

Rotor Assembly

The 2-pole rotor must maintain 3600 rpm to supply a 60 Hertz AC frequency. The term “2-pole” means the rotor has a single north magnetic pole and a single south magnetic pole. As the rotor rotates, the lines of magnetic flux cut across the stator assembly windings and a voltage is induced into the stator windings. The rotor shaft mounts a positive (+) and a negative (-) slip ring, with the positive (+) slip ring nearest the rear bearing carrier. The rotor bearing is pressed onto the end of the rotor shaft. The tapered rotor shaft is mounted to a tapered crankshaft and is held in place with a single through bolt.

Stator Assembly

The stator can houses the dual AC power windings, an excitation winding, and two battery charge windings.

See [Figure 1-2](#). A total of thirteen (13) stator leads extend from the stator can.

NOTE: On older style generators the sense leads are 11S and 44S. On newer style generators the sense leads are 11S and 22S.

The stator can is positioned between an engine adapter and a rear bearing carrier. It is retained in position by four stator studs.

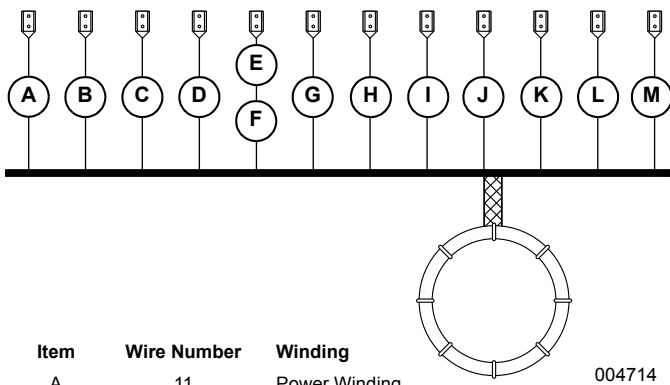

Item	Wire Number	Winding	
A	11	Power Winding	004714
B	44	Power Winding	
C	22	Power Winding	
D	11S	Sense Lead Power	
E	44S	Sense Lead Power (Older Style)	
F	22S	Sense Lead Power (Newer Style)	
G	55A	Battery Charge	
H	66A	Battery Charge	
I	77A	Battery Charge	
J	2	Excitation	
K	6	Excitation	
L	55	10 Amp Battery Charge	
M	66	10 Amp Battery Charge	
N	77	10 Amp Battery Charge	

Figure 1-2. Stator Assembly Leads

Brush Holder and Brushes

The brush holder is retained to the rear bearing carrier with two self-tapping screws. A positive (+) and a negative (-) brush are retained in the brush holder, with the positive (+) brush riding on the slip ring nearest the rotor bearing.

See Figure 1-3. Wire 4 connects to the positive (+) brush and wire 0 to the negative (-) brush. Wire 0 connects to frame ground. Rectified and regulated excitation current, as well as current from a field boost circuit, are delivered to the rotor windings via wire 4, and the positive (+) brush and slip ring. The excitation and field boost current passes through the windings and to frame ground via the negative (-) slip ring and brush, and wire 0. This current flow creates a magnetic field around the rotor having a flux concentration that is proportional to the amount of current flow.

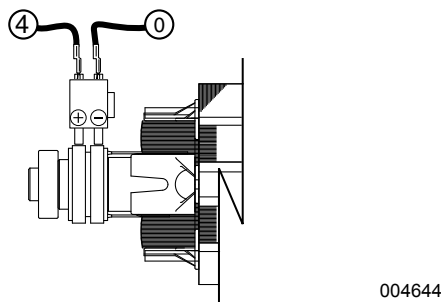

Figure 1-3. Brush Holder and Brushes

Other AC Generator Components

Some AC generator components are housed in the generator control panel enclosure. These are the excitation circuit breaker, the voltage regulator, and the main line circuit breaker.

Excitation Circuit Breaker

See Figure 1-4. The excitation circuit breaker (CB2) is housed in the generator control panel enclosure and electrically connected in series with the excitation (DPE) winding output to the voltage regulator. The breaker is self-resetting, therefore its contacts will close again when excitation current drops to a safe value.

If the circuit breaker has failed open, excitation current flow to the voltage regulator and rotor windings will be lost. Without excitation current flow, AC voltage induced into the stator AC power windings will drop to a value in proportion with the rotor residual magnetism.

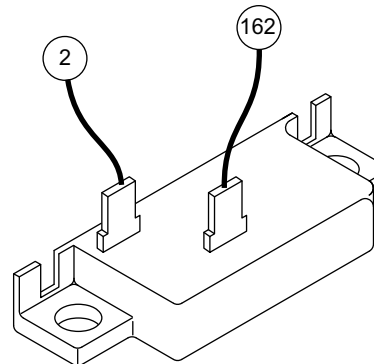
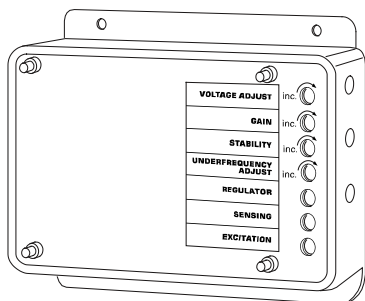

Figure 1-4. Excitation Circuit Breaker

Voltage Regulator

A typical Voltage Regulator is shown in Figure 1-5 (12.5 kW & Older 15 kW Units) or Figure 1-6 (Newer 15 kW and all 17.5 kW Units). See Figure 1-4. Unregulated AC output from the stator excitation winding is delivered to the regulator's DPE terminals, via wire 2, the excitation circuit breaker and wire 162, and wire 6. The voltage regulator rectifies the current and based on stator AC power winding sensing, regulates it. The rectified and regulated excitation current is then delivered to the rotor windings from the positive (+) and negative (-) regulator terminals, via wire 4 and wire 0. Stator AC power winding sensing is delivered to the regulator "SEN" terminals via wires 11S and 44S, or 11S and 22S, depending on the model.

The regulator provides over-voltage protection, but does not protect against under-voltage. On occurrence of an over-voltage condition, the regulator will shut down and complete loss of excitation current to the rotor will occur. Without excitation current, the generator AC output voltage will drop to approximately one-half (or lower) of the unit's rated voltage.



004711

Figure 1-5. Voltage Regulator Found on 12.5 kW and Older Style 15 kW Units (Typical)

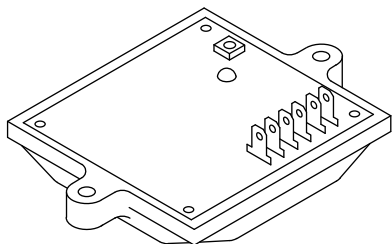

004712

Figure 1-6. Voltage Regulator Found on Newer Style 15 kW Units and All 17.5 kW Units (Typical)

Adjustment Procedure (12.5 kW and Older 15 kW Units)

The voltage regulator is equipped with three light emitting diodes (LED's). These LED's are normally on during operation when no system faults exist. The red regulator LED is on when the regulator is on and functioning. The yellow sensing LED is powered by sensing input to the regulator from the stator AC power windings. The green excitation LED is powered by stator excitation winding output.

The following four adjustment potentiometers are provided:

- Voltage Adjust
 - Gain
 - Stability
 - Under Frequency Adjust
1. Connect an AC voltage/frequency meter across wires 11 and 44 at the 50A main circuit breaker. Verify frequency is between 59-61Hz.
 2. On the regulator, set the adjustment pots as follows:
 - Voltage Adjust – turn fully counterclockwise
 - Gain – turn to midpoint (12 O'clock)
 - Stability – turn to midpoint (12 O'clock)
 - Under Frequency – turn to midpoint (12 O'clock)
 3. Start the generator. This adjustment will be done under a no-load condition.

4. Turn the regulator voltage adjust pot clockwise to obtain a line to line voltage of 238-242 VAC.

NOTE: If the red regulator LED is flashing, slowly turn the Stability pot either direction until flashing stops.

Adjustment Procedure (Newer 15 kW and All 17.5 kW Units)

A single red lamp (LED) illuminates during normal operation. The lamp will become dim if excitation winding AC output diminishes. It will extinguish on occurrence of an open condition in the sensing AC output circuit.

An adjustment potentiometer permits the stator AC power winding voltage to be adjusted. Perform this adjustment with the generator running at no-load, and with a 62 Hz AC frequency (62 Hz equals 3720 rpm). At the stated no-load frequency, adjust to obtain a line-to-line AC voltage of approximately 252 volts.

Circuit Breakers

Each individual outlet on the generator is protected by a circuit breaker to prevent overload.

Rotor Residual Magnetism

The generator revolving field (rotor) may be considered to be a permanent magnet. Some residual magnetism is always present in the rotor. This residual magnetism is sufficient to induce a voltage into the stator AC power windings of approximately 2-12 VAC.

Field Boost Circuit

When the engine is cranked during start-up, the start stop relay (SSR) will be energized. The normally open contacts of the SSR will close and wire 15 will supply 12 VDC to wire 14. Connected to wire 14 is a resistor (R1) and a diode (D1). The resistor will limit current flow, and the diode will block voltage regulator DC output. Once through the resistor and diode it becomes wire 4, and wire 4 then connects to the positive brush. The effect is to flash the field every time the engine is cranked. Field boost current ensures sufficient pickup voltage is available on every startup to turn the voltage regulator on and build AC output voltage.

While the SSR remains energized, field boost current is always available during cranking and running. Diode D1 prevents or blocks the higher voltage regulator DC output from reaching the wire 14 run circuit.

Field boost voltage is reduced from battery voltage by resistor R1. A digital multimeter will indicate approximately 9 to 10 VDC.

Operation

Startup

When the engine is started, residual plus field boost magnetism from the rotor induces a voltage into the stator AC power windings, the stator excitation or DPE windings, and the stator battery charge windings. In an “on-speed” (engine cranking) condition, residual plus field boost magnetism are capable of creating approximately one-half the rated unit voltage.

On-Speed Operation

As the engine accelerates, the voltage induced into the stator windings increases rapidly, with the increasing rotor speed.

Field Excitation

An AC voltage is induced into the stator excitation (DPE) windings. The DPE winding circuit is completed to the voltage regulator, via wire 2, excitation circuit breaker, wire 162, and wire 6. Unregulated alternating current can flow from the winding to the regulator.

The voltage regulator senses AC power winding output voltage and frequency via stator wires 11S and 44S, or 11S and 22S.

The regulator changes the AC from the excitation winding to DC. In addition, based on the sensing signals, it regulates the flow of direct current to the rotor.

The rectified and regulated current flow from the regulator is delivered to the rotor windings, via wire 4, and the positive brush and slip ring. This field excitation current flows through the rotor windings and is directed to ground through the negative (-) slip ring and brush, and wire 0.

The greater the current flow through the rotor windings, the more concentrated the lines of flux around the rotor become.

The more concentrated the lines of flux around the rotor that cut across the stationary stator windings, the greater the voltage that is induced into the stator windings.

The AC power winding voltage initially sensed by the regulator is low. The regulator reacts by increasing the flow of field excitation current to the rotor until voltage increases to a desired level. The regulator then monitors and maintains the desired voltage. For example, if voltage exceeds the desired level, the regulator will decrease the flow of field excitation current. However, if voltage drops below the desired level, the regulator responds by increasing the flow of field excitation current.

AC Power Winding Output

A regulated voltage is induced into the stator AC power windings. When electrical loads are connected across the AC power windings to complete the circuit, current can flow in the circuit. The regulated AC power winding output voltage will be in direct proportion to the AC frequency. For example, on units rated 120/240 volts at 60 Hz, the regulator will try to maintain 240 volts (line-to-line) at 60 Hz. This type of regulation system provides greatly improved motor starting capability over other types of systems.

Battery Charge Winding Output

A voltage is induced into the battery charge winding. Output from these windings is delivered to a battery charge rectifier (BCR2), via wires 55A, 66A and 77A. The resulting direct current from the BCR is delivered to the unit battery, via wire 15, a 10 amp fuse, and wire 13. This output is used to maintain battery state of charge during operation.

10 Amp Battery Charge Winding Output

A voltage is induced into the battery charge winding. Output from these windings is delivered to a battery charge rectifier (BCR1), via wires 55, 66 and 77. The resulting direct current from the BCR is delivered to the 12 VDC receptacle, via wire 13A, CB1, and wire 15A. This receptacle allows the capability to recharge a 12 VDC storage battery with provided battery charge cables.

Specifications

MODEL	GPS 12500 Ultra Source/Centurion	GPS 15000 Ultra Source/Guardian/ Centurion	GPS 17500 Ultra Source/Guardian
Model #	004451 004986	004582 004987 005209 005734	004583 005308 005735
GENERATOR SPECIFICATIONS			
Rated Max. Power	12.5 kW	15.0 kW	17.5 kW
Surge Power	18.75 kW	22.5 kW	26.25 kW
Rated AC Voltage	120/240	120/240	120/240
Rated Max AC Load	–	–	–
Current @ 240V	52.0 Amps	62.5 Amps	72.9 Amps
Current @ 120V	104.0 Amps	125.0 Amps	145.8 Amps
Rated Frequency	60 Hz @ 3600 RPM	60 Hz @ 3600 RPM	60 Hz @ 3600 RPM
Phase	Single Phase	Single Phase	Single Phase
Rated DC Voltage	12 Volts	12 Volts	12 Volts
Rated Max DC Load Current @ 12 Volts	10 Amperes	10 Amperes	10 Amperes
ENGINE SPECIFICATIONS			
Rated Horsepower @3600 RPM	27	30	33
Displacement	763 cc	992 cc	992 cc
Spark Plug Type	Champion RC14YC or Equivalent		
Spark Plug Gap	0.040 inch or (1.01 mm)		
Gasoline Capacity	16 U.S. gallons (60.56 liters)		
Oil Type	Summer – SAE 30 or 10W-30 Winter – Synthetic 5W-20 or 5W-30		
Oil Capacity	w/ Filter Change = 1.7 Qts. (1.6 liters) w/o Filter Change = 1.4 Qts. (1.32 liters)		
Run Time/Fuel Consumption-1/2 Load	10 Hours / 1.6 gallons (6.05 liters) per hour		

ENGINE SPEEDS AND VOLTAGE SPECIFICATIONS		
LOAD %	VOLTAGE (VAC)	FREQUENCY (Hz)
0	238-242	59-61
50	238-242	59-61
100	238-242	59-61

Refer to Engine Service Manual No. 0F6923 for complete GTV-760/990 V-Twin OHVI engine service information.

TORQUE SPECIFICATIONS	
Flywheel Nut	150 ft-lbs
Cylinder Head Bolts	22 ft-lbs
Valve Cover Bolts	4.8-5.5 ft-lbs
Rocker Arm Jam Nut	14 ft-lbs
Ignition Coil	9 ft-lbs
Intake Manifold	14 ft-lbs
Exhaust Manifold	14 ft-lbs
Stator Bolts	6 ft-lbs
Rotor Bolt	30 ft-lbs
Spark Plug	15 ft. lbs.
Starter Bracket To Block	18 ft-lbs
TRIM TORQUE SPECIFICATIONS	
M3-.5 Phillips Pan Head Screw Into Aluminum	50 in-lbs
M6-1 Taptite Screw Into Aluminum	96 in-lbs
M6-1 Taptite Screw Into Weldnut	96 in-lbs
M8-1.25 Taptite Screw Into Aluminum	18 ft-lbs

Section 2 Engine DC Control System

Printed Circuit Board

General Theory

The printed circuit board is responsible for cranking, startup, running and shutdown operations. It interconnects with other components of the DC control system to cycle them on and off at the proper times. It is powered by fused 12 VDC power from the unit battery.

Circuit Board Connections

See **Figure 2-1**. The circuit board mounts 12-pin receptacle J2 and 5-pin receptacle J1. **Table 2-1** shows 12-pin receptacle J2, the associated wires and the function of each pin and wire.

Dip Switch Positions

NOTE: See **Figure 2-1**. These switches must remain in the factory settings.

1. Stepper Motor Rotation
 - a. Switch set to ON for clockwise rotation (Factory Position).
 - b. Switch set to OFF for counterclockwise rotation.
2. Frequency Setting
 - a. Switch set to OFF for 60 Hertz (Factory Position).
 - b. Switch set to ON for 50 Hertz.

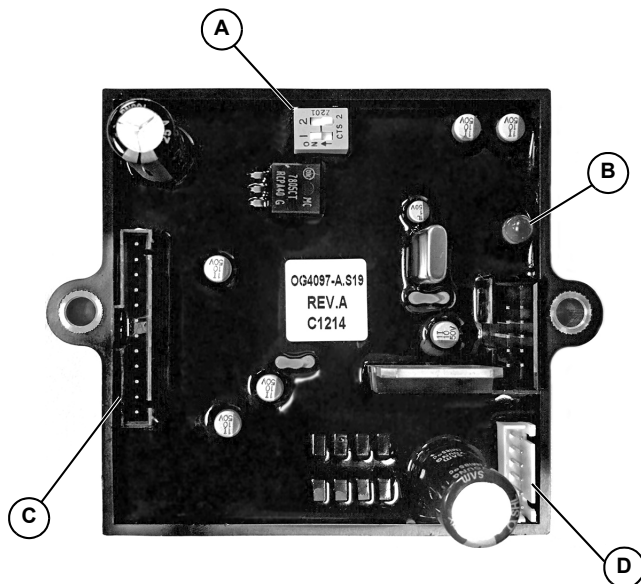

- A. Dip Switches
 B. Sensing LED
 C. J2 Connector
 D. J1 Connector

004571

Figure 2-1. Printed Circuit Board

Terminal	Wire	Function
1	15B	12 VDC input when the start stop relay (SSR) is energized.
2	83	Ground input when the idle control switch (SW2) is placed in the CLOSED position
3	TR1	AC voltage input from the idle control transformers.
4	0	Common ground for the PCB
5	167	12 VDC input when SW1 is placed in the START position. Ground input when SW1 is placed in the STOP position.
6	TR2	AC voltage input from the idle control transformers.
7	86	Fault shutdown circuit. When grounded by closure of the low oil pressure switch (LOP) engine will shut down.
8	229	Switched to ground for start stop relay (SSR) operation.
9		NOT USED
10	44S	AC input for frequency control. 11S/44S 240VAC (Older Style)
	22S	AC input for frequency control. 11S/22S 240 VAC (Newer Style)
11		NOT USED
12	11S	AC input for frequency control. 11S/44S 240 VAC or 11S/22S 240 VAC

NOTE: J1 connector is utilized for governor control.

Battery

Recommended Battery

When anticipated ambient temperatures will be consistently above 32 °F. (0 °C.), use a 12 VDC Group U1 storage battery capable of delivering at least 360 CCA (cold cranking amperes).

Control Panel Component Identification

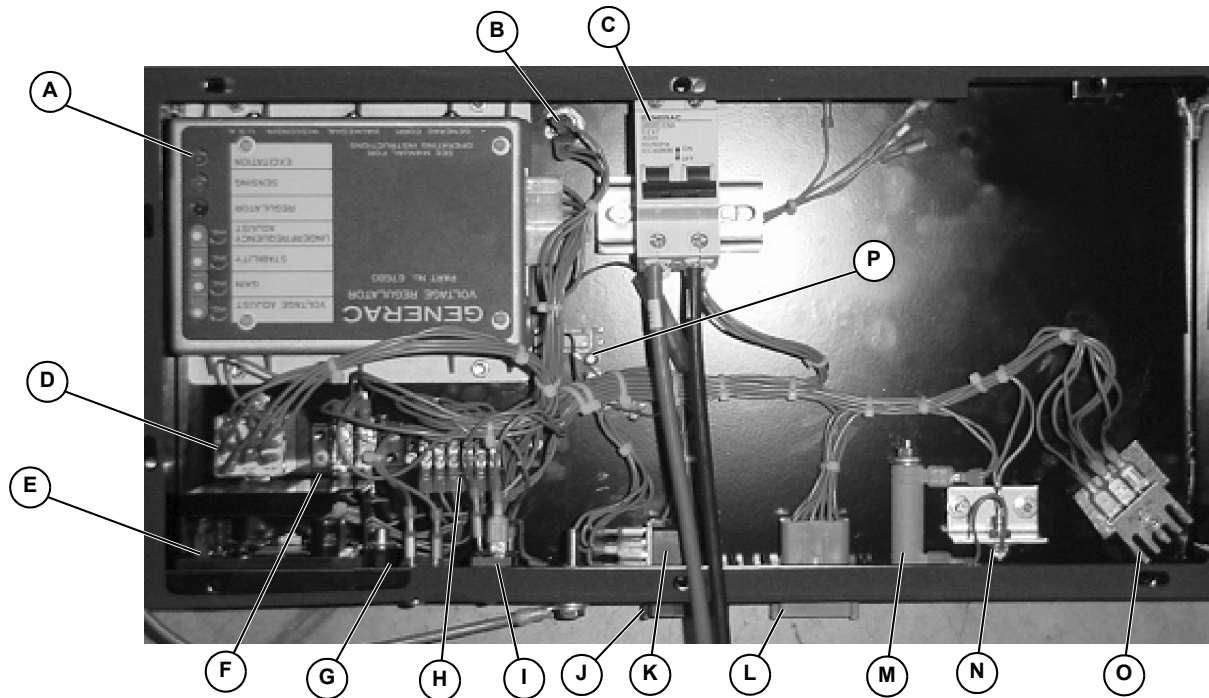

Figure 2-2. Control Panel Component Identification (Older Units)

004572

- | | |
|-------------------------------------|--|
| A. Voltage Regulator | I. 10 Amp Auto Reset Breaker (CB1) |
| B. 10 Amp Fuse (F1) | J. Connector (C2) |
| C. 50 Amp Circuit Breaker | K. Starter Contactor Relay (SCR) |
| D. Start Stop Relay (SSR) | L. Connector (C1) |
| E. Printed Circuit Board | M. Resistor (R1) |
| F. Terminal Board (TB2) | N. Diode (D1) |
| G. Excitation Circuit Breaker (CB2) | O. Battery Charge Rectifiers (BCR1 & BCR2) |
| H. Terminal Board (TB2) | P. Idle Control Transformers (ICT) |

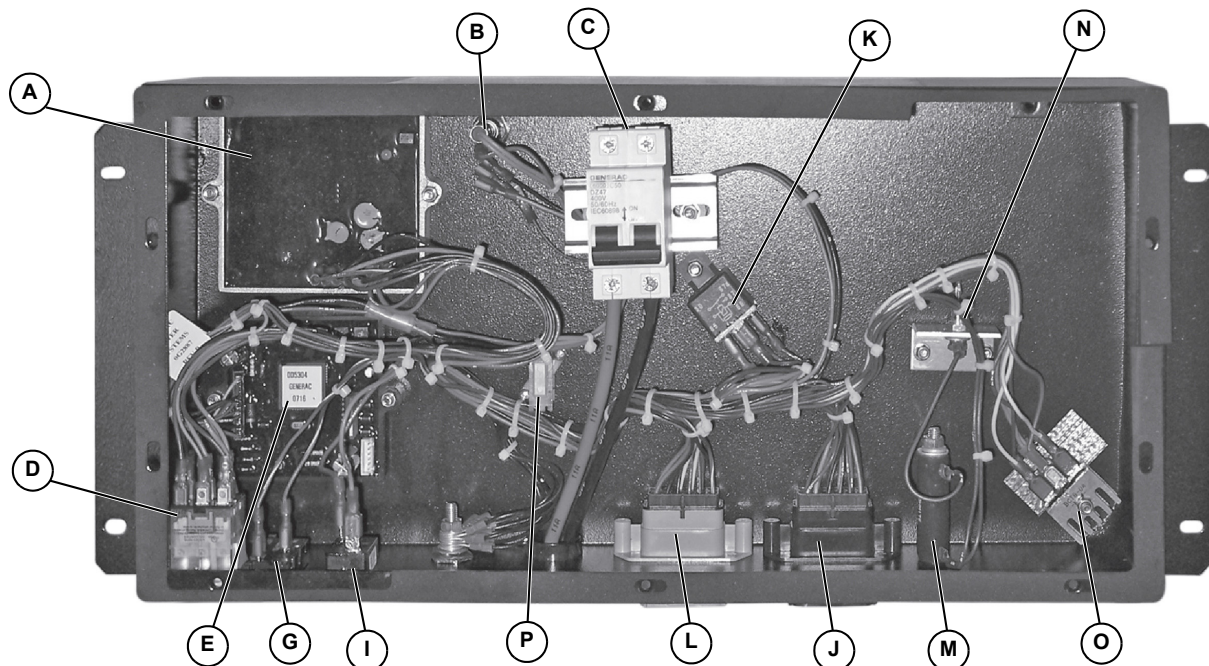

Figure 2-3. Control Panel Component Identification (Newer Units)

004573

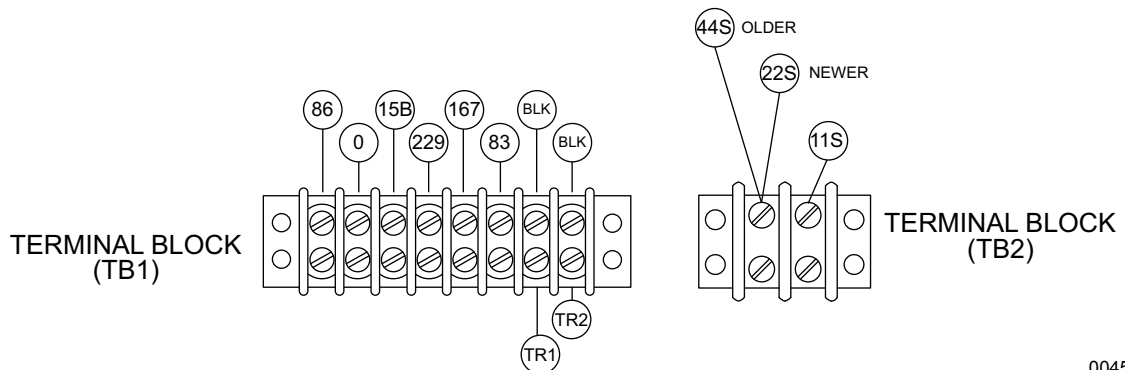
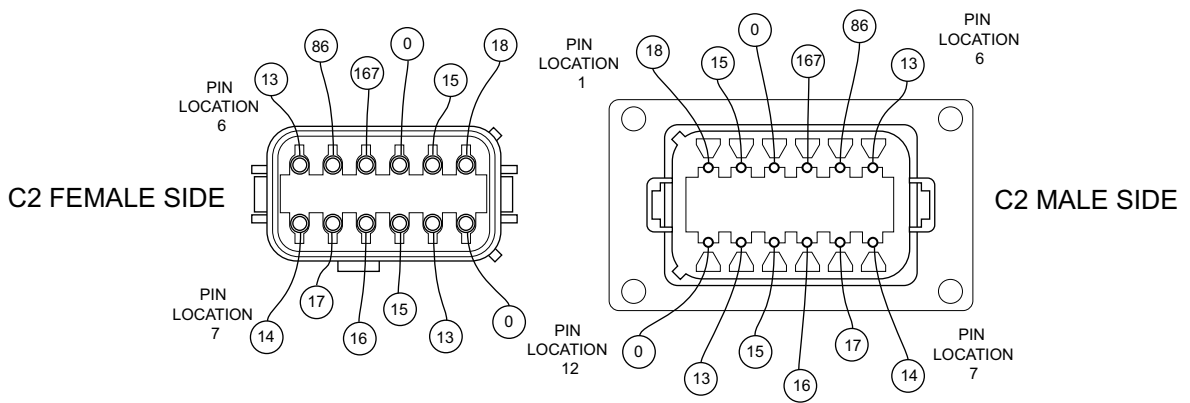
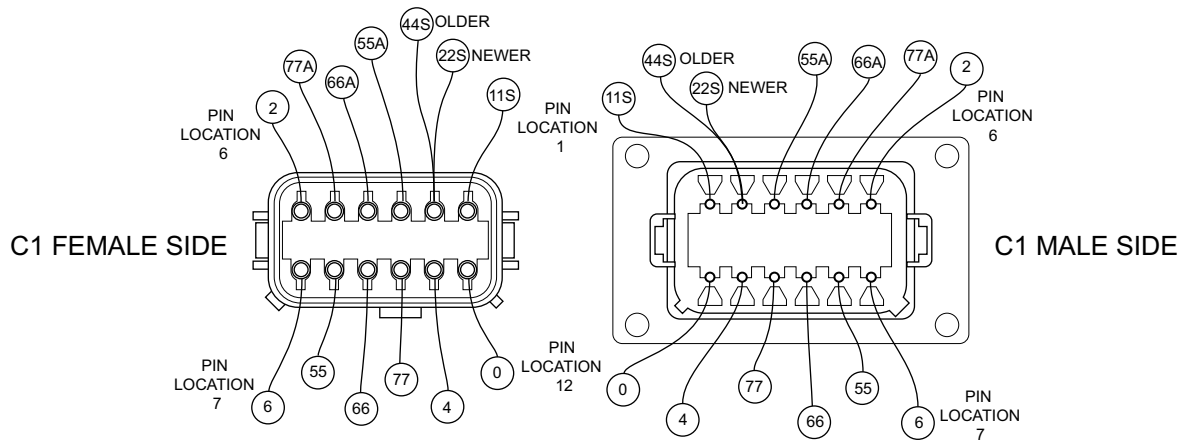

Figure 2-4. Connector Pin Identification

004574

Operational Analysis (Older Units)

Circuit Condition - Rest

Battery voltage is supplied to components of the control system from the unit battery via the red battery cable connected to the contacts of the starter contactor (SC), wire 13, a 10 Amp fuse (F1), and wire 15.

Wire 13 is unfused battery supply voltage and is connected to the contacts of the starter contactor relay (SCR).

Wire 15 is 12 VDC fused battery supply voltage to the SCR. DC voltage flows through the SCR coil and exits the coil as wire 17. Wire 17 is connected to the start-run-stop switch (SW1) and is held open to ground. Current does not flow through the circuit and the SCR is de-energized.

Wire 15 is 12 VDC fused battery voltage supplied to the SW1 and is held open to wire 167.

Wire 15 is 12 VDC fused battery voltage to the start stop relay (SSR). DC voltage flows through the SSR coil and exits the coil as wire 229. Wire 229 will be 12 VDC held open from ground by the printed circuit board. Current does not flow through the circuit and the SSR is de-energized.

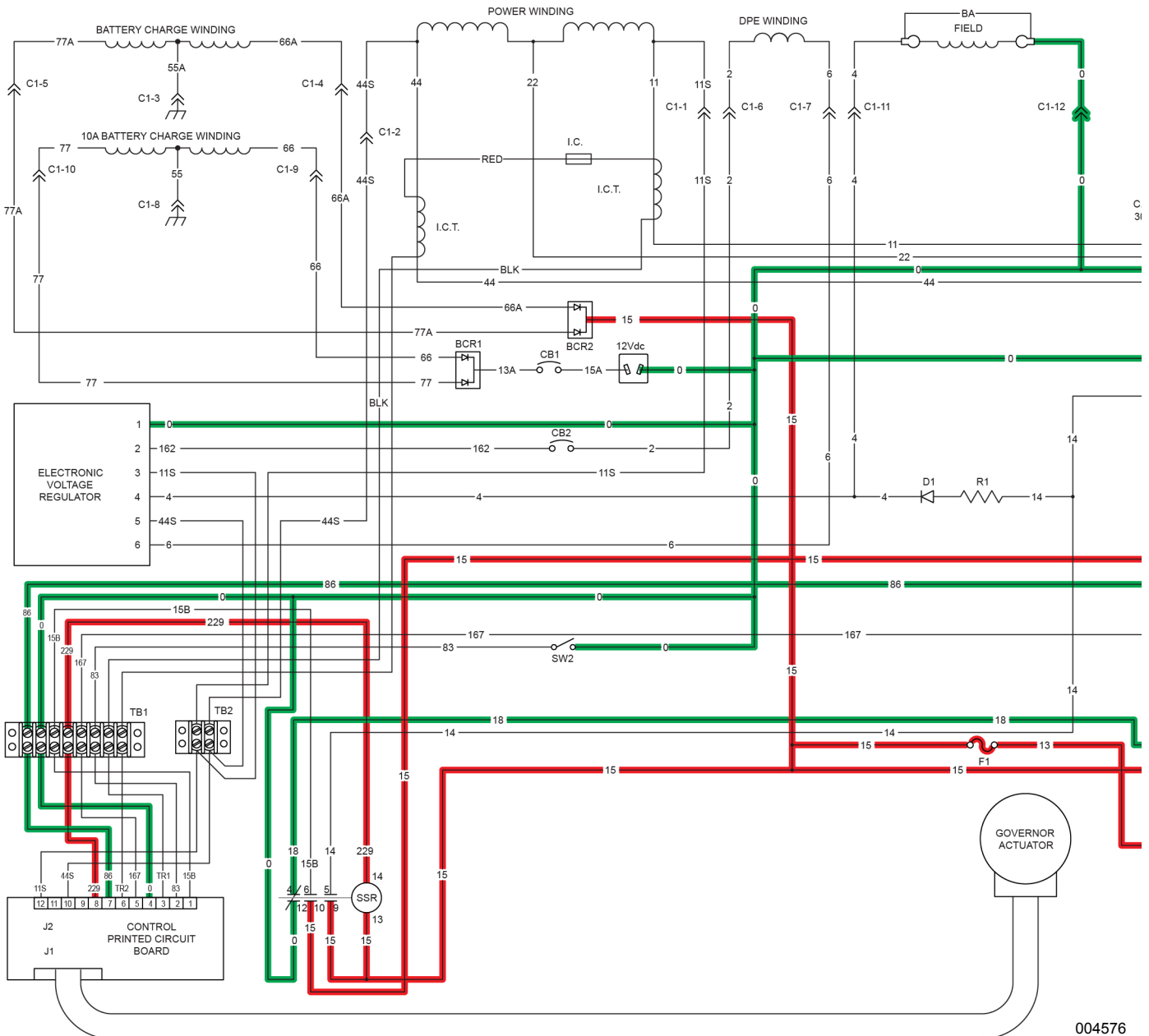

Wire 15 is 12 VDC fused battery supply voltage supplied to the normally open contacts of the SSR. One set of normally open contacts are connected to wire 15B, the other set of normally open contacts are connected to wire 14. The SSR is de-energized and no voltage is available through the contacts.

Wire 15 is 12 VDC fused battery supply voltage supplied to the battery charge rectifier 2 (BCR2). This is a return current path for battery charging. No current flows at this time.

Wire 18 connects to the ignition magnetos and to the normally closed contacts of the SSR. The normally closed contacts are also connected to wire 0. Wire 0 is frame ground.

The SSR is de-energized and the magnetos are grounded out at this time. No spark is available.

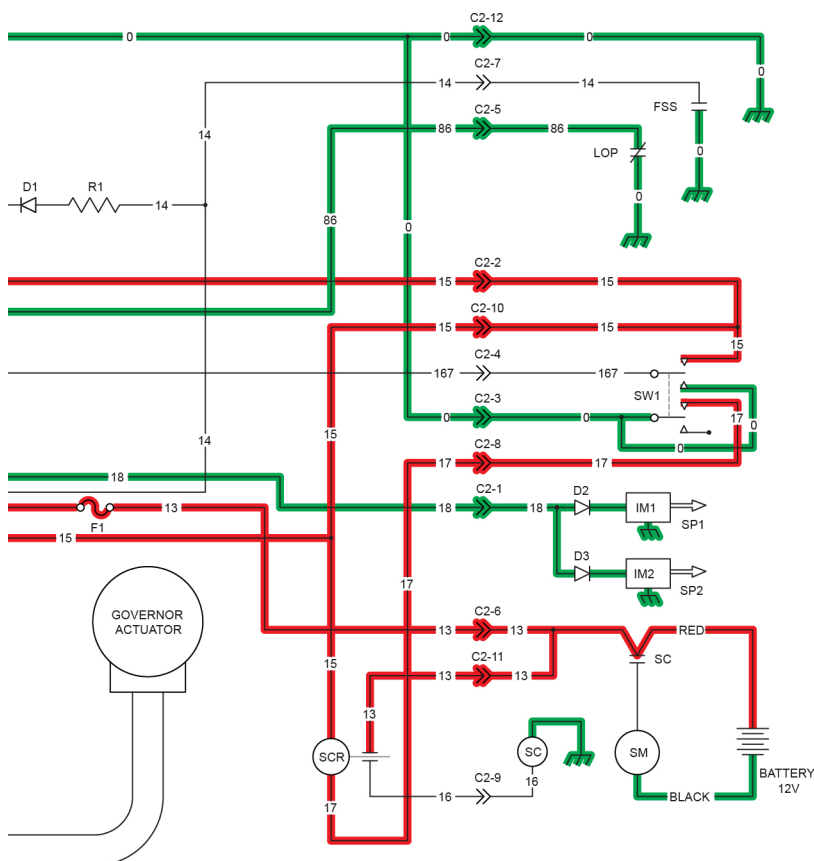
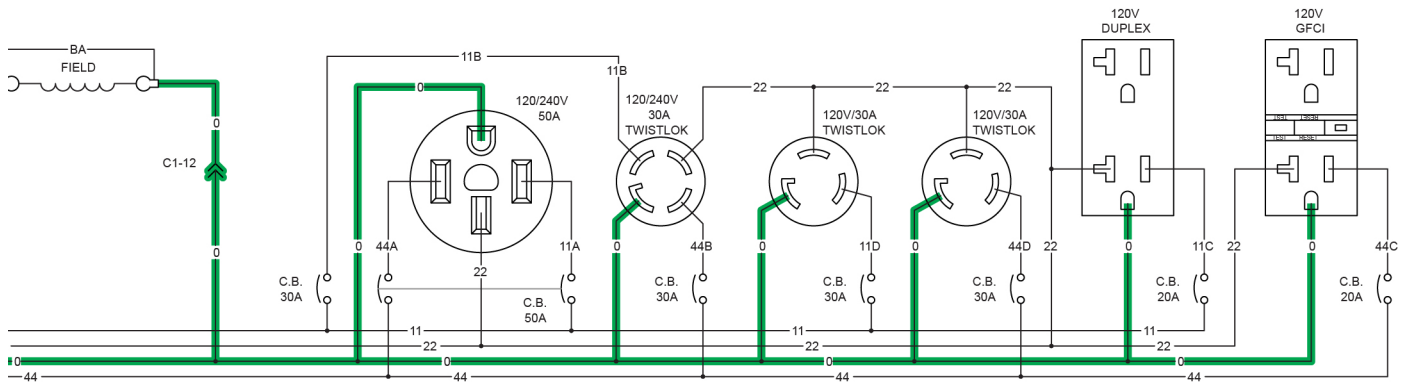

- LEGEND**
- BA - BRUSH ASSEMBLY
 - BCR1 - BATTERY CHARGE RECTIFIER, 10A
 - BCR2 - BATTERY CHARGE RECTIFIER
 - CB1 - 10AMP AUTO RESET BREAKER
 - CB2 - 5AMP AUTO RESET BREAKER
 - D1 - 600V 12A DIODE
 - D2, D3 - ENGINE SHUTDOWN DIODE
 - F1 - 10A FUSE
 - FSS - FUEL SHUT OFF SOLENOID
 - GND - GROUND BAR
 - I.C.T. - IDLE CONTROL TRANSFORMER
 - IM1 - IGNITION MODULE, CYL. 1
 - IM2 - IGNITION MODULE, CYL. 2
 - LOP - LOW OIL PRESSURE
 - R1 - 25 OHM, 25W RESISTOR
 - SC - STARTER CONTACTOR
 - SCR - STARTER CONTACTOR RELAY
 - SM - STARTER MOTOR
 - SP1 - SPARK PLUG, CYL. 1
 - SP2 - SPARK PLUG, CYL. 2
 - SSR - START / STOP RELAY
 - SW1 - START-RUN-STOP SWITCH
 - SW2 - IDLE CONTROL SWITCH
 - TB1, TB2 - TERMINAL BLOCK

- = 12 VDC SUPPLY
- = 12 VDC CONTROL
- = AC POWER
- = GROUND

004576

Circuit Condition - Start

With the start-run-stop switch (SW1) held in the START position, wire 17 is internally closed to ground via wire 0. By grounding wire 17, current is allowed to flow through the SCR and energize the SCR coil. The SCR contacts internally close wire 13 to wire 16. Wire 16 then delivers battery voltage to the starter contactor (SC) on the starter motor (SM). The SC is energized and the contacts close, delivering battery voltage to the starter motor and the engine will start cranking.

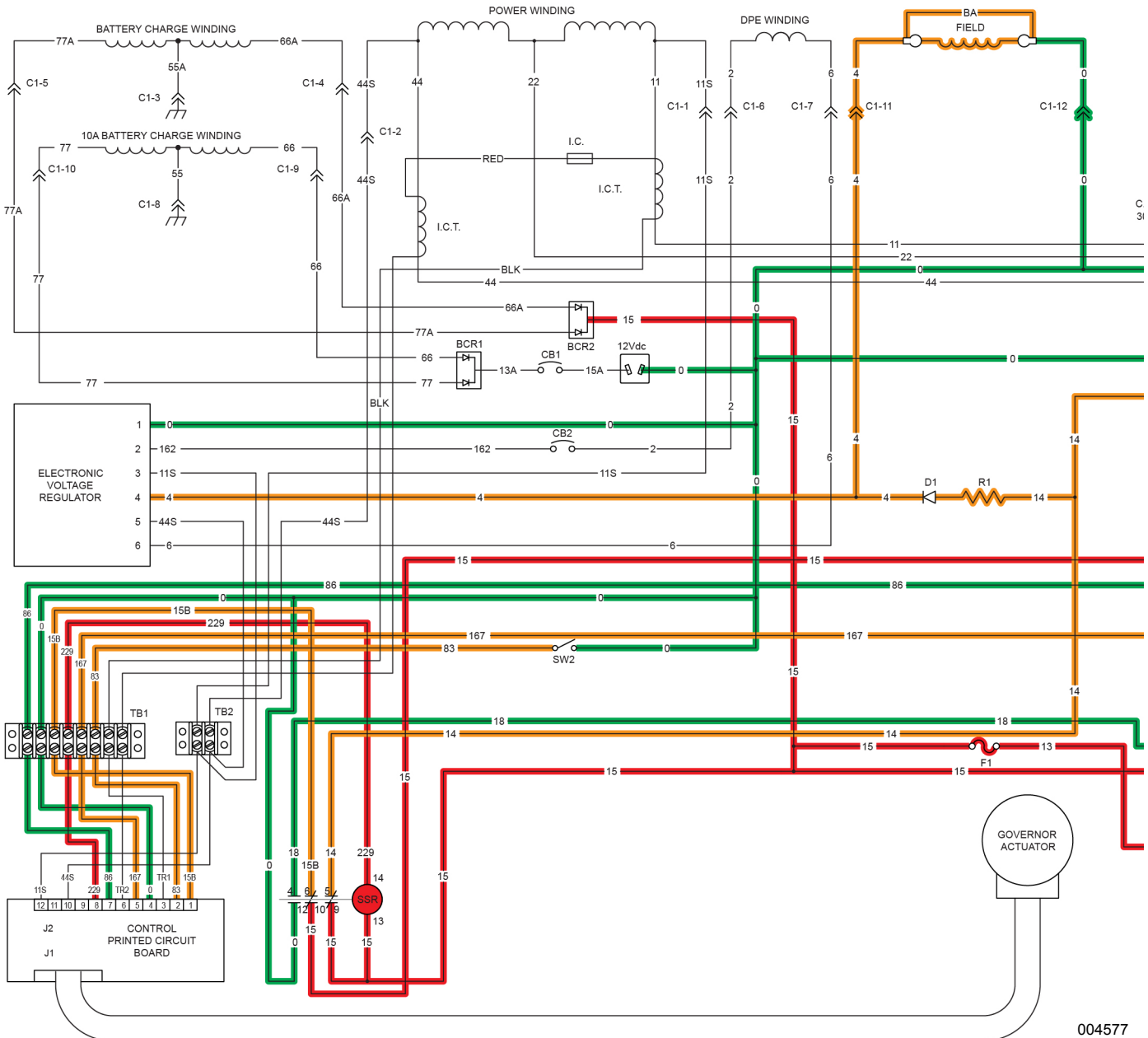

004577

With the start-run-stop switch (SW1) held in the START position, wire 15 is connected to wire 167. Wire 15 supplies fused battery power via wire 167 to the printed circuit board. This 12 VDC input signals the printed circuit board to internally ground wire 229 which is connected to the coil of the start stop relay (SSR). This action allows current to flow and the SSR is energized. The normally open contacts close, supplying battery power from wire 15 to wire 14. Wire 14 supplies power to the fuel shutoff solenoid (FSS). It is energized and fuel is available to the engine. Wire 14 also supplies power through resistor R1 and diode D1 to wire 4. Wire 4 connects to the field or the rotor assembly and is used as field boost. The second set of normally open contacts on the SSR also close connecting wire 15 to wire 15B. Wire 15B now supplies 12 VDC to the printed circuit board for use with the governor control system. The normally closed contacts now open, wire 18 is no longer connected to wire 0 and the magnetos are no longer grounded out, allowing voltage to flow to the spark plugs.

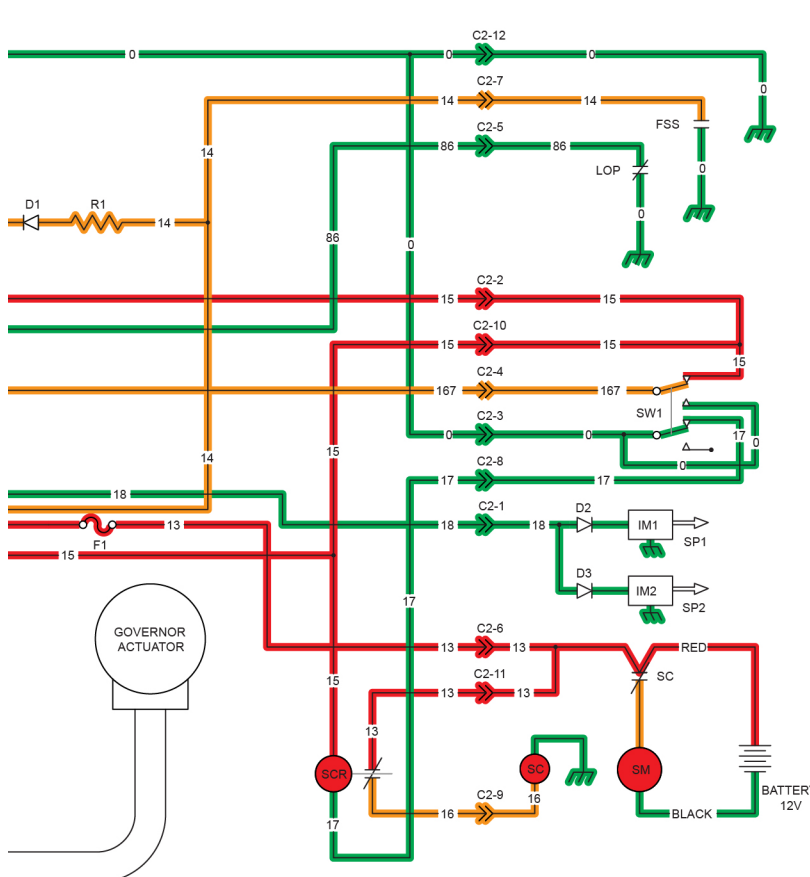
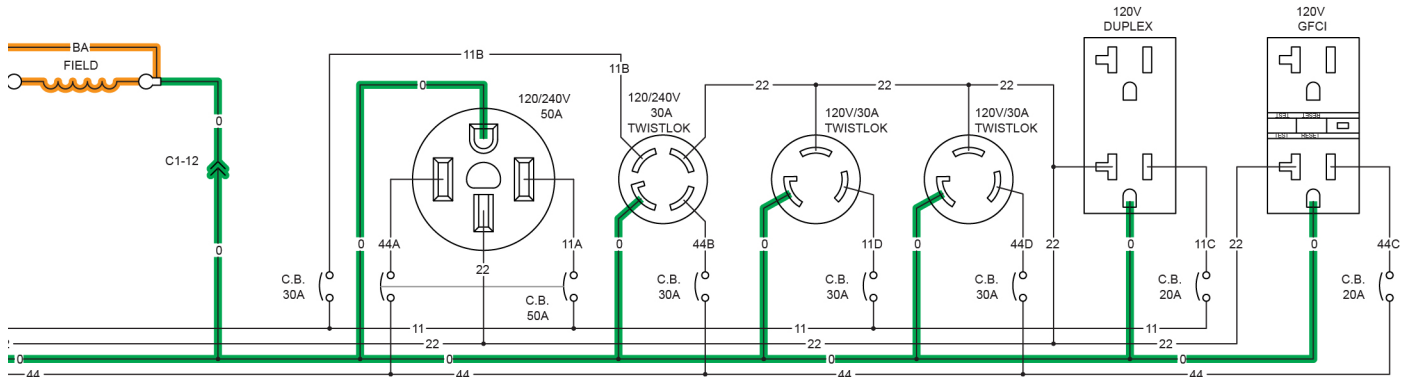

- LEGEND**
- BA - BRUSH ASSEMBLY
 - BCR1 - BATTERY CHARGE RECTIFIER, 10A
 - BCR2 - BATTERY CHARGE RECTIFIER
 - CB1 - 10AMP AUTO RESET BREAKER
 - CB2 - 5AMP AUTO RESET BREAKER
 - D1 - 600V 12A DIODE
 - D2, D3 - ENGINE SHUTDOWN DIODE
 - F1 - 10A FUSE
 - FSS - FUEL SHUT OFF SOLENOID
 - GND - GROUND BAR
 - I.C.T. - IDLE CONTROL TRANSFORMER
 - IM1 - IGNITION MODULE, CYL. 1
 - IM2 - IGNITION MODULE, CYL. 2
 - LOP - LOW OIL PRESSURE
 - R1 - 25 OHM, 25W RESISTOR
 - SCR - STARTER CONTACTOR RELAY
 - SM - STARTER MOTOR
 - SP1 - SPARK PLUG, CYL. 1
 - SP2 - SPARK PLUG, CYL. 2
 - SSR - START / STOP RELAY
 - SW1 - START-RUN-STOP SWITCH
 - SW2 - IDLE CONTROL SWITCH
 - TB1, TB2 - TERMINAL BLOCK

- = 12 VDC SUPPLY
- = 12 VDC CONTROL
- = AC POWER
- = GROUND

004577

The printed circuit board is supplied with AC voltage from wires 11S and 44S. This voltage, frequency signal is used by the printed circuit board for governor control operation.

When the idle control switch (SW2) is activated to the ON position, wire 83 from the printed circuit board will be connected to wire 0 (frame ground). There are two idle control transformers (ICT) that sense current flow off the main power windings. The voltage signal from the ICT's connect to the printed circuit board via wires TR1/TR2 and are used for sensing load on the generator. With no-load on the generator there is no current supplied from the ICT's and the engine will run at a lower RPM. When a load is applied to the generator, the ICT's supply a voltage signal to the printed circuit board and the engine RPM will be increased to running RPM, approximately 3600 RPM.

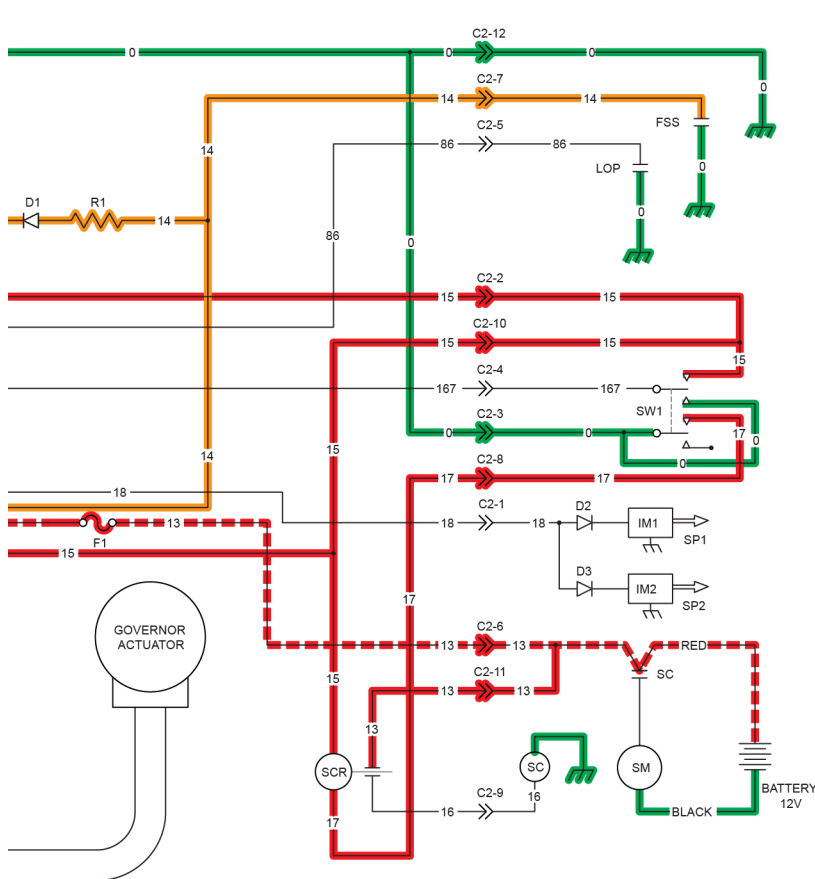
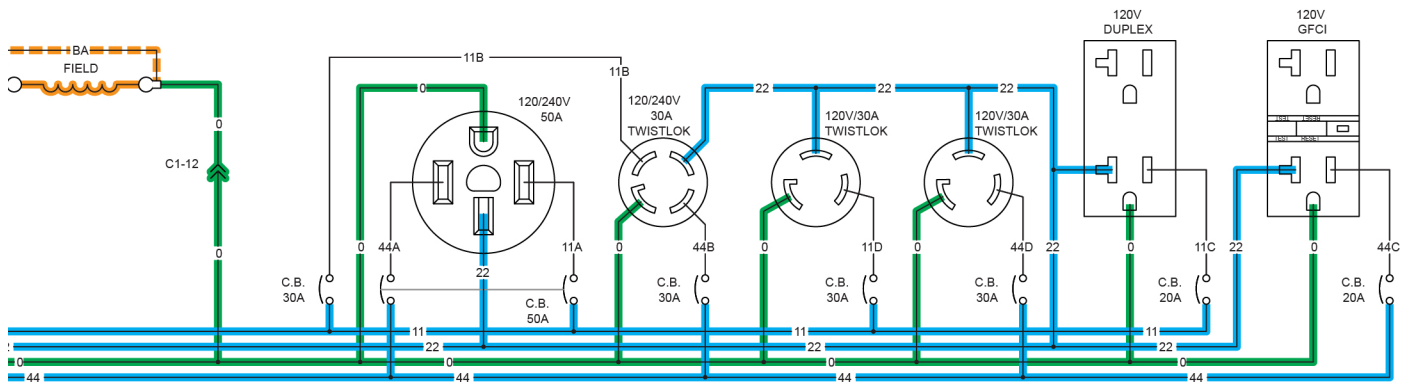

LEGEND

- BA - BRUSH ASSEMBLY
- BCR1 - BATTERY CHARGE RECTIFIER, 10A
- BCR2 - BATTERY CHARGE RECTIFIER
- CB1 - 10AMP AUTO RESET BREAKER
- CB2 - 5AMP AUTO RESET BREAKER
- D1 - 600V 12A DIODE
- D2, D3 - ENGINE SHUTDOWN DIODE
- F1 - 10A FUSE
- FSS - FUEL SHUT OFF SOLENOID
- GND - GROUND BAR
- I.C.T. - IDLE CONTROL TRANSFORMER
- IM1 - IGNITION MODULE, CYL. 1
- IM2 - IGNITION MODULE, CYL. 2
- LOP - LOW OIL PRESSURE
- R1 - 25 OHM, 25W RESISTOR
- SC - STARTER CONTACTOR
- SCR - STARTER CONTACTOR RELAY
- SM - STARTER MOTOR
- SP1 - SPARK PLUG, CYL. 1
- SP2 - SPARK PLUG, CYL. 2
- SSR - START / STOP RELAY
- SW1 - START-RUN-STOP SWITCH
- SW2 - IDLE CONTROL SWITCH
- TB1, TB2 - TERMINAL BLOCK

- = 12 VDC SUPPLY
- = 12 VDC CONTROL
- = AC POWER
- = GROUND

004578

Circuit Condition - Stop

With the start-run-stop switch (SW1) placed in the STOP position, wire 167 is connected to wire 0 (frame ground). The ground signal is supplied via wire 167 to the printed circuit board. The printed circuit board will internally open wire 229 from ground. This action will de-energize the start stop relay (SSR). With the SSR de-energized, wire 14 will no longer have 12 VDC supplied to it through the relay. This de-energizes the fuel shutoff solenoid (FSS), stopping fuel to the engine. With the SSR de-energized, wire 18 will now be connected to wire 0.

This action will ground the magnetos out through wire 18 causing loss of spark to the engine. With the loss of fuel and loss of spark the engine will shutdown.

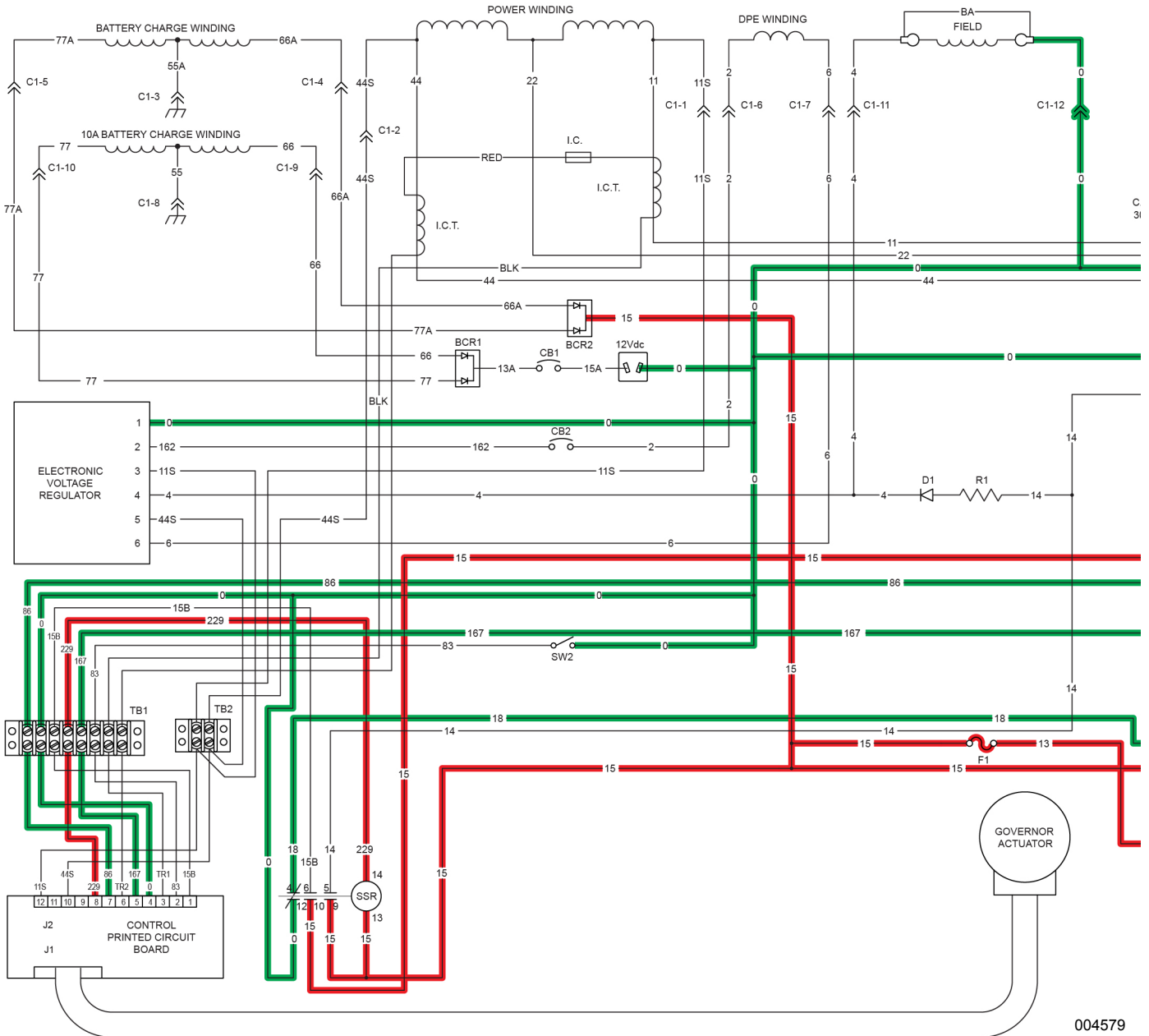

Fault Shutdown

With the generator running, if the low oil pressure (LOP) closes, wire 86 will be connected to wire 0 (frame ground). Printed circuit board action will open wire 229 from ground; this action will de-energize the start stop relay (SSR). This action will cause a shutdown.

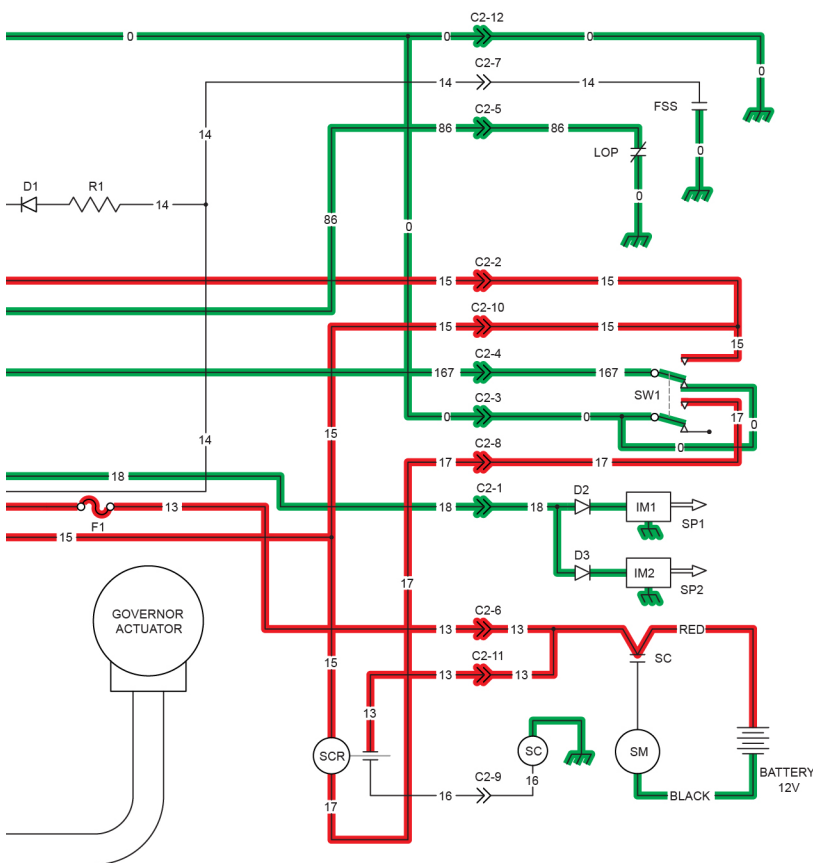
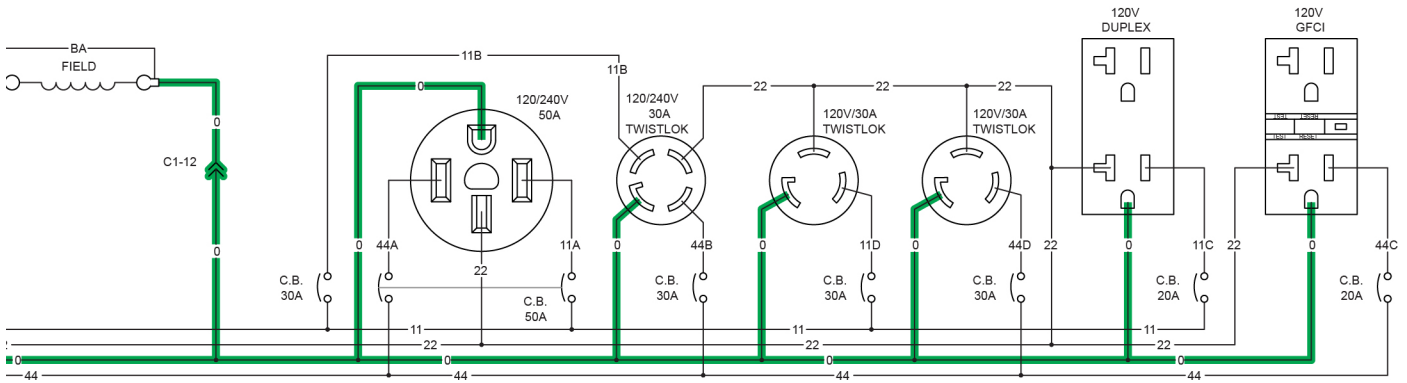

LEGEND

- BA - BRUSH ASSEMBLY
- BCR1 - BATTERY CHARGE RECTIFIER, 10A
- BCR2 - BATTERY CHARGE RECTIFIER
- CB1 - 10AMP AUTO RESET BREAKER
- CB2 - 5AMP AUTO RESET BREAKER
- D1 - 600V 12A DIODE
- D2, D3 - ENGINE SHUTDOWN DIODE
- F1 - 10A FUSE
- FSS - FUEL SHUT OFF SOLENOID
- GND - GROUND BAR
- I.C.T. - IDLE CONTROL TRANSFORMER
- IM1 - IGNITION MODULE, CYL. 1
- IM2 - IGNITION MODULE, CYL. 2
- LOP - LOW OIL PRESSURE
- R1 - 25 OHM, 25W RESISTOR
- SC - STARTER CONTACTOR
- SCR - STARTER CONTACTOR RELAY
- SM - STARTER MOTOR
- SP1 - SPARK PLUG, CYL. 1
- SP2 - SPARK PLUG, CYL. 2
- SSR - START / STOP RELAY
- SW1 - START-RUN-STOP SWITCH
- SW2 - IDLE CONTROL SWITCH
- TB1, TB2 - TERMINAL BLOCK

- = 12 VDC SUPPLY
- = 12 VDC CONTROL
- = AC POWER
- = GROUND

004579

Operational Analysis (Newer Units)

Circuit Condition - Rest

Battery voltage is supplied to components of the control system from the unit battery via the red battery cable connected to the contacts of the starter contactor (SC), wire 13, a 10 Amp fuse (F1), and wire 15.

Wire 13 is unfused battery supply voltage and is connected to the contacts of the starter contactor relay (SCR).

Wire 15 is 12 VDC fused battery supply voltage to the SCR. DC voltage flows through the SCR coil and exits the coil as wire 17. Wire 17 is connected to the start-run-stop switch (SW1) and is held OPEN to ground. Current does not flow through the circuit and the SCR is de-energized.

Wire 15 is 12 VDC fused battery voltage supplied to the SW1 and is held open to wire 167.

Wire 15 is 12 VDC fused battery voltage to the start stop relay (SSR). DC voltage flows through the SSR coil and exits as wire 229. Wire 229 will be 12 VDC held OPEN from ground by the printed circuit board. Current does not flow through the circuit and the SSR is de-energized.

Wire 15 is 12 VDC fused battery supply voltage supplied to the normally open contacts of the SSR. One set of normally open contacts are connected to wire 15B, the other set of normally open contacts are connected to wire 14. The SSR is de-energized and no voltage is available through the contacts.

Wire 15 is 12 VDC fused battery supply voltage supplied to the battery charge rectifier 2 (BCR2). This is a return current path for battery charging. No current flows at this time.

Wire 18 connects to the ignition magnetos and to the normally closed contacts of the SSR. The normally closed contacts are also connected to wire 0 (frame ground).

The SSR is de-energized and the magnetos are grounded out at this time. No spark is available.

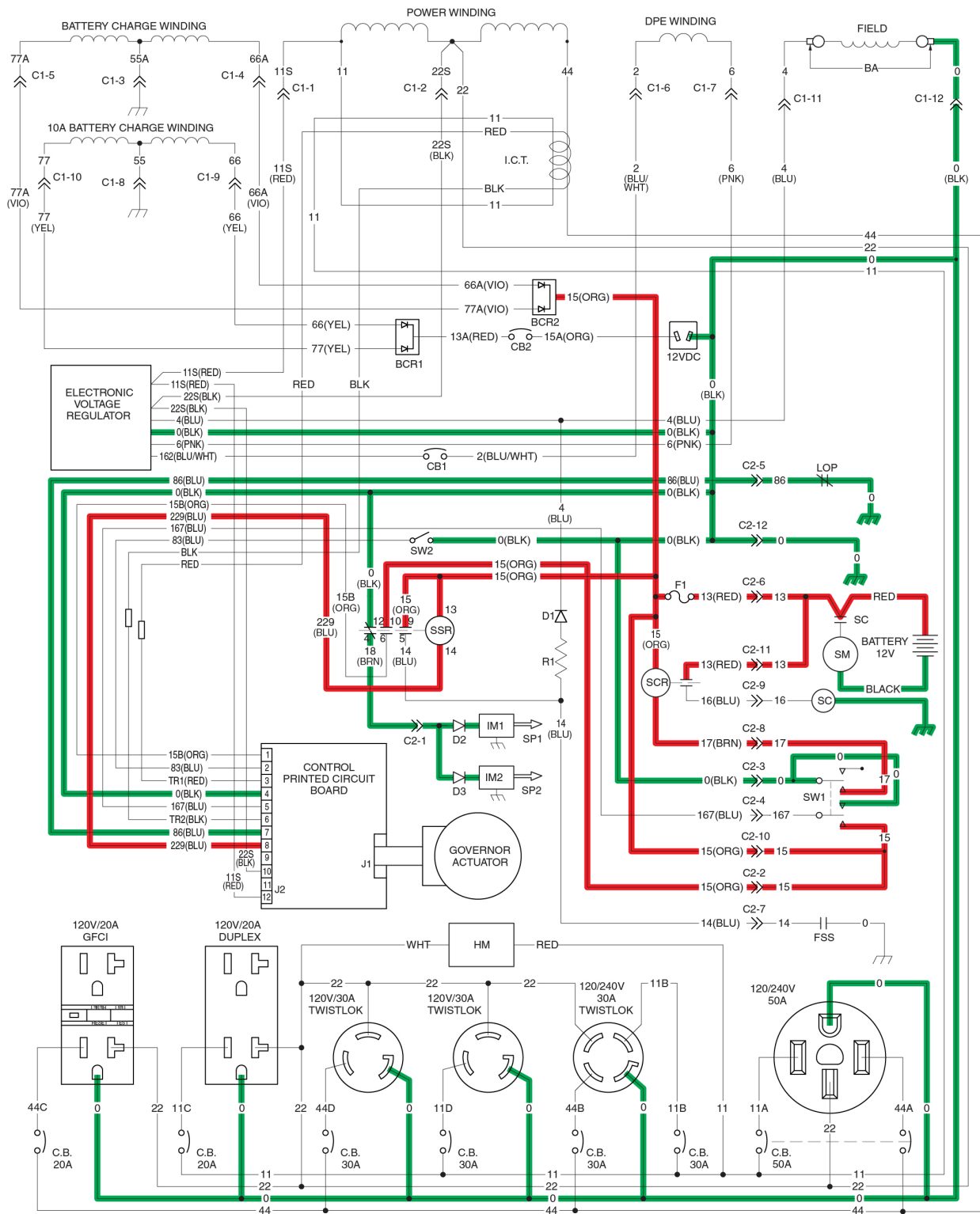

— = 12 VDC SUPPLY

— = 12 VDC CONTROL

— = AC POWER

— = GROUND

— = 1-2 VAC

- - - - = DC BATTERY CHARGING VOLTAGE

- - - - = DC FIELD EXCITATION

LEGEND

- BA - BRUSH ASSEMBLY
- BCR1 - BATTERY CHARGE RECTIFIER
- BCR2 - BATTERY CHARGE RECTIFIER, 10A
- CB1 - 6AMP AUTO RESET BREAKER
- CB2 - 10AMP AUTO RESET BREAKER
- D1 - 600V 12A DIODE
- D2, D3 - ENGINE SHUTDOWN DIODE
- F1 - 10A FUSE
- FSS - FUEL SHUT OFF SOLENOID
- GND - GROUND STUD
- HM - HOUR METER
- I.C.T. - IDLE CONTROL TRANSFORMER
- IM1 - IGNITION MODULE, CYL. 1
- IM2 - IGNITION MODULE, CYL. 2
- LOP - LOW OIL PRESSURE
- SC - STARTER CONTACTOR
- SCR - STARTER CONTACTOR RELAY
- SM - STARTER MOTOR
- SP1 - SPARK PLUG, CYL. 1
- SP2 - SPARK PLUG, CYL. 2
- SSR - START / STOP RELAY
- SW1 - START / STOP SWITCH
- SW2 - IDLE CONTROL SWITCH

004580

Circuit Condition - Start

With the start-run-stop switch (SW1) held in the START position, wire 17 is internally closed to ground via wire 0. By grounding wire 17, current is allowed to flow through the SCR and energize the SCR coil. The SCR contacts internally close wire 13 to wire 16.

Wire 16 then delivers battery voltage to the starter contactor (SC) on the starter motor (SM). The SC is energized and the contacts close, delivering battery voltage to the starter motor and the engine will start cranking.

With the start-run-stop switch (SW1) held in the START position, wire 15 is connected to wire 167. Wire 15 supplies fused battery power via wire 167 to the printed circuit board. This 12 VDC input signals the printed circuit board to internally ground wire 229 which is connected to the coil of the start stop relay (SSR). This action allows current to flow and the SSR is energized. The normally open contacts close supplying battery power from wire 15 to wire 14. Wire 14 supplies power to the fuel shutoff solenoid (FSS).

The FSS is energized and fuel is available to the engine. Wire 14 also supplies power through resistor (R1) and diode (D1) to wire 4. Wire 4 connects to the field or the rotor assembly and is used as field boost. The second set of normally open contacts on the SSR also close connecting wire 15 to wire 15B.

Wire 15B now supplies 12 VDC to the printed circuit board for use with the governor control system. The normally closed contacts now open, wire 18 is no longer connected to wire 0 and the magnetos are no longer grounded out, allowing voltage to flow to the spark plugs.

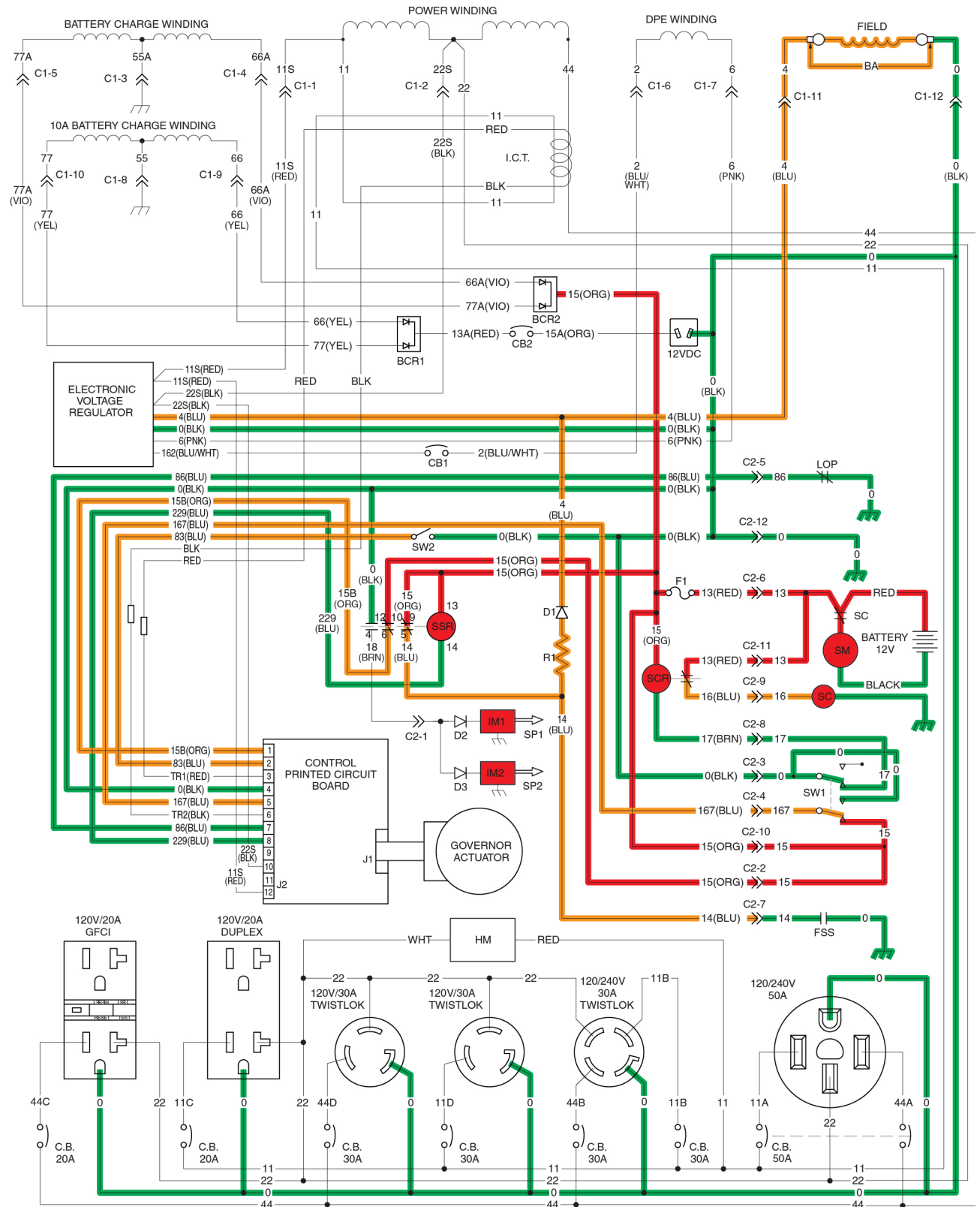

- = 12 VDC SUPPLY
 - = 12 VDC CONTROL
 - = AC POWER
 - = GROUND
 - ■ ■ ■ = DC BATTERY CHARGING VOLTAGE
- | | | |
|---|---|---|
| <p>LEGEND</p> <p>BA - BRUSH ASSEMBLY
 BCR1 - BATTERY CHARGE RECTIFIER
 BCR2 - BATTERY CHARGE RECTIFIER, 10A
 CB1 - 6AMP AUTO RESET BREAKER
 CB2 - 10AMP AUTO RESET BREAKER
 D1 - 600V 12A DIODE
 D2, D3 - ENGINE SHUTDOWN DIODE
 F1 - 10A FUSE</p> | <p>FSS - FUEL SHUT OFF SOLENOID
 GND - GROUND STUD
 HM - HOUR METER
 I.C.T. - IDLE CONTROL TRANSFORMER
 IM1 - IGNITION MODULE, CYL. 1
 IM2 - IGNITION MODULE, CYL. 2
 LOP - LOW OIL PRESSURE
 R1 - 25 OHM, 25W RESISTOR</p> | <p>SC - STARTER CONTACTOR
 SCR - STARTER CONTACTO
 SM - STARTER MOTOR
 SP1 - SPARK PLUG, CYL. 1
 SP2 - SPARK PLUG, CYL. 2
 SSR - START / STOP RELAY
 SW1 - START-RUN-STOP SW
 SW2 - IDLE CONTROL SWIT</p> |
|---|---|---|

004581

Circuit Condition - Run

Once the engine has started, the start-run-stop switch (SW1) is released and returns to the RUN position. At this point SW1 is not activated. This action will de-energize the starter contactor relay (SCR) causing the starter motor to disengage.

The printed circuit board holds wire 229 to ground. This action holds the start stop relay (SSR) energized. With the SSR energized, wire 14 maintains 12 VDC to the fuel shutoff solenoid. Once the voltage regulator starts functioning the field boost circuit is no longer a factor in operation. With the SSR energized, wire 15B maintains 12 VDC to the printed circuit board. With the SSR energized, wire 18 is not grounded and the magnetos continue to produce voltage to the spark plug.

The two independent battery charge windings are now producing AC voltage and supplying this to BCR1 and BCR2. The AC voltage is rectified through BCR1 and used to supply DC voltage to the 12 VDC accessory outlet. The AC voltage is rectified through BCR2 and used to supply DC voltage to the battery for battery charging.

The printed circuit board is supplied with AC voltage from wires 11S and 22S. This voltage, frequency signal is used by the printed circuit board for governor control operation.

When the idle control switch (SW2) is activated to the ON position, wire 83 from the printed circuit board will be connected to wire 0 frame ground. There are two idle control transformers (ICT) that sense current flow off the main power windings. The voltage signal from the ICT's connect to the printed circuit board via wires TR1/TR2 and are used for sensing load on the generator. With no-load on the generator there is no current supplied from the ICT's and the engine will run at a lower RPM. When a load is applied to the generator, the ICT's supply a voltage signal to the printed circuit board and the engine RPM will be increased to running RPM, approximately 3600 RPM.

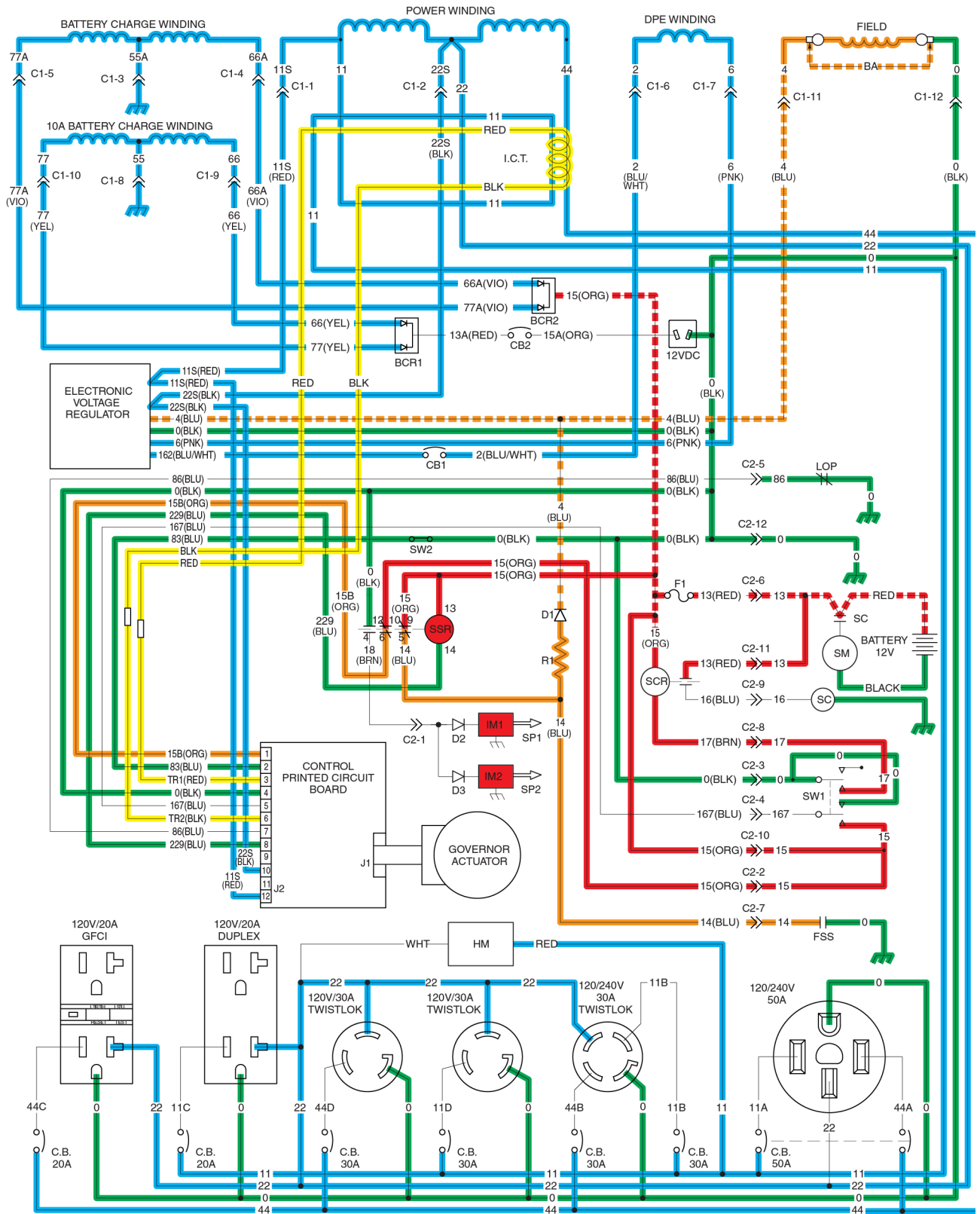

- LEGEND**
- = 12 VDC SUPPLY
 - = 12 VDC CONTROL
 - = AC POWER
 - = GROUND
 - - - - = DC BATTERY CHARGING VOLTAGE
- | | | |
|---|---|--|
| <ul style="list-style-type: none"> BA - BRUSH ASSEMBLY BCR1 - BATTERY CHARGE RECTIFIER BCR2 - BATTERY CHARGE RECTIFIER, 10A CB1 - 6AMP AUTO RESET BREAKER CB2 - 10AMP AUTO RESET BREAKER D1 - 800V 12A DIODE D2, D3 - ENGINE SHUTDOWN DIODE F1 - 10A FUSE | <ul style="list-style-type: none"> FSS - FUEL SHUT OFF SOLENOID GND - GROUND STUD HM - HOUR METER I.C.T. - IDLE CONTROL TRANSFORMER IM1 - IGNITION MODULE, CYL. 1 IM2 - IGNITION MODULE, CYL. 2 | <ul style="list-style-type: none"> SC - STARTER CONTACTOR GND - GROUND STUD SCR - STARTER CONTACTOR SM - STARTER MOTOR SP1 - SPARK PLUG, CYL. 1 SP2 - SPARK PLUG, CYL. 2 SSR - START / STOP RELAY LOP - LOW OIL PRESSURE SW1 - START/RUN-STOP SW SW2 - IDLE CONTROL SWIT |
|---|---|--|

Circuit Condition - Stop

With the start-run-stop switch (SW1) placed in the STOP position, wire 167 is connected to wire 0 (frame ground). The ground signal is supplied via wire 167 to the printed circuit board. The printed circuit board will internally open wire 229 from ground. This action will de-energize the start stop relay (SSR). With the SSR de-energized, wire 14 will no longer have 12 VDC supplied to it through the relay. This de-energizes the fuel shutoff solenoid (FSS) stopping fuel to the engine. With the SSR de-energized, wire 18 will now be connected to wire 0. This action will ground the magnetos out through wire 18 causing loss of spark to the engine. With the loss of fuel and loss of spark the engine will shutdown.

Fault Shutdown

With the generator running, if the low oil pressure (LOP) closes, wire 86 will be connected to wire 0 frame ground. Printed circuit board action will open wire 229 from ground; this action will de-energize the start stop relay (SSR). This action will cause a shutdown.

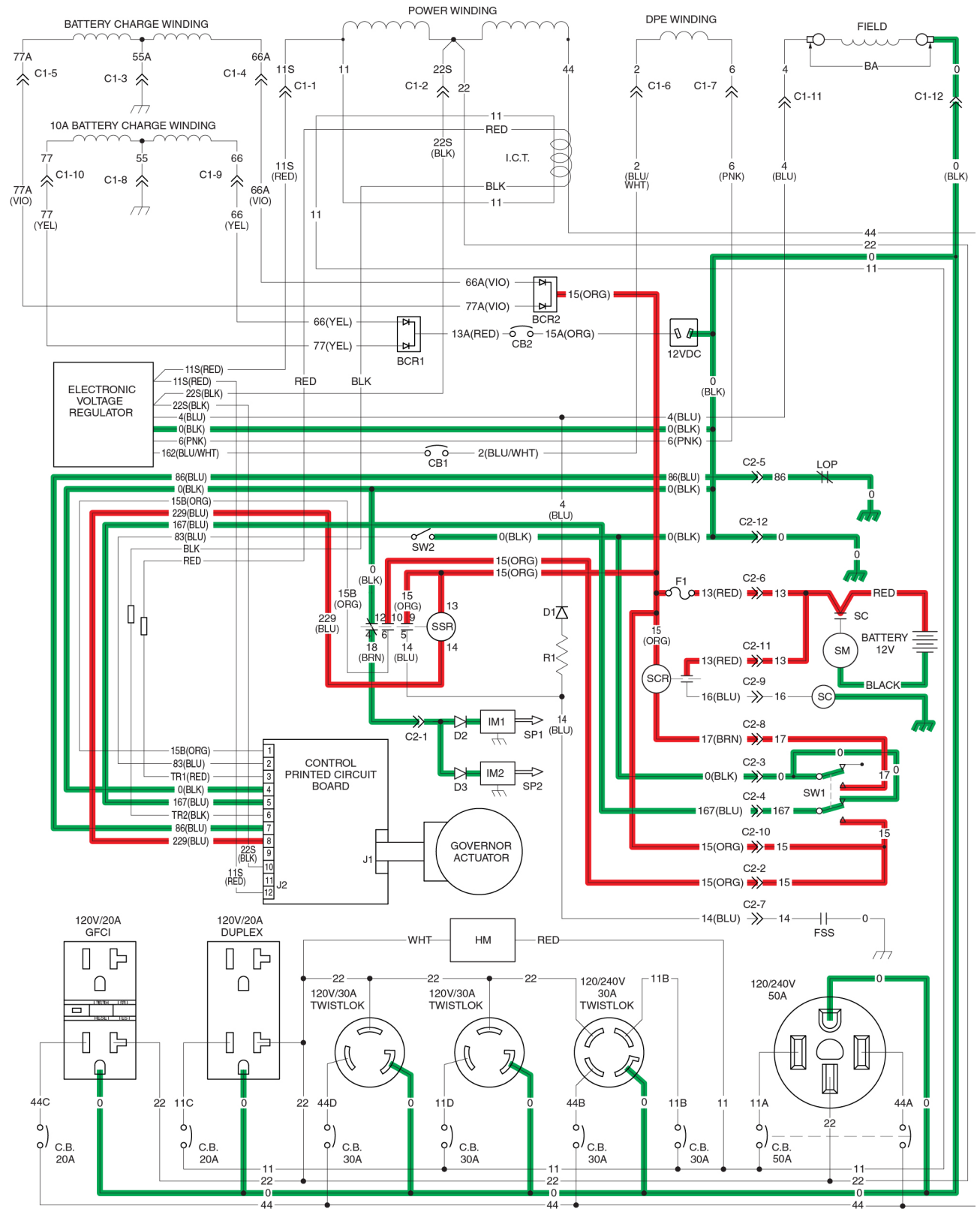

- LEGEND**
- = 12 VDC SUPPLY
 - = 12 VDC CONTROL
 - = AC POWER
 - = GROUND
 - ■ ■ ■ = DC BATTERY CHARGING VOLTAGE
- | | | |
|---|---|---|
| <ul style="list-style-type: none"> BA - BRUSH ASSEMBLY BCR1 - BATTERY CHARGE RECTIFIER BCR2 - BATTERY CHARGE RECTIFIER, 10A CB1 - 6AMP AUTO RESET BREAKER CB2 - 10AMP AUTO RESET BREAKER D1 - 600V 12A DIODE D2, D3 - ENGINE SHUTDOWN DIODE F1 - 10A FUSE | <ul style="list-style-type: none"> FSS - FUEL SHUT OFF SOLENOID GND - GROUND STUD HM - HOUR METER I.C.T. - IDLE CONTROL TRANSFORMER IM1 - IGNITION MODULE, CYL. 1 IM2 - IGNITION MODULE, CYL. 2 | <ul style="list-style-type: none"> SC - STARTER CONTACTOR SCR - STARTER CONTACTOR SM - STARTER MOTOR SP1 - SPARK PLUG, CYL. 1 SP2 - SPARK PLUG, CYL. 2 SSR - START / STOP RELAY LOP - LOW OIL PRESSURE SW1 - START-RUN-STOP SW SW2 - IDLE CONTROL SWIT |
|---|---|---|

004583

This page intentionally left blank.

Section 3 Troubleshooting Flowcharts

Introduction

The most important step in troubleshooting is identifying the actual problem. The next step is to determine the applicable flow chart to use to help diagnose the problem.

For each flow chart, start at the top and use the indicated test to verify whether or not a component or control item is working properly. At the end of each test follow the GOOD or BAD arrows and perform the next test.

Use the flow charts in conjunction with the detailed instructions in section 4. Test numbers used in the flow charts correspond to the numbered tests in section 4. For best results, perform all tests in the exact sequence shown in the flow charts.

If Problem Involves AC Output

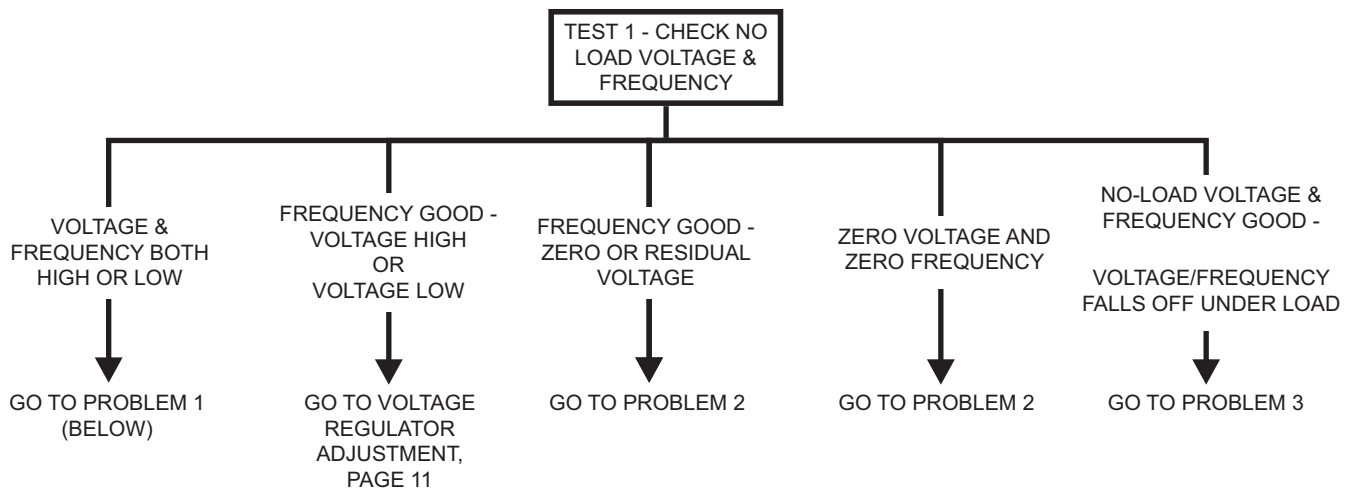

Problem 1 – Voltage and Frequency Are Both High or Low

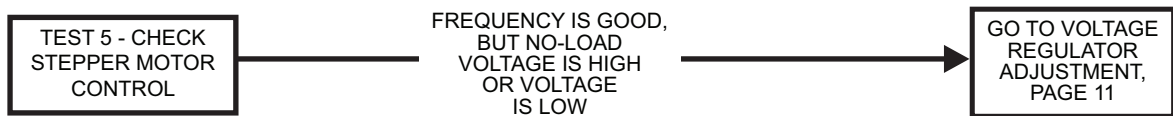

Problem 2 – Generator Produces Zero Voltage or Residual Voltage (2-12 VAC)

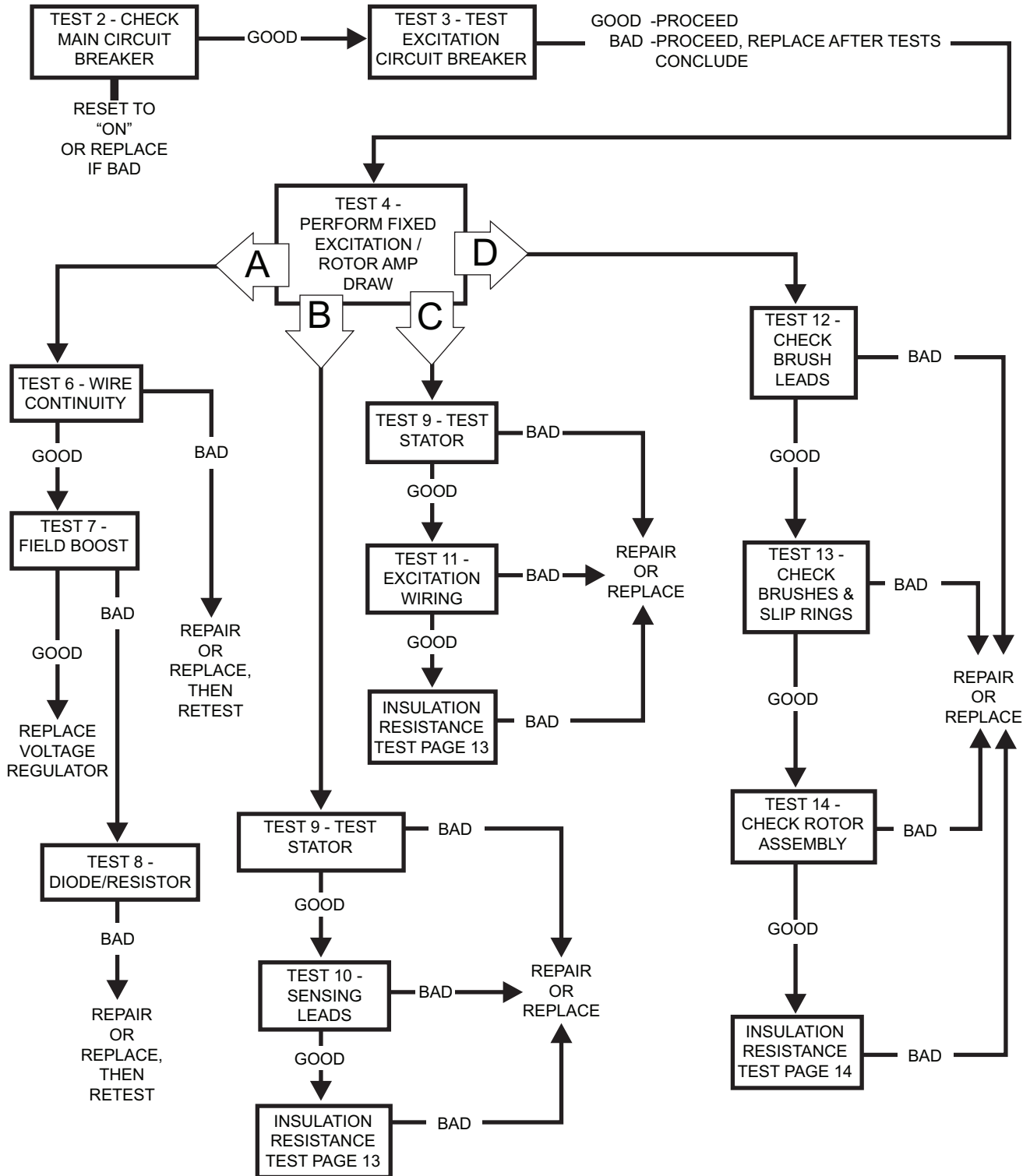

Problem 2 – Generator Produces Zero Voltage or Residual Voltage (2-12 VAC) (continued)

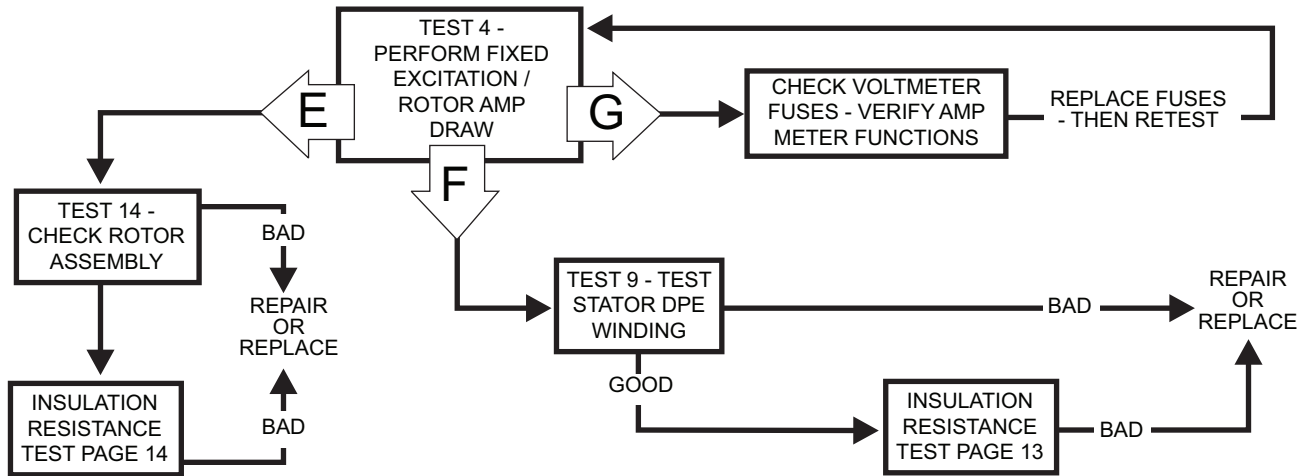

Problem 3 – Excessive Voltage/Frequency Droop When Load is Applied

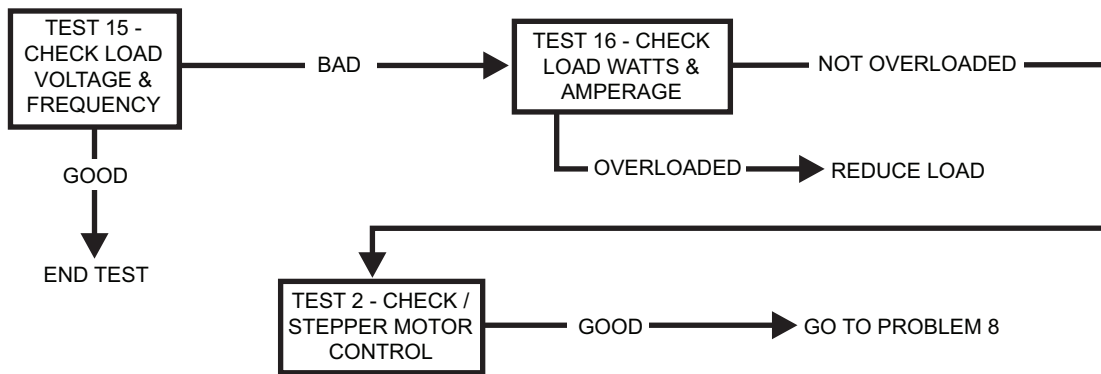

Problem 4 – No Battery Charge Output

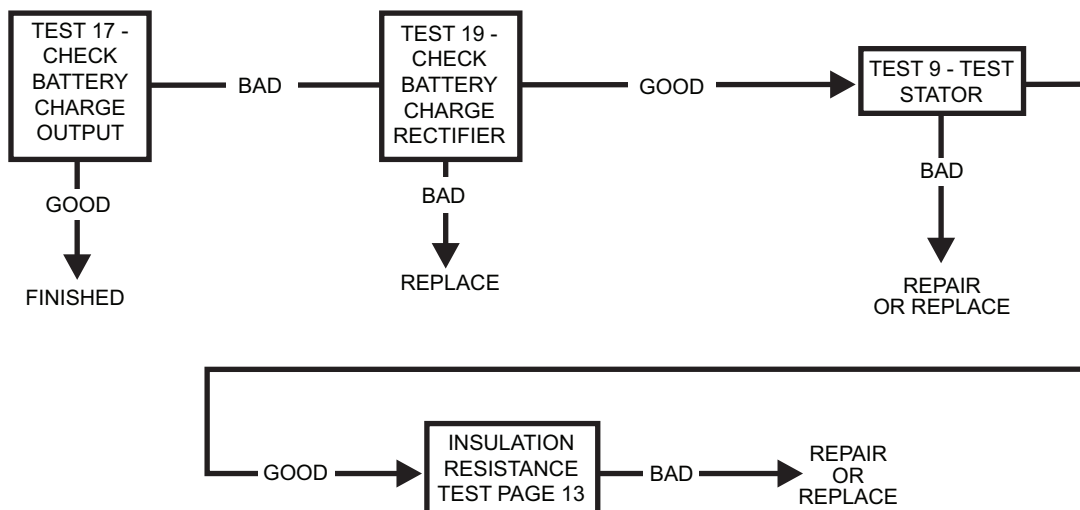

Problem 5 - No 10A Battery Charge Output

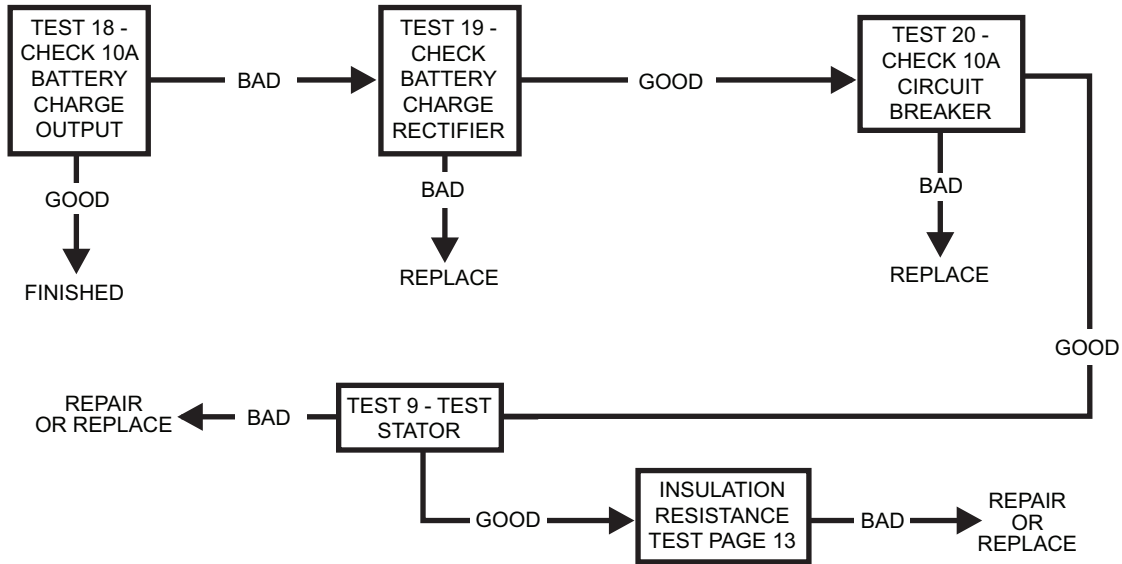

Problem 6 – Engine Will Not Crank

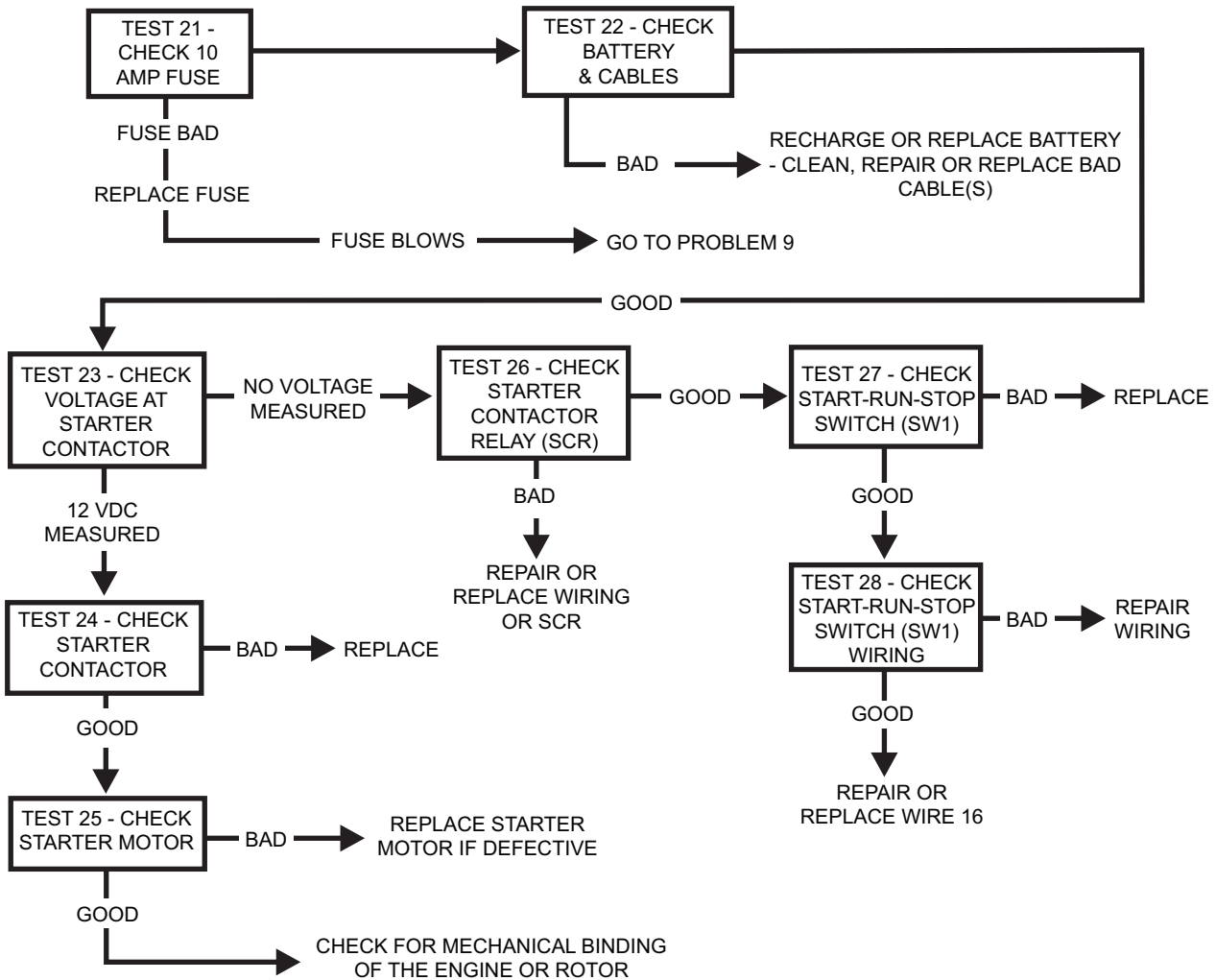

Problem 7 – Engine Cranks But Will Not Start

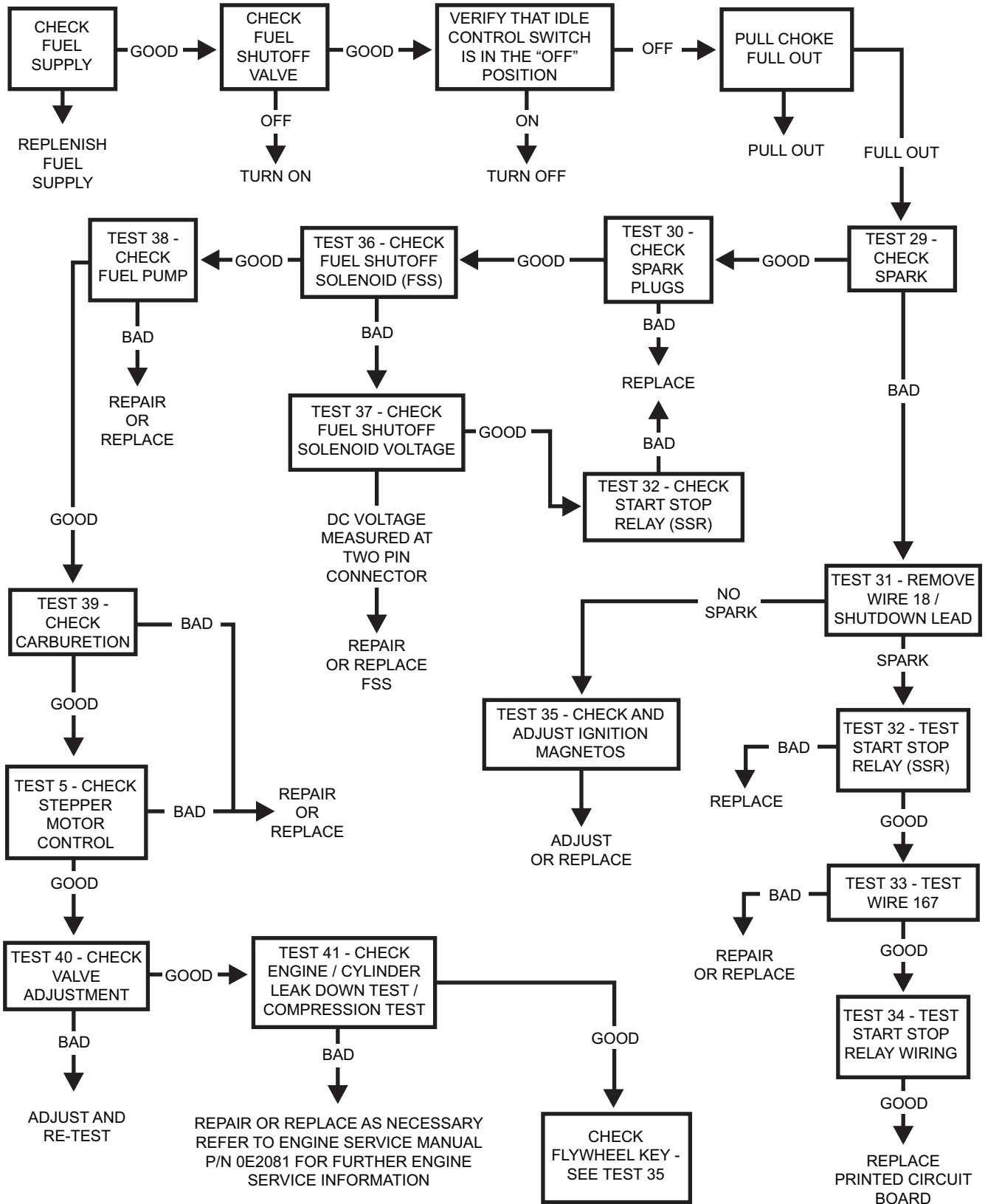

Problem 8 – Engine Starts Hard and Runs Rough

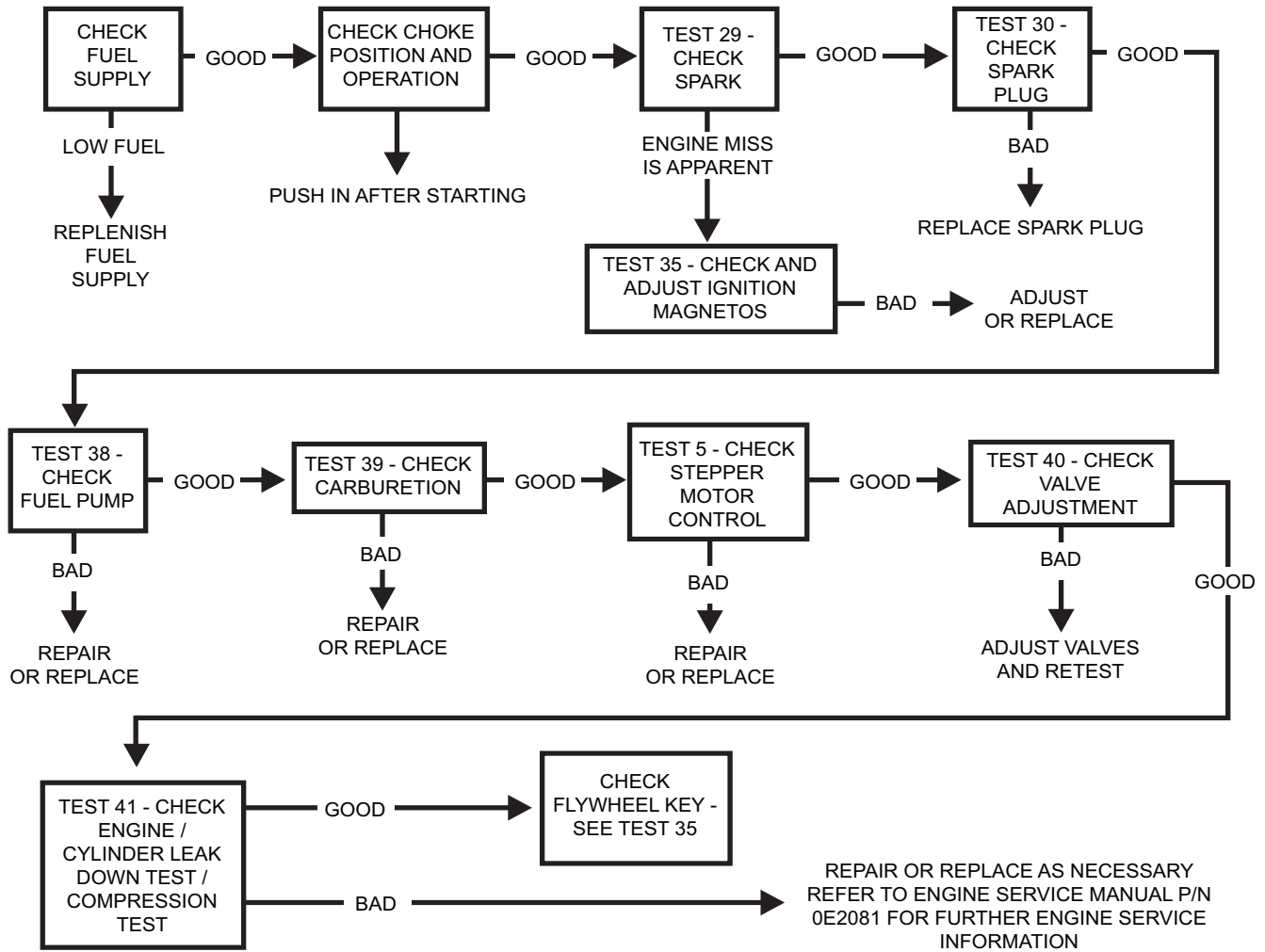

Problem 9 – Engine Starts Then Shuts Down

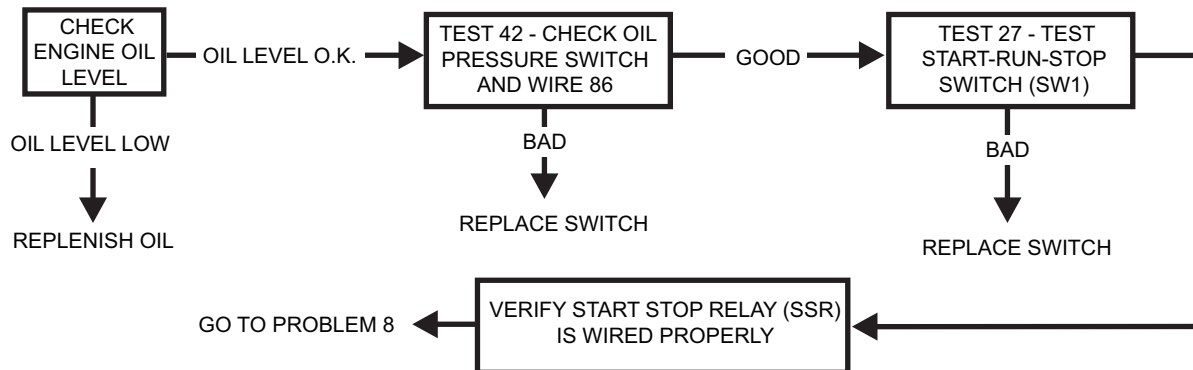

Problem 10 – 10 Amp Fuse (F1) Blowing

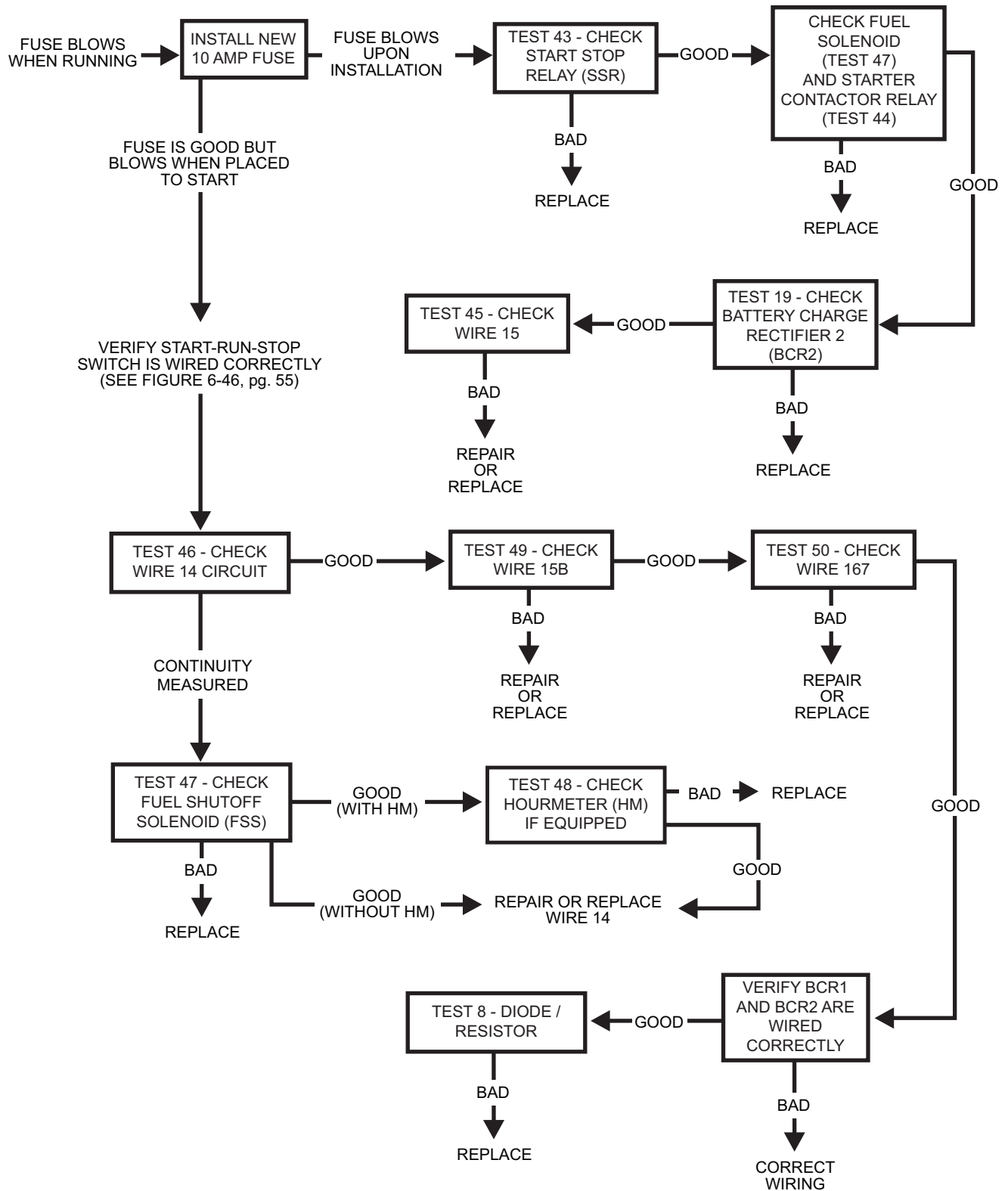

Problem 11 – Engine Overspeeds

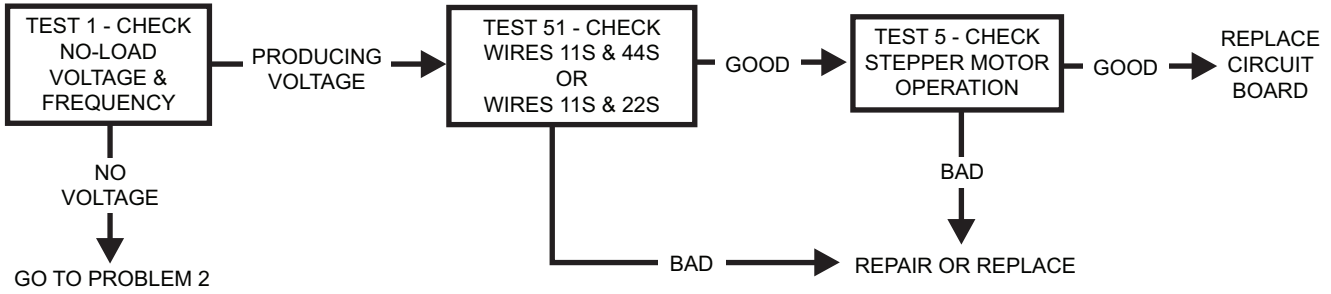

Problem 12 – Idle Control “RPM Does Not Decrease”

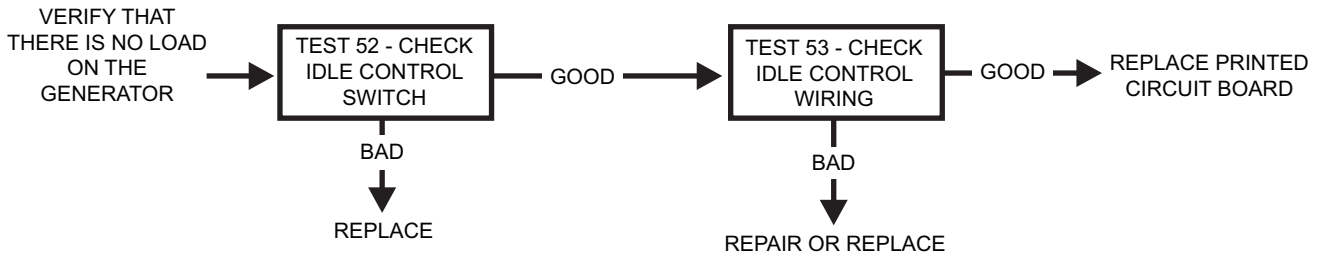

Problem 13 – Idle Control “RPM Does Not Increase When Load Is Applied”

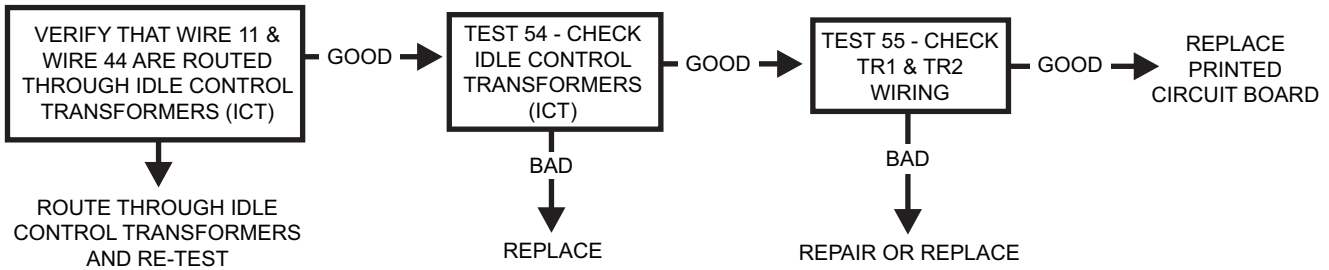

Problem 14 - Engine “Hunts” / Erratic Idle

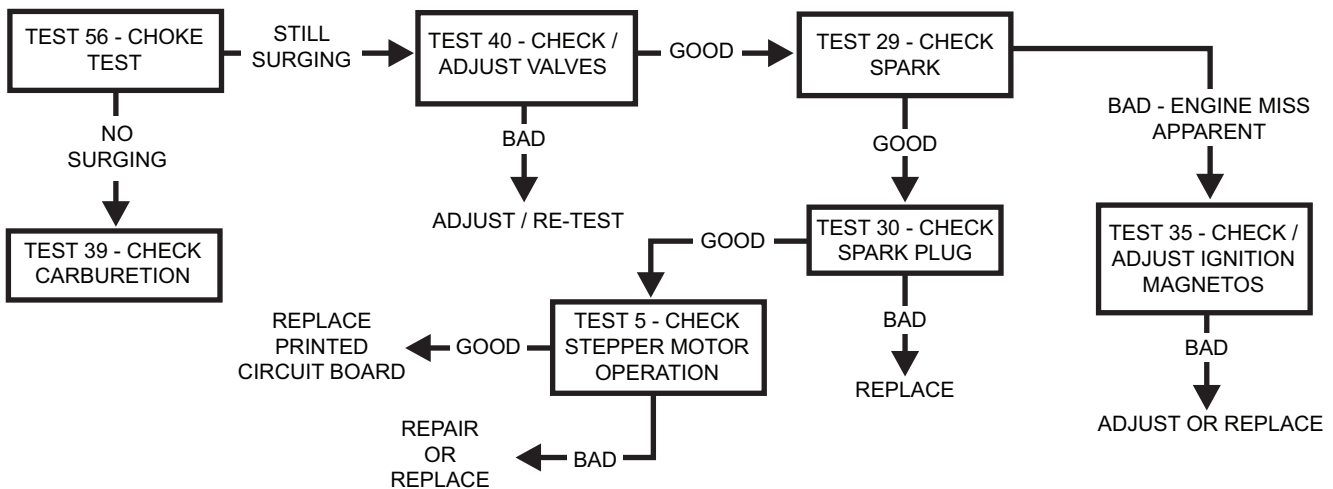

Section 4 AC Diagnostic Tests

Introduction

This section familiarizes the service technician with acceptable procedures for the testing and evaluation of various problems that can occur on portable generators. Use this section in conjunction with the [Troubleshooting Flow Charts](#). The numbered tests in this section correspond with those of the flow charts.

These test procedures require a basic knowledge of electricity and electrical safety, hand tool skills, and use of multimeters.

Some test procedures in this section require the use of specialized test equipment, meters or tools. Most tests can be performed with a digital multimeter (DMM). An AC frequency meter is required where frequency readings must be taken. To measure AC loads it is acceptable to use a clamp-on ammeter.

Testing and troubleshooting methods covered in this manual are not exhaustive. No attempt has been made to discuss, evaluate and advise the home standby service trade of all conceivable ways in which service and trouble diagnosis must be performed. Any test method not recommended herein must be deemed safe for personnel and equipment.

Safety

Service personnel who work on this equipment should be aware of the dangers of such equipment. Lethal voltages are present and can kill or cause serious injury. Gaseous fuels are highly explosive and can ignite by the slightest spark. Engine exhaust gases contain deadly carbon monoxide gas that can cause unconsciousness or even death. Contact with moving parts can cause serious injury.

When working on this equipment, use common sense and remain alert at all times. Never work on this equipment while you are physically or mentally fatigued. If you do not understand a component, device or system, do not work on it.

Important Note Concerning Connectors

A number of the tests require the use of a multimeter and a set of test probes.

It is very easy to damage the female pins in the connectors on the control panel. Do not attempt to push probe tips into the connector pins of any connectors. Doing so will damage the female pin which will create additional problems. Use the appropriate probes on specific wires to check voltage. Use the flexible pin leads, available from the manufacturer (PN 0J09460SRV) to

work with AMP connector plugs. Another alternative is to use approved back probes from the back side of the connector.

Test 1 – Check No-Load Voltage and Frequency

Procedure

1. Disconnect or turn all electrical loads connected to the generator OFF.
2. Reset all circuit breakers to ON.
3. Turn the idle control switch to OFF.
4. Start engine and let stabilize and warm up.

NOTE: If the generator is not producing AC power, loss of governor control may occur causing an extremely high RPM condition (overspeed). If this condition occurs manually control throttle (60 Hz /3600 rpm) to perform test.

5. Set a digital multimeter (DMM) to measure AC voltage.
6. See [Figure 4-1](#). Place the meter test leads into the 50A outlet.

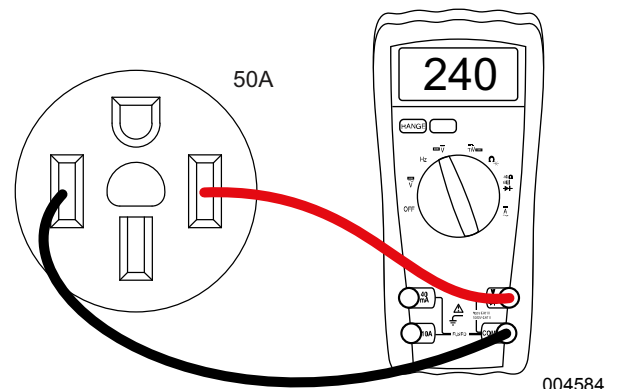

Figure 4-1. DMM Test Leads Connected to 50A Outlet

7. Read AC voltage.
8. Connect an AC frequency meter as described in step 6.
9. Read AC frequency.

Results

For units rated 60 Hertz, no load voltage and frequency should be approximately 238-242 VAC at 59-61 Hertz. See [Problem 1 – Voltage and Frequency Are Both High or Low](#) in section 3.

Test 2 – Check Main Circuit Breaker

Procedure

The generator has seven circuit breakers located on the control panel. If outlets are not receiving power, verify the breakers are set to the ON or CLOSED position.

See **Figure 4-2**. If a breaker failure is suspected, it can be tested as follows:

1. Set DMM to measure resistance.
2. With generator shut down, disconnect all wires from suspected circuit breaker terminals to prevent interaction.
3. See **Figure 4-2**. With the generator shut down, connect one meter test lead to one terminal of the breaker and the other meter test lead to the other terminal.
4. Set breaker to ON or CLOSED. Continuity should be measured.
5. Set breaker to OFF or OPEN. Infinity should be measured.

Results

1. If circuit breaker tests good, refer to flow chart.
2. If breaker tests bad, replace.

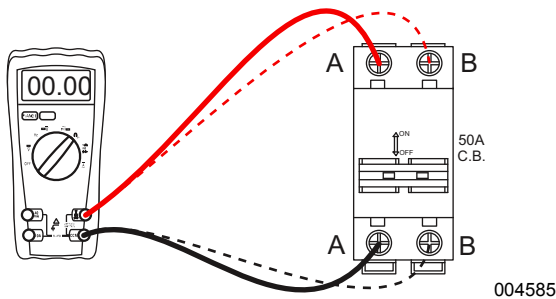

Figure 4-2. 50 Amp Breaker Test Points

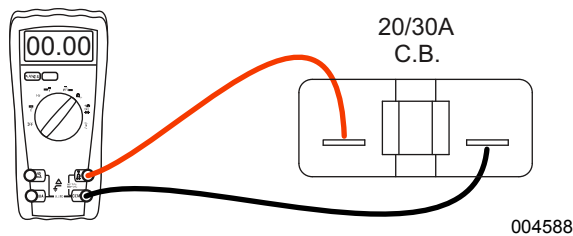

Figure 4-3. 20/30 Amp Breaker Test Points

Test 3 – Test Excitation Circuit Breaker

Procedure

1. Shut down the generator and allow to cool for at least two minutes.
2. Locate the excitation circuit breaker in the control panel.
3. Disconnect wires from the breaker to prevent interaction.

4. Set DMM to measure resistance.
5. Connect the DMM test probes across the circuit breaker terminals. Continuity should be measured.

Results

1. If circuit breaker tests bad (meter reads Continuity) proceed to Test 4 and replace the breaker after completing Test 4.
2. If circuit breaker is good, proceed to Test 4.

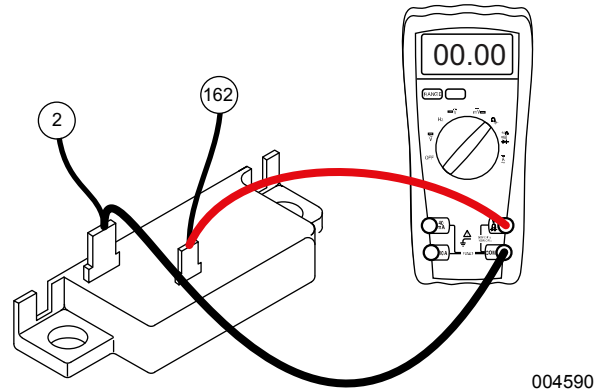

Figure 4-4. Testing Excitation Circuit Breaker

Test 4 – Fixed Excitation Test/Rotor Amp Draw Test

NOTE: If the generator is not producing AC power, loss of governor control may occur causing an extremely high RPM condition (overspeed). If this condition occurs manually control throttle (60 Hz /3600 rpm) to perform test.

Procedure

1. If testing a unit with the older style voltage regulator, unplug the six pin connector from the voltage regulator.
2. If testing a unit with the newer style voltage regulator, disconnect wires 11S, 22S, 4, 0, 6 and 162 from the voltage regulator.

NOTE: For testing purposes the six pin connector reference is the same as the six individual wires on the newer style voltage regulator.

3. Connect a jumper from wire 0 to a good ground.
4. Disconnect wire 14 from resistor R1.
5. See **Figure 4-5**. Connect a jumper wire between the removed end of wire 14 and wire 4 where it is soldered at diode D1.
6. Set DMM to measure AC voltage
7. See **Figure 4-6** or **Figure 4-7**. Disconnect wire 2 from the excitation circuit breaker and connect one meter test lead to it.
8. Connect the other meter test lead to wire 6.

NOTE: If testing older style voltage regulator, be careful not to damage the pin connectors with the test leads.

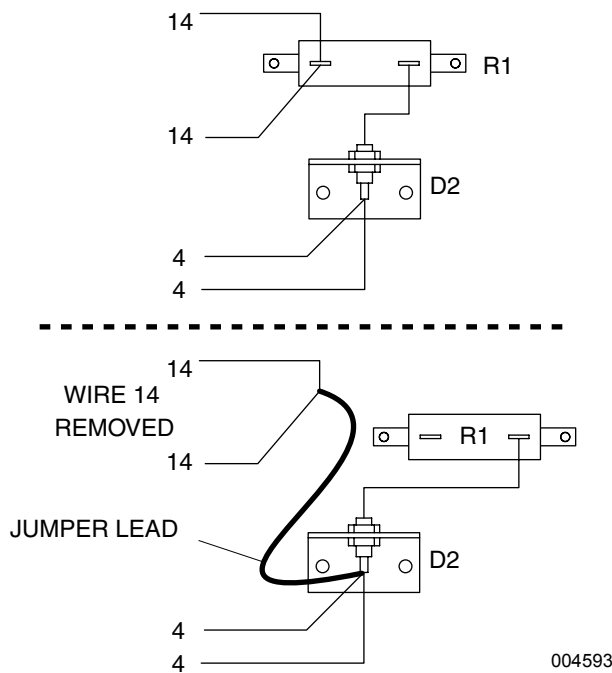

Figure 4-5. Fixed Excitation Test/Rotor Amp Draw Test

9. Set idle control switch to OFF.
10. Start the generator.
11. Measure and record the output voltage across wire 2 and wire 6.

AC voltage across wires 2 and 6 = _____

12. Shut down the generator.
13. Connect wire 2 to the excitation circuit breaker.
14. See Figure 4-6 or Figure 4-7. Connect one meter test lead to wire 11S.
15. Connect the other meter test lead to wire 44S or 22S, depending on older or newer style voltage regulator.
16. Start the generator.
17. Measure and record the output voltage across wires 11S and 44S, or 11S and 22S.

AC Voltage across wires 11S and 44S = _____

AC Voltage across wires 11S and 22S = _____

18. Set start-run-stop switch (SW1) to STOP.

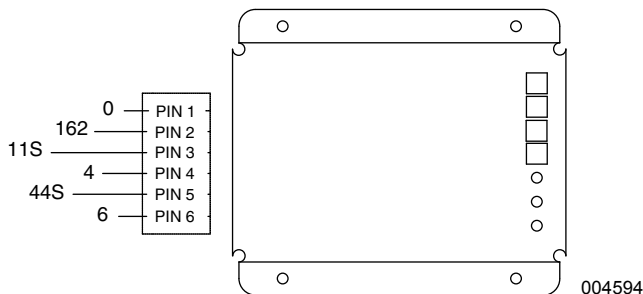

Figure 4-6. Old Style Voltage Regulator Wire Number Locations

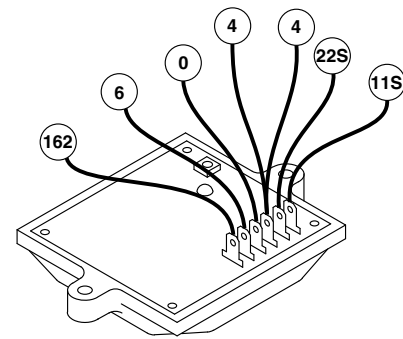

Figure 4-7. New Style Voltage Regulator Wire Number Locations

19. Shut down the generator.
20. Remove the jumper lead between wire 14 and Diode D1.
21. Set the DMM to measure DC amperage (10 amp range).
 - a. Switch the test leads on the meter if required.
22. See Figure 4-8. Connect the positive meter test lead to wire 14.
23. Connect the negative test lead to wire 4 at diode D1.
24. Start the generator.
25. Measure and record the DC rotor amp draw.

Rotor Amp Draw = _____

26. Shutdown the generator.
27. Connect the six pin connector, or wires to terminals.
28. Connect wire 14 to the resistor R1.

Results

Refer to Table 4-1.

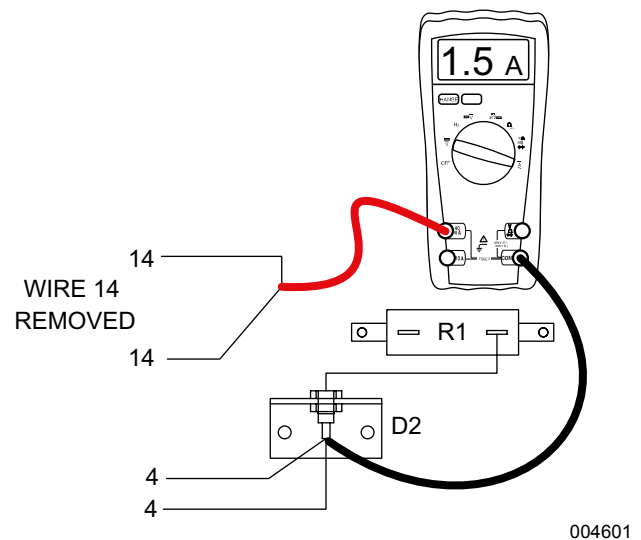

Figure 4-8. Measuring Amp Draw

Table 4-1. Test 4 Results – Fixed Excitation Test/Rotor Amp Draw Test (8-20 kW)

Results:	A	B	C	D	E	F	G
Voltage Results Wire 2 & 6 Excitation Winding	Above 60 VAC	Above 60 VAC	Below 60 VAC	Zero or Residual Volts	Below 60 VAC	Below 60 VAC	Above 60 VAC
Voltage Results Wire 11S & 44S	Above 50 VAC	Below 50 VAC	Above 50 VAC	Zero or Residual Volts	Below 50 VAC	Below 50 VAC	Above 50 VAC
Voltage Results Wire 11S & 44S	Above 50 VAC	Below 50 VAC	Above 50 VAC	Zero or Residual Volts	Below 50 VAC	Below 50 VAC	Above 50 VAC
Rotor Amp Draw 12.5 kW	1.76-2.05	1.76-2.05	1.76-2.05	Zero Current Draw	Above 2.5A	1.76-2.05	Zero Current Draw
Rotor Amp Draw 15 kW	1.76-2.05	1.76-2.05	1.76-2.05	Zero Current Draw	Above 2.5A	1.76-2.05	Zero Current Draw
Rotor Amp Draw 17.5 kW	1.76-2.05	1.76-2.05	1.76-2.05	Zero Current Draw	Above 2.5A	1.76-2.05	Zero Current Draw

← Match results with letter and refer to flow chart "Problem 2" →

Test 5 – Check Stepper Motor Control

Procedure

1. Remove air cleaner cover to access stepper motor.
2. Move throttle by hand and verify stepper motor, linkage and throttle do not bind in any way. If any binding is felt, repair or replace components as needed. Some resistance should be felt as the stepper motor is moved.

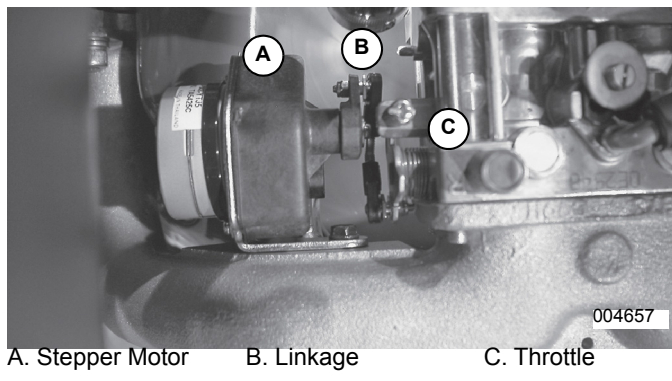

Figure 4-9. Stepper Motor, Linkage and Throttle

- a. Set the idle control switch to OFF.
 - b. Set the start-run-stop switch (SW1) to START.
 - c. Watch for stepper motor movement. It should move to the wide open position during cranking. Once the unit starts the stepper motor should move the throttle to a position to maintain 60 Hertz.
4. If no movement is seen in step 3 remove the control panel cover.
 - a. Verify the six pin connector on the printed circuit board is seated properly. Remove the connector and then replace it and test again.
 - b. See **Figure 2-1**. Verify the switches are set correctly.
 5. See **Figure 4-11**. If problem continues remove six pin connector from printed circuit board.
 6. Set DMM to measure resistance (ohms).
 7. Carefully measure from the end of the six pin harness as follows:

NOTE: Press down with the meter leads on the exposed connector terminals. Do not probe into the connector.

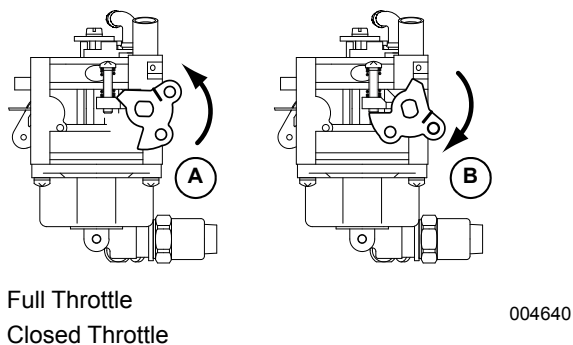
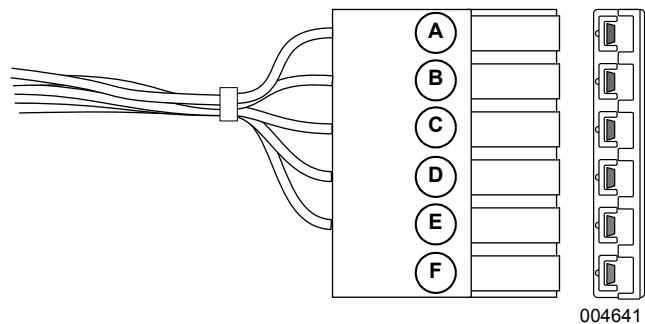

Figure 4-10. Throttle Positions



- | | |
|-----------|-----------|
| A. Black | D. Orange |
| B. Brown | E. Red |
| C. Yellow | F. Empty |

Figure 4-11. Six Pin Connector Wire Colors

3. Move the throttle to the closed position by pushing the throttle down as looking from above.

- a. Connect one meter lead to red. Connect the remaining test lead to orange. Approximately 10 ohms should be measured.
 - b. Connect one meter lead to red. Connect the remaining test lead to yellow. Approximately 10 ohms should be measured.
 - c. Connect one meter lead to red. Connect the remaining test lead to brown. Approximately 10 ohms should be measured.
 - d. Connect one meter lead to red. Connect the remaining test lead to black. Approximately 10 ohms should be measured.
 - e. Connect one meter lead to red. Connect the remaining test to the stepper motor case. Infinity should be measured.
8. Set DMM to measure DC voltage.
 9. See [Figure 4-12](#).
 - a. Connect the positive meter test lead to wire 15B at terminal block 1 (TB1).

NOTE: Where terminal block is not present, place meter test lead on the wire at the termination point. If necessary, use a small paper clip to probe beside the wire so as not to damage the terminal in the connector.

- b. Connect the negative meter test lead to ground.
- c. Set the start-run-stop switch (SW1) to START.
- d. If 12 VDC was measured proceed to step 8.
- e. If voltage was not measured, proceed to results.

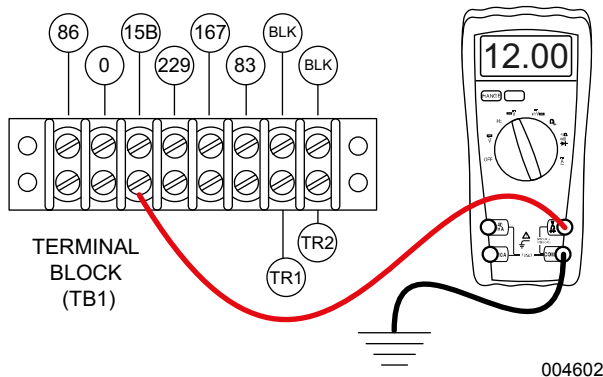

Figure 4-12. Testing Wire 15B

10. Set DMM to measure resistance.
11. See [Figure 4-13](#). Disconnect the J2 connector from the printed circuit board.
 - a. Connect one meter test lead to pin location J2-1 (wire 15B).
 - b. Connect the other meter test lead to wire 15B at terminal block 1 (TB1).
 - c. Continuity should be measured.

NOTE: Verify the test probe connector is sharp and is making contact the with the connector.

Results

1. If the stepper motor fails any part of step 5, replace the stepper motor.
2. If step 7 fails repair or replace wire 15B between the start stop relay (SSR) and terminal block TB1.
3. If the stepper motor passes all steps replace the printed circuit board.

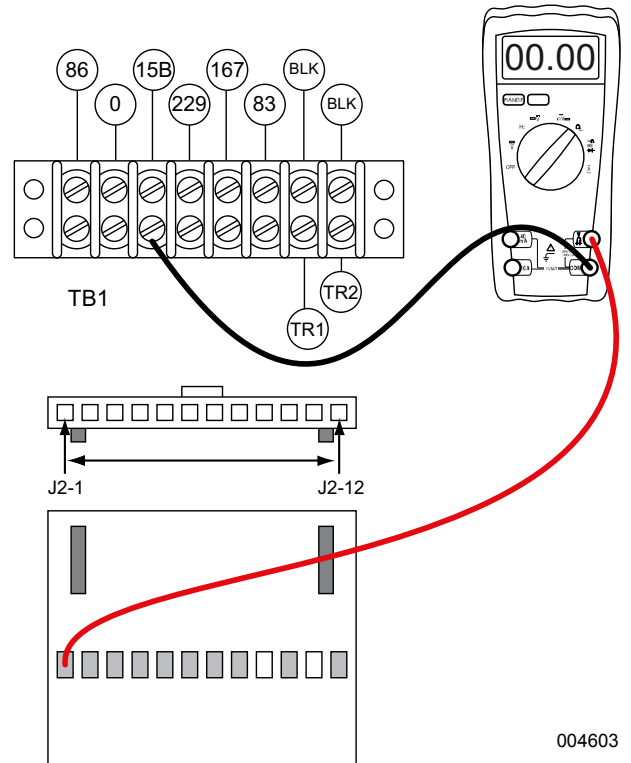

Figure 4-13. Testing J2-1

Test 6 – Wire Continuity

Procedure

1. Set DMM to measure resistance.
2. Remove the six pin connector from the voltage regulator.
3. See [Figure 4-11](#). Connect one meter test lead to wire 0 in the six pin connector removed from the voltage regulator.
4. Connect the other test lead to the ground terminal in the control panel.
 - a. Continuity should be measured.
5. See [Figure 4-11](#). Connect one meter test lead to wire 162 in the six pin connector removed from the voltage regulator.
6. Remove wire 162 from the excitation circuit breaker (CB1).
7. Connect the other meter test lead to wire 162.
 - a. Continuity should be measured.

Results

If Continuity was not measured across each wire, repair or replace the wires as needed. If Continuity was measured refer back to flow chart.

Test 7 – Check Field Boost

Procedure

1. Set DMM to measure DC voltage.
2. Disconnect the six pin connector from the voltage regulator.
3. Disconnect connector C1. See [Control Panel Component Identification](#) for connector location.
4. See [Figure 4-14](#). Disconnect wire 16 from the starter contactor relay (SCR). This will prevent the unit from cranking when placed in the START position.

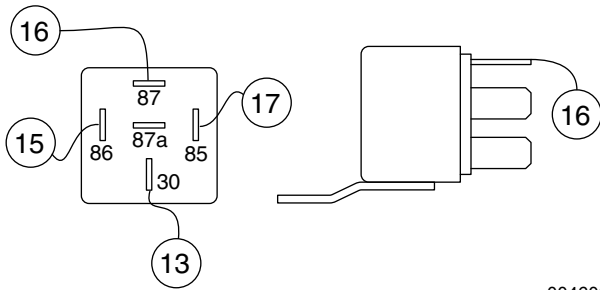

004606

Figure 4-14. Starter Contactor Relay

5. See [Figure 4-15](#).
 - a. Connect the positive meter test lead to wire 4 at diode D1. Wire 4 is soldered to the diode.
 - b. Connect the negative meter test lead to the ground terminal.

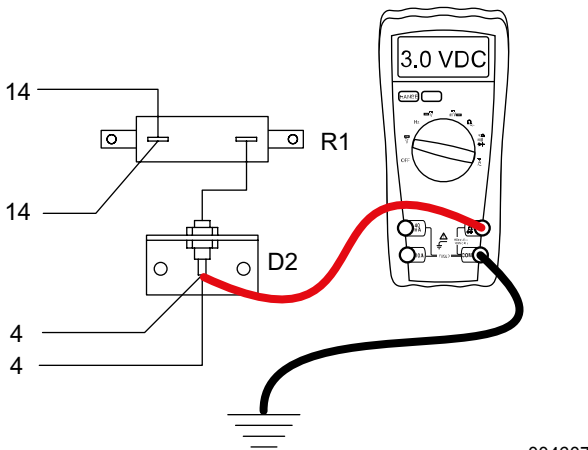

004607

Figure 4-15. Testing Field Boost

6. Set the start-run-stop switch (SW1) to START and measure the DC voltage.
 - a. Approximately 12 VDC should be measured.
7. Connect the six pin connector to the voltage regulator.

8. Connect the C1 connector.
9. Connect wire 16 to the starter contactor relay.

Results

1. If 12 VDC was measured in step 6 the field boost circuit is working. Refer back to the flow chart.
2. If field boost voltage was not measured refer back to the flow chart.

Test 8 – Diode/Resistor

Procedure

1. Set DMM to the diode test range.
2. Disconnect the six pin connector from the voltage regulator.
3. Disconnect connector C1. See [Control Panel Component Identification](#) for connector location.
4. Disconnect both wires from resistor R1.
5. See [Figure 4-16](#).
 - a. Connect the positive meter test lead to the top terminal of diode D1.
 - a. Connect the negative meter test lead to the bottom of the diode.
 - a. Infinity or “Open” should be measured.

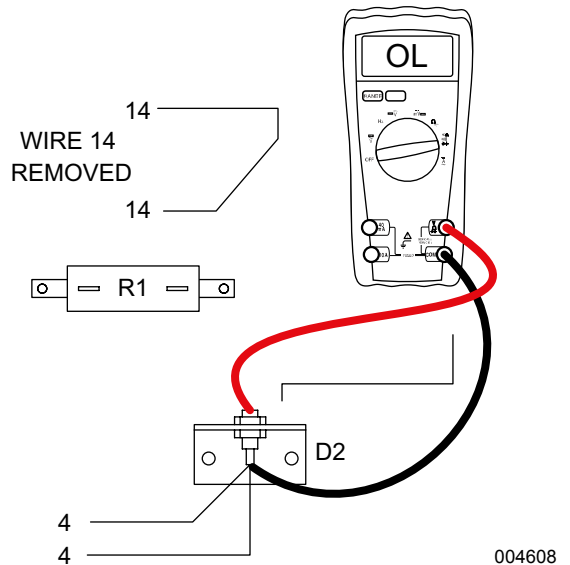

004608

Figure 4-16. Diode Test Step 5

6. See [Figure 4-17](#).
 - a. Connect the positive meter test lead to the bottom terminal of diode D1.
 - b. Connect the negative meter test lead to the top of the diode.
 - c. Approximately 0.5 volts should be measured.
7. Set DMM to measure resistance.
 - a. Connect one meter test lead to the top terminal of diode D1.

- b. Connect the other meter test lead to the ground terminal.
- c. Infinity or "Open" should be measured.

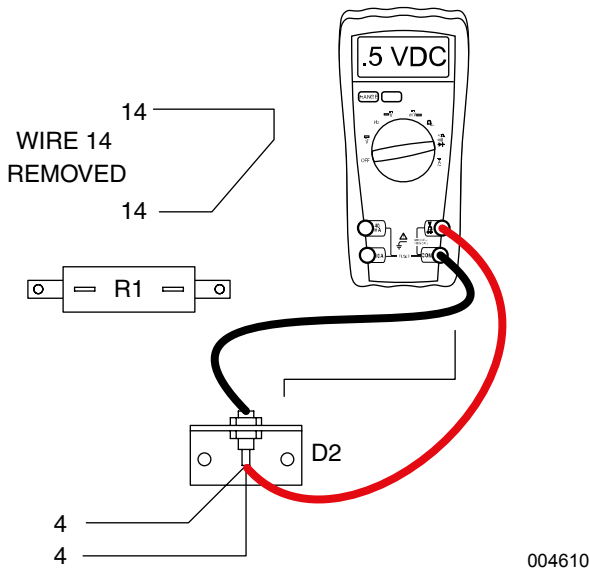

Figure 4-17. Diode Test Step 6

8. See [Figure 4-18](#).
 - a. Connect one meter test lead to one terminal of resistor R1.
 - b. Connect the other meter lead to the remaining terminal of resistor.
 - c. Approximately 25 ohms should be measured.

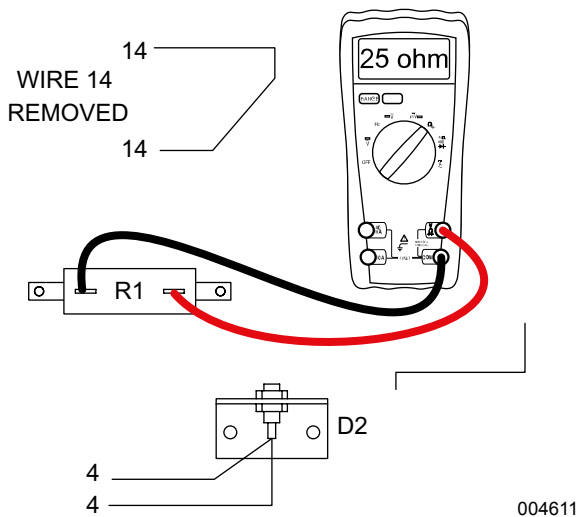

Figure 4-18. Diode Test Step 9

9. Connect one meter test lead to the top terminal of resistor R1.
10. Connect the other meter test lead to the ground terminal.
 - a. Infinity or "Open" should be measured.
11. Connect the six pin connector, or wires to terminals.

12. Connect the C1 connector.
13. Connect the two wires removed from resistor R1.

Results

1. If the diode or resistor failed any step it should be replaced.

Test 9 – Test Stator

Procedure

1. Disconnect wires 11 and 44 from the 50 amp circuit breaker.
2. Disconnect wire 22 from the 50 amp receptacle.
3. Disconnect connector C1. See [Control Panel Component Identification](#) for connector location.
4. Set DMM to measure resistance.
5. Connect the meter test leads across stator leads 11 and 22.
 - a. Normal power winding resistance should be measured.
6. Connect the meter test leads across stator leads 44 and 22.
 - a. Normal power winding resistance should be measured.

See [Figure 4-19](#) for the following steps.

7. Connect the meter test leads across stator leads 11S (pin 1) and stator lead 44S (pin 2) at the C1 connector female side.
 - a. Normal power winding resistance should be measured.

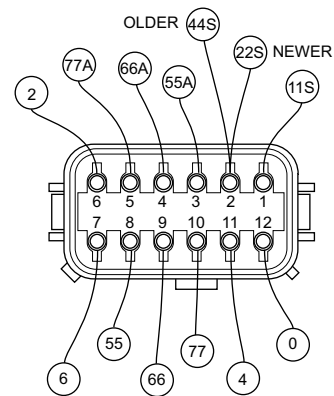

Figure 4-19. C1 Connector, Female Side

8. Connect the meter test leads across stator leads 66A (pin 4) and stator lead 77A (pin 5) at the C1 connector female side.
 - a. Normal battery charge winding resistance should be measured.
9. Connect the meter test leads across stator leads 2 (pin 6) and stator lead 6 (pin 7) at the C1 connector female side.

- a. Normal excitation winding resistance should be measured.
- 10. Connect the meter test leads across stator leads 66 (pin 9) and stator lead 77 (pin 10) at the C1 connector female side.
 - a. Normal 10 amp battery charge winding resistance should be measured.
- 11. Connect the meter test leads across stator lead 11 and frame ground.
 - a. Infinity should be measured.
- 12. Connect the meter test leads across stator lead 66A (pin 4) and stator lead 2 (pin 6) at the C1 connector female side and frame ground.
 - a. Infinity should be measured.
- 13. Connect the meter test leads across stator lead 2 (pin 6) at the C1 connector female side and frame ground.
 - a. Infinity should be measured.
- 14. Connect the meter test leads across stator lead 66 (pin 9) at the C1 connector female side and frame ground.
 - a. Infinity should be measured.
- 15. Connect the meter test leads across stator leads wire 11 and stator lead 66A (pin 4) at the C1 connector female side.
 - a. Infinity should be measured.
- 16. Connect the meter test leads across stator leads wire 11 and stator lead 2 (pin 6) at the C1 connector female side.
 - a. Infinity should be measured.
- 17. Connect the meter test leads across stator leads wire 11 and stator lead 66 (pin 9) at the C1 connector female side.
 - a. Infinity should be measured.
- 18. Connect the meter test leads across stator lead 66A (pin 4) and stator lead 2 (pin 6) at the C1 connector female side.
 - a. Infinity should be measured.
- 19. Connect the meter test leads across stator lead 66A (pin 4) and stator lead 66 (pin 9) at the C1 connector female side.
 - a. Infinity should be measured.
- 20. Connect the meter test leads across stator lead 2 (pin 6) and stator lead 66 (pin 9) at the C1 connector female side.
 - a. Infinity should be measured.

Results

If the stator fails any step replace it. For steps 1-10 keep in mind resistance values may vary depending on ambient temperature and calibration of the meter used. If the stator passes all tests refer back to the flow chart.

Winding	Wire Numbers	12.5 kW	15 kW	17.5 kW
Power	11 & 22	0.125 Ω	0.0852 Ω	0.067 Ω
Power	44 & 22	0.125 Ω	0.088 Ω	0.067 Ω
Sensing	11S & 44S	0.25 Ω	0.176 Ω	0.134 Ω
Sensing	11S & 22S	0.25 Ω	0.176 Ω	0.134 Ω
Excitation	2 & 6	0.576 Ω	0.824 Ω	0.80 Ω
Battery Charge	66A & 77A	0.132 Ω	0.107 Ω	0.0939 Ω
10A Battery Charge	66 & 77	0.145 Ω	0.124 Ω	0.117 Ω

* Resistance values in ohms at 20 °C. (68 °F.). Actual readings may vary depending on ambient temperature. A tolerance of plus or minus 5% is allowed.

Test 10 – Sensing Leads

Procedure

1. Set a DMM to measure resistance.
2. Disconnect connector C1. See **Control Panel Component Identification** for connector location.

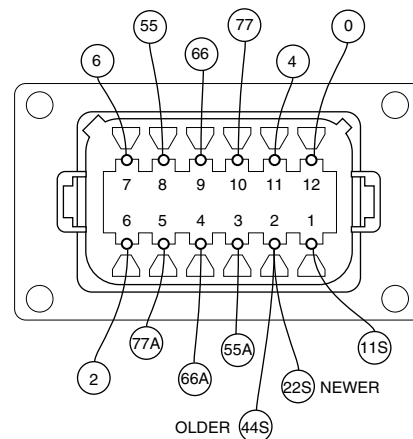

Figure 4-20. C1 Connector, Male Side

004643

3. See **Figure 4-20**. Locate the male side of the connector located on the bottom of the control panel.
 - a. Connect one meter test lead to pin 1 wire 11S. It may be helpful to connect a small jumper lead to the individual pin.
 - b. Connect the other meter test lead to wire 11S at terminal block 2 (TB2). See **Control Panel Component Identification** for terminal block 2 location.
 - c. Continuity should be measured.
4. See **Figure 4-20**. Locate the male side of the connector located on the bottom of the control panel.
 - a. Connect one meter test lead to pin 2 wire 44S. It may be helpful to connect a small jumper lead to the individual pin.
 - b. Connect the other meter test lead to wire 44S at terminal block 2 (TB2).
 - c. Continuity should be measured.

5. Unplug the six pin connector, or wires to terminals, at the voltage regulator.
6. See [Figure 4-20](#).
 - a. Connect the one meter test lead to wire 11S at terminal block 2 (TB2).
 - b. Connect the other meter test lead to wire 11S at the six pin connector previously removed from the voltage regulator.
 - c. Continuity should be measured.
7. See [Figure 4-20](#).
 - a. Connect the one meter test lead to wire 44S at terminal block 2 (TB2).
 - b. Connect the other meter test lead to wire 44S at the six pin connector previously removed from the voltage regulator.
 - c. Continuity should be measured.

Results

1. If continuity was not measured in any of the steps repair or replace defective wire.
2. If all steps pass refer back to flow chart.

Test 11 – Excitation Wiring

Procedure

1. Set DMM to measure resistance.
2. Disconnect connector C1. See [Control Panel Component Identification](#) for connector location.
3. See [Figure 4-20](#). Locate the male side of the connector located on the bottom of the control panel.
 - a. Connect one meter test lead to pin 6 wire 2. It may be helpful to connect a small jumper lead to the individual pin.
 - b. Disconnect wire 2 from the excitation circuit breaker (CB1). See [Control Panel Component Identification](#) for excitation circuit breaker location.
 - c. Connect the other meter test lead to wire 2.
 - d. Continuity should be measured.
4. Unplug the six pin connector at the voltage regulator.
5. Locate the male side of the C1 connector located on the bottom of the control panel.
 - a. Connect one meter test lead to pin 7, wire 6. It may be helpful to connect a small jumper lead to the individual pin.
 - b. Connect the other meter test lead to wire 6 located in the six pin connector previously removed from the voltage regulator.
 - c. Continuity should be measured.

Results

1. If continuity was not measured in any of the steps repair or replace defective wire.
2. If all steps pass refer back to flow chart.

Test 12 – Check Brush Leads

Procedure

1. Set DMM to measure resistance.
2. Disconnect connector C1. See [Control Panel Component Identification](#) for connector location.
3. See [Figure 4-19](#). Connect the meter test leads across wire 4 (pin 11) and wire 0 (pin 12) at the C1 connector female side.
 - a. Rotor resistance should be measured approximately 7-14 ohms.
 - b. If resistance is measured proceed to step 6.
 - c. If no resistance is measured continue.
4. See [Figure 4-22](#). Remove the control panel assembly to access the brushes.
 - a. Connect one meter test lead across wire 4 (pin 11) at the C1 connector female side.
 - b. Connect the other meter test lead to wire 4 at the brush assembly.
 - c. Continuity should be measured.
 - d. If Infinity is measured repair or replace wire 4.
5. See [Figure 4-19](#).
 - a. Connect one meter test lead across wire 0 (pin 12) at the C1 connector female side.
 - b. Connect the other meter test lead to wire 0 at the brush assembly.
 - c. Continuity should be measured.
 - d. If Infinity is measured repair or replace wire 0.
6. Unplug the six pin connector at the voltage regulator.
7. See [Figure 4-20](#). Locate the male side of connector C1 located on the bottom of the control panel.
 - a. Connect one meter test lead to pin 11 wire 4.
 - b. See [Figure 4-11](#). Connect the other meter test lead to wire 4 at the six pin connector previously removed from the voltage regulator.
 - c. Continuity should be measured.
 - d. If continuity is not measured repair or replace wire 4 between the C1 connector and the six pin voltage regulator connector.
8. Connect one meter test lead to pin 12 wire 0. Connect the other meter test lead to the ground terminal in the control panel.
 - a. Continuity should be measured.

- b. If continuity is not measured repair or replace wire 0 between the C1 connector and the ground terminal.

Results

1. Repair or replace wiring/terminals as needed.
2. If no faults are found refer to flow chart.

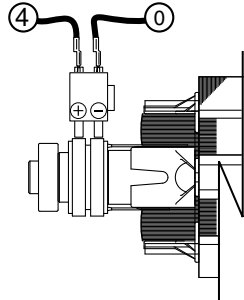

004644

Figure 4-21. Brush Leads

Test 13 – Check Brushes & Slip Rings

Procedure

1. Gain access to the brushes and slip rings.

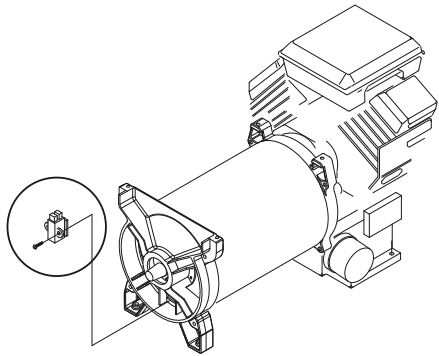

004648

Figure 4-22. Brush Location

2. Remove wire 4 from the positive (+) brush terminal.
3. Remove the ground wire (0) from the negative (-) brush.
4. Remove the brush holder, with brushes.
5. Inspect the brushes for excessive wear, damage, cracks, chipping, etc.
6. Inspect the brush holder. Replace if damaged.
7. Inspect the slip rings.
 - a. If slip rings appear dull or tarnished they may be cleaned and polished with fine sandpaper. **DO NOT USE ANY METALLIC GRIT TO CLEAN SLIP RINGS.** (A 400 grit wet sandpaper is recommended).
 - b. After cleaning slip rings, blow away any sandpaper residue.

Results

1. Replace bad brushes. Clean slip rings, if necessary.
2. If brushes and rings are good, go to Test 14.

Test 14 – Check Rotor Assembly

Procedure

Gain access to the brushes and slip rings. Disconnect wire 4 and wire 0 from their respective brushes and remove the brush holder. Then, test the Rotor as follows:

1. Set DMM to measure resistance.
2. Connect the positive (+) meter test lead to the positive (+) slip ring (nearest the rotor bearing).
3. Connect the common (-) test lead to the negative (-) slip ring.
4. Read the resistance of the rotor windings, in ohms.
5. Connect the positive (+) meter test lead to the positive (+) slip ring.
6. Connect the common (-) test lead to a clean frame ground (such as the rotor shaft).
 - a. Infinity should be measured.

Rotor Resistance *	
kW	Ohms
12.5	7.01 Ω
15.0	8.48 Ω
17.5	9.33 Ω

* Resistance values in ohms at 20 °C. (68 °F.). Actual readings may vary depending on ambient temperature. A tolerance of plus or minus 5% is allowed.

Results

1. Replace the rotor if it fails the test.
2. If rotor checks good, perform **Rotor Insulation Resistance Test**.

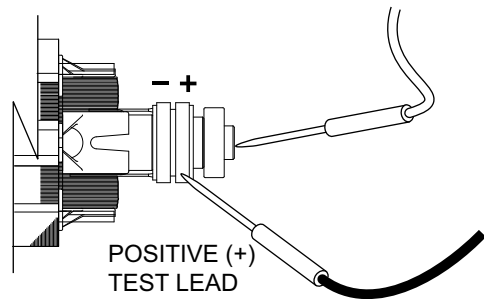

Figure 4-23. Testing at Slip Rings

Test 15 – Check Load Voltage and Frequency

Procedure

Perform this test in the same manner as Test 1, but apply a load to the generator equal to its rated capacity. With load applied check voltage and frequency.

Frequency should not drop below about 59 Hertz with the load applied.

Voltage should not drop below about 235 VAC with load applied.

Results

1. If voltage and/or frequency drop excessively when the load is applied, go to Test 16.
2. If load voltage and frequency are within limits, end tests.

Test 16 – Check Load Watts and Amperage

Procedure

Add up the wattages or amperages of all loads powered by the generator at one time. If desired, a clamp-on ammeter may be used to measure current flow.

Results

1. If the unit is overloaded, reduce the load.
2. If load is within limits, but frequency and voltage still drop excessively, refer back to flow chart.

Test 17 – Check Battery Charge Output

Procedure

1. Disconnect wire 15 (center terminal) from battery charge rectifier 2 (BCR2), which is located under BCR1. They are stacked.

See [Control Panel Component Identification](#) for BCR1 and BCR2 location.

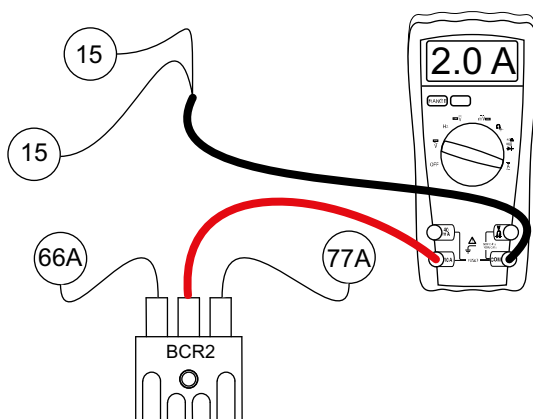

Figure 4-24. Testing BCR2

004613

2. Set DMM to measure DC Amps.
 - a. Connect the positive (+) test lead to the center terminal of the battery charge rectifier.
 - b. Connect the negative (-) test lead to wire 15 disconnected in step 1.
3. Start the generator.
 - a. The amp reading on the meter should be approximately 0.6 Amps.
 - b. Apply full load to the generator.
 - c. The amp reading should increase to approximately 2 Amps.

Results

1. If amperage was measured between 0.6 to 2 Amps in step 2 and step 3, the charging system is working.
2. If no amperage was measured, check the meter fuses and verify the functioning of the meter. If meter is good and no current is measured refer to flow chart.

Test 18 – Check 10 Amp Battery Charge Output

Procedure

NOTE: The battery charge cable must be connected to the 12 VDC panel receptacle and be charging a separate battery to perform this test.

1. Disconnect wire 13A (center terminal) from battery charge rectifier 1 (BCR1), which is located on top of BCR2. See [Control Panel Component Identification](#) for BCR1 and BCR2 location.
2. See [Figure 4-25](#). Set DMM to measure DC Amperage.
 - a. Connect the positive (+) test lead to the center terminal of the battery charge rectifier.
 - b. Connect the negative (-) test lead to wire 13A previously disconnected.

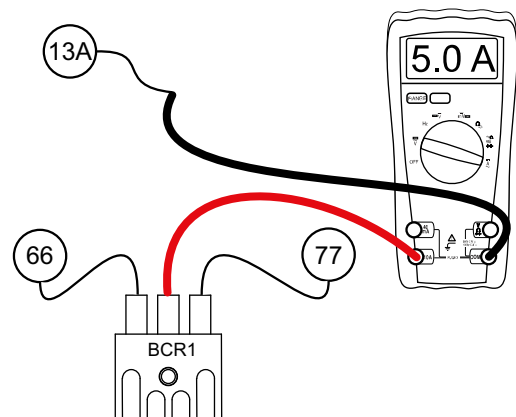

Figure 4-25. Testing BCR1

004614

3. Start the generator.
 - a. The amp reading on the meter should be approximately 0.2 Amps.
 - b. Apply full load to the generator.
 - c. The amp reading should increase.
 - d. Normal ranges at full load can be 3-7 amps, but can get as high as 10 amps depending on the state of charge of the battery.

Results

1. If amperage was measured between 0.2 to 10 Amps in step 2 and step 3, the charging system is working.
2. If no amperage was measured, check the meter fuses and verify the functioning of the meter. If meter is good and no current is measured refer to flow chart.

Test 19 – Check Battery Charge Rectifier (BCR2)

Procedure

1. Disconnect all wires from battery charge rectifier 2 (BCR2).
2. Set the DMM to the Diode Test range.
3. Connect the negative (-) test lead to the center terminal of BCR2.
4. Connect the positive (+) test lead to an outer terminal.
 - a. The meter should measure approximately 0.5 volts.
5. Connect the positive test lead to the other outer terminal.
 - a. The meter should measure approximately 0.5 volts.
6. Connect the positive (+) test lead to the center terminal of BCR2.
7. Connect the negative (-) test lead to an outer terminal.
 - a. The meter should measure Infinity.
8. Connect the negative test lead to the other outer terminal.
 - a. The meter should measure Infinity.

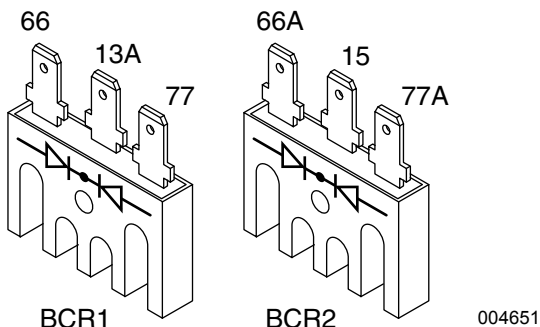

Figure 4-26. Battery Charge Rectifier

Short to Ground

9. Set the DMM to measure resistance.
10. Connect the positive (+) test lead to the case housing of BCR2.
11. Connect the negative (-) test lead to an outer terminal.
 - a. The meter should measure Infinity.
12. Connect the negative test lead to the BCR center terminal.
 - a. The meter should measure Infinity.
13. Connect the negative test lead to the remaining outer BCR terminal.
 - a. The meter should measure Infinity.

Results

1. If any of the previous steps failed, replace BCR2.
2. If BCR2 tests good, refer back to the flow chart.

Test 20 – Check 10 Amp Circuit Breaker

Procedure

1. Set DMM to measure resistance.
2. Locate the 10 Amp circuit breaker (CB1) in the control panel. See [Control Panel Component Identification](#) for circuit breaker location.
3. See [Figure 4-27](#). Disconnect wire 15A and wire 13A from the circuit breaker.
4. Connect one meter test lead to one terminal of the circuit breaker.
5. Connect the other meter test lead to the remaining terminal on the circuit breaker.
 - a. Continuity should be measured.

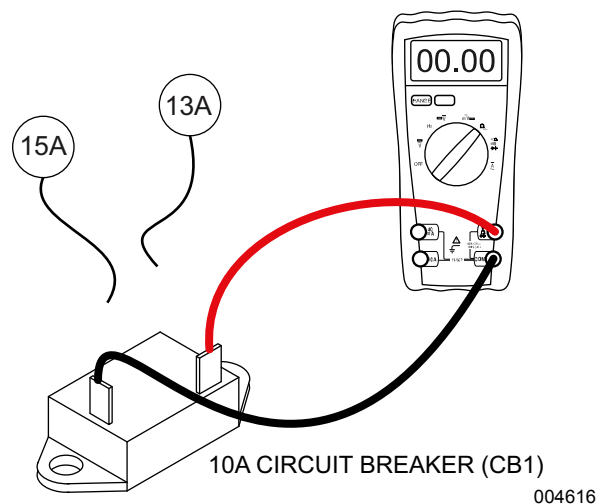

Figure 4-27. Testing 10 Amp Breaker

Results

1. If continuity was measured the breaker is good refer back to the flow chart.
2. If Infinity or a open condition was measured replace the circuit breaker.

Test 21 – Check 10 Amp Fuse

Procedure

Push in on fuse holder cap and turn counterclockwise to remove the cap with fuse. Inspect the fuse.

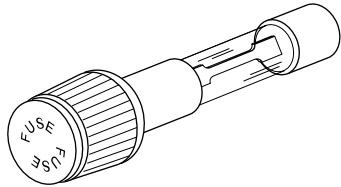

003971

Figure 4-28. 10 Amp Fuse (Located in Rear of Control Panel)

Results

If the fuse element has melted open, replace with an identical size fuse. If fuse is good, refer back to flow chart.

Test 22 – Check Battery and Cables

General Theory

Battery power is used to (a) crank the engine and (b) to power the circuit board. Low or no battery voltage can result in failure of the engine to crank.

The battery charging circuit is not designed to recharge a dead battery. As well, if there is a loose connection or corrosion associated with a wire (positive or negative), battery voltage may be present, but due to high resistance, will not allow current to flow.

Electrical voltage drop varies according to current flow. Voltage drop cannot be measured unless the circuit is operated so current can flow through it. A crank attempt will need to be performed to properly measure voltage drop. This test will determine whether the battery, battery cables, or both are at fault.

Procedure A – Perform Starter Circuit Voltage Drop Test

1. Set a DMM to measure DC voltage.
2. Connect the red meter test lead to the positive battery post and connect the black meter test lead to the negative battery post.
 - a. If battery voltage is 12.1 VDC or below, recharge the battery and retest.
 - b. If battery voltage is 12.2 VDC or above, proceed to next step. (For this test, battery voltage should be at least 12.2 VDC)

3. To inhibit any possible startup, turn off the fuel source and ground wire 18 at the stud located above the oil cooler. See [Figure 4-39](#).
4. Refer to battery post and starter connections in [Figure 4-29](#) and [Figure 4-30](#) then perform a voltage drop test as indicated.
5. Set the start-run-stop switch to START. Allow the engine to crank long enough to obtain a steady measurement.
6. Record voltage readings from test points V1, V2, V3 and V4. Although resistance-free connections, wires and cables would be ideal, most of them will contain at least some voltage drop. The maximum voltage readings should be as follows:
 - a. 0.00-0.10 VDC across a connection or battery post (V4).
 - b. 0.10-0.20 VDC on a ground connection.
 - c. 0.20-0.30 VDC across a wire or cable (V1, V2).
 - d. 0.20-0.30 VDC across a switch or starter contactor (V3).
 - e. 0.40-0.50 VDC across the entire circuit

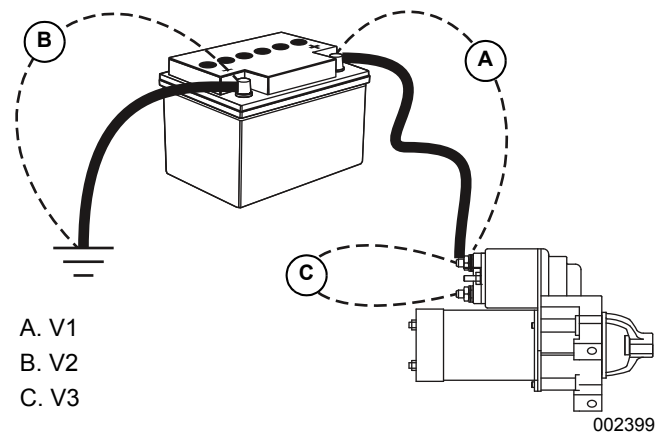

002399

Figure 4-29.

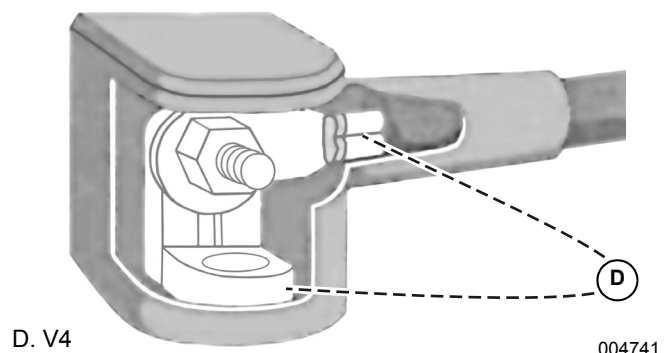

004741

Figure 4-30.

7. If voltage drop is greater than the above, based on the circuit or component, clean or replace the failed connection or component. If voltage drop test results are within the above, based on the circuit or component, refer back to the flowchart.

Test 23 – Check Voltage At Starter Contactor (SC)

Procedure

1. Set DMM to measure DC voltage.
2. Disconnect wire 16 from the starter contactor located on the starter motor.
3. Connect the positive meter test lead to wire 16 removed in step 2.
4. Connect the negative meter test lead to frame ground.
5. Set the start-run-stop switch to START.
 - a. 12 VDC should be measured.
6. Connect wire 16 to the starter motor.

Results

Refer back to flow chart.

Test 24 – Check Starter Contactor (SC)

Procedure

1. Carefully inspect the starter motor cable that runs from the battery to the starter motor.
 - a. Cable connections should be clean and tight.
 - b. If connections are dirty or corroded, remove cable and clean cable terminals and studs.
 - c. Replace any cable that is defective or badly corroded.
2. Set DMM to measure DC voltage.
3. See [Figure 4-31](#), Test Point 1. Connect the positive (+) meter test lead to the starter contactor stud that the battery cable is connected to.
4. Connect the negative (-) meter test lead to a clean frame ground.
 - a. Battery voltage should be measured.

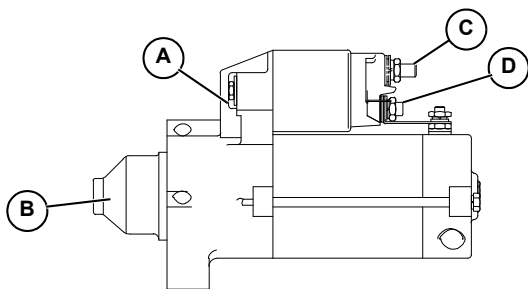

A. Starter Contactor

C. Test Point 1

B. Starter Motor

D. Test Point 2

004652

Figure 4-31. The Starter Contactor (SC)

5. Set DMM to measure DC voltage.
6. See [Figure 4-31](#), Test Point 2. Connect the positive (+) meter test lead to the starter contactor stud that has the small jumper wire connected to the starter.

7. Connect the negative (-) meter test lead to a clean frame ground.
8. Set the start-run-stop switch to START.
 - a. Battery voltage should be measured.

Results

1. If battery voltage was not measured in step 1, repeat Test 22.
2. If battery voltage was measured in step 4a, but not in step 8a, replace the starter contactor.
3. If battery voltage was measured in step 8a but the engine still does not crank, refer back to the flow chart.

Test 25 – Check Starter Motor

Conditions Affecting Starter Motor Performance

1. A binding or seizing condition in the starter motor bearings.
2. A shorted, open or grounded armature.
 - Shorted, armature (wire insulation worn and wires touching one another). Will be indicated by low or no RPM.
 - Open armature (wire broken) will be indicated by low or no RPM and excessive current draw.
 - Grounded armature (wire insulation worn and wire touching armature lamination or shaft). Will be indicated by excessive current draw or no RPM.
3. A defective starter motor switch.
4. Broken, damaged or weak magnets.
5. Starter drive dirty or binding.

Procedure

The battery should be fully charged and checked prior to this test.

Set DMM to measure DC voltage (12 VDC).

Connect the meter positive (+) test lead to the starter contactor stud which has the small jumper wire connected to the starter. Connect the common (-) test lead to the starter motor frame.

Set the start-run-stop switch to START and observe the meter. Meter should indicate battery voltage, starter motor should operate and engine should crank.

Results

1. If battery voltage is indicated on the meter but starter motor did not operate, remove and bench test the starter motor.
2. If battery voltage was indicated and the starter motor tried to engage (pinion engaged), but engine did not crank, check for mechanical binding of the engine or rotor.

NOTE: If a starting problem is encountered, check the engine for freedom of rotation. Remove the spark plugs and turn the crankshaft over slowly by hand, to verify that it rotates freely.



WARNING

Explosion. Turn fuel supply OFF before checking for spark. Failure to do so could result in death or severe injury.

(000333)



DANGER

Explosion and fire. Fuel and vapors are extremely flammable and explosive. No leakage of fuel is permitted. Keep fire and spark away. Failure to do so will result in death or serious injury.

(000192)

IMPORTANT NOTE: On engines with electric starter, rotating the crankshaft too quickly can cause arcing at the spark plug ends. Arcing may ignite the gasoline vapor exiting the spark plug hole.

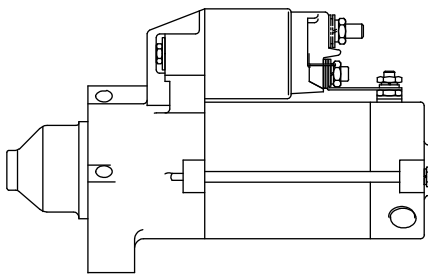

002405

Figure 4-32. Starter Motor (SM)

Checking The Pinion

When the starter motor is activated, the pinion gear should move and engage the flywheel ring gear. If the pinion does not move normally, inspect the pinion for binding or sticking.

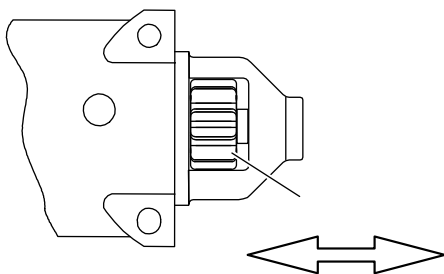

002403

Figure 4-33. Check Pinion Gear Operation

Test 26 – Test Starter Contactor Relay (SCR)

Procedure

1. Set DMM to measure DC voltage.

2. Remove wire 15 from the starter contactor relay (SCR).
3. Connect the positive meter test lead to wire 15 removed in step 2.
4. Connect the negative meter test lead to frame Ground.
 - a. 12 VDC should be measured.
 - b. If 12 VDC is not measured on wire 15 stop testing and repair or replace wire 15 between the fuse (F1) and the SCR.
5. Connect wire 15 to the SCR.
6. Remove wire 13 from the starter contactor relay (SCR).
7. Connect the positive meter test lead to wire 13 previously removed.
8. Connect the negative meter test lead to frame Ground.
 - a. 12 VDC should be measured.
 - b. If 12 VDC is not measured on wire 13 stop testing and repair or replace wire 13 between the starter contactor (SC) and the starter contactor relay (SCR).
9. Connect wire 13 to the SCR.

NOTE: Jumper leads may be used if necessary.

10. Set DMM to measure resistance.
11. Remove wire 13, wire 16, and wire 17 from the starter contactor relay (SCR)
12. See [Figure 4-34](#). Connect the meter leads across terminal 87 and terminal 30 of the SCR.

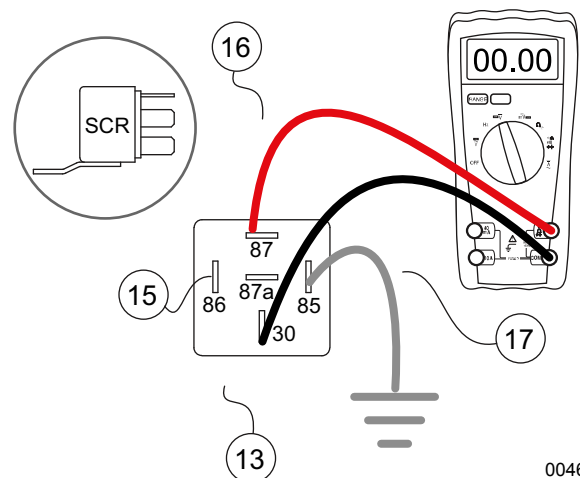

004617

Figure 4-34. Starter Contactor Relay Test

13. See [Figure 4-34](#). Connect a jumper wire from terminal 85 to ground.
 - a. The relay should energize and Continuity should be measured.
14. Connect all wires.

Results

If Continuity was not measured in step 13 replace the starter contactor relay. If all steps passed refer back to flow chart.

Test 27 – Check Start-Run-Stop Switch (SW1)

Procedure

1. Set DMM to measure resistance.
2. Remove all wires from the start-run-stop switch (SW1).
3. Use the chart below to check the condition of the start-run-stop switch.
4. Connect one meter test lead to one terminal and the other meter test lead to the other terminal.
5. With meter leads connected activate the switch to START, STOP or RUN and follow the chart.
6. Connect all wires to the switch.

CONDITION	TERMINALS	RESULT
STOP	5,4	OPEN
STOP	5,6	CLOSED
STOP	2,1	OPEN
STOP	2,3	CLOSED
RUN	ALL CONDITIONS	OPEN
START	5,4	CLOSED
START	5,6	OPEN
START	2,1	CLOSED
START	2,3	OPEN

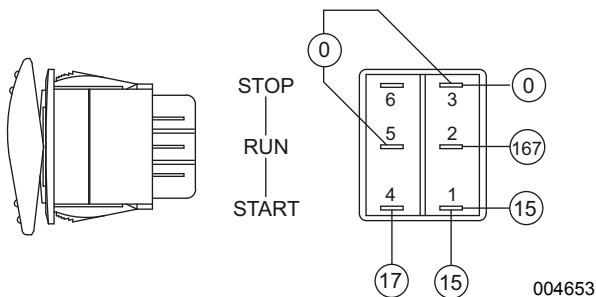

Figure 4-35. Start-Run-Stop Switch (SW1)

Results

If the switch fails any part of the test procedure replace the switch.

Test 28 – Check Start-Run-Stop Switch (SW1) Wiring

Procedure

1. Set DMM to measure resistance.
2. Remove wire 17 from the starter contactor relay (SCR).
3. Connect one meter test lead to wire 17.
4. Remove wire 17 from the start-run-stop switch (SW1).
5. Connect the other meter test lead to wire 17.
 - a. Continuity should be measured.
6. See [Figure 4-35](#). Remove wire 0 from both positions on the start-run-stop switch (SW1).
7. Connect a meter test lead to each wire 0.
 - a. Continuity should be measured.
8. Connect one meter test lead to one wire 0 and connect the other meter test lead to frame ground.
 - a. Continuity should be measured.
9. Set DMM to measure DC voltage.
10. Remove wire 15 from the start-run-stop switch (SW1).
11. Connect the positive meter test lead to wire 15.
12. Connect the negative meter test lead to frame ground.
 - a. 12 VDC should be measured.

Results

Repair or replace any wiring that did not have continuity. If voltage was not measured in step 12 repair wiring between the starter contactor relay (SCR) and the start-run-stop switch (SW1).

If all steps passed, repair or replace wire 16 between the starter contactor (SC) and the starter contactor relay (SCR).

Test 29 – Check Ignition Spark

Procedure

A commercially available spark tester may be used to test the engine ignition system. One can also be purchased from Generac Power Systems (Part No. 0C5969).

1. Disconnect a high tension lead from a spark plug.
2. Attach the high tension lead to the spark tester terminal.
3. See [Figure 4-36](#). Ground the spark tester clamp by attaching to the cylinder head.

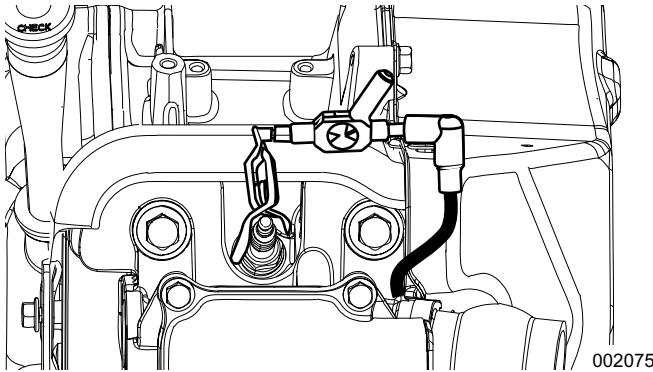

Figure 4-36. Testing Ignition System

4. Crank the engine rapidly. Engine must be cranking at 350 rpm or more.
 - a. If spark jumps the tester gap, the ignition system is working properly.
 - b. Repeat on remaining cylinder spark plug.
5. If spark jumps the tester gap intermittently, the problem may be in the ignition magneto.

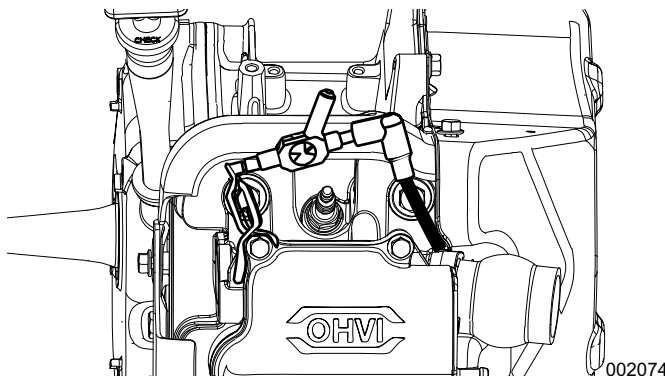

Figure 4-37. Checking Engine Miss

Results

Refer back to the flow chart.

Test 30 – Check Spark Plugs

Procedure

1. Remove spark plugs.
2. Clean with a commercial solvent. DO NOT BLAST CLEAN SPARK PLUGS.
3. Replace spark plugs if badly fouled, if ceramic is cracked, or if badly worn or damaged.
4. Set gap to 0.040 inch (1.016 mm).
5. Use a Champion RC14YC (or equivalent) replacement spark plug.

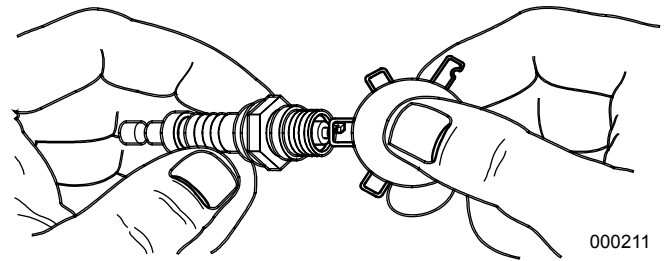

Figure 4-38. Setting Spark Plug Gap

Results

1. Clean and re-gap or replace spark plug as necessary.
2. Refer back to the flow chart.

Test 31 – Remove Wire 18 / Shutdown Lead

Procedure

1. See [Figure 4-39](#). Disconnect wire 18 from the stud located above the oil cooler.
2. Perform Test 29 again checking for spark.

Results

Refer back to flow chart.

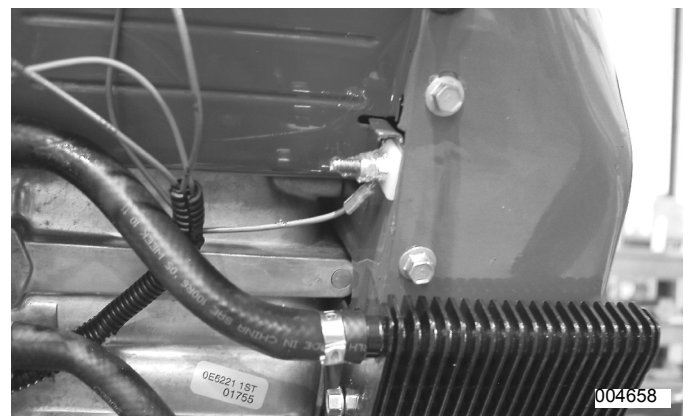

Figure 4-39. Wire 18

Test 32 – Test Start Stop Relay (SSR)

Procedure

1. Set DMM to measure DC voltage.
2. See [Figure 4-40](#). Remove wire 15 from Terminal 13 on the start stop relay (SSR).
3. Connect the positive meter test lead to wire 15 removed in step 2.
4. Connect the negative meter test lead to frame ground.
 - a. If 12 VDC is measured proceed to step 5.
 - b. If 12 VDC is not measured repair or replace wire 15 between the SSR and battery charge rectifier 2 (BCR2).

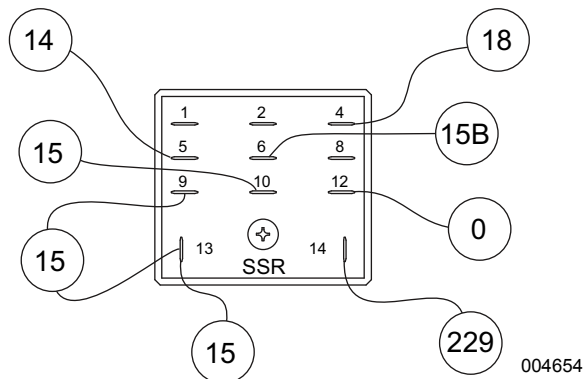

Figure 4-40. Start Stop Relay (SSR)

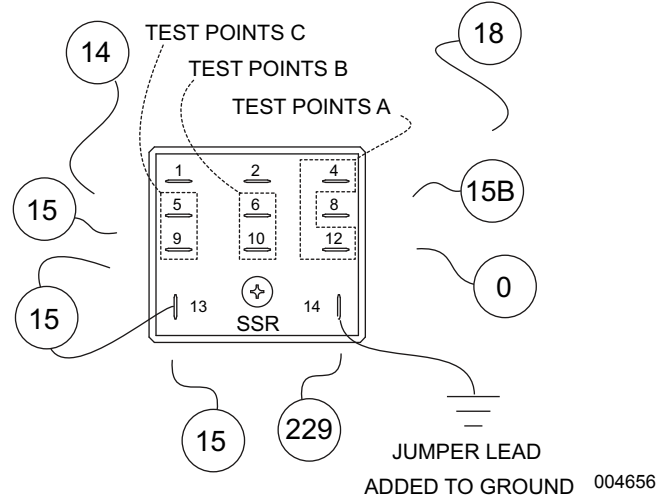

Figure 4-42. Start Stop Relay (SSR) Energized

5. See **Figure 4-40**. Connect wire 15 to the SSR and remove wire 229 from the SSR.
6. Connect a jumper lead from the terminal of the SSR where wire 229 was just removed and to frame ground.
 - a. The relay should energize closed. Visually inspect it to see if it closes.
 - b. If the relay energizes closed proceed to step 4.
 - c. If the relay does not energize closed replace it.
7. See **Figure 4-41**. Remove wire 0, wire 18, wire 15B, wire 15, and wire 14.
8. Set DMM to measure resistance.
9. Remove jumper lead from step 6.
10. Connect meter test leads across TEST POINTS A
 - a. Continuity (closed) should be measured.
11. Connect meter test leads across TEST POINTS B
 - a. Infinity should be measured.
12. Connect meter test leads across TEST POINTS C.
 - a. Infinity should be measured.
13. If the SSR fails any test replace it.

16. Set DMM to measure resistance.
17. Connect meter test leads across TEST POINTS A
 - a. Infinity should be measured.
18. Connect meter test leads across TEST POINTS B
 - a. Continuity (closed) should be measured.
19. Connect meter test leads across TEST POINTS C
 - a. Continuity (closed) should be measured.
20. If the SSR fails any test replace it.

Results

Refer to Flow Chart.

Test 33 – Test Wire 167

Procedure

1. Set DMM to measure DC voltage.
2. See **Figure 4-43**. Remove the J2 connector from the circuit board.
3. Connect the positive meter test lead to pin location J2-5, wire 167 on the removed harness connector.
4. Connect the negative meter test lead to frame ground.
5. Set the start-run-stop switch (SW1) to START. The engine will crank and 12 VDC should be measured.
 - a. If 12 VDC is measured, stop testing.
 - b. If 12 VDC is not measured continue testing.
6. See **Figure 4-44**. Connect the positive test lead to wire 167 at terminal block 1 (TB1).

NOTE: Where terminal block is not present, place meter test lead on the wire at the termination point. If necessary, use a small paper clip to probe beside the wire so as not to damage the terminal in the connector.

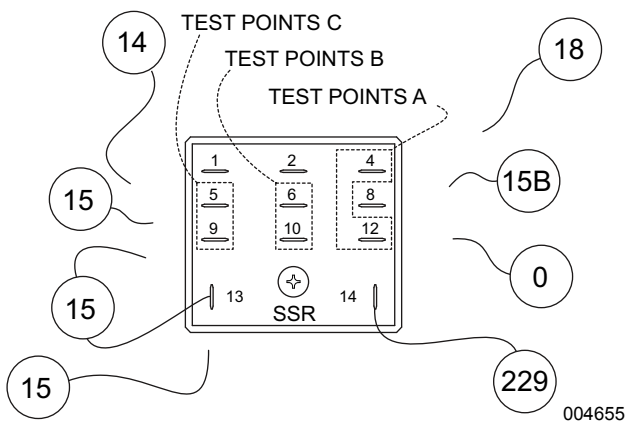

Figure 4-41. Start Stop Relay (SSR) Not Energized

14. See **Figure 4-42**. Remove wire 229 from the SSR.
15. Connect a jumper lead from the terminal of the SSR that wire 229 was just removed from and to frame ground.
 - a. The relay should energize closed.

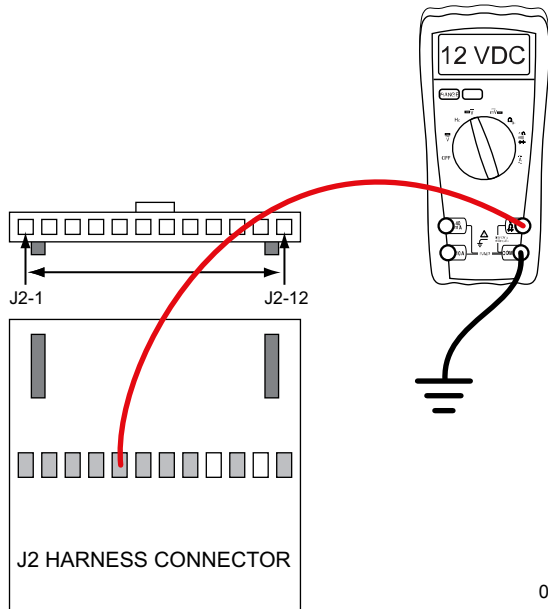

Figure 4-43. Test Wire 167, Steps 2-5

7. Connect the negative meter test lead to frame ground.
8. Set the start-run-stop switch (SW1) to START. 12 VDC should be measured.
 - a. If 12 VDC is measured, replace wire 167 between TB1 and the J2 connector.
 - b. If 12 VDC is not measured continue testing.
9. Connect the positive test lead to wire 167 connected at the start-run-stop switch (SW1).
10. Connect the negative meter test lead to frame ground.

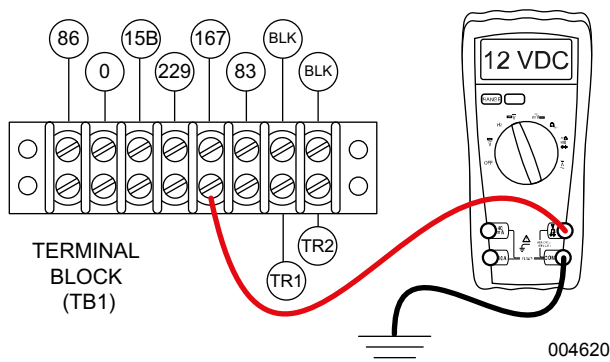

Figure 4-44. Test Wire 167, Steps 6-8

11. Set the start-run-stop switch (SW1) to START. 12 VDC should be measured.
 - a. If 12 VDC is measured, repair or replace wire 167 between SW1 and the TB1.
 - b. If 12 VDC is not measured continue testing.
12. See **Figure 4-45**. Connect the positive meter test to wire 15 at SW1.

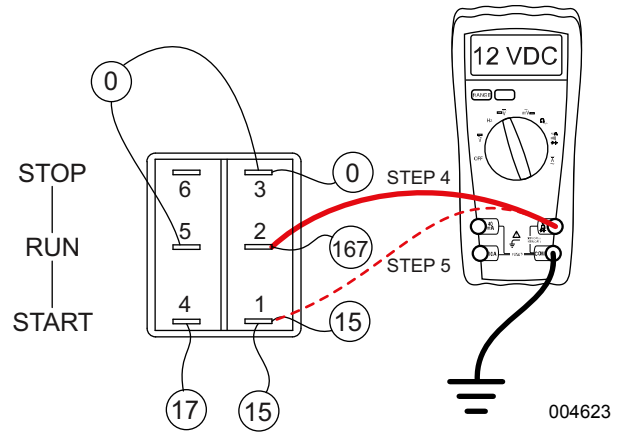

Figure 4-45. Test Wire 167, Steps 9-13

13. Connect the negative meter test lead to frame ground. 12 VDC should be measured.
 - a. If 12 VDC is measured, replace SW1.
 - b. If 12 VDC is not measured repair or replace wire 15 between SW1 and the Starter Contactor Relay (SCR).

Test 34 – Test Start Stop Relay Wiring

Procedure

1. Set DMM to the diode test range.
2. Disconnect wire 229 from the start stop relay (SSR).
3. Connect the positive meter test lead to wire 229 removed in step 2.
4. Connect the negative meter test lead to frame ground.
5. See **Figure 4-46**. Set the start-run-stop switch (SW1) to START. The meter should read approximately 1.0 VDC.
 - a. If the correct voltage is indicated, stop testing.

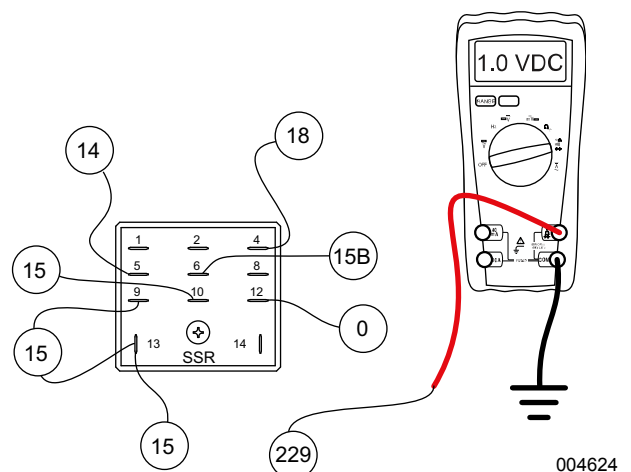

Figure 4-46. Testing Wire 229 to Ground

6. Set DMM to measure resistance.

7. If voltage was not measured in step 3 connect one meter test lead to wire 229 removed from the SSR.
8. Connect the other meter test lead to wire 229 at the terminal block 1 (TB1). Continuity should be measured.
 - a. If continuity is not measured repair or replace wire 229 between SSR and TB1.

NOTE: Where terminal block is not present, place meter test lead on the wire at the termination point. If necessary, use a small paper clip to probe beside the wire so as not to damage the terminal in the connector.

9. Remove the J2 connector the printed circuit board.
10. Connect one meter test lead to pin location J2-8 (wire 229)

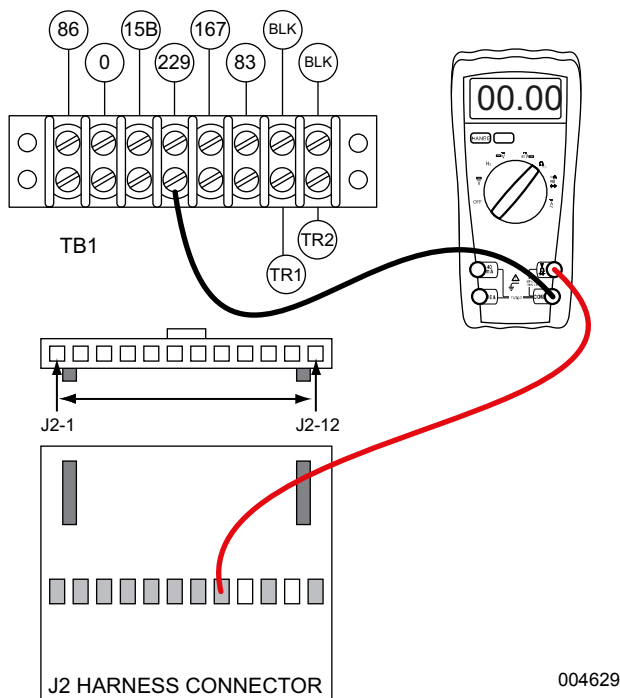

Figure 4-47. Testing Wire 229 Between J2 Connector and Terminal Block 1 (TB1)

11. See [Figure 4-47](#). Connect the other meter test lead to wire 229 at TB1. Continuity should be measured.
 - a. If continuity is not measured repair or replace wire 229 between the J2 connector and TB1.

Results

1. If step 5 passed refer to Flow Chart.
2. If step 5 failed and step 11 passed replace the printed circuit board.

Test 35 – Check and Adjust Ignition Magnetos

Procedure

1. See [Figure 4-48](#). Rotate the flywheel until the magnet is under the module (armature) laminations.
2. Place a 0.008-0.012 inch (0.20-0.30mm) thickness gauge between the flywheel magnet and the module laminations.

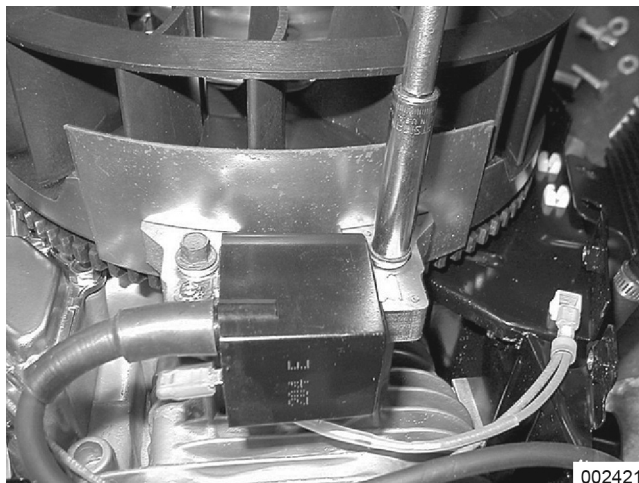

Figure 4-48. Setting Ignition Magneto Air Gap

3. Loosen the mounting screws and let the magnet pull the magneto down against the thickness gauge.
4. Tighten both mounting screws.
5. To remove the thickness gauge, rotate the flywheel.
6. Repeat the above procedure for the second magneto.
7. Repeat [Test 29 – Check Ignition Spark](#) and check for spark across the spark tester gap.
8. If air gap was not out of adjustment, remove engine ground harness from magnetos. Repeat [Test 29 – Check Ignition Spark](#). If sparking now occurs replace engine ground harness.
9. Check the flywheel magnet by holding a screwdriver at the extreme end of its handle and with its point down. When the tip of the screwdriver is moved to within 3/4 inch (19 mm) of the magnet, the blade should be pulled in against the magnet.
10. Check the flywheel key. The flywheel's taper is locked on the crankshaft taper by the torque of the flywheel nut. A keyway is provided for alignment only and theoretically carries no load.

NOTE: If the flywheel key becomes sheared or even partially sheared, ignition timing can change. Incorrect timing can result in hard starting or failure to start.

Results

If sparking still does not occur after adjusting the armature air gap, testing the ground wires and performing the basic flywheel test, replace the ignition magneto(s).

Test 36 – Test Fuel Shutoff Solenoid (FSS)**Procedure**

1. Disconnect wire 16 from the starter contactor (SC) located on the starter motor.
2. Remove the air cleaner cover.
3. Set the start-run-stop switch (SW1) to STOP then to START. When SW1 is activated a click should be heard and or activation of the fuel shutoff solenoid should be felt, indicating that the fuel shutoff solenoid is functioning.

Results

Refer to flow chart.

Test 37 – Test Fuel Shutoff Solenoid Voltage**Procedure**

1. Set DMM to measure DC voltage.
2. Disconnect the two pin connector from the fuel shutoff solenoid (FSS).
3. Connect the positive meter test lead to the red wire.
4. Connect the negative meter test lead to the black wire.
5. Set the start-run-stop switch (SW1) to START. During cranking, 12 VDC should be measured.
 - a. If DC voltage is not measured continue testing.
6. Set DMM to measure resistance.
7. Connect one meter test lead to the black wire.
8. Connect the other meter test lead to frame ground. Continuity should be measured.
 - a. If continuity is not measured repair or replace the black ground wire or correct poor ground connection.
9. Set DMM to measure DC voltage.
10. See [Figure 4-53](#). Remove wire 14 from the Start Stop Relay (SSR).
11. Connect the positive meter test lead to the terminal of the SSR that wire 14 was just removed.
12. Connect the negative meter test lead to frame ground.

13. Set the start-run-stop switch (SW1) to START. 12 VDC should be measured.
 - a. If 12 VDC is measured repair or replace wire 14 between the SSR and resistor R1 or between resistor R1 and the FSS.

Results

Refer to flow chart.

Test 38 – Check Fuel Pump**Procedure**

1. Remove the fuel line from the fuel filter on the inlet side of the carburetor. Use a suitable container to catch fuel.

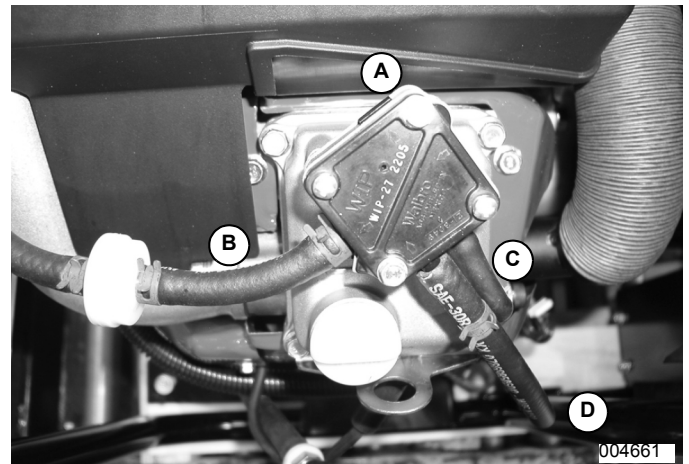

A. Fuel pump
B. Fuel to carburetor
C. Pulse line
D. Fuel from tank

Figure 4-49. Fuel Pump and Fuel Lines

2. Crank the engine. Fuel should flow from the fuel line.
 - a. If fuel does not flow, verify that fuel is available to the pump.
 - b. If fuel is available to the pump inspect the fuel filter, pulse line, and or replace the fuel pump.

Results

Refer to flow chart.

Test 39 – Check Carburetion**Procedure**

Before making a carburetion check, verify the fuel supply tank has an ample supply of fresh, clean gasoline.

Check that all shutoff valves are open and fuel flows freely through the fuel line.

Verify the choke operates properly.

If the engine will not start, remove and inspect the spark plug. If the spark plug is wet, look for the following:

- Overchoking
- Excessively rich fuel mixture
- Water in fuel
- Intake valve stuck open
- Needle/float stuck open

If the spark plug is dry look for the following:

- Leaking carburetor mounting gaskets
- Intake valve stuck closed
- Inoperative fuel pump
- Plugged fuel filter(s)
- Varnished carburetor

If the engine starts hard or will not start, look for the following:

- Physical damage to the AC generator. Check the rotor for contact with the stator.
 - Starting under load. Verify all loads are disconnected or turned off before attempting to crank and start the engine.
 - Check that the choke is working properly.
1. Remove fuel line at carburetor and verify that there is an adequate amount of fuel entering the carburetor.
 2. Remove the float bowl and check to see if there is any foreign matter in bottom of carburetor bowl.
 3. The float is plastic and can be removed to access the needle for cleaning.
 4. Carburetor cleaner can be used to clean the rest of the carburetor before assembly.
 5. After cleaning carburetor with an approved carburetor cleaner, blow dry with compressed air and assemble.

Shelf life of gasoline is 30 days. Proper procedures need to be taken prevent fuel from varnishing over time. Use a fuel stabilizer to ensure that the fuel remains fresh.

Results

If carburetor is varnished, clean or replace.

Refer to Flow Chart.

Test 40 – Valve Adjustment

Adjusting Valve Clearance

The valve lash must be adjusted correctly in order to provide the proper air/fuel mixture to the combustion chamber.

Adjust valve clearance with the engine at room temperature. The piston should be at top dead center (TDC) of its compression stroke (both valves closed).

An alternative method is to turn the engine over and position the intake valve fully open (intake valve spring compressed) and adjust the exhaust valve clearance. Turn the engine over and position the exhaust valve fully open (exhaust valve spring compressed) and adjust the intake valve clearance.

The correct clearance for intake and exhaust valves is 0.002-0.004 inch (0.05-0.1 mm).

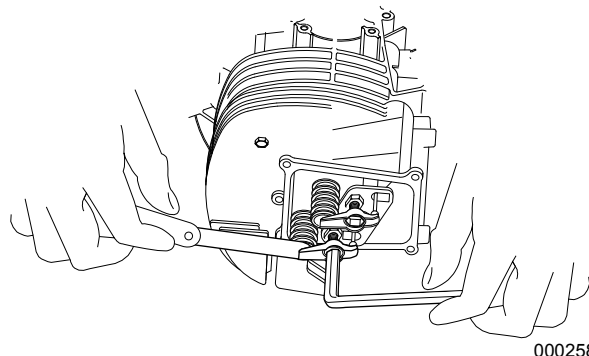

Figure 4-50. Adjusting Valve Clearance

1. See [Figure 4-50](#). Loosen the rocker arm jam nut. Use a 10mm allen wrench to turn the pivot ball stud while checking the clearance between the rocker arm and valve stem with a feeler gauge.
2. When clearance is correct, hold the pivot ball stud with the allen wrench and tighten the rocker arm jam nut to the specified torque with a suitable wrench. After tightening the jam nut, check valve clearance again to verify it did not change.

Torque Specification Rocker Arm Jam Nut:

168 in-lbs (19 Nm)

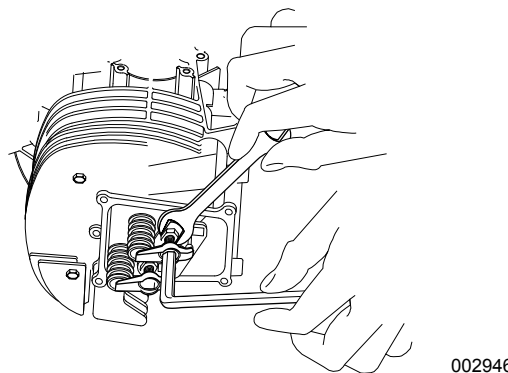

Figure 4-51. Tightening the Jam Nut

Install Rocker Arm Cover

1. Use a new rocker arm cover gasket. Install the rocker arm cover and retain with four screws.

Results

Adjust valves to specification and repeat test. If problem continues, refer to flow chart.

Test 41 – Check Engine / Cylinder Leak Down Test / Compression Test

Most engine problems may be classified as one or a combination of the following:

- Will not start
- Starts hard
- Lack of power
- Runs rough
- Vibration
- Overheating
- High oil consumption.

The cylinder leak down tester (Generac P/N 0F77000SRV) checks the sealing (compression) ability of the engine by measuring air leakage from the combustion chamber. Compression loss can present many different symptoms. This test is designed to detect the section of the engine where the fault lies before disassembling the engine.

Procedure

1. Remove a spark plug.
2. Gain access to the flywheel.
3. Remove the valve cover.
4. Rotate the engine crankshaft until the piston reaches top dead center (TDC). Both valves should be closed.
5. Lock the flywheel at top dead center.
6. Attach cylinder leak down tester adapter to spark plug hole.
7. Connect an air source of at least 90 psi to the leak down tester.
8. Adjust the regulated pressure on the gauge to 80 psi.
9. Read the right hand gauge on the tester for cylinder pressure. 20 percent leakage is normally acceptable.

NOTE: Use good judgment, and listen for air escaping at the carburetor, the exhaust, and the crankcase breather. This will determine where the fault lies.

10. Repeat steps 1 through 9 on remaining cylinder.

Results

- Air escapes at the carburetor – check intake valve.
- Air escapes through the exhaust – check exhaust valve.
- Air escapes through the breather – check piston rings.
- Air escapes from the cylinder head – the head gasket should be replaced.

Check Compression

Lost or reduced engine compression can result in failure of the engine to start, or rough operation. One or more of the following will usually cause loss of compression:

- Blown or leaking cylinder head gasket.
- Improperly seated or sticking-valves.
- Worn piston rings or cylinder. (This will also result in high oil consumption).

Procedure

1. Remove both spark plugs.
2. Insert a compression gauge into either cylinder.
3. Crank the engine until there is no further increase in pressure.
4. Record the highest reading obtained.
5. Repeat the procedure for the remaining cylinder and record the highest reading.

Results

Normal compression is approximately 150 psi. The difference in pressure between the two cylinders should not exceed 25 percent. If the difference is greater than 25 percent, loss of compression in the lowest reading cylinder is indicated.

Example 1: If the pressure reading of cylinder 1 is 165 psi and of cylinder 2, 160 psi, the difference is 5 psi. Divide “5” by the highest reading (165) to obtain the percentage of 3.0 percent.

Example 2: Cylinder 1 reads 160 psi; cylinder 2 reads 100 psi. The difference is 60 psi. Divide “60” by “160” to obtain “37.5” percent. Loss of compression in cylinder 2 is indicated.

If compression is poor, look for one or more of the following causes:

- Loose cylinder head bolts
- Failed cylinder head gasket
- Burned valves or valve seats
- Insufficient valve clearance
- Warped cylinder head
- Warped valve stem
- Worn or broken piston ring(s)
- Worn or damaged cylinder bore
- Broken connecting rod
- Worn valve seats or valves
- Worn valve guides

NOTE: Refer to Engine Service Manual Generac P/N 0F6923 for further engine service information.

Test 42 – Check Oil Pressure Switch and Wire 86

- If the engine cranks and starts, then shuts down almost immediately, the cause may be one or more of the following:
 - Low engine oil level
 - Low oil pressure
 - A defective oil pressure switch



Figure 4-52. Low Oil Pressure Switch

Procedure

1. Check engine crankcase oil level. If necessary, add the recommended oil to the dipstick FULL mark.

NOTE: Do not overfill above the full mark.

2. Disconnect wire 86 and wire 0 from the oil pressure switch terminals.
3. Remove the switch and install an oil pressure gauge in its place.
4. Start the engine while observing the oil pressure reading on gauge. Normal oil pressure is approximately 35-40 psi with engine running.
 - a. If normal oil pressure is indicated, go to step 11 of this test.
 - b. If oil pressure is below about 10 psi, shut engine down immediately. A problem exists in the engine lubrication system.

NOTE: The oil pressure switch is rated at 10 psi for v-twin engines.

NOTE: Refer to Service Manual, Generac P/N 0F6923 for engine service recommendations.

5. Remove the oil pressure gauge and install the oil pressure switch.

NOTE: Do not connect wire 86 or wire 0 to the switch terminals.

6. Set DMM to measure resistance.
7. Connect the meter test leads across the switch terminals.
 - a. With engine shut down, Continuity should be measured.

8. Crank and start the engine.
 - a. Infinity should be measured.
9. Connect one test lead to wire 0 (disconnected from LOP).
10. Connect the other test lead to a clean frame ground.
 - a. Continuity should be measured.
 - b. If continuity is not measured repair or replace wire 0 between the LOP and the ground terminal connection on the engine mount.
11. If the LOP switch tests good in steps 5-10 and oil pressure is good in steps 2-4, but the unit still shuts down with a LOP fault, check wire 86 for a short to ground.
12. Set DMM to measure resistance.
13. Disconnect the J2 connector from the circuit board.
14. Remove wire 86 from the LOP switch.
15. Connect one test lead to wire 86.
16. Connect the other test lead to a clean frame ground.
 - a. Infinity should be measured.
 - b. If Continuity is measured, repair or replace wire 86 between the LOP switch and the J2 connector.

Results

1. If switch tests good, refer to Flow Chart.
2. Replace switch if it fails the test.

Test 43 - Check Start Stop Relay (SSR)

Procedure

1. Set DMM to measure resistance.
2. See [Figure 4-53](#). Disconnect wire 15 and wire 229 from the Start Stop Relay (SSR).

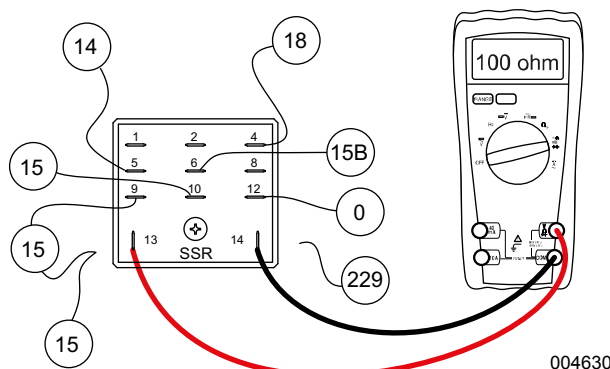

Figure 4-53. Testing Start Stop Relay (SSR)

3. Connect one meter test lead to the terminal that wire 15 was removed from.
4. Connect the other meter test lead to the terminal that wire 229 was removed from.

- a. Resistance measured should be approximately 100 ohms.

Results

1. If the SSR measures continuity or zero resistance it is shorted to ground and should be replaced.
2. If the SSR resistance is correct refer to flow chart.

Test 44 – Test Starter Contactor Relay (SCR)

Procedure

1. Set DMM to measure resistance.
2. See [Figure 4-54](#). Disconnect wire 15 and wire 17 from the starter contactor relay (SCR).
3. Connect one meter test lead to the terminal that wire 15 was removed from.

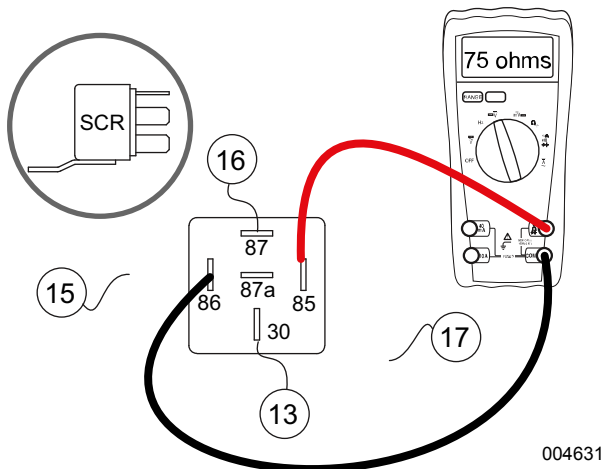

Figure 4-54. Testing Starter Contactor Relay (SCR)

4. Connect the other meter test lead to the terminal that wire 17 was removed from.
 - a. Resistance measured should be approximately 75 ohms.

Results

1. If the SCR measures continuity or zero resistance it is shorted to ground and should be replaced.
2. If the SCR resistance is correct refer to flow chart.

Test 45 – Check Wire 15 Circuit

Procedure

1. Set DMM to measure resistance.
2. Remove fuse F1.
3. Disconnect wire 15 from the start stop relay (SSR).

NOTE: See [Figure 4-53](#). wire 15 connects to the SSR at three terminals.

4. Disconnect wire 15 from the starter contactor (SC).

5. Disconnect wire 15 from the start-run-stop switch (SW1).
6. Disconnect wire 15 from the battery charge rectifier 2 (BCR2).
7. Remove wire 15 from the fuse holder (F1).
8. Connect one meter test lead to wire 15 just removed.
9. Connect the other meter test lead to frame ground.
10. Infinity should be measured.

Results

If Infinity was not measured a short on wire 15 to ground exists. Inspect each wire 15 for a shorted condition. Repair or replace as needed.

Test 46 – Check Wire 14 Circuit

Procedure

1. Set DMM to measure resistance.
2. Disconnect wire 14 from the start stop relay (SSR).
3. Connect one meter test lead to wire 14 previously removed. Connect the other meter test lead to frame ground. Approximately 38 ohms should be measured.

Results

Refer back to flow chart.

Test 47 – Check Fuel Shutoff Solenoid (FSS)

Procedure

1. Set DMM to measure resistance.
2. Disconnect the plug from the fuel shutoff solenoid (FSS).
3. Connect one meter test lead to one pin on the FSS.
4. Connect the other meter test lead to the remaining pin on the FSS.
 - a. Approximately 38 ohms should be measured.
5. Connect one meter test lead to one pin on the FSS.
6. Connect the other meter test lead to frame ground.
 - a. Infinity should be measured.

Results

1. If continuity or zero was measured in step 3 or step 6 replace the FSS.
2. (Units without hour meter) If correct resistance was measured refer to flow chart, repair or replace wire 14 between the FSS and resistor R1.
3. (Units with hour meter) Refer back to flow chart.

Test 48 – Check Hour Meter

Procedure

1. Disconnect wire 14 from the hour meter.
2. Install new 10 Amp fuse.
3. Set start-run-stop switch (SW1) to START.
4. Check to see if fuse blows open.

Results

1. If fuse did not blow open replace the hour meter.
2. If fuse blows open repair or replace wire 14 between the resistor (R1) and the hour meter (HM) or between the HM and the fuel shutoff solenoid (FSS).

Test 49 – Check Wire 15B

Procedure

1. Set DMM to measure resistance.
2. See [Figure 4-55](#). Disconnect wire 15B from the Start Stop Relay (SSR).
3. Connect one meter test lead to wire 15B previously removed.
4. Connect the other meter test lead to frame ground.
5. If continuity or zero resistance was measured remove the J2 connector from the printed circuit board and repeat steps 3 and 4.

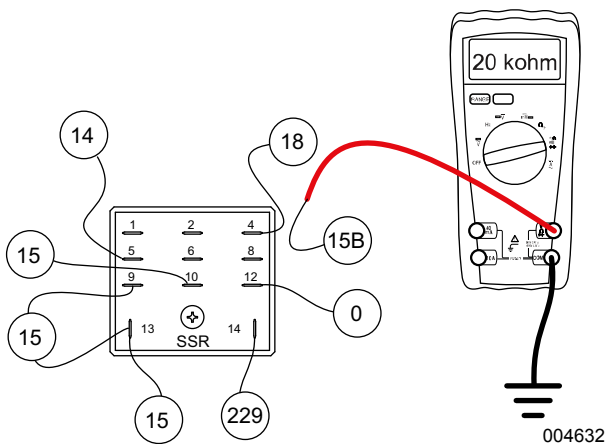

Figure 4-55. Check Wire 15B

Results

1. If continuity was measured in step 4 but not in step 5, replace the printed circuit board.
2. If continuity was measured in step 5, wire 15B is shorted to ground, repair or replace wire 15B between the SSR and printed circuit board.

Test 50 – Check Wire 167

Procedure

1. Set DMM to measure resistance.
2. See [Figure 4-56](#). Disconnect wire 167 from the start-run-stop switch (SW1).
3. Connect one meter test lead to wire 167 previously removed.
4. Connect the other meter test lead to frame ground.
5. If continuity or zero resistance was measured remove the J2 connector from the printed circuit board and repeat steps 3 and 4.

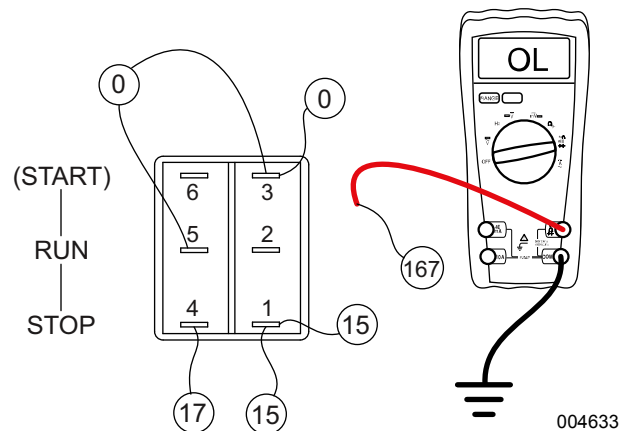

Figure 4-56. Check Wire 167

Results

1. If continuity was measured in step 4 but not in step 5, replace the printed circuit board.
2. If continuity was measured in step 5 wire 167 is shorted to ground. Repair or replace wire 167 between the SW1 and printed circuit board.

Test 51 – Check Wires 11S & 44S or 11S & 22S

Procedure

1. Set DMM to measure resistance.
2. Disconnect the J2 connector from the printed circuit board.
3. Connect one meter test lead to pin location J2-10 wire 44S of the connector just removed.
4. Connect the other meter test lead to wire 44S at terminal block 2 (TB2).
5. Connect one meter test lead to pin location J2-12 wire 11S.

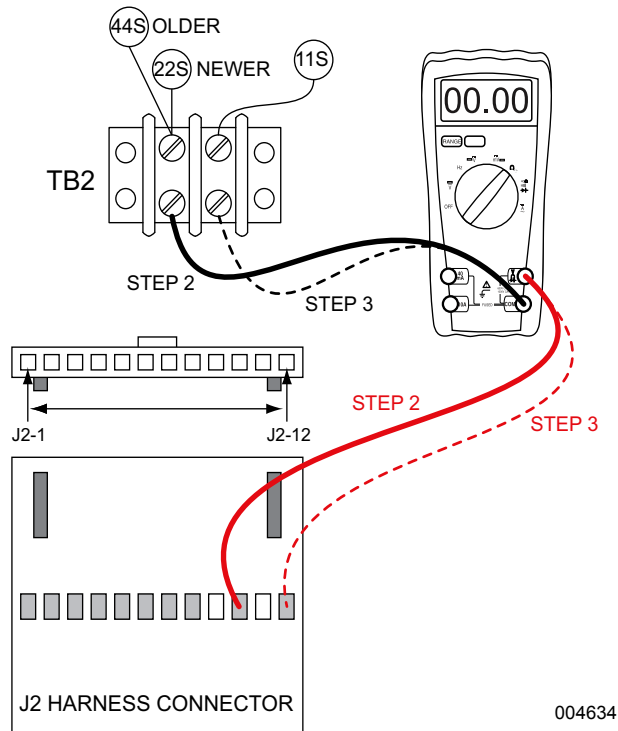

Figure 4-57. Check Wires 11S & 44S or 11S & 22S

6. Connect the other meter test lead to wire 11S at terminal block 2 (TB2).
 - a. Continuity should be measured.

NOTE: Where terminal block is not present, place meter test lead on the wire at the termination point. If necessary, use a small paper clip to probe beside the wire so as not to damage the terminal in the connector.

Results

1. If Continuity was not measured, repair or replace the wire harness.
2. If Continuity was measured, refer back to the flow chart.

Test 52 – Check Idle Control Switch (SW2)

Procedure

1. Set DMM to measure resistance.
2. Disconnect wire 0 and wire 83 from the idle control switch (SW2).
3. See [Figure 4-58](#). Connect meter test leads across both terminals of SW2.
 - a. In the OFF position Infinity should be measured.
 - b. In the ON position Continuity should be measured.

Results

1. If the switch fails step 3 replace it.
2. If the switch is good refer back to the flow chart.

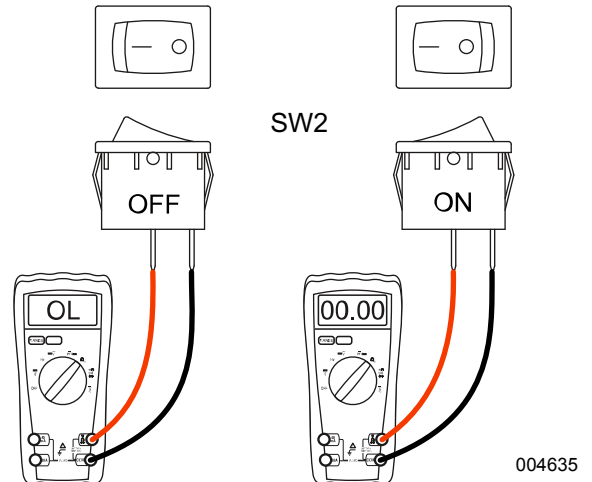

Figure 4-58. Check Idle Control Switch (SW2)

Test 53 – Check Idle Control Wiring

Procedure

1. Set DMM to measure resistance.
2. Disconnect wire 0 from the Idle Control Switch (SW2).
3. Connect one meter test lead to wire 0.
4. Connect the other meter test lead to frame ground. Continuity should be measured.
 - a. If continuity is not measured repair or replace wire 0 between SW2 and the ground terminal.
5. Disconnect wire 83 from SW2.
6. Disconnect the J2 connector from the printed circuit board.

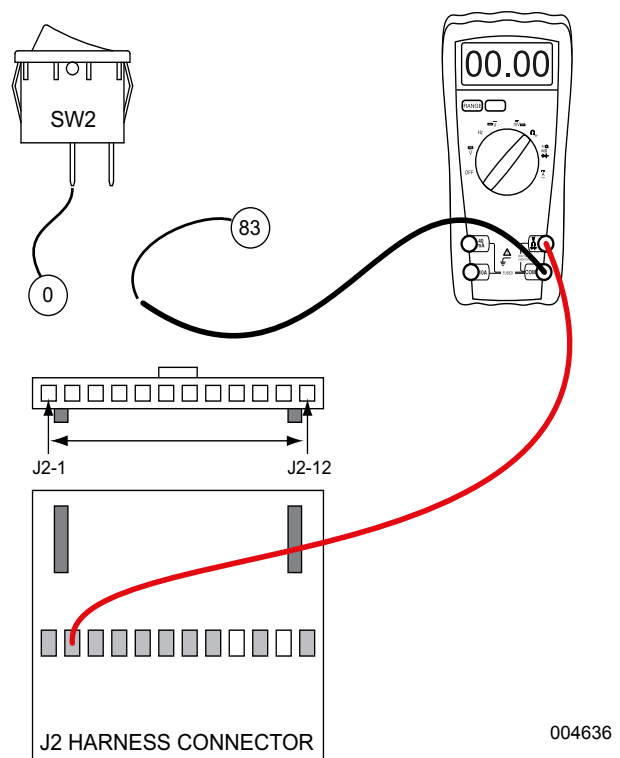

Figure 4-59. Check Idle Control Wiring

7. Connect one meter test lead to wire 83 previously removed from SW2.
8. See **Figure 4-59**. Connect the other meter test lead to pin location J2-2 on the J2 connector.
 - a. Continuity should be measured.
 - b. If Continuity is not measured repair or replace wire 83 between the J2 connector and terminal block or between the terminal block and SW2.

Results

Repair or replace wiring as needed. Refer back to the flow chart.

Test 54 – Check Idle Control Transformers (ICT)

Procedure

1. Set DMM to measure resistance.
2. See **Figure 4-60**. Remove the two idle control transformer (ICT) wires from terminal block 1 (TB1).

NOTE: Where terminal block is not present, place meter test lead on the wire at the termination point. If necessary, use a small paper clip to probe beside the wire so as not to damage the terminal in the connector.

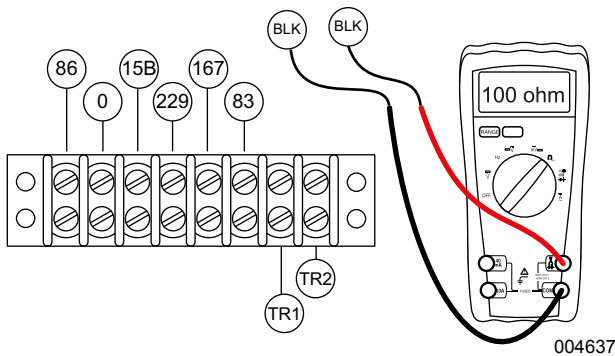

Figure 4-60. Check Idle Transformer Wiring

3. Connect one meter test lead to one wire.
4. Connect the other meter test lead to the other wire.
 - a. Approximately 100 ohms should be measured.
 - b. If resistance is not measured repair or replace the idle control transformers.
 - c. If resistance was measured proceed with step 5.
5. Set DMM to measure AC Voltage.
6. Connect one meter test lead to one wire.
7. Connect the other meter test lead to the other wire.
8. Turn the idle control switch (SW2) to OFF. The generator should be running at about 60 HZ.
9. Apply a light load to the generator, such as an electric drill.

10. When the drill is activated measure the voltage output. The AC voltage should measure around 1-2 VAC.

Results

Refer back to flow chart.

Test 55 – Check TR1 & TR2 Wiring

Procedure

1. Set DMM to measure resistance.
2. Disconnect the J2 connector from the printed circuit board.
3. See **Figure 4-61**. Connect one meter test lead to wire TR2 at terminal block 1 (TB1).

NOTE: Where terminal block is not present, place meter test lead on the wire at the termination point. If necessary, use a small paper clip to probe beside the wire so as not to damage the terminal in the connector.

4. Connect the other meter test lead to pin location J2-6 on the J2 connector previously removed.
 - a. Continuity should be measured.
5. See **Figure 4-62**. Connect one meter test lead to wire TR1 at terminal block 1 (TB1).
6. Connect the other meter test lead to pin location J2-3 on the J2 connector previously removed.
 - a. Continuity should be measured.

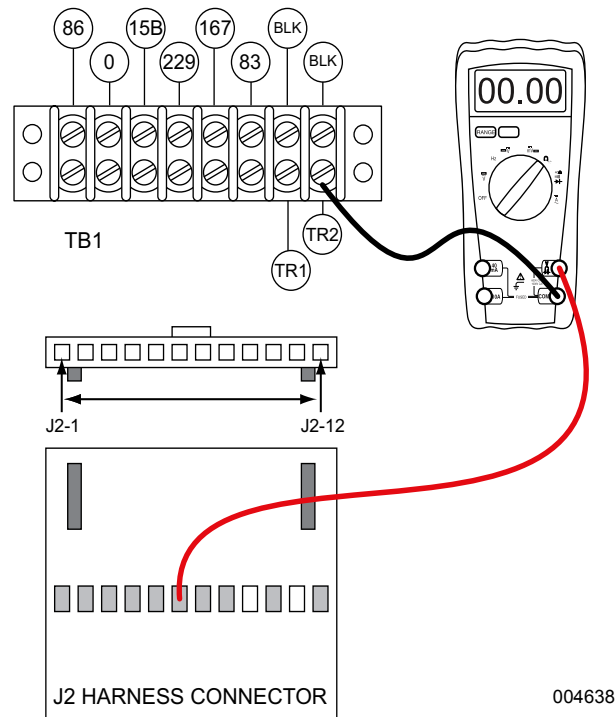

Figure 4-61. Check TR2 Wiring

Results

1. Repair or replace defective wiring.
2. If wiring tests good replace printed circuit board.

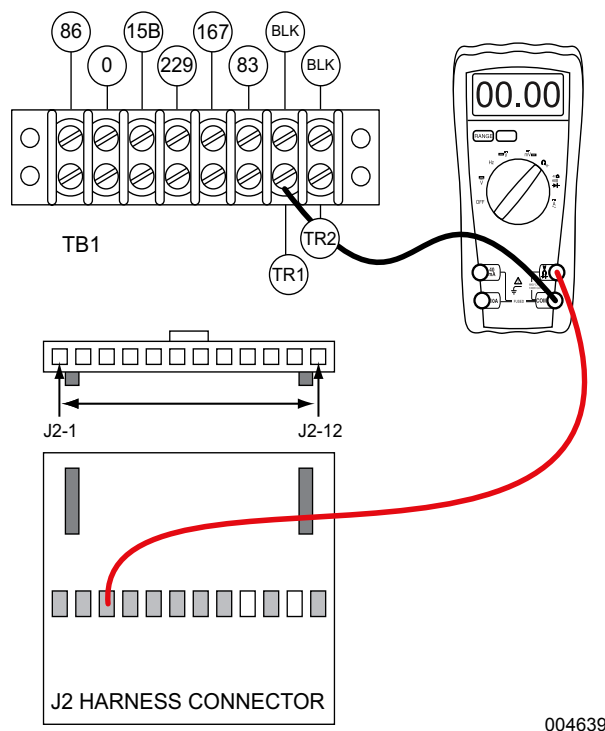

Figure 4-62. Check TR1 Wiring

Test 56 – Choke Test

Procedure

If the generator is surging it may have a carburetion problem. A lean condition can cause erratic RPM. Slowly pull the choke out to see if surging stops. If it does stop, carburetion should be checked.

Insulation Resistance

The insulation resistances of stator and rotor windings are a measurement of the integrity of the insulating material that separates the electrical windings from the generator steel core. This resistance can degrade over time or due to such contaminants as dust, dirt, oil, grease and especially moisture. In most cases, failures of stator and rotor windings are due to a break down in the insulation. In many cases, a low insulation resistance is caused by moisture that collects while the generator is shut down.

When problems are caused by moisture buildup on the windings, this can usually be corrected by drying the windings. Cleaning and drying the windings can usually eliminate dirt and moisture that has built up in the generator windings.

The Megohmmeter

Introduction

A megohmmeter (often called a megger), consists of a meter calibrated in megohms and a power supply.

IMPORTANT NOTE: When testing stators and rotors, set Megohmmeter to 500 volts and apply voltage for a maximum of one second. Follow the megohmmeter manufacturers instructions carefully. Do not exceed 500 volts or apply voltage longer than 1 second. megohmmeter high voltages could cause damage to other components on the generator. Take the proper precautions before testing.

Testing Stator Insulation

See [Figure 4-64](#). All parts that might be damaged by the high megger voltages must be disconnected before testing. Isolate all stator leads and connect all of the stator leads together.

IMPORTANT NOTE: Follow the megger manufacturer's instructions carefully.

Use a megohmmeter power setting of 500 volts. Connect one megohmmeter test lead to the junction of all the stator leads. Connect the other test lead to a frame ground on the stator can. Read the number of megohms on the meter.

To calculate the minimum acceptable megohmmeter readings use the following formula:

$$\text{Minimum Insulation Resistance (In "Megohms")} = \frac{\text{Generator Rated Volts}}{1000} + 1$$

EXAMPLE: Generator is rated at 120 volts AC. Divide "120" by "1000" to obtain "0.12". Then add "1" to obtain "1.12" megohms. Minimum insulation resistance for a 120 VAC stator is 1.12 megohms.

If the stator insulation resistance is less than the calculated minimum resistance, clean and dry the stator. Then, repeat the test. If resistance is still low, replace the stator.

Use the megohmmeter to test for shorts between isolated windings as outlined in [Stator Insulation Resistance Test](#).

Also test between parallel windings. See [Test Between Windings](#).

Testing Rotor Insulation

Apply a voltage of 500 volts across the rotor positive slip ring (nearest the rotor bearing), and a ground (i.e. the rotor shaft).

IMPORTANT NOTE: When testing stators and rotors, set megohmmeter to 500 volts and apply voltage for a maximum of one second. Follow the megohmmeter manufacturers instructions carefully. Do not exceed 500 volts or apply voltage longer than 1 second. megohmmeter high voltages could cause damage to other components on the generator. Take the proper precautions before testing.

Rotor Minimum Insulation Resistance:
1.5 Megohms

IMPORTANT NOTE: Before attempting to measure Insulation resistance, first disconnect and Isolate all leads of the winding to be tested. electronic components, diodes, surge protectors, relays, voltage regulators, etc., can be destroyed if subjected to high megger voltages.

Hi-Pot Tester

A hi-pot tester is shown in *Figure 4-63*. The model shown is only one of many that are commercially available. The tester shown is equipped with a voltage selector switch that permits the power supply voltage to be selected. It also mounts a breakdown lamp that will illuminate to indicate an insulation breakdown during the test.

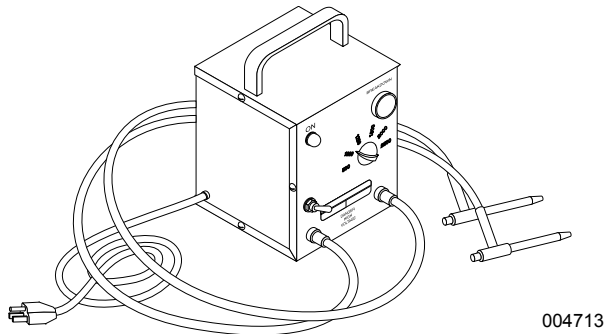

Figure 4-63. One Type of Hi-Pot Tester

Stator Insulation Resistance Test

Units with air-cooled engines are equipped with center tapped AC power windings, an excitation or DPE winding, a center tapped battery charge winding and a 10 Amp center tapped battery charge winding. Insulation tests of the stator consist of testing all windings to ground, testing between isolated windings, and testing between parallel windings. *Figure 4-64* is a pictorial representation of the various stator leads on units with air-cooled engine.

Testing All Stator Windings To Ground

1. Disconnect stator output leads wire 11 and wire 44 from the generator 50A circuit breaker.
2. Remove stator output lead wire 22 from the neutral terminal on the back of the 50A outlet.
3. Disconnect the C1 connector from the bottom of the control panel. See *Control Panel Component Identification*. The C1 connector is on the right when facing the control panel.
4. Connect the terminal ends of wires 11, 22, and 44 together. Make sure the wire ends are not touching any part of the generator frame or any terminal.

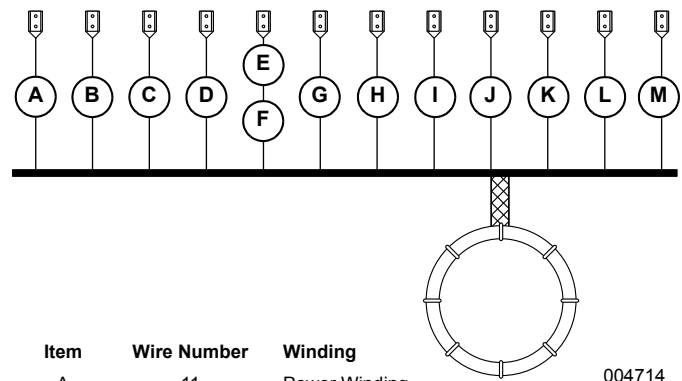

004714

Figure 4-64. Stator Assembly Leads

5. Connect the red test probe of the Hi-Pot tester to the joined terminal ends of stator leads 11, 22, and 44. Connect the black tester lead to a clean frame ground on the stator can. With tester leads connected in this manner, proceed as follows:
 - a. Turn the hi-pot tester switch OFF.
 - b. Plug the tester cord into a 120 volt AC wall socket and set its voltage selector switch to "1500 volts".
 - c. Turn the tester switch ON and observe the breakdown lamp on tester. **DO NOT APPLY VOLTAGE LONGER THAN 1 SECOND.** After one (1) second, turn the tester switch OFF.

If the breakdown lamp comes on during the one-second test, the stator should be cleaned and dried. After cleaning and drying, repeat the insulation test. If, after cleaning and drying, the stator fails the second test, the stator assembly should be replaced.

6. Now proceed to the C1 connector (female side – just removed). Each winding will be individually tested for a short to ground. Insert a large paper clip (or similar item) into the C1 connector at the following pin locations:

Next refer to steps 5a through 5c of the hi-pot procedure. Example: Insert paper clip into pin 1, hi-pot from pin 1 (wire 11S) to ground. Proceed to pin 2, pin 3, etc. through pin 10.

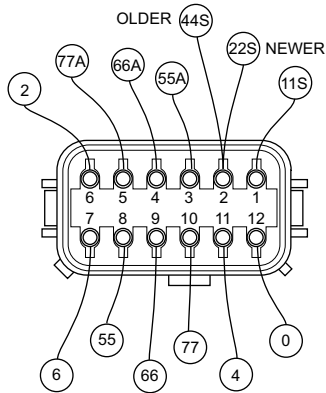

004642

Figure 4-65. C1 Connector Pin Location Numbers (Female Side)

Test Between Windings

1. Insert a paper clip into pin Location 3 (wire 55A). Connect the red tester probe to the paper clip. Connect the black tester probe to stator lead 11. Refer to steps 5a through 5c of **Testing All Stator Windings To Ground**.
2. Repeat step 1 at pin Location 6 (wire 2) and stator Lead 11.
3. Repeat step 1 at pin Location 8 (wire 55) and stator lead 11.

For the following steps (4 through 6) an additional paper clip (or similar item) will be needed:

4. Insert a paper clip into pin Location 3 (wire 55A). Connect the red tester probe to the paper clip. Insert additional paper clip into pin Location 6 (wire 2). Connect the black tester probe to this paper clip. Refer to steps 5a through 5c of **Testing All Stator Windings To Ground**.
5. Insert a paper clip into pin Location 3 (wire 55A). Connect the red tester probe to the paper clip. Insert additional paper clip into pin Location 8 (wire 55). Connect the black tester probe to this paper clip. Refer to steps 5a through 5c of **Testing All Stator Windings To Ground**.
6. Insert a paper clip into pin Location 6 (wire 2). Connect the red tester probe to the paper clip. Insert the additional paper clip into pin Location 8 (wire 55). Connect the black tester probe to this paper clip. Refer to steps 5a through 5c of **Testing All Stator Windings To Ground**.

Rotor Insulation Resistance Test

Before attempting to test rotor insulation, the brush holder must be completely removed. The rotor must be completely isolated from other components before starting the test. Attach all leads of all stator windings to ground.

1. Connect the red tester lead to the positive (+) slip ring (nearest the rotor bearing).

2. Connect the black tester probe to a clean frame ground, such as a clean metal part of the rotor shaft.

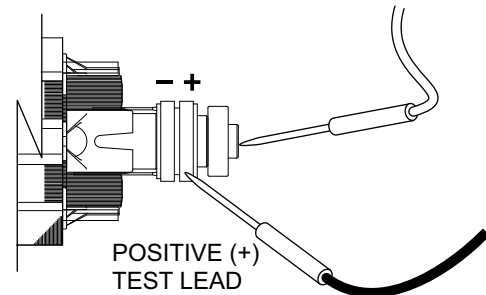

004649

Figure 4-66. Testing Rotor Insulation

3. Turn the tester switch OFF.
4. Plug the tester into a 120 volts AC wall socket and set the voltage switch to "1500 volts".
5. Turn the tester switch ON and make sure the pilot light has turned on.
6. Observe the breakdown lamp, then turn the tester switch OFF. **DO NOT APPLY VOLTAGE LONGER THAN ONE (1) SECOND.**

If the breakdown lamp came on during the one (1) second test, cleaning and drying of the rotor may be necessary. After cleaning and drying, repeat the insulation breakdown test. If breakdown lamp comes on during the second test, replace the rotor assembly.

Cleaning the Generator

Caked or greasy dirt may be loosened with a soft brush or a damp cloth. A vacuum system may be used to clean up loosened dirt. Dust and dirt may also be removed using dry, low-pressure air (25 psi maximum).

IMPORTANT NOTE: Do not use sprayed water to clean the generator. Some of the water will be retained on generator windings and terminals, and may cause very serious problems.

Drying the Generator

To dry a generator, proceed as follows:

1. Open the generator main circuit breaker. **NO ELECTRICAL LOADS MUST BE APPLIED TO THE GENERATOR WHILE DRYING.**
2. Provide an external source to blow warm, dry air through the generator interior (around the rotor and stator windings. **DO NOT EXCEED 185 °F. (85 °C.).**
3. Start the generator and let it run for 2 or 3 hours.
4. Shut the generator down and repeat the stator and rotor insulation resistance tests.

Wattage Reference Guide			
Device	Running Watts	Device	Running Watts
*Air Conditioner (12,000 Btu)	1700	Hand Drill	250 to 1100
*Air Conditioner (24,000 Btu)	3800	Hedge Trimmer	450
*Air Conditioner (40,000 Btu)	6000	Impact Wrench	500
Battery Charger (20 Amp)	500	Iron	1200
Belt Sander (3")	1000	*Jet Pump	800
Chain Saw	1200	Lawn Mower	1200
Circular Saw (6-1/2")	800 to 1000	Light Bulb	100
*Clothes Dryer (Electric)	5750	Microwave Oven	700 to 1000
*Clothes Dryer (Gas)	700	*Milk Cooler	1100
*Clothes Washer	1150	Oil Burner on Furnace	300
Coffee Maker	1750	Oil Fired Space Heater (140,000 Btu)	400
*Compressor (1 HP)	2000	Oil Fired Space Heater (85,000 Btu)	225
*Compressor (3/4 HP)	1800	Oil Fired Space Heater (30,000 Btu)	150
*Compressor (1/2 HP)	1400	*Paint Sprayer, Airless (1/3 HP)	600
Curling Iron	700	Paint Sprayer, Airless (hand held)	150
*Dehumidifier	650	Radio	50 to 200
Disc Sander (9")	1200	*Refrigerator	700
Edge Trimmer	500	Slow Cooker	200
Electric Blanket	400	*Submersible Pump (1-1/2 HP)	2800
Electric Nail Gun	1200	*Submersible Pump (1 HP)	2000
Electric Range (per element)	1500	*Submersible Pump (1/2 HP)	1500
Electric Skillet	1250	*Sump Pump	800 to 1050
*Freezer	700	*Table Saw (10")	1750 to 2000
*Furnace Fan (3/5 HP)	875	Television	200 to 500
*Garage Door Opener	500 to 750	Toaster	1000 to 1650
Hair Dryer	1200	Weed Trimmer	500
* Allow 3 times the listed watts for starting these devices.			

Section 5 Disassembly

Major Disassembly

Stator, Rotor, and Engine Removal

See [Figure 5-11](#) and [Figure 5-12](#) for component location.

1. Disconnect and remove the battery from the generator. ([Figure 5-12](#), Item 15)
2. Remove Fuel Tank. Use proper safety precautions when handling gasoline. ([Figure 5-12](#), Item 4)

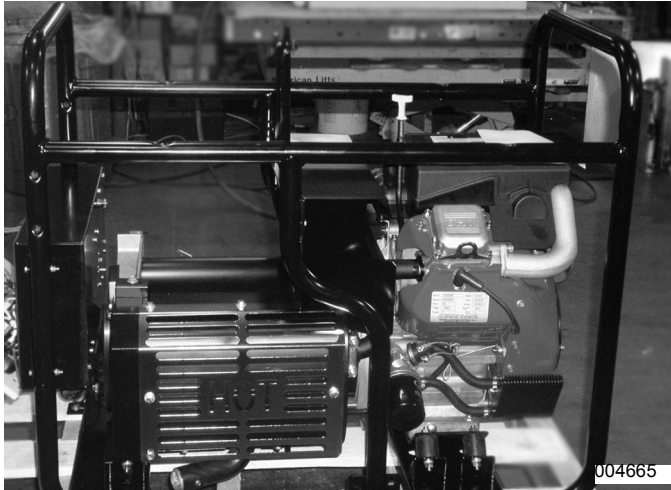

Figure 5-1. Fuel Tank Removed

Remove Control Panel

1. Disconnect wire 11 and wire 44 from the 50 Amp circuit breaker.
2. Disconnect wire 22 from the 50 Amp receptacle.
3. Disconnect the stepper motor harness from the printed circuit board.
4. Disconnect the C1 and C2 connectors below the control panel.
5. Remove the control panel.



Figure 5-2. Stepper Motor Harness



Figure 5-3. Control Panel Removed



Figure 5-4. Remove Air Deflector

Remove the Muffler

1. Remove air deflector from cross member. ([Figure 5-12](#), Item 45)
2. Remove the four screws holding the alternator air cover on the rear of the alternator. ([Figure 5-11](#), Item 8)
3. Remove the muffler heat shield labeled HOT. ([Figure 5-11](#), Item 34)
4. Remove the rear muffler box end panel. ([Figure 5-11](#), Item 38)
5. Remove the nut and washers from the top of the rear rubber mounts attached to the rear bearing carrier. ([Figure 5-11](#), Item 32)
6. Remove the back muffler box back panel. ([Figure 5-11](#), Item 37)

7. Remove the M8 bolt from the rear bearing carrier. (*Figure 5-11*, Item 15)
8. Remove the exhaust clamp. (*Figure 5-11*, Item 35)
9. Remove the muffler. (*Figure 5-11*, Item 6)



Figure 5-5. Remove Muffler

Remove Stator

1. Disconnect wire 4 and wire 0 from the brush assembly. (*Figure 5-11*, Item 21)
2. Remove the brush assembly. Remove the four stator hold down bolts. (*Figure 5-11*, Item 12)
3. Lift the rear end of the alternator up to clear the muffler frame from the rubber alternator mount. Place a 2x4 under the front bearing carrier for support.
4. Using a rubber mallet carefully remove the rear bearing carrier. (*Figure 5-11*, Item 4)
5. Rotate the rotor so that the steel laminations face the top and bottom.
6. Remove the stator can.

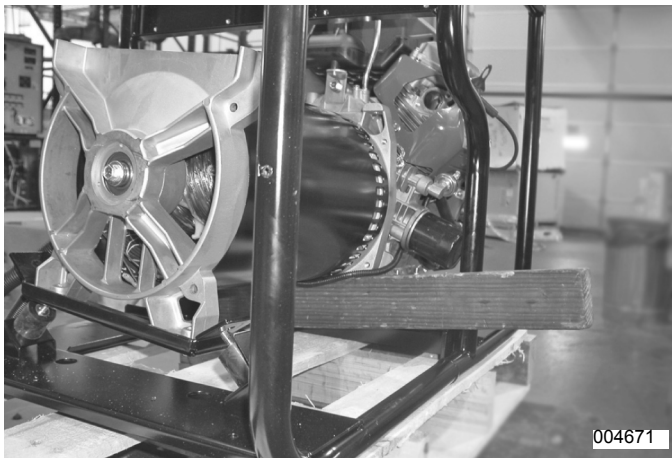

Figure 5-6. Support Alternator

Remove Rotor

1. Remove rotor bolt. (*Figure 5-11*, Item 11)

2. Cut 2.5 inches from the hex head end of the rotor bolt.
3. Slot the end of the bolt to suit a flat blade screwdriver.
4. Slide the rotor bolt back through the rotor and use a screwdriver to screw it into the crankshaft.
5. Use a 3" M12 x 1.75 bolt to screw into the rotor.
6. Apply torque to the 3" bolt until the taper breaks.

NOTE: If necessary use a rubber mallet on the end of the rotor shaft to break the taper when torque is applied to the 3" bolt.

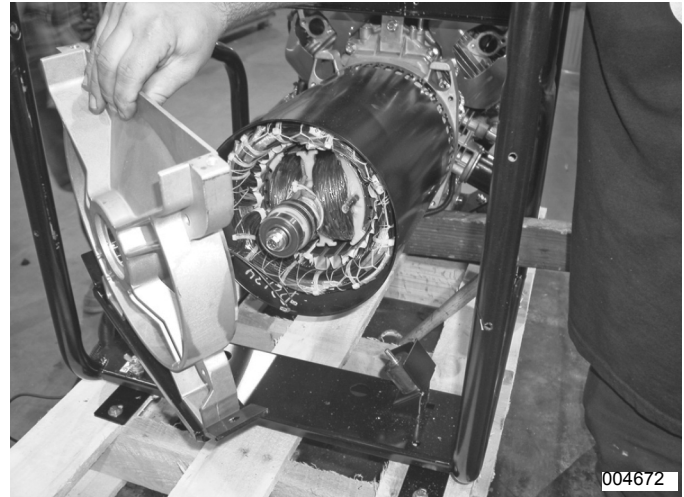

Figure 5-7. Remove Bearing Carrier

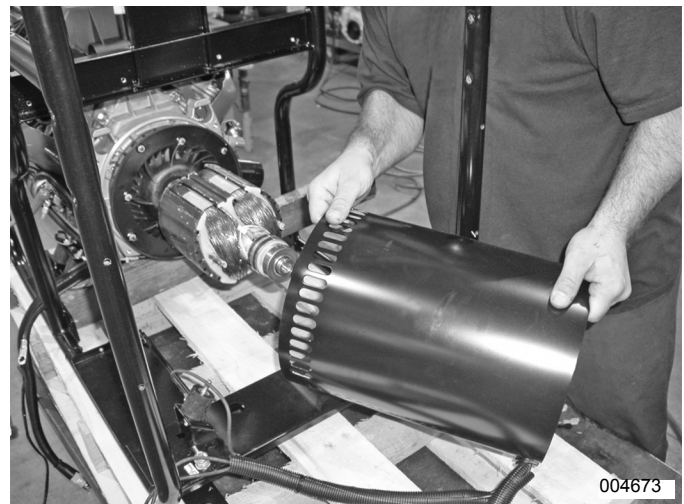

Figure 5-8. Remove Stator

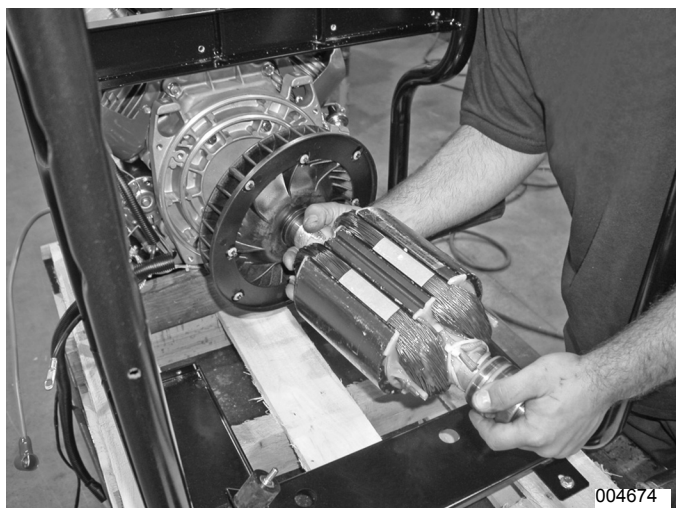

Figure 5-9. Remove Rotor

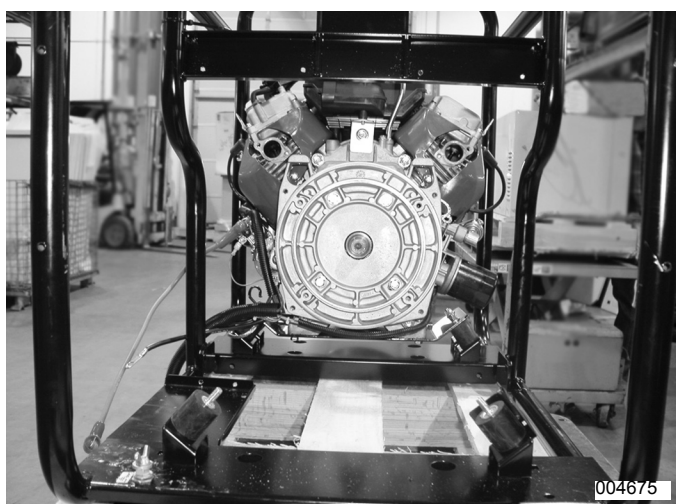

Figure 5-10. Engine Ready for Removal

Remove Engine

7. Remove the four nuts from rubber engine mounts.
([Figure 5-11](#), Item 29)
8. Remove engine.

Reverse procedure for assembly.

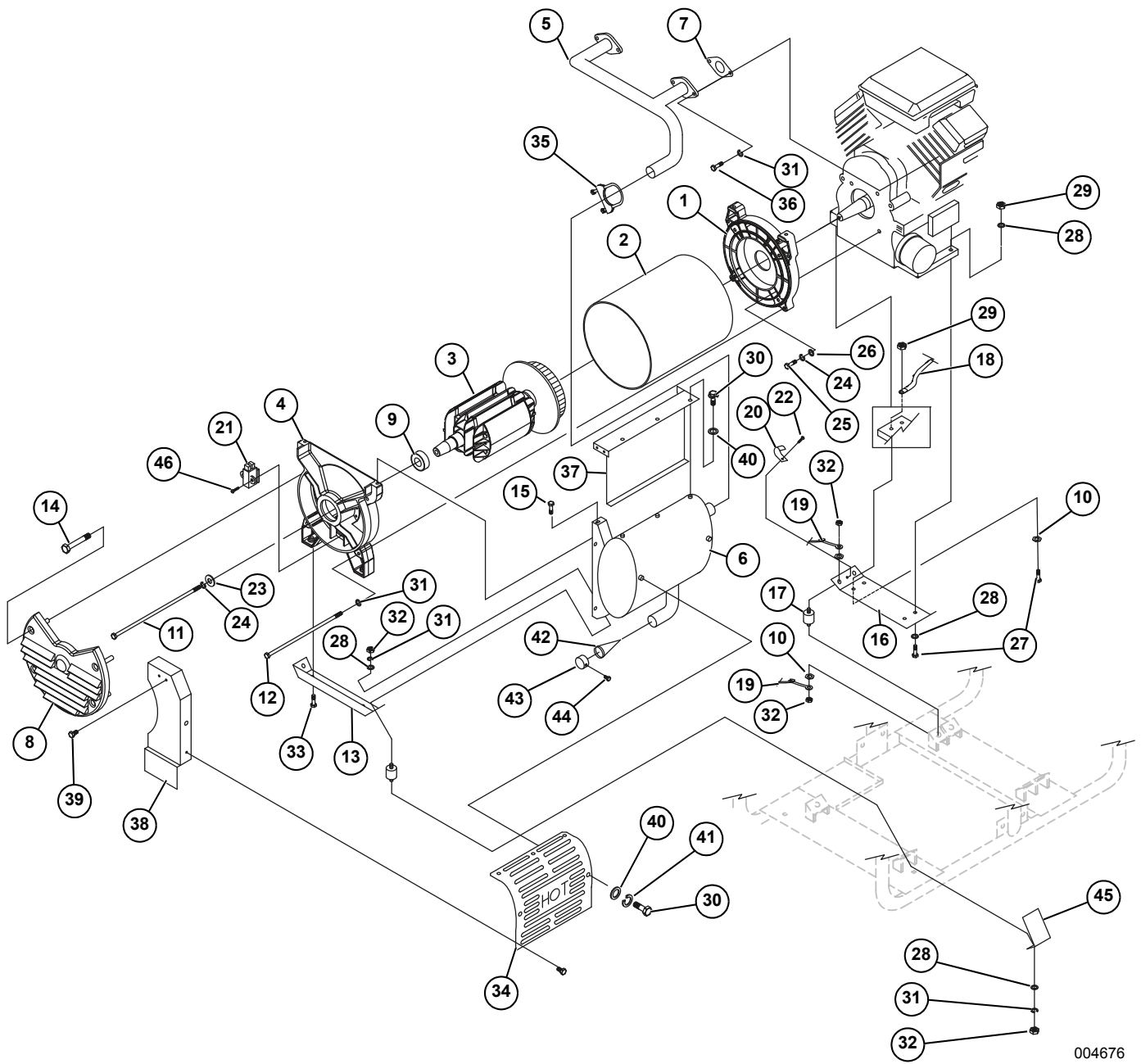
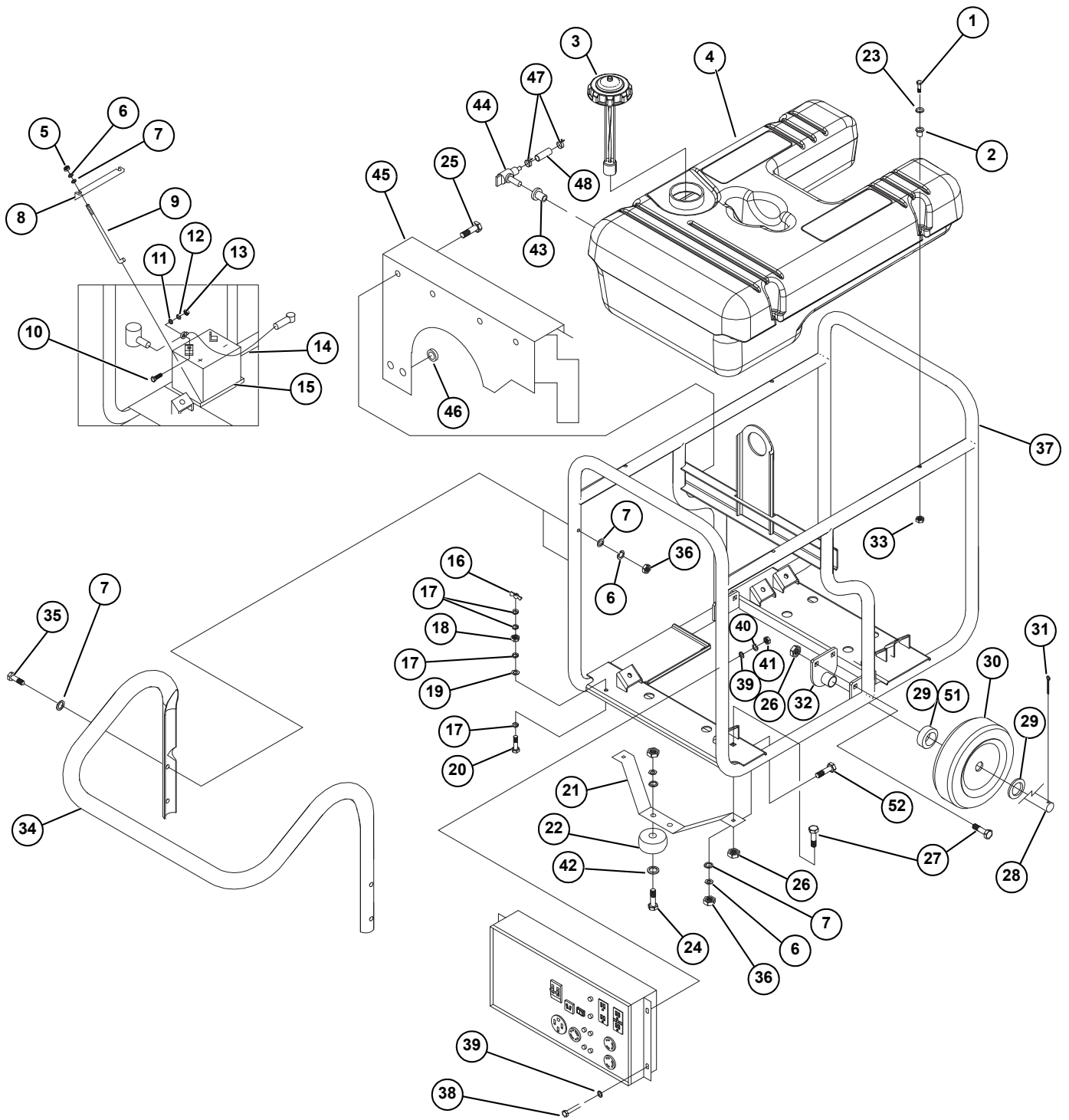

Figure 5-11. Exploded View Generator

004676

Item	Qty.	Description	Item	Qty.	Description
1	1	Adaptor, Engine	24	5	Washer Lock 3/8
2	1	Stator	25	4	Screw HHC 3/8-16 X 1-1/4 G5
3	1	Assembly, Rotor W/Fan	26	4	Washer Flat 3/8-M10 Zinc
4	1	Carrier, Rear Bearing	27	4	Screw HHC M8-1.25 X 50 G8.8
5	1	Exhaust Manifold	28	21	Washer Flat 5/16 Zinc
6	1	Muffler	29	4	Nut Lock Hex M8-1.25 Nylon Insert
7	1	Gasket, Exhaust	30	7	Screw HHC M6-1.0 X 12
8	1	Cover, Alternator Air Intake	31	18	Washer Lock M8-5/16
9	1	Bearing	32	12	Nut Hex 5/16-18 Steel
10	3	5/16 Special Lock Washer	33	2	Screw Taptite 3/8-16 X 3/4 BP
11	1	Screw IHHC 3/8-24 X 15.50 G5	34	1	Shield, Muffler Heat
12	4	Screw IHHC M8-1.25 X 400 G8.8	35	1	U-bolt & Saddle
13	1	Bracket, ALT Mounting	36	4	Screw SHC M8-1.25 X 18
14	4	Screw HHTT #10-32 X 1.75	37	1	Panel, Muffler Box Back
15	1	Screw HHTT M8-1.2 X 20	38	1	Panel, Muffler Box End
16	1	Engine Mounting Plate	39	3	Screw HHTT M6-1.0 X 12
17	6	Rubber Mount	40	7	Washer Flat M6-1/4
18	1	Battery Cable, Black	41	7	Washer Lock M6-1/4
19	1	Earth Strap 3/8x 3/8	42	1	Spark Arrestor Screen
20	1	Clip-j Vinyl Coat .625 ID	43	1	Retainer, Spark Arrest Screen
21	1	Assembly, Brush Holder	44	1	Screw HHTT M4-0.7 X 8
22	1	Screw Tap-R #10-32 X 9/16	45	1	Shield, Rubber Mount
23	1	Washer Flat 3/8 Zinc	46	2	Screw HHTT M5-0.8 X 16



004677

Figure 5-12. Exploded View Frame, Handle, and Wheels

ITEM	QTY.	DESCRIPTION	ITEM	QTY.	DESCRIPTION
1	4	Screw HHC M6-1.0 X 55	28	1	Axle, 3/4" Dia X 30" (15 kW)
2	4	Rubber Tank Mount		1	Axle, 3/4" Dia X 27.25" (12.5 kW)
3	1	Cap, Fuel With Gauge & Vent	29	2	Washer Flat 3/4" (15 kW)
4	1	Kit, Fuel Tank		4	Washer Flat 3/4" (12.5 kW)
5	4	Nut Hex M8-1.25	30	2	12.3" Pneum Wheel 3/4" Axle (15 kW)
6	10	Washer Lock M8-5/16		2	10" Pneum Wheel 3/4" Axle (12.5 kW)
7	14	Washer Flat 5/16	31	2	Pin Cotter 1/8 X 1-1/4
8	1	Bracket Battery	32	2	Bracket, Wheel Spacer
9	2	Bolt, Battery J-Bolt	33	4	Nut Flange M6-1.0 Nylok
10	2	Screw HHC 1/4-20 X 3/4 G5	34	1	Handle
11	2	Washer Flat 1/4	35	4	Screw HHC 5/16-18 X 2-1/2 G5
12	2	Washer Lock M6-1/4	36	6	Nut Lock Hex 5/16-18 Nylon Insert
13	2	Nut Hex 1/4-20	37	1	Frame
14	1	Battery Cable, Red	38	4	Screw HHC M5-0.8 X 45 G8.8
15	1	Battery U1	39	8	Washer Flat M5
16	1	Nut Wing 5/16-18 Brass	40	4	Washer Lock M5
17	4	Washer Flat 5/16 Brass	41	4	Nut Hex M5-0.8
18	1	Nut Hex 5/16-18 Brass	42	2	Washer Flat 1"
19	1	5/16 Special L/wash	43	1	Bushing Tank Dexter
20	1	Screw HHC 5/16-18 X 1.5 Brass	44	1	Valve, Plastic Tank
21	1	Bracket Front Foot	45	1	Air Deflector
22	2	Vib Mount	46	2	Grommet .75 X .06 X .50
23	4	Washer Flat .25ID X 1"OD	47	2	Clamp Hose Band 1/4
24	2	Screw HHC M8-1.25 X 30	48	18"	Hose 1/4 Id
25	4	Screw HHTT M6-1.0 X 12	49	1	Boot Battery Cable
25	4	Screw HHTT M6-1.0 X 12	50	1	Boot Starter Cable
26	6	Nut Lock FI 3/8-16	51	2	Spacer, Axle (15 kW)
27	6	Bolt Carr 3/8-16 X 1	52	2	Screw HHC 5/16"-18 X 1"

This page intentionally left blank.

Section 6 Electrical Data

Introduction

The diagrams in this section are provided for general reference only. For unit specific diagrams refer to the Service and Support page at the manufacturer's website.

Wiring Diagram 12.5 & 15 kW (Units Without Hourmeter) – Drawing No. 0E0228

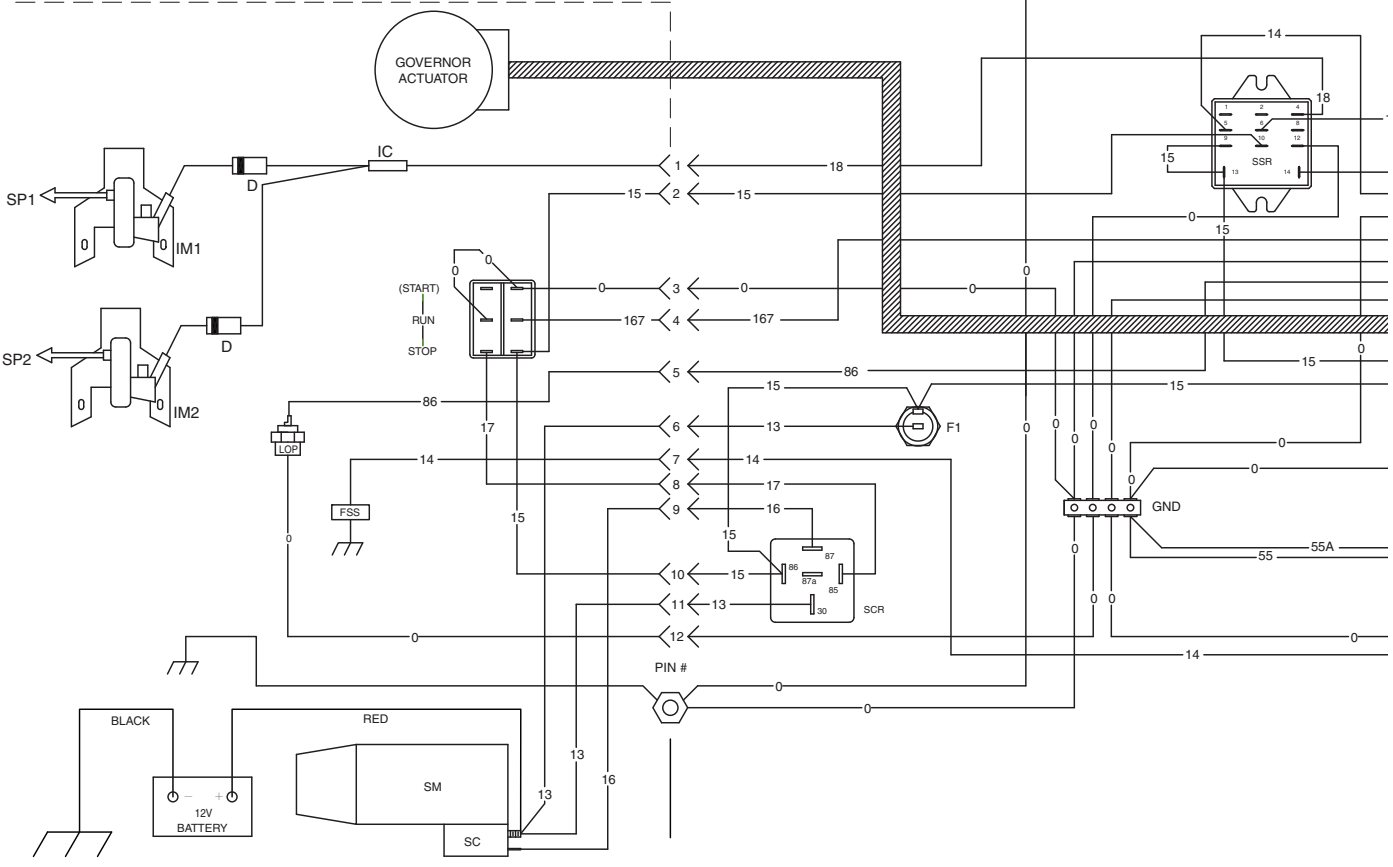
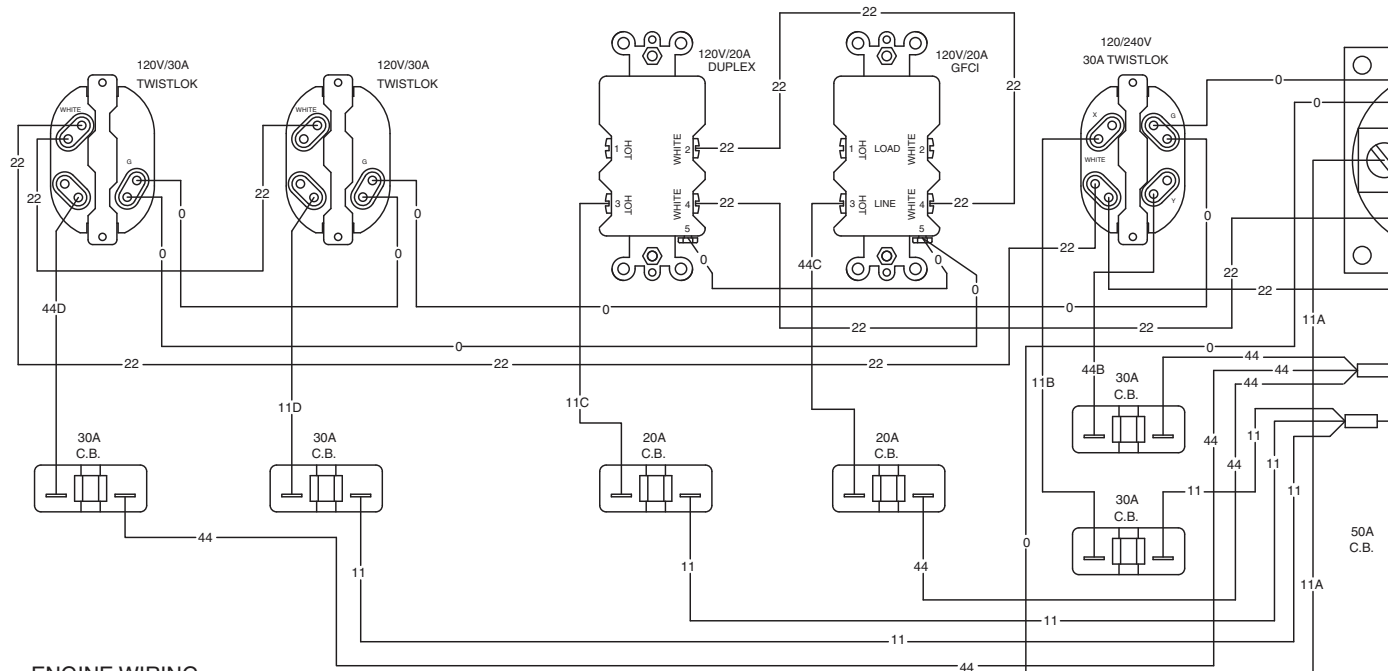

Electrical Schematic 12.5 & 15 kW (Units Without Hourmeter) – Drawing No. 0E0229-A

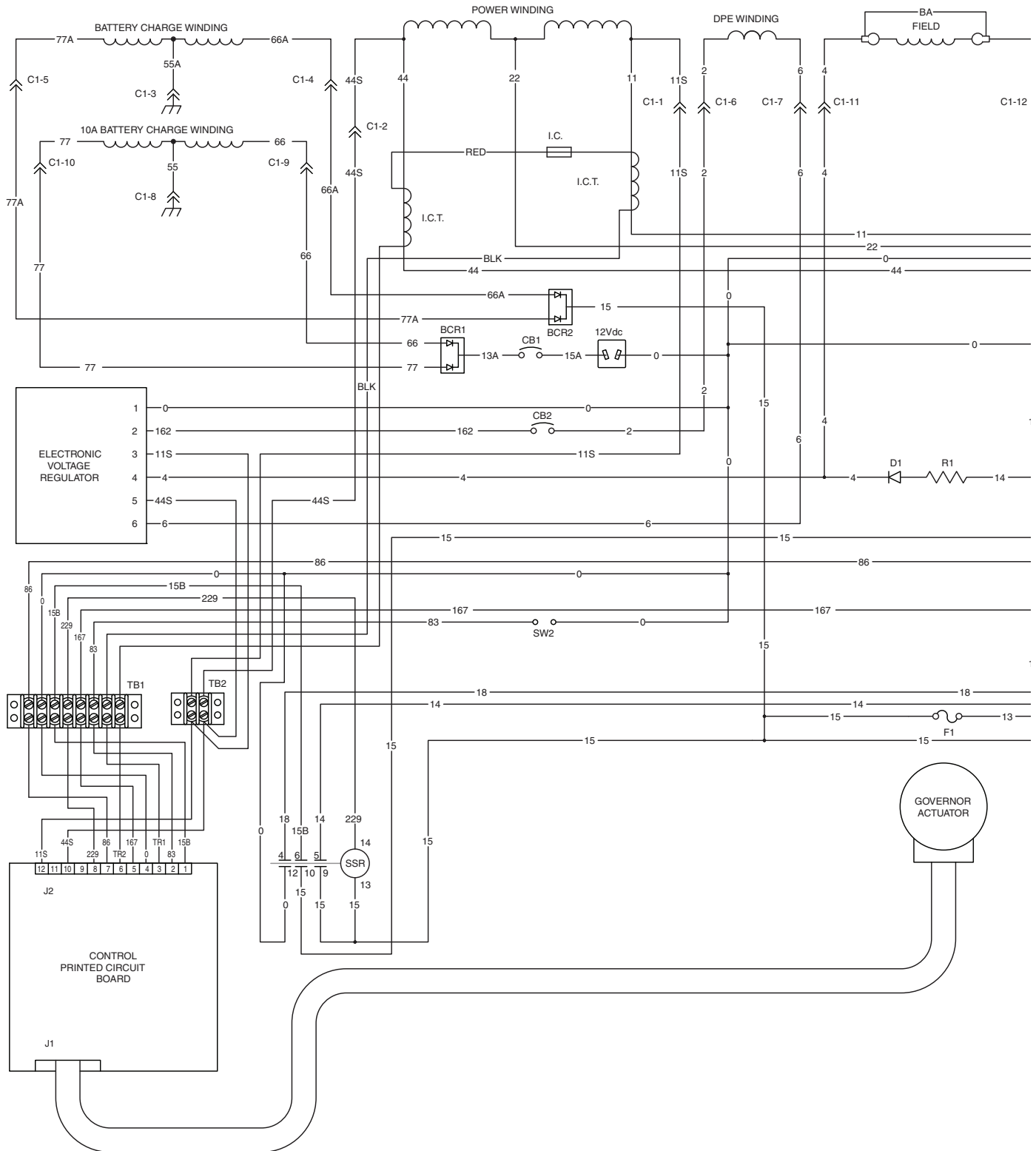

Electrical Schematic 12.5 & 15 kW (Units Without Hourmeter) – Drawing No. 0E0229-A

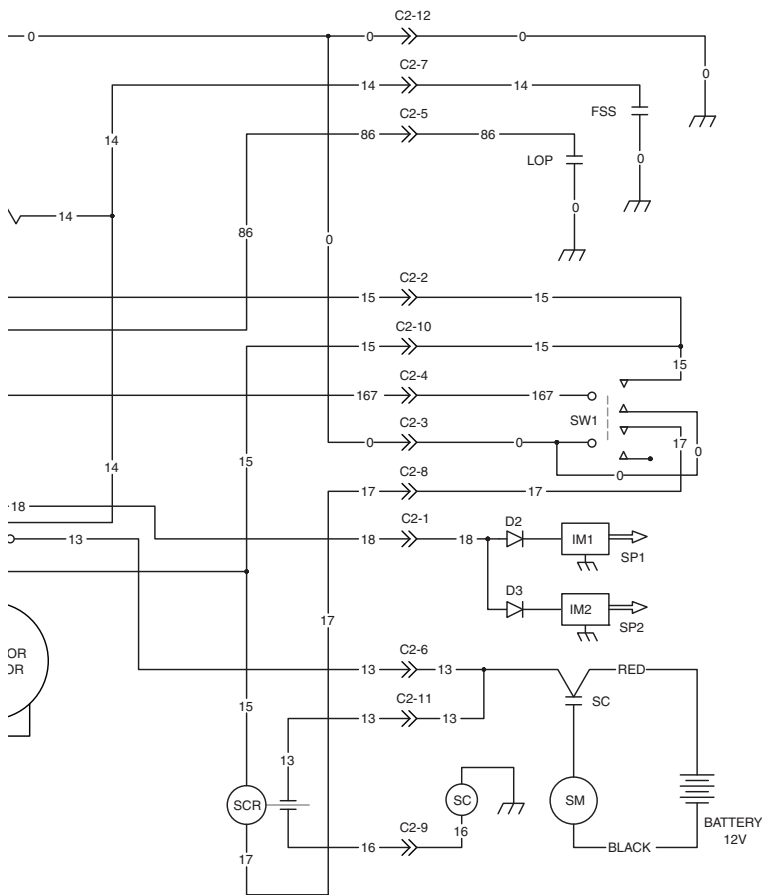
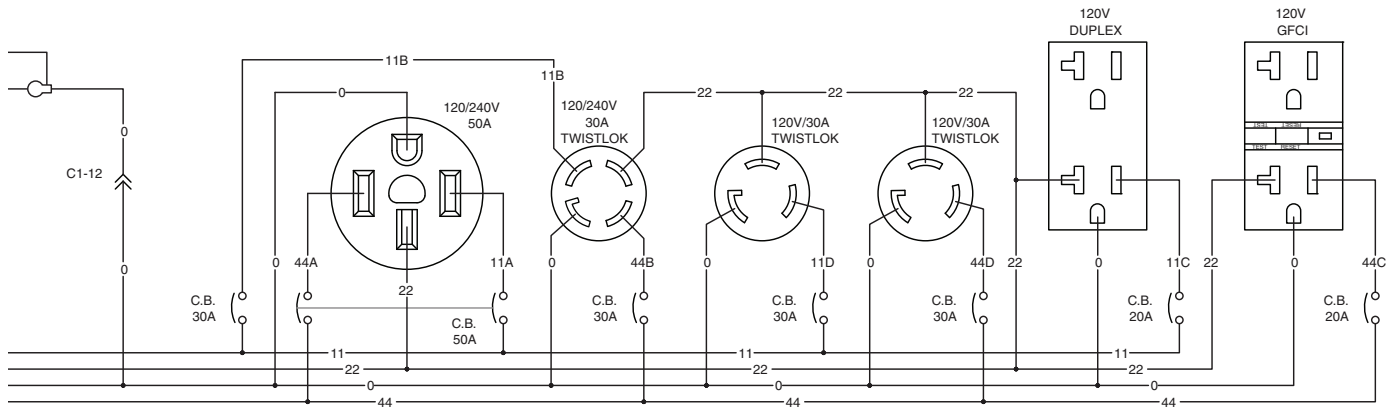

LEGEND

- BA - BRUSH ASSEMBLY
- BCR1 - BATTERY CHARGE RECTIFIER, 10A
- BCR2 - BATTERY CHARGE RECTIFIER
- CB1 - 10AMP AUTO RESET BREAKER
- CB2 - 5AMP AUTO RESET BREAKER
- D1 - 600V 12A DIODE
- D2, D3 - ENGINE SHUTDOWN DIODE
- F1 - 10A FUSE
- FSS - FUEL SHUT OFF SOLENOID
- GND - GROUND BAR
- I.C.T. - IDLE CONTROL TRANSFORMER
- IM1 - IGNITION MODULE, CYL. 1
- IM2 - IGNITION MODULE, CYL. 2
- LOP - LOW OIL PRESSURE
- R1 - 25 OHM, 25W RESISTOR
- SC - STARTER CONTACTOR
- SCR - STARTER CONTACTOR RELAY
- SM - STARTER MOTOR
- SP1 - SPARK PLUG, CYL. 1
- SP2 - SPARK PLUG, CYL. 2
- SSR - START / STOP RELAY
- SW1 - START-RUN-STOP RELAY
- SW2 - IDLE CONTROL SWITCH
- TB1, TB2 - TERMINAL BLOCK

Wiring Diagram 12.5 & 15 kW (Units With Hourmeter) – Drawing No. 0D4609-D

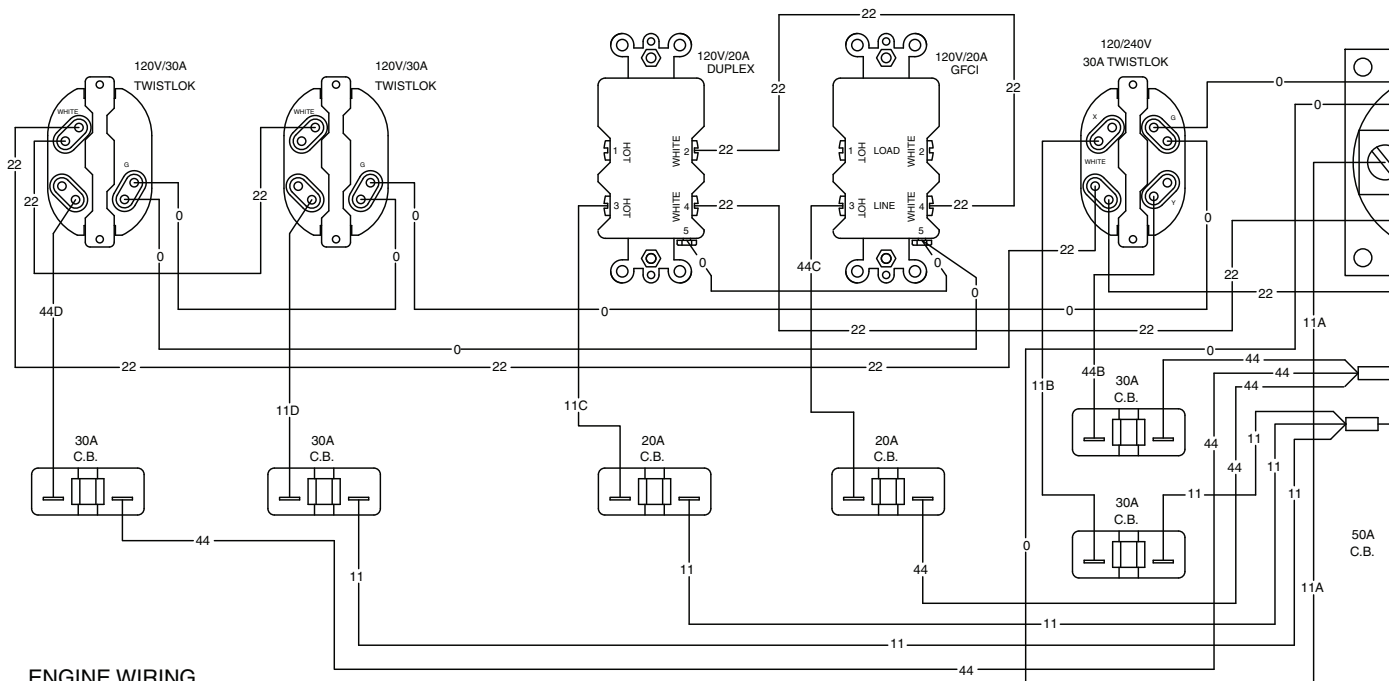

ENGINE WIRING

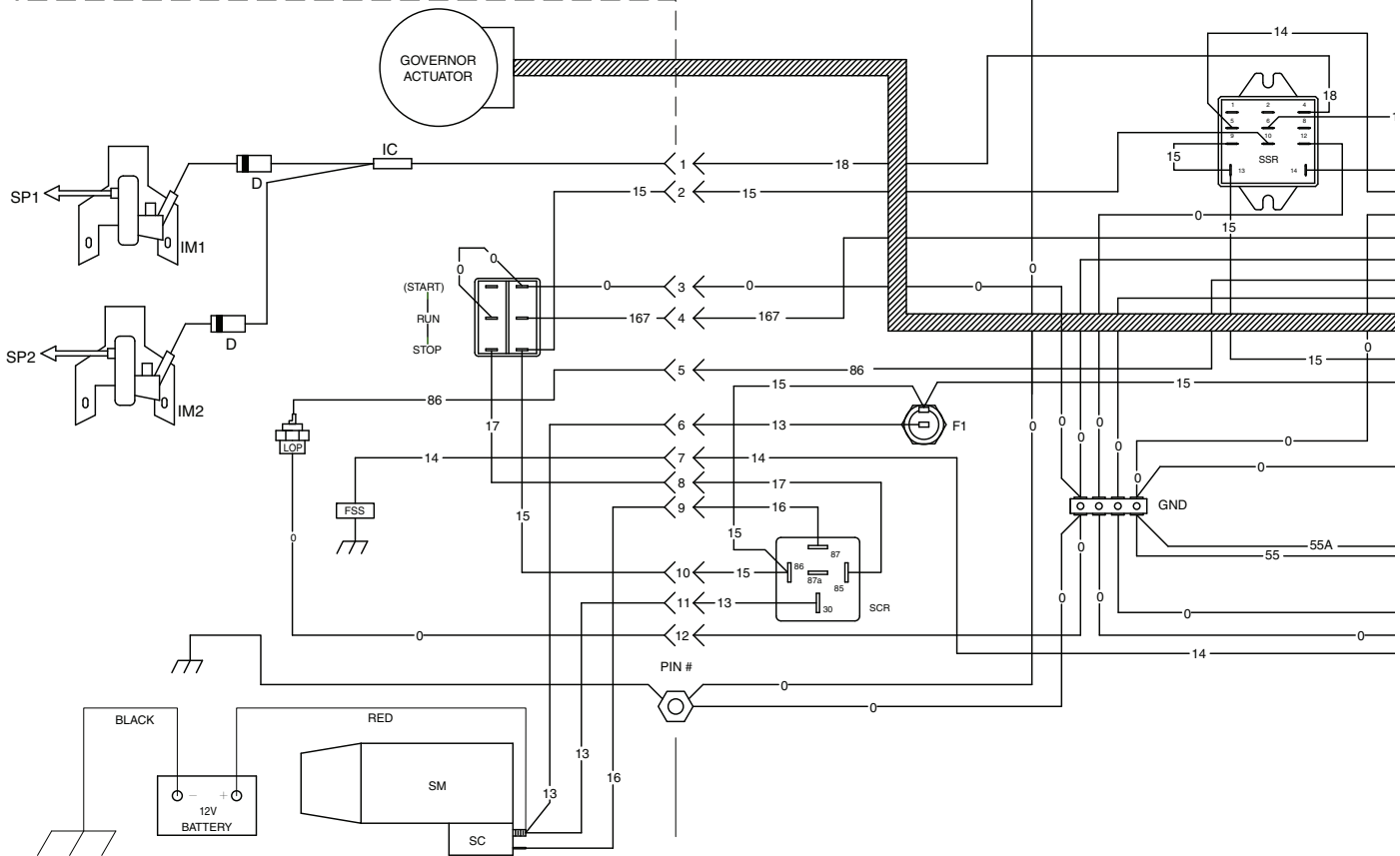

Wiring Diagram 12.5 & 15 kW (Units With Hourmeter) – Drawing No. 0D4609-D

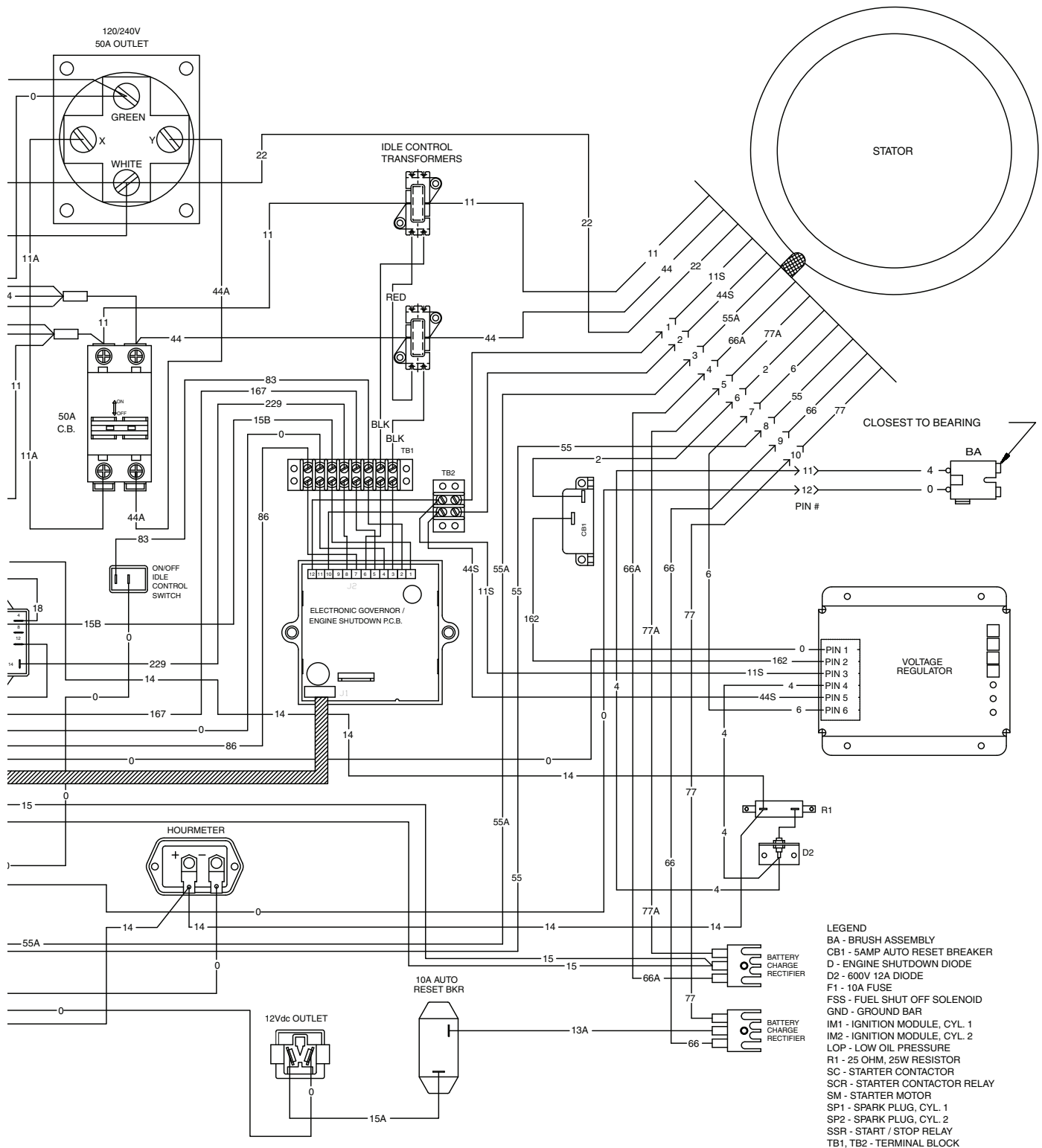

Electrical Schematic 12.5 & 15 kW (Units With Hourmeter) – Drawing No. 0D6297-A

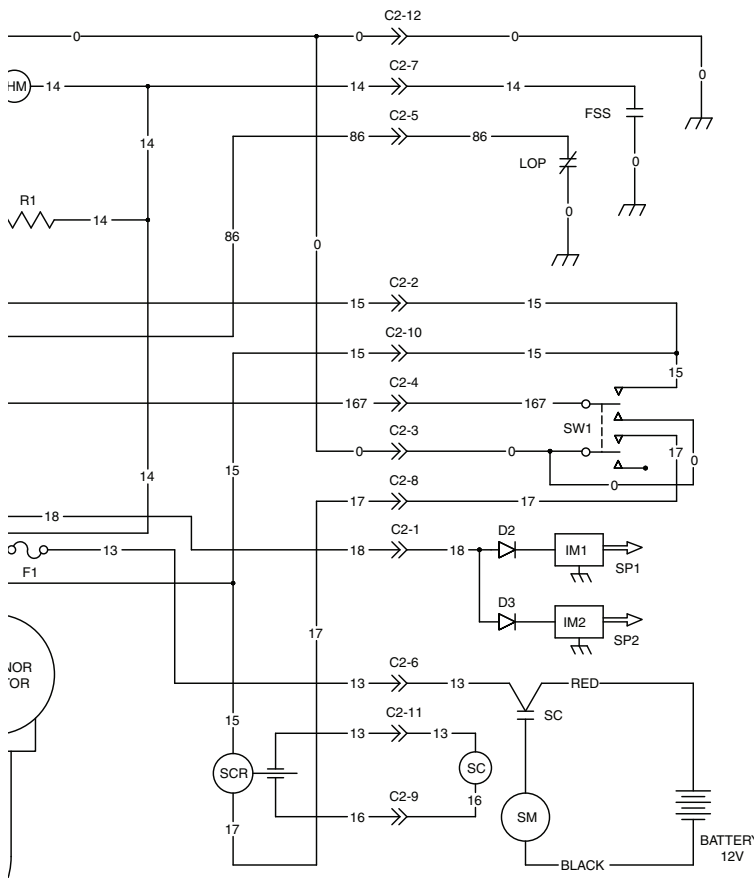
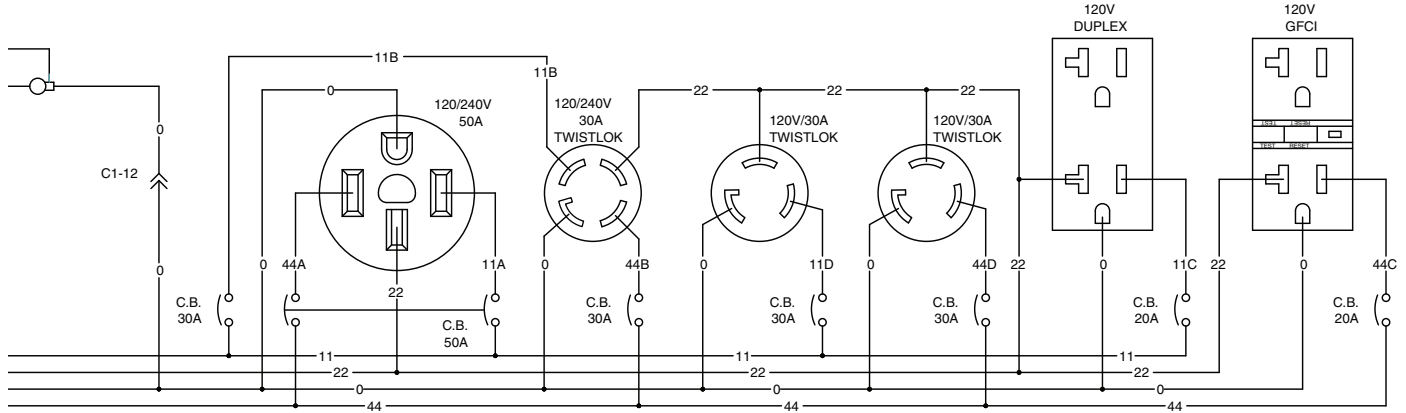

- LEGEND**
- BA - BRUSH ASSEMBLY
 - BCR1 - BATTERY CHARGE RECTIFIER, 10A
 - BCR2 - BATTERY CHARGE RECTIFIER
 - CB1 - 10AMP AUTO RESET BREAKER
 - CB2 - 5AMP AUTO RESET BREAKER
 - D1 - 600V 12A DIODE
 - D2, D3 - ENGINE SHUTDOWN DIODE
 - F1 - 10A FUSE
 - FSS - FUEL SHUT OFF SOLENOID
 - GND - GROUND BAR
 - HM - HOURMETER
 - I.C.T. - IDLE CONTROL TRANSFORMER
 - IM1 - IGNITION MODULE, CYL. 1
 - IM2 - IGNITION MODULE, CYL. 2
 - LOP - LOW OIL PRESSURE
 - R1 - 25 OHM, 25W RESISTOR
 - SC - STARTER CONTACTOR
 - SCR - STARTER CONTACTOR RELAY
 - SM - STARTER MOTOR
 - SP1 - SPARK PLUG, CYL. 1
 - SP2 - SPARK PLUG, CYL. 2
 - SSR - START / STOP RELAY
 - SW1 - START-RUN-STOP RELAY
 - SW2 - IDLE CONTROL SWITCH
 - TB1, TB2 - TERMINAL BLOCK

Wiring Diagram 17.5 kW – Drawing No. 0G0731

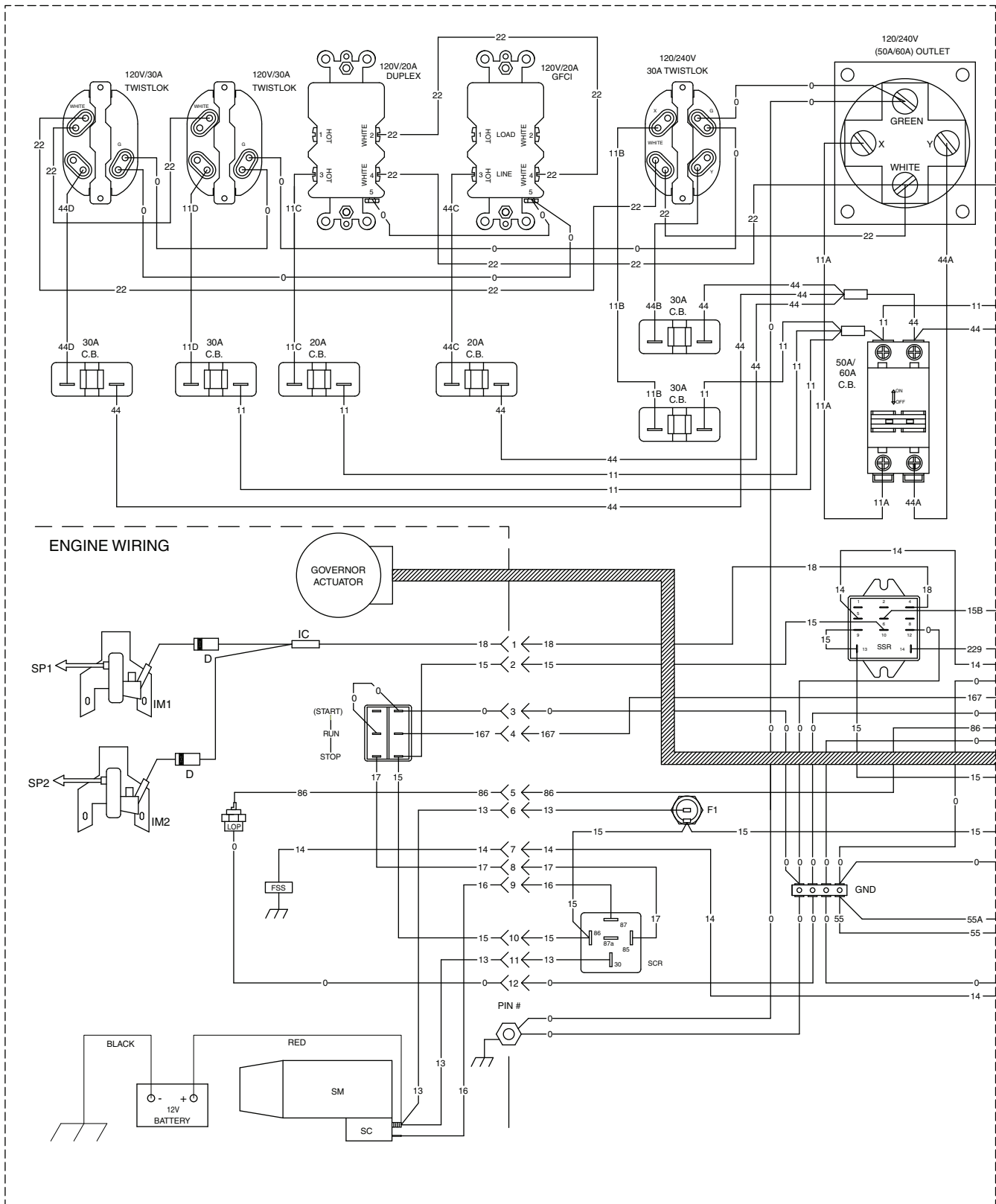

Wiring Diagram 17.5 kW – Drawing No. 0G0731

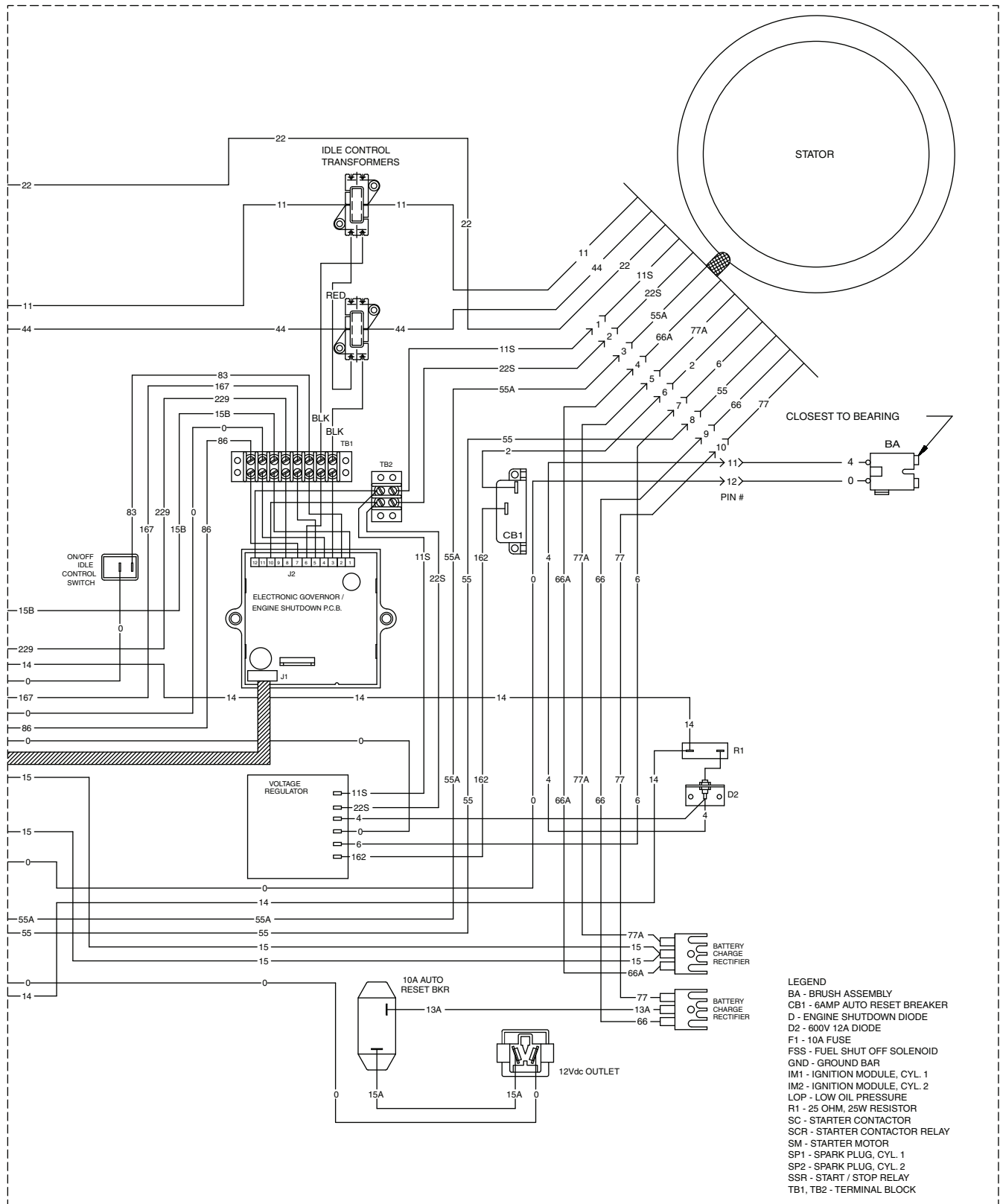

- LEGEND**
- BA - BRUSH ASSEMBLY
 - CB1 - 6AMP AUTO RESET BREAKER
 - D - ENGINE SHUTDOWN DIODE
 - D2 - 600V 12A DIODE
 - F1 - 10A FUSE
 - FSS - FUEL SHUT OFF SOLENOID
 - GND - GROUND BAR
 - IM1 - IGNITION MODULE, CYL. 1
 - IM2 - IGNITION MODULE, CYL. 2
 - LOP - LOW OIL PRESSURE
 - R1 - 25 OHM, 25W RESISTOR
 - SC - STARTER CONTACTOR RELAY
 - SCR - STARTER CONTACTOR RELAY
 - SM - STARTER MOTOR
 - SP1 - SPARK PLUG, CYL. 1
 - SP2 - SPARK PLUG, CYL. 2
 - SSR - START / STOP RELAY
 - TB1, TB2 - TERMINAL BLOCK

Electrical Schematic 17.5 kW – Drawing No. 0G0733

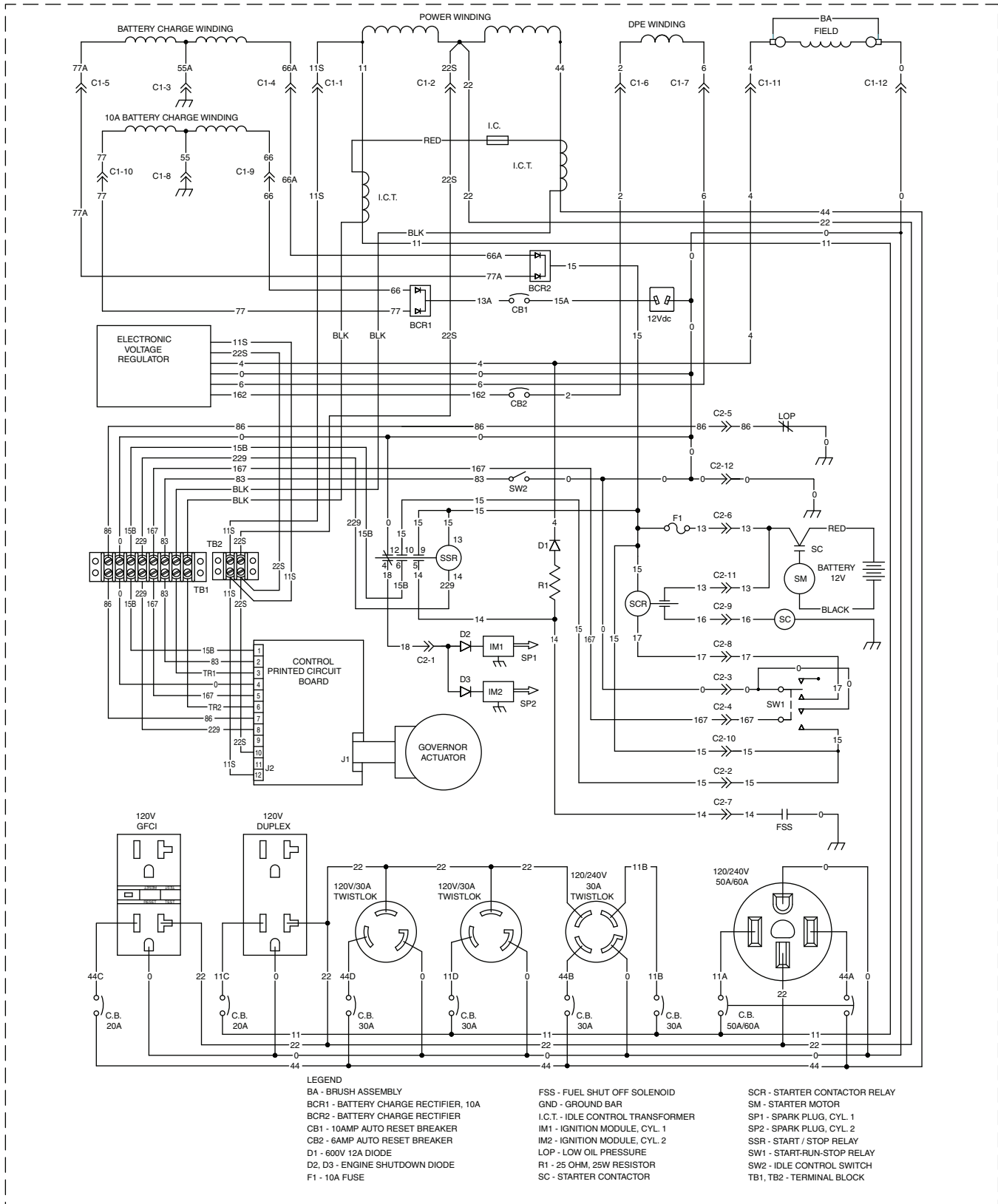

Electrical Schematic 17.5 kW – Drawing No. 0H0729

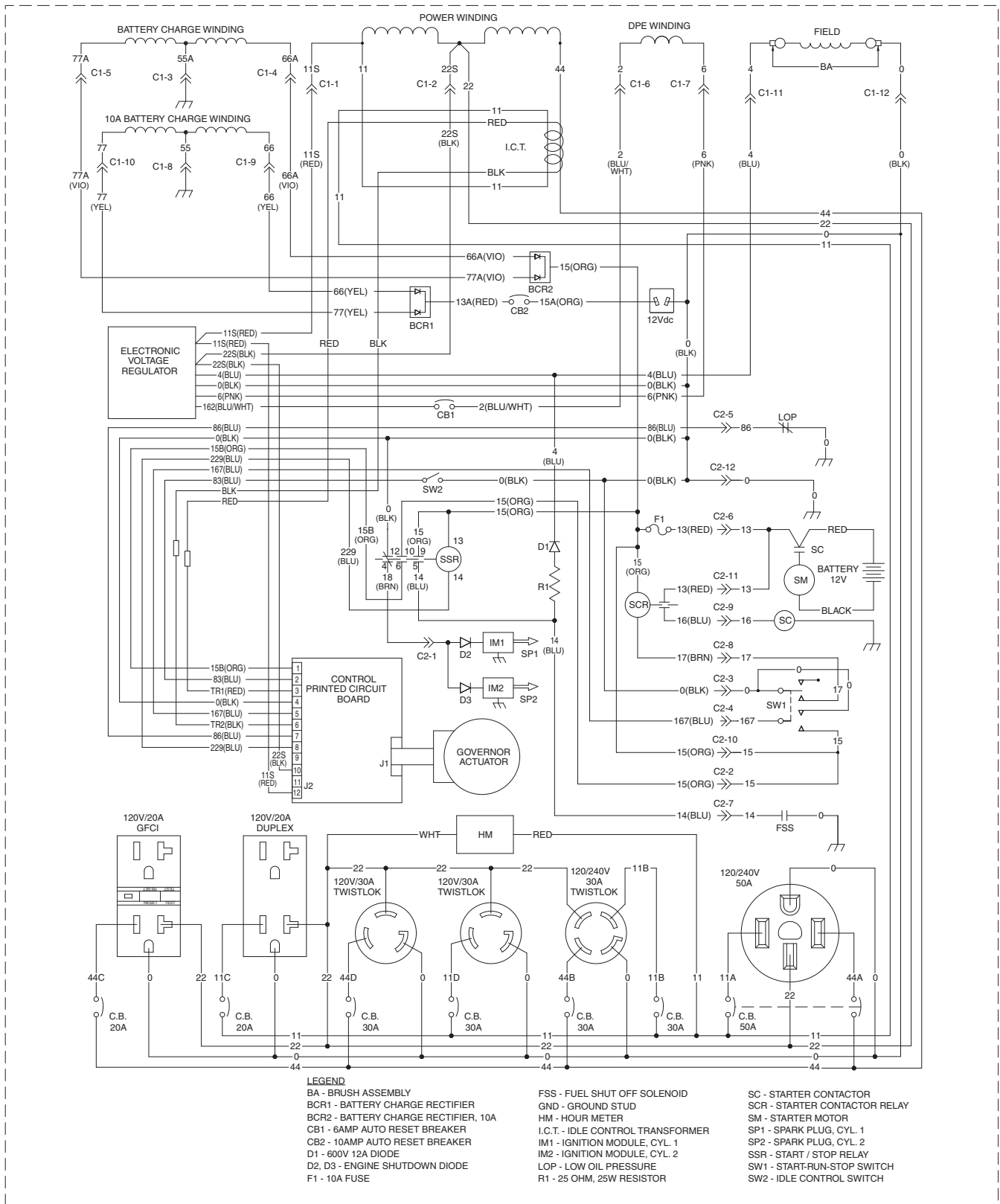

Wiring Diagram 17.5 kW – Drawing No. 0H0730

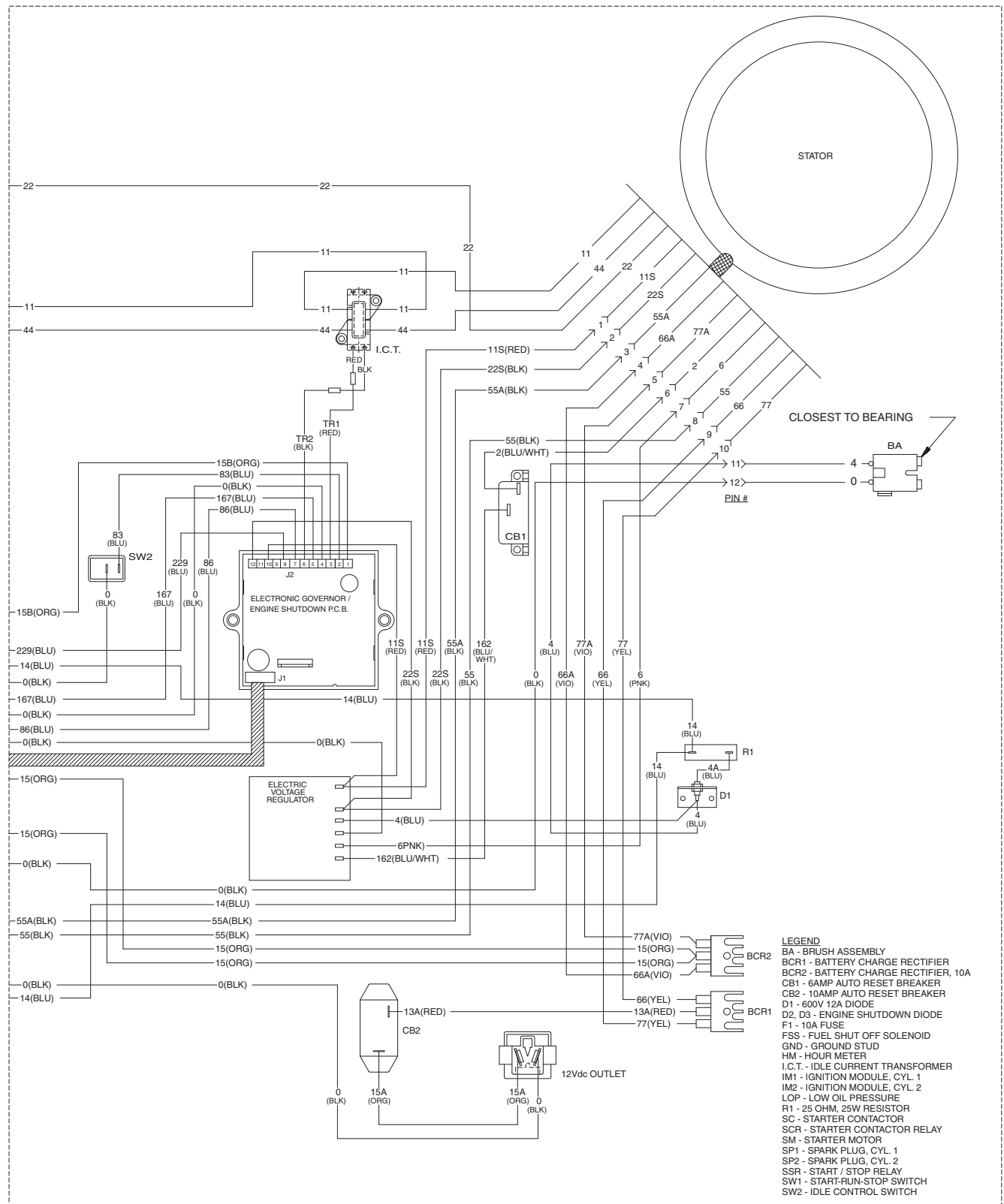

Wiring Diagram, 17.5 kW Manual Transfer Switch – Drawing No. 0G1065

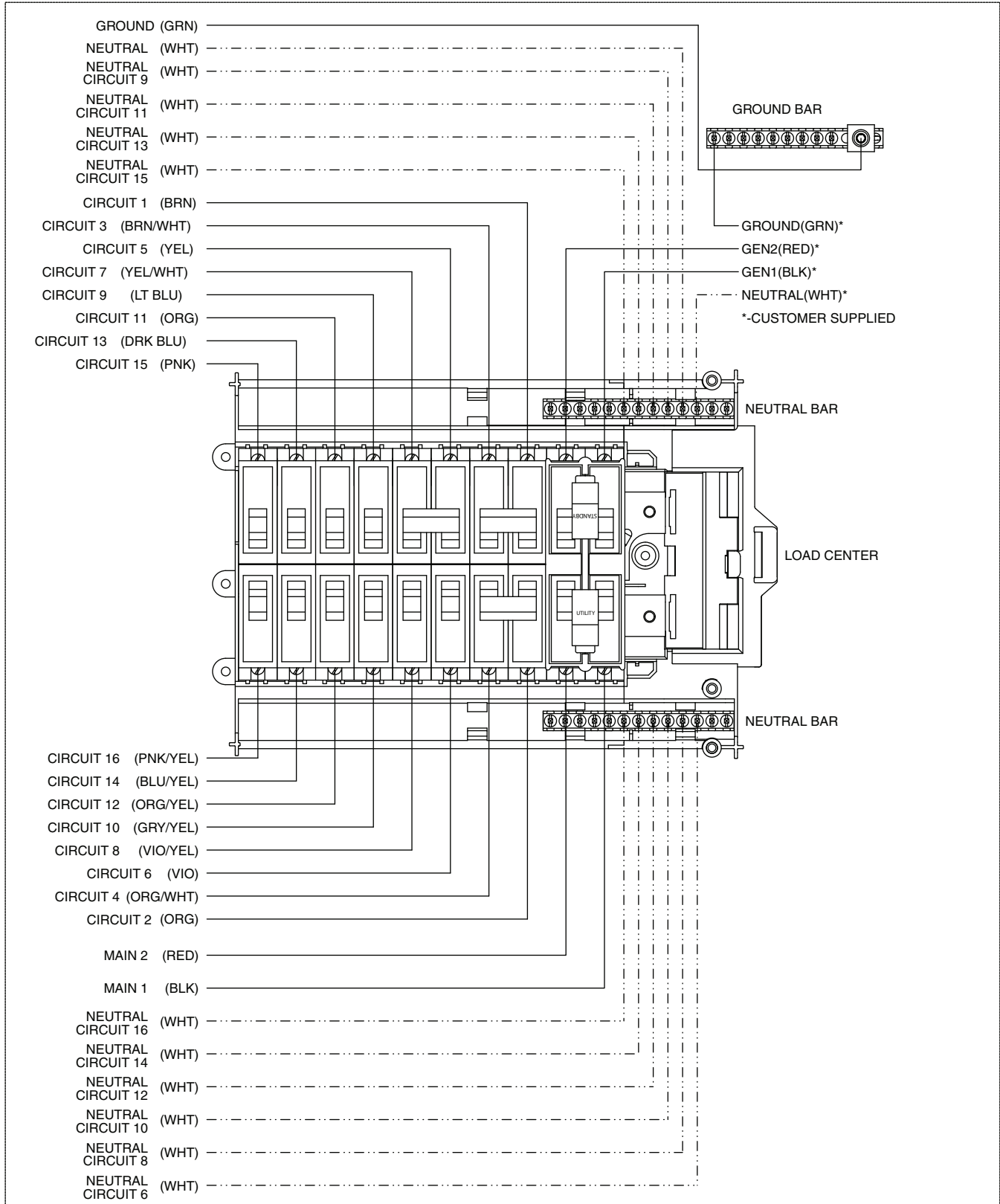

Interconnection Drawing – 17.5 kW generator connected to the external connection box, manual transfer switch and home’s main electrical distribution panel

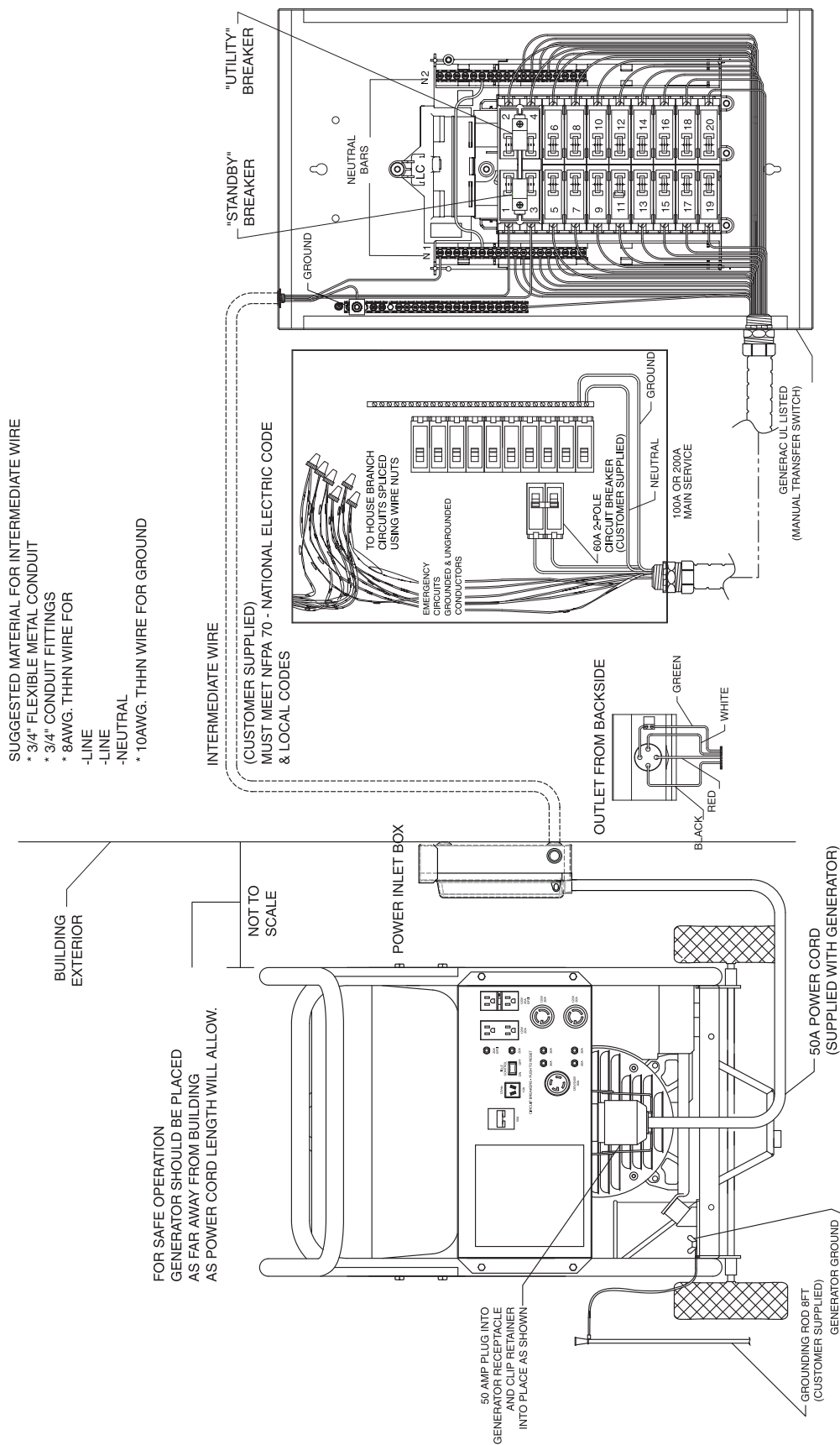

This page intentionally left blank.

Part No. 0F7713 Rev. C 05/09/2017
©2017 Generac Power Systems, Inc.
All rights reserved
Specifications are subject to change without notice.
No reproduction allowed in any form without prior written
consent from Generac Power Systems, Inc.

GENERAC®

Generac Power Systems, Inc.
S45 W29290 Hwy. 59
Waukesha, WI 53189
1-888-GENERAC (1-888-436-3722)
www.generac.com