

AUTOMATIC HOME STANDBY GENERATORS

DIAGNOSTIC REPAIR MANUAL

MODELS

**6 kW NG, 7 kW LP
9 kW NG, 10 kW LP
13 kW NG, 13 kW LP
15 kW NG, 16 kW LP
16 kW NG, 18 kW LP**



ELECTRICAL FORMULAS

TO FIND	KNOWN VALUES	1-PHASE	3-PHASE
KILOWATTS (kW)	Volts, Current, Power Factor	$\frac{E \times I}{1000}$	$\frac{E \times I \times 1.73 \times PF}{1000}$
KVA	Volts, Current	$\frac{E \times I}{1000}$	$\frac{E \times I \times 1.73}{1000}$
AMPERES	kW, Volts, Power Factor	$\frac{kW \times 1000}{E}$	$\frac{kW \times 1000}{E \times 1.73 \times PF}$
WATTS	Volts, Amps, Power Factor	Volts x Amps	$E \times I \times 1.73 \times PF$
NO. OF ROTOR POLES	Frequency, RPM	$\frac{2 \times 60 \times \text{Frequency}}{\text{RPM}}$	$\frac{2 \times 60 \times \text{Frequency}}{\text{RPM}}$
FREQUENCY	RPM, No. of Rotor Poles	$\frac{\text{RPM} \times \text{Poles}}{2 \times 60}$	$\frac{\text{RPM} \times \text{Poles}}{2 \times 60}$
RPM	Frequency, No. of Rotor Poles	$\frac{2 \times 60 \times \text{Frequency}}{\text{Rotor Poles}}$	$\frac{2 \times 60 \times \text{Frequency}}{\text{Rotor Poles}}$
kW (required for Motor)	Motor Horsepower, Efficiency	$\frac{HP \times 0.746}{\text{Efficiency}}$	$\frac{HP \times 0.746}{\text{Efficiency}}$
RESISTANCE	Volts, Amperes	$\frac{E}{I}$	$\frac{E}{I}$
VOLTS	Ohm, Amperes	$I \times R$	$I \times R$
AMPERES	Ohms, Volts	$\frac{E}{R}$	$\frac{E}{R}$

E = VOLTS

I = AMPERES

R = RESISTANCE (OHMS)

PF = POWER FACTOR

Contents

SPECIFICATIONS	4	Overspeed Shutdown	23
Generator	4	RPM Sensor Failure.....	23
Stator Winding Resistance Values/ Rotor Resistance.....	4	Overcrank Shutdown	24
Engine	5	1.6 Operating Instructions	25
Fuel Consumption	5	Control Panel	25
Mounting Dimensions.....	6-7	To Select Automatic Operation	26
Major Features	8	Manual Transfer To “Standby” And Manual Startup.....	26
PART 1 - GENERAL INFORMATION	9	Manual Shutdown And Retransfer Back To “Utility”	27
1.1 Generator Identification	10	1.7 Automatic Operating Parameters	28
1.2 Installation Basics.....	11	Introduction	28
Introduction	11	Automatic Operating Sequences	28
Selecting A Location	11	PART 2 - AC GENERATORS	29
Grounding The Generator	11	2.1 Description and Components	30
The Fuel Supply.....	11	Introduction	30
The Transfer Switch / Load Center.....	11	Engine-generator Drive System.....	30
Power Source And Load Lines.....	13	The AC Generator.....	30
System Control Interconnections.....	13	Rotor Assembly.....	30
1.3 Preparation Before Use	14	Stator Assembly.....	31
General	14	Brush Holder And Brushes	31
Fuel Requirements.....	14	Other AC Generator Components	31
Fuel Consumption.....	14	2.2 Operational Analysis	33
Reconfiguring The Fuel System.....	14	Rotor Residual Magnetism.....	33
Engine Oil Recommendations	16	Field Boost.....	33
1.4 Testing, Cleaning and Drying.....	16	Operation	34
Meters	17	2.3 Troubleshooting Flowcharts.....	35
The VOM.....	17	Problem 1 – Generator Produces Zero Voltage or Residual Voltage	35-36
Measuring AC Voltage	17	Problem 2 – Generator Produces Low Voltage at No-Load	37
Measuring DC Voltage	17	Problem 3 – Generator Produces High Voltage at No-Load	37
Measuring AC Frequency	17	Problem 4 – Voltage and Frequency Drop Excessively When Loads are Applied	38
Measuring Current.....	18	2.3 Diagnostic Tests	39
Measuring Resistance	18	Introduction	39
Electrical Units	19	Safety	39
Ohm’s Law	19	Test 1 – Check Main Circuit Breaker.....	39
Visual Inspection.....	20	Test 2 – Check AC Output Voltage.....	39
Insulation Resistance.....	20	Test 4 – Fixed Excitation Test/Rotor Amp Draw Test	40
The Megohmmeter.....	20	Test 5 – Wire Continuity	41
Stator Insulation Resistance Test.....	21	Test 6 – Check Field Boost	42
Rotor Insulation Resistance Test.....	22	Test 7 – Testing The Stator With a VOM.....	42
Cleaning The Generator.....	22	Test 8 – Resistance Check of Rotor Circuit	44
Drying The Generator	22	Test 9 – Check Brushes and Slip Rings.....	44
1.5 Engine-Generator Protective Devices	23	Test 10 – Test Rotor Assembly.....	45
General	23	Test 11 – Check AC Output Frequency.....	45
Low Battery.....	23		
Low Oil Pressure Shutdown.....	23		
High Temperature Switch.....	23		

Test 12 – Check And Adjust Engine Governor (Single Cylinder Units).....	46	Test 24 – Check Manual Transfer Switch Operation	68
Test 12A – Check Stepper Motor Control (V-twin Engine Units).....	46	Test 25 – Test Limit Switch XB1	69
Test 13 – Check And Adjust Voltage Regulator.....	48	Test 26 – Check 23 And 194 Wiring/Connections	69
Test 14 – Check Voltage And Frequency Under Load.....	48	Test 27 – Check Voltage At Terminal Lugs N1, N2.....	70
Test 15 – Check For Overload Condition	48	Test 28 – Check Voltage At Utility 1 And Utility 2 Terminals.....	70
Test 16 – Check Engine Condition.....	48	Test 29 – Check Voltage At Utility Closing Coil C1	71
PART 3 - “W/V-Type TRANSFER SWITCHES	49	Test 30 – Check Fuses F1 And F2.....	71
3.1 Description and Components	50	Test 31 – Test Limit Switch Xa1	72
General	50	Test 32 – Continuity Test Of Wiring (C1)	72
Enclosure.....	50	Test 33 – Continuity Test Of Wiring (C2)	72
Transfer Mechanism.....	51	Test 34 – Check N1 And N2 Wiring.....	73
Transfer Relay	51	Test 35 – Check Transformer (Tx).....	73
Neutral Lug	52	PART 4 - DC CONTROL	75
Manual Transfer Handle	52	4.1 Description and Components	76
Terminal Block	52	General	76
Fuse Holder	53	Terminal Strip / Interconnection Terminal.....	76
3.2 Operational Analysis	54	Transformer (TX).....	76
Utility Source Voltage Available	56	Circuit Board	76
Utility Source Voltage Failure	57	AUTO-OFF-MANUAL Switch	80
Transfer To Standby	58	15 Amp Fuse.....	80
Utility Restored.....	60	4.2 Operational Analysis	82
Utility Restored, Transfer Switch De-energized.....	61	Introduction	82
Utility Restored, Retransfer Back To Utility	62	Utility Source Voltage Available.....	82
Transfer Switch In Utility.....	63	Initial Dropout Of Utility Source Voltage	84
3.3 Troubleshooting Flow Charts.....	64	Utility Voltage Dropout And Engine Cranking.....	86
Introduction To Troubleshooting	64	Engine Startup And Running	88
Problem 5 – In Automatic Mode, No Transfer to Standby	64	Initial Transfer To The “Standby” Source.....	90
Problem 6 – In Automatic Mode, Generator Starts When Loss of Utility Occurs, Generator Shuts Down When Utility Returns But There Is No Retransfer To Utility Power.....	65	Utility Voltage Restored / Re-transfer To Utility	92
Problem 7 – Blown F1 or F2 Fuse	65	Engine Shutdown	94
3.4 Diagnostic Tests	66	4.3 Troubleshooting Flow Charts	96
General	66	Problem 8 – Engine Will Not Crank When Utility Power Source Fails	96
Test 21 – Check Voltage at Terminal Lugs E1, E2.....	66	Problem 9 – Engine Will Not Crank When AUTO-OFF-MANUAL Switch is Set to “MANUAL”	96
Test 22 – Check Voltage at Standby Closing Coil C2	67	Problem 10 – Engine Cranks but Won’t Start.....	97
Test 23 – Test Transfer Relay TR.....	67	Problem 11 – Engine Starts Hard and Runs Rough / Lacks Power	98
		Problem 12 – Engine Starts and Runs, Then Shuts Down.....	99
		Problem 13 – No Battery Charge.....	100

Problem 14 – Unit Starts and Transfer Occurs When Utility Power is Available	101	Test 67 – Check Battery Charge Relay (BCR)	123
Problem 15 – Generator Starts Immediately in Auto - No Transfer to Standby. Utility Voltage is Present	101	Test 68 – Check Battery Charge Winding Harness	123
Problem 16 – 15 Amp Fuse (F1) Blown	102	Test 69 – Check Battery Charger Wiring	124
Problem 17 – Generator Will Not Exercise	102	Test 70 – Check Wire 18 Continuity	124
Problem 18 – No Low Speed Exercise	102	Test 71 – Check N1 And N2 Voltage	125
4.4 Diagnostic Tests	103	Test 72 – Check Utility Sensing Voltage At The Circuit Board	125
Introduction	103	Test 73 – Test Set Exercise Switch	125
Test 41 – Check Position Of AUTO-OFF-MANUAL Switch	103	Test 75 – Check Battery Voltage Circuit	125
Test 42 – Try A Manual Start	103	Test 76 – Check Cranking And Running Circuits	126
Test 43 – Test AUTO-OFF-MANUAL Switch	103	Test 77 – Test Exercise Function	127
Test 44 – Check Wire 15/15A/15B/239/0 Voltage	104	Test 78 – Check Dip Switch Settings	127
Test 45 – Check 15 Amp Fuse	105	Test 79 – Check Idle Control Transformer (V-twin Units Only)	127
Test 46 – Check Battery	105	Test 80 – Check LC1 & LC2 Wiring	128
Test 47 – Check Wire 56 Voltage	106	Test 81 – Check Idle Control Transformer Primary Wiring	128
Test 48 – Test Starter Contactor Relay (V-twin Only)	106	PART 5 - OPERATIONAL TESTS	129
Test 49 – Test Starter Contactor	106	5.1 System Functional Tests	130
Test 50 – Test Starter Motor	107	Introduction	130
Test 51 – Check Fuel Supply And Pressure	109	Manual Transfer Switch Operation	130
Test 52 – Check Circuit Board Wire 14 Output	110	Electrical Checks	130
Test 53 – Check Fuel Solenoid	111	Generator Tests Under Load	131
Test 54 – Check Choke Solenoid (V-twins Units Only)	112	Checking Automatic Operation	132
Test 55 – Check For Ignition Spark	113	Setting The Exercise Timer	132
Test 56 – Check Spark Plugs	114	PART 6 - DISASSEMBLY	133
Test 57 – Check Engine / Cylinder Leak Down Test / Compression Test	114	6.1 Major Disassembly	134
Test 58 – Check Shutdown Wire	115	Front Engine Access	136
Test 59 – Check And Adjust Ignition Magnetos	116	Torque Requirements (Unless Otherwise Specified)	136
Test 60 – Check Oil Pressure Switch And Wire 86	119	PART 7 - ELECTRICAL DATA	137
Test 61 – Check High Oil Temperature Switch	119	Drawing 0F7820 Wiring Diagram, 6/7 kW HSB	138
Test 62 – Check And Adjust Valves	120	Drawing 0F7821 Wiring Schematic, 6/7 kW HSB	140
Test 63 – Check Fuel Regulator (6/7 kW Natural Gas Units Only)	121	Drawing 0F7822 Wiring Diagram, 9, 10, 13 & 16 kW HSB	142
Test 64 – Check Battery Charge Output	121	Drawing 0F7823 Schematic, 9, 10, 13 & 16 kW HSB	144
Test 65 – Check Transformer (TX) Voltage Output	122	Drawing 0F9070 Wiring Diagram, Transfer Switch 8 Circuit/16 Circuit	146
Test 66 – Check AC Voltage At Battery Charger	122	Drawing 0F9775 Wiring Diagram, Schematic 8 Circuit/16 Circuit	148

SPECIFICATIONS

GENERATOR					
Unit	6/6/7 kW	9/9/10 kW	13/13 kW	15/16 kW	18/18 kW
Rated Max. Continuous Power Capacity (Watts*)	6,000 NG/7,000 LP	9,000 NG/10,000 LP	13,000 NG/13,000 LP	15,000 NG/16,000 LP	16,000 NG/18,000 LP
Rated Voltage	120/240	120/240	120/240	120/240	120/240
Rated Max. Continuous Load Current (Amps)					
120 Volts**	50.0 NG/58.3 LP	75.0 NG/83.3 LP	108.3 NG/108.3 LP	125 NG/133.3 LP	133.3 NG/150 LP
240 Volts	25.0 NG/29.2 LP	37.5 NG/41.7 LP	54.1 NG/54.1 LP	62.5 NG/66.6 LP	66.6 NG/75 LP
Main Line Circuit Breaker	30 Amp	45 Amp	55 Amp	65 Amp	80 Amp
Circuits***					
50A, 240V	-	-	-	1	
40A, 240V	-	-	1	1	
30A, 240V	1	1	1	-	
20A, 240V	-	1	-	1	
20A, 120V	1	3	3	5	
15A, 120V	5	3	5	5	
Phase	1	1	1	1	1
Number of Rotor Poles	2	2	2	2	2
Rated AC Frequency	60 Hz	60 Hz	60 Hz	60 Hz	60 Hz
Power Factor	1	1	1	1	1
Battery Requirement	Group 26 12 Volts and 350 Cold-cranking Amperes Minimum	Group 26 12 Volts and 525 Cold-cranking Amperes Minimum	Group 26 12 Volts and 525 Cold-cranking Amperes Minimum	Group 26 12 Volts and 525 Cold-cranking Amperes Minimum	Group 26 12 Volts and 525 Cold-cranking Amperes Minimum
Battery Warming Blanket	0F6148DSRV				
Weight (Unit Only)	336 Pounds	375 Pounds	425.5 Pounds	445 & 414 Pounds	451 Pounds
Enclosure	Steel/Aluminum				
Normal Operating Range	-20°F (-28.8°C) to 104°F (40°C)				

* Maximum wattage and current are subject to and limited by such factors as fuel Btu content, ambient temperature, altitude, engine power and condition, etc. Maximum power decreases about 3.5 percent for each 1,000 feet above sea level; and also will decrease about 1 percent for each 6° C (10° F) above 16° C (60° F) ambient temperature.

** Load current values shown for 120 volts are maximum TOTAL values for two separate circuits. The maximum current in each circuit must not exceed the value stated for 240 volts.

*** Circuits to be moved from main panel to transfer switch load center must be protected by same size breaker. For example, a 15 amp circuit in main panel must be a 15 amp circuit in transfer switch.

Model Identification		
7 Digit Serial Numbers	XXXX-1 Figure 1	XXXX-0 Figure 2
10 Digit Serial Numbers	0007V25880 and above use Figure 1	0007V25879 and below use Figure 2

FIGURE 1 – STATOR WINDING RESISTANCE VALUES / ROTOR RESISTANCE

	10 kW	13 kW	16 kW	18 kW
Power Winding: Across 11 & 22	0.051-0.060 ohms	0.101-0.118 ohms	0.075-0.087 ohms	0.051-0.060 ohms
Power Winding: Across 33 & 44	0.051-0.060 ohms	0.101-0.118 ohms	0.075-0.087 ohms	0.051-0.060 ohms
Excitation Winding: Across 2 & 6	0.764-0.888 ohms	0.885-1.029 ohms	0.780-0.906 ohms	0.764-0.888 ohms
Battery Charge Winding: Across 66 & 77	0.104-0.121 ohms	0.110-0.128 ohms	0.010-0.116 ohms	0.104-0.121 ohms
Rotor Resistance	7.76-9.02 ohms	7.76-9.02 ohms	8.46-9.83 ohms	9.50-11.05 ohms

FIGURE 2 – STATOR WINDING RESISTANCE VALUES / ROTOR RESISTANCE

	7 kW	10 kW	13 kW	16 kW
Power Winding: Across 11 & 22	0.223-0.259 ohms	0.144 ohms	0.115 ohms	0.080 ohms
Power Winding: Across 33 & 44	0.223-0.259 ohms	.0144 ohms	.0115 ohms	0.080 ohms
Excitation Winding: Across 2 & 6	1.528-1.769 ohms	1.238 ohms	1.256 ohms	1.092 ohms
Battery Charge Winding: Across 66 & 77	0.146-0.169 ohms	0.158 ohms	0.164 ohms	0.130 ohms
Rotor Resistance	11.88-13.76 ohms	11.8 ohms	12.6 ohms	13.9 ohms

SPECIFICATIONS

ENGINE				
Model	6/6/7 kW	9/9/10 kW	13/13 kW	15/16/18 kW
Type of Engine	GH-410	GT-530	GT-990	GT-990
Number of Cylinders	1	2	2	2
Rated Horsepower	14.5 @ 3,600 rpm	18 @ 3,600 rpm	30 @ 3,600 rpm	30 @ 3,600 rpm
Displacement	410cc	530cc	992cc	992cc
Cylinder Block	Aluminum w/Cast Iron Sleeve	Aluminum w/Cast Iron Sleeve	Aluminum w/Cast Iron Sleeve	Aluminum w/Cast Iron Sleeve
Valve Arrangement	Overhead Valves	Overhead Valves	Overhead Valves	Overhead Valves
Ignition System	Solid-state w/Magneto	Solid-state w/Magneto	Solid-state w/Magneto	Solid-state w/Magneto
Recommended Spark Plug	RC14YC	BPR6HS	RC12YC	RC12YC
Spark Plug Gap	0.76 mm (0.030 inch)	0.76 mm (0.030 inch)	1.02 mm (0.040 inch)	1.02 mm (0.040 inch)
Compression Ratio	8.6:1	9.5:1	9.5:1	9.5:1
Starter	12 VDC	12 VDC	12 VDC	12 VDC
Oil Capacity Including Filter	Approx. 1.5 Qts	Approx. 1.7 Qts	Approx. 1.7 Qts	Approx. 1.7 Qts
Recommended Oil Filter	Part # 070185B	Part # 070185B	Part # 070185B	Part # 070185B
Recommended Air Filter	Part # 0C8127	Part # 0E9581	Part # 0C8127	Part # 0C8127
Operating RPM	3,600	3,600	3,600	3,600

FUEL CONSUMPTION				
Model #	Natural Gas*		LP Vapor**	
	1/2 Load	Full Load	1/2 Load	Full Load
6/7 kW	66	119	0.82/30	1.47/54
9/10 kW	102	156	1.25/46	1.93/70
13/13 kW	156	220	1.55/57	2.18/80
15/16 kW	173	245	1.59/59	2.51/92
18/18 kW	184	262	1.83/66.4	2.85/103.5

* Natural gas is in cubic feet per hour.

**LP is in gallons per hour/cubic feet per hour.

Values given are approximate.

SPECIFICATIONS

MOUNTING DIMENSIONS

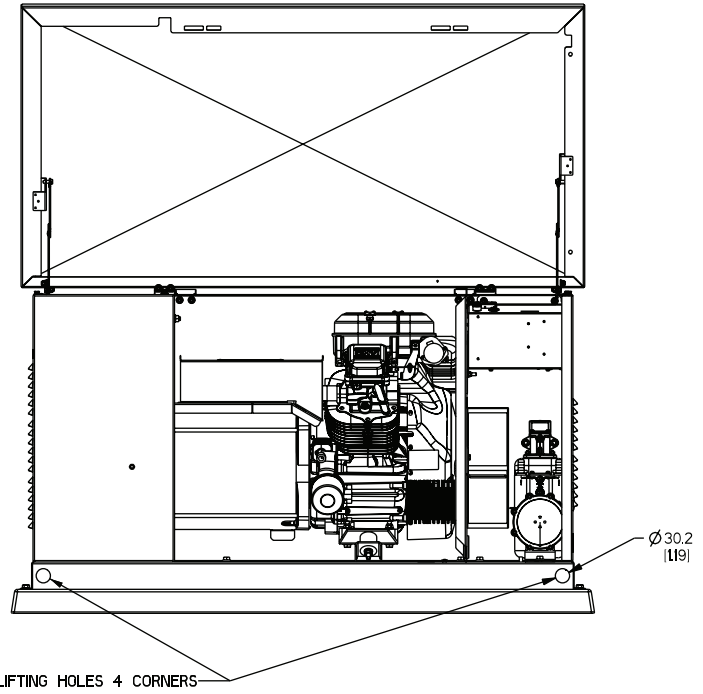
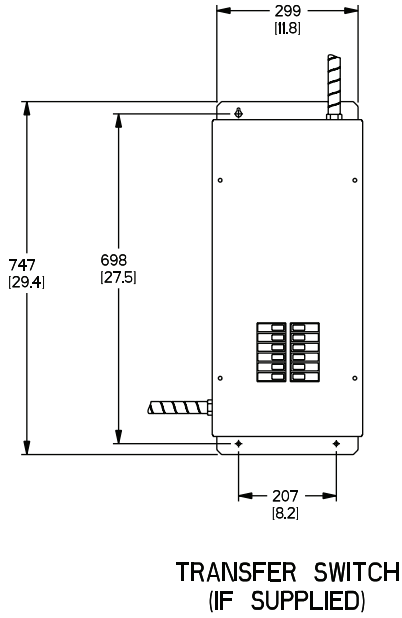

“DO NOT LIFT BY ROOF”

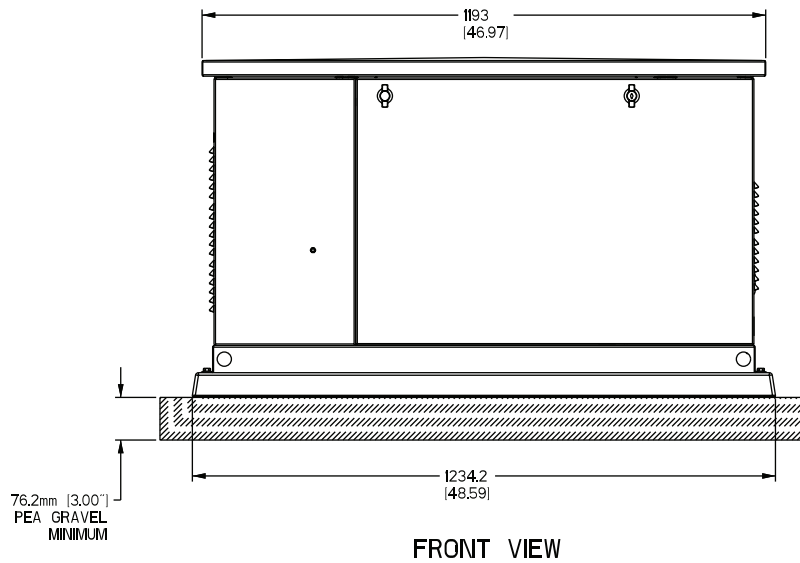
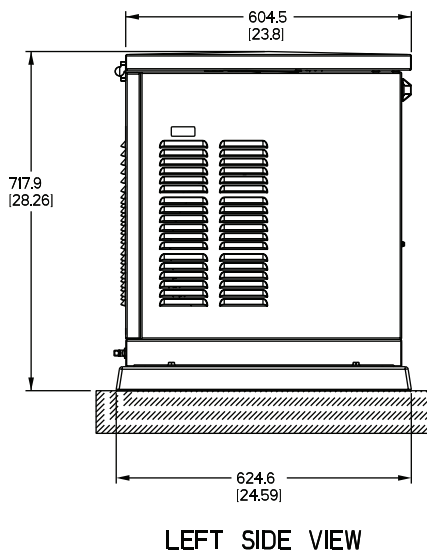

MOUNTING DIMENSIONS

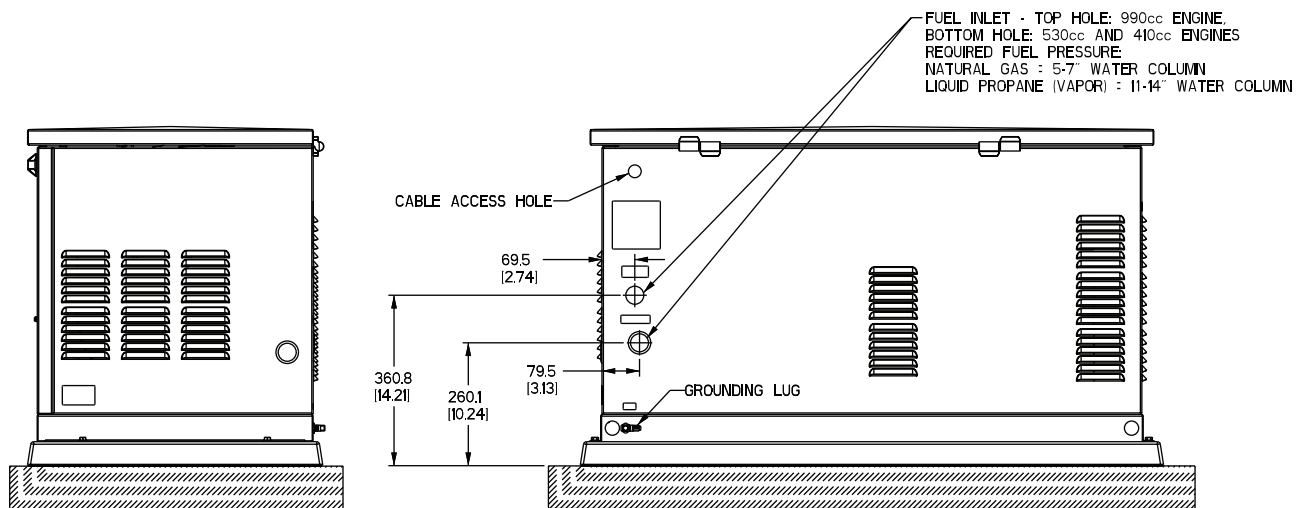
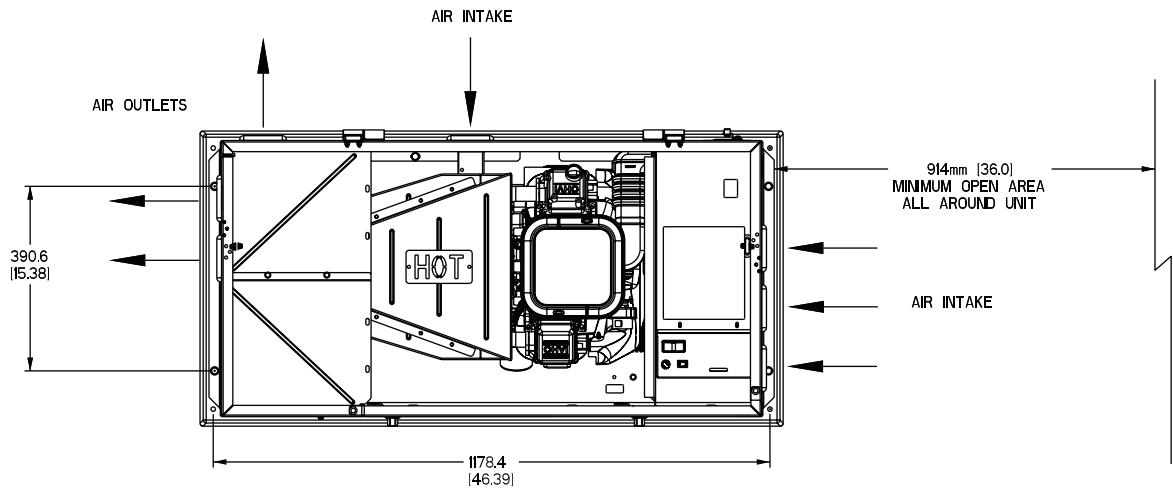

RIGHT SIDE VIEW

REAR VIEW

ALL DIMENSIONS IN:
MILLIMETERS (INCHES)

SPECIFICATIONS

MAJOR FEATURES

6/7 kW, Single Cylinder GH-410 Engine

9/10 kW, V-twin GT-530 Engine

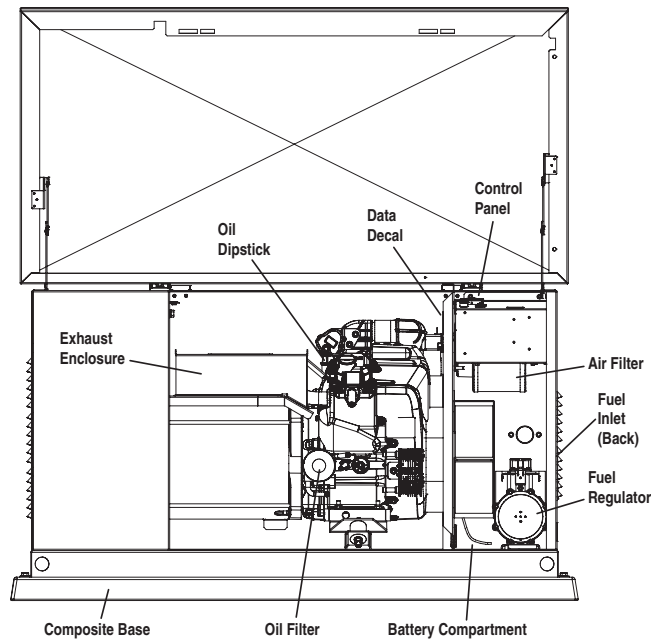
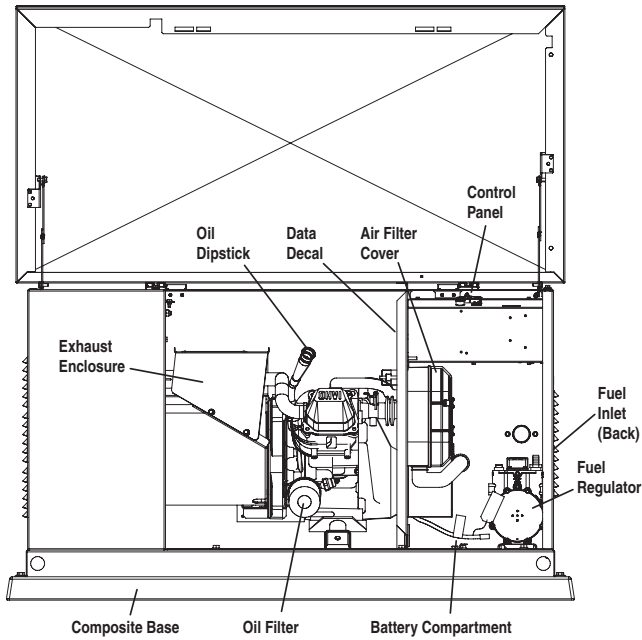

13 kW, 15/16 kW and 18 kW, V-twin GT-990 Engine

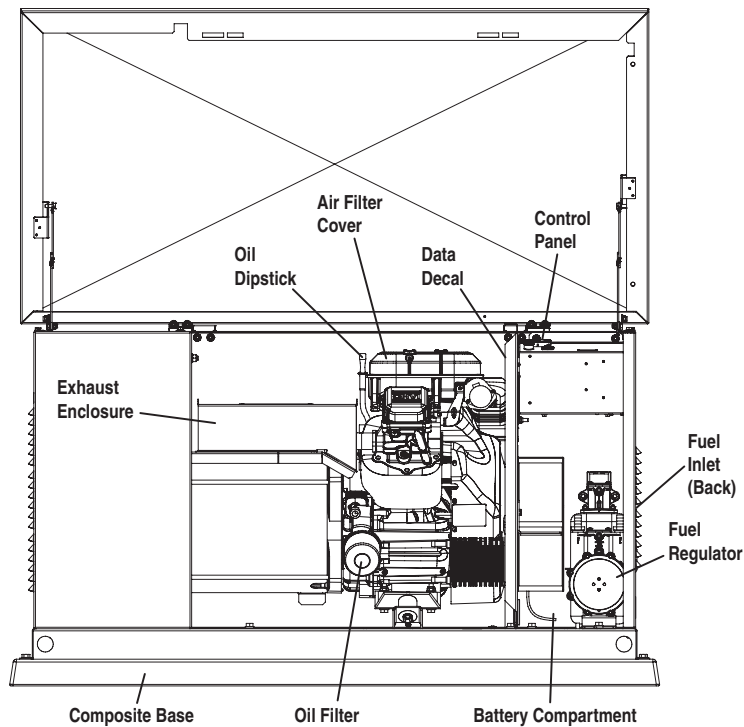

PART 1 GENERAL INFORMATION

TABLE OF CONTENTS		
PART	TITLE	PAGE
1.1	Generator Identification	10
1.2	Installation Basics	11
1.3	Preparation Before Use	14
1.4	Testing, Cleaning and Drying	16
1.5	Engine-Generator Protective Devices	23
1.6	Operating Instructions	25
1.7	Automatic Operating Parameters	28

Air-cooled, Automatic Standby Generators

1.1 Generator Identification	10	Visual Inspection.....	20
1.2 Installation Basics.....	11	Insulation Resistance.....	20
Introduction	11	The Megohmmeter.....	20
Selecting A Location	11	Stator Insulation Resistance Test.....	21
Grounding The Generator	11	Rotor Insulation Resistance Test.....	22
The Fuel Supply.....	11	Cleaning The Generator.....	22
The Transfer Switch / Load Center.....	11	Drying The Generator	22
Power Source And Load Lines.....	13	1.5 Engine-Generator Protective Devices	23
System Control Interconnections	13	General	23
1.3 Preparation Before Use	14	Low Battery.....	23
General	14	Low Oil Pressure Shutdown.....	23
Fuel Requirements.....	14	High Temperature Switch	23
Fuel Consumption.....	14	Overspeed Shutdown	23
Reconfiguring The Fuel System.....	14	RPM Sensor Failure.....	23
Engine Oil Recommendations	16	Overcrank Shutdown	24
1.4 Testing, Cleaning and Drying.....	16	1.6 Operating Instructions	25
Meters	17	Control Panel	25
The VOM.....	17	To Select Automatic Operation	26
Measuring AC Voltage	17	Manual Transfer To “Standby” And Manual Startup	26
Measuring DC Voltage	17	Manual Shutdown And Retransfer Back To “Utility”	27
Measuring AC Frequency	17	1.7 Automatic Operating Parameters	28
Measuring Current.....	18	Introduction	28
Measuring Resistance	18	Automatic Operating Sequences	28
Electrical Units	19		
Ohm’s Law	19		

INTRODUCTION

This Diagnostic Repair Manual has been prepared especially for the purpose of familiarizing service personnel with the testing, troubleshooting and repair of air-cooled, automatic standby generators. Every effort has been expended to ensure that information and instructions in the manual are both accurate and current. However, changes, alterations or other improvements may be made to the product at any time without prior notification.

The manual has been divided into PARTS. Each PART has been divided into SECTIONS. Each SECTION consists of two or more SUBSECTIONS.

It is not our intent to provide detailed disassembly and reassemble instructions in this manual. It is our intent to (a) provide the service technician with an understanding of how the various assemblies and systems work, (b) assist the technician in finding the cause of malfunctions, and (c) effect the expeditious repair of the equipment.

ITEM NUMBER:

Many home standby generators are manufactured to the unique specifications of the buyer. The Model Number identifies the specific generator set and its unique design specifications.

SERIAL NUMBER:

Used for warranty tracking purposes.

Item #	0055555
Serial	1234567
Volts	120/240 AC
Amps	108.3/108.3
Watts	13000
1 PH, 60 HZ, RPM 3600 RAINPROOF ENCLOSURE FITTED CLASS F INSULATION MAX OPERATING AMBIENT TEMP - 120F/49C	
FOR STANDBY SERVICE	
NEUTRAL FLOATING	
MAX LOAD UNBALANCED - 50%	

MODEL #	0055555	WATTS	13000
SERIAL #	1234567	VOLTS	120/240 AC
		AMPS	108.3/108.3
1PH, 60Hz, 3600 RPM, CLASS F INSULATION RAINPROOF ENCLOSURE FITTED RATED AMBIENT TEMP - 40°C			
FOR STANDBY SERVICE, NEUTRAL FLOATING			
Model Number -		Serial Number -	

Figure 1. Typical Data Plates

INTRODUCTION

Information in this section is provided so that the service technician will have a basic knowledge of installation requirements for home standby systems. Problems that arise are often related to poor or unauthorized installation practices.

A typical home standby electric system is shown in Figure 1 (next page). Installation of such a system includes the following:

- Selecting a Location
- Grounding the generator.
- Providing a fuel supply.
- Mounting the load center.
- Connecting power source and load lines.
- Connecting system control wiring.
- Post installation tests and adjustments.

SELECTING A LOCATION

Install the generator set as close as possible to the electrical load distribution panel(s) that will be powered by the unit, ensuring that there is proper ventilation for cooling air and exhaust gases. This will reduce wiring and conduit lengths. Wiring and conduit not only add to the cost of the installation, but excessively long wiring runs can result in a voltage drop.

Control system interconnections between the transfer switch and generator consist of N1 and N2, and leads 23 and 194. Control system interconnection leads must be run in a conduit that is separate from the AC power leads. Recommended wire gauge size depends on the length of the wire:

Max. Cable Length	Recommended Wire Size
460 feet (140m)	No. 18 AWG.
461 to 730 feet (223m)	No. 16 AWG.
731 to 1,160 feet (354m)	No. 14 AWG.
1,161 to 1850 feet (565m)	No. 12 AWG.

GROUNDING THE GENERATOR

The National Electric Code requires that the frame and external electrically conductive parts of the generator be properly connected to an approved earth ground. Local electrical codes may also require proper grounding of the unit. For that purpose, a grounding lug is attached to the unit. Grounding may be accomplished by attaching a stranded copper wire of the proper size to the generator grounding lug and to an earth-driven copper or brass grounding-rod (electrode). Consult with a local electrician for grounding requirements in your area.

THE FUEL SUPPLY

Units with air-cooled engines were operated, tested and adjusted at the factory using natural gas as a fuel. These air-cooled engine units can be converted to use LP (propane) gas by making a few adjustments for best operation and power.

LP (propane) gas is usually supplied as a liquid in pressure tanks. Both the air-cooled and the liquid cooled units require a "vapor withdrawal" type of fuel supply system when LP (propane) gas is used. The vapor withdrawal system utilizes the gaseous fuel vapors that form at the top of the supply tank.

The pressure at which LP gas is delivered to the generator fuel solenoid valve may vary considerably, depending on ambient temperatures. In cold weather, supply pressures may drop to "zero". In warm weather, extremely high gas pressures may be encountered. A primary regulator is required to maintain correct gas supply pressures.

Current recommended gaseous fuel pressure at the inlet side of the generator fuel solenoid valve is as follows:

	LP	NG
Minimum water column	11 inches	5 inches
Maximum water column	14 inches	7 inches

A primary regulator is required to ensure that proper fuel supply pressures are maintained.



DANGER: LP AND NATURAL GAS ARE BOTH HIGHLY EXPLOSIVE. GASEOUS FUEL LINES MUST BE PROPERLY PURGED AND TESTED FOR LEAKS BEFORE THIS EQUIPMENT IS PLACED INTO SERVICE AND PERIODICALLY THEREAFTER. PROCEDURES USED IN GASEOUS FUEL LEAKAGE TESTS MUST COMPLY STRICTLY WITH APPLICABLE FUEL GAS CODES. DO NOT USE FLAME OR ANY SOURCE OF HEAT TO TEST FOR GAS LEAKS. NO GAS LEAKAGE IS PERMITTED. LP GAS IS HEAVIER THAN AIR AND TENDS TO SETTLE IN LOW AREAS. NATURAL GAS IS LIGHTER THAN AIR AND TENDS TO SETTLE IN HIGH PLACES. EVEN THE SLIGHTEST SPARK CAN IGNITE THESE FUELS AND CAUSE AN EXPLOSION.

Use of a flexible length of hose between the generator fuel line connection and rigid fuel lines is required. This will help prevent line breakage that might be caused by vibration or if the generator shifts or settles. The flexible fuel line must be approved for use with gaseous fuels.

Flexible fuel line should be kept as straight as possible between connections. The bend radius for flexible fuel line is nine (9) inches. Exceeding the bend radius can cause the fittings to crack.

THE TRANSFER SWITCH / LOAD CENTER

A transfer switch is required by electrical code, to prevent electrical feedback between the utility and standby power sources, and to transfer electrical loads from one power supply to another safely.

TRANSFER SWITCHES:

Instructions and information on transfer switches may be found in Part 3 of this manual.

SECTION 1.2 INSTALLATION BASICS

PART 1

GENERAL INFORMATION

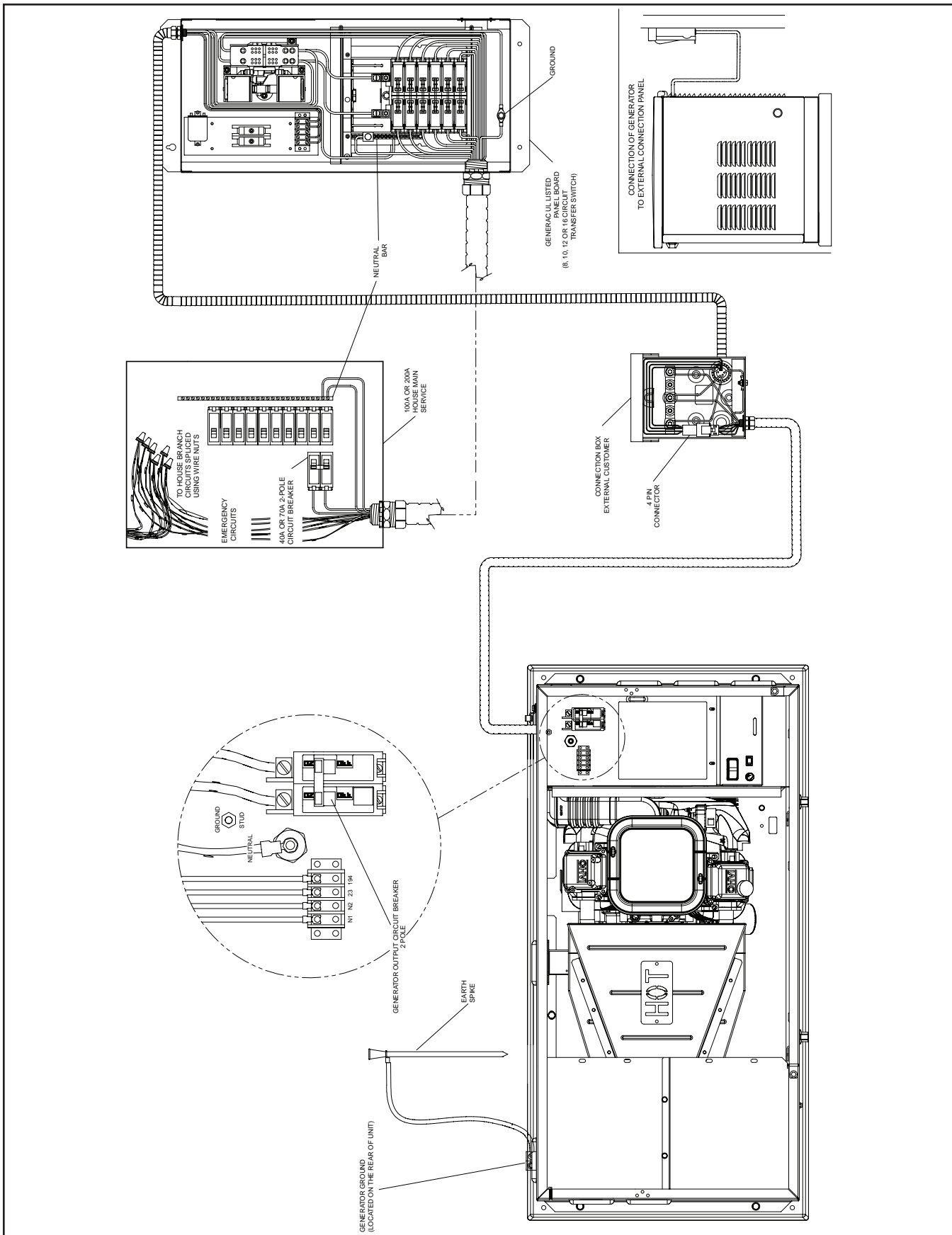

Figure 1. Typical Installation

POWER SOURCE AND LOAD LINES

The utility power supply lines, the standby (generator) supply lines, and electrical load lines must all be connected to the proper terminal lugs in the transfer switch. The following rules apply: In 1-phase systems with a 2-pole transfer switch, connect the two utility source hot lines to Transfer Switch Terminal Lugs N1 and N2. Connect the standby source hot lines (E1, E2) to Transfer Switch Terminal Lugs E1 and E2. Connect the load lines from Transfer Switch Terminal Lugs T1 and T2 to the electrical load circuit. Connect UTILITY, STANDBY and LOAD neutral lines to the neutral block in the transfer switch.

SYSTEM CONTROL INTERCONNECTIONS

Home standby generators are equipped with a terminal board identified with the following terminals: (a) UTILITY 1, (b) UTILITY 2, (c) 23, and (d) 194. Load centers house an identically marked terminal board. When these four terminals are properly interconnected, dropout of utility source voltage below a preset value will result in automatic generator startup and transfer of electrical loads to the "Standby" source. On restoration of utility source voltage above a preset value will result in retransfer back to that source and generator shutdown.

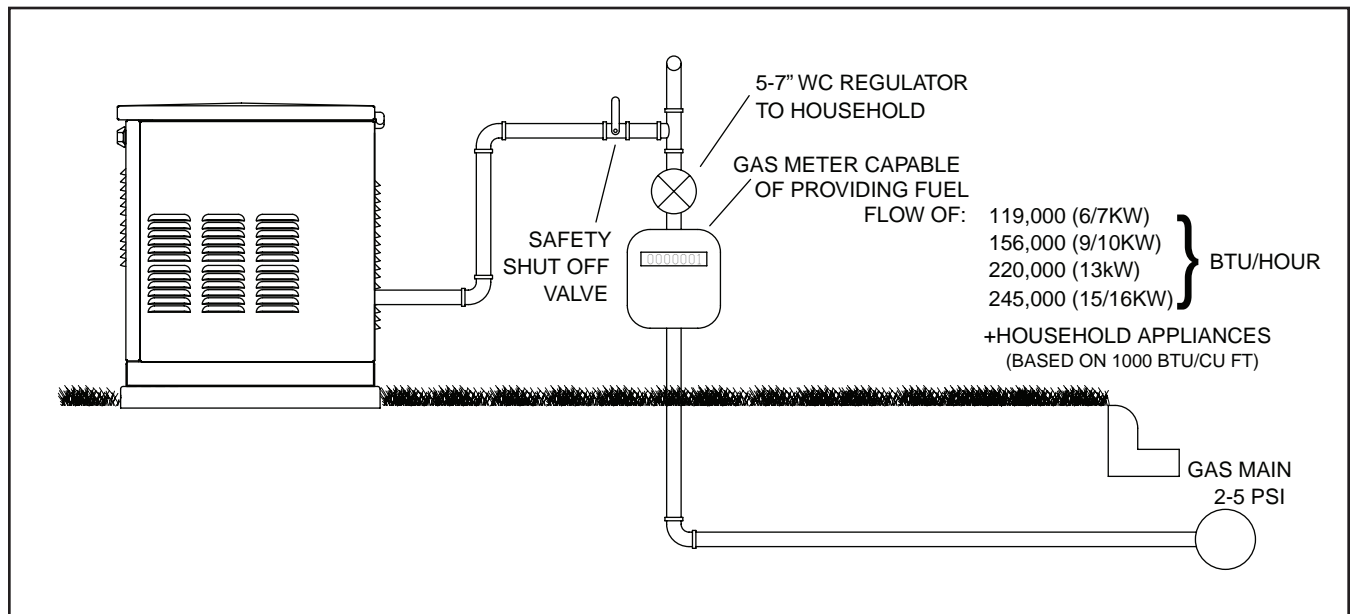

Figure 2. Proper Fuel Installation

GENERAL

The installer must ensure that the home standby generator has been properly installed. The system must be inspected carefully following installation. All applicable codes, standards and regulations pertaining to such installations must be strictly complied with. In addition, regulations established by the Occupational Safety and Health Administration (OSHA) must be complied with.

Prior to initial startup of the unit, the installer must ensure that the engine-generator has been properly prepared for use. This includes the following:

- An adequate supply of the correct fuel must be available for generator operation.
- The engine must be properly serviced with the recommended oil.

FUEL REQUIREMENTS

With LP gas, use only the vapor withdrawal system. This type of system uses the vapors formed above the liquid fuel in the storage tank.

The engine has been fitted with a fuel carburetion system that meets the specifications of the 1997 California Air Resources Board for tamper-proof dual fuel systems. The unit will run on natural gas or LP gas, but it has been factory set to run on natural gas. Should the primary fuel need to be changed to LP gas, the fuel system needs to be reconfigured. See the Reconfiguring the Fuel System section for instructions on reconfiguration of the fuel system.

Recommended fuels should have a Btu content of at least 1,000 Btus per cubic foot for natural gas; or at least 2,520 Btus per cubic foot for LP gas. Ask the fuel supplier for the Btu content of the fuel.

Required fuel pressure for natural gas is 5 inches to 7 inches water column (0.18 to 0.25 psi); and for liquid propane, 11 inches to 14 inches of water column (0.36 to 0.43 psi).

NOTE: All pipe sizing, construction and layout must comply with NFPA 54 for natural gas applications and NFPA 58 for liquid propane applications. Once the generator is installed, verify that the fuel pressure NEVER drops below four (4) inches water column for natural gas or 10 inches water column for liquid propane.

Prior to installation of the generator, the installer should consult local fuel suppliers or the fire marshal to check codes and regulations for proper installation. Local codes will mandate correct routing of gaseous fuel line piping around gardens, shrubs and other landscaping to prevent any damage.

Special considerations should be given when installing the unit where local conditions include flooding, tornados, hurricanes, earthquakes and unstable ground for the flexibility and strength of piping and their connections.

Use an approved pipe sealant or joint compound on all threaded fitting.

All installed gaseous fuel piping must be purged and leak tested prior to initial start-up in accordance with local codes, standards and regulations.

FUEL CONSUMPTION

The fuel consumption rates are listed in the SPECIFICATIONS section at the front of this manual.

BTU FLOW REQUIREMENTS - NATURAL GAS:

BTU flow required for each unit based on 1000 BTU per cubic foot.

6/7 kW -	119,000 BTU/Hour
9/10 kW -	156,000 BTU/Hour
13 kW -	220,000 BTU/Hour
15/16 kW -	245,000 BTU/Hour
18 kW -	288,000 BTU/Hour



Gaseous fuels such as natural gas and liquid propane (LP) gas are highly explosive. Even the slightest spark can ignite such fuels and cause an explosion. No leakage of fuel is permitted. Natural gas, which is lighter than air, tends to collect in high areas. LP gas is heavier than air and tends to settle in low areas.

NOTE: A minimum of one approved manual shut-off valve must be installed in the gaseous fuel supply line. The valve must be easily accessible. Local codes determine the proper location.

RECONFIGURING THE FUEL SYSTEM

6/7 kW, 410CC ENGINE:

To reconfigure the fuel system from NG to LP, follow these steps (Figure 1):

NOTE: The primary regulator for the propane supply is NOT INCLUDED with the generator. A fuel pressure of 11 to 14 inches of water column (0.36 to 0.43 psi) to the fuel inlet of the generator must be supplied.

1. Turn off the main gas supply (if connected).
2. Open the roof and remove the door.
3. Remove the battery (if installed).
4. Disconnect Wire 0 and Wire 14 from the gas solenoid on top of the demand regulator.
5. Remove the carburetor fuel hose from the outlet port of the demand regulator.
6. Remove the demand regulator by removing the fastener that retains the regulator mounting bracket.

7. Remove the square headed steel pipe plug from outlet port #1 and the brass hose barb fitting from outlet port #2.
8. Refit the brass hose barb fitting to outlet port #1 and the square headed steel pipe plug to outlet port #2.

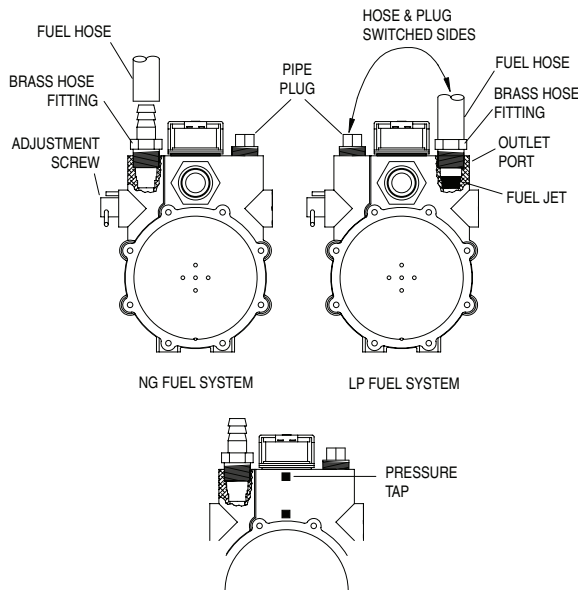

Figure 1. Demand Regulator

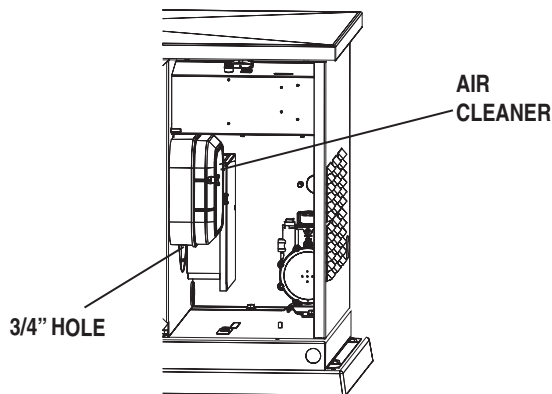

Figure 2. Demand Regulator

NOTE: Use an approved pipe sealant or joint compound on all threaded fittings to reduce the possibility of leakage.

9. Reverse procedure Steps 1-6 to reinstall demand regulator.
10. Take the plastic plug supplied in the poly-bag with the generator and press it into the 3/4" hole on the bottom of the air cleaner base (Figure 2).
11. Reverse the procedure to convert back to natural gas.

12. Check for gas leakage at the pipe plug, hose connection and fittings.

9, 10, 13, 16 AND 18 KW, V-TWIN ENGINES:

To reconfigure the fuel system from NG to LP, follow these steps:

NOTE: The primary regulator for the propane supply is NOT INCLUDED with the generator. A fuel pressure of 11 to 14 inches of water column (0.36 to 0.43 psi) to the fuel inlet of the generator must be supplied.

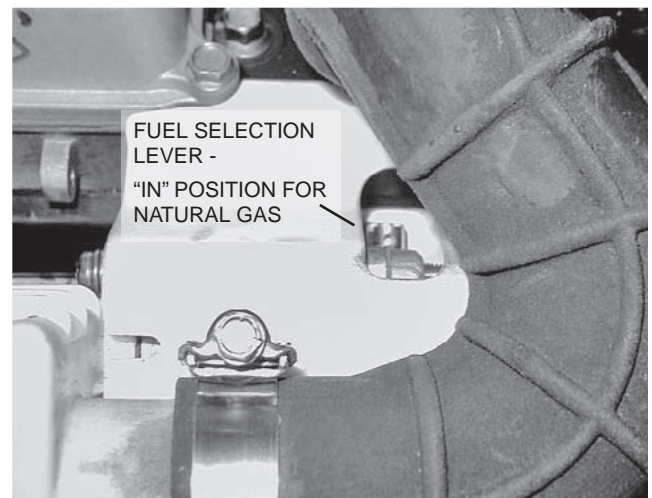

Figure 3. 9/10 kW, GT-530 (Inlet Hose Slid Back)

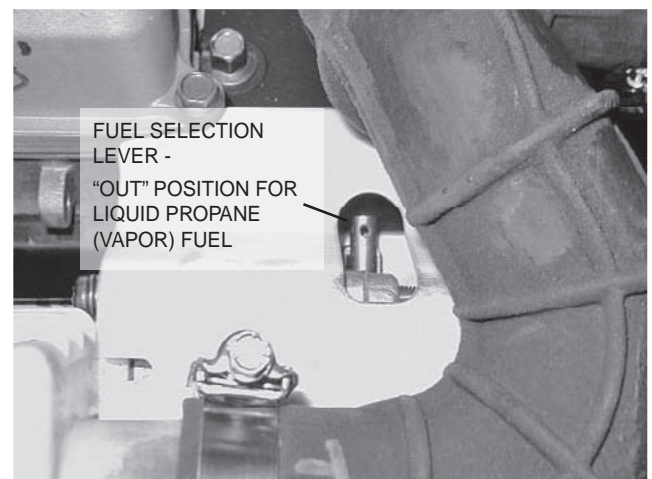

Figure 4. 9/10 kW, GT-530 (Inlet Hose Slid Back)

1. Open the roof.
 2. **For 9/10 kW units:** Loosen clamp and slide back the air inlet hose.
 - Slide fuel selector on carburetor out towards the back of the enclosure (Figures 3 and 4).
 - Return the inlet hose and tighten clamp securely.
- For 13, 16 and 18 kW units:** remove the air cleaner cover.

SECTION 1.3 PREPARATION BEFORE USE

- Slide the selector lever out towards the back of the enclosure (Figures 5 and 6).
 - Return the air cleaner cover and tighten the two thumb screws.
3. Close the roof.
 4. Reverse the procedure to convert back to natural gas.

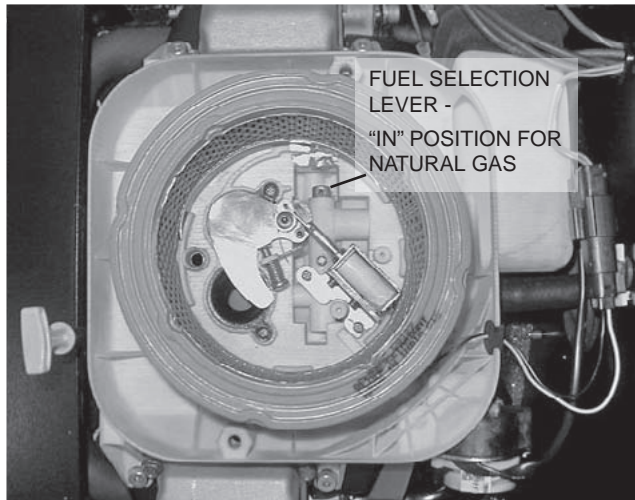

Figure 5. 13/16/18 kW, GT-990
(Airbox Cover Removed)

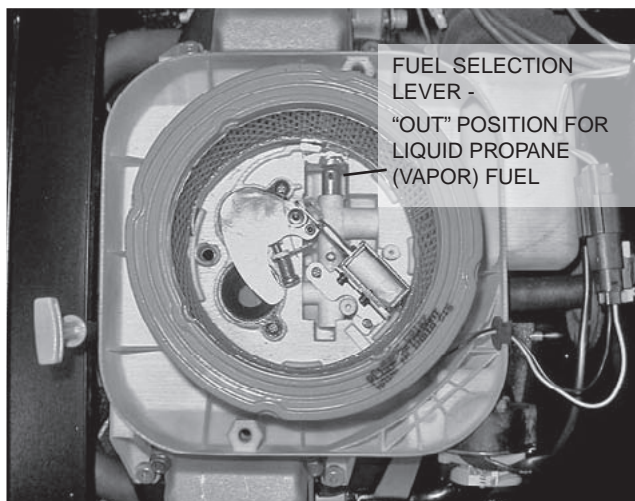

Figure 6. 13/16/18 kW, GT-990
(Airbox Cover Removed)

ENGINE OIL RECOMMENDATIONS

The primary recommended oil for units with air-cooled, single cylinder or V-Twin engines is synthetic oil. Synthetic oil provides easier starts in cold weather and maximum engine protection in hot weather. Use high quality detergent oil that meets or exceeds API (American Petroleum Institute) Service class SG, SH, or SJ requirements for gasoline engines. The following chart lists recommended viscosity ranges for the lowest anticipated ambient temperatures.

Engine crankcase oil capacities for the engines covered in this manual can be found in the specifications section at the beginning of the book.

Lowest Anticipated Ambient Temperature	Oil Grade (Recommended)
Above 60° F (16° C)	Use SAE 30 oil
20° to 59° F (-7° to 15° C)	Use SAE 10W-30 oil
Below 20° F (-7° C)	SAE 5W-20/5W-30
For all seasons	Use SAE 5W-30 Synthetic oil

METERS

Devices used to measure electrical properties are called meters. Meters are available that allow one to measure (a) AC voltage, (b) DC voltage, (c) AC frequency, and (d) resistance in ohms. The following apply:

- To measure AC voltage, use an AC voltmeter.
- To measure DC voltage, use a DC voltmeter.
- Use a frequency meter to measure AC frequency in “Hertz” or “cycles per second”.
- Use an ohmmeter to read circuit resistance, in “ohms”.

THE VOM

A meter that will permit both voltage and resistance to be read is the “volt-ohm-milliammeter” or “VOM”.

Some VOMs are of the “analog” type (not shown). These meters display the value being measured by physically deflecting a needle across a graduated scale. The scale used must be interpreted by the user.

“Digital” VOM’s (Figure 1) are also available and are generally very accurate. Digital meters display the measured values directly by converting the values to numbers.

NOTE: Standard AC voltmeters react to the AVERAGE value of alternating current. When working with AC, the effective value is used. For that reason a different scale is used on an AC voltmeter. The scale is marked with the effective or “rms” value even though the meter actually reacts to the average value. That is why the AC voltmeter will give an incorrect reading if used to measure direct current (DC).

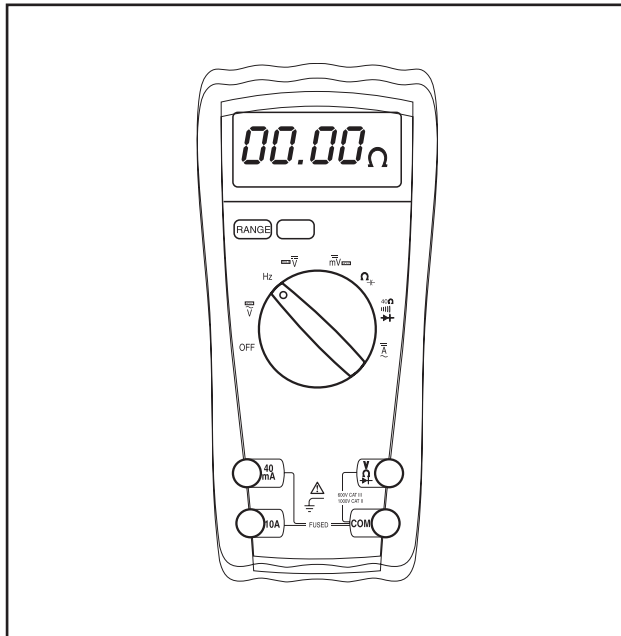

Figure 1. Digital VOM

MEASURING AC VOLTAGE

An accurate AC voltmeter or a VOM may be used to read the generator’s AC output voltage. The following apply:

1. Always read the generator’s AC output voltage only at the unit’s rated operating speed and AC frequency.
2. The generator’s Voltage Regulator can be adjusted for correct output voltage only while the unit is operating at its correct rated speed and frequency.
3. Only an AC voltmeter may be used to measure AC voltage. DO NOT USE A DC VOLTMETER FOR THIS PURPOSE.



DANGER!: GENERATORS PRODUCE HIGH AND DANGEROUS VOLTAGES. CONTACT WITH HIGH VOLTAGE TERMINALS WILL RESULT IN DANGEROUS AND POSSIBLY LETHAL ELECTRICAL SHOCK.

MEASURING AC VOLTAGE

A DC voltmeter or a VOM may be used to measure DC voltages. Always observe the following rules:

1. Always observe correct DC polarity.
 - a. Some VOM’s may be equipped with a polarity switch.
 - b. On meters that do not have a polarity switch, DC polarity must be reversed by reversing the test leads.
2. Before reading a DC voltage, always set the meter to a higher voltage scale than the anticipated reading. If in doubt, start at the highest scale and adjust the scale downward until correct readings are obtained.
3. The design of some meters is based on the “current flow” theory while others are based on the “electron flow” theory.
 - a. The “current flow” theory assumes that direct current flows from the positive (+) to the negative (-).
 - b. The “electron flow” theory assumes that current flows from negative (-) to positive (+).

NOTE: When testing generators, the “current flow” theory is applied. That is, current is assumed to flow from positive (+) to negative (-).

MEASURING AC FREQUENCY

The generator’s AC output frequency is proportional to Rotor speed. Generators equipped with a 2-pole Rotor must operate at 3600 rpm to supply a frequency of 60 Hertz. Units with 4-pole Rotor must run at 1800 rpm to deliver 60 Hertz.

Correct engine and Rotor speed is maintained by an engine speed governor. For models rated 60 Hertz, the governor is generally set to maintain a no-load frequency of about 62 Hertz with a corresponding output voltage of about 124 volts AC line-to-neutral. Engine speed and frequency at no-load are set slightly high to prevent excessive rpm and frequency droop under heavy electrical loading.

MEASURING CURRENT

CLAMP-ON:

To read the current flow, in AMPERES, a clamp-on ammeter may be used. This type of meter indicates current flow through a conductor by measuring the strength of the magnetic field around that conductor. The meter consists essentially of a current transformer with a split core and a rectifier type instrument connected to the secondary. The primary of the current transformer is the conductor through which the current to be measured flows. The split core allows the Instrument to be clamped around the conductor without disconnecting it.

Current flowing through a conductor may be measured safely and easily. A line-splitter can be used to measure current in a cord without separating the conductors.

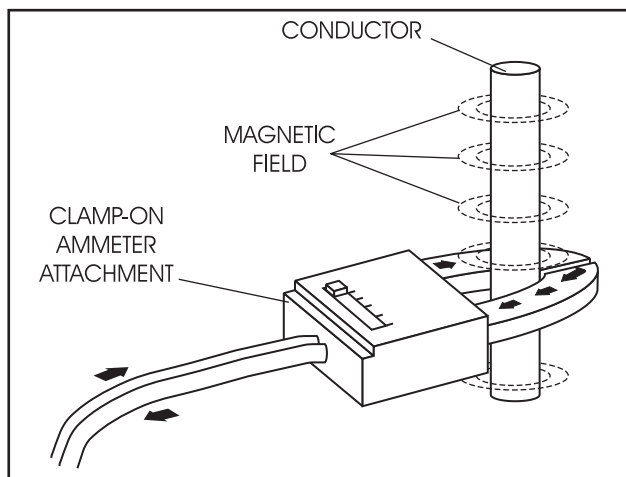

Figure 2. Clamp-On Ammeter

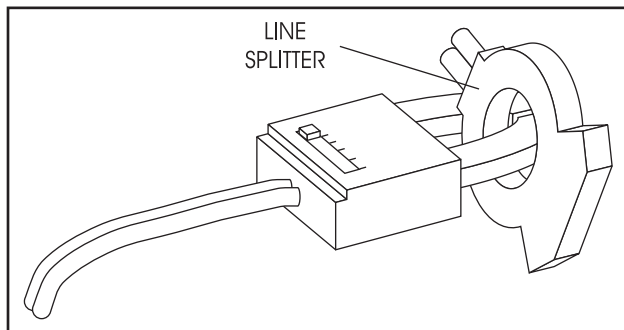

Figure 3. A Line-Splitter

NOTE: If the physical size of the conductor or ammeter capacity does not permit all lines to be measured simultaneously, measure current flow in each individual line. Then, add the Individual readings.

IN-LINE:

Alternatively, to read the current flow in AMPERES, an in-line ammeter may be used. Most Digital Volt Ohm Meters (VOM) will have the capability to measure amperes.

This usually requires the positive meter test lead to be connected to the correct amperes plug, and the meter to be set to the amperes position. Once the meter is properly set up to measure amperes the circuit being measured must be physically broken. The meter will be in-line or in series with the component being measured.

In Figure 4 the control wire to a relay has been removed. The meter is used to connect and supply voltage to the relay to energize it and measure the amperes going to it.

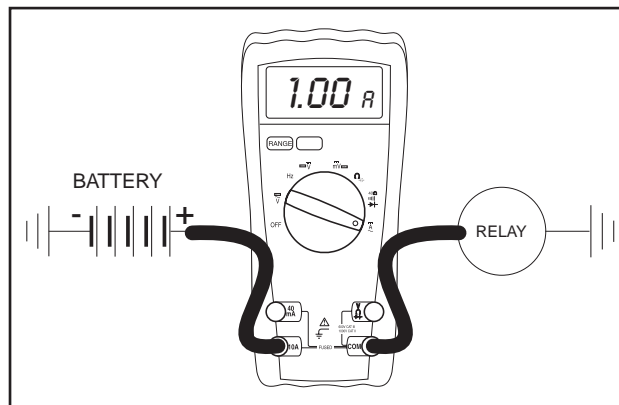

Figure 4. A VOM as an In-line meter

MEASURING RESISTANCE

The volt-ohm-milliammeter may be used to measure the resistance in a circuit. Resistance values can be very valuable when testing coils or windings, such as the Stator and Rotor windings.

When testing Stator windings, keep in mind that the resistance of these windings is very low. Some meters are not capable of reading such a low resistance and will simply read CONTINUITY.

If proper procedures are used, the following conditions can be detected using a VOM:

- A "short-to-ground" condition in any Stator or Rotor winding.
- Shorting together of any two parallel Stator windings.
- Shorting together of any two isolated Stator windings.
- An open condition in any Stator or Rotor winding.

Component testing may require a specific resistance value or a test for INFINITY or CONTINUITY. Infinity is an OPEN condition between two electrical points, which would read as no resistance on a VOM. Continuity is a closed condition between two electrical points, which would be indicated as very low resistance or "ZERO" on a VOM.

ELECTRICAL UNITS

AMPERE:

The rate of electron flow in a circuit is represented by the AMPERE. The ampere is the number of electrons flowing past a given point at a given time. One AMPERE is equal to just slightly more than six thousand million billion electrons per second.

With alternating current (AC), the electrons flow first in one direction, then reverse and move in the opposite direction. They will repeat this cycle at regular intervals. A wave diagram, called a "sine wave" shows that current goes from zero to maximum positive value, then reverses and goes from zero to maximum negative value. Two reversals of current flow is called a cycle. The number of cycles per second is called frequency and is usually stated in "Hertz".

VOLT:

The VOLT is the unit used to measure electrical PRESSURE, or the difference in electrical potential that causes electrons to flow. Very few electrons will flow when voltage is weak. More electrons will flow as voltage becomes stronger. VOLTAGE may be considered to be a state of unbalance and current flow as an attempt to regain balance. One volt is the amount of EMF that will cause a current of 1 ampere to flow through 1 ohm of resistance.

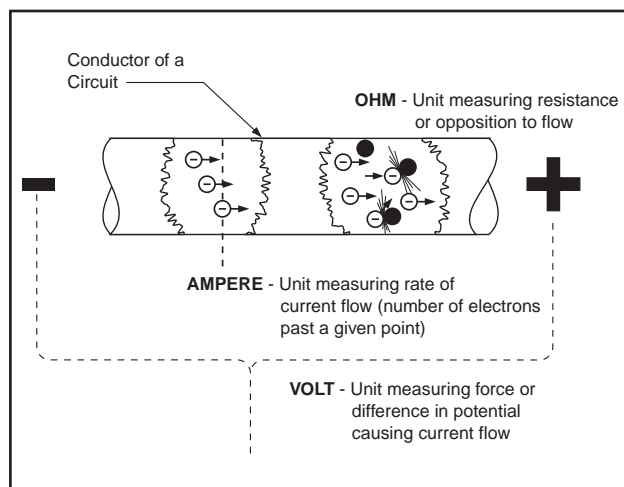

Figure 5. Electrical Units

OHM:

The OHM is the unit of RESISTANCE. In every circuit there is a natural resistance or opposition to the flow of electrons. When an EMF is applied to a complete circuit, the electrons are forced to flow in a single direction rather than their free or orbiting pattern. The resistance of a conductor depends on (a) its physical makeup, (b) its cross-sectional area, (c) its length, and (d) its temperature. As the conductor's temperature increases, its resistance increases in direct proportion. One (1) ohm of resistance will permit one (1) ampere of current to flow when one (1) volt of electromotive force (EMF) is applied.

OHM'S LAW

A definite and exact relationship exists between VOLTS, OHMS and AMPERES. The value of one can be calculated when the value of the other two are known. Ohm's Law states that in any circuit the current will increase when voltage increases but resistance remains the same, and current will decrease when resistance increases and voltage remains the same.

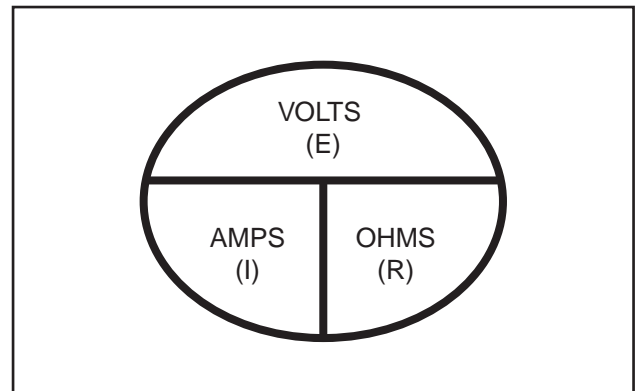

Figure 6. Ohm's Law

If AMPERES is unknown while VOLTS and OHMS are known, use the following formula:

$$\text{AMPERES} = \frac{\text{VOLTS}}{\text{OHMS}}$$

If VOLTS is unknown while AMPERES and OHMS are known, use the following formula:

$$\text{VOLTS} = \text{AMPERES} \times \text{OHMS}$$

If OHMS is unknown but VOLTS and AMPERES are known, use the following:

$$\text{OHMS} = \frac{\text{VOLTS}}{\text{AMPERES}}$$

VISUAL INSPECTION

When it becomes necessary to test or troubleshoot a generator, it is a good practice to complete a thorough visual inspection. Remove the access covers and look closely for any obvious problems. Look for the following:

- Burned or broken wires, broken wire connectors,

MINIMUM INSULATION RESISTANCE (in "Megohms")	=	$\frac{\text{GENERATOR RATED VOLTS}}{1000}$	+1
---	---	---	----

damaged mounting brackets, etc.

- Loose or frayed wiring insulation, loose or dirty connections.
- Check that all wiring is well clear of rotating parts.
- Verify that the Generator properly connected for the correct rated voltage. This is especially important on new installations. See Section 1.2, "AC Connection Systems".
- Look for foreign objects, loose nuts, bolts and other fasteners.
- Clean the area around the Generator. Clear away paper, leaves, snow, and other objects that might blow against the generator and obstruct its air openings.

INSULATION RESISTANCE

The insulation resistance of stator and rotor windings is a measurement of the integrity of the insulating materials that separate the electrical windings from the generator steel core. This resistance can degrade over time or due to such contaminants as dust, dirt, oil, grease and especially moisture. In most cases, failures of stator and rotor windings is due to a breakdown in the insulation. And, in many cases, a low insulation resistance is caused by moisture that collects while the generator is shut down. When problems are caused by moisture buildup on the windings, they can usually be corrected by drying the windings. Cleaning and drying the windings can usually eliminate dirt and moisture built up in the generator windings.

THE MEGOHMMETER

GENERAL:

A megohmmeter, often called a "megger", consists of a meter calibrated in megohms and a power supply. Use a power supply of 500 volts when testing stators or rotors. **DO NOT APPLY VOLTAGE LONGER THAN ONE (1) SECOND.**

TESTING STATOR INSULATION:

All parts that might be damaged by the high megger voltages must be disconnected before testing. Isolate all stator leads (Figure 8) and connect all of the stator leads together. **FOLLOW THE MEGGER MANUFACTURER'S INSTRUCTIONS CAREFULLY.**

Use a megger power setting of 500 volts. Connect one megger test lead to the junction of all stator leads, the other test lead to frame ground on the stator can. Read the number of megohms on the meter.

The MINIMUM acceptable megger reading for stators may be calculated using the following formula:

EXAMPLE: Generator is rated at 120 volts AC. Divide "120" by "1000" to obtain "0.12". Then add "1" to obtain "1.12" megohms. Minimum Insulation resistance for a 120 VAC stator is 1.12 megohms.

If the stator insulation resistance is less than the calculated minimum resistance, clean and dry the stator. Then, repeat the test. If resistance is still low, replace the stator.

Use the Megger to test for shorts between isolated windings as outlined "Stator Insulation Tests".

Also test between parallel windings. See "Test Between Windings" on next page.

TESTING ROTOR INSULATION:

Apply a voltage of 500 volts across the rotor positive (+) slip ring (nearest the rotor bearing), and a clean frame ground (i.e. the rotor shaft). **DO NOT EXCEED 500 VOLTS AND DO NOT APPLY VOLTAGE LONGER THAN 1 SECOND. FOLLOW THE MEGGER MANUFACTURER'S INSTRUCTIONS CAREFULLY.**

ROTOR MINIMUM INSULATION RESISTANCE:

1.5 megohms



CAUTION: Before attempting to measure Insulation resistance, first disconnect and Isolate all leads of the winding to be tested. Electronic components, diodes, surge protectors, relays, voltage regulators, etc., can be destroyed if subjected to high megger voltages.

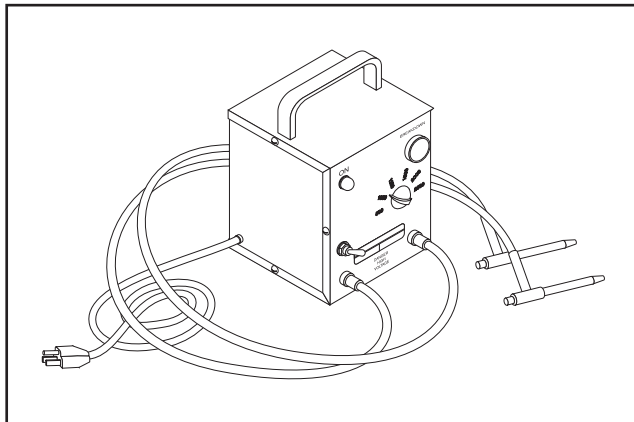

Figure 7. One Type of Hi-Pot Tester

HI-POT TESTER:

A "Hi-Pot" tester is shown in Figure 7. The model shown is only one of many that are commercially available. The tester shown is equipped with a voltage

selector switch that permits the power supply voltage to be selected. It also mounts a breakdown lamp that will illuminate to indicate an insulation breakdown during the test.

STATOR INSULATION RESISTANCE TEST

GENERAL:

Units with air-cooled engines are equipped with (a) dual stator AC power windings, (b) an excitation or DPE winding, and (c) a battery charge winding. Insulation tests of the stator consist of (a) testing all windings to ground, (b) testing between isolated windings, and (c) testing between parallel windings. Figure 8 is a pictorial representation of the various stator leads on units with air-cooled engine.

TESTING ALL STATOR WINDINGS TO GROUND:

1. Disconnect stator output leads 11 and 44 from the generator main line circuit breaker.
2. Remove stator output leads 22 and 33 from the neutral connection and separate the two leads.
3. Disconnect C2 Connector from the side of the control panel. The C2 Connector is the closest to the back panel (see Figure 9, Section 6.1).

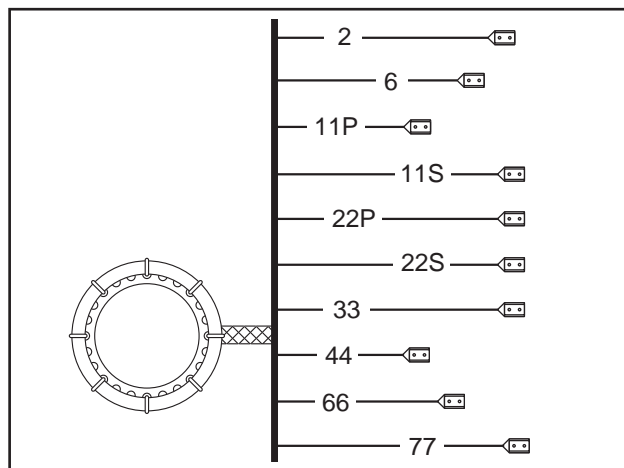

Figure 8. Stator Winding Leads

4. Connect the terminal ends of Wires 11, 22, 33 and 44 together. Make sure the wire ends are not touching any part of the generator frame or any terminal.
5. Connect the red test probe of the Hi-Pot tester to the joined terminal ends of stator leads 11, 22, 33 and 44. Connect the black tester lead to a clean frame ground on the stator can. With tester leads connected in this manner, proceed as follows:
 - a. Turn the Hi-Pot tester switch OFF.
 - b. Plug the tester cord into a 120 volt AC wall socket and set its voltage selector switch to "1500 volts".

- c. Turn the tester switch ON and observe the breakdown lamp on tester. DO NOT APPLY VOLTAGE LONGER THAN 1 SECOND. After one (1) second, turn the tester switch OFF.

If the breakdown lamp comes on during the one-second test, the stator should be cleaned and dried. After cleaning and drying, repeat the insulation test. If, after cleaning and drying, the stator fails the second test, the stator assembly should be replaced.

6. Now proceed to the C2 Connector. Each winding will be individually tested for a short to ground. Insert a large paper clip (or similar item) into the C2 Connector at the following pin locations:

Pin Location	Wire Number	Winding
1	77	Battery Charge
2	66	Battery Charge
3	22S	Sense Lead Power
4	11S	Sense Lead Power
5	6	Excitation
6	2	Excitation
7	0	Ground
8	4	Positive to Brush

Next refer to Steps 5a through 5c of the Hi-Pot procedure.

Example: Insert paper clip into Pin 1, Hi-Pot from Pin 1 (Wire 77) to ground. Proceed to Pin 2, Pin 3, etc. through Pin 8.

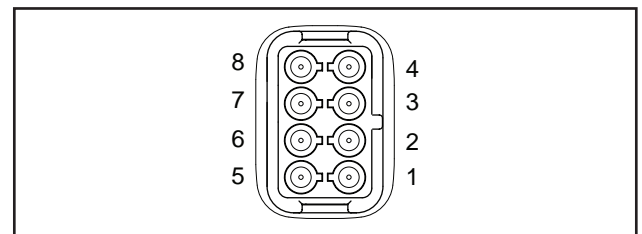

Figure 9. C2 Connector Pin Location Numbers (Female Side)

TEST BETWEEN WINDINGS:

1. Insert a large paper clip into Pin Location 1 (Wire 77). Connect the red tester probe to the paper clip. Connect the black tester probe to Stator Lead 11. Refer to Steps 5a through 5c of "TESTING ALL STATOR WINDINGS TO GROUND" on previous page.
2. Repeat Step 1 at Pin Location 5 (Wire 6) and Stator Lead 11.
3. Connect the red test probe to Stator Lead 33. Connect the black test probe to Stator Lead 11. Refer to Steps 5a through 5c of "TESTING ALL STATOR WINDINGS TO GROUND" on previous page.

SECTION 1.4 TESTING, CLEANING AND DRYING

PART 1

GENERAL INFORMATION

4. Insert a large paper clip into Pin Location No. 1 (Wire 77). Connect the red tester probe to the paper clip. Connect the black tester probe to Stator Lead 33. Refer to Steps 5a through 5c of "TESTING ALL STATOR WINDINGS TO GROUND" on the previous page.
5. Repeat Step 4 at Pin Location 3 (Wire 6) and Stator Lead 33.

For the following Step (7) an additional large paper clip (or similar item) will be needed:

7. Insert a large paper clip into Pin Location 1 (Wire 77). Connect the red tester probe to the paper clip. Insert the additional large paper clip into Pin Location 5 (Wire 6). Connect the black tester probe to this paper clip. Refer to Steps 5a through 5c of "TESTING ALL STATOR WINDINGS TO GROUND" on the previous page.

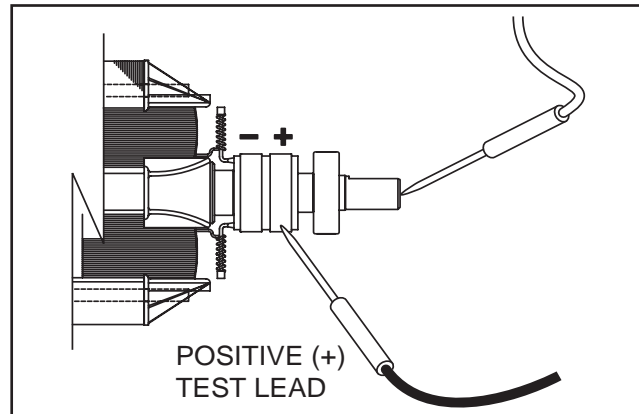

Figure 10. Testing Rotor Insulation

ROTOR INSULATION RESISTANCE TEST

Before attempting to test rotor insulation, the brush holder must be completely removed. The rotor must be completely isolated from other components before starting the test. Attach all leads of all stator windings to ground.

1. Connect the red tester lead to the positive (+) slip ring (nearest the rotor bearing).
2. Connect the black tester probe to a clean frame ground, such as a clean metal part of the rotor shaft.
3. Turn the tester switch OFF.
4. Plug the tester into a 120 volts AC wall socket and set the voltage switch to "1500 volts".
5. Turn the tester switch "On" and make sure the pilot light has turned on.
6. Observe the breakdown lamp, then turn the tester switch OFF. DO NOT APPLY VOLTAGE LONGER THAN ONE (1) SECOND.

If the breakdown lamp came on during the one (1) second test, cleaning and drying of the rotor may be necessary. After cleaning and drying, repeat the insulation breakdown test. If breakdown lamp comes on during the second test, replace the rotor assembly.

CLEANING THE GENERATOR

Caked or greasy dirt may be loosened with a soft brush or a damp cloth. A vacuum system may be used to clean up loosened dirt. Dust and dirt may also be removed using dry, low-pressure air (25 psi maximum).



CAUTION: Do not use sprayed water to clean the generator. Some of the water will be retained on generator windings and terminals, and may cause very serious problems.

DRYING THE GENERATOR

To dry a generator, proceed as follows:

1. Open the generator main circuit breaker. NO ELECTRICAL LOADS MUST BE APPLIED TO THE GENERATOR WHILE DRYING.
2. Disconnect all Wires 4 from the voltage regulator.
3. Provide an external source to blow warm, dry air through the generator interior (around the rotor and stator windings. DO NOT EXCEED 185° F. (85° C.).
4. Start the generator and let it run for 2 or 3 hours.
5. Shut the generator down and repeat the stator and rotor insulation resistance tests.

GENERAL

Standby electric power generators will often run unattended for long periods of time. Such operating parameters as (a) battery voltage, (b) engine oil pressure, (c) engine temperature, (d) engine operating speed, and (e) engine cranking and startup are not monitored by an operator during automatic operation. Because engine operation will not be monitored, the use of engine protective safety devices is required to prevent engine damage in the event of a problem.

Generator engines mount several engine protective devices. These devices work in conjunction with a circuit board, to protect the engine against such operating faults as (a) low battery, (b) low engine oil pressure, (c) high temperature, (d) overspeed, and (e) overcrank. On occurrence of any one or more of those operating faults, circuit board action will effect an engine shutdown.

LOW BATTERY

The microprocessor will continually monitor the battery voltage and turn on the Low Battery LED if the battery voltage falls below 11.0 volts for one (1) minute. No other action is taken on a low battery condition. Low battery voltage is a non-latching alarm which will automatically clear if the battery voltage rises above 11.0 volts. Battery voltage is NOT monitored during the crank cycle.

LOW OIL PRESSURE SHUTDOWN

See Figure 1. An oil pressure switch is mounted on the engine oil filter adapter. This switch has normally closed contacts that are held open by engine oil pressure during cranking and startup. Should oil pressure drop below approximately 8 psi, the switch contacts will close. On closure of the switch contacts, a Wire 86 circuit from the circuit board will be connected to ground. Circuit board action will then de-energize a "run relay" (on the circuit board). The run relay's normally open contacts will then open and a 12 volts DC power supply to a Wire 14 circuit will then be terminated. This will result in closure of a fuel shutoff solenoid and loss of engine ignition.

HIGH TEMPERATURE SWITCH

This switch's contacts (Figure 1) close if the temperature should exceed approximately 140° C (284° F), initiating an engine shutdown. The generator will automatically restart and the LED on the generator control panel will reset once the temperature has returned to a safe operating level.

OVERSPEED SHUTDOWN

During engine cranking and operation, the circuit board receives AC voltage and frequency signals from the ignition magneto, via Wire 18. Should the speed exceed approximately 72 Hz (4320 rpm), circuit board action will de-energize a "run relay" (mounted on the circuit board). The relay's contacts will open, to terminate engine ignition and close a fuel shutoff solenoid. The engine will then shut down. This feature protects the engine-generator against damaging overspeeds.

NOTE: The circuit board also uses rpm sensing to terminate engine cranking.

RPM SENSOR FAILURE

During cranking, if the board does not see a valid RPM signal within three (3) seconds, it will shut down and latch out on RPM sensor loss.

During running, if the RPM signal is lost for one full second the board will shut down the engine, wait 15 seconds, then re-crank the engine.

- If an RPM signal is not detected within the first three (3) seconds of cranking, the control board will shut the engine down and latch out on RPM sensor loss.
- If the RPM signal is detected the engine will start and run normally. If the RPM signal is subsequently lost again, the control board will try one more re-crank attempt before latching out and flashing the overspeed LED.

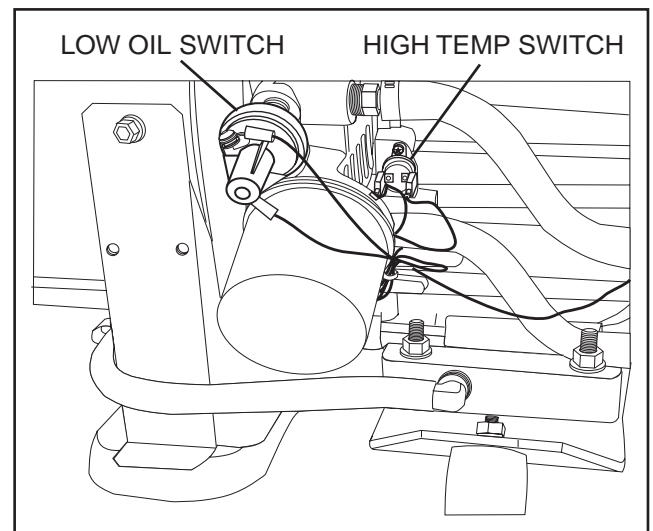

Figure 1. Engine Protective Switches on an Air-Cooled Engine

OVERCRANK SHUTDOWN

This feature prevents the generator from damaging itself when it continually attempts to start and another problem, such as no fuel supply, prevents it from starting. The unit will crank and rest for a preset time limit. Then, it will stop cranking, and the LED on the generator control panel will light indicating an overcrank failure. The AUTO/OFF/MANUAL switch will need to be set to OFF and then back to AUTO to reset the generator control board.

NOTE: If the fault is not repaired, the overcrank feature will continue to activate.

APPROXIMATE CRANK CYCLE TIMES:

6/7 KW UNITS:

- 15 seconds ON
- 7 seconds OFF
- 7 seconds ON
- 7 seconds OFF
- 7 seconds ON
- 7 seconds OFF
- 7 seconds ON
- 7 seconds OFF
- 7 seconds ON
- 7 seconds OFF
- 7 seconds ON

If the unit fails to start, the overcrank alarm LED will be illuminated.

9/10 KW, 13 KW, 16KW AND 18 KW UNITS:

- 16 seconds ON
- 7 seconds OFF
- 16 seconds ON
- 7 seconds OFF
- 7 seconds ON
- 7 seconds OFF
- 7 seconds ON
- 7 seconds OFF
- 7 seconds ON
- 7 seconds OFF

If the unit fails to start, the overcrank alarm LED will be illuminated.

CONTROL PANEL**GENERAL:**

See Figure 1 for control panel configurations.

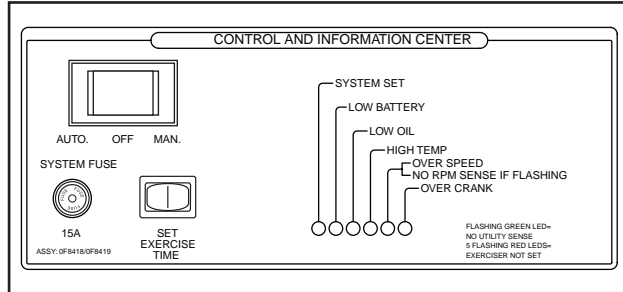

Figure 1. Control Panel

AUTO-OFF-MANUAL SWITCH:

Use this switch to (a) select fully automatic operation, (b) to crank and start the engine manually, and (c) to shut the unit down or to prevent automatic startup.

1. AUTO position:
 - a. Select AUTO for fully automatic operation.
 - b. When AUTO is selected, circuit board will monitor utility power source voltage.
 - c. Should utility voltage drop below a preset level and remain at such a low level for a preset time, circuit board action will initiate engine cranking and startup.
 - d. Following engine startup, circuit board action will initiate transfer of electrical loads to the "Standby" source side.
 - e. On restoration of utility source voltage above a preset level, circuit board action will initiate retransfer back to the "Utility Source" side.
 - f. Following retransfer, circuit board will shut the engine down and will then continue to monitor utility source voltage.
2. OFF Position:
 - a. Set the switch to OFF to stop an operating engine.
 - b. To prevent an automatic startup from occurring, set the switch to OFF.
3. MANUAL Position:
 - a. Set switch to MANUAL to crank and start unit manually.
 - b. Engine will crank cyclically and start (same as automatic startup, but without transfer). The unit will transfer if utility voltage is not available.



DANGER: WHEN THE GENERATOR IS INSTALLED IN CONJUNCTION WITH AN AUTOMATIC TRANSFER SWITCH, ENGINE CRANKING AND STARTUP CAN OCCUR AT

ANY TIME WITHOUT WARNING (PROVIDING THE AUTO-OFF-MANUAL SWITCH IS SET TO AUTO). TO PREVENT AUTOMATIC STARTUP AND POSSIBLE INJURY THAT MIGHT BE CAUSED BY SUCH STARTUP, ALWAYS SET THE AUTO-OFF-MANUAL SWITCH TO ITS OFF POSITION BEFORE WORKING ON OR AROUND THIS EQUIPMENT.

15 AMP FUSE:

This fuse protects the DC control circuit (including the circuit board) against overload. If the fuse element has melted open due to an overload, engine cranking or running will not be possible. Should fuse replacement become necessary, use only an identical 15 amp replacement fuse.

THE SET EXERCISE SWITCH:

This generator is equipped with an exercise timer. Once it is set, the generator will start and exercise once every seven days, on the day of the week and at the time of day the following sequence is completed. During this exercise period, the unit runs for approximately 12 minutes and then shuts down. Transfer of loads to the generator output does not occur during the exercise cycle unless utility power is lost.

A switch on the control panel (see Figure 1) permits selection of the day and time for the system to exercise. At the chosen time, perform the following sequence to select the desired day and time of day the system will exercise. Remember seasonal time changes affect the exercise time settings.

1. Verify that the AUTO/OFF/MANUAL switch is set to AUTO.
2. Press and hold the "Set Exercise Time" switch for several seconds, then release. All the red LED's will flash for approximately 10 seconds and then stop.
3. Once the red LED's stop flashing, the generator will start and run for approximately 12 minutes and then shut down. The exerciser is now set to run at this time of day each week.

Example: If the "Set Exercise Time" switch is pressed on Saturday afternoon at 2:00 p.m., the generator will start and exercise for approximately 12 minutes every Saturday at 2:00 p.m.

NOTE: The exerciser will only work in the AUTO mode and will not work unless this procedure is performed. The exerciser will need to be reset every time the 12 volt battery is disconnected and then reconnected, and when the 15A fuse is removed.

The 16 and 18 kW units have a low speed exercise option. Dip switch 1 on the control board is factory set to OFF. This allows the engine to run at a slower speed during weekly exercise periods for quieter operation. If this Dip switch is set to ON, the generator will exercise at it's normal speed.

SECTION 1.6 OPERATING INSTRUCTIONS

This DIP switch position is only read at board power up. If the DIP switch position is changed, power to the board must be cycled for the micro controller to recognize the new DIP switch position.

Low speed exercise will be handled as follows:

1. The standard start sequence will be initiated.
2. The unit will run at 2,400 RPM.
3. If utility is lost during exercise, the controller will do the following:
 - Wait 10 seconds for utility to return.
 - If utility returns within 10 seconds, continue to exercise at 2,400 RPM.
 - If utility is still lost after 10 seconds, run the engine up to 3600 RPM and transfer the load. At this time the controller will exit the exercise routine and assume full automatic operation.

PROTECTION SYSTEMS:

Unlike an automobile engine, the generator may have to run for long periods of time with no operator present to monitor engine conditions. For that reason, the engine is equipped with the following systems that protect it against potentially damaging conditions:

- Low Battery
- Low Oil Pressure Sensor
- High Temperature Sensor
- Overcrank
- Overspeed
- No RPM Sense

There are LED readouts on the control panel to notify you that one of these faults has occurred. There is also a "System Set" LED that is lit when all of the following conditions are true:

1. The AUTO-OFF-MANUAL switch is set to the AUTO position.
2. The NOT IN AUTO dip switch is set to the OFF position on the control board.
3. No alarms are present.

TO SELECT AUTOMATIC OPERATION

The following procedure applies only to those installations in which the air-cooled, automatic standby generator is installed in conjunction with a transfer switch. Transfer switches do not have an intelligence circuit of their own. Automatic operation on transfer switch and generator combinations is controlled by circuit board action.

To select automatic operation when a transfer switch is installed along with a home standby generator, proceed as follows:

1. Check that the transfer switch main contacts are at their UTILITY position, i.e., the load is connected to the power supply. If necessary, manually actuate the switch main contacts to their UTILITY source side. See Part 3 of this manual, as appropriate, for instructions.
2. Check that utility source voltage is available to transfer switch terminal lugs N1 and N2 (2-pole, 1-phase transfer switches).
3. Set the generator AUTO-OFF-MANUAL switch to its AUTO position.
4. Actuate the generator main line circuit breaker to its "On" or "Closed" position. With the preceding Steps 1 through 4 completed, a dropout in utility supply voltage below a preset level will result in automatic generator cranking and start-up. Following startup, the transfer switch will be actuated to its "Standby" source side, i.e., loads powered by the standby generator.

MANUAL TRANSFER TO "STANDBY" AND MANUAL STARTUP

To transfer electrical loads to the "Standby" (generator) source and start the generator manually, proceed as follows:

1. On the generator panel, set the AUTO-OFF-MANUAL switch to OFF.
2. On the generator, set the main line circuit breaker to its OFF or "Open" position.
3. Turn OFF the power supply to the transfer switch, using whatever means provided (such as a utility source line circuit breaker).
4. Manually actuate the transfer switch main contacts to their "Standby" position, i.e., loads connected to the "Standby" power source side.

NOTE: For instructions on manual operation of transfer switches, see Part 3.

5. On the generator panel, set the AUTO-OFF-MANUAL switch to MANUAL. The engine should crank and start.
6. Let the engine warm up and stabilize for a minute or two at no-load.
7. Set the generator main line circuit breaker to its "On" or "Closed" position. The generator now powers the electrical loads.

***MANUAL SHUTDOWN AND RETRANSFER
BACK TO "UTILITY"***

To shut the generator down and retransfer electrical loads back to the UTILITY position, proceed as follows:

1. Set the generator main line circuit breaker to its OFF or "Open" position.
2. Let the generator run at no-load for a few minutes, to cool.
3. Set the generator AUTO-OFF-MANUAL switch to OFF. Wait for the engine to come to a complete stop.
4. Turn off the utility power supply to the transfer switch using whatever means provided (such as a utility source main line circuit breaker)
5. Manually actuate the transfer switch to its UTILITY source side, i.e., load connected to the utility source.
6. Turn on the utility power supply to the transfer switch, using whatever means provided.
7. Set the generator AUTO-OFF-MANUAL switch to AUTO.

INTRODUCTION

When the generator is installed in conjunction with a transfer switch, either manual or automatic operation is possible. Manual transfer and engine startup, as well as manual shutdown and re-transfer are covered in Section 1.6. Selection of fully automatic operation is also discussed in that section. This section will provide a step-by-step description of the sequence of events that will occur during automatic operation of the system.

AUTOMATIC OPERATING SEQUENCES

The generator's control panel houses a control logic circuit board. This board constantly monitors utility power source voltage. Should that voltage drop below a preset level, circuit board action will signal the engine to crank and start. After the engine starts, the circuit board signals the transfer switch to activate and connect load circuits to the standby power supply (load terminal lugs T1/T2 connect to terminal lugs E1/E2). Refer to the Electrical Data section.

The generator must run at 50 Hz or greater for the transfer output to be activated. Once activated, it will remain active even if the frequency dips below 50 Hz.

Upon restoration of utility source voltage above a preset level, generator circuit board action signals the transfer switch to transfer loads back to that power supply. After retransfer, the engine is signalled to shut down.

The actual sequence of operation is controlled by sensors and timers on a control logic circuit board, as follows:

A. Utility Voltage Dropout Sensor

- This sensor monitors utility source voltage.
- If utility source voltage drops below about 65 percent of the nominal supply voltage, the sensor energizes a 10 second timer.
- Once the timer has expired, the engine will crank and start if utility is still low.

B. Engine Warm-up Time Delay

- This mechanism lets the engine warm up for about five (5) seconds before the load is transferred to the standby source.

C. Standby Voltage Sensor

- This sensor monitors generator AC output voltage. When the voltage has reached 50 percent of the nominal rated voltage, transfer to standby can occur.

D. Utility Voltage Pickup Sensor

- This sensor monitors utility power supply voltage. When that voltage is restored above 75 percent of the nominal source voltage, a retransfer time delay starts timing.

E. Retransfer Time Delay

- This timer runs for about 15 seconds.
- At end of a 15-second delay, circuit board action de-energizes transfer relay in the transfer switch if utility is still present.
- Retransfer to utility power source then occurs.

F. Engine Cool-down Timer

- When the load is transferred back to utility power source, the engine cool-down timer starts timing.
- The timer will run for about one minute, and the generator will then shut down.

PART 2 AC GENERATORS

Air-cooled, Automatic Standby Generators

TABLE OF CONTENTS		
PART	TITLE	PAGE#
2.1.	Description and Components	30
2.2	Operational Analysis	33
2.3	Troubleshooting Flow Charts	35
2.4	Diagnostic Tests	39

2.1 Description and Components.....	30	Test 1 – Check Main Circuit Breaker.....	39
Introduction	30	Test 2 – Check AC Output Voltage.....	39
Engine-generator Drive System.....	30	Test 4 – Fixed Excitation Test/Rotor Amp Draw Test	40
The AC Generator.....	30	Test 5 – Wire Continuity	41
Rotor Assembly.....	30	Test 6 – Check Field Boost	42
Stator Assembly.....	31	Test 7 – Testing The Stator With a VOM.....	42
Brush Holder And Brushes	31	Test 8 – Resistance Check of Rotor Circuit	44
Other AC Generator Components	31	Test 9 – Check Brushes and Slip Rings.....	44
2.2 Operational Analysis	33	Test 10 – Test Rotor Assembly.....	45
Rotor Residual Magnetism.....	33	Test 11 – Check AC Output Frequency.....	45
Field Boost.....	33	Test 12 – Check And Adjust Engine Governor (Single Cylinder Units).....	46
Operation	34	Test 12A – Check Stepper Motor Control (V-twin Engine Units).....	46
2.3 Troubleshooting Flowcharts.....	35	Test 13 – Check And Adjust Voltage Regulator.....	48
Problem 1 – Generator Produces Zero Voltage or Residual Voltage	35-36	Test 14 – Check Voltage And Frequency Under Load.....	48
Problem 2 – Generator Produces Low Voltage at No-Load	37	Test 15 – Check For Overload Condition	48
Problem 3 – Generator Produces High Voltage at No-Load	37	Test 16 – Check Engine Condition.....	48
Problem 4 – Voltage and Frequency Drop Excessively When Loads are Applied	38		
2.3 Diagnostic Tests	39		
Introduction	39		
Safety	39		

INTRODUCTION

The air-cooled, automatic standby system is an easy to install, fully enclosed and self-sufficient electric power system. It is designed especially for homeowners, but may be used in other applications as well. On occurrence of a utility power failure, this high performance system will (a) crank and start automatically, and (b) automatically transfer electrical loads to generator AC output.

The generator revolving field (rotor) is driven by an air-cooled engine at about 3600 rpm.

The generator may be used to supply electrical power for the operation of 120 and/or 240 volts, 1-phase, 60 Hz, AC loads.

A 2-pole, "W/V-Type" transfer switch is offered (see Part 3). The transfer switch does not include an "intelligence circuit" of it's own. Instead, automatic startup, transfer, running, retransfer and shutdown operations are controlled by a solid state circuit board in the generator control panel.

ENGINE-GENERATOR DRIVE SYSTEM

The generator revolving field is driven by an air-cooled, horizontal crankshaft engine. The generator is directly coupled to the engine crankshaft (see Figure

1), and mounted in an enclosure. Both the engine and generator rotor are driven at approximately 3600 rpm, to provide a 60 Hz AC output.

THE AC GENERATOR

Figure 1 shows the major components of the AC generator.

ROTOR ASSEMBLY

The 2-pole rotor must be operated at 3600 rpm to supply a 60 Hertz AC frequency. The term "2-pole" means the rotor has a single north magnetic pole and a single south magnetic pole. As the rotor rotates, its lines of magnetic flux cut across the stator assembly windings and a voltage is induced into the stator windings. The rotor shaft mounts a positive (+) and a negative (-) slip ring, with the positive (+) slip ring nearest the rear bearing carrier. The rotor bearing is pressed onto the end of the rotor shaft. The tapered rotor shaft is mounted to a tapered crankshaft and is held in place with a single through bolt.

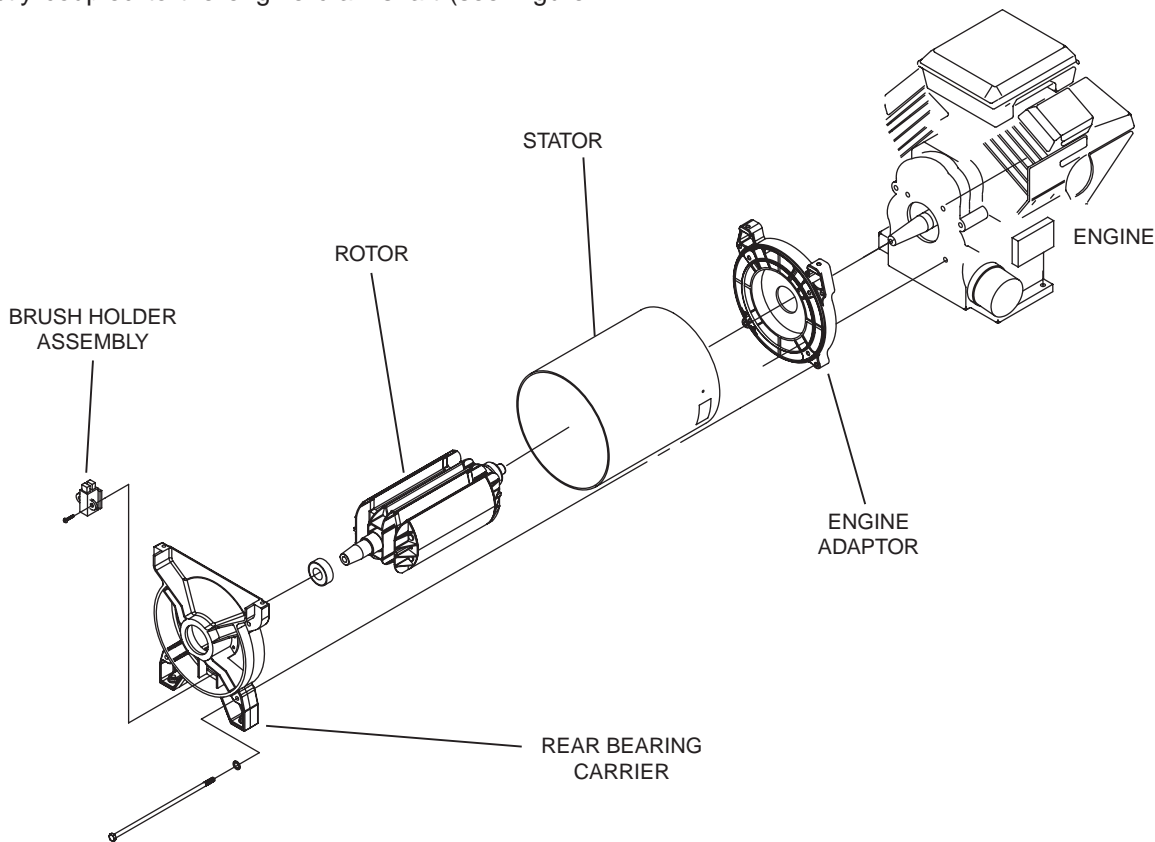

Figure 1. AC Generator Exploded View

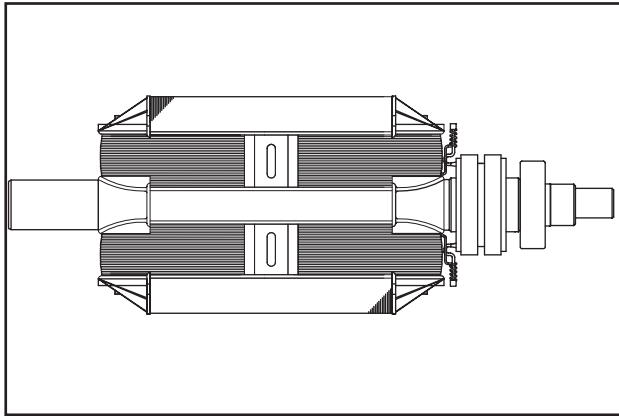

Figure 2. The 2-Pole Rotor Assembly

STATOR ASSEMBLY

The stator can houses and retains (a) dual AC power windings, (b) excitation winding, and (c) battery charge winding. A total of ten (10) stator leads are brought out of the stator can as shown in Figure 3.

The stator can is sandwiched between an engine adapter and a rear bearing carrier. It is retained in that position by four stator studs.

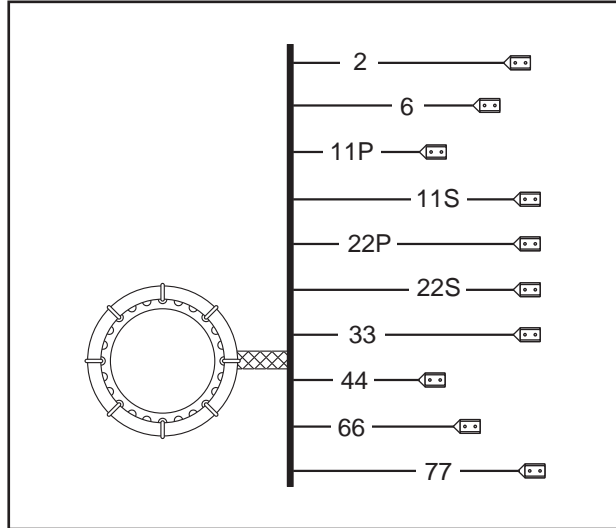

Figure 3 Stator Assembly Leads

BRUSH HOLDER AND BRUSHES

The brush holder is retained to the rear bearing carrier by means of two #10-32 x 9/16 Taptite screws. A positive (+) and a negative (-) brush are retained in the brush holder, with the positive (+) brush riding on the slip ring nearest the rotor bearing.

Wire 4 connects to the positive (+) brush and Wire 0 to the negative (-) brush. Wire 0 connects to frame ground. Rectified and regulated excitation current, as well as current from a field boost circuit, are delivered to the rotor windings via Wire 4, and the positive (+) brush and slip ring. The excitation and field boost current passes through the windings and to frame ground via the negative (-) slip ring and brush, and Wire 0. This current flow creates a magnetic field around the rotor having a flux concentration that is proportional to the amount of current flow.

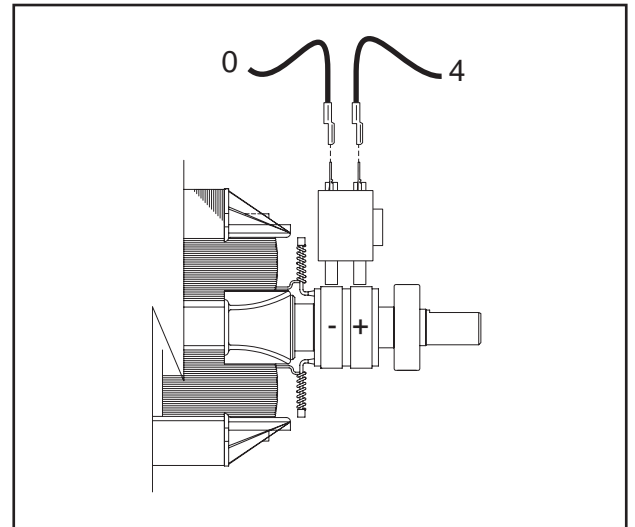

Figure 4. Brush Holder and Brushes

OTHER AC GENERATOR COMPONENTS

Some AC generator components are housed in the generator control panel enclosure, and are not shown in Figure 1. These are (a) a voltage regulator, and (b) a main line circuit breaker.

VOLTAGE REGULATOR:

A typical voltage regulator is shown in Figure 5. Unregulated AC output from the stator excitation winding is delivered to the regulator's DPE terminals, via Wire 2 and Wire 6. The voltage regulator rectifies that current and, based on stator AC power winding sensing, regulates it. The rectified and regulated excitation current is then delivered to the rotor windings from the positive (+) and negative (-) regulator terminals, via Wire 4 and Wire 0. Stator AC power winding "sensing" is delivered to the regulator "SEN" terminals via Wires 11 and 22.

The regulator provides "over-voltage" protection, but does not protect against "under-voltage". On occurrence of an "over-voltage" condition, the regulator will "shut down" and complete loss of excitation current to the rotor will occur. Without excitation current, the generator AC output voltage will drop to approximately one-half (or lower) of the unit's rated voltage.

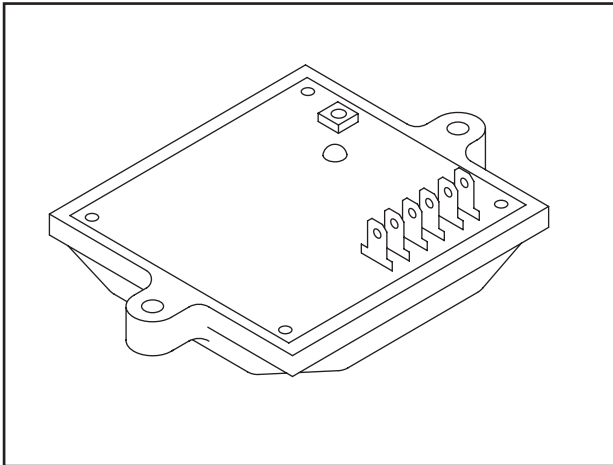

Figure 5. Typical Voltage Regulator

A single red lamp (LED) glows during normal operation. The lamp will become dim if excitation winding AC output diminishes. It will go out on occurrence of an open condition in the sensing AC output circuit.

An adjustment potentiometer permits the stator AC power winding voltage to be adjusted. Perform this adjustment with the generator running at no-load, and with a frequency of:

- 57.5-59.5 Hz (V-Twin units)
- 62-63 Hz (Single Cylinder units)

At the stated no-load frequency, adjust to obtain a line-to-line AC voltage of:

- 250-252 volts (V-Twin units)
- 247-252 volts (Single Cylinder units)

MAIN LINE CIRCUIT BREAKER:

The main line circuit breaker protects the generator against electrical overload. See "Specifications" in front of manual for amp ratings.

ROTOR RESIDUAL MAGNETISM

The generator revolving field (rotor) may be considered to be a permanent magnet. Some "residual" magnetism is always present in the rotor. This residual magnetism is sufficient to induce a voltage into the stator AC power windings that is approximately 2-12 volts AC.

FIELD BOOST**FIELD BOOST CIRCUIT:**

When the engine is cranking, direct current flow is delivered from a circuit board to the generator rotor windings, via Wire 4.

The field boost system is shown schematically in Figure 2. Manual and automatic engine cranking is initiated by circuit board action, when that circuit board energizes a crank relay. Battery voltage is then delivered to field boost Wire 4 (and to the rotor), via a field boost resistor and diode. The crank relay, field boost resistor and diode are all located on the circuit board.

Notice that field boost current is available only while the crank relay is energized, i.e., while the engine is cranking.

Field boost voltage is reduced from that of battery voltage by the resistor action and, when read with a DC voltmeter, will be approximately 9 or 10 volts DC.

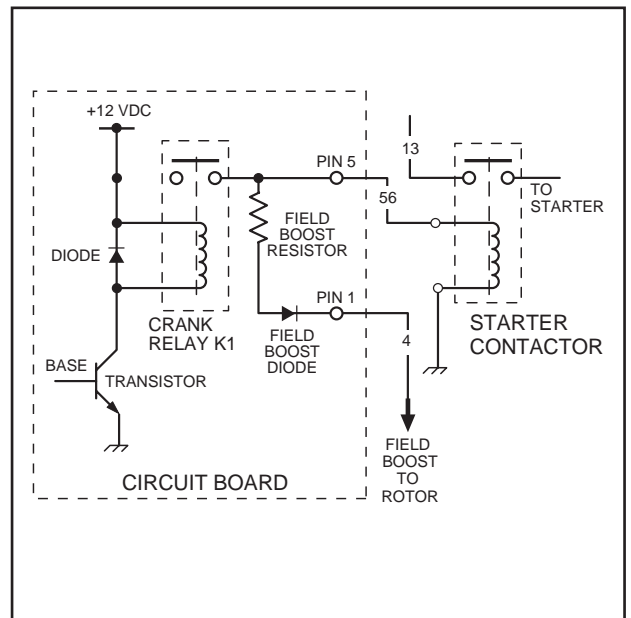

Figure 2. Field Boost Circuit Schematic

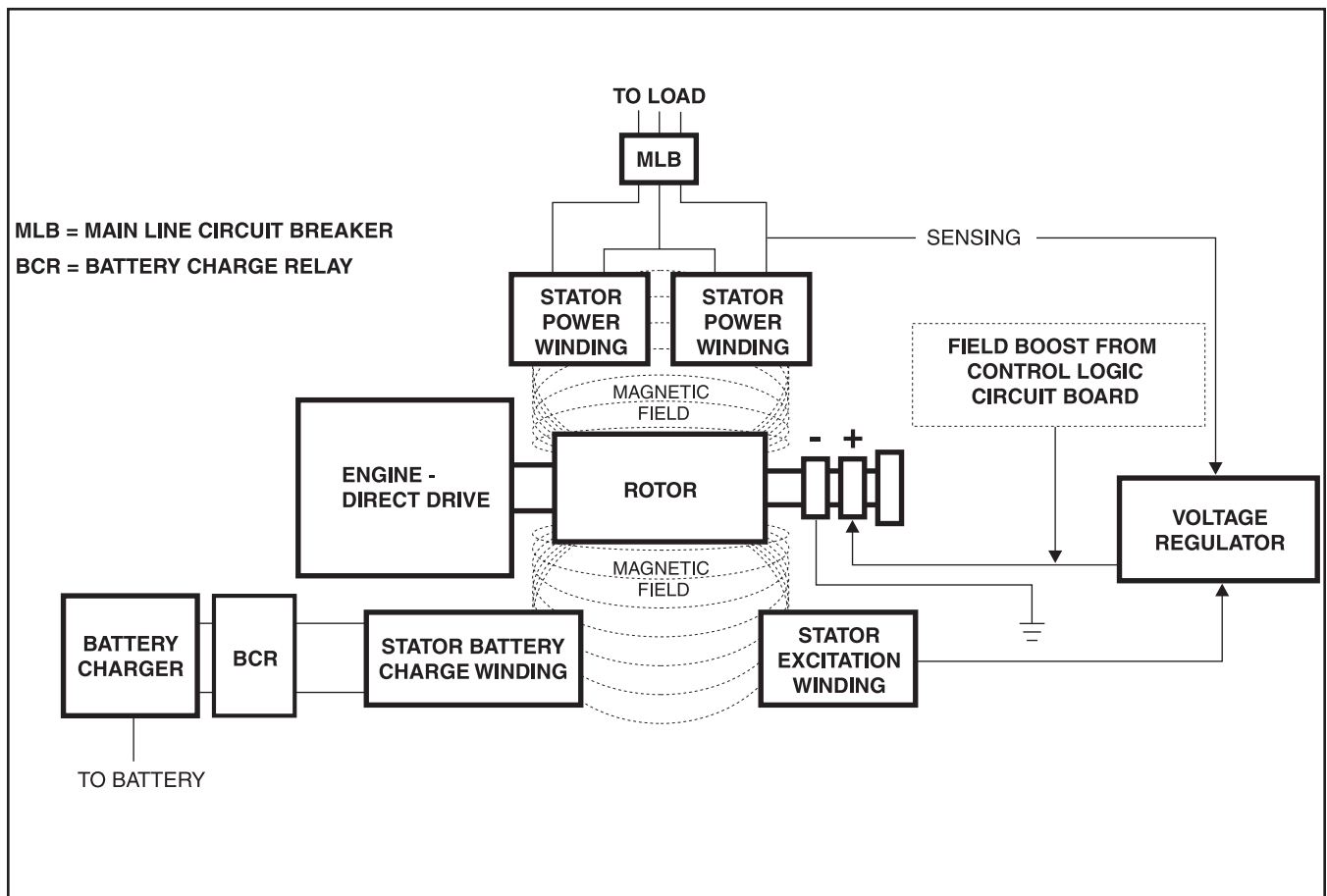

Figure 1. Operating Diagram of AC Generator

OPERATION

STARTUP:

When the engine is started, residual plus field boost magnetism from the rotor induces a voltage into (a) the stator AC power windings, (b) the stator excitation or DPE windings, and (c) the stator battery charge winding. In an "on-speed" condition, residual plus field boost magnetism are capable of creating approximately one-half the unit's rated voltage.

ON-SPEED OPERATION:

As the engine accelerates, the voltage that is induced into the stator windings increases rapidly, due to the increasing speed at which the rotor operates.

FIELD EXCITATION:

An AC voltage is induced into the stator excitation (DPE) windings. The DPE winding circuit is completed to the voltage regulator, via Wire 2 and Wire 6. Unregulated alternating current can flow from the winding to the regulator.

The voltage regulator "senses" AC power winding output voltage and frequency via stator Wires 11 and 22.

The regulator changes the AC from the excitation winding to DC. In addition, based on the Wires 11 and 22 sensing signals, it regulates the flow of direct current to the rotor.

The rectified and regulated current flow from the regulator is delivered to the rotor windings, via Wire 4, and the positive brush and slip ring. This excitation current flows through the rotor windings and is directed to ground through the negative (-) slip ring and brush, and Wire 0.

The greater the current flow through the rotor windings, the more concentrated the lines of flux around the rotor become.

The more concentrated the lines of flux around the rotor that cut across the stationary stator windings, the greater the voltage that is induced into the stator windings.

Initially, the AC power winding voltage sensed by the regulator is low. The regulator reacts by increasing the flow of excitation current to the rotor until voltage increases to a desired level. The regulator then maintains the desired voltage. For example, if voltage exceeds the desired level, the regulator will decrease the flow of excitation current. Conversely, if voltage drops below the desired level, the regulator responds by increasing the flow of excitation current.

AC POWER WINDING OUTPUT:

A regulated voltage is induced into the stator AC power windings. When electrical loads are connected across the AC power windings to complete the circuit, current can flow in the circuit. The regulated AC power winding output voltage will be in direct proportion to the AC frequency. For example, on units rated 120/240 volts at 60 Hz, the regulator will try to maintain 240 volts (line-to-line) at 60 Hz. This type of regulation system provides greatly improved motor starting capability over other types of systems.

BATTERY CHARGE WINDING OUTPUT:

A voltage is induced into the battery charge windings. Output from these windings is delivered to a battery charger, via Wires 66 and 77. The resulting direct current from the battery charger is delivered to the unit battery, via Wire 13. This output is used to maintain battery state of charge during operation.

GENERAL

Use the "Flow Charts" in conjunction with the detailed instructions in Section 2.4. Test numbers used in the flow charts correspond to the numbered tests in Section 2.4.

The first step in using the flow charts is to correctly identify the problem. Once that has been done, locate the problem on the following pages. For best results, perform all tests in the exact sequence shown in the flow charts.

Problem 1 – Generator Produces Zero Voltage or Residual Voltage

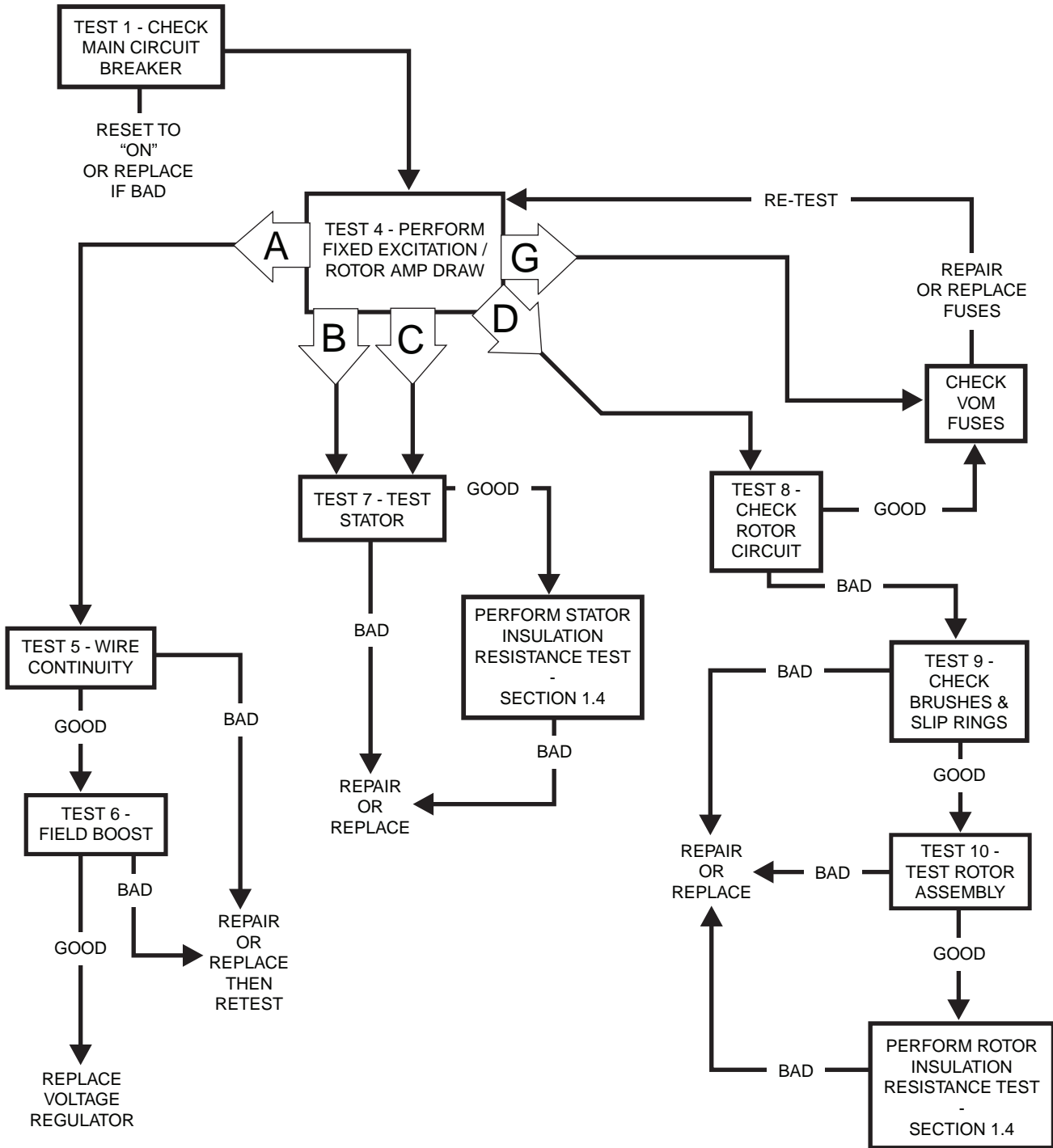

SECTION 2.3
TROUBLESHOOTING FLOWCHARTS

*Problem 1 – Generator Produces Zero Voltage or Residual Voltage
(Continued)*

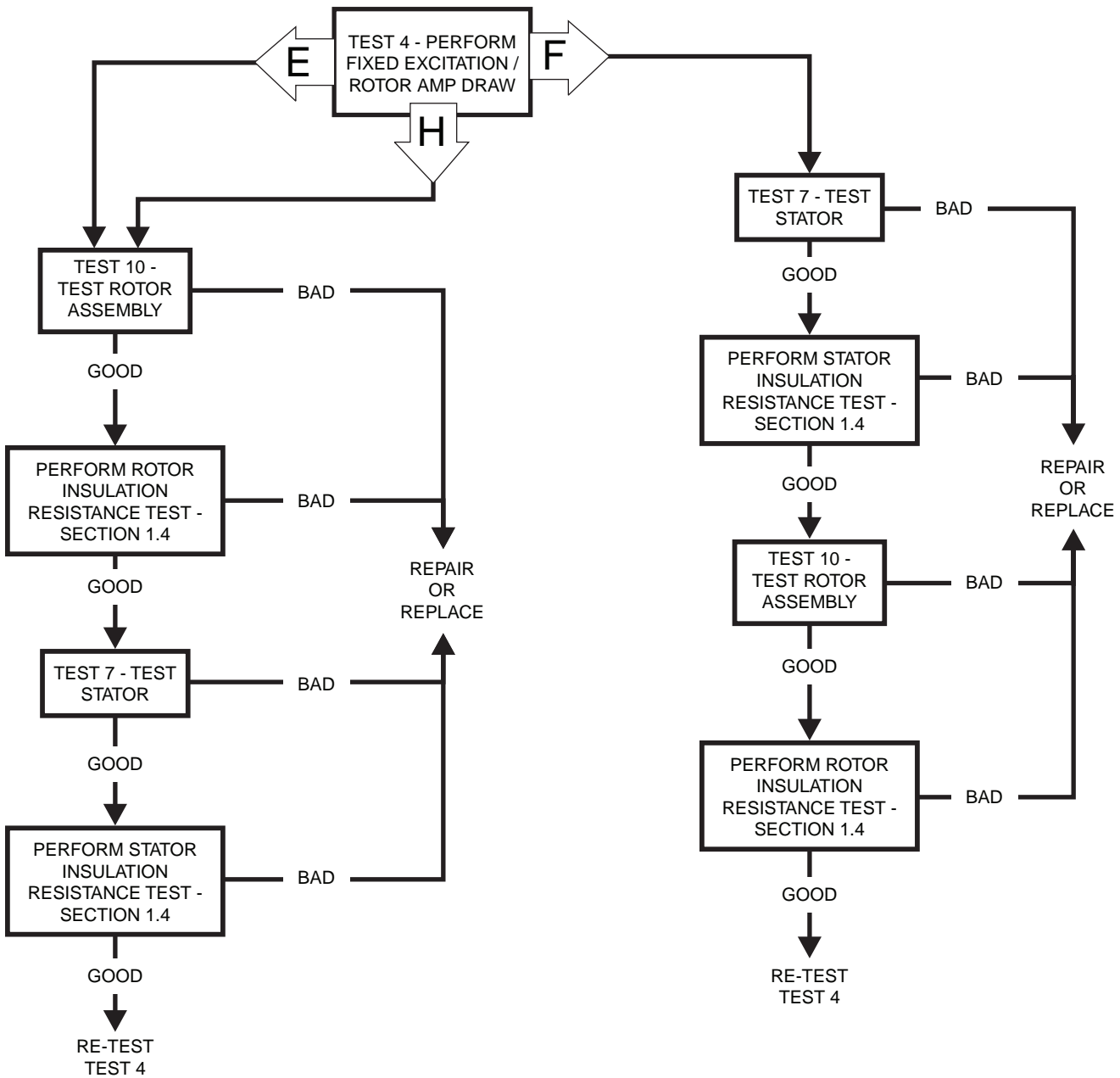

Problem 2 – Generator Produces Low Voltage at No-Load

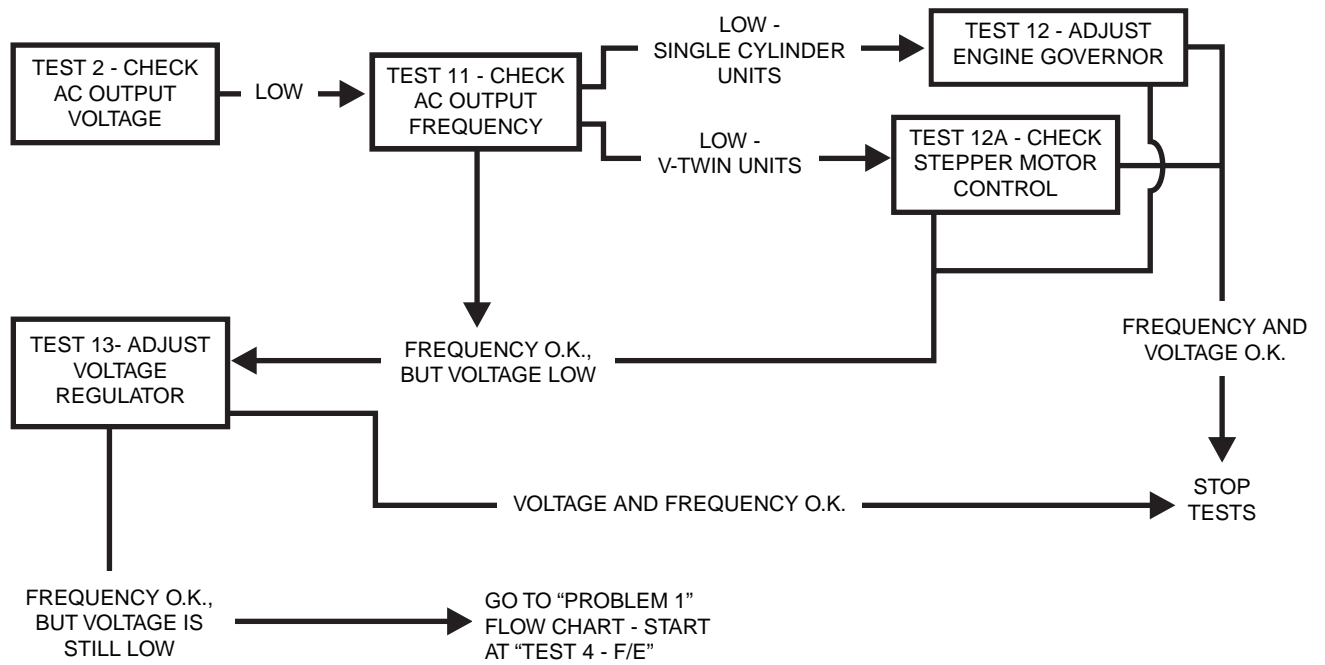

Problem 3 – Generator Produces High Voltage at No-Load

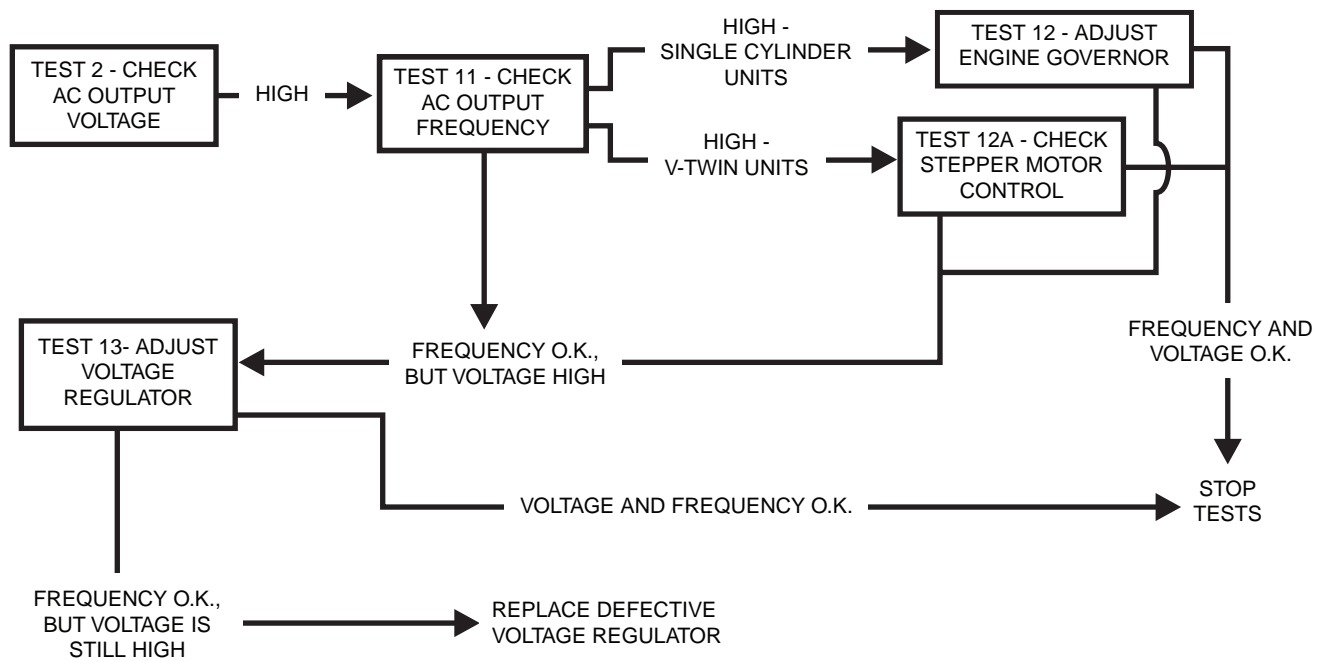

**SECTION 2.3
TROUBLESHOOTING FLOWCHARTS**

Problem 4 – Voltage and Frequency Drop Excessively When Loads are Applied

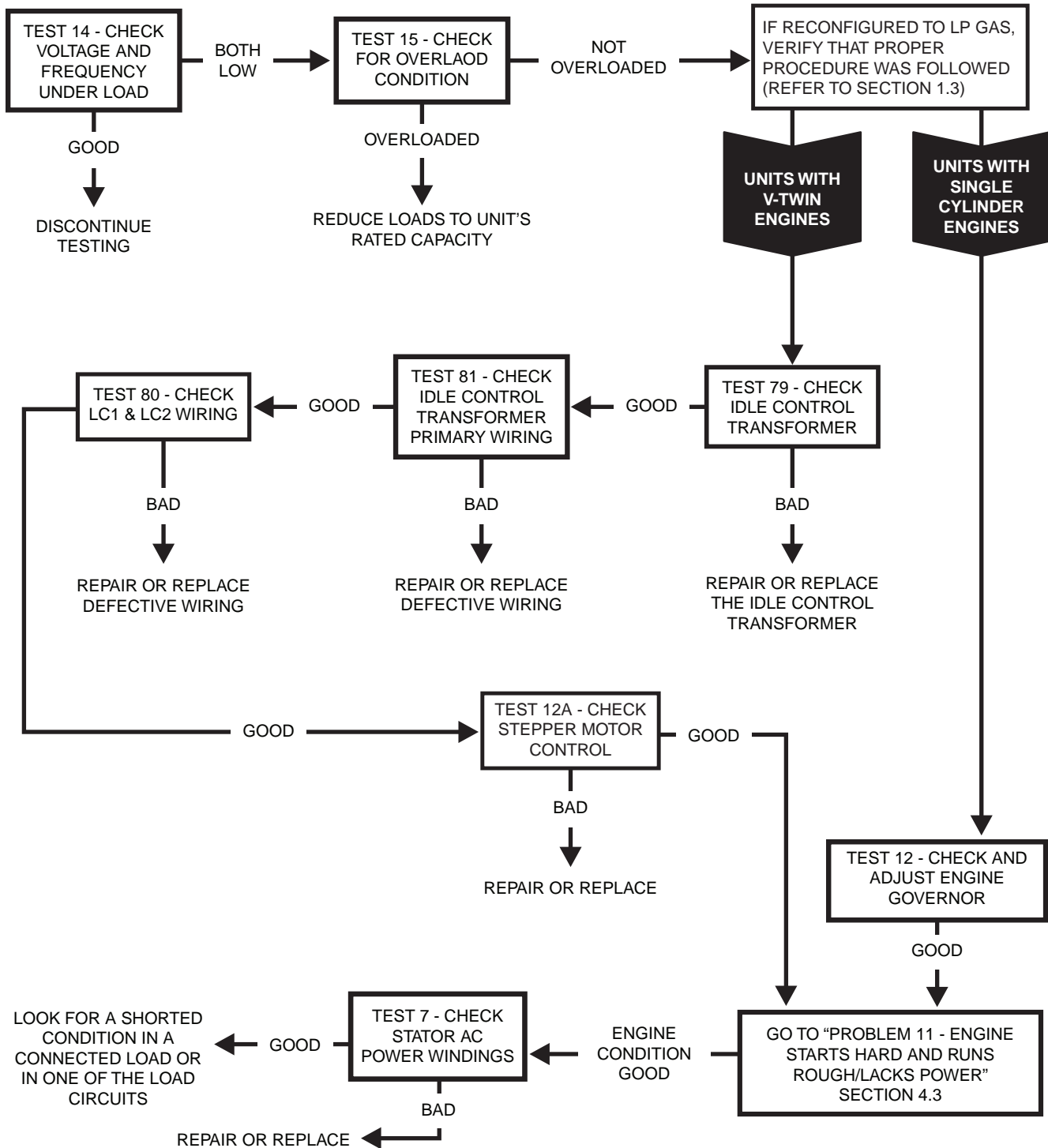

INTRODUCTION

This section is provided to familiarize the service technician with acceptable procedures for the testing and evaluation of various problems that could be encountered on standby generators with air-cooled engine. Use this section of the manual in conjunction with Section 2.3, "Troubleshooting Flow Charts". The numbered tests in this section correspond with those of Section 2.3.

Test procedures in this section do not require the use of specialized test equipment, meters or tools. Most tests can be performed with an inexpensive volt-ohm-milliammeter (VOM). An AC frequency meter is required, where frequency readings must be taken. A clamp-on ammeter may be used to measure AC loads on the generator.

Testing and troubleshooting methods covered in this section are not exhaustive. We have not attempted to discuss, evaluate and advise the home standby service trade of all conceivable ways in which service and trouble diagnosis might be performed. We have not undertaken any such broad evaluation. Accordingly, anyone who uses a test method not recommended herein must first satisfy himself that the procedure or method he has selected will jeopardize neither his nor the product's safety.

SAFETY

Service personnel who work on this equipment must be made aware of the dangers of such equipment. Extremely high and dangerous voltages are present that can kill or cause serious injury. Gaseous fuels are highly explosive and can be ignited by the slightest spark. Engine exhaust gases contain deadly carbon monoxide gas that can cause unconsciousness or even death. Contact with moving parts can cause serious injury. The list of hazards is seemingly endless.

When working on this equipment, use common sense and remain alert at all times. Never work on this equipment while you are physically or mentally fatigued. If you don't understand a component, device or system, do not work on it.

TEST 1 – CHECK MAIN CIRCUIT BREAKER**DISCUSSION:**

Often the most obvious cause of a problem is overlooked. If the generator main line circuit breaker is set to OFF or "Open", no electrical power will be supplied to electrical loads. If loads are not receiving power, perhaps the main circuit breaker is open or has failed.

PROCEDURE:

The generator main circuit breaker is located on the control panel. If loads are not receiving power, make sure the breaker is set to "On" or "Closed".

If you suspect the breaker may have failed, it can be tested as follows (see Figure 1):

1. Set a volt-ohm-milliammeter (VOM) to its "R x 1" scale and zero the meter.
2. With the generator shut down, disconnect all wires from the main circuit breaker terminals, to prevent interaction.
3. With the generator shut down, connect one VOM test probe to the Wire 11 terminal of the breaker and the other test probe to the Wire E1 terminal.
4. Set the breaker to its "On" or "Closed" position. The VOM should read CONTINUITY.
5. Set the breaker to its OFF or "Open" position and the VOM should indicate INFINITY.
6. Repeat Steps 4 and 5 with the VOM test probes connected across the breaker's Wire 44 terminal and the E2 terminal.

RESULTS:

1. If the circuit breaker tests good, go on to Test 2.
2. If the breaker tests bad, it should be replaced.

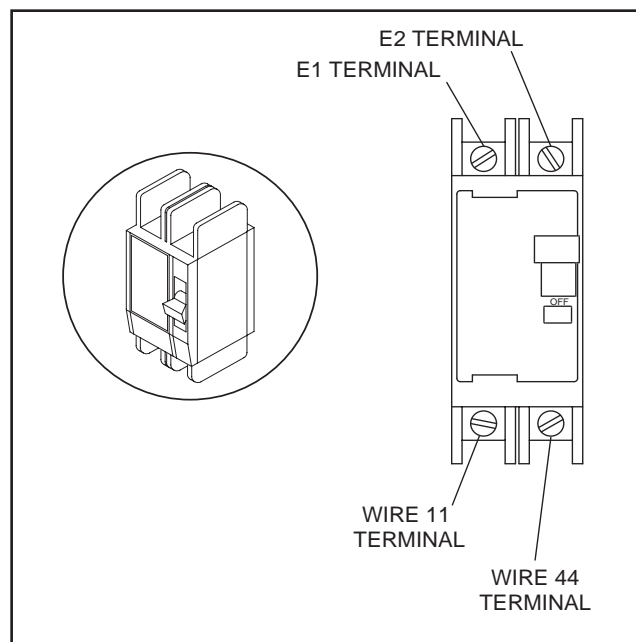

Figure 1. Generator Main Circuit Breaker Test Points

TEST 2 – CHECK AC OUTPUT VOLTAGE**DISCUSSION:**

A volt-ohm-milliammeter (VOM) may be used to check the generator output voltage. Output voltage may be checked at the unit's main circuit breaker terminals. Refer to the unit's DATA PLATE for rated line-to-line and line-to-neutral voltages.

SECTION 2.4 DIAGNOSTIC TESTS

PART 2

AC GENERATORS



DANGER: USE EXTREME CAUTION DURING THIS TEST. THE GENERATOR WILL BE RUNNING. HIGH AND DANGEROUS VOLTAGES WILL BE PRESENT AT THE TEST TERMINALS. CONNECT METER TEST CLAMPS TO THE HIGH VOLTAGE TERMINALS WHILE THE GENERATOR IS SHUT DOWN. STAY CLEAR OF POWER TERMINALS DURING THE TEST. MAKE SURE METER CLAMPS ARE SECURELY ATTACHED AND WILL NOT SHAKE LOOSE.

PROCEDURE:

1. With the engine shut down, connect the AC voltmeter test leads across the Wires 11 and 44 terminals of the generator main circuit breaker (see Figure 1). These connections will permit line-to-line voltages to be read.
2. Set the generator main circuit breaker to its OFF or "Open" position. This test will be conducted with the generator running at no-load.
3. Start the generator, let it stabilize and warm up for a minute or two.
4. Take the meter reading. On unit's having a rated line-to-line voltage of 240 volts, the no-load voltage should be about 242-252 volts AC.
5. Shut the engine down and remove the meter test leads.

RESULTS:

1. If zero volts or residual voltage is indicated, go on to Test 4.
2. If the voltage reading is higher than residual, but is lower than the stated limits, go to Test 11.
3. If a high voltage is indicated, go on to Test 11.

NOTE: "Residual" voltage may be defined as the voltage that is produced by rotor residual magnetism alone. The amount of voltage induced into the stator AC power windings by residual voltage alone will be approximately 2 to 16 volts AC, depending on the characteristics of the specific generator. If a unit is supplying residual voltage only, either excitation current is not reaching the rotor or the rotor windings are open and the excitation current cannot pass. On current units with air-cooled engine, "field boost" current flow is available to the rotor only during engine cranking.

TEST 4 – FIXED EXCITATION TEST/ ROTOR AMP DRAW TEST

DISCUSSION:

Supplying a fixed DC current to the rotor will induce a magnetic field in the rotor. With the generator running, this should create a proportional voltage output from the stator windings.

PROCEDURE:

1. Disconnect Wire 4 from the voltage regulator, 3rd terminal from the top. See Figure 2.
2. Connect a jumper wire to the disconnected Wire 4 and to the 12 volt fused battery supply Wire 15 (located at 15A fuse).
3. Set VOM to AC volts.

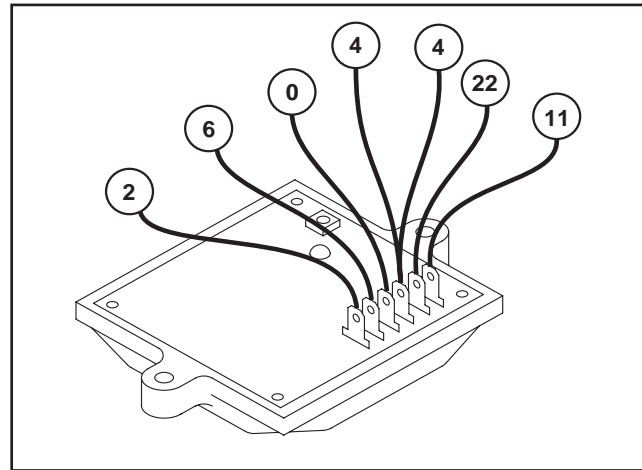

Figure 2. Voltage Regulator

4. Disconnect Wire 2 from the voltage regulator and connect one meter test lead to that wire. Disconnect Wire 6 from the voltage regulator and connect the other meter test lead to that wire. Wires 2 and 6 are located at the bottom two terminals of the voltage regulator (see Figure 2).
5. Set the AUTO-OFF-MANUAL switch to MANUAL. Once the engine starts, record the AC voltage.
6. Set the AUTO-OFF-MANUAL switch to OFF. Reconnect Wire 2 and Wire 6.
7. Disconnect Wire 11 from the voltage regulator and connect one meter test lead to that wire. Disconnect Wire 22 from the voltage regulator and connect the other meter test lead to that wire (both wires are located at the top two terminals of the voltage regulator, see Figure 2).
8. Set the AUTO-OFF-MANUAL switch to MANUAL. Once the engine starts, record the AC voltage.
9. Set the AUTO-OFF-MANUAL switch to OFF. Reconnect Wire 11 and Wire 22.
10. Set VOM to DC amperage.
11. Remove jumper lead connected to Wire 4 and Wire 15.
12. Connect one meter test lead to battery positive twelve-volt supply Wire 15, located at the 15A fuse. Connect the other meter test lead to Wire 4 (still disconnected from previous tests). Measure and record static rotor amp draw.

13. Set the AUTO-OFF-MANUAL switch to the MANUAL position. Once the engine starts, repeat Step 12. Measure and record running rotor amp draw with the engine running.

14. Set the AUTO-OFF-MANUAL switch to OFF. Reconnect Wire 4 to the voltage regulator.

RESULTS:

Refer to the chart on this page: "Results - Fixed Excitation Test/Rotor Amp Draw Test".

NOTE: See Page 4, "Model Identification" to identify which Figure to use.

EXAMPLE:

MODEL	7 kW
WIRE 2 & 6 VOLTAGE	87 VAC
WIRE 11 & 22 VOLTAGE	31 VAC
STATIC ROTOR AMP DRAW	1.0 AMP
RUNNING ROTOR AMP DRAW	1.0 AMP

These results match Column B in the chart. Refer back to Problem 1 Flow Chart and follow Letter B.

TEST 5 – WIRE CONTINUITY**DISCUSSION:**

The voltage regulator receives unregulated alternating current from the stator excitation winding, via Wires 2 and 6. It also receives voltage sensing from the stator AC power windings, via Wires 11 and 22. The regulator rectifies the AC from the excitation winding and based on the sensing signals, regulates the DC current flow to the rotor. The rectified and regulated current flow is delivered to the rotor brushes via Wires 4 (positive) and 0 (negative). This test will verify the integrity of Wire 0.

PROCEDURE:

1. Set VOM to its "R x 1" scale.
2. Remove Wire 0 from the voltage regulator, 4th terminal from the top. Also, voltage regulator is labeled (-) next to terminal.
3. Connect one test lead to Wire 0, connect the other test lead to a clean frame ground. The meter should read CONTINUITY.

RESULTS:

If CONTINUITY was not measured, repair or replace the wire as needed.

TEST 4 Results - Fixed Excitation Test/Rotor Amp Draw Test, Figure 1

Results:	Model #	A	B	C	D	E	F	G	H
Voltage Results Wire 2 & 6	ALL	Above 60 VAC	Above 60 VAC	Below 60 VAC	Zero or Residual Volts	Below 60 VAC	Below 60 VAC	Above 60 VAC	Below 60 VAC
Voltage Results Wire 11 & 22	ALL	Above 60 VAC	Below 60 VAC	Above 60 VAC	Zero or Residual Volts	Below 60 VAC	Below 60 VAC	Above 60 VAC	Below 60 VAC
Static Rotor Amp Draw	10 kW	1.8-1.2A	1.8-1.2A	1.8-1.2A	Zero Current Draw	Above 2.5A	1.8-1.2A	Zero Current Draw	1.8-1.2A
	13 kW	1.8-1.2A	1.8-1.2A	1.8-1.2A		Above 2.5A	1.8-1.2A		1.8-1.2A
	16 kW	1.6-1.1A	1.6-1.1A	1.6-1.1A		Above 2.5A	1.6-1.1A		1.6-1.1A
	18 kW	1.0-1.5A	1.0-1.5A	1.0-1.5A		Above 2.5A	1.0-1.5A		1.0-1.5A
Running Rotor Amp Draw	10 kW	1.8-1.2A	1.8-1.2A	1.8-1.2A	Zero Current Draw	Above 2.5A	1.8-1.2A	Zero Current Draw	Above 2.5A
	13 kW	1.8-1.2A	1.8-1.2A	1.8-1.2A		Above 2.5A	1.8-1.2A		Above 2.5A
	16 kW	1.6-1.1A	1.6-1.1A	1.6-1.1A		Above 2.5A	1.6-1.1A		Above 2.5A
	18 kW	1.0-1.5A	1.0-1.5A	1.0-1.5A		Above 2.5A	1.0-1.5A		Above 2.5A

← MATCH RESULTS WITH LETTER AND REFER TO FLOW CHART IN SECTION 2.3 "Problem 1" →

TEST 4 Results - Fixed Excitation Test/Rotor Amp Draw Test, Figure 2

Results:	Model #	A	B	C	D	E	F	G	H
Voltage Results Wire 2 & 6	ALL	Above 60 VAC	Above 60 VAC	Below 60 VAC	Zero or Residual Volts	Below 60 VAC	Below 60 VAC	Above 60 VAC	Below 60 VAC
Voltage Results Wire 11 & 22	ALL	Above 60 VAC	Below 60 VAC	Above 60 VAC	Zero or Residual Volts	Below 60 VAC	Below 60 VAC	Above 60 VAC	Below 60 VAC
Static Rotor Amp Draw	7 kW	1.2-0.8A	1.2-0.8A	1.2-0.8A	Zero Current Draw	Above 1.5A	1.2-0.8A	Zero Current Draw	1.2-0.8A
	10 kW	1.3-0.9A	1.3-0.9A	1.8-1.2A		Above 1.5A	1.3-0.9A		1.3-0.9A
	13 kW	1.2-0.8A	1.2-0.8A	1.8-1.2A		Above 1.5A	1.2-0.8A		1.2-0.8A
	16 kW	1.1-0.8A	1.1-0.8A	1.6-1.1A		Above 1.5A	1.1-0.8A		1.1-0.8A
Running Rotor Amp Draw	ALL	1.2-0.8A	1.2-0.8A	1.2-0.8A	Zero Current Draw	Above 1.5A	1.2-0.8A	Zero Current Draw	Above 1.5A

← MATCH RESULTS WITH LETTER AND REFER TO FLOW CHART IN SECTION 2.3 "Problem 1" →

TEST 6 – CHECK FIELD BOOST

DISCUSSION:

See “Field Boost Circuit” in Section 2.2. Field boost current (from the circuit board) is available to the rotor only while the engine is cranking. Loss of field boost output to the rotor may or may not affect power winding AC output voltage. The following facts apply:

- A small amount of voltage must be induced into the DPE winding to turn the voltage regulator on.
- If rotor residual magnetism is sufficient to induce a voltage into the DPE winding that is high enough to turn the voltage regulator on, regulator excitation current will be supplied even if field boost has failed. Normal AC output voltage will then be supplied.
- If rotor residual magnetism has been lost or is not sufficient to turn the regulator on, and field boost has also been lost, excitation current will not be supplied to the rotor. Generator AC output voltage will then drop to zero or nearly zero.

PROCEDURE:

1. Disconnect Wire 4 from the voltage regulator, third terminal from the top (see Figure 4).
2. Set a VOM to read DC volts.
3. Disconnect C2 Connector from the control panel (see Figure 3).
4. Connect the positive (+) VOM test probe to the terminal end of disconnected Wire 4.
5. Connect the common (-) VOM test probe to the grounding lug.
6. Crank the engine while observing the VOM reading. While the engine is cranking, the VOM should read approximately 9-10 volts DC. When engine is not cranking, VOM should indicate “zero” volts (see Figure 4).
7. Reconnect the C2 Connector and Wire 4.

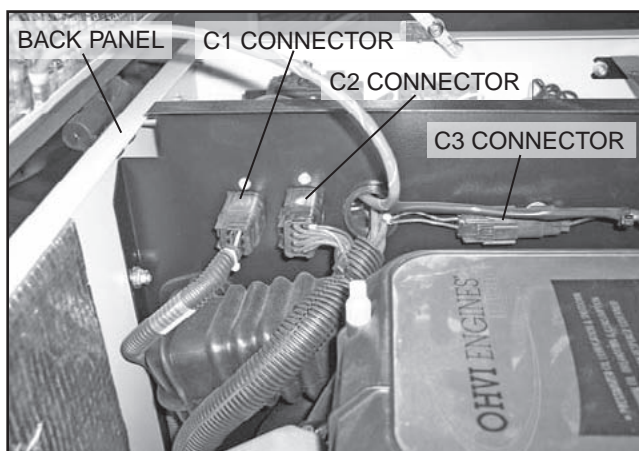

Figure 3. C2 Connector Location

RESULTS:

1. If normal field boost voltage is indicated in Step 6, replace the voltage regulator.
2. If normal field boost voltage is NOT indicated in Step 6, check Wire 4 (between regulator and circuit board) for open or shorted condition. If wire is good, replace the circuit board.

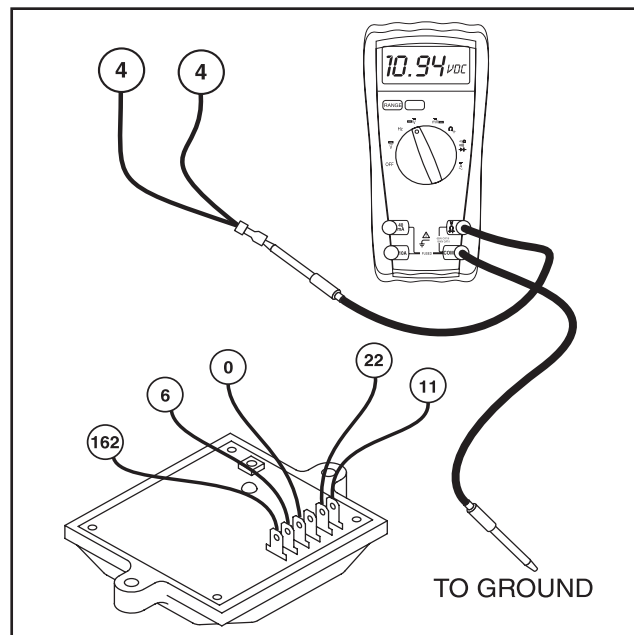

Figure 4. Field Boost Test Points

TEST 7 – TESTING THE STATOR WITH A VOM

DISCUSSION:

A Volt-Ohm-Milliammeter (VOM) can be used to test the stator windings for the following faults:

- An open circuit condition
- A “short-to-ground” condition
- A short circuit between windings

Note: The resistance of stator windings is very low. Some meters will not read such a low resistance, and will simply indicate CONTINUITY. Recommended is a high quality, digital type meter capable of reading very low resistances.

PROCEDURE:

1. Disconnect stator leads 11 and 44 from the main circuit breaker.
2. Disconnect stator leads 22 and 33 from the neutral connection separate the leads.
3. Disconnect C2 Connector from the side of the control panel (see Figure 3).
4. Make sure all of the disconnected leads are isolated

from each other and are not touching the frame during the test.

5. **Set a VOM to measure resistance.**
6. Refer to Figure 5 for pin locations of C2 Connector. Use a large paper clip or similar metallic object to access pins in C2 Connector (Female Side).

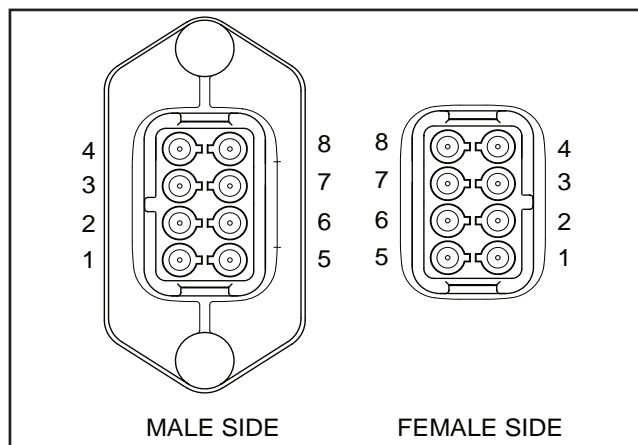

Figure 5. C2 Connector Pin Locations

Pin Location	Wire Number	Winding
1	77	Battery Charge
2	66	Battery Charge
3	22S	Sense Lead Power
4	11S	Sense Lead Power
5	6	Excitation
6	2	Excitation
7	0	Ground
8	4	Positive to Brush

7. Connect one test lead to stator lead Wire 11. Connect the other test lead to stator lead Wire 22 (power winding). Note the resistance reading and compare to the specifications in the front of this manual.
 8. Connect one test lead to stator lead Wire 33. Connect the other test lead to stator lead Wire 44 (power winding). Note the resistance reading and compare to the specifications in the front of this manual.
 9. Connect one test lead to Pin 1. Connect the other test lead to Pin 2 (battery charge winding). Note the resistance reading, compare to specifications in the front of this manual.
 10. Connect one test lead to Pin 3. Connect the other test lead to Pin 4 (power winding-sense leads). Note the resistance reading, compare to specification in the front of this manual.
 11. Connect on test lead to Pin 5. Connect the other test lead to Pin 6 (excitation winding). Note the resistance reading, compare to specifications in the front of this manual.
- TEST WINDINGS FOR A SHORT TO GROUND:
12. Make sure all leads are isolated from each other and are not touching the frame.
 13. Connect one test lead to a clean frame ground. Connect the other test lead to stator lead Wire 11.
 - a. The meter should read INFINITY.
 - b. Any reading other than INFINITY indicates a "short-to-ground" condition.
 14. Repeat Step 13 using stator lead Wire 33.
 15. Repeat Step 13 using Pin 1.
 16. Repeat Step 13 using Pin 3.
 17. Repeat Step 13 using Pin 5.
- TEST FOR A SHORT CIRCUIT BETWEEN WINDINGS:
18. Connect one test lead to stator lead Wire 11. Connect the other test lead to stator lead Wire 33.
 - a. The meter should read INFINITY.
 - b. Any reading other than INFINITY indicates a short circuit between windings.
 19. Repeat Step 18 using stator lead Wire 11; Pin 1.
 20. Repeat Step 18 using stator lead Wire 11; Pin 5.
 21. Repeat Step 18 using stator lead Wire 33; Pin 1.
 22. Repeat Step 18 using stator lead Wire 33; Pin 5.
 23. Repeat Step 18 using Pin 1; Pin 3.
 24. Repeat Step 18 using Pin 1; Pin 5.
 25. Repeat Step 18 using Pin 3; Pin 5.
- TEST CONTROL PANEL WIRES FOR CONTINUITY:
26. Disconnect the C2 Connector from the control panel. Refer to Figure 5 for the pin locations (**Male Side**).
 27. Connect one meter test lead to Pin 3 of the C2 Connector (Male Side), connect the other test lead to Wire 22 at the voltage regulator. CONTINUITY should be measured.
 28. Connect one meter test lead to Pin 4 of the C2 Connector (Male Side), connect the other test lead to Wire 11 at the voltage regulator. CONTINUITY should be measured.
 29. Connect one meter test lead to Pin 5 of the C2 Connector (Male Side), connect the other test lead to Wire 6 at the voltage regulator. CONTINUITY should be measured.
 30. Connect one meter test lead to Pin 6 of the C2 Connector (Male Side), connect the other test lead to Wire 2. CONTINUITY should be measured at the voltage regulator.

SECTION 2.4 DIAGNOSTIC TESTS

RESULTS:

1. Stator winding resistance values is a test of winding continuity and resistance. If a very high resistance or INFINITY is indicated, the winding is open or partially open.
2. Testing for a "grounded" condition: Any resistance reading indicates the winding is grounded.
3. Testing for a "shorted" condition: Any resistance reading indicates the winding is shorted.
4. If the stator tests good and wire continuity tests good, perform "Insulation Resistance Test" in Section 1.4.
5. If any test of wire continuity failed in the control panel, repair or replace the wire, terminal or pin connectors for that associated wire as needed.

NOTE: Read Section 1.4, "Testing, Cleaning and Drying" carefully. If the winding tests good, perform an insulation resistance test. If the winding fails the insulation resistance test, clean and dry the stator as outlined in Section 1.4. Then, repeat the insulation resistance test. If the winding fails the second resistance test (after cleaning and drying), replace the stator assembly.

TEST 8 – RESISTANCE CHECK OF ROTOR CIRCUIT

DISCUSSION:

To verify the zero current draw reading and measure the rotor circuit.

PROCEDURE:

1. Disconnect Wire 4 from the voltage regulator. It is located 3rd terminal from the top of the volt regulator.
2. Set VOM to measure resistance.
3. Connect one test lead to Wire 4. Connect the other test lead to a clean frame ground. Note the resistance reading. Compare to specifications in the front of this manual.

RESULTS:

1. If the resistance reading is correct, check your VOM meters fuse and repeat Test 4.
2. If INFINITY is measured on your VOM meter, go to Test 9.

TEST 9 – CHECK BRUSHES AND SLIP RINGS

DISCUSSION:

The function of the brushes and slip rings is to provide for passage of excitation current from stationary components to the rotating rotor. Brushes are made of a special long lasting material and seldom wear

out or fail. However, slip rings can develop a tarnish or film that can inhibit or offer a resistance to the flow of electricity. Such a non-conducting film usually develops during non-operating periods. Broken or disconnected wiring can also cause loss of excitation current to the rotor.

PROCEDURE:

1. Disconnect C2 Connector. Refer to Figure 3 on Page 40.
2. Set a VOM to measure resistance.

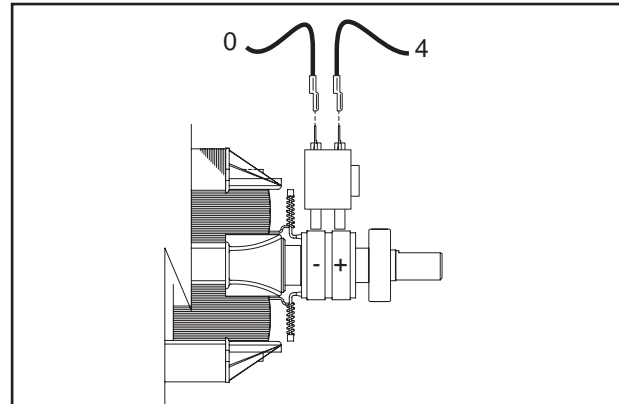

Figure 6. Checking Brushes and Slip Rings

3. Connect one meter test lead to Pin 7 (Wire 0) of the C2 Connector (female side). Connect the other meter test lead to Pin 8 (Wire 4) of the C2 Connector (female side). Rotor resistance should be measured (see Specifications in front of book). If rotor resistance is not measured proceed to Step 4. If rotor resistance is measured proceed to Step 12. Refer to Figure 5.
4. See Figure 6. Carefully inspect brush wires; make sure they are properly and securely connected.
5. Wire 0 from the negative (-) brush terminal connects to Pin 7 of the C2 Connector. Test this wire for an open condition. Remove Wire 0 from the brush assembly. Connect one meter test lead to Wire 0. Connect the other test lead to Pin 7 (Wire 0) of the C2 Connector (female side). CONTINUITY should be measured. If INFINITY is measured repair or replace Wire 0 between the brush assembly and the C2 Connector.
6. Wire 4 from the positive (+) brush terminal connects to Pin 8 of the C2 Connector. Test this wire for an open condition. Remove Wire 4 from the brush assembly. Connect one meter test lead to Wire 4. Connect the other meter test lead to Pin 8 (Wire 0) of the C2 Connector (female side). CONTINUITY should be measured. If INFINITY is measured repair or replace Wire 4 between the brush assembly and the C2 Connector.

7. Connect one meter test lead to Wire 4 Connect the other meter test lead to frame ground. INFINITY should be measured. If CONTINUITY is measured a short to ground exists on Wire 4 repair or replace Wire 4 between the brush assembly and the C2 Connector.
8. If CONTINUITY was measured in Steps 5 and 6 proceed to Step 9.
9. Disconnect Wire 0 and Wire 4 from the brush assembly. Remove the brush assembly from the bearing carrier. Inspect the brushes for excessive wear, or damage.
10. Inspect the rotor slip rings. If they appear dull or tarnished, they may be polished with a fine sandpaper. DO NOT USE METALLIC GRIT TO POLISH SLIP RINGS.
11. If brush assembly and slip rings look good proceed to Test 10 (Test Rotor Assembly)
12. Wire 0 connects from the C2 Connector to the control panel ground lug. Connect one meter test lead to Pin 7 (Wire 0) of the C2 Connector (male side). Connect the other meter test lead to the ground terminal in the control panel. CONTINUITY should be measured. If INFINITY is measured repair or replace Wire 0 between the C2 Connector and the ground terminal.
13. Remove Wire 4 from the voltage regulator.
14. Connect one meter test lead to Pin 8 (Wire 4) of the C2 Connector (male side). Connect the other meter test lead to Wire 4 removed from the Voltage regulator. CONTINUITY should be measured. If INFINITY is measured repair or replace Wire 4 between the C2 Connector and the voltage regulator.

RESULTS:

1. Repair, replace or reconnect wires as necessary.
2. Replace any damaged slip rings or brush holder.
3. Clean and polish slip rings as required.

TEST 10 – TEST ROTOR ASSEMBLY**DISCUSSION:**

A rotor having completely open windings will cause loss of excitation current flow and, as a result, generator AC output voltage will drop to “residual” voltage. A “shorted” rotor winding can result in a low voltage condition.

PROCEDURE:

1. Disconnect the brush wires or remove the brush holder, to prevent interaction.
2. Set a VOM to measure resistance.
3. Connect the positive (+) VOM test lead to the posi-

tive (+) rotor slip ring (nearest the rotor bearing); and the common (-) test lead to the negative (-) slip ring. The meter should read rotor resistance. Compare to “Specifications,” in the front of this manual.

4. Connect the positive (+) VOM test lead to the positive (+) slip ring and the common (-) test lead to a clean frame ground. The meter should indicate INFINITY.

RESULTS:

1. Replace rotor assembly if it is open or shorted.
2. If rotor tests good, perform “Insulation Resistance Test” in Section 1.4.

NOTE: Be sure to read Section 1.4, “Testing, Cleaning and Drying”, carefully. If the rotor tests good, try performing an insulation resistance test. Clean and dry the rotor if it fails that test. Then, repeat the test. If the rotor fails the second insulation resistance test, it should be replaced.

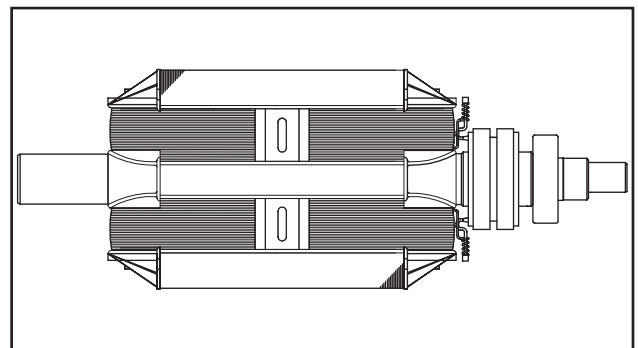

Figure 7. The Rotor Assembly

TEST 11 – CHECK AC OUTPUT FREQUENCY**DISCUSSION:**

The generator AC frequency is proportional to the operating speed of the rotor. The 2-pole rotor will supply a 60 Hertz AC frequency at 3600 rpm. The unit's AC output voltage is proportional to the AC frequency. For example, a unit rated 240 volts (line-to-line) will supply that rated voltage (plus or minus 2 percent) at a frequency of 60 Hertz. If, for any reason, the frequency should drop to 30 Hertz, the line-to-line voltage will drop to a matching voltage of 120 volts AC. Thus, if the AC voltage output is high or low and the AC frequency is correspondingly high or low, the engine speed governor may require adjustment.

PROCEDURE:

1. Connect an accurate AC frequency meter across the Wires 11 and 44 terminals of the generator main line circuit breaker (see Figure 1, Section 2.4).

2. Start the engine, let it stabilize and warm up at no-load.
3. When engine has stabilized, read the frequency meter. The no-load frequency for single cylinder units should be about 62-63 Hertz. For V-Twin units, the no-load frequency should be about 57.5-59.5 Hertz.

RESULTS:

1. If the AC frequency is high or low, go on to Test 12 for single cylinder units, or Test 12A for V-Twin units.
2. If frequency is good, but voltage is high or low, go to Test 13.
3. If frequency and voltage are both good, tests may be discontinued.

TEST 12 – CHECK AND ADJUST ENGINE GOVERNOR (SINGLE CYLINDER UNITS)

DISCUSSION:

The generator AC frequency output is directly proportional to the speed of the rotor. A two-pole rotor (having a single north and a single south magnetic pole) will produce an AC frequency of 60 hertz at 3600 RPM.

The generator is equipped with a “voltage over frequency” type AC voltage regulator. The units AC output voltage is generally proportional to AC frequency. A low or high governor speed will result in a correspondingly low or high AC frequency and voltage output. The governed speed must be adjusted before any attempt to adjust the voltage regulator is made.

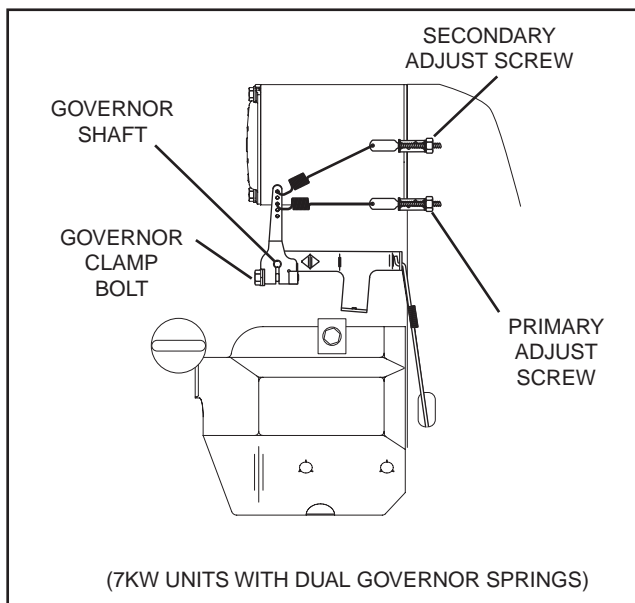

Figure 8. Engine Governor Adjustment Single Cylinder Engines

PROCEDURE

(6/7 kW UNITS WITH DUAL GOVERNOR SPRINGS):

1. Loosen the governor clamp bolt (Figure 8).
2. Hold the governor lever at its wide open throttle position, and rotate the governor shaft clockwise as far as it will go. Then, tighten the governor lever clamp bolt to 70 inch-pounds (8 N-m).
3. Start the generator; let it stabilize and warm up at no-load.
4. Connect a frequency meter across the generators AC output leads.
5. Turn the primary adjust screw to obtain a frequency reading of 61.5 Hz. Turn the secondary adjust screw to obtain a frequency reading of 62.5 Hz.
6. When frequency is correct at no load, check the AC voltage reading. If voltage is incorrect, the voltage regulator may require adjustment.

RESULTS:

1. If, after adjusting the engine governor, frequency and voltage are good, tests may be discontinued.
2. If frequency is now good, but voltage is high or low, go to Test 13.
3. If engine was overspeeding, check linkage and throttle for binding. If no governor response is indicated refer to engine service manual.
4. If engine appears to run rough and results in low frequency, proceed to Problem 11, Section 4.3.

TEST 12A – CHECK STEPPER MOTOR CONTROL (V-TWIN ENGINE UNITS)

PROCEDURE:

1. Remove air cleaner cover to access stepper motor.
2. Physically grab the throttle and verify the stepper motor, linkage and throttle do not bind in any way, if any binding is felt repair or replace components as needed. Some resistance should be felt as the stepper motor moves through it's travel.
3. Physically move the throttle to the closed position by pulling the stepper motor arm towards the idle stop. See Figures 9 and 10 (for 9/10 kW units) or Figure 11 (for 13/16/18 kW Units).
 - a. Place the AUTO-OFF-MANUAL switch (SW1) to MANUAL and watch for stepper motor movement. It should move to the wide open position during cranking. Once the unit starts the stepper motor should move the throttle to a position to maintain 57.5-59.5 Hertz.

4. If no movement is seen in Step 3 remove the control panel cover. Verify the six pin connector on the printed circuit board is seated properly, remove the connector and then replace it and test again. Verify the switches are correctly set.
5. If problem continues remove six pin connector from printed circuit board. Set Volt meter to measure ohms. Carefully measure from the end of the six pin harness as follows:

NOTE: Press down with the meter leads on the connectors exposed terminals, do not probe into the connector.

- a. Connect one meter lead to Red, connect the remaining test lead to Orange, approximately 10 ohms should be measured.
- b. Connect one meter lead to Red, connect the remaining test lead to Yellow, approximately 10 ohms should be measured.

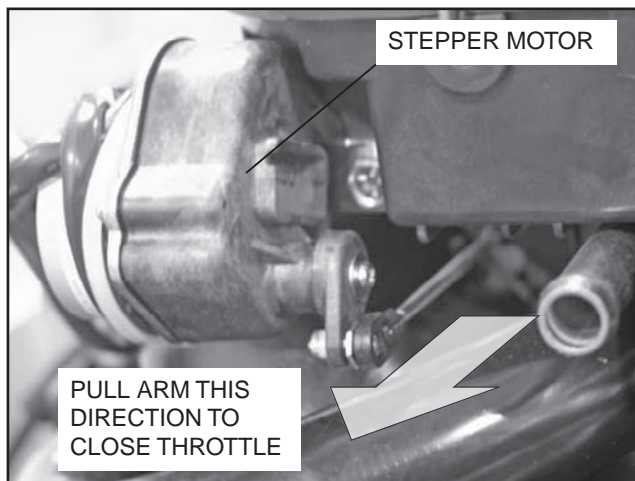

Figure 9. Throttle Positions 9/10 kW Units

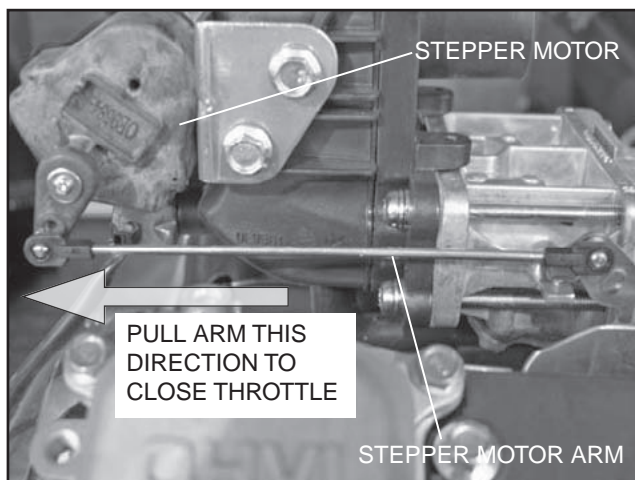

Figure 10. Throttle Positions 9/10 kW Units

- c. Connect one meter lead to Red, connect the remaining test lead to Brown, approximately 10 ohms should be measured.
- d. Connect one meter lead to Red, connect the remaining test lead to Black, approximately 10 ohms should be measured.
- e. Connect one meter lead to Red, connect the remaining test to the stepper motor case. No resistance should be measured INFINITY or Open.

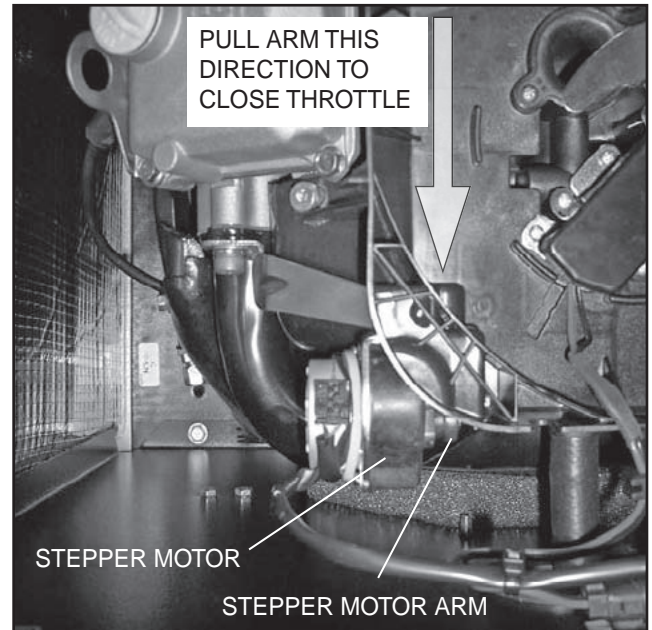

Figure 11. Throttle Positions 13/16 kW Units

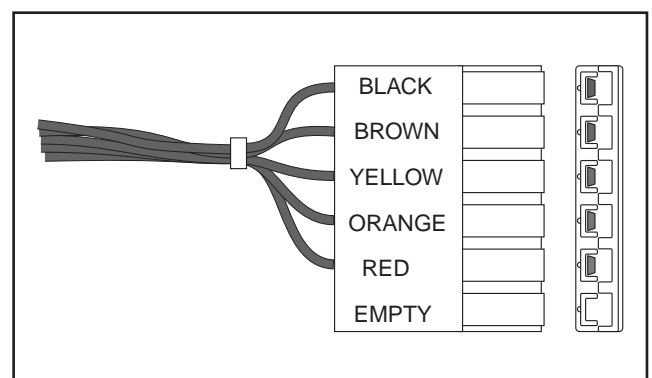

Figure 12. Six Pin Connector Wire Colors

RESULTS:

1. If the stepper motor fails any part of Step 5 replace the stepper motor.
2. If the stepper motor passes all steps replace the Printed Circuit Board.

**TEST 13 – CHECK AND ADJUST VOLTAGE
REGULATOR**

DISCUSSION:

For additional information, refer to description and components Section 2.1.

PROCEDURE (SINGLE CYLINDER UNITS):

With the frequency between 62-63 Hertz, slowly turn the slotted potentiometer (Figure 13) until line voltage reads 247-252 volts.

PROCEDURE (V-TWIN ENGINE UNITS):

With the frequency between 58-59 Hertz, slowly turn the slotted potentiometer (Figure 13) until line voltage reads 250-252 volts.

NOTE: You must remove the access panel on top of the control panel to adjust the voltage regulator.

NOTE: The voltage regulator is housed above the generator control panel. The regulator maintains a voltage in direct proportion to frequency at a 2-to-1 ratio. For example, at 62 Hertz, line-to-neutral voltage will be 124 volts.

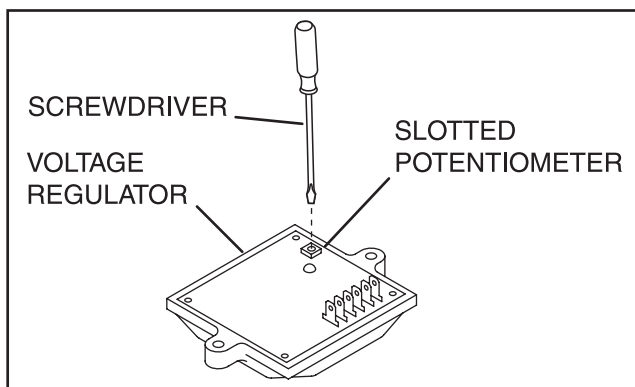

Figure 13. Voltage Adjustment Potentiometer

RESULTS:

1. If the frequency and voltage are now good, discontinue tests.
2. If frequency is now good but voltage is high or low, go to Problem 1, Test 4.

**TEST 14 – CHECK VOLTAGE AND
FREQUENCY UNDER LOAD**

DISCUSSION:

It is possible for the generator AC output frequency and voltage to be good at no-load, but they may drop excessively when electrical loads are applied. This condition, in which voltage and frequency drop excessively when loads are applied, can be caused by (a) overloading the generator, (b) loss of engine power, or (c) a shorted condition in the stator windings or in one or more connected loads.

PROCEDURE:

1. Connect an accurate AC frequency meter and an AC voltmeter across the stator AC power winding leads.
2. Start the engine, let it stabilize and warm-up.
3. Apply electrical loads to the generator equal to the rated capacity of the unit.
4. Check the AC frequency and voltage.
 - a. Single Cylinder Units: Frequency should not drop below approximately 58 Hertz. Voltage should not drop below about 230 volts.
 - b. V-Twin Engine Units: Frequency should not drop below approximately 60 Hertz. Voltage should not drop below about 240 volts.

RESULTS:

1. If frequency and voltage drop excessively under load, go to Test 15.
2. If frequency and voltage under load are good, discontinue tests.

TEST 15 – CHECK FOR OVERLOAD CONDITION

DISCUSSION:

An “overload” condition is one in which the generator rated wattage/amperage capacity has been exceeded. To test for an overload condition on an installed unit, the best method is to use an ammeter. See “Measuring Current” in Section 1.4.

PROCEDURE:

Use a clamp-on ammeter to measure load current draw, with the generator running and all normal electrical loads turned on.

RESULTS:

1. If the unit is overloaded, reduce loads to the unit’s rated capacity.
2. If unit is not overloaded, but rpm and frequency drop excessively when loads are applied, go to Test 16.

TEST 16 – CHECK ENGINE CONDITION

DISCUSSION:

If engine speed and frequency drop excessively under load, the engine may be under-powered. An under-powered engine can be the result of a dirty air cleaner, loss of engine compression, faulty fuel settings, incorrect ignition timing, etc.

PROCEDURE:

For engine testing, troubleshooting and repair procedures refer to Problem 11 in Section 4.3. For further engine repair information refer to the appropriate engine service manuals.

PART 3 “W/V-TYPE” TRANSFER SWITCHES

Air-cooled, Automatic Standby Generators

TABLE OF CONTENTS		
PART	TITLE	PG#
3.1.	Description and Components	50
3.2	Operational Analysis	54
3.3	Troubleshooting Flow Charts	64
3.4	Diagnostic Tests	66

<p>3.1 Description and Components 50</p> <p style="padding-left: 20px;">General50</p> <p style="padding-left: 20px;">Enclosure50</p> <p style="padding-left: 20px;">Transfer Mechanism.....51</p> <p style="padding-left: 20px;">Transfer Relay51</p> <p style="padding-left: 20px;">Neutral Lug52</p> <p style="padding-left: 20px;">Manual Transfer Handle52</p> <p style="padding-left: 20px;">Terminal Block52</p> <p style="padding-left: 20px;">Fuse Holder53</p> <p>3.2 Operational Analysis 54</p> <p style="padding-left: 20px;">Utility Source Voltage Available56</p> <p style="padding-left: 20px;">Utility Source Voltage Failure57</p> <p style="padding-left: 20px;">Transfer To Standby58</p> <p style="padding-left: 20px;">Transfer To Standby59</p> <p style="padding-left: 20px;">Utility Restored.....60</p> <p style="padding-left: 20px;">Utility Restored, Transfer Switch De-energized.....61</p> <p style="padding-left: 20px;">Utility Restored, Retransfer Back To Utility62</p> <p style="padding-left: 20px;">Transfer Switch In Utility.....63</p> <p>3.3 Troubleshooting Flow Charts 64</p> <p style="padding-left: 20px;">Introduction To Troubleshooting64</p> <p style="padding-left: 20px;">Problem 5 – In Automatic Mode, No Transfer to Standby64</p> <p style="padding-left: 20px;">Problem 6 – In Automatic Mode, Generator Starts When Loss of Utility Occurs, Generator Shuts Down When Utility Returns But There Is No Retransfer To Utility Power.....65</p> <p style="padding-left: 20px;">Problem 7 – Blown F1 or F2 Fuse65</p>	<p>3.4 Diagnostic Tests 66</p> <p style="padding-left: 20px;">General66</p> <p style="padding-left: 20px;">Test 21 – Check Voltage at Terminal Lugs E1, E266</p> <p style="padding-left: 20px;">Test 22 – Check Voltage at Standby Closing Coil C267</p> <p style="padding-left: 20px;">Test 23 – Test Transfer Relay TR.....67</p> <p style="padding-left: 20px;">Test 24 – Check Manual Transfer Switch Operation68</p> <p style="padding-left: 20px;">Test 25 – Test Limit Switch XB169</p> <p style="padding-left: 20px;">Test 26 – Check 23 And 194 Wiring/Connections69</p> <p style="padding-left: 20px;">Test 27- Check Voltage At Terminal Lugs N1, N2.....70</p> <p style="padding-left: 20px;">Test 28 – Check Voltage At Utility 1 And Utility 2 Terminals.....70</p> <p style="padding-left: 20px;">Test 29 – Check Voltage At Utility Closing Coil C171</p> <p style="padding-left: 20px;">Test 30 – Check Fuses F1 And F2.....71</p> <p style="padding-left: 20px;">Test 31 – Test Limit Switch Xa172</p> <p style="padding-left: 20px;">Test 32 – Continuity Test Of Wiring (C1)72</p> <p style="padding-left: 20px;">Test 33 – Continuity Test Of Wiring (C2)72</p> <p style="padding-left: 20px;">Test 34 – Check N1 And N2 Wiring.....73</p> <p style="padding-left: 20px;">Test 35 – Check Transformer (Tx)73</p>
---	---

SECTION 3.1 DESCRIPTION & COMPONENTS

PART 3

"W/V-TYPE" TRANSFER SWITCHES

GENERAL

The "W/V-Type" transfer switch is rated 100 amps at 250 volts maximum. It is available in 2-pole configuration only and, for that reason, is usable with 1-phase systems only.

Transfer switches do not have an intelligence system of their own. Instead, automatic operation of these transfer switches is controlled by a circuit board housed in the generator control panel.

ENCLOSURE

The "W/V-Type" transfer switch enclosure is a NEMA 1 type ("NEMA" stands for "National Electrical Manufacturer's Association"). Based on NEMA Standard 250, the NEMA 1 enclosure may be defined as one that is intended for indoor use primarily to provide a degree of protection against contact with the enclosed equipment and where unusual service conditions do not exist.

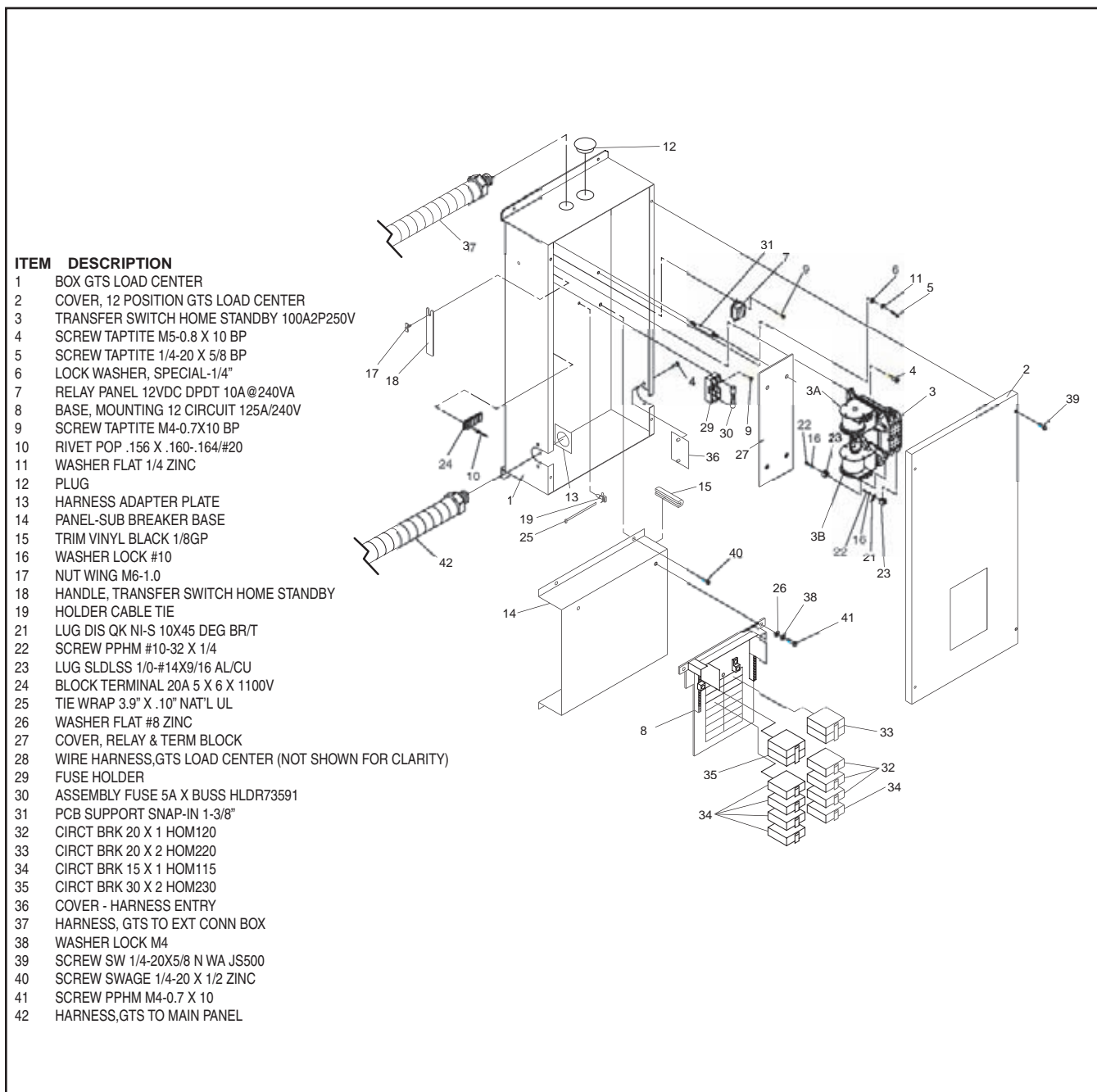

Figure 1. Exploded View of W/V-Type Transfer Switch

TRANSFER MECHANISM

The 2-pole transfer mechanism consists of a pair of moveable LOAD contacts, a pair of stationary UTILITY contacts, and a pair of stationary STANDBY contacts. The load contacts can be connected to the utility contacts by a utility closing coil; or to the standby contacts by a standby closing coil. In addition, the load contacts can be actuated to either the UTILITY or STANDBY side by means of a manual transfer handle. See Figures 2 and 3.

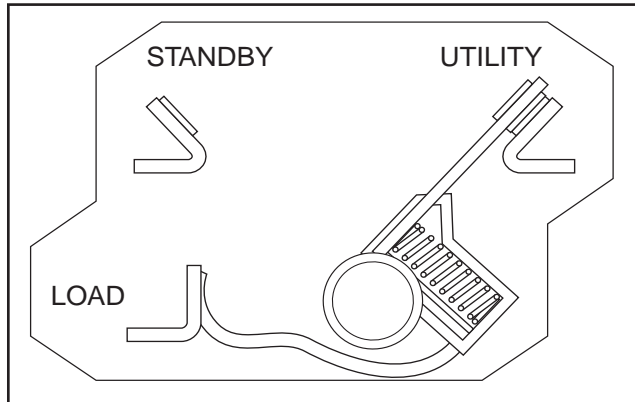

Figure 2. Load Connected to Utility Power Source

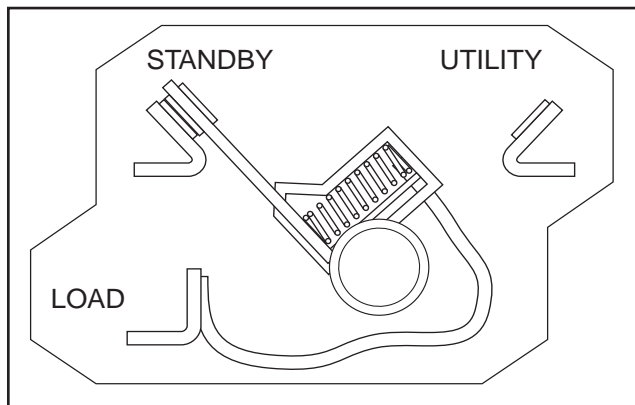

Figure 3. Load Connected to Standby Power Source

UTILITY CLOSING COIL C1:

See Figure 4. This coil is energized by rectified utility source power, to actuate the load contacts to the UTILITY power source side. When energized, the coil will move the main contacts to an "overcenter" position. A limit switch will then be actuated to open the circuit and spring force will complete the retransfer to STANDBY. A bridge rectifier, which changes the utility source alternating current (AC) to direct current (DC), is sealed in the coil wrappings. If coil or bridge rectifier replacement becomes necessary, the entire coil and bridge assembly should be replaced.

STANDBY CLOSING COIL C2:

Coil C2 is energized by rectified standby source power, to actuate the load contacts to their "Standby"

source side. Energizing the coil moves the load contacts to an overcenter position; limit switch action then opens the circuit and spring force will complete the transfer action to "Standby". This coil's bridge rectifier is also sealed in the coil wrappings. Replace the coil and bridge rectifier as a unit.

LIMIT SWITCHES XA1 AND XB1:

Switches are mechanically actuated by load contacts movement. When the load contacts are connected to the utility contacts, limit switch XA1 opens the utility circuit to utility closing coil C1 and limit switch XB1 closes the standby circuit to standby closing coil C2. The limit switches "arm" the system for retransfer back to UTILITY when the load contacts are connected to the STANDBY side. Conversely, when the load contacts are connected to the UTILITY side, the switches "arm" the system for transfer to STANDBY. An open condition in limit switch XA1 will prevent retransfer to "Utility". An open switch XB1 will prevent transfer to STANDBY.

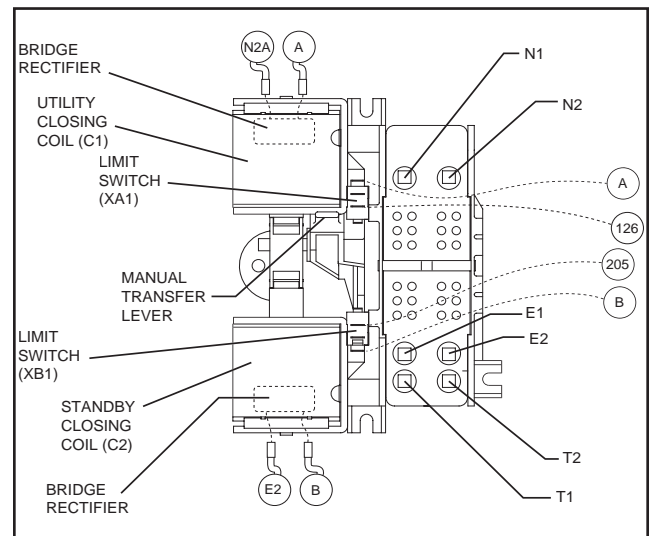

Figure 4. The "W/V-Type" Transfer Mechanism

TRANSFER RELAY

Transfer relay operation is controlled by a circuit board. That circuit board is a part of a control panel assembly, mounted on the standby generator set.

Figure 5 shows the transfer relay pictorially and schematically. Relay operation may be briefly described as follows:

1. Generator battery voltage (12 volts DC) is available to the transfer relay coil from the generator circuit board, via Wire 194 and Relay Terminal A.
 - a. The 12 volts DC circuit is completed through the transfer relay coil and back to the generator circuit board, via Wire 23.
 - b. Circuit board action normally holds the Wire 23 circuit open to ground and the relay is de-energized.

- c. When de-energized, the relay's normally open contacts are open and its normally-closed contacts are closed.
- d. The normally-closed relay contacts will deliver utility source power to the utility closing circuit of the transfer mechanism.
- e. The normally open relay contacts will deliver standby source power to the transfer mechanism's standby closing circuit.

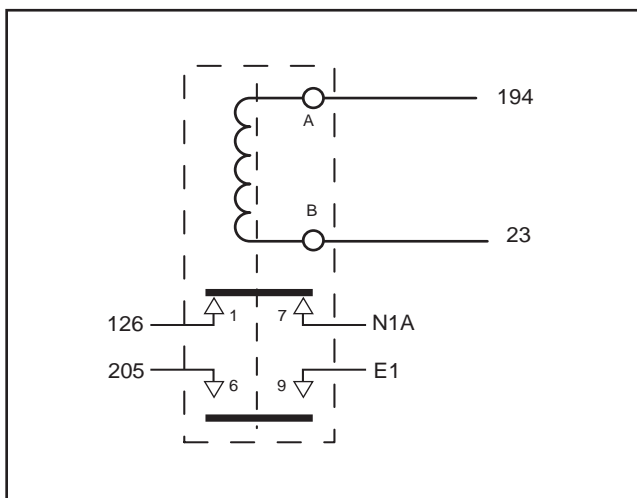

Figure 5. Transfer Relay Schematic

- 2. During automatic system operation, when the generator circuit board “senses” that utility source voltage has dropped out, the circuit board will initiate engine cranking and startup.
- 3. When the circuit board “senses” that the engine has started, an “engine warm-up timer” on the circuit board starts timing.
- 4. When the “engine warm-up timer” has timed out, circuit board action completes the Wire 23 circuit to ground.
 - a. The transfer relay then energizes.
 - b. The relay's normally-closed contacts open and its normally open contacts close.
 - c. When the normally open contacts close, standby source power is delivered to the standby closing coil and transfer to “Standby” occurs.
- 5. When the generator circuit board “senses” that utility source voltage has been restored above a preset level, the board will open the Wire 23 circuit to ground.
 - a. The transfer relay will de-energize, its normally-closed contacts will close and its normally open contacts will open.
 - b. When the normally-closed relay contacts close, utility source voltage is delivered to the utility closing coil to energize that coil.
 - c. Retransfer back to UTILITY occurs.

NEUTRAL LUG

The standby generator is equipped with an UNGROUNDED neutral. The neutral lug in the transfer switch is isolated from the switch enclosure.

MANUAL TRANSFER HANDLE

The manual transfer handle is retained in the transfer switch enclosure by means of a wing stud. Use the handle to manually actuate the transfer mechanism load contacts to either the UTILITY or STANDBY source side.

Instructions on use of the manual transfer handle may be found in Part 5, “Operational Tests and Adjustments”.

TERMINAL BLOCK

During system installation, this 5-point terminal block must be properly interconnected with an identically labeled terminal block in the generator control panel assembly.

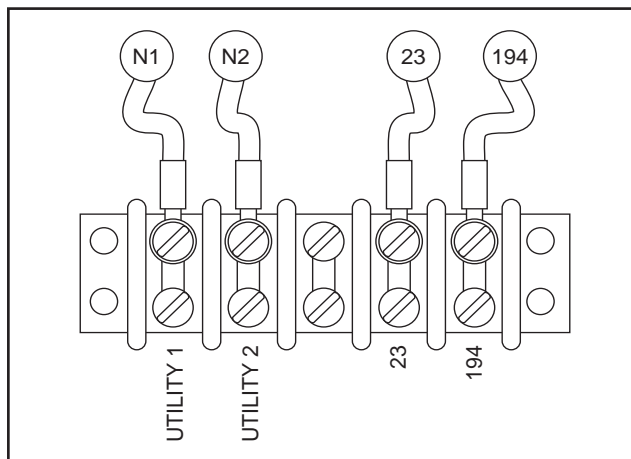

Figure 6. Transfer Switch Terminal Block

Terminals used on the terminal block are identified as Utility N1 and N2; 23 and 194.

UTILITY N1 AND N2:

Interconnect with identically labeled terminals in the generator control panel assembly. This is the utility voltage signal to the circuit board. The signal is delivered to a step-down transformer in the control module assembly and the resultant reduced voltage is then delivered to the circuit board. Utility 1 and 2 power is used by the circuit board as follows:

- If utility source voltage should drop below a preset level, circuit board action will initiate automatic cranking and startup, followed by automatic transfer to the standby source.
- Utility source voltage is used to operate a battery trickle charge circuit which helps to maintain battery state of charge during non-operating periods.

TERMINALS 23 AND 194:

These terminals connect the transfer relay to the generator circuit board. See "Transfer Relay" in Section 3.1.

FUSE HOLDER

The fuse holder holds two (2) fuses, designated as fuses F1 and F2. Each fuse is rated 5 amperes.

FUSES F1, F2:

These two fuses protect the terminal board UTILITY 1 and 2 circuit against overload.

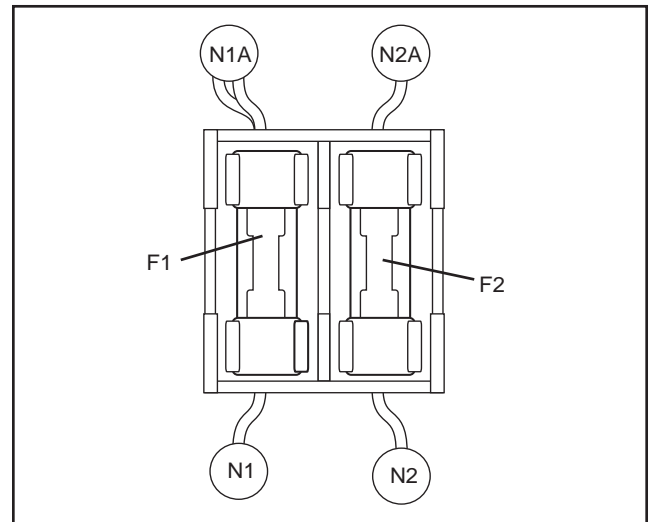

Figure 7. The Fuse Holder

OPERATIONAL ANALYSIS

Figure 1 is a schematic for a typical "W/V-Type" transfer switch.

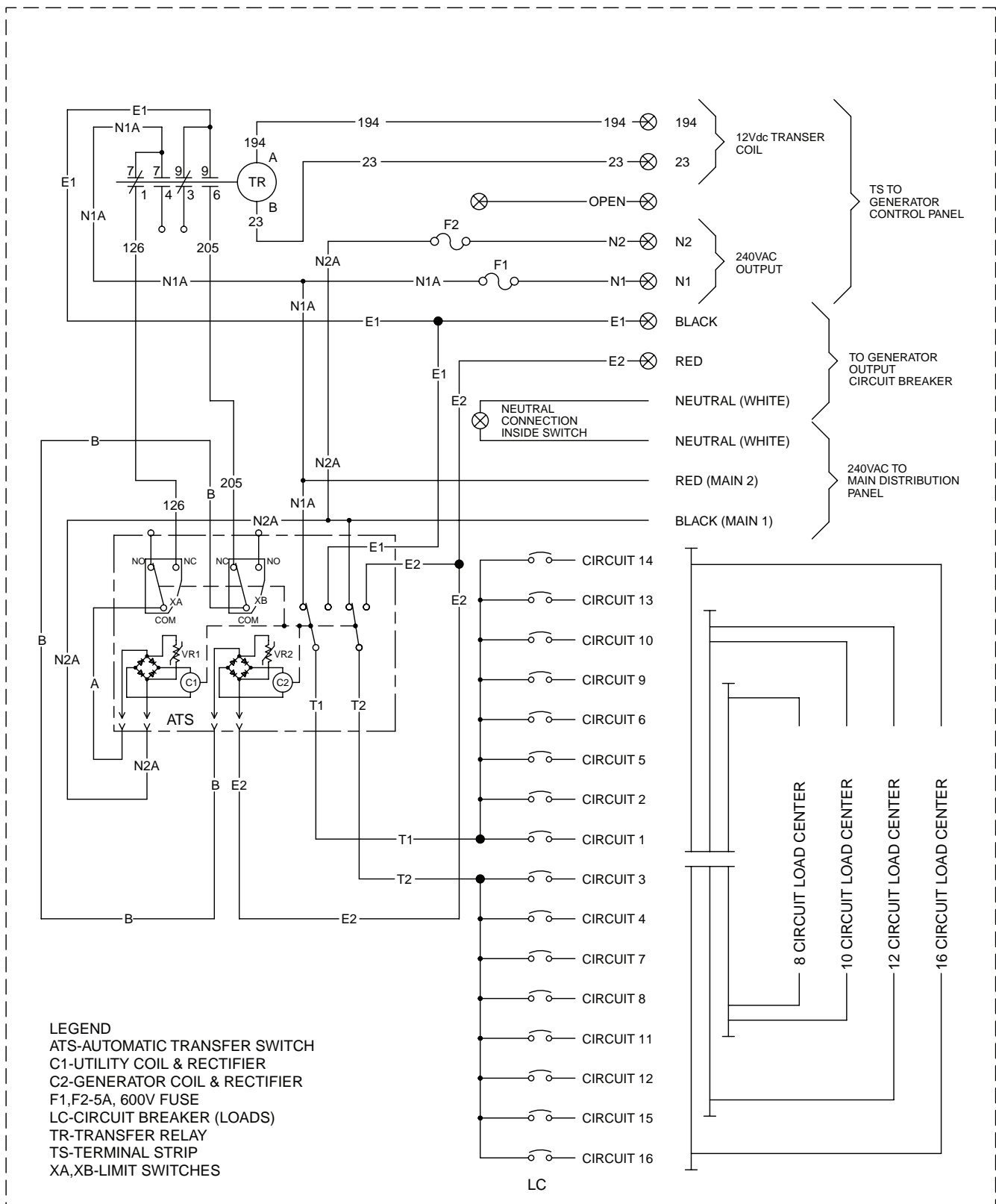

Figure 1. Schematic

Figure 2 is a wiring diagram for a typical "W/V-Type" transfer switch.

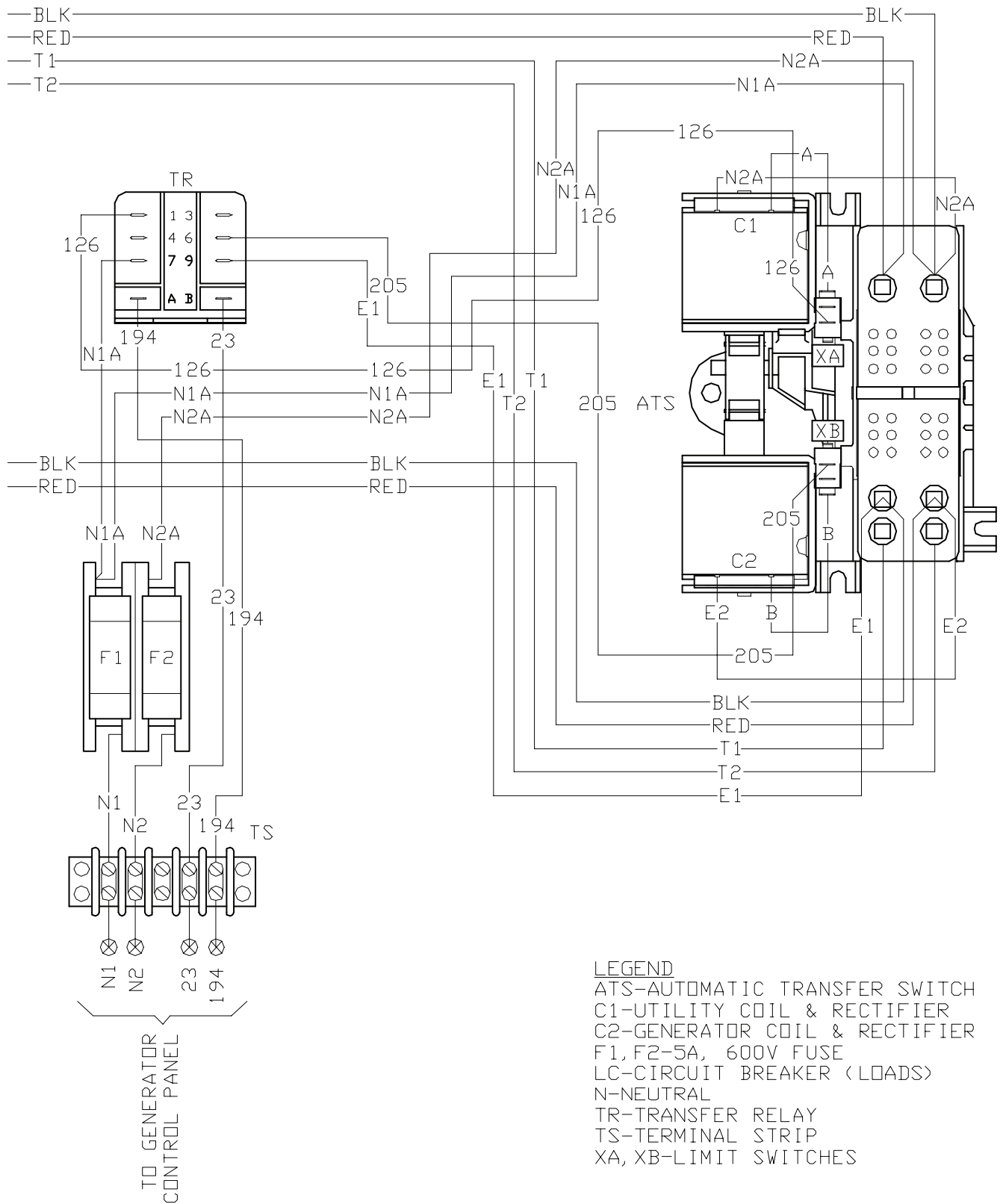

Figure 2. Wiring Diagram

UTILITY SOURCE VOLTAGE AVAILABLE

Figure 3 is a schematic representation of the transfer switch with utility source power available. The circuit condition may be briefly described as follows:

- Utility source voltage is available to terminal lugs N1 and N2 of the transfer mechanism, transfer switch is in the UTILITY position and source voltage is available to T1, T2 and customer load.
- Utility source voltage is available to limit switch (XA1) via the normally-closed transfer relay contacts (1 and 7) and Wire 126. However, XA1 is open and the Circuit to the utility closing coil is open.
- Utility voltage "sensing" signals are delivered to a circuit board on the generator, via Wire N1A, a 5 amp fuse (F1), transfer switch Terminal N1, generator Terminal N1 and a sensing transformer. The second line of the utility voltage "sensing" circuit is via Wire N2A, a 5 amp Fuse (F2), transfer switch Terminal N2, generator Terminal N2, and the sensing transformer.

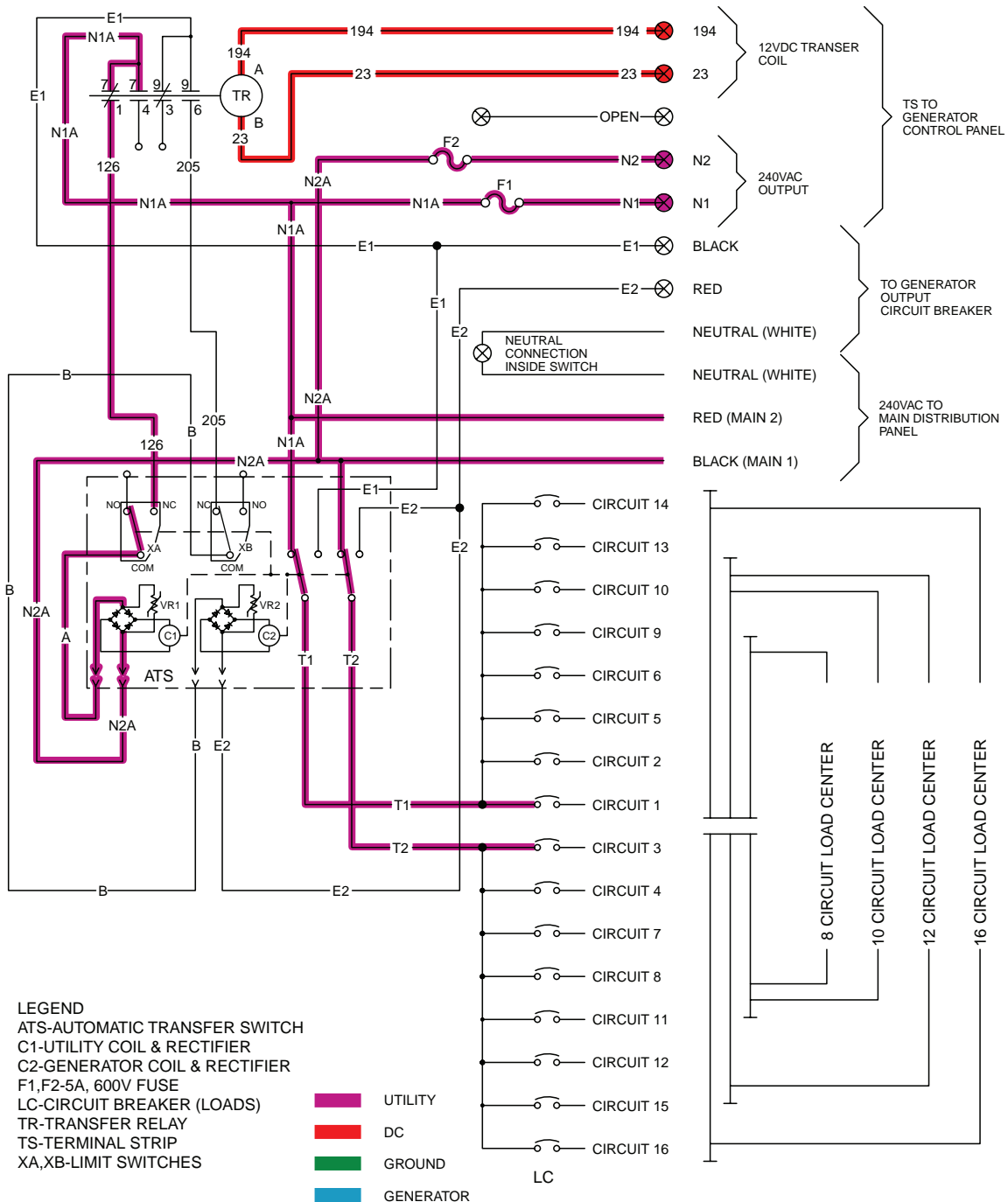

Figure 3. Utility Source Power Available

TRANSFER TO STANDBY

The generator circuit board delivers 12 volts DC to the transfer relay, via Terminal 194 and back to the circuit board via Terminal 23. However, circuit board action holds the Wire 23 circuit open and the transfer relay remains de-energized. On generator startup, an "engine warm-up timer" on the generator circuit board starts timing. When that timer has timed out, circuit board action completes the Wire 23 circuit to ground. The transfer relay then energizes, its normally open contacts close, and standby source voltage is delivered to the standby closing coil via Wires E1 and E2, the transfer relay (TR) contacts, limit switch (XB1), Wire "B", and a bridge rectifier. The standby closing coil energizes and the main contacts actuate to their "Standby" side.

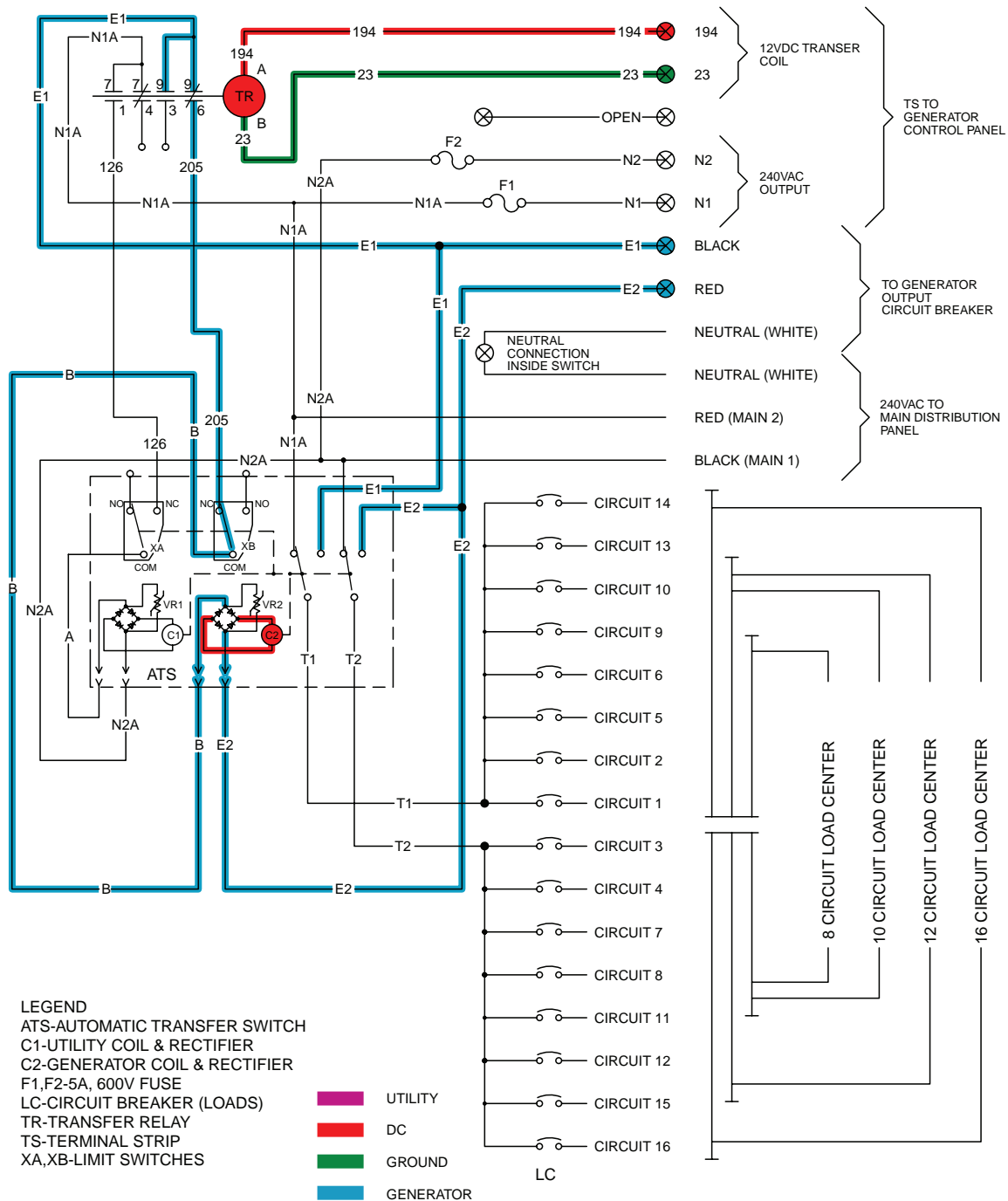

Figure 5. Transfer Action to Standby Position

TRANSFER TO STANDBY

When the standby coil is energized it pulls the transfer switch mechanism to a overcenter position towards the standby power source side, the transfer switch mechanically snaps to the standby position. On closure of the main contacts to the standby power source side, limit switches XA1 and XB1 are mechanically actuated to "arm" the circuit for re- transfer to utility power source side.

Generator power from E1 and E2 is now connected to the customer load through T1 and T2.

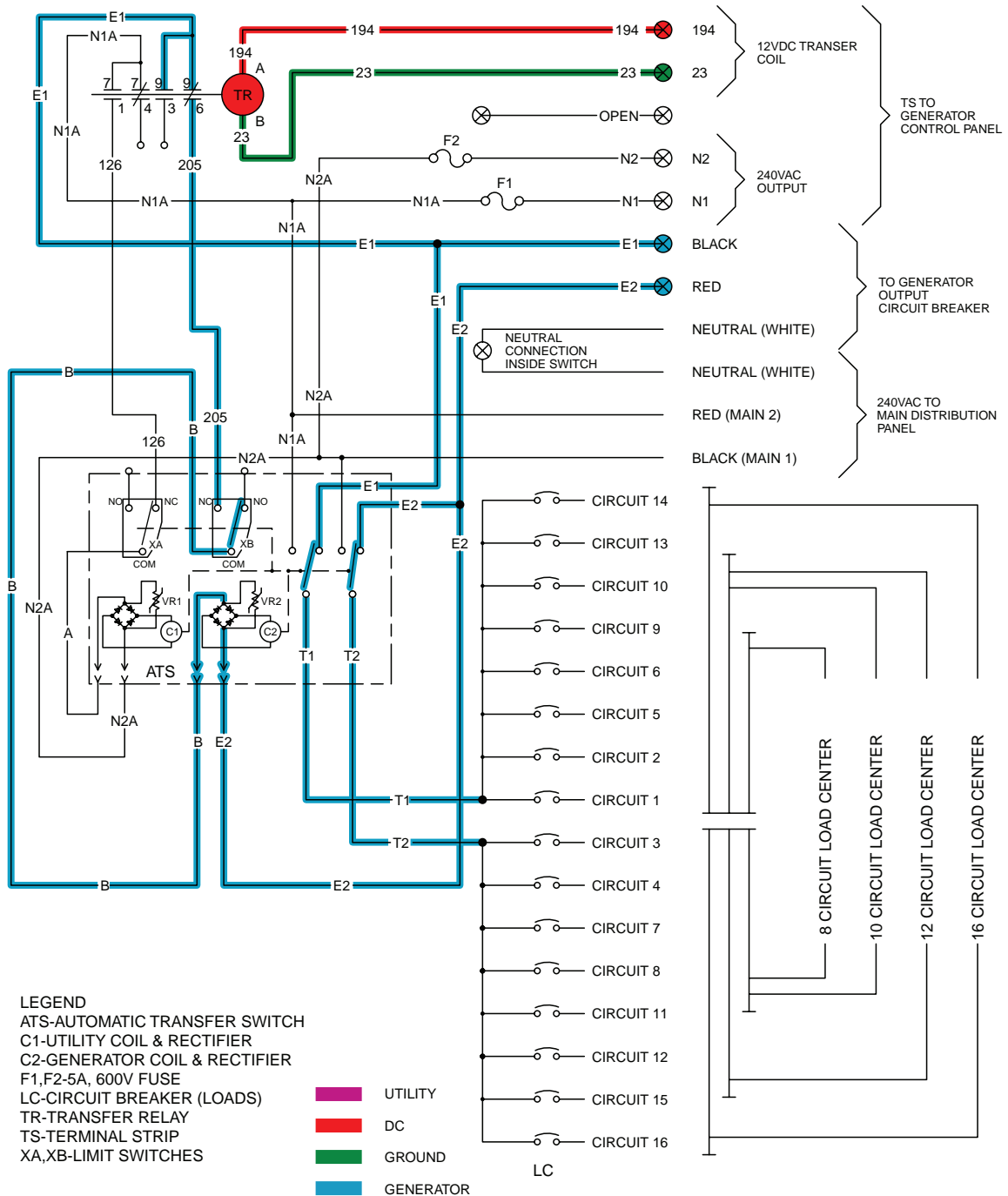

Figure 6. Generator Powering Load.

UTILITY RESTORED

Utility voltage is restored and is available to Terminals N1 and N2. The utility voltage is sensed by the generators circuit board. If it is above a preset value for a preset time interval a transfer back to utility power will occur.

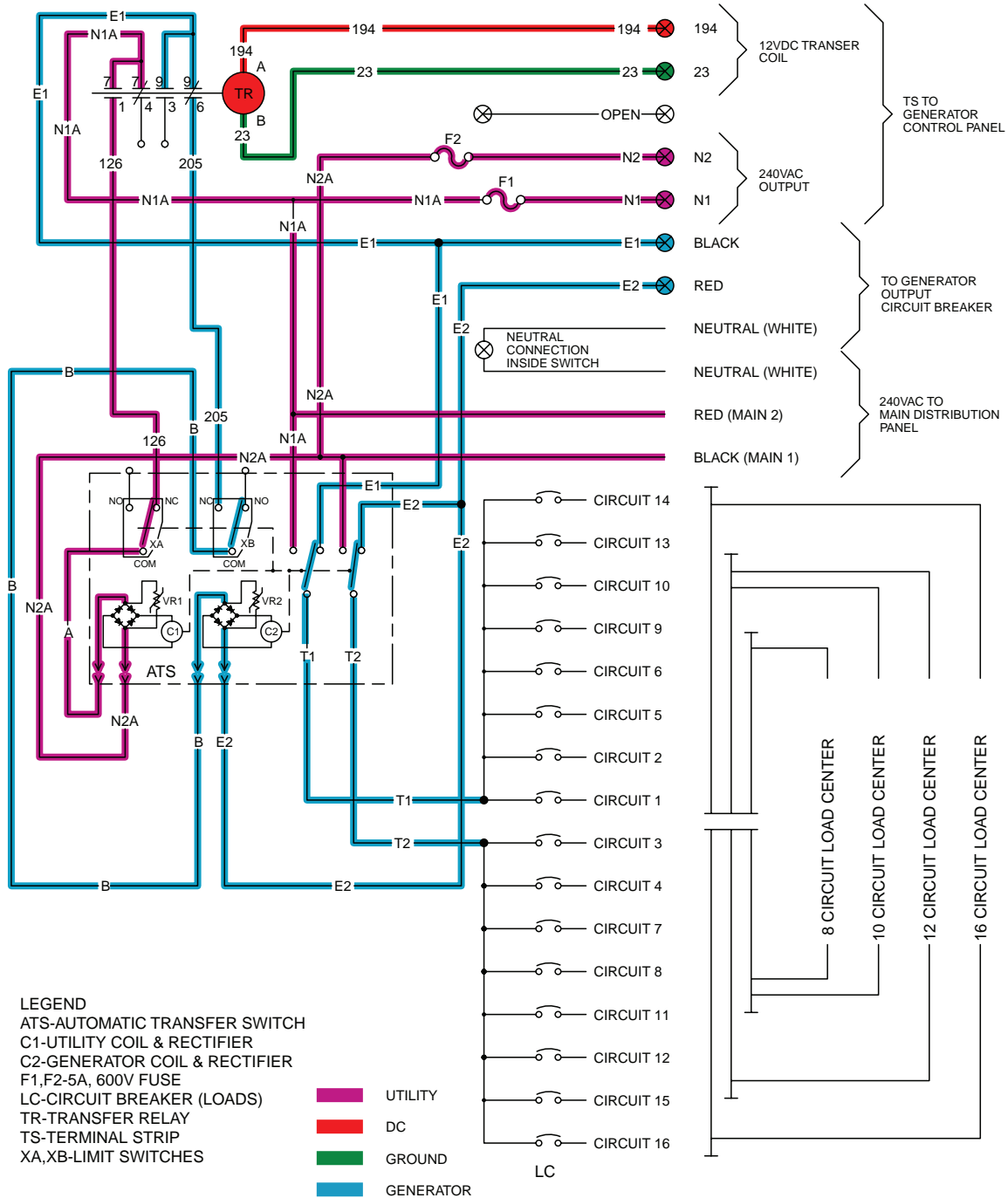

Figure 7. Utility Restored, Generator Still Providing Output to Load.

UTILITY RESTORED, RETRANSFER BACK TO UTILITY

As the utility coil pulls the transfer switch to an OVER CENTER position, the switch mechanically snaps to Utility. On closure of the main contacts to the utility power source side, Limit Switches XA1 and XB1 are mechanically actuated to "arm" the circuit for transfer to standby.

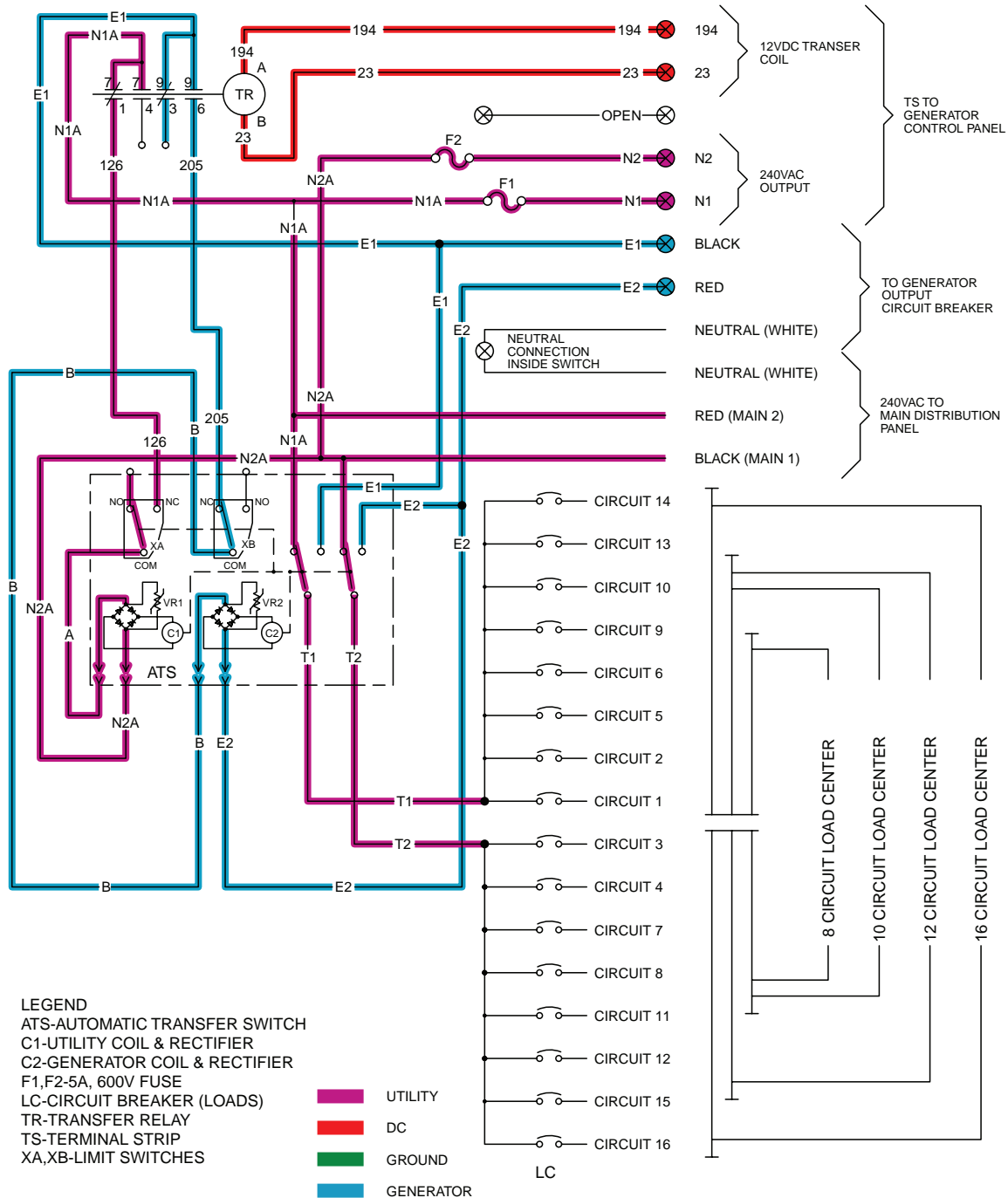

Figure 9. Utility Restored, Retransfer Back to Utility.

TRANSFER SWITCH IN UTILITY

When the transfer switch returns to the utility side, generator shutdown occurs after approximately one (1) minute.

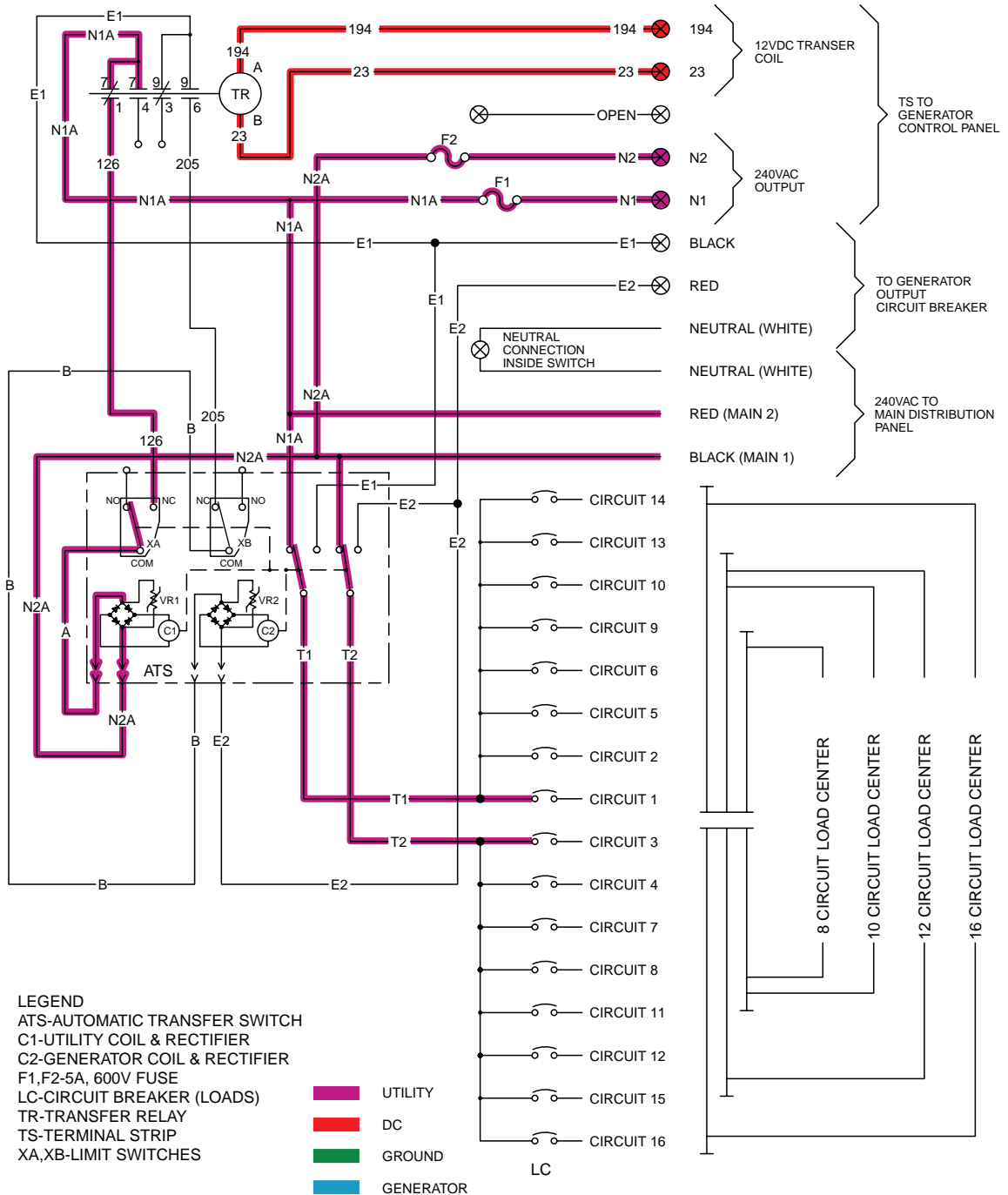

Figure 10. Transfer Switch in UTILITY.

INTRODUCTION TO TROUBLESHOOTING

The first step in troubleshooting is to correctly identify the problem. Once that is done, the cause of the problem can be found by performing the tests in the appropriate flow chart.

Test numbers assigned in the flow charts are identical to test numbers in Section 3.4, "Diagnostic Tests." Section 3.4 provides detailed instructions for performance of each test.

Problem 5 - In Automatic Mode, No Transfer to Standby

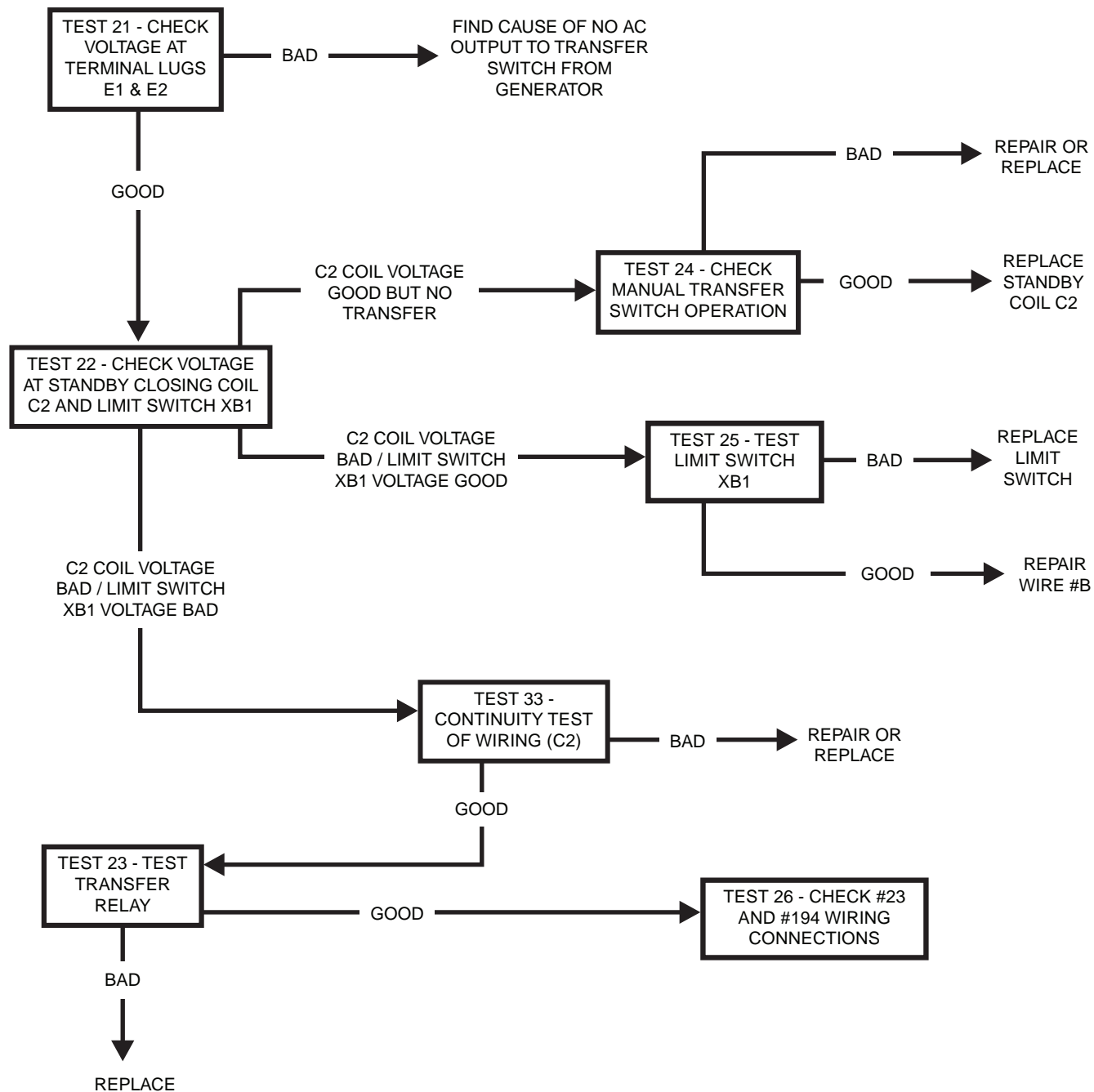

Problem 6 - In Automatic Mode, Generator Starts When Loss of Utility Occurs, Generator Shuts Down When Utility Returns But There Is No Retransfer To Utility Power

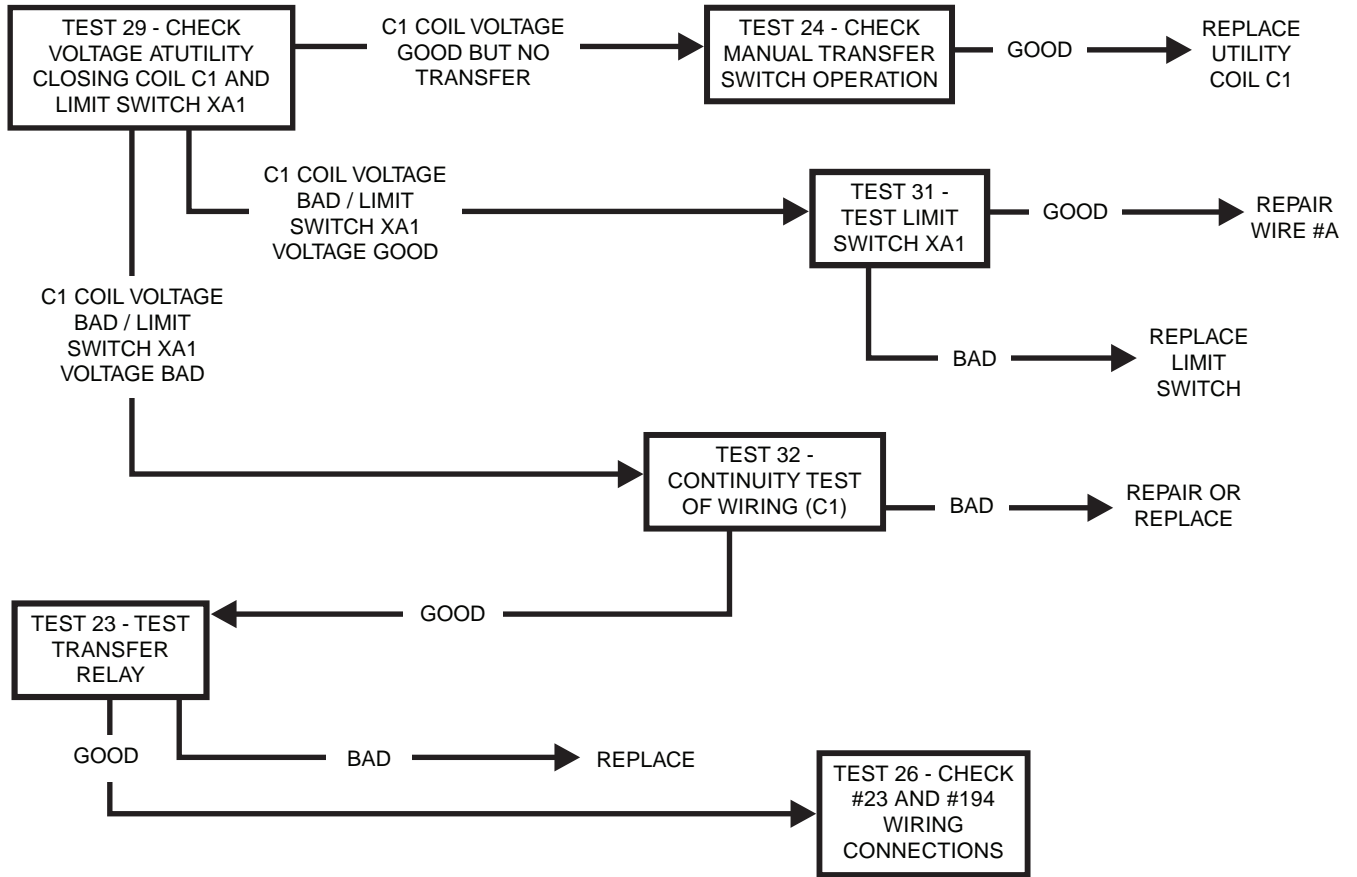

Problem 7 - Blown F1 or F2 Fuse

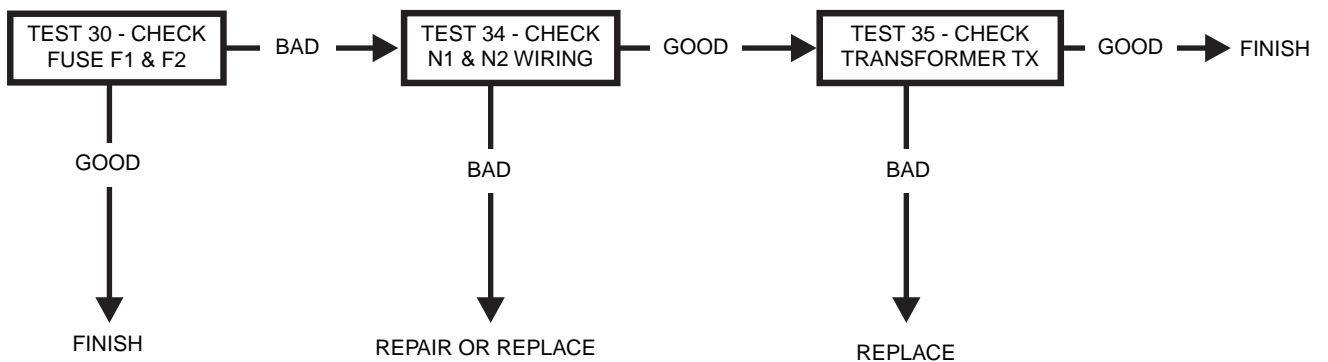

GENERAL

Test numbers in this section correspond to the numbered tests in Section 3.3, "Troubleshooting Flow Charts". When troubleshooting, first identify the problem. Then, perform the diagnostic tests in the sequence given in the flow charts.

TEST 21 – CHECK VOLTAGE AT TERMINAL LUGS E1, E2

DISCUSSION:

In automatic mode, the standby closing coil (C2) must be energized by standby generator output if transfer to the "Standby" source is to occur. Transfer to "Standby" cannot occur unless that power supply is available to the transfer switch.



DANGER: BE CAREFUL! HIGH AND DANGEROUS VOLTAGES ARE PRESENT AT TERMINAL LUGS E1 AND E2 WHEN THE GENERATOR IS RUNNING. AVOID CONTACT WITH HIGH VOLTAGE TERMINALS OR DANGEROUS AND POSSIBLY LETHAL ELECTRICAL SHOCK MAY RESULT. DO NOT PERFORM THIS VOLTAGE TEST WHILE STANDING ON WET OR DAMP GROUND, WHILE BAREFOOT, OR WHILE HANDS OR FEET ARE WET.

PROCEDURE:

1. If the generator engine has started automatically (due to a utility power source outage) and is running, check the position of the generator main circuit breaker. The circuit breaker must be set to its "On" or "Closed" position. When you are sure the generator main circuit breaker is set to ON (or closed), check the voltage at transfer mechanism Terminal Lugs E1 and E2 with an accurate AC voltmeter or with an accurate volt-ohm-milliammeter (VOM). The generator line-to-line voltage should be indicated.
2. If the generator has been shut down, proceed as follows:
 - a. On the generator control panel, set the AUTO-OFF-MANUAL switch to OFF.
 - b. Turn off all power voltage supplies to the transfer switch. Both the utility and standby power supplies must be positively turned off before proceeding.
 - c. Check the position of the transfer mechanism main contacts. The moveable LOAD contacts must be connected to the stationary UTILITY source contacts. If necessary, manually actuate the main contacts to the "Utility" power source side.
 - d. Actuate the generator main line circuit breaker to its "On" or "Closed" position. The utility power supply to the transfer switch must be turned off.

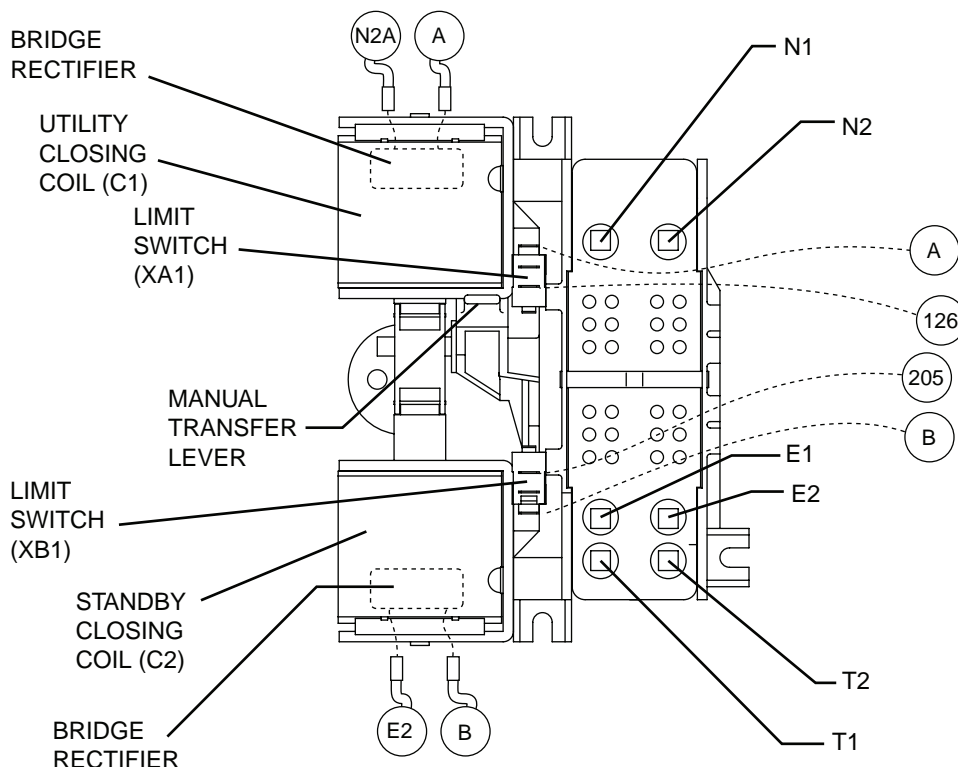

Figure 1. The "W/V-Type" Transfer Mechanism

- e. Set the generator AUTO-OFF-MANUAL switch to AUTO.
- (1) The generator should crank and start.
 - (2) When the generator starts, an "engine warm-up timer" should start timing. After about 15 seconds, the transfer relay should energize and transfer to the "Standby" source should occur.
- f. If transfer to "Standby" does NOT occur, check the voltage across transfer switch Terminal Lugs E1 and E2. The generator line-to-line voltage should be indicated.

RESULTS:

1. If normal transfer to "Standby" occurs, discontinue tests.
2. If transfer to "Standby" does NOT occur and no voltage is indicated across Terminal Lugs E1/E2, determine why generator AC output has failed.
3. If transfer to "Standby" does NOT occur and voltage reading across Terminal Lugs E1/E2 is good, go on to Test 22.

TEST 22 – CHECK VOLTAGE AT STANDBY CLOSING COIL C2**DISCUSSION:**

Standby source voltage is used to energize the standby closing coil and actuate the main contacts to their "Standby" source side. Standby source alternating current (AC) is changed to direct current (DC) by a bridge rectifier before reaching the closing coil. This test will determine if voltage is available to the closing coil.

If normal source voltage is available to the terminals of the closing coil but transfer to "Standby" does not occur, look for (a) binding or sticking in the transfer mechanism, (b) a defective coil, or (c) a bad bridge rectifier. The coil and the bridge rectifier must be replaced as a unit.

PROCEDURE:

1. Set the generator main line circuit breaker to the OFF or "Open" position.
2. Set the generators AUTO-OFF-MANUAL switch to the OFF position.
3. Set a VOM to measure AC voltage.



DANGER: BE CAREFUL! HIGH AND DANGEROUS VOLTAGES ARE PRESENT AT TERMINAL LUGS WHEN THE GENERATOR IS RUNNING. AVOID CONTACT WITH HIGH VOLTAGE TERMINALS OR DANGEROUS AND POSSIBLY LETHAL ELECTRICAL SHOCK MAY RESULT. DO NOT PERFORM THIS

VOLTAGE TEST WHILE STANDING ON WET OR DAMP GROUND, WHILE BAREFOOT, OR WHILE HANDS OR FEET ARE WET.

4. Disconnect Wire E2 from the standby closing coil (C2). Connect one meter test Lead to Wire E2. Use a suitable and safe connection to this wire, such as an alligator clip that attaches to the meter test probe. Isolate this wire and test probe from any other potential source or ground.
5. If necessary, repeat Step 2 under "Procedure" of Test 21. The system must be in automatic operating mode, with engine running, and standby source voltage available to Terminal Lugs E1 and E2.
6. Locate on the standby closing coil the terminal that Wire B is connected to. (Figure 1, previous page). Connect the other meter test lead to this terminal. Generator line to line voltage should be indicated. If generator voltage is NOT indicated, proceed to Step 7.
7. With Wire E2 still connected to one test probe, connect the other meter test lead to Wire 205 on Limit Switch XB1 (see Figure 1 on previous page). Generator line to line voltage should be measured.

RESULTS:

1. If generator line-to-line voltage is indicated in "Procedure, Step 6," but transfer does NOT occur, proceed to Test 24.
2. If generator line-to-line voltage is NOT indicated in "Procedure, Step 7," proceed to Test 33.
3. If generator line-to-line voltage is indicated in "Procedure, Step 7," proceed to Test 25.

TEST 23 – TEST TRANSFER RELAY TR**DISCUSSION:**

In automatic operating mode, the transfer relay must be energized by circuit board action or standby source power will not be available to the standby closing coil. Without standby source power, the closing coil will remain de-energized and transfer to "Standby" will not occur. This test will determine if the transfer relay is functioning normally.

PROCEDURE:

1. See Figure 2. Disconnect all wires from the transfer relay, to prevent interaction.
2. Set a VOM to its "R x 1" scale and zero the meter.
3. Connect the VOM test leads across Relay Terminals 6 and 9 with the relay de-energized. The VOM should read INFINITY.

SECTION 3.4 DIAGNOSTIC TESTS

CONNECT VOM TEST LEADS ACROSS	DESIRED METER READING	
	ENERGIZED	DE-ENERGIZED
Terminals 6 and 9	Continuity	Infinity
Terminals 1 and 7	Infinity	Continuity

4. Using jumper wires, connect the positive (+) post of a 12 volt battery to relay Terminal "A" and the negative (-) battery post to Relay Terminal "B". The relay should energize and the VOM should read CONTINUITY.

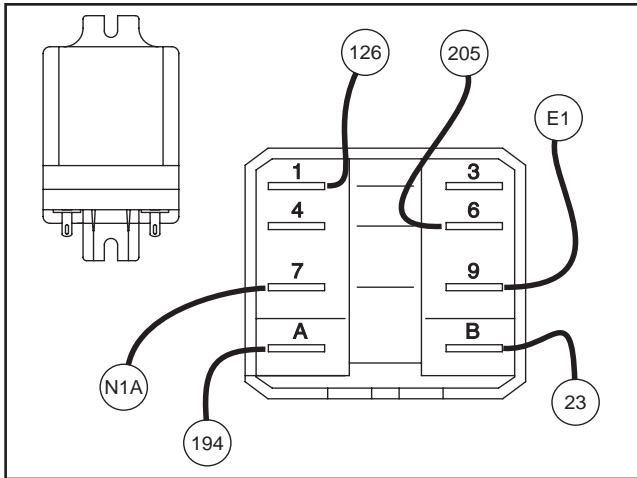

Figure 2. Transfer Relay Test Points

5. Now, connect the VOM test leads across Relay Terminals 1 and 7.
- Energize the relay and the meter should indicate INFINITY.
 - De-energize the relay and the VOM should read CONTINUITY.

RESULTS:

- Replace transfer relay if it is defective.
- If transfer relay checks good go to Test 26.

TEST 24 – CHECK MANUAL TRANSFER SWITCH OPERATION

DISCUSSION:

In automatic operating mode, when utility source voltage drops below a preset level, the engine should crank and start. On engine startup, an "engine warm-up timer" on the generator circuit board should start timing. When that timer has timed out (about 15 seconds), the transfer relay should energize to deliver utility source power to the standby closing coil terminals. If normal utility source voltage is available to the standby closing coil terminals, but transfer to Standby does not occur, the cause of the failure may be (a) a failed standby closing coil and/or bridge rectifier, or (b) a seized or sticking actuating coil or load contact. This test will help you evaluate whether any sticking or binding is present in the transfer mechanism.

PROCEDURE:

- With the generator shut down, set the generator AUTO-OFF-MANUAL switch to OFF.
- Set the generator main circuit breaker to OFF or "Open".
- Turn off the utility power supply to the transfer switch, using whatever means provided (such as a utility source main line breaker).



DANGER: DO NOT ATTEMPT MANUAL TRANSFER SWITCH OPERATION UNTIL ALL POWER VOLTAGE SUPPLIES TO THE SWITCH HAVE BEEN POSITIVELY TURNED

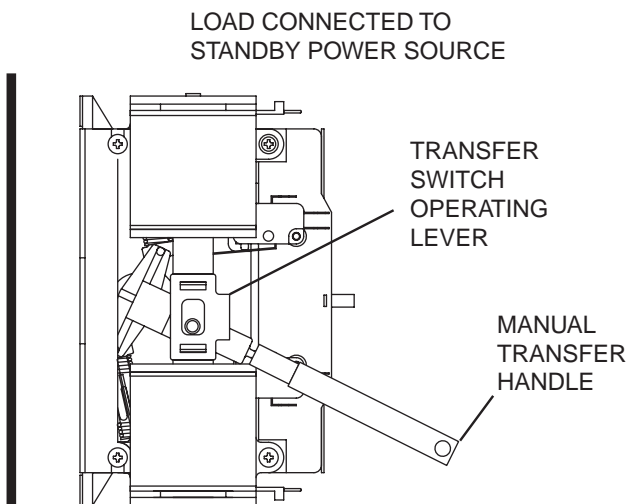
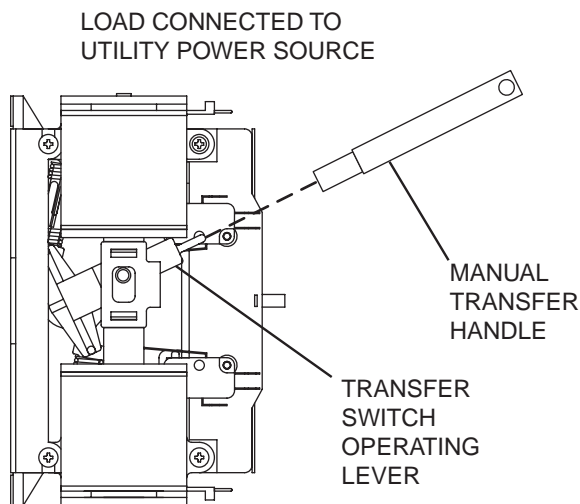

Figure 3. Manual Transfer Switch Operation

OFF. FAILURE TO TURN OFF ALL POWER VOLTAGE SUPPLIES MAY RESULT IN EXTREMELY HAZARDOUS AND POSSIBLY LETHAL ELECTRICAL SHOCK.

4. In the transfer switch enclosure, locate the manual transfer handle. Handle is retained in the enclosure with a wing nut. Remove the wing nut and handle.
5. See Figure 3. Insert the un-insulated end of the handle over the transfer switch operating lever.
 - a. Move the transfer switch operating lever up to actuate the load contacts to the Utility position, i.e., load connected to the utility source.
 - b. Actuate the operating lever down to move the load contacts against the standby contacts, i.e., load connected to the Standby source.
6. Repeat Step 5 several times. As the transfer switch operating lever is moved slight force should be needed until the lever reaches its center position. As the lever moves past its center position, an over-center spring should snap the moveable load contacts against the stationary STANDBY or UTILITY contacts.
7. Finally, actuate the main contacts to their UTILITY power source side, i.e., load contacts against the UTILITY contacts (upward movement of the operating lever).

RESULTS:

1. If there is no evidence of binding, sticking, excessive force required, replace the appropriate closing coil.
2. If evidence of sticking, binding, excessive force required to move main contacts, find cause of binding or sticking and repair or replace damaged part(s).

TEST 25 – TEST LIMIT SWITCH XB1**DISCUSSION:**

Standby power source voltage must be available to the standby closing coil in order for a transfer to standby action to occur. To deliver that source voltage to the coil, limit switch XB1 must be closed to the "Standby" power source side. If the limit switch did not get actuated or has failed open, the source voltage will not be available to the closing coil and transfer to "Standby" will not occur.

PROCEDURE:

With the generator shut down, the generator main circuit breaker turned OFF, and with the utility power supply to the transfer switch turned OFF, test limit switch XB1 as follows:

1. To prevent interaction, disconnect Wire 205 and Wire B from the limit switch terminals.
2. Set a VOM to its "R x 1" scale and zero the meter.

3. See Figure 1. Connect the VOM test probes across the two outer terminals from which the wires were disconnected.
4. Manually actuate the main contacts to their "Standby" position. The meter should read INFINITY.
5. Manually actuate the main contacts to their UTILITY position. The meter should read CONTINUITY.
6. Repeat Steps 4 and 5 several times and verify the VOM reading at each switch position.

RESULTS:

1. If Limit Switch XB1 fails the test, remove and replace the switch or adjust switch until it is actuated properly.
2. If limit switch is good, repair or replace Wire B between limit switch and Standby Coil (C2).

TEST 26 – CHECK 23 AND 194 WIRING/ CONNECTIONS**DISCUSSION:**

An open circuit in the transfer switch control wiring can prevent a transfer action from occurring. In the auto mode, the circuit board supplies +12 VDC to Wire 194. This DC voltage is supplied to the transfer relay (TR) at Terminal Location "A". The opposite side of the transfer relay (TR) coil (Terminal B) is connected to Wire 23. Positive 12 VDC is present on this also. Circuit board action will allow current to flow through the circuit and the (TR) is energized.

PROCEDURE/RESULTS:

1. Set VOM to DC volts
2. Place generator AUTO-OFF-MANUAL switch to the AUTO position. Utility power should be present; the generator should not start.
3. Connect the negative (-) test lead to a suitable frame ground in the transfer switch.
4. Connect the positive (+) test lead to Wire 194 at the terminal strip in the transfer switch.
 - a. If voltage is present, proceed to Step 5.
 - b. If voltage is not present, proceed to Step 9.
5. Connect the positive (+) test lead to Wire 23 at the terminal strip in the transfer switch.
 - a. If voltage is present, proceed to Step 6.
 - b. If voltage is not present, repair wiring between terminal strip and transfer relay (TR).
6. Connect the negative (-) test lead to the ground lug in the generator control panel. Connect the positive (+) test lead to Wire 23 in the generator control panel at the interconnection terminals (ICT) or at the terminal strip.

SECTION 3.4 DIAGNOSTIC TESTS

PART 3

"W/V-TYPE" TRANSFER SWITCHES

- a. If voltage is present, proceed to Step 7.
 - b. If voltage is not present, repair wiring between transfer switch and generator control panel.
7. Connect the positive (+) test lead to Wire 23 located in the J1 Connector Pin Location 3, connected to the circuit board (see Figure 3, Section 4.1).
- a. If voltage is present, proceed to Step 8.
 - b. If voltage is not present, repair wiring between (ICT and J1 Connector).
8. Turn off utility power to transfer switch, simulating a utility failure.
- a. Generator starts and transfer occurs, discontinue tests.
 - b. Generator starts and transfer does not occur. With the generator running and utility off, ground Wire 23 in the control panel at interconnection terminals (ICT) or at the terminal strip. If transfer occurs replace circuit board.
9. Connect the negative (-) test lead to the ground lug in the generator control panel. Connect the positive (+) test lead to Wire 194 in the generator control panel at the interconnection terminals (ICT) or at the terminal strip.
- a. If the voltage is present, repair wiring between ICT (or terminal strip) and transfer switch
 - b. If voltage is not present, proceed to Step 10.
10. Connect the positive (+) test lead to Wire 194 located at AUTO-OFF-MANUAL switch (SW1) (see Figure 3, Section 4.1).
- a. If voltage is present, repair wiring between J1 Connector and ICT (or terminal strip).
 - b. If voltage is not present, perform Test 44. Repair or replace SW1 or wiring as needed.

TEST 27 – CHECK VOLTAGE AT TERMINAL LUGS N1, N2

DISCUSSION:

If retransfer to the "Utility" power source side is to occur, utility source voltage must be available to Terminal Lugs N1 and N2 of the transfer mechanism. In addition, if that source voltage is not available to N1/N2 terminals, automatic startup and transfer to STANDBY will occur when the generator AUTO-OFF-MANUAL switch is set to AUTO. This test will prove that "Utility" voltage is available to those terminals, or is not available. It is the first test in a series of tests that should be accomplished when (a) retransfer back to "Utility" does not occur, or (b) startup and transfer occurs unnecessarily.



DANGER: PROCEED WITH CAUTION! HIGH AND DANGEROUS VOLTAGES ARE PRESENT AT TERMINAL LUGS N1/N2. CONTACT WITH HIGH VOLTAGE TERMINALS WILL RESULT

IN DANGEROUS AND POSSIBLY LETHAL ELECTRICAL SHOCK. DO NOT ATTEMPT THIS TEST WHILE STANDING ON WET OR DAMP GROUND, WHILE BAREFOOT, OR WHILE HANDS OR FEET ARE WET.

PROCEDURE:

1. Make sure that all main line circuit breakers in the utility line to the transfer switch are "On" or "Closed."
2. Test for utility source line-to-line voltage across Terminal Lugs N1 and N2 (see Figure 1). Normal utility source voltage should be indicated.

RESULTS:

1. If low or no voltage is indicated, find the cause of the problem and correct.
2. If normal utility source voltage is indicated, go on to Test 28.
3. For Problem 14 ONLY, if voltage is good, repair or replace Wire N1A/N2A between Transfer Switch Lugs N1/N2 and Fuse Holder connections.

TEST 28 – CHECK VOLTAGE AT UTILITY 1 AND UTILITY 2 TERMINALS

The UTILITY 1 and UTILITY 2 terminals in the transfer switch deliver utility voltage "sensing" to a circuit board. If voltage at the terminals is zero or low, standby generator startup and transfer to the "Standby" source will occur automatically as controlled by the circuit board. A zero or low voltage at these terminals will also prevent retransfer back to the "Utility" source.

PROCEDURE:

With utility source voltage available to terminal lugs N1 and N2, use an AC voltmeter or a VOM to test for utility source line-to-line voltage across terminal block UTILITY 1 and UTILITY 2 terminals. Normal line-to-line utility source voltage should be indicated.

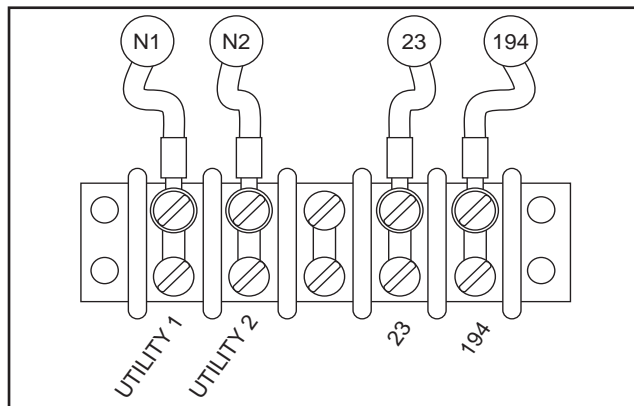

Figure 4. Transfer Switch Terminal Block

RESULTS:

1. If voltage reading across the UTILITY 1 and UTILITY 2 terminals is zero, go to Test 30.
2. If voltage reading is good, go to Test 29.
3. For Problem 14 ONLY; if voltage is good, repair N1/N2 open wiring between Transfer Switch and Generator.

TEST 29 – CHECK VOLTAGE AT UTILITY CLOSING COIL C1**DISCUSSION:**

Utility source voltage is required to energize utility closing coil C1 and effect retransfer back to the "Utility" source. This voltage is delivered to the utility closing coil via Wires N1A and N2A, the transfer relay's normally-closed contacts (relay de-energized), Wire 126, Limit Switch XA1, and a bridge rectifier.

PROCEDURE:

1. On the generator control panel, set the AUTO-OFF-MANUAL switch to OFF.
2. Turn off the utility power supply to the transfer switch, using whatever means provided (such as a utility source main line circuit breaker).
3. Set the generator main line circuit breaker to its OFF or "Open" position.
4. Check the position of the transfer mechanism main contacts. The moveable load contacts must be connected to the stationary utility contacts. If necessary, manually actuate the main contacts to their "Utility" source side (load connected to the "Utility" source).



DANGER: BE CAREFUL! HIGH AND DANGEROUS VOLTAGES ARE PRESENT AT TERMINAL LUGS WHEN THE GENERATOR IS RUNNING. AVOID CONTACT WITH HIGH VOLTAGE TERMINALS OR DANGEROUS AND POSSIBLY LETHAL ELECTRICAL SHOCK MAY RESULT. DO NOT PERFORM THIS VOLTAGE TEST WHILE STANDING ON WET OR DAMP GROUND, WHILE BAREFOOT, OR WHILE HANDS OR FEET ARE WET.

5. Disconnect Wire N2A from the utility closing coil (C1). Connect one meter test Lead to Wire N2A. Use a suitable and safe connection to this wire, such as an alligator clip that attaches to the meter test probe. Isolate this wire and test probe from any other potential source or ground.
6. Set the generator main line circuit breaker to its "On" or "Closed" position.
7. Set the generator AUTO-OFF-MANUAL switch to AUTO.
 - a. The generator should crank and start.

- b. About 15 seconds after engine startup, the transfer relay should energize and transfer to the "Standby" source should occur.
8. When you are certain that transfer to "Standby" has occurred, turn ON the utility power supply to the transfer switch. After a 15 seconds, retransfer back to the "Utility" source should occur.
 9. Locate on the utility closing coil the terminal that Wire A is connected to (see Figure 1, Section 3.4). Connect the other meter test lead to this terminal. Utility line to line voltage should be indicated. If utility voltage is NOT indicated, proceed to Step 10.
 10. With Wire N2A still connected to one test probe, connect the other meter test lead to Wire 126 on Limit Switch XA1 (see Figure 1, Section 3.4). Utility line to line voltage should be measured.

RESULTS:

1. In Step 7, if the generator does NOT crank or start, refer to Part 4, "DC Control".
2. In Step 7, if transfer to the "Standby" source does NOT occur, go to Problem 1.
3. In Step 9, if normal utility source line-to-line voltage is indicated but retransfer back to "Utility" does NOT occur, go to Test 24.
4. If normal utility source line-to-line voltage is NOT indicated in Step 9, but is indicated in Step 10, proceed to Test 31.
5. If normal utility source line-to-line voltage is NOT indicated in Step 8, and is NOT indicated in Step 9, proceed to Test 32.

TEST 30 – CHECK FUSES F1 AND F2**DISCUSSION:**

Fuses F1 and F2 are connected in series with the UTILITY 1 and UTILITY 2 circuits, respectively. A blown fuse will open the applicable circuit and will result in (a) generator startup and transfer to "Standby", or (b) failure to retransfer back to the utility source.

PROCEDURE:

1. On the generator panel, set the AUTO-OFF-MANUAL switch to OFF.
2. Turn off the utility power supply to the transfer switch, using whatever means provided.
3. Remove fuses F1 and F2 from the fuse holder (see Figure 5).
4. Inspect and test fuses for blown condition.

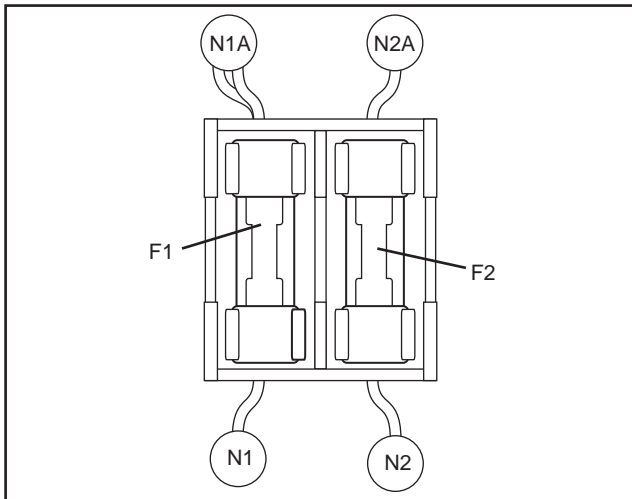

Figure 5. Fuse Holder and Fuses

RESULTS:

1. Replace blown fuse(s) and proceed to Test 34.
2. For Problem 7 (DC Control, Section 4), go to Test 27.

TEST 31 – TEST LIMIT SWITCH XA1

DISCUSSION:

When the transfer switch main contacts are actuated to their "Utility" position, limit switch XA1 should be mechanically actuated to its open position. On transfer to the "Standby" position, the limit switch should actuate to its closed position. If the switch does not actuate to its closed position, retransfer back to "Utility" will not occur.

PROCEDURE:

1. With the standby generator shut down, set its AUTO-OFF-MANUAL switch to OFF.
2. Turn off the utility power supply to the transfer switch, using whatever means provided.
3. To prevent interaction, disconnect Wire 126 and Wire A from the limit switch terminals.
4. Set a VOM to its "R x 1" scale and zero the meter.
5. Connect the VOM test leads across the two limit switch terminals from which Wires A and 126 were removed.
6. Manually actuate the main contacts to their "Standby" position. The VOM should indicate CONTINUITY.
7. Manually actuate the main contacts to their "Utility" position. The VOM should read INFINITY.

RESULTS:

Replace limit switch XA1 if it checks bad.

NOTE: Problems with transfer switch operation can also be caused by (a) defective wiring between the generator and transfer switch, or (b) a defective component in the generator circuit board. See Part 4, "DC Control".

TEST 32 – CONTINUITY TEST OF WIRING (C1)

DISCUSSION:

This test will ensure that all control wiring has continuity.

1. Set the AUTO-OFF-MANUAL switch to the OFF position.
2. Turn the generator main circuit breaker to the OFF position.
3. Turn off the utility power supply to the transfer switch using whatever means provided. (Such as utility source main line circuit breaker).
4. Set your VOM to the "R x 1" scale.
5. Disconnect Wire N2A from the Utility Coil C1 and connect one test lead to it. Connect the other test lead to Terminal Lug N2 of the transfer switch. CONTINUITY should be read. Reconnect Wire N2A.
6. Disconnect Wire 126 from transfer relay (TR) and connect one test lead to it. Connect the other test lead to limit switch XA1 bottom Terminal Wire 126. CONTINUITY should be read. Reconnect Wire 126.
7. Disconnect Wire N1A from transfer relay (TR) terminal and connect one test lead to it. Connect the other test lead to F1 top fuse Terminal Wire N1A. CONTINUITY should be read. Reconnect Wire N1A.

RESULTS:

Repair any defective wiring that does not read CONTINUITY. If wiring tests good, proceed to Test 23.

TEST 33 – CONTINUITY TEST OF WIRING (C2)

DISCUSSION:

This test will ensure that all control wiring has continuity.

1. See Test 32, Step 1
2. See Test 32, Step 2
3. See Test 32, Step 3
4. See Test 32, Step 4
5. Disconnect Wire E2 from the standby coil (C2) and connect one test lead to it. Connect the other test lead to Terminal Lug E2 of the transfer switch. CONTINUITY should be read. Reconnect Wire E2.
6. Disconnect Wire 205 from transfer relay (TR) Terminal 6 and connect one test lead to it. Connect the other test lead to limit switch XB1 top Terminal Wire 205. CONTINUITY should be read. Reconnect Wire 205.

7. Disconnect Wire E1 from Transfer Relay (TR) Terminal 9 and connect one test lead to it. Connect the other test lead to Terminal Lug E1 of the transfer switch. CONTINUITY should be read. Reconnect Wire E1.

RESULTS:

Repair any defective wiring that does not read CONTINUITY. If wiring tests good, proceed to Test 23.

TEST 34 – CHECK N1 AND N2 WIRING**DISCUSSION:**

A shorted Wire N1 or N2 to ground can cause fuse F1 or F2 to blow.

PROCEDURE:

1. On the generator panel, set the AUTO-OFF-MANUAL switch to OFF.
2. Turn off the utility power supply to the transfer switch, using whatever means are provided.
3. Remove fuses F1 and F2 from the fuse holder (see Figure 5).
4. Remove the generator control panel cover. Disconnect Wire N1 and Wire N2 from the interconnection terminal in the control panel, or the terminal strip.
5. Set your VOM to the "R x 1" scale. Connect the positive meter test lead to Wire N1.
 - a. Connect the negative meter lead to the ground lug. INFINITY should be measured.
 - b. Connect the negative meter lead to Wire 23 at ICT or terminal strip. INFINITY should be measured.
 - c. Connect the negative meter lead to Wire 194 at ICT or terminal strip. INFINITY should be measured.
 - d. Connect the negative meter lead to the neutral connection. INFINITY should be measured.
6. Set your VOM to the "R x 1" scale. Connect the positive meter test lead to Wire N2.
 - a. Connect the negative meter lead to the ground lug. INFINITY should be measured.
 - b. Connect the negative meter lead to Wire 23 at ICT or terminal strip. INFINITY should be measured.
 - c. Connect the negative meter lead to Wire No. 194 at ICT or terminal strip. INFINITY should be measured.
 - d. Connect the negative meter lead to the neutral connection. INFINITY should be measured.
7. Disconnect Wire N1 and Wire N2 from transformer TX.
8. Connect one test lead to Wire N1 removed in Step 7, and the other test lead to the ground terminal. INFINITY should be measured.
9. Connect one test lead to Wire N2 removed in Step 7, and the other test lead to the ground terminal. INFINITY should be measured.
10. If no short is indicated in Steps 5 through 9, proceed with Steps 11 through 15. If a short is indicated in Steps 5 through 9, repair shorted wiring.
11. Reconnect Wires N1 and N2 to the interconnection terminal or terminal strip.
12. Replace fuses F1 and F2 in the fuse holder.
13. Turn on the utility power supply to the transfer switch using whatever means is provided.
14. Set VOM to measure AC voltage. Connect one test lead to Wire N1 and the other test lead to Wire N2. Utility line to line voltage should be measured.
15. Turn off the utility power supply to the transfer switch using whatever means is provided.

RESULTS:

If a short is indicated in Steps 5 through 9, repair wiring and re-test. If utility line to line voltage is measured in Step 14, proceed to Test 35.

TEST 35 – CHECK TRANSFORMER (TX)**DISCUSSION:**

The transformer is a step down type and has two functions. It supplies approximately 16 VAC to the control board for utility sensing. It also supplies approximately 16 VAC to the battery charger when utility is available for trickle charge. A shorted transformer can result in fuse F1 or F2 blowing.

PROCEDURE:

1. On the generator panel, set the AUTO-OFF-MANUAL switch to OFF.
2. Turn off the utility power supply to the transfer switch, using whatever means is provided.
3. See Figure 6. Disconnect Wires N1, N2, 224, 225, 224A, 225A from transformer (TX).
4. Set a VOM to the "R x 1" scale.
5. Connect one test lead to TX Terminal 1. Connect the other test lead to TX Terminal 5. Approximately 38.5 ohms should be measured.
6. Connect one test lead to TX Terminal 10. Connect the other test lead to TX Terminal 9. Approximately 1.5 ohms should be measured.
7. Connect one test lead to TX Terminal 7. Connect the other test lead to TX Terminal 6. Approximately 0.3 ohms should be measured.

SECTION 3.4 DIAGNOSTIC TESTS

PART 3

"W/V-TYPE" TRANSFER SWITCHES

8. Connect one test lead to TX Terminal 1. Connect the other test lead to the transformer case. INFINITY should be measured.
9. Connect one test lead to TX Terminal 7. Connect the other test lead to the transformer case. INFINITY should be measured.
10. Connect one test lead to TX Terminal 9. Connect the other test lead to the transformer case. INFINITY should be measured.
11. Connect one test lead to TX Terminal 1. Connect the other test lead to TX Terminal 10. INFINITY should be measured.
12. Connect one test lead to TX Terminal 1. Connect the other test lead to TX Terminal 7. INFINITY should be measured.
13. Connect one test lead to TX Terminal 10. Connect the other test lead to TX Terminal 7. INFINITY should be measured.

RESULTS:

For Steps 5, 6, and 7, replace transformer if an open is indicated, or if the resistance value indicated is zero. If the resistance value is not within the approximate range, proceed to test 65.

For Steps 8 through 13, replace the transformer if it fails any of these steps.

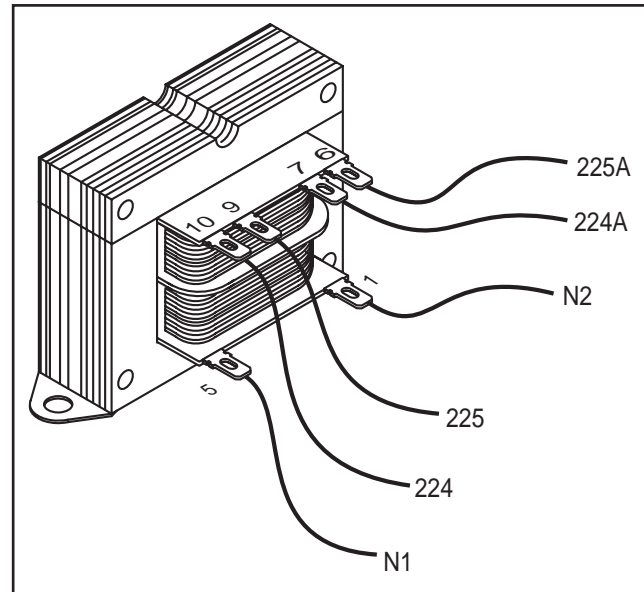

Figure 6. Transformer (TX)

PART 4 DC CONTROL

Air-cooled, Automatic Standby Generators

4.1 Description and Components	76
General	76
Terminal Strip / Interconnection Terminal.....	76
Transformer (TX).....	76
Circuit Board.....	76
AUTO-OFF-MANUAL Switch	80
15 Amp Fuse	80
4.2 Operational Analysis.....	82
Introduction.....	82
Utility Source Voltage Available.....	82
Initial Dropout Of Utility Source Voltage.....	84
Utility Voltage Dropout And	
Engine Cranking	86
Engine Startup And Running	88
Initial Transfer To The "Standby" Source	90
Utility Voltage Restored /	
Re-transfer To Utility.....	92
Engine Shutdown	94
4.3 Troubleshooting Flow Charts	96
Problem 8 – Engine Will Not Crank	
When Utility Power Source Fails	96
Problem 9 – Engine Will Not Crank	
When AUTO-OFF-MANUAL Switch	
is Set to "MANUAL".....	96
Problem 10 – Engine Cranks	
but Won't Start	97
Problem 11 – Engine Starts Hard and	
Runs Rough / Lacks Power.....	98
Problem 12 – Engine Starts and Runs,	
Then Shuts Down	99
Problem 13 – No Battery Charge.....	100
Problem 14 – Unit Starts and Transfer Occurs	
When Utility Power is Available	101
Problem 15 – Generator Starts	
Immediately in Auto - No Transfer to	
Standby. Utility Voltage is Present.....	101
Problem 16 – 15 Amp Fuse (F1) Blown.....	102
Problem 17 – Generator Will Not Exercise	102
Problem 18 – No Low Speed Exercise	102
4.4 Diagnostic Tests.....	103
Introduction	103
Test 41 – Check Position Of	
AUTO-OFF-MANUAL Switch	103
Test 42 – Try A Manual Start	103
Test 43 – Test AUTO-OFF-MANUAL Switch	103
Test 44 – Check Wire 15/15A/15B/239/0	
Voltage	104
Test 45 – Check 15 Amp Fuse.....	105
Test 46 – Check Battery	105
Test 47 – Check Wire 56 Voltage	106

TABLE OF CONTENTS		
PART	TITLE	PAGE#
4.1.	Description and Components	76
4.2	Operational Analysis	82
4.3	Troubleshooting Flow Charts	96
4.4	Diagnostic Tests	103

Test 48 – Test Starter Contactor Relay	
(V-twin Only).....	106
Test 49 – Test Starter Contactor	106
Test 50 – Test Starter Motor.....	107
Test 51 – Check Fuel Supply	
And Pressure	109
Test 52 – Check Circuit Board	
Wire 14 Output.....	110
Test 53 – Check Fuel Solenoid	111
Test 54 – Check Choke Solenoid	
(V-twins Units Only).....	112
Test 55 – Check For Ignition Spark.....	113
Test 56 – Check Spark Plugs.....	114
Test 57 – Check Engine / Cylinder Leak Down	
Test / Compression Test.....	114
Test 58 – Check Shutdown Wire	115
Test 59 – Check And Adjust	
Ignition Magnetos.....	116
Test 60 – Check Oil Pressure Switch	
And Wire 86	119
Test 61 – Check High Oil	
Temperature Switch	119
Test 62 – Check And Adjust Valves	120
Test 63 – Check Fuel Regulator	
(6/7 kW Natural Gas Units Only).....	121
Test 64 – Check Battery Charge Output.....	121
Test 65 – Check Transformer (TX)	
Voltage Output	122
Test 66 – Check AC Voltage At	
Battery Charger.....	122
Test 67 – Check Battery Charge	
Relay (BCR)	123
Test 68 – Check Battery Charge	
Winding Harness.....	123
Test 69 – Check Battery Charger Wiring	124
Test 70 – Check Wire 18 Continuity.....	124
Test 71 – Check N1 And N2 Voltage.....	125
Test 72 – Check Utility Sensing Voltage	
At The Circuit Board.....	125
Test 73 – Test Set Exercise Switch	125
Test 75 – Check Battery Voltage Circuit.....	125
Test 76 – Check Cranking And	
Running Circuits.....	126
Test 77 – Test Exercise Function	127
Test 78 – Check Dip Switch Settings	127
Test 79 – Check Idle Control Transformer	
(V-twin Units Only)	127
Test 80 – Check LC1 & LC2 Wiring	128
Test 81 – Check Idle Control Transformer	
Primary Wiring	128

SECTION 4.1 DESCRIPTION AND COMPONENTS

PART 4

DC CONTROL

GENERAL

This section will familiarize the reader with the various components that make up the DC control system.

Major DC control system components that will be covered include the following:

- A Terminal Strip / Interconnection Terminal
- A Transformer (TX)
- A Circuit Board.
- An AUTO-OFF-MANUAL Switch.
- A 15 Amp Fuse.
- A 5 Amp Fuse.

TERMINAL STRIP / INTERCONNECTION TERMINAL

The terminals of this terminal strip are connected to identically numbered terminals on a transfer switch terminal board. The terminal board connects the transfer switch to the circuit board and transformer.

The terminal board provides the following connection points:

A. UTILITY 1 and UTILITY 2

1. Connect to identically marked terminals on a transfer switch terminal board.
2. The circuit delivers "Utility" power source voltage to the transformer (TX) located in the control panel assembly.

B. 23 and 194

1. Connect to identically numbered terminals on the terminal board of the transfer switch.
2. This circuit connects the circuit board to the transfer relay coil in the transfer switch.

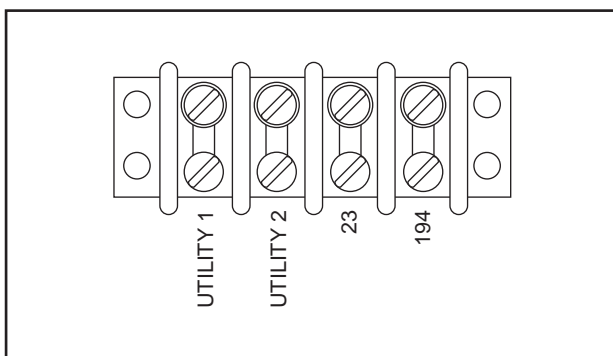

Figure 1. Terminal Board

TRANSFORMER (TX)

The control panel assembly's transformer is a step-down type. The line-to-line voltage from the UTILITY 1/UTILITY 2 terminals is delivered to the transformer's primary winding. Transformer action then induces a reduced voltage (about 12 to 16 volts) into both

secondary transformer windings. Reduced voltage from one secondary winding is delivered to the circuit board as "Utility" source sensing voltage. Reduced voltage from the other secondary winding is delivered to the battery charger for trickle charging.

- If the Utility sensing voltage drops below a preset value, circuit board action will initiate automatic generator startup and transfer to the "Standby" source side.

The sensing transformer is shown in Figure 2, both pictorially and schematically.

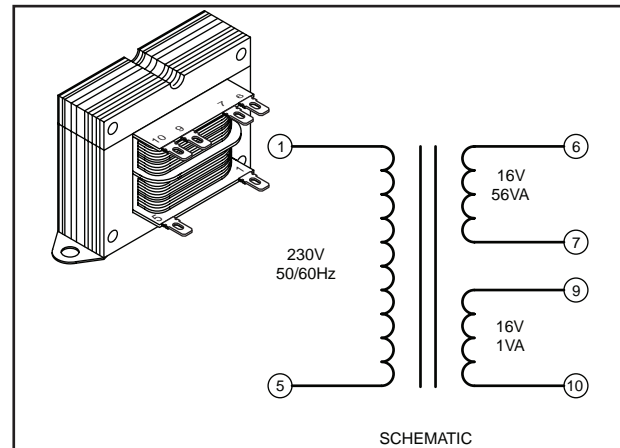

Figure 2. The Transformer

CIRCUIT BOARD

The circuit board controls all standby electric system operations including (a) engine startup, (b) engine running, (c) automatic transfer, (d) automatic retransfer, and (e) engine shutdown. In addition, the circuit board performs the following functions:

- Delivers "field boost" current to the generator rotor windings (see "Field Boost Circuit" in Section 2.2).
- Starts and "exercises" the generator once every seven days.
- Provides automatic engine shutdown in the event of low oil pressure, low battery, high oil temperature, or overspeed.

A 23-pin and a 5-pin connector are used to interconnect the circuit board with the various circuits of the DC systems. Connector pin numbers, associated wires and circuit functions are listed in the CHART on the next page.

The run relay is energized by circuit board action at the same time as the crank relay, to energize and open a fuel solenoid valve.



DANGER: THE GENERATOR ENGINE WILL CRANK AND START WHEN THE 7-DAY EXERCISER SWITCH IS ACTUATED. THE UNIT WILL ALSO CRANK AND START EVERY 7 DAYS THEREAFTER, ON THE DAY AND AT THE TIME OF DAY THE SWITCH WAS ACTUATED.

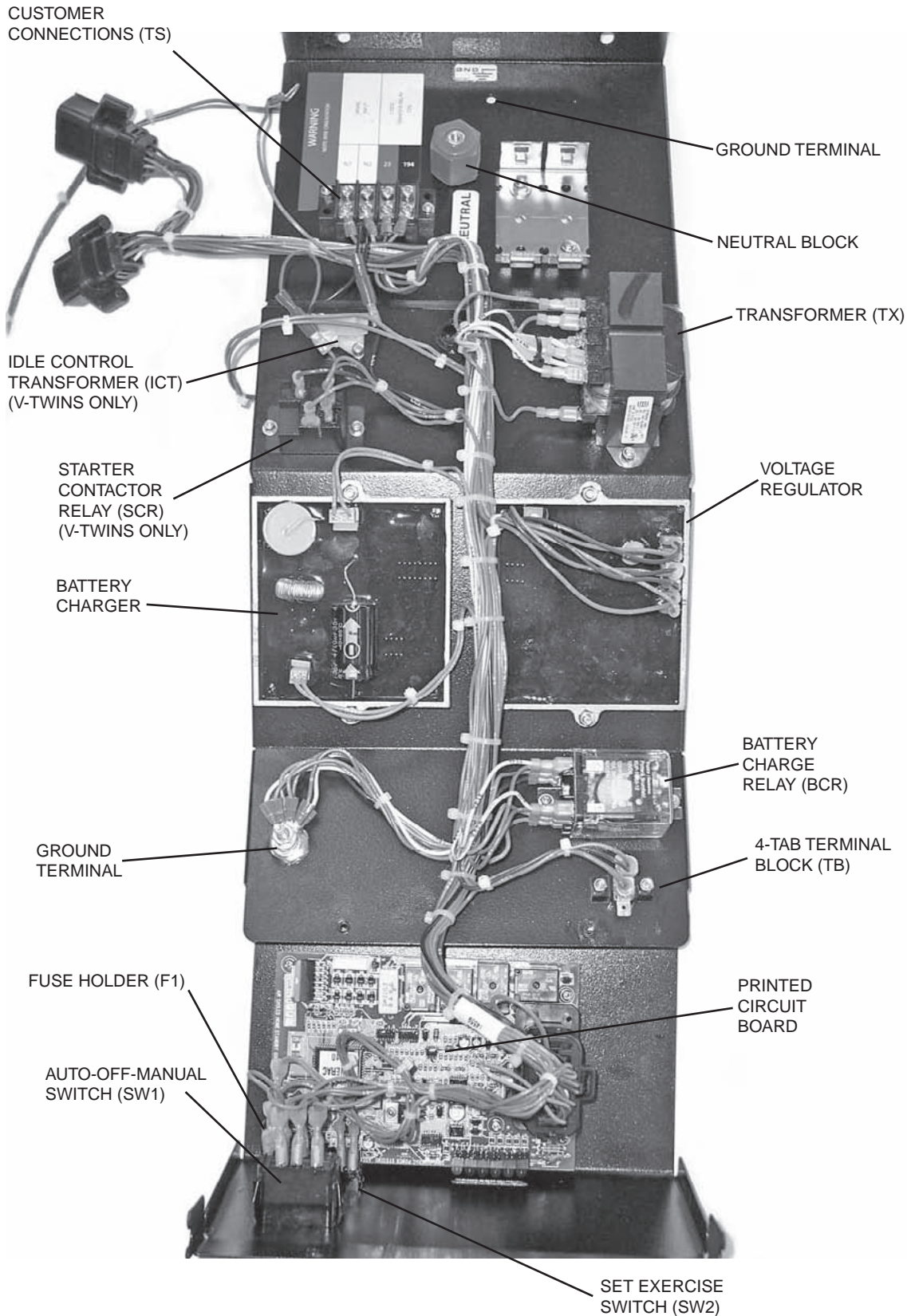

Figure 3. Control Panel Component Identification

SECTION 4.1 DESCRIPTION AND COMPONENTS

PART 4

DC CONTROL

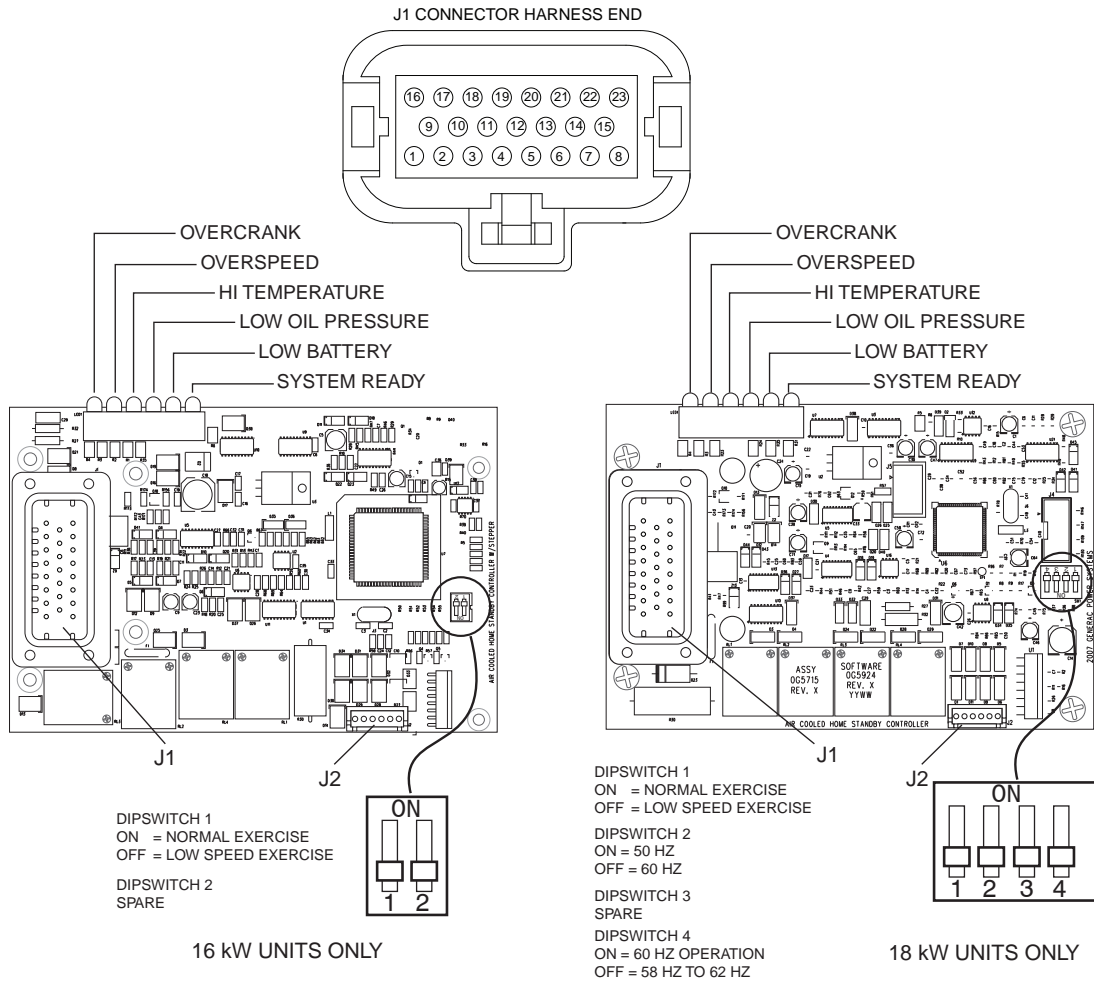

Figure 4. 10/13/16/18 kW Printed Circuit Boards and J1 Connector

10/13/16/18 kW J1 Connector Pin Descriptions

PIN	WIRE	CIRCUIT FUNCTION
1	15A	12 VDC into the circuit board for source voltage when SW1 is in the AUTO or MANUAL position
2	4	Field boost current to rotor (about 9-10 volts DC)
3	23	Switched to ground for Transfer Relay (TR) operation
4	86	Low oil pressure shutdown: Shutdown occurs when Wire 86 is grounded by loss of oil pressure to the LOP
5	18	Ignition Shutdown: Circuit board action grounds Wire 18 for ignition shutdown RPM Sense: Circuit board monitors ignition magneto voltage/frequency for engine speed when running
6	BROWN	INTERNAL USE
7	BROWN	INTERNAL USE
8	LC1	Current sensing for governor control
9	56	12 VDC output to starter contactor relay for V-twin engine
10	224	Transformer reduced "Utility" source sensing voltage

PIN	WIRE	CIRCUIT FUNCTION
11	239	12 VDC input when SW1 is in the MANUAL position
12	85	High temperature shutdown: Shutdown occurs when Wire 85 is grounded by contact closure of the HTO
13		NOT USED
14		NOT USED
15	LC2	Current sensing for governor control
16	14	12 VDC output for engine run condition. Used for fuel solenoid and battery charge relay
17	225	Transformer reduced "Utility" source sensing voltage
18		NOT USED
19	15B	12 VDC source voltage for the circuit board. Also runs timer for exerciser
20	0	Common ground.
21	GREY	INTERNAL USE
22	GREY	INTERNAL USE
23	90	Switched to ground for choke solenoid operation

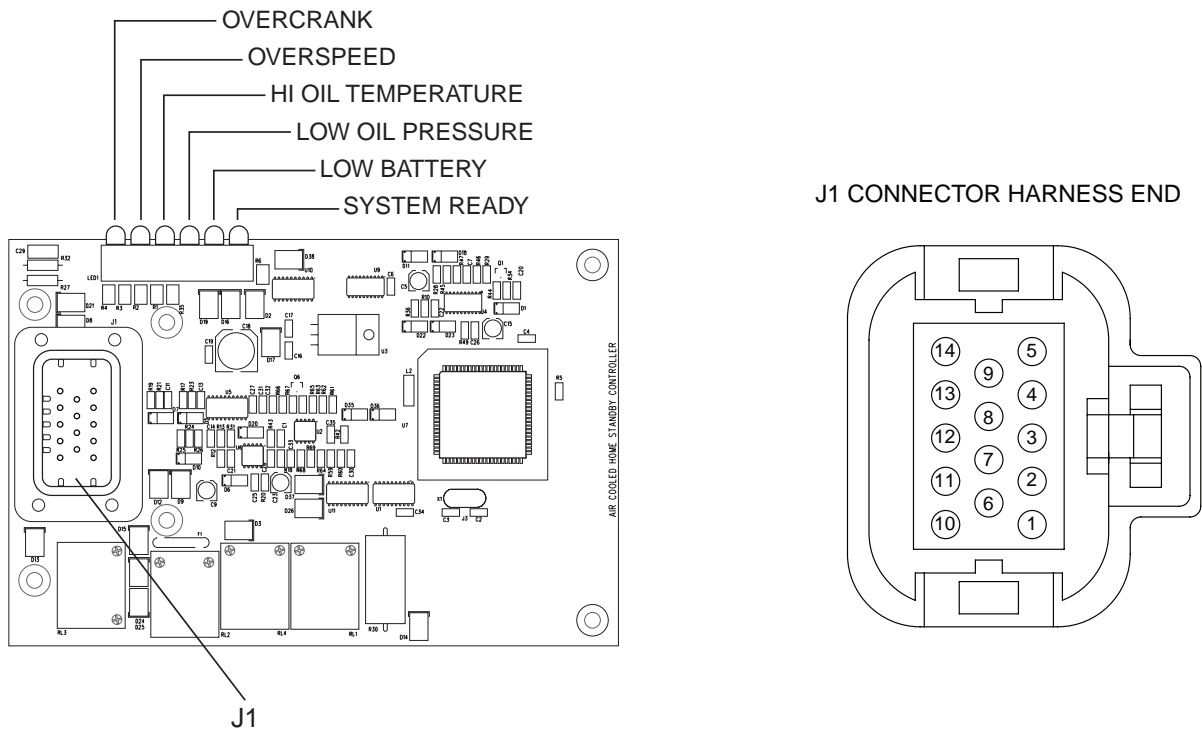

Figure 5. 6/7 kW Printed Circuit Board and J1 Connector

6/7 kW J1 Connector Pin Descriptions

PIN	WIRE	CIRCUIT FUNCTION
1	15A	12 VDC into the circuit board for source voltage when SW1 is in the AUTO or MANUAL position
2	4	Field boost current to rotor (about 9-10 volts DC).
3	23	Switched to ground for Transfer Relay (TR) operation
4	86	Low oil pressure shutdown: Shutdown occurs when Wire 86 is grounded by loss of oil pressure to the LOP
5	18	Ignition Shutdown: Circuit board action grounds Wire 18 for ignition shutdown RPM Sense: Circuit board monitors ignition magneto voltage/frequency for engine speed when running
6	56	12 VDC output to starter contactor for single cylinder engine

PIN	WIRE	CIRCUIT FUNCTION
7	224	Transformer reduced "Utility" source sensing voltage
8	239	12 VDC input when SW1 is in the MANUAL position
9	85	High temperature shutdown: Shutdown occurs when Wire 85 is grounded by contact closure of the HTO
10	14	12 VDC output for engine run condition. Used for fuel solenoid and battery charge relay
11	225	Transformer reduced "Utility" source sensing voltage
12		NOT USED
13	15B	12 VDC source voltage for the circuit board. Also runs timer for exerciser
14	0	Common ground

AUTO-OFF-MANUAL SWITCH

This 3-position switch permits the operator to (a) select fully automatic operation, (b) start the generator manually, or (c) stop the engine and prevent automatic startup. Switch terminals are shown pictorially and schematically in Figure 6, below.

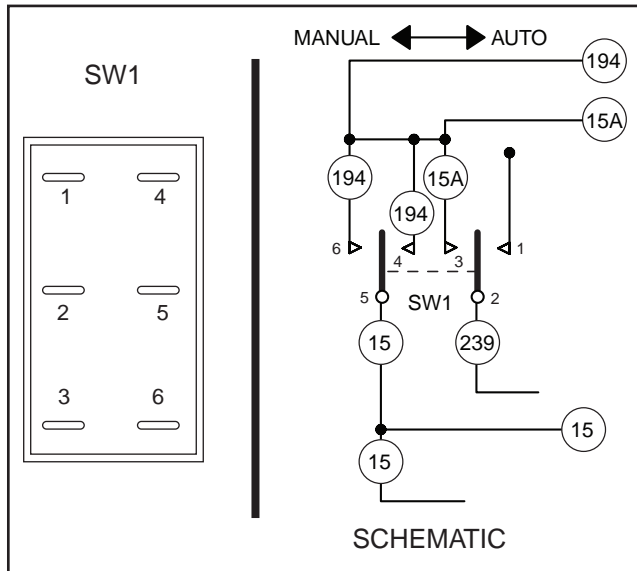

Figure 6. The AUTO-OFF-MANUAL Switch

15 AMP FUSE

This fuse protects the circuit board against excessive current. If the fuse has blown, engine cranking and operation will not be possible. Should fuse replacement become necessary, use only an identical 15-amp replacement fuse.

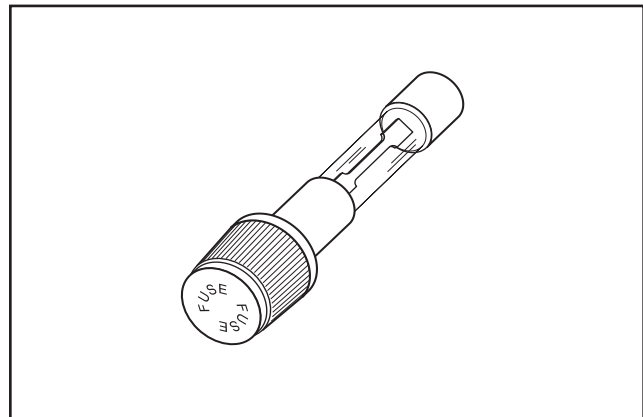

Figure 7. 15 Amp Fuse

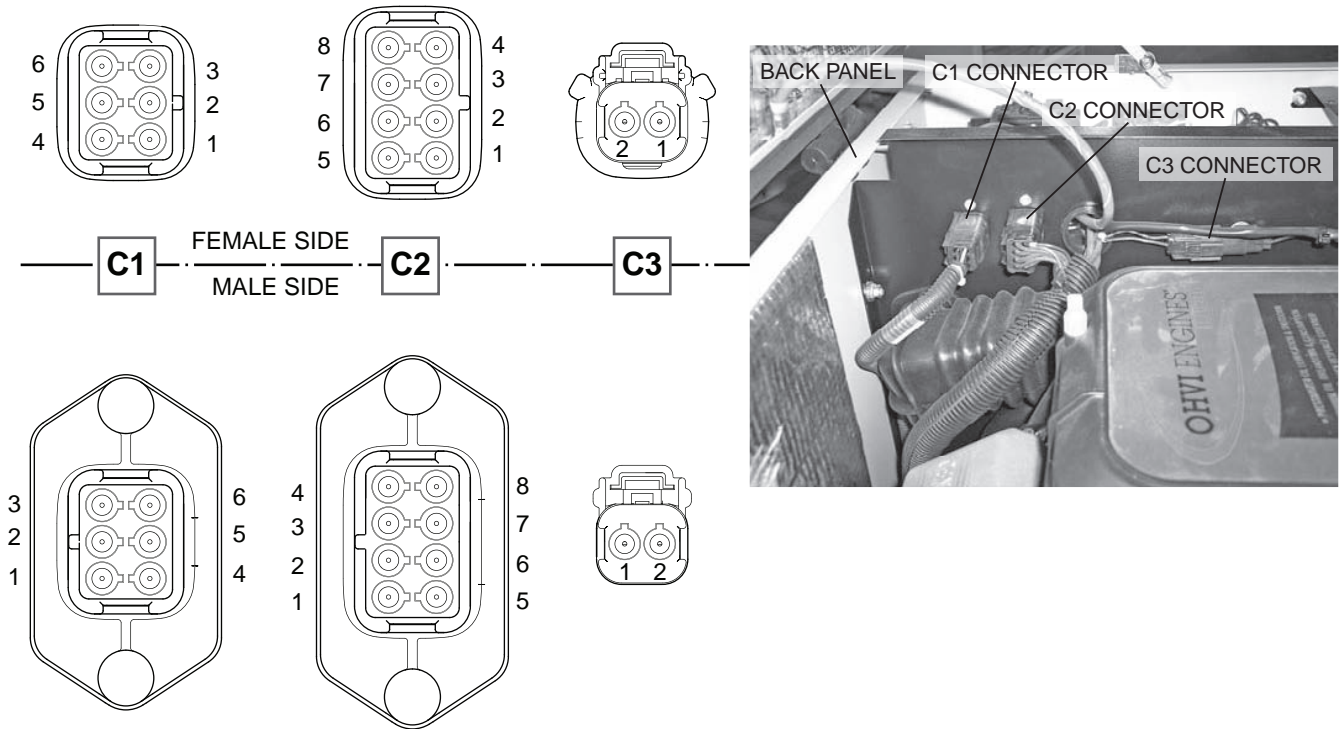

Figure 8. C1, C2 & C3 Connector Locations and Pin Number Identification

INTRODUCTION

This "Operational Analysis" is intended to familiarize the service technician with the operation of the DC control system on units with air-cooled engine. A thorough understanding of how the system works is essential to sound and logical troubleshooting. The DC control system illustrations on the following pages include a "W/V-Type" transfer switch.

UTILITY SOURCE VOLTAGE AVAILABLE

See Figure 1, below. The circuit condition with the AUTO-OFF-MANUAL switch set to AUTO and with "Utility" source power available can be briefly described as follows:

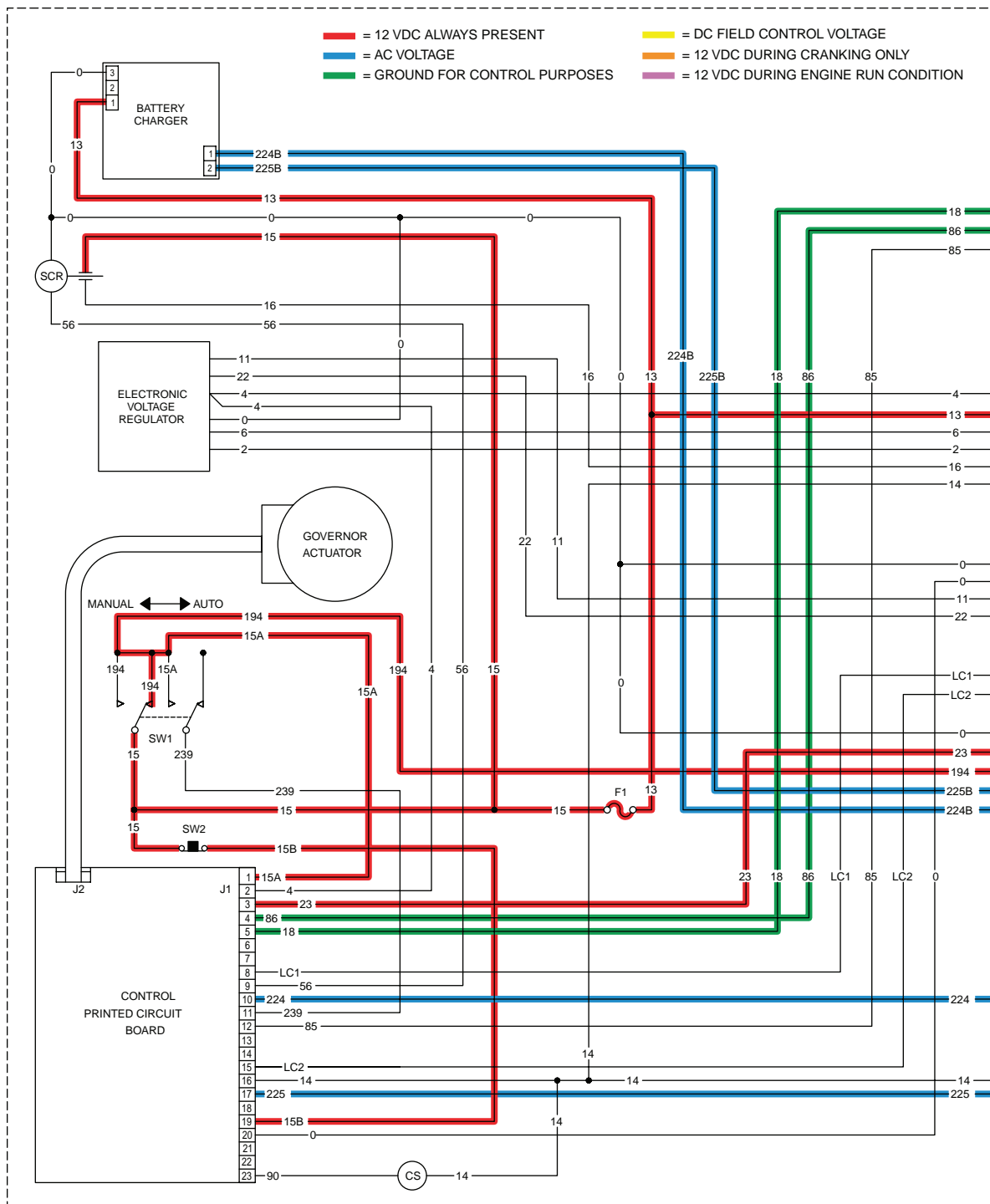

- Utility source voltage is available to transfer switch Terminal Lugs N1/N2. With the transfer switch main contacts at their "Utility" side, this source voltage is available to Terminal Lugs T1/T2 and to the "Load" circuits.
- Utility voltage is delivered to the primary winding of a sensing transformer (TX), via transfer switch Wires N1/N2, fuses F1/F2, connected wiring, and Control Panel UTILITY 1 and UTILITY 2 terminals. A resultant voltage (about 16 volts AC) is induced into the transformer secondary windings and then delivered to the circuit board via Wires 224/225. The circuit board uses this reduced utility voltage as sensing voltage. Wires 224A/225A supply 16 VAC to the battery charger.
- Battery output is delivered to the circuit board with the AUTO-OFF-MANUAL switch (SW1) set to AUTO, as shown.

Figure 1. Circuit Condition – Utility Source Voltage Available

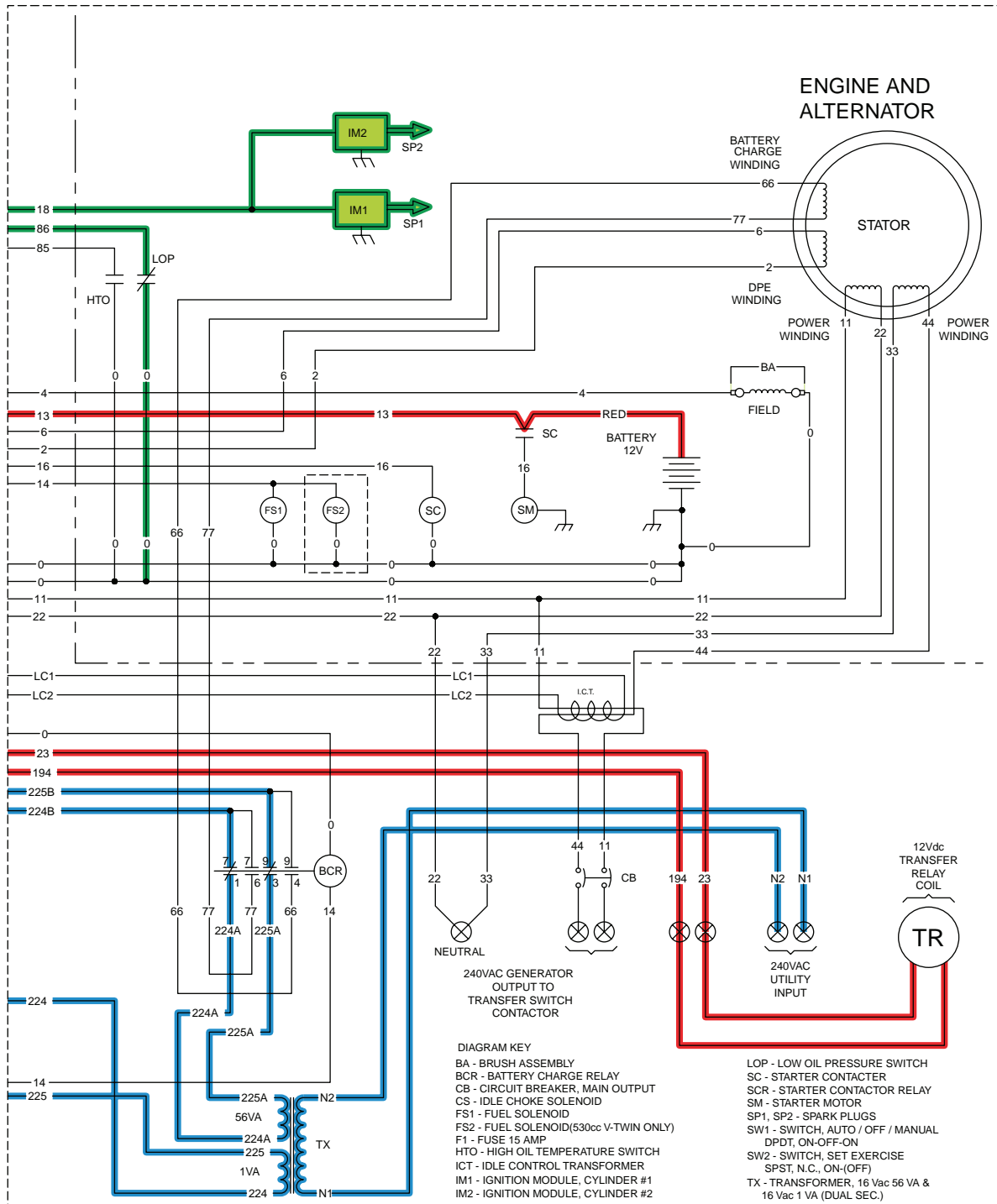

INITIAL DROPOUT OF UTILITY SOURCE VOLTAGE

Refer to Figure 2, below. Should a "Utility" power source failure occur, circuit condition may be briefly described as follows:

- The circuit board constantly senses for an acceptable "Utility" source voltage, via transfer switch fuses F1/F2, transfer switch UTILITY 1 and UTILITY 2 terminals, connected wiring, control panel UTILITY 1 and UTILITY 2 terminals, the sensing transformer (TX), and Wires 224/225.

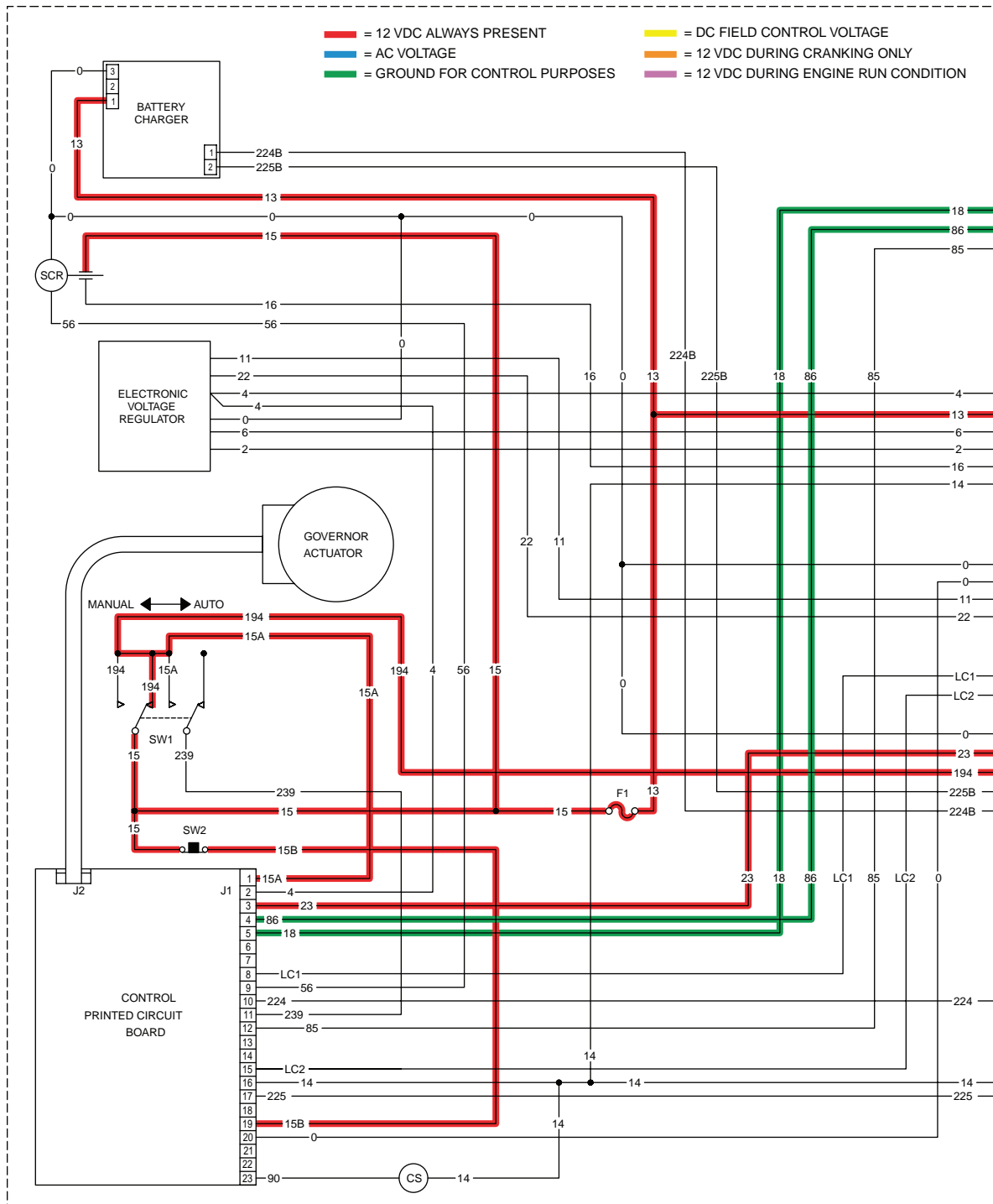

- Should utility voltage drop below approximately 65 percent of the nominal source voltage, a 10-second timer on the circuit board will turn on.
- In Figure 2, the 10-second timer is still timing and engine cranking has not yet begun.
- The AUTO-OFF-MANUAL switch is shown in its AUTO position. Battery voltage is available to the circuit board, via Wire 13, 15 amp fuse (F1), Wire 15, the AUTO-OFF-MANUAL switch (SW1), Wire 15A, and Pin 1 of the circuit board connector.

Figure 2. Circuit Condition – Initial Dropout of Utility Source Voltage

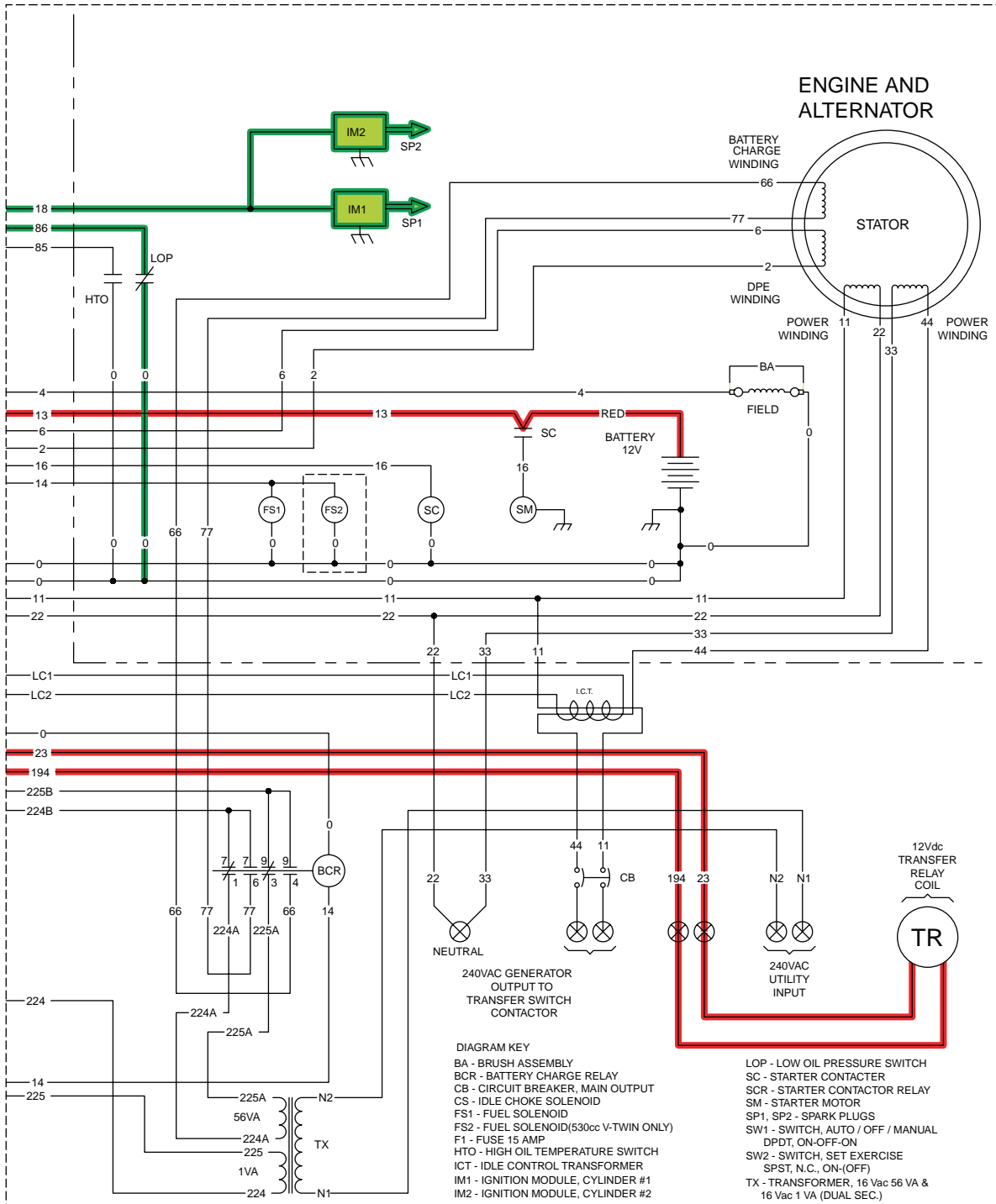

UTILITY VOLTAGE DROPOUT AND ENGINE CRANKING

- After ten (10) seconds and when the circuit board's 10-second timer has timed out, if utility voltage is still below 65 percent of nominal, circuit board action will energize the circuit board's crank and run relays simultaneously.
- Printed circuit board action delivers 12 volts DC to a starter contactor relay (SCR), via Wire 56. When the SCR energizes, its contacts close and battery power is delivered to a starter contactor (SC). When the SC energizes, its contacts close and battery power is delivered to the starter motor (SM). The engine cranks.

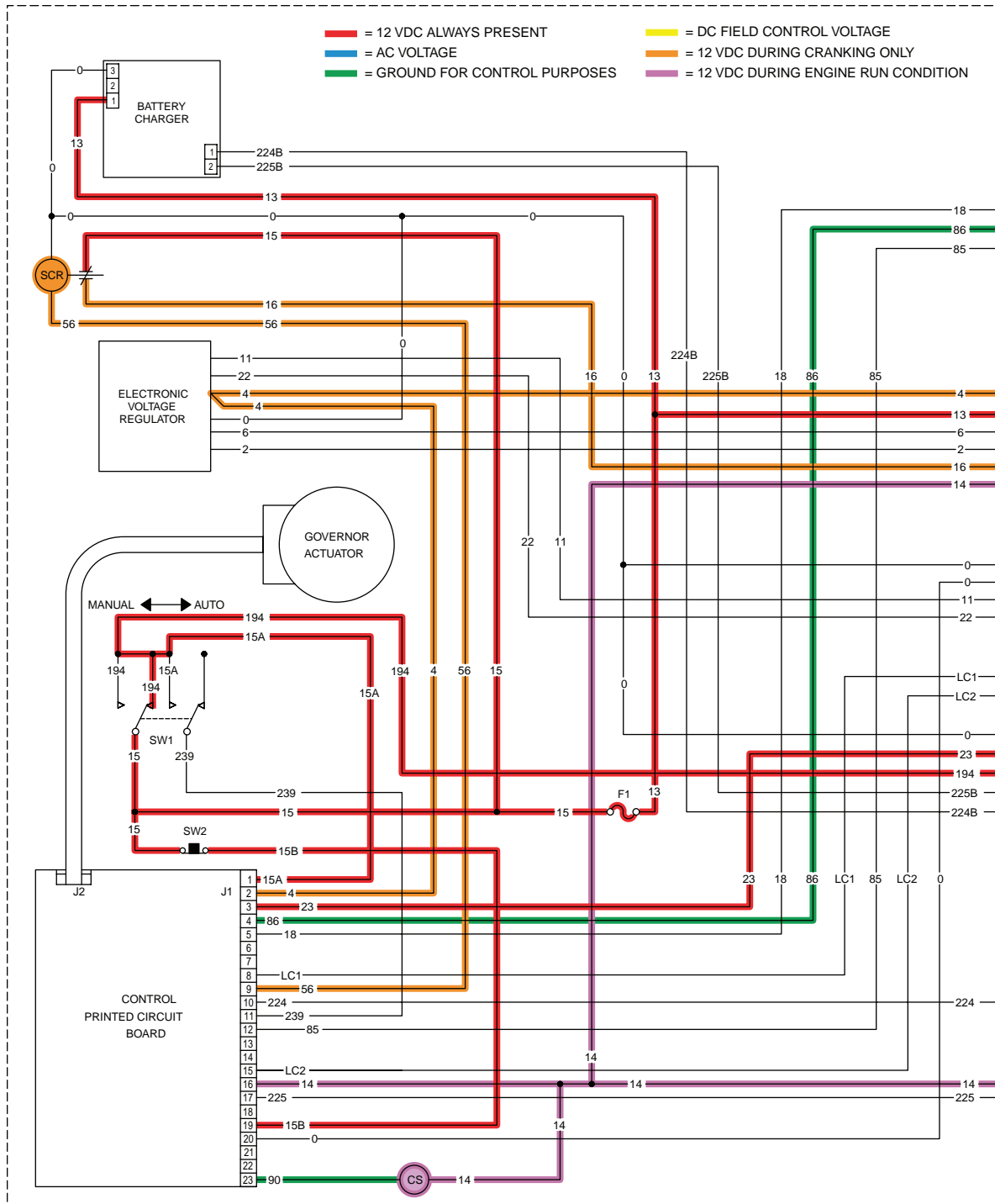

- Printed circuit board action delivers 12 volts DC to the fuel solenoids (FS1 & FS2), via Wire 14. The fuel solenoids energize open and fuel is available to the engine. Wire 14 energizes the battery charge relay (BCR), which will allow the BCR to power the battery charger. Wire 14 supplies power to the choke solenoid (CS). Circuit board action grounds Wire 90, energizing the choke solenoid cyclically during cranking and continuously while running.
- As the engine cranks, magnets on the engine flywheel induce a high voltage into the engine ignition magnetos (IM1/IM2). A spark is produced that jumps the spark plug (SP1/SP2) gap.
- During cranking, Wire 4 supplies 3-5 VDC (9-10 VDC isolated) to the rotor for field flash.
- With ignition and fuel flow available the engine can start.

Figure 3. Circuit Condition – Engine Cranking

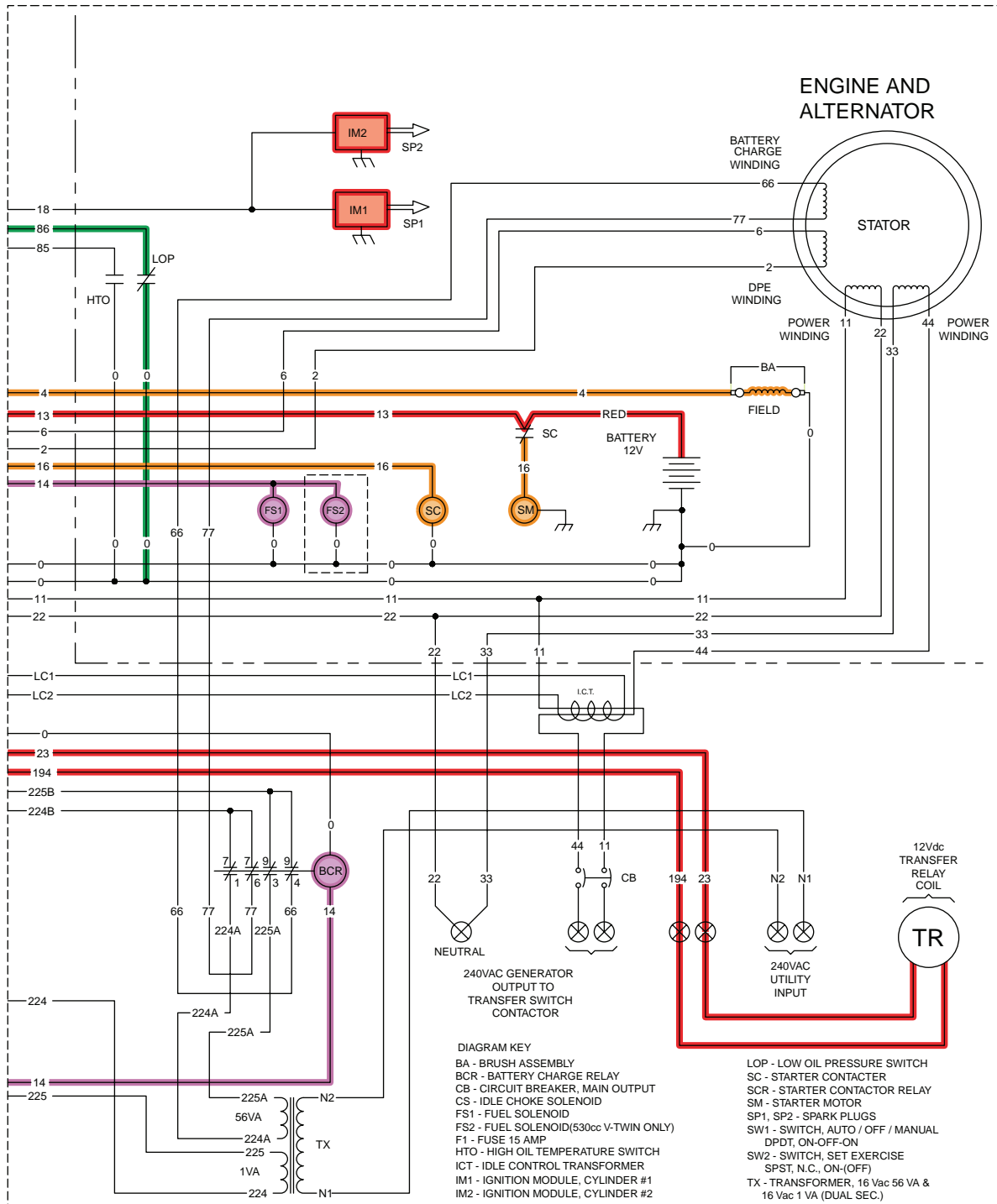

ENGINE STARTUP AND RUNNING

With the fuel solenoids open and ignition occurring, the engine starts. Engine startup and running may be briefly described as follows:

- Voltage pulses from the ignition magnetos are delivered to the circuit board via Wire 18. Once the circuit board determines that the engine is running, the circuit board (a) terminates cranking, and (b) terminates the choke solenoid (CS), and (c) turns on an "engine warm-up timer".

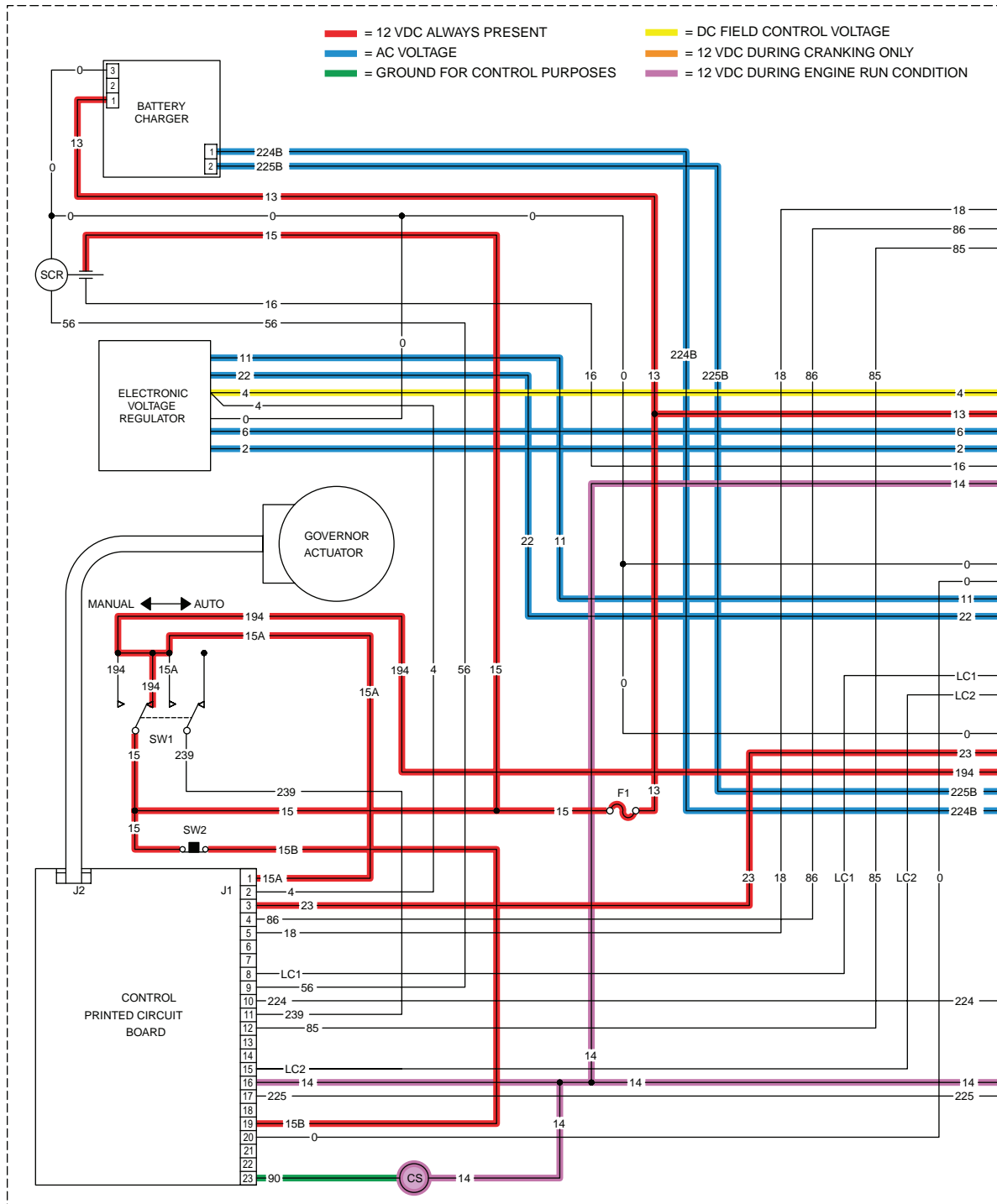

INITIAL TRANSFER TO THE "STANDBY" SOURCE

The generator is running, the circuit board's "engine warm-up timer" is timing, and generator AC output is available to transfer switch terminal lugs E1 and E2 and to the open contacts on the transfer relay. Initial transfer to the STANDBY power supply may be briefly described as follows:

- 12 volts DC output is delivered to the transfer relay (TR) actuating coil, via Wire 194, and terminal A of the transfer relay (TR) in the transfer switch. This 12 volts DC circuit is completed back to the board, via transfer relay terminal B, and Wire 23. However, circuit board action holds the Wire 23 circuit open to ground and the transfer relay (TR) is de-energized.
- When the circuit board's "engine warm-up timer" times out, circuit board action completes the Wire 23 circuit to ground. The transfer relay then energizes and its normally open contacts close.

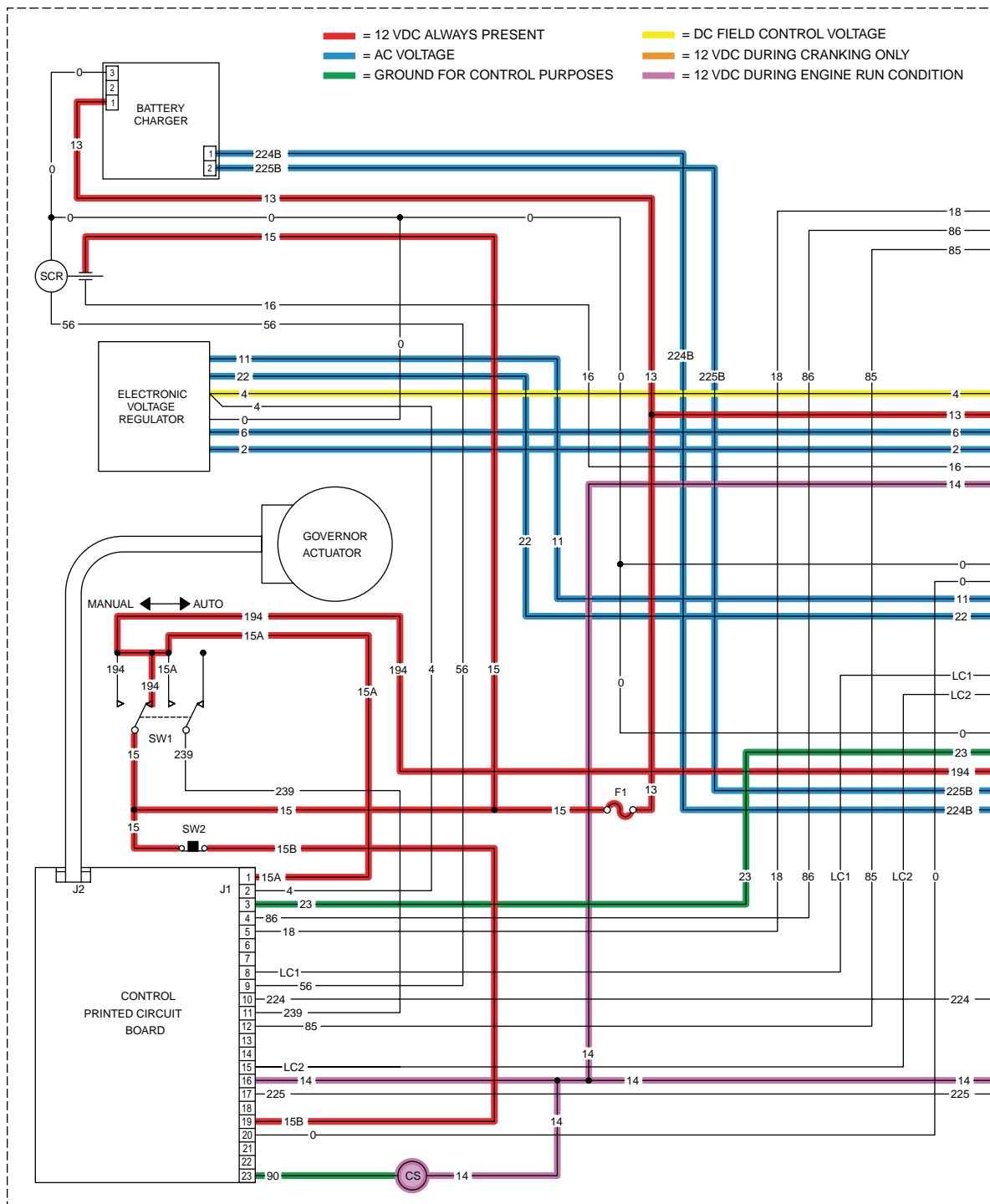

- Standby power is now delivered to the standby closing coil (C2), via Wires E1 /E2, the normally open transfer relay contacts, Wire 205, limit switch XB1, Wire B, and a bridge rectifier. The standby closing coil energizes and the main current carrying contacts of the transfer switch are actuated to their STANDBY source side.
- As the main contacts move to their STANDBY source side, a mechanical interlock actuates limit switch XB1 to its open position and limit switch XA1 to its "Utility" side position. When XB1 opens, standby closing coil C2 3 de-energizes.
- Standby power is delivered to the LOAD terminals (T1/T2) of the transfer switch.
- As load is applied to the generator, the current transformer (ICT) induces AC voltage that is applied to the circuit board via Wires LC1 & LC2. This voltage is utilized for stepper motor control.

Figure 5. Circuit Condition – Initial Transfer to Standby

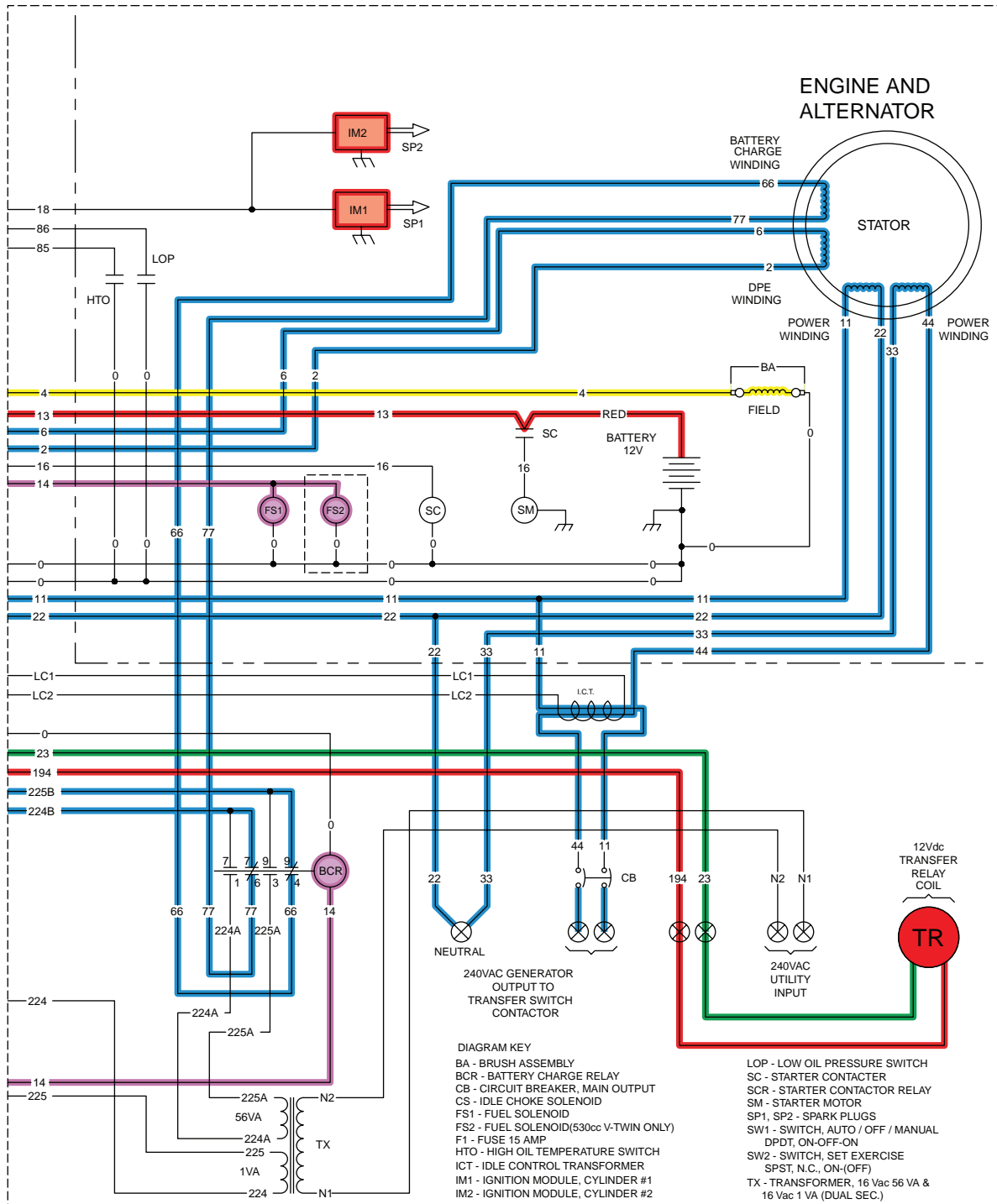

UTILITY VOLTAGE RESTORED / RE-TRANSFER TO UTILITY

The "Load" is powered by the standby power supply. The circuit board continues to seek an acceptable utility source voltage. On restoration of utility source voltage, the following events will occur:

- On restoration of utility source voltage above 75 percent of the nominal rated voltage, a "retransfer time delay" on the circuit board starts timing. The timer will run for about fifteen (15) seconds.
- At the end of fifteen (15) seconds, the "retransfer time delay" will stop timing and circuit board action will open the Wire 23 circuit to ground. The transfer relay (TR) will then de-energize.
- When the transfer relay (TR) de-energizes, its normally-closed contacts close. Utility source voltage is then delivered to the utility closing coil (C1), via Wires N1A/N2A, the closed TR contacts, Wire 126, limit switch XA1, and a bridge rectifier.

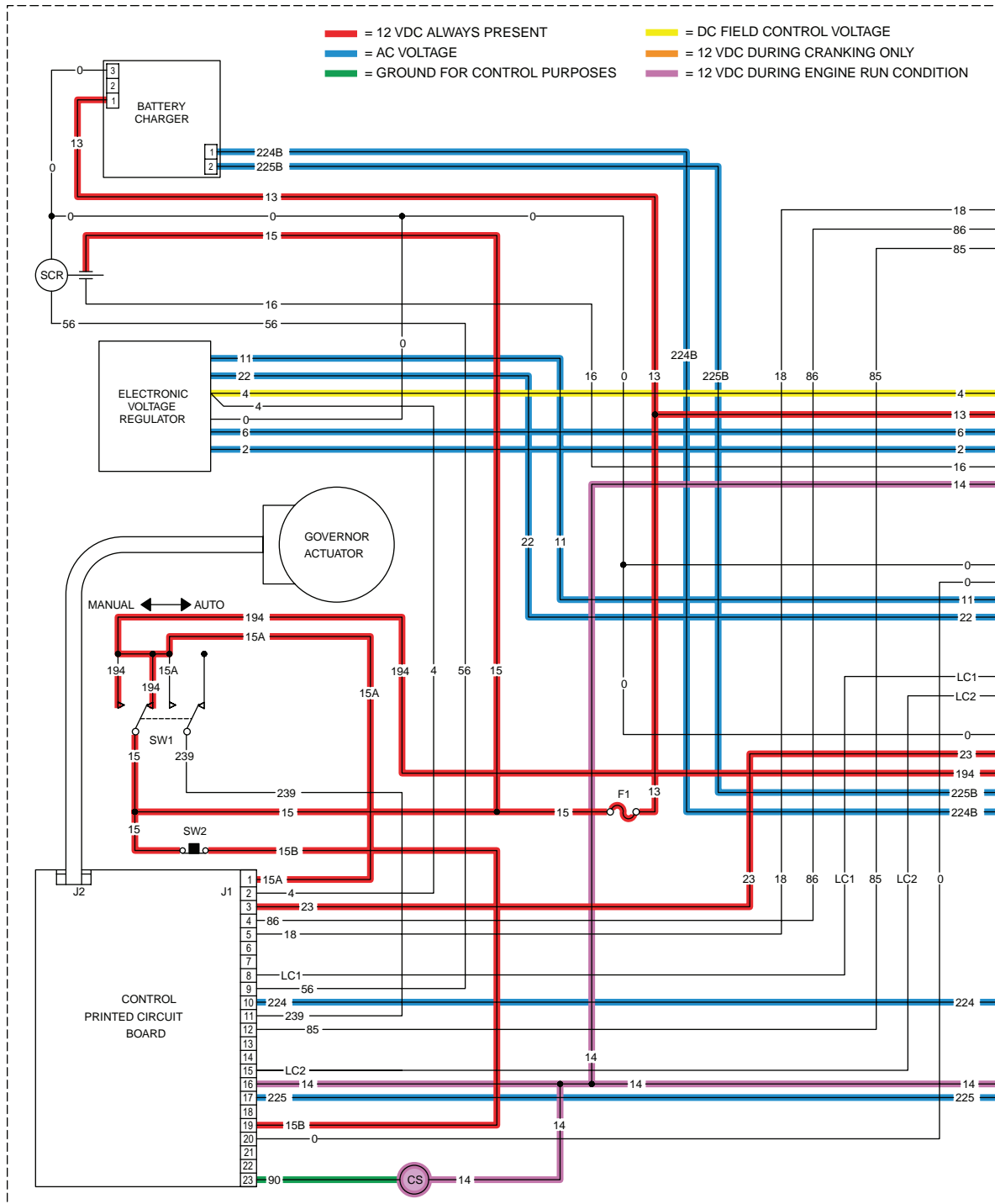

- The utility closing coil (C1) energizes and moves the main current carrying contacts to their NEUTRAL position. The main contacts move to an over center position past NEUTRAL and spring force closes them to their UTILITY side. LOAD terminals are now powered by the UTILITY source.
- Movement of the main contacts to UTILITY actuates limit switches XA1/XB1. XA1 opens and XB1 actuates to its STANDBY source side.
- The generator continues to run.

Figure 6. Circuit Condition – Utility Voltage Restored

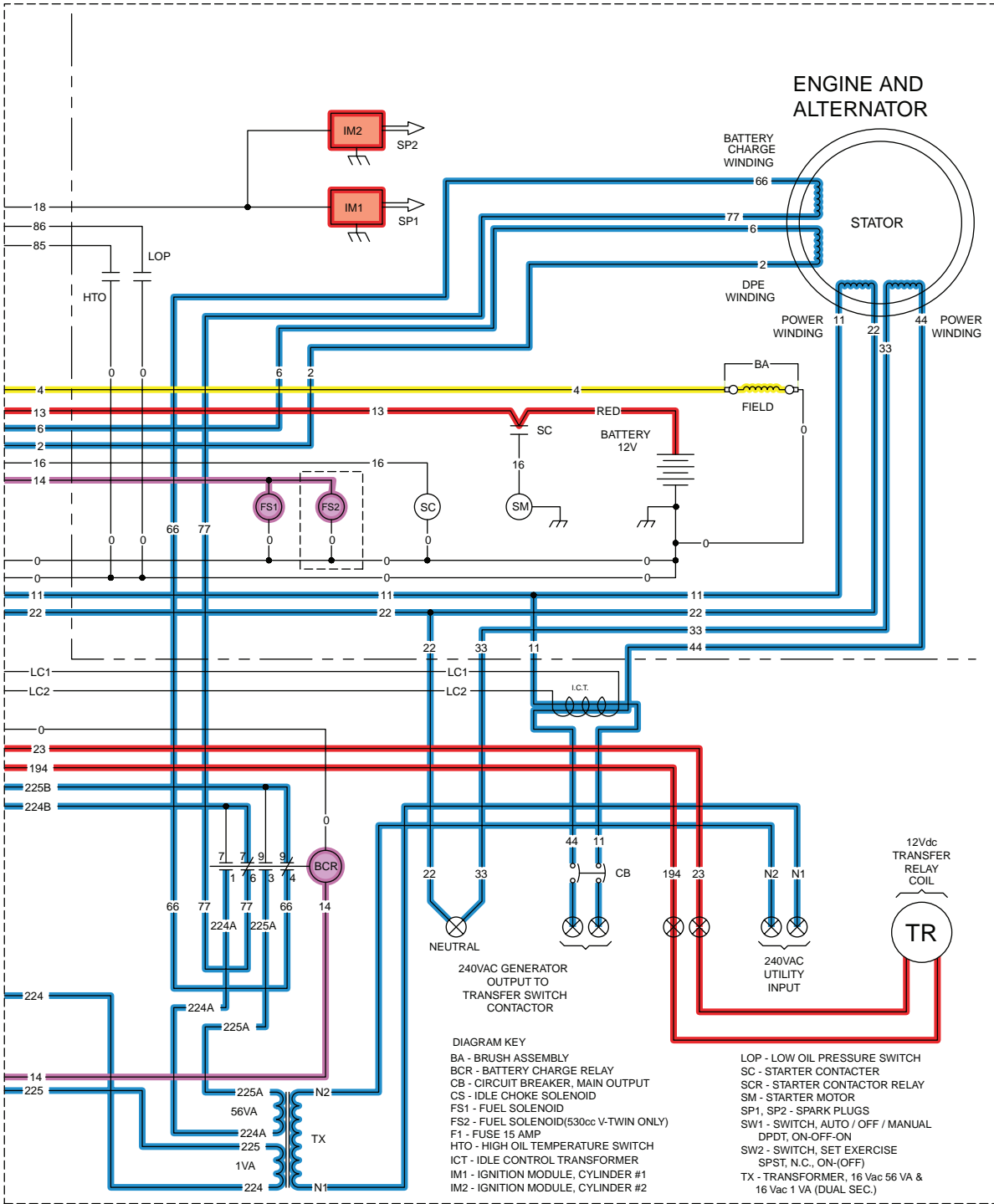

ENGINE SHUTDOWN

Following retransfer back to the utility source, an “engine cool-down timer” on the circuit board starts timing. When that timer has timed out (approximately one minute), circuit board action will de-energize the circuit board’s run relay. The following events will then occur:

- The DC circuit to Wire 14 and the fuel solenoids (FS1 & FS2) will be opened. The fuel solenoids will de-energize and close to terminate the engine fuel supply.

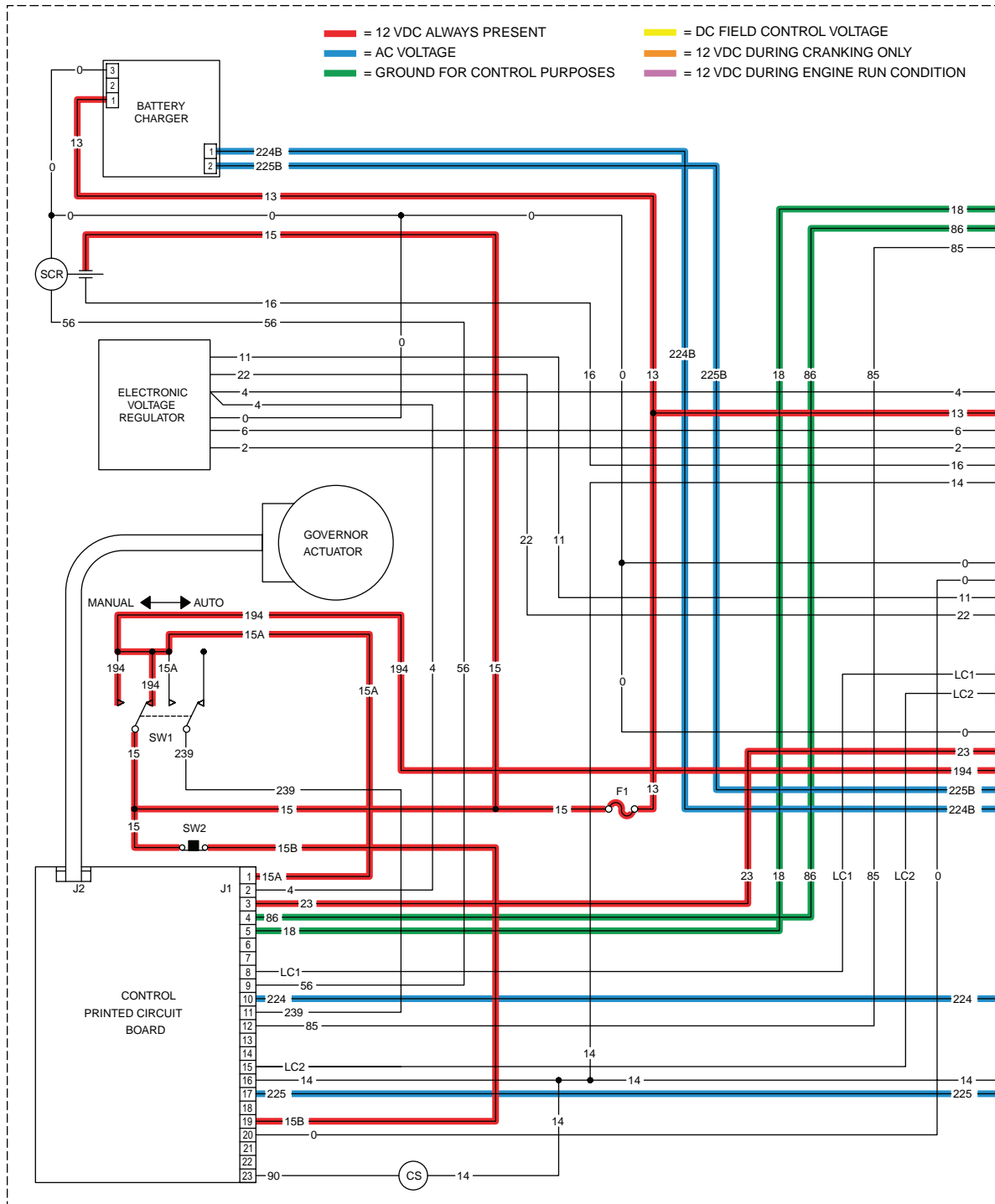

- The battery charge relay (BCR) connected to Wire 14 will be de-energized. This will cause transformer (TX) voltage to power the battery charger again.
- Circuit board action will connect the engine's ignition magnetos (IM1 & IM2) to ground, via Wire 18. Ignition will be terminated.
- Without fuel flow and without ignition, the engine will shut down.

Figure 7. Circuit Condition – Retransfer to “Utility” and Engine Shutdown

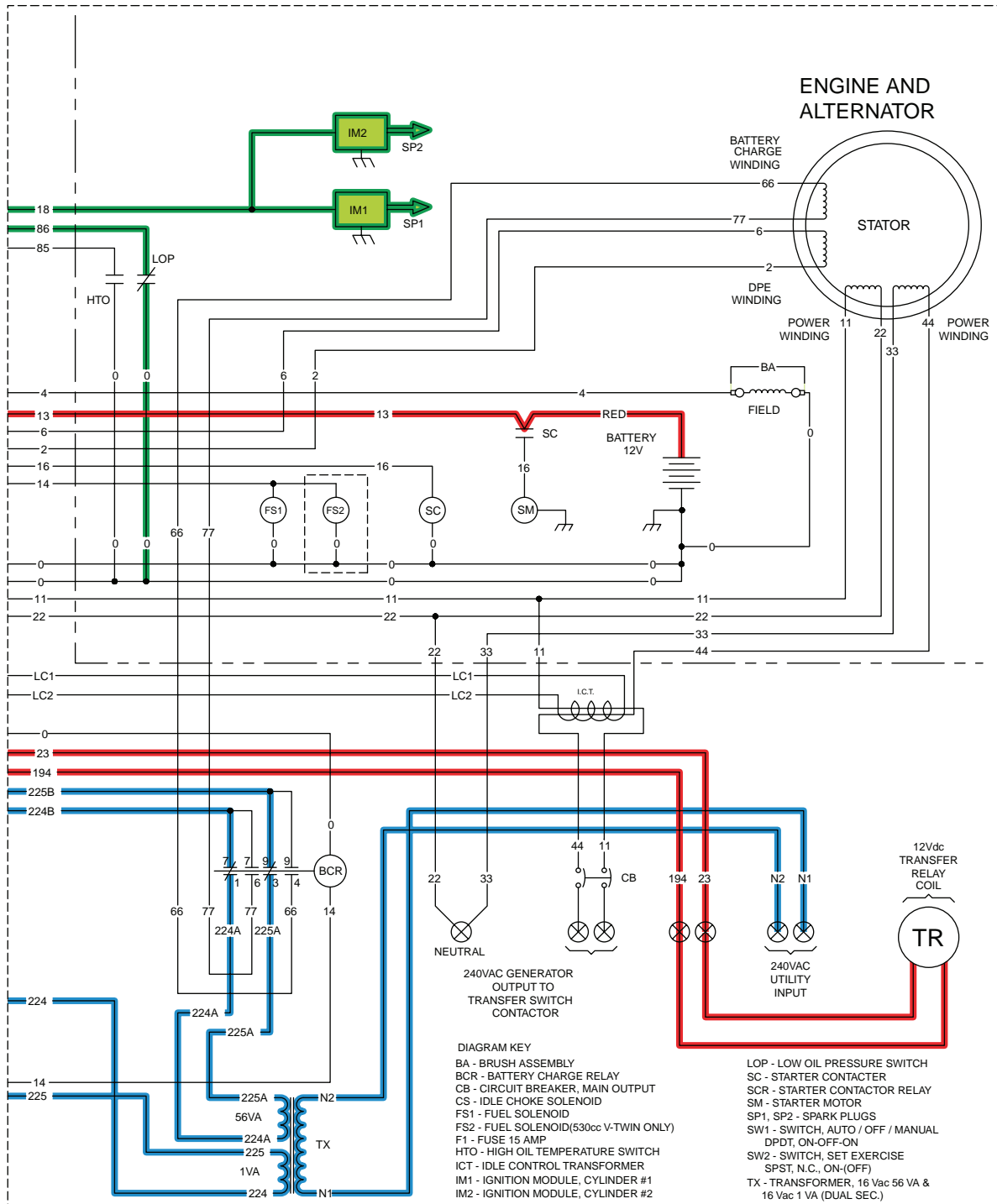

SECTION 4.3
TROUBLESHOOTING FLOW CHARTS

Problem 8 - Engine Will Not Crank When Utility Power Source Fails

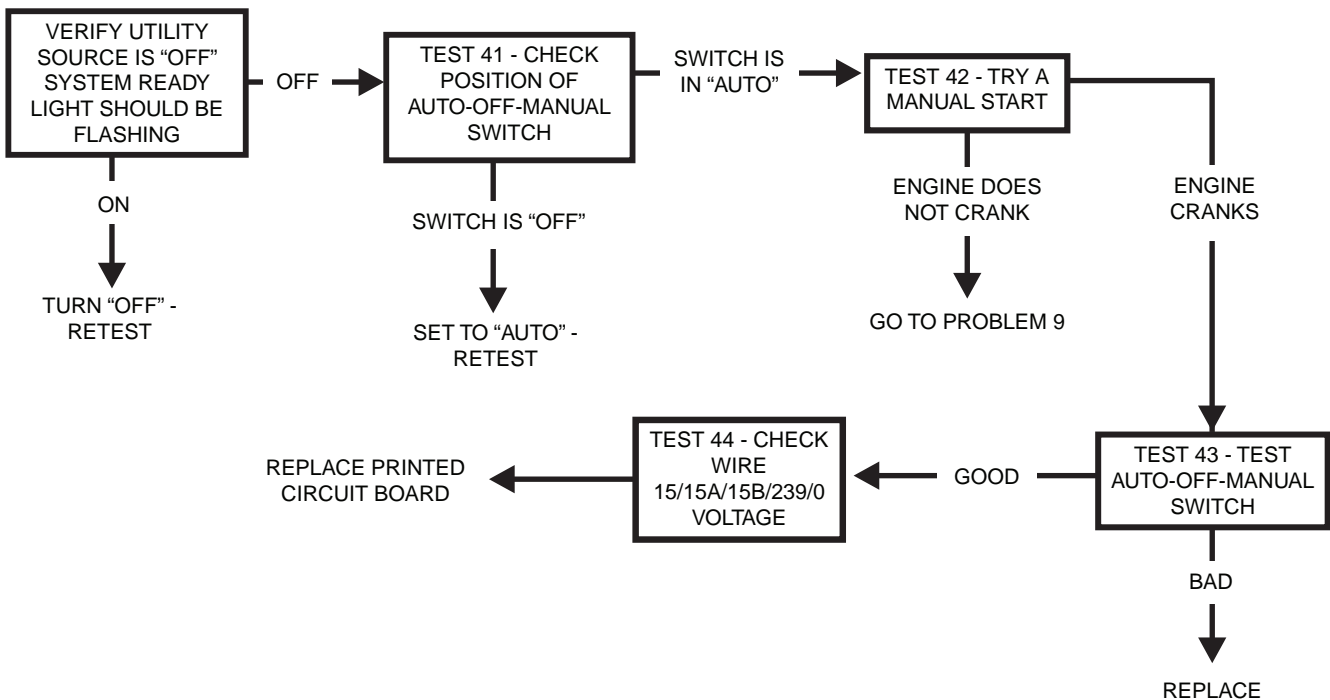

Problem 9 - Engine Will Not Crank When AUTO-OFF-MANUAL Switch is Set to "MANUAL"

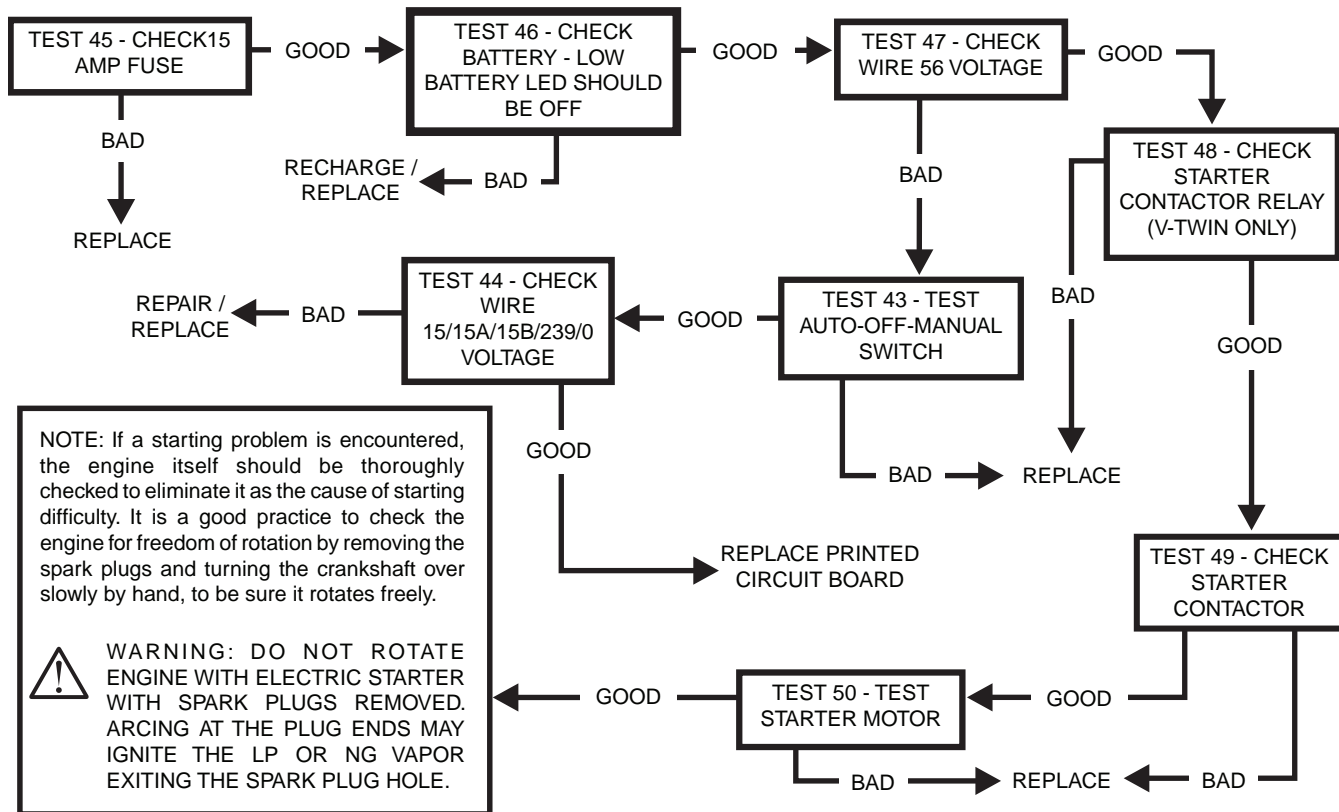

Problem 10 - Engine Cranks but Won't Start

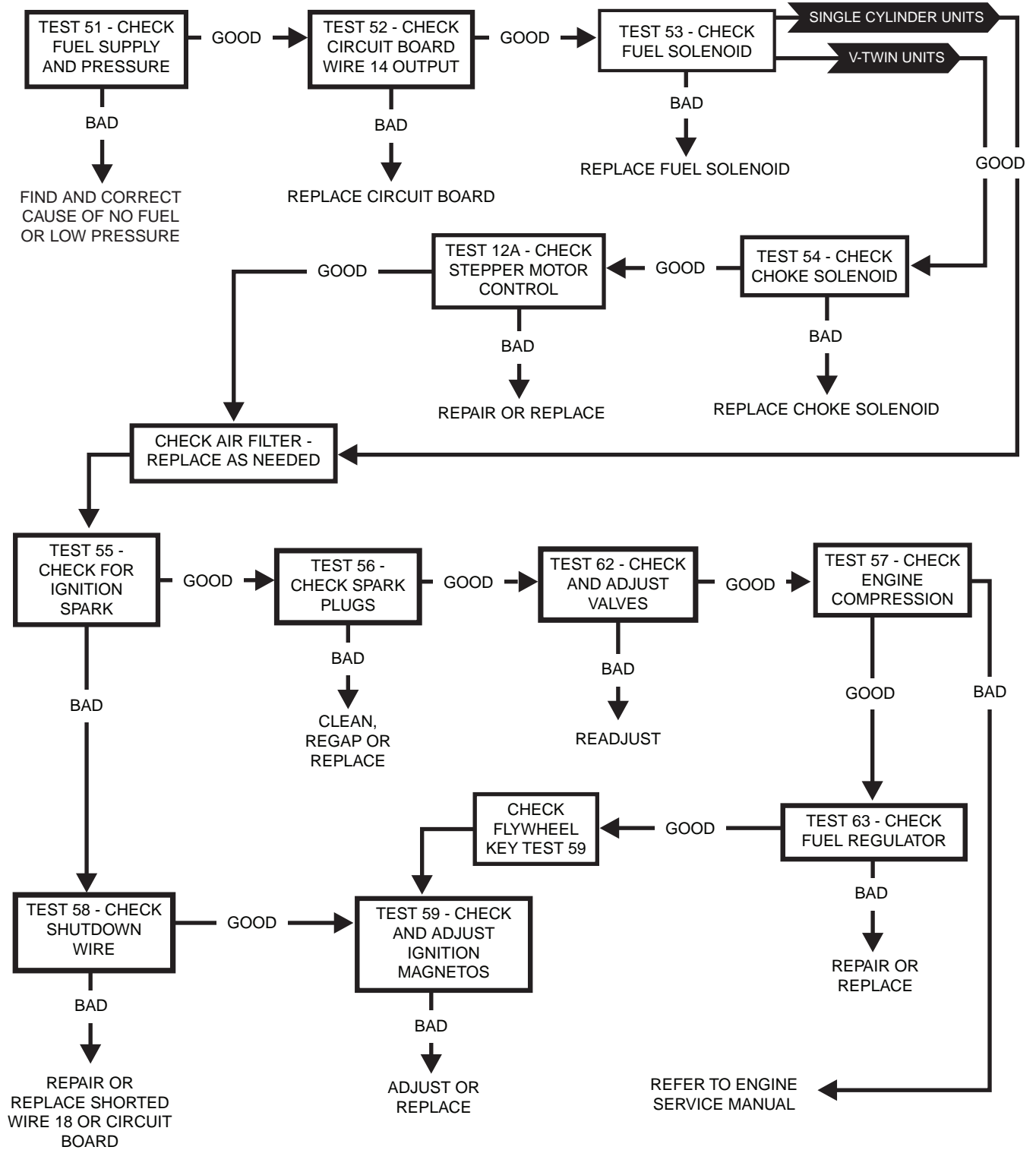

Problem 11 - Engine Starts Hard and Runs Rough / Lacks Power

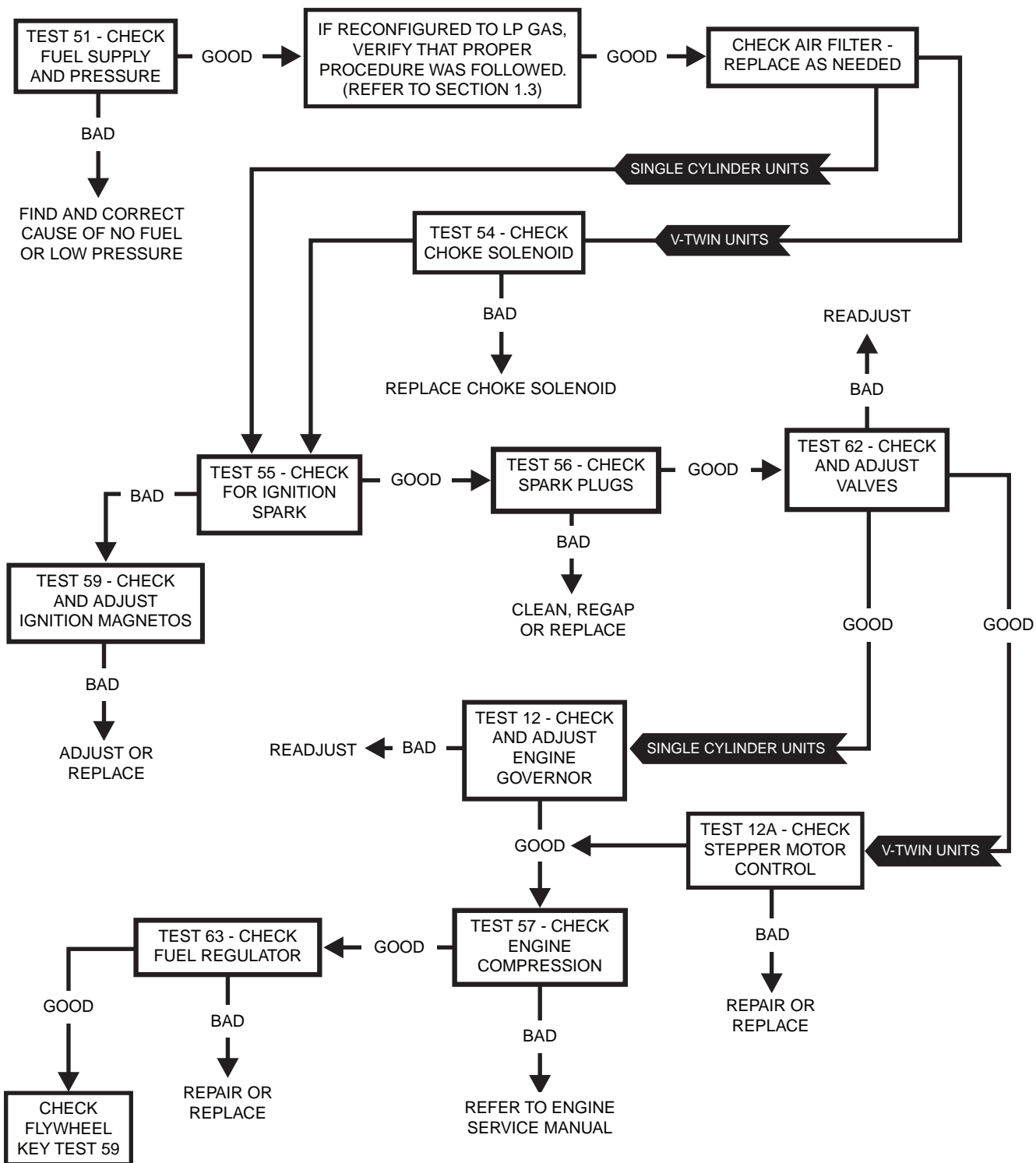

Problem 12 - Engine Starts and Runs, Then Shuts Down

CHECK FAULT LIGHTS

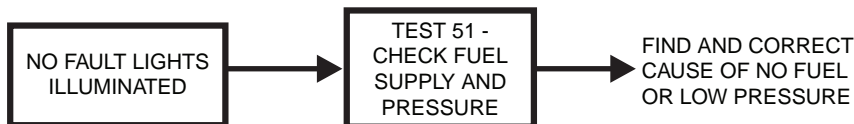
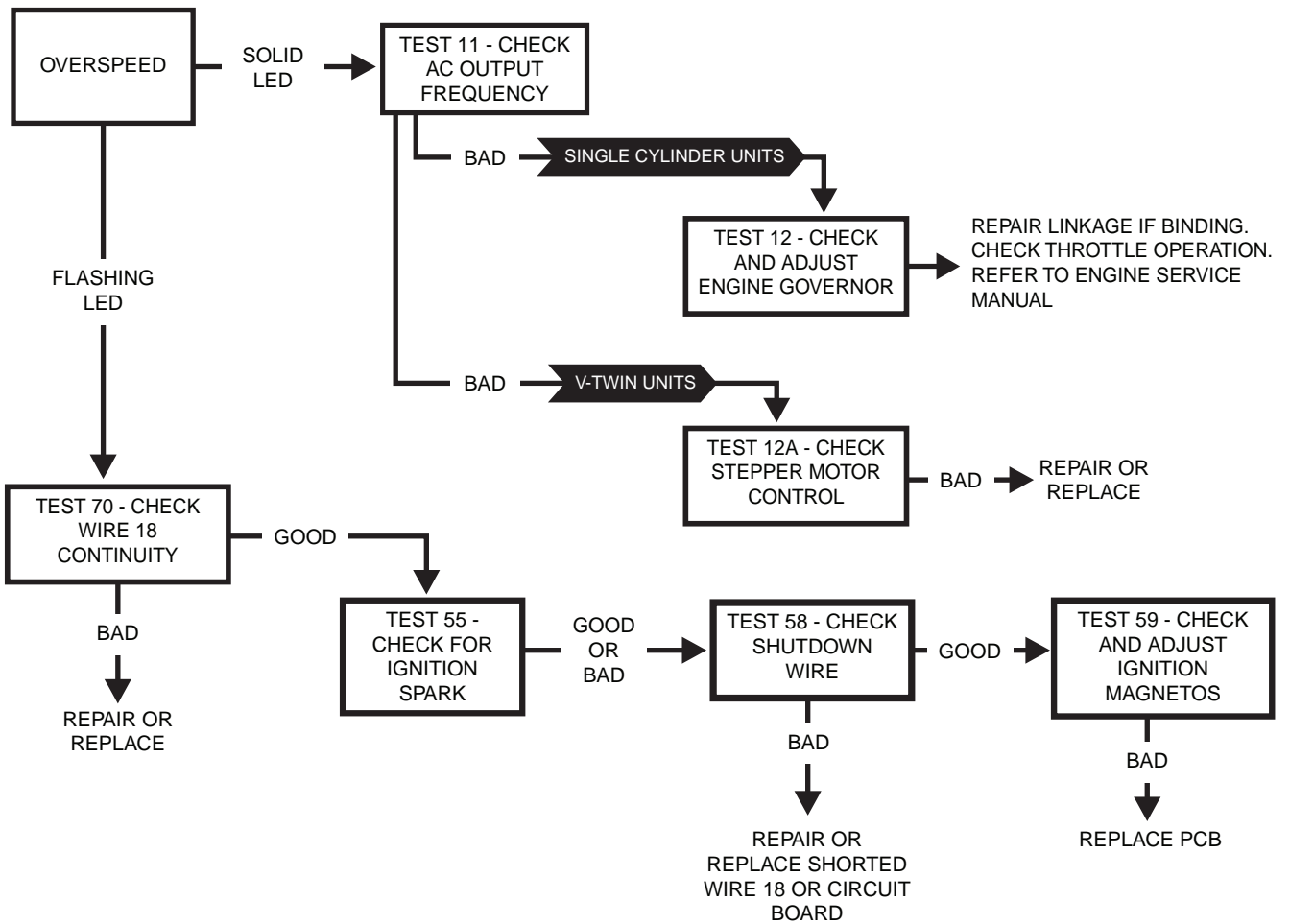
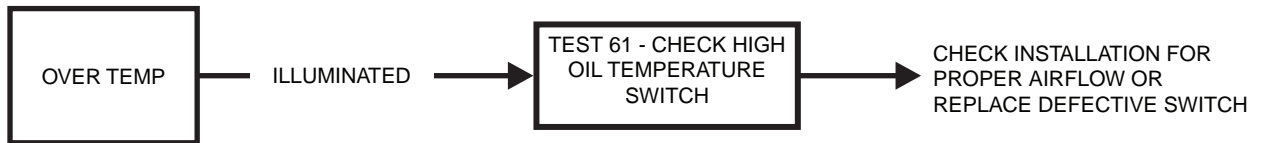

Problem 13 - No Battery Charge

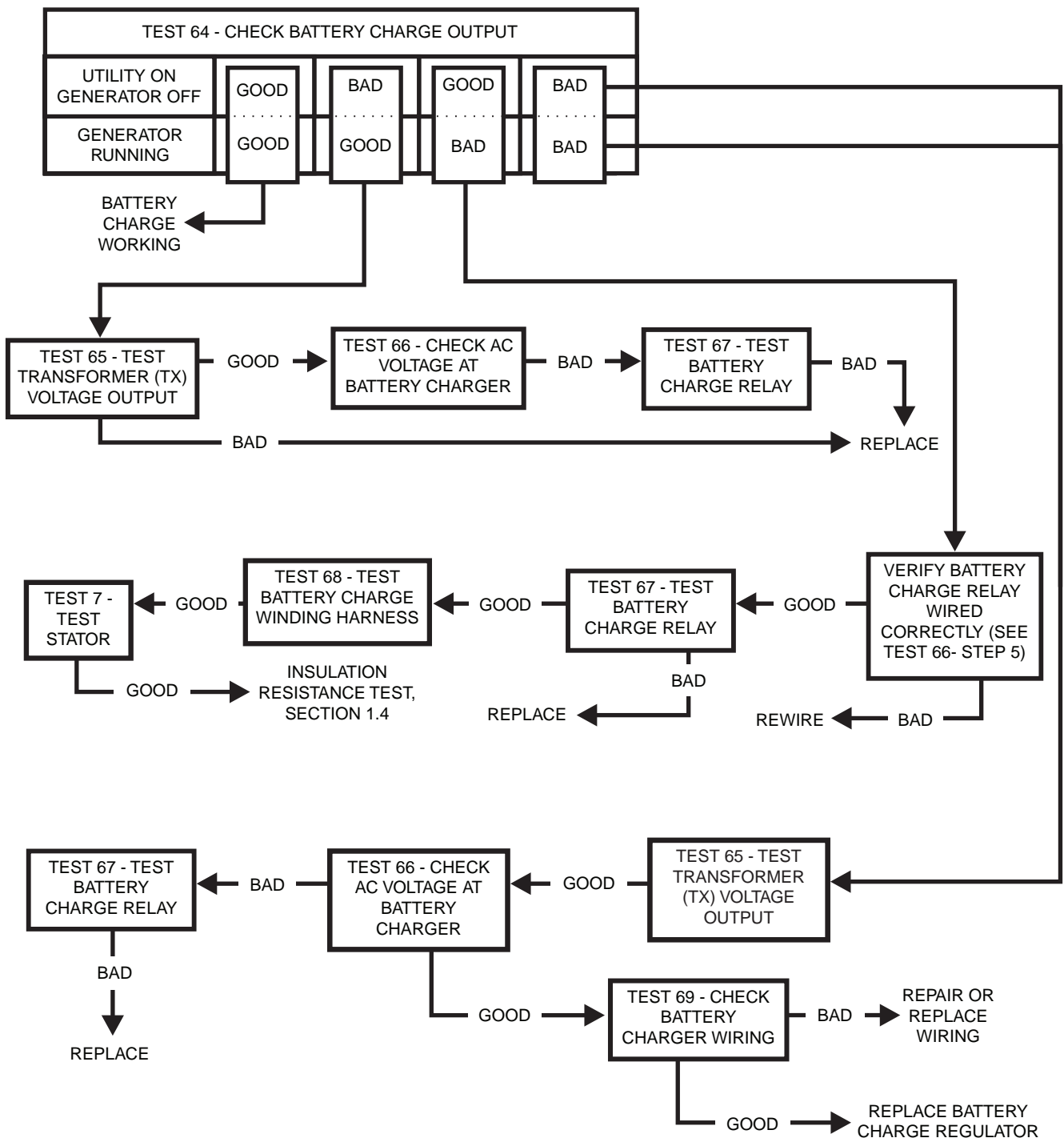

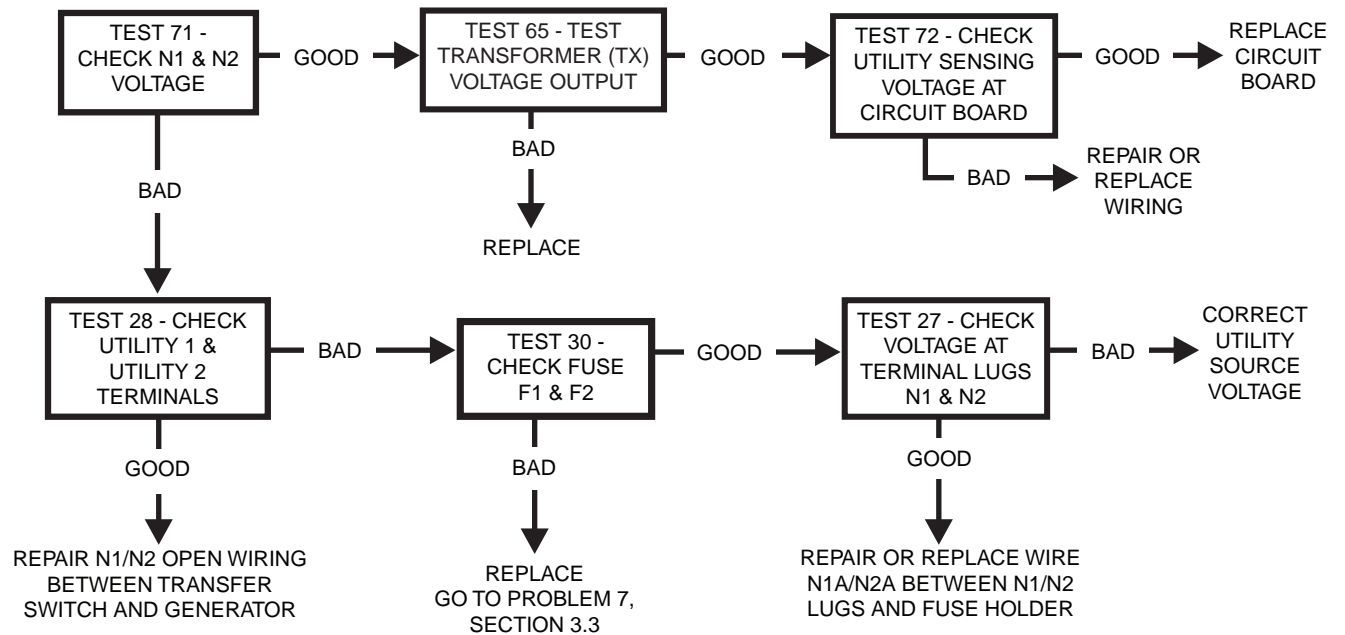
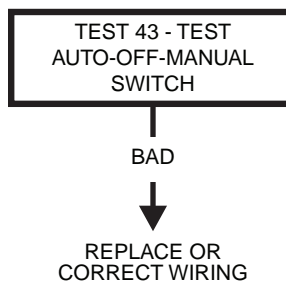
Problem 14 - Unit Starts and Transfer Occurs When Utility Power Is Available**Problem 15 - Generator Starts Immediately in Auto - No Transfer to Standby. Utility Voltage is Present**

Problem 16 - 15 Amp Fuse (F1) Blown

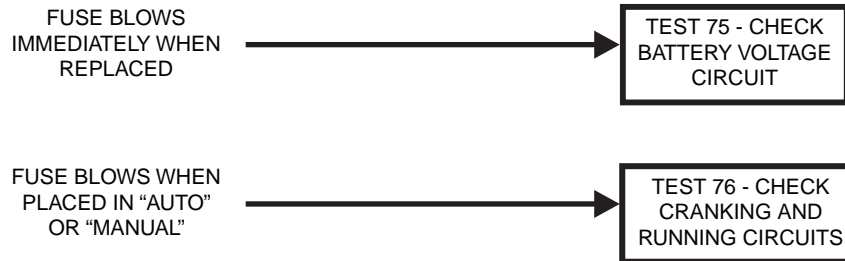

Problem 17 - Generator Will Not Exercise

TEST 77 - TEST EXERCISE FUNCTION

Problem 18 - No Low Speed Exercise

TEST 78 - CHECK DIP SWITCH SETTINGS

INTRODUCTION

Perform these “Diagnostic Tests” in conjunction with the “Troubleshooting Flow Charts” of Section 4.3.

The test procedures and methods presented in this section are not exhaustive. We could not possibly know of, evaluate and advise the service trade of all conceivable ways in which testing and trouble diagnosis might be performed. We have not undertaken any such broad evaluation.

TEST 41 – CHECK POSITION OF AUTO-OFF-MANUAL SWITCH**DISCUSSION:**

If the standby system is to operate automatically, the generator AUTO-OFF-MANUAL switch must be set to AUTO. That is, the generator will not crank and start on occurrence of a “Utility” power outage unless that switch is at AUTO. In addition, the generator will not exercise every seven (7) days as programmed unless the switch is at AUTO.

PROCEDURE:

With the AUTO-OFF-MANUAL switch set to AUTO, test automatic operation. Testing of automatic operation can be accomplished by turning off the Utility power supply to the transfer switch. When the utility power is turned off, the standby generator should crank and start. Following startup, transfer to the standby source should occur. Refer to Section 1.8 in this manual.

Following generator startup and transfer to the standby source, turn ON the utility power supply to the transfer switch. Retransfer back to the “Utility” source should occur. After an “engine cooldown timer” has timed out, generator shutdown should occur.

RESULTS:

1. If normal automatic operation is obtained, discontinue tests.
2. If engine does NOT crank when utility power is turned off, proceed to Test 42.
3. If engine cranks but won't start, go to Problem 10 in Section 4.3.
4. If engine cranks and starts, but transfer to “Standby” does NOT occur, go to Problem 5 in Section 3.3.
5. If transfer to “Standby” occurs, but retransfer back to “Utility” does NOT occur when utility source voltage is restored, go to Problem 6 in Section 3.3.

TEST 42 – TRY A MANUAL START**DISCUSSION:**

The first step in troubleshooting for an “engine won't

crank” condition is to determine if the problem is peculiar to automatic operations only or if the engine won't crank manually either.

PROCEDURE:

1. On the generator panel, set the AUTO-OFF-MANUAL switch to OFF.
2. Set the generator main line circuit breaker to its OFF (or open) position.
3. Set the generator AUTO-OFF-MANUAL switch to MANUAL.
 - a. The engine should crank cyclically through it's “crank-rest” cycles until it starts.
 - b. Let the engine stabilize and warm up for a few minutes after it starts.

RESULTS:

1. If the engine cranks manually but does NOT crank automatically, go to Test 43.
2. If the engine does NOT crank manually, proceed to Problem 9 in the “Troubleshooting Flow Charts”.

TEST 43 – TEST AUTO-OFF-MANUAL SWITCH**DISCUSSION:**

When the AUTO-OFF-MANUAL switch is set to AUTO position, battery voltage (12 volts DC) is delivered to the circuit board via Wire 15A, the closed switch terminal. This voltage is needed to operate the circuit board.

Setting the switch to its “Manual” position delivers battery voltage to the circuit board for its operation. In addition, when the switch is set to “Manual”, 12 volts DC is supplied to the circuit board via Wire 239.

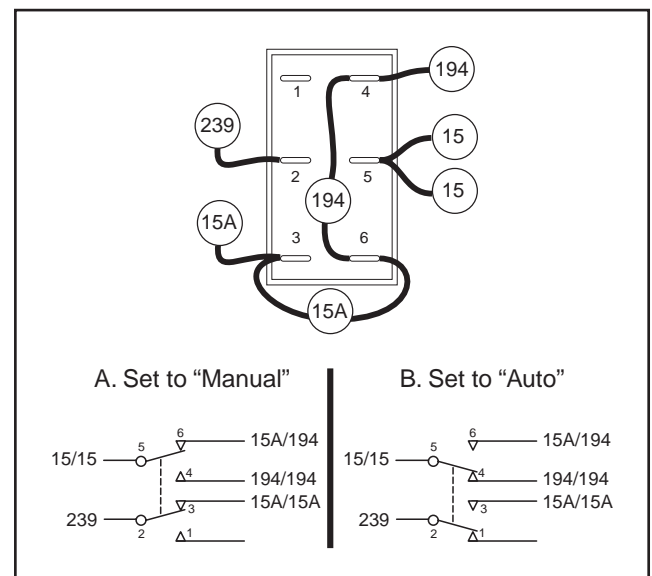

Figure 1. Schematic of AUTO-OFF-MANUAL Switch

SECTION 4.3 TROUBLESHOOTING FLOW CHARTS

PART 4

DC CONTROL

PROCEDURE:

Disconnect all wires from switch terminals, to prevent interaction. Then, use a volt-ohm-milliammeter (VOM) to test for continuity across switch terminals as shown in the following chart. Reconnect all wires and verify correct positions when finished.

RESULTS:

1. Replace AUTO-OFF-MANUAL switch, if defective. Refer back to flow chart if necessary.

TERMINALS	SWITCH POSITION	READING
2 and 3	AUTO	INFINITY
	MANUAL	CONTINUITY
	OFF	INFINITY
2 and 1	AUTO	CONTINUITY
	MANUAL	INFINITY
	OFF	INFINITY
5 and 6	AUTO	INFINITY
	MANUAL	CONTINUITY
	OFF	INFINITY
5 and 4	AUTO	CONTINUITY
	MANUAL	INFINITY
	OFF	INFINITY

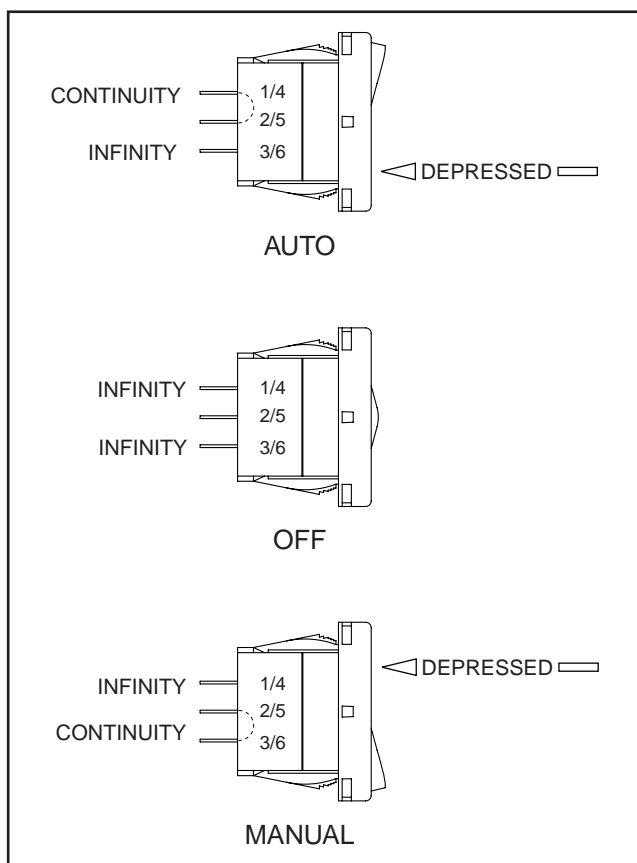

Figure 2. AUTO-OFF-MANUAL Switch Test Points

TEST 44 – CHECK WIRE 15/15A/15B/239/0 VOLTAGE

DISCUSSION:

The circuit board will not turn on unless battery voltage is available to the board via Wire 15, Wire 15A, and Wire 239 for manual operation. If battery voltage is not available, automatic or manual operation will not be possible.

PROCEDURE:

(For Problem 8 Flow Chart perform Steps 1-3 only)

(For Problem 9 Flow Chart perform all steps)

1. Set a VOM to measure DC voltage.
2. Testing Wire 15:

SW1 in Auto

Connect the positive (+) test lead to Terminal 5 Wire 15 on SW1. Wiring must still be connected to SW1. Connect the negative meter test lead to frame ground. Battery voltage should be measured-proceed to Step 3. If battery voltage is not measured repair or replace Wire 15 between SW1 and Fuse holder F1.

3. Testing Wire 15A:

SW1 in Auto

Connect the positive (+) test lead to Terminal 3 Wire 15A on SW1. Wiring must still be connected to SW1. Connect the negative meter test lead to frame ground. Battery voltage should be measured- proceed to Step 4. If battery voltage is not measured repair or replace Wire 15A between Terminal 6 and 3 or Wire 194 between Terminal 4 and 6 on SW1.

4. Testing Wire 15A:

SW1 in Auto and J1 Connector disconnected from PCB

Connect the positive meter test lead to Pin Location J1-1, Wire 15A. Wiring must still be connected to SW1. Connect the negative meter test lead to frame ground. Battery voltage should be measured. If battery voltage is not measured repair or replace Wire 15A between SW1 and the J1 Connector. See Figures 4 or 5 on Pages 76 or 77.

5. Testing Wire 15B:

J1 Connector disconnected.

- a. Connect the positive meter test lead to Pin Location J1-19, Wire 15B for V-twins or Pin Location J1-13 Wire 15B, for single cylinders. Connect the negative meter test lead to frame ground. Battery voltage should be measured-proceed to Step 6. See Figures 4 or 5 on Pages 76 or 77.

- b. If battery voltage is not measured connect positive meter test lead to Wire 15B at the set exer-

cise switch (SW2). If battery voltage is measured repair or replace Wire 15B between SW2 and The J1 Connector. If battery voltage is not measured connect the positive meter test lead to Wire 15 at SW2. If battery voltage is measured replace SW2. If battery voltage is not measured connect the positive meter test lead to Wire 15 at (SW1). Battery voltage should be measured. If battery voltage is not measured repair or replace Wire 15 between SW1 and SW2.

6. Testing Wire 239:

SW1 in Manual and J1 Connector disconnected from the printed circuit board.

- Connect the positive meter test lead to Pin Location J1-11, Wire 239 for V-twins or Pin Location J1-8, Wire 239 for single cylinders. Connect the negative meter test lead to frame ground. Battery voltage should be measured—refer to flow chart.
- If battery voltage is not measured repair or replace Wire 239 between SW1 and the J1 Connector.

7. Testing Wire 0:

J1 disconnected from printed circuit board.

- Set VOM to measure resistance.
- Connect the one meter test lead to Pin Location J1-20, Wire 0 for V-twins or Pin Location J1-14, Wire 0 for single cylinders. Connect the negative meter test lead to frame ground. Continuity should be measured. If continuity is not measured repair or replace Wire 0 between J1 Connector and ground.

RESULTS:

Repair or replace wiring as described. Refer back to flow chart.

TEST 45 – CHECK 15 AMP FUSE

DISCUSSION:

The 15 amp fuse is located on the generator console. A blown fuse will prevent battery power from reaching the circuit board, with the same result as setting the AUTO-OFF-MANUAL switch to OFF.

PROCEDURE:

Remove the 15 amp fuse (F1) by pushing in on fuse holder cap and turning the cap counterclockwise. Inspect the fuse visually and with a VOM for an open condition.

RESULTS:

- If the fuse is good, go on to Test 46.
- If the fuse is bad, it should be replaced. Use only an identical 15 amp replacement fuse.
- If fuse continues to blow, go to Problem 16 Flow Chart.

TEST 46 – CHECK BATTERY

DISCUSSION:

Battery power is used to (a) crank the engine and (b) to power the circuit board. Low or no battery voltage can result in failure of the engine to crank, either manually or during automatic operation.

PROCEDURE:

A. Inspect Battery Cables:

- Visually inspect battery cables and battery posts.
- If cable clamps or terminals are corroded, clean away all corrosion.
- Install battery cables, making sure all cable clamps are tight. The red battery cable from the starter contactor (SC) must be securely attached to the positive (+) battery post; the black cable from the frame ground stud must be tightly attached to the negative (-) battery post.

B. Test Battery State of Charge:

- Use an automotive type battery hydrometer to test battery state of charge.
- Follow the hydrometer manufacturer's instructions carefully. Read the specific gravity of the electrolyte fluid in all battery cells.
- If the hydrometer does not have a "percentage of charge" scale, compare the reading obtained to the following:
 - An average reading of 1.260 indicates the battery is 100% charged.
 - An average reading of 1.230 means the battery is 75% charged.
 - An average reading of 1.200 means the battery is 50% charged.
 - An average reading of 1.170 indicates the battery is 25% charged.

C. Test Battery Condition:

- If the difference between the highest and lowest reading cells is greater than 0.050 (50 points), battery condition has deteriorated and the battery should be replaced.
- However, if the highest reading cell has a specific gravity of less than 1.230, the test for condition is questionable. Recharge the battery to a 100 percent state of charge, then repeat the test for condition.

RESULTS:

- Remove the battery and recharge with an automotive battery charger, if necessary.
- If battery condition is bad, replace the battery with a new one.

SECTION 4.4 DIAGNOSTIC TESTS

PART 4

DC CONTROL

TEST 47 – CHECK WIRE 56 VOLTAGE

DISCUSSION:

During an automatic start or when starting manually, a crank relay on the circuit board should energize. Each time the crank relay energizes, the circuit board should deliver 12 volts DC to a starter contactor relay (SCR), or starter contactor (SC), and the engine should crank. This test will verify (a) that the crank relay on the circuit board is energizing, and (b) that circuit board action is delivering 12 volts DC to the starter contactor relay or starter contactor.

PROCEDURE:

1. Set a VOM to measure DC voltage.
2. Connect the positive (+) test probe of a DC voltmeter (or VOM) to the Wire 56 connector of the starter contactor relay (SCR, on models with v-twin engines) or the starter contactor (SC, on models with single cylinder engines). Connect the common (-) test probe to frame ground.
3. Observe the meter. Then, actuate the AUTO-OFF-MANUAL switch to MANUAL position. The meter should indicate battery voltage. If battery voltage is measured stop testing.
4. Set a VOM to measure resistance.
5. Remove Wire 56 from the starter contactor relay (V-twin units) or from the starter contactor (single cylinder units). Connect one meter test lead to that Wire 56. Remove J1 Connector from the printed circuit board. Connect the other test lead to Wire 56 at J1-9 (V-twins) or J1-6 (single cylinder units). CONTINUITY should be measured. If CONTINUITY is not measured, repair or replace Wire 56.

RESULTS:

1. If battery voltage is indicated in Step 3, proceed to Test 48 for V-twin units or Test 49 for single cylinder units.

TEST 48 – TEST STARTER CONTACTOR RELAY (V-TWIN ONLY)

DISCUSSION:

The starter contactor relay (SCR) located in the control panel must be energized for cranking to occur. Once the SCR is energized, its normally open contacts will close and battery voltage will be available to Wire 16 and to the starter contactor (SC).

PROCEDURE:

1. Set a VOM to measure DC voltage.
2. Remove Wire 15 from the Starter Contactor Relay.
3. Connect the positive (+) meter test lead to the Wire 15 connector. Connect the negative (-) meter test lead to a clean frame ground. Battery voltage should be measured.

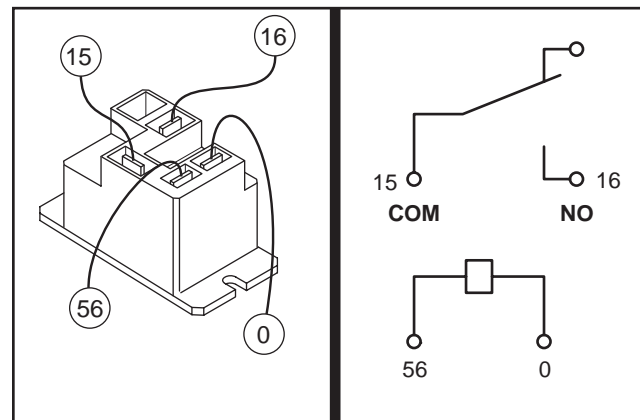

Figure 3. The Starter Contactor Relay

4. Reconnect Wire 15 to the SCR.
5. Remove Wire 16 from the SCR. Connect the positive (+) meter test lead to the SCR terminal from which Wire 16 was removed. Connect the negative(-) meter test lead to a clean frame ground.
6. Set the AUTO-OFF-MANUAL switch to MANUAL. Observe the meter reading. Battery voltage should be measured. If battery voltage is NOT measured, proceed to Step 7.
7. Set the VOM to its "R x 1" scale to measure ohms.
8. Connect one test lead to the Wire 0 connector. Connect the other test lead to a clean frame ground. CONTINUITY should be measured.

RESULTS:

1. If battery voltage is NOT measured in Step 3, repair or replace wiring between starter contactor relay and fuse (F1).
2. If battery voltage is NOT measured in Step 6 and CONTINUITY is measured in Step 8, replace the starter contactor relay.
3. If battery voltage is measured in Step 6 proceed to Test 49.

TEST 49 – TEST STARTER CONTACTOR

DISCUSSION:

The starter contactor (SC) must energize and its heavy duty contacts must close or the engine will not crank. This test will determine if the starter contactor is in working order.

PROCEDURE:

Carefully inspect the starter motor cable that runs from the battery to the starter motor. Cable connections must be clean and tight. If connections are dirty

or corroded, remove the cable and clean cable terminals and terminal studs. Replace any cable that is defective or badly corroded.

Use a DC voltmeter (or a VOM) to perform this test. Test the starter contactor as follows:

1. Connect the positive (+) meter test lead to the starter contactor stud (to which the red battery cable connects). Connect the common (-) meter test lead to a clean frame ground. Battery voltage (12 volts DC) should be indicated.
2. Now, connect the positive (+) meter test lead to the starter contactor stud to which the starter motor cable attaches (see Figure 4 or 5). Connect the common (-) test lead to frame ground.
 - a. No voltage should be indicated initially.
 - b. Set the AUTO-OFF-MANUAL switch to MANUAL. The meter should now indicate battery voltage as the starter contactor energizes.

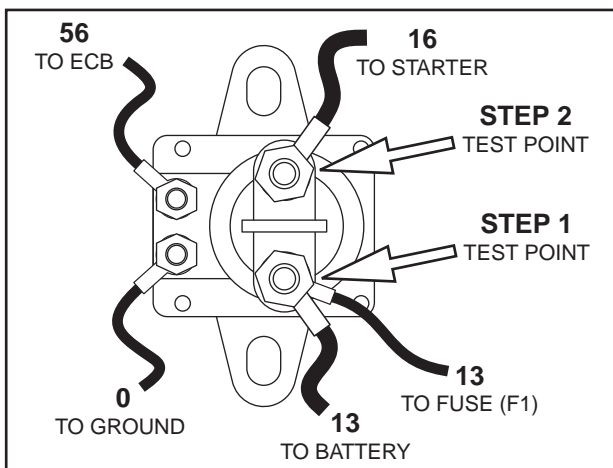

Figure 4. The Starter Contactor (Single Cylinder Units)

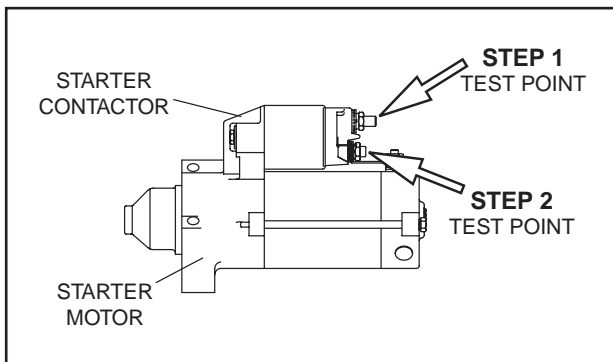

Figure 5. The Starter Contactor (V-twin Units)

RESULTS:

1. If battery voltage was indicated in Step 1, but NOT in Step 2b, replace the starter contactor.

2. If battery voltage was indicated in Step 2b, but the engine did NOT crank, go on to Test 50.

TEST 50 – TEST STARTER MOTOR

CONDITIONS AFFECTING STARTER MOTOR

PERFORMANCE:

1. A binding or seizing condition in the starter motor bearings.
2. A shorted, open or grounded armature.
 - a. Shorted armature (wire insulation worn and wires touching one another). Will be indicated by low or no RPM.
 - b. Open armature (wire broken) will be indicated by low or no RPM and excessive current draw.
 - c. Grounded armature (wire insulation worn and wire touching armature lamination or shaft). Will be indicated by excessive current draw or no RPM.
3. A defective starter motor switch.
4. Broken, damaged or weak magnets.
5. Starter drive dirty or binding.

DISCUSSION:

Test 47 verified that circuit board action is delivering DC voltage to the starter contactor relay (SCR). Test 48 verified the operation of the SCR. Test 49 verified the operation of the starter contactor (SC). Another possible cause of an “engine won’t crank” problem is a failure of the starter motor.

PROCEDURE:

The battery should have been checked prior to this test and should be fully charged.

Set a VOM to measure DC voltage (12 VDC). Connect the meter positive (+) test lead to the starter contactor stud which has the small jumper wire connected to the starter. Connect the common (-) test lead to the starter motor frame.

Set the START-STOP Switch to its “START” position and observe the meter. Meter should indicate battery voltage, starter motor should operate and engine should crank.

RESULTS:

1. If battery voltage is indicated on the meter but starter motor did NOT operate, remove and bench test the starter motor (see following test).
2. If battery voltage was indicated and the starter motor tried to engage (pinion engaged), but engine did NOT crank, check for mechanical binding of the engine or rotor.

If engine turns over slightly, go to Test 62 “Check and Adjust Valves.” Compression release on single cylinder engines may not be working, or mechanical binding is occurring.

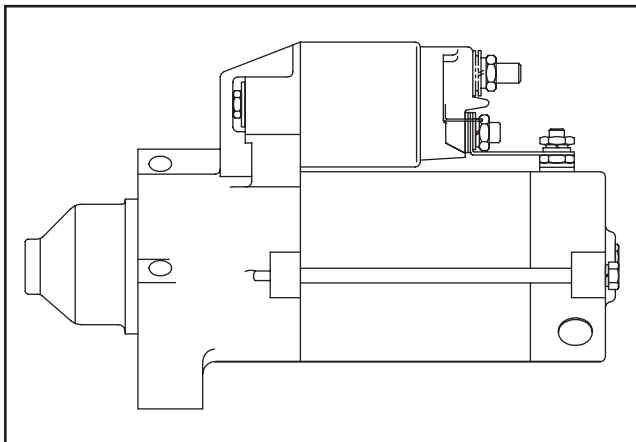

Figure 6. Starter Motor (V-Twin Engines)

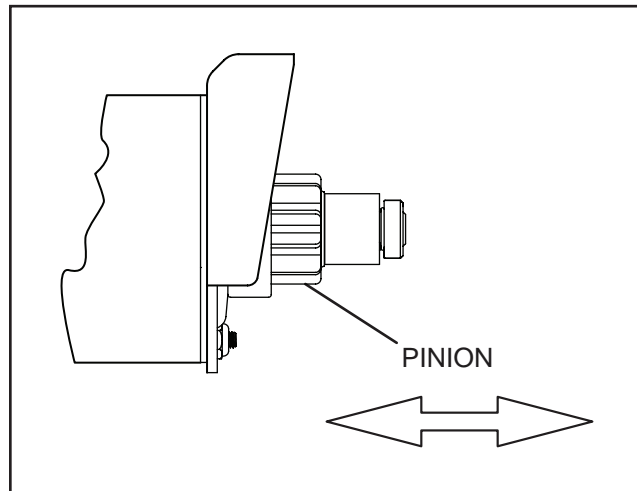

Figure 9. Check Pinion Gear Operation (Single Cylinder)

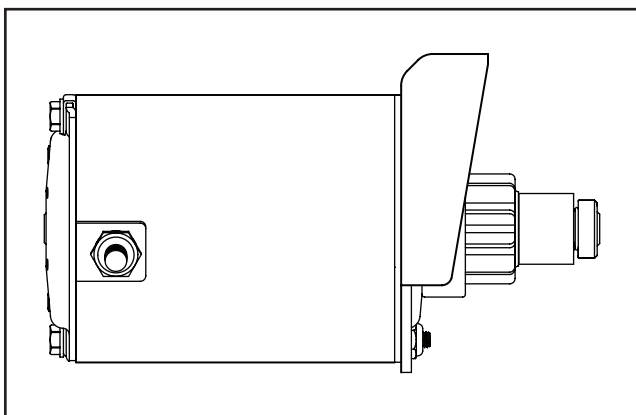

Figure 7. Starter Motor (Single Cylinder Engines)

CHECKING THE PINION:

When the starter motor is activated, the pinion gear should move and engage the flywheel ring gear. If the pinion does not move normally, inspect the pinion for binding or sticking.

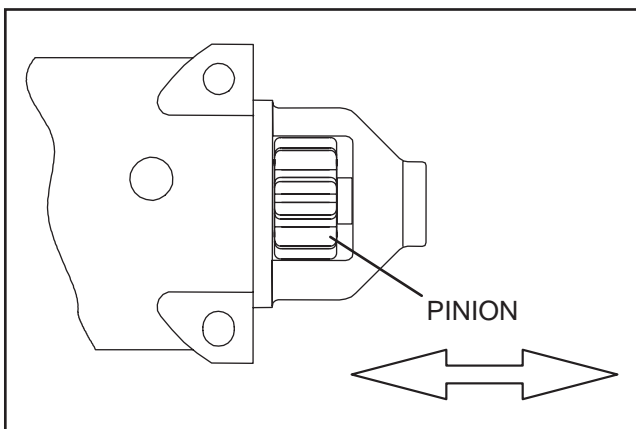

Figure 8. Check Pinion Gear Operation (V-Twin)

TOOLS FOR STARTER PERFORMANCE TEST:

The following equipment may be used to complete a performance test of the starter motor:

- A clamp-on ammeter.
- A tachometer capable of reading up to 10,000 rpm.
- A fully charged 12 volt battery.

MEASURING CURRENT:

To read the current flow, in AMPERES, a clamp-on ammeter may be used. This type of meter indicates current flow through a conductor by measuring the strength of the magnetic field around that conductor.

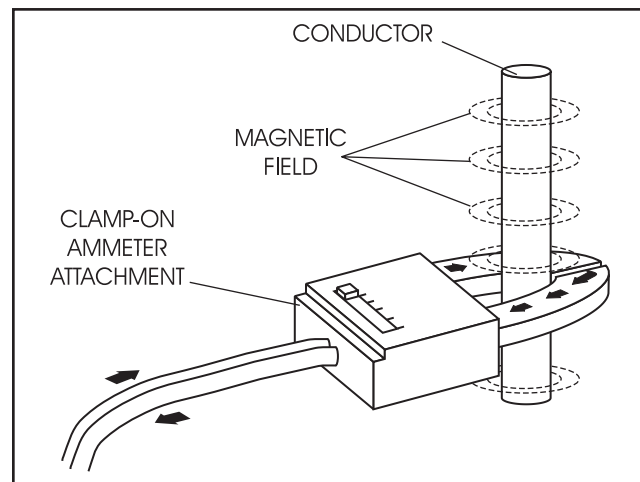

Figure 10. Clamp-On Ammeter

TACHOMETER:

A tachometer is available from your parts source. The tachometer measures from 800 to 50,000 rpm, Figure 11.

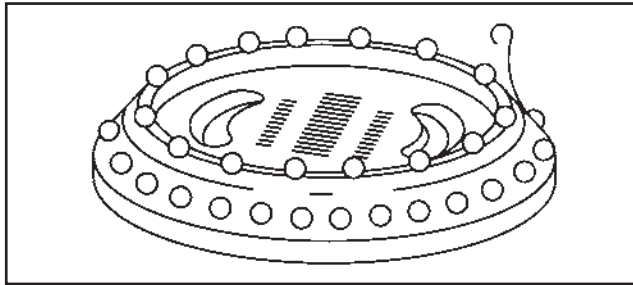

Figure 11. Tachometer

TEST BRACKET:

A starter motor test bracket may be made as shown in Figure 12. A growler or armature tester is available from an automobile diagnostic service supplier.

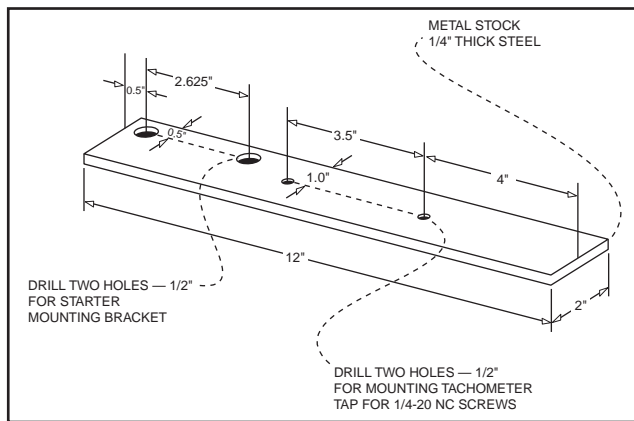

Figure 12. Test Bracket

REMOVE STARTER MOTOR:

It is recommended that the starter motor be removed from the engine when testing starter motor performance. Assemble starter to test bracket and clamp test bracket in vise, Figure 13.

TESTING STARTER MOTOR:

1. A fully charged 12 volt battery is required.
2. Connect jumper cables and clamp-on ammeter as shown in Figure 15.
3. With the starter motor activated (jump the terminal on the starter contactor to battery voltage), note the reading on the clamp-on ammeter and on the tachometer (rpm).

Note: Take the reading after the ammeter and tachometer are stabilized, approximately 2-4 seconds.

4. A starter motor in good condition will be within the following specifications:

	V-twin	Single Cylinder
Minimum rpm	3250	4500
Maximum Amps	62	9

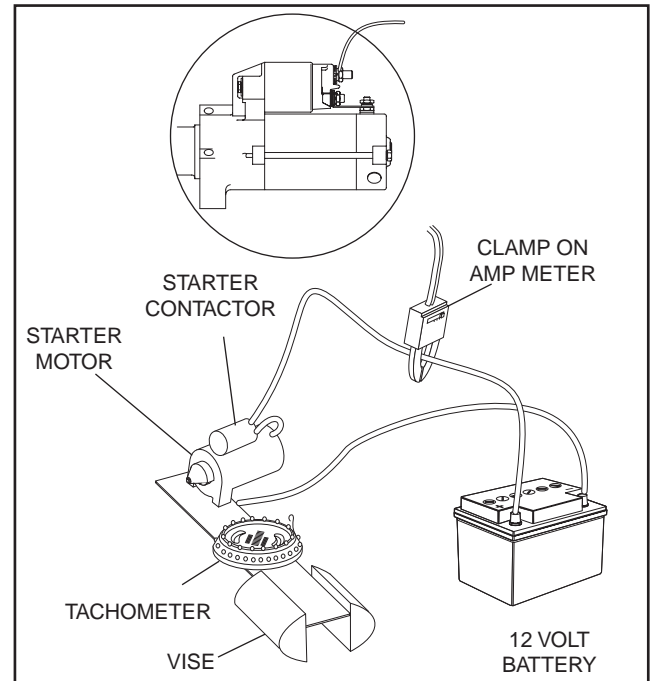

Figure 13. Testing Starter Motor Performance

TEST 51 – CHECK FUEL SUPPLY AND PRESSURE**DISCUSSION:**

The air-cooled generator was factory tested and adjusted using natural gas as a fuel. If desired, LP (propane) gas may be used. However, when changing over to propane, some minor adjustments are required. The following facts apply:

- An adequate gas supply and sufficient fuel pressure must be available or the engine will not start.
- Minimum recommended gaseous fuel pressure at the generator fuel inlet connection is 5 inches water column for natural gas (NG) or 11 inches water column for LP gas.
- Maximum gaseous fuel pressure at the generator fuel inlet connection is 7 inches water column for natural gas or 14 inches water column for LP gas.
- When propane gas is used, only a “vapor withdrawal” system may be used. This type of system utilizes the gas that form above the liquid fuel the vapor pressure must be high enough engine operation.
- The gaseous fuel system must be properly tested for leaks following installation and periodically thereafter. No leakage is permitted. Leak test methods must comply strictly with gas codes.



DANGER: GASEOUS FUELS ARE HIGHLY EXPLOSIVE. DO NOT USE FLAME OR HEAT TO TEST THE FUEL SYSTEM FOR LEAKS. NATURAL GAS IS LIGHTER THAN AIR, TENDS TO SETTLE IN HIGH PLACES. LP

SECTION 4.4 DIAGNOSTIC TESTS

PART 4

DC CONTROL

(PROPANE) GAS IS HEAVIER THAN AIR, TENDS TO SETTLE IN LOW AREAS. EVEN THE SLIGHTEST SPARK CAN IGNITE THESE GASES AND CAUSE AN EXPLOSION.

PROCEDURE:

A water manometer or a gauge that is calibrated in "ounces per square inch" may be used to measure the fuel pressure. Fuel pressure at the inlet side of the fuel solenoid valve should be between 5 - 7 inches water column for natural gas (NG) or 11 - 14 inches water column for LP gas.

The fuel pressure can be checked at the fuel regulator. See Figures 14, 15 and 16 for the gas pressure test point on the fuel regulator.

NOTE: Where a primary regulator is used to establish fuel inlet pressure, adjustment of that regulator is usually the responsibility of the fuel supplier or the fuel supply system installer.

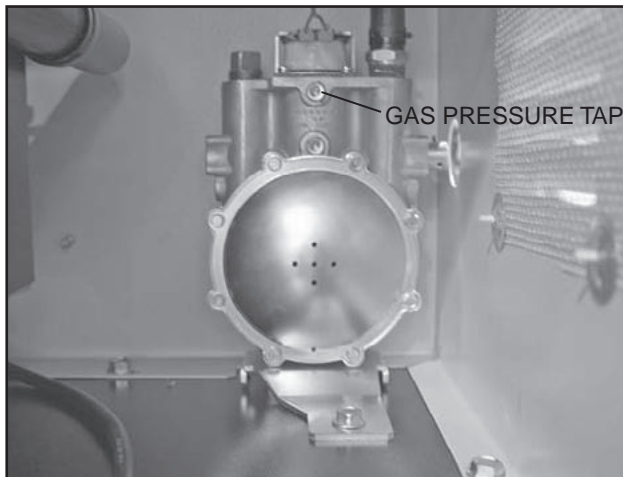

Figure 14. Gas Pressure Test point on 6/7 kW Unit

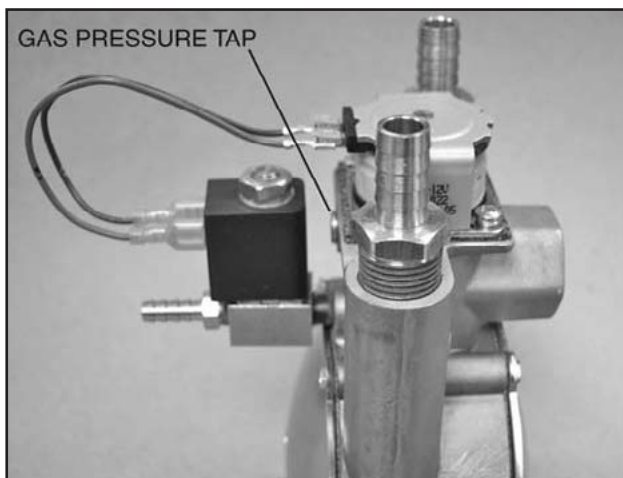

Figure 15. Gas Pressure Test point on 9/10 kW Unit

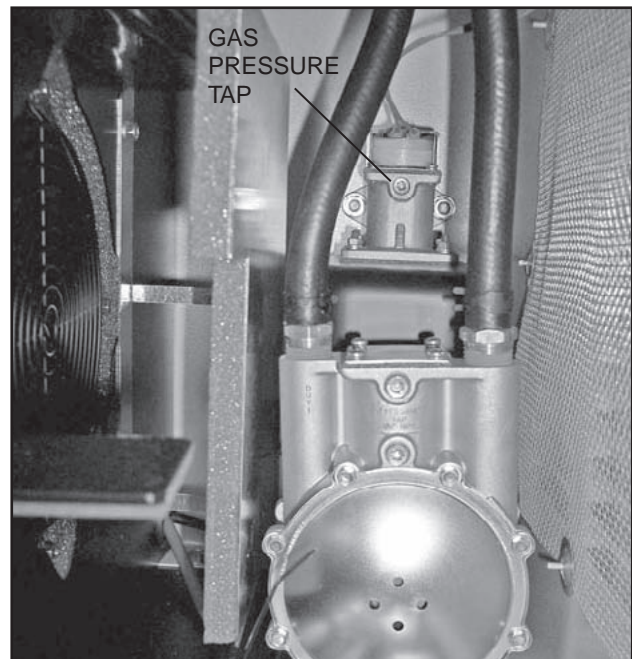

Figure 16. Gas Pressure Test point on 13, 16 and 18 kW Units

RESULTS:

1. If fuel supply and pressure are adequate, but engine will not start, go on to Test 52.
2. If generator starts but runs rough or lacks power, repeat the above procedure with the generator running and under load. The fuel system must be able to maintain 11"-14" water column at all load requirements. If proper fuel supply and pressure is maintained, refer to Problem 11 Flow Chart.

TEST 52 – CHECK CIRCUIT BOARD WIRE 14 OUTPUT

DISCUSSION:

During any cranking action, the circuit board's crank relay and run relay both energize simultaneously. When the run relay energizes, its contacts close and 12 volts DC is delivered to Wire 14 and to a fuel solenoid. The solenoid energizes open to allow fuel flow to the engine. This test will determine if the circuit board is working properly.

PROCEDURE:

1. Set AUTO-OFF-MANUAL switch (SW1) to OFF.
2. Set a VOM to measure DC voltage.
3. Connect the positive meter test lead to the 4-tab terminal block in the control panel. Connect the negative meter test lead to a clean frame ground.

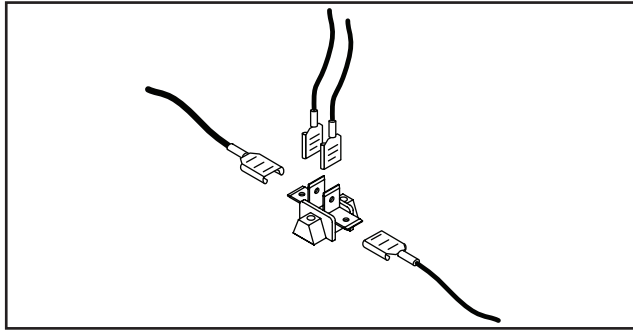

Figure 17. 4-Tab Terminal Block

4. Set SW1 to the MANUAL position. The meter should indicate battery voltage.
 - a. If battery voltage is indicated proceed to Step 5.
 - b. If battery voltage is not measured remove J1 Connector from the printed circuit board. See Figures 4 or 5 on Pages 76 or 77.
 - c. Set a VOM to measure resistance.
 - d. Connect one meter test lead to the 4-Tab terminal block.
 - e. Connect the other meter test lead to Wire 14 at J1-16 for V-twins or J1-10 for single cylinder units. See Figures 4 or 5 on Pages 76 or 77.
 - f. CONTINUITY should be measured. If CONTINUITY is measured replace the printed circuit board.
 - g. If CONTINUITY is not measured repair or replace Wire 14 between the J1 Connector and 4-tab terminal block.
5. Set a VOM to measure resistance.
 - a. Connect the positive meter test lead to Wire 14 at the 4-tab terminal block.
 - b. Connect the negative meter test lead to Wire 14 at Battery charge relay (BCR). CONTINUITY should be measured.
 - c. Repeat the procedure at the following components:
 - Fuel Solenoid (FS1),
 - Fuel solenoid (FS2) if equipped.
 - d. Repair or replace any wire as needed.
6. Set a VOM to measure resistance.
 - a. Connect the positive meter test lead to Wire 0 at the battery charge relay (BCR).
 - b. Connect the negative meter test lead to frame ground. CONTINUITY should be measured.
 - c. Repeat the procedure at the following components:
 - Fuel Solenoid (FS1),
 - Fuel solenoid (FS2) if equipped.
 - d. Repair or replace any wire as needed.

RESULTS:

Refer to flow chart.

TEST 53 – CHECK FUEL SOLENOID

DISCUSSION:

In Test 52, if battery voltage was delivered to Wire 14, the fuel solenoid should have energized open. This test will verify whether or not the fuel solenoid is operating.

Fuel Solenoid (FS1) Nominal Resistance 27-33 ohms.

Fuel Solenoid (FS2) Nominal Resistance 29 ohms.

PROCEDURE: 7/13/16/18 kW

1. Install a manometer to the bottom pipe fitting on the fuel regulator. See Figure 18 or 19.
2. Set the AUTO-OFF-MANUAL Switch (SW1) to MANUAL.
3. During cranking correct gas pressure should be measured. If gas pressure is measured the fuel solenoid is operating. If gas pressure is not measured repair or replace fuel solenoid.

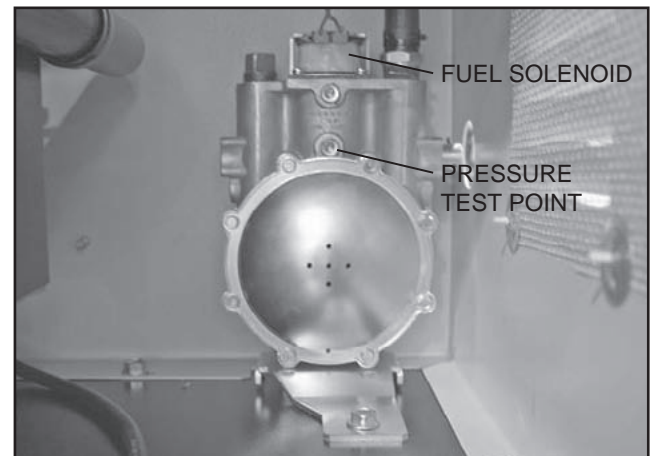

Figure 18. Fuel Solenoid and Pressure Test point on 6/7 kW Unit

PROCEDURE: 9/10 kW

1. Remove the hose from fuel solenoid (FS2) and install a manometer to the fitting. See Figure 20.
2. Set the AUTO-OFF-MANUAL Switch (SW1) to MANUAL.
3. During cranking correct gas pressure should be measured. If gas pressure is measured then both fuel solenoids are operating. Stop Testing
4. If gas pressure was not measured in Step 3 remove (FS2) and install manometer to bottom port of fuel regulator.
5. Set the AUTO-OFF-MANUAL Switch (SW1) to MANUAL.
6. During cranking correct gas pressure should be measured.

sure. If gas pressure is measured then fuel solenoid (FS1) is operating, replace FS2. If gas pressure is not measured repair or replace fuel solenoid (FS1).

RESULTS:

Refer to flow chart.

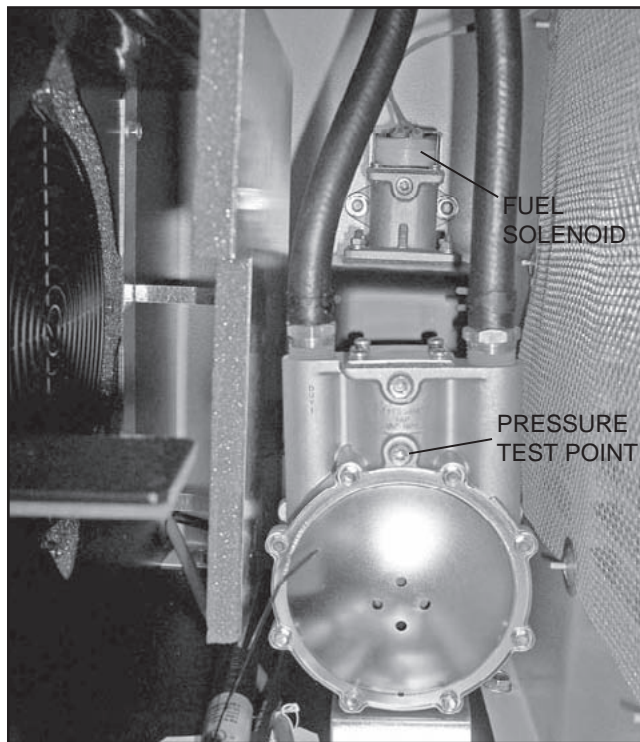

Figure 19. Fuel Solenoid and Pressure Test point on 13/16/18 kW Unit

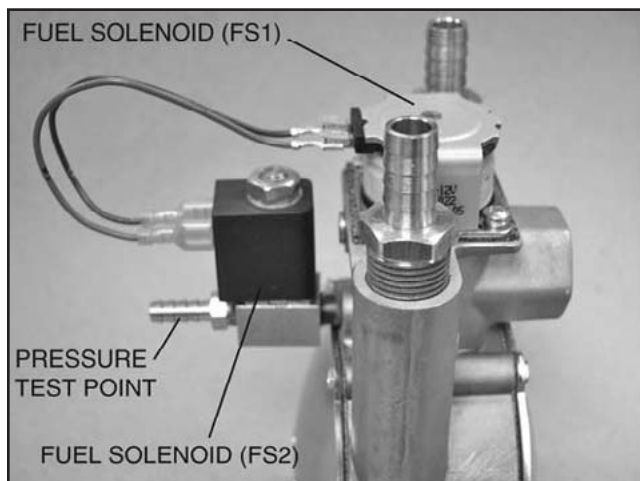

Figure 20. Fuel Solenoid and Pressure Test point on 9/10 kW Unit

TEST 54 – CHECK CHOKE SOLENOID (V-TWINS UNITS ONLY)

DISCUSSION:

The automatic choke is active cyclically during cranking and energized ON during running. For low speed exercise the choke will be closed. The 13/16/18 kW units utilize a plate that covers the throttle bores. The 10 kW units utilize a throttle plate located in the choke housing and the choke is open when the solenoid de-energized. On 13/16/18 kW units the choke is closed if the solenoid is de-energized.

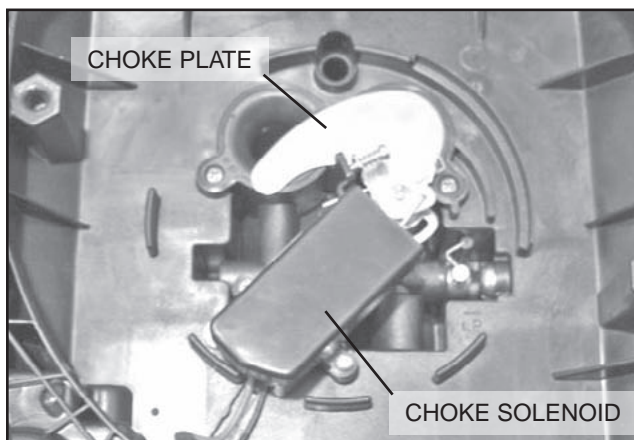

Figure 21. Solenoid De-Energized, Choke Closed 13/16/18 kW Units

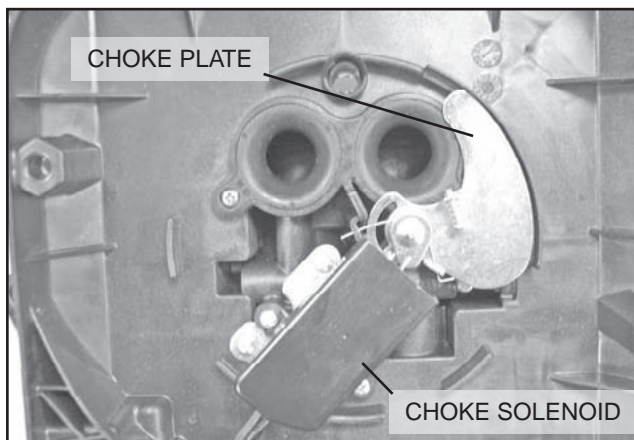

Figure 22. Solenoid Energized, Choke Open 13/16/18 kW Units

PROCEDURE:

1. Operational Check: Set the AUTO-OFF-MANUAL Switch (SW1) to MANUAL. While cranking the choke solenoid should pull the choke plate open cyclically (2 seconds off – 2 seconds on). If the choke solenoid does not pull in, verify that the choke can be manually opened. There should be no binding or interference.

Note: The 10 kW choke is open when the solenoid de-energized

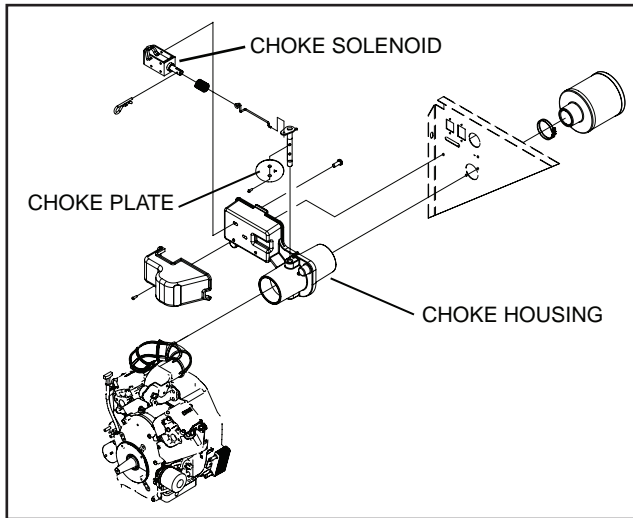

Figure 23. Exploded View Showing Location of Choke Plate - 10 kW Units

- Disconnect C3 Connector. Set a VOM to measure DC voltage. Connect the positive (+) test lead to Wire 14 (Pin 1) of C3 Connector going to the control panel (Female Side) Connect the negative (-) test lead to Wire 90 (Pin 2). Set the AUTO-OFF-MANUAL Switch (SW1) to MANUAL. While cranking, battery voltage should be measured cyclically. If battery voltage was not measured verify continuity of Wire 90 between C3 Connector and the printed circuit board J1 Connector Pin Location J1-23. Verify continuity of Wire 14 between the C3 Connector and J2 connector pin location J2-3. Repair or replace any wiring as needed.

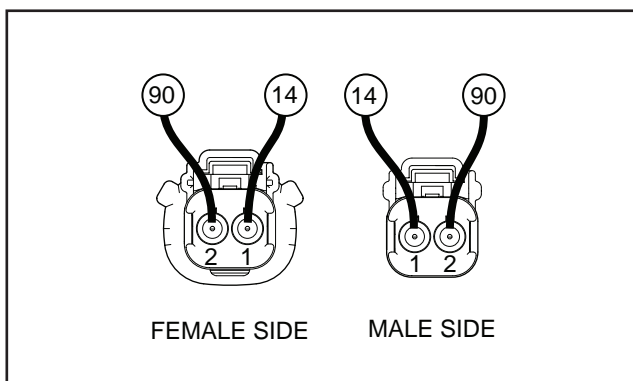

Figure 24. C3 Connector

- Disconnect C3 Connector. Set a VOM to measure resistance. Connect the positive (+) test lead to Wire 14 (Pin 1) of C3 Connector going to the choke solenoid (Male Side) Connect the negative (-) test lead to Wire 90 (Pin 2). Approximately 3.7 ohms should be measured.

- With the generator running at a speed of approximately 60 Hertz, verify the choke is energized and holding the choke plate open. Repeat Step 2 procedure, however once it starts, manually hold choke open while making voltage measurement.

RESULTS:

- If Battery voltage was not measured in Step 2 and wire continuity is good, replace the printed circuit board.
- If Choke Solenoid coil resistance is not measured in Step 3, replace the Choke Solenoid.
- If battery voltage was not measured in step 4 replace the printed circuit board.

TEST 55 – CHECK FOR IGNITION SPARK

DISCUSSION:

If the engine cranks but will not start, perhaps an ignition system failure has occurred. A special "spark tester" can be used to check for ignition spark.

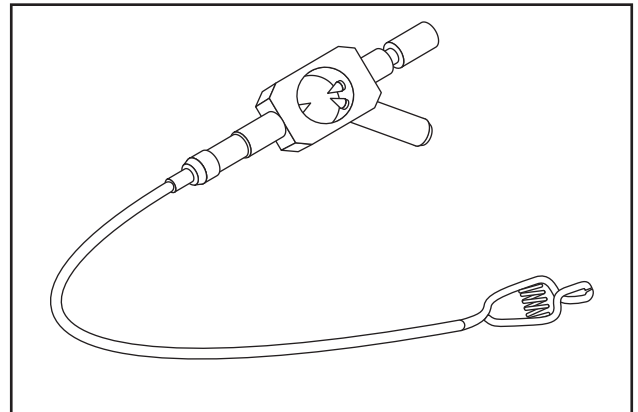

Figure 25. Spark Tester

PROCEDURE:

- Remove spark plug leads from the spark plugs (Figure 26).
- Attach the clamp of the spark tester to the engine cylinder head.
- Attach the spark plug lead to the spark tester terminal.
- Crank the engine while observing the spark tester. If spark jumps the tester gap, you may assume the engine ignition system is operating satisfactorily.

NOTE: The engine flywheel must rotate at 350 rpm (or higher) to obtain a good test of the solid state ignition system.

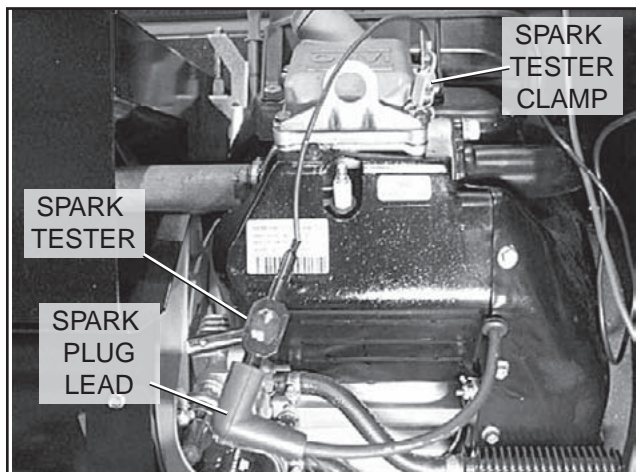

Figure 26. Checking Ignition Spark

To determine if an engine miss is ignition related, connect the spark tester in series with the spark plug wire and the spark plug (Figure 27). Then, crank and start the engine. A spark miss will be readily apparent. If spark jumps the spark tester gap regularly but the engine miss continues, the problem is in the spark plug or in the fuel system.

NOTE: A sheared flywheel key may change ignition timing but sparking will still occur across the spark tester gap.

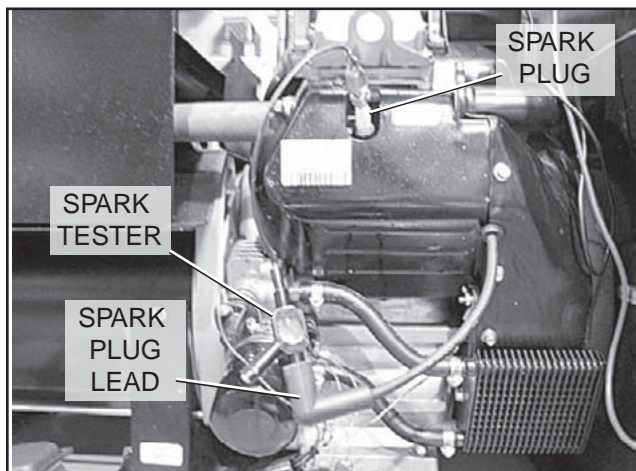

Figure 27. Checking Engine Miss

RESULTS:

1. If no spark or very weak spark occurs, go to Test 58.
2. If sparking occurs but engine still won't start, go to Test 56.
3. When checking for engine miss, if sparking occurs at regular intervals but engine miss continues, go to Test 16.
4. When checking for engine miss, if a spark miss is readily apparent, go to Test 59.

TEST 56 – CHECK SPARK PLUGS

DISCUSSION:

If the engine will not start and Test 55 indicated good ignition spark, perhaps the spark plug(s) are fouled or otherwise damaged. Engine miss may also be caused by defective spark plug(s).

PROCEDURE:

1. Remove spark plugs and clean with a penknife or use a wire brush and solvent.
2. Replace any spark plug having burned electrodes or cracked porcelain.
3. Set gap on new or used spark plugs as follows:

Engine Size	kW Rating	Plug Gap
410 cc	6/7 kW	0.030 inch
530 cc	9/10 kW	0.030 inch
990 cc	13/16/18 kW	0.040 inch

RESULTS:

1. Clean, re-gap or replace spark plugs as necessary.
2. If spark plugs are good, go to Test 62.

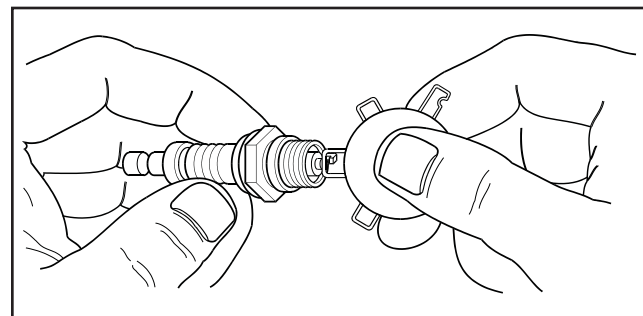

Figure 28. Checking Spark Plug Gap

TEST 57 – CHECK ENGINE / CYLINDER LEAK DOWN TEST / COMPRESSION TEST

GENERAL:

Most engine problems may be classified as one or a combination of the following:

- Will not start.
- Starts hard.
- Lack of power.
- Runs rough.
- Vibration.
- Overheating.
- High oil consumption.

DISCUSSION:

The Cylinder Leak Down Tester checks the sealing (compression) ability of the engine by measuring air leakage from the combustion chamber. Compression loss can present many different symptoms. This test is designed to detect the section of the engine where the fault lies before disassembling the engine.

PROCEDURE:

1. Remove a spark plug.
2. Gain access to the flywheel. Remove the valve cover.
3. Rotate the engine crankshaft until the piston reaches top dead center (TDC). Both valves should be closed.
4. Lock the flywheel at top dead center.
5. Attach cylinder leak down tester adapter to spark plug hole.
6. Connect an air source of at least 90 psi to the leak down tester.
7. Adjust the regulated pressure on the gauge to 80 psi.
8. Read the right hand gauge on the tester for cylinder pressure. 20 percent leakage is normally acceptable. Use good judgement, and listen for air escaping at the carburetor, the exhaust, and the crankcase breather. This will determine where the fault lies.
9. Repeat Steps 1 through 8 on remaining cylinder.

RESULTS:

- Air escapes at the carburetor – check intake valve.
- Air escapes through the exhaust – check exhaust valve.
- Air escapes through the breather – check piston rings.
- Air escapes from the cylinder head – the head gasket should be replaced.

CHECK COMPRESSION:

Lost or reduced engine compression can result in (a) failure of the engine to start, or (b) rough operation. One or more of the following will usually cause loss of compression:

- Blown or leaking cylinder head gasket.
- Improperly seated or sticking-valves.
- Worn Piston rings or cylinder. (This will also result in high oil consumption).

NOTE: For the single cylinder engine, the minimum allowable compression pressure for a cold engine is 60 psi.

NOTE: It is extremely difficult to obtain an accurate compression reading without special equipment. For that reason, compression values are not published for the V-Twin engine. Testing has proven that an accurate compression indication can be obtained using the following method.

PROCEDURE:

1. Remove both spark plugs.
2. Insert a compression gauge into either cylinder.
3. Crank the engine until there is no further increase in pressure.
4. Record the highest reading obtained.
5. Repeat the procedure for the remaining cylinder and record the highest reading.

RESULTS:

The difference in pressure between the two cylinders should not exceed 25 percent. If the difference is greater than 25 percent, loss of compression in the lowest reading cylinder is indicated.

Example 1: If the pressure reading of cylinder #1 is 165 psi and of cylinder #2, 160 psi, the difference is 5 psi. Divide "5" by the highest reading (165) to obtain the percentage of 3.0 percent.

Example 2: No. 1 cylinder reads 160 psi; No. 2 cylinder reads 100 psi. The difference is 60 psi. Divide "60" by "160" to obtain "37.5" percent. Loss of compression in No. 2 cylinder is indicated.

If compression is poor, look for one or more of the following causes:

- Loose cylinder head bolts.
- Failed cylinder head gasket.
- Burned valves or valve seats.
- Insufficient valve clearance.
- Warped cylinder head.
- Warped valve stem.
- Worn or broken piston ring(s).
- Worn or damaged cylinder bore.
- Broken connecting rod.
- Worn valve seats or valves.
- Worn valve guides.

NOTE: Refer to Engine Service manual for further engine service information.

TEST 58 – CHECK SHUTDOWN WIREDISCUSSION:

Circuit board action during shutdown will ground Wire 18. Wire 18 is connected to the Ignition Magneto(s). The grounded magneto will not be able to produce spark.

PROCEDURE:

1. On V-twin generators, remove Wire 18 from the stud located above the oil cooler. On single cylinder generators, disconnect Wire 18 at the bullet connector. See Figures 29 or 30.
2. Depending on engine type, do the following:

- a. On V-twin units, remove Wire 56 from the Starter Contactor Relay (SCR). Using a jumper lead, jump 12 VDC from Wire 15 at Fuse (F1) to the terminal on the SCR that Wire 56 was removed from. The generator will start cranking. As it is cranking, repeat Test 55. Reconnect Wire 56 when done.
- b. On single cylinder units, connect a jumper lead from the stud that Wire 56 is connected to on the Starter Contactor (SC) and 12 VDC Wire 15 at Fuse (F1). The generator will start cranking. As it is cranking, repeat Test 55.

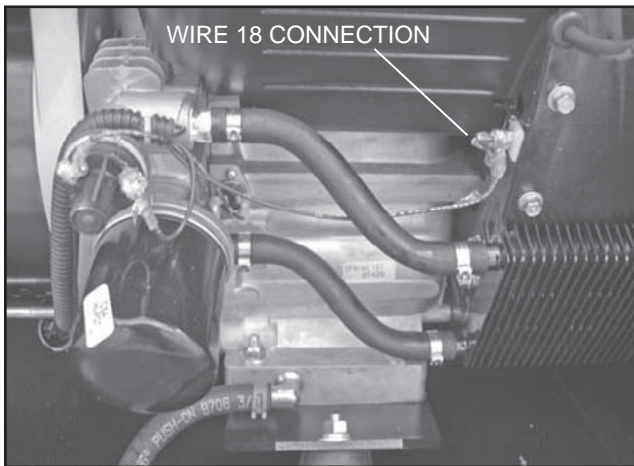

Figure 29. Wire 18 Connection 9/10/13/16/18 kW Units

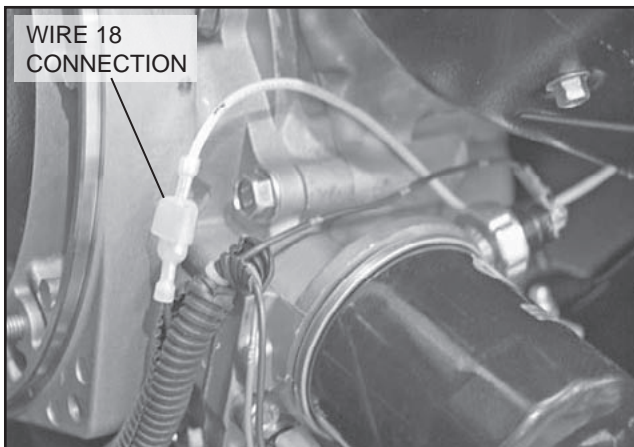

Figure 30. Wire 18 Connection 6/7 kW Units

3. If spark now occurs with Wire 18 removed, check for a short to ground. Remove the J1 Connector from the circuit board.
4. Set a VOM to measure resistance. Connect one test lead to Wire 18 (disconnected in Step 1). Connect the other test lead to a clean frame ground. INFINITY should be measured.
5. Reconnect the J1 Connector to the circuit board.

RESULTS:

1. If INFINITY was NOT measured in Step 4, repair or replace shorted ground Wire 18 between the J1 Connector from the circuit board to the stud or bullet connector.
2. If INFINITY was measured in Step 4, replace the circuit board and retest for spark.
3. If ignition spark still has not occurred, proceed to Test 59.

TEST 59 – CHECK AND ADJUST IGNITION MAGNETOS

DISCUSSION:

In Test 55, a spark tester was used to check for engine ignition. If sparking or weak spark occurred, one possible cause might be the ignition magneto(s). This test consists of checking ohm values across the primary and secondary windings of the magneto and adjusting the air gap between the ignition magneto(s) and the flywheel. The flywheel and flywheel key will also be checked during this test. A diode is installed before the primary winding inside the coil, this is done to inhibit a spark occurring on both magnetos at the same time.

PROCEDURE:

1. Disconnect Wire 18 from the terminal connector located by the oil cooler (Figure 29).
2. Disconnect spark plug wires from the spark plugs on cylinder one and two.
3. Set VOM to measure resistance.
4. Connect the positive (red) meter lead to the stud connector where Wire 18 was disconnected in Step 1. Connect the negative (black) meter lead to a clean frame ground. An ohm reading of approximately 300K \pm 10K ohms should be measured. This reading is the primary winding of both coils in parallel.
5. Connect the positive meter lead to the spark plug wire and connect the negative meter lead to a clean frame ground. Approximately 14K \pm 3K ohms should be measured, if INFINITY or a low or high ohm reading is measured, replace the magnetos.
6. Connect the negative (black) meter lead to the stud connector where Wire 18 was disconnected in Step 1. Connect the positive (red) meter lead to the spark plug wire on cylinder number two. The meter should indicate INFINITY. This step is testing the diodes in both magnetos to ensure they are still functioning.
7. Repeat Step 6 on cylinder two. If INFINITY is not measured, replace the magnetos.

Note: It is recommended to replace magnetos in pairs.

PROCEDURE, ADJUSTING MAGNETO FLYWHEEL GAP:

Note: The air gap between the ignition magneto and the flywheel on single cylinder engines is non-adjustable. Proceed directly to Step 10 for single cylinder engines. For V-twin engines, proceed as follows.

1. See Figure 31. Rotate the flywheel until the magnet is under the module (armature) laminations.
2. Place a 0.008-0.012 inch (0.20-0.30mm) thickness gauge between the flywheel magnet and the module laminations.

Note: A business card is approximately .010 inch

3. Loosen the mounting screws and let the magnet pull the magneto down against the thickness gauge.
4. Tighten both mounting screws.

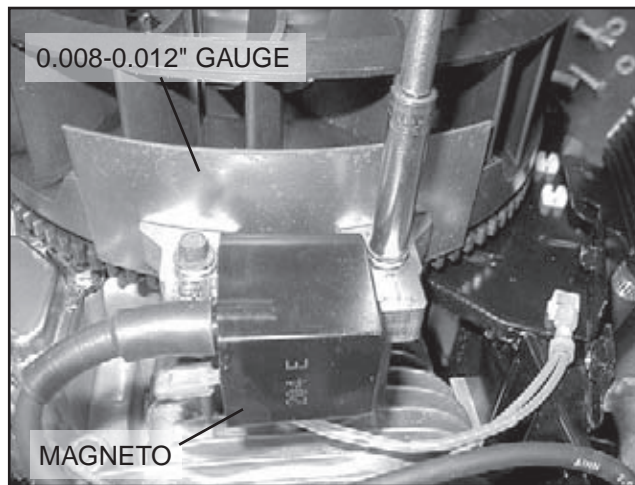

Figure 31. Setting Ignition Magneto (Armature) Air Gap

5. To remove the thickness gauge, rotate the flywheel.
6. Repeat the above procedure for the second magneto.
7. Repeat Test 55 and check for spark across the spark tester gap
 - a. A spark test may be conducted with unit disassembled by following this procedure.
 - b. The battery must be connected
 - c. The J1 Connector must be connected to the printed circuit board
 - d. Remove Wire 56 from the SCR located beneath the printed circuit board.

Warning: Make sure all debris is cleared from the engine compartment and all body parts are clear from flywheel before proceeding.

- e. Utilizing a jumper wire connect a wire to Wire 15 at the fuse holder (F1). Connect the other end to where Wire 56 was disconnected in Step 7d. The engine should crank once the jumper from 15 is connected.

- f. Refer to Test 55 for the procedure to check for spark.

8. If spark was not indicated, replace the magnetos.

Note: If only the gap is adjusted, ensure to properly test the magnetos by cranking the engine over before reassembly occurs. Spark should be present on both cylinders before reassembly should be completed.

9. If air gap was not out of adjustment, test ground wires.
10. Set a VOM to the measure resistance.
11. Disconnect the engine wire harness from the ignition magnetos (Figure 32).
 - a. On V-twin generators, remove Wire 18 from the stud located above the oil cooler. See Figure 29.
 - b. On single cylinder generators, disconnect Wire 18 at the bullet connector. See Figure 30.

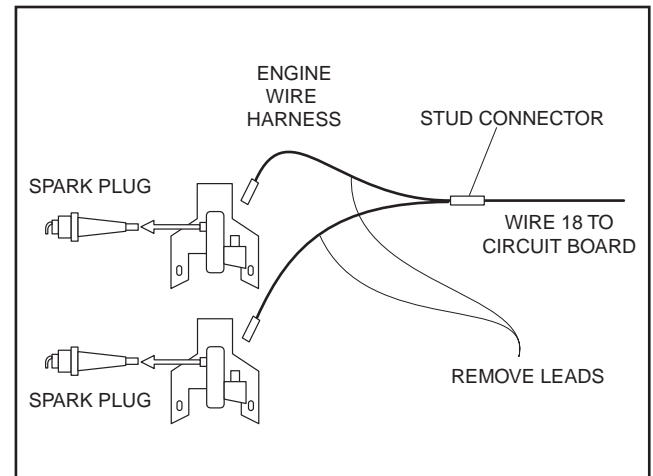

Figure 32. Engine Ground Harness

12. Connect one meter test lead to one of the wires removed from the ignition magneto(s). Connect the other test lead to frame ground. INFINITY should be measured. If CONTINUITY is measured, replace the shutdown harness.
13. Now check the flywheel magnet by holding a screwdriver at the extreme end of its handle and with its point down. When the tip of the screwdriver is moved to within 3/4 inch (19mm) of the magnet, the blade should be pulled in against the magnet.
14. For rough running or hard starting engines check the flywheel key. The flywheel's taper is locked on the crankshaft taper by the torque of the flywheel nut. A keyway is provided for alignment only and theoretically carries no load.

Note: If the flywheel key becomes sheared or even partially sheared, ignition timing can change. Incorrect timing can result in hard starting or failure to start.

SECTION 4.4 DIAGNOSTIC TESTS

15. As stated earlier, the armature air gap is fixed for single cylinder engine models and is not adjustable. Visually inspect the armature air gap and hold down bolts.

RESULTS:

If sparking still does not occur after adjusting the armature air gap and testing the ground wires and performing the basic flywheel test, replace the ignition magneto(s).

PROCEDURE, REPLACING MAGNETOS:

1. Follow all steps of the Major Disassembly procedures that are located in this manual
2. Once the magnetos are visible, make note to how they are connected.

Note: Each magneto has its own part number. Verify the part number prior to installation.

3. Cylinder one is the back cylinder (Figure 33) and cylinder two is the front cylinder (Figure 34).

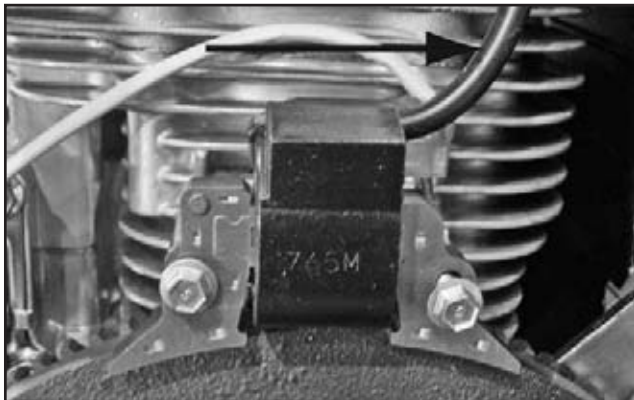

Figure 33. Cylinder One (Back, Short)

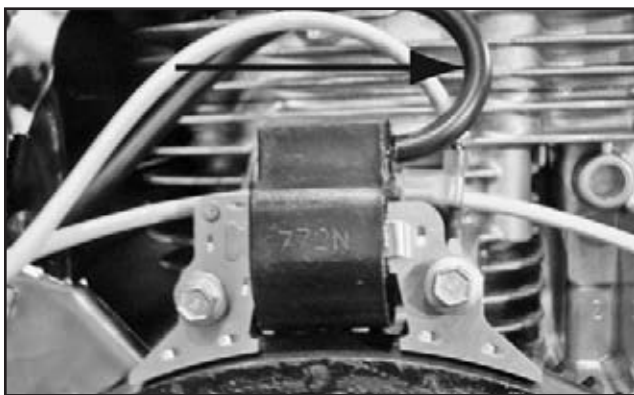

Figure 34. Cylinder Two (Front, Long)

4. When installing new magnetos there will be one with a short plug wire and one with a longer plug wire (Figure 35).

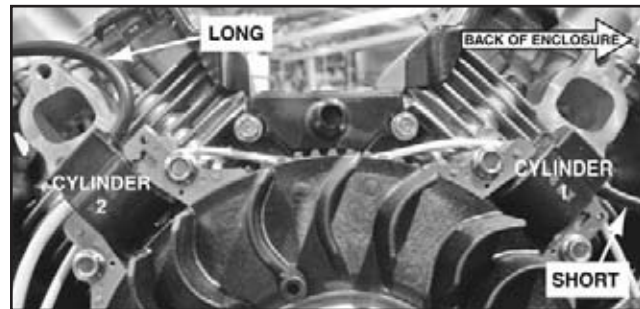

Figure 35.

Note: Magneto gap between flywheel needs to be 0.010 inch.

5. Long plug wire (B) will be installed on front cylinder number two.
6. Short plug Wire (A) will be installed on back cylinder number one.
7. Verify installation of magnetos correctly by ensuring both spark plug wires point to the back of the enclosure and shutdown terminals are nearest cylinder head as shown in Figures 36 and 37.

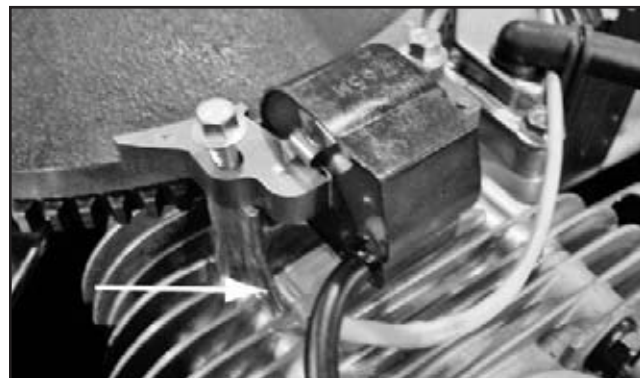

Figure 36.



Figure 37.

**TEST 60 – CHECK OIL PRESSURE SWITCH
AND WIRE 86****DISCUSSION:**

If the oil pressure switch contacts have failed in their closed position, the engine will probably crank and start. However, shutdown will then occur within about 5 (five) seconds. If the engine cranks and starts, then shuts down almost immediately with a LOP fault light, the cause may be one or more of the following:

- Low engine oil level.
- Low oil pressure.
- A defective oil pressure switch.

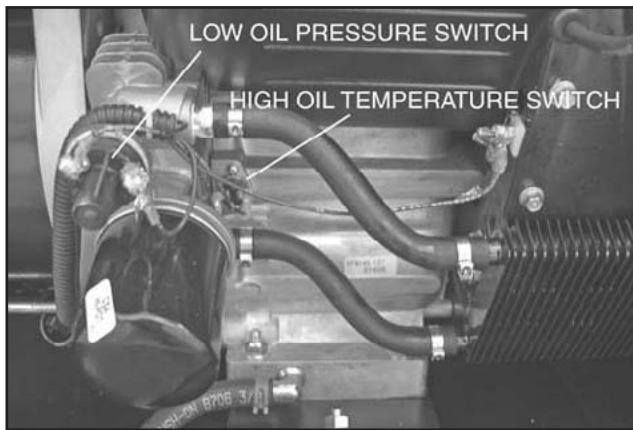

Figure 38. Oil Pressure Switch

PROCEDURE:

1. Check engine crankcase oil level.
 - a. Check engine oil level.
 - b. If necessary, add the recommended oil to the dipstick FULL mark. DO NOT OVERFILL ABOVE THE FULL MARK.
2. With oil level correct, try starting the engine.
 - a. If engine still cranks and starts, but then shuts down, go to Step 3.
 - b. If engine cranks and starts normally, discontinue tests.
3. Do the following:
 - a. Disconnect Wire 86 and Wire 0 from the oil pressure switch terminals. Remove the switch and install an oil pressure gauge in its place.
 - b. Start the engine while observing the oil pressure reading on gauge.
 - c. Note the oil pressure.
 - (1) Normal oil pressure is approximately 35-40 psi with engine running. If normal oil pressure is indicated, go to Step 4 of this test.
 - (2) If oil pressure is below about 4.5 psi, shut engine down immediately. A problem exists in the engine lubrication system.

Note: The oil pressure switch is rated at 10 psi for V-twin engines, and 8 psi for single cylinder engines.

4. Remove the oil pressure gauge and reinstall the oil pressure switch. Do NOT connect Wire 86 or Wire 0 to the switch terminals.
 - a. Set a VOM to measure resistance.
 - b. Connect the VOM test leads across the switch terminals. With engine shut down, the meter should read CONTINUITY. If INFINITY is measured with the engine shutdown, replace the LOP switch.
 - c. Crank and start the engine. The meter should read INFINITY.
5. Set a VOM to measure resistance.
 - a. Disconnect the J1 Connector from the printed circuit board.
 - b. Connect one test lead to Wire 86 (disconnected from LOP). Connect the other test lead to Pin Location 4 (Wire 86) of the J1 Connector at the Circuit Board (for all models). CONTINUITY should be measured. If CONTINUITY is not measured, repair or replace Wire 86 between the LOP switch and the J1 Connector.
 - c. Connect one test lead to Wire 0 (disconnected from LOP). Connect the other test lead to a clean frame ground. CONTINUITY should be measured. If CONTINUITY is NOT measured repair or replace Wire 0 between the LOP and the ground terminal connection on the engine mount.
7. If the LOP switch tests good in Step 4 and oil pressure is good in Step 3 but the unit still shuts down with a LOP fault, check Wire 86 for a short to ground. Set a VOM to measure resistance. Disconnect the J1 Connector from the circuit board. Remove Wire 86 from the LOP switch. Connect one test lead to Wire 86. Connect the other test lead to a clean frame ground. INFINITY should be measured. If CONTINUITY is measured, repair or replace Wire 86 between the LOP switch and the J1 Connector.

RESULTS:

1. Replace switch if it fails the test.

**TEST 61 – CHECK HIGH OIL TEMPERATURE
SWITCH****DISCUSSION:**

If the temperature switch contacts have failed in a closed position, the engine will fault out on "OVERTEMP". If the unit is in an overheated condition, the switch contacts will close at 284° F. This will normally occur from inadequate airflow through the generator.

PROCEDURE:

1. Verify that the engine has cooled down (engine block

is cool to the touch). This will allow the contacts in the High Oil Temperature Switch to close.

2. Check the installation and area surrounding the generator. There should be at least three feet of clear area around the entire unit. Make sure that there are no obstructions preventing incoming and outgoing air.
3. Disconnect Wire 85 and Wire 0 from the High Oil Temperature Switch.
4. Set a VOM to measure resistance. Connect the test leads across the switch terminals. The meter should read INFINITY.
5. If the switch tested good in Step 4, and a true overtemperature condition has not occurred, check Wire 85 for a short to ground. Remove J1 Connector from the circuit board. Set the VOM to measure resistance. Connect one test lead to Wire 85 (disconnected from High Oil Temperature Switch). Connect the other test lead to a clean frame ground. INFINITY should be measured.

TESTING HIGH OIL TEMPERATURE SWITCH:

6. Remove the High Oil Temperature Switch.
7. Immerse the sensing tip of the switch in oil as shown in Figure 39, along with a suitable thermometer.
8. Set a VOM to measure resistance. Then, connect the VOM test leads across the switch terminal and the switch body. The meter should read INFINITY.
9. Heat the oil in the container. When the thermometer reads approximately 274°-294° F. (134°-146° C.), the VOM should indicate CONTINUITY.

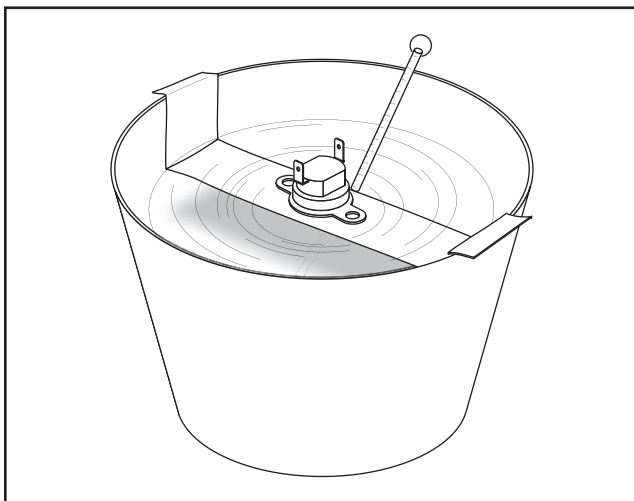

Figure 39. Testing the Oil Temperature Switch

RESULTS:

1. If the switch fails Step 4, or Steps 8-9, replace the switch.

2. If INFINITY was NOT measured in Step 5, repair or replace Wire 85 between the Circuit Board and the High Oil Temperature Switch.

TEST 62 – CHECK AND ADJUST VALVES

DISCUSSION:

Improperly adjusted valves can cause various engine related problems including, but not limited to, hard starting, rough running and lack of power. The valve adjustment procedure for both the single cylinder and the V-twin engines is the same.

PROCEDURE (INTAKE AND EXHAUST):

Make sure that the piston is at Top Dead Center (TDC) of it's compression stroke (both valves closed). The valve clearance should be 0.05-0.1mm (0.002-0.004 in) cold.

Check and adjust the valve to rocker arm clearance as follows:

1. Remove the four (4) screws from the rocker cover.
2. Remove the rocker cover and rocker cover gasket.
3. Loosen the rocker arm jam nut. Use a 10mm allen wrench to turn the pivot ball stud and check the clearance between the rocker arm and the valve stem with a flat feeler gauge (see Figure 40).
4. When the valve clearance is correct, hold the pivot ball stud with the allen wrench and tighten the rocker arm jam nut. Torque the jam nut to 174 inch pounds. After tightening the jam nut, recheck the valve clearance to make sure it did not change.

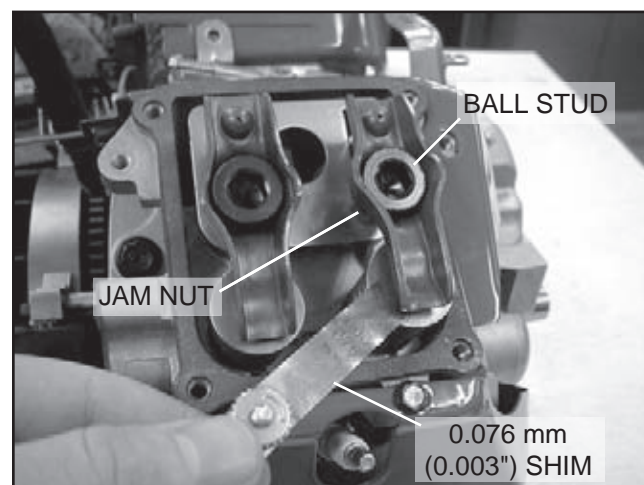

Figure 40.

5. Re-install the rocker cover gasket, rocker cover and the four (4) screws.

RESULTS:

Adjust valve clearance as necessary, the retest.

TEST 63 – CHECK FUEL REGULATOR (6/7 KW NATURAL GAS UNITS ONLY)

DISCUSSION:

The fuel regulator is rarely the cause of a hard start or no start condition. The most common causes are insufficient fuel pressure supplied to the unit, or the adjustment screw on the 6/7 kW fuel regulator being out of adjustment. The fuel regulator is an “ON DEMAND” type. During cranking and running, negative pressure from the airbox or carburetor unseats the fuel regulator diaphragms and allows fuel flow through the regulator.

PROCEDURE:

Note: No adjustments are available on V-twin engines units.

1. Turn off utility power to the main distribution panel in the house. This can be done by switching the service main breaker to the OFF or “Open” position.
2. Allow the generator to start. Before loading the generator, confirm that the No Load Frequency, with the roof open and the door off, is set to 62-63 Hertz. Transfer load to emergency circuits.
3. Turn on appliances, lights, pumps, etc., that are on the emergency circuits in an attempt to fully load the generator. Be cautious not to overload the generator. Use the following chart as a guide:

Unit	120 Volts	240 Volts
6/7 kW	50.0 amps	25.0 amps

4. When full load has been achieved, connect a frequency meter to the output lugs of the generator main line circuit breaker.
 - a. The 6/7 kW fuel regulator is fitted with one adjustment screw. While watching the frequency meter, slowly turn the adjustment screw clockwise or counterclockwise until highest frequency is read on the meter.
- Note: There is no adjustment available when the unit has been converted to LP gas.**
- Note: Only limited adjustment is available between the set pins on fuel regulators. Under no circumstance should any of the pins be removed (see Figure 41).**
5. When the highest frequency is reached, maximum power has been set. From this point turn the adjustment screw(s) 1/4 turn counterclockwise. The regulator is now set.

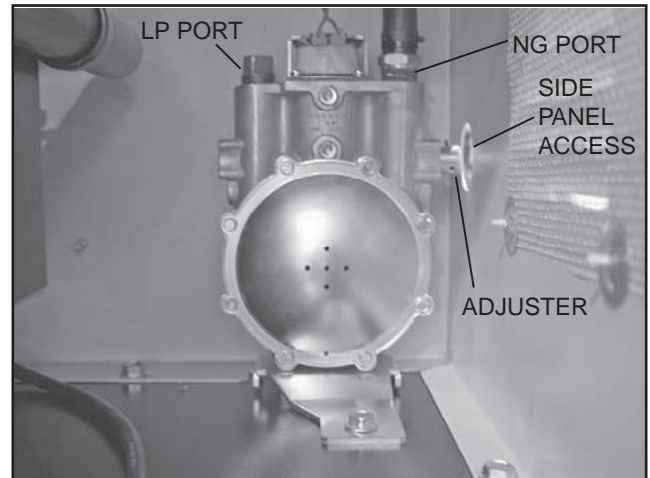

Figure 41.

6. Turn utility power to the main distribution panel back on. This can be done by switching the service main breaker to the “ON” or closed position. Allow the generator to shut down.



WARNING



DO NOT MAKE ANY UNNECESSARY ADJUSTMENTS. FACTORY SETTINGS ARE CORRECT FOR MOST APPLICATIONS. HOWEVER, WHEN MAKING ADJUSTMENTS, BE CAREFUL TO AVOID OVERSPEEDING THE ENGINE.

TEST 64 – CHECK BATTERY CHARGE OUTPUT

DISCUSSION:

The battery charging system is a 2.5 amp trickle charge. It is capable of maintaining a charge on a functional battery. It is not intended to, nor capable of charging a completely dead battery.

The system will charge when utility source power is available to the generator or if the generator is running. The system consists of a transformer (TX), battery charge relay (BCR), battery charger (BC), and a battery charge winding. The BCR contacts allow AC voltage to the battery charger. When the BCR is de-energized, voltage from the TX is available to the battery charger. When the generator starts, Wire 14 energizes the BCR. This allows battery charge winding AC output to power the battery charger.

PROCEDURE:

Note: Utility source voltage MUST be available to the generator.

1. Set the Auto-OFF-Manual (SW1) switch to off.

2. Disconnect the negative battery cable.
3. Set a VOM to measure DC amps.
4. Disconnect Wire 13 from the starter contactor (SC), secure battery cable back to SC. Connect the positive meter test lead to disconnected Wire 13. Connect the negative meter test lead to the post of the SC that Wire 13 was removed from.
5. Connect the negative battery cable. The amp meter should read 0.050 to 2.5 amps, depending upon the state of charge of the battery. Record the results. Now set SW1 to manual, the generator will start and run. The amp meter should again read 0.050 to 2.5 amps, depending upon the state of charge of the battery. Record the results.

RESULTS:

Refer to Problem 13 flow chart in Section 4.3.

**TEST 65 – CHECK TRANSFORMER (TX)
VOLTAGE OUTPUT**

DISCUSSION:

The Transformer (TX) is a “step down” type and has two functions. It supplies approximately 16 VAC to the control panel circuit board for utility sensing. It also supplies approximately 16 VAC to the battery charger for trickle charging. A defective transformer will:

- a. not supply AC to the battery charger, and
- b. not supply sensing voltage to the circuit board.

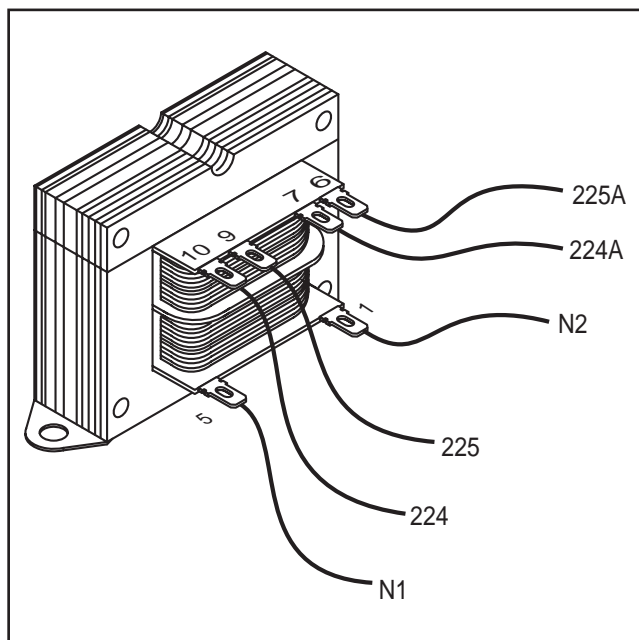

Figure 42. Transformer (TX)

PROCEDURE:

1. Set a VOM to measure AC voltage.
2. Connect one meter test lead to the Transformer (TX) Terminal 5, Wire N1. Connect the other meter test lead to the Transformer (TX) Terminal 1, Wire N2. Utility line-to-line voltage (240 VAC) should be measured.
3. Connect one meter test lead to the Transformer (TX) Terminal 6 with Wire 225A removed. Connect the other meter test lead to the Transformer (TX) Terminal 7 with Wire 224A removed. This output supplies power to the battery charger. The VOM should measure approximately 16 VAC.
4. Connect one meter test lead to the Transformer (TX) Terminal 9 with Wire 224 removed. Connect the other meter test lead to the Transformer (TX) Terminal 10 with Wire 224 removed. This AC output is used as utility sensing, and is supplied to the circuit board. The VOM should measure approximately 16 VAC.

RESULTS:

1. If line-to-line voltage was NOT measured in Step 2, go to Problem 7, Section 3.3.
2. If correct voltage was measured in Step 2, and no voltage was measured in Step 3, replace the Transformer.
3. If correct voltage was measured in Step 2, and no voltage was measured in Step 4, replace the Transformer.
4. If voltage output was correct for Step 3 and for Step 4, refer back to the Flow Chart (Section 4.3).

**TEST 66 – CHECK AC VOLTAGE AT BATTERY
CHARGER**

DISCUSSION:

The battery charger needs to be supplied with approximately 16 VAC. When the generator is not running and utility source power is available, the battery charger still receives voltage from the Transformer (TX). When the generator is running, voltage is supplied to the battery charger from the battery charge winding.

PROCEDURE:

1. Set the AUTO-OFF-MANUAL switch to OFF.
- Note: Utility source voltage MUST be available to the generator.**
2. Set a VOM to measure AC voltage.
 3. Disconnect the two pin connector (Wire 224B and Wire 225B) at the battery charger.
 4. Connect one meter test lead to Wire 224B at the two pin connector. Connect the other test lead to Wire 225B at the two pin connector. Approximately 16 VAC should be measured.

- Verify that the battery charge relay (BCR) is wired correctly (Figure 44).
- Connect one meter test lead to Terminal 1, Wire 224A on the BCR. Connect the other test lead to Terminal 3, Wire 225A. Approximately 16 VAC should be measured.

RESULTS:

- If voltage was NOT measured in Step 6, but was measured in Test 65, repair or replace Wire 224A and Wire 225A between the transformer (TX) and the battery charge relay (BCR).
- If voltage was not measured in Step 4, go to Test 67.

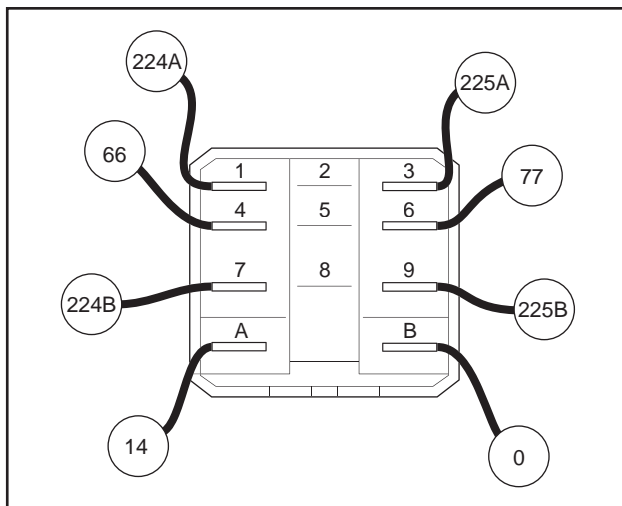

Figure 44. Battery Charge Relay Test Points

TEST 67 – CHECK BATTERY CHARGE RELAY (BCR)**DISCUSSION:**

The battery charge relay is used to switch the AC source delivered to the battery charger. When the BCR is de-energized, the Normally Closed (NC) contacts deliver AC power from the transformer. When the BCR is energized by Wire 14, the Normally Open (NO) contacts close and battery charge winding AC source is delivered to the battery charger.

PROCEDURE:

- See Figure 44. Disconnect all wires from the battery charge relay, to prevent interaction.
- Set a VOM to its “R x 1” scale and zero the meter.
- Follow the chart below and test each set of contacts. Connect the VOM test leads to the relay terminals indicated in the chart provided below.
- To energize or de-energize the relay. Connect a jump-

er wire to a positive (+)12 VDC source and to relay Terminal “A”. Connect a jumper wire to the negative (-)12 VDC source and to relay Terminal “B”. The relay will ENERGIZE. Disconnect the positive jumper from Terminal “A” of the relay and the relay will DE-ENERGIZE.

CONNECT VOM TEST LEADS ACROSS	DESIRED METER READING	
	ENERGIZED	DE-ENERGIZED
Terminals 6 and 9	Continuity	Infinity
Terminals 3 and 9	Infinity	Continuity
Terminals 4 and 7	Continuity	Infinity
Terminals 1 and 7	Infinity	Continuity

RESULTS:

- Replace the battery charge relay if it fails any of the steps in this chart.
- If the BCR tests good, but still does not function during generator operation, check Wire 14 and Wire 0 connected to the BCR.
 - Set a VOM to measure DC volts. Disconnect Wire 14 from BCR Terminal “A”. Connect the positive (+) test lead to Wire 14. Connect the negative (-) test lead to a clean frame ground. Set the AUTO-OFF-MANUAL switch to MANUAL. Battery voltage should be measured. If battery voltage is not measured, repair or replace Wire 14 between the BCR and the 4-tab terminal block.
 - If voltage was measured in “a”, set the VOM to measure resistance. Disconnect Wire 0 from BCR Terminal “B”. Connect one test lead to Wire 0. Connect the other test lead to a clean frame ground. CONTINUITY should be measured. If CONTINUITY was not measured, repair or replace Wire 0 between the BCR and the ground terminal.

TEST 68 – CHECK BATTERY CHARGE WINDING HARNESS**DISCUSSION:**

This test will check the continuity of Wire 66 and Wire 77 between C2 Connector and the battery charge relay.

PROCEDURE:

- Disconnect C2 Connector from the side of the control panel. The C2 Connector is the closest to the back panel (see Figure 9, Section 6.1).
- Disconnect Wire 66 from Terminal 6, and Wire 77 from Terminal 4 of the BCR.
- Set a VOM to measure resistance.

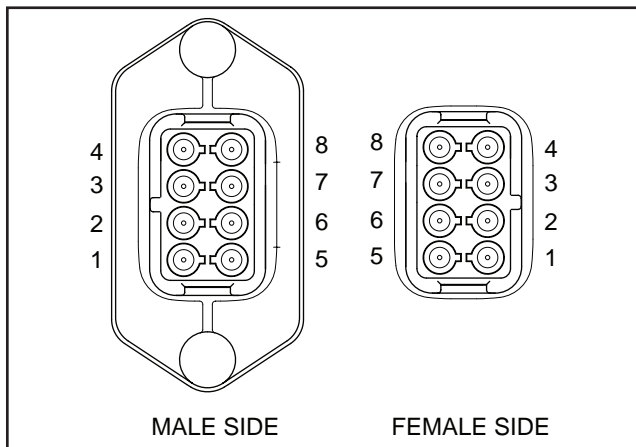

Figure 45. C2 Connector Pin Locations

4. Connect one meter test lead to the male side C2 Connector Pin Location 1 (Wire 77). Connect the other test lead to the end of Wire 77 which was previously removed from the BCR. CONTINUITY should be measured.
5. Connect one meter test lead to the male side C2 Connector Pin Location 2 (Wire 66). Connect the other test lead to the end of Wire 66 which was previously removed from the BCR. CONTINUITY should be measured.

RESULTS:

If CONTINUITY was not measured in Step 4 or Step 5, repair or replace defective wiring between C2 Connector and the battery charge relay.

TEST 69 – CHECK BATTERY CHARGER WIRING

DISCUSSION:

The three pin connector on the battery charger connects the charger to ground and to battery power.

PROCEDURE:

1. Set the AUTO-OFF-MANUAL switch to OFF.
2. Disconnect the three pin connector from the battery charger.
3. Set a VOM to measure resistance.
4. Connect one meter test lead to Wire 13 at the three pin connector. Connect the other test lead to Wire 13 at Fuse F2. CONTINUITY should be measured.
5. Connect one meter test lead to Wire 0 at the three pin connector. Connect the other test lead to the ground terminal. CONTINUITY should be measured.

RESULTS:

1. If CONTINUITY was NOT measured in Step 4, repair or replace Wire 13 between the battery charger and Fuse F1.
2. If CONTINUITY was NOT measured in Step 5, repair or replace Wire 0 between the battery charger and frame ground.

TEST 70 – CHECK WIRE 18 CONTINUITY

DISCUSSION:

During cranking and running the printed circuit board receives a pulse from the ignition magnetos via Wire 18. If this signal is not received by the printed circuit board it will shut down for no RPM sensing.

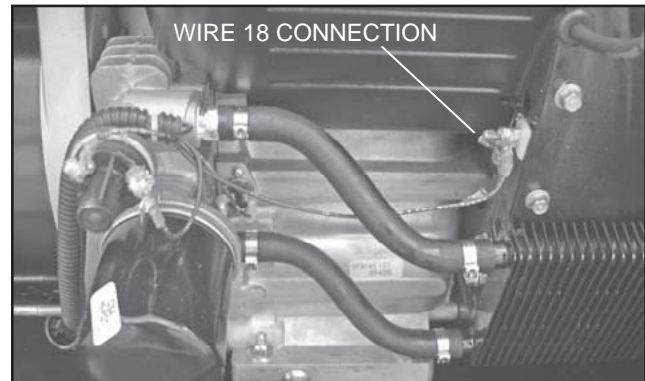

Figure 46. Wire 18 Connection 10/13/16/18 kW Units

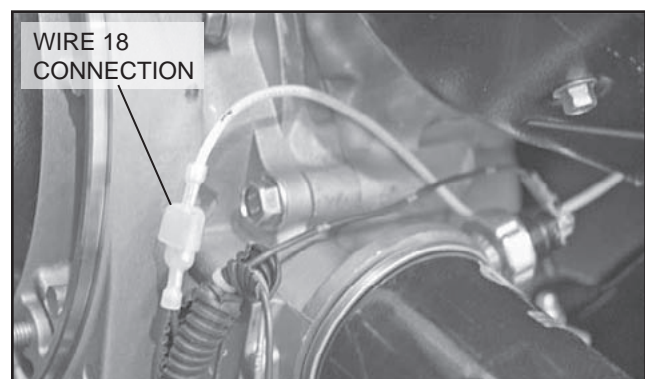

Figure 47. Wire 18 Connection 10/13/16/18 kW Units

PROCEDURE:

1. Set a VOM to measure resistance.
2. Remove Wire 18 from the stud connector for V-twin units or disconnect the in-line bullet connector for single cylinder engine units. Disconnect the J1 Connector from the printed circuit board.

3. Verify the continuity of Wire 18. Connect one meter test lead to Wire 18 removed from the stud connector or bullet connector. Connect the other meter test lead to Pin Location J1-5 for all models. Continuity should be measured. If continuity was not measured verify proper connection of the C1 Connector, repair or replace Wire 18 as needed.

RESULTS:

Refer to flow chart.

TEST 71 – CHECK N1 AND N2 VOLTAGE**DISCUSSION:**

Loss of utility source voltage to the generator will initiate a startup and transfer by the generator. Testing at the control panel terminal strip will divide the system in two, thereby reducing troubleshooting time.

PROCEDURE:

Note: Verify that Utility Source Voltage is present.

1. Set the AUTO-OFF-MANUAL switch to OFF.
2. Set a VOM to measure AC voltage.
3. Connect one test lead to Wire N1 at the terminal strip in the generator control panel. Connect the other test lead to Wire N2. Utility line-to-line voltage should be measured.

RESULTS:

1. If voltage was measured in Step 3, go to Test 65.
2. If voltage was not measured in Step 3, go to Test 28.

TEST 72 – CHECK UTILITY SENSING VOLTAGE AT THE CIRCUIT BOARD**DISCUSSION:**

If the generator starts and transfer to STANDBY occurs in the automatic mode, even though an acceptable UTILITY source voltage is available from the Transformer (TX), the next step is to determine if that sensing voltage is reaching the circuit board.

Note: The System Ready LED will flash in AUTO.

PROCEDURE:

1. Set the AUTO-OFF-MANUAL switch to OFF.
2. Disconnect J1 Connector from the circuit board.
3. Set a VOM to measure AC voltage.
4. Connect one meter test lead to Wire 225 at Pin Location J1-17 for V-twin units, or J1-11 for single cylinder engine units. Connect the other meter test lead to Wire 224 at Pin Location J1-10 for V-twin units, or J1-7 for single

cylinder engine units. Approximately 14-16 VAC should be measured.

RESULTS:

1. If voltage was measured in Step 4 and the pin connections are good, replace the circuit board.
2. If voltage was NOT measured in Step 4, repair or replace Wire 224 and/or No. Wire 225 between Transformer (TX) and Circuit Board J1 Connector.

TEST 73 – TEST SET EXERCISE SWITCH**DISCUSSION:**

If the Set Exercise Switch (SW2) fails to open when activated, the exercise time will not be able to be set.

PROCEDURE:

1. Set a VOM to measure resistance.
2. Disconnect Wire 15B and Wire 15 from the Set Exercise Switch (SW2).
3. Connect one meter test lead to one terminal of SW2. Connect the other test lead to the remaining terminal of SW2. The meter should read CONTINUITY.
4. With the meter test leads connected to SW2, depress and hold the switch activated. The meter should read INFINITY.

RESULTS:

1. If the Set Exercise Switch (SW2) fails Step 3 or Step 4, replace the switch.

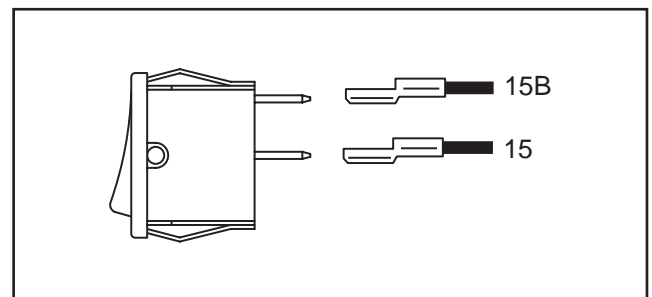

Figure 48. The Set Exercise Switch

TEST 75 – CHECK BATTERY VOLTAGE CIRCUIT**DISCUSSION:**

If the 15 amp fuse blows immediately after replacement, Wire 15 should be checked for a fault.

SECTION 4.4 DIAGNOSTIC TESTS

PART 4

DC CONTROL

PROCEDURE:

1. Set the AUTO-OFF-MANUAL switch to OFF.
2. Disconnect the J1 Connector from the circuit board.
3. Set a VOM to measure resistance.
4. Disconnect Wire 15 from the fuse holder (F1).
5. Connect one meter test lead to Wire 15 (removed from fuse holder in previous step). Connect the other meter test lead to the ground terminal. INFINITY should be measured.

RESULTS:

1. If CONTINUITY was measured in Step 5, repair or replace Wire 15 between the fuse holder (F1) and SW1, or between SW1 and SW2, or between the fuse holder (F1) and the starter contactor relay (SCR).
2. If INFINITY was measured in Step 5, replace the circuit board and retest.

TEST 76 – CHECK CRANKING AND RUNNING CIRCUITS

DISCUSSION:

This test will check all of the circuits that are “HOT” with battery voltage and which could cause the F1 Fuse to blow.

PROCEDURE:

1. Set a VOM to measure resistance.
2. Disconnect the J1 Connector from the circuit board.
3. Connect one meter test lead to the ground terminal. Connect the other meter test lead to each of the following J1 Connector pin locations:

SW1, Wire 194	If CONTINUITY was measured, go to Step 4. Average nominal resistance reading: 110-120 ohms. See Note 1
J1-9, Wire 56 (V-twin) J1-6, Wire 56 (Single Cylinder)	If CONTINUITY was measured, go to Step 5. Average nominal resistance reading: V-twin (SCR): 150-160 ohms Single Cylinder (SC): 4 ohms.
J1-1, Wire 15A	If CONTINUITY was measured, repair or replace shorted to ground Wire 15A between J1 Connector and switch SW1. See Note 2
J1-16, Wire 14 (V-twin) J1-10, Wire 14 (Single Cylinder)	If CONTINUITY was measured, go to Step 6.

NOTE 1: Disconnect the jumper between Wires 15A and 194 at SW1. Reconnect after completing tests.

NOTE 2: (V-twins equipped with Wire 15 connected to SCR) Disconnect Wire 16 from the Starter Contactor Relay. Install new 15A fuse. Place AUTO-OFF-MANUAL switch to MANUAL. If fuse does not blow, repair or replace Wire 16 between the SCR or the Starter Contactor (SC) located on the starter.

Optional Test Method: Set VOM to measure DC amps. Remove Wire 16 from the SCR. Connect the positive (+) test lead to Battery Positive, Connect the negative (-) test lead to Wire 16. The starter motor should engage and crank. Nominal current to Starter Contactor should be 4-5 Amps.

4. Disconnect Wire 194 from the terminal strip. Repeat Step 3 at SW1.
 - a. If CONTINUITY was measured, Wire 194 is shorted to ground between SW1 and terminal strip.
 - b. If INFINITY was measured, disconnect Wire 194 from the transfer switch terminal strip. Connect one meter test lead to the end of Wire 194 which was removed from the transfer switch terminal strip. Connect the other meter test lead to the ground terminal. If CONTINUITY was measured, Wire 194 is shorted to ground between the generator and the transfer switch.
 - 1) If INFINITY was measured, disconnect Wire 194 from the transfer relay (TR). Connect one meter test lead to the transfer relay terminal from which Wire 194 was previously removed. Connect the other test lead to Wire 23 at the transfer switch terminal strip. If CONTINUITY “ZERO RESISTANCE” was measured, replace the transfer relay. Normal coil resistance is approximately 113 ohms.
 - 2) If coil resistance of 113 ohms was measured, the short is in Wire 194 between the transfer relay and the terminal strip. Repair or replace Wire 194.
5. Disconnect Wire 56 from the starter contactor relay (SCR on V-twin) or the starter contactor (SC on single cylinder). Connect one meter test lead to the SCR or SC terminal from which Wire 56 was removed. Connect the other meter test lead to the ground terminal. If CONTINUITY or zero resistance was measured, replace the SCR or SC. Coil resistance for the SCR is 155 ohms. Coil resistance for the SC is 4 ohms. If coil resistance was measured, Wire 56 is shorted to ground between J1 Connector and the SCR or SC. Repair or replace the shorted wire.
6. Disconnect and isolate each Wire 14 from the 4-tab insulated terminal block. Repeat Step 3 for Pin Location J1-16. If CONTINUITY was measured, repair or replace Wire 14 between J1 Connector and the 4-tab terminal block. If INFINITY was measured, proceed as follows:

- a. Disconnect Wire 14 from the following: fuel solenoid (FS, FS1 or FS2 depending on model), battery charge relay (BCR) and idle choke solenoid (CS, V-twins only).
- b. Connect the negative (-) meter test lead to the ground terminal. Connect the positive (+) meter test lead to each of the listed components at the terminal from which Wire 14 was removed. If CONTINUITY or zero resistance was measured, the component has shorted to ground. Replace the component. The average nominal resistance value that should be measured for each component is:

Battery Charge Relay (BCR)	112 ohms
Fuel Solenoid (FS)	27-33 ohms
Fuel Solenoid (FS2)	29 ohms
Idle Choke Solenoid (CS)	3.7 ohms

- c. If each component tests good, there is no short to ground. The fault exists in one of the Wire 14 wires. Connect one meter test lead to the ground terminal. Connect the other meter test lead to each Wire 14 individually (on the end removed from the BCR, FS or CS). The Wire 14 which measures CONTINUITY is shorted to ground. Repair or replace the affected wire between the component and the 4-tab terminal block.

TEST 77 – TEST EXERCISE FUNCTION

DISCUSSION:

The following parameters must be met in order for the weekly exercise to occur:

- AUTO-OFF-MANUAL switch (SW1) set to AUTO.

PROCEDURE:

1. Set the AUTO-OFF-MANUAL switch (SW1) to MANUAL. The generator should start. Set SW1 back to AUTO. Verify that SW1 has been in AUTO for weekly exercise to function.
2. Hold the Set Exercise (SW2) switch until the generator starts (approximately 10 seconds) and then release. All of the red LEDs will flash for approximately 10 seconds and then stop. The generator will start and run for approximately 12 minutes and then shutdown on its own. The exerciser will then be set to start and run at that time of that day each week. If the unit does not start, go to Test 73. Retest after performing Test 73. If the generator still will not start, replace the circuit board. If the generator does not start after depressing the Set Exercise switch, wait one week and watch for exercise operation. If exercise fails to operate, replace the circuit board.

TEST 78 – CHECK DIP SWITCH SETTINGS (16 AND 18 KW UNITS)

DISCUSSION:

The printed circuit board on 16 and 18 kW units must be set for low speed operation. When set for low speed it will run at 2,400 RPM on exercise only.

PROCEDURE:

1. Access the printed circuit board (PCB). Refer to Figure 4 on page 76.
2. Verify that Dip Switch one is in the OFF position. If the dip switch is reset remove the Fuse (F1) first set dip switch the replace F1. If the dip switch was set correctly remove fuse F1 for 15 seconds then replace.
3. Verify that the AUTO-OFF-MANUAL switch is set to AUTO.
4. Press and hold the “Set Exercise Time” switch for several seconds, then release. All the red LED’s will flash for approximately 10 seconds and then stop.
5. Once the red LED’s stop flashing, the generator will start and run for approximately 12 minutes and then shut down. The exerciser is now set to run at this time of day each week.

Results:

1. If the generator still will not low speed exercise replace the printed circuit board.

TEST 79 – CHECK IDLE CONTROL TRANSFORMER (V-TWIN UNITS ONLY)

PROCEDURE:

1. Set the AUTO-OFF-MANUAL switch (SW1) to OFF.
2. Set a voltmeter to measure resistance.
3. Remove the two Idle Control Transformer (ICT) wires (red and black) from the two in-line connectors (IC) (Wire LC1/RED and Wire LC2/BLACK).
4. Connect one meter test lead to one wire and connect the other meter test lead to the other wire. Approximately 50 ohms should be measured. If resistance is not measured repair or replace the Idle Control Transformer.

RESULTS:

Refer back to Flow Chart.

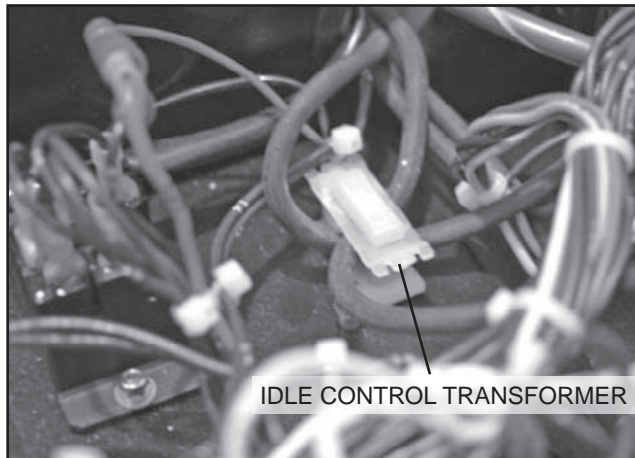

Figure 49. The Idle Control Transformer

**TEST 81 – CHECK IDLE CONTROL
TRANSFORMER PRIMARY WIRING**

PROCEDURE:

1. Set the AUTO-OFF-MANUAL switch (SW1) to OFF.
2. Remove Fuse F1.
3. Visually verify that Wires 11 and 44 cross through the Idle Control Transformer (ICT) from opposite sides. (Refer to Wiring Diagram 0F7822 in Part 7).

RESULTS:

1. Correct the wiring of Wires 11 and 44 through the Idle Control Transformer (ICT) per Wiring Diagram 0F7822.
2. If wiring checks good, replace the printed circuit board.

TEST 80 – CHECK LC1 & LC2 WIRING

PROCEDURE:

1. Set the AUTO-OFF-MANUAL switch (SW1) to OFF.
2. Set a voltmeter to measure resistance.
3. Disconnect the J1 Connector from the printed circuit board.
4. Connect one meter test lead to Wire LC1 (red) at the In-Line Connector (IC). Connect the other meter test lead to Pin Location J1-8 on the J1 Connector previously removed. Be careful not to damage the pin connectors with the test leads. CONTINUITY should be measured.
5. Connect one meter test lead to Wire LC2 (black) at the In-Line Connector (IC). Connect the other meter test lead to Pin Location J1-15 on the J1 Connector previously removed. Be careful not to damage the pin connectors with the test leads. CONTINUITY should be measured.

RESULTS:

1. Repair or replace defective wiring.
2. Refer back to Flow Chart.

PART 5 OPERATIONAL TESTS

Air-cooled, Automatic Standby Generators

TABLE OF CONTENTS	
PART	TITLE
5.1.	System Functional Tests

INTRODUCTION

Following home standby electric system installation and periodically thereafter, the system should be tested. Functional tests of the system include the following:

- Manual transfer switch operation.
- System voltage tests.
- Generator Tests Under Load.
- Testing automatic operation.

Before proceeding with functional tests, read instructions and information on tags or decals affixed to the generator and transfer switch. Perform all tests in the exact order given in this section.

MANUAL TRANSFER SWITCH OPERATION

“W/V-TYPE” TRANSFER SWITCHES:

1. On the generator panel, set the AUTO-OFF-MANUAL switch to OFF.
2. Turn OFF the utility power supply to the transfer switch using whatever means provided (such as a “Utility” main line circuit breaker).
3. Set the generator main line circuit breaker to OFF (or open).



DANGER: BE SURE TO TURN OFF ALL POWER VOLTAGE SUPPLIES TO THE TRANSFER SWITCH BEFORE ATTEMPTING MANUAL OPERATION. FAILURE TO TURN OFF POWER VOLTAGE SUPPLIES TO THE TRANSFER SWITCH MAY RESULT

IN DANGEROUS AND POSSIBLY LETHAL ELECTRICAL SHOCK.

4. Remove the manual transfer handle from the enclosure.
5. Place open end of the manual transfer handle over transfer switch operating lever.
6. To connect LOAD terminal lugs to the utility power source, move the handle upward.
7. To connect LOAD terminals to the standby power source, move the handle downward.
8. Actuate the switch to UTILITY and to MANUAL several times. Make sure no evidence of binding or interference is felt.
9. When satisfied that manual transfer switch operation is correct, actuate the main contacts to their UTILITY position (Load connected to the utility power supply).

ELECTRICAL CHECKS

Complete electrical checks as follows:

1. Set the generator main circuit breaker to its OFF (or open) position.
2. Set the generator AUTO-OFF-MANUAL switch to the OFF position.
3. Turn off all loads connected to the transfer switch Terminals T1 and T2.
4. Turn on the utility power supply to the transfer switch using the means provided (such as a utility main line circuit breaker).

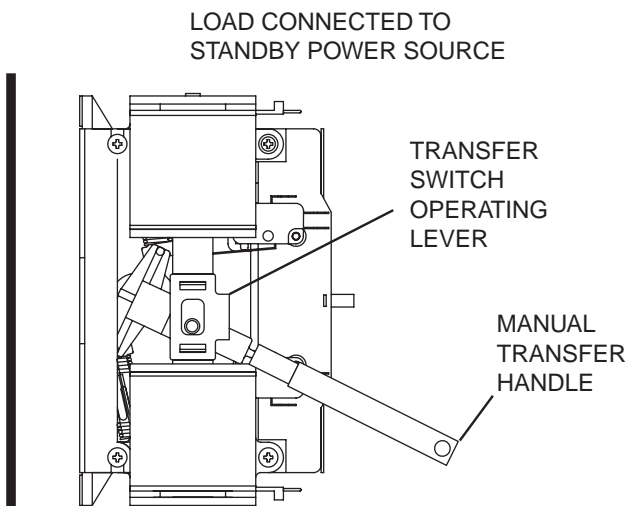
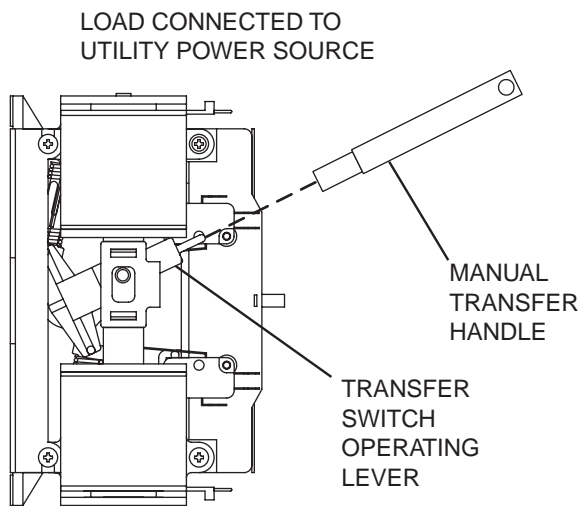

Figure 1. Manual Operation “V-Type” Switch

**DANGER**

THE TRANSFER SWITCH IS NOW ELECTRICALLY “HOT”, CONTACT WITH “HOT” PARTS WILL RESULT IN EXTREMELY HAZARDOUS AND POSSIBLY FATAL ELECTRICAL SHOCK. PROCEED WITH CAUTION.

5. Use an accurate AC voltmeter to check utility power source voltage across transfer switch Terminals N1 and N2. Nominal line-to-line voltage should be 240 volts AC.
6. Check utility power source voltage across Terminals N1 and the transfer switch neutral lug; then across Terminal N2 and neutral. Nominal line-to-neutral voltage should be 120 volts AC.
7. When certain that utility supply voltage is compatible with transfer switch and load circuit ratings, turn off the utility power supply to the transfer switch.
8. On the generator panel, set the AUTO-OFF-MANUAL switch to MANUAL. The engine should crank and start.
9. Let the engine warm up for about five minutes to allow internal temperatures to stabilize. Then, set the generator main circuit breaker to its “ON” (or closed) position.

**DANGER**

PROCEED WITH CAUTION! GENERATOR POWER VOLTAGE IS NOW SUPPLIED TO THE TRANSFER SWITCH. CONTACT WITH LIVE TRANSFER SWITCH PARTS WILL RESULT IN DANGEROUS AND POSSIBLY FATAL ELECTRICAL SHOCK.

10. Connect an accurate AC voltmeter and a frequency meter across transfer switch Terminal Lugs E1 and E2. Voltage should be 242-252 volts; frequency should read about 61-63 Hertz (6/7 kW units) and about 59 Hertz on 9/10/13/16/18 kW units..
11. Connect the AC voltmeter test leads across Terminal Lug E1 and neutral; then across E2 and neutral. In both cases, voltage reading should be 121-126 volts AC.
12. Set the generator main circuit breaker to its OFF (or open) position. Let the engine run at no-load for a few minutes to stabilize internal engine generator temperatures.
13. Set the generator AUTO-OFF-MANUAL switch to OFF. The engine should shut down.

NOTE: It is important that you do not proceed until you are certain that generator AC voltage and frequency are correct and within the stated limits. Generally, if both AC frequency and voltage are

high or low, the engine governor requires adjustment. If frequency is correct, but voltage is high or low, the generator voltage regulator requires adjustment.

GENERATOR TESTS UNDER LOAD

To test the generator set with electrical loads applied, proceed as follows:

1. Set generator main circuit breaker to its OFF (or open) position.
2. Turn OFF all loads connected to the Transfer Switch Terminals T1 and T2.
3. Set the generator AUTO-OFF-MANUAL switch to OFF.
4. Turn off the utility power supply to the transfer switch, using the means provided (such as a utility main line circuit breaker).

**WARNING**

DO NOT ATTEMPT MANUAL TRANSFER SWITCH OPERATION UNTIL ALL POWER VOLTAGE SUPPLIES TO THE TRANSFER SWITCH HAVE BEEN POSITIVELY TURNED OFF. FAILURE TO TURN OFF ALL POWER VOLTAGE SUPPLIES WILL RESULT IN EXTREMELY HAZARDOUS AND POSSIBLY FATAL ELECTRICAL SHOCK.

5. Manually set the transfer switch to the STANDBY position, i.e., load terminals connected to the generator E1/ E2 terminals. The transfer switch operating lever should be down.
6. Set the generator AUTO-OFF-MANUAL switch to MANUAL. The engine should crank and start immediately.
7. Let the engine stabilize and warm up for a few minutes.
8. Set the generator main circuit breaker to its ON (or closed) position. Loads are now powered by the standby generator.
9. Turn ON electrical loads connected to transfer switch T1 and T2. Apply an electrical load equal to the full rated wattage/ampere capacity of the installed generator.
10. Connect an accurate AC voltmeter and a frequency meter across Terminal Lugs E1 and E2. Voltage should be greater than 230 volts; frequency should be greater than 58 Hertz on 6/7 kW units and less than 62 Hertz on 9/10/13/16/18 kW units..
11. Let the generator run at full rated load for 20-30 minutes. Listen for unusual noises, vibration or other indications

of abnormal operation. Check for oil leaks, evidence of overheating, etc.

12. When testing under load is complete, turn off electrical loads.
13. Set the generator main circuit breaker to its OFF (or open) position.
14. Let the engine run at no-load for a few minutes.
15. Set the AUTO-OFF-MANUAL switch to OFF. The engine should shut down.

CHECKING AUTOMATIC OPERATION

To check the system for proper automatic operation, proceed as follows:

1. Set generator main circuit breaker to its OFF (or open) position.
2. Check that the AUTO-OFF-MANUAL switch is set to OFF.
3. Turn off the utility power supply to the transfer switch, using means provided (such as a utility main line circuit breaker).
4. Manually set the transfer switch to the UTILITY position, i.e., load terminals connected to the utility power source side.
5. Turn on the utility power supply to the transfer switch, using the means provided (such as a utility main line circuit breaker).
6. Set the AUTO-OFF-MANUAL switch to AUTO. The system is now ready for automatic operation.
7. Turn off the utility power supply to the transfer switch.

With the AUTO-OFF-MANUAL switch at AUTO, the engine should crank and start when the utility source power is turned off. After starting, the transfer switch should connect load circuits to the standby side. Let the system go through its entire automatic sequence of operation.

With the generator running and loads powered by generator AC output, turn ON the utility power supply to the transfer switch. The following should occur:

- After about fifteen seconds, the switch should transfer loads back to the utility power source.
- About one minute after retransfer, the engine should shut down.

SETTING THE EXERCISE TIMER

Your generator is equipped with an exercise timer. Once it is set, the generator will start and exercise once every seven days, on the day of the week and at the time of day you complete the following sequence. During this exercise period, the unit runs for approximately 12 minutes and then shuts down. Transfer of loads to the generator output does not occur during the exercise cycle unless utility power is lost.

A switch on the control panel (see Figure 1, Section 1.6) allows you to select the day and time for system exercise. To select the desired day and time of day, you must perform the following sequence at that time.

1. Verify that the AUTO-OFF-MANUAL switch is set to AUTO.
2. Hold down the set exercise time switch for several seconds and then release. All of the red LEDs will flash for approximately 10 seconds and then stop.
3. The generator will start and run for approximately 12 minutes and then shut down on its own. The exerciser will then be set to run at that time of day every week.

NOTE: The exerciser will only work in the AUTO mode and will not work unless this procedure is performed. The exerciser will need to be reset every time the 12 volt battery is disconnected and then reconnected.

PART 6 DISASSEMBLY

Air-cooled, Automatic Standby Generators

TABLE OF CONTENTS	
PART	TITLE
6.1.	Major Disassembly
6.2	Torque Specifications

MAJOR DISASSEMBLY

STATOR/ROTOR/ENGINE REMOVAL:

For stator removal, follow Steps 1-14. For rotor removal, follow Steps 1-15. For Engine removal follow Steps 1-16.

1. Remove door.
2. Set the AUTO-OFF-MANUAL switch to OFF. Disconnect battery cables. Remove Fuse F1. Remove the utility power source to the generator. Turn off fuel supply to the generator.
3. **Remove Control Panel Cover:** Using a 10 mm socket, remove the control panel cover. Remove two nuts located on back panel using a 7mm socket. Remove two control panel screws.
4. **Disconnect Stator Leads/Connectors:** Remove the stator leads (Wire 11 and Wire 44) from the main circuit breaker (on 9/10/13/16/18 kW units remove Wires 11 and 44 from the Idle Control Transformer also). Remove the stator leads (Wire 22 and Wire 33) from the neutral lug. Unplug C1, C2 and C3 connectors from the control panel. For control panel removal only, remove Wires N1/ N2 and Wires 23/194 from the terminal strip, and the ground and neutral wires from the control panel.
5. **Disconnect Fuel Hoses:** Remove the two fuel hoses at the air box assembly. Some models are equipped with an additional third fuel hose. Remove it also if equipped. Pull hoses back into the battery compartment. For control panel removal only remove Wire Nos. 0 and 14 from the fuel solenoid.
6. **Remove Front and Back Exhaust Enclosure Covers:** Using a 10mm socket, remove the six bolts and four nuts from the exhaust covers. Remove the covers. Remove the nut and bolt attaching to the roof left side folding support and bottom support bracket.

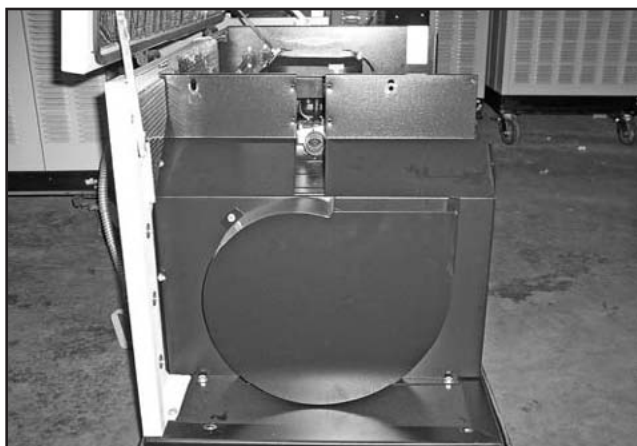

Figure 1. Exhaust Side Enclosure Removed

7. **Remove Muffler:** Using a 10mm socket remove the eight bolts from the flex cover. Loosen the muffler pipe clamp closest to the engine exhaust manifold. Loosen the exhaust clamp and remove the tailpipe. Remove four bolts from the bracket for muffler access located in the center of the alternator divider panel. Using a 13mm socket remove two muffler nuts and remove two bolts that mount the muffler. Pull back on the muffler flex pipe and remove the muffler assembly. Using a 10mm socket remove four bolts from the flex base and remove flex base.
8. **Remove Exhaust Side Enclosure:** Using a 13mm socket remove the three bottom base enclosure bolts. Using a 10mm socket remove three side enclosure mounting bolts. Remove enclosure.
9. **Remove fan housing cover:** Using a 10mm socket remove four 10mm bolts from the cover. Remove the fan housing cover.
10. **Remove Rotor Bolt:** Using a 9/16" socket, remove one rotor bolt.
11. **Remove Fan:** Attach a steering wheel puller to the fan using two M8 x 1.25 bolts. Remove the fan from the rotor.
12. **Remove Alternator Divider Panel:** Using a 10mm socket remove two side panel nuts. Using a 13mm socket remove two bottom base bolts. Remove the panel.

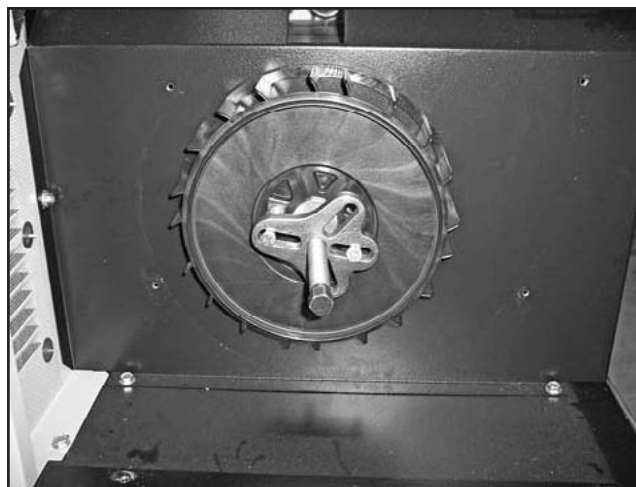

Figure 2. Using a Steering Wheel Puller to Remove Fan From Rotor

13. **Stator Removal:** Using a 13mm socket, remove the two nuts from the alternator mounting bracket/rubber mounts. Lift the back end of the alternator up and place a 2"x 4" piece of wood under the engine adapter.

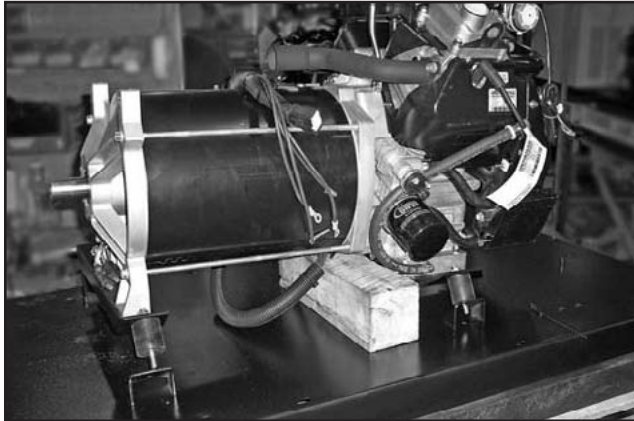

Figure 3. Engine Adapter Supported by Piece of Wood

Using a 1/4" socket, remove Wire 0 and Wire 4 from the brush assembly. Remove the two brush assembly hold down bolts. Remove the brushes.

Using a 13mm socket, remove the four stator hold down bolts. Using a small rubber mallet remove the rear bearing carrier. Remove the stator.

14. **Rotor Removal:** Cut 2.5 inches from the rotor bolt. Slot the end of the bolt to suit a flat blade screwdriver. Slide the rotor bolt back through the rotor and use a screwdriver to screw it into the crankshaft. Use a 3" M12x1.75 bolt to screw into rotor. Apply torque to the 3" M12x1.75 bolt until taper breaks. If necessary, when torque is applied to 3" M12x1.75 bolt, use a rubber mallet on the end of the rotor shaft to break taper.



Figure 4. Rear Bearing Carrier Removed



Figure 5. Removing the Stator

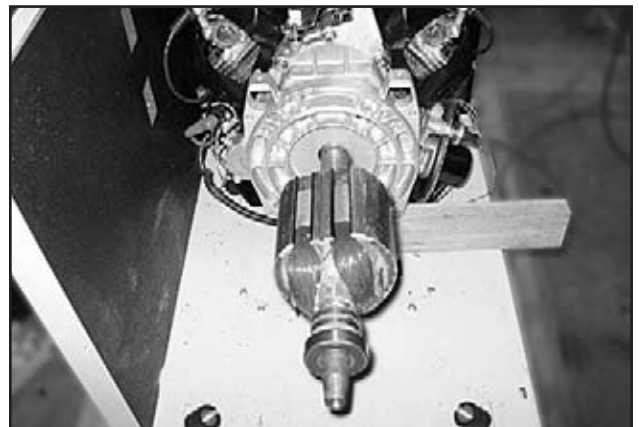

Figure 6. Removing the Rotor

15. **Remove Engine:** Using a 13mm socket, remove the two engine mount nuts, and ground wires. Remove the engine.

16. Reverse the previous steps to re-assemble.

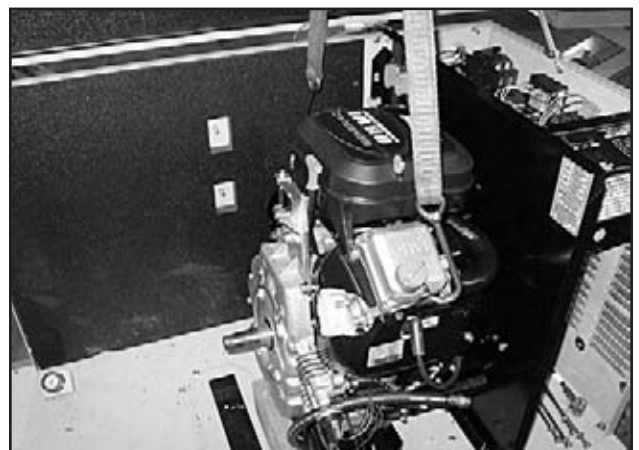

Figure 7. Removing the Engine

FRONT ENGINE ACCESS

1. Follow Stator/Rotor/Engine removal procedures, Steps 1-5.
2. **Control Panel Removal:** Using a 7mm socket remove the four bolts from male C1 and C2 connectors. Remove connectors from engine divider panel.

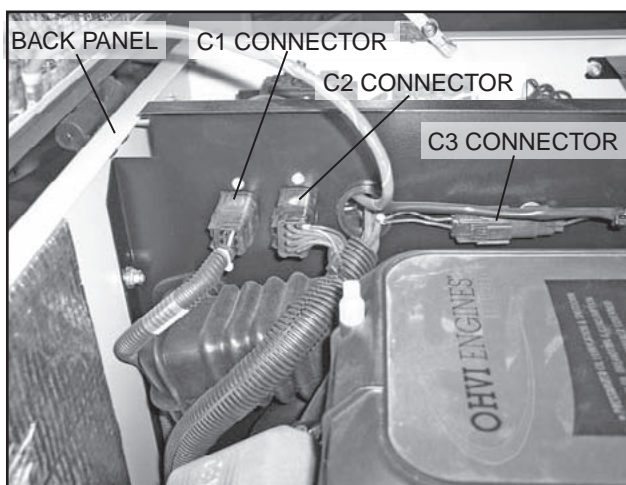

Figure 9. C1 and C2 Connectors Located on the Engine Divider Panel

Using a 10mm socket, remove the six (6) nuts attaching the control panel to the side/back enclosure and the engine divider panel. Remove the two (2) nuts connected to the back enclosure located on the top side of control panel. Remove the two (2) nuts located underneath the middle of the control panel, connecting to the back/side enclosure and the engine divider panel. Remove the two (2) nuts from the front top side of the control panel, connecting to the back/side enclosure and the engine divider panel. Remove the control panel.

3. **Remove Engine Divider Panel:** Using a 10mm socket, remove the two (2) nuts attached to the back enclosure. Remove the two bolts attached to the base enclosure. Remove the engine divider panel.

4. **Remove Intake manifolds:** Using a 6mm allen wrench, remove the four (4) socket head cap screws from the intake manifolds. Remove the intake manifolds. Remove the air intake snorkel.
5. **Remove Air Box:** Using a 5/32" allen wrench, remove the four (4) air box allen head shoulder bolts. While removing the air box remove the four rubber washers and disconnect the throttle linkage and anti-lash spring.
6. **Unbolt Oil Cooler:** Using a 10mm socket, remove the four (4) oil cooler bolts.
7. **Remove Blower Housing:** Using an 8mm socket, remove the nine (9) bolts around the blower housing. Remove the blower housing.
8. **Remove flywheel:** Use a 36mm socket, a steering wheel puller, two (2) M8x1.25 bolts and a 13 mm socket. Remove the flywheel hex nut, remove the fan plate and fan. Install the puller using the M8x1.25 bolts and remove the flywheel.

TORQUE REQUIREMENTS
(UNLESS OTHERWISE SPECIFIED)

FLYWHEEL NUT	50 ft-lbs
STATOR BOLTS	6 ft-lbs
ROTOR BOLT	30 ft-lbs
ENGINE ADAPTER	25 ft-lbs
EXHAUST MANIFOLD	18 ft-lbs
INTAKE MANIFOLD (TO CYLINDER HEAD)	22 ft-lbs
M5-0.8 TAPTITE SCREW INTO ALUMINUM	25-50 in-lbs
M5-0.8 TAPTITE SCREW INTO PIERCED HOLE ...	25-50 in-lbs
M6-1.0 TAPTITE SCREW INTO ALUMINUM	50-96 in-lbs
M6-1.0 TAPTITE SCREW INTO PIERCED HOLE ...	50-96 in-lbs
M6-1.0 TAPTITE SCREW INTO WELDNUT	50-96 in-lbs
M8-1.25 TAPTITE SCREW INTO ALUMINUM	12-18 ft-lbs
M6-1.0 NYLOK NUT ONTO STUD	16-65 in-lbs

Note: torques are dynamic values with ±10% tolerance unless otherwise noted.

**PART 7
ELECTRICAL
DATA**

**Air-cooled, Automatic
Standby Generators**

TABLE OF CONTENTS	
DWG#	TITLE
0F7820	WIRING DIAGRAM, 6/7 KW HSB
0F7821	SCHEMATIC, 6/7 KW HSB
0F7822	WIRING DIAGRAM, 9/10/12/16/18 KW HSB
0F7823	SCHEMATIC, 9/10/12/16/18 KW HSB
0F9070	WIRING DIAGRAM 9/10/12/16/18 CIRCUIT TRANSFER SWITCH
0F9775	SCHEMATIC 9/10/12/16/18 CIRCUIT TRANSFER SWITCH
0F9994	Wiring Diagram 100/200/400 Service Entrance

DRAWING #0F7820-A

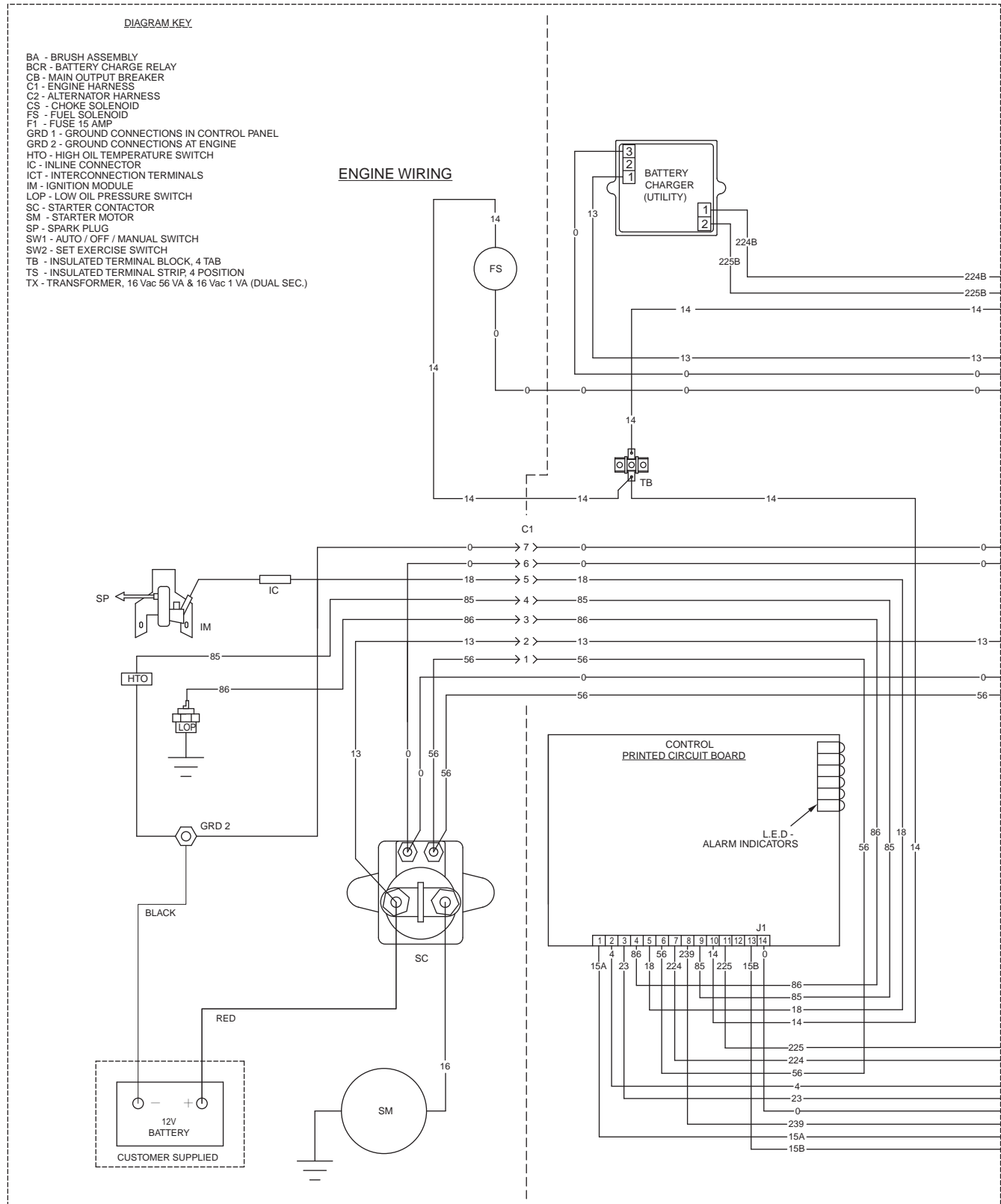

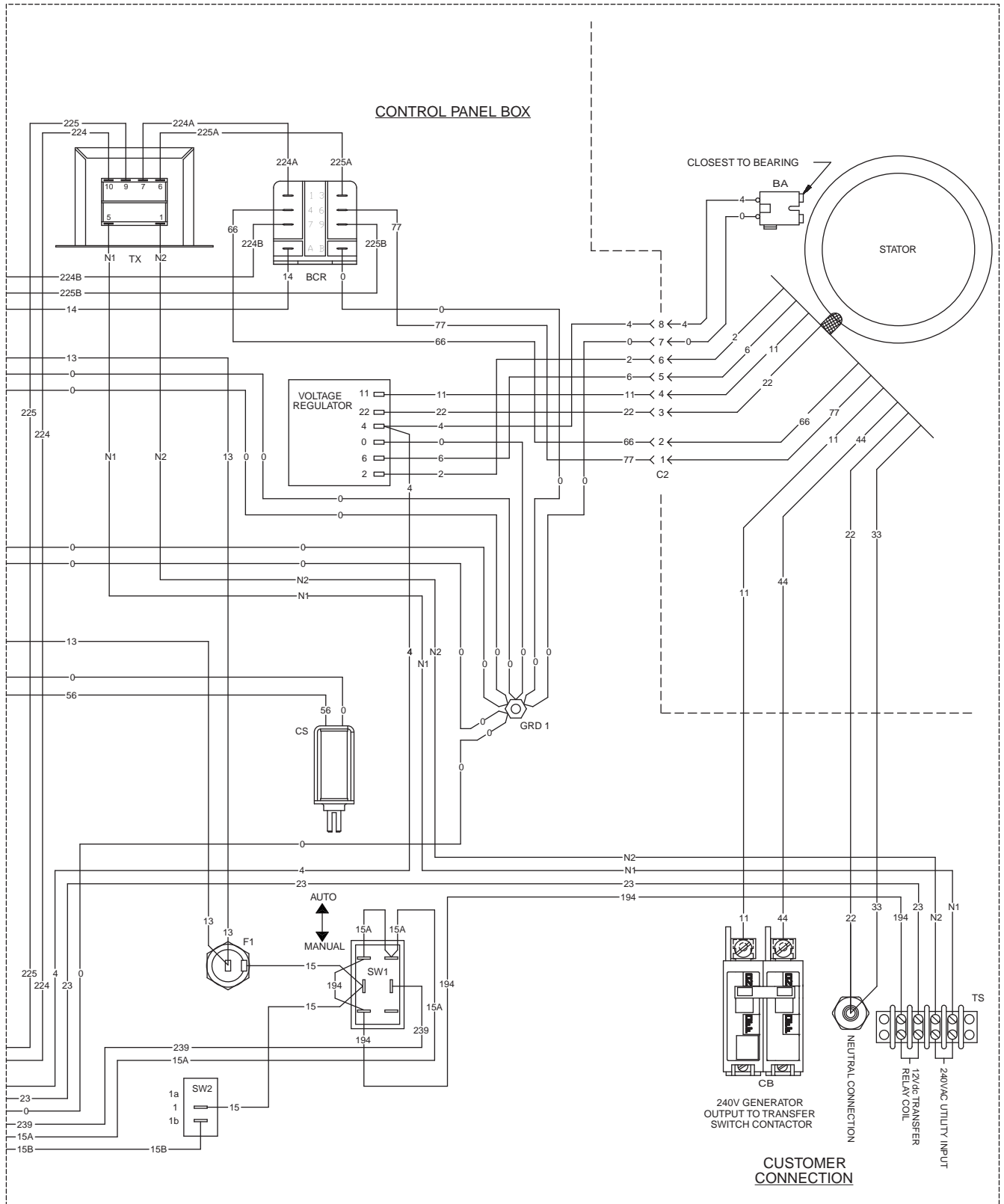

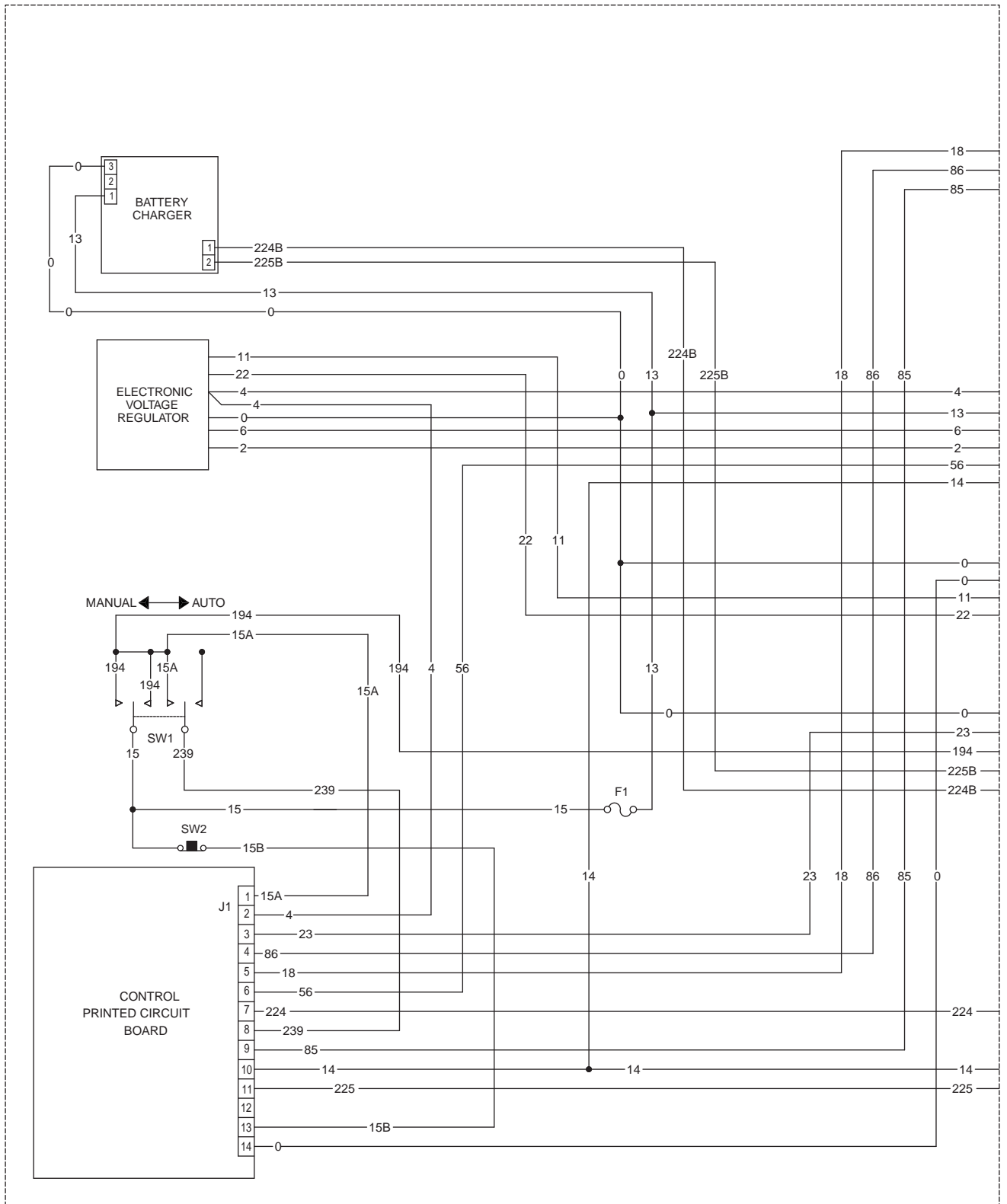

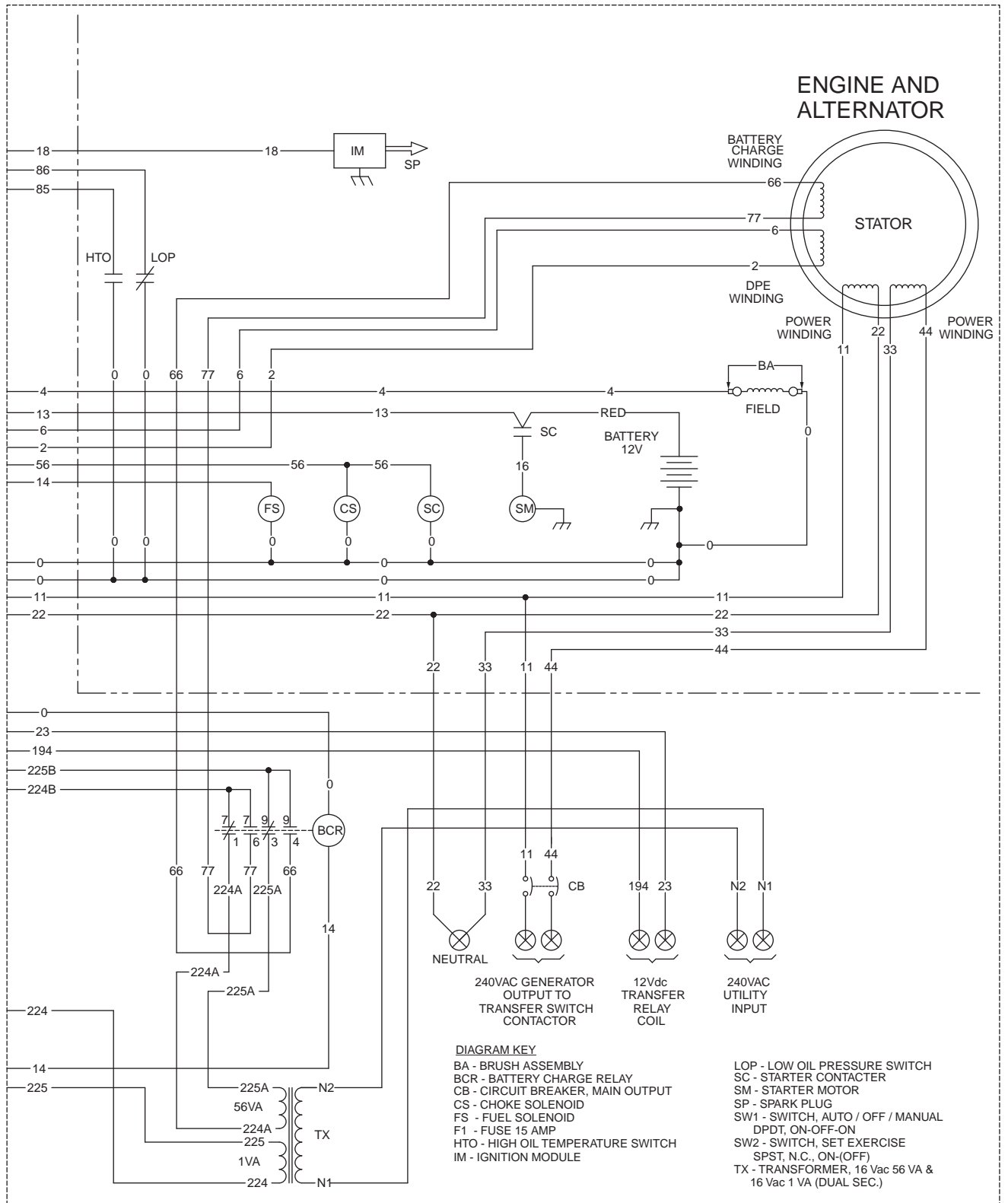

DRAWING #0F7822-A

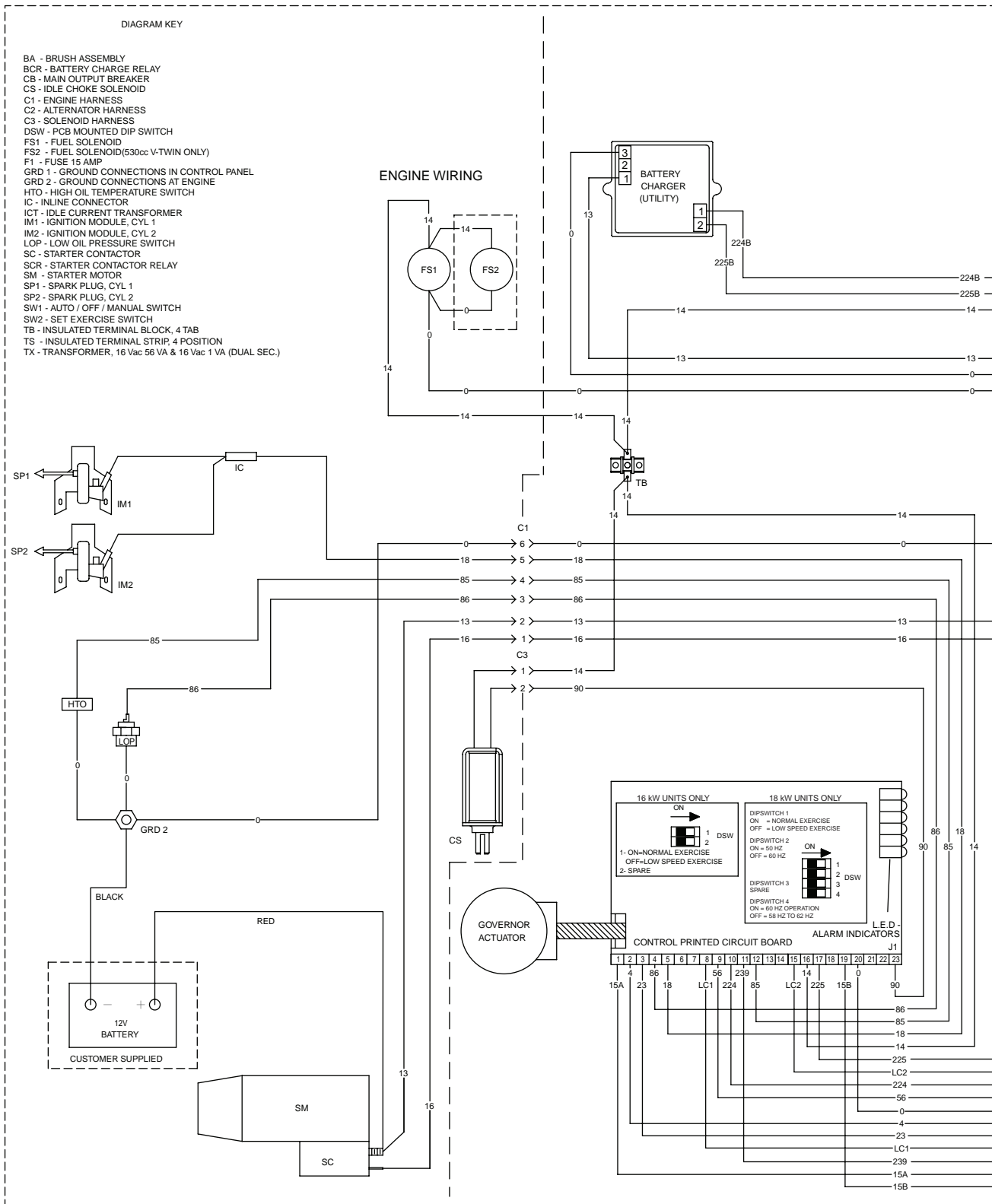

DRAWING #0F7823-A

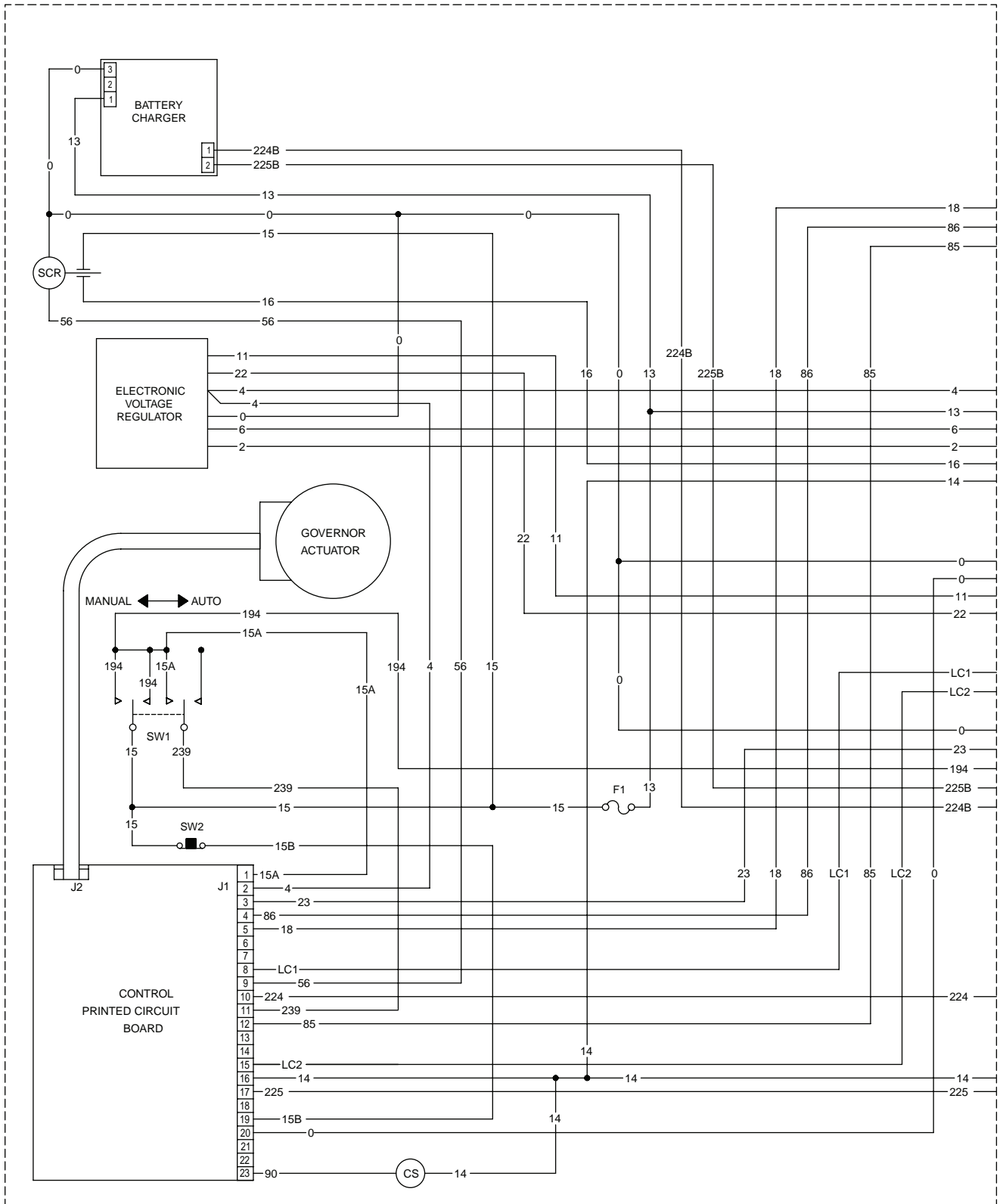

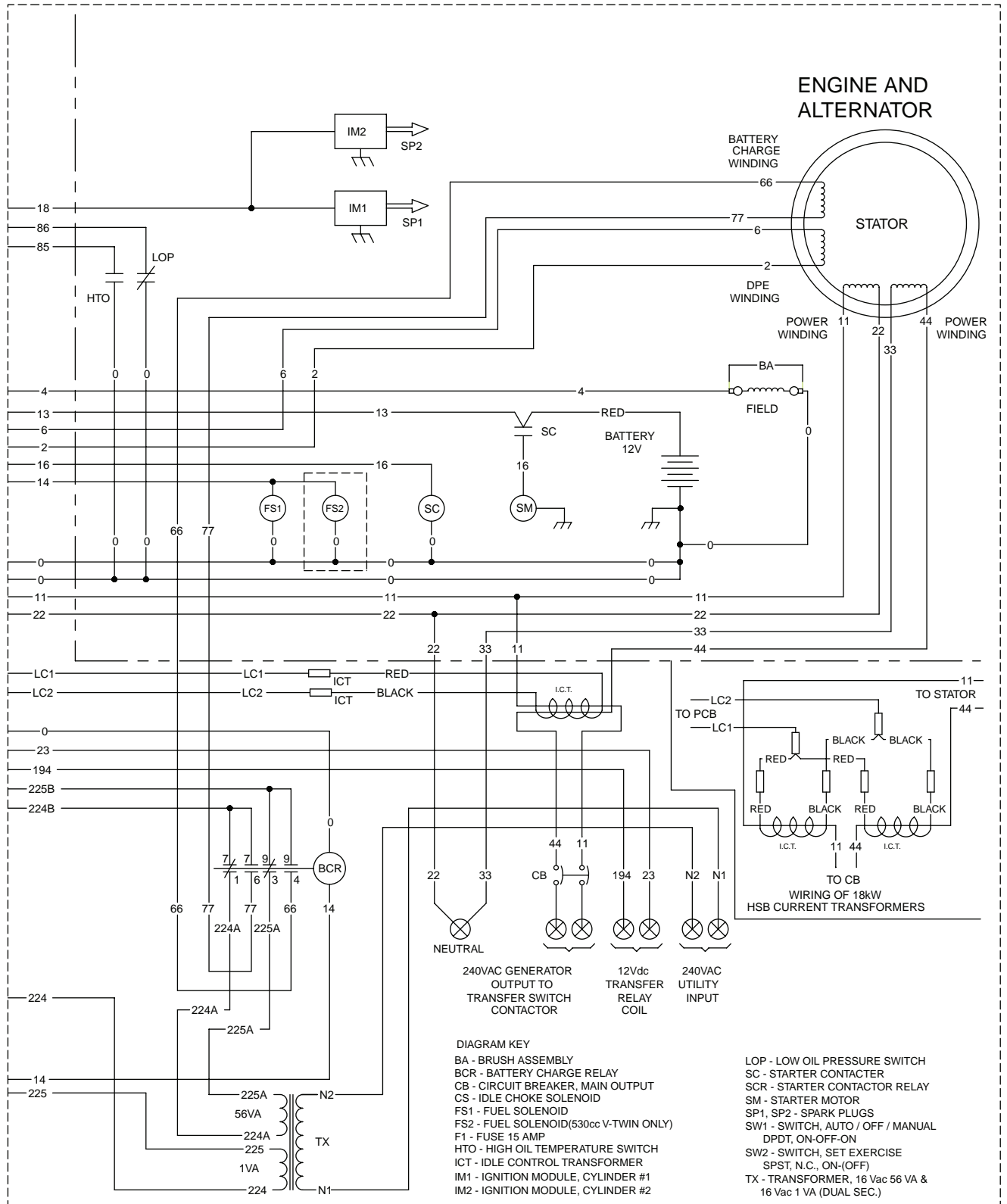

**WIRING DIAGRAM, HOME STANDBY
TRANSFER SWITCH, 10 THRU 16 CIRCUIT**

PART 7

ELECTRICAL DATA

DRAWING #0F9070-A

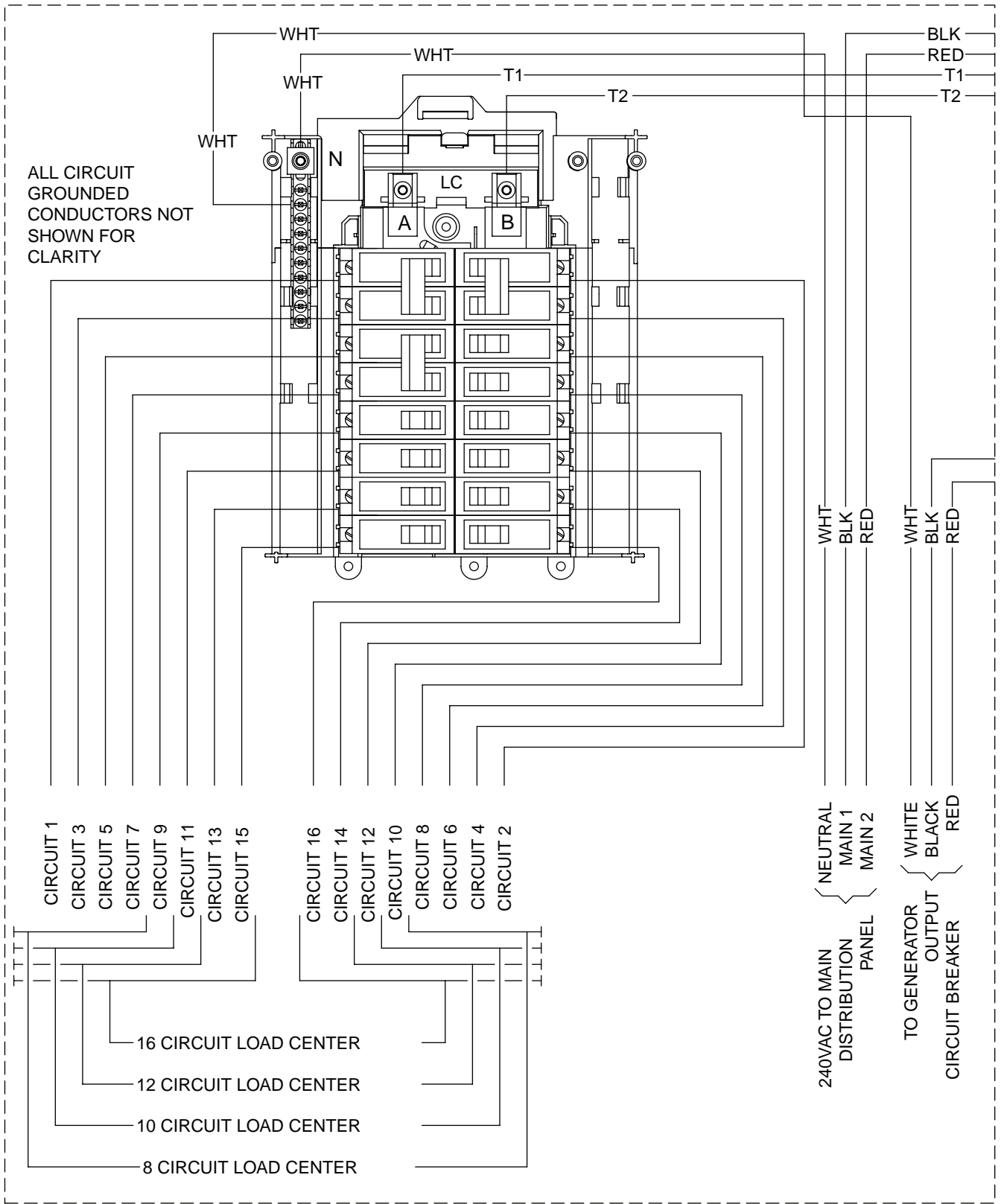

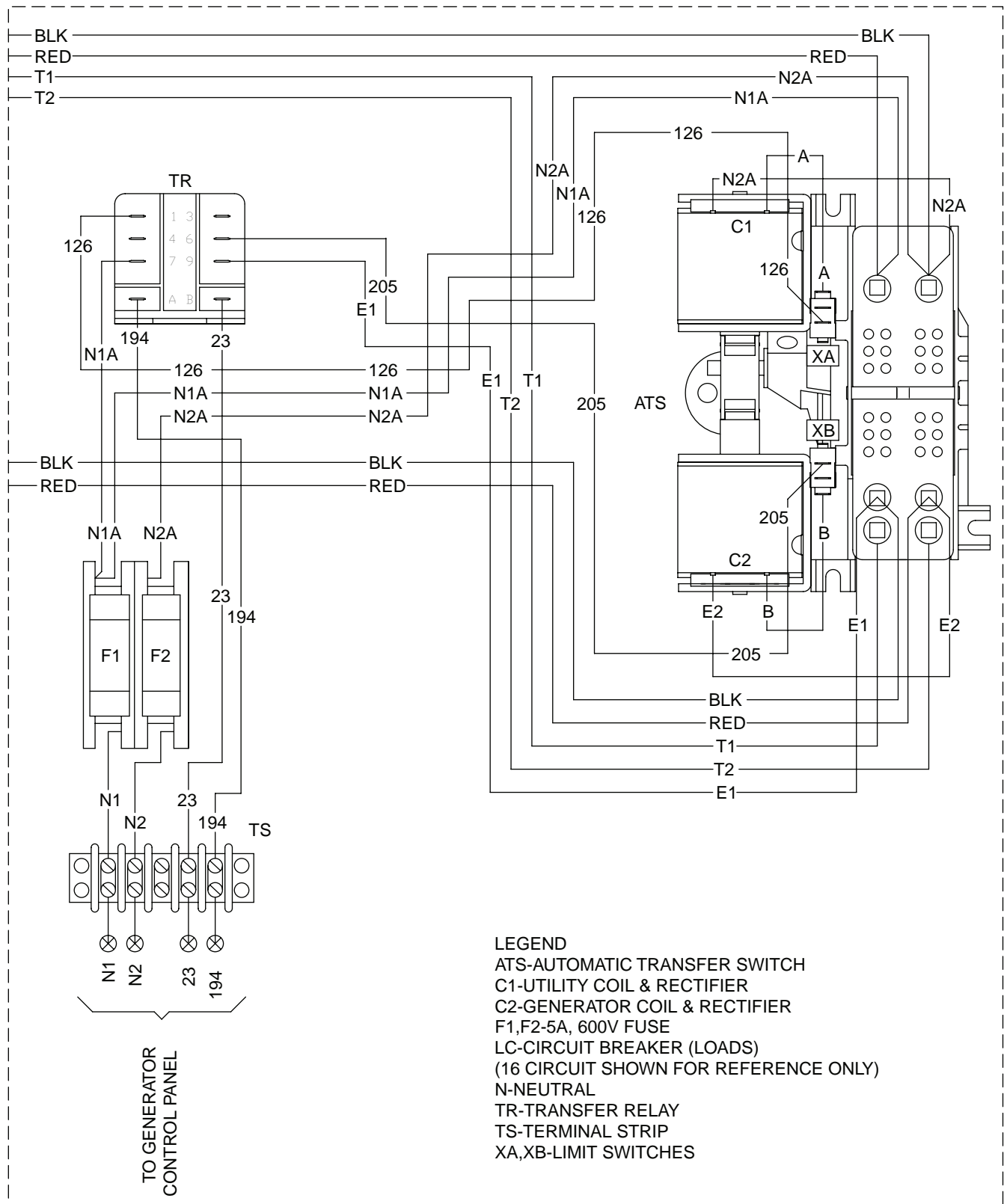

SCHEMATIC, HOME STANDBY TRANSFER SWITCH, 10 THRU 16 CIRCUIT

PART 7

ELECTRICAL DATA

DRAWING #0F9775

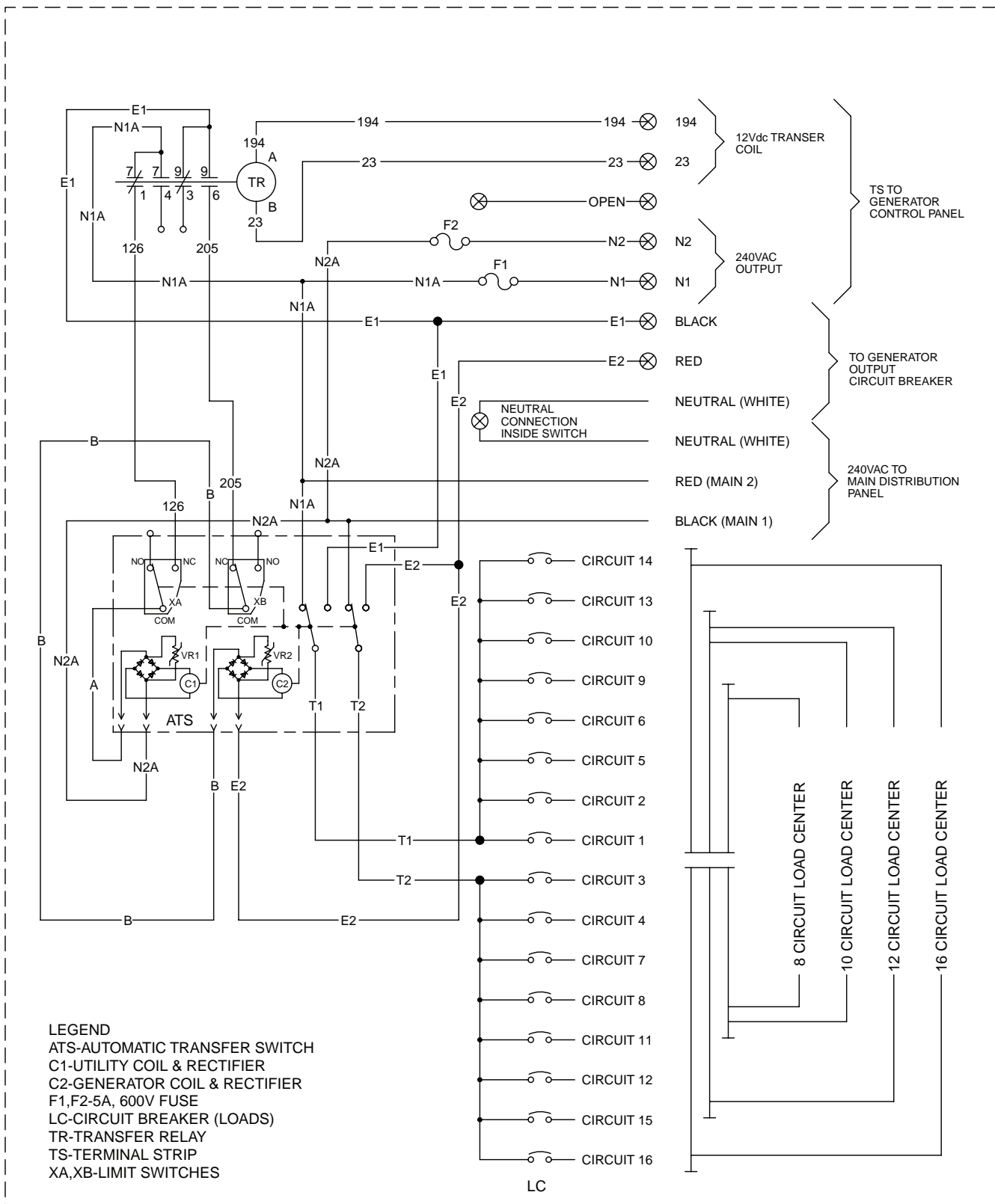

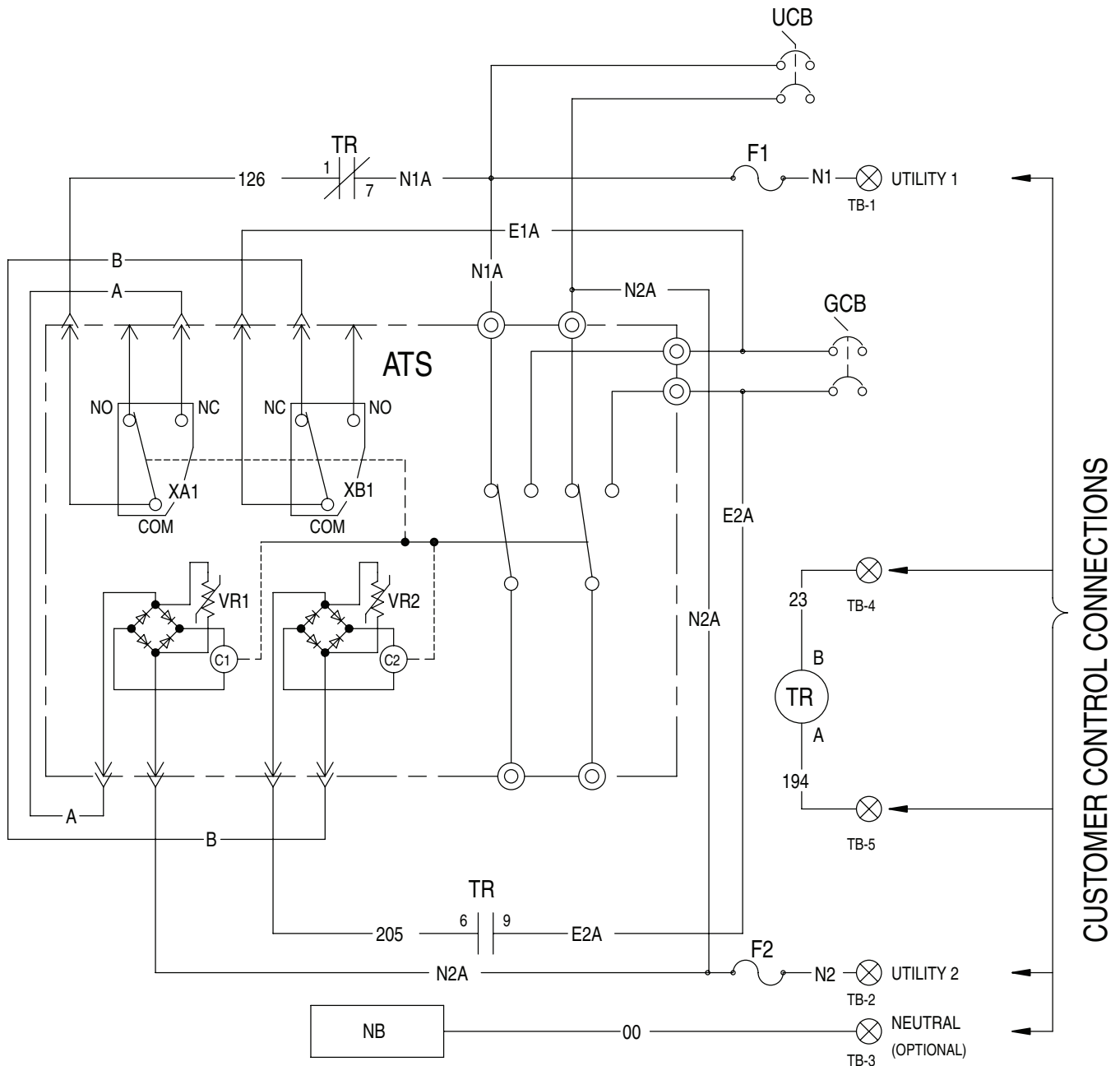

NOTE:
ALL CONTACTS SHOWN WITH
TRANSFER SWITCH IN UTILITY
POSITION.

LEGEND	
ATS	TRANSFER SWITCH CONTACTOR
C1	SOLENOID COIL (UTILITY CLOSING)
C2	SOLENOID COIL (STANDBY CLOSING)
F1,F2	FUSE, 5A
GCB	GENERATOR CIRCUIT BREAKER
NB	NB - NEUTRAL BLOCK
TB	TERMINAL STRIP (CUSTOMER CONNECTION)
TR	RELAY, TRANSFER
UCB	UTILITY CIRCUIT BREAKER
VR1,VR2	VARISTOR
XA1,XB1	LIMIT SWITCHES, ACTUATOR

**WIRING DIAGRAM, HOME STANDBY
100/200/400 SERVICE ENTRANCE**

PART 7

ELECTRICAL DATA

DRAWING #0F9994 PAGE 2 OF 2

