

**DIAGNOSTIC
REPAIR
MANUAL**

GENERAC®
POWER SYSTEMS, INC.

Air-Cooled Product



MODELS:

7 KW NG, 8 KW LP
9 KW NG, 10 KW LP
13 KW NG, 14 KW LP
16 KW NG, 17 KW LP
18 KW NG, 20 KW LP

AUTOMATIC STANDBY GENERATORS

ELECTRICAL FORMULAS

TO FIND	KNOWN VALUES	1-PHASE	3-PHASE
KILOWATTS (kW)	Volts, Current, Power Factor	$\frac{E \times I}{1000}$	$\frac{E \times I \times 1.73 \times PF}{1000}$
KVA	Volts, Current	$\frac{E \times I}{1000}$	$\frac{E \times I \times 1.73}{1000}$
AMPERES	kW, Volts, Power Factor	$\frac{kW \times 1000}{E}$	$\frac{kW \times 1000}{E \times 1.73 \times PF}$
WATTS	Volts, Amps, Power Factor	Volts x Amps	$E \times I \times 1.73 \times PF$
NO. OF ROTOR POLES	Frequency, RPM	$\frac{2 \times 60 \times \text{Frequency}}{\text{RPM}}$	$\frac{2 \times 60 \times \text{Frequency}}{\text{RPM}}$
FREQUENCY	RPM, No. of Rotor Poles	$\frac{\text{RPM} \times \text{Poles}}{2 \times 60}$	$\frac{\text{RPM} \times \text{Poles}}{2 \times 60}$
RPM	Frequency, No. of Rotor Poles	$\frac{2 \times 60 \times \text{Frequency}}{\text{Rotor Poles}}$	$\frac{2 \times 60 \times \text{Frequency}}{\text{Rotor Poles}}$
kW (required for Motor)	Motor Horsepower, Efficiency	$\frac{HP \times 0.746}{\text{Efficiency}}$	$\frac{HP \times 0.746}{\text{Efficiency}}$
RESISTANCE	Volts, Amperes	$\frac{E}{I}$	$\frac{E}{I}$
VOLTS	Ohm, Amperes	$I \times R$	$I \times R$
AMPERES	Ohms, Volts	$\frac{E}{R}$	$\frac{E}{R}$

E = VOLTS

I = AMPERES

R = RESISTANCE (OHMS)

PF = POWER FACTOR

Contents

Specifications	4	1.6 Engine-Generator Protective Devices	25
Generator	4	General	25
Engine	5	Low Battery	25
Fuel Consumption	5	Low Oil Pressure Shutdown.....	25
Mounting Dimensions.....	6	High Temperature Switch.....	25
Mounting Dimensions.....	7	Overspeed Shutdown	25
Major Features	8	Rpm Sensor Failure	25
PART 1 - GENERAL INFORMATION	9	Overcrank Shutdown	26
1.1 Generator Identification	10	1.7 Operating Instructions	27
Introduction	10	Control Panel	27
1.2 Installation Basics.....	11	To Select Automatic Operation	28
Introduction	11	Manual Transfer To “Standby”	
Selecting A Location	11	and Manual Startup	28
Grounding The Generator.....	11	Manual Shutdown And	
The Fuel Supply.....	11	Retransfer Back To “Utility”	28
The Transfer Switch / Load Center.....	11	1.8 Automatic Operating Parameters	29
Power Source And Load Lines.....	13	Introduction	29
System Control Interconnections	13	Automatic Operating Sequences	29
Natural Gas Fuel Interconnections	13	PART 2 - AC GENERATORS	31
1.3 Non-prepackaged Interconnections	14	2.1 Description and Components	32
Connect a Pre-2008 Load Center Switch		Introduction	32
To a Current or Future		Engine-Generator Drive System	32
Air-Cooled Generator.....	14	The AC Generator.....	32
Connect a 2008 And Later Load Center		Rotor Assembly.....	32
Switch to a Pre-2008		Stator Assembly.....	33
Air-Cooled Generator.....	15	Brush Holder And Brushes (12-20 kW)	34
1.4 Preparation Before Use	16	Other AC Generator Components	34
General	16	2.2 Operational Analysis	35
Fuel Requirements.....	16	Rotor Residual Magnetism.....	35
Fuel Consumption.....	16	Field Boost (12-20 kW)	35
Reconfiguring The Fuel System.....	16	Operation (8/10 kW).....	36
Engine Oil Recommendations	18	Operation (12-20 kW)	36
1.5 Testing, Cleaning and Drying.....	19	2.3 Troubleshooting Flowcharts.....	37
Meters	19	Problem 1 – Generator Produces Zero	
The Vom.....	19	Voltage or Residual Voltage (12-20 kW)...	37-38
Measuring AC Voltage	19	Problem 2 – Generator Produces Zero	
Measuring DC Voltage	19	Voltage or Residual Voltage (8/10 kW)	38
Measuring AC Frequency	19	Problem 3 – Generator Produces	
Measuring Current.....	20	Low Voltage at No-Load.....	39
Measuring Resistance	20	Problem 4 – Generator Produces	
Electrical Units	21	High Voltage at No-Load.....	39
Ohm’s Law	21	Problem 5 – Voltage and Frequency Drop	
Visual Inspection.....	22	Excessively When Loads are Applied.....	40
Insulation Resistance.....	22	2.4 Diagnostic Tests	41
The Megohmmeter.....	22	Introduction	41
Stator Insulation Resistance Test (12-20 kW)	23	Safety	41
Stator Insulation Resistance Test (8-10 kW)	23	Test 1 – Check Main Circuit Breaker.....	41
Rotor Insulation Resistance Test (8-10 kW)	24	Test 2 – Check AC Output Voltage.....	41
Rotor Insulation Resistance Test (12-20 kW)	24	Test 4 – Fixed Excitation Test/Rotor	
Cleaning The Generator.....	24	Amp Draw Test	42
Drying The Generator	24	Test 5 – Wire Continuity (12-20 kW)	43
		Test 6 – Check Field Boost (12-20 kW)	44

Test 7 – Testing The Stator With A Vom (12-20 kW).....	44	Problem 11 – No Battery Charge (Pre-Packed Load Center)	73
Test 8 – Test Brushless Stator.....	45	Problem 12 – No Battery Charge (RTSN & RTSE Transfer Switch)	73
Test 9 – Check Capacitor.....	46	Problem 13 – No Battery Charge (Gen-Ready Load Center)	73
Test 10 – Test DPE Winding on Brushless units	47	Problem 14 – No Battery Charge (Load Shed Transfer Switch).....	73
Test 11 – Resistance Check Of Rotor Circuit (12-20 kW).....	48	3.4 Diagnostic Tests	74
Test 12 – Check Brushes And Slip Rings (12-20 kW).....	48	General	74
Test 13 – Test Rotor Assembly(12-20 kW)	49	Test 26 – Check Voltage at Terminal Lugs E1, E2	74
Test 14 – Check AC Output Frequency.....	49	Test 27 – Check Manual Transfer Switch Operation.....	75
Test 15 – Check and Adjust Engine Governor (Single Cylinder Units).....	49	Test 28 – Check 23 And 15B Wiring/Connections	76
Test 16 – Check Stepper Motor Control (V-twin Engine Units).....	50	Test 29 – Test Transfer Relay TR.....	77
Test 17 – Check And Adjust Voltage Regulator (12-20 kW).....	51	Test 30 – Standby Control Circuit	78
Test 18 – Check Voltage And Frequency Under Load.....	52	Test 31 – Check Wire 23	78
Test 19 – Check For Overload Condition.....	52	Test 32 – Utility Control Circuit.....	80
Test 20 – Check Engine Condition.....	52	Test 33 – Test Limit Switch SW2 and SW3	82
Test 21 – Field Flash Alternator (8-10 kW)	52	Test 34 – Check Fuses F1 and F2	82
PART 3 - TRANSFER SWITCH.....	55	Test 35 – Check N1 and N2 Wiring.....	83
3.1 Description and Components	56	Test 36 – Check N1 and N2 Voltage	83
General	56	Test 37 – Check Utility Sensing Voltage at the Circuit Board.....	84
Enclosure.....	56	Test 38 – Check Utility Sense Voltage	84
Transfer Mechanism.....	57	Test 39 – Check Voltage at Terminal Lugs N1, N2.....	84
Transfer Relay	57	Test 40 – Check Battery Charger Supply Voltage “Pre-Wire Load Center”	86
Neutral Lug	58	Test 41 – Check Battery Charger Output Voltage “Pre-Wire Load Center”	86
Manual Transfer Handle	58	Test 42 – Check Wire 0 and Wire15B “Pre-Wire Load Center”	86
Terminal Block	58	Test 43 – Check Battery Charger Supply Voltage “RTSN & RTSE Transfer Switch”	87
Fuse Holder	59	Test 44 – Check Battery Charger Output Voltage “RTSN & RTSE Transfer Switch”	87
3.2 Operational Analysis	60	Test 45 – Check Wire 0/ “RTSN & RTSE Transfer Switch”	87
Operational Analysis.....	60	Test 46 – Check Battery Charger Supply Voltage “GenReady Load Center”	90
Utility Source Voltage Available	62	Test 47 – Check Battery Charger Output Voltage “GenReady Load Center”	90
Utility Source Voltage Failure	63	Test 48 – Check Wire 0/15B “GenReady Load Center”	90
Transfer To Standby	64	Test 49 – Check Battery Charger Supply Voltage “Load Shed Transfer Switch”	92
Transfer To Standby	65	Test 50 – Check Battery Charger Output Voltage “Load Shed Transfer Switch”	92
Utility Restored.....	66	Test 51 – Check Wire 0 and Wire 15B “Load Shed Transfer Switch”	94
Utility Restored, Transfer Switch De-energized ...	67		
Utility Restored, Retransfer Back To Utility.....	68		
Transfer Switch In Utility.....	69		
3.3 – Troubleshooting Flowcharts.....	70		
Introduction To Troubleshooting	70		
Problem 7 – In Automatic Mode, No Transfer to Standby	70		
Problem 8 – In Automatic Mode, Generator Starts When Loss of Utility Occurs, Generator Shuts Down When Utility Returns But There Is No Retransfer To Utility Power / or Generator Transfers to Standby During Exercise Or In Manual Mode.....	71		
Problem 9 – Blown F1 or F2 Fuse	71		
Problem 10 – Units Starts And Transfer Occurs When Utility Power Is On.....	72		

PART 4 - DC CONTROL	95	Test 68 – Check Fuel Solenoid	132
4.1 Description and Components	96	Test 69 – Check Choke Solenoid	132
General	96	Test 70 – Check for Ignition Spark	134
Terminal Strip / Interconnection Terminal	96	Test 71 – Check Spark Plugs	136
Circuit Board	96	Test 72 – Check Engine / Cylinder Leak Down Test / Compression Test	136
Auto-Off-Manual Switch	96	Test 73 – Check Shutdown Wire	137
7.5 Amp Fuse	96	Test 74 – Check and Adjust Ignition Magnetos	138
Menu System Navigation	102	Test 75 – Check Oil Pressure Switch and Wire 86	141
4.2 Operational Analysis	104	Test 76 – Check High Oil Temperature Switch	142
Introduction	104	Test 77 – Check and Adjust Valves	142
Utility Source Voltage Available	104	Test 78 – Check Wire 18 Continuity	143
Initial Dropout of Utility Source Voltage	106	Test 79 – Test Exercise Function	144
Utility Voltage Dropout and Engine Cranking	108	Test 80 – Check Cranking and Running Circuits	144
Engine Startup and Running	110	Test 81 – Check to see if Low Speed Function is enabled	146
Initial Transfer to the “Standby” Source	112	Test 82 – Check operation of the Choke Solenoid	146
Utility Voltage Restored / Re-transfer to Utility	114		
Engine Shutdown	116	PART 5 - OPERATIONAL TESTS	147
4.3 Troubleshooting Flowcharts	118	5.1 System Functional Tests	148
Problem 15 – Engine Will Not Crank When Utility Power Source Fails	118	Introduction	148
Problem 16 – Engine Will Not Crank When AUTO-OFF-MANUAL Switch is Set to “MANUAL”	118	Manual Transfer Switch Operation	148
Problem 17 – Engine Cranks but Won’t Start	119	Electrical Checks	148
Problem 18 – Engine Starts Hard and Runs Rough / Lacks Power / Backfires	120	Generator Tests Under Load	149
Problem 19 – Shutdown Alarm / Fault Occurred	121	Checking Automatic Operation	150
Problem 20 – 7.5 Amp Fuse (F1) Blown	122	Setting The Exercise Timer	150
Problem 21 – Generator Will Not Exercise	122	PART 6 - DISASSEMBLY	151
Problem 22 – No Low Speed Exercise	122	6.1 Major Disassembly	152
4.4 Diagnostic Tests	123	Front Engine Access	152
Introduction	123	Major Disassembly	156
Test 56 – Check Position Of Auto-Off- Manual Switch	123	Torque Requirements (Unless Otherwise Specified)	162
Test 57 – Try a Manual Start	123	PART 7 - ELECTRICAL DATA	163
Test 58 – Auto-Off-Manual Switch (V-Twin Only)	123	Wiring Diagram, 8 kW Home Standby	164
Test 59 – Test Auto Operations	124	Schematic, 8 kW Home Standby	166
Test 60 – Check 7.5 Amp Fuse	124	Wiring Diagram, 10 kW Home Standby	168
Test 61 – Check Battery	124	Schematic, 10 kW Home Standby	170
Test 62 – Check Wire 56 Voltage	126	Wiring Diagram, 14 kW Home Standby	172
Test 63 – Test Starter Contactor Relay (V-twin Only)	126	Schematic, 14 kW Home Standby	174
Test 64 – Test Starter Contactor (Single Cylinder Engine)	127	Wiring Diagram, 17 kW Home Standby	176
Test 65 – Test Starter Motor	128	Schematic, 17 kW Home Standby	178
Test 66 – Check Fuel Supply and Pressure	130	Wiring Diagram, 20 kW Home Standby	180
Test 67 – Check Circuit Board Wire 14 Output	131	Schematic, 20 kW Home Standby	182
		Wiring Diagram, Home Standby Transfer Switch, 9/10/12/16 Circuit	184
		Schematic, Home Standby Transfer Switch, 9/10/12/16 Circuit	186

SPECIFICATIONS

GENERATOR							
Unit	8 kW	10 kW	12 kW	14 kW	16 kW	17 kW	20 kW
Rated Max. Continuous Power Capacity (Watts*)	7,000 NG 8,000 LP	9,000 NG 10,000 LP	12,000 NG 12,000 LP	13,000 NG 14,000 LP	16,000 NG 16,000 LP	16,000 NG 17,000 LP	18,000 NG 20,000 LP
Rated Voltage	120/240						
Rated Voltage at No-Load (NG)	220-235			247-249			
Rated Max. Continuous Load Current (Amps)							
120 Volts** (NG/LP)	58.3/66.6	75.0/83.3	100.0/100.0	108.3/116.6	133.3/133.3	133.3/141.6	150.0/166.6
240 Volts (NG/LP)	29.2/33.3	37.5/41.6	50.0/50.0	54.2/58.3	66.6/66.6	66.6/70.8	75.0/83.3
Main Line Circuit Breaker	35 Amp	45 Amp	50 Amp	60 Amp	65 Amp	65 Amp	100 Amp
Circuits*** 50A, 240V	-	-	-	1	1	1	-
40A, 240V	-	-	1	1	1	1	-
30A, 240V	1	1	1	-	-	-	-
20A, 240V	-	1	-	1	1	1	-
20A, 120V	1	3	3	4	5	5	-
15A, 120V	5	3	5	4	5	5	-
Phase	1						
Number of Rotor Poles	2						
Rated AC Frequency	60 Hz						
Power Factor	1						
Battery Requirement	Group 26R, 12 Volts and 350 CCA Minimum	Group 26R, 12 Volts and 525 CCA Minimum					
Weight (unit only in lbs.)	340	387	439	439	455	455/421	450
Enclosure	Steel	Steel	Steel	Steel	Steel	Steel/Aluminum	Aluminum
Normal Operating Range	-20° F (-28.8° C) to 77° F (25° C)						

* Maximum wattage and current are subject to and limited by such factors as fuel Btu content, ambient temperature, altitude, engine power and condition, etc. Maximum power decreases about 3.5 percent for each 1,000 feet above sea level; and also will decrease about 1 percent for each 6 C (10 F) above 16 C (60 F) ambient temperature.

** Load current values shown for 120 volts are maximum TOTAL values for two separate circuits. The maximum current in each circuit must not exceed the value stated for the 240 volts.

*** Circuits to be moved must be protected by same size breaker. For example, a 15 amp circuit in the main panel must be a 15 amp circuit in the transfer switch.

STATOR WINDING RESISTANCE VALUES / ROTOR RESISTANCE							
	8 kW	10 kW	12 kW	14 kW	16 kW	17 kW	20 kW
Power Winding: Across 11 & 22	0.123-0.1439	0.090-0.105	0.100-0.116	0.100-0.116	0.074-0.086	0.074-0.086	0.0415-0.0483
Power Winding: Across 33 & 44	0.123-0.1439	0.090-0.105	0.100-0.116	0.100-0.116	0.074-0.086	0.074-0.086	0.0415-0.0483
Excitation Winding: Across 2 & 6	0.776-0.902	0.511-0.594	0.876-1.018	0.876-1.018	0.780-0.906	0.780-0.906	0.731-0.850
Rotor Resistance	3.01-3.49	3.22-3.74	7.96-9.25	7.96-9.25	8.79-10.21	8.79-10.21	10.02-11.65

SPECIFICATIONS

ENGINE				
Model	8 kW	10 kW	12/14/16/17 kW	20 kW
Type of Engine	GH-410	GT-530	GT-990	GT-999
Number of Cylinders	1	2	2	2
Rated Horsepower @ 3,600 rpm	14.8	18	32	34
Displacement	407cc	530cc	992cc	999cc
Cylinder Block	Aluminum w/Cast Iron Sleeve			
Valve Arrangement	Overhead Valves			
Ignition System	Solid-state w/Magneto			
Recommended Spark Plug	RC14YC	BPR6HS	RC14YCA	RC12YC
Spark Plug Gap	0.76 mm (0.030 inch)	0.76 mm (0.030 inch)	1.02 mm (0.040 inch)	1.02 mm (0.040 inch)
Compression Ratio	9.4:1	9.5:1	9.5:1	9.5:1
Starter	12 VDC			
Oil Capacity Including Filter	Approx. 1.5 Qts	Approx. 1.8 Qts	Approx. 1.9 Qts	Approx. 1.9 Qts
Recommended Oil Filter	Part # 070185F			
Recommended Air Filter	Part # 0G3332	Part # 0E9581	Part # 0C8127	Part # 0G5894
Operating RPM	3,600			

FUEL CONSUMPTION				
Model #	Natural Gas*		LP Vapor**	
	1/2 Load	Full Load	1/2 Load	Full Load
7/8 kW	77	140	0.94/34	1.68/62
9/10 kW	102	156	1.25/46	1.93/70
12/12 kW	152	215	1.53/56	2.08/76
13/14 kW	156	220	1.56/58	2.30/84
16/16 kW	183	261	1.59/58	2.51/91
16/17 kW	183	261	1.61/59	2.57/94
18/20 kW	206	294	1.89/69	2.90/106

* Natural gas is in cubic feet per hour.

**LP is in gallons per hour/cubic feet per hour.

Values given are approximate.

SPECIFICATIONS

MOUNTING DIMENSIONS

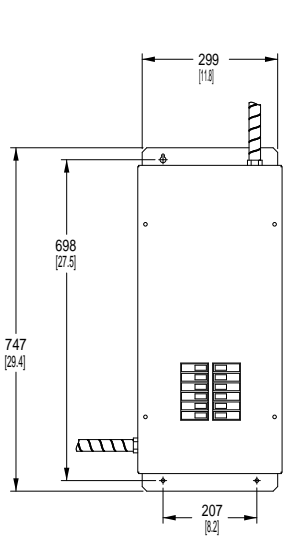

TRANSFER SWITCH
8KW - 17KW
(IF SUPPLIED)

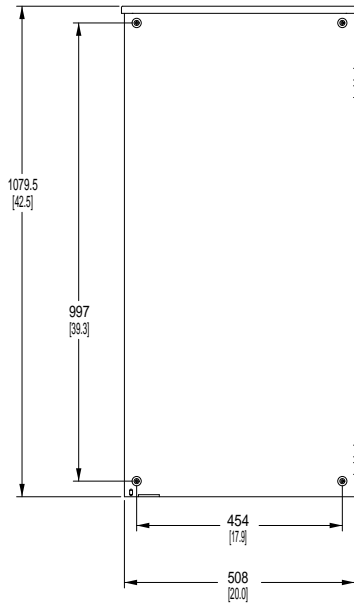

TRANSFER SWITCH
20KW
(IF SUPPLIED)

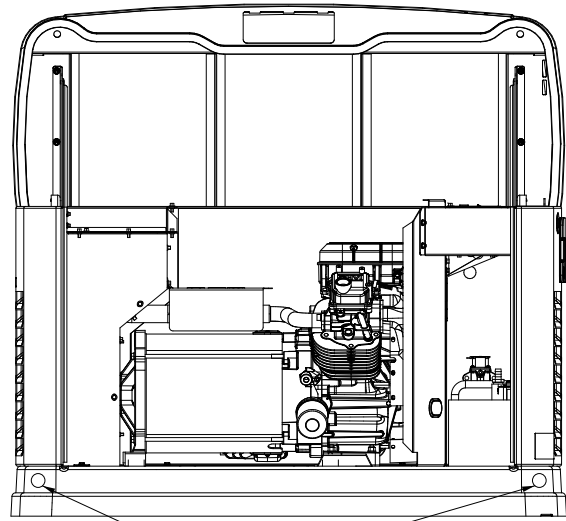

LIFTING HOLES 4 CORNERS
Ø30.2 [Ø1.2]

"DO NOT LIFT BY ROOF"

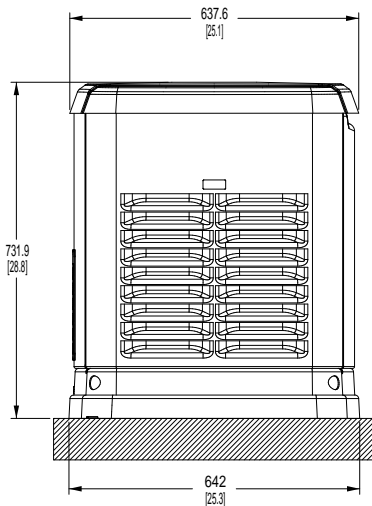

LEFT SIDE VIEW

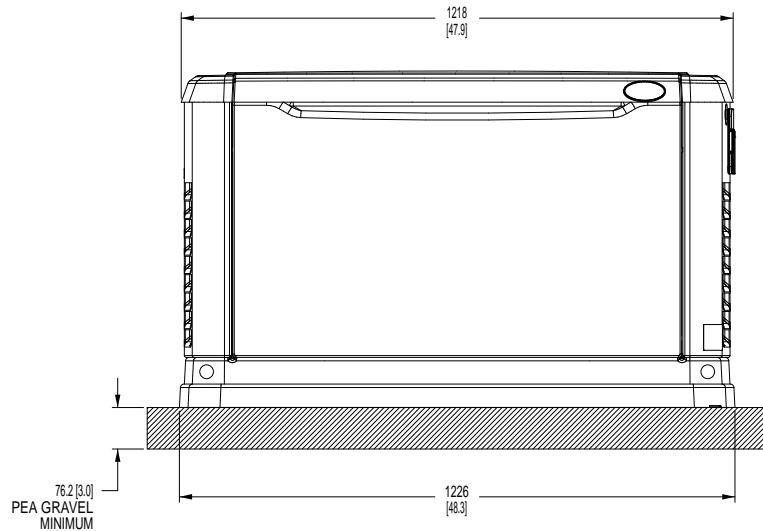

FRONT VIEW

MOUNTING DIMENSIONS

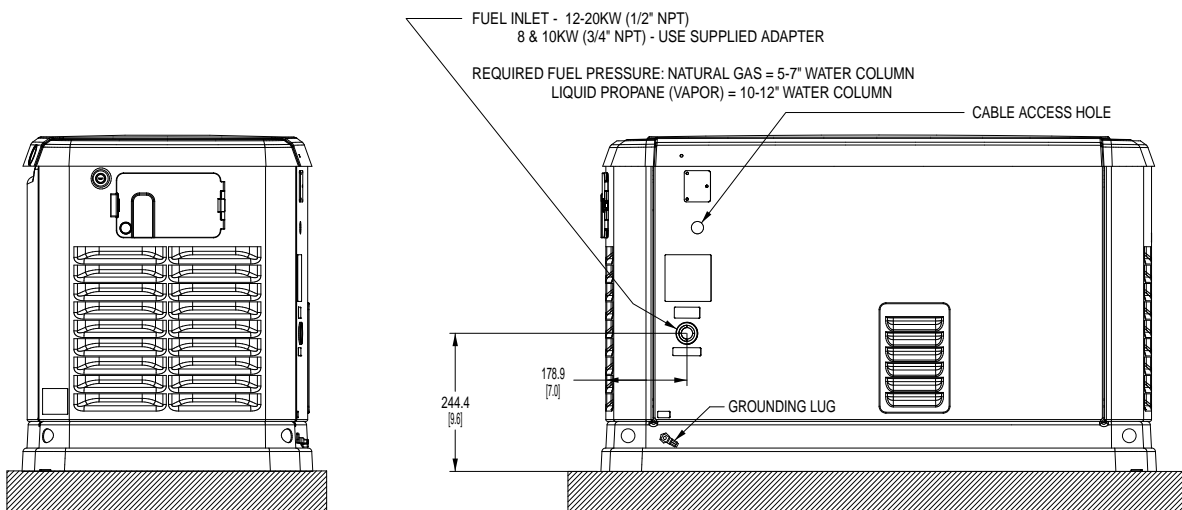
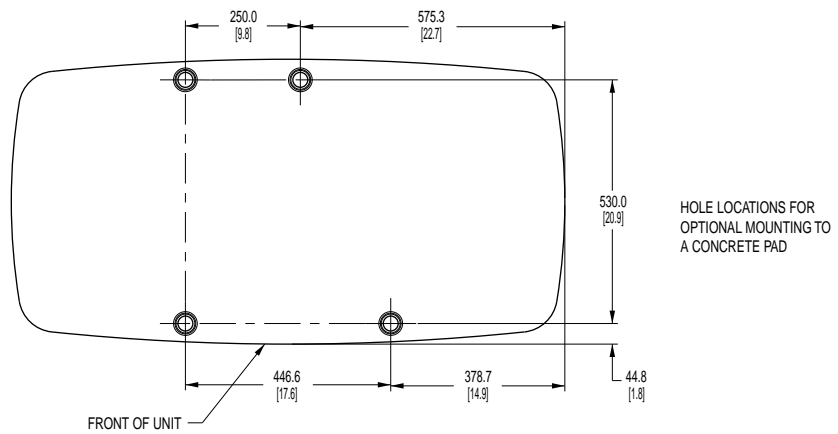
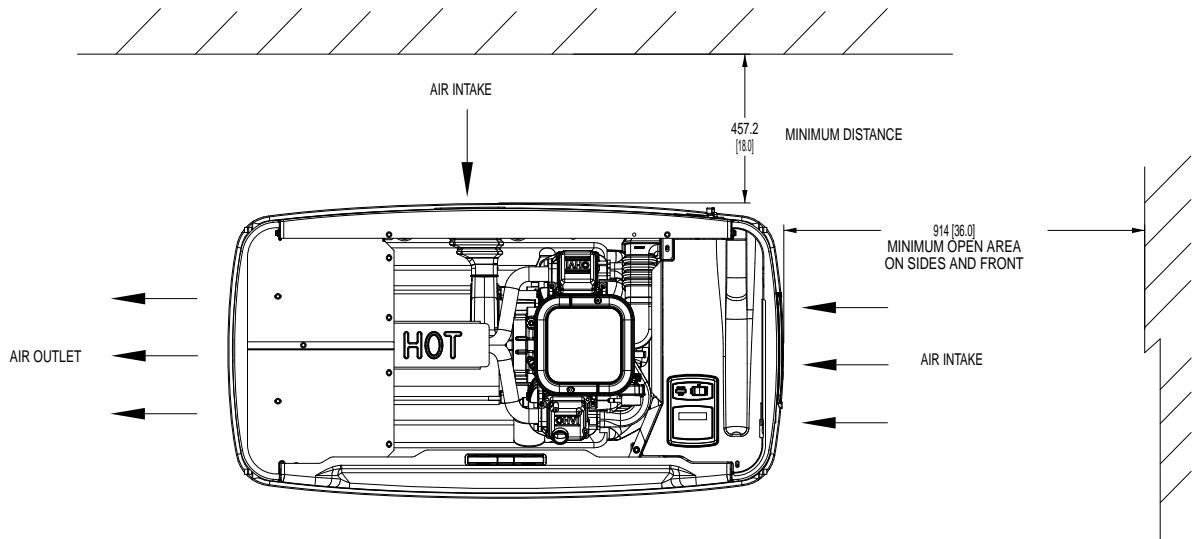

RIGHT SIDE VIEW

REAR VIEW

SPECIFICATIONS

MAJOR FEATURES

8kW, Single Cylinder, GH-410 Engine
(door removed)

10kW, V-twin, GT-530 Engine
(door removed)

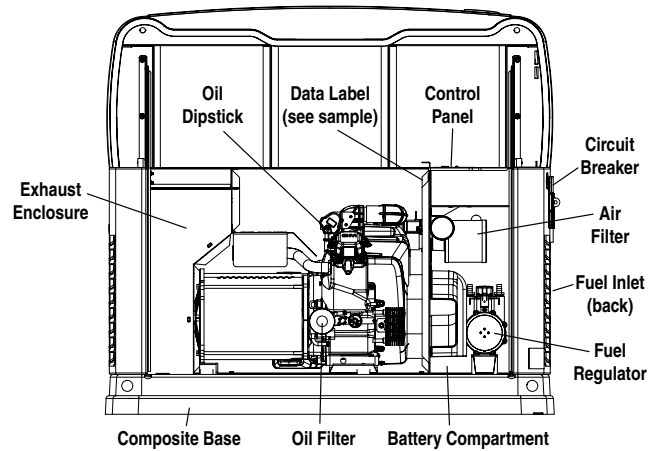
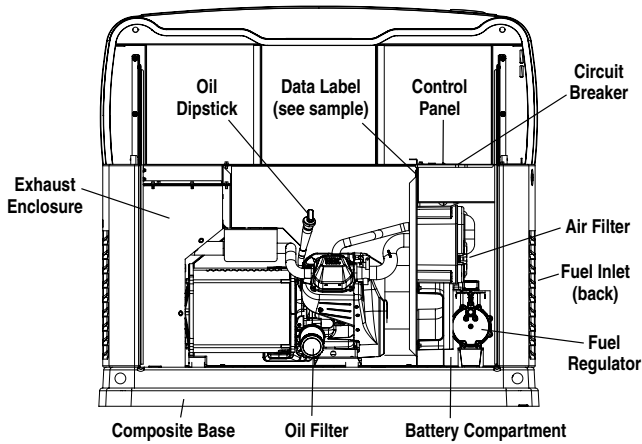
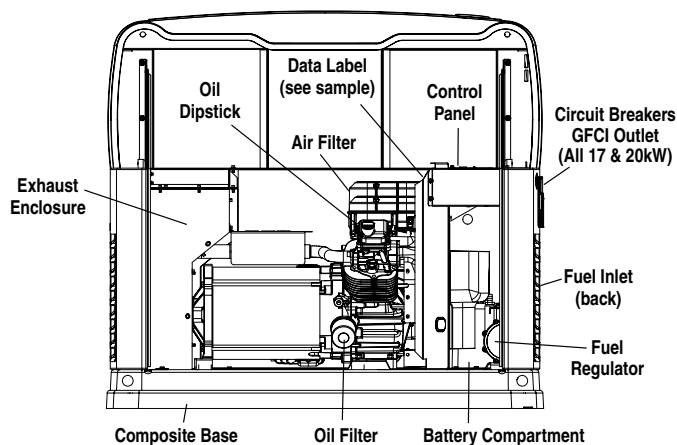

Figure 1.3 – 12, 14, 16, 17 and 20kW, V-twin,
GT-990/GT-999 Engine (door removed)



PART 1 GENERAL INFORMATION

Air-cooled, Automatic Standby Generators

1.1 Generator Identification	10
Introduction	10
1.2 Installation Basics.....	11
Introduction	11
Selecting A Location	11
Grounding The Generator	11
The Fuel Supply.....	11
The Transfer Switch / Load Center.....	11
Power Source And Load Lines.....	13
System Control Interconnections	13
Natural Gas Fuel Interconnections	13
1.3 Non-prepackaged Interconnections	14
Connect a Pre-2008 Load Center Switch To a Current or Future Air-Cooled Generator.....	14
Connect a 2008 And Later Load Center Switch to a Pre-2008 Air-Cooled Generator.....	15
1.4 Preparation Before Use	16
General	16
Fuel Requirements.....	16
Fuel Consumption.....	16
Reconfiguring The Fuel System.....	16
Engine Oil Recommendations	18
1.5 Testing, Cleaning and Drying.....	19
Meters	19
The Vom.....	19
Measuring AC Voltage	19
Measuring DC Voltage	19
Measuring AC Frequency	19
Measuring Current.....	20

TABLE OF CONTENTS		
PART	TITLE	PAGE
1.1	Generator Identification	10
1.2	Installation Basics	11
1.3	Non-Prepackaged Interconnections	14
1.3	Preparation Before Use	16
1.4	Testing, Cleaning and Drying	18
1.5	Engine-Generator Protective Devices	25
1.6	Operating Instructions	27
1.7	Automatic Operating Parameters	29

Measuring Resistance	20
Electrical Units	21
Ohm's Law	21
Visual Inspection.....	22
Insulation Resistance.....	22
The Megohmmeter.....	22
Stator Insulation Resistance Test (12-20kW) ...	23
Stator Insulation Resistance Test (8-10kW)	23
Rotor Insulation Resistance Test (8-10kW).....	24
Rotor Insulation Resistance Test (12-20kW)....	24
Cleaning The Generator.....	24
Drying The Generator	24
1.6 Engine-Generator Protective Devices	25
General	25
Low Battery.....	25
Low Oil Pressure Shutdown.....	25
High Temperature Switch.....	25
Overspeed Shutdown	25
Rpm Sensor Failure	25
Overcrank Shutdown	26
1.7 Operating Instructions	27
Control Panel	27
To Select Automatic Operation	28
Manual Transfer To "Standby" and Manual Startup	28
Manual Shutdown And Retransfer Back To "Utility"	28
1.8 Automatic Operating Parameters	29
Introduction	29
Automatic Operating Sequences	29

**SECTION 1.1
GENERATOR IDENTIFICATION**

INTRODUCTION

This Diagnostic Repair Manual has been prepared especially for the purpose of familiarizing service personnel with the testing, troubleshooting and repair of air-cooled, automatic standby generators. Every effort has been expended to ensure that information and instructions in the manual are both accurate and current. However, changes, alterations or other improvements may be made to the product at any time without prior notification.

The manual has been divided into PARTS. Each PART has been divided into SECTIONS. Each SECTION consists of two or more SUBSECTIONS.

It is not our intent to provide detailed disassembly and reassemble instructions in this manual. It is our intent to (a) provide the service technician with an understanding of how the various assemblies and systems work, (b) assist the technician in finding the cause of malfunctions, and (c) effect the expeditious repair of the equipment.

ITEM NUMBER:

Many home standby generators are manufactured to the unique specifications of the buyer. The Model Number identifies the specific generator set and its unique design specifications.

SERIAL NUMBER:

Used for warranty tracking purposes.

Item #	0055555
Serial	1234567
Volts	120/240 AC
Amps	108.3/108.3
Watts	13000
1 PH, 60 HZ, RPM 3600 RAINPROOF ENCLOSURE FITTED CLASS F INSULATION MAX OPERATING AMBIENT TEMP - 120F/49C	
FOR STANDBY SERVICE	
NEUTRAL FLOATING	
MAX LOAD UNBALANCED - 50%	

MODEL #	0055555	WATTS	13000
SERIAL #	1234567	VOLTS	120/240 AC
		AMPS	108.3/108.3
1PH, 60Hz, 3600 RPM, CLASS F INSULATION RAINPROOF ENCLOSURE FITTED RATED AMBIENT TEMP - 40°C			
FOR STANDBY SERVICE, NEUTRAL FLOATING			
Model Number -		Serial Number -	

Figure 1. Typical Data Plates

INTRODUCTION

Information in this section is provided so that the service technician will have a basic knowledge of installation requirements for home standby systems. Problems that arise are often related to poor or unauthorized installation practices.

A typical home standby electric system is shown in Figure 1 (next page). Installation of such a system includes the following:

- Selecting a Location
- Grounding the generator.
- Providing a fuel supply.
- Mounting the load center.
- Connecting power source and load lines.
- Connecting system control wiring.
- Post installation tests and adjustments.

SELECTING A LOCATION

Install the generator set as close as possible to the electrical load distribution panel(s) that will be powered by the unit, ensuring that there is proper ventilation for cooling air and exhaust gases. This will reduce wiring and conduit lengths. Wiring and conduit not only add to the cost of the installation, but excessively long wiring runs can result in a voltage drop.

Control system interconnections between the transfer switch and generator consist of N1 and N2, and leads 23, 15B and 0. Control system interconnection leads must be run in a conduit that is separate from the AC power leads. Recommended wire gauge size depends on the length of the wire:

Max. Cable Length	Recommended Wire Size
35 feet (10.67m)	No. 16 AWG.
60 feet (18.29m)	No. 14 AWG.
90 feet (27.43m)	No. 12 AWG.

GROUNDING THE GENERATOR

The National Electric Code requires that the frame and external electrically conductive parts of the generator be properly connected to an approved earth ground. Local electrical codes may also require proper grounding of the unit. For that purpose, a grounding lug is attached to the unit. Grounding may be accomplished by attaching a stranded copper wire of the proper size to the generator grounding lug and to an earth-driven copper or brass grounding-rod (electrode). Consult with a local electrician for grounding requirements in your area.

THE FUEL SUPPLY

Units with air-cooled engines were operated, tested and adjusted at the factory using natural gas as a fuel. These air-cooled engine units can be converted to use LP (propane) gas by making a few adjustments for best operation and power.

LP (propane) gas is usually supplied as a liquid in pressure tanks. Both the air-cooled and the liquid cooled units require a "vapor withdrawal" type of fuel supply system when LP (propane) gas is used. The vapor withdrawal system utilizes the gaseous fuel vapors that form at the top of the supply tank.

The pressure at which LP gas is delivered to the generator fuel solenoid valve may vary considerably, depending on ambient temperatures. In cold weather, supply pressures may drop to "zero". In warm weather, extremely high gas pressures may be encountered. A primary regulator is required to maintain correct gas supply pressures.

Current recommended gaseous fuel pressure at the inlet side of the generator fuel solenoid valve is as follows:

	LP	NG
Minimum water column	10 inches	5 inches
Maximum water column	12 inches	7 inches

A primary regulator is required to ensure that proper fuel supply pressures are maintained.



DANGER: LP AND NATURAL GAS ARE BOTH HIGHLY EXPLOSIVE. GASEOUS FUEL LINES MUST BE PROPERLY PURGED AND TESTED FOR LEAKS BEFORE THIS EQUIPMENT IS PLACED INTO SERVICE AND PERIODICALLY THEREAFTER. PROCEDURES USED IN GASEOUS FUEL LEAKAGE TESTS MUST COMPLY STRICTLY WITH APPLICABLE FUEL GAS CODES. DO NOT USE FLAME OR ANY SOURCE OF HEAT TO TEST FOR GAS LEAKS. NO GAS LEAKAGE IS PERMITTED. LP GAS IS HEAVIER THAN AIR AND TENDS TO SETTLE IN LOW AREAS. NATURAL GAS IS LIGHTER THAN AIR AND TENDS TO SETTLE IN HIGH PLACES. EVEN THE SLIGHTEST SPARK CAN IGNITE THESE FUELS AND CAUSE AN EXPLOSION.

Use of a flexible length of hose between the generator fuel line connection and rigid fuel lines is required. This will help prevent line breakage that might be caused by vibration or if the generator shifts or settles. The flexible fuel line must be approved for use with gaseous fuels.

Flexible fuel line should be kept as straight as possible between connections. The bend radius for flexible fuel line is nine (9) inches. Exceeding the bend radius can cause the fittings to crack.

THE TRANSFER SWITCH / LOAD CENTER

A transfer switch is required by electrical code, to prevent electrical feedback between the utility and standby power sources, and to transfer electrical loads from one power supply to another safely.

TRANSFER SWITCHES:

Instructions and information on transfer switches may be found in Part 3 of this manual.

SECTION 1.2 INSTALLATION BASICS

PART 1

GENERAL INFORMATION

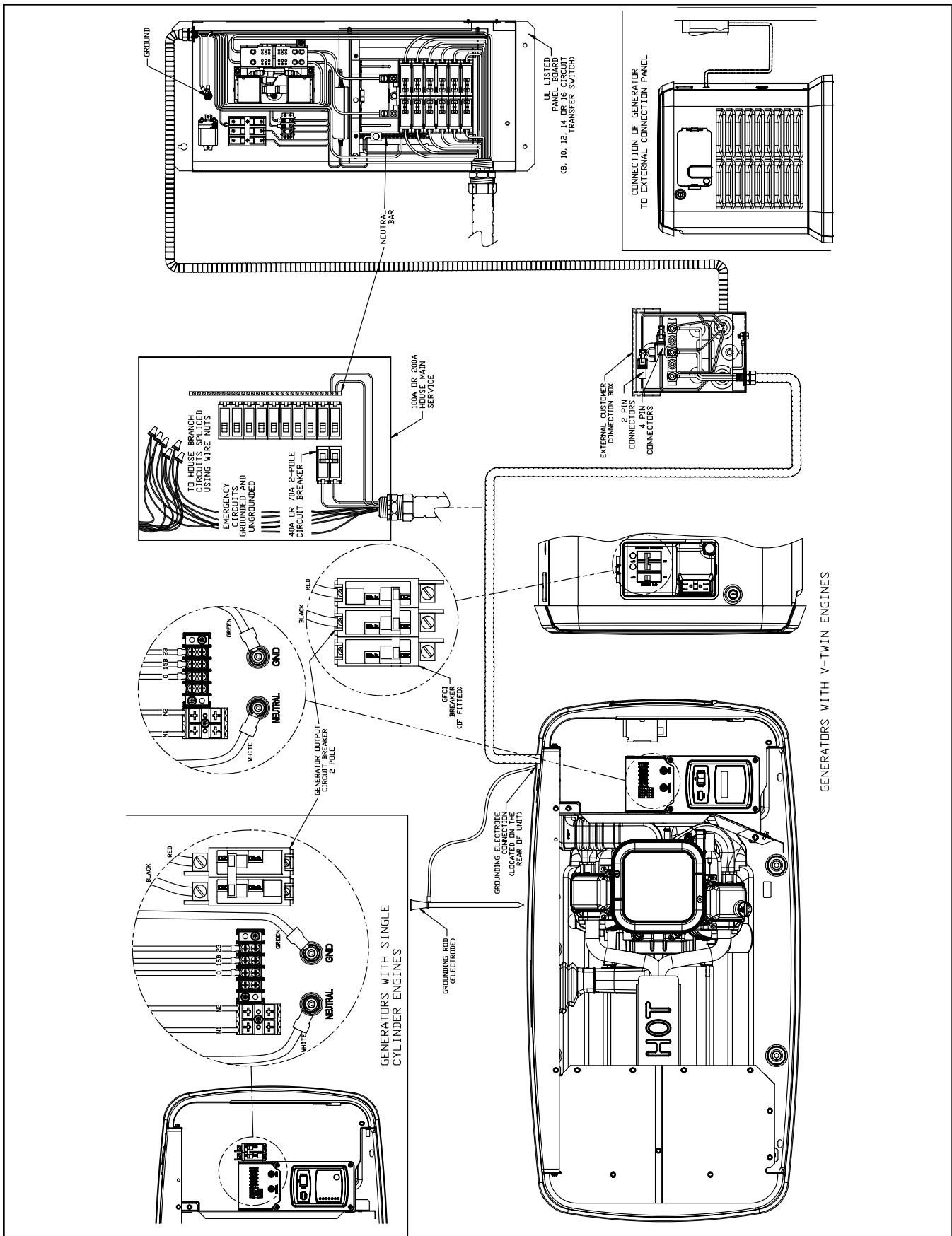

Figure 1. Typical Installation

POWER SOURCE AND LOAD LINES

The utility power supply lines, the standby (generator) supply lines, and electrical load lines must all be connected to the proper terminal lugs in the transfer switch. The following rules apply: In 1-phase systems with a 2-pole transfer switch, connect the two utility source hot lines to Transfer Switch Terminal Lugs N1 and N2. Connect the standby source hot lines (E1, E2) to Transfer Switch Terminal Lugs E1 and E2. Connect the load lines from Transfer Switch Terminal Lugs T1 and T2 to the electrical load circuit. Connect UTILITY, STANDBY and LOAD neutral lines to the neutral block in the transfer switch.

SYSTEM CONTROL INTERCONNECTIONS

Home standby generators are equipped with a terminal board identified with the following terminals: (a) UTILITY 1, (b) UTILITY 2, (c) 23, and (d) 15B. Load centers house an identically marked terminal board. When these four terminals are properly interconnected, dropout of utility source voltage below a preset value will result in automatic generator startup and transfer of electrical loads to the "Standby" source. On restoration of utility source voltage above a preset value will result in retransfer back to that source and generator shutdown.

NATURAL GAS FUEL INTERCONNECTIONS

Figure 2. Proper Fuel Installation

SECTION 1.3 NON-PREPACKAGED INTERCONNECTIONS

DISCUSSION:

On the current model air-cooled generators Wire 194 was changed to 15B. Wire 15B is still utilized for positive voltage for the transfer relay and Wire 23 is still the control ground for transferring the generator. By following the procedures below it is possible to connect new product with Wire 15B to old or current product that still utilize Wire 194, such as an RTS switch.

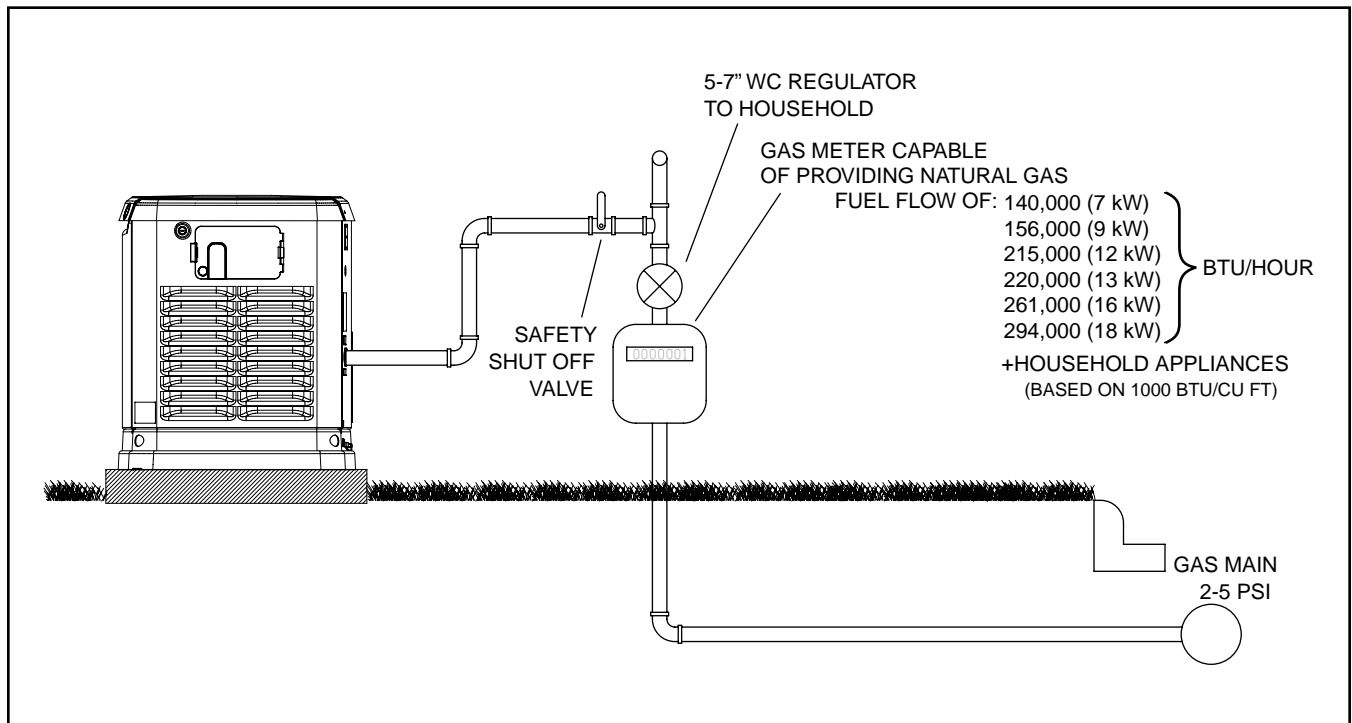
CONNECT A PRE-2008 LOAD CENTER SWITCH TO A CURRENT OR FUTURE AIR-COOLED GENERATOR.

PROCEDURE:

1. Follow all instructions located in the Installation Manual that was supplied with the unit regarding mounting of the switch, junction box, and generator.

Note: When installing a standalone 5500 series generator, the battery charger will be located in the generator on the side of the control assembly.

2. Inside the Junction box between the generator and the transfer switch there will be 5 wires coming from the generator and 4 wires from the transfer switch.

3. Using the following diagram and UL approved wire nuts connect the following wires together. Wire 0 will not be utilized for this setup.

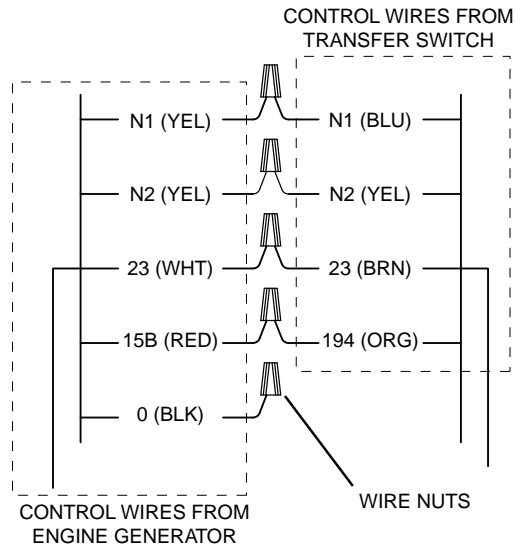

Figure 1. Wire Connections

**“08” & LATER HSB AIR-COOLED GENERATORS
SINGLE & V-TWIN ENGINES**

**PRE “08” LOAD CENTER
TRANSFER SWITCH**

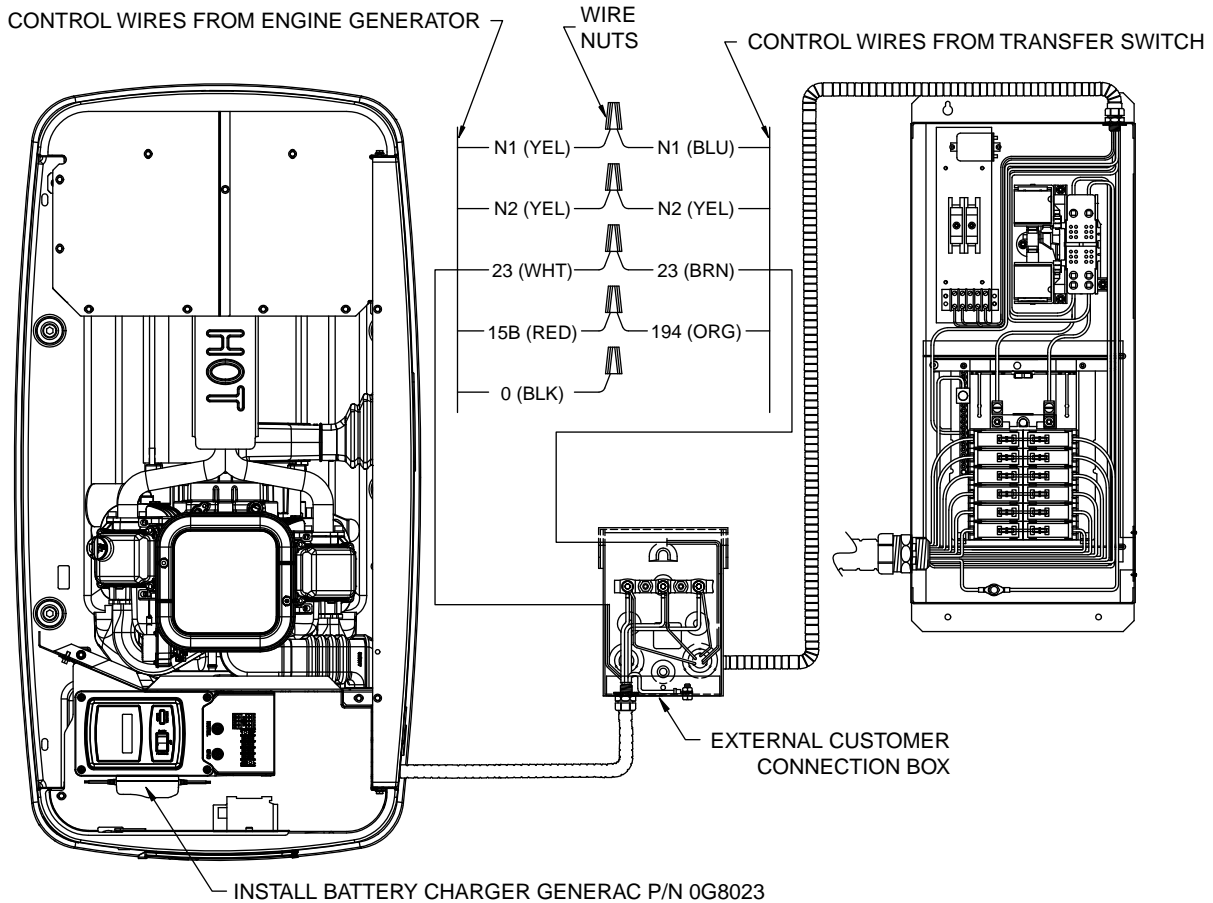

Figure 2. Post 2008 HSB Interconnections

CONNECT A 2008 AND LATER LOAD CENTER SWITCH TO A PRE-2008 AIR-COOLED GENERATOR.**PROCEDURE:**

1. Follow all instructions located in the Installation Manual that was supplied with the unit regarding mounting of the switch, junction box, and generator.

Note: When installing a standalone pre-2008 generator, the battery charger will be located in the generator utilizing the 12 VDC trickle charger.

2. Inside the Junction box between the generator and the transfer switch there will be 4 wires coming from the generator and 5 wires from the transfer switch.
3. Using the following diagram and UL approved wire nuts connect the following wires together. Wire 0 will not be utilized for this setup.

Note: Remove the battery charger from the transfer switch; it will not be utilized in the operation of the generator.

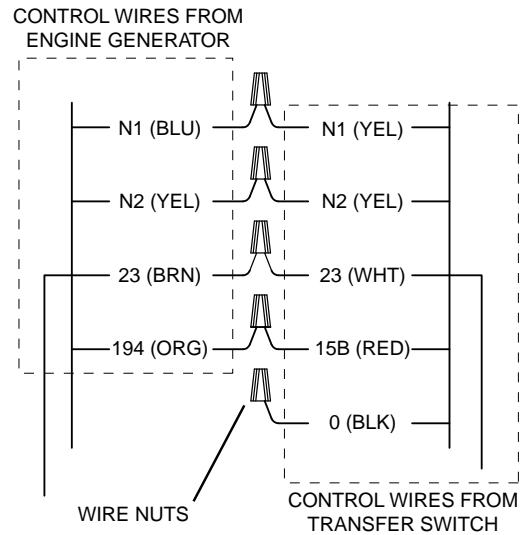

Figure 3. Wire Connections

**PRE "08" HSB AIR-COOLED GENERATORS
SINGLE & V-TWIN ENGINES****"08" & LATER LOAD CENTER
TRANSFER SWITCH**

Figure 4. Pre-2008 HSB Interconnections

GENERAL

The installer must ensure that the home standby generator has been properly installed. The system must be inspected carefully following installation. All applicable codes, standards and regulations pertaining to such installations must be strictly complied with. In addition, regulations established by the Occupational Safety and Health Administration (OSHA) must be complied with.

Prior to initial startup of the unit, the installer must ensure that the engine-generator has been properly prepared for use. This includes the following:

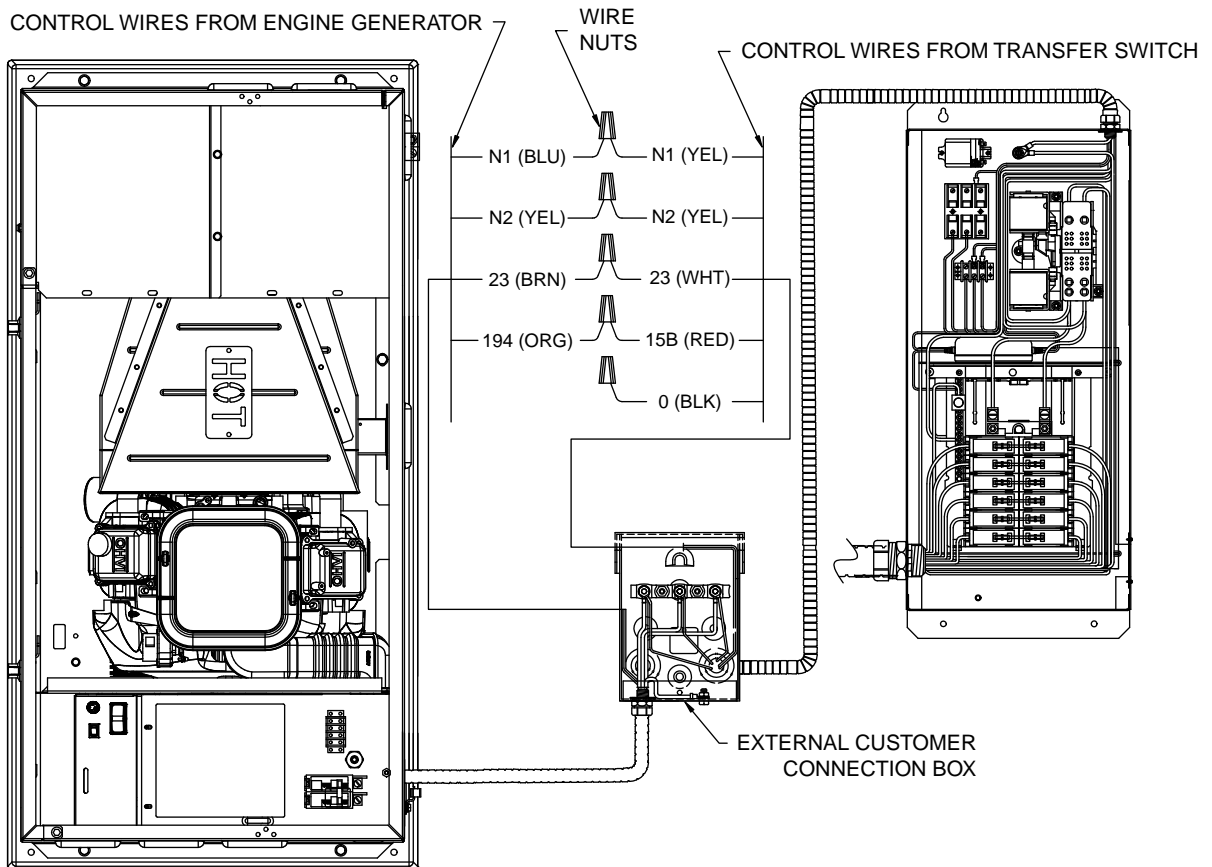
- An adequate supply of the correct fuel must be available for generator operation.
- The engine must be properly serviced with the recommended oil.

FUEL REQUIREMENTS

With LP gas, use only the vapor withdrawal system. This type of system uses the vapors formed above the liquid fuel in the storage tank.

The engine has been fitted with a fuel carburetion system that meets the specifications of the 1997 California Air Resources Board for tamper-proof dual fuel systems. The unit will run on natural gas or LP gas, but it has been factory set to run on natural gas. Should the primary fuel need to be changed to LP gas, the fuel system needs to be reconfigured. See the Reconfiguring the Fuel System section for instructions on reconfiguration of the fuel system.

Recommended fuels should have a Btu content of at least 1,000 Btus per cubic foot for natural gas; or at least 2,520 Btus per cubic foot for LP gas. Ask the fuel supplier for the Btu content of the fuel.

Required fuel pressure for natural gas is 5 inches to 7 inches water column (0.18 to 0.25 psi); and for liquid propane, 10 inches to 12 inches of water column (0.36 to 0.43 psi).

NOTE: All pipe sizing, construction and layout must comply with NFPA 54 for natural gas applications and NFPA 58 for liquid propane applications. Once the generator is installed, verify that the fuel pressure NEVER drops below four (4) inches water column for natural gas or 10 inches water column for liquid propane.

Prior to installation of the generator, the installer should consult local fuel suppliers or the fire marshal to check codes and regulations for proper installation. Local codes will mandate correct routing of gaseous fuel line piping around gardens, shrubs and other landscaping to prevent any damage.

Special considerations should be given when installing the unit where local conditions include flooding, tornados, hurricanes, earthquakes and unstable ground for the flexibility and strength of piping and their connections.

Use an approved pipe sealant or joint compound on all threaded fitting.

All installed gaseous fuel piping must be purged and leak tested prior to initial start-up in accordance with local codes, standards and regulations.

FUEL CONSUMPTION

The fuel consumption rates are listed in the SPECIFICATIONS section at the front of this manual.

BTU FLOW REQUIREMENTS - NATURAL GAS:

BTU flow required for each unit based on 1000 BTU per cubic foot.

7 kW -	140,000 BTU/Hour
9 kW -	156,000 BTU/Hour
12 kW -	215,000 BTU/Hour
13 kW -	220,000 BTU/Hour
16 kW -	261,000 BTU/Hour
18 kW -	294,000 BTU/Hour



Gaseous fuels such as natural gas and liquid propane (LP) gas are highly explosive. Even the slightest spark can ignite such fuels and cause an explosion. No leakage of fuel is permitted. Natural gas, which is lighter than air, tends to collect in high areas. LP gas is heavier than air and tends to settle in low areas.

NOTE: A minimum of one approved manual shut-off valve must be installed in the gaseous fuel supply line. The valve must be easily accessible. Local codes determine the proper location.

RECONFIGURING THE FUEL SYSTEM

8 kW, 410CC ENGINE:

To reconfigure the fuel system from NG to LP, follow these steps (Figure 1):

NOTE: The primary regulator for the propane supply is NOT INCLUDED with the generator. A fuel pressure of 10 to 12 inches of water column (0.36 to 0.43 psi) to the fuel inlet of the generator must be supplied.

1. Turn off the main gas supply (if connected).
2. Open the roof and remove the door.
3. Remove the battery (if installed).
4. Locate the plastic T-handle fuel selector in the poly bag supplied with the generator.
5. Locate the selector knob on the air box cover, behind the yellow air filter door and power bulge. The unit comes from the factory in the NG (Natural Gas) position. Grasping the T-handle, insert the pin end into the hole

in the selector knob and pull out to overcome spring pressure and then twist clockwise 90 degrees and allow the selector to return in once aligned with the LP (Liquid Propane) position.

6. Save this tool with the Owner's Manual.
7. Install the battery, door and close the roof.
8. Reverse the procedure to convert back to natural gas.



Figure 1. Demand Regulator

10, 12, 14, 16, 17 AND 20 KW, V-TWIN ENGINES:

To reconfigure the fuel system from NG to LP, follow these steps:

NOTE: The primary regulator for the propane supply is NOT INCLUDED with the generator. A fuel pressure of 10 to 12 inches of water column (0.36 to 0.43 psi) to the fuel inlet of the generator MUST BE SUPPLIED.

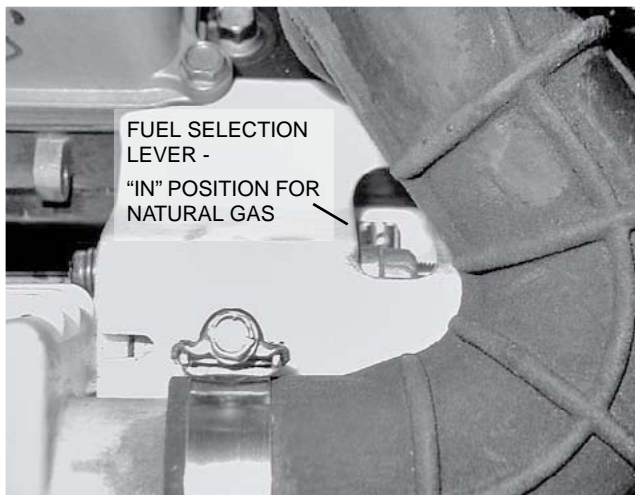

Figure 2. 10 kW, GT-530 (Inlet Hose Slid Back)

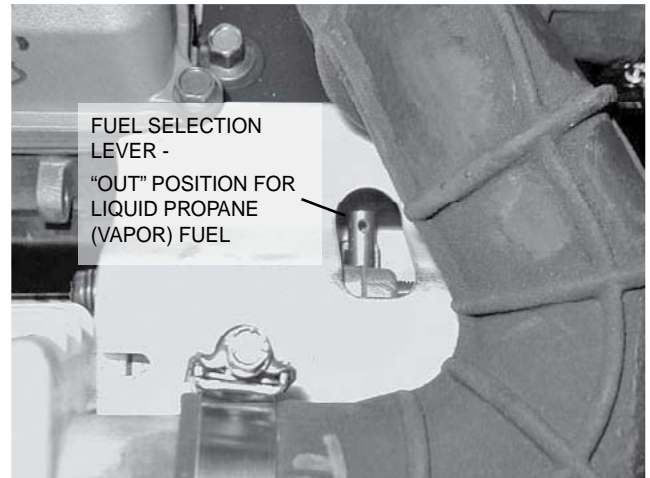

Figure 3. 10 kW, GT-530 (Inlet Hose Slid Back)

1. Open the roof.
2. **For 10 kW units:** Loosen clamp and slide back the air inlet hose.
 - Slide fuel selector on carburetor out towards the back of the enclosure (Figures 2 and 3).
 - Return the inlet hose and tighten clamp securely.
- For 12, 14, 16, 17 and 20 kW units:** remove the air cleaner cover.
 - Slide the selector lever out towards the back of the enclosure (Figures 4 and 5).
 - Return the air cleaner cover and tighten the two thumb screws.
3. Close the roof.
4. Reverse the procedure to convert back to natural gas.

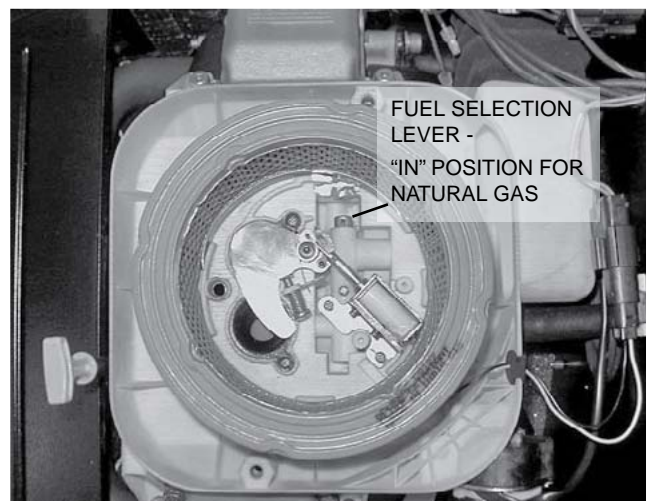

Figure 4. 12/14/16/17/20 kW, GT-990/GT-999 (Airbox Cover Removed)

METERS

Devices used to measure electrical properties are called meters. Meters are available that allow one to measure (a) AC voltage, (b) DC voltage, (c) AC frequency, and (d) resistance in ohms. The following apply:

- To measure AC voltage, use an AC voltmeter.
- To measure DC voltage, use a DC voltmeter.
- Use a frequency meter to measure AC frequency in “Hertz” or “cycles per second”.
- Use an ohmmeter to read circuit resistance, in “ohms”.

THE VOM

A meter that will permit both voltage and resistance to be read is the “volt-ohm-milliammeter” or “VOM”.

Some VOMs are of the “analog” type (not shown). These meters display the value being measured by physically deflecting a needle across a graduated scale. The scale used must be interpreted by the user.

“Digital” VOM’s (Figure 1) are also available and are generally very accurate. Digital meters display the measured values directly by converting the values to numbers.

NOTE: Standard AC voltmeters react to the AVERAGE value of alternating current. When working with AC, the effective value is used. For that reason a different scale is used on an AC voltmeter. The scale is marked with the effective or “rms” value even though the meter actually reacts to the average value. That is why the AC voltmeter will give an incorrect reading if used to measure direct current (DC).

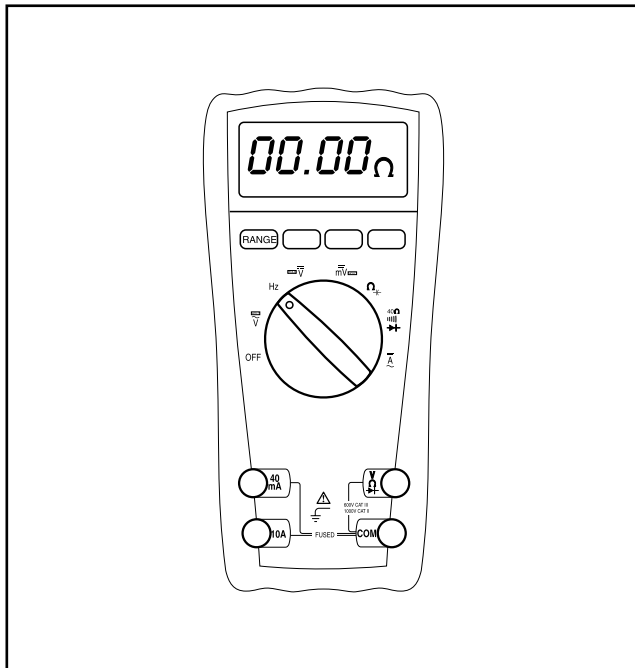

Figure 1. Digital VOM

MEASURING AC VOLTAGE

An accurate AC voltmeter or a VOM may be used to read the generator’s AC output voltage. The following apply:

1. Always read the generator’s AC output voltage only at the unit’s rated operating speed and AC frequency.
2. The generator’s Voltage Regulator can be adjusted for correct output voltage only while the unit is operating at its correct rated speed and frequency.
3. Only an AC voltmeter may be used to measure AC voltage. **DO NOT USE A DC VOLTMETER FOR THIS PURPOSE.**



DANGER!: GENERATORS PRODUCE HIGH AND DANGEROUS VOLTAGES. CONTACT WITH HIGH VOLTAGE TERMINALS WILL RESULT IN DANGEROUS AND POSSIBLY LETHAL ELECTRICAL SHOCK.

MEASURING DC VOLTAGE

A DC voltmeter or a VOM may be used to measure DC voltages. Always observe the following rules:

1. Always observe correct DC polarity.
 - a. Some VOM’s may be equipped with a polarity switch.
 - b. On meters that do not have a polarity switch, DC polarity must be reversed by reversing the test leads.
2. Before reading a DC voltage, always set the meter to a higher voltage scale than the anticipated reading. If in doubt, start at the highest scale and adjust the scale downward until correct readings are obtained.
3. The design of some meters is based on the “current flow” theory while others are based on the “electron flow” theory.
 - a. The “current flow” theory assumes that direct current flows from the positive (+) to the negative (-).
 - b. The “electron flow” theory assumes that current flows from negative (-) to positive (+).

NOTE: When testing generators, the “current flow” theory is applied. That is, current is assumed to flow from positive (+) to negative (-).

MEASURING AC FREQUENCY

The generator’s AC output frequency is proportional to Rotor speed. Generators equipped with a 2-pole Rotor must operate at 3600 rpm to supply a frequency of 60 Hertz. Units with 4-pole Rotor must run at 1800 rpm to deliver 60 Hertz.

MEASURING CURRENT

CLAMP-ON:

To read the current flow, in AMPERES, a clamp-on ammeter may be used. This type of meter indicates current flow through a conductor by measuring the strength of the magnetic field around that conductor. The meter consists essentially of a current transformer with a split core and a rectifier type instrument connected to the secondary. The primary of the current transformer is the conductor through which the current to be measured flows. The split core allows the Instrument to be clamped around the conductor without disconnecting it.

Current flowing through a conductor may be measured safely and easily. A line-splitter can be used to measure current in a cord without separating the conductors.

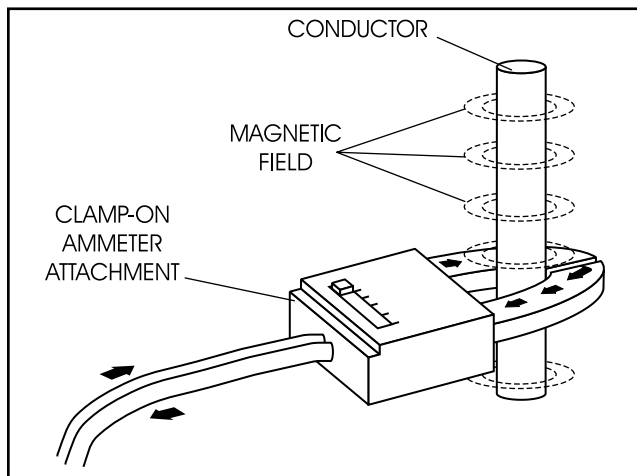

Figure 2. Clamp-On Ammeter

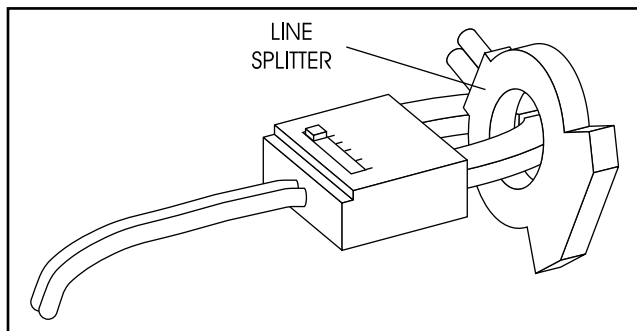

Figure 3. A Line-Splitter

NOTE: If the physical size of the conductor or ammeter capacity does not permit all lines to be measured simultaneously, measure current flow in each individual line. Then, add the Individual readings.

IN-LINE:

Alternatively, to read the current flow in AMPERES, an in-line ammeter may be used. Most Digital Volt Ohm Meters (VOM) will have the capability to measure amperes.

This usually requires the positive meter test lead to be connected to the correct amperes plug, and the meter to be set to the amperes position. Once the meter is properly set up to measure amperes the circuit being measured must be physically broken. The meter will be in-line or in series with the component being measured.

In Figure 4 the control wire to a relay has been removed. The meter is used to connect and supply voltage to the relay to energize it and measure the amperes going to it.

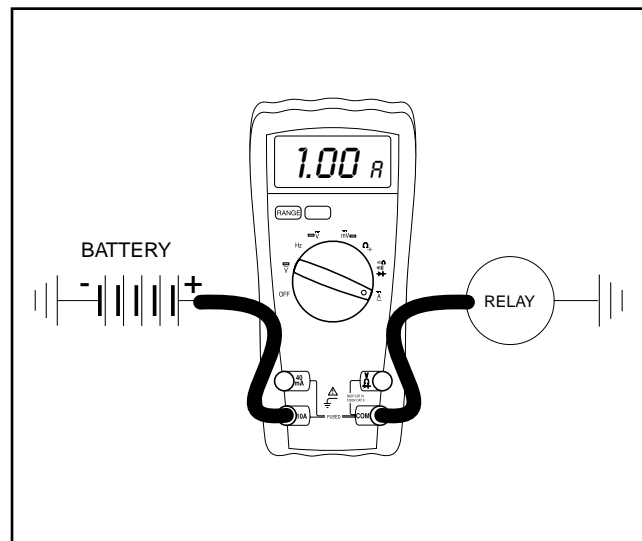

Figure 4. A VOM as an In-line meter

MEASURING RESISTANCE

The volt-ohm-milliammeter may be used to measure the resistance in a circuit. Resistance values can be very valuable when testing coils or windings, such as the Stator and Rotor windings.

When testing Stator windings, keep in mind that the resistance of these windings is very low. Some meters are not capable of reading such a low resistance and will simply read CONTINUITY.

If proper procedures are used, the following conditions can be detected using a VOM:

- A "short-to-ground" condition in any Stator or Rotor winding.
- Shorting together of any two parallel Stator windings.
- Shorting together of any two isolated Stator windings.
- An open condition in any Stator or Rotor winding.

Component testing may require a specific resistance value or a test for INFINITY or CONTINUITY. Infinity is an OPEN condition between two electrical points, which would read as no resistance on a VOM. Continuity is a closed condition between two electrical points, which would be indicated as very low resistance or "ZERO" on a VOM.

ELECTRICAL UNITS

AMPERE:

The rate of electron flow in a circuit is represented by the AMPERE. The ampere is the number of electrons flowing past a given point at a given time. One AMPERE is equal to just slightly more than six thousand million billion electrons per second.

With alternating current (AC), the electrons flow first in one direction, then reverse and move in the opposite direction. They will repeat this cycle at regular intervals. A wave diagram, called a "sine wave" shows that current goes from zero to maximum positive value, then reverses and goes from zero to maximum negative value. Two reversals of current flow is called a cycle. The number of cycles per second is called frequency and is usually stated in "Hertz".

VOLT:

The VOLT is the unit used to measure electrical PRESSURE, or the difference in electrical potential that causes electrons to flow. Very few electrons will flow when voltage is weak. More electrons will flow as voltage becomes stronger. VOLTAGE may be considered to be a state of unbalance and current flow as an attempt to regain balance. One volt is the amount of EMF that will cause a current of 1 ampere to flow through 1 ohm of resistance.

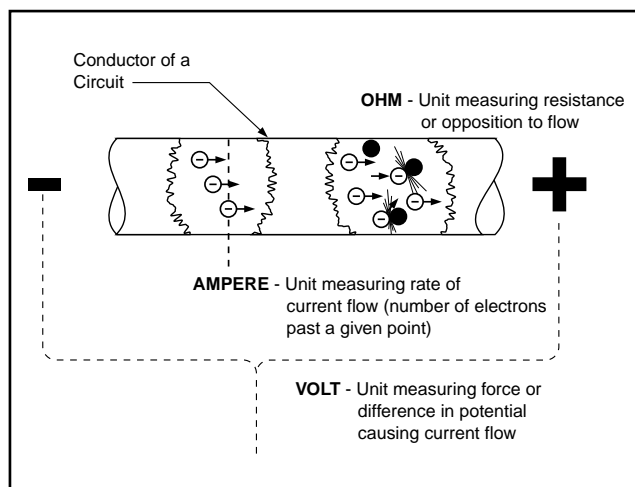

Figure 5. Electrical Units

OHM:

The OHM is the unit of RESISTANCE. In every circuit there is a natural resistance or opposition to the flow of electrons. When an EMF is applied to a complete circuit, the electrons are forced to flow in a single direction rather than their free or orbiting pattern. The resistance of a conductor depends on (a) its physical makeup, (b) its cross-sectional area, (c) its length, and (d) its temperature. As the conductor's temperature increases, its resistance increases in direct proportion. One (1) ohm of resistance will permit one (1) ampere of current to flow when one (1) volt of electromotive force (EMF) is applied.

OHM'S LAW

A definite and exact relationship exists between VOLTS, OHMS and AMPERES. The value of one can be calculated when the value of the other two are known. Ohm's Law states that in any circuit the current will increase when voltage increases but resistance remains the same, and current will decrease when resistance increases and voltage remains the same.

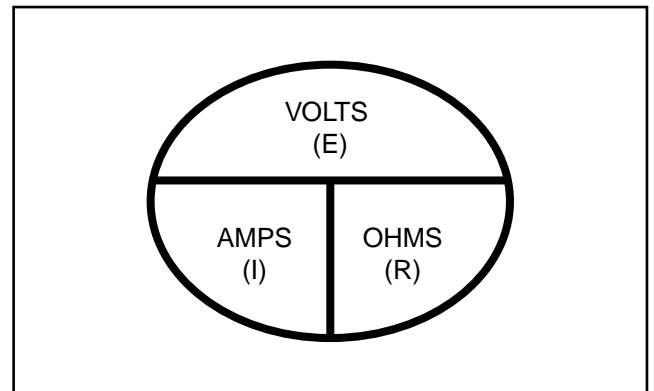

Figure 6. Ohm's Law

If AMPERES is unknown while VOLTS and OHMS are known, use the following formula:

$$\text{AMPERES} = \frac{\text{VOLTS}}{\text{OHMS}}$$

If VOLTS is unknown while AMPERES and OHMS are known, use the following formula:

$$\text{VOLTS} = \text{AMPERES} \times \text{OHMS}$$

If OHMS is unknown but VOLTS and AMPERES are known, use the following:

$$\text{OHMS} = \frac{\text{VOLTS}}{\text{AMPERES}}$$

VISUAL INSPECTION

When it becomes necessary to test or troubleshoot a generator, it is a good practice to complete a thorough visual inspection. Remove the access covers and look closely for any obvious problems. Look for the following:

- Burned or broken wires, broken wire connectors, damaged mounting brackets, etc.
- Loose or frayed wiring insulation, loose or dirty connections.
- Check that all wiring is well clear of rotating parts.
- Verify that the Generator properly connected for the correct rated voltage. This is especially important on new installations. See Section 1.2, "AC Connection Systems".
- Look for foreign objects, loose nuts, bolts and other fasteners.
- Clean the area around the Generator. Clear away paper, leaves, snow, and other objects that might blow against the generator and obstruct its air openings.

INSULATION RESISTANCE

The insulation resistance of stator and rotor windings is a measurement of the integrity of the insulating materials that separate the electrical windings from the generator steel core. This resistance can degrade over time or due to such contaminants as dust, dirt, oil, grease and especially moisture. In most cases, failures of stator and rotor windings is due to a breakdown in the insulation. And, in many cases, a low insulation resistance is caused by moisture that collects while the generator is shut down. When problems are caused by moisture buildup on the windings, they can usually be corrected by drying the windings. Cleaning and drying the windings can usually eliminate dirt and moisture built up in the generator windings.

THE MEGOHMMETER

GENERAL:

A megohmmeter, often called a "megger", consists of a meter calibrated in megohms and a power supply. Use a power supply of 500 volts when testing stators or rotors. **DO NOT APPLY VOLTAGE LONGER THAN ONE (1) SECOND.**

TESTING STATOR INSULATION:

All parts that might be damaged by the high megger voltages must be disconnected before testing. Isolate all stator leads (Figure 8) and connect all of the stator leads together. **FOLLOW THE MEGGER MANUFACTURER'S INSTRUCTIONS CAREFULLY.**

Use a megger power setting of 500 volts. Connect one megger test lead to the junction of all stator leads, the other test lead to frame ground on the stator can. Read the number of megohms on the meter.

The MINIMUM acceptable megger reading for stators may be calculated using the following formula:

MINIMUM INSULATION RESISTANCE (in "Megohms")	=	$\frac{\text{GENERATOR RATED VOLTS}}{1000}$	+1
---	---	---	----

EXAMPLE: Generator is rated at 120 volts AC. Divide "120" by "1000" to obtain "0.12". Then add "1" to obtain "1.12" megohms. Minimum Insulation resistance for a 120 VAC stator is 1.12 megohms.

If the stator insulation resistance is less than the calculated minimum resistance, clean and dry the stator. Then, repeat the test. If resistance is still low, replace the stator.

Use the Megger to test for shorts between isolated windings as outlined "Stator Insulation Tests".

Also test between parallel windings. See "Test Between Windings" on next page.

TESTING ROTOR INSULATION (12-20kW):

Apply a voltage of 500 volts across the rotor positive (+) slip ring (nearest the rotor bearing), and a clean frame ground (i.e. the rotor shaft). **DO NOT EXCEED 500 VOLTS AND DO NOT APPLY VOLTAGE LONGER THAN 1 SECOND. FOLLOW THE MEGGER MANUFACTURER'S INSTRUCTIONS CAREFULLY.**

ROTOR MINIMUM INSULATION RESISTANCE:

1.5 megohms

TESTING ROTOR INSULATION (8-10kW):

No test available.



CAUTION: Before attempting to measure insulation resistance, first disconnect and isolate all leads of the winding to be tested. Electronic components, diodes, surge protectors, relays, voltage regulators, etc., can be destroyed if subjected to high megger voltages.

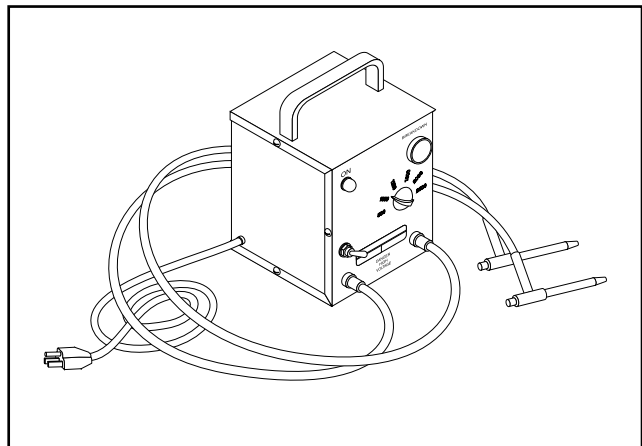

Figure 7. One Type of Hi-Pot Tester

HI-POT TESTER:

A “Hi-Pot” tester is shown in Figure 7. The model shown is only one of many that are commercially available. The tester shown is equipped with a voltage selector switch that permits the power supply voltage to be selected. It also mounts a breakdown lamp that will illuminate to indicate an insulation breakdown during the test.

STATOR INSULATION RESISTANCE TEST (12-20 KW)

GENERAL:

Units with air-cooled engine are equipped with (a) dual stator AC power windings, and (b) excitation or DPE winding. Insulation tests of the stator consist of (a) testing all windings to ground, (b) testing between isolated windings, and (c) testing between parallel windings. Figure 8 is a pictorial representation of the various stator leads on units with air-cooled engines.

TESTING ALL STATOR WINDINGS TO GROUND:

1. Disconnect stator output leads 11 and 44 from the generator main line circuit breaker.
2. Remove stator output leads 22 and 33 from the neutral connection and separate the two leads.
3. Disconnect Wires 11 and 22 from Voltage Regulator. Ensure these wires are not touching any other components on the generator.

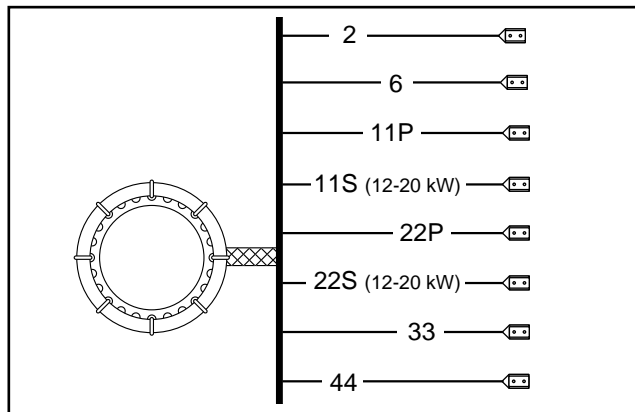

Figure 8. Stator Winding Leads

4. Connect the terminal ends of Wires 11, 22, 33 and 44 together. Make sure the wire ends are not touching any part of the generator frame or any terminal.
5. Connect the red test probe of the Hi-Pot tester to the joined terminal ends of stator leads 11, 22, 33 and 44. Connect the black tester lead to a clean frame ground on the stator can. With tester leads connected in this manner, proceed as follows:
 - a. Turn the Hi-Pot tester switch OFF.

- b. Plug the tester cord into a 120 volt AC wall socket and set its voltage selector switch to “1500 volts”.
- c. Turn the tester switch ON and observe the breakdown lamp on tester. **DO NOT APPLY VOLTAGE LONGER THAN 1 SECOND.** After one (1) second, turn the tester switch OFF.

If the breakdown lamp comes on during the one-second test, the stator should be cleaned and dried. After cleaning and drying, repeat the insulation test. If, after cleaning and drying, the stator fails the second test, the stator assembly should be replaced.

6. Proceed to the Voltage Regulator. Each winding will be individually tested for a short to ground. Refer to Steps 5a-5c and perform the same test on the following wires:

Wire Number	Winding
22S	Sense Lead Power
11S	Sense Lead Power
6	Excitation
2	Excitation
0	Ground
4	Positive to Brush Ground

TEST BETWEEN WINDINGS:

1. Disconnect Stator Output Leads 11 and 44 from the generator main line circuit breaker.
2. Remove Stator Output Leads 22 and 33 from the neutral connection and separate the two leads.
3. Disconnect Wires 11, 22, 2, and 6 from Voltage Regulator. Ensure these wires are not touching any other components on the generator.
4. Connect the red tester probe to Wire 2. Connect the black tester probe to Stator Lead 11. Refer to Steps 5a through 5c of “TESTING ALL STATOR WINDINGS TO GROUND” on previous page.
5. Repeat Step 4 between Wire 2 and Stator Lead 33.
6. Repeat Step 4 between Stator Lead 11 and Stator Lead 33.

STATOR INSULATION RESISTANCE TEST (8-10 KW)

GENERAL:

Units with air-cooled engine are equipped with (a) dual stator AC power windings, and (b) excitation or DPE winding. Insulation tests of the stator consist of (a) testing all windings to ground, (b) testing between isolated windings, and (c) testing between parallel windings. Figure 8 is a pictorial representation of the various stator leads on units with air-cooled engines.

SECTION 1.5 TESTING, CLEANING AND DRYING

PART 1

GENERAL INFORMATION

TESTING ALL STATOR WINDINGS TO GROUND:

1. Disconnect Stator Output Leads 11 and 44 from the generator main line circuit breaker.
2. Disconnect Stator Output Leads 2 and 6 from the capacitor located on the end of the stator assembly.
3. Remove Stator Output Leads 22 and 33 from the neutral connection and separate the two leads.
4. Connect the terminal ends of Wires 11, 22, 33, and 44 together. Make sure the wire ends are not touching any part of the generator frame or any terminal.
5. Connect the red test probe of the Hi-Pot tester to the joined terminal ends of Stator Leads 11, 22, 33, and 44. Connect the black tester lead to a clean frame ground on the stator can. With tester leads connected in this manner, proceed as follows:
 - a. Turn the Hi-Pot tester switch OFF.
 - b. Plug the tester cord into a 120 volt AC wall socket and set its voltage selector switch to "1500 volts".
 - c. Turn the tester switch ON and observe the breakdown lamp on tester. DO NOT APPLY VOLTAGE LONGER THAN 1 SECOND. After one (1) second, turn the tester switch OFF.
6. Connect the terminal ends of Wires 2 and 6 together. Make sure the wire ends are not touching any part of the generator frame or any terminal.
7. Repeat Step 5.

If the breakdown lamp came on during the one (1) second test, cleaning and drying of the rotor may be necessary. After cleaning and drying, repeat the insulation breakdown test. If breakdown lamp comes on during the second test, replace the rotor assembly.

ROTOR INSULATION RESISTANCE TEST (8-10 KW)

No test available.

ROTOR INSULATION RESISTANCE TEST (12-20 KW)

Before attempting to test rotor insulation, the brush holder must be completely removed. The rotor must be completely isolated from other components before starting the test. Attach all leads of all stator windings to ground.

1. Connect the red tester lead to the positive (+) slip ring (nearest the rotor bearing).
2. Connect the black tester probe to a clean frame ground, such as a clean metal part of the rotor shaft.
3. Turn the tester switch OFF.

4. Plug the tester into a 120 volts AC wall socket and set the voltage switch to "1500 volts".
5. Turn the tester switch "On" and make sure the pilot light has turned on.
6. Observe the breakdown lamp, then turn the tester switch OFF. DO NOT APPLY VOLTAGE LONGER THAN ONE (1) SECOND.

If the breakdown lamp came on during the one (1) second test, cleaning and drying of the rotor may be necessary. After cleaning and drying, repeat the insulation breakdown test. If breakdown lamp comes on during the second test, replace the rotor assembly.

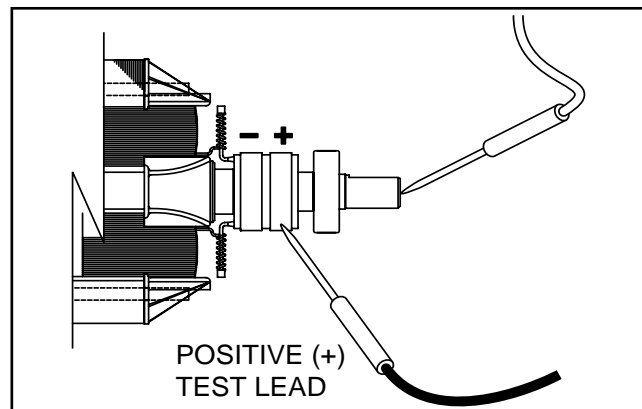

Figure 9. Testing Rotor Insulation (12-20kW)

CLEANING THE GENERATOR

Caked or greasy dirt may be loosened with a soft brush or a damp cloth. A vacuum system may be used to clean up loosened dirt. Dust and dirt may also be removed using dry, low-pressure air (25 psi maximum).



CAUTION: Do not use sprayed water to clean the generator. Some of the water will be retained on generator windings and terminals, and may cause very serious problems.

DRYING THE GENERATOR

To dry a generator, proceed as follows:

1. Open the generator main circuit breaker. NO ELECTRICAL LOADS MUST BE APPLIED TO THE GENERATOR WHILE DRYING.
2. Disconnect all Wires 6 from the voltage regulator.
3. Provide an external source to blow warm, dry air through the generator interior (around the rotor and stator windings. DO NOT EXCEED 185° F. (85° C.).
4. Start the generator and let it run for 2 or 3 hours.
5. Shut the generator down and repeat the stator and rotor insulation resistance tests.

GENERAL

Standby electric power generators will often run unattended for long periods of time. Such operating parameters as (a) battery voltage, (b) engine oil pressure, (c) engine temperature, (d) engine operating speed, and (e) engine cranking and startup are not monitored by an operator during automatic operation. Because engine operation will not be monitored, the use of engine protective safety devices is required to prevent engine damage in the event of a problem.

Generator engines mount several engine protective devices. These devices work in conjunction with a circuit board, to protect the engine against such operating faults as (a) low battery, (b) low engine oil pressure, (c) high temperature, (d) overspeed, and (e) overcrank. On occurrence of any one or more of those operating faults, circuit board action will effect an engine shutdown.

LOW BATTERY

The microprocessor will continually monitor the battery voltage and turn on the Low Battery Warning if the battery voltage falls below 10.8 volts for one (1) minute. No other action is taken on a low battery condition. Low battery voltage is a non-latching alarm which will automatically clear if the battery voltage rises above 11.0 volts. Battery voltage is NOT monitored during the crank cycle.

LOW OIL PRESSURE SHUTDOWN

See Figure 1. An oil pressure switch is mounted on the engine oil filter adapter. This switch has normally closed contacts that are held open by engine oil pressure during cranking and startup. Should oil pressure drop below approximately 5 psi, the switch contacts will close. On closure of the switch contacts, a Wire 86 circuit from the circuit board will be connected to ground. Circuit board action will then de-energize a "run relay" (on the circuit board). The run relay's normally open contacts will then open and a 12 volts DC power supply to a Wire 14 circuit will then be terminated. This will result in closure of a fuel shutoff solenoid and loss of engine ignition.

HIGH TEMPERATURE SWITCH

This switch's contacts (Figure 1) close if the temperature should exceed approximately 144° C (293° F), initiating an engine shutdown. The generator will automatically restart and the fault on the generator control panel will reset once the temperature has returned to a safe operating level.

OVERSPEED SHUTDOWN

During engine cranking and operation, the circuit board receives AC voltage and frequency signals from the ignition magneto, via Wire 18. Should the speed exceed approximately 72 Hz (4320 rpm), circuit board action will de-energize a "run relay" (mounted on the circuit board). The relay's contacts will open, to terminate engine ignition and close a fuel shutoff solenoid. The engine will then shut down. This feature protects the engine-generator against damaging overspeeds.

NOTE: The circuit board also uses rpm sensing to terminate engine cranking.

RPM SENSOR FAILURE

During cranking, if the board does not see a valid RPM signal within three (3) seconds, it will shut down and latch out on RPM sensor loss.

During running, if the RPM signal is lost for one full second the board will shut down the engine, wait 15 seconds, then re-crank the engine.

- If an RPM signal is not detected within the first three (3) seconds of cranking, the control board will shut the engine down and latch out on RPM sensor loss.
- If the RPM signal is detected the engine will start and run normally. If the RPM signal is subsequently lost again, the control board will try one more re-crank attempt before latching out and flashing the overspeed LED or RPM Sensor Failure.

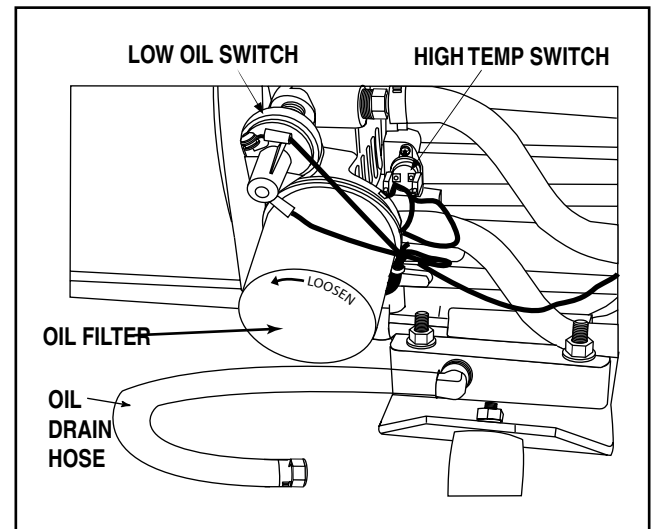

Figure 1. Engine Protective Switches on an Air-Cooled Engine

OVERCRANK SHUTDOWN

This feature prevents the generator from damaging itself when it continually attempts to start and another problem, such as no fuel supply, prevents it from starting. The unit will crank and rest for a preset time limit. Then, it will stop cranking, and the LCD screen or the LED on the generator control panel will light indicating an overcrank failure. The AUTO-OFF-MANUAL switch will need to be set to OFF and then back to AUTO to reset the generator control board.

NOTE: If the fault is not repaired, the overcrank feature will continue to activate.

The system will control the cyclic cranking as follows: 16 second crank, seven (7) second rest, 16 second crank, seven (7) second rest followed by three (3) additional cycles of seven (7) second cranks followed by seven (7) second rests.

CHOKE OPERATION:

1. The 990/999cc engines have an electric choke in the air box that is automatically controlled by the electronic control board.
2. The 530cc engines have an electric choke on the divider panel air inlet hose that is automatically controlled by the electronic control board.
3. The 410cc engines have a choke behind the air box that is automatically controlled by the electronic control board.

FAILURE TO START:

This is defined as any of the following occurrences during cranking.

1. Not reaching starter dropout within the specified crank cycle. Starter dropout is defined as four (4) cycles at 1,500 RPM (1,800 RPM for 8 kW units).
2. Reaching starter dropout, but then not reaching 2200 RPM within 15 seconds. In this case the control board will go into a rest cycle for seven (7) seconds, then continue the rest of the crank cycle.

During a rest cycle the start and fuel outputs are de-energized and the magneto output is shorted to ground.

CRANKING CONDITIONS:

The following notes apply during cranking cycle.

1. Starter motor will not engage within five (5) seconds of the engine shutting down.
2. The fuel output will not be energized with the starter.
3. The starter and magneto outputs will be energized together.
4. Once the starter is energized the control board will begin looking for engine rotation. If it does not see an RPM signal within three (3) seconds it will shut down and latch out on RPM sensor loss.
5. Once the control board sees an RPM signal it will energize the fuel solenoid, drive the throttle open and continue the crank sequence.
6. Starter motor will disengage when speed reaches starter dropout.
7. If the generator does not reach 2200 RPM within 15 seconds, re-crank cycle will occur.
8. If engine stops turning between starter dropout and 2200 RPM, the board will go into a rest cycle for seven (7) seconds then re-crank (if additional crank cycles exist).
9. Once started, the generator will wait for a hold-off period before starting to monitor oil pressure and oil temperature (refer to the Alarm Messages section for hold-off times).
10. During Manual start cranking, if the Mode switch is moved from the Manual position, the cranking stops immediately.
11. During Auto mode cranking, if the Utility returns, the cranking cycle does NOT abort but continues until complete. Once the engine starts, it will run for one (1) minute, then shut down.

CONTROL PANEL

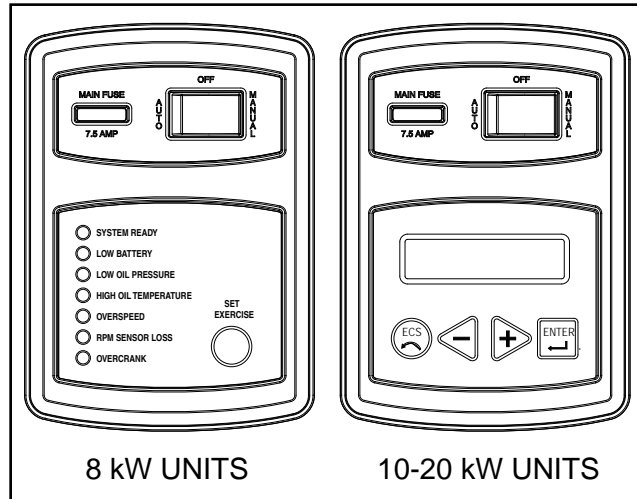

Figure 1. Generator Control Panel

AUTO-OFF-MANUAL SWITCH:

Use this switch to (a) select fully automatic operation, (b) to crank and start the engine manually, and (c) to shut the unit down or to prevent automatic startup.

1. AUTO position:
 - a. Select AUTO for fully automatic operation.
 - b. When AUTO is selected, circuit board will monitor utility power source voltage.
 - c. Should utility voltage drop below a preset level and remain at such a low level for a preset time, circuit board action will initiate engine cranking and startup.
 - d. Following engine startup, circuit board action will initiate transfer of electrical loads to the "Standby" source side.
 - e. On restoration of utility source voltage above a preset level, circuit board action will initiate retransfer back to the "Utility Source" side.
 - f. Following retransfer, circuit board will shut the engine down and will then continue to monitor utility source voltage.
2. OFF Position:
 - a. Set the switch to OFF to stop an operating engine.
 - b. To prevent an automatic startup from occurring, set the switch to OFF.
3. MANUAL Position:
 - a. Set switch to MANUAL to crank and start unit manually.
 - b. Engine will crank cyclically and start (same as automatic startup, but without transfer). The unit will transfer if utility voltage is not available.



DANGER: WHEN THE GENERATOR IS INSTALLED IN CONJUNCTION WITH AN AUTOMATIC TRANSFER SWITCH, ENGINE CRANKING AND STARTUP CAN OCCUR AT ANY TIME WITHOUT WARNING (PROVIDING THE AUTO-OFF-MANUAL SWITCH IS SET TO AUTO). TO PREVENT AUTOMATIC STARTUP AND POSSIBLE INJURY THAT MIGHT BE CAUSED BY SUCH STARTUP, ALWAYS SET THE AUTO-OFF-MANUAL SWITCH TO ITS OFF POSITION BEFORE WORKING ON OR AROUND THIS EQUIPMENT.

7.5 AMP FUSE:

This fuse protects the DC control circuit (including the circuit board) against overload. If the fuse element has melted open due to an overload, engine cranking or running will not be possible. Should fuse replacement become necessary, use only an identical 7.5 amp replacement fuse.

SETTING THE EXERCISE TIMER:

This generator is equipped with an exercise timer. Once it is set, the generator will start and exercise every seven days, on the day of the week and at the time of day specified. During this exercise period, the unit runs for approximately 12 minutes and then shuts down. Transfer of loads to the generator output does not occur during the exercise cycle unless utility power is lost.

8KW:

A switch on the control panel (see Figure1) permits selection of the day and time for the system to exercise. At the chosen time, perform the following sequence to select the desired day and time of day the system will exercise. Remember seasonal time changes affect the exercise settings.

1. Verify that the AUTO-OFF-MANUAL switch is set to AUTO.
2. Press and hold the "Set Exercise" switch for several seconds. All the red LED's will stop flashing immediately and the generator will start.
3. The generator will start and run for approximately 12 minutes and then shut down. The exerciser is now set to run at this time of day each week.

Example: If the "Set Exercise" pressed on Saturday afternoon at 2:00 p.m., the generator will start and exercise for approximately 12 minutes every Saturday at 2:00 p.m.

NOTE: The exerciser will only work in the AUTO mode and will not work unless this procedure is performed. The exerciser will need to be reset every time the 12 Volt battery is disconnected and then reconnected, and when the fuse is removed and/or replaced.

10-20 KW – INSTALLATION ASSISTANT:

Upon first power up of the generator, the display interface will begin an installation assistant. The assistant will prompt the user to set the minimum settings to operate. These settings are simply: Current Date/Time and Exercise Day/Time. The maintenance intervals will be initialized when the exercise time is entered for the first time (Figure 3.2).

The exercise settings can be changed at any time via the "EDIT" menu (see Appendix, "Menu System").

If the 12 Volt battery is disconnected or the fuse removed, the Installation Assistant will operate upon power restoration. The only difference is the display will only prompt the customer for the current Time and Date.

If the installer tests the generator prior to installation, press the "ENTER" key to avoid setting up the exercise time. This will ensure that when the customer powers up the unit, he will still be prompted to enter an exercise time.

NOTE: The exerciser will only work in the AUTO mode and will not work unless this procedure is performed. The current date/time will need to be reset every time the 12 Volt battery is disconnected and then reconnected, and/or when the fuse is removed.

TO SELECT AUTOMATIC OPERATION

The following procedure applies only to those installations in which the air-cooled, automatic standby generator is installed in conjunction with a transfer switch. Transfer switches do not have an intelligence circuit of their own. Automatic operation on transfer switch and generator combinations is controlled by circuit board action.

To select automatic operation when a transfer switch is installed along with a home standby generator, proceed as follows:

1. Check that the transfer switch main contacts are at their UTILITY position, i.e., the load is connected to the power supply. If necessary, manually actuate the switch main contacts to their UTILITY source side. See Part 3 of this manual, as appropriate, for instructions.
2. Check that utility source voltage is available to transfer switch terminal lugs N1 and N2 (2-pole, 1-phase transfer switches).
3. Set the generator AUTO-OFF-MANUAL switch to its AUTO position.
4. Actuate the generator main line circuit breaker to its "On" or "Closed" position. With the preceding Steps 1 through 4 completed, a dropout in utility supply voltage below a preset level will result in automatic generator cranking and start-up. Following startup, the transfer switch will be actuated to its "Standby" source side, i.e., loads powered by the standby generator.

**MANUAL TRANSFER TO "STANDBY" AND
MANUAL STARTUP**

To transfer electrical loads to the "Standby" (generator) source and start the generator manually, proceed as follows:

1. On the generator panel, set the AUTO-OFF-MANUAL switch to OFF.
2. On the generator, set the main line circuit breaker to its OFF or "Open" position.
3. Turn OFF the power supply to the transfer switch, using whatever means provided (such as a utility source line circuit breaker).
4. Manually actuate the transfer switch main contacts to their "Standby" position, i.e., loads connected to the "Standby" power source side.

NOTE: For instructions on manual operation of transfer switches, see Part 3.

5. On the generator panel, set the AUTO-OFF-MANUAL switch to MANUAL. The engine should crank and start.
6. Let the engine warm up and stabilize for a minute or two at no-load.
7. Set the generator main line circuit breaker to its "On" or "Closed" position. The generator now powers the electrical loads.

**MANUAL SHUTDOWN AND RETRANSFER
BACK TO "UTILITY"**

To shut the generator down and retransfer electrical loads back to the UTILITY position, proceed as follows:

1. Set the generator main line circuit breaker to its OFF or "Open" position.
2. Let the generator run at no-load for a few minutes, to cool.
3. Set the generator AUTO-OFF-MANUAL switch to OFF. Wait for the engine to come to a complete stop.
4. Turn off the utility power supply to the transfer switch using whatever means provided (such as a utility source main line circuit breaker)
5. Manually actuate the transfer switch to its UTILITY source side, i.e., load connected to the utility source.
6. Turn on the utility power supply to the transfer switch, using whatever means provided.
7. Set the generator AUTO-OFF-MANUAL switch to AUTO.

INTRODUCTION

When the generator is installed in conjunction with a transfer switch, either manual or automatic operation is possible. Manual transfer and engine startup, as well as manual shutdown and re-transfer are covered in Section 1.7. Selection of fully automatic operation is also discussed in that section. This section will provide a step-by-step description of the sequence of events that will occur during automatic operation of the system.

UTILITY FAILURE

Initial Conditions: Generator in Auto, ready to run, load being supplied by utility source. When utility fails (below 65% of nominal), a 10 second (optionally programmable on the 17 and 20 kW only) line interrupt delay time is started. If the utility is still gone when the timer expires, the engine will crank and start. Once started, a five (5) second engine warmup timer will be initiated.

When the warm-up timer expires, the control will transfer the load to the generator. If the utility power is restored (above 75% of nominal) at any time from the initiation of the engine start until the generator is ready to accept load (5 second warm-up time has not elapsed), the controller will complete the start cycle and run the generator through its normal cool down cycle; however, the load will remain on the utility source.

CRANKING

The system will control the cyclic cranking as follows:

16 second crank, seven (7) second rest, 16 second crank, seven (7) second rest followed by three (3) additional cycles of seven (7) second cranks followed by seven (7) second rests.

CHOKE OPERATION:

1. The 990/999cc engines have an electric choke in the air box that is automatically controlled by the electronic control board.
2. The 530cc engines have an electric choke on the divider panel air inlet hose that is automatically controlled by the electronic control board.
3. The 410cc engines have a choke behind the air box that is automatically controlled by the electronic control board.

FAILURE TO START:

This is defined as any of the following occurrences during cranking.

1. Not reaching starter dropout within the specified crank cycle. Starter dropout is defined as four (4) cycles at 1,000 RPM.
2. Reaching starter dropout, but then not reaching 2200 RPM within 15 seconds. In this case the control board will go into a rest cycle for seven (7) seconds, then continue the rest of the crank cycle.

During a rest cycle the start and fuel outputs are de-energized and the magneto output is shorted to ground.

CRANKING CONDITIONS:

The following notes apply during cranking cycle.

1. Starter motor will not engage within five (5) seconds of the engine shutting down.
2. The fuel output will not be energized with the starter.
3. The starter and magneto outputs will be energized together.
4. Once the starter is energized the control board will begin looking for engine rotation. If it does not see an RPM signal within three (3) seconds it will shut down and latch out on RPM sensor loss.
5. Once the control board sees an RPM signal it will energize the fuel solenoid, drive the throttle open and continue the crank sequence.
6. Starter motor will disengage when speed reaches starter dropout.
7. If the generator does not reach 2200 RPM within 15 seconds, re-crank cycle will occur.
8. If engine stops turning between starter dropout and 2200 RPM, the board will go into a rest cycle for seven (7) seconds then re-crank (if additional crank cycles exist).
9. Once started, the generator will wait for a holdoff period before starting to monitor oil pressure and oil temperature (refer to the Alarm Messages section for hold-off times).
10. During Manual start cranking, if the Mode switch is moved from the Manual position, the cranking stops immediately.
11. During Auto mode cranking, if the Utility returns, the cranking cycle does NOT abort but continues until complete. Once the engine starts, it will run for one (1) minute, then shut down.

LOAD TRANSFER

The transfer of load when the generator is running is dependent upon the operating mode as follows:

1. Manual

- Will not transfer to generator if utility is present.
- Will transfer to generator if utility fails (below 65% of nominal for 10 consecutive seconds).
- Will transfer back when utility returns for 15 consecutive seconds. The engine will continue to run until removed from the Manual mode.

2. Auto

- Will start and run if Utility fails for 10 consecutive seconds.
- Will start a five (5) second engine warm-up timer.
- Will not transfer if utility subsequently returns.
- Will transfer to generator if utility is still not present.
- Will transfer back to utility once utility returns (above 75% of nominal) for 15 seconds.
- Will transfer back to utility if the generator is shut down for any reason (such as the switch is in the OFF position or a shutdown alarm).
- After transfer, will shut down engine after one (1) minute cool-down time.

3. Exercise

- Will not exercise if generator is already running in either Auto or Manual mode.
- During exercise, the controller will only transfer if utility fails during exercise for 10 seconds, and will switch to Auto mode.

UTILITY RESTORED

Initial Condition: Generator supplying power to customer load. When the utility returns (above 75% of nominal), a 15 second return to utility timer will start. At the completion of this timer, if the utility supply is still present and acceptable, the control will transfer the load back to the utility and run the engine through a one (1) minute cool down period and then shut down. If utility fails for three (3) seconds during this cool down period, the control will transfer load back to the generator and continue to run while monitoring for utility to return.

PART 2 AC GENERATORS

Air-cooled, Automatic Standby Generators

TABLE OF CONTENTS		
PART	TITLE	PAGE#
2.1.	Description and Components	32
2.2	Operational Analysis	35
2.3	Troubleshooting Flow Charts	37
2.4	Diagnostic Tests ⁴¹	

2.1 Description and Components	32	Test 1 – Check Main Circuit Breaker.....	41
Introduction	32	Test 2 – Check AC Output Voltage.....	41
Engine-Generator Drive System	32	Test 4 – Fixed Excitation Test/Rotor Amp Draw Test	42
The AC Generator.....	32	Test 5 – Wire Continuity (12-20 kW)	43
Rotor Assembly.....	32	Test 6 – Check Field Boost (12-20 kW)	44
Stator Assembly.....	33	Test 7 – Testing The Stator With A Vom (12-20 kW).....	44
Brush Holder And Brushes (12-20 kW)	34	Test 8 – Test Brushless Stator.....	45
Other AC Generator Components	34	Test 9 – Check Capacitor.....	46
2.2 Operational Analysis	35	Test 10 – Test DPE Winding on Brushless units.....	47
Rotor Residual Magnetism.....	35	Test 11 – Resistance Check Of Rotor Circuit (12-20 kW).....	48
Field Boost (12-20 KW Units)	35	Test 12 – Check Brushes And Slip Rings (12-20 kW).....	48
Operation (8/10 kW).....	36	Test 13 – Test Rotor Assembly(12-20 kW).....	49
Operation (12-20 kW)	36	Test 14 – Check AC Output Frequency.....	49
2.3 Troubleshooting Flowcharts.....	37	Test 15 – Check and Adjust Engine Governor (Single Cylinder Units).....	49
Problem 1 – Generator Produces Zero Voltage or Residual Voltage 12-20 kW	37-38	Test 16 – Check Stepper Motor Control (V-twin Engine Units).....	50
Problem 2 – Generator Produces Zero Voltage or Residual Voltage 8/10 kW	38	Test 17 – Check And Adjust Voltage Regulator (12-20 kW).....	51
Problem 3 – Generator Produces Low Voltage at No-Load	39	Test 18 – Check Voltage And Frequency Under Load.....	52
Problem 4 – Generator Produces High Voltage at No-Load	39	Test 19 – Check For Overload Condition.....	52
Problem 5 – Voltage and Frequency Drop Excessively When Loads are Applied	40	Test 20 – Check Engine Condition.....	52
2.4 Diagnostic Tests	41	Test 21 – Field Flash Alternator (8-10 kW)	52
Introduction	41		
Safety	41		

INTRODUCTION

The air-cooled, automatic standby system is an easy to install, fully enclosed and self-sufficient electric power system. It is designed especially for homeowners, but may be used in other applications as well. On occurrence of a utility power failure, this high performance system will (a) crank and start automatically, and (b) automatically transfer electrical loads to generator AC output.

The generator revolving field (rotor) is driven by an air-cooled engine at about 3600 rpm.

The generator may be used to supply electrical power for the operation of 120 and/or 240 volts, 1-phase, 60 Hz, AC loads.

A 2-pole, "W/V-Type" transfer switch is offered (see Part 3). The transfer switch does not include an "intelligence circuit" of it's own. Instead, automatic startup, transfer, running, retransfer and shutdown operations are controlled by a solid state circuit board in the generator control panel.

ENGINE-GENERATOR DRIVE SYSTEM

The generator revolving field is driven by an air-cooled, horizontal crankshaft engine. The generator is directly coupled to the engine crankshaft (see Figure

1), and mounted in an enclosure. Both the engine and generator rotor are driven at approximately 3600 rpm, to provide a 60 Hz AC output.

THE AC GENERATOR

Figure 1 shows the major components of the AC generator.

ROTOR ASSEMBLY

12-20 KW:

The 2-pole rotor must be operated at 3600 rpm to supply a 60 Hertz AC frequency. The term "2-pole" means the rotor has a single north magnetic pole and a single south magnetic pole. As the rotor rotates, its lines of magnetic flux cut across the stator assembly windings and a voltage is induced into the stator windings. The rotor shaft mounts a positive (+) and a negative (-) slip ring, with the positive (+) slip ring nearest the rear bearing carrier. The rotor bearing is pressed onto the end of the rotor shaft. The tapered rotor shaft is mounted to a tapered crankshaft and is held in place with a single through bolt.

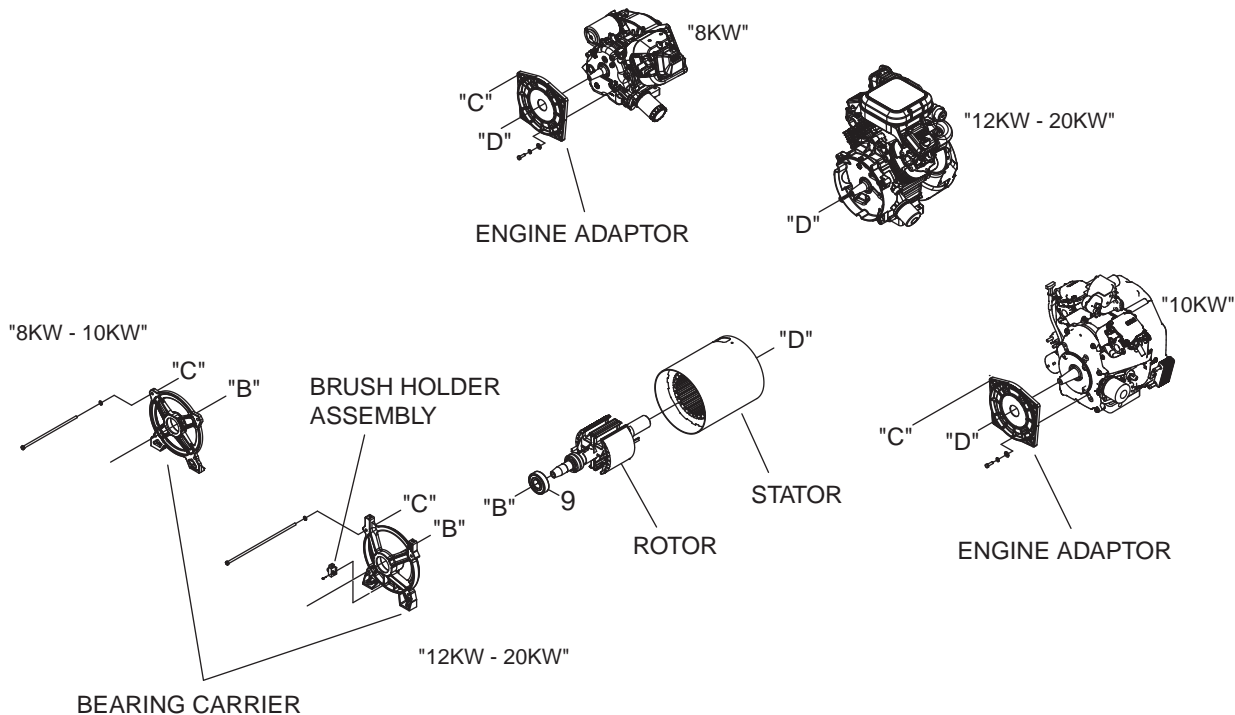

Figure 1. AC Generator Exploded View

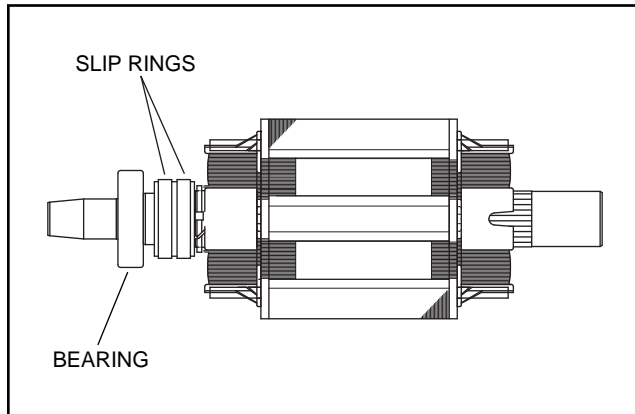

Figure 2. The 2-Pole Rotor Assembly 12-20 kW

8/10KW:

Like the 12-20 kW rotor, the 8/10 kW 2-pole rotor must be operated at 3600 rpm to supply a 60 Hertz AC frequency. However, the 8/10kW rotor uses no slip rings. As the rotor rotates in the generator voltage is induced from the Excitation winding using a capacitor that is in turn excited by the rotor. A continuous loop of charging and discharging of the capacitor is maintained that acts as a voltage regulation system. The rotor bearing is pressed onto the end of the rotor shaft. The tapered rotor shaft is mounted to a tapered crankshaft and is held in place with a single through bolt.

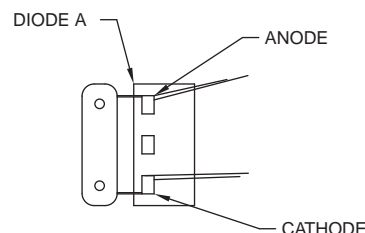
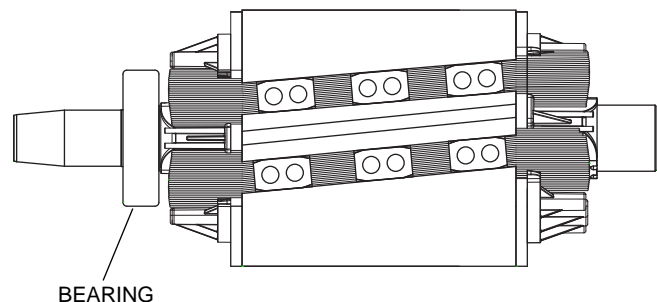
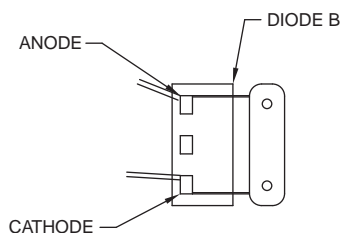
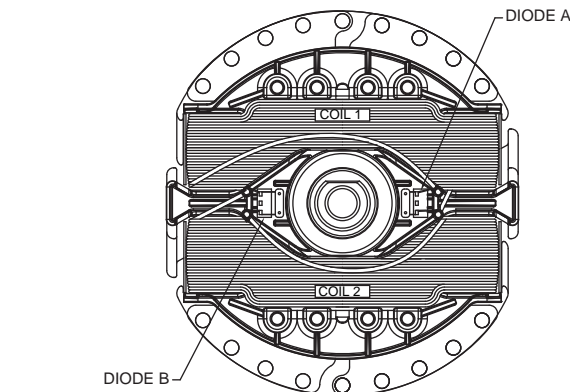

Figure 3. The 2-Pole Rotor Assembly 8/10kW

STATOR ASSEMBLY

The stator can houses and retains (a) dual AC power windings, and (b) excitation winding. A total of six (6) or eight (8) stator leads are brought out of the stator can as shown in Figure 4.

The stator can is sandwiched between an engine adapter and a rear bearing carrier. It is retained in that position by four stator studs.

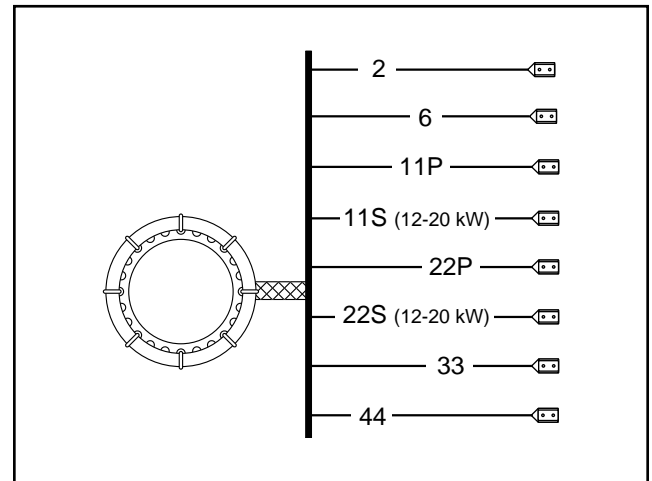

Figure 4. Stator Assembly Leads

BRUSH HOLDER AND BRUSHES
(12-20 KW)

The brush holder is retained to the rear bearing carrier by means of two #10-32 x 9/16 Taptite screws. A positive (+) and a negative (-) brush are retained in the brush holder, with the positive (+) brush riding on the slip ring nearest the rotor bearing.

Wire 4 connects to the positive (+) brush and Wire 0 to the negative (-) brush. Wire 0 connects to frame ground. Rectified and regulated excitation current, as well as current from a field boost circuit, are delivered to the rotor windings via Wire 4, and the positive (+) brush and slip ring. The excitation and field boost current passes through the windings and to frame ground via the negative (-) slip ring and brush, and Wire 0. This current flow creates a magnetic field around the rotor having a flux concentration that is proportional to the amount of current flow.

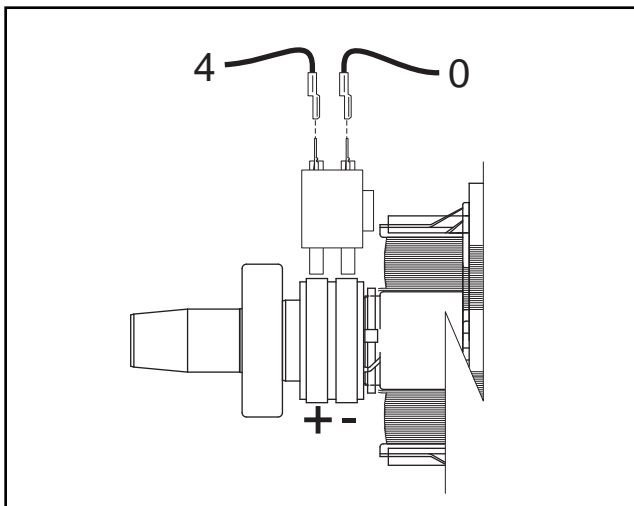

Figure 4. Brush Holder and Brushes (12-20 kW)

OTHER AC GENERATOR COMPONENTS

Some AC generator components are housed in the generator control panel enclosure, and are not shown in Figure 1. These are (a) a voltage regulator, and (b) a main line circuit breaker.

VOLTAGE REGULATOR (12-20 KW):

A typical voltage regulator is shown in Figure 5. Unregulated AC output from the stator excitation winding is delivered to the regulator's DPE terminals, via Wire 2 and Wire 6. The voltage regulator rectifies that current and, based on stator AC power winding sensing, regulates it. The rectified and regulated excitation current is then delivered to the rotor windings from the positive (+) and negative (-) regulator terminals, via Wire 4 and Wire 0. Stator AC power winding "sensing" is delivered to the regulator "SEN" terminals via Wires 11 and 22.

The regulator provides "over-voltage" protection, but does not protect against "under-voltage". On occurrence of an "over-voltage" condition, the regulator will "shut down" and complete loss of excitation current to the rotor will occur. Without excitation current, the generator AC output voltage will drop to approximately one-half (or lower) of the unit's rated voltage.

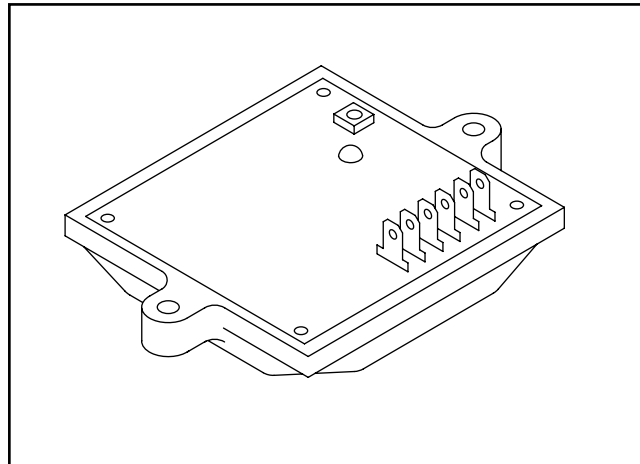

Figure 5. Typical Voltage Regulator

A single red lamp (LED) glows during normal operation. The lamp will become dim if excitation winding AC output diminishes. It will go out on occurrence of an open condition in the sensing AC output circuit.

An adjustment potentiometer permits the stator AC power winding voltage to be adjusted. Perform this adjustment with the generator running at no-load, and with a frequency of 60 Hz

At the stated no-load frequency, adjust to obtain a line-to-line AC voltage of 247-249 volts.

MAIN LINE CIRCUIT BREAKER:

The main line circuit breaker protects the generator against electrical overload. See "Specifications" in front of manual for amp ratings.

ROTOR RESIDUAL MAGNETISM

The generator revolving field (rotor) may be considered to be a permanent magnet. Some "residual" magnetism is always present in the rotor. This residual magnetism is sufficient to induce a voltage into the stator AC power windings that is approximately 2-12 volts AC.

FIELD BOOST (12-20 KW)

FIELD BOOST CIRCUIT:

When the engine is cranking, direct current flow is delivered from a circuit board to the generator rotor windings, via Wire 4.

The field boost system is shown schematically in Figure 2. Manual and automatic engine cranking is initiated by circuit board action, when that circuit board energizes a crank relay. Battery voltage is then delivered to field boost Wire 4 (and to the rotor), via a field boost resistor and diode. The crank relay, field boost resistor and diode are all located on the circuit board.

Notice that field boost current is available only while the crank relay is energized, i.e., while the engine is cranking.

Field boost voltage is reduced from that of battery voltage by the resistor action and, when read with a DC voltmeter, will be approximately 9 or 10 volts DC.

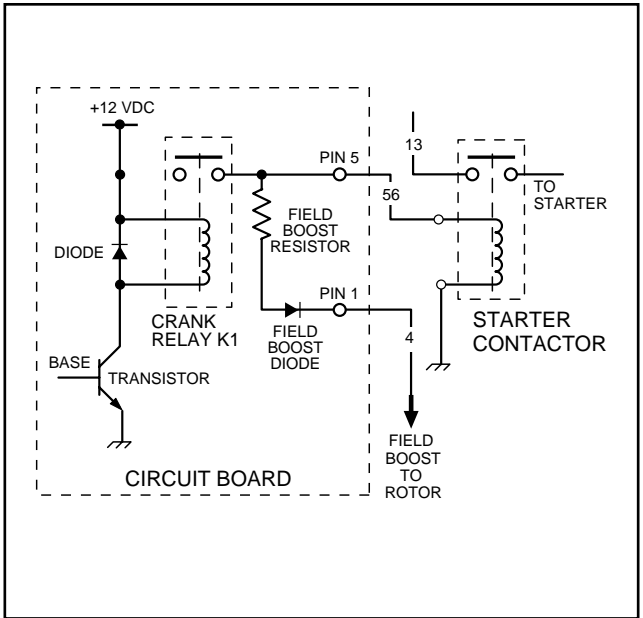

Figure 2. Field Boost Circuit Schematic

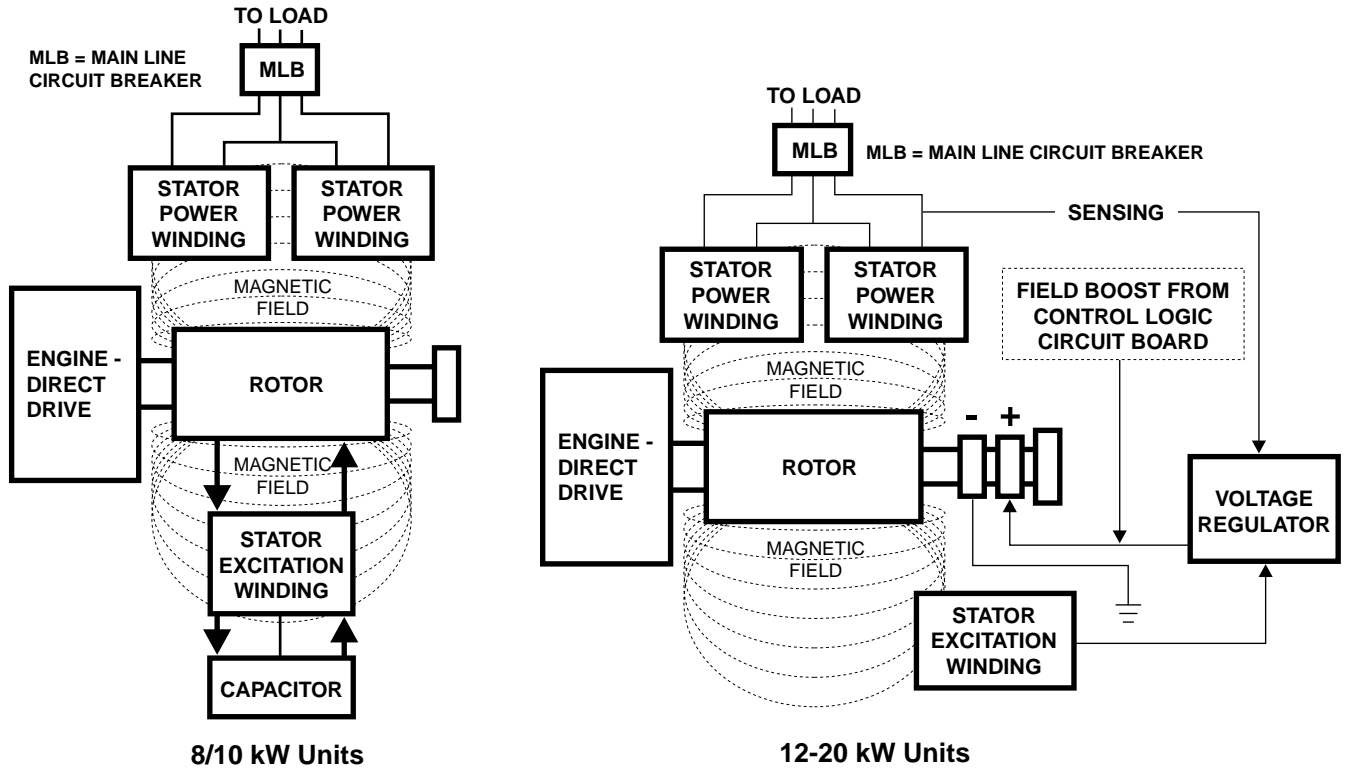

Figure 1. Operating Diagram of AC Generator

OPERATION (8/10 KW)

STARTUP:

When the engine is started, residual magnetism from the rotor induces a voltage into (a) the stator AC power windings, and (b) the stator excitation or DPE windings. The capacitor on the DPE winding will be charged and then will discharge causing a voltage to be induced back into the rotor.

FIELD EXCITATION:

An AC voltage is induced into the stator excitation (DPE) windings. The DPE winding circuit is completed to the capacitor, via Wire 2 and Wire 6.

The capacitor will charge at a rate that is dependant on the amount of voltage that is being induced into it. Once the capacitor is fully charged the voltage that it discharges is a constant voltage and will in-turn increase the size of the magnetic field of the rotor.

The greater the current flow through the rotor windings, the more concentrated the lines of flux around the rotor become.

The more concentrated the lines of flux around the rotor that cut across the stationary stator windings, the greater the voltage that is induced into the stator windings.

AC POWER WINDING OUTPUT:

A regulated voltage is induced into the stator AC power windings. When electrical loads are connected across the AC power windings to complete the circuit, current can flow in the circuit.

OPERATION (12-20 KW)

STARTUP:

When the engine is started, residual plus field boost magnetism from the rotor induces a voltage into (a) the stator AC power windings, and (b) the stator excitation or DPE windings. In an "on-speed" condition, residual plus field boost magnetism are capable of creating approximately one-half the unit's rated voltage.

ON-SPEED OPERATION:

As the engine accelerates, the voltage that is induced into the stator windings increases rapidly, due to the increasing speed at which the rotor operates.

FIELD EXCITATION:

An AC voltage is induced into the stator excitation (DPE) windings. The DPE winding circuit is completed to the voltage regulator, via Wire 2 and Wire 6. Unregulated alternating current can flow from the winding to the regulator.

The voltage regulator "senses" AC power winding output voltage and frequency via stator Wires 11 and 22.

The regulator changes the AC from the excitation winding to DC. In addition, based on the Wires 11 and 22 sensing signals, it regulates the flow of direct current to the rotor.

The rectified and regulated current flow from the regulator is delivered to the rotor windings, via Wire 4, and the positive brush and slip ring. This excitation current flows through the rotor windings and is directed to ground through the negative (-) slip ring and brush, and Wire 0.

The greater the current flow through the rotor windings, the more concentrated the lines of flux around the rotor become.

The more concentrated the lines of flux around the rotor that cut across the stationary stator windings, the greater the voltage that is induced into the stator windings.

Initially, the AC power winding voltage sensed by the regulator is low. The regulator reacts by increasing the flow of excitation current to the rotor until voltage increases to a desired level. The regulator then maintains the desired voltage. For example, if voltage exceeds the desired level, the regulator will decrease the flow of excitation current. Conversely, if voltage drops below the desired level, the regulator responds by increasing the flow of excitation current.

AC POWER WINDING OUTPUT:

A regulated voltage is induced into the stator AC power windings. When electrical loads are connected across the AC power windings to complete the circuit, current can flow in the circuit. The regulated AC power winding output voltage will be in direct proportion to the AC frequency. For example, on units rated 120/240 volts at 60 Hz, the regulator will try to maintain 240 volts (line-to-line) at 60 Hz. This type of regulation system provides greatly improved motor starting capability over other types of systems.

GENERAL

Use the "Flow Charts" in conjunction with the detailed instructions in Section 2.4. Test numbers used in the flow charts correspond to the numbered tests in Section 2.4.

The first step in using the flow charts is to correctly identify the problem. Once that has been done, locate the problem on the following pages. For best results, perform all tests in the exact sequence shown in the flow charts.

Problem 1 - Generator Produces Zero Voltage or Residual Voltage (12-20 kW)

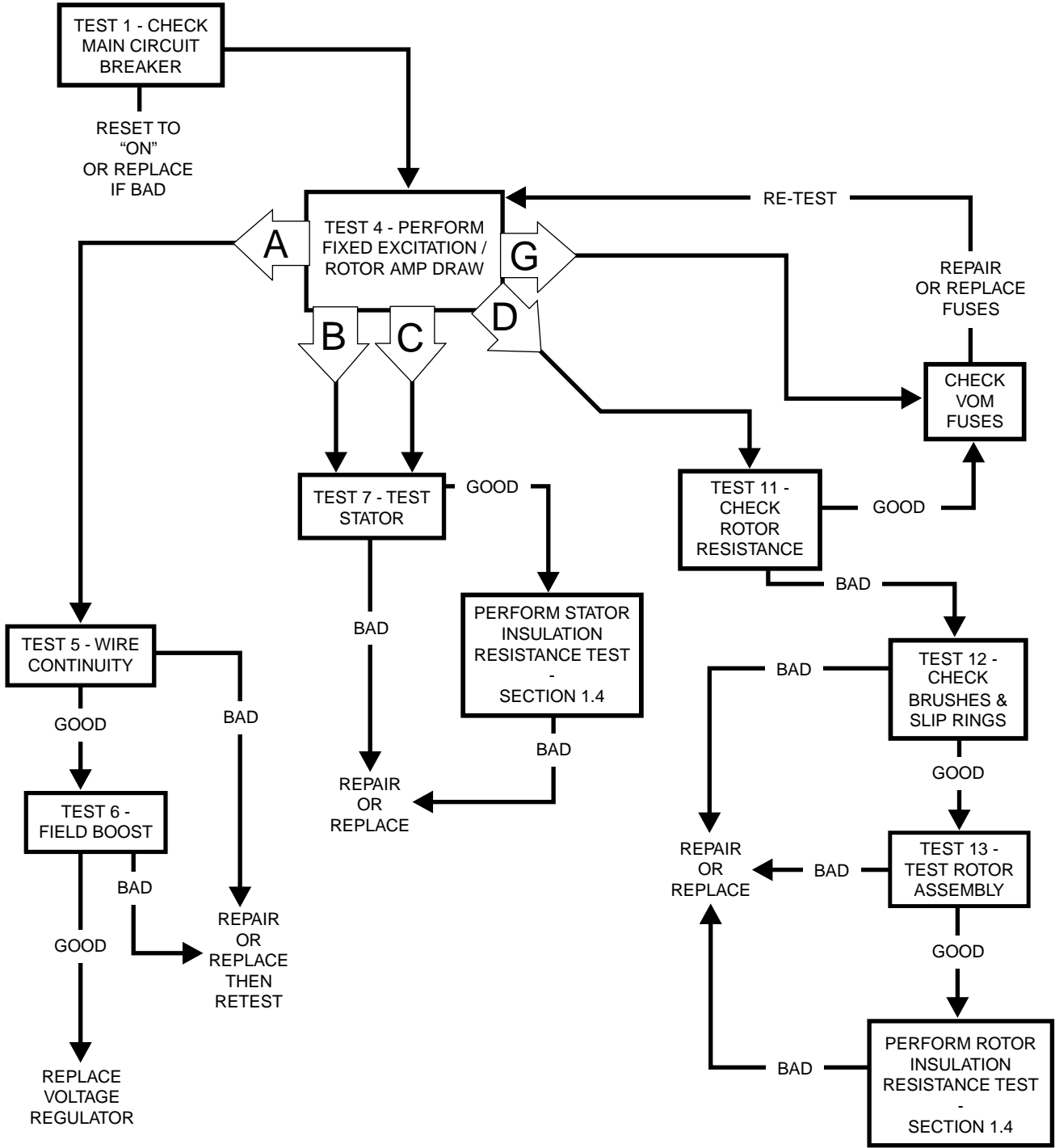

SECTION 2.3
TROUBLESHOOTING FLOWCHARTS

**Problem 1 - Generator Produces Zero Voltage or Residual Voltage
(12-20 kW Continued)**

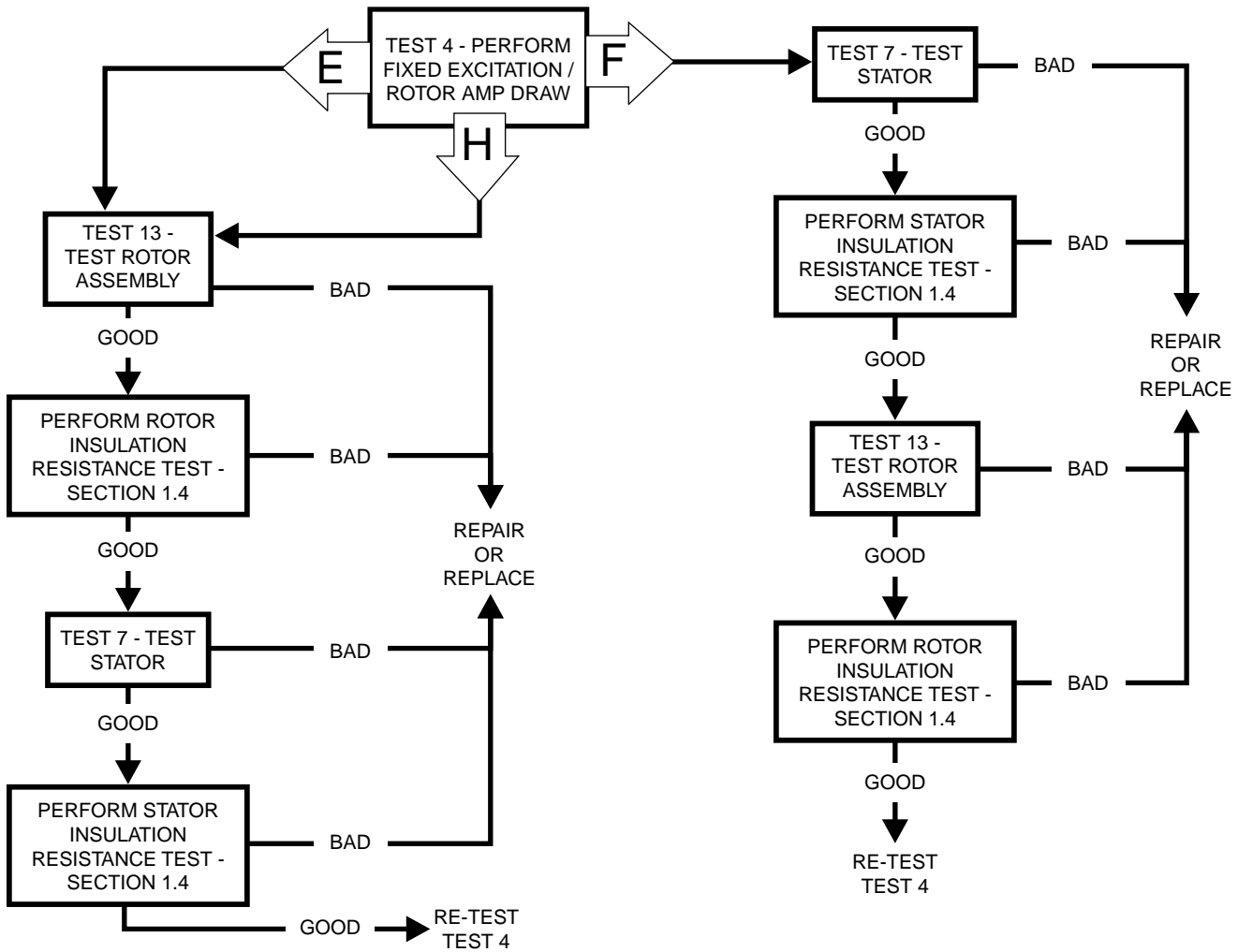

**Problem 2 - Generator Produces Zero Voltage or Residual Voltage
(8/10 kW)**

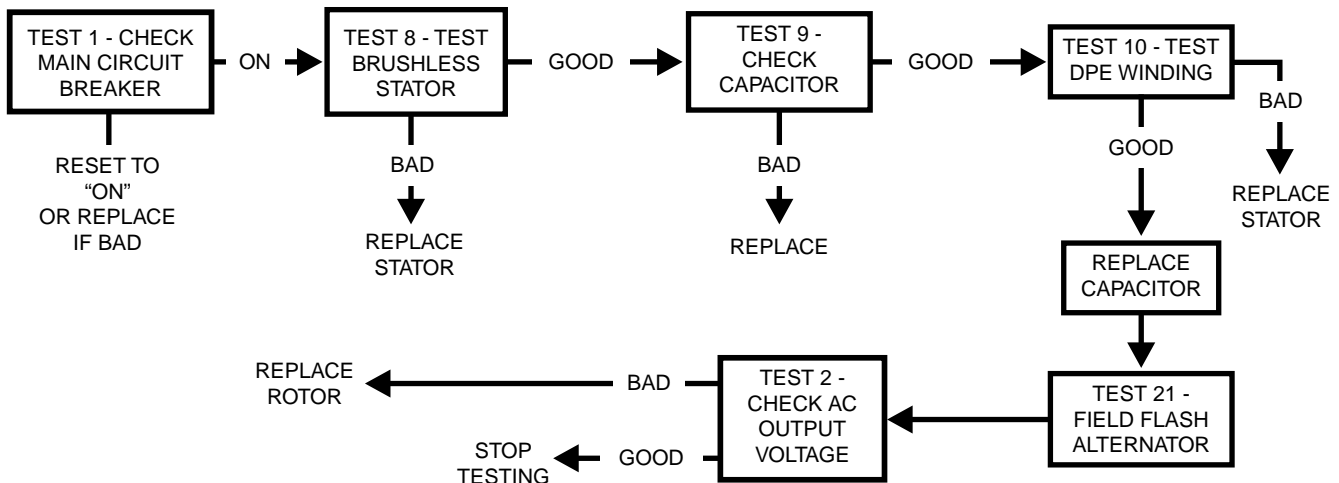

Problem 3 - Generator Produces Low Voltage at No-Load

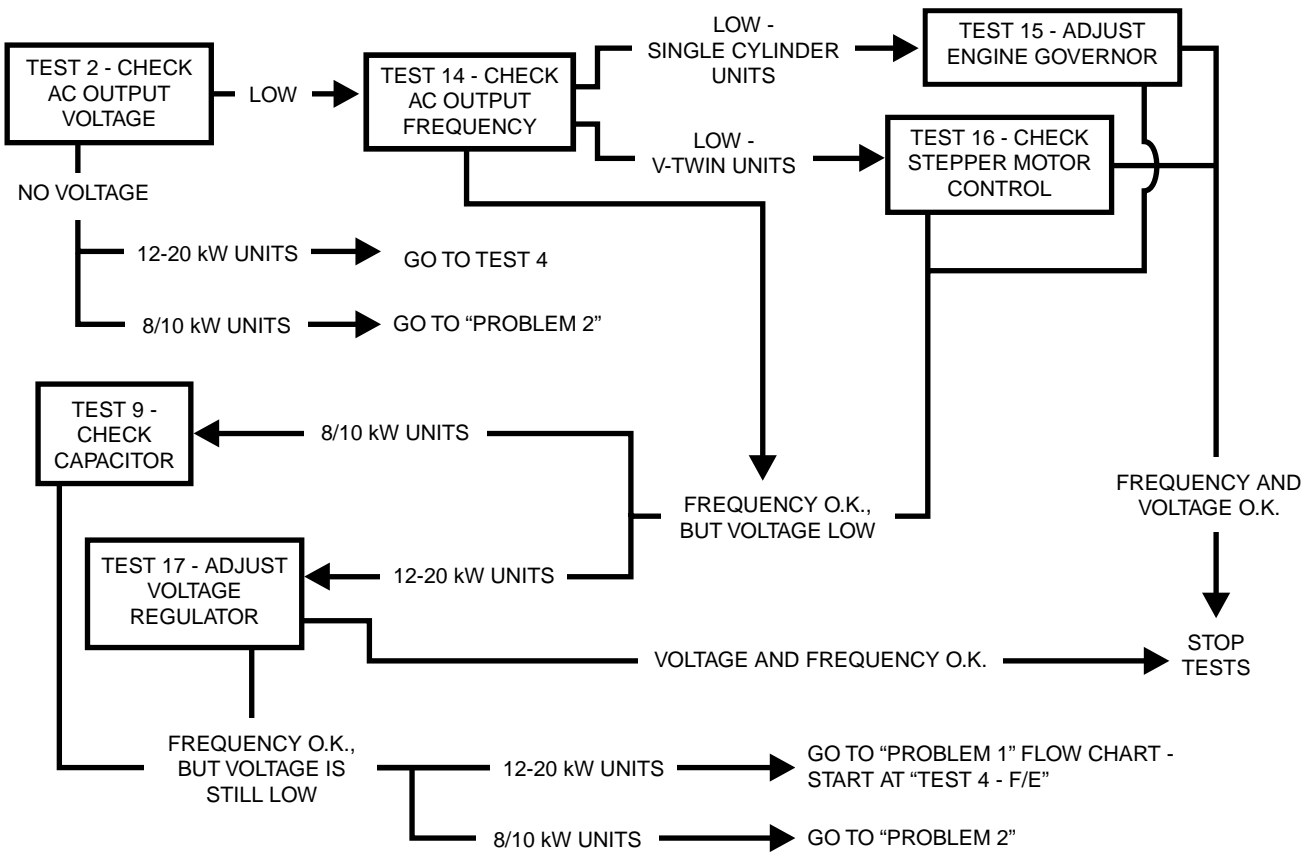

Problem 4 - Generator Produces High Voltage at No-Load

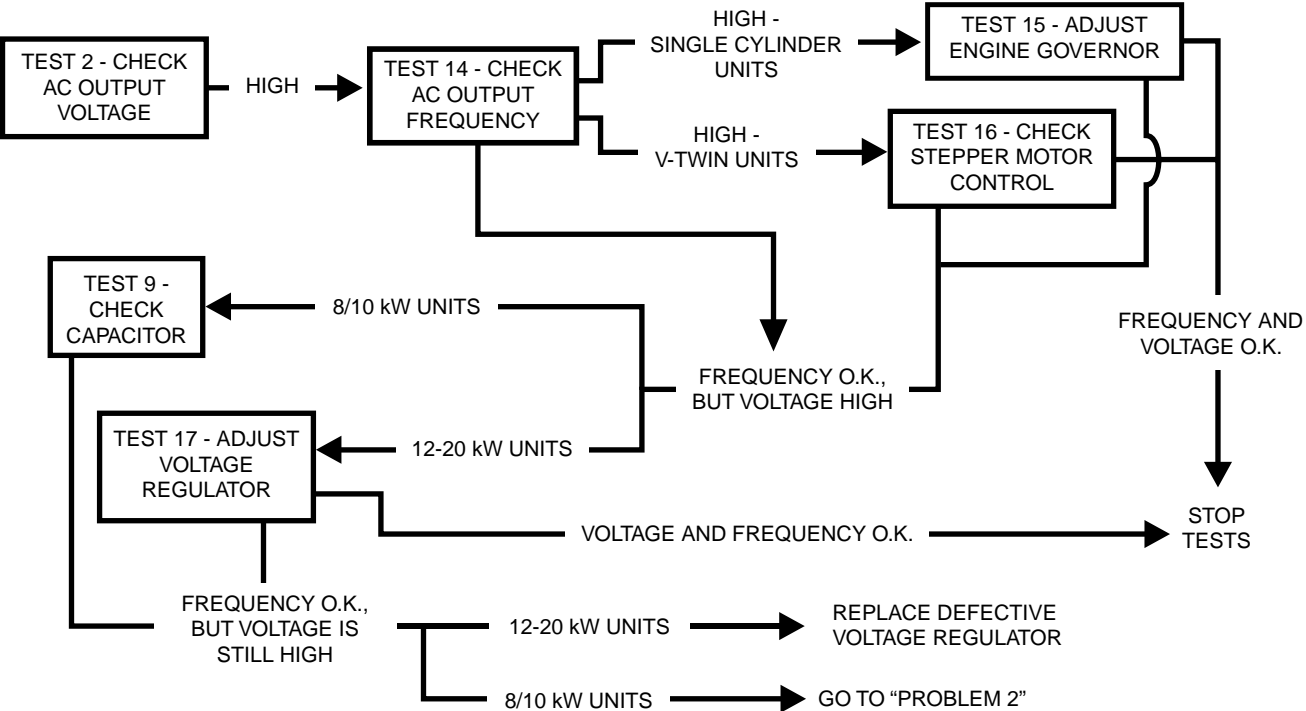

**SECTION 2.3
TROUBLESHOOTING FLOWCHARTS**

Problem 4 - Voltage and Frequency Drop Excessively When Loads Are Applied

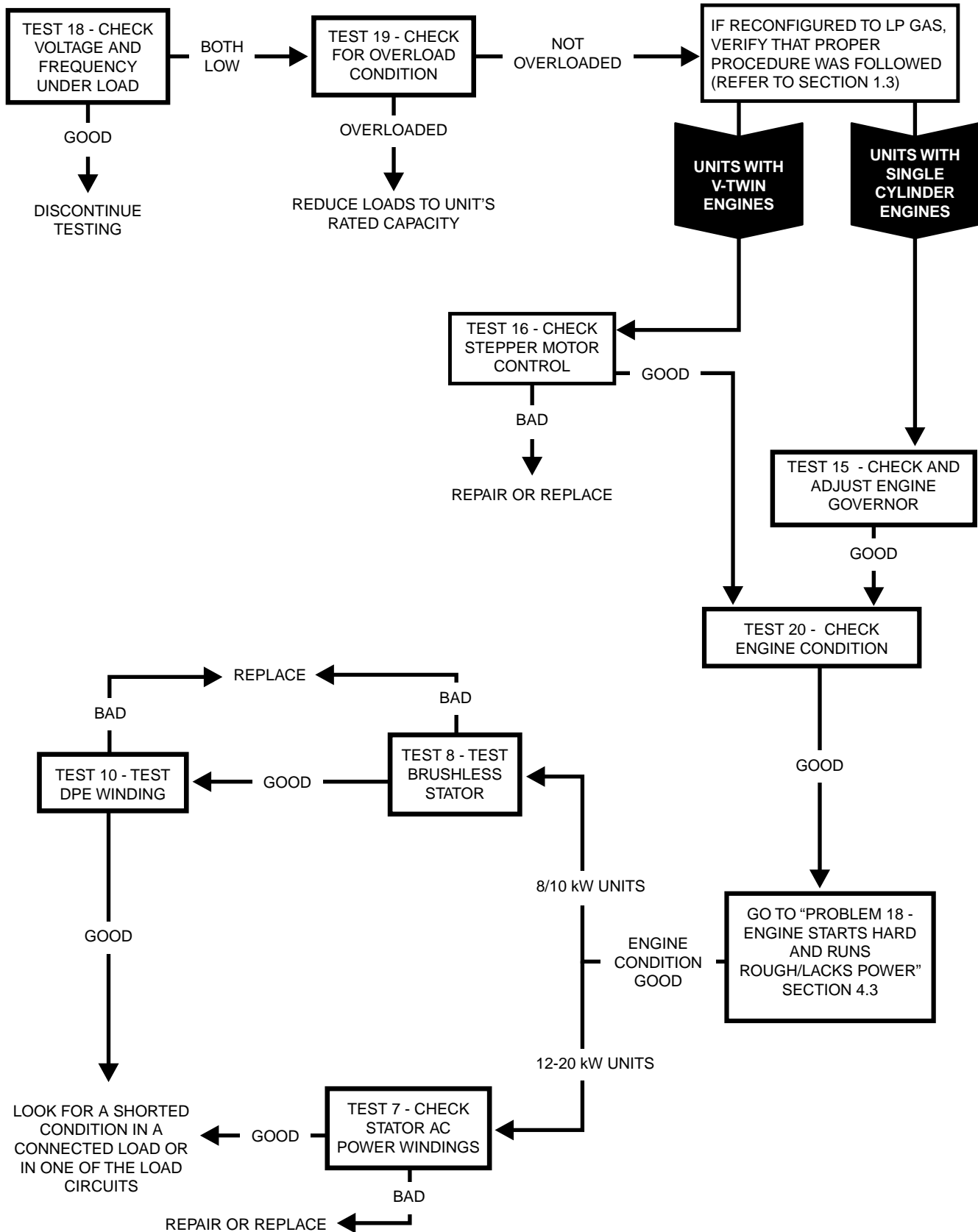

INTRODUCTION

This section is provided to familiarize the service technician with acceptable procedures for the testing and evaluation of various problems that could be encountered on standby generators with air-cooled engine. Use this section of the manual in conjunction with Section 2.3, "Troubleshooting Flow Charts". The numbered tests in this section correspond with those of Section 2.3.

Test procedures in this section do not require the use of specialized test equipment, meters or tools. Most tests can be performed with an inexpensive volt-ohm-milliammeter (VOM). An AC frequency meter is required, where frequency readings must be taken. A clamp-on ammeter may be used to measure AC loads on the generator.

Testing and troubleshooting methods covered in this section are not exhaustive. We have not attempted to discuss, evaluate and advise the home standby service trade of all conceivable ways in which service and trouble diagnosis might be performed. We have not undertaken any such broad evaluation. Accordingly, anyone who uses a test method not recommended herein must first satisfy himself that the procedure or method he has selected will jeopardize neither his nor the product's safety.

SAFETY

Service personnel who work on this equipment must be made aware of the dangers of such equipment. Extremely high and dangerous voltages are present that can kill or cause serious injury. Gaseous fuels are highly explosive and can be ignited by the slightest spark. Engine exhaust gases contain deadly carbon monoxide gas that can cause unconsciousness or even death. Contact with moving parts can cause serious injury. The list of hazards is seemingly endless.

When working on this equipment, use common sense and remain alert at all times. Never work on this equipment while you are physically or mentally fatigued. If you don't understand a component, device or system, do not work on it.

TEST 1 – CHECK MAIN CIRCUIT BREAKER**DISCUSSION:**

Often the most obvious cause of a problem is overlooked. If the generator main line circuit breaker is set to OFF or "Open", no electrical power will be supplied to electrical loads. If loads are not receiving power, perhaps the main circuit breaker is open or has failed.

PROCEDURE:

The generator main circuit breaker is located on the control panel. If loads are not receiving power, make sure the breaker is set to "On" or "Closed".

If you suspect the breaker may have failed, it can be tested as follows (see Figure 1):

1. Set a volt-ohm-milliammeter (VOM) to its "R x 1" scale and zero the meter.
2. With the generator shut down, disconnect all wires from the main circuit breaker terminals, to prevent interaction.
3. With the generator shut down, connect one VOM test probe to the Wire 11 terminal of the breaker and the other test probe to the Wire E1 terminal.
4. Set the breaker to its "On" or "Closed" position. The VOM should read CONTINUITY.
5. Set the breaker to its OFF or "Open" position and the VOM should indicate INFINITY.
6. Repeat Steps 4 and 5 with the VOM test probes connected across the breaker's Wire 44 terminal and the E2 terminal.

RESULTS:

1. If the circuit breaker tests good, go on to Test 2.
2. If the breaker tests bad, it should be replaced.

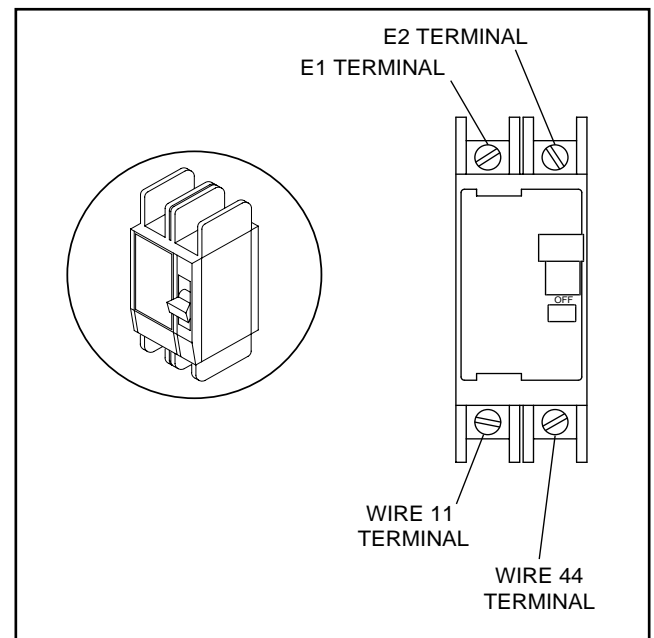

Figure 1. Generator Main Circuit Breaker Test Points

TEST 2 – CHECK AC OUTPUT VOLTAGE**DISCUSSION:**

A volt-ohm-milliammeter (VOM) may be used to check the generator output voltage. Output voltage may be checked at the unit's main circuit breaker terminals. Refer to the unit's DATA PLATE for rated line-to-line and line-to-neutral voltages.

SECTION 2.4 DIAGNOSTIC TESTS

PART 2

AC GENERATORS



DANGER: USE EXTREME CAUTION DURING THIS TEST. THE GENERATOR WILL BE RUNNING. HIGH AND DANGEROUS VOLTAGES WILL BE PRESENT AT THE TEST TERMINALS. CONNECT METER TEST CLAMPS TO THE HIGH VOLTAGE TERMINALS WHILE THE GENERATOR IS SHUT DOWN. STAY CLEAR OF POWER TERMINALS DURING THE TEST. MAKE SURE METER CLAMPS ARE SECURELY ATTACHED AND WILL NOT SHAKE LOOSE.

PROCEDURE:

1. With the engine shut down, connect the AC voltmeter test leads across the Wires 11 and 44 terminals of the generator main circuit breaker (see Figure 1). These connections will permit line-to-line voltages to be read.
2. Set the generator main circuit breaker to its OFF or "Open" position. This test will be conducted with the generator running at no-load.
3. Start the generator, let it stabilize and warm up for a minute or two.
4. Take the meter reading. On 12-20 kW units the no-load voltage should be between 249-247 VAC. On 8-10 kW units the no-load voltage should be between 220-235 VAC.
5. Shut the engine down and remove the meter test leads.

RESULTS:

1. If Step 4 indicated proper voltages, discontinue testing.
2. If any other readings were measured, refer back to flow chart.

NOTE: "Residual" voltage may be defined as the voltage that is produced by rotor residual magnetism alone. The amount of voltage induced into the stator AC power windings by residual voltage alone will be approximately 2 to 16 volts AC, depending on the characteristics of the specific generator. If a unit is supplying residual voltage only, either excitation current is not reaching the rotor or the rotor windings are open and the excitation current cannot pass. On current units with air-cooled engine, "field boost" current flow is available to the rotor only during engine cranking.

TEST 4 – FIXED EXCITATION TEST/ ROTOR AMP DRAW TEST

DISCUSSION:

Supplying a fixed DC current to the rotor will induce a magnetic field in the rotor. With the generator running, this should create a proportional voltage output from the stator windings.

PROCEDURE:

1. Disconnect Wire 4 from the voltage regulator, 3rd terminal from the top. See Figure 2.
2. Connect a jumper wire to the disconnected Wire 4 and to the 12 volt fused battery supply Wire 15B (located at TB1 terminal board).
3. **Set VOM to AC volts.**

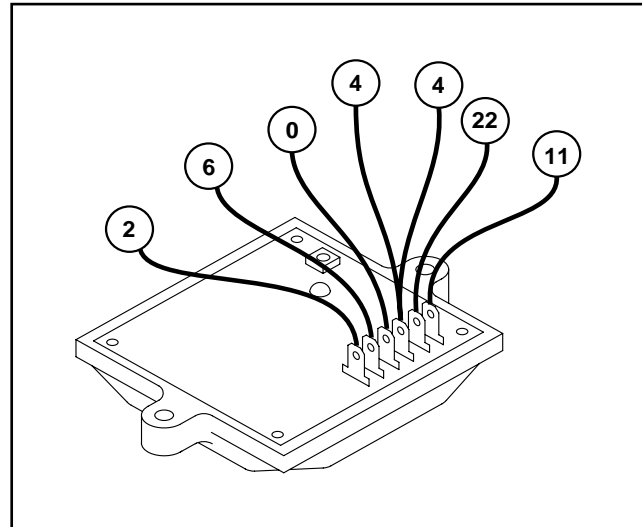

Figure 2. Voltage Regulator

4. Disconnect Wire 2 from the voltage regulator and connect one meter test lead to that wire. Disconnect Wire 6 from the voltage regulator and connect the other meter test lead to that wire. Wires 2 and 6 are located at the bottom two terminals of the voltage regulator (see Figure 2).
5. Set the AUTO-OFF-MANUAL switch to MANUAL. Once the engine starts, record the AC voltage.
6. Set the AUTO-OFF-MANUAL switch to OFF. Reconnect Wire 2 and Wire 6.
7. Disconnect Wire 11 from the voltage regulator and connect one meter test lead to that wire. Disconnect Wire 22 from the voltage regulator and connect the other meter test lead to that wire (both wires are located at the top two terminals of the voltage regulator, see Figure 2).
8. Set the AUTO-OFF-MANUAL switch to MANUAL. Once the engine starts, record the AC voltage.
9. Set the AUTO-OFF-MANUAL switch to OFF. Reconnect Wire 11 and Wire 22.
10. **Set VOM to DC amperage.**
11. Remove jumper lead connected to Wire 4 and Wire 15B.
12. Connect one meter test lead to battery positive 12 VDC supply Wire 15B, located at TB1 terminal board.

Connect the other meter test lead to Wire 4 (still disconnected from previous tests). Measure and record static rotor amp draw.

13. Set the AUTO-OFF-MANUAL switch to the MANUAL position. Once the engine starts, repeat Step 12. Measure and record running rotor amp draw with the engine running.
14. Set the AUTO-OFF-MANUAL switch to OFF. Reconnect Wire 4 to the voltage regulator.

RESULTS:

Refer to the chart on this page: "Results - Fixed Excitation Test/Rotor Amp Draw Test".

Note: A calculated amp draw can be done by taking the battery voltage that is applied divided by the actual resistance reading of the rotor. A resistance reading can be taken by measuring ohms between Wires 4 and 0 at the voltage regulator.

EXAMPLE:

MODEL	5517
WIRE 2 & 6 VOLTAGE	87 VAC
WIRE 11 & 22 VOLTAGE	31 VAC
STATIC ROTOR AMP DRAW	1.0 AMP
RUNNING ROTOR AMP DRAW	1.0 AMP

These results match Column B in the chart. Refer back to Problem 1 Flow Chart and follow Letter B.

TEST 5 – WIRE CONTINUITY (12-20 KW)

DISCUSSION:

The voltage regulator receives unregulated alternating current from the stator excitation winding, via Wires 2 and 6. It also receives voltage sensing from the stator AC power windings, via Wires 11 and 22. The regulator rectifies the AC from the excitation winding and based on the sensing signals, regulates the DC current flow to the rotor. The rectified and regulated current flow is delivered to the rotor brushes via Wires 4 (positive) and 0 (negative). This test will verify the integrity of Wire 0.

PROCEDURE:

1. Set VOM to its "R x 1" scale.
2. Remove Wire 0 from the voltage regulator, 4th terminal from the top. Also voltage regulator is labeled (-) next to terminal.
3. Connect one test lead to Wire 0, connect the other test lead to a clean frame ground. The meter should read CONTINUITY.

RESULTS:

If CONTINUITY was not measured, repair or replace the wire as needed.

TEST 4 Results - Fixed Excitation Test/Rotor Amp Draw Test (12-20 kW)									
Results:	(Model #)	A	B	C	D	E	F	G	H
Voltage Results Wire 2 & 6	ALL	Above 60 VAC	Above 60 VAC	Below 60 VAC	Zero or Residual Volts	Below 60 VAC	Below 60 VAC	Above 60 VAC	Below 60 VAC
Voltage Results Wire 11 & 22	ALL	Above 60 VAC	Below 60 VAC	Above 60 VAC	Zero or Residual Volts	Below 60 VAC	Below 60 VAC	Above 60 VAC	Below 60 VAC
Static Rotor Amp Draw	12 kW	1.75 - 1.17	1.75 - 1.17	1.75 - 1.17	Zero Current Draw	Above 2.5A	1.75 - 1.17	Zero Current Draw	1.75 - 1.17
	14 kW	1.75 - 1.17	1.75 - 1.17	1.75 - 1.17		Above 2.5A	1.75 - 1.17		1.75 - 1.17
	16 kW	1.59 - 1.07	1.59 - 1.07	1.59 - 1.07		Above 2.3A	1.59 - 1.07		1.59 - 1.07
	17 kW	1.59 - 1.07	1.59 - 1.07	1.59 - 1.07		Above 2.3A	1.59 - 1.07		1.59 - 1.07
	20 kW	1.39 - 0.93	1.39 - 0.93	1.39 - 0.93		Above 2.0A	1.39 - 0.93		1.39 - 0.93
Running Rotor Amp Draw	12 kW	1.75 - 1.17	1.75 - 1.17	1.75 - 1.17	Zero Current Draw	Above 2.5A	1.75 - 1.17	Zero Current Draw	Above 2.5A
	14 kW	1.75 - 1.17	1.75 - 1.17	1.75 - 1.17		Above 2.5A	1.75 - 1.17		
	16 kW	1.59 - 1.07	1.59 - 1.07	1.59 - 1.07		Above 2.5A	1.59 - 1.07		
	17 kW	1.59 - 1.07	1.59 - 1.07	1.59 - 1.07		Above 2.5A	1.59 - 1.07		
	20 kW	1.39 - 0.93	1.39 - 0.93	1.39 - 0.93		Above 2.5A	1.39 - 0.93		

← MATCH RESULTS WITH LETTER AND REFER TO FLOW CHART IN SECTION 2.3 "Problem 1" →

TEST 6 – CHECK FIELD BOOST (12-20 KW)

DISCUSSION:

See “Field Boost Circuit” in Section 2.2. Field boost current (from the circuit board) is available to the rotor only while the engine is cranking. Loss of field boost output to the rotor may or may not affect power winding AC output voltage. The following facts apply:

- A small amount of voltage must be induced into the DPE winding to turn the voltage regulator on.
- If rotor residual magnetism is sufficient to induce a voltage into the DPE winding that is high enough to turn the voltage regulator on, regulator excitation current will be supplied even if field boost has failed. Normal AC output voltage will then be supplied.
- If rotor residual magnetism has been lost or is not sufficient to turn the regulator on, and field boost has also been lost, excitation current will not be supplied to the rotor. Generator AC output voltage will then drop to zero or nearly zero.

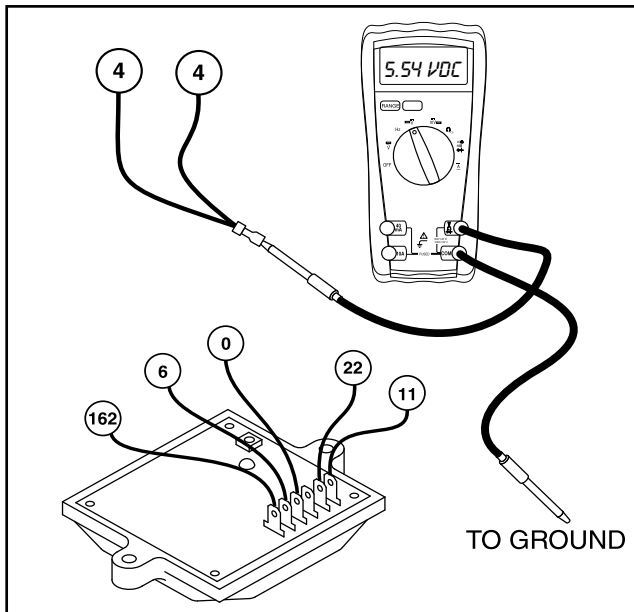

Figure 3. Field Boost Test Points

PROCEDURE:

1. Disconnect Wire 4 from the voltage regulator, third terminal from the top (see Figure 3).
2. Set a VOM to read DC volts.
3. Connect the positive (+) VOM test probe to the terminal end of disconnected Wire 4.
4. Connect the common (-) VOM test probe to the grounding lug.
5. Crank the engine while observing the VOM reading. While the engine is cranking, the VOM should read approximately 4-6 Volts DC. When engine is not cranking, VOM should indicate “zero” volts (see Figure 3).

6. Reconnect Wire 4.

RESULTS:

1. If normal field boost voltage is indicated in Step 6, replace the voltage regulator.
2. If normal field boost voltage is NOT indicated in Step 6, check Wire 4 (between regulator and circuit board) for open or shorted condition. If wire is good, replace the circuit board.

TEST 7 – TESTING THE STATOR WITH A VOM (12-20 KW)

DISCUSSION:

A Volt-OHM-Milliammeter (VOM) can be used to test the stator windings for the following faults:

- An open circuit condition
- A “short-to-ground” condition
- A short circuit between windings

Note: The resistance of stator windings is very low. Some meters will not read such a low resistance, and will simply indicate CONTINUITY. Recommended is a high quality, digital type meter capable of reading very low resistances.

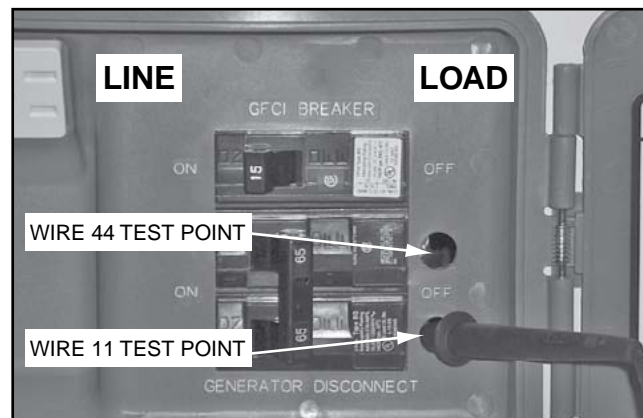

Figure 4. Test 7 Test Points

PROCEDURE:

1. Isolate the generator from the transfer switch by disconnecting the load wires from the main breaker inside the generator.
2. Disconnect Stator Leads 22 and 33 from the neutral connection and separate the leads.
3. Disconnect and isolate Wires 2 and 6 and Wires 11 and 22 from the voltage regulator.
4. Make sure all of the disconnected leads are isolated from each other and are not touching the frame during the test.

5. Turn the Main Breaker to the "ON" or CLOSED position.
6. **Set a VOM to measure resistance.**
7. Connect one meter test lead to Wire 11 on the load side of the main breaker. Connect the other meter test lead to Wire 22 (power winding). Note the resistance reading and compare to the specifications in the front of this manual.
8. Connect one test lead to stator lead Wire 44 on the load side of the main breaker. Connect the other test lead to stator lead Wire 33 (power winding). Note the resistance reading and compare to the specifications in the front of this manual.

Note: Wire 11 and Wire 44 could be switched on the main breaker. If an INFINITY reading is indicated try putting the meter leads on the other output terminal of the breaker. If INFINITY is still read then an actual fault may exist.

9. Connect one test lead to Wire 22 at the voltage regulator. Connect the other test lead to Wire 11 at the voltage regulator (power winding sense leads). Note the resistance reading and compare to the specifications in the front of this manual.

TEST WINDINGS FOR A SHORT TO GROUND:

10. Make sure all leads are isolated from each other and are not touching the frame.
11. Connect one test lead to a clean frame ground. Connect the other test lead to stator lead Wire 11 on the load side of the main circuit breaker.
 - a. The meter should read INFINITY.
 - b. Any reading other than INFINITY indicates a "short-to-ground" condition.
12. Repeat Step 11 using stator lead Wire 33.
13. Repeat Step 11 using Wire 22 at the voltage regulator.
14. Repeat Step 11 using Wire 6 at the voltage regulator.

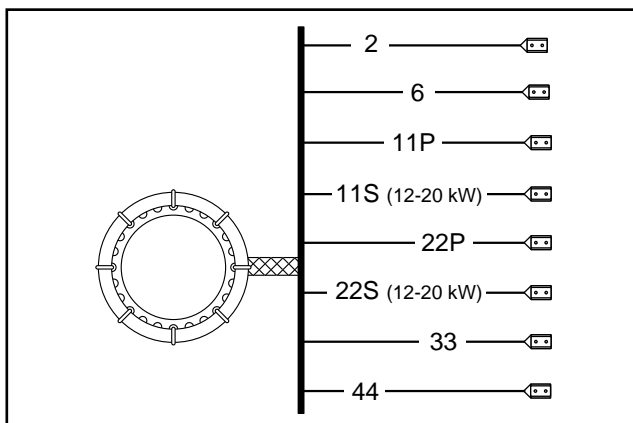

Figure 5. Stator Assembly Leads

TEST FOR A SHORT CIRCUIT BETWEEN WINDINGS:

15. Connect one test lead to stator lead Wire 11 on the load side of the main circuit breaker. Connect the other test lead to stator lead Wire 33.
 - a. The meter should read INFINITY.
 - b. Any reading other than INFINITY indicates a short circuit between windings.
16. Repeat Step 15 using stator lead Wire 11; Wire 6.
17. Repeat Step 15 using stator lead Wire 33; Wire 6.
18. Repeat Step 15 using Wire 11 at the voltage regulator; Wire 6 at the voltage regulator.

TEST CONTROL PANEL WIRES FOR CONTINUITY:

19. Connect one test lead to Wire 11 at the voltage regulator and the other test lead at stator lead Wire 11. Continuity should be measured.
20. Connect one test lead to Wire 22 at the voltage regulator and the other test lead at stator lead Wire 22. Continuity should be measured.

RESULTS:

1. Stator winding resistance values is a test of winding continuity and resistance. If a very high resistance or INFINITY is indicated, the winding is open or partially open.
2. Testing for a "grounded" condition: Any resistance reading indicates the winding is grounded.
3. Testing for a "shorted" condition: Any resistance reading indicates the winding is shorted.
4. If the stator tests good and wire continuity tests good, perform "Insulation Resistance Test" in Section 1.5.
5. If any test of wire continuity failed in the control panel, repair or replace the wire, terminal or pin connectors for that associated wire as needed.

NOTE: Read Section 1.5, "Testing, Cleaning and Drying" carefully. If the winding tests good, perform an insulation resistance test. If the winding fails the insulation resistance test, clean and dry the stator as outlined in Section 1.5. Then, repeat the insulation resistance test. If the winding fails the second resistance test (after cleaning and drying), replace the stator assembly.

TEST 8 – TEST BRUSHLESS STATOR

DISCUSSION:

The brushless stator has three internal windings, two main power windings and a DPE winding. This test will ensure that there are no shorts between the power windings or shorts to ground.

A VOM meter can be used to test the stator windings for the following faults:

SECTION 2.4 DIAGNOSTIC TESTS

PART 2

AC GENERATORS

- An open circuit condition
- A “short-to-ground” condition
- A short circuit between windings

Note: The resistance of stator windings is very low. Some meters will not read such a low resistance, and will simply indicate CONTINUITY. Recommended is a high quality, digital type meter capable of reading very low resistances.

PROCEDURE, 8 KW:

1. Disconnect Stator Leads 11 and 44 from the main circuit breaker.
2. Disconnect Stator Leads 22 and 33 from the neutral connection separate the leads.
3. Make sure all of the disconnected leads are isolated from each other and are not touching the frame during the test.
4. **Set a VOM to measure resistance.**
5. Connect one test lead to Stator Lead 11. Connect the other test lead to Stator Lead 22. Note the resistance reading and compare to the specifications in the front of this manual.
6. Connect one test lead to Stator Lead 33. Connect the other test lead to Stator Lead 44. Note the resistance reading and compare to the specifications in the front of this manual.

PROCEDURE, 10 KW:

1. Isolate the generator from the transfer switch by disconnecting the load wires from the main breaker inside the generator.
2. Disconnect Stator Leads 22 and 33 from the neutral connection and separate the leads.
3. Make sure all of the disconnected leads are isolated from each other and are not touching the frame during the test.
4. Turn the Main Breaker to the "ON" or CLOSED position.
5. **Set a VOM to measure resistance.**
6. **See Figure 4 for proper testing points.** Connect one meter test lead to Wire 11 on the load side of the main breaker. Connect the other meter test lead to Wire 22 (power winding). Note the resistance reading and compare to the specifications in the front of this manual.
7. Connect one test lead to Stator Lead 44 on the load side of the main breaker. Connect the other test lead to Stator Lead 33 (power winding). Note the resistance reading and compare to the specifications in the front of this manual.

Note: Wire 11 and Wire 44 could be switched on the main breaker. If an INFINITY reading is indicated try putting the meter leads on the other output terminal of the breaker. If INFINITY is still read then an actual fault may exist.

TEST WINDINGS FOR A SHORT TO GROUND:

7. Make sure all leads are isolated from each other and are not touching the frame.
8. Connect one test lead to a clean frame ground. Connect the other test lead to stator lead Wire 11.
 - a. The meter should read INFINITY.
 - b. Any reading other than INFINITY indicates a “short to ground” condition.
9. Repeat Step 7 using stator lead 44

TEST FOR A SHORT CIRCUIT BETWEEN WINDINGS:

10. Connect one test lead to stator lead 11. Connect the other test lead to stator lead 33.
 - a. The meter should read INFINITY.
 - b. Any reading other than INFINITY indicates a short between windings.
11. Repeat Step 10 using Wire 44.

RESULTS:

1. Stator winding resistance values is a test of winding continuity and resistance. If a very high resistance or INFINITY is indicated, the winding is open or partially open.
2. Testing for a “grounded” condition: Any resistance reading indicated the winding is grounded.
3. Testing for a “shorted” condition: Any resistance reading indicated the winding is shorted.
4. If stator tests good and wire continuity tests good, refer back to flow chart.

TEST 9 – CHECK CAPACITOR

DISCUSSION:

The brushless rotor system relies on the charging and discharging of a capacitor to induce voltage into the rotor and also to regulate voltage once 240 VAC is achieved. If the capacitor fails, only residual magnetism of the rotor will be measured at the Main Breaker.



Danger: The capacitor may need to be discharged before testing. A capacitor can be discharged by crossing the terminals with a metal insulated screw driver.



Danger: Use proper protective equipment when dealing with a capacitor that has exploded.

PROCEDURE:

1. Consult the owner's manual of the meter being used for directions on measuring capacitance. Figure 7 shows a typical meter and how to check capacitance.
2. Connect the meter leads directly across the terminals of the capacitor. The rated μf (micro farad) of the capacitor is marked on the side of the canister.
3. The meter should display the correct μf reading $\pm 5\mu\text{f}$. If anything other than the indicated rating is displayed, replace the capacitor.

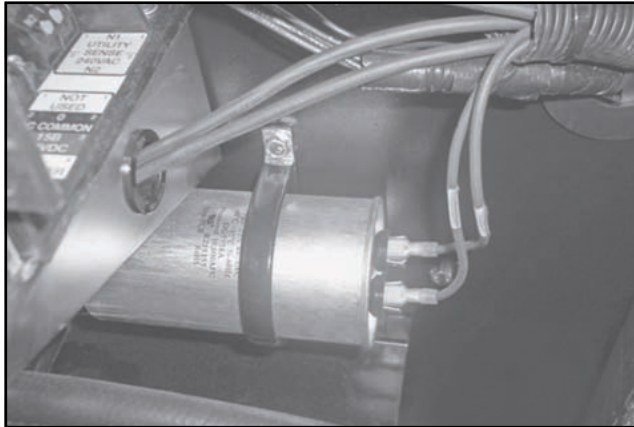

Figure 6. Capacitor

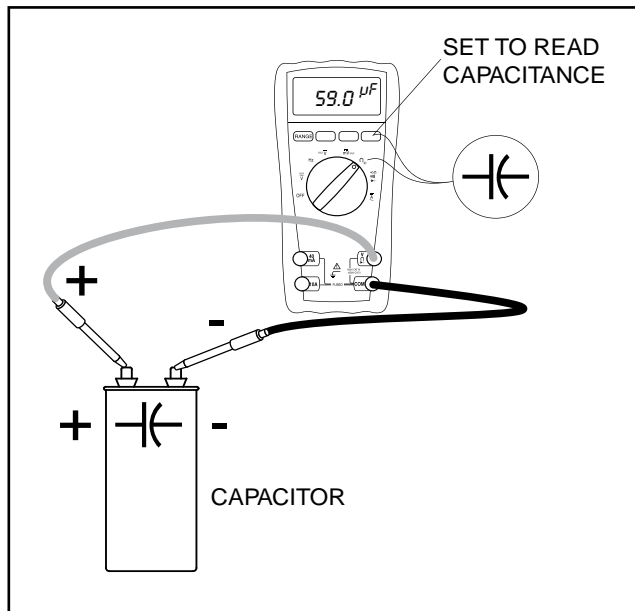

Figure 7. Field Boost Test Points

RESULTS:

1. Refer back to flow chart
2. Common observations can be made by visually inspecting the capacitor.

- a. A capacitor that has gone bad can have a tendency to explode. Use caution when dealing with an exploded capacitor, the gel from inside a capacitor can cause skin irritation.
- b. A capacitor is defective if the terminal connections are loose on the canister.
- c. A capacitor is defective if it wobbles while sitting on a flat surface.
- d. If any of the above observations are observed, replace the capacitor.

TEST 10 – TEST DPE WINDING ON BRUSHLESS UNITSDISCUSSION:

A DPE winding or Displaced Phase Excitation winding is used to charge a capacitor that discharges and charges releasing a voltage that is induced into the rotor. If the DPE winding fails, only residual magnetism of the rotor will be measured at the Main Breaker.

Note: The resistance of stator windings is very low. Some meters will not read such a low resistance, and will simply indicate CONTINUITY. Recommended is a high quality, digital type meter capable of reading very low resistances.



Warning: The capacitor may need to be discharged before testing. A capacitor can be discharged by crossing the terminals with a metal insulated screw driver.

PROCEDURE:

1. Disconnect Wire 2 and Wire 6 from the capacitor.
 2. **Set VOM to measure resistance.**
 3. Connect one meter lead to Wire 2 and connect the other meter lead to Wire 6.
 - a. Refer to the specifications in the front of this manual for the correct resistance reading.
 4. Connect one meter lead to Wire 2 and connect the other meter lead to a clean frame ground, INFINITY should be measured.
 5. Disconnect Wires 11 and 44 from the main line circuit breaker.
 6. Disconnect Wire 22 and Wire 33 from the neutral connection
- Note: Isolate all main stator leads before proceeding.**
7. Connect one meter lead to Wire 2 and connect the other meter lead to Wire 11. INFINITY should be measured.
 8. Repeat Step 7 using Wires 2 and 44.

RESULTS:

1. Stator winding resistance values is a test of winding continuity and resistance. If a very high resistance or INFINITY is indicated, the winding is open or partially open.

SECTION 2.4 DIAGNOSTIC TESTS

PART 2

AC GENERATORS

2. Testing for a “grounded” condition: Any resistance reading indicated the winding is grounded.
3. Testing for a “shorted” condition: Any resistance reading indicated the winding is shorted.
4. If stator tests good and wire continuity tests good, refer back to flow chart.

TEST 11 – RESISTANCE CHECK OF ROTOR CIRCUIT (12-20 KW)

DISCUSSION:

To verify the zero current draw reading and measure the rotor circuit.

PROCEDURE:

1. Disconnect Wire 4 and Wire 0 from the voltage regulator, located third and fourth terminals from the top of the voltage regulator.
2. **Set VOM to measure resistance.**
3. Connect one test lead to Wire 4. Connect the other test lead to a clean frame ground. Note the resistance reading. Compare to specifications in the front of this manual.

RESULTS:

1. If the resistance reading is correct, check the VOM meter fuse and repeat Test 4.
2. If INFINITY or a high reading is measured on the VOM, refer back to flow chart.

TEST 12 – CHECK BRUSHES AND SLIP RINGS (12-20 KW)

DISCUSSION:

The function of the brushes and slip rings is to provide for passage of excitation current from stationary components to the rotating rotor. Brushes are made of a special long lasting material and seldom wear out or fail. However, slip rings can develop a tarnish or film that can inhibit or offer a resistance to the flow of electricity. Such a non-conducting film usually develops during non-operating periods. Broken or disconnected wiring can also cause loss of excitation current to the rotor.

PROCEDURE:

1. See Figure 8. Carefully inspect brush wires; make sure they are properly and securely connected.
2. Wire 0 from the negative (-) brush terminal connects to Wire 0 at the voltage regulator. Test this wire for an open condition. Remove Wire 0 from the brush assembly. Connect one meter test lead to Wire 0. Connect the other test lead to Wire 0 at the voltage regulator.

CONTINUITY should be measured. If INFINITY is measured repair or replace Wire 0 between the brush assembly and the voltage regulator.

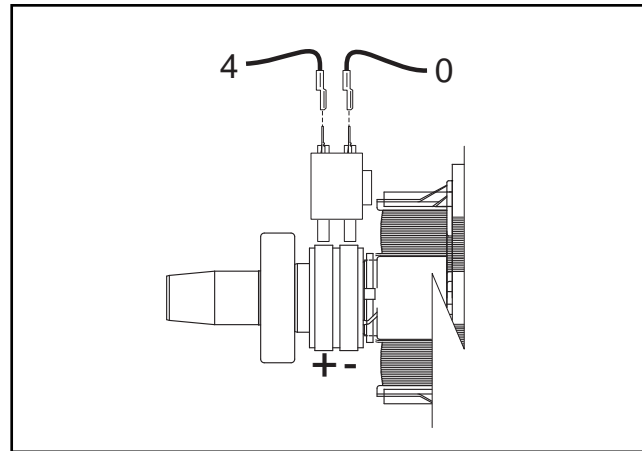

Figure 8. Checking Brushes and Slip Rings

3. Wire 4 from the positive (+) brush terminal connects to Wire 4 at the voltage regulator. Test this wire for an open condition. Remove Wire 4 from the brush assembly. Connect one meter test lead to Wire 4. Connect the other meter test lead to Wire 4 at the voltage regulator. CONTINUITY should be measured. If INFINITY is measured repair or replace Wire 4 between the brush assembly and the voltage regulator.
4. Connect one meter test lead to Wire 4. Connect the other meter test lead to frame ground. INFINITY should be measured. If CONTINUITY is measured a short to ground exists on Wire 4 repair or replace Wire 4 between the brush assembly and the voltage regulator.
5. If CONTINUITY was measured in Steps 5 and 6 proceed to Step 9.
6. Disconnect Wire 0 and Wire 4 from the brush assembly. Remove the brush assembly from the bearing carrier. Inspect the brushes for excessive wear, or damage.
7. Inspect the rotor slip rings. If they appear dull or tarnished, they may be polished with fine sandpaper. **DO NOT USE METALLIC GRIT TO POLISH SLIP RINGS.**
8. If brush assembly and slip rings look good proceed to Test 13 (Test Rotor Assembly)
9. Wire 0 connects from the voltage regulator in the control panel ground lug. Connect one meter test lead to Wire 0 at the voltage regulator. Connect the other meter test lead to the ground terminal in the control panel. CONTINUITY should be measured. If INFINITY is measured repair or replace Wire 0 between the voltage regulator and the ground terminal.
10. Remove Wire 4 from the voltage regulator.

RESULTS:

1. Repair, replace or reconnect wires as necessary.
2. Replace any damaged slip rings or brush holder.
3. Clean and polish slip rings as required.

TEST 13 – TEST ROTOR ASSEMBLY (12-20 KW)

DISCUSSION:

A rotor having completely open windings will cause loss of excitation current flow and, as a result, generator AC output voltage will drop to “residual” voltage. A “shorted” rotor winding can result in a low voltage condition.

PROCEDURE:

1. Disconnect the brush wires or remove the brush holder, to prevent interaction.
2. Set a VOM to measure resistance.
3. Connect the positive (+) VOM test lead to the positive (+) rotor slip ring (nearest the rotor bearing); and the common (-) test lead to the negative (-) slip ring. The meter should read rotor resistance. Compare to “Specifications,” in the front of this manual.
4. Connect the positive (+) VOM test lead to the positive (+) slip ring and the common (-) test lead to a clean frame ground. The meter should indicate INFINITY.

RESULTS:

1. Replace rotor assembly if it is open or shorted.
2. If rotor tests good, perform “Insulation Resistance Test” in Section 1.5.

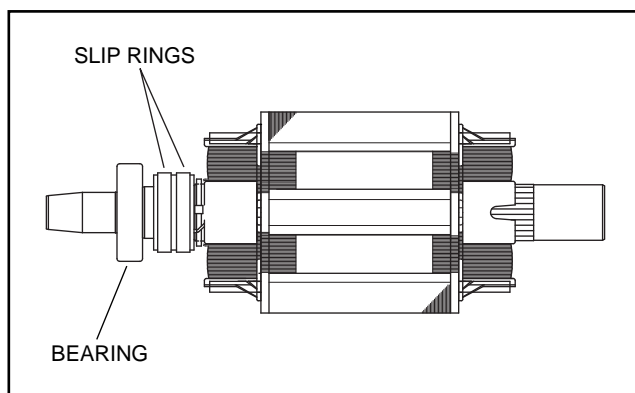

Figure 9. The Rotor Assembly

NOTE: Be sure to read Section 1.5, “Testing, Cleaning and Drying”, carefully. If the rotor tests good, try performing an insulation resistance test. Clean and dry the

rotor if it fails that test. Then, repeat the test. If the rotor fails the second insulation resistance test, it should be replaced.

TEST 14 – CHECK AC OUTPUT FREQUENCY

DISCUSSION:

The generator AC frequency is proportional to the operating speed of the rotor. The 2-pole rotor will supply a 60 Hertz AC frequency at 3600 rpm. The unit's AC output voltage is proportional to the AC frequency. For example, a unit rated 240 volts (line-to-line) will supply that rated voltage (plus or minus 2 percent) at a frequency of 60 Hertz. If, for any reason, the frequency should drop to 30 Hertz, the line-to-line voltage will drop to a matching voltage of 120 volts AC. Thus, if the AC voltage output is high or low and the AC frequency is correspondingly high or low, the engine speed governor may require adjustment.

PROCEDURE:

1. Connect an accurate AC frequency meter across the Wires 11 and 44 terminals of the generator main line circuit breaker (see Figure 1, Section 2.4).
2. Start the engine, let it stabilize and warm up at no-load.
3. When engine has stabilized, read the frequency meter. The no-load frequency for single cylinder units should be about 62-63 Hertz. For V-Twin units, the no-load frequency should be about 60 Hertz.

RESULTS:

1. If the AC frequency is high or low, go on to Test 15 for single cylinder units, or Test 16 for V-Twin units.
2. If frequency is good, but voltage is high or low, go to Test 17.
3. If frequency and voltage are both good, tests may be discontinued.

TEST 15 – CHECK AND ADJUST ENGINE GOVERNOR (SINGLE CYLINDER UNITS)

DISCUSSION:

The generator AC frequency output is directly proportional to the speed of the rotor. A two-pole rotor (having a single north and a single south magnetic pole) will produce an AC frequency of 60 hertz at 3600 RPM.

The generator is equipped with a “voltage over frequency” type AC voltage regulator. The units AC output voltage is generally proportional to AC frequency. A low or high governor speed will result in a correspondingly low or high AC frequency and voltage output. The governed speed must be adjusted before any attempt to adjust the voltage regulator is made.

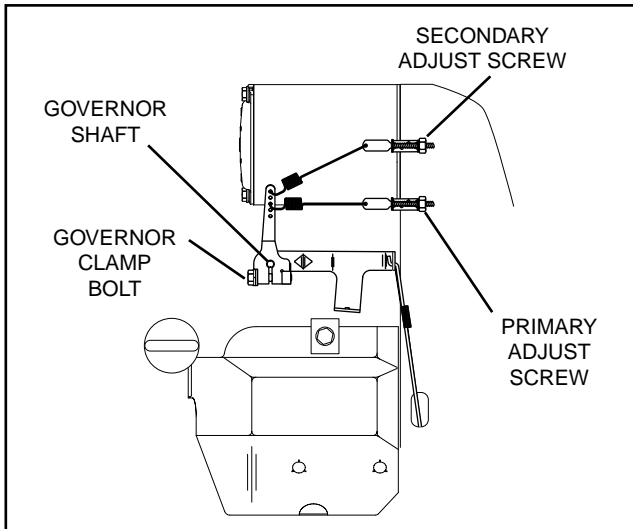

Figure 10. Engine Governor Adjustment Single Cylinder Engines

PROCEDURE

(8 kW UNITS WITH DUAL GOVERNOR SPRINGS):

1. Loosen the governor clamp bolt (Figure 10).
2. Hold the governor lever at its wide open throttle position, and rotate the governor shaft clockwise as far as it will go. Then, tighten the governor lever clamp bolt to 70 inch-pounds (8 N-m).
3. Start the generator; let it stabilize and warm up at no-load.
4. Connect a frequency meter across the generators AC output leads.
5. Turn the primary adjust screw to obtain a frequency reading of 61.5 Hz. Turn the secondary adjust screw to obtain a frequency reading of 62.5 Hz.
6. When frequency is correct at no load, check the AC voltage reading. If voltage is incorrect, the voltage regulator may require adjustment.

RESULTS:

1. If, after adjusting the engine governor, frequency and voltage are good, tests may be discontinued.
2. If frequency is now good, but voltage is high or low, refer back to flow chart.
3. If engine was overspeeding, check linkage and throttle for binding. If no governor response is indicated refer to engine service manual.
4. If engine appears to run rough and results in low frequency, proceed to Problem 18, Section 4.3.

TEST 16 – CHECK STEPPER MOTOR CONTROL (V-TWIN ENGINE UNITS)

PROCEDURE:

1. Remove air cleaner cover to access stepper motor.
2. Physically grab the throttle and verify the stepper motor, linkage and throttle do not bind in any way, if any binding is felt repair or replace components as needed. Some resistance should be felt as the stepper motor moves through it's travel.
3. Physically move the throttle to the closed position by pulling the stepper motor arm towards the idle stop. See Figures 11 and 12 (for 9/10 kW units) or Figure 13 (for 12-20 kW Units).
4. Place the AUTO-OFF-MANUAL switch to MANUAL and watch for stepper motor movement. It should move to the wide open position during cranking. Once the unit starts the stepper motor should move the throttle to a position to maintain 60 Hertz.
5. If no movement is seen in Step 4 remove the control panel cover. Verify the six pin connector on the printed circuit board is seated properly, remove the connector and then replace it and test again. Verify the switches are correctly set.
6. If problem continues the remove six pin connector from the printed circuit board. Set Volt meter to measure ohms. Carefully measure from the end of the six pin harness as follows:

NOTE: Press down with the meter leads on the connectors exposed terminals, do not probe into the connector.

- a. Connect one meter lead to Red, connect the remaining test lead to Orange, approximately 10 ohms should be measured.
- b. Connect one meter lead to Red, connect the remaining test lead to Yellow, approximately 10 ohms should be measured.
- c. Connect one meter lead to Red, connect the remaining test lead to Brown, approximately 10 ohms should be measured.
- d. Connect one meter lead to Red, connect the remaining test lead to Black, approximately 10 ohms should be measured.
- e. Connect one meter lead to Red, connect the remaining test to the stepper motor case. No resistance should be measured INFINITY or Open.

RESULTS:

1. If the stepper motor fails any part of Step 6 replace the stepper motor.
2. If the stepper motor passes all steps replace the Printed Circuit Board.

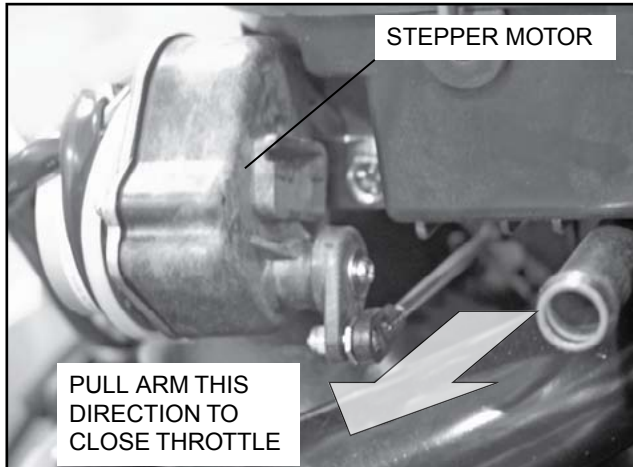

Figure 11. Throttle Positions 9/10 kW Units

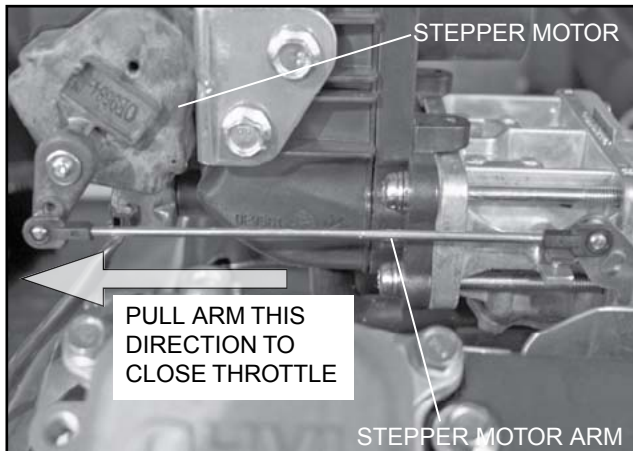

Figure 12. Throttle Positions 9/10 kW Units

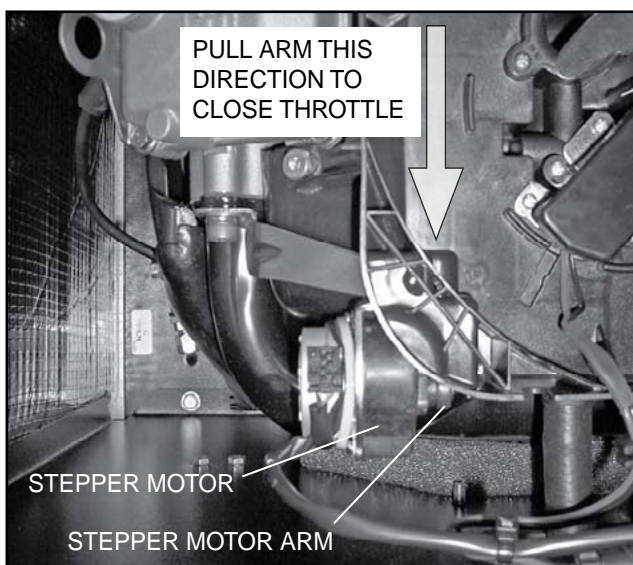

Figure 13. Throttle Positions 12-20 kW Units

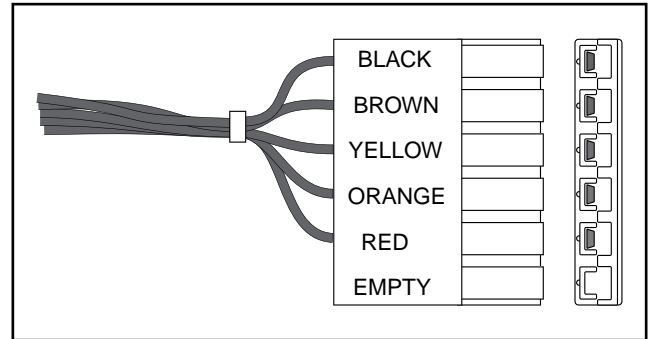

Figure 14. Six Pin Connector Wire Colors

**TEST 17 – CHECK AND ADJUST VOLTAGE
REGULATOR (12-20 KW)****DISCUSSION:**

For additional information, refer to description and components Section 2.1.

PROCEDURE (V-TWIN ENGINE UNITS):

With the frequency at 60 Hertz, slowly turn the slotted potentiometer (Figure 15) until line voltage reads 247-249 volts.

NOTE: The access panel on top of the control panel must be removed to adjust the voltage regulator.

NOTE: The voltage regulator is housed in the back of the generator control panel. The regulator maintains a voltage in direct proportion to frequency at a 2-to-1 ratio. For example, at 60 Hertz, line-to-neutral voltage will be 120 volts.

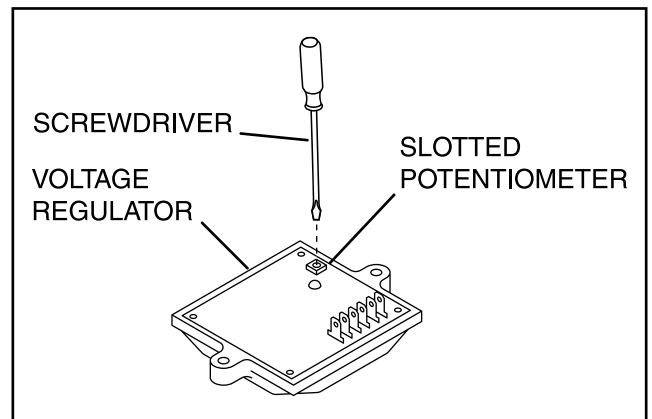

Figure 15. Voltage Adjustment Potentiometer

RESULTS:

1. If the frequency and voltage are now good, discontinue tests.
2. If frequency is now good but voltage is high or low, refer back to flow chart.

**TEST 18 – CHECK VOLTAGE AND
FREQUENCY UNDER LOAD**

DISCUSSION:

It is possible for the generator AC output frequency and voltage to be good at no-load, but they may drop excessively when electrical loads are applied. This condition, in which voltage and frequency drop excessively when loads are applied, can be caused by (a) overloading the generator, (b) loss of engine power, or (c) a shorted condition in the stator windings or in one or more connected loads.

PROCEDURE:

1. Connect an accurate AC frequency meter and an AC voltmeter across the stator AC power winding leads.
2. Start the engine, let it stabilize and warm-up.
3. Apply electrical loads to the generator equal to the rated capacity of the unit.
4. Check the AC frequency and voltage.
 - a. Single Cylinder Units: Frequency should not drop below approximately 58 Hertz. Voltage should not drop below about 230 volts.
 - b. V-Twin Engine Units: Frequency should not drop below approximately 60 Hertz. Voltage should not drop below about 240 volts.

RESULTS:

1. If frequency and voltage drop excessively under load, refer back to flow chart.
2. If frequency and voltage under load are good, discontinue tests.

**TEST 19 – CHECK FOR OVERLOAD
CONDITION**

DISCUSSION:

An “overload” condition is one in which the generator rated wattage/amperage capacity has been exceeded. To test for an overload condition on an installed unit, the best method is to use an ammeter. See “Measuring Current” in Section 1.5.

PROCEDURE:

Use a clamp-on ammeter to measure load current draw, with the generator running and all normal electrical loads turned on.

RESULTS:

1. If the unit is overloaded, reduce loads to the unit’s rated capacity.
2. If unit is not overloaded, but rpm and frequency drop excessively when loads are applied, go to Test 16.

TEST 20 – CHECK ENGINE CONDITION

DISCUSSION:

If engine speed and frequency drop excessively under load, the engine may be under-powered. An under-powered engine can be the result of a dirty air cleaner, loss of engine compression, faulty fuel settings, incorrect ignition timing, etc.

PROCEDURE:

For engine testing, troubleshooting and repair procedures refer to Problem 11 in Section 4.3. For further engine repair information refer to the appropriate engine service manuals.

**TEST 21 – FIELD FLASH ALTERNATOR
(8-10 KW UNITS)**

DISCUSSION:

The alternator utilizes residual magnetism within the windings to charge the capacitor. If the generator has been sitting for a long period of time with no activity the residual magnetism could be lost within the rotor. Field flashing the rotor while connected in parallel with the capacitor will force a charge of electricity through the DPE winding. The voltage that is induced into the rotor will return and charge the capacitor enough to take over voltage regulation of the unit.

Note: It is crucial that the generator exercise once a week to help maintain this residual magnetism.

 **Warning: Please keep safety in mind while performing this test.**

PROCEDURE:

1. Construct an energizing cord that is similar to that shown in Figure 17 and connect it as shown in Figure 18.
2. Set the AUTO-OFF-MANUAL switch to the OFF position.

 **Warning: Do NOT energize the capacitor for more than 1 second at a time.**

3. Momentarily turn on the energizing cord (one second).
4. Disconnect the energizing cord from the capacitor.
5. If the field flash was successful, the generator should now be producing approximately 240 VAC at the main circuit breaker of the generator when the AUTO-OFF-MANUAL is set to the MANUAL position.

 **Warning: Do not field flash alternator more than two times in sequence. If the unit has not produced power after two attempts, other issues exist and need to be addressed.**

RESULTS:

1. Refer back to flow chart.

CRIMP ON STANDARD FEMALE BLADE CONNECTORS

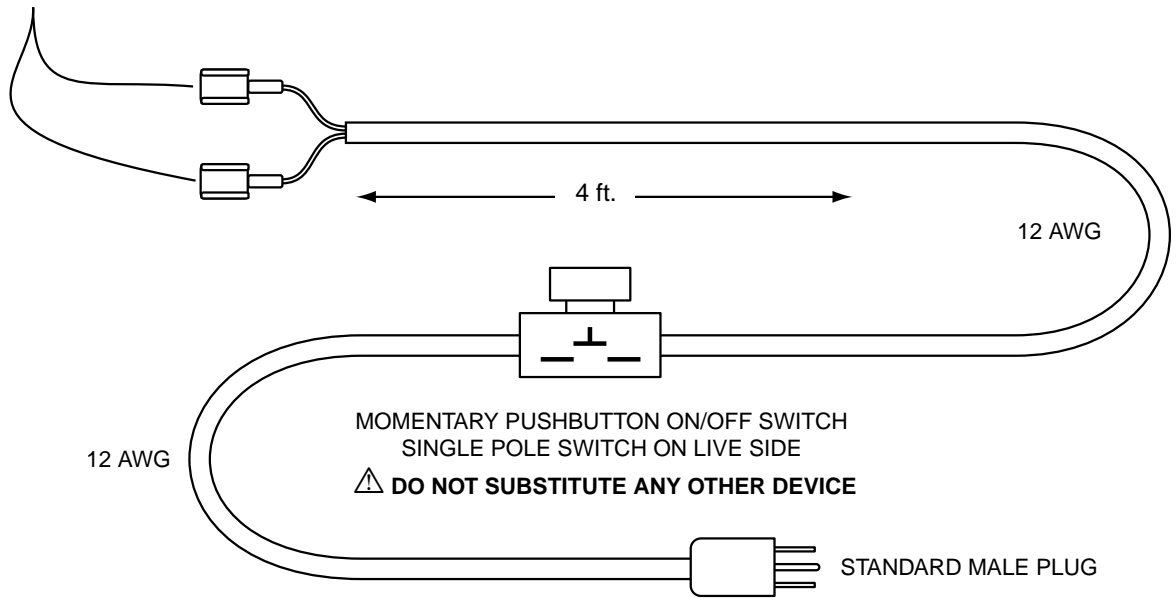

Figure 17. Construction of Energizing Cord

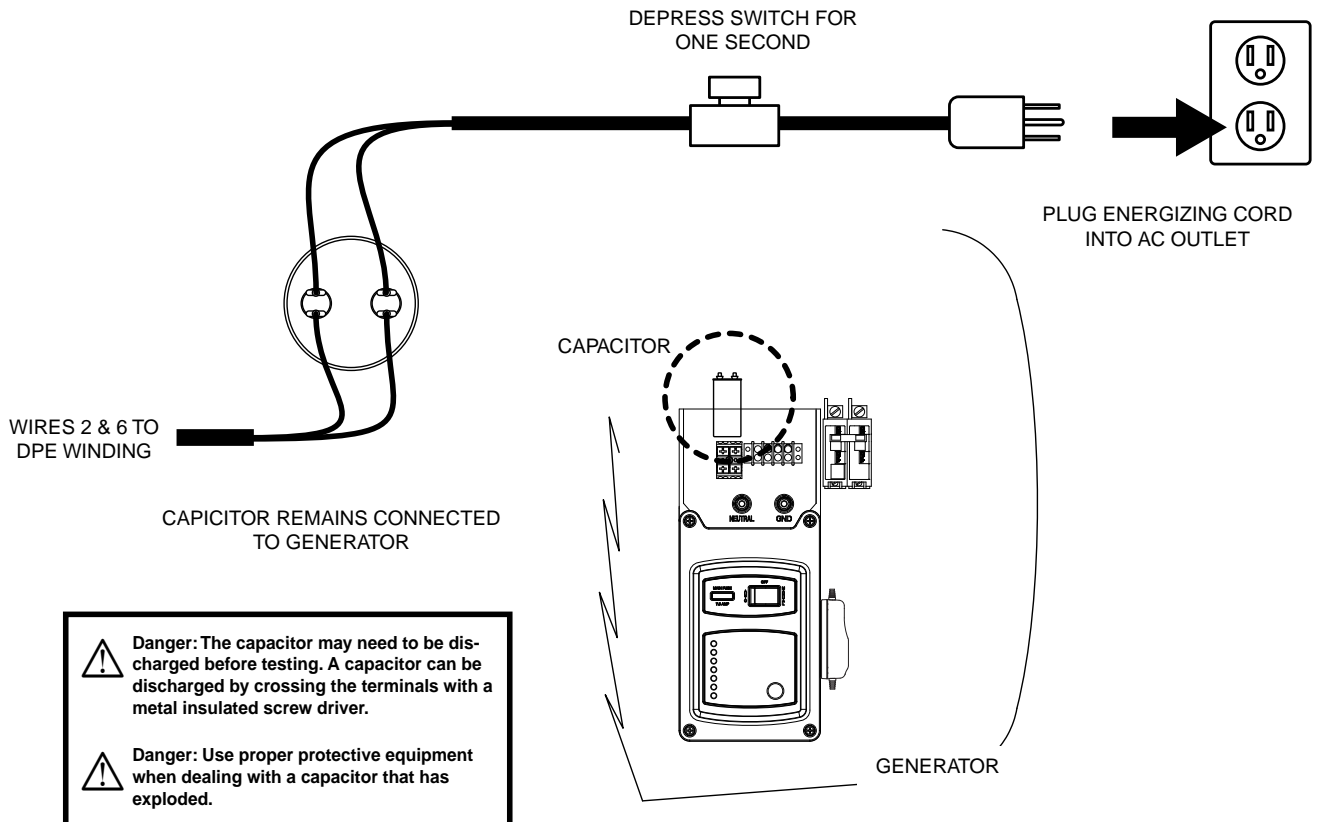

Figure 18. Energizing Cord Connection

PART 3 TRANSFER SWITCH

Air-cooled, Automatic Standby Generators

3.1 Description and Components	56
General 6	
Enclosure	56
Transfer Mechanism	57
Transfer Relay	57
Neutral Lug	58
Manual Transfer Handle	58
Terminal Block	58
Fuse Holder	59
3.2 Operational Analysis	60
Operational Analysis	60
Utility Source Voltage Available	62
Utility Source Voltage Failure	63
Transfer To Standby	64
Transfer To Standby	65
Utility Restored	66
Utility Restored, Transfer Switch De-energized	67
Utility Restored, Retransfer Back To Utility	68
Transfer Switch In Utility	69
3.3 – Troubleshooting Flowcharts	70
Introduction To Troubleshooting	70
Problem 7 – In Automatic Mode, No Transfer to Standby	70
Problem 8 – In Automatic Mode, Generator Starts When Loss of Utility Occurs, Generator Shuts Down When Utility Returns But There Is No Retransfer To Utility Power / or Generator Transfers to Standby During Exercise Or In Manual Mode	71
Problem 9 – Blown F1 or F2 Fuse	71
Problem 10 – Units Starts And Transfer Occurs When Utility Power Is On	72
Problem 11 – No Battery Charge (Pre-Packed Load Center)	73
Problem 12 – No Battery Charge (RTSN + RTSE Transfer Switch)	73
Problem 13 – No Battery Charge (Gen-Ready Load Center)	73
Problem 14 – No Battery Charge (Load Shed Transfer Switch)	73
3.4 Diagnostic Tests	74
General	74
Test 26 – Check Voltage at Terminal Lugs E1, E2	74
Test 27 – Check Manual Transfer Switch Operation	75

TABLE OF CONTENTS		
PART	TITLE	PG#
3.1.	Description and Components	56
3.2	Operational Analysis	60
3.3	Troubleshooting Flow Charts	70
3.4	Diagnostic Tests	74

Test 28 – Check 23 And 15B Wiring/Connections	76
Test 29 – Test Transfer Relay TR	77
Test 30 – Standby Control Circuit	78
Test 31 – Check Wire 23	78
Test 32 – Utility Control Circuit	80
Test 33 – Test Limit Switch SW2 and SW3	82
Test 34 – Check Fuses F1 and F2	82
Test 35 – Check N1 and N2 Wiring	83
Test 36 – Check N1 and N2 Voltage	83
Test 37 – Check Utility Sensing Voltage at the Circuit Board	84
Test 38 – Check Utility Sense Voltage	84
Test 39 – Check Voltage at Terminal Lugs N1, N2	84
Test 40 – Check Battery Charger Supply Voltage “Pre-Wire Load Center”	86
Test 41 – Check Battery Charger Output Voltage “Pre-Wire Load Center”	86
Test 42 – Check Wire 0 and Wire 15B “Pre-Wire Load Center”	86
Test 43 – Check Battery Charger Supply Voltage “RTSN & RTSE Transfer Switch”	87
Test 44 – Check Battery Charger Output Voltage “RTSN & RTSE Transfer Switch”	87
Test 45 – Check Wire 0/ “RTSN & RTSE Transfer Switch”	87
Test 46 – Check Battery Charger Supply Voltage “GenReady Load Center”	90
Test 47 – Check Battery Charger Output Voltage “GenReady Load Center”	90
Test 48 – Check Wire 0/15B “GenReady Load Center”	90
Test 49 – Check Battery Charger Supply Voltage “Load Shed Transfer Switch”	92
Test 50 – Check Battery Charger Output Voltage “Load Shed Transfer Switch”	92
Test 51 – Check Wire 0 and Wire 15B “Load Shed Transfer Switch”	94

SECTION 3.1

DESCRIPTION & COMPONENTS

PART 3

TRANSFER SWITCH

GENERAL

The "W/V-Type" transfer switch is rated 100 amps at 250 volts maximum. It is available in 2-pole configuration only and, for that reason, is usable with 1-phase systems only.

Transfer switches do not have an intelligence system of their own. Instead, automatic operation of these transfer switches is controlled by a circuit board housed in the generator control panel.

ENCLOSURE

The "W/V-Type" transfer switch enclosure is a NEMA 1 type ("NEMA" stands for "National Electrical Manufacturer's Association"). Based on NEMA Standard 250, the NEMA 1 enclosure may be defined as one that is intended for indoor use primarily to provide a degree of protection against contact with the enclosed equipment and where unusual service conditions do not exist.

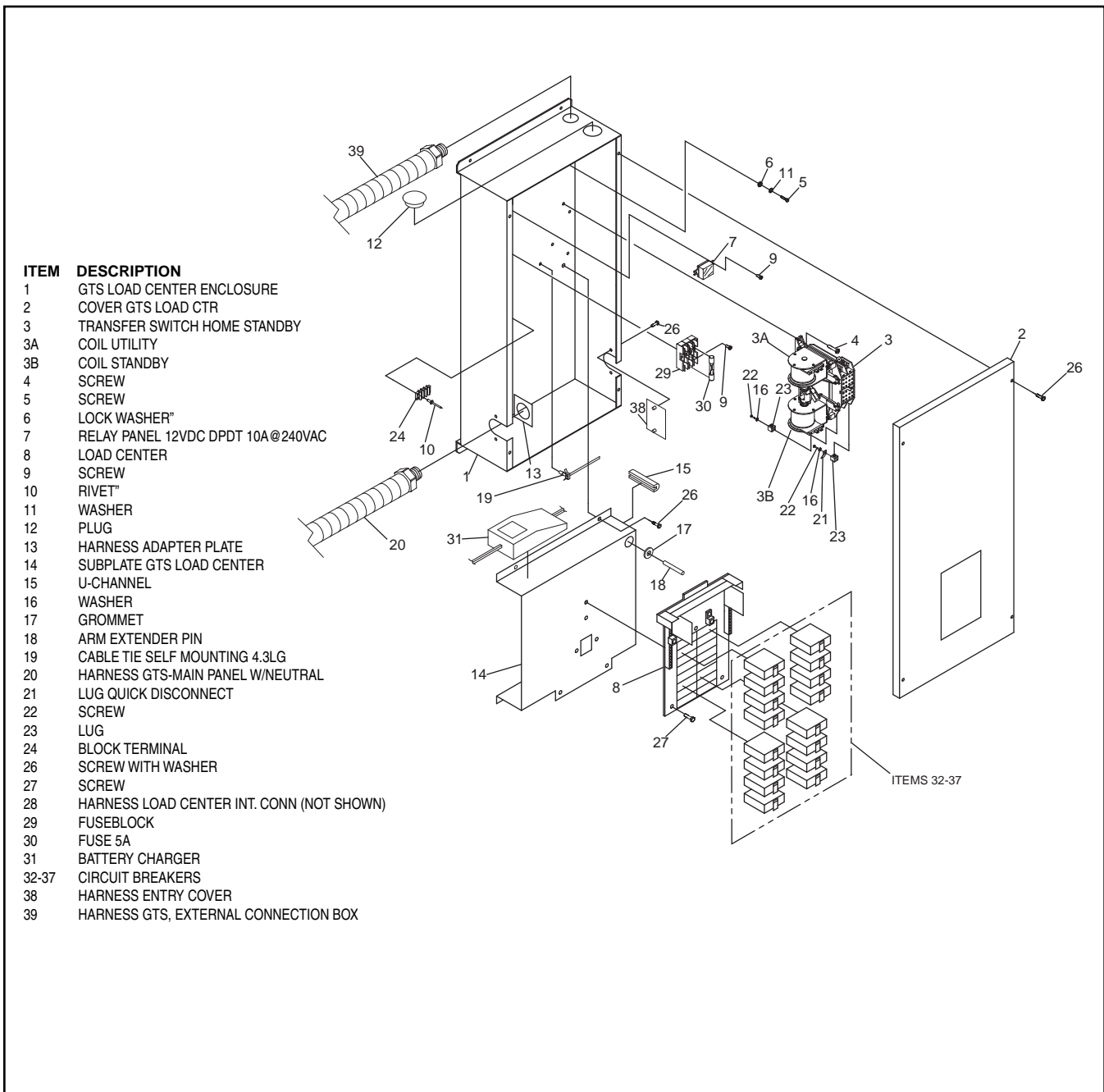

Figure 1. Exploded View of W/V-Type Transfer Switch

TRANSFER MECHANISM

The 2-pole transfer mechanism consists of a pair of moveable LOAD contacts, a pair of stationary UTILITY contacts, and a pair of stationary STANDBY contacts. The load contacts can be connected to the utility contacts by a utility closing coil; or to the standby contacts by a standby closing coil. In addition, the load contacts can be actuated to either the UTILITY or STANDBY side by means of a manual transfer handle. See Figures 2 and 3.

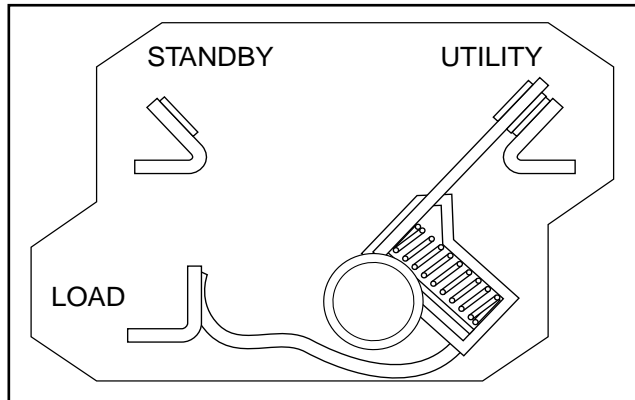

Figure 2. Load Connected to Utility Power Source

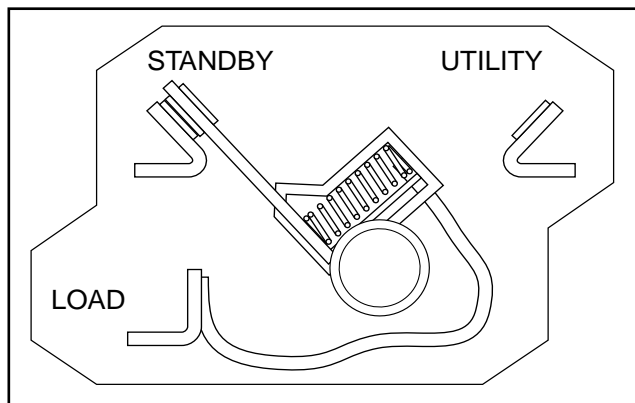

Figure 3. Load Connected to Standby Power Source

UTILITY CLOSING COIL C1:

See Figure 4. This coil is energized by rectified utility source power, to actuate the load contacts to the UTILITY power source side. When energized, the coil will move the main contacts to an "overcenter" position. A limit switch will then be actuated to open the circuit and spring force will complete the retransfer to STANDBY. A bridge rectifier, which changes the utility source alternating current (AC) to direct current (DC), is sealed in the coil wrappings. If coil or bridge rectifier replacement becomes necessary, the entire coil and bridge assembly should be replaced.

STANDBY CLOSING COIL C2:

Coil C2 is energized by rectified standby source power, to actuate the load contacts to their "Standby"

source side. Energizing the coil moves the load contacts to an overcenter position; limit switch action then opens the circuit and spring force will complete the transfer action to "Standby". This coil's bridge rectifier is also sealed in the coil wrappings. Replace the coil and bridge rectifier as a unit.

LIMIT SWITCHES SW2 AND SW3:

Switches are mechanically actuated by load contacts movement. When the load contacts are connected to the utility contacts, limit switch SW2 opens the utility circuit to utility closing coil C1 and limit switch SW3 closes the standby circuit to standby closing coil C2. The limit switches "arm" the system for retransfer back to UTILITY when the load contacts are connected to the STANDBY side. Conversely, when the load contacts are connected to the UTILITY side, the switches "arm" the system for transfer to STANDBY. An open condition in limit switch SW2 will prevent retransfer to "Utility". An open switch SW3 will prevent transfer to STANDBY.

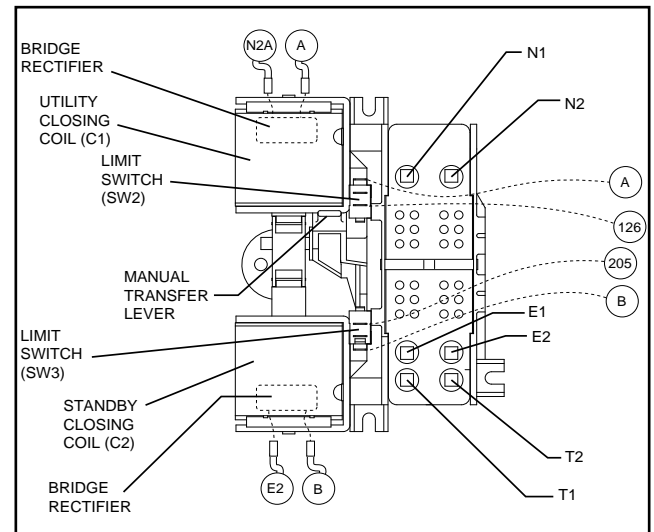

Figure 4. The "W/V-Type" Transfer Mechanism

TRANSFER RELAY

Transfer relay operation is controlled by a circuit board. That circuit board is a part of a control panel assembly, mounted on the standby generator set.

Figure 5 shows the transfer relay pictorially and schematically. Relay operation may be briefly described as follows:

1. Generator battery voltage (12 volts DC) is available to the transfer relay coil from the generator circuit board, via Wire 15B and Relay Terminal A.
 - a. The 12 volts DC circuit is completed through the transfer relay coil and back to the generator circuit board, via Wire 23.
 - b. Circuit board action normally holds the Wire 23 circuit open to ground and the relay is de-energized.

- c. When de-energized, the relay's normally open contacts are open and its normally-closed contacts are closed.
- d. The normally-closed relay contacts will deliver utility source power to the utility closing circuit of the transfer mechanism.
- e. The normally open relay contacts will deliver standby source power to the transfer mechanism's standby closing circuit.

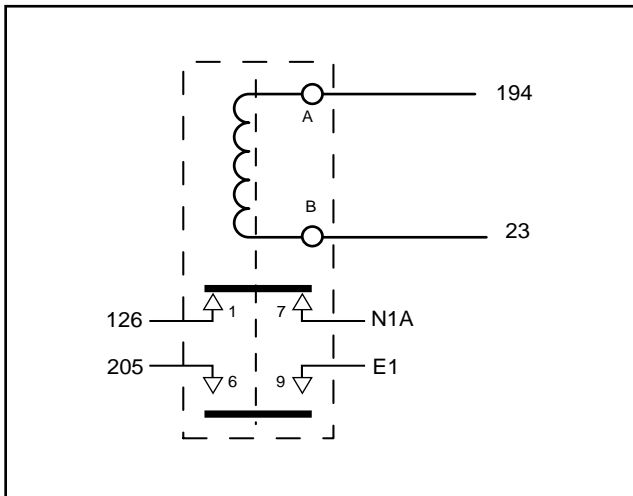

Figure 5. Transfer Relay Schematic

- 2. During automatic system operation, when the generator circuit board “senses” that utility source voltage has dropped out, the circuit board will initiate engine cranking and startup.
- 3. When the circuit board “senses” that the engine has started, an “engine warm-up timer” on the circuit board starts timing.
- 4. When the “engine warm-up timer” has timed out, circuit board action completes the Wire 23 circuit to ground.
 - a. The transfer relay then energizes.
 - b. The relay's normally-closed contacts open and its normally open contacts close.
 - c. When the normally open contacts close, standby source power is delivered to the standby closing coil and transfer to “Standby” occurs.
- 5. When the generator circuit board “senses” that utility source voltage has been restored above a preset level, the board will open the Wire 23 circuit to ground.
 - a. The transfer relay will de-energize, its normally-closed contacts will close and its normally open contacts will open.
 - b. When the normally-closed relay contacts close, utility source voltage is delivered to the utility closing coil to energize that coil.
 - c. Retransfer back to UTILITY occurs.

NEUTRAL LUG

The standby generator is equipped with an UNGROUNDED neutral. The neutral lug in the transfer switch is isolated from the switch enclosure.

MANUAL TRANSFER HANDLE

The manual transfer handle is retained in the transfer switch enclosure by means of a wing stud. Use the handle to manually actuate the transfer mechanism load contacts to either the UTILITY or STANDBY source side.

Instructions on use of the manual transfer handle may be found in Part 5, “Operational Tests and Adjustments”.

TERMINAL BLOCK

During system installation, this 3-point terminal block must be properly interconnected with an identically labeled terminal block in the generator control panel assembly.

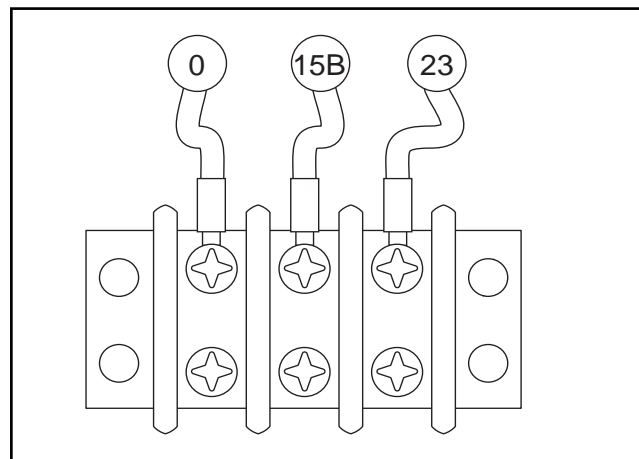

Figure 6. Transfer Switch Terminal Block

Terminals used on the terminal block are identified as 0, 15B and 23.

UTILITY N1 AND N2:

Interconnect with identically labeled terminals in the generator control panel assembly. This is the utility voltage signal to the circuit board. The signal is delivered to a step-down transformer in the control module assembly and the resultant reduced voltage is then delivered to the circuit board. Utility 1 and 2 power is used by the circuit board as follows:

- If utility source voltage should drop below a preset level, circuit board action will initiate automatic cranking and startup, followed by automatic transfer to the standby source.
- Utility source voltage is used to operate a battery trickle charge circuit which helps to maintain battery state of charge during non-operating periods.

TERMINALS 0, 15B AND 23:

These terminals connect the transfer relay to the generator circuit board. See "Transfer Relay" in Section 3.1.

FUSE HOLDER

The fuse holder holds three (3) fuses, designated as fuses F1, F2 and F3. Each fuse is rated 5 amperes.

FUSES F1, F2:

These two fuses protect the UTILITY 1 and UTILITY 2 circuit against overload.

FUSES F3:

This fuse protects the battery charger against overload.

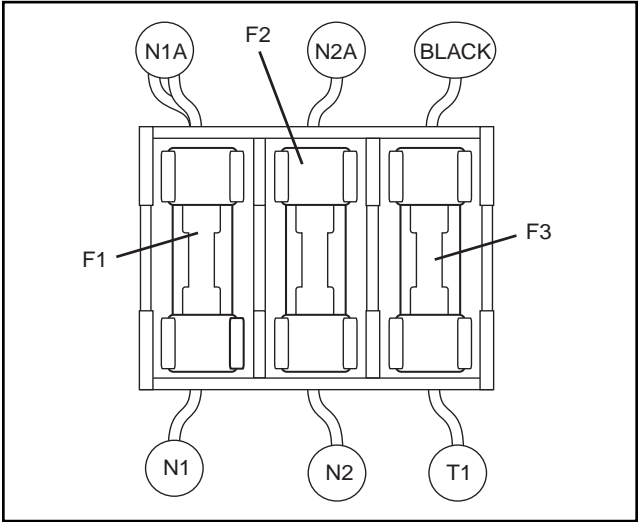

Figure 7. The Fuse Holder

OPERATIONAL ANALYSIS

Figure 1 is a schematic for a typical "W/V-Type" transfer switch.

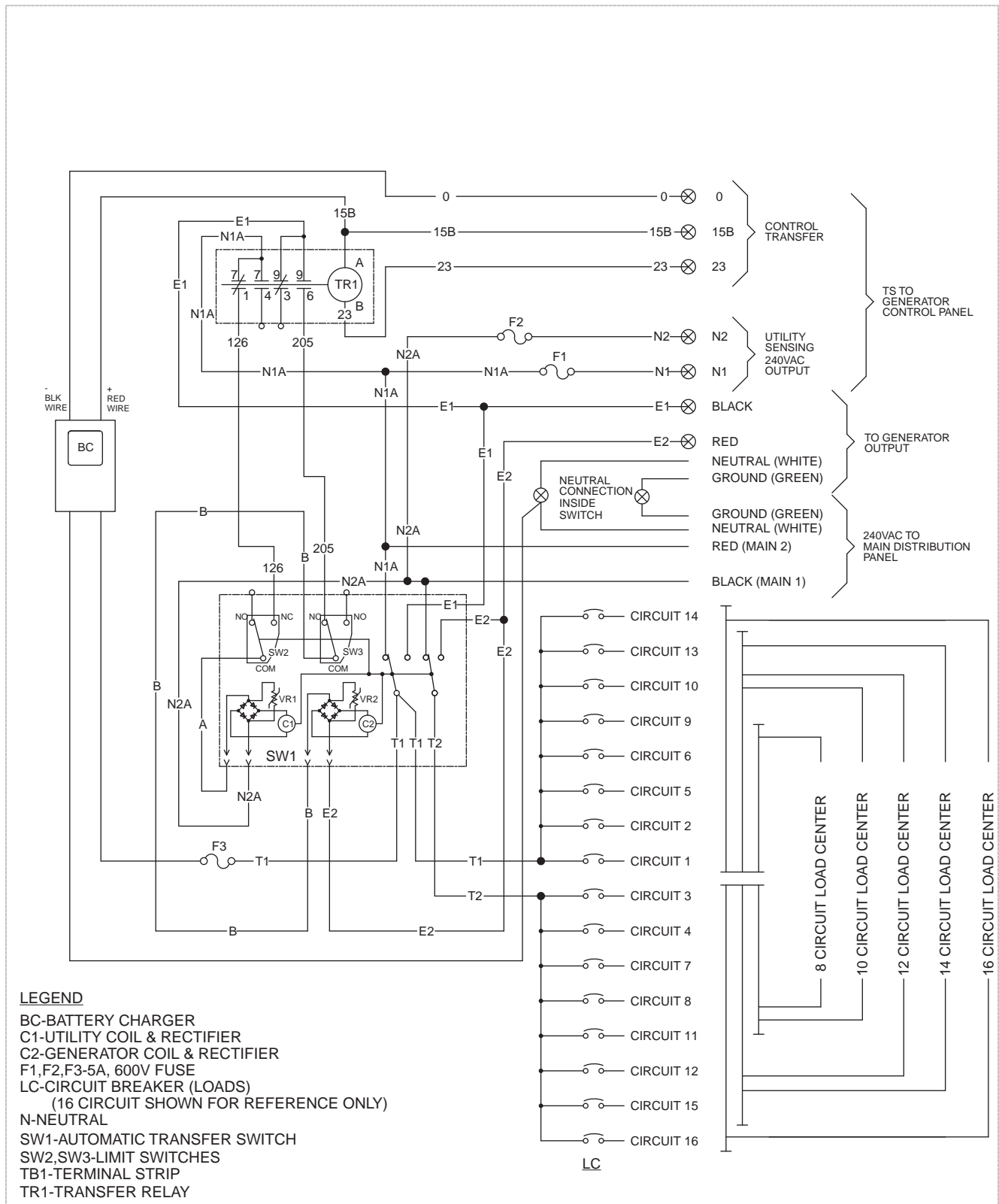

Figure 1. Schematic

Figure 2 is a wiring diagram for a typical "W/V-Type" transfer switch.

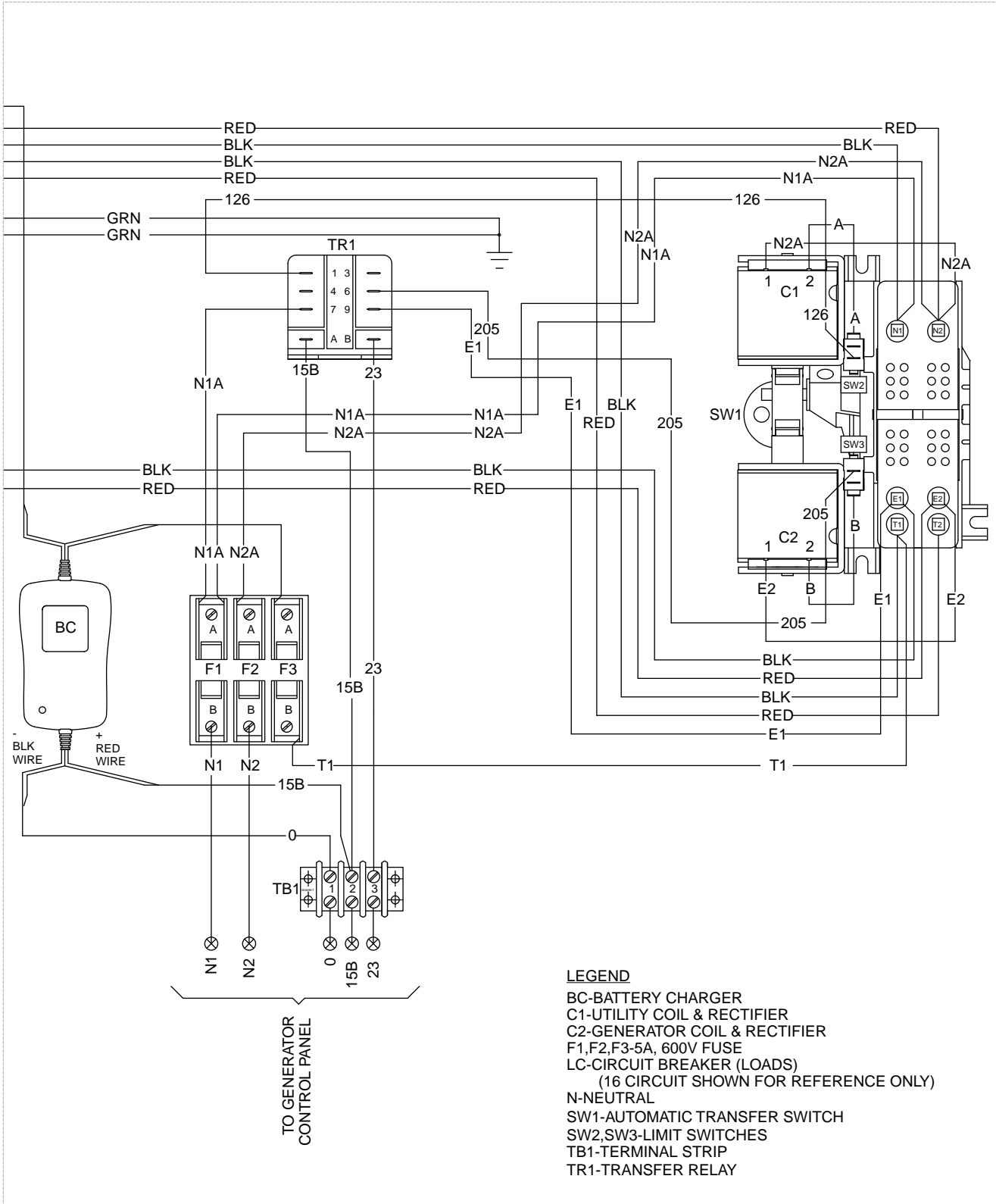

Figure 2. Wiring Diagram

UTILITY SOURCE VOLTAGE AVAILABLE

Figure 3 is a schematic representation of the transfer switch with utility source power available. The circuit condition may be briefly described as follows:

- Utility source voltage is available to terminal lugs N1 and N2 of the transfer mechanism, transfer switch is in the UTILITY position and source voltage is available to T1, T2 and customer load.
- Utility source voltage is available to limit switch (SW2) via the normally-closed transfer relay contacts (1 and 7) and Wire 126. However, SW2 is open and the Circuit to the utility closing coil is open.
- Utility voltage “sensing” signals are delivered to a circuit board on the generator, via Wire N1A, a 5 amp fuse (F1). The second line of the utility voltage “sensing” circuit is via Wire N2A, a 5 amp Fuse (F2).

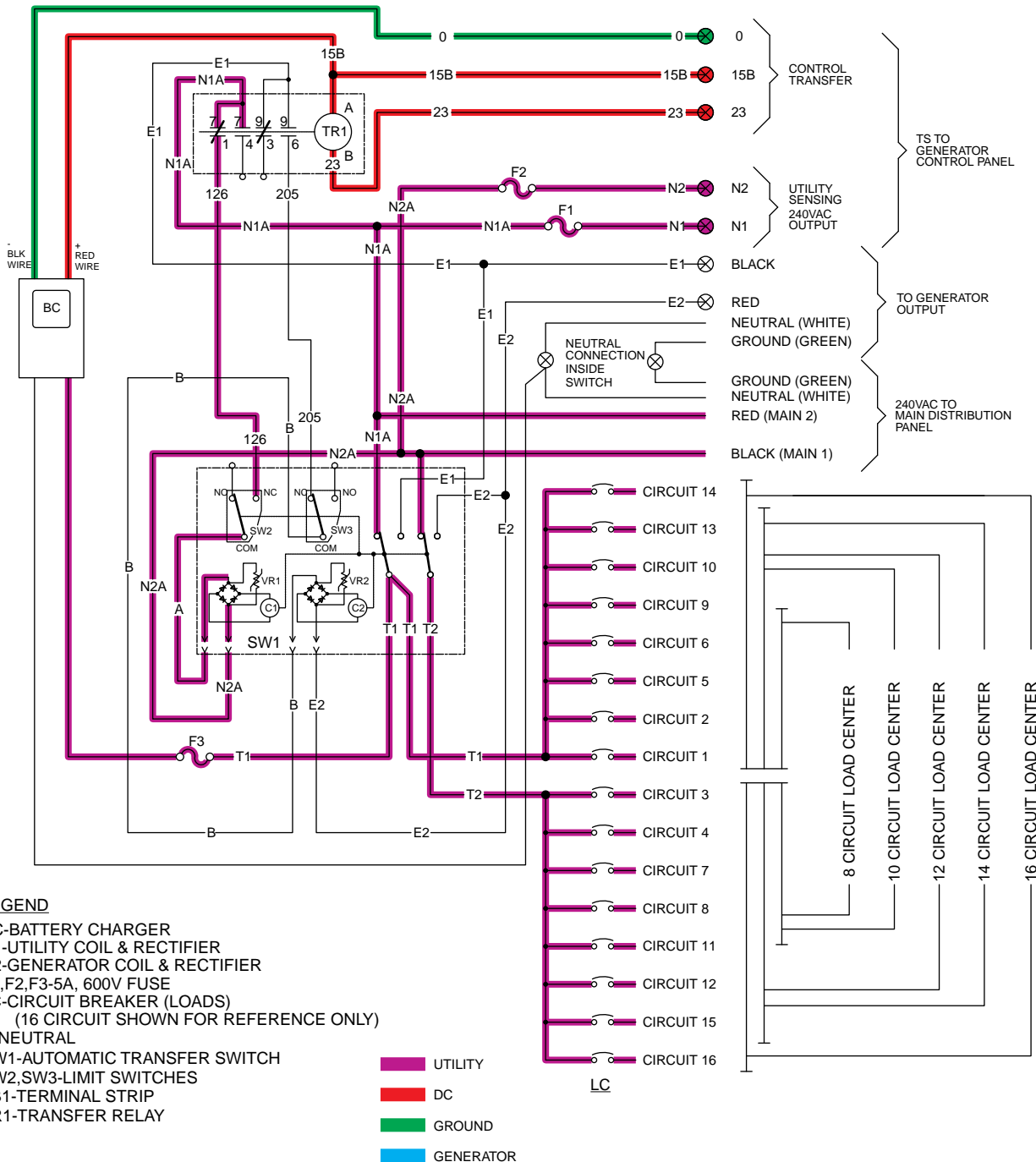

Figure 3. Utility Source Power Available

UTILITY SOURCE VOLTAGE FAILURE

If utility source voltage should drop below a preset value, the generator circuit board will sense the dropout. The circuit board will then initiate generator cranking and startup after a time delay circuit times out.

Figure 4 is a schematic representation of the transfer switch with generator power available, waiting to transfer.

- Generator voltage available E1, E2.
- Circuit board action holding Wire 23 open to ground.
- Power available to standby coil C2, upon closure of TR1, normally open contacts (9 & 6) will close and initiate a transfer.

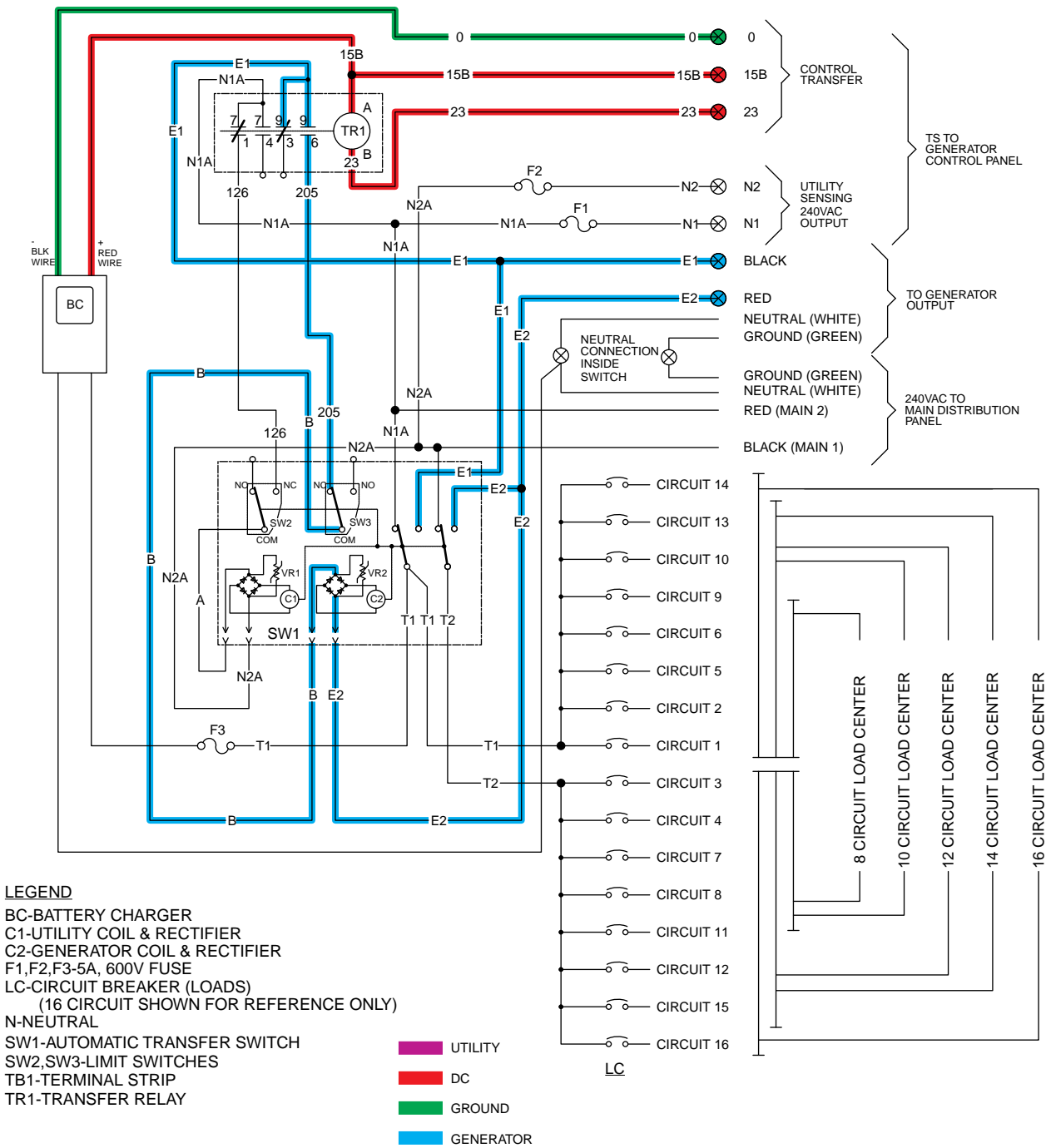

Figure 4. Generator Power Available, Waiting to Transfer.

TRANSFER TO STANDBY

12 VDC is delivered to the transfer relay via Wire 15B and back to the circuit board via Wire 23. However, circuit board action holds the Wire 23 circuit open and the transfer relay remains de-energized. On generator startup, an "engine warm-up timer" on the generator circuit board starts timing. When that timer has timed out, circuit board action completes the Wire 23 circuit to ground. The transfer relay then energizes, its normally open contacts close, and standby source voltage is delivered to the standby closing coil via Wires E1 and E2, the transfer relay (TR1) contacts, limit switch (SW3), Wire "B", and a bridge rectifier. The standby closing coil energizes and the main contacts actuate to their "Standby" side.

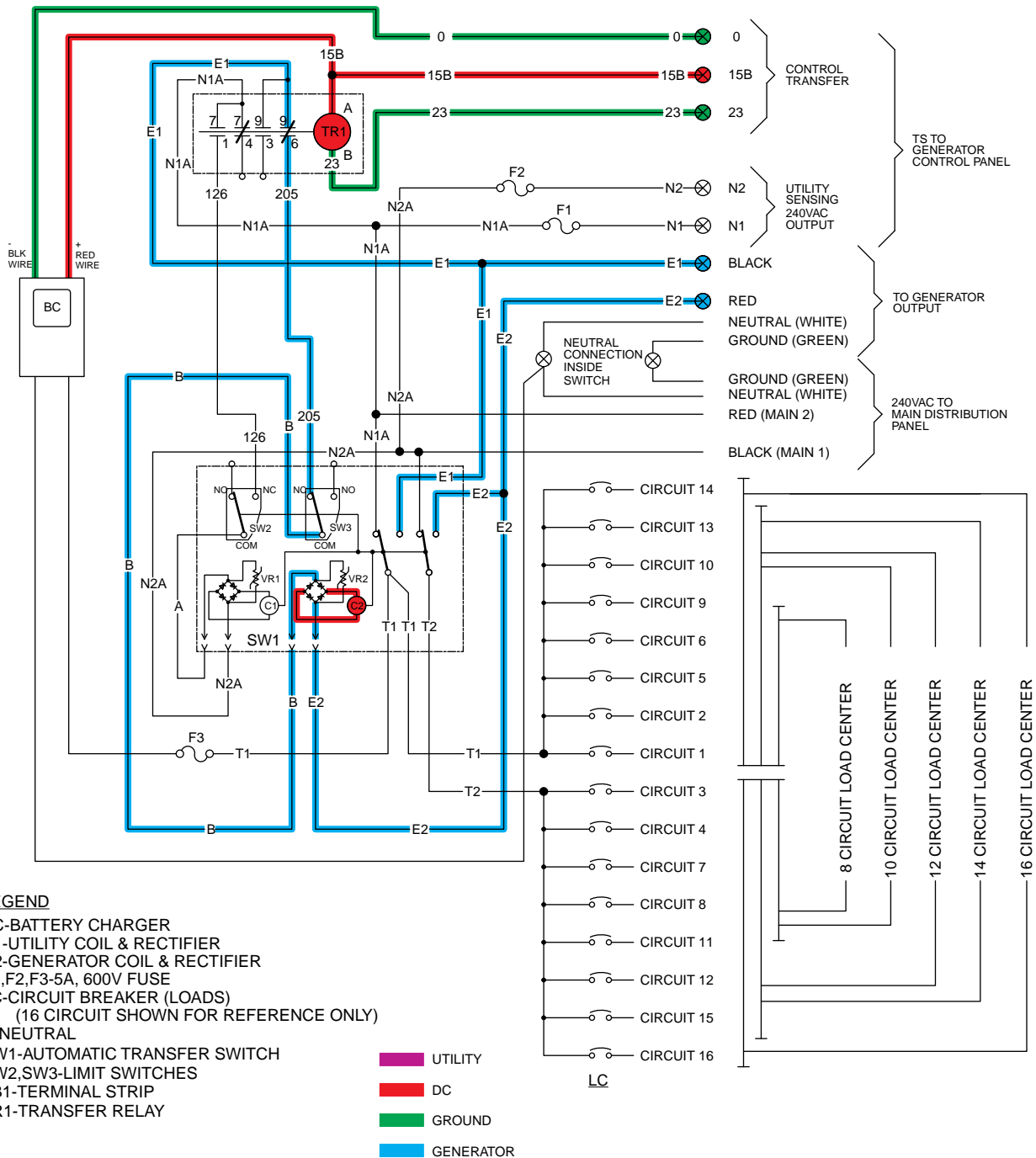

Figure 5. Transfer Action to Standby Position

TRANSFER TO STANDBY

When the standby coil is energized it pulls the transfer switch mechanism to an overcenter position towards the standby power source side, the transfer switch mechanically snaps to the standby position. On closure of the main contacts to the standby power source side, limit switches SW2 and SW3 are mechanically actuated to “arm” the circuit for re-transfer to utility power source side.

Generator power from E1 and E2 is now connected to the customer load through T1 and T2.

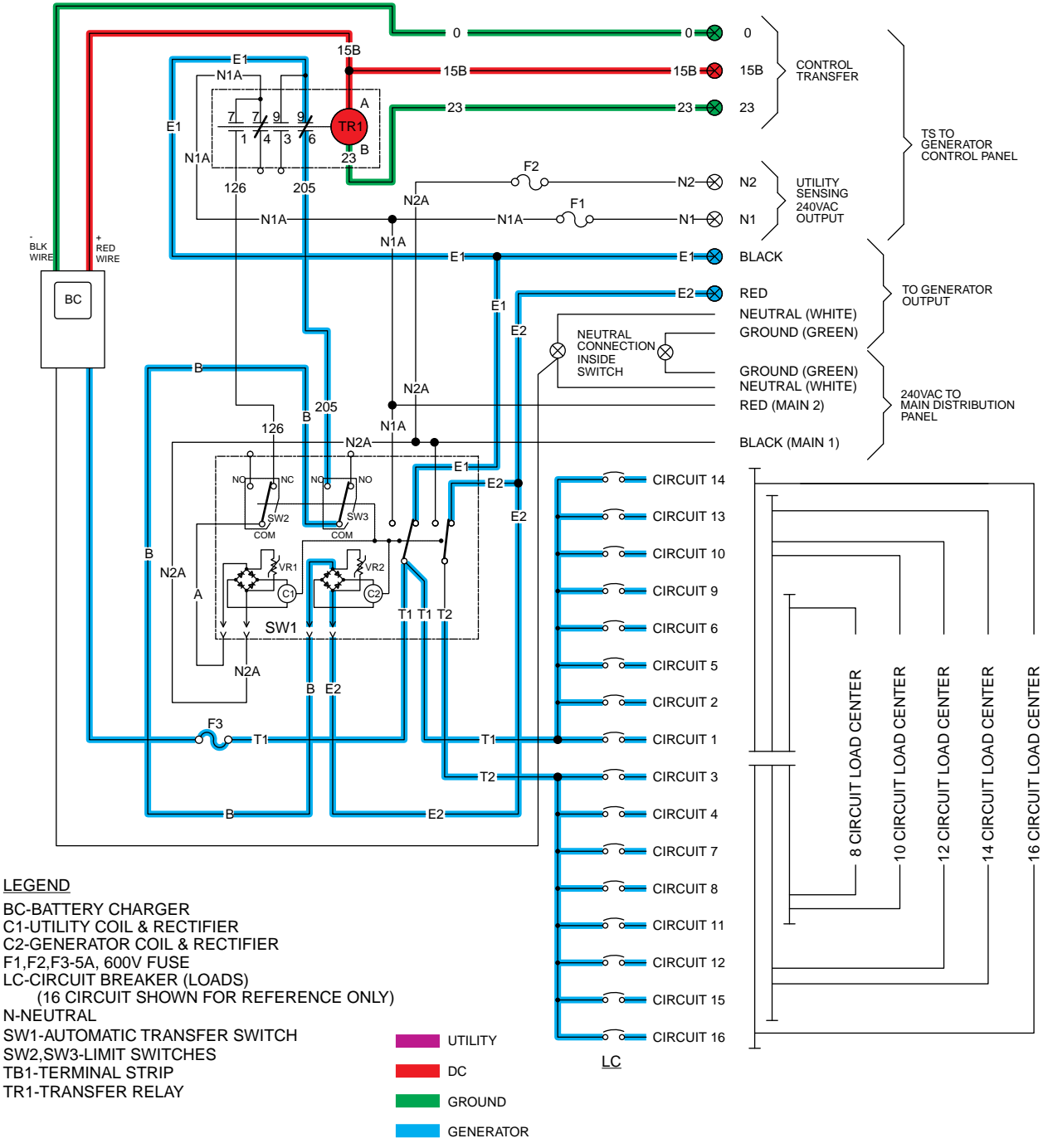

Figure 6. Generator Powering Load.

UTILITY RESTORED

Utility voltage is restored and is available to Terminals N1 and N2. The utility voltage is sensed by the generators circuit board. If it is above a preset value for a preset time interval a transfer back to utility power will occur.

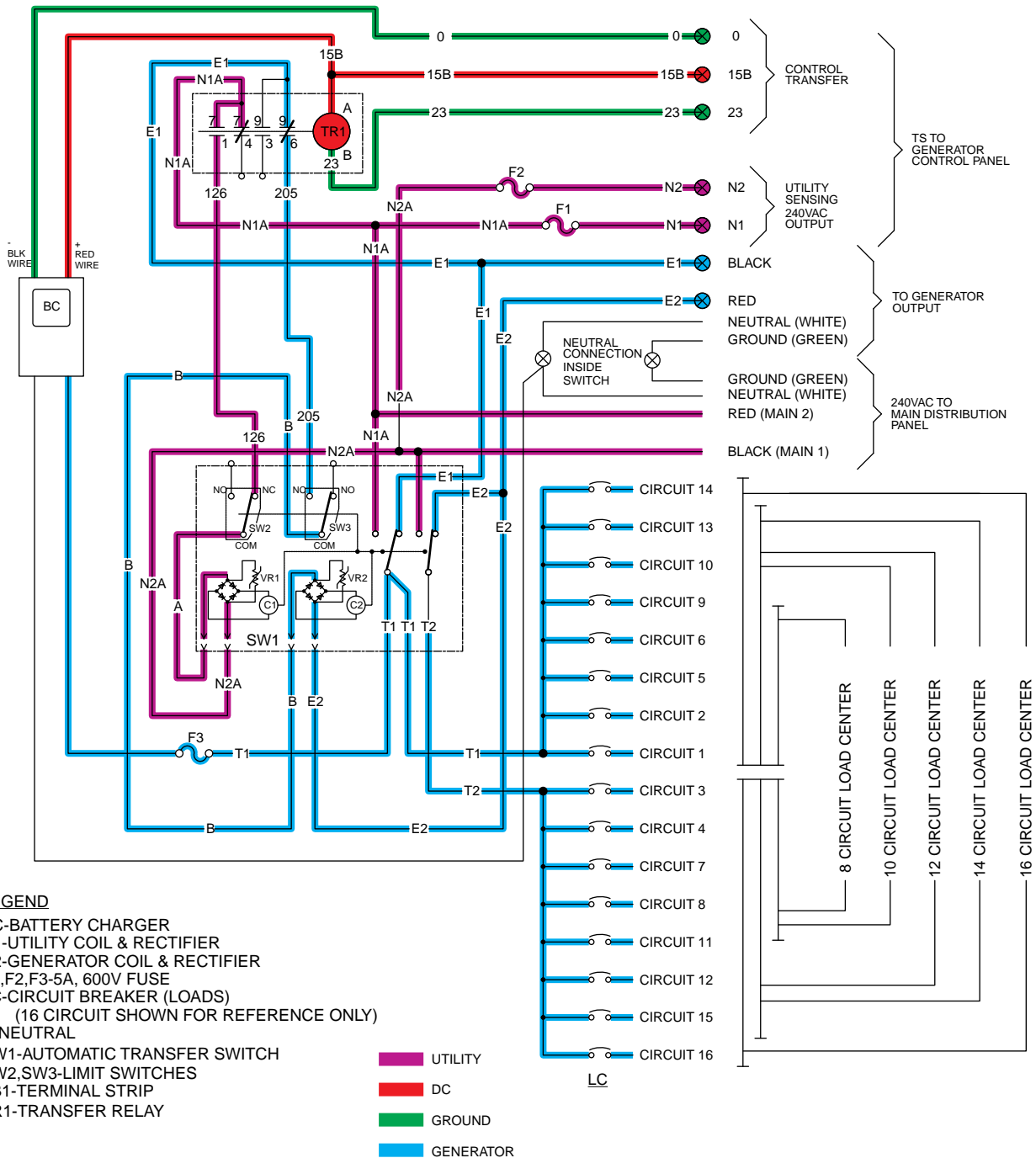

Figure 7. Utility Restored, Generator Still Providing Output to Load.

UTILITY RESTORED, TRANSFER SWITCH DE-ENERGIZED

After the preset time interval expires the circuit board will open the Wire 23 circuit to ground. The transfer relay de-energizes, it's normally closed contacts close, and utility source voltage is delivered to the utility closing coil (C1), via Wires N1A and N2A, closed Transfer Relay Contacts 1 and 7, and Limit Switch SW2.

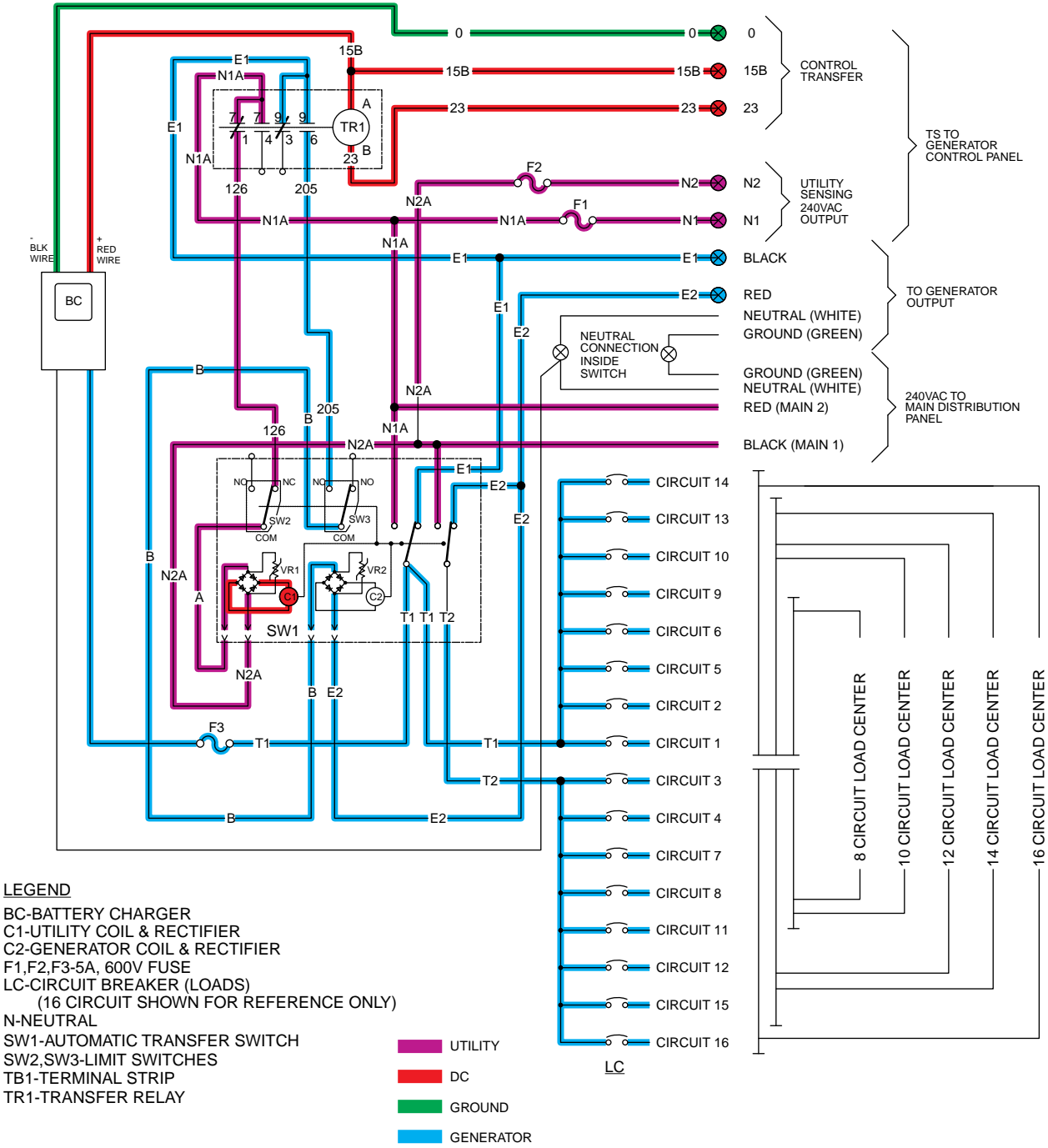

Figure 8. Utility Restored, Transfer Relay De-energized.

UTILITY RESTORED, RETRANSFER BACK TO UTILITY

As the utility coil pulls the transfer switch to an OVER CENTER position, the switch mechanically snaps to Utility. On closure of the main contacts to the utility power source side, Limit Switches SW2 and SW3 are mechanically actuated to "arm" the circuit for transfer to standby.

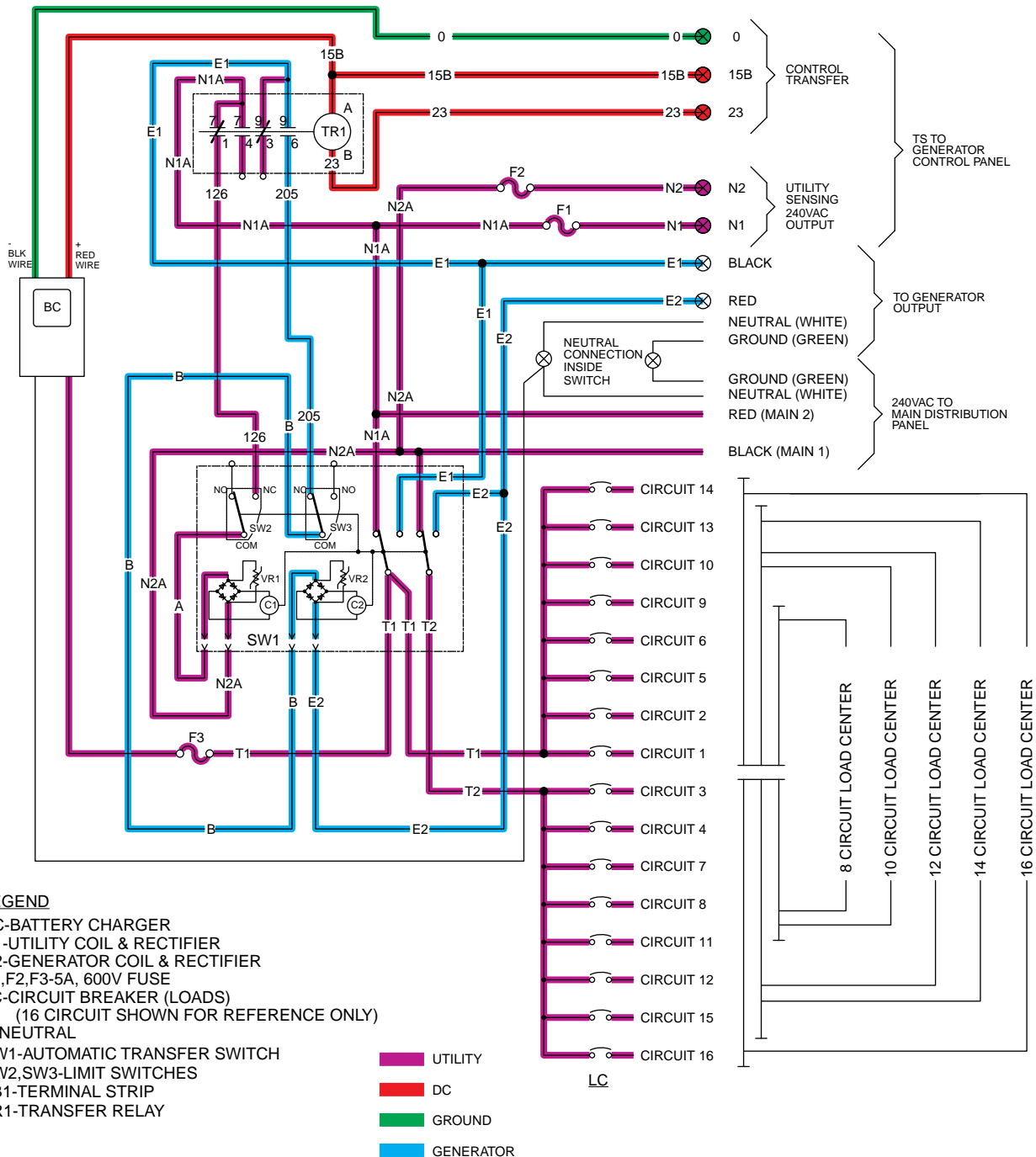

Figure 9. Utility Restored, Retransfer Back to Utility.

TRANSFER SWITCH IN UTILITY

When the transfer switch returns to the utility side, generator shutdown occurs after approximately one (1) minute.

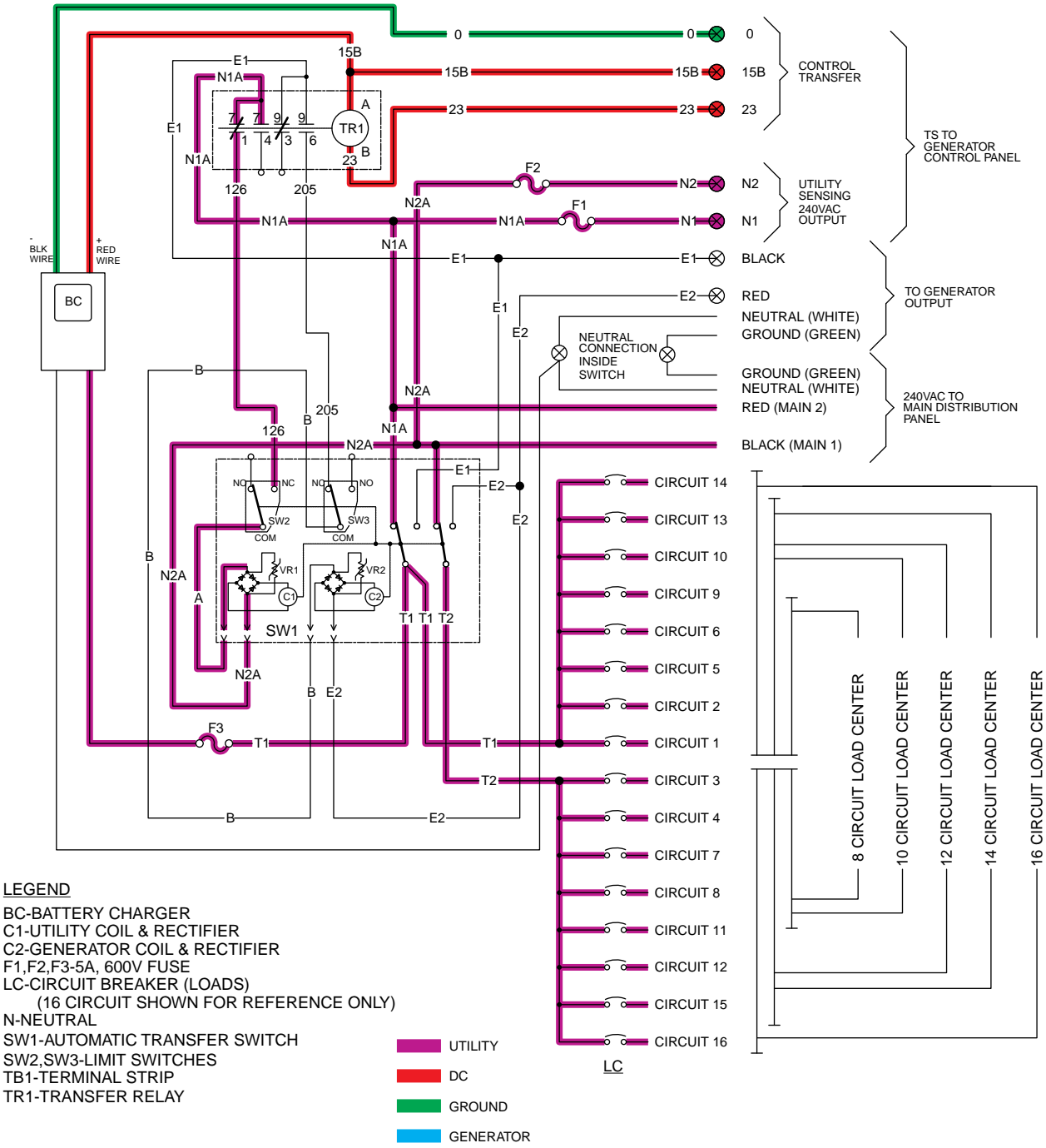

Figure 10. Transfer Switch in UTILITY.

INTRODUCTION TO TROUBLESHOOTING

The first step in troubleshooting is to correctly identify the problem. Once that is done, the cause of the an be found by performing the tests in the appropriate flow chart.

Test numbers assigned in the flow charts are identical to test numbers in Section 3.4, "Diagnostic Tests." Section 3.4 provides detailed instructions for performance of each test.

Problem 7 – In Automatic Mode, No Transfer to Standby

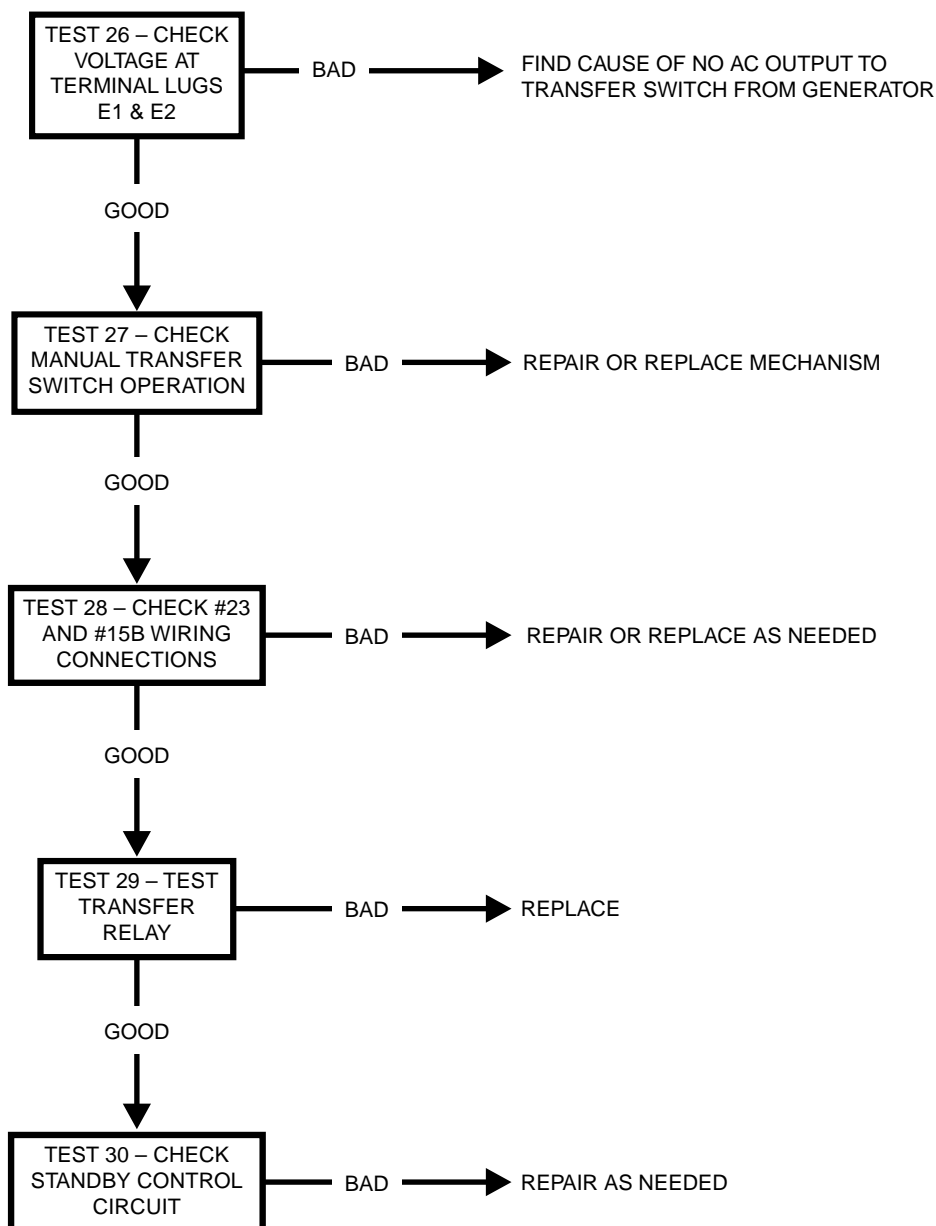

**Problem 8 – In Automatic Mode, Generator Starts When Loss of Utility Occurs, Generator Shuts Down When Utility Returns But There Is No Retransfer To Utility Power
OR
Generator Transfers to Standby During Exercise or in Manual Mode**

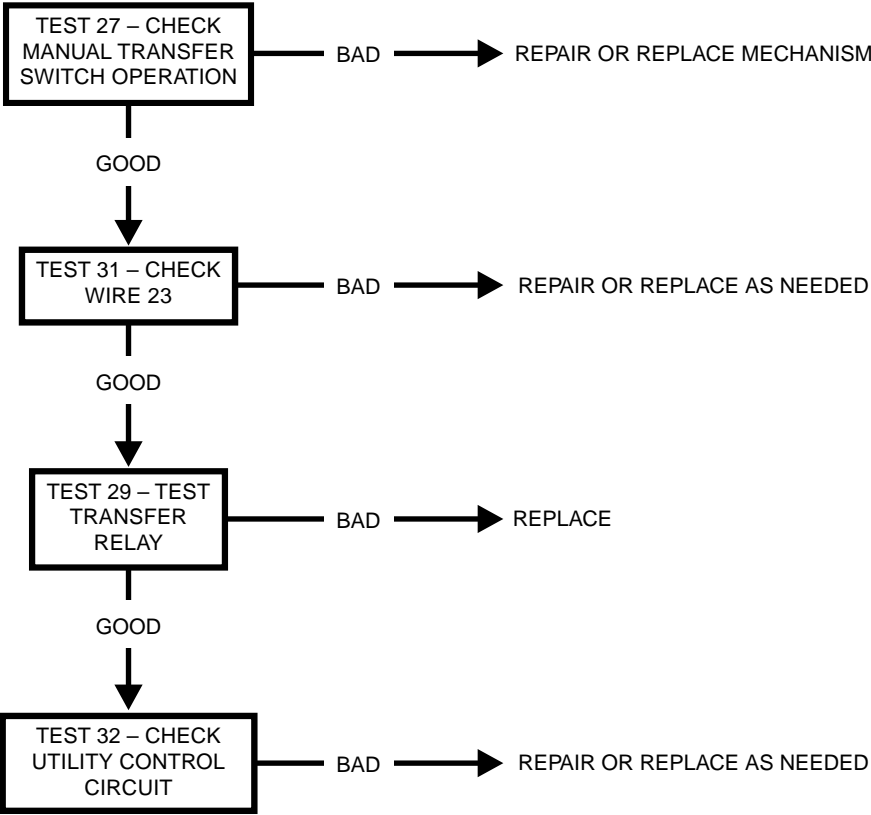

Problem 9 – Blown F1 or F2 Fuse

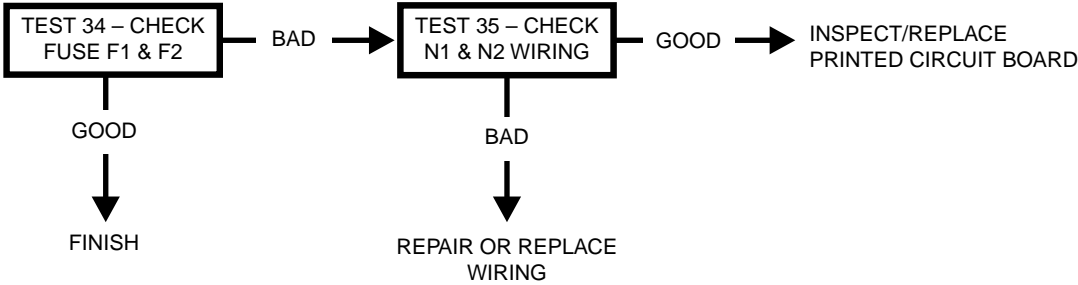

SECTION 3.3
TROUBLESHOOTING FLOW CHARTS

Problem 10 – Unit Starts and Transfer Occurs When Utility Power Is On
8 kW: Green LED Flashes
10-20 kW: Status – Utility Lost

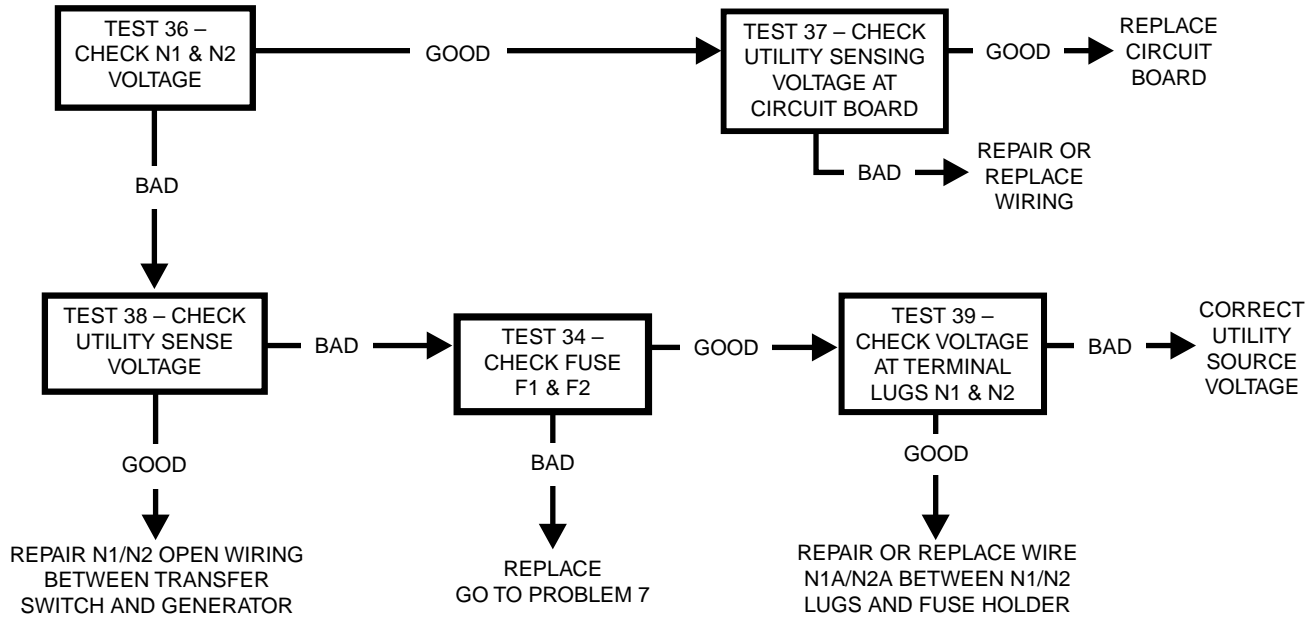

Problem 11 – No Battery Charge
“Pre-Wire Load Center”

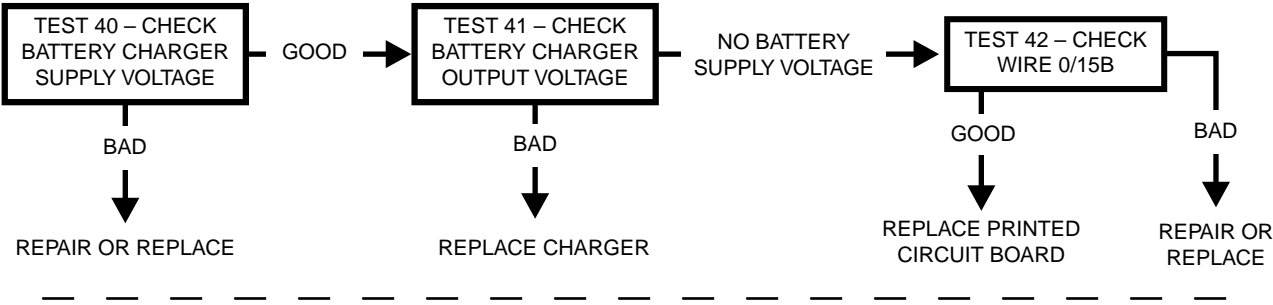

Problem 12 – No Battery Charge
“RTSN & RTSE Transfer Switch”

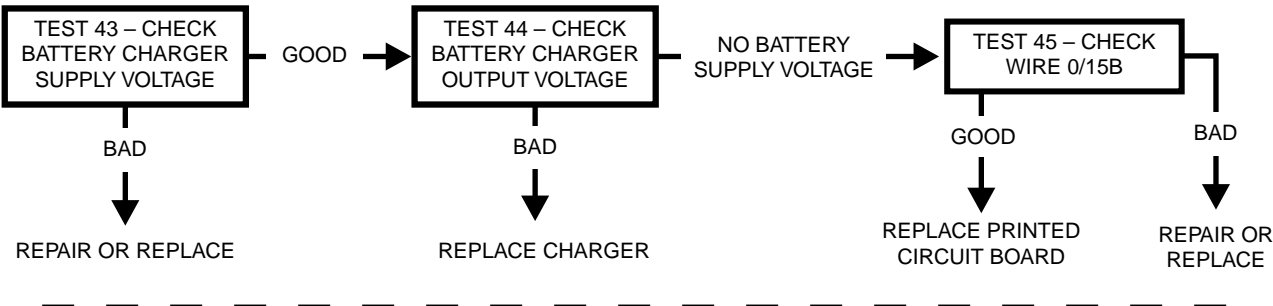

Problem 13 – No Battery Charge
“GenReady Load Center”

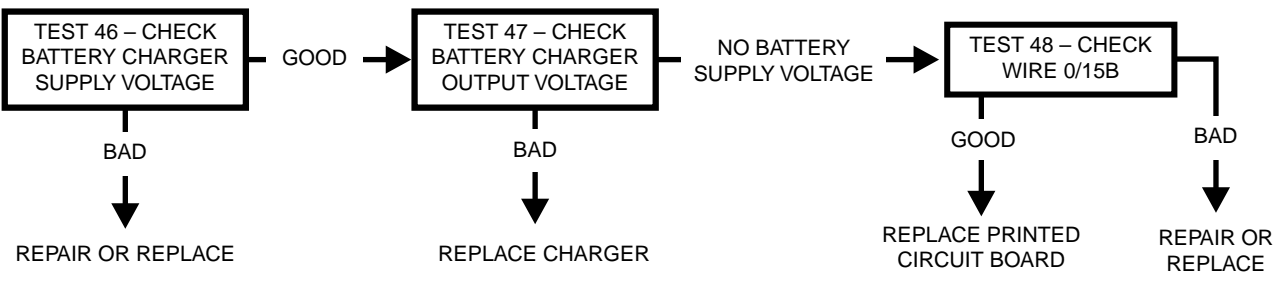

Problem 14 – No Battery Charge
“Load Shed Transfer Switch”

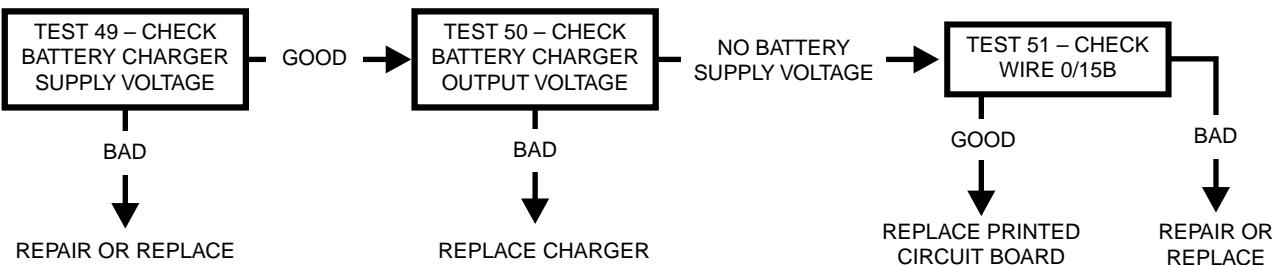

GENERAL

Test numbers in this section correspond to the numbered tests in Section 3.3, "Troubleshooting Flow Charts". When troubleshooting, first identify the problem. Then, perform the diagnostic tests in the sequence given in the flow charts.

TEST 26 – CHECK VOLTAGE AT TERMINAL LUGS E1, E2

DISCUSSION:

In automatic mode, the standby closing coil (C2) must be energized by standby generator output if transfer to the "Standby" source is to occur. Transfer to "Standby" cannot occur unless that power supply is available to the transfer switch.



DANGER: BE CAREFUL! HIGH AND DANGEROUS VOLTAGES ARE PRESENT AT TERMINAL LUGS E1 AND E2 WHEN THE GENERATOR IS RUNNING. AVOID CONTACT WITH HIGH VOLTAGE TERMINALS OR DANGEROUS AND POSSIBLY LETHAL ELECTRICAL SHOCK MAY RESULT. DO NOT PERFORM THIS VOLTAGE TEST WHILE STANDING ON WET OR DAMP GROUND, WHILE BAREFOOT, OR WHILE HANDS OR FEET ARE WET.

PROCEDURE:

1. If the generator engine has started automatically (due to a utility power source outage) and is running, check the position of the generator main circuit breaker. The circuit breaker must be set to its "On" or "Closed" position. After confirming that the generator main circuit breaker is set to ON (or closed), check the voltage at transfer mechanism Terminal Lugs E1 and E2 with an accurate AC voltmeter or with an accurate volt-ohm-milliammeter (VOM). The generator line-to line voltage should be indicated.
2. If the generator has been shut down, proceed as follows:
 - a. On the generator control panel, set the AUTO-OFF-MANUAL switch to OFF.
 - b. Turn off all power voltage supplies to the transfer switch. Both the utility and standby power supplies must be positively turned off before proceeding.
 - c. Check the position of the transfer mechanism main contacts. The moveable LOAD contacts must be connected to the stationary UTILITY source contacts. If necessary, manually actuate the main contacts to the "Utility" power source side.
 - d. Actuate the generator main line circuit breaker to its "On" or "Closed" position. The utility power supply to the transfer switch must be turned off.

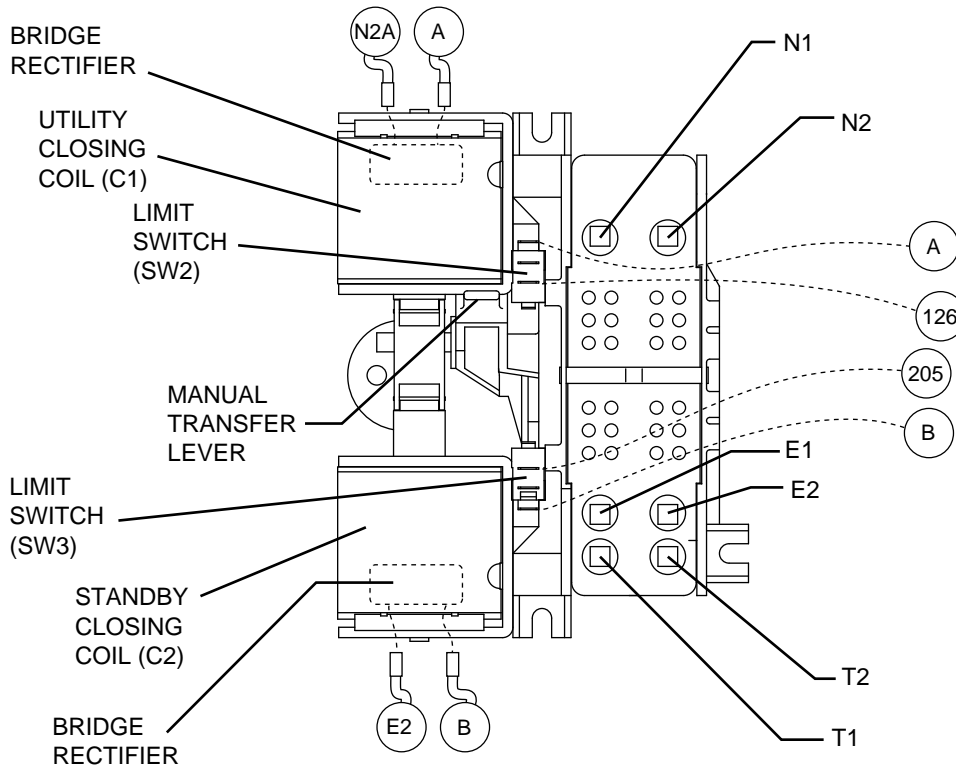

Figure 1. The Transfer Mechanism

- e. Set the generator AUTO-OFF-MANUAL switch to AUTO.
- (1) The generator should crank and start.
 - (2) When the generator starts, an “engine warm-up timer” should start timing. After about 15 seconds, the transfer relay should energize and transfer to the “Standby” source should occur.
- f. If transfer to “Standby” does NOT occur, check the voltage across transfer switch Terminal Lugs E1 and E2. The generator line-to-line voltage should be indicated.

RESULTS:

1. If normal transfer to “Standby” occurs, discontinue tests.
2. If transfer to “Standby” does NOT occur and no voltage is indicated across Terminal Lugs E1/E2, determine why generator AC output has failed.
3. If transfer to “Standby” does NOT occur and voltage reading across Terminal Lugs E1/E2 is good, refer to Flow Chart.

TEST 27 – CHECK MANUAL TRANSFER SWITCH OPERATION**DISCUSSION:**

In automatic operating mode, when utility source voltage drops below a preset level, the engine should crank and start. On engine startup, an “engine warm-up timer” on the generator circuit board should start timing. When that timer has timed out (about 15 seconds), the transfer relay should energize to deliver utility source power to the standby closing coil terminals. If normal

utility source voltage is available to the standby closing coil terminals, but transfer to Standby does not occur, the cause of the failure may be (a) a failed standby closing coil and/or bridge rectifier, or (b) a seized or sticking actuating coil or load contact. This test will help you evaluate whether any sticking or binding is present in the transfer mechanism.

PROCEDURE:

1. With the generator shut down, set the generator AUTO-OFF-MANUAL switch to OFF.
2. Set the generator main circuit breaker to OFF or “Open”.
3. Turn off the utility power supply to the transfer switch, using whatever means provided (such as a utility source main line breaker).



DANGER: DO NOT ATTEMPT MANUAL TRANSFER SWITCH OPERATION UNTIL ALL POWER VOLTAGE SUPPLIES TO THE SWITCH HAVE BEEN POSITIVELY TURNED OFF. FAILURE TO TURN OFF ALL POWER VOLTAGE SUPPLIES MAY RESULT IN EXTREMELY HAZARDOUS AND POSSIBLY LETHAL ELECTRICAL SHOCK.

4. In the transfer switch enclosure, locate the manual transfer handle. Handle is retained in the enclosure with a wing nut. Remove the wing nut and handle.
5. See Figure 2. Insert the un-insulated end of the handle over the transfer switch operating lever.
 - a. Move the transfer switch operating lever up to actuate the load contacts to the Utility position, i.e., load connected to the utility source.

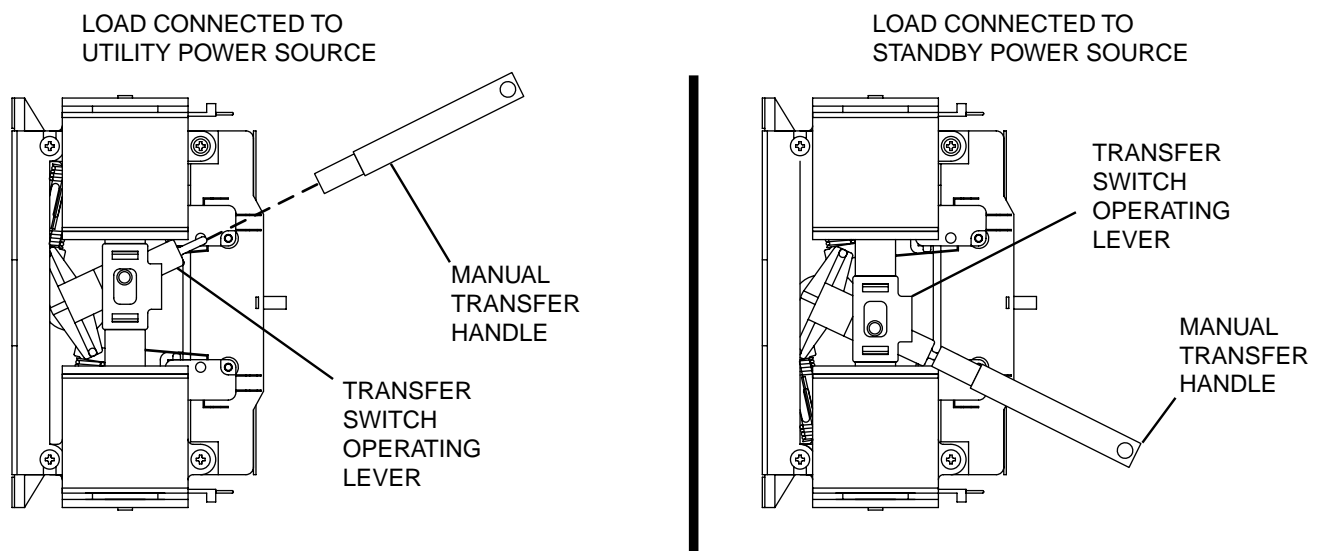

Figure 2. Manual Transfer Switch Operation

SECTION 3.4 DIAGNOSTIC TESTS

PART 3

TRANSFER SWITCH

- b. Actuate the operating lever down to move the load contacts against the standby contacts, i.e., load connected to the Standby source.
6. Repeat Step 5 several times. As the transfer switch operating lever is moved slight force should be needed until the lever reaches its center position. As the lever moves past its center position, an over-center spring should snap the moveable load contacts against the stationary STANDBY or UTILITY contacts.
7. Finally, actuate the main contacts to their UTILITY power source side, i.e., load contacts against the UTILITY contacts (upward movement of the operating lever).

RESULTS:

1. If there is no evidence of binding, sticking, or excessive force required, refer back to flow chart.
2. If evidence of sticking, binding, excessive force required to move main contacts, find cause of binding or sticking and repair or replace damaged part(s).

TEST 28 – CHECK 23 AND 15B WIRING/ CONNECTIONS

DISCUSSION:

An open circuit in the transfer switch control wiring can prevent a transfer action from occurring. Battery voltage +12 VDC is supplied on Wire 15B. This DC voltage is supplied to the transfer relay (TR) at Terminal Location "A". The opposite side of the transfer relay (TR) coil (Terminal B) is connected to Wire 23. Positive 12 VDC is present on this also. Circuit board action will allow current to flow through the circuit and the (TR) is energized.

PROCEDURE/ RESULTS:

Refer to Figure 3.

1. Remove transfer relay mounting screws so that contact movement can be visually observed.
2. Set the generator AUTO-OFF-MANUAL switch to the AUTO position. Turn off utility power supply to the transfer switch, simulating a utility failure. Visually watch the transfer relay for contact movement. The relay should be energized and contact movement seen approximately 10 seconds after the generator starts.
 - a. If the transfer relay energizes, discontinue testing. Refer to flow chart.
 - b. If the transfer relay does not energize, continue to Step 3.
3. Set the generator AUTO-OFF-MANUAL switch to the OFF position.
4. Remove the battery charger fuse (F3) from the transfer switch to disable the battery charge circuit.



Caution: After removing the fuse from the battery charger, wait 5 minutes before proceeding.

5. Set VOM to measure DC voltage.
6. Connect the negative (-) test lead to Wire 0 at the terminal strip in the transfer switch. Connect the positive (+) test lead to Wire 15B at the terminal strip in the transfer switch.
 - a. If voltage is present, proceed to Step 7.
 - b. If voltage is not present proceed to Step 17.
7. Connect the positive (+) test lead to Wire 23 at the terminal strip in the transfer switch.
 - a. If voltage is present, proceed to Step 8.
 - b. If voltage is not present, set VOM to measure resistance.
 - c. Remove Wire 23 and Wire 15B going to the transfer relay from the transfer switch terminal strip. Connect the meter test leads across Wire 23 and Wire 15B.
 - d. Transfer coil resistance of approximately 115 ohms should be measured.
 - e. If coil resistance is not measured, remove Wire 23 and Wire 15B from the transfer relay. Measure across Terminal A and Terminal B of the transfer relay.
 - f. If coil resistance is measured repair or replace Wire 23 or Wire 15B between the terminal strip and the transfer relay.
 - g. If coil resistance is not measured replace transfer relay and retest.
8. Connect the negative (-) test lead to the ground lug in the generator control panel. Connect the positive (+) test lead to Wire 23 in the generator control panel at the terminal strip.
 - a. If voltage is present, proceed to Step 9.
 - b. If voltage is not present, repair wiring between transfer switch and generator control panel.
9. Remove the J2 connector from the circuit board.
10. Set VOM to measure resistance.
11. Connect one meter test lead to Wire 23 Pin Location J2-5. Connect the other meter test lead to Wire 15B Pin Location J2-8. Approximately 115 ohms should be measured. (see Figures 4 through 7, Section 4.1).
 - a. If approximately 115 ohms is measured proceed to Step 12.
 - b. If infinity or an open is measured, repair Wire 23 between PCB Connector J2 and the generator terminal strip.
 - c. If resistance is not within specification, go to Test 29 – Test Transfer Relay.
12. Reconnect the J2 connector to the PCB.

13. Set VOM to measure DC voltage.
14. Connect the (-) negative meter test lead to Wire 0 at the terminal strip in the generator. Connect the (+) positive meter test lead to Wire 23 at the terminal strip in the generator. 12 VDC should be measured.
15. Place generator AUTO-OFF-MANUAL switch to the AUTO position. Turn off utility power supply to the transfer switch, simulating a utility failure. After the generator starts 10 seconds should elapse before transfer occurs. At that time the VOM DC voltage should drop to zero. This indicates the PCB energized the transfer relay.
 - a. If DC voltage drops to zero, refer to Flow Chart.
 - b. If DC voltage remains constant at 12 VDC, proceed to Step 16.
16. With the generator running and utility off, ground Wire 23 in the control panel at the terminal strip. If transfer relay energizes and or transfer occurs, replace the PCB.
17. Set VOM to measure DC voltage.
18. Connect the negative (-) test lead to the ground lug in the transfer switch. Connect the positive (+) test lead to Wire 15B at the terminal strip in the transfer switch.
 - a. If voltage is present repair or replace Wire 0 between transfer switch and generator ground lug.
 - b. If voltage is not present proceed to Step 19.
19. Connect the negative (-) test lead to the ground lug in the generator control panel. Connect the positive (+) test lead to Wire 15B at the terminal strip in the generator control panel.
 - a. If voltage is present, repair Wire 15B between generator terminal strip and transfer switch terminal strip.
 - b. If voltage is not present, proceed to Step 20.
20. Remove the J2 connector from the circuit board.
21. Set VOM to measure ohms. Connect one meter test lead to Wire 15B at the control panel terminal strip. Connect the other meter test lead to Wire 15B Pin Location J2-8. Continuity should be measured.
 - a. If continuity is not measured, repair pin connection and or Wire 15B between the J2 connector and terminal strip.
 - b. If continuity is measured proceed to Step 22.
22. Remove the 7.5A fuse.
23. Reconnect J2 connector.
24. Install the 7.5A fuse.
25. Disconnect Wire 15B from the generator terminal strip.
26. Set VOM to measure DC voltage.



Caution: After installing the 7.5A fuse and disconnecting Wire 15B from the generator terminal strip, wait 5 minutes before proceeding.

27. Connect one meter test lead to Wire 15B. Connect the other meter test lead to Wire 0. 12 VDC should be measured.
 - a. If 12 VDC is not measured, replace the printed circuit board.
 - b. If 12 VDC is measured, a short exists on Wire 15B or the transfer relay is shorted. Repair or replace as needed.

TEST 29 – TEST TRANSFER RELAY TR

DISCUSSION:

In automatic operating mode, the transfer relay must be energized by circuit board action or standby source power will not be available to the standby closing coil. Without standby source power, the closing coil will remain de-energized and transfer to “Standby” will not occur. This test will determine if the transfer relay is functioning normally.

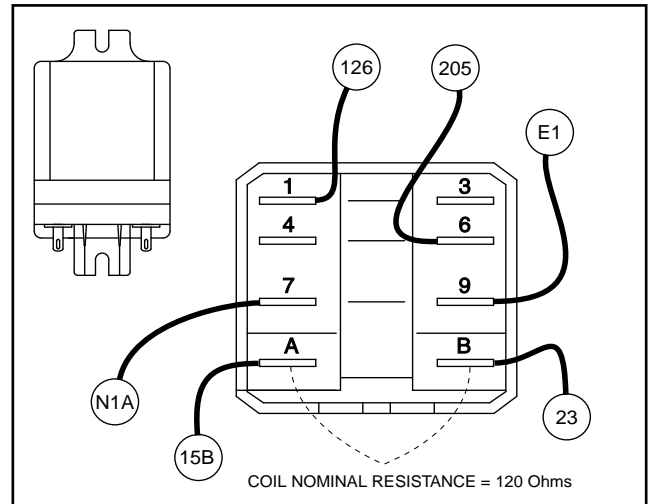

Figure 3. Transfer Relay Test Points

PROCEDURE:

1. See Figure 3. Disconnect all wires from the transfer relay, to prevent interaction.
2. Set a VOM to its “R x 1” scale and zero the meter.
3. Connect the VOM test leads across Relay Terminals 6 and 9 with the relay de-energized. The VOM should read INFINITY.

CONNECT VOM TEST LEADS ACROSS	DESIRED METER READING	
	ENERGIZED	DE-ENERGIZED
Terminals 6 and 9	Continuity	Infinity
Terminals 1 and 7	Infinity	Continuity

SECTION 3.4 DIAGNOSTIC TESTS

PART 3

TRANSFER SWITCH

4. Using jumper wires, connect the positive (+) post of a 12 volt battery to relay Terminal "A" and the negative (-) battery post to Relay Terminal "B". The relay should energize and the VOM should read CONTINUITY.
5. Now, connect the VOM test leads across Relay Terminals 1 and 7.
 - a. Energize the relay and the meter should indicate INFINITY.
 - b. De-energize the relay and the VOM should read CONTINUITY.

RESULTS:

1. Replace transfer relay if it is defective.
2. If transfer relay checks good go to Test 31.

TEST 30 – STANDBY CONTROL CIRCUIT

DISCUSSION:

Refer to Figure 4. The standby coil (C2) requires 240 VAC to energize. When the transfer relay is energized, 240 VAC is applied to standby coil C2. Once energized, the coil will pull the transfer switch down to the standby position. Once in the standby position, limit switch SW3 will open, removing AC to standby coil C2.

PROCEDURE/ RESULTS:

1. Set VOM to measure AC voltage.
2. Verify the transfer switch is up in the utility position.
3. Remove Wire E2 from standby coil C2.
4. Set the generator AUTO-OFF-MANUAL switch in the AUTO position. Turn off the utility power supply to the transfer switch, simulating a utility failure. The generator should start and the transfer relay should energize.
5. Measure across points A and B. 240 VAC should be measured.
 - a. If 240 VAC is not measured go back to Test 26.
 - b. If 240 VAC is measured, proceed to Step 6.
6. Measure across points C (Wire E2 previously removed) and B. 240 VAC should be measured.
 - a. If 240 VAC is not measured, repair or replace Wire E2.
 - b. If 240 VAC is measured, proceed to Step 7.
7. Measure across points A and D. 240 VAC should be measured.
 - a. If 240 VAC is not measured, repair or replace Wire E1.
 - b. If 240 VAC is measured, proceed to Step 8.
8. Measure across points A and E. 240 VAC should be measured.

- a. If 240 VAC is not measured, replace transfer relay.
 - b. If 240 VAC is measured, proceed to Step 9.
9. Measure across points A and F. 240 VAC should be measured.
 - a. If 240 VAC is not measured, repair or replace Wire 205.
 - b. If 240 VAC is measured, proceed to Step 10.
10. Measure across points A and G. 240 VAC should be measured.
 - a. If 240 VAC is not measured, verify limit switch SW3 is wired correctly. Proceed to Test 33.
 - b. If 240 VAC is measured, proceed to Step 11.
11. Measure across points A and H. 240 VAC should be measured.
 - a. If 240 VAC is not measured, repair or replace Wire B.
 - b. If 240VAC is measured, replace standby coil C2.

Coil nominal resistance is 1-2 megohms.

TEST 31 – CHECK WIRE 23

DISCUSSION:

Printed circuit board action controls grounding Wire 23 to initiate a transfer to standby. When Wire 23 is grounded the transfer relay (TR1) is energized. To initiate a transfer back to utility the TR1 relay must be de-energized. If Wire 23 is grounded, TR1 will always be energized.

PROCEDURE/ RESULTS:

1. Set VOM to measure DC voltage.
2. Set the generator AUTO-OFF-MANUAL switch in the OFF position.
3. Connect the positive (+) meter test lead to Wire 15B at the terminal strip in the transfer switch. Connect the negative (-) meter test lead to Wire 23 at the terminal strip in the transfer switch.
 - a. If 0 VDC is measured, proceed to Step 4.
 - b. If 12 VDC is measured, proceed to Step 6.
4. Set the generator AUTO-OFF-MANUAL switch in the AUTO position.
5. Connect the positive (+) meter test lead to Wire 15B at the terminal strip in the transfer switch. Connect the negative (-) meter test lead to Wire 23 at the terminal strip in the transfer switch
 - a. If 12 VDC is measured, proceed to Step b.
 - b. Navigate to the Digital Output Display Screen (see Figure 5).
 - (1) Press "ESC" until the main menu is reached.

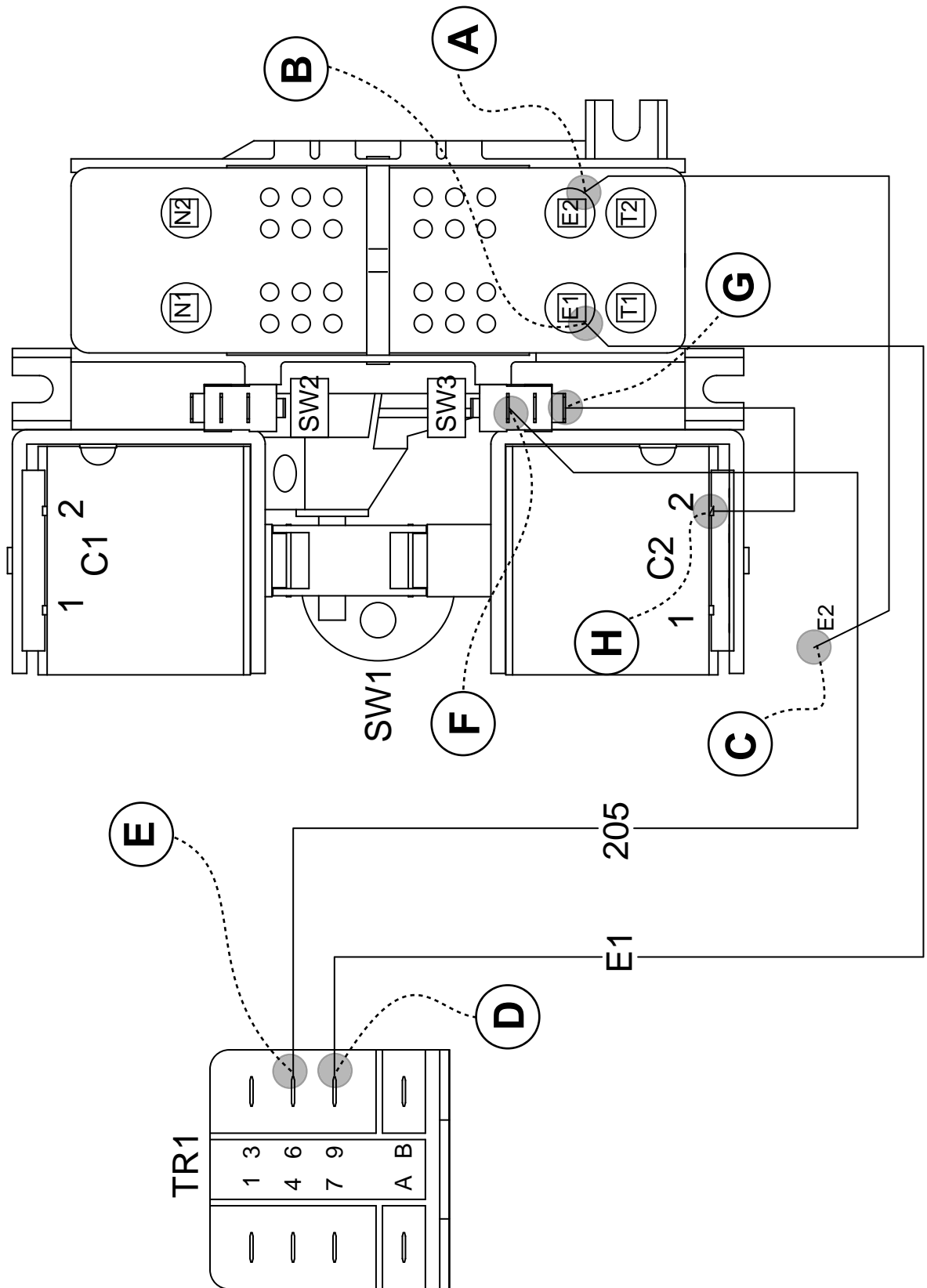

Figure 4. Standby Control Circuit Test Points

SECTION 3.4 DIAGNOSTIC TESTS

PART 3

TRANSFER SWITCH

- (2) Press the right arrow key until "Debug" is flashing.
 - (3) Press "Enter".
 - (4) Press the right arrow key until "Outputs" is flashing.
 - (5) Press "Enter".
 - (6) Digital Output 8 is Wire 23 output from the board. Refer to Figure 5.
 - (7) If Output 8 shows a "1" then the control board is grounding Wire 23. Replace the printed circuit board.
- c. If 0 VDC is measured, the Wire 23 circuit is good. Refer to flow chart.

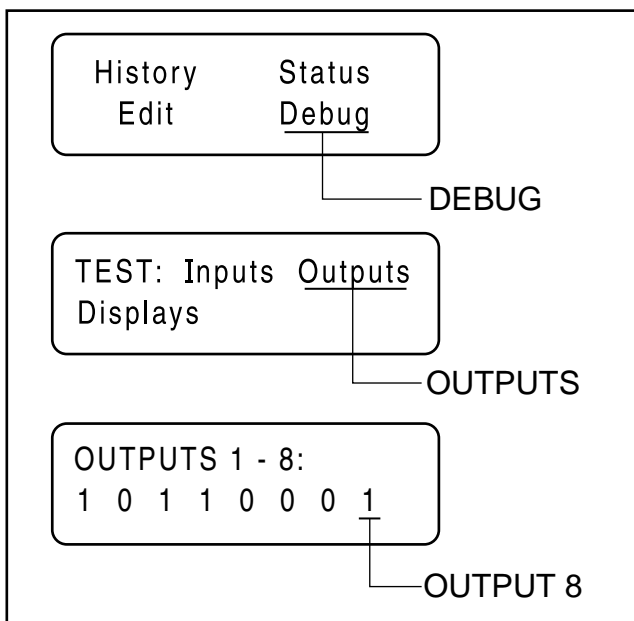

Figure 5. The Home Page, Debug and Output Screens

6. Locate the terminal strip in the generator control panel. Disconnect Wire 23 coming in from the transfer switch (customer connection, side-see Figure 6).
7. Connect the positive (+) meter test lead to Wire 15B at the terminal strip in the generator. Connect the negative (-) meter test lead to Wire 23 just removed from the terminal strip.
 - a. If 0 VDC is measured, proceed to Step 8.
 - b. If 12 VDC is measured, a short to ground exists on Wire 23 between the generator and transfer switch. Repair or replace Wire 23 as needed between generator control panel and transfer switch relay (TR1).
8. Locate the terminal strip in the generator control panel. Disconnect Wire 23 coming in from the transfer switch (customer connection, side - see Figure 6).

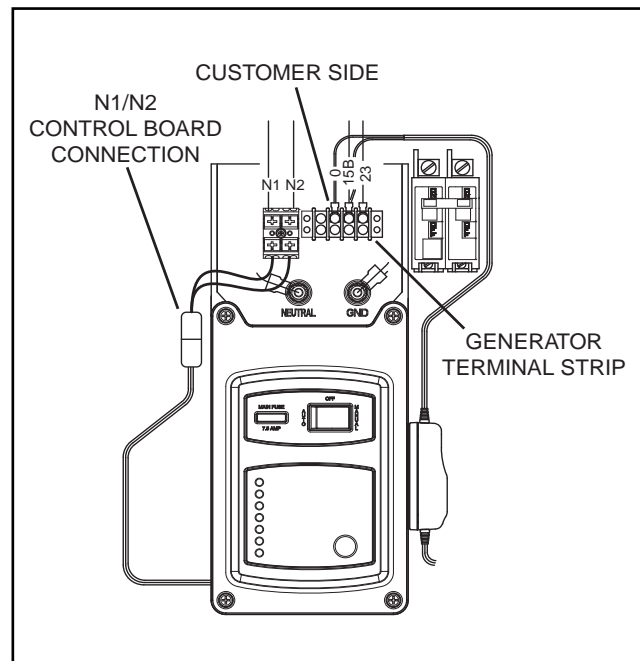

Figure 6. Transfer Relay Test Points

9. Disconnect the J2 connector from the printed circuit board.
10. Set VOM to measure resistance.
11. Connect one meter test lead to Wire 23 connected at generator terminal strip. See Figure 6. Connect the other meter test lead to control panel ground.
 - a. If INFINITY or open is measured, replace the printed circuit board
 - b. If continuity measured, Wire 23 is shorted to ground. Repair or replace Wire 23 between the J2 connector and the generator terminal strip.

TEST 32 – UTILITY CONTROL CIRCUIT

DISCUSSION:

Printed circuit board action controls grounding Wire 23 to initiate a transfer to standby. When Wire 23 is grounded the transfer relay (TR1) is energized. To initiate a transfer back to utility the TR1 relay must be de-energized. If Wire 23 is grounded, TR1 will always be energized.

PROCEDURE/ RESULTS:

Refer to Figure 7.

1. Turn off utility supply voltage to the transfer switch.
2. Set VOM to measure AC voltage.
3. Set the generator AUTO-OFF-MANUAL switch in the OFF position. Remove Wire 15B from the transfer switch terminal strip.
4. Verify the transfer switch is down in the standby position.

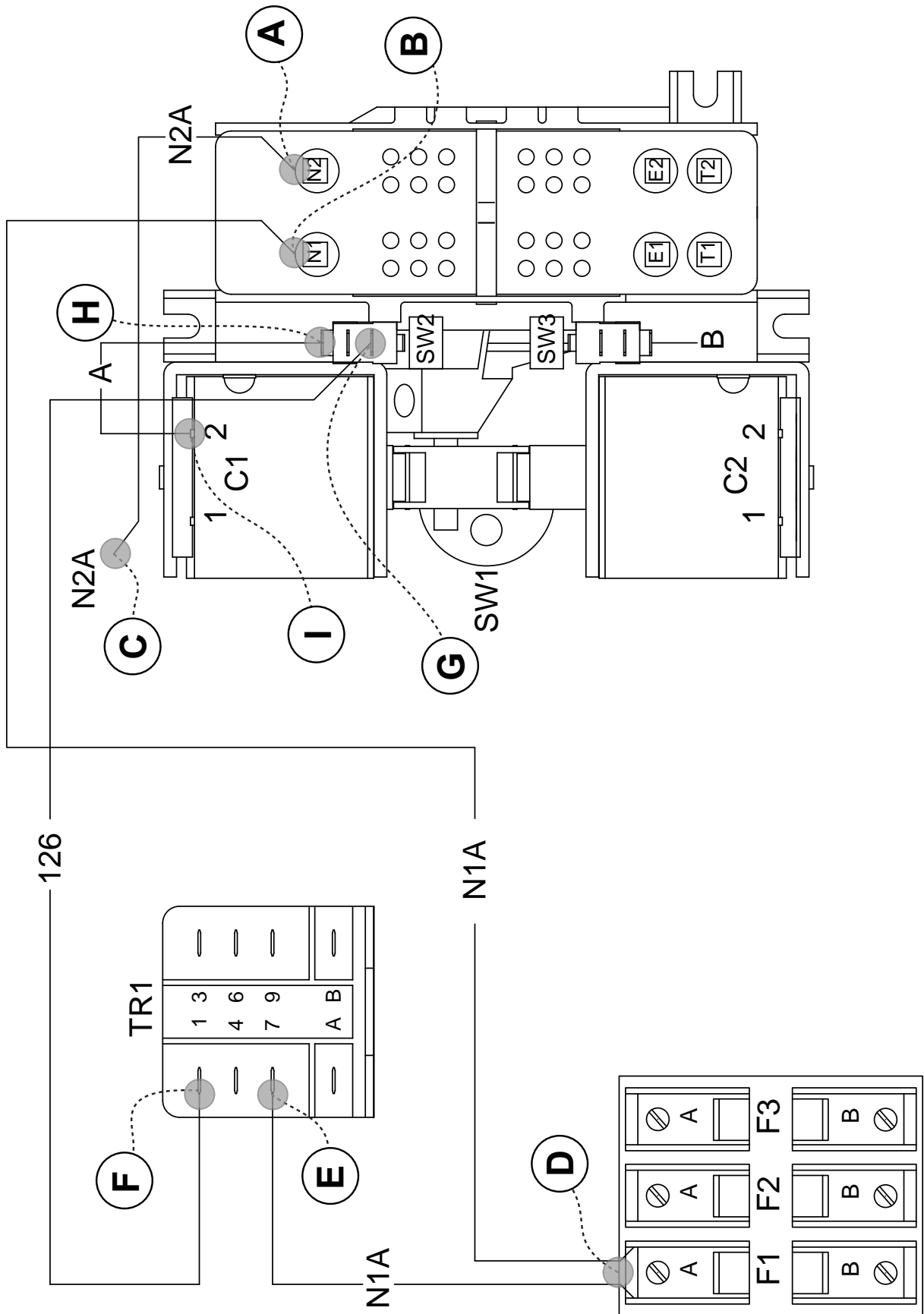

Figure 7. Utility Control Circuit Test Points

SECTION 3.4 DIAGNOSTIC TESTS

PART 3

TRANSFER SWITCH

5. Remove Wire N2A from the utility coil C1.
6. Turn on utility power supply to the transfer switch.
 - a. If transfer to utility occurs, Wire 23 is grounded. Proceed to Test 31.
 - b. If transfer to utility does not occur, proceed to Step 7.
7. Measure across points A and B. 240 VAC should be measured.
 - a. If 240 VAC is not measured, verify utility source.
 - b. If 240 VAC is measured, proceed to Step 8.
8. Measure across points C (Wire N2A previously removed) and B. 240 VAC should be measured.
 - a. If 240 VAC is not measured, repair or replace Wire N2A.
 - b. If 240 VAC is measured, proceed to Step 9.
9. Measure across points A and D. 240 VAC should be measured.
 - a. If 240 VAC is not measured, repair or replace Wire N1A.
 - b. If 240 VAC is measured, proceed to Step 10.
10. Measure across points A and E. 240 VAC should be measured.
 - a. If 240 VAC is not measured, repair or replace Wire N1A.
 - b. If 240 VAC is measured, proceed to Step 11.
11. Measure across points A and F. 240 VAC should be measured.
 - a. If 240 VAC is not measured, replace transfer relay.
 - b. If 240 VAC is measured, proceed to Step 12.
12. Measure across points A and G. 240 VAC should be measured.
 - a. If 240 VAC is not measured, repair or replace Wire 126.
 - b. If 240 VAC is measured, proceed to Step 13.
13. Measure across points A and H. 240 VAC should be measured.
 - a. If 240 VAC is not measured, verify limit switch SW2 is wired correctly. Proceed to Test 33.
 - b. If 240 VAC is measured, proceed to Step 14.
14. Measure across points A and I. 240 VAC should be measured.
 - a. If 240 VAC is not measured, repair or replace Wire A.
 - b. If 240 VAC is measured, replace utility coil C1.

Coil nominal resistance is 1-2 megohms.

TEST 33 – TEST LIMIT SWITCH SW2 AND SW3

DISCUSSION:

The limit switches are wired to the normally closed contacts. When the switches are activated the contacts open.

PROCEDURE:

With the generator shut down, the generator main circuit breaker turned OFF, and with the utility power supply to the transfer switch turned OFF, test limit switch SW2/SW3 as follows:

1. To prevent interaction, disconnect Wire 126 and Wire A from limit switch SW2 terminals.
2. Set a VOM to its "R x 1" scale and zero the meter.
3. See Figure 1. Connect the VOM meter test leads across the two outer terminals from which the wires were disconnected.
4. Manually actuate the main contacts to their Standby position. The meter should read CONTINUITY.
5. Manually actuate the main contacts to their Utility position. The meter should read INFINITY.
6. Repeat Steps 4 and 5 several times and verify the VOM reading at each switch position.
7. To prevent interaction, disconnect Wire 205 and Wire B from limit switch SW3 terminals.
8. See Figure 1. Connect the VOM meter test leads across the two outer terminals from which the wires were disconnected.
9. Manually actuate the main contacts to their Standby position. The meter should read INFINITY.
10. Manually actuate the main contacts to their Utility position. The meter should read CONTINUITY.
11. Repeat Steps 4 and 5 several times and verify the VOM reading at each switch position.

RESULTS:

1. If Limit Switch SW2 or SW3 fails the test, remove and replace the switch or adjust switch until it is actuated properly.

TEST 34 – CHECK FUSES F1 AND F2

DISCUSSION:

Fuses F1 and F2 are connected in series with the N1 and N2 circuits, respectively. A blown fuse will open the applicable circuit and will result in (a) generator startup and transfer to "Standby", or (b) failure to retransfer back to the utility source.

PROCEDURE:

1. On the generator panel, set the AUTO-OFF-MANUAL switch to OFF.
2. Turn off the utility power supply to the transfer switch, using whatever means provided.
3. Remove fuses F1 and F2 from the fuse holder (see Figure 8).
4. Inspect and test fuses for blown condition. With a VOM set to measure resistance, CONTINUITY should be measured across the fuse.

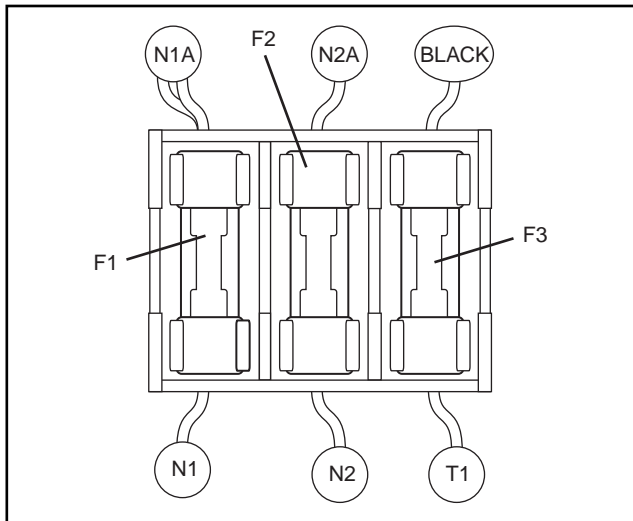

Figure 8. Fuse Holder and Fuses

RESULTS:

1. Replace blown fuse(s) as needed.

TEST 35 – CHECK N1 AND N2 WIRINGDISCUSSION:

A shorted Wire N1 or N2 to ground can cause fuse F1 or F2 to blow.

PROCEDURE:

1. On the generator panel, set the AUTO-OFF-MANUAL switch to OFF.
2. Turn off the utility power supply to the transfer switch, using whatever means provided.
3. Remove fuses F1, F2, and F3 from the fuse holder (see Figure 7).
4. Remove the generator control panel cover. Disconnect the N1/N2 connector that supplies the printed circuit board located in the control panel (see Figure 6).
5. Set VOM to measure resistance.

6. Connect the positive meter test lead to Wire N1 at the terminal block in the control panel.
 - a. Connect the negative meter lead to the ground lug. INFINITY should be measured.
 - b. Connect the negative meter lead to Wire 23 at the terminal strip. INFINITY should be measured.
 - c. Connect the negative meter lead to Wire 15B at the terminal strip. INFINITY should be measured.
 - d. Connect the negative meter lead to Wire 0 at the terminal strip. INFINITY should be measured.
 - e. Connect the negative meter lead to Wire N2 at the terminal block. INFINITY should be measured.
 - f. Connect the negative meter lead to the neutral connection. INFINITY should be measured.
7. Connect the positive meter test lead to Wire N2 at the terminal block in the control panel.
 - a. Connect the negative meter lead to the ground lug. INFINITY should be measured.
 - b. Connect the negative meter lead to Wire 23 at the terminal strip. INFINITY should be measured.
 - c. Connect the negative meter lead to Wire 15B at the terminal strip. INFINITY should be measured.
 - d. Connect the negative meter lead to Wire 0 at the terminal strip. INFINITY should be measured.
 - e. Connect the negative meter lead to the neutral connection. INFINITY should be measured.

RESULTS:

If a short is indicated in Step 6 or Step 7, repair wiring and re-test.

TEST 36 – CHECK N1 AND N2 VOLTAGEDISCUSSION:

Loss of utility source voltage to the generator will initiate a startup and transfer by the generator. Testing at the control panel terminal block will divide the system in two, thereby reducing troubleshooting time.

PROCEDURE:

1. Set the AUTO-OFF-MANUAL switch to OFF.
2. Set a VOM to measure AC voltage.
3. See Figure 9. Connect one test lead to Wire N1 at the terminal block in the generator control panel. Connect the other test lead to Wire N2. Utility line-to-line voltage should be measured.

RESULTS:

Refer to Flow Chart

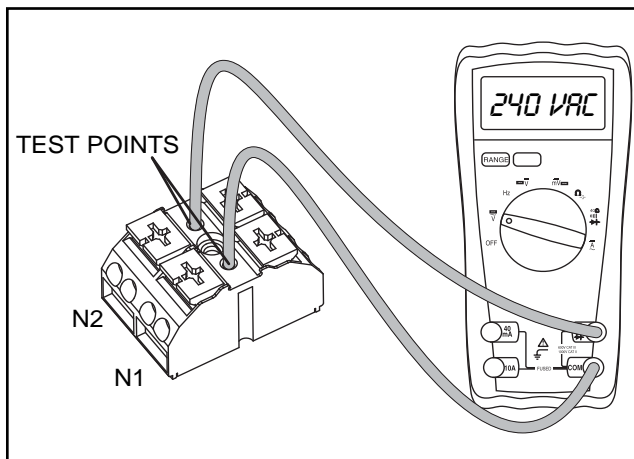

Figure 9. Terminal Block Test Points

TEST 37 – CHECK UTILITY SENSING VOLTAGE AT THE CIRCUIT BOARD

DISCUSSION:

If the generator starts and transfer to STANDBY occurs in the automatic mode when acceptable UTILITY source voltage is available at the terminal block, the next step is to determine if sensing voltage is reaching the printed circuit board.

Note: The System Ready LED will flash in AUTO or UTILITY LOST will display on the panel.

PROCEDURE:

1. Set the AUTO-OFF-MANUAL switch to OFF.
2. Disconnect the N1/N2 connector in the control panel (see Figure 6).
3. Set a VOM to measure AC voltage.
4. Connect one meter test lead to Wire N1. Connect the other meter test lead to Wire N2. Approximately 240 VAC should be measured. See Figure 9.

RESULTS:

1. If voltage was measured in Step 4 and the pin connections are good, replace the circuit board.
2. If voltage was NOT measured in Step 4, repair or replace Wire N1/N2 between connector and terminal block.

TEST 38 – CHECK UTILITY SENSE VOLTAGE

The N1 and N2 terminals in the transfer switch deliver utility voltage “sensing” to a circuit board. If voltage at the terminals is zero or low, standby generator startup and transfer to the “Standby” source will occur automatically as controlled by the circuit board. A zero or low voltage at these terminals will also prevent retransfer back to the “Utility” source.

PROCEDURE:

With utility source voltage available to terminal lugs N1 and N2, use a VOM to test for utility source line-to-line voltage across terminal locations N1 and N2 terminals. Normal line-to-line utility source voltage should be indicated.

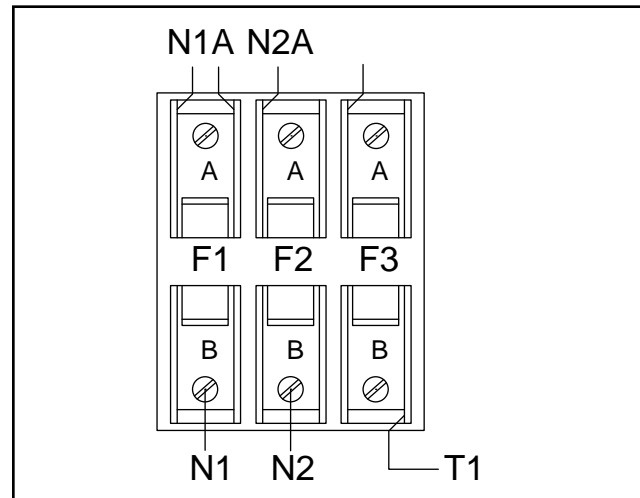

Figure 10. Transfer Switch Fuse Block

RESULTS:

1. If voltage reading across the N1 and N2 terminals is zero or low, refer to Flow Chart.
2. If voltage reading is good, refer to Flow Chart.

TEST 39 – CHECK VOLTAGE AT TERMINAL LUGS N1, N2

DISCUSSION:

If source voltage is not available to N1/N2 terminals, automatic startup and transfer to STANDBY will occur when the generator AUTO-OFF-MANUAL switch is set to AUTO. This test will prove that “Utility” voltage is available to those terminals, or is not available.



DANGER: PROCEED WITH CAUTION! HIGH AND DANGEROUS VOLTAGES ARE PRESENT AT TERMINAL LUGS N1/N2. CONTACT WITH HIGH VOLTAGE TERMINALS WILL RESULT IN DANGEROUS AND POSSIBLY LETHAL ELECTRICAL SHOCK. DO NOT ATTEMPT THIS TEST WHILE STANDING ON WET OR DAMP GROUND, WHILE BAREFOOT, OR WHILE HANDS OR FEET ARE WET.

PROCEDURE:

1. Make sure that all main line circuit breakers in the utility line to the transfer switch are “On” or “Closed.”

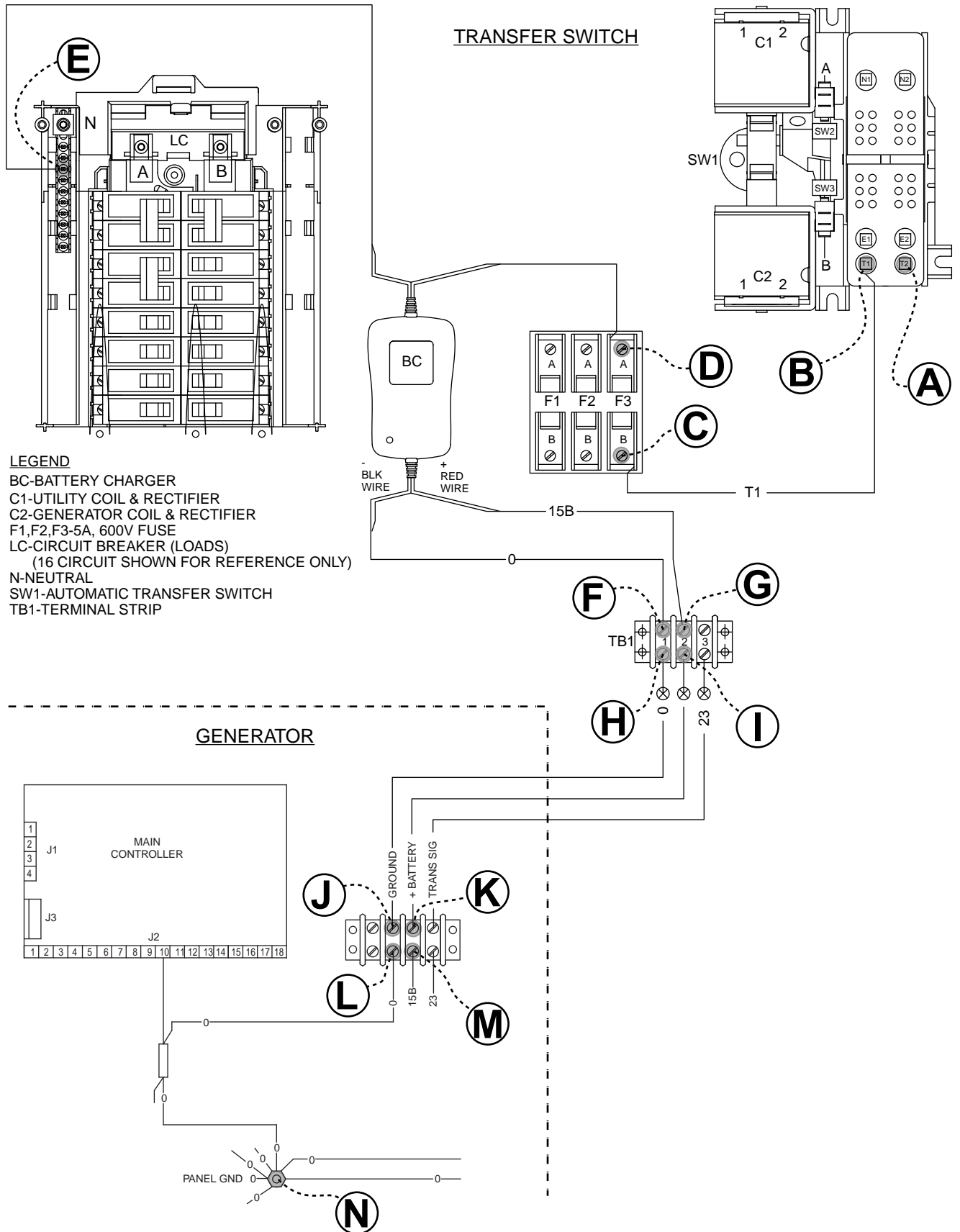

LEGEND
 BC-BATTERY CHARGER
 C1-UTILITY COIL & RECTIFIER
 C2-GENERATOR COIL & RECTIFIER
 F1,F2,F3-5A, 600V FUSE
 LC-CIRCUIT BREAKER (LOADS)
 (16 CIRCUIT SHOWN FOR REFERENCE ONLY)
 N-NEUTRAL
 SW1-AUTOMATIC TRANSFER SWITCH
 TB1-TERMINAL STRIP

Figure 11. Test 40, 41, and 42 "Pre-Wire Load Center" Test Points.

SECTION 3.4 DIAGNOSTIC TESTS

PART 3

TRANSFER SWITCH

2. Test for utility source line-to-line voltage across Terminal Lugs N1 and N2 (see Figure 1). Normal utility source voltage should be indicated.

RESULTS:

1. If low or no voltage is indicated, find the cause of the problem and correct.
2. If normal utility source voltage is indicated, refer to Flow Chart.

TEST 40 – CHECK BATTERY CHARGER SUPPLY VOLTAGE “PRE-WIRE LOAD CENTER”

DISCUSSION:

The battery charger is supplied with 120 VAC. The output of the battery charger is 13.4 VDC / 2.5A.

PROCEDURE:

Refer to Figure 11.

1. Set VOM to measure AC voltage.
2. Measure across points A and B. 240 VAC should be measured.
 - a. If 240 VAC is not measured, verify load source voltage.
 - b. If 240 VAC is measured go to Step 3.
3. Measure across points A and C. 240 VAC should be measured.
 - a. If 240 VAC is not measured, repair or replace Wire T1.
 - b. If 240VAC is measured, proceed to Step 4.
4. Measure across points A and D. 240 VAC should be measured.
 - a. If 240 VAC is not measured, replace fuse F3.
 - b. If 240VAC is measured, proceed to Step 5.
5. Remove Fuse F3. Measure across points D and C. 120 VAC should be measured.
 - a. If 120 VAC is not measured, verify neutral wire is connected at point E. If good, replace battery charger, then retest.
 - b. If 120VAC is measured, refer to Flow Chart.

TEST 41 – CHECK BATTERY CHARGER OUTPUT VOLTAGE “PRE-WIRE LOAD CENTER”

DISCUSSION:

The battery charger is supplied with 120VAC. The output of the battery charger is 13.4 VDC / 2.5A.

PROCEDURE:

Refer to Figure 11.

1. Set VOM to measure DC voltage.
2. Remove Wire 0 and Wire 15B from transfer switch terminal strip points F and G.
3. Measure across points H and I. Battery supply voltage (12 VDC) should be measured.
 - a. If battery voltage is not measured, wait 5 minutes and repeat Step 3.
 - b. If battery supply voltage is still not available, refer to Flow Chart.
 - c. If battery voltage is measured, proceed to Step 4.
4. Reconnect Wire 0 and Wire 15B previously removed in Step 2.
5. Measure across points H and I. 13.4 VDC should be measured.
 - a. If 13.4 VDC is not measured, replace the battery charger
 - b. If 13.4 VDC is measured, the charger is working.

***NOTE: Battery charger voltage will be higher than battery supply voltage.**

TEST 42 – CHECK WIRE 0 AND WIRE15B “PRE-WIRE LOAD CENTER”

DISCUSSION:

In order for the battery charger to function, battery supply voltage must be available to the battery charger.

PROCEDURE:

Refer to Figure 11.

1. Set VOM to measure DC voltage.
2. Disconnect Wire 0 and Wire 15B from generator terminal strips, locations J and K.
3. Wait five (5) minutes after removing wires.
4. Measure across points L and M on the terminal strip. 12 VDC should be measured.
 - a. If 12 VDC is measured, proceed to Step 6.
 - b. If 12 VDC is not measured, proceed to Step 5.
5. Measure across points M and N. 12 VDC should be measured.
 - a. If 12 VDC is measured, repair or replace Wire 0 between the generator terminal strip and the ground lug.
 - b. If 12 VDC is not measured, proceed to Step 8.
6. Set VOM to measure resistance.
7. Connect the meter test leads across the disconnected Wire 0 and Wire 15B. Approximately 115 Ohms should be measured.

- a. If 115 Ohms is measured, proceed to Step 10.
 - b. If zero resistance or CONTINUITY is measured, connect the meter test leads across Terminals A and B on the transfer relay (TR1)
 - c. If zero resistance is measured, a short exists. Replace TR1.
 - d. If 115 Ohms is measured, repair or replace Wire 15B between the generator and the transfer switch.
8. Set VOM to measure resistance.
 9. Disconnect the J2 connector from the printed circuit board.
 10. Measure across point M and pin location J2-8 of the connector just removed. Continuity should be measured.
 - a. If continuity is not measured, repair or replace Wire 15B between the J2 connector and the terminal strip.
 - b. If continuity is measured and the pin connection looks good, the internal fuse on the PCB has failed. Replace printed circuit board.

**TEST 43 – CHECK BATTERY CHARGER
SUPPLY VOLTAGE
“RTSN & RTSE TRANSFER SWITCH”**

DISCUSSION:

The battery charger is supplied with 120 VAC. The output of the battery charger is 13.4 VDC/2.5A.

PROCEDURE:

Refer to Figure 12 or Figure 12A.

1. Set VOM to measure AC voltage.
2. Measure across points A and B. 240 VAC should be measured.
 - a. If 240 VAC is not measured, verify load source voltage.
 - b. If 240 VAC is measured, proceed to Step 3.
3. Measure across points A and C. 240 VAC should be measured.
 - a. If 240 VAC is not measured, repair or replace wire between fuse block and T1 terminal.
 - b. If 240VAC is measured, proceed to Step 4.
4. Measure across points A and D. 240 VAC should be measured.
 - a. If 240 VAC is not measured, replace 5A fuse.
 - b. If 240 VAC is measured, proceed to Step 5.
5. Measure across points E and F. 120 VAC should be measured.
 - a. If 120 VAC is not measured, repair or replace supply wires BC line and BC 00.
 - b. If 120 VAC is measured, refer to flow chart.

**TEST 44 – CHECK BATTERY CHARGER
OUTPUT VOLTAGE
“RTSN & RTSE TRANSFER SWITCH”**

DISCUSSION:

The battery charger is supplied with 120 VAC. The output of the battery charger is 13.4 VDC/2.5A.

PROCEDURE:

Refer to Figure 12 or Figure 12A.

1. Set VOM to measure DC voltage.
2. Remove and isolate battery charger black and red leads from generator terminal strip points G and H.
3. Measure across points G and H. Battery supply voltage (12 VDC) should be measured.
 - a. If battery voltage is not measured, wait 5 minutes and repeat Step 3. If battery supply voltage is still not available, refer to Flow Chart.
 - b. If battery voltage is measured, proceed to Step 4.
4. Reconnect battery charger black and red lead wires previously removed in Step 2.
5. Measure across points G and H. 13.4 VDC should be measured.
 - a. If 13.4 VDC is not measured, replace the battery charger
 - b. If 13.4 VDC is measured, the charger is working.

***NOTE : Battery charger voltage will be higher than battery supply voltage.**

**TEST 45 – CHECK WIRE 0/15B
“RTSN & RTSE TRANSFER SWITCH”**

DISCUSSION:

In order for the battery charger to function, battery supply voltage must be available to the battery charger.

PROCEDURE:

Refer to Figure 12 or Figure 12A.

1. Set VOM to measure DC voltage.
2. Remove and isolate battery charger black and red leads from generator terminal strip points G and H.
3. Measure across points G and H on the terminal strip. 12VDC should be measured.
 - a. If 12 VDC is measured, the charger should be functioning.
 - b. If 12 VDC is not measured, proceed to Step 4.
4. Remove Wire 0 and Wire 15B from generator terminal strip locations G and H.
5. Wait five (5) minutes after removing wires.

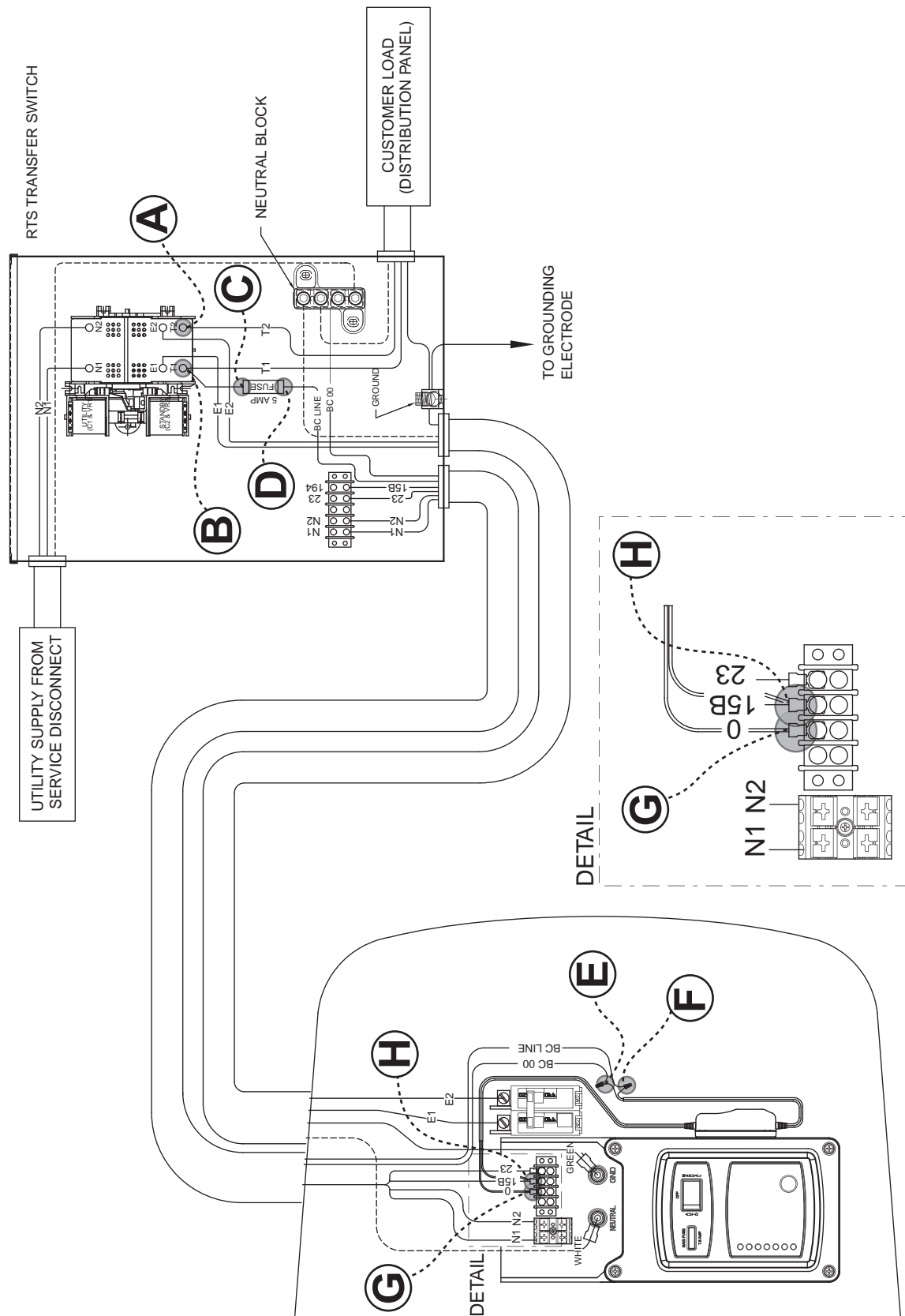

Figure 12. Test 43, 44, and 45 "RTSN Transfer Switch" Test Points.

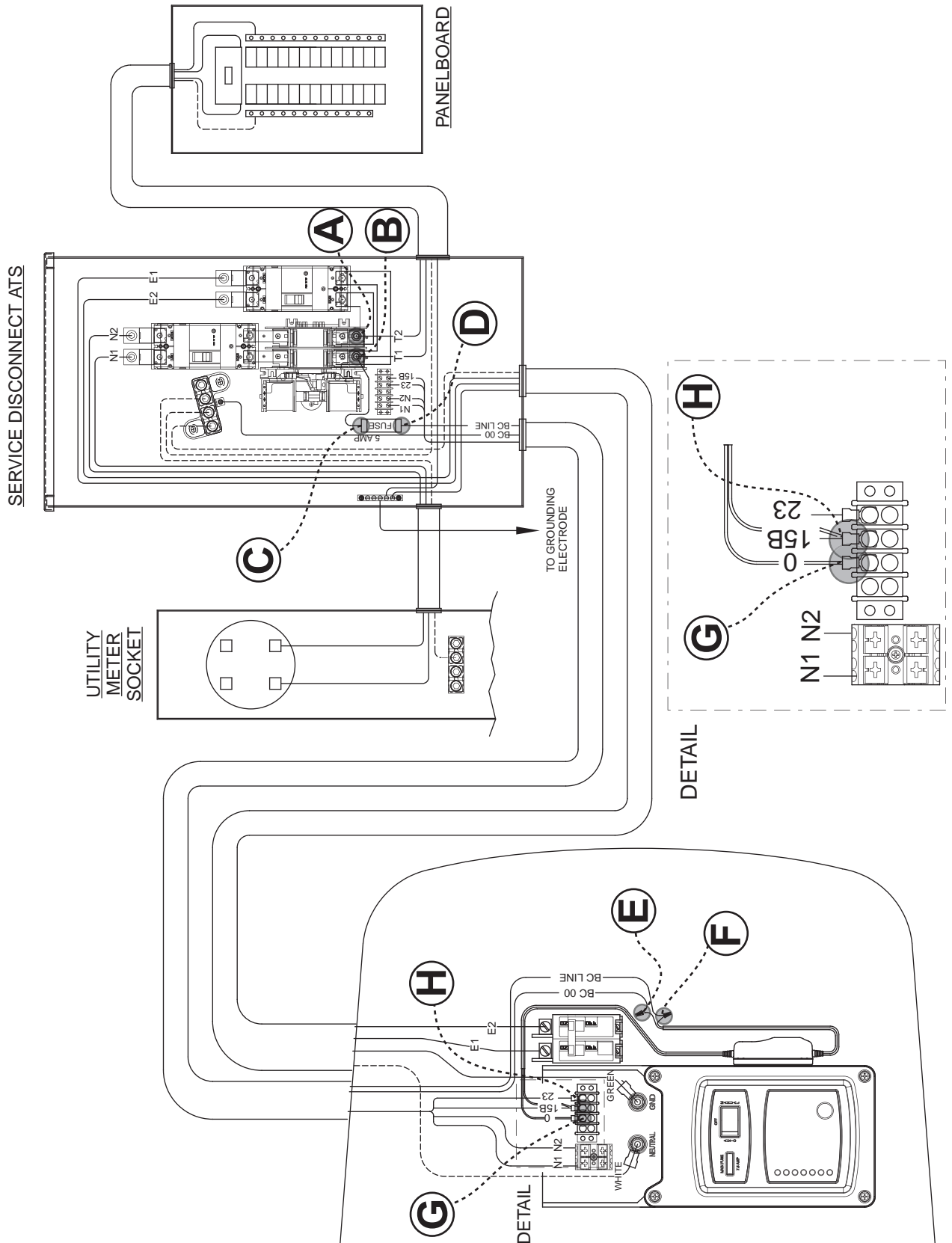

Figure 12A. Test 43, 44, and 45 "RTSE Transfer Switch" Test Points.

SECTION 3.4 DIAGNOSTIC TESTS

PART 3

TRANSFER SWITCH

6. Measure across points G and H on the terminal strip. 12 VDC should be measured.
 - a. If 12 VDC is measured, proceed to Step 8.
 - b. If 12 VDC is not measured, proceed to Step 7.
7. Measure across point H and ground lug. 12 VDC should be measured.
 - a. If 12 VDC is measured, repair or replace Wire 0 between the generator terminal strip and the ground lug.
 - b. If 12 VDC is not measured, proceed to Step 8.
8. Set VOM to measure resistance.
9. Connect the meter test leads across the disconnected Wire 0 and Wire 15B. Approximately 115 Ohms should be measured.
 - a. If 115 Ohms is measured, proceed to Step 11.
 - b. If zero resistance or CONTINUITY is measured, connect the meter test leads across Terminals A and B on the transfer relay (TR1)
 - c. If zero resistance is measured, a short exists. Replace TR1.
 - d. If 115 Ohms is measured, repair or replace Wire 15B between the generator and the transfer switch.
10. Disconnect the J2 connector from the printed circuit board.
11. Measure across point M and pin location J2-8 of the connector just removed. CONTINUITY should be measured.
 - a. If CONTINUITY is not measured, repair or replace Wire 15B between the J2 connector and the terminal strip.
 - b. If CONTINUITY was measured and the pin connection looks good, the internal fuse on the PCB has failed. Replace the printed circuit board.

TEST 46 – CHECK BATTERY CHARGER SUPPLY VOLTAGE “GENREADY LOAD CENTER”

DISCUSSION:

The battery charger is supplied with 120VAC. The output of the battery charger is 13.4 VDC / 2.5A.

PROCEDURE:

Refer to Figure 13.

1. Set VOM to measure AC voltage.
2. Measure across points A and B. 120 VAC should be measured.
 - a. If 120 VAC is not measured, verify that load source voltage is available, and that the duplex circuit breaker is ON.

- b. If 120 VAC is measured, proceed to Step 3.
3. Measure across points C and D. 120 VAC should be measured.
 - a. If 120 VAC is not measured, repair or replace Wire BC LINE or BC 00 between the load center and the generator.
 - b. If 120 VAC is measured, refer to Flow Chart.

TEST 47 – CHECK BATTERY CHARGER OUTPUT VOLTAGE “GENREADY LOAD CENTER”

DISCUSSION:

The battery charger is supplied with 120VAC. The output of the battery charger is 13.4 VDC / 2.5A.

PROCEDURE:

Refer to Figure 13.

1. Set VOM to measure DC voltage.
2. Remove and isolate battery charger black and red leads from generator terminal strip points E and F.
3. Measure across points E and F. Battery supply voltage (12 VDC) should be measured.
 - a. If battery voltage is not measured, wait 5 minutes and repeat Step 3. If battery supply voltage is still not available, refer to Flow Chart.
 - b. If battery voltage is measured, proceed to Step 4.
4. Reconnect battery charger black and red lead wires previously removed in Step 2.
5. Measure across points E and F. 13.4 VDC should be measured.
 - a. If 13.4 VDC is not measured, replace the battery charger.
 - b. If 13.4 VDC is measured, the charger is working.

***NOTE: Battery charger voltage will be higher than battery supply voltage.**

TEST 48 – CHECK WIRE 0/15B “GENREADY LOAD CENTER”

DISCUSSION:

In order for the battery charger to function, battery supply voltage must be available to the battery charger.

PROCEDURE:

Refer to Figure 13.

1. Set VOM to measure DC voltage.
2. Remove and isolate battery charger black and red leads from generator terminal strip points E and F.

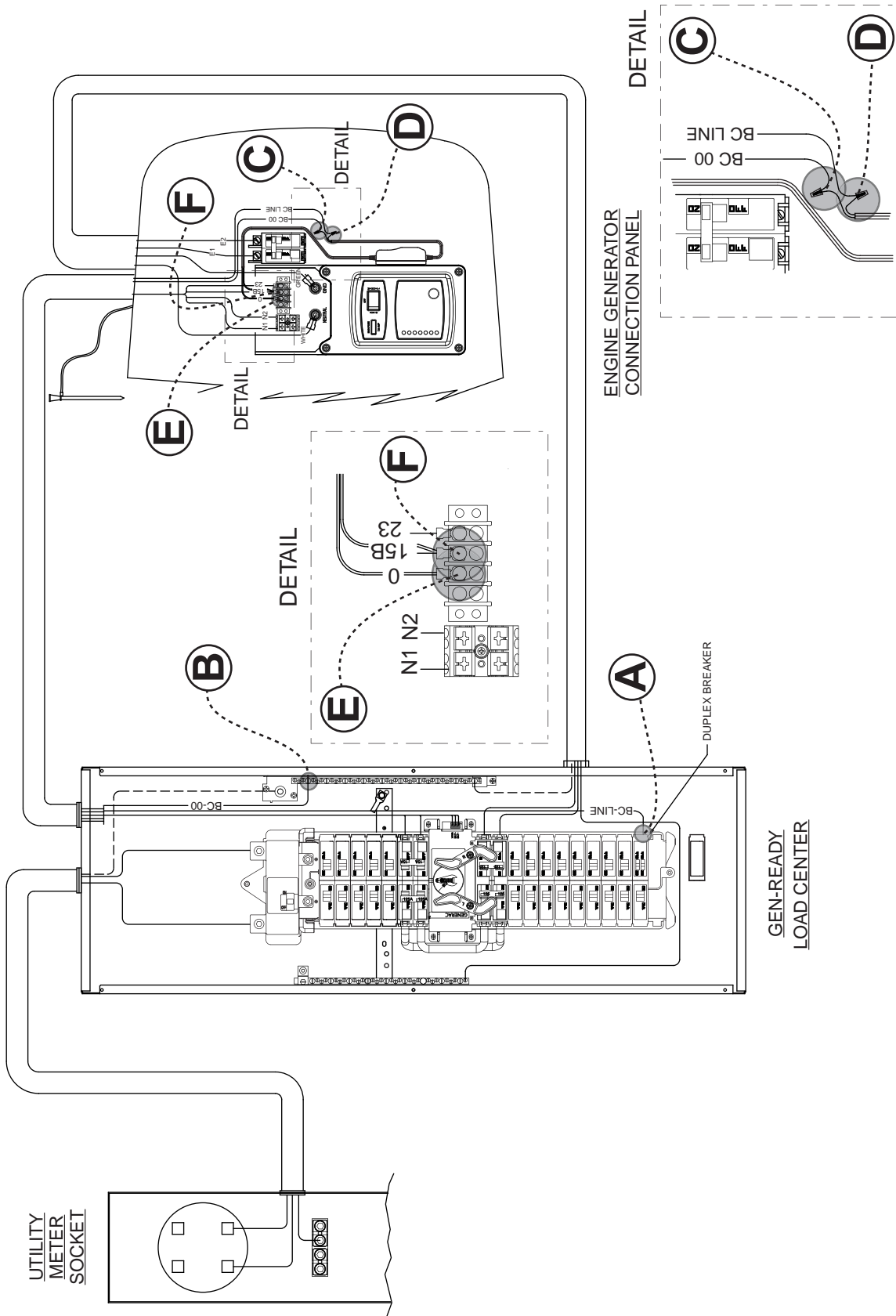

Figure 13. Test 46, 47, and 48 "GenReady Load Center" Test Points.

3. Measure across points G and H on the terminal strip. 12VDC should be measured.
 - a. If 12 VDC is measured, the charger should be functioning.
 - b. If 12 VDC is not measured, proceed to Step 4.
4. Remove Wire 0 and Wire 15B from generator terminal strip locations E and F.
5. Wait five (5) minutes after removing wires.
6. Measure across points E and F on the terminal strip. 12 VDC should be measured.
 - a. If 12 VDC is measured, proceed to Step 8.
 - b. If 12 VDC is not measured, proceed to Step 7.
7. Measure across point H and ground lug. 12 VDC should be measured.
 - a. If 12 VDC is measured, repair or replace Wire 0 between the generator terminal strip and the ground lug.
 - b. If 12 VDC is not measured, proceed to Step 8.
8. Set VOM to measure resistance.
9. Connect the meter test leads across the disconnected Wire 0 and Wire 15B. Approximately 200 Ohms should be measured.
 - a. If 200 Ohms is measured, proceed to Step 11.
 - b. If zero resistance or CONTINUITY is measured, connect the meter test leads across BAT- and XFER on the load center motor.
 - c. If zero resistance is measured, a short exists. Replace the load center motor.
 - d. If 200 Ohms to INFINITY is measured, repair or replace Wire 15B between the generator and the load center.
10. Disconnect the J2 connector from the printed circuit board.
11. Measure across point M and pin location J2-8 of the connector just removed. CONTINUITY should be measured.
 - a. If CONTINUITY is not measured, repair or replace Wire 15B between the J2 connector and the terminal strip.
 - b. If CONTINUITY is measured and the pin connection looks good, the internal fuse on the PCB has failed. Replace the printed circuit board.

**TEST 49 – CHECK BATTERY CHARGER
SUPPLY VOLTAGE
“LOAD SHED TRANSFER SWITCH”**

DISCUSSION:

The battery charger is supplied with 120 VAC. The output of the battery charger is 13.4 VDC/2.5A.

PROCEDURE:

Refer to Figure 14.

1. Set VOM to measure AC voltage.
2. Measure across points A and B. 240 VAC should be measured.
 - a. If 240 VAC is not measured, verify load source voltage at ATS.
 - b. If 240 VAC is measured, proceed to Step 3.
3. Measure across points A and C. 240 VAC should be measured.
 - a. If 240 VAC is not measured, repair or replace Wire T1 between LSS and J3 terminal of load shed controller.
 - b. If 240VAC is measured, proceed to Step 4.
4. Measure across points C and D. 120 VAC should be measured.
 - a. If 120 VAC is not measured, repair or replace Wire 00 between J3 terminal and neutral block (NB).
 - b. If 120 VAC is measured, proceed to Step 5.
5. Measure across points E and D. 120 VAC should be measured.
 - a. If 120 VAC is not measured, replace fuse F3 on load shed controller.
 - b. If 120 VAC is measured, proceed to Step 6.
6. Measure across points E and F. 120 VAC should be measured.
 - a. If 120 VAC is not measured, replace load shed controller.
 - b. If 120 VAC is measured, refer to Flow Chart.

**TEST 50 – CHECK BATTERY CHARGER
OUTPUT VOLTAGE
“LOAD SHED TRANSFER SWITCH”**

DISCUSSION:

The battery charger is supplied with 120 VAC. The output of the battery charger is 13.4 VDC/2.5A.

PROCEDURE:

Refer to Figure 14.

1. Set VOM to measure DC voltage.
2. Remove and isolate battery charger black and red leads from generator terminal strip points G and H.
3. Measure across points G and H. Battery supply voltage (12 VDC) should be measured.
 - a. If battery voltage is not measured, wait 5 minutes and repeat Step 3. If battery supply voltage is still not available, refer to Flow Chart.
 - b. If battery voltage is measured, proceed to Step 4.

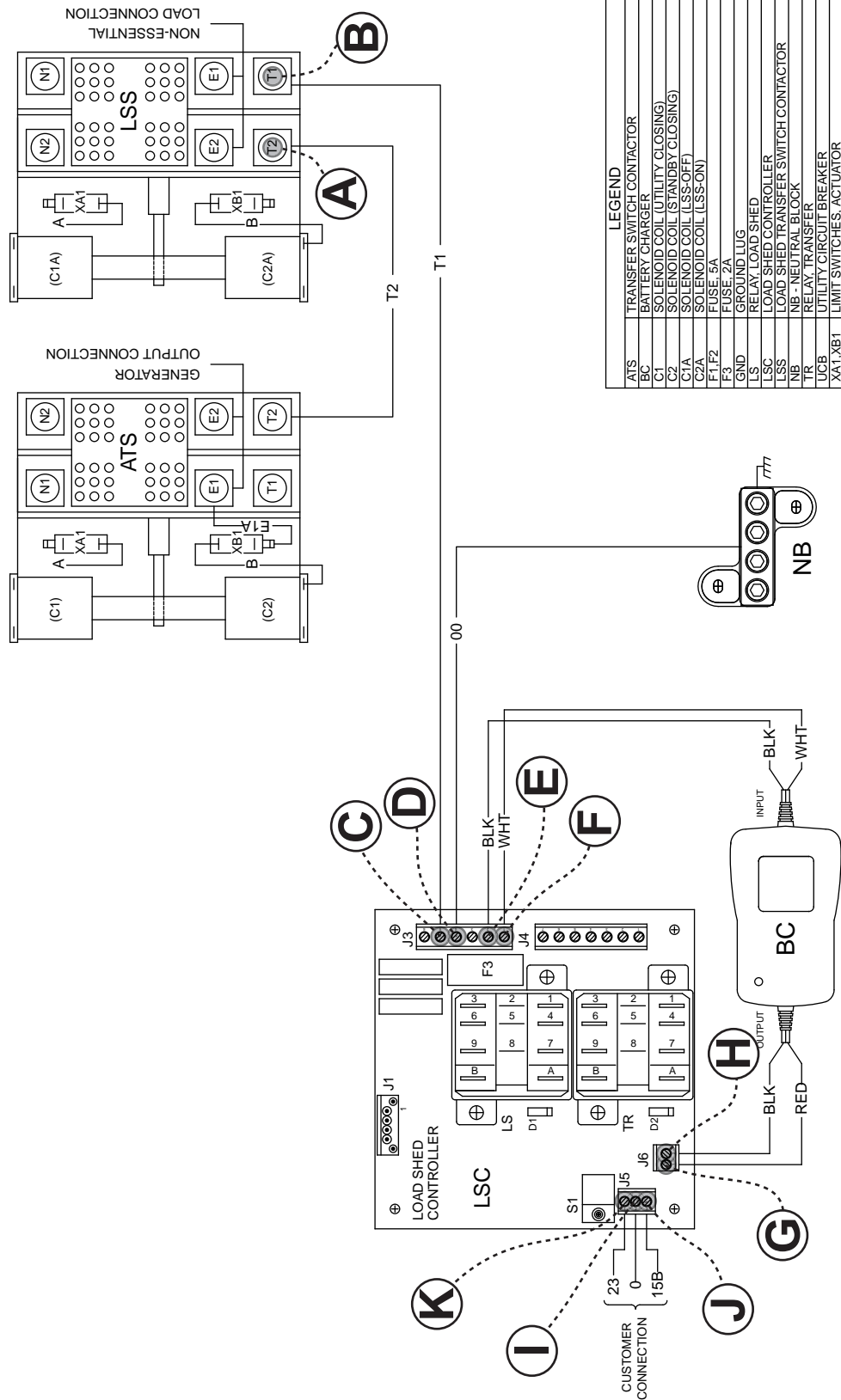

Figure 14. Test 49, 50, and 51 "Load Shed Transfer Switch" Test Points.

SECTION 3.4 DIAGNOSTIC TESTS

PART 3

TRANSFER SWITCH

4. Reconnect battery charger black and red lead wires previously removed in Step 2.
5. Measure across points G and H. 13.4 VDC should be measured.
 - a. If 13.4 VDC is not measured, replace the battery charger.
 - b. If 13.4 VDC is measured, the charger is working.

***NOTE: Battery charger voltage will be higher than battery supply voltage.**

TEST 51 – CHECK WIRE 0 AND WIRE 15B “LOAD SHED TRANSFER SWITCH”

DISCUSSION:

In order for the battery charger to function, battery supply voltage must be available to the battery charger.

PROCEDURE:

Refer to Figure 14.

1. Set VOM to measure DC voltage.
2. Remove and isolate battery charger black and red leads from terminal strip points G and H.
3. Measure across points I and J on the terminal strip. 12 VDC should be measured.
 - a. If 12 VDC is measured, the charger should be functioning.
 - b. If 12 VDC is not measured, proceed to Step 4.
4. Remove Wire 0 and Wire 15B from generator terminal strip. Refer to Figure 6.
5. Wait five (5) minutes after removing wires.
6. Measure across points J and K on the terminal strip. Refer to Figure 6. 12 VDC should be measured.
 - a. If 12 VDC is measured, proceed to Step 8.
 - b. If 12 VDC is not measured, proceed to Step 7.
7. In the generator control panel, measure across Wire 15B and Wire 0 at the customer connection. 12 VDC should be measured.
 - a. If 12 VDC is measured, repair or replace Wire 0 or Wire 15B between the generator terminal strip and the ground lug.
 - b. If 12 VDC is not measured, proceed to Step 5.
8. Set VOM to measure resistance.
9. Connect the meter test leads across the disconnected Wire 0 and Wire 15B. Approximately 115 Ohms should be measured.
 - a. If 115 Ohms is measured, proceed to Step 11.
 - b. If zero resistance or CONTINUITY is measured, connect the meter test leads across locations J and K on the load shed controller, Figure 12.
 - c. If zero resistance is measured, a short exists. Replace the transfer relay (TR).
 - d. If 200 115 is measured, repair or replace Wire 15B between the generator and the transfer switch.
10. Disconnect the J2 connector from the printed circuit board.
11. In the generator control panel, measure across Wire 15B at the customer connection and pin location J2-8 of the connector just removed. CONTINUITY should be measured.
 - a. If CONTINUITY is not measured, repair or replace Wire 15B between the J2 connector and the terminal strip.
 - b. If CONTINUITY is measured, proceed to Step 12.
12. In the generator control panel, measure across Wire 0 at the customer connection and the ground lug. CONTINUITY should be measured.
 - a. If CONTINUITY is not measured, repair or replace Wire 0 between the customer connection and the ground lug.
 - b. If CONTINUITY is measured and the pin connection of J2 looks good, the internal fuse on the PCB has failed. Replace the printed circuit board.

PART 4 DC CONTROL

TABLE OF CONTENTS		
PART	TITLE	PAGE#
4.1.	Description and Components	96
4.2	Operational Analysis	104
4.3	Troubleshooting Flow Charts	118
4.4	Diagnostic Tests	123

Air-cooled, Automatic Standby Generators

4.1 Description and Components.....	96	Test 57 – Try a Manual Start	123
General	96	Test 58 – Auto-Off-Manual Switch (V-Twin Only).....	123
Terminal Strip / Interconnection Terminal.....	96	Test 59 – Test Auto Operations	124
Circuit Board	96	Test 60 – Check 7.5 Amp Fuse.....	124
Auto-Off-Manual Switch	96	Test 61 – Check Battery.....	124
7.5 Amp Fuse.....	96	Test 62 – Check Wire 56 Voltage	126
Menu System Navigation	102	Test 63 – Test Starter Contactor Relay (V-twin Only)	126
4.2 Operational Analysis	104	Test 64 – Test Starter Contactor (Single Cylinder Engine)	127
Introduction	104	Test 65 – Test Starter Motor.....	128
Utility Source Voltage Available.....	104	Test 66 – Check Fuel Supply and Pressure.....	130
Initial Dropout of Utility Source Voltage.....	106	Test 67 – Check Circuit Board Wire 14 Output.....	131
Utility Voltage Dropout and Engine Cranking	108	Test 68 – Check Fuel Solenoid	132
Engine Startup and Running.....	110	Test 69 – Check Choke Solenoid.....	132
Initial Transfer to the “Standby” Source	112	Test 70 – Check for Ignition Spark	134
Utility Voltage Restored / Re-transfer to Utility	114	Test 71 – Check Spark Plugs.....	136
Engine Shutdown.....	116	Test 72 – Check Engine / Cylinder Leak Down Test / Compression Test.....	136
4.3 Troubleshooting Flowcharts.....	118	Test 73 – Check Shutdown Wire	137
Problem 15 – Engine Will Not Crank When Utility Power Source Fails	118	Test 74 – Check and Adjust Ignition Magnetos.....	138
Problem 16 – Engine Will Not Crank When AUTO-OFF-MANUAL Switch is Set to “MANUAL”	118	Test 75 – Check Oil Pressure Switch and Wire 86.....	141
Problem 17 – Engine Cranks but Won’t Start.....	119	Test 76 – Check High Oil Temperature Switch	142
Problem 18 – Engine Starts Hard and Runs Rough / Lacks Power / Backfires	120	Test 77 – Check and Adjust Valves	142
Problem 19 – Shutdown Alarm / Fault Occurred.....	121	Test 78 – Check Wire 18 Continuity	143
Problem 20 – 7.5 Amp Fuse (F1) Blown	122	Test 79 – Test Exercise Function.....	144
Problem 21 – Generator Will Not Exercise.....	122	Test 80 – Check Cranking and Running Circuits.....	144
Problem 22 – No Low Speed Exercise.....	122	Test 81 – Check to see if Low Speed Function is enabled.....	146
4.4 Diagnostic Tests	123	Test 82 – Check operation of the Choke Solenoid.....	146
Introduction	123		
Test 56 – Check Position Of Auto-Off- Manual Switch	123		

GENERAL

This section will familiarize the reader with the various components that make up the DC control system.

Major DC control system components that will be covered include the following:

- A Terminal Strip / Interconnection Terminal
- A Circuit Board.
- An AUTO-OFF-MANUAL Switch.
- A 7.5 Amp Fuse.

TERMINAL STRIP / INTERCONNECTION TERMINAL

The terminals of this terminal strip are connected to identically numbered terminals on a transfer switch terminal board. The terminal board connects the transfer switch to the circuit board.

The terminal board provides the following connection points:

- A. UTILITY 1 and UTILITY 2
1. Connect to identically marked terminals on a transfer switch terminal board.
- B. 23 and 15B
1. Connect to identically numbered terminals on the terminal board of the transfer switch.
 2. This circuit connects the circuit board to the transfer relay coil in the transfer switch.

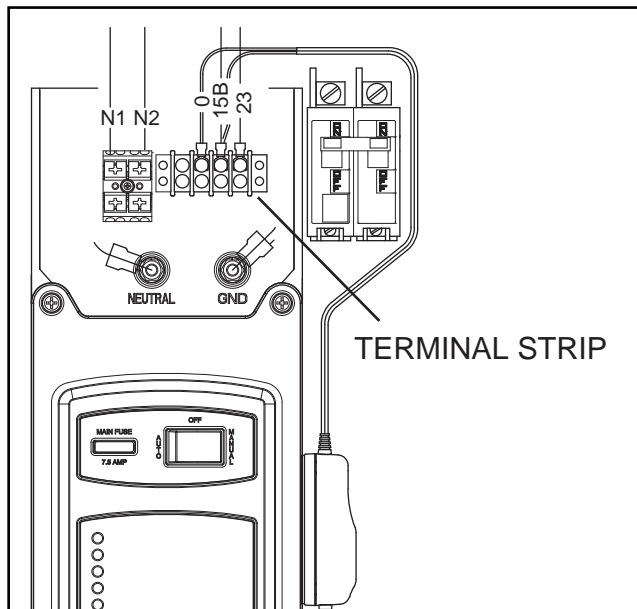

Figure 1. Terminal Strip

CIRCUIT BOARD

The circuit board controls all standby electric system operations including (a) engine startup, (b) engine running, (c) automatic transfer, (d) automatic retransfer, and (e) engine shutdown. In addition, the circuit board performs the following functions:

- Delivers “field boost” current to the generator rotor windings (see “Field Boost Circuit” in Section 2.2).
- Starts and “exercises” the generator once every seven days.
- Provides automatic engine shutdown in the event of low oil pressure, high oil temperature, overspeed, no RPM sense, overcrank, or low battery.

An 18-pin and a 4-pin connector are used to interconnect the circuit board with the various circuits of the DC systems. Connector pin numbers, associated wires and circuit functions are listed in the CHART on the next page.

If the Utility sensing voltage drops below a preset value, circuit board action will initiate automatic generator startup and transfer to the “Standby” source side.

The crank relay and fuel solenoid valve are energized by circuit board action at the same time.

DIGITAL INPUT/OUTPUT FUNCTIONS:

Position	Digital Inputs	Digital Outputs
1	Low Oil Pressure	Not Used
2	High Temperature	Not Used
3	Internal Use	Not Used
4	Internal Use	Not Used
5	Internal Use	Fuel
6	Not Used	Starter
7	Auto	Ignition
8	Manual	Transfer



DANGER: THE GENERATOR ENGINE WILL CRANK AND START WHEN THE 7-DAY EXERCISER SWITCH IS ACTUATED. THE UNIT WILL ALSO CRANK AND START EVERY 7 DAYS THEREAFTER, ON THE DAY AND AT THE TIME OF DAY THE SWITCH WAS ACTUATED.

AUTO-OFF-MANUAL SWITCH

This 3-position switch permits the operator to (a) select fully automatic operation, (b) start the generator manually, or (c) stop the engine and prevent automatic startup. Switch terminals are shown pictorially and schematically in Figure 6, below.

7.5 AMP FUSE

This fuse protects the circuit board against excessive current. If the fuse has blown, engine cranking and operation will not be possible. Should fuse replacement become necessary, use only an identical 7.5 amp replacement fuse.



Figure 2. A Typical 7.5 Amp Fuse

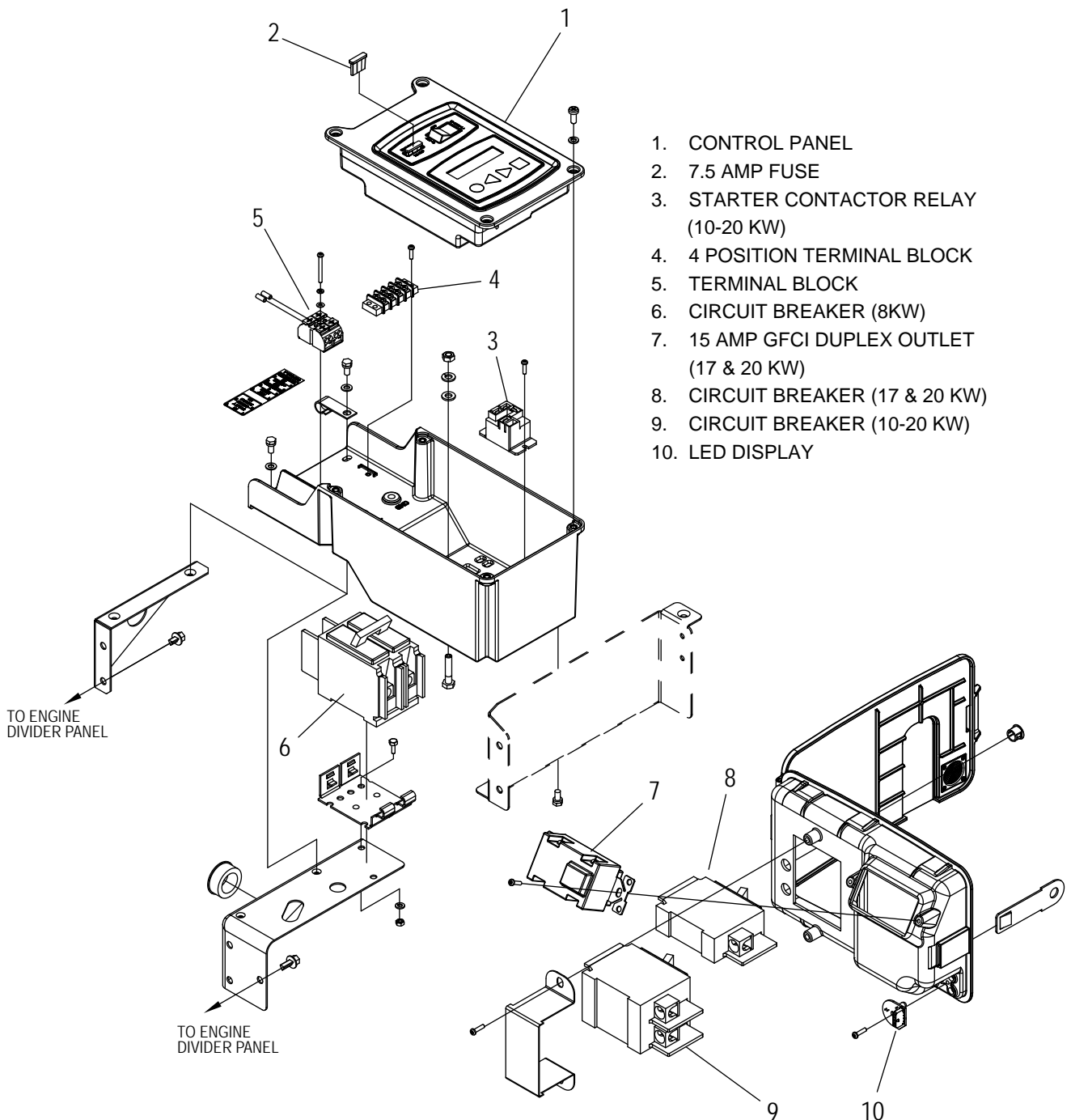

Figure 3. Control Panel Component Identification

SECTION 4.1
DESCRIPTION AND COMPONENTS

PART 4

DC CONTROL

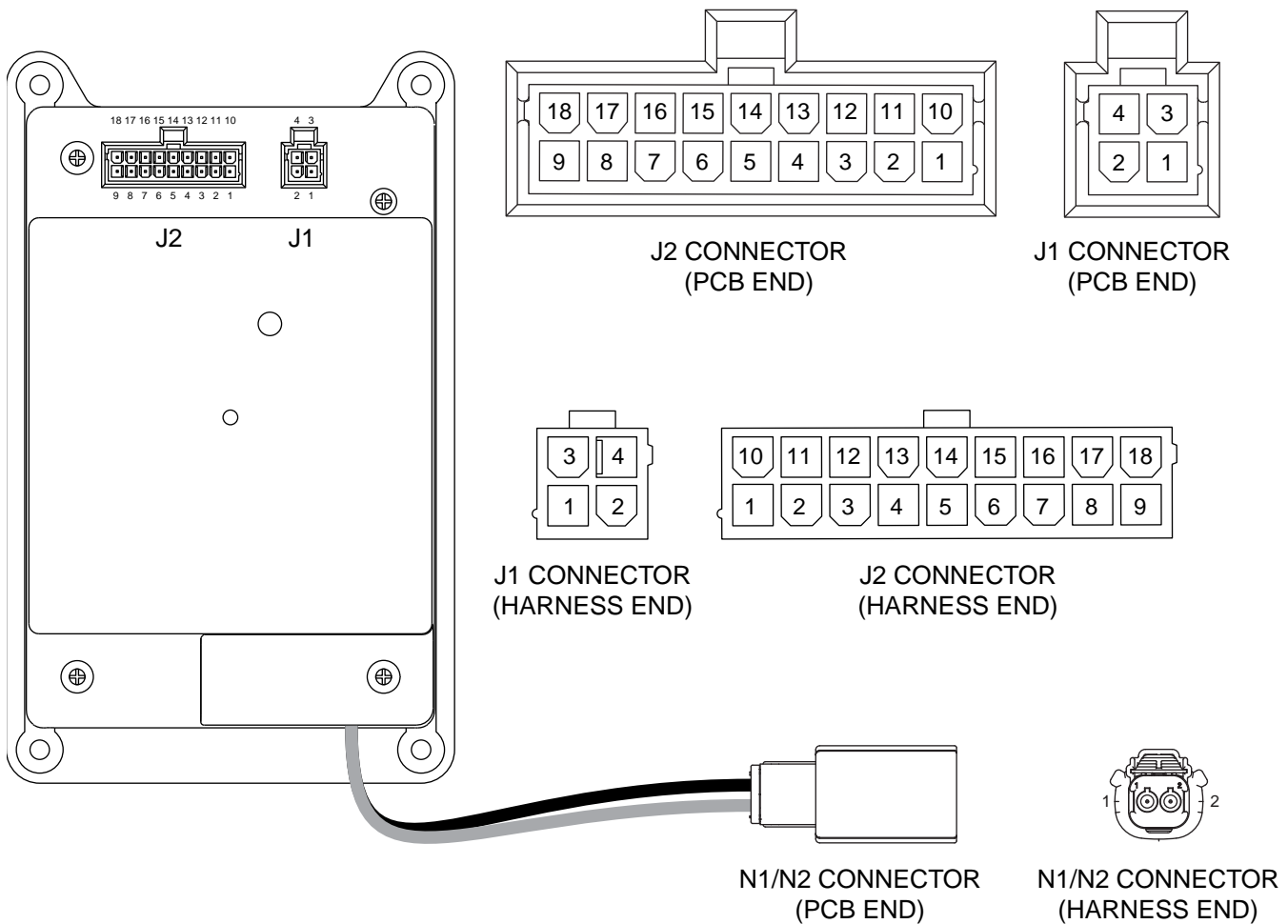

Figure 4. 8 kW Printed Circuit Boards and J1 Connector

8 kW J1 Connector Pin Descriptions

PIN	WIRE	CIRCUIT FUNCTION
J1-1	85	High temperature shutdown: Shutdown occurs when Wire 85 is grounded by contact closure in HTO
J1-2	86	Low oil pressure shutdown: Shutdown occurs when Wire 86 is grounded by loss of oil pressure to the LOP
J1-3	13	12 VDC source voltage for the circuit board
J1-4	18	Ignition Shutdown: Circuit board action grounds Wire 18 for ignition shutdown.
J2-1	0	INTERNAL USE
J2-2	0	INTERNAL USE
J2-3	14	12 VDC output for engine run condition. Used for fuel solenoid.
J2-5	23	Switched to ground for transfer relay operation
J2-6		NOT USED

PIN	WIRE	CIRCUIT FUNCTION
J2-7		NOT USED
J2-8	15B	Provides an electrical connection for charge current to reach the battery from the battery charger. Provides 12VDC to the Transfer Relay
J2-9		NOT USED
J2-10	0	Common Ground
J2-11	56	12 VDC output to starter contactor for single cylinder engines.
J2-15		NOT USED
J2-16		NOT USED
J2-17		NOT USED
J2-18		NOT USED
Wired Plug 1	N1	240 VAC sensing for control board.
Wired Plug 2	N2	240 VAC sensing for control board.

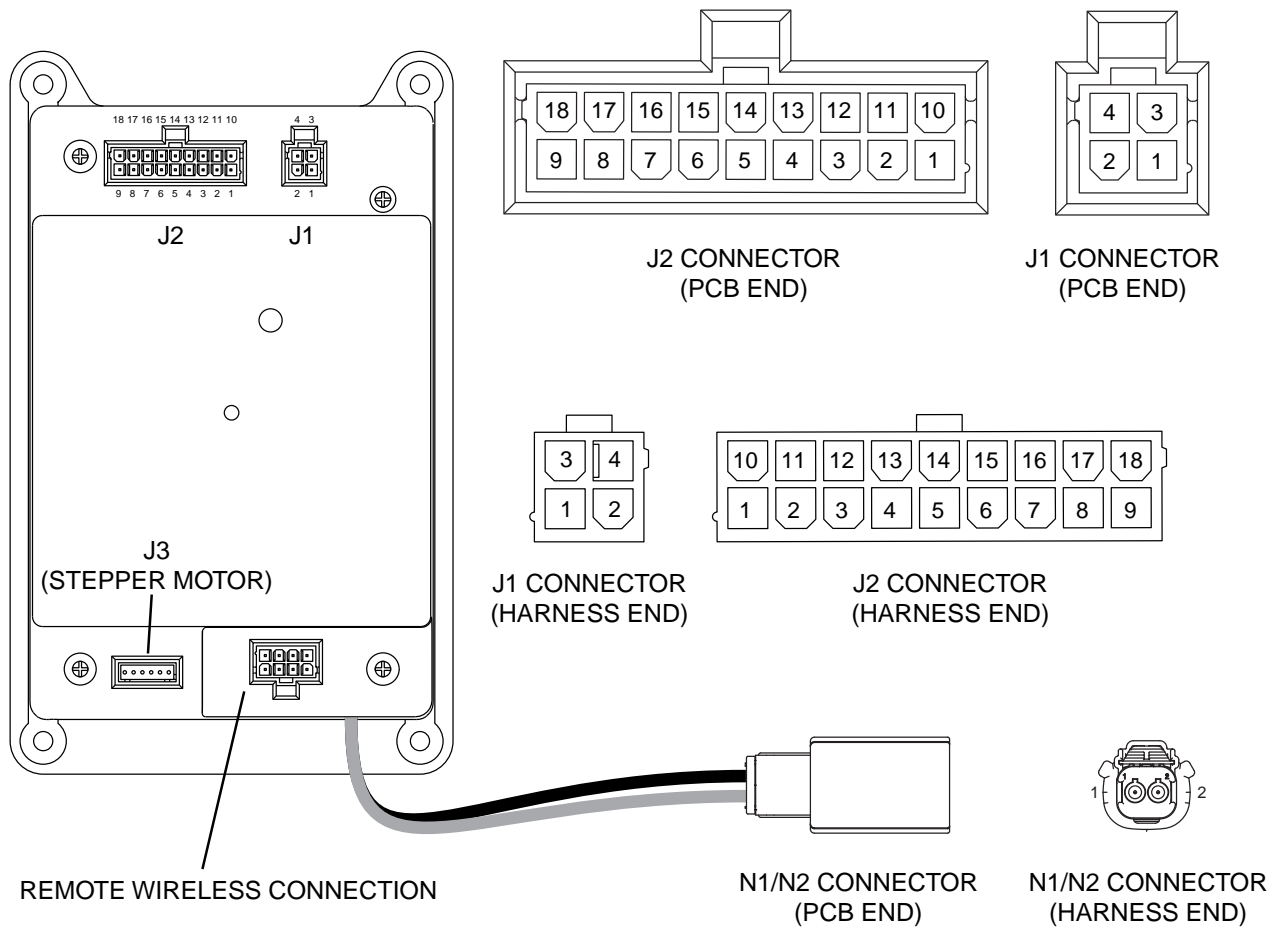

Figure 5. 10 kW Printed Circuit Board and J1 Connector

10 kW J1 Connector Pin Descriptions

PIN	WIRE	CIRCUIT FUNCTION
J1-1	85	High temperature shutdown: Shutdown occurs when Wire 85 is grounded by contact closure in HTO
J1-2	86	Low oil pressure shutdown: Shutdown occurs when Wire 86 is grounded by loss of oil pressure to the LOP
J1-3	13	12 VDC source voltage for the circuit board
J1-4	18	Ignition Shutdown: Circuit board action grounds Wire 18 for ignition shutdown.
J2-1		INTERNAL USE ONLY
J2-2		INTERNAL USE ONLY
J2-3	14	12 VDC output for engine run condition. Used for fuel solenoid and choke solenoid operation.
J2-4	817	Grounded by printed circuit board to turn on System Ready (Green) LED.
J2-5	23	Switched to ground for transfer relay operation
J2-6		NOT USED
J2-7		NOT USED

PIN	WIRE	CIRCUIT FUNCTION
J2-8	15B	Provides an electrical connection for charge current to reach the battery from the battery charger. Provides 12 VDC to the Transfer Relay
J2-9	820	Positive voltage (+5 VDC) for status LEDs.
J2-10	0	Common Ground
J2-11	56	12 VDC output to starter contactor relay for V-Twin engines
J2-12		NOT USED
J2-13	818	Grounded by board to turn on the Alarm (Red) LED.
J2-14		NOT USED
J2-15	90	Switched to ground for choke solenoid operation
J2-16		INTERNAL USE ONLY
J2-17		NOT USED
J2-18		NOT USED
J3		Control wires for Stepper Motor
Wired Plug-1	N1	240 VAC sensing for control board.
Wired Plug-2	N2	240 VAC sensing for control board.

SECTION 4.1
DESCRIPTION AND COMPONENTS

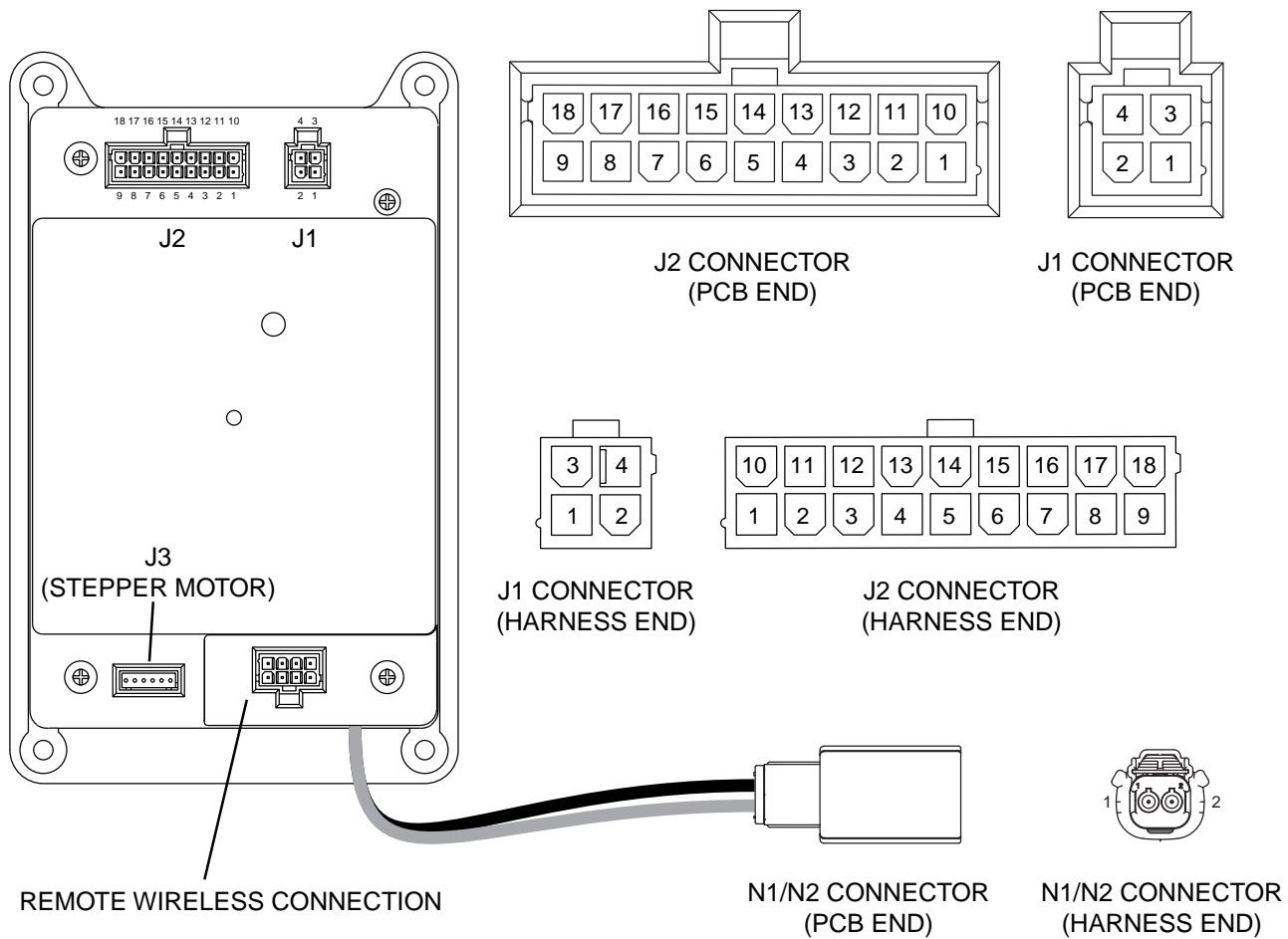

Figure 6. 12/14 kW Printed Circuit Board and J1 Connector

12/14 kW J1 Connector Pin Descriptions

PIN	WIRE	CIRCUIT FUNCTION
J1-1	85	High temperature shutdown: Shutdown occurs when Wire 85 is grounded by contact closure in HTO
J1-2	86	Low oil pressure shutdown: Shutdown occurs when Wire 86 is grounded by loss of oil pressure to the LOP
J1-3	13	12 VDC source voltage for the circuit board
J1-4	18	Ignition Shutdown: Circuit board action grounds Wire 18 for ignition shutdown.
J2-1		INTERNAL USE ONLY
J2-2		INTERNAL USE ONLY
J2-3	14	12 VDC output for engine run condition. Used for fuel solenoid and choke solenoid operation.
J2-4	817	Grounded by printed circuit board to turn on System Ready (Green) LED.
J2-5	23	Switched to ground for transfer relay operation
J2-6		NOT USED
J2-7		NOT USED

PIN	WIRE	CIRCUIT FUNCTION
J2-8	15B	Provides an electrical connection for charge current to reach the battery from the battery charger. Provides 12 VDC to the Transfer Relay
J2-9	820	Positive voltage (+5 VDC) for status LEDs.
J2-10	0	Common Ground
J2-11	56	12 VDC output to starter contactor relay for V-Twin engines
J2-12		NOT USED
J2-13	818	Grounded by board to turn on the Alarm (Red) LED.
J2-14		NOT USED
J2-15	90	Switched to ground for choke solenoid operation
J2-16		INTERNAL USE ONLY
J2-17		NOT USED
J2-18		NOT USED
J3		Control wires for Stepper Motor
Wired Plug-1	N1	240 VAC sensing for control board.
Wired Plug-2	N2	240 VAC sensing for control board.

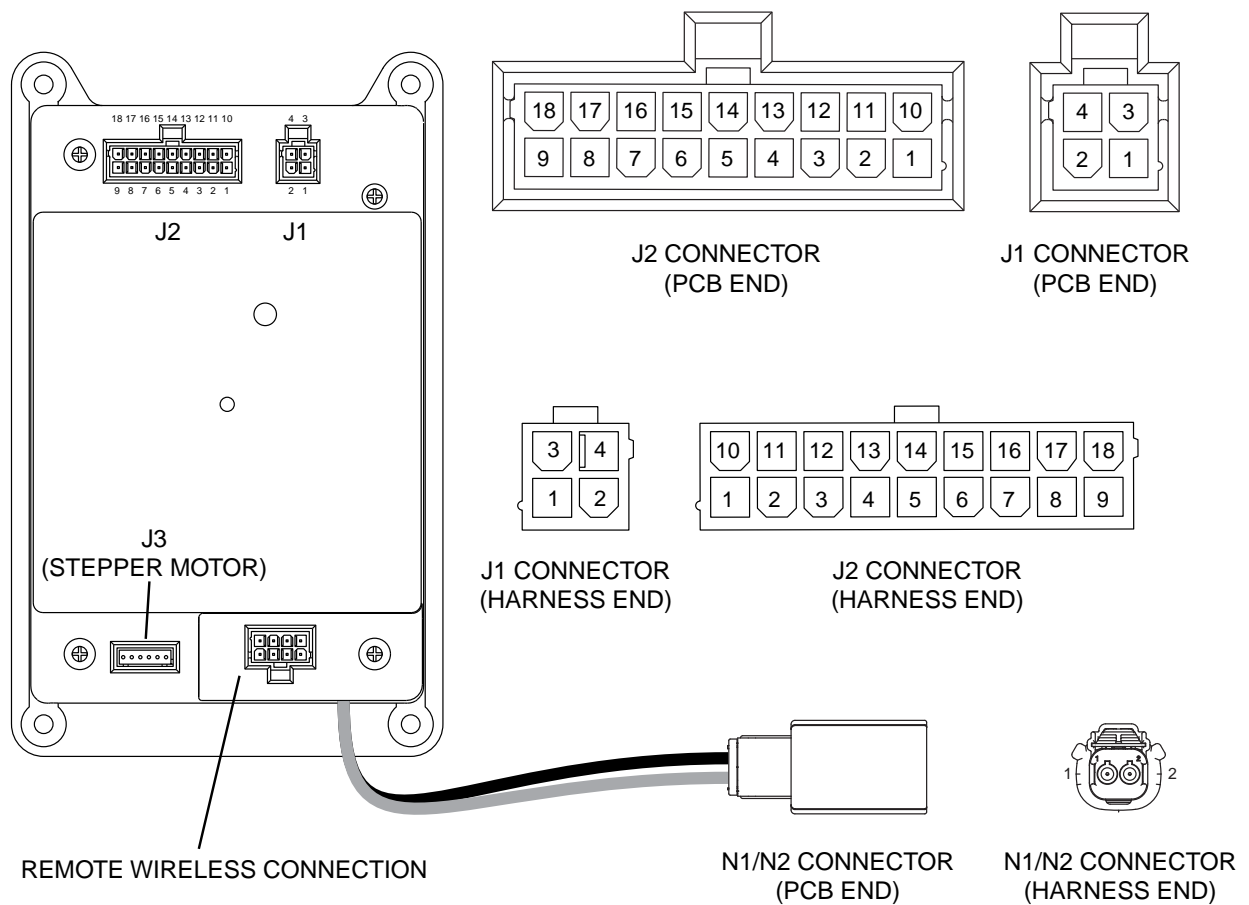

Figure 7. 16, 17 and 20 kW Printed Circuit Board and J1 Connector

16, 17 and 20 kW J1 Connector Pin Descriptions

PIN	WIRE	CIRCUIT FUNCTION
J1-1	85	High temperature shutdown: Shutdown occurs when Wire 85 is grounded by contact closure in HTO
J1-2	86	Low oil pressure shutdown: Shutdown occurs when Wire 86 is grounded by loss of oil pressure to the LOP
J1-3	13	12 VDC source voltage for the circuit board
J1-4	18	Ignition Shutdown: Circuit board action grounds Wire 18 for ignition shutdown.
J2-1		INTERNAL USE ONLY
J2-2		INTERNAL USE ONLY
J2-3	14	12VDC output for engine run condition. Used for fuel solenoid and choke solenoid operation.
J2-4	817	Grounded by printed circuit board to turn on System Ready (Green) LED.
J2-5	23	Switched to ground for transfer relay operation
J2-6		NOT USED
J2-7		NOT USED

PIN	WIRE	CIRCUIT FUNCTION
J2-8	15B	Provides an electrical connection for charge current to reach the battery from the battery charger. Provides 12 VDC to the Transfer Relay
J2-9	820	Positive voltage (+5 VDC) for status LEDs.
J2-10	0	Common Ground
J2-11	56	12 VDC output to starter contactor relay for V-Twin engines
J2-12	4	Field Boost output
J2-13	818	Grounded by board to turn on the Alarm (Red) LED.
J2-14	819	Grounded by board to turn on the Maintenance Required (Yellow) LED.
J2-15	90	Switched to ground for choke solenoid operation
J2-16		INTERNAL USE ONLY
J2-17		NOT USED
J2-18		NOT USED
J3		Control wires for Stepper Motor
Wired Plug-1	N1	240 VAC sensing for control board.
Wired Plug-2	N2	240 VAC sensing for control board.

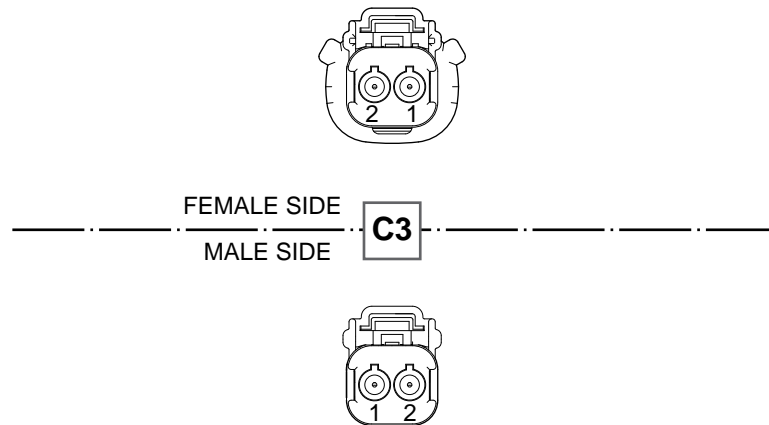

Figure 8. Choke Solenoid Connector Pin Number Identification

MENU SYSTEM NAVIGATION

To get to the MENU, use the "Esc" key from any page. It may need to be pressed many times before getting to the menu page. The currently selected menu is displayed as a flashing word. Navigate to the menu required by using the +/- keys. When the menu required is flashing, press the ENTER key. Depending on the menu selected, there may be a list of choices presented. Use the same navigation method to select the desired screen (refer to the Menu System diagram).

CHANGING SETTINGS (EDIT MENU):

To change a setting such as display contrast, go to the EDIT menu and use the +/- keys to navigate to the setting to change. Once this setting is displayed (e.g. Contrast), press the ENTER key to go into the edit mode. Use the +/- keys to change the setting, press the ENTER key to store the new setting.

NOTE: If the ENTER key is not pressed to save the new setting, it will only be saved temporarily. The next time the battery is disconnected, the setting will revert back to the old setting.

MENU SYSTEM

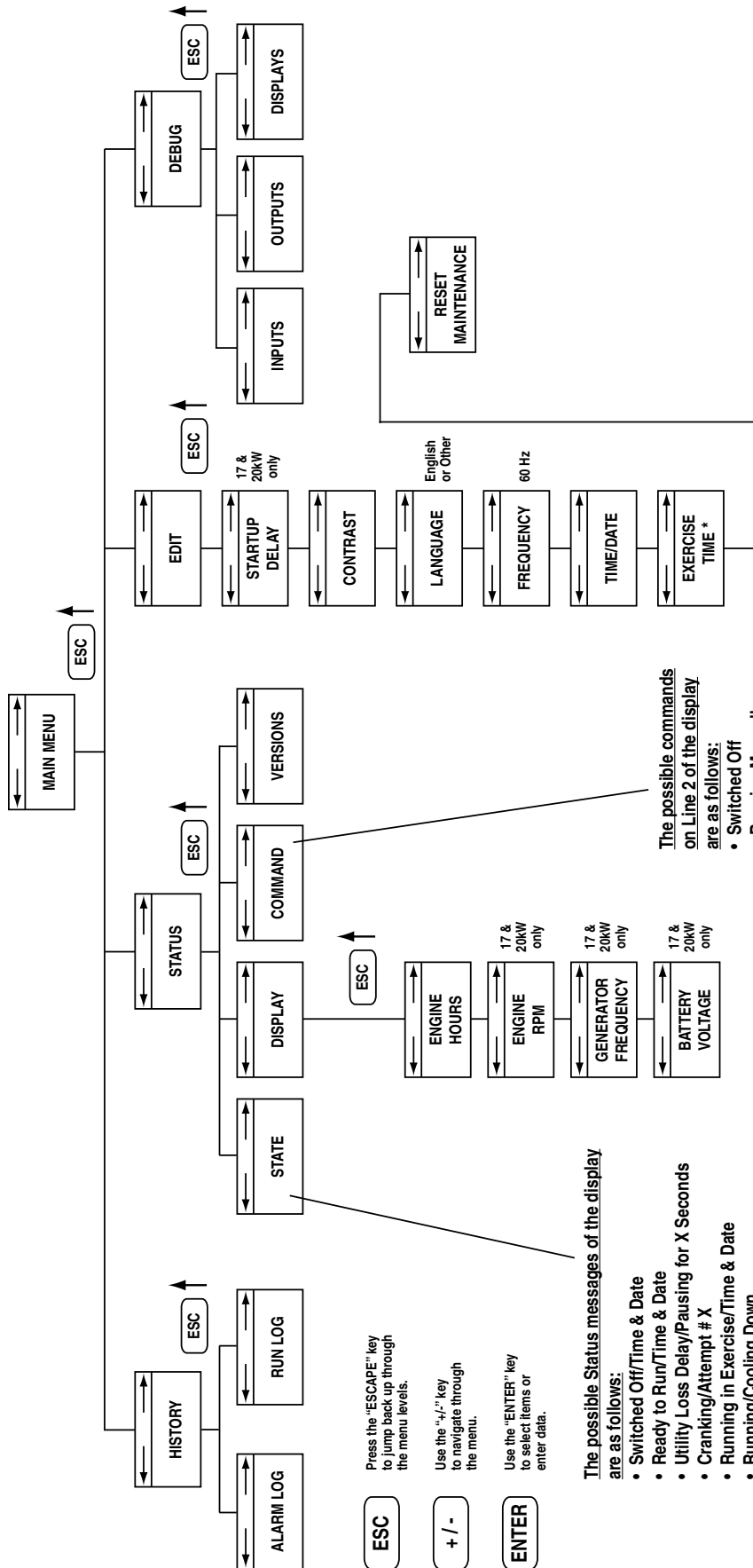

ESC

+ / -

ENTER

Press the "ESCAPE" key to jump back up through the menu levels.

Use the "+ / -" key to navigate through the menu.

Use the "ENTER" key to select items or enter data.

The possible Status messages of the display are as follows:

- Switched Off/Time & Date
- Ready to Run/Time & Date
- Utility Loss Delay/Pausing for X Seconds
- Cranking/Attempt # X
- Running in Exercise/Time & Date
- Running/Cooling Down
- Running - Warning/Warning Message
- Running - Alarm/Alarm Message
- Stopped - Alarm/Alarm Message
- Stopped - Warning/Warning Message
- Cranking/Pausing for X Seconds
- Running/Time & Date
- Running/Warming Up
- Cranking - Warning/Warning Message
- Cranking - Alarm/Alarm Message

The possible commands on Line 2 of the display are as follows:

- Switched Off
- Running Manually
- Stopped in Auto Mode
- Running - Utility Lost
- Running in Exercise
- Running from Radio

* Low speed exercise can be set in the EXERCISE TIME menu

INTRODUCTION

This "Operational Analysis" is intended to familiarize the service technician with the operation of the DC control system on units with air-cooled engine. A thorough understanding of how the system works is essential to sound and logical troubleshooting. The DC control system illustrations on the following pages represent a 14 kW unit.

UTILITY SOURCE VOLTAGE AVAILABLE

See Figure 1, below. The circuit condition with the AUTO-OFF-MANUAL switch set to AUTO and with "Utility" source power available can be briefly described as follows:

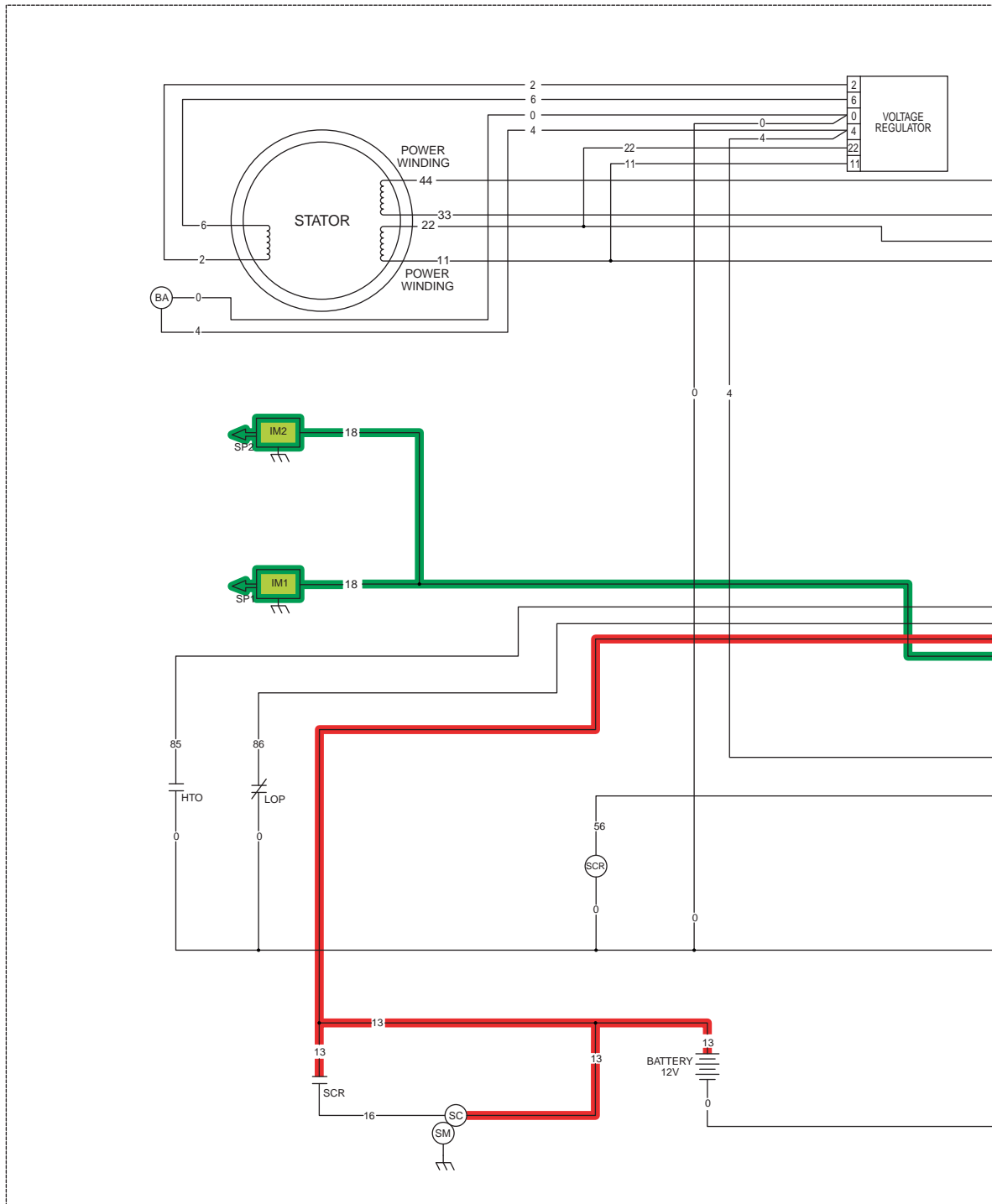

- Utility source voltage is available to transfer switch Terminal Lugs N1/N2. With the transfer switch main contacts at their "Utility" side, this source voltage is available to Terminal Lugs T1/T2 and to the "Load" circuits.
- Utility voltage is delivered to the Control Board Wires N1/N2, fuses F1/F2, connected wiring, and Control Panel UTILITY 1 and UTILITY 2 terminals. A voltage of 240 AC is delivered to the circuit board.
- Battery output is delivered to the circuit board via Wire 13 when the Battery is installed.

Figure 1. Circuit Condition - Utility Source Voltage Available

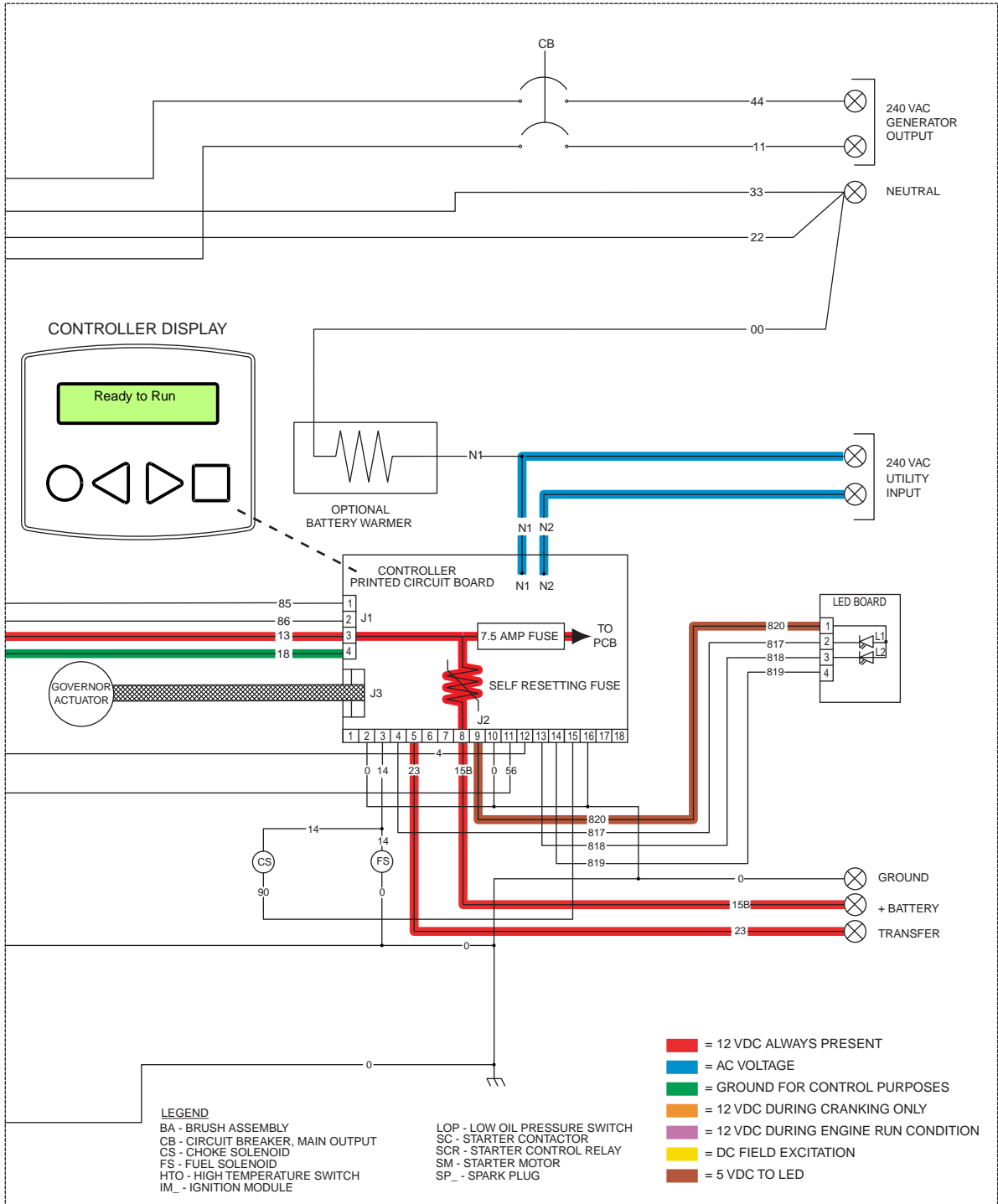

INITIAL DROPOUT OF UTILITY SOURCE VOLTAGE

Refer to Figure 2, below. Should a "Utility" power source failure occur, circuit condition may be briefly described as follows:

- The circuit board constantly senses for an acceptable "Utility" source voltage, via transfer switch fuses F1/F2, transfer switch UTILITY 1 and UTILITY 2 terminals, connected wiring, control panel UTILITY 1 and UTILITY 2 terminals, and Wires N1/N2.

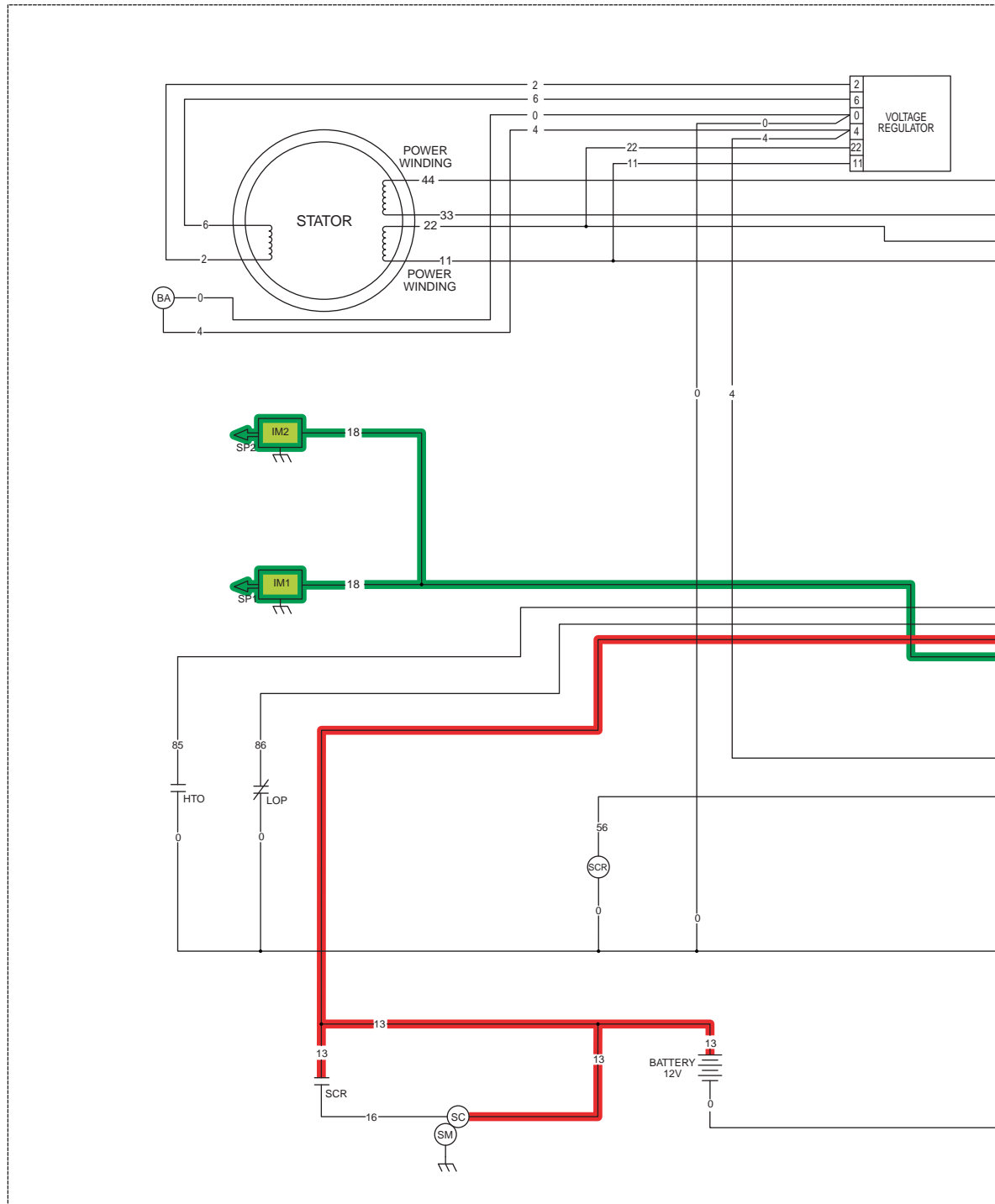

- Should utility voltage drop below approximately 65 percent of the nominal source voltage, a programmable timer on the circuit board will turn on.
- In Figure 2, the 10-second timer is still timing and engine cranking has not yet begun.
- The AUTO-OFF-MANUAL switch is shown in its AUTO position. Battery voltage is available to the circuit board via Wire 13, a 7.5 amp fuse (F1), and Wire 15B.

Figure 2. Circuit Condition - Initial Dropout of Utility Source Voltage

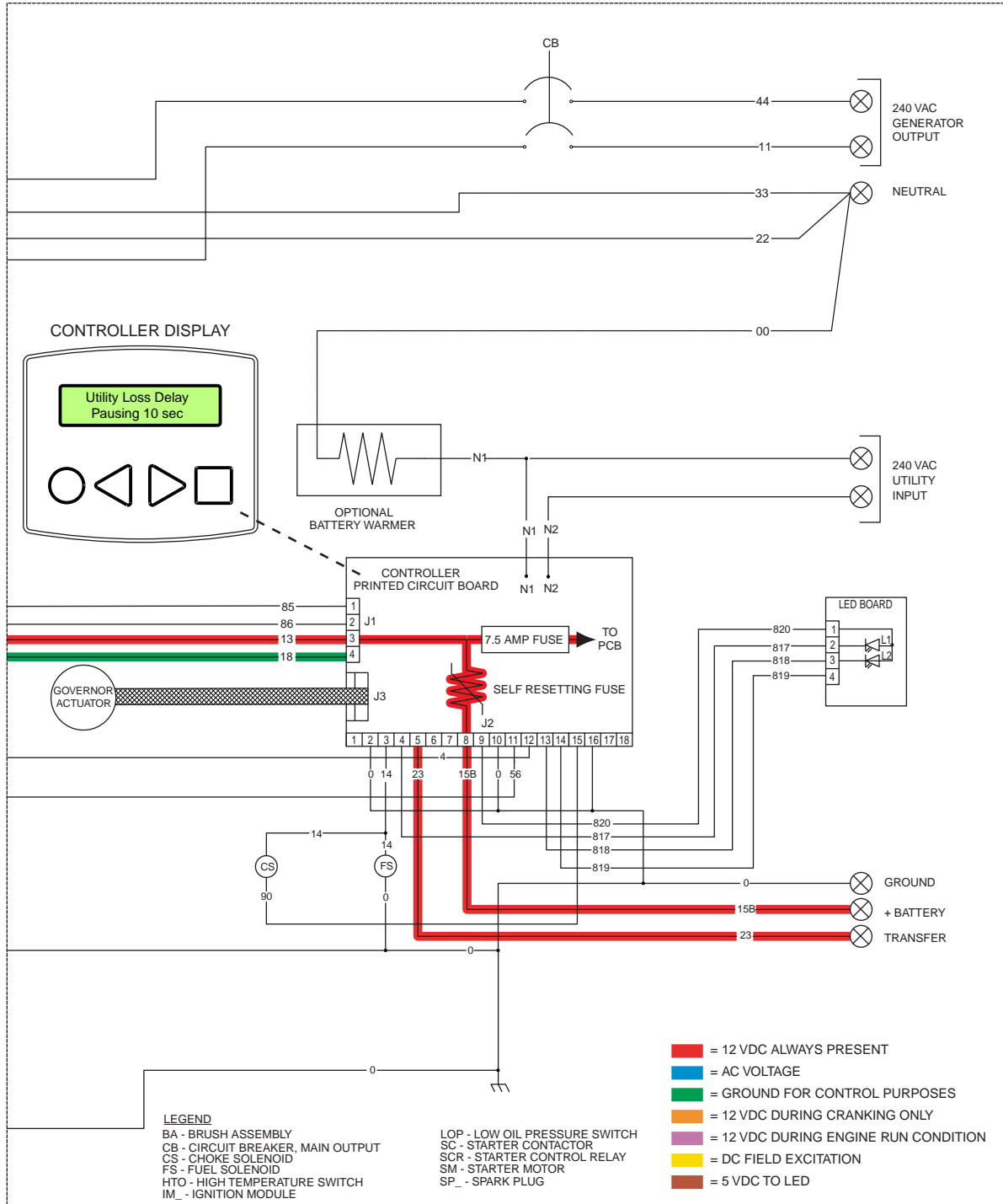

UTILITY VOLTAGE DROPOUT AND ENGINE CRANKING

- After ten (10) seconds and when the circuit board's 10-second timer has timed out, if utility voltage is still below 65 percent of nominal, circuit board action will energize the circuit board's crank and run relays simultaneously.
- Printed circuit board action delivers 12 volts DC to a starter contactor relay (SCR), via Wire 56. When the SCR energizes, its contacts close and battery power is delivered to a starter contactor (SC). When the SC energizes, its contacts close and battery power is delivered to the starter motor (SM). The engine cranks.

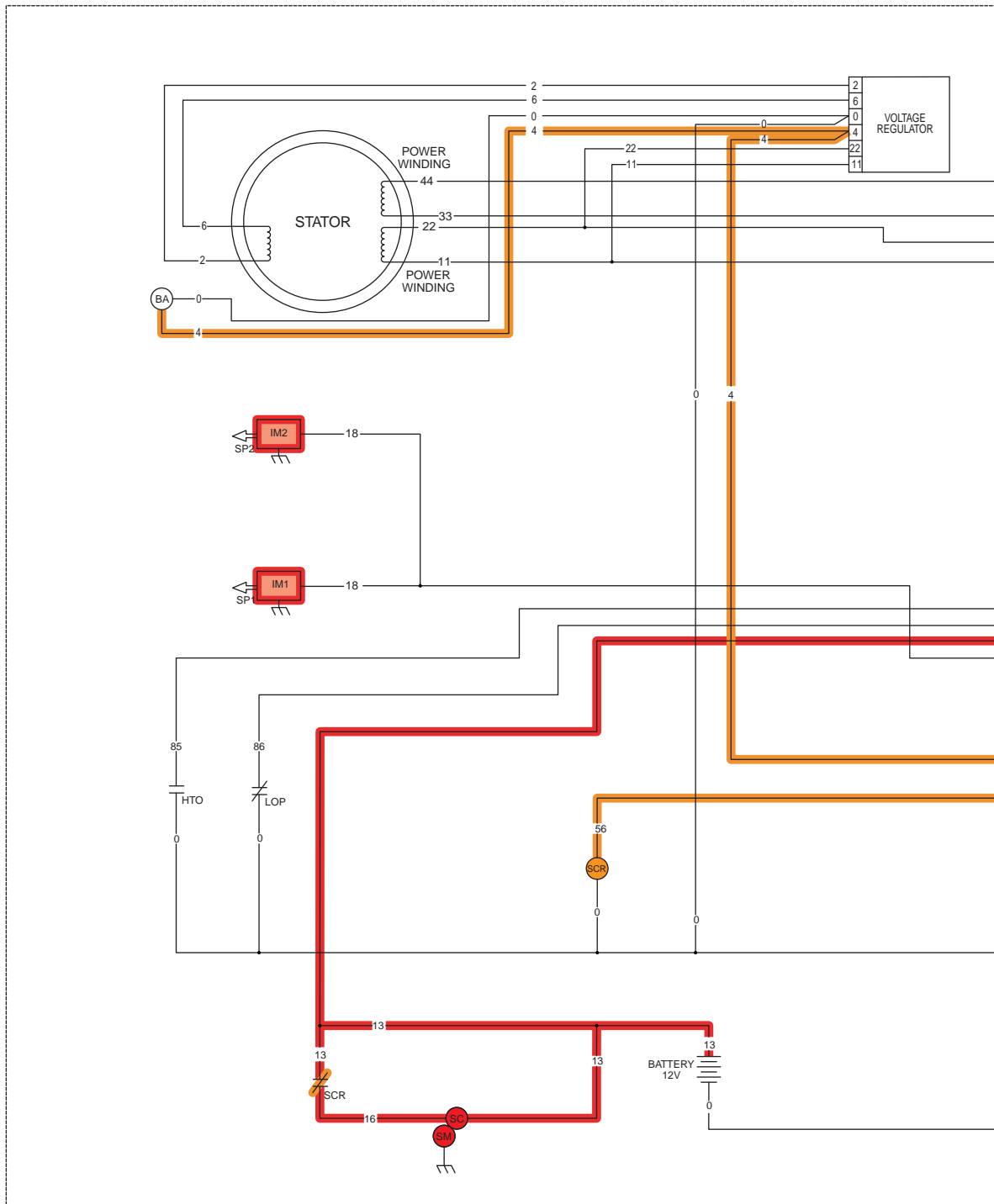

- Printed circuit board action delivers 12 volts DC to the fuel solenoids (FS1 & FS2), via Wire 14. The fuel solenoids energize open and fuel is available to the engine. Wire 14 supplies power to the choke solenoid (CS). Circuit board action grounds Wire 90, energizing the choke solenoid cyclically during cranking and continuously while running.
- As the engine cranks, magnets on the engine flywheel induce a high voltage into the engine ignition magnetos (IM1/IM2). A spark is produced that jumps the spark plug (SP1/SP2) gap.
- During cranking, Wire 4 supplies 3-5 VDC (9-10 VDC isolated) to the rotor for field flash.
- With ignition and fuel flow available the engine can start.

Figure 3. Circuit Condition - Engine Cranking

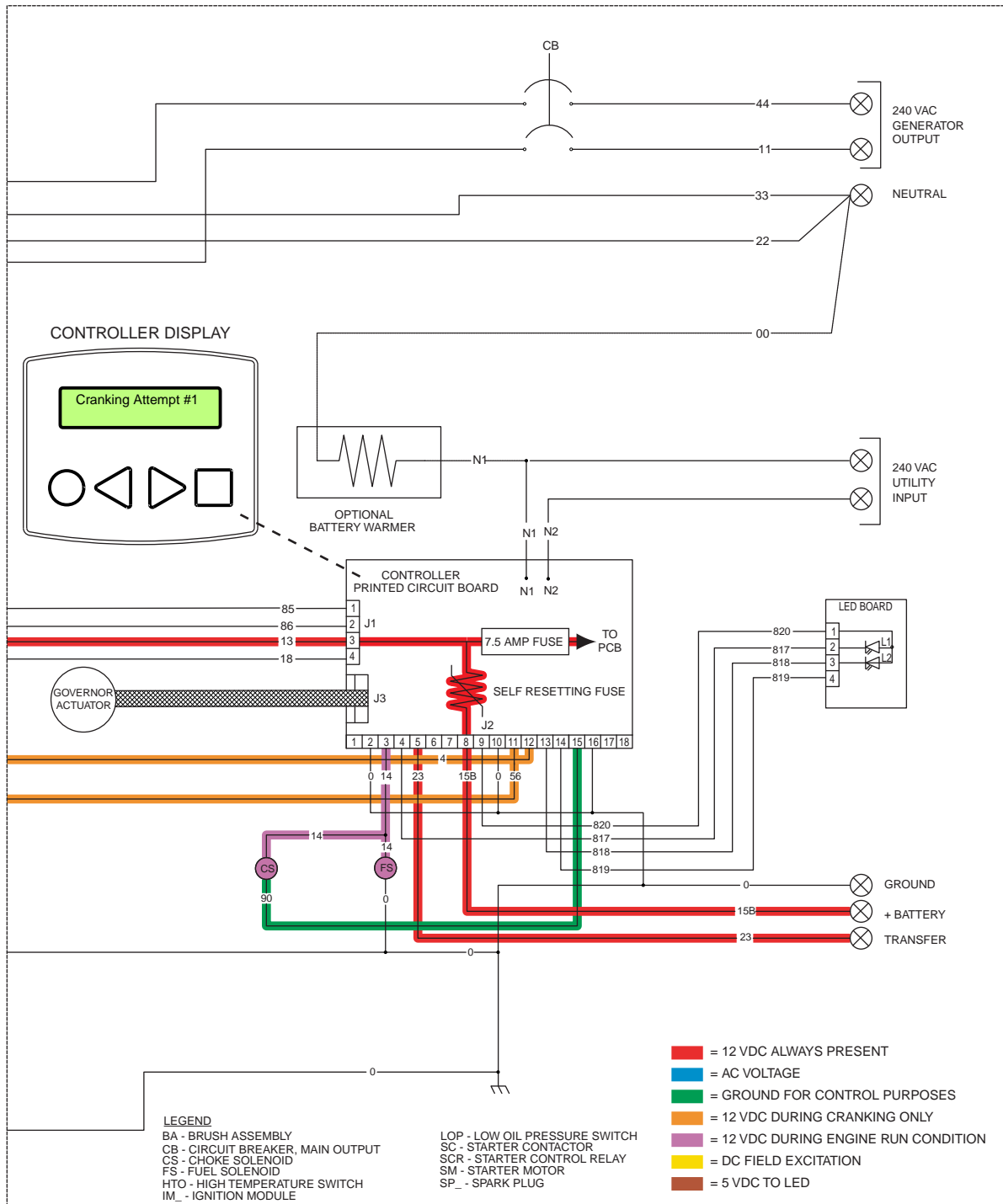

ENGINE STARTUP AND RUNNING

With the fuel solenoids open and ignition occurring, the engine starts. Engine startup and running may be briefly described as follows:

- Voltage pulses from the ignition magnetos are delivered to the circuit board via Wire 18. Once the circuit board determines that the engine is running, the circuit board (a) terminates cranking, and (b) terminates the choke solenoid (CS), and (c) turns on an “engine warm-up timer”.

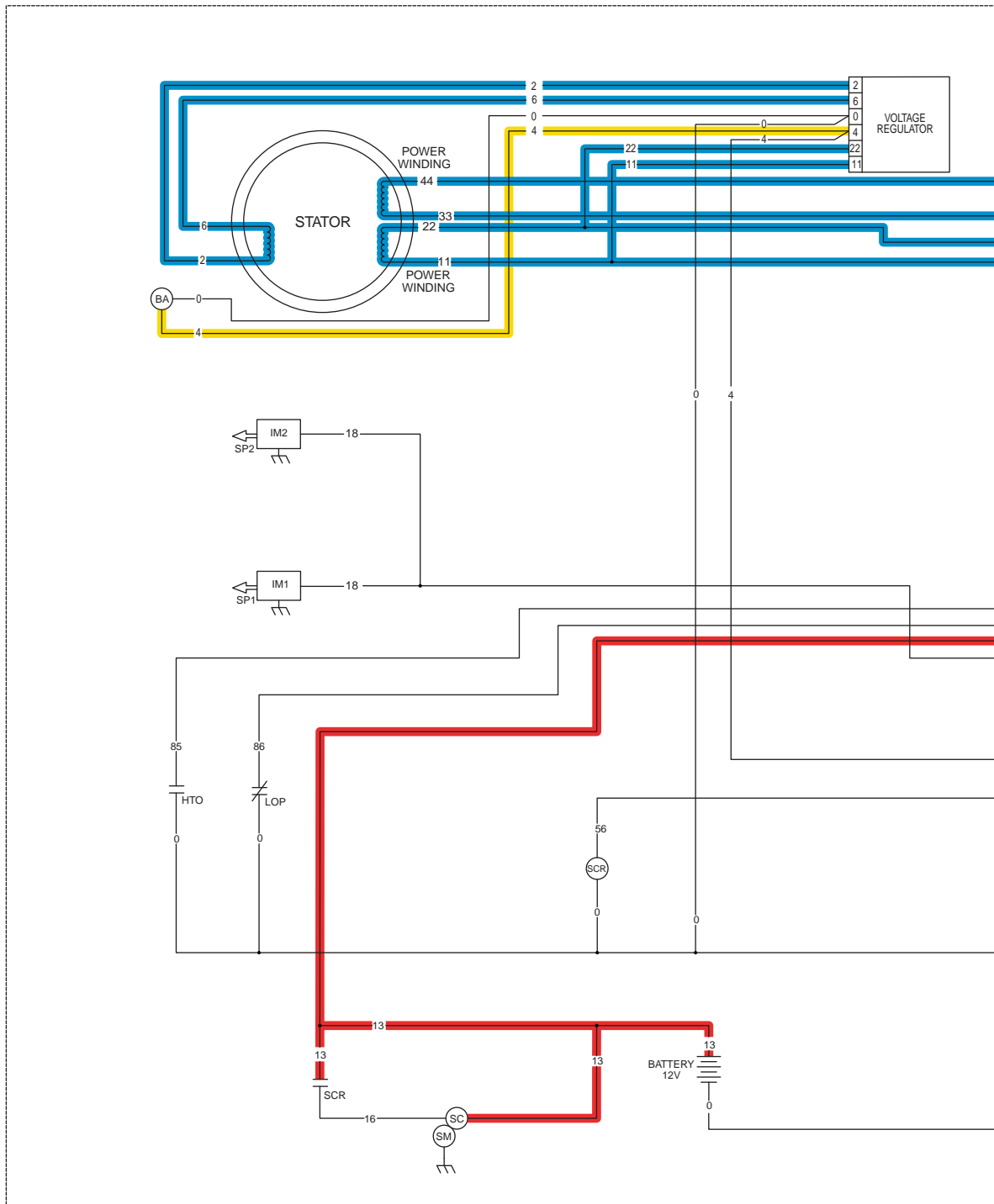

- The “engine warm-up timer” will run for about 5 seconds. When this timer finishes timing, board action will initiate transfer to the STANDBY power source. As shown in Figure 4 (below), the timer is still running and transfer has not yet occurred.
- Generator AC output is available to transfer switch Terminal Lugs E1/E2 and to the normally open contacts of a transfer relay. However, the transfer relay is de-energized and its contacts are open.

Figure 4. Circuit Condition - Engine Startup and Running

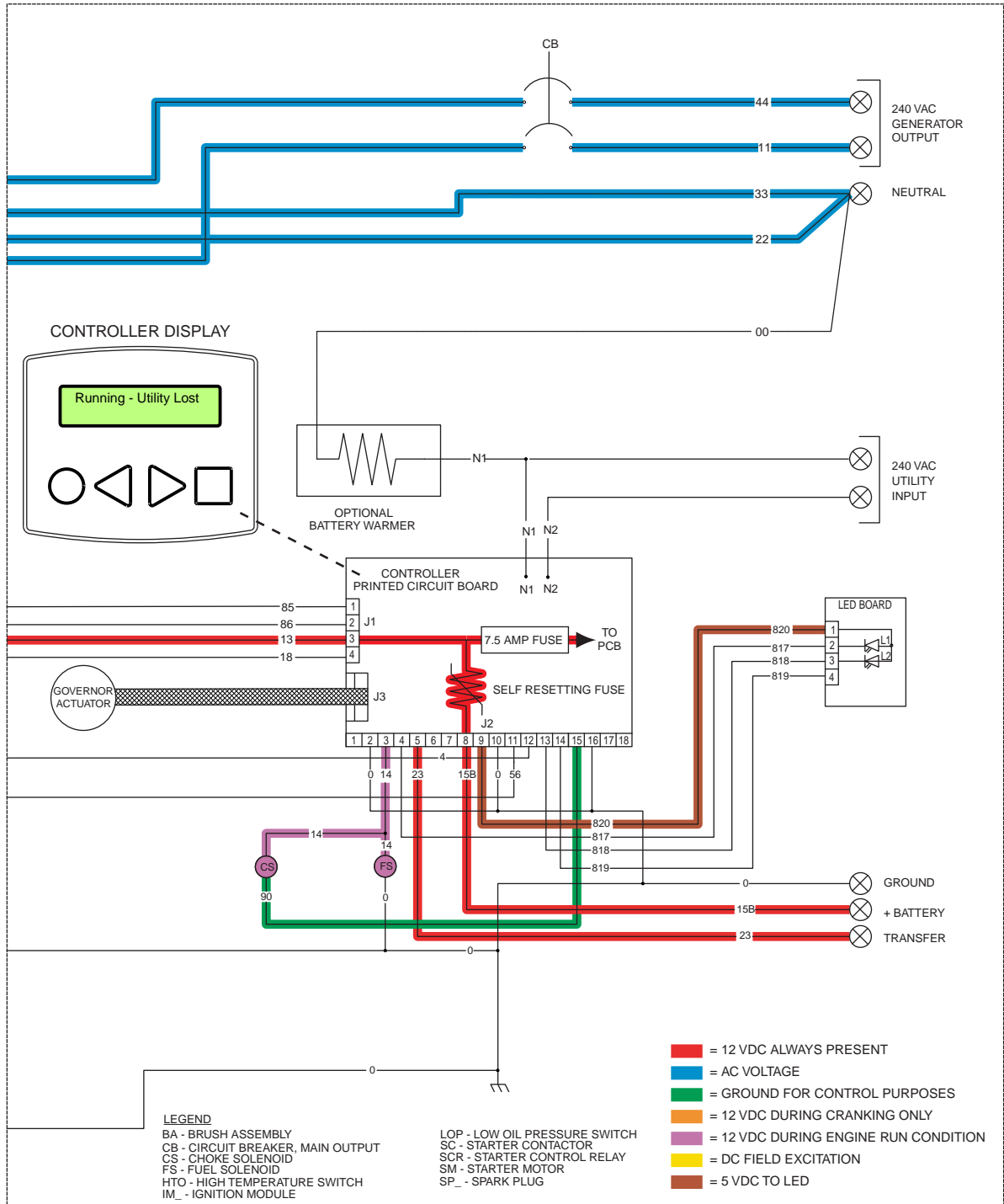

INITIAL TRANSFER TO THE "STANDBY" SOURCE

The generator is running, the circuit board's "engine warm-up timer" is timing, and generator AC output is available to transfer switch terminal lugs E1 and E2 and to the open contacts on the transfer relay. Initial transfer to the STANDBY power supply may be briefly described as follows:

- 12 volts DC output is delivered to the transfer relay (TR) actuating coil, via Wire 15B, and terminal A of the transfer relay (TR) in the transfer switch. This 12 volts DC circuit is completed back to the board, via transfer relay terminal B and Wire 23. However, circuit board action holds the Wire 23 circuit open to ground and the transfer relay (TR) is de-energized.

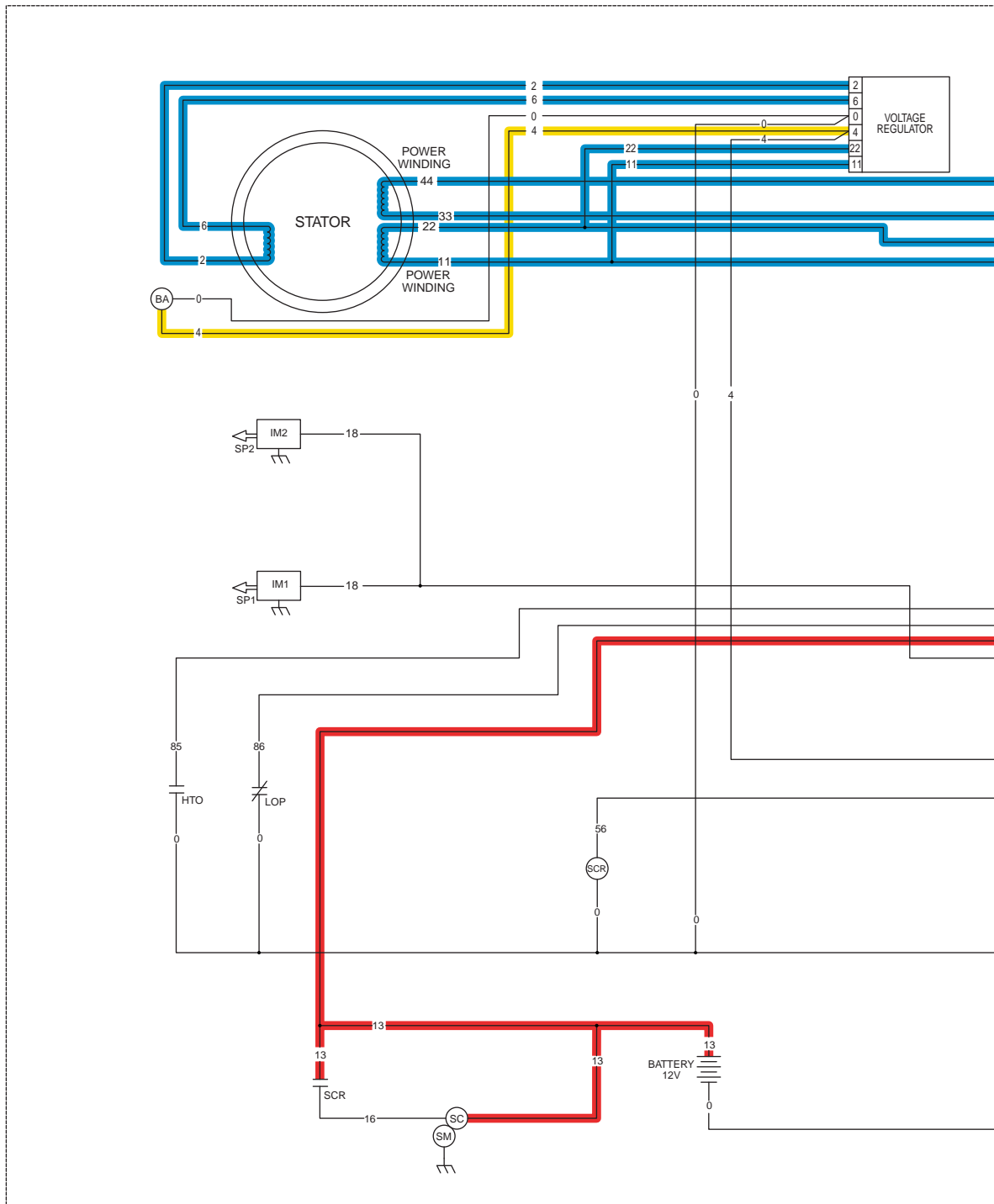

- When the circuit board's "engine warm-up timer" times out, circuit board action completes the Wire 23 circuit to ground. The transfer relay then energizes and its normally open contacts close.
- Standby power is now delivered to the standby closing coil (C2), via Wires E1/E2, the normally open transfer relay contacts, Wire 205, limit switch XB1, Wire B, and a bridge rectifier. The standby closing coil energizes and the main current carrying contacts of the transfer switch are actuated to their STANDBY source side.
- As the main contacts move to their STANDBY source side, a mechanical interlock actuates limit switch XB1 to its open position and limit switch XA1 to its "Utility" side position. When XB1 opens, standby closing coil C2 3 de-energizes.
- Standby power is delivered to the LOAD terminals (T1/T2) of the transfer switch.

Figure 5. Circuit Condition - Initial Transfer to Standby

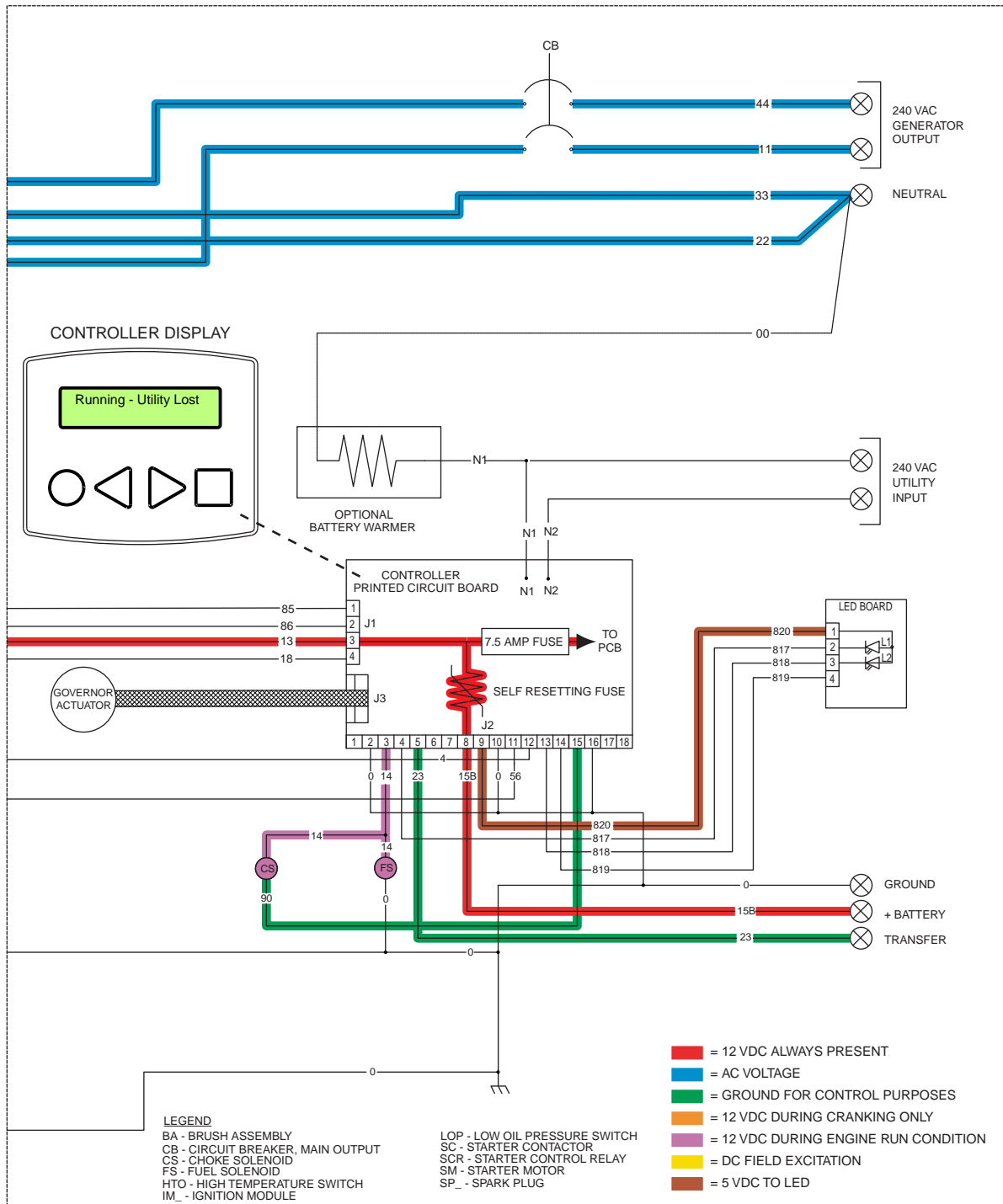

UTILITY VOLTAGE RESTORED / RE-TRANSFER TO UTILITY

The "Load" is powered by the standby power supply. The circuit board continues to seek an acceptable utility source voltage. On restoration of utility source voltage, the following events will occur:

- On restoration of utility source voltage above 75 percent of the nominal rated voltage, a "retransfer time delay" on the circuit board starts timing. The timer will run for about fifteen (15) seconds.
- At the end of fifteen (15) seconds, the "retransfer time delay" will stop timing and circuit board action will open the Wire 23 circuit to ground. The transfer relay (TR) will then de-energize.
- When the transfer relay (TR) de-energizes, its normally-closed contacts close. Utility source voltage is then delivered to the utility closing coil (C1), via Wires N1A/N2A, the closed TR contacts, Wire 126, limit switch XA1, and a bridge rectifier.

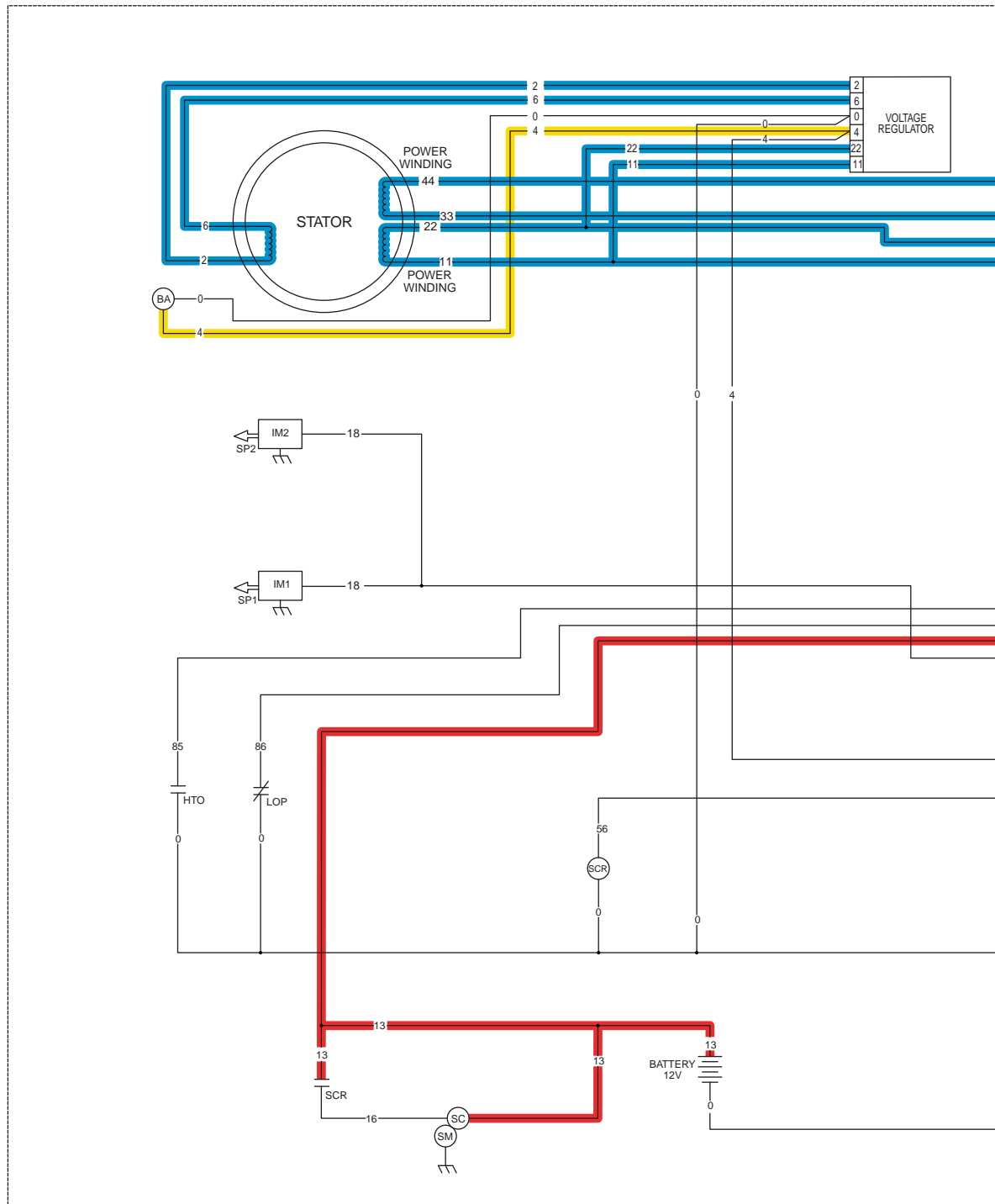

- The utility closing coil (C1) energizes and moves the main current carrying contacts to their NEUTRAL position. The main contacts move to an over center position past NEUTRAL and spring force closes them to their UTILITY side. LOAD terminals are now powered by the UTILITY source.
- Movement of the main contacts to UTILITY actuates limit switches XA1/XB1. XA1 opens and XB1 actuates to its STANDBY source side.
- The generator continues to run.

Figure 6. Circuit Condition - Utility Voltage Restored

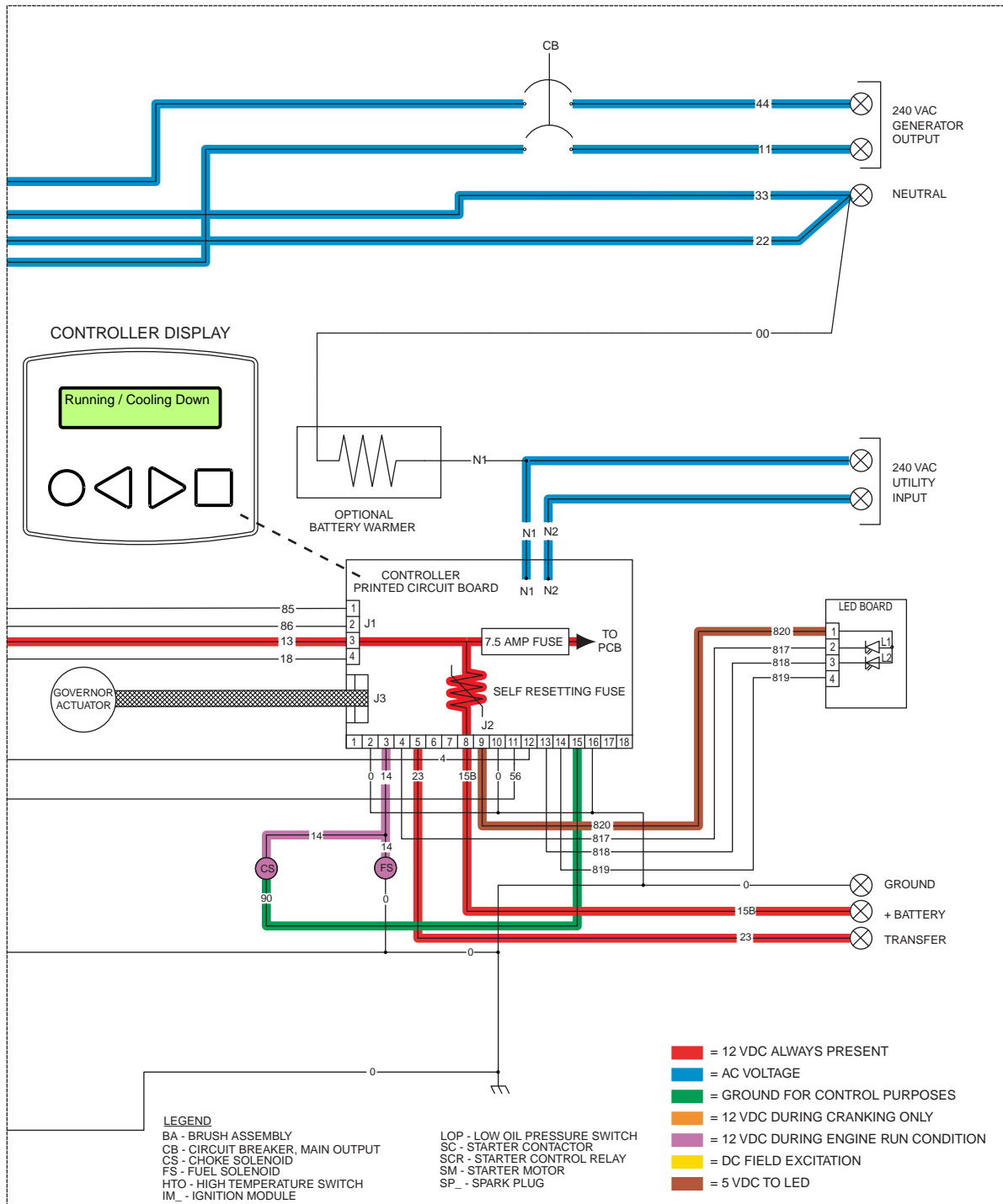

ENGINE SHUTDOWN

Following retransfer back to the utility source, an "engine cool-down timer" on the circuit board starts timing. When that timer has timed out (approximately one minute), circuit board action will de-energize the circuit board's run relay. The following events will then occur:

- The DC circuit to Wire 14 and the fuel solenoids (FS1 & FS2) will be opened. The fuel solenoids will de-energize and close to terminate the engine fuel supply.

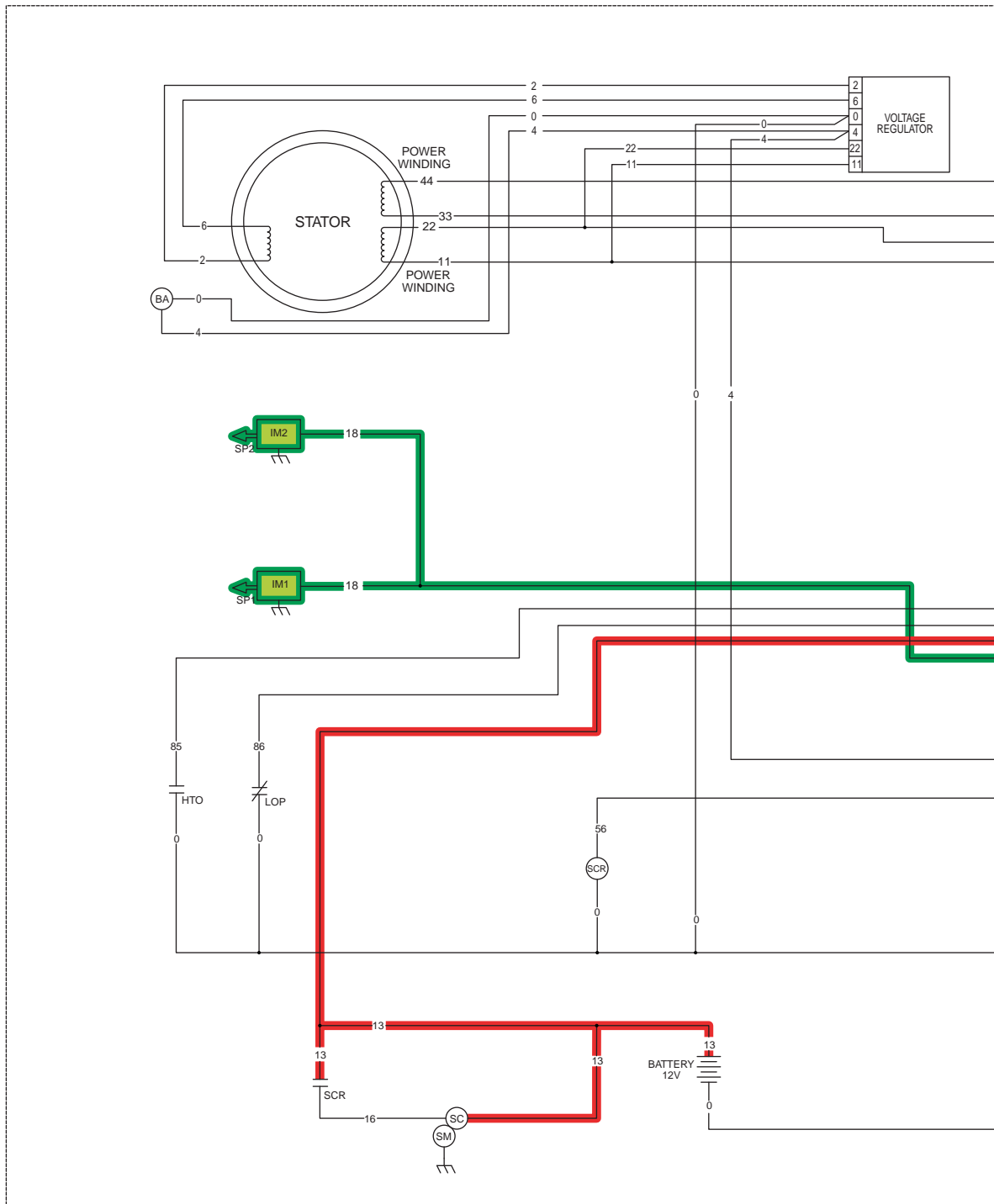

- Circuit board action will connect the engine's ignition magnetos (IM1 & IM2) to ground, via Wire 18. Ignition will be terminated.
- Without fuel flow and without ignition, the engine will shut down.

Figure 7. Circuit Condition - Retransfer to "Utility" and Engine Shutdown

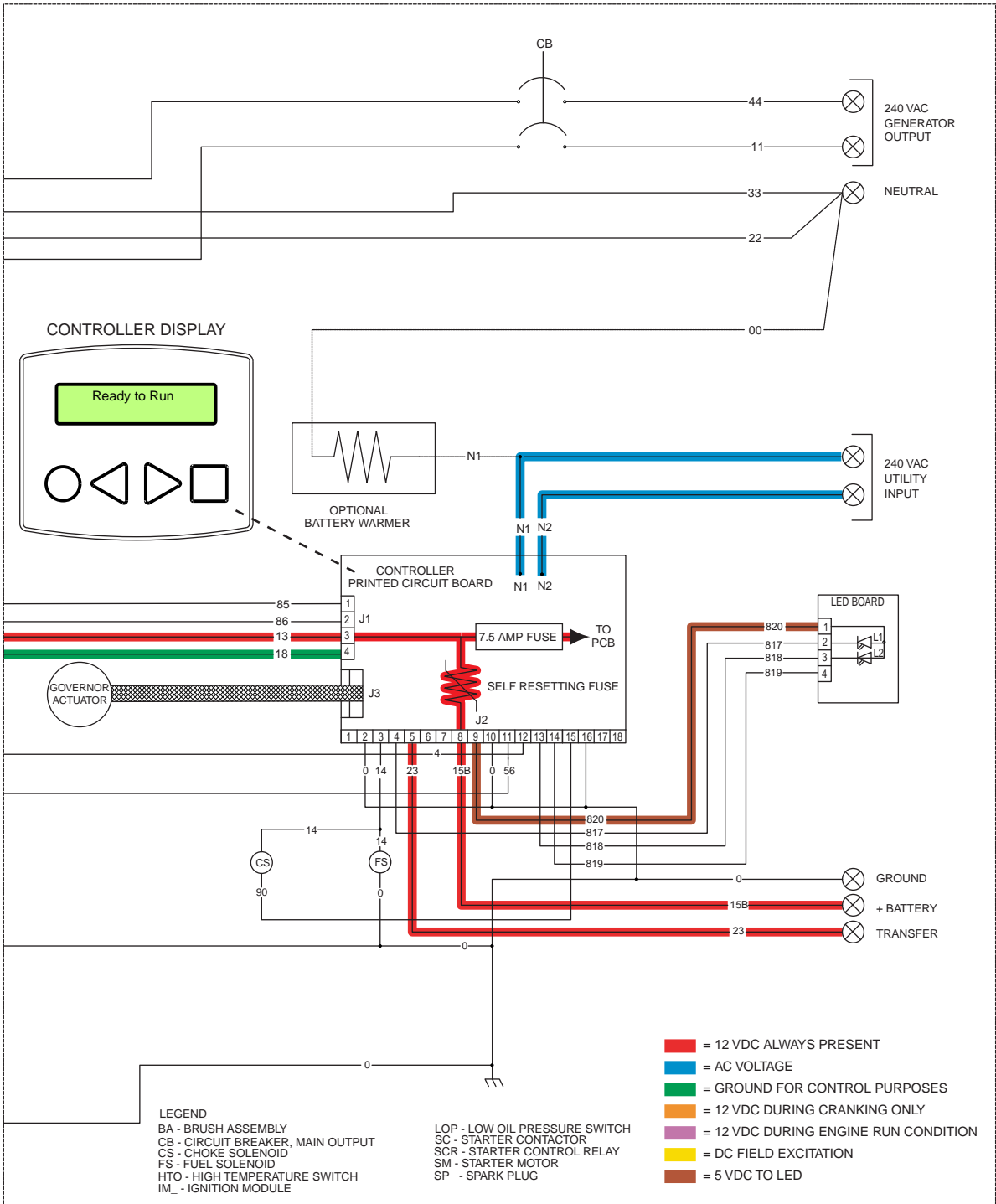

SECTION 4.3
TROUBLESHOOTING FLOW CHARTS

Problem 15 – Engine Will Not Crank When Utility Power Source Fails

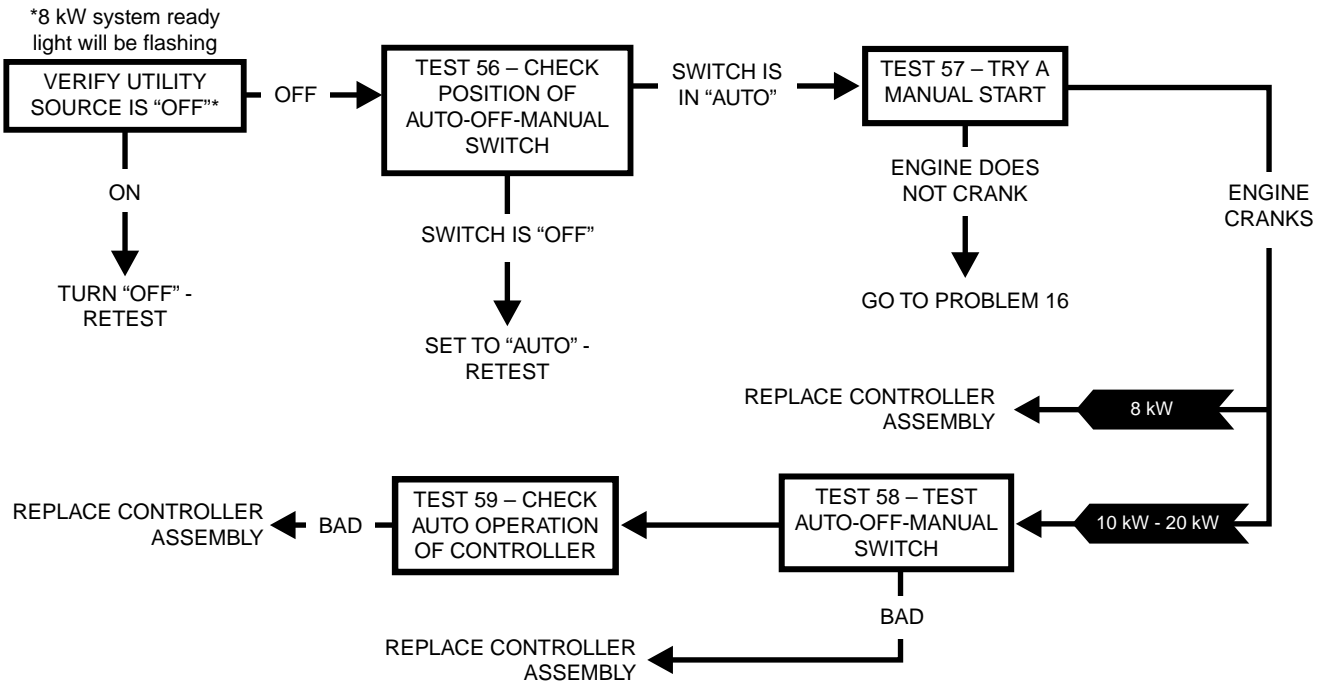

Problem 16 – Engine Will Not Crank When AUTO-OFF-MANUAL Switch is Set to “MANUAL”

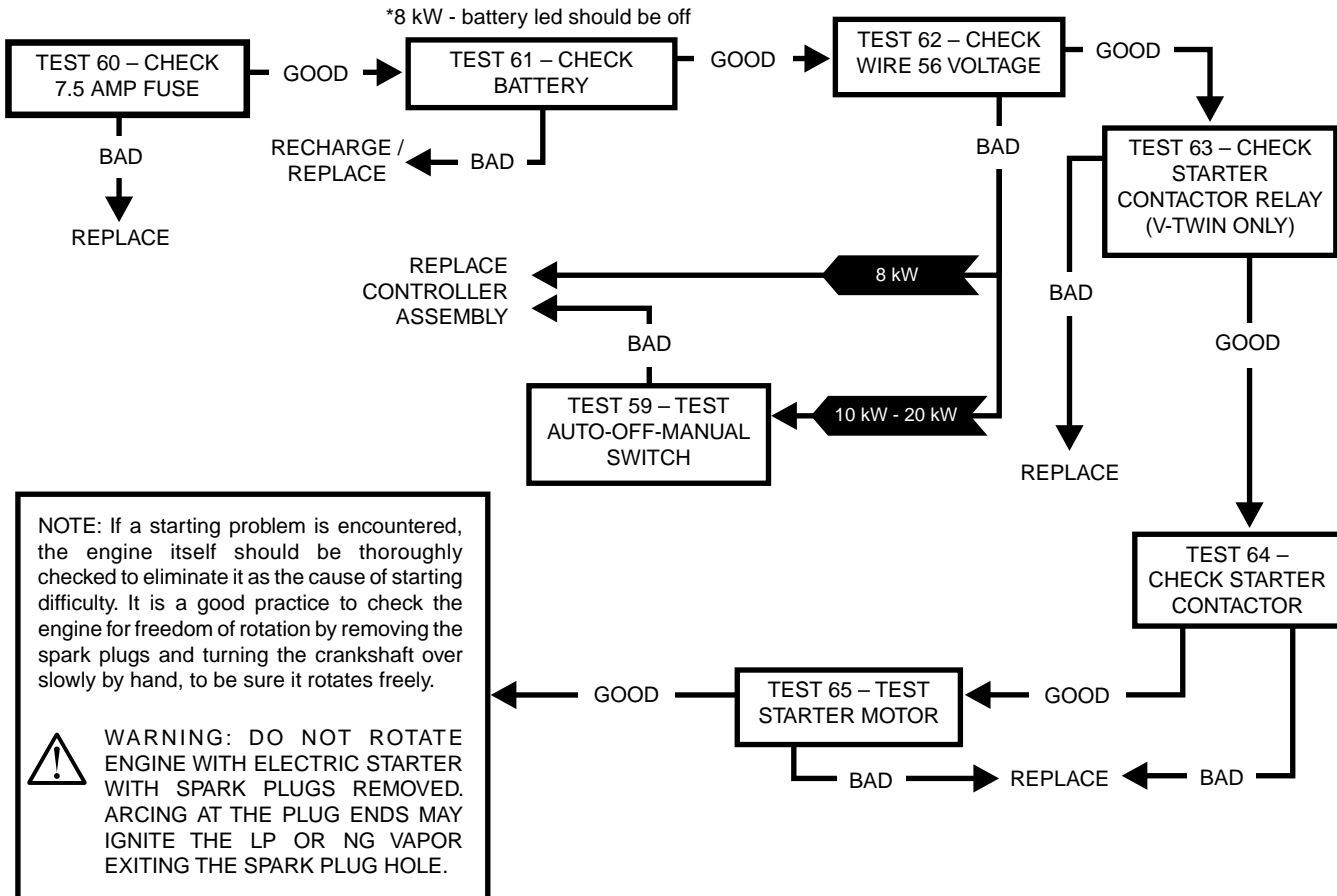

Problem 18 – Engine Starts Hard and Runs Rough / Lacks Power / Backfires

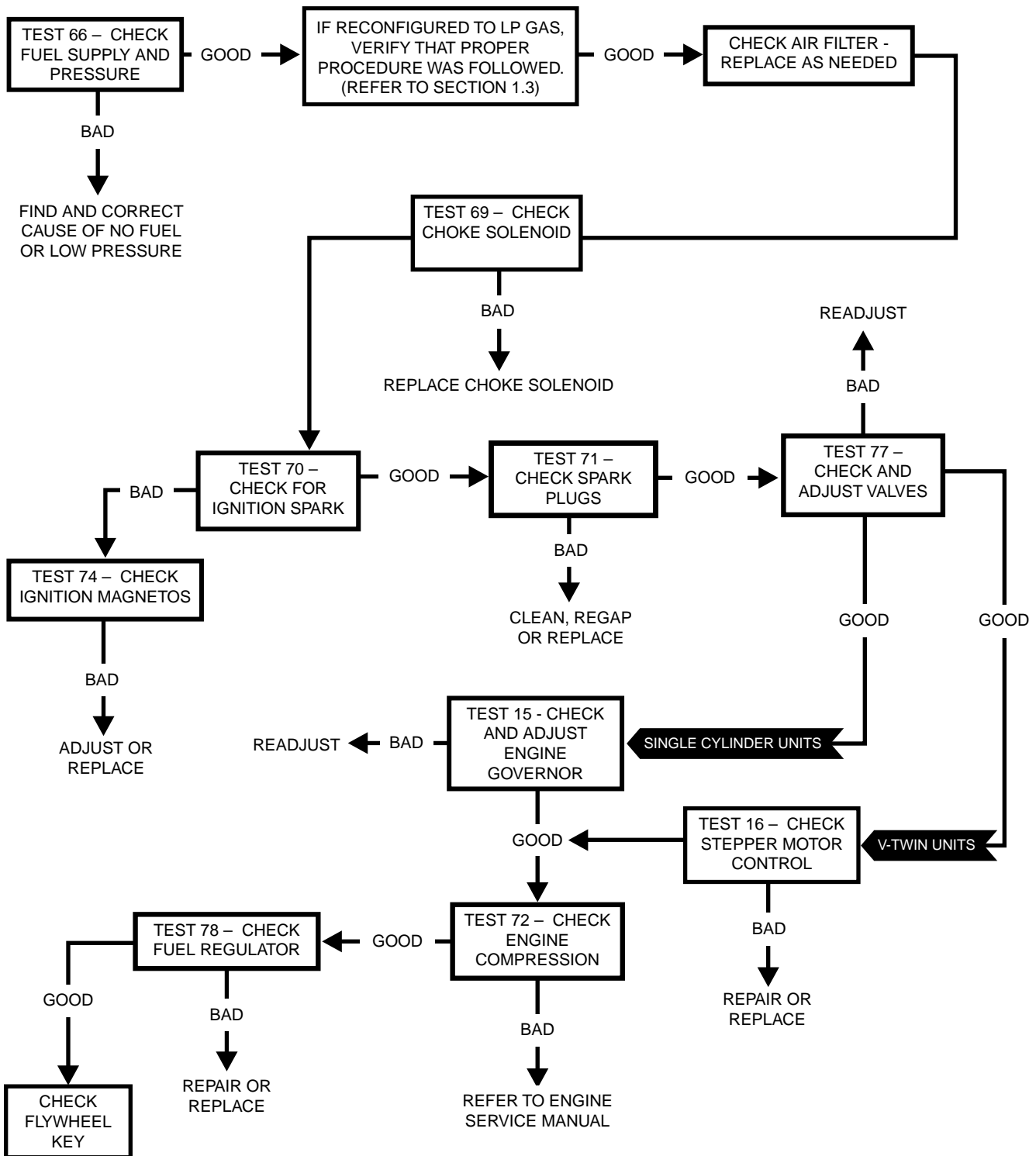

Problem 19 – Shutdown Alarm/Fault Occured

CHECK FAULT LIGHTS

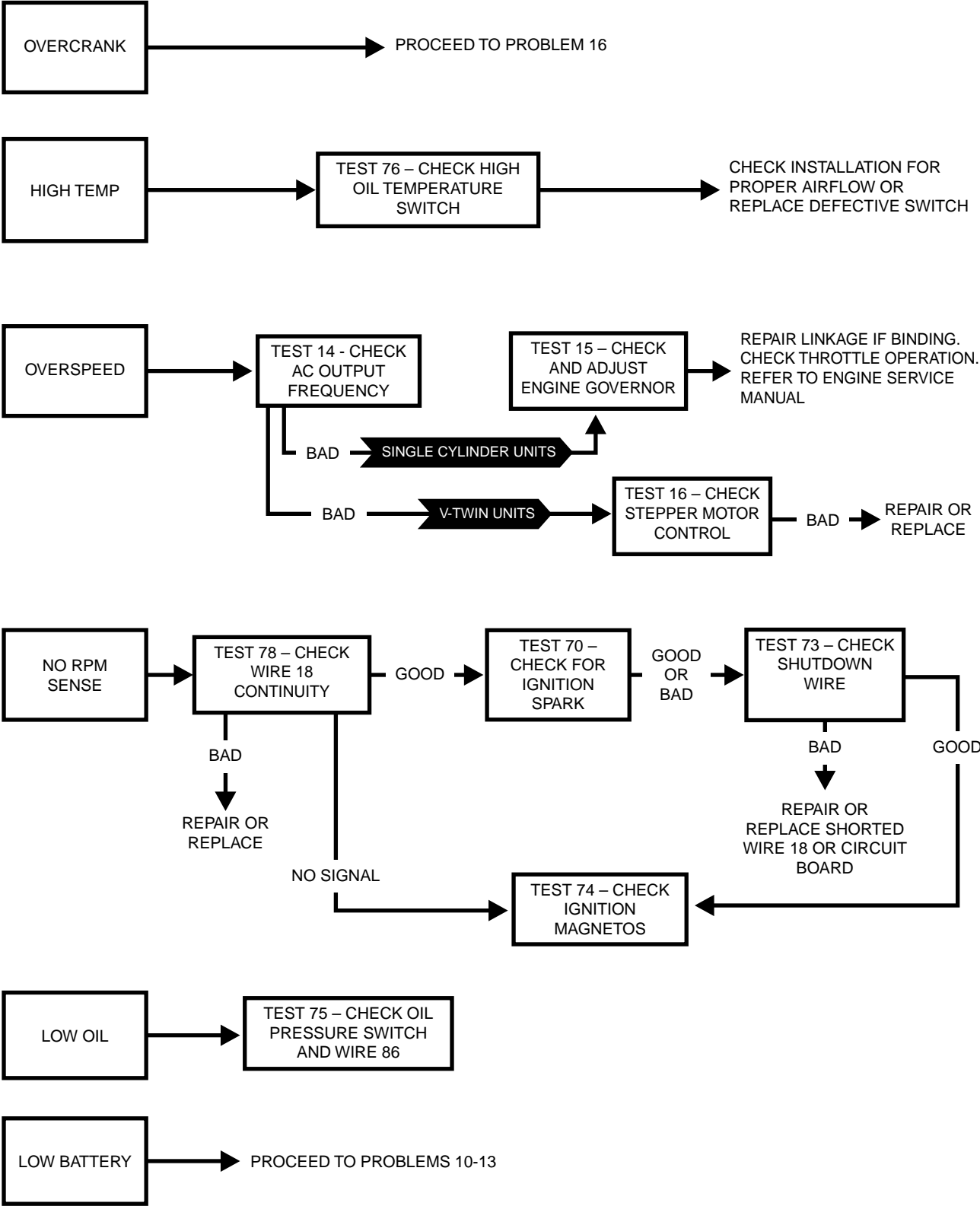

Problem 20 – 7.5 Amp Fuse (F1) Blown

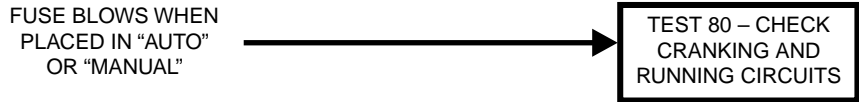

Problem 21 – Generator Will Not Exercise

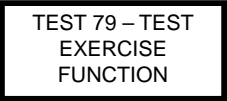

Problem 22 – No Low Speed Exercise

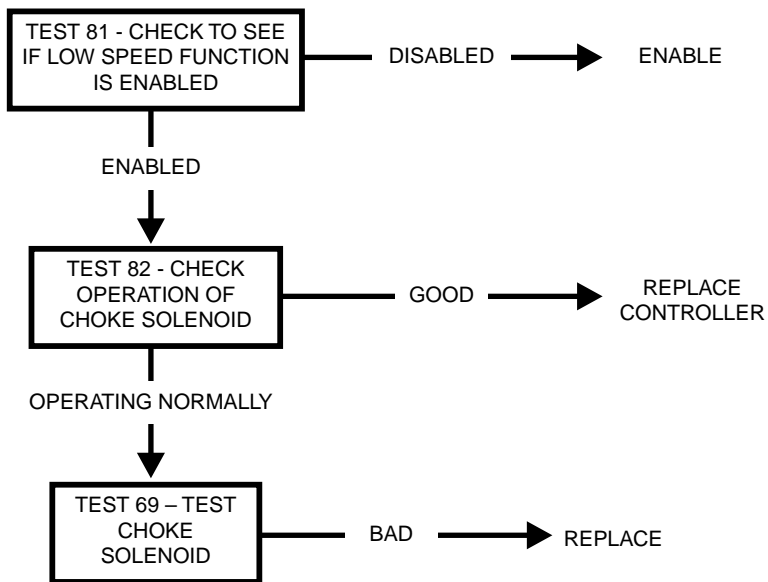

INTRODUCTION

Perform these “Diagnostic Tests” in conjunction with the “Troubleshooting Flow Charts” of Section 4.3.

The test procedures and methods presented in this section are not exhaustive. The manufacturer could not possibly know of, evaluate and advise the service trade of all conceivable ways in which testing and trouble diagnosis might be performed. The manufacturer has not undertaken any such broad evaluation.

TEST 56 – CHECK POSITION OF AUTO-OFF-MANUAL SWITCH**DISCUSSION:**

If the standby system is to operate automatically, the generator AUTO-OFF-MANUAL switch must be set to AUTO. That is, the generator will not crank and start on occurrence of a “Utility” power outage unless that switch is at AUTO. In addition, the generator will not exercise every seven (7) days as programmed unless the switch is at AUTO.

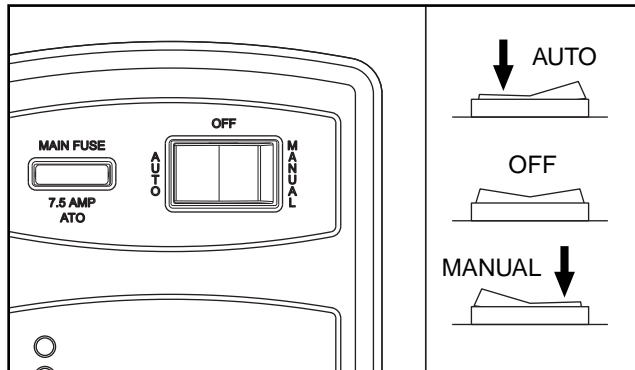

Figure 1. AUTO-OFF-MANUAL Switch Positions

PROCEDURE:

With the AUTO-OFF-MANUAL switch set to AUTO, test automatic operation. Testing of automatic operation can be accomplished by turning off the Utility power supply to the transfer switch. When the utility power is turned off, the standby generator should crank and start. Following startup, transfer to the standby source should occur. Refer to Section 1.8 in this manual.

Following generator startup and transfer to the standby source, turn ON the utility power supply to the transfer switch. Retransfer back to the “Utility” source should occur. After an “engine cooldown timer” has timed out, generator shutdown should occur.

RESULTS:

1. If normal automatic operation is obtained, discontinue tests.
2. If engine does not crank when utility power is turned off, proceed to Problem 15 Flow Chart, Section 4.3.

3. If engine cranks but won't start, go to Problem 17 in Section 4.3.
4. If engine cranks and starts, but transfer to “Standby” does NOT occur, go to Problem 7 in Section 3.3.
5. If transfer to “Standby” occurs, but retransfer back to “Utility” does NOT occur when utility source voltage is restored, go to Problem 8 in Section 3.3.

TEST 57 – TRY A MANUAL START**DISCUSSION:**

The first step in troubleshooting for an “engine won't crank” condition is to determine if the problem is peculiar to automatic operations only or if the engine won't crank manually either.

PROCEDURE:

1. On the generator panel, set the AUTO-OFF-MANUAL switch to OFF.
2. Set the generator main line circuit breaker to its OFF (or open) position.
3. Set the generator AUTO-OFF-MANUAL switch to MANUAL.
 - a. The engine should crank cyclically through it's “crank-rest” cycles until it starts.
 - b. Let the engine stabilize and warm up for a few minutes after it starts.

RESULTS:

1. If the engine cranks manually but does not crank automatically, go to Problem 15, Section 4.3.
2. If the engine does not crank manually, proceed to Problem 16 in the “Troubleshooting Flow Charts”.

TEST 58 – AUTO-OFF-MANUAL SWITCH (V-TWIN ONLY)**PROCEDURE:**

1. Press the “ESC” key on the controller until the home page is reached.
2. Press the right arrow key until “Debug” flashes. Press “Enter” and the following screen will appear. See Figure 2, Screen 2.
3. Press “Enter” when “Inputs” is flashing.
4. With the Inputs Screen displayed, place the AUTO-OFF-MANUAL switch to the AUTO Position. If the controller reads an input from the switch, Input 7 will change from “0” to “1”.

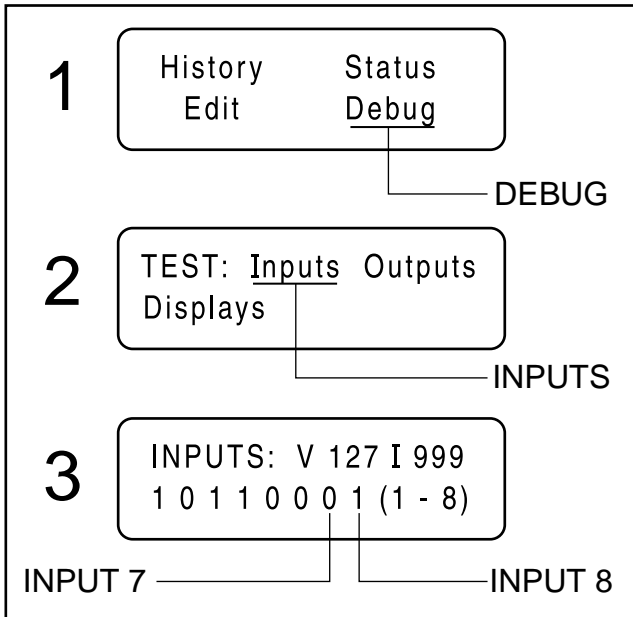

Figure 2. The Home Page, Debug and Input Screens

- With the Inputs Screen displayed place the AUTO-OFF-MANUAL switch to the MANUAL Position. If the controller reads an input from the switch input 8 will change from "0" to "1".
- With the AUTO-OFF-MANUAL Switch in the OFF position, both inputs will read zero.

RESULTS:

- If controller failed either Step 4 or Step 5 ,replace the controller assembly.
- If the controller passed Step 4 and Step 5, refer back to flow chart.

TEST 59 – TEST AUTO OPERATIONS

DISCUSSION:

Initial Conditions: The generator is in AUTO, ready to run, and load is being supplied by the utility source. When utility fails (below 65% of nominal), a 10 second (optionally programmable) line interrupt delay time is started. If the utility is still gone when the timer expires, the engine will crank and start. Once started, a five (5) second engine warm-up timer will be initiated. When the warm-up timer expires, the control will transfer the load to the generator. If the utility power is restored (above 75% of nominal) at any time from the initiation of the engine start until the generator is ready to accept a load (5 second warm-up time has not elapsed), the controller will complete the start cycle and run the generator through its normal cool down cycle; however, the load will remain on the utility source.

PROCEDURE:

- Simulate a power failure by disconnecting main breaker.
- If the generator does not perform the sequence of events listed in the above discussion, replace the printed circuit board.

RESULTS:

Refer back to flow chart

TEST 60 – CHECK 7.5 AMP FUSE

DISCUSSION:

The 7.5 amp fuse is located on the generator control console. A blown fuse will prevent battery power from reaching the circuit board, with the same result as setting the AUTO-OFF-MANUAL switch to OFF.

PROCEDURE:

Remove the 7.5 amp fuse (F1) by pushing the fuse.

RESULTS:

- If the fuse is good, refer back to Flow Chart.
- If the fuse is bad, it should be replaced. Use only an identical 7.5 amp replacement fuse.
- If fuse continues to blow, proceed to Problem 20 Flow Chart.

TEST 61 – CHECK BATTERY

DISCUSSION:

Battery power is used to (a) crank the engine and (b) to power the circuit board. Low or no battery voltage can result in failure of the engine to crank, either manually or during automatic operation. The trickle charger that is included in the generator will not recharge a dead battery.

PROCEDURE:

A. Inspect Battery Cables:

- Visually inspect battery cables and battery posts.
- If cable clamps or terminals are corroded, clean away all corrosion.
- Install battery cables, making sure all cable clamps are tight. The red battery cable from the starter contactor (SC) must be securely attached to the positive (+) battery post; the black cable from the frame ground stud must be tightly attached to the negative (-) battery post.
- Disconnect both negative and positive cables.

***Note: Disconnect negative battery cable first.**

- Using a DC Volt meter, measure DC volts on the battery.

**B. Perform a load test on the Battery:
(Maintenance Free Battery)**

- Using a lead acid battery load tester test the load capability of the battery.
- Follow the load tester's manufacturer's instructions carefully.

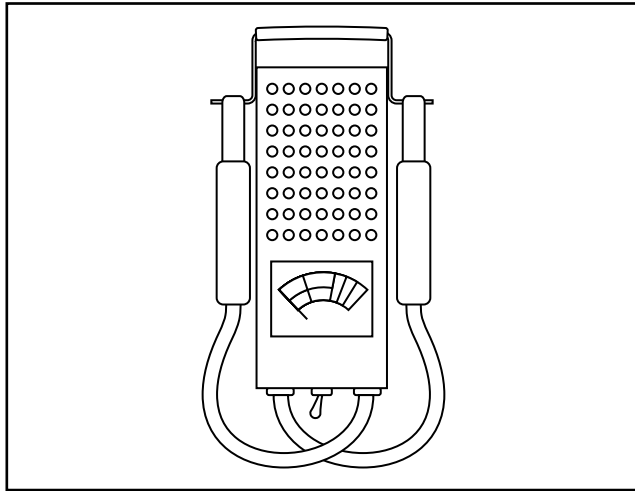

Figure 3. A Typical Battery Load Tester

- An average reading of 1.230 means the battery is 75% charged.
- An average reading of 1.200 means the battery is 50% charged.
- An average reading of 1.170 indicates the battery is 25% charged.

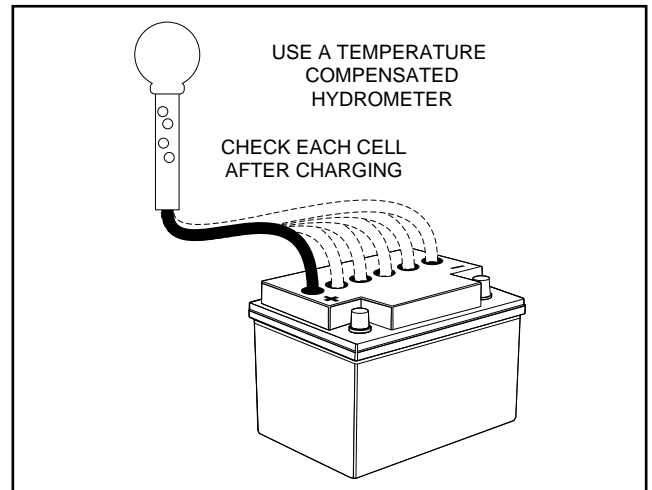

Figure 4. Using a Battery Hydrometer

**C. Test Battery State of Charge:
(Non-Maintenance Free Battery)**

- Use an automotive type battery hydrometer to test battery state of charge.
- Follow the hydrometer manufacturer's instructions carefully. Read the specific gravity of the electrolyte fluid in all battery cells.
- If cells are low, distilled water can be added to refill cell compartment.
- If the hydrometer does not have a "percentage of charge" scale, compare the reading obtained to the following:
 - An average reading of 1.260 indicates the battery is 100% charged.

5. Test Battery Condition:

- If the difference between the highest and lowest reading cells is greater than 0.050 (50 points), battery condition has deteriorated and the battery should be replaced.
- However, if the highest reading cell has a specific gravity of less than 1.230, the test for condition is questionable. Recharge the battery to a 100 percent state of charge, and then repeat the test for condition.

RESULTS:

- Remove the battery and recharge with an automotive battery charger, if necessary.
- If battery condition is bad, replace with a new battery.

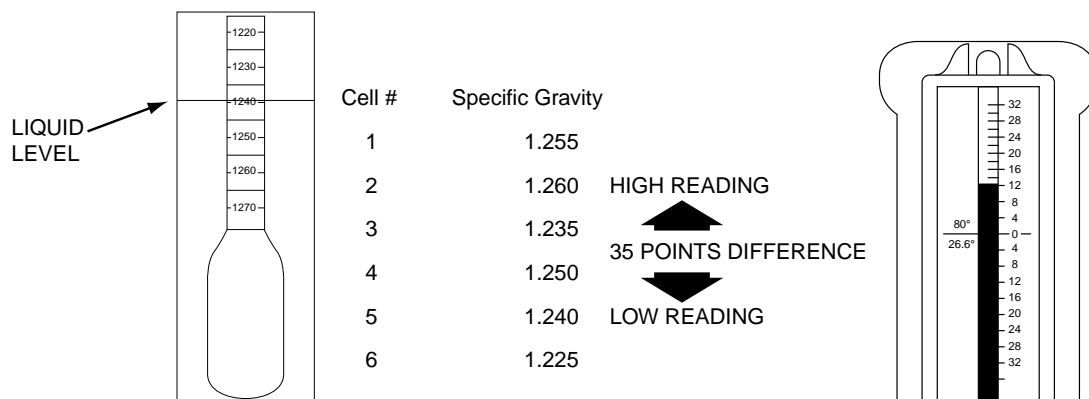

Figure 5. Reading a Battery Hydrometer

TEST 62 – CHECK WIRE 56 VOLTAGE

DISCUSSION:

During an automatic start or when starting manually, a crank relay on the circuit board should energize. Each time the crank relay energizes, the circuit board should deliver 12 VDC to a starter contactor relay (SCR), or starter contactor (SC), and the engine should crank. This test will verify (a) that the crank relay on the circuit board is energizing, and (b) that circuit board action is delivering 12 VDC to the starter contactor relay or starter contactor.

PROCEDURE:

1. Set a VOM to measure DC voltage.
2. Connect the positive (+) test probe of a DC voltmeter (or VOM) to the Wire 56 connector of the starter contactor relay (SCR, on models with V-twin engines) or the starter contactor (SC, on models with single cylinder engines). Connect the common (-) test probe to frame ground.
3. Observe the meter. Then, set the AUTO-OFF-MANUAL switch to the MANUAL position. The meter should indicate battery voltage. If battery voltage is measured, stop testing and refer back to flow chart.
4. Navigate to the Digital output display screen.
 - a. Press “ESC” until the main menu is reached.
 - b. Press the right arrow key until “Debug” is flashing.
 - c. Press “Enter”.
 - d. Press the right arrow key until “Outputs” is flashing.
 - e. Press “Enter”.
 - f. Digital Output 6 is Wire 56 output from the board. Refer to Figure 6.
5. Actuate the AUTO-OFF-MANUAL switch to the MANUAL position and observe digital output Number 6. If the printed circuit board is working correctly output Number 6 will change from a “0” to a “1”. If output did not change replace printed circuit board.
6. Set a VOM to measure resistance.

Note: Remove 7.5 amp fuse before disconnecting J1 connector.

7. Remove Wire 56 from the starter contactor relay (V-twin units) or from the starter contactor (single cylinder units). Connect one meter test lead to disconnected Wire 56. Remove the J2 Connector from the printed circuit board. Connect the other test lead to Wire 56 at J2. CONTINUITY should be measured. If CONTINUITY is not measured, repair or replace Wire 56.

RESULTS:

1. If battery voltage is indicated in Step 3 refer back to flow chart.

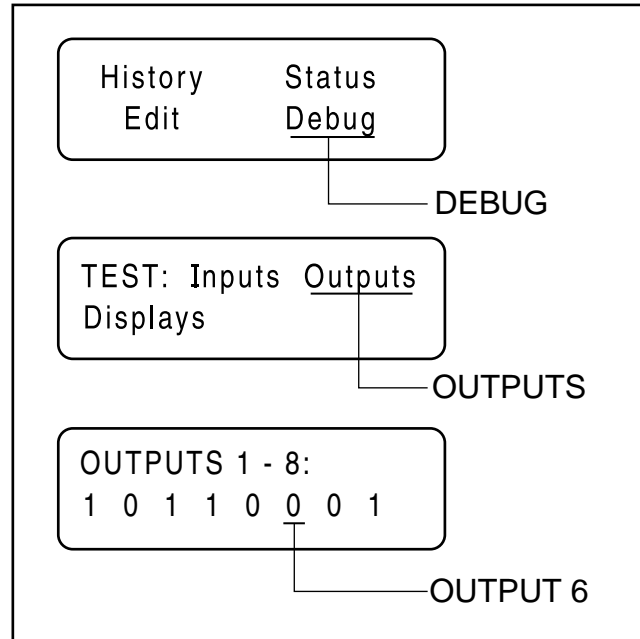

Figure 6. The Home Page, Debug and Output Screens

TEST 63 – TEST STARTER CONTACTOR RELAY (V-TWIN ONLY)

DISCUSSION:

The starter contactor relay (SCR) located in the control panel must be energized for cranking to occur. Once the SCR is energized, it's normally open contacts will close and battery voltage will be available to Wire 16 and to the starter contactor (SC).

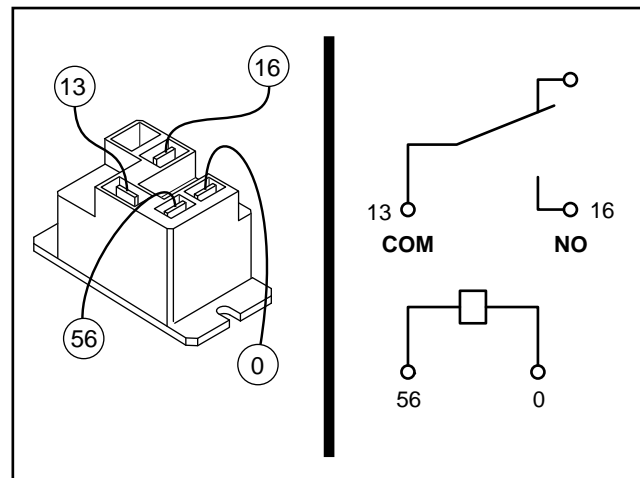

Figure 7. The Starter Contactor Relay

PROCEDURE:

1. Set a VOM to measure DC voltage.
2. Remove Wire 13 from the Starter Contactor Relay located under the printed circuit board.
3. Connect the positive (+) meter test lead to the Wire 13 connector. Connect the negative (-) meter test lead to a clean frame ground. Battery voltage should be measured.
4. Reconnect Wire 13 to the SCR.
5. Remove Wire 16 from the SCR. Connect the positive (+) meter test lead to the SCR terminal from which Wire 16 was removed. Connect the negative (-) meter test lead to a clean frame ground.
6. Set the AUTO-OFF-MANUAL switch to MANUAL. Observe the meter reading. Battery voltage should be measured. If battery voltage is not measured, proceed to Step 7.
7. Set the VOM to measure resistance.
8. Remove Wire 0 from the SCR. Connect the positive (+) meter test lead to the disconnected Wire 0. Connect the negative (-) meter test lead to a clean frame ground. CONTINUITY should be measured.

RESULTS:

1. If battery voltage is not measured in Step 3, repair or replace wiring between the starter contactor relay and the starter solenoid.
2. If battery voltage is not measured in Step 6 and CONTINUITY is measured in Step 8, replace the starter contactor relay.
3. If battery voltage is measured in Step 6 refer back to flow chart.

TEST 64 – TEST STARTER CONTACTOR (SINGLE CYLINDER ENGINE)

DISCUSSION:

The starter contactor (SC) must energize and its heavy duty contacts must close or the engine will not crank. This test will determine if the starter contactor is in working order.

PROCEDURE:

Carefully inspect the starter motor cable that runs from the battery to the starter motor. Cable connections must be clean and tight. If connections are dirty or corroded, remove the cable and clean cable terminals and terminal studs. Replace any cable that is defective or badly corroded.

Use a DC voltmeter (or a VOM) to perform this test. Test the starter contactor as follows:

1. Connect the positive (+) meter test lead to the starter contactor stud (to which the red battery cable connects). Connect the common (-) meter test lead to a clean frame ground. Battery voltage (12 VDC) should be indicated.
2. Connect the positive (+) meter test lead to the starter contactor stud to which the starter motor cable attaches (see Figure 8 or Figure 9). Connect the common (-) test lead to frame ground.
 - a. No voltage should be indicated initially.
 - b. Set the AUTO-OFF-MANUAL switch to MANUAL. The meter should now indicate battery voltage as the starter contactor energizes.

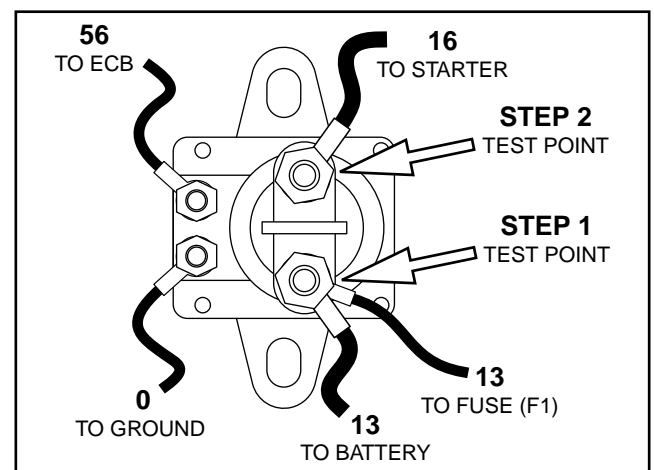

Figure 8. The Starter Contactor (Single Cylinder Units)

RESULTS:

1. If battery voltage was indicated in Step 1, but NOT in Step 2b, replace the starter contactor.
2. If battery voltage was indicated in Step 2b, but the engine did NOT crank, refer back to flow chart.

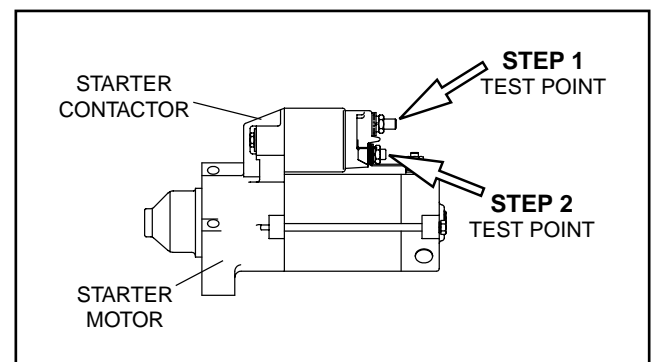

Figure 9. The Starter Contactor (V-twin Units)

TEST 65 – TEST STARTER MOTOR

CONDITIONS AFFECTING STARTER MOTOR PERFORMANCE:

1. A binding or seizing condition in the starter motor bearings.
2. A shorted, open or grounded armature.
 - a. Shorted armature (wire insulation worn and wires touching one another). Will be indicated by low or no RPM.
 - b. Open armature (wire broken) will be indicated by low or no RPM and excessive current draw.
 - c. Grounded armature (wire insulation worn and wire touching armature lamination or shaft). Will be indicated by excessive current draw or no RPM.
3. A defective starter motor switch.
4. Broken, damaged or weak magnets.
5. Starter drive dirty or binding.

DISCUSSION:

Test 62 verified that circuit board action is delivering DC voltage to the starter contactor relay (SCR). Test 63 verified the operation of the SCR. Test 64 verified the operation of the starter contactor (SC). Another possible cause of an “engine won’t crank” problem is a failure of the starter motor.

PROCEDURE:

The battery should have been checked prior to this test and should be fully charged.

Set a VOM to measure DC voltage (12 VDC). Connect the meter positive (+) test lead to the starter contactor stud which has the small jumper wire connected to the starter. Connect the common (-) test lead to the starter motor frame.

Set the AUTO-OFF MANUAL Switch to its “MANUAL” position and observe the meter. Meter should indicate battery voltage, starter motor should operate and engine should crank.

RESULTS:

1. If battery voltage is indicated on the meter but starter motor did NOT operate, remove and bench test the starter motor (see following test).
2. If battery voltage was indicated and the starter motor tried to engage (pinion engaged), but engine did NOT crank, check for mechanical binding of the engine or rotor.

If engine turns over slightly, go to Test 77 “Check and Adjust Valves.”

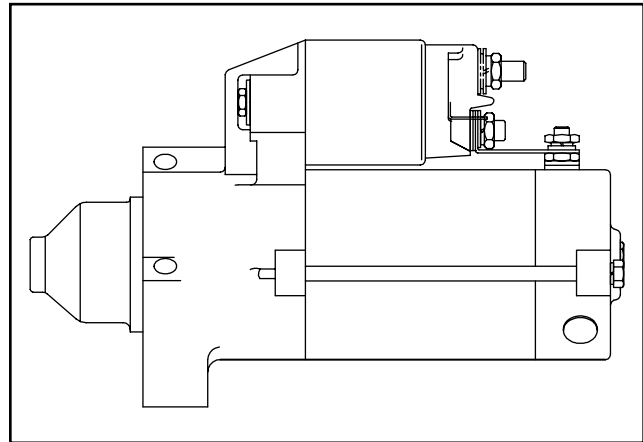

Figure 10. Starter Motor (V-Twin Engines)

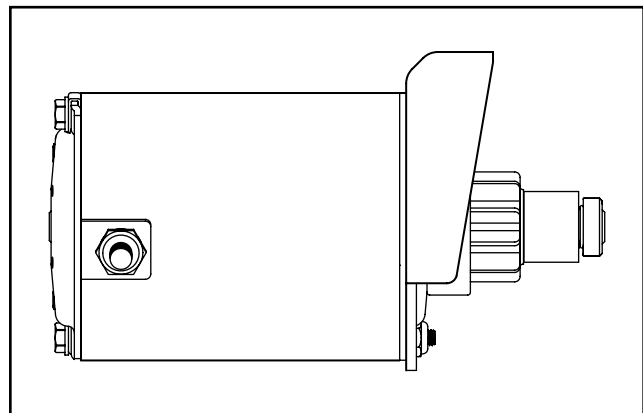

Figure 11. Starter Motor (Single Cylinder Engines)

CHECKING THE PINION:

When the starter motor is activated, the pinion gear should move and engage the flywheel ring gear. If the pinion does not move normally, inspect the pinion for binding or sticking.

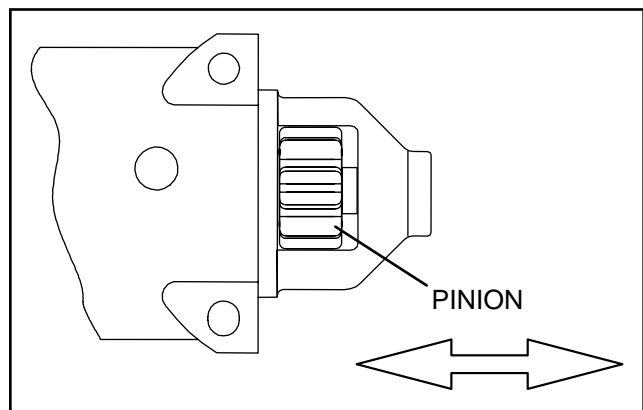

Figure 12. Check Pinion Gear Operation (V-Twin)

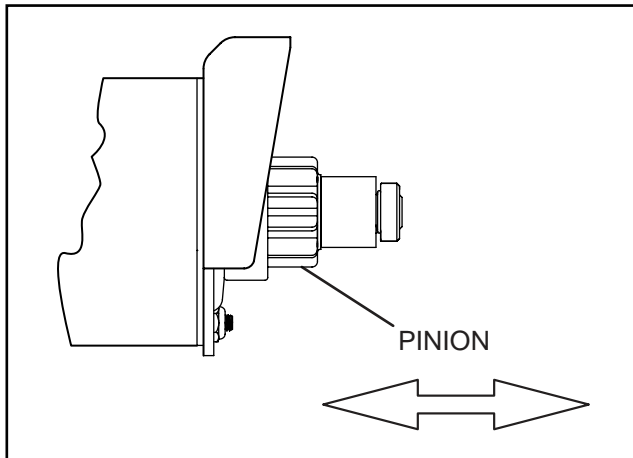

Figure 13. Check Pinion Gear Operation
(Single Cylinder)

TOOLS FOR STARTER PERFORMANCE TEST:

The following equipment may be used to complete a performance test of the starter motor:

- A clamp-on ammeter.
- A tachometer capable of reading up to 10,000 rpm.
- A fully charged 12 volt battery.

MEASURING CURRENT:

To read the current flow, in AMPERES, a clamp-on ammeter may be used. This type of meter indicates current flow through a conductor by measuring the strength of the magnetic field around that conductor.

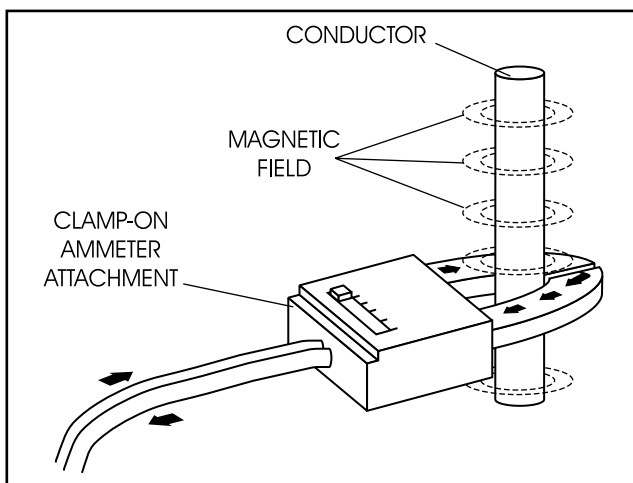

Figure 14. Clamp-On Ammeter

TACHOMETER:

A tachometer is available from your parts source. The tachometer measures from 800 to 50,000 rpm, (see Figure 15).

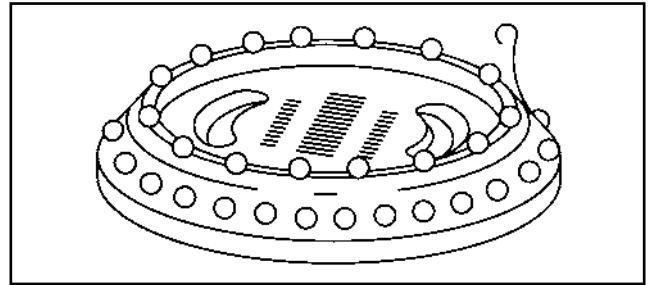

Figure 15. Tachometer

TEST BRACKET:

A starter motor test bracket may be made as shown in Figure 16. A growler or armature tester is available from an automobile diagnostic service supplier.

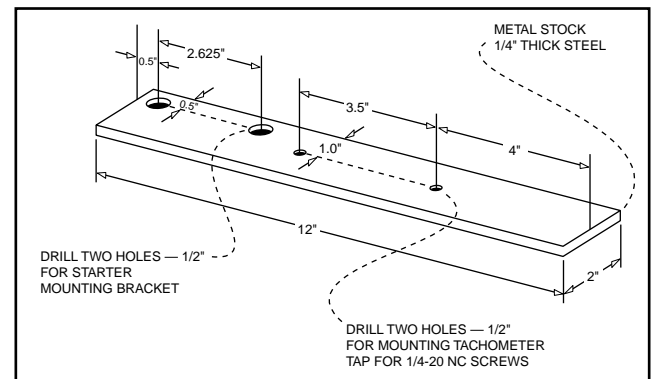

Figure 16. Test Bracket

REMOVE STARTER MOTOR:

It is recommended that the starter motor be removed from the engine when testing starter motor performance. Assemble starter to test bracket and clamp test bracket in vise, Figure 17.

TESTING STARTER MOTOR:

1. A fully charged 12 volt battery is required.
2. Connect jumper cables and clamp-on ammeter as shown in Figure 17.
3. With the starter motor activated (jump the terminal on the starter contactor to battery voltage), note the reading on the clamp-on ammeter and on the tachometer (rpm).

Note: Take the reading after the ammeter and tachometer are stabilized, approximately 2-4 seconds.

4. A starter motor in good condition will be within the following specifications:

	V-twin	Single Cylinder
Minimum rpm	3250	4500
Maximum Amps	62	9

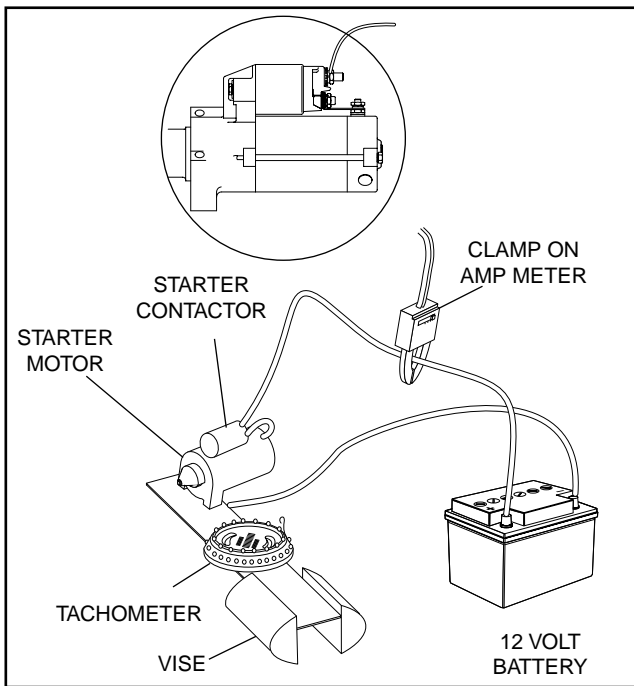

Figure 17. Testing Starter Motor Performance

TEST 66 – CHECK FUEL SUPPLY AND PRESSURE

DISCUSSION:

The air-cooled generator was factory tested and adjusted using natural gas as a fuel. If desired, LP (propane) gas may be used. However, when converting to propane, some minor adjustments are required. The following facts apply:

- An adequate gas supply and sufficient fuel pressure must be available or the engine will not start.
- Minimum recommended gaseous fuel pressure at the generator fuel inlet connection is 5 inches water column for natural gas (NG) or 10 inches water column for LP gas.
- Maximum gaseous fuel pressure at the generator fuel inlet connection is 7 inches water column for natural gas or 12 inches water column for LP gas.
- When propane gas is used, only a “vapor withdrawal” system may be used. This type of system utilizes the gas that forms above the liquid fuel. The vapor pressure must be high enough to ensure engine operation.
- The gaseous fuel system must be properly tested for leaks following installation and periodically thereafter. No leakage is permitted. Leak test methods must comply strictly with gas codes.



DANGER: GASEOUS FUELS ARE HIGHLY EXPLOSIVE. DO NOT USE FLAME OR HEAT TO TEST THE FUEL SYSTEM FOR LEAKS. NATURAL GAS IS LIGHTER THAN AIR, AND

TENDS TO SETTLE IN HIGH PLACES. LP (PROPANE) GAS IS HEAVIER THAN AIR, AND TENDS TO SETTLE IN LOW AREAS. EVEN THE SLIGHTEST SPARK CAN IGNITE THESE GASES AND CAUSE AN EXPLOSION.

PROCEDURE:

A water manometer or a gauge that is calibrated in “ounces per square inch” may be used to measure the fuel pressure. Fuel pressure at the inlet side of the fuel solenoid valve should be between 5-7 inches water column for natural gas (NG) or 10-12 inches water column for LP gas.

1. See Figures 18, 19 or 20 for the gas pressure test point on the fuel regulator. The fuel pressure can be checked at Port 1 on all fuel regulators, and at Port 3 on 12-20 kW units.
2. With the manometer connected properly, crank the engine. Nominal fuel pressure should be measured. If pressure is not measured while cranking refer back to flow chart.

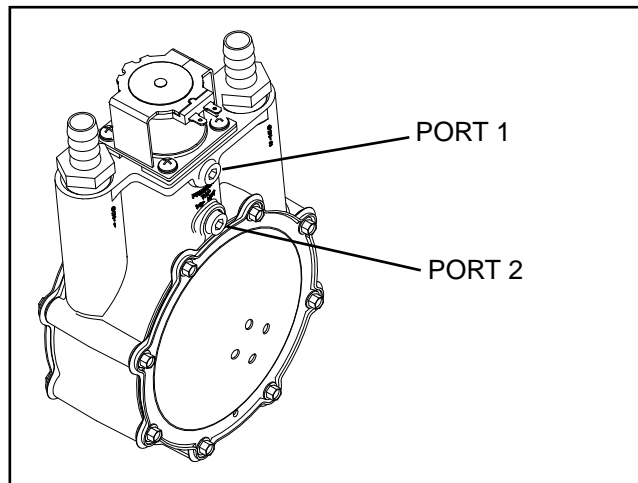

Figure 18 (8 kW) Gas Pressure Test point

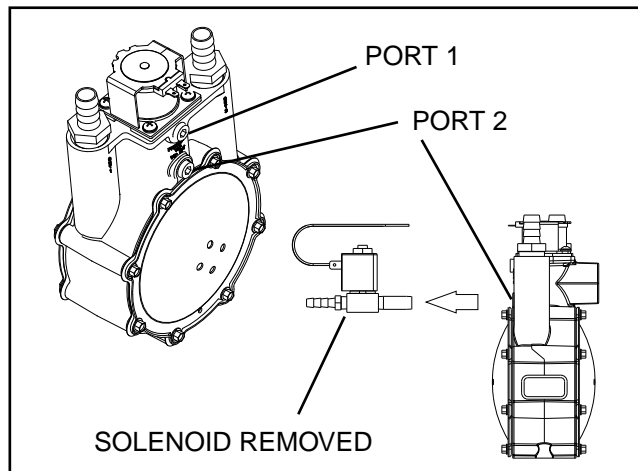

Figure 19 (10 kW) Gas Pressure Test point

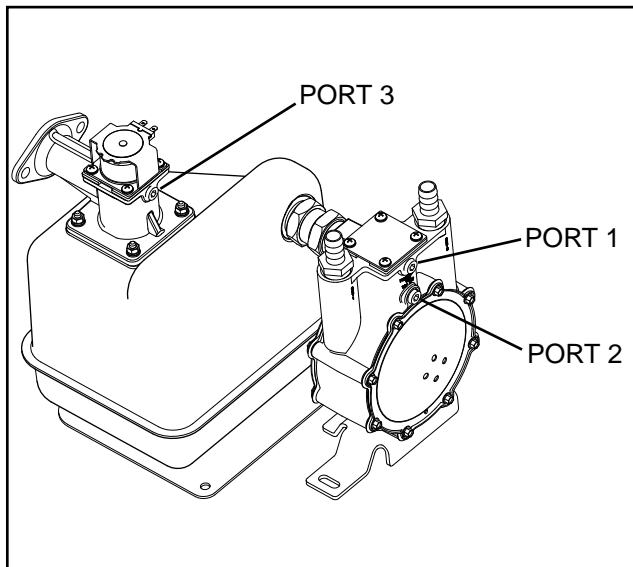

Figure 20 (12-20 kW) Gas Pressure Test point

Note: Where a primary regulator is used to establish fuel inlet pressure, adjustment of that regulator is usually the responsibility of the fuel supplier or the fuel supply system installer.

12-20 kW UNITS ONLY:

Note: The test port (Port 3) below the fuel solenoid maybe used to take a fuel pressure reading before the fuel solenoid. Consistent pressure should be measured at this port while the generator is running and when the generator is off.

RESULTS:

1. If fuel supply and pressure are adequate, but engine will not start refer back to flow chart.
2. If generator starts but runs rough or lacks power, repeat the above procedure with the generator running and under load. The fuel system must be able to maintain 10-12 inches water column at all load requirements for propane, and 5-7 inches water column for natural gas. If proper fuel supply and pressure is maintained, refer to Problem 18 Flow Chart.

TEST 67 – CHECK CIRCUIT BOARD WIRE 14 OUTPUT

DISCUSSION:

During any cranking action, the circuit board's crank relay and run relay both energize simultaneously. When the run relay energizes, it's contacts close and 12 VDC is delivered to Wire 14 and to a fuel solenoid. The solenoid energizes open to allow fuel flow to the engine. This test will determine if the circuit board is working properly.

PROCEDURE: 12-20 kW UNITS

1. Set the AUTO-OFF-MANUAL switch to OFF.
2. Set a VOM to measure DC voltage.
3. Disconnect Wire 14 from the fuel solenoid (FS).
4. Connect the positive test lead to the disconnected Wire 14 from Step 3. Connect the negative test lead to a clean frame ground.
5. Set AUTO-OFF-MANUAL switch to the MANUAL position. The meter should indicate battery voltage.
 - a. If battery voltage is indicated, refer back to flow chart.
 - b. If battery voltage is not measured, navigate to the Digital Output display.
 - c. Press "ESC" until the display screen is present.
 - d. Press the right arrow key until "Debug" is flashing. Press "Enter".
 - e. Press the right arrow key until "Outputs" is flashing. Press "Enter".

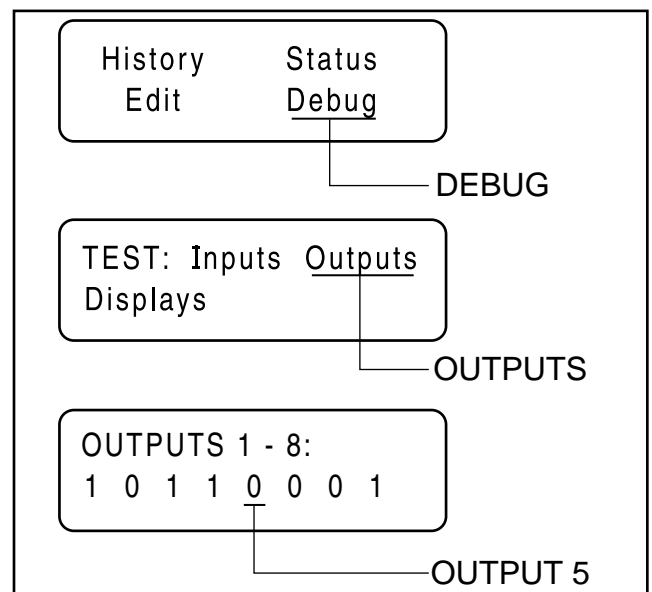

Figure 21. The Home Page, Debug and Output Screens

- f. Output 5 is Wire 14 out from the printed circuit board. If the printed circuit board is functioning properly, Output 5 will change from a "0" to a "1" while the unit is cranking.
- g. If voltage was not measured in Step 5 and output did not change in Step 5f, replace the printed circuit board.

Note: Disconnect the 7.5 amp Fuse before disconnecting the J2 connector.

- h. If voltage was not measured in Step 5 and output changed in Step 5f, remove the J1 connector from the printed circuit board. See Figures on Pages 92-95.

SECTION 4.4 DIAGNOSTIC TESTS

PART 4

DC CONTROL

- i. Set a VOM to measure resistance.
- j. Connect one meter test lead to Wire 14 that was disconnected in Step 3.
- k. Connect the other meter test lead to Wire 14 at J2-3. See Figures on Pages 92-95.
- l. CONTINUITY should be measured. If CONTINUITY is measured, repeat Step 5 and then retest.
- m. If CONTINUITY is not measured, repair or replace Wire 14 between the J2 Connector and the fuel solenoid.

PROCEDURE: 8 kW UNITS

1. Set AUTO-OFF-MANUAL switch to OFF.
 2. Set a VOM to measure DC voltage.
 3. Disconnect Wire 14 from the fuel solenoid.
 4. Connect the positive test lead to disconnected Wire 14 and the negative test lead to a clean frame ground.
 5. Set the AUTO-OFF-MANUAL switch to the MANUAL position.
 6. Battery voltage should be measured. If battery voltage is measured, refer back to flow chart.
- Note: Disconnect the 7.5 amp fuse before disconnecting the J2 connector.**
7. Disconnect the J2 connector from printed circuit board.
 8. Set VOM to measure resistance.
 9. Connect the positive test lead to disconnected Wire 14 and the negative test lead to J2 Pin 3.
 10. CONTINUITY should be measured. If CONTINUITY is not measured, repair or replace Wire 14 between J2 Pin 3 and the fuel solenoid.

RESULTS:

Refer to flow chart.

TEST 68 – CHECK FUEL SOLENOID

DISCUSSION:

In Test 67, if battery voltage was delivered to Wire 14, the fuel solenoid should have energized open. This test will verify whether or not the fuel solenoid is operating.

Fuel Solenoid FS1 Nominal Resistance – 27-33 ohms.

Fuel Solenoid FS2 Nominal Resistance – 29 ohms.

PROCEDURE: 8 AND 12-20 kW UNITS

1. Install a manometer to Port 2 on the fuel regulator. See Figure 18 or Figure 20.
2. Set the AUTO-OFF-MANUAL Switch to MANUAL.
3. Proper gas pressure should be measured during cranking.

If gas pressure is measured, the fuel solenoid is operating. If gas pressure is not measured, repair or replace the fuel solenoid.

PROCEDURE: 10 kW UNITS

1. Remove the hose from fuel solenoid (FS2) and install a manometer to Port 2 on the fuel regulator. See Figure 19.
2. Set the AUTO-OFF-MANUAL Switch to MANUAL.
3. Proper gas pressure should be measured during cranking. If gas pressure is measured, both fuel solenoids are operating. Discontinue testing.
4. If gas pressure was not measured in Step 3, remove fuel solenoid FS2 and install a manometer to the bottom port of the fuel regulator.
5. Set the AUTO-OFF-MANUAL Switch to MANUAL.
6. Proper gas pressure should be measured during cranking. If gas pressure is measured, fuel solenoid FS1 is operating. Replace fuel solenoid FS2. If gas pressure is not measured, repair or replace fuel solenoid FS1.

RESULTS:

Refer to flow chart.

TEST 69 – CHECK CHOKE SOLENOID

DISCUSSION:

The automatic choke is active cyclically during cranking and energized ON during running. For low speed exercise the choke will be closed.

The 12-20 kW units utilize a plate that covers the throttle bores. The choke is closed if the solenoid is not energized.

The 10 kW unit utilizes a throttle plate located in the choke housing and the choke is open when the solenoid is de-energized.

The 8 kW unit has a choke solenoid that is closed during the entire crank cycle when the solenoid is energized and the engine is cranking.

PROCEDURE: 10-20 kW UNITS

1. **Operational Check:** Set the AUTO-OFF-MANUAL Switch to MANUAL. While cranking, the choke solenoid should pull the choke plate open cyclically. The duration of the cycle will vary depending on it's position in the crank cycle sequence. Refer to the Crank Cycle Sequence Table on the following page for crank cycle sequences and duration times. If the choke solenoid does not pull in, verify that the choke can be manually opened. There should be no binding or interference.
2. Disconnect the C3 Connector.

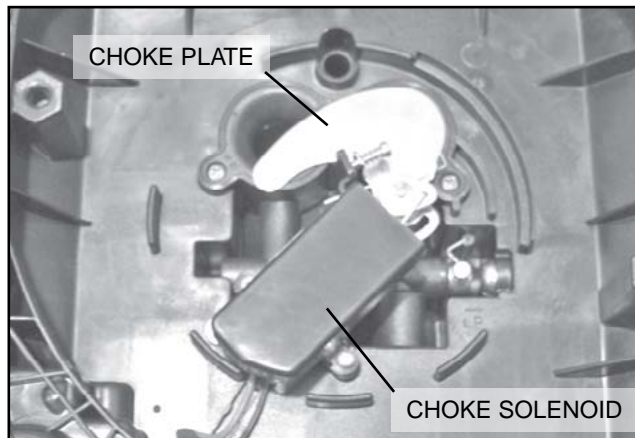

Figure 22. Solenoid De-Energized, Choke Closed
12-20 kW Units

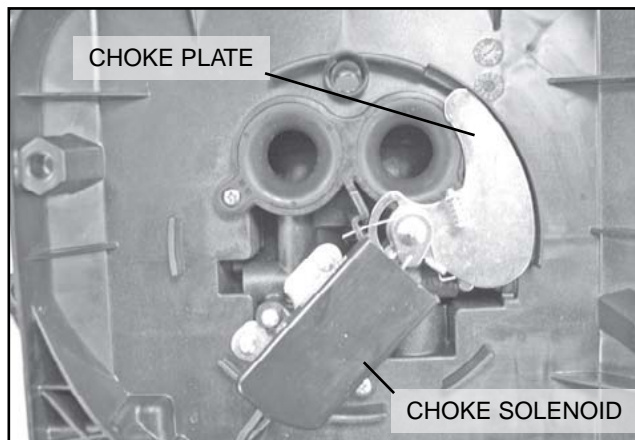

Figure 23. Solenoid Energized, Choke Open
12-20 kW Units

3. Set a VOM to measure DC voltage.
4. Connect the positive (+) test lead to Wire 14 (Pin 1) of the C3 Connector going to the control panel (Female Side). Connect the negative (-) test lead to Wire 90 (Pin 2).
5. Set the AUTO-OFF-MANUAL Switch to MANUAL. While cranking, battery voltage should be measured cyclically. If battery voltage was not measured, verify continuity of Wire 90 between the C3 Connector and the printed circuit board J1 Connector, Pin Location J1-23. Verify continuity of Wire 14 between the C3 Connector and J2 connector Pin Location J2-3. Repair or replace any wiring as needed.
6. Disconnect C3 Connector. Set a VOM to measure resistance. Connect the positive (+) test lead to Wire 14 (Pin 1) of C3 Connector going to the choke solenoid (Male Side). Connect the negative (-) test lead to Wire 90 (Pin 2). Approximately 3.7 ohms should be measured.

7. With the generator running at a speed of approximately 60 Hertz, verify that the choke is energized and holding the choke plate open. Repeat Step 2 procedure, however, once the unit starts, manually hold the choke open while taking the voltage measurement.

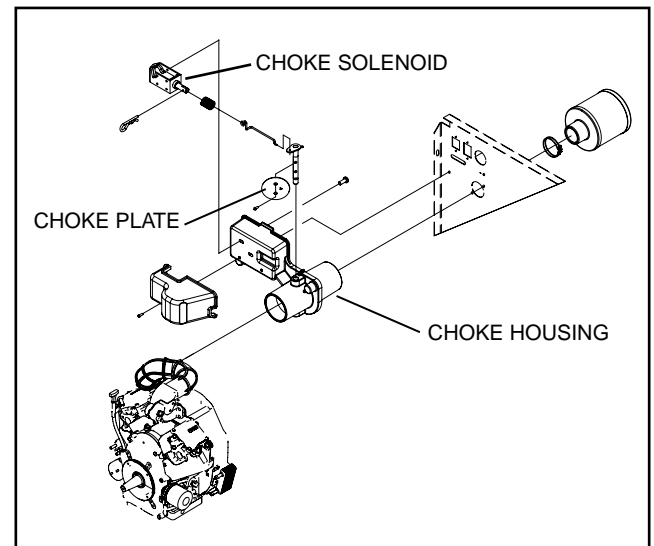

Figure 24. Exploded View Showing Location of Choke Plate - 10 kW Units

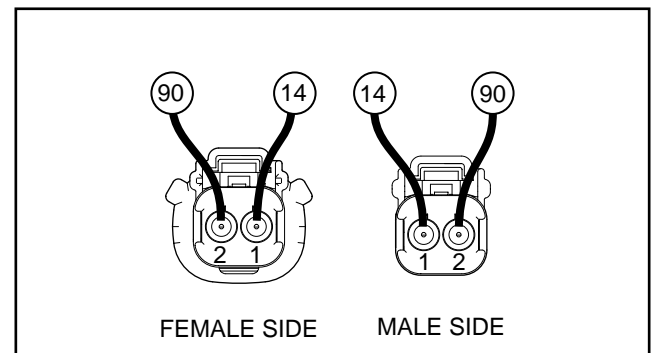

Figure 25. C3 Choke Solenoid Connector

RESULTS:

1. If Battery voltage was not measured in Step 5 and wire continuity is good, replace the printed circuit board.
2. If Choke Solenoid coil resistance is not measured in Step 6, replace the Choke Solenoid.

PROCEDURE: 8 kW UNITS

1. **Operational Check:** Set the AUTO-OFF-MANUAL Switch to MANUAL. While cranking the choke solenoid should energize and pull the choke plate closed. If the choke solenoid does not pull in, verify that the choke can be manually closed. There should be no binding or interference.

SECTION 4.4 DIAGNOSTIC TESTS

PART 4

DC CONTROL

2. Disconnect the C3 Connector.
3. Set a VOM to measure DC voltage.
4. Connect the positive (+) test lead to Wire 56 (Pin 1) of C3 Connector going to the control panel (Female Side) Connect the negative (-) test lead to Wire 0 (Pin 2).
5. Set the AUTO-OFF-MANUAL Switch to MANUAL. While cranking, battery voltage should be measured. If battery voltage was not measured, verify continuity of Wire 0 between C3 Connector and a clean frame ground. Verify continuity of Wire 56 between the C3 Connector and Wire 56 connector and J2 Connector Pin Location J2-11. Repair or replace any wiring as needed.
6. Disconnect C3 Connector.
7. Set a VOM to measure resistance.
8. Connect the positive (+) test lead to Wire 56 (Pin 1) of C3 Connector going to the choke solenoid (Male Side). Connect the negative (-) test lead to Wire 0 (Pin 2). Approximately 3.7 ohms should be measured.

RESULTS:

1. If Battery voltage was not measured in Step 5 and wire continuity is good, replace the printed circuit board.

2. If Choke Solenoid coil resistance is not measured in Step 8, replace the Choke Solenoid.
3. If battery voltage was not measured in Step 4, replace the printed circuit board.

TEST 70 – CHECK FOR IGNITION SPARK

DISCUSSION:

If the engine cranks but will not start, perhaps an ignition system failure has occurred. A special “spark tester” can be used to check for ignition spark.

PROCEDURE:

1. Remove spark plug leads from the spark plugs (Figure 28).
2. Attach the clamp of the spark tester to the engine cylinder head.
3. Attach the spark plug lead to the spark tester terminal.
4. Crank the engine while observing the spark tester. If spark jumps the tester gap, you may assume the engine ignition system is operating satisfactorily.

NOTE: The engine flywheel must rotate at 350 rpm (or higher) to obtain a good test of the solid state ignition system.

Crank Cycle Sequence Table																
1=CHOKED 0=OPEN	Note: The first second of each crank cycle is equal to two (2) revolutions of the engine.															
	Seconds															
Crank Cycle 1	1	2	3	4	5	6	7	8	9	10	11	12	13	14	15	16
10 kW	0	0	0	0	1	0	0	0	0	1	1	0	0	0	0	0
12 kW-20 kW	0	1	1	0	0	1	1	1	0	0	0	1	1	1	1	1
Crank Cycle 2	Seconds															
10 kW	0	0	0	0	1	0	0	0	0	1	1	0	0	0	0	0
12 kW-20 kW	0	1	1	0	0	0	0	0	0	0	0	1	1	1	1	1
Crank Cycle 3	Seconds															
10 kW	0	1	1	1	1	0	0									
12 kW-20 kW	0	0	1	1	1	1	1									
Crank Cycle 4	Seconds															
10 kW	0	1	0	0	0	0	0									
12 kW-20 kW	0	1	0	0	0	0	0									
Crank Cycle 5	Seconds															
10 kW	0	1	1	1	1	0	0									
12 kW-20 kW	0	1	0	0	0	0	1									

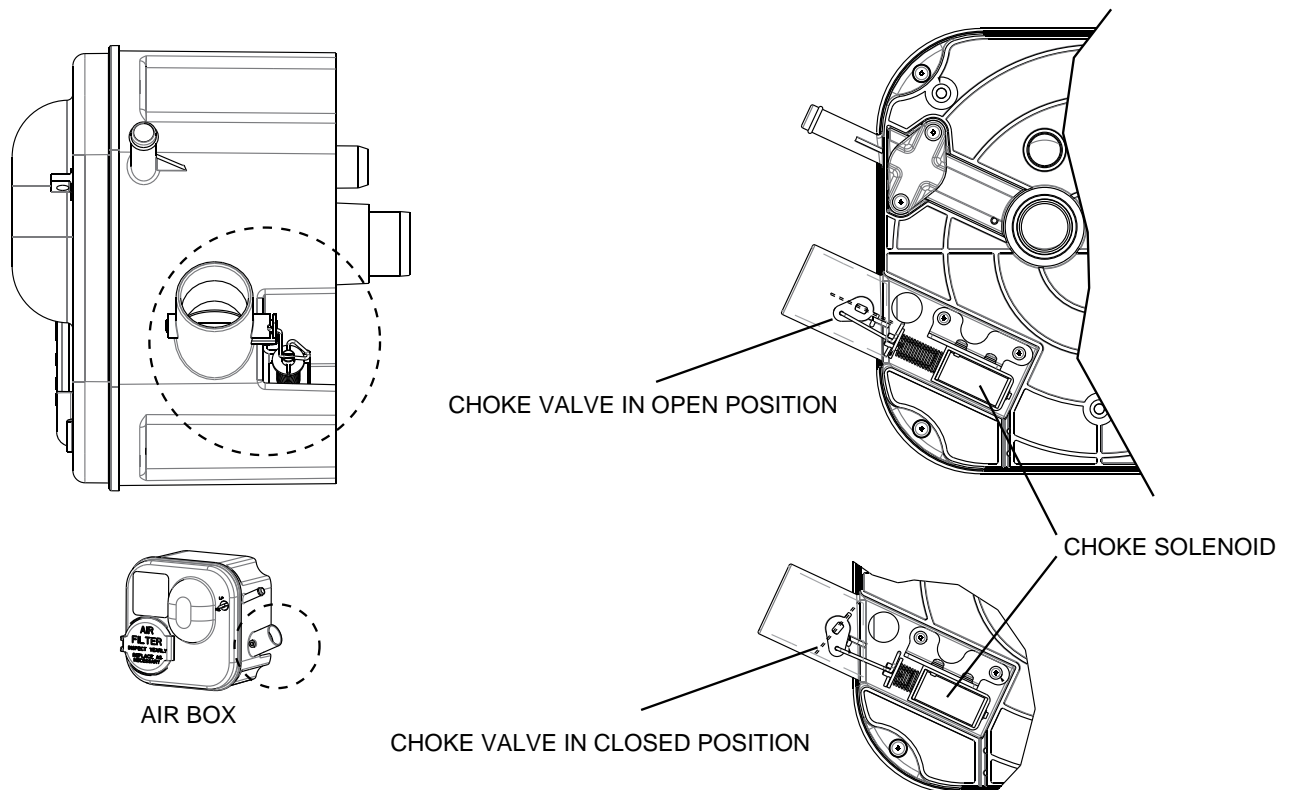

Figure 26. 8kW Choke Solenoid



Figure 27. Spark Tester



Figure 28. Checking Ignition Spark

To determine if an engine miss is ignition related, connect the spark tester in series with the spark plug wire and the spark plug (Figure 29). Then, crank and start the engine. A spark miss will be readily apparent. If spark jumps the spark tester gap regularly but the engine miss continues, the problem is in the spark plug or in the fuel system.

NOTE: A sheared flywheel key may change ignition timing but sparking will still occur across the spark tester gap.



Figure 29. Checking Engine Miss

RESULTS:

1. If no spark or very weak spark occurs, go to Test 73.
2. If sparking occurs but engine still won't start, go to Test 71.
3. When checking for engine miss, if sparking occurs at regular intervals but engine miss continues, go to Test 20.
4. When checking for engine miss, if a spark miss is readily apparent, go to Test 74.

TEST 71 – CHECK SPARK PLUGS

DISCUSSION:

If the engine will not start and Test 70 indicated good ignition spark, perhaps the spark plug(s) are fouled or otherwise damaged. Engine miss may also be caused by defective spark plug(s).

PROCEDURE:

1. Remove spark plugs and clean with a penknife or use a wire brush and solvent.
2. Replace any spark plug having burned electrodes or cracked porcelain.
3. Set gap on new or used spark plugs as follows:

Engine Size	kW Rating	Plug Gap	Recommended Plug
410 cc	8 kW	0.030 inch	RC14YC
530 cc	10 kW	0.030 inch	BPR6HS
990 cc	10-17 kW	0.040 inch	RC14YC
999 cc	20 kW	0.030 inch	RC12YC

RESULTS:

1. Clean, re-gap or replace spark plugs as necessary.
2. If spark plugs are good, refer back to flow chart.

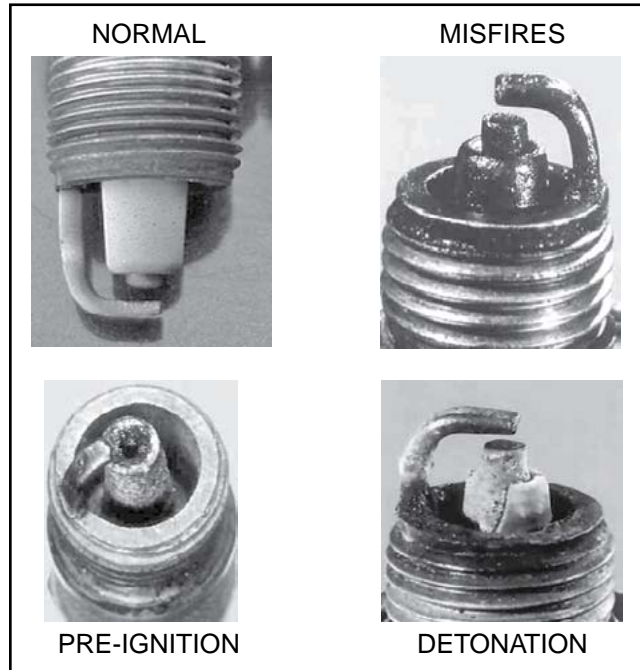

Figure 30. Spark Plug Conditions

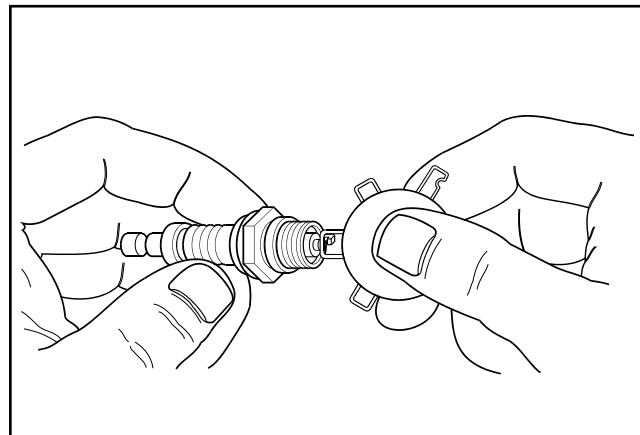

Figure 31. Checking Spark Plug Gap

**TEST 72 – CHECK ENGINE / CYLINDER LEAK
DOWN TEST / COMPRESSION TEST**

GENERAL:

Most engine problems may be classified as one or a combination of the following:

- Will not start
- Starts hard
- Lack of power
- Runs rough
- Vibration
- Overheating
- High oil consumption

DISCUSSION:

The Cylinder Leak Down Tester checks the sealing (compression) ability of the engine by measuring air leakage from the combustion chamber. Compression loss can present many different symptoms. This test is designed to detect the section of the engine where the fault lies before disassembling the engine.

PROCEDURE:

1. Remove a spark plug.
2. Gain access to the flywheel. Remove the valve cover.
3. Rotate the engine crankshaft until the piston reaches top dead center (TDC). Both valves should be closed.
4. Lock the flywheel at top dead center.
5. Attach cylinder leak down tester adapter to spark plug hole.
6. Connect an air source of at least 90 psi to the leak down tester.
7. Adjust the regulated pressure on the gauge to 80 psi.
8. Read the right hand gauge on the tester for cylinder pressure. 20 percent leakage is normally acceptable. Use good judgement, and listen for air escaping at the carburetor, the exhaust, and the crankcase breather. This will determine where the fault lies.
9. Repeat Steps 1 through 8 on remaining cylinder.

RESULTS:

- Air escapes at the carburetor – check intake valve.
- Air escapes through the exhaust – check exhaust valve.
- Air escapes through the breather – check piston rings.
- Air escapes from the cylinder head – the head gasket should be replaced.

CHECK COMPRESSION:

Lost or reduced engine compression can result in (a) failure of the engine to start, or (b) rough operation. One or more of the following will usually cause loss of compression:

- Blown or leaking cylinder head gasket
- Improperly seated or sticking-valves
- Worn Piston rings or cylinder. (This will also result in high oil consumption)

NOTE: For the single cylinder engine, the minimum allowable compression pressure for a cold engine is 60 psi.

NOTE: It is extremely difficult to obtain an accurate compression reading without special equipment. For that reason, compression values are not published for the V-Twin engine. Testing has proven that an accurate compression indication can be obtained using the following method.

PROCEDURE:

1. Remove both spark plugs.
2. Insert a compression gauge into either cylinder.
3. Crank the engine until there is no further increase in pressure.
4. Record the highest reading obtained.
5. Repeat the procedure for the remaining cylinder and record the highest reading.

RESULTS:

The difference in pressure between the two cylinders should not exceed 25 percent. If the difference is greater than 25 percent, loss of compression in the lowest reading cylinder is indicated.

Example 1: If the pressure reading of cylinder #1 is 165 psi and of cylinder #2, 160 psi, the difference is 5 psi. Divide "5" by the highest reading (165) to obtain the percentage of 3.0 percent.

Example 2: No. 1 cylinder reads 160 psi; No. 2 cylinder reads 100 psi. The difference is 60 psi. Divide "60" by "160" to obtain "37.5" percent. Loss of compression in No. 2 cylinder is indicated.

If compression is poor, look for one or more of the following causes:

- Loose cylinder head bolts
- Failed cylinder head gasket
- Burned valves or valve seats
- Insufficient valve clearance
- Warped cylinder head
- Warped valve stem
- Worn or broken piston ring(s)
- Worn or damaged cylinder bore
- Broken connecting rod
- Worn valve seats or valves
- Worn valve guides

NOTE: Refer to Engine Service manual for further engine service information.

TEST 73 – CHECK SHUTDOWN WIREDISCUSSION:

Circuit board action during shutdown will ground Wire 18. Wire 18 is connected to the Ignition Magneto(s). The grounded magneto will not be able to produce spark.

PROCEDURE:

1. On V-twin generators, remove Wire 18 from the stud located above the oil cooler. On single cylinder generators, disconnect Wire 18 at the bullet connector. See Figures 32 or 33.

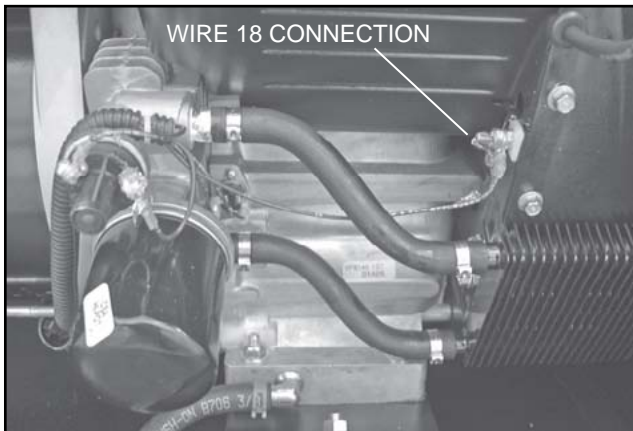

Figure 32. Wire 18 Connection 10-20 kW Units

2. Depending on engine type, do the following:
 - a. On V-twin units, remove Wire 56 from the Starter Contactor Relay (SCR). Using a jumper lead, jump 12 VDC from Wire 15B at TB1 (Customer Connection) to the terminal on the SCR from which Wire 56 was removed. The generator will start cranking. As it is cranking, repeat Test 70. Reconnect Wire 56 when done.
 - b. On single cylinder units, connect a jumper lead from the stud to which Wire 56 is connected on the Starter Contactor (SC) and 12 VDC Wire 15B at TB1 (Customer Connection). The generator will start cranking. As it is cranking, repeat Test 70.

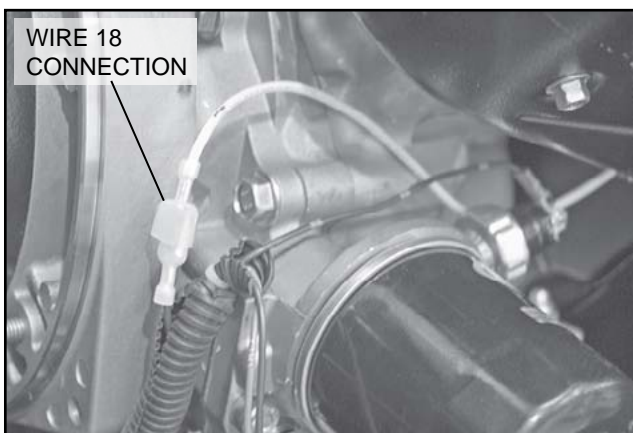

Figure 33. Wire 18 Connection 8 kW Units

3. If spark now occurs with Wire 18 removed, check for a short to ground. Remove the J1 Connector from the circuit board.
4. Set a VOM to measure resistance. Connect one test lead to Wire 18 (disconnected in Step 1). Connect the other test lead to a clean frame ground. INFINITY should be measured.
5. Reconnect the J1 Connector to the circuit board.

RESULTS:

1. If INFINITY was not measured in Step 4, repair or replace shorted ground Wire 18 between the J1 Connector from the circuit board to the stud or bullet connector.
2. If INFINITY was measured in Step 4, replace the circuit board and retest for spark.
3. If ignition spark still has not occurred, proceed to Test 74.

TEST 74 – CHECK AND ADJUST IGNITION MAGNETOS

DISCUSSION:

In Test 70, a spark tester was used to check for engine ignition. If sparking or weak spark occurred, one possible cause might be the ignition magneto(s). This test consists of checking ohm values across the primary and secondary windings of the magneto and adjusting the air gap between the ignition magneto(s) and the flywheel. The flywheel and flywheel key will also be checked during this test. A diode is installed before the primary winding inside the coil. This is done to inhibit a spark occurring on both magnetos at the same time.

PROCEDURE: TESTING MAGNETOS V-TWIN ONLY

1. Disconnect the J1 connector from the printed circuit board.
2. Disconnect spark plug wires from the spark plugs on cylinder one and two.
3. Set VOM to measure resistance.
4. Connect the positive (**red**) meter lead to the bolt connector where Wire 18 was disconnected in Step 1. Connect the negative (**black**) meter lead to a clean frame ground. A resistance of approximately 300K ±10K ohms should be measured. This reading is the primary winding of both coils in parallel.
5. Connect the positive meter lead to the spark plug wire and connect the negative meter lead to a clean frame ground. Approximately 14K ±3 ohms should be measured. This reading is the secondary winding of both coils in parallel. If INFINITY, or a low or high ohm reading is measured, replace the magnetos.
6. Connect the negative (black) meter lead to the bolt connector where Wire 18 was disconnected in Step 1. Connect the positive (red) meter lead to the spark plug wire on cylinder number two. The meter should indicate INFINITY. This step is testing the diodes in both magnetos to ensure they are still functioning.
7. Repeat Step 6 on cylinder two. If INFINITY is not measured, replace the magnetos.

Note: It is recommended to replace Magnetos in pairs.

PROCEDURE. ADJUSTING MAGNETO FLYWHEEL GAP:

Note: The air gap between the ignition magneto and the flywheel on single cylinder engines is not adjustable. Proceed directly to Step 10 for single cylinder engines. For V-twin engines, proceed as follows.

1. See Figure 34. Rotate the flywheel until the magnet is under the module (armature) laminations.
2. Place a 0.008-0.012 inch (0.20-0.30mm) thickness gauge between the flywheel magnet and the module laminations.

Note: A business card is approximately 0.010 inch thick.

3. Loosen the mounting screws and let the magnet pull the magneto down against the thickness gauge.
4. Tighten both mounting screws.
5. To remove the thickness gauge, rotate the flywheel.
6. Repeat the above procedure for the second magneto.



Figure 34. Setting Ignition Magneto (Armature) Air Gap

7. Repeat Test 70 and check for spark across the spark tester gap
 - a. A spark test may be conducted with unit disassembled by following this procedure.
 - b. Battery must be connected.
 - c. J2 Connector must be connected to the printed circuit board.
 - d. Remove Wire 56 from the SCR located beneath the printed circuit board.

Warning: Make sure all debris is cleared from the engine compartment and all body parts are clear from flywheel before proceeding.

- e. Refer to Test 70 to check for spark.
- f. Utilizing a jumper wire, connect a wire to the 15B terminal block. Connect the other end to

where Wire 56 was disconnected in Step 7. The engine should crank once the jumper from 15B is connected.

8. If spark was not indicated, replace magnetos.

Note: If gap is only adjusted, ensure to properly test the magnetos by cranking the engine over before reassembly occurs. Spark should be present on both cylinders before reassembly should be completed.

9. If air gap was not out of adjustment, test ground wires.
10. Set a VOM to the measure resistance.
11. Disconnect the engine wire harness from the ignition magnetos (Figure 35).
 - a. On V-twin generators, remove Wire 18 from the stud located above the oil cooler. See Figure 45.
 - b. On single cylinder generators, disconnect Wire 18 at the bullet connector. See Figure 44.

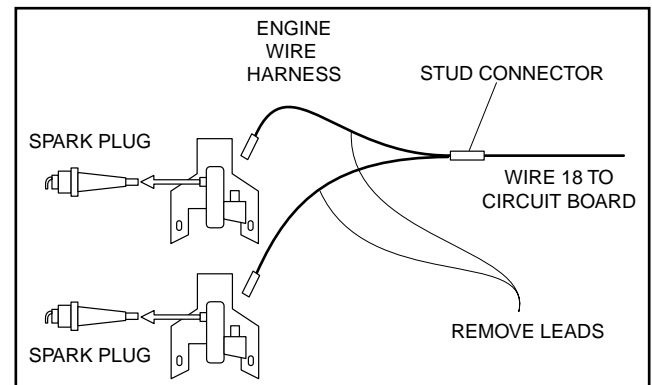

Figure 35. Engine Ground Harness

12. Connect one meter test lead to one of the wires removed from the ignition magneto(s). Connect the other test lead to frame ground. INFINITY should be measured. If CONTINUITY is measured, replace the shutdown harness.
13. Now check the flywheel magnet by holding a screwdriver at the extreme end of its handle and with its point down. When the tip of the screwdriver is moved to within 3/4 inch (19mm) of the magnet, the blade should be pulled in against the magnet.
14. For rough running or hard starting engines check the flywheel key. The flywheel's taper is locked on the crankshaft taper by the torque of the flywheel nut. A keyway is provided for alignment only and theoretically carries no load.

Note: If the flywheel key becomes sheared or even partially sheared, ignition timing can change. Incorrect timing can result in hard starting or failure to start.

15. As stated earlier, the armature air gap is fixed for single cylinder engine models and is not adjustable. Visually inspect the armature air gap and hold down bolts.

SECTION 4.4 DIAGNOSTIC TESTS

PART 4

DC CONTROL

RESULTS:

If sparking still does not occur after adjusting the armature air gap, testing the ground wires and performing the basic flywheel test, replace the ignition magneto(s).

PROCEDURE, REPLACING MAGNETOS:

1. Follow all steps of the Major Disassembly procedures that are located in Section 6.
2. Once the magnetos are visible, make note to how they are connected.

Note: Each magneto has its own part number. Verify the part number prior to installation.

3. Cylinder one is the back cylinder (Figure 36) and cylinder two is the front cylinder (Figure 37).

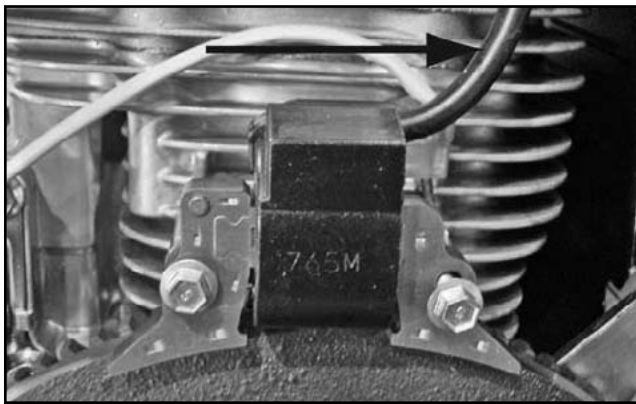

Figure 36. Cylinder One (Back, Short)

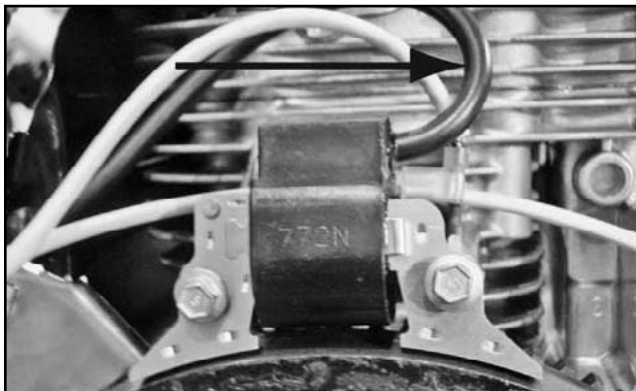

Figure 37. Cylinder Two (Front, Long)

4. When installing new magnetos there will be one with a short plug wire and one with a longer plug wire (Figure 38).

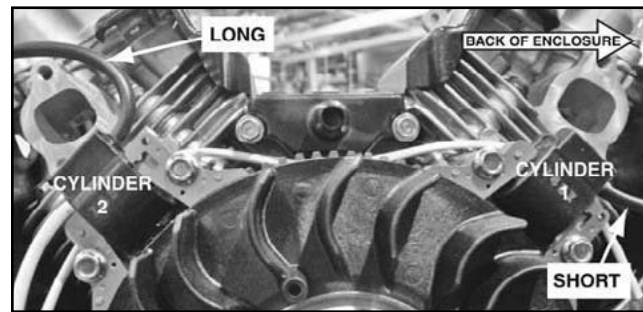

Figure 38.

Note: Magneto gap between flywheel needs to be 0.010 inch.

5. Long plug wire (B) will be installed on front cylinder number two.
6. Short plug Wire (A) will be installed on back cylinder number one.
7. Verify installation of magnetos correctly by ensuring both spark plug wires point to the back of the enclosure and shutdown terminals are nearest cylinder head as shown in Figures 39 and 40.

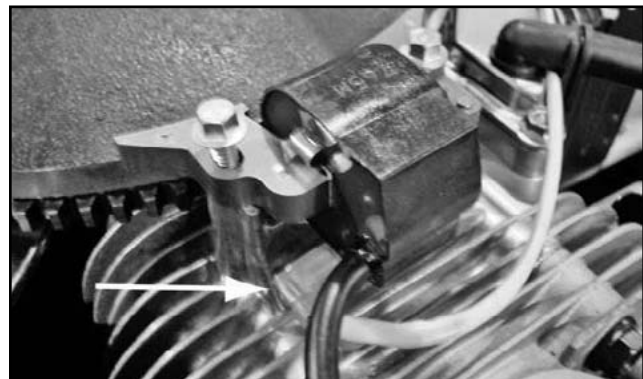

Figure 39.

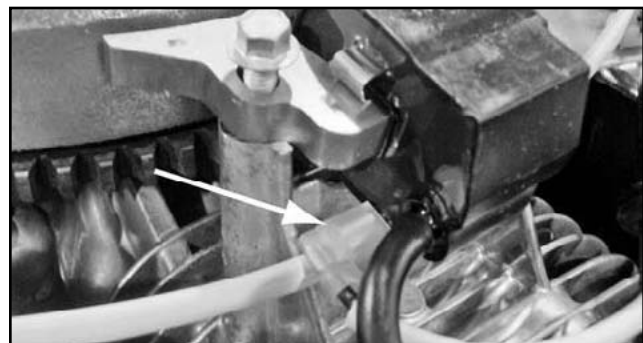

Figure 40.

**TEST 75 – CHECK OIL PRESSURE SWITCH
AND WIRE 86****DISCUSSION:**

If the oil pressure switch contacts have failed in their closed position, the engine will probably crank and start. However, shutdown will then occur within about 5 (five) seconds. If the engine cranks and starts, then shuts down almost immediately with a LOP fault light, the cause may be one or more of the following:

- Low engine oil level.
- Low oil pressure.
- A defective oil pressure switch.

PROCEDURE:

1. Navigate to the Digital inputs display screen.
 - a. Press “ESC” until the main menu is reached.
 - b. Press the right arrow key until “Debug” is flashing.
 - c. Press “Enter”.
 - d. Press the right arrow key until “Inputs” is flashing.
 - e. Press “Enter”.

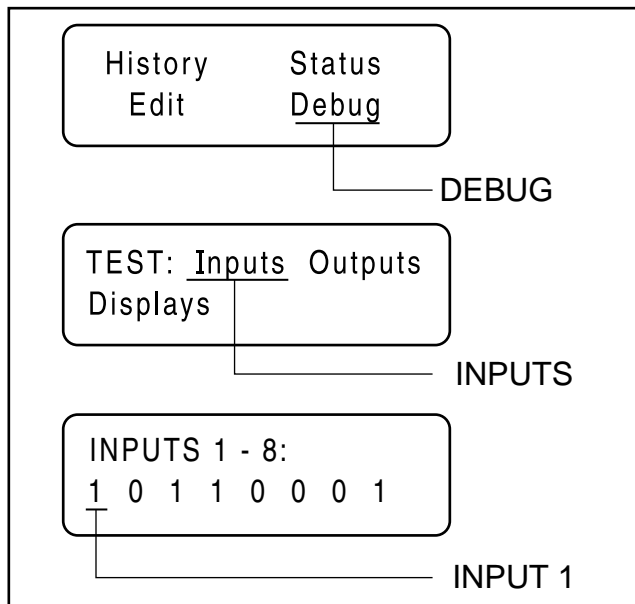

Figure 41. The Home Page, Debug and Input Screens

- f. Digital Input 1 is Wire 86 from the Low Oil Pressure switch to the board. Refer to Figure 41.
- g. Set the AUTO-OFF-MANUAL switch to the MANUAL position.
- h. Observe Input 1 for a change from "1" to "0". A change from "1" to "0" indicates that the control board sensed the LOP switch change states. If the generator still shuts down, replace printed circuit board.
- i. If the input did not change states, proceed to Step 2

2. Check engine crankcase oil level.
 - a. Check engine oil level.
 - b. If necessary, add the recommended oil to the dipstick FULL mark. DO NOT OVERFILL ABOVE THE FULL MARK.
3. With oil level correct, try starting the engine.
 - a. If engine still cranks and starts, but then shuts down, go to Step 4.
 - b. If engine cranks and starts normally, discontinue tests.
4. Do the following:
 - a. Disconnect Wire 86 and Wire 0 from the oil pressure switch terminals. Remove the switch and install an oil pressure gauge in its place.
 - b. Start the engine while observing the oil pressure reading on gauge.
 - c. Note the oil pressure.
 - (1) Normal oil pressure is approximately 35-40 psi with engine running. If normal oil pressure is indicated, go to Step 4 of this test.
 - (2) If oil pressure is below about 4.5 psi, shut engine down immediately. A problem exists in the engine lubrication system.

Note: The oil pressure switch is rated at 10 psi for V-twin engines, and 8 psi for single cylinder engines.

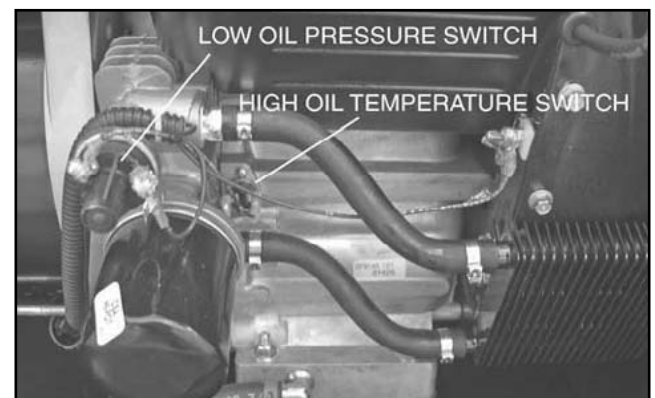

Figure 42. Oil Pressure Switch

5. Remove the oil pressure gauge and reinstall the oil pressure switch. Do NOT connect Wire 86 or Wire 0 to the switch terminals.
 - a. Set a VOM to measure resistance.
 - b. Connect the VOM test leads across the switch terminals. With engine shut down, the meter should read CONTINUITY. If INFINITY is measured with the engine shutdown, replace the LOP switch.
 - c. Crank and start the engine. The meter should read INFINITY.
6. Set a VOM to measure resistance.

SECTION 4.4 DIAGNOSTIC TESTS

PART 4

DC CONTROL

- a. Disconnect the J1 Connector from the printed circuit board.
 - b. Connect one test lead to Wire 86 (disconnected from LOP). Connect the other test lead to Pin Location 4 (Wire 86) of the J1 Connector at the Circuit Board (for all models). CONTINUITY should be measured. If CONTINUITY is not measured, repair or replace Wire 86 between the LOP switch and the J1 Connector.
 - c. Connect one test lead to Wire 0 (disconnected from LOP). Connect the other test lead to a clean frame ground. CONTINUITY should be measured. If CONTINUITY is NOT measured repair or replace Wire 0 between the LOP and the ground terminal connection on the engine mount.
7. If the LOP switch tests good in Step 5 and oil pressure is good in Step 4 but the unit still shuts down with a LOP fault, check Wire 86 for a short to ground. Set a VOM to measure resistance. Disconnect the J1 Connector from the circuit board. Remove Wire 86 from the LOP switch. Connect one test lead to Wire 86. Connect the other test lead to a clean frame ground. INFINITY should be measured. If CONTINUITY is measured, repair or replace Wire 86 between the LOP switch and the J1 Connector.

RESULTS:

1. Replace switch if it fails the test.

TEST 76 – CHECK HIGH OIL TEMPERATURE SWITCH

DISCUSSION:

If the temperature switch contacts have failed in a closed position, the engine will fault out on "OVERTEMP". If the unit is in an overheated condition, the switch contacts will close at 293° F. This will normally occur from inadequate airflow through the generator.

PROCEDURE:

1. Verify that the engine has cooled down (engine block is cool to the touch). This will allow the contacts in the High Oil Temperature Switch to close.
2. Check the installation and area surrounding the generator. There should be at least three feet of clear area around the entire unit. Make sure that there are no obstructions preventing incoming and outgoing air.
3. Disconnect Wire 85 and Wire 0 from the High Oil Temperature Switch.
4. Set a VOM to measure resistance. Connect the test leads across the switch terminals. The meter should read INFINITY.
5. If the switch tested good in Step 4, and a true overtemperature condition has not occurred, check Wire 85 for a

short to ground. Remove J1 Connector from the circuit board. Set the VOM to measure resistance. Connect one test lead to Wire 85 (disconnected from High Oil Temperature Switch). Connect the other test lead to a clean frame ground. INFINITY should be measured.

TESTING HIGH OIL TEMPERATURE SWITCH:

6. Remove the High Oil Temperature Switch.
7. Immerse the sensing tip of the switch in oil as shown in Figure 43, along with a suitable thermometer.
8. Set a VOM to measure resistance. Then, connect the VOM test leads across the switch terminal and the switch body. The meter should read INFINITY.
9. Heat the oil in the container. When the thermometer reads approximately 283°-305° F. (139°-151° C.), the VOM should indicate CONTINUITY.

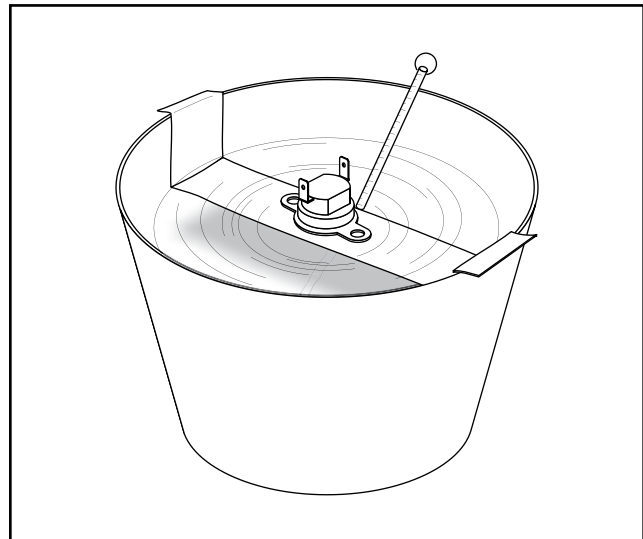

Figure 43. Testing the Oil Temperature Switch

RESULTS:

1. If the switch fails Step 4, or Steps 8-9, replace the switch.
2. If INFINITY was NOT measured in Step 5, repair or replace Wire 85 between the Circuit Board and the High Oil Temperature Switch.

TEST 77 – CHECK AND ADJUST VALVES

DISCUSSION:

Improperly adjusted valves can cause various engine related problems including, but not limited to, hard starting, rough running and lack of power. The valve adjustment procedure for both the single cylinder and the V-twin engines is the same.

PROCEDURE: (INTAKE AND EXHAUST)

Make sure that the piston is at Top Dead Center (TDC) of it's compression stroke (both valves closed). The valve clearance should be 0.05-0.1mm (0.002-0.004 in.) cold.

Check and adjust the valve to rocker arm clearance as follows:

1. Remove the four (4) screws from the rocker cover.
2. Remove the rocker cover and rocker cover gasket.
3. Loosen the rocker arm jam nut. Use a 10mm allen wrench to turn the pivot ball stud and check the clearance between the rocker arm and the valve stem with a flat feeler gauge (see Figure 44).
4. When the valve clearance is correct, hold the pivot ball stud with the allen wrench and tighten the rocker arm jam nut. Torque the jam nut to 174 inch pounds. After tightening the jam nut, recheck the valve clearance to make sure it did not change.

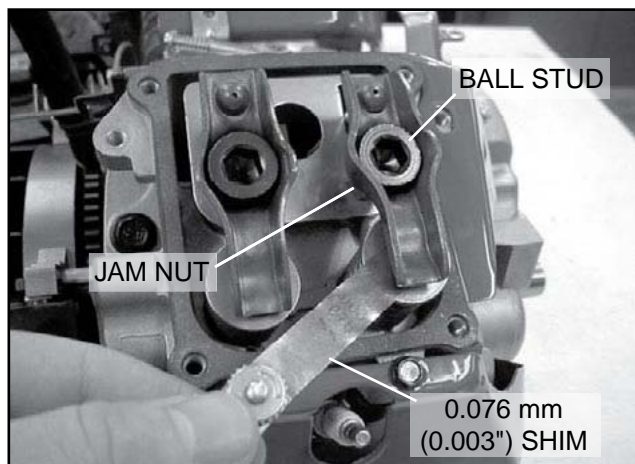

Figure 44

5. Re-install the rocker cover gasket, rocker cover and the four (4) screws.

RESULTS:

Adjust valve clearance as necessary, then retest.

TEST 78 – CHECK WIRE 18 CONTINUITYDISCUSSION:

During cranking and running the printed circuit board receives a pulse from the ignition magnetos via Wire 18. This signal has an AC voltage of 4-6 volts on V-Twin engines only. If this signal is not received by the printed circuit board the unit will shut down due to no RPM sensing.

PROCEDURE: (V-TWIN ONLY)

1. Set a VOM to measure AC voltage.

2. Connect one meter test lead to Wire 18 that is connected to the bolt connector shown in Figure 46. Connect the other meter test lead to a clean frame ground.
3. Set the AUTO-OFF-MANUAL switch to the MANUAL position.
4. When the generator comes up to rated speed, measure and record the voltage reading. 4-6 VAC should be measured.
5. If the correct voltage was not measured in Step 4, refer back to flow chart. If the correct voltage was measured, proceed to Step 6.

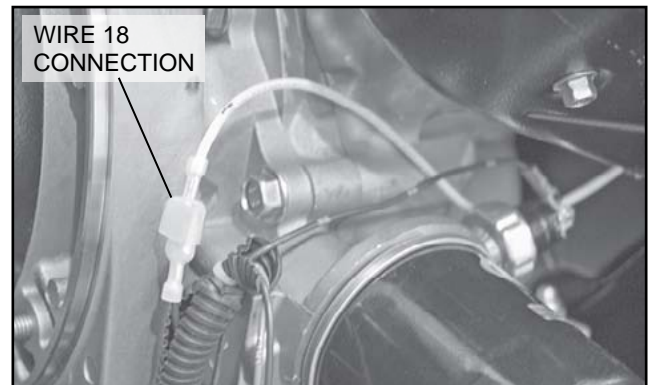

Figure 45. Wire 18 Connection 8 kW Units

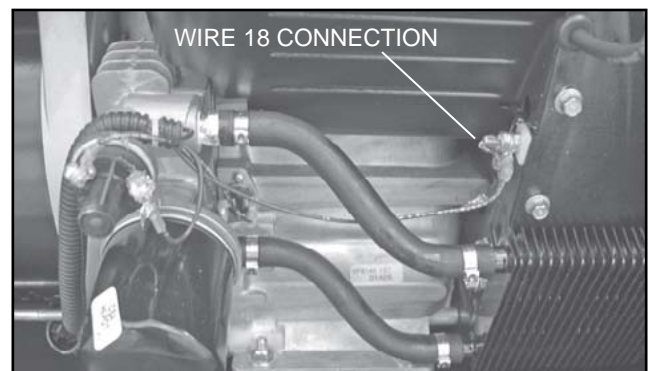

Figure 46. Wire 18 Connection 10-20 kW Units

6. Set a VOM to measure resistance.
7. Disconnect the J1 Connector from the printed circuit board.
8. Verify the continuity of Wire 18. Connect one meter test lead to a clean frame ground. Connect the other meter test lead to Pin Location J1-4 for all models. A reading of 275K - 325K ohms should be measured. If CONTINUITY is measured (0.1 ohms) a short to ground could be present.
9. Disconnect Wire 18 from the stud connector. Continue to leave J1 disconnected from Step 7.

SECTION 4.4 DIAGNOSTIC TESTS

PART 4

DC CONTROL

10. Connect one meter test lead to Wire 18 removed from the stud connector. Connect the other meter test lead to a clean frame ground. INFINITY should be measured. If CONTINUITY is measured, repair or replace Wire 18 between the stud connector and the J1 Connector.

RESULTS:

Refer to flow chart.

PROCEDURE: (SINGLE CYLINDER)

1. Set a VOM to measure resistance.
2. Remove Wire 18 from the in-line bullet connector. Disconnect the J1 Connector from the printed circuit board.
3. Verify the continuity of Wire 18. Connect one meter test lead to Wire 18 removed from the stud connector or bullet connector. Connect the other meter test lead to Pin Location J1-4. CONTINUITY should be measured. If CONTINUITY is not measured, repair or replace Wire 18 as needed.

RESULTS:

Refer to flow chart.

TEST 79 – TEST EXERCISE FUNCTION

DISCUSSION:

The following parameters must be met in order for the weekly exercise to occur:

- AUTO-OFF-MANUAL switch set to AUTO.

PROCEDURE: 8KW

1. Set the AUTO-OFF-MANUAL switch to MANUAL. The generator should start. Set AUTO-OFF-MANUAL switch back to AUTO. Verify that AUTO-OFF-MANUAL switch has been in AUTO for weekly exercise to function.
2. Hold the Set Exercise switch until the generator starts (approximately 10 seconds) and then release. All of the red LEDs will flash for approximately 10 seconds and then stop. The generator will start and run for approximately 12 minutes and then shutdown on its own. The exerciser will then be set to start and run at that time of that day each week. If the unit does not start, replace the circuit board.

PROCEDURE: 10KW-20KW

Note: Make a record of the date and time the generator is set to exercise.

1. Record the current date and time of the unit.
2. Press the “ESC” key till the main menu is displayed.

3. Press the right arrow key till a line is present under “EDIT”.
4. Press “Enter”.
5. Press the right arrow key until “EXERCISE TIME/DAY” is displayed.
6. Press “Enter”.

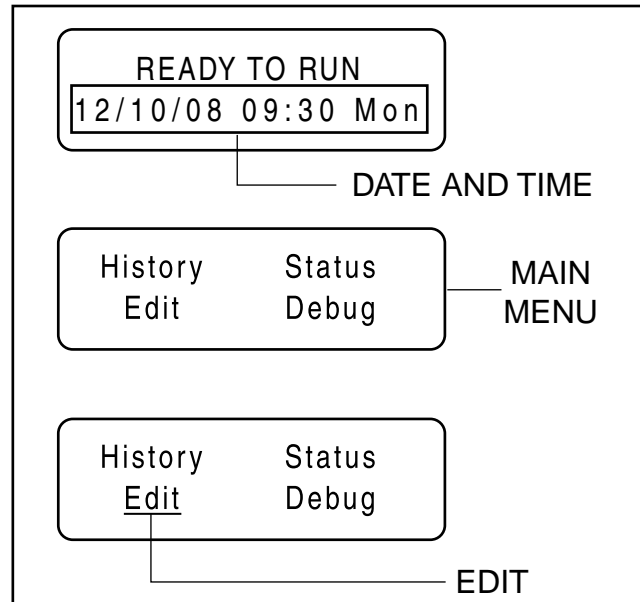

Figure 47. The Date and Time, and Main Menu Screens

7. Adjust exercise time to about 3 to 4 minutes ahead of the date and time noted in Step 1.
8. Press “ESC” until “READY TO RUN” is displayed. The AUTO-OFF-MANUAL switch must be in AUTO for the unit to exercise.
9. Watch the generator display and note the time. When the date and time reaches the time that was programmed for exercise, the unit will display "Running in Exercise" if the exercise feature is working properly.

RESULTS:

1. In all models, if the unit starts in MANUAL, but fails to exercise without any ALARMS present, replace the printed circuit board.

TEST 80 – CHECK CRANKING AND RUNNING CIRCUITS

DISCUSSION:

This test will check all of the circuits that are “HOT” with battery voltage and which could cause the Main Fuse to blow.

PROCEDURE:

1. Set a VOM to measure resistance.
2. Disconnect the J2 Connector from the controller.
3. Connect one meter test lead to the ground terminal. Connect the other meter test lead to each of the following J2 connector pin locations.

J2-11 Wire 56	
8kW	If CONTINUITY was measured, go to Step 4. Average nominal resistance reading is 4 ohms: Single Cylinder Starter Contactor (SC) 4 ohms, Choke Solenoid (CS) is 4 ohms.
10 kW - 20 kW	If CONTINUITY was measured, go to Step 5. Average nominal resistance reading is 150-160 ohms. V-twin Starter Contact Relay (SCR): 150-160 ohms. Choke Solenoid (CS) 4 ohms.
J2-3 Wire 14	
8kW	If CONTINUITY was measured, go to Step 6. Average nominal resistance reading is 16 ohms: Fuel Solenoid (FS): 16 ohms.
10kw	If CONTINUITY was measured, go to Step 7. Average nominal resistance reading is 16 ohms. Fuel Solenoids (FS) 16 ohms, (FS2) 7 ohms. Choke Solenoid (CS) 4 ohms.
10 kW - 20 kW	If CONTINUITY was measured, go to Step 8. Average nominal resistance reading is 16 ohms. Fuel Solenoid (FS) 16 ohms. Choke Solenoid (CS) 4 ohms.
J2-12 Wire 4	
10 kW - 20 kW	If RESISTANCE was measured, go to Step 9. For average nominal resistance reading of the rotor, refer to the front of the manual.

4. Disconnect Wire 56 and Wire 0 from the Starter Contactor (SC). Disconnect the Choke Solenoid (CS) connector.

- a. Connect one meter test lead to the SC terminal from which Wire 56 was removed. Connect the other meter test lead to the ground terminal, 4 ohms should be measured. If zero resistance was measured, replace the SC.
 - b. Connect one meter test lead to the CS connector Wire 56. Connect the other meter test lead to the CS connector Wire 90. 4 ohms should be measured. If zero resistance was measured, replace the Choke Solenoid.
 - c. If coil resistance was measured in the Starter Contactor, and Choke Solenoid Wire 56 is shorted to ground between the J2 Connector and SC or CS, repair or replace the shorted wire.
5. Disconnect Wire 56 from the Starter Contactor Relay (SCR). Disconnect the Choke Solenoid (CS) connector.
 - a. Connect one meter test lead to the SCR terminal from which Wire 56 was removed. Connect the other meter test lead to the ground terminal. 4 ohms should be measured. If zero resistance was measured, replace the Starter Contactor Relay.
 - b. Connect one meter test lead to the CS connector Wire 56. Connect the other meter test lead to the CS connector Wire 90. 4 ohms should be measured. If zero resistance was measured, replace the Choke Solenoid.
- If coil resistance was measured in SCR and CS Wire 56 is shorted to ground between J2 connector and SC or CS, repair or replace the shorted wire.
6. Disconnect Wire 14 from the Fuel Solenoid (FS).
 - a. Connect one meter test lead to the FS terminal from which Wire 14 was removed. Connect the other meter test lead to the ground terminal. 16 ohms should be measured. If zero resistance was measured, replace the Fuel Solenoid.
 - b. If coil resistance was measured in FS Wire 14 is shorted to ground between J2 connector and FS, repair or replace the shorted wire.
7. Disconnect Wire 14 from the Fuel Solenoid (FS), Fuel Solenoid 2 (FS2), and Choke Solenoid (CS),
 - a. Connect one meter test lead to the FS terminal from which Wire 14 was removed. Connect the other meter test lead to the ground terminal. 16 ohms should be measured. If zero resistance was measured, replace the Fuel Solenoid.
 - b. Connect one meter test lead to the FS2 terminal from which Wire 14 was removed. Connect the other meter test lead to the ground terminal. 7 ohms should be measured. If zero resistance was measured, replace Fuel Solenoid 1.
 - c. At the CS connector, connect one meter test lead to Wire 14 connect the other meter test lead to Wire 90. 4 ohms should be measured. If zero resistance was measured, replace the Choke Solenoid.

- d. If coil resistance was measured in CS and FS, and FS2 Wire 14 is shorted to ground between J2 connector and CS, FS, or FS2, repair or replace the shorted wire.
- 8. Disconnect Wire 14 from the Fuel Solenoid (FS) and Choke Solenoid (CS).
 - a. Connect one meter test lead to the FS terminal from which Wire 14 was removed. Connect the other meter test lead to the ground terminal. 16 ohms should be measured. If zero resistance was measured, replace the FS.
 - b. At the CS connector, connect one meter test lead to Wire 14. Connect the other meter test lead to Wire 90. 4 ohms should be measured. If zero resistance was measured, replace the Choke Solenoid.
 - c. If coil resistance was measured in the Choke Solenoid, and FS Wire 14 is shorted to ground between the J2 Connector and CS or FS, repair or replace the shorted wire.
- 9. Disconnect Wire 4 and Wire 0 from the Voltage Regulator (VR).
 - a. At the J2 connector, connect one meter test lead to Wire 4. Connect the other meter test lead to a clean frame ground. Note the resistance reading and compare to the rotor resistance in the front of this manual. If zero resistance was measured, test Wire 4 for a short to ground. Check brushes, slip rings, and rotor.

TEST 81 – CHECK TO SEE IF LOW SPEED FUNCTION IS ENABLED

DISCUSSION:

The Low speed exercise function when it is enabled allows the generator to exercise at 2400 rpm. If it is disabled it will exercise at its 3600 rpm during exercise.

PROCEDURE:

1. Press the “ESC” key till the main menu is reached.
2. Press the right arrow key until “Edit” is flashing.
3. Press “Enter”
4. Press the right arrow key until “Exercise Time” appears on the controller.
5. Press “Enter”.
6. Press the right arrow key until the Low speed exercise option is displayed.
7. Ensure that it is enabled.

RESULTS:

Refer back to flow chart.

TEST 82 – CHECK OPERATION OF THE CHOKE SOLENOID

DISCUSSION:

The choke solenoid should be closed when it is in low speed exercise.

PROCEDURE:

1. Remove the air box cover and filter from the engine.
2. Refer to test 79 for Test Exercise Function
3. When the generator starts and the display reflects that it is exercising, confirm that the choke solenoid is fully closed over one port.

RESULTS:

1. If the solenoid did not close, confirm that utility voltage is present. If the generator believes that there is a power outage it will run at full speed until utility is returned.
2. If the solenoid closed, replace the controller.

PART 5 OPERATIONAL TESTS

TABLE OF CONTENTS	
PART	TITLE
5.1.	System Functional Tests

Air-cooled, Automatic Standby Generators

5.1 System Functional Tests.....	148
Introduction	148
Manual Transfer Switch Operation	148
Electrical Checks	148
Generator Tests Under Load.....	149
Checking Automatic Operation	150
Setting The Exercise Timer	150

INTRODUCTION

Following home standby electric system installation and periodically thereafter, the system should be tested. Functional tests of the system include the following:

- Manual transfer switch operation.
- System voltage tests.
- Generator Tests Under Load.
- Testing automatic operation.

Before proceeding with functional tests, read instructions and information on tags or decals affixed to the generator and transfer switch. Perform all tests in the exact order given in this section.

MANUAL TRANSFER SWITCH OPERATION

“W/V-TYPE” TRANSFER SWITCHES:

1. On the generator panel, set the AUTO-OFF-MANUAL switch to OFF.
2. Turn OFF the utility power supply to the transfer switch using whatever means provided (such as a “Utility” main line circuit breaker).
3. Set the generator main line circuit breaker to OFF (or open).



DANGER: BE SURE TO TURN OFF ALL POWER VOLTAGE SUPPLIES TO THE TRANSFER SWITCH BEFORE ATTEMPTING MANUAL OPERATION. FAILURE TO TURN OFF POWER VOLTAGE SUPPLIES TO THE TRANSFER SWITCH MAY RESULT

IN DANGEROUS AND POSSIBLY LETHAL ELECTRICAL SHOCK.

4. Remove the manual transfer handle from the enclosure.
5. Place open end of the manual transfer handle over transfer switch operating lever.
6. To connect LOAD terminal lugs to the utility power source, move the handle upward.
7. To connect LOAD terminals to the standby power source, move the handle downward.
8. Actuate the switch to UTILITY and to MANUAL several times. Make sure no evidence of binding or interference is felt.
9. When satisfied that manual transfer switch operation is correct, actuate the main contacts to their UTILITY position (Load connected to the utility power supply).

ELECTRICAL CHECKS

Complete electrical checks as follows:

1. Set the generator main circuit breaker to its OFF (or open) position.
2. Set the generator AUTO-OFF-MANUAL switch to the OFF position.
3. Turn off all loads connected to the transfer switch Terminals T1 and T2.
4. Turn on the utility power supply to the transfer switch using the means provided (such as a utility main line circuit breaker).

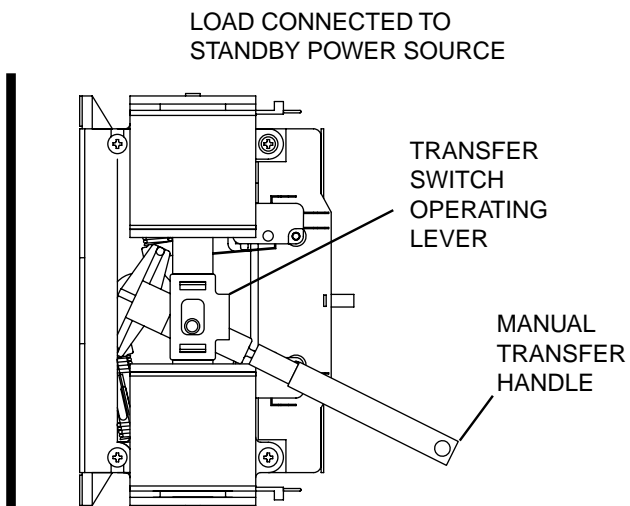
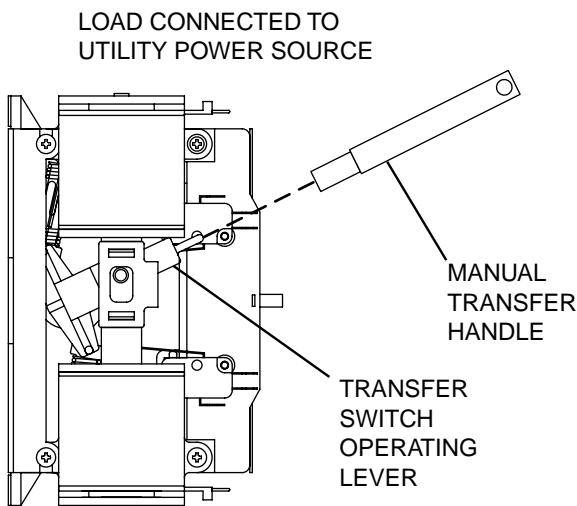

Figure 1. Manual Operation “V-Type” Switch



THE TRANSFER SWITCH IS NOW ELECTRICALLY “HOT”, CONTACT WITH “HOT” PARTS WILL RESULT IN EXTREMELY HAZARDOUS AND POSSIBLY FATAL ELECTRICAL SHOCK. PROCEED WITH CAUTION.

5. Use an accurate AC voltmeter to check utility power source voltage across transfer switch Terminals N1 and N2. Nominal line-to-line voltage should be 240 volts AC.
6. Check utility power source voltage across Terminals N1 and the transfer switch neutral lug; then across Terminal N2 and neutral. Nominal line-to-neutral voltage should be 120 volts AC.
7. When certain that utility supply voltage is compatible with transfer switch and load circuit ratings, turn off the utility power supply to the transfer switch.
8. On the generator panel, set the AUTO-OFF-MANUAL switch to MANUAL. The engine should crank and start.
9. Let the engine warm up for about five minutes to allow internal temperatures to stabilize. Then, set the generator main circuit breaker to its “ON” (or closed) position.



PROCEED WITH CAUTION! GENERATOR POWER VOLTAGE IS NOW SUPPLIED TO THE TRANSFER SWITCH. CONTACT WITH LIVE TRANSFER SWITCH PARTS WILL RESULT IN DANGEROUS AND POSSIBLY FATAL ELECTRICAL SHOCK.

10. Connect an accurate AC voltmeter and a frequency meter across transfer switch Terminal Lugs E1 and E2. Voltage should be 242-252 volts; frequency should read about 61-63 Hertz (7/8 kW units) and about 60 Hertz on 10-20 kW units.
11. Connect the AC voltmeter test leads across Terminal Lug E1 and neutral; then across E2 and neutral. In both cases, voltage reading should be 121-126 volts AC.
12. Set the generator main circuit breaker to its OFF (or open) position. Let the engine run at no-load for a few minutes to stabilize internal engine generator temperatures.
13. Set the generator AUTO-OFF-MANUAL switch to OFF. The engine should shut down.

NOTE: It is important that you do not proceed until you are certain that generator AC voltage and frequency are correct and within the stated limits.

Generally, if both AC frequency and voltage are high or low, the engine governor requires adjustment. If frequency is correct, but voltage is high or low, the generator voltage regulator requires adjustment.

GENERATOR TESTS UNDER LOAD

To test the generator set with electrical loads applied, proceed as follows:

1. Set generator main circuit breaker to its OFF (or open) position.
2. Turn OFF all loads connected to the Transfer Switch Terminals T1 and T2.
3. Set the generator AUTO-OFF-MANUAL switch to OFF.
4. Turn off the utility power supply to the transfer switch, using the means provided (such as a utility main line circuit breaker).



DO NOT ATTEMPT MANUAL TRANSFER SWITCH OPERATION UNTIL ALL POWER VOLTAGE SUPPLIES TO THE TRANSFER SWITCH HAVE BEEN POSITIVELY TURNED OFF. FAILURE TO TURN OFF ALL POWER VOLTAGE SUPPLIES WILL RESULT IN EXTREMELY HAZARDOUS AND POSSIBLY FATAL ELECTRICAL SHOCK.

5. Manually set the transfer switch to the STANDBY position, i.e., load terminals connected to the generator E1/E2 terminals. The transfer switch operating lever should be down.
6. Set the generator AUTO-OFF-MANUAL switch to MANUAL. The engine should crank and start immediately.
7. Let the engine stabilize and warm up for a few minutes.
8. Set the generator main circuit breaker to its ON (or closed) position. Loads are now powered by the standby generator.
9. Turn ON electrical loads connected to transfer switch T1 and T2. Apply an electrical load equal to the full rated wattage/ampere capacity of the installed generator.
10. Connect an accurate AC voltmeter and a frequency meter across Terminal Lugs E1 and E2.
 - a. 7/8kW voltage should be greater than 230 volts and frequency should be greater than 58 Hz.
 - b. 10-20 kW voltage should be greater than 240 volts and frequency should be 60 Hz.

11. Let the generator run at full rated load for 20-30 minutes. Listen for unusual noises, vibration or other indications of abnormal operation. Check for oil leaks, evidence of overheating, etc.
12. When testing under load is complete, turn off electrical loads.
13. Set the generator main circuit breaker to its OFF (or open) position.
14. Let the engine run at no-load for a few minutes.
15. Set the AUTO-OFF-MANUAL switch to OFF. The engine should shut down.

CHECKING AUTOMATIC OPERATION

To check the system for proper automatic operation, proceed as follows:

1. Set generator main circuit breaker to its OFF (or open) position.
2. Check that the AUTO-OFF-MANUAL switch is set to OFF.
3. Turn off the utility power supply to the transfer switch, using means provided (such as a utility main line circuit breaker).
4. Manually set the transfer switch to the UTILITY position, i.e., load terminals connected to the utility power source side.
5. Turn on the utility power supply to the transfer switch, using the means provided (such as a utility main line circuit breaker).
6. Set the AUTO-OFF-MANUAL switch to AUTO. The system is now ready for automatic operation.
7. Turn off the utility power supply to the transfer switch.

With the AUTO-OFF-MANUAL switch at AUTO, the engine should crank and start when the utility source power is turned off. After starting, the transfer switch should connect load circuits to the standby side. Let the system go through its entire automatic sequence of operation.

With the generator running and loads powered by generator AC output, turn ON the utility power supply to the transfer switch. The following should occur:

- After about fifteen seconds, the switch should transfer loads back to the utility power source.
- About one minute after retransfer, the engine should shut down.

SETTING THE EXERCISE TIMER

This generator is equipped with an exercise timer. Once it is set, the generator will start and exercise every seven days, on the day of the week and at the time of day specified. During this exercise period,

the unit runs for approximately 12 minutes and then shuts down. Transfer of loads to the generator output does not occur during the exercise cycle unless utility power is lost.

PROCEDURE 8 KW UNITS:

A switch on the control panel (see Figure 3.1) permits selection of the day and time for the system to exercise. At the chosen time, perform the following sequence to select the desired day and time of day the system will exercise. Remember, seasonal time changes affect the exercise settings.

1. Verify that the AUTO-OFF-MANUAL switch is set to AUTO.
2. Press and hold the "Set Exercise" switch for several seconds. All the red LED's will stop flashing immediately and the generator will start.
3. The generator will start and run for approximately 12 minutes and then shut down. The exerciser is now set to run at this time of day each week. Example: If the "Set Exercise" is pressed on Saturday afternoon at 2:00 p.m. the generator will start and exercise for approximately 12 minutes every Saturday at 2:00 p.m.

10-20 kW - INSTALLATION ASSISTANT:

Upon first power up of the generator, the display interface will enter an installation assistant. The assistant will prompt the user to set the minimum settings to operate. These settings are simply: "Current Date/Time" and "Exercise Day/Time". The maintenance intervals will be initialized when the exercise time is entered.

The exercise settings can be changed at any time via the "EDIT" menu (see Appendix, "Menu System"). If the 12 volt battery is disconnected or the fuse removed, the Installation Assistant will operate upon power restoration. The only difference being that the display will only prompt the customer for the current Time and Date.

ALL UNITS:

Note: If the installer tests the generator prior to installation, press the "ENTER" key to avoid setting the exercise time. This will ensure that the customer will still be prompted to enter an exercise time when the unit is first powered up.

NOTE: The exerciser will only work in the AUTO mode and will not work unless this procedure is performed. The current date/time will need to be reset every time the 12 volt battery is disconnected and then reconnected, and/or when the fuse is removed.

PART 6 DISASSEMBLY

TABLE OF CONTENTS	
PART	TITLE
6.1.	Major Disassembly

Air-cooled, Automatic Standby Generators

6.1 Major Disassembly	152
Front Engine Access	152
Major Disassembly.....	156
Torque Requirements (Unless Otherwise Specified)	162

FRONT ENGINE ACCESS

SAFETY:

1. Set the AUTO-OFF-MANUAL switch to OFF.
2. Remove the 7.5 amp main fuse. See Figure 1.
3. Remove the N1 and N2 fuse from the transfer switch.



Figure 1. Remove 7.5 Amp Fuse

4. Turn off fuel supply to the generator and remove the flex-line from the fuel regulator.
5. Remove utility power from the generator.
6. Remove front door.
7. Remove battery from the generator.

FRONT ENGINE ACCESS:

1. Remove Controls Cover: Using a Torx T-27 socket remove two bolts and ground washer from the controls cover. Remove the controls cover. See Figure 2.



Figure 2.

2. Remove controller: Using a Phillips screwdriver remove the four mounting screws from the controller. See Figure 3.

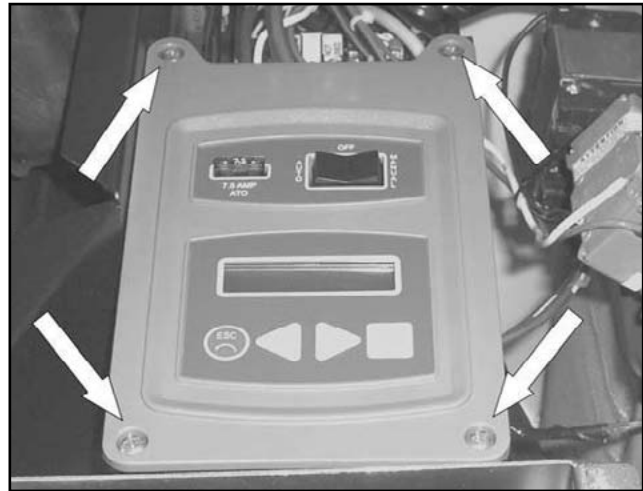

Figure 3.

3. Remove control harnesses:
 - a. Remove engine wiring harness at the J1 port.
 - b. Remove control wiring harness at the J2 port.
 - c. Remove stepper motor wiring harness at the J3 port. See Figure 4.

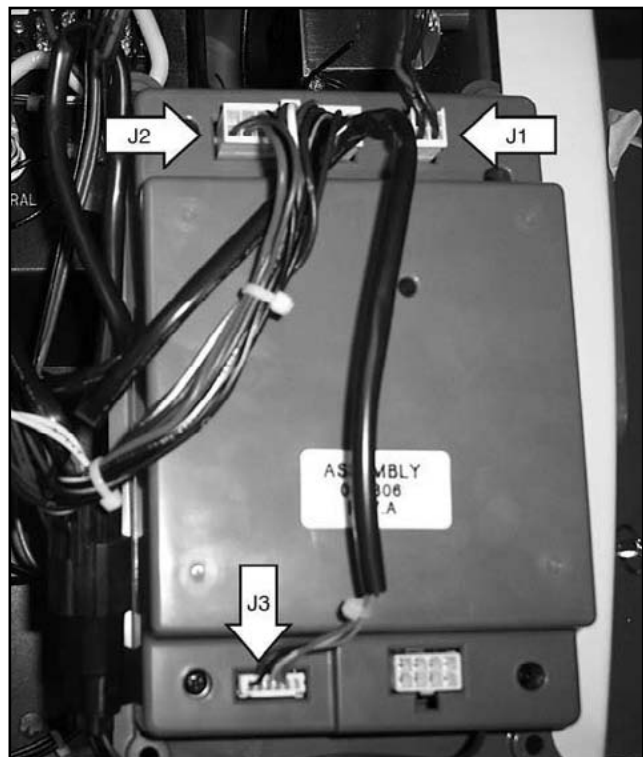

Figure 4.

4. Remove Stator Wires: Remove all wires from the voltage regulator, remove the neutral and ground wires from landing lugs, and remove N1 & N2 wires from main bearers. See Figure 5.
5. Remove Control Wires: Remove Wires #N1,#N2, #0, #15B, #23, GFCI Outlet, and unit status lights from the control box. See Figure 6.

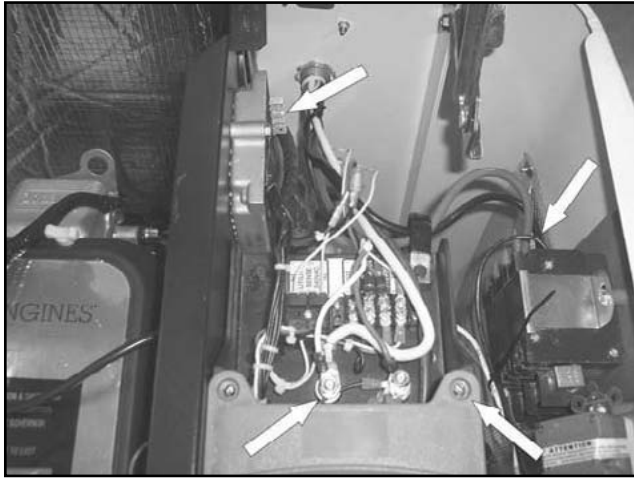

Figure 5.

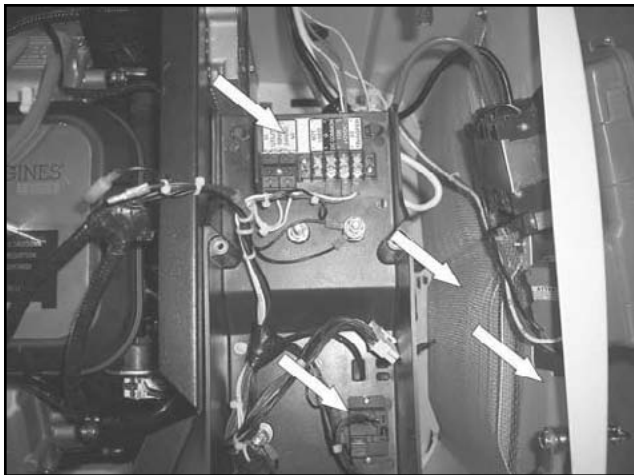

Figure 6.

6. Remove controller mounting box: Using an 8mm socket remove the two screws from the rear of the controller mounting box. See Figure 7. Using a 10mm socket remove the two bolts from under the front of the controller mounting box. See Figure 8.

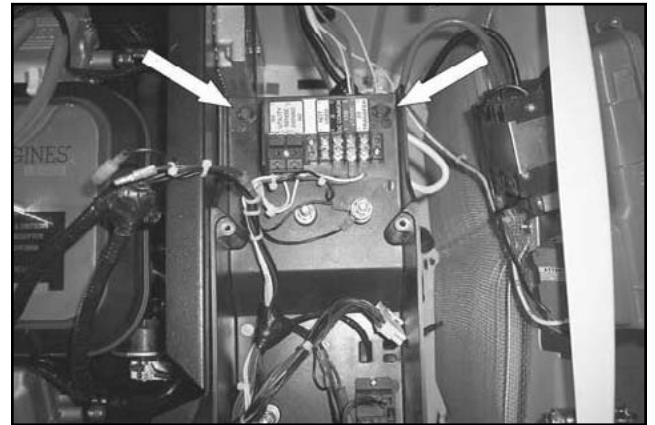

Figure 7.

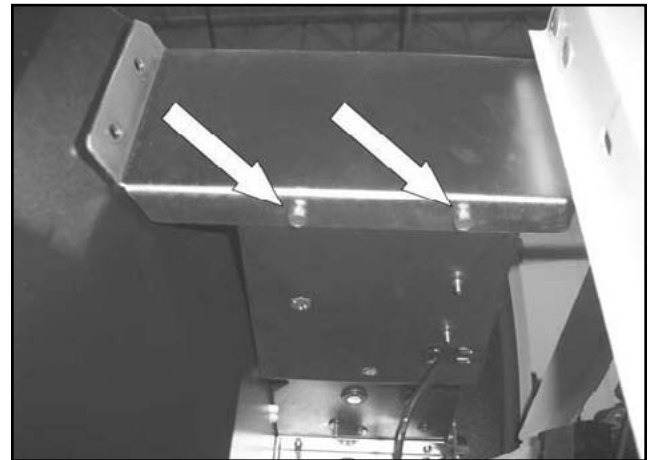

Figure 8.

7. Remove engine intake baffle: Using a 10mm socket remove the two bolts from the engine intake baffle. Pull baffle toward you carefully, there are tabs holding the backside of the baffle to the divider panel. See Figure 9.

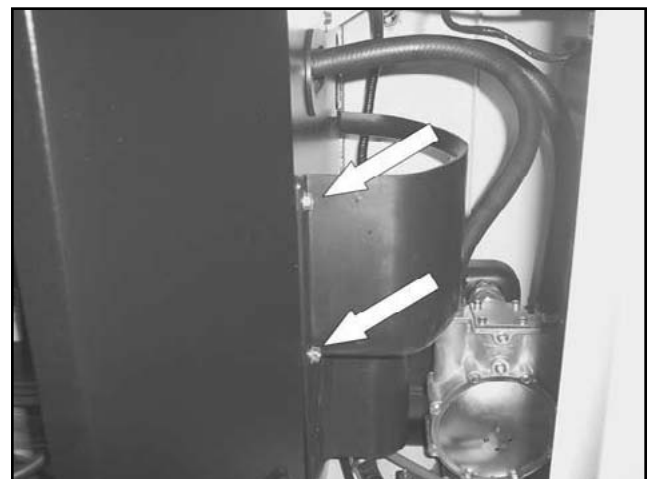

Figure 9.

SECTION 6.1 MAJOR DISASSEMBLY

PART 6

DISASSEMBLY

- Loosen side panel: Using a 10mm socket remove the two bolts from the base of the enclosure side panel. See Figure 10.
- Unbolt enclosure side panel mounting bracket: Using a 10mm socket remove the two bolts from the enclosure side panel mounting bracket. See Figure 11.



Figure 10.

- Remove fuel regulator: Remove the two fuel hoses at the top of the regulator. Using a 10mm socket remove one 10mm bolt from the base of the plenum and one 10mm bolt from the base of the fuel regulator. Flex the enclosure side out to allow for room to remove the regulator assemble. See Figure 12.



Figure 12.

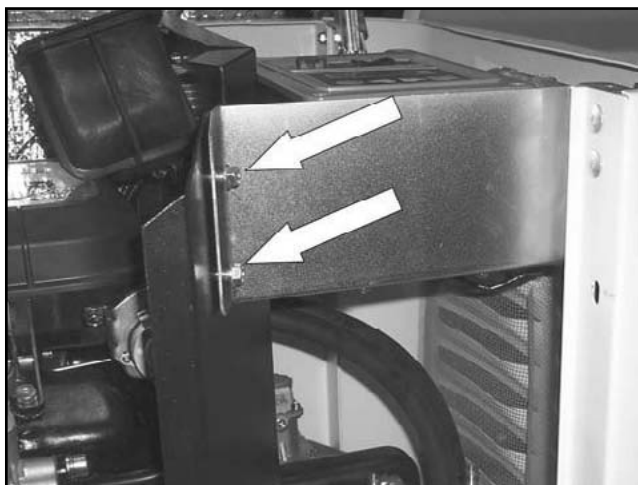

Figure 11.

- Remove engine divider panel: Using a 10mm socket remove the rear 10mm bolt from the base of the enclosure. See Figure 13. Remove the front 10mm bolt from the base of the enclosure. See Figure 14.



Figure 13.

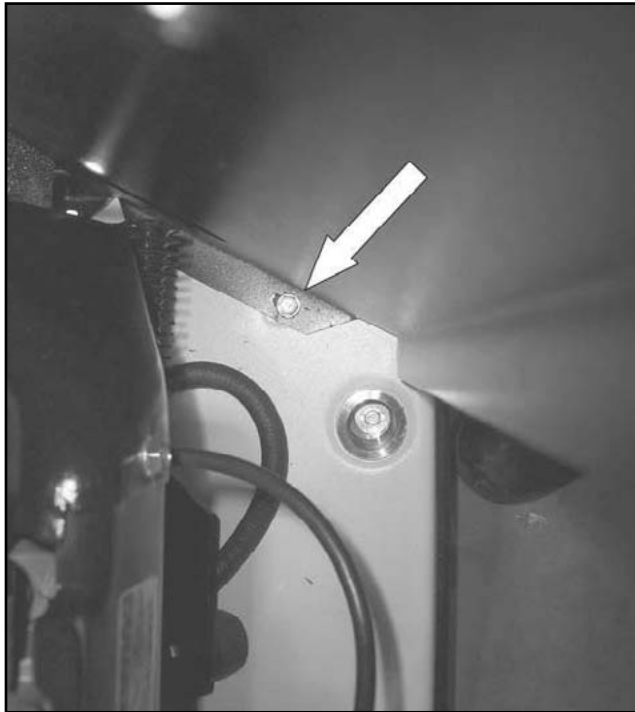

Figure 14.

12. Remove Air Box: Using a 6mm allen wrench remove the four intake manifold socket head cap screws. See Figure 15. Using a 4mm allen wrench, remove the four airbox allen head shoulder bolts. While removing the airbox remove the four rubber washers. See Figure 16.

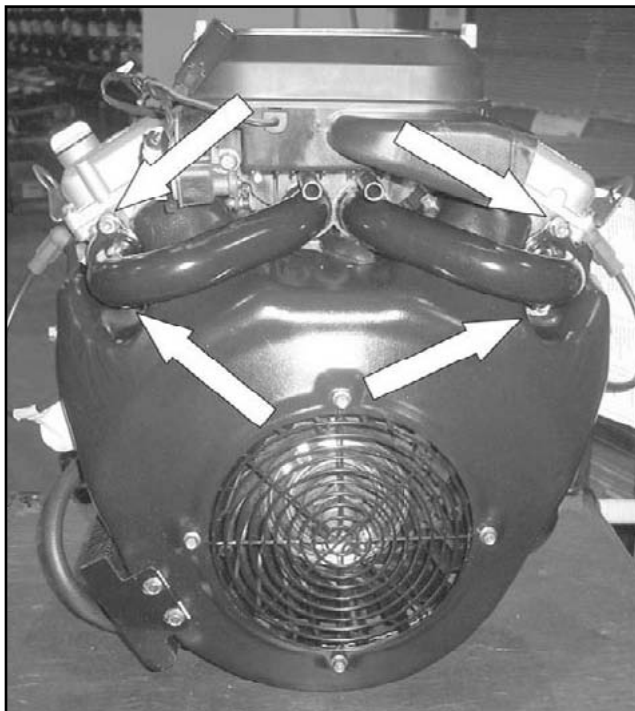

Figure 15.



Figure 16.

13. Unbolt Oil Cooler: Using a 10mm socket remove the two 10mm bolts from the front of the oil cooler. See Figure 17. Remove the two 10mm bolts from the rear of the oil cooler. See Figure 18.



Figure 17.

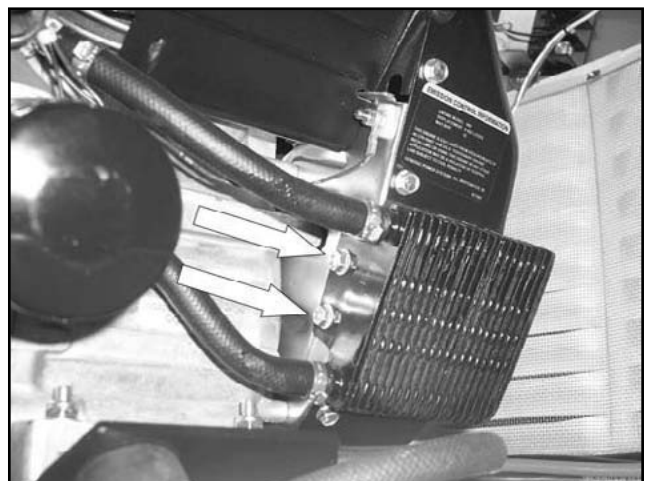

Figure 18.

SECTION 6.1 MAJOR DISASSEMBLY

PART 6

DISASSEMBLY

14. Remove Blower Housing: Using a 4mm allen wrench remove one button head cap screw from top of blower housing. Using a 10mm socket remove one 10mm bolt from the top of the blower housing. See Figure 19. Using a 10mm socket remove four 10mm bolts from the right-side of the blower housing, (see Figure 20) and four 10mm bolts from the left-side of the blower housing. See Figure 21. Remove blower housing.



Figure 19.

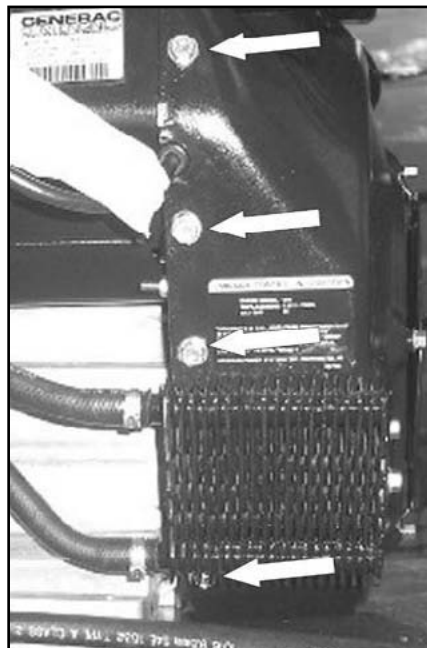

Figure 20.

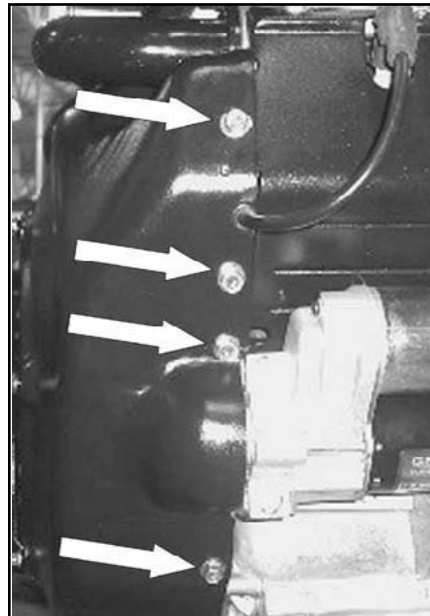

Figure 21.

MAJOR DISASSEMBLY

SAFETY:

1. Set the AUTO-OFF-MANUAL switch to OFF.
2. Remove the 7.5 amp main fuse. See Figure 22.
3. Remove the N1 and N2 fuse from the transfer switch.



Figure 22. Remove 7.5 Amp Fuse

4. Turn off fuel supply to the generator and remove the flex-line from the fuel regulator.
5. Remove utility power from the generator.
6. Remove front door.
7. Remove battery from the generator.

STATOR/ROTOR/ENGINE REMOVAL:

1. Remove Top Exhaust Enclosure Covers: Using a 10mm socket, remove the nine bolts from the exhaust top covers. Remove covers. See Figure 23.

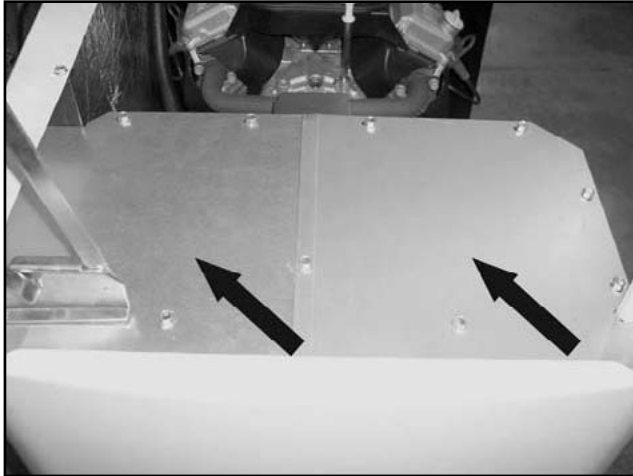

Figure 23.

2. Remove Side Exhaust Enclosure Cover: Using a 10mm socket, remove the five bolts from the exhaust side cover. Remove side covers. See Figure 24.

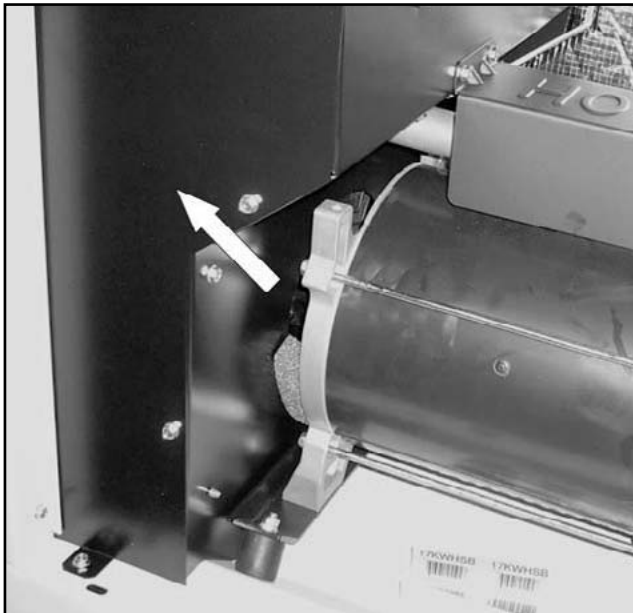

Figure 24.

3. Remove Exhaust Flex Cover: Using a 10mm socket, remove the two bolts from the exhaust flex pipe cover. Remove the cover. See Figure 25.

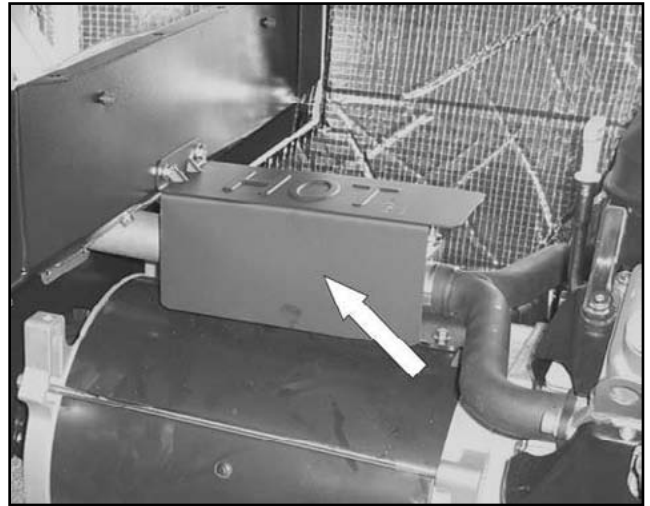

Figure 25.

4. Remove Exhaust Flex Pipe: Using a 1/2" socket remove the front and rear muffler clamp. Slide exhaust flex toward engine completely exposing the muffler flange. See Figure 26.

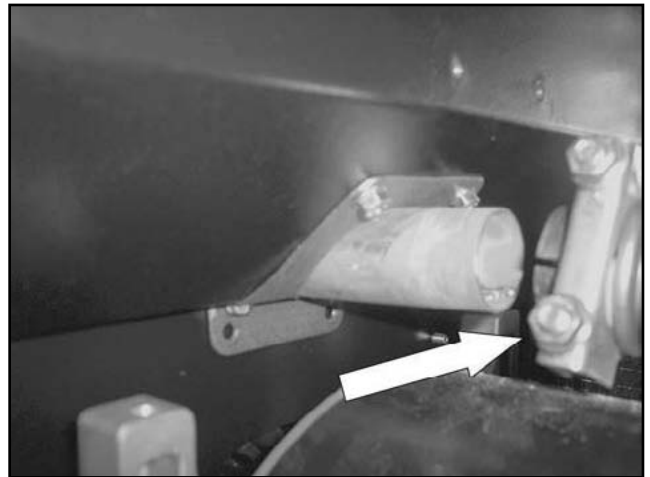

Figure 26.

5. Remove Muffler and Tail Pipe: Using a 1/2" socket remove the muffler clamp and tail pipe. Using a 10mm socket, remove the four bolts from the muffler mounts and remove muffler. See Figure 27.

SECTION 6.1
MAJOR DISASSEMBLY



Figure 27.



Figure 29.

6. Remove Left-side enclosure: Using a 10mm ratchet wrench remove the horizontal 10mm bolt that connects the side panel to the back panel. Using a 10mm socket, remove three bolts from the base of the enclosure. See Figure 28. Using a 10mm socket and wrench remove the top hinge bolt and loosen the bottom bolt. See Figure 29. Holding the roof, remove the bottom hinge bolt, remove the side panel by sliding it forward then re-install the hinge bolt.

7. Remove Fan Housing Cover: Using a 10mm socket remove four bolts from the fan housing cover. Remove the fan housing cover. See Figure 30.

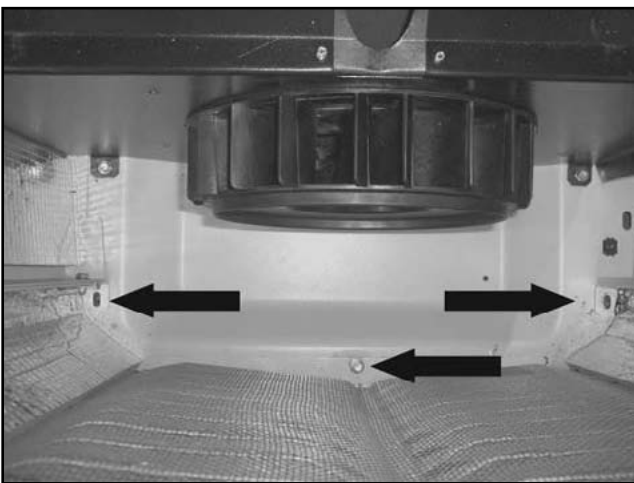

Figure 28.



Figure 30.

8. Remove Rotor Bolt: Using a 9/16" socket, remove rotor bolt. Figure 31.

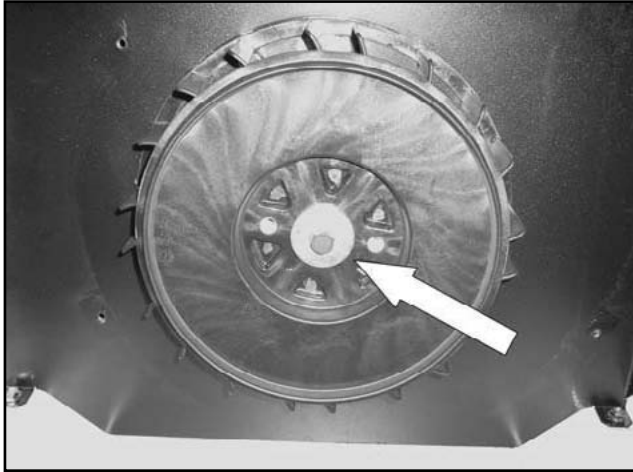

Figure 31.

9. Remove Fan: Attach a steering wheel puller to the fan using two M8 x 1.25 bolts. Remove the fan from the rotor. Figure 32.

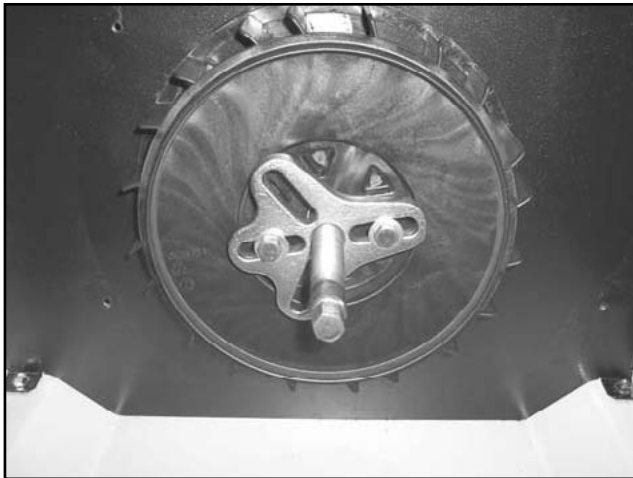

Figure 32.

10. Remove Brushes: Using a 7mm socket remove brushes. See Figure 33.

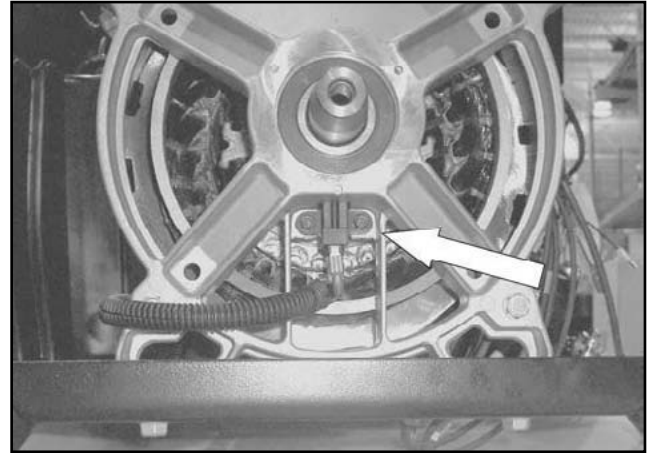

Figure 33.

11. Remove Alternator Divider Panel: Using a 10mm socket remove two bottom base bolts. Using a T27 torx driver remove one top rear bolt. Remove the panel. See Figure 34.

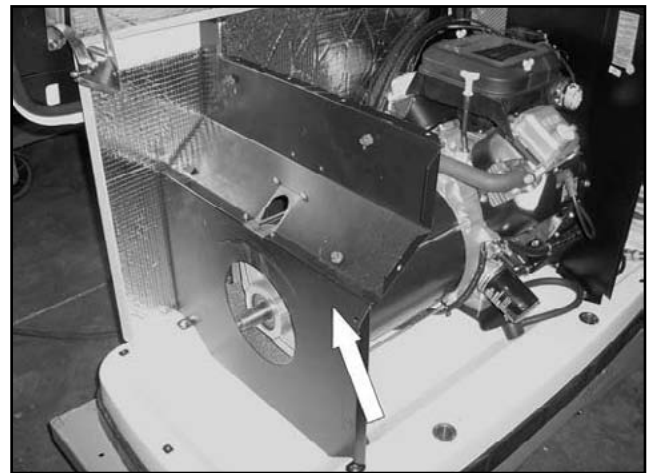

Figure 34.

SECTION 6.1 MAJOR DISASSEMBLY

PART 6

DISASSEMBLY

12. Remove Brush Wires: Using a side cutters remove the tie wraps securing the brush wires to the outside of stator. See Figure 35.

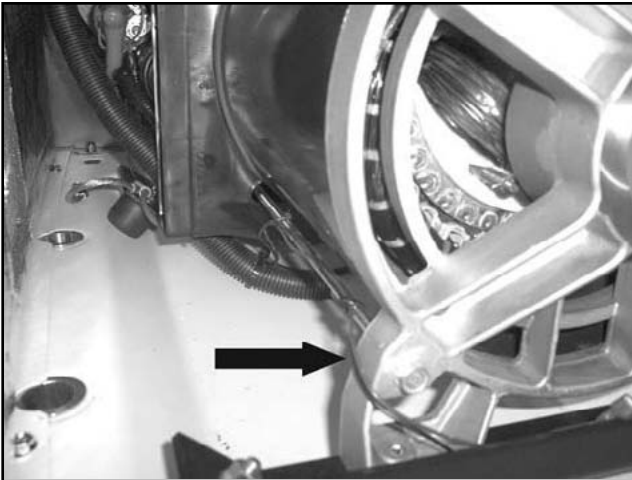

Figure 35.

13. Remove Controls Cover: Using a Torx T-27 socket remove two bolts and ground washer from the controls cover. Remove the controls cover. See Figure 36.



Figure 36.

14. Remove Stator Wires: Remove all wires from the voltage regulator, remove the common and ground wires from landing lugs, and remove N1 & N2 wires from main breakers. See Figure 37.

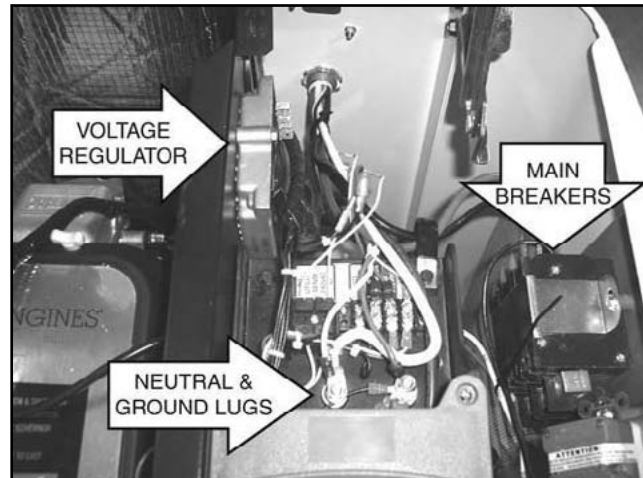

Figure 37.

15. Alternator Air Intake Bellows Removal: Remove alternator intake bellows. See Figure 38.

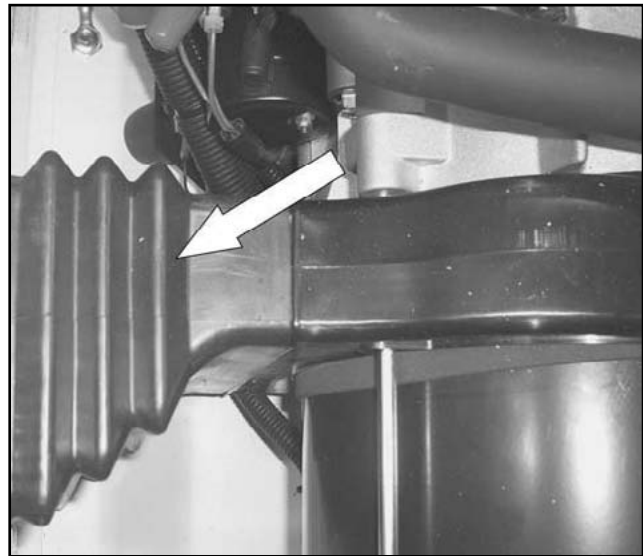

Figure 38.

16. Rear Bearing Carrier Removal: Using a 13mm socket, remove the two nuts from the alternator mounting bracket rubber mounts. Lift the back end of the alternator up and place a 2"x 4" piece of wood under the engine. See Figure 40. Using a 13mm socket, remove the four stator hold down bolts. See Figure 41. Using a small rubber mallet remove the rear bearing carrier. See Figure 42. Remove stator. See Figure 43.

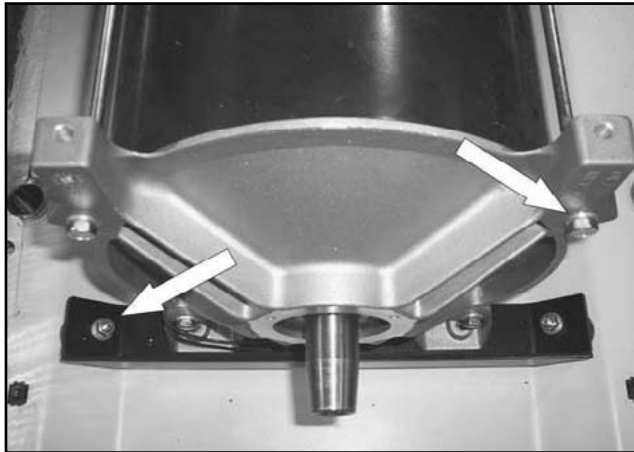

Figure 39.



Figure 40.

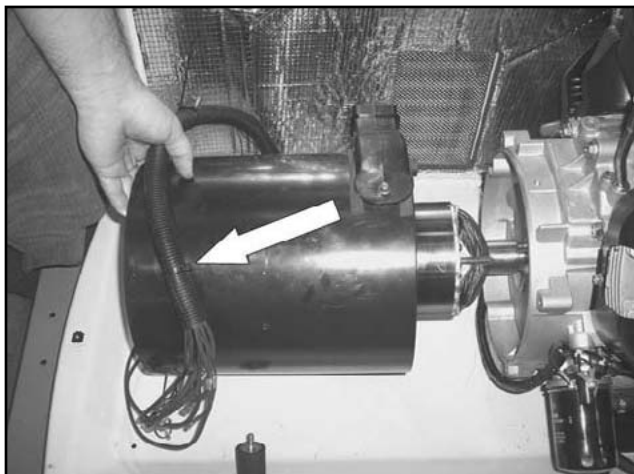

Figure 41.

17. Rotor Removal: Cut 2.5 inches from the rotor bolt. Slot the end of the bolt to suit a flat blade screwdriver. Slide the rotor bolt back through the rotor and use a screwdriver to screw it into the crankshaft. Use a 3" M12x1.75 bolt to screw into rotor. Apply torque to the 3" M12x1.75 bolt until taper breaks. See Figure 43.



Figure 42.

11. Remove Engine: Using a 13mm socket, remove the two engine mount nuts with ground wires. See Figure 43.



Figure 43.

SECTION 6.1 MAJOR DISASSEMBLY

PART 6

DISASSEMBLY

12. Remove Engine: Using proper lifting equipment remove the engine. See Figure 44.

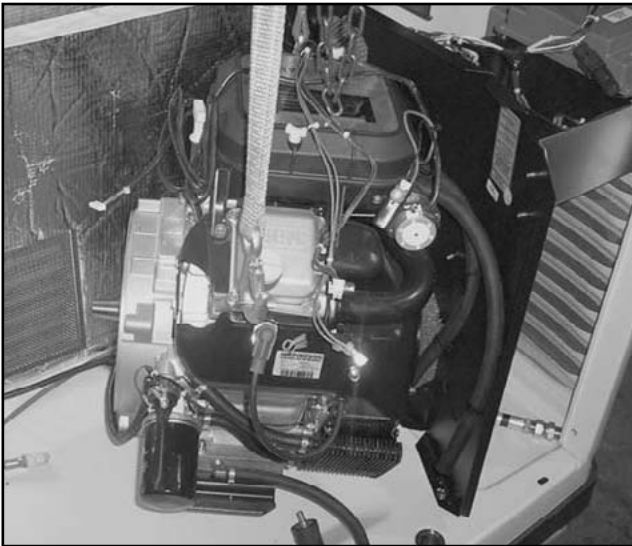

Figure 44.

TORQUE REQUIREMENTS (UNLESS OTHERWISE SPECIFIED)

STATOR BOLTS	6 ft-lbs (+1 / -0)
ROTOR BOLT	30 ft-lbs
ENGINE ADAPTOR	25 ft-lbs
EXHAUST MANIFOLD	18 ft-lbs
M5-0.8 TAPTITE SCREW INTO ALUMINUM	25-50 in-lbs
M5-0.8 TAPTITE SCREW INTO PIERCED HOLE ...	25-50 in-lbs
M6-1.0 TAPTITE SCREW INTO ALUMINUM	50-96 in-lbs
M6-1.0 TAPTITE SCREW INTO PIERCED HOLE ...	50-96 in-lbs
M6-1.0 TAPTITE SCREW INTO WELDNUT	50-96 in-lbs
M8-1.25 TAPTITE SCREW INTO ALUMINUM	12-18 ft-lbs
M8-1.25 TAPTITE SCREW INTO PIERCED HOLE ...	12-18 ft-lbs
M6-1.0 NYLOK NUT ONTO WELD STUD	16-65 in-lbs
M6-1.0 NYLOK NUT ONTO HINGE STUD	30-36 in-lbs

Note: torques are dynamic values with $\pm 10\%$ tolerance unless otherwise noted.

PART 7 ELECTRICAL DATA

Air-cooled, Automatic Standby Generators

TABLE OF CONTENTS	
DWG#	TITLE
0G7945	WIRING DIAGRAM, 8 KW HSB
0G8511	SCHEMATIC, 8 KW HSB
0G7946	WIRING DIAGRAM, 10 KW HSB
0G8512	SCHEMATIC, 10 KW HSB
0G7947	WIRING DIAGRAM, 14 KW HSB
0G8513	SCHEMATIC, 14 KW HSB
0G7948	WIRING DIAGRAM, 17 KW HSB
0G8514	SCHEMATIC, 17 KW HSB
0G8186	WIRING DIAGRAM, 20 KW HSB
0G8515	SCHEMATIC, 20 KW HSB
0G7958	WIRING DIAGRAM 9/10/12/16 CIRCUIT TRANSFER SWITCH
0G7959	SCHEMATIC 9/10/12/16 CIRCUIT TRANSFER SWITCH

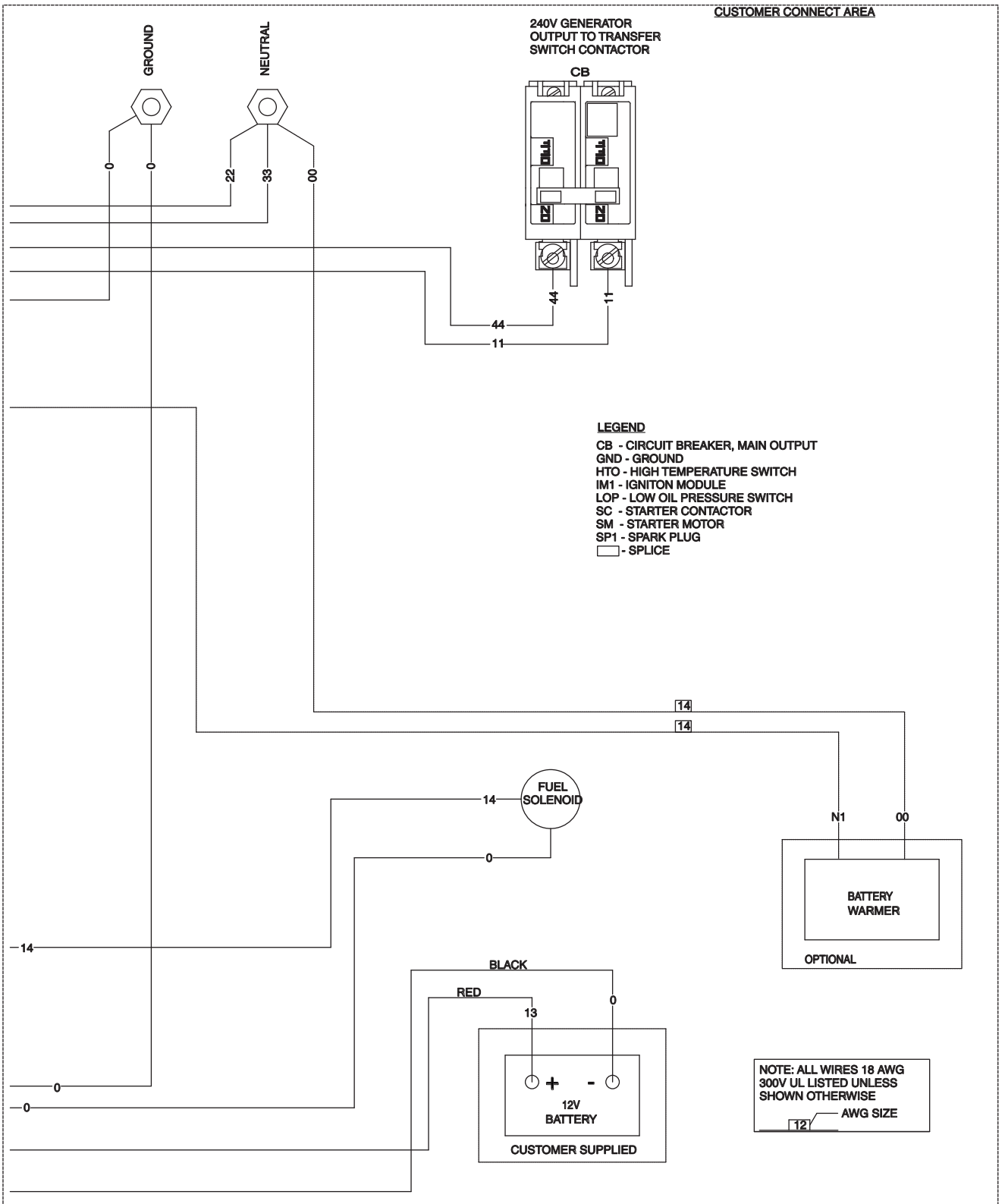

DRAWING #0G8511

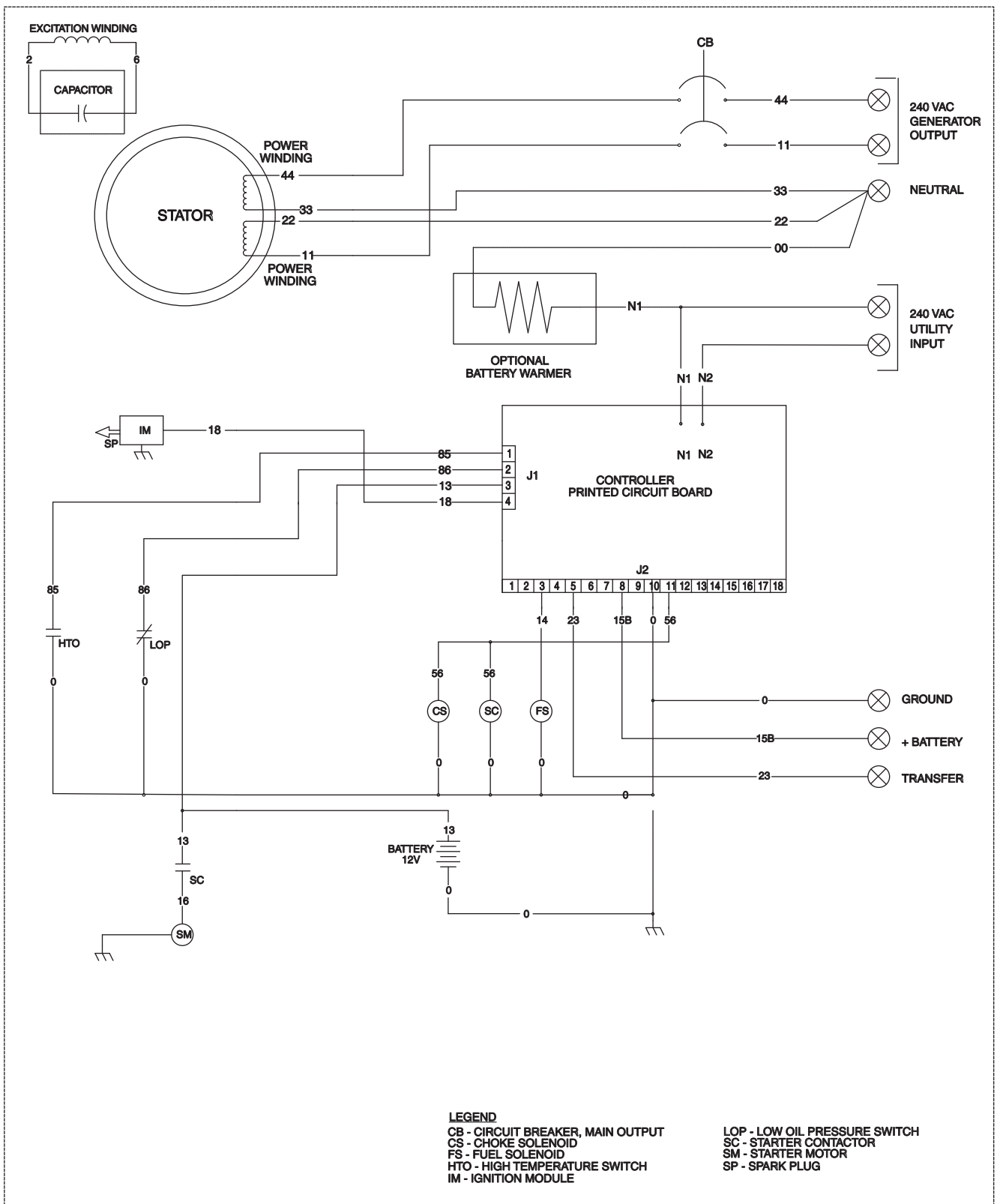

PAGE LEFT PLANK INTENTIONALLY

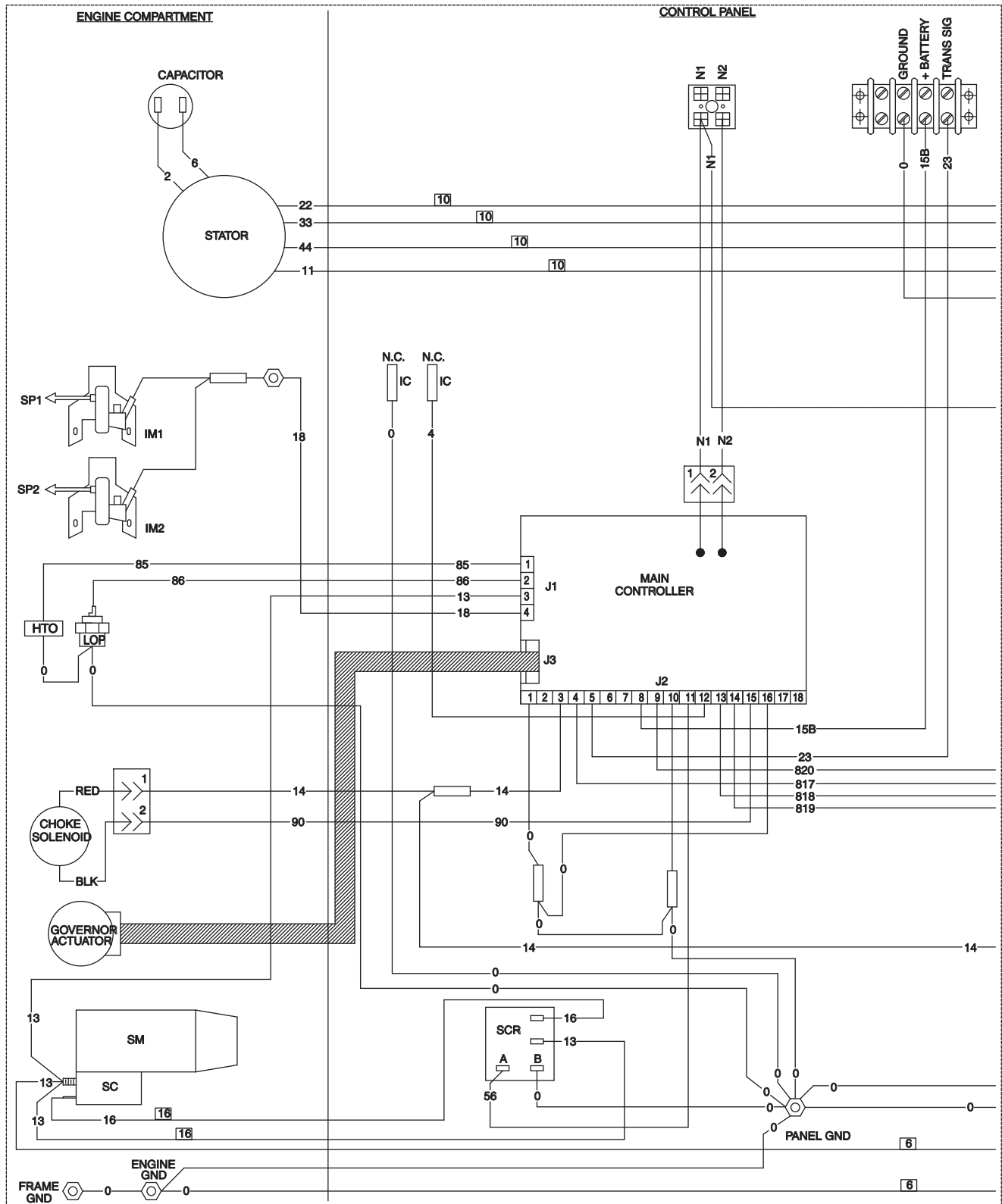

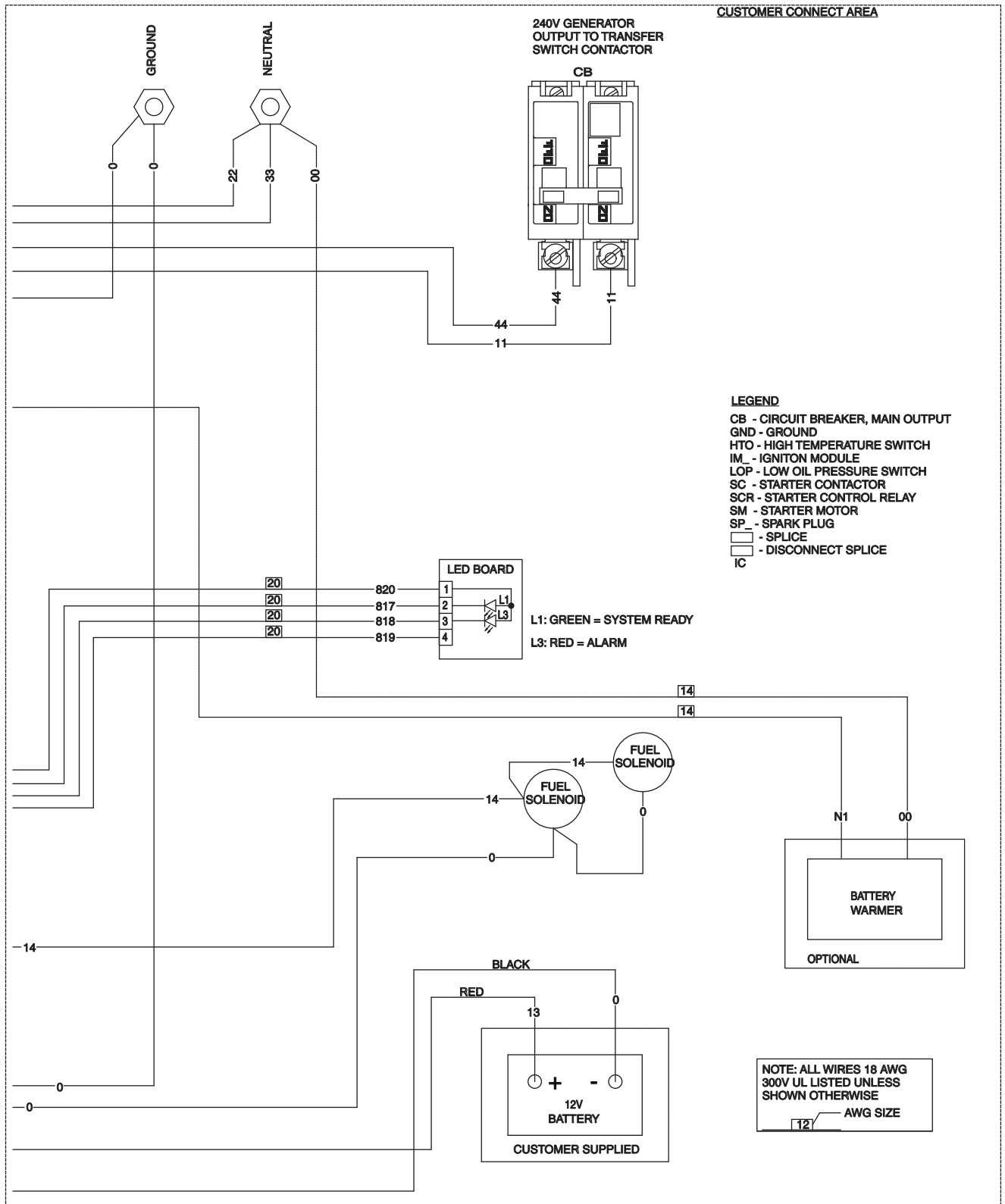

DRAWING #0G8512

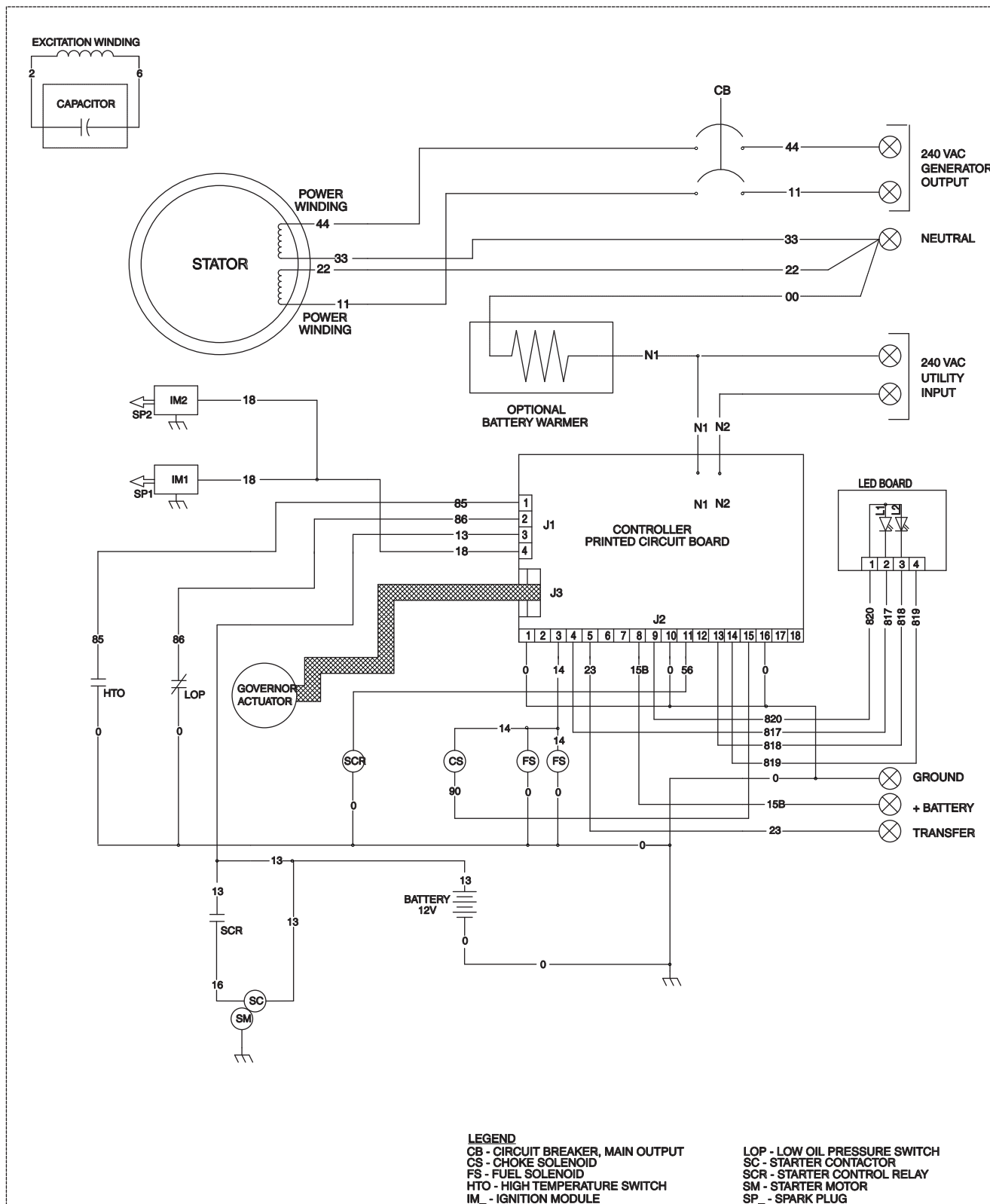

PAGE LEFT BLANK INTENTIONALLY

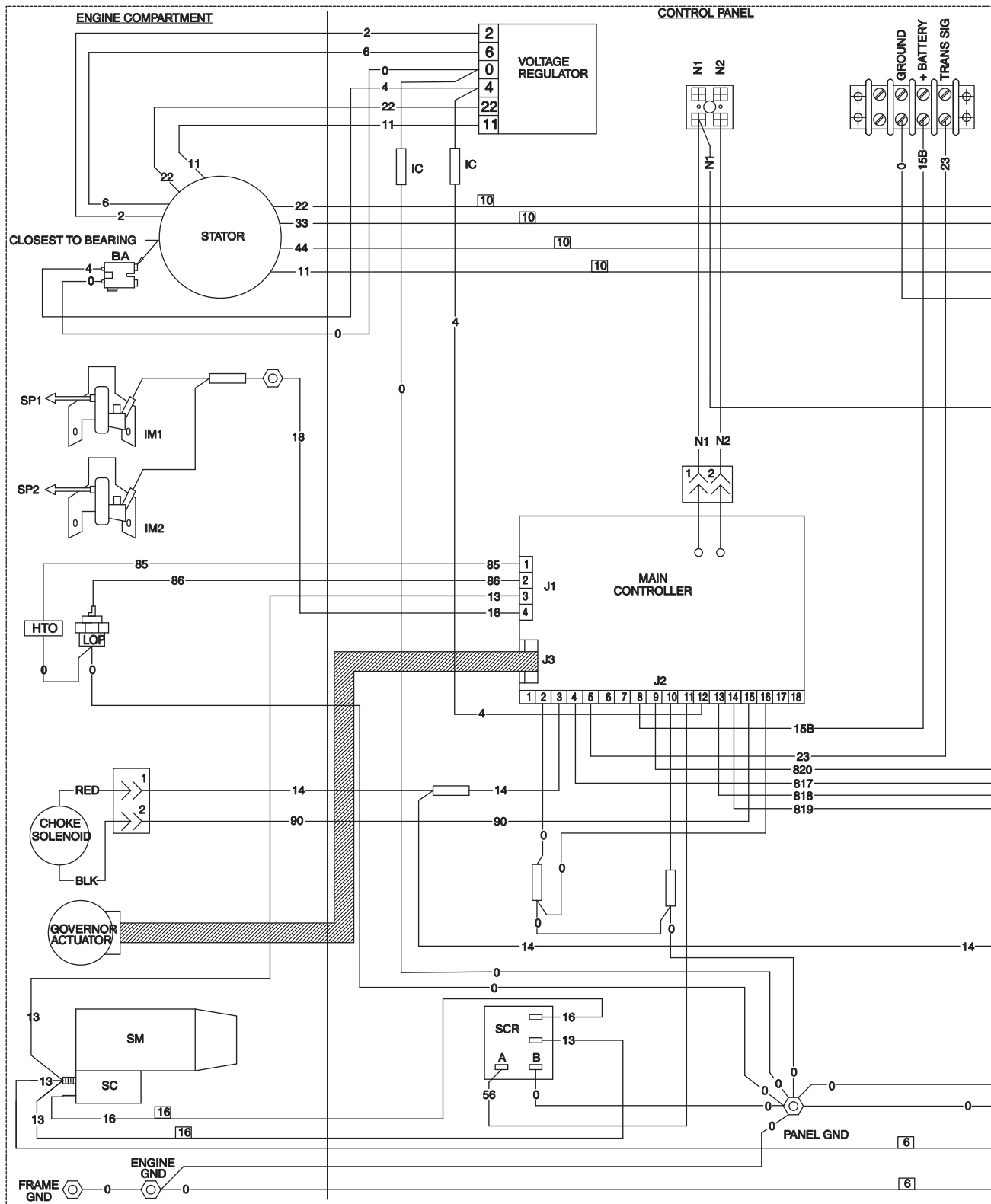

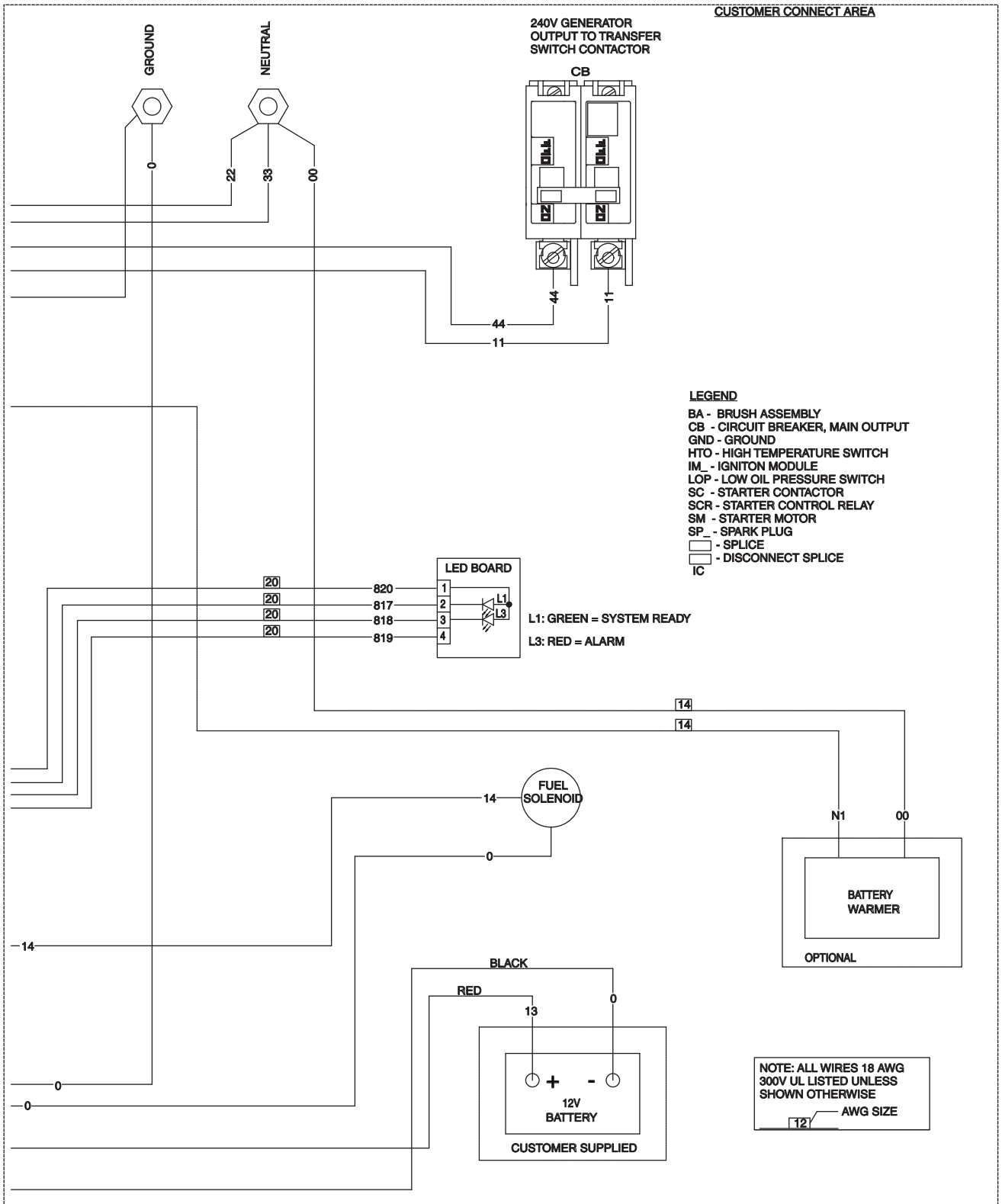

DRAWING #0G8513

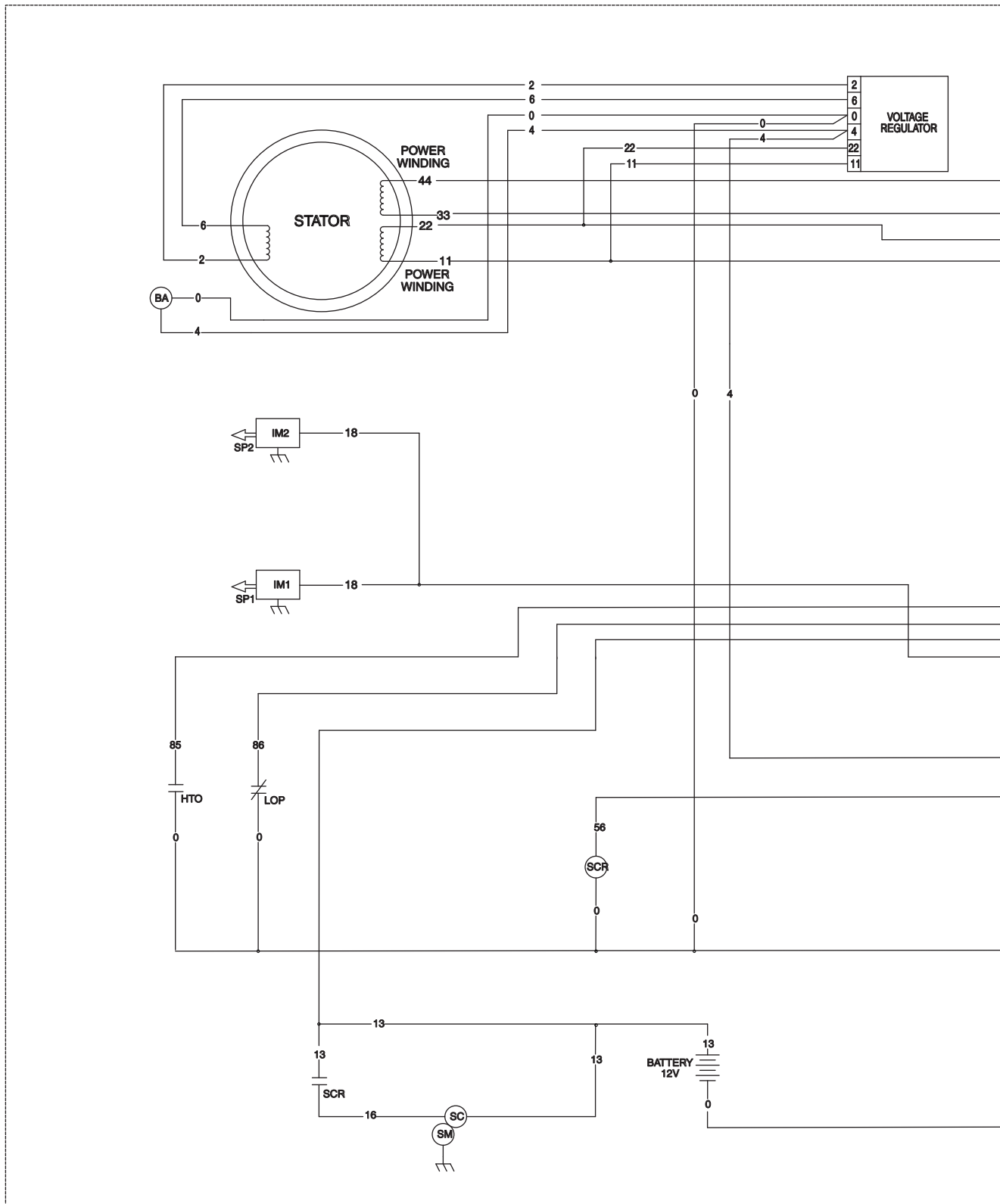

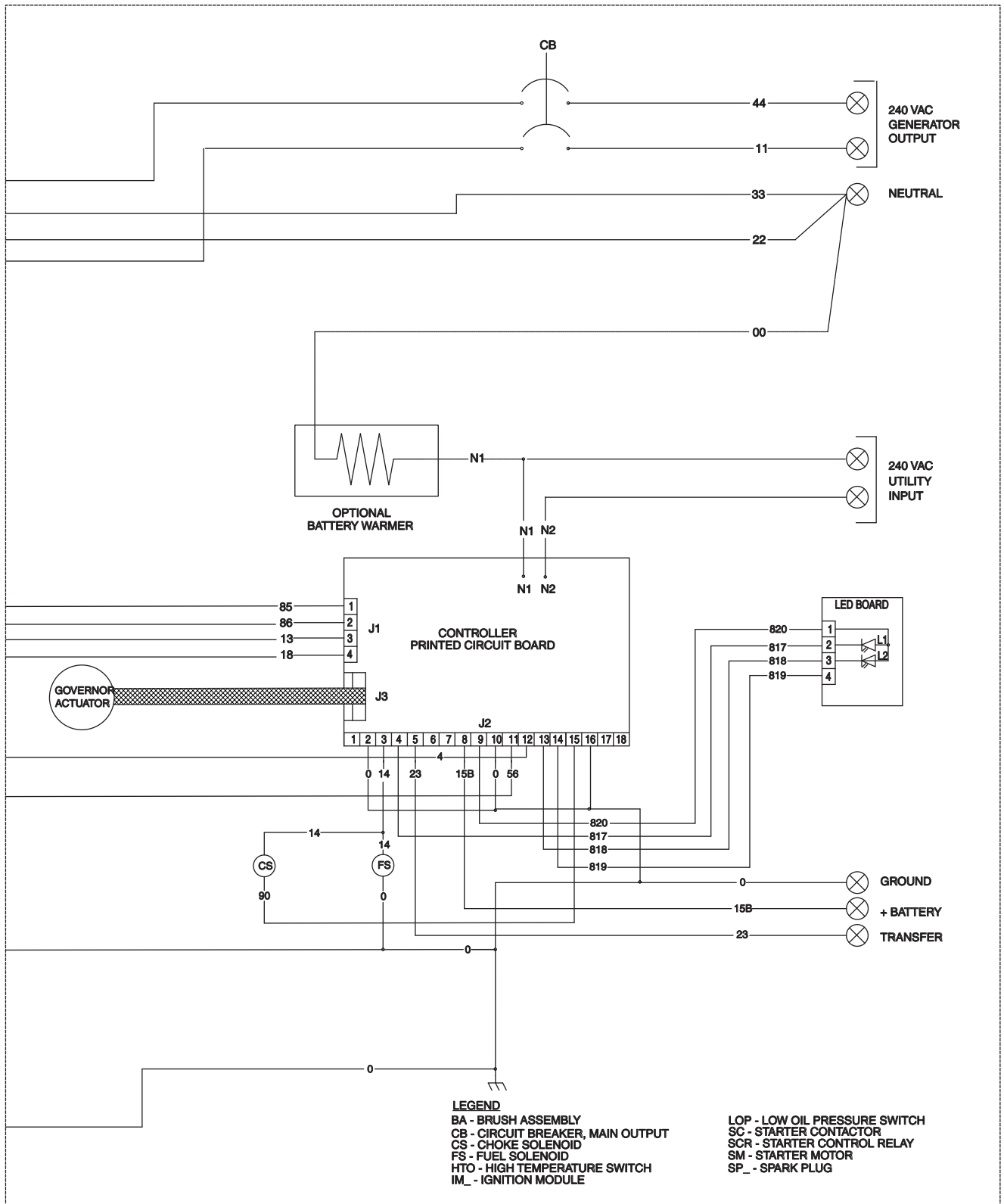

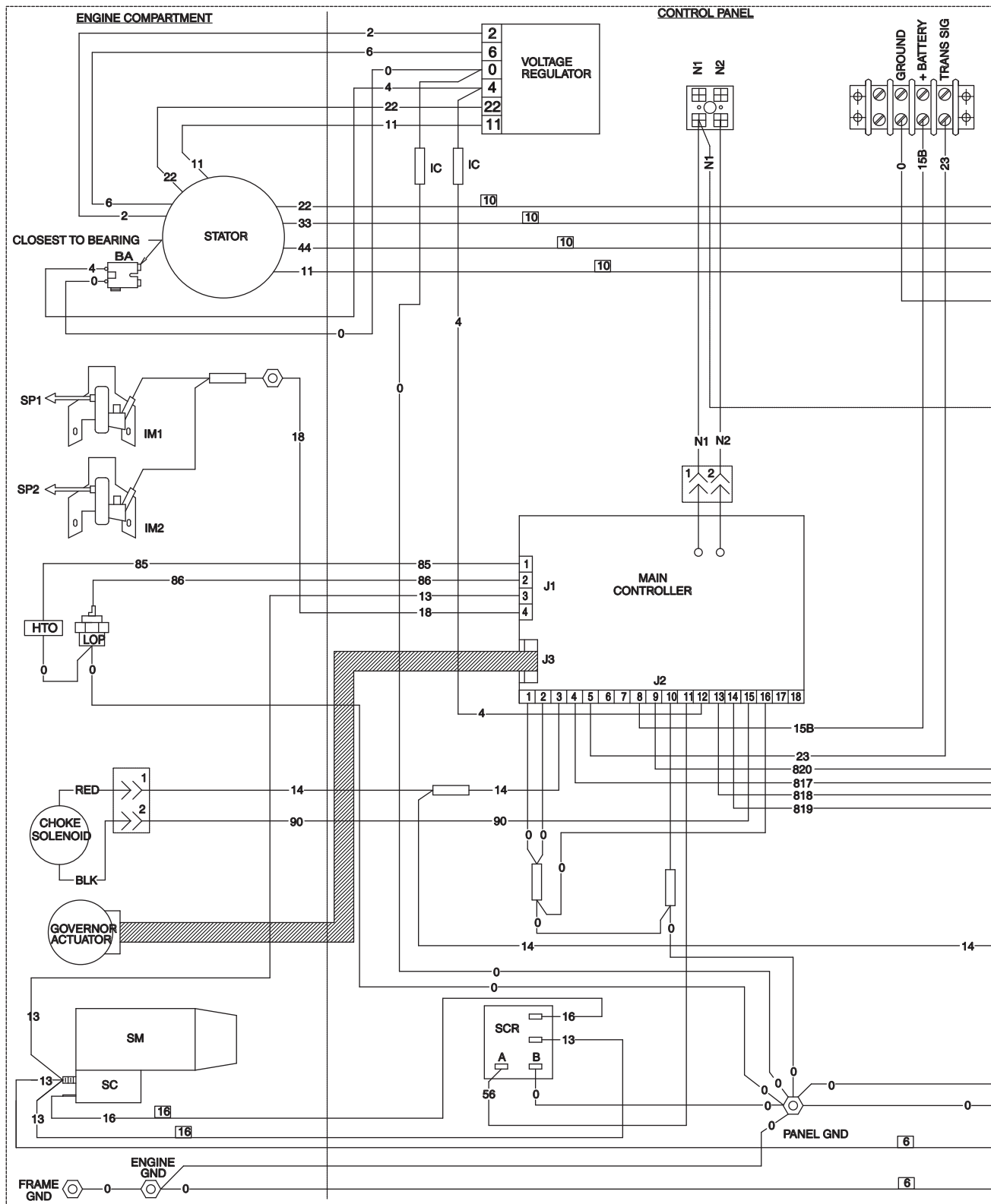

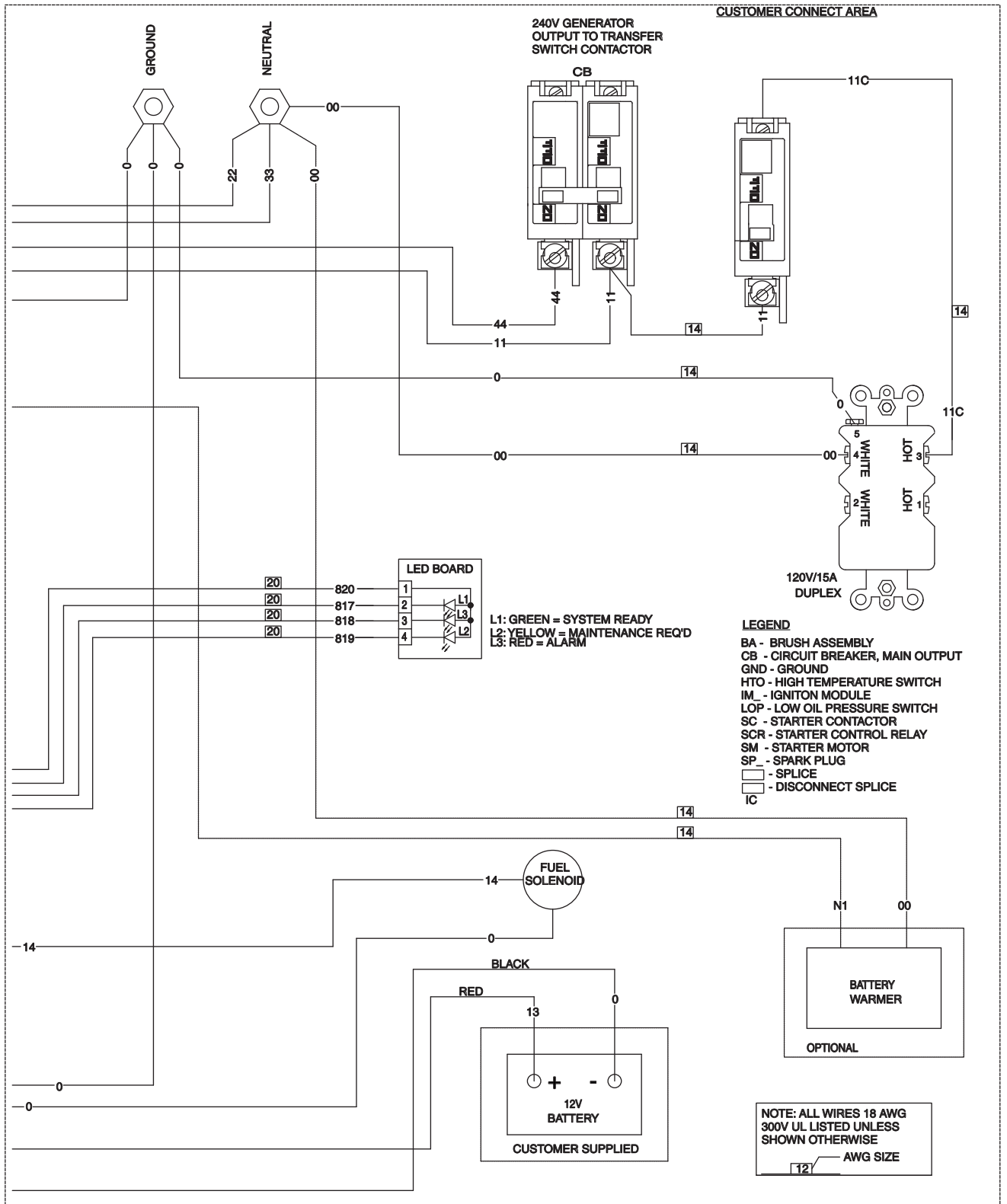

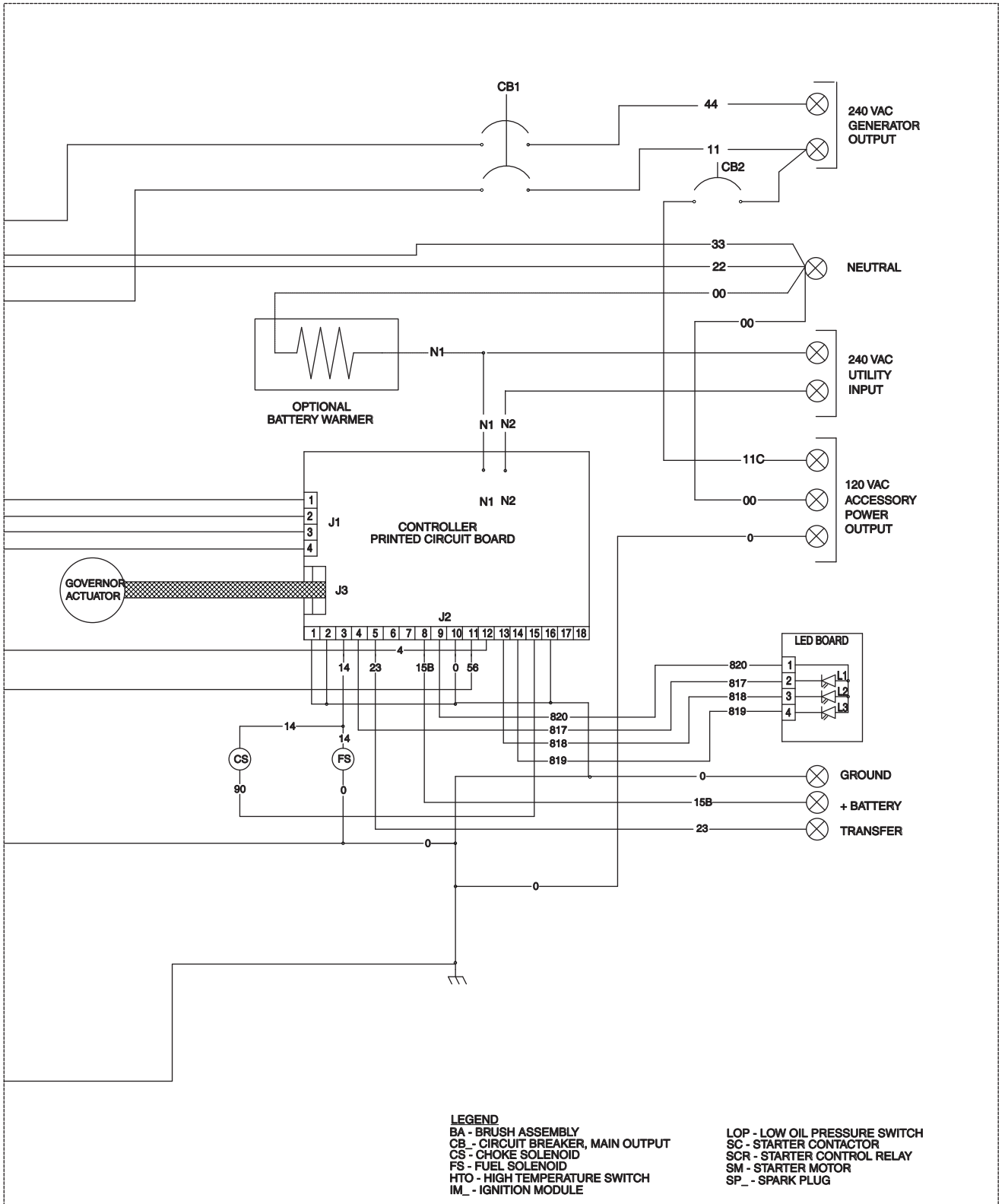

DRAWING #0G8186

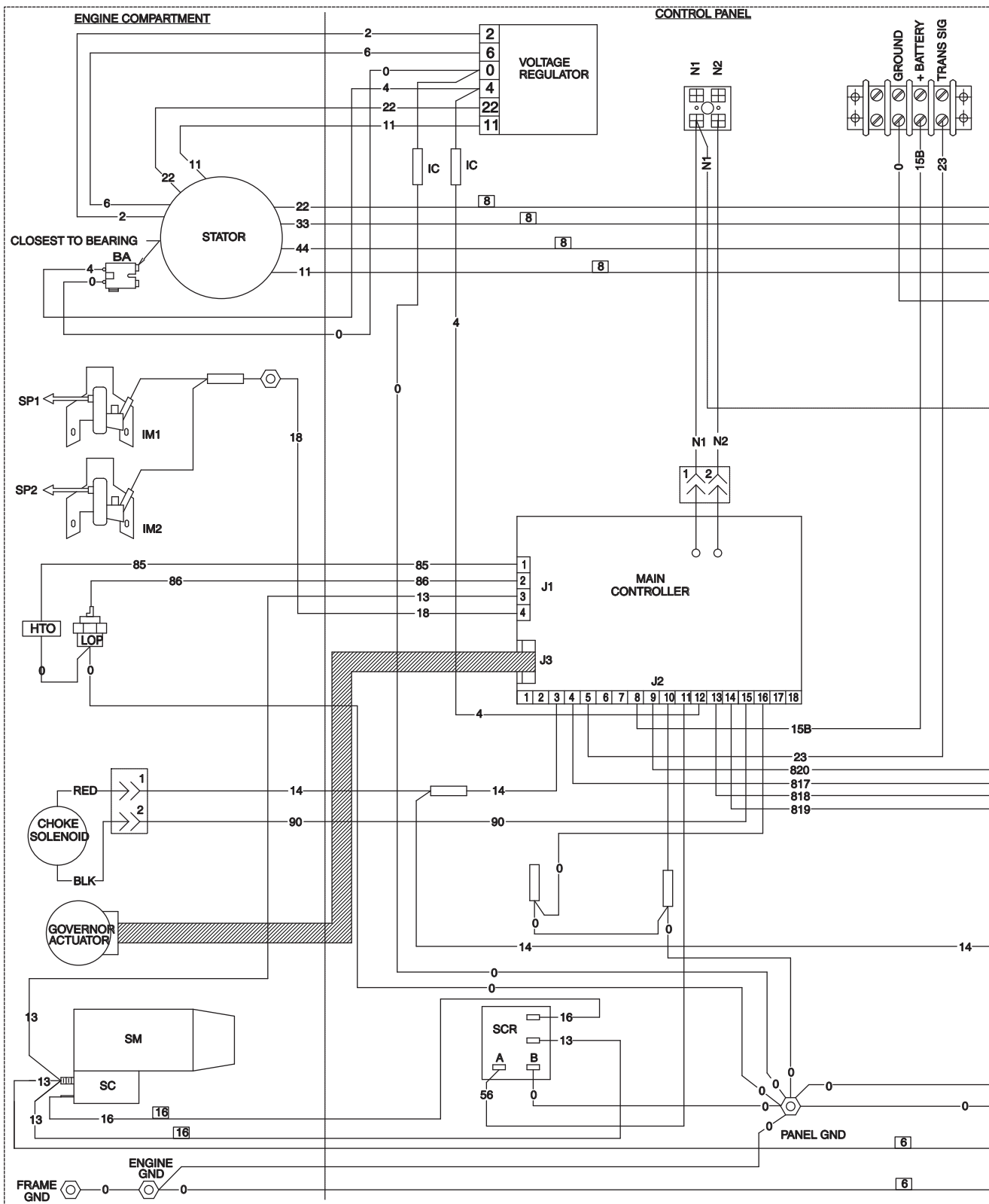

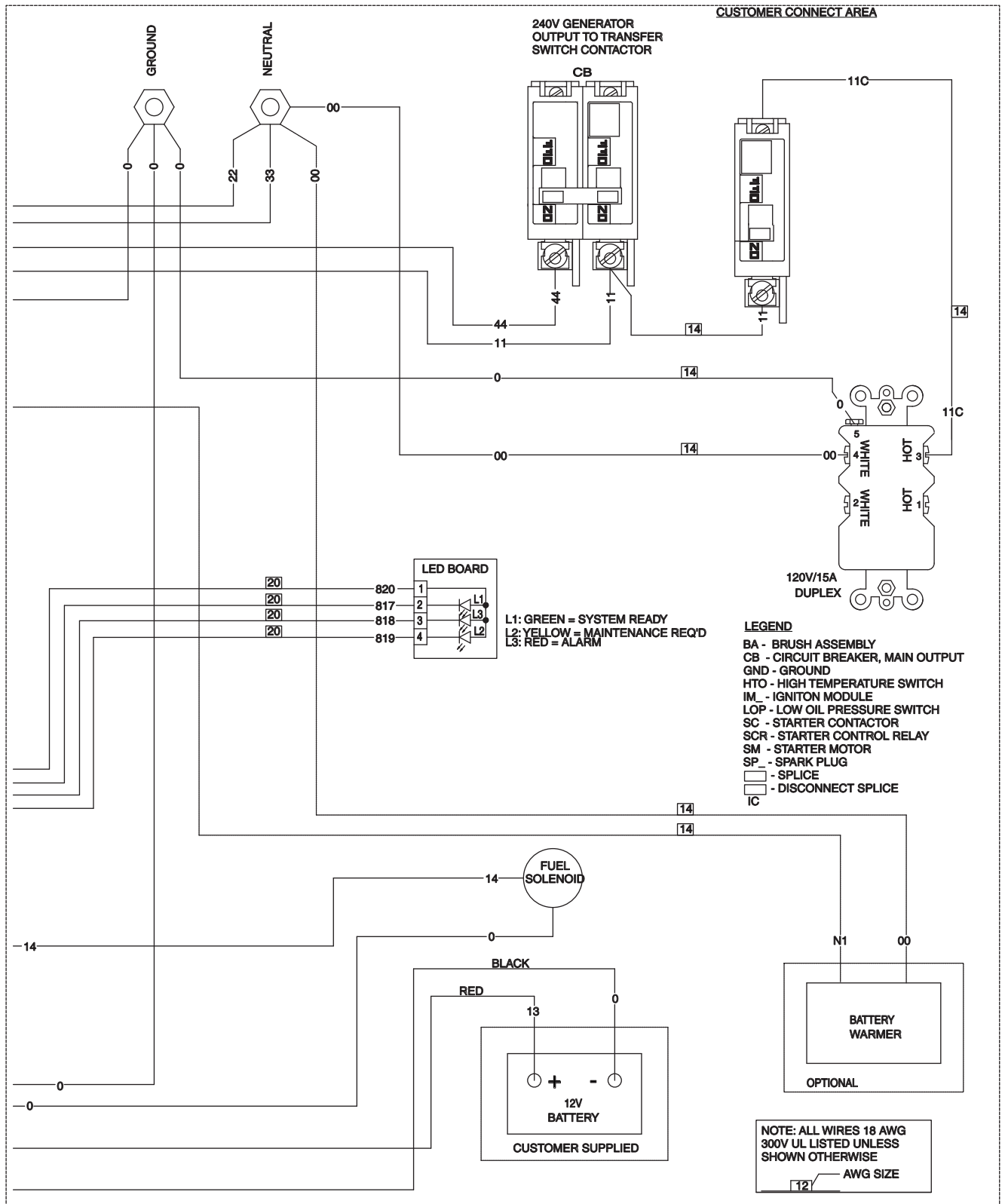

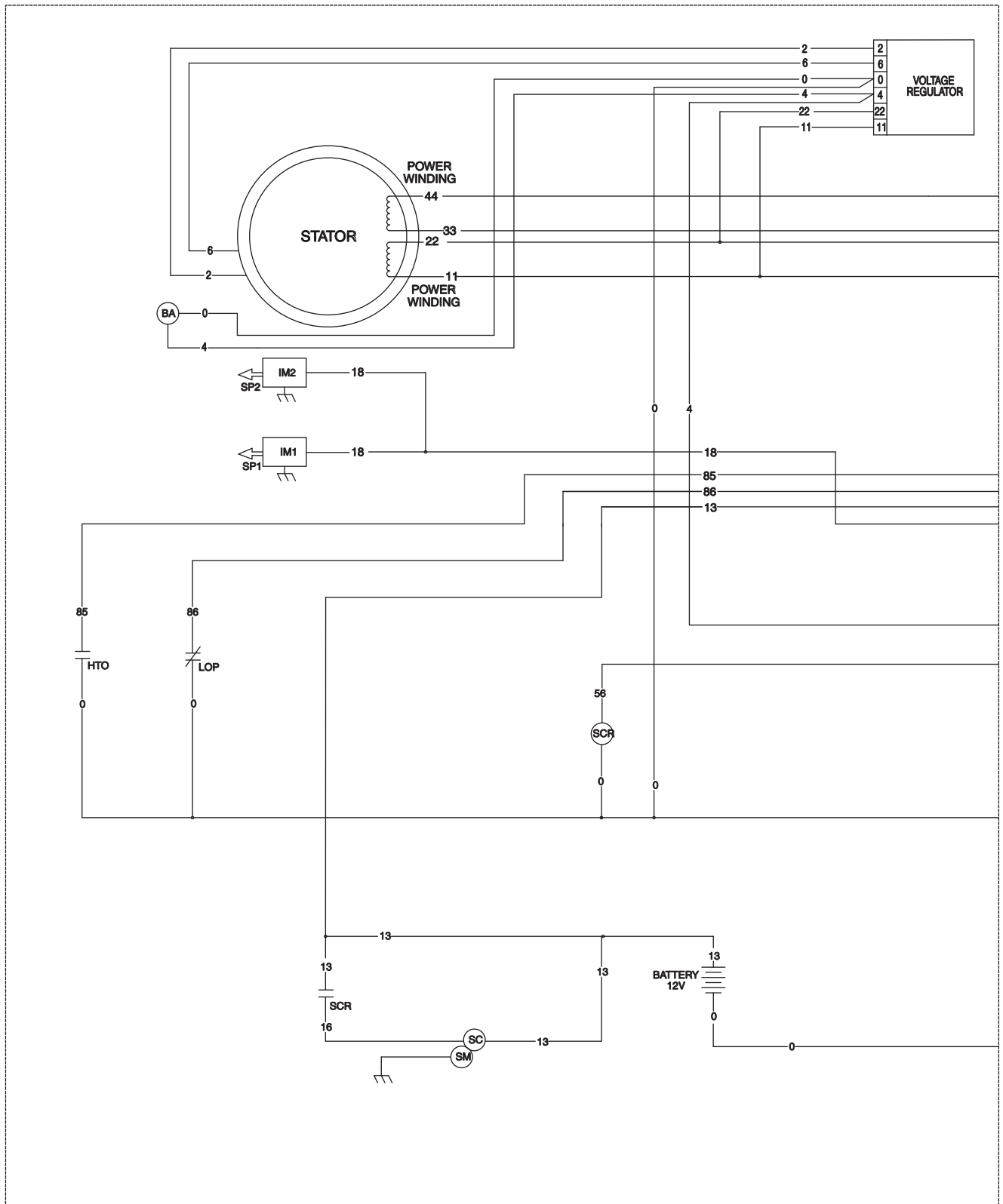

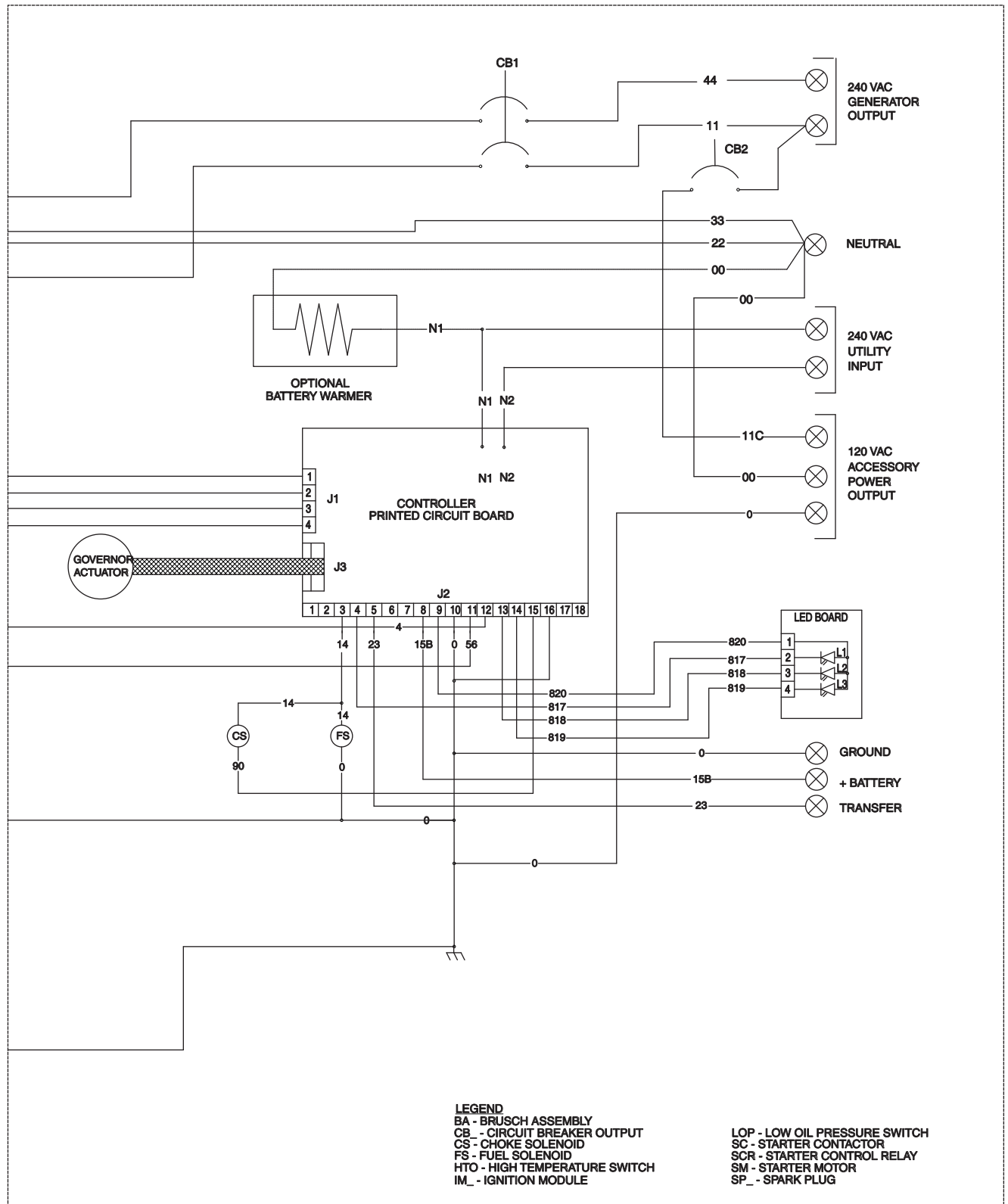

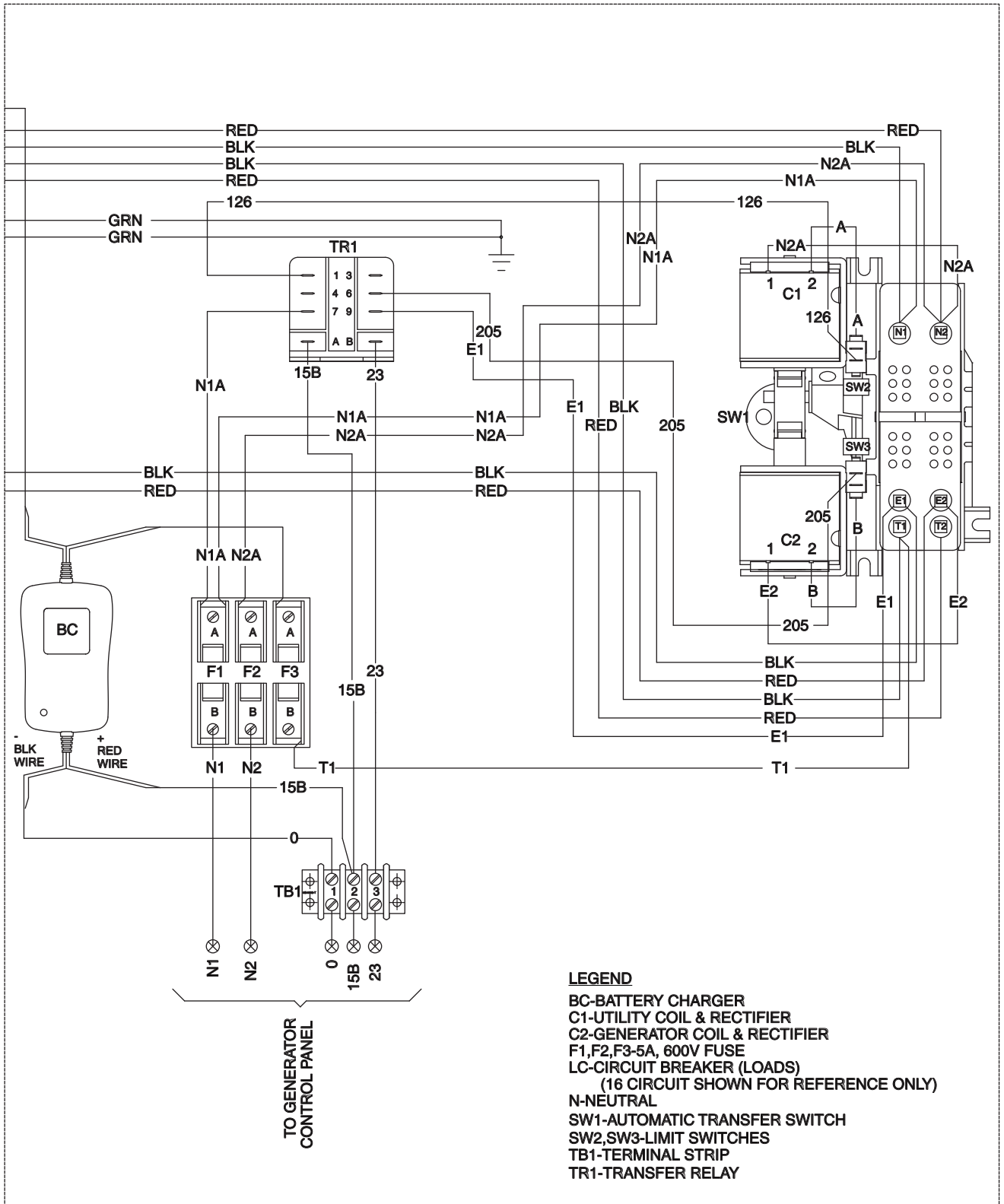

SCHEMATIC, HOME STANDBY TRANSFER SWITCH, 9/10/12/16 CIRCUIT

PART 7

ELECTRICAL DATA

DRAWING #0G7959

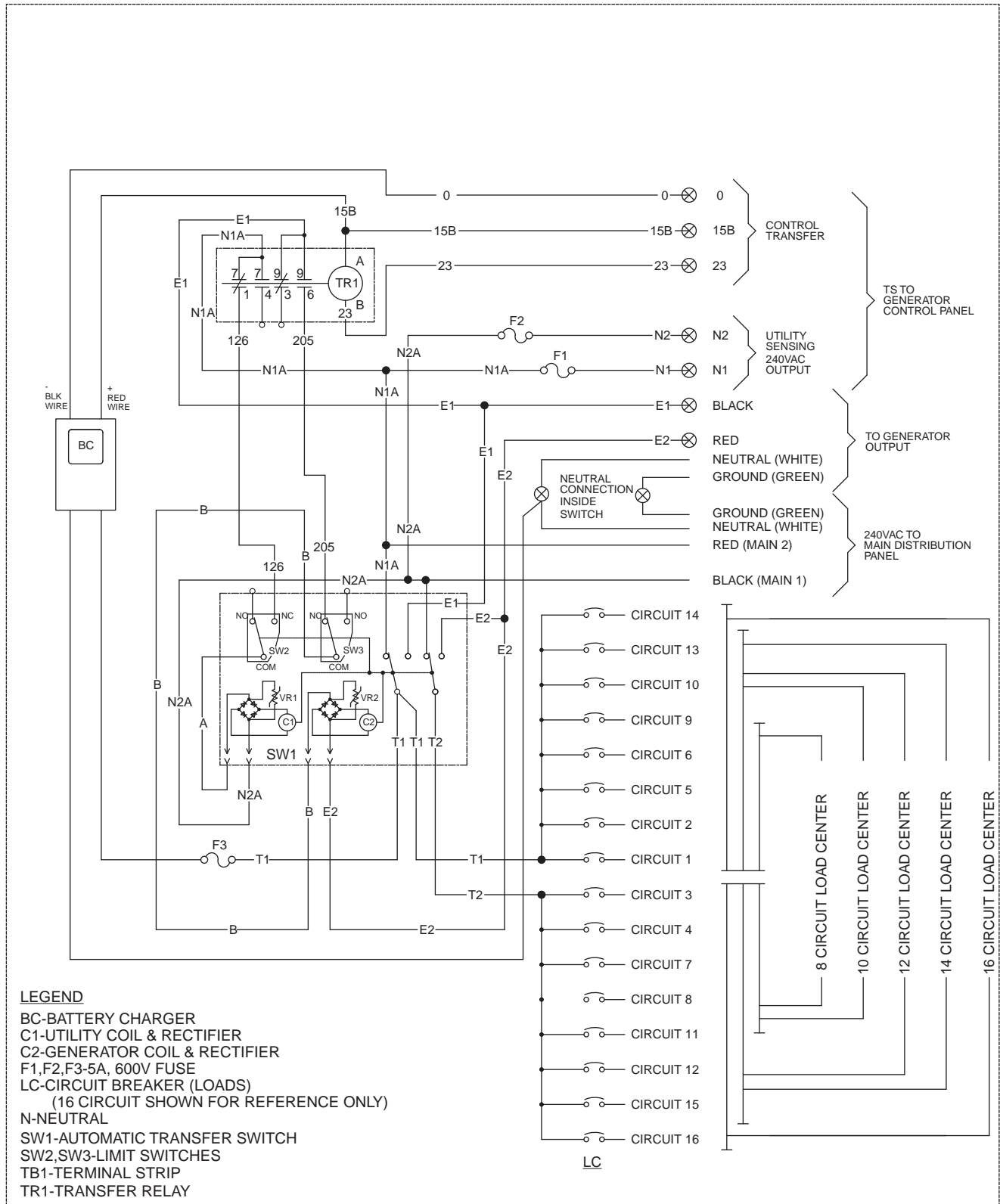

GENERAC[®]
POWER SYSTEMS, INC.

Generac Power Systems, Inc.
Highway 59 & Hillside Rd.
P.O. Box 8

Waukesha, WI 53187
1-888-GENERAC

MyGenerac.com

©2008 Generac Power Systems, Inc. All rights reserved.
Specifications are subject to change without notice.
Part No. 0G9266 rev. A / Printed in USA 09.08