

# DIAGNOSTIC REPAIR Manual

---

## PREPACKAGED HOME STANDBY GENERATORS

8 kW Air-Cooled  
10.0, 12.5, 16 & 20 kW Liquid-Cooled

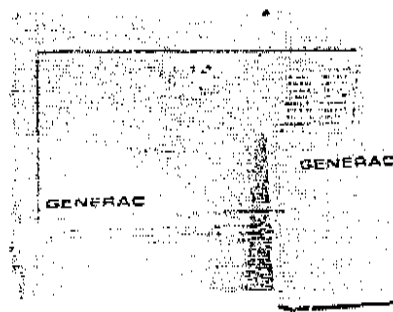

---

P. O. Box 8  
PHONE: (414) 544-4811

Waukesha, WI 53187  
FAX: (414) 544-4851

---

# GENERAC

# ELECTRICAL FORMULAS

TO FIND	KNOWN VALUES	1-PHASE	3-PHASE
KILOWATTS (kW)	Volts, Current, Power Factor	$\frac{E \times I}{1000}$	$\frac{E \times I \times 1.73 \times PF}{1000}$
KVA	Volts, Current	$\frac{E \times I}{1000}$	$\frac{E \times I \times 1.73}{1000}$
AMPERES	kW, Volts, Power Factor	$\frac{kW \times 1000}{E}$	$\frac{kW \times 1000}{E \times 1.73 \times PF}$
WATTS	Volts, Amps, Power Factor	Volts x Amps	$E \times I \times 1.73 \times PF$
NO. OF ROTOR POLES	Frequency, RPM	$\frac{2 \times 60 \times \text{Frequency}}{\text{RPM}}$	$\frac{2 \times 60 \times \text{Frequency}}{\text{RPM}}$
FREQUENCY	RPM, No. of Rotor Poles	$\frac{\text{RPM} \times \text{Poles}}{2 \times 60}$	$\frac{\text{RPM} \times \text{Poles}}{2 \times 60}$
RPM	Frequency, No. of Rotor Poles	$\frac{2 \times 60 \times \text{Frequency}}{\text{Rotor Poles}}$	$\frac{2 \times 60 \times \text{Frequency}}{\text{Rotor Poles}}$
kW (required for Motor)	Motor Horsepower, Efficiency	$\frac{HP \times 0.746}{\text{Efficiency}}$	$\frac{HP \times 0.746}{\text{Efficiency}}$
RESISTANCE	Volts, Amperes	$\frac{E}{I}$	$\frac{E}{I}$
VOLTS	Ohm, Amperes	$I \times R$	$I \times R$
AMPERES	Ohms, Volts	$\frac{E}{R}$	$\frac{E}{R}$

E = VOLTS

I = AMPERES

R = RESISTANCE (OHMS)

PF = POWER FACTOR

# SPECIFICATIONS

## GENERATOR SPECIFICATIONS:

RATED POWER	8 kW	12.5 kW	16 kW	20 kW
RATED VOLTS	120/240, 1-Phase	120/240, 1-Phase 120/240, 3-Phase 120/208, 3-Phase	120/240, 1-Phase 120/240, 3-Phase 120/208, 3-Phase	120/240, 1-Phase 120/240, 3-Phase 120/208, 3-Phase
MAX. LOAD CURRENT AT 120/240 VOLTS, 1-PHASE	66.6/33.3	104.2/52.1	133.3/66.5	166.6/83.3
MAX. LOAD CURRENT AT 120/208 VOLTS, 3-PHASE	Not Applicable	104.2/52.1	96.3/55.5	120.4/69.5
ENGINE	480 cc OHV V-Twin	1.2 Liter OHC, 4-Cylinder		
ENGINE COOLING	Air-Cooled	Liquid-Cooled		
FUEL	LP or Natural Gas			
RATED FREQUENCY	60 Hz at 3600 rpm	60 Hz at 1800 rpm	60 Hz at 3600 rpm	60 Hz at 3600 rpm
TYPE OF ROTOR	2-Pole	4-Pole	2-Pole	2-Pole
ROTOR WINDING RESISTANCE	12.6 Ohms	10.9 Ohms	8.0 Ohms	8.5 Ohms

### STATOR WINDING RESISTANCE VALUES:

#### 8 kW, 120/240 Volts, 1-Phase Units:

Battery Charge Winding ..... 0.06 Ohm  
 Excitation Winding ..... 1.09 Ohm  
 AC Power Winding (each winding) ..... 0.16 Ohm

Across Leads S3-S5 ..... 0.21 Ohm  
 Across Leads S9-S12 ..... 0.21 Ohm  
 Across Leads S2-S5 ..... 0.21 Ohm  
 Across Leads 2-6 ..... 0.75 Ohm

#### 12.5 kW, 120/240 Volts, 1-Phase Units:

Across Wires 11-22 ..... 0.13 Ohm  
 Across Wires 33-44 ..... 0.13 Ohm  
 Across Wires 5-6 ..... 0.87 Ohm

#### 16 kW, 120/240 Volts, 1-Phase Units:

Across Leads 11-22 ..... 0.10 Ohm  
 Across Leads 33-44 ..... 0.10 Ohm  
 Across Leads 2-6 ..... 0.63 Ohm

#### 12.5 kW, 120/240 Volts, 3-Phase Units:

Across Leads S1-S4 ..... 0.12 Ohm  
 Across Leads S7-S10 ..... 0.12 Ohm  
 Across Leads S8-S11 ..... 0.19 Ohm  
 Across Leads S3-S6 ..... 0.19 Ohm  
 Across Leads S9-S12 ..... 0.19 Ohm  
 Across Leads S2-S5 ..... 0.19 Ohm  
 Across Leads 2-6 ..... 0.78 Ohm

#### 16 kW, 120/240 Volts, 3-Phase Units:

Across Leads S1-S4 ..... 0.12 Ohm  
 Across Leads S7-S10 ..... 0.12 Ohm  
 Across Leads S8-S11 ..... 0.19 Ohm  
 Across Leads S3-S6 ..... 0.19 Ohm  
 Across Leads S9-S12 ..... 0.19 Ohm  
 Across Leads S2-S5 ..... 0.19 Ohm  
 Across Leads 5-6 ..... 0.94 Ohm

#### 12.5 kW, 120/208 Volts, 3-Phase Units:

Across Leads S1-S4 ..... 0.21 Ohm  
 Across Leads S7-S10 ..... 0.21 Ohm  
 Across Leads S8-S11 ..... 0.21 Ohm

(Continued on Next Page)

# SPECIFICATIONS

## STATOR WINDING RESISTANCE VALUES (CONTINUED)

### 16 kW, 120/208 Volts, 3-Phase Units:

Across Leads S1-S4	0.18 Ohm
Across Leads S7-S10	0.18 Ohm
Across Leads S8-S11	0.18 Ohm
Across Leads S3-S6	0.18 Ohm
Across Leads S9-S12	0.18 Ohm
Across Leads S2-S5	0.18 Ohm
Across Leads 5-6	0.94 Ohm

### 20 kW, 120/240 Volts, 1-Phase Units:

Across Leads 11-22	0.05 Ohm
Across Leads 33-44	0.05 Ohm
Across Leads 2-6	0.50 Ohm

### 20 kW, 120/240 Volts, 3-Phase Units:

Across Leads S1-S4	0.08 Ohm
Across Leads S7-S10	0.08 Ohm
Across Leads S8-S11	0.135 Ohm
Across Leads S3-S6	0.135 Ohm
Across Leads S9-S12	0.135 Ohm
Across Leads S2-S5	0.135 Ohm
Across Leads 5-6	0.45 Ohm

### 20 kW, 120/208 Volts, 3-Phase Units:

Across Leads S1-S4	0.15 Ohm
Across Leads S7-S10	0.15 Ohm
Across Leads S8-S11	0.15 Ohm
Across Leads S3-S6	0.15 Ohm
Across Leads S9-S12	0.15 Ohm
Across Leads S2-S5	0.15 Ohm
Across Leads 5-6	0.39 Ohm

## AIR-COOLED V-TWIN ENGINE SPECIFICATIONS

Type of Engine	Twin Cylinder
Cooling	Air-Cooled
Rated Horsepower	16 at 3000 rpm
Displacement	480 cc's
Compression Ratio	8.5 to 1
Cylinder Block	Aluminum with cast iron sleeve
Type of Governor	Mechanical, Fixed Speed
Governed Speed	3600 rpm
Air Cleaner	Paper element with foam pre-cleaner
Type of Starter	12 volts DC electric
Ignition System	Solid State with flywheel magneto
Recommended Spark Plugs	
Champion	RC12YC
AC	R45S
Fram Autolite	65
Spark Plug Gap	0.030 inch
Armature Air Gap	0.008-0.012 inch
Valve Clearance- Cold	0.004-0.006 inch
Oil Filter	FRAM PH3614
Engine Cranking Current	100 DC amperes

### Engine Torque Specifications:

Engine Flywheel	125 foot-pounds
Cylinder Head Bolts	165 inch-pounds
Connecting Rod	115 inch-pounds
Crankcase Cover	150 inch-pounds
Governor Lever Lock Nut	70 inch-pounds
Spark Plugs	200 inch-pounds
Starter Mounting Bolts	140 inch-pounds

NOTE: A service manual is available for the V-Twin engine. The manual is entitled "V-Twin OHV Horizontal and Vertical Shaft Engines" and may be ordered by specifying Manual Part No. 81134.

## LIQUID-COOLED 1.2 LITER ENGINE SPECIFICATIONS

Number of Cylinders	4, In-Line
Cooling	Liquid-Cooled
Valve Arrangement	Overhead Cam
Displacement	1.2 liters (73 Cu. In.)
Compression Ratio	9.0 to 1
Rated Horsepower	42 at 3600 rpm
Crankcase Oil Capacity	3.0 U.S. quarts (with filter change)
Cooling System Capacity	2 U.S. gallons
Type of Cooling System	Pressurized, closed recovery
Air Cleaner	Replaceable dry type cartridge
Cooling Air Requirements	1590 cubic feet/Min.
Combustion Air Requirements	72 cubic feet/Min.
Governor	Mechanical, Fixed Speed
Starter	12 volts DC electric

THE 8 KW, AIR-COOLED PREPACKAGED GENERATOR

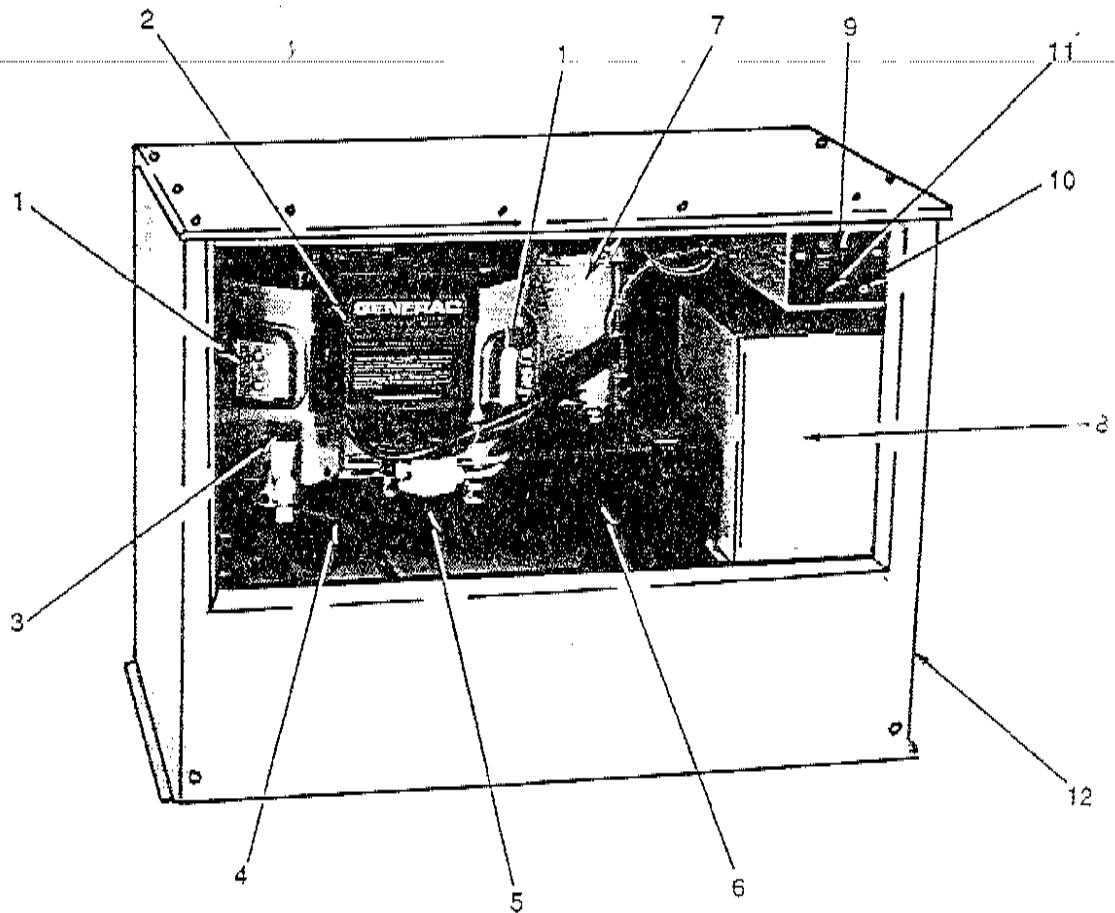

ITEM	NOMENCLATURE	ITEM	NOMENCLATURE
1	Engine Valve Cover	7	AC Generator
2	Engine Air Cleaner	8	Battery Compartment
3	Oil Dipstick & Fill Tube	9	Line Circuit Breaker
4	Oil Drain Hose	10	15 amp Fuse
5	Oil Filter	11	Auto-Off-Manual Switch
6	Oil Makeup Tank	12	Enclosure

# SPECIFICATIONS

## TYPICAL PREPACKAGED GENERATOR WITH 1.2 LITER ENGINE

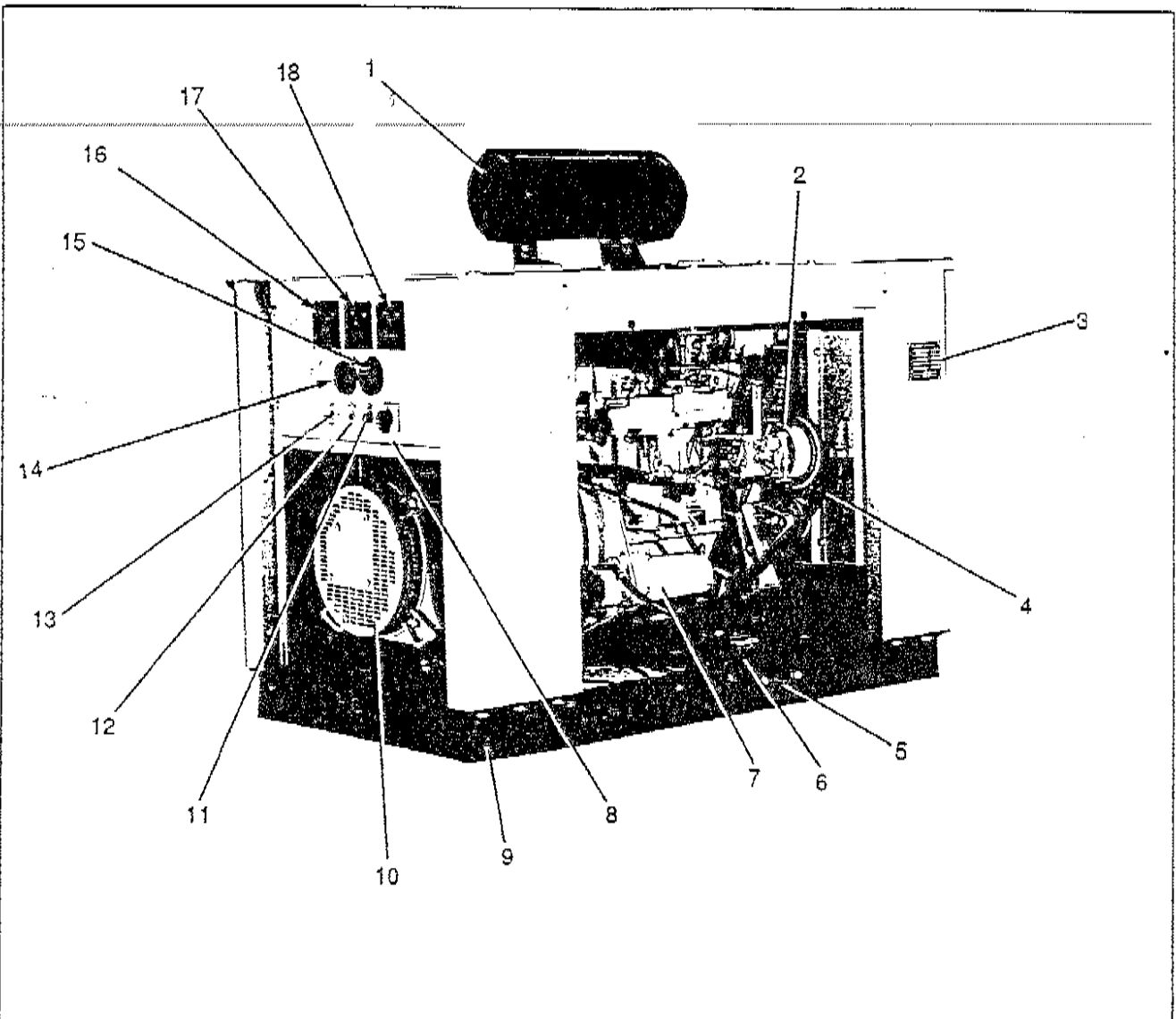

ITEM	DESCRIPTION	ITEM	DESCRIPTION
1	Exhaust Muffler	10	Bearing Carrier Cover
2	Engine Governor	11	30 Amp Fuse
3	Data Plate	12	Fault Indicator Lamp
4	Oil Drain Hose	13	Auto-Off-Manual Switch
5	Fuel Connection	14	Battery Voltmeter
6	Fuel Solenoid Valve	15	Hourmeter
7	Starter Motor	16	AC Voltmeter
8	Voltage-Phase Selector Switch	17	AC Ammeter
9	Mounting Base	18	AC Frequency Meter

**DIAGNOSTIC  
REPAIR  
MANUAL**

GENERAC II  
**PREPACKAGED  
HOME STANDBY  
ELECTRIC POWER  
SYSTEMS**

**TABLE OF CONTENTS**

PART	TITLE
1	General Information
2	Prepackaged Air-Cooled AC Generators
3	Prepackaged Liquid Cooled AC Generators
4	"V-Type" Prepackaged Transfer Switches
5	"Y-Type" Prepackaged Transfer Switches
6	DC Control- Units with Air-Cooled Engine
7	DC Control- Liquid Cooled Engine Units
8	Operational Tests and Adjustments
9	Electrical Data

# NOTES

---

**PART 1**  
**GENERAL**  
**INFORMATION**

GENERAC II  
**PREPACKAGED**  
**HOME STANDBY**  
**ELECTRIC POWER**  
**SYSTEMS**  
8 kW Air-Cooled  
10, 12.5, 16 & 20 kW Liquid-Cooled

**TABLE OF CONTENTS**

SECTION	TITLE
1.1	Generator Identification
1.2	AC Connection Systems
1.3	Prepackaged Installation Basics
1.4	Preparation Before Use
1.5	Testing, Cleaning and Drying
1.6	Engine-Generator Protective Devices
1.7	Operating Instructions
1.8	Automatic Operating Parameters

# NOTES

---

Section 1.1  
**GENERATOR IDENTIFICATION**

**Introduction**

This *Diagnostic Repair Manual* has been prepared especially for the purpose of familiarizing service personnel with the testing, troubleshooting and repair of *Generac II* prepackaged home standby systems. Every effort has been expended to ensure that information and instructions in the manual are both accurate and current. However, Generac reserves the right to change, alter or otherwise improve the product at any time without prior notification.

The manual has been divided into ten PARTS. Each PART has been divided into SECTIONS. Each SECTION consists of two or more SUBSECTIONS.

It is not our intent to provide detailed disassembly and reassembly instructions in this manual. It is our intent to (a) provide the service technician with an understanding of how the various assemblies and systems work, (b) assist the technician in finding the cause of malfunctions, and (c) effect the expeditious repair of the equipment.

**Units with Air-Cooled V-Twin Engine**

See Page 3 at front of this manual. These units are driven by an air-cooled, "V-Twin" engine. The driving engine and AC generator are mounted vertically and side by side inside an all-weather enclosure. The AC generator is a "2-bearing" type and is driven by the engine through a belt and pulley arrangement.

A DATA PLATE is prominently affixed to the unit. The unit Model Number, Serial Number, wattage rating and other pertinent information can be found on this DATA PLATE (see Figure 1).

**Units with Liquid Cooled Engine**

A typical prepackaged generator with liquid cooled engine is shown on Page 4 at front of this manual.

A DATA PLATE, affixed to the unit, contains important information pertaining to the unit, including its Model Number, Serial Number, kW rating, rated rpm, rated voltage, etc.

In addition to the data plate, a DATA CARD is included with each unit shipped from the factory. A typical data card is shown in Figure 2. You may be asked to supply some of the information from the data card when requesting information, ordering parts, etc. The card lists the following information:

**MODEL NUMBER:**

Many home standby generators are manufactured to the unique specifications of the buyer. The Model Number identifies the specific generator set and its unique design specifications.

**DATE:**

Indicates the date of manufacture for the unit.

**GENERATOR IDENTIFICATION CODE:**

Specific features of the generator, as well as any options that might be installed, are included in this code. The various parts of the identification code are identified on Page 1.1-2. Also see "Voltage Code" in this section.

**GROUP LETTERS/ASSEMBLY NUMBERS:**

The various GROUPS (or subassemblies) that make up the entire generator set are identified by means of the letters "A" through "G". Adjacent to the GROUP letter is the GROUP DESCRIPTION and one or more ASSEMBLY NUMBERS. Assembly numbers refer to specific engineering drawings, exploded views and electrical diagrams applicable to a specific GROUP.

**Voltage Codes**

The letter following the "Rated Kilowatts" numeral in the generator identification code indicates the unit's rated voltage, phase and AC frequency. At the time of this writing, liquid cooled prepackaged units were available with Voltage Codes "A", "B" or "D" (see CHART below). Additional information on these Voltage Codes and what they mean can be found in Section 1.2, "AC Connection Systems".

VOLTAGE CODE	RATED VOLTAGE	PHASE	RATED FREQUENCY
A	120/240	1	60 Hz
B	120/208	3	60 Hz
D	120/240	3	60 Hz

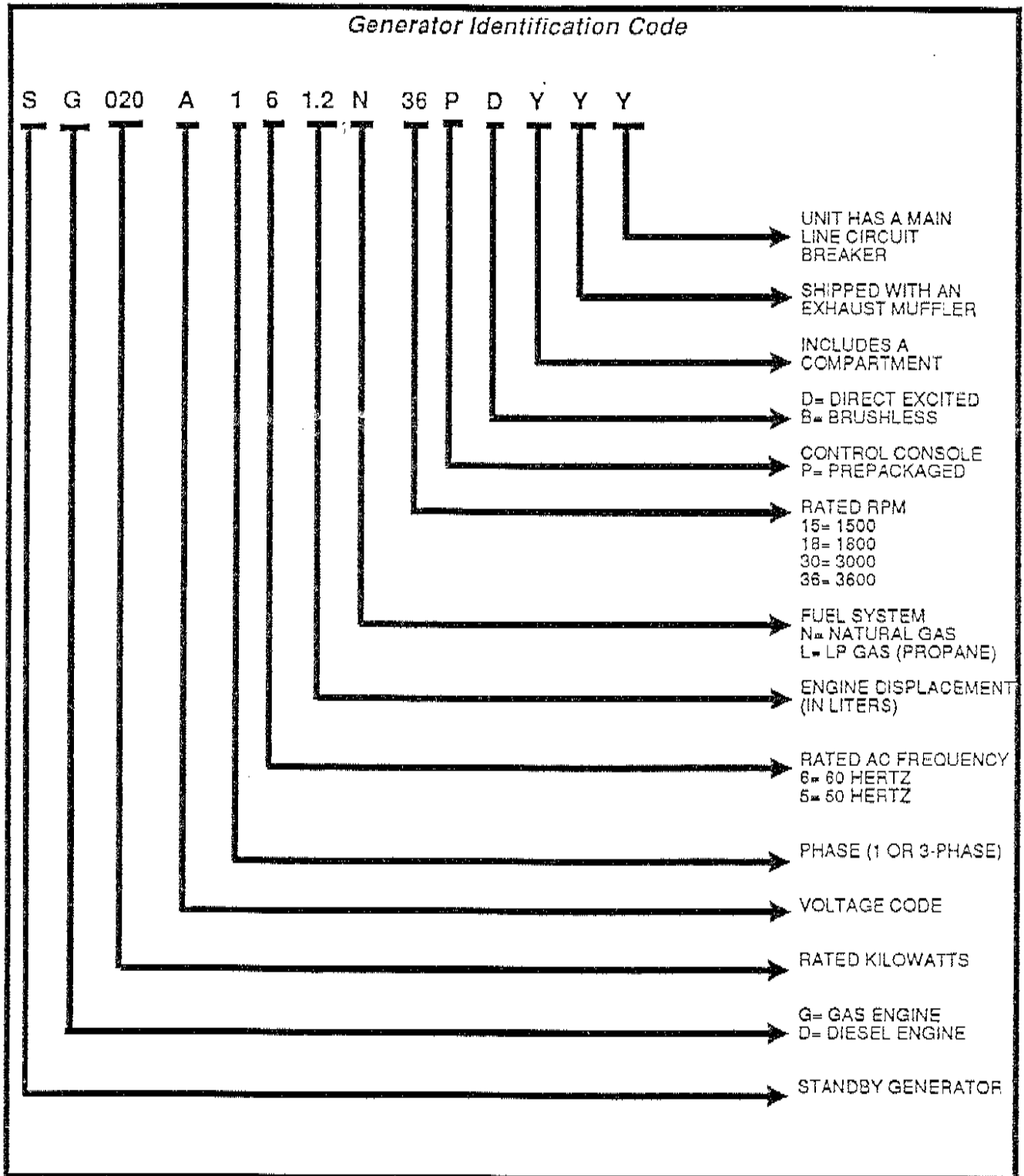

**PART 1  
GENERAL INFORMATION**

**SECTION 1.1  
GENERATOR IDENTIFICATION**

ALTERNATOR DATA			
MODEL	<input type="text"/>	KVA	<input type="text"/>
SERIAL	<input type="text"/>	PHASE	<input type="text"/>
VOLTS	<input type="text"/>	HERTZ	<input type="text"/>
AMPS	<input type="text"/>	RPM	<input type="text"/>
POWER FACTOR	<input type="text"/>	KW	<input type="text"/>
CLASS F WINDING INSULATION AT 40° C.			
<b>GENERAC CORP. WAUKESHA, WI</b>			
45452	MADE IN U.S.A.		

*Figure 1. A Typical Data Plate*

GENERAC CORP.			
MODEL NO. 91A01256S		DATE 5/09/91	
SG012-A101 2N18CDYNY			
GROUP	DESCRIPTION	ASSEMBLY NUMBERS	
A	Generator	00000	00000
B	Control Panel	00000	00000 00000
C	Mounting Base	00000	00000
D	Engine & Accy.	00000	
E	Fuel System	00000	
G	Wiring Diagram	00000	00000 00000

*Figure 2. A Typical Data Card*



**Section 1.2  
AC CONNECTION SYSTEMS**

**Voltage Codes**

Also see "Voltage Codes" on Page 1.1-1. At the present time, prepackaged home standby generators were available with voltage codes "A", "B" or "D".

**Voltage Code "A"**

Units with voltage code "A" are rated 120/240 volts, 1-phase, 60 Hz. Dual stator AC power windings each supply 120 volts AC; when the two windings are connected together in series, a 240 volts AC output results.

See Figure 1. The stator AC power windings are connected to form a "3-wire" connection system in which leads 11 and 44 form the two "hot" lines; and the junction of Leads 22 and 33 form the "neutral" line.

**Voltage Code "B"**

These units are rated 120/208 volts, 3-phase, 60 Hz. The stator's AC power winding is a "parallel wye" type as shown in Figure 2. The winding consists of six (6) coils, with twelve (12) leads brought out into the generator's AC connection (lower) panel. The leads are numbered S1 through S12. The twelve leads are connected together by means of "bolted" junctions, as shown in the following chart, to form Lines E1, E2, E3 and "neutral" (00). Also see Figure 3.

BOLTED JUNCTION	CONNECT LEADS	TO FORM
1	S4, S5, S6, S10, S11, S12	Neutral (00)
2	S1 and S7	Line E1
3	S2 and S8	Line E2
4	S3 and S9	Line E3

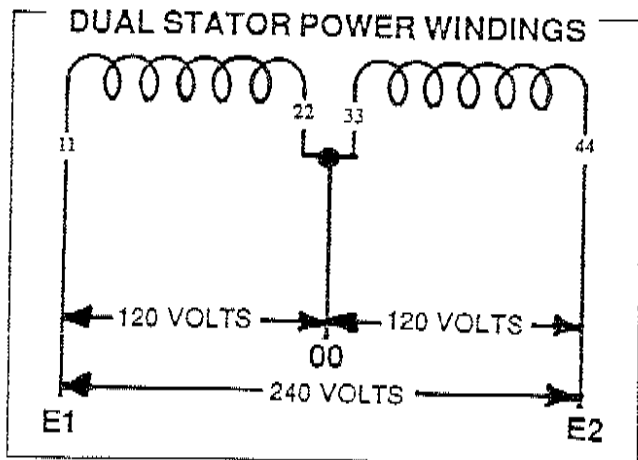

Figure 1. Stator Windings- Voltage Code "A"

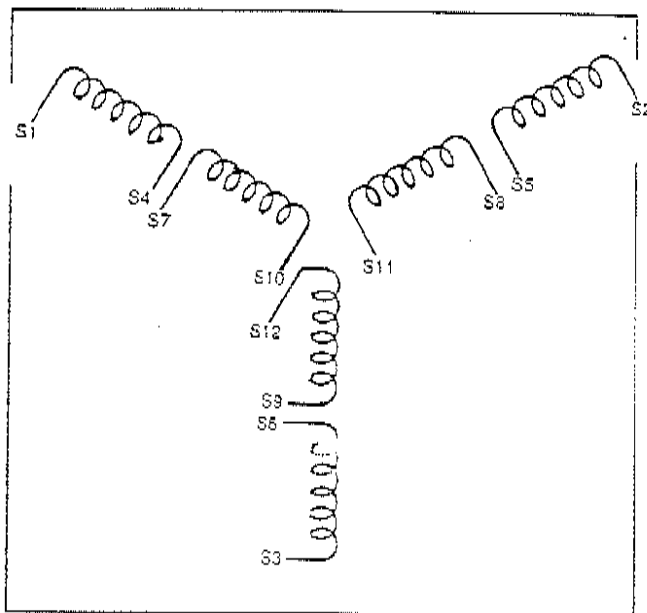

Figure 2. Stator Windings- Voltage Code "B"

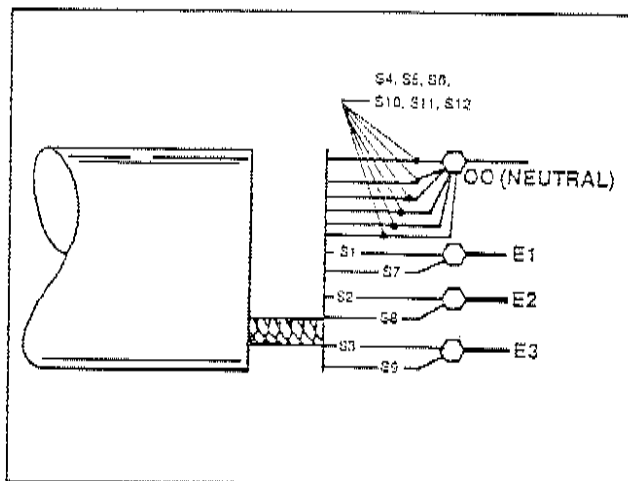

Figure 3. Bolted Junctions- Voltage Code "B"

**Voltage Code "D"**

These units are rated 120/240 volts, 1 or 3-phase, 60 Hz. The stator AC power windings are "delta connected". Two of the stator's six (6) coils are double-wound, to supply the unit's full rated capacity at 1-phase. When used as a 120/240 volts, 1-phase system, connect leads as follows:

- Connect 240 volts AC loads across Lines E1 and E3.
- Connect 120 volts AC loads across Lines E1 to 00; or across lines E3 to 00.

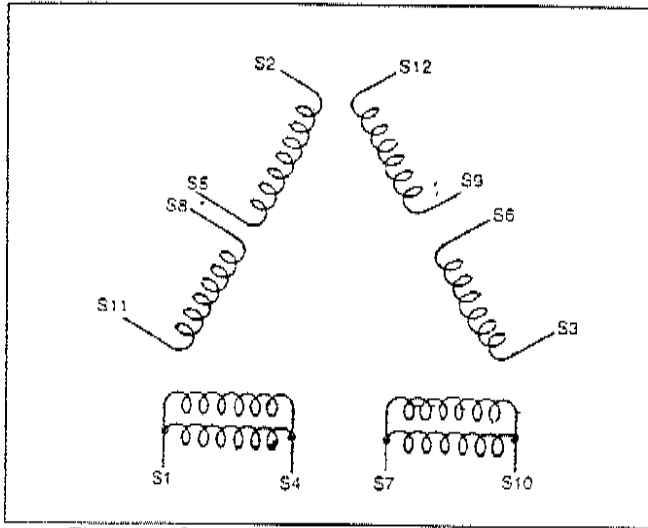

Figure 4. Stator Windings- Voltage Code "D"

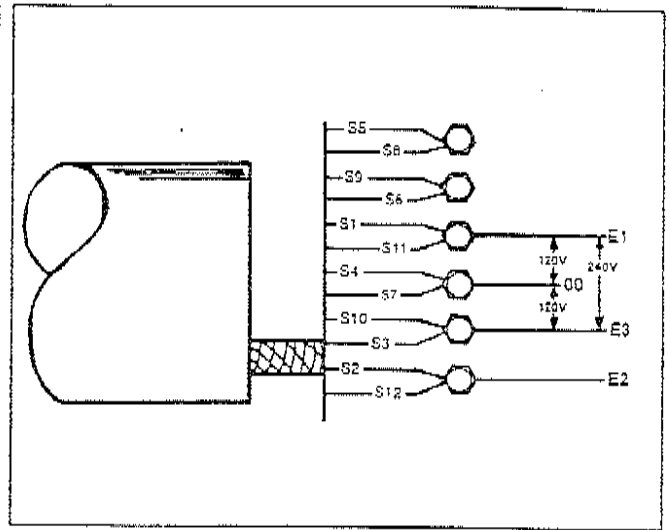

Figure 5. Bolted Junctions- Voltage Code "D"

# PREPACKAGED INSTALLATION BASICS

## Introduction

Information in this section is provided so that the service technician will have a basic knowledge of installation requirements for prepackaged home standby systems. Problems that arise are often related to poor or unauthorized installation practices.

A typical prepackaged home standby electric system is shown in Figure 1, below. Installation of such a system includes the following:

- Selecting a location.
- Mounting of the generator.
- Grounding the generator.
- Providing a fuel supply.
- Mounting the transfer switch.
- Connecting power source and load lines.
- Connecting system control wiring.
- Post installation tests and adjustments.

## Selecting a Location

Install the generator set as close as possible to the electrical load distribution panel(s) that will be powered by the unit. This will reduce wiring and conduit lengths. Wiring and conduit not only add to the cost of the installation, but excessively long wiring runs can result in a voltage drop.

## Mounting the Generator

Mount the generator set to a concrete slab. The slab should extend past the generator and to a distance of at least twelve (12) inches on all sides. The unit can be retained to the concrete slab with masonry anchor bolts.

## Grounding the Generator

The National Electric Code requires that the frame and external electrically conductive parts of the generator be properly connected to an approved earth ground. Local electrical codes may also require proper grounding of the unit. For that purpose, a grounding lug is attached to the unit. Grounding may be accomplished by attaching a stranded copper wire of the proper size to the generator's grounding lug and to an earth-driven copper or brass grounding rod (electrode). Consult with a local electrician for grounding requirements in your area.

## The Fuel Supply

Prepackaged units with air-cooled engine were operated, tested and adjusted at the factory using nat-

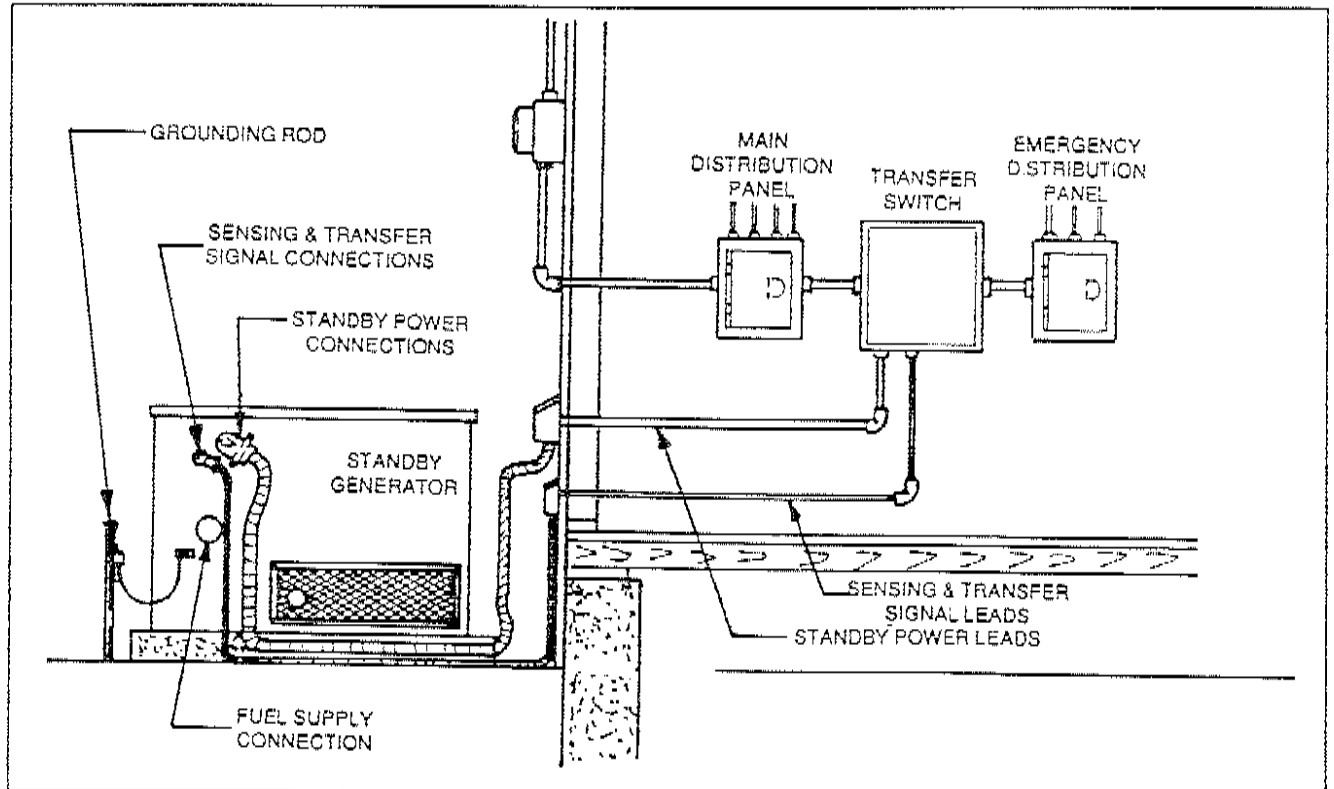

Figure 1. Typical Prepackaged Installation

*The Fuel Supply (Continued)*

ural gas as a fuel. These air-cooled engine units can be converted to use LP (propane) gas by making a few adjustments for best operation and power.

Units with liquid cooled engine are shipped from the factory with either a natural gas fuel system, or with an LP (propane) gas fuel system. It is the responsibility of the installer to ensure that models with natural gas fuel system are used only with a natural gas fuel supply; and that units with LP gas fuel system are used only with an LP gas fuel supply.

LP (propane) gas is usually supplied as a liquid in pressure tanks. Both the air-cooled and the liquid cooled units require a "vapor withdrawal" type of fuel supply system when LP (propane) gas is used. The vapor withdrawal system utilizes the gaseous fuel vapors that form at the top of the supply tank.

The pressure at which LP gas is delivered to the generator's fuel solenoid valve may vary considerably, depending on ambient temperatures. In cold weather, supply pressures may drop to "zero". In warm weather, extremely high gas pressures may be encountered. A primary regulator may be required to maintain correct gas supply pressures.

Recommended gaseous fuel pressure at the inlet side of the generator's fuel solenoid valve is (a) a minimum of 11 inches water column (6.38 ounces per square inch), and (b) a maximum of 14 inches water column (8 ounces per square inch). A primary regulator may be required to ensure that proper fuel supply pressures are maintained.

**DANGER: LP AND NATURAL GAS ARE BOTH HIGHLY EXPLOSIVE. GASEOUS FUEL LINES MUST BE PROPERLY PURGED AND TESTED FOR LEAKS BEFORE THIS EQUIPMENT IS PLACED INTO SERVICE AND PERIODICALLY THEREAFTER. PROCEDURES USED IN GASEOUS FUEL LEAKAGE TESTS MUST COMPLY STRICTLY WITH APPLICABLE FUEL GAS CODES. DO NOT USE FLAME OR ANY SOURCE OF HEAT TO TEST FOR GAS LEAKS. NO GAS LEAKAGE IS PERMITTED. LP GAS IS HEAVIER THAN AIR AND TENDS TO SETTLE IN LOW AREAS. NATURAL GAS IS LIGHTER THAN AIR AND TENDS TO SETTLE IN HIGH PLACES. EVEN THE SLIGHTEST SPARK CAN IGNITE THESE FUELS AND CAUSE AN EXPLOSION.**

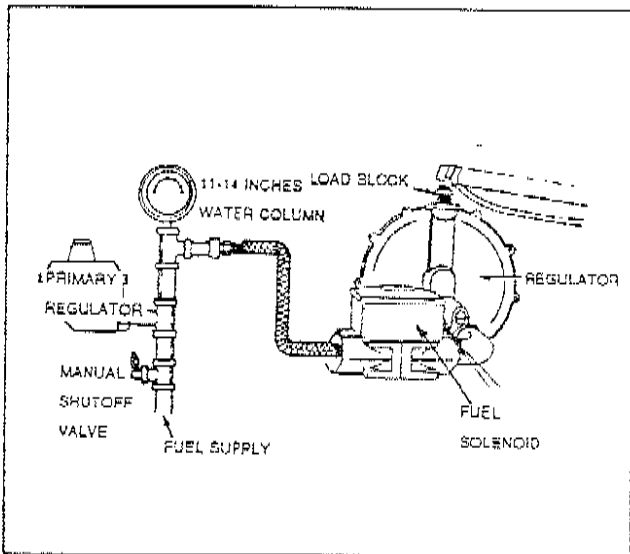

Figure 2. LP/Natural Gas System (Air-Cooled Units)

Use of a flexible length of hose between the generator fuel line connection and rigid fuel lines is required. This will help prevent line breakage that might be caused by vibration or if the generator shifts or settles. The flexible fuel line must be approved for use with gaseous fuels.

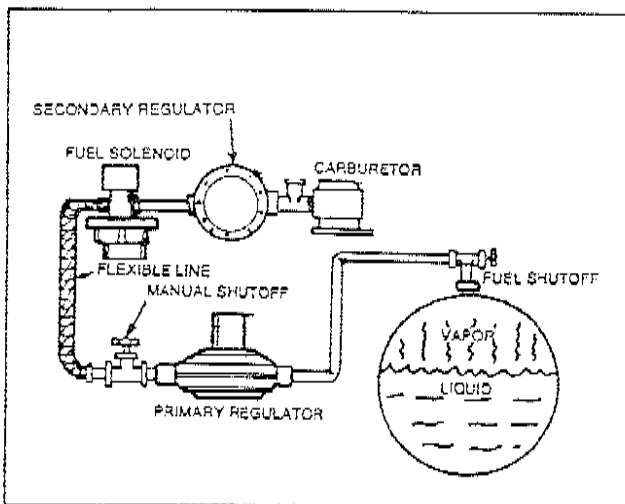

Figure 3. LP Gas System (Liquid Cooled Units)

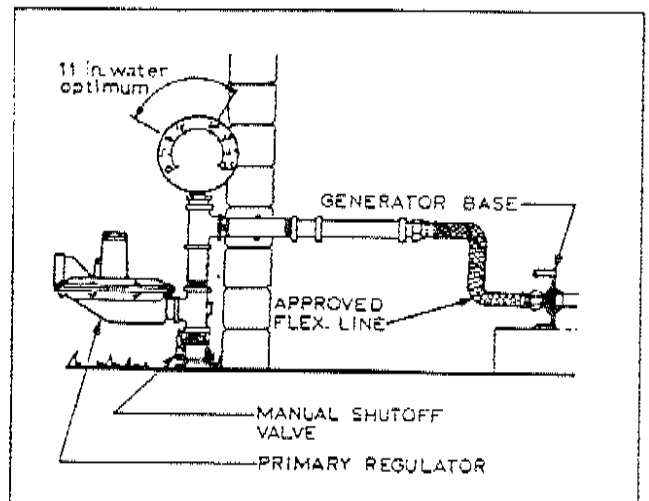

Figure 4. Natural Gas System-Liquid Cooled Units

***The Transfer Switch***

A transfer switch is required by electrical code, to prevent electrical feedback between the utility and standby power sources, and to transfer electrical loads from one power supply to another safely.

**PREPACKAGED TRANSFER SWITCHES:**

Instructions and information on prepackaged transfer switches may be found in Parts 4 and 5 of this manual. These include the "V-Type" and "Y-Type" prepackaged transfer switches.

**GENERAC "GTS" TYPE TRANSFER SWITCHES:**

Air-cooled prepackaged standby generators must be installed and used in conjunction with a compatible, approved prepackaged transfer switch.

Units with liquid cooled engine are usually installed and used in conjunction with a prepackaged transfer switch as well. However, liquid cooled units may also be installed and used in conjunction with Generac's standard "GTS" type automatic transfer switch. (See "Installation with a GTS Transfer Switch" in this section.)

***Power Source and Load Lines***

The utility power supply lines, the standby (generator) supply lines, and electrical load lines must all be connected to the proper terminal lugs in the transfer switch. The following rules apply:

In 1-phase systems with a 2-pole transfer switch, connect the two "Utility" source hot lines to transfer switch terminal lugs N1 and N2. Connect the "Standby" source hot lines (E1, E2) to transfer switch terminal lugs E1 and E2. Connect the load lines from transfer switch terminal lugs T1/T2 to the electrical load circuit. Connect "Utility", "Standby" and "Load" neutral lines to the neutral block in the transfer switch.

In 3-phase systems, where a 3-pole transfer switch is installed, connect the 3-phase "Utility" lines to transfer switch terminal lugs N1, N2 and N3; connect "Standby" lines to terminal lugs E1, E2, E3; and connect load lines to terminal lugs T1, T2 and T3. Power source and load neutral lines must be connected to the transfer switch neutral block.

***System Control Interconnections***

Prepackaged home standby generators are equipped with a terminal board identified with the following terminals: (a) utility 1, (b) utility 2, (c) load 1, (d) load 2, (e) 23, and (f) 194. Prepackaged transfer switches house an identically marked terminal board. Suitable, approved wiring must be interconnected between identically numbered terminals in the generator and transfer switch. When these six terminals are properly interconnected, dropout of utility source voltage below a preset value will result in automatic generator startup and transfer of electrical loads to the "Standby" source. On restoration of utility source voltage above a preset value will result in retransfer back to that source and generator shutdown. System control wiring must be routed through its own separate conduit.

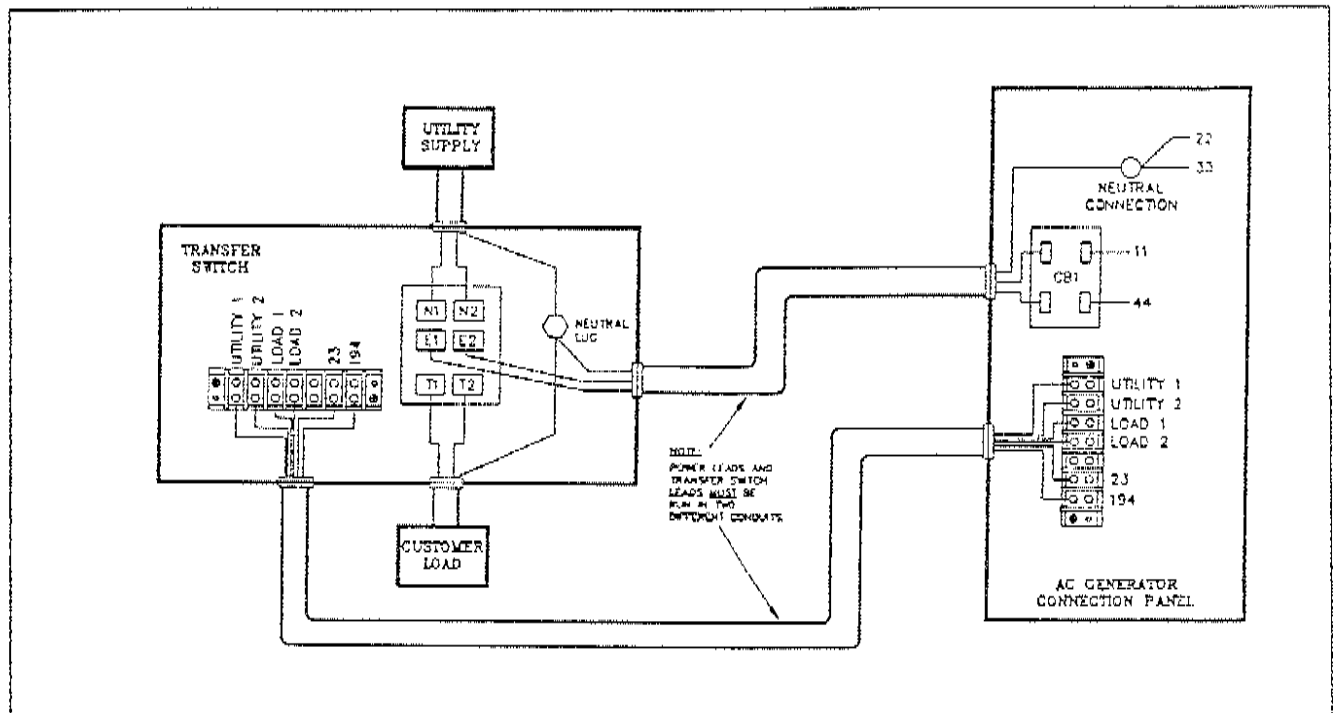

Figure 5. Prepackaged Interconnection Diagram

*Installation with a GTS Transfer Switch*

Prepackaged home standby generators with liquid cooled engine may be installed in conjunction with a standard "GTS" type transfer switch, if desired. This can be done as shown in Figure 6, below.

Connect utility, standby and load lines in the same manner as described under "Power Source and Load Lines" on previous page. Connect all neutral lines in the same fashion.

The "GTS" type transfer switch houses a terminal strip with terminals 178 and 183 identified. A similarly identified terminal strip is housed in the generator. Interconnect suitable wiring between these two terminal strips as shown in the interconnection diagram (Figure 6).

A CMA circuit board, mounted on the standby generator set, provides a "7-day exercise" feature. This feature allows the standby generator to start and run once every 7 days, on a day and at a time of day selected. The timer clock that controls this automatic exercise of the unit must be powered by voltage from the transfer switch Load 1/Load 2 terminals. If the exercise function is to be made available, connect suitable wiring from the GTS transfer switch load terminal lugs to the "Load 1/Load 2" terminals in the generator.

The CMA circuit board in the generator also provides a battery "trickle charge" circuit. This circuit, when powered by utility source voltage, will deliver a charging voltage to the battery during non-operating periods to keep the battery charged. To use the trickle charge feature, connect suitable wiring to the generator's "Utility 1/Utility 2" terminals and to the appropriate terminals in the "GTS" transfer switch.

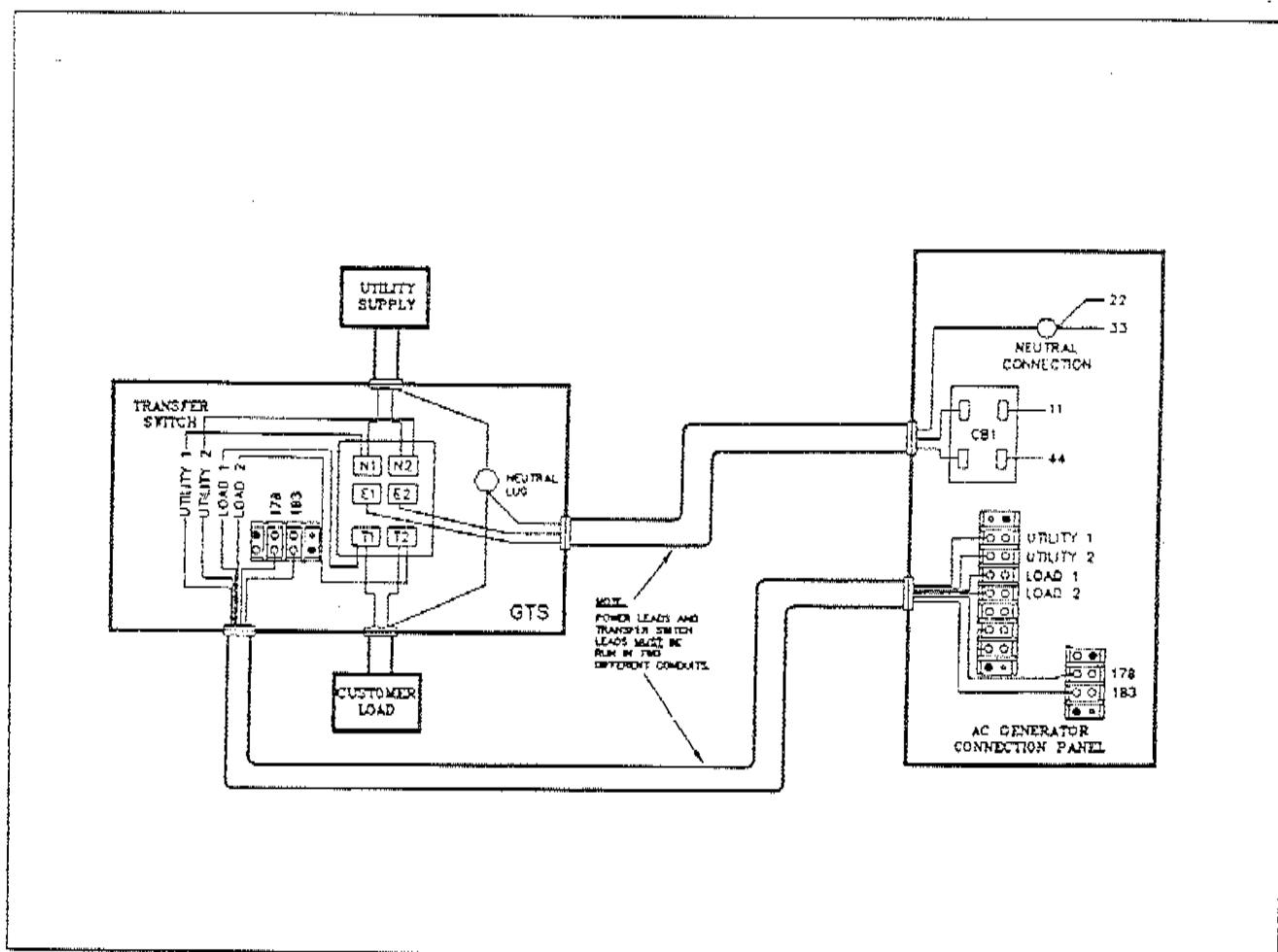

Figure 6. Installation with GTS Transfer Switch

**Section 1.4  
PREPARATION BEFORE USE**

**General**

The installer must ensure that the home standby generator has been properly installed. The system must be inspected carefully following installation. All applicable codes, standards and regulations pertaining to such installations must be strictly complied with. In addition, regulations established by the Occupational Safety and Health Administration (OSHA) must be complied with.

Prior to initial startup of the unit, the installer must ensure that the engine-generator has been properly prepared for use. This includes the following:

- An adequate supply of the correct fuel must be available for generator operation.
- The engine must be properly serviced with the recommended oil.
- The engine cooling system must be properly serviced with the recommended coolant (liquid cooled models only).
- The engine governor must be properly serviced with the recommended oil.

**Fuel Requirements:**

**UNITS WITH AIR-COOLED ENGINE:**

Generators with air-cooled engine have been factory tested and adjusted using natural gas as a fuel. If LP (propane) gas is to be used at the installation site, adjustment of the gaseous fuel load block will be required for best performance. Refer to Part 9, "Operational Tests and Adjustments" for load block adjustment procedures.

**UNITS WITH LIQUID COOLED ENGINE:**

Liquid cooled engine units are shipped from the factory with either (a) a natural gas fuel system, or (b) an LP gas vapor withdrawal fuel system. The installer must ensure that the correct fuel supply system has been installed and is compatible with engine-generator requirements. Read "The Fuel Supply" on Pages 1.3-1 and 1.3-2 carefully.

**ALL UNITS:**

- When natural gas is used as a fuel, it should be rated at least 1000 BTU's per cubic foot.
- When LP (propane) gas is used as a fuel, it should be rated at least 2520 BTU's per cubic foot.

**Engine Oil Recommendations**

**UNITS WITH AIR-COOLED ENGINE:**

The primary recommended oil for units with air-cooled V-Twin engine is a synthetic oil, such as "MOBIL®" Formula 5W-30 oil. Synthetic oil provides easier starts in cold weather and maximum engine protection in hot weather. If a non-synthetic oil is used, its viscosity must be suitable for the lowest temperature at which the engine will be operated. Use a high quality

detergent oil that meets or exceeds API (American Petroleum Institute) Service SF, SF/CC, or SF/CD requirements for gasoline engines. The following chart lists recommended viscosity ranges for the lowest anticipated ambient temperatures.

LOWEST ANTICIPATED AMBIENT TEMPERATURE	AIR-COOLED ENGINE RECOMMENDED OIL
Above 60° F. (16° C.)	Use SAE 30 oil
20°-59° F. (-7° to 15° C.)	Use SAE 10W-30 oil
Below 20° F. (-7° C.)	SAE 5W-20/5W-30 oil
For all seasons	Use SAE 5W-30 Synthetic oil

Some air-cooled engine models (such as Model 9067) are equipped with an oil makeup tank (Figure 1). When this is the case, both that tank and the engine crankcase must be properly serviced with the recommended oil. The air-cooled V-Twin engine has an oil crankcase capacity of about 1.5 U.S. quarts. Oil makeup tank capacity is about 2.5 U.S. quarts.

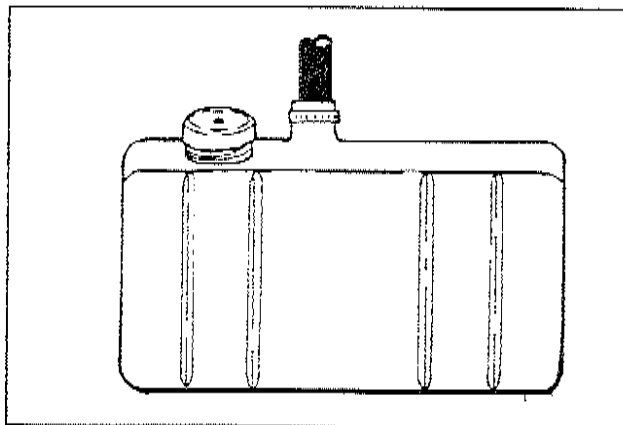

Figure 1. Oil Makeup Tank (Model 9067)

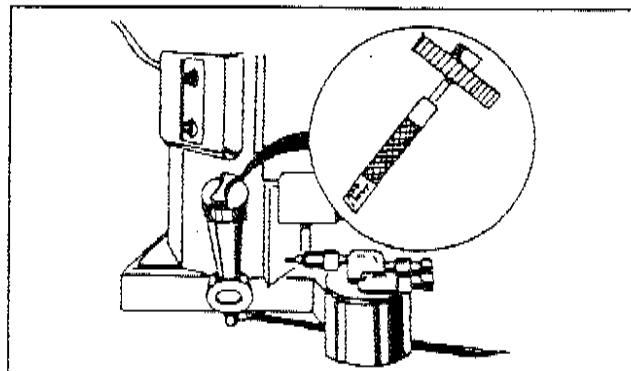

Figure 2. Oil Filler Tube and Dipstick (Model 9067)

***Engine Oil Recommendations (Continued)***

**UNITS WITH LIQUID COOLED ENGINE:**

For prepackaged generators with liquid cooled engine, use a high quality detergent oil that meets or exceeds API Service SC, SD, SE or SF. Detergent oils keep the engine cleaner and reduce carbon deposits. Use oil having the following SAE viscosity rating, based on the anticipated ambient temperature range before the next oil change:

AMBIENT TEMPERATURE RANGE	RECOMMENDED OIL
Above 86° F. (30° C.)	Use SAE 40 oil
32°-85° F. (0°-30° C.)	Use SAE 30 oil
Below 32° F. (0° C.)	Use SAE 20W oil
All Seasons	Use SAE 10W-30 oil

Engine crankcase oil capacity for the 1.2 liter liquid cooled engine is 3.0 U.S. quarts, with oil filter change); or 2.5 U.S. quarts without oil filter change.

***Recommended Engine Coolant***

Cooling system capacity for units with liquid cooled engine is approximately 2 U.S. gallons (8.5 liters).

Use a mixture of 50 percent soft water and 50 percent ethylene glycol base anti-freeze in the engine cooling system. Use only **SOFT WATER** and **LOW SILICATE** anti-freeze. If so equipped, a coolant recovery bottle must also be properly serviced with the recommended 50-50 mixture. When adding coolant to the radiator or to the coolant recovery bottle, use only the recommended mixture.

If desired, a high quality rust inhibitor may be added to the recommended coolant mixture.

**CAUTION: Do NOT use any chromate base rust inhibitor with ethylene glycol base anti-freeze, or the formation of chromium hydroxide (called "green slime") may result and cause overheating of the engine. The use of high silicate anti-freeze boosters or additives may also cause overheating. In addition, use of any soluble oil type rust inhibitor is NOT recommended.**

***Engine Governor Oiling***

**AIR-COOLED ENGINE UNITS:**

The air-cooled V-Twin engine governor is an integral part of the engine and is lubricated by engine crankcase oil. No special oil servicing procedure is required for air-cooled engine units.

**UNITS WITH LIQUID-COOLED ENGINE:**

Prepackaged liquid cooled engine models are equipped with a belt driven engine governor/DC alternator assembly (Figure 3). The governor was properly serviced with oil at the factory prior to shipment. However, it is recommended that the governor oil level be checked prior to initial use and every 50 operating hours thereafter. To check oil level and to add oil, proceed as follows:

- Remove the oil filler plug and the oil level check plug.
- Add SAE 30 oil through the oil filler plug opening. Pour slowly, until oil starts to come out of the oil level check plug opening.
- When oil level is correct, install the oil level check plug and the oil filler plug.

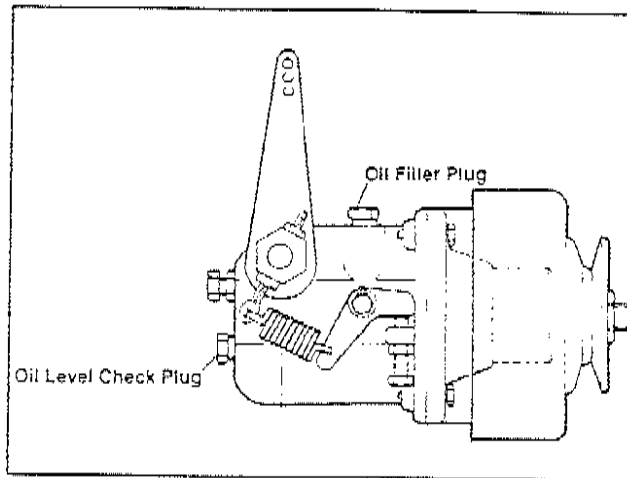

*Figure 3. Engine Governor Oil Servicing Points*

Section 1.5  
**TESTING, CLEANING AND DRYING**

**Visual Inspection**

When it becomes necessary to test or troubleshoot a generator, it is a good practice to complete a thorough visual inspection. Remove access covers and look closely for any obvious problems. Look for the following:

- Burned or broken wires, broken wire connectors, damaged mounting brackets, etc.
- Loose or frayed wiring insulation, loose or dirty connections.
- Check that all wiring is well clear of rotating parts.
- Verify that the generator is properly connected for the correct rated voltage. This is especially important on new installations. See Section 1.2, "AC Connection Systems".
- Look for foreign objects, loose nuts, bolts and other fasteners.
- Clean the area around the generator. Clear away paper, leaves, snow, and other objects that might blow against the generator and obstruct its air openings.

**Measuring Voltages**

When troubleshooting and testing the generator set, the technician will be required to measure both AC and DC voltages. Measurement of voltage requires that the user be thoroughly familiar with the meter being used for such tests. Consult the instruction manual for the meter being used.

When measuring voltage, it is best to connect the meter test leads to the terminals being tested while the generator is shut down or while power to those terminals is turned off.

**DANGER: POWER VOLTAGES GENERATED BY THIS EQUIPMENT ARE EXTREMELY HIGH AND DANGEROUS. USE EXTREME CARE WHEN MEASURING POWER VOLTAGES SUCH AS GENERATOR AC OUTPUT VOLTAGE. CONTACT WITH LIVE TERMINALS AND CONDUCTORS MAY RESULT IN HARMFUL AND POSSIBLY LETHAL ELECTRICAL SHOCK. DO NOT ATTEMPT TO READ POWER VOLTAGES WHILE STANDING ON WET OR DAMP GROUND, OR WHILE HANDS OR FEET ARE WET. STAY WELL CLEAR OF HIGH VOLTAGE POWER TERMINALS. CONNECT METER TEST LEADS TO TERMINALS AND LEADS WHILE THE GENERATOR IS SHUT DOWN OR WHEN THE POWER SUPPLY TO SUCH LEADS AND TERMINALS IS TURNED OFF. THE USE OF INSULATIVE RUBBER MATS IS RECOMMENDED. TAKE POWER VOLTAGE READINGS ONLY WHILE STANDING ON SUCH INSULATIVE MATS.**

**Measuring Current**

Alternating current (AC) can be measured with a clamp-on ammeter. Most clamp-on ammeters will not measure direct current (DC). Load current readings should never exceed the generator's data plate rating for continuous operation. However, momentary surges in load current may be encountered when starting electric motors.

On 1-phase generators, the data plate generally lists rated line-to-line and line-to-neutral current.

On 3-phase generators, the data plate usually lists rated line-to-line (or phase-to-phase) current.

**Measuring Resistance**

The resistance (in ohms) of generator stator and rotor windings can be measured using an ohmmeter or an accurate volt-ohm-milliammeter (VOM).

The nominal (approximate) resistance values of some stator windings are listed on Pages 1 and 2 at front of this manual. Nominal resistances of some rotors are given in the "Generator Specifications" chart at top of Page 1. Resistance readings of stator and rotor windings can be taken and then compared to the listed values.

The resistance of some windings is extremely low. Some readings are so low that a meter capable of reading in the "milliohms" range would be required. Many meters will simply read "continuity". However, a standard volt-ohm-milliammeter (VOM) may be used to test for continuity, or for a shorted or grounded condition. Section 1.2 discusses many of the more common 1 and 3-phase stator windings and how they are configured.

**Insulation Resistance**

The insulation resistance of stator and rotor windings is a measurement of the integrity of the insulating materials that separate the electrical windings from the generator's steel core. This resistance can degrade over time or due to such contaminants as dust, dirt, oil, grease and especially moisture. In most cases, failures of stator and rotor windings is due to a breakdown in the insulation. And, in many cases, a low insulation resistance is caused by moisture that collects while the generator is shut down. When problems are caused by moisture buildup on the windings, they can usually be corrected by drying the windings. Dirt and moisture that are combined on generator windings can usually be eliminated by cleaning and drying the windings.

***Insulation Resistance (Continued)***

**MEGGER:**

The normal resistance of generator winding insulation is on the order of millions of ohms. This high resistance can be measured with a device called a "megger". The megger is a megohm meter ("meg" stands for million) and a power supply. The power supply voltage varies between megger models and is selectable on some models. The most common power supply voltage is 500 volts. Use of a power supply greater than 500 volts is not recommended on prepackaged generators.

**CAUTION:** Before attempting to measure insulation resistance, first disconnect and isolate all leads of the winding to be tested. Electronic components, diodes, surge protectors, relays, voltage regulators, etc., can be destroyed if subjected to high megger voltages.

**HI-POT TESTER:**

A "Hi-Pot" tester is shown in Figure 1. The model shown is only one of many that are commercially available. The tester shown is equipped with a voltage selector switch which permits the power supply voltage to be selected. It also mounts a breakdown lamp that will illuminate to indicate an insulation breakdown during the test.

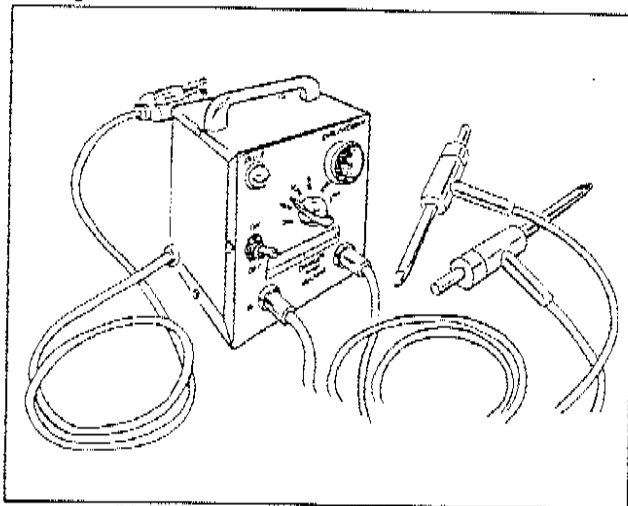
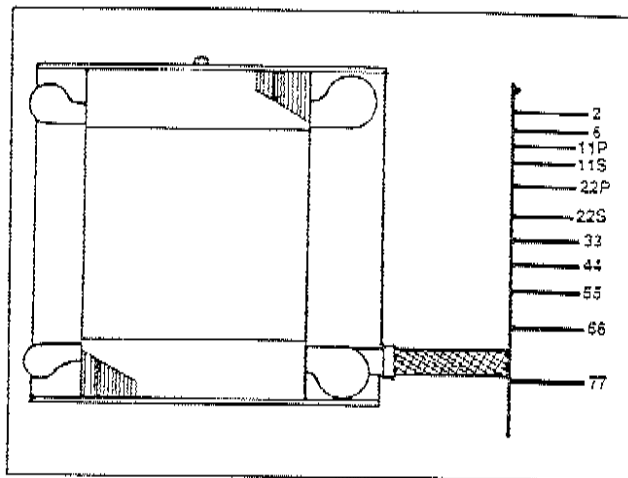

*Figure 1. One Type of Hi-Pot Tester*

***Stator Insulation Tests- Air Cooled Units***

**GENERAL:**

Units with the air-cooled V-Twin engine are equipped with (a) dual stator AC power windings, (b) an excitation or DPE winding, and (c) a battery charge winding. Insulation tests of the stator consist of (a) testing all windings to ground, (b) testing between isolated windings, and (c) testing between parallel windings. Figure 2 is a pictorial representation of the various stator leads on units with air-cooled engine.



*Figure 2. Stator Winding Leads (Air-Cooled Units)*

**TESTING ALL STATOR WINDINGS TO GROUND:**

1. Disconnect stator AC output leads 11 and 44 from the generator main line circuit breaker.
2. Remove the wire nut that joins stator leads 22 and 33 and separate the two leads.
3. At the excitation circuit breaker (CB2), disconnect stator excitation winding lead 2.
4. At the voltage regulator, disconnect stator excitation winding lead 6.
5. At the battery charge grounding resistor, disconnect stator battery charge winding lead 55.
6. At the battery charge rectifier (BCR), disconnect stator battery charge winding leads 66 and 77.
7. Connect the terminal ends of all stator leads (11, 22, 33, 44, 2, 6, 55, 66, and 77) together. Make sure the wire terminal ends are not touching any part of the generator frame or any terminal.
8. Connect the red test probe of the Hi-Pot tester to the joined terminal ends of all stator leads. Connect the black tester lead to a clean frame ground on the stator can. With tester leads connected in this manner, proceed as follows:
  - a. Turn the Hi-Pot tester switch "Off".
  - b. Plug the tester cord into a 120 volts AC wall socket and set its voltage selector switch to "500 volts".
  - c. Turn the tester switch "On" and observe the breakdown lamp on tester. **DO NOT APPLY VOLTAGE LONGER THAN 1 SECOND.** After one (1) second, turn the tester switch "Off".

If the breakdown lamp comes on during the one second test, the stator should be cleaned and dried. After cleaning and drying, repeat the insulation test. If, after cleaning and drying, the stator fails the second test, the stator assembly should be replaced.

**TEST BETWEEN ISOLATED WINDINGS:**

1. Connect the red tester probe to terminal end of stator lead 2 and the black probe to stator lead 11.
2. Turn the tester switch "On" and make sure the pilot lamp is on.

***Stator Insulation Tests- Air Cooled Units  
(Continued)***

3. Set voltage to "500 volts". Apply voltage for one (1) second while observing the breakdown lamp. After one (1) second, turn the tester switch "Off".
4. Connect the red tester probe to stator lead 11, the black test probe to stator lead 66.
5. Set voltage to "500 volts". Turn the tester switch "On" and check that the pilot lamp is on. Apply voltage for one (1) second while observing the breakdown lamp. After one (1) second, turn the tester switch "Off".

If the breakdown lamp comes on during any one (1) second test, the stator should be cleaned, dried and retested. If the breakdown lamp illuminates during the second test (after cleaning and drying), replace the stator assembly.

**TEST BETWEEN PARALLEL WINDINGS:**

1. Set the tester's voltage selector switch to "500 volts".
2. Connect the red tester probe to stator lead 11; the black tester probe to stator lead 33.
3. Turn the tester switch "On" and check that the pilot lamp is on.
4. Apply voltage for one (1) second while observing the breakdown lamp.
5. After one (1) second, turn the tester switch "Off".

If the breakdown lamp turns on during the one (1) second test, clean and dry the stator. Then, repeat the test. If breakdown lamp turns on during the second test (after cleaning and drying), replace the stator assembly.

***Stator Insulation Tests- Liquid Cooled Units with 1-Phase Stator***

**GENERAL:**

Units with liquid cooled engine and 1-phase stator windings are equipped with (a) dual stator AC power windings, and (b) an excitation or DPE winding. These units are not equipped with a battery charge winding. Stator winding insulation tests consist of (a) testing all windings to ground, (b) testing between isolated windings, and (c) testing between parallel windings. Figure 3 represents the various stator AC output leads on 1-phase units with liquid-cooled engine.

**TEST ALL WINDINGS TO GROUND:**

1. Disconnect and isolate stator leads 11, 22, 33, 44, 2 and 6.
2. Connect terminal ends of all stator leads together. Make sure all wire terminal ends are completely isolated from frame ground.
3. Connect the red test probe of the Hi-Pot tester to the terminal ends of all stator leads. Connect the black tester probe to a clean frame ground on the stator can. Then, proceed as follows:
  - a. Turn the Hi-Pot tester switch "Off".

- b. Plug the tester cord into a 120 volts AC wall socket and set its voltage selector switch to "500 volts".
- c. Turn the tester switch "On" and observe the breakdown lamp. After one (1) second, turn the tester switch "Off".

If the breakdown lamp turned on during the one (1) second test, clean and dry the stator. Then, repeat the test. If breakdown lamp comes on during the second test, replace the stator assembly.

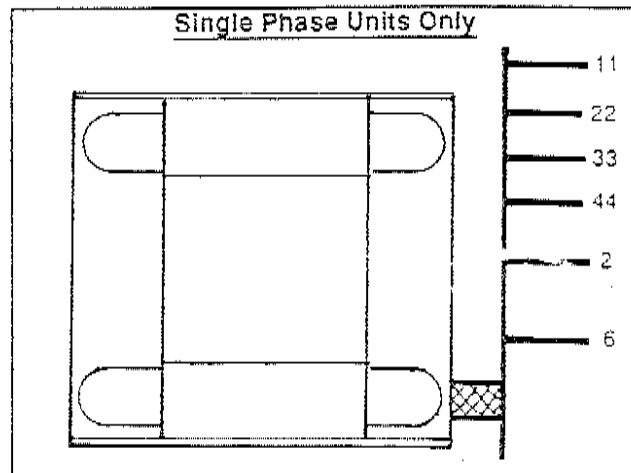

*Figure 3. Stator Winding Leads (Liquid Cooled Units)*

**TEST BETWEEN ISOLATED WINDINGS:**

1. Connect the red test probe to stator lead 2, the black probe to stator lead 11.
2. Set the tester switch to "500 volts".
3. Turn the tester switch "On" and check that the pilot lamp is lighted.
4. Wait one (1) second while observing the tester breakdown lamp. **DO NOT EXCEED ONE SECOND.** After one (1) second, turn the tester switch "Off".
5. Connect the red test probe to stator lead 2, the black probe to stator lead 33. Then, repeat Steps 2, 3 and 4.

If the breakdown lamp turned on during any one (1) second test, the stator should be cleaned and dried. After cleaning and drying, repeat the test. If the breakdown lamp turns on during the second test, replace the stator assembly.

**TEST BETWEEN PARALLEL WINDINGS:**

1. Set the tester's voltage switch to "500 volts".
2. Connect the red tester probe to stator lead 11, the black probe to stator lead 33.
3. Turn the tester switch "On" and check that the pilot lamp is on.
4. Wait one (1) second while observing the breakdown lamp. Then, turn the tester switch "Off".

If the breakdown lamp came on during the one (1) second test, clean and dry the stator. Then, repeat the test. If breakdown lamp comes on during second test, replace the stator assembly.

**Stator Insulation Tests- Liquid Cooled Units with 3-Phase Stator**

GENERAL:

Units with liquid cooled engine and having a 3-phase stator may be rated either (a) 120/240 volts, or (b) 120/208 volts. The stator configuration for units rated 120/240 volts, 3-phase is illustrated in Figure 4; units rated 120/208 volts, 3-phase are shown in Figure 5. These 3-phase stators consist of six (6) coils, with each coil having two (2) leads, so that twelve (12) stator AC power leads are brought out of the stator assembly. These twelve stator AC power leads are identified as leads S1 through S12.

In addition to the stator's AC power winding leads (S1 through S12), the stator can house an excitation winding. The excitation winding AC output leads are identified as Wires 2 and 6 (or 5 and 6 on some units).

TESTING ALL WINDINGS TO GROUND:

1. Disconnect and isolate stator leads S1 through S12, and 2 and 6 (or 5 and 6).
2. Connect all stator AC output leads together.
3. See "Stator Insulation Tests-Liquid Cooled Units with 1-Phase Stator" on Page 1.5-3. Test all windings to ground as outlined in Steps 3(a) through 3(c) of that subsection.

TEST BETWEEN ISOLATED WINDINGS:

1. Turn the Hi-Pot tester switch "Off".
2. Set the tester switch to "500 volts".
3. Connect the red tester probe to stator lead 2 (or 5).
4. Connect the black tester probe to stator lead S1.
5. Turn the tester switch "On" and observe the breakdown lamp. DO NOT EXCEED ONE SECOND.
6. With the red tester probe still connected to stator lead 2 (or 5), connect the black probe to the following stator leads one at a time and repeat Steps 1 through 5: (a) to stator lead S7, (b) stator lead S9, (c) stator lead S3, (d) stator lead S8, and (e) stator lead S2.

TEST BETWEEN PARALLEL WINDINGS:

Perform this test in the same manner as "Test Between Isolated Windings" but with the red and black tester probes connected across the following windings, in turn:

- S1 to S7; S1 to S12; S1 to S6; S1 to S11; S1 to S5.
- S7 to S12; S7 to S9; S7 to S11; S7 to S5.
- S12 to S6; S12 to S11; S12 to S5.
- S6 to S11; S6 to S5.
- S11 to S5.

**Testing Rotor Insulation**

Before attempting to test rotor insulation, either the brush leads must be completely removed from the brushes or the brush holders must be completely removed. The rotor must be completely isolated from other components before starting the test.

1. Connect the red tester lead to the positive (+) slip ring (nearest the rotor bearing).

2. Connect the black tester probe to a clean frame ground, such as a clean metal part of the rotor.
3. Turn the tester switch "Off".
4. Plug the tester into a 120 volts AC wall socket and set the voltage switch to "500 volts".
5. Turn the tester switch "On" and make sure the pilot light has turned on.
6. Observe the breakdown lamp, then turn the tester switch "Off". DO NOT APPLY VOLTAGE LONGER THAN ONE (1) SECOND.

If the breakdown lamp came on during the one (1) second test, cleaning and drying of the rotor may be necessary. After cleaning and drying, repeat the insulation breakdown test. If breakdown lamp comes on during the second test, replace the rotor assembly.

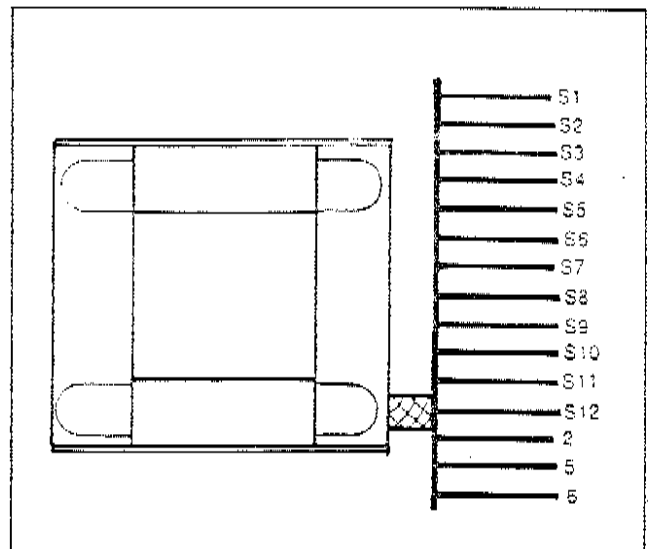

Figure 4. Stator on 120/240 Volts, 3-Phase Units

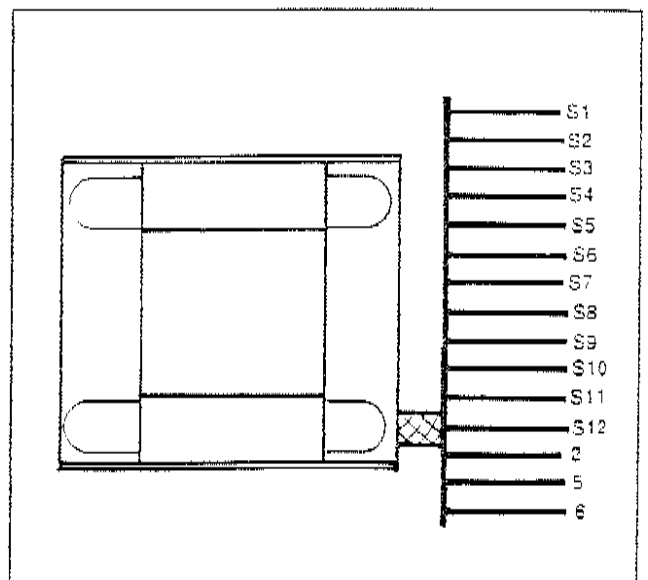
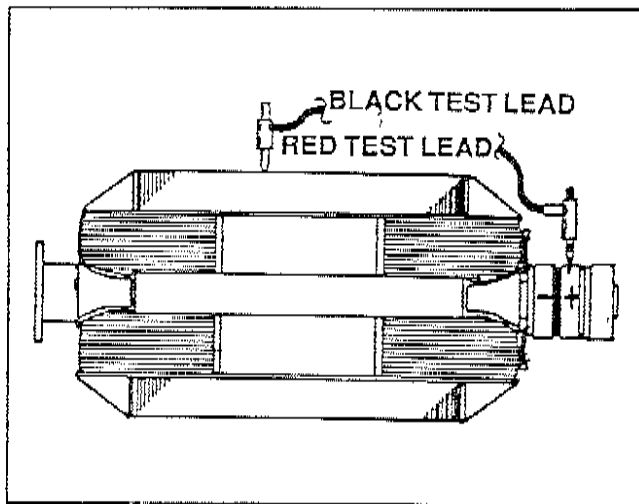

Figure 5. Stator on 120/208 Volts, 3-Phase Units

*Testing Rotor Insulation (Continued)*



*Figure 6. Testing Rotor Insulation*

***Cleaning the Generator***

Caked or greasy dirt may be loosened with a soft brush or a damp cloth. A vacuum system may be used to clean up loosened dirt. Dust and dirt may also be removed using dry, low pressure air (25 psi maximum).

**CAUTION: Do not use sprayed water to clean the generator. Some of the water will be retained on generator windings and terminals, and may cause very serious problems.**

***Drying the Generator***

To dry a generator, proceed as follows:

1. Open the generator main circuit breaker. NO ELECTRICAL LOADS MUST BE APPLIED TO THE GENERATOR WHILE DRYING.
2. Disconnect all wires No. 4 from the voltage regulator.
3. Provide an external source to blow warm, dry air through the generator interior (around the rotor and stator windings. DO NOT EXCEED 185° F. (85° C.).
4. Start the generator and let it run for 2 or 3 hours.
5. Shut the generator down and repeat the stator and rotor insulation resistance tests.



Section 1.6  
**ENGINE-GENERATOR PROTECTIVE DEVICES****General**

Standby electric power generators will often run unattended for long periods of time. Such operating parameters as (a) engine oil pressure, (b) engine temperature, (c) engine operating speed, and (d) engine cranking and startup are not monitored by an operator during automatic operation. Because engine operation will not be monitored, the use of engine protective safety devices is required to prevent engine damage in the event of a problem.

Prepackaged generator engines mount several engine protective devices. These devices work in conjunction with a control module assembly (CMA) circuit board, to protect the engine against such operating faults as (a) low engine oil pressure, (b) high temperature, (c) overspeed, and (d) overcrank. On occurrence of any one or more of those operating faults, CMA circuit board action will effect an engine shutdown.

**Units with Air-Cooled Engine****LOW OIL PRESSURE SHUTDOWN:**

See Figure 1. An oil pressure switch is mounted on the engine oil filter adapter. This switch has normally-closed contacts which are held open by engine oil pressure during cranking and startup. Should oil pressure drop below approximately 8-12 psi, the switch contacts will close. On closure of the switch contacts, a Wire 85 circuit from the CMA circuit board will be connected to ground. CMA circuit board action will then de-energize a "run relay" (on the circuit board). The run relay's normally-open contacts will then open and a 12 volts DC power supply to a Wire 14 circuit will then be terminated. This will result in closure of a fuel shutoff solenoid and loss of engine ignition.

**HIGH OIL TEMPERATURE SHUTDOWN:**

An oil temperature switch (Figure 1) is mounted on the engine oil filter adapter. The thermal switch has normally-open contacts which will close if oil temperature should exceed approximately 284° F. (140° C.). This will result in the same action as a low oil pressure shutdown.

**OVERSPEED SHUTDOWN:**

During engine cranking and operation, the CMA circuit board receives AC voltage and frequency signals from the generator's stator battery charge windings, via Wire 66. Should the AC frequency exceed approximately 72 Hz (4320 rpm), CMA circuit board action will de-energize a "run relay" (mounted on the circuit board). The relay's contacts will open, to terminate engine ignition and close a fuel shutoff solenoid. The engine will then shut down. This feature protects the engine-generator against damaging overspeeds.

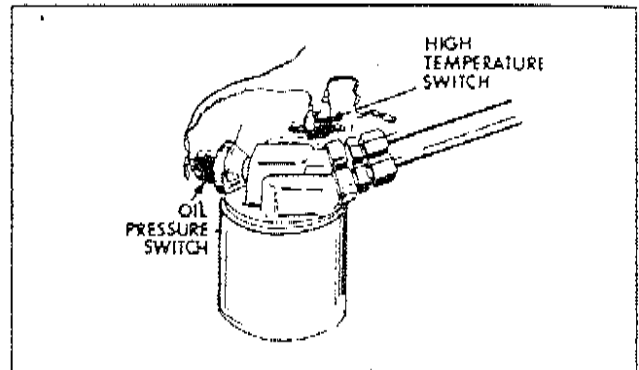

Figure 1. Engine Protective Switches on Air-Cooled Engine

*NOTE: The CMA circuit board also uses stator battery charge winding output to terminate engine cranking at approximately 30 Hz (1800 rpm). In addition, the stator battery charge output is used by the circuit board as an "engine running" signal. The circuit board will not initiate transfer of electrical loads to the "Standby" source unless the engine is running at 30 Hz or above.*

**OVERCRANK SHUTDOWN:**

Automatic engine cranking and startup normally occurs when the CMA circuit board senses that utility source voltage has dropped below approximately 60 percent of its nominal rated voltage and remains at that low level longer than six (6) seconds. At the end of six (6) seconds, CMA circuit board action will energize a crank relay and a run relay (both relays are on the CMA circuit board). On closure of the crank relay contacts, CMA board action will deliver 12 volts DC to a control contactor (CC). The control contactor will energize and battery power will be delivered across its closed contacts to the starter motor (SM). The engine will then crank.

During a manual startup (auto-off-manual switch at "Manual"), action is the same as during an automatic start, except that cranking will begin immediately when the switch is set to "Manual".

CMA circuit board action (during both a manual and an automatic start) will hold the crank relay energized for about 7-9 seconds. The relay will then de-energize for about 7-9 seconds, and then energize again. In this manner, the engine will be cranked for 7-9 seconds, will rest for 7-9 seconds, will crank again, and so on until the engine starts.

If the engine has not started after approximately 90 seconds of these crank-rest cycles, cranking will automatically terminate and shutdown will occur. The CMA circuit board uses AC signals from the stator battery charge windings as an indication that the engine has started.

*Units with Liquid Cooled Engine*

LOW OIL PRESSURE SHUTDOWN:

See Figure 2. Prepackaged generators with liquid cooled engine are equipped with an oil pressure switch having a closing pressure of about 15 psi. Should oil pressure drop below that value, an automatic engine shutdown will occur. Circuit operation is similar to that of air-cooled units.

HIGH COOLANT TEMPERATURE SHUTDOWN:

The engine is equipped with a coolant temperature switch. Should engine coolant temperature exceed approximately 225° F. (107° C.), the engine will be shut down automatically by CMA circuit board action.

LOW COOLANT LEVEL SENSOR:

It is possible that engine coolant level might drop low enough so that the high temperature switch is no longer immersed in the liquid coolant. If this happens engine temperatures could increase rapidly but the temperature switch would not sense the high temperature condition and the engine would continue to run. To prevent this occurrence, a low coolant level sensor is provided on some units. The sensor is immersed in cooling system liquid. If coolant level drops below the level of the low coolant level sensor, the device will complete a Wire 85 circuit to ground. Engine shutdown will occur.

OVERSPEED SHUTDOWN:

The CMA circuit board on liquid cooled units receives AC frequency (rpm) signals directly from the stator AC power windings, via sensing leads S15 and S16. Should AC frequency exceed approximately 72 Hz, circuit board action will initiate an automatic engine shutdown.

*NOTE: For units rated 3600 rpm, a frequency of 72 Hz is equal to 4320 rpm. For units rated 1800 rpm, 72 Hz is equal to 2160 rpm.*

*NOTE: The CMA circuit board also uses the sensing lead signals (S15, S16) (a) to terminate cranking at about 50% of rated frequency, and (b) as an "engine running" signal. The circuit board will not initiate transfer of electrical loads to the "Standby" source until sensing voltage and frequency is greater than 50 % of the unit's rated values.*

OVERCRANK SHUTDOWN:

Overcrank shutdown is the same as for units with air-cooled engine. After 90 seconds of crank-rest cycles, cranking will end and shutdown will occur.

Refer to "Overcrank Shutdown" on Page 1.6-1.

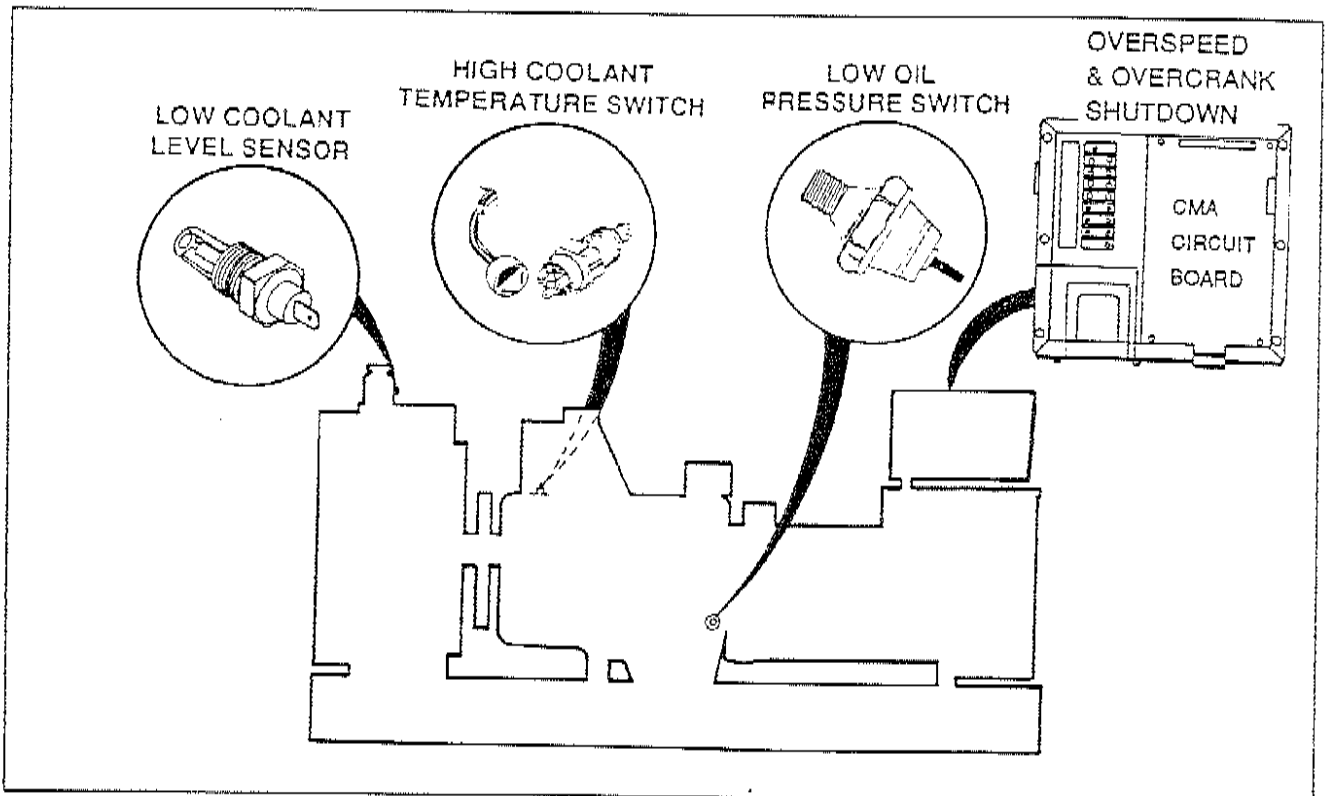

Figure 2. Protective Devices on Liquid Cooled Engine

Section 1.7  
**OPERATING INSTRUCTIONS**

**Control Panel- Units with Air-Cooled Engine ;**

**GENERAL:**

See Figure 1. The front face of this panel mounts (a) a main line circuit breaker, (b) a 15 amp fuse, and (c) a manual-off-auto switch.

**MAIN LINE CIRCUIT BREAKER:**

Air-cooled engine units rated 8000 watts (8.0 kW) employ a 2-pole, 240 volts circuit breaker having a trip rating of 35 AC amperes. Stator AC power winding leads 11 and 44 connect to one side of the breaker; customer lines E1 and E2 to the other side of the breaker.

**15 AMP FUSE:**

This fuse protects the DC control circuit (including the CMA circuit board) against overload. If the fuse element has melted open due to an overload, engine cranking or running will not be possible. Should fuse replacement become necessary, use only an identical 15 amp replacement fuse.

**MANUAL-OFF-AUTO SWITCH:**

Use this switch to (a) select fully automatic operation, (b) to crank and start the engine manually, and (c) to shut the unit down or to prevent automatic startup.

1. "Auto" Position
  - a. Select "Auto" for fully automatic operation.
  - b. When "Auto" is selected, CMA circuit board will monitor utility power source voltage.
  - c. Should utility voltage drop below a preset level and remain at such a low level for a preset time, CMA board action will initiate engine cranking and startup.
  - d. Following engine startup, CMA board action will initiate transfer of electrical loads to the "Standby" source side.
  - e. On restoration of utility source voltage above a preset level, CMA board action will initiate retransfer back to the "Utility" side.
  - f. Following retransfer, CMA board will shut the engine down and will then continue to monitor utility source voltage.
2. "Off" Position
  - a. Set the switch to "Off" to stop an operating engine.
  - b. To prevent an automatic startup from occurring, set the switch to "Off".
3. "Manual" Position
  - a. Set switch to "Manual" to crank and start unit manually.
  - b. Engine will crank cyclically and start (same as automatic startup, but without transfer).

**DANGER: WHEN THE GENERATOR IS INSTALLED IN CONJUNCTION WITH AN AUTOMATIC TRANSFER SWITCH, ENGINE CRANKING AND STARTUP CAN OCCUR AT ANY TIME WITHOUT WARNING (PROVIDING THE MANUAL-OFF-AUTO SWITCH IS SET TO "AUTO"). TO PREVENT AUTOMATIC STARTUP AND POSSIBLE INJURY THAT MIGHT BE CAUSED BY SUCH STARTUP, ALWAYS SET THE MANUAL-OFF-AUTO SWITCH TO ITS "OFF" POSITION BEFORE WORKING ON OR AROUND THIS EQUIPMENT.**

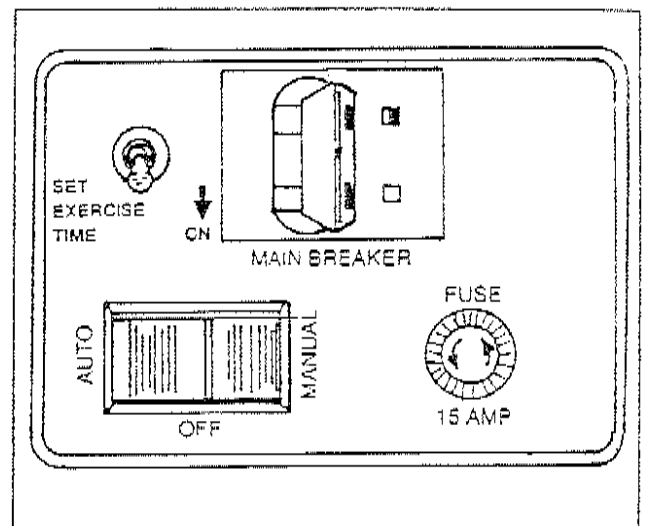

Figure 1. Control Panel- Units with Air-Cooled Engine

**Control Panel- Units with Liquid Cooled Engine**

**GENERAL:**

See Figure 2. A typical prepackaged control panel on units with liquid cooled engine includes (a) an AC voltmeter, (b) an AC ammeter, (c) an AC frequency meter, (d) a DC voltmeter, (e) an hourmeter, (f) an auto-off-start switch, (g) a fault indicator lamp, (h) a 30 amp fuse, and (i) a voltage-phase selector switch.

*NOTE: Some models may not be equipped with all of the features shown. For example, some units may not have the AC meters (voltmeter, ammeter, frequency meter).*

**AC VOLTMETER:**

This AC meter permits an operator to monitor the generator's AC voltage output. Refer to the generator DATA PLATE for the unit's rated voltage.

**Control Panel- Units with Liquid Cooled Engine (Continued)**

When taking AC voltmeter readings, keep in mind the fact that, if all systems are functioning properly, voltage will be proportional to AC frequency. For example, on models rated 120/240 volts AC and 60 Hz, when the no-load frequency is 62 Hz the no-load voltage will be approximately 248 volts (line-to-line) or 124 volts (line-to-neutral).

**AC AMMETER:**

This meter will indicate the current draw of connected electrical loads. The generator's rated amperage should never be exceeded for continuous operation. Refer to the unit's DATA PLATE for rated maximum continuous amperage.

**AC FREQUENCY METER:**

The frequency meter indicates generator AC output frequency, in HERTZ (cycles per second). The no-load frequency reading should be about 61-63 Hz.

The frequency meter is also an indicator of engine-generator operating speed. Units with 4-pole rotor will supply 60 Hz at 1800 rpm, or 50 Hz at 1500 rpm; units with 2-pole rotor will deliver 60 Hz at 3600 rpm, or 50 Hz at 3000 rpm. Generally, if frequency is incorrect, engine operating speed is also incorrect and the engine governor requires adjustment.

**DC VOLTMETER:**

The 1.2 liter liquid cooled engine is equipped with a combination engine governor and DC alternator. The DC alternator functions to maintain battery state of charge during operation. With the engine running, the meter should read approximately 12.5-14.5 volts DC, depending on battery state of charge. A low reading means the battery is discharging.

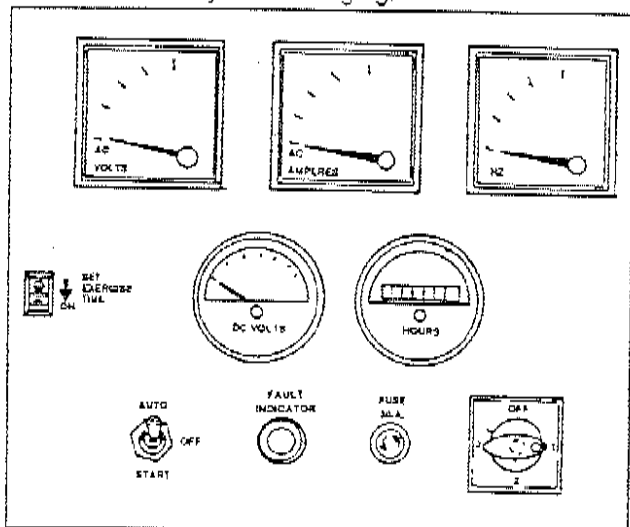

Figure 2. Control Panel- Liquid Cooled Engine Units

**HOURMETER:**

The hourmeter indicates engine-generator operating time, in hours and tenths of hours. Use the meter in conjunction with the periodic maintenance schedule for the applicable generator set. CMA circuit board action turns the hourmeter on at startup, via the same (Wire 14) circuit that powers the engine ignition system and the fuel shutoff solenoid.

**AUTO-OFF-START SWITCH:**

Switch operation is the same as for units with air-cooled engine. The "Start" position of the switch is identical to the "Manual" position on air-cooled unit switches. See "Manual-Off-Auto Switch" on Page 1.7-1.

**FAULT INDICATOR LAMP:**

This advisory lamp is a light emitting diode (LED). The lamp will turn on in the event that any one or more of the following engine fault conditions should occur: (a) low oil pressure, (b) high coolant temperature, (c) low coolant level, (d) overspeed, and (e) overcrank.

**30 AMP FUSE:**

Fuse protects the DC control system, including the CMA circuit board, against overload. If the fuse has blown, engine cranking and running will not be possible. Should fuse replacement become necessary, use only an identical 30 amp replacement fuse.

**VOLTAGE-PHASE SELECTOR SWITCH:**

This 4-position switch permits the operator to select specific line-to-line or line-to-neutral readings on the panel AC voltmeter and ammeter. AC voltmeter and ammeter readings will be determined by switch position, as shown in the chart below.

SWITCH POSITION	1-PHASE UNITS	3-PHASE UNITS
1	Line E1 to Neutral	Line E1 to E2
2	Line E3 to Neutral	Line E2 to E3
3	Line E1 to E2	Line E3 to E1
OFF	No Reading	No Reading

Figure 3, on the next page, is a schematic representation of the voltage-phase selector switch on a 1-phase generator set. Switch positions and switch contacts conditions are shown in the chart below.

CONTACT NUMBERS	SWITCH POSITION			
	1	2	3	OFF
14 & 13	Closed	Open	Closed	Open
16 & 15	Open	Closed	Open	Open
20 & 19	Closed	Open	Open	Open
18 & 17	Open	Closed	Closed	Open
1 & 2	Open	Closed	Closed	Closed
3 & 4	Closed	Open	Open	Open
5 & 6	Closed	Open	Closed	Closed
7 & 8	Open	Closed	Open	Open
9 & 10	Closed	Closed	Open	Closed
11 & 12	Open	Open	Closed	Open

Control Panel- Units with Liquid Cooled Engine (Continued)

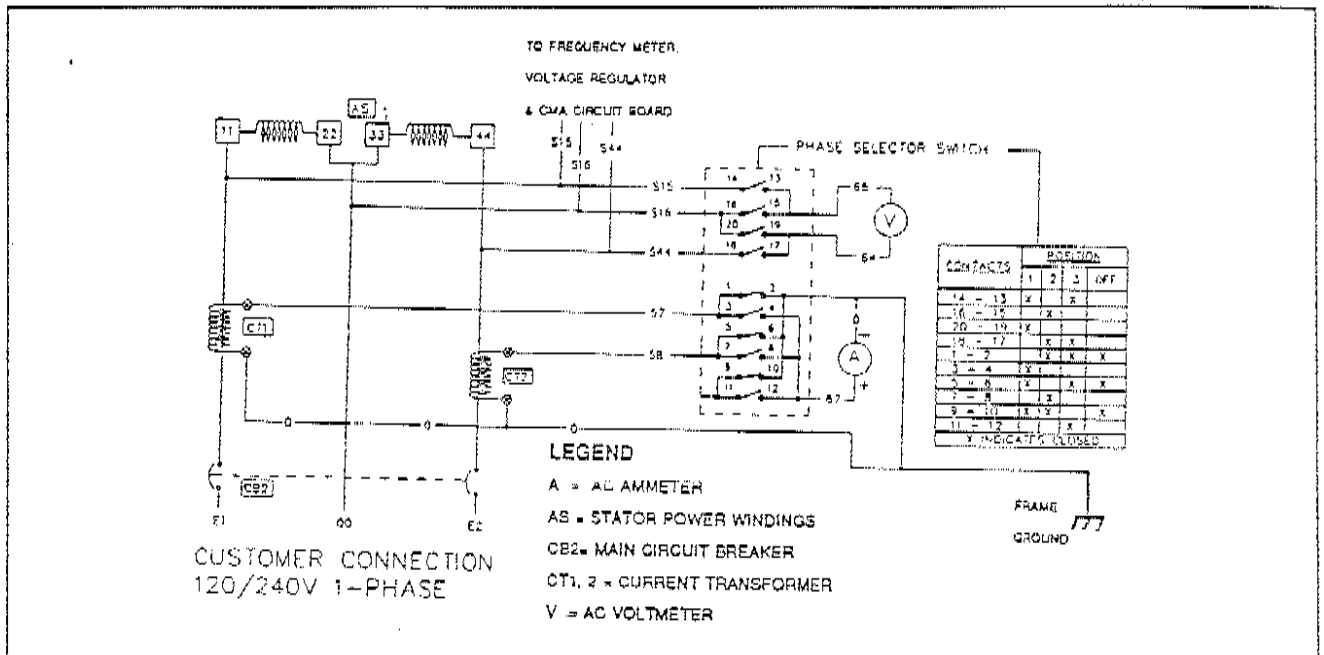

Figure 3. Voltage-Phase Selector Switch Schematic

**To Select Automatic Operation**

The following procedure applies only to those installations in which the prepackaged home standby generator is installed in conjunction with a prepackaged transfer switch. Prepackaged transfer switches do not have an intelligence circuit of their own, as do Generac "GTS" type transfer switches. Instead, automatic operation on prepackaged transfer switch and generator combinations is controlled by a circuit board housed in the generator's control module assembly (CMA).

*NOTE: Liquid cooled prepackaged generators can be installed in conjunction with Generac's "GTS" type automatic transfer switch, if desired. See "Installation with a GTS Transfer Switch" on Page 1.3-4. When this is done, automatic operation will be controlled by circuit boards housed in the GTS transfer switch. For automatic operating sequences and parameters when a GTS transfer switch is used, refer to the appropriate transfer switch instructions.*

To select automatic operation when a prepackaged transfer switch is installed along with a prepackaged home standby generator, proceed as follows:

1. Check that the prepackaged transfer switch main contacts are at their "Utility" position, i.e., the load is connected to the utility power supply. If necessary, manually actuate the switch main contacts to their "Utility" source side. See Part 4, 5 or 6 of this manual, as appropriate, for instructions.

2. Check that utility source voltage is available to transfer switch terminal lugs N1 and N2 (2-pole, 1-phase transfer switches) or to terminal lugs N1, N2, N3 (for 3-pole, 3-phase transfer switches).
3. Set the generator's auto-off-manual switch to its "Auto" position.

4. Actuate the generator's main line circuit breaker to its "On" or "Closed" position.
- With the preceding Steps 1 through 4 completed, a dropout in utility supply voltage below a preset level will result in automatic generator cranking and startup. Following startup, the prepackaged transfer switch will be actuated to its "Standby" source side, i.e., loads powered by the standby generator.

**Manual Transfer to "Standby" and Manual Startup**

To transfer electrical loads to the "Standby" (generator) source and start the generator manually, proceed as follows:

1. On the generator panel, set the auto-off-manual switch to "Off".
2. On the generator, set the main line circuit breaker to its "Off" or "Open" position.
3. Turn OFF the utility power supply to the transfer switch, using whatever means provided (such as a utility source line circuit breaker).
4. Manually actuate the transfer switch main contacts to their "Standby" position, i.e., loads connected to the "Standby" power source side.

### ***Manual Transfer to "Standby" and Manual Startup (Continued)***

*NOTE: For instructions on manual operation of prepackaged transfer switches, see Part 4 or 5 as appropriate.*

5. On the generator panel, set the auto-off-manual switch to "Manual". The engine should crank and start.
6. Let the engine warm up and stabilize for a minute or two at no-load.
7. Set the generator's main line circuit breaker to its "On" or "Closed" position. Electrical loads are now powered by the generator.

### ***Manual Shutdown and Retransfer Back to "Utility"***

To shut the generator down and retransfer electrical loads back to the "Utility" position, proceed as follows:

1. Set the generator's main line circuit breaker to its "Off" or "Open" position.
2. Let the generator run at no-load for a few minutes, to cool.
3. Set the generator's auto-off-manual switch to "Off". Wait for the engine to come to a complete stop.
4. Turn OFF the "Utility" power supply to the transfer switch using whatever means provided (such as a "Utility" source main line circuit breaker).
5. Manually actuate the prepackaged transfer switch to its "Utility" power source side, i.e., "Load" connected to the "Utility" source.
6. Turn ON the "Utility" power supply to the transfer switch, using whatever means provided.
7. Set the generator's auto-off-manual switch to "Auto".

### ***The Set Exercise Time Switch***

The prepackaged home standby generator will start and exercise once every seven (7) days, on a day and at a time of day selected by the owner or operator. The set exercise time switch is provided to select the day and time of day for system exercise.

See Part 8, Section 8.2 ("The 7-Day Exercise Cycle") for instructions on how to set exercise time.

<p><b>DANGER: THE GENERATOR WILL CRANK AND START WHEN THE SET EXERCISE TIME SWITCH IS SET TO "ON". DO NOT ACTUATE THE SWITCH TO "ON" UNTIL AFTER YOU HAVE READ THE INSTRUCTIONS IN SECTION 8.2.</b></p>
---

Section 1.8  
**AUTOMATIC OPERATING PARAMETERS**

**Introduction**

When the prepackaged generator is installed in conjunction with a prepackaged transfer switch, either manual or automatic operation is possible. Manual transfer and engine startup, as well as manual shutdown and retransfer, are covered in Section 1.7. Selection of fully automatic operation is also discussed in that section. This section will provide a step-by-step description of the sequence of events that will occur during automatic operation of the system.

**Automatic Operating Sequences**

**PHASE 1- UTILITY VOLTAGE AVAILABLE:**

With utility source voltage available to the transfer switch, that source voltage is sensed by a CMA circuit board in the generator panel and the circuit board takes no action.

Electrical loads are powered by the "Utility" source and the auto-off-manual switch is set to "Auto".

**PHASE 2- UTILITY VOLTAGE DROPOUT:**

If a dropout in utility source voltage should occur below about 60 percent of the nominal utility source voltage, a six (6) second timer on the CMA board will start timing. This timer is required to prevent false generator starts that might be caused by transient utility voltage dips.

**PHASE 3- ENGINE CRANKING:**

When the CMA board's six (6) second timer has finished timing and if utility source voltage is still below 60 percent of the nominal source voltage, CMA circuit board action will energize a crank relay and a run relay. Both of these relays are mounted on the CMA circuit board.

CMA board action will hold the crank relay energized for about 7-9 seconds. The relay will then be de-energized for about 7-9 seconds, energized again for 7-9 seconds, and so on. When the crank relay energizes the engine will crank, when it is de-energized, engine cranking will stop. This cyclic action of crank/rest, crank/rest, etc., will continue until either (a) the engine starts, or (b) until ninety (90) seconds have elapsed.

If the engine has not started within ninety (90) seconds, cranking will terminate and shutdown will occur. On liquid cooled engine units, a fault indicator lamp (LED) on the generator panel will illuminate.

If the engine starts, cranking will terminate when generator AC output frequency reaches approximately 30 Hz.

**PHASE 4-ENGINE STARTUP AND RUNNING:**

The CMA circuit board senses that the engine is running by receiving a voltage/frequency signal from the generator stator windings.

When generator AC frequency reaches approximately 30 Hz, an engine warmup timer on the CMA circuit board turns on. That timer will run for about fifteen (15) seconds. At the same time, an engine minimum run timer will turn on.

The engine warmup timer lets the engine warmup up and stabilize before transfer to the "Standby" source can occur.

The engine minimum run timer prevents a cold engine from being shut down, as might happen if utility source power is restored very quickly. The minimum run timer will run for about 13-15 minutes. That means the engine must run for 13-15 minutes before it can be shut down automatically.

*NOTE: The engine can be shut down manually at any time, by setting the auto-off-manual switch to "Off".*

**PHASE 5- TRANSFER TO "STANDBY":**

When the CMA board's engine warmup timer has timed out, CMA circuit board action completes a transfer relay circuit to ground. The transfer relay is housed in the prepackaged transfer switch enclosure.

The transfer relay energizes and transfer of loads to the "Standby" power source occurs. Loads are now powered by standby generator AC output.

**PHASE 6- "UTILITY" POWER RESTORED:**

When utility source voltage is restored above about 60 percent of the nominal supply voltage, a six (6) second timer on the CMA board starts timing. If utility voltage remains sufficiently high at the end of six (6) seconds, a "retransfer time delay" will start timing and will time for about six (6) seconds.

**PHASE 7- RETRANSFER BACK TO "UTILITY":**

When the retransfer time delay has finished timing, CMA board action will open a circuit to a transfer relay (housed in the transfer switch). The transfer relay will then de-energize and retransfer back to the "Utility" source will occur. Loads are now powered by "Utility" source power. On retransfer, an "engine cooldown timer" starts timing and will run for about one (1) minute.

**PHASE 8- GENERATOR SHUTDOWN:**

When the engine cooldown timer has finished timing, and if the minimum run timer has timed out, engine shutdown will occur.

Automatic Operating Sequences Chart

SEQ.	CONDITION	ACTION	SENSOR , TIMER OR OTHER
1	"Utility" source voltage is available.	No action	Voltage Dropout Sensor on CMA circuit board.
2	"Utility" voltage dropout below 60% of rated voltage occurs.	A 6-second timer on CMA board turns on.	Voltage Dropout Sensor and 6 second timer on CMA board.
3	"Utility" voltage is still below 60% of rated voltage.	6-second timer runs for 6 seconds., then stops.	Voltage Dropout Sensor and 6 second timer.
4	"Utility" voltage still low after 6 seconds.	CMA board action energizes a crank relay and a run relay. The engine cranks for 7-9 seconds, rests for 7-9 seconds, and so on, until engine starts. See NOTE 1.	CMA circuit board crank and run relays.
5	"Utility" voltage still low and the engine has started.	CMA board's "engine warmup timer" and "engine minimum run timer" both turn on.	Engine Warmup Timer (15 seconds) Minimum Run Timer (13 minutes)
6	Engine running and "engine warmup timer" times out	CMA board action energizes a transfer relay in transfer switch and transfer to "Standby" occurs.	CMA board transfer relay circuit Transfer switch transfer relay.
7	Engine running and load is powered by "Standby" power.	No further action.	CMA board's "voltage pickup sensor" continues to seek an acceptable "Utility" voltage.
8	"Utility" source voltage is restored above 80% of rated source voltage.	CMA board's "voltage pickup sensor" reacts and a "return to utility timer" turns on.	Voltage Pickup Sensor (80%) Return to Utility Timer (6 seconds)
9	"Utility" voltage still high after 6 seconds.	"Return to utility timer" times out.	Return to Utility Timer
10	"Utility" voltage still high.	CMA board action opens the transfer relay circuit to ground. Transfer relay de-energizes and retransfer to "Utility" occurs.	CMA board transfer relay circuit Transfer switch transfer relay.
11	Engine still running, loads are powered by "Utility" source.	CMA boards "engine cooldown timer" starts running.	CMA board's Engine Cooldown Timer (1 minute).
12		After 1 minute, "engine cooldown timer" stops and CMA board's run relay de-energizes. Engine shuts down.	Engine Cooldown Timer CMA board Run Relay.
13	Engine is shut down, loads are powered by "Utility" source. Return to Sequence 1.	No action.	Voltage Dropout Sensor on CMA circuit board.

NOTE 1: In Sequence 4, if engine has not started in 90 seconds cranking will end and shutdown will occur.

**PART 2**  
**PREPACKAGED**  
**AIR-COOLED**  
**AC GENERATORS**

GENERAC II  
**PREPACKAGED**  
**HOME STANDBY**  
**ELECTRIC POWER**  
**SYSTEMS**

**TABLE OF CONTENTS**

SECTION	TITLE
2.1	Description and Components
2.2	Operational Analysis
2.3	Troubleshooting Flow Charts
2.4	Diagnostic Tests

# NOTES

---

**Section 2.1  
DESCRIPTION AND COMPONENTS**

**Introduction**

The "Generac II" air-cooled home standby system is an easy to install, fully enclosed and self sufficient electric power system. It is designed especially for home owners, but may be used in other applications as well. On occurrence of a utility power failure, this high performance system will (a) crank and start automatically, and (b) automatically transfer electrical loads to generator AC output.

The generator's "2-bearing" revolving field (rotor) is driven by an air-cooled V-Twin engine at about 3600 rpm, through a drive belt and pulley arrangement.

The generator may be used to supply electrical power for the operation of 120 and/or 240 volts, 1-phase, 60 Hz, AC loads requiring up to 8000 watts (8.0 kW) of power. Electrical loads requiring up to 66.7 AC amperes of current at 120 volts (line-to-neutral), or up to 33.3 AC amperes at 240 volts (line-to-line) may be powered by the unit.

A 2-pole, "V-Type", prepackaged transfer switch is usually shipped with the unit (see Part 4). Prepackaged transfer switches do not include an "intelligence circuit" of their own. Instead, automatic startup, transfer, running, retransfer and shutdown operations are controlled by a solid state circuit board in a control module assembly (CMA).

**Engine-Generator Drive System**

The generator's revolving field is driven by an air-cooled, vertical crankshaft, twin cylinder engine through a drive belt and pulleys arrangement. The engine and generator are mounted side-by-side and vertically in a compartment enclosure, to accommodate drive pulleys in the bottom of the compartment. Both the engine and generator rotor are driven at approximately 3600 rpm, to provide a 60 Hz AC output.

**The AC Generator**

See Figure 1. Major components of the "2-bearing" AC generator are listed below.

ITEM	DESCRIPTION	ITEM	DESCRIPTION
1	Lower Bearing Carrier	9	Brush Holder
2	Rotor Assembly	10	Screw
3	Lower Rotor Bearing	11	Stator Lead Clamp
4	Upper Rotor Bearing	12	Screw
5	Stator Assembly	13	Nylon Washer
6	Upper Bearing Carrier	14	Generator Top Cover
7	Generator Studs (4)	15	Flanged Lock Nut
8	Hex Nuts		

**Lower Bearing Carrier**

The cast and machined lower bearing carrier supports the AC generator at its lower end. A machined bore in the center of the bearing carrier accepts the lower rotor bearing. Four holes are provided around the outer periphery of the carrier for passage of stator studs. The extra long stator studs pass through the four bearing carrier holes and are also used to retain the carrier to a mounting base by means of slotted holes. Tensioning springs, installed over the ends of the stator studs, separate the carrier from the mounting base and allow it to slide the length of the slotted holes on nylon slides. The slotted holes permit drive belt tension to be adjusted. The two flanged legs of the bearing carrier allow for passage of spring-loaded drive belt tensioning bolts. By turning the tensioning bolts, the bearing carrier is moved laterally on the mounting base to establish proper belt tension.

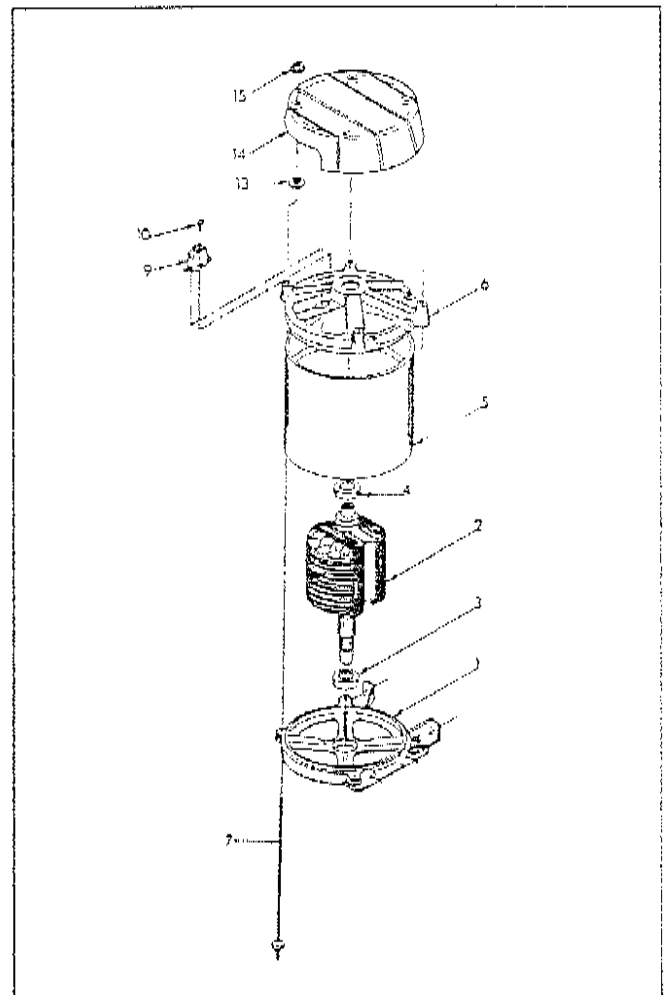

Figure 1. AC Generator Exploded View

*Lower Bearing Carrier (Continued)*

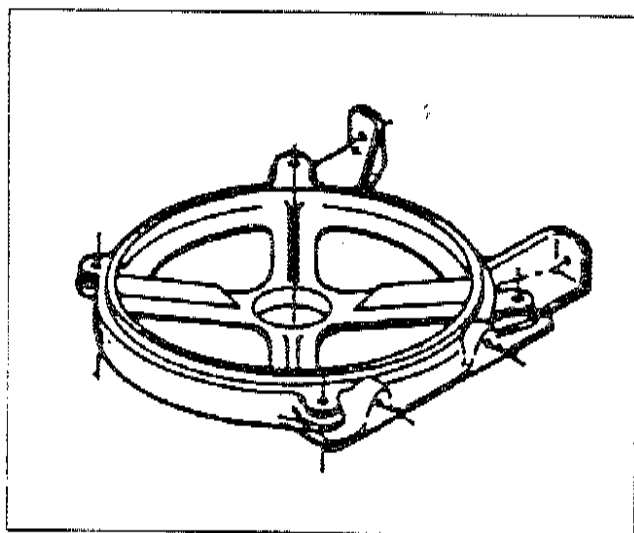

Figure 2. Lower Bearing Carrier

**Rotor Assembly**

The 2-pole rotor must be operated at 3600 rpm to supply a 60 Hertz AC frequency. The term "2-pole" means the rotor has a single north magnetic pole and a single south magnetic pole. As the rotor rotates, its lines of magnetic flux cut across the stator assembly windings and a voltage is induced into the stator windings. The upper rotor shaft mounts a positive (+) and a negative (-) slip ring, with the positive (+) slip ring nearest the upper rotor bearing. Rotor bearings are pressed onto both the upper and lower shaft of the rotor.

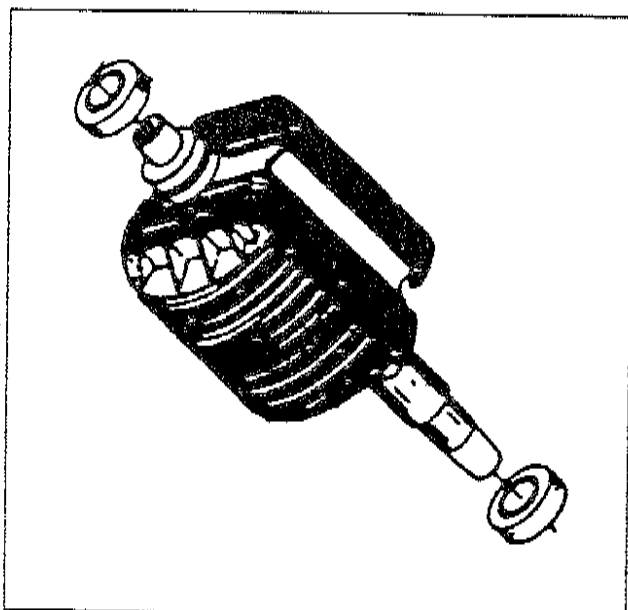

Figure 3. The 2-Pole Rotor Assembly

**Stator Assembly**

The stator can houses and retains (a) dual AC power windings, (b) an excitation winding, and (c) dual battery charge windings. Leads are brought out of the stator can to form a "3-wire", 1-phase, AC connection system (see "Voltage Code A" on Page 1.2-1). In addition, excitation winding leads 2 and 6 plus battery charge winding leads 55, 66 and 77 are brought out, for a total of eleven (11) leads as shown in Figure 4.

The stator can is sandwiched between the upper and lower bearing carriers. It is retained in that position by four stator studs.

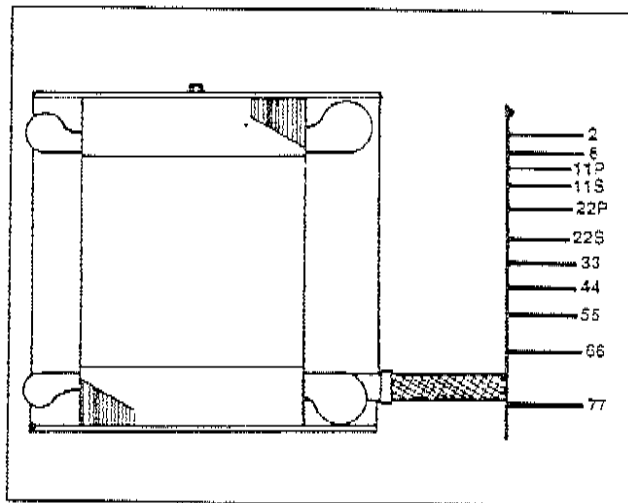

Figure 4. Stator Assembly Leads

**Upper Bearing Carrier**

Refer to Figure 1. The four stator studs pass through holes in the upper bearing carrier, to retain the stator can in its "sandwiched" position. A machined bore in the center of the carrier accepts the upper ball bearing of the rotor assembly. Bosses on the upper bearing carrier provide for retention of a brush holder assembly.

**Brush Holder and Brushes**

The brush holder is retained to the upper bearing carrier by means of two M5-0.80 x 15mm (Taptite) screws. A positive (+) and a negative (-) brush are retained in the brush holder, with the positive (+) brush riding on the slip ring nearest the rotor bearing.

Wire No. 4 connects to the positive (+) brush and Wire No. 0 to the negative (-) brush. Wire No. 0 connects to frame ground. Rectified and regulated excitation current, as well as current from a field boost circuit, are delivered to the rotor windings via Wire No. 4, and the positive (+) brush and slip ring. The excitation and field boost current passes through the windings and to frame ground via the negative (-) slip ring and brush, and Wire No. 0. This current flow creates a magnetic field around the rotor having a flux concentration that is proportional to the amount of current flow.

*Brush Holder and Brushes (Continued)*

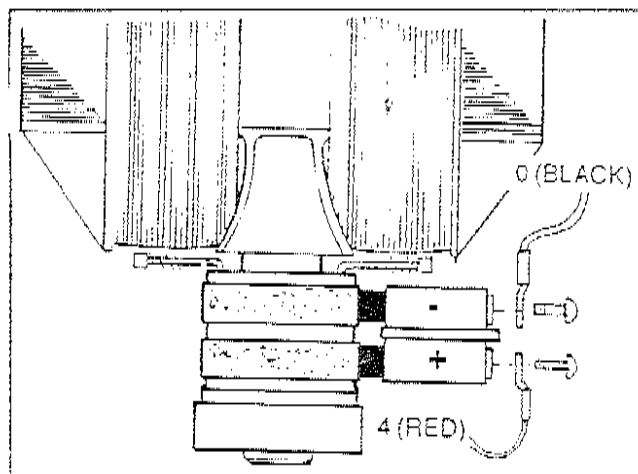

Figure 5. Brush Holder and Brushes

**Other AC Generator Components**

Some AC generator components are housed in the generator control panel enclosure, and are not shown in Figure 1. These are (a) an excitation circuit breaker, (b) a voltage regulator, (c) a battery charge rectifier, (d) a battery charge resistor, and (e) a main line circuit breaker.

**EXCITATION CIRCUIT BREAKER:**

The excitation circuit breaker (CB2) is housed in the generator panel enclosure and electrically connected in series with the excitation (DPE) winding output to the voltage regulator. The breaker is self resetting, i.e., its contacts will close again when excitation current drops to a safe value.

If the circuit breaker has failed open, excitation current flow to the voltage regulator and, subsequently, to the rotor windings will be lost. Without excitation current flow, AC voltage induced into the stator AC power windings will drop to a value that is commensurate with the rotor's residual magnetism plus field boost magnetism. Residual magnetism plus field boost magnetism (without excitation) will result in an AC voltage output that is somewhere near one-half the unit's rated voltage.

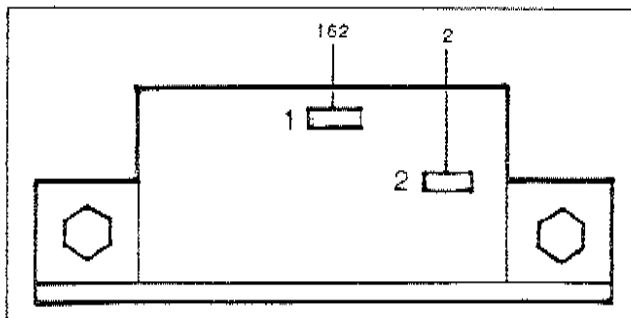

Figure 6. Excitation Circuit Breaker

**VOLTAGE REGULATOR:**

A typical prepackaged voltage regulator is shown in Figure 7. Unregulated AC output from the stator excitation winding is delivered to the regulator's "DPE" terminals, via Wire No. 2, the excitation circuit breaker, Wire No. 162, and Wire No. 6. The voltage regulator rectifies that current and, based on stator AC power winding sensing, regulates it. The rectified and regulated excitation current is then delivered to the rotor windings from the "+" and "-" regulator terminals, via Wire No. 4 and 1. Stator AC power winding "sensing" is delivered to the regulator "SEN" terminals via Wires No. 11 and 22.

The regulator used on prepackaged units provides "overvoltage" protection, but does not protect against "undervoltage". On occurrence of an "overvoltage" condition, the regulator will "shut down" and complete loss of excitation current to the rotor will occur. Without excitation current, the generator's AC output voltage will drop to approximately one-half the unit's rated voltage (residual plus field boost).

A single red lamp (LED) glows during normal operation. The lamp will become dim if excitation winding AC output diminishes. It will go out on occurrence of an open condition in the excitation winding AC output circuit, or in the rotor's excitation circuit.

An adjustment potentiometer permits the stator's AC power winding voltage to be adjusted. Perform this adjustment with the generator running at no-load, and with a 62 Hz AC frequency (62 Hz equals 3720 rpm). At the stated no-load frequency, adjust to obtain a line-to-line AC voltage of about 248 volts.

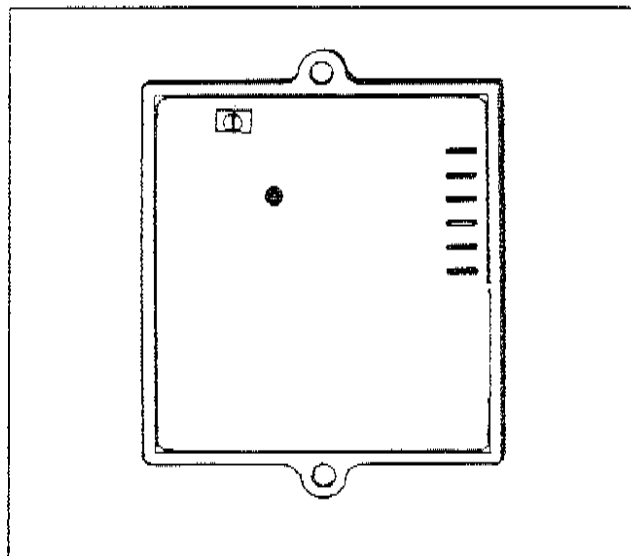

Figure 7. Typical Voltage Regulator

**BATTERY CHARGE RECTIFIER:**

The "full-wave" battery charge rectifier (BCR) changes the battery charge winding AC output to "DC". The rectified current is then delivered to the unit battery during operation. See Figure 8.

*Other AC Generator Components (Continued)*

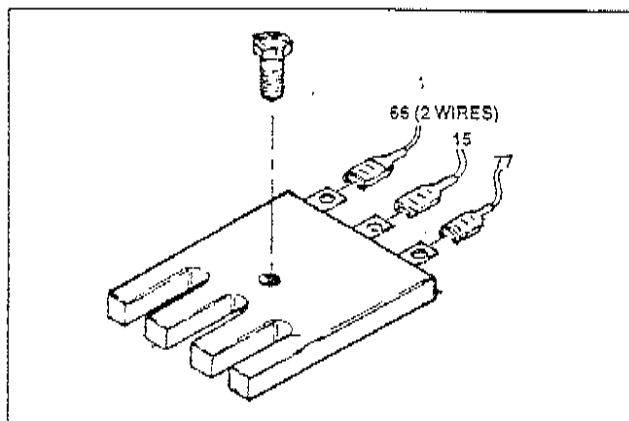

Figure 8. Battery Charge Rectifier

**BATTERY CHARGE RESISTOR:**

This resistor is electrically connected in series with battery charge winding Wire No. 55. The resistor is rated 1 ohm, 20 or 25 watt.

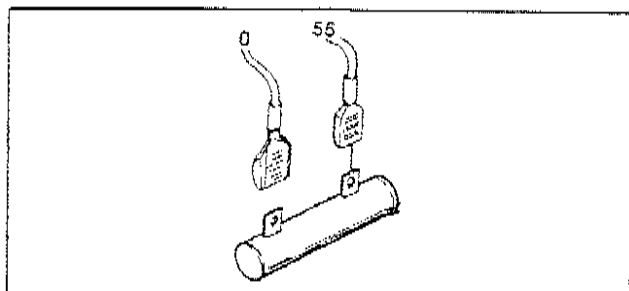

Figure 9. Battery Charge Resistor

**MAIN LINE CIRCUIT BREAKER:**

The main line circuit breaker protects the generator against electrical overload. The 2-pole breaker is rated 35 AC amperes. Also see "Control Panel- Units with Air-Cooled Engine" on Page 1.7-1.

**Field Boost Circuit**

When the engine is cranking, direct current flow is delivered from a CMA circuit board to the generator rotor windings, via Wire No. 4.

The field boost system is shown schematically in Figure 10. Manual and automatic engine cranking is initiated by CMA circuit board action, when that circuit board energizes a crank relay (K1). Battery voltage is then delivered to field boost Wire No. 4 (and to the rotor), via a field boost resistor and diode. The crank relay, field boost resistor and diode are all located on the CMA circuit board.

Notice that field boost current is available only while the crank relay (K1) is energized, i.e., while the engine is cranking.

Field boost voltage is reduced from that of battery voltage by the resistor action and, when read with a DC voltmeter, will be approximately 9 or 10 volts DC.

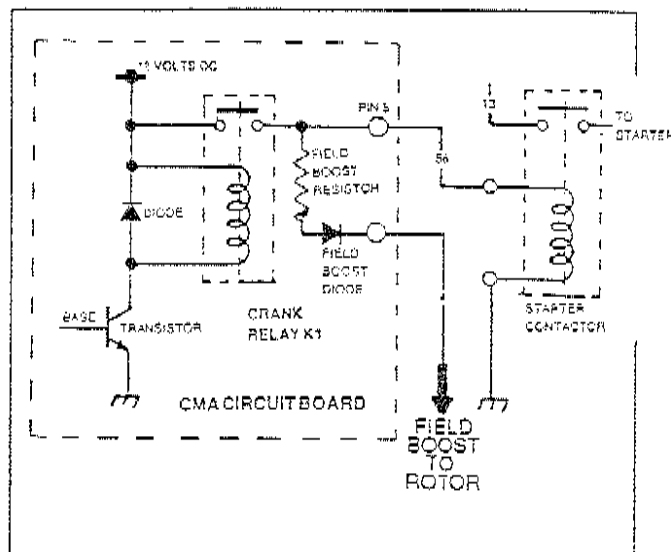

Figure 10. Field Boost Circuit Schematic

Section 2.2  
**OPERATIONAL ANALYSIS**

**Rotor Residual Magnetism**

The generator's revolving field (rotor) may be considered to be a permanent magnet. Some "residual" magnetism is always present in the rotor. This residual magnetism is sufficient to induce a voltage into the stator's AC power windings that is approximately 2-12 volts AC.

**Field Boost**

See "Field Boost Circuit" on Page 2.1-4. During engine cranking (when crank relay K1 is energized), approximately 9-10 volts DC is delivered to the rotor windings from a CMA circuit board. This voltage is only available while the engine is cranking.

**Operation**

STARTUP:

When the engine is started, residual plus field boost magnetism from the rotor induces a voltage into (a) the stator AC power windings, (b) the stator excitation or DPE windings, and (c) into the stator battery charge windings. In an "on-speed" condition, residual plus field boost magnetism are capable of creating approximately one-half the unit's rated voltage.

ON-SPEED OPERATION:

As the engine accelerates, the voltage that is induced into the stator windings increases rapidly, due to the increasing speed at which the rotor operates.

FIELD EXCITATION:

An AC voltage is induced into the stator excitation (DPE) windings. The DPE winding circuit is completed to the voltage regulator, via Wire No. 2, excitation circuit breaker, Wire No. 162, and Wire No. 6. Unregulated alternating current can flow from the winding to the regulator.

The voltage regulator "senses" AC power winding output voltage and frequency via stator Wires No. 11 and 22.

The regulator changes the AC from the excitation winding to DC. In addition, based on the Wires 11 and 22 sensing signals, it regulates the flow of direct current.

The rectified and regulated current flow from the regulator is delivered to the rotor windings, via Wire No. 4, and the positive brush and slip ring. This excitation current flows through the rotor windings and is directed to ground through the negative (-) slip ring and brush, and Wire No. 0.

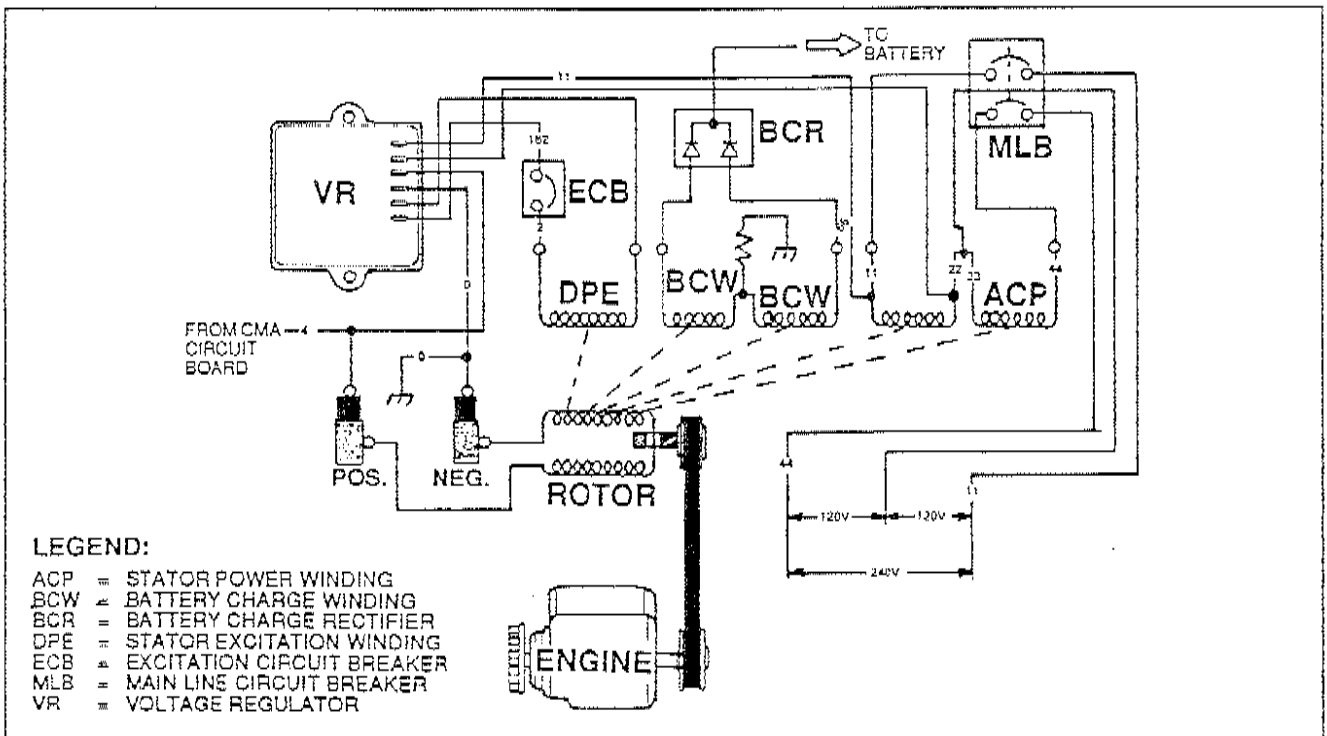

Figure 1. Operating Diagram of AC Generator

*Operation (Continued)*

The greater the current flow through the rotor windings, the more concentrated the lines of flux around the rotor become.

The more concentrated the lines of flux around the rotor that cut across the stationary stator windings, the greater the voltage that is induced into the stator windings.

Initially, the AC power winding voltage sensed by the regulator is low. The regulator reacts by increasing the flow of excitation current to the rotor until voltage increases to a desired level. The regulator then maintains the desired voltage. For example, if voltage exceeds the desired level, the regulator will decrease the flow of excitation current. Conversely, if voltage drops below the desired level, the regulator responds by increasing the flow of excitation current.

AC POWER WINDING OUTPUT:

A regulated voltage is induced into the stator AC power windings. When electrical loads are connected across the AC power windings to complete the circuit, current can flow in the circuit. The regulated AC power winding output voltage will be in direct proportion to the AC frequency. For example, on units rated 120/240 volts at 60 Hz, the regulator will try to maintain 240 volts (line-to-line) at 60 Hz. This type of regulation system provides greatly improved motor starting capability over other types of systems.

BATTERY CHARGE WINDING OUTPUT:

A voltage is induced into the battery charge windings. Output from these windings is delivered to a battery charge rectifier, via Wires No. 66 and 77. The rectifier consists of a pair of diodes which rectify the current (change it to DC). The resulting direct current flow is delivered to the unit battery, via Wire No. 15, a 15 amp fuse, and Wire No. 13. This output is used to maintain battery state of charge during operation.

*NOTE: Battery charge winding output is also delivered to a solid state circuit board in a control module assembly (CMA), via Wire No. 66. This output "tells" the circuit board that the engine has started and what its operating speed and voltage is. The CMA circuit board uses these signals from the battery charge winding to (a) terminate cranking, and (b) turn on various timing circuits that control automatic operation. See Part 7, "DC Control- Units with Air-Cooled Engine".*

Section 2.3  
**TROUBLESHOOTING FLOW CHARTS**

**General**

Use the "Flow Charts" in conjunction with the detailed instructions in Section 2.4. Test numbers used in the flow charts correspond to the numbered tests in Section 2.4

The first step in using the flow charts is to correctly identify the problem. Once that has been done, locate the problem on the following pages. For best results, perform all tests in the exact sequence shown in the flow charts.

**Problem 1- Generator Produces Zero or Residual Voltage**

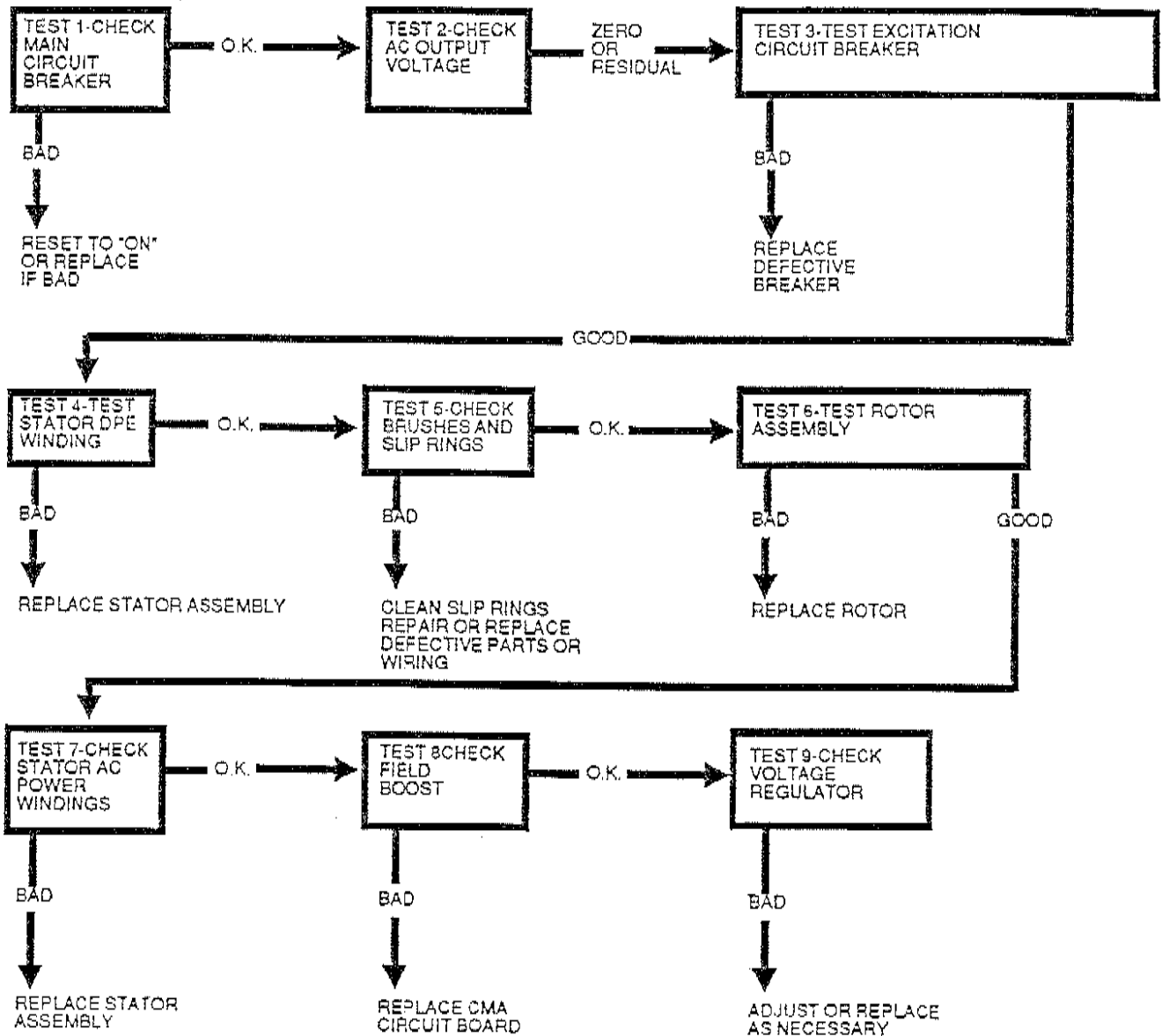

*Problem 2- Generator Produces Low Voltage at No-Load*

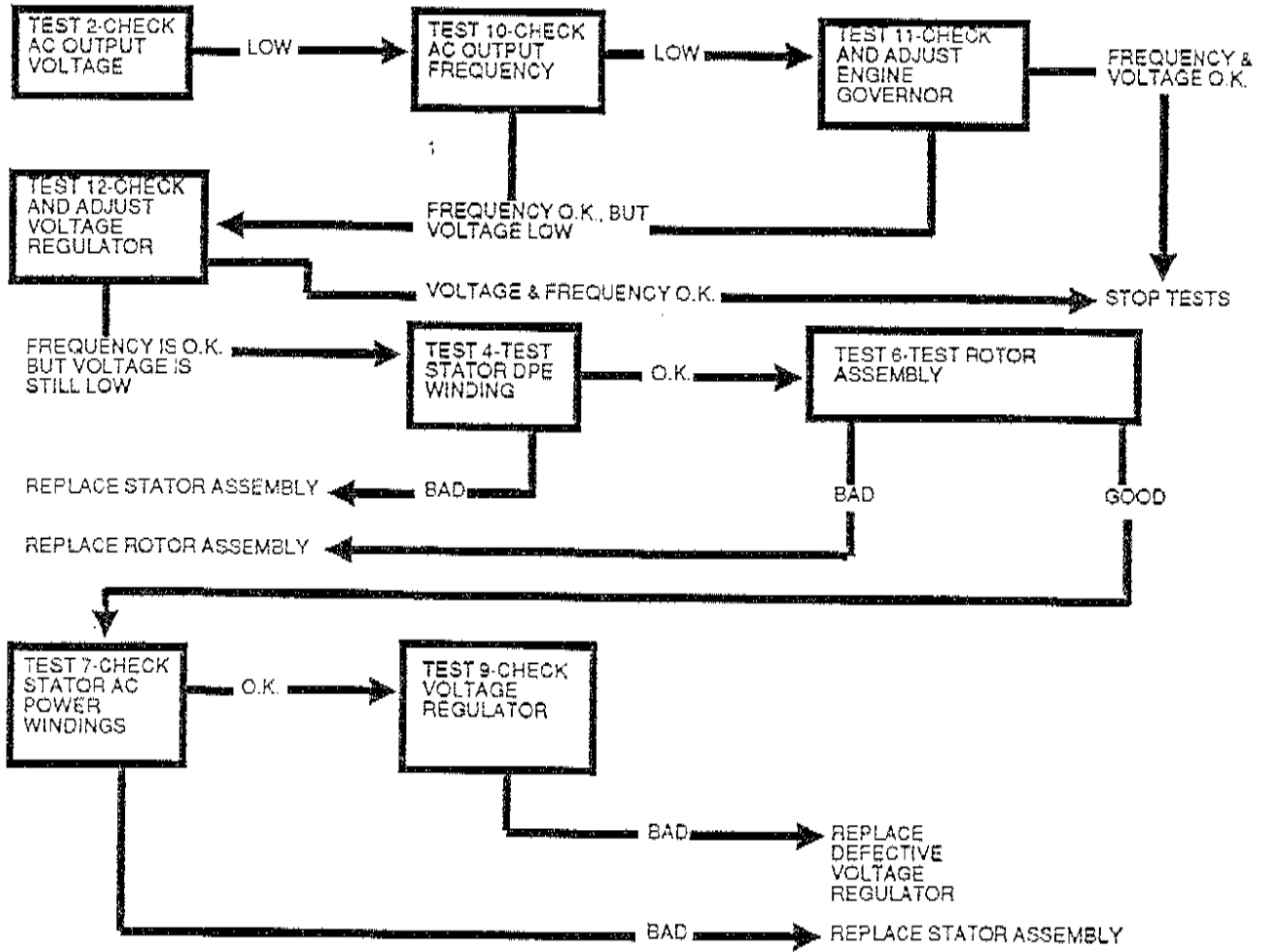

*Problem 3- Generator Produces High Voltage at No-Load*

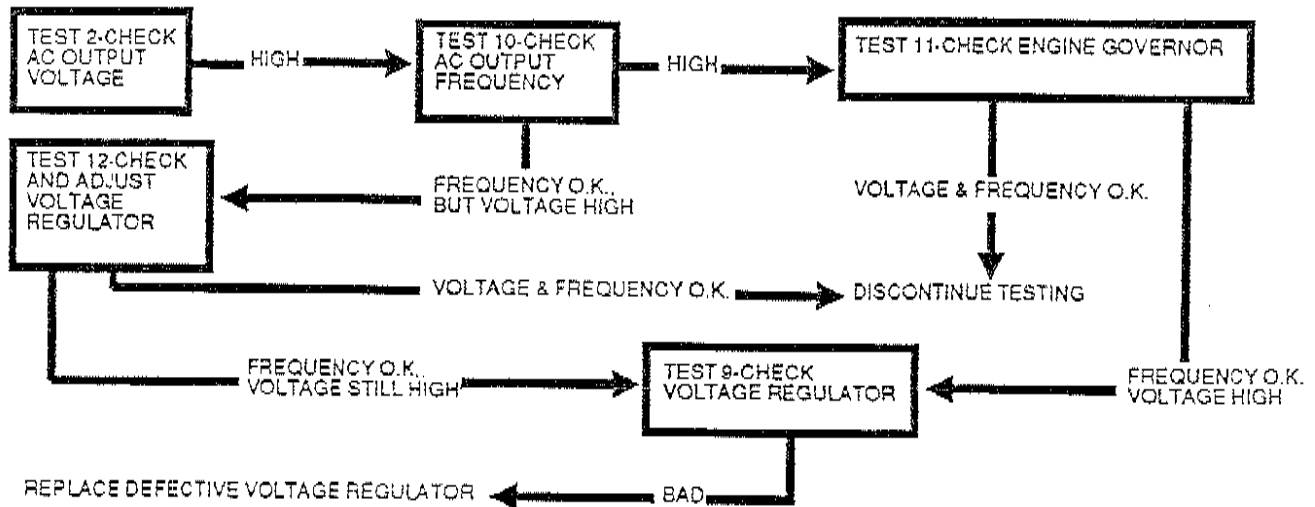

*Problem 4- Voltage and Frequency Drop Excessively When Loads are Applied*

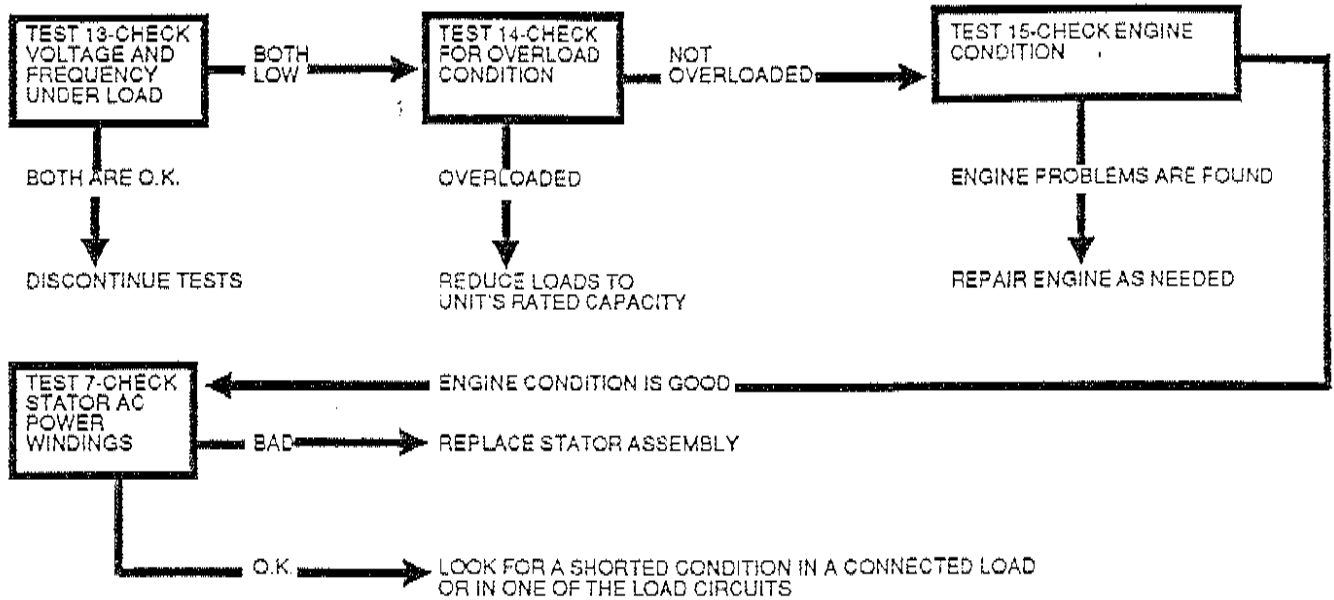



Section 2.4  
**DIAGNOSTIC TESTS**

**Introduction**

This section is provided to familiarize the service technician with acceptable procedures for the testing and evaluation of various problems that could be encountered on prepackaged standby generators with air-cooled engine. Use this section of the manual in conjunction with Section 2.3, "Troubleshooting Flow Charts". The numbered tests in this section correspond with those of Section 2.3.

Test procedures in this section do not require the use of specialized test equipment, meters or tools. Most tests can be performed with an inexpensive volt-ohm-milliammeter (VOM). An AC frequency meter is required, where frequency readings must be taken. A clamp-on ammeter may be used to measure AC loads on the generator.

Testing and troubleshooting methods covered in this section are not exhaustive. We have not attempted to discuss, evaluate and advise the home standby service trade of all conceivable ways in which service and trouble diagnosis might be performed. We have not undertaken any such broad evaluation. Accordingly, anyone who uses a test method not recommended herein must first satisfy himself that neither his nor the product's safety will be jeopardized by the procedure or method he has selected.

**Safety**

Service personnel who work on this equipment must be made aware of the dangers of such equipment. Extremely high and dangerous voltages are present that can kill or cause serious injury. Gaseous fuels are highly explosive and can be ignited by the slightest spark. Engine exhaust gases contain deadly carbon monoxide gas that can cause unconsciousness or even death. Contact with moving parts can cause serious injury. The list of hazards is seemingly endless.

When working on this equipment, use common sense and remain alert at all times. Never work on this equipment while you are physically or mentally fatigued. If you don't understand a component, device or system, don't work on it.

**Test 1- Check Main Circuit Breaker**

**DISCUSSION:**

Often the most obvious cause of a problem is overlooked. If the generator's main line circuit breaker is set to "Off" or "Open", no electrical power will be supplied to electrical loads. If loads are not receiving power, perhaps the main circuit breaker is open or has failed.

**PROCEDURE:**

The generator's main circuit breaker is located on the control panel. If loads are not receiving power, make sure the breaker is set to "On" or "Closed".

If you suspect the breaker may have failed, it can be tested as follows (see Figure 1):

1. Set a volt-ohm-milliammeter (VOM) to its "Rx1" scale and zero the meter.
2. Disconnect all wires from the circuit breaker terminals, to prevent interaction.
3. With the generator shut down, connect one VOM test probe to the Wire No. 11 terminal of the breaker and the other test probe to the Wire E1 terminal.
4. Set the breaker to its "On" or "Closed" position. The VOM should read "continuity".
5. Set the breaker to its "Off" or "Open" position and the VOM should indicate "infinity".
6. Repeat Steps 4 and 5 with the VOM test probes connected across the breaker's Wire No. 44 terminal and the E2 terminal.

**RESULTS:**

1. If the circuit breaker tests good, go on to Test 2.
2. If the breaker tests bad, it should be replaced.

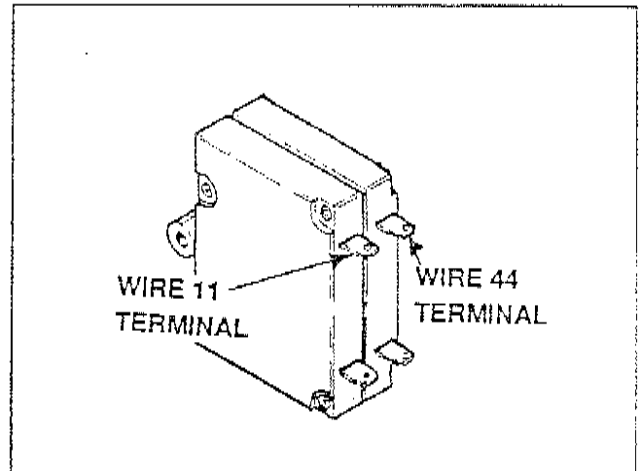

Figure 1. Generator Main Circuit Breaker Test Points

**Test 2- Check AC Output Voltage**

**DISCUSSION:**

If the generator is not equipped with an AC voltmeter, a volt-ohm-milliammeter (VOM) may be used to check its output voltage. Output voltage may be checked at the unit's main circuit breaker terminals, or even at the transfer switch's E1 and E2 terminals, if desired. Refer to the unit's DATA PLATE for rated line-to-line and line-to-neutral voltages.

**Test 2- Check AC Output Voltage (Continued)**

**DANGER: USE EXTREME CAUTION DURING THIS TEST. THE GENERATOR WILL BE RUNNING. HIGH AND DANGEROUS VOLTAGES WILL BE PRESENT AT THE TEST TERMINALS. CONNECT METER TEST CLAMPS TO THE HIGH VOLTAGE TERMINALS WHILE THE GENERATOR IS SHUT DOWN. STAY CLEAR OF POWER TERMINALS DURING THE TEST. MAKE SURE METER CLAMPS ARE SECURELY ATTACHED AND WILL NOT SHAKE LOOSE.**

**PROCEDURE:**

1. With the engine shut down, connect the AC voltmeter test leads across the Wires 11 and 44 terminals of the generator main circuit breaker (see Figure 1). Test leads may also be connected across transfer switch terminal lugs E1 and E2, if desired. These connections will permit line-to-line voltages to be read.
2. Set the generator's main circuit breaker to its "Off" or "Open" position. This test will be conducted with the generator running at no-load.
3. Start the generator, let it stabilize and warm up for a minute or two.
4. Take the meter reading. On unit's having a rated line-to-line voltage of 240 volts, the no-load voltage should be about 242-252 volts AC.
5. Shut the engine down and remove the meter test leads.

**RESULTS:**

1. If zero volts or residual voltage is indicated, go on to Test 3.
2. If the voltage reading is higher than residual, but is lower than the stated limits, go to Test 10.
3. If a high voltage is indicated, go on to Test 10.

**NOTE:** "Residual" voltage may be defined as the voltage that is produced by rotor residual magnetism alone. The amount of voltage induced into the stator's AC power windings by residual voltage alone will be approximately 2 to 10 volts AC, depending on the characteristics of the specific generator. If a unit is supplying residual voltage only, either excitation current is not reaching the rotor or the rotor windings are open and the excitation current cannot pass. On current units with air-cooled engine, "field boost" current flow is available to the rotor only during engine cranking.

**Test 3- Test Excitation Circuit Breaker**

**DISCUSSION:**

Unregulated excitation current is delivered to the voltage regulator from the stator excitation (DPE) winding, via Wire No. 2, an excitation circuit breaker (CB2), Wire No. 162, and Wire No. 6. If the excitation circuit breaker has failed open, excitation current will not be available to the voltage regulator or to the rotor. Stator AC power winding output will then be reduced to a voltage that is the product of residual magnetism alone.

**PROCEDURE:**

1. With the generator shut down, locate the excitation circuit breaker in the generator panel. Disconnect wires from the breaker, to prevent interaction.
2. Set a volt-ohm-milliammeter (VOM) to its "Rx1" scale and zero the meter.
3. Connect the VOM test probes across the circuit breaker terminals. The meter should read "continuity".
4. Use the VOM to test Wires No. 2, 6, and 162 for an open or shorted condition.

**RESULTS:**

1. Replace circuit breaker if defective.
2. If circuit breaker is good, go on to Test 4.

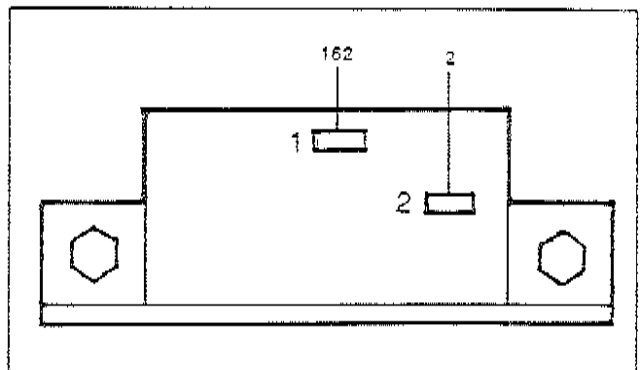

Figure 2. Excitation Circuit Breaker

**Test 4- Test Stator DPE Winding**

**DISCUSSION:**

Stator excitation (DPE) winding AC output is delivered to the voltage regulator during operation, via Wires 2, 6, 162 and the excitation circuit breaker. The voltage regulator (a) rectifies the current, and (b) regulates the current flow based on sensing signals from the stator AC power leads. The rectified and regulated DC current is then delivered to the rotor, via Wire No. 4, and the positive (+) brush and slip ring. The current flows through the rotor windings and to frame ground, via the negative (-) slip ring and brush. An open circuit in the DPE winding can result in complete loss of the rectified and regulated current flow to the rotor. Output voltage from the stator AC power windings will then be the result of residual voltage only (approximately 2-10 volts AC). A shorted condition in the DPE winding can result in partial loss of the rectified and regulated current flow to the rotor. In the latter case, output voltage from the stator AC power windings may be reduced but greater than residual voltage alone.

**PROCEDURE:**

1. In the control panel, disconnect Wire No. 2 from the excitation circuit breaker. Also disconnect Wire No. 6 from the voltage regulator.
2. Set a VOM to its "Rx1" scale and zero the meter.
3. Connect the VOM test leads across the terminal ends of Wires No. 2 and 6. The VOM should read approximately 1.1 ohms.

**Test 4- Test Stator DPE Winding (Continued)**

4. Now, set the VOM to a high resistance scale (such as "Rx10,000" or "Rx1K"). Again, zero the meter.
5. Connect one VOM test lead to terminal end of Wire No. 2, the other test lead to a clean frame ground on the stator can. The meter should read "infinity".
6. With the VOM still set to a high resistance scale, connect one VOM test lead to terminal end of Wire No. 2 and the other test lead to terminal end of Wire No. 11 (on the main circuit breaker). The VOM should indicate "infinity". Finally, connect the VOM test leads across Wire No. 2 and 44 (on the main circuit breaker).
7. Disconnect terminal end of Wire No. 66 from the battery charge rectifier. Connect the VOM test leads across terminal end of Wire No. 2 and terminal end of Wire No. 66. Connect the VOM test leads across these two wires. The meter should read "infinity".

**RESULTS:**

1. Step 3 is a test of DPE winding continuity and resistance. If a very high resistance or "infinity" is indicated, the winding is open or partially open.
2. Step 5 is a test for "grounded" condition. Any upscale movement of the meter needle or dial indicates the DPE winding is grounded.
3. Steps 6 and 7 are tests for "shorted" condition. Any upscale movement of the VOM needle or dial indicates the DPE winding is shorted.

**NOTE:** Read Section 1.5, "Testing, Cleaning and Drying" carefully. If the DPE winding tests bad, perform an insulation resistance test. If the winding fails the insulation resistance test, clean and dry the stator as outlined in Section 1.5. Then, repeat the insulation resistance test. If the winding fails the second resistance test (after cleaning and drying), replace the stator assembly.

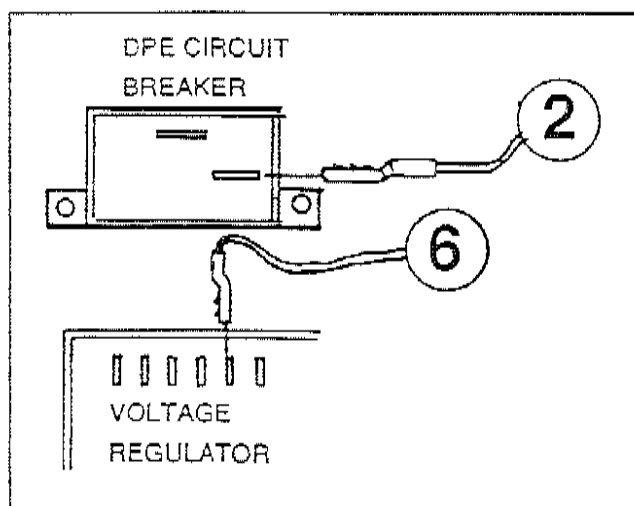

Figure 3. DPE Winding Test Points

**Test 5- Check Brushes and Slip Rings**

**DISCUSSION:**

The function of the brushes and slip rings is to provide for passage of excitation current from stationary components to the rotating rotor. Brushes are made of a special long lasting material and seldom wear out or fail. However, slip rings can develop a tarnish or film that can inhibit or offer a resistance to the flow of electricity. Such a non-conducting film usually develops during non-operating periods. Broken or disconnected wiring can also cause loss of excitation current to the rotor.

**PROCEDURE:**

1. See Figure 4. Carefully inspect brush wires, make sure they are properly and securely connected.
2. Wire No. 0 from the negative (-) brush connects to a 4-tab grounding lug in the control panel. Test that wire for an open condition. Also make sure it is properly connected to the grounding lug.
3. Wire No. 4 from the positive (+) brush connects to a voltage regulator terminal. Test Wire No. 4 for an open or grounded condition and make sure it is properly connected to the correct regulator terminal.
4. Disconnect Wires No. 0 and 4 from the brushes. Remove the brush holder from the bearing carrier.
5. Inspect the brushes for excessive wear, damage.
6. Inspect the rotor slip rings. If they appear dull or tarnished, they may be polished with fine sandpaper. **DO NOT USE ANY METALLIC GRIT TO POLISH SLIP RINGS.**

**RESULTS:**

1. Repair, replace or reconnect wires as necessary.
2. Replace any damaged slip rings or brush holder.
3. Clean and polish slip rings as required.
4. Test unit for AC output voltage. If AC voltage is still not acceptable, go on to Test 6.

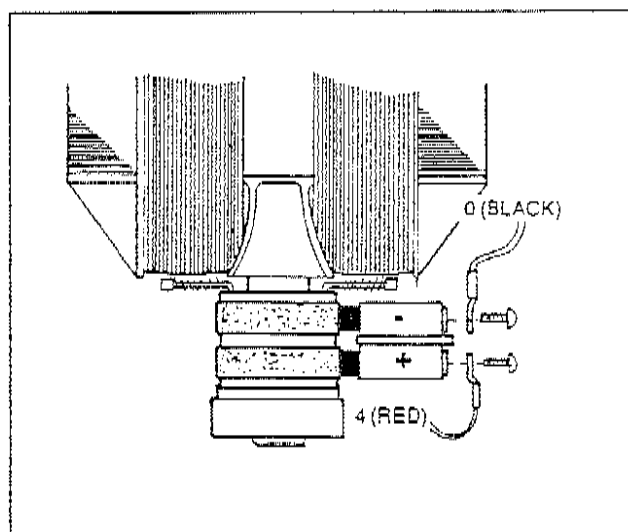

Figure 4. Checking Brushes and Slip Rings

**Test 6- Test Rotor Assembly**

**DISCUSSION:**

A rotor having completely open windings will cause loss of excitation current flow and, as a result, generator AC output voltage will drop to "residual" voltage. A "shorted" rotor winding can result in a low voltage condition.

**PROCEDURE:**

1. Disconnect the brush wires or remove the brush holder, to prevent interaction.
2. Set a VOM to its "Rx1" scale and zero the meter.
3. Connect the positive (+) VOM test lead to the positive (+) rotor slip ring (nearest the rotor bearing); and the common (-) test lead to the negative (-) slip ring. The meter should read approximately 12-13 ohms.
4. Now, set the VOM to a high resistance scale (such as "Rx10,000" or "Rx1K"). Again, zero the meter.
5. Connect the positive (+) VOM test lead to the positive (+) slip ring and the common (-) test lead to a clean frame ground. The meter should indicate "infinity".

**RESULTS:**

1. Replace rotor assembly if it is open or shorted.
2. If rotor tests good, go on to Test 7.

*NOTE: Be sure to read Section 1.5, "Testing, Cleaning and Drying", carefully. If rotor tests bad, try performing an insulation resistance test. Clean and dry rotor if it fails that test. Then, repeat the test. If rotor fails the second insulation resistance test, it should be replaced.*

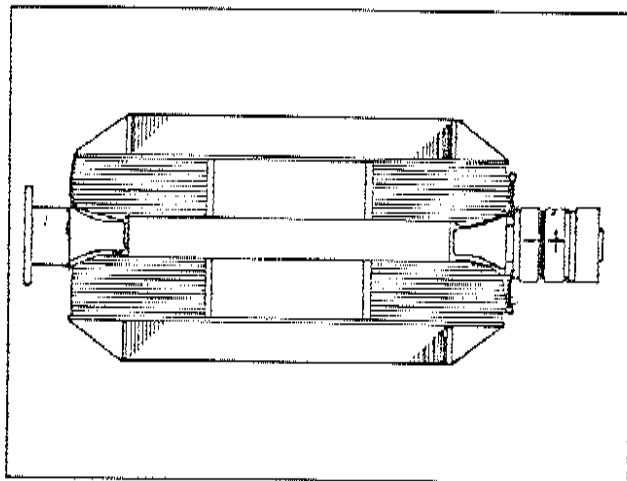

Figure 5. The Rotor Assembly

**Test 8- Check Field Boost**

**DISCUSSION:**

See "Field Boost Circuit" on Page 2.1-4. Field boost current (from the CMA circuit board) is available to the rotor only while the engine is cranking. Loss of field boost output to the rotor may or may not affect power winding AC output voltage. The following facts apply:

- A small amount of voltage must be induced into the DPE winding to turn the voltage regulator on.
- If a rotor's residual magnetism is sufficient to induce a voltage into the DPE winding that is high enough to turn the voltage regulator on, regulator excitation current will be supplied even if field boost has failed. Normal AC output voltage will then be supplied.
- If rotor residual magnetism has been lost or is not sufficient to turn the regulator on, and field boost has also been lost, excitation current will not be supplied to the rotor. Generator AC output voltage will then drop to zero or nearly zero.

**PROCEDURE:**

1. Locate Wire No. 4 that is routed from the CMA circuit board and connects to a voltage regulator terminal. Disconnect that wire from the voltage regulator terminal.
2. Set a VOM to read DC volts, and to a DC volts scale greater than 12 volts.
3. Connect the positive (+) VOM test probe to the terminal end of disconnected Wire No. 4 (from the CMA board).
4. Connect the common (-) VOM test probe to the 4-place grounding lug.
5. Crank the engine while observing the VOM reading. While the engine is cranking, the VOM should read approximately 9-10 volts DC. When engine is not cranking, VOM should indicate "zero" volts.

**RESULTS:**

1. If normal field boost voltage is indicated in Step 5, go on to Test 9.
2. If normal field boost voltage is NOT indicated in Step 5, check Wire No. 4 (between regulator and CMA board) for open or shorted condition. If wire is good, replace the CMA circuit board.

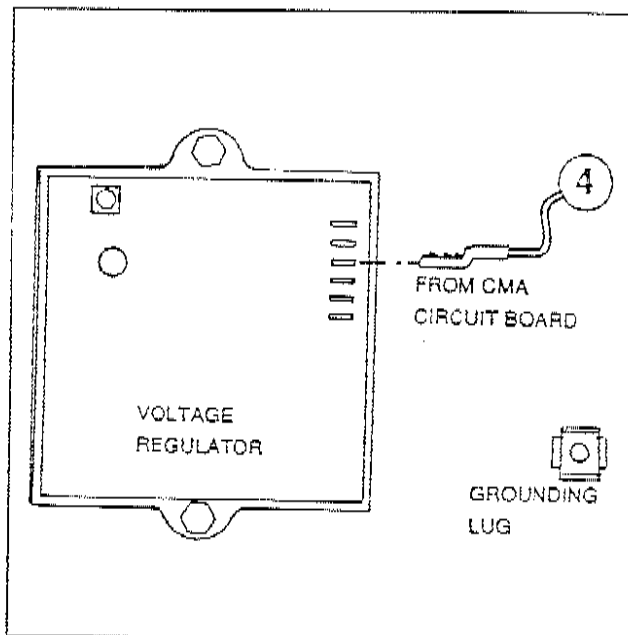

Figure 6. Field Boost Test Points

**Test 9- Check Voltage Regulator**

**DISCUSSION:**

The voltage regulator receives unregulated alternating current from the stator DPE winding, via Wires No. 2, 6 and 162. It also receives voltage and frequency signals from the stator AC power windings, via Wires No. 11 and 22. The regulator rectifies the AC from the DPE winding and, based on the sensing signals, regulates that current flow. The rectified and regulated current flow is delivered to the rotor brushes via Wires No. 4 (+) and 0 (-).

The regulator mounts an LED (light emitting diode) and a single adjustment potentiometer. The LED turns on when sensing voltage is available; goes out when sensing is lost. The adjustment potentiometer permits generator AC output voltage to be adjusted.

**PROCEDURE:**

1. With the generator running at no-load, observe the red LED on the voltage regulator. If the light is "On", go to Step 2 of this test.
  - a. If the LED is "Out", use a VOM to test for AC voltage at the Wires No. 11 and 22 terminals of the regulator.
  - b. The meter should read about one-half the line-to-line voltage that was indicated in Test 2 (line-to-neutral voltage).
2. Now check the voltage across the regulator's Wires No. 6 and 162 terminals. This is DPE winding AC voltage output to the regulator. With the unit running at no-load, this reading should be around 130-150 volts AC.
3. Finally, check for a DC output voltage at the regulator's No. 4 (+) and 0 (-) terminals.

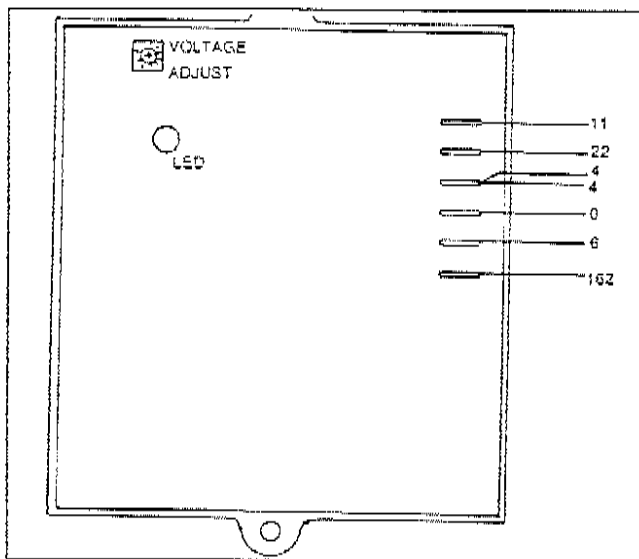

*Figure 7. Voltage Regulator Test Points*

**RESULTS:**

1. In Step 1, if the red LED is out and no voltage is indicated at the Wire No. 11/22 terminals, test sensing leads 11 and 22 for an open condition.
  - a. Repair or replace open sensing leads as necessary.
  - b. If sensing leads are good, repeat Test 7.
  - c. If the red LED is out and DPE voltage is good, replace the voltage regulator.
2. In Step 2, if voltage reading is bad, repeat Test 4. Also test DPE winding AC output leads for open or shorted condition.
3. If voltage readings in Steps 1 and 2 were good, but no output was indicated in Step 3, replace the voltage regulator.

**Test 10- Check AC Output Frequency**

**DISCUSSION:**

The generator's AC frequency is proportional to the operating speed of the rotor. The 2-pole rotor will supply a 60 Hertz AC frequency at 3600 rpm. The unit's AC output voltage is proportional to the AC frequency. For example, a unit rated 240 volts (line-to-line) will supply that rated voltage (plus or minus 2 percent) at a frequency of 60 Hertz. If, for any reason, the frequency should drop to 30 Hertz, the line-to-line voltage will drop to a matching voltage of 120 volts AC. Thus, if the AC voltage output is high or low and the AC frequency is correspondingly high or low, the engine speed governor may require adjustment.

**PROCEDURE:**

1. Connect an accurate AC frequency meter across the Wires 11 and 44 terminals of the generator main line circuit breaker (see Figure 1, Page 2.4-1).
2. Start the engine, let it stabilize and warm up at no-load.
3. When engine has stabilized, read the frequency meter. The no-load frequency should be about 61-63 Hertz.

**RESULTS:**

1. If the AC frequency is high or low, go on to Test 11.
2. If frequency is good, but voltage is high or low, go to Test 12.
3. If frequency and voltage are both good, tests may be discontinued.

**Test 11- Check and Adjust Engine Governor**

**DISCUSSION:**

A low or high governed speed will result in a correspondingly low or high AC frequency and voltage output as measured in Tests 2 and 10. The governed speed must be correct before any attempt to adjust the voltage regulator is made.

***Test 11- Check and Adjust Engine  
Governor (Continued)***

**PROCEDURE:**

Refer to Part 9, "Operational Tests and Adjustments".

**RESULTS:**

1. If, after adjusting the engine governor, frequency and voltage are good, tests may be discontinued.
2. If frequency is now good, but voltage is high or low, go on to Test 12.

***Test 12- Check and Adjust Voltage  
Regulator***

**DISCUSSION:**

The prepackaged voltage regulator mounts a single adjustment potentiometer, for the adjustment of generator AC voltage output. Prior to adjusting the voltage regulator, you must make sure that the engine speed governor is properly adjusted and operating speed is correct.

**PROCEDURE:**

See Part 9 of this manual, "Operational Tests and Adjustments".

**RESULTS:**

1. If frequency and voltage are now good, discontinue tests.
2. If frequency is now good but voltage is high or low, go to Test 4.

***Test 13- Check Voltage and Frequency  
Under Load***

**DISCUSSION:**

It is possible for the generator's AC output frequency and voltage to be good at no-load, but they may drop excessively when electrical loads are applied. This condition, in which voltage and frequency droop excessively when loads are applied, can be caused by (a) overloading the generator, (b) loss of engine power, or (c) a shorted condition in the stator windings or in one or more connected loads.

**PROCEDURE:**

1. Connect an accurate AC frequency meter and an AC voltmeter across the stator's AC power winding leads.
2. Start the engine, let it stabilize and warm up.
3. Apply electrical loads to the generator equal to the rated capacity of the unit.
4. Check the AC frequency and voltage. Frequency should not droop below approximately 58-59 Hertz. Voltage should not droop below about 232-236 volts (plus or minus 2 percent).

**RESULTS:**

1. If frequency and voltage droop excessively under load, go to Test 14.
2. If frequency and voltage under load are good, discontinue tests.

***Test 14- Check for Overload Condition***

**DISCUSSION:**

An "overload" condition is one in which the generator's rated wattage/amperage capacity has been exceeded. To test for an overload condition on an installed unit, the best method is to use an ammeter. See "Measuring Current" on Page 1.5-1.

**PROCEDURE:**

Use a clamp-on ammeter to measure load current draw, with the generator running and all normal electrical loads turned on.

**RESULTS:**

1. If the unit is overloaded, reduce loads to the unit's rated capacity.
2. If unit is not overloaded, but rpm and frequency droop excessively when loads are applied, go to Test 15.

***Test 15- Check Engine Condition***

**DISCUSSION:**

If engine speed and frequency droop excessively under load, the engine may be underpowered. An underpowered engine can be the result of a dirty air cleaner, loss of engine compression, faulty carburetor settings, incorrect ignition timing, etc.

**PROCEDURE:**

For engine testing, troubleshooting and repair procedures, refer to "Service Manual- V-Twin OHV Horizontal and Vertical Shaft Engines". That manual is available from Generac by specifying Manual Part No. 81134.

**RESULTS:**

1. Repair engine, or replace defective part(s), or adjust as necessary.
2. If no engine problems are found, go to Test 7.

**PART 3**  
**PREPACKAGED**  
**LIQUID-COOLED**  
**AC GENERATORS**

GENERAC II  
PREPACKAGED  
HOME STANDBY  
ELECTRIC POWER  
SYSTEMS

**TABLE OF CONTENTS**

SECTION	TITLE
3.1	Description and Major Components
3.2	Operational Analysis
3.3	Troubleshooting Flow Charts
3.4	Diagnostic Tests

# NOTES

---

Section 3.1  
**DESCRIPTION AND MAJOR COMPONENTS**

***Introduction***

This section covers the major components of the AC generator proper, i.e., those generator assemblies that provide for the production of AC electrical power.

The single bearing rotor (revolving field) is driven by a 1.2 liter, liquid cooled gas engine. The rotor is coupled to the engine flywheel, by means of a flexible coupling and a fan and ring gear assembly, so the engine crankshaft and rotor operate at the same speed.

Major components of the AC generator are shown in Figure 1 on the next page. These components are (a) a flexible coupling, (b) fan and ring gear, (c) rotor, (d) blower housing, (e) stator assembly, (f) rear bearing carrier, and (g) a rear bearing carrier cover.

***Blower Housing***

The blower housing is bolted to the engine and supports the engine end of the AC generator. It houses the fan and ring gear assembly. A cutout area on one side of the housing allows a blower air outlet screen to be mounted.

***Flexible Disk***

A flexible disk bolts to the engine flywheel and to the fan and ring gear assembly. The disk maintains proper alignment between the engine and generator parts.

***Fan and Ring Gear Assembly***

The fan and ring gear assembly are retained to the flexible disk which, in turn, is retained to the engine flywheel. The fan draws cooling air into the generator interior through slots in a rear bearing carrier cover, then expels the heated air outward through a screen on the blower housing. The ring gear teeth mate with teeth on a starter motor pinion gear, when the engine is cranked.

***Rotor Assembly***

The rotor assembly on units rated 1800 rpm is a 4-pole type, having two north magnetic poles and two south magnetic poles.

Units rated 3600 rpm have a 2-pole rotor, with a single south and a single north magnetic pole.

The rear end of the rotor is bolted and keyed to the fan and ring gear. A ball bearing has been pressed onto the rotor's front shaft which is retained in a machined bore in the rear bearing carrier.

A positive (+) and a negative (-) slip ring is provided on the rotor shaft that retains the ball bearing. Brushes will ride on these slip rings.

The combination of slip rings and brushes allow rotor excitation current to be transmitted from stationary components into the rotating rotor windings. The positive (+) slip ring is the one nearest the rotor bearing.

***Rear Bearing Carrier***

The rear bearing carrier supports the front of the generator. Mounting feet at the carrier bottom permit the carrier to be bolted to the generator mounting base. A machined bore, in the center of the carrier, accepts the rotor bearing. Bosses allow for the retention of brush holders. Long stator bolts pass through holes in the carrier's outer periphery, to sandwich and retain the stator can between the carrier and the blower housing. A rear bearing carrier gasket helps prevent dust from entering the bearing area.

***Stator Assembly***

Stator windings may be connected as (a) a 3-wire, 1-phase system, (b) a 3-phase, 12 lead, parallel wye type system, or (c) a 3-phase, 12 lead, delta connected system. (See Section 1.2, "AC Connection Systems".)

A notched cutout has been provided in the rear bearing carrier end of the stator can. A rubber grommet has been placed into that notch, for protection of the stator leads that are brought out of the stator.

The stator can is sandwiched between the blower housing and the rear bearing carrier, and retained in that position by four (4) stator bolts

***Rear Bearing Carrier Plate***

This plate is retained to the rear bearing carrier by four (4) capscrews, lockwashers and flatwashers. The plate provides slotted air inlet openings for the passage of cooling and ventilating air into the generator.

***Brush Holders and Brushes***

Brushes are retained in a brush holder which is retained to drilled and threaded bosses on the rear bearing carrier. In most cases, two brush holders are used having two brushes per holder. Brush holders are precisely positioned so that one of the two brushes slides on a positive (+) slip ring, the other on a negative (-) slip ring. The positive (+) brush and slip ring are nearest the rotor bearing. The positive (+) side of the DC excitation circuit (Wire No. 4, red) connects to the positive (+) brush; the negative (-) or grounded side (Wire No. 0) to the negative (-) brush. Brushes and brush holders are illustrated in Figure 2, on Page 3.1-3.

ITEM	DESCRIPTION	ITEM	DESCRIPTION	ITEM	DESCRIPTION
1	Rotor Assembly	14	Rear Bearing Carrier	28	Hex Head Capscrew
2	Blower Housing	15	Brush Holder	29	Lockwasher
3	Air Outlet Screen	16	Hex Head Screw	30	Hex Head Capscrew
4	Hex Head Capscrew	17	Bearing Carrier Gasket	31	Lockwasher
5	Lockwasher	18	Plug	32	Hex Nut
6	Flatwasher	19	Bearing Carrier Plate	33	Hex Head Capscrew
7	Hex Head Capscrew	20	Stator Bolt	34*	Stainless Steel Hex Nut
8	Hex Head Capscrew	21	Hex Head Capscrew	35*	RPM Sensor
9	Flatwasher	22	Lockwasher	36	Rubber Grommet
10	Lockwasher	23	Flatwasher	37	Plastic Plug
11	Hex Nut	24	Fan and Ring Gear	38	*Flex Guard* Conduit
12	Dowel	25	Square Key		
13	Stator Assembly	26	Spacer		
		27	Flexible Coupling		

\* Items 34 and 35 are NOT used on prepackaged standby generators. On prepackaged units, the threaded RPM Sensor hole is covered by a Plastic Plug (Item 37).

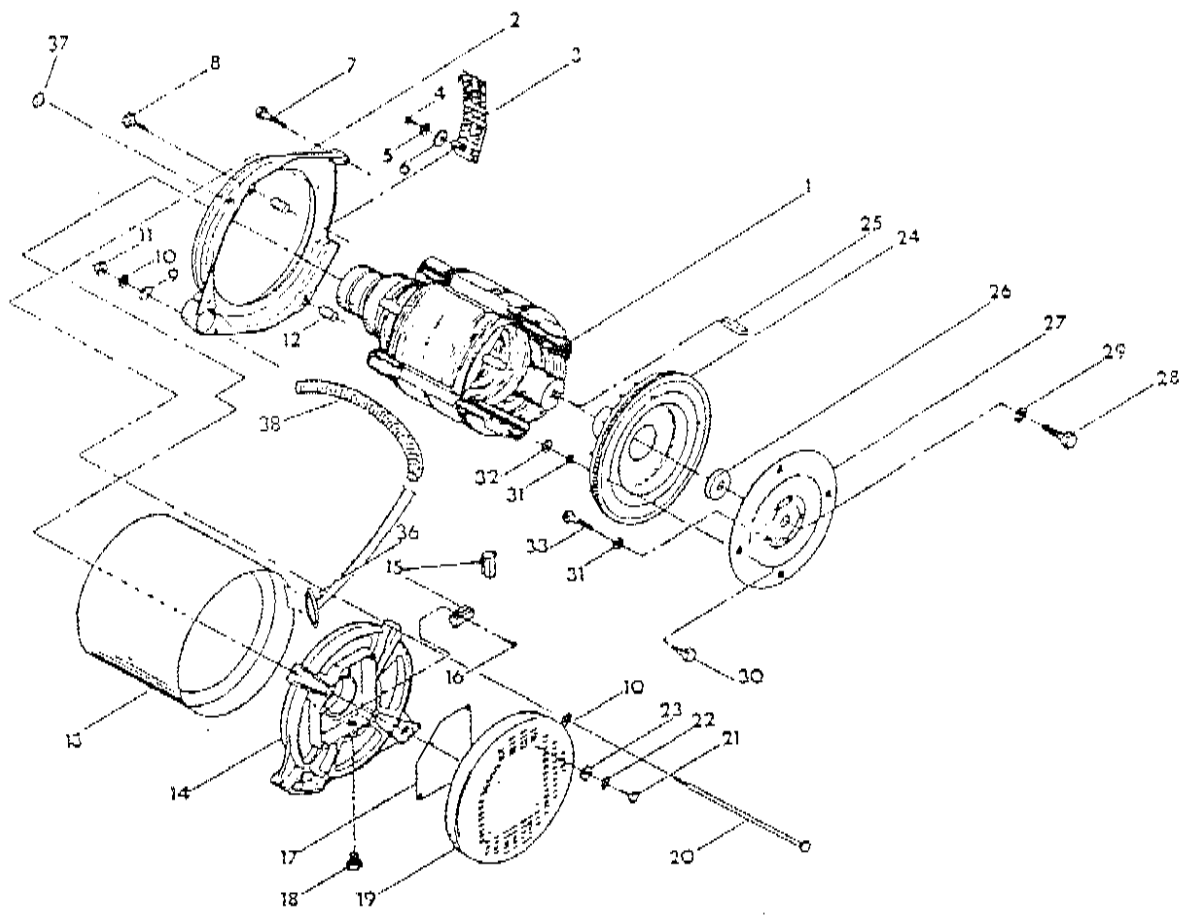

Figure 1. Exploded View of AC Generator Components

*Brush Holders and Brushes (Continued)*

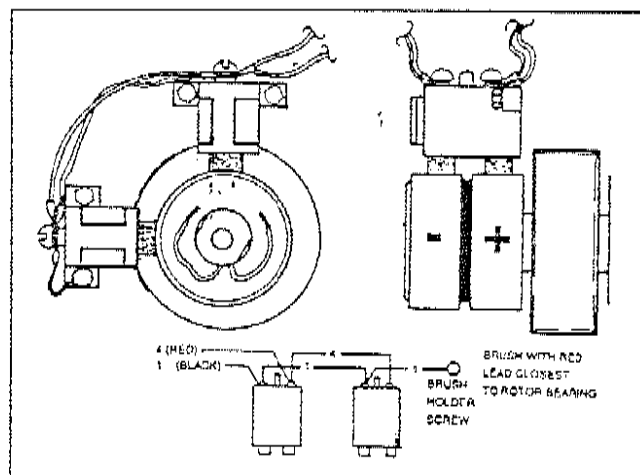

Figure 2. Brush Holders and Brushes

*The Excitation Circuit*

AC output from the stator excitation (DPE) winding is delivered to the voltage regulator, via a thermal protector (TP), Wire No. 2, an excitation circuit breaker (CB1), Wire No. 162, and Wire No. 6. This is "unregulated" excitation current.

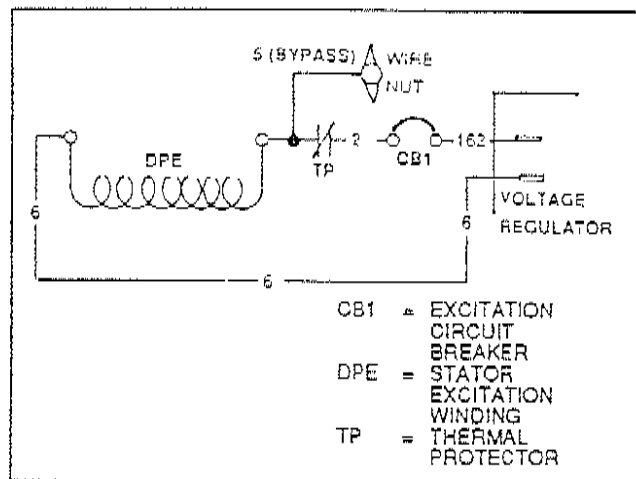

Figure 3. Schematic- Excitation Circuit

THERMAL PROTECTOR:

This normally-closed thermal switch protects the stator windings against excessively high internal temperatures. The switch is physically imbedded in the stator windings and electrically connected in series with the DPE winding AC output to the regulator. If internal stator temperature exceeds a safe value, the switch contacts will open and DPE output to the voltage regulator will be terminated. Without excitation current flow to the rotor, generator AC output voltage will drop to a value commensurate with rotor residual magnetism.

The thermal protector is self resetting. That is, when internal stator temperatures drop to a safe value, its contacts will re-close and normal DPE output to the regulator will resume.

Wire No. 5 is a thermal protector "bypass" lead. If the thermal switch has failed in its open position, it can be bypassed. The Wire No. 5 bypass lead is brought out of the stator and has a wire nut on its end.

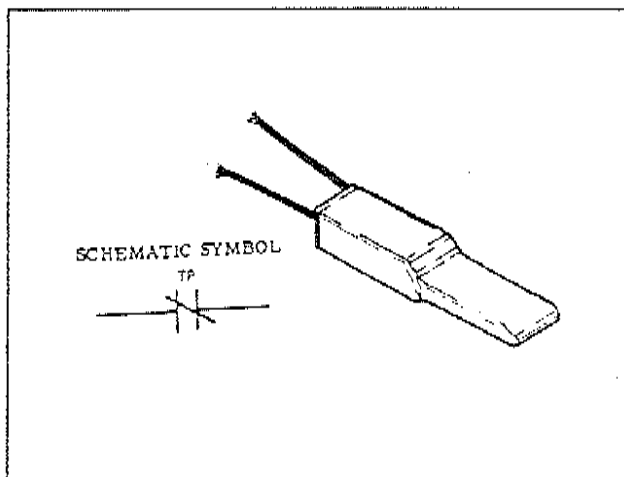

Figure 4. The Thermal Protector

EXCITATION CIRCUIT BREAKER:

This circuit breaker protects the regulator against high voltage surges. If the breaker has tripped open, loss of excitation current will occur. Stator power winding AC output voltage will then drop to a value commensurate with residual magnetism in the rotor. The breaker is self resetting.

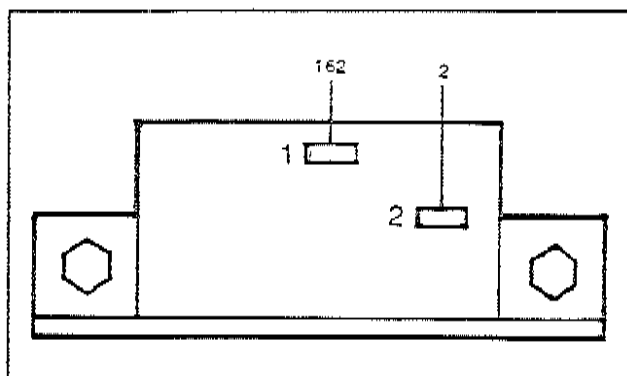

Figure 5. Excitation Circuit Breaker

VOLTAGE REGULATOR:

See Figure 6. Unregulated AC output from the stator DPE winding is delivered to the voltage regulator, via Wires No. 6 and 162. Stator power winding AC voltage and frequency signals are delivered to the regulator, via "sensing" Wires No. S15 and S16. The regulator rectifies the DPE output and, based on the sensing lead signals, regulates the DPE output. An LED (light emitting diode) is incorporated on the regulator. This red light senses the "sensing" (S15/S16) input.

*The Excitation Circuit (Continued)*

If the red LED goes "out", sensing signals to the regulator have been lost. The following rules apply:

- Loss of sensing can be caused by an "open" circuit condition in sensing leads S15 and S16. These sensing leads also operate the generator's panel-mounted AC frequency meter. Thus, if the red LED is out and the panel frequency meter is not operating, you may assume that an open circuit exists in the sensing circuit.
- Loss of sensing to the regulator will usually result in a "full field" condition and resultant high voltage output from stator AC power windings. The maximum voltage that regulator action can deliver is limited by a "claming" action on the part of the regulator.
- A complete open circuit condition in the stator AC power windings will cause loss of sensing voltage and frequency. However, this will result in a zero voltage output from the stator windings.

Based on the "sensing" signals, the regulator delivers direct current (DC) to the rotor, via Wire No. 4 and the positive (+) brush and slip ring. This regulated current flows through the rotor and to frame ground, via the negative (-) slip ring and brush and Wire No. 1. The following apply:

- The concentration of magnetic lines of flux around the rotor will be proportional to the regulated excitation current flow through the rotor plus any residual magnetism.
- An increase in excitation current flow through the rotor windings will increase the concentration of magnetic flux lines around the rotor which, in turn, will increase the AC voltage induced into the stator AC power windings.

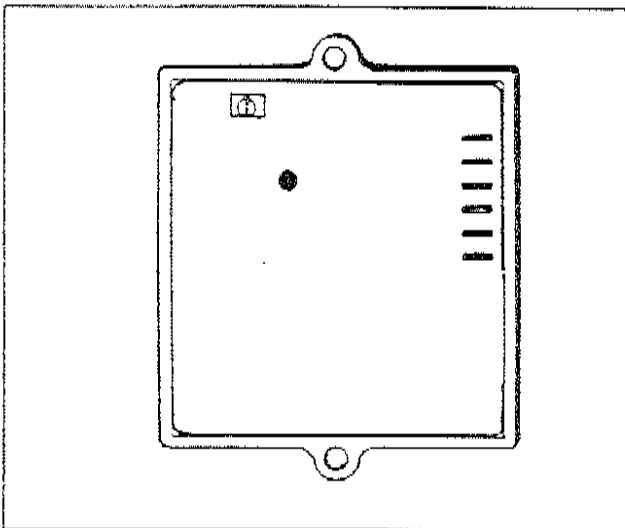

Figure 6. Prepackaged Voltage Regulator

**Field Boost**

See Figure 7. The prepackaged system provides a "field boost" feature. Field boost, in effect, "flashes the field" whenever the engine is cranking to ensure an early "pickup voltage" in the stator windings.

A field boost diode and a field boost resistor are installed in a CMA circuit board. Field boost DC output to the rotor is reduced to approximately 9-10 volts by the field boost resistor.

Manual and automatic cranking is initiated by CMA board action, when that board energizes a crank relay (K1). When the relay is energized, battery voltage is delivered across its closed contacts and to the rotor, via a field boost resistor, field boost diode, and Wire No. 4. Notice that field boost current flow is available only while the engine is cranking.

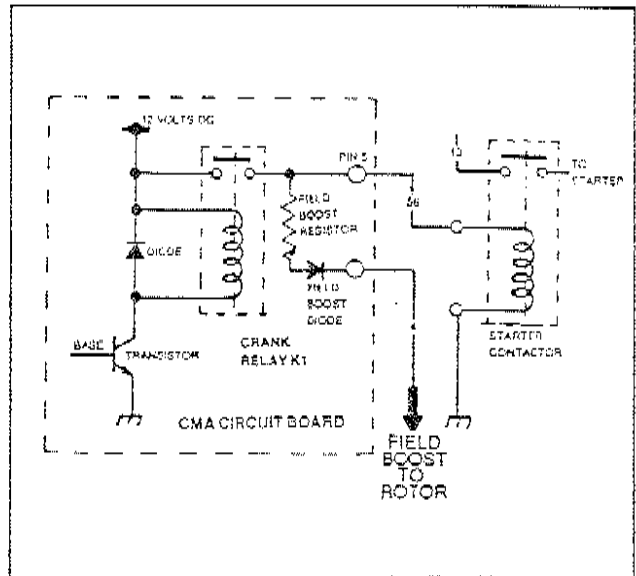

Figure 7. The Field Boost Circuit

**AC Meters**

An AC frequency meter, voltmeter and ammeter may be mounted on the generator panel. (See Section 1.7, "Operating Instructions".)

The AC frequency meter is powered by sensing leads S15 and S16 from the stator power windings.

The AC voltmeter is powered by Wires No. S15, S16 and S44 from the stator AC power windings. These wires feed the voltmeter through a "voltage-phase selector switch". Line S15 is connected to stator AC output line E1; line S16 to "Neutral" (00); and line S44 to stator lead E2. The voltage-phase selector switch permits the operator to select either "line-to-line" or "line to neutral" readings on the meter.

The AC ammeter is powered by the induced output of current transformers and by way of the "voltage-phase selector switch". All 1-phase units will have two (2) transformers; 3-phase units will have three (3) transformers. The voltage-phase selector switch permits operator selection of either "line-to-line" ammeter readings or "line-to-neutral" readings.

Section 3.2 OPERATIONAL ANALYSIS

**Rotor Residual Magnetism**

The rotor (or revolving field) is a permanent magnet. That is, a small amount of "residual magnetism" is always present in the rotor. The "residual magnetism" of a typical rotor should be sufficient to induce a voltage into the stator power windings of approximately 2-12 volts AC.

**Operation**

**STARTUP:**

When the engine is cranked, residual plus field boost magnetism in the rotor will induce a voltage into the

stator's AC power windings and excitation (DPE) winding that is the equivalent sum of those two magnetic fields. If field boost is lost for any reason, residual magnetism alone may or may not be able to induce a "pickup" voltage into the stator windings.

**FIELD EXCITATION:**

As the rotor's magnetic field cuts across the stator excitation (DPE) windings, a voltage is induced into those windings. The circuit is completed through a voltage regulator and unregulated alternating current flows to the regulator, via Wire No. 2, a thermal protector (TP), an excitation circuit breaker (CB1), Wire No. 162, and Wire No. 6.

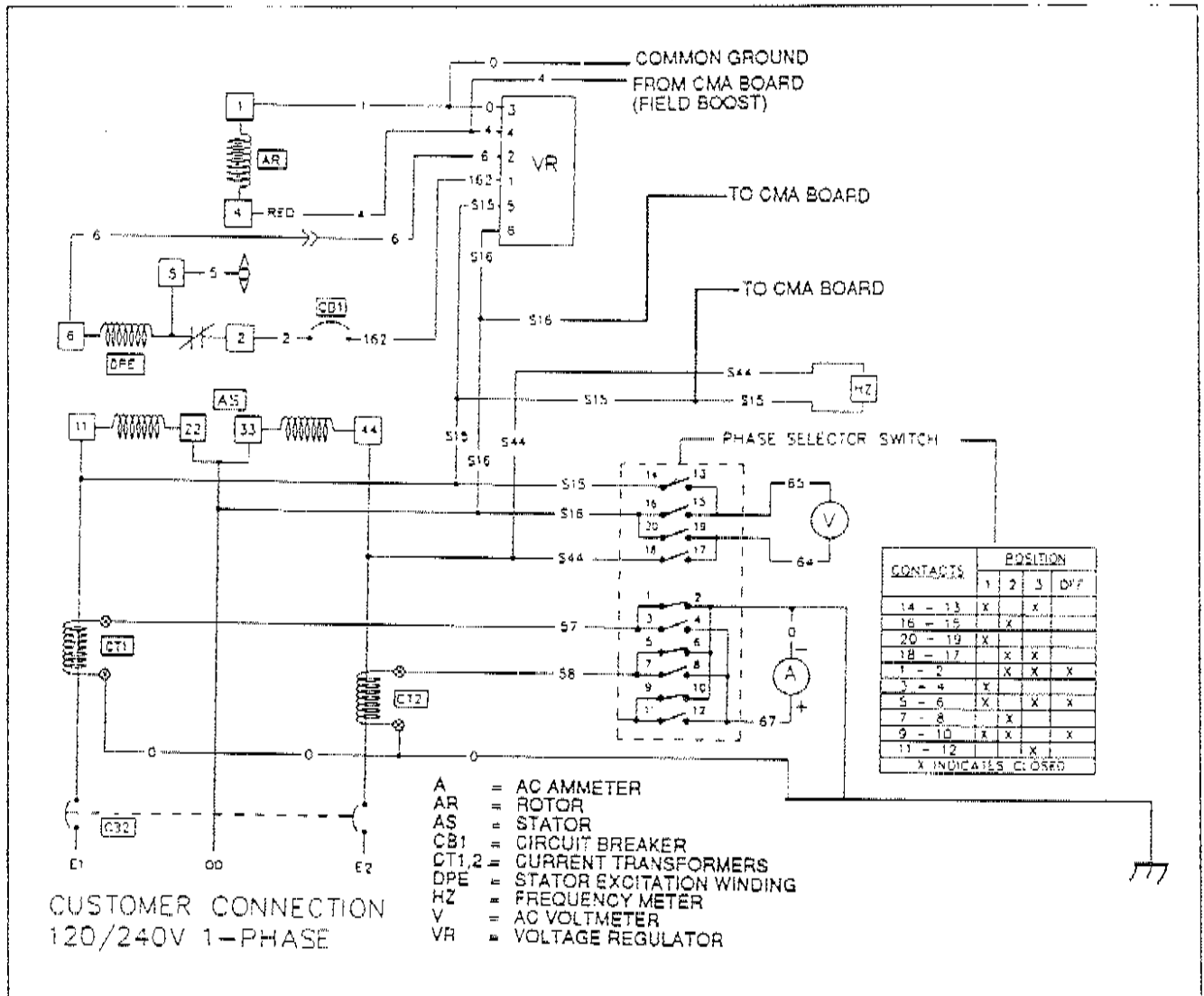

Figure 1. Schematic Diagram of AC Generator

*Operation (Continued)*

The voltage regulator senses AC power winding output voltage and frequency, via sensing leads S15 and S16. The regulator rectifies the excitation (DPE) winding current and, based on the sensing signals, regulates that current. The rectified and regulated excitation current is then delivered to the rotor, via Wire No. 4, and the positive (+) brush and slip ring. The circuit is completed through the rotor and to frame ground through the negative (-) slip ring and brush and Wire No. 1.

The higher the current flow through the rotor windings, the more concentrated the lines of magnetic flux around the rotor. The more concentrated the lines of flux, the greater the voltage that is induced into the stator windings. Thus, by regulating the excitation current, the voltage regulator regulates the rotor's magnetic field and, in turn, the stator power winding voltage is regulated.

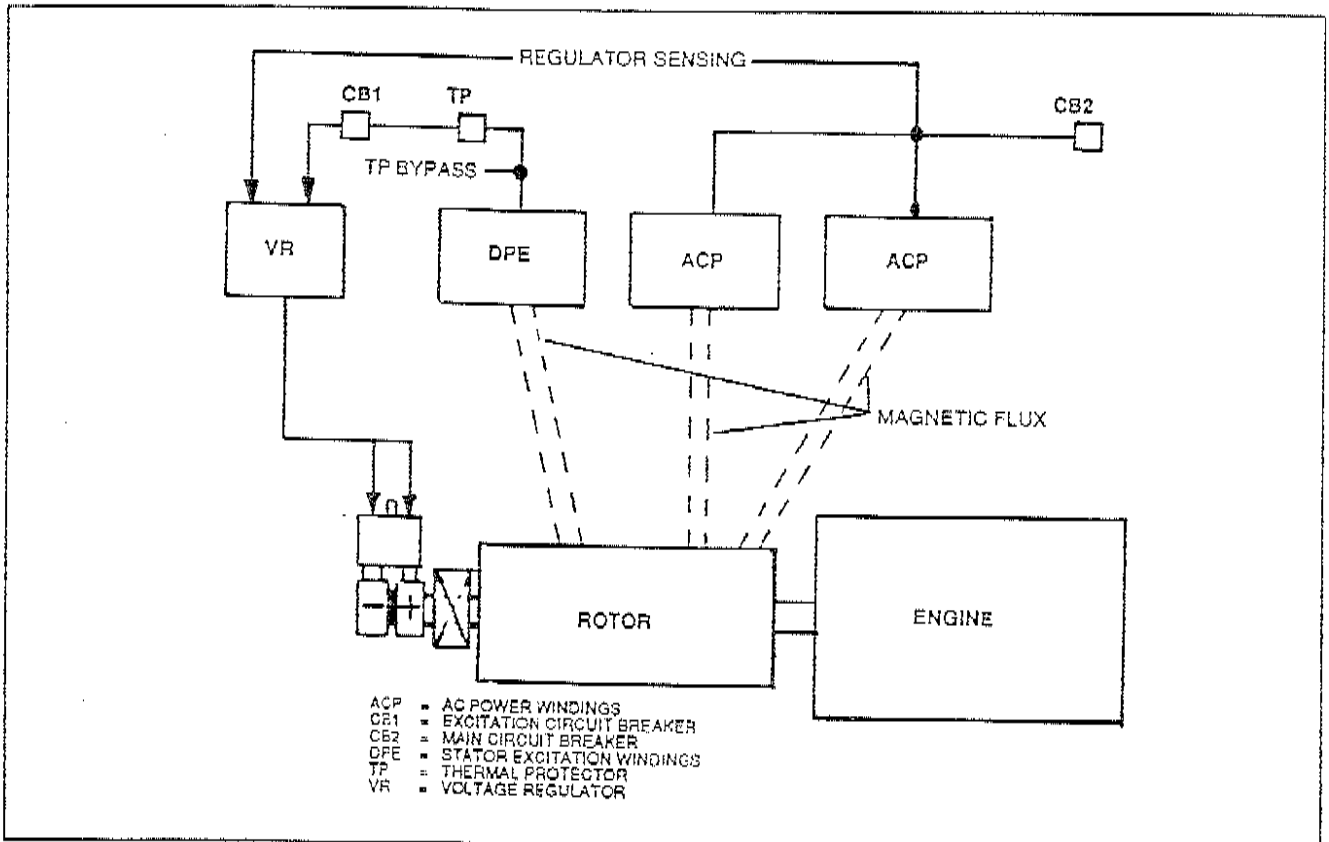
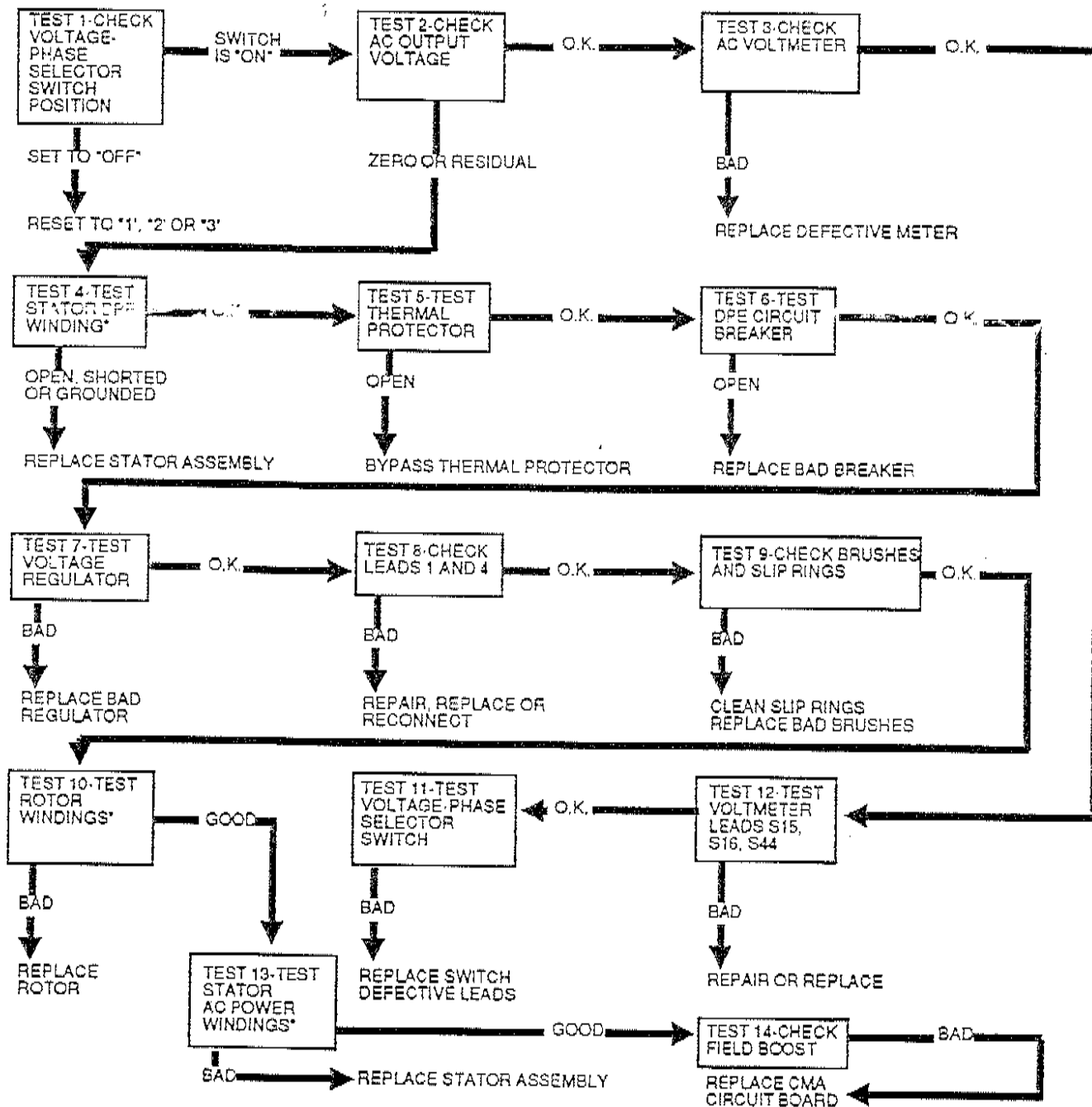

Figure 2. Block Diagram of AC Generator

TROUBLESHOOTING FLOW CHARTS

Problem 1- Generator Produces Zero or Residual Voltage



\*NOTE: Be sure to read Section 1.5, "Testing, Cleaning and Drying". Some stator and rotor problems may be caused by insulation failure. Dirt and moisture can contribute to insulation breakdown. A shorted or grounded winding should be tested for insulation breakdown. If the winding(s) fail the insulation breakdown test, they should be cleaned and dried, followed by a second insulation breakdown test. Replace the winding(s) if they fail the second test (after cleaning and drying).

*Problem 2- Generator Produces Low Voltage at No-Load*

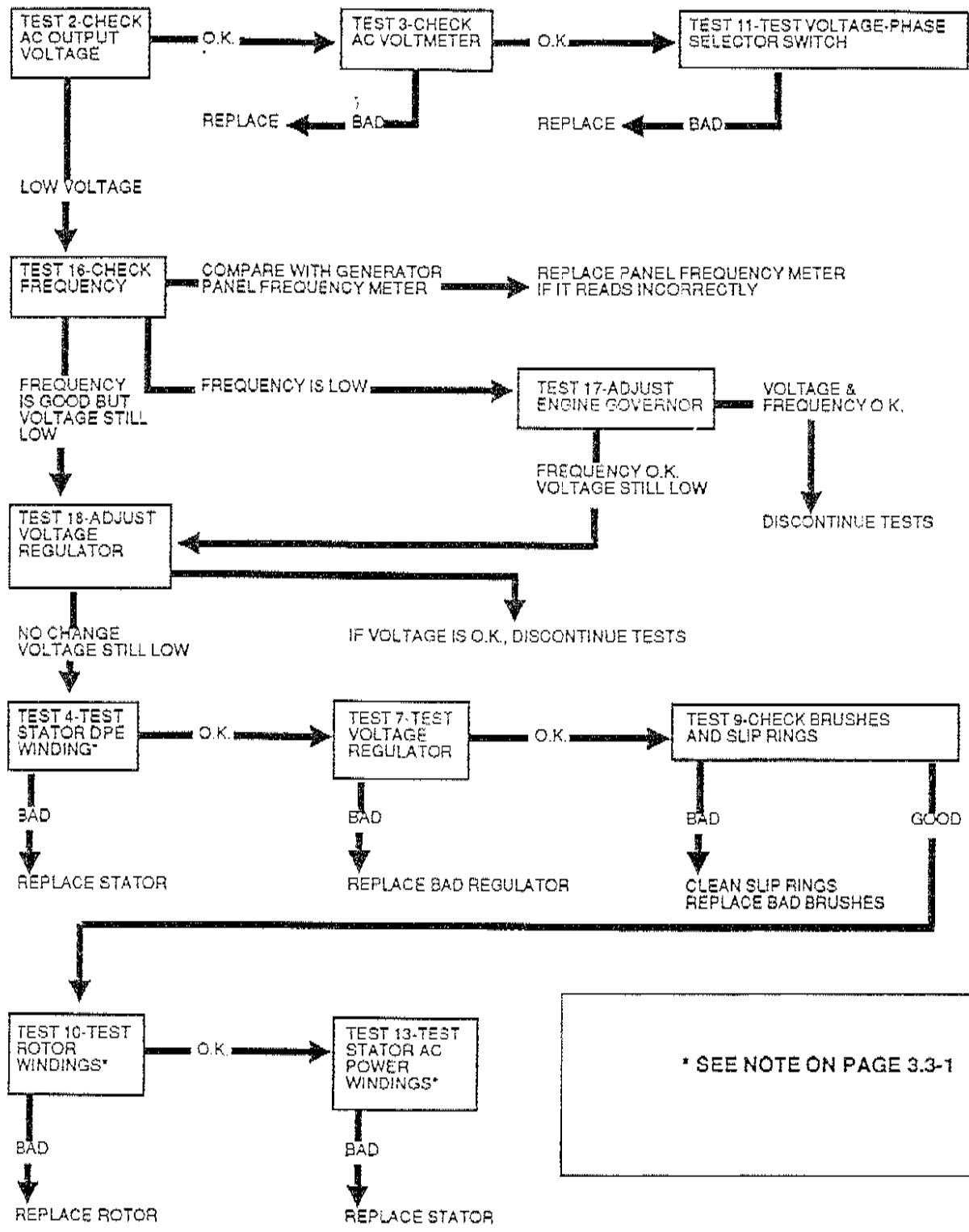

\* SEE NOTE ON PAGE 3.3-1

*Problem 3- Generator Produces High Voltage at No-Load*

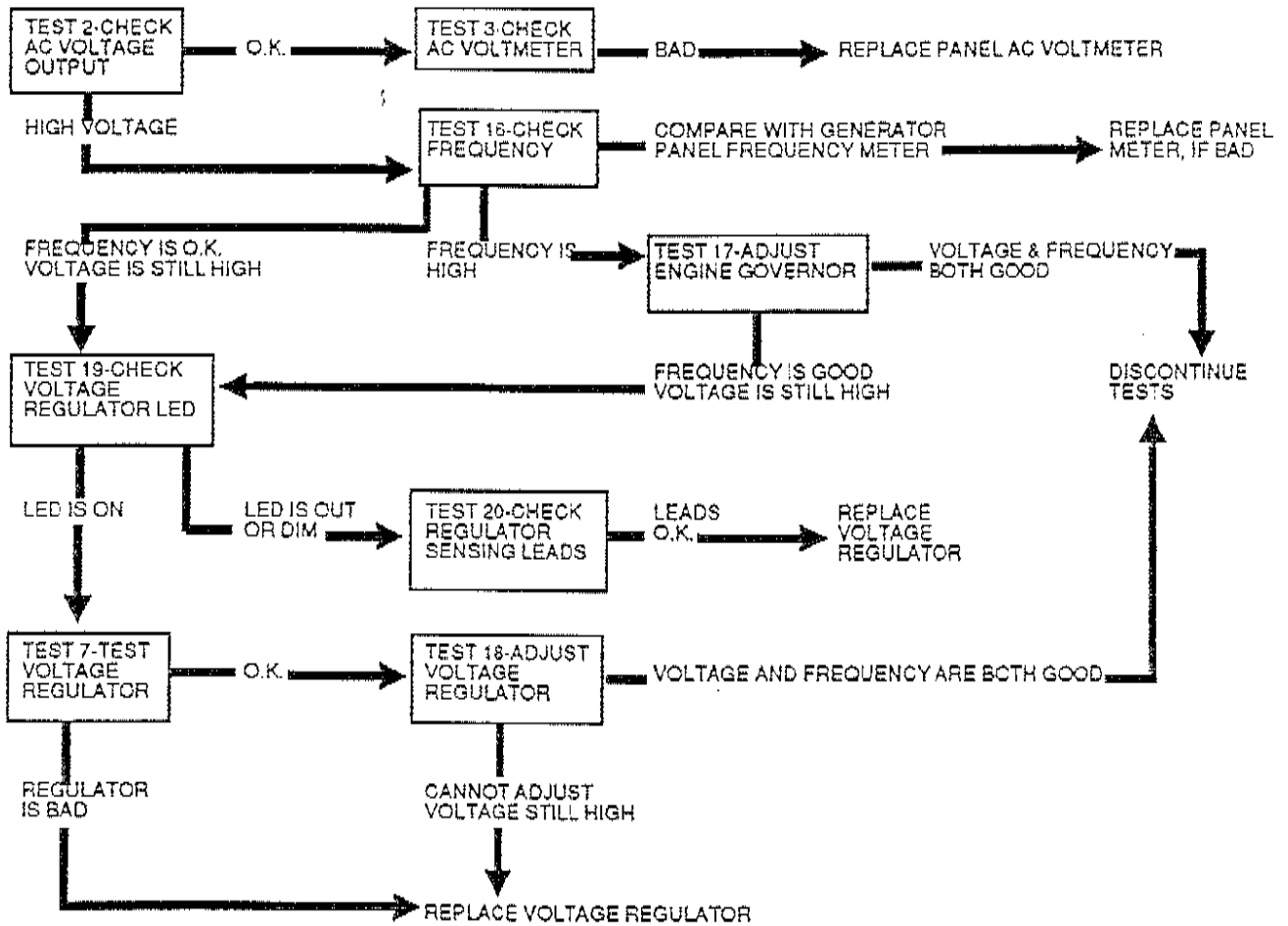

*Problem 4- Generator Produces Low Voltage and Frequency When Load is Applied*

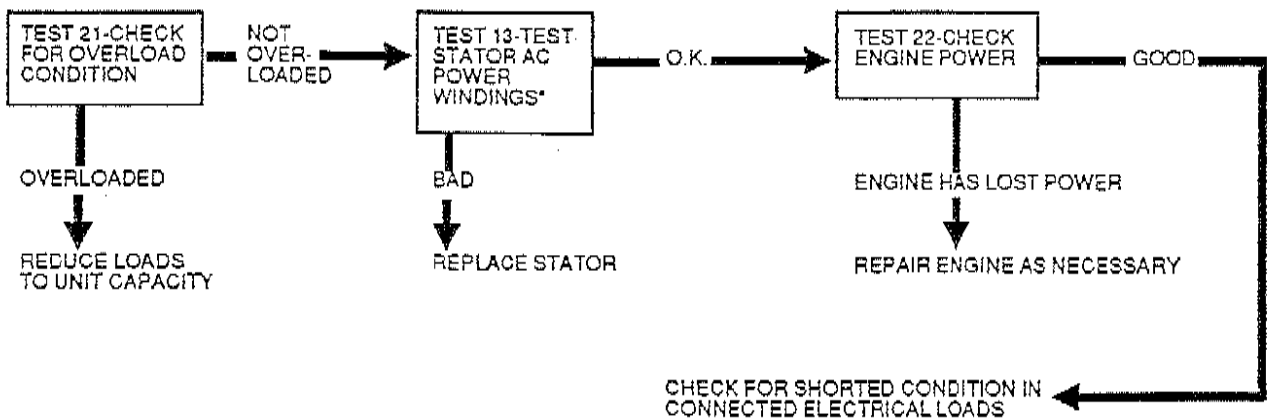

\* SEE "NOTE" ON PAGE 3.3-1



Section 3.4  
**DIAGNOSTIC TESTS****General**

Perform the tests in this section in conjunction with the "Troubleshooting Flow Charts" of Section 3.3. Test numbers assigned in this section are identical to the test numbers used in the flow charts.

**Test 1- Check Voltage-Phase Selector  
Switch Position****DISCUSSION:**

See "Control Panel-Units with Liquid Cooled Engine" in Part 1, Section 1.7. Prepackaged units with liquid cooled engines may be equipped with panel-mounted AC voltmeters. Such meters are typically very reliable. If the voltmeter reads "zero", it is possible that the voltage-phase selector switch has been set to "Off". When the switch is set to "Off", neither the AC voltmeter nor the AC ammeter will function.

**PROCEDURE:**

Make sure the switch is set to Position "1", "2" or "3".

**RESULTS:**

1. If necessary, reset switch to "1", "2" or "3".
2. If meter is not set to "Off" and panel voltmeter reads "zero" or low voltage, go on to Test 2.

**Test 2- Check AC Output Voltage****DISCUSSION:**

When the panel AC voltmeter indicates that generator output voltage is incorrect, it is best to read AC output voltage with an external meter. The external meter reading can then be compared to the reading on the panel meter, to see if the latter is in error.

**PROCEDURE:**

Set a VOM to an "AC Volts" scale greater than the rated line-to-line voltage of the unit being tested. Connect the meter test leads across the terminals of the generator main circuit breaker, on the generator side of the breaker. Start the engine, let it stabilize and warm up at no-load. Then, observe the meter reading. Refer to the generator DATA PLATE for rated voltage.

**RESULTS:**

1. If VOM reading is good, but panel meter reading is not, go to Test 3.
2. If VOM reading is zero, residual, low, or high refer to the appropriate flow chart in Section 3.3. Go to the test indicated on the proper flow chart.

**Test 3- Check AC Voltmeter****DISCUSSION:**

You should have already determined that the actual AC voltage is not the same as the voltage indicated on the panel AC voltmeter. The next step is to find out if the voltmeter itself is at fault.

**PROCEDURE:**

1. Connect an accurate AC voltmeter across the terminals of the AC voltmeter on the generator panel.
2. With the engine running at no-load, read the voltage on the external meter and compare that reading to the reading obtained in Test 2.
3. Also, compare the external meter reading in this test to the reading on the generator panel voltmeter.

**RESULTS:**

1. If the external meter reading obtained in Step 2 is different than the reading obtained in Test 2, go on to Test 11.
2. In Step 3, above, if the external meter reading is different than the reading on the panel meter, replace the panel-mounted AC voltmeter.

**Test 4- Test Stator DPE Winding****DISCUSSION:**

If excitation winding output is lost for any reason, generator AC output voltage will drop to a voltage that is commensurate with the rotor's residual voltage only. The voltage produced as a result of residual magnetism alone is very low (around 2-10 volts AC). The source of excitation voltage is the stator excitation (DPE) winding.

**PROCEDURE:**

1. In the control panel, disconnect stator lead No. 6 from the voltage regulator.
2. Remove the wire nut from end of Wire No. 5 from the DPE winding.
3. Set a VOM to its "Rx1" scale and zero the meter.
4. With the engine shut down, connect the VOM test leads across Wires No. 5 and 6. The VOM should indicate the resistance of the stator DPE winding. See "Stator Winding Resistance Values" on Page 1 at front of this manual. A high resistance or a reading of "infinity" indicates an open circuit condition.
5. Now, set the VOM to a high resistance scale (such as "Rx10,000" or "Rx1K"). Again, zero the meter.
6. Connect one VOM test lead to Wire No. 5, the other to a clean frame ground on the stator can. The meter should read "infinity". Any upscale reading indicates a "grounded" condition.
7. With the meter still set to a high resistance scale, connect one test lead to Wire No. 5 and the other test

**Test 4- Test Stator DPE Winding (Continued)**

lead to to stator AC power winding lead No. 11. The meter should read "infinity". Any upscale meter reading indicates a shorted condition.

**RESULTS:**

1. If DFE winding is open, grounded or shorted, replace the stator assembly. (See Section 1.5, "Testing, Cleaning and Drying".)
2. If the DPE winding tests good, go to Test 5.

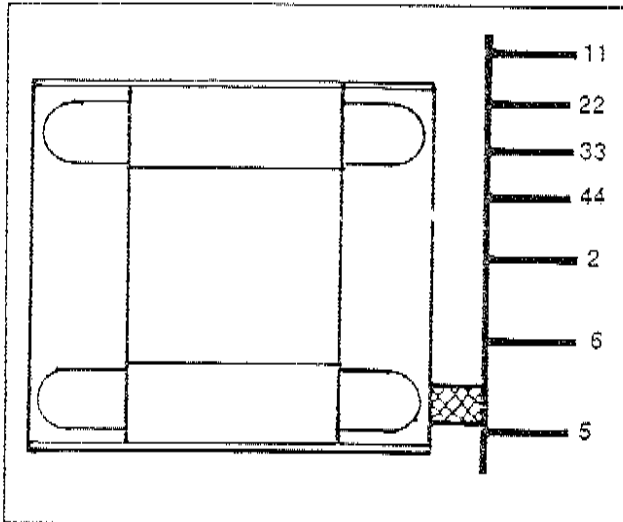

Figure 1. Stator Leads

**Test 5- Test Thermal Protector**

**DISCUSSION:**

Also see "The Excitation Circuit" on Page 3.1-3, especially the subsection entitled "Thermal Protector". An open thermal protector will result in loss of excitation. Generator AC output voltage will then drop to a residual voltage.

**PROCEDURE:**

1. Locate DPE Wire No. 2 where it connects to the excitation circuit breaker. Disconnect the wire from the circuit breaker.
2. Disconnect DPE Wire No. 6 from the voltage regulator.
3. Set a VOM to its "Rx1" scale and zero the meter.
4. Connect the VOM test leads across Wires No. 2 and 6. The meter should indicate the resistance of the stator excitation (DPE) winding. If the meter indicated "infinity" in this test, but read normal resistance in Test 4, the thermal protector is open.

**RESULTS:**

1. If normal DPE winding resistance was indicated in Test 4, but "infinity" is indicated in Test 5, bypass the thermal protector by connecting Wire No. 5 to the excitation circuit breaker (CB1). See Figure 2.

2. If normal resistance is indicated in both Test 4 and Test 5, go to Test 6.

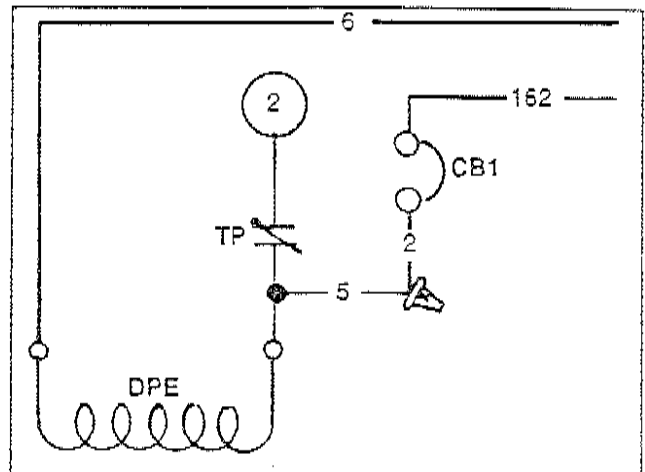

Figure 2. Bypassing the Thermal Protector

**Test 6- Test DPE Circuit Breaker**

**DISCUSSION:**

Like the thermal protector, if the excitation (DPE) circuit breaker has failed open, loss of excitation to the rotor will result. The result will be a generator AC output voltage that is commensurate with rotor residual magnetism alone.

**PROCEDURE:**

1. Disconnect both wires from the circuit breaker terminals, to prevent interaction.
2. Set a VOM to its "Rx1" scale and zero the meter.
3. Connect the VOM test probes across the circuit breaker terminals (Figure 3). The meter should read "continuity".

**RESULTS:**

1. If the VOM reads other than "continuity", replace the excitation circuit breaker.
2. If "continuity" is indicated, go to Test 7.

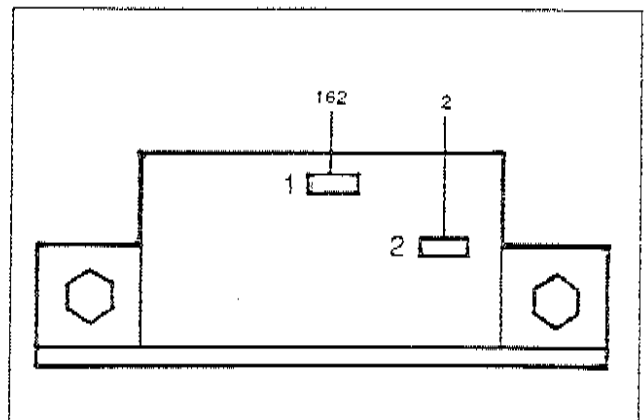

Figure 3. Excitation (DPE) Circuit Breaker

**Test 7- Test Voltage Regulator**

**DISCUSSION:**

See Figure 4. The voltage regulator receives unregulated AC output from the stator excitation (DPE) windings, via Wires No. 162 and 6. Voltage and frequency sensing signals from the stator AC power windings are delivered to the regulator, via Wires No. S15 and S16. A regulated, DC output is delivered to the rotor windings, via Wires No. 4 (positive) and 0 (negative). A red LED (light emitting diode) is turned on by the sensing voltage (light will go out if sensing voltage is not available). The following facts apply to regulator operation:

- Regulator operating voltage is the sensing voltage from the stator AC power windings (Wires No. S15, S16).
- On 1-phase units Wires No. S15/S16 will normally supply a line-to-neutral voltage input to the regulator, i.e., about 120 volts AC on 120/240 volts, 1-phase units.
- On 3-phase units Wires No. S15/S16 will normally deliver a line-to-line voltage input to the regulator (Line E1 to E3). For example, sensing voltage will be approximately 208 volts on 3-phase units rated 208 volts; about 240 volts on 3-phase units rated 240 volts.
- If sensing voltage should drop below approximately 30-40 volts AC, the red LED will go out and the regulator will be inoperative.
- On 1-phase units, protection against over-voltage is provided by a "clamping" action, which will not allow the excitation circuit to build voltage above approximately 135 volts AC (line-to-neutral).
- On 3-phase units, the over-voltage "clamping" action will not permit the excitation circuit to build voltages above approximately 270 volts AC (line-to-line).
- The regulator will NOT shut down on occurrence of an over-voltage condition. It will merely limit the voltage to the previously stated values.

**PROCEDURE:**

1. Start the generator, let it stabilize and warm up at no-load.
2. Observe the red LED on the regulator.
  - a. If the LED is out, sensing voltage is not available or a fault exists in the regulator.
  - b. If the LED is very dim, sensing voltage must be very low or a fault exists in the regulator.
  - c. If the LED is on, sensing voltage is available and the regulator should be supplying an excitation voltage.
3. Use an accurate AC voltmeter to check the voltage across the regulator's S15 and S16 terminals.
  - a. On 1-phase units, the voltage reading should be the same as the generator's line-to-neutral AC output voltage (about 120 volts AC on 120/240 volts, 1-phase units).
  - b. On 3-phase units, the reading should be the same as the generator's line-to-line AC output voltage (about 240 volts AC on 120/240 volts, 3-phase units; or 208 volts on units rated 120/208 volts).
4. Now, check the voltage across regulator terminals 1 and 2 (Wires 162 and 6, respectively). This is unregulated AC output voltage from the stator excitation (DPE) winding. The no-load DPE winding output should be about 130-160 volts AC.

5. Finally, use a DC voltmeter to check the voltage across regulator terminals 3 (-) and 4 (+).

**RESULTS:**

1. If voltage readings in both Steps 3 and 4 are good, but no output voltage is indicated in Step 5, replace the voltage regulator.
2. If the LED is out but voltage reading in Step 4 is good, replace the voltage regulator.
3. If zero or low voltage is indicated in Step 3, test sensing leads S15 and S16.
  - a. Repair or replace bad sensing leads as necessary.
  - b. If sensing leads are good, go on to Test 8.
4. If no voltage or low voltage is indicated in Step 4, repeat Tests 4, 5 and 6.

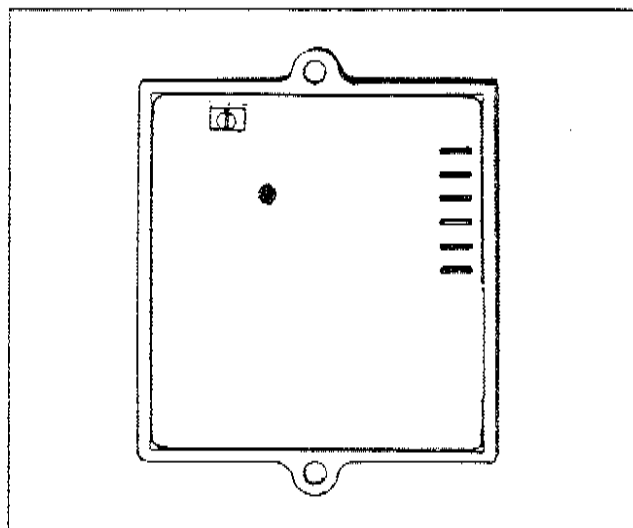

Figure 4. Voltage Regulator

**Test 8- Check Leads 1 and 4**

**DISCUSSION:**

The regulated and rectified excitation current from the voltage regulator is delivered to the brushes via Wires No. 4 (+) and 1 (-). You should have already checked the DC voltage at regulator terminals 3 (-) and 4 (+). Now, check Wires No. 1 and 4 to the brushes by checking for continuity.

**PROCEDURE:**

1. Generator engine must be shut down for this test.
2. See Figure 1 on Page 3.1-2. Remove the bearing carrier plate and gasket to gain access to the brushes.
3. Connect the positive (+) test lead of a VOM to the Wire No. 4 terminal screw (on the brush nearest the rotor bearing).
4. Connect the VOM common (-) test lead to the Wire No. 4 terminal on the voltage regulator. The VOM should read "continuity".
5. Disconnect Wire No. 1 from terminal board TB1 in the generator panel. Connect VOM test probes to disconnected terminal end of Wire No. 1 and to the

**Test 8- Check Leads 1 and 4 (Continued)**

grounded brush holder mounting screw. The VOM should read "continuity".  
6. Carefully inspect the Wires 1 and 4 connections. Repair or reconnect any bad connections, as necessary.

**RESULTS:**

1. Repair, reconnect or replace bad leads as necessary.
2. If Wires No. 1 and 4 are good, go on to Test 9.

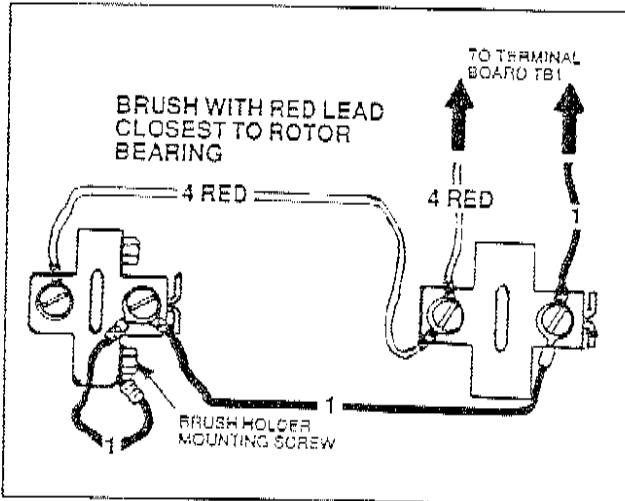

Figure 5. Routing of Brush Leads (Typical)

**Test 9- Check Brushes and Slip Rings**

**DISCUSSION:**

Brushes are made of long-life materials. During non-operating periods, a film can develop on slip rings that will inhibit the flow of excitation current to the rotor. If problems are encountered, it is a good idea to inspect the brushes and slip rings. See Figure 6.

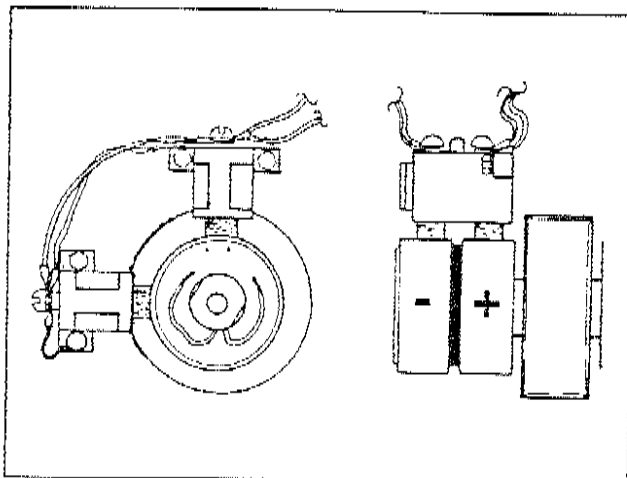

Figure 6. Brushes and Slip Rings

**PROCEDURE:**

1. Remove the brush holders from the rear bearing carrier. Visually inspect the brushes for cracks, chipping, or other damage. Replace brushes in pairs, if necessary.
2. If the slip rings appear dull or tarnished, they may be cleaned with fine sandpaper. **DO NOT USE ANY METALLIC GRIT TO CLEAN SLIP RINGS.** After polishing the slip rings, use low pressure air to blow away any sandpaper residue.
3. Test unit operation.

**Test 10- Test Rotor Windings**

**DISCUSSION:**

An open circuit in the rotor windings will probably result in a generator AC output voltage that is commensurate with the rotor's "residual" magnetism. A shorted rotor winding will usually result in a reduced magnetic field and resultant low voltage output.

**PROCEDURE:**

1. With engine shut down, remove the brush holders to prevent interaction.
2. Set a VOM to its "Rx1" scale and zero the meter.
3. Connect the positive (+) VOM test probe to the positive (+) slip ring (nearest the rotor bearing).
4. Connect the common (-) VOM test probe to the negative (-) slip ring. The VOM should indicate the resistance of the rotor windings. See "Generator Specifications" on Page 1 at front of this manual for nominal rotor resistance values.
5. Set the VOM to a high resistance scale and zero the meter.
6. Now, connect the positive (+) VOM test probe to the positive (+) slip ring and the common (-) test probe to a clean frame ground. The meter should read "infinity". Any upscale reading indicates a shorted condition.

**RESULTS:**

1. If rotor windings test good, go on to Test 13.
2. If rotor windings test bad, refer to Section 1.5, "Testing, Cleaning and Drying".

**Test 11- Test Voltage-Phase Selector Switch**

**DISCUSSION:**

See "Control Panel- Units with Liquid Cooled Engine" on Page 1.7-2. If this switch is set to "Off", the AC voltmeter on the generator panel will read "zero" volts. If the switch is defective, a faulty AC voltage reading can result. You may wish to look at Figure 1 on Page 3.2-1.

**PROCEDURE:**

1. Gain access to the terminal end of the voltage-phase selector switch.
2. Set a VOM to its "Rx1" scale and zero the meter.

**Test 11- Test Voltage-Phase Selector Switch (Continued)**

3. See Figure 7. Connect the VOM test leads across switch terminals 14 and 13.
  - a. Set the switch to "1" and observe the meter reading.
  - b. Set the switch to "2" and note the meter reading.
  - c. Set the switch to "3" and note the VOM reading.
  - d. Set the switch to "Off" and observe the reading.
4. See CHART below. Connect the VOM test probes across terminals indicated in the chart and check readings at all switch positions. Test all terminals at all switch positions as indicated in the chart. Readings obtained should be either "continuity" or "infinity" as shown in the chart, where "Infin." stands for "infinity" and "Cont." means "continuity".

CONNECT TEST LEADS ACROSS TERMINALS	SWITCH POSITION			
	1	2	3	OFF
14-13	Cont.	Infin.	Cont.	Infin.
16-15	Infin.	Cont.	Infin.	Infin.
20-19	Cont.	Infin.	Infin.	Infin.
18-17	Infin.	Cont.	Cont.	Infin.
1-2	Infin.	Cont.	Cont.	Cont.
3-4	Cont.	Infin.	Infin.	Infin.
5-6	Cont.	Infin.	Cont.	Cont.
7-8	Infin.	Cont.	Infin.	Infin.
9-10	Cont.	Cont.	Infin.	Cont.
11-12	Infin.	Infin.	Cont.	Infin.

**RESULTS:**

1. Replace switch, if defective.

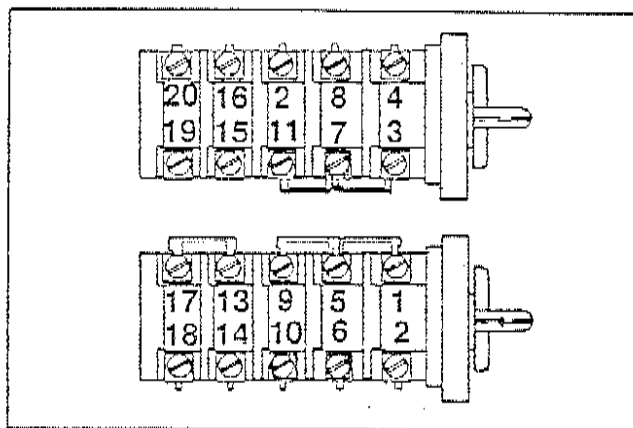

Figure 7. Voltage-Phase Selector Switch Terminals

**Test 12- Test Voltmeter Leads S15, S16, S44**

**DISCUSSION:**

If these leads are open or shorted, erroneous AC voltmeter readings will result.

**PROCEDURE:**

Refer to appropriate wiring diagram. Inspect the AC voltmeter leads S15, S16 and S44 carefully. Check connections against the wiring diagram. Make sure all leads are properly connected to the correct voltage-

phase selector switch terminal. Test leads for an open or shorted condition.

**RESULTS:**

1. Repair, reconnect or replace leads as necessary.

**Test 13- Test Stator AC Power Windings**

**DISCUSSION:**

An open condition in the stator's AC power windings will result in a loss of AC output voltage.

**PROCEDURE:**

1. Testing 1-Phase Stators (Figure 8)
  - a. Disconnect stator leads 11 and 44 from the generator main circuit breaker terminals.
  - b. Disconnect stator leads 22 and 33 from the neutral block (00).
  - c. Complete a resistance test across stator leads 11 and 22. The resistance of a single stator AC power winding should be indicated. Compare the resistance with the "Stator Winding Resistance Values" on Page 1.
  - d. Test for resistance across stator leads 33 and 44. Again, the resistance of that winding should be indicated.
  - e. Set the meter to a high resistance scale. Then, test for a shorted condition as follows:
    - (1) Connect one test probe to stator lead 11, the other test probe to a clean frame ground on the stator can. The meter should read "infinity".
    - (2) Connect one meter test probe to stator lead 33 and the other to frame ground. The meter should read "infinity".
  - f. With the meter still set to a high resistance scale, check for a shorted condition between parallel windings as follows:
    - (1) Connect one meter test probe to stator lead 11.
    - (2) Connect the second meter test probe to stator lead 33. The meter should read "infinity".

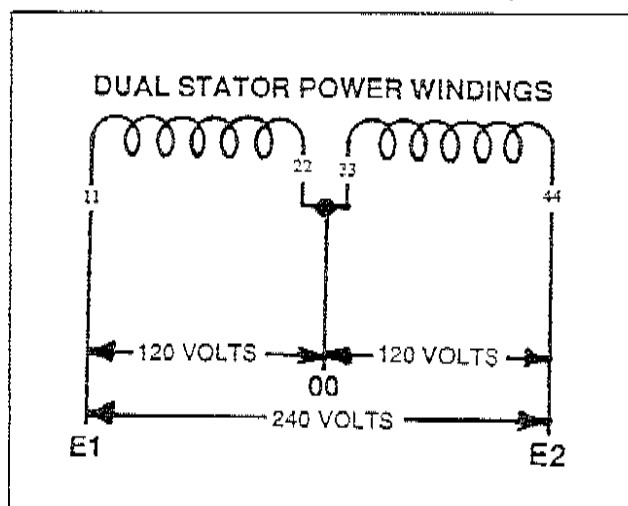

Figure 8. Typical 1-Phase Stator Windings

**Test 13- Test Stator AC Power Windings (Continued)**

2. Testing 3-Phase Stators
  - a. Disconnect and isolate stator power winding leads S1 through S12. Also disconnect and isolate stator DPE winding leads 2 and 6.
  - b. See Figure 9. Test all six of the stator AC power winding coils for continuity by connecting VOM test probes across each of the following pairs of leads. Refer to "Stator Winding Resistance Values" on Page 1 for nominal resistance values. A very high reading or "infinity" indicates an open condition.
    - (1) S1 to S4.
    - (2) S7 to S10.
    - (3) S8 to S11
    - (4) S3 to S6.
    - (5) S9 to S12.
    - (6) S2 to S5.
  - c. Test all six stator coils for shorted condition by testing between the following stator leads and a clean frame ground on the stator can, one lead at a time. The meter should indicate "infinity" in all cases.
    - (1) S1 to frame ground.
    - (2) S7 to frame ground.
    - (3) S8 to frame ground.
    - (4) S3 to frame ground.
    - (5) S9 to frame ground.
    - (6) S2 to frame ground.
  - d. Now, test for a shorted condition between individual stator coils by connecting the VOM test leads across the following stator leads. In all cases, the VOM should read "infinity".
    - (1) Leads S1 to S7.
    - (2) Leads S7 to S8.
    - (3) Leads S8 to S3.
    - (4) Leads S3 to S9.
    - (5) Leads S9 to S2.
    - (6) Leads S2 to S1.
  - e. Finally, test for a shorted condition between isolated windings as follows. The meter should indicate "infinity" in all cases. Lead No. 6 is from the stator DPE winding.
    - (1) Lead S1 to 6.
    - (2) Lead S7 to 6.
    - (3) Lead S8 to 6.
    - (4) Lead S3 to 6.
    - (5) Lead S9 to 6.
    - (6) Lead S2 to 6.

**RESULTS:**

1. If the AC power windings fail any test, the stator should be replaced. However, be sure to comply with instructions for insulation breakdown tests, cleaning and drying of stators in Section 1.5.
2. If the stator AC power windings test good, go on to Test 14.

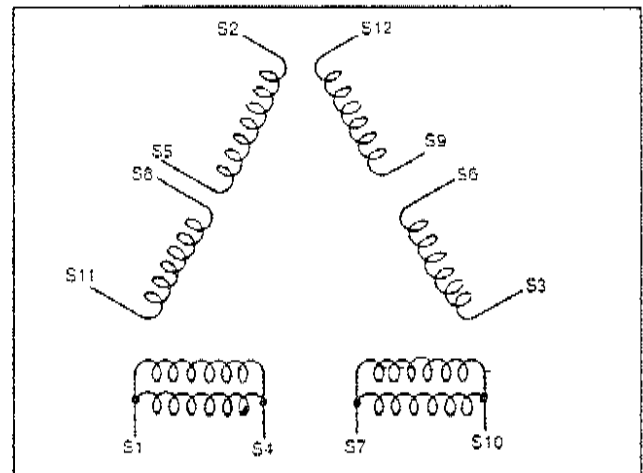

Figure 9. Stator Output Leads (3-Phase)

**Test 14- Check Field Boost**

**DISCUSSION:**

See "Field Boost" on Page 3.1-4. Field boost voltage is available to the rotor only while the engine is cranking. The field boost system, in effect, "flashes the field" on every startup. Loss of field boost may or may not result in loss of generator AC output voltage, depending on individual generator characteristics. The following apply:

- If residual magnetism in the rotor is sufficient to induce a "pickup voltage" into stator AC power windings, normal AC output may be obtained even if field boost has failed.
- Stator AC power winding output must build to approximately 30-40 volts AC before the voltage regulator will turn on.

**PROCEDURE:**

In the generator panel, locate the CMA circuit board. Wire No. 4 attaches to that circuit board's connector plug and is routed to the large terminal board (TB1) in the panel. To test for field boost output voltage, proceed as follows:

*NOTE: If you wish to prevent the engine from starting while cranking, disconnects Wire No. 14 from the large terminal board (TB1).*

1. Disconnect Wire No. 4 from terminal board TB1.
2. Connect the positive (+) test probe of a DC voltmeter (or VOM) to the terminal end of disconnected Wire No. 4 from the CMA circuit board.
3. Connect the common (-) meter test probe to terminal No. 0 of the terminal board (TB1).
4. Crank the engine manually. While the engine is cranking, the meter should indicate approximately 9-10 volts DC. This is field boost voltage.

**RESULTS:**

If field boost voltage is not indicated while cranking, replace the CMA circuit board.

**Test 14- Check Field Boost (Continued)**

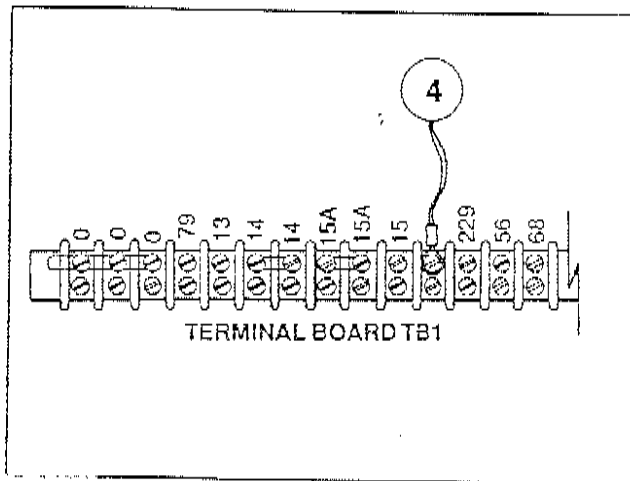

Figure 10. Checking Field Boost Voltage

**Test 16- Check Frequency**

DISCUSSION:

The rotor's driven speed and AC frequency are directly proportional. Voltage and AC frequency are directly proportional. Thus, if rpm and frequency drop off, voltage will also decrease. When a low voltage is encountered, it is a good idea to check the frequency. If frequency is low, the engine governor may require adjustment.

PROCEDURE:

1. Connect an accurate AC frequency meter across the generator's AC output leads. Also, connect an AC voltmeter across the AC output leads (see Test 2).
2. Start the engine, let it stabilize and warm up at no-load.
3. Read the AC voltmeter and frequency meter.
  - a. The no-load (line-to-line) voltage should be approximately 242-252 volts AC.
  - b. The no-load AC frequency should be approximately 61-63 Hertz.
4. Compare the external frequency meter reading with the panel frequency meter reading.

RESULTS:

1. If frequency is below normal, go to Test 17.
2. If frequency is above normal, go to Test 17.
3. If frequency is good but voltage is low or high, go on to Test 18.
4. If panel frequency meter is incorrect, replace that meter.

**Test 17- Adjust Engine Governor**

DISCUSSION:

If frequency is high or low and voltage appears to be correspondingly high or low, engine speed may be incorrect.

PROCEDURE:

Refer to Part 9, "Operational Tests and Adjustments" for governor adjustment procedures.

RESULTS:

1. If frequency is good after adjustment, but voltage is still low or high, go on to Test 18.
2. If both frequency and voltage are now good, discontinue tests.

**Test 18- Adjust Voltage Regulator**

DISCUSSION:

Do not attempt to adjust the voltage regulator until the AC frequency is correct. The prepackaged voltage regulator provides a single adjustment potentiometer, for the adjust of voltage.

PROCEDURE:

See Part 9, "Operational Tests and Adjustments" for voltage regulator adjustment procedures.

RESULTS:

1. If voltage is still low, go to Test 4.
2. If voltage is good after adjustment of regulator, testing may be discontinued.

**Test 19- Check Voltage Regulator LED**

DISCUSSION:

The voltage regulator mounts a single LED (light emitting diode). This LED is turned on when sensing voltage from Wires No. S15 and S16 is greater than 30-40 volts AC. Loss of sensing voltage from S15/S16 will usually result in a "full field" condition and a high AC power winding output voltage. The voltage regulator is equipped with a "clamping" circuit which acts to prevent voltages in excess of approximately 135 volts AC (1-phase units) or 270 volts AC (3-phase units).

PROCEDURE:

See Test 7, "Test Voltage Regulator".

RESULTS:

1. If the LED is out or dim, go to Test 20.
2. If the LED is on, go to Test 7.

**Test 20- Check Regulator Sensing Leads**

DISCUSSION:

See Test 19.

PROCEDURE:

See Test 7.

RESULTS:

If sensing leads S15/S16 are good and an AC output voltage is available from the stator AC power windings, but the LED is out, replace the voltage regulator.

*Test 21- Check for Overload Condition*

DISCUSSION:

If voltage and frequency are good at no-load condition, but droop excessively when electrical loads are applied to the generator, the generator may be overloaded. That is, the unit's wattage/amperage capacity may be exceeded. In many instances, the maximum wattage and amperage that a generator can supply are limited by available engine power.

PROCEDURE:

The AC ammeter on the generator panel is very accurate and can usually be used to indicate current draw of connected loads. To test for an overload condition, proceed as follows:

1. On the generator panel, set the manual-off-auto switch to "Off".
2. Turn OFF all power voltage supplies to the transfer switch (turn off both the utility and standby power supplies). This can be done by turning both the utility and generator main circuit breakers "Off".
3. Manually actuate the transfer switch to the "Standby" position, i.e., loads connected to the "Standby" side. See Part 4, 5 or 6, as appropriate for the type of installed transfer switch.
4. Turn on all electrical loads that are normally powered by generator output.
5. Start the generator engine manually. Let the engine stabilize and warm up.
6. Turn the generator's main circuit breaker "On". Loads are now powered by the generator.
7. On the generator panel, check the AC ammeter readings at switch positions "1", "2" and "3".
8. Refer to the generator DATA PLATE for rated maximum load current (amperage).

*NOTE: To check the panel ammeter for accuracy, use a clamp on ammeter to check amperage draw at the stator AC output leads E1 and E2 for 1-phase units; or E1, E2, E3 for 3-phase units.*

RESULTS:

1. If the unit is overloaded, reduce the load to unit capacity. Instruct the customer on how to prevent overloading the generator.
2. If unit is NOT overloaded, perform Test 13. A shorted AC power winding can also cause voltage and frequency droop when loads are turned on.

*Test 22- Check Engine Power*

DISCUSSION:

The maximum available amperage capacity of a generator is often limited by available engine power. Such a simple fault as a dirty engine air cleaner will result in engine power loss. Low engine compression, incorrect ignition timing, faulty spark plugs, etc., can result in engine power loss and a reduced wattage capacity.

PROCEDURE:

Refer to the appropriate engine service manual. Determine if an engine power loss has occurred and then troubleshoot to find the cause of the power loss.

RESULTS:

Repair or replace engine as necessary to restore engine power.

**PART 4**  
**"V-TYPE"**  
**PREPACKAGED**  
**TRANSFER**  
**SWITCHES**

GENERAC II  
**PREPACKAGED**  
**HOME STANDBY**  
**ELECTRIC POWER**  
**SYSTEMS**

**TABLE OF CONTENTS**

SECTION	TITLE
4.1	Description and Components
4.2	Operational Analysis
4.3	Troubleshooting Flow Charts
4.4	Diagnostic Tests

# NOTES

---

Section 4.1

DESCRIPTION AND COMPONENTS

General

The prepackaged, "V-Type" transfer switch is rated 100 amps at 250 volts maximum. It is available in 2-pole configuration only and, for that reason, is useable with 1-phase systems only.

Prepackaged transfer switches do not have an intelligence system of their own. Instead, automatic operation of these transfer switches is controlled by a CMA circuit board housed in the generator control panel.

In a typical installation, both the utility and standby power source conductors are connected to the transfer switch, as well as load lines. See Part 1, Section 1.3 for prepackaged interconnections.

Transfer Switch Major Components

Figure 1, below, shows the transfer switch components. Major components include the following:

ITEM	DESCRIPTION	ITEM	DESCRIPTION
1	Enclosure	16	No. 10 Lockwasher
2	Enclosure Cover	17	Wing Stud
3	Transfer Mechanism	18	Manual Transfer Handle
4	Cap screw - M5-0.60	19	Flatwasher - 3/8"
5	M5 Lockwasher	20	Power Terminal Cover
6	M5 Flatwasher	21	Adapter
7	Transfer Relay	22	No. 10-32 Screw
8	3/8"-18 Hex Nut	23	Solderless Lug
9	No. 8-32 Screw	24	Terminal Block
10	No. 8-32 Screw	25	Main Disconnect Adapter
11	No. 8 Lockwasher	26	Relay Cover
12	No. 6 Flatwasher	27	Standoff
13	Tie Wrap Mount	28	No. 8-32 Hex Nut
14	Neutral Lug	29	Fuse Holder
15	No. 10-32 Screw	30	2 amp, 600 volts Fuse

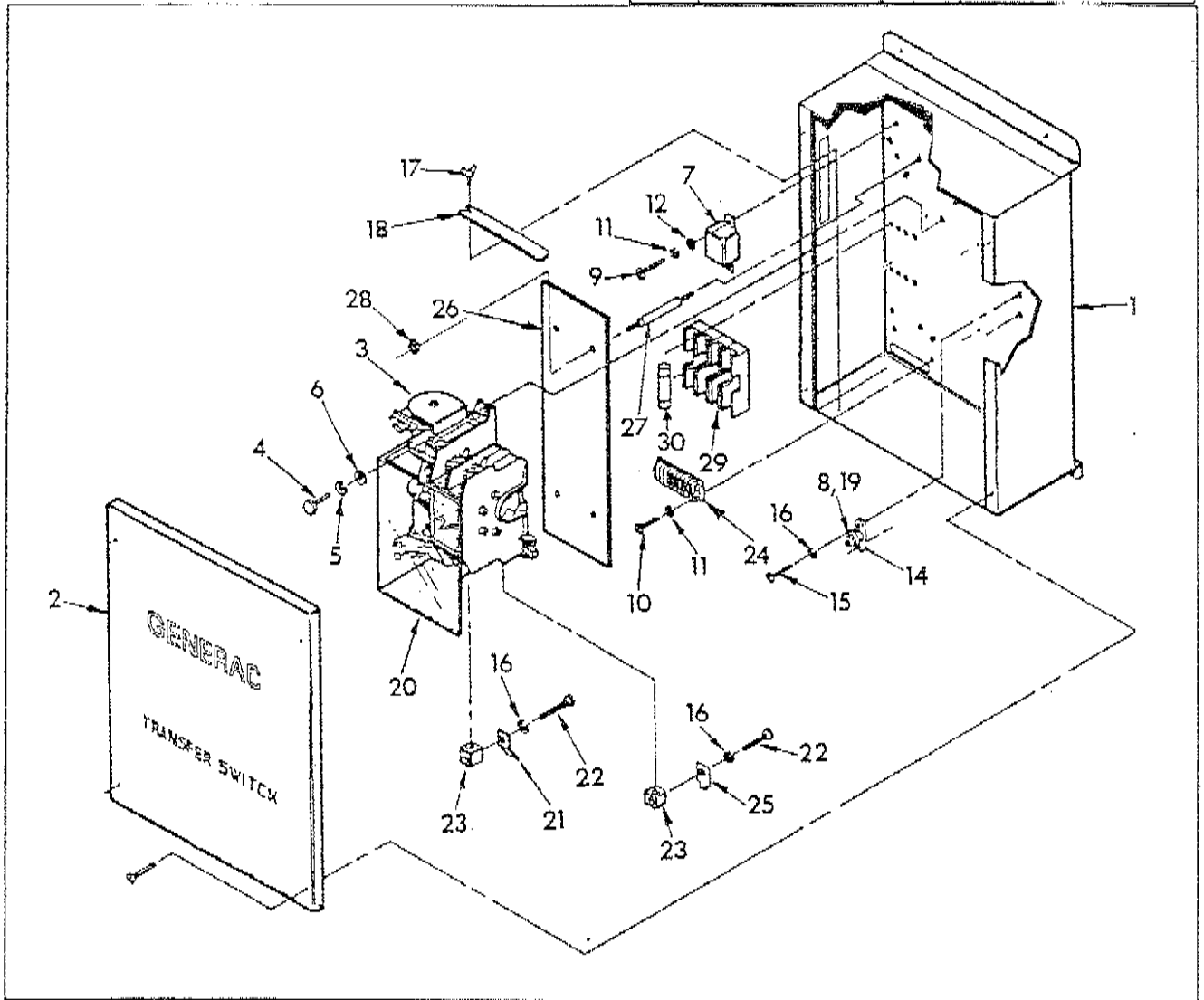

Figure 1. Exploded View of V-Type Prepackaged Transfer Switch

*Enclosure*

The standard prepackaged, V-Type transfer switch enclosure is a NEMA 1 type ("NEMA" stands for "National Electrical Manufacturer's Association"). Based on NEMA Standard 250, the NEMA 1 enclosure may be defined as one that is intended for indoor use primarily to provide a degree of protection against contact with the enclosed equipment and where unusual service conditions do not exist.

*Transfer Mechanism*

The 2-pole transfer mechanism consists of a pair of moveable LOAD contacts, a pair of stationary UTILITY contacts, and a pair of stationary STANDBY contacts. The LOAD contacts can be connected to the UTILITY contacts by a utility closing coil; or to the STANDBY contacts by a standby closing coil. In addition, the LOAD contacts can be actuated to either the UTILITY or STANDBY side by means of a manual transfer handle. See Figures 2 and 3.

UTILITY CLOSING COIL C1:

See Figure 4. This coil is energized by rectified utility source power, to actuate the load contacts to the "Utility" power source side. When energized, the coil will move the main contacts to an "overcenter" position. A limit switch will then be actuated to open the circuit and spring force will complete the retransfer to "Standby". A bridge rectifier, which changes the utility source alternating current (AC) to direct current (DC), is sealed in the coil wrappings. If coil or bridge rectifier replacement becomes necessary, the entire coil and bridge assembly should be replaced.

STANDBY CLOSING COIL C2:

Coil C2 is energized by rectified standby source power, to actuate the load contacts to their "Standby" source side. Energizing the coil moves the load contacts to an overcenter position; limit switch action then opens the circuit and spring force will complete the transfer action to "Standby". This coil's bridge rectifier is also sealed in the coil wrappings. Replace the coil and bridge rectifier as a unit.

LIMIT SWITCHES XA1 AND XB1:

Switches are mechanically actuated by load contacts movement. When the load contacts are connected to the utility contacts, limit switch XA1 opens the utility circuit to utility closing coil C1 and limit switch XB1 closes the standby circuit to standby closing coil C2. The limit switches "arm" the system for retransfer back to "Utility" when the load contacts are connected to the "Standby" side. Conversely, when the load contacts are connected to the "Utility" side, the switches "arm" the system for transfer to "Standby". An open condition in limit switch XA1 will prevent retransfer to "Utility". An open switch XB1 will prevent transfer to "Standby".

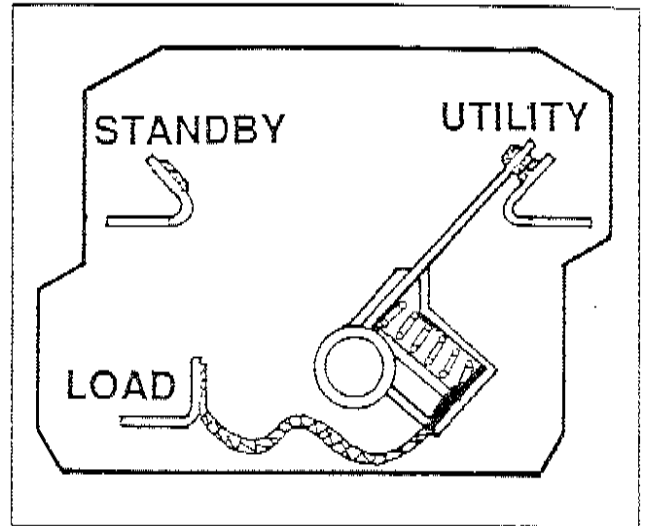

Figure 2. Load Connected to Utility Power Source

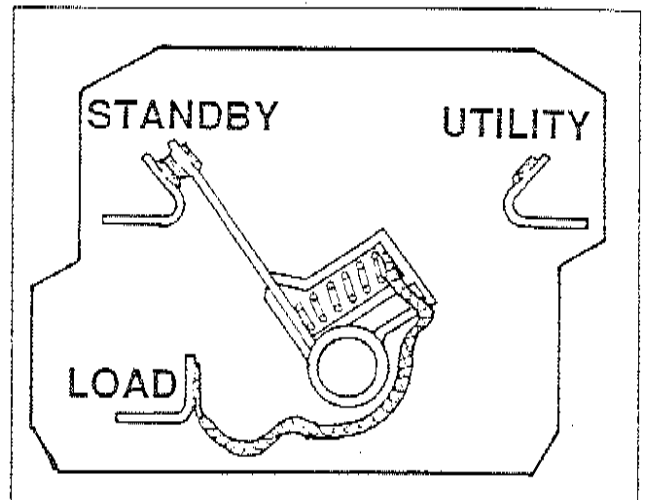

Figure 3. Load Connected to Standby Power Source

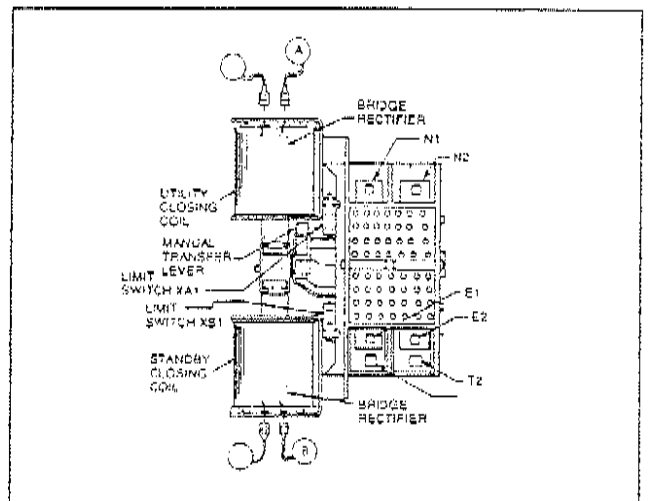

Figure 4. The "V-Type" Transfer Mechanism

### Transfer Relay

Transfer relay operation is controlled by a control module assembly (CMA) circuit board. That circuit board is a part of a control module assembly (CMA), mounted on the standby generator set. The standby system installer must interconnect suitable wiring to terminals 23 and 194 of a transfer switch terminal block. He must interconnect that wiring with identically numbered terminals in the generator's control module assembly (CMA). See Figure 5 on Page 1.3-3.

Figure 5 on this page shows the transfer relay pictorially and schematically. Relay operation may be briefly described as follows:

1. Generator set battery voltage (12 volts DC) is available to the transfer relay coil from the generator's CMA circuit board, via terminal 194 and relay terminal A.
  - a. The 12 volts DC circuit is completed through the transfer relay coil and back to the generator's CMA circuit board, via transfer switch terminal 23, customer installed wiring, and CMA terminal 23.
  - b. CMA circuit board action normally holds the Wire No. 23 circuit open to ground and the relay is de-energized.
  - c. When de-energized, the relay's normally-open contacts are open and its normally-closed contacts are closed.
  - d. The normally-closed relay contacts will deliver utility source power to the utility closing circuit of the transfer mechanism.
  - e. The normally-open relay contacts will deliver standby source power to the transfer mechanism's standby closing circuit.
2. During automatic system operation, when the generator's CMA circuit board "senses" that utility source voltage has dropped out, the circuit board will initiate engine cranking and startup.
3. When the CMA board "senses" that the engine has started, an "engine warmup timer" on the circuit board starts timing.
4. When the "engine warmup timer" has timed out, CMA board action completes the Wire No. 23 circuit to ground.
  - a. The transfer relay then energizes.
  - b. The relay's normally-closed contacts open and its normally-open contacts close.
  - c. When the normally-open contacts close, standby source power is delivered to the standby closing coil and transfer to "Standby" occurs.
5. When the generator's CMA circuit board "senses" that utility source voltage has been restored above a preset level, the board will open the Wire No. 23 circuit to ground.
  - a. The transfer relay will de-energize, its normally-closed contacts will close and its normally-open contacts will open.
  - b. When the normally-closed relay contacts close, utility source voltage is delivered to the utility closing coil to energize that coil.
  - c. Retransfer back to "Utility" occurs.

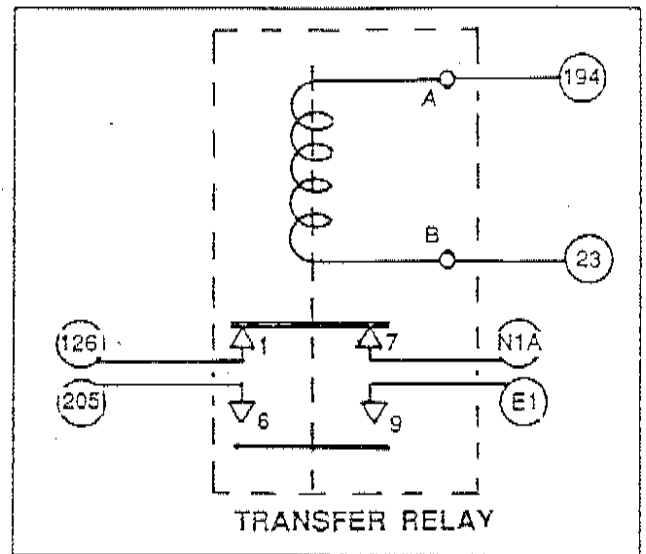

Figure 5. Transfer Relay Schematic

### Neutral Lug

See Figure 1, Item 14. The standby generator is equipped with an UNGROUNDED neutral. The neutral lug in the transfer switch is isolated from the switch enclosure, since its base is of plastic. Load, Utility and Standby neutral lines all should be attached to the neutral lug's 3/8 inch stud and securely retained with the 3/8"-16 hex nut.

### Manual Transfer Handle

The manual transfer handle (Figure 1, Item 18) is retained in the transfer switch enclosure by means of a wing stud (Figure 1, Item 17). Use the handle to manually actuate the transfer mechanism load contacts to either the "Utility" or "Standby" source side.

Instructions on use of the manual transfer handle may be found in Part 9, "Operational Tests and Adjustments".

### Terminal Block

During system installation, this 7-point terminal block must be properly interconnected with an identically labeled terminal block in the generator's control module assembly.

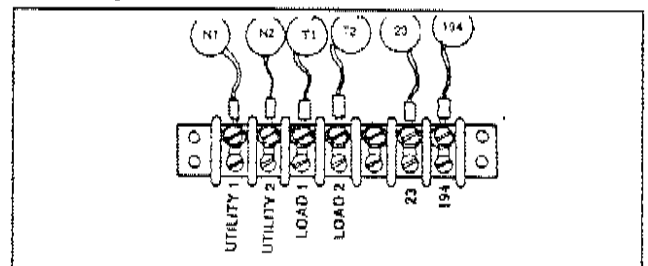

Figure 6. Transfer Switch Terminal Block

***Terminal Block (Continued)***

Terminals used on the terminal block are identified as Utility 1 and 2; Load 1 and 2; 23 and 194.

**UTILITY 1 AND 2:**

Interconnect with identically labelled terminals in the generator's control module assembly (CMA). This is the "Utility Voltage" signal to the CMA circuit board. The signal is delivered to a "stepdown" transformer in the control module assembly and the resultant reduced voltage is then delivered to the circuit board. Utility 1 and 2 power is used by the CMA circuit board as follows:

- If utility source voltage should drop below a preset level, CMA board action will initiate automatic cranking and startup, followed by automatic transfer to the "Standby" source.
- Utility source voltage is used by the CMA board to operate a battery "trickle charge" circuit which helps to maintain battery state of charge during non-operating periods.

**LOAD 1 AND 2:**

The CMA circuit board is equipped with a "7-Day Exerciser" circuit which will start the generator and let it "exercise" once every seven (7) days on a preselected day and at a preselected time of day. The "Load 1/2" terminals provide power to operate the exerciser timer clock.

**TERMINALS 23 AND 194:**

These terminals connect the transfer relay to the generator's CMA circuit board. See "Transfer Relay" on Page 4.1-3.

***Fuse Holder***

The fuse holder holds four (4) fuses, designated as fuses F1, F2, F3 and F4. Each fuse is rated 2 amperes.

**FUSES F1, F2:**

These two fuses protect the terminal boards "Utility 1 and 2" circuit against overload.

**FUSES F3, F4:**

These two fuses protect the "Load 1 and 2" circuit against overload.

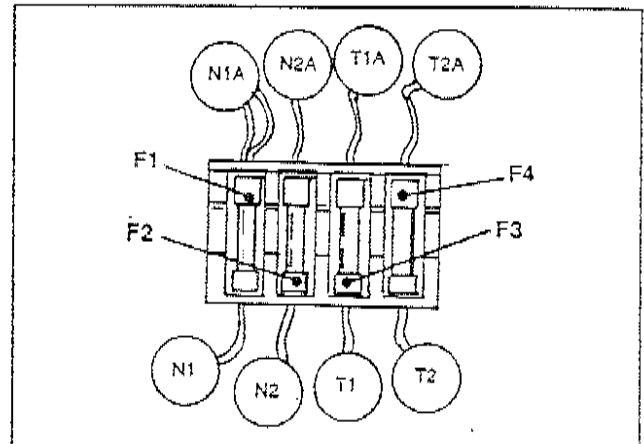

*Figure 7. The Fuse Holder*

Section 4.2  
OPERATIONAL ANALYSIS

*Utility Source Voltage Available*

Figure 1 is a schematic representation of the transfer switch with utility source power available. The circuit condition may be briefly described as follows:

- Utility source voltage is available to terminal lugs N1 and N2 of the transfer mechanism.
- Line N2A is closed to the utility closing coil (C1), via a bridge rectifier.
- Utility source voltage is available to limit switch (XA1), via the normally-closed transfer relay contacts (1 and 7) and Wire No. 126. However, XA1 is open and the circuit to the utility closing coil is open.
- Utility voltage "sensing" signals are delivered to a CMA circuit board on the generator, via Wire No. N1A, a 2 amp fuse (F1), transfer switch terminal N1, generator terminal N1, and a sensing transformer. The second line of the utility voltage "sensing" circuit is via Wire No. N2A, a 2 amp fuse (F2), transfer switch terminal N2, generator terminal N2, and the sensing transformer.

*NOTE: Transfer switch terminals N1 and N2 (Utility 1 and 2) must be properly connected to generator terminals N1 and N2 (Utility 1 and 2) by the installer. Generator terminals N1 (Utility 1) and N2 (Utility 2) are not shown in Figure 1. See Part 7, "DC Control-Units with Air-Cooled Engine" or Part 8, "DC Control-Liquid Cooled Engine Units".*

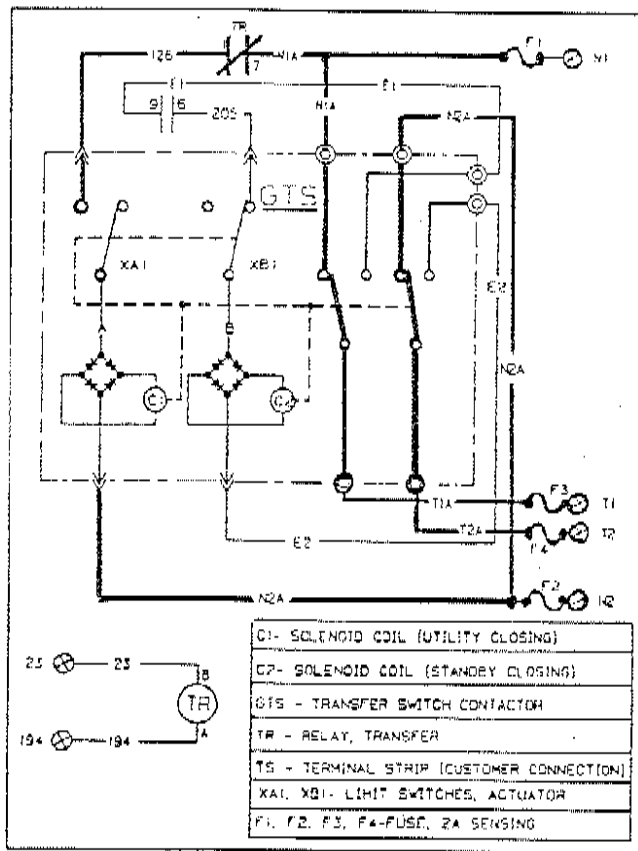

Figure 1. Circuit Condition- Utility Source Voltage Available

*Utility Source Voltage Dropout*

If utility source voltage should drop below a preset value, the generator's CMA circuit board will sense the dropout. That circuit board will then initiate generator cranking and startup after a time delay circuit times out.

*Transfer to Standby*

The generator's CMA circuit board delivers 12 volts DC to the transfer relay, via terminals 194 and back to the circuit board via terminals 23. However, circuit board action holds the Wire No. 23 circuit open and the transfer relay remains de-energized.

On generator startup, an "engine warmup timer" on the generator's CMA circuit board starts timing. When that timer has timed out, CMA circuit board action completes the Wire No. 23 circuit to ground. The transfer relay then energizes, its normally-open contacts close, and standby source voltage is delivered to the standby closing coil via Wires No. E1 and E2, the transfer relay (TR) contacts, limit switch (XB1), Wire "B", and a bridge rectifier. The standby closing coil energizes and the main contacts actuate to their "Standby" side.

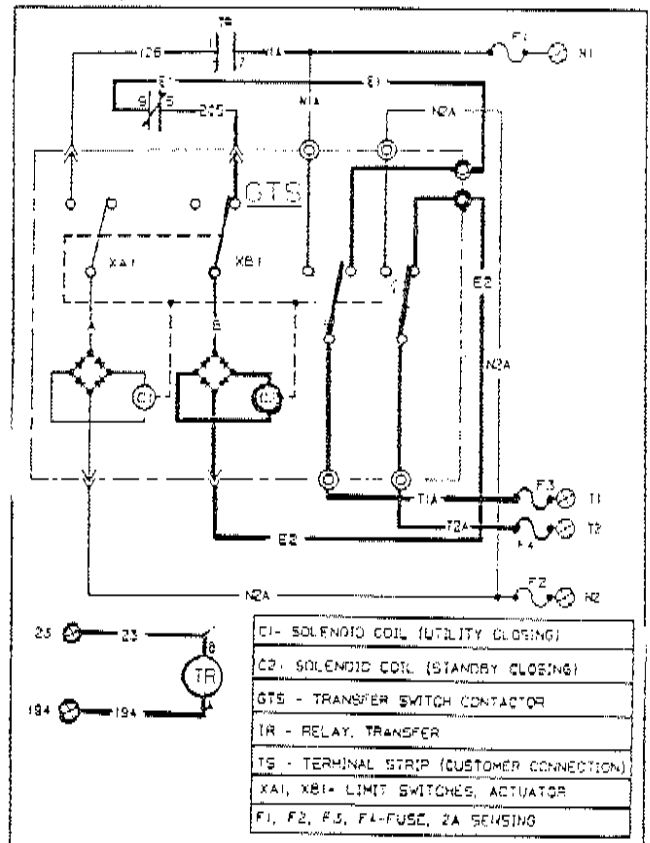

Figure 2. Circuit Condition- Transfer to Standby

**Retransfer Back to Utility**

On restoration of utility source voltage above a preset value, the generator's CMA circuit board "senses" that voltage via terminals N1 and N2. After a preset time interval, that circuit board opens the terminal 23 circuit to ground. The transfer relay, de-energizes, its normally-closed contacts close, and utility source voltage is delivered to utility closing coil (C1), via Wires N1A and N2A, closed transfer relay (TR) contacts, limit switch XA1, and a bridge rectifier.

On closure of the main contacts to the utility power source side, limit switches XA1 and XB1 are mechanically actuated to "arm" the circuit for transfer to standby.

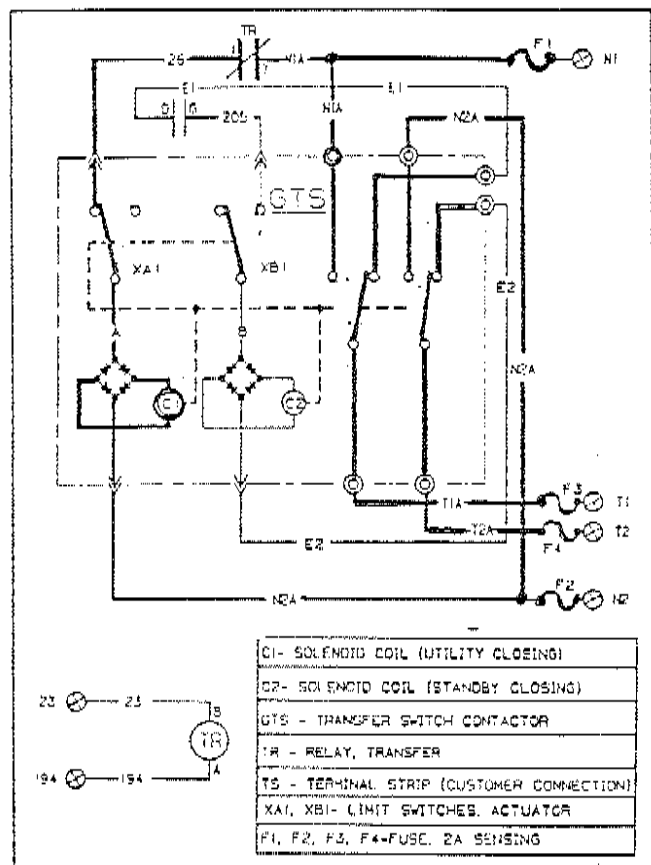

Figure 3. Initial Retransfer to Utility

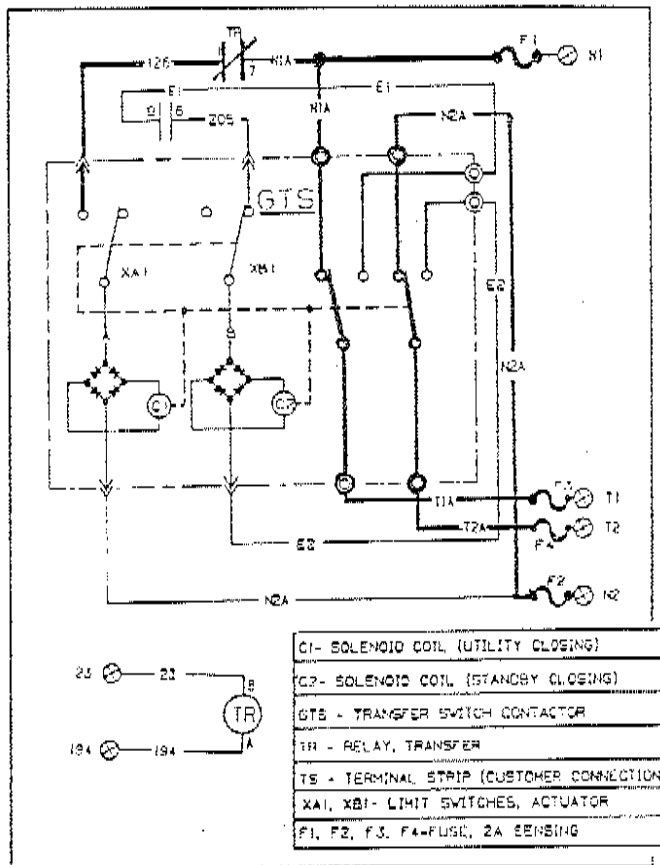

Figure 4. Final Retransfer to Utility

# TROUBLESHOOTING FLOW CHARTS

## Introduction to Troubleshooting

The first step in troubleshooting is to correctly identify the problem. Once that is done, the cause of the problem can be found by performing the tests in the appropriate flow chart.

Test numbers assigned in the flow charts are identical to the test numbers in Section 4.4, "Diagnostic Tests". Section 4.4 provides detailed instructions for performance of each test.

### Problem 1- In Automatic Mode, No Transfer to Standby

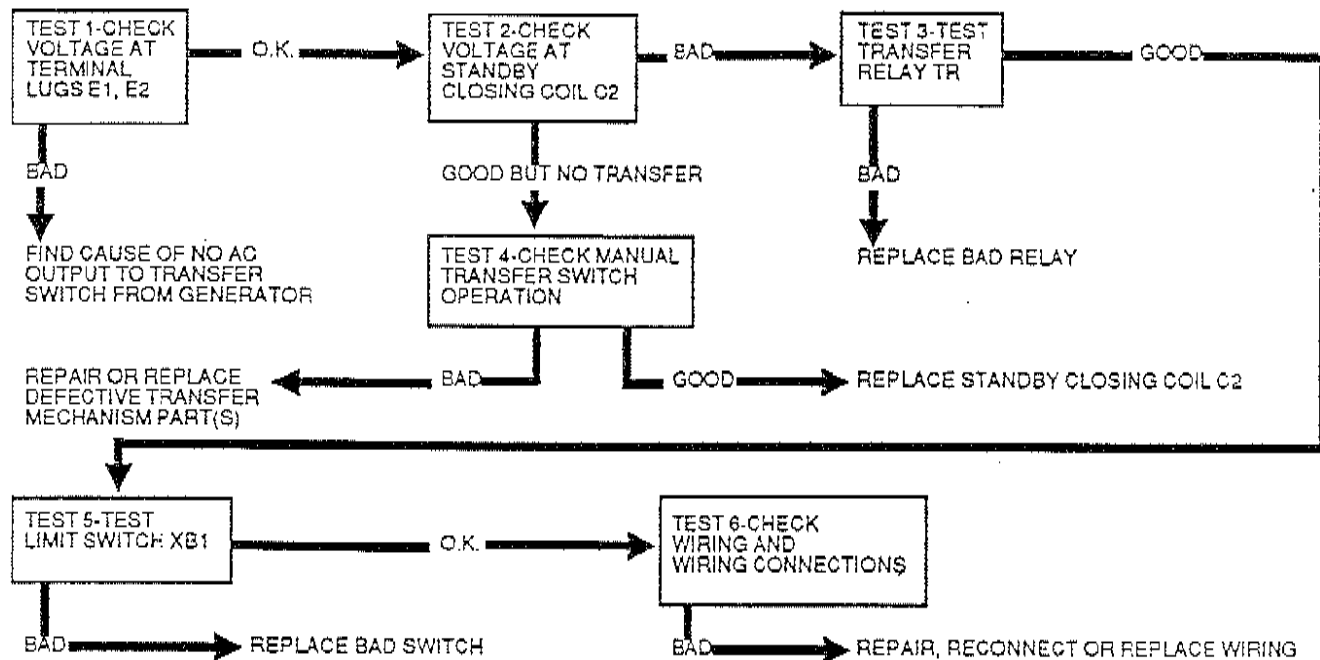

### Problem 2- In Automatic Mode, No Retransfer Back to Utility

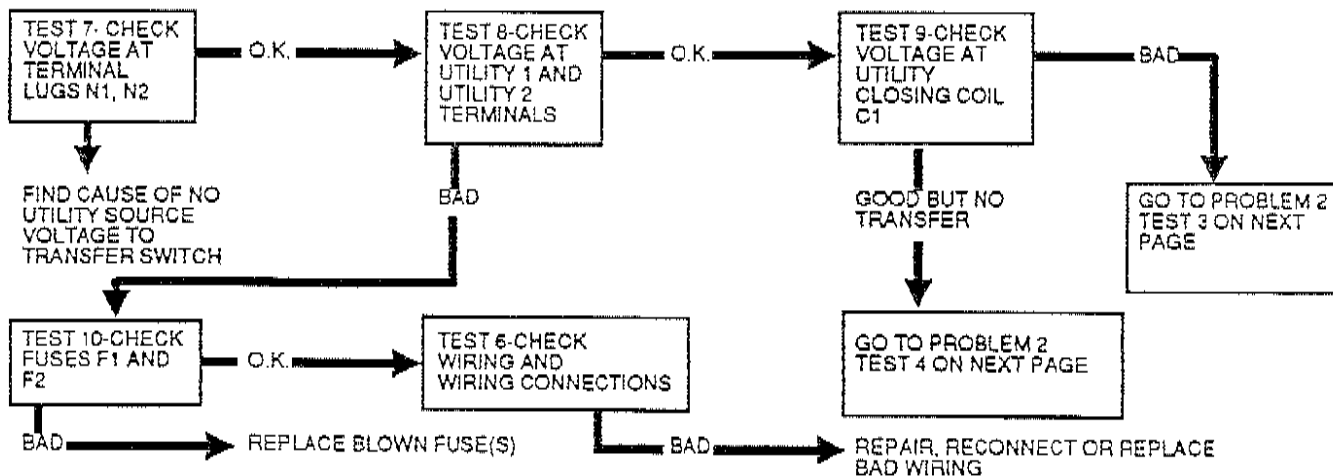

*Problem 2- In Automatic Mode, No Retransfer Back to Utility (Continued)*

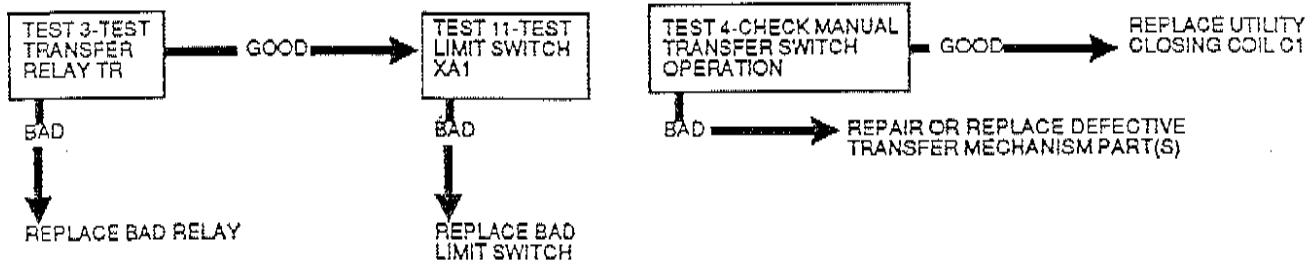

*Problem 3- In Automatic Mode, Generator Starts and Transfer to Standby Occurs When Utility Source Voltage is Available*

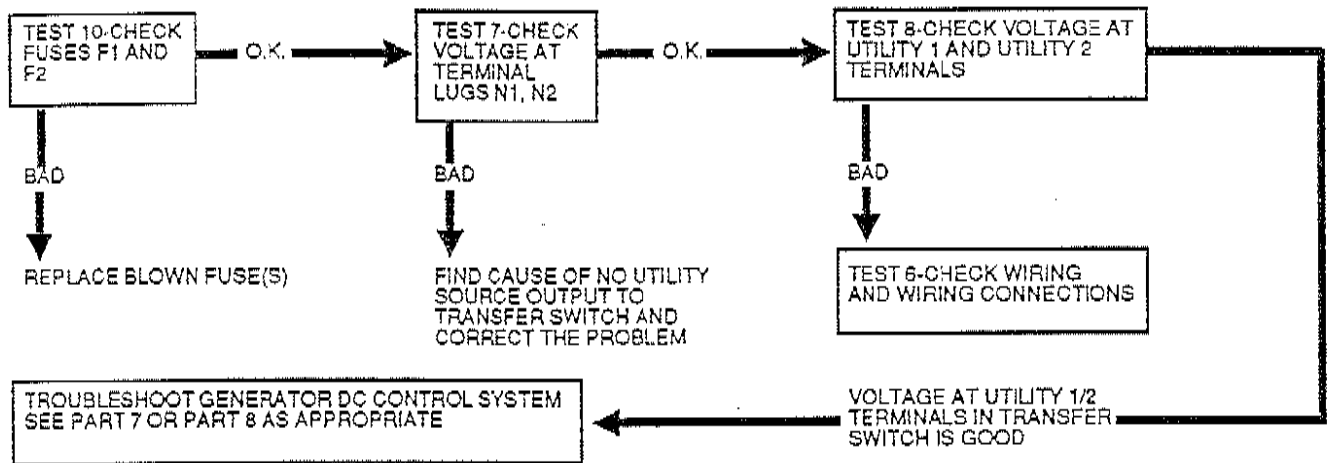

Section 4.4  
**DIAGNOSTIC TESTS**

*General*

Test numbers in this section correspond to the numbered tests in Section 4.3, "Troubleshooting Flow Charts". When troubleshooting, first identify the problem. Then, perform the diagnostic tests in the sequence given in the flow charts.

**Test 1- Check Voltage at Terminal Lugs E1, E2**

DISCUSSION:

In automatic mode, the standby closing coil (C2) must be energized by standby generator output if transfer to the "Standby" source is to occur. Transfer to "Standby" cannot occur unless that power supply is available to the transfer switch.

**DANGER: BE CAREFUL! HIGH AND DANGEROUS VOLTAGES ARE PRESENT AT TERMINAL LUGS E1 AND E2 WHEN THE GENERATOR IS RUNNING. AVOID CONTACT WITH HIGH VOLTAGE TERMINALS OR DANGEROUS AND POSSIBLY LETHAL ELECTRICAL SHOCK MAY RESULT. DO NOT PERFORM THIS VOLTAGE TEST WHILE STANDING ON WET OR DAMP GROUND, WHILE BAREFOOT, OR WHILE HANDS OR FEET ARE WET.**

PROCEDURE:

1. If the generator engine has started automatically (due to a utility power source outage) and is running, check the position of the generator's main circuit breaker. The circuit breaker must be set to its "On" or "Closed" position. When you are sure the generator's main circuit breaker is set to "On" or "Closed", check the voltage at transfer mechanism terminal lugs E1 and E2 with an accurate AC voltmeter or with an accurate volt-ohm-milliammeter (VOM). The generator's line-to-line voltage should be indicated.

2. If the generator has been shut down, proceed as follows:

- a. On the generator control panel, set the manual-off-auto switch to "Off".
- b. Turn OFF all power voltage supplies to the transfer switch. Both the "Utility" and "Standby" power supplies must be positively turned off before proceeding.
- c. Check the position of the transfer mechanism main contacts. The moveable LOAD contacts must be connected to the stationary "Utility" source contacts. If necessary, manually actuate the main contacts to the "Utility" power source side. See Part 9 for manual operating procedures.
- d. Actuate the generator's main line circuit breaker to its "On" or "Closed" position. The "Utility" power supply to the transfer switch must be turned OFF.

e. Set the generator's manual-off-auto switch to "Auto".

- (1) The generator should crank and start.
- (2) When the generator starts, an "engine warmup timer" should start timing. After about 15 seconds, the transfer relay should energize and transfer to the "Standby" source should occur.

f. If transfer to "Standby" does NOT occur, check the voltage across transfer switch terminal lugs E1 and E2. The generator's line-to-line voltage should be indicated.

RESULTS:

- 1. If normal transfer to "Standby" occurs, discontinue tests.
- 2. If transfer to "Standby" does NOT occur and no voltage is indicated across terminal lugs E1/E2, determine why generator AC output has failed.
- 3. If transfer to "Standby" does NOT occur and voltage reading across terminal lugs E1/E2 is good, go on to Test 2.

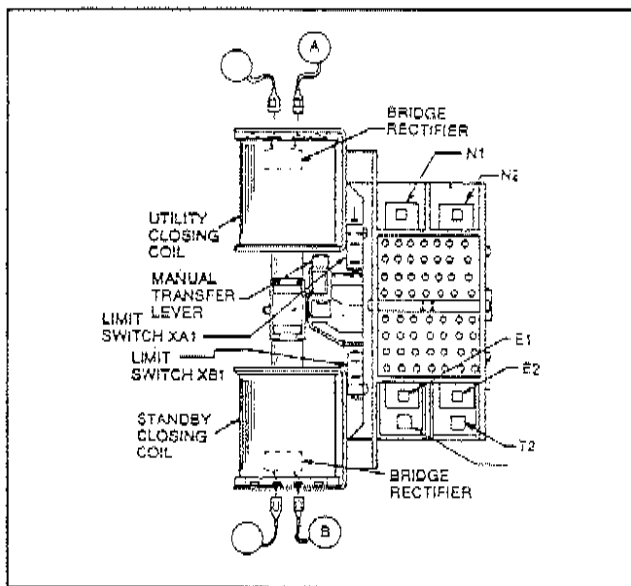

Figure 1. The "V-Type" Transfer Mechanism

**Test 2- Check Voltage at Standby Closing Coil C2**

DISCUSSION:

Standby source voltage is used to energize the standby closing coil and actuate the main contacts to their "Standby" source side. Standby source alternating current (AC) is changed to direct current (DC) by a bridge rectifier before it reaches the closing coil. This test will determine if standby voltage is available to the closing coil.

**Test 2- Check Voltage at Standby Closing Coil C2 (Continued)**

If normal standby source voltage is available to the terminals of the standby closing coil but transfer to "Standby" does not occur, look for (a) binding or sticking in the transfer mechanism, (b) a defective coil, or (c) a bad bridge rectifier. The coil and the bridge rectifier must be replaced as a unit.

**PROCEDURE:**

1. If necessary, repeat Step 2 under "Procedure" of Test 1. The system must be in automatic operating mode, with engine running, and standby source voltage available to terminal lugs E1 and E2.
2. On the standby closing coil, locate the two terminals to which Wires E1 and E2 connect (Figure 1). Use an accurate AC voltmeter (or a VOM) to check the voltage across these two terminals. Generator line-to-line voltage must be indicated.

**RESULTS:**

1. If generator line-to-line voltage is indicated and transfer to "Standby" occurs, discontinue tests.
2. If generator line-to-line voltage is indicated but transfer does NOT occur, go to Test 4.
3. If generator line-to-line voltage is NOT indicated, go to Test 3.

**Test 3- Test Transfer Relay TR**

**DISCUSSION:**

In automatic operating mode, the transfer relay must be energized by CMA circuit board action or standby source power will not be available to the standby closing coil. Without standby source power, the closing coil will remain de-energized and transfer to "Standby" will not occur. This test will determine if the transfer relay is functioning normally.

**PROCEDURE:**

1. See Figure 2. Disconnect all wires from the transfer relay, to prevent interaction.
2. Set a VOM to its "Rx1" scale and zero the meter.
3. Connect the VOM test leads across relay terminals 6 and 9 with the relay de-energized. The VOM should read "infinity".
4. Connect the positive (+) post of a 12 volts battery to relay terminal "A" and the negative (-) battery post to relay terminal "B". The relay should energize and the VOM should read "continuity".
5. Now, connect the VOM test leads across relay terminals 1 and 7.
  - a. Energize the relay and the meter should indicate "infinity".
  - b. De-energize the relay and the VOM should read "continuity".

CONNECT VOM TEST LEADS ACROSS	DESIRED METER READING	
	ENERGIZED	DE-ENERGIZED
Terminals 6 and 9	Continuity	Infinity
Terminals 1 and 7	Infinity	Continuity

**RESULTS:**

1. Replace transfer relay if it is defective.
2. If transfer relay checks good, go to Test 5.

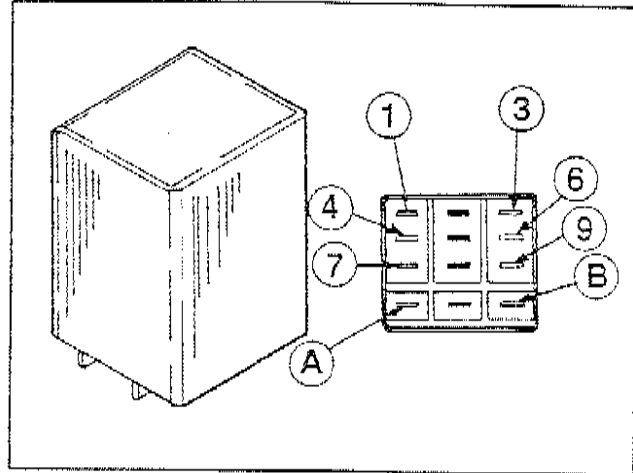

Figure 2. Transfer Relay Test Points

**Test 4- Check Manual Transfer Switch Operation**

**DISCUSSION:**

In automatic operating mode, when utility source voltage drops below a preset level, the engine should crank and start. On engine startup, an "engine warmup timer" on the generator's CMA circuit board should start timing. When that timer has timed out (about 15 seconds), the transfer relay should energize to deliver utility source power to the standby closing coil terminals. If normal utility source voltage is available to the standby closing coil terminals, but transfer to "Standby" does not occur, the cause of the failure may be (a) a failed standby closing coil and/or bridge rectifier, or (b) a seized or sticking actuating coil or load contact. This test will help you evaluate whether any sticking or binding is present in the transfer mechanism.

**PROCEDURE:**

1. With the generator shut down, set the generator's manual-off-auto switch to "Off".
2. Set the generator's main circuit breaker to "Off" or "Open".
3. Turn off the "Utility" power supply to the transfer switch, using whatever means provided (such as a utility source main line breaker).

**DANGER: DO NOT ATTEMPT MANUAL TRANSFER SWITCH OPERATION UNTIL ALL POWER VOLTAGE SUPPLIES TO THE SWITCH HAVE BEEN POSITIVELY TURNED OFF. FAILURE TO TURN OFF ALL POWER VOLTAGE SUPPLIES MAY RESULT IN EXTREMELY HAZARDOUS AND POSSIBLY LETHAL ELECTRICAL SHOCK.**

**Test 4- Check Manual Transfer Switch  
Operation (Continued)**

4. In the transfer switch enclosure, locate the manual transfer handle. Handle is retained in the enclosure with a wing stud. Remove the wing stud and handle.
5. See Figure 3. Insert the uninsulated end of the handle over the transfer switch operating lever.
  - a. Move the transfer switch operating lever up to actuate the load contacts to the "Utility" position, i.e., load connected to the "Utility" source.
  - b. Actuate the operating lever down to move the load contacts against the "Standby" contacts, i.e., load connected to the "Standby" source.
6. Repeat Step 5 several times. As the transfer switch operating lever is moved, slight force should be needed until the lever reaches its center position. As the lever moves past its center position, an over-center spring should snap the moveable load contacts against the stationary "Standby" or "Utility" contacts.
7. Finally, actuate the main contacts to their "Utility" power source side, i.e., load contacts against the "Utility" contacts (upward movement of the operating lever).

**RESULTS:**

1. If there is no evidence of binding, sticking, excessive force required, replace the standby closing coil (C2).
2. If evidence of sticking, binding, excessive force required to move main contacts, find cause of binding or sticking and repair or replace damaged part(s).

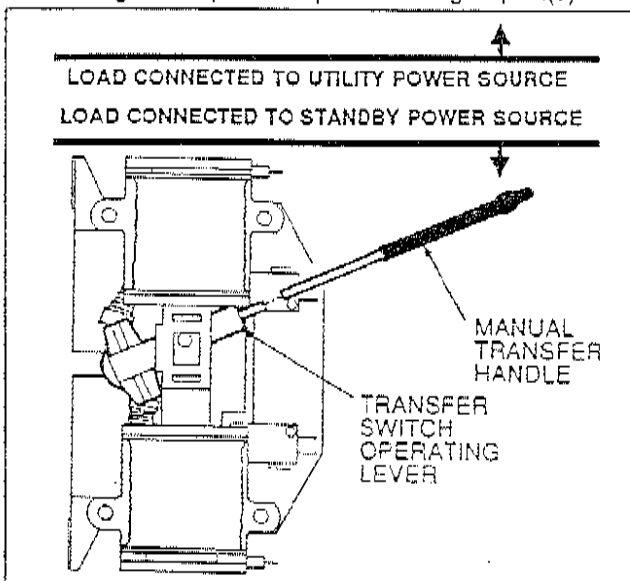

Figure 3. Manual Transfer Switch Operation

**Test 5- Test Limit Switch XB1**

**DISCUSSION:**

Standby power source voltage must be available to the standby closing coil in order for a "transfer to standby" action to occur. To deliver that source voltage to the

coil, limit switch XB1 must be closed to the "Standby" power source side. If the limit switch did not get actuated or has failed open, the source voltage will not be available to the closing coil and transfer to "Standby" will not occur.

**PROCEDURE:**

With the generator shut down and with the "Utility" power supply to the transfer switch turned OFF, test limit switch XB1 as follows:

1. To prevent interaction, disconnect Wire No. 205 and Wire "B" from the limit switch terminals.
2. Set a VOM to its "Rx1" scale and zero the meter.
3. See Figure 1. Connect the VOM test probes across the two terminals from which the wires were disconnected.
4. Manually actuate the main contacts to their "Standby" position. The meter should read "infinity".
5. Manually actuate the main contacts to their "Utility" position. The meter should read "continuity".
6. Repeat Steps 4 and 5 several times and verify the VOM reading at each switch position.

**RESULTS:**

1. If limit switch XB1 fails the test, remove and replace the switch or adjust switch until it is actuated properly.
2. If limit switch is good, go on to Test 6.

**Test 6- Check Wiring and Wiring Connections**

**DISCUSSION:**

An open circuit in transfer switch wiring can prevent a transfer action from occurring.

**PROCEDURE:**

See Figure 1. Inspect transfer switch wiring carefully. Make sure all wires are properly and securely attached to the correct terminals. Test wiring for an open or shorted condition.

**RESULTS:**

Repair, reconnect or replace any damaged, disconnected, incorrectly connected, open or shorted wire(s).

**Test 7- Check Voltage at Terminal Lugs  
N1, N2**

**DISCUSSION:**

If retransfer to the "Utility" power source side is to occur, utility source voltage must be available to terminal lugs N1 and N2 of the transfer mechanism. In addition, if that source voltage is not available to N1/N2 terminals, automatic startup and transfer to "Standby" will occur when the generator's manual-off-auto switch is set to "Auto". This test will prove that "Utility" voltage is available to those terminals, or is not available. It is the first test in a series of tests that should be accomplished when (a) retransfer back to "Utility" does not occur, or (b) startup and transfer occurs unnecessarily.

**Test 7- Check Voltage at Terminal Lugs  
N1, N2 (Continued)**

**DANGER: PROCEED WITH CAUTION! HIGH AND DANGEROUS VOLTAGES ARE PRESENT AT TERMINAL LUGS N1/N2. CONTACT WITH HIGH VOLTAGE TERMINALS WILL RESULT IN DANGEROUS AND POSSIBLY LETHAL ELECTRICAL SHOCK. DO NOT ATTEMPT THIS TEST WHILE STANDING ON WET OR DAMP GROUND, WHILE BAREFOOT, OR WHILE HANDS OR FEET ARE WET.**

**PROCEDURE:**

1. Make sure that all main line circuit breakers in the utility line to the transfer switch are "On" or "Closed".
2. Test for utility source line-to-line voltage across terminal lugs N1 and N2 (see Figure 1). Normal utility source voltage should be indicated.

**RESULTS:**

1. If low or no voltage is indicated, find the cause of the problem and correct.
2. If normal utility source voltage is indicated, go on to Test 8.

**Test 8- Check Voltage at Utility 1 and  
Utility 2 Terminals**

**DISCUSSION:**

During installation the installer should have connected the "Utility 1" and "Utility 2" terminals in the transfer switch with identically labelled terminals on a terminal block in the generators control module assembly (CMA). These terminals deliver utility voltage "sensing" to a CMA circuit board. If voltage at the terminals is zero or low, standby generator startup and transfer to the "Standby" source will occur automatically as controlled by the CMA circuit board. A zero or low voltage at these terminals will also prevent retransfer back to the "Utility" source.

**PROCEDURE:**

With utility source voltage available to terminal lugs N1 and N2, use an AC voltmeter or a VOM to test for utility source line-to-line voltage across terminal block "Utility 1" and "Utility 2" terminals. Normal line-to-line utility source voltage should be indicated.

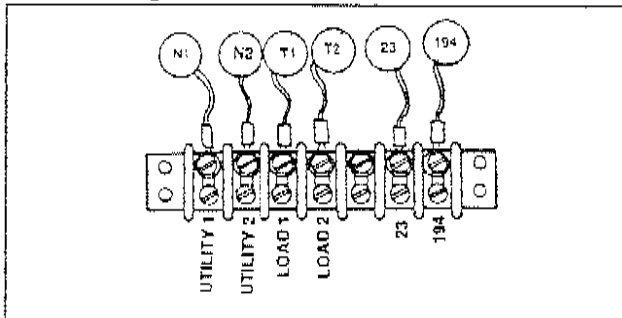

Figure 4. Transfer Switch Terminal Block

**RESULTS:**

1. If voltage reading across the "Utility 1" and "Utility 2" terminals is zero, go to Test 10.
2. If voltage reading is good, go to Test 9.

**Test 9- Check Voltage at Utility Closing  
Coil C1**

**DISCUSSION:**

Utility source voltage is required to energize utility closing coil C1 and effect retransfer back to the "Utility" source. This voltage is delivered to the utility closing coil via Wires No. N1A and N2A, the transfer relay's normally-closed contacts (relay de-energized), Wire No. 126, limit switch XA1, and a bridge rectifier.

**PROCEDURE:**

1. On the generator control panel, set the manual-off-auto switch to "Off".
2. Turn OFF the utility power supply to the transfer switch, using whatever means provided (such as a utility source main line circuit breaker).
3. Set the generator's main line circuit breaker to its "Off" or "Open" position.
4. Check the position of the transfer mechanism main contacts. The moveable load contacts must be connected to the stationary utility contacts. If necessary, manually actuate the main contacts to their "Utility" source side (load connected to the "Utility" source).
5. Set the generator's main line circuit breaker to its "On" or "Closed" position.
6. Set the generator's manual-off-auto switch to "Auto".
  - a. The generator should crank and start.
  - b. About 15 seconds after engine startup, the transfer relay should energize and transfer to the "Standby" source should occur.
7. When you are certain that transfer to "Standby" has occurred, turn ON the utility power supply to the transfer switch. After a short wait, retransfer back to the "Utility" source should occur.
8. If retransfer back to "Utility" does not occur, use an AC voltmeter (or a VOM) to test the voltage across the two terminals of the utility closing coil. Normal utility source line-to-line voltage should be indicated.

**RESULTS:**

1. In Step 6, if the generator does not crank or start, refer to Part 7, "DC Control- Units with Air Cooled Engine".
2. In Step 6, if transfer to the "Standby" source does not occur, go to Problem 1.
3. In Step 8, if normal utility source line-to-line voltage is NOT indicated, go to Test 3.
4. In Step 8, if normal utility source line-to-line voltage is indicated but retransfer back to "Utility" does not occur, go to Test 4.

**Test 10- Check Fuses F1 and F2**

**DISCUSSION:**

Fuses F1 and F2 are connected in series with the Utility 1 and Utility 2 circuits, respectively. A blown fuse will open the applicable circuit and will result in (a) generator startup and transfer to "Standby", or (b) failure to retransfer back to the "Utility" source.

**PROCEDURE:**

1. On the generator panel, set the manual-off-auto switch to "Off".
2. Turn OFF the utility power supply to the transfer switch, using whatever means provided.
3. See Figure 5. Remove fuses F1 and F2 from the fuse holder.
4. Inspect and test fuses for blown condition.

**RESULTS:**

1. Replace blown fuse(s).
2. If fuses both check good, go to Test 6.

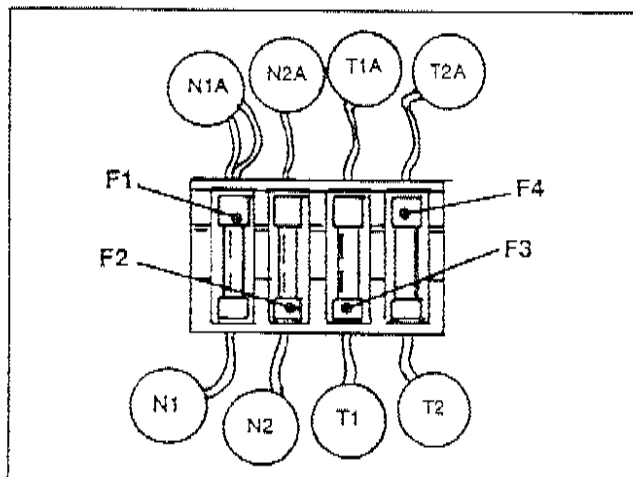

Figure 5. Fuse Holder and Fuses

**Test 11- Test Limit Switch XA1**

**DISCUSSION:**

When the transfer switch main contacts are actuated to their "Utility" position, limit switch XA1 should be mechanically actuated to its open position. On transfer to the "Standby" position, the limit switch should actuate to its closed position. If the switch does not actuate to its closed position, retransfer back to "Utility" will not occur.

**PROCEDURE:**

1. With the standby generator shut down, set its manual-off-auto switch to "Off".
2. Turn OFF the utility power supply to the transfer switch, using whatever means provided.
3. To prevent interaction, disconnect Wire No. 126 and Wire "A" from the limit switch terminals.

4. Set a VOM to its "Rx1" scale and zero the meter.
5. Connect the VOM test leads across the two limit switch terminals from which Wires "A" and 126 were removed.
6. Manually actuate the main contacts to their "Standby" position. The VOM should indicate "continuity".
7. Manually actuate the main contacts to their "Utility" position. The VOM should read "infinity".

**RESULTS:**

Replace limit switch XA1 if it checks bad.

*NOTE: Problems with transfer switch operation can also be caused by (a) defective wiring between the generator and transfer switch, or (b) a defective component in the generator's control module assembly (CMA). See Part 7, "DC Control- Units with Air Cooled Engine".*



**PART 5**  
**"Y-TYPE"**  
**PREPACKAGED**  
**TRANSFER**  
**SWITCHES**

GENERAC II  
PREPACKAGED  
HOME STANDBY  
ELECTRIC POWER  
SYSTEMS

**TABLE OF CONTENTS**

SECTION	TITLE
5.1	Description and Components
5.2	Operational Analysis
5.3	Troubleshooting Flow Charts
5.4	Diagnostic Tests
5.5	Disassembly, Testing, Reassembly

# NOTES

---

DESCRIPTION AND COMPONENTS

General

The "Y-Type" prepackaged transfer switches are available as 100 amp, 3-pole units; or as 200 amp, 2 or 3-pole units. Like the "V-Type" switches, the "Y-Type" have no intelligence circuit of their own. The circuit that controls automatic transfer switch operation is housed in a control module assembly (CMA) on the generator set.

The 3-pole models are intended for use with 3-phase utility and standby power source systems. These units are equipped with a 3-phase power monitor (PM).

The 2-pole models are intended for use with 1-phase power systems. These units do not have a 3-phase power monitor.

Since prepackaged generators with air cooled engine are available only as 1-phase units, the 3-pole transfer switches are normally used in conjunction with liquid cooled engine units.

Major Components

See Figure 1, below. Major transfer switch components include the following:

ITEM	NOMENCLATURE	ITEM	NOMENCLATURE
1	Transfer Mechanism	5*	Power Monitor Socket
2	Prepackaged Terminal Strip	7	Switch Enclosure
3	Manual Transfer Handle	8	Transfer Relay
4	Wing Stud	9	Neutral Lug
5*	3-Phase Power Monitor		

\* Items 5 and 6 are included on 3-pole units only.

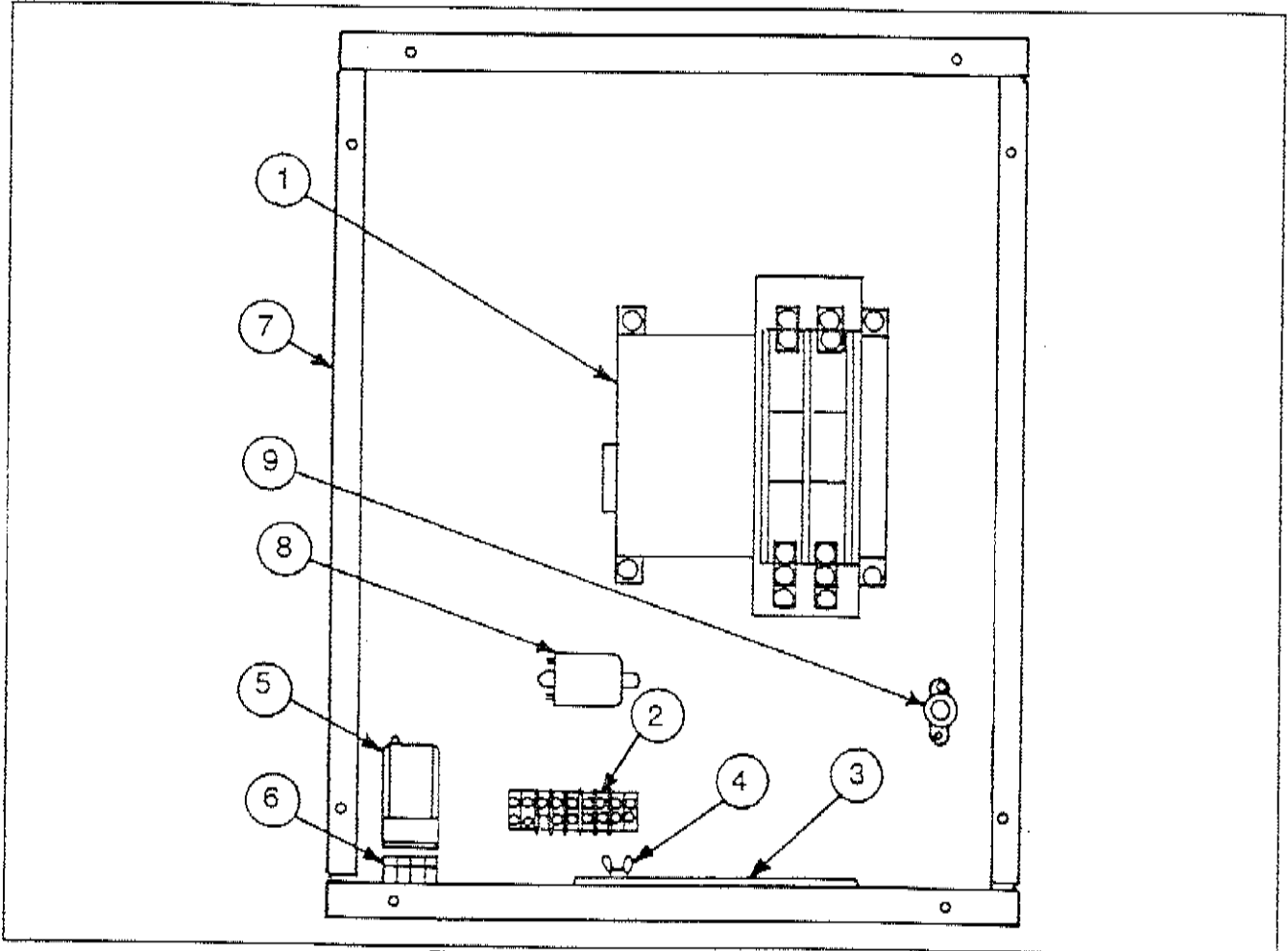

Figure 1. The "Y-Type" Transfer Switch

**Transfer Mechanism**

**GENERAL:**

The "Y-Type" transfer mechanism is a single solenoid, electrically actuated and mechanically held type switch. Contact surfaces of the main current carrying contacts are of 87 percent silver and 13 percent cadmium oxide, for better wear and conductivity. A typical 2-pole and 3-pole transfer mechanism is shown in Figures 2 and 3, respectively.

**STATIONARY MAIN CONTACTS:**

The stationary main contacts are retained in a "pole assembly" which may consist of either two (2) or three (3) poles that are sandwiched together. The pole assembly is retained in the transfer mechanism by two (2) thru-bolts. See Figure 4.

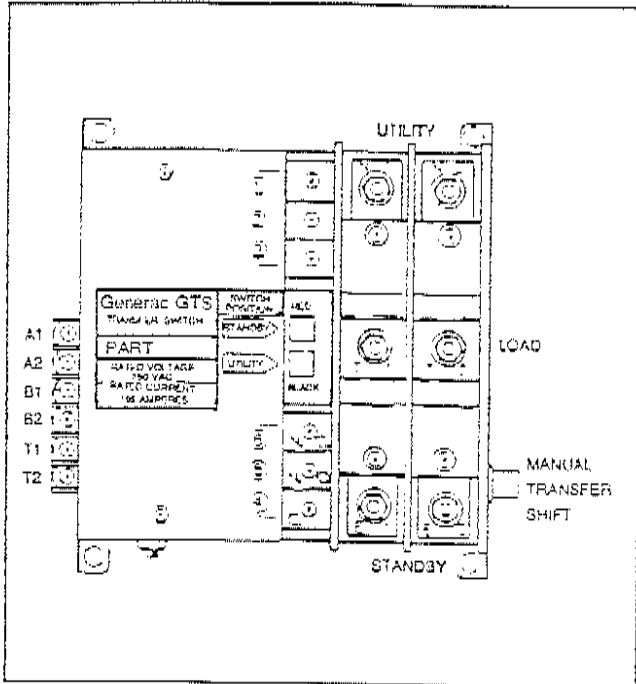

Figure 2. Typical 2-Pole Transfer Mechanism

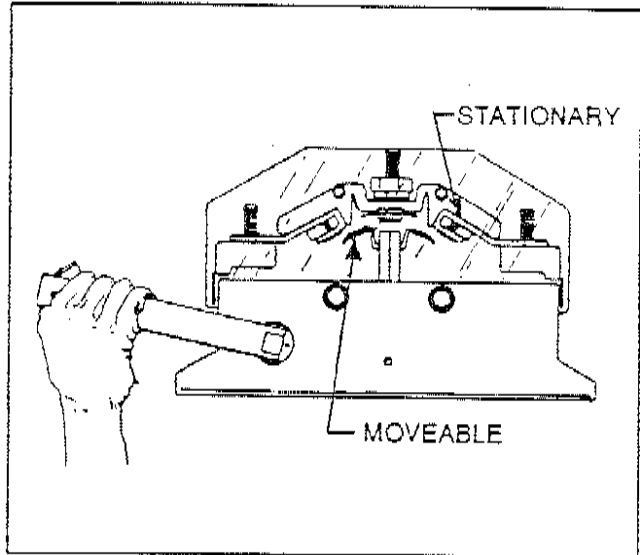

Figure 4. Stationary and Moveable Main Contacts

**MOVEABLE CONTACTS CARRIER:**

This one-piece carrier (Figure 4) pivots on a single shaft. It is available as a 2-pole or a 3-pole carrier, as required. Each set of moveable contacts is retained in the carrier by a spring.

**MAIN CONTACTS OPERATION:**

A dual set of moveable main contacts provides the interconnection between the load and power source terminals. The moveable main contacts are spring loaded to ensure proper alignment between contact surfaces. Figure 5 shows the moveable main contacts as they are held in place mechanically, to supply the load from the "Utility" power source side.

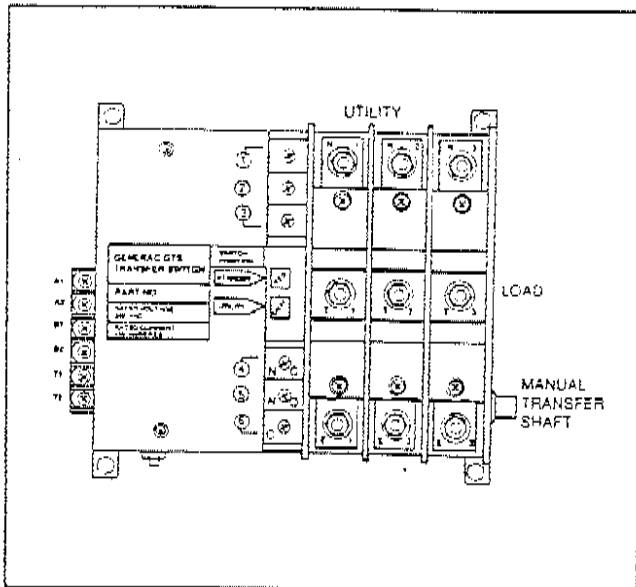

Figure 3. Typical 3-Pole Transfer Mechanism

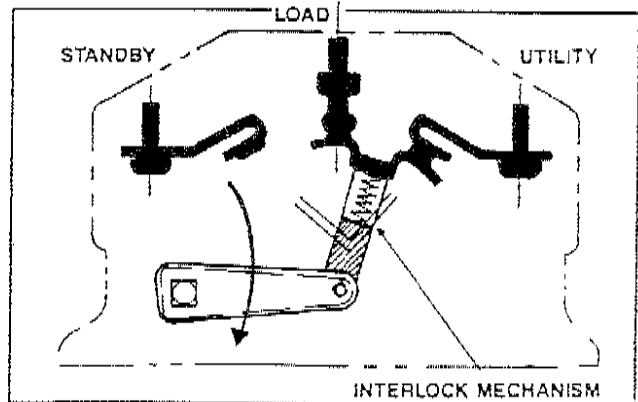

Figure 5. Main Contacts at "Utility" Position

*Transfer Mechanism (Continued)*

MAIN CONTACTS OPERATION (CONT'D):

Figure 6 shows the moveable main contacts at "Neutral" position, with the load disconnected from both power supplies. During electrical (automatic) operation, the main contacts will remain at "Neutral" as long as the main contacts actuating coil remains energized.

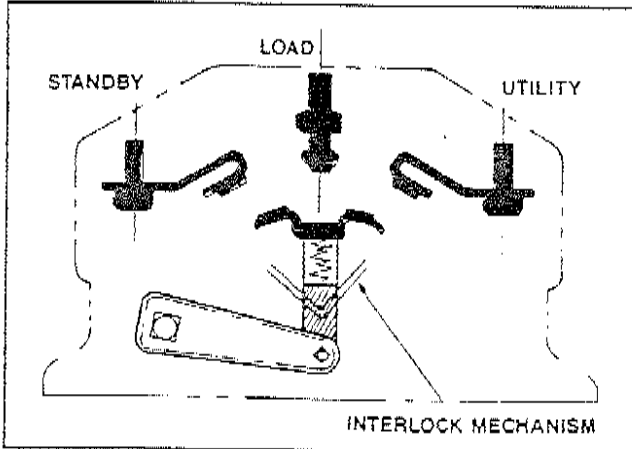

Figure 6. Main Contacts at "Neutral"

In Figure 7, the main contacts are held in place mechanically to supply the load from the "Standby" power source.

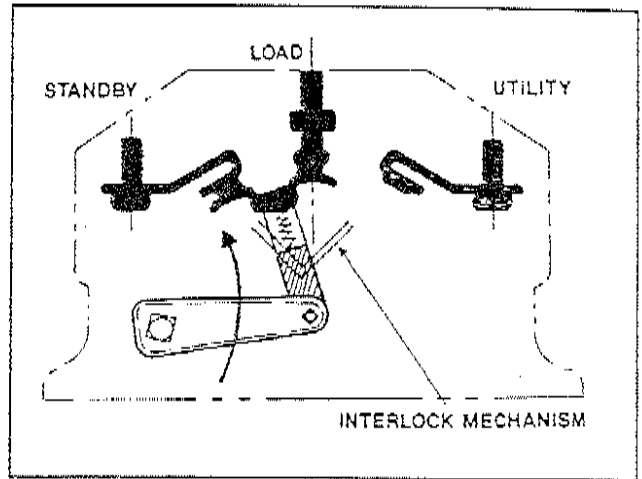

Figure 7. Main Contacts at "Standby"

ELECTRICAL COMPONENTS:

See Figure 8, below. The following electrical components are part of the transfer mechanism:

1. Control Terminal Strip
  - a. Terminals A1/A2 provide the actuating command voltage to the "Utility" power source side.
  - b. Terminals B1/B2 provide the actuating command to the "Standby" power source side.

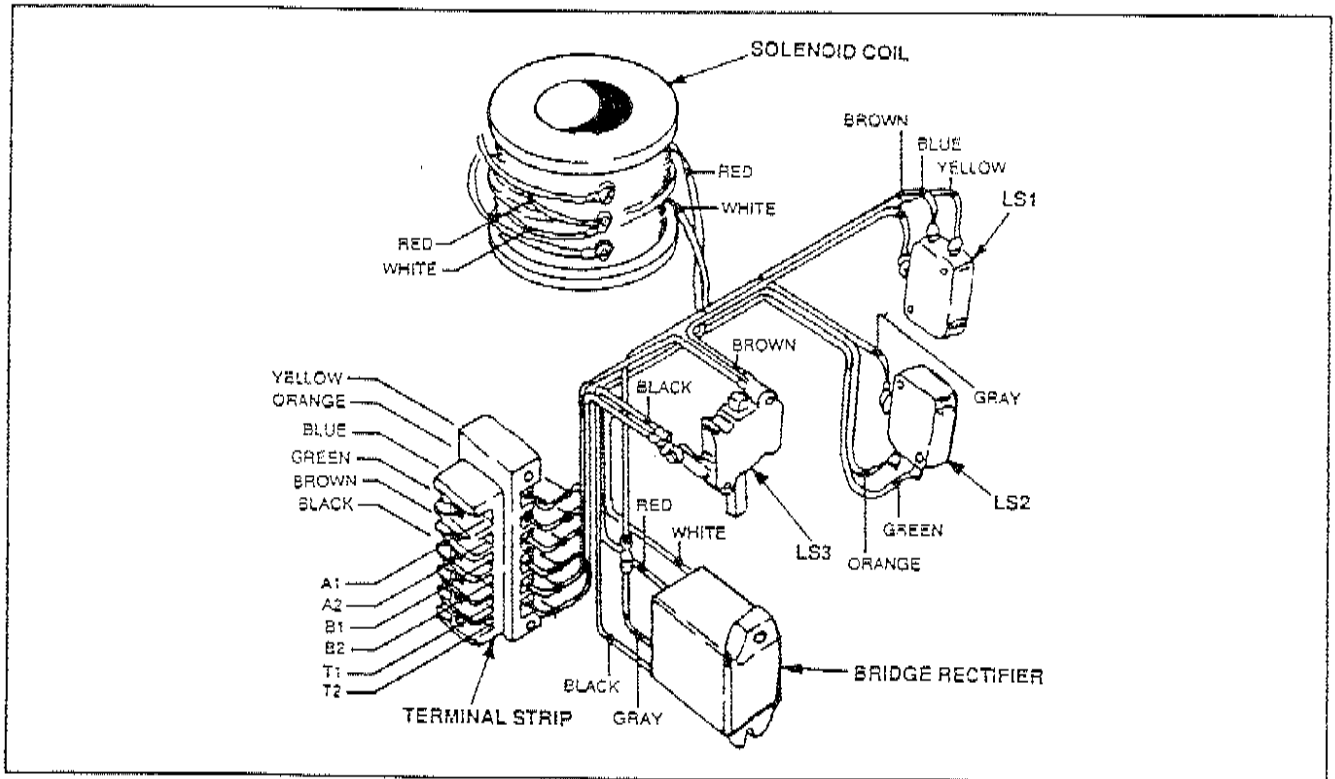

Figure 8. Transfer Mechanism Electrical Components

*Transfer Mechanism (Continued)*

ELECTRICAL COMPONENTS (CONT'D):

- c. Terminals T1/T2 are for use with an optional "time delay at neutral" feature. This feature is not generally used on prepackaged units.
- 2. Solenoid Coil
  - a. Current flow through this coil provides the magnetic field which actuates the moveable main contacts via a solenoid plunger.
  - b. The solenoid coil's rated voltage must be compatible with both "Utility" and "Standby" rated voltage.
- 3. Bridge Rectifier
  - a. To actuate the main contacts to their "Utility" side, the solenoid coil is energized by "Utility" source power.
  - b. For movement to the "Standby" source side, the solenoid coil is energized by "Standby" source power.
  - c. The bridge rectifier changes the alternating current (AC) from either power source side to direct current (DC).
  - d. The rectified direct current (DC) from either power source side energizes the solenoid coil.
- 4. Neutral Limit Switch LS3
  - a. During automatic transfer operations, the solenoid coil is energized to actuate the main contacts to their "Neutral" position.
  - b. When the main contacts reach their "Neutral" position, limit switch LS3 will be mechanically actuated to its "Open" position.
  - c. When switch LS3 opens, current flow to the solenoid coil is interrupted. The coil de-energizes and spring force completes the transfer action to either power source side.
  - d. The solenoid coil will remain energized at main contacts will remain at "Neutral" as long as limit switch LS3 remains closed.
- 5. Limit Switches LS1/LS2
  - a. Main contacts movement to either power source side will actuate these limit switches.
  - b. With the main contacts at their "Utility" position (load connected to "Utility" source), limit switches LS1/LS2 will be closed to the terminals B1/B2 side. This action "arms" the solenoid coil circuit for transfer to "Standby".
  - c. When the main contacts are at their "Standby" position, the two limit switches will close to the terminals A1/A2 side. This "arms" the solenoid coil circuit for retransfer back to "Utility".

AUXILIARY CONTACTS:

See Figures 2 and 3 on Page 5.1-2. The auxiliary contacts may be identified by the circled numbers "1" through "6" and by the letters "C" (common), "N.C." (normally-closed), and "N.O." (normally-open). These contacts may be used by the customer, if desired, for operating accessories (such as advisory lights, etc.).

One example of how these auxiliary contacts might be used is shown in Figure 9. Advisory lamps are

connected across the contacts as shown, along with a power supply for the lamps. When properly connected, one of the advisory lamps will illuminate when the main contacts are at their "Utility" position. The second lamp will turn on when the main contacts are at their "Standby" position. By using the auxiliary contacts in this manner, the operator can identify the position of the main contacts by simply looking at the lamps.

**DO NOT EXCEED THE RATED CURRENT AND VOLTAGE OF THE AUXILIARY CONTACTS.** The contacts are rated as follows:

- 15 amperes at 125, 250 or 480 volts AC.
- 1/2 ampere at 125 volts DC.
- 1/4 ampere at 250 volts DC.

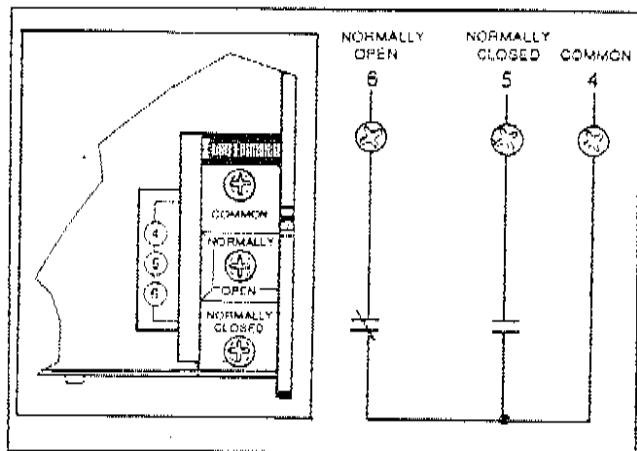

Figure 9. Auxiliary Contacts Schematic

*Prepackaged Terminal Strip*

The 7-point prepackaged terminal strip (Figure 10) must be properly interconnected with an identically numbered terminal strip in the generator's control module assembly (CMA). See "System Control Interconnections on Page 1.3-3.

Terminals N1/N2 deliver a utility voltage sensing signal to the generator's control module assembly. If this voltage signal drops low, CMA circuit board action will initiate generator startup and transfer to "Standby". The CMA circuit board also uses this power to operate a battery trickle charger, which helps maintain battery state of charge when the generator is not running.

Terminals T1/T2 deliver power from the transfer switch LOAD terminal lugs to the CMA circuit board, for the operation of a 7-day exercise timer clock. CMA circuit board action will start the generator and let it "exercise" once every seven days, on a day and at a time of day selected by the installer or user.

Terminals 194/23 connect the transfer relay to the generator's CMA circuit board, so that relay operation can be controlled by the circuit board.

*Prepackaged Terminal Strip (Continued)*

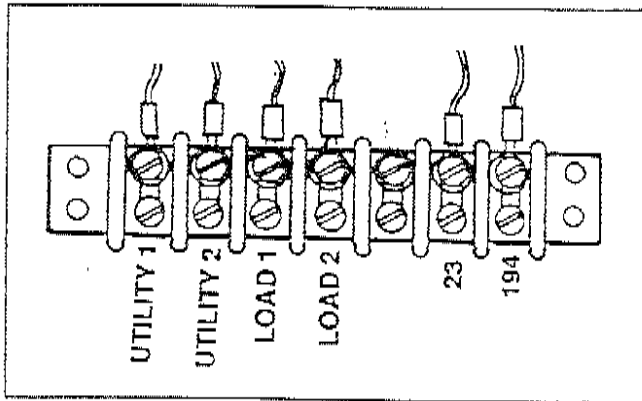

Figure 10. Prepackaged Terminal Strip

**Manual Transfer Handle**

Use this handle for testing and maintenance purposes, to actuate the transfer switch main contacts manually. To actuate the main contacts manually, proceed as follows:

1. On the generator panel, set the manual-off-auto switch to "Off".
2. Turn OFF all power voltage supplies to the transfer switch. Both the "Utility" and "Standby" power supplies must be turned OFF before proceeding.

**DANGER: ANY ATTEMPT TO OPERATE THE TRANSFER SWITCH MANUALLY WHEN POWER VOLTAGES ARE AVAILABLE TO THE SWITCH MAY RESULT IN EXTREMELY HAZARDOUS AND POSSIBLY LETHAL ELECTRICAL SHOCK.**

3. Attach the square opening of the manual handle over the square shaft at lower right corner of the transfer mechanism.
4. Move the handle upward. When movement stops, the main contacts will be at "Neutral". Return the handle to its original position and actuate again.
5. Observe the changeover display on the transfer mechanism.
  - a. If the "Utility" arrow is aligned with the green band, load terminals are connected to the "Utility" power supply.
  - b. If the "Standby" arrow is aligned with the green band, load terminals are connected to the "Standby" power supply.

**3-Phase Power Monitor**

This monitoring device is used only on 3-pole transfer switches. The monitor "senses" utility power source voltage in all three lines of the 3-phase system. A voltage dropout in one line, two lines, or all three lines will cause the power monitor contacts to open. The power monitor contacts are electrically connected in series with the terminal N1A circuit to the generator's control module assembly (CMA).

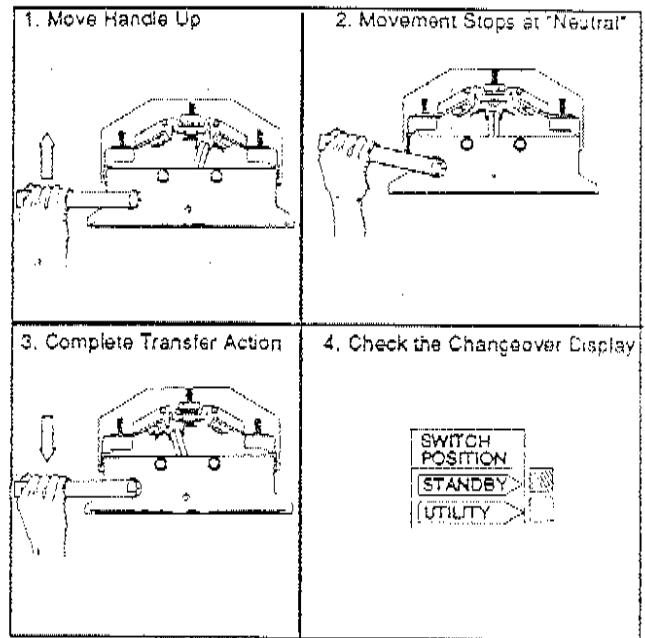

Figure 11. Using the Manual Transfer Handle

The 3-phase power monitor is adjustable. That is, the line voltage at which its contacts open can be adjusted. See Part 9, "Operational Tests and Adjustments" for adjustment procedures.

Opening of the power monitor contacts will result in loss of the "Utility" voltage sensing signal to the generator's CMA circuit board. The circuit board will then initiate automatic engine startup and transfer of loads to the "Standby" power source.

**Switch Enclosure**

The transfer switch is a NEMA 1 type. "NEMA" stands for "National Electrical Manufacturer's Association". NEMA 1 type enclosures are intended for indoor use primarily to provide a degree of protection against contact with the enclosed components and in locations where unusual service conditions do not exist.

**Transfer Relay**

The transfer relay is rated 12 volts DC and 10 amps. Relay operation is controlled by the generator's CMA circuit board. Relay operation may be briefly described as follows:

- The generator's CMA circuit board delivers 12 volts DC to the transfer relay coil, via wires and terminals 194 and 23. However, that circuit board normally holds the circuit 23 open to ground and the relay is normally de-energized.
- During a transfer to "Standby" action, the CMA circuit board completes the Wire 23 circuit to ground. The relay energizes, its normally open contacts close and "Standby" source power is delivered to transfer mechanism terminals B1/B2. Transfer to "Standby" occurs.

*Transfer Relay (Continued)*

During a "retransfer back to Utility" action, action of the generator's CMA circuit board opens the Wire 23 circuit to ground. The transfer relay then de-energizes, its normally-closed contacts close, and retransfer back to "Utility" occurs.

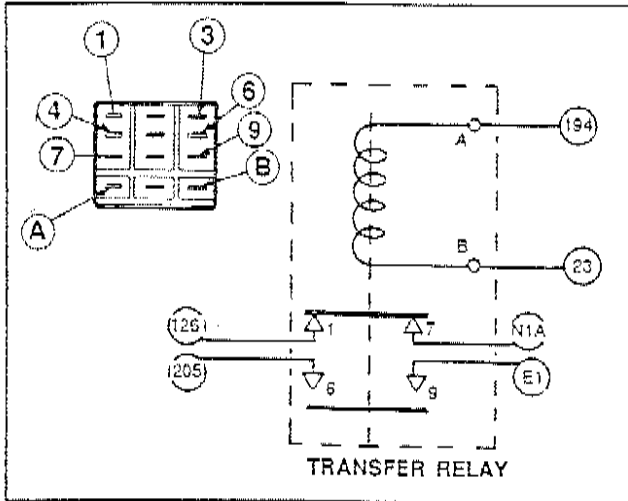

Figure 12. Transfer Relay Pictorial and Schematic

**Neutral Lug**

The transfer switch "Neutral" lug consists of a 3/8"-16 threaded stud which is insulated from the switch enclosure by a plastic base. Thus, the "Neutral" lug is ungrounded. Utility, standby and load neutral lines should be connected to this lug.

The prepackaged standby generators usually have a "floating" or "ungrounded" neutral. Strict compliance with electrical codes and standards is required when connecting these "floating" neutral lines. In most cases where a floating neutral line is used, only the "Neutral" lug at the main electrical service entrance is permitted to be grounded. However, electrical codes may vary widely in different areas.

Section 5.2  
**OPERATIONAL ANALYSIS**

*Utility Voltage Available (2-Pole Units)*

1. Utility voltage is available to terminal lugs N1/N2, across the main contacts and to the T1/T2 terminal lugs. Utility voltage is also available to terminals N1/N2 and to the generator's control module assembly (CMA).
2. Utility voltage is available to transfer mechanism terminals A1/A2. However, limit switches LS1/LS2 are closed to the terminals B1/B2 side and the A1/A2 circuit to the solenoid coil is open.
3. From the T1/T2 terminal lugs, power is delivered to the generator's control module (CMA) to operate a 7-day exercise timer.
4. The generator's CMA board senses normal "Utility" source voltage and takes no action. The generator is shut down and the transfer relay de-energized.

*Utility Voltage Available (3-Pole Units)*

1. Action is the same as for 2-pole units, except that utility source voltage applied to terminals N1, N2, N3 energize a 3-phase power monitor. That monitor's normally-open contacts are closed and line-to-line "Utility" voltage signals are available to the generator's CMA board via terminals N1A and N2.
2. Utility voltage is available to transfer mechanism terminals A1/A2. However, LS1 and LS2 are closed to the B1/B2 side and the solenoid coil is de-energized.
3. The generator's CMA circuit board takes no action and the transfer relay (TR) is de-energized.
4. Output from load terminals T1/T2 is delivered to the generator's CMA board, for operation of a 7-day exerciser clock.

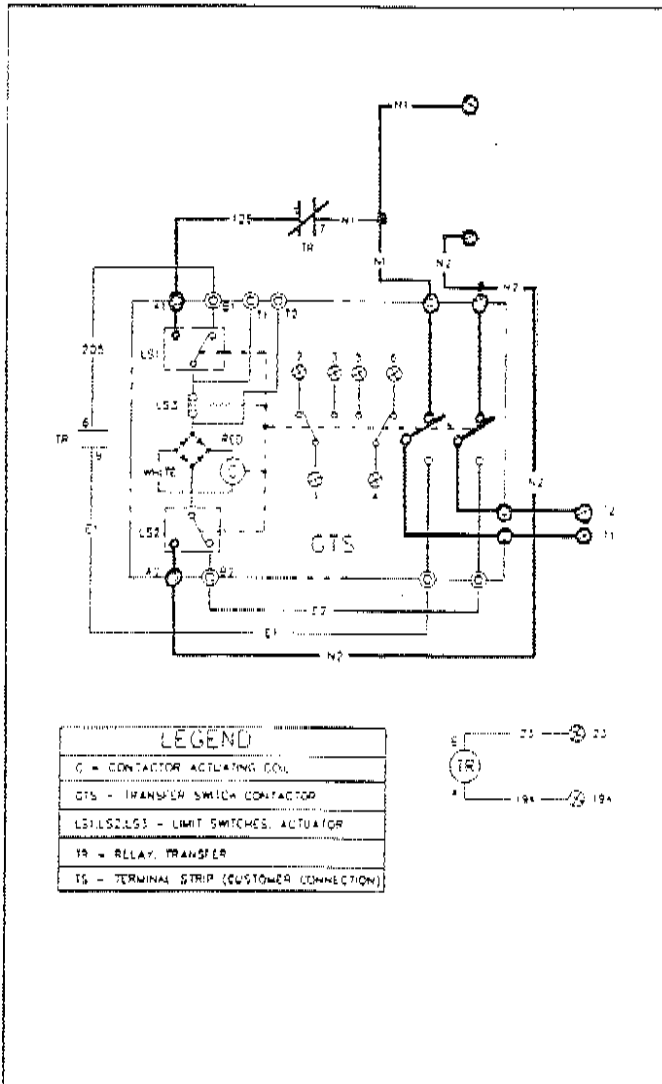

Figure 1. Utility Power Available (1-Phase Units)

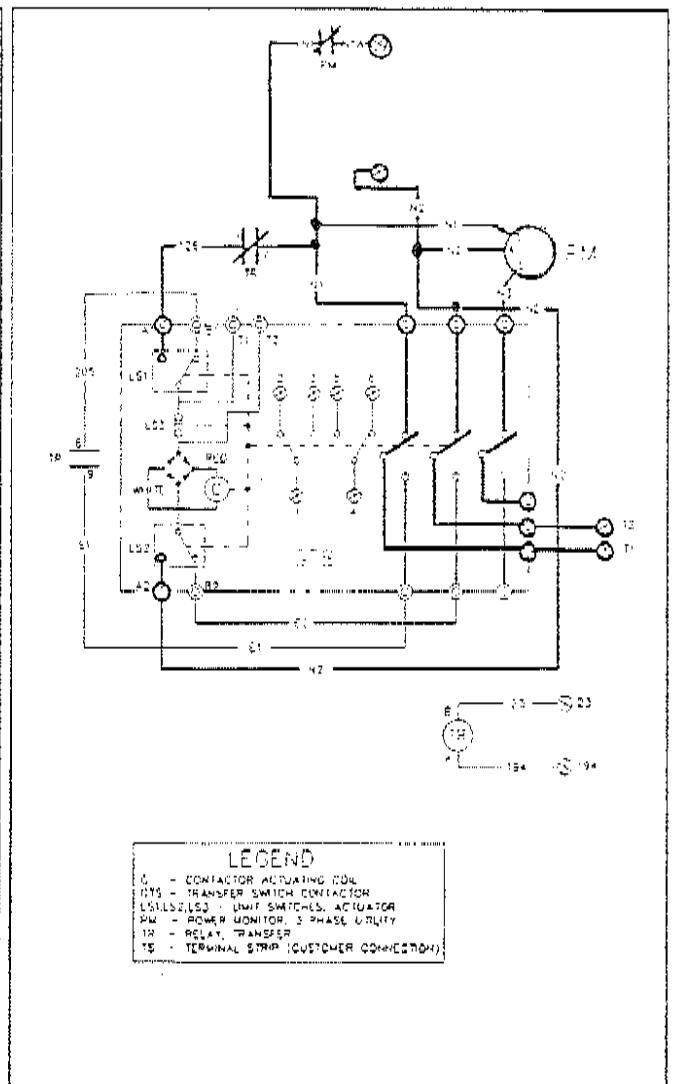

Figure 2. Utility Voltage Available (3-Phase Units)

**Utility Voltage Dropout (2-Pole Units)**

1. Utility voltage is sensed by the generator's CMA board, via wiring connected to terminals N1/N2.
2. If voltage drops below a preset value, CMA board action will start the generator.
3. With the generator running, "Standby" source voltage is available to terminal lugs E1/E2.
4. Loads connected to terminal lugs T1/T2 are not powered.
5. The Wire 23 circuit from the transfer relay coil is held open to ground by action of the generator's CMA board. The transfer relay is de-energized.
6. The transfer relay's normally-open contacts are open and "Standby" source power is not available to transfer mechanism terminals B1/B2.
7. The transfer switch main contacts remain at their "Utility" position.

**Utility Power Outage (3-Pole Units)**

1. If voltage in lines N1, N2 or N3 drop low, the 3-phase power monitor (PM) will de-energize and its normally-open contacts will open.
2. With the monitor contacts open, loss of sensing voltage to terminals N1/N2 will occur.
3. The generator's CMA board senses the power outage and initiates generator startup.
4. Standby source power is delivered to transfer switch terminal lugs E1, E2, E3.
5. The transfer relay (TR) is de-energized, its normally-open contacts are open and the circuit to transfer mechanism terminals B1/B2 is open. The solenoid coil remains de-energized.

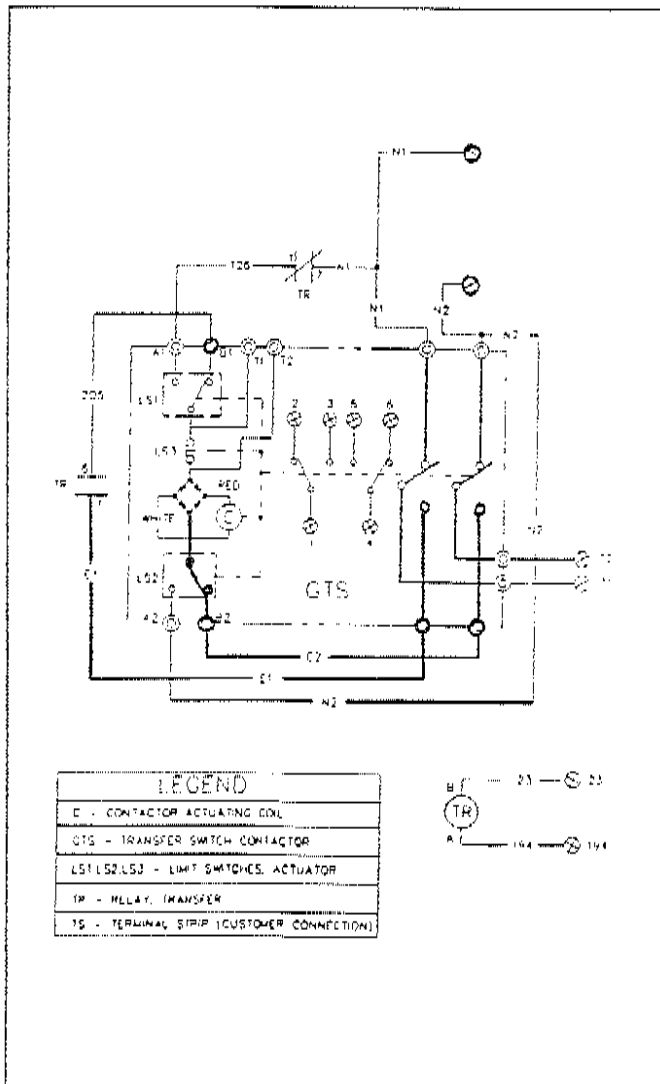

Figure 3. Utility Power Outage (1-Phase Units)

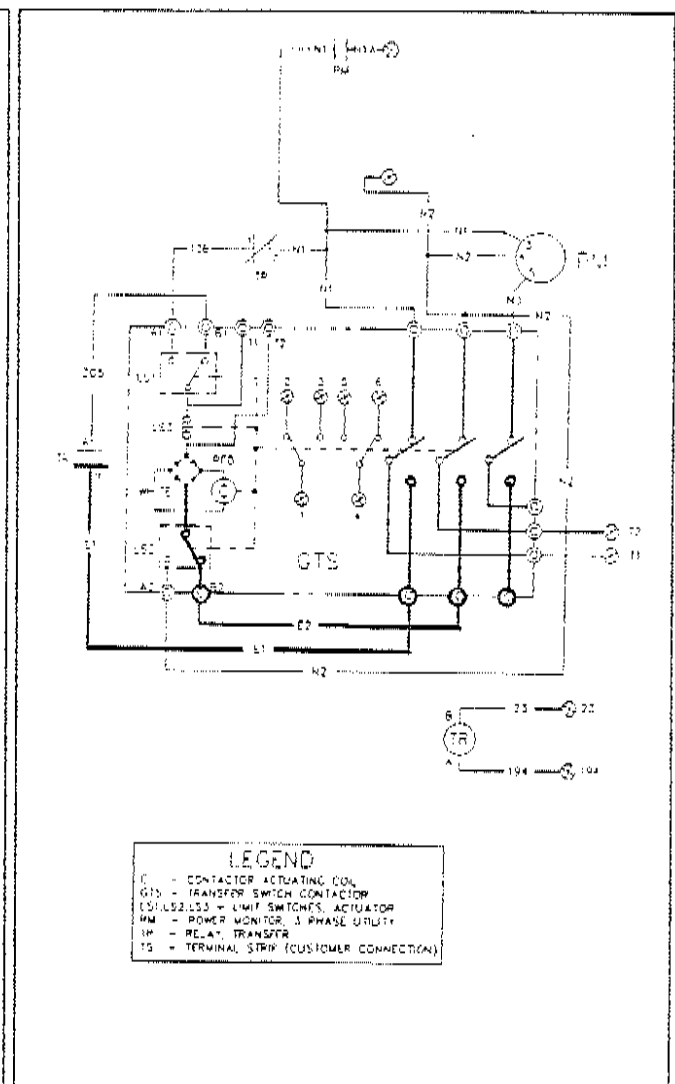

Figure 4. Utility Power Outage (3-Phase Units)

*Initial Transfer to Standby (2-Pole Units)*

1. The CMA board in the generator delivers 12 volts DC to terminal "A" of transfer relay TR, via Wire No. 194. The DC circuit is completed through the TR coil and back to the circuit board, via Wire No. 23. However, CMA board action holds the Wire 23 circuit open to ground and the relay is de-energized.
2. An "engine warmup timer" on the generator's CMA circuit board times for about 15 seconds. When that timer has timed out, the generator's CMA board closes the Wire No. 23 circuit to ground and TR energizes. The TR normally-open contacts (6 & 9) close and standby source power energizes the solenoid coil via Wire E1/E2, TR contacts, terminals B1/B2, limit switches, and a bridge rectifier.
3. Solenoid coil (C) energizes and actuates the main contacts to their "Neutral" position. The main contacts will remain at "Neutral" as long as the solenoid coil (C) remains energized.

*Initial Transfer to Standby (3-Pole Units)*

1. The generator's CMA circuit board delivers 12 volts DC to transfer relay (TR) terminal "A" via Wire 194. The DC circuit is completed through the TR coil and back to the CMA board, via Wire No. 23. However, CMA board action holds the Wire 23 circuit open to ground and TR remains de-energized.
2. An "engine warmup timer" on the generator's CMA board times for about 15 seconds. When that timer has timed out, CMA board action closes the Wire 23 circuit to ground and TR energizes. The relay's normally-open contacts (6 & 9) close to deliver standby voltage to the solenoid coil, via Wires E1/E2, the TR closed contacts, terminals B1/B2, limit switches, and a bridge rectifier.
3. The solenoid coil (C) energizes to actuate the main contacts to "Neutral". The main contacts will remain at "Neutral" as long as solenoid coil (C) remains energized.

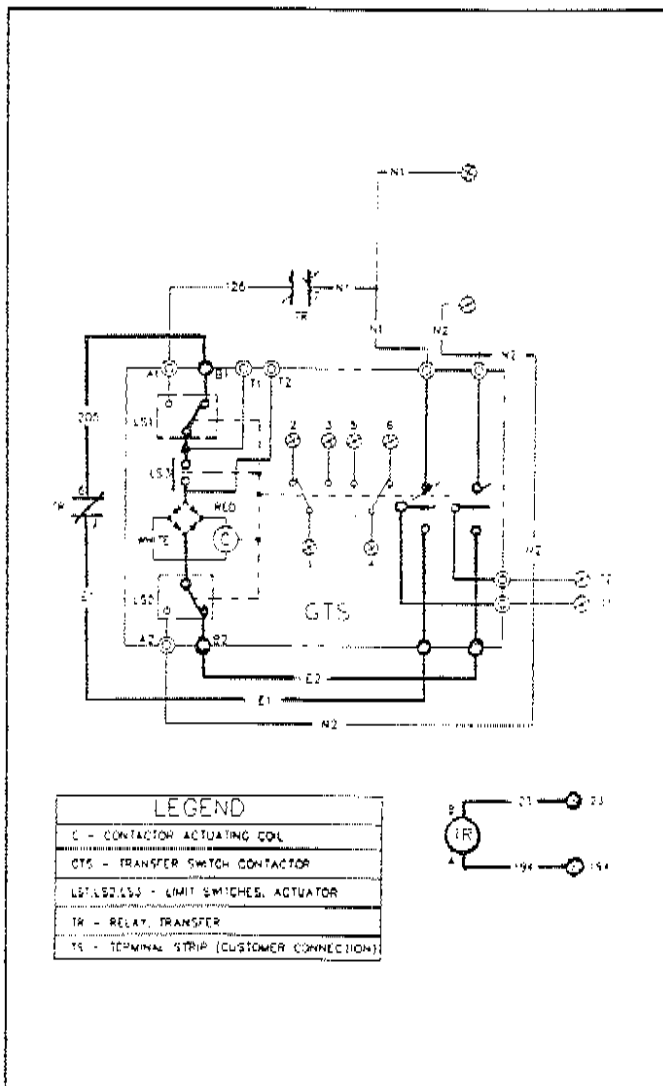

Figure 5. Initial Transfer to "Standby" (1-Phase Units)

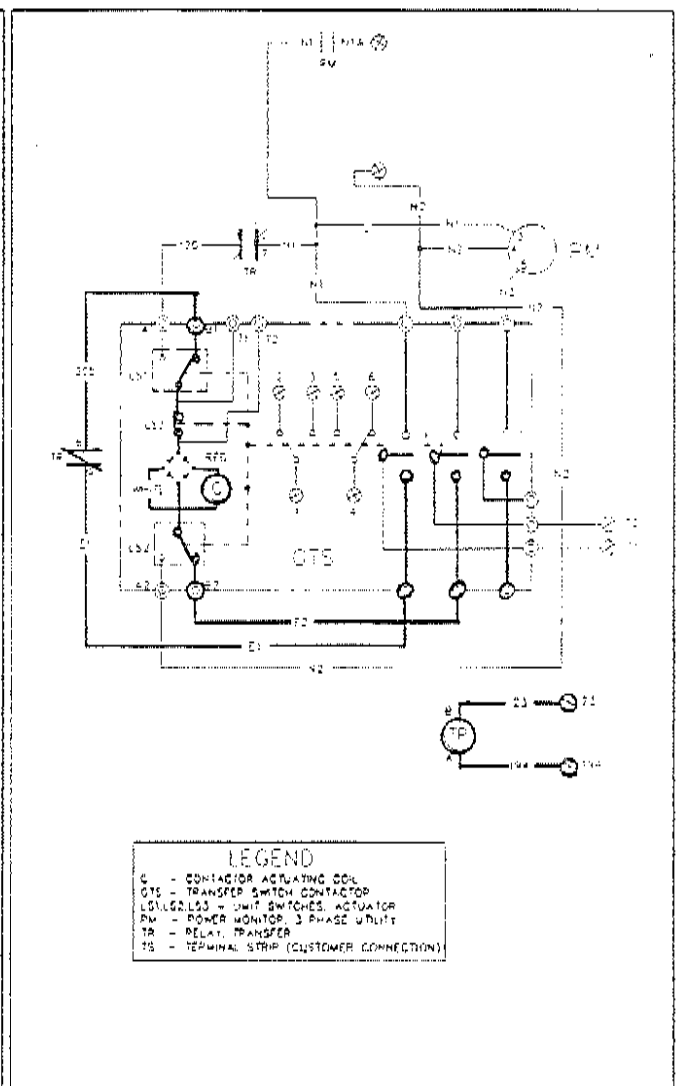

Figure 6. Initial Transfer to "Standby" (3-Phase Units)

**Final Transfer to Standby (2-Pole Units)**

1. As the main contacts reach their "Neutral" position, a mechanical interlock opens limit switch LS3.
2. The circuit to the solenoid coil (C) is now open. Solenoid coil (C) de-energizes and spring force completes the transfer action to the "Standby" source side.
3. As the main contacts slam to their "Standby" position, a mechanical interlock actuates limit switches LS1/LS2 to the terminals A1/A2 side.
4. Load terminals T1/T2 are now connected to terminal lugs E1/E2 and loads are powered by the generator.
5. The auxiliary contacts (indicated by numbers 1 through 6) are mechanically actuated to positions 3 and 6.
- 6.

**Final Transfer to Standby (3-Pole Units)**

1. As the main contacts reach "Neutral" position, a mechanical interlock opens limit switch LS3.
2. The circuit to solenoid coil (C) is now open and the solenoid de-energizes. Spring force then completes the transfer action to "Standby" position.
3. As the main contacts actuate to their "Standby" position, a mechanical interlock actuates limit switches LS1/LS2 to the terminals A1/A2 side. The circuit is now ready for retransfer back to the "Utility" source.
4. Load terminals T1, T2 and T3 are now connected to terminal lugs E1, E2 and E3, respectively. Loads are powered by the standby generator.
5. Auxiliary contacts have been mechanically repositioned as shown.

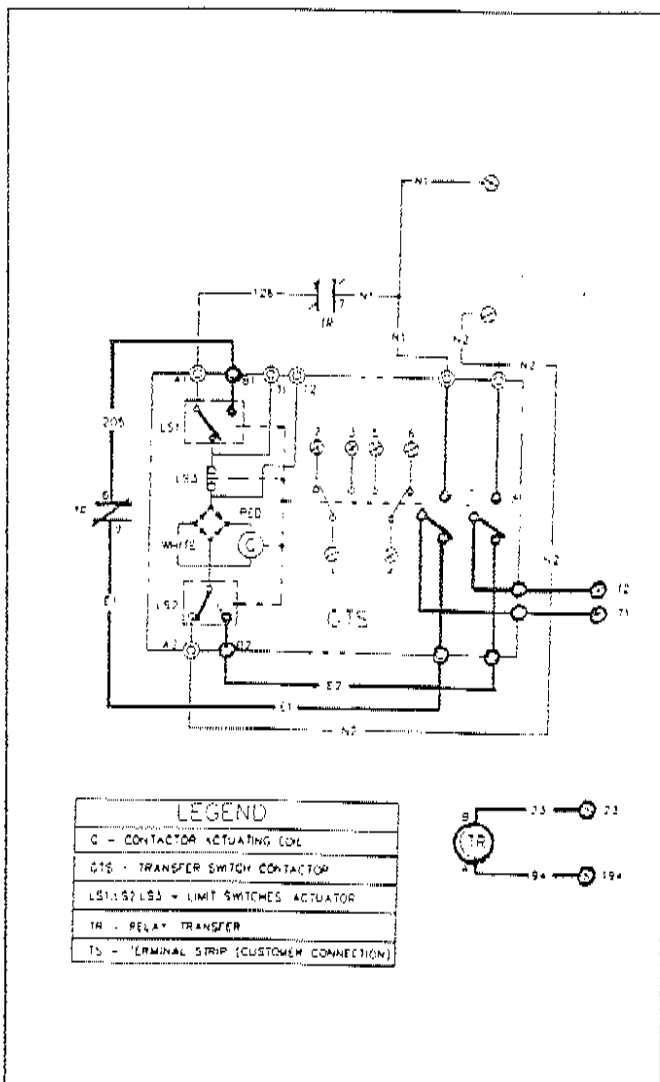

Figure 7. Final Transfer to "Standby" (1-Phase Units)

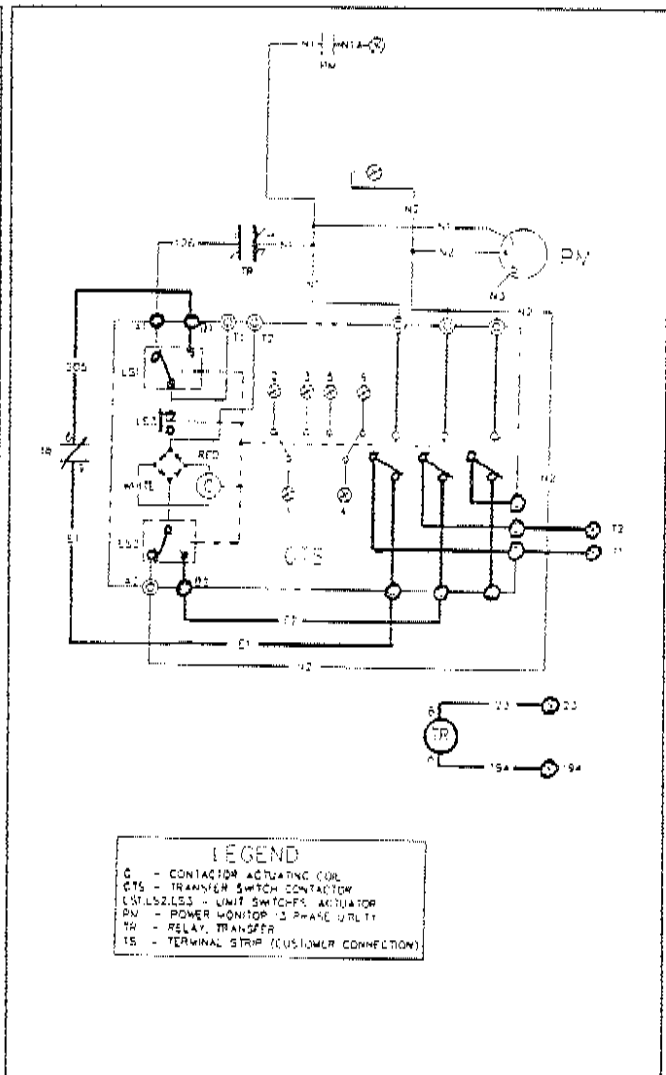

Figure 8. Final Transfer to "Standby" (3-Phase Units)

*Retransfer to Utility (2-Pole Units)*

1. When "Utility" source voltage is restored, it is available to transfer switch terminal lugs N1/N2 and to terminal strip terminals N1/N2. The voltage is also available to the generator's CMA circuit board via wiring connected to terminal strip terminals N1/N2.
2. CMA circuit board action opens the Wire 23 circuit to ground and transfer relay TR de-energizes. The TR normally-closed contacts close and utility voltage is delivered to terminals A1/A2 and to solenoid coil (C). That coil energizes to actuate the main contacts to "Neutral". When the main contacts reach "Neutral" LS3 opens, solenoid coil (C) de-energizes, and spring force completes the retransfer action back to "Utility".
3. Limit switches LS1/LS2 are actuated to the B1/B2 side.
4. The auxiliary contacts are repositioned as shown.

*Retransfer to Utility (3-Pole Units)*

1. When utility voltage is restored, the 3-phase power monitor energizes and its normally-open contacts close. Utility voltage sensing is now available to the generator's CMA board via terminal strip terminal N1A.
2. CMA board action de-energizes transfer relay TR.
3. Retransfer back to the "Utility" source occurs as described under "Retransfer to Utility (2-Pole Units)".

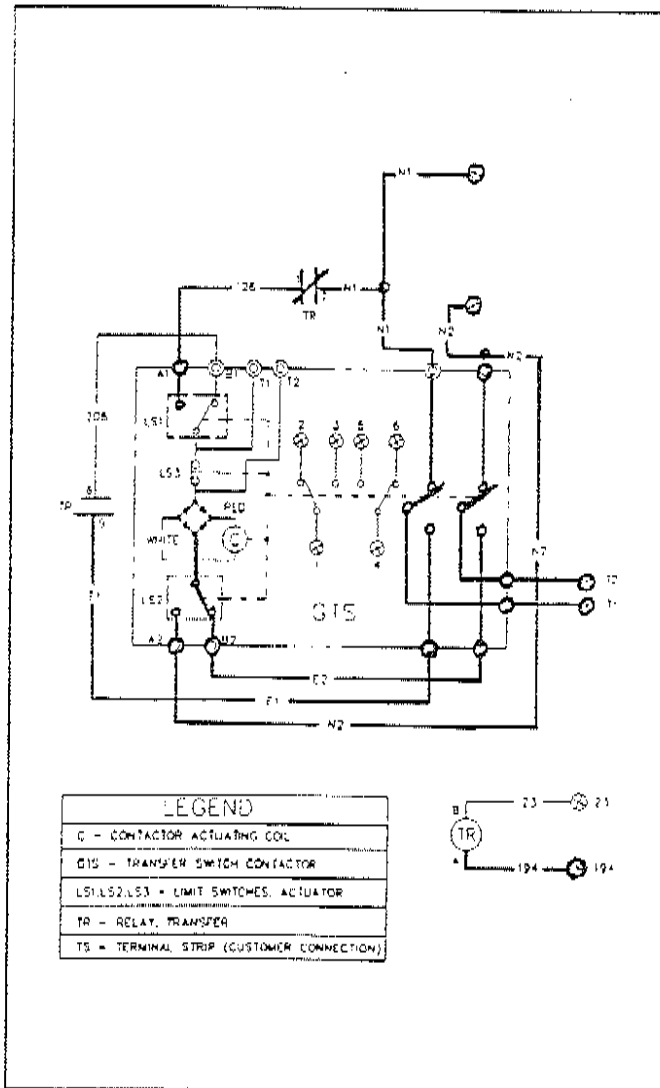

Figure 9. Retransfer to "Utility" (1-Phase Units)

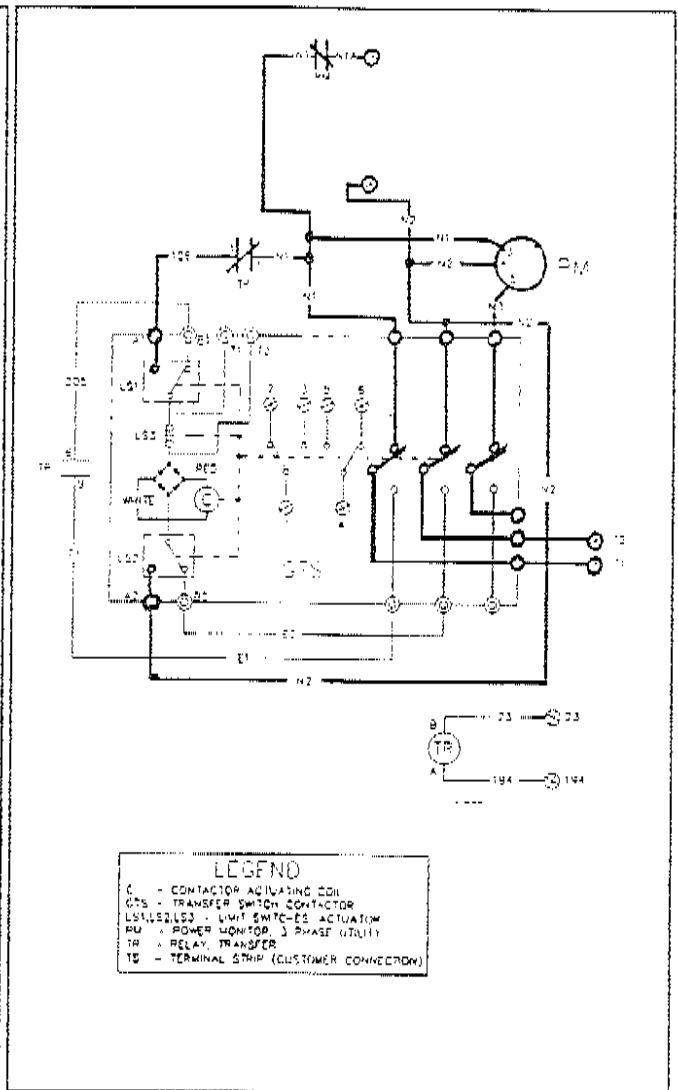
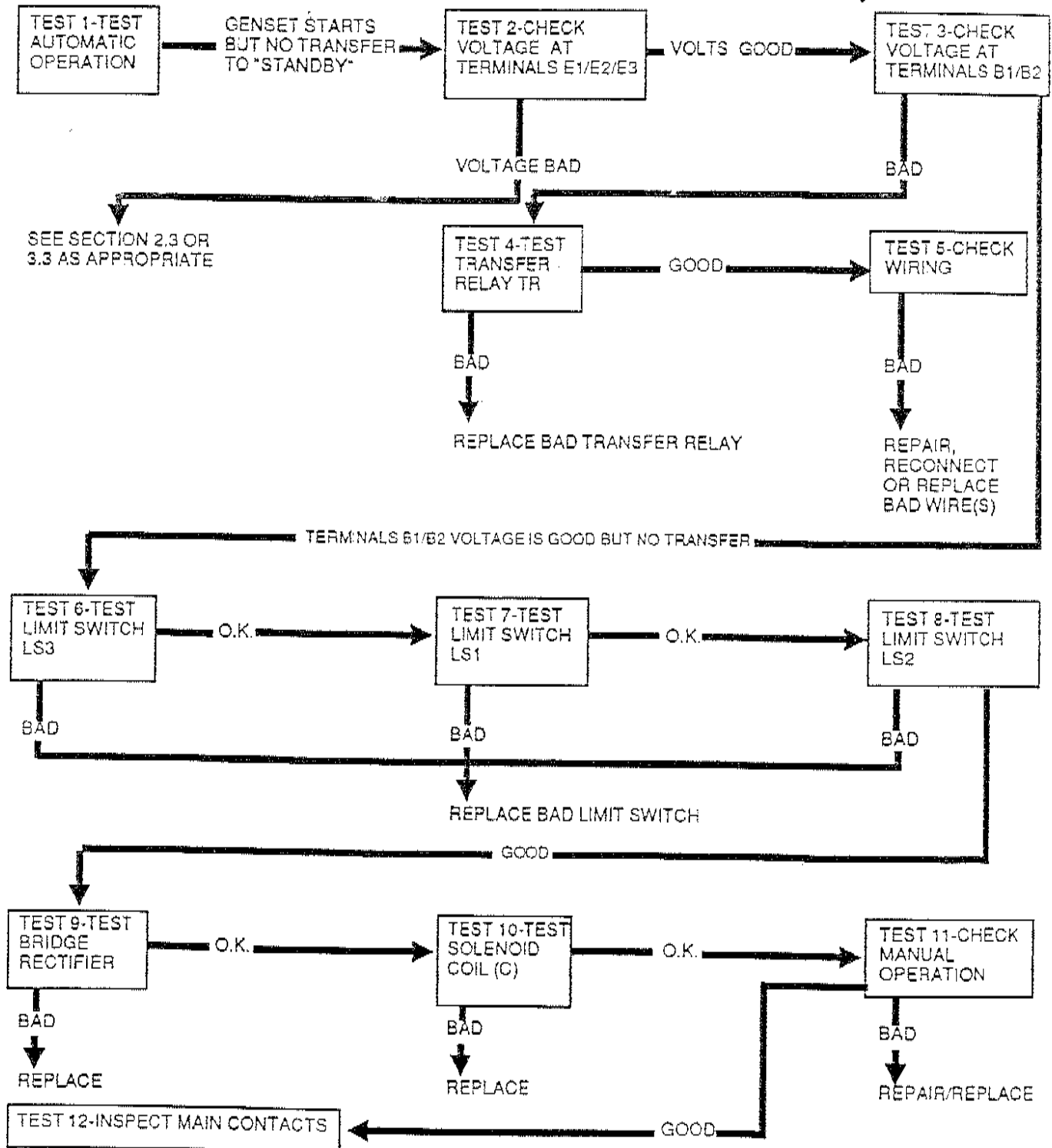

Figure 10. Retransfer to "Utility" (3-Phase Units)



Section 5.3  
**TROUBLESHOOTING FLOW CHARTS**

*Problem 1- In Automatic Mode, Will Not Transfer to "Standby"*



*Problem 2- In Automatic Mode, Will Not Retransfer to "Utility"*

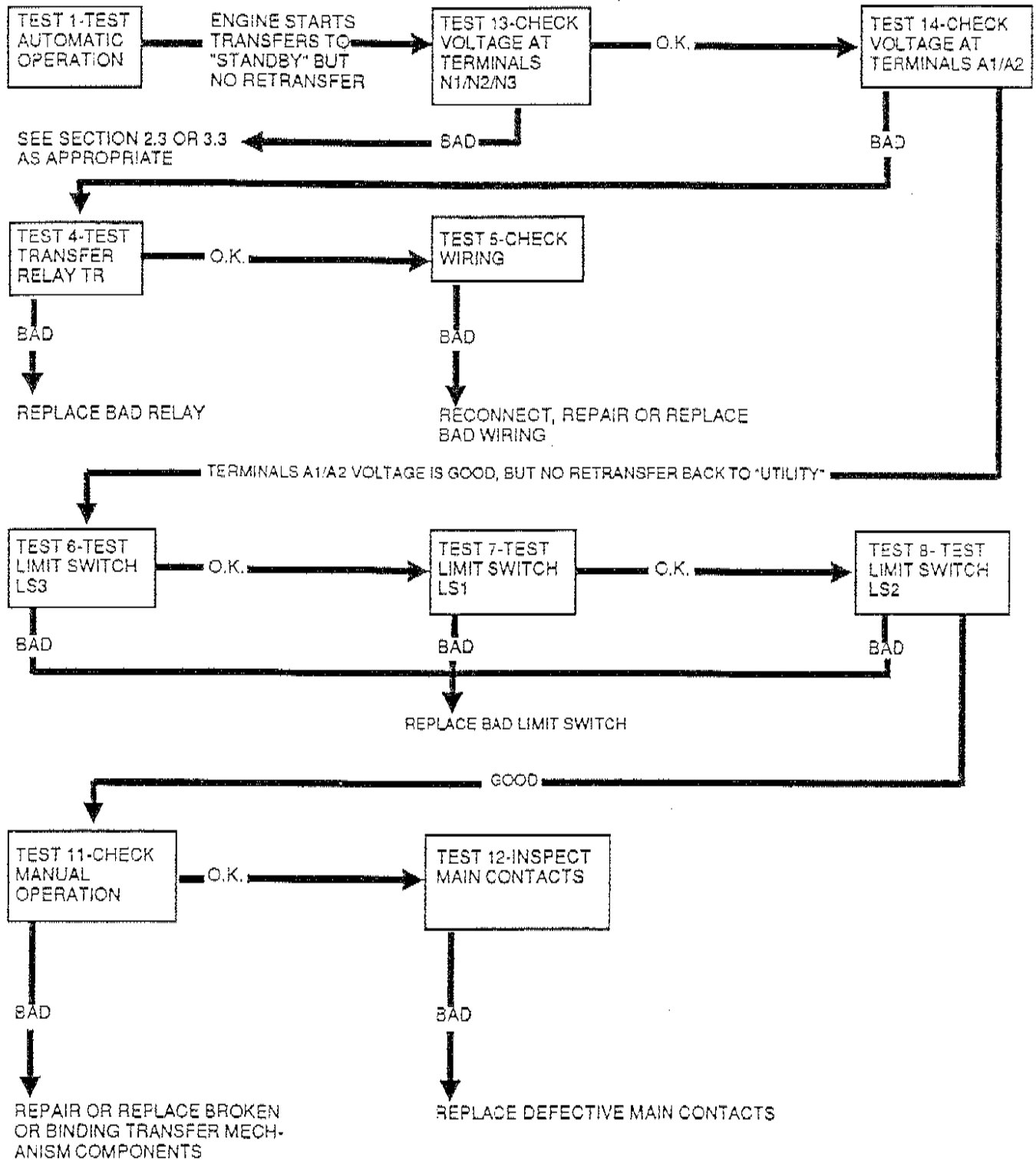

*Problem 3- GenSet Starts and Transfer Occurs When Utility Power is Available  
(3-Phase Transfer Switches)*

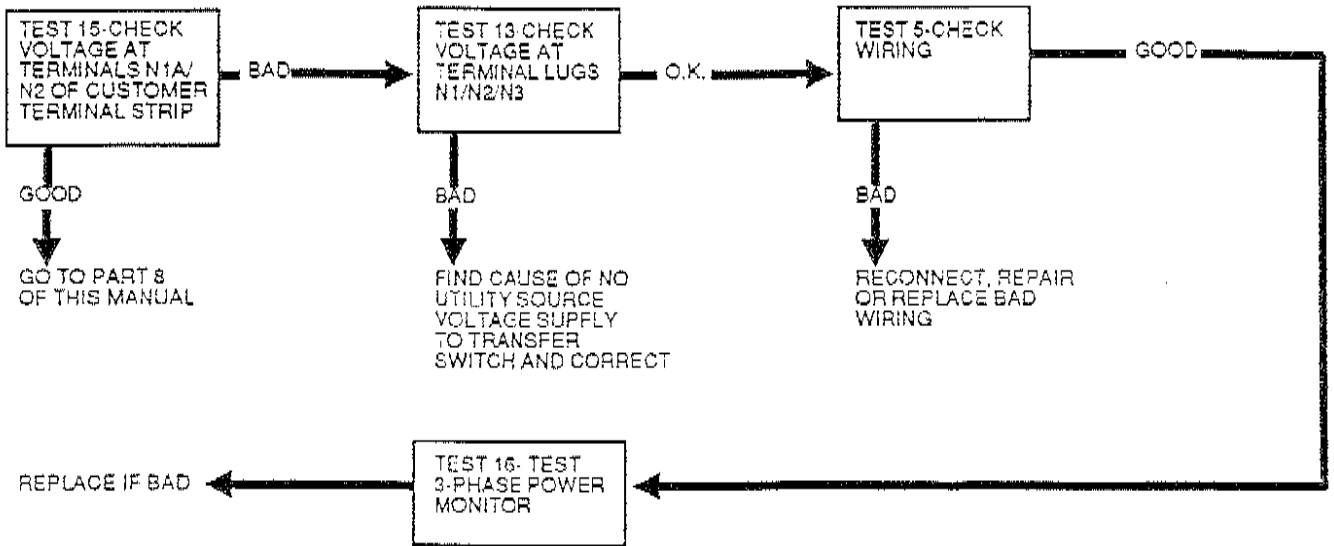



Section 5.4  
**DIAGNOSTIC TESTS**

*General*

Complete the diagnostic tests in this section in conjunction with the "Troubleshooting Flow Charts" of Section 5.3. Numbered tests in this section correspond to the test numbers of the charts in Section 5.3.

**Test 1- Test Automatic Operation**

**DISCUSSION:**

A CMA circuit board on the prepackaged generator set constantly senses "Utility" power source voltage. Should that source voltage drop below a preset value, that circuit board will initiate engine cranking and startup. Following engine startup and after an "engine warmup timer" on the CMA circuit board has timed out, circuit board action should complete the transfer relay circuit to ground. The transfer relay should then energize, its normally-open contacts should close and transfer to the "Standby" power source should occur.

On restoration of "Utility" source voltage above a preset level, and after a preset time delay, CMA circuit board action should open the transfer relay circuit to ground. The relay should then de-energize, its normally-closed contacts should close, and retransfer back to the "Utility" power source should occur.

If problems are encountered with any part of the automatic operating sequences described above, the technician should be able to duplicate the problem by performing a test of automatic operation.

**DANGER: EXTREMELY HIGH AND DANGEROUS VOLTAGES ARE PRESENT AT TERMINALS AND EXPOSED WIRING INSIDE THE TRANSFER SWITCH. PROCEED WITH CAUTION. CONTACT WITH HIGH VOLTAGE TERMINALS AND WIRING MAY RESULT IN EXTREMELY HAZARDOUS AND POSSIBLY LETHAL ELECTRICAL SHOCK.**

**PROCEDURE:**

1. On the generator panel, set the manual-off-auto switch to "Off".
2. Turn OFF all power voltage supplies to the transfer switch, using whatever means provided (such as the generator's main line circuit breaker and a "Utility" source main line circuit breaker).
3. On the transfer mechanism (inside transfer switch enclosure), check the changeover display. Make sure the transfer switch main contacts are at their "Utility" power source side (load connected to the "Utility" source). The changeover display's "Utility" arrow must be pointing to the "green" display window. If necessary, manually actuate the main contacts to their "Utility" power source side. See "Manual Transfer Handle" in Section 5.1 (Page 5.1-5).

4. With the generator shut down, set the generator's main line circuit breaker to its "On" or "Closed" position.
5. Remove the screws that retain the cover to the transfer switch enclosure and remove the cover. One person should be stationed at the transfer switch to observe the transfer relay and the transfer mechanism. A second person will be required at the generator.

**DANGER: BEFORE PROCEEDING TO STEP 6, MAKE SURE ALL PERSONNEL ARE WELL CLEAR OF THE GENERATOR SET. THE ENGINE WILL CRANK AND START WHEN THE MANUAL-OFF-AUTO SWITCH IS SET TO "AUTO".**

*NOTE: This section covers only the automatic operation as it applies to the "Y-Type" transfer switch. For more complete coverage of system automatic operation, testing and diagnosis, you may wish to refer to Part 8, "DC Control- Units with Air Cooled Engine", or Part 9, "DC Control- Units with Liquid Cooled Engine".*

6. Set the generator's manual-off-auto switch to "Auto".
  - a. The engine should crank and start.
  - b. Following engine startup, the transfer relay should energize and transfer to the "Standby" source side should occur. The observer stationed at the transfer switch should be able to see these occurrences.
7. Check the changeover display on the transfer mechanism.
  - a. The "Standby" arrow should point to the green display window.
  - b. The "Utility" arrow should point to the red display window.

**RESULTS:**

1. If transfer to "Standby" did NOT occur, go to Test 2 and follow the testing sequence given in Problem 1 of the "Troubleshooting Flow Charts".
2. If normal transfer to "Standby" occurred in Step 7, go on to Step 8 of this test.
3. If the generator did not crank and start in Step 6, refer to Part 8 or 9 of this manual as appropriate. A problem exists in the DC control system of the generator.

**PROCEDURE:**

8. Turn ON the "Utility" power supply to the transfer switch using whatever means provided (such as the "Utility" main line circuit breaker).
  - a. After approximately six (6) seconds, generator CMA circuit board action should open the transfer relay circuit to ground and the transfer relay should de-energize. Retransfer back to the "Utility" power source should occur.
  - b. After retransfer and after a "minimum run timer" and an "engine cooldown timer" on the CMA board have "timed out", the generator should shut down.

**Test 1- Test Automatic Operation (Continued)**

**RESULTS:**

1. If normal retransfer back to the "Utility" source did not occur in Step 8, refer to Problem 2 of the "Troubleshooting Flow Charts". Go to Test 13 of Problem 2.
2. If normal retransfer occurred in Step 8, discontinue testing.

**Test 2- Check Voltage at Terminals E1/E2/E3**

**DISCUSSION:**

Transfer of electrical loads to the "Standby" source cannot occur unless generator AC output voltage is available to the transfer switch. This test should be performed if transfer to "Standby" will not occur during automatic operation and will prove whether generator AC output voltage is available or not. The test is a continuation of Test 1 and should be performed at the end of Step 7 of that test.

**PROCEDURE:**

1. Under "Procedure" of Test 1, complete Steps 1 through 7.
2. If, at the end of Step 7, transfer to "Standby" did not occur, use an AC voltmeter or a VOM to test for correct AC voltage at transfer mechanism terminal lugs E1, E2 and E3.
  - a. On 2-pole (1-phase) transfer switches, check for correct line-to-line voltage across terminal lugs E1 and E2.
  - b. On 3-pole (3-phase) switches, check for correct line-to-line (phase-to-phase) voltage across terminal lugs E1 to E2; E2 to E3; E3 to E1.

**RESULTS:**

1. If transfer to "Standby" does not occur but normal line-to-line voltage is indicated across terminal lugs E1/E2/E3, go on to Test 3.
2. If normal line-to-line voltage is NOT indicated across the terminal lugs go to Part 2 or Part 3 of this manual, as appropriate.

**Test 3- Check Voltage at Terminals B1/B2**

**DISCUSSION:**

This test is a continuation of Test 1. If normal generator voltage is available to terminal lugs E1/E2/E3, but not to terminals B1/B2, either the transfer relay has failed or interconnecting wiring is bad.

**PROCEDURE:**

1. Complete Steps 1 through 7 under "Procedure" of Test 1.
2. If transfer to "Standby" does not occur, complete Test 2.

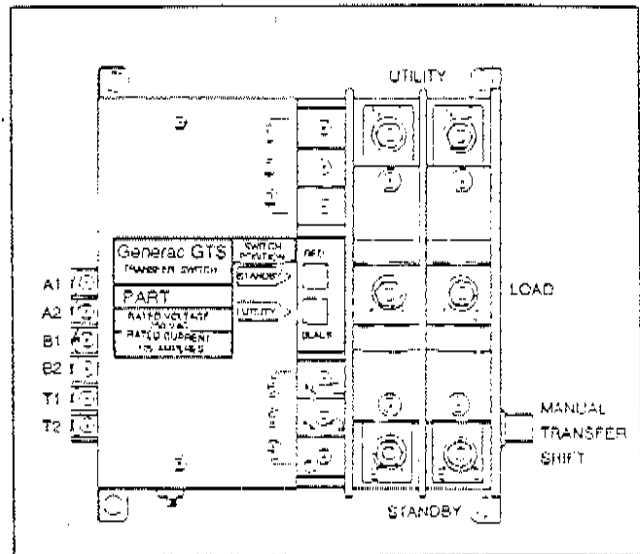

Figure 1. The 2-Pole Transfer Mechanism

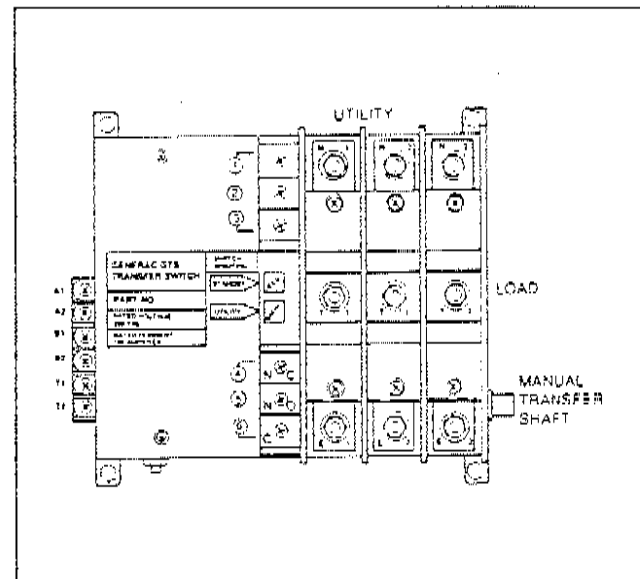

Figure 2. The 3-Pole Transfer Mechanism

3. If normal generator AC output voltage is available in Test 2, but transfer to "Standby" did not occur, go on to Step 4 of this test.
4. Connect the test probes of an AC voltmeter or a VOM across transfer mechanism terminals B1/B2. Normal generator AC output voltage should be indicated.

**RESULTS:**

1. If normal generator voltage is indicated, but transfer to "Standby" does not occur, go to Test 6. The problem is in the transfer mechanism.
2. If normal generator voltage is NOT indicated and transfer to "Standby" does not occur, go to Test 4. The problem may be (a) a bad transfer relay, (b) bad wiring, or (c) a defective CMA circuit board.

**Test 4- Test Transfer Relay TR**

**DISCUSSION:**

A failed transfer relay will prevent the transfer of loads to the "Standby" source side. This test of the transfer relay will verify whether or not the relay coil is defective, and also whether the relay contacts are in good condition.

**PROCEDURE:**

1. On the generator panel, set the manual-off-auto switch to "Off". The generator must be shut down before proceeding.
2. Turn OFF all power voltage supplies to the transfer switch.
3. Disconnect all wires from the transfer relay terminals, to prevent interaction.
4. Set a VOM to its "Rx1" scale and zero the meter.
5. Connect the VOM test leads across relay terminals 6 and 9.
  - a. Connect the positive (+) post of a 12 volts battery to relay terminal "A", and the battery negative (-) post to relay terminal "B".
  - b. The transfer relay should energize and the VOM should read "continuity".
  - c. Disconnect the battery leads from relay terminals "A" and "B". The relay should de-energize, and the VOM should read "infinity".
6. Now connect the VOM test leads across relay terminals 1 and 7.
  - a. Connect the positive (+) post of a 12 volts battery to relay terminal "A", the negative (-) battery post to relay terminal "B".
  - b. The relay should energize and the VOM should read "infinity".
  - c. Disconnect the battery from the relay terminals. The relay should de-energize and the VOM should indicate "continuity".

CONNECT VOM TEST LEADS	METER READING	
	ENERGIZED	DE-ENERGIZED
6 and 9	"Continuity"	"Infinity"
1 and 7	"Infinity"	"Continuity"

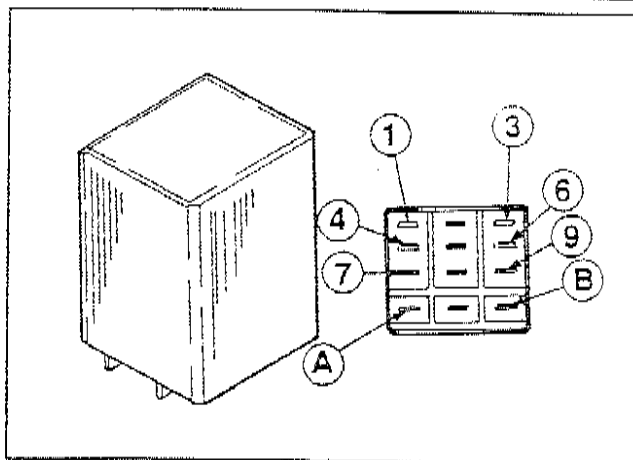

Figure 3. Transfer Relay Test Points

**RESULTS:**

1. If the transfer relay tests bad, it should be replaced.
2. If the transfer relay tests good, go to Test 5.

**Test 5- Check Wiring**

**DISCUSSION:**

If transfer to "Standby" does not occur and Test 2, 3 and 4 have all checked good, the wiring between transfer mechanism terminal lugs E1 and E2, and the B1/B2 terminals is suspect.

If retransfer back to "Utility" does not occur, wiring between terminal lugs N1 and N2 and terminals A1/A2 may be defective or disconnected.

**PROCEDURE:**

Carefully inspect wiring and test for open or shorted condition. Refer to the appropriate wiring diagram and make sure all wires are properly connected to the correct terminals. Use a VOM to test wires for an open condition.

**RESULTS:**

1. Reconnect, repair or replace any damaged, defective, or shorted wire(s).
2. If wiring checks good, refer to Part 7 or 8 as appropriate (problem is in generator's DC control system).

**Test 6- Test Limit Switch LS3**

**DISCUSSION:**

Limit switch LS3 is actuated to its open position mechanically by movement of the main contacts to their "Neutral" position (load disconnected from both power sources). For an illustration of "Neutral" position, see Figure 6 on Page 5.1-3. During electrical operation, the main contacts will remain at "Neutral" as long as the solenoid coil (C) remains energized. However, when the main contacts are actuated to "Neutral", LS3 is actuated to its open position to break the circuit. Solenoid coil (C) is then de-energized and spring force completes the transfer action to the appropriate power source side. If limit switch LS3 does not open when the main contacts reach "Neutral", solenoid coil (C) will remain energized and the main contacts will remain at "Neutral".

*NOTE: The changeover display on the transfer mechanism does NOT indicate "Neutral" position. If the main contacts remain at "Neutral" the display will remain at the last position of the main contacts. For example, if the main contacts were at "Utility" and are then actuated to "Neutral", the green window will remain adjacent to the "Utility" arrow on the changeover display.*

**PROCEDURE:**

1. On the generator panel, set the auto-off-manual switch to "Off".
2. Turn OFF all power voltage supplies to the transfer switch, using whatever means provided (such as the "Utility" and "Standby" main line circuit breakers).

**Test 6- Test Limit Switch LS3 (Continued)**

**PROCEDURE (CONT'D):**

**DANGER: DO NOT ATTEMPT TO PERFORM THIS TEST UNTIL BOTH THE "STANDBY" AND "UTILITY" POWER SUPPLIES TO THE TRANSFER SWITCH ARE POSITIVELY TURNED OFF. FAILURE TO TURN OFF ALL POWER VOLTAGE SUPPLIES MAY RESULT IN ELECTRICAL SHOCK AND POSSIBLE DAMAGE TO THE TEST METER BEING USED.**

3. Set a VOM to its "Rx1" scale and zero the meter.
4. Connect the VOM test leads across transfer mechanism terminals T1 and T2 (Figure 4).
5. The VOM should indicate "continuity".
6. Attach the manual transfer handle to the square shaft on the transfer mechanism.
  - a. While observing the VOM, move the manual handle all the way up until it stops. This is "Neutral" position. Hold the handle all the way up (at "Neutral") and the VOM should read "infinity". A reading of "infinity" indicates that LS3 has opened and is functioning properly.
  - b. Now, return the handle to its original position and let the main contacts complete their movement to the next power source side. The VOM should now indicate "continuity", indicating that LS3 has re-closed and is functioning properly.
7. Before proceeding, actuate the main contacts to their "Utility" position. The green window display must be adjacent to the "Utility" arrow on the changeover display.

**RESULTS:**

1. If limit switch LS3 is not opening at "Neutral" and re-closing at both power source positions, further testing is required to determine if the switch has failed, or if a mechanical linkage failure has occurred in the transfer mechanism. Refer to Section 5.5.
2. If switch operation is good, go on to Test 7.

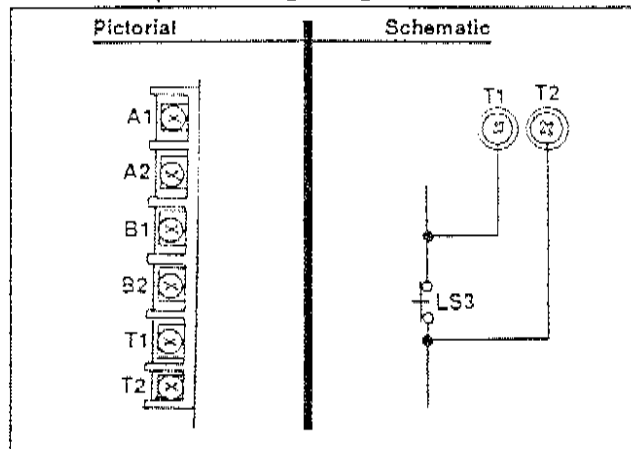

Figure 4. Limit Switch LS3 Test Points

**Test 7- Test Limit Switch LS1**

**DISCUSSION:**

When the main contacts are at their "Utility" position ("Load" connected to "Utility" source, limit switch LS1 should have actuated to its terminal B1 side. Conversely, when the load is connected to the "Standby" side, LS1 should be actuated to its terminal A1 side. Failure of this limit switch will result in a failure of the main contacts to actuate to either power source side.

**PROCEDURE:**

1. On the generator panel, set the auto-off-manual switch to "Off".
2. Turn OFF all power voltage supplies to the transfer switch, using whatever means provided (such as the "Utility" and "Standby" main line circuit breakers).

**DANGER: DO NOT ATTEMPT TO PERFORM THIS TEST UNTIL BOTH THE "STANDBY" AND "UTILITY" POWER SUPPLIES TO THE TRANSFER SWITCH ARE POSITIVELY TURNED OFF. FAILURE TO TURN OFF ALL POWER VOLTAGE SUPPLIES MAY RESULT IN ELECTRICAL SHOCK AND MAY ALSO DAMAGE THE TEST METER BEING USED.**

3. Set a VOM to its "Rx1" scale and zero the meter.
4. Connect the VOM test leads across transfer mechanism terminals B1 and T1 (Figure 5).
5. Manually actuate the main contacts to their "Standby" position. The VOM should read "Infinity".
6. Now actuate the main contacts back to "Utility" and the VOM should read "continuity".
7. Connect the VOM test leads across transfer mechanism terminals A1 and T1.
8. Manually actuate the main contacts to their "Standby" position. The VOM should read "continuity".
9. Manually actuate the main contacts back to "Utility" and the VOM should indicate "infinity".

CONNECT METER TEST LEADS	MAIN CONTACTS POSITION	
	UTILITY	STANDBY
B1 to T1	Continuity	Infinity
A1 to T1	Infinity	Continuity

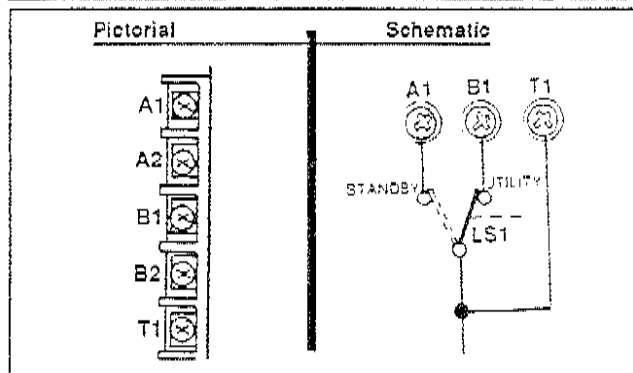

Figure 5. Limit Switch LS1 Test Points

**Test 7- Test Limit Switch LS1 (Con-  
tinued)**

**RESULTS:**

1. If LS1 fails the test, additional testing is required. After additional testing, replace switch if defective. See Section 5.5.
2. If switch checks good, go on to Test 8.

**Test 8- Test Limit Switch LS2**

**DISCUSSION:**

Refer to "Discussion" under Test 7.

**PROCEDURE:**

1. On the generator panel, set the manual-off-auto switch to "Off".
2. Turn OFF all power voltage supplies to the transfer switch, using whatever means provided (such as the "Utility" and "Standby" source main line circuit breakers).

**DANGER: DO NOT ATTEMPT THIS TEST UNTIL ALL POWER VOLTAGE SUPPLIES TO THE TRANSFER SWITCH HAVE BEEN POSITIVELY TURNED OFF. FAILURE TO TURN OFF ALL POWER VOLTAGE SUPPLIES MAY RESULT IN ELECTRICAL SHOCK AND MAY ALSO DAMAGE THE TEST METER BEING USED.**

3. Remove the two (2) screws (with flatwashers and lockwashers) that retain the cover (Figure 6). Then, remove the cover and proceed as follows:
  - a. Locate the gray wire (Figure 7) that is routed from limit switch LS2 to the bridge rectifier.
  - b. Locate the wire connector on the gray wire. Separate the two halves of the wire connector.
4. Set a VOM to its "Rx1" scale and zero the meter.
5. Connect the meter test leads across transfer mechanism terminal A2 and the gray wire connector.

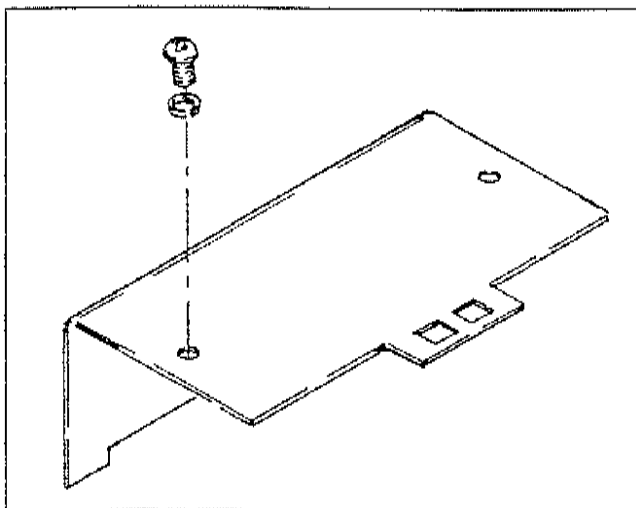

Figure 6. Cover Removal

6. Manually actuate the main contacts to their "Standby" side. The VOM should read "continuity".
7. Manually actuate the main contacts to their "Utility" side. The VOM should indicate "infinity".
8. Now, connect the VOM test leads across transfer mechanism terminal B2 and the gray wire connector.
9. Repeat Step 6 and the VOM should read "infinity".
10. Repeat Step 7 and the VOM should indicate "continuity".

**RESULTS:**

1. If limit switch LS2 checks bad, replace the switch. See Section 5.5.
2. If limit switch tests good, go on to Test 9.

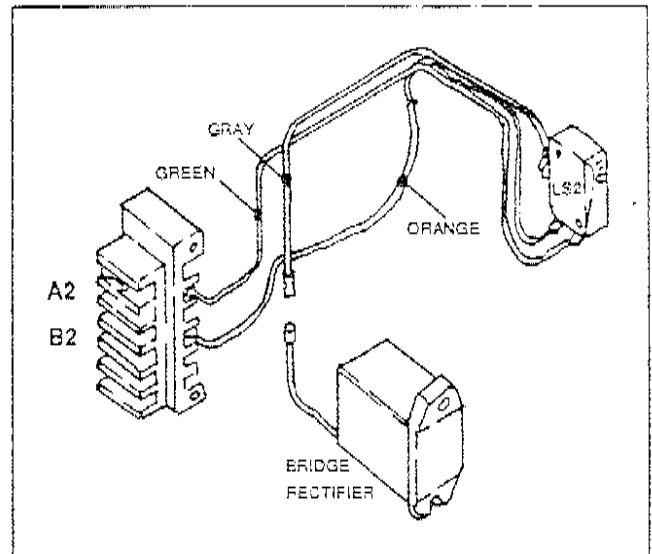

Figure 7. Test Points for Limit Switch LS2

**Test 9- Test Bridge Rectifier**

**DISCUSSION:**

The transfer mechanism's bridge rectifier rectifies both the "Utility" and the "Standby" current to the solenoid coil (C). A defective bridge rectifier will prevent any transfer or retransfer action at all in the automatic mode. See Figure 8.

**PROCEDURE:**

1. On the generator panel, set the manual-off-auto switch to "Off".
2. Turn OFF all power voltage supplies to the transfer switch, using whatever means provided (such as the "Utility" and "Standby" main line circuit breakers).

**DANGER: DO NOT PROCEED WITH THIS TEST UNTIL ALL POWER VOLTAGE SUPPLIES TO THE TRANSFER SWITCH ARE POSITIVELY TURNED OFF. FAILURE TO TURN OFF POWER VOLTAGE SUPPLIES MAY RESULT IN ELECTRICAL SHOCK AND MAY ALSO RESULT IN DAMAGE TO THE TEST METER USED.**

**Test 9- Test Bridge Rectifier (Continued)**

PROCEDURE (CONT'D):

3. The cover (Figure 6 on Page 5.4-5) has already been removed and the solenoid coil is exposed. Remove the clear plastic insulator from the solenoid coil. A red (+) and a white (-) wire connect to the coil. Remove these two wires from the coil.
4. Make sure the main contacts are at their "Utility" side, i.e., the "Utility" arrow is pointing to the green display window.
5. Set a VOM to its "Rx1" scale and zero the meter. If the VOM has a polarity switch, set it to "+DC".
6. Test one bridge rectifier diode as follows:
  - a. Connect one VOM test lead to red wire terminal end and the other test lead to transfer mechanism terminal B2. Note the VOM reading.
  - b. Now, reverse the test leads (reverse the test polarity). Again, note the meter reading.
  - c. The forward resistance of a diode should be indicated at one polarity only. At the opposite polarity, "infinity" should be indicated.
7. Test a second bridge rectifier diode as follows:
  - a. Connect one VOM test lead to terminal end of the white wire, the other test lead to terminal B2. Note the meter reading.
  - b. Now, reverse the test leads (reverse the polarity). Again, observe the VOM reading.
  - c. The forward resistance of the second diode should be indicated at one polarity only, "infinity" at the opposite polarity.
8. Test a third diode as follows:
  - a. Connect one VOM test lead to the white wire, the other test lead to transfer mechanism terminal B1. Note the meter reading.
  - b. Now, reverse the polarity (reverse the VOM test leads). Note the reading.
  - c. The diode's forward resistance should be indicated at one polarity only, "infinity" at the opposite polarity.
9. Test the fourth bridge rectifier diode as follows:
  - a. Connect first VOM test lead to the red wire, the second test lead to terminal B1. Note the meter reading.
  - b. Reverse the test polarity (reverse the test leads). Note the reading.
  - c. Forward resistance of the diode should be indicated at one polarity only, "infinity" at the opposite polarity.

RESULTS:

1. If all diodes test good, go on to Test 10.
2. In Steps 6 through 9, if any diode reads "infinity" at both polarities, replace the bridge rectifier.
3. In Steps 6 through 9, if any upscale VOM reading is indicated at both polarities, replace the bridge rectifier.

*NOTE: For information on transfer mechanism disassembly, testing and reassembly, refer to Section 5.5, "Disassembly, Testing, Reassembly". Final testing of the bridge rectifier and other components can be accomplished when the component is removed during the disassembly process.*

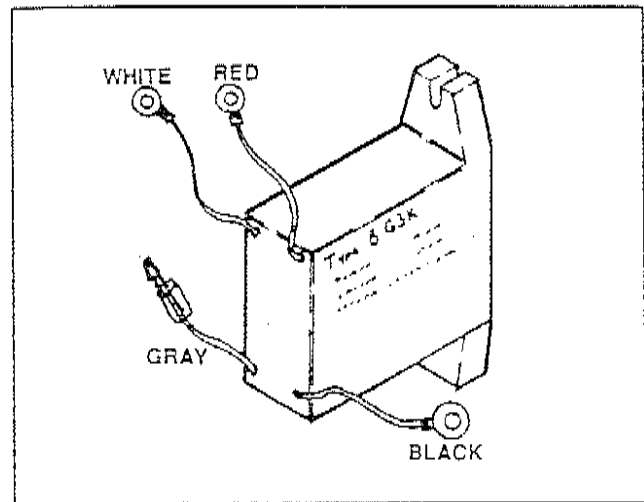

Figure 8. Bridge Rectifier

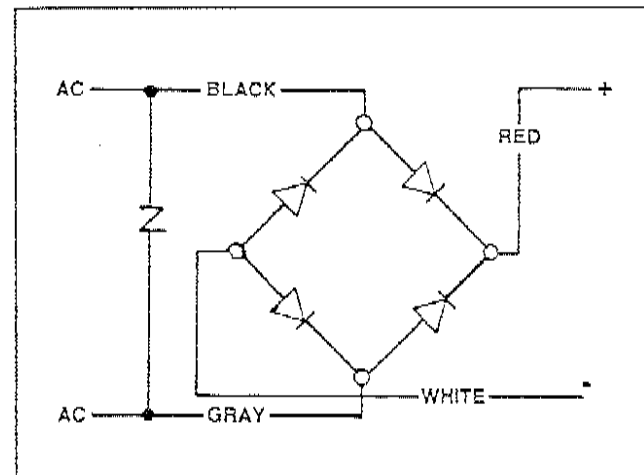

Figure 9. Schematic- Bridge Rectifier Test Points

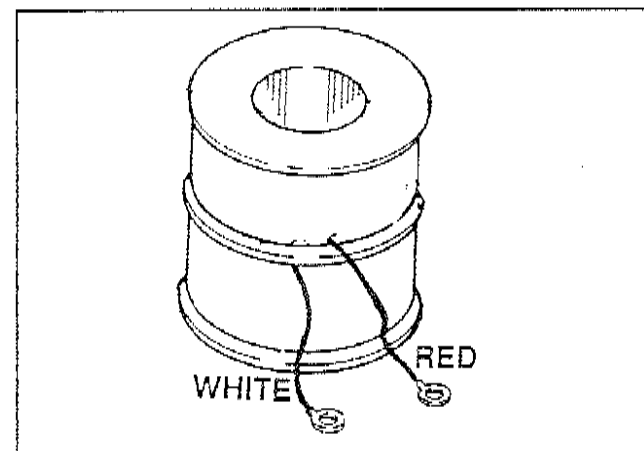

Figure 10. Red and White Wires on Solenoid Coil

**Test 10- Test Solenoid Coil**

**DISCUSSION:**

If the transfer mechanism's solenoid coil (C) has failed, transfer to "Standby" as well as retransfer back to "Utility" will not be possible.

**PROCEDURE:**

1. On the generator panel, set the manual-off-auto switch to "Off".
2. Turn OFF all power voltage supplies to the transfer switch, using whatever means provided (such as the "Standby" and "Utility" source main line circuit breakers).

**DANGER: IF POWER VOLTAGE SUPPLIES TO THE TRANSFER SWITCH ARE NOT TURNED OFF, DANGEROUS ELECTRICAL SHOCK COULD RESULT. IN ADDITION, THE TEST METER COULD BE DAMAGED.**

3. If not already done, disconnect the red (+) and white (-) wires from the solenoid coil (see Figure 10).
4. Use an accurate volt-ohm-milliammeter (VOM) to test solenoid coil resistance, as follows (Figure 11):
  - a. Connect one VOM test lead to terminal end of the red wire; the other test lead to the outer (right hand) terminal. Read the resistance.
  - b. Connect one meter test lead to terminal end of white wire; the other test lead to outer (left hand) terminal. Read the resistance.

**NOMINAL RESISTANCE = 0.209-0.215 OHM**

**RESULTS:**

1. If "infinity" or a very high resistance is indicated, replace the solenoid coil. See Section 5.5.
2. If solenoid coil tests good, go on to Test 11.

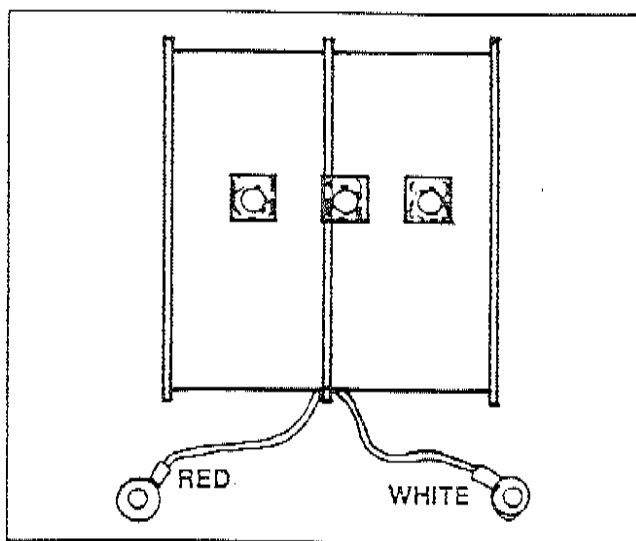

Figure 11. Solenoid Coil Test Points

**Test 11- Check Manual Operation**

**DISCUSSION:**

Failure to transfer or retransfer can be caused by a mechanical failure in the transfer mechanism. Such failures can often be detected by operating the mechanism manually. Binding, sticking, broken mechanical components, etc., can often be found.

**PROCEDURE:**

1. On the generator panel, set the manual-off-auto switch to "Off".
2. Turn OFF all power voltage supplies to the transfer switch using whatever means provided (such as the "Utility" and "Standby" main line circuit breakers).

**DANGER: DO NOT ATTEMPT MANUAL OPERATION UNTIL ALL POWER VOLTAGE SUPPLIES TO THE TRANSFER SWITCH HAVE BEEN POSITIVELY TURNED OFF. FAILURE TO TURN OFF POWER VOLTAGE SUPPLIES MAY RESULT IN DANGEROUS AND POSSIBLY LETHAL ELECTRICAL SHOCK.**

3. Use the manual transfer handle to actuate the main contacts to their "Utility" and "Standby" sides several times. See "Manual Transfer Handle" on Page 5.1-5. Watch for binding or sticking during the operation. Also check the changeover display on the transfer mechanism carefully as each switch position is selected.

**RESULTS:**

1. If binding is evident or if the changeover display does not operate properly, further disassembly of the transfer mechanism is required to find the problem.
2. If the transfer mechanism operates properly, go to Test 12.

**Test 12- Inspect Main Contacts**

**DISCUSSION:**

If severe arcing has occurred, main contacts can be damaged. A visual inspection of the main contacts will reveal (a) any damage caused by arcing, (b) failure of the contacts to close to either power source side, and (c) any other damage that can be seen visually.

**PROCEDURE:**

Visually inspect the main contacts through the clear plastic shield at extreme right side of the transfer mechanism. Look for evidence of arcing, burning, pitting, obvious damage, etc.

**RESULTS:**

If any problems are discovered during the visual inspection, further disassembly of the transfer mechanism will be required. See Section 5.5.

***Test 13- Check Voltage at Terminals  
N1/N2/N3***

**DISCUSSION:**

A dual requirement exists before loads can be retransferred back to the "Utility" power source. First, the solenoid coil (C) must be energized by "Utility" source power. Second, "Utility" voltage must be available to the transfer switch or the generator's CMA circuit board will not initiate a retransfer action. If, when "Utility" source voltage is restored, retransfer does not occur or if generator startup and transfer to "Standby" occurs when there is no "Utility" power failure, the first step in troubleshooting is to determine if "Utility" voltage is available to the transfer switch.

**PROCEDURE:**

1. Use an AC voltmeter or a VOM to test for correct rated AC voltage at transfer mechanism terminal lugs N1/N2 (2-pole) or N1/N2/N3 (3-pole).
2. Correct rated "Utility" power source voltage should be indicated.

**RESULTS:**

1. If normal "Utility" source voltage is indicated but retransfer does not occur, go to Test 14.
2. If normal "Utility" source voltage is available but generator starts in automatic mode, go to Test 5.
3. If "Utility" voltage is NOT indicated, find cause of problem and correct.

***Test 14- Check Voltage at Terminals  
A1/A2***

**DISCUSSION:**

During a retransfer operation, action of the generator's CMA circuit board must de-energize the transfer relay. The transfer relay's normally-closed contacts must then close to deliver "Utility" source power from terminal lugs N1/N2 to terminals A1/A2. It is this "Utility" power that must energize the solenoid coil and initiate the retransfer action.

**PROCEDURE:**

1. See Test 1 on Page 5.4-1. Complete Steps 1 through 7 of that test. The generator should crank and start. Transfer to the "Standby" power supply should occur.
2. Complete Step 8 of Test 1. Retransfer back to "Utility" should occur, followed by generator shutdown.
3. If retransfer does NOT occur, use an AC voltmeter (or a VOM) to check for correct "Utility" source voltage at terminals A1/A2.

**RESULTS:**

1. If "Utility" source voltage is NOT indicated, go to Test 4.
2. If voltage reading is good but retransfer does NOT occur, go to Test 6.

***Test 15- Check Voltage at Terminals  
N1A/N2 of Customer Terminal Strip***

**DISCUSSION:**

Terminals N1A and N2 of this terminal strip must be properly interconnected with an identically numbered terminal strip in the generator's control module assembly (CMA). This is the "Utility" voltage sensing line to the CMA circuit board. Any dropout in the voltage sensing signal will result in generator startup followed by transfer to "Standby". A preset voltage signal must be available at these terminals or retransfer back to "Utility" will not occur. On 3-phase systems, the 3-pole transfer switch is equipped with a 3-phase power monitor. Loss of any phase output will cause that monitor to de-energize. With the 3-phase monitor de-energized, its contacts will open and loss of "Utility" voltage output to terminals N1A/N2 will occur.

**PROCEDURE:**

Use an accurate AC voltmeter or VOM to check the voltage across terminals N1A and N2. Normal rated "Utility" source voltage should be indicated.

**RESULTS:**

1. If voltage reading is good, go to Part 8 of this manual. A problem exists in the generator's DC control system.
2. If voltage reading is bad, complete Tests 13 and 5. Then, go to Test 16.

***Test 16- Test 3-Phase Power Monitor***

**DISCUSSION:**

The 3-phase power monitor is used only on 3-pole (3-phase) transfer switches. See "Discussion" under Test 15.

**PROCEDURE:**

1. On the generator panel, set the manual-off-auto switch to "Off".
2. Check for correct line-to-line (phase-to-phase) voltage across terminals 3 and 4; across 4 and 5; and across 5 and 3 of the power monitor's socket (see Figure 12).
3. Check line-to-line voltage across monitor socket terminal 1 and terminal N2 of the terminal strip. Normal utility source voltage (line-to-line) should be indicated.
4. Check voltage across monitor socket terminal 8 and terminal N2 of the terminal strip. Normal utility source line-to-line voltage should be indicated.
5. Turn OFF the "Utility" power supply to the transfer switch, using whatever means provided (such as the "Utility" main line circuit breaker).
6. Set a VOM to its "Rx1" scale and zero the meter. Connect the VOM test leads across terminals 1 and 8 of the power monitor. The VOM should read "infinity".

Test 16- Test 3-Phase Power Monitor (Continued)

RESULTS:

1. If line-to-line voltage is NOT indicated across any pair of terminals in Step 2, inspect and test wires N1, N2, N3 for open or disconnected condition.
2. If line-to-line voltage is NOT indicated in Step 3, inspect and test Wires N1/N2 for open or disconnected condition.
3. If normal line-to-line voltage is indicated in Step 3 but not in Step 4, the power monitor contacts have failed open. Replace the power monitor.
4. In Step 6, any reading other than "infinity" indicates the monitor contacts have failed closed. Replace the power monitor.

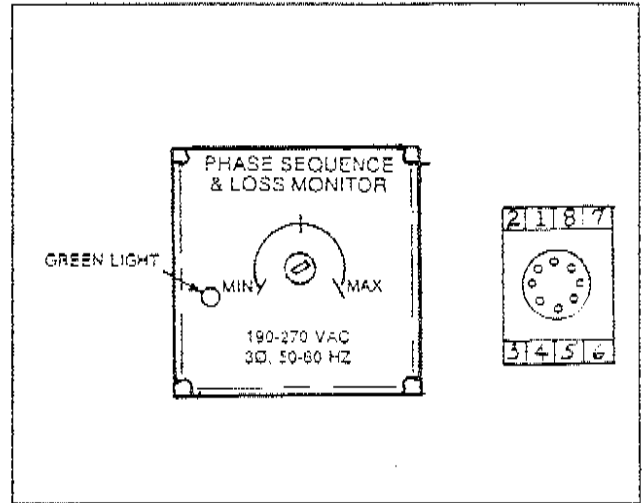

Figure 12. 3-Phase Power Monitor and Socket



DISASSEMBLY, TESTING, REASSEMBLY

*Transfer Mechanism Removal*

To remove the transfer mechanism from the transfer switch enclosure, proceed as follows:

1. On the generator panel, set the manual-off-auto switch to "Off". Then place a "DO NOT OPERATE" tag in a conspicuous place on or near the generator panel.
2. As a safety measure to prevent inadvertent generator startup, disconnect the battery cables from the generator battery.
3. Turn OFF all power voltage supplies to the transfer switch, using whatever means provided (such as the "Utility" and "Standby" main line circuit breakers).

**DANGER: DO NOT PROCEED UNTIL ALL POWER VOLTAGE SUPPLIES TO THE TRANSFER SWITCH HAVE BEEN POSITIVELY TURNED OFF. FAILURE TO TURN OFF ALL POWER VOLTAGE SUPPLIES TO THE TRANSFER SWITCH WILL RESULT IN EXTREMELY HAZARDOUS AND POSSIBLY LETHAL ELECTRICAL SHOCK. BOTH THE "UTILITY" AND "STANDBY" POWER SUPPLIES TO THE TRANSFER SWITCH MUST BE POSITIVELY TURNED OFF.**

4. Disconnect all wires from transfer mechanism terminal lugs N1, N2, T1, T2, E1, E2.
5. Disconnect all wires from transfer mechanism terminals A1, A2, B1, B2.
6. Remove the M5-0.80 capscrews, lockwashers and flatwashers that retain the transfer mechanism in the enclosure. Then, remove the transfer mechanism.

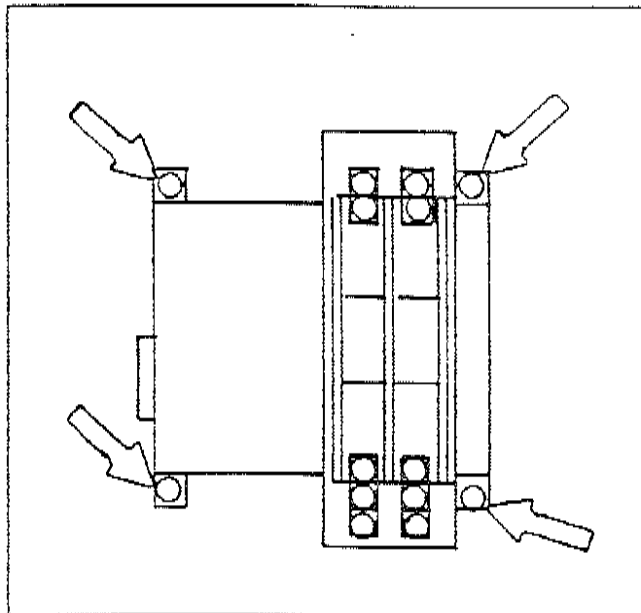

Figure 1. Transfer Mechanism Removal

*Electrical Section Disassembly*

PRELIMINARY STEPS:

1. Remove two (2) screws that retain the outer cover to the transfer mechanism (Figure 2).

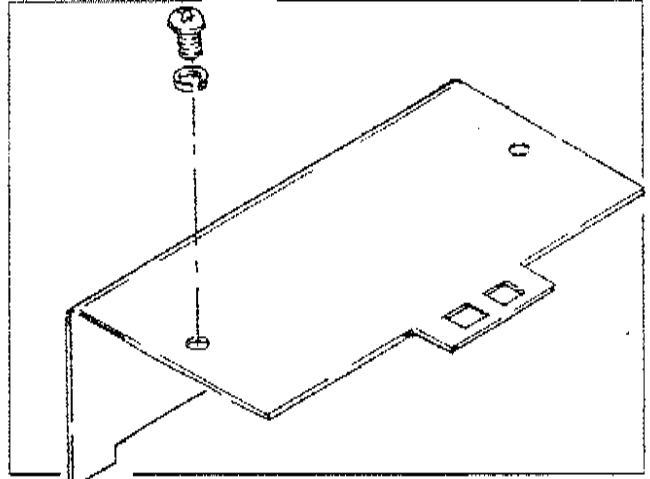

Figure 2. Outer Cover Removal

2. Remove four (4) screws that retain the inner cover (Figure 3).

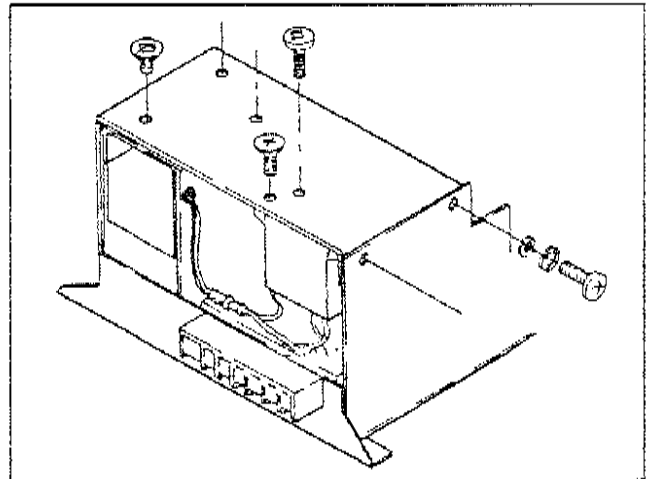

Figure 3. Removal of Inner Cover Screws

3. Limit switch LS3 is retained to the inner cover by means of two long screws with countersunk heads (Figure 3) and a retaining bar with threaded holes. Lift up on the inner cover slightly and remove the two long screws with countersunk heads.

4. See Figure 4. Remove the inner cover and the limit switch retaining bar, as well as a limit switch actuating lever bracket, limit switch actuating lever and actuating lever spring.

*Electrical Section Disassembly (Continued)*

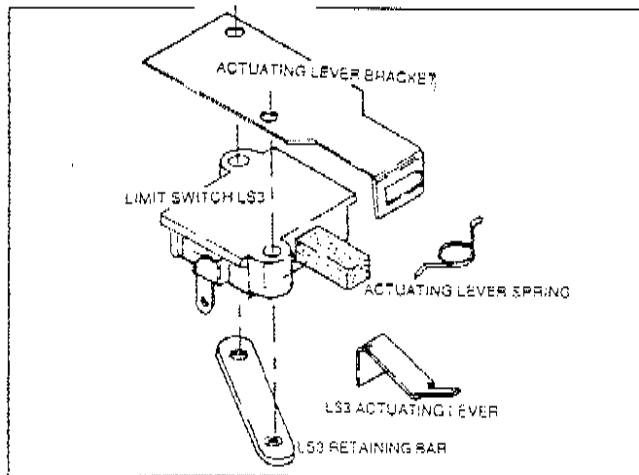

Figure 4. Limit Switch LS3 Actuating Parts

**LIMIT SWITCH LS3 REMOVAL:**

1. The limit switch retaining screws and bar were previously removed during removal of the inner cover.
2. Disconnect all wires from limit switch LS3 and completely remove the limit switch from the transfer mechanism.
3. Limit switch LS3 parts are shown in Figure 5.

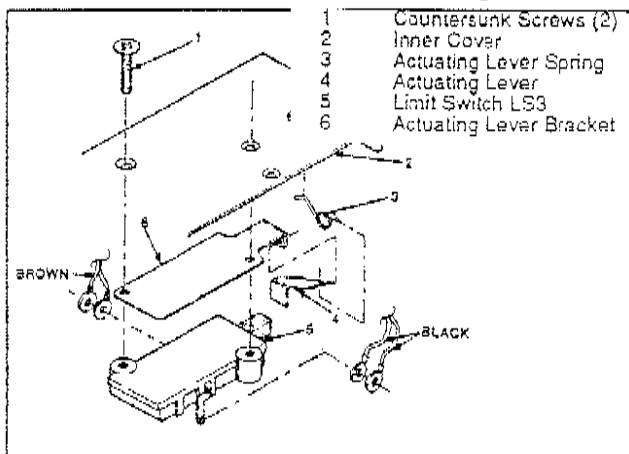

Figure 5. Exploded View of Limit Switch LS3

**TERMINAL STRIP REMOVAL:**

1. See Figure 6. Remove two (2) screws that retain the terminal strip to the transfer mechanism.
2. Loosen- DO NOT REMOVE- the wire retaining screws at back of terminal strip. Remove all wires and remove the terminal strip.

**SOLENOID COIL REMOVAL:**

1. See Figure 7. Remove four capscrews that retain the coil backing plate. Also remove the capscrew that retains the solenoid coil to the backing plate.

2. Rotate the coil slightly to allow access to the coil terminal screws. Remove the terminal screws and disconnect the coil red and white wires.
3. Remove the solenoid coil along with the coil cylinder.

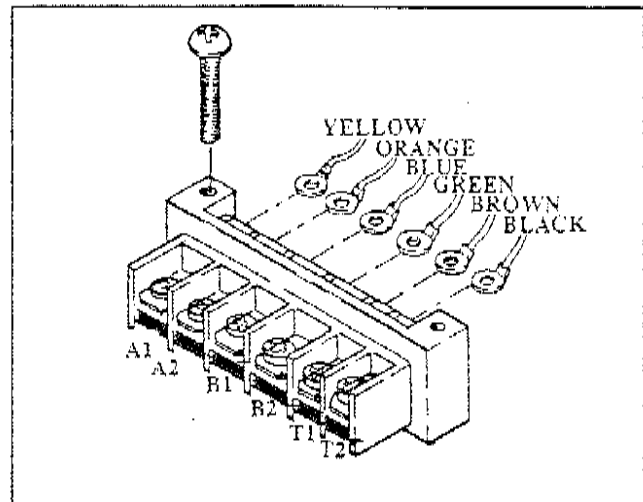

Figure 6. Terminal Strip Removal

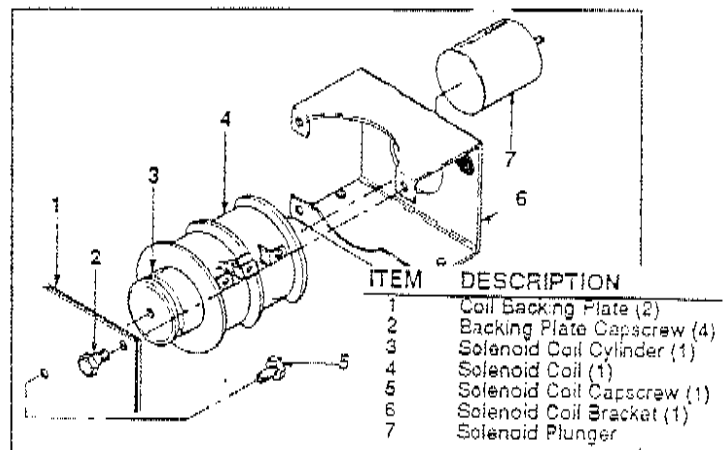

Figure 7. Solenoid Coil Removal

**BRIDGE RECTIFIER REMOVAL:**

With the solenoid coil removed, guide the bridge rectifier wires out through the protective rubber grommet and remove the bridge rectifier. See Figure 8.

**SOLENOID COIL BRACKET REMOVAL:**

Remove two (2) screws that retain the bracket to the base. Then, remove the coil bracket. See Figure 9.

**LIMIT SWITCH LS1 REMOVAL:**

With the solenoid coil removed, limit switch LS1 is accessible. Remove two (2) screws, then remove LS1 along with two insulator strips. Wires on switch LS1 are soldered connections.

*Electrical Section Disassembly (Continued)*

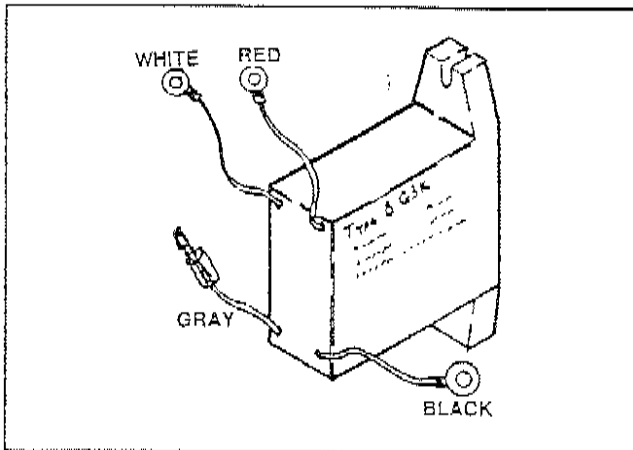

Figure 8. Bridge Rectifier Assembly

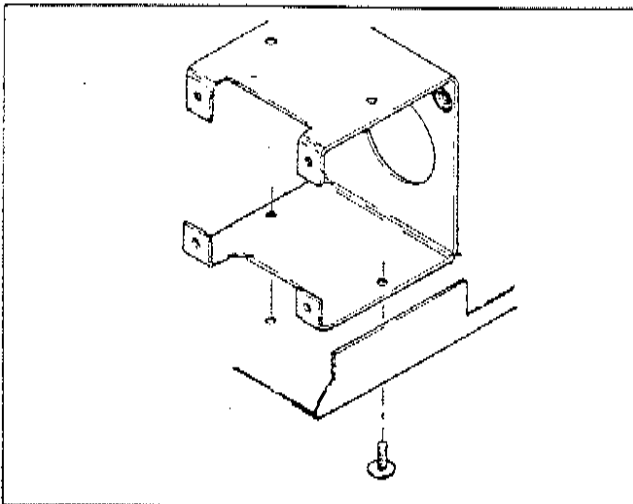

Figure 9. Solenoid Coil Bracket Removal

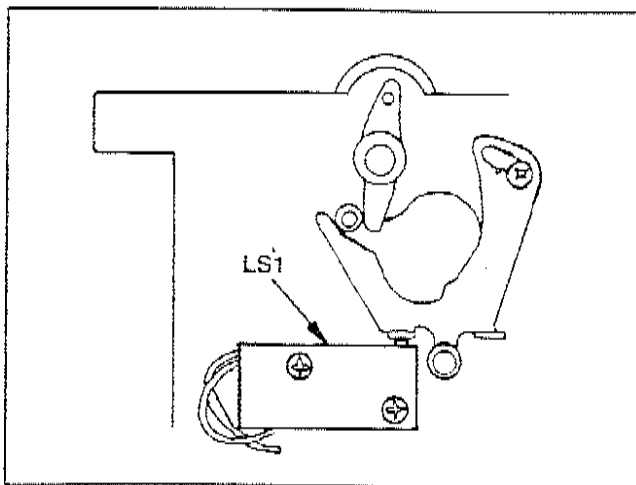

Figure 10. Limit Switch LS1 Removal

LIMIT SWITCH LS2 REMOVAL:

1. See Figure 11. Remove the spring retaining pin.
2. See Figure 12. Remove two (2) screws that retain the actuating link assembly to the transfer mechanism base.
3. You should be able to lift the actuating link assembly sufficiently high to remove the two (2) screws that retain limit switch LS2 to its support.
4. Remove the two (2) screws.
5. Remove limit switch LS2, along with two (2) insulator strips. LS2 wires have soldered connections.

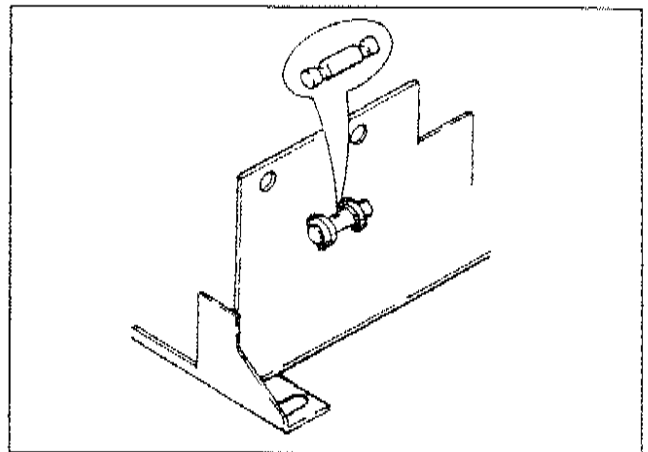

Figure 11. Spring Retaining Pin Removal

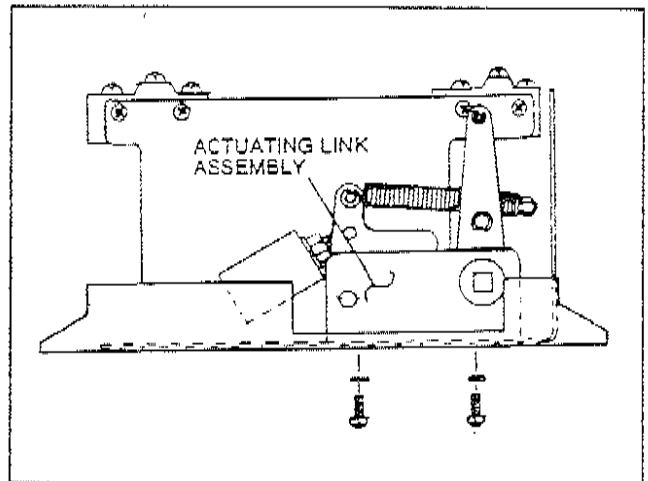

Figure 12. Actuating Link Assembly Screws

AUXILIARY CONTACTS REMOVAL:

See Figure 13 on next page. Remove two (2) screws that retain the first auxiliary contacts. Remove the auxiliary contacts. The second auxiliary contacts can be removed in the same manner.

*Electrical Section Disassembly (Continued)*

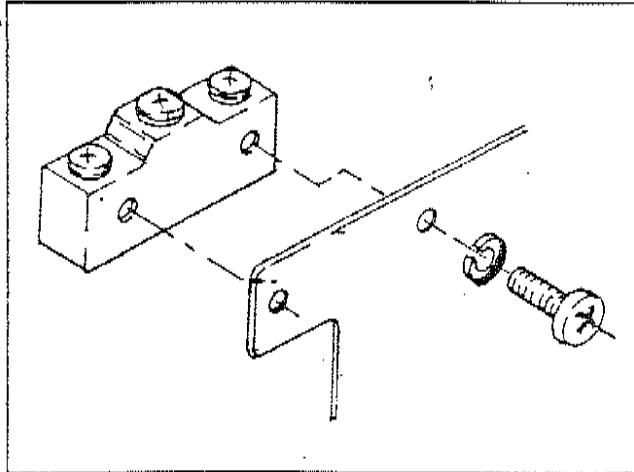

Figure 13. Auxiliary Contacts Removal

**Stationary Main Contacts Removal**

See Figure 14. Remove the two (2) long thru-bolts that retain the stationary main contacts assembly. Carefully remove the stationary main contacts.

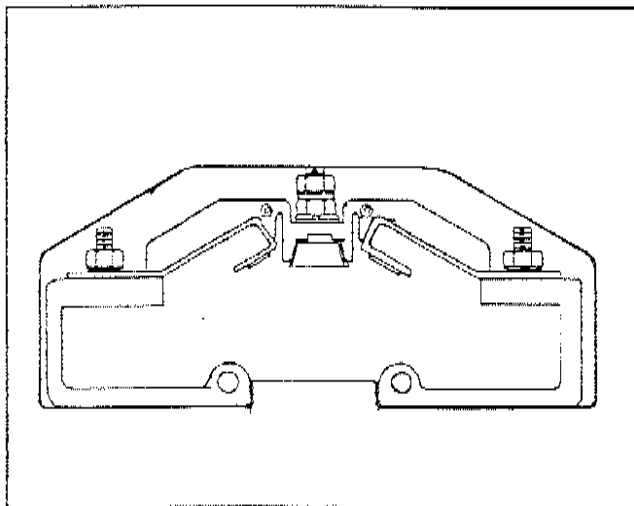

Figure 14. Stationary Main Contacts Assembly

**Moveable Main Contacts**

The dual moveable main contacts are now exposed and may be inspected, removed or replaced as necessary. See Figure 15.

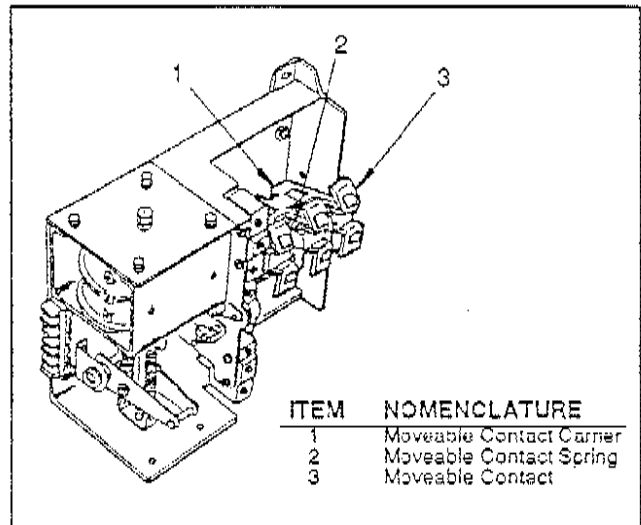

Figure 15. Moveable Main Contacts

**Testing and Inspection**

Inspect the stationary and moveable main contacts closely. Inspect springs, linkage, retaining pins, etc. for damage, excessive wear. Replace any defective components.

Switches may be tested using a volt-ohm-milliammeter. Replace any defective switch.

*NOTE: Test procedures for most switches, bridge rectifier, and solenoid coil are discussed in Section 5.4.*

**Reassembly**

Reassemble the transfer mechanism in the reverse order of disassembly.

Following reassembly, the transfer mechanism should be tested thoroughly. Actuate the main contacts manually several times, using the manual transfer handle. Also test electrical operation of the transfer switch.

**PART 6**  
**DC CONTROL**  
**(UNITS WITH**  
**AIR COOLED**  
**ENGINE)**

GENERAC II  
PREPACKAGED  
HOME STANDBY  
ELECTRIC POWER  
SYSTEMS

<b>TABLE OF CONTENTS</b>	
<b>SECTION</b>	<b>TITLE</b>
6.1	Description and Components
6.2	Operational Analysis
6.3	Troubleshooting Flow Charts
6.4	Diagnostic Tests

# NOTES

---

Section 6.1  
**DESCRIPTION AND COMPONENTS**

*General*

This section will familiarize the reader with the various components that make up the DC control system. You may also wish to read Section 1.7, especially the subsection entitled "Control Panel- Units with Air Cooled Engine".

Major DC control system components that will be covered include the following:

- Control Module Assembly (CMA).
- An Auto-Off-Manual Switch.
- The Battery.
- A 15 Amp Fuse.
- Engine Starter Contactor.
- Starter Motor.
- Fuel Solenoid Valve.
- Engine protective Shutdown Switches.
- Engine Ignition System.
- Battery Charge Circuit.

**Control Module Assembly (CMA)**

The control module assembly (Figure 1) is mounted on the rear panel of the standby generator enclosure. This assembly, called simply the "CMA", mounts (a) a terminal board, (b) a current transformer, and (c) a CMA circuit board.

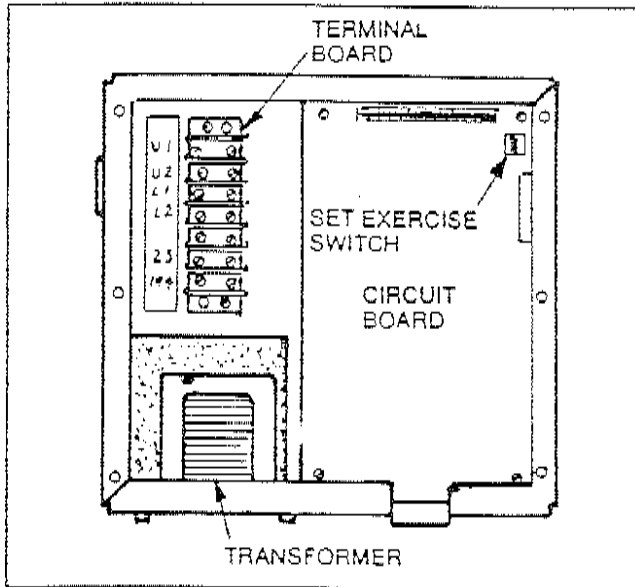

Figure 1. The Control Module Assembly

**TERMINAL BOARD:**

Suitable, approved wiring must be connected to the terminals of this terminal board and to identically numbered terminals on a prepackaged transfer switch terminal board. The terminal board connects the transfer switch to the CMA circuit board and transformer.

The terminal board provides the following connection points:

- A. Utility 1 and Utility 2
  1. Connect to identically marked terminals on a prepackaged transfer switch terminal board.
  2. The circuit delivers "Utility" power source voltage to the control module assembly's sensing transformer.
- B. Load 1 and Load 2
  1. Connects to identically marked terminals on the terminal board of the prepackaged transfer switch.
  2. Power from the transfer switch load terminals is used to operate a 7-day exerciser circuit on the CMA circuit board.
- C. 23 and 194
  1. Connect to identically numbered terminals on the terminal board of the prepackaged transfer switch.
  2. This circuit connects the CMA circuit board to the transfer relay coil in the prepackaged transfer switch.

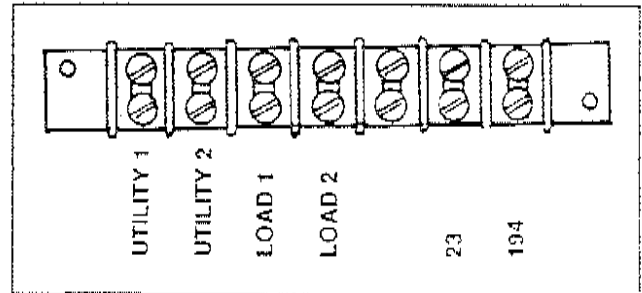

Figure 2. CMA Terminal Board

**SENSING TRANSFORMER:**

The control module assembly's sensing transformer is a step-down type. The line-to-line voltage from the Utility 1/Utility 2 terminals is delivered to the transformer's primary winding. Transformer action then induces a reduced voltage (about 12 volts at 2 amps) into the secondary transformer winding. This reduced voltage is delivered to the CMA circuit board as "Utility" source sensing voltage. The reduced sensing voltage is used by the CMA circuit board for the following:

- If the "Utility" sensing voltage drops below a preset value, CMA board action will initiate automatic generator startup and transfer to the "Standby" source side.
- The CMA board also uses the "Utility" power to operate a battery trickle charge circuit. This circuit maintains battery state of charge when the engine is not running.

The sensing transformer is shown in Figure 3, both pictorially and schematically.

Control Module Assembly (Continued)

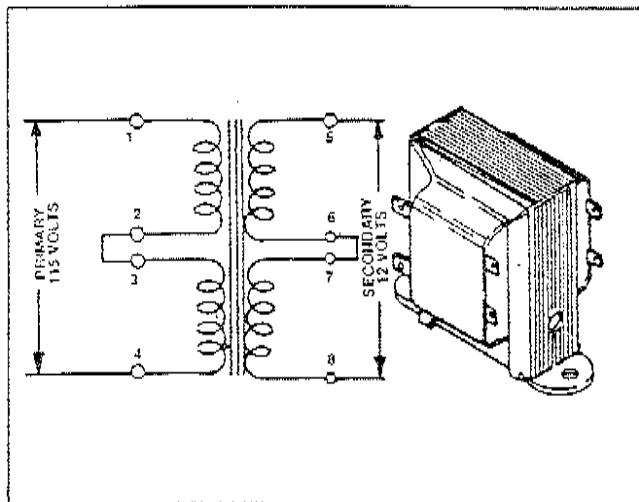

Figure 3. The Sensing Transformer

CMA CIRCUIT BOARD:

The CMA circuit board controls all standby electric system operations including (a) engine cranking, (b) engine startup, (c) engine running, (d) automatic transfer, (e) automatic retransfer, and (f) engine shutdown. In addition, the circuit board performs the following functions:

- Delivers "field boost" current to the generator rotor windings (see "Field Boost Circuit" on Page 2.1-4).
- Starts and "exercises" the generator once every seven days.
- Delivers a "trickle charge" to the generator battery during non-operating periods.
- Provides automatic engine shutdown in the event of low oil pressure, high oil temperature, or over-speed.

A 17-pin connector interconnects the CMA circuit board with the various circuits of the DC systems. Connector pin numbers, associated wires and circuit functions are listed in the CHART on this page.

The circuit board mounts a CRANK RELAY (K1) and a RUN RELAY (K2). See Figure 4. Crank relay (K1) is energized by circuit board action during both manual and automatic startup to crank the engine. Cranking is accomplished in equal duration crank-rest cycles. That is, K1 will energize and the engine will crank for about 7-9 seconds. Relay K1 will then de-energize and cranking will end for about 7-9 seconds. This cyclic cranking action continues until either (a) the engine starts, or (b) approximately 90 seconds of the crank-rest cycles have elapsed.

The RUN RELAY is energized by circuit board action at the same time as the CRANK RELAY, to energize and open a fuel solenoid valve.

The CMA circuit board also mounts a push-button type "7-day exerciser switch" (Figure 4), used to select the day and time of day for the system to start and exercise.

**DANGER: THE GENERATOR ENGINE WILL CRANK AND START WHEN THE 7-DAY EXERCISER SWITCH IS ACTUATED. THE UNIT WILL ALSO CRANK AND START EVERY 7 DAYS THEREAFTER, ON THE DAY AND AT THE TIME OF DAY THE SWITCH WAS ACTUATED.**

PIN	WIRE	CIRCUIT FUNCTION
1	4	Field boost current to rotor (about 9-10 volts DC)
2	85	Low oil pressure/high oil temperature fault. Automatic shutdown occurs when Wire 85 is grounded by oil pressure/oil temperature switch closing action.
3	23	Grounded side of transfer relay circuit.
4	194	Positive (+) side of transfer relay circuit (12 volts DC).
5	55	Energized (12 volts DC) by circuit board's crank relay (K1) to crank engine.
6	18	Engine shutdown. Circuit is grounded by circuit board action to ground the engine's ISD module and terminate ignition.
7	14	During startup, circuit board delivers 12 volts DC to this circuit to open the fuel solenoid.
8	66	Engine running and speed signals from generator's battery charge winding.
9	17	Manual start signal from auto-off-manual switch.
10	15A	Battery voltage (12 volts DC) for circuit board operation.
11	239	12 volts DC when auto-off-manual switch is set to "Manual".
12	15	Battery trickle charge circuit (+12 volts DC).
13	0	Common ground.
14	224	Transformer reduced "Utility" source sensing voltage.
15	225	Transformer reduced "Utility" source sensing voltage.
16	T2	From transfer switch load terminal lug T2, for operation 7-day exerciser clock circuit.
17	T1	From transfer switch load terminal lug T1, for operation of 7-day exerciser clock circuit.

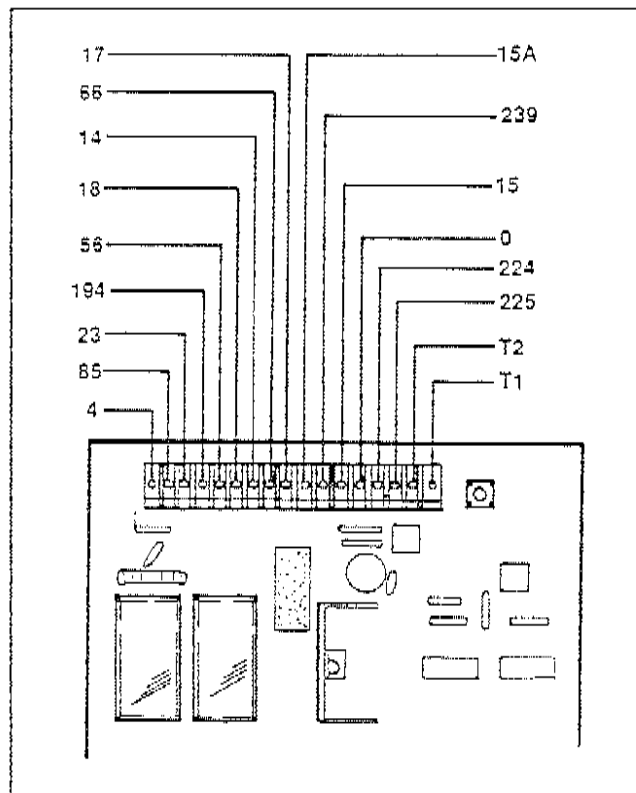
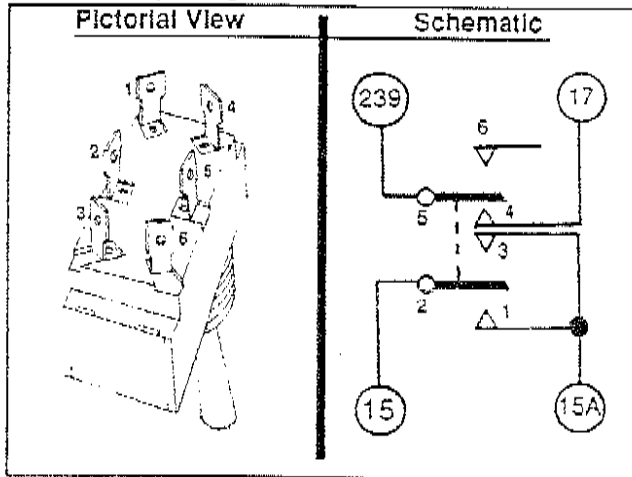

Figure 4. CMA circuit Board

***Auto-Off-Manual Switch***

*NOTE: Also see "Control Panel- Units with Air-Cooled Engine" on Page 1.7-1.*

This 3-position switch permits the operator to (a) select fully automatic operation, (b) start the generator manually, or (c) stop the engine and prevent automatic startup. Switch terminals are shown pictorially and schematically in Figure 5, below.



*Figure 5. The Auto-Off-Manual Switch*

***15 Amp Fuse***

This fuse protects the CMA circuit board against excessive current. If the fuse has blown, engine cranking and operation will not be possible. Should fuse replacement become necessary, use only an identical 15 amp replacement fuse.



Section 6.2  
**OPERATIONAL ANALYSIS**

**Introduction**

This "Operational Analysis" is intended to familiarize the service technician with the operation of the DC control system on prepackaged units with air-cooled engine. A thorough understanding of how the system works is essential to sound and logical troubleshooting. The DC control system illustrations on the following pages include a "V-Type" prepackaged transfer switch.

**Utility Source Voltage Available**

See Figure 1, below. The circuit condition with the auto-off-manual switch set to "Auto" and with "Utility" source power available can be briefly described as follows:

- "Utility" source voltage is available to transfer switch terminal lugs N1/N2, via installer connected wiring. With the transfer switch main contacts at their "Utility" side, this source voltage is available to terminal lugs T1/T2 and to the "Load" circuits.
- "Utility" voltage is delivered to the primary winding of a sensing transformer (T1), via transfer switch wires N1A/N2A, fuses F1/F2, installer connected wiring, and CMA "Utility 1/Utility 2" terminals. A resultant voltage (about 12 volts AC) is induced into the transformer secondary windings and then delivered to the circuit board via Wires 224/225. The circuit board uses this reduced "Utility" voltage as (a) sensing voltage and (b) to deliver a battery trickle charge to the unit battery, via circuit board Pin 12, Wire 15, a 15 amp fuse (F1), and Wire 13.
- Power is available to the CMA circuit board, via transfer switch T1/T2 terminals, fuses F3/F4, installer connected wiring, and the "Load 1/Load 2" terminals of the CMA terminal board. This voltage is used to operate a "7-day exerciser" clock circuit in the circuit board.
- Battery output is delivered to the circuit board with the auto-off-manual switch (SW1) set to "Auto", as shown.

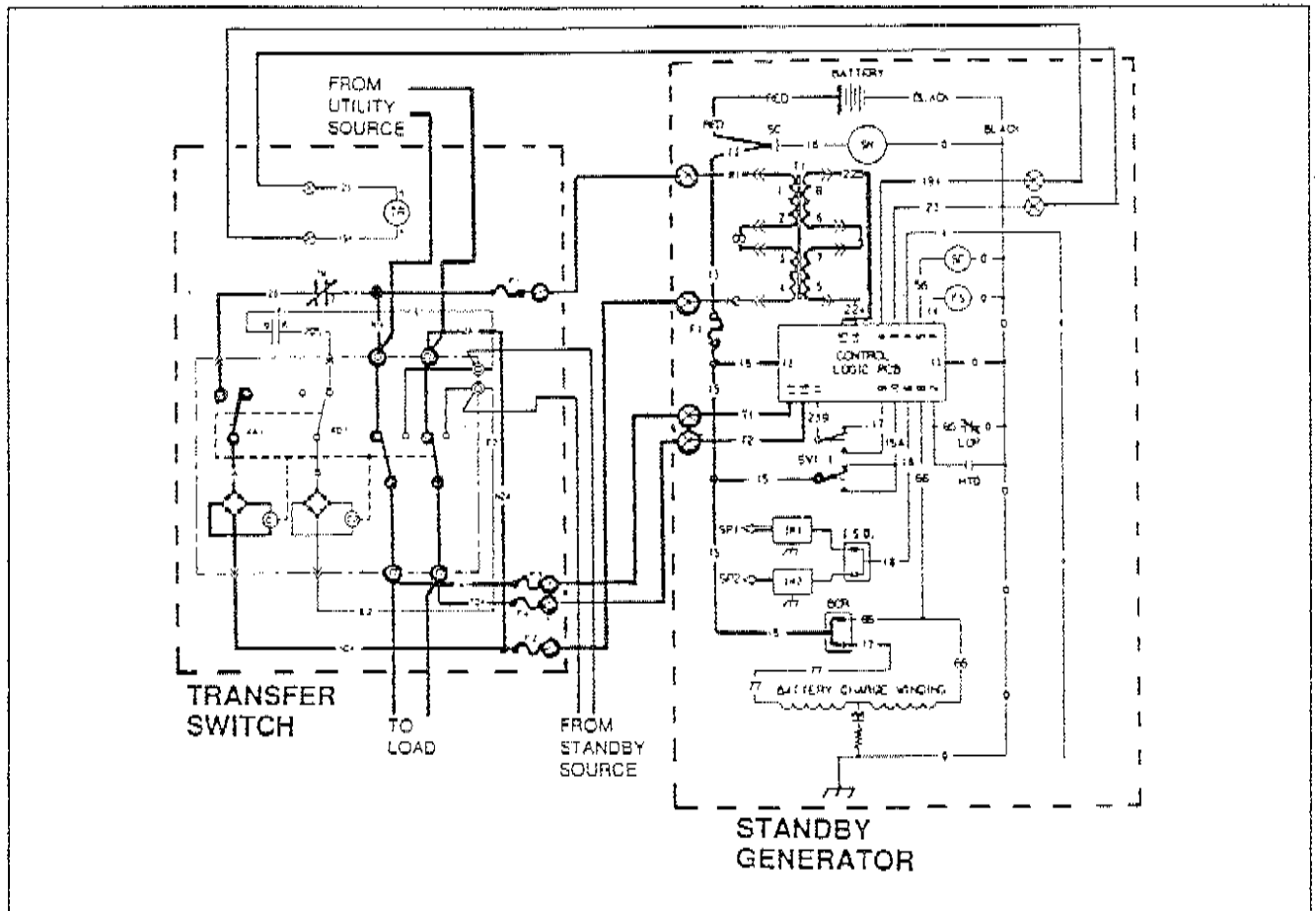

Figure 1. Circuit Condition- Utility Source Voltage Available

*Initial Dropout of Utility Source Voltage*

Refer to Figure 2, below. Should a "Utility" power source failure occur, circuit condition may be briefly described as follows:

- The CMA circuit board constantly senses for an acceptable "Utility" source voltage, via transfer switch fuses F1/F2, transfer switch "Utility 1/Utility 2" terminals, installer connected wiring, control module assembly (CMA) "Utility 1/Utility 2" terminals, the CMA sensing transformer (T1), Wires 224/225.
- Should "Utility" voltage drop below approximately 60 percent of the nominal source voltage, a 6-second timer on the CMA circuit board will turn on.
- In Figure 2, the 6-second timer is still timing and engine cranking has not yet begun.
- The auto-off-manual switch is shown in its "Auto" position. Battery voltage is available to the CMA circuit board, via Wire 13, 15 amp fuse (F1), Wire 15, the auto-off-manual switch (SW1), Wire 15A, and Pin 10 of the circuit board connector.

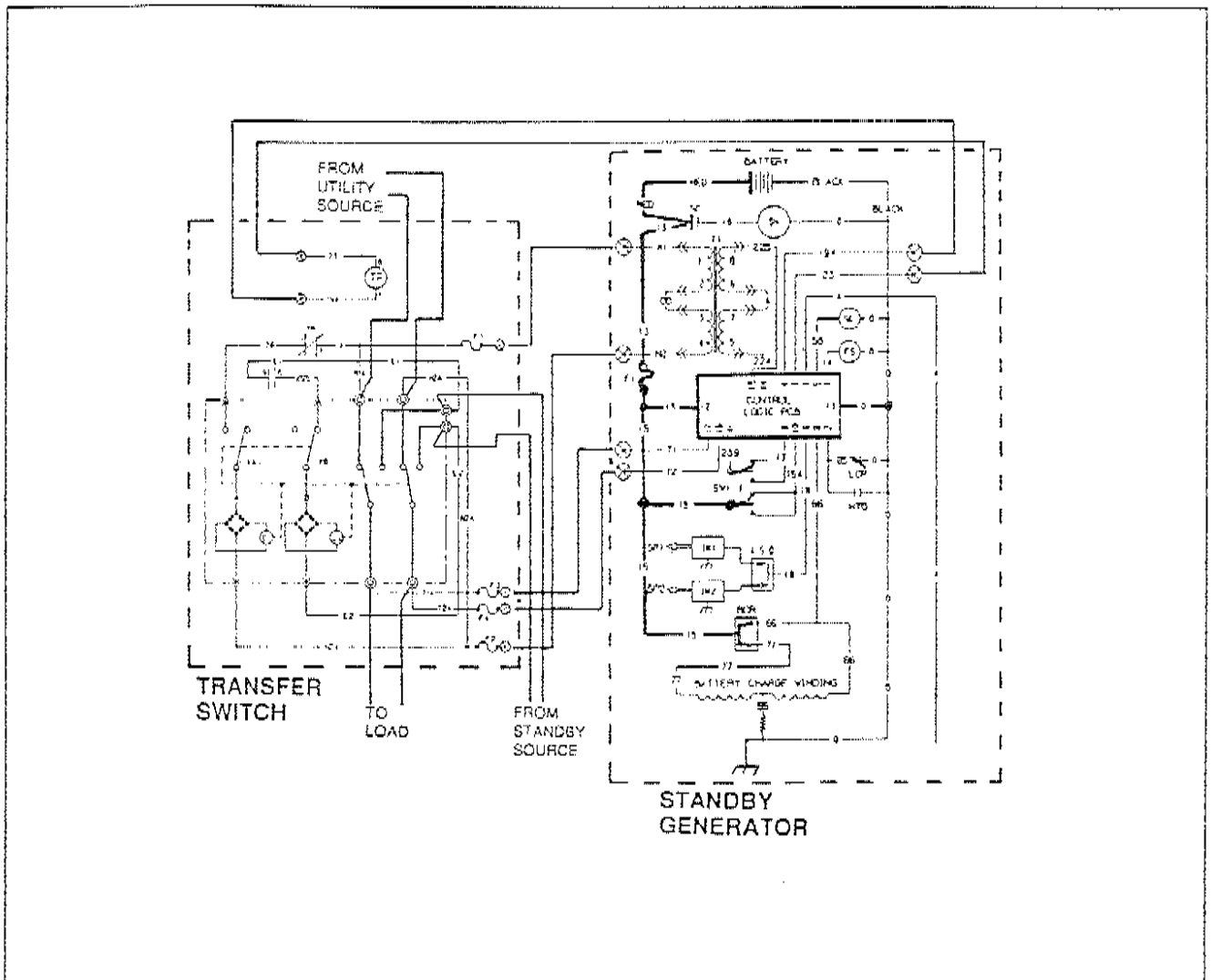

Figure 2. Circuit Condition- Initial Dropout of Utility Source Voltage

*Utility Voltage Dropout and Engine Cranking*

- After six (6) seconds and when the circuit board's 6-second timer has timed out, if "Utility" voltage is still below 60 percent of nominal, CMA board action will energize the circuit board's crank and run relays (K1 and K2) simultaneously.
- The crank relay (K1) will remain energized for about 7-9 seconds. The relay will then de-energize for 7-9 seconds and will again energize. Thus, the engine will crank cyclically for 7-9 second crank-rest cycles. This cyclic cranking will continue until either the engine starts or until about ninety (90) seconds of crank-rest cycles have been used up.
- When the crank relay (K1) is energized, circuit board action delivers 12 volts DC to a starter contactor (SC), via Wire 56. SC energizes, its contacts close and battery power is delivered to a starter motor (SM). The engine cranks.
- When the circuit board's run relay (K2) energizes, 12 volts DC is delivered to a fuel solenoid (FS), via Wire 14. The fuel solenoid (FS) energizes open and fuel is available to the engine.
- As the engine cranks, magnets on the engine flywheel induce a high voltage into the engine ignition modules (IM1/IM2). A spark is produced that jumps the spark plug (SP1/SP2) gap.
- As the engine cranks oil pressure builds and the contacts of a low oil pressure switch (LOS) are opened by oil pressure.
- With ignition and fuel flow available the engine can start.

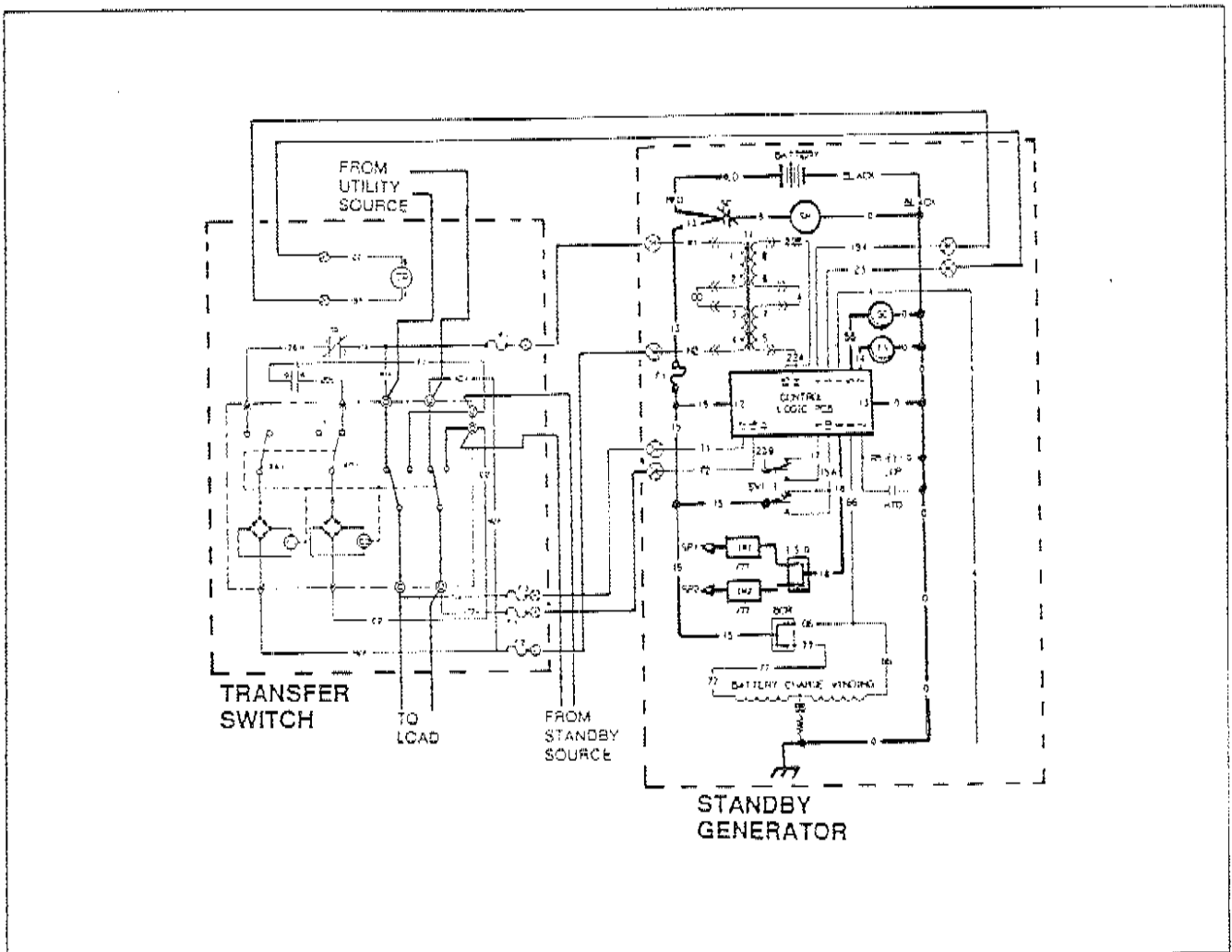

Figure 3. Circuit Condition- Engine Cranking

*Engine Startup and Running*

With the fuel solenoid open and ignition occurring, the engine starts. Engine startup and running may be briefly described as follows:

- An AC voltage/frequency signal is delivered to the CMA circuit board from the generator's battery charge winding, via Wire 66. When AC frequency reaches approximately 30 Hz, the circuit board (a) terminates cranking, (b) turns on an "engine minimum run timer", and (c) turns on an "engine warmup timer".
- The circuit board's "minimum run timer" will run for about 13-15 minutes. Automatic shutdown cannot occur while that timer is running. The timer prevents shutdown of a cold engine.
- The "engine warmup timer" will run for about 15 seconds. When this timer finishes timing, CMA board action will initiate transfer to the "Standby" power source. As shown in Figure 4 (below), the timer is still running and transfer has not yet occurred.
- Generator AC output is available to transfer switch terminal lugs E1/E2 and to the normally-open contacts of a transfer relay. However, the transfer relay is de-energized and its contacts are open.

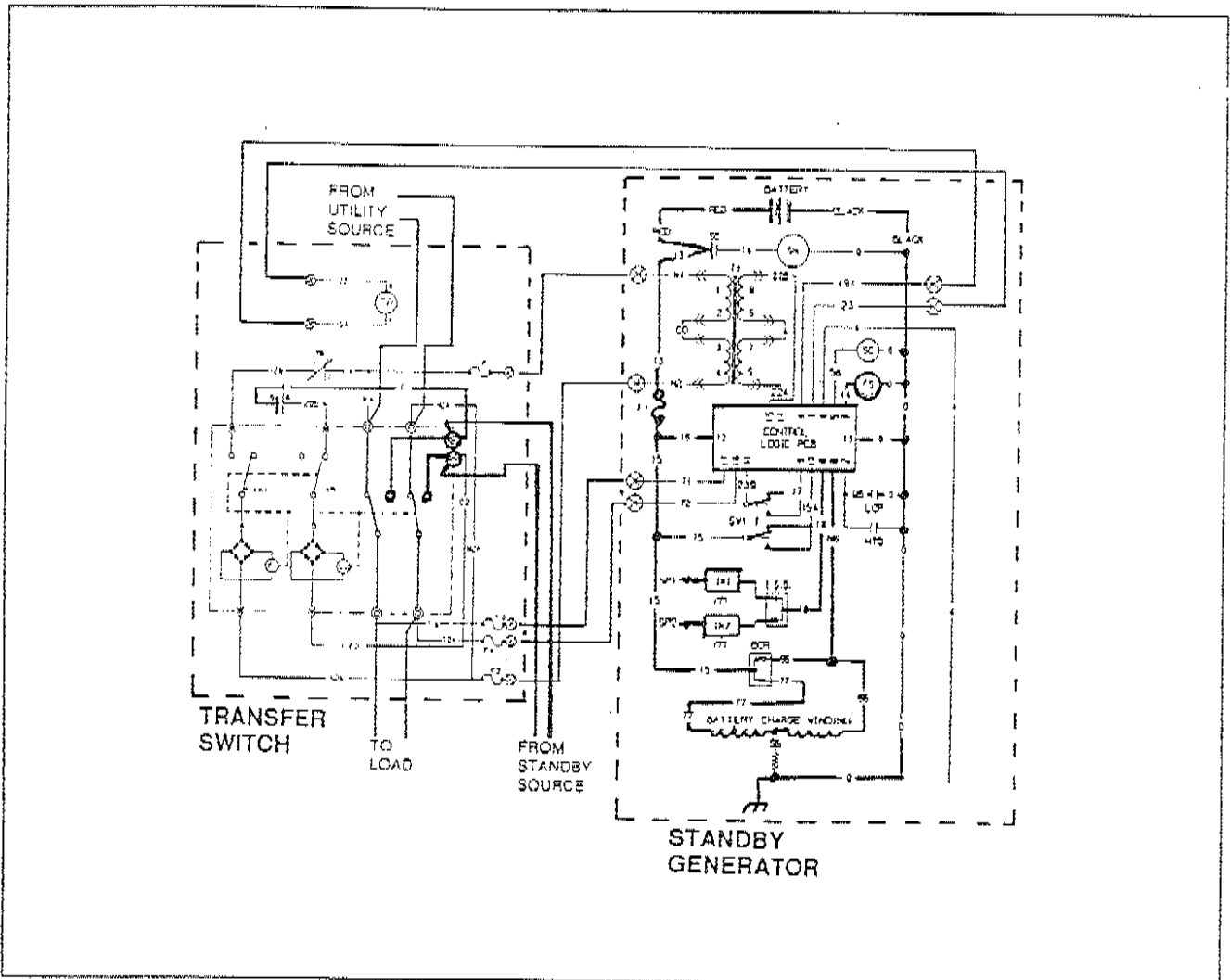

Figure 4. Circuit Condition- Engine Startup and Running

*Initial Transfer to the "Standby" Source*

The generator is running, the CMA circuit board's "engine warmup timer" is timing, and generator AC output is available to transfer switch terminal lugs E1/E2 and to the open contacts of the transfer relay. Initial transfer to the "Standby" power supply may be briefly described as follows:

- The CMA circuit board delivers a 12 volts DC output to the transfer relay (TR) actuating coil, via Wire 194, CMA terminal 194, installer connected wiring, transfer switch terminal 194, Wire 194, and terminal A of the transfer relay terminal B, Wire 23, installer connected wiring, CMA terminal 23, Wire 23, and circuit board connector Pin 3. However, circuit board action holds the Wire 23 circuit open to ground and the transfer relay (TR) is de-energized.
- When the CMA board's "engine warmup timer" times out, circuit board action completes the Wire 23 circuit to ground, via circuit board connector Pin 13 and Wire 0. The transfer relay then energizes and its normally-open contacts close.
- "Standby" power is now delivered to the standby closing coil (C2), via Wires E1/E2, the normally-open transfer relay contacts, Wire 205, limit switch XB1, Wire B, and a bridge rectifier. The standby closing coil energizes and the main current carrying contacts of the transfer switch are actuated to their "Standby" source side.
- As the main contacts move to their "Standby" source side, a mechanical interlock actuates limit switch XB1 to its open position and limit switch XA1 to its "Utility" side position. When XB1 opens, standby closing coil C2 de-energizes.
- "Standby" power is delivered to the "Load" terminals (T1/T2) of the transfer switch.

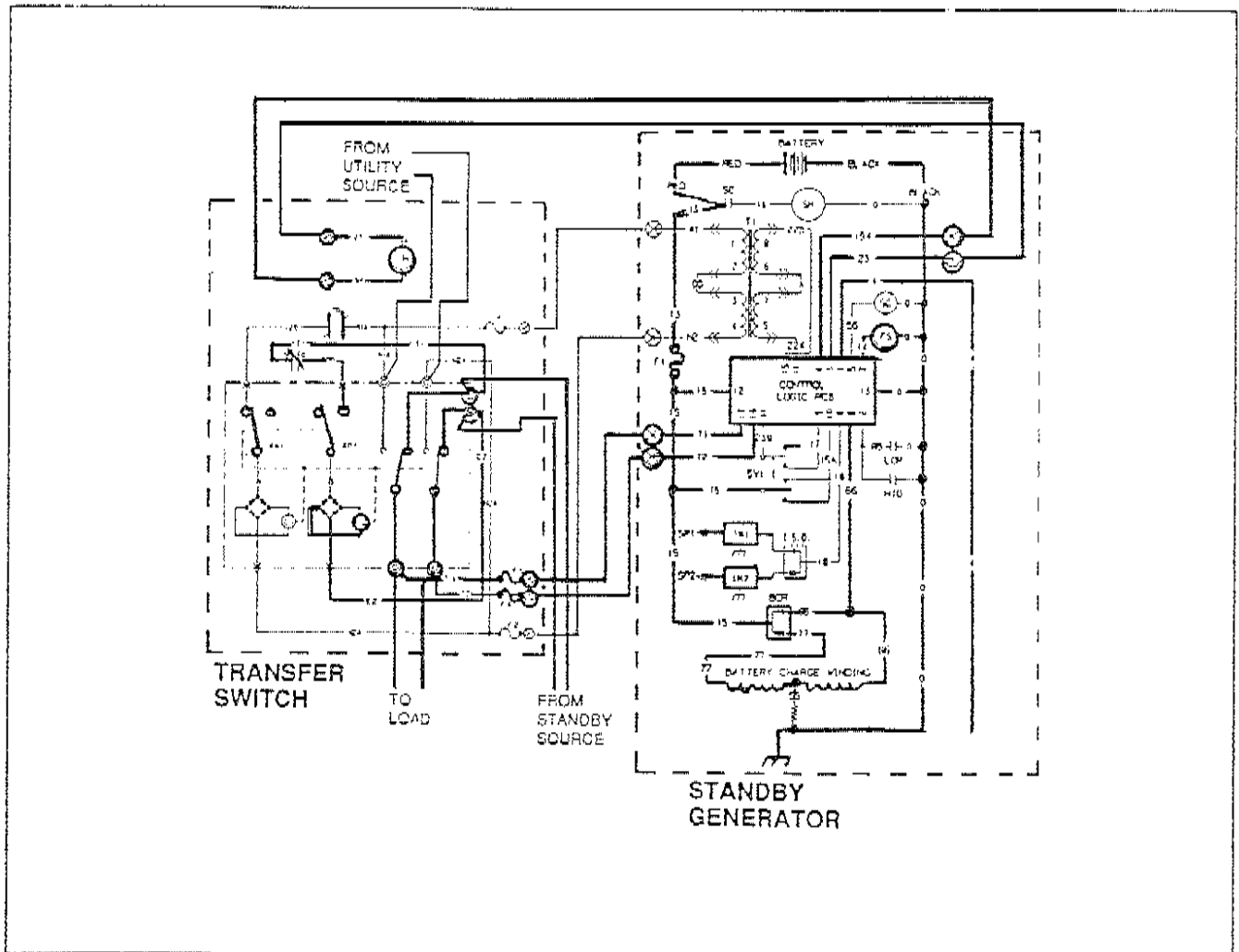

Figure 5. Circuit Condition- Initial Transfer to Standby

*Utility Voltage Restored and Retransfer to "Utility"*

The "Load" is powered by the "Standby" power supply. The CMA circuit board continues to seek an acceptable "Utility" source voltage. On restoration of "Utility" source voltage, the following events will occur:

- On restoration of "Utility" source voltage above 80 percent of the nominal rated voltage, a "retransfer time delay" on the CMA circuit board starts timing. The timer will run for about six (6) seconds.
- At the end of six (6) seconds, the "retransfer time delay" will stop timing and CMA board action will open the Wire 23 circuit to ground. The transfer relay (TR) will then de-energize.
- When the transfer relay (TR) de-energizes, its normally-closed contacts close. "Utility" source voltage is then delivered to the utility closing coil (C1), via Wires N1A/N2A, the closed TR contacts, Wire 126, limit switch XA1, and a bridge rectifier.
- The utility closing coil (C1) energizes and moves the main current carrying contacts to their "Neutral" position. The main contacts move to an overcenter position past "Neutral" and spring force closes them to their "Utility" side. "Load" terminals are now powered by the "Utility" source.
- Movement of the main contacts to "Utility" actuates limit switches XA1/XB1. XA1 opens and XB1 actuates to its "Standby" source side.
- The generator continues to run.

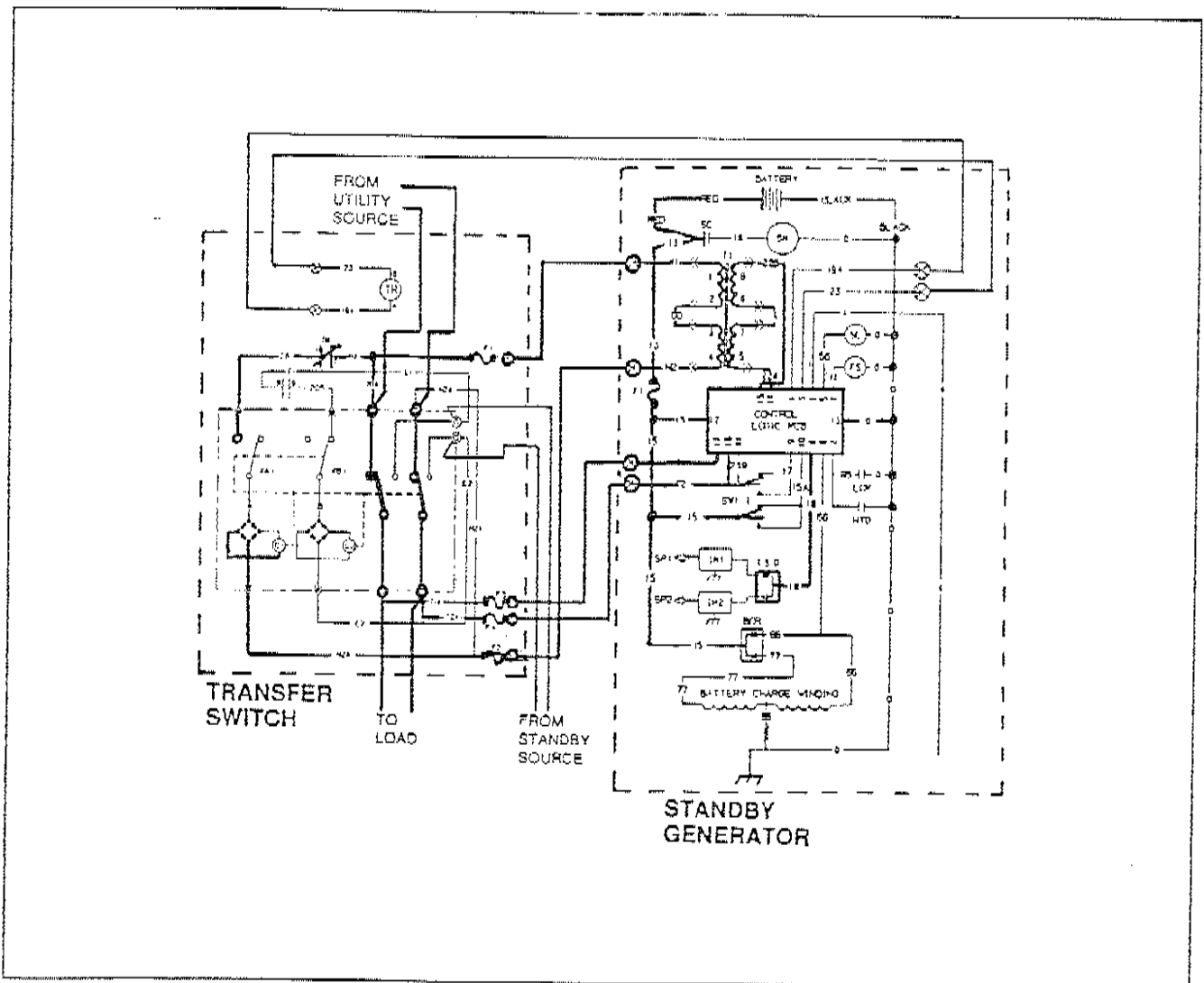

Figure 6. Circuit Condition- Retransfer to "Utility"

*Engine Shutdown*

Following retransfer back to the "Utility" source, an "engine cooldown timer" on the CMA circuit board starts timing. When that timer has timed out (and providing an "engine minimum run timer" has also timed out), CMA circuit board action will de-energize the circuit board's run relay (K2). The following events will then occur:

- The DC circuit to Wire 14 and the fuel solenoid (FS) will be opened. The fuel solenoid (FS) will de-energize and close to terminate the engine fuel supply.
- CMA board action will connect the engine's ignition shutdown module (ISM) to ground, via Wire 18, circuit board Pin 13, and Wire 0. Ignition will be terminated.
- Without fuel flow and without ignition, the engine will shut down.

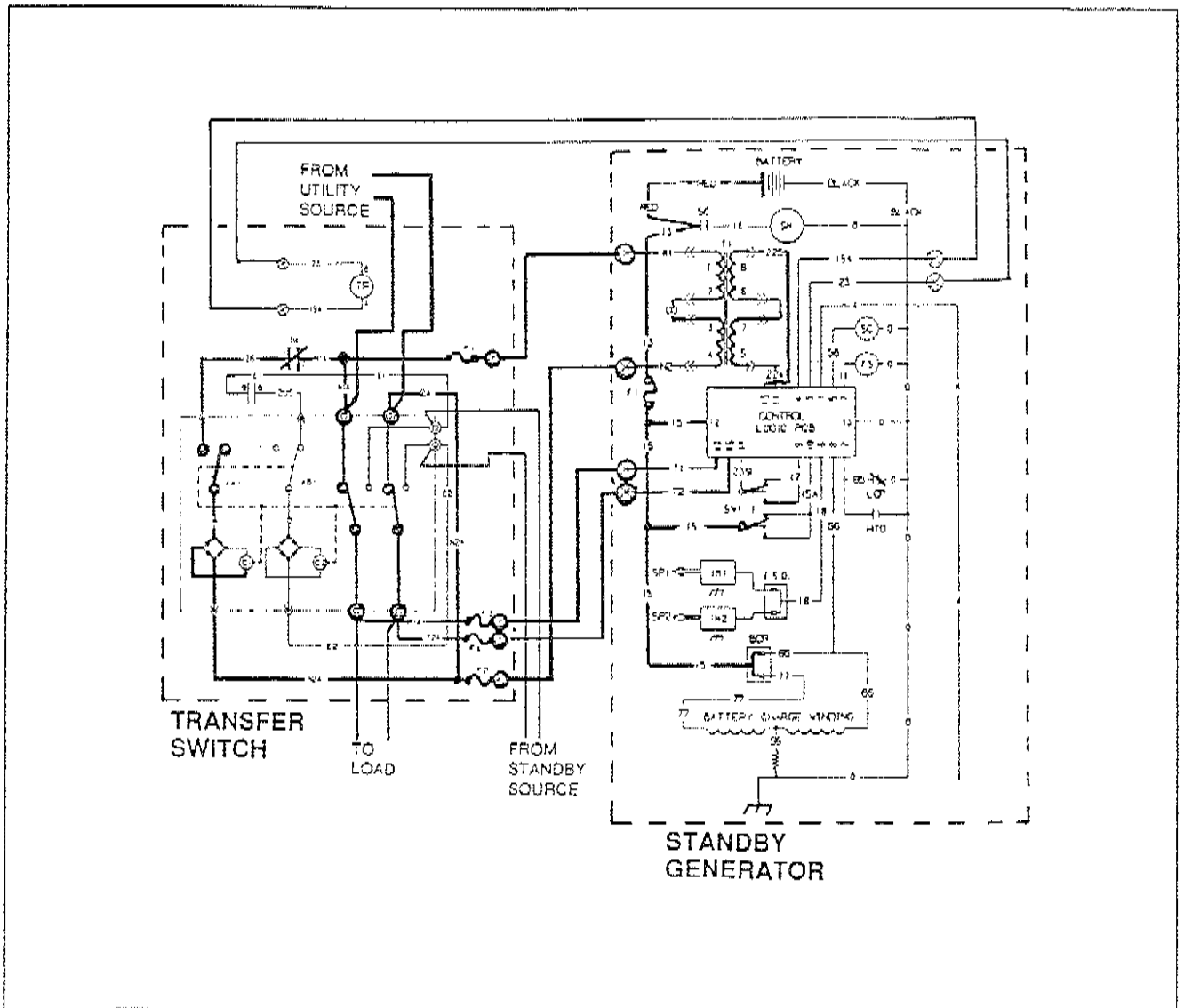
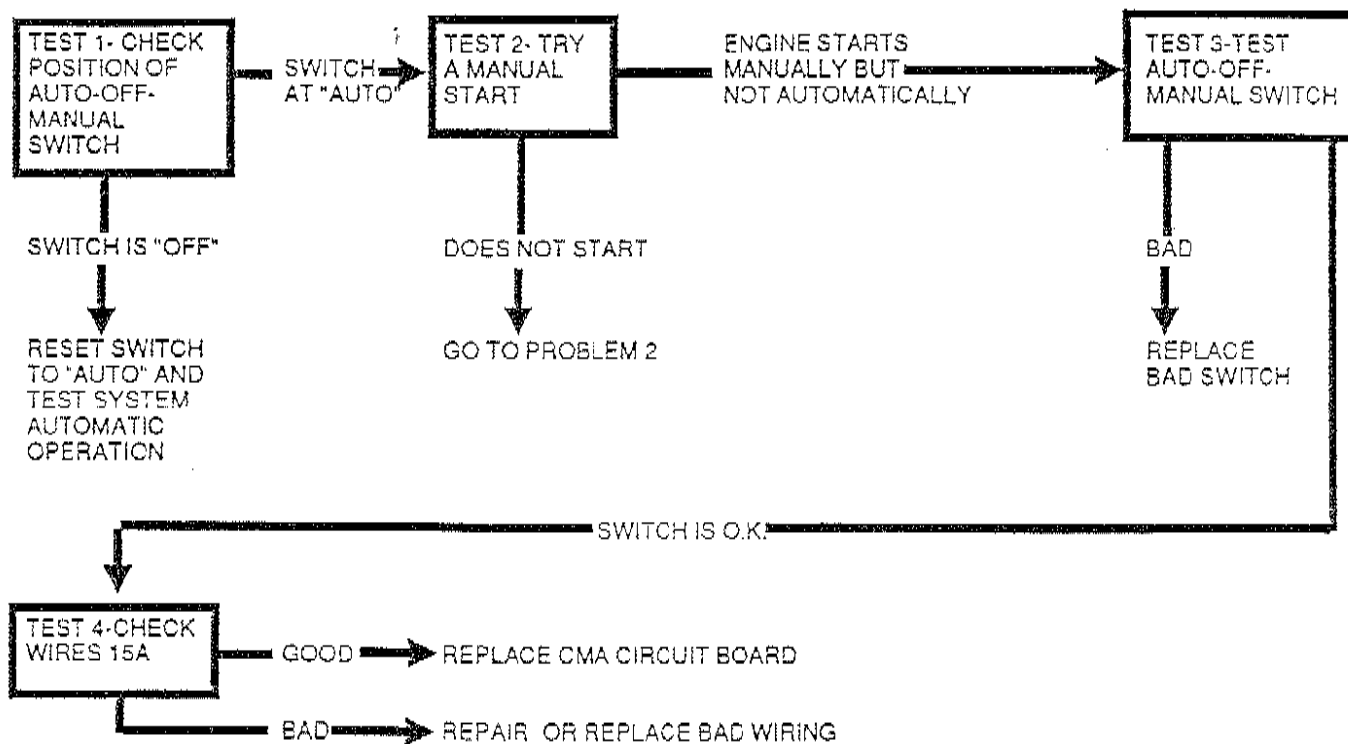

Figure 7. Circuit Condition- Engine Shutdown



# TROUBLESHOOTING FLOW CHARTS

## Problem 1 - Engine Will Not Crank When Utility Power Source Fails



## Problem 2- Engine Will Not Crank When Auto-Off-Manual Switch is Set to "Manual"

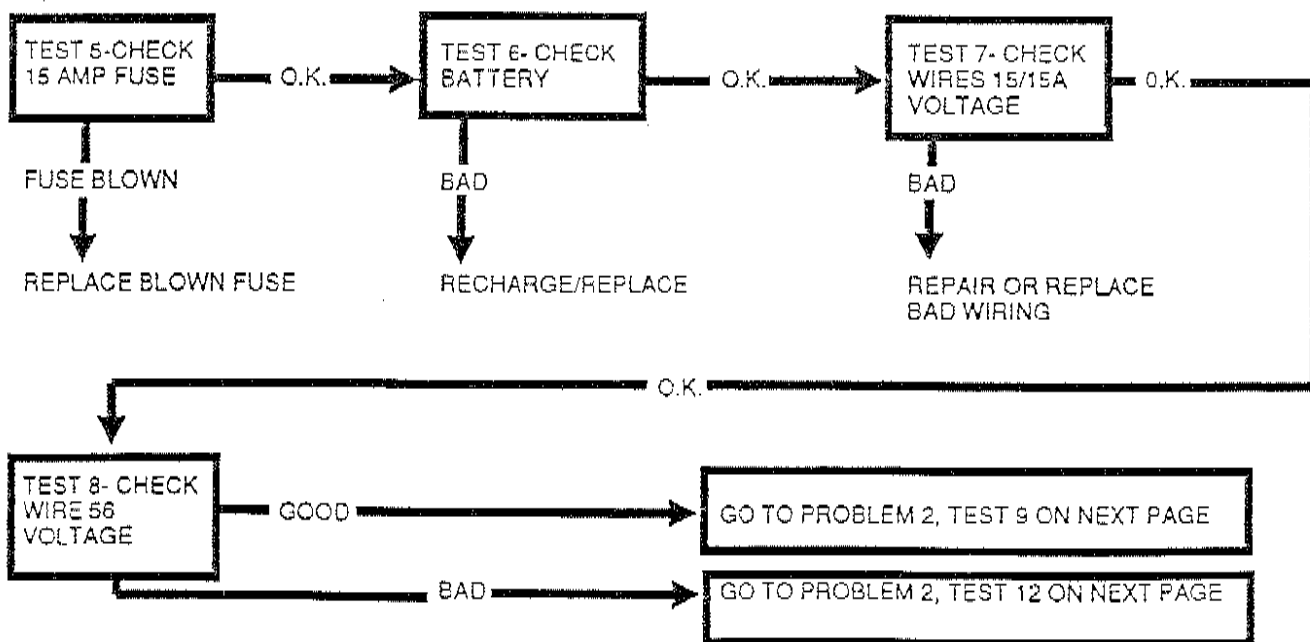

*Problem 2- Engine Will Not Crank When Auto-Off-Manual Switch is Set to "Manual" (Continued)*

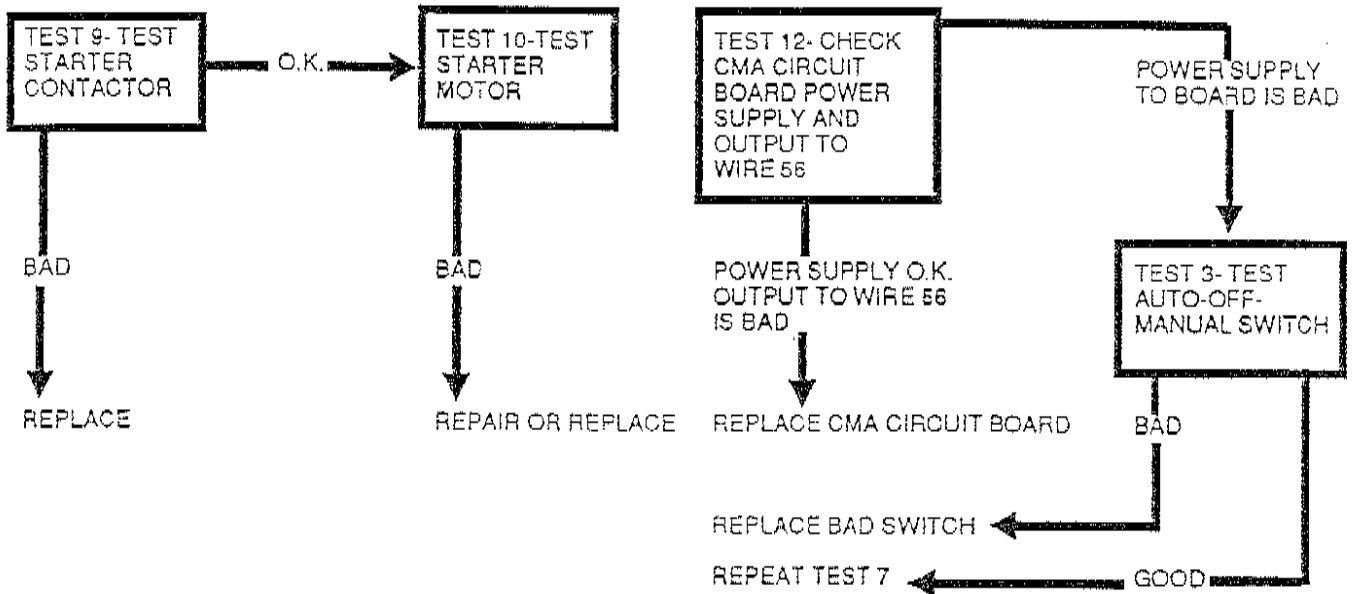

*Problem 3- Engine Cranks But Won't Start*

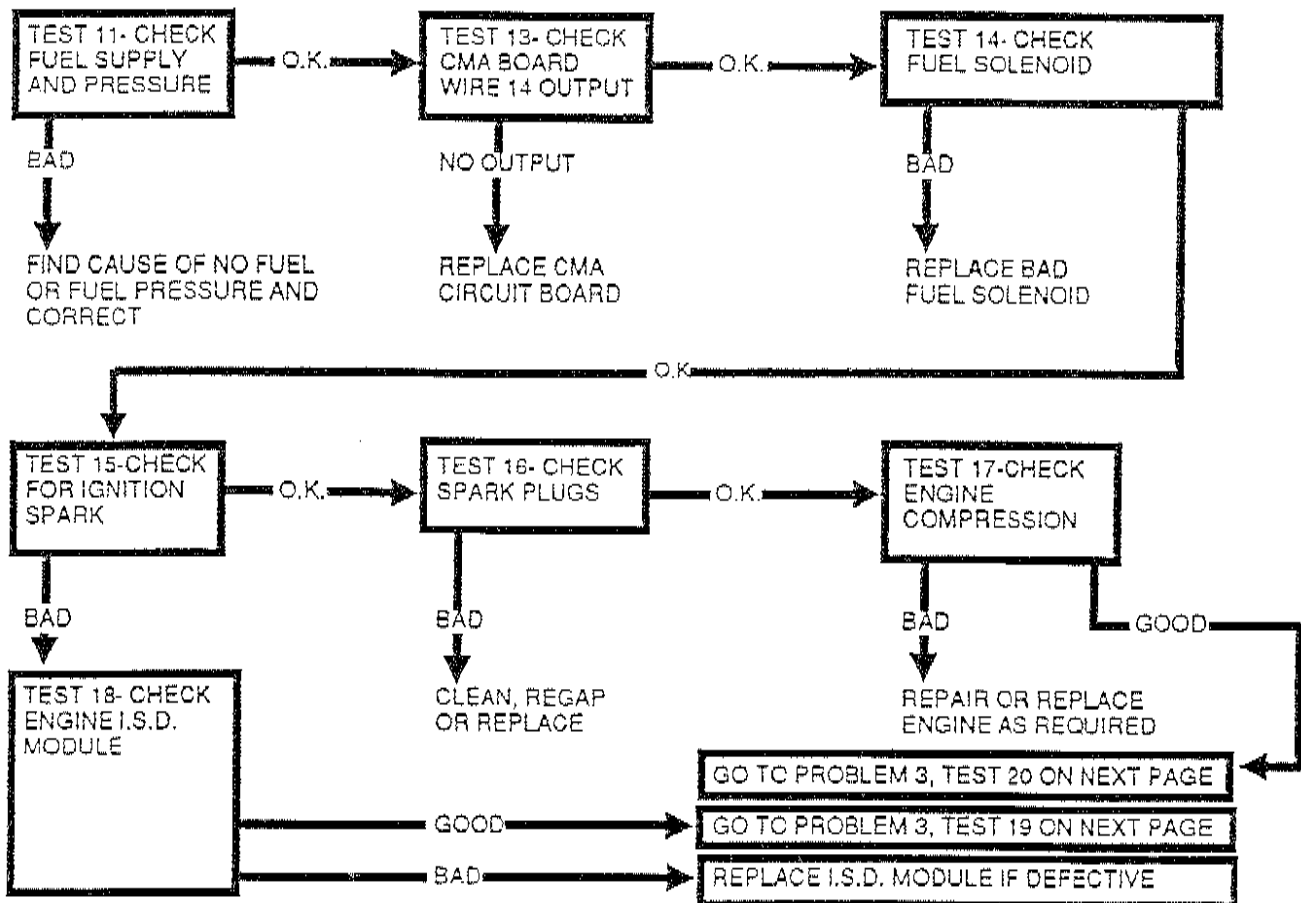

*Problem 3- Engine Cranks But Won't Start (Continued)*

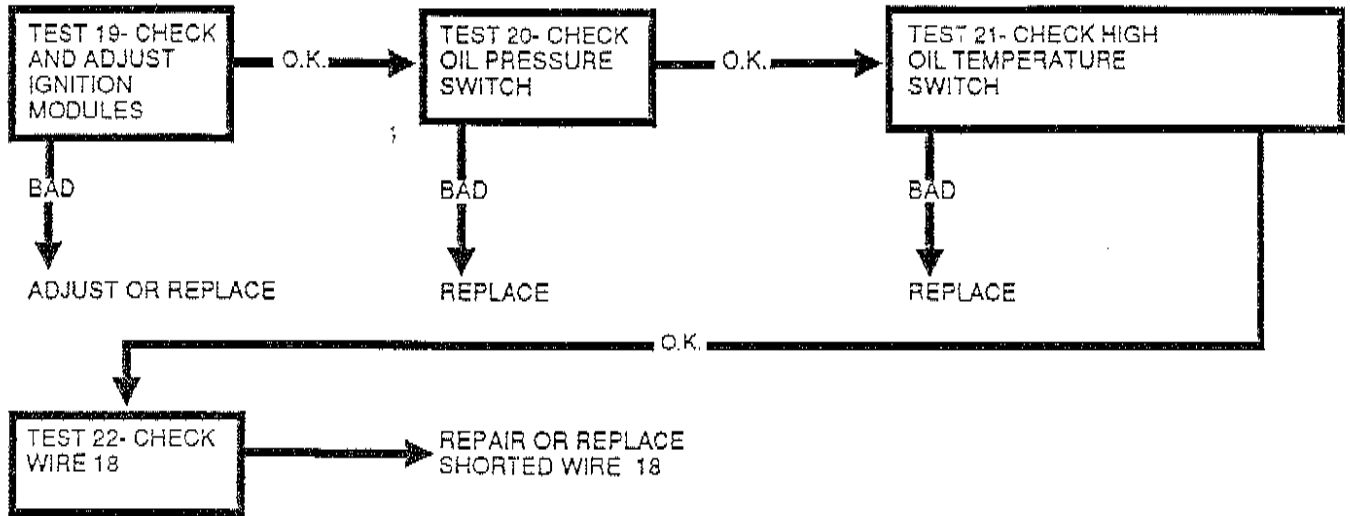

*Problem 4- Engine Cranks and Starts But No Transfer to Standby*

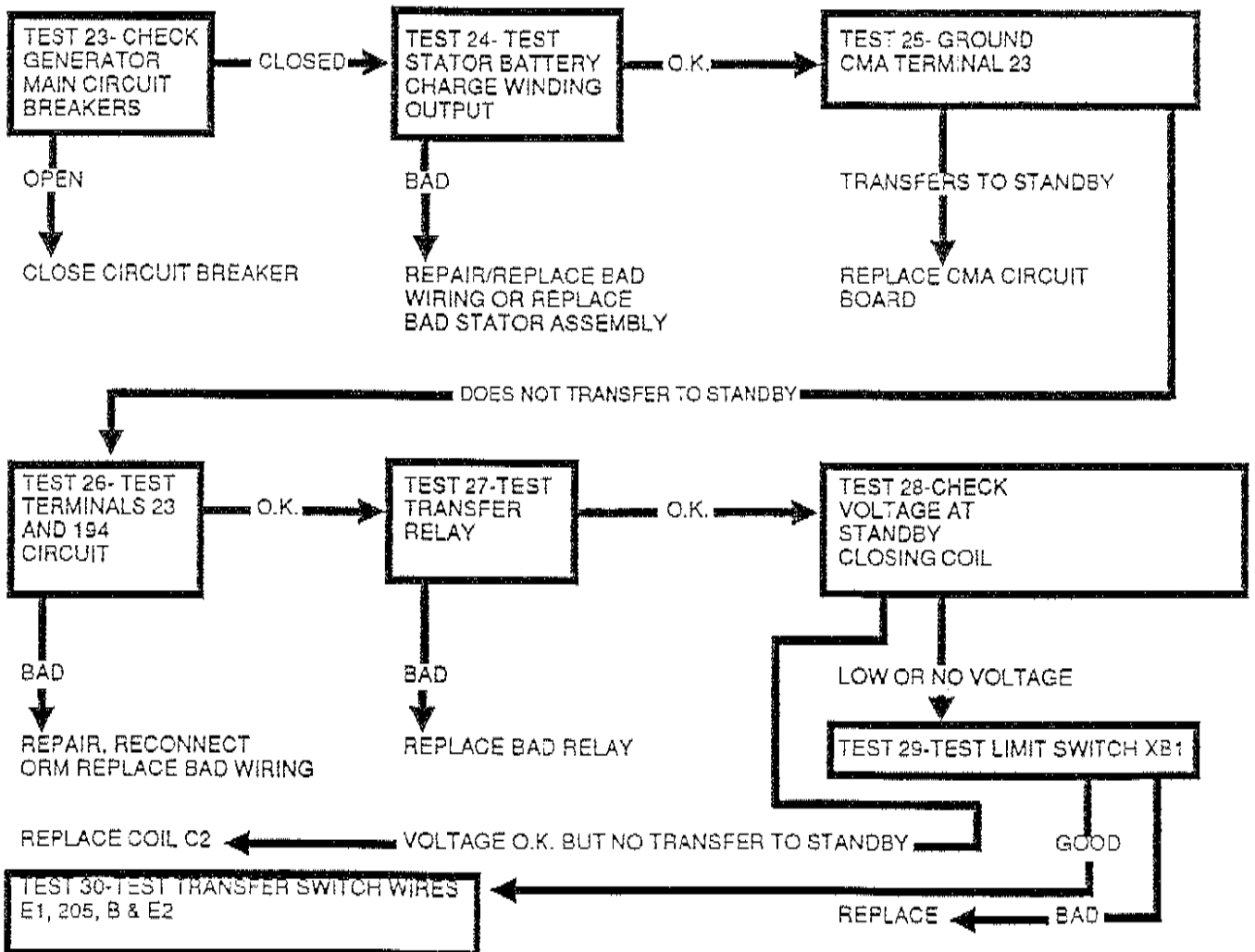

*Problem 5- No Automatic Retransfer Back to Utility*

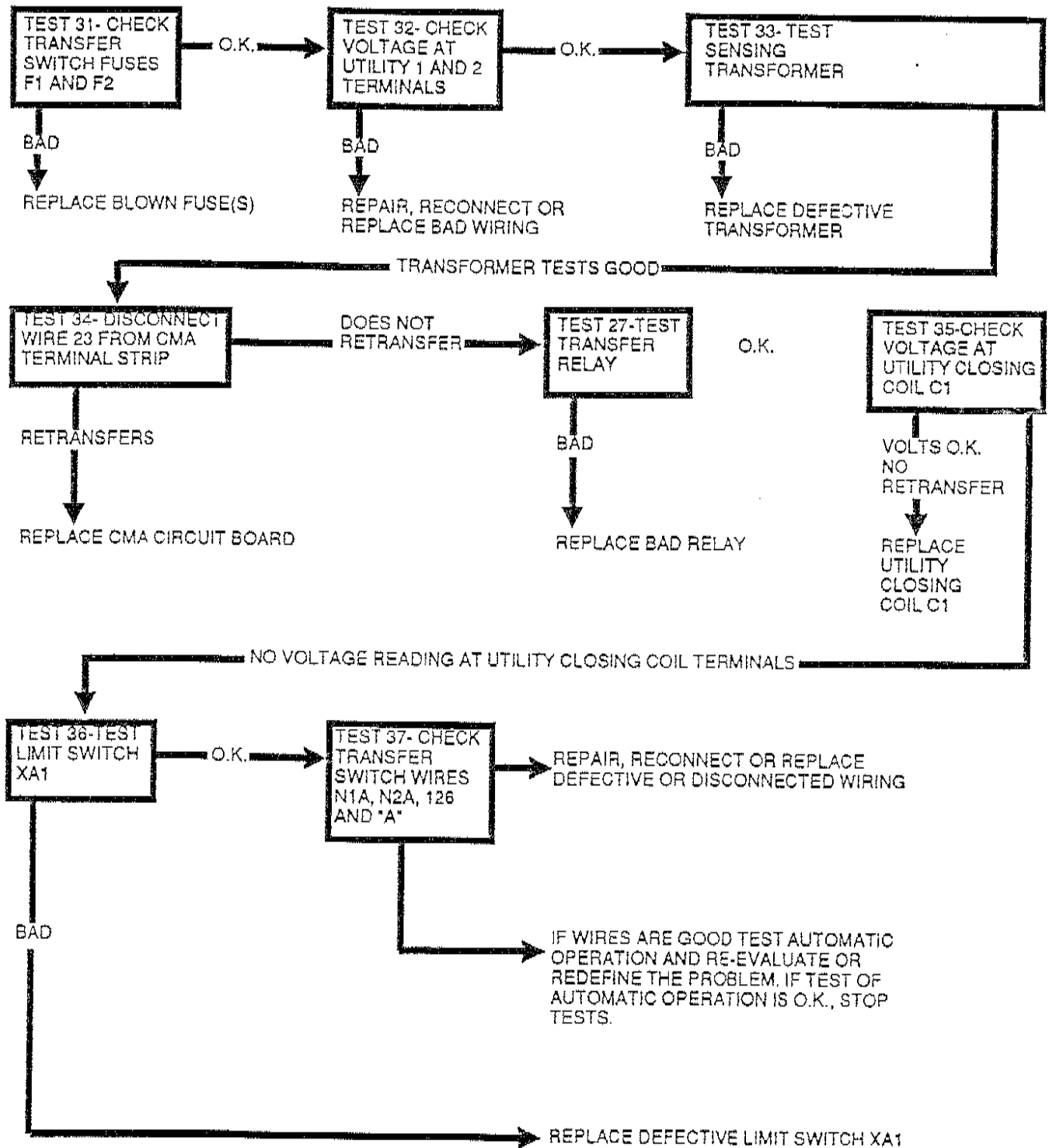

*Problem 6- Unit Starts & Transfer Occurs When Utility Power is Available*

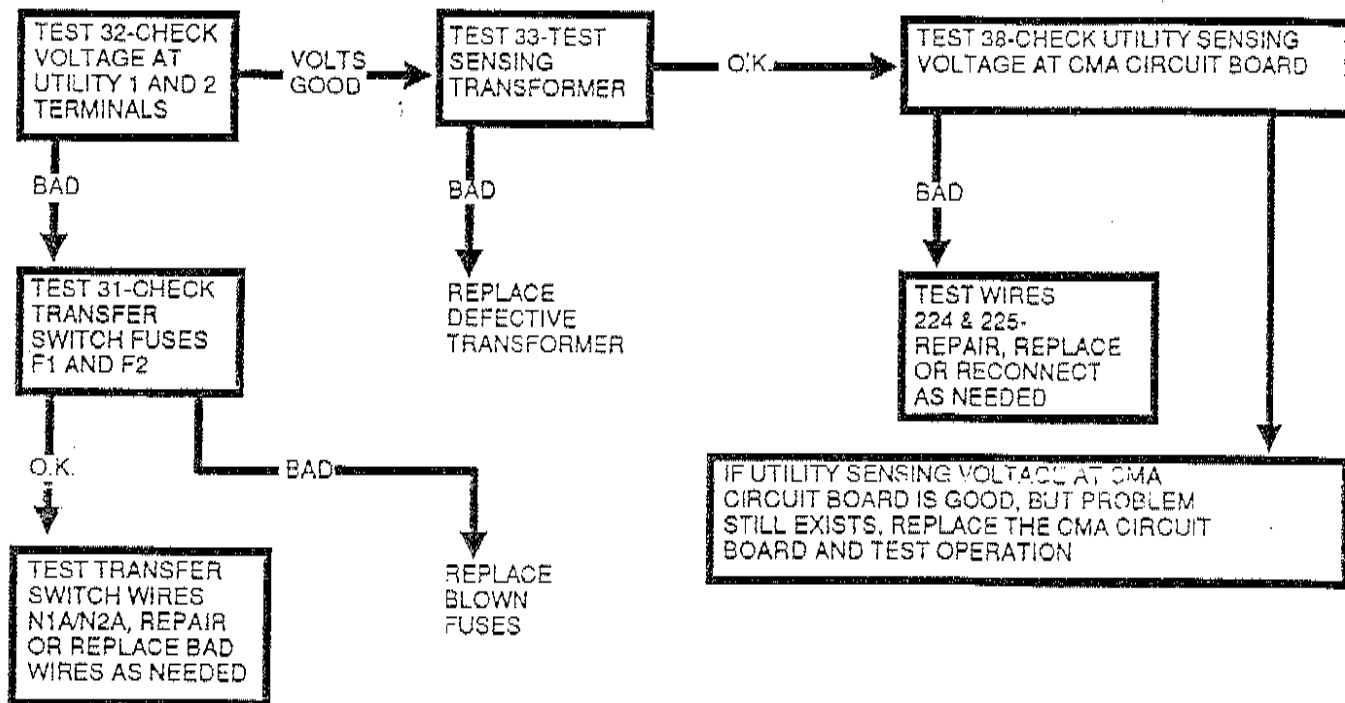

*Problem 7- Generator Does Not Start and Exercise as Programmed*

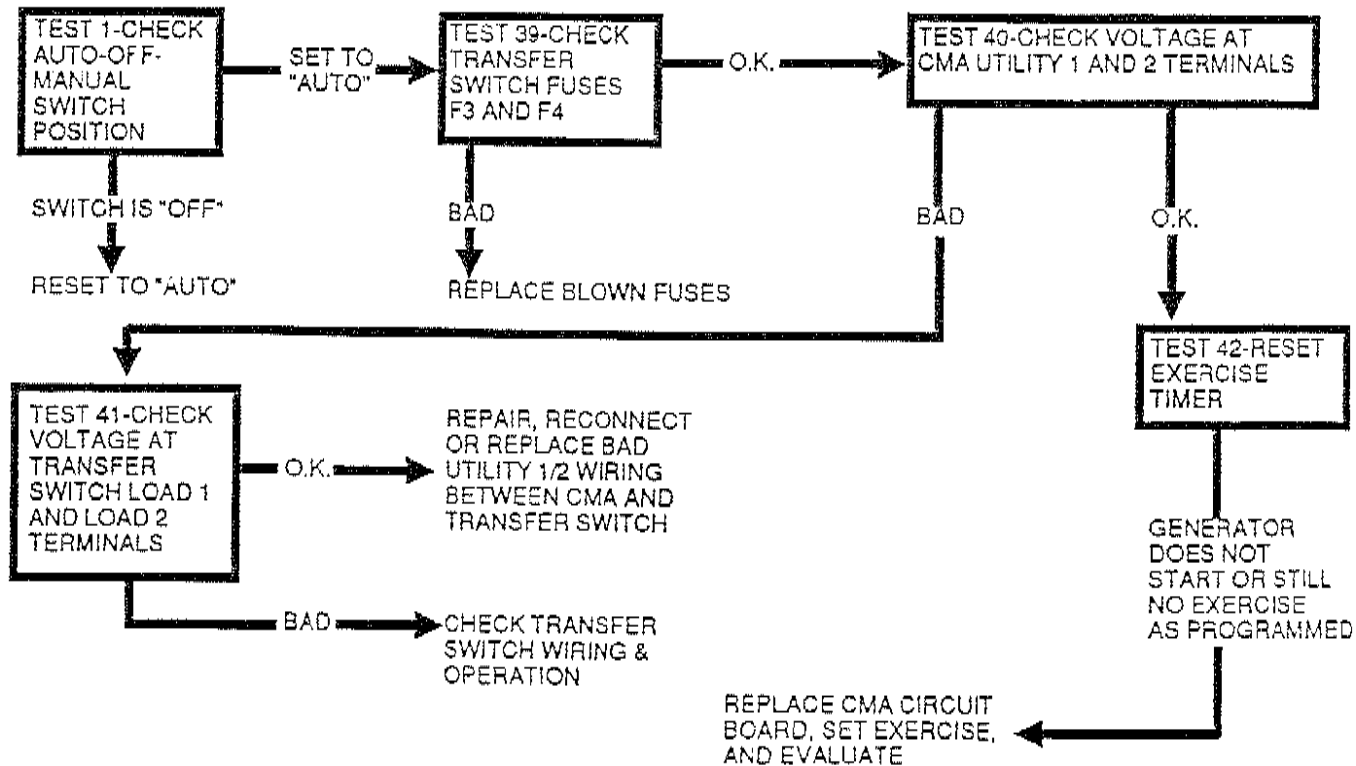



**Section 6.4  
DIAGNOSTIC TESTS**

**Introduction**

Perform these "Diagnostic Tests" in conjunction with the "Troubleshooting Flow Charts" of Section 6.3. Test numbers in this section correspond with the numbered tests in Section 6.3.

The test procedures and methods presented in this section are not exhaustive. We could not possibly know of, evaluate and advise the service trade of all conceivable ways in which testing and trouble diagnosis might be performed. We have not undertaken any such broad evaluation.

**Test 1- Check Position of Auto-Off-  
Manual Switch**

**DISCUSSION:**

If the standby system is to operate automatically, the generator's auto-off-manual switch must be set to "Auto". That is, the generator will not crank and start on occurrence of a "Utility" power outage unless that switch is at "Auto". In addition, the generator will not exercise every seven (7) days as programmed unless the switch is at "Auto".

**PROCEDURE:**

With the auto-off-manual switch set to "Auto", test automatic operation. Testing of automatic operation can be accomplished by turning OFF the "Utility" power supply to the transfer switch. When the "Utility" power is turned OFF, the standby generator should crank and start. Following startup, transfer to the "Standby" source should occur. Refer to Section 1.8 in this manual. An "Automatic Operating Sequences Chart" is provided on Page 1.8-2. Use the "Chart" as a guide in evaluating automatic operation.

Following generator startup and transfer to the "Standby" source, turn ON the "Utility" power supply to the transfer switch. Retransfer back to the "Utility" source should occur. After a "minimum run timer" and an "engine cooldown timer" have timed out, generator shutdown should occur.

**RESULTS:**

1. If normal automatic operation is obtained, discontinue tests.
2. If engine does not crank when "Utility" power is turned off, go on to Test 2 of Problem 1 in Section 6.3.
3. If engine cranks but won't start, go to Problem 2 in Section 6.3.
4. If engine cranks and starts, but transfer to "Standby" does not occur, go to Problem 4 in Section 6.3.
5. If transfer to "Standby" occurs, but retransfer back to "Utility" does not occur when that source voltage is restored, go to Problem 5.

**Test 2- Try a Manual Start**

**DISCUSSION:**

The first step in troubleshooting for an "engine won't crank" condition is to determine if the problem is peculiar to automatic operations only or if the engine won't crank manually either.

**PROCEDURE:**

1. On the generator panel, set the auto-off-manual switch to "Off".
2. Set the generator's main line circuit breaker to its "Off" or "Open" position.
3. Set the generator's auto-off-manual switch to "Manual".
  - a. The engine should crank cyclically in 7-9 second "crank-rest" cycles until it starts.
  - b. Let the engine stabilize and warm up for a few minutes after it starts.

**RESULTS:**

1. If the engine cranks manually but does not crank automatically, go to Test 3.
2. If the engine does not crank manually, go to Problem 2 in the "Troubleshooting Flow Charts".

**Test 3- Test Auto-Off-Manual switch**

**DISCUSSION:**

When the auto-off-manual switch is set to "Auto" position, battery voltage (12 volts DC) is delivered to the CMA circuit board via Wire 15, the closed switch terminal, Wire 15A, and Pin 10 of the circuit board connector. This voltage is needed to operate the circuit board.

Setting the switch to its "Manual" position also delivers battery voltage to the circuit board for its operation. In addition, when the switch is set to "Manual", 12 volts DC is supplied to the circuit board via Pin 11 of the board, Wire 239, the closed switch contacts, Wire 17 and Pin 9 of the circuit board connector.

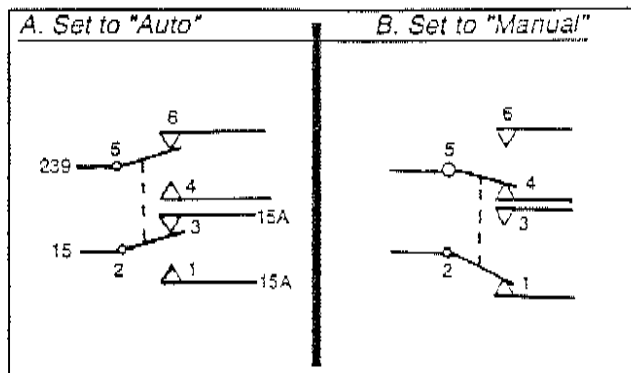

Figure 1. Schematic of Auto-Off-Manual switch

**Test 3- Test Auto-Off-Manual Switch  
(Continued)**

**PROCEDURE:**

Disconnect all wires from switch terminals, to prevent interaction. Then, use a volt-ohm-milliammeter (VOM) to test for continuity across switch terminals as shown in the following chart:

CONNECT ACROSS TERMINALS	SWITCH POSITION	METER READING
1 and 2	AUTO	Continuity
	MANUAL	Infinity
	OFF	Infinity
1 and 3	AUTO	Infinity
	MANUAL	Continuity
	OFF	Infinity
4 and 5	AUTO	Continuity
	MANUAL	Infinity
	OFF	Infinity
4 and 6	AUTO	Infinity
	MANUAL	Continuity
	OFF	Infinity

**RESULTS:**

1. Replace auto-off-manual switch, if defective.
2. If switch is good, go on to Test 4.

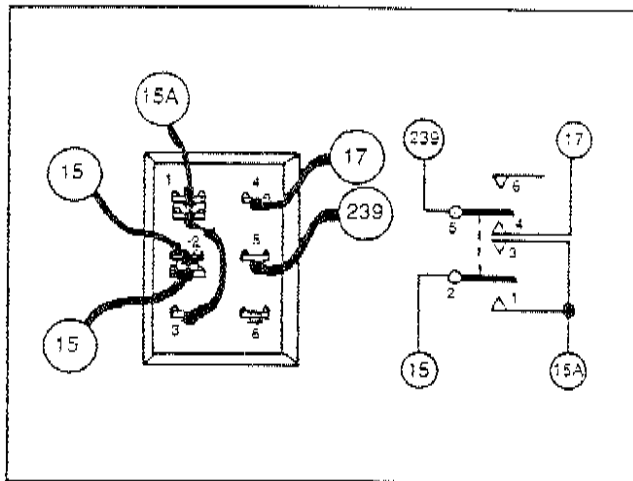

Figure 2. Auto-Off-Manual Switch Test Points

**Test 4- Check Wires 15A**

**DISCUSSION:**

Wires 15A serve to deliver fused 12 volts DC (battery power) to the CMA circuit board when the auto-off-manual switch is set to either "Auto" or "Manual". An open condition in this circuit will have the same effect as setting the auto-off-manual switch to "Off". One Wire 15A is simply a "jumper", used to interconnect two of the switch terminals. The other Wire 15A connects the switch to the CMA circuit board.

**PROCEDURE:**

Carefully inspect the two Wires 15A (Figure 2). Make sure they are properly connected to the switch. Use a VOM to test the wires for an open or shorted condition.

**RESULTS:**

1. If engine starts manually but not automatically; if auto-off-manual switch tests good; if Wires 15A are good; but cranking does not occur during a "Utility" power source outage, replace the CMA circuit board.
2. If Wires 15A are open, shorted, or improperly connected, repair, reconnect or replace bad wires. Then, test automatic operation.

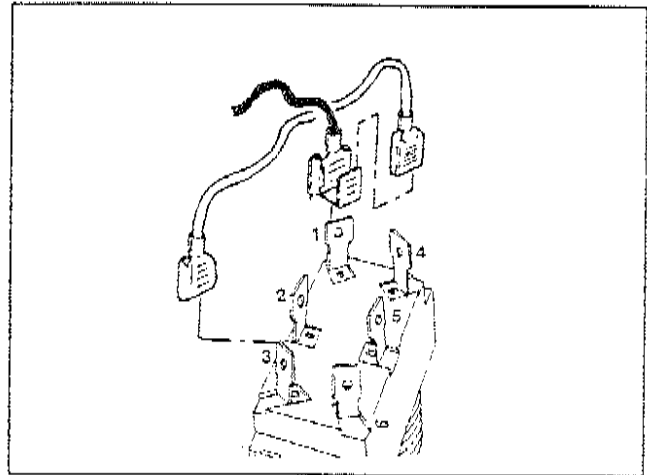

Figure 3. Wires 15A

**Test 5- Check 15 Amp Fuse**

**DISCUSSION:**

The 15 amp fuse is located on the generator console. A blown fuse will prevent battery power from reaching the CMA circuit board, with the same result as setting the auto-off-manual switch to "Off".

**PROCEDURE:**

Remove the 15 amp fuse (F1) by pushing in on fuse holder cap and turning the cap counterclockwise. Inspect the fuse visually and with a VOM for an open condition.

**RESULTS:**

1. If the fuse is good, go on to Test 6.
2. If the fuse is bad, it should be replaced. Use only an identical 15 amp replacement fuse.

**Test 6- Check Battery**

**DISCUSSION:**

Battery power is used to (a) crank the engine and (b) to power the CMA circuit board. Low or no battery voltage can result in failure of the engine to crank, either manually or during automatic operation.

***Test 6- Check Battery (Continued)***

**PROCEDURE:**

**A. Inspect battery Cables:**

1. Visually inspect battery cables and battery posts.
2. If cable clamps or terminals are corroded, clean away all corrosion.
3. Install battery cables, making sure all cable clamps are tight. The red battery cable (from starter contactor (SC) must be securely attached to the positive (+) battery post; the black cable (from the frame ground stud) must be tightly attached to the negative (-) battery post.

**B. Test Battery State of Charge:**

1. Use an automotive type battery hydrometer to test battery state of charge.
2. Follow the hydrometer manufacturer's instructions carefully. Read the specific gravity of the electrolyte fluid in all battery cells.
3. If the hydrometer does not have a "percentage of charge" scale, compare the reading obtained to the following:
  - a. An average reading of 1.260 indicates the battery is 100% charged.
  - b. An average reading of 1.230 means the battery is 75% charged.
  - c. An average reading of 1.200 means the battery is 50% charged.
  - d. An average reading of 1.170 indicates the battery is 25% charged.

**C. Test Battery Condition:**

1. If the difference between the highest and lowest reading cells is greater than 0.050 (50 points), battery condition has deteriorated and the battery should be replaced.
2. However, if the highest reading cell has a specific gravity of less than 1.230, the test for condition is questionable. Recharge the battery to a 100 percent state of charge, then repeat the test for condition.

**RESULTS:**

1. Remove the battery and recharge with an automotive battery charger, if necessary.
2. If battery condition is bad, replace the battery with a new one.

***Test 7- Check Wires 15/15A Voltage***

**DISCUSSION:**

The CMA circuit board will not turn on unless battery voltage is available to the board, via Wire 15, the auto-off-manual switch and Wire 15A. If the board does not "turn on", neither automatic or manual cranking will be possible.

**PROCEDURE:**

See Figures 2 and 3. Test the voltage at Wire 15 and 15A terminal ends as follows:

1. Connect the positive (+) test probe of a DC voltmeter (or VOM) to auto-off-manual switch Terminal 4. Con-

nect the common (-) test probe to frame ground. The meter should indicate battery voltage (12 volts DC).

2. Connect the positive (+) meter test probe to Terminal 5 of the auto-off-manual switch.

- a. Set the switch to "Auto" and the meter should read battery voltage.
- b. Set the switch to "Manual"- no voltage should be indicated.

3. Connect the positive (+) test probe to switch terminal 6 and the common (-) test probe to frame ground.

- a. Set the switch to "Auto"- the meter should read zero volts.
- b. Set the switch to "Manual"- meter should indicate battery voltage.

4. Test Wires 15A between auto-off-manual switch and the CMA circuit board connector for open condition.

**RESULTS:**

1. If no voltage is indicated in Step 1, check the Wire 15 circuit for open condition.
2. If voltage is indicated in Step 1 but not in Step 2 (switch at "Auto"), replace the auto-off-manual switch.
3. If voltage is indicated in Step 1 but not in Step 3 ("Manual" position), replace the auto-off-manual switch.
4. Repair or replace any defective wire 15A.

***Test 8- Check Wire 56 Voltage***

**DISCUSSION:**

During an automatic start or when starting manually, a crank relay (K1) on the CMA circuit board should energize for about 7-9 seconds, de-energize for 7-9 seconds, and so on. Each time the crank relay energizes, the CMA circuit board should deliver 12 volts DC to a starter contactor (SC) and the engine should crank. This test will verify (a) that the crank relay on the circuit board is energizing, and (b) that circuit board action is delivering 12 volts DC to the starter contactor.

**PROCEDURE:**

1. Connect the positive (+) test probe of a DC voltmeter (or VOM) to the Wire 56 terminal of the starter contactor. Connect the common (-) test probe to frame ground.

2. Gain access to the control module assembly (CMA) so the circuit board crank relay (K1) and run relay (K2) can be observed. The CMA is mounted on the rear panel of the generator enclosure. See Figure 4 on Page 6.1-2 for location of circuit board crank and run relays.

3. Observe the meter and the circuit board relays. Then, actuate the auto-off-manual switch to "Manual" position.

- a. The circuit board's crank and run relays should energize.
- b. The meter should indicate battery voltage.

4. Insert the positive (+) meter test probe into Pin 5 of the CMA board connector, connect the common (-) test probe to a clean frame ground. Then, repeat Step 2.

- a. The circuit board's crank and run relays should energize.
- b. The meter should read battery voltage.

**Test 8- Check Wire 56 Voltage (Continued)**

**RESULTS:**

1. If battery voltage is indicated in Step 4, but not in Step 3, Wire 56 (between the CMA board and starter contactor) is open. Repair or replace this wire as required.
2. If battery voltage is not indicated in Step 4, replace the CMA circuit board.
3. If battery voltage is indicated in both Steps 3 and 4, but engine does not crank, go on to Test 9.

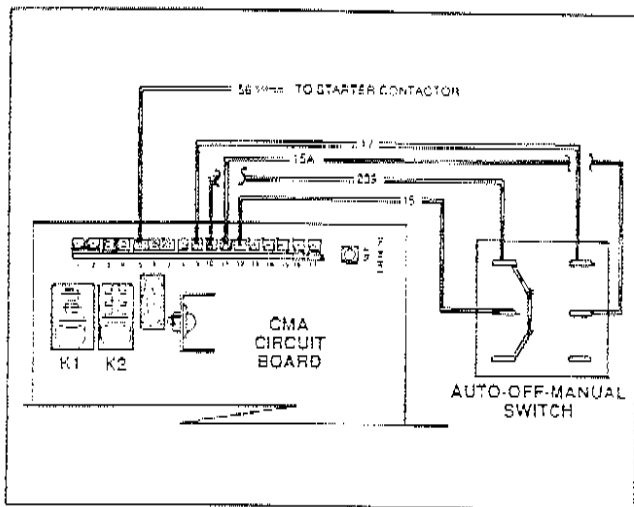

Figure 4. The Wire 56 Circuit

**Test 9- Test Starter Contactor**

**DISCUSSION:**

The starter contactor (SC) must energize and its heavy duty contacts must close or the engine will not crank. This test will determine if the starter contactor is in working order.

**PROCEDURE:**

Use a DC voltmeter (or a VOM) to perform this test. Test the starter contactor as follows:

1. Connect the positive (+) meter test lead to the large starter contactor stud (to which the red battery cable connects). Connect the common (-) meter test lead to a clean frame ground. Battery voltage (12 volts DC) should be indicated.
2. Now, connect the positive (+) meter test lead to the large starter contactor stud to which the starter motor cable attaches (Wire 16). Connect the common (-) test lead to frame ground.
  - a. No voltage should be indicated initially.
  - b. Set the auto-off-manual switch to "Manual". The meter should now indicate battery voltage as the starter contactor energizes.

**RESULTS:**

1. If battery voltage was indicated in Step 1, but not in Step 2(b), replace the starter contactor.

2. If battery voltage was indicated in Step 2(b), but the engine did not crank, go on to Test 10.

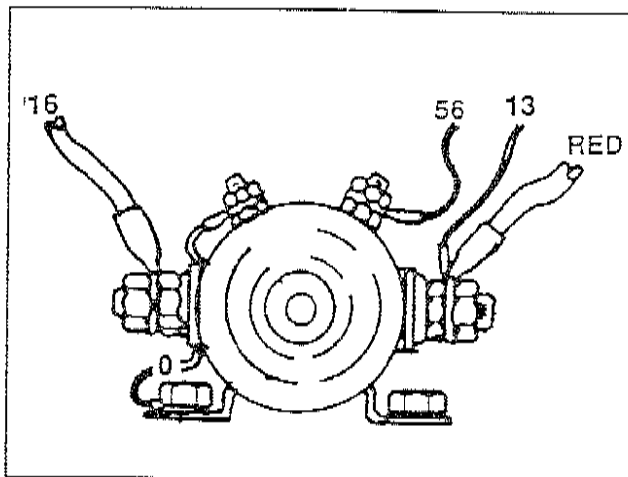

Figure 5. The Starter Contactor

**Test 10- Test Starter Motor**

**DISCUSSION:**

Test 8 should have been performed to verify that CMA circuit board action is delivering a DC voltage to the starter contactor coil. Test 9 verified that the starter contactor is functioning properly. Another possible cause of an "engine won't crank" problem is a failure of the starter motor.

**PROCEDURE:**

1. Carefully inspect the starter motor cable that runs from the starter contactor to the starter motor. Cable connections must be clean and tight. If connections are dirty or corroded, remove the cable and clean cable terminals and terminal studs. Replace any cable that is defective or badly corroded.
2. Use a DC voltmeter (or a VOM) to perform the following test:
  - a. Connect the positive (+) meter test lead to the starter motor terminal lug and the common (-) test lead to frame ground.
  - b. Set the auto-off-manual switch to "Manual". The meter should indicate battery voltage and the engine should crank.

**RESULTS:**

1. If battery voltage is indicated and the engine cranks, discontinue tests.
2. If battery voltage is indicated but engine does not crank, go to Step 3.

**PROCEDURE:**

3. To test starter motor performance, remove the starter and proceed as follows:
  - a. See Figure 6. Connect the starter motor, a fully charged 12 volts battery, tachometer and an ammeter as shown.

**Test 10- Test Starter Motor (Continued)**

b. Operate the starter motor and note the readings of the ammeter and the tachometer. A starter motor in good condition will be within the test specifications shown below:

<b>MAXIMUM MOTOR RPM</b>	<b>6500</b>
<b>MAXIMUM AMPERES</b>	<b>35</b>

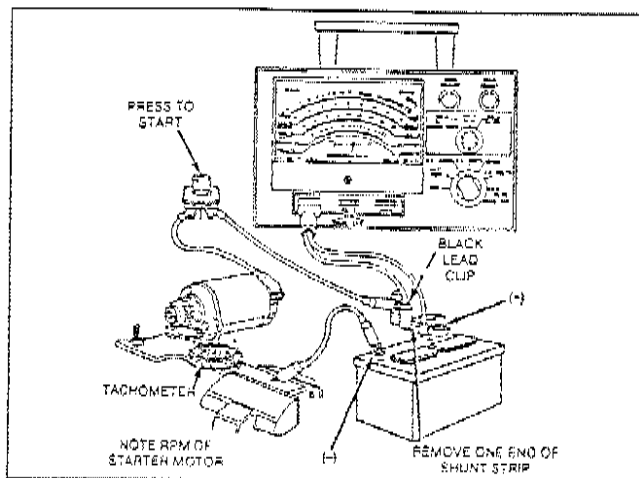

*Figure 6. Testing Starter Motor Performance*

4. Check starter pinion operation (Figure 7).
  - a. When the motor is energized, the pinion gear should move outward to engage the flywheel ring gear and crank the engine.
  - b. If the gear does not move properly, inspect the helix and pinion gear for binding and sticking. Correct such binding and sticking as necessary.

*NOTE: If the pinion sticks on the helix, problem must be corrected. Parts may be washed in a solvent such as "Stanisok®" or "Varsok®". DO NOT OIL OR GREASE THE HELIX OR PINION GEAR.*

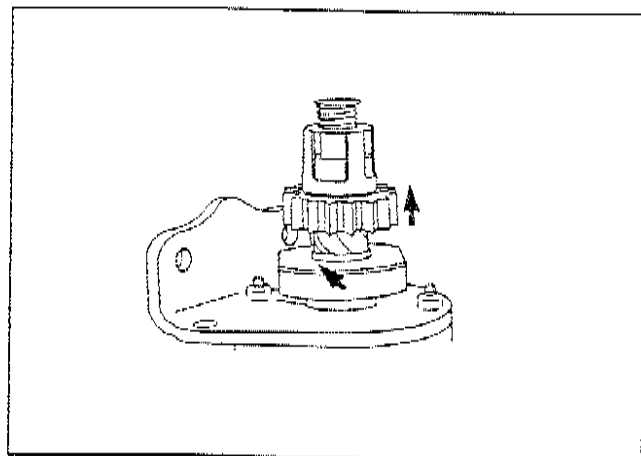

*Figure 7. Checking Pinion Gear Operation*

**Test 11- Check Fuel Supply and Pressure**

**DISCUSSION:**

The air-cooled prepackaged generator was factory tested and adjusted using natural gas as a fuel. If desired, LP (propane) gas may be used. However, when changing over to propane, some minor adjustments are required. See Part 8, "Operational Tests and Adjustments". The following facts apply:

- An adequate gas supply and sufficient fuel pressure must be available or the engine will not start.
- Minimum recommended gaseous fuel pressure at the generator's fuel inlet connection is 11 inches water column (6.38 ounces per square inch).
- Maximum gaseous fuel pressure at the generator's fuel inlet connection is 14 inches water column (8 ounces per square inch).
- When propane gas is used, only a "vapor withdrawal" type system may be used. This type of system utilizes the gas vapors that form above the liquid fuel in a storage tank. The vapor pressure must be high enough to sustain engine operation.
- The gaseous fuel system must be properly tested for leaks following installation and periodically thereafter. No leakage is permitted. Leak test methods must comply strictly with applicable fuel-gas codes.

**DANGER: GASEOUS FUELS ARE HIGHLY EXPLOSIVE. DO NOT USE FLAME OR HEAT TO TEST THE FUEL SYSTEM FOR LEAKS. NATURAL GAS IS LIGHTER THAN AIR, TENDS TO SETTLE IN HIGH PLACES. LP (PROPANE) GAS IS HEAVIER THAN AIR, TENDS TO SETTLE IN LOW AREAS. EVEN THE SLIGHTEST SPARK CAN IGNITE THESE GASES AND CAUSE AN EXPLOSION.**

**PROCEDURE:**

A water manometer or a gauge that is calibrated in "ounces per square inch" may be used to measure the fuel pressure. Fuel pressure at the inlet side of the fuel solenoid valve should be between 11-14 inches water column as measured with a manometer, or 6.38-14.000 ounces per square inch as measure with a pressure gauge.

*NOTE: Where a primary regulator is used to establish fuel inlet pressure, adjustment of that regulator is usually the responsibility of the fuel supplier or the fuel supply system installer.*

**RESULTS:**

If fuel supply and pressure are adequate, but engine will not start, go on to Test 13. You may wish to review Section 1.3, "Prepackaged Installation Basics".

**Test 11- Check Fuel Supply and Pressure (Continued)**

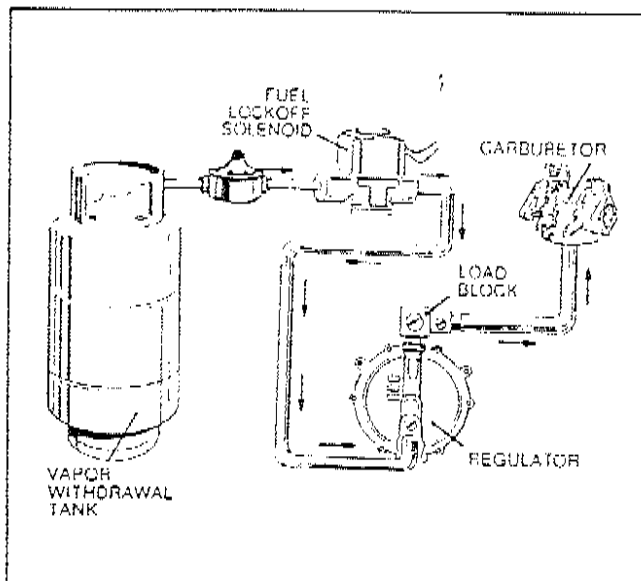

Figure 8. Air Cooled Engine Fuel System

**Test 12- Check CMA Circuit Board Power Supply and Output to Wire 56**

**DISCUSSION:**

If the engine will not crank when the auto-off-manual switch is set to "Manual", it is possible that (a) the DC power supply to the CMA circuit board is lost, or (b) the circuit board is defective and its DC output to Wire 56 and the starter contactor is lost.

**PROCEDURE:**

1. Complete Test 7, "Check Wires 15/15A Voltage".
2. Complete Test 8, "Check Wire 56 Voltage".

**RESULTS:**

1. In Test 7, if battery voltage is indicated and engine cranks and starts, discontinue tests.
2. In Test 7, if the power supply to the circuit board is bad, perform Test 3.
3. If power supply to the circuit board was good, but no DC output to Wire 56, replace the CMA circuit board.

**Test 13- Check CMA Board Wire 14 Output**

**DISCUSSION:**

During any cranking action, the CMA board's crank relay (K1) and run relay (K2) both energize simultaneously. When the run relay energizes, its contacts close and 12 volts DC is delivered to Wire 14 and to a fuel solenoid. The solenoid energizes open to allow fuel flow to the engine. This test will determine if the CMA circuit board is working properly.

**PROCEDURE:**

1. Set the auto-off-manual switch to "Off".
2. Connect the positive (+) test lead of a DC voltmeter (or VCM) into Pin 7 (Wire 14) of the CMA circuit board connector. Connect the common (-) test lead to frame ground.
3. While observing the meter, set the manual-off-auto switch to "Manual".
  - a. The circuit board's crank and run relays should energize and the engine should crank and start.
  - b. The meter should indicate battery voltage.

**RESULTS:**

1. If the engine cranks but does not start and DC voltage is not indicated, replace the CMA circuit board.
2. If the engine cranks but does not start and DC voltage is indicated, go to Test 14.

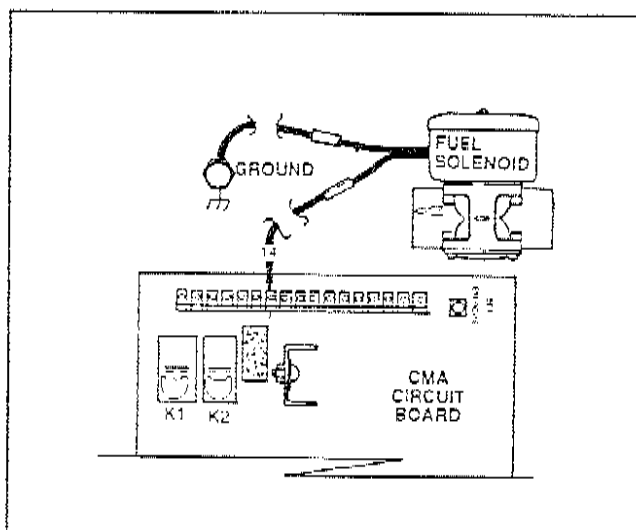

Figure 9. The Wire 14 Circuit

**Test 14- Check Fuel Solenoid**

**DISCUSSION:**

In Test 13, if battery voltage was delivered to Wire 14, the fuel solenoid should have energized open. This test will verify whether or not the fuel solenoid is operating.

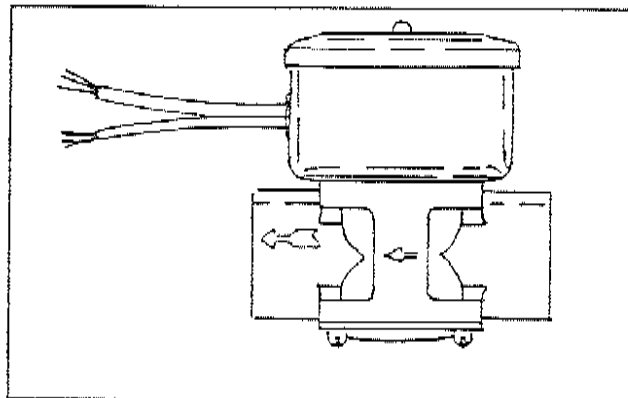

Figure 10. The Fuel Solenoid (FS)

**Test 14- Check Fuel Solenoid (Continued)**

**PROCEDURE:**

Place one hand on the fuel solenoid and crank the engine. You should be able to feel the solenoid actuate as well as hear it actuate.

**RESULTS:**

1. If solenoid actuates, go to Test 15.
2. Replace the solenoid if it does not actuate.

**Test 15- Check For Ignition Spark**

**DISCUSSION:**

If the engine cranks but will not start, perhaps an ignition system failure has occurred. A special "spark tester" can be used to check for ignition spark.

**PROCEDURE:**

1. Remove spark plug leads from the spark plugs (Figure 11).
2. Attach the clamp of the spark tester to the engine cylinder head.
3. Attach the spark plug lead to the spark tester terminal.
4. Crank the engine while observing the spark tester. If spark jumps the tester gap, you may assume the engine ignition system is operating satisfactorily.

*NOTE: The engine flywheel must rotate at 350 rpm (or higher) to obtain a good test of the solid state ignition system.*

To determine if an engine miss is ignition related, connect the spark tester in series with the spark plug wire and the spark plug (Figure 12). Then, crank and start the engine. A spark miss will be readily apparent. If spark jumps the spark tester gap regularly but the engine miss continues, the problem is in the spark plug or in the fuel system.

*NOTE: A sheared flywheel key may change ignition timing but sparking will still occur across the spark tester gap.*

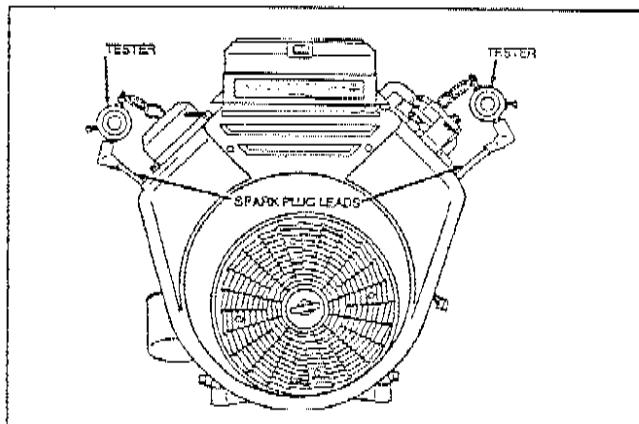

Figure 11. Checking Ignition Spark

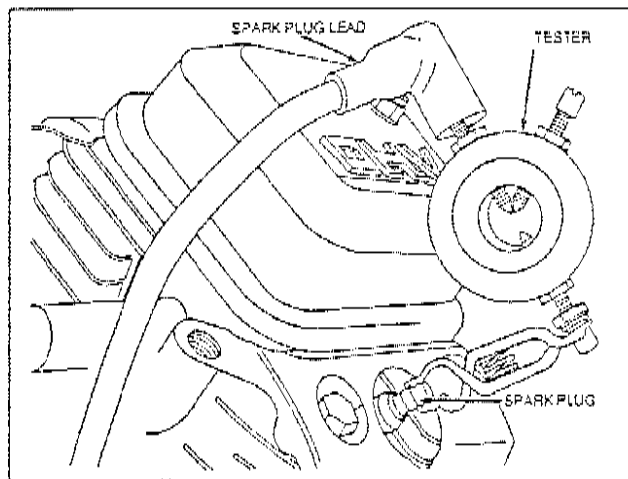

Figure 12. Checking Engine Miss

**RESULTS:**

1. If no spark or very weak spark occurs, go to Test 18.
2. If sparking occurs but engine still won't start, go to Test 16.
3. When checking for engine miss, if sparking occurs at regular intervals but engine miss continues, go to Test 16.
4. When checking for engine miss, if a spark miss is readily apparent, go to Test 18.

**Test 16- Check Spark Plugs**

**DISCUSSION:**

If the engine will not start and Test 15 indicated good ignition spark, perhaps the spark plugs are fouled or otherwise damaged. Engine miss may also be caused by defective spark plug(s).

**PROCEDURE:**

1. Remove spark plugs and clean with a pen knife or use a wire brush and solvent.
2. Replace any spark plug having burned electrodes or cracked porcelain.
3. Set gap on new or used spark plugs to 0.030 inch (0.76mm).

**RESULTS:**

1. Clean, regap or replace spark plugs as necessary.
2. If spark plugs are good, go to Test 17.

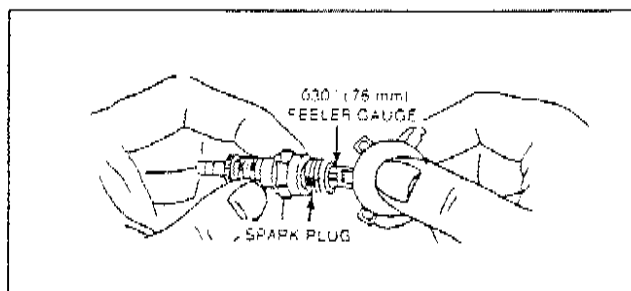

Figure 13. Checking Spark Plug Gap

### Test 17- Check Engine Compression

#### DISCUSSION:

Lost or reduced engine compression can result in (a) failure of the engine to start, or (b) rough operation. Loss of compression will usually be caused by one or more of the following:

- Blown or leaking cylinder head gasket.
- Improperly seated or sticking valves.
- Worn piston rings or cylinder. (This will also result in high oil consumption.

*NOTE: It is extremely difficult to obtain an accurate compression reading without special equipment. For that reason, compression values are not published for the V-Twin engine. Testing has proven that an accurate compression indication can be obtained using the following method.*

#### PROCEDURE:

1. Remove both spark plugs.
2. Insert a compression gauge into either cylinder.
3. Crank the engine until there is no further increase in pressure.
4. Record the highest reading obtained.
5. Repeat the procedure for the remaining cylinder and record the highest reading.

#### RESULTS:

The difference in pressure between the two cylinders should not exceed 25 percent. If the difference is greater than 25 percent, loss of compression in the lowest reading cylinder is indicated.

**Example 1:** If the pressure reading of cylinder #1 is 65 psi and of cylinder #2, 60 psi, the difference is 5 psi. Divide "5" by the highest reading (65) to obtain the percentage of 7.6 percent.

**Example 2:** No. 1 cylinder reads 75 psi; No. 2 cylinder reads 55 psi. The difference is 20 psi. Divide "20" by "75" to obtain "26.7 percent. Loss of compression in No. 2 cylinder is indicated.

### Test 18- Check Engine I.S.D. Module

#### DISCUSSION:

The I.S.D. module is electrically connected in series with the two engine ignition modules and Pin 6 of the CMA circuit board. The module consists of diodes which permit current flow in one direction only. Wire 18 connects the module to the circuit board. During normal operation, circuit board action holds the Wire 18 and Pin 6 circuit open to ground. For shutdown, circuit board action closes that circuit to ground. Termination of engine ignition is the result and the engine will shut down.

#### PROCEDURE:

1. Set a VOM to its "Rx1" scale and zero the meter.
2. If the meter has a polarity switch, set it to "+DC".
3. See Figure 14. Connect the VOM positive (+) test lead to test point "A", the common (-) to test point "B".

4. Check the meter reading.

5. Now, reverse the test leads. That is, connect the positive (+) test lead to test point "B", the common (-) test lead to test point "A". Again, note the meter reading. The VOM should indicate the forward resistance of the I.S.D. diodes at one polarity only and should indicate "infinity" at the opposite polarity.

6. Now, connect the positive (+) VOM test lead to test point "B", the common (-) to test point "C". The VOM should read "infinity".

7. Reverse the test leads, i.e., connect the positive (+) test lead to test point "C" and the common (-) to test point "B". The meter should indicate "infinity".

#### RESULTS:

If the I.S.D. module fails the test, it should be replaced.

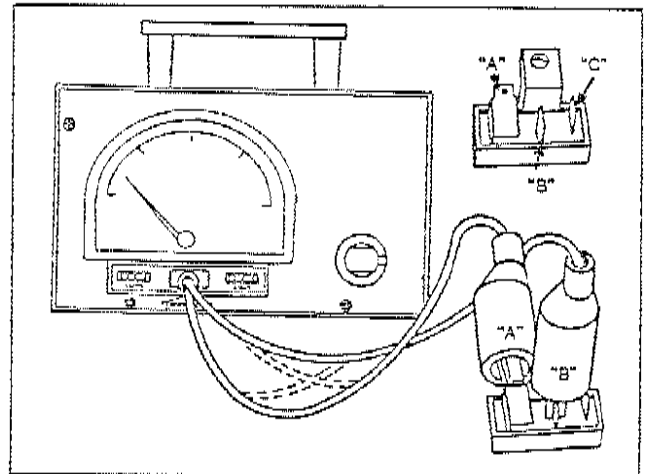

Figure 14. Testing I.S.D. Module (Steps 3-5)

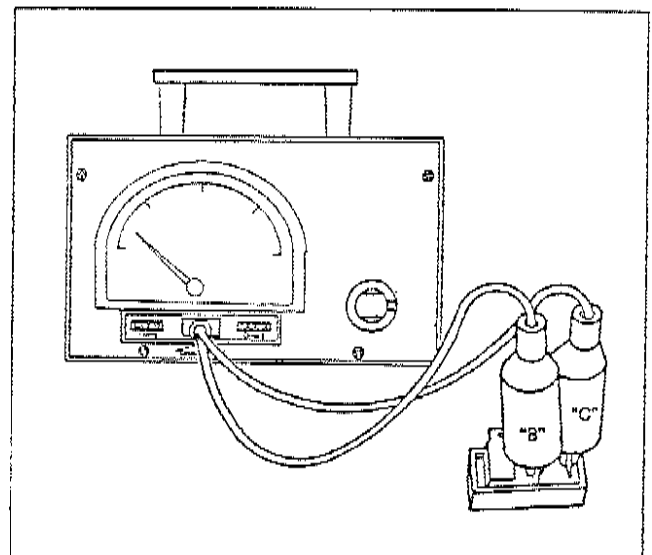

Figure 15. Testing I.S.D. Module (Steps 6-7)

**Test 19- Check and Adjust Ignition Modules**

**DISCUSSION:**

In Test 15, a spark tester was used to check for engine ignition. If sparking or weak spark occurred, one possible cause might be the ignition module(s). This test consists of adjusting the air gap between the ignition modules and the flywheel.

**PROCEDURE:**

1. See Figure 16. Rotate the flywheel until the magnet is under the module (armature) laminations.
2. Place an 0.008-0.012 inch (0.20-0.30mm) thickness gauge between the flywheel magnet and the module laminations.
3. Loosen the mounting screws and let the magnet pull the module down against the thickness gauge.
4. Tighten both mounting screws.
5. To remove the thickness gauge, rotate the flywheel.
6. Repeat the above procedure for the second module.
7. Repeat Test 15 and check for spark across the spark tester gap.

**RESULTS:**

After setting air gap, if sparking does not occur, replace the appropriate ignition module (armature).

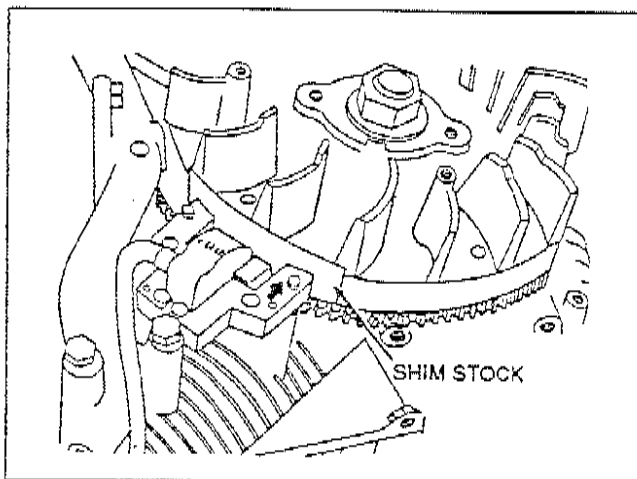

Figure 16. Setting Ignition Module (Armature) Air Gap

**Test 20- Check Oil Pressure Switch**

**DISCUSSION:**

Also see Section 1.6 in this manual. If the oil pressure switch contacts have failed in their closed position, the engine will probably crank and start. However, shut-down will then occur within a second or two. If the engine cranks and starts, then shuts down almost immediately, the cause may be one or more of the following:

- Low engine oil level.
- Low oil pressure.
- A defective oil pressure switch.

**PROCEDURE:**

1. Check engine crankcase oil level.
  - a. Check engine oil level.
  - b. If necessary, add the recommended oil to the dipstick "Full" mark. **DO NOT OVERFILL ABOVE THE "FULL" MARK.**
  - c. Check oil level in the oil makeup tank. Fill tank, if necessary, using the same type and grade of oil used in the engine crankcase.
  - d. If engine oil level is low and oil makeup tank is full, check the oil makeup system as follows:
    - (1) Inspect oil makeup system lines and fittings for leaks, tightness.
    - (2) Check the oil fill tube and oil filler cap for tightness.
2. With oil level correct, try starting the engine.
  - a. If engine still cranks and starts, but then shuts down, go to Step 3.
  - b. If engine cranks and starts normally, discontinue tests.
3. Disconnect Wire 85 from the oil pressure switch terminal. Remove the switch and install an oil pressure gauge in its place.
  - a. Crank the engine while observing the oil pressure reading on gauge.
  - b. If engine starts and runs with Wire 85 removed, note the oil pressure.
    - (1) Normal oil pressure is approximately 10-15 psi with engine running. If normal oil pressure is indicated, go to Step 4 of this test.
    - (2) If oil pressure is below about 4.5 psi, shut engine down immediately. A problem exists in the engine lubrication system.
  - c. If engine starts and then shuts down with Wire 85 disconnected from switch, go to Test 21.
4. Remove the oil pressure gauge and reinstall the oil pressure switch. Do NOT connect Wire 85 to the switch terminal.
  - a. Set a VOM to its "Rx1" scale and zero the meter.
  - b. Connect the VOM test leads across the switch terminal and the switch body. With engine shut down, the meter should read "continuity".
  - c. Crank and start the engine. The meter should read "infinity".

**RESULTS:**

1. If switch tests good, go to Test 21.
2. Replace switch if it fails the test.

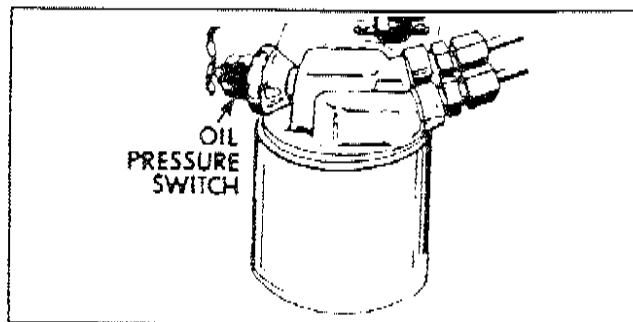

Figure 17. Oil Pressure Switch

**Test 21- Check High Oil Temperature  
Switch**

**DISCUSSION:**

Also see Section 1.6. If the temperature switch contacts have failed in a closed position, engine will generally crank and start. However, shutdown will then occur within a second or two.

**PROCEDURE:**

1. Disconnect Wire 85 from the switch.
2. Remove the oil temperature switch.
3. Immerse the sensing tip of the switch in oil as shown in Figure 18, along with a suitable thermometer.
4. Set a VOM to its "Rx1" scale and zero the meter. Then, connect the VOM test leads across the switch terminal and the switch body. The meter should read "infinity".
5. Heat the oil in the container. When the thermometer reads approximately 274°-294° F. (134°-146° C.), the VOM should indicate "continuity".

**RESULTS:**

1. If the switch tests good, reinstall it and go to Test 22.
2. If the switch tests bad, it should be replaced.

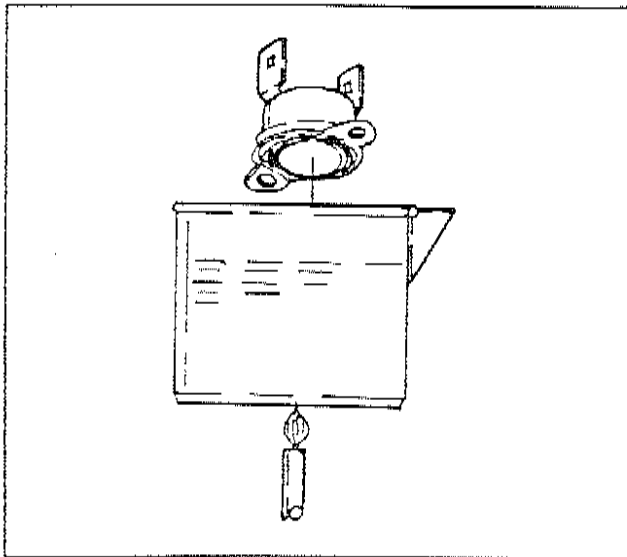

Figure 18. Testing the Oil Temperature Switch

**Test 22- Check Wire 18**

**DISCUSSION:**

Wire 18 connects the engine's I.S.D. module to the CMA circuit board. During a shutdown operation, circuit board action connects Wire 18 and the I.S.D. module to ground. Thus, ignition is terminated. If Wire 18 is shorted to ground, engine startup cannot occur. If Wire 18 is open, ignition will not be terminated to effect shutdown. However, shutdown will still occur since the fuel solenoid (FS) will be de-energized by circuit board action.

**PROCEDURE:**

Use a VOM to test Wire 18, between the I.S.D. module and the CMA circuit board connector, for an open or shorted condition.

**RESULTS:**

Repair or replace defective Wire 18 as necessary.

**Test 23- Check Generator Main Circuit  
Breakers**

Refer to Test 1 in Section 2.4 (Page 2.4-1).

**Test 24- Test Stator Battery Charge  
Winding Output**

**DISCUSSION:**

The CMA circuit board utilizes battery charge winding output as (a) an indication the engine has started, and (b) as an engine speed indicator. When battery charge winding output is detected by the circuit board, an "engine warmup timer" starts timing. If battery charge winding output is non-existent or low, transfer of loads to the "Standby" source cannot occur.

**PROCEDURE:**

1. See Figure 19. Connect an accurate AC frequency meter across Pin #8 of the CMA circuit board connector (to which Wire 66 connects) and the terminal on the battery charge rectifier to which Wire 77 connects.
2. Start the engine. The frequency meter should read approximately 61-63 Hz at no-load.

*NOTE: An AC voltmeter can also be used to check for an "engine running" signal. With engine running the voltmeter should indicate approximately 15 volts AC (RMS).*

3. Inside the generator panel, disconnect stator Wire 55 from the resistor. Also, disconnect Wires 66 and 77 from the battery charge rectifier (BCR). Test the battery charge windings for continuity as follows:
  - a. Set a VOM to its "Rx1" scale and zero the meter.
  - b. Connect one VOM test lead to terminal end of Wire 55, the other test lead to Wire 66. A resistance of approximately 0.06 ohm should be indicated. Some meters will simply read continuity.
  - c. Connect one test lead to Wire 55, the other to Wire 77. Again, resistance should be about 0.06 ohm.
  - d. If reading is very high or if "infinity" is read, an open circuit results in the stator battery charge winding.
4. Now, set the VOM to a very high resistance scale and zero the meter.
  - a. Connect one test lead to Wire 66, the other test lead to a clean frame ground. The VOM should read "infinity".
  - b. If the VOM reads other than "infinity" a shorted condition exists.

**Test 24- Test Stator Battery Charge  
Winding Output (Continued)**

**RESULTS:**

1. If an open circuit is indicated, remove and replace stator assembly.
2. If a shorted condition is indicated, refer to Section 1.5, "Testing, Cleaning and Drying".

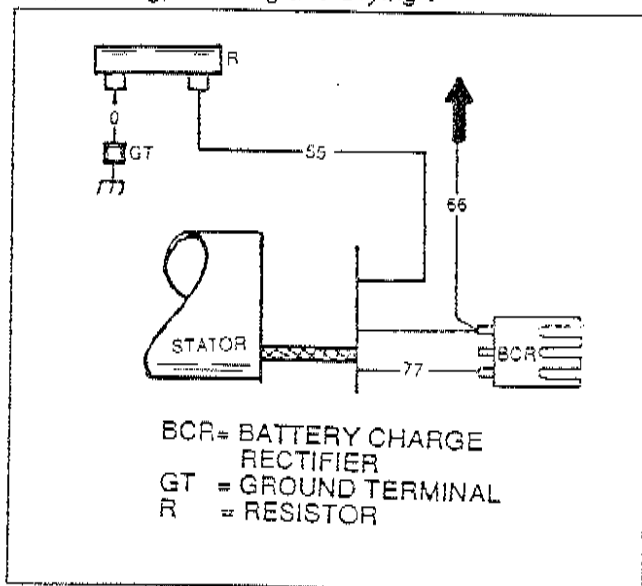

Figure 19. Battery Charge Winding Test Points

**Test 25- Ground CMA Terminal 23**

**DISCUSSION:**

To initiate a transfer to "Standby" action, the CMA board connects the terminal 23 circuit to ground. This causes the transfer relay in the transfer switch to energize and transfer to "Standby" occurs. If, during automatic operating mode, transfer to the "Standby" source does not occur, this test will determine if the problem is in the generator's control module assembly (CMA) or in the prepackaged transfer switch.

**PROCEDURE:**

1. On the generator panel, set the auto-off-manual switch to "Off".
2. Turn OFF all power voltage supplies to the transfer switch, using whatever means provided.
3. Check that the transfer switch main contacts have been actuated to their "Utility" power source side.
4. Turn ON the "Utility" power supply to the transfer switch.
5. Set the generator's auto-off-manual switch to "Auto".
6. Actuate the generator's main line circuit breaker to its "On" or "Closed" position.
7. Turn OFF the "Utility" power supply to the transfer switch using whatever means provided.
  - a. After a slight delay, the engine should crank and start.

b. Following startup, transfer to "Standby" should occur.

8. If transfer to the "Standby" source does NOT occur, connect a jumper wire from terminal 23 of the CMA and to a clean frame ground. On connection of the jumper wire, the transfer relay (in transfer switch) should energize and transfer to "Standby" should occur.

**RESULTS:**

1. If transfer to "Standby" occurs in Step 8 but did not occur in Step 7, replace the CMA circuit board.
2. If transfer to "Standby" did not occur in either Step 7 or Step 8, go on to Test 26.

**Test 26- Test Terminals 23 and 194 Circuit**

**DISCUSSION:**

Terminals 23/194 of the CMA terminal strip should have been properly connected to identically numbered terminals in the prepackaged transfer switch. If this circuit is open at any point, transfer to "Standby" will not occur in automatic mode.

**PROCEDURE:**

Inspect and test Wires 23/194, between the generator and transfer switch.

**RESULTS:**

1. Repair, reconnect or replace interconnecting Wires 23/194 as required.
2. If Wires 23 and 194 are good, go on to Test 27.

**Test 27- Test Transfer Relay**

Refer to Test 3 in Part 4, Section 4.4.

**Test 28- Check Voltage at Standby Closing Coil**

See Test 2 in Part 4, Section 4.4.

**Test 29- Test Limit Switch XB1**

Refer to Test 5 in Part 4, Section 4.4.

**Test 30- Test Transfer Switch Wires E1, 205, B and E2**

See Section 4.4.

**Test 31- Check Transfer Switch Fuses F1 and F2**

See Test 10 in Section 4.4.

**Test 32- Check Voltage at Utility 1 and 2 Terminals**

Refer to Test 8 in Section 4.4.

**Test 33- Test Sensing Transformer**

**DISCUSSION:**

A sensing transformer is housed in the control module assembly (CMA). Utility 1/Utility 2 voltage is delivered to the primary winding of this transformer. The transformer reduces the line-to-line "Utility" source voltage to about 14 volts AC. The reduced voltage is then delivered to the CMA circuit board as "Utility" sensing voltage. An open circuit condition in the transformer can (a) prevent automatic retransfer back to "Utility", and (b) initiate generator startup and transfer to "Standby" when "Utility" source power is available.

**PROCEDURE:**

1. Check that "Utility" source voltage is available to the transfer switch.
2. Use an AC voltmeter (or a VOM) to check the voltage at transformer terminals 1 and 4. "Utility" source line-to-line voltage should be indicated.
3. Now, check the voltage at transformer terminals 5 and 8. The meter should read approximately 14 volts AC.

**RESULTS:**

1. If voltage readings in both Steps 2 and 3 are good, go on to Test 34.
2. If voltage in Step 2 is good, but reading in Step 3 is bad, replace the sensing transformer.

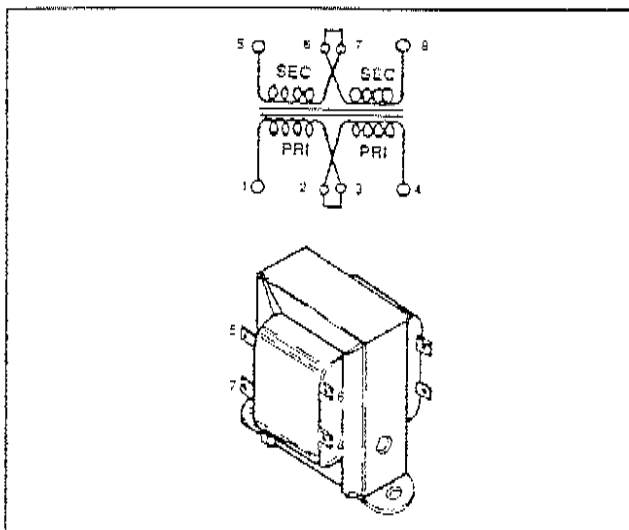

Figure 20. Sensing Transformer T1

**Test 34- Disconnect Wire 23 from CMA Terminal Strip**

**DISCUSSION:**

During automatic operation, when "Utility" power has been restored, CMA circuit board action should open the Wire 23 circuit to ground. With Wire 23 open, the transfer relay should de-energize and retransfer back to the "Utility" source should occur.

If the CMA board malfunctions and does not open the ground on the Wire 23 circuit, retransfer back to "Utility" will not occur.

**PROCEDURE:**

With the generator running and loads powered by the "Standby" source, disconnect Wire 23 from the CMA terminal strip. The transfer relay should de-energize and retransfer back to the "Utility" source should occur.

**RESULTS:**

1. If retransfer to "Utility" occurs when Wire 23 is disconnected, but does not occur during normal automatic operation, replace the CMA circuit board.
2. If retransfer does not occur when Wire 23 is disconnected and does not occur during normal automatic operation, complete Test 27. If the transfer relay checks good in Test 27, go on to Test 35.

**Test 35- Check Voltage at Utility Closing Coil C1**

Refer to Test 9 in Section 4.4.

**Test 36- Test Limit Switch XA1**

See Test 11 in Section 4.4.

**Test 37- Check Transfer Switch Wires N1A, N2A, 126 and "A"**

Refer to Test 6 in Section 4.4.

**Test 38- Check Utility Sensing Voltage at CMA Circuit Board**

**DISCUSSION:**

If the generator starts and transfer to "Standby" occurs in automatic mode even though an acceptable "Utility" source voltage is available to the transfer switch, follow the troubleshooting sequence given in Section 6.3, Problem 6. Complete Tests 32 and 33. In Test 33, if a normal reduced sensing voltage is available from the sensing transformer, the next step is to determine if that sensing voltage is reaching the CMA circuit board.

**PROCEDURE:**

Insert the test probes of an AC voltmeter (or a VOM) into terminals 14 and 15 of the CMA circuit board connector. Wires 224 and 225 connect to those terminals. The meter should indicate approximately 14 volts AC.

**RESULTS:**

1. If the meter reads about 14 volts AC, replace the CMA circuit board and test automatic operation.
2. If the sensing transformer checked good in Test 33, but transformer reduced sensing voltage is not available to the circuit board in this test, an open condition must exist in Wire(s) 224 and 225. Repair, reconnect or replace defective wire(s) as necessary.

**Test 39- Check Transfer Switch Fuses  
F3 and F4**

**DISCUSSION:**

Fuses F3/F4 are located in the V-Type transfer switch assembly and are electrically connected in series with the "Load 1" and "Load 2" circuit. This circuit delivers line-to-line "Load" terminal power to the CMA circuit board. The board uses that power to operate a "7-day exercise" circuit. If the generator does not start and exercise every seven days as programmed, it is possible that one or both of these 2 amp fuse(s) have blown.

**PROCEDURE:**

See Figure 21. Remove fuses F1 and F2. Inspect the fuses visually and with a VOM.

**RESULTS:**

1. Replace any blown fuse(s).
2. If fuses are good, go on to Test 40.

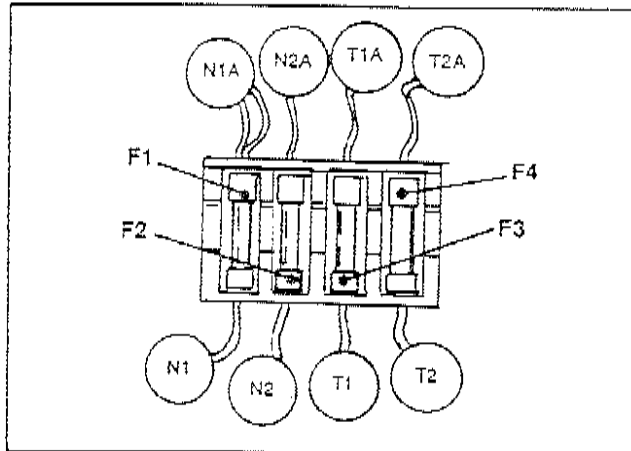

Figure 21. Transfer Switch Fuse Block

**Test 40- Check Voltage at CMA Utility 1  
and 2 Terminals**

**DISCUSSION:**

Loss of voltage at the Utility 1/2 terminals of the CMA will result in loss of the timing count for 7-day exercise.

**PROCEDURE:**

Use an AC voltmeter (or a VOM) to check the voltage across the "Utility 1/Utility 2" terminals of the control module assembly (CMA) terminal board.

**RESULTS:**

1. If normal line-to-line voltage is indicated in the test, go to Test 42.
2. If normal line-to-line voltage is NOT indicated in the test, go to Test 41.

**Test 41- Check Voltage at Transfer  
Switch Load 1 and Load 2 Terminals**

**DISCUSSION:**

If the voltage reading in Test 40 was bad, an open circuit somewhere between the transfer switch and the generator is indicated. This test will help you locate where the open circuit is.

**PROCEDURE:**

Use an AC voltmeter (or VOM) to test the line-to-line load voltage at transfer switch terminals "Utility 1 and 2".

**RESULTS:**

1. If load voltage is good, but was not good in Test 40, an open or shorted condition exists in the "Utility 1/2" wiring between the transfer switch and generator. Repair, reconnect or replace bad wiring as necessary.
2. If load voltage is bad in this test and was also bad in Test 40, several possibilities exist as follows:
  - a. Check Wires T1A and T2A, between the transfer switch terminal board and terminal lugs T1/T2.
  - b. Check voltage across terminal lugs T1/T2.
  - c. If voltage reading across T1/T2 is bad, check "Utility" source voltage across transfer switch terminal lugs N1/N2.
  - d. If voltage reading across N1/N2 is good, but reading across T1/T2 is bad, the main contacts are not closed to the "Utility" power source side or the transfer mechanism is defective. Operate the main contacts manually to test switch operation.

**Test 42- Reset Exercise Timer**

**DISCUSSION:**

A miniature pushbutton switch is provided on the CMA circuit board for selecting day and time of day for exercise to occur. If the standby generator does not start and exercise as originally programmed, perhaps the circuit board's "timing count" has been lost.

**PROCEDURE:**

1. Set the generator's auto-off-manual switch to "Off".
2. Check that the transfer switch main contacts are at their "Utility" power source side, i.e., "Load" is connected to the "Utility" source.
3. Check that "Utility" power source voltage is available to terminal lugs N1/N2 of the transfer mechanism.
4. Set the auto-off-manual switch to "Auto".
5. On the CMA circuit board, locate the small switch identified by the words "Set Exercise" (Figure 22).

**DANGER: THE GENERATOR WILL CRANK AND START WHEN THE "SET EXERCISE" SWITCH IS ACTUATED. STAND CLEAR OF THE GENERATOR SET.**

6. Push the "Set Exercise" switch in and hold for about 15 seconds.

*Test 42- Reset Exercise Timer (Continued)*

When the "Set Exercise" switch is actuated, the generator engine should crank and start. The engine should run for about 20 minutes and then shut down. Transfer to the "Standby" source does not normally occur during the "exercise" operation.

Every seven (7) days thereafter, on the selected day and at the selected time of day, the generator should start and exercise.

RESULTS:

1. If all tests under Problem 7 (Section 6.3) have been completed and no problems have been found, replace the CMA circuit board if the following conditions are met:
  - a. If the generator does not start when the "Set Exercise" switch is depressed.
  - b. If the generator does not start and exercise every seven (7) days as programmed.
2. If the generator starts when the "Set Exercise" switch is actuated and exercise occurs as programmed, discontinue tests.

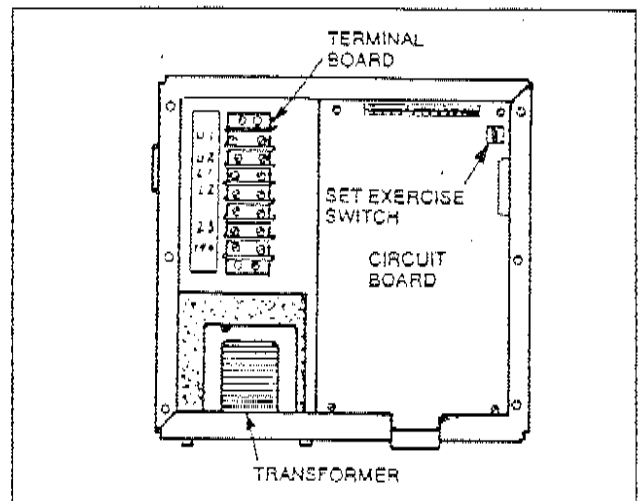

Figure 22. The "Set Exercise" Switch

**PART 7**  
**DC CONTROL**  
**LIQUID COOLED**  
**ENGINE**  
**UNITS**

GENERAC II  
PREPACKAGED  
HOME STANDBY  
ELECTRIC POWER  
SYSTEMS

**TABLE OF CONTENTS**

SECTION	TITLE
7.1	Description and Components
7.2	Operational Analysis
7.3	Troubleshooting Flow Charts
7.4	Diagnostic Tests

# NOTES

---

DESCRIPTION AND COMPONENTS

**General**

Information in this section is provided to familiarize the reader with the various components that make up the DC control system on prepackaged units having a liquid cooled engine. These components may be arbitrarily divided into four (4) broad categories as follows:

- Components on a control module assembly (CMA).
- Components on the generator control console.
- Engine mounted components.
- Transfer switch components.

**Control Module Assembly**

LOCATION AND DESCRIPTION:

The control module assembly (CMA) is housed in the generator control console. The CMA includes (a) a terminal board, (b) a sensing transformer, and (c) a circuit board.

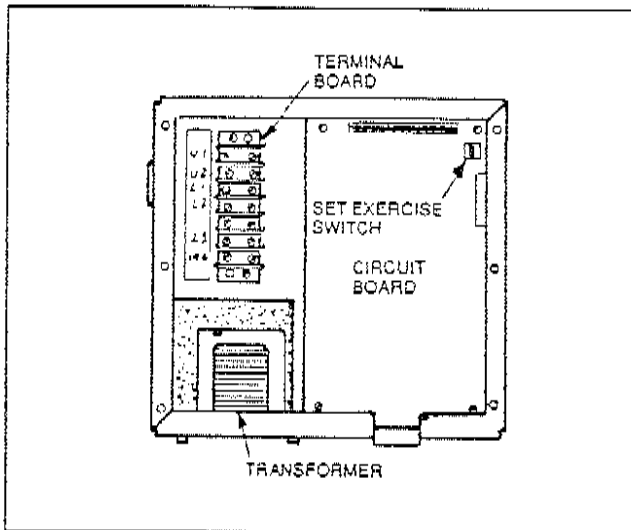

Figure 1. Control Module Assembly (CMA)

CMA TERMINAL BOARD:

The 7-position terminal board provides convenient attachment points for control system wiring that must be interconnected between the prepackaged transfer switch and generator during system installation. This wiring must be installed and interconnected between the CMA terminal board and an identically marked terminal board in the prepackaged transfer switch. The following terminals are identified:

**A. N1A and N2 (Utility 1 and Utility 2)**

1. These terminals deliver "Utility" power source line-to-line voltage from the prepackaged transfer switch and to the primary coil of a sensing transformer.

2. Dropout of the "Utility" sensing voltage below a preset value will result in generator startup due to CMA circuit board action.

3. This line-to-line "Utility" voltage is also used by the CMA board to operate a battery "trickle charge" circuit. That circuit helps maintain battery state of charge when the engine is not running.

**B. T1 and T2 (Load 1 and Load 2):**

1. This line-to-line power is taken from transfer switch "Load" terminal lugs T1 and T2.

2. This "Load" voltage power is used by the CMA circuit board to operate a "7-day exercise" clock or timer circuit. This circuit starts and exercises the generator once every seven days, on a day and at a time of day selected by the installer.

**C. Terminals 23 and 194:**

1. The CMA circuit board delivers a +12 volts DC signal to a transfer relay coil in the transfer switch, via terminal and Wire 194. The 12 volts DC circuit is completed through the transfer relay coil and back to the CMA circuit board, via Wire 23.

2. The CMA board normally holds the terminal 23 circuit open to ground and the transfer relay is de-energized.

3. During a "Utility" power source outage, CMA circuit board action will crank and start the generator. Following generator startup, CMA board action will complete the terminal 23 circuit to ground. The transfer relay will then energize to initiate transfer of "Load" circuits to the "Standby" power source.

4. When "Utility" source voltage is restored, CMA board action will again open the terminal 23 circuit to ground. The transfer relay will then de-energize to initiate retransfer back to the "Utility" source.

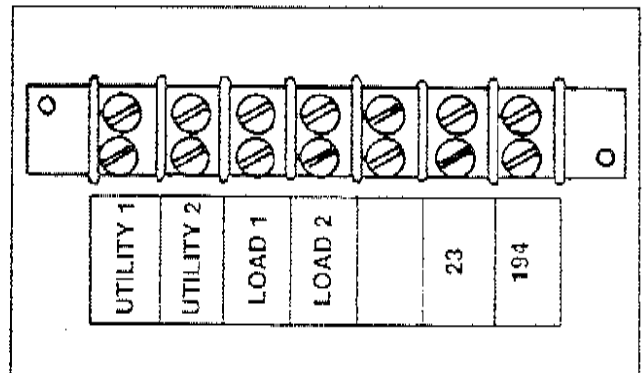

Figure 2. CMA Terminal Board

TRANSFORMER T1:

The line-to-line voltage from the "Utility 1/Utility 2" terminals is delivered to the primary coil of this step-down transformer. A voltage of about 14 volts AC is induced into the transformer's secondary coil and is delivered to the CMA circuit board as sensing voltage.

**Control Module Assembly (Continued)**

The reduced secondary coil output from the transformer is used by the CMA circuit board not only as "Utility" source sensing voltage, but also to operate a battery trickle charge circuit. The latter helps maintain the battery at a high state of charge during non-operating periods.

**CMA CIRCUIT BOARD:**

This solid state circuit board controls all standby electric system operations, including engine cranking, startup, running, automatic transfer and shutdown. Other operations controlled by the circuit board include the following:

- The board delivers "field boost" current to the generator rotor, via connector pin 1, and Wire 4. Also see "Field Boost" on Page 3.1-4.
- The circuit board provides automatic engine shutdown in the event of (a) low engine oil pressure, (b) high engine coolant temperature, (c) low coolant level, (d) overspeed and (e) overcrank. See Section 1.6, "Engine-Generator Protective Devices" (Page 1.6-2). On occurrence of any one (or more) of these engine faults, the circuit board will turn on a fault indicator lamp.

The various functions handled by the CMA circuit board are listed in the following chart, along with appropriate circuit board connector pin numbers and wire numbers.

PIN	WIRE	FUNCTION
1	4	Field boost to rotor (9-10 volts DC)
2	85	Engine shutdown fault line (low oil pressure, high coolant temperature)
3	23	Grounded (-) side of transfer relay circuit
4	194	Positive (+) DC side of transfer relay circuit
5	56	+12 volts DC to control contactor for cranking
5	---	Not used
7	14	+12 volts DC to ignition coil and hourmeter
8	---	Not used
9	178	Manual start line to auto-off-manual switch
10	15A	+12 volts DC with auto-off-manual switch at "Auto" or "Manual"
11	239	+12 volts DC to auto-off-manual switch
12	15	+12 volts DC (battery trickle charge)
13	0	Common ground
14	224	14 volts AC from CMA sensing transformer
15	225	14 volts AC from CMA sensing transformer
16	T2	Line-to-line AC voltage from "Load" terminal lugs of transfer switch
17	T1	Line-to-line AC voltage from "Load" terminal lugs of transfer switch
A	S15	Frequency (rpm) sensing from AC power winding
B	S15	Frequency (rpm) sensing from AC power winding
C	150	Engine preheat (only on diesel engine units)
D	229	Negative (-) side of optional alarm relay connection. Circuit board action will complete this circuit to ground on occurrence of a fault shutdown.
E	176	Negative (-) side of fault indicator lamp circuit. Circuit board action will complete this circuit to ground on occurrence of a fault shutdown.

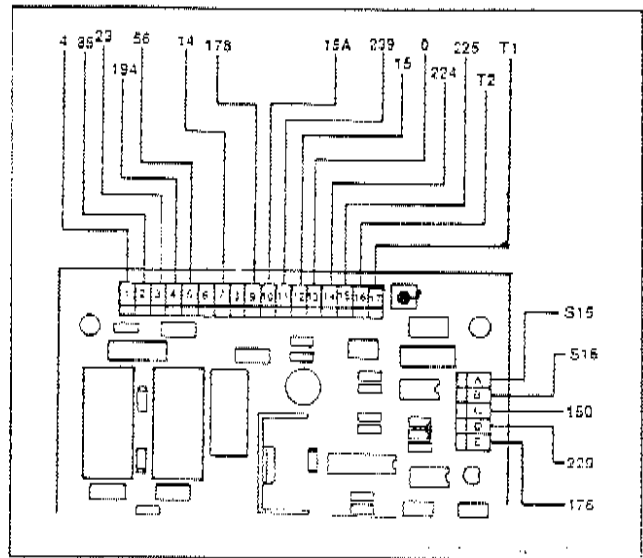

Figure 3. CMA Circuit Board Connector Terminals

**Control Console Components**

**TERMINAL BOARD TB1:**

This 20-position terminal board (Figure 4) provides a convenient connection point for DC control system wiring. Terminals, associated wires and their functions are listed in the following chart.

TERM.	WIRE	FUNCTION
0	0	Common ground
79	---	Not used on prepackaged units
13	13	Unfused battery volts (12 volts DC)
14	14	12 volts DC with engine running only- used to turn on ignition, open a fuel solenoid and turn on an hourmeter.
15	---	No factory connected wires (fused 12 volts DC)- see Terminal 229.
4	4	Regulated excitation and field boost current to rotor
229	---	For connection of optional remote alarm relay
56	56	12 volts DC when cranking only
68	68	Oil pressure sender to panel gauge
69	69	coolant temperature sender to panel gauge
85	85	Low oil pressure switch connection
86	86	High coolant temperature switch connection
150	---	For preheat on diesel engine units only
218	---	Not used on prepackaged units
219	---	Not used on prepackaged units

*NOTE: For additional information on Terminal 229 and an optional alarm relay, see "Optional Alarm Relay" in this section.*

*NOTE: Terminal board TB2 is mounted in the control module assembly (CMA).*

*Control Console Components (Continued)*

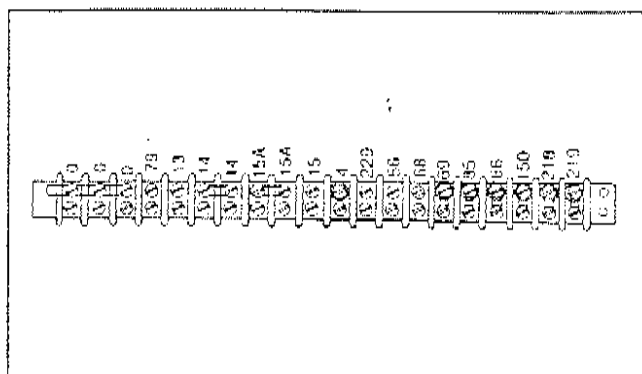

Figure 4. Terminal Board TB1

OPTIONAL ALARM RELAY:

Terminal 229 on terminal board TB1 is a convenient connection point for an optional alarm relay. The terminal will support any relay requiring up to a maximum of 100 milli-amps of current draw. See Figure 5, below. The optional relay coil is connected across terminals 15 and 229. A remote alarm device is connected across the relay contacts so that, on contacts closure, a separate power supply will turn the alarm device on. Terminal 15 is fused battery voltage (12 volts DC). On occurrence of any monitored engine fault, CMA circuit board action will complete the terminal 229 circuit to ground, to energize the relay and turn the alarm on.

TERMINAL BOARD TB3:

This 2-position terminal board (terminals 178 and 183) must be used when the standby generator is installed in conjunction with a standard "GTS" type automatic transfer switch. See Page 1.3-4.

AUTO-OFF-MANUAL SWITCH:

Switch is shown pictorially and schematically in Figure 6. Also see Section 1.7, "Operating Instructions".

FUSE F1:

Fuse F1 is connected in series with Wires 13 and 15 and is rated 30 DC amperes. If fuse replacement becomes necessary, use only an identical 30 amp replacement fuse.

FAULT INDICATOR LAMP L1:

Lamp L1 is powered by the Wire 15 circuit (fused battery voltage). The lamp circuit is completed to the CMA circuit board, via Wire 176. On occurrence of a monitored engine fault, circuit board action will complete the Wire 176 circuit to ground and the lamp will turn ON. Engine faults that will cause the lamp to turn on are discussed in Section 1.6, "Engine-Generator Protective Devices".

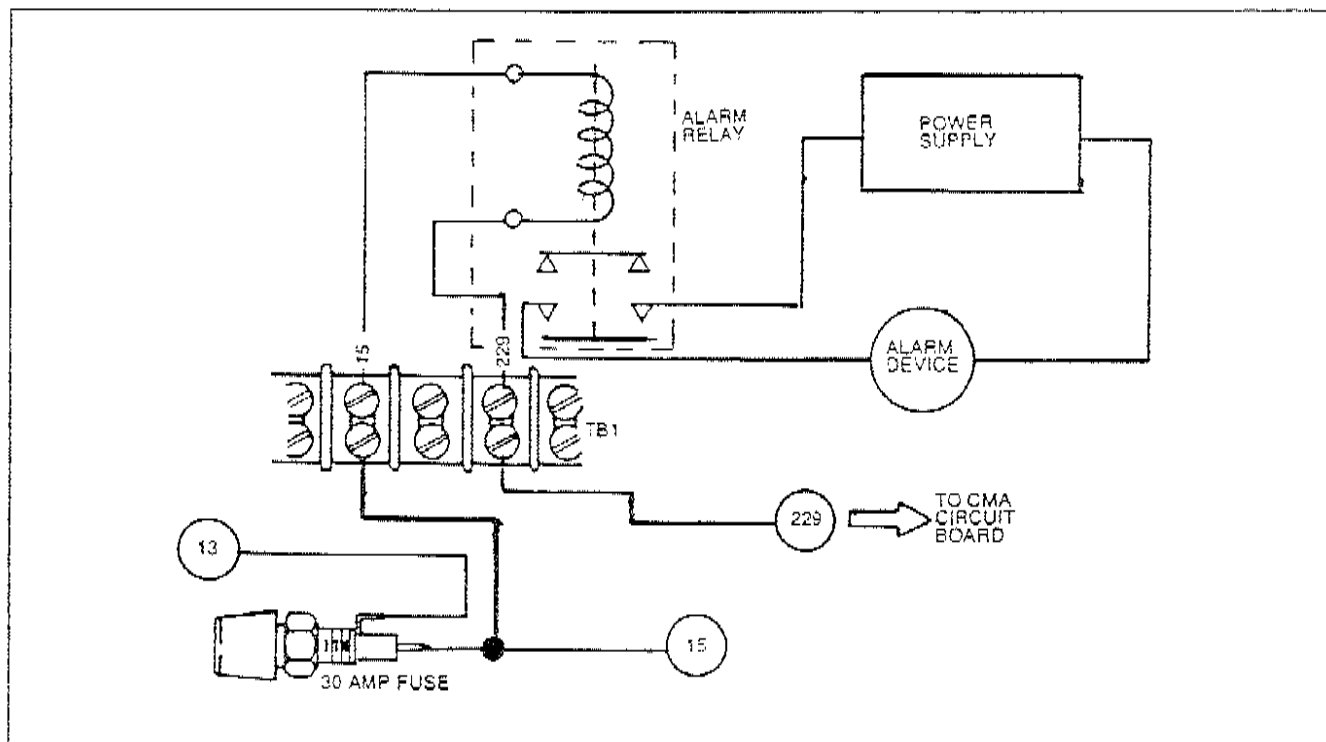

Figure 5. Connections for Optional Alarm Relay

**Control Console Components (Cont'd)**

**HOURMETER:**

During startup, a run relay (K2) is energized by CMA circuit board action. That relay's normally-open contacts will then close to deliver 12 volts DC to a Wire 14 circuit. Wire 14 (a) powers the hourmeter, (b) opens an engine fuel solenoid, and (c) energizes the engine ignition system.

**BATTERY VOLTMETER:**

During engine operation, the battery state of charge is maintained by an engine-driven DC alternator. Alternator output to the battery is regulated by a DC regulator. The panel mounted battery voltmeter indicates charging voltage to the battery. When the engine is running, the DC voltmeter should read approximately 12.5-14.5 volts. A low reading indicates the battery is discharging.

**Engine Mounted Components**

Engine mounted DC control system components include the following"

- A 12 volts battery and battery charge components.
- A starter motor (SM).
- A control contactor (CC).
- Low Oil Switch (LOS) and high water temperature switch (HWT).
- A fuel solenoid (FS).
- Engine ignition system parts.

**BATTERY AND BATTERY CHARGE SYSTEM:**

See Figure 6. An alternator delivers a charging voltage to the battery during engine operation. The charging voltage is regulated and rectified by the DC regulator. The charging circuit is protected by a 30 amp fuse.

The belt driven alternator is a permanent magnet type which is a part of the engine speed governor. Alternator maintenance is limited to replacement of defective parts.

The DC voltage regulator is housed in an aluminum heat sink. All components are covered with epoxy resin. The regulator is NOT repairable. Regulator connector pins are numbered from left to right, as follows:

PIN	FUNCTION
1	Charging output to battery (12.5-14.5 volts DC)
2	Charging input from alternator (AC)
3	Charging input from alternator (AC)
4	Charge indicating lamp connection (not used)
5	Sensing voltage from battery (Wire #15)

*NOTE: The alternator supplies alternating current (AC) which is changed to direct current (DC) by the regulator.*

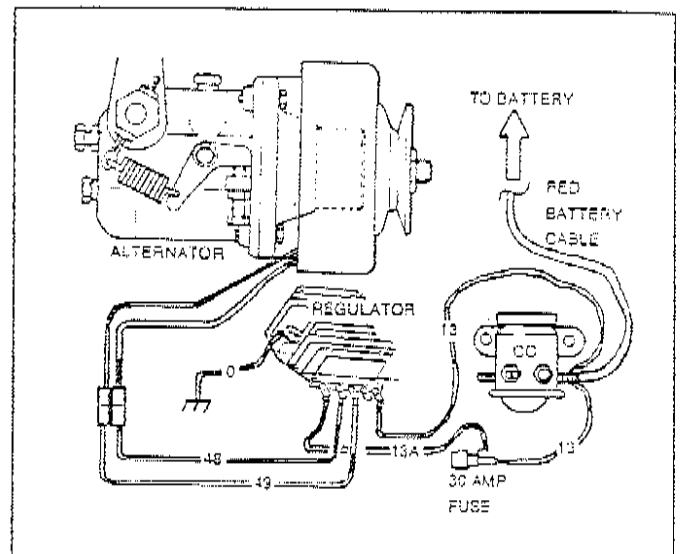

Figure 6. Battery Charging System

**STARTER MOTOR AND CONTROL CONTACTOR:**

During manual or automatic startup, CMA circuit board action delivers 12 volts DC to a control contactor (CC) coil. The coil energizes, its contacts close, and battery power is delivered to the starter motor (SM). The starter motor then energizes and the engine is cranked.

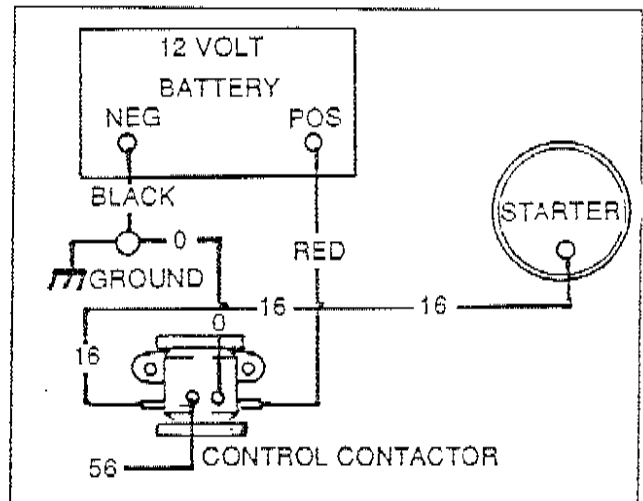

Figure 7. Engine Cranking Circuit

**LOW OIL/HIGH TEMPERATURE SWITCHES:**

The low oil pressure switch has normally-closed contacts which are held open by engine oil pressure during cranking and running conditions. Should engine oil pressure drop below approximately 8-12 psi, the switch contacts will close. CMA circuit board action will then effect an automatic engine shutdown and the fault indicator lamp (L1) will turn on.

The high coolant temperature switch (HWT) has normally-open contacts. Contacts are thermally actuated. If engine coolant temperature should exceed

*Engine Mounted Components (Continued)*

approximately 284° F. (140° C.), CMA circuit board action will shut the engine down. The fault indicator lamp (L1) will then illuminate.

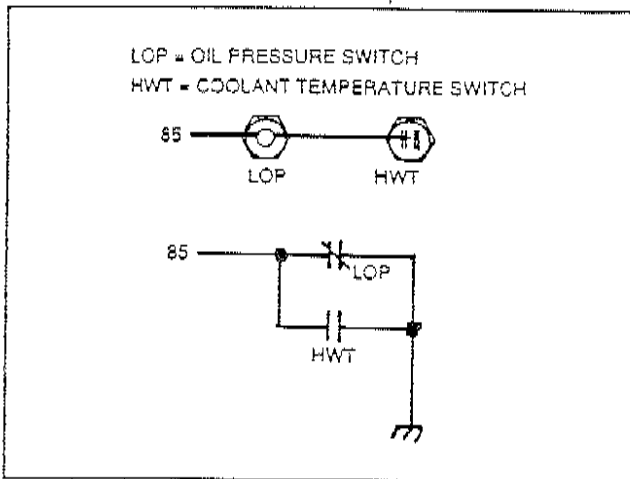

Figure 8. Oil Pressure & Coolant Temperature Circuit

**FUEL SOLENOID:**

The fuel solenoid (FS) provides a positive shutoff of fuel when the engine is not running. The solenoid is energized open by 12 volts DC (Wire 14); it is de-energized closed.

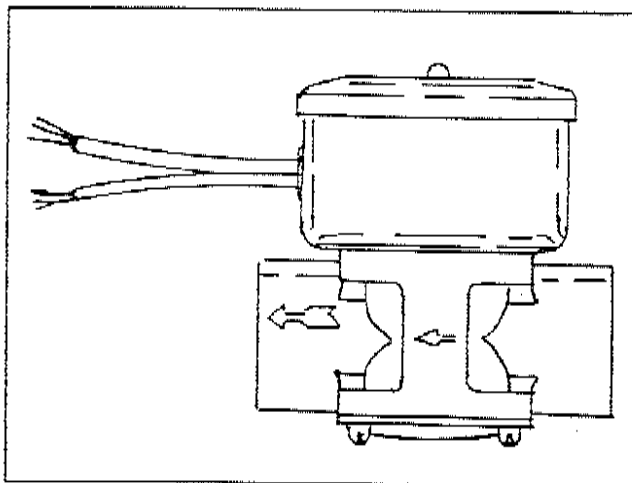

Figure 9. Fuel Solenoid (FS)

**ENGINE IGNITION SYSTEM:**

The CMA circuit board acts as the "ignition switch", i.e., it turns the ignition system on for startup and turns the system off for shutdown. During startup, a crank relay (K1) on the CMA circuit board energizes, its contacts close, and 12 volts DC is delivered to the ignition coil via Wire 14. The ignition system consists of (a) the ignition coil, (b) distributor, (c) spark plug wires, (d) spark plugs, and (e) an ignition resistor.

See Figure 10. Battery voltage is available to the CMA circuit board, via Wire 15A. During cranking and running conditions, circuit board action delivers the battery voltage through a resistor, through the primary winding of the ignition coil, through the closed distributor points and to ground. The current flow through the coil's primary winding produces a magnetic field around the primary coil which cuts across the coil's secondary winding. Each time the distributor points open, current flow through the coil primary winding terminates. The magnetic field then collapses to induce a high voltage into the coil's secondary winding. Secondary winding output is then delivered to the distributor rotor and to the desired spark plug in a timed sequence.

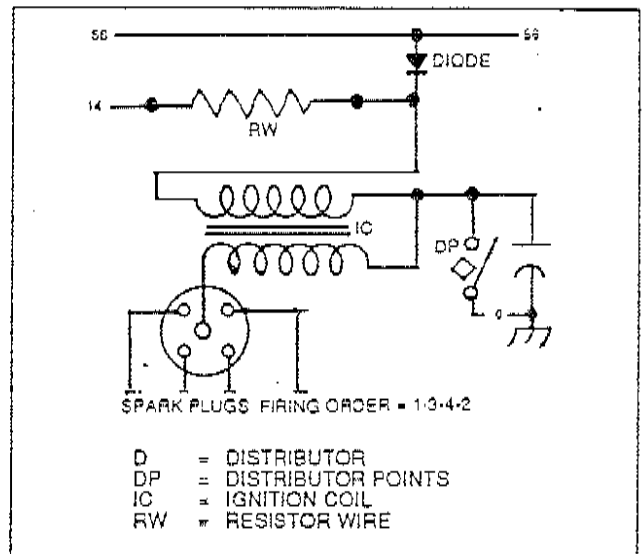

Figure 10. Engine Ignition System Diagram

**Transfer Switch**

See Part 4, "V-Type Prepackaged Transfer Switches" or Part 5, "Y-Type Prepackaged Transfer Switches".

Section 7.2, "Operational Analysis", assumes that the liquid cooled generator is installed in conjunction with a "Y-Type" transfer switch.



Section 7.2  
**OPERATIONAL ANALYSIS**

**Introduction**

The schematic diagram on this and following pages shows the DC control system in three (3) major areas, i.e., the standby generator area, the engine, and the prepackaged transfer switch. The "Y-Type" prepackaged transfer switch is used.

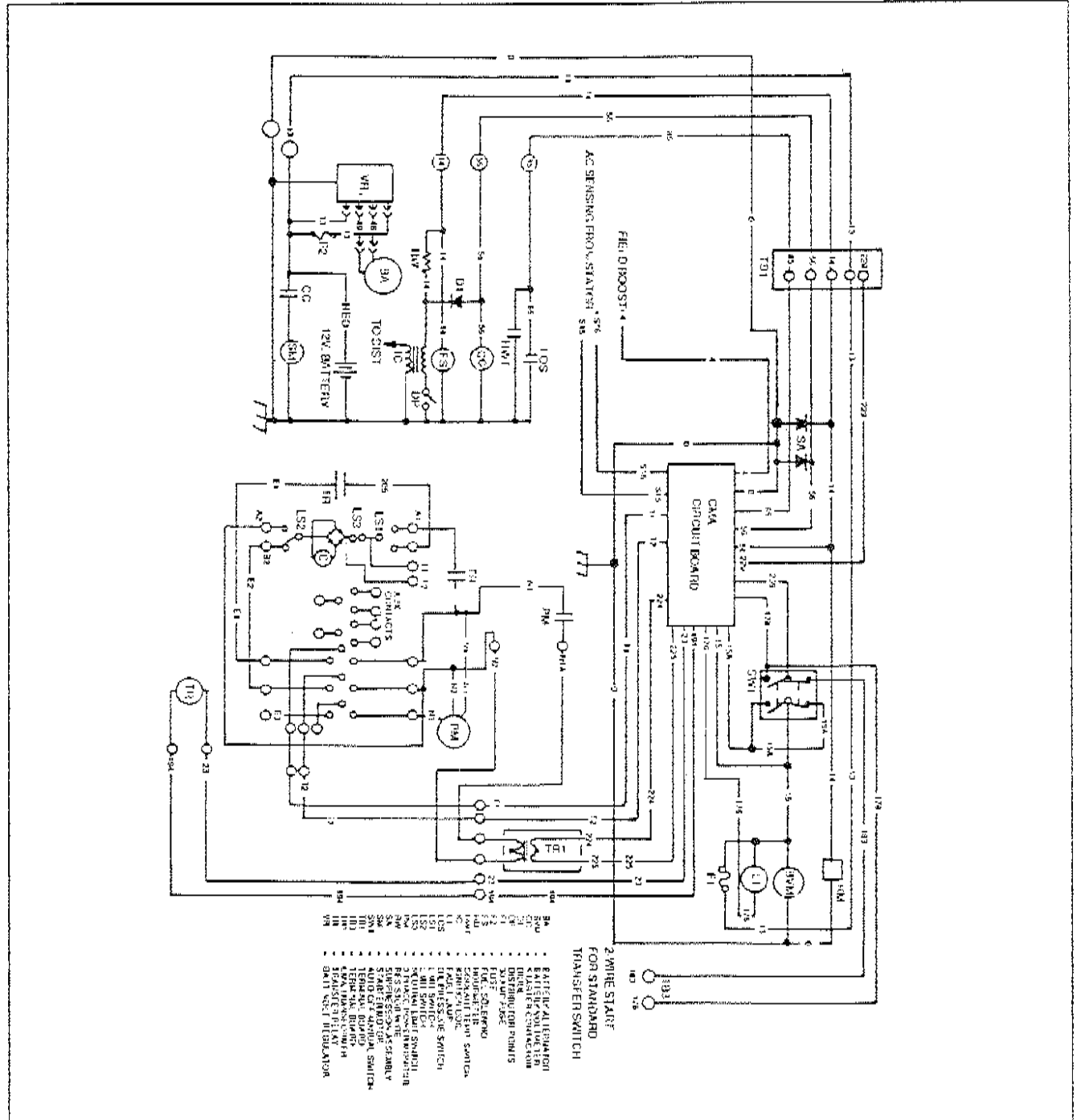

Figure 1. DC Control System Schematic

*Circuit Condition- Utility Source Voltage Available*

- Utility source voltage is available to transfer mechanism terminal lugs N1, N2, N3, via installer attached utility source lines.
- Transfer mechanism main contacts are at their "Utility" source side, i.e., "Utility" voltage is across the closed main contacts and to transfer mechanism terminal lugs T1, T2, T3. Loads connected to lugs T1, T2, T3 are powered by the "Utility" supply.
- Utility source voltage is available to transfer mechanism terminals A1/A2, via Wires N1 and N2, normally-closed transfer relay (TR) contacts, and Wire 126.
- Limit switches LS1/LS2 in the transfer mechanism are closed to their terminals B1/B2 side. Thus, the A1/A2 circuit to the main contacts actuating coil (C) is open and the actuating coil (c) is de-energized.
- On 3-phase units, "Utility" voltage is delivered to a 3-phase power monitor (PM). The power monitor is energized, its contacts are closed, and "Utility" power is delivered to the primary winding of a sensing transformer (T1) on the generator, via Wires N1A/N2, transfer switch N1A/N2 terminals, installer connected wires, and CMA terminals N1A/N2.

*NOTE: The 3-phase power monitor (PM) is NOT used on 1-phase units. Instead the 1-phase line-to-line voltage is delivered directly to the primary winding of the sensing transformer (T1).*

- Transformer (T1) action induces a reduced voltage (about 14 volts AC) into the transformer (T1) secondary coil. This reduced sensing voltage is delivered to the CMA circuit board. As long as the sensing voltage remains above 60 percent of nominal rated line-to-line voltage, the CMA circuit board takes no action.
- The transformer reduced sensing voltage is used to operate a "trickle charge" circuit to the unit battery. This trickle charge output is delivered to the battery from the CMA board via Wire 15, a 30 amp fuse (F1), and Wire 13.
- Battery power is available to the auto-off-manual switch (SW1) via Wire 13, terminal 13 of terminal board TB1, Wire 13, 30 amp fuse (F1), and Wire 15. With the auto-off-manual switch set to "Auto", battery power is available to the CMA circuit board via Wire 15A.
- Line-to-line load voltage from transfer mechanism terminal lugs T1/T2 is delivered to the CMA circuit board via Wires T1/T2, transfer switch terminals T1/T2, installer connected wires, and terminals T1/T2 of the CMA board's terminal board. This power is used by the circuit board to operate a 7-day exerciser circuit.

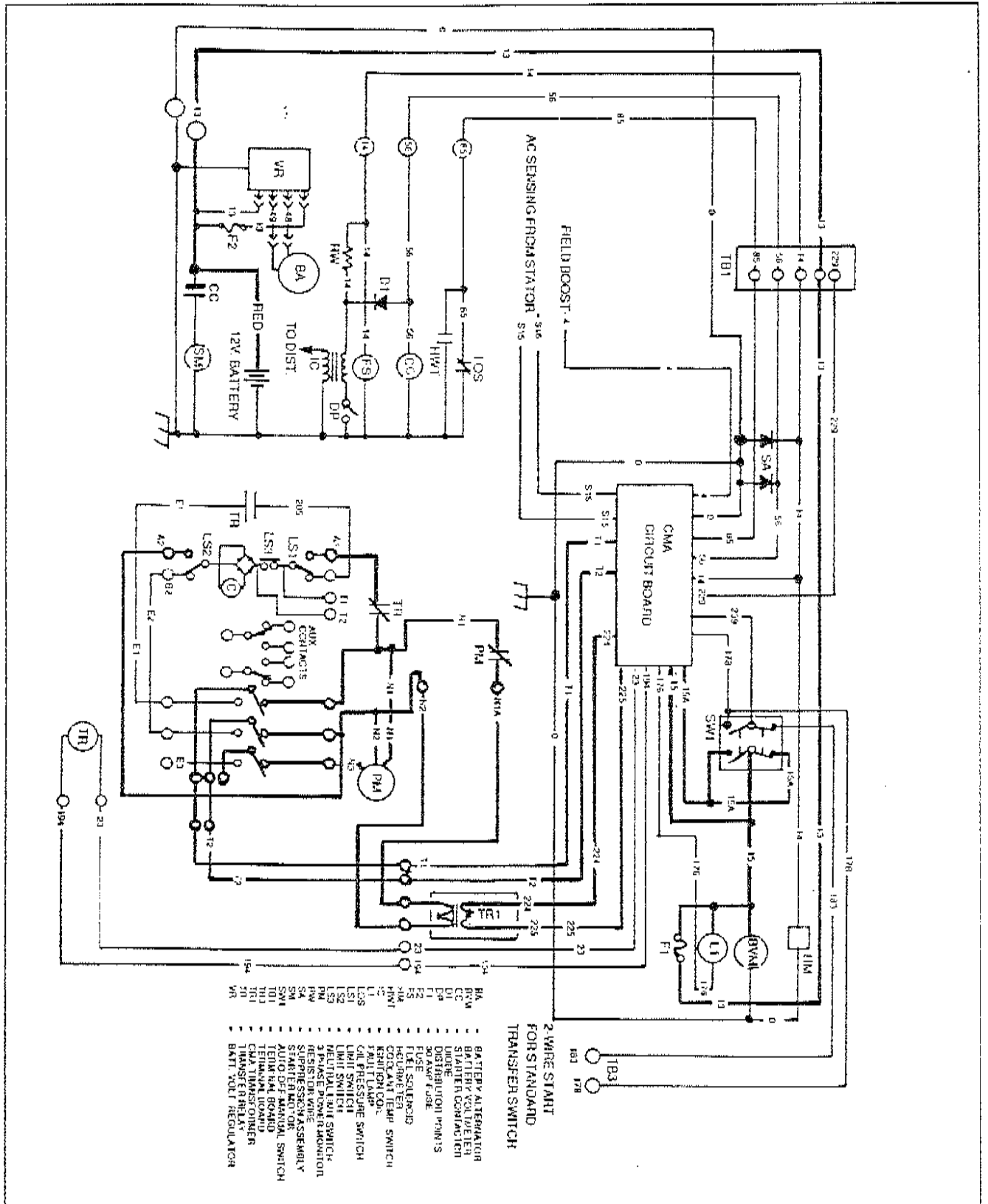

Figure 2. Circuit Condition- Utility Source Voltage Available

*Circuit Condition- Initial Utility Voltage Dropout*

- On 3-phase systems, dropout of "Utility" source voltage below the setting of a 3-phase power monitor (PM) will cause the power monitor to de-energize. Its contacts will then open, to break the circuit to sensing transformer (T1). Output of the sensing transformer's secondary winding will then drop to zero. The CMA circuit board will "sense" this loss of voltage and a "6-second timer" will start timing.
- On 1-phase systems, a 3-phase power monitor is not used. Line-to-line "Utility" current is delivered to the sensing transformer. Transformer action reduces the line-to-line voltage to approximately 14 volts AC. The reduced voltage is delivered to the CMA board as "Utility" sensing voltage. If "Utility" source voltage drops below about 60 percent of rated voltage, CMA board action will turn on a "6-second timer".
- Voltage is unavailable from both power sources to load terminals T1/T2. Some timing loss may occur on the CMA circuit board's 7-day exerciser clock.

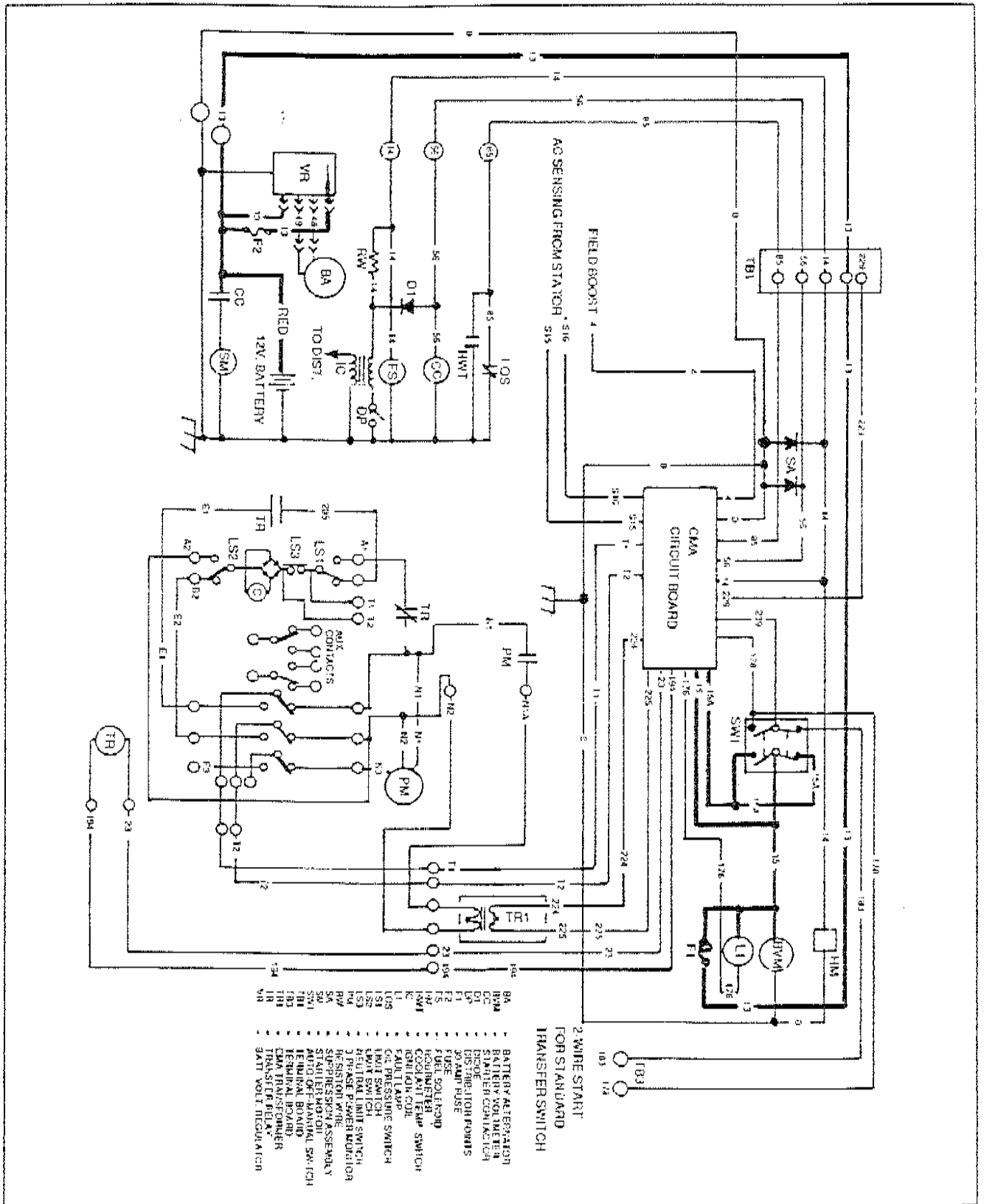

Figure 3. Circuit Condition- Initial Utility Voltage Dropout

*Circuit Condition- Cranking and Initial Startup*

- The CMA board's 6-second timer will time for 6 seconds. If "Utility" source voltage is still low after 6 seconds, a crank relay (K1) and a run relay (K2) on the circuit board will energize simultaneously.
- When the crank relay (K1) energizes, its contacts will close to deliver 12 volts DC to a control contactor (CC) coil via Wire 56. The contactor energizes and its contacts close to deliver battery power to the engine starter motor (SM). Starter motor (SM) energizes and the engine is cranked.
- Circuit board action will hold crank relay (K1) energized for about 7-9 seconds, will de-energize the relay for 7-9 seconds, energize it again for 7-9 seconds, and so on. Thus, the engine will crank for 7-9 seconds, rest for 7-9 seconds, and so on. This cyclic crank/rest action will continue until either the engine starts, or about ninety (90) seconds have been used up. If the engine has not started in 90 seconds, cranking will end and the fault indicator lamp will light ("overcrank" condition).
- When the engine is cranking, a DC output is delivered to the generator rotor. This is "field boost" current, which is delivered cyclically (during cranking only). See "*Field Boost Circuit*" on Page 2.1-4.
- When the engine run relay (K2) is energized by circuit board action, 12 volts DC is delivered to (a) a fuel solenoid, (b) the engine ignition system, and (c) to the panel hourmeter. The fuel solenoid (FS) is energized open to allow fuel flow to the fuel system. Ignition occurs. The hourmeter starts running.
- With fuel available to the carburetor and with engine ignition occurring, the engine will start.
- Generator AC output voltage and frequency signals are available to the CMA circuit board, via Wires S15 and S13.
- When generator AC output frequency reaches approximately 50% of the rated AC frequency, an "engine warmup timer" and an "engine minimum run timer" on the CMA circuit board are both turned on.

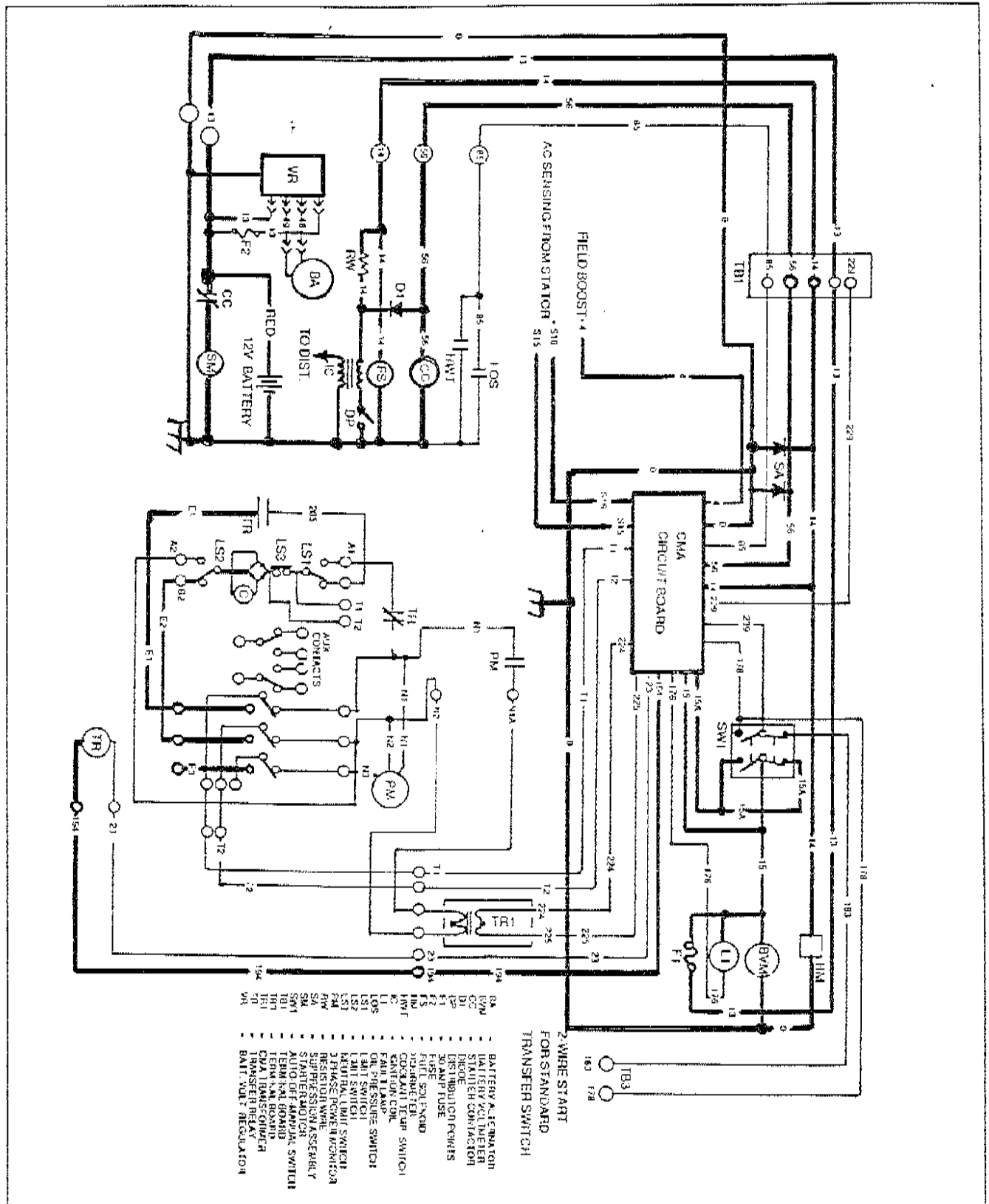

Figure 4. Circuit Condition- Cranking and Initial Startup

*Circuit Condition- Initial Transfer to Standby*

- The "engine warmup timer" will run for approximately 15 seconds. The "minimum run timer" will run for about 13 minutes. Engine cannot be shut down in automatic mode until the "minimum run timer" has finished timing (prevents shutdown of a cold engine).
- At approximately 30 Hz, engine cranking terminates. The circuit board's run relay (K2), however, remains energized.
- A DC (battery) voltage is delivered to the transfer switch's transfer relay (TR) coil, via Wire 194. This voltage is available through the relay coil and back to the circuit board, via Wire 23. However, CMA board action holds the Wire 23 circuit open.
- When the "engine warmup timer" has timed out, CMA circuit board action closes the Wire 23 circuit to ground. The transfer relay (TR) energizes, its normally-closed contacts (1 & 7) open; its normally-open contacts (6 & 9) close.
- With TR normally-open contacts closed, "Standby" source power is available to the main contacts actuating coil (C), via Wires E1/E2, transfer mechanism terminals B1/B2, limit switches LS1, LS2, LS3, and a bridge rectifier. Actuating coil (C) energizes.
- When actuating coil (C) energizes, the main current carrying contacts of the transfer mechanism are actuated to their "Neutral" position ("Load" terminals disconnected from both power supplies). The main contacts will remain at "Neutral" as long as actuating coil (C) remains energized.

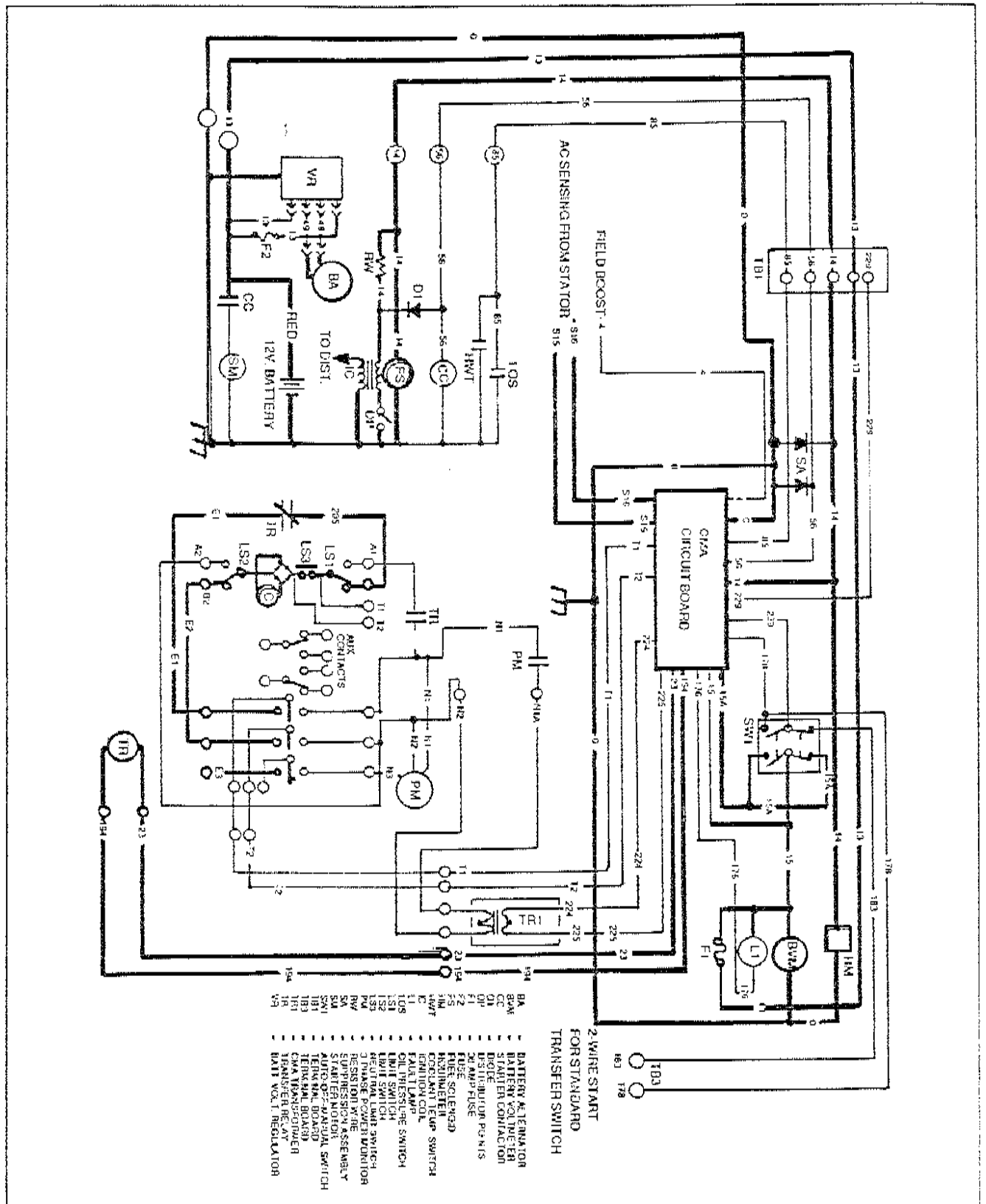

Figure 5. Circuit Condition- Initial Transfer to Standby

*Circuit Condition- Final Transfer to Standby*

- When the transfer mechanism's main load carrying contacts reach "Neutral" position (disconnected from both power sources), a mechanical interlock opens limit switch LS3. This opens the circuit to actuating coil (C) and the coil de-energizes.
- With coil (C) de-energized, spring force closes the main contacts to their "Standby" power source side ("Load" connected to the "Standby" source).
- As the main contacts close to the "Standby" side, a mechanical interlock actuates limit switches LS1/LS2 to their terminals A1/A2 side. This action "prepares" the circuit for retransfer back to "Utility".
- Electrical load circuits (T1, T2, T3) are now powered by generator AC output.



*Circuit Condition- Utility Voltage Restored*

- **3-Phase Units:** When utility source voltage is restored above the setting of the 3-phase power monitor (PM), the power monitor energizes and its contacts close. Utility voltage is then available to the primary winding of sensing transformer (T1). A voltage is then induced into the transformer secondary winding which is then delivered to the CMA circuit board.
- **1-Phase Units:** These units do not have a 3-phase power monitor. Utility source line-to-line voltage is delivered directly to the sensing transformer's primary winding. A resultant sensing voltage is then delivered from the transformer's secondary winding to the CMA board. If the "Utility" sensing voltage is above about 80 percent of the nominal rated voltage, the CMA circuit board will react.
- On restoration of "Utility" source voltage, CMA circuit board action will turn on a "return to utility timer".

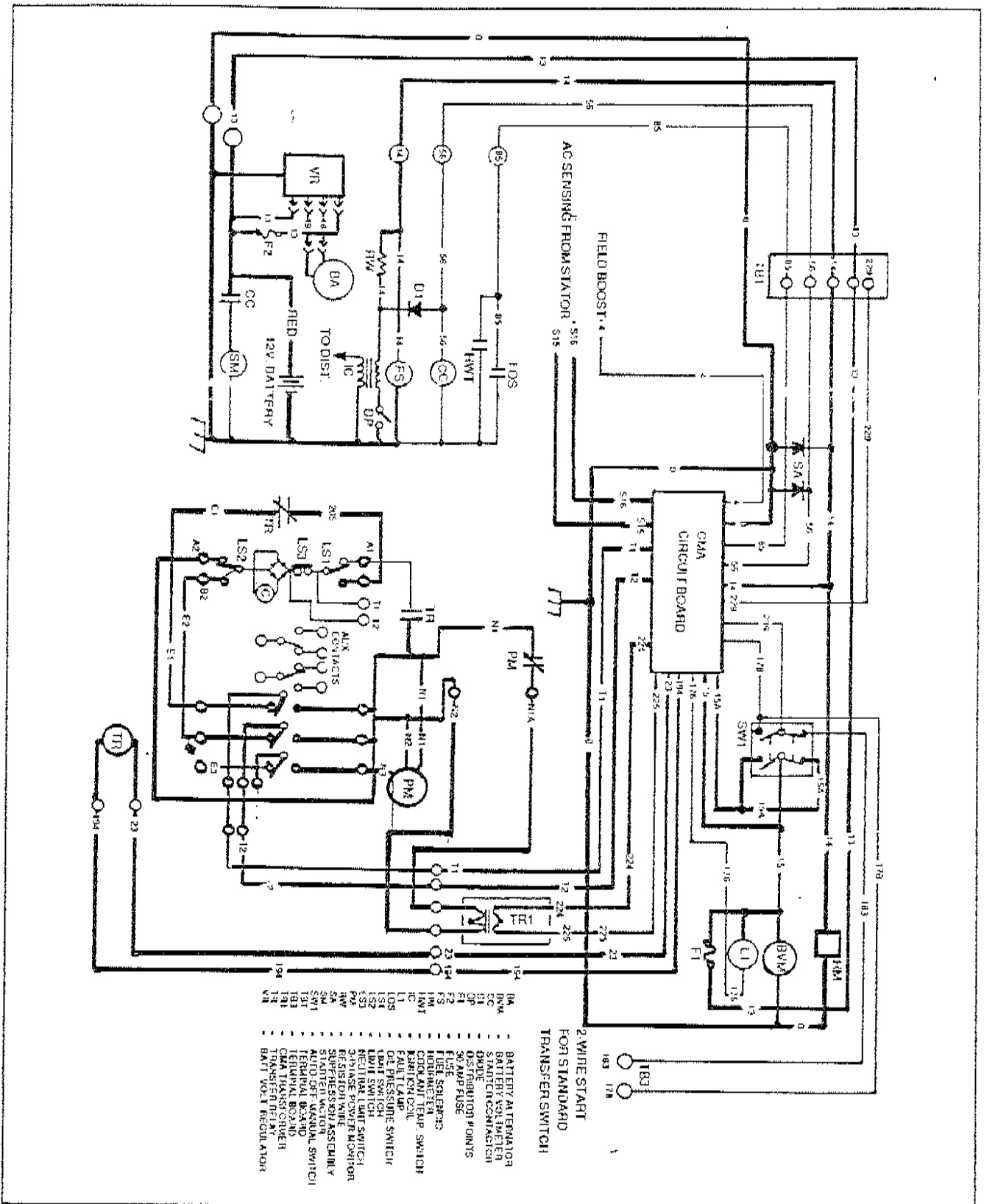

Figure 7. Circuit Condition- Utility Voltage Restored

*Circuit Condition- Initial Retransfer Back to Utility*

- When the "return to utility timer" times out (about 6 seconds), CMA circuit board action will open the Wire 23 circuit to ground.
- With Wire 23 circuit open, the transfer relay (TR) will de-energize. The relay's normally-closed contacts will close.
- Utility source power is now delivered to the main contacts actuating coil (C), via Wires N1/N2, the closed TR contacts, transfer mechanism terminals A1/A2, limit switches LS1, LS2, LS3, and the bridge rectifier.
- Actuating coil (C) energizes and the main contacts are pulled to their "Neutral" position. The main contacts will remain at "Neutral" ("Load" disconnect from both power supplies) as long as actuating coil (C) remains energized.



*Circuit Condition- Final Retransfer to Utility*

- When the transfer mechanism's main contacts reach "Neutral" position ("Load" disconnected from both power sources), limit switch LS3 is opened by a mechanical interlock. This opens the circuit to actuating coil (C). Coil (C) de-energizes.
- With coil (C) de-energized, spring force completes the transfer action back to the "Utility" side ("Load" connected to the "Utility" supply).
- Loads are now powered by the "Utility" power source.
- The standby generator is still running and generator AC output voltage is still available to transfer mechanism terminal lugs E1, E2, E3.
- Following retransfer back to the "Standby" source, an "engine cooldown timer" starts timing. This timer will time for about 1 minute. Purpose of this timer is to allow the engine to run at no-load for about one (1) minute to stabilize internal engine-generator temperatures.



*Circuit Condition- Generator Shutdown*

- When the "engine cooldown timer" has finished timing (about 1 minute) and providing the "minimum run timer" (about 13 minutes) has also timed out, CMA circuit board action will de-energize the board's run relay.
- With the run relay de-energized, its contacts open and the 12 volts DC power supply to Wire 14 is terminated.
- The Wire 14 circuit is now "dead". The hourmeter stops running, the fuel solenoid (FS) is de-energized closed, and engine ignition is terminated.
- The engine shuts down.





TROUBLESHOOTING FLOW CHARTS

*Problem 1 - Engine Will Not Crank When Utility Power Failure Occurs*

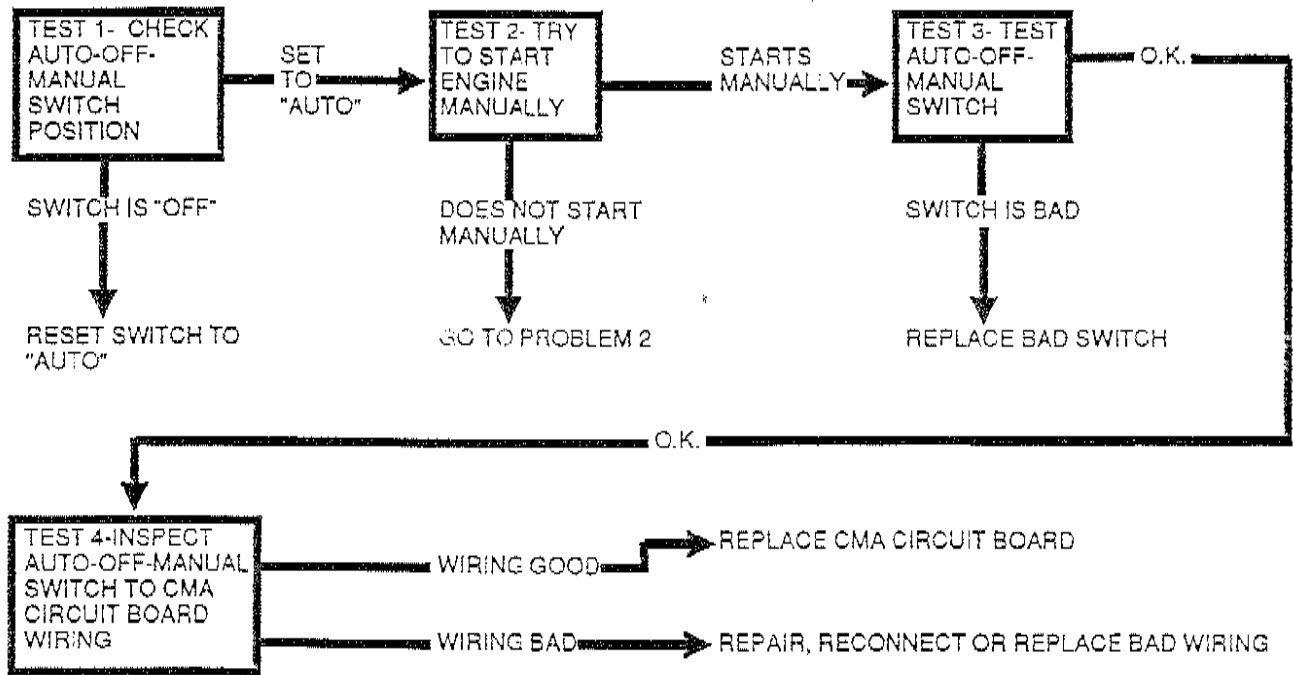

*Problem 2- Engine Will Not Crank When Auto-Off-Manual Switch Is Set to "Manual"*

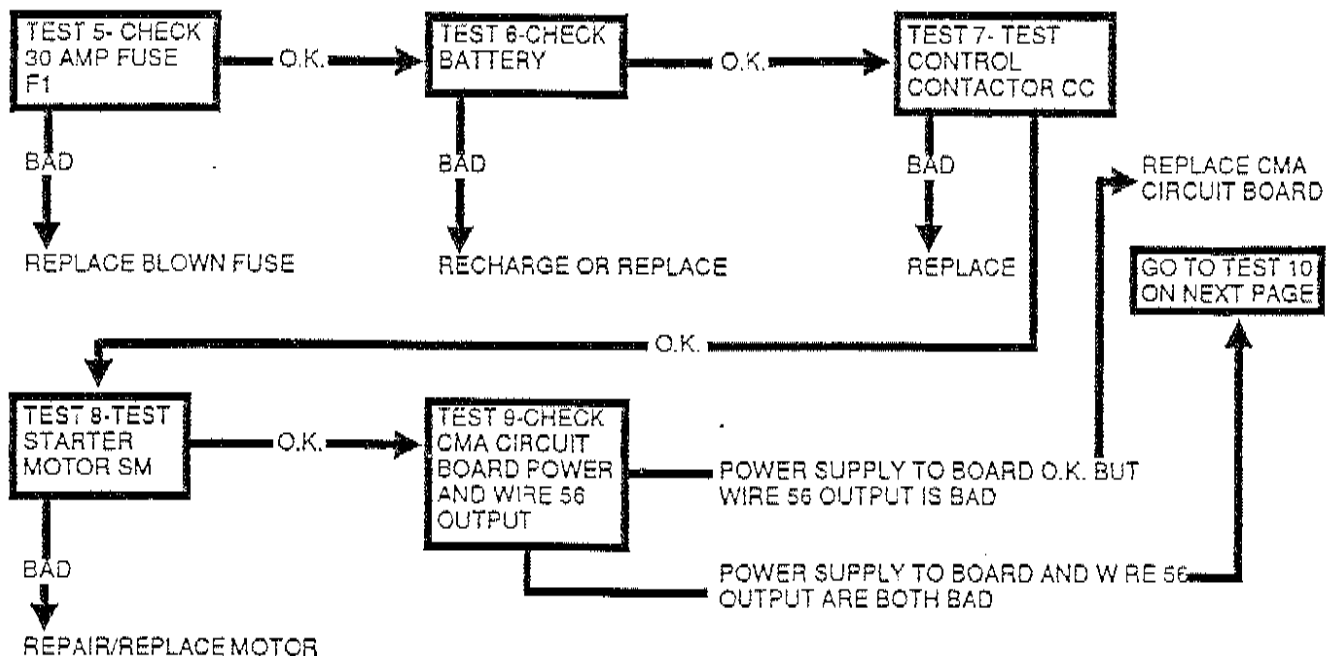

*Problem 2- Engine Will Not Crank When Auto-Off-Manual Switch is Set to "Manual" (Continued)*

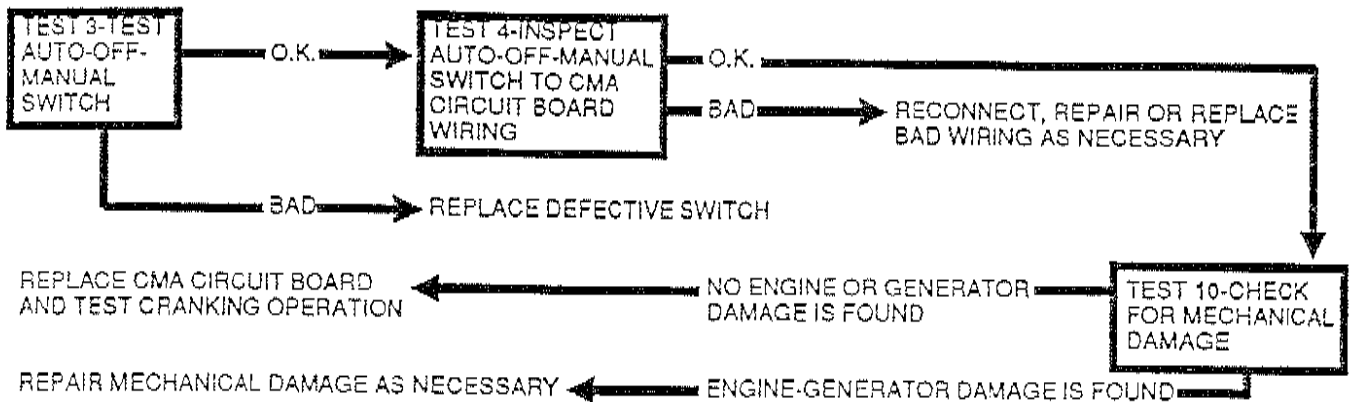

*Problem 3- Engine Cranks But Won't Start*

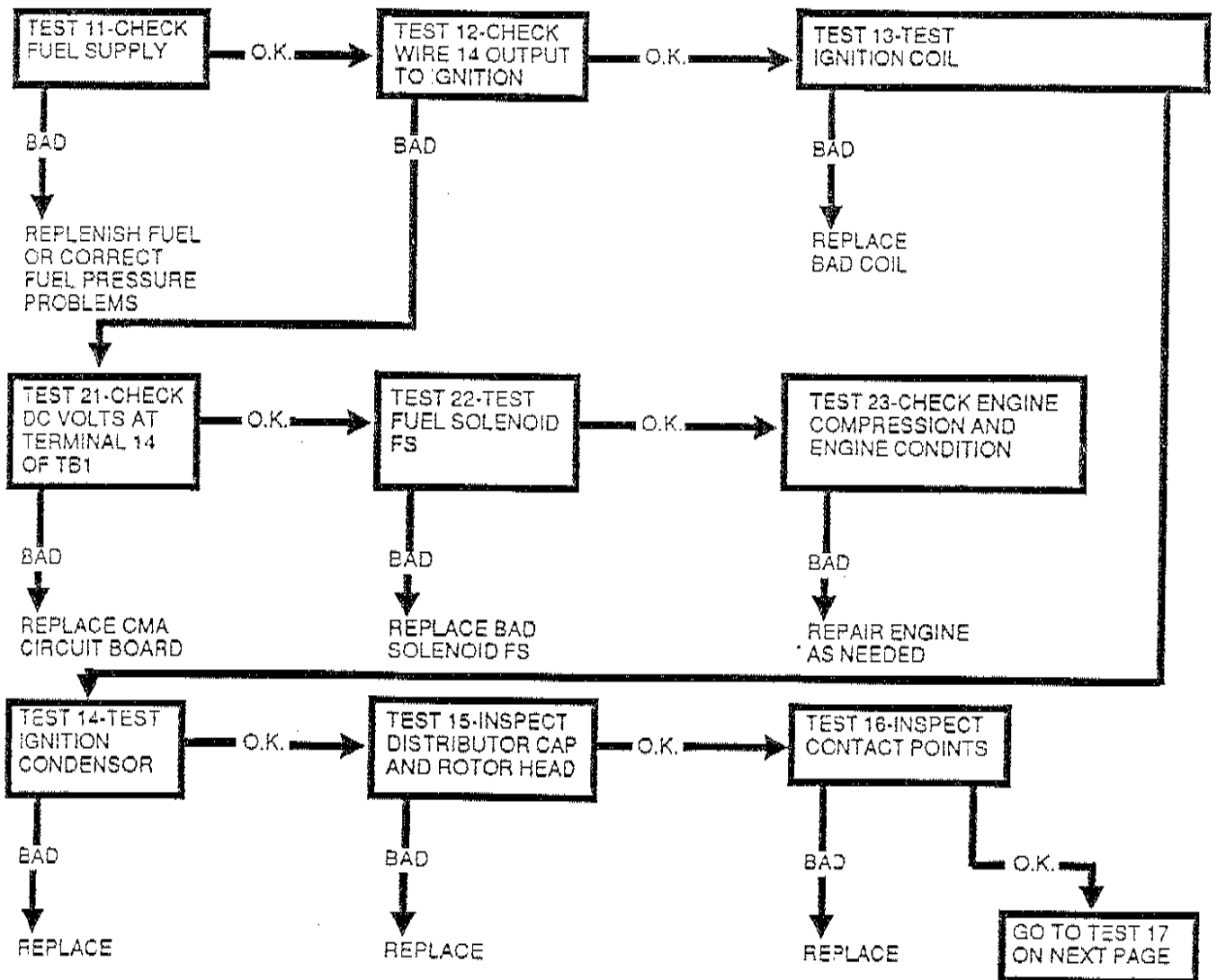

*Problem 3- Engine Cranks But Won't Start (Continued)*

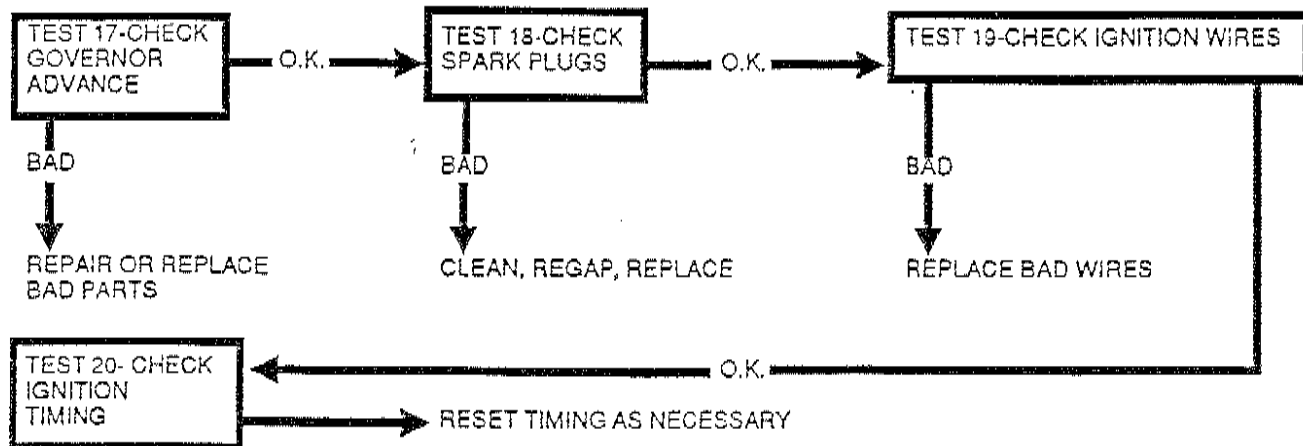

*Problem 4- Engine Cranks and Starts, But Won't Transfer to Standby*

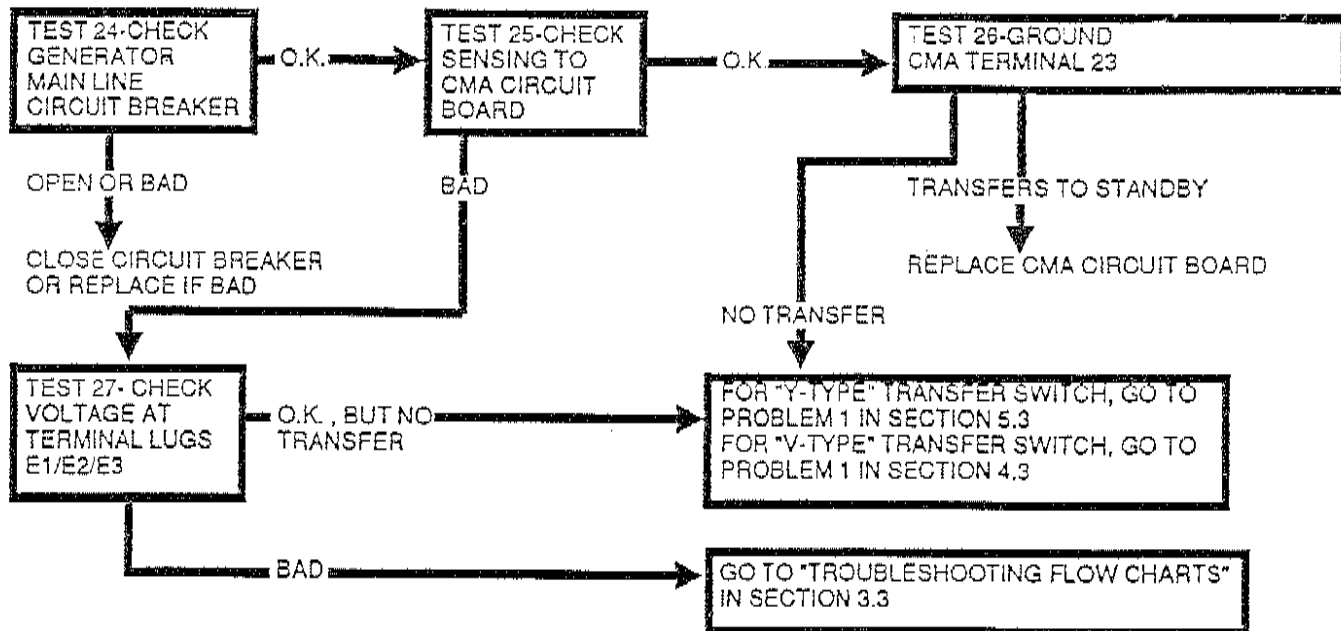

*Problem 5- Engine Starts and Transfer Occurs When Utility Power is Available*

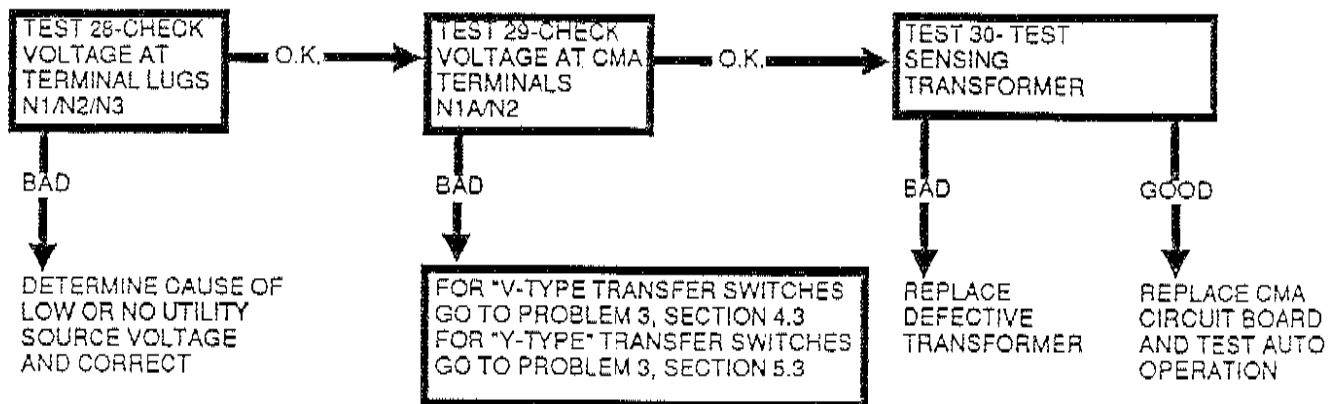

1

1. Check the engine oil level. If the oil level is low, add oil to the correct level. If the oil level is correct, proceed to step 2.

**Section 7.4  
DIAGNOSTIC TESTS**

**General**

Perform the tests in this section in conjunction with the "Troubleshooting Flow Charts" of Section 7.3. Test numbers in this section correspond with the numbered tests in Section 7.3.

**Test 1- Check Auto-Off-Manual Switch Position**

**DISCUSSION:**

In order for automatic operation to occur, the auto-off-manual switch must be set to its "Auto" position. The only other possible switch positions are "Off", where engine cranking and startup cannot occur; or "Manual", where the engine should crank and start, but transfer to "Standby" will not occur. Thus, if a "Utility" voltage dropout occurs and the generator will not crank and start, the first check to perform is to make sure the switch is set to "Auto".

**PROCEDURE:**

Check the position of the auto-off-manual switch. If necessary, set the switch to "Auto".

**RESULTS:**

1. If switch is already set to "Auto" and engine will not crank on occurrence of a "Utility" power failure, go on to Test 2.
2. If switch is set to "Off", reset it to "Auto" and test automatic operation.

*NOTE: To test automatic operation, see Test 1 in Section 6.4. This test is the same for both air cooled and liquid cooled engine units.*

**Test 2- Try to Start Engine Manually**

**DISCUSSION:**

With the auto-off-manual switch set to "Auto", a "Utility" power source outage should result in engine cranking and startup. If that power source fails and the engine does not crank, the first step in troubleshooting should be to see if a manual startup can be accomplished.

**PROCEDURE:**

1. On the generator panel, set the auto-off-manual switch to "Off".
2. Set the generator's main line circuit breaker to its "Off" or "Open" position.
3. Set the auto-off-manual switch to "Manual". The engine should crank and start.

**RESULTS:**

1. If the engine will not start manually either, go to Problem 2 in the "Troubleshooting Flow Charts".
2. If the engine cranks and starts manually, but will not crank in automatic mode, go to Test 3.

**Test 3- Test Auto-Off-Manual Switch**

**DISCUSSION:**

Power for CMA circuit board operation is taken from the Wire 15 circuit (fused 12 volts DC) and delivered to the circuit board through auto-off-manual switch contacts when the switch is set to "Auto" or "Manual". A defective switch can produce the same results as setting the switch to "Off" (engine will not crank).

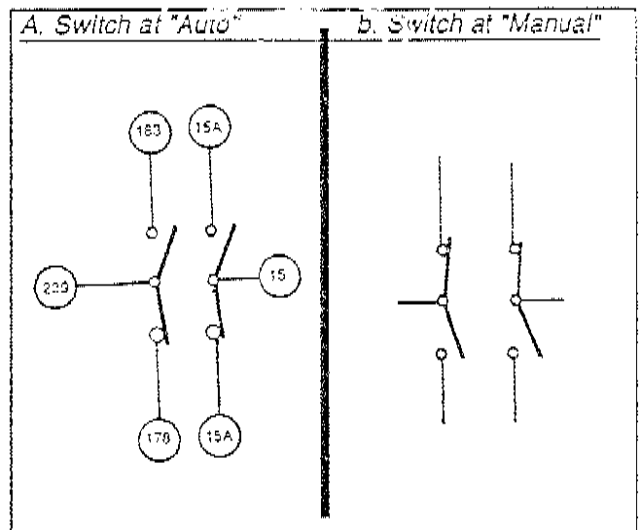

Figure 1. Schematic of Auto-Off-Manual Switch

**PROCEDURE:**

Disconnect all wires from switch terminals, to prevent interaction. Use a volt-ohm-milliammeter (VOM) to test for continuity across switch terminals as follows:

CONNECT ACROSS TERMINALS	SWITCH POSITION	METER READING
1 and 2	"Auto" "Manual" "Off"	Continuity Infinity Infinity
1 and 3	"Auto" "Manual" "Off"	Infinity Continuity Infinity
4 and 5	"Auto" "Manual" "Off"	Continuity Infinity Infinity
4 and 6	"Auto" "Manual" "Off"	Infinity Continuity Infinity

**Test 3- Test Auto-Off-Manual Switch  
(Continued)**

**RESULTS:**

1. Replace switch is defective.
2. If switch is good, go to Test 4.

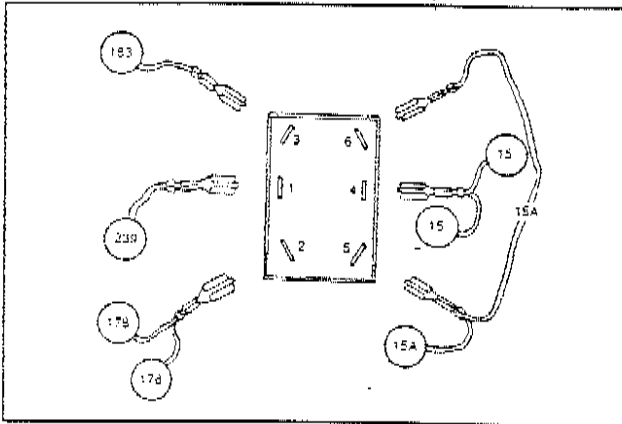

Figure 2. Auto-Off-Manual Switch Test Points

**Test 4- Inspect Auto-Off-Manual Switch  
to CMA Circuit Board Wiring**

**DISCUSSION:**

Any open or disconnected wiring between the switch and the CMA circuit board, or between the switch and other components, can have the same effect as an open or defective switch. See Figure 3.

**PROCEDURE:**

Inspect and test all wires connected to the switch terminals for open, disconnected or shorted condition. This includes (a) jumper wire 15A between switch terminals 5 and 6; (b) Wire 15 between terminal 4 and the circuit board; (c) Wire 15A between switch and circuit board; (d) Wire 183 between terminal 2 and TB3; (e) Wire 239 between terminal 1 and the circuit board; Wire 178 between terminal 3 and TB3; (f) Wire 178 between terminal 3 and the circuit board.

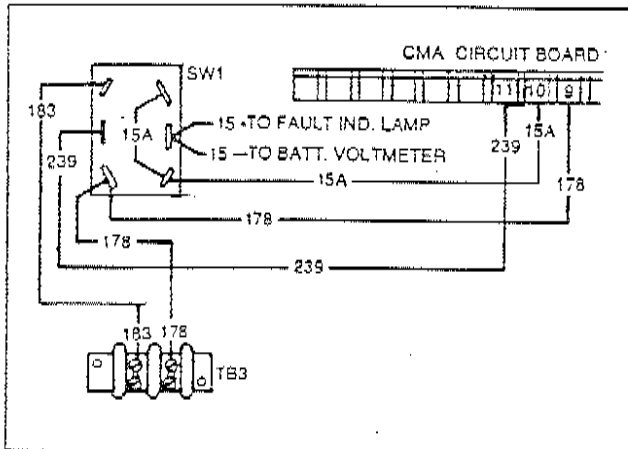

Figure 3. Auto-Off-Manual Switch Wiring

**RESULTS:**

Repair, reconnect or replace any bad wiring.

**Test 5- Check 30 Amp Fuse F1**

**DISCUSSION:**

A blown fuse F1 will open the DC power supply to the auto-off-manual switch and to the CMA circuit board. This will render the circuit board incapable of cranking or starting the engine, since its power supply is gone.

**PROCEDURE:**

Push in on fuse holder cap and turn counterclockwise to remove cap and fuse. Check the fuse with a VOM for open condition indicating that fuse is blown.

**RESULTS:**

1. Replace fuse if blown.
2. If fuse is good but engine won't crank, go on to Test 6.

**Test 6- Check battery**

**DISCUSSION:**

A weak or dead battery can result in inability of the engine to crank either manually or automatically.

**PROCEDURE:**

Inspect and test the unit's 12 volts battery. Refer to Test 6, "Check Battery" in Part 6, Section 6.4.

**RESULTS:**

1. Clean, tighten or replace any defective battery cables.
2. If battery is discharged, remove it and recharge with an automotive type battery charger.
3. If battery is worn out, replace it.
4. If battery is good, go to Test 7.

**Test 7- Test Control Contactor CC**

**DISCUSSION:**

During any startup, CMA circuit board action delivers 12 volts DC to the coil of a control contactor. The control contactor energizes, its contacts close, and battery power is delivered to the starter motor (SM) to crank the engine. A defective control contactor (CC) can prevent the engine from being cranked in both the automatic and manual modes of operation.

**PROCEDURE:**

Use a DC voltmeter (or VOM) to test control contactor (CC) operation, as follows:

**Test 7- Test Control Contactor (Continued)**

Step 1. Connect the positive (+) test lead to the control contactor's Wire 56 terminal, the common (-) test lead to a clean frame ground.

Step 2. Set the auto-off-manual switch to "Manual". The meter should indicate battery voltage (about 12 volts DC).

**RESULTS:**

1. If battery voltage is not indicated, go to Step 3.
2. If battery voltage is indicated but engine does not crank, go to Step 4.

Step 3. Connect the meter test leads across terminals 0 and 56 of terminal board TB1 (in the control console). Set the auto-off-manual switch to "Manual". The meter should read battery voltage.

**RESULTS:**

1. If battery voltage is indicated in Step 3 but not in Step 2, Wire 56 between the control contactor and terminal board TB1 is open. Repair, reconnect or replace Wire 56 as necessary.
2. If battery voltage is not indicated in either Step 2 or Step 3, replace the CMA circuit board.
3. If battery voltage is indicated in both Steps 2 and 3, but the engine does not crank, go on to Step 4.

Step 4. Connect the meter test leads across the large terminal stud on the control contactor to which the battery cable (Wire 13) attaches and frame ground. The meter should read battery voltage.

Step 5. Now, connect the positive (+) meter test lead to the starter motor (SM) terminal stud and the common (-) test lead to frame ground. Set the auto-off-manual switch to "Manual". The meter should read battery voltage and engine should crank.

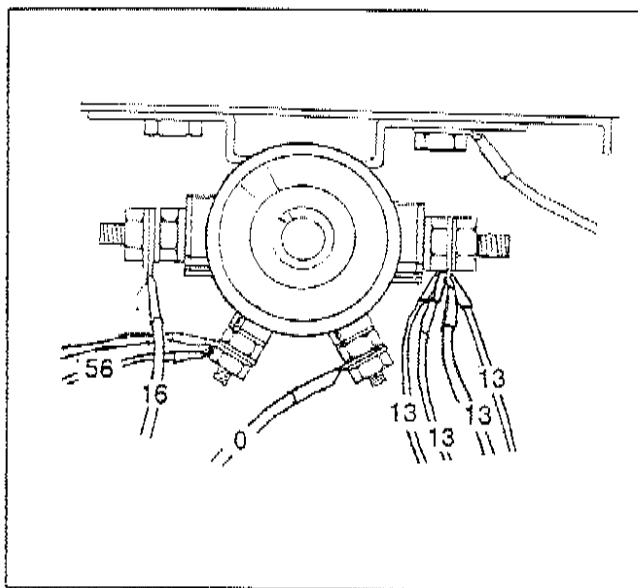

Figure 4. Control Contactor Test Points

**RESULTS:**

1. If battery voltage is indicated in Step 5, but engine does not crank, go on to Test 8.
2. If battery voltage is not indicated in Step 5, replace the control contactor (CC).

**Test 8- Test Starter Motor SM**

**DISCUSSION:**

The starter motor must develop adequate torque to crank the engine efficiently at sufficient rpm for startup to occur.

**PROCEDURE:**

1. Repeat Step 5 of Test 7. If battery voltage is indicated during the test, but engine does not crank, the starter is probably defective and should be replaced or repaired.
2. If desired, starter performance can be tested as follows:
  - a. Remove the starter.
  - b. See Figure 5. Connect the starter motor, a fully charged 12 volts battery, a tachometer and an ammeter as shown.
  - c. Operate the starter motor and note the ammeter and tachometer readings. A starter motor in good condition will be within the test specifications shown below:

MAXIMUM MOTOR RPM	6000-7200
MAXIMUM AMPERES	17

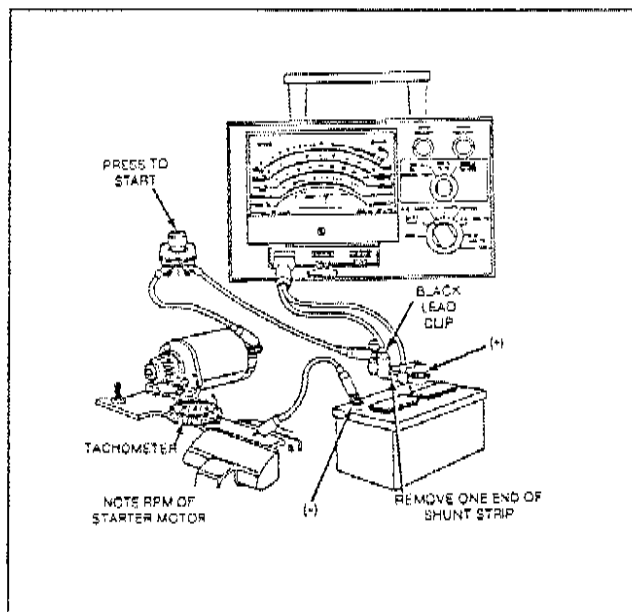

Figure 5. Starter Motor Performance Test

**RESULTS:**

1. Repair or replace bad starter motor.
2. If motor is good, go to Test 9.

**Test 9- Check CMA Circuit Board Power and Wire 56 Output**

**DISCUSSION:**

A 12 volts DC power supply must be available to the CMA circuit board or the board will not operate. A 2 volts DC output must be delivered from the circuit board to Wire 56 or engine cranking cannot occur. In this test, you will check the DC power supply to the board and you will also check for a DC output to Wire 56.

**PROCEDURE:**

To check for a 12 volts DC power supply to the CMA circuit board, proceed as follows:

1. See Figure 6. Connect the positive (+) test lead of a DC voltmeter (or a VOM) to terminal 4 of the auto-off-manual switch.
2. Connect the common (-) meter test lead to frame ground. The meter should read 12 volts DC.
3. Now, set the auto-off-manual switch to "O!".
  - a. Connect the positive (+) meter test lead to switch terminal 6; the common (-) test lead to frame ground. The meter should indicate "zero" volts.
  - b. Set the switch to "Manual". The meter should read battery voltage.
4. Locate Pin 10 of the CMA circuit board connector, to which Wire 15A attaches.
  - a. Connect the positive (+) meter test lead to Pin 10 (Wire 15A), the common (-) test lead to frame ground. Zero volts should be indicated.
  - b. Set the auto-off-manual switch to "Manual". The meter should read battery voltage.
5. Locate Pin 5 of the CMA circuit board connector, to which Wire 56 attaches.
  - a. Connect the positive (+) meter test lead to connector Pin 5.
  - b. Connect the common (-) meter test lead to frame ground. The meter should indicate "zero" volts.
  - c. Set the auto-off-manual switch to "Manual". Crank relay K1 on the CMA board should energize and the meter should read battery voltage.

**RESULTS:**

1. In Step 2, if the meter does not indicate battery voltage, repeat Test 5. Also check the Wire 15 circuit for an open condition.
2. In Step 3, if battery voltage is not indicated when "Manual" is selected, the auto-off-manual switch is suspect. Repeat Test 3 and replace the switch, if bad.
3. In Step 4(b), if battery voltage is not indicated, Wire 15A (between the auto-off-manual switch and circuit board) is suspect. Reconnect, repair or replace Wire 15A as needed.
4. In Step 5, if battery voltage is not indicated, the CMA circuit board is bad. Replace the circuit board and test manual and automatic operation.

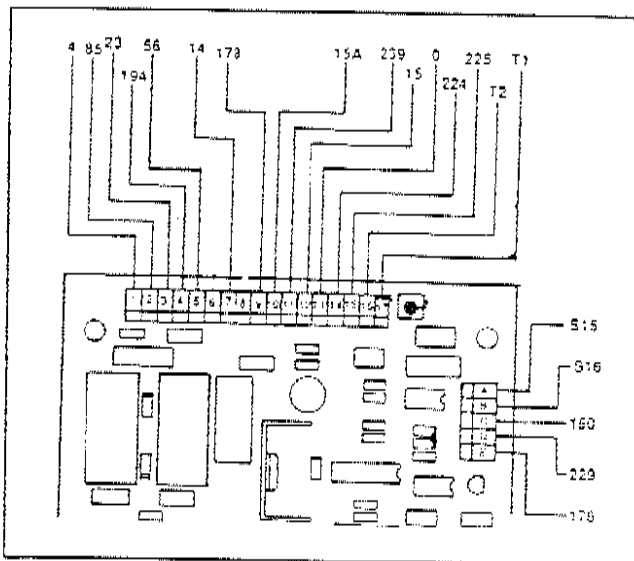

Figure 6. Check Circuit Board Power Input and Output

**Test 10- Check for Mechanical Damage**

**DISCUSSION:**

If the engine will not crank when "Manual" position is selected, the problem is most likely to be an electrical fault. However, the possibility that engine or generator damage is preventing the unit from cranking cannot be overlooked.

**PROCEDURE:**

Examine the engine and generator carefully for evidence of seizure.

**RESULTS:**

If engine-generator is seized due to mechanical damage, repair the unit as necessary.

**Test 11- Check Fuel Supply**

**DISCUSSION:**

Often the most obvious cause of a problem is overlooked. If the engine cranks, but will not start, perhaps the fuel supply is exhausted or fuel pressure is too low. The following facts apply:

- For propane (LP) gas fuel systems, only a "vapor withdrawal" type supply system should be used on prepackaged units. The vapor pressure in the storage tank must be high enough to sustain engine operation.
- Minimum recommended gas pressure at the generator's fuel inlet connection is 11 inches water column (6.38 ounces per square inch). Maximum gas pressure is approximately 14 inches water column (8 ounces per square inch).

*Test 11- Check Fuel Supply (Continued)*

- The gaseous fuel system must be tested for leaks following installation and periodically thereafter. No leakage is permitted. Leak test methods and procedures must comply strictly with applicable fuel-gas codes.
- A schematic diagram of a simple propane (LP) gas vapor withdrawal system is shown in Figure 7. A typical natural gas fuel system is shown in Figure 8.

**DANGER: GASEOUS FUELS ARE EXPLOSIVE. DO NOT USE FLAME TO TEST FOR LEAKS. NATURAL GAS IS LIGHTER THAN AIR, SETTLES IN HIGH AREAS. LP GAS IS HEAVIER THAN AIR, SETTLES IN LOW PLACES. THE SLIGHTEST SPARK CAN IGNITE THE FUELS AND CAUSE AN EXPLOSION.**

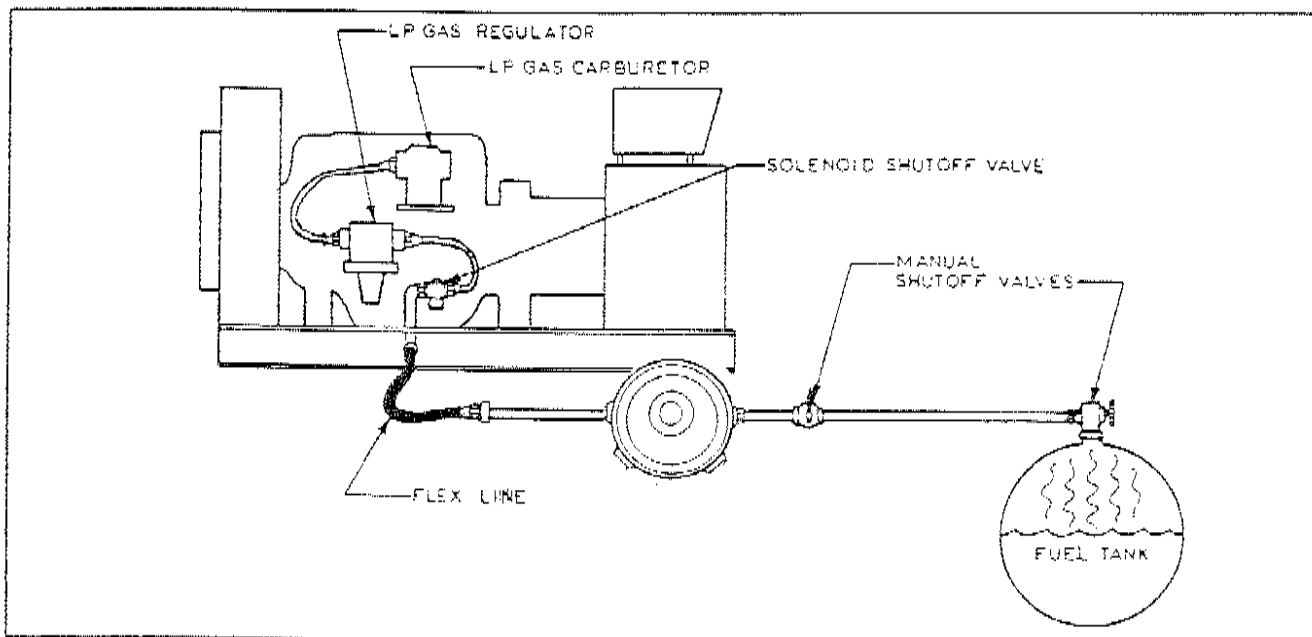

*Figure 7. Typical LP Gas Fuel System*

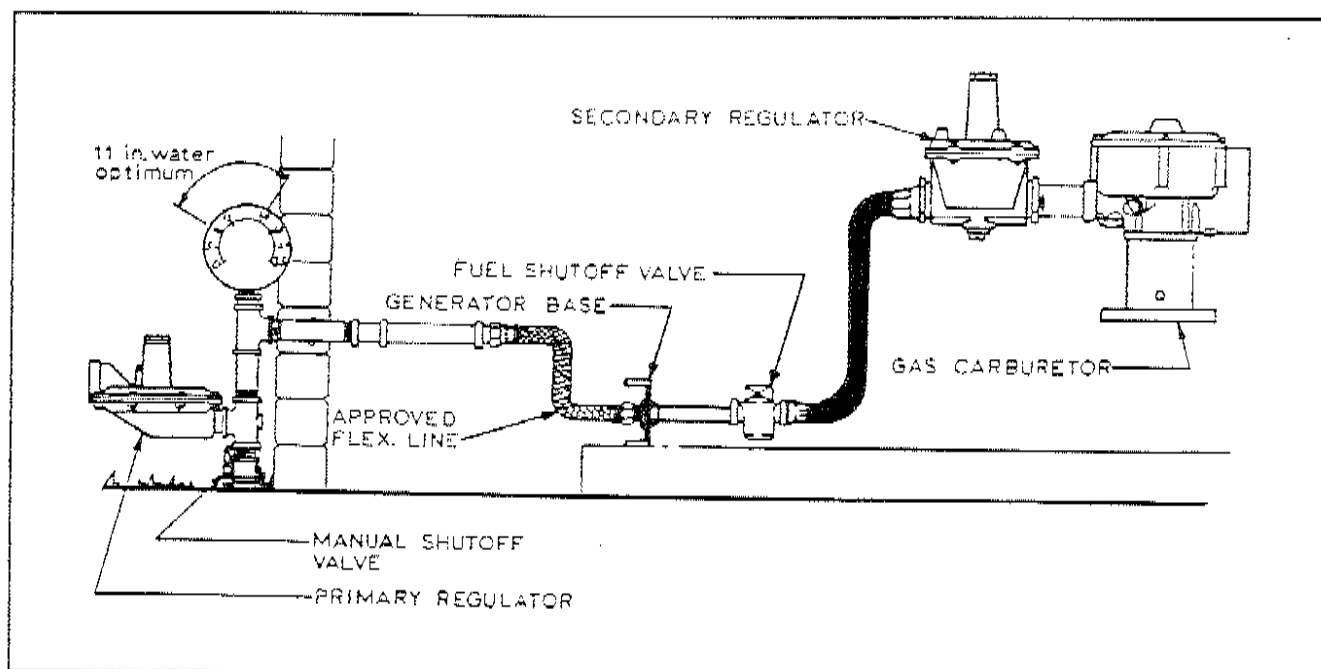

*Figure 8. Typical Natural Gas Fuel System*

**Test 11- Check Fuel Supply (Continued)**

**PROCEDURE:**

In the case of LP (propane) gas, some supply tanks will be equipped with a gauge that indicates when the tank is low on fuel.

For natural gas systems, the gas distribution company will usually provide piping from the main transmission line to the generator site. The primary regulator may or may not be furnished and adjusted by the supplier. It is the responsibility of the supplier to ensure that adequate gas pressure is available to operate the primary regulator.

Where the primary regulator is furnished and is to be maintained by the gas supplier, primary regulator outlet pressure may be adjusted by the supplier. In any event, adjustment of the primary regulator pressure should be accomplished by a gas service technician. Gaseous fuel pressures are usually measured with a water manometer or with a pressure gauge that reads "ounces per square inch".

**RESULTS:**

If fuel supply and pressure are adequate, but engine will not start, go to Test 12.

**Test 12- Check Wire 14 Output to Ignition**

**DISCUSSION:**

When the engine is cranked either automatically or manually, a crank relay (K1) and a run relay (K2) on the CMA circuit board are energized simultaneously. See Figure 9, below. When the engine is cranking, battery voltage is delivered to the positive (+) terminal of the ignition coil (IC), via Wire 56, a diode (D1), and Wire 14. Thus, when cranking, the full 12 volts DC is available to the coil to produce a hotter spark.

On startup, crank relay (K1) de-energizes while the run relay (K2) remains energized. Battery voltage is delivered to the ignition coil's positive (+) terminal via Wire 14, a resistor wire, and Wire 14. The resistor wire reduces the voltage to about 9-10 volts DC for running operations.

*NOTE: If the resistor wire (RW) circuit is open, ignition will be available while cranking only and the engine will start. However, as soon as the circuit board's crank relay de-energizes, ignition will terminate and shutdown will occur.*

**PROCEDURE:**

1. On the ignition coil, locate the terminal to which Wire 14 attaches.
2. Connect the positive (+) test lead of a DC voltmeter (or VCM) to the coil's Wire 14 terminal. Connect the other test lead to a clean frame ground.
3. Set the auto-off-manual switch to "Manual". The engine should crank and the meter should indicate battery voltage.

*NOTE: When the circuit board's crank relay (K1) de-energizes, voltage reading should drop to about 9-10 volts DC. If voltage drops to zero and engine shuts down when the crank relay de-energizes, an open circuit exists in the resistor wire (RW) circuit to the coil.*

4. On startup and when crank relay K1 de-energizes, the meter voltage reading should drop to about 9-10 volts DC.

**RESULTS:**

1. If meter indicates battery voltage while cranking, then drops to about 9-10 volts DC, you may assume that Wire 14 output to the ignition coil is normal. Go to Test 13.

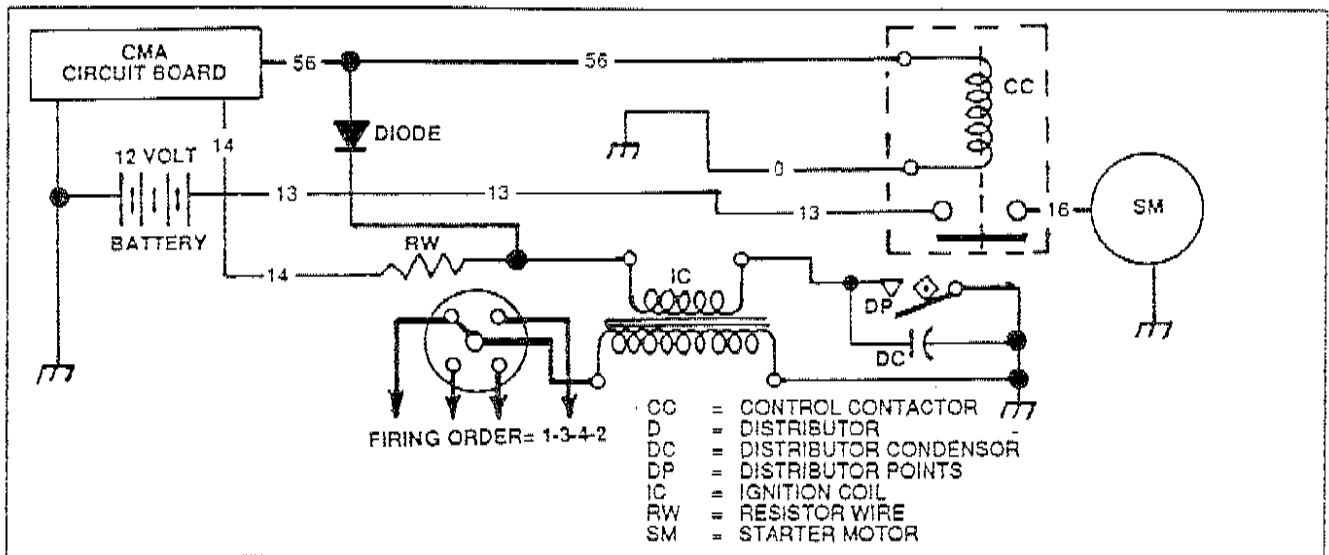

Figure 9. Typical Prepackaged Ignition Circuit

**Test 12- Check Wire 14 Output to Ignition (Continued)**

2. If meter indicates 9-10 volts DC only, check Wire 14, diode D1 and Wire 56 between the ignition coil and the control contactor CC for an open condition.
3. If meter indicates battery voltage while cranking, but voltage drops to zero and shutdown occurs when cranking terminates, go to Test 21.

**Test 13- Test Ignition Coil**

**DISCUSSION:**

The engine ignition coil can be tested quickly and easily by checking the resistance of its primary and secondary coil.

**PROCEDURE:**

1. To test the coil primary winding, connect the test probes of an ohmmeter (or VOM) across the positive (+) and negative (-) terminals of the coil and read the resistance. See Figure 10.

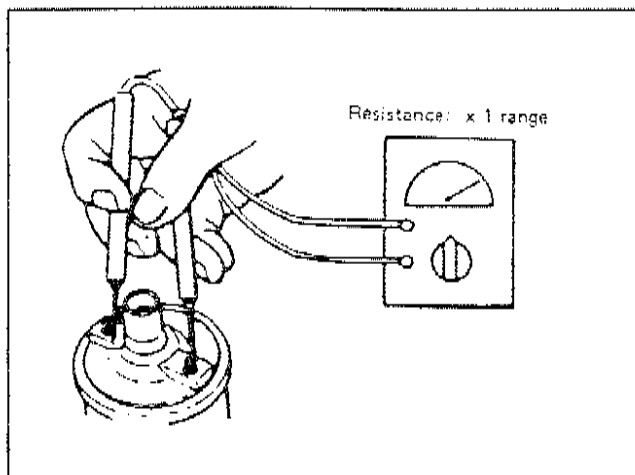

Figure 10. Testing Primary Winding Resistance

2. To test secondary coil resistance, connect the meter test probes as shown in Figure 11.

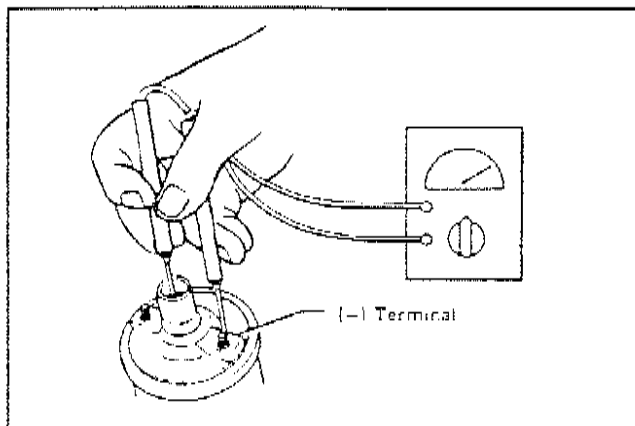

Figure 11. Testing Secondary Coil Resistance

Primary Coil Resistance at 68° F. (20° C.)= 1.3-1.5 Ohms  
Secondary Coil Resistance at 68° F. (20° C.)= 8700-11,700 Ohms

**Test 14- Test Ignition Condensator**

**DISCUSSION:**

The condensator is located in the engine ignition distributor. The condensator functions to prevent arcing across the distributor contact points.

**PROCEDURE:**

Use a capacity tester to test the condensator, if one is available. If such a tester is not available, a VOM may be used with its resistance scale set to a very high value. See Figure 12. When the meter needle swings violently and then moves back to "infinity" gradually, the condensator is good.

**RESULTS:**

1. If the meter reads "zero" or if it indicates a steady reading, replace the condensator.
2. If meter indicates a good condensator, go to Test 15.

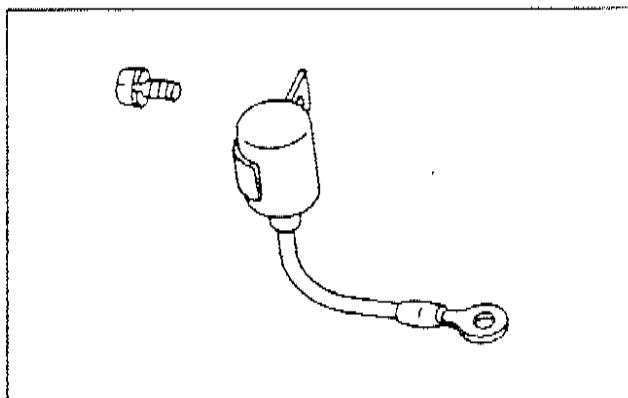

Figure 12. Distributor Condensator

**Test 15- Inspect Distributor Cap and Rotor Head**

**DISCUSSION:**

This test continues the testing of engine ignition system components.

**PROCEDURE:**

Inspect the distributor cap and rotor head for dust, carbon deposits, cracks.

**RESULTS:**

1. Replace distributor cap, if defective.
2. If inspection reveals the cap is good, go on to Test 16.

### Test 16- Inspect Contact Points

#### DISCUSSION:

This test is a continuation of the tests of engine ignition system parts.

#### PROCEDURE:

Inspect the surfaces of the distributor contact points. Irregularities may be removed with "500" or "600" sandpaper, or with oilstone. Loosen the breaker point set screw and adjust gap with a feeler gauge.

Breaker Point Gap = 0.018-0.022 inch

#### RESULTS:

1. Replace contact points, if defective.
2. If points are in good condition, go on to Test 17.

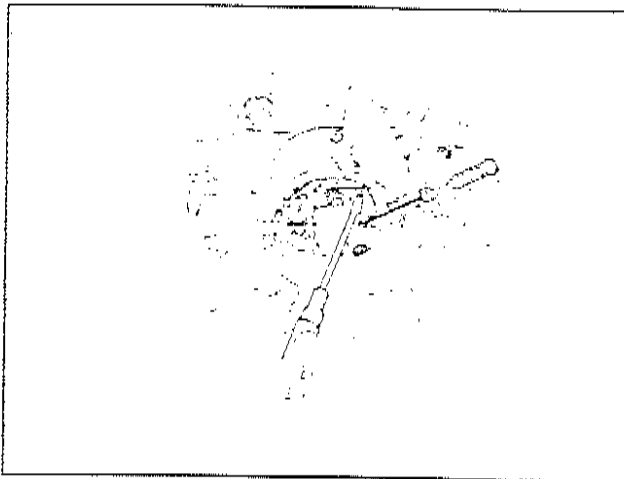

Figure 13. Setting Contacts Point Gap

### Test 17- Check Governor Advance

#### DISCUSSION:

This is a continuation of tests of the engine ignition system.

#### PROCEDURE:

In the distributor, turn the rotor shaft counterclockwise. Then, release it and check that it returns to the clockwise direction. Also check the rotor shaft for looseness.

#### RESULTS:

1. Replace distributor if governor advance is bad.
2. If test is good, go to Test 18.

### Test 18- Check Spark Plugs

#### DISCUSSION:

This test is a continuation of the tests on the engine ignition system.

#### PROCEDURE:

1. Disconnect spark plug wires by grasping the boot. Do NOT pull on the wires.
2. Use a spark plug wrench to remove the spark plugs.
3. Spark plugs may be cleaned in a sand blast cleaner. Inspect the plug insulators for cracks and chipping. Inspect the gaskets for damage, deterioration. Check electrodes for wear, burring, pitting. Check spark plug gap and set to 0.031-0.035 inch.
4. Replace spark plugs, if bad.
5. Install spark plugs and tighten to 14-22 foot-pounds of torque (20-29 N-m).

NOTE: Use NGK BPR6ES, or Champion RN9YC, or AC R42XLS replacement spark plugs.

#### RESULTS:

1. Replace bad spark plugs.
2. If spark plugs are good, go to Test 19.

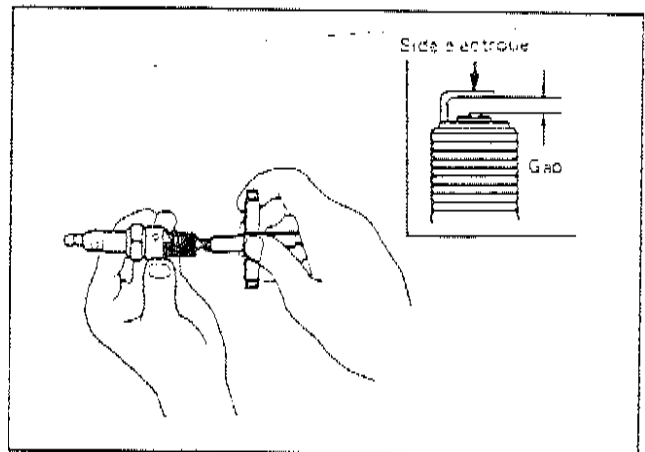

Figure 14. Checking Spark Plug Gap

### Test 19- Check Ignition Wires

#### DISCUSSION:

This is a continuation of tests on the engine ignition system.

#### PROCEDURE:

Check high tension ignition wires for damage, cracks, burned terminals, proper fit. Measure the resistance of each wire. Shake each wire as the resistance reading is taken. Resistance should be less than 30,000 ohms.

#### RESULTS:

1. Replace any defective ignition wire.
2. If wires test good, go on to Test 20.

***Test 20- Check Ignition Timing***

**DISCUSSION:**

If engine starts hard and runs rough, or if it does not start, it may be out of time. If badly out of time, backfiring may result.

**PROCEDURE:**

Use an automotive timing light to check and adjust ignition timing. A timing mark is provided on the crankshaft pulley and a degree indicator is provided (Figure 15).

Set timing to 21° BTDC at 1860 rpm and with the generator at no-load.

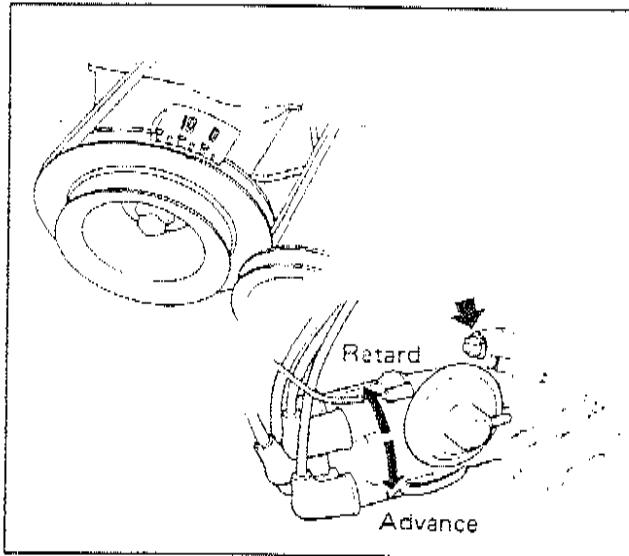

*Figure 15. Ignition Timing Marks*

***Test 21- Check DC Volts at Terminal 14 of TB1***

**DISCUSSION:**

This test will determine if CMA circuit board action is delivering battery voltage to the Wire 14 circuit. Wire 14 circuit voltage is required to (a) power the engine ignition system and (b) open the fuel solenoid. Terminal board TB1 is housed in the generator control console. See "Control Console Components" on Page 7.1-2 (Part 7, Section 7.1).

**PROCEDURE:**

1. Use a DC voltmeter (or VOM) to check for battery voltage at Terminal 14 of terminal board TB1.
2. Connect the positive (+) meter test lead to terminal 14, the common (-) test lead to terminal 0 (ground).
3. Set the auto-off-manual switch to "Manual". The meter should indicate battery voltage.

**RESULTS:**

1. If battery voltage is not indicated, test Wire 14 between terminal board TB1 and the CMA circuit board for an open condition.
  - a. If Wire 14 is good, replace the CMA circuit board.
  - b. If Wire 14 is bad, repair, reconnect or replace as necessary.
2. If battery voltage is indicated, go to Test 22.

***Test 22- Test Fuel Solenoid FS***

**DISCUSSION:**

The fuel solenoid is opened by 12 volts DC power from Wire 14 and from the CMA circuit board.

**PROCEDURE:**

1. Connect a DC voltmeter (or VOM) across Wire 14 at the fuel solenoid and frame ground.
2. Set the auto-off-manual switch to "Manual". The engine should crank and start. The meter should indicate battery voltage. The fuel solenoid should energize.

**RESULTS:**

1. If battery voltage is indicated but the fuel solenoid does not energize, replace the solenoid.
2. If the fuel solenoid is good, go on to Test 23.

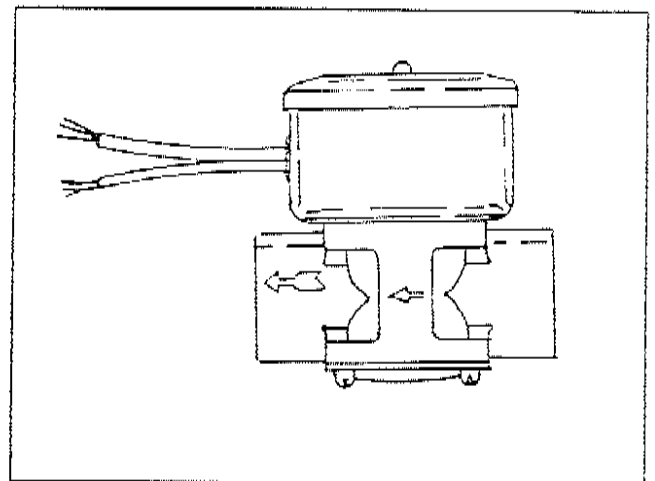

*Figure 16. Fuel Solenoid FS*

***Test 23- Check Engine Compression and Condition***

**DISCUSSION:**

If the engine cranks but will not start, or if it starts hard and runs rough, one possible cause of the problem is a mechanical failure in the engine.

**PROCEDURE:**

1. Warm up the engine.
2. Shut engine down and remove all spark plugs.
3. Use an automotive type compression tester to check engine compression.

**Test 23- Check Engine Compression and Condition (Continued)**

*NOTE: When checking compression, hold the carburetor throttle wide open. Then, crank engine and read the compression pressure.*

4. Compression pressure should be as follows:

Standard = 192 psi (13.5 kg/cm<sup>2</sup>) at 350 rpm  
 Minimum = 164 psi (11.5 kg/cm<sup>2</sup>) at 350 rpm  
 Difference between cylinders should not exceed  
 14 psi (1.0 kg/cm<sup>2</sup>)

If compression is low in any cylinder, pour a small amount of clean engine oil into the spark plug opening. Then, retest compression and evaluate as follows:

- If compression pressure increases after adding the oil, check for worn or damaged piston rings.
- If compression pressure did NOT increase after adding the oil, check for sticking or improperly seated valves.
- If compression in any two adjacent cylinders is low and adding oil did NOT increase the compression pressure, check for a leaking head gasket.

**Test 24- Check Generator Main Line Circuit Breaker**

DISCUSSION:

Transfer to the "Standby" power source cannot occur unless that power supply is available to the transfer switch. If automatic startup occurs while the generator's main line circuit breaker is open, transfer to "Standby" will not occur.

PROCEDURE:

1. Check that the generator's main line circuit breaker is "On" or "Closed".
2. Use an AC voltmeter (or a VOM) to check for proper generator AC output to the circuit breaker.
3. With the breaker set to "On" or "Closed", check for correct AC output to the circuit breaker output terminals.

RESULTS:

1. If necessary, set the main circuit breaker to its "On" or "Closed" position.
2. If normal rated AC power is available to the breaker input terminals, but not to the output terminals, replace the circuit breaker.
3. If normal rated AC power is not available to the breaker AC input terminals, refer to Part 3 of this manual.

**Test 25- Check Sensing to CMA Circuit Board**

DISCUSSION:

In automatic mode and when a "Utility" power source dropout occurs, the CMA circuit board will initiate engine cranking and startup. A line-to-neutral voltage/frequency sensing signal is delivered to the CMA circuit board from the generator's AC power windings, via Wires S15 and S16. This sensing signal "tells" the circuit board that the engine has started and is running. Starter cutout occurs when the sensing signal voltage reaches approximately 50 volts AC. The board's minimum run and engine warmup timers will then turn on.

Transfer of loads to the "Standby" power supply cannot occur until after the board's engine warmup timer has timed out. Thus, if the Wires S15/S16 signal is lost, transfer will not occur. This test will determine if the line-to-neutral sensing signal is available to the CMA circuit board.

PROCEDURE:

1. Set the auto-off-manual switch to "Off".
2. Turn OFF both the "Utility" and "Standby" power supplies to the transfer switch.
3. If necessary, manually actuate the transfer switch main contacts to their "Utility" position ("Load" terminals connected to the "Utility" terminals).
4. Insert the test probes of an AC voltmeter across Pins A and B of the CMA circuit board, to which Wires S15 and S16 attach.
5. Turn ON the "Utility" power supply to the transfer switch.
6. Set the generator's main line circuit breaker to its "On" or "Closed" position.
7. Set the generator's auto-off-manual switch to "Auto".
8. While observing the AC voltmeter, turn OFF the "Utility" power supply to the transfer switch.
  - a. The engine should crank and start in automatic mode.
  - b. Starter cutout should occur at approximately 50 volts AC as indicated on the AC voltmeter.
  - c. With engine running at rated speed, the voltmeter should read about 122-126 volts AC.

RESULTS:

1. If correct voltage is indicated in Step 8, but transfer to "Standby" did not occur, go on to Test 26.
2. If low or no voltage is indicated in Step 8, repeat Test 24.
  - a. If correct AC voltage is indicated in Test 24, but not in Step 8 of this test, check sensing leads S15 and S16 for an open or disconnected condition.
  - b. If low or no voltage was indicated in Test 24, refer to Part 3 of this manual.

**Test 26- Ground CMA Terminal 23**

DISCUSSION:

Following automatic startup and when the CMA board's engine warmup timer has timed out (15 seconds), circuit board action should connect Wire 23

***Test 26- Ground CMA Terminal 23 (Continued)***

circuit to ground. The transfer relay (in transfer switch) should then energize and transfer to the "Standby" source should occur. This test will determine if the CMA circuit board is working properly and is grounding the Wire 23 circuit.

**PROCEDURE:**

1. Set the auto-off-manual switch to "Off".
2. Turn OFF both the "Utility" and "Standby" power supplies to the transfer switch using whatever means provided.
3. If necessary, manually actuate the transfer switch main contacts to their "Utility" position, i.e., "Load" connected to the "Utility" power supply.
4. Turn ON the "Utility" power supply to the transfer switch.
5. Set the generator's main line circuit breaker to its "On" or "Closed" position.
6. Set the auto-off-manual switch to "Auto".
7. Turn OFF the "Utility" power supply to the transfer switch.
  - a. Engine should crank and start in automatic mode.
  - b. After the CMA board's engine warmup timer has timed out, the transfer relay (in transfer switch) should energize and transfer to "Standby" should occur.
8. If the engine starts and runs but transfer does NOT occur, proceed as follows:
  - a. With the engine running, connect a jumper wire across terminal 23 of terminal board TB2 and terminal 0 of terminal board TB1.
    - (1) The transfer relay should energize.
    - (2) Transfer to "Standby" should occur.

**RESULTS:**

1. In Step 8, if transfer to "Standby" occurs when the jumper wire is connected across terminals 23 and 0, proceed as follows:
  - a. Test Wire 23 (between terminal board TB2 and the CMA board connector) for an open condition.
  - b. If Wire 23 is good, replace the CMA circuit board.
2. In Step 8, if transfer to "Standby" does NOT occur when the jumper wire is connected, refer to Section 4.3 or 5.3 of this manual as appropriate.

***Test 27- Check Voltage at Terminal Lugs E1, E2, E3***

**DISCUSSION:**

Transfer to the "Standby" source cannot occur unless that power supply is available to the transfer switch. This test will determine if "Standby" power is available to the transfer switch terminal lugs.

**DANGER: PROCEED WITH CAUTION. HIGH AND DANGEROUS VOLTAGES ARE NORMALLY PRESENT AT THE TRANSFER SWITCH TERMINAL LUGS. CONTACT WITH THESE HIGH VOLTAGE TERMINALS WILL RESULT IN EXTREMELY DANGEROUS AND POSSIBLY DEADLY ELECTRICAL SHOCK.**

**PROCEDURE:**

1. Start the generator engine manually, let it stabilize and warm up.
2. Set the generator's main line circuit breaker to "On" or "Closed".
3. Use an AC voltmeter to test generator line-to-line voltage across transfer switch terminal lugs E1 and E2 (2-pole), or across E1 to E2, E2 to E3 and E3 to E1 (3-pole). Normal rated generator AC output voltage should be indicated.

**RESULTS:**

1. If normal "Standby" source voltage is indicated, but transfer to "Standby" does not occur, go to Section 4.3 or 5.3 of this manual, as appropriate.
2. If normal "Standby" source voltage is NOT indicated, refer to "Troubleshooting Flow Charts" in Section 3.3.

***Test 28- Check Voltage at Terminal Lugs N1, N2, N3***

**DISCUSSION:**

Automatic startup of the generator engine will occur if the voltage delivered to transfer switch terminal lugs N1/N2 (2-pole) or N1/N2/N3 (3-pole) is below a preset value.

**PROCEDURE:**

Use an AC voltmeter to check line-to-line voltage across terminal lugs N1/N2 (2-pole transfer switch) or across N1/N2/N3 (3-pole switch). Normal rated "Utility" power source voltage should be indicated.

**RESULTS:**

1. If normal "Utility" voltage is read, but generator startup and transfer to "Standby" occurs in automatic mode, go to Test 29.
2. If normal "Utility" voltage is NOT indicated, automatic startup and transfer is a normal condition.

***Test 29- Check Voltage at CMA Terminals N1A and N2***

**DISCUSSION:**

"Utility" power source voltage is delivered to CMA terminals N1A and N2 (Utility 1 and 2), and from there to the CMA transformer. The step-down transformer

**Test 29- Check Voltage at CMA Terminals N1A and N2 (Continued)**

reduces this sensing voltage. The reduced sensing voltage is then delivered to the CMA circuit board. If, for any reason, the reduced sensing voltage to the CMA board is lost, the circuit board will initiate engine startup and transfer to "Standby". This test will determine if "Utility" source voltage is available to the CMA.

**PROCEDURE:**

With "Utility" source power available to the transfer switch, connect the test leads of an AC voltmeter across terminals N1A and N2 of the CMA terminal board. Normal rated "Utility" source voltage should be indicated.

**RESULTS:**

1. If voltage reading in Test 28 was good, but reading in this test is bad, go to Section 4.3 or 5.3 as appropriate.
2. If voltage reading in both Test 28 and this test are good, go on to Test 30.

**Test 30- Test Sensing Transformer**

**DISCUSSION:**

Normal line-to-line "Utility" source voltage is delivered to the primary winding of the CMA transformer. Transformer action reduces this voltage to approximately 14 volts AC. The reduced sensing voltage is then delivered to the CMA circuit board. This is a test of the CMA transformer.

**PROCEDURE:**

1. See Figure 17. Connect an AC voltmeter across transformer terminals 1 and 4. Normal "Utility" power source voltage should be indicated.
2. Now, connect the meter test leads across transformer terminals 5 and 8. Approximately 12-14 volts AC should be indicated.

**RESULTS:**

1. If normal "Utility" source voltage is indicated in Step 1, but not in Step 2, replace the CMA transformer.
2. If the transformer checks good, but startup and transfer still occur when "Utility" power is available, replace the CMA circuit board and test automatic operation.

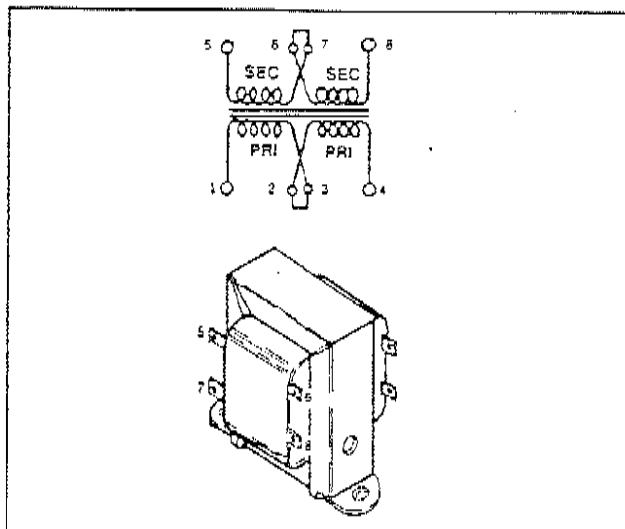

Figure 17. The CMA Transformer

**PART 8**  
**OPERATIONAL TESTS**  
**AND**  
**ADJUSTMENTS**

GENERAC II  
PREPACKAGED  
HOME STANDBY  
ELECTRIC POWER  
SYSTEMS

**TABLE OF CONTENTS**

SECTION	TITLE
8.1	System Functional Tests
8.2	Adjustments- Air Cooled Units
8.3	Adjustments- Liquid Cooled Units

# NOTES

---

Section 8.1  
**SYSTEM FUNCTIONAL TESTS**

**Introduction**

Following standby electric system installation and periodically thereafter, the system should be tested. Functional tests of the system include the following:

- Manual transfer switch operation.
- System voltage tests.
- Generator Tests Under Load.
- Testing automatic operation.

Before proceeding with functional tests, read instructions and information on tags or decals affixed to the generator and transfer switch. Perform all tests in the exact order given in this section.

**Manual Transfer Switch Operation**

**"V-TYPE" TRANSFER SWITCHES:**

1. On the generator panel, set the auto-off-manual switch to "Off".
2. Turn OFF the "Utility" power supply to the transfer switch using whatever means provided (such as a "Utility" main line circuit breaker).
3. Set the generator's main line circuit breaker to "Off" or "Open".

**DANGER: BE SURE TO TURN OFF ALL POWER VOLTAGE SUPPLIES TO THE TRANSFER SWITCH BEFORE ATTEMPTING MANUAL OPERATION. FAILURE TO TURN OFF POWER VOLTAGE SUPPLIES TO THE TRANSFER SWITCH MAY RESULT IN DANGEROUS AND POSSIBLY LETHAL ELECTRICAL SHOCK.**

4. Remove the manual transfer handle from the enclosure.
5. Place open end of the manual transfer handle over transfer switch operating lever.
6. To connect "Load" terminal lugs to the "Standby" power source, move the handle upward.
7. To connect "Load" terminals to the "Utility" power source, move the handle downward.
8. Actuate the switch to "Utility" and to "Manual" several times. Make sure no evidence of binding or interference is felt.
9. When satisfied that manual transfer switch operation is correct, actuate the main contacts to their "Utility" position ("Load" connected to the "Utility" power supply).

**"Y-TYPE" TRANSFER SWITCHES:**

1. On the generator panel, set the auto-off-manual switch to "Off".
2. Turn OFF the "Utility" power supply to the transfer switch, using whatever means provided (such as a "Utility" main line circuit breaker).
3. Set the generator's main line circuit breaker to "Off" or "Open".

**DANGER: BE SURE TO TURN OFF ALL POWER VOLTAGE SUPPLIES TO THE TRANSFER SWITCH BEFORE ATTEMPTING MANUAL OPERATION. FAILURE TO TURN OFF POWER VOLTAGE SUPPLIES MAY RESULT IN DANGEROUS AND POSSIBLY LETHAL ELECTRICAL SHOCK.**

4. Remove the manual transfer handle from the enclosure.
5. Attach the handle opening over the square shaft at lower right corner of transfer mechanism.
6. Move the handle upward. When movement stops (main contacts at "Neutral"), return handle to its original position and actuate again.
7. Observe the changeover display on the transfer mechanism as follows:
  - a. If the "Utility" arrow is aligned with the green band, "Load" is connected to the "Utility" power source.
  - b. If "Standby" source is aligned with the green band, "Load" is connected to the "Standby" source.
8. Repeat Steps 6 and 7 several times. Make sure manual operation is accomplished with no evidence of binding, sticking, etc.
9. When certain the transfer switch works properly, actuate the main contacts to their "Utility" position ("Load" connected to "Utility" source).

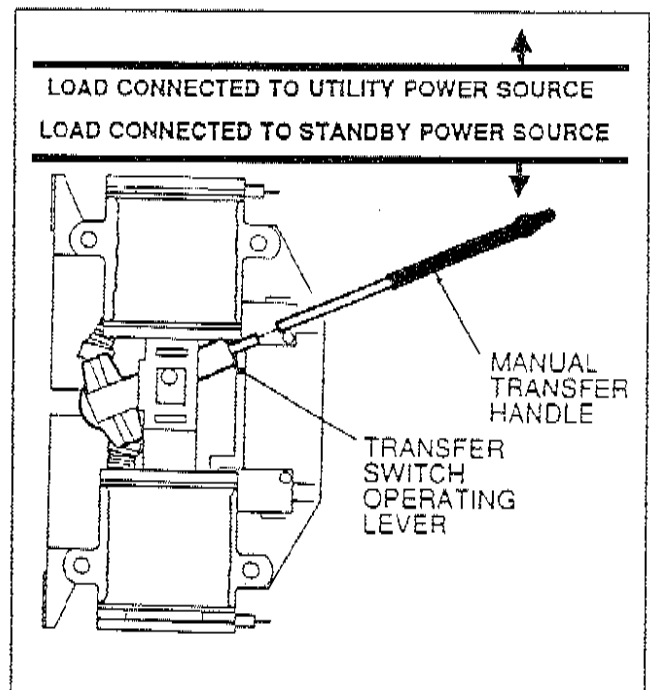

Figure 1. Manual Operation "V-Type" Switch

*Manual Transfer Switch Operation (Continued)*

**DANGER: PROCEED WITH CAUTION. THE TRANSFER SWITCH IS ELECTRICALLY HOT. CONTACT WITH LIVE TERMINALS OR WIRES WILL CAUSE DANGEROUS AND POSSIBLY DEADLY ELECTRICAL SHOCK.**

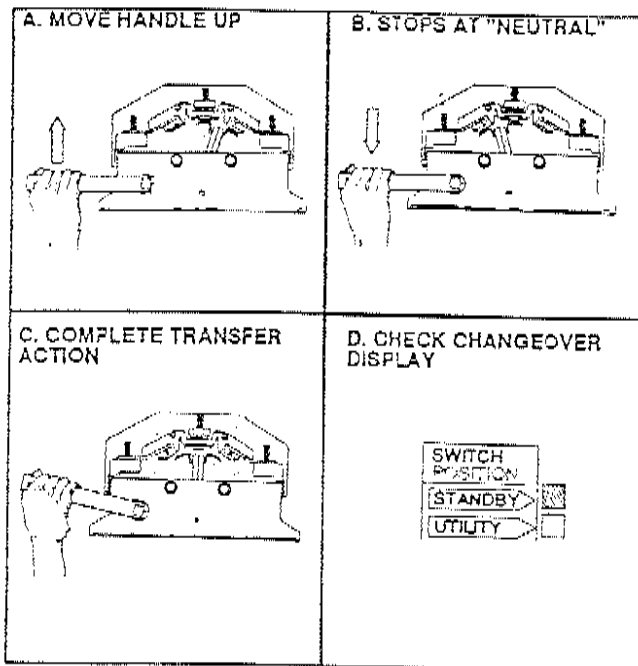

Figure 2. Manual Operation- "Y-Type" Switch

**System Voltage Tests**

1. Turn ON the "Utility" power supply to the transfer switch using whatever means provided (such as a "Utility" main line circuit breaker).

**DANGER: PROCEED WITH CAUTION. THE TRANSFER SWITCH IS ELECTRICALLY HOT. CONTACT WITH LIVE TERMINALS OR WIRES WILL CAUSE HAZARDOUS AND POSSIBLY DEADLY ELECTRICAL SHOCK.**

2. Use an accurate AC voltmeter to check line-to-line voltage. On 2-pole switches, check across terminals N1 and N2. On 3-pole switches, check across terminals N1 and N2; terminals N2 and N3; terminals N3 and N1. The voltage must be correct and compatible with rated transfer switch voltage, as listed on the transfer switch DATA PLATE.

3. When certain that "Utility" source voltage is correct and compatible, set the generator's auto-off-manual switch to "Off".

4. Turn OFF the "Utility" power supply to the transfer switch.

5. Check that the generator's main line circuit breaker is set to "On" or "Closed".

6. On the generator panel, set the auto-off-manual switch to "Manual". The engine should crank and start.

7. Let the generator engine stabilize and warm up for a few minutes.

8. Use an accurate AC voltmeter to check line-to-line voltage across terminal lugs E1 and E2 (2-pole units). For 3-phase systems, check line-to-line voltage across terminals E1-E2; across terminals E2-E3; across terminals E3-E1. Rated generator voltage should be indicated and must be compatible with the transfer switch rated voltage.

9. Use an accurate AC frequency meter to check for proper frequency. Connect the frequency meter test leads across terminal E1 and the "Neutral" block. Frequency at no-load should be about 61-63 Hertz.

10. After all voltage and frequency measurements have been completed, set the generator's main circuit breaker to its "Off" or "Open" position.

*NOTE: Do NOT proceed until generator AC output voltage and frequency are correct. If no-load voltage and frequency are both correspondingly high or low, the engine governor may require adjustment. If AC frequency is good, but AC voltage is high or low, the AC voltage regulator may require adjustment.*

**Generator Tests Under Load**

1. Set the generator's main line circuit breaker to "Off" or "Open".

2. Set the auto-off-manual switch to "Off".

3. Turn OFF the "Utility" power supply to the transfer switch using whatever means provided (such as a "Utility" main line circuit breaker).

4. Manually actuate the transfer switch main contacts to their "Standby" position, i.e., "Load" connected to the "Standby" source.

5. Set the auto-off-manual switch to "Manual". The engine should crank and start. When it starts, let it stabilize and warm up for a few minutes.

6. Actuate the generator's main circuit breaker to its "On" or "Closed" position.

7. Turn ON electrical loads equal to the full rated wattage/amperage capacity of the generator. DO NOT OVERLOAD THE UNIT.

8. With maximum rated load applied, check AC voltage and frequency across transfer switch terminals E1/E2 (1-phase) or across E1/E2/E3 (3-phase). Voltage should be greater than 230 volts AC. Frequency should be greater than 58 Hz.

9. Let the generator run at its maximum rated load for 30 minutes. Listen for unusual noises, evidence of vibration, overheating, oil and coolant leaks, etc.

10. When checkout under load is completed, set the generator's main line circuit breaker to "Off" or "Open".

11. Let the generator run at no-load for a few minutes. Then, set the auto-off-manual switch to "Off" to stop the engine.

12. Make sure all power supplies to the transfer switch are turned OFF. Then, actuate the transfer switch back to its "Utility" position ("Load" connected to "Utility" power source).

*Generator Tests Under Load (Continued)*

13. Turn ON the "Utility" power supply to the transfer switch.
14. Set the auto-off-manual switch to "Auto". The system is now set for fully automatic operation.

*Testing Automatic Operation*

1. Set the generator's auto-off-manual switch to "Off".
2. Turn OFF both the "Utility" and "Standby" power supplies to the transfer switch.
3. If necessary, manually actuate the transfer switch main contacts to their "Utility" position, i.e., "Load" connected to the "Utility" source.
4. Turn ON the "Utility" power supply to the transfer switch.
5. Set the generator's main line circuit breaker to its "On" or "Closed" position.
6. Set the generator's auto-off-manual switch to its "Auto" position.
7. Turn OFF the "Utility" power supply to the transfer switch.
  - a. The generator engine should crank and start.
  - b. After the CMA board's "engine warmup timer" has timed out, transfer of "Load" circuits to the "Standby" power supply should occur.
8. Wait about 10-15 minutes, then turn ON the "Utility" power supply to the transfer switch.
  - a. After about six (6) seconds, retransfer back to the "Utility" source should occur.
  - b. After an "engine cooldown timer" (1 minute) has timed out and after any time remaining on an "engine minimum run timer" has elapsed, the engine should shut down.

*NOTE: The "engine minimum run timer" comes on during startup in automatic mode. Engine must run for about 13 minutes before it can be shut down automatically. The timer prevents shutdown of a cold engine. Engine can be shut down manually at any time.*



Section 8.2  
ADJUSTMENTS- AIR COOLED UNITS**The 7-Day Exercise Cycle**

The engine-generator will start every seven (7) days, on a day and at a time of day selected by the owner-operator. The unit will run for a few minutes and then shut down.

A Set Exercise Time toggle switch is provided on the generator console. Use the switch to select day and time of day for exercise, as follows:

- Place the Auto-Manual-Off switch to "Off".
- Place the Set Exercise Time switch to "On" and hold for 5 seconds.
- Wait 30 seconds, then place the auto-manual-off switch to "Auto". The generator will now start and exercise every 7 days at the preset time.

**NOTE:** Failure to wait 30 seconds may result in engine startup. If the engine does start, it will shut down automatically within about 2 minutes.

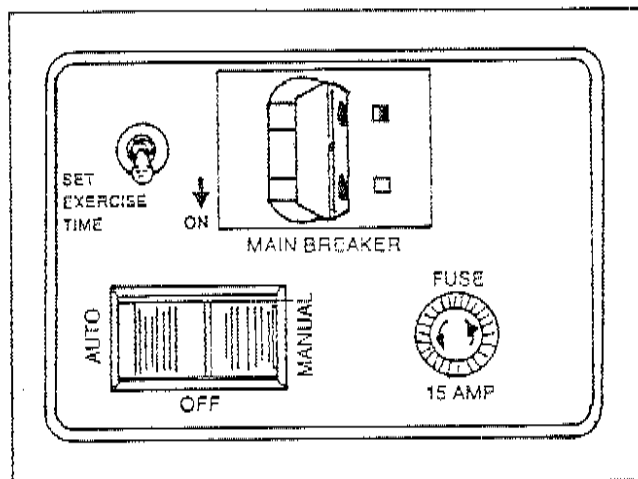

Figure 1. Location of Set Exercise Time Switch

**Adjusting the Engine Governor****DISCUSSION:**

The generator's AC frequency output is directly proportional to the driven speed of the rotor. A 2-pole rotor (having a single north and a single south magnetic pole) will produce an AC frequency of 60 Hertz at 3600 rpm. A 4-pole rotor (with 2 north and 2 south poles) will provide 60 Hertz at 1800 rpm.

Because the generator is equipped with a "voltage-over-frequency" type AC voltage regulator, the unit's AC output voltage is generally proportional to AC frequency. For example, the air cooled prepackaged generator will provide a line-to-line voltage of approximately 240 volts at a frequency of 60 Hertz. Any reduction in driven speed and frequency will result in a corresponding decrease in the voltage output.

**DANGER: ADJUSTMENT OF THE ENGINE GOVERNOR SHOULD BE ACCOMPLISHED IN TWO STAGES. FIRST, COMPLETE THE STATIC ADJUSTMENT. THEN, PERFORM ADJUSTMENTS WITH THE ENGINE RUNNING. FAILURE TO COMPLETE THE STATIC ADJUSTMENT COULD RESULT IN OVERSPEEDING THE ENGINE WITH POSSIBLE RESULTANT INJURY TO PEOPLE OR DAMAGE TO THE ENGINE-GENERATOR.**

**PROCEDURE:****A. The Static Governor Adjustment**

1. The static governor adjustment **MUST** be completed after any disassembly and before starting and operating the engine. **ALL LINKAGE MUST BE INSTALLED WHEN MAKING THIS ADJUSTMENT.**
2. To complete the static adjustment, proceed as follows, with engine shut down (Figure 2):
  - a. Loosen the GOVERNOR CLAMP NUT.
  - b. Actuate the GOVERNOR LEVER until the throttle is wide open. **DO NOT USE EXCESSIVE FORCE.**
  - c. While holding the GOVERNOR LEVER in the "wide open throttle" position, insert a screwdriver into the slotted end of the GOVERNOR SHAFT. Rotate the GOVERNOR SHAFT counterclockwise (CCW) as far as it will go.
  - d. Hold the GOVERNOR SHAFT in its fully counterclockwise position, then tighten the GOVERNOR CLAMP NUT. Tighten the GOVERNOR CLAMP NUT to 70 inch-pounds (8 N-m) torque.

**B. Adjustment with Engine Running**

**IMPORTANT: THE STATIC GOVERNOR ADJUSTMENT MUST BE PROPERLY COMPLETED BEFORE PROCEEDING WITH THIS RUNNING ADJUSTMENT. IN ADDITION, THE GASEOUS FUEL LOAD BLOCK ADJUSTMENT SHOULD BE COMPLETED.**

1. Inspect the ANTI-LASH SPRING. Make sure it is not broken or disengaged.
2. Connect an accurate AC frequency meter across the generator's AC output leads.

***Adjusting the Engine Governor (Continued)***

3. Start the generator, let it stabilize and warm up at no-load (all electrical loads disconnected).
4. For units rated 60 Hertz, turn the ADJUSTER NUT to obtain a frequency reading as close as possible to 62 Hertz. On units rated 50 Hertz, frequency reading should be as close as possible to 51 Hertz.
5. Apply electrical loads and test the unit with loads applied.
  - a. Total wattage/amperage of all applied loads should be as close as possible to the generator's full rated wattage/amperage capacity.
  - b. Check the amount of frequency droop when electrical loads are turned on.
    - (1) If frequency droops below about 59 Hertz when loads are applied, disconnect the electrical loads. Then, move the GOVERNOR SPRING in the ADJUSTMENT BRACKET closer to the ANTI-LASH SPRING.
    - (2) After repositioning the GOVERNOR SPRING in the ADJUSTMENT BRACKET, reset the ADJUSTER NUT to obtain a no-load AC frequency as close as possible to 62 Hertz.
    - (3) Apply electrical loads again and recheck frequency droop.
  - c. Disconnect electrical loads and note whether excessive "hunting" occurs when the loads are disconnected.
6. Repeat the above procedures until:
  - a. No-load speed is as close as possible to 62 Hertz.
  - b. Excessive droop does not occur when loads are applied.
  - c. Excessive "hunting" does not occur when loads are disconnected.

***Voltage Regulator Checks and Adjustments***

**GENERAL:**

For additional information on the prepackaged AC voltage regulator, see "Other AC Generator Components" in Section 2.1 (Page 2.1-3).

**ADJUSTMENT PROCEDURE:**

1. Start the generator engine, let it stabilize and warm up at no-load.
2. Note the frequency reading. The no-load frequency should be as close as possible to 62 Hertz (61-63 Hertz).
  - a. If necessary, adjust the engine governor to obtain a no-load speed that is as close as possible to 62 Hertz.
  - b. Do not attempt voltage regulator adjustments until the engine is running at the correct no-load speed.
3. Slowly turn the slotted potentiometer on the AC voltage regulator (Figure 3) until the generator's line-to-line voltage reads as close as possible to 243 volts AC (244-252 volts).

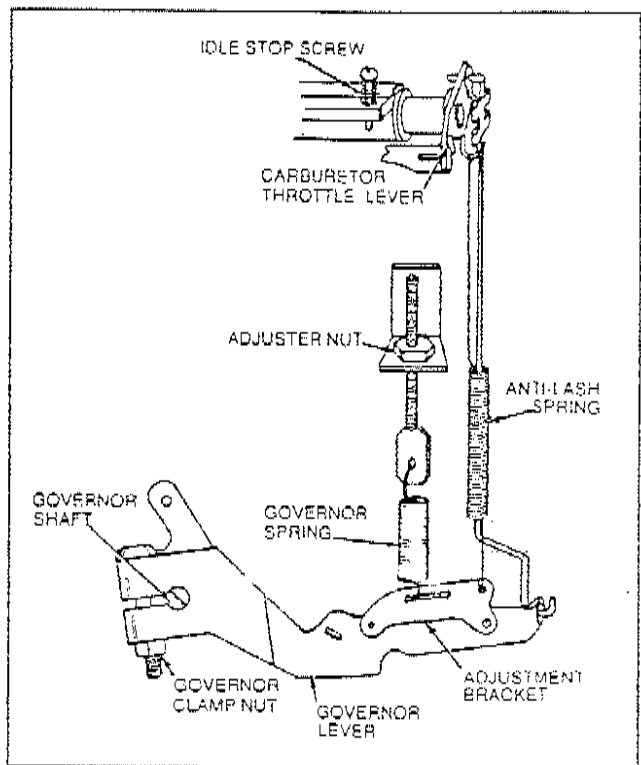

*Figure 2. Engine Governor Adjustment*

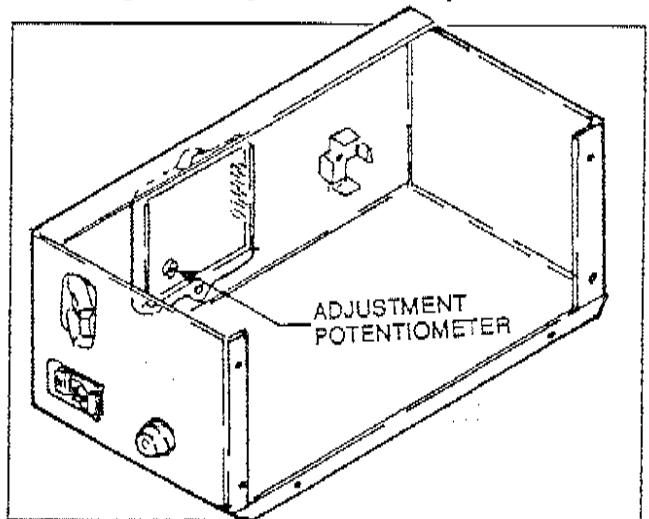

*Figure 3. The AC Voltage Regulator*

***Load Block Adjustments***

**TOOLS REQUIRED:**

The following are required to adjust the gaseous fuel system load block:

- A straight slot screwdriver,
- A 17mm open-end wrench
- An AC frequency meter with 55-65 Hertz range.

*Load Block Adjustments (Continued)*

IF NATURAL GAS IS USED:

1. On the generator panel, set the auto-off-manual switch to "Off".
2. Turn OFF the "Utility" power supply to the transfer switch using whatever means provided (such as a "Utility" main line circuit breaker).
3. Set the generator's main line circuit breaker to its "Off" or "Open" position.

**DANGER: DO NOT PROCEED TO STEP 4 UNTIL ALL POWER VOLTAGE SUPPLIES TO THE TRANSFER SWITCH HAVE BEEN POSITIVELY TURNED OFF. ANY ATTEMPT TO OPERATE THE TRANSFER SWITCH MANUALLY WHILE POWER VOLTAGES ARE AVAILABLE MAY RESULT IN HAZARDOUS AND POSSIBLY DEADLY ELECTRICAL SHOCK.**

4. Manually actuate the transfer switch main contacts to their "Standby" position, i.e., "Load" connected to the "Standby" power supply.
5. Turn ON electrical loads equal to about 13.5 amperes at 240 volts or 27 amperes at 120 volts.
6. Complete initial adjustment of the load block as follows (Figure 4):
  - a. Loosen the LOAD BLOCK LOCK NUT.
  - b. Turn the SLOTTED ADJUSTMENT and LOAD BLOCK IDLE ADJUST clockwise until they just bottom. DO NOT FORCE.
  - c. Turn the LOAD BLOCK IDLE ADJUST counterclockwise one-half (1/2) turn.
  - d. Turn the SLOTTED ADJUSTMENT counterclockwise one and one-half (1-1/2) turns.
7. Connect an accurate AC frequency meter across transfer switch terminal lugs E1 and E2.
8. Set the auto-off-manual switch to "Manual". The engine should crank and start.
9. Let the engine stabilize and warm up for a few minutes.
10. If the engine runs rough, slowly turn the SLOTTED ADJUSTMENT clockwise until a maximum frequency of 62 Hertz is reached. DO NOT EXCEED 62 HERTZ.
11. Now, apply the load of 13.5 amperes at 240 volts, or 27 amperes at 120 volts. These loads were turned on in Step 5. To apply the loads, simply set the generator's main line circuit breaker to "On" or "Closed".
12. With the prescribed electrical load applied, slowly turn the SLOTTED ADJUSTMENT clockwise until a reading of 62 Hertz is obtained. DO NOT EXCEED 62 HERTZ.
13. With engine running at 62 Hertz, back out the SLOTTED ADJUSTMENT three (3) full turns. Hold that adjustment and tighten the LOAD BLOCK LOCK NUT. The main fuel setting is now correct.
14. Set the generator's main line circuit breaker to its "Off" or "Open" position. Step 15 must be accomplished with the engine running at no-load.
15. Adjust the LOAD BLOCK IDLE ADJUST until engine is running smoothly at 62 Hertz. Idle setting at this point is complete.

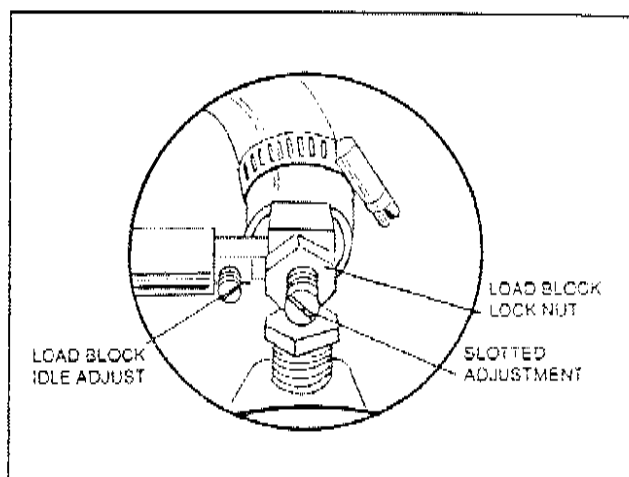

Figure 4. Load Block Adjustments

IF LP (PROPANE) GAS IS USED:

1. On the generator panel, set the auto-off-manual switch to "Off".
2. Turn OFF the "Utility" power supply to the transfer switch, using whatever means provided (such as a "Utility" main line circuit breaker).
3. Set the generator's main line circuit breaker to its "Off" or "Open" position.

**DANGER: DO NOT PROCEED TO STEP 4 UNTIL ALL POWER VOLTAGE SUPPLIES TO THE TRANSFER SWITCH HAVE BEEN POSITIVELY TURNED OFF. IF POWER VOLTAGE SUPPLIES ARE NOT TURNED OFF, DANGEROUS AND POSSIBLY LETHAL ELECTRICAL SHOCK MAY RESULT WHEN ATTEMPTING MANUAL TRANSFER SWITCH OPERATION.**

4. Manually actuate the transfer switch main contacts to their "Standby" position, i.e., "Load" connected to the "Standby" source side.
5. Turn on electrical loads equal to about 25 amps at 240 volts; or 50 amps at 120 volts.
6. Complete initial adjustment of the load block as follows (Figure 4):
  - a. Turn the SLOTTED ADJUSTMENT and the LOAD BLOCK IDLE ADJUST clockwise until they are softly seated. DO NOT FORCE.
  - b. Turn the SLOTTED ADJUSTMENT counterclockwise one and one-half (1-1/2) turns. Hold that adjustment and tighten the LOAD BLOCK LOCK NUT.
  - c. Turn the LOAD BLOCK IDLE ADJUST counterclockwise one-half (1/2) turn.
7. Connect an accurate AC frequency meter across transfer switch terminal lugs E1 and E2.
8. Set the auto-off-manual switch to "Manual". The engine should crank and start.
9. Let the engine stabilize and warm up for a few minutes.

***Load Block Adjustments (Continued)***

10. If the engine runs rough, slowly turn the SLOTTED ADJUSTMENT clockwise until a maximum frequency reading of 62 Hertz is reached. DO NOT EXCEED 62 HERTZ.

11. Now, apply the load of 25 amperes at 240 volts, or 50 amperes at 120 volts. These loads were turned on in Step 5. To apply the loads, set the generator's main line circuit breaker to "On" or "Closed".

12. With the electrical load applied, slowly turn the SLOTTED ADJUSTMENT until a reading of 62 Hertz is obtained. DO NOT EXCEED 62 HERTZ.

13. With the engine running at 62 Hertz, turn the SLOTTED ADJUSTMENT counterclockwise one and one-half (1-1/2) turns. Hold that adjustment and tighten the LOAD BLOCK LOCK NUT.

14. Disconnect the load by setting the generator's main line circuit breaker to its "Off" or "Open" position.

15. Turn the LOAD BLOCK IDLE ADJUST slowly clockwise and counterclockwise until engine runs smoothly at 62 Hertz (no-load).

***Adjusting Drive Belt Tension***

The engine and generator are mounted vertically and side-by-side. A drive belt extends from an engine pulley to a generator pulley, to drive the generator rotor at the same speed as the engine. The drive belt should require adjustment only when (a) a new belt is installed, or (b) belt tensioning hardware has been removed or replaced. Adjust drive belt tension as follows:

1. First, adjust the spring on the four stator can bolts to a length of 1/2 inch (13mm).
2. Adjust the two sets of springs that are positioned laterally at the generator's lower bearing carrier to a length of 5/8 inch (16mm).

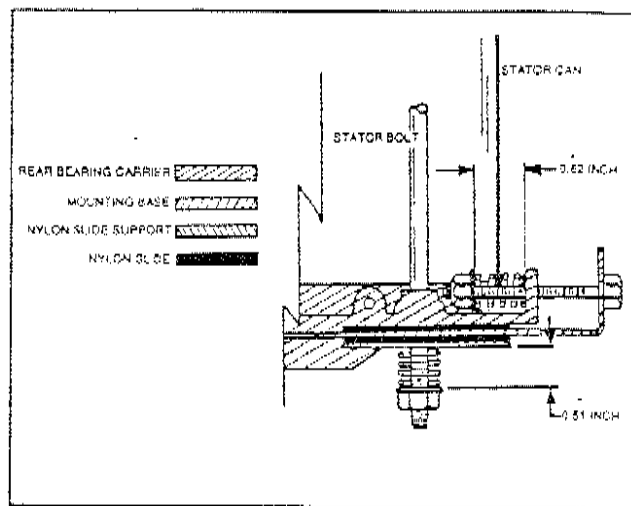

*Figure 5. Drive Belt Tension Adjustment*

## ADJUSTMENTS- LIQUID COOLED UNITS

### Setting Weekly Exercise Cycle

The generator will start and exercise once every seven (7) days, on a day and at a time of day selected by the installer or operator. The unit will run for approximately 13-15 minutes during this "exercise" cycle, will then shut down. Transfer of electrical loads to the "Standby" power source will not occur during the exercise.

A switch, located on the generator control console, permits the day and time of exercise to be selected. To select the day and time of day for the system to exercise, proceed as follows:

- Place the auto-off-manual switch to its "Off" position.
- Hold the set exercise time switch at its "On" position for about five (5) seconds.
- After five seconds, release the set exercise time switch to its "Off" position. Wait 30 seconds, then place the auto-off-manual switch at "Auto". The generator will exercise every seven (7) days at the selected time.

*NOTE: Failure to wait 30 seconds before placing the auto-off-manual switch to "Auto" may result in engine cranking and startup. If the engine does crank and start, it will shut down automatically within about two (2) minutes.*

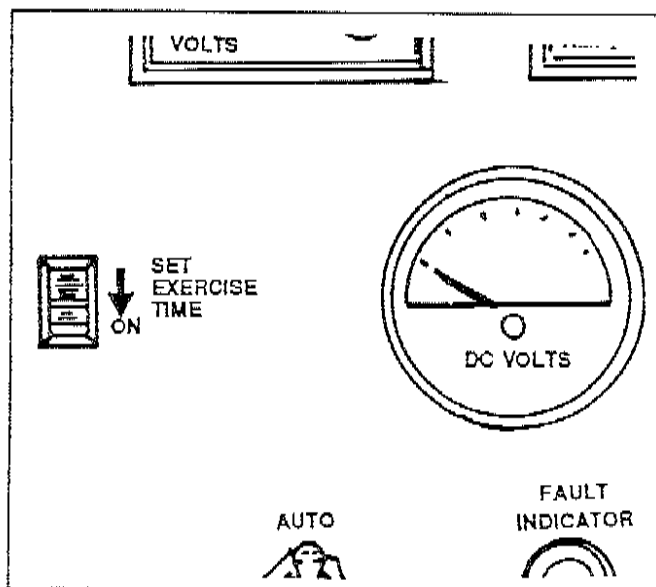

Figure 1. The "Set Exercise Time" Switch

### Engine Governor Adjustment

#### GOVERNOR DESCRIPTION:

The mechanical, centrifugal type governor utilizes spring tension versus centrifugal force to maintain a steady state operating speed regardless of the load on the engine. When centrifugal force acting on a set of flyweights exceeds governor spring tension, flyweight force will decrease carburetor throttle setting and rpm. Should engine speed decrease, flyweight force will also decrease. Spring tension then becomes the stronger force and will increase throttle setting and rpm. Governor action will cease when centrifugal force and spring tension are in equilibrium.

The engine governor also supports and drives a battery charge alternator which maintains battery state of charge during operation.

#### GOVERNOR LUBRICATION:

Remove OIL FILLER PLUG and OIL LEVEL CHECK PLUG. Add engine oil through OIL FILLER PLUG opening until oil just starts to drain from the OIL LEVEL CHECK PLUG opening. Install and tighten both plugs.

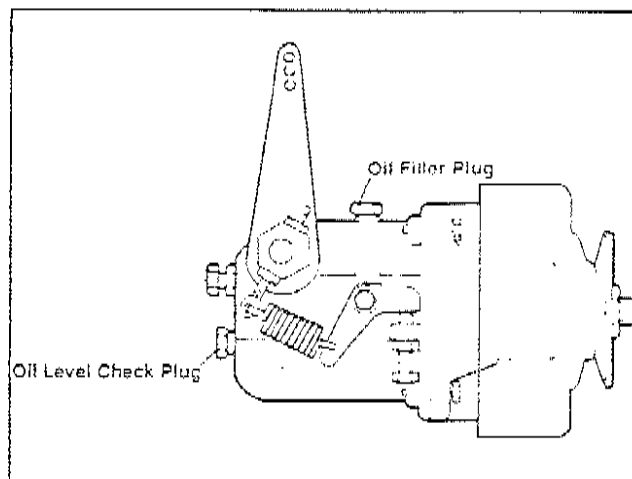

Figure 2. Governor Oil Servicing Points

#### GOVERNOR LEVER TO CARBURETOR LINK:

When installing the governor lever to carburetor linkage, adjust the rod length to 4-3/8 inches (measured between ball joint centerlines).

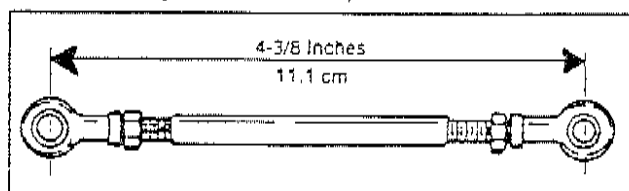

Figure 3. Governor Lever to Carburetor Link

***Engine Governor Adjustment (Continued)***

**ADJUSTMENT:**

1. Connect an accurate AC frequency meter across stator AC output leads E1 and E2, to read the generator's line-to-line frequency.
2. Set the generator's main line circuit breaker to its "Off" or "Open" position. Initial checks and adjustments will be accomplished with the engine at no-load.
3. Start the engine, let it stabilize and warm up for a few minutes.
4. With engine running at no-load, adjust the NO-LOAD SPEED ADJUST SCREW to obtain a frequency reading as close as possible to 61.5 Hertz (60 Hertz units); or to 50.0 Hertz (50 Hertz units).
5. Adjust the NO-LOAD BUMPER SCREW to obtain a frequency reading of 62 Hertz (60 Hertz units); or 51 Hertz (50 Hertz units).
6. Apply an electrical load to the generator that is as close as possible to the rated wattage/ampere capacity of the generator.
7. Check the AC frequency with the load applied. If frequency droops below about 58 Hertz with load applied for 60 Hertz units, or below about 49 Hertz with load applied for 50 Hertz units, adjust the DROOP ADJUSTMENT downward. Adjust the DROOP ADJUSTMENT until application of electrical loads results in the smallest possible frequency droop when load is applied.
8. If surging occurs when electrical loads are disconnected, adjust the NO-LOAD BUMPER SCREW inward. If BUMPER SCREW adjustment changes the frequency reading, back the NO-LOAD BUMPER SCREW out until the no-load frequency returns to 62 Hertz (60 Hertz units); or to 51 Hertz (50 Hertz units).

***Voltage Regulator Adjustment***

**GENERAL:**

For additional information on the prepackaged AC voltage regulator, see "The Excitation Circuit" in Section 3.1 of this manual (Page 3.1-3).

Before adjusting the voltage regulator for correct AC voltage output, make sure engine governed speed is correct.

**ADJUSTMENT PROCEDURE:**

1. Connect an accurate AC voltmeter and frequency meter across the generator's AC output leads. Readings of line-to-line voltage may be used.
2. Start the engine, let it stabilize and warm up at no-load.
3. Check the AC frequency reading. Frequency should be as close as possible to 62 Hertz (61-63 Hertz) at no-load. Adjust the engine governor, if necessary.
4. With engine running at correct speed (frequency), slowly turn the slotted potentiometer on the regulator to obtain the proper AC voltage as follows:
  - a. For units rated 120/240 volts AC, the no-load line-to-line voltage should be as close as possible to 248 volts (244-252 volts).
  - b. For units rated 120/208 volts AC, the no-load line-to-line voltage should be as close as possible to 215 volts (212-218 volts).

*NOTE: The no-load voltage is generally proportional to AC frequency. For units rated 240 volts, the no-load (line-to-line) voltage at 62 Hertz will be approximately 248 volts. For units rated 120/208 volts, the no-load (line-to-line) voltage will be about 215 volts.*

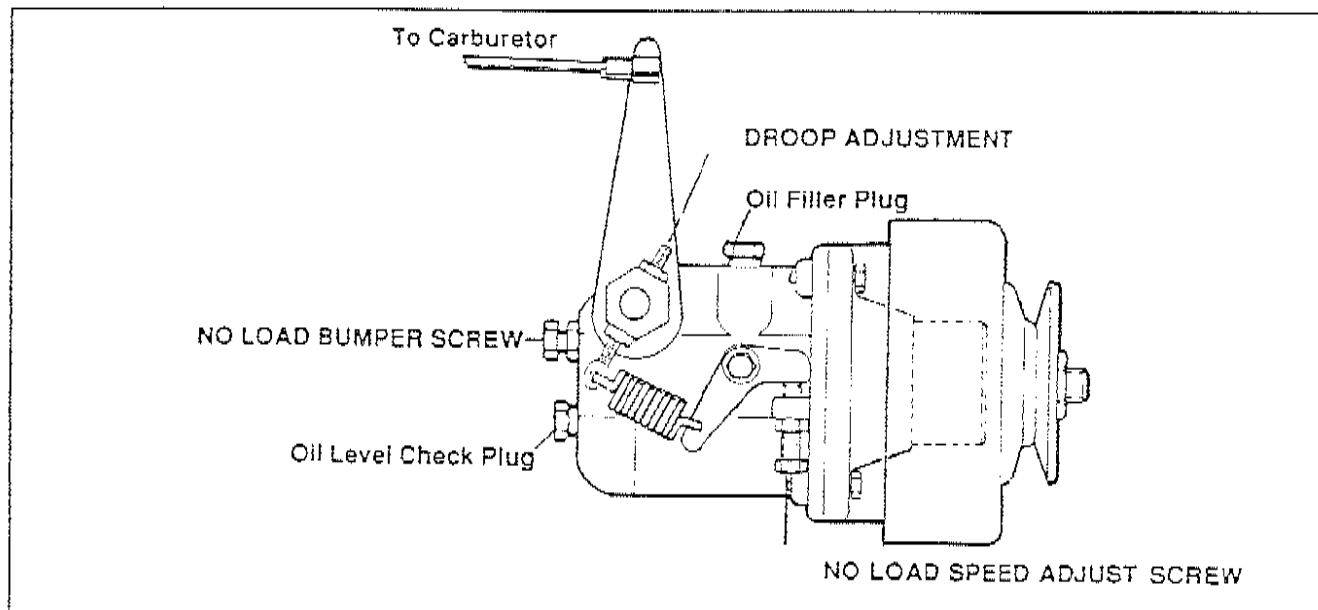

*Figure 4. Engine Governor Adjustment Points*

*Voltage Regulator Adjustment (Continued)*

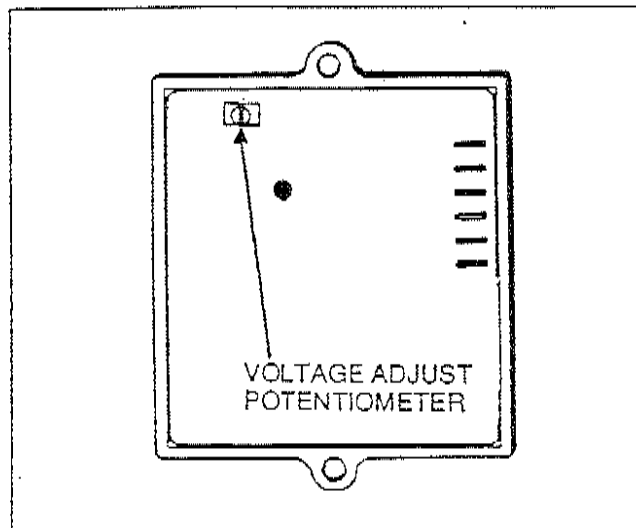

Figure 5. Voltage Regulator

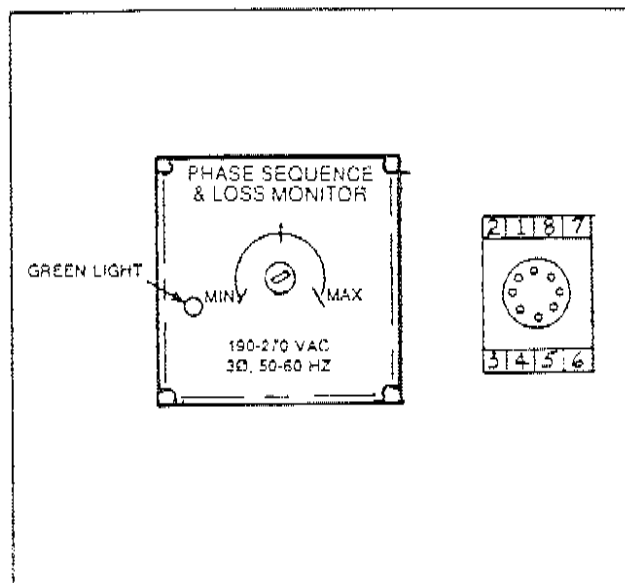

Figure 6. The 3-Phase Power Monitor

**Adjustment of 3-Phase Power Monitor**

DISCUSSION:

This device (Figure 6) is used on 3-phase, "Y-Type" prepackaged transfer switches. It senses "Utility" power source voltage in all three (3) lines of the 3-phase system. A voltage dropout in one line, two lines, or all three lines of the system will result in opening of the power monitor contacts and loss of "Utility" voltage sensing to the CMA circuit board. CMA circuit board action will then initiate generator startup and transfer of "Loads" to the "Standby" power supply. The device is rated 5 amperes at 240 volts AC.

The power monitor is equipped with a green light which is normally on, but goes out on loss of one or more of the 3-phase lines. A slotted voltage dropout adjustment is provided and is adjustable from 190-270 volts AC. The adjustment is linear.

When the adjustment is turned fully counterclockwise to "Min", the power monitor will de-energize and its contacts will open at about 190 volts AC.

When turned fully clockwise to "Max", it will de-energize and its contacts will open at about 270 volts AC.

When set to its "mid-position", the unit will de-energize and its contacts will open at approximately 230 volts AC.



**PART 9  
ELECTRICAL  
DATA**

**GENERAC II  
PREPACKAGED  
HOME STANDBY  
ELECTRIC POWER  
SYSTEMS**

**TABLE OF CONTENTS**

DRAWING	TITLE
74498	"Y-Type" Transfer Switch 200 Amp, 2-Pole
74499	"Y-Type" Transfer Switch 100 & 200 Amp, 3-Pole
81222	"V-Type" Transfer Switch 100 Amp, 2-Pole
76049	Wiring Diagram 1-Phase Liquid Cooled Generator
76062	Schematic 1-Phase, Liquid Cooled Generator
76066	Wiring Diagram 3-Phase Liquid Cooled Generator
76058	Schematic 3-Phase Liquid Cooled Generator
79961	Wiring Diagram Liquid Cooled Engine (Gasoline)
79962	Schematic Liquid Cooled Engine (Gasoline)
76045	Wiring Diagram Liquid Cooled Engine (Gaseous Fuel)
76046	Schematic Liquid Cooled Engine (Gaseous Fuel)
77042	Wiring Diagram & Schematic Air Cooled Engine Unit

# NOTES

---

WIRING DIAGRAM

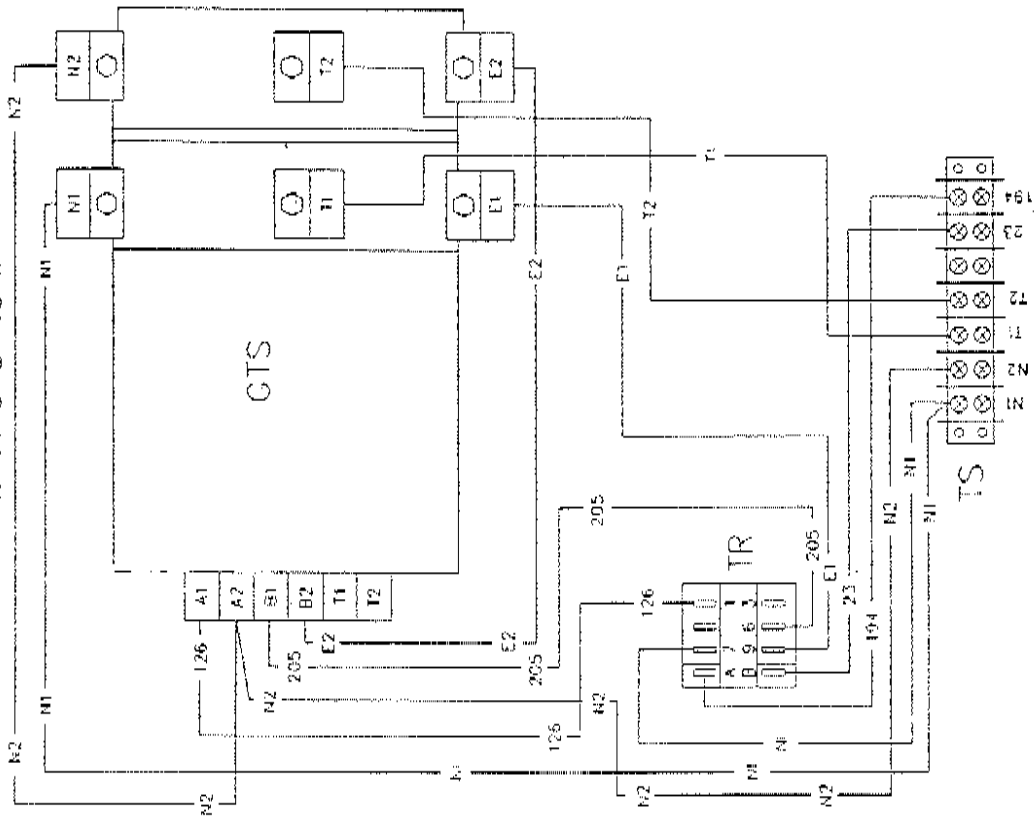

SCHEMATIC DIAGRAM

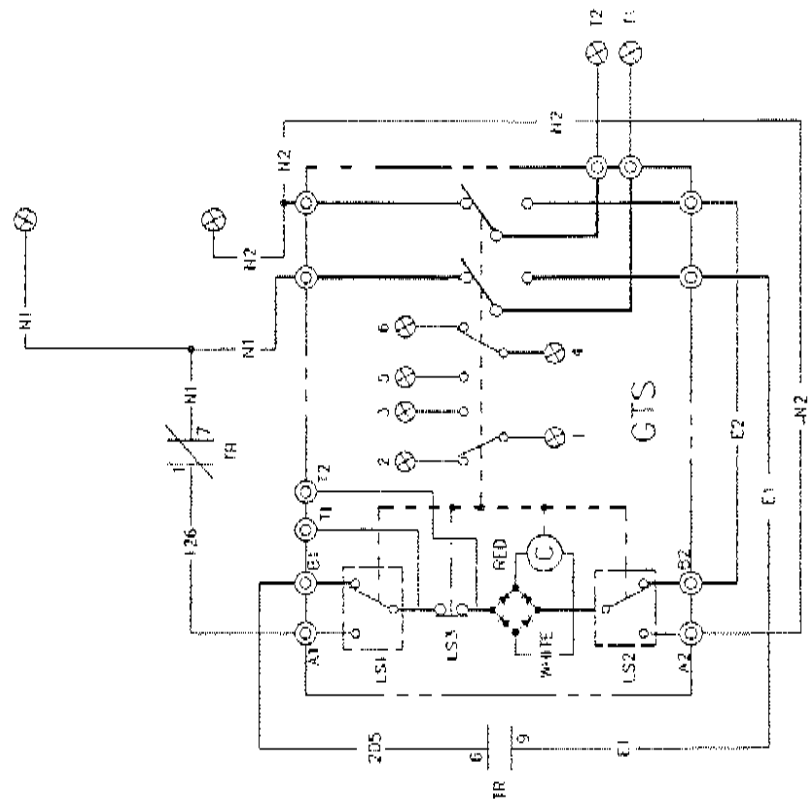

LEGEND	
C	CONTACTOR ACTUATING COIL
GTS	TRANSFER SWITCH CONTACTOR
LS1,LS2,LS3	UNIT SWITCHES, ACTUATOR
TR	RELAY, TRANSFER
TS	TERMINAL STRIP (CUSTOMER CONNECTION)

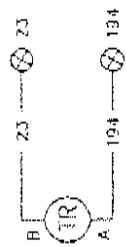

NOTE:  
ALL CONTACTS SHOWN WITH  
TRANSFER SWITCH IN UTILITY  
POSITION.



WIRING DIAGRAM

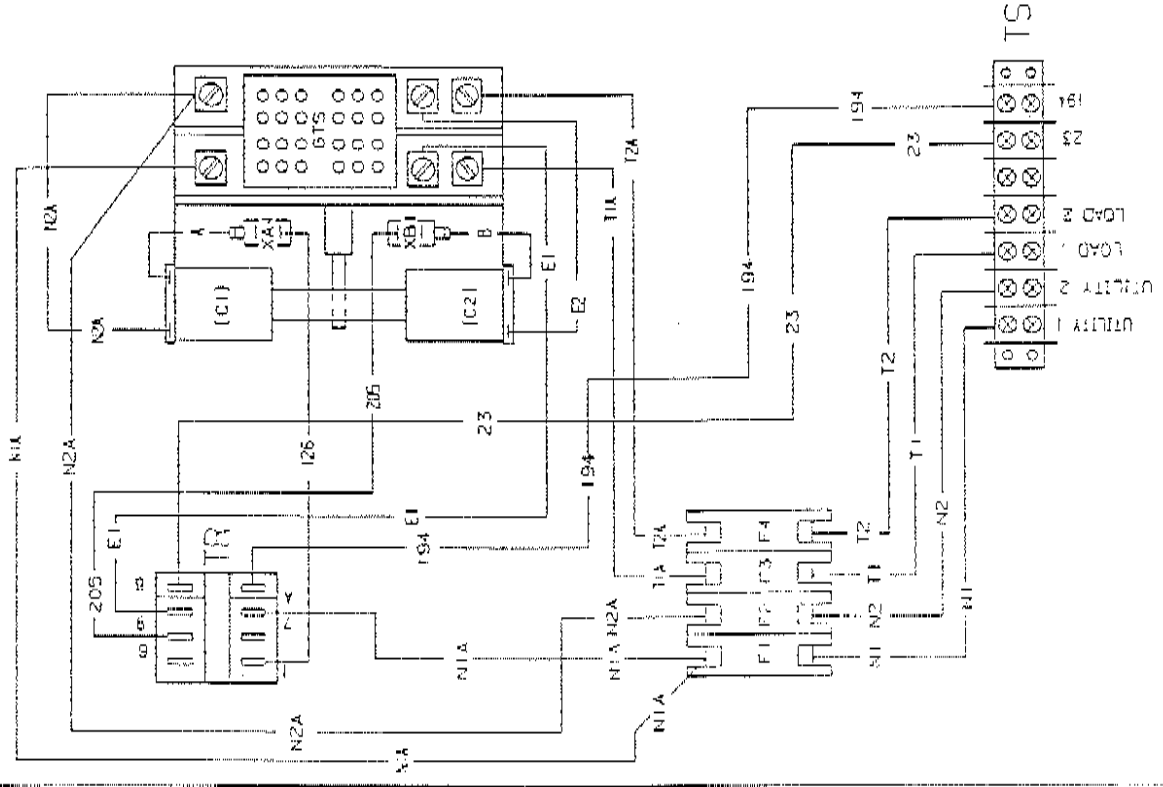

SCHEMATIC DIAGRAM

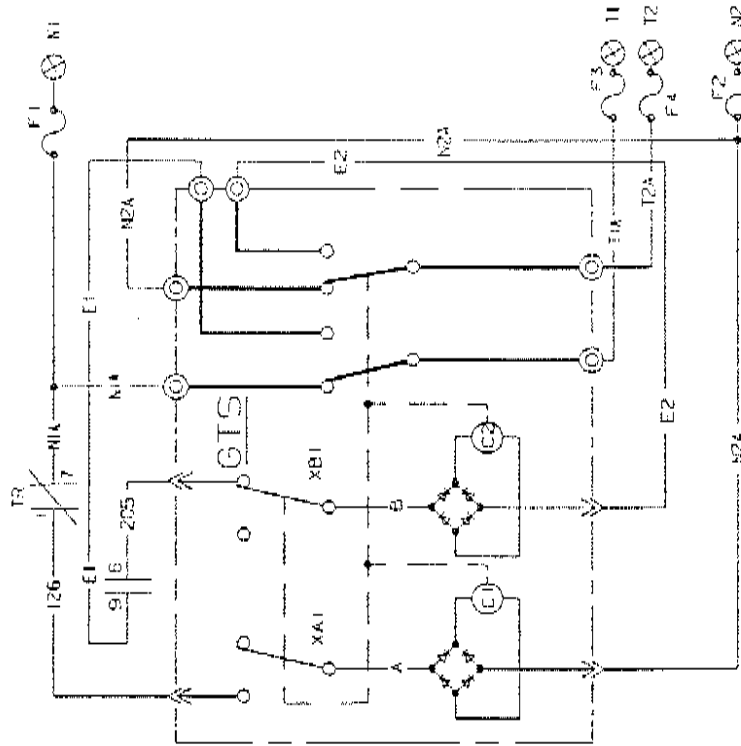

LEGEND	
C1-	SOLENOID COIL (UTILITY CLOSING)
C2-	SOLENOID COIL (STANDBY CLOSING)
GTS -	TRANSFER SWITCH CONTACTOR
TR -	RELAY, TRANSFER
TS -	TERMINAL STRIP (CUSTOMER CONNECTION)
XA1, XB1-	LIMIT SWITCHES, ACTUATOR
F1, F2, F3, F4-	FUSE, 2A SENSING

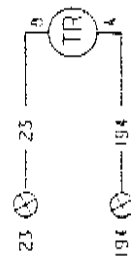

NOTE:  
ALL CONTACTS SHOWN WITH  
TRANSFER SWITCH IN UTILITY  
POSITION.



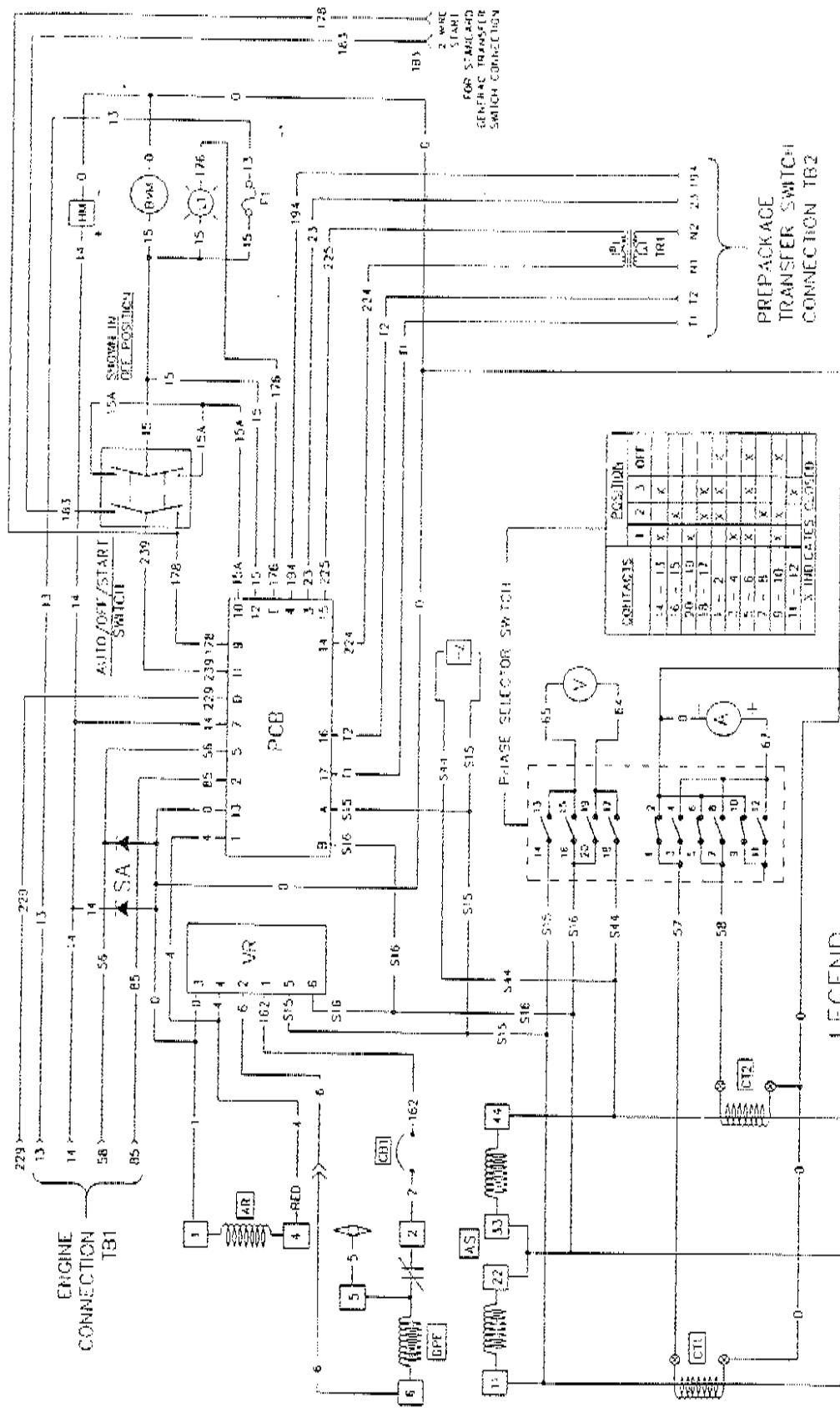

CONTACTS	POSITION		
	1	2	3
1-4	X	X	X
5-8	X	X	X
9-12	X	X	X
13-16	X	X	X
17-20	X	X	X
21-24	X	X	X
25-28	X	X	X
29-32	X	X	X
33-36	X	X	X
37-40	X	X	X
41-44	X	X	X
45-48	X	X	X
49-52	X	X	X
53-56	X	X	X
57-60	X	X	X
61-64	X	X	X
65-68	X	X	X
69-72	X	X	X
73-76	X	X	X
77-80	X	X	X
81-84	X	X	X
85-88	X	X	X
89-92	X	X	X
93-96	X	X	X
97-100	X	X	X
101-104	X	X	X
105-108	X	X	X
109-112	X	X	X
113-116	X	X	X
117-120	X	X	X
121-124	X	X	X
125-128	X	X	X
129-132	X	X	X
133-136	X	X	X
137-140	X	X	X
141-144	X	X	X
145-148	X	X	X
149-152	X	X	X
153-156	X	X	X
157-160	X	X	X
161-164	X	X	X
165-168	X	X	X
169-172	X	X	X
173-176	X	X	X
177-180	X	X	X
181-184	X	X	X
185-188	X	X	X
189-192	X	X	X
193-196	X	X	X
197-200	X	X	X
201-204	X	X	X
205-208	X	X	X
209-212	X	X	X
213-216	X	X	X
217-220	X	X	X
221-224	X	X	X
225-228	X	X	X
229-232	X	X	X
233-236	X	X	X
237-240	X	X	X
241-244	X	X	X
245-248	X	X	X
249-252	X	X	X
253-256	X	X	X
257-260	X	X	X
261-264	X	X	X
265-268	X	X	X
269-272	X	X	X
273-276	X	X	X
277-280	X	X	X
281-284	X	X	X
285-288	X	X	X
289-292	X	X	X
293-296	X	X	X
297-300	X	X	X
301-304	X	X	X
305-308	X	X	X
309-312	X	X	X
313-316	X	X	X
317-320	X	X	X
321-324	X	X	X
325-328	X	X	X
329-332	X	X	X
333-336	X	X	X
337-340	X	X	X
341-344	X	X	X
345-348	X	X	X
349-352	X	X	X
353-356	X	X	X
357-360	X	X	X
361-364	X	X	X
365-368	X	X	X
369-372	X	X	X
373-376	X	X	X
377-380	X	X	X
381-384	X	X	X
385-388	X	X	X
389-392	X	X	X
393-396	X	X	X
397-400	X	X	X
401-404	X	X	X
405-408	X	X	X
409-412	X	X	X
413-416	X	X	X
417-420	X	X	X
421-424	X	X	X
425-428	X	X	X
429-432	X	X	X
433-436	X	X	X
437-440	X	X	X
441-444	X	X	X
445-448	X	X	X
449-452	X	X	X
453-456	X	X	X
457-460	X	X	X
461-464	X	X	X
465-468	X	X	X
469-472	X	X	X
473-476	X	X	X
477-480	X	X	X
481-484	X	X	X
485-488	X	X	X
489-492	X	X	X
493-496	X	X	X
497-500	X	X	X
501-504	X	X	X
505-508	X	X	X
509-512	X	X	X
513-516	X	X	X
517-520	X	X	X
521-524	X	X	X
525-528	X	X	X
529-532	X	X	X
533-536	X	X	X
537-540	X	X	X
541-544	X	X	X
545-548	X	X	X
549-552	X	X	X
553-556	X	X	X
557-560	X	X	X
561-564	X	X	X
565-568	X	X	X
569-572	X	X	X
573-576	X	X	X
577-580	X	X	X
581-584	X	X	X
585-588	X	X	X
589-592	X	X	X
593-596	X	X	X
597-600	X	X	X
601-604	X	X	X
605-608	X	X	X
609-612	X	X	X
613-616	X	X	X
617-620	X	X	X
621-624	X	X	X
625-628	X	X	X
629-632	X	X	X
633-636	X	X	X
637-640	X	X	X
641-644	X	X	X
645-648	X	X	X
649-652	X	X	X
653-656	X	X	X
657-660	X	X	X
661-664	X	X	X
665-668	X	X	X
669-672	X	X	X
673-676	X	X	X
677-680	X	X	X
681-684	X	X	X
685-688	X	X	X
689-692	X	X	X
693-696	X	X	X
697-700	X	X	X
701-704	X	X	X
705-708	X	X	X
709-712	X	X	X
713-716	X	X	X
717-720	X	X	X
721-724	X	X	X
725-728	X	X	X
729-732	X	X	X
733-736	X	X	X
737-740	X	X	X
741-744	X	X	X
745-748	X	X	X
749-752	X	X	X
753-756	X	X	X
757-760	X	X	X
761-764	X	X	X
765-768	X	X	X
769-772	X	X	X
773-776	X	X	X
777-780	X	X	X
781-784	X	X	X
785-788	X	X	X
789-792	X	X	X
793-796	X	X	X
797-800	X	X	X
801-804	X	X	X
805-808	X	X	X
809-812	X	X	X
813-816	X	X	X
817-820	X	X	X
821-824	X	X	X
825-828	X	X	X
829-832	X	X	X
833-836	X	X	X
837-840	X	X	X
841-844	X	X	X
845-848	X	X	X
849-852	X	X	X
853-856	X	X	X
857-860	X	X	X
861-864	X	X	X
865-868	X	X	X
869-872	X	X	X
873-876	X	X	X
877-880	X	X	X
881-884	X	X	X
885-888	X	X	X
889-892	X	X	X
893-896	X	X	X
897-900	X	X	X
901-904	X	X	X
905-908	X	X	X
909-912	X	X	X
913-916	X	X	X
917-920	X	X	X
921-924	X	X	X
925-928	X	X	X
929-932	X	X	X
933-936	X	X	X
937-940	X	X	X
941-944	X	X	X
945-948	X	X	X
949-952	X	X	X
953-956	X	X	X
957-960	X	X	X
961-964	X	X	X
965-968	X	X	X
969-972	X	X	X
973-976	X	X	X
977-980	X	X	X
981-984	X	X	X
985-988	X	X	X
989-992	X	X	X
993-996	X	X	X
997-1000	X	X	X

LEGEND

- A - AC AMMETER
- AR - ALTERNATOR ROTOR
- AS - ALTERNATOR STARTER
- BVM - BATTERY VOLTAGE DETECTOR
- CB1,2 - CIRCUIT BREAKERS
- CT1,2 - CURRENT TRANSFORMER
- DPC - EXCITATION WINDING
- F1 - FUSE 30 AMP
- FIM - HOURMETER
- FIZ - FREQUENCY METER
- LI - LIGHT FAULT INDICATOR
- PCB - CIRCUIT BOARD CONTROLLER
- SA - SUPPRESSOR ASSEMBLY
- SB1,2,3 - TERMINAL BOARDS
- V - AC VOLT METER
- VR - VOLTAGE REGULATOR
- WT1 - TRANSFORMER WELDED SCREEN

CUSTOMER CONNECTION  
120/240V 1-PHASE

PART 9  
ELECTRICAL DATA

WIRING DIAGRAM (DRAWING 76066)  
3-PHASE, LIQUID COOLED GENERATOR

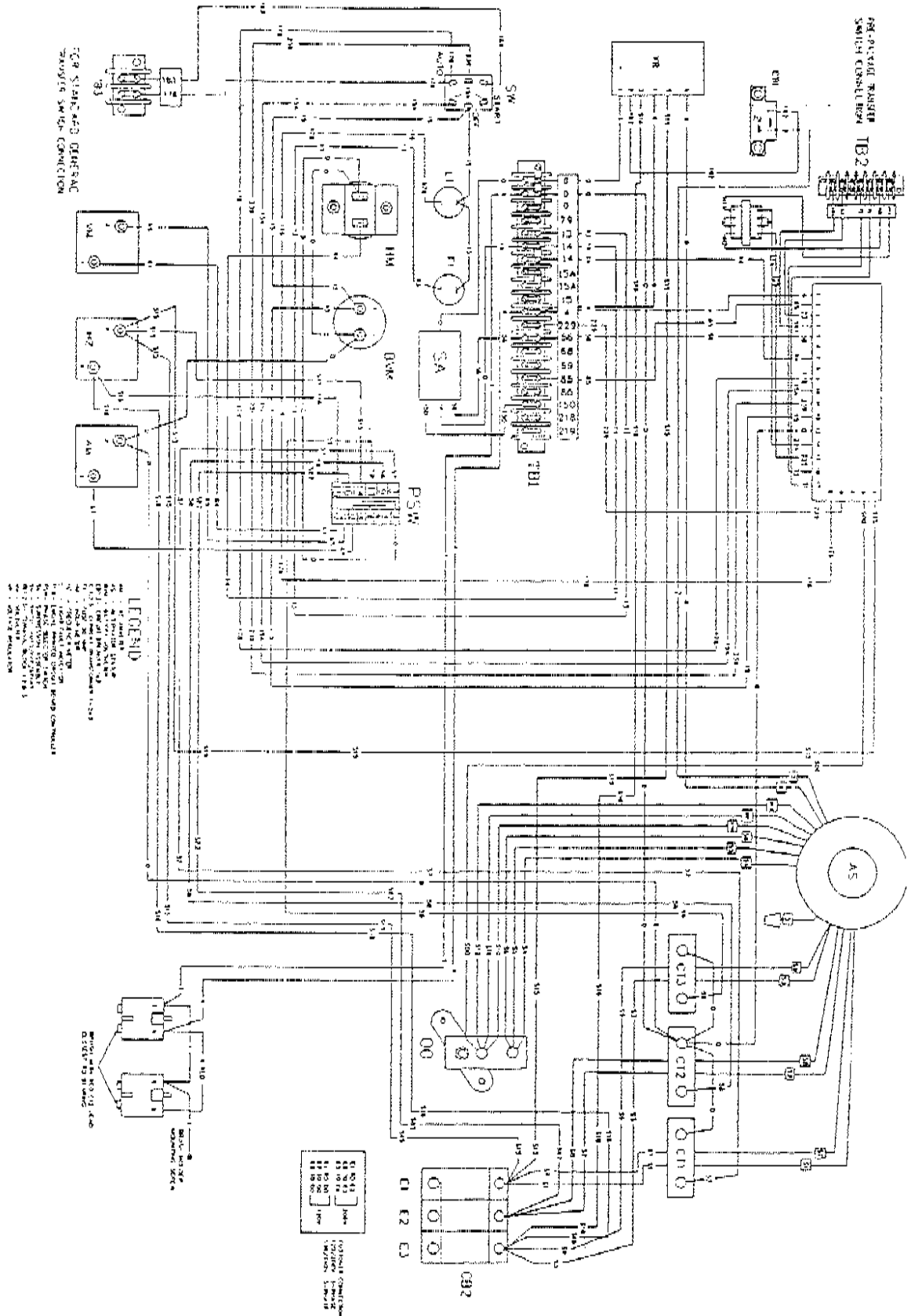

PART 9  
ELECTRICAL DATA

SCHMATIC (DRAWING 76058)  
3-PHASE, LIQUID COOLED GENERATOR

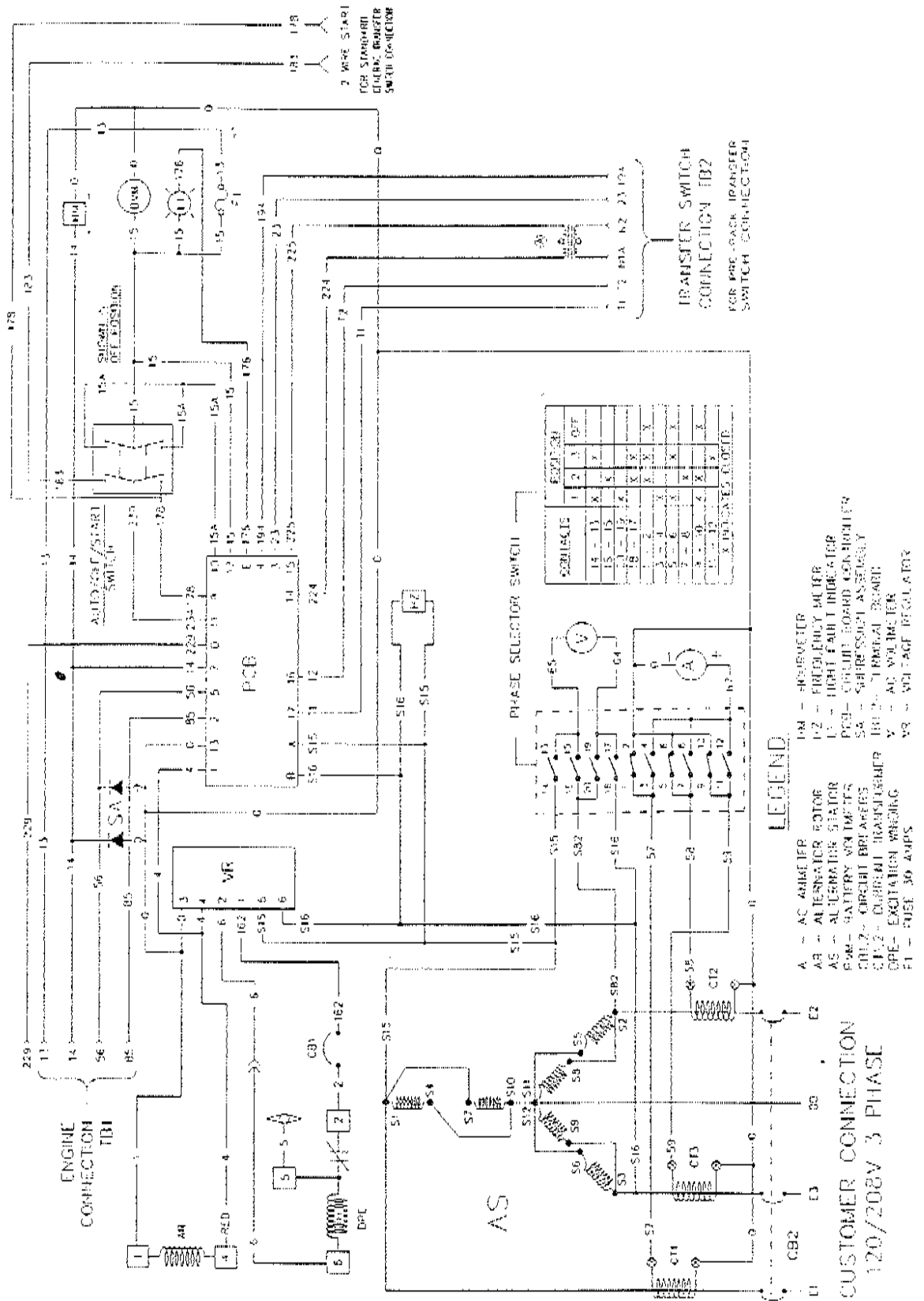

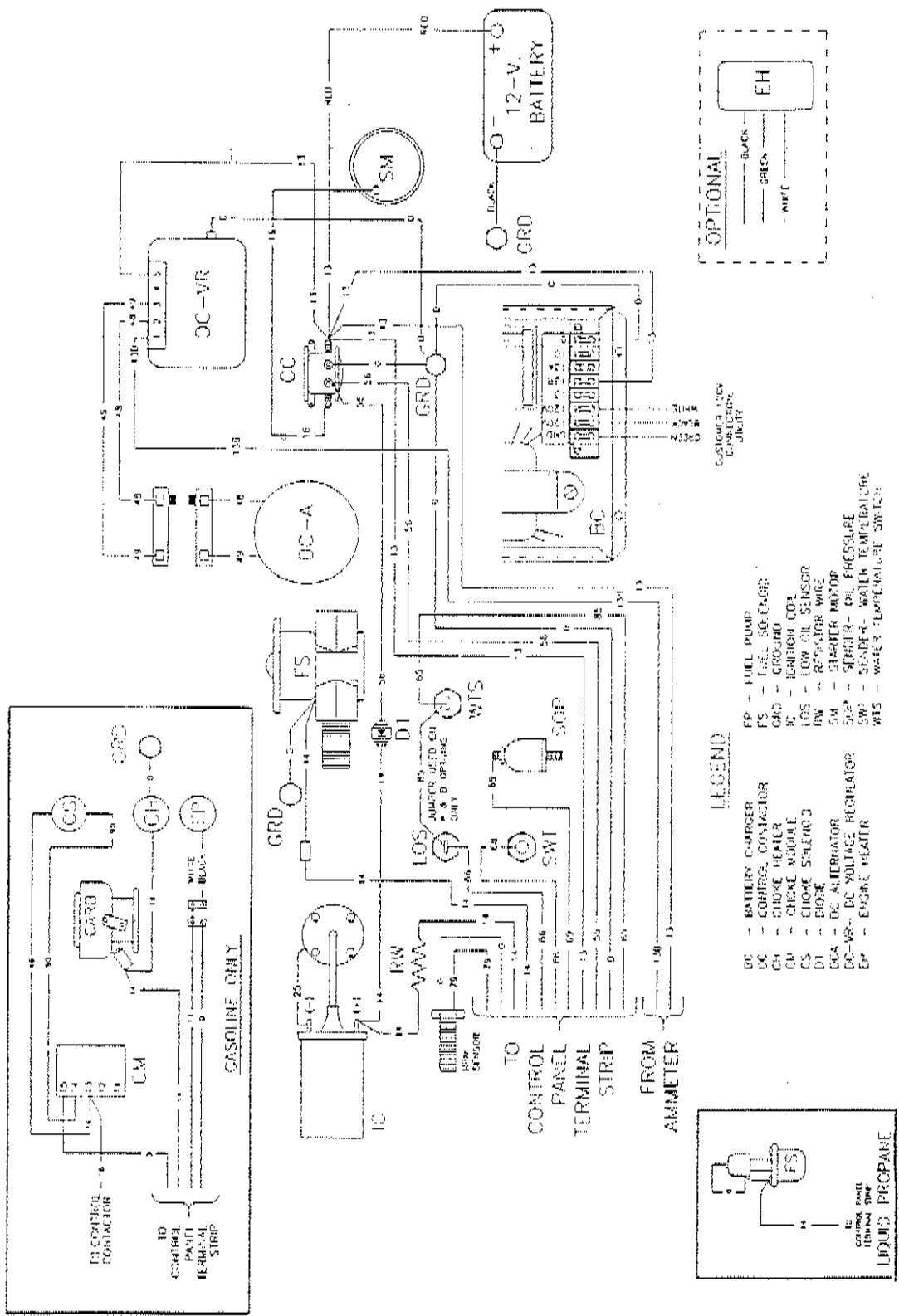

OPTIONAL

— BLACK —  
— GREEN —  
— WHITE —

EH

Customer's 120V  
Utility

LEGEND

- DC - BATTERY CHARGER
- DC-VR - DC VOLTAGE REGULATOR
- FS - FUEL SOLENOID
- IC - IGNITION COIL
- CH - CHOKER HEATER
- CS - CHOKE MODULE
- D1 - DIODE
- RW - RECTIFIER
- WTS - WATER TEMPERATURE SENDER
- SOP - STARTER MOTOR
- EH - ENGINE HEATER
- GRD - GROUND
- LOS - LOW OIL SENSOR
- DC - DC ALTERNATOR
- SWT - SWITCH
- FP - FUEL PUMP
- GRD - GROUND
- IC - IGNITION COIL
- LOS - LOW OIL SENSOR
- RW - RECTIFIER
- SOP - STARTER MOTOR
- WTS - WATER TEMPERATURE SENDER

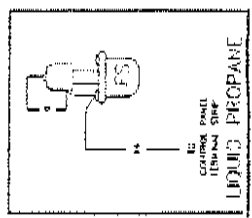

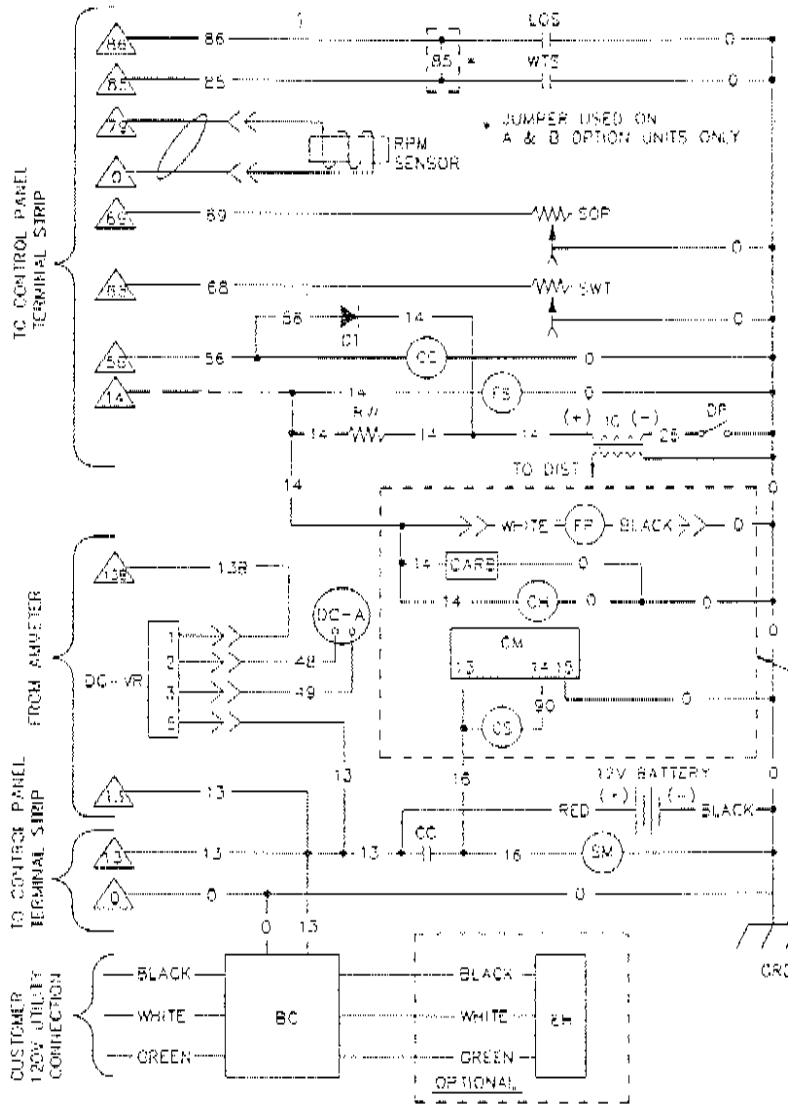

LEGEND

- BC - BATTERY CHARGER
- CC - CONTROL CONTACTOR
- CH - CHOKE HEATER
- CM - CHOKE MODULE
- CS - CHOKE SOLENOID
- D1 - DIODE
- DCA - DC ALTERNATOR
- DC-VR - DC VOLTAGE REGULATOR
- DP - DISTRIBUTOR POINTS
- EH - ENGINE HEATER
- FS - FUEL SOLENOID
- FP - FUEL PUMP
- GRD - GROUND
- IC - IGNITION COIL
- LOS - LOW OIL SWITCH
- RW - RESISTOR WIRE
- SM - STARTER MOTOR
- SOP - SENDER - OIL PRESSURE
- SWT - SENDER - WATER TEMPERATURE
- WTS - WATER TEMPERATURE SWITCH

FOR GASOLINE  
UNITS ONLY

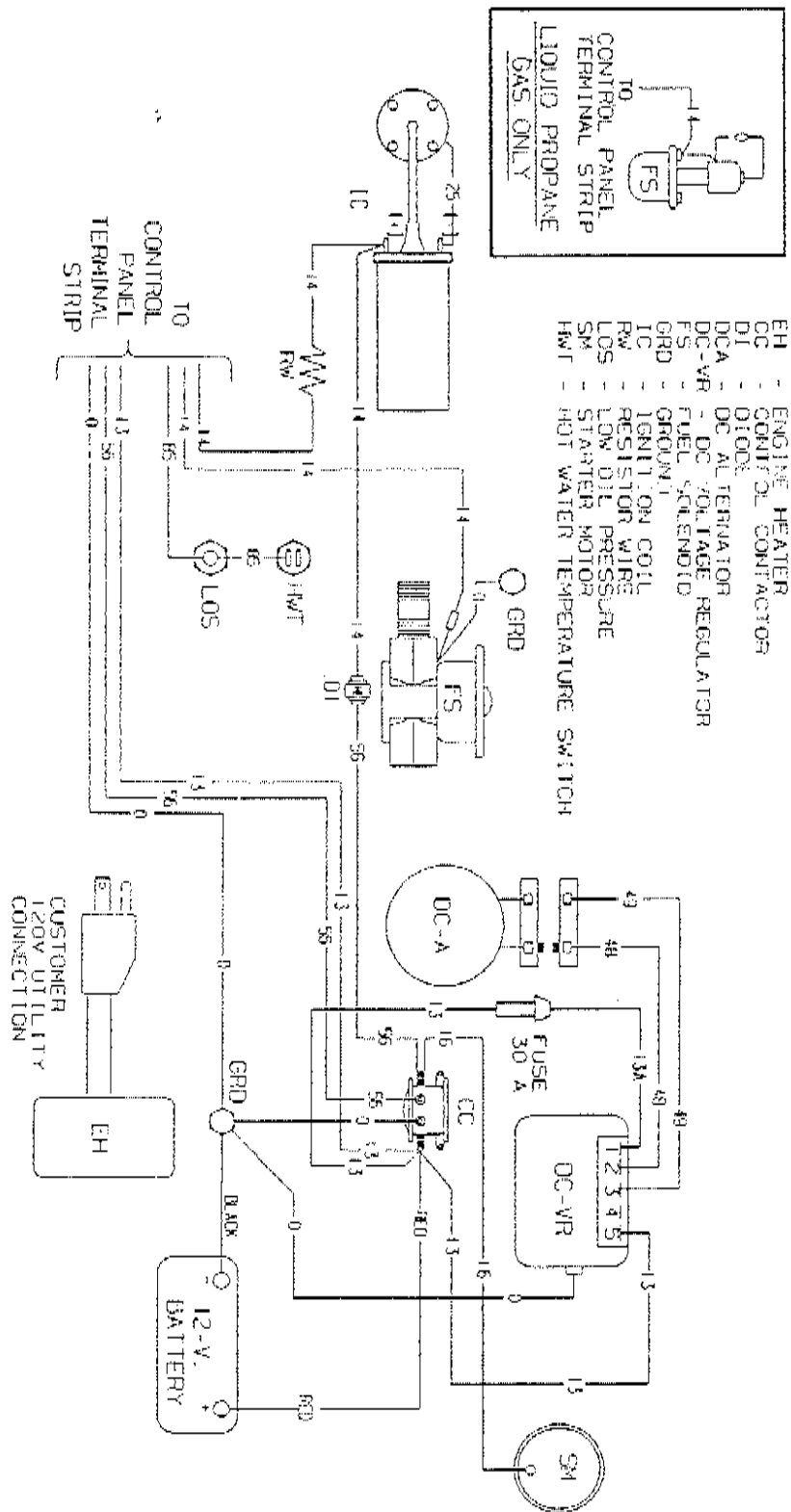





# NOTES

---

# NOTES

---

# NOTES

---

---

GENERAC CORPORATION      P.O. BOX 8      WAUKESHA, WISCONSIN 53187

---