

DIAGNOSTIC REPAIR MANUAL

GP-i, GP-iO, iQ, and iX Series Inverter



MODELS:

iQ2000	C0010020
iX800	C0010030
iX1600	INV 2000 DMN
iX2000	INV 3000 DMN
GP2200i	
GP3000i	
iQ3500	
GP3500iO	

PORTABLE GENERATORS

Safety

Throughout this publication and on tags and decals affixed to the generator, DANGER, WARNING, and CAUTION blocks are used to alert personnel to special instructions about a particular operation that may be hazardous if performed incorrectly or carelessly. Observe them carefully. Their definitions are as follows:

**DANGER**

Indicates a hazardous situation which, if not avoided, will result in death or serious injury.

(000001)

**WARNING**

Indicates a hazardous situation which, if not avoided, could result in death or serious injury.

(000002)

**CAUTION**

Indicates a hazardous situation which, if not avoided, could result in minor or moderate injury.

(000003)

NOTE: Notes provide additional information important to a procedure or component.

These safety alerts cannot eliminate the hazards they indicate. Observing safety precautions and strict compliance with the special instructions while performing the action or service are essential to preventing accidents.

**WARNING**

CANCER AND REPRODUCTIVE HARM

www.P65Warnings.ca.gov

(000393a)

Read This Manual Thoroughly

This diagnostic manual has been written and published by Generac to aid dealer technicians and company service personnel when servicing the products described herein.

It is assumed that these personnel are familiar with the servicing procedures for these products, or like or similar products manufactured and marketed by Generac, and that they have been trained in the recommended servicing procedures for these products, including the use of common hand tools and any special Generac tools or tools from other suppliers.

Generac could not possibly know of and advise the service trade of all conceivable procedures by which a service might be performed and of the possible hazards and/or results of each method. We have not undertaken any such wide evaluation. Therefore, anyone who uses a procedure or tool not recommended by Generac must first satisfy themselves that neither his nor the products safety will be endangered by the service procedure selected.

All information, illustrations and specifications in this manual are based on the latest product information available at the time of publication.

When working on these products, remember that the electrical system and engine ignition system are capable of violent and damaging short circuits or severe electrical shocks. If you intend to perform work where electrical terminals could be grounded or touched, the battery cables should be disconnected at the battery.

Any time the intake or exhaust openings of the engine are exposed during service, they should be covered to prevent accidental entry of foreign material. Entry of such materials will result in extensive damage when the engine is started.

During any maintenance procedure, replacement fasteners must have the same measurements and strength as the fasteners that were removed. Metric bolts and nuts have numbers that indicate their strength. Customary bolts use radial lines to indicate strength while most customary nuts do not have strength markings. Mismatched or incorrect fasteners can cause damage, malfunction and possible injury.

Replacement Parts

When servicing this equipment, it is extremely important that all components be properly installed and tightened. If improperly installed and tightened, sparks could ignite fuel vapors from fuel system leaks.

Safety	ii
Replacement Parts	ii

Section 1 General Information

Unit Identification	1
iX Unit Identification	1
iQ Unit Identification	2
GP-i Unit Identification	3
GP-iO Unit Identification	4
Internal Major Engine Components	5
Internal Major Electrical Components	7
Operational Analysis	8

Section 2 Troubleshooting and Diagnostic Tests

Troubleshooting Flow Charts	11
Diagnostic Tests	15
Check Engine RPM	15
Test Sub Coil of Stator	15
Test Main Coil of Stator	16
Test DC Circuit Breaker	17
Test DC Rectifier	17
Test DC Coil on Stator	18
Test Recoil Function	18
Test Engine Function	18
Check Spark	19
Check Spark Plug	19
Check Fuel Pump	19
Check Carburetion	20
Check Engine Compression	20
Test Ignition Trigger Assembly	21
Test Ignition Coil	22
Test Fuel Shutoff Switch	23
Check Choke Assembly	23
Test Stepper Motor	23
Results	24
Test Oil Level Switch	24
Test Ignition Coil Winding	24
Test FlexPower/MODE Switch	25
Check/Adjust Valves	26
Fuel Display Inaccurate	26
Test Inverter	26

Section 3 Disassembly

iX Disassembly	29
iQ Disassembly	32
iQ2000 Torque specifications	44
GP3000i Torque specifications	44
Standard Fastener Torque Specification	44
GP3500io/iQ3500 Torque specifications	45
Standard Fastener Torque Specification	45
79.8cc Inverter Engine Torque Specifications	45
Exploded View – iX800	46
Exploded View – iX1600	50
Exploded View – iX2000	54
Exploded View – iQ2000	58

Section 4 Electrical Data

Introduction	65
Wiring Diagram, iQ2000 Drawing No. 0L4354-B ...	66
Wiring Diagram, iQ2000 Drawing No. 0L4354-B ...	67
Wiring Diagram, iX800	68
Wiring Diagram, iX1600 and iX2000	69
Wiring Diagram and Electrical Schematic, GP2200i, Craftsman 2200i C0010020/Premier 2200i INV2200DMN Drawing No. 1000001954-A	70
Wiring Diagram and Electrical Schematic, GP3000i, Craftsman 3000i C00010030/PRO-3000i INV3000DMN INV 60HZ 120 VAC Drawing No. 10000017588-A	71
Wiring Diagram and Electrical Schematic, GP3500iO 60HZ 120 VAC Drawing No. 10000017616-A	72
Wiring Diagram and Electrical Schematic, iQ3500 Drawing No. 10000033847-A	73
Wiring Diagram and Electrical Schematic, iQ3500 Drawing No. 10000033847-A	74
Electrical Formulas	75

This page intentionally left blank.

Section 1 General Information

Unit Identification

Unit identification is broken down into two basic categories:

- items that are visual from the outside
- items located on the electrical control panel

Internal major components are grouped into two categories:

- mechanical and engine related items
- electrical items

iX Unit Identification

See [Figure 1-1](#).

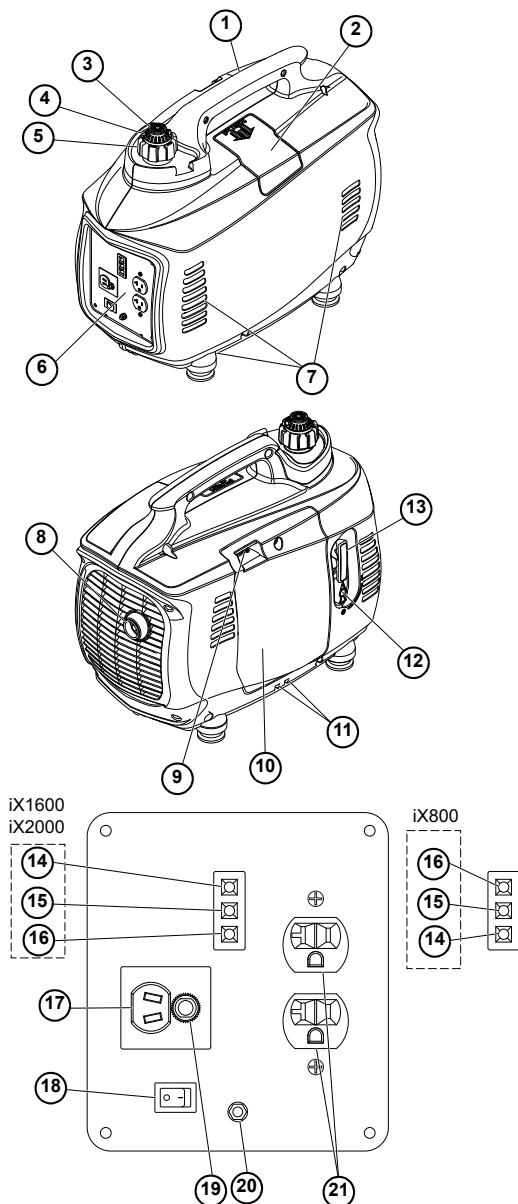

Figure 1-1.

1. Carrying Handle: Lift the generator by this handle only.
2. Spark Plug Cover: Allows access to the engine spark plug.
3. Fuel System Primer: Used to prime the fuel system for starting.
4. Fuel Cap Pressure Valve: Allows air to enter the fuel tank to equalize pressure.
5. Fuel Tank Cap: Access to fuel tank for filling.
6. Control Panel: location of generator controls and output receptacles.
7. Air Intake Slats: Allows for cooling air to enter the housing.
8. Muffler: Lowers engine exhaust noise.
9. Choke: Cold engine starting aid
10. Left Side Service Cover: Allows access to air filter, fuel filter and oil fill.
11. Vent Hoses: Allow venting of the carburetor.
12. Fuel Shutoff: Controls fuel supply to the carburetor.
13. Starter Rope: Pull rope for starting engine.

Control Panel

14. Low Oil Level LED (yellow): Lights up when oil level is below safe operating level and the engine shuts down.
15. Overload LED (red): Lights up if the generator experiences a load greater than the rated output, low voltage, overheats or the powered circuit experiences a short. The output is stopped even though the engine keeps running.
16. Ready LED (green): Indicates output from the generator unless there is a low oil or overload condition.
17. 12 VDC Plug (if equipped): Connection for re-charging 12VDC automotive-style batteries while generator is in operation.
18. FlexPower™ Switch: This switch slows the engine speed when the load is reduced to save fuel and engine wear.
19. 12 VDC Circuit Breaker (if equipped): Overload protection for the 12 VDC charging system.
20. Ground (Earth) Connection Lug: Grounding point for the generator; consult state and local electrical codes before use (floating ground).
21. 120 VAC Receptacles: Two (2) receptacles for connecting accessories.

008573

iQ Unit Identification

See **Figure 1-2**.

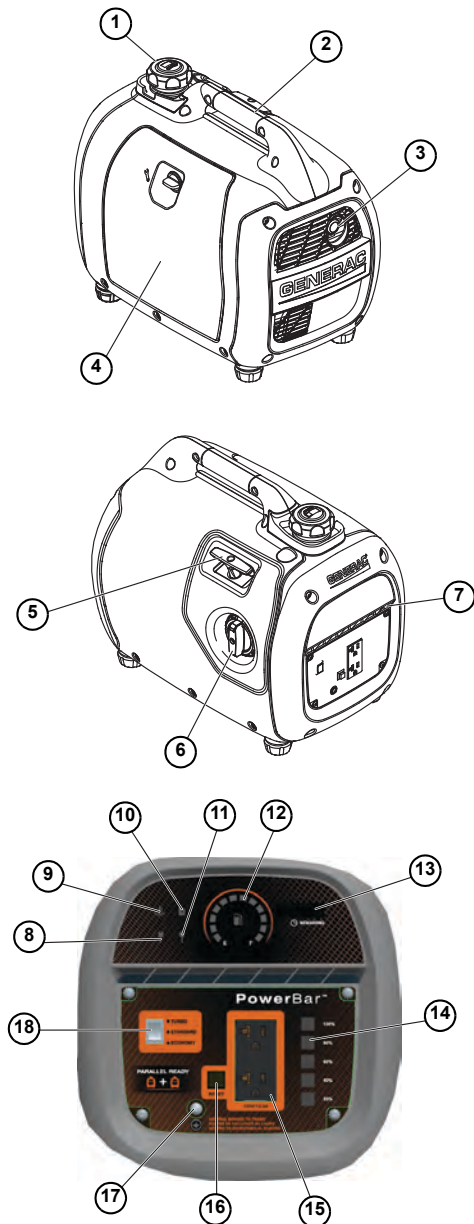

Figure 1-2.

008574

1. Fuel Cap: Access to fuel tank for filling.
2. Carrying Handle: Lift the generator by this handle only.
3. Muffler: Lowers engine exhaust noise.
4. Service Door: Allows access to air filter, fuel filter and oil fill.
5. Recoil Handle: Pull to start engine.
6. PowerDial: Controls ON/OFF functions, choke and fuel valve operation.
7. Air Intake: Allows for cooling air to enter the housing.

Control Panel

8. Ready to Load LED (green): Indicates output from generator (unless there is a low oil or overload condition).
9. Overheat LED (red): Illuminates when unit temperatures exceed normal operating conditions.
10. Low Oil LED (orange): Lights up when oil level is below safe operating level and engine shuts down.
11. Overload LED (red): Lights up if generator experiences load greater than rated output, low voltage, overheats or the powered circuit experiences a short. The output is stopped even though the engine keeps running.
12. Fuel Gauge: Indicates fuel level in tank.
13. Run Time Display: Shows engine run time hours.
14. PowerBar: Indicates amount of power being used from the generator.
15. Parallel Ready 120 Volts AC Duplex Outlet: Two (2) 5-20R receptacles for connecting accessories or iQ2000 parallel kit (sold separately)
16. Reset Button: Press for 1 second and release to reset any faults and to restore output power.
17. Grounding Location: Grounding point for the generator; consult state and local electrical codes before use (floating ground).
18. Turbo/Standard/Economy Switch: Determines mode of operation.

GP-i Unit Identification

See [Figure 1-3](#).

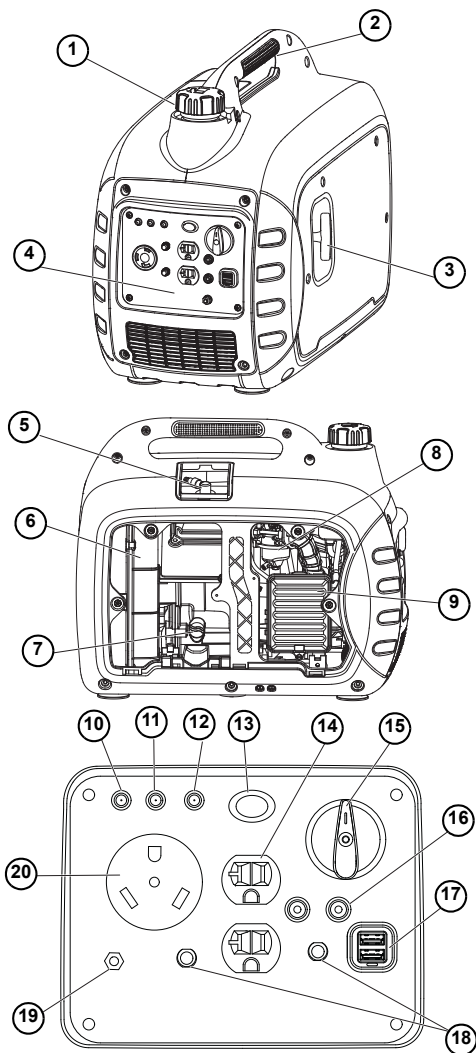

1. Fuel Cap: Access to fuel tank for filling.
2. Carrying Handle: Lift the generator by this handle only.
3. Recoil Handle: Pull to start engine.
4. Control Panel
5. Spark Plug
6. Muffler
7. Oil Fill/Drain
8. Carburetor
9. Air Cleaner

Control Panel

10. Low Oil Warning
11. Overload Warning
12. AC Power Light
13. Economy Mode Switch
14. 120V, 20A Receptacle
15. Off/Run/Choke Switch
16. Parallel Operation Cable Connection
17. 1A/2.1A, 5 VDC USB Outlet
18. AC Breaker
19. Grounding Location
20. 120V, 30A Receptacle (NEMA L5-30R)

008592

Figure 1-3.

GP-iO Unit Identification

See **Figure 1-3**.

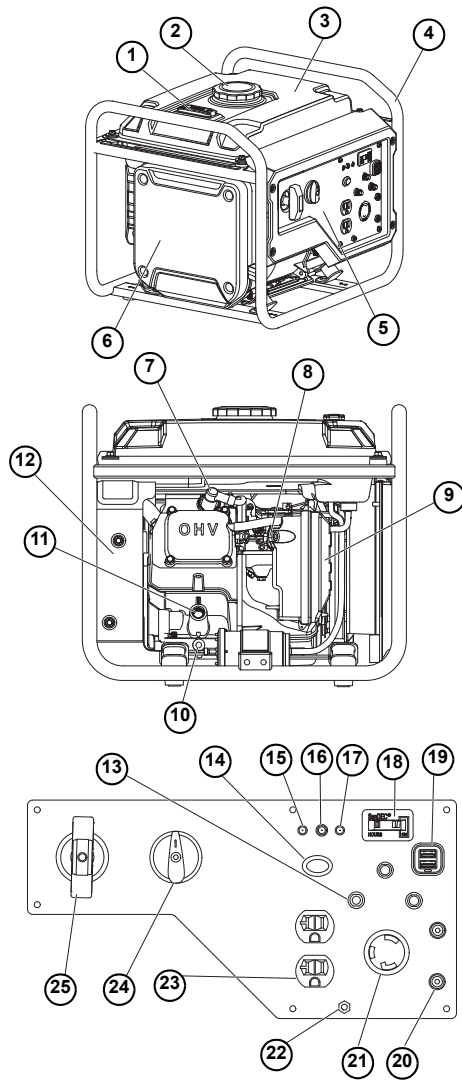

Figure 1-4.

1. Fuel Gauge
2. Fuel Tank Cap
3. Fuel Tank
4. Frame
5. Control Panel
6. Inverter Module
7. Spark Plug
8. Carburetor
9. Air Cleaner
10. Oil Drain
11. Oil Fill
12. Muffler

Control Panel

13. AC Breaker
14. Engine Smart Control (ESC)
15. Low Oil Warning
16. Overload Warning
17. AC Power Light
18. Hour Meter
19. 1A/2.1A, 5 VDC USB Outlet
20. Parallel Outlets
21. 120V, 30A Receptacle (NEMA L5-30R)
22. Grounding Location
23. 120V, 20A Receptacle
24. Off/On/Choke Switch
25. Recoil Starter

008593

Internal Major Engine Components

Engine

A 4 stroke engine attached to the rotor creates the mechanical energy necessary to maintain current flow at the receptacles.

Ignition Coil

The ignition coil provides spark for the engine. Spark timing is determined by LED module and the Trigger Assembly (Hall Effect Sensor).

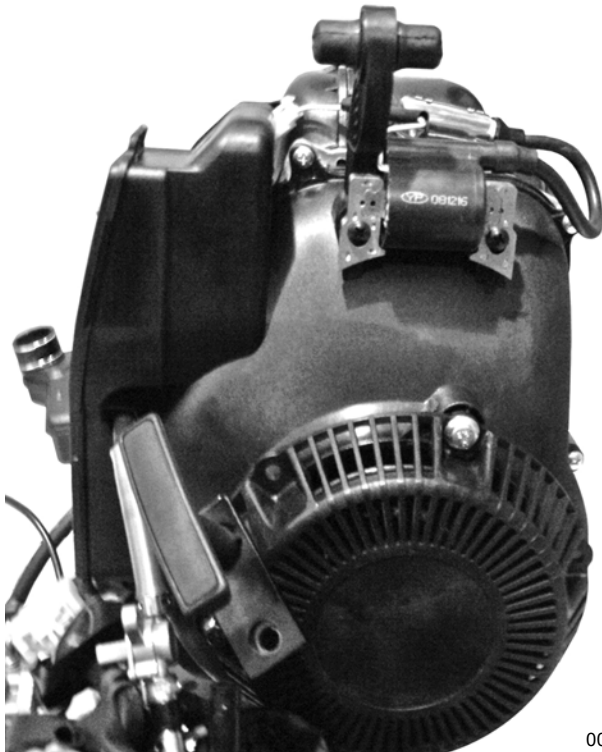

008599

Figure 1-5. iX Ignition Coil



008600

Figure 1-6. iQ Ignition Coil

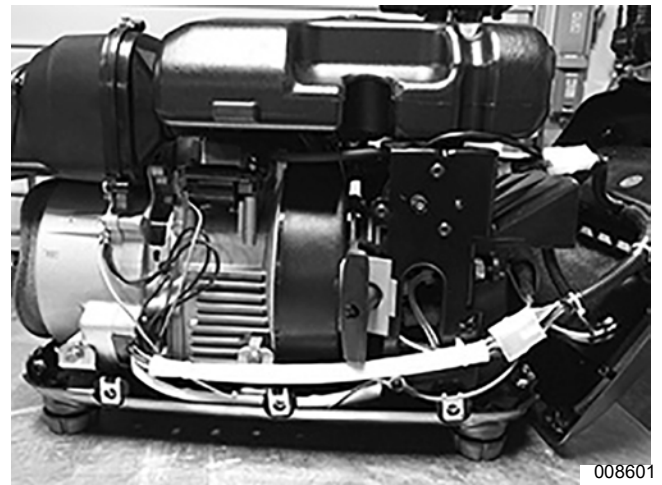

008601

Figure 1-7. Right Side of Unit

Trigger Assembly (Hall Effect Sensor)

The trigger assembly is located directly underneath the stator on the iX series and under the Alternator cover on the iQ2000. The stator sends timing pulses to the trigger assembly, depending on the position of the engine, to determine the correct timing for spark. This voltage is delivered to the LED module.



008602

Figure 1-8. iX Trigger Assembly



Figure 1-9. iQ Trigger Assembly

Ignition Shutoff Switch

The ignition shutoff switch is mechanically connected to the fuel shutoff valve. The internal contacts of the ignition shutoff switch are open when the fuel shutoff valve is in its ON position. The contacts are closed when the fuel shutoff valve is in its OFF position. When the contacts are closed it completes a path to ground to the LED module that will inhibit spark and shutdown the engine.



Figure 1-10. Ignition Shutoff Switch

Low Oil Level Switch

The low oil level switch is a float type switch located inside the engine on the bottom of the crank case casting. When the internal contact is closed it completes a path to ground to the LED module that will inhibit spark and shutdown the engine.

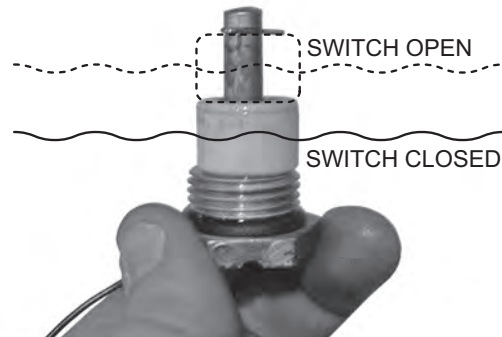

Figure 1-11. Low Oil Level Switch

Carburetor

The carburetor provides a sufficient air/fuel mixture to the engine to maintain the required speed. A stepper motor incorporated in the carburetor allows the engine to run at variable speeds. The speed of the engine is maintained by the inverter which will increase or decrease speed to maintain the output current necessary for loads.

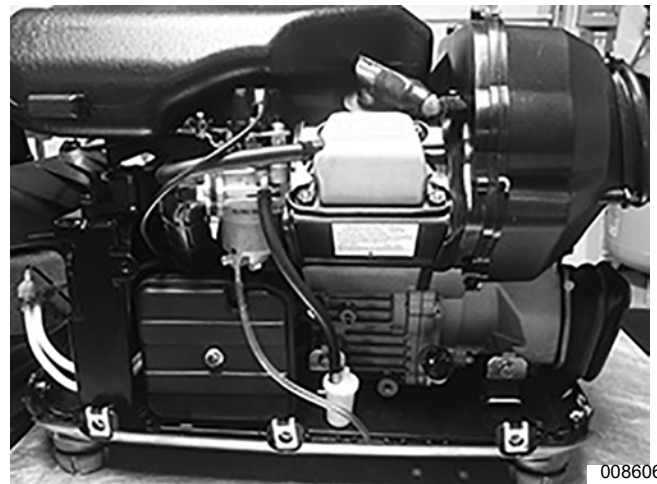

Figure 1-12. Carburetor Side View, iQ2000

Fuel Pump

The mechanical fuel pump is located on the exterior of the housing around the engine on the iX, and on the support bracket for the iQ2000 which is accessible by removing the side panels. Changes in pressure from the crankcase actuates a diaphragm inside the pump which then supplies fuel to the carburetor.



Figure 1-13. iX Fuel Pump, Stepper Motor and Carburetor

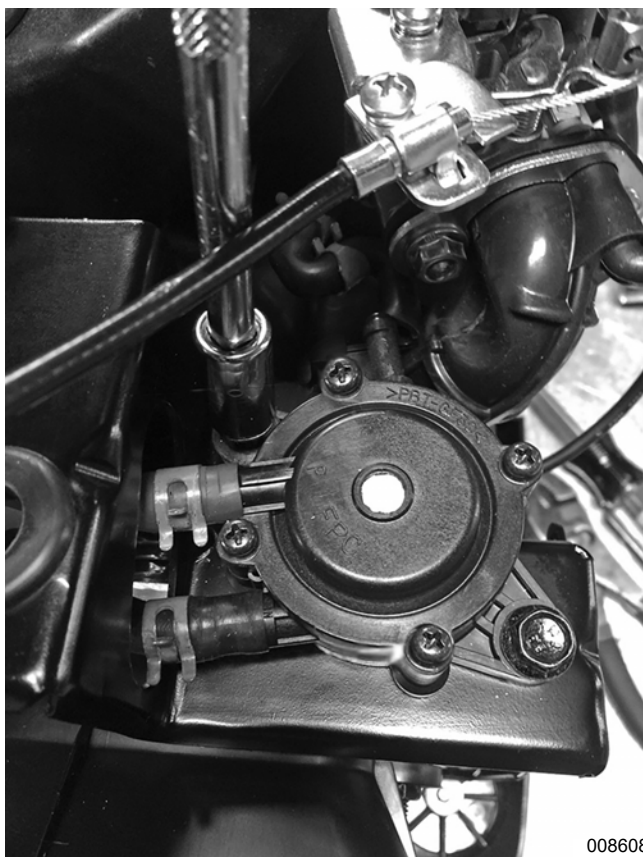

Figure 1-14. iQ Fuel Pump

Stepper Motor

The Stepper Motor consists of a motor along with a gear and cam arrangement which allows motor movement to change the engine carburetor throttle setting. The Motor is controlled by output signals from the inverter assembly, which calculates the number of steps the stepper needs

to take and generates the required signals to the Motor. The inverter signals the Motor to actuate in response to changes in AC output voltage. Thus, in response to decreasing AC output voltages, the Motor will increase the throttle setting and engine speed will increase. Conversely, increasing AC output voltages will cause the Motor to decrease throttle setting and engine speed will decrease.

Recoil Assembly

The recoil assembly connected directly to the crank shaft of the engine and allows the engine to spin over when pulled and reach a speed that allows the engine to maintain that speed.

Internal Major Electrical Components

Inverter Module

The inverter module receives voltage from two windings in the stator and produces a sine wave where the voltage is 120 VAC and the frequency is 60 Hz. It is also responsible for maintaining the correct engine speed needed to maintain current flow to the connected loads.

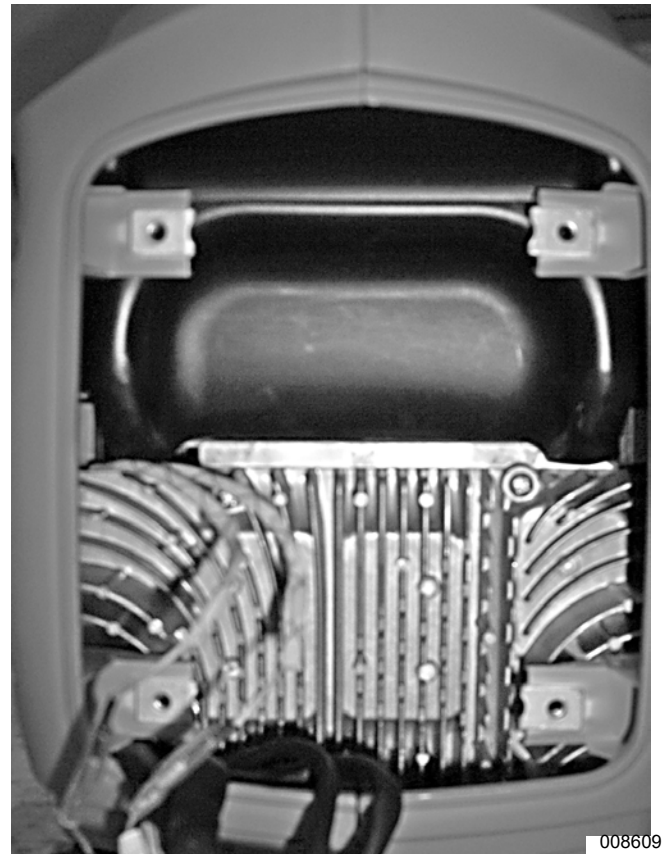

Figure 1-15. iX Inverter

Fuel Sender (iQ2000 only)

The fuel sending unit located in the fuel tank is an electronic fuel level sensor that reports fuel level

percentage information back to the display (LED) module. Power from the LED module provides the required voltage and ground to the fuel sending unit to which the fuel sending unit communicates the fuel level information over these wires to the LED module.

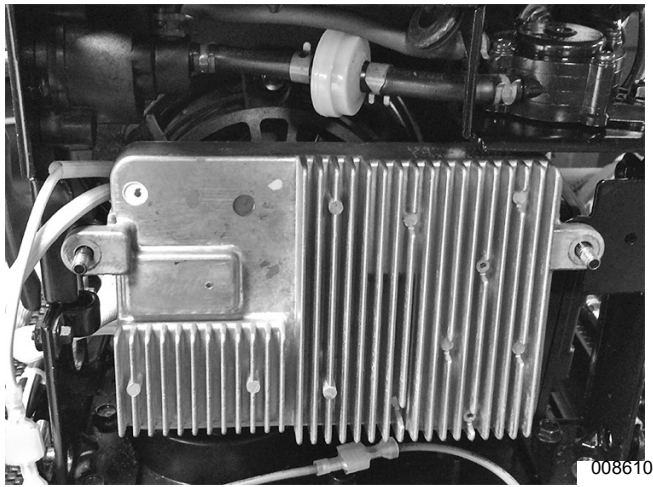

Figure 1-16. iQ Inverter

LED Module

The LED module receives inputs from the inverter assembly to monitor an Overload condition. It also illuminates the Green Ready light when unit is producing voltage and ready to accept load. An AC voltage is delivered to the module from the stator for firing of the ignition coil. The module determines when to deliver spark to the ignition coil by receiving timing pulses from the trigger assembly and fires the coil using the voltage from the stator winding.

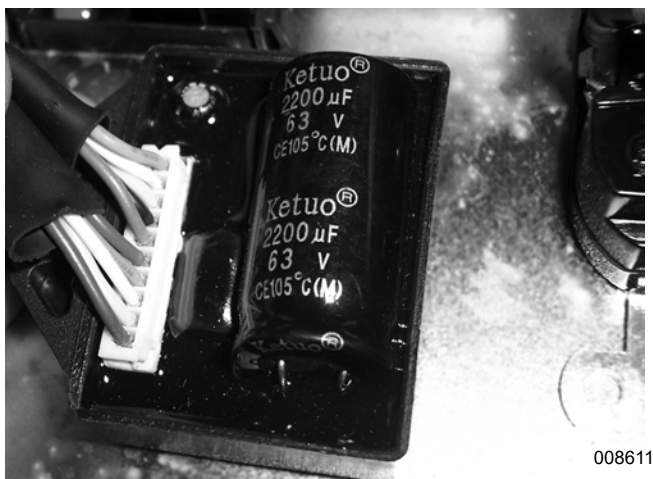

Figure 1-17. iX LED Module

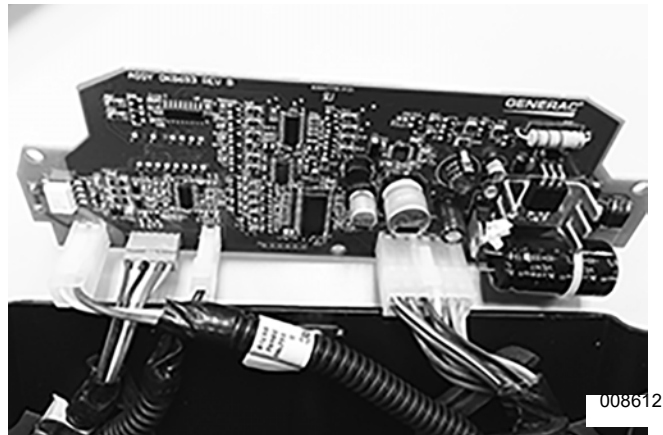

Figure 1-18. iQ LED Module

Permanent Magnet Rotor

Sixteen (16) permanent magnets have been affixed to the Rotor on the iX and twelve (12) on the iQ. The Rotor and Hub are balanced at the factory as an assembly and must be replaced as an assembly.

Stator

The stator has 4 separate windings that provide AC voltage to several different components. The DC Coil provides AC voltage to the bridge rectifier where 12 VDC is provided for charging on the iX. The same winding on the iQ is for the LED display. The Main Coil provides voltage to the inverter which provides the 120 VAC to the receptacles. The Sub Coil provides operating voltage to the Inverter for operation. Finally, the Ignition winding provides AC voltage to the LED module which triggers the ignition coil to fire at the correct position.

Operational Analysis

General

Figures 33 (iX) and 29 (iQ) are block diagrams of the inverter generators. The diagrams are only for the purpose of illustrating generator operation. Refer to actual wiring diagram for wiring interconnections.

Operational Description

1. The iX and iQ inverter units are computer controlled generators that use an inverter to create a superior sine wave and maintain a steady frequency of 60 hz. the permanent magnet rotor is directly coupled to the engine and rotates at the same speed as the engine.
2. As the rotor turns, its magnetic field cuts across stator windings, to induce a voltage into those windings as follows:
 - a. The main coil winding provides the AC voltage necessary for the inverter to supply rated output voltage to the receptacles.

- b. The sub coil winding provides the AC voltage needed to operate the Inverter.
 - c. The DC coil winding provides the AC voltage necessary to provide the DC charging outlet with 12 VDC (iX only).
 - d. The LED winding powers the fuel LED's, run time clock, status LED's and supplies power to the LED module for the PowerBar display (iQ2000 only).
 - e. The ignition winding provides the voltage needed for the LED module to fire the ignition coil.
3. While unit is running, it continues to monitor current on receptacles and make needed adjustments to engine speed by changing output signals to the STEPPER MOTOR to either increase or decrease engine speed based on load demand.

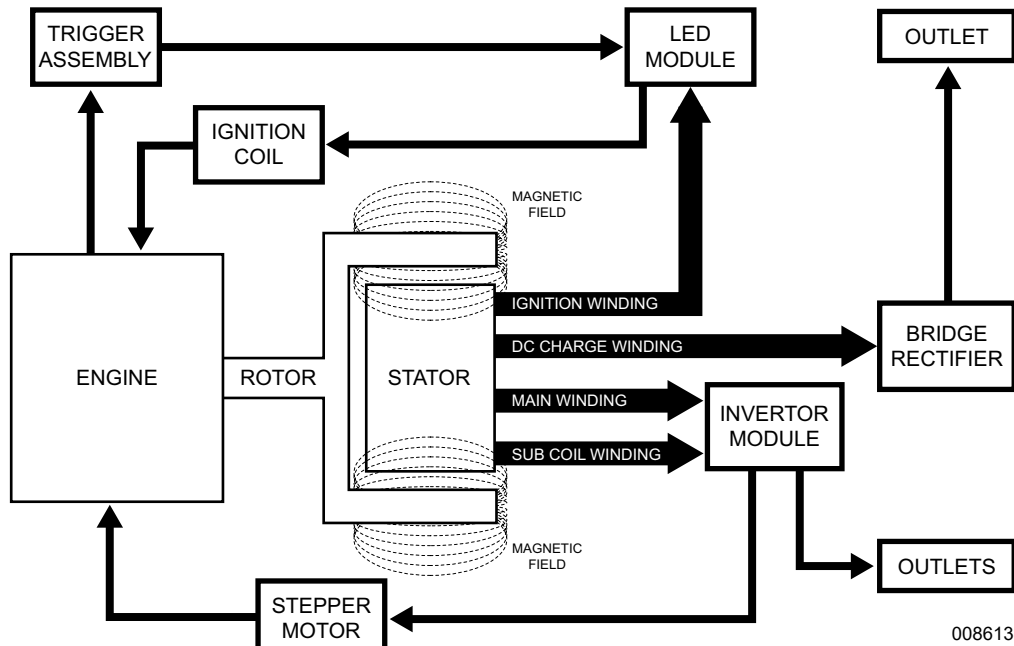

Figure 1-19. iX Inverter Operating Diagram

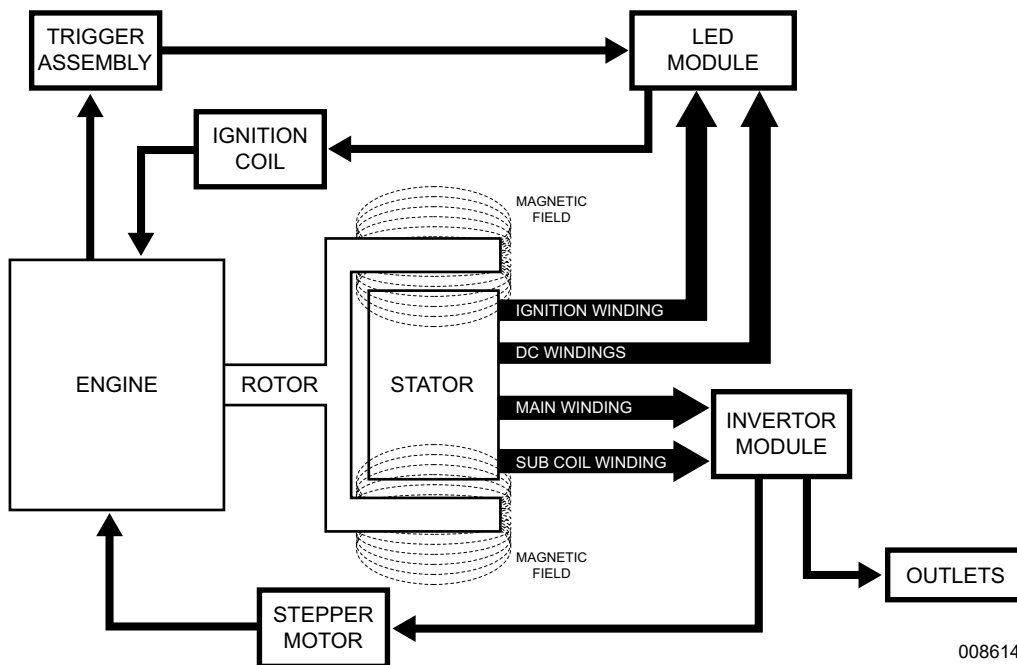

Figure 1-20. iQ, GP-i, GP-iO Inverter Operating Diagram

This page intentionally left blank.

Section 2 Troubleshooting and Diagnostic Tests

Troubleshooting Flow Charts

Problem 1 – No AC Output

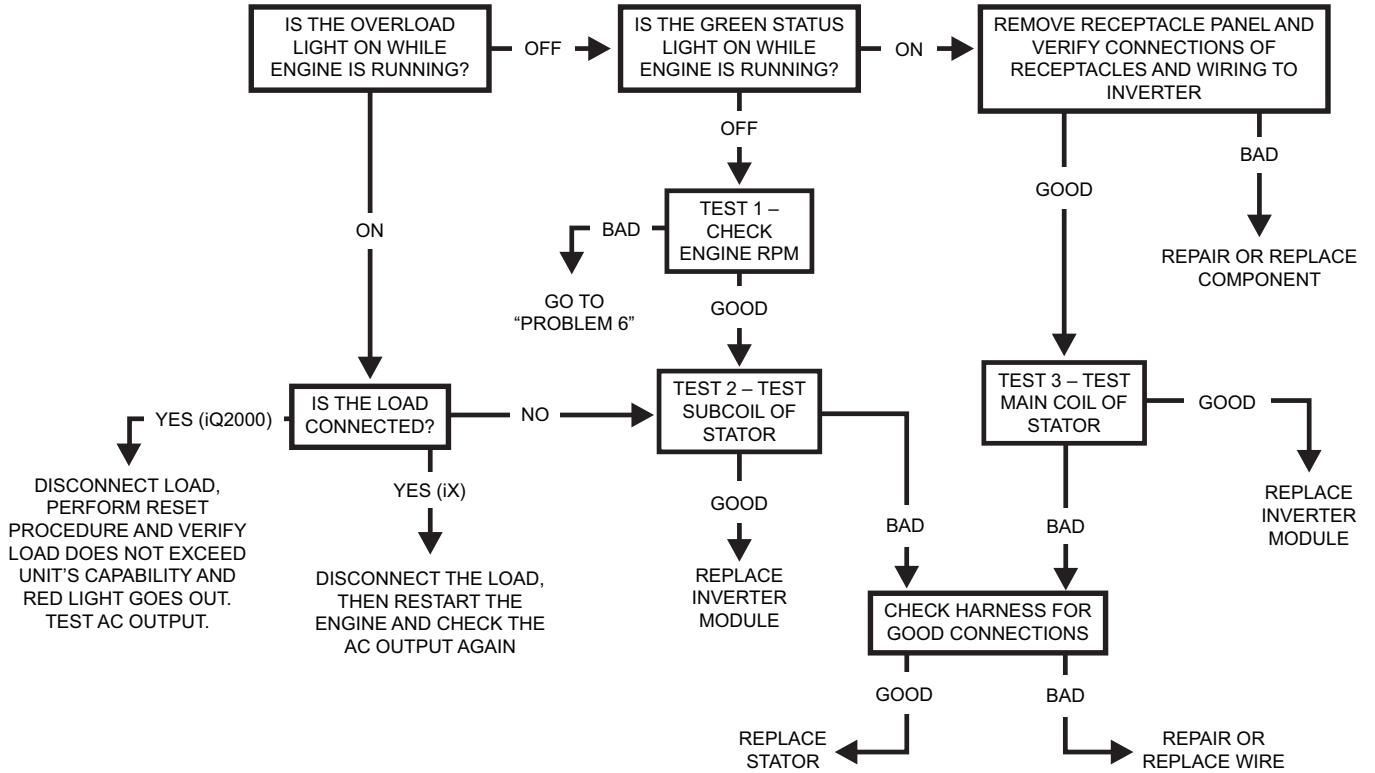

Problem 2 – No DC Output (iX Units Only)

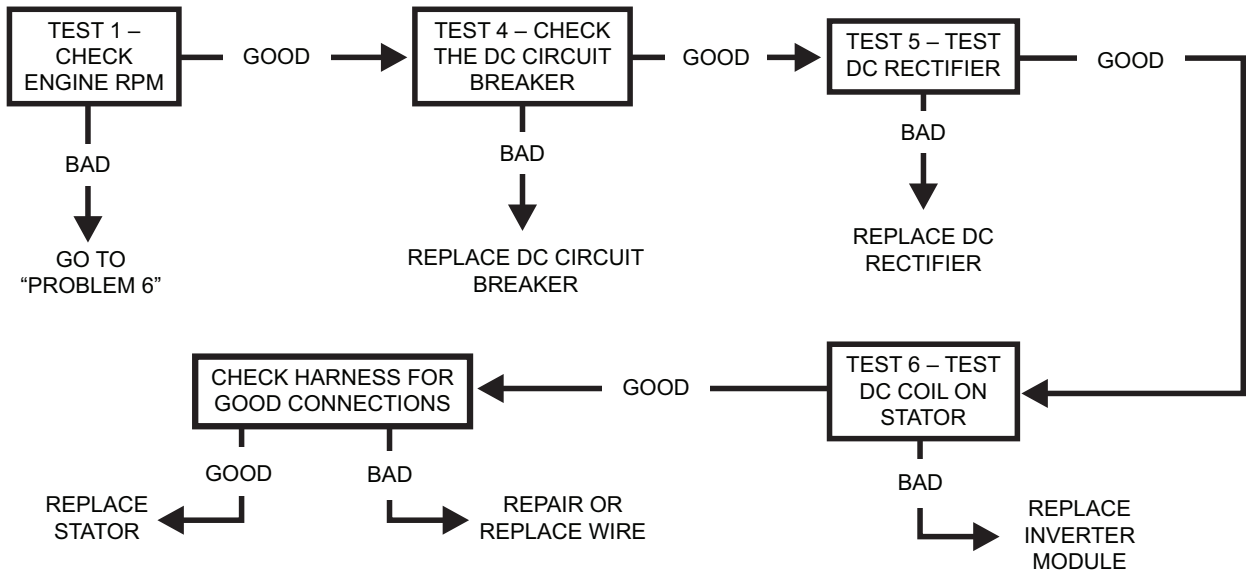

Problem 3 – Overload Light Is On

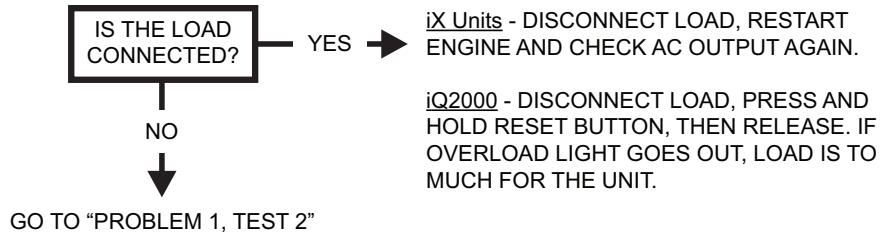

Problem 4 – Engine Will Not Pull Start

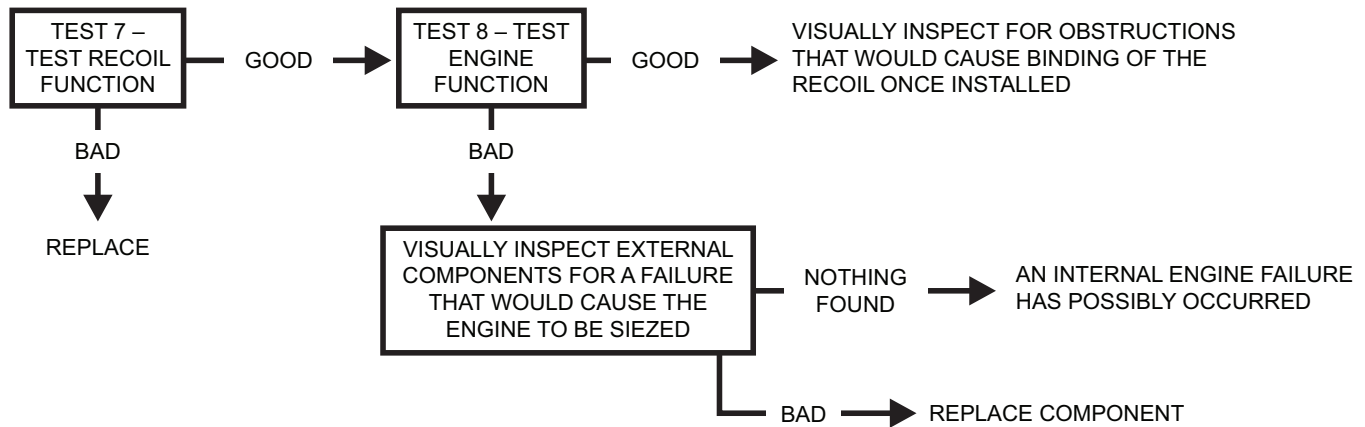

Problem 5 – Flex Power/Mode Feature is Not Responding

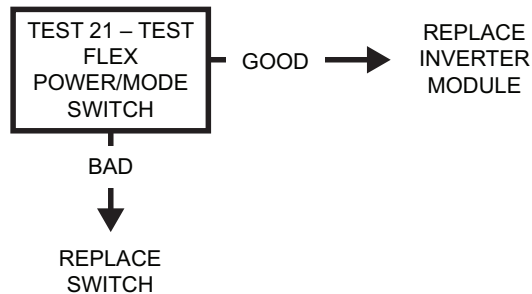

Problem 6 – Engine Will Not Start

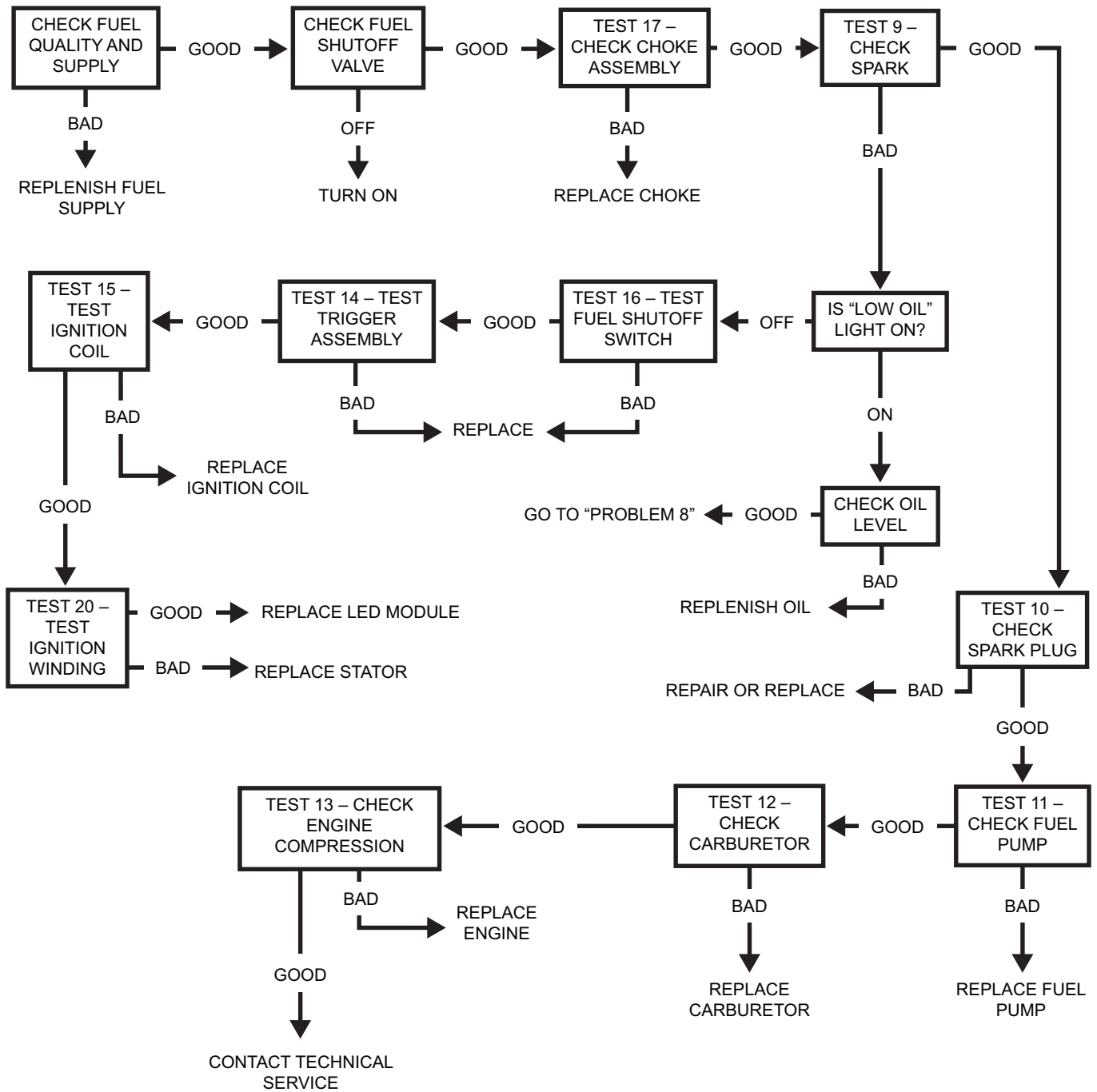

Problem 7 – Engine Hunts / Erratic Idle or Will Not Come Up to Speed

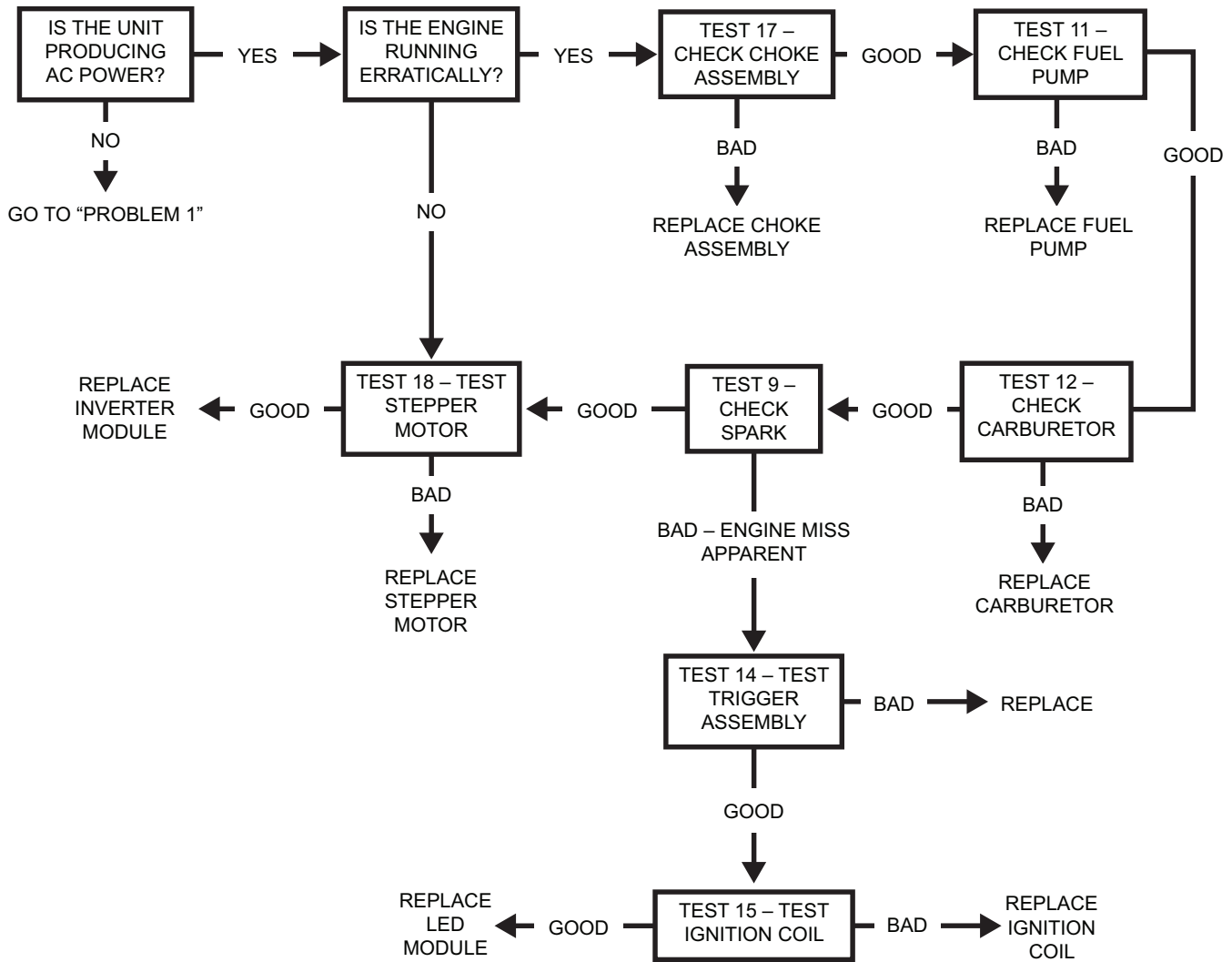

Problem 8 – Unit Shuts Down for Low Oil

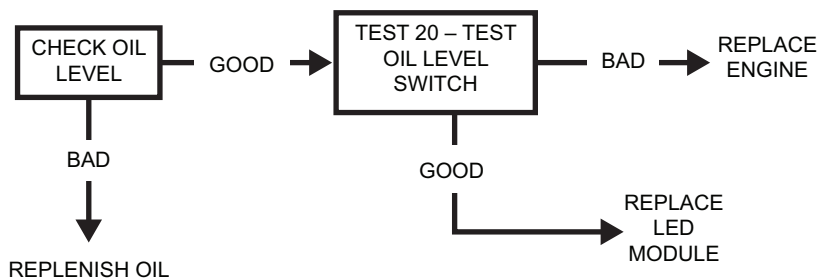

Problem 9 – LED Display INOP

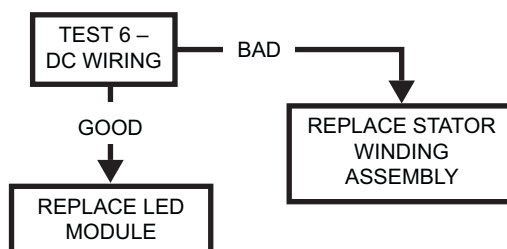

Diagnostic Tests

Check Engine RPM

Tools Required

Small Engine Tachometer or Inductive Tachometer

iX Procedure

1. With engine running, connect engine tachometer according to manufactures instructions and record the engine RPM.

Results

1. If engine rpm is 3000 ± 200 rpm it is running within rated specs. Refer to flow chart.
2. If engine rpm is outside range of 3000 ± 200 rpm, go to Problem 7 flowchart.

iQ2000 Procedure

1. With no load on unit, verify rpm based on each of the mode selections:

Turbo Mode	4500 ± 200 RPM
Standard Mode	3600 ± 200 RPM
ECO Mode	3000 ± 200 RPM

2. If engine rpm is running within rated specs, refer to flow chart.
3. If engine rpm is outside range of rated specs, go to Problem 7 flowchart.

Test Sub Coil of Stator

Procedure

1. Stop engine.



⚠ DANGER

Explosion and Fire. Fuel and vapors are extremely flammable and explosive. Add fuel in a well ventilated area. Keep fire and spark away. Failure to do so will result in death or serious injury. (000105)

2. Drain fuel from tank.
3. Remove electrical box assembly, back window, and upper enclosure half.
4. Take out C4 connector.

NOTE: Do not remove harness of control panel.

5. Set DMM to measure resistance.
6. Disconnect C4 connector. On female side of connector, connect one meter test lead to Pin 1 and the other meter test lead to Pin 4. Measure and record resistance.

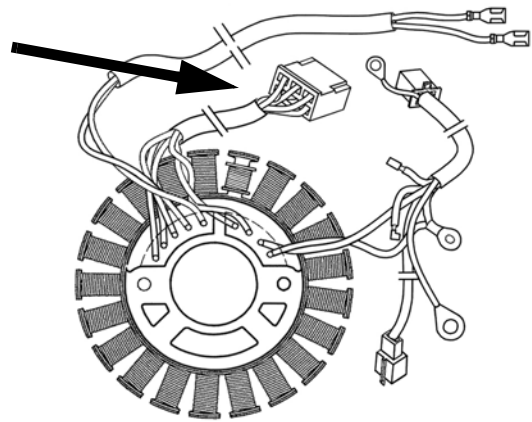

008616

Figure 1-21. C4 Connector Pin Locations, Male Side



008617

Figure 1-22. Sub Coil Connector

- 1 – YELLOW
- 2 – YELLOW

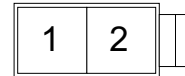

008618

Figure 1-23. F2 Sub Coil Connector

- 1 – GRAY
- 2 – EMPTY
- 3 – ORANGE
- 4 – GRAY
- 5 – ORANGE
- 6 – ORANGE

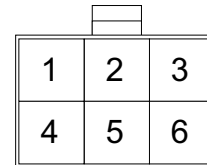

008619

Figure 1-24. C4 Connector Pin Locations, Male Side

Results

1. Resistance measured between Pin 1 and Pin 4 should be as follows:

iX 800	0.5 Ohms
iX 1600	0.7 Ohms
iX 2000	0.3 Ohms

2. If resistance measured is between specified values, refer to flow chart.
3. If resistance reading is outside tolerance, replace stator.

iQ2000 Control Winding Procedure

1. Remove electrical panel so components are exposed.
2. Disconnect F2 connector from inverter (2 wire connector).
3. Set DMM to measure resistance.
4. On female side of connector, connect one meter test lead back probe to Pin 1 and the other meter test lead back probed to Pin 4. Measure and record resistance.
5. With one lead still back probed into Pin 1 connect the other lead to ground. Measure and record resistance.



Figure 1-25. Stator Connector

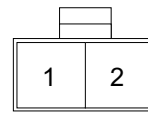

B
 1 – ORANGE
 2 – BLACK

Sender Connector
 1 – RED
 2 – BLACK

008622

Figure 1-27. Fuel Sender Connector

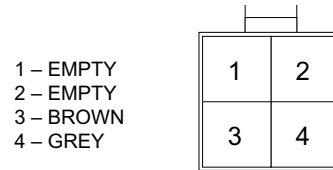

1 – EMPTY
 2 – EMPTY
 3 – BROWN
 4 – GREY

008623

Figure 1-28. C Comms (Connected to LED Board)

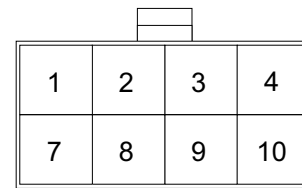

1 – DK BLUE
 2 – EMPTY
 3 – BLACK
 4 – EMPTY

5 – GREY
 6 – YELLOW
 7 – BROWN
 8 – RED

008624

Figure 1-29. F (Connected to Inverter)

Results

1. Resistance measured between Pin 1 and Pin 2 and compare to chart.
2. Connection to ground should read INFINITY
3. If not within specifications replace stator assembly.

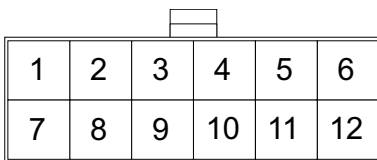

**Board Jumper
 Harness Connector
 A**

- 1 – YELLOW
- 2 – GREY
- 3 – BLACK
- 4 – BROWN
- 5 – PURPLE
- 6 – DK BLUE
- 7 – ORANGE
- 8 – PINK
- 9 – WHITE
- 10 – RED/BLACK
- 11 – RED
- 12 – BLUE/WHITE

**Power Head
 Connector
 G**

- 1 – LT BLUE
- 2 – DK BLUE
- 3 – BLACK
- 4 – BLACK
- 5 – BLACK
- 6 – BLACK
- 7 – GREEN
- 8 – YELLOW/GREEN
- 9 – WHITE
- 10 – DK GREEN
- 11 – DK GREEN
- 12 – BLACK

008621

Figure 1-26. iQ Connector ID

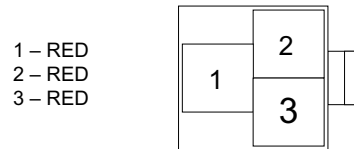

1 – RED
 2 – RED
 3 – RED

008625

Figure 1-30. F1 Stator Connection

Test Main Coil of Stator

iX Procedure

1. Stop engine.



⚠ DANGER

Explosion and Fire. Fuel and vapors are extremely flammable and explosive. Add fuel in a well ventilated area. Keep fire and spark away. Failure to do so will result in death or serious injury. (000105)

2. Drain fuel from tank.
3. Remove electrical box assembly, back window, and upper enclosure half.
4. Take out 6 pin connector

NOTE: Do not remove harness of control panel.

5. Set DMM to measure resistance.

6. Disconnect C4 connector. On female side of connector, connect one meter test lead to Pin 3 and the other meter test lead to Pin 5. Measure and record resistance.
7. Repeat Step 6 between these test points:
 - Pin 3 and Pin 6
 - Pin 6 and Pin 5

Results

1. Resistance measured between tests points should be as follows:

iX 800	1.9 Ohms
iX 1600	1.9 Ohms
iX 2000	1.6 Ohms \pm 0.4 Ohms

2. If resistance measured is within specified values, refer to flow chart.
3. If resistance reading is outside tolerance, replace stator.

iQ2000 procedure

1. Set DMM to measure resistance.
2. Disconnect F1 connector from Inverter (3-wire connector).
3. On female side of connector, connect one meter test lead back probe to Pin 1 and the other meter test lead to Pin 2. Measure and record resistance.
4. Measure and record resistance between 2 and 3 and 1 to 3.
5. Compare readings to [Table 1-1](#).
6. Check each connection to ground. They should read INFINITY.

Results

1. Resistance measured between tests points and compare to chart.
2. Resistance to ground from each test point. They should read INFINITY.
3. If not within specifications replace stator assembly.

Table 1-1. iQ Resistance Values	
Main Winding Red 1-2	1.97-2.18 Ohms
Main Winding Red 1-3	1.97-2.18 Ohms
Main Winding Red 2-3	1.97-2.18 Ohms
Control Winding: Yellow-Yellow	0.16-0.18 Ohms
Ignition: Blue-Yellow/Green	0.63-0.71 Ohms
DC Winding: Green-Green	0.13-0.15 Ohms

Table 1-2. iQ3500/GP3500io Resistance Values	
Main Winding Brown	0.75-0.85 Ohms
Secondary Winding Orange	0.50-0.55 Ohms
DC Winding Blue	0.19-0.21 Ohms

Table 1-3. GP3000i Resistance Values	
Main Winding Brown	0.97 Ohms \pm 15%
Secondary Winding Orange	0.42 Ohms \pm 15%
DC Winding Blue	0.86 Ohms \pm 15%

Test DC Circuit Breaker

Procedure

1. Remove electrical panel to expose the DC circuit breaker and remove both wires from breaker. Verify the breaker is reset from front of panel and is not tripped.
2. Set DMM to measure resistance.
3. Connect one meter test lead to each side of breaker. Measure resistance. CONTINUITY should be measured.

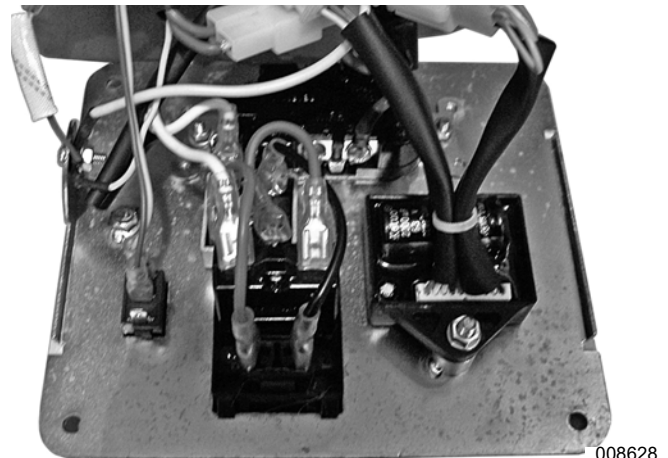

Figure 1-31. DC Breaker and DC Bridge Rectifier

Results

1. If CONTINUITY is measured across circuit breaker, refer to flow chart.
2. If circuit breaker reads open, replace DC circuit breaker and test.

Test DC Rectifier

Procedure

1. With electrical panel still exposed, remove wires on DC rectifier and mark location of each wire on rectifier.
2. Set DMM to Diode test feature (marked on most meters by diode symbol).

3. Connect meter test leads according to chart and record results.

Results

1. If meter indicated correct readings at all test points, refer back to chart.
2. If meter indicated any reading other than specified, replace rectifier.

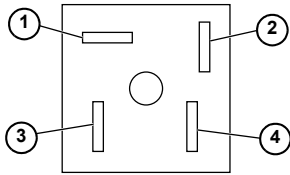

008629

(+) Test Lead	1	2	3	4
(-) Test Lead				
1		CONTINUITY	CONTINUITY	CONTINUITY
2	INFINITY		INFINITY	CONTINUITY
3	INFINITY	INFINITY		CONTINUITY
4	INFINITY	INFINITY	INFINITY	

Figure 1-32. DC Rectifier iX

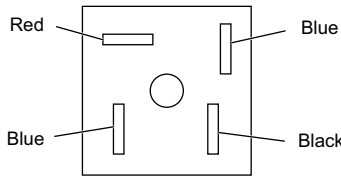

009030

(+) Test Lead	Blue	Blue	Red	Black
(-) Test Lead				
Blue		INFINITY	INFINITY	CONTINUITY
Blue	INFINITY		INFINITY	CONTINUITY
Red	CONTINUITY	CONTINUITY		CONTINUITY
Black	INFINITY	INFINITY	INFINITY	

Figure 1-33. DC Rectifier GP3000i

Test DC Coil on Stator

iX Procedure

1. Locate two white wires coming from stator. One will be located on the DC circuit breaker, and the other will be located on the rectifier.
2. Set DMM to measure resistance.
3. Connect one meter lead to each wire. Measure and record resistance.

Results

1. The resistance measured between all tests points should be as follows:

iX 1600	0.2 Ohms
iX 2000	0.3 Ohms

2. If resistance measured is within specified values, refer to flow chart.
3. If resistance reading is outside tolerance, replace stator.

iQ2000 Procedure

1. Locate the G connector and disconnect.
2. Set DMM to measure resistance.
3. Connect one meter lead back probed into Pin 10 and connect the other meter lead back probed into Pin 11. Measure and record resistance.
4. With one lead still back probed into Pin 10 connect the other lead to ground. Measure and record resistance.

Results

1. The resistance measured between Pin 10 and Pin 11 should be within specs of the chart.
2. Connection to ground should read INFINITY.
3. If not within specifications replace stator assembly.

Test Recoil Function

Procedure

Attempt to pull start engine and observe the following:

- Does cord pull easily and smoothly?
- Does cord return with no assistance?
- Does engine turn over as cord is pulled?

Results

If recoil did not perform correctly, these problems could exist:

- Engine could be seized.
- Recoil could have become detached from flywheel.
- Recoil mechanism could be broken and not retracting properly.

Test Engine Function

Procedure

1. Remove recoil and front cover assembly.
2. Remove spark plug from unit.
3. Attempt to turn engine over by hand.

Results

1. If engine can not turn over freely with spark plug removed, engine has an internal failure and has seized.
2. Refer to flow chart.

Check Spark

Procedure

A commercially available spark tester may be used to test engine ignition system.

1. Disconnect spark plug lead from spark plug.
2. Attach high tension lead to spark tester terminal.
3. See [Figure 1-34](#). Ground spark tester clamp by attaching to cylinder head.



Figure 1-34. Ground Spark Tester

4. Attempt to pull start engine. If spark jumps tester gap, ignition system is working properly.

NOTE: The fuel shutoff switch should be in the open position.

NOTE: It may take several start attempts before a good spark is observed in the tester.

Results

1. Refer back to flow chart

Check Spark Plug

Procedure

Remove spark plug. Clean with a commercial solvent. DO NOT BLAST CLEAN SPARK PLUG. Replace spark plug if badly fouled, if ceramic is cracked, or if badly worn or damaged.

Results

1. Clean and regap, or replace sparks plug as necessary.

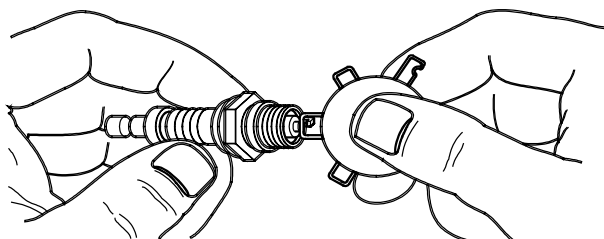

Figure 1-35. Setting Spark Plug Gap

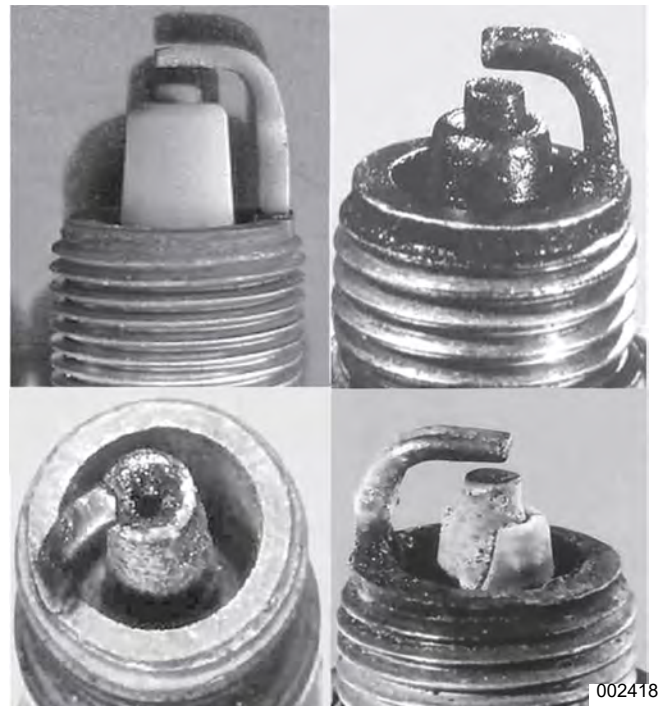

Figure 1-36. Spark Plug Conditions

Series	Spark Plug Gap
iQ/GP3500io/IQ3500	0.024 - 0.028 in (0.6 - 0.7 mm)
iX (all)	0.03 in (0.76 mm)
GP3000i	0.028-0.031in (0.7-0.8mm)

2. Refer to flow chart.

Check Fuel Pump

Procedure

1. See [Figure 1-34](#). Open up side panel to expose carburetor (A) and fuel pump (B).
2. Carefully remove fuel line from filter on inlet side of carburetor



⚠ DANGER

Explosion and Fire. Fuel and vapors are extremely flammable and explosive. Add fuel in a well ventilated area. Keep fire and spark away. Failure to do so will result in death or serious injury. (000105)

3. Using a suitable container to catch fuel, slowly pull on recoil cord and turn engine over. Fuel should flow from fuel line. If fuel does not flow, verify fuel is available to pump. If fuel is available to pump inspect fuel filter and pulse line.

Results

1. If fuel does not flow, replace fuel pump.
2. If fuel flow has been verified proceed to Test 12.

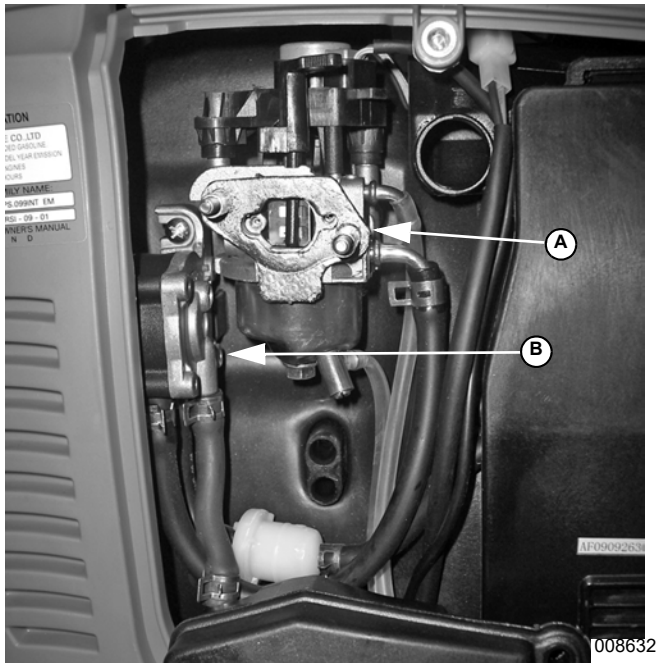

Figure 1-37. Check Fuel Pump (iX)

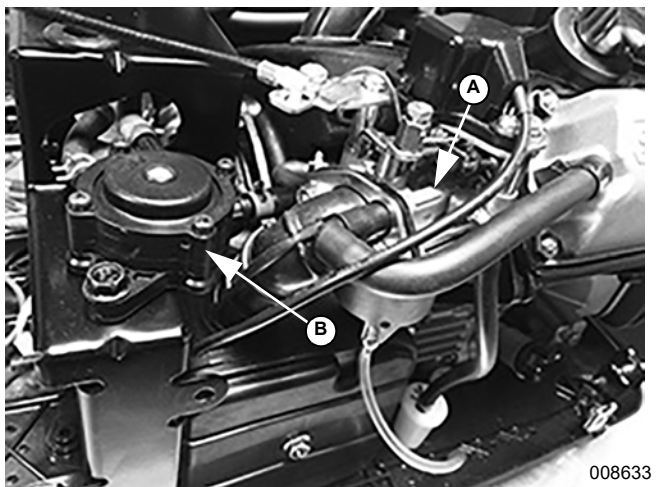

Figure 1-38. Check Fuel Pump (iQ)

Check Carburetion

Before checking carburetor, be sure fuel tank has an ample supply of fresh, clean gasoline. Check all shutoff valves are open and fuel flows freely through fuel line. Make sure choke operates properly. If engine will not start, remove and inspect spark plug.

If spark plug is wet, check for:

- Over choking.
- Excessively rich fuel mixture.
- Water in fuel.
- Intake valve stuck open.
- Needle/float stuck open.

If spark plug is dry, check for:

- Leaking carburetor mounting gaskets.
 - Intake valve stuck closed.
 - Inoperative fuel pump.
 - Plugged fuel filter(s).
 - Varnished carburetor
 - Check the choke is working properly.
1. Remove fuel line at carburetor and ensure there is an adequate amount of fuel entering the carburetor.
 2. Remove float bowl and check for any foreign matter in bottom of bowl.
 3. Remove plastic float to gain access to needle.
 4. Remove needle for cleaning.
 5. Use a suitable carburetor cleaner to clean carburetor before assembly.
 6. After cleaning the carburetor, blow dry with compressed air and assemble.

NOTE: The shelf life of gasoline is about 30 days. Proper procedures need to be taken so the fuel doesn't varnish over time. A fuel stabilizer should always be used to ensure the fuel stays fresh.

Results

1. If carburetor is varnished, clean or replace. Refer to flow chart.

Check Engine Compression

Discussion

Most engine problems may be classified as one, or a combination of the following:

- Will not start.
- Starts hard.
- Lack of power.
- Runs rough.
- Vibration.
- Overheating.
- High oil consumption.

Check Compression

To check engine compression, remove spark plug. Insert an automotive type compression gauge into spark plug hole. Crank engine until there is no further increase in pressure. The highest reading obtained is the engine compression pressure.

Minimum allowable compression pressure cold engine	60 psi
--	--------

If compression is poor, look for any of these causes:

- Loose cylinder head bolts.
- Failed cylinder head gasket.
- Burned valves or valve seats.
- Insufficient valve clearance.
- Warped cylinder head.
- Warped valve stem.
- Worn or broken piston ring(s).
- Worn or damaged cylinder bore.
- Broken connecting rod.
- Worn valve seats or valves.
- Worn valve guides.

NOTE: Due to the decompression system on the iQ2000, performing a compression test will not be valid. You will typically get about 5 PSI. Verify valve adjustment, fuel system and ignition system and start unit again. If it is determined there is an internal issue with the engine, contact technical service.

Test Ignition Trigger Assembly

iX Procedure

1. See [Figure 1-39](#). Remove electrical panel so the LED module is exposed and disconnect J1 connector.
2. Set DMM to measure resistance.
3. Locate Pin 3 on J1 connector. Connect one meter test lead to Pin 3 and the other meter test lead to engine ground. Measure and record resistance.

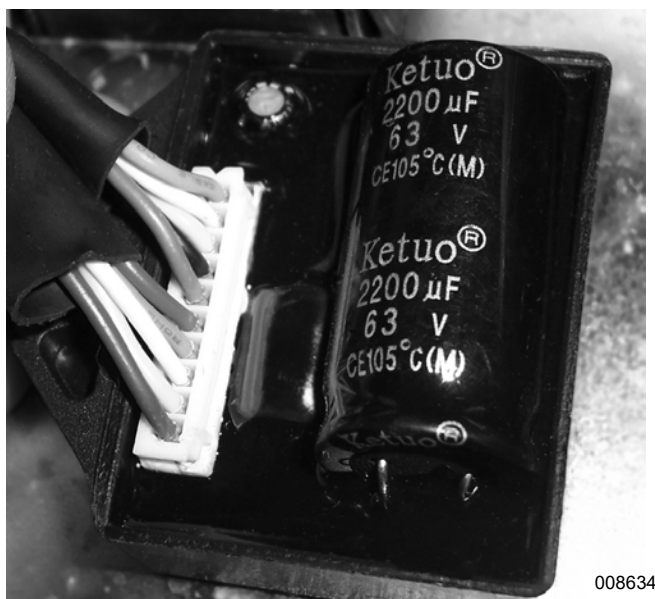

Figure 1-39. J1 Connector on LED Module

008634



Figure 1-40. iQ Trigger

008635

Table 1-4. Table 1. J1 Connector Pin Chart

Location	Function	Wire Color
Pin 1	Ignition Coil	Blue
Pin 2	Low Oil Switch	Yellow
Pin 3	Trigger Assembly	White
Pin 4	Ground	Pink
Pin 5	Ignition Winding	Red
Pin 6	Fuel Shutoff Switch	Gray
Pin 7	Inverter	Purple
Pin 8	Inverter	Yellow
Pin 9	Inverter	White
Pin 10	Inverter	Green

Results

1. If meter reading is within ± 5 ohms of correct resistance, refer to flow chart.

iX 800	30 Ohms
iX 1600	30 Ohms
iX 2000	129 Ohms

2. If meter did not indicate correct resistance, replace trigger assembly.

iQ 2000 Procedure

1. Remove electrical panel.
2. Locate the G connector and disconnect.
3. Set DMM to measure resistance.
4. Locate Pin 12 on G connector. Connect one meter test lead to Pin 12 and the other meter test lead to engine ground. Measure and record resistance.

Results

1. If meter reading is within ± 5 ohms of correct resistance, 128 Ohms is spec go to step 3.
2. If meter did not indicate correct resistance, replace trigger assembly.
3. If within specs set your meter to measure AC voltage with the meter set to Min/Max recording, the fuel system shut off pull the recoil several times and record the AC voltage output on the Min/Max recordings typically 1.2 to 1.4 volts if low check pickup trigger gap, readjust and retest.
4. If all measurements are good go back to the flow chart.

Test Ignition Coil

iX Procedure

1. Open electrical panel to expose control panel wiring.
2. Disconnect J1 connector and ignition coil boot from spark plug.
3. Set DMM to measure resistance.
4. Connect one meter test lead to ground and the other test lead to Pin 1 on the J1 connector. Measure and record resistance.



Figure 1-41. Test Ignition Coil

5. Connect one meter test lead to spark plug wire and the other test lead to engine ground. Measure and record resistance.

Test Point	iX	GPI
Pin 1 to Ground	1.7 Ohms \pm 0.5 Ohms	
Spark Plug to Ground	12.5K Ohms \pm 2K Ohms	
Primary coil		0.8-1.0 Ohms
Secondary coil		5.9-7.1 Ohms

Results

1. Refer to chart. If correct values were measured in Steps 4 and 5, refer to flow chart.
2. If incorrect values were measured in Steps 4 and 5, inspect ignition coil connector for bad connection. If connection is verified good, replace ignition coil.
3. If incorrect value was measured in Step 5, inspect ground connection on Pin 2 of C2 connector going to ignition coil.



Figure 1-42. Measured Values (iX Shown)

iQ2000 Procedure

1. Open electrical panel to expose control panel wiring.
2. Disconnect G connector and ignition coil spark plug boot from spark plug.
3. Set DMM to measure resistance.
4. Connect one meter test lead to ground and the other test lead back probed into Pin 1 on the G connector Measure and record resistance. Meter readings should be INFINITY.
5. Connect one meter test lead to ground and the other test lead back probed into Pin 7. Measure and record resistance. Meter readings should be INFINITY.
6. With one meter lead still on ground measure resistance on the shield (metal cover) at the spark plug boot. CONTNUIITY (low resistance) should be measured.

7. With the meter lead still to ground measure the resistance of the spark plug lead inside the spark plug boot should read INFINITY.
8. Connect one meter test lead back probe to Pin 1 and connect the other lead and back probe to Pin 7 of the G connector Measure and record resistance. Typical reading 1.2 Ohms +/- 0.2 ohms.
9. With one meter lead still connected to Pin 1 take the other lead and connect to spark plug lead inside spark plug boot typically a reading of 17.7k plus or minus 1000 Ohms is typical.
10. If these readings are not correct replace ignition coil assembly.
11. If the readings are correct refer back to the flow chart.

Test Fuel Shutoff Switch

ix Procedure

1. Open up electrical panel to expose control panel wiring.
2. Set fuel shutoff valve to CLOSED.
3. Disconnect J1 connector from LED module.
4. Set DMM to measure resistance.
5. Connect one meter test lead to J1 Pin 6 and the other test lead to ground. Measure and record the resistance.
6. Set fuel shutoff valve to OPEN.
7. Repeat Step 5.

Fuel Shutoff Valve Position	Fuel Shutoff Switch Reading
CLOSED	OPEN (INFINITY)
OPEN	CLOSED (CONTINUITY)

Results

1. If INFINITY was measured when shutoff valve was CLOSED, and CONTINUITY was indicated when valve was OPEN, refer to flow chart.
2. If CONTINUITY to ground was not measured when valve was in the OPEN position, verify mechanical connection between valve and switch. If mechanical connection is good, replace switch.
3. If meter read CONTINUITY when shutoff valve was in either the open or closed position, verify mechanical connection between valve and switch. If mechanical connection is good, replace shutoff switch.

NOTE: A fuel shutoff switch that does not read INFINITY when the fuel shutoff valve is in the closed position will cause a no spark condition.

Procedure

1. Open up electrical panel to expose control panel wiring.
2. Set fuel shutoff valve to STOP position.
3. Disconnect the G connector from LED module.
4. Set DMM to measure resistance.
5. Connect one meter test lead to Pin 9 and the other test lead to ground. Measure and record the resistance.
6. Then set the fuel shutoff valve to RUN and then CHOKE position.
7. Repeat Step 5 for RUN and CHOKE position and record your results. Fuel Shutoff Valve Position Fuel Shutoff Switch Reading RUN and CHOKE position (INFINITY) to ground STOP (CONTINUITY) to ground.

Results

1. If INFINITY was measured when shutoff valve was RUN and CHOKE position, and CONTINUITY was indicated when valve was in the STOP position, refer back to the flow chart.
2. If CONTINUITY to ground was not measured when valve was in the STOP position, verify electrical connections between G connector and switch.

Re-test at the 2 wire connector of the fuel shut off switch pig tail and check for continuity when in the STOP position. If no continuity replace the fuel shutoff switch and re-test.

If CONTINUITY - check black wire from fuel shut off switch to the LED module. If wire is good check the ground connections to the LED module. If these connections are good replace the LED module and retest operation.

Check Choke Assembly

Procedure

1. If generator surges, it may be a carburetion problem. A lean condition can cause erratic RPM. Slowly slide choke to see if surging stops. If it stops, check carburetion.
2. Verify the choke and mechanical connection to carburetor are functioning properly.

Results

1. If choke is functioning correctly, refer to flow chart.
2. If choke is not functioning correctly, replace choke assembly.

Test Stepper Motor

Procedure

1. Disconnect Stepper Motor connector from Inverter module.
2. Set DMM to measure resistance.

NOTE: Connector view is from the harness side on the iQ2000. When testing these connections the backside of this connector is epoxied so use extreme caution when front probing these connections to prevent damaging terminals.

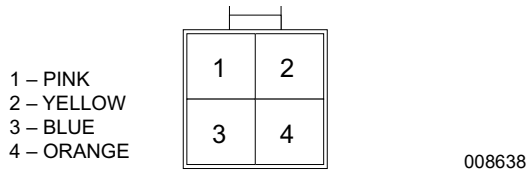

Figure 1-43. C3 Connector Female Side, iX800

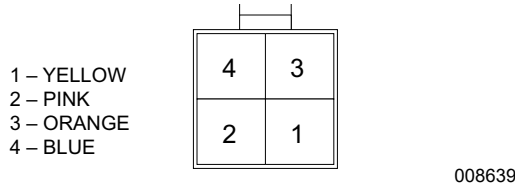

Figure 1-44. F3 Connector Female Side, iQ2000

3. Connect DMM test leads across these test points:
 - a. Pin 1 and Pin 4 – approximately 50 ohms should be measured.
 - b. Pin 1 and Pin 3 – INFINITY should be measured.
 - c. Pin 1 and Pin 2 – INFINITY should be measured.
 - d. Pin 2 and Pin 3 – approximately 50 ohms should be measured.
 - e. Pin 2 and Pin 4 – INFINITY should be measured.
 - f. Pin 3 and Pin 4 – INFINITY should be measured.
 - g. Test all pins to clean ground INFINITY should be measured.

Results

1. If values in steps 3a through 3f are good, refer to flow chart.
2. If any values in steps 3a through 3f tested bad, replace stepper motor.

Procedure

1. Disconnect C3 connector (Stepper motor) from Inverter module.
2. Set DMM to measure resistance.
3. Connect a DMM test leads across these test points:
 - a. Pin 1 to Pin 5 – approximately 195 ohms should be measured.
 - b. Pin 2 to Pin 5 – approximately 195 ohms should be measured.
 - c. Pin 3 to Pin 5 – approximately 195 ohms should be measured.

- d. Pin 4 to Pin 5 – approximately 195 ohms should be measured.

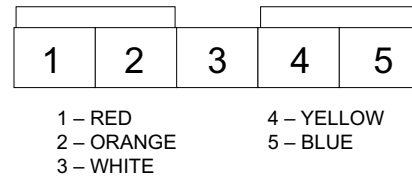

Figure 1-45. C3 Connector Female Side, iX1600, iX2000

Results

1. If values in steps 3a through 3d are good, refer to flow chart.
2. If any values in steps 3a through 3d tested bad, replace stepper motor.

Test Oil Level Switch

Procedure

1. Verify engine is filled with appropriate amount of oil.
2. Locate low oil shutdown wire on engine and isolate from the rest of the harness.
3. Set DMM to measure resistance.
4. Connect one meter lead to wire that running through plastic engine housing to oil level switch. Connect the other test lead to engine frame ground. Measure and record resistance.

Results

1. If oil level was good and meter indicated an open circuit, check for a short to ground on wire between low oil level switch and LED module.
2. If oil level was good and meter indicated a closed circuit to ground, replace engine.

Test Ignition Coil Winding

iX Procedure

1. Remove electrical panel so components are exposed.
2. Disconnect J1 Connector.
3. Set DMM to measure resistance.
4. Connect one meter lead to Pin 5 of the J1 connector and the other meter test lead to ground. Measure and record resistance. Refer to Table 1.

Results

1. Refer to chart. If meter reading is within ± 0.2 ohms, refer to flow chart.

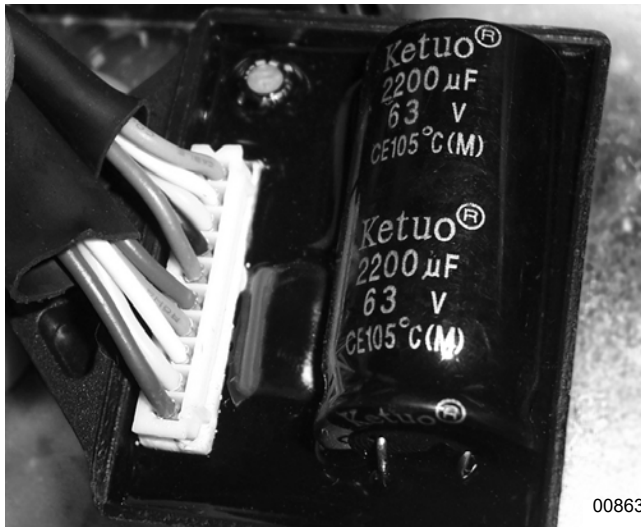

008634

Figure 1-46. J1 Connector on LED Module

iX 800	0.8 Ohms
iX 1600	0.5 Ohms
iX 2000	0.7 Ohms

A Side Position	G Side Position
1 - Yellow	1 - Blue
2 - Grey	2 - Blue
3 - Black	3 - Black
4 - Brown	4 - Black
5 - Violet	5 - Black
6 - Blue	6 - Black
7 - Orange	7 - Green
8 - Pink	8 - Green/Yellow
9 - White	9 - White
10 - Black/Red	10 - Green
11 - Red	11 - Green
12 - Blue/White	12 - Black

iQ2000 Procedure

1. Remove electrical panel to expose components.
2. Disconnect G connector.
3. Set DMM to measure resistance.
4. Connect one meter lead back probed into Pin 2 of the G connector and the other meter test lead back probe into Pin 8.
5. Measure and record resistance. Compare your meter reading to the chart and is within ± 0.2 ohms,
6. With one lead still back probed into Pin 2 connect the other lead to ground. Measure and record resistance.

7. If readings are within specifications refer to back to flow chart. If not replace stator assembly.

Test FlexPower/MODE Switch

Procedure (iX switch)

1. Disconnect orange and brown wires from FlexPower switch (FPS).
2. Set DMM to measure resistance.
3. Set FPS to "ECO" position.
4. Connect one meter test lead to Pin 1 and the other meter test lead to Pin 2. Measure resistance and record results.
5. Set FPS to "HIGH" position.
6. Repeat Step 4. Measure resistance and record results.



- 1 - ORANGE
 - 2 - BROWN
 - 3 - EMPTY
- (iX units ONLY)

- 1 - YELLOW
 - 2 - BLACK
 - 3 - RED
- (iQ units ONLY)

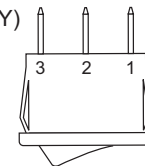

008641

Figure 1-47. FlexPower Switch Test Points

Test Points	ECO	HIGH
Pin 1 to Pin 2	INFINITY	CONTINUITY

Results (iX Switch)

1. If INFINITY was measured in Step 4 and CONTINUITY in Step 5, replace inverter module.
2. If either CONTINUITY was measured in Step 4 or INFINITY in Step 5, replace FPS switch.

Procedure (iQ switch)

1. Disconnect wires from switch.
2. Set DMM to measure resistance.
3. Connect one meter test lead to Pin 2 and the other meter lead to 1 or 3 based on switch position.
4. Set switch to each position and measure resistance.
5. Record results compared to chart below.

TURBO	2 and 3 continuity ONLY
STANDARD	NO continuity on any terminal
ECO	1 and 2 continuity ONLY

- If values are correct check the wires to the inverter board. If the wires and connections are good replace the inverter.

Procedure (GP3000i Economy Switch)

- Disconnect wires from switch.
- Set DMM to measure resistance.
- Set switch to "ON" position.
- Connect one meter test lead to Pin 1 and the other meter test lead to Pin 2. Measure resistance and record results.
- Set switch to "OFF" position.
- Repeat Step 4. Measure resistance and record results.

Test Points	ON	OFF
Pin 1 to Pin 2	CONTINUITY	INFINITY

Results (GP3000i Switch)

- If CONTINUITY was measured in Step 4 and INFINITY in Step 5, replace inverter module.
- If either INFINITY was measured in Step 4 or CONTINUITY in Step 5, replace switch.

Check/Adjust Valves

Discussion

Improperly adjusted valves can cause various engine related problems including, but not limited to, hard starting, rough running and lack of power. The valve adjustment procedure for all units the same process.

Procedure: Intake and Exhaust

Verify the piston is at top dead center (TDC) of its compression stroke (both valves closed).

Check and adjust the valve to rocker arm clearance as follows:

- Remove four (4) screws from rocker cover.
- Remove rocker cover and rocker cover gasket.
- See [Figure 1-48](#). Loosen rocker arm jam nut. Use a proper size socket to turn adjustment screw in to decrease clearance or out to increase clearance. Hold socket steady to tighten lock nut to specification. Check clearance. Make minor adjustments until proper clearance is achieved.

GP3000i/ GP3500io/IQ3500	0.004-0.006 in (0.10-0.15 mm)
iQ and iX	0.004 ± 0.001 in (0.10 ± 0.02 mm)

- When valve clearance is correct, tighten the jam nut to proper specifications. After tightening the

jam nut, check valve clearance to make sure it did not change.



Figure 1-48. Valve Adjustment

- Install rocker cover and inspect/replace rocker cover gasket and four (4) screws. Tighten screws to appropriate specifications.

Fuel Display Inaccurate

iQ2000

Fuel level is displayed by the LED module based on the information sent via the Fuel sending unit.

If the LED display is not accurately displaying fuel level, the problem may be the LED module, wiring, or fuel sending unit.

- Remove the screws holding the front cover in place leaving all connectors connected. Locate the 2 wire connector to the Fuel sending unit and back probe the connector on the LED Module side.
- Set VOM to measure DC volts.
- Start and run the unit in ECO mode and record your reading.

Based on the reading perform the following:

- Reading of 13 VDC or higher replace the Fuel Tank assembly.
- Reading below 13 VDC disconnect 2 wire connector and recheck.
- With 2 wire connector disconnected and a reading of 13 VDC replace fuel tank assembly.
- With 2 wire connector disconnected and a reading of below 13 VDC replace the LED module assembly.

Test Inverter

Check inverter leads, electric parts, connectors, and connecting wires for bulging blisters or visible color change or damage.

Short Circuit Input (Low-voltage)

Neither the red nor the green light are illuminated. No output is produced.

Use the Ohm scale to measure low-voltage connectors. If measured resistance value is zero or INFINITY, replace the inverter.

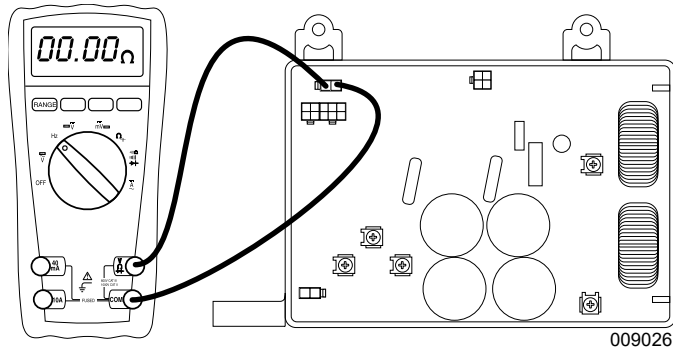

Figure 1-49.

Short Circuit Output

Green light not illuminated, red light remains on all the time. Use the Ohm scale to measure output terminals. If measured resistance value is zero or INFINITY, replace the inverter.

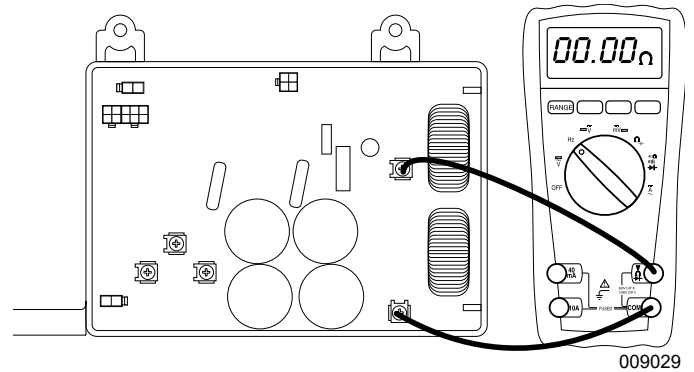

Figure 1-52.

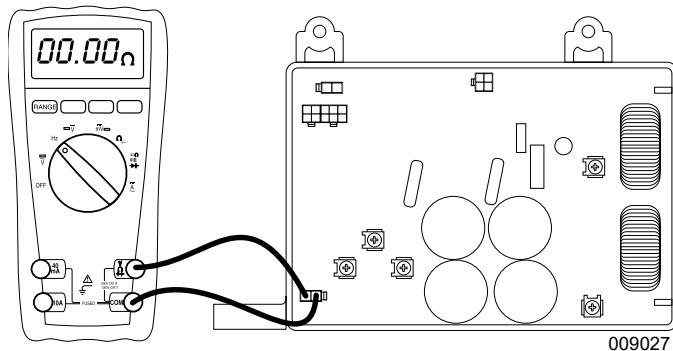

Figure 1-50.

Short Circuit Input (3-phase)

Green light remains on all the time, red light flashes (during loading). Use the Ohm scale to measure 3-phase connectors (measure resistance between each pair). If measured resistance value is zero or INFINITY, replace the inverter.

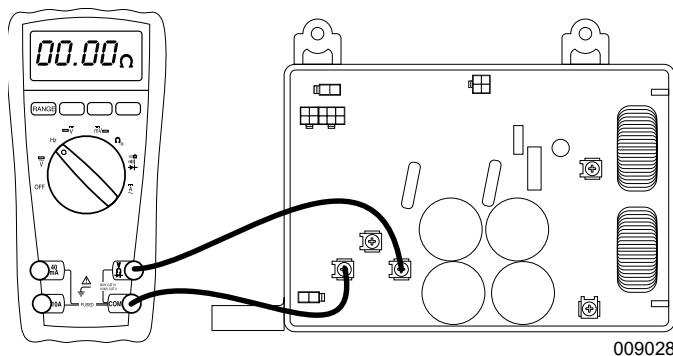

Figure 1-51.

This page intentionally left blank.

Section 3 Disassembly

Discussion

During the process of tearing a unit apart, it's critical to make notes as to the location of parts inside. There is no room for error when putting unit back together. When assembling unit, it's good to be proactive and always thinking about the next step to eliminate back tracking. It is also a good idea to continually check what parts are left for assembly to ensure that no parts are forgotten during the process.

iX Disassembly

Muffler Removal

1. Drain all fuel and oil from unit.
2. Remove four (4) Phillips screws located on black exhaust cover.
3. Remove rubber muffler gasket (note orientation of seal before removing).

Enclosure Removal

1. Remove one (1) flat head screw holding the service access panel.



Figure 1-53. Remove Screw

Service and replace these items:

- Fuel pump
- Stepper motor
- Carburetor
- Air filter



Figure 1-54. Servicable Items

2. Remove retaining clip underneath fuel fill cap cover.



Figure 1-55. Remove Retaining Clip

3. Remove four (4) Phillips screws holding control panel to the housing.



Figure 1-56. Remove Control Panel

4. Disconnect connectors and ground wires. Remove control panel.
5. Remove one (1) Phillips screw to remove fuel shutoff knob.
6. Remove one (1) Phillips screw from recoil access area.
7. Remove three (3) Phillips screws located on handle. (two on iX 800).
8. Carefully orient assembly so the side with access cover is facing down (Figure 38).
9. Remove two (2) Phillips bolts on underside of plastic housing.
10. The side with spark plug access should now be facing up. Remove this half of enclosure.

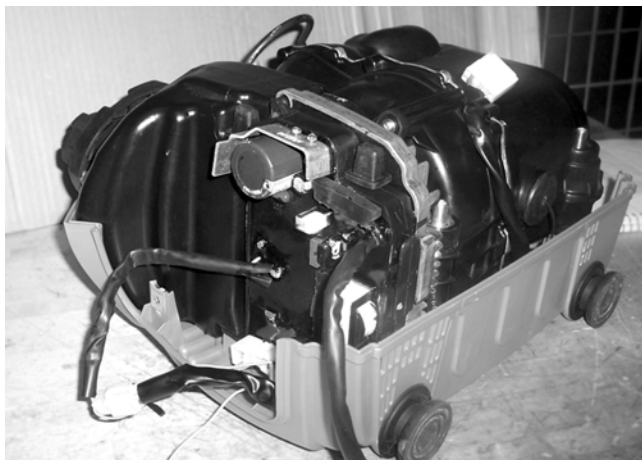

Figure 1-57. Remove Enclosure

11. Disconnect fuel tank by removing the hose clamp and hose from fuel shutoff valve.
12. Remove one (1) Phillips screw from fuel shutoff valve so it is isolated from enclosure.

NOTE: Make note of the orientation of fuel shutoff valve for assembly.

13. On the iX1400, iX1600 and iX2000 disconnect connectors and remove inverter. On the iX800 the inverter is connected to the fuel shutoff switch and can not be removed.
14. Feed recoil cord through lower enclosure piece.
15. Lift engine assembly out and set aside.

Time to reach this point: 15 minutes

Service and replace these items:

- Inverter assembly
- Fuel shutoff valve
- Fuel shutoff switch
- Lower and upper enclosures
- ignition coil
- Recoil assembly

Engine Housing Removal

1. Remove one (1) Phillips screw from fuel pump housing.
2. Remove two (2) 8 mm nuts from carburetor plastic intake assembly and remove fuel pump and carburetor as one assembly. Isolate fuel hose from fuel shutoff valve.

Note: Keep the two spacers with the housing when removed.

3. Remove ten (10) Phillips screws around top and bottom seams of housing. There are two different sizes of screws. Make note of which one is which for assembly.
4. Isolate wiring harness from housing and remove low oil plug. Pull wire through for removal.
5. Separate housings to expose engine.



Figure 1-58. Housing Removed

Time to reach this point: 25 minutes

The following items can now be serviced:

- Engine
- Rotor
- Stator
- Low oil switch
- Fan
- Trigger assembly

The following items can now be replaced:

- Low oil switch
- Trigger assembly

Rotor/Stator Removal

1. Remove 8mm bolt in center of recoil jaw.



Figure 1-59. Recoil Jaw

2. Remove two 8mm bolts from recoil jaw seat.
3. Remove fan.
4. Remove 15mm nut in center of rotor by inserting the socket wrench first, then install a steering wheel puller over the socket wrench (Figure 41). Use an adjustable wrench to counter the torque from the socket to break nut free.



Figure 1-60. Remove 15mm Nut

5. With nut removed, install steering puller with the center bolt tight against the center shaft and remove rotor assembly.

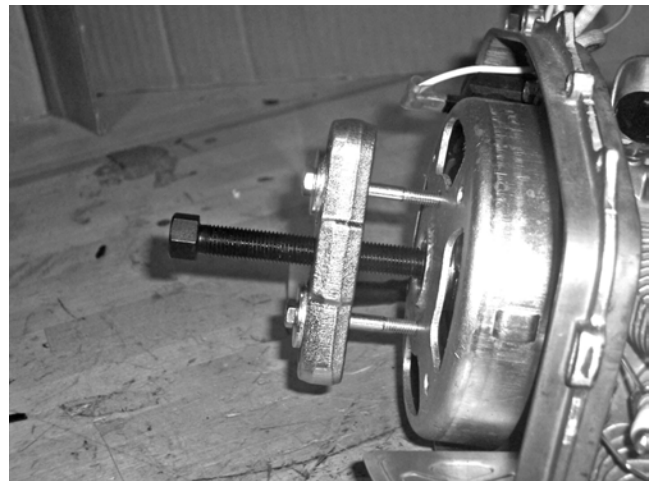

Figure 1-61. Remove iX Rotor Assembly

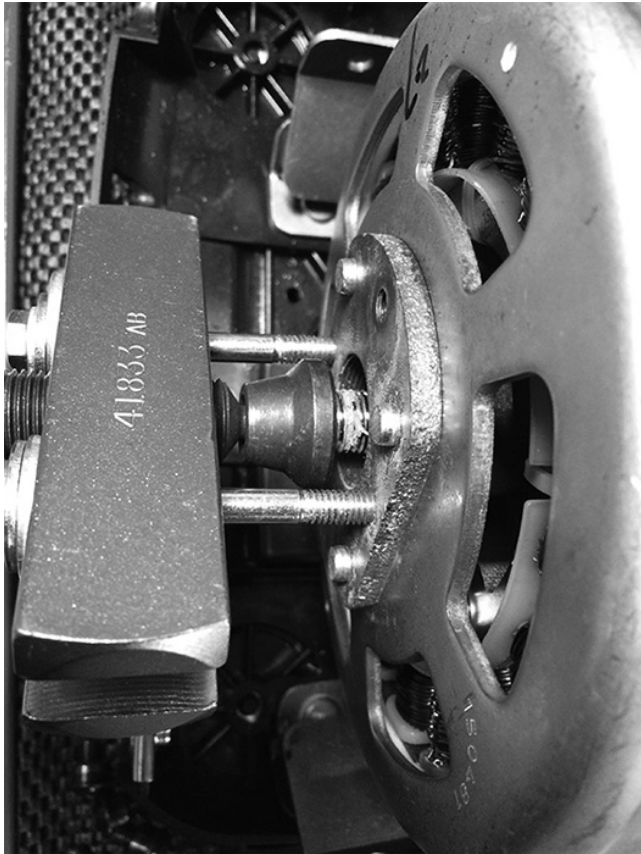

Figure 1-62. Remove iQ Rotor Assembly

6. Remove two (2) 8mm bolts holding stator to engine casting.
7. Remove stator.

Time to reach this point: 45 minutes

The following items can now be replaced:

- Engine
- Stator
- Rotor

Assembly Notes

The above procedure should be reversed to assemble unit.

Order of assembly:

1. Engine
2. Stator
3. Rotor
4. Engine housing
5. Fuel pump
6. Carburetor
7. Place engine housing in lower enclosure

NOTE: Locate all harnesses and fuel lines to ensure they will not be obstructed during assembly process. The stepper motor harness must be able to reach inverter.

8. Fuel Shutoff Switch

NOTE: Test fuel switch for correct orientation before putting halves together.

9. Fuel Tank
10. Inverter
11. Upper Enclosure
12. Retaining Clip below fuel cap
13. Receptacle panel

iQ Disassembly

Enclosure removal and assembly.

1. Remove the four (4) screws on the front and back panels of unit.

When removing the front panel, carefully tilt cover away from unit to note the routing of the harnesses. They run along the outside of the inverter air duct on both sides. Disconnect electrical connectors, fuel level sensor, outlet connections, and panel connector. Set panel aside.



Figure 1-63. Front Cover



Figure 1-64. Back Cover

- Remove the screw on, and behind, the PowerDial. Remove screws from guide plate for recoil handle.

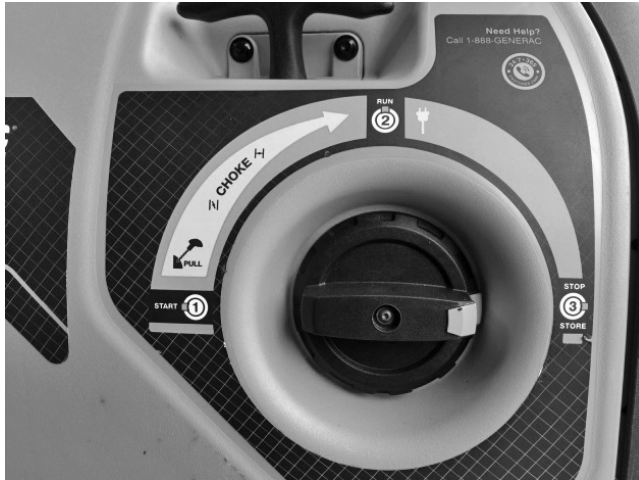

Figure 1-65. Remove Screw from PowerDial

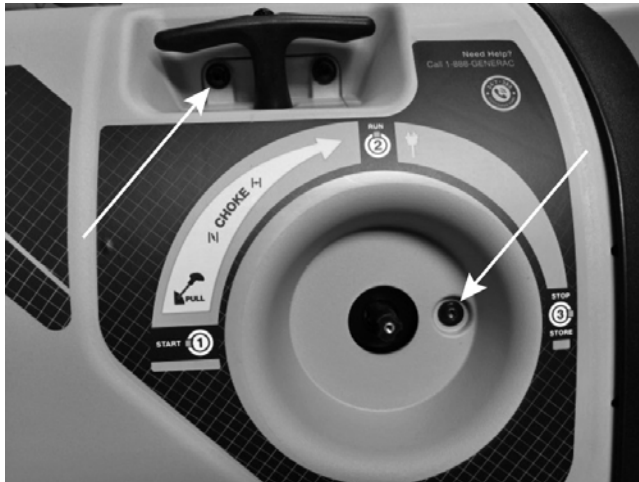

Figure 1-66. Remove Screw from PowerDial and Recoil Handle

- Remove service access panel and all allen head screws which hold the side panels and base frame together. Be aware of the two rubber isolators supporting the fuel tank as you separate the side panels.

Testing with Enclosure OFF

With enclosure panels off, front panel harnesses connected, and PowerDial attached, carefully pull start unit to verify operation to check for leaks etc. With testing complete, install sides of enclosure and test unit for full operation.

Assembly Of Enclosure

When installing enclosure panels, make sure the support grommets on both sides of the fuel tank are in place.

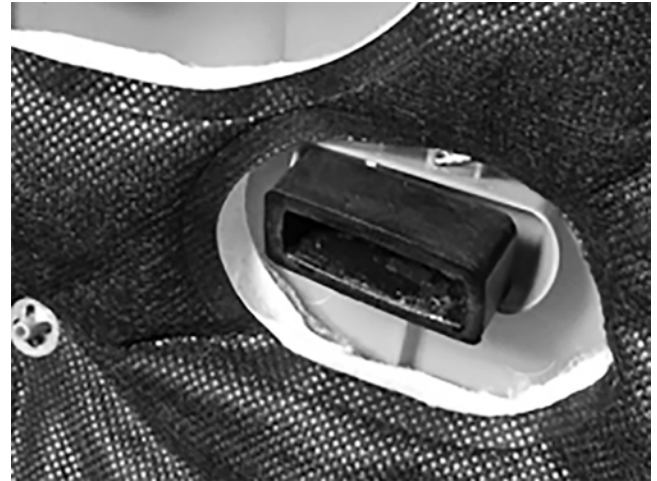

Figure 1-67. Fuel Tank Isolator Grommets



Figure 1-68. Fuel Tank Isolator Tab

Fuel Tank Isolator Grommets

- Assemble halves and be sure of proper alignment of side panels and fuel tank support tabs.

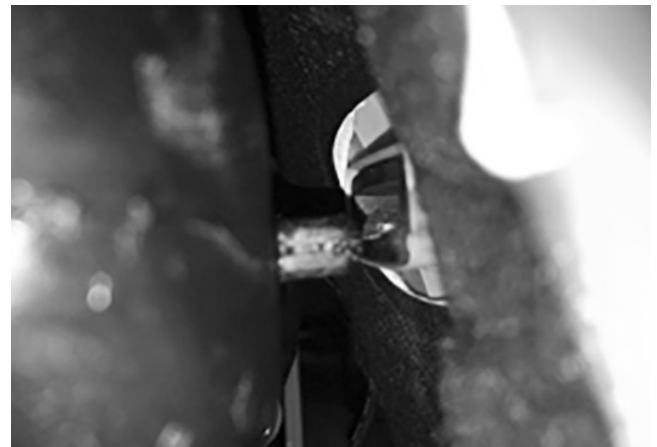

Figure 1-69. Fuel Tank Support Grommet Alignment

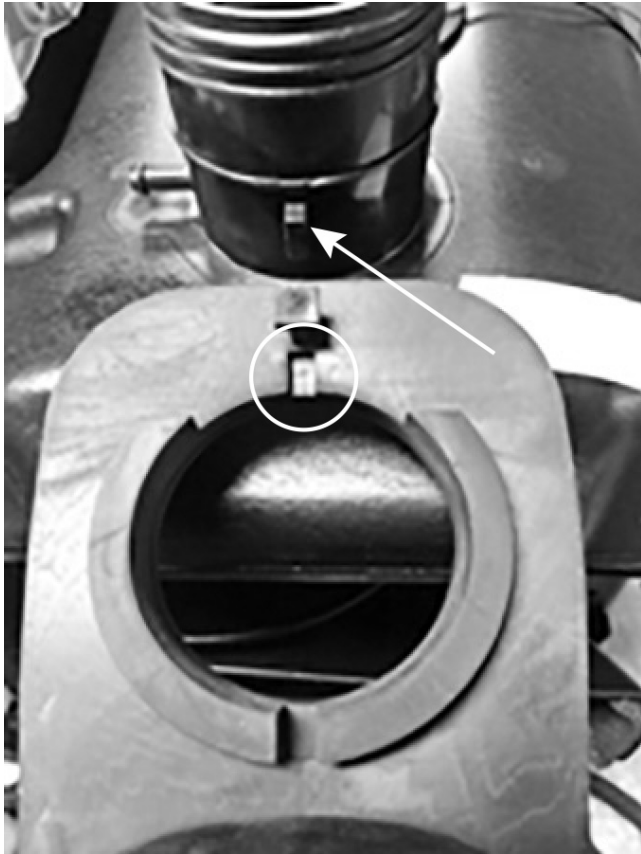

Figure 1-70. Fuel Neck Grommet

Be sure the rubber seal around fuel tank filler neck is aligned with enclosure sides.

NOTE: Graphic shows grommet removed for better view of tab.

2. Install back panel.
3. Connect all connectors on front panel.

NOTE: Note routing of harnesses as in disassembly and fasten panel into place.

4. Check/fill to proper oil and fuel level. Test unit for operation.

Disassembly Of Unit After Enclosure Removal

The following items are now accessible for servicing:

- Fuel tank
- Fuel sending unit
- Inverter
- Fuel pump
- Fuel filter
- Fuel lines
- Stepper motor/carburetor
- Air filter housing
- Muffler
- Rotary control

- Recoil
- Rotor
- Stator
- Ignition magneto
- Trigger unit
- Powerhead assembly

Fuel Tank Assembly (After Enclosure Removal)

1. Carefully lift fuel tank from mount and disconnect fuel line. Set tank aside.
2. Install in reverse order.

NOTE: Note routing and seating of fuel tank. Choke cable cannot be between tank and support bracket.

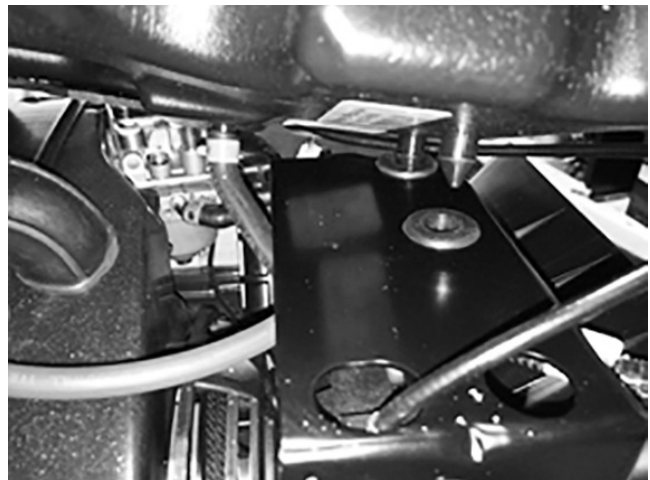

Figure 1-71. Fuel Pin to Grommets

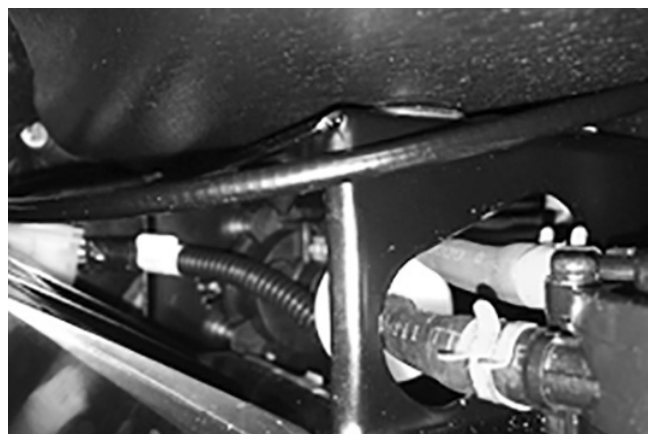

Figure 1-72. Routing of Choke Cable

Inverter Removal And Install (Enclosure Removed)

NOTE: Access and testing of the Inverter can also be done with just the front cover off.

1. Remove two mounting nuts from air inlet duct. Remove duct, slide inverter off studs, and disconnect harness connectors.

With the inverter removed, the fuel filter, rotary control, fuel pump, and recoil can be serviced.

2. Install in reverse order and be sure connectors are plugged in securely.



Figure 1-73. Inverter Inlet Duct

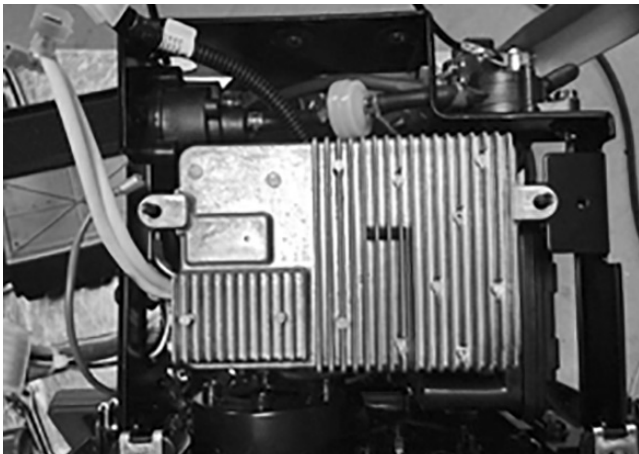

Figure 1-74. Inverter

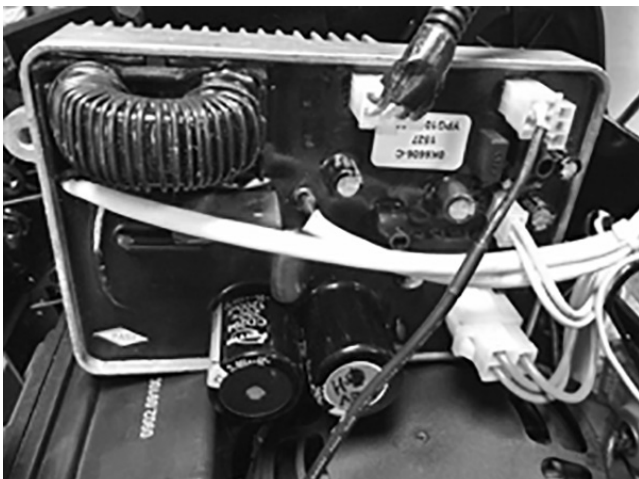

Figure 1-75. Connection Side of Inverter

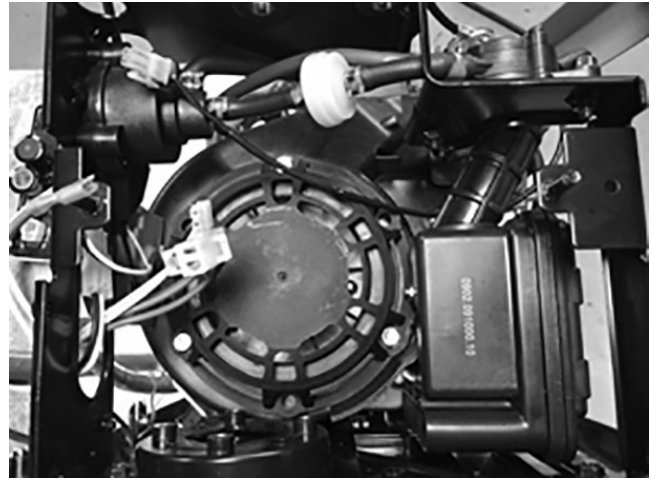

Figure 1-76. Inverter Removed

Access to Carburetor (with the enclosure off, fuel tank out, and inverter out)

1. Remove air filter cover and filter for access to filter housing mounting bolts.
2. Remove the two nuts for inlet duct to carburetor and the vent tube. Remove air cleaner housing as an assembly.

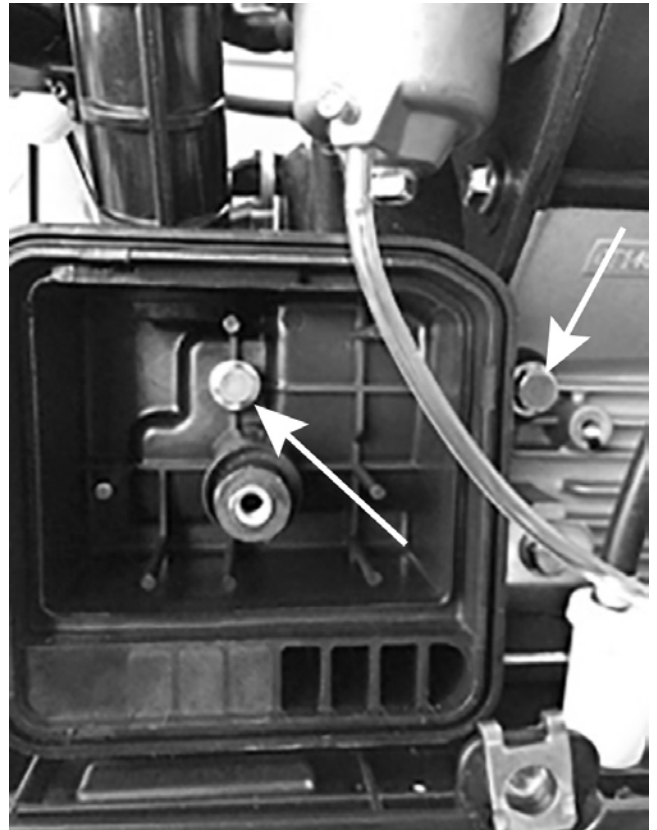

Figure 1-77. Air Filter Housing

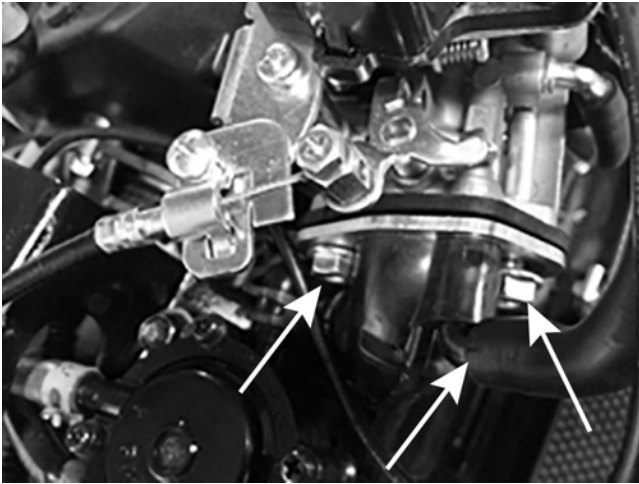

Figure 1-78. Carburetor Inlet Duct

3. Disconnect choke cable and stepper motor connector from Inverter.
4. Disconnect black vent tube from carburetor.

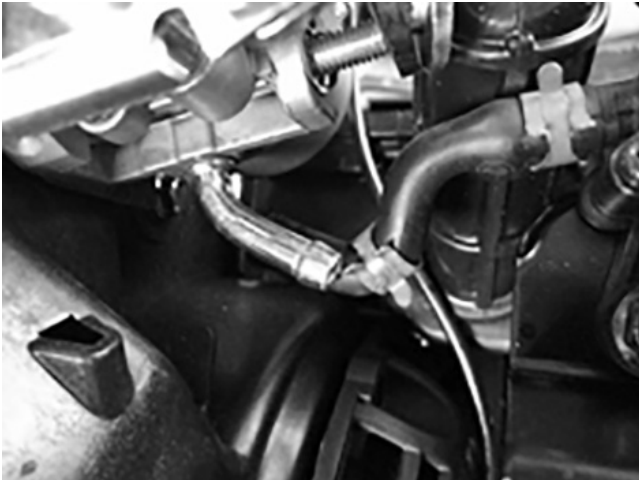

Figure 1-79. Disconnect Fuel Inlet Line

5. Disconnect fuel line at carburetor fuel inlet.
6. Remove fuel tank support bracket mounting bolts on right side. Only loosen left side.

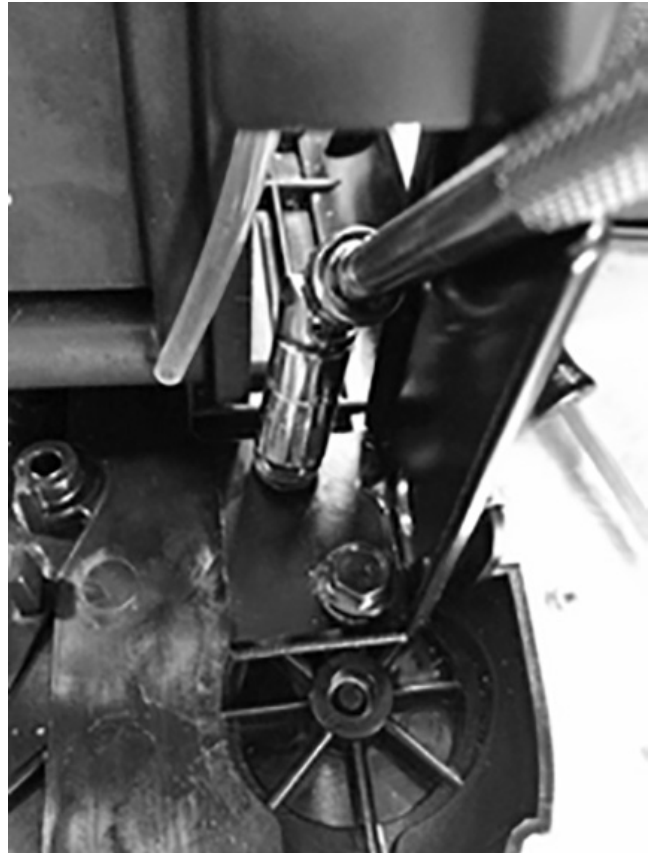

Figure 1-80. Right Side Support Bracket



Figure 1-81. Left Side Support Bracket

7. Move fuel tank support bracket enough to slide carburetor assembly off the studs.
8. Assemble in reverse order, use new gaskets.

Access to Trigger Pickup, Alternator Fan, Rotor, Stator Assembly (enclosure assembly removed)

1. Remove fasteners attaching muffler housing to back support and remove. Be aware of seal grommet on bottom right.

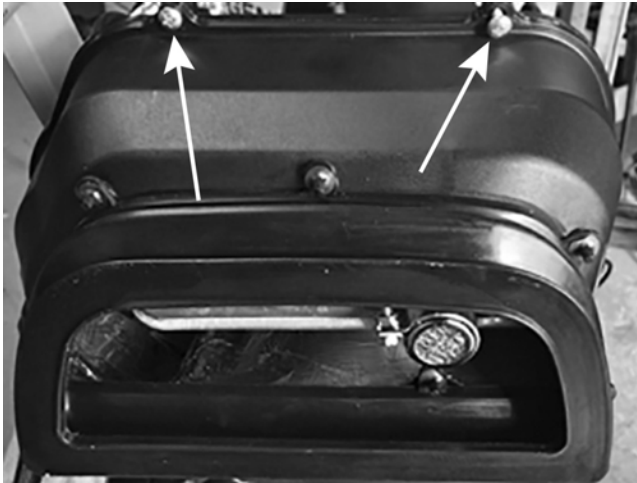

Figure 1-82. Muffler Cover



Figure 1-83. Grommet On Cover

2. Remove two nuts attaching the muffler to cylinder head, and one cap screw on bottom right. Remove muffler and set aside.



Figure 1-84. Muffler to Cylinder Head

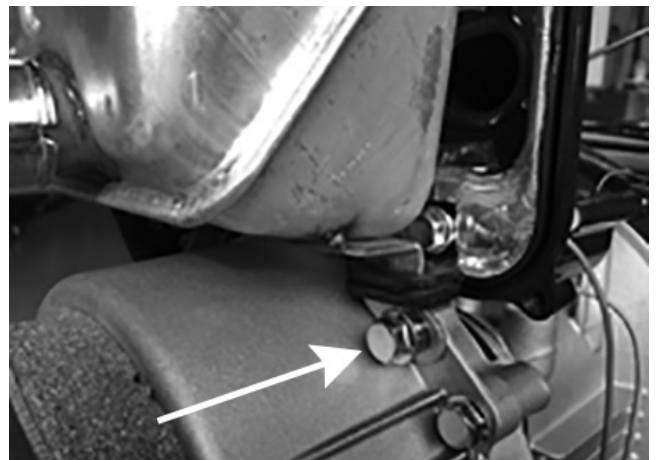

Figure 1-85. Lower Support Bracket

3. Remove fasteners from alternator cover. Make note of wires attached and routing for assembly. Remove cap screws on sides of alternator cover to support mounts. Remove alternator cover.



Figure 1-86. Alternator Cover

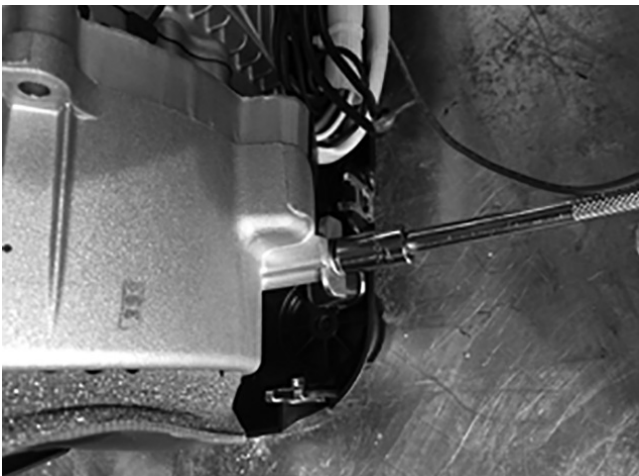

Figure 1-87. Isolator Mounting Bolt

Lift engine assembly slightly to slide alternator cover off unit. Be aware of seal grommet located by the trigger pickup and be sure to reinstall when reassembling. Removing the cover allows access to the trigger pickup, rotor, and stator components.



Figure 1-88. Alternator Cover

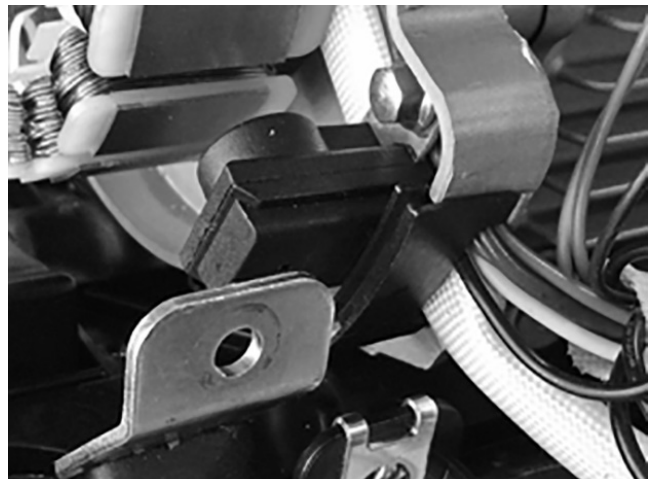

Figure 1-89. Trigger Pickup and Seal

Trigger pickup

With alternator cover removed, replacement and adjustment of trigger pickup is possible. Two fasteners hold the pickup in place.

1. Make sure routing of wires is correct and not pinched when installing or replacing the pickup. The holes in pickup bracket are oval for adjustment purposes. With rotor in place, set gap to 0.20-0.30mm.
2. Align trigger point on rotor outside surface in-line with sensor and check/adjust gap using a non-metallic feeler gauge.
3. Tighten mounting screws to specification and check gap. Adjust if necessary.



Figure 1-90. Rotor View



Figure 1-92. Adjustment Mounting Screws



Figure 1-91. Trigger Pickup Gap

Fan, Rotor, Stator Assembly (with alternator cover removed)

The two screws on the fan have thread locking compound.

1. Use a socket and ratchet to hold main shaft in place while breaking loose two fan cap screws with another ratchet and socket.

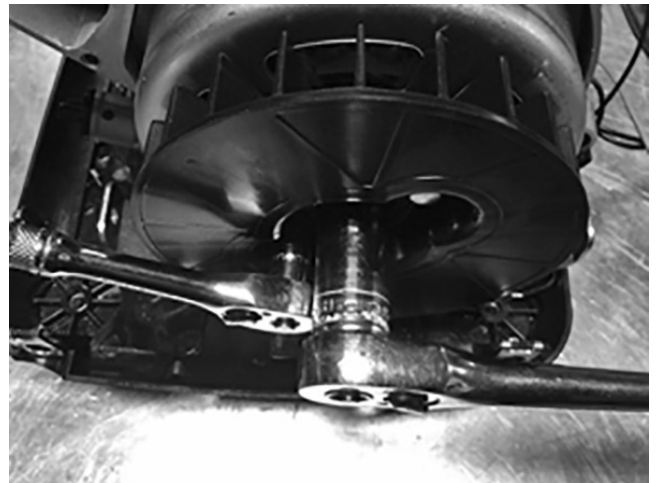

Figure 1-93. Alternator Fan



Figure 1-94. Rotor View

- Remove the rotor nut using the setup shown to break the rotor nut loose. Do not remove this nut using an impact which can cause issues with the magnets. The nut has thread locking compound and will be challenging to remove.



Figure 1-95. Breaking Nut Loose

- Use a suitable puller to separate the rotor. Use the puller as a handle to help pull the rotor off the unit.

NOTE: The magnets are strong and will make it difficult to remove rotor completely from the taper. DO NOT get fingers pinched between the edge of the rotor and back housing.

- Reverse sequence for assembly.



Figure 1-96. Remove Rotor with Puller

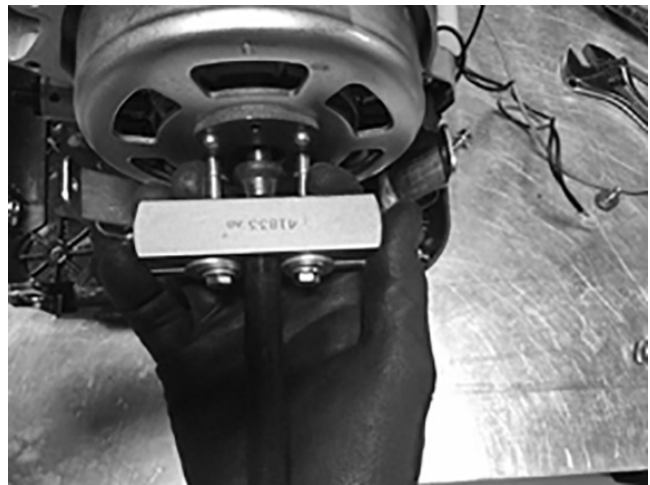

Figure 1-97. Use Puller as Handle

- Remove two screws (with thread locking compound) from stator winding.
- Slide stator off center hub.
- Install in reverse order and to proper torque.

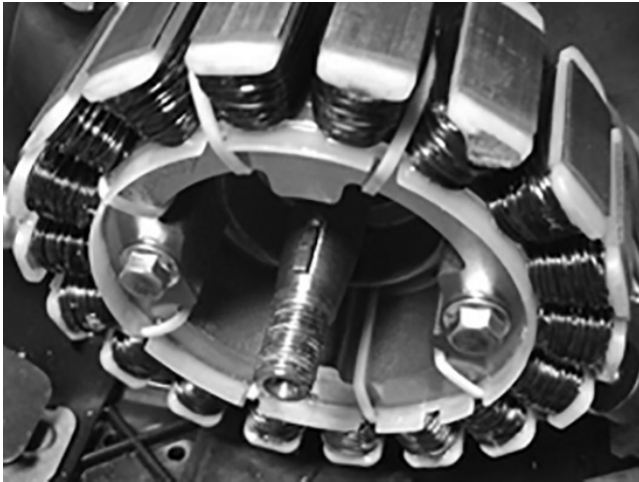

Figure 1-98. Remove Stator Assembly



Figure 1-99. Remove Stator Assembly



Figure 1-100. Remove Stator Assembly

8. Install rotor and be sure of proper alignment of the key-way.

NOTE: Note: The magnets are strong. DO NOT get fingers pinched between the edge of the rotor and back housing.

9. Attach puller to use as a handle to for proper assembly and alignment of the rotor to shaft.
10. Apply thread locking compound to crankshaft threads. Install nut and torque rotor nut to specifications.
11. Check trigger pickup gap for proper gap.
12. Assemble unit in reverse order and place thread locking compound on the rotor fan cap screws.
13. When torquing the rotor nut to specifications, use the puller to hold the rotor as when used to break the rotor nut loose.

Fuel Filter and/or Pump Removal

With enclosure and air duct removed, access fuel filter and fuel pump.

NOTE: Fuel filter can be serviced with the enclosure still on via removing the front panel and Inverter.

Assemble connection lines to proper location. Perform "Test with Enclosure OFF" to verify operation and no leaks.



Figure 1-101. Fuel Pump

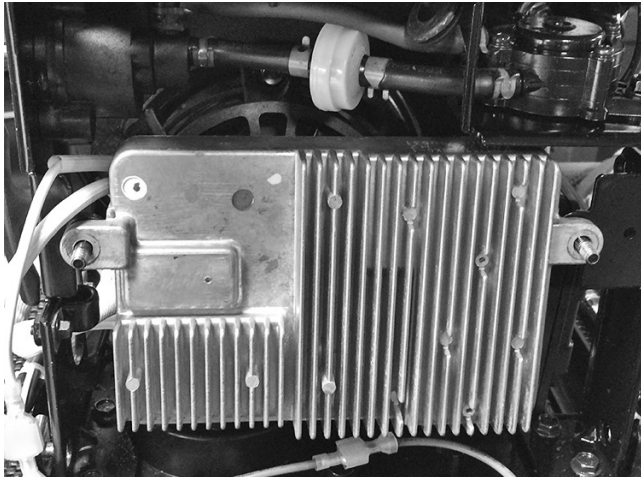

Figure 1-102. Inverter

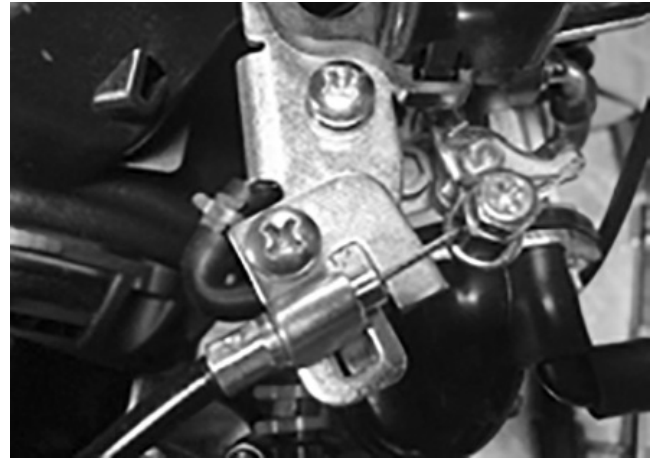

Figure 1-104. Choke Cable Mount

Rotary control assembly (fuel shutoff, Ignition stop switch, Choke control)

1. To service the rotary control, remove mounting screws holding the control to the support bracket.
2. Disconnect the 2-wire connector, choke cable from carburetor mount, and lever. Note routing of choke cable when removing for proper assembly.
3. Disconnect fuel line.
4. Assemble in reverse order.
5. When connecting the choke cable to the carburetor, place choke in choked position (to left).
6. Turn rotary knob to choke position.
7. Route cable through cable clamp.
8. Seat cable end in mount. Hold choke lever to the left and pull cable taut through clamp and tighten.
9. Test choke to be sure of proper opening and closing. Adjust if necessary.

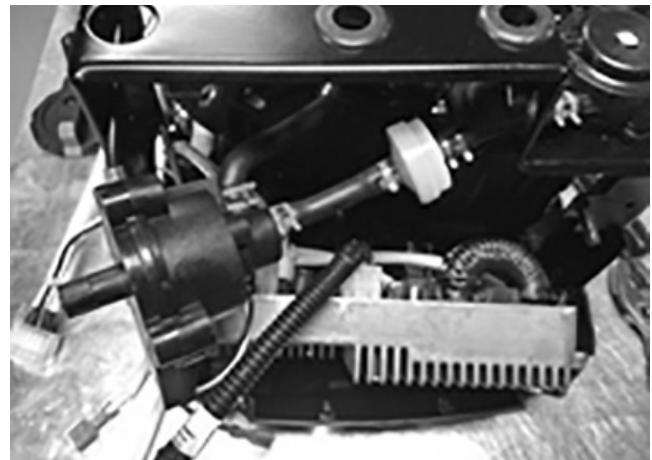

Figure 1-105. Powerdial Control and Fuel Filter

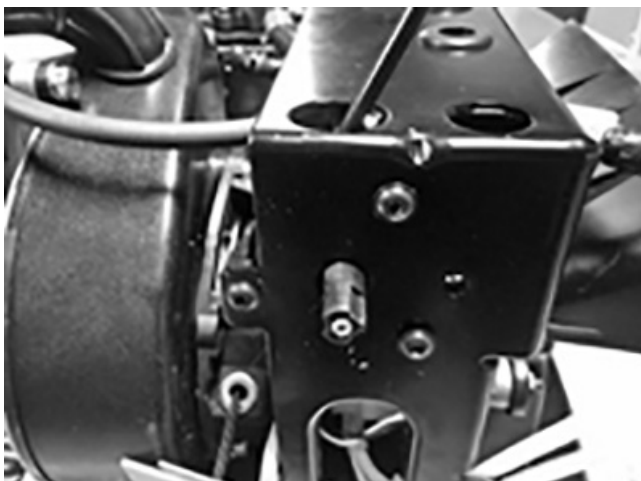

Figure 1-103. Powerdial Control Mount Screws



Figure 1-106. Fuel Tank Support Grommet Alignment

Powerhead

1. With fuel tank removed, harnesses, choke cable, fuel line and vent lines at carburetor disconnected, disconnect the green ground wire from Alternator cover bolt.
2. Remove four support mount cap screws (2 per side) and lift powerhead assembly from base.
3. Assemble in reverse order.

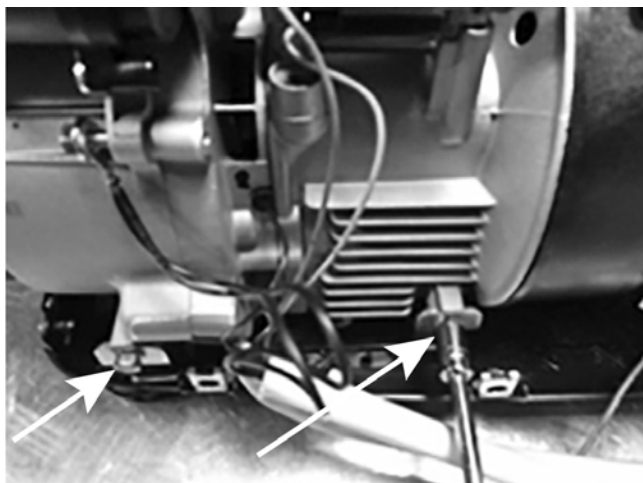

Figure 1-107. Isolator Mount Screws

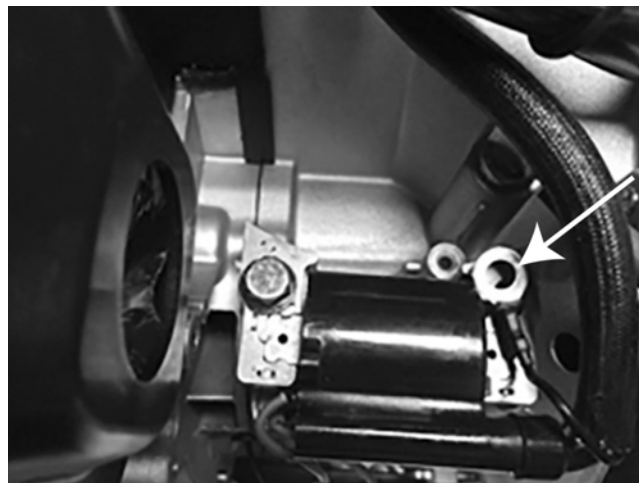

Figure 1-110. Shield Ground

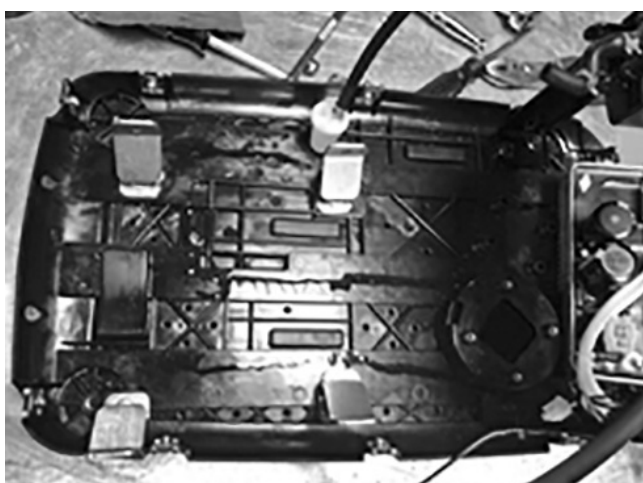

Figure 1-108. Base of Unit

Ignition Coil

1. With enclosure removed, remove blower duct from muffler housing.
2. Remove two cap screws holding coil in place. Be aware of spark plug wire routing.
3. Install in reverse order and be sure the blower duct is properly seated in the muffler housing.



Figure 1-109. Magneto

iQ2000 Torque specifications

Item	Bolt Dimension	Torque	
Feet to Base	Screw HHFCS M6-1.0 X 10 G8.8	5 ft-lb	6.7 Nm
Iso Mount to Base	Nut Hex FL Whiz M6-1.0 BLK	5 ft-lb	6.7 Nm
Iso Mount to Power Head	Screw HHFC M6-1X12 8.8 W/Patch	5 ft-lb	6.7 Nm
Bracket to Base	SCREW HHFCS M6-1.0 X 10 G8.8	5 ft-lb	6.7 Nm
Power Dial to Bracket	Screw BFHSC M5-0.8 X 16 BLK ZP	20 in-lb	2.2 Nm
Pump to Bracket	Screw HHFCS M6-1.0 X 20 G8.8	5 ft-lb	6.7 Nm
Ground Lugs to Base	Extrdtite M5 X 10 LG	6.5 ft-lb	8.8 Nm
Fuel Fitting to Base	Screw SHC M4-0.7 X 10 G10.9	2.5 ft-lb	3.3 Nm
Inverter Module to Bracket	Nut Hex FL Whiz M6-1.0 BLK	3 ft-lb	4 Nm
Enclosure M5's	Screw BFHSC M5-0.8 X 12 BLK ZP	2.5 ft-lb	3.3 Nm
Enclosure M6's	Screw SHC M6-1.0 X 10 G10.9	2.5 ft-lb	3.3 Nm
Carb Drain	Screw SHC M4-1.0 X 10 G10.9	1.0 ft-lb	1.3 Nm
On-Off Selector to Power Dial	Screw BFHSC M3-0.5 X 16 BLK ZP	6 in-lb	0.67 Nm

GP3000i Torque specifications

Item	Bolt Dimension	Torque	
Connecting rod	Bolt M6 X 1	8.8-10.3 ft-lb	12-14 Nm
Cylinder head	Bolt M8 X 1.25	23.6-25.8 ft-lb	32-35 Nm
Flywheel mounting	Nut M14 X 1.5	59-66.3 ft-lb	80-90 Nm
Crankcase cover	Bolt M8 X 1.25	19.9-22.1 ft-lb	27-30 Nm
Air cleaner mounting	Nut M6 X 1	5.9- 8.8 ft-lb	8-12 Nm
Valve	Nut M5 X 0.5	3.6-5.9 ft-lb	5-8 Nm
Muffler mounting	Nut M8 X 1.25	14.7-20.6ft-lb	20-28 Nm
Muffler mounting	Bolt M8 X 1.25	14.7-20.6 ft-lb	20-28 Nm
Breather chamber	Cap bolt M5 X 0.75	3.6-5.9 ft-lb	5-8 Nm
Starter motor fastening	Bolt M6 X 1.25	5.9- 8.8 ft-lb	8-12 Nm
Spark plug		18.4-22.1 ft-lb	25-30 Nm

Standard Fastener Torque Specification

Component	Torque	
5mm bolt, nut	2.9-5.1 ft-lb	4-7 Nm
6mm bolt, nut	5.9- 8.8 ft-lb	8-12 Nm
8mm bolt, nut	14.7-20.6 ft-lb	20-28 Nm
10mm bolt, nut	25.8-29.5 ft-lb	35-40 Nm
12mm bolt, nut	36.8-44.2 ft-lb	50-60 Nm

GP3500io/IQ3500 Torque specifications

Item	Bolt Dimension	Torque	
		ft-lb	Nm
Connecting rod bolt	M7×1	8.8-10.3	12-14
Cylinder head bolt	M8×1.25	23.6-25.8	32-35
Flywheel mounting bolt	M8×1.5	22.1-26.5	30-36
Crankcase cover bolt	M8×1.25	19.1-23.6	26-32
Oil drain bolt (in crankcase)	M10×1.25	14.7-18.4	20-25
Air cleaner mounting nut	M6×1	5.9- 8.8	8-12
Pivot adjusting nut	M9	2.9-5.9	4-8
Muffler mounting nut	M8×1.25	19.9-22.1	27-30
Governor arm nut	M6×1.0	6.6-9.5	9-13
Starter motor fastening bolt	M6×1.25	5.9- 8.8	8-12
Spark plug		19.9-22.1	27-30

Standard Fastener Torque Specification

Component	Torque	
	ft-lb	Nm
5mm bolt, nut	2.9-5.1	4-7
6mm bolt, nut	5.9- 8.8	8-12
8mm bolt, nut	14.7-20.6	20-28
10mm bolt, nut	25.8-29.5	35-40
12mm bolt, nut	36.8-44.2	50-60

79.8cc Inverter Engine Torque Specifications

Component	Torque	
	ft-lb	Nm
Connecting Rod	2-2.2	9-10
Crankcase Cover	2-2.5	9-11
Spark Plug	4-4.9	18-22
Cylinder	2.7-3.1	12-14
Valve Lock Nut	1.1-1.8	5-8
Valve Cover	2.2-2.7	10-12
Cooling Fan	1.1-1.3	5-6
Crankshaft Nut	7.9-10.1	35-45
Fan Cover	1.3-1.8	6-8
Recoil	0.9-1.1	4-5
Ignition Coil	2.2-2.7	10-12
Stator	2-2.5	9-11
Alternator Cover	1.8-2.2	8-10
Muffler Cover - back	1.8-2.7	8-12
Muffler	2.2-2.7	10-12

NOTE: Go to www.generac.com (<http://www.generac.com/service-support/product-support-lookup>) for the most current diagrams. Use model and/or serial number.

Exploded View – iX800

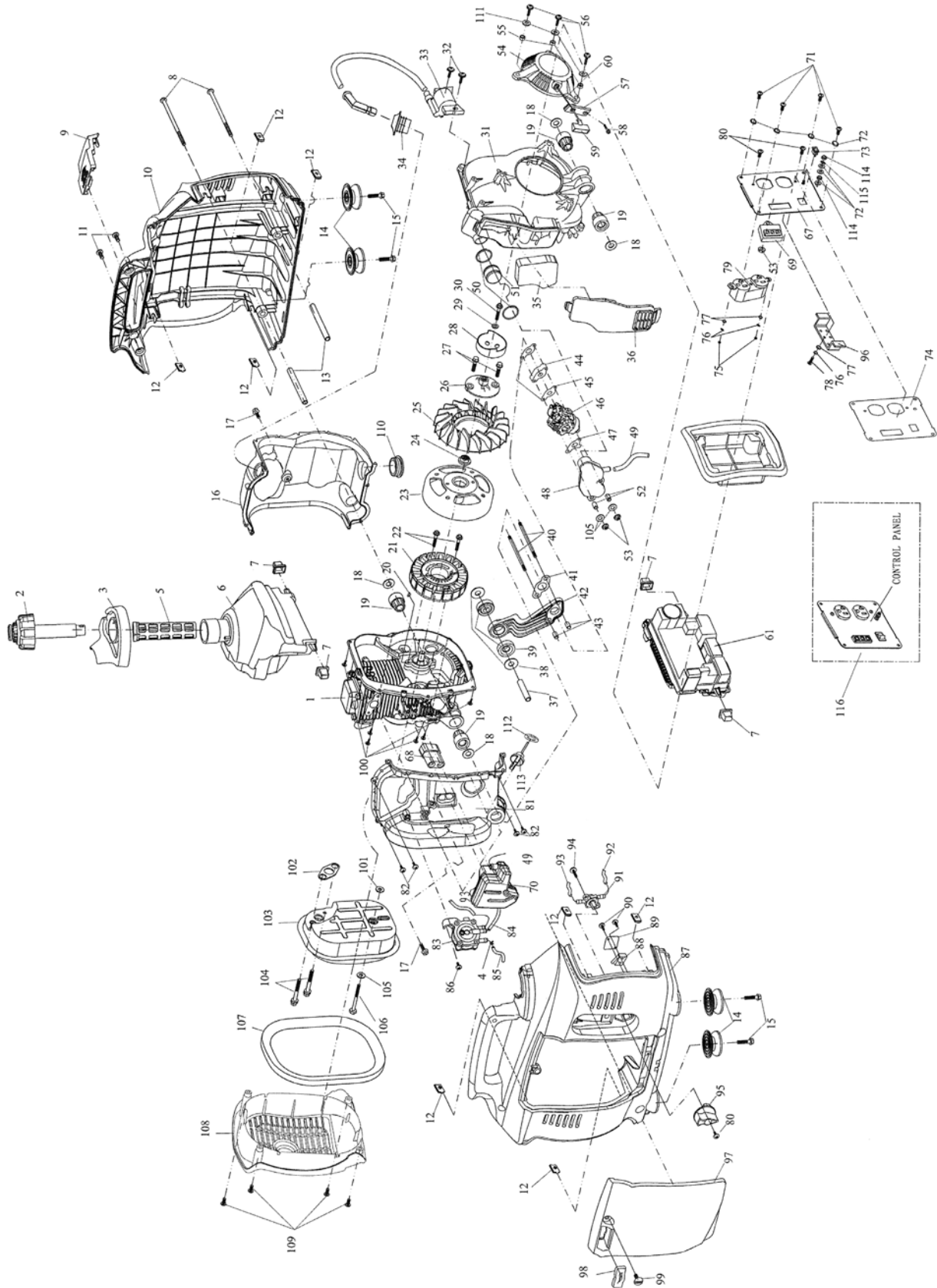

ITEM	QTY.	DESCRIPTION
1	1	Engine Assy.
2	1	Supercharged Cap Assy, Fuel Tank
3	1	Fuel Filler Inlet Rubber Ring
4	8	Clamp, Fuel Hose
5	1	Cup, Fuel Filter
6	1	Tank, Fuel
7	4	Shock Absorber Block
8	2	Screw, Cross Recessed Pan Head, M6x120
9	1	Cover, Upper Shell
10	1	Shell, Upper
11	2	Screw, Cross Recessed Pan Head, M6x14
12	8	Lock Slice/screw Clip
13	2	Alignment Pin
14	4	Feet, Vibration Mounts
15	4	Bolt, Hex, Flange Face (M6x12)
16	1	Lower Casing, Engine
17	2	Bolt, Hex, Flange Face (M5x16)
18	4	Washer
19	4	Sleeve, Damping/vibration Mounts
20	1	Key, Woodruff--3x5x13
21	1	Stator Assy.
22	2	Bolt, Hex, Flange Face (M5x25)
23	1	Flywheel Rotor Assy.
24	1	Nut, Hex Flange Face(M10x1.25-8)
25	1	Fan
26	1	Seat, Starting Jaw
27	2	Bolt, Hex , Flange Face(M6x14)
28	1	Jaw, Starting
29	1	Washer (6)
30	1	Bolt, Hex, Flange Face(M6x18)
31	1	Cowling & Inlet Cover Assy.
32	2	Screw, Cross Recessed Pan Head Tapping
33	1	Coil, Ignition
34	1	Sleeve, Rubber (High Voltage)
35	2	Sponge, Air Filter
36	1	Cover, Air Filter
37	1	Alignment Pin

ITEM	QTY.	DESCRIPTION
38	2	Washer
39	2	Damping Ring, Pothook
40	2	Stud Bolt
41	1	Gasket, Pothook
42	1	Pothook
43	2	Pin, Hollow Fixed Position
44	1	Block, Carburetor Cushion
45	2	Seal Gasket, Carburetor (In)
46	1	Carburetor Regulating Assy.
47	1	Seal Gasket, Carburetor (In)
48	1	Filter Adapter Box (Breather)
49	1	Tube, Breather
50	2	Circlip, Adapter
51	1	Sleeve, Filter Adapter
52	2	Alignment Pin, Adapter Box
53	3	Nut, Hex Flange Face
54	1	Starter Assy.
55	3	Safeguard Tube
56	3	Rec. Pan Head Screw/washer Assy.(M5x12)
57	1	Handle Panel
58	1	Recessed Head Bolt & Washer Assy.
59	1ea	Handle, Recoil Assy
59a	1ea	Starter Handle Hood
60	1	Cord, Recoil Assy
61	1	Inverter
66	1	Frame, Front Panel
67	1	Panel, Ic
68	1	Adapter Sleeve, Respirator
69	1	Igniter (With Indicator)
70	1	Backoil Assy. Respirator
71	4	Screw, Cross Recessed Pan Head (M5x12)
72	7	Washer, Flat(5)
73	1	Switch, Flexpower
74	1	Ic Screen
75	2	Nut, I Type Hex.(M4)
76	8	Washer, Flat, M4
77	8	Washer, Lock, M4

NOTE: Go to www.generac.com (<http://www.generac.com/service-support/product-support-lookup>) for the most current diagrams. Use model and/or serial number.

Exploded View – iX800 (Continued)

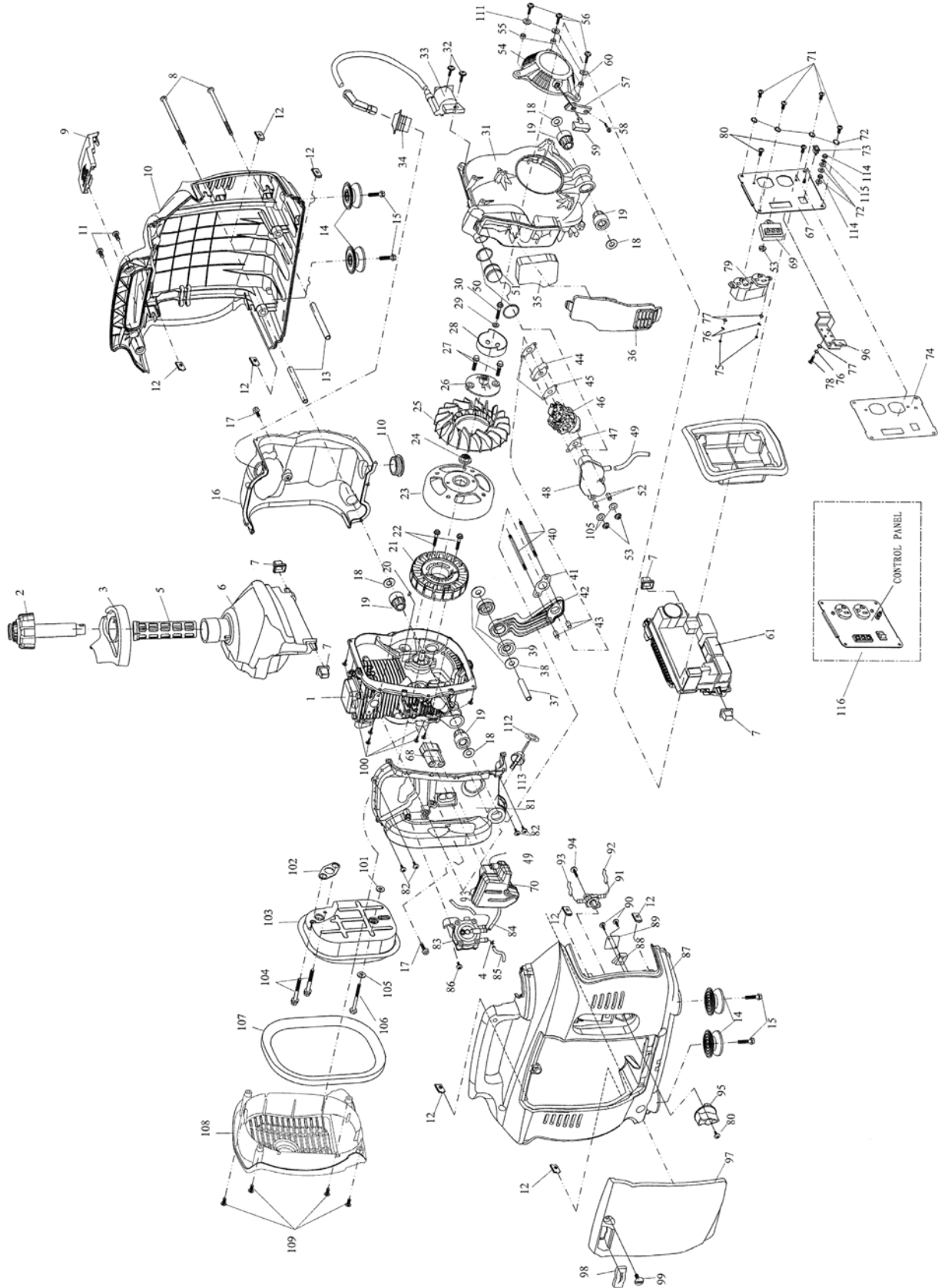

ITEM	QTY.	DESCRIPTION
77	8	Washer, Lock, M4
78	6	Screw, Crossed Recessed Pan Head
79	1	Outlet Assy 120v
80	3	Screw, M4x12
81	1	Casing, Engine Upper
82	4	Screw, Tapping, Cross, Recsd, P/ head(St4.2x13)
83	1	Pump Assy. Fuel
84	1	Gaspipeline, Fuel Pump
85	1	Outlet Pipe, Fuel Pump
86	1	Screw, Phillips, St4.8x19
87	1	Shell, Lower
88	1	Switch, Ignition On/off
89	1	Cover, Switch
90	2	Screw, Tap/crs/recsd(St4.8x19)
91	1	Switch/valve. Fuel
92	1	Pipe, Outlet
93	1	Pipe, Inlet, Fuel Pump
94	1	Screw, Tap,crs,recd(St6.3x16)
95	1	Knob, On/off Fuel Switch
96	1	Connection-peg, Grounded
97	1	Cover, Lower Shell

ITEM	QTY.	DESCRIPTION
98	1	Seal, Lower Shell Cover
99	1	Screw(M6x14)
100	6	Screw, Tap/crs/rec/(St4.2x16)
101	1	Washer, Flat
102	1	Shim, Muffler
103	1	Muffler Assy.
104	2	Bolt, Hex, Flange Face(M6x50)
105	3	Washer, Flat
106	1	Bolt, Hex (M5x70)
107	1	Gasket, Rubber, Back Window
108	1	Window, Back
109	4	Screw, Ph Recessed M5x20
110	1	Seal Cover, Oil Sensor
111	3	Gasket, Shaft
112	1	O-ring
113	1	Dipstick/cover, Oil
114	2	Nut, Hexagonal
115	1	Spring Washer, Standard Type
116	1	Panel Assy., Control

NOTE: Go to www.generac.com (<http://www.generac.com/service-support/product-support-lookup>) for the most current diagrams. Use model and/or serial number.

Exploded View – iX1600

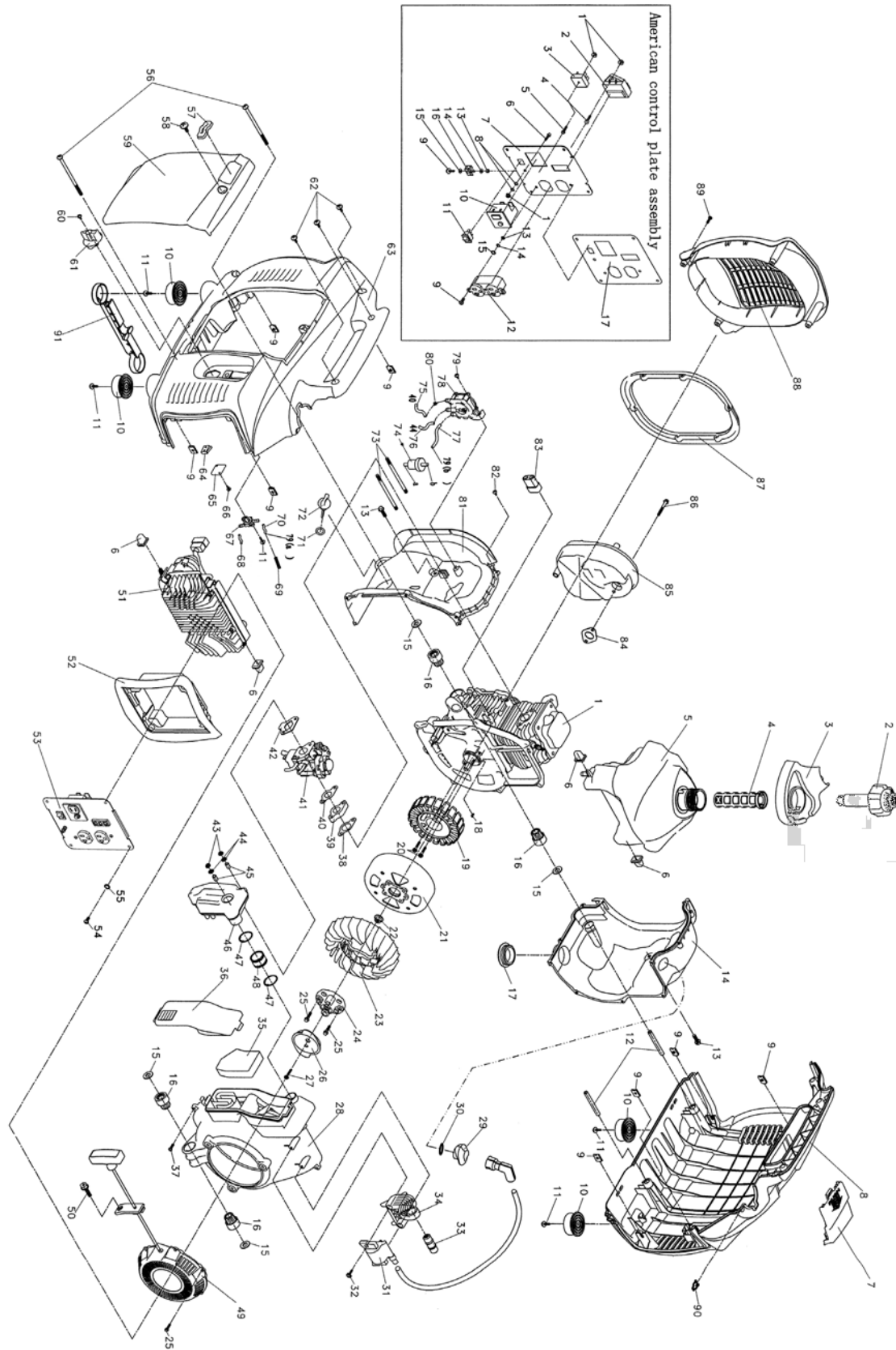

Item	Qty.	Description
1	1	Engine
2	1	Cap Assy., Fuel Tank
3	1	Cover, Fuel Filler Port
4	1	Cup, Fuel Filter
5	1	Tank, Fuel
6	4	Block, Shock Absorber
7	1	Cover, Lower Shell
8	1	Shell, Lower
9	8	Clip, Screw
10	4	Feet, Vibration Mounts
11	5	Recessed Pan Head Screw, St6. 3x19
12	2	Alignment Pin
13	2	Bolt, Hex, W/ Flange M6x12
14	1	Casing, Lower, Engine
15	4	Washer
16	4	Sleeve, Damping
17	1	Seal Cover, Oil Sensor
18	1	Key, Woodruff, 3x5x13
19	1	Stator Assy.
20	2	Bolt, Hex, W/ Flange M5x30
21	1	Flywheel/Rotor Assy.
22	1	Nut, Hex/flanged M10x1.25-8
23	1	Fan
24	1	Jaw Seat, Starting
25	5	Bolt, Hex, Flanged, M6x16
26	1	Coupler, Starting Jaw
27	1	Bolt, Hex/flanged, M8x14
28	1	Cover Assy, Cowling And Inlet
29	1	Plug, Rubber
30	1	O-ring, Rubber, 20x1.8
31	1	Coil, Ignition
32	2	Tapping Screw, Recessed Pan/hd Str. 8x14
33	1	Pin, Mounting (Pothook Pillar)
34	1	Pot Hook
35	1	Cleaner, Air
36	1	Cover, Air Filter
37	6	Screw, Pan Head, Tapping Str.8x32

Item	Qty.	Description
38	1	Gasket, Carburetor (B) Out
39	1	Block, Carburetor Spacer (Cushion)
40	1	Carburetor, Seal Gasket A (Out)
41	1	Regulating Assy. Carburetor
42	1	Gasket, Carburetor In
43	2	Nut, Hex/ Flanged, M5
44	2	Washer, Flat
45	2	Spacer, Filter Case Liner
46	1	Case Assy., Filter
47	2	Spring Clip
48	1	Filter, Adapter Sleeve
49		Starter, Recoil Assy.
50	1	Bolt, Hex Head W/washer, M5x12
51	1	Inverter Assy
52	1	Frame, Front Panel
353	1	Plate Assy, Control
54	4	Screw, Pan Head, Recessed, M5x25
55	4	Washer, Flat 5
56	2	Screw, Pan Head Recessed, M6x120
57	1	Seal Cover, Lower Shell
58	1	Screw, M6x14
59	1	Cover, Upper Shell
60	1	Screw, Pan Head M4x12
61	1	Switch, Fuel On/off
62	3	Screw, Pan Head, Recessed, M6x14
63	1	Shell, Upper
64	1	Switch, Ignition, On/off
65	1	Cover, Switch
66	2	Screw, Recessed Pan Head/ St4.2x9.5 Tapping
67	1	Valve, Fuel
68	1	Hose, Oil Discharge
69	1	Shield, Pipe Spring
70	1	Hose, Fuel Pumpi Oil Inj.
71	1	O-ring
72	1	Cover, Oil W/dipstick

Item	Qty.	Description
73	2	Stud/bolt
74	1	Filter, Fuel
75	1	Pipe, Fuel Pump Outlet
76	1	Gaspipes, Fuel Pump
77	1	Pipe-b, Fuel Pump Inlet
78	1	Pump Assy., Fuel
79	1	Screw, Pan Head , Recessed,
80	10	Clamp, Fuel Hose
81	1	Casing, Upper Engine
82	4	Screw, Tapping-pan Head Recessedst4.2x16
83	1	Sleeve, Resperator Adaptor
84	1	Shim, Muffler
85	1	Muffler Assy.
86	3	Bolt, Hex Head, Flanged, M6x55
87	1	Rubber Seal, Back Window
88	1	Window, Back (Exhaust Cover)
89	4	Screw, Recessed Pan Head/ M5x20
90	1	Retaining Clip, Shell
91	1	Baffle, Thermal

Control Plate Assembly		
Item	Qty.	Description
1	3	Nut, Hex/ Flanged, M5
2	1	Ignition .led Indicator
3	1	Rectifier 1010a
4	1	Bolt, Ignition Apparatus
5	1	Bolt, Hex, With Flange
6	1	Bolt, Hex, With Flange
7	1	Control Plate Assembly
8	2	Washer, Flat
9	1	Screw, Recessed Pan Head
10	1	12vdc Plug Assy.
11	1	Switch, Flexpower
12	1	120v Outlet Assy.
13	3	Nut, I- Type Hex
14	3	Washer, Spring, Standard
15	3	Washer, Flat, M4
16	1	Peg, Ground Connection
17	1	Decal, Control Plate

NOTE: Go to www.generac.com (<http://www.generac.com/service-support/product-support-lookup>) for the most current diagrams. Use model and/or serial number.

Exploded View – iX2000

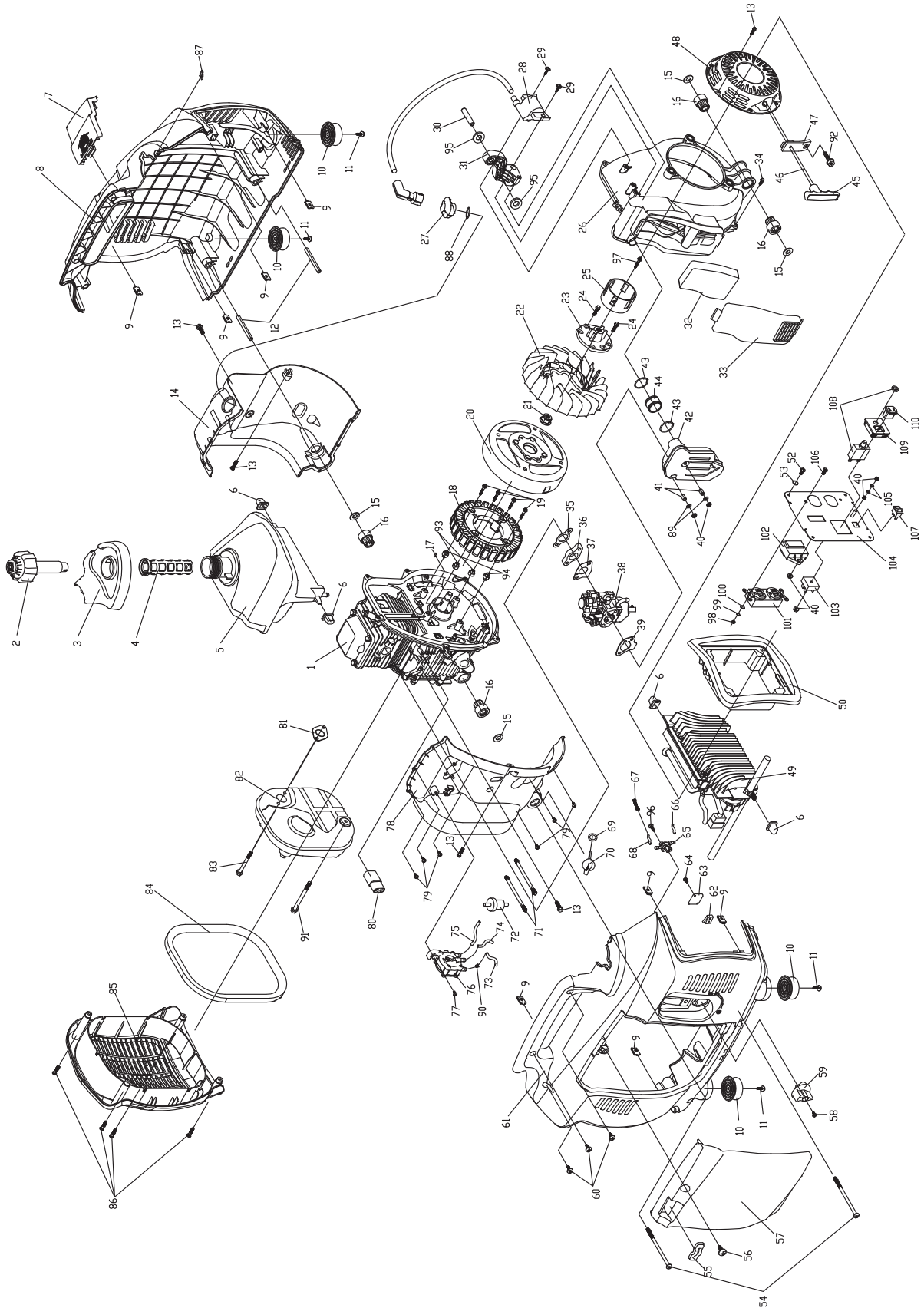

Item	Qty.	Description
1	1	Engine Assembly
2	1	Cap, Fuel Filler
3	1	Cover, Fuel Filler Port
4	1	Cup, Fuel Filter
5	1	Tank, Fuel
6	4	Block, Shock Absorber
7	1	Cover, Upper Shell
8	1	Shell, Upper
9	8	Clip, Screw
10	4	Shock Absorber, Foot Of Chassis
11	5	Screw, Philips, St6, 3x19
12	2	Mounting Pin, Bottom
13	5	Bolt, Hex Head W/flange M6x12
14	1	Wrapper, Side
15	4	Gasket
16	4	Reducer Ring, Vibration
17	1	Key, Woodruff, 3x5x13
18	1	Stator Assy.
19	4	Bolt, Hex Head W/flange M5x30
20	1	Flywheel Rotor Assy
21	1	Nut, Hex Screw, W/ Flange
22	1	Fan Blades
23	1	Seat, Starting Jaw
24	3	Bolt, Hex Head W/flange M6x16
25	1	Jaw, Starter
26	1	Cover
27	1	Rubber Set, High Pressure
28	1	Ignition Coil
29	2	Screw, Philips, St4. 8x22
30	1	Mounting Pin, Top
31	1	Hook
32	1	Air Cleaner
33	1	Cover, Air Filter
34	6	Bolt, Hex Head W/flange, M5x16
35	1	Gasket, Carburetor, (Out B)
36	1	Spacer
37	1	Gasket, Carburetor, (Out A)

Item	Qty.	Description
38	1	Carburetor Assy.
39	1	Gasket, Carburetor (In)
40	6	Nut, Hex. With Flange, M6
41	2	Spacer, Oil Splash Cover
42	1	Oil Splash Sub-assy.
43	2	Clip, Spring
44	1	Air Tube
45	1	Handle , Recoil Assy.
46	1	Cord, Recoil Assy.
47	1	Stop, Handle
48	1	Recoil Assy.
49	1	Inverter Sub Assy
50	1	Brace, Control Panel
51	1	Control Panel W/ Decal
52	4	Screw, Crossed Pan Head, M5x25
53	4	Washer
54	2	Screw, Crossed Pan Head, M6x130
55	1	Seal, Cover
56	1	Screw, M6x14
57	1	Cover, Upper Shell
58	1	Screw, Cross Pan Head, M4x12
59	1	Switch, Fuel On/off
60	3	Screw, Cross Pan Head, M6x14
61	1	Shell, Upper
62	1	Switch, Ignition, On/off
63	1	Cover, Switch
64	2	Screw, Philips, St4,2x9.5
65	1	Valve, Fuel
66	1	Hose, Oil Discharge
67	2	Clamp, Hose
68	1	Hose, Fuel Pump Oil Injection A
69	1	O-ring
70	1	Dipstick
71	2	Studs
72	1	Filter, Gas

Item	Qty.	Description
73	1	HOSE, FUEL PUMP
74	1	HOSE, FUEL PUMP AIR
75	1	HOSE, FUEL PUMP OIL INJECTION B
76	1	FUEL PUMP ASSY.
77	1	SCREW, PHILIPS, ST4.8X19
78	1	WRAPPER, ENGINE, UPPER
79	6	SCREW, PHILIPS, ST4.2X13
80	1	REDUCER
81	1	GASKET, MUFFLER
82	1	MUFFLER ASSY.
83	2	BOLT, HEX HEAD W/FLANGE, M6X60
84	1	SEAL, EXHAUST COVER
85	1	COVER, EXHAUST
86	4	SCREW, CROSS PAN HEAD, M5X20
87	1	CLIP, RETAINING, CHASSIS
88	1	O-RING, RUBBER
89	2	WASHER
90	10	CLIP, HOSE, FUEL
91	1	BOLT, HEX HEAD W/FLANGE, M6X80
92	1	SCREW, PHILIPS W/WASHER, M5X12
93	2	PIN, GUIDE, A
94	2	PIN, GUIDE, B
95	2	WASHER/ GASKET, HOOK
96	1	SCREW, PHILIPS
97	1	BOLT, HEX WITH FLANGE
98	2	NUT, M4
99	8	WASHER, LOCK, M4
100	8	WASHER, FLAT, M4
101	1	OUTLET, 120 VAC 20 AMP
102	1	DISPLAY, LED
103	1	DIODE, RECTIFIER
104	1	PANEL, FRONT
105	2	WASHER, STAR LOCK M6
106	2	SCREW M4X12
107	1	SWITCH, FLEXPPOWER
108	1	BREAKER, DC CIRCUIT
109	1	HOLDER, DC COMPONENTS
110	1	RECEPTACLE, 12 VDC

NOTE: Go to www.generac.com (<http://www.generac.com/service-support/product-support-lookup>) for the most current diagrams. Use model and/or serial number.

Exploded View – iQ2000

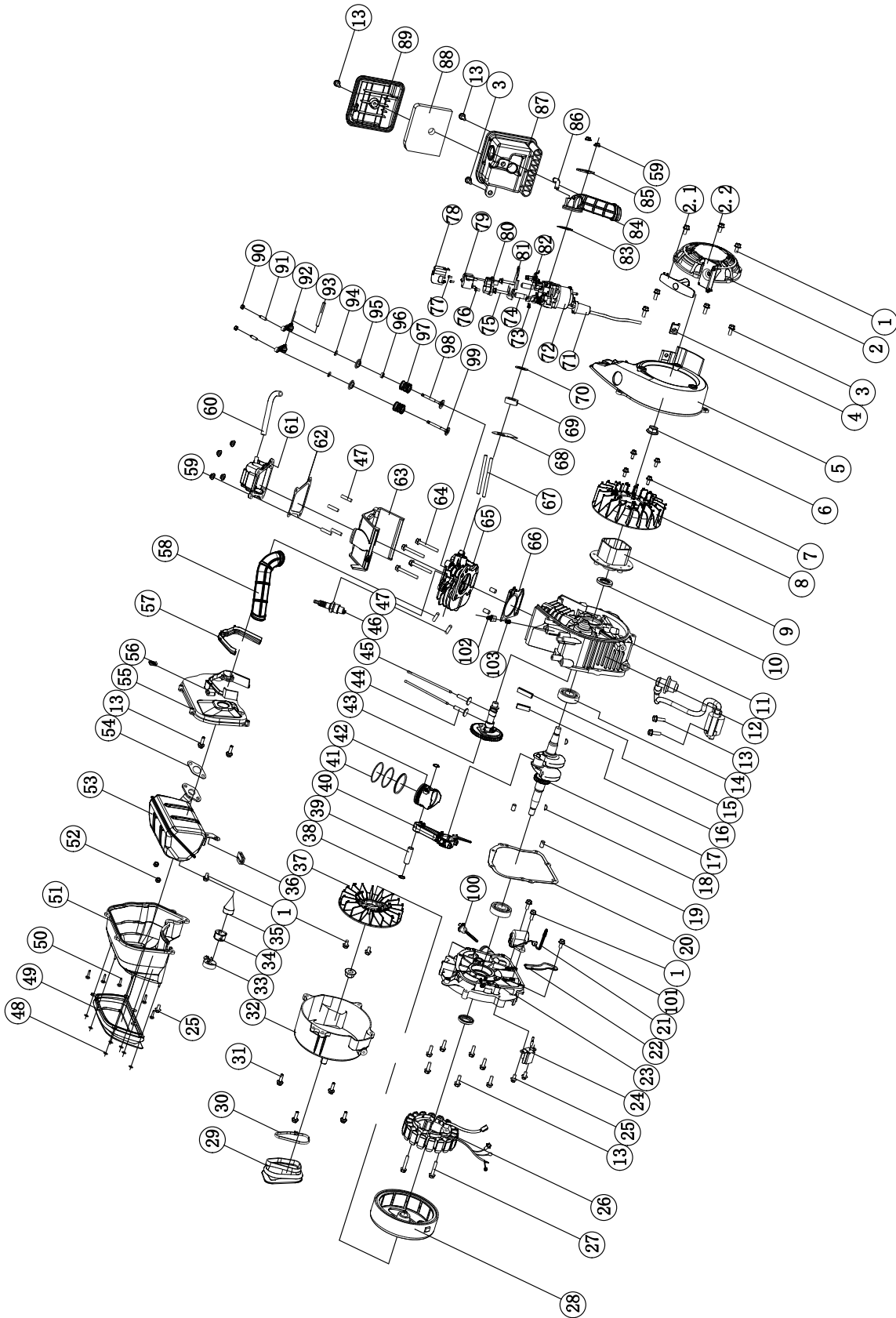

Item	Qty.	Description
1	8	Bolt (M6x12)
2	1	Starter Assembly
2.1	1	Handle
2.2	1	Handle Guide
3	5	Bolt (M6x15)
4	1	Nut
5	1	Blower Housing
6	2	Nut (M12)
7	4	Bolt (M5x12)
8	1	Engine Cooling Fan
9	1	Starting Hub
10	2	Oil Seal
11	1	Crankcase
12	1	Ignition Coil Assembly
13	13	Bolt (M6x20)
14	2	Bearing
15	1	Protector Cover Seal 2
16	1	Protector Cover Seal 1
17	1	Crankshaft Assembly
18	2	Woodruff Key
19	4	Dowel Pin
20	1	Crankcase Gasket
21	1	Oil Level Switch
22	1	Oil Level Switch Plate
23	1	Crankcase Cover
24	1	Trigger Assembly
25	3	Bolt (M6x12)
26	1	Stator Assembly
27	2	Bolt (M6x35)
28	1	Rotor Assembly
29	1	Alternator Boot
30	1	Zip-tie
31	4	Bolt (M6x22)
32	1	Rotor And Stator End Cover
33	1	Spark Arrestor Clamp
34	1	Spark Arrestor Base
35	1	Spark Arrestor

Item	Qty.	Description
36	1	Rubber Seal
37	1	Generator Fan
38	2	Piston Pin Retainer Clip
39	1	Piston Pin
40	1	Connecting Rod Assembly
41	1	Piston Ring Set
42	1	Piston
43	1	Camshaft Assembly
44	2	Valve Lifter
45	2	Pushrod
46	1	Spark Plug
47	6	Exhaust Stud
48	7	Spring Strip
49	1	Muffler Boot
50	5	Self-tapping Screw
51	1	Muffler Shroud
52	2	Nut (M6)
53	1	Muffler Assembly
54	1	Exhaust Gasket
55	1	Muffler Wrapper Front
56	1	Setting Flash Board
57	1	Muffler Protector Seal
58	1	Rubber Air Duct
59	6	Nut (M6)
60	1	Breather Pipe
61	1	Cylinder Head Cover Assembly
62	1	Cylinder Head Cover Gasket
63	1	Cylinder Head Air Shroud
64	4	Bolt(M6x50)
65	1	Cylinder Head Assembly
66	1	Cylinder Head Gasket
67	2	Carburetor Bolt
68	1	Insulator Gasket
69	1	Carburetor Insulator
70	1	Carburetor Gasket

NOTE: Go to www.generac.com (<http://www.generac.com/service-support/product-support-lookup>) for the most current diagrams. Use model and/or serial number.

Exploded View – iQ2000 (Continued)

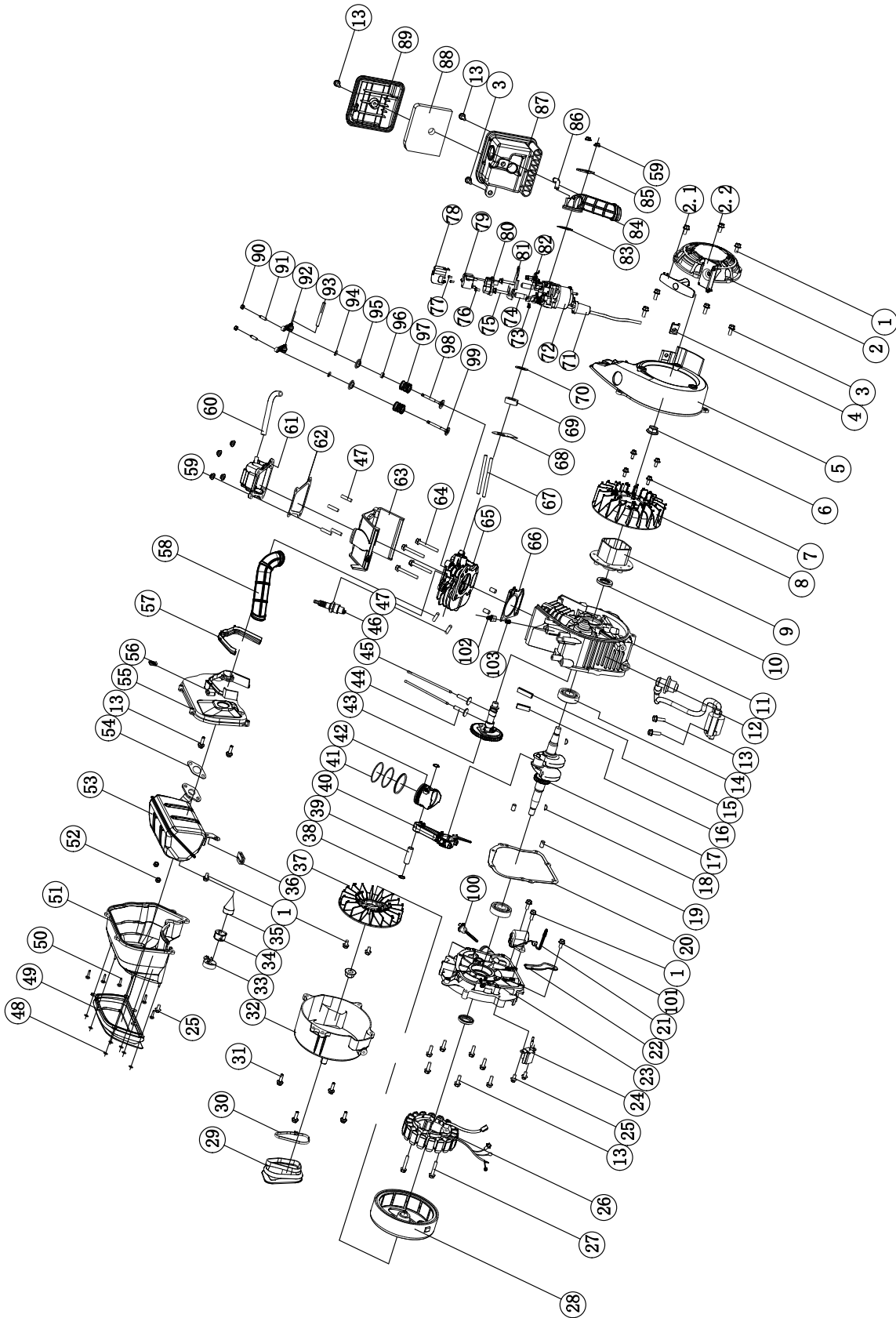

Item	Qty.	Description
71	1	Fuel Canister
72	1	Carburetor Assembly
73	1	Connector Spring/clamp
74	2	Spacer Support
75	2	Screw (M5x35)
76	2	Screw (M4x8)
77	2	Screw (M3x6)
78	1	Stepper Motor Cover
79	1	Stepper Motor Assembly
80	1	Stepper Motor Seat
81	1	Stepper Motor Support
82	1	Starter Connector
83	1	Air Cleaner Gasket
84	1	Air Cleaner Pipe
85	1	Air Cleaner Pipe Gasket
86	1	Breather Pipe
87	1	Air Cleaner Assembly
88	1	Air Filter Element
89	1	Air Cleaner Cover
90	2	Valve Adjusting Nut
91	2	Valve Adjusting Screw
92	2	Valve Rocker Arm
93	1	Screw Rocker Arm Shaft
94	2	Valve Lock Clip
95	2	Valve Spring Retainer
96	1	Valve Oil Seal
97	2	Valve Spring
98	1	Intake Valve
99	1	Exhaust Valve
100	1	Oil Filler Cap Assembly
101	1	Bolt (M6x8)
102	1	Vacuum Fitting
103	1	Metal Filter

NOTE: Go to www.generac.com (<http://www.generac.com/service-support/product-support-lookup>) for the most current diagrams. Use model and/or serial number.

Exploded View – iQ2000 (Continued)

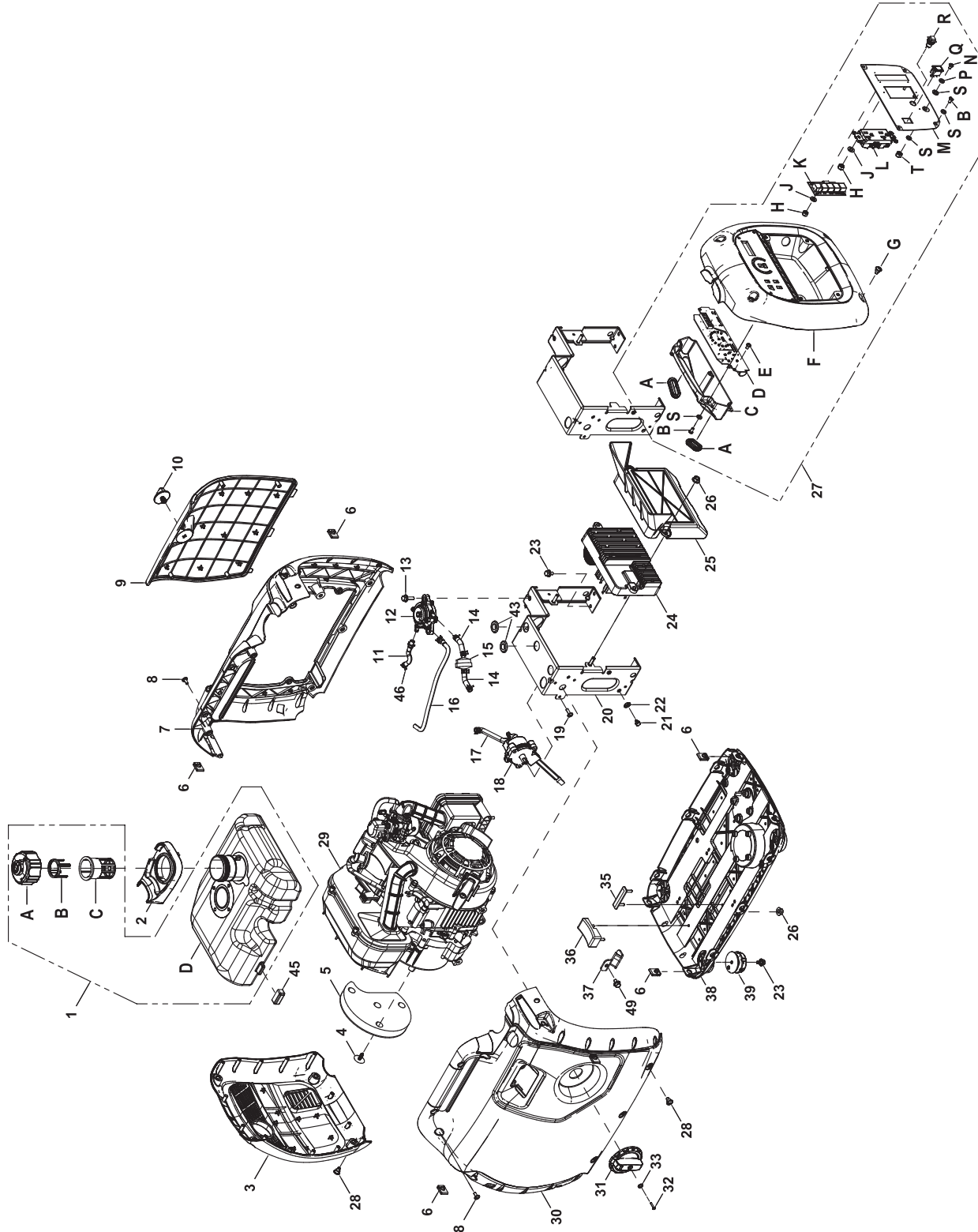

Item	Qty.	Description
1	1	Assembly Fuel Tank W/vent
A	1	Fuel Cap Vented On/off
B	1	Fuel Fill Level Insert
C	1	Fuel Fill Filter Screen
D	1	Fuel Tank Assy W/o Vent
2	1	Fuel Fill Spill Guard
3	1	Exhaust Air Out Panel
4	4	Fastener Ribbed Shank Chrstm T
5	1	Foam, Alternator Cover
6	14	Nut Clip-on M6 X 1
7	1	Enclosure Side Service
8	10	Screw Bfhsc M5-0.8 X 12 Blk Zp
9	1	Enclosure Service Door
10	1	Knob Service Door
11	1	Hose Fuel Formed 2kw 4.5-6mm
12	1	Pump, impulse
13	2	Screw Hhfcs M6-1.0 X 20 G8.8
14	2	Fuel Hose 6 X 10 X 55mm Long
15	1	Filter, fuel, gt990
16	1	Evap Hose Formed Nom 251
17	1	Fuel Hose Formed 6id X 10od
18	1	Power Dial Assy Inverter
19	3	Screw Bfhsc M5-0.8 X 16 Blk Zp
20	1	Bracket Mounting Inverter
21	1	Extrdtite M5 X 10 Lg
22	1	Washer Lock Special #10
23	8	Screw Hhfcs M6-1.0 X 10 G8.8
24	1	Inverter Module 2kw
25	1	Airfoil Intake
26	6	Nut Hex FI Whiz M6-1

Item	Qty.	Description
27	1	Assembly Control Panel
A	2	Grommet Wire Sleeve
B	8	Screw Bhsc M5-0.8 X 10mm
C	1	Back Box Top 2kw Inverter
D	1	Assy Pcb 2kw Display Panel
E	3	Screw Pphm M3-0.5 X 5 Zp
F	1	Enclosure Control Panel
G	4	Screw Bhss M6-1.0 X 12mm
H	5	Nut Hex Lock M4-0.7 Ny Ins
J	5	Washer Flat M4
K	1	Assy Pcb Invtgen Pwr Bar
L	1	Outlet 20a 120v Dplx
M	1	Weldment Control Panel
N	1	Screw Pphm M5-0.8 X 8 Zinc
P	1	Washer Flat M5
Q	1	Switch, Rocker, 3 Position
R	1	Switch, Self Reset
S	10	Washer Lock #10
T	1	Nut Hex Lock M5-0.8 Nyins Zinc
28	10	Screw Bhss M6-1.0 X 12mm
29	1	Power Head Assembly
30	1	Enclosure Side - Recoil
31	1	Dial On/off Selector
32	1	Screw Bfhsc M3-0.5 X 16 Blk Zp
33	1	Washer Lock Ext #5 Steel Bz
35	3	Engine Stop
36	1	Alternator Stop
37	4	Angled Vibration Mounts
38	1	Enclosure Base W/o Aux Tank
39	4	Mounting Foot
43	2	Grommet .75 X .09 X .50
45	2	Rubber Isolator
46	9	Clamp Hose Band .41
47	1	Clamp Hose Band .31
49	4	Screw Hhfc M6-1x12 8.8 W/patch

This page intentionally left blank.

Section 4 *Electrical Data*

Introduction

Go to www.generac.com (<http://www.generac.com/service-support/product-support-lookup>) for the most current wiring diagrams and electrical schematics. Use model or serial number.

Wiring Diagram, iQ2000 Drawing No. 0L4354-B

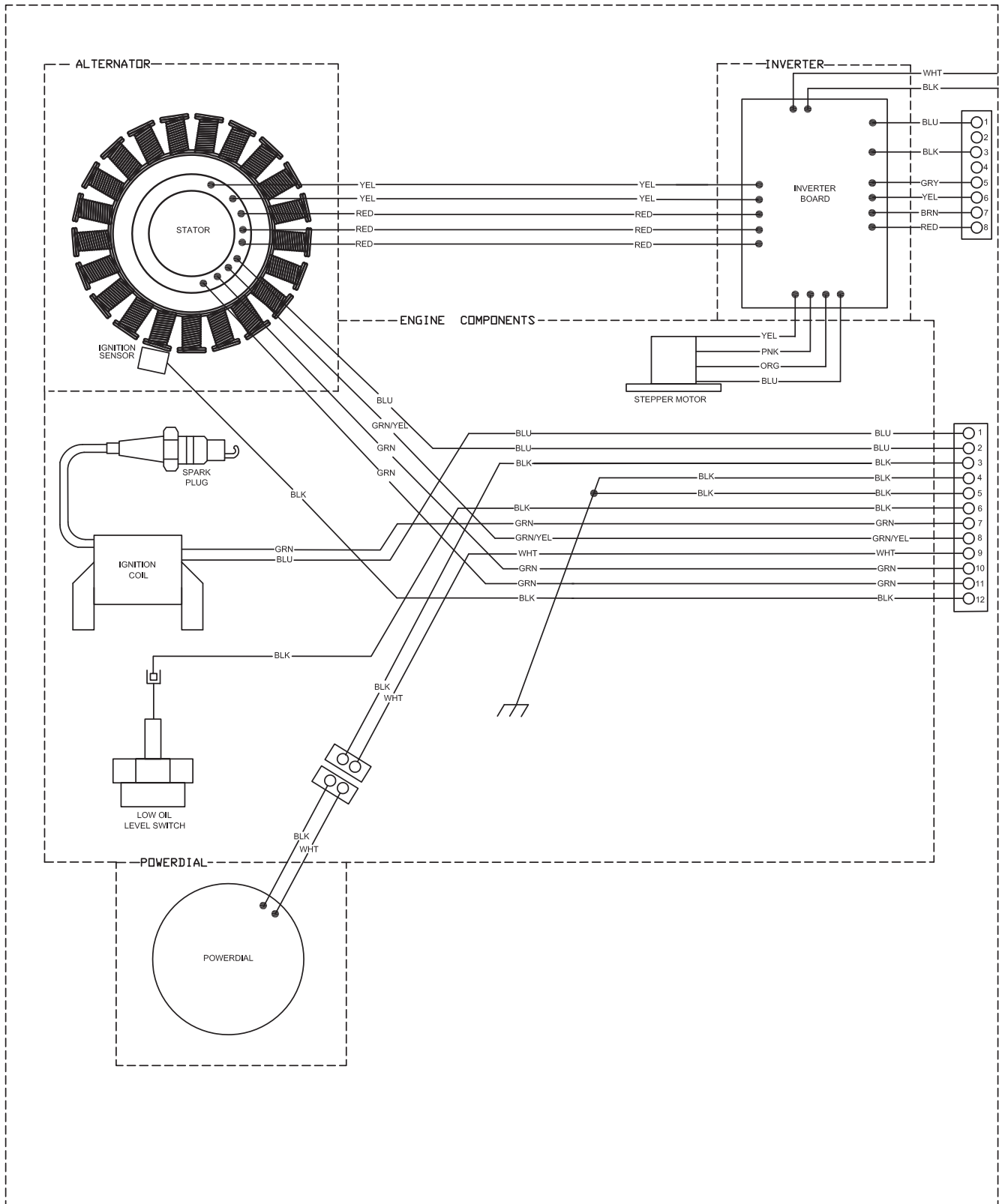

Wiring Diagram, iQ2000 Drawing No. 0L4354-B

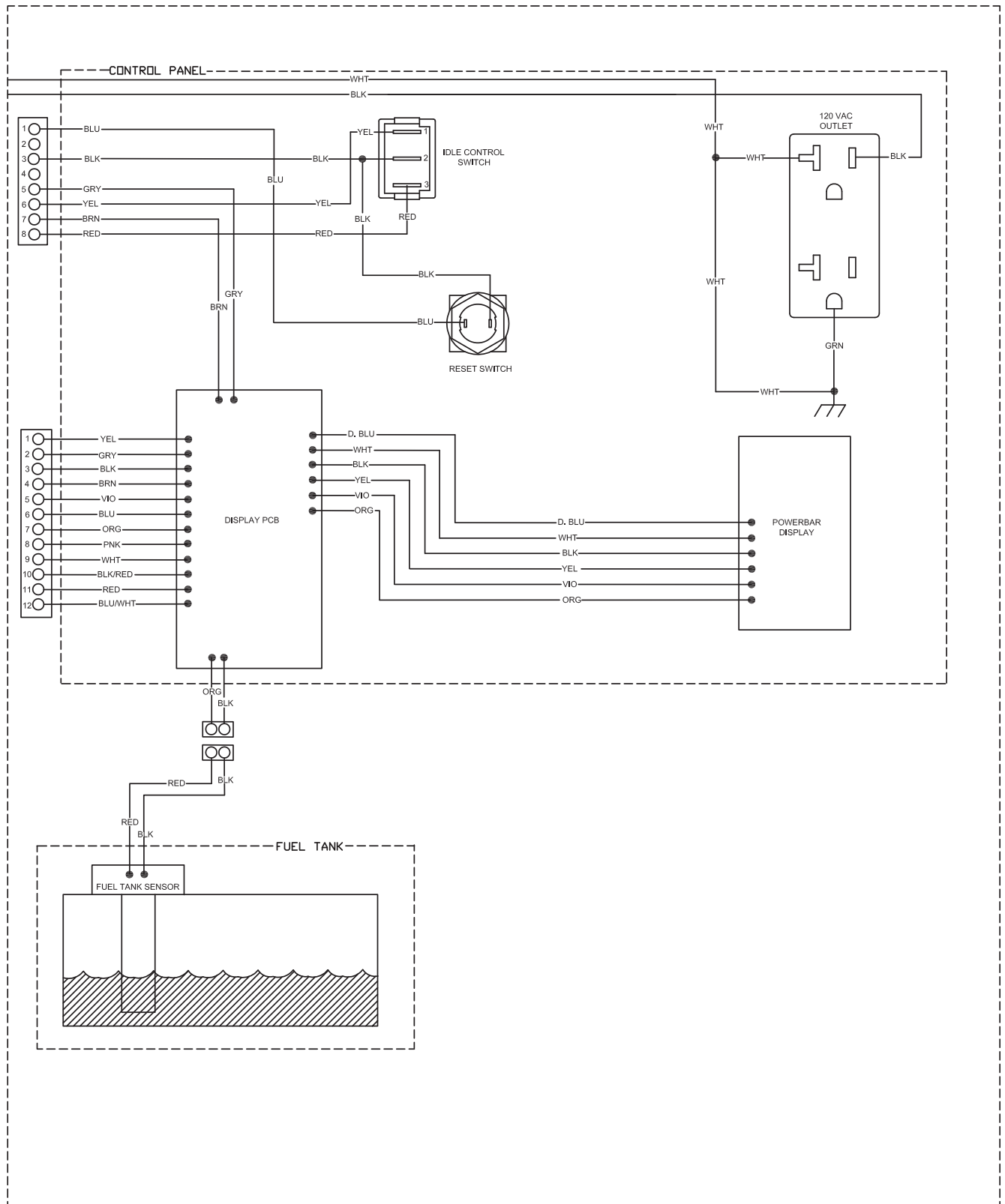

Wiring Diagram, iX800

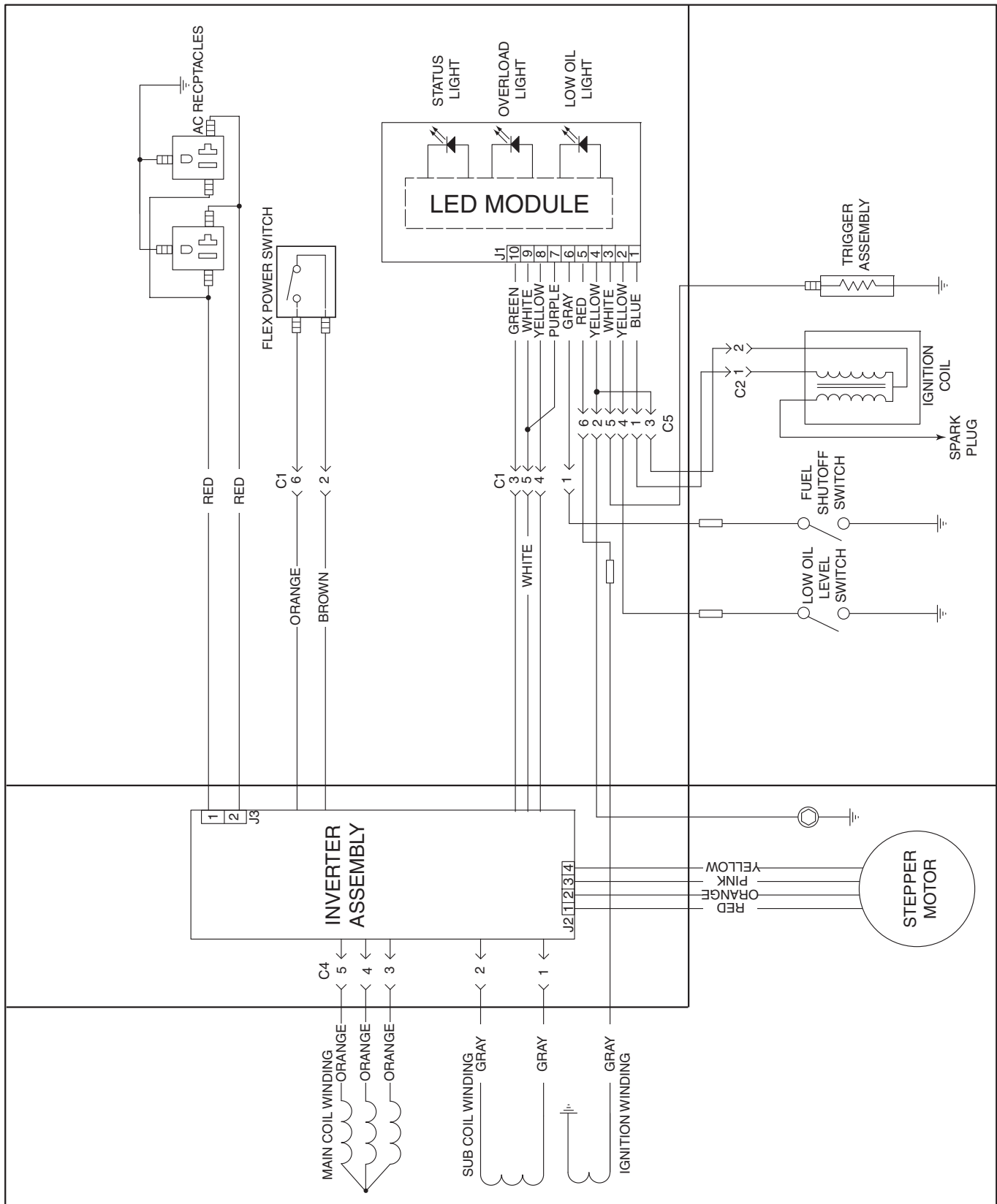

Wiring Diagram, iX1600 and iX2000

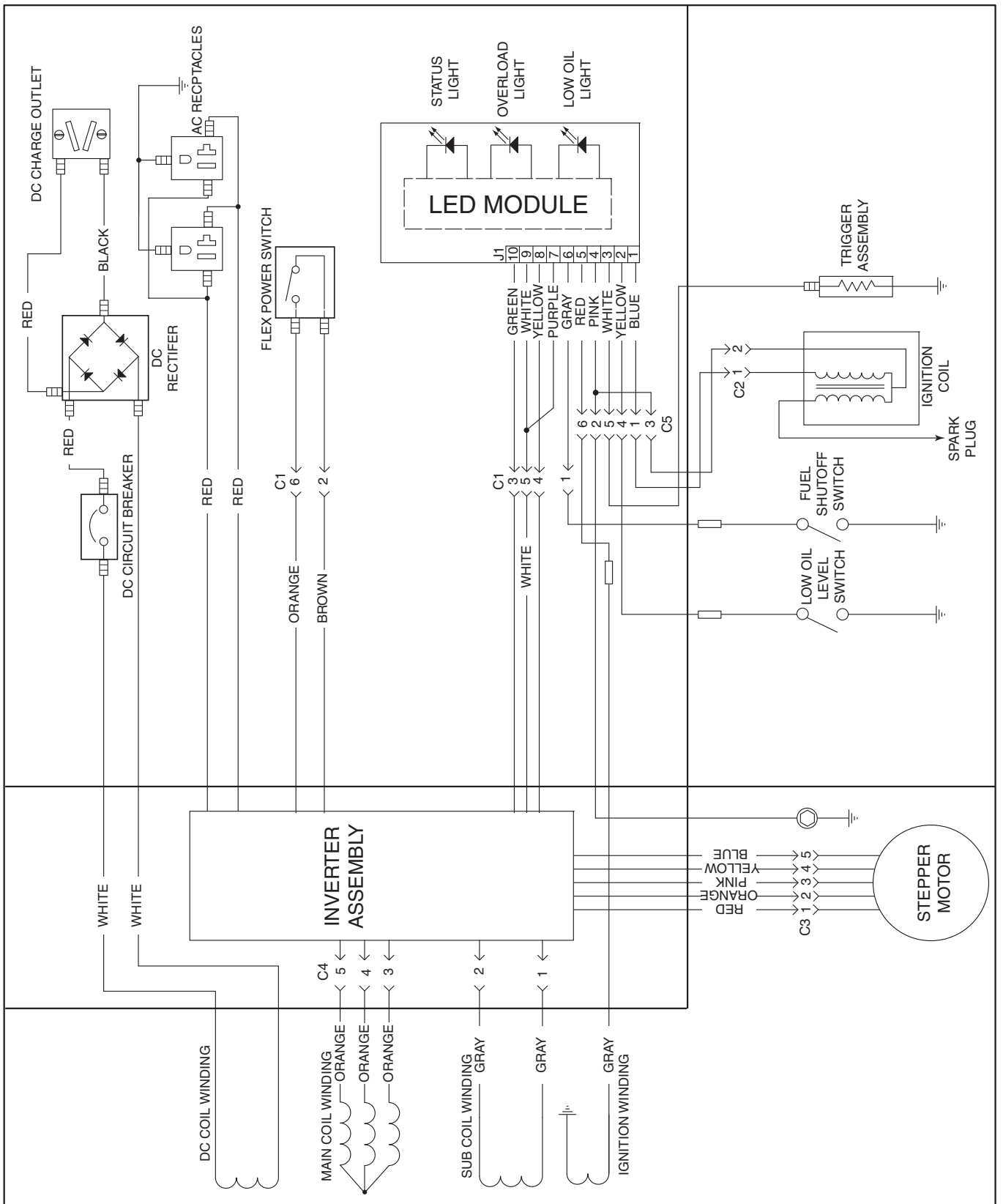

Wiring Diagram and Electrical Schematic, GP2200i, Craftsman 2200i C0010020/Premier 2200i INV2200DMN Drawing No. 1000001954-A

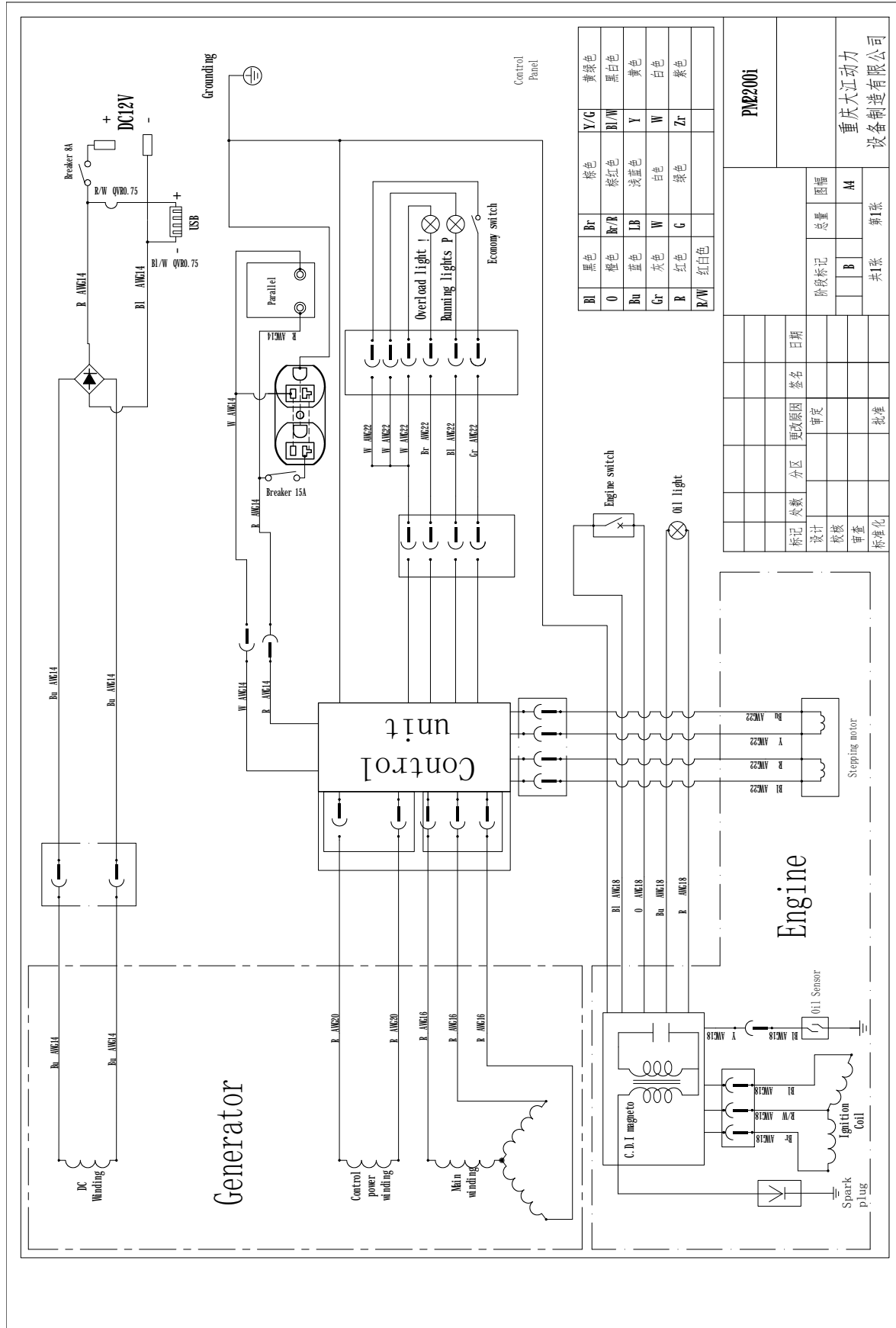

**Wiring Diagram and Electrical Schematic, GP3000i, Craftsman 3000i C00010030/PRO-3000i
INV3000DMN INV 60HZ 120 VAC Drawing No. 10000017588-A**

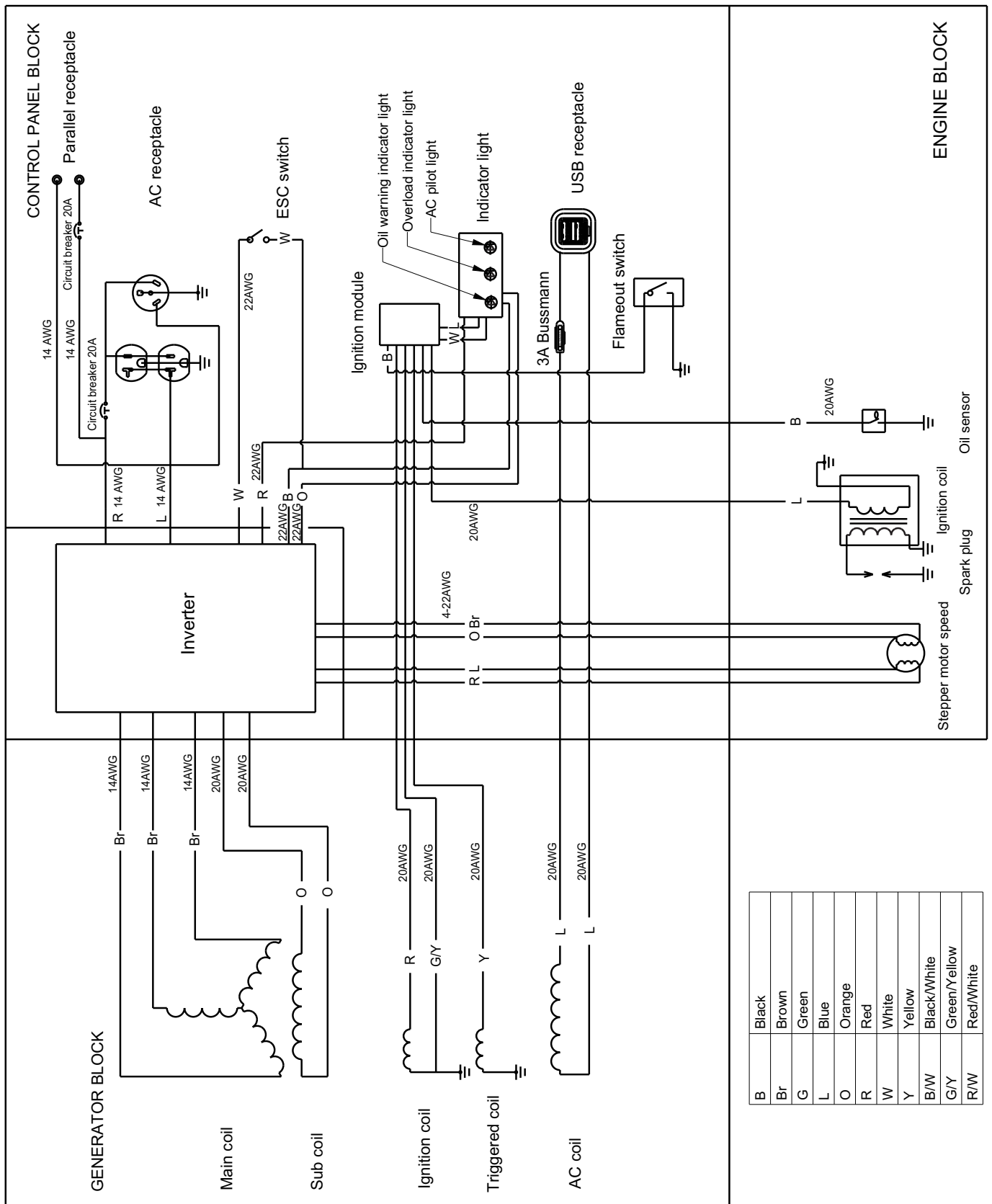

Wiring Diagram and Electrical Schematic, GP3500iO 60HZ 120 VAC Drawing No. 10000017616-A

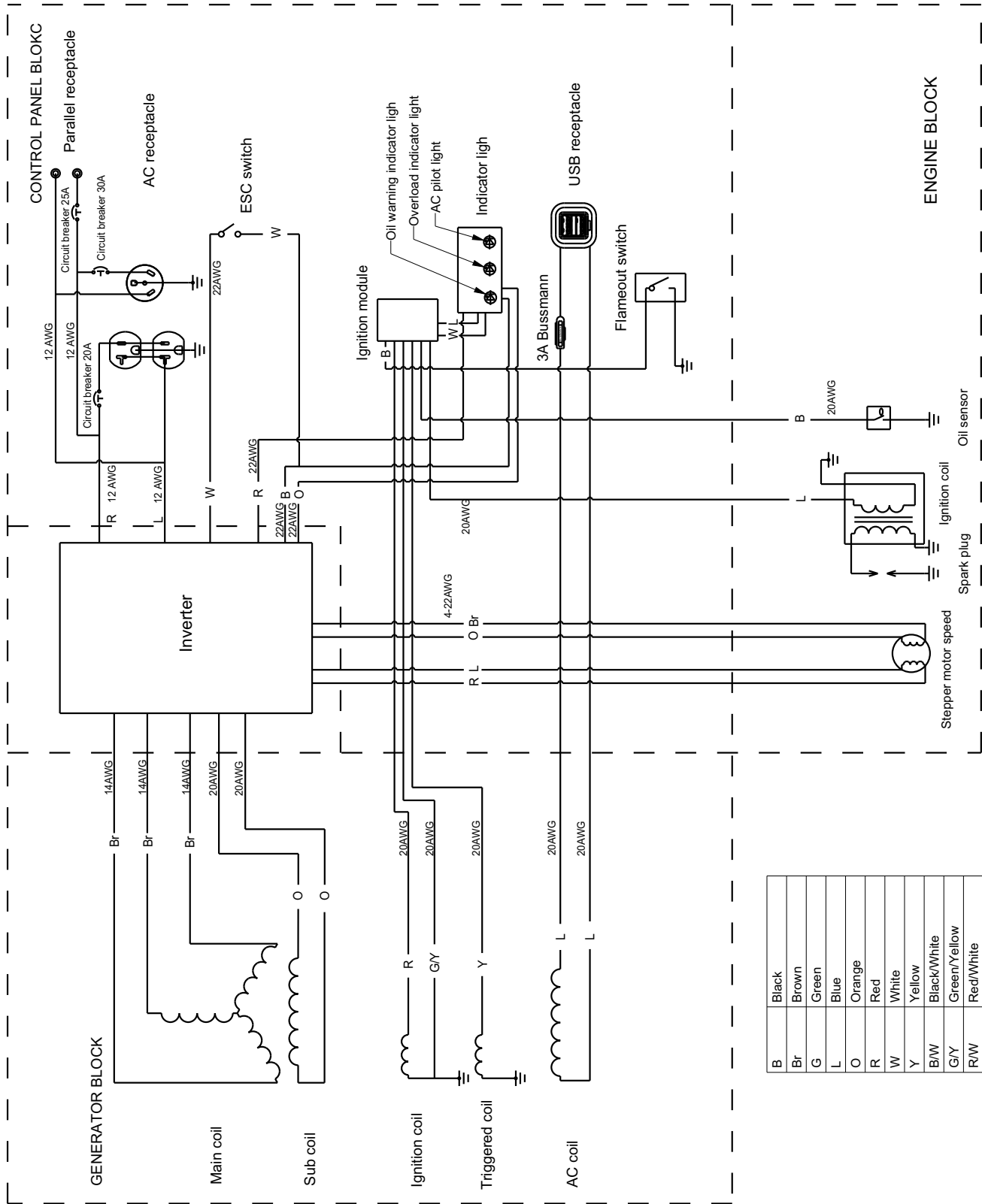

B	Black
Br	Brown
G	Green
L	Blue
O	Orange
R	Red
W	White
Y	Yellow
B/W	Black/White
G/Y	Green/Yellow
R/W	Red/White

Wiring Diagram and Electrical Schematic, iQ3500 Drawing No. 1000033847-A

GROUP A

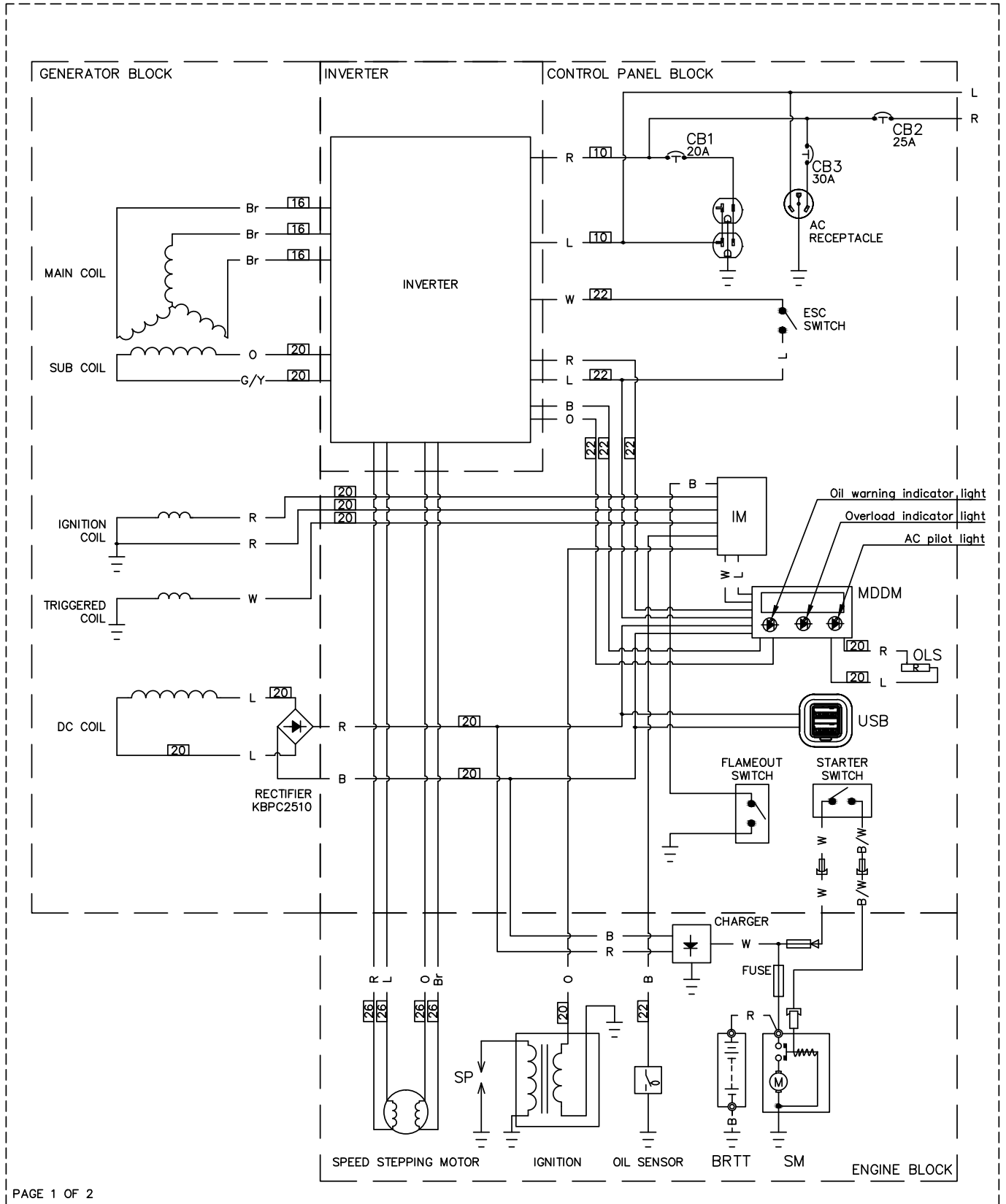

PAGE 1 OF 2

SCHMATIC - DIAGRAM / WIRING - DIAGRAM

REVISION: A
DATE: 3/28/18

PAGE 1 OF 2

iQ3500 60HZ 120VAC
DRAWING #: 1000033847

Wiring Diagram and Electrical Schematic, iQ3500 Drawing No. 1000033847-A

GROUP A

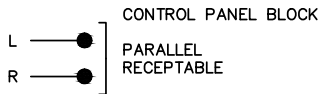

NOTE: ALL WIRES 18 AWG
BLACK 300V UL LISTED
UNLESS SHOWN OTHERWISE.

AWG SIZE
18

LEGEND OF WIRE COLOR			
B	- Black	W	- White
Br	- Brown	Y	- Yellow
G	- Green	B/W	- Black/White
L	- Blue	G/Y	- Green/Yellow
O	- Orange	R/W	- Red/White
R	- Red		

LEGEND			
CB_	- CIRCUIT BREAKER	SM	- STARTER MOTOR
IM	- IGNITION MODULE	USB	- UNIVERSAL SERIAL BUS
MDDM	- MULTIFUNCTION DIGITAL DISPLAY METER	SP	- SPARK PLUG
OLS	- OIL LEVEL SENSOR	BATT	- BATTERY

PAGE 2 OF 2

SCHEMATIC - DIAGRAM / WIRING - DIAGRAM

REVISION: A
DATE: 3/28/18

PAGE 2 OF 2

iQ3500 60HZ 120VAC
DRAWING #: 1000033847

Electrical Formulas

To Find	Known Values	1-phase	3-phase
Kilowatts (kW)	Volts, Current, Power Factor	$\frac{E \times I}{1000}$	$\frac{E \times I \times 1.73 \times PF}{1000}$
KVA	Volts, Current	$\frac{E \times I}{1000}$	$\frac{E \times I \times 1.73}{1000}$
Amperes	kW, Volts, Power Factor	$\frac{kW \times 1000}{E}$	$\frac{kW \times 1000}{E \times 1.73 \times PF}$
Watts	Volts, Amps, Power Factor	Volts x Amps	$E \times I \times 1.73 \times PF$
No. of Rotor Poles	Frequency, RPM	$\frac{2 \times 60 \times \text{Frequency}}{\text{RPM}}$	$\frac{2 \times 60 \times \text{Frequency}}{\text{RPM}}$
Frequency	RPM, No. of Rotor Poles	$\frac{\text{RPM} \times \text{Poles}}{2 \times 60}$	$\frac{\text{RPM} \times \text{Poles}}{2 \times 60}$
RPM	Frequency, No. of Rotor Poles	$\frac{2 \times 60 \times \text{Frequency}}{\text{Rotor Poles}}$	$\frac{2 \times 60 \times \text{Frequency}}{\text{Rotor Poles}}$
kW (required for Motor)	Motor Horsepower, Efficiency	$\frac{HP \times 0.746}{\text{Efficiency}}$	$\frac{HP \times 0.746}{\text{Efficiency}}$
Resistance	Volts, Amperes	$\frac{E}{I}$	$\frac{E}{I}$
Volts	Ohm, Amperes	$I \times R$	$I \times R$
Amperes	Ohms, Volts	$\frac{E}{R}$	$\frac{E}{R}$

E = Volts

I = Amperes

R = Resistance (Ohms)

PF = Power Factor

Term	Symbol	Measurement
Current	I	Amps
Wattage	P	Watts
Voltage	E	Volts
Resistance	R	Ohms

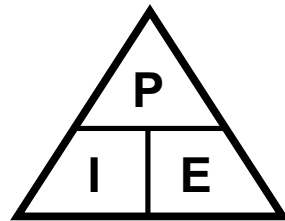
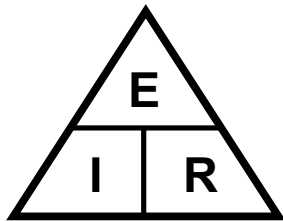

003003

Constant	Shift		Result	
Voltage E	Resistance Increase	↑	Current Decrease	↓
Voltage E	Resistance Decrease	↓	Current Increase	↑
Resistance R	Voltage Decrease	↓	Current Decrease	↓
Resistance R	Voltage Increase	↑	Current Increase	↑
Current I	Resistance Decrease	↓	Voltage Decrease	↓
Current I	Resistance Increase	↑	Voltage Increase	↑
Power P	Voltage Increase	↑	Power Increase	↑
Power P	Voltage Decrease	↓	Power Decrease	↓
Power P	Current Increase	↑	Power Increase	↑
Power P	Current Decrease	↓	Power Decrease	↓

Part No. 0H5039 Rev. C 09/24/2018

©2018 Generac Power Systems, Inc.
All rights reserved
Specifications are subject to change without notice.
No reproduction allowed in any form without prior written
consent from Generac Power Systems, Inc.



Generac Power Systems, Inc.
S45 W29290 Hwy. 59
Waukesha, WI 53189
1-888-GENERAC (1-888-436-3722)
www.generac.com