

TECHNICAL

Information

"NP" SERIES RECREATIONAL VEHICLE GENERATORS

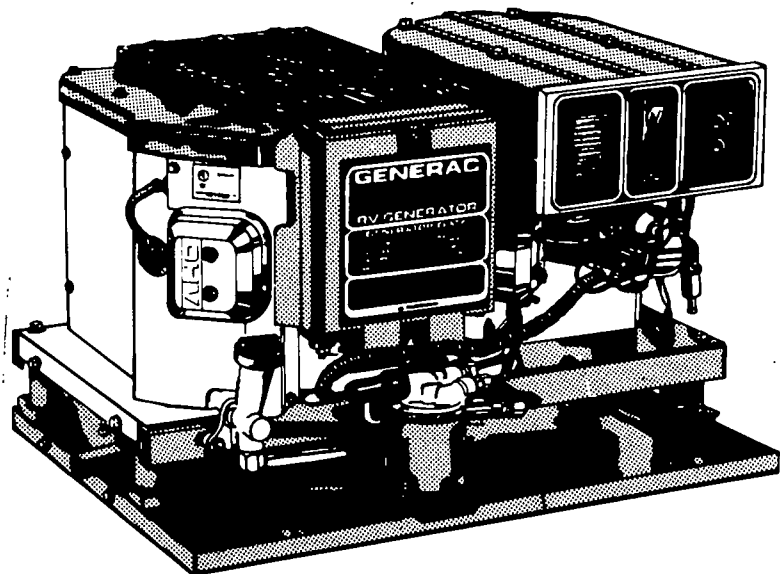

*GENERAC CORPORATION

*P. O. BOX 8

*WAUKESHA, WI 53187

TABLE OF CONTENTS

	Page
Section One - Introduction	1
Section Two - Specifications	
Specifications Charts.....	2
Engine Specifications.....	3
Dimensions and Features.....	4
Generator Features.....	5
Some Additional Features.....	6
Section Three - Installation	
General.....	7
Compartment Installations.....	7
Under the Floor Mounting.....	7
Exhaust System.....	8
Reconnection for Dual Voltage Output.....	8
Installations When a Transfer Switch is Used.....	10
Installation with an Isolation Type Receptacle.....	11
Batteries.....	11
Bonding Requirements.....	12
Optional Remote Start/Stop Panels.....	12
Section Four - Operating Instructions	
Before Startup.....	14
Generator Control Panel.....	14
Starting the Generator.....	15
Stopping the Generator.....	15
Section Five - Adjustments	
Carburetor Adjustment.....	16
Automatic Choke Adjustment.....	16
Engine Ignition System Adjustments.....	17
Valve Adjustment.....	17
Adjusting Drive Belt Tension.....	18
Engine Governor Adjustment.....	18
Section Six - DC Circuits Operational Analysis	
Circuit Condition- Engine Shut Down.....	20
Circuit Condition- Engine Cranking.....	21
Circuit Condition- Startup and Running.....	22
Circuit Condition- Normal Shutdown.....	23
Section Seven - AC Generator Operation	
Initial Startup.....	24
Operation.....	24
Section Eight - Troubleshooting Flow Charts	25-29
Section Nine - Diagnostic Tests	30-37

Section One Introduction

This booklet has been prepared especially for the purpose of familiarizing the user with Generac's "NP" series recreational vehicle generators. The "NP" series generators produce electrical energy exactly like any other generator. However, they are designed for installation into recreational vehicles. Such vehicles must meet Recreational Vehicle Industry Association (RVIA) safety standards and, for that reason, some of the design features of the "NP" series are unique.

These generators are driven by an air-cooled, 16 horsepower, "V-Twin" engine through a belt and pulley arrangement. The generator and engine are mounted vertically and side by side on a steel mounting base. Large capacity blower fans are retained to the generator's rotor shaft and to the engine crankshaft. A drive belt spans the two blower fans, to turn the generator rotor at a fixed ratio of engine speed. The blower fan draws cooling air downward and across the engine and generator. The heated air is then delivered into a blower housing, which ducts the air downward and away from the unit.

Six different generator models are currently being manufactured (see "Specifications"). All models use the same engine. In addition, DC control system components of all models are identical. Because so many parts are identical between the various models, servicing and parts logistics are greatly simplified. Nevertheless, some differences do exist and the technician should be aware of them. These differences are as follows:

- **Rotors and Stators:** Rotors and stators are different and are not interchangeable between models. Be sure to select the correct part number from the repair parts list.
- **Engine and Generator Pulleys:** Correct operating speed for all rotors is 3600 rpm. However, the engine's governed speed varies between models. Thus, unit pulley sizes will differ between models.
- **Rated Voltage:** All models are shipped from the factory wired for 120 volts AC output only. However, the installing electrician may have reconnected the unit for dual voltage output (120 and/or 240 volts AC).

Section Two Specifications

SPECIFICATIONS CHARTS:

Series NP45G:

Rated Maximum Continuous
 AC Power Output..... 4500 watts (4.5 kW)
 Rated Voltage 120/240 volts AC*
 Rated Maximum Continuous Load Current
 At 120 Volts AC 37.5 amperes
 At 240 volts AC 18.75 amperes
 Phase..... 1-Phase
 Rated Frequency 60 Hertz
 No. of Rotor Poles 2
 Driven Speed of Rotor 3600 rpm
 Power Factor 1.0

Series NP55G:

Rated Maximum Continuous
 AC Power Output..... 5500 watts (5.5 kW)
 Rated Voltage 120/240 volts AC*
 Rated Maximum Continuous Load Current
 At 120 volts AC 45.8 amperes
 At 240 volts AC 22.9 amperes
 Phase..... 1-Phase
 Rated Frequency 60 Hertz
 No. of Rotor Poles 2
 Driven Speed of Rotor 3600 rpm
 Power Factor 1.0

Series NP65G:

Rated Maximum Continuous
 AC Power Output..... 6500 watts (6.5 kW)
 Rated Voltage 120/240 volts AC*
 Rated Maximum Continuous Load Current
 At 120 volts AC 54.2 amperes
 At 240 volts AC 27.1 amperes
 Phase..... 1-Phase
 Rated Frequency 60 Hertz
 No. of Rotor Poles 2
 Driven Speed of Rotor 3600 rpm
 Power Factor 1.0

Series NP52G:

Rated Maximum Continuous
 AC Power Output 5200 watts (5.2 kW)
 Rated Voltage..... 120/240 volts AC*
 Rated Maximum Continuous Load Current
 At 120 volts AC..... 43.3 amperes*
 At 240 volts AC..... 21.7 amperes
 Phase 1-Phase
 Rated Frequency 60 Hertz
 No. of Rotor Poles 2
 Driven Speed of Rotor..... 3600 rpm
 Power Factor..... 1.0

Series NP66G:

Rated Maximum Continuous
 AC Power Output 6600 watts (6.6 kW)
 Rated Voltage..... 120/240 volts AC*
 Rated Maximum Continuous Load Current
 At 120 volts AC..... 55 amperes
 At 240 volts AC..... 27.5 amperes
 Phase 1-Phase
 Rated Frequency 60 Hertz
 No. of Rotor Poles 2
 Driven Speed of Rotor 3600 rpm
 Power Factor 1.0

Series NP72G:

Rated Maximum Continuous
 AC Power Output 7200 watts (7.2 kW)
 Rated Voltage..... 120/240 volts AC*
 Rated Maximum Continuous Load Current
 At 120 volts AC..... 60 amperes
 At 240 volts AC..... 30 amperes
 Phase 1-Phase
 Rated Frequency 60 Hertz
 No. of Rotor Poles 2
 Driven Speed of Rotor..... 3600 rpm
 Power Factor 1.0

* Units are factory connected for a 120 volts AC output, but may be reconnected for dual voltage output.

ENGINE SPECIFICATIONS:

Type of Engine	V-Twin
Cooling	Air-Cooled
Rated Engine Horsepower	16 at 3000 rpm
Displacement.....	479.4 cc
Compression Ratio.....	8.5 to 1
Cylinder Block	Aluminum with cast iron sleeve
Type of Governor	Mechanical, fixed speed
Air Cleaner	Paper element with foam pre-cleaner
Type of Starter.....	12 volts d-c electric
Ignition System.....	Solid state with fly-wheel magneto
Recommended Spark Plugs	
Champion	RC12YC
AC.....	R45S
Fram Autolite	65
Spark Plug Gap.....	0.030 inch (0.8mm)
Armature Air Gap	0.008-0.012inch
Valve Clearance (Cold, both Intake and Exhaust Valves).....	0.004-0.006 inch
Oil Filter	FRAM PH3614
Engine Cranking Current.....	Approximately 100 d-c amperes
Engine Governed Speed Settings*	
Series NP45G.....	2160 rpm
Series NP55G.....	2571 rpm
Series NP65G.....	2805 rpm
Series NP52G.....	2300 rpm
Series NP66G.....	2700 rpm
Series NP72G.....	2900 rpm

* At the stated governed, no-load engine speed, the generator rotor will operate at 3600 rpm and a-c frequency will be about 60 Hertz.

Engine Torque Specifications

Engine Flywheel	125 foot-pounds
Cylinder Head.....	165 inch-pounds
Connecting Rod	115 inch-pounds
Crankcase Cover	150 inch-pounds
Governor Lever Lock Nut.....	70 inch-pounds
Spark Plugs	200 inch-pounds
Starter Mounting Bolts	140 inch-pounds

DIMENSIONS AND FEATURES:

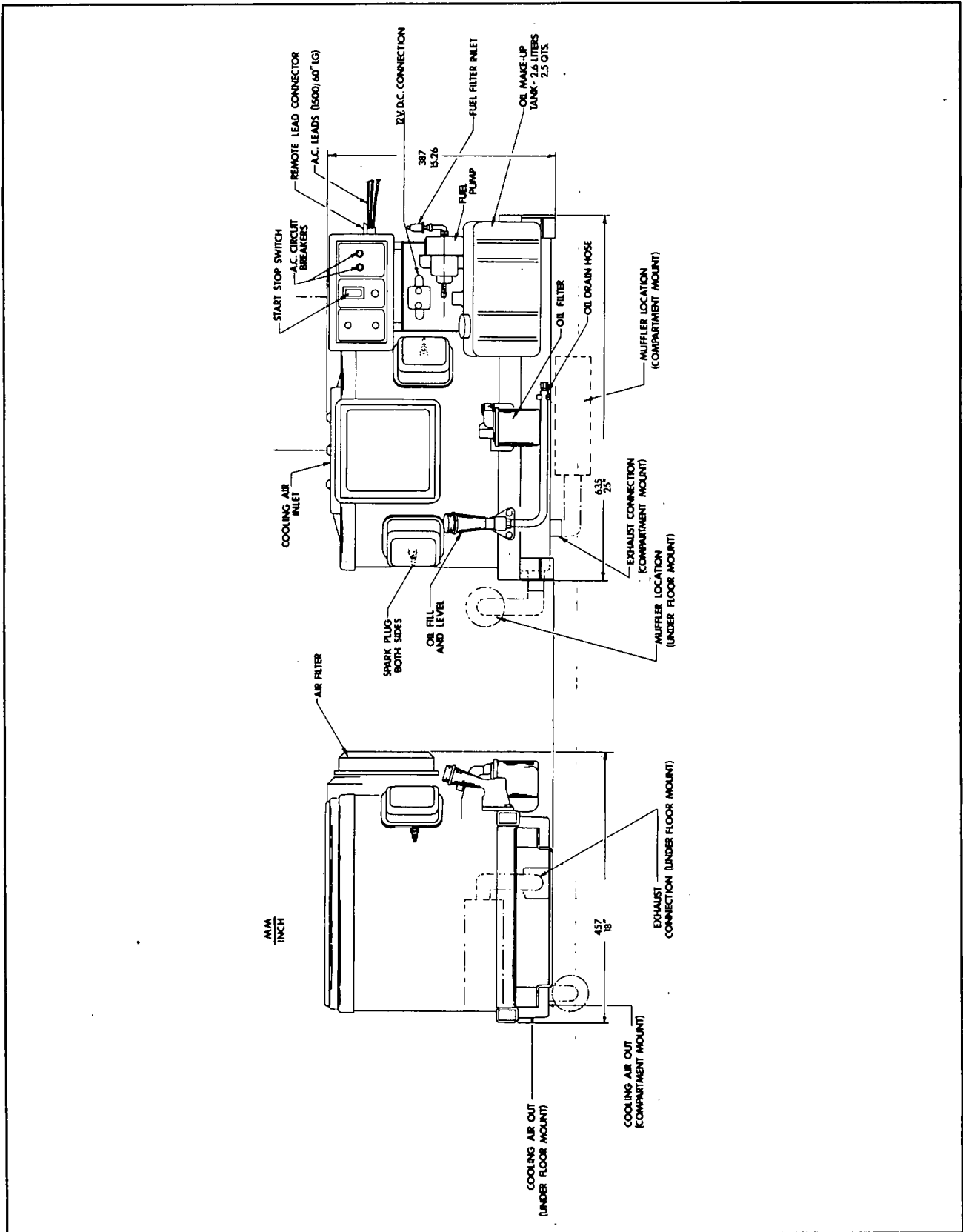

GENERATOR FEATURES:

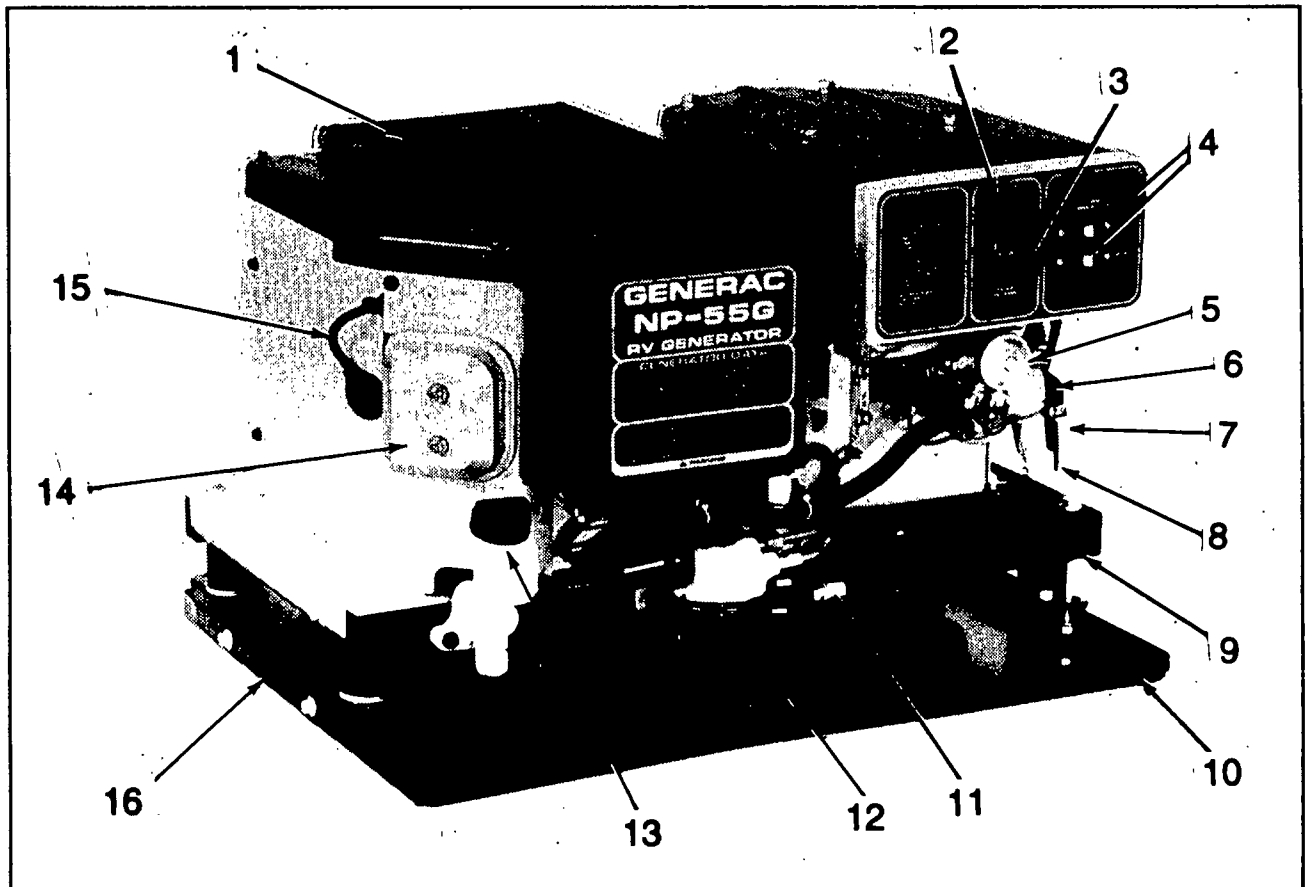

ITEM	NOMENCLATURE
1	Engine Air Inlet Screen
2	Engine Start/Stop Switch
3	15 amp d-c Circuit Breaker
4	Line Breakers
5	Starter Solenoid
6	Electric Fuel Pump
7	Inlet Fuel Filter
8	Fuel Supply Connection

ITEM	NOMENCLATURE
9	Mounting Base
10	Slide Tray
11	Oil Drain Hose
12	Oil Filter
13	Oil Fill Tube and Dipstick
14	Valve Cover
15	Spark Plug Lead
16	Exhaust Pipe

SOME ADDITIONAL FEATURES:

Low Oil Pressure Shutdown:

See Figure 1. An oil pressure switch is installed on the engine's oil filter body. The switch has normally-closed contacts which are held open by engine oil pressure during cranking and operation. Should oil pressure drop below approximately 2-6 psi, the switch contacts will close and an automatic engine shutdown will result.

High Temperature Shutdown:

See Figure 1. A high temperature switch is mounted on the engine oil filter body. Should oil temperature exceed approximately 284° F. (140° C.), the switch contacts will close and an automatic engine shutdown will occur.

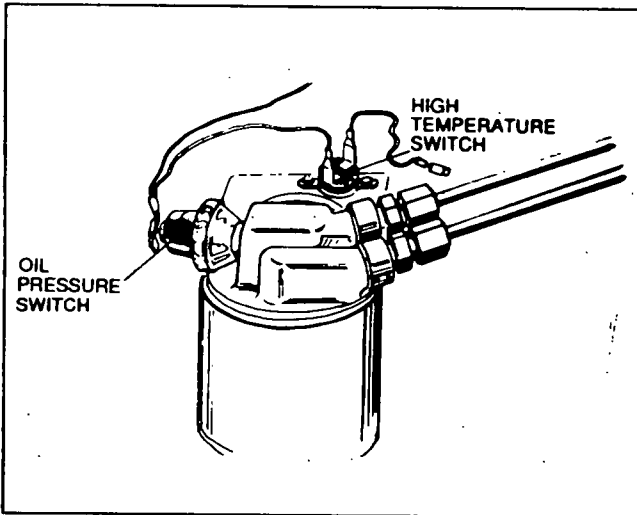

Figure 1. Oil Pressure & High Temperature Switches

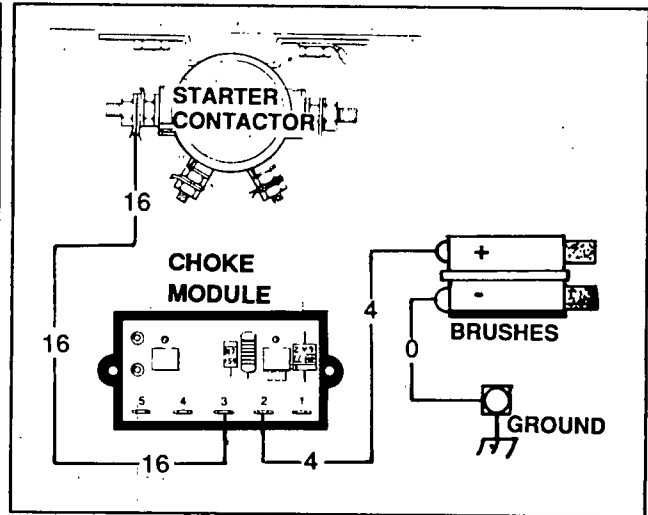

Figure 2. Field Boost Circuit

Field Boost:

See Figure 2. During engine cranking only, generator set battery voltage is delivered to the generator rotor, via wire 16, a field boost diode, and a field boost resistor. Resistor action reduces the voltage to approximately 9 volts d-c. This action "flashes the field" on every startup. The end result is to ensure that the rotor's magnetic field is sufficiently strong on startup to produce the required "pickup voltage" in the generator stator windings.

The field boost diode and resistor are housed in a solid state automatic choke module, but are not a part of the automatic choke operating circuit.

Overvoltage and Surge Protection:

The generator's solid state voltage regulator incorporates an overvoltage protection circuit, which prevents troublesome surges in generator AC output voltage. Voltage surge is a common cause of damage to such devices as television sets, VCR's, microwave ovens, etc.

Section Three Installation

GENERAL:

You will probably never have to install the generator into a recreational vehicle. But, you should be aware of some of the safety standards that govern such installations. For fire safety, the "NP" series generators must have been installed in strict compliance with (a) Article 551, ANSI C1-1975, (b) ANSI A119.2-1975/NFPA 501C-1974, STANDARD FOR RECREATIONAL VEHICLES (Part 3, Installation of Electrical Systems), and (c) the manufacturer's installation instructions. Once the installation has been completed, nothing must be done that might render the installation in non-compliance with applicable standards and instructions.

Generator installation will vary with each vehicle manufacturer. However, the basic installation requirements will remain the same.

COMPARTMENT INSTALLATIONS:

Two basic installation methods are (a) in a compartment and (b) under the floor. The compartment method of installation utilizes a specially constructed compartment which has been vapor sealed at all seams and joints. Vapor sealing will prevent entry of explosive, combustible or poisonous vapors into the vehicle interior. The compartment must be adequately supported by structural frame members. Openings must be provided in the compartment floor for the escape of engine-generator cooling and ventilating air. A typical compartment is shown in Figure 3, below. An air inlet opening must be provided, usually in the compartment door. The air inlet must provide a minimum free air inlet of at least 100 square inches. Restrictions offered by such materials as screening, louvers, expanded metal, etc., must be compensated for by making the actual air opening size proportionally larger.

UNDER-THE-FLOOR MOUNTING:

In some cases, the generator set may be suspended below the vehicle's horizontal support members as shown in Figure 4. When this is the case, the unit must be protected against road splash and debris. In addition, adequate cooling and ventilating air flow must be available to the installed unit.

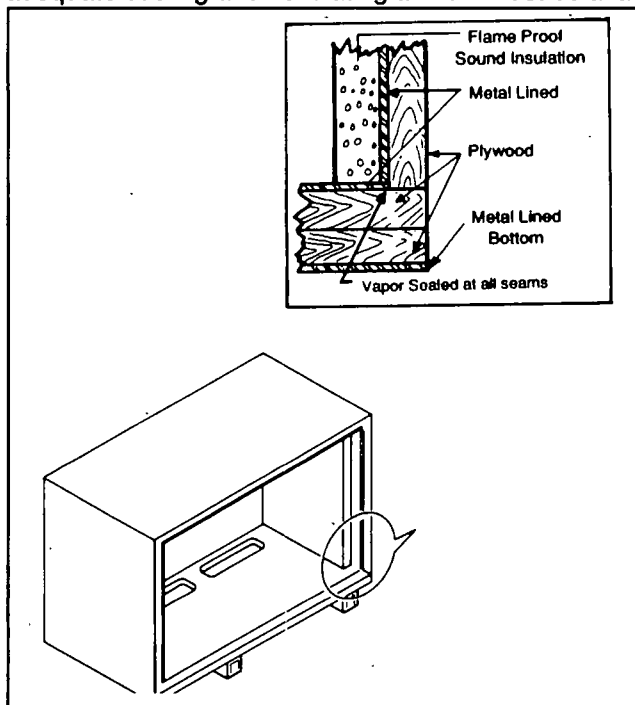

Figure 3. A Typical Generator Compartment

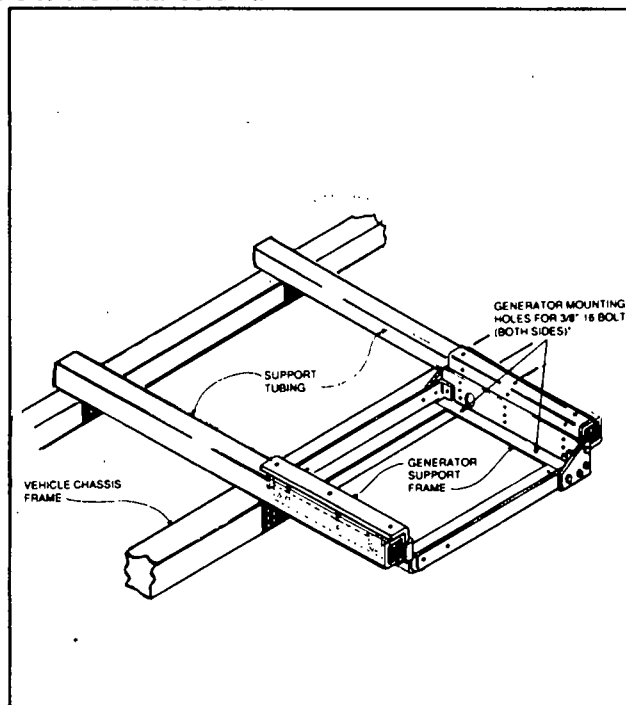

Figure 4. Typical Under-the-Floor Mounting System

EXHAUST SYSTEM:

The type of exhaust system used in an installation may be either (a) an "out-the-side" type or (b) an "out-the-bottom" type. Generally, an "out-the-side" type exhaust system is used in conjunction with an "under-the-floor" or "suspended" mounting system; the "out-the-bottom" type with a compartment type mounting system. Figures 5 and 6 below illustrate both types of exhaust system.

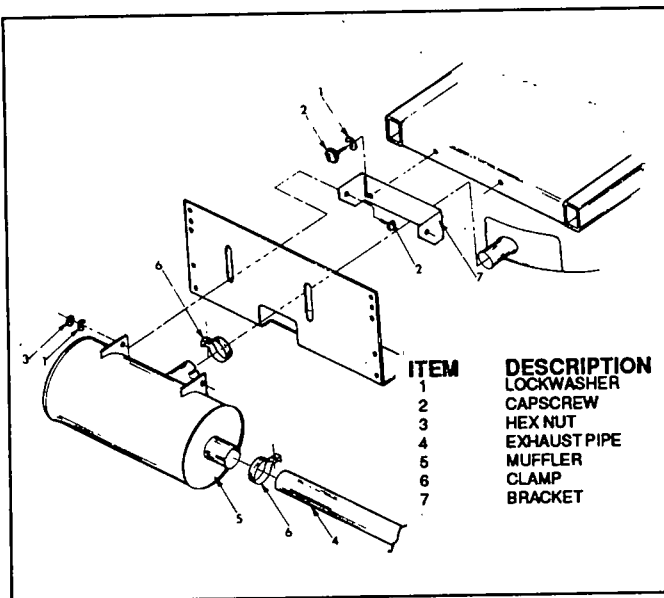

Figure 5. An Out-the-Side Exhaust System

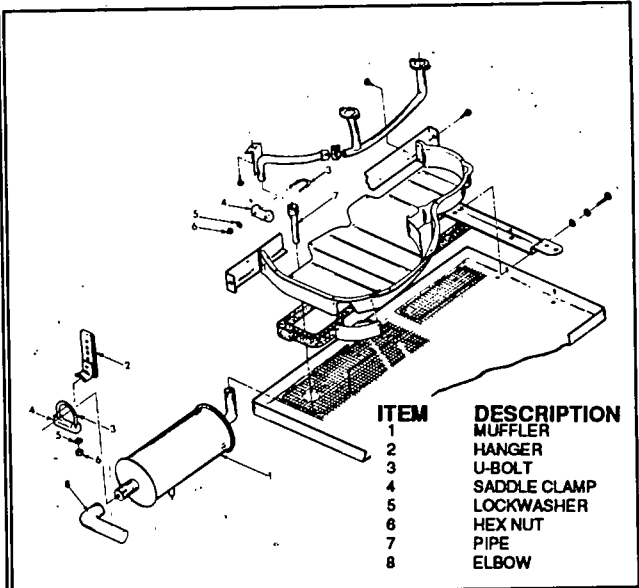

Figure 6. An Out-the-Bottom Exhaust System

RECONNECTION FOR DUAL VOLTAGE OUTPUT:

General:

In most cases, the generator is factory wired for a 120 volts AC output only. This arrangement is shown schematically in Figure 7. Note that the generator has a GROUNDING neutral.

Units may be reconnected for dual voltage output, if required. This is illustrated in Figure 8. Again, the neutral is grounded.

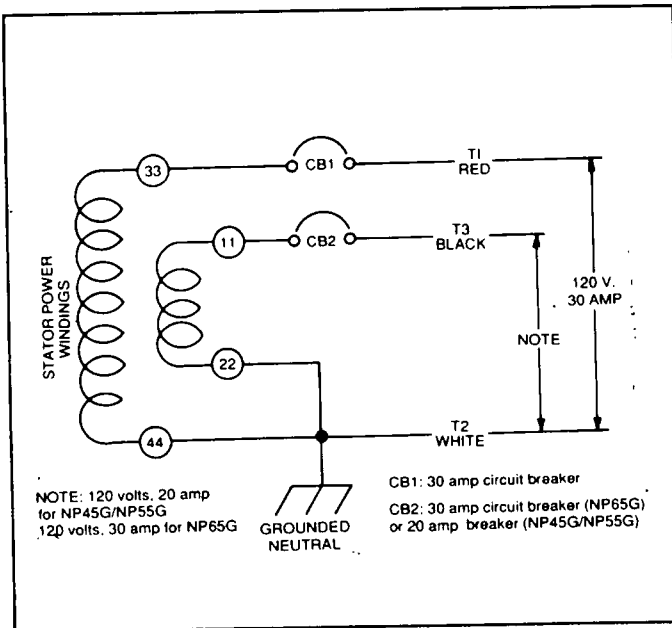

Figure 7. Connection for 120 Volts AC Only

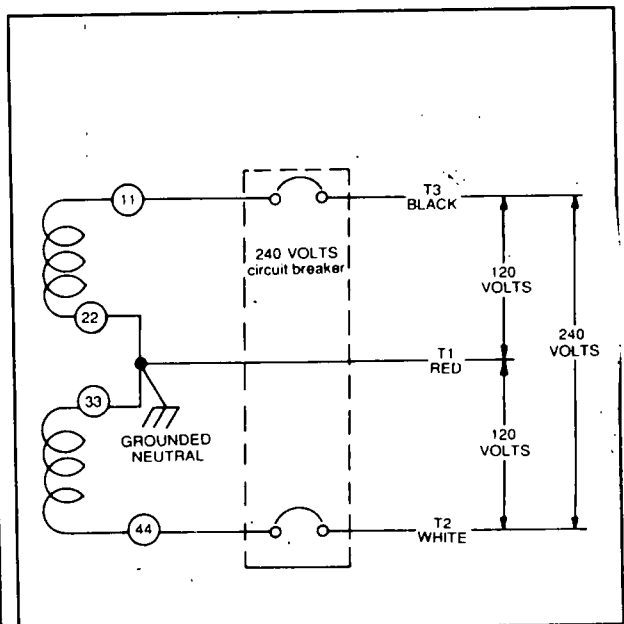

Figure 8. Reconnected for Dual Voltage Output

RECONNECTION FOR DUAL VOLTAGE OUTPUT (CONTINUED):

Circuit Breakers:

Some units will be equipped with both a 20 amp and a 30 amp main circuit breaker. Other units may have two 30 amp main breakers. When a unit has two 30 amp circuit breakers, the two original equipment breakers may be used for dual voltage output with a slight modification. However, when a unit is equipped with a 20 and a 30 amp main breaker, the existing breakers must be replaced with suitable 2-pole, 240 volts circuit breakers. Replacement breakers must provide adequate protection against overload and must come as two breakers in one, with a connection between the handles so both will operate simultaneously.

Reconnection Procedure:

1. Gain access to the generator panel interior by removing the generator cover and the front panel. See Figure 9.
2. See Figure 10. Locate stator leads 11 and 33 that connect to circuit breakers CB1 and CB2. Also locate leads T1 (red) and T3 (black). Disconnect all of these leads from the two circuit breakers.
3. Set aside the red (T1) and the black (T3) wires for later use.
4. Disconnect stator leads 22 and 44 from the grounding terminal (GT).
5. Disconnect one of the two white (T2) leads that attach to the grounding terminal (GT).
6. Install new breakers or, if existing breakers are both rated 30 amps, modify them by installing a rod or bolt between the two breaker handles. Both breakers must be "On" and "Off" at the same time. That is, both breakers must operate simultaneously.
7. See Figure 11. Connect stator a-c output leads 11 and 44 to the 2-pole circuit breaker as shown. Attach leads T1 (red) and T3 (black) to the circuit breaker as shown. Connect stator a-c output leads 22 and 33 together. From the junction of leads 22 and 33, route a wire to the grounding terminal (GT).
8. Reassemble the panel and generator cover after all connections are completed.

Conclusion:

See Figure 11. The red (T1) and black (T3) leads have become the two "hot" leads. The white (T2) lead has become the "Neutral" lead. Notice that "Neutral" is grounded.

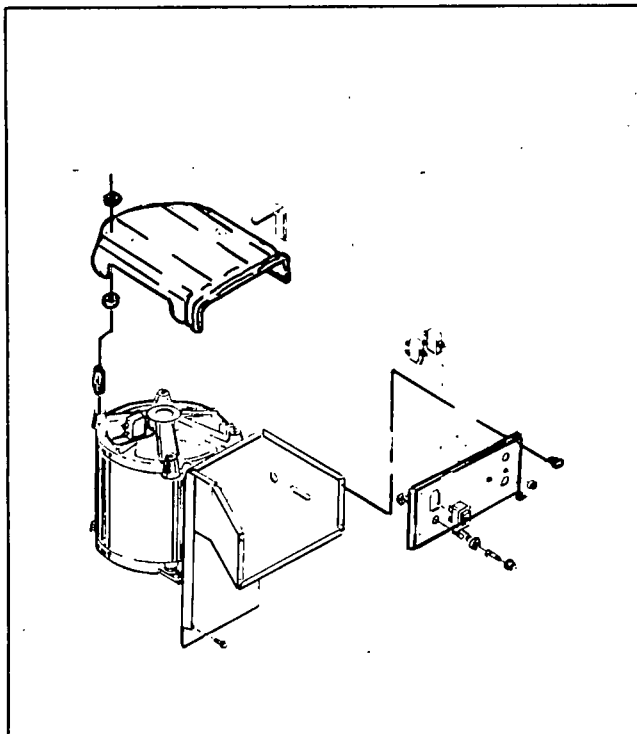

Figure 9. Cover and Panel Removal

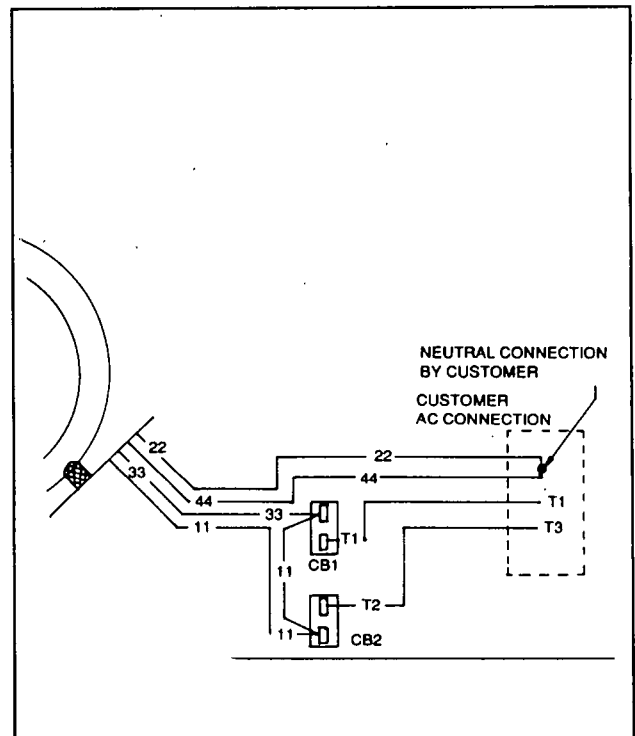

Figure 10. Wiring Connections- 120 Volts Output

RECONNECTION FOR DUAL VOLTAGE OUTPUT (CONTINUED):

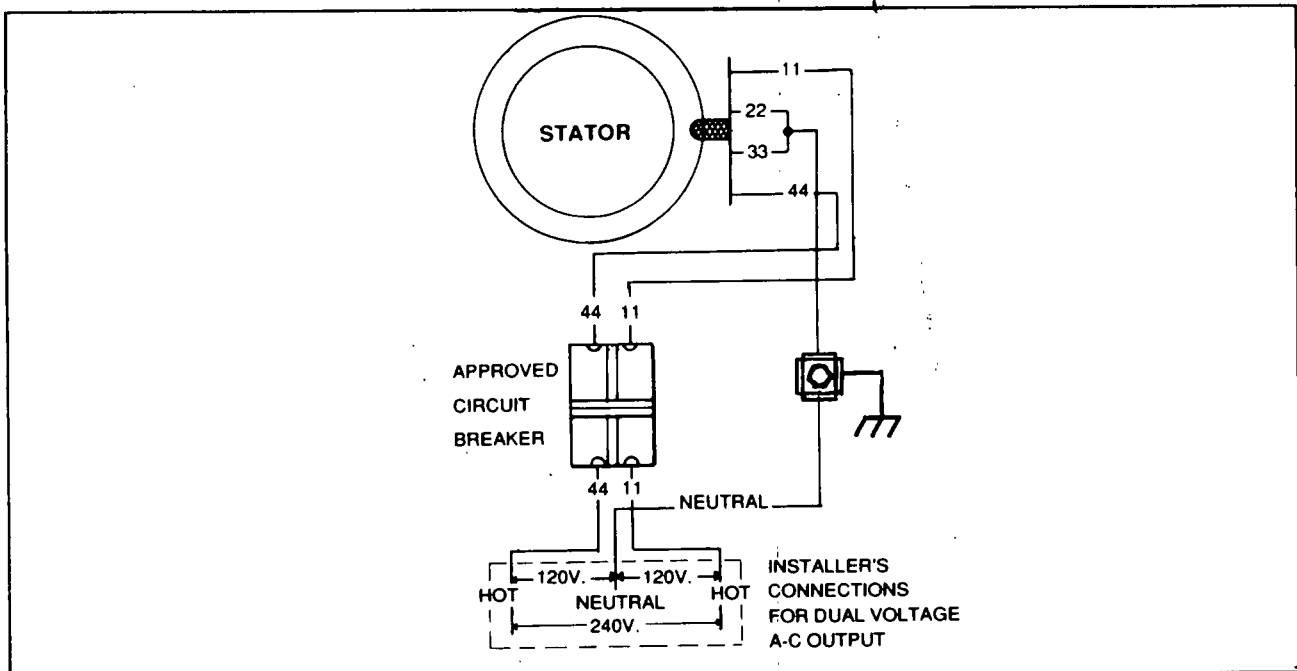

Figure 11. Wiring Connections for Dual Voltage Output

INSTALLATIONS WHEN A TRANSFER SWITCH IS USED:

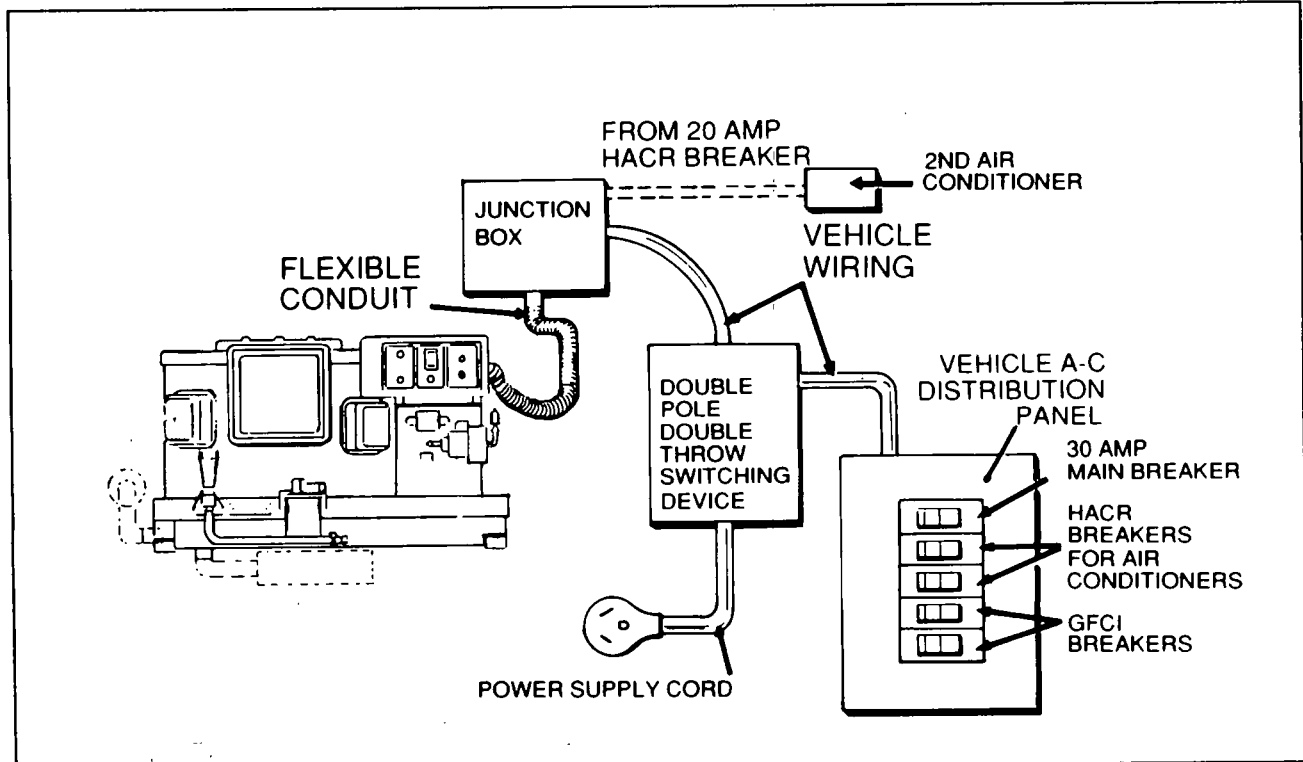

Figure 12. Interconnections with a Double Pole, Double Throw Transfer Switch

INSTALLATION WITH AN ISOLATION TYPE RECEPTACLE:

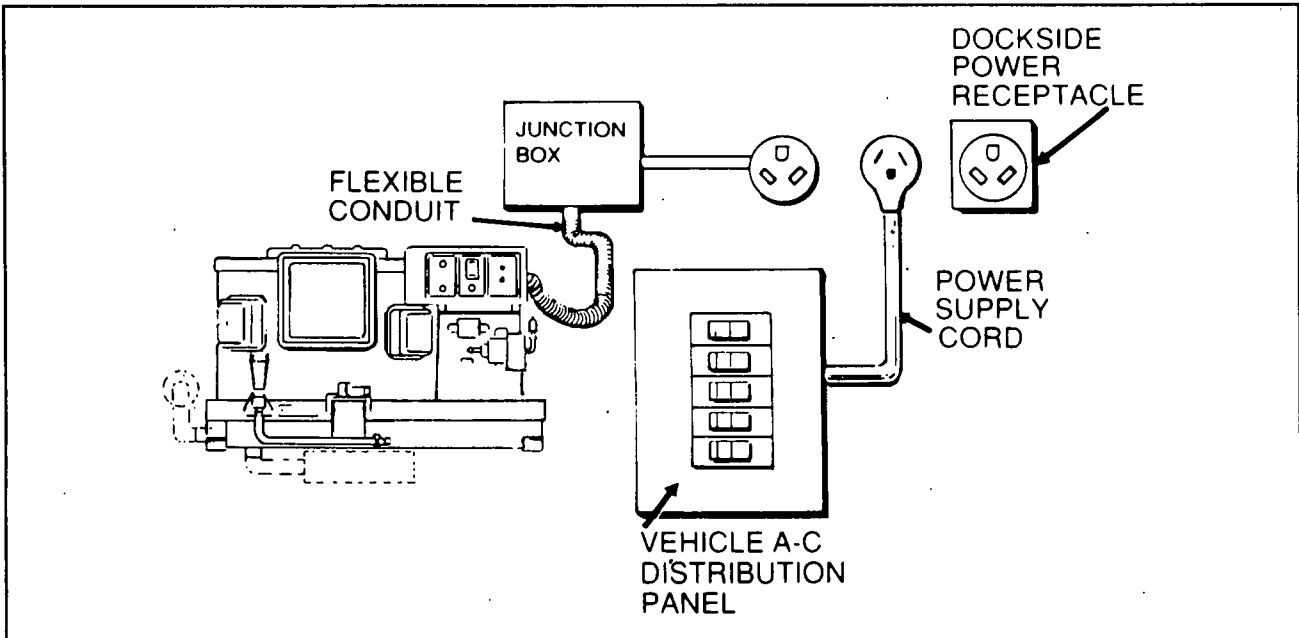

Figure 13. Typical Installation with Isolation Receptacle

BATTERIES:

Recommended Battery:

If prevailing ambient temperatures are above 32° F., use a battery rated 70 amp-hours and capable of delivering 360 cold cranking amperes.

When prevailing ambient temperatures are below 32° F., use a battery rated 95 amp-hours and capable of delivering 450 cold cranking amperes.

Battery Cables:

Using battery cables that are too long or too small in diameter can result in voltage drop. For best cold weather starting, voltage drop between the battery terminals and the generator should not exceed 0.12 volts per 100 amperes of cranking current. Select battery cables based on (a) cable length and (b) prevailing ambient temperatures. The following chart applies when selecting battery cables:

CABLE LENGTH FEET (METERS)	CABLE SIZE
0-10 (0-3)	2
11-15 (3-4.5)	0
16-20 (4.6-6)	000

Cable Connections:

The generator is negatively grounded. Connect battery cable from positive (+) battery post to the large terminal lug on starter contactor. Connect cable from negative (-) battery post to generator's frame ground connection. See Figure 14.

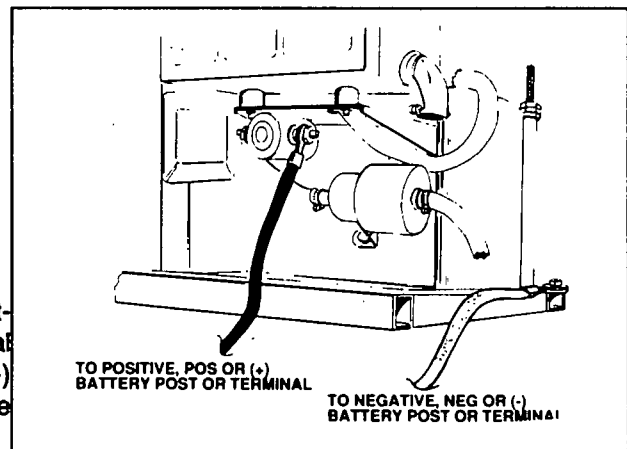

Figure 14. Battery Cable Connections

BATTERIES (CONTINUED):

Battery Compartment:

The RV generator requires its own battery. The generator should not be connected to the vehicle engine's battery. The generator battery should be installed in its own vented compartment having adequate ventilation openings at both the top and bottom of the compartment.

BONDING REQUIREMENTS:

Exposed non-current carrying parts of the generator set that are likely to become energized must have metal-to-metal contact or otherwise be electrically connected or bonded together to provide a common ground connection. If the generator is not mounted solidly to the vehicle frame or chassis, it must be provided with a designated bonding terminal. Such a bonding terminal should not be installed on any part of the unit that is disassembled during routine maintenance. The bonding terminal must be of adequate size to accept a flexible grounding conductor. The grounding conductor must be No. 8 AWG copper wire minimum.

OPTIONAL REMOTE START/STOP PANELS:

General:

Optional remote mounted panels are available that allow the generator to be started and stopped from some convenient location in the vehicle. Figure 16 shows the Model 9042 remote panel, which features a start/stop switch and a "generator run" advisory lamp. A Model 9043 remote panel is also available which mounts a start/stop switch, a lamp, and an hourmeter.

Remote Panel Connections:

A plug-in receptacle is located on the generator panel, next to the a-c connection leads. A mating connector plugs into the receptacle. Leads from the connector are routed through the vehicle and to the remote panel. See Figure 17. Figures 18 and 19 are connection diagrams for the Models 9042 and 9043 remote panels, respectively.

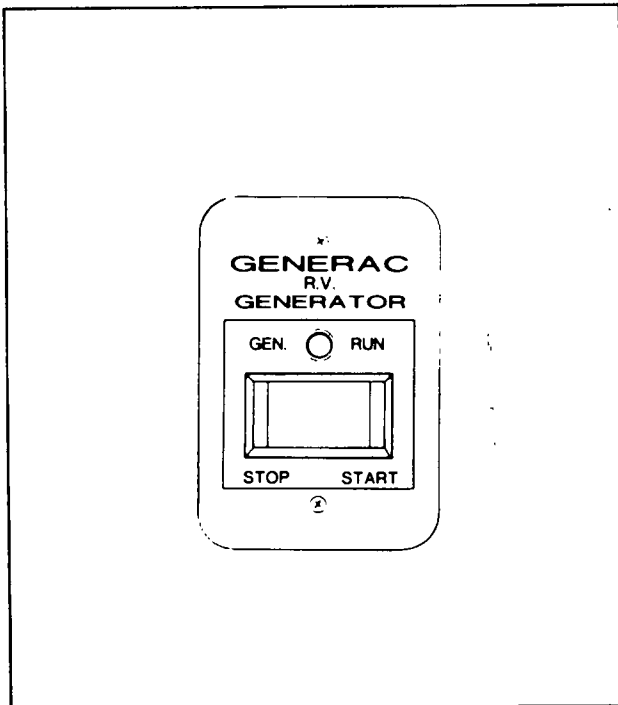

Figure 16. Model 9042 Remote Panel

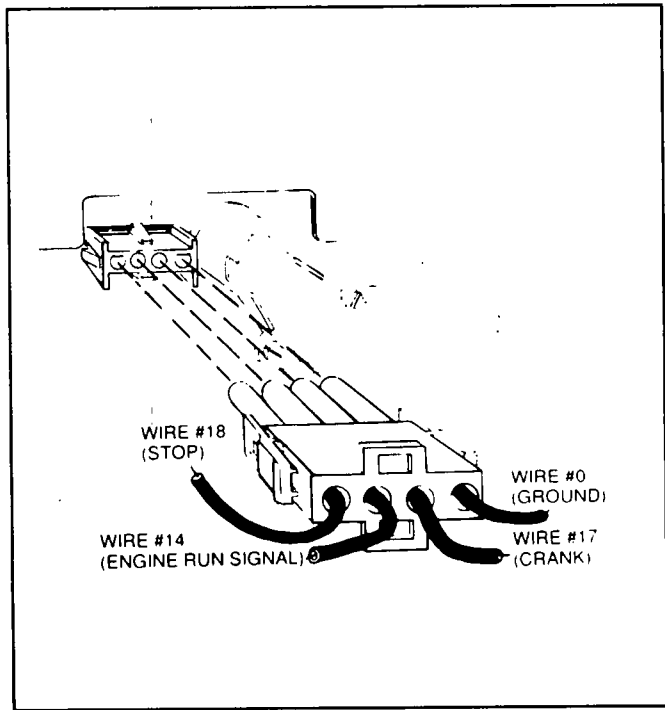

Figure 17. Remote Panel Receptacle and Connector

OPTIONAL REMOTE START/STOP PANELS (CONTINUED):
Remote Panel Connections (Continued):

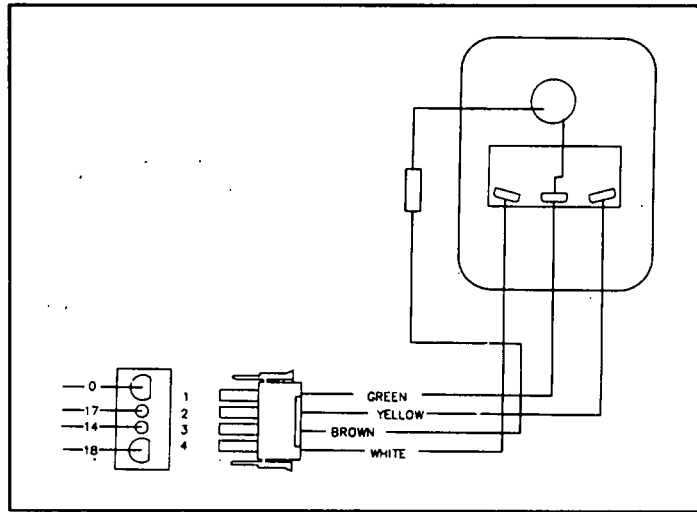

Figure 18. Model 9042 Connection Diagram

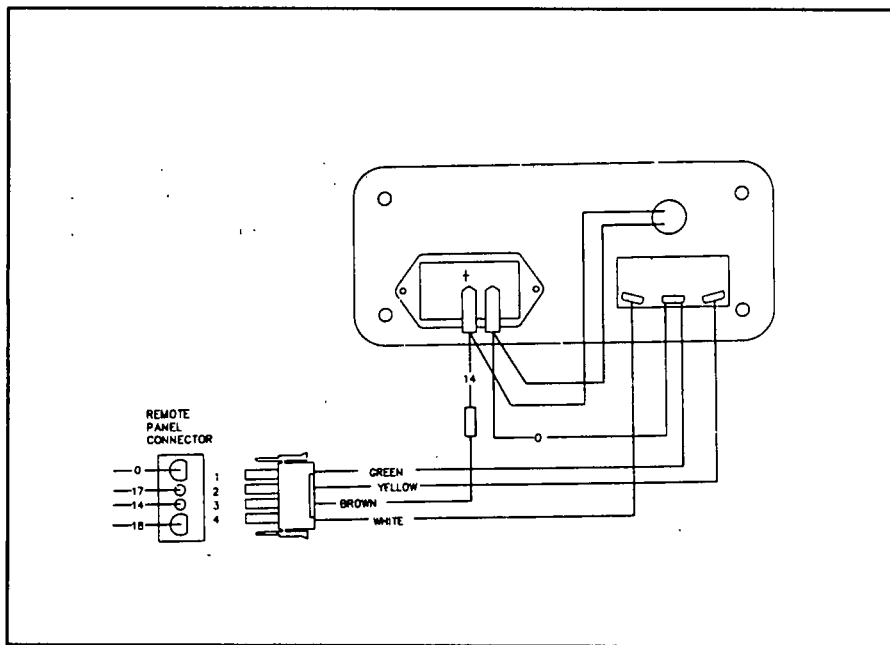

Figure 19. Model 9043 Connection Diagram

Section Four Operating Instructions

BEFORE STARTUP:

General:

Prior to starting the generator engine, check the installation over. You may wish to review the information in Section three. A careful examination of the installation is a safety precaution, to prevent damage to the generator and/or vehicle that might be caused by a faulty installation. Perform the following checks:

- Check air inlet and outlet openings. These openings must be properly sized to provide sufficient cooling and ventilating air flow for generator operation.
- Inspect wiring connections. Make sure they comply with code and are safe.
- Check the generator exhaust system. Never operate a generator having defective exhaust piping or muffler.
- Inspect the engine-generator assembly. Never operate a damaged or defective unit.

Engine Preparation:

Before starting the engine, be sure to check engine oil level. Also make sure an adequate supply of the proper fuel is available for generator set operation.

A gasoline fuel system is standard equipment. Some vehicles may have a separate fuel tank for the generator. Other vehicles may "share" the vehicle engine's fuel tank. The generator engine will perform satisfactorily on any high quality UNLEADED gasoline. Leaded REGULAR grade gasoline is an acceptable substitute. Do NOT use any highly leaded premium gasoline. Use of any gasoline containing alcohol, such as "gasohol", is NOT recommended.

Some generators may be equipped with an optional propane gas fuel system. Propane gas is usually supplied as a liquid in pressure tanks.

Remove the oil dipstick and check engine oil level. Recommended is any high quality detergent oil classified "For Service SF" and having a viscosity rating of SAE 10W-30. Engine crankcase oil capacity is 1-1/2 U.S. quarts.

GENERATOR CONTROL PANEL:

Start/Stop Switch:

See Figure 20. Hold the start/stop switch at "Start" to crank and start engine. Release the switch to its centered or "Run" position when the engine starts. To stop an operating engine, hold the switch at "Stop" until engine comes to a complete stop. The engine is equipped with an automatic choke, so there is no choke to set manually. More on the automatic choke can be found in Section 5, "Adjustments".

15 Amp Fuse:

This fuse protects the engine DC control circuit against overload. If the fuse has blown, engine cranking and startup will not be possible. When replacing the fuse, use only an identical 15 amp replacement fuse. You will find additional information on the d-c control circuit and the role of the 15 amp fuse in Section 6, "DC Circuits Operational Analysis".

Line Breakers:

The line breakers protect the generator AC output circuit against overload. Some units will have a 30 amp and a 20 amp fuse. Other units will have two 30 amp breakers. If the a-c wiring has been reconnected for dual voltage output (see Pages 8, 9 and 10), the two line breakers may have been replaced with a single two-pole breaker having a different rating.

GENERATOR CONTROL PANEL (CONTINUED):

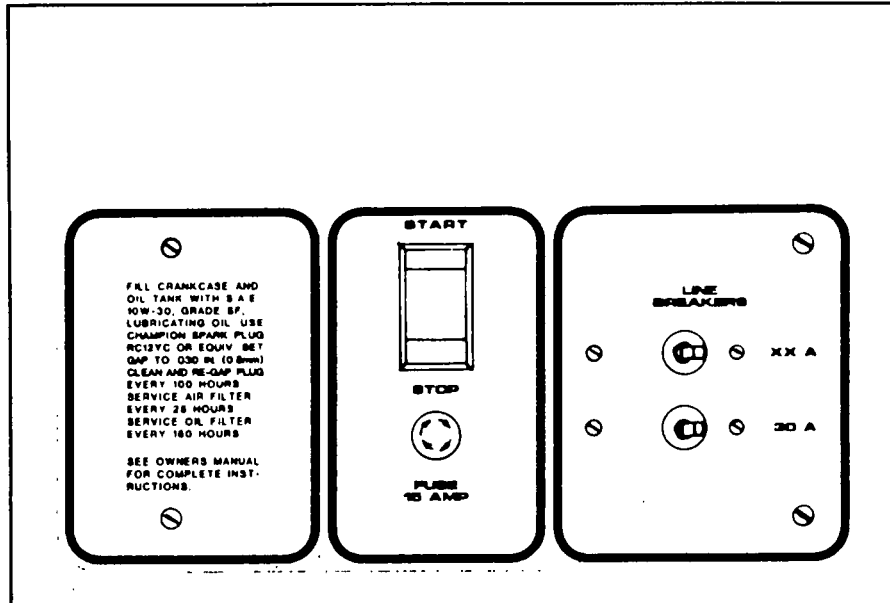

Figure 20. Typical Control Panel

STARTING THE GENERATOR:

To crank and start the generator, proceed as follows:

1. Set the line breaker(s) to their "Off" or "Open" position.
2. To crank and start engine, hold the start/stop switch at "Start". Release the switch when the engine starts.
3. Connect the generator a-c output to the vehicle load circuits.
 - a. If vehicle is equipped with an isolating transfer switch, actuate that switch to its "Generator" position. See "Installations when a Transfer Switch is Used" on Page 10.
 - b. If the vehicle has an isolating receptacle, plug the external power cord into the generator receptacle. See "Installation with an Isolation Type Receptacle" on Page 11.
4. Let the generator engine stabilize and warm up.
5. Set the line breaker(s) to their "On" or "Closed" position. Vehicle circuits are now powered by the generator set.

STOPPING THE GENERATOR:

1. Set the line breaker(s) to "Off" or "Open".
2. Let the engine run at no-load for a minute or two, to stabilize internal temperatures.
3. Hold the start/stop switch at "Stop". Wait for engine to come to a complete stop.

Section Five Adjustments

CARBURETOR ADJUSTMENT:

See Figure 21. To adjust idle mixture, turn the idle mixture screw clockwise until it just seats. Then, turn the screw counterclockwise 1-1/4 turns.

There is no main jet adjustment. That jet is fixed and tested up to 8000 feet altitude.

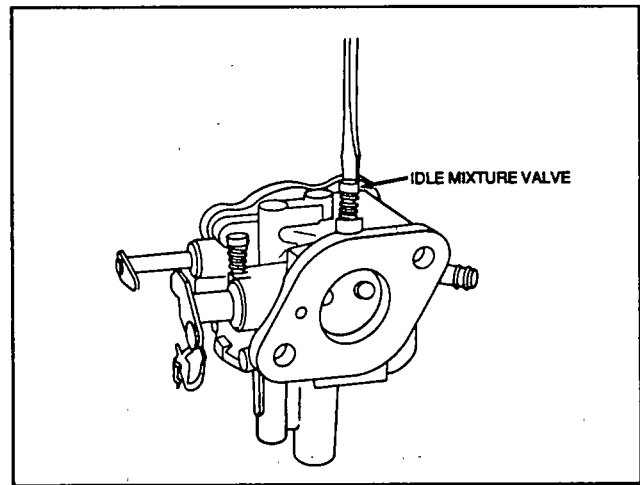

Figure 21. Carburetor Adjustment

AUTOMATIC CHOKE ADJUSTMENT:

See Figure 22. The choke solenoid and choke heater are one assembly and both are adjustable.

To Adjust the Choke Solenoid:

Push choke solenoid plunger in until it bottoms out. With plunger bottomed, the carburetor choke plate should be closed. If it is not fully closed, loosen two solenoid screws and reposition the solenoid until choke plate is fully closed. Then, tighten the solenoid screws.

To Adjust Choke Heater:

With engine cold and solenoid NOT actuated, check position of carburetor choke plate. The choke plate should be 1/8 inch from its full open position. If adjustment is off by a small amount, tip of bi-metal may be bent to obtain proper setting. If off by a large amount, loosen two heater set screws. Reposition the heater and tighten the two set screws.

Choke Operation:

Observe automatic choke operation while cranking the engine. The choke solenoid should energize and choke plate should close for about 0.2 to 0.4 seconds. The choke solenoid should then de-energize and choke plate should open for about 2 seconds. This cyclic action should repeat until the engine starts and cranking is terminated.

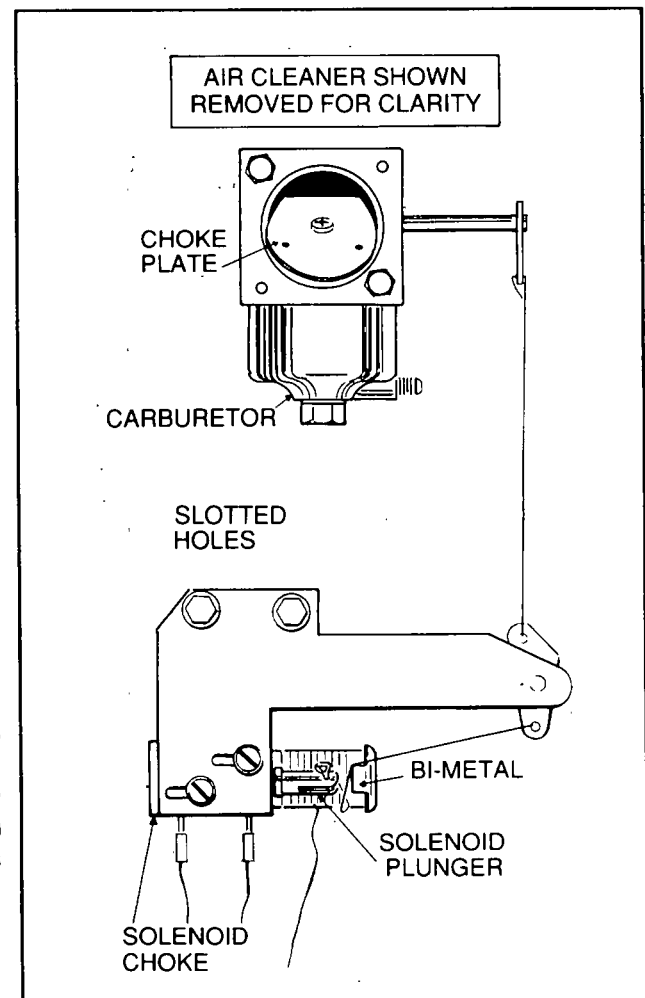

Figure 22. Automatic Choke

ENGINE IGNITION SYSTEM ADJUSTMENTS:

Spark Plug Gap:

Set spark plug gap to 0.030 inch. Refer to Section 2, "Specifications" for recommended spark plugs and spark plug tightening torque.

Ignition Module Air Gap:

See Figure 24. Place a piece of 0.008-0.010 shim stock between the ignition module (or armature) and the flywheel. Loosen mounting screws and let the magnet pull the armature down against the shim stock. Then, tighten both mounting screws. Rotate the flywheel to remove shim stock.

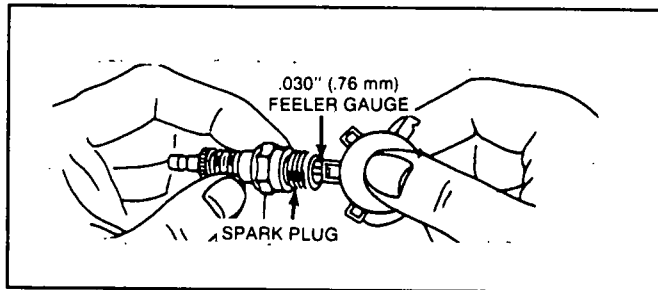

Figure 23. Setting Spark Plug Gap

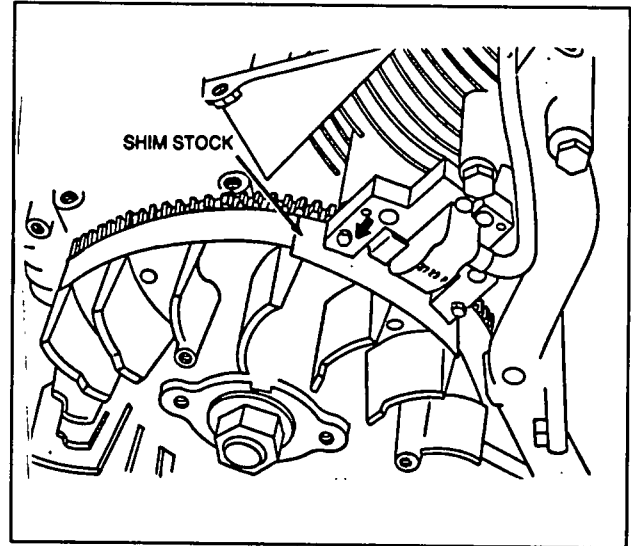

Figure 24. Ignition Module Air Gap

VALVE ADJUSTMENT:

To adjust the valves, the valve covers must be removed (Figure 25). Once that is done, adjust the valves as follows (see Figure 26):

- Turn the crankshaft until piston in cylinder being checked is at top dead center (TDC) of its compression stroke.
- Insert a screwdriver through spark plug hole so that it contacts the piston. Turn the crankshaft past top dead center until piston has moved downward 1/4 inch (6.35mm).
- Insert a feeler gauge between valve stem and rocker arm. Clearance should be 0.004-0.006 inch (0.10-0.16mm). Adjust clearance as required until it is correct.
- When clearance is correct, hold the adjusting screw and tighten locknut to 60 inch-pounds torque.
- Recheck valve clearance and readjust if needed.

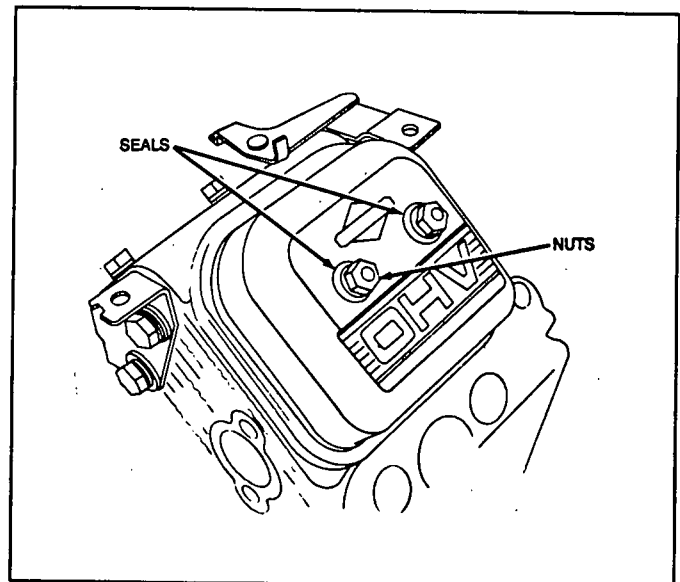

Figure 25. Engine Valve Cover

VALVE ADJUSTMENT (CONTINUED):

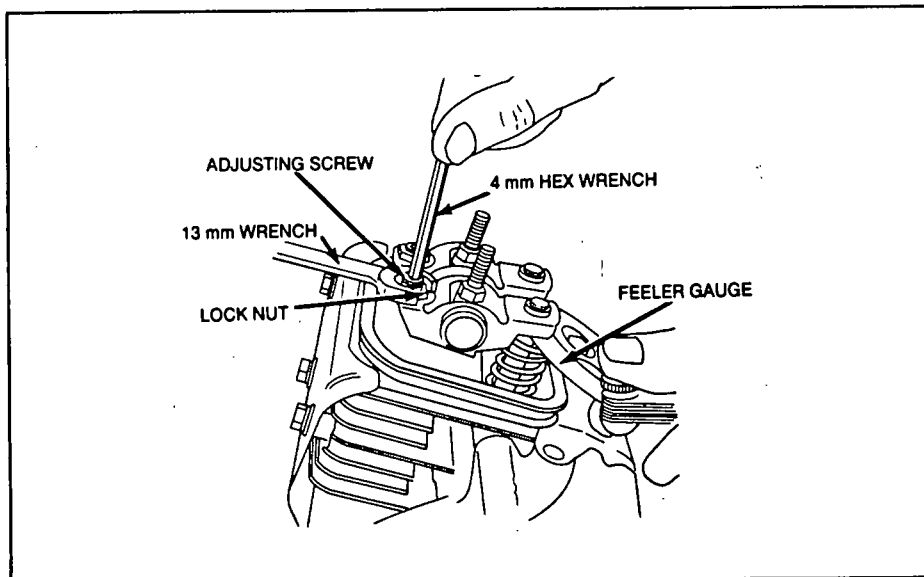

Figure 26. Adjusting the Valves

ADJUSTING DRIVE BELT TENSION:

The generator drive belt should require adjustment only when a new belt is installed or when belt tensioning hardware has been removed. First, adjust the spring on four stator can bolts to a length of 13mm (1/2 inch). Then, adjust two sets of springs on the side of the generator to a length of 16mm (5/8 inch). This will provide proper belt tension.

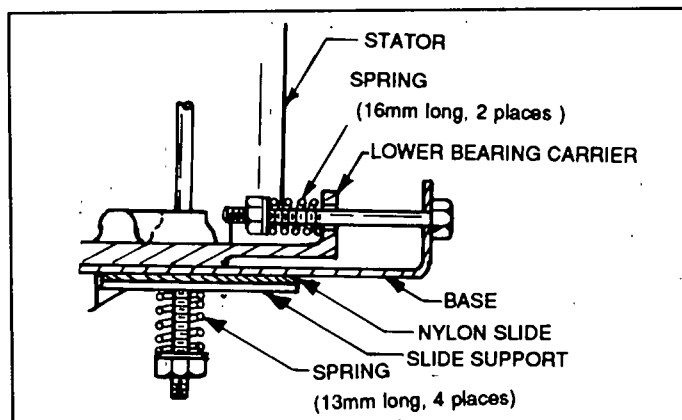

Figure 27. Drive Belt Adjustment

ENGINE GOVERNOR ADJUSTMENT:

General:

The engine governor must be adjusted with the generator set in a "No-Load" condition. The no-load governed speed is correct when generator AC frequency is about 62 Hertz, as measured with an a-c frequency meter. If a tachometer device is used to measure engine speed, keep in mind that engine speed will be different between models. See "Engine Governed Speed Settings" on Page 3.

Initial Adjustment:

Refer to Figure 28. Visually inspect the anti-lash spring. Make sure it is not broken or disengaged. Spring ends must be hooked into the governor lever and into the carburetor throttle lever.

Loosen the governor clamp nut. Hold the governor lever in its wide open throttle position, then use a screwdriver to rotate the governor shaft fully counterclockwise. Hold this position and tighten the governor clamp nut to 70 inch-pounds torque.

ENGINE GOVERNOR ADJUSTMENT (CONTINUED):

Final Adjustment:

- If an AC frequency meter is to be used as an indicator of correct speed, connect the meter across the generator's AC output leads.
- Start the engine, let it stabilize and warm up. Both line breakers should be set to their "Off" or "Open" position.
- Turn the adjuster nut to obtain a frequency reading of 62 Hz. If an engine tachometer device is used to indicate engine speed, set the engine speed as follows:
 - Series NP45G = 2160 rpm
 - Series NP55G = 2571 rpm
 - Series NP65G = 2805 rpm
 - Series NP52G = 2300 rpm
 - Series NP66G = 2700 rpm
 - Series NP72G = 2900 rpm
- Determine if the governor spring is properly located in the notched teeth of the governor adjustment bracket as follows:
 - a. If droop is excessive, move the governor spring to the left (toward the governor shaft) on the notched teeth.
 - b. For greater stability, move the governor spring to the right on the notched teeth.
- After repositioning the governor spring on the notched teeth, recheck frequency (or rpm) and, if necessary, readjust the adjuster nut to 62 Hertz or to the correct engine speed.
- When frequency is correct, check the generator's AC output voltage. If voltage is incorrect, the voltage regulator may require adjustment. Regulator is housed in the generator control panel.

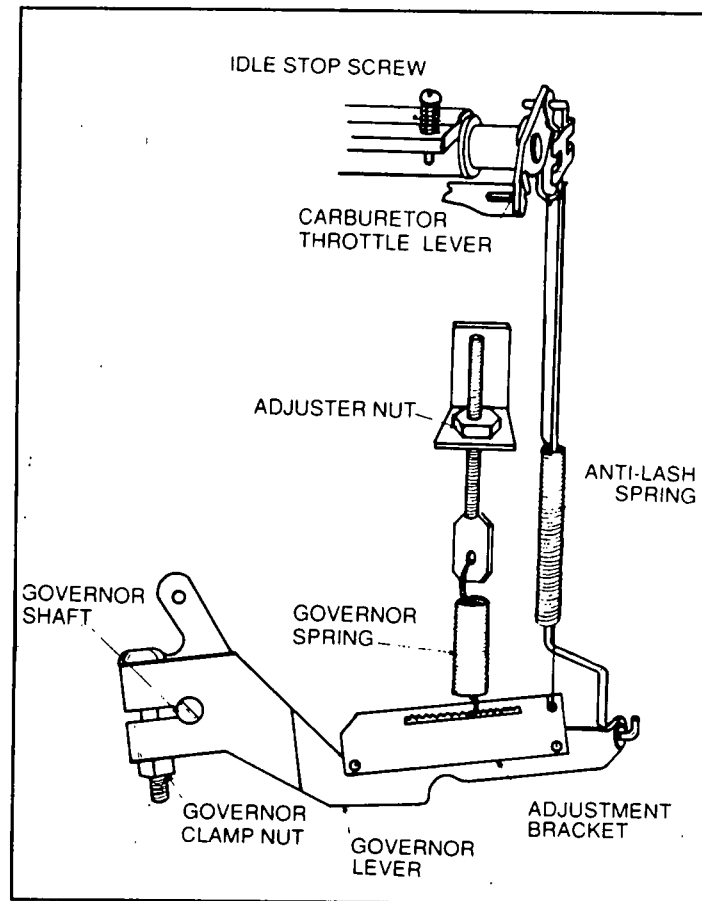

Figure 28. Engine Governor Adjustment

Section Six D-C Circuits Operational Analysis

CIRCUIT CONDITION- ENGINE SHUT DOWN:

- Battery voltage is available to the normally-open contacts of the starter contactor (SC). However, the contacts are open and the circuit is incomplete.
- Battery voltage is available through the 15 amp fuse (F1) and to the normally-open contacts of a control relay (CR1). The relay contacts are open and the circuit is incomplete.
- Fused battery voltage is available to the start/stop switch via the normally-closed contacts of control relay (CR1), wire 56, a starter contactor (SC) coil and wire 17. The start/stop switch is centered and the circuit is incomplete.
- Fused battery voltage is available to the start/stop switch via wire 15, control relay (CR2) coil, and wire 17. With the start/stop switch centered, the circuit is incomplete.
- Fused battery voltage is available to a battery charge rectifier (BCR) via wire 15. However, diode action inhibits current flow in this direction.

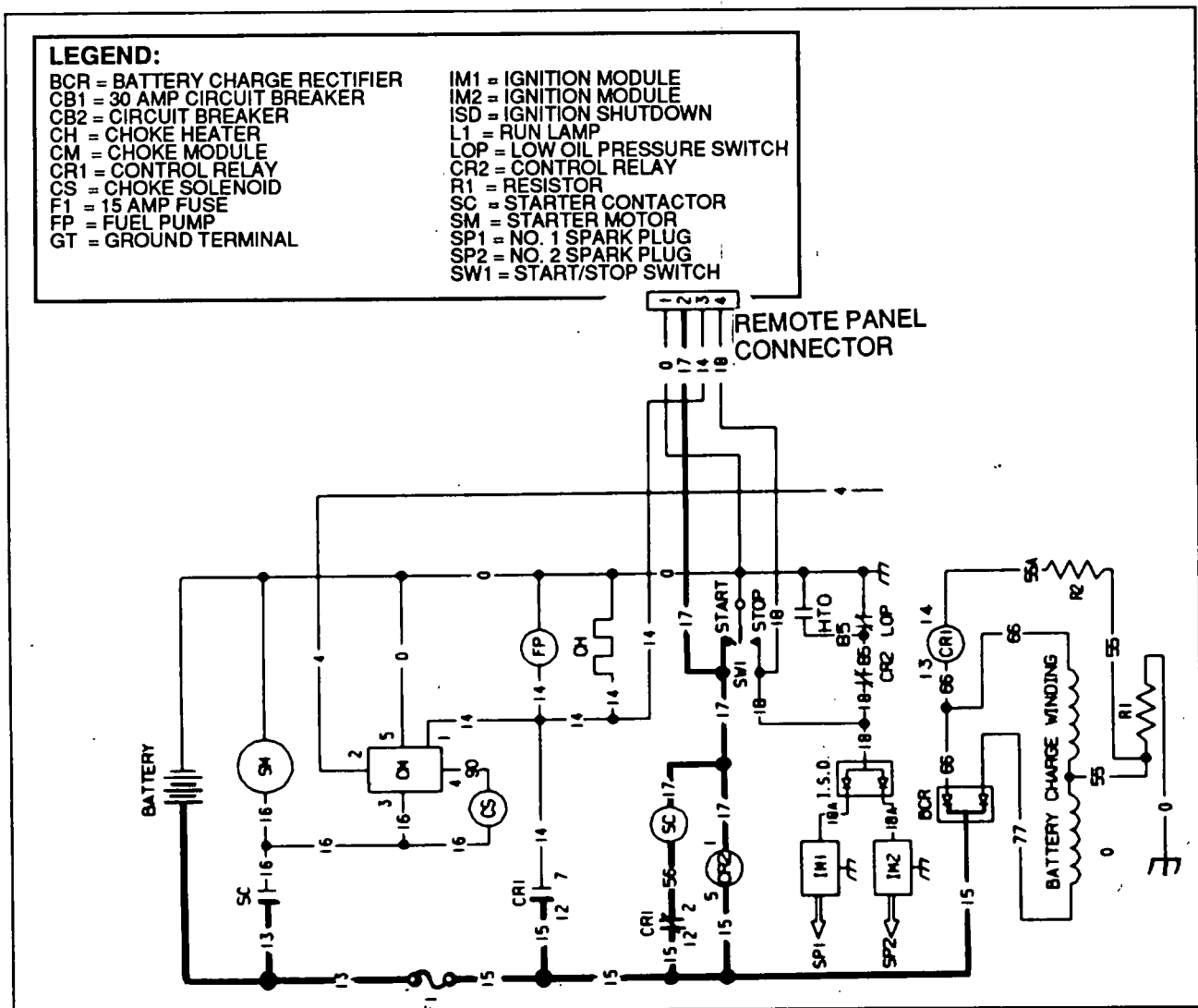

Figure 29. Circuit Condition- Engine Shut Down

CIRCUIT CONDITION- ENGINE CRANKING:

When the start/stop switch (SW1) is held at "Start" position, the following sequence of events will occur:

- Switch contacts closure to the "Start" side connects the actuating coils of control relay (CR2) and the starter contactor (SC) to ground.
- Starter contactor (SC) energizes and its normally-open contacts close to energize (a) starter motor (SM). With SC energized, battery voltage is also delivered through choke solenoid (CS) and to a choke module (CM). The starter motor (SM) energizes and the engine cranks. Choke module (CM) action opens and closes the choke solenoid (CS) circuit to ground at a rate dependent on ambient temperature. The latter causes the choke solenoid to open and close the carburetor choke.
- Battery voltage is delivered to the choke module (CM) via wire 16. This voltage is delivered through a field boost diode and resistor housed in the choke module (CM), and then to the rotor via wire 4. This is field boost voltage.
- Battery voltage is available to a fuel pump (FP) from choke module (CM), via wire 14. The fuel pump operates. Wire 14 also delivers battery voltage to a choke heater (CH), to establish amount of choke closure while cranking.
- Control relay (CR2) energizes, its normally-closed contacts open, and the wire 18 circuit is isolated from frame ground. Ignition can now occur since that circuit is now open to ground.
- Fuel flow, ignition and automatic choking are all available and the engine will start.
- Engine oil pressure opens the oil pressure switch (LOP) contacts.

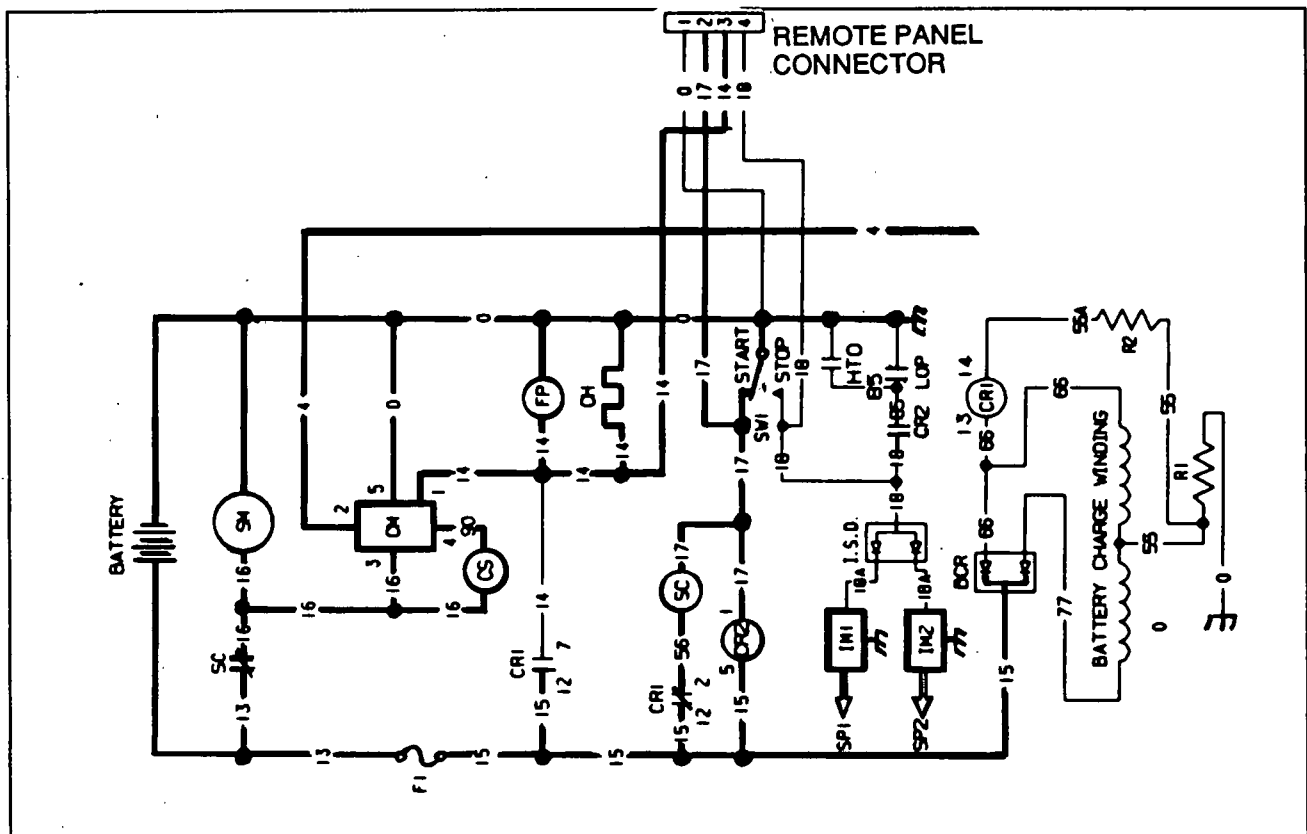

Figure 30. Circuit Condition- Engine Cranking

CIRCUIT CONDITION- STARTUP AND RUNNING:

When the engine fires and starts, the operator will release the start/stop switch, to open its contacts. Circuit condition may then be described as follows:

- When AC output from the generator's battery charge windings reaches approximately 9-12 volts AC, control relay (CR1) will energize and its normally-open contacts will close. Closure of the relay (CR1) contacts will deliver fused battery voltage to the fuel pump (FP) and to the choke heater (CH). The fuel pump continues to operate. The choke heater will establish an amount of choke plate opening based on ambient temperature and will allow the choke plate to open gradually as the choke heater (CH) warms up.
- The starter contactor (SC) circuit to ground is opened and SC de-energizes. With the SC contacts open, starter motor (SM) de-energizes and cranking ends.
- With relay (CR1) energized, its normally-closed contacts open to prevent the starter contactor (SC) from being energized while engine is running.
- With starter contactor (SC) de-energized, its contacts open. Choke action terminates, field boost ends and current flow through wire 14 from the choke module (CM) ends.
- Stator battery charge output is delivered to the battery, via wires 66 and 77, battery charge rectifier, and wire 15.

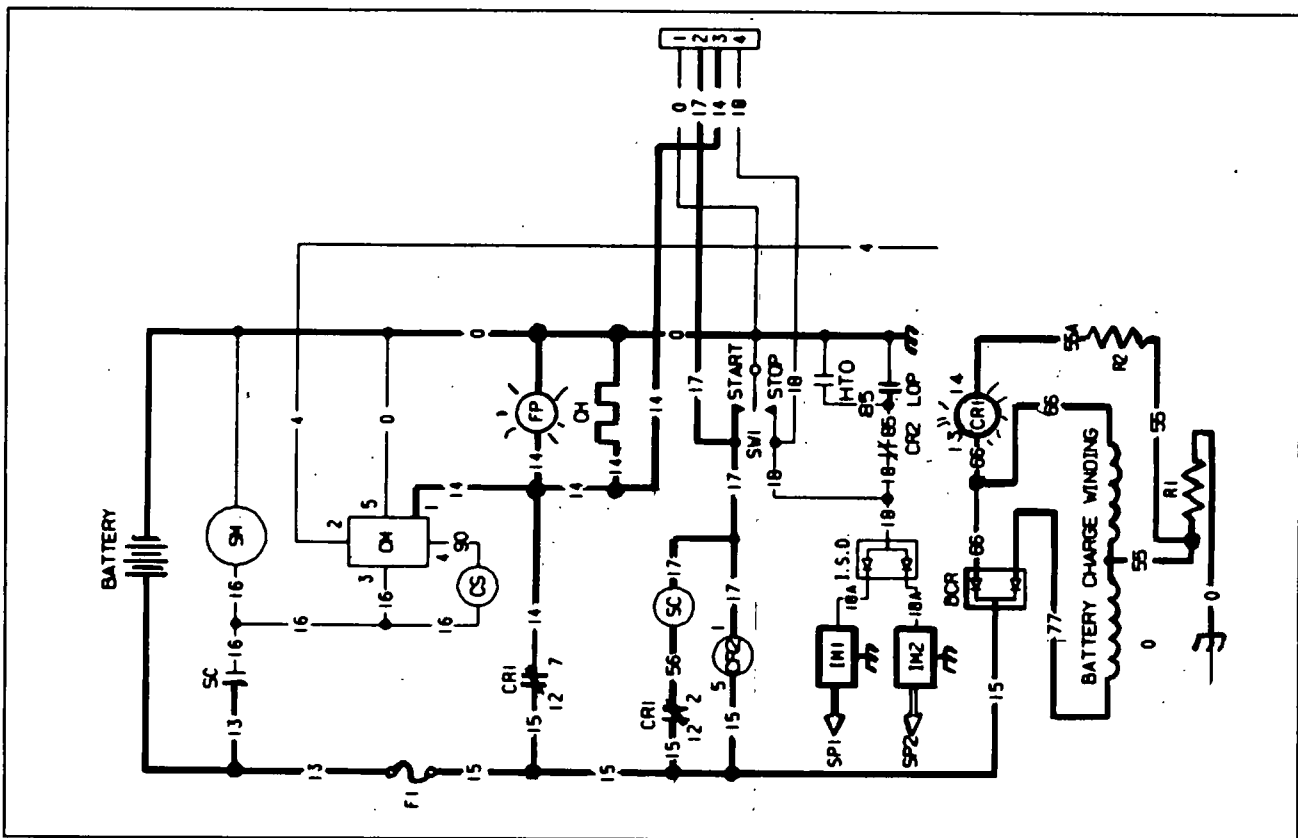

Figure 31. Circuit Condition- Startup and Running

CIRCUIT CONDITION- NORMAL SHUTDOWN:

Closure of the start/stop switch to its "Stop" position provides a ground for the engine ignition circuit, via wire 18 from the ignition shutdown module (ISD). Ignition ends and the engine will then shut down.

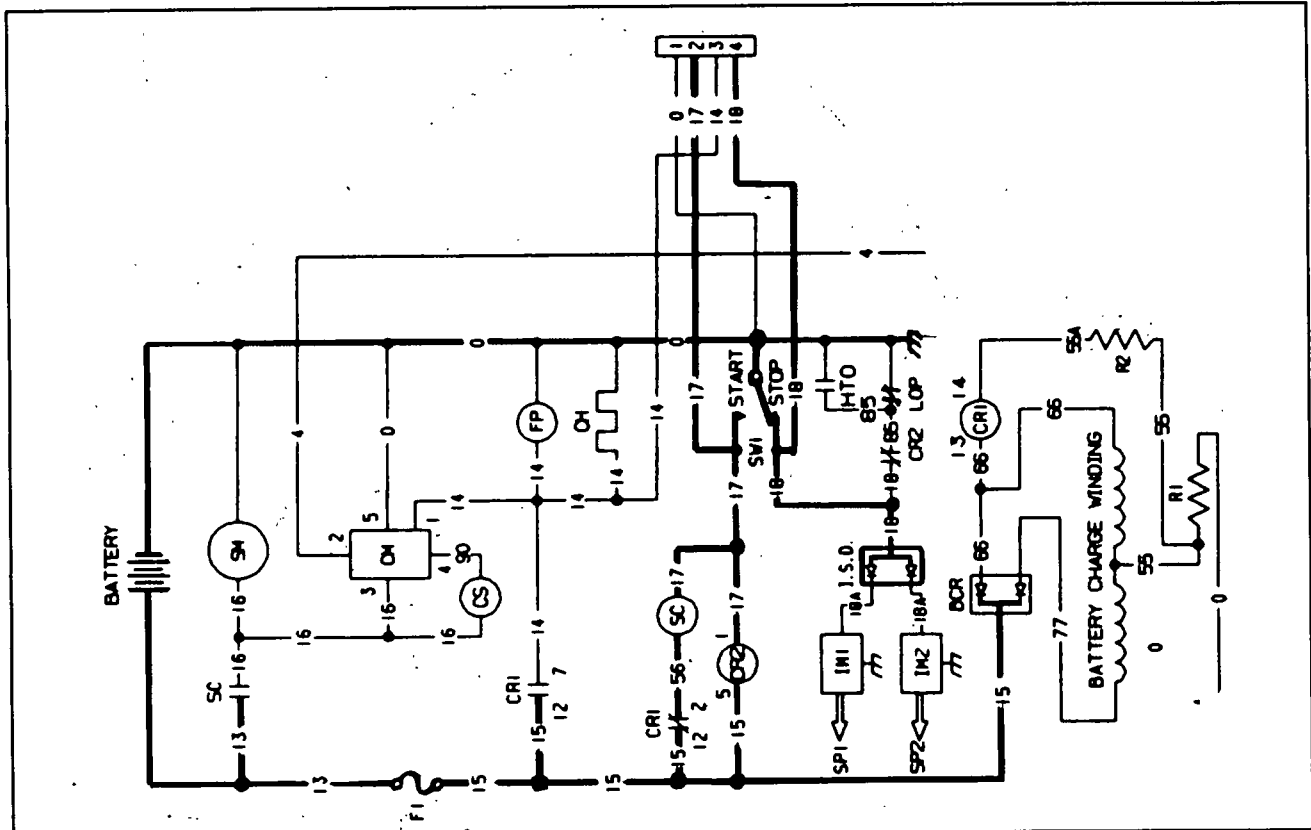

Figure 32. Circuit Condition- Normal Shutdown

Section Seven AC Generator Operation

INITIAL STARTUP:

During startup, residual magnetism in the rotor, plus the magnetism produced by field boost current flow through wire 4, induce a voltage into (a) a dual stator AC power winding, (b) an excitation winding, and (c) a battery charge winding.

Current flows from the excitation (DPE) winding to the electronic voltage regulator, via wires 2 and 6. Stator power winding sensing is also delivered to the regulator, via wires 11 and 22. The regulator rectifies the excitation winding current and, based on power winding sensing lead signals, regulates it. The rectified and regulated excitation winding output current is then delivered to the rotor windings, via wires 0 and 4 and the brushes and slip rings. Because excitation current is regulated, the strength of the rotor's magnetic field is regulated. And, because the rotor's magnetic field strength is regulated, the voltage induced into the stator power windings is regulated.

OPERATION:

A regulated voltage is present in the stator's dual AC power windings. When a load is connected across these windings, current can flow.

A voltage is also induced into the dual stator battery charge windings. Current then flows through a battery charge rectifier (BCR) and to the unit battery via wire 15. Battery charge winding output current is also delivered through a 47 ohm resistor (R2) and is used to energize control relay (CR1). See Section 6 for control relay (CR1) operation.

The voltage regulator continues to rectify and regulate excitation winding output current. The regulator also provides several safety features, as follows:

- Loss of sensing voltage from wires 11 and 22 will result in voltage regulator shutdown.
- If excitation (DPE) winding output to the regulator is lost, regulator DC output to the rotor will be lost.
- The regulator provides a 4 percent overvoltage limit. That is, when generator AC output voltage is set to 124 volts, the regulator will not permit stator power winding output to exceed 129 volts a-c. This is accomplished through sensing and a current limiter built into the regulator.

Only one adjustment is provided on the voltage regulator. That is used to set the AC voltage output at no-load. The regulator's red lamp (LED) turns on to indicate that sensing voltage is present.

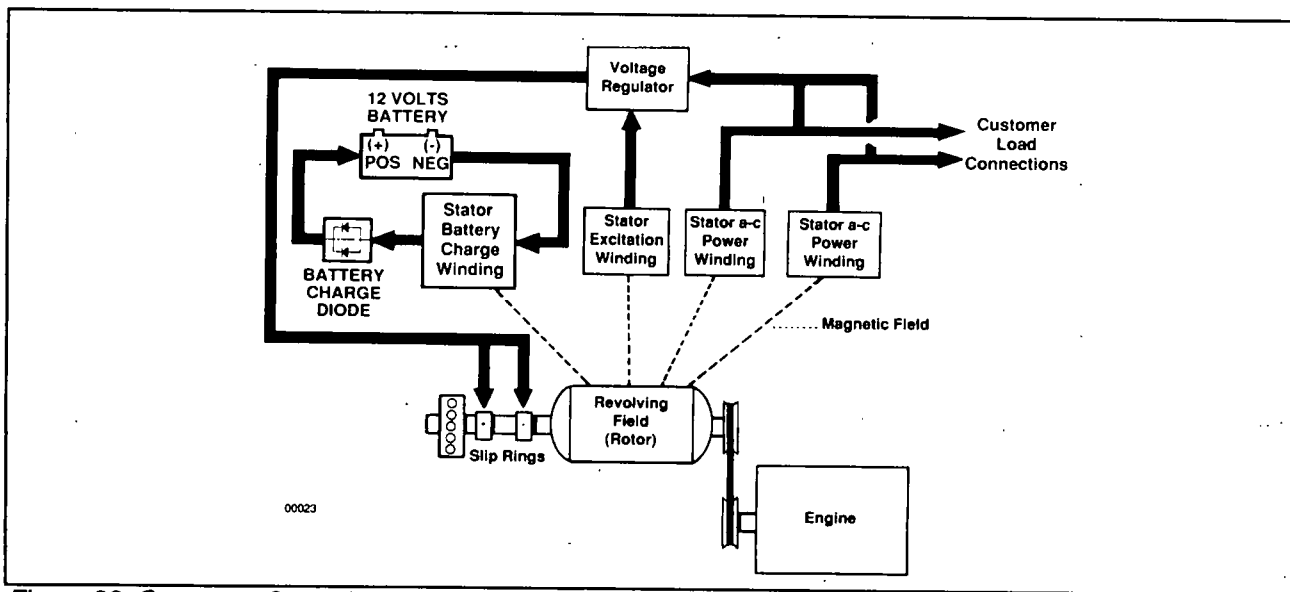

Figure 33. Generator Operating Diagram

Section Eight Troubleshooting Flow Charts

INTRODUCTION:

To use the "Flow Charts", first identify the specific problem you have encountered. Then, locate that problem in this section. Finally, complete all tests in the exact order indicated in the chart to find the cause of the problem. If you are uncertain of exactly how to complete any test, refer to Section 9 for instructions.

PROBLEM 1- ENGINE WON'T CRANK

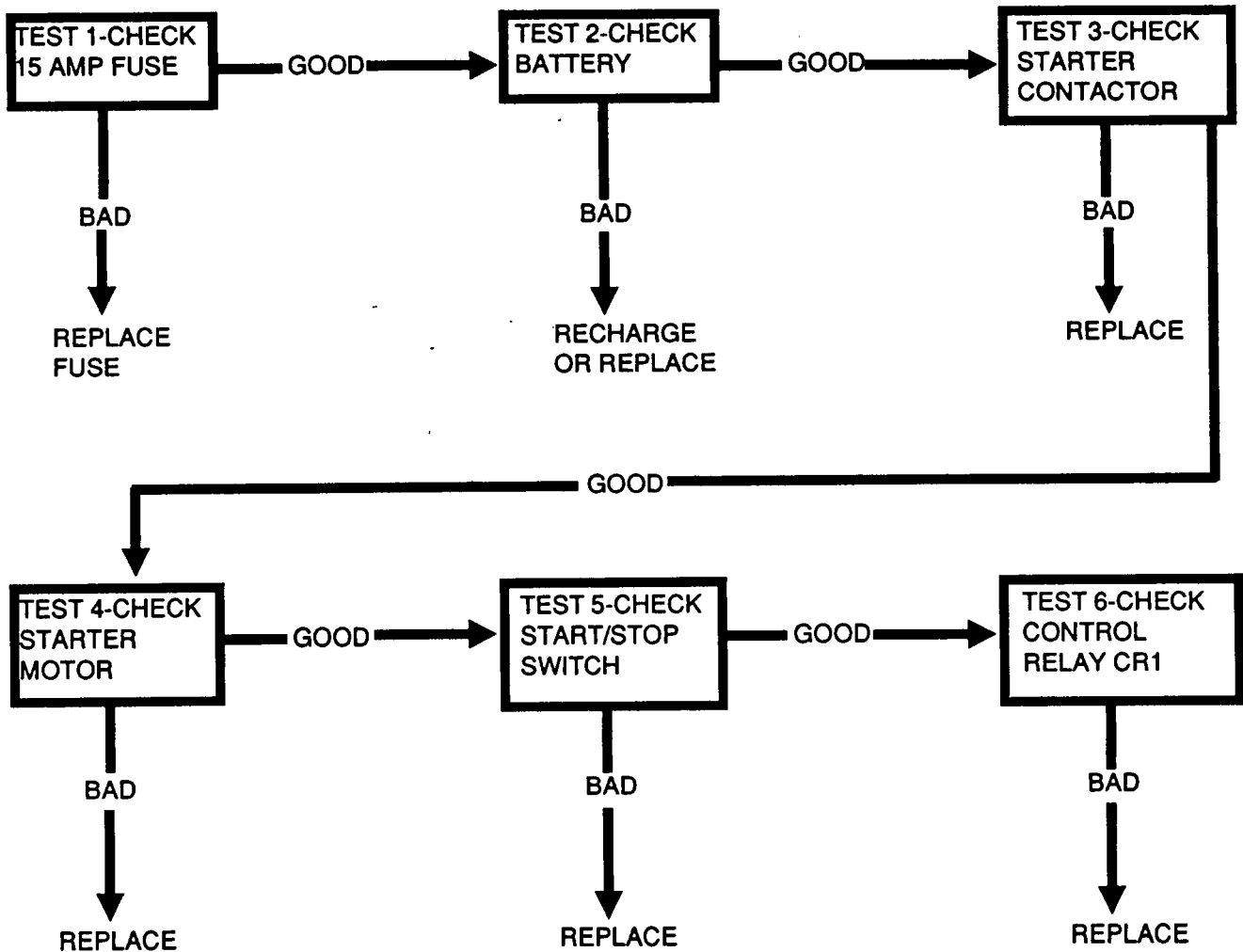

PROBLEM 2- ENGINE CRANKS, BUT WON'T START:

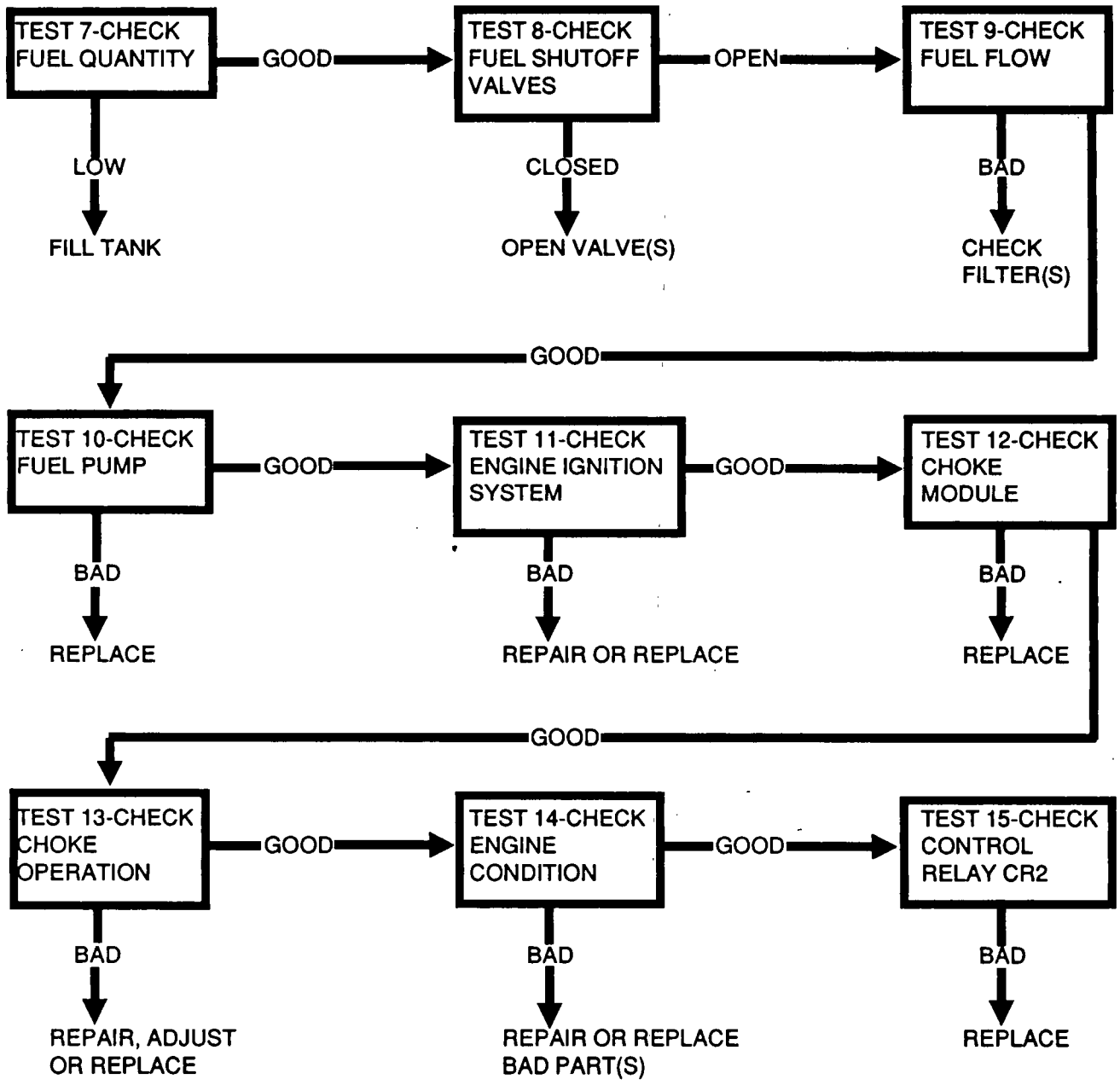

PROBLEM 3- ENGINE STARTS, SHUTS DOWN WHEN START/STOP SWITCH IS RELEASED:

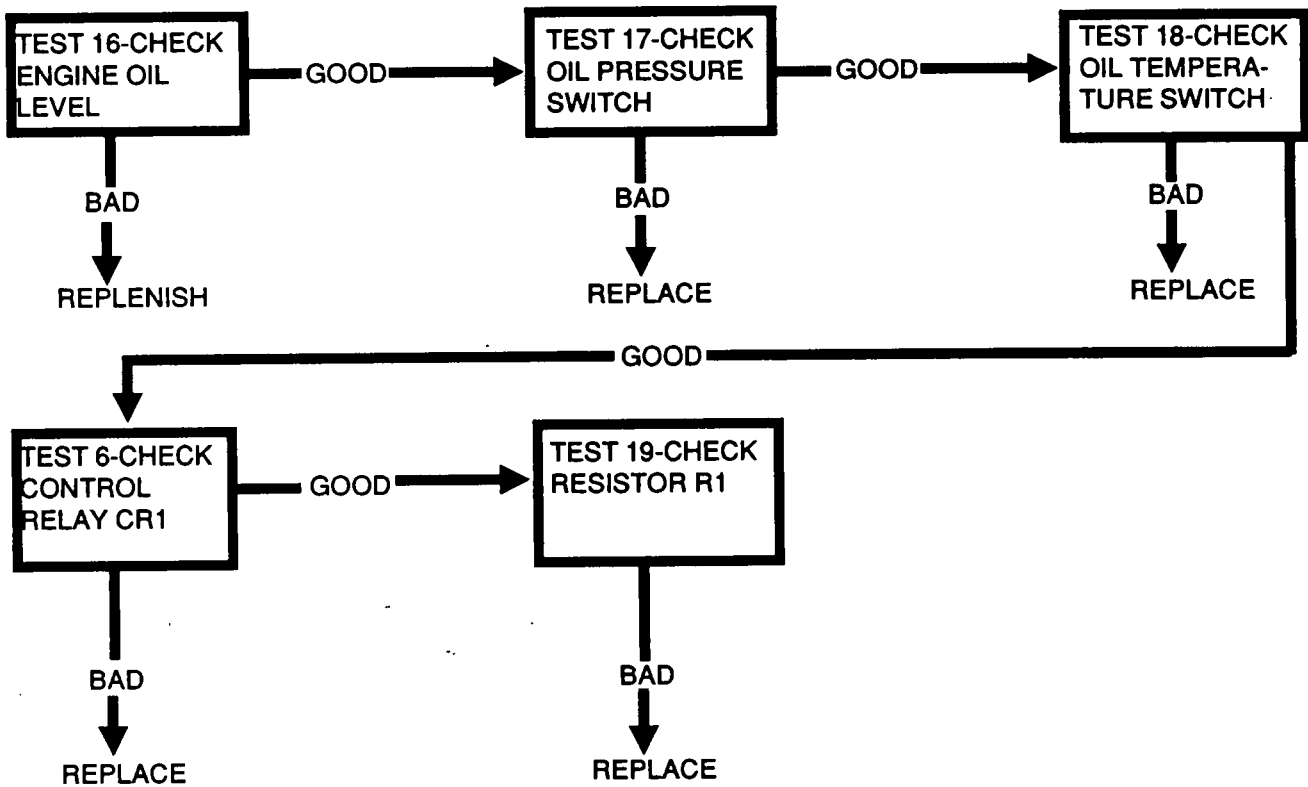

PROBLEM 4- ENGINE STARTS HARD, RUNS ROUGH:

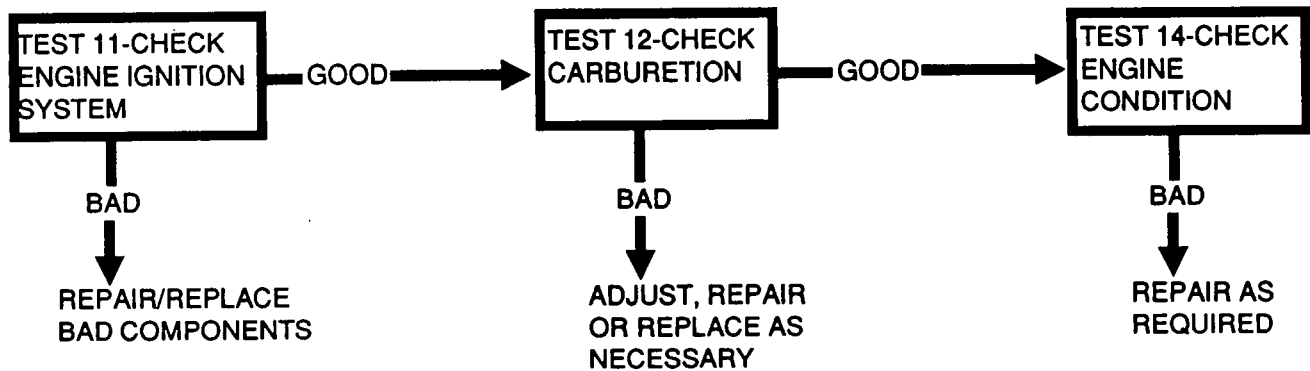

PROBLEM 5- ENGINE WON'T SHUT DOWN

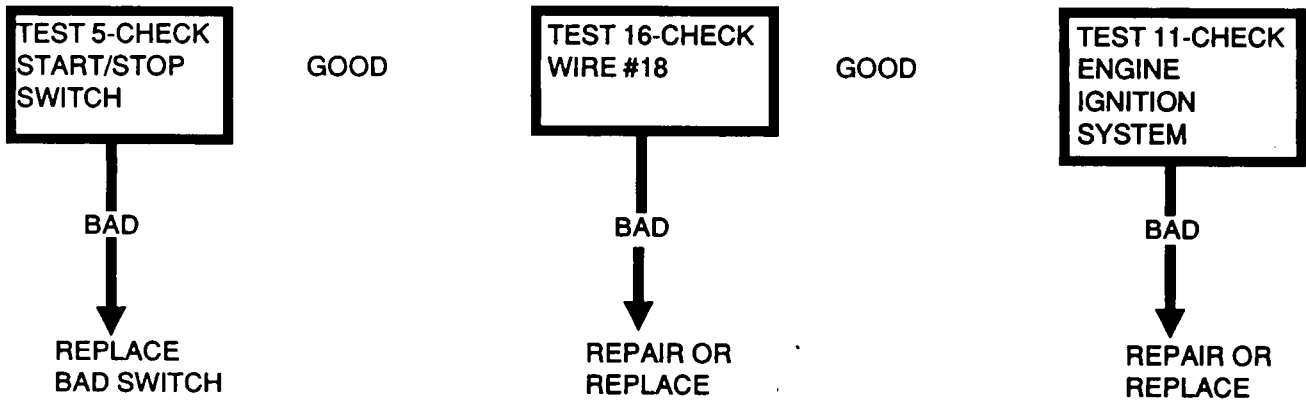

PROBLEM 6- LOW OR NO A-C GENERATOR OUTPUT

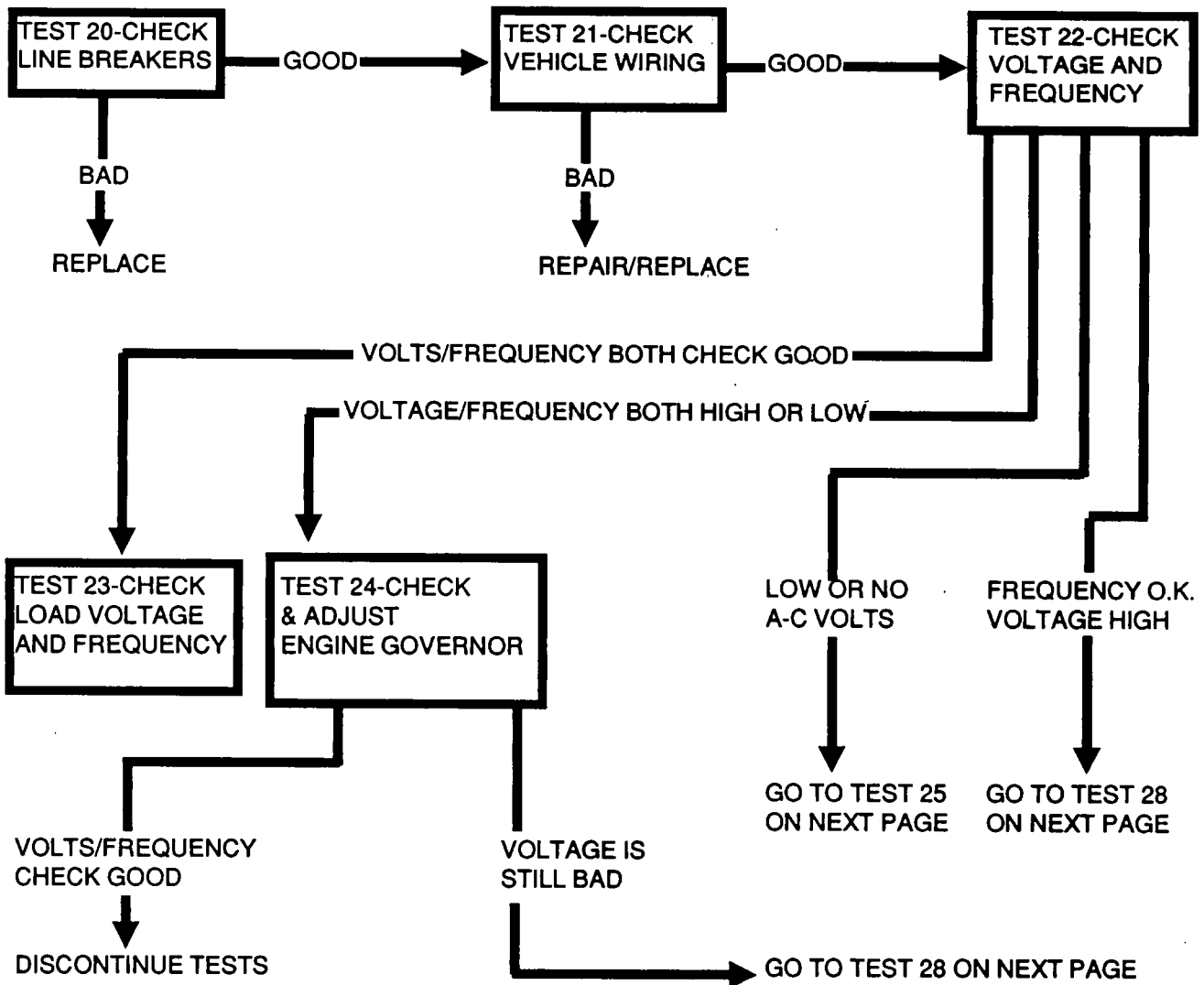

PROBLEM 6- LOW OR NO A-C GENERATOR OUTPUT (CONTINUED):

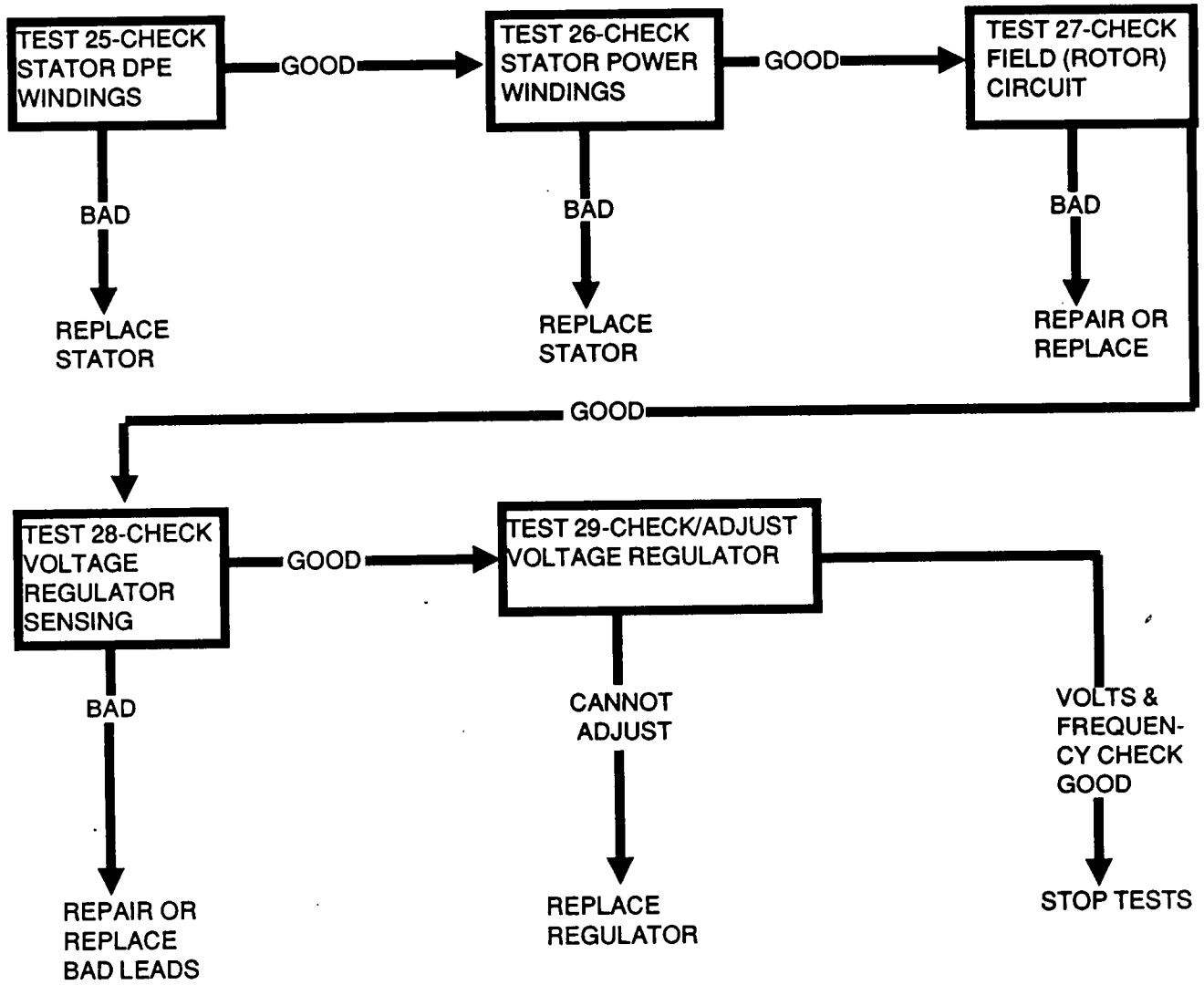

Section Nine Diagnostic Tests

INTRODUCTION:

Use the test procedures in this section in conjunction with the "Troubleshooting Flow Charts" of Section Eight. Test numbers assigned in this section correspond to test numbers in Section Eight.

TEST 1- CHECK 15 AMP FUSE:

Remove the 15 amp fuse from the generator panel. Inspect fuse element. If necessary, use a volt-ohm-milliammeter to check the fuse for continuity. Replace fuse if its element has melted open.

TEST 2- CHECK BATTERY:

Inspect battery terminals and cables. Clean and/or tighten cable clamps and connections as necessary. Replace any defective cable.

Use an automotive type battery hydrometer to test battery state of charge and condition. Recharge battery if it is discharged, replace if defective.

TEST 3- CHECK STARTER CONTACTOR:

See Figure 34. Connect the positive (+) test lead of a DC voltmeter across the Wire 56 terminal of starter contactor and the common (-) test lead to frame ground. Battery voltage should be indicated.

- If battery voltage is NOT indicated, go to Test 6, "Check Control Relay CR1".
- If battery voltage is indicated, continue with this test.

Connect the VOM positive (+) test lead to the wire 16 terminal stud and the negative (-) test lead to frame ground. Zero volts should be indicated. With the voltmeter still connected to the wire 16 terminal stud and to frame ground, disconnect wire 17 from its terminal stud on starter contactor. Connect a jumper wire from the wire 17 terminal stud on starter contactor and to frame ground. The DC voltmeter should read battery voltage and the engine should crank.

- If battery voltage is good and engine cranks in this test, but will not crank with start/stop switch, go to Test 5.
- If battery voltage is good, but engine does not crank, go to Test 4.
- If battery voltage is zero with jumper wire connected and engine does not crank, replace the starter contactor (SC).

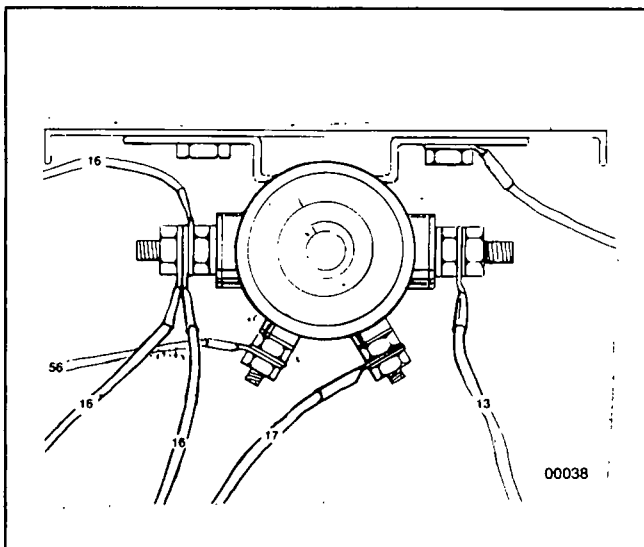

Figure 34. Starter Contactor (SC)

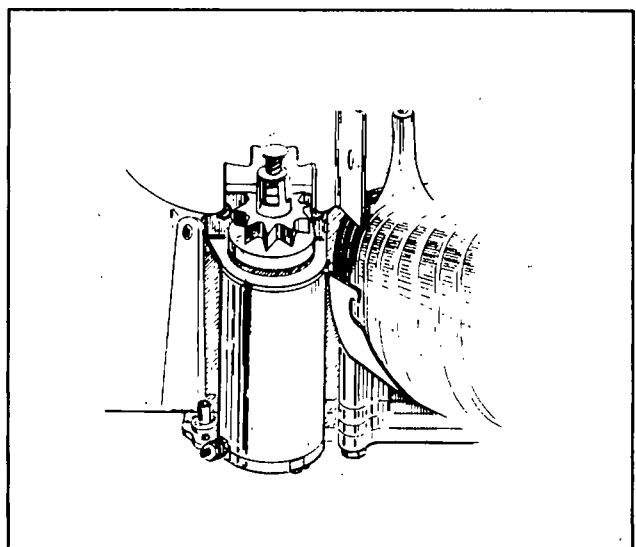

Figure 35. Starter Motor (SM)

TEST 4- CHECK STARTER MOTOR:

See Figures 34 and 35. Connect a jumper cable to the large (Wire 13) terminal stud of the starter contactor and to the terminal stud on the starter motor. The engine should crank.

- If engine cranks during test but does not crank with start/stop switch, go to Test 5.
- If engine does not crank during the test, replace the starter motor.

TEST 5- CHECK START/STOP SWITCH:

See Figure 36. Use a volt-ohm-milliammeter (VOM) to test for continuity between the switch Wire 0 terminal and frame ground. The VOM should read continuity.

- If continuity is not indicated, repair or replace Wire 0 between the switch and frame ground connection.
- If VOM indicates continuity, continue the test.

Connect a jumper wire between the switch Wire 17 terminal and frame ground. The engine should crank. To terminate cranking when engine starts, disconnect the jumper wire. To stop the engine, connect jumper wire to the switch Wire 18 terminal and frame ground.

- If engine cranks, starts and shuts down normally when using the jumper wire, but does not when using the start/stop switch, replace the start/stop switch.
- If engine does not crank when using the jumper wire, go to Test 6.
- If engine cranks, starts and shuts down normally with both jumper wire and when using the start/stop switch, discontinue tests.

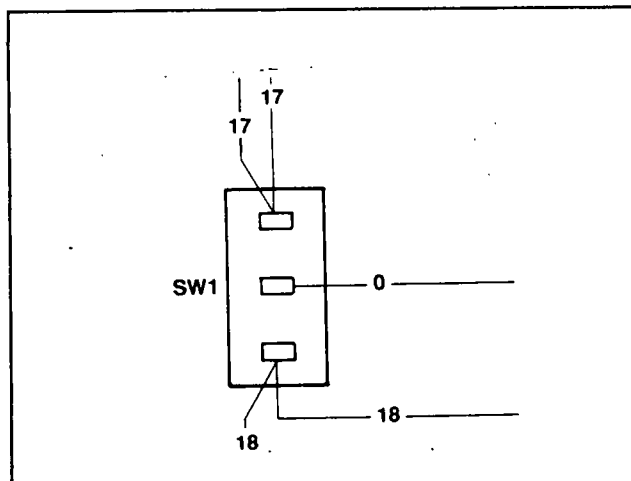

Figure 36. Start/Stop Switch Terminals

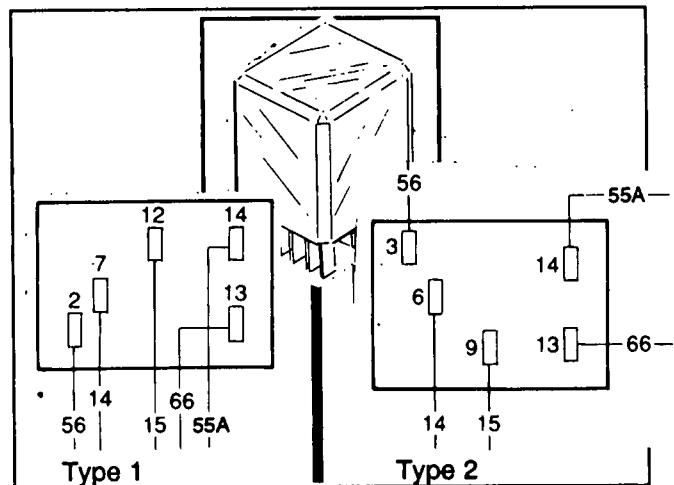

Figure 37. Control Relay CR1

TEST 6- CHECK CONTROL RELAY CR1:

Either of two different types of control relays may be used as shown in Figure 37. To test the CR1 relay, proceed as follows:

1. Connect a DC voltmeter across the relay's Wire 15 terminal and frame ground. Meter should read battery voltage.

- If battery voltage is indicated, continue the test.
- If battery voltage is not indicated, check Wire 15 between relay and fuse; check Wire 13 between fuse and starter contactor; check positive battery cable to starter contactor.

2. Connect a DC voltmeter across the relay's Wire 56 terminal and frame ground. Battery voltage should be indicated.

- If battery voltage is not read, replace relay CR1.
- If battery voltage is indicated, test wiring for open or shorted condition.

TEST 7- CHECK FUEL QUANTITY:

If engine will not start, be sure to check fuel quantity. An adequate supply of fuel must be available for generator operation. Many installations with a "shared" fuel tank use a generator fuel pickup tube in the tank that is shorter than the vehicle engine's pickup tube. Thus, the generator engine will run out of gas while fuel is still available for the vehicle engine.

TEST 8- CHECK FUEL SHUTOFF VALVES:

Failure of the engine to start could be caused by one or more fuel shutoff valves in the generator fuel supply line being closed. If the fuel supply system is equipped with shutoff valves, they must be open.

TEST 9- CHECK FUEL FLOW:

Disconnect the fuel line at the engine carburetor inlet. Crank the engine and check for fuel flow from open end of the disconnected line.

- If fuel flow is good, go to Test 11.
- If fuel flow is inadequate, check the generator fuel filter. Replace filter if clogged. If filter is not clogged, go to Test 10.

TEST 10- CHECK FUEL PUMP:

Connect a d-c voltmeter to the fuel pump's Wire 14 terminal and to frame ground. Crank the engine and the meter should read battery voltage. When the meter reads battery voltage, the fuel pump should operate.

- If battery voltage is indicated and fuel pump operates, but engine will not start, go to Test 11.
- If battery voltage is indicated but fuel pump does not operate, replace the fuel pump.

TEST 11- CHECK ENGINE IGNITION SYSTEM:

If the engine won't start or if it starts hard and runs rough, you should check the engine ignition system. Use a suitable spark tester to check for ignition spark. Inspect the spark plugs. Repair or replace any defective ignition system component(s). See Section Five, "Adjustments", for spark plug gap and ignition module air gap.

TEST 12- CHECK CHOKE MODULE:

The following procedure will test (a) the Wire 14 diode, (b) the field boost diode, (c) the field boost resistor. To test these components, it is recommended that a VOM having a "diode test" capability be used. The solid state circuit that regulates automatic choke opening and closing cannot normally be tested in the field. That

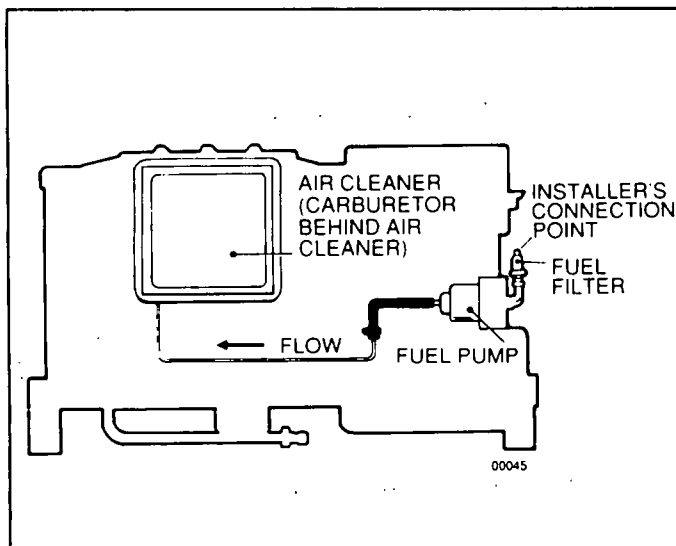

Figure 38. Engine Fuel System

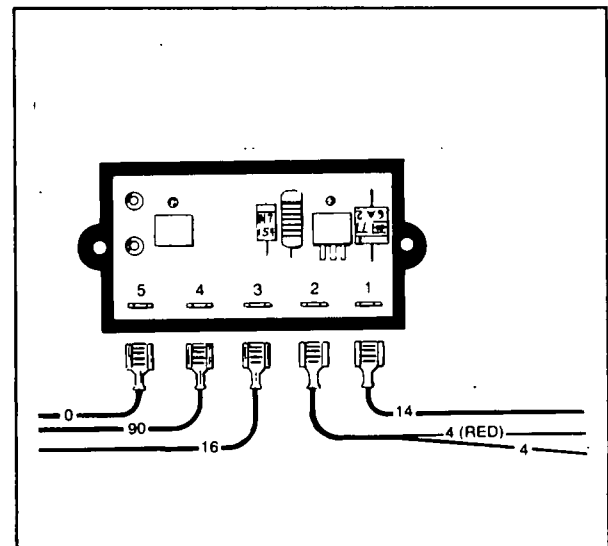

Figure 39. Choke Module

TEST 12- CHECK CHOKE MODULE (CONTINUED):

See Figure 39. Disconnect all wires from the choke module terminals to prevent interaction. Then, proceed as follows:

To Test the Wire 14 Diode:

Connect one VOM test lead to Choke Module terminal 3, the second test lead to terminal 1. Observe the meter reading. Then, reverse the VOM test leads (reverse the polarity and again note the VOM reading. At one polarity, the meter should read infinity. At the opposite polarity, the meter should indicate the forward resistance of the 6 amp, 100 volts diode in the wire 14 circuit. If you are using a meter having the "diode test" feature, allowable voltage drop across the diode is 0.6-0.8 volt. Replace any diode that test bad.

To Test the Field Boost Diode and Resistor:

Connect one VOM test lead to terminal 3 of the choke module, the other test lead to terminal 2. Note the meter reading. Then, reverse the test leads (reverse polarity) and again note the meter reading. At one polarity, the meter should read infinity. At the opposite polarity, the meter should indicate the forward resistance of the diode plus the resistance of the field boost resistor. If the meter has a "diode test" capability, allowable voltage drop will be 0.6-0.8 volt plus the voltage drop across the resistor. The field boost resistor is rated 47 ohms at 2 watts; the field boost diode is rated 1 amp at 600 volts.

Testing the Varistor:

The choke module circuit includes a metal oxide varistor, rated 22 volts, 0.6-0.8 Joule. There is no good method of testing a varistor in the field. Typically, when a varistor fails it will overheat and melt. Inspect the choke module carefully. If evidence of overheating and melting is observed, replace the choke module.

TEST 13- CHECK CHOKE OPERATION:

See Figure 40. While cranking the engine, observe automatic choke operation. The choke solenoid (CS) should pull in to close the choke for about 0.2-0.4 second. It should then de-energize to open the choke for about 2 seconds. This cyclic action should continue while the engine is cranking. If the choke solenoid does not actuate, check for binding. Also check for proper choke adjustment (see "Adjustments" section).

- If choke operates normally, but engine will not start, go to Test 14.
- If choke does NOT operate normally, try adjusting it. If it still doesn't operate try replacing the choke module.

TEST 14- CHECK ENGINE CONDITION:

Failure of the engine to start or a poorly running engine may be caused by a mechanical failure. Check engine compression. Repair engine as needed.

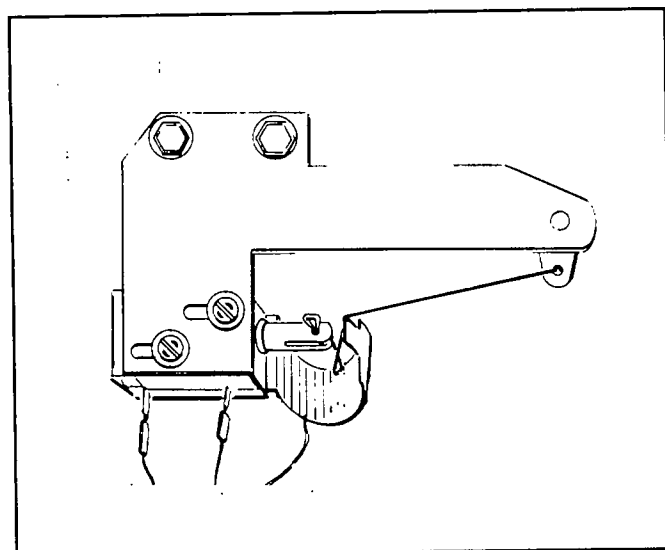

Figure 40. Automatic Choke

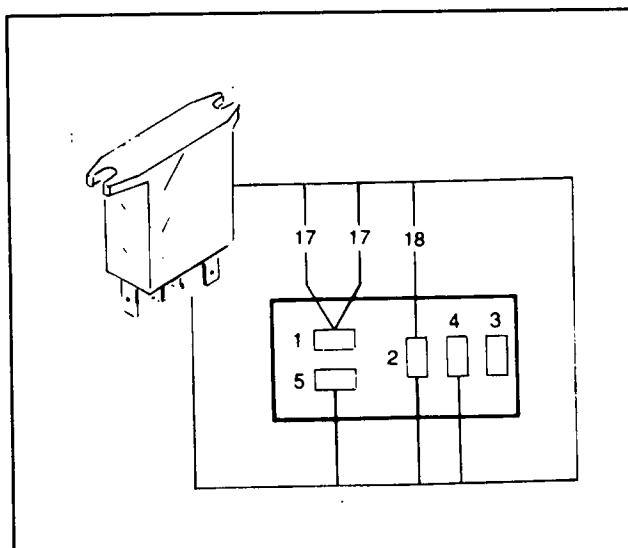

Figure 41. Control Relay CR2

TEST 15- CHECK CONTROL RELAY CR2:

Refer to Figure 41. Disconnect Wire 18 from relay terminal 2 and Wire 85 from terminal 4, to prevent interaction. Connect the test leads of a VOM across terminals 2 and 4. The meter should read continuity. Now, hold the start/stop switch at "Start" to crank the engine. The meter should now indicate infinity. Replace relay CR2 if it tests bad.

TEST 16- CHECK ENGINE OIL LEVEL:

If the engine cranks and starts, but shuts down as soon as the start/stop switch is released, engine oil level may be low. A low oil level can prevent sufficient oil pressure to open the oil pressure switch contacts from being developed. You may also wish to check engine oil pressure. The latter can be done by removing the oil pressure switch and installing a direct reading pressure gauge.

TEST 17- CHECK OIL PRESSURE SWITCH:

To test the oil pressure switch (Figure 42), disconnect Wire 85 from the switch terminal. Then, connect a VOM across the switch terminal and frame ground. With engine shut down, the meter should read continuity. Now, crank the engine and the meter should drop downscale to infinity as oil pressure increases.

If the engine starts and runs, hold the terminal end of Wire 85 into contact with a clean frame ground. The engine should shut down.

TEST 18- CHECK OIL TEMPERATURE SWITCH:

See Figure 42. Connect the VOM test leads across the oil temperature switch terminal and frame ground. The meter should read infinity. If the engine starts and runs, hold the terminal end of Wire 85 into contact with frame ground. The engine should shut down.

TEST 19- CHECK RESISTOR R1:

Resistor R1 is located inside the generator panel. First, test Wire 0 (between Resistor R1 and frame ground) for an open condition. Correct any open condition before proceeding.

Now, disconnect Wire 55 from the resistor. Connect test probe of a VOM across the Wire 55 terminal and frame ground. The meter should read approximately 1 ohm (plus or minus 5%). Replace resistor R1 if it tests bad.

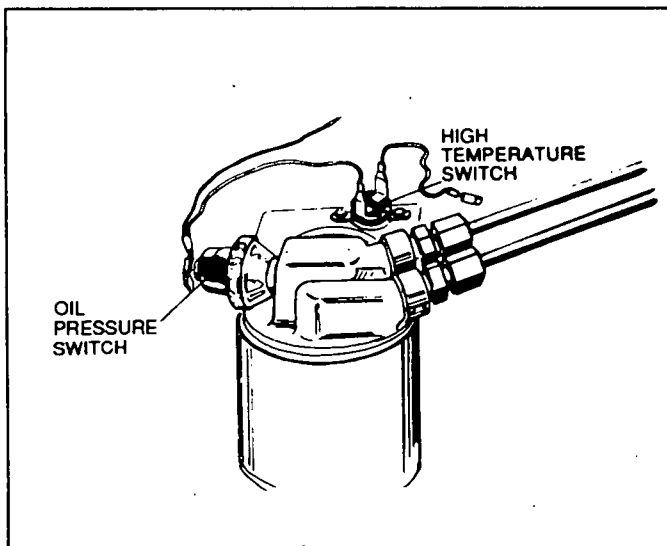

Figure 42. Oil Pressure & Oil Temperature Switch

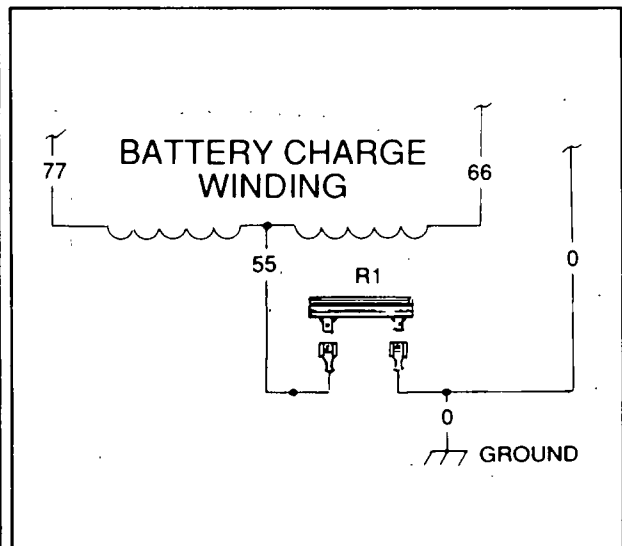

Figure 43. The Resistor R1 Circuit

TEST 20- CHECK LINE BREAKERS:

Try resetting the appropriate line circuit breaker on the generator panel. If this does not correct the problem, test the breakers using standard test procedures.

TEST 21- CHECK VEHICLE WIRING:

If voltage output is good at the line breakers, but electrical energy is not reaching the vehicle loads, check vehicle wiring. Repair or replace any damaged or defective wiring and wiring connections.

TEST 22- CHECK VOLTAGE AND FREQUENCY:

See Figure 44. Connect an AC voltmeter and an AC frequency meter across generator a-c output leads T1, T2 and T3. Open the generator line breakers and start the engine. Let engine stabilize and warm up. Read the AC voltage and frequency. Line to Neutral volts and frequency should be 124 volts at 62 Hertz. Some units are wired for single voltage output only. Other units may have been reconnected to supply a dual voltage AC output. See "Reconnection for Dual Voltage Output" on Pages 8, 9 and 10.

- If voltage and frequency both check good, go to Test 23.
- If voltage and frequency are BOTH high, go to Test 24.
- If reading indicates low or no voltage, go to Test 12.
- If frequency is good, but voltage reads high, go to Test 28.

TEST 23- CHECK LOAD VOLTAGE AND FREQUENCY:

Connect a voltmeter and frequency meter across generator AC output leads. Start the generator, let it stabilize and warm up. Turn on electrical loads using whatever means provided in the vehicle. Turn on electrical loads as close as possible to the unit's rated maximum continuous wattage/ampere capacity. Voltage under full rated load should be at least 116 volts. Frequency at full rated load should be at least 58 Hertz.

If voltage and frequency are good at no-load, but drop excessively when electrical loads are applied, look for the following:

- Generator may be overloaded. Add up the wattages and/or amperes of all loads turned on at one time. This total should not be more than the unit's rated wattage/ampere capacity. Reduce electrical loading as required.
- A ground fault condition may exist in the generator windings or in one or more connected electrical loads.
- Loss of engine power may have occurred. Check for adequate air flow, clogged air cleaner, incorrect ignition timing, bad spark plug(s), incorrectly adjusted carburetor, etc.

TEST 24- CHECK AND ADJUST ENGINE GOVERNOR:

For engine governor adjustment procedures, refer to Section 5, "Adjustments".

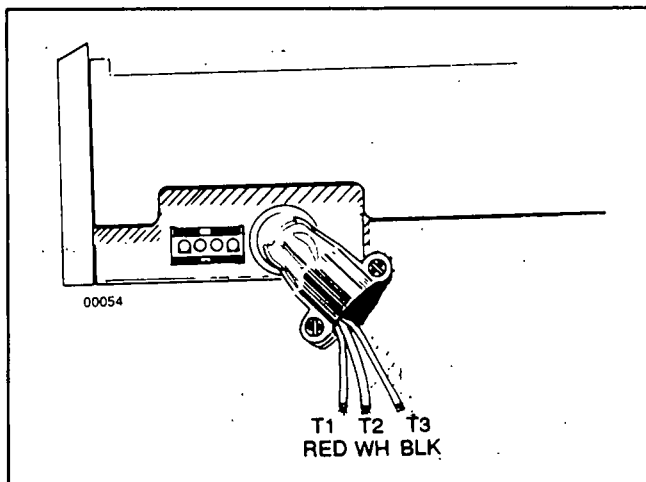

Figure 44. Generator AC Output Leads

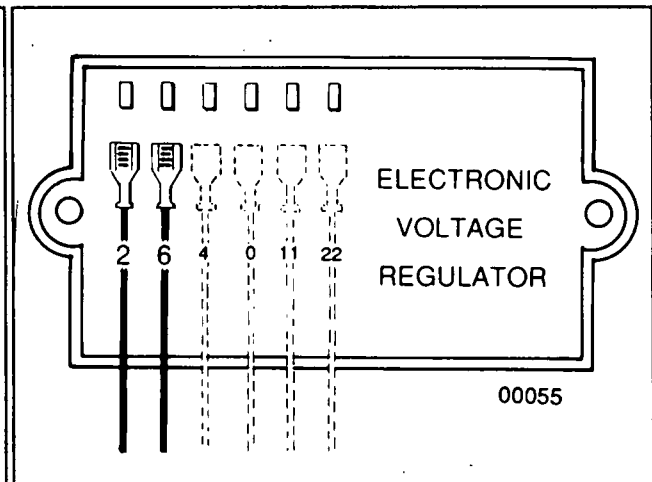

Figure 45. Stator DPE Winding Test Points

TEST 25- CHECK STATOR DPE WINDINGS:

At the voltage regulator, disconnect stator winding leads 2 and 6 (Figure 45), Check the resistance across these two leads with a VOM. Resistance readings should be as follows:

NP45G & NP52G = 2.2 ohms
NP55G & NP66G = 1.8 ohms
NP65G & NP72G = 1.6 ohms

Now, set the meter to a high resistance scale (such as "Rx10,000" or "Rx1K"). Connect one test lead to wire 2, the other test lead to a clean frame ground on the stator can. The meter should read infinity. Any upscale movement of the meter indicates a shorted condition.

Replace the stator assembly if it tests bad.

TEST 26- CHECK STATOR POWER WINDINGS:

Disconnect stator leads 11 and 22 from the voltage regulator (Figure 45). Then, disconnect stator lead 33 from circuit breaker CB1. Also separate the junction of stator leads 22 and 44. See Figure 46. Read the resistance across stator leads 11 and 22. Then, read the resistance across stator leads 33 and 44. Resistance reading should be about 0.1 to 0.5 ohm. In most cases, a defective stator will be indicated by a reading of infinity.

Now, set the meter to a very high resistance scale. Connect the meter test leads across wire 11 and frame ground. Then, connect the meter across wire 33 and frame ground. In each case, the meter should read infinity. Replace stator if it is defective.

TEST 27- CHECK FIELD (ROTOR) CIRCUIT:

First, test wire 4 (between the voltage regulator and the choke module for an open or shorted condition). Then, test wire 4 (between choke module and brushes). Repair or replace any open or shorted wire 4.

Remove wires 0 and 4 from the brushes (Figure 47). Inspect brushes and brush holder. Replace if cracked, damaged, worn excessively, etc. Inspect slip rings. If slip rings are dull or tarnished, they can be polished with fine sandpaper. Use low pressure air (25 psi or less) to blow away brush cleaning residue.

Test rotor winding resistance by connecting a VOM across the positive (+) and negative (-) slip rings. Meter should indicate the following resistance at 68° F. (all values are plus or minus 10%) :

NP45G/NP52G = 13.9 ohms
NP55G/NP66G = 15.5 ohms
NP65G/NP72G = 11.1 ohms

Assemble brushes into brush holder. Install brush holder making sure it is properly aligned. Rotate rotor several times to seat brushes against slip rings.

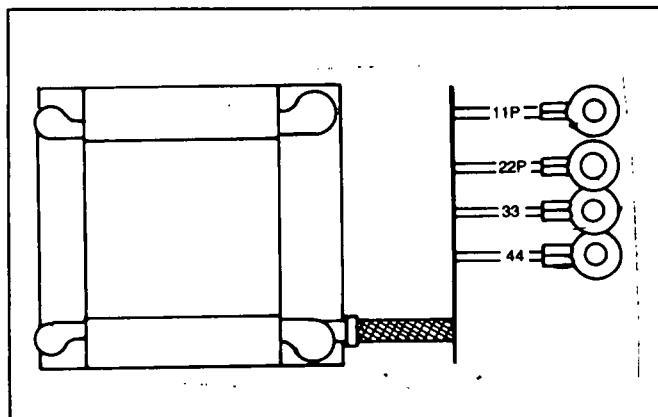

Figure 46. Stator Power Winding Leads

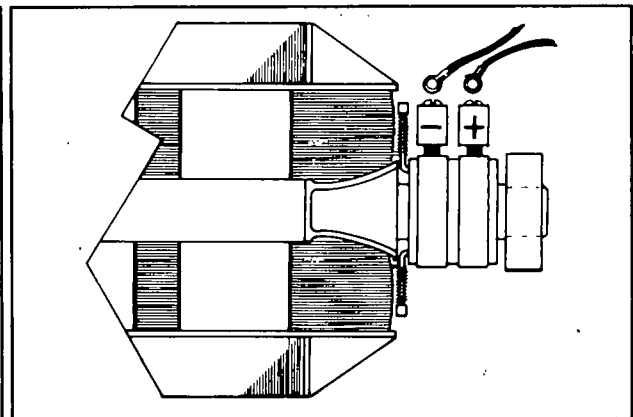

Figure 47. Rotor, Brushes and Slip Rings

TEST 28- CHECK VOLTAGE REGULATOR SENSING:

See Figure 45. Test wires 11 and 22, between the voltage regulator and the stator, for an open or shorted condition. Repair or replace any open or shorted wire as needed.

TEST 29- CHECK/ADJUST VOLTAGE REGULATOR:

The voltage regulator is equipped with a signal adjusting potentiometer. With correct frequency indicated, adjust the potentiometer to obtain correct voltage.

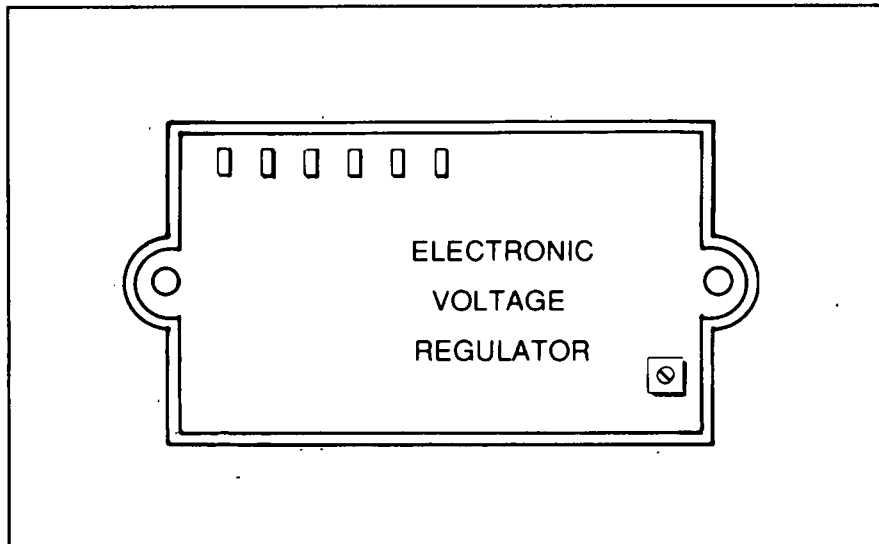

Figure 48. Voltage Regulator Adjustment Potentiometer

ELECTRICAL FORMULAS

(Alternating Current)

DESIRED DATA	SINGLE PHASE	3-PHASE
Kilowatts (Generator output or load input)	$\frac{\text{Volts} \times \text{Amps} \times \text{P.F.}}{1000}$	$\frac{1.73 \times \text{Volts} \times \text{Amps} \times \text{P.F.}}{1000}$
KVA (Generator output or load input)	$\frac{\text{Volts} \times \text{Amps}}{1000}$	$\frac{1.73 \times \text{Volts} \times \text{Amps}}{1000}$
Horsepower (Engine Output)	$\frac{\text{Volts} \times \text{Amps} \times 100 \times \text{P.F.}}{746 \times \text{Efficiency}}$	$\frac{1.73 \times \text{Volts} \times \text{Amps} \times 100 \times \text{P.F.}}{746 \times \text{Efficiency}}$
Amperes (When Horsepower is known)	$\frac{\text{H.P.} \times 746 \times \text{Efficiency}}{\text{Volts} \times 100 \times \text{P.F.}}$	$\frac{\text{H.P.} \times 746 \times \text{Efficiency}}{1.73 \times \text{Volts} \times 100 \times \text{P.F.}}$
Amperes (When kilowatts are known)	$\frac{\text{Kilowatts} \times 1000}{\text{Volts} \times \text{P.F.}}$	$\frac{\text{Kilowatts} \times 1000}{1.73 \times \text{Volts} \times \text{P.F.}}$
Amperes (When kVa is known)	$\frac{\text{kVa} \times 1000}{\text{Volts}}$	$\frac{\text{kVa} \times 1000}{1.73 \times \text{Volts}}$
Frequency	$\frac{\text{RPM} \times \text{No. of Rotor Poles}}{2 \times 60}$	
No. of Rotor Poles	$\frac{2 \times 60 \times \text{Frequency}}{\text{RPM}}$	
RPM	$\frac{2 \times 60 \times \text{Frequency}}{\text{No. of Rotor Poles}}$	

Efficiency is expressed in PERCENT (such as 95%).

P.F. = Power Factor is expressed as a decimal, as 0.80.

NOTE: Volts refers to line-to-line measurement.

ELECTRICAL SCHEMATIC

LEGEND:

- BCR - BATTERY CHARGE RECTIFIER
- CB1 - LINE BREAKER
- CB2 - LINE BREAKER
- CH - CHOKE HEATER
- CM - CHOKE MODULE
- CR1 - 12 VOLTS AC RELAY
- CR2 - 12 VOLTS DC RELAY
- CS - CHOKE SOLENOID
- F1 - 15 AMP FUSE
- FP - FUEL PUMP
- GT - GROUND TERMINAL
- HM - OPTIONAL HOURMETER
- HTO - HIGH OIL TEMP. SWITCH
- IM1 - NO. 1 IGNITION MAGNETO
- IM2 - NO. 2 IGNITION MAGNETO
- ISD - IGNITION SHUTDOWN
- L1 - GENERATOR RUN LAMP
- LOP - LOW OIL PRESSURE SWITCH
- R1 - 1 OHM, 25 WATT RESISTOR
- R2 - 47 OHM, 1 WATT RESISTOR
- SC - STARTER CONTACTOR
- SM - STARTER MOTOR
- SW1 - START/STOP SWITCH
- SP1 - NO. 1 SPARK PLUG
- SP2 - NO. 2 SPARK PLUG
- TC - TERMINAL CONNECTOR

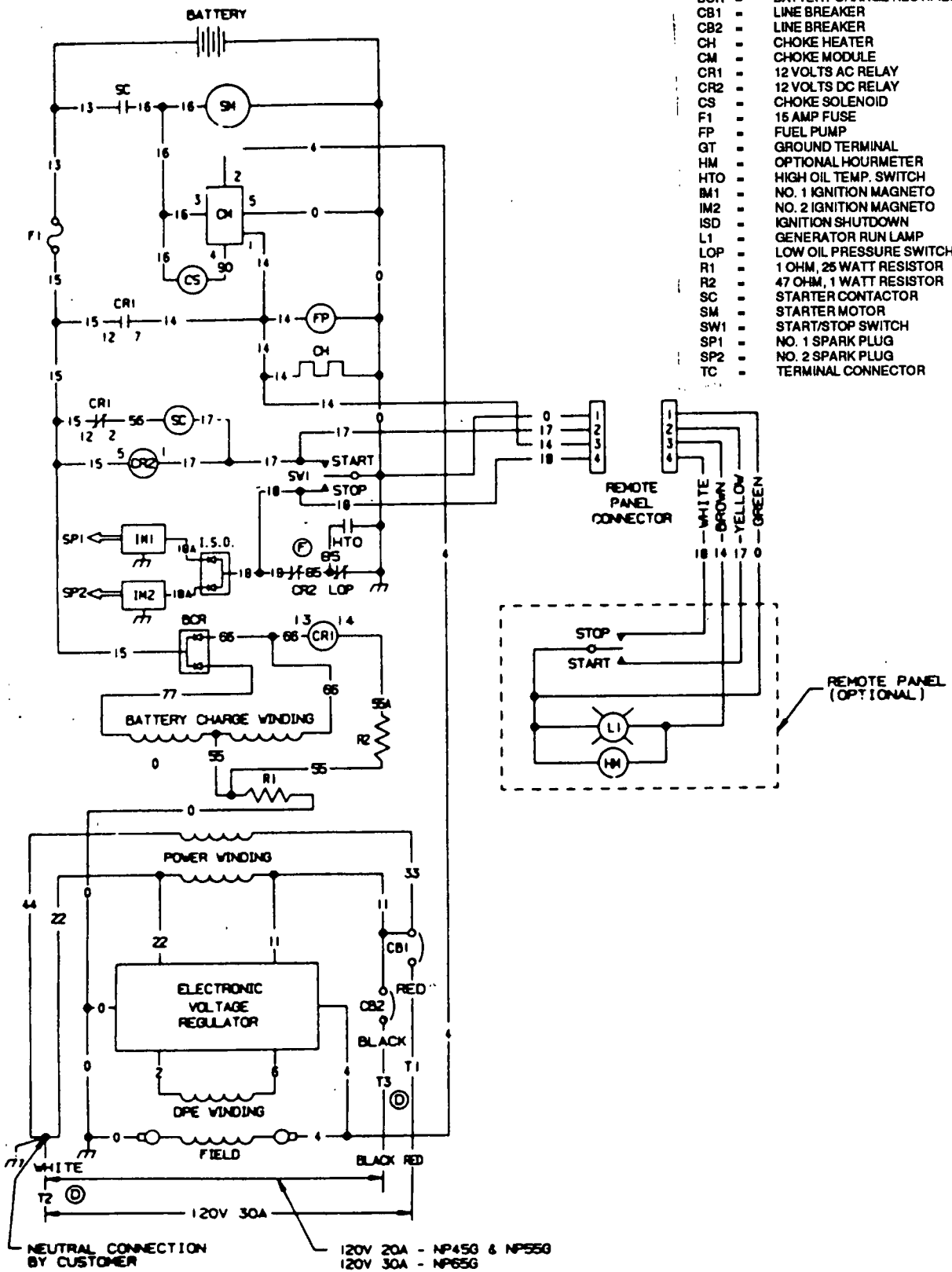

WIRING DIAGRAM

