

# MAGNAMAX<sup>®</sup> VOLTAGE REGULATOR



TECHNICAL  
MANUAL FOR  
MODELS  
PM100 AND PM200

 **MARATHON<sup>®</sup>  
ELECTRIC**

WAUSAU, WISCONSIN 54401

## TABLE OF CONTENTS

### Section

#### **1 INTRODUCTION**

General Description  
Specifications  
Features

#### **2 THEORY OF OPERATION**

Main Regulator  
Protective Features  
Paralleling Circuit

#### **3 INSTALLATION**

Mounting  
Interconnections

#### **4 ADJUSTMENTS AND STARTUP PROCEDURES**

General  
Voltage Adjust  
Stability Adjust  
Underfrequency Adjust  
Droop Adjust  
Generator Current Limit Adjust  
(Model PM200 only)  
Adjustments

#### **5 TROUBLESHOOTING**

#### **6 FIELD APPLICATION**

Manual Voltage Control  
Var-Power Factor Controller

#### **7 DRAWINGS AND DIAGRAMS**

# MagnaMAX Voltage Regulator

Back View

Front View

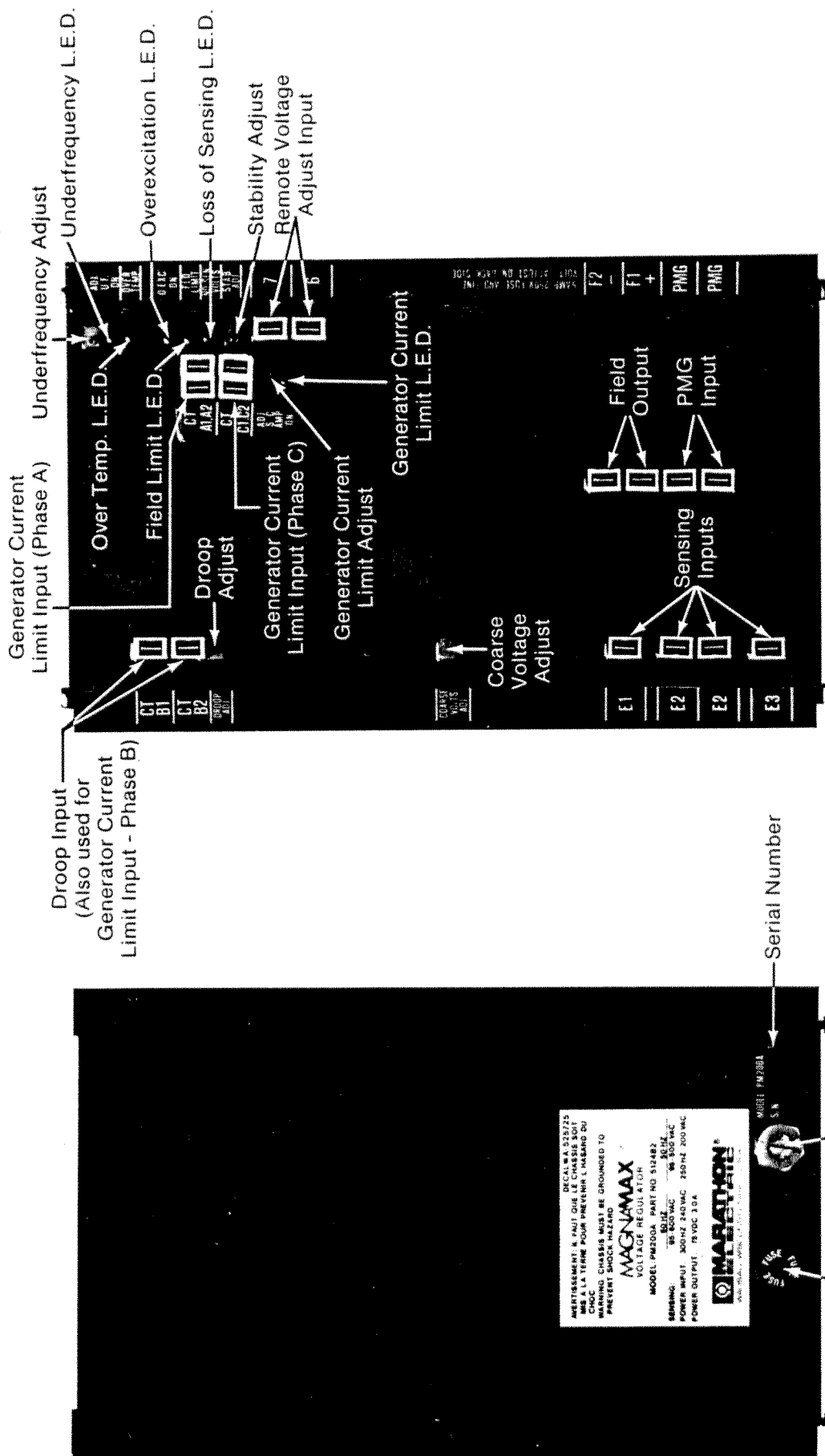

Fig. 1

# INTRODUCTION

## GENERAL DESCRIPTION SPECIFICATIONS

## FEATURES

### GENERAL DESCRIPTION

The MagnaMAX Voltage Regulator is a sealed electronic voltage regulator which controls the output of a brushless ac generator by regulating the current into the exciter field. Unlike most regulators, the input power is from a multi-pole high frequency permanent magnet generator (PMG) incorporated within the main generator assembly.

### SPECIFICATIONS

Sensing	60 Hz 95-600 Vac 50 Hz 95-500 Vac
Sensing Mode	RMS (Single or Three Phase)
Input Requirements	300 Hz 180-240 Vac 250 Hz 150-200 Vac
Output Power Continuous Max Forcing (1-min.)	75 Vdc at 3.0 Adc 170 Vdc at 7.5 Adc
Nominal Hot Field Resistance	20-26 ohms
Regulation	0.5%
Regulator Response	Less than 10 milli-seconds
Remote Voltage Adjust Current	Less than 10 milli-amps
Operating Ambient Temperature	-40° C to +70° C
Storage Temperature	-40° C to +85° C
Voltage Drift with Temperature	Less than 0.5% over a 40° C change
Size	9.5L x 6.0W x 3.2H (24.1cm x 15.2cm x 8.13cm)
Weight	5.5 Lbs. (2.5 Kg)
Fuse Size and Type	.25 x 1.25 5-amp Littelfuse 314005 or Bussman ABC-5
Power Dissipation	12 watts (continuous) 22 watts (forcing)

### FEATURES

#### Sensing Voltage

The voltage regulator is equipped for either 3-phase or 1-phase sensing. The sensing voltage is continuously adjustable over the entire voltage range with the 15 turn coarse voltage adjust control (Figure 1). The single turn fine voltage adjust control gives a minimum of  $\pm 10\%$  voltage variation at any setting of the coarse adjust. A 10,000 ohm optional remote rheostat can be added. This remote rheostat can also give a  $\pm 10\%$  variation independent of the coarse adjust setting.

#### Loss of Sensing

If an open circuit occurs in one of the sensing leads (or if the E2-E3 Jumper is not properly connected when using single phase sensing), the regulator will turn off and the loss of sensing LED will turn on (Figure 1). At this time, the generator output voltage will go to residual. The regulator will automatically reset when proper sensing is restored. This loss of sensing circuit will **not** activate under a generator short circuit condition but rather the regulator will turn to its full forcing capabilities for a minimum of 10 seconds for fault clearing.

**CAUTION:** Whenever a potential transformer is used for sensing, a break on the primary side of the transformer will cause maximum forcing from the regulator, and the loss of sensing circuit will not activate.

#### Underfrequency

The underfrequency control (Figure 1) changes the regulator's mode of operation. When not operating in the underfrequency mode, the regulator has a flat regulation, constant voltage over a frequency range. When operating in the underfrequency mode, the regulator has a constant volts per hertz characteristic (a linear relationship of voltage with respect to frequency). The transition frequency is adjustable from 40 Hz to 70 Hz (Figure 2A, 2B, and 2C for typical volts/hertz characteristics).

SECTION  
1

# INTRODUCTION

## FEATURES

SECTION  
1

### Underfrequency Operation

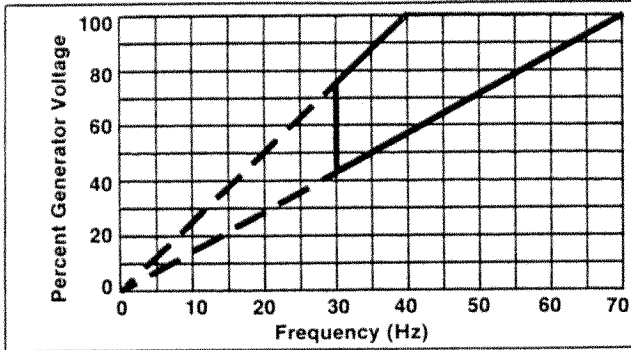

Fig. 2A

### Typical 60 Hz Operation

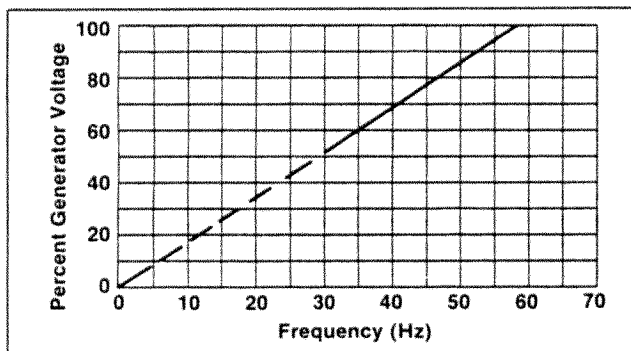

Fig. 2B

### Typical 50 Hz Operation

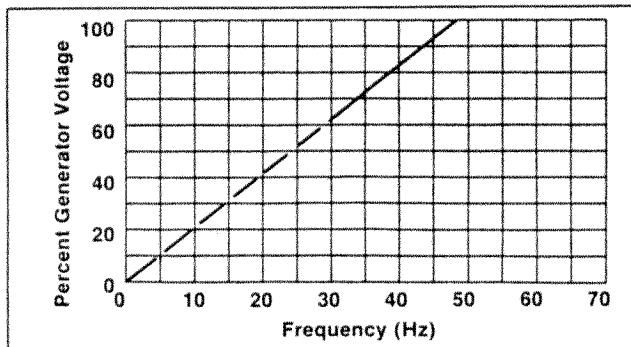

Fig. 2C

### Overexcitation

The overexcitation circuit senses when the regulator output voltage is above a set level. If this voltage remains above that level, the overexcitation LED (Figure 1) will turn on and a protective function with an inverse time characteristic turns the regulator off. The generator voltage will go to a residual level and the overexcitation LED (Figure 1) will remain lit. The generator must be stopped or input power must be removed for a minimum of 10 seconds to reset the circuit and restore normal operation.

### Paralleling

Provisions are included in the regulator to allow paralleling using either reactive droop or reactive differential (cross current) compensation with the addition of an external 5 amp, 5 VA current transformer.

### Overtemperature Protection

The regulator will turn itself off before it is damaged by overheating. This will occur at an ambient temperature in excess of 70°C. The generator voltage will go to a residual level and both the overtemperature LED and the field current limit LED (Figure 1) will turn on and remain lit. When the regulator cools it will automatically return to normal operation.

### Field Current Limit

The regulator output is current limited. Should a heavy current load or short circuit occur across the field output terminals (Figure 1) the regulator switches to a current limit condition and the field limit LED (Figure 1) will turn on. The limiting circuit automatically resets itself when the output current drops below the current limit set point. This current limit set point is **not** adjustable.

### Generator Current Limit (Model PM200 Only)

The generator current limit is designed to control the maximum short circuit current that will be sustained by the generator (Figure 1). Current sensing is through external 5 amp, 5 VA current transformers. Depending upon the current transformer ratio, the regulator will limit the generator current from about 150% to about 400%.

# THEORY OF OPERATION

## FEATURES

## PROTECTIVE FEATURES

Isolation is provided on the regulator inputs so any conventional current transformer interconnections typically used in meter panels or switchgear are acceptable.

For adjustment procedures on these features, see Adjustments and Startup Procedures.

### Environmental Protection

The MagnaMAX Voltage Regulator is a totally encapsulated design to limit application problems even in harsh environments. The ability of the

regulator to withstand harsh environments has been illustrated through hundreds of hours of salt fog tests (ASTM B117-73), humidity tests (MIL-STD-705B Method 711-1C), thermal cycles (-40°C to +70°C), shock tests (5 G's in all three planes), and vibration tests (.035 in. at 20-60 Hz).

### EMI Suppression

The standard PM100/200 regulator meets MIL-STD-461B part 9 for conducted and radiated emissions when mounted in the generator conduit box.

SECTION  
1

# THEORY OF OPERATION

## MAIN REGULATOR

## PROTECTIVE FEATURES

### MAIN REGULATOR

There are four basic function blocks to the Magna-MAX Voltage Regulator. These blocks are the sensing input circuit, the main summing amplifier, the pulsed driver circuit, and the power output switching circuit (Figure 3A).

### PM100/200 Block Diagram

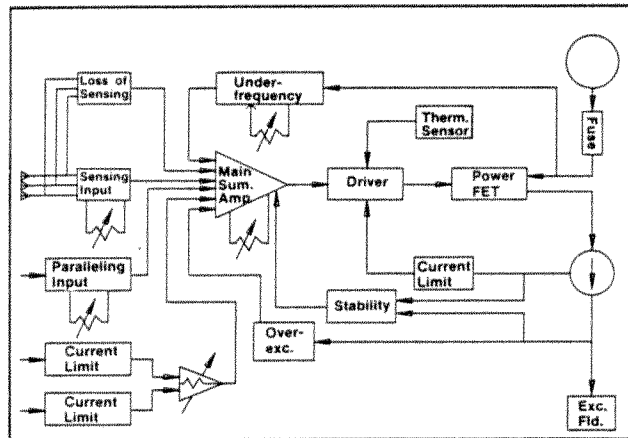

Fig. 3A

The generator voltage is fed into a circuit that calculates the RMS value of the incoming signal. The magnitude of the output is controlled by a feedback resistor. The output signal varies as this feedback resistor is adjusted. This adjustable feedback resistor is the coarse voltage adjust.

The output from the sensing circuit is then fed to the main summing amplifier. As the name implies, signals from the protective circuits, as well as the external fine voltage adjust and the remote voltage adjust are combined at this point. This combined signal is then passed to the driver circuit.

The driver circuit converts the signal from the main summing amplifier to gate pulses that control the output power FET (Field Effect Transistor).

The power FET controls the current to the exciter field. The longer the pulse to the gate of the FET, the greater the generator output voltage. Conversely the shorter the pulse to the gate of the FET, the shorter the current pulse to the exciter field and the lower the generator voltage.

These four circuits are tied together with one feedback circuit to make the regulator self-controlling. This is the function of the stability circuit. The stability circuit senses both exciter field current and exciter field voltage. The adjustable signal output is fed back to one of the inputs of the main summing amplifier. As load is applied, the generator voltage tends to decrease. The stability circuit increases the control signal thereby increasing the exciter field current and the output voltage. As the generator voltage increases, the stability circuit decreases the feedback signal. Adjusting the stability control changes the response time of the regulator thereby obtaining the best match for any particular generator (Figure 3B).

### Transient Voltage Response with Various Stability Settings

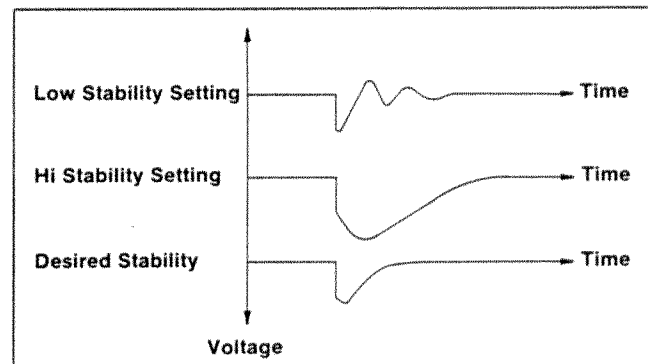

Fig. 3B

## PROTECTIVE FEATURES

There are six protection features (Figure 3A): (1) loss of sensing, (2) underfrequency, (3) overexcitation, (4) overtemperature, (5) field current limit, and (6) generator current limit (model PM200 only).

1. The loss of sensing circuit monitors continuity in the sensing leads. If any of these leads should open an LED is lit and a signal is sent to the main summing amplifier which turns the regulator off. Reconnecting the sensing lead will automatically reset the regulator and restore normal operation.
2. The underfrequency circuit operates when the generator frequency drops below the adjustable set point (See Adjustments and Startup Procedures for proper adjustment). An LED is lit and a voltage signal proportional to frequency is sent to the main summing amplifier.

# THEORY OF OPERATION

## PROTECTIVE FEATURES

3. The overexcitation circuit monitors the regulator output voltage. If this voltage exceeds a preset value an LED turns on and a timer starts to operate. After the timeout period, a signal is sent to the main summing amplifier to turn the regulator off. Input power must be disconnected from the regulator or the generator must be shutdown for a minimum of 10 seconds to reset the circuit.
4. The regulator has a thermal sensor which monitors temperature. When the ambient temperature is in excess of 70°C the regulator turns off. The regulator is automatically reset when the ambient temperature drops below 70°C.
5. Output current is continuously monitored by the field current limit circuit. When it reaches the preset point or tries to exceed this level, pulses are sent to the driver which limits this output current. Normal operation is resumed when the output current drops below the present value.

## PARALLELING CIRCUIT

6. The generator current limit circuit (available on PM200 models only) receives a signal from three generator current transformers (See Figure 1 for location of input terminals and adjustment control). (The paralleling terminals are the inputs for one of the current transformers.) Each current signal is converted to a voltage signal and combined. Its composite is then sent to the main summing amplifier. The amount of control signal is determined by the setting of the current limit adjustment (See Section 4 for proper adjustment).

## PARALLELING CIRCUIT

The paralleling input requires a current signal from a 5 amp 5 VA current transformer. The current signal is converted to a voltage signal, amplified, and feed into the RMS sensing circuit. The gain control of the voltage amplifier is the droop adjustment. (For instructions on connecting the paralleling circuit see Section 3.)

SECTION  
**2**

# INSTALLATION

## MOUNTING

### MOUNTING

The MagnaMAX Voltage Regulator is normally located in the generator conduit box, but is also designed to operate in remote switchgear cabinets with convection cooling. It is equipped with two sets of mounting holes. The first set is located on the back of the regulator. These are the normal mounting holes for mounting in the generator conduit box or when the box panel assembly is moved to a remote site. If the regulator is to be remote mounted in the switchgear or auxiliary control enclosures, the second set of mounting holes can be used. This leaves both sides of the regulator accessible. (See Figure 4A and 4B for mounting hole dimensions.)

### WARNING

THE REGULATOR CHASSIS MUST BE PROPERLY CONNECTED TO A SUITABLE POWER SYSTEM GROUND TO PREVENT THE POSSIBILITY OF ELECTRICAL SHOCK HAZARD.

The environmental protective anodizing on the regulator case is an insulator, therefore, when mounting the regulator a secure ground must be established. One method of establishing this ground is to mount the regulator using lock washers that pierce the anodizing and connect a wire from the regulator case to the power system ground.

### Normal Mounting Hole Pattern

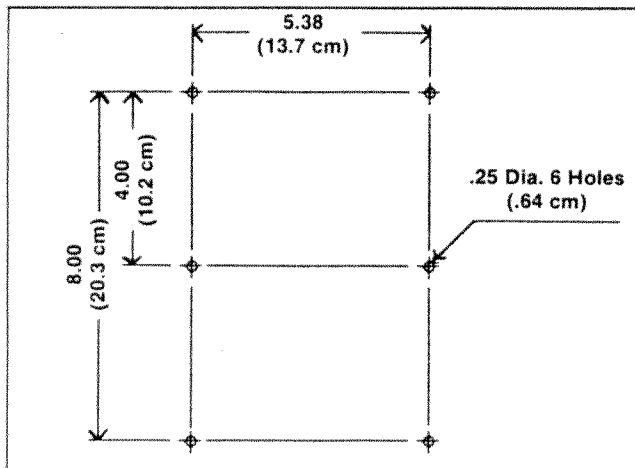

Fig. 4A

**CAUTION:** DO NOT megger or hi-pot the generator with the regulator connected. DO NOT megger or hi-pot the regulator.

## INTERCONNECTIONS

The regulator can be mounted in any of the three planes. However, it is recommended that the regulator be mounted with the heatsink fins in the vertical plane.

### Side Mounting Hole Pattern

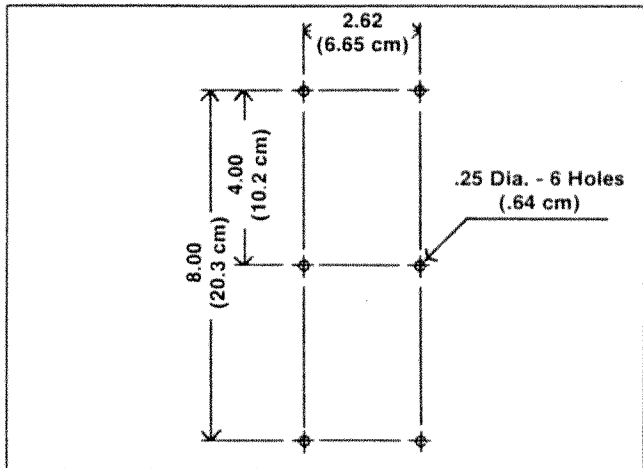

Fig. 4B

## INTERCONNECTIONS

For typical wiring diagrams see the **Outline Drawings and Diagrams** (Section 7).

**CAUTION:** For use on generators with outputs greater than 600 V, an external potential transformer must be used for voltage sensing.

Whenever a potential transformer is used for sensing, an open circuit on the primary side of the transformer will cause maximum forcing from the regulator, and the loss of sensing circuit will not activate. Assure that all connections on the primary side of the transformer are tight and secured from possible vibration.

### Remote Voltage Adjust

If a remote voltage adjust is required, use a 10,000 ohm, 1-watt potentiometer (1-watt is the minimum power requirement needed, however, to minimize the effect of vibration, a 25-watt rheostat is recommended). Remove the jumper from terminals 6 and 7 and connect the remote voltage adjust to these terminals. This connection should be made using two conductor non-shielded moderately twisted pair cable of wire gauges 18-22. The remote voltage adjust cabling should be kept separated from any power or sensing leads. For applications where the remote voltage adjust will be mounted at distances greater than 35-feet from the regulator, it is recommended that the complete regulator be remotely mounted. As an alternate, the installation of a potential transformer in the regulator sensing circuit, extends this distance beyond 150 feet. Finally, a motorized potentiometer can also be used.

# INSTALLATION

## INTERCONNECTIONS

**Note which terminal is connected to the wiper arm. If this is reversed, the remote control will function backwards.**

### Sensing Voltage

The MagnaMAX Voltage Regulator comes equipped for 3-phase sensing as standard. It can optionally be used with single phase sensing by connecting the generator sensing voltage to terminals E1 and E2 and installing a jumper from the second terminal E2 to terminal E3.

### Power Output

The power output terminals of the regulator are labeled as F1+ and F2-. These terminals are connected to the F1 and F2 generator leads respectively. DO NOT ground either one of the field leads.

### Power Input

The two power input terminals of the regulator are labeled PMG. The leads of the Permanent Magnet Generator are connected to these terminals. DO NOT ground either one of the PMG leads.

### WARNING

THE VOLTAGE REGULATOR POWER OUTPUT TERMINALS (F1+ AND F2-) SHOULD NEVER BE DISCONNECTED DURING OPERATION. THIS CAN RESULT IN PERMANENT DAMAGE TO THE REGULATOR. IF A REGULATOR POWER SWITCH IS DESIRED, IT SHOULD BE PLACED AT THE POWER INPUT TERMINALS.

### Paralleling Input

The MagnaMAX Voltage Regulator comes with paralleling provisions. The paralleling input terminals are labeled CTB1 and CTB2. If paralleling is desired, connect the leads from a standard 5 amp 5 VA current transformer to these input terminals.

The standard MagnaMAX generator phase rotation is C-B-A with CCW rotation when facing the conduit box or opposite drive end. For C-B-A generator phase rotation the connection is as follows:

With three phase sensing, connect generator sensing lead

- T1 to regulator terminal E1,
- T2 to regulator terminal E2, and
- T3 to regulator terminal E3.

With single phase sensing, connect generator sensing lead

- T1 to regulator terminal E1,
- T3 to regulator terminal E2, and
- jumper regulator terminal E2 to regulator terminal E3.

For either of the above sensing connections, the paralleling transformer must be in the generator T2 lead with the H1 towards the generator and the X1 connected to the regulator CTB1 terminal.

**Note:** If a different phase rotation is desired, it is recommended that the regulator CT connections be made as stated above and the phase rotation change be performed beyond these connections.

**CAUTION:** The polarity and phasing of the current transformer and sensing connections must be observed or improper operation will result. (Refer to Section 7 for typical connections.)

To determine if the paralleling function is operating properly, see Section 4.

If a unit paralleling or CT shorting switch is used, a 0.1 ohm, 10 watt resistor must be placed in series with the lead to the CTB1 terminal. See Section 7-Drawings & Diagrams for the typical connection of this resistor.

The current transformer used for paralleling can also be used for generator current metering.

### Generator Current Limit

The PM200 model voltage regulator is equipped with generator current limit. There are four input terminals for this. Two are labeled CTA and two are labeled CTC. Connect a standard 5 amp 5 VA current transformer located in phase A to the CTA1 and CTA2 terminals and a transformer located in phase C to the CTC1 and CTC2 terminals. Observing polarity is not necessary with these connections. The remaining input terminals are the paralleling terminals mentioned above. The current transformers used here can also be used for generator current metering and paralleling.

### Field Flashing

The MagnaMAX Voltage Regulator is powered by a permanent magnet generator therefore field flashing is neither required or necessary.

SECTION

3

# ADJUSTMENTS & STARTUP PROCEDURES

## GENERAL

## VOLTAGE ADJUSTMENT STABILITY ADJUSTMENT

**NOTE: Read and understand this section completely before attempting any adjustments and starting the generator. If the adjustments do not produce the specified results, proceed to the "Troubleshooting" section.**

### GENERAL

Below is a listing of the adjustments associated with the MagnaMAX Voltage Regulator and the number of turns required to traverse the full range of the control. The multi-turn controls have slip clutches in them to prevent damage by overrotation.

Control	Turns
Coarse Voltage Adjustment.....	15
Fine Voltage Adjustment .....	1
Stability Adjustment .....	15
Underfrequency Adjustment.....	15
Droop Adjustment .....	15
Current Limit Adjustment (PM200 only) .....	15

Before starting the generator, the following adjustments should be made:

Control	Setting
Coarse Voltage Adjustment.....	Full CCW
Fine Voltage Adjustment .....	Full CW*
Remote Voltage Adjustment (if used)...	Mid Point
Stability Adjustment .....	Full CW
Underfrequency Adjustment.....	Full CCW
Droop Adjustment .....	Full CCW
Current Limit Adjustment (PM200) .....	Full CCW

\*If a remote voltage adjustment is not used, set the fine voltage adjustment to the mid point of its range and install a jumper between terminals 6 and 7.

Because generator stability is most noticeable when monitoring field voltage, connect a 50V DC voltmeter to the regulator output terminals F1 and F2. Be sure to observe polarity. F1 is positive and F2 is negative. If a DC voltmeter is not available, an alternate method of monitoring stability is to observe generator output voltage.

Connect an ac voltmeter of proper size to the generator output leads.

Start and run the generator at **no load and rated speed.**

### VOLTAGE ADJUSTMENTS

There are three possible voltage adjustment points on the MagnaMAX Voltage Regulator. The large

single turn, regulator mounted, voltage adjust control is for fine adjustments in generator output voltage. Turning this control clockwise will increase the output voltage. The range is  $\pm 10\%$  of the nominal voltage from the mid-setting. The miniature 15-turn voltage adjust control is used for coarse adjustments in generator voltage. Turning this control clockwise will increase the output voltage. The third adjustment can be an optional remote voltage control. (For proper sizing of this control, refer to the Section 3, Interconnections.) Turning this control clockwise will increase the output voltage. This adjustment can also give a  $\pm 10\%$  variation in output voltage from a mid-setting.

Rotate the coarse voltage adjustment clockwise until the desired generator output is reached.

If a remote voltage adjust rheostat is used, the fine voltage adjust should be full CW. This will give a minimum  $\pm 10\%$  variation in generator voltage with the remote adjust.

If finer control is desired, set the fine adjust to the minimum setting and reset the desired output with the coarse adjust. This gives approximately  $\pm 4\%$  voltage adjustment with the remote adjust rheostat.

### STABILITY ADJUSTMENT

The miniature 15-turn stability control adjusts the transient response time of the system (Figure 3B). Turning the stability control counter-clockwise decreases the level of stability which decreases the response time of the system. Turning the control clockwise increases the level of stability which increases the response time of the system. Generally the stability control should be adjusted as far counter-clockwise as possible while still maintaining the desired level of stability. This gives the best transient performance.

Turn the stability adjustment counter-clockwise until the instability is shown on the DC voltmeter (use the ac voltmeter on the generator output terminals if a dc voltmeter is not available). With the system operating in an unstable condition, slowly adjust the stability control in a clockwise direction until generator stability is reached. If the system is stable with control fully counter-clockwise, interrupt the regulator input power for a short time (approximately 1-2 seconds). If the system is still stable, further stability adjustment is not needed.

# ADJUSTMENTS & STARTUP PROCEDURES

## STABILITY ADJUSTMENT UNDERFREQUENCY ADJUSTMENT

Below is a chart of general stability settings for normal operation. The actual desired setting may vary depending upon specific applications.

Generator Frame Size	Setting From Full CCW
430 Frame Series .....	2-4 Turns
570 Frame Series .....	2-4 Turns
740 Frame Series .....	9-12 Turns

## UNDERFREQUENCY ADJUSTMENT

The underfrequency control adjusts the frequency at which the regulator begins to operate on a constant volts/hertz ramp. Turning the control clockwise increases the set point frequency. Turning the control counter-clockwise decreases the set point frequency (See Figure 2B and 2C for typical 60 Hz and 50 Hz operation). As an example, when changing from 60 Hz operation to 50 Hz operation, the control must be adjusted counter-clockwise to lower the set point frequency to just below 50 Hz.

For normal underfrequency characteristics rotate the underfrequency adjustment clockwise until the underfrequency LED turns on. Rotate the control counter-clockwise until the LED just turns off and then rotate the control one quarter turn counter-clockwise further. If a longer flat voltage response is desired, every turn counter-clockwise will decrease the transition frequency about 8 hertz. (For 50 hertz transition adjustment is about 5 hertz per turn.)

If continuous operation on the volts/hertz ramp is desired, rotate the underfrequency control to the full clockwise position and increase the generator voltage with the coarse voltage adjust until the required voltage for that speed is obtained.

## DROOP ADJUSTMENT

The droop adjustment is used when paralleling generators. Turning the droop control clockwise increases the amount of generator voltage droop with application of reactive load. A 5.0 amp signal into terminals CTB1 and CTB2 will give a minimum of 10% voltage droop with the application of 0.8 PF load and the control set to its full clockwise position.

The best way to set the droop is to run each generator individually and apply rated or near rated current at 0.8 PF. The amount of droop can then be adjusted directly.

## DROOP ADJUSTMENT GENERATOR CURRENT LIMIT ADJUST

If a reactive load is not available, there is an alternate method of adjusting the generator droop. With the droop CT installed in the generator T2 lead (as specified in Section 3), temporarily connect generator sensing lead

- E1 to generator lead T2,
- E2 to generator lead T3, and
- E3 to generator lead T1.

If single phase sensing is used, temporarily connect generator sensing lead

- E1 to generator lead T2,
- E2 to generator lead T1, and
- jumper regulator terminal E2 to regulator terminal E3.

Run each generator individually and apply rated or near rated current at unity PF. The amount of droop can now be set by adjusting the droop control as needed for the application.

If the droop adjustment does not cause the generator voltage to droop or decrease with application of load, recheck the CT polarity and sensing connections.

After the adjustments are complete, reconnect the regulator sensing leads as outlined in Section 3. When the generators are operated in parallel they will share load equally. If no reactive load is present, the generator voltage should not droop. If it does droop, recheck sensing connections, CT connections, and CT polarity. If necessary, repeat the adjustment procedure.

Figure 5 shows the number of turns required by the droop adjustment for a desired percentage droop with a given CT secondary current.

See Section 3 — INSTALLATION for proper connection of the droop circuit.

If the generator is not used in parallel operation, it is recommended that the droop control be set to its full counter-clockwise position.

## SECTION 4

# ADJUSTMENTS & STARTUP PROCEDURES

## DROOP ADJUSTMENT

## GENERATOR CURRENT LIMIT ADJUST

### Droop Adjustment

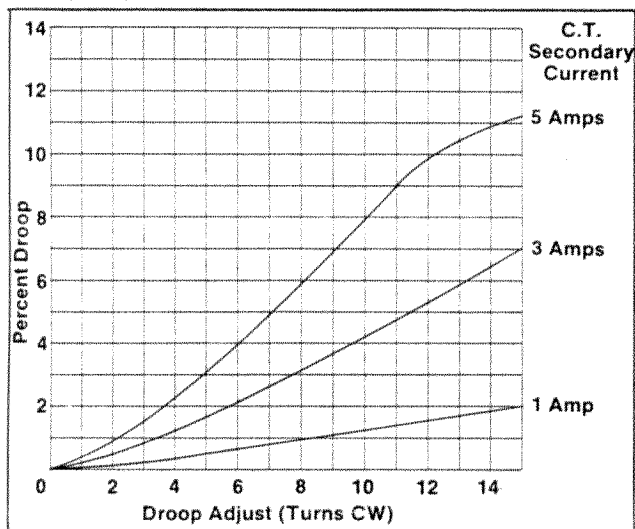

Fig. 5

### GENERATOR CURRENT LIMIT ADJUST (MODEL PM200 ONLY)

SECTION  
4

The generator current limit is designed to control the maximum short circuit current that will be sustained by the generator. Rotating the control clockwise will increase the amount of generator short circuit current. Depending on the current

transformer ratio, the control will limit the generator current from about 150% to about 400%. The 400% limit is only achieved with a line-neutral or line-line single phase short. With a 3-phase symmetrical short, the built in regulator field current limit will control the short circuit to a level of 300% minimum to about 350% maximum.

To set the generator current limit, first determine the current transformer secondary current corresponding to the desired sustained fault current. This secondary current must be between 5 and 20 amps.

After the secondary current is known, refer to figure 6 for the proper number of turns of adjustment.

### Armature Current Limit Adjustment

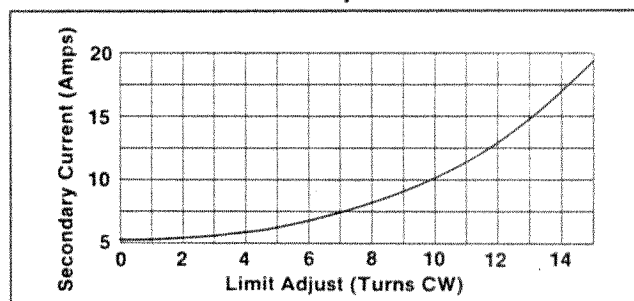

Fig. 6

# TROUBLESHOOTING

Symptom	Cause	Action
Residual Voltage Output (No Buildup)	<p>F1, F2 leads not connected.</p> <p>PMG leads not connected.</p> <p>No PMG Voltage - Possible shorted 5uf capacitor or defective PMG. (Refer to generator manual for PMG replacement procedure.)</p> <p>Fuse blown.</p> <p>Generator not up to speed.</p> <p>Coarse Voltage Adjust turned full CCW.</p> <p>Overexcitation LED on.</p> <p>L.O.S. LED on.</p> <p>Overtemperature LED on.</p> <p>Faulty regulator.</p> <p>Defective generator.</p>	<p>Connect field leads F1, F2.</p> <p>Connect PMG leads.</p> <p>Check PMG Voltage. Nominally 180-190v with 5uf capacitor connected and 150-160v without 5uf capacitor connected.</p> <p>Replace fuse. (Littelfuse type 314005) or (Bussman type ABC-5)</p> <p>Increase generator speed. (Consult prime mover manual)</p> <p>Rotate coarse voltage adjust CW until desired voltage is reached.</p> <p>Interrupt input power to regulator or shut down generator for a minimum of 10 seconds.</p> <p>Loss of sensing. Check sensing leads - reconnect.</p> <p>PMG and/or field grounded. Check PMG and field connections to be sure neither circuit is grounded.</p> <p>Regulator temperature too high. Increase cooling air to regulator or let ambient cool down.</p> <p>Replace regulator.</p> <p>Consult generator manual.</p>
Output Voltage Low	<p>Coarse Voltage Adjust turned down.</p> <p>Fine Voltage Adjust turned down.</p> <p>Remote Voltage Adjust turned down.</p> <p>Remote Voltage Control not connected or terminals 6 &amp; 7 not jumpered.</p>	<p>Rotate coarse voltage adjust CW until desired voltage is reached.</p> <p>Adjust control CW to desired output voltage.</p> <p>Adjust control CW to desired output voltage.</p> <p>Connect Remote Voltage Control or jumper terminals 6 &amp; 7.</p>
Voltage does not increase as Coarse Voltage is turned clockwise.	<p>Fine Voltage Adjust turned down.</p> <p>Remote Voltage Adjust turned down.</p>	<p>Adjust control CW to the desired setting.</p> <p>Adjust control CW to the desired setting.</p>
Output Voltage High	<p>Coarse Voltage Adjust turned too high.</p> <p>Fine Voltage Adjust turned too high.</p> <p>Remote Voltage Adjust turned too high.</p>	<p>Adjust control CCW to desired voltage.</p> <p>Adjust control CCW to desired voltage.</p> <p>Adjust control CCW to desired voltage.</p>

SECTION

5

# TROUBLESHOOTING

Symptom	Cause	Action
Poor Voltage Regulation	<p>6-7 not jumpered.</p> <p>Shielded cable used for remote pot leads.</p> <p>Interference on remote voltage adjust leads.</p> <p>Regulator not grounded.</p> <p>Field leads or PMG leads grounded.</p>	<p>Connect a jumper from 6-7.</p> <p>Remove connection from shield to frame.</p> <p>Isolate the remote voltage adjust leads from other power or sensing leads.</p> <p>Use smaller gauge wire. 18-22 gauge recommended.</p> <p>If Possible, shorten distance between remote pot and regulator to 35-feet or less, or remote mount regulator.</p> <p>Properly ground regulator.</p> <p>Check field leads &amp; PMG leads for continuity to ground. If grounded, remove ground connection.</p>
Output Voltage High - No Adjustment	Faulty regulator.	Replace regulator.
Remote Voltage Control Operates Backwards.	Control wired backwards.	Reverse the wiring of the wiper arm on the remote voltage control.
Generator Voltage Hunting	<p>Stability control not set properly.</p> <p>Intermittent connection to PMG terminals.</p> <p>Intermittent connection to sensing terminals.</p>	<p>Adjust stability control in a CW direction until hunting stops.</p> <p>Check wiring in PMG circuit.</p> <p>Check wiring in sensing circuit.</p>
Underfrequency LED on.	<p>Generator operating at reduced speed, or control adjusted incorrectly.</p> <p>Intermittent connection to PMG</p>	<p>Readjust control CCW or increase speed of generator.</p> <p>Check wiring to PMG circuit.</p>
Overexcitation LED on	<p>Generator overloaded.</p> <p>Defective regulator.</p>	<p>Reduce load to generator.</p> <p>Replace regulator.</p>
Field Limit LED on. (Overexcitation LED may be on also.)	Regulator operating in field current limit mode.	<p>Reduce load on generator.</p> <p>Check field leads for short.</p> <p>Check exciter field winding resistance - possible shorted turns. (See generator manual.)</p> <p>Check exciter armature winding resistance - possible shorted turns. (See generator manual.)</p> <p>Check rotating bridge rectifier - possible shorted diodes. (See generator manual.)</p> <p>Check generator field resistance - possible shorted turns. (See generator manual.)</p>

SECTION

5

# TROUBLESHOOTING

Symptom	Cause	Action
No Droop Control or Negative Droop (Generator does not share load.)	Open connection to terminals CTB1 & CTB2.  Droop transformer connected backwards.  Paralling current transformer in wrong phase.  Sensing connections incorrect.  Regulator defective.	Check connections of terminals CTB1 & CTB2 and paralleling current transformer.  Reverse connections to terminals CTB1 & CTB2.  Refer to Sections 3 and 7 for proper installation.  Refer to Sections 3 and 7 for proper sensing connections.  Replace regulator.
Generator Current Limit LED on. (PM200 Models Only)	Generator overloaded.	Reduce load to generator.
Generator Fault Current Limited to Undesired Level.	Current limit control not set properly.  Current transformers are of incorrect ratio for application.	Readjust generator current limit control.  Re-size current transformer ratio.

SECTION

5

# FIELD APPLICATIONS

---

## MANUAL VOLTAGE CONTROL

## VAR-POWER FACTOR CONTROLLER

### MANUAL VOLTAGE CONTROL

The MagnaMAX Voltage Regulator is designed to operate with most commercially available manual voltage controls.

For typical operation of the regulator with a manual voltage control, refer to Marathon Electric.

### VAR-POWER FACTOR CONTROLLER

The MagnaMAX Voltage Regulator is designed to operate with most commercially available var-power factor controllers.

For typical operation of the regulator with a var-power factor controller, refer to Marathon Electric.

SECTION  
**6**

# DRAWINGS & DIAGRAMS

## Remote Voltage Adjust Rheostat

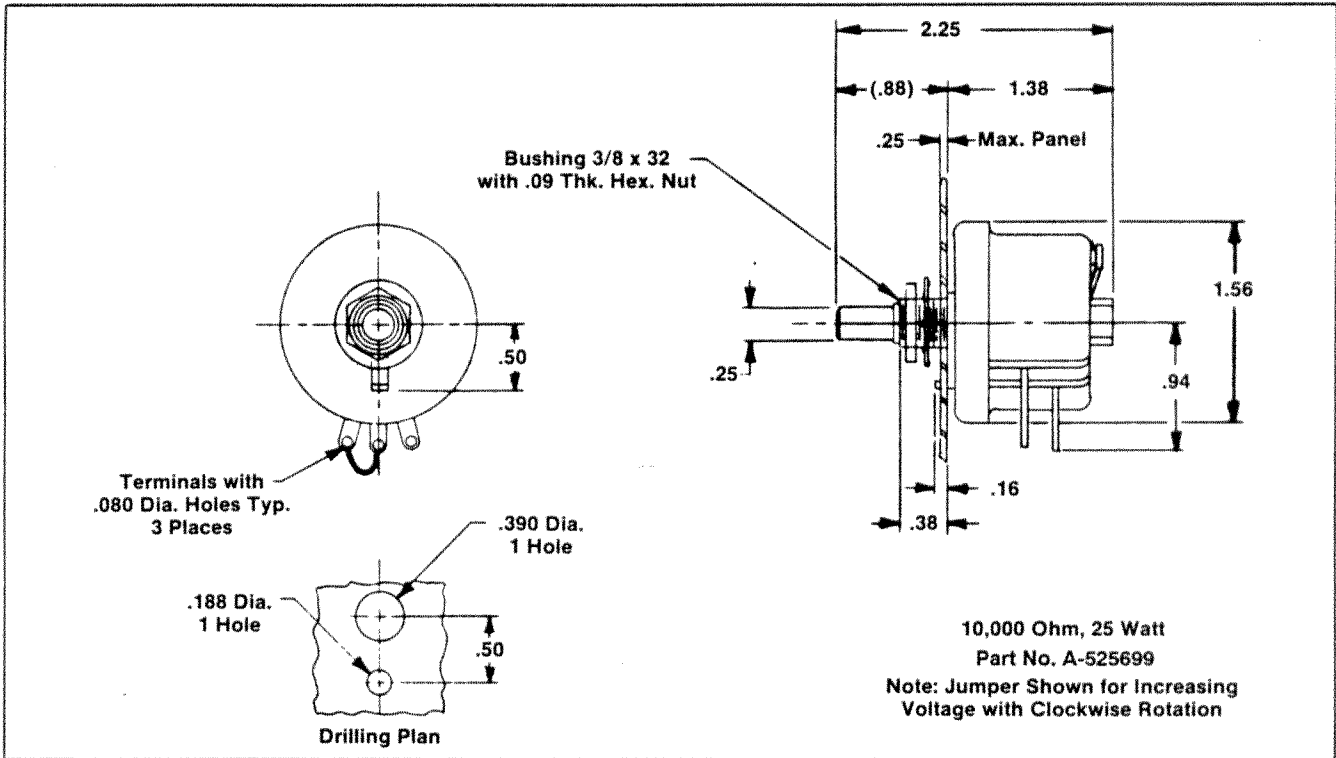

## Paralleling Burden Resistor

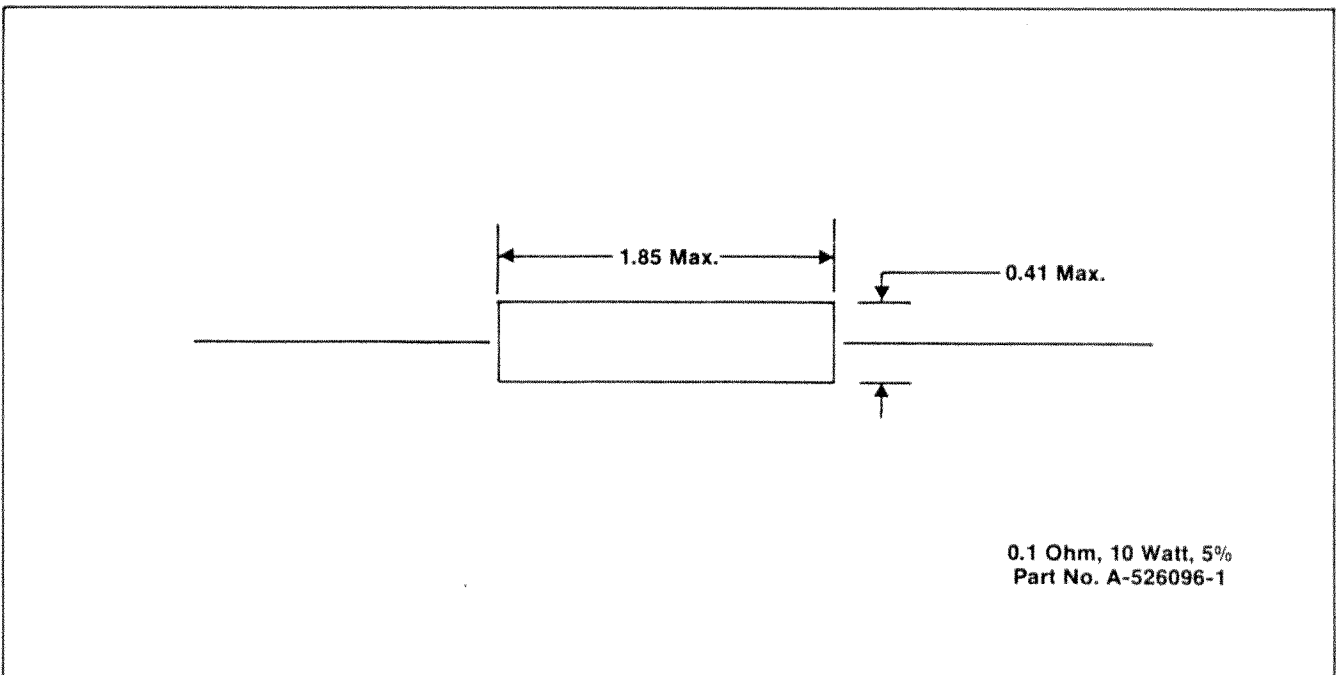

SECTION  
7

# DRAWINGS & DIAGRAMS

Outline Drawing of Regulator

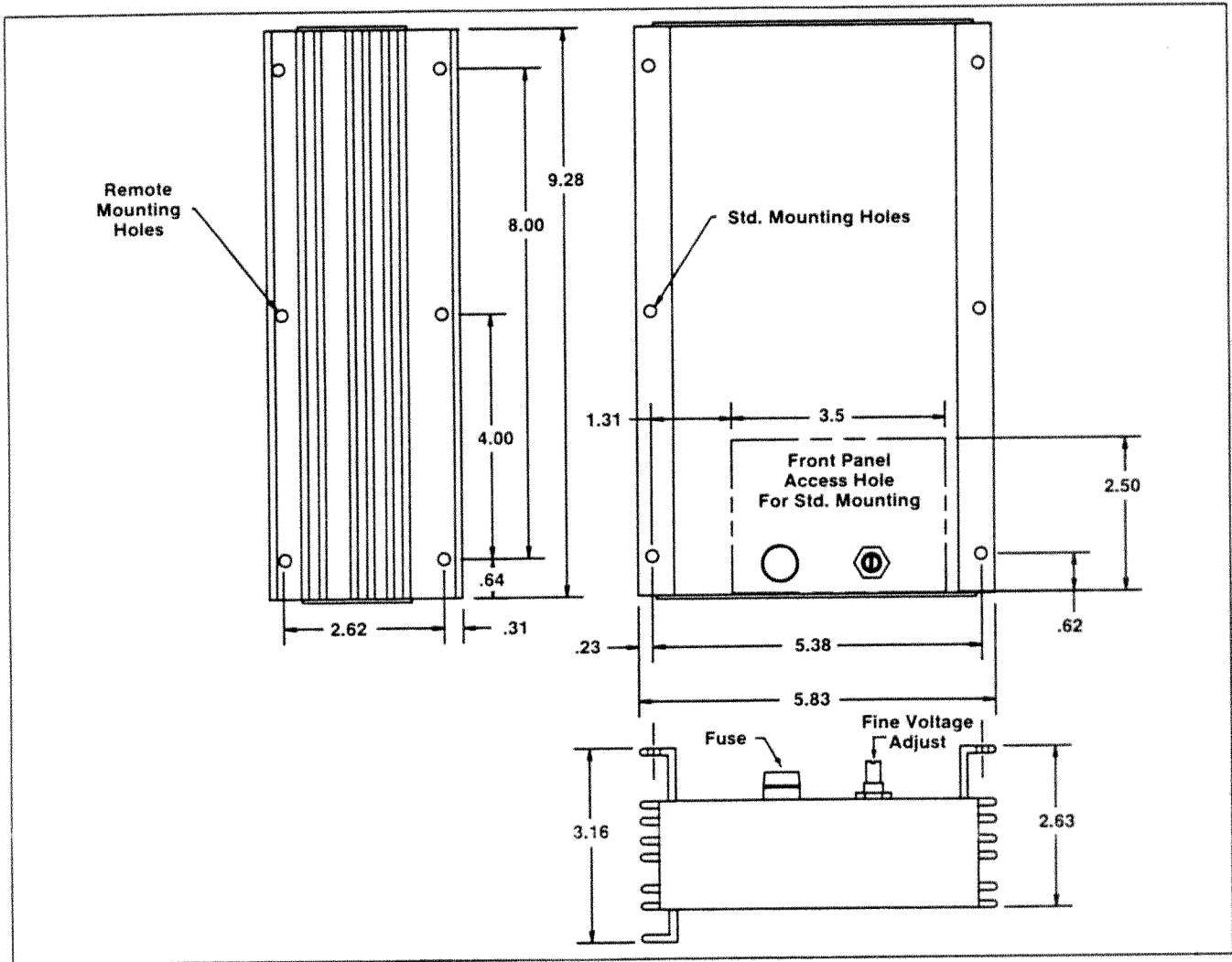

SECTION  
7

# DRAWINGS & DIAGRAMS

Typical Connection - Three Phase Sensing (95-600 Volts)

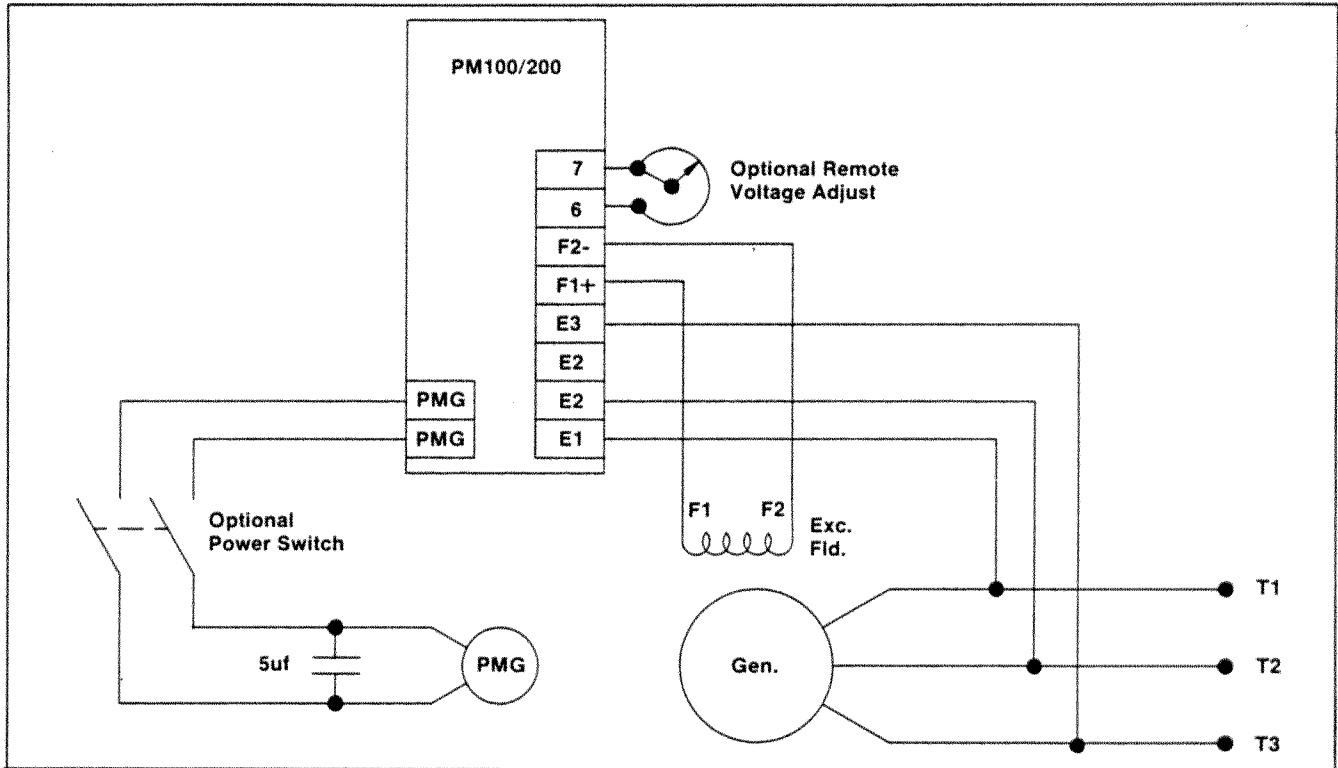

Typical Connection - Three Phase Sensing (95-600 Volts) with Reactive Droop Paralleling

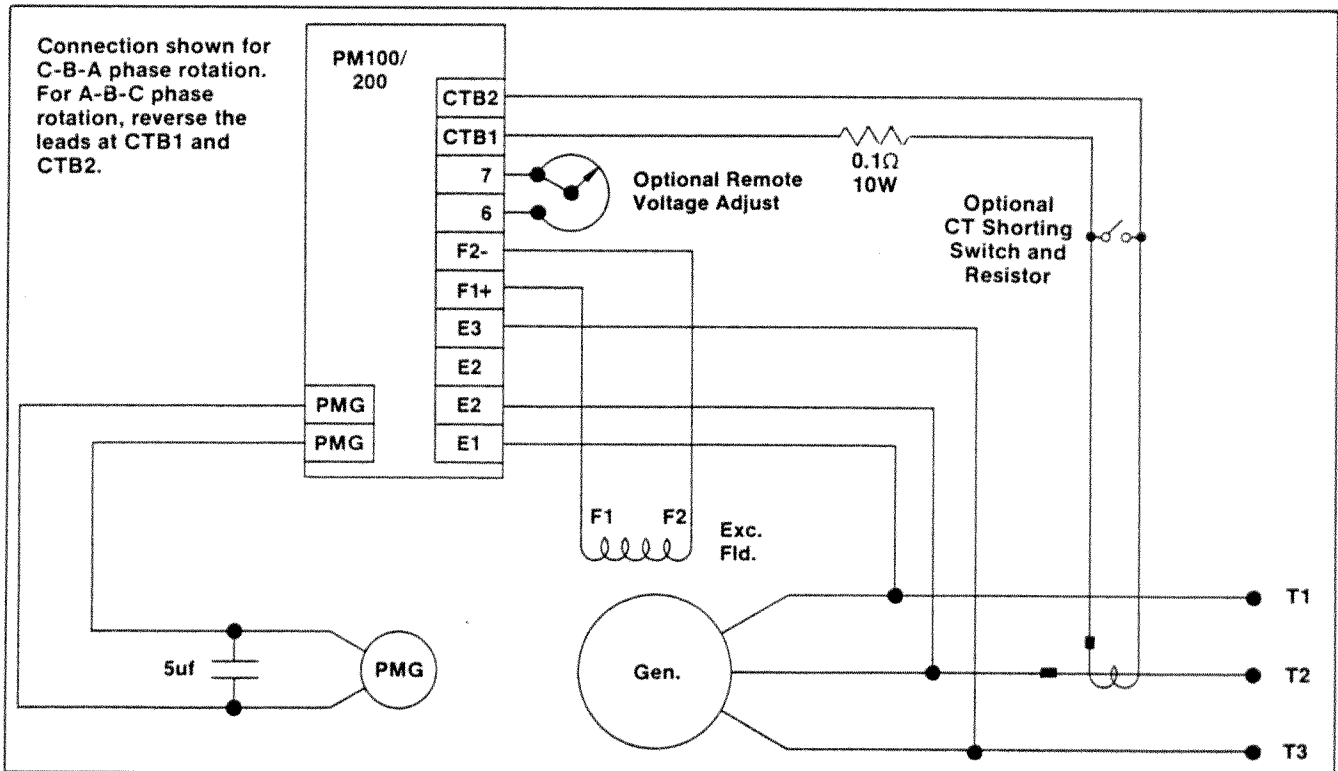

SECTION  
7

# DRAWINGS & DIAGRAMS

Typical Connection - Single Phase Sensing (95-600 Volts)

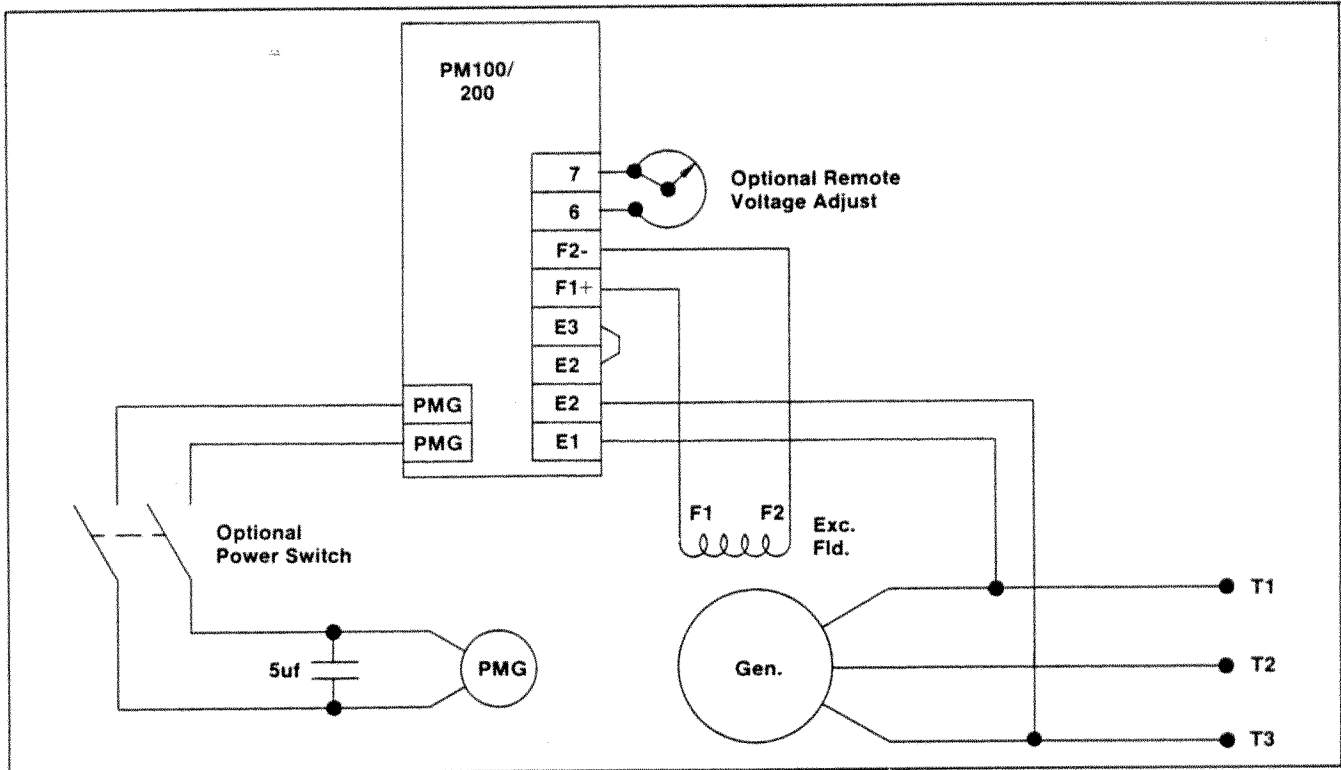

Typical Connection - Single Phase Sensing (95-600 Volts) with Reactive Droop Paralleling

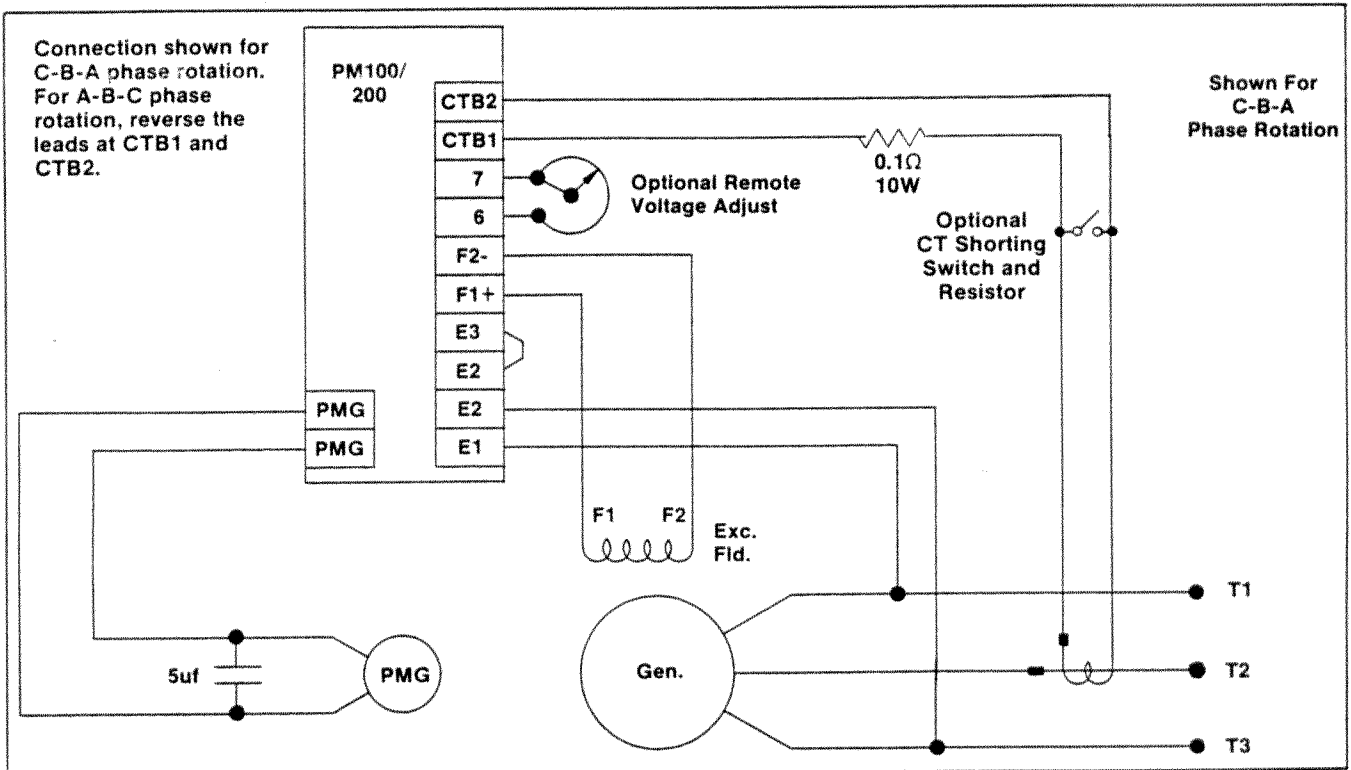

SECTION  
7

# DRAWINGS & DIAGRAMS

Typical Connection - Three Phase Sensing (601-6600 Volts)

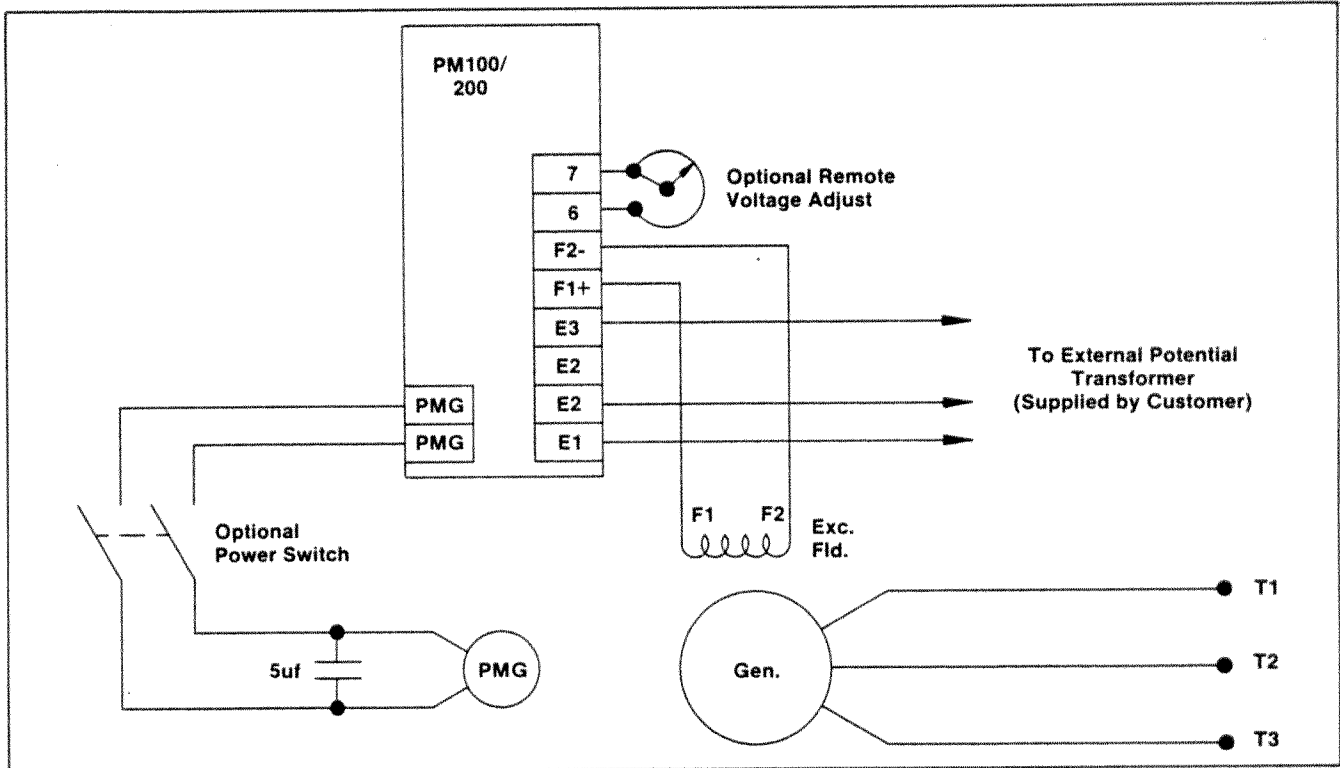

Typical Connection - Three Phase Sensing (601-6600 Volts) with Reactive Droop Paralleling

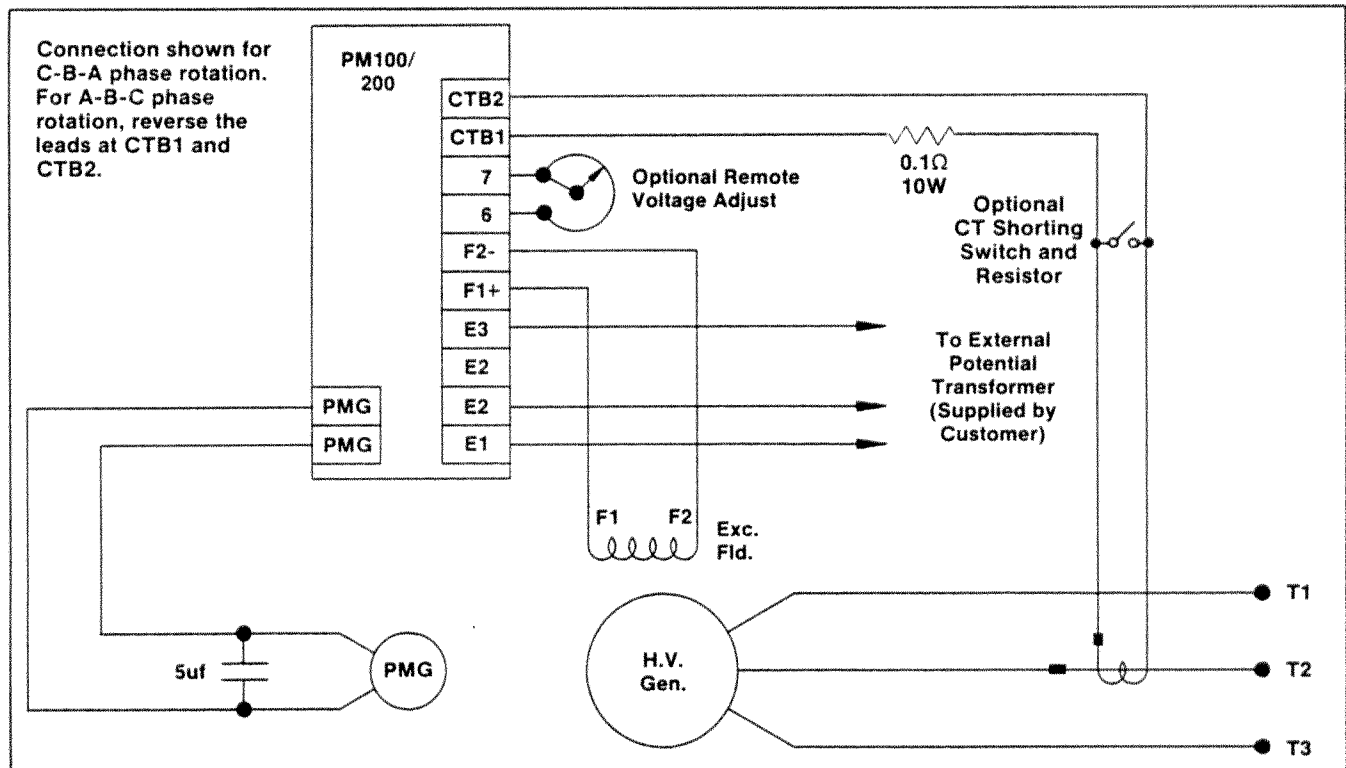

SECTION  
7

# DRAWINGS & DIAGRAMS

Typical Connection - Three Phase Sensing (95-600 Volts) with Reactive Differential Paralleling

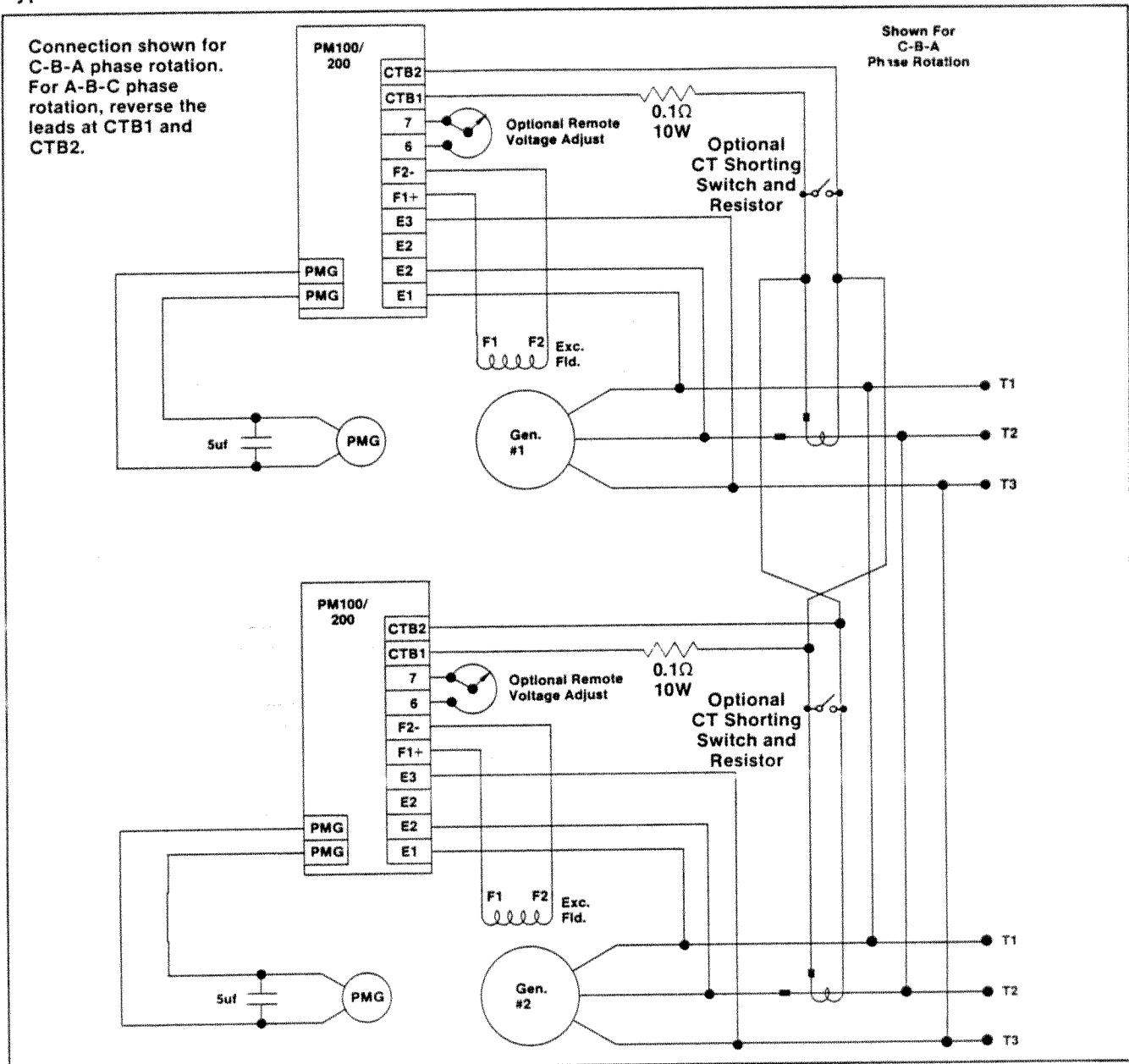

SECTION  
**7**

# DRAWINGS & DIAGRAMS

Typical Connection - Three Phase Sensing (95-600 Volts) with Generator Current Limit

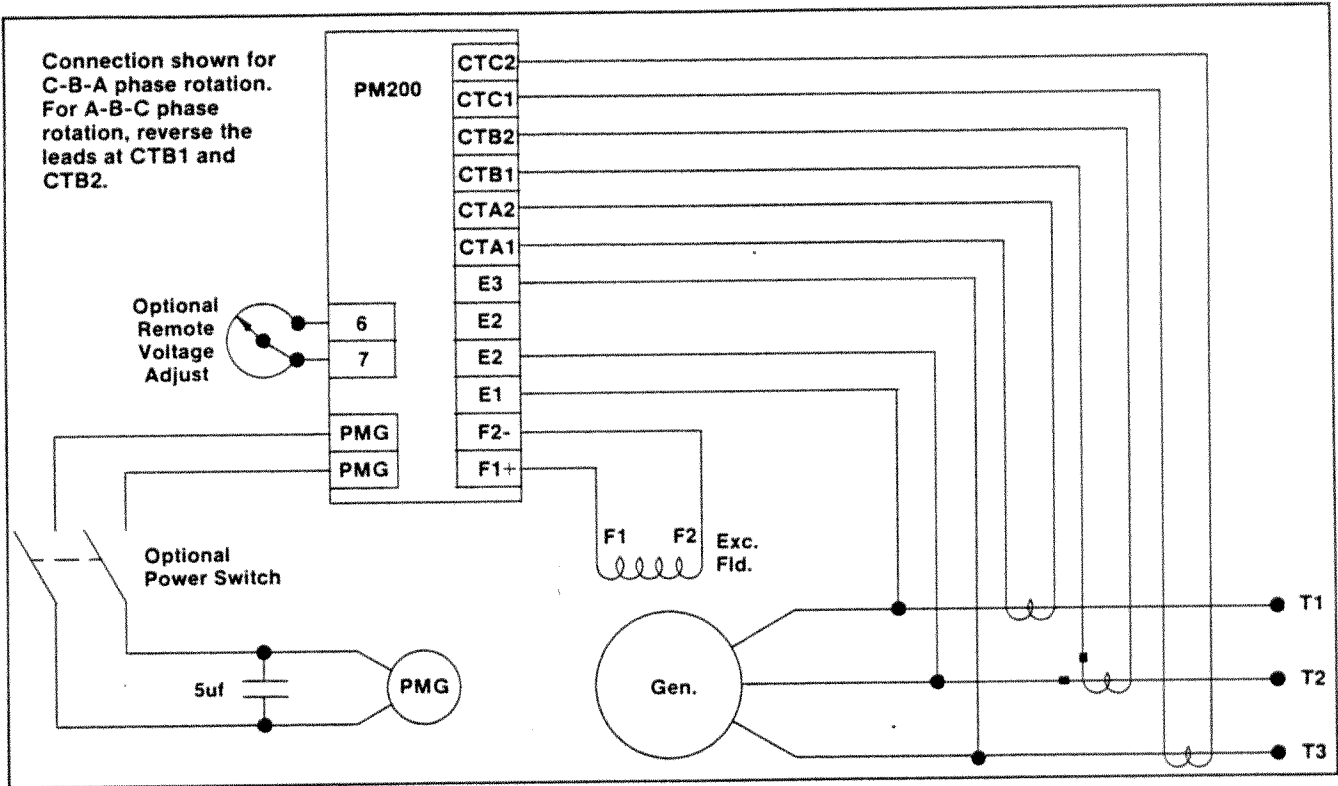

SECTION

7

Marathon Electric Mfg. Corp.  
100 East Randolph Street  
P.O. Box 8003  
Wausau, WI 54402-8003  
Phone: (715) 675-3311  
TWX: 910-281-1521  
Telex: 260175 ME WAS

 **MARATHON**  
**ELECTRIC**

*A Subsidiary of Regal-Beilco Corporation*

**RUNS.**  
**AND RUNS.**  
**AND RUNS.**  
**AND RUNS.**  
**AND RUNS.**

