

100-1000 Amp
Single-Coil Contactor
Solid-State
Automatic Transfer
and
Bypass - Isolation Switch

Operation and Service Manual

KOHLER
Transfer Switches

CONTENTS

	Page
Introduction	2
Installation	2
Functional Test	3
Bypass	6
Isolation	6
General Maintenance	7
Sequence of Operation	8
Troubleshooting	8
Accessories	9
Battery Charger	9
Generator Set Exercise Timer	10
Auxiliary Contacts	11
In-phase Monitor	11
Transfer Switch Removal	12
Transfer Switch Installation	13
Manual Load Transfer	14
Disconnecting the Control Panel	14
Sensor Adjustments	14
Time Delay Adjustments	15
Wiring Diagrams	18
Outline and Mounting	22
Enclosure Outline	26

Switch No. _____

Serial No. _____

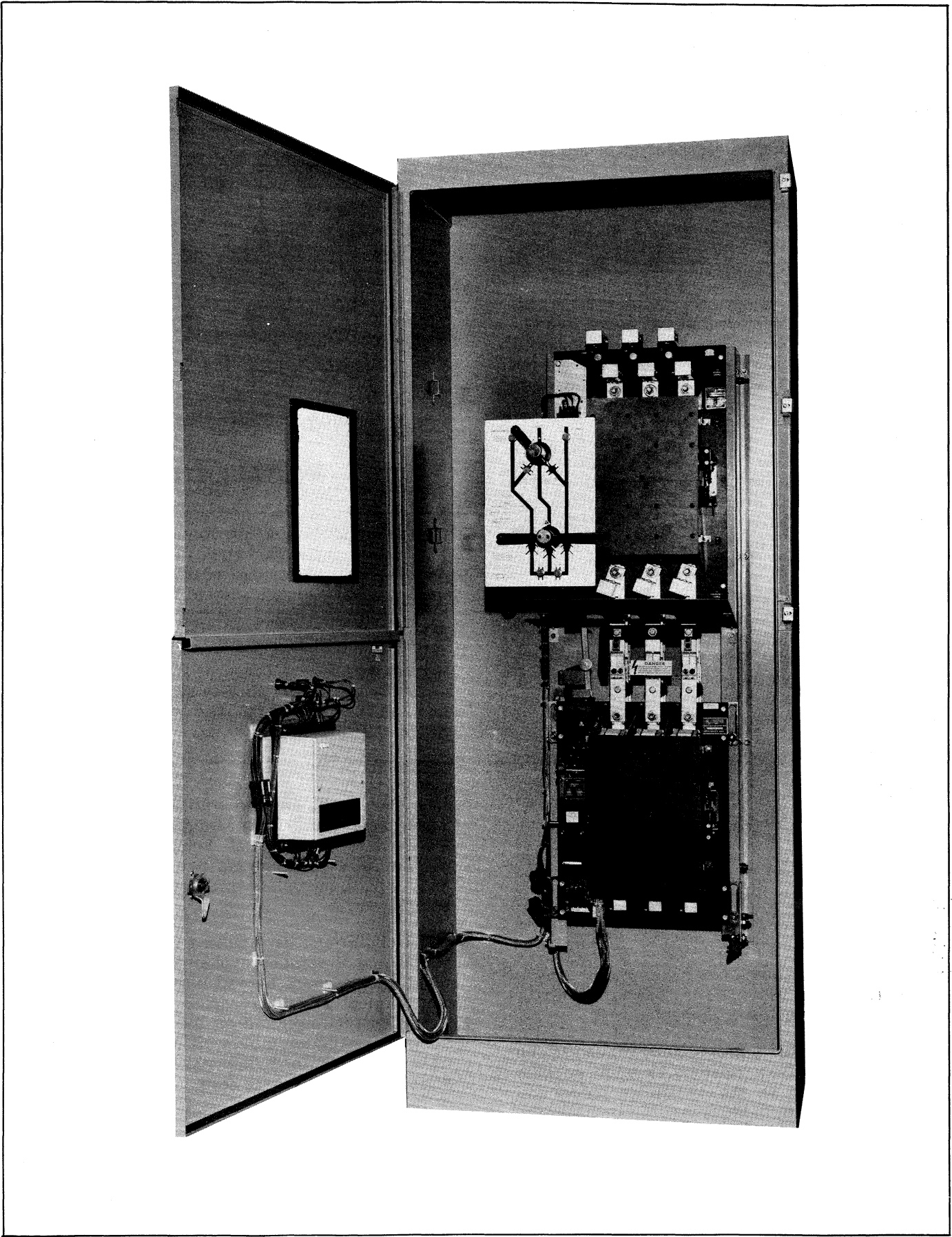

Figure 1. Automatic Transfer and Bypass Isolation Switch

INTRODUCTION

The Kohler **Automatic Transfer and Bypass-Isolation Switch** is designed to give maximum flexibility and to assure continuity of service under various conditions. It provides a means for maintaining essential load circuits. At the same time, it permits periodic testing, maintenance, and inspection of the Automatic Transfer Switch.

The equipment combines manual and automatic switches to achieve these functions. The Bypass and Isolation Switches are manually operated. The Automatic Transfer Switch operates electrically.

The **Bypass Switch** is manually operated to bypass the Automatic Transfer Switch contacts closed on either source. There is no interruption to the load. If the Automatic Transfer Switch is out of service, the Bypass Switch also serves as a manually operated Transfer Switch.

The **Isolation Switch** is manually operated (only after the Bypass Switch is operated) to withdraw the Automatic Transfer Switch from service for ease of scheduled periodic maintenance. The Isolation Switch also provides a test position for checking electrical operation of the Automatic Transfer Switch without interruption of the load.

The **Automatic Transfer Switch** is an emergency device used for transferring critical loads from a normal (preferred) source to an emergency (stand-by) source of power. This transfer automatically occurs when the normal source voltage fails or is substantially reduced and the emergency source voltage has reached an acceptable level.

Upon normal source failure, the Automatic Transfer Switch signals the start of the engine-driven generator set. The Automatic Transfer Switch continuously senses for the presence of an acceptable normal source and will retransfer the load to the normal source after it has been restored to an acceptable level. After retransfer of the load, the start signal from the Automatic Transfer Switch is cancelled and the generator set is allowed to shut down.

Figure 2 shows the location of the equipment in the system. The switch should be as close as possible to the critical electrical loads connected to it.

The **RATING LABEL** is prominently affixed to the Transfer Switch. Data relating to each specific switch is included on the nameplate. Long and trouble-free equipment life is assured by using the switch within the limits shown on the rating label and nameplate.

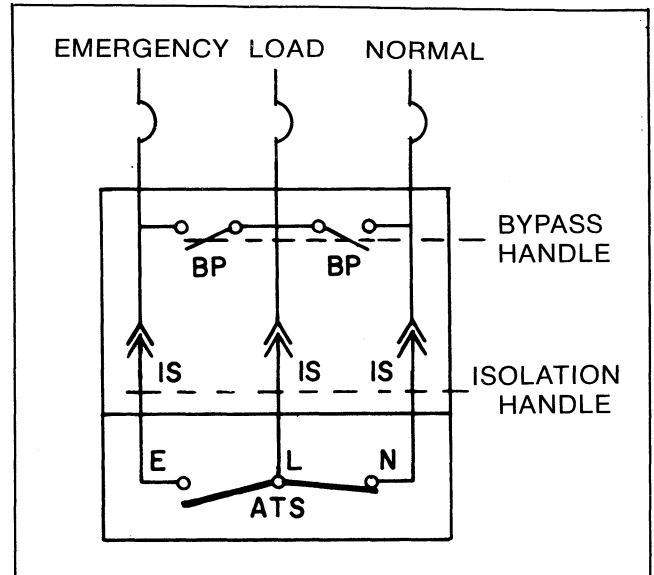

Figure 2. Switch Connection

INSTALLATION

Kohler Transfer Switches are factory wired and tested. Installation simply requires mounting, and connection of service cables and auxiliary control circuits. Do not remove protective packing until ready for complete installation. Protect switch at all times from moisture, construction grit, and metal chips.

Unpacking

Carefully unpack or uncrate switch and check for damage. Report any damage immediately to your Kohler Distributor.

Mounting

Two **Composite Outline and Mounting Diagrams** and two **Enclosure Outline Diagrams** are provided at the back of the manual. Select the appropriate diagram by switch ampere size. Mount the switch according to the details and instructions shown on the diagram.

The switch must be mounted vertically to a rigid supporting structure. Level all mounting points by using flat washers behind holes to avoid forced distortion of switch. Enclosed switches have the Control Panel mounted on the cabinet door. For open type switches, mount the Control Panel to the right of the Transfer Switch, preferably on the inside surface of the enclosure door.

Lifting

Any lifting devices must be attached to the switch mounting holes or enclosure eye bolts only. See Figure 3. Do not lift the switch at any other points. Protect arc barriers at all times from impact.

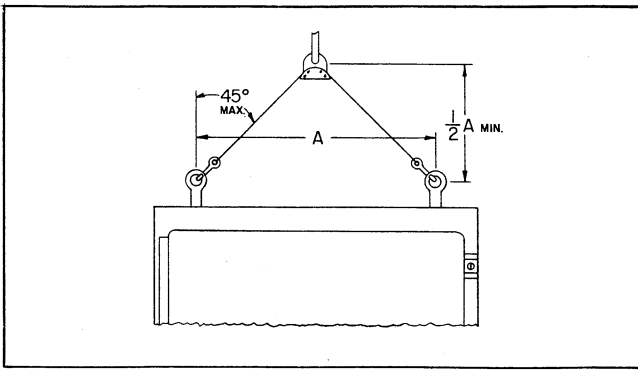

Figure 3. Lifting

WARNING

De-energize the normal source branch to be connected to the Switch before making any line or auxiliary circuit connections.

Line Connections

Two **Composite Elementary Wiring Diagrams** are furnished at the back of this manual. One diagram is for 150 and 260-ampere switches; the other is for 400-1000-ampere switches. Select appropriate diagram.

All conductors should enter enclosure adjacent to the Bypass Switch terminals. Pilot knockouts are provided on enclosed 100 and 260-ampere switches only. Protect the switch from metal chips and construction grit at all times. Standard terminal lugs are solderless screw type and will accept the conductor sizes listed on the **Composite Outline and Mounting Diagrams**.

On 400-1000-ampere switches, remove the barrier between Bypass Switch and Transfer Switch. This will facilitate connecting emergency source conductors. Install barrier when finished.

Connect source and load conductors to clearly marked Bypass Switch terminal lugs. Remove surface oxides from conductors by cleaning with wire brush. When aluminum conductor is used, apply joint compound to conductor. Tighten conductor and carefully wipe away excess compound.

Do not run cables behind the switch. Cables can be bundled to the left side of the switch. Maintain proper electrical clearance between the live metal parts and grounded metal.

All internal connections are made at the factory. The Bypass Switch, Transfer Switch, and Control Panel are joined together by an interconnecting wire harness. The In-Line Disconnect Plugs are already engaged on enclosed switches. For open type switches, the Control Panel's plug must be engaged after installation is completed. Extension harnesses are available in standard lengths.

Auxiliary Connections

Connect auxiliary circuit wires to appropriate terminals as shown on the **Composite Elementary Wiring Diagrams**. External circuits can include engine-generator set start signal, auxiliary contacts, signal lights, and Reset and Test Switches. The Toggle switches and signal lights are already installed on enclosed switches. For open type switches the Reset Switch, Test Switch, and signal lights are supplied loose.

When making connections to Acc. 15 auxiliary contacts, leave enough slack in the wiring to allow for Transfer Switch movement. The Transfer Switch moves 3" away from the Bypass Switch when the Isolation handle is turned to the open position.

Note any Optional Accessories that may have been furnished on this switch, and make auxiliary connections if necessary. Refer to "ACCESSORIES."

FUNCTIONAL TEST

Read and understand all instructions on the **Composite Elementary Wiring Diagram** and on labels affixed to the switch. Note any Optional Accessories that may have been furnished on this switch, and review their operation. Refer to "ACCESSORIES". Check the following:

- Bypass Handle should be in the "Automatic" position.
- Isolation Handle should be in the "Closed" position.
- Automatic Transfer Switch should be in the "Normal" position.

If handles are not in correct position, follow instructions for Bypassing and Isolating Automatic Transfer Switch. **Do not force handles.** Interlocks prevent wrong Sequence of Operation.

Perform the following voltage check and manual operation test **before** attempting to electrically test the Automatic Transfer Switch. The purpose is to verify that all switches operate smoothly and that there is no damage from shipping or installation.

Voltage and Emergency Check

First check nameplate for rated voltage. It should be the same as the normal and emergency line voltages.

WARNING

The switch will now be energized. Proceed with care!

1. Close normal source circuit breaker. Normal "source available" and "load connected to normal" lamps should light.
2. Use an accurate voltmeter to check phase-to-phase and phase-to-neutral voltages present at the Bypass Switch normal source terminals.
3. Close emergency source circuit breaker.

4. Manually start the generator set. Emergency "source available" lamp should light.
5. Use an accurate voltmeter to check phase-to-phase and phase-to-neutral voltages present at the Bypass Switch emergency source terminals.
6. If necessary, adjust the voltage regulator on the generator according to the manufacturer's recommendations. The Automatic Transfer Switch will respond only to rated voltage and frequency specified on the nameplate.
7. Shut down the generator set by turning off engine starting control.

Manual Operation Test

This procedure will check the manual operation of the Bypass Switch, Isolation Switch, and Transfer Switch. Close normal source circuit breaker.

1. Bypass Automatic Transfer Switch as follows (Figure 4.)

100—260-Ampere

Operate and **hold** "Lock Release Switch" toward normal source while turning Bypass Handle to "Normal" position. Release toggle switch.

400—1000-Ampere

Turn Bypass Handle to "Normal" position (window indicator shows closed contact).

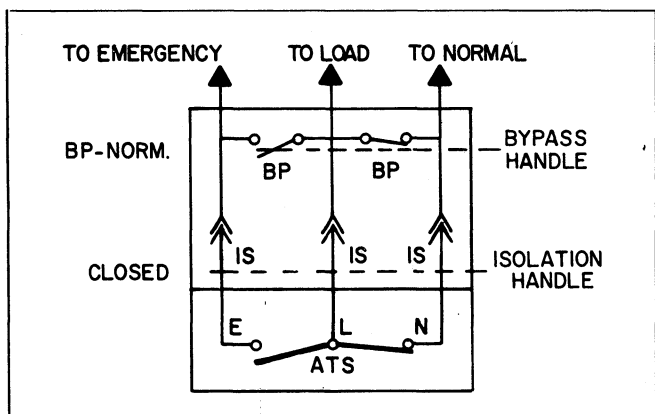

Figure 4. Bypass

2. Isolate Automatic Transfer Switch as follows (Figure 5).

100—260-Ampere

Turn Isolation Handle to "Test" position, then to "Open" position. Padlock the Isolation Handle.

400—1000-Ampere

Push in and turn Isolation Handle to "T" Test position, then push in and turn to "O" Open position. Padlock the Isolation Handle.

WARNING

The switch is energized. Proceed with care!

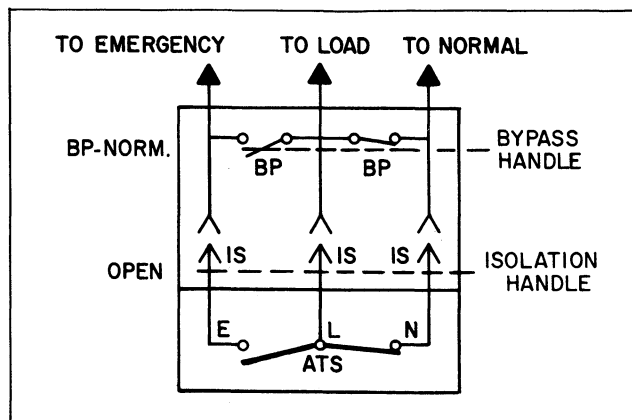

Figure 5. Isolation

3. A detachable manual operator handle is provided on the Transfer Switch for maintenance purposes only. Install the handle as shown.

100—260-Ampere (Figure 6)

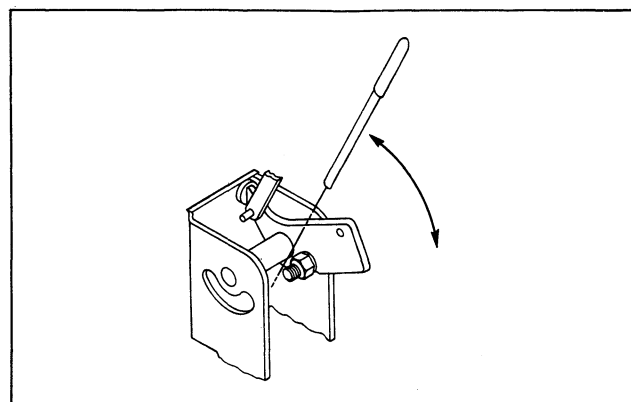

Figure 6. Operator Handle

Insert manual handle between lever pivot and 5/16" threaded bolt.

400—1000-Ampere (Figure 7)

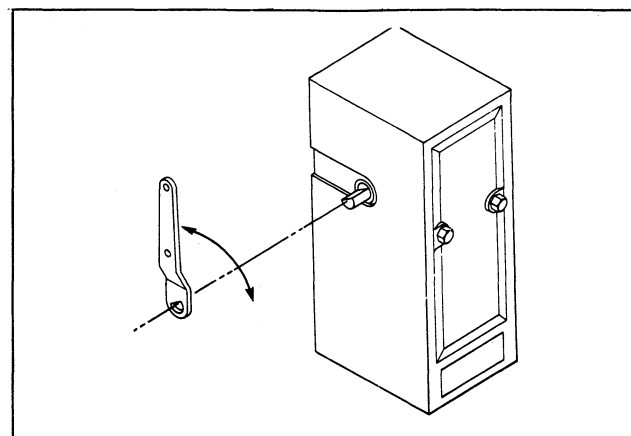

Figure 7. Operator Handle

Insert manual handle into pivot shaft extension, left side of operator.

Move the installed handle up and down to manually operate the Transfer Switch. The switch should operate smoothly without binding. Return the Transfer Switch to the Normal position. Remove manual operator handle and store it on the Transfer Switch in the place provided.

Electrical Operation Test (Figure 8 thru 10)

This procedure will check the electrical operation of the Automatic Transfer Switch. Put generator set starting control in "automatic" position.

1. Unlock the Isolation Handle, then put the handle in the Test position as follows:

100—260-Ampere

Turn Isolation Handle to "Test" position.

400—1000-Ampere

Push in and turn Isolation Handle to "T" Test position.

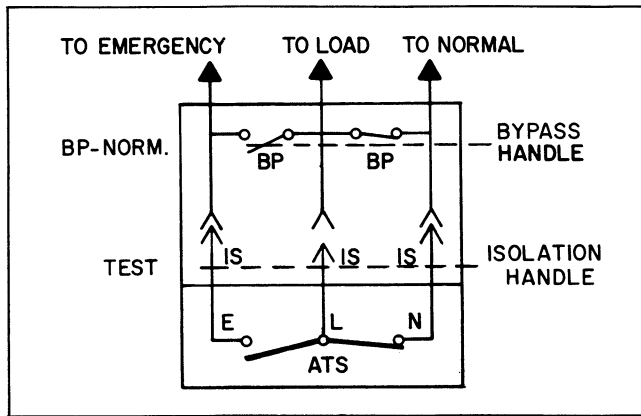

Figure 8. Test Isolation

2. Operate and **hold** Transfer Test toggle switch to "Test" position until engine starts and runs. This should happen within 15 seconds. Release the toggle switch.

Emergency "source available" lamp should light. The Automatic Transfer Switch should operate to the emergency position. If Acc. 01-A is used, the transfer will occur after a time delay (up to 5 minutes). The Automatic Transfer Switch should operate back to normal after Acc. 03-C time delay (up to 30 minutes). Operation of Acc. 08 Reset to Normal toggle switch will bypass the time delay. Acc. 04-C time delay should keep the generator set running for an unloaded cool-down period (up to 5 minutes).

3. Close Isolation Contacts as follows:

100—260-Ampere

Operate and **hold** "Lock Release Switch" toward normal source while turning Isolation Handle to "Closed" position. Release toggle switch.

400—1000-Ampere

Push in and turn Isolation Handle to "C" Closed position.

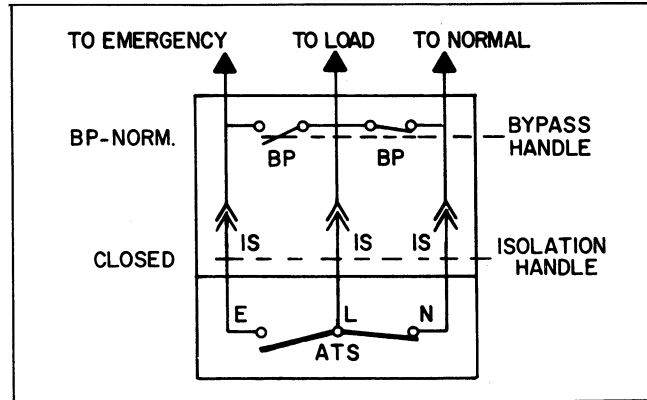

Figure 9. Isolation Closed

4. Return Bypass Switch to Automatic position as follows:

100—260-Ampere

Turn Bypass Handle to "Automatic" position.

400—1000-Ampere

Turn Bypass Handle to "Automatic" position (window indicator shows open contact).

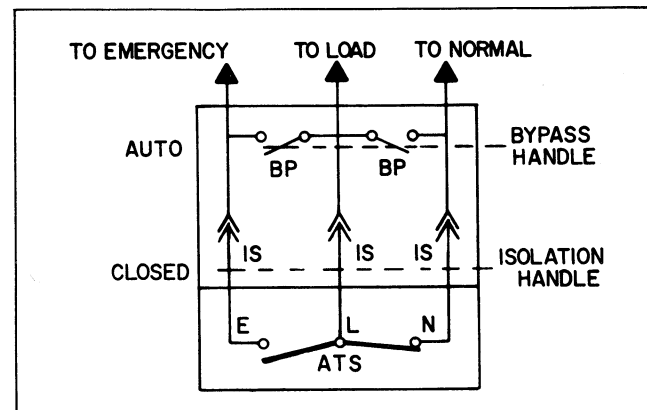

Figure 10. Automatic Position

This completes the functional test. The generator set starting control should be left in the "automatic" position.

BYPASS

This procedure will bypass the closed Automatic Transfer Switch contacts. Bypassing is required before the ATS can be tested or isolated.

1. Note which "Load Connected To" lamp is on (Normal or Emergency). This is the position of the Automatic Transfer Switch (Figure 11).

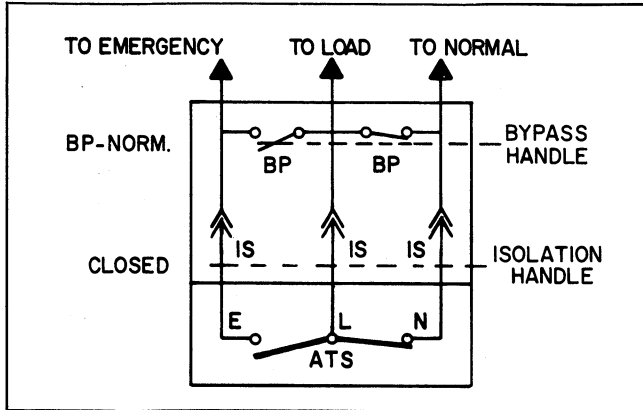

Figure 11. Source Bypass

2. Bypass to the **same** source connected to the Load as follows:

100—260-Ampere

Operate and **hold** "Lock Release Source" toward source connected to load while turning Bypass Handle to the same source. Release toggle switch.

400—1000-Ampere

Turn Bypass Handle to the same source connected to the load (window indicator shows closed bypass switch contact).

The Isolation Switch can now be put in the **Test** or **Open** position. See "ISOLATION" following.

Return the Bypass Switch to the **Automatic** position as follows (Figure 12):

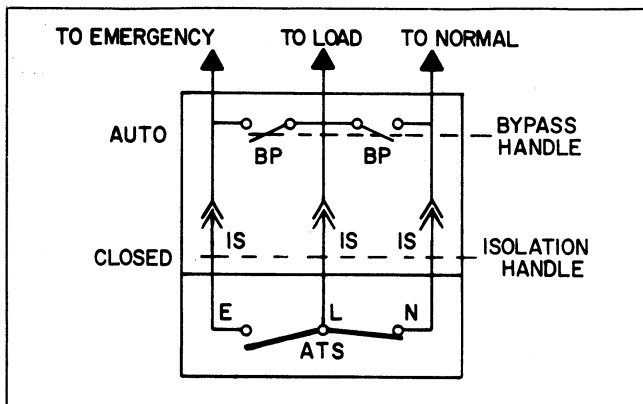

Figure 12. Automatic Position

1. The Isolation Handle must be in the **Closed** position. (Carefully follow directions under ISOLATION if handle is not in **Closed** position).

2. Bypass to Automatic as follows:

100—260-Ampere

Operate and **hold** "Lock Release Switch" toward source connected to load (observe lamp) while turning Bypass Handle to the Automatic position. Release toggle switch.

400—1000-Ampere

Turn Bypass Handle to the Automatic position (window indicator shows open bypass switch contact).

ISOLATION

This procedure will isolate the Automatic Transfer Switch. Isolating is required before any service work can be performed.

1. Bypass the closed Automatic Transfer Switch contacts by carefully following directions under "BYPASS".

2. Isolate Automatic Transfer Switch as follows (Figure 13).

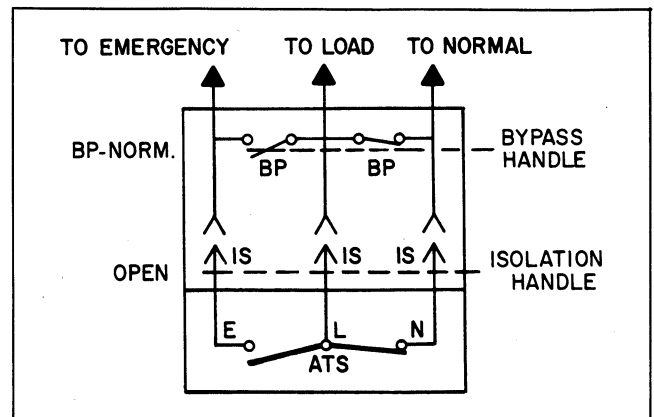

Figure 13. Isolation

100—260-Ampere

Turn Isolation Handle to "Test" position, then to "Open" position. Padlock the Isolation Handle.

400—1000-Ampere

Push in and turn Isolation Handle to "T" Test position, then push in and turn to "O" Open position. Padlock the Isolation Handle.

The Transfer Switch can now be removed for bench inspection and maintenance. See "TRANSFER SWITCH REMOVAL."

Return the Isolation Switch to the **Closed** position as follows (Figure 14):

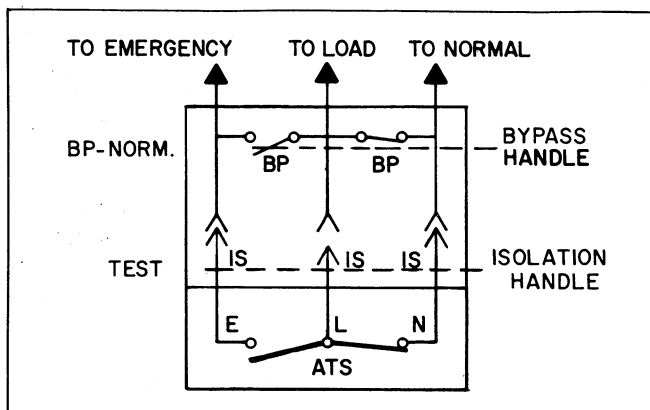

Figure 14. Load Isolation

1. Unlock the Isolation Handle, then put the handle in the Test position as follows:

100—260-Ampere

Turn Isolation Handle to "Test" position.

400—1000-Ampere

Turn Isolation Handle to "T" Test position.

2. The Isolation contacts **cannot** be closed until the Transfer Switch is in the **same** position as the Bypass Switch. Observe the window indicator showing the closed Bypass Switch contacts and note which "Load Connected To" lamp is on (position of Automatic Transfer Switch). If necessary, change the Transfer Switch position as follows:

- To operate Transfer Switch to Normal position, depress Acc. 08 Reset toggle switch. Check that the "Load Connect To Normal" lamp comes on.
- To operate Transfer Switch to Emergency position, depress and **hold** the Transfer Test toggle switch for 10 seconds. If Acc 01-A is used, there will be a delay of up to 5 minutes before transfer.

NOTE

With Normal available, the Automatic Transfer Switch will not stay in the Emergency position unless Acc. 03-C time delay is used. Temporarily remove the cover from the Control Panel and place the slide switch in the "Max." position (up). This will provide at least ½ minute (after depressing Transfer Test switch) to close the Isolation contacts.

3. Close Isolation contacts as follows (Figure 15).

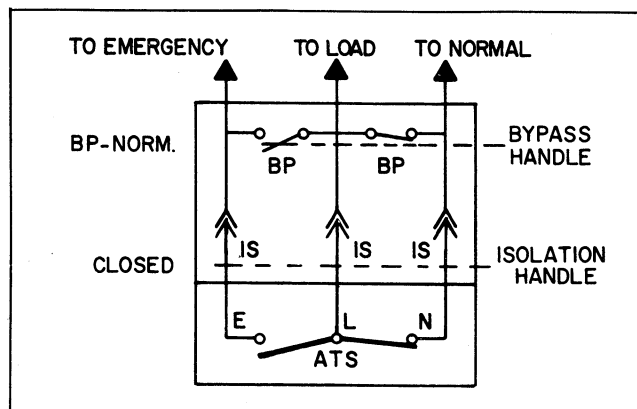

Figure 15. Source Bypass

100—260-Ampere

Operate and **hold** "Lock Release Switch" toward source connected to load while turning Isolation Handle to "Closed" position. Release toggle switch.

400—1000-Ampere

Push in and turn Isolation Handle to "C" Closed position.

The Bypass Switch can now be returned to the Automatic position. See "BYPASS".

GENERAL MAINTENANCE

Reasonable care in preventive maintenance will insure high reliability and long life for the Automatic Transfer Switch.

Operate Transfer Switch at least once a week. The generator set should be exercised under load for at least 30 minutes a week. First check the following:

- Bypass Handle — "Automatic" position.
- Isolation Handle — "Closed" position.
- Transfer Switch — "Normal" position.

Use the door-mounted Transfer Test switch to check the electrical operation of the Automatic Transfer Switch. Because the Test switch only simulates failure of the normal source, service is interrupted only during the actual transfer of the load.

Maintain Transfer Switch lubrication. The Transfer Switch has been properly lubricated, and under normal operating conditions no further lubrication is required. Renew factory lubrication if the switch is subjected to severe dust or abnormal operating conditions. Relubricate the operator if the TS coil is replaced. Use #44 Silicon Grease (DOW).

Inspect main current carrying contacts. Once a year de-energize all sources, then remove barriers to check condition of contact material. Replace contacts when pitted or worn excessively.

SEQUENCE OF OPERATION

Automatic Transfer Switch

Note any Optional Accessories that may have been furnished on this switch, and review their operation. Refer to "ACCESSORIES".

Normal Source Failure

Load transfer to the emergency source automatically begins when the voltage sensor detects reduced voltage or total loss of the normal source. Relay SE will de-energize whenever the voltage level falls below the preset dropout point of the voltage sensor. An under-voltage condition on any phase of a three-phase system, or a phase-to-phase reduction of a single-phase system, is detected by the sensor.

SE relay de-energizes, signalling a failure, and relay NR begins its timing cycle (Acc. 1). NR relay is provided with a time delay on dropout to override momentary outages. This delay prevents nuisance starting of the generator set. If the normal source voltage returns above the sensor dropout setting before the time delay expires, the SE relay energizes and the timing cycle is reset to zero.

NR relay de-energizes after the time delay and signals the generator set to start. At the same time, a voltage and frequency sensor begins monitoring the emergency source. The sensor will accept the emergency source only when **both** voltage and frequency reach preset pickup points. Usually about ten seconds elapse from dropout of the NR relay to acceptance by the sensor. This time span occurs because the generator set must crank, start, and run up to nominal pickup points. If the emergency source is available immediately, the sensor may accept as soon as NR relay drops out.

When the emergency source is accepted by the sensor, relay ER begins its timing cycle. ER relay is provided with a time delay on pickup to prevent immediate load transfer to the emergency source.

ER relay energizes, the TS coil is energized, the Transfer Switch operates, and all switch contacts (mains, controls, auxiliaries) reverse position. The Transfer Switch is now supplying the load from the emergency source.

The switch will remain in this position until the normal source is restored.

Normal Source Restoration

Load retransfer to the normal source automatically begins when the voltage sensor detects restoration of the normal source. The voltage level must rise above the preset pickup point on all phases before the sensor will accept the normal source again.

When the normal source is accepted by the sensor, relay SE begins its timing cycle (Acc. 03-C). SE relay is provided with a time delay on pickup to prevent immediate load retransfer to the normal source. The

delay insures that the normal source has stabilized before reconnection of vital loads. If the normal source voltage falls below the preset dropout point before the time delay expires, the timing cycle is reset to zero. If the emergency source fails during the timing cycle, ER relay drops out, and the load is immediately retransferred to the normal source, if acceptable. Reset switch (Acc. 08) bypasses the time delay for immediate retransfer.

SE relay energizes and ER relay is dropped out. The TS coil is energized, the Transfer Switch operates, and all switch contacts (mains, controls, auxiliaries) reverse position. The Transfer Switch is now supplying the load from the normal source.

Upon retransfer to the normal source, NR relay begins its timing cycle (Acc. 04-C). NR relay is provided with a time delay on pickup to keep the engine running for a cool down period.

NR relay energizes after the time delay and signals the generator set to shut down. All circuits are reset for any future normal source failure.

TROUBLESHOOTING

Bypass Switch in "automatic", Isolation Switch "closed"

WARNING

The Automatic Transfer Switch is energized; proceed with care!

Note any Optional Accessories that may have been furnished on this switch, and review their operation. Refer to "ACCESSORIES".

Generator Set does not start when Test Switch is operated and held.

1. **Check Operation.** Make sure switch is held in "Test" position for 15 seconds.
2. **Check Generator Set Controls.** Make sure control is in "automatic" position. Make sure batteries are charged and connected.
3. **Check Wiring.** Make sure start signal wires from generator set controls are connected to the correct terminals on the Control Panel. See Wiring Diagram.
4. **Check Signal Circuit.** Disconnect and tape start signal wires. Connect ohmmeter between terminals CP16 and CP17. Reading should indicate a closed circuit. Depress and hold Test Switch for 15 sec. After Acc. 02-A time delay, ohmmeter should indicate an open circuit.

Transfer Switch does not retransfer the load after Normal returns or after Test Switch is released.

1. **Check Operation.** Make sure at least 30 minutes have passed to allow for Acc. 03-C time delay.

2. **Check Normal Source Voltage Levels.** On a three phase system, voltmeter should read phase-to-phase voltage between terminals CP28 and CP29, CP29 and CP30, CP30 and CP28. On a single phase system, voltmeter should read system voltage between terminals CP30 and CP29.
3. **Check Signal Circuit.** Confirm that Test Switch has reclosed by measuring 0 volts between terminals CP26 and CP27. Voltmeter should read phase-to-phase voltage between terminals CP3 and CP4. If there is no voltage reading, the problem is on the Transfer Switch. If voltage is present between CP3 and CP4, it should also be present between terminals CP2 and CP5. If voltage is not present between CP2 and CP5, the problem is in the Control Panel.

With Generator Set running, Transfer Switch does not transfer the load to emergency.

1. **Check Operation.** Make sure at least 7 minutes have passed to allow for Acc. 01-A time delay.
2. **Check Engine Controls.** Check generator output frequency and voltage. Output should be at least 90% of nominal voltage and 95% of nominal frequency. Make sure generator output circuit breaker is closed.
3. **Check Wiring.** Voltmeter should read phase-to-phase voltage between Transfer Switch terminals EA and EC, and also between Control Panel terminals CP14 and CP15.
4. **Check Signal Circuit.** Voltmeter should read phase-to-phase voltage between terminals CP1 and CP6. If there is no voltage reading, the problem is on the Transfer Switch. If voltage is present between CP1 and CP6, it should also be present between terminals CP2 and CP5. If the voltage is not present between terminals CP2 and CP5, the problem is in the Control Panel.

Transfer Switch retransfers the load, but Generator Set continues to run.

1. **Check Operation.** Make sure at least 8 minutes have passed to allow for Acc. 04-C time delay.
2. **Check Engine Controls.** Make sure engine starting control is in "automatic" position.
3. **Check Signal Circuit.** Disconnect and tape wires to terminals CP19 and CP20. Connect ohmmeter between these terminals; reading should indicate a closed circuit.

If the problem is isolated to signal circuits on the Control Panel or the Transfer Switch, call your local Kohler Distributor or Authorized Representative for further assistance.

Bypass Handle cannot be turned.

1. Make sure a "Source Available" lamp is on.

2. On 100—260-Amp. Switches make sure "Lock Release Switch" is operated and **held** toward either available source while turning Bypass Handle.
3. Observe Acc. 12 signal lights. Make sure the Transfer Switch contacts are closed on the same source to which you are trying to bypass.

Isolation Handle cannot be turned to Closed position.

1. Make sure a "Source Available" lamp is on.
2. On 400—1000-Amp. switches make sure Isolation Handle is **pushed in** before turning it.
3. Observe Acc. 12 signal lights. Make sure the Transfer Switch contacts are closed on the same source to which you are bypassed.
4. On 100—260-Amp. switches make sure "Lock Release Switch" is operated and **held** toward either available source while turning Isolation Handle.

Normal Fails While in Bypass Normal Position.

1. Check that Emergency "Source Available" light is on.
2. Put Isolation Switch in the Test position. See "ISOLATION". (Automatic Transfer Switch will operate to the emergency position.)
3. Manually transfer the load to the Emergency source as follows:

100—260-Ampere

Operate and **hold** "Lock Release Switch" toward Emergency source while turning Bypass Handle to "Automatic" position, then to "Emergency" source. Release toggle switch.

400—1000-Ampere

Turn Bypass Handle to "Automatic" position, then to "Emergency" source (window indicators show open contacts then closed contact on Emergency source).

4. Close Isolation Switch. See "ISOLATION."

ACCESSORIES

Optional Accessory 24 Battery Charger

Battery charger, if furnished, is mounted in a separate enclosure when the Automatic Transfer Switch is ordered with an enclosure. Battery chargers are shipped loose for open type switches. Mount the Charger vertically to a flat surface. The table below provides mounting dimensions.

Accessory	Dimensions (in inches)							
	open type							
	A	B	C	D	E	F	G	H
<input type="checkbox"/> 24A 12 volt D.C.	9 $\frac{5}{8}$	3 $\frac{1}{2}$	3 $\frac{3}{4}$	2	2 $\frac{1}{2}$	$\frac{1}{2}$	3-15/32	10
<input type="checkbox"/> 24B 24 volt D.C.	11 $\frac{1}{8}$	4 $\frac{1}{4}$	4 $\frac{1}{4}$	2 $\frac{7}{8}$	3 $\frac{3}{8}$	9/16	3-15/16	13
<input type="checkbox"/> 24C 32 volt D.C.								

Wiring

Connect Charger terminal "+" to the positive battery terminal. Connect Charger terminal "-" to the negative battery terminal. It is important that correct polarity be observed. Connect input terminals as indicated on nameplate diagram. Note that different input voltages require different terminal connections.

Operation

The Charger is designed to provide a small trickle charge suitable for replacing internal battery losses, or it can provide a high rate of charge. The charge rate is adjustable up to two amperes maximum.

Turn rheostat clockwise to raise the charge rate; turn it counterclockwise to lower the charge rate. Observe ammeter while adjusting charge rate. **Do not exceed 2 amperes!**

Be sure to lower the charging rate to 0.15 ampere or less after the battery is fully charged. Continued overcharging is harmful to battery life.

If battery is fully charged, adjust the charging rate so as not to exceed 0.15 ampere. A new battery in good condition requires a trickle charge of only 0.1 to 0.125 ampere to maintain proper charge condition.

If battery is not fully charged, increase the charging rate, but do not exceed 2 amperes.

Optional Accessory 23-Generator Set Exercising Timer (Figure 16.)

This timer, if furnished, is used for periodic exercising of the emergency engine-generator plant. This timer is factory set for a 30 minute minimum exercise period once a week. The time period can be lengthened and can be set to occur more often than once a week. The generator set should be exercised under load once a week for a minimum time period of 30 minutes. Optional Accessory 23 can be added later in kit form. Include Serial Number and Catalog Number of Automatic Transfer Switch when ordering kit.

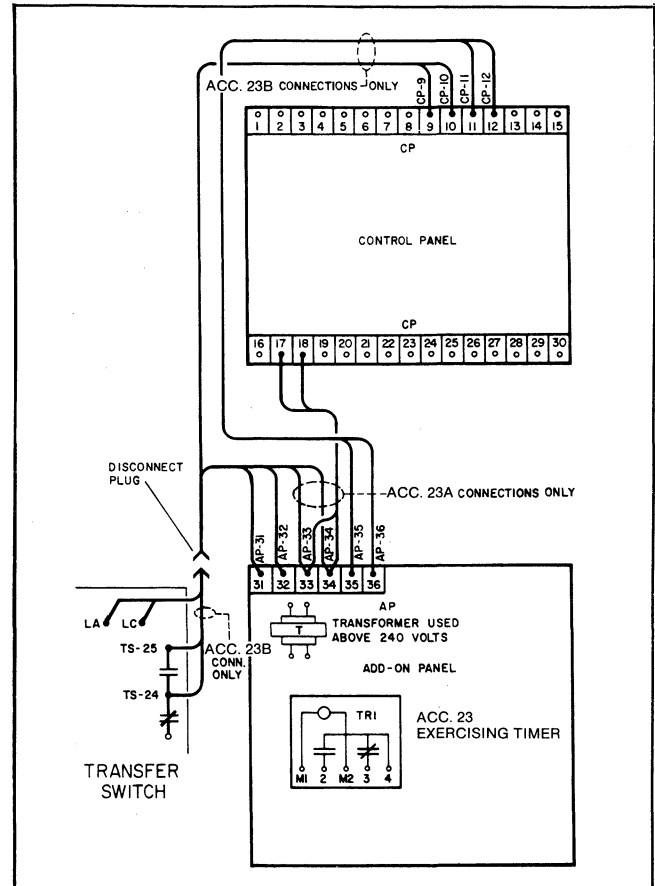

Figure 16. Accessory 23 Connections

Acc. 23-C timer does not simulate a normal source failure. The Automatic Transfer Switch is not affected. The engine-generator plant is signalled to run unloaded for the set time period.

Set Exercise Day

1. Decide what day (or days) of the week to exercise the plant.
2. Remove the screw from the star wheel lobe marked with the decided day.

Set Exercise Period

1. Decide what time of the day to start the exercise period. Position light color tripper on dial edge at decided start time. Tighten knurled screw.

- Decide what time of the day to stop the exercise period. Position dark color tripper on dial edge to decided stop time. Tighten knurled screw.

Set Present Time and Day

- Find the present time of day on the dial. Turn the dial counterclockwise (direction of arrow) until the present time is adjacent the "time" arrow.
- Find the star wheel lobe marked with the present day. Turn the star wheel clockwise until present day lobe is adjacent to the red lever.

Acc. 23-D timer simulates a normal source failure. The Automatic Transfer Switch transfers the electrical load to the emergency generator during the exercise period.

In Case of Trouble

If Acc. 23-C timer contact 4-2 does not close during the set exercise period, the generator set will not be signalled to run. If the contact remains closed beyond the set exercise period, the set will continue running. In either case, Acc. 23-C timer is malfunctioning.

If Acc. 23-D timer contact 4-3 does not open during the set exercise period, the generator set will not be signalled to run and the load will not be transferred to the emergency source. If the contact remains open beyond the set exercise period, the set will continue running and the load will remain connected to the emergency source. Immediate retransfer may be accomplished by manually shutting down the engine. Make sure that full rated normal voltage is available before doing this. In either case, Acc. 23-D timer is malfunctioning.

**Optional Accessory 15-
Auxiliary Contacts**

Acc. 15-A Auxiliary contact closed when Automatic Transfer Switch is connected to the normal source.

Acc. 15-B Auxiliary contact closed when Automatic Transfer Switch is connected to the emergency source.

One Acc. 15-A and one Acc. 15-B are supplied standard on all Automatic Transfer Switches. The following table provides the terminal numbers for standard and optional indicators, if furnished: (Consult factory for location of 3rd optional Acc. 15).

Accessory	Indicator Terminal Numbers		
	standard	1st optional	2nd optional
15-A	12-13	31-32	35-36
15-B	10-11	29-30	33-34

The location of the auxiliary contacts varies according to the ampere size of the Transfer Switch as shown in Figure 17.

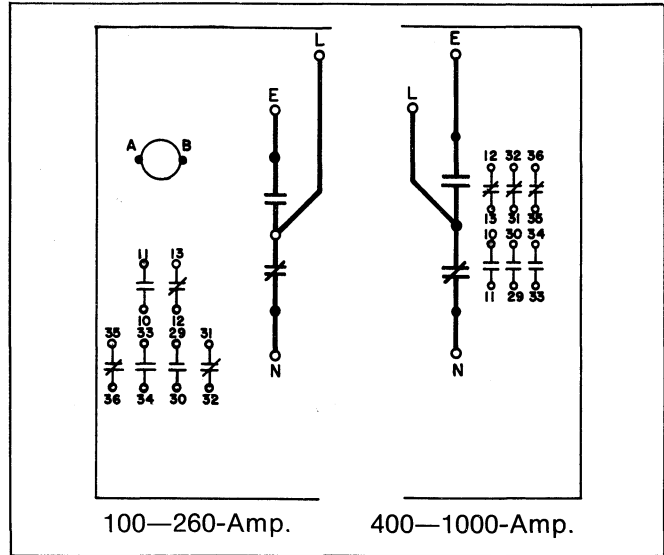

Figure 17. Contact Location

Optional Accessory 15's can be added later in kit form. Include Serial Number and Catalog Number of Automatic Transfer Switch when ordering kit.

**Optional Accessory
34-A—Inphase Monitor
(Figure 18)**

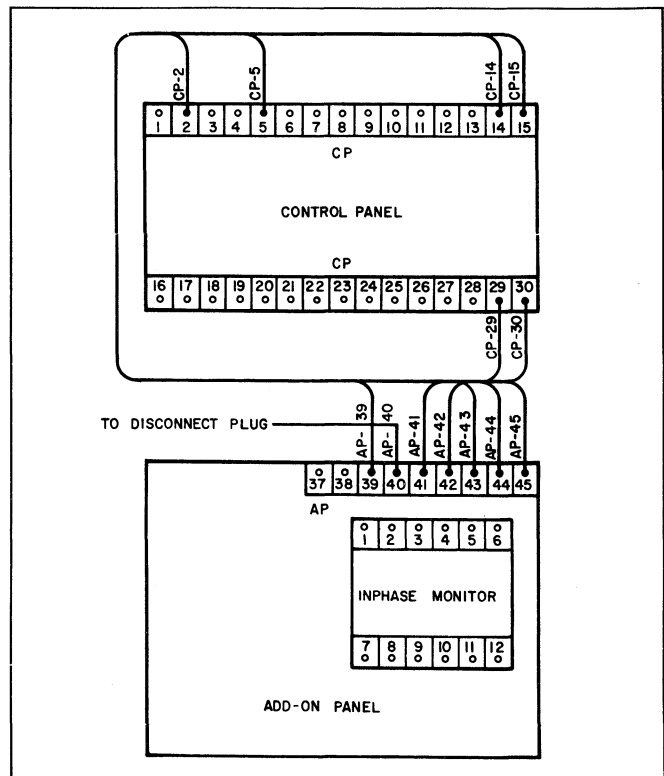

Figure 18. In Phase Monitor

□ **Acc. 34-A**, if furnished, is an inphase monitor control for transfer and retransfer of motor loads, so that in-rush currents do not exceed normal starting current, to avoid nuisance tripping of circuit breakers and possible mechanical damage to motor couplings.

Sequence of Operation

Normal Source Restoration: SE relay energizes and ER relay is dropped out. After approximately 2 seconds the inphase monitor senses both sources of power, and its output relay energizes to initiate inphase transfer. The TS coil is energized and the standard Sequence of Operation is resumed.

When test switch Acc. 06 is used, the inphase monitor senses both sources of power approximately 2 seconds after the ER relay energizes. The TS coil is energized and the standard Sequence of Operation is resumed.

If either source of power is **not** available when the inphase monitor starts its sensing mode, the output relay picks up after 2 seconds and allows the TS coil to be energized.

Optional Accessory 34-A can be added later in kit form. Include Serial Number and Catalog Number of Automatic Transfer Switch when ordering Acc. 34-A

In Case of Trouble

1. Connect a voltmeter between terminals NA and EA on the Transfer Switch. Set the meter scale to at least twice the system phase-to-phase voltage.
2. Manually start the generator set. After it has reached maximum output voltage, the meter needle should sweep back and forth at a regular rate between 0 volts and about twice the system voltage.
3. Depress and **hold** the Test Switch. The load should transfer to the emergency source when the meter needle is near 0 volts. If transfer does not occur, Acc. 34-A is malfunctioning.
4. Release the Test Switch. The load should retransfer back to the normal source after Acc. 03-C time delay, if used. The retransfer should occur when the needle is near 0 volts. If retransfer does not occur after the time delay, Acc. 34-A is malfunctioning.
5. Immediate retransfer may be accomplished by manually shutting down the engine. Make sure that full rated normal voltage is available before doing this.
6. Disconnect and remove voltmeter.

TRANSFER SWITCH REMOVAL

This procedure will allow removal of the Transfer Switch for bench inspection and maintenance.

1. Bypass and Isolate Automatic Transfer Switch by carefully following directions under **BYPASS** and **ISOLATION**. Padlock the Isolation Handle in the "Open" position.

WARNING

The switch is energized. Proceed with care!

2. Open cabinet door (right door on 100—260-Amp., lower door on 400—1000-Amp. sizes).
3. Separate two In-Line Disconnect Plugs (P2 & P4) by grasping and squeezing plugs. Do not pull on the wires. Label, tape, and disconnect wires to Acc. 15 auxiliary contacts.
4. Remove Transfer Switch as follows (Figure 19).

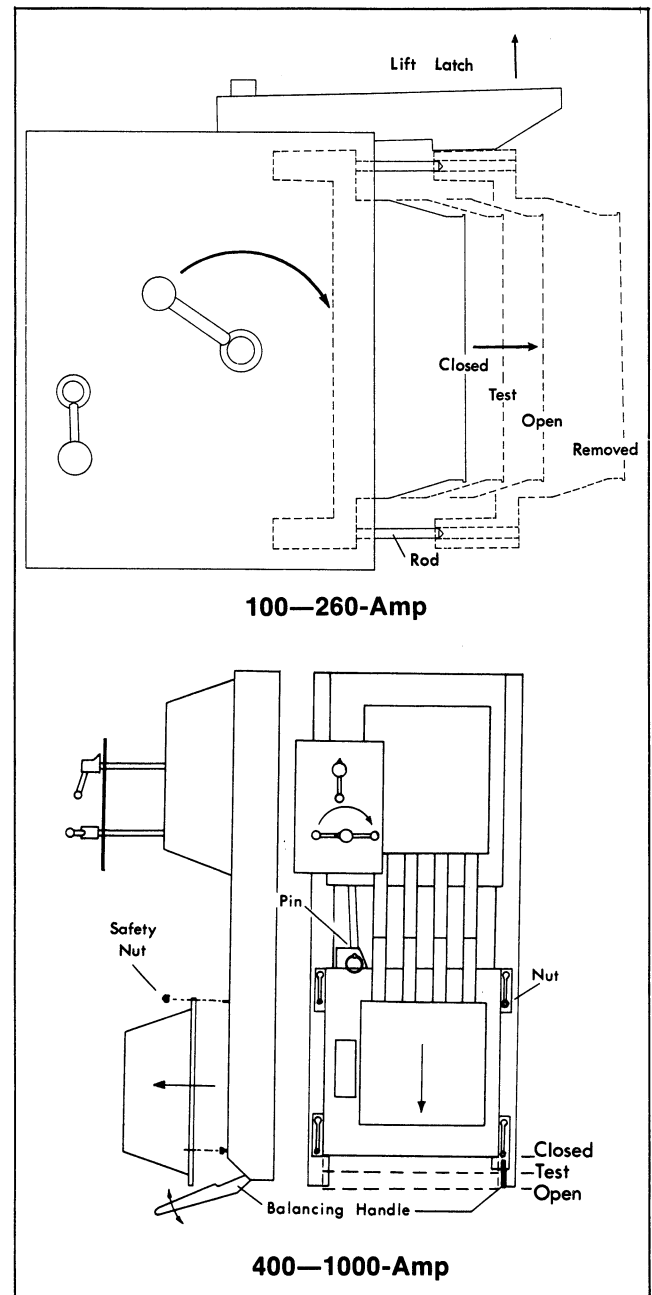

Figure 19. Transfer Switch Removal

100—260-Ampere

Lift the latch to release Transfer Switch. Grasp back panel of Transfer Switch and slide it to the right until it is free from the guide rods. Then lift Transfer Switch out of cabinet (protect barriers). Transfer Switch weighs about 35 lbs.

400—1000-Ampere

Pull out quick-disconnect pin to release linkage to Isolation Handle. Remove safety retaining nut from upper right mounting bushing. Push down spring-loaded balancing handle (right side) until bushings are at top of key-slots. Grasp back panel of Transfer Switch and pull it straight out. Do not lift at any other points (protect barriers). Then lift Transfer Switch out of cabinet. Transfer Switch weighs 100-150 lbs.

5. Close cabinet door.

TRANSFER SWITCH INSTALLATION

This procedure will allow installation of the Transfer Switch after bench inspection and maintenance.

WARNING

The switch is energized. Proceed with care!

1. Open cabinet door (lower door on large switches).
2. Install Transfer Switch as follows (Figure 20).

100—260-Ampere

Grasp back panel of Transfer Switch and lift it onto the guide rods (right side, operator out). Slide Transfer Switch to the left until it stops. The latch will secure the panel.

400—1000-Ampere

Grasp back panel of Transfer Switch and lift it onto two support brackets extending out from the mounting channels. Press down balancing handle (right side) until the slots accept the mounting bushings. Push panel flat against rails and secure it by lifting up handle. Install stop nut (upper right corner). Position linkage from Isolation Handle between U-bracket on Transfer Switch (use handle to line up), then insert quick-disconnect pin and press ring flush.

Be sure to install safety retaining nut onto upper right mounting bushing to prevent Transfer Switch from falling outward.

3. Reconnect two In-Line Disconnect Plugs (P2 & P4) by grasping and pressing together. Reconnect wires previously removed from Acc. 15 auxiliary contacts.
4. Close cabinet door.

5. Unlock Isolation Handle. Carefully follow directions under "ISOLATION" to put Isolation Handle in Test position, then Closed position. Finally, follow directions under "BYPASS" to put Bypass Handle in Automatic position.

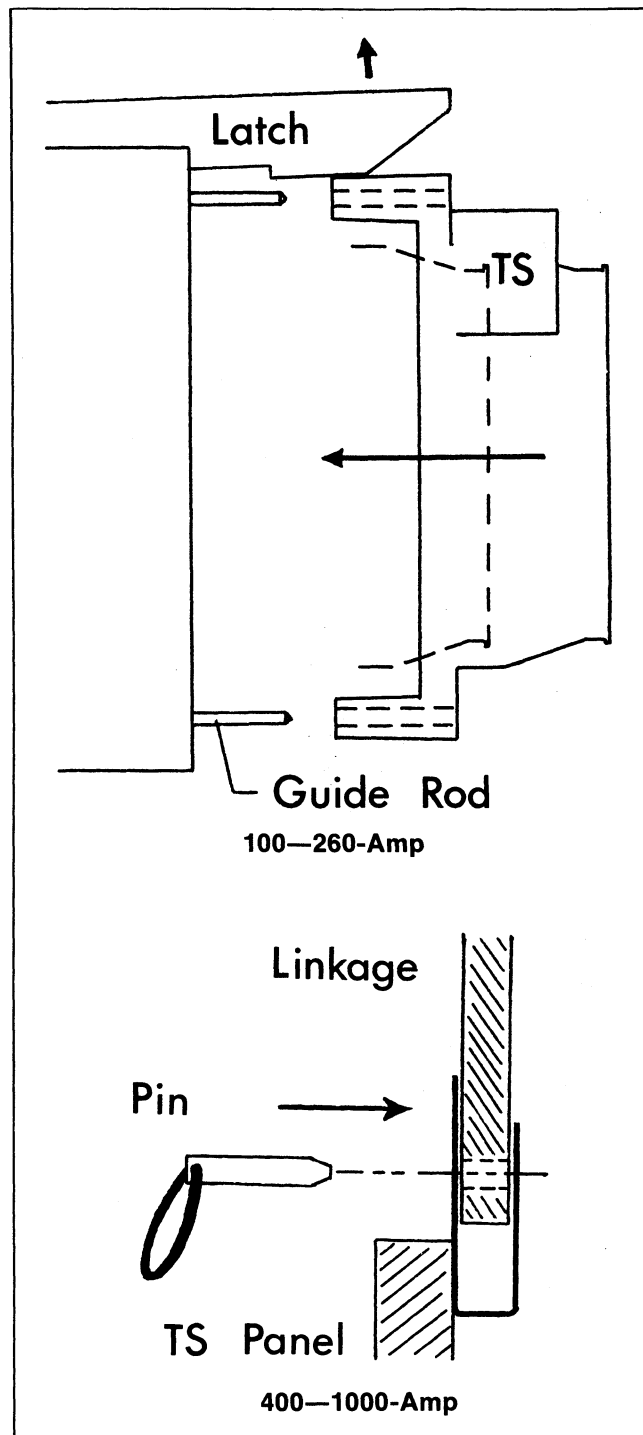

Figure 20. Transfer Switch Installation

MANUAL LOAD TRANSFER

This procedure will allow manual transfer of the load to the opposite source if the Automatic Transfer Switch is out of service. A brief interruption to the load occurs during manual transfer.

1. Bypass and Isolate Automatic Transfer Switch by carefully following directions on "BYPASS" and "ISOLATION".
2. Check that "Source Available" lights are on. Start the generator at the set, if necessary.
3. Manually transfer the load to the opposite source as follows:

100—260-Ampere

Operate and **hold** "Lock Release Switch" toward connected source while turning Bypass Handle to "Automatic" position. Then operate and **hold** "Lock Release Switch" toward desired source while turning Bypass Handle to that source. Release toggle switch.

400—1000-Ampere

Turn Bypass Handle to "Automatic" position, then to opposite source (window indicators show open contacts then closed contact on opposite source).

DISCONNECTING THE CONTROL PANEL

In-Line Disconnect Plug P1 is furnished for repair purposes **only** and should not have to be separated. If it must be separated, follow these steps carefully.

WARNING

The switch is energized. Proceed with care!

Disconnecting the Plug

1. Bypass and Isolate Automatic Transfer Switch by carefully following directions under "BYPASS" and "ISOLATION". Padlock the Isolation Handle in the "Open" position.
2. Open cabinet door.
3. Separate P1 plug by grasping and squeezing plug. Do not pull on the wires.

Reconnecting the Plug

1. Engage P1 plug by grasping and pressing together.
2. Close cabinet door.
3. Unlock Isolation Handle. Carefully follow directions under "ISOLATION" to put Isolation Handle in Test position, then Closed position. Finally, follow directions under "BYPASS" to put Bypass Handle in Automatic position.

SENSOR ADJUSTMENTS

The voltage and frequency sensor pickup and drop-out points have been factory set in accordance with the job specifications. If these settings must be changed, contact your local Kohler Generator Distributor.

CAUTION

Any indiscriminate change in these settings may effect the normal operation of the Automatic Transfer Switch thereby allowing the load circuits to remain connected to a low voltage source.

Normal Source Voltage Sensor

Pickup Setting

Adjustment Range	85-100% of nominal
Factory Setting (unless otherwise specified)	95% of nominal

Dropout Setting

Adjustment Range	75-98% of pickup
Factory Setting (unless otherwise specified)	85% of nominal

Emergency Source Voltage and Frequency Sensor

Voltage Pickup Setting

Adjustment Range	85-100% of nominal
Factory Setting (unless otherwise specified)	90% of nominal

Voltage Dropout Setting

A fixed differential of approximately 15% below the pickup setting.

Frequency Pickup Setting

Adjustment Range	90-100% of nominal
Factory Setting (unless otherwise specified)	95% of nominal

Frequency Dropout Setting

A fixed differential of approximately 12% below the pickup setting.

TIME DELAY ADJUSTMENTS

Acc. 02-A, 01-A, 03-C, and 04-C time delays have been factory set in accordance with the job specifications. If these time delays must be changed, follow these steps.

CAUTION

Do not remove or install A1 board while the Control Panel is energized.

1. Bypass the closed Automatic Transfer Switch contacts by carefully following directions under "BYPASS."
2. Turn the Isolation handle to the open position. See "ISOLATION."
3. Remove the cover from the Control Panel as follows: Locate the two fasteners on the face of the cover. Use a screwdriver to turn the fasteners $\frac{1}{4}$ turn until cover is released (Figure 21).

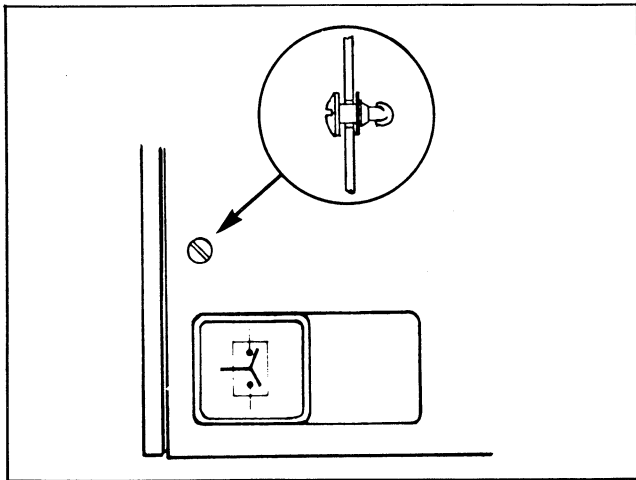

Figure 21. Cover Removal

4. Remove Time Delay Board "A1" from its socket (Figure 22). Grasp board by edges and gently rock it loose.

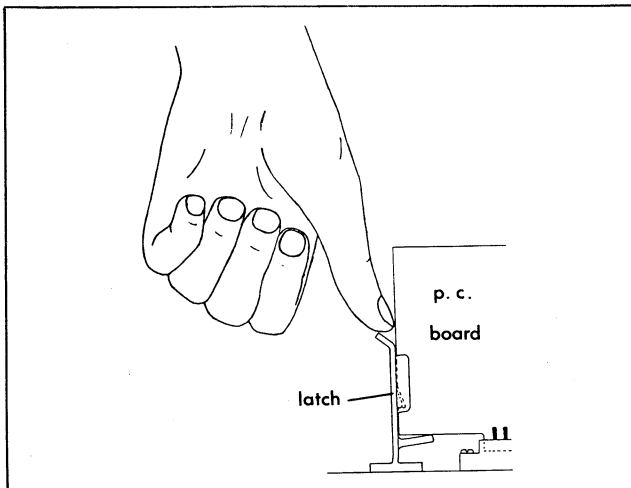

Figure 22. Latch

5. Scrape "pot.seal" from potentiometer to be adjusted. (Support potentiometer with fingers as shown here.) See Figure 23.

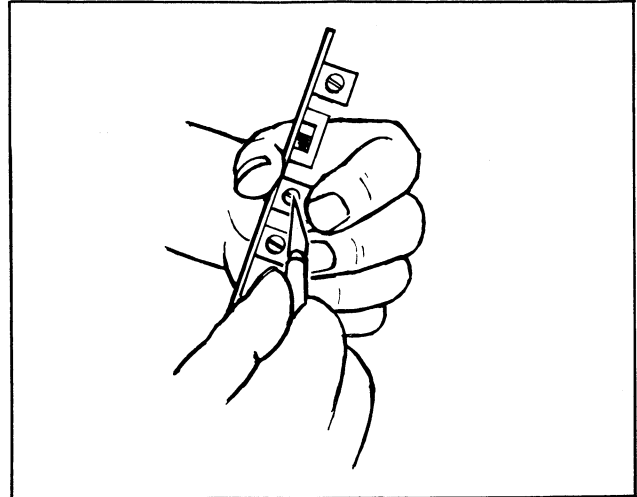

Figure 23. Pot Seal Removal

6. Each time delay is adjusted by turning a potentiometer; clockwise to increase, counterclockwise to decrease. See Figure 24. Use the table below to approximate time delays and their corresponding pot.settings. The pots are shown with A1 board vertical.

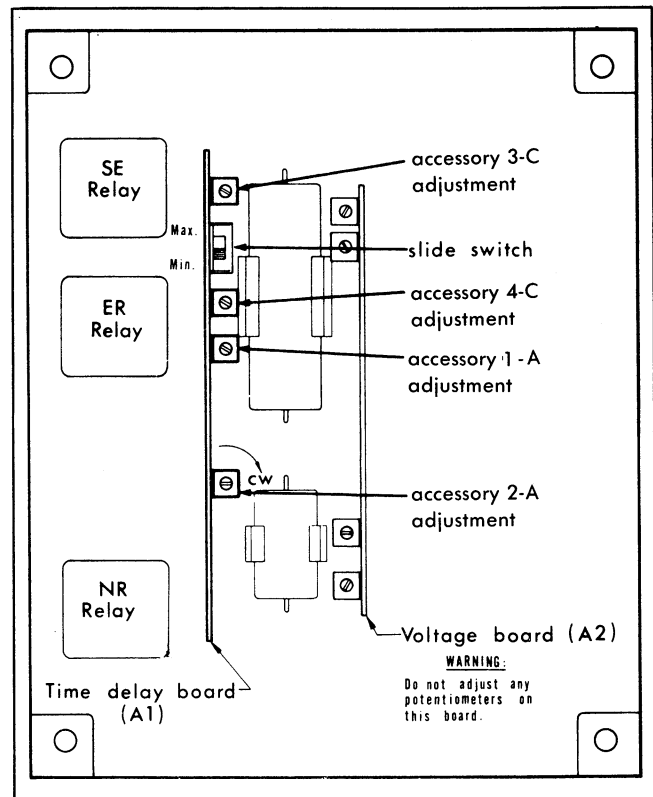





Figure 24. Adjustments

Adjustable Time Delays	potentiometer settings			
	standard factory setting	max. ccw 	1/2 cw 	max. cw 
Acc. 02-A override momentary outages	1	1/2	3	6 seconds
Acc. 01-A transfer to emergency	0	0	2 1/2	5 minutes
Acc. 03-C retransfer to normal (See Note)	30	1/2	15	30 minutes
Acc. 04-C gen-set cool down	5	0	2 1/2	5 minutes
approximate values				

NOTE

If the slide switch is in the Min. Position, Acc. 03-C is not used.

- Reinstall Time Delay Board "A1" into its socket Figure 25.

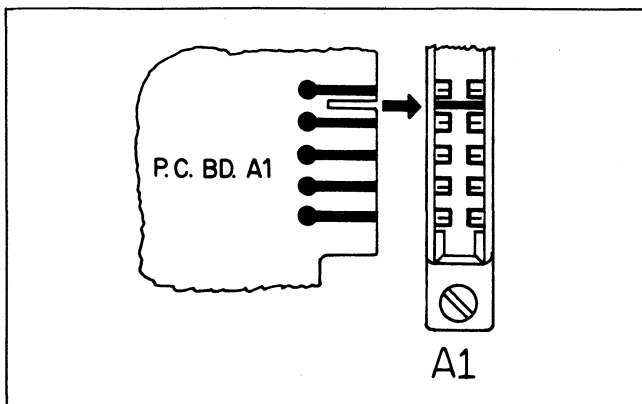

Figure 25. Slot Alignment

- Install the cover on the Control Panel as follows: Align the cover over the two standing brackets and push it toward the panel. Then turn the two fasteners until they secure the cover (1/4 turn). See Figure 21.
- Turn the Isolation handle to the Test position. See "ISOLATION."
- Return the Isolation handle to the closed position (see "ISOLATION"). Then return the Bypass Switch to the Automatic position (see "BY-PASS").

NOTES

STANDARD ACCESSORIES

VOLTAGE AND FREQUENCY SENSING

- A. Close differential voltage sensing on all phases of normal source. Pickup voltage is adjustable from 85% to 100% of nominal and the dropout is adjustable from 75% to 98% of the pickup value. Factory set to pickup at 95% and dropout at 85% of nominal unless otherwise specified.
- B. Single phase voltage sensing of emergency source. Pickup adjustable from 85% to 100% of nominal factory set to pickup at 90% unless otherwise specified.
- C. Frequency sensing of emergency source. Pickup adjustable from 90% to 100% of nominal. Factory set to pickup at 95% unless otherwise specified.

TIME DELAYS

- D. Time delay to override momentary normal source outages to delay all transfer switch and engine starting signals. Adjustable from 0.5 to 6 seconds. Factory set at 1 second unless otherwise specified. Standard Acc. 2.
- E. Retransfer to normal time delay. Time delay is automatically bypassed if emergency source fails and normal source is available. Adjustable from 0 to 30 minutes. Factory set at 30 minutes unless otherwise specified. Standard Acc. 3.
- F. Unloaded running time delay for emergency engine generator cool down. Adjustable from 0 to 5 minutes. Factory set at 5 minutes unless otherwise specified. Standard Acc. 04-C.
- G. Transfer to emergency time delay. Adjustable from 0 to 5 minutes. Factory set at 0 minutes unless otherwise specified. Standard Acc. 01-A.

ENGINE CONTROL CONTACT

- H. A contact that closes when normal source fails. Gold plated contacts for low voltage engine start signals or other customer use. Rated 10 amps 32 volts D.C.

MANUAL CONTROLS

- J. Reset switch TGL-2 to manually bypass time delay on retransfer to normal. Gold plated low voltage contacts. Installed and connected on enclosure door. Shipped loose for open types. Standard Acc. 08.
- K. Test switch TGL with gold plated low voltage contacts to momentarily simulate normal source failure. Installed and connected on enclosure door. Shipped loose on open types. Standard Acc. 06.
- L. TGL1 - Bypass lock release switch three position momentarily on, off, momentarily on. Mounted to bypass switch face plate.

INDICATORS

- M. One auxiliary contact closed when automatic transfer switch is connected to normal note. Additional auxiliary contacts are available as options. Standard Acc. 15-A.
- N. One auxiliary contact closed when automatic transfer switch is connected to emergency. **NOTE:** Additional auxiliary contacts are available as options. Standard Acc. 15-B.
- P. Signal light PL1, white, indicates when automatic transfer switch is connected to normal source. Installed and connected on enclosed types. Shipped loose for open types. Use Chicago miniature bulb #28PSB, Standard Acc. 12-A, C
- Q. Signal light PL2, yellow, indicates when automatic transfer switch is connected to emergency source. Installed and connected on enclosed types. Shipped loose for open types. Use Chicago miniature bulb #28PSB, Standard Acc. 12-C, D.
- R. Signal light PL3, white, indicates when normal source is available. Mounted to bypass switch face plate. Use Chicago miniature bulb #120PSB.
- S. Signal light PL4, white, indicates when emergency source is available. Mounted to bypass switch face plate. Use Chicago miniature bulb #120PSB.

GENERAL NOTES

1. Switch shown de-energized connected to normal source.
2. Device symbols and designations are in accordance with NEMA Pub. ICS-1970. Part. 1-101.
3. All wires are #16 AWG stranded copper and follow NEMA Standard ICS-1-112-64 color code unless otherwise specified.
4. 0 indicates customer connection points.
5. * indicates factory connection points.
6. Connection points that have both customer connections and factory connections are shown open as customer connection points.
7. When an additional accessory mounting panel is required to mount the optional accessories, it is located directly below the control panel.
8. Publication TP-5090 Operator's Manual is furnished with each automatic transfer switch. Refer to this publication prior to installation and operation of the switch.
9. Mating plug and jack terminal numbers match when plugged together.
10. SL1 - (solenoid lock) to prevent connecting ATS unless source to load is same as source bypassed.
11. SL2, SL3 - allow bypass only to the source to which the transfer switch load is connected.
12. This sign # indicates a branch circuit.

OPTIONAL ACCESSORIES

- Acc. 36-A Overlapping neutral transfer contacts.

WIRING DIAGRAM 100—260-Amp.

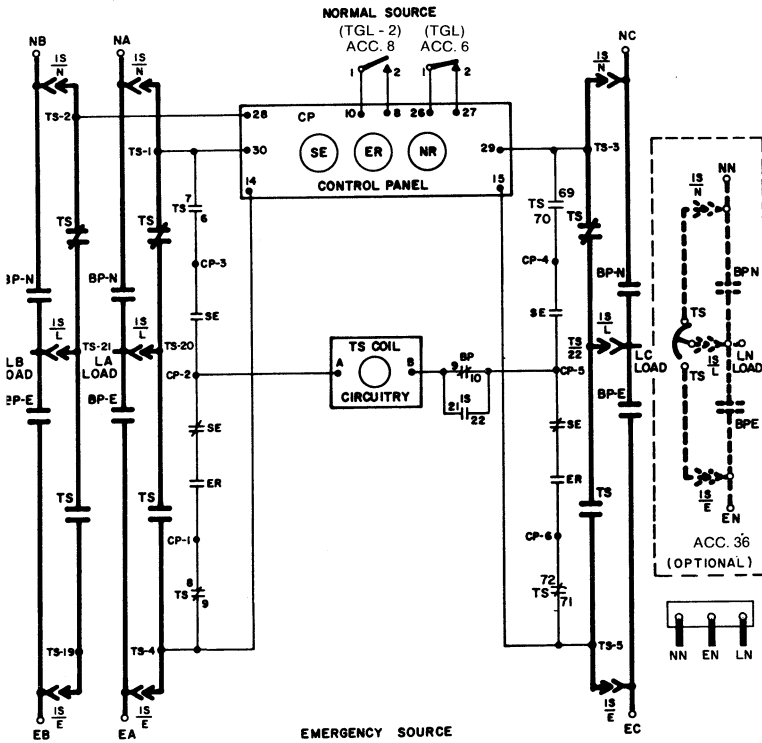

EMERGENCY SOURCE

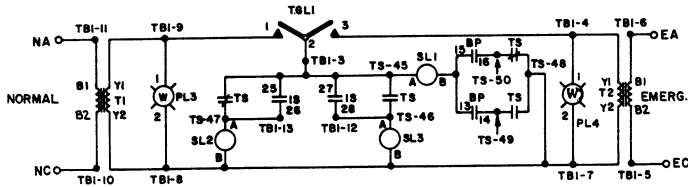
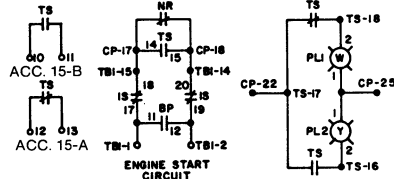

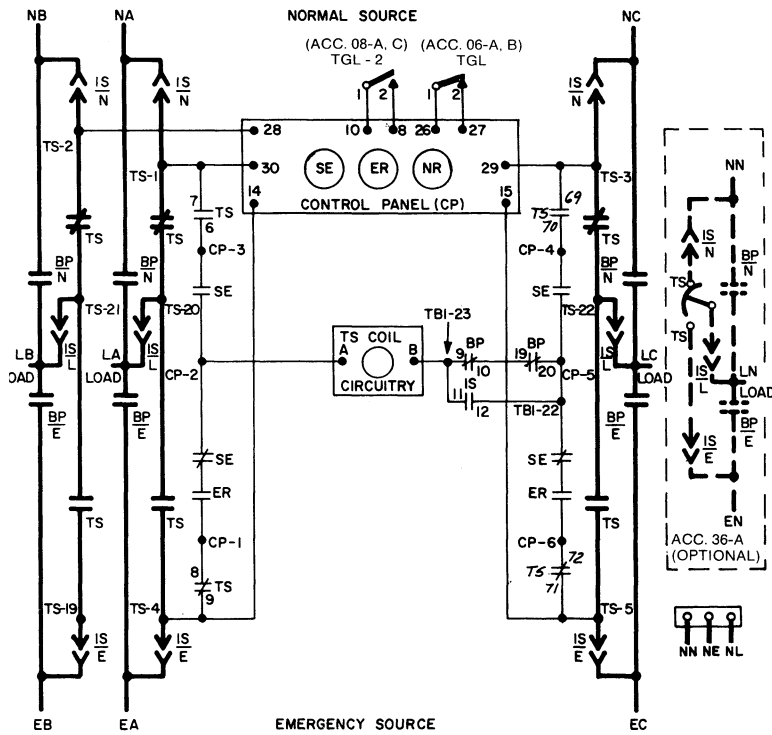

STANDARD ACCESSORIES

VOLTAGE AND FREQUENCY SENSING

- A. Close differential voltage sensing on all phases of normal source. Pickup voltage is adjustable from 85% to 100% of nominal and the dropout is adjustable from 75% to 98% of the pickup value. Factory set to pickup at 95% and dropout at 85% of nominal unless otherwise specified.
- B. Single phase voltage sensing of emergency source. Pickup adjustable from 85% to 100% of nominal. Factory set to pickup at 90% unless otherwise specified.
- C. Frequency sensing of emergency source. Pickup adjustable from 90% to 100% of nominal. Factory set to pickup at 95% unless otherwise specified.

TIME DELAYS

- D. Time delay to override momentary normal source outages to delay all transfer switch and engine starting signals. Adjustable from 0.5 seconds to 6 seconds. Factory set at 1 second unless otherwise specified. Standard Acc. 02-A.
- E. Retransfer to normal time delay. Time delay is automatically bypassed if emergency source fails and normal source is available. Adjustable from 0 to 30 minutes. Factory set at 30 minutes unless otherwise specified. Standard Acc. 03-C.
- F. Unloaded running time delay for emergency engine generator cool down. Adjustable from 0 to 5 minutes. Factory set at 5 minutes unless otherwise specified. Standard Acc. 04-C.
- G. Transfer to emergency time delay. Adjustable from 0 to 5 minutes. Factory set at 0 minutes unless otherwise specified. Standard Acc. 01-A.

ENGINE CONTROL CONTACT

- H. A contact that closes when normal source fails. Gold plated for low voltage engine start signals or other customer use. Rated 10 amps., 32 volts D.C. Standard Acc. 7.

MANUAL CONTROLS

- K. Test switch TGL, gold plated low voltage contacts to momentarily simulate normal source failure. Installed and connected on enclosure door. Shipped loose on open types. Standard Acc. 06-A, B.
- L. Reset switch TGL-2, to manually bypass time delay on retransfer to normal. Gold plated low voltage contacts. Installed and connected on enclosure door. Shipped loose for open types. Standard Acc. 08-A, C.

INDICATORS

- M. One auxiliary contact closed when automatic transfer switch is connected to normal. **NOTE:** Additional auxiliary contacts are available as options. Standard Acc. 15-A.
- N. One auxiliary contact closed when automatic transfer switch is connected to emergency. **NOTE:** Additional auxiliary contacts are available as options. Standard Acc. 15-B.
- P. Signal light PL1, white, indicates when automatic transfer switch is connected to normal source. Installed and connected on enclosed types. Shipped loose for open types. Use Chicago miniature bulb #28PSB. Standard Acc. 12-A, C.
- Q. Signal light PL2, yellow, indicates when automatic transfer switch is connected to emergency source. Installed and connected on enclosed types. Shipped loose for open types. Use Chicago miniature bulb #28PSB. Standard Acc. 12-C, D.
- R. Signal light PL3, white, indicates when normal source is available. Mounted to bypass switch face plate. Use Chicago miniature bulb #120PSB.
- S. Signal light PL4, white, indicates when emergency source is available. Mounted to bypass switch face plate. Use Chicago miniature bulb #120PSB.
- T. Signal light PL5, white, indicates automatic transfer switch contacts closed on normal. Mounted to bypass switch face plate. Use Chicago miniature bulb #28PSB.
- U. Signal light PL6, white, indicates automatic transfer switch contacts closed on emergency. Mounted to bypass switch face plate. Use Chicago miniature bulb #28PSB.

GENERAL NOTES

1. This sign indicates a branch circuit #.
2. Device symbols and designations are in accordance with NEMA Pub. ICS-1970, Part 1 - 101.
3. All wires are #16 AWG stranded copper and follow NEMA Standard ICS-1-112-64 color code unless otherwise specified.
4. 0 indicates customer connection points.
5. • indicates factory connection points.
6. Connection points that have both customer connections and factory connections are shown open as customer connection points.
7. When an additional accessory mounting panel is required to mount the optional accessories, it is located directly below the control panel.
8. Publication TP-5090 Operator's Manual is furnished with each automatic transfer switch. Refer to this publication prior to installation and operation of the switch.
9. Mating plug and jack terminal numbers match when plugged together.
10. SL-1 (solenoid lock) to prevent connecting ATS unless source to load is same as source bypassed.
11. SL2, SL3 - allow bypass only to the source to which the transfer switch load is connected.

OPTIONAL ACCESSORIES

- ACC. 36-A Overlapping neutral transfer contacts.

WIRING DIAGRAM 400—1000-Amp.

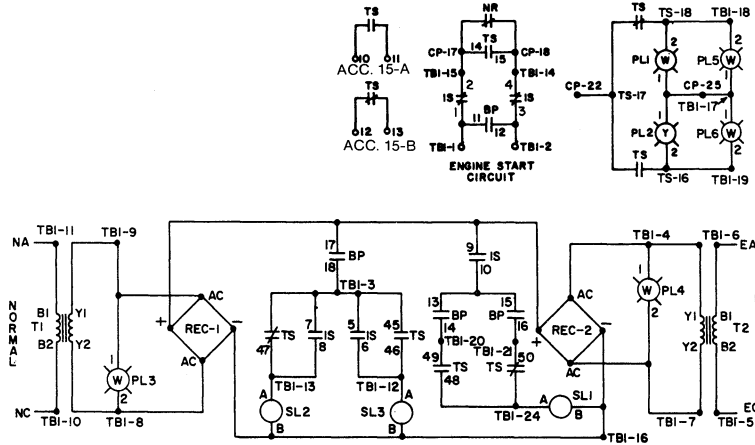

CENTER OF GRAVITY LOCATIONS

-  SWITCH
-  ACCESSORY GROUP PACKAGE

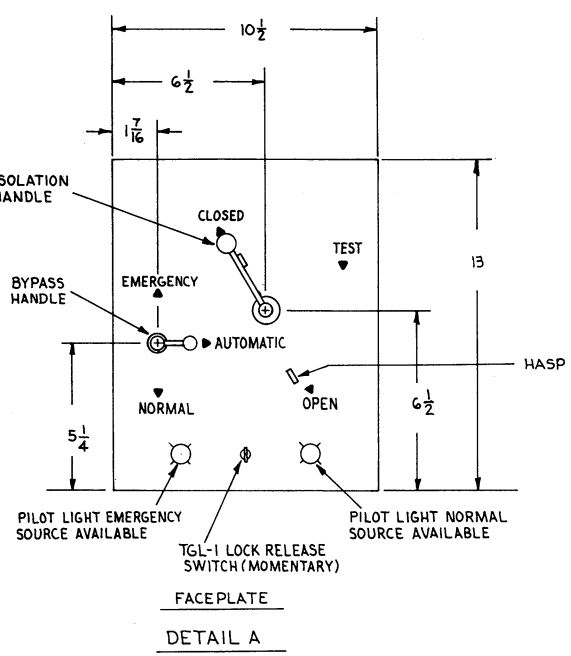
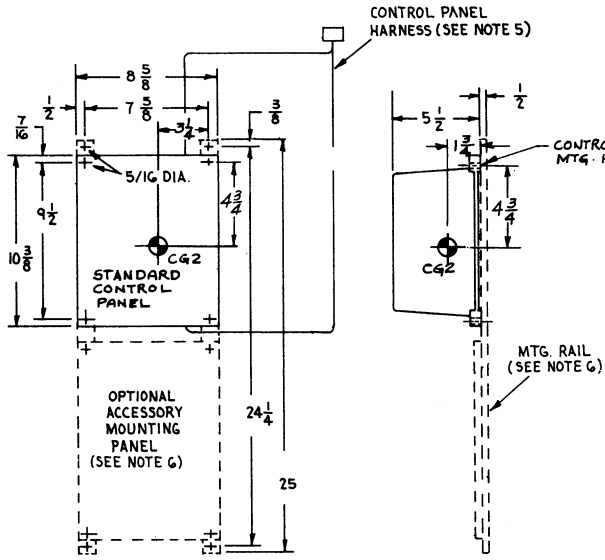
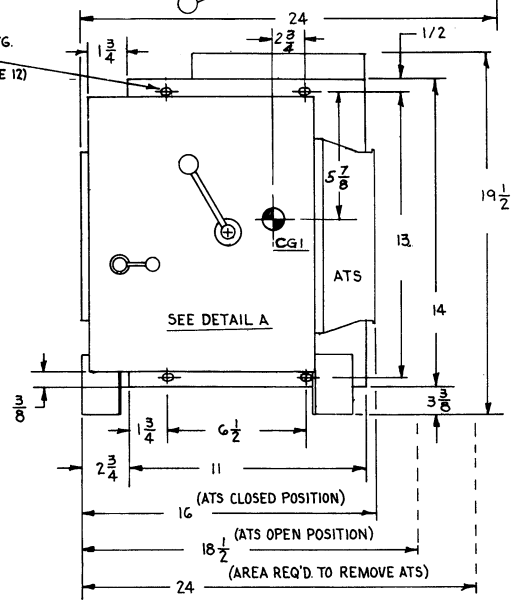
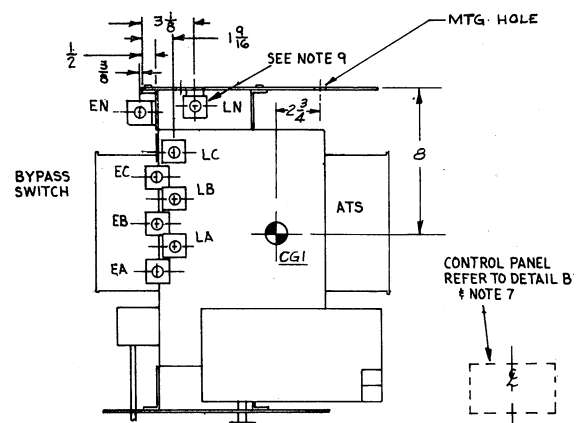
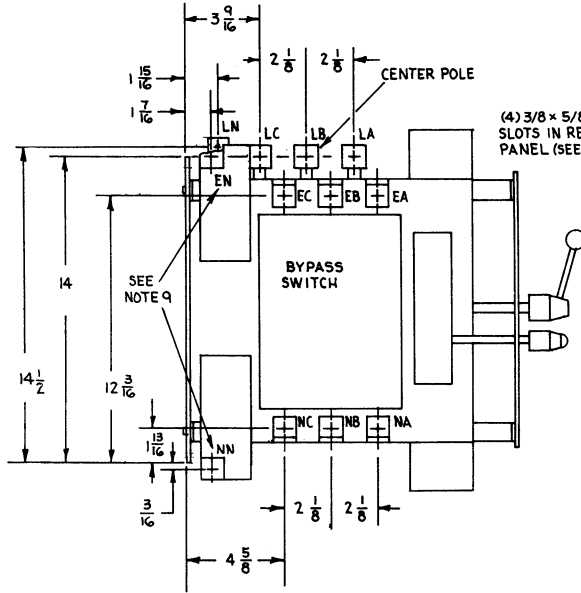

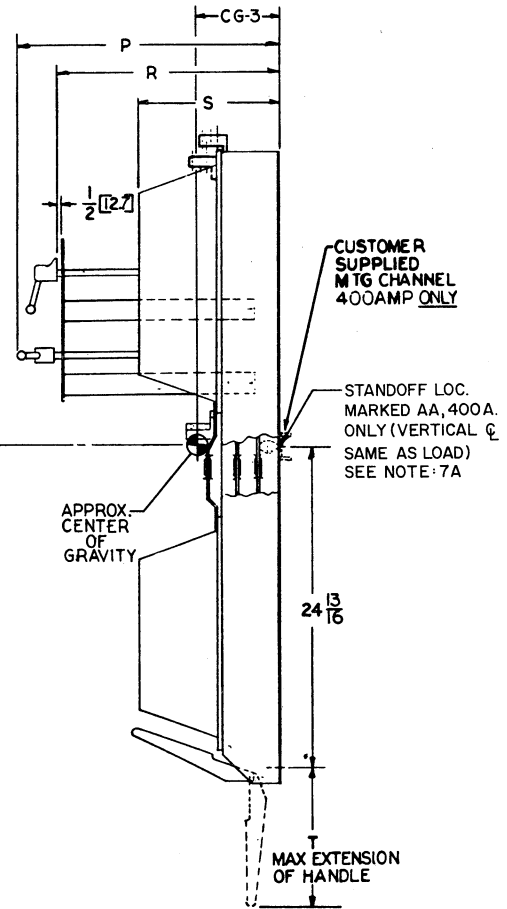
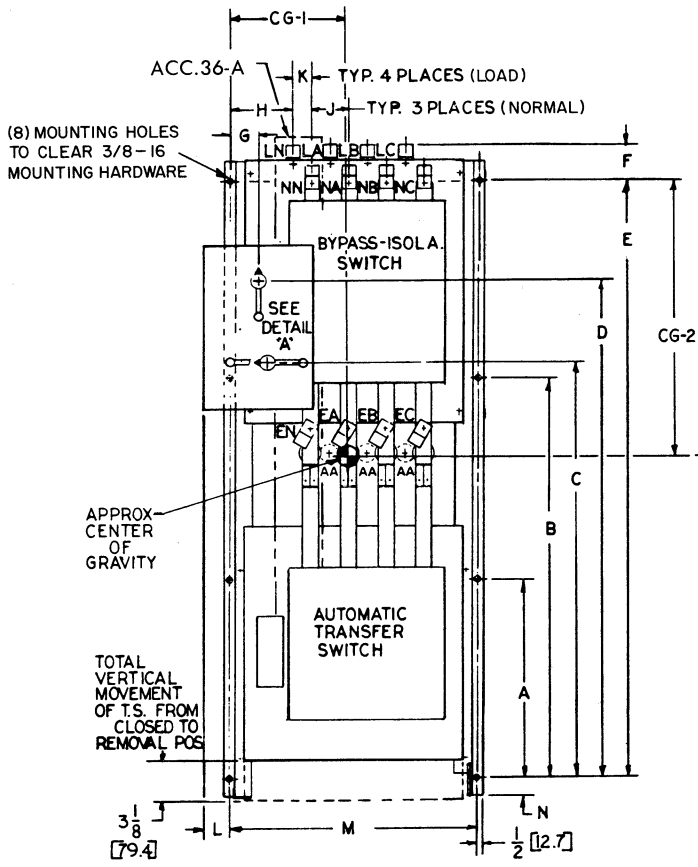

AMP SIZE	OPEN TYPE DIMENSIONS INCHES (MM)									
	A	B	C	D	E	F	G	H	J	
400	14.75 [374.7]	24.81 [630.2]	32.25 [819.1]	40.00 [1016.0]	45.75 [1162.0]	4.75 [120.7]	2.00 [50.8]	4.94 [125.4]	3.12 [79.4]	
600	18.75 [476.3]	37.75 [948.9]	39.25 [997.0]	47.00 [1193.8]	56.60 [1435.1]	3.50 [89]	2.62 [66.7]	5.81 [147.6]	3.50 [88.9]	

AMP SIZE	OPEN TYPE DIMENSIONS INCHES (MM)									
	K	L	M-1 **	M-2 **	N	P	R	S	T	
400	1.56 [39.7]	3.12 [79.4]	16.75 [425.5]	19.88 [504.8]	2.50 [63.5]	23.00 [584.2]	19.25 [488.9]	11.50 [292.1]	14.00 [355.6]	
600	1.75 [44.4]	2.50 [63.5]	19.75 [501.7]	23.25 [590.6]	1.75 [44.4]	24.75 [628.7]	21.25 [539.8]	13.50 [342.9]	13.25 [337.0]	

** M-1: Without Acc. 36-A
M-2: With Acc. 36-A

WEIGHTS		
AMP. SIZE	POLES	APPROX. SHIPPING WEIGHT LBS. Kg.
400	2	280 [127]
	3	300 [136]
	3 W/ACC. 36-A	330 [150]
600	2	355 [161]
	3	375 [170]
	3 W/ACC. 36-A	400 [181]
800	2	370 [168]
	3	385 [175]
	3 W/ACC. 36-A	425 [193]

CENTER OF GRAVEY				
AMPS	POLES	CG-1	CG-2	CG-3
400	2	7.50 [190.5]	20 [508]	4.50 [114.3]
	3	7.75 [197.3]	20 [508]	4.56 [115.8]
	3W/36-A	9 [228.6]	20 [508]	4.62 [117.5]
	2	9.88 [250.8]	24.75 [628.7]	6.75 [171.9]
600	3	10 [254]	24.88 [631.8]	7 [177.8]
	3W/36-A	11.38 [288.9]	25 [635]	6.81 [173]
	2	9.88 [250.8]	24.81 [630.2]	6.75 [171.5]
800	3	10 [254]	25 [635]	7 [177.8]
	3W/36-A	11.38 [288.9]	25.12 [638.2]	6.88 [174.6]

DIMENSIONS ARE IN INCHES (MM) APPROX.

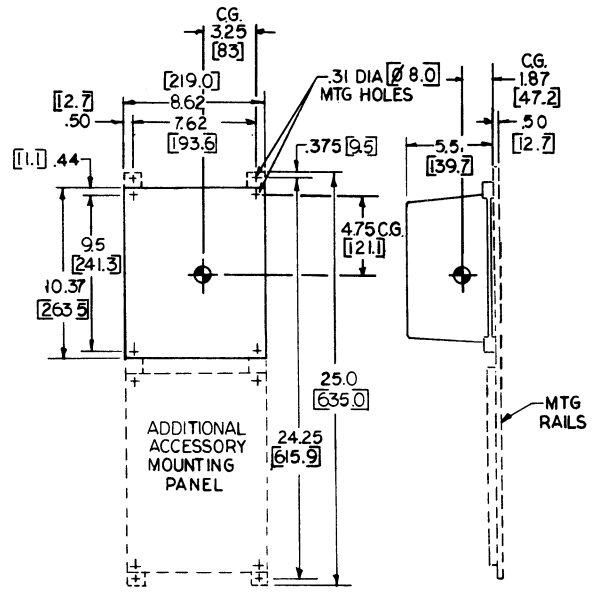

GENERAL NOTES

1. For two pole switches, omit center pole.
2. When installing, connect normal, emergency, and load conductors to clearly marked terminals.
3. All internal connections are made at the factory.
4. Maintain electrical clearance of 1/2 inch (12.7 mm) minimum between live metal parts and grounded metal for 400 amp., and 1.0 inch (25.4 mm) for 600, 800 and 1,000 amp.
5. The control panel is connected to the automatic transfer and bypass-isolation switch. By wire harnesses with a common in-line quick disconnect plug (consult factory for available extension harnesses).
6. Mounting rails are furnished only with open type switches that require additional accessory mounting panel.
7. When open type switches are intended for enclosure type mounting by others:
 - A. 400 amp. - mount the switch unit and stand-off supports, location marked A-A (% - 16 bolts) on inside back surface.
 - B. 600, 800 and 1,000 amp - mount the switch unit on inside back surface.
 - C. The control panel(s) on the inside door surface. Refer to detail "B".
8. Publication TP-5090 Operator's Manual is furnished with each automatic transfer and bypass isolation switch. Refer to this publication prior to installation, and operation on the switch.
9. Sizes of AL-CU U.L. listed solderless screw type terminals for external power connections:

- 400 amp. -
 One cable per lug: no. 4 min. to 600 MCM max.
 Two cables per lug: 1/0 min. to 250 MCM max.
- 600, 800 and 1,000 amp. -
 Three cables per lug: no. 2 min. to 600 MCM max.

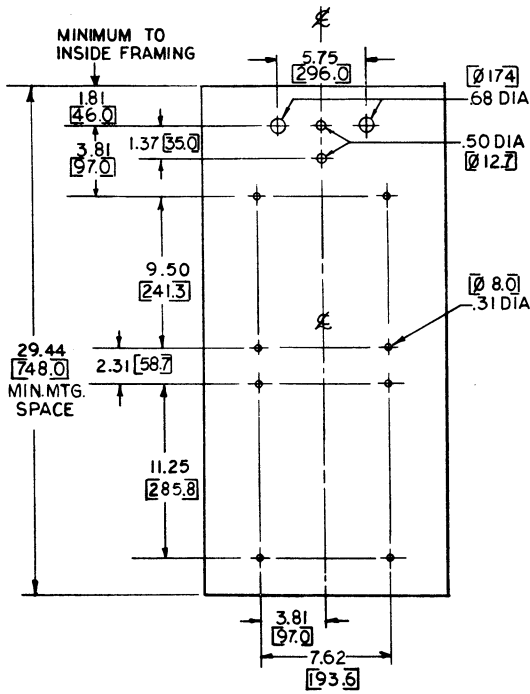

DETAIL-B (NOTE-7C)

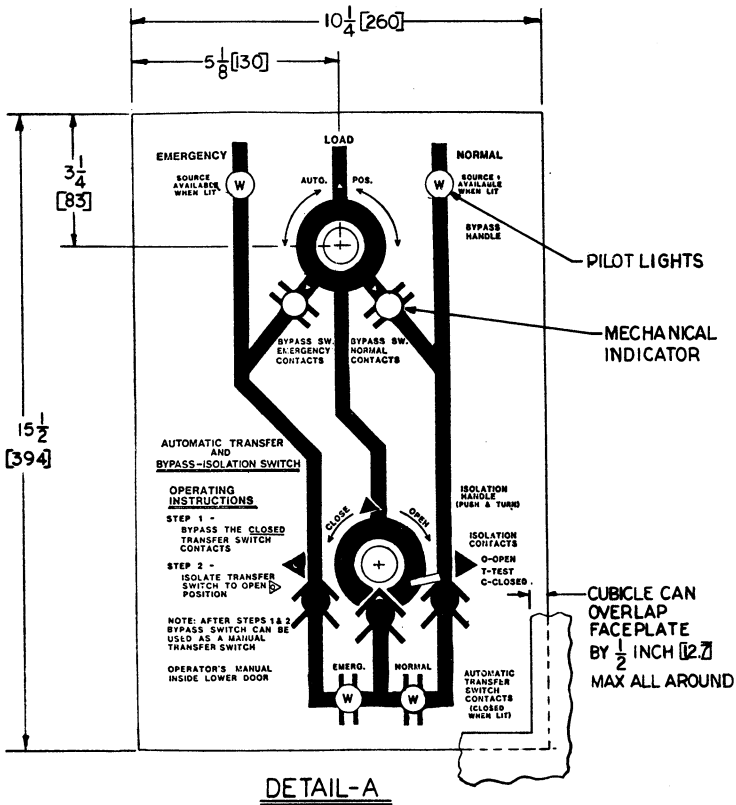

DETAIL-A

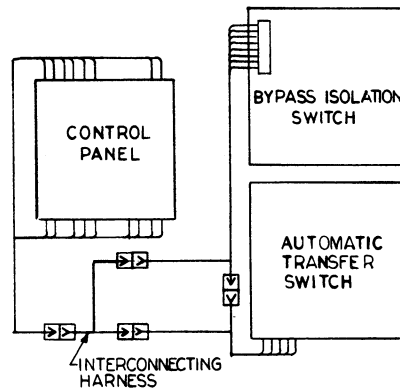

**OUTLINE AND MOUNTING
 400—1000-Amp.
 2 or 3-Pole**

TOP VIEW

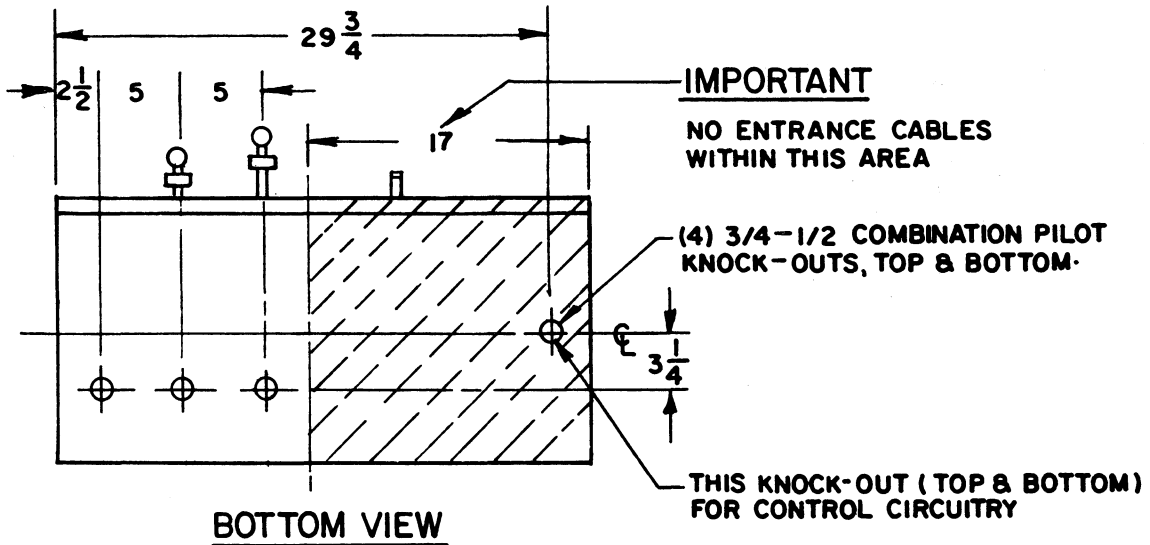
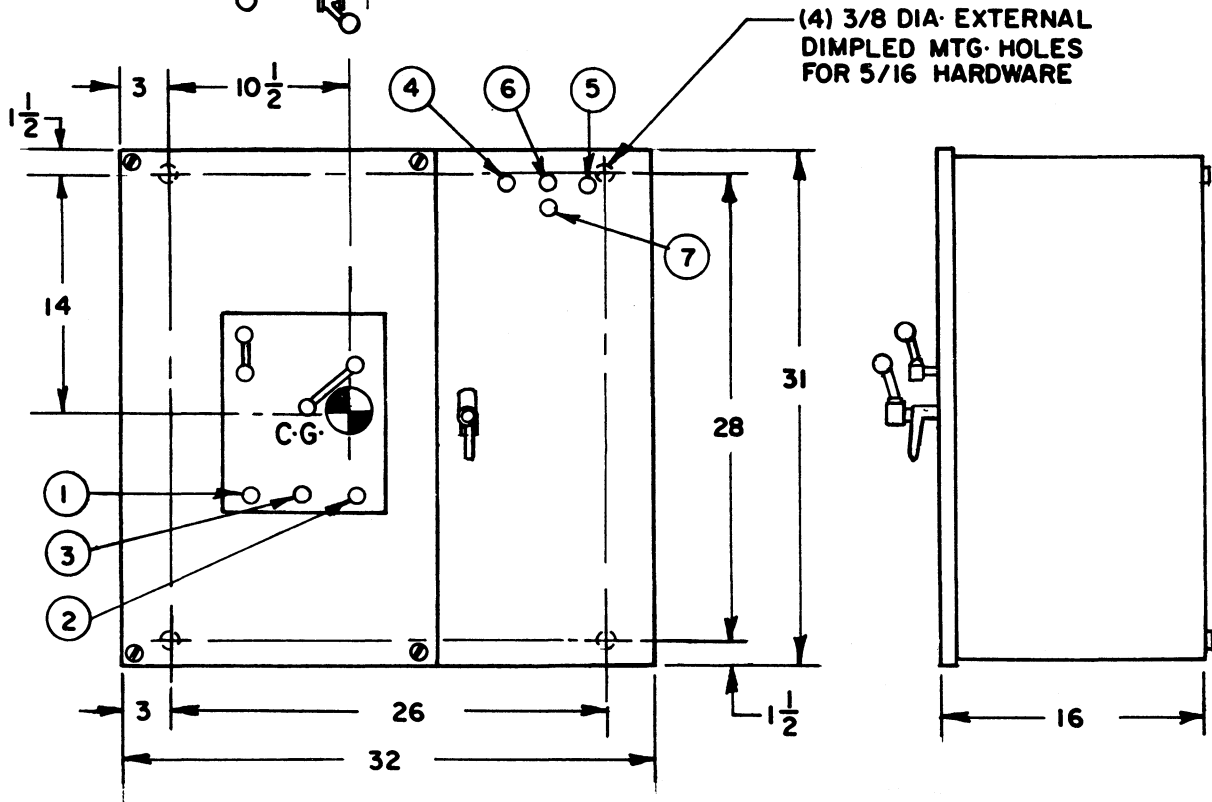
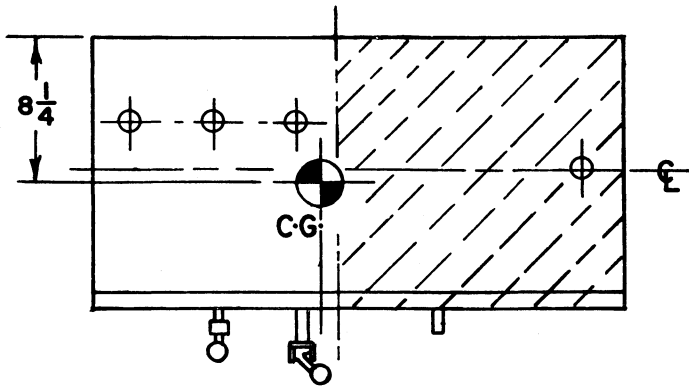

BOTTOM VIEW

ENCLOSURE SPECIFICATIONS

1. Type 1 and type 5 (dustproof) wall mounted enclosure.
2. Double door, left door secured with pan head screws, right door has lever handle with lock and 2 keys for single point catch.
3. Material - #14 gauge sheet steel.
4. Finish - ANSI #61 light gray over suitably prepared surface.
5. = center of gravity.
6. Weight - approximately 190 pounds.

COMPONENT LEGEND

1. Pilot light indicating emergency source availability.
2. Pilot light indicating normal source availability.
3. Bypass lock release switch (TGL - 1).
4. Pilot light indicating switch in normal position (Acc. 12-A, C).
5. Pilot light indicating switch in emergency position (Acc. 12-C, D).
6. Test switch to simulate normal failure (Acc. 06-A, B).
7. Bypass time delay switch (Acc. 08-A, C).

ENCLOSURE OUTLINE
100—260-Amp.
Wall Mounted

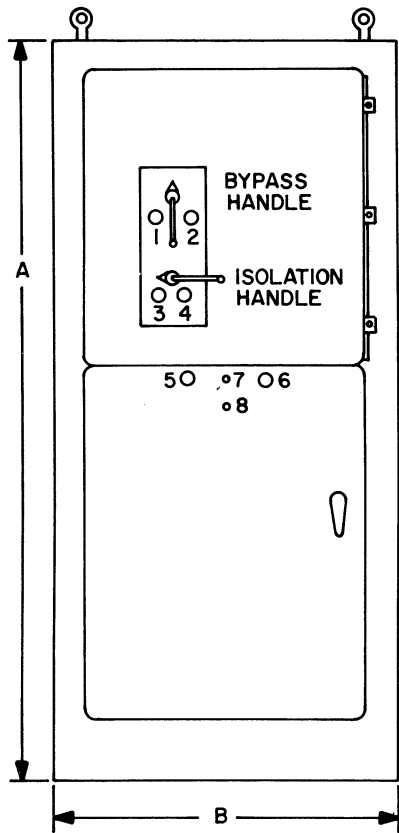

FRONT VIEW
(WITH DOORS)

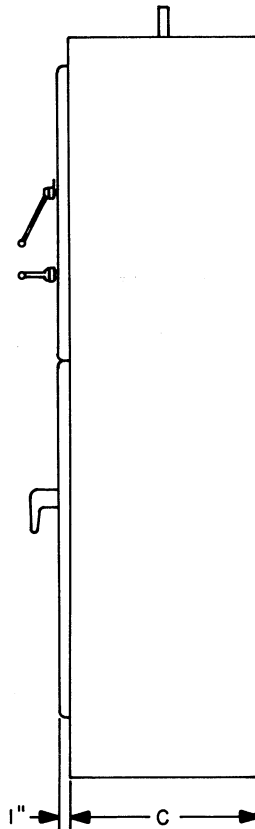

SIDE VIEW

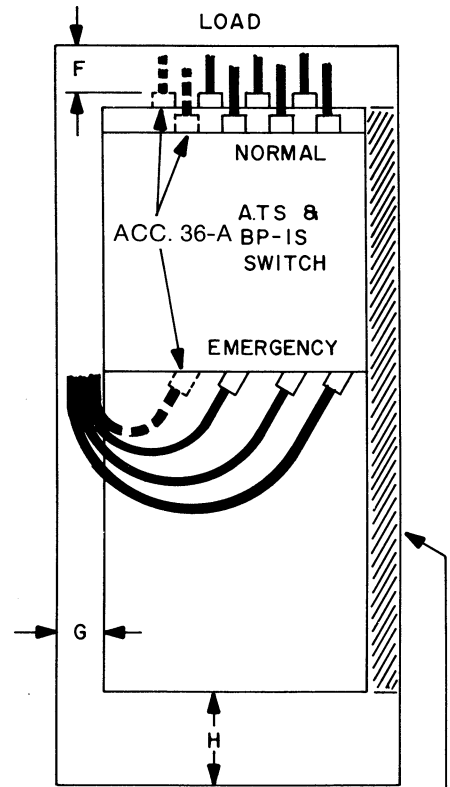

FRONT VIEW
(WITHOUT DOORS)

KEEP THIS AREA
FREE FROM CABLES

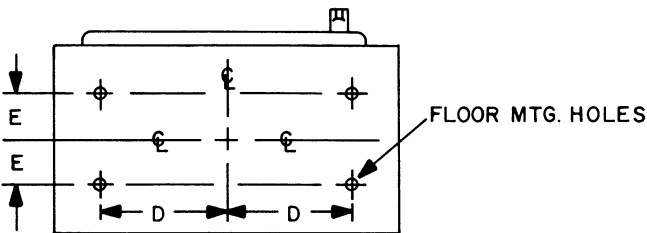

BOTTOM VIEW

AVAILABLE
GUTTER SPACE

AMP	APPLICATION	A	B	C	D	E	F	G	H	FLOOR MTG. HOLES
400	STD. 3 POLE	72	30	18	10	6	9 1/4	8 1/4	10 3/8	3/4 DIA.
400	3 POLE W/ACC. 36-A	72	30	18	10	6	9 1/4	8 1/4	10 3/8	3/4 DIA.
600,800	STD. 3 POLE	90	36	20	13	7	14 7/8	10 3/4	12 1/8	3/4 DIA.
600,800	3 POLE W/ACC. 36-A	90	36	20	13	7	14 7/8	10 3/4	12 1/8	3/4 DIA.

ENCLOSURE SPECIFICATIONS

1. Floor mounted, free standing, general purpose type.
2. Pan type door and cover.
3. Material #12 gauge sheet steel.
4. Finish - ANSI #16 light gray over suitably prepared surface.
5. All seams welded.
6. Continuous hinges on door and cover.
7. Heavy duty lifting eyes.
8. Bypass switch operating handles do not exceed 75' from the floor.

COMPONENT LEGEND

1. Pilot light indicating emergency source availability.
2. Pilot light indicating normal source availability.
3. Pilot light indicating ATS contacts closed on emergency.
4. Pilot light indicating ATS contacts closed on normal.
5. Pilot light indicating ATS is connected to normal source.
6. Pilot light indicating ATS is connected to emergency source.
7. Test switch to simulate normal source failure (Acc. 06-A, B).
8. Bypass time delay switch (Acc. 08-A, C).

NOTES

NOTES

NOTES

KOHLER GENERATORS