

Operation and Installation

Automatic Transfer Switches

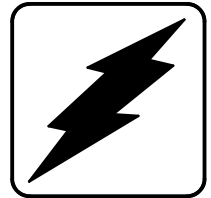

Models:

M340

Logic:

Microprocessor

KOHLER[®]
POWER SYSTEMS

ISO 9001
KOHLER
GENERATORS
INTERNATIONALLY REGISTERED
U.S.A. Plant ISO Registered

TP-5569 1/92b

Contents

Safety Precautions	i
Interpreting a Transfer Switch Part Number	iv
Local Control Panel	1
LED Indicators	1
Programming Mode Switch Positions	2
Control Switches	3
LCD Display Summaries	5
LCD Display Menus	5
Display Notes	5
Programming Mode Switch Off/Remote	7
Normal-Source Voltage & Frequency– Index 1	7
Emergency-Source Voltage & Frequency– Index 2	8
Records, Total & Resettable– Index 3	9
Clock & Calendar– Index 4	10
Time Delays– Index 5	11
Normal Source Voltage & Hz Settings & Set Points– Index 6	12
Emergency Source Voltage & Hz Settings & Trip Points– Index 7	14
Plant Exerciser Settings– Index 8	16
Load Shed Settings– Index 9	23
Source History– Index 10	24
Installed Control Options– Index 11	25
Voltage Sensing Calibration– Index 12	26
Remote Control & Monitoring Settings– index 13	27
Programming Mode Switch Local	29
Records, Total & Resettable– Index 3	29
Clock & Calendar– Index 4	30
Time Delays– Index 5	31
Normal Source Voltage and Frequency, Set Points– Index 6	32
Emergency Source Voltage and Frequency, Set Points– Index 7	35
PlantExerciserSettings– Index 8	38
Load Shed Settings– Index 9	46
Load Shed Settings– Index 9	46
Voltage Sensing Calibration– Index 12	47
RemoteControl & Monitoring Settings– Index 13	49
Microprocessor-Controlled Transfer Logic	51
Appendix I, General Message Codes	69
Appendix II, Source History Message Summary	69
Appendix III, System Alert Message Summary	69
Appendix IV, Setting Ranges	70
Appendix V, Local/Remote/Network Communications Installation	71

Safety Precautions

A Transfer Switch, like any other electro-mechanical device can pose potential dangers to life and limb if improperly maintained or imprudently operated. The best safeguards against accident are to be ever mindful of the potential dangers and to always use good common sense. In the interest of safety, some general precautions relating to operating of a transfer switch follow. Keep these in mind. This manual contains several types of safety precautions which are explained below.

DANGER

Danger is used to indicate the presence of a hazard which will cause severe personal injury, death, or substantial property damage if the warning is ignored.

WARNING

Warning is used to indicate the presence of a hazard which can cause severe personal injury, death, or substantial property damage if the warning is ignored.

CAUTION

Caution is used to indicate the presence of a hazard which will or can cause minor personal injury or property damage if the warning is ignored.

NOTE

Note is used to notify people of installation, operation, or maintenance information which is important but not hazard-related.



EXPLOSIVE BATTERY GASES! The gases generated by a battery being charged are highly explosive. Do not smoke or permit flame or spark to occur near a battery at any time, particularly when it is being charged. Avoid contacting terminals with tools, etc., to prevent burns and to prevent sparks that could cause an explosion. Remove wristwatch, rings, and any other jewelry before handling battery. Any compartment containing batteries must be well ventilated to prevent accumulation of explosive gases. To avoid sparks, do not disturb battery charger connections while battery is being charged and always turn charger off before connecting or disconnecting charger clips to battery terminals.

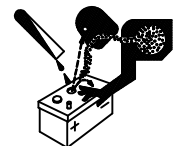

SULFURIC ACID! Avoid contact with battery electrolyte. It contains acid which can eat holes in clothing, burn skin, and cause permanent damage to eyes. Always wear splash-proof safety goggles when working around the battery. If battery electrolyte is splashed in the eyes or on skin, immediately flush the affected area for 15 minutes with large quantities of clean water. In the case of eye contact, seek immediate medical aid. Never add acid to a battery once the battery has been placed in service. Doing so may result in dangerous spattering of electrolyte.



HAZARDOUS VOLTAGE! The Transfer Switch is energized: proceed with care! High Voltage can cause personal injury, damage equipment, or lead to future failures. Remove watch, rings, and jewelry than can cause short circuits.



SHOCK HAZARD! De-energize the normal source branch to be connected to the Transfer Switch before making any line or auxiliary connections.



HAZARDOUS VOLTAGE! Disconnect inner panel harness at in-line connector. This will de-energize circuit board and logic circuitry, but allow transfer switch to continue to supply utility power to necessary lighting and equipment. Potential electrocution will exist if any accessories mounted to inner panel are NOT wired through and de-energized by harness separation. Such accessories may be at line voltage.



SHOCK HAZARD! De-energize both normal and emergency sources before proceeding. Move Generator Master Switch on controller to OFF position and disconnect battery negative (-) before working on transfer switch! Turn the transfer switch selector switch to the OFF position.



SHOCK HAZARD! The Transfer Switch will now be energized. Proceed with care!



HAZARDOUS VOLTAGE! The Automatic Transfer Switch is energized; proceed with care! High Voltage can cause personal injury, damage equipment, or lead to future failures. Remove rings, watches, and jewelry that can cause short circuits. This test should be done only by a qualified electrician. Follow manufacturer's instructions when operating tester.



SHOCK HAZARD! To prevent the possibility of electrical shock, de-energize the normal power source branch to be connected to the Transfer Switch before making any line or auxiliary connections.



SHOCK HAZARD! De-energize both normal and emergency sources before proceeding!

Safety Precautions



SHOCK HAZARD! Disconnect harness plug before installing any accessories involving connection to transformer assembly primary terminals 76, 77, 78, and 79. Terminals are at line voltage!



HIGH VOLTAGE! Remember that wherever electrical energy is present, there is the potential danger of electrocution. Keep everyone away from the set and take precautions to prevent unqualified personnel from tampering. Have the set and electrical circuits serviced only by qualified technicians. Wiring should be inspected at the recommended interval shown in the service schedule -- replace leads that are frayed or in poor condition. Do not operate electrical equipment when standing in water, on wet ground, or when your hands are wet.



UNIT STARTS WITHOUT NOTICE! Units with Automatic Transfer Switch start automatically. Potential injury or electrocution can result. De-energize both normal and emergency power source before proceeding. Turn Generator Master Switch on controller to OFF position, and disconnect battery cables (remove negative lead first and reconnect it last) to disable generator set before working on any equipment connected to generator. Turn the transfer switch selector switch to the OFF position.

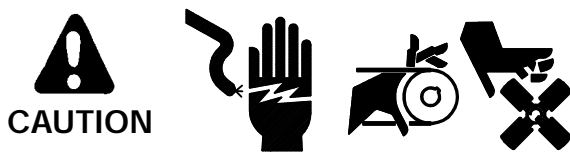

UNIT STARTS WITHOUT NOTICE! Units with Automatic Transfer Switches start automatically. Turn Generator Master Switch on controller to OFF position, and remove battery cables (remove negative lead first and reconnect it last) to disable generator set before working on any equipment connected to generator.

Interpreting a Transfer Switch Part Number

Use Model Number Code to Identify Type, Capacity and Characteristics of this Transfer Switch.

Enter the nameplate code number for this Kohler Switch (fill in boxes below)...

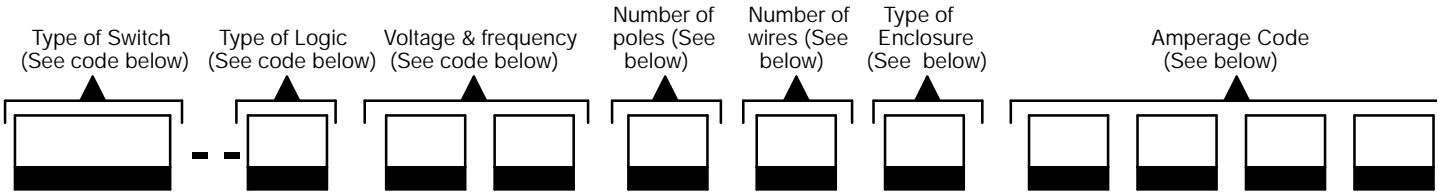

Kohler Model Number Key

This diagram explains the Kohler Transfer Switch model numbering code system. The sample number shown is for a microprocessor-logic Automatic Transfer Switch, 480 volt, 60 hertz, 3 phase, 3 pole, 4 wire, 150 Ampere model in a NEMA 1 enclosure.

SAMPLE MODEL NUMBER

K-566341-0150

Type Of Transfer Switch

- K -- Automatic Transfer Switch
- KB -- Automatic Transfer and Bypass Isolation Switch
- KN -- Nonautomatic Transfer Switch

Includes domestic packing. Add prefix PE for above or below deck export packing.

Type Of Logic

- 1 -- Solid State
- 2 -- Relay
- 3 -- Manual Relay
- 4 -- Elevator Control Switch
- 5 -- Microprocessor

Voltage & Frequency Phase to Phase

600 Volt AC Max

- | | |
|------------------|------------------|
| 60 -- 600V 60 Hz | 67 -- 190V 50 Hz |
| 61 -- 110V 50 Hz | 68 -- 208V 60 Hz |
| 62 -- 120V 60 Hz | 69 -- 440V 60 Hz |
| 63 -- 220V 50 Hz | 70 -- 400V 50 Hz |
| 64 -- 240V 60 Hz | 71 -- 380V 50 Hz |
| 65 -- 550V 60 Hz | 72 -- 380V 60 Hz |
| 66 -- 480V 60 Hz | 73 -- 416V 50 Hz |

Number of Poles

- 2 -- 2 Pole 1-phase
- 3 -- 3 Pole 3-phase
- 4 -- 3 Pole 1-phase
- 5 -- 3 Pole 3-phase with overlapping neutral contacts

Number of Wires

- 2 -- 2 Wire
- 3 -- 3 Wire
- 4 -- 4 Wire

Type of Enclosure

- 0 -- Open
- 1 -- NEMA 1
- 2 -- NEMA 12
- 3 -- NEMA 3R
- 4 -- NEMA 1 CSA
- 7 -- Open CSA

Amperes

- | | |
|---------------------|----------------------|
| 0030 -- 30 Amperes | 0800 -- 800 Amperes |
| 0070 -- 70 Amperes | 1000 -- 1000 Amperes |
| 0100 -- 100 Amperes | 1200 -- 1200 Amperes |
| 0104 -- 104 Amperes | 1600 -- 1600 Amperes |
| 0150 -- 150 Amperes | 2000 -- 2000 Amperes |
| 0225 -- 225 Amperes | 2500 -- 2500 Amperes |
| 0260 -- 260 Amperes | 3000 -- 3000 Amperes |
| 0400 -- 400 Amperes | 4000 -- 4000 Amperes |
| 0600 -- 600 Amperes | |

Local Control Panel

Control Panel

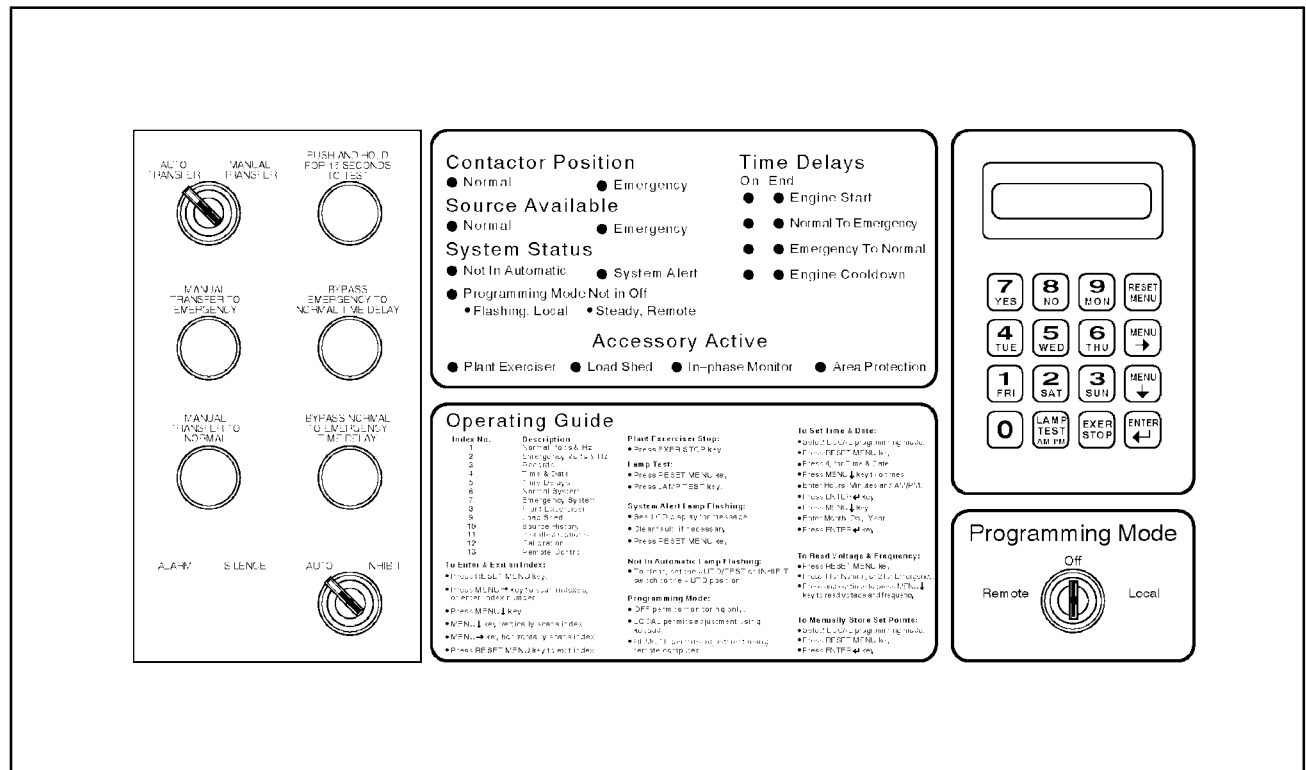

Figure 1. Local Controls and Indicators

LED Indicators

Contactor Position LEDs indicate source supplying voltage— Normal (green) or Emergency (red)

Source Available LEDs indicate source with acceptable voltage and frequency— Normal (green) and/or Emergency (green)

System Status

Not in Automatic (red) flashes to show that Test switch is actuated, or Auto-Manual switch is in the Manual position.

System Alert (red) flashes to show possible problem with contactor or logic operation. System alert will also flash, if any auxiliary signals are received from the generator set.

Programming Mode Not in Off (yellow) flashes to show that programming mode switch is in the Local position. A steady, non-flashing light shows that the programming mode switch is in the Remote position.

Time Delays

Engine Start (if emergency source is a generator set).
 ON indicates that engine start time delay is timing.
 END shows that engine has been signaled to start.

Normal to Emergency

ON shows that the normal-to-emergency time delay is timing.
 END shows that the time delay has completed timing.

Emergency to Normal

ON shows that the emergency-to-normal time delay is timing.
 END shows that the time delay has completed timing.

Engine Cool-Down

ON shows that the generator set engine cool-down timer is timing.
END lights momentarily as engine is signaled to shut down.

Accessory Active

Plant Exerciser shows that system exerciser is operating.

Load Shed shows that programmed load shedding is active. (See Load Shed Operation and setting following).

In-Phase Monitor shows that sources are being monitored for phase relationship to allow in-phase transfer. The in-phase monitor will permit transfer from emergency to normal when sources are near synchronization.

Area Protection shows that selected load circuits (areas) have signaled the emergency source to start.

Programming Mode Switch Positions

Caution

It is recommended that programming mode switch keys be kept in a safe place to prevent unwanted tampering with transfer switch control. It is *not* recommended that you leave the programming switch in the LOCAL position, with the transfer switch unattended.

REMOTE: Allows both status monitoring and setting of the transfer switch controls by a local, or remotely connected personal computer. Computer(s) may be singly connected to the switch, or connected through area networks. Allows monitoring at the transfer switch, same as in OFF.

OFF: Transfer switch status settings and power sources may be monitored from the local LCD display or connected computers. Settings cannot be changed when the programming mode switch is in the OFF position.

LOCAL: Allows both status monitoring and setting of transfer switch controls from the local LCD display and keypad. The transfer switch may be monitored by a computer, same as with the programming mode switch in the OFF position.

Control Switches

Test Push Button/Switch: (Push and hold for 15 seconds to test) Operating the button (or switch) to test will simulate a normal source outage. Not-in-Automatic system status light will flash.

Bypass N-E Time Delay Push Button: If pushed when normal-to-emergency time delay is on, time delay will end.

Bypass E-N Time Delay Push Button: If pushed when emergency-to-normal time delay is on, time delay will end.

Alarm Silencer Switch: Turn to Silence position to silence the audible alarm.

Transfer Mode Selector Switch, accessory KD-29

AUTO Transfer Position

The AUTO position enables full-automatic transfer sequence in cases when normal source is not acceptable, or when testing transfer switch operation.

MANUAL Transfer Position

When normal source fails:

1. Generator set will start after time delay and emergency available LED will light.
2. System Alert LED flashes (see display).
3. Normal-to-Emergency time delay will complete timing.
4. LCD display will show MANUAL TRANSFER. Push transfer-to-emergency button. Contactor position will transfer to Emergency.

When normal source returns:

1. Both source-available LEDs will light.
2. System Alert flashes and LCD will show MANUAL TRANSFER.
3. Emergency-to-normal delay will complete timing.
4. Push transfer to normal button, contactor position transfers to Normal.
5. Generator set goes to cool-down LED lights.
6. Generator set shuts down as cool-down completes timing. Emergency Available LED goes out.

KD-29 accessories also include a selector switch override circuit, to automatically transfer, if the connected source fails and the other source is available.

Auto-Inhibit Switch (option 09-G, J, K) Auto position enables automatic operation. Inhibit position prevents transfer in either direction and opens the engine start circuit.

Exer Stop Key: Pressing this key will end a generator set exercise run. The transfer switch will transfer to normal (if the generator set is being exercised under load) and the generator set will continue running through its time-delay-engine-cooldown period before shutting down.

Notes

LCD Display Menus

This is a list of local programming and monitoring menus and the key entry (index) numbers that will get you into each submenu. A walk through these modes and menus will give you familiarity with keypad functions and displays.

- J Normal Voltage & Frequency (NORMAL VOLT & FREQ),**
Index 1, reads actual normal source voltage, frequency and phase sequence.
- J Emergency Voltage & Frequency (EMER VOLT & FREQ),**
Index 2, reads actual emergency source voltage, frequency and phase sequence.
- J Operational Records (RECORDS TOTAL, RECORDS RESET),**
Index 3, two sets of records: *TOTAL* and *RESETable*. *TOTAL* records are cumulative, since initial controller setup. *RESETable* records are those kept by the control, since the last time of reset.
- J Clock, Day & Calendar (TIME, DATE, DAY),**
Index 4, shows time, date, day and day's occurrence number (1-5) in the present month.
- J Time Delays (TIME DELAY MN:SE),**
Index 5, shows time delay settings associated with ON-END LEDs on the front panel.
- J Normal Voltage & Frequency Settings & Trip Points (NORMAL SYSTEM),**
Index 6. Shows normal-source trip point settings that will initiate a transfer sequence.
- J Emergency Voltage & Frequency Settings & Trip Points (EMERGENCY SYSTEM),**
Index 7, shows emergency-source trip point settings that will initiate a transfer sequence.
- J Plant Exerciser (PLANT EXERCISER),**
Index 8, shows the exerciser schedule type selections and settings for scheduled days and times.
- J Load Shed (LOAD SHED MN:SE),**
Index 9, shows settings for the number of load blocks to be shed and/or returned, and time between each load-shed and/or return signal.
- J Source History (SOURCE HISTORY),**
Index 10, shows fault status and summaries describing the four most recent source failures.
- J Installed Options (CONTROL OPTIONS),**
Index 11, shows various control options as either enabled or disabled.
- J Voltage Calibration (CALIBRATION),**
Index 12, shows source voltage calibration settings.
- J Remote Control Setup (REMOTE CONTROL),**
Index 13, shows connection type and communication settings for monitoring and controlling the transfer switch using a personal computer.

Display Notes

- b** Tells you to go to the next screen. Press the down arrow key to view. These are looping menus. Pressing the down arrow will take you to the next screen, and return to the first screen in the index when scrolling has finished.
- '** Tells you that there are more screens to the right. Press the right arrow key to view. These are looping menus. Pressing the down arrow will take you to the next display.
- ?** Asks for an answer with YES or NO key. Otherwise use a digit, day, AM or PM key, as requested by display.









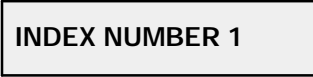

Notes

Programming Switch Modes



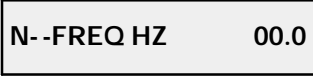

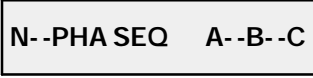

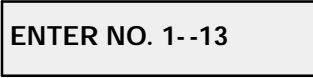

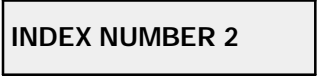

Off Mode

In this first mode, key entries will give you displays of system status and switch settings.











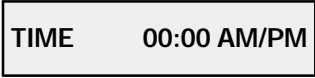

Note: If display reads "CODE ERROR", press RESET MENU to proceed.

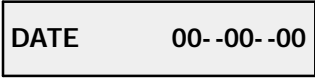
Key Entry	Display	Description
		Normal-Source Voltage & Frequency— Index 1
		Reads actual normal-source voltage, frequency and phase sequence.
		Normal-source voltmeter (single-phase shown)
<p>Note: For single-phase switches both voltage and frequency are on phase A-C. For three-phase switches, voltage will be for A-B, B-C, then A-C as down arrow is pressed.</p>		
		Normal-source frequency meter
		Shows for three-phase only, if phase sequence option is enabled. Proper sequence is A-B-C. B-A-C indicates loss-of-phase sequence, loss of phase voltage or incorrect phase sequence.
		Allows a new index number to be entered.



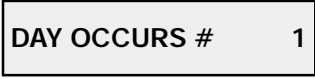







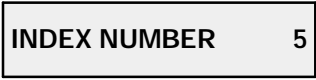

OFF Mode— continued

Key Entry	Display	Description
		Emergency-Source Voltage & Frequency— Index 2
		Reads actual normal-source voltage, frequency and phase sequence.
		Emergency-source voltmeter
		Emergency-source frequency meter
Note		
For single-phase switches both voltage and frequency are on phase A-C. For three-phase switches, voltage will be for A-B, B-C, then A-C as down arrow is pressed.		
		Three-phase only, if enabled. Proper sequence is A-B-C. B-A-C indicates loss-of-phase sequence, loss of phase voltage or incorrect phase sequence.
		Allows a new index number to be entered.

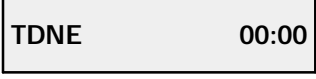
OFF Mode— continued

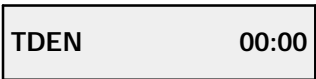
Key Entry	Display	Description
		Clock & Calendar— Index 4
		Current time of day
		Current month, day, year
		Current day of week
		The number that appears (1-5) relates to the number of times that a given day occurs in the current month. For instance, if the current day is TUEsday, this screen example shows that the current day is the first Tuesday of the month. The control uses these numbers in the calendar exercise mode.
		If 14-day exerciser mode has been selected, this additional screen will show week 1 or 2 of the current 2-week (14-day) period.
		Allows a new index number to be entered.









Off/monitor Mode

Key Entry	Display	Description
		Time Delays— Index 5
		Time delays are shown in Minutes:Seconds
		Engine Start Time Delay setting, in Minutes:Seconds
		Normal-to-Emergency transfer Time Delay setting in Minutes:Seconds
		Emergency-to-Normal transfer Time Delay setting in Minutes:Seconds
		Engine Cool Down time setting in Minutes:Seconds
		Allows a new index number to be entered.

OFF Mode—continued

Key Entry	Display	Description
	INDEX NUMBER 6	Normal Source Voltage & Hz Settings & Set Points—Index 6
	NORMAL SYSTEM	Settings give reference points for starting transfer sequences. Dropout (DRO) points are those at which the source is unacceptable. Pickup (PKU) points are those at which the source is acceptable.
	NORM VOLTS 000	Normal source <i>rated</i> system voltage for control setpoint reference. Must be same as system voltage.
	NORM HERTZ 00.0	Normal source, <i>rated</i> system frequency (HERTZ) for control setpoint reference. Must be same as system frequency.
	N- -ONE PH. SENSE?	Shows one (single)-phase or 3-phase sensing enabled. Press down arrow key to continue. If you try to make an entry, display will say CHECK KEY SWITCH.
	N- -OV DRO % 000'	Normal dropout overvoltage setting % of <i>rated</i> voltage (if option 34-J is enabled)
	N- -OV DRO V 000'	Normal overvoltage dropout voltage setting (if option 34-J is enabled)
	N- -OV PKU % 000'	Normal overvoltage pickup setting % of <i>rated</i> voltage (if option 34-J is enabled)
	N- -OV PKU V 000'	Normal overvoltage pickup setting (if option 34-J enabled)
	N- -UV PKU % 00'	Normal undervoltage pickup setting % of <i>rated</i> voltage
	N- -UV PKU V 000'	Normal undervoltage pickup voltage setting
	N- -UV DRO % 00'	Normal undervoltage dropout setting % of <i>rated</i> voltage
	N- -UV DRO V 000'	Normal undervoltage dropout voltage setting









Off/monitor Mode

Key Entry	Display	Description
	N- -OF DRO % 00'	Normal overfrequency dropout setting %of <i>rated</i> frequency (if option 34-J enabled)
	N- -OF DRO HZ 00.0'	Normal overfrequency dropout Hz setting (if option 34-J enabled)
	N- -OF PKU % 00'	Normal overfrequency pickup setting %of <i>rated</i> frequency (if option 34-J enabled)
	N- -OF PKU HZ 00.0'	Normal overfrequency pickup Hz setting (if option 34-J enabled)
	N- -UF PKU % 00'	Normal underfrequency pickup setting %of <i>rated</i> frequency (if option 34-J enabled)
	N- -UF PKU HZ 00.0'	Normal underfrequency pickup Hz setting (if option 34-J enabled)
	N- -UF DRO % 00'	Normal underfrequency dropout setting %of <i>rated</i> frequency (if option 34-J enabled)
	N- -UF DRO HZ 00.0'	Normal underfrequency dropout Hz setting (if option 34-J enabled)
	ENTER NO. 1--13	Allows a new index number to be entered.

OFF Mode—continued

Key Entry	Display	Description
	INDEX NUMBER 7	<h3>Emergency Source Voltage & Hz Settings & Trip Points— Index 7</h3> <p>Settings give reference points for starting transfer sequences. Dropout (DRO) points are those at which the source is unacceptable. Pickup (PKU) points are those at which the source is acceptable.</p> <p>Emergency source <i>rated</i> system voltage for control setpoint reference</p> <p>Emergency source <i>rated</i> system frequency (Hertz)</p> <p>Shows one (single)-phase or 3-phase sensing enabled. Press down arrow key to continue. If you try to make an entry, display will say CHECK KEY SWITCH.</p> <p>Emergency source overvoltage dropout setting % of <i>rated</i> voltage (if option 34-J enabled)</p> <p>Emergency source overvoltage dropout voltage setting (if option 34-J enabled)</p> <p>Emergency source overvoltage pickup setting % of <i>rated</i> voltage (if option 34-J enabled)</p> <p>Emergency source overvoltage pickup setting (if option 34-J enabled)</p> <p>Emergency source undervoltage pickup setting % of <i>rated</i> (if option 34-J enabled)</p> <p>Emergency source undervoltage pickup setting (if option 34-J enabled)</p> <p>Emergency source undervoltage dropout setting % of <i>rated</i> voltage (if option 34-J enabled)</p> <p>Emergency source undervoltage dropout setting (if option 34-J enabled)</p>
	EMERGENCY SYSTEM	
	EMER VOLTS 000	
	EMER HERTZ 00.0	
	E- -ONE PH.SENSE ?	
	E- -OV DRO % 000 '	
	E- -OV DRO V 000'	
	E- -OV PKU % 000'	
	E- -OV PKU V 000 '	
	E- -UV PKU % 00 '	
	E- -UV PKU V 000 '	
	E- -UV DRO % 00 '	
	E- -UV DRO V 000'	

Off/monitor Mode

Key Entry	Display	Description
	E- -OF DRO % 000'	Emergency source overfrequency dropout setting % of <i>rated</i> frequency (if option 34-J enabled)
	EOF DRO HZ 00.0'	Emergency source overfrequency dropout Hz setting (if option 34-J enabled)
	E- -OF PKU % 000 '	Emergency source overfrequency pickup setting % of <i>rated</i> frequency (if option 34-J enabled)
	EOF PKU HZ 00.0'	Emergency source overfrequency pickup Hz setting (if option 34-J enabled)
	E- -UF PKU % 00'	Emergency source underfrequency pickup setting % of <i>rated</i> frequency
	EUF PKU HZ 00.0'	Emergency source underfrequency pickup setting
	E- -UF DRO % 00'	Emergency source underfrequency dropout % of <i>rated</i> frequency
	EUF DRO HZ 00.0'	Emergency source underfrequency dropout setting
	ENTER NO. 1--13	Allows a new index number to be entered.

OFF Mode—continued

Key
Entry

Display

Description



Plant Exerciser Settings— Index 8



Display will show if Plant Exerciser (option 23) is enabled



Indicates exercise schedule type selected.
Mode types are calendar, 14-day, or 7-day.

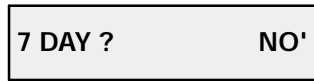
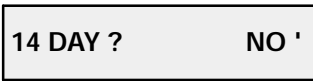

Shows that calendar mode has been selected.

The **calendar mode** allows up to 5 events, with 1, or 2, exercise occurrences each. The calendar date for each occurrence is automatically set according to the date setting entered in Index 4. This is a “true calendar,” that “knows” the occurrences of days in any month. Relationships of calendar days and dates to occurrence days are illustrated below. Occurrence numbers for days in a typical month are shown in shaded columns.

SUN	MON	TUE	WED	THU	FRI	SAT
↓	↓	↓	↓	↓	↓	↓
		1	2	3	4	5
		1	1	1	1	1
6	7	8	9	10	11	12
1	1	2	2	2	2	2
13	14	15	16	17	18	19
2	2	3	3	3	3	3
20	21	22	23	24	25	26
3	3	4	4	4	4	4
27	28	29	30	31		
4	4	5	5	5		

Off/monitor Mode

Calendar Mode Summary

EXERCISE EVENT	START TIME	DAY OF WEEK	OCCURENCE #		RUN TIME HR:MN	LOAD TRANSFER
			1ST	2ND		
#1 ENABLED	07:30 AM	SAT	2	4	00:45	NO
#2 DISABLED	09:00 AM	TUE	1	1	00:00	NO
#3 DISABLED	09:00 AM	TUE	1	1	00:00	NO
#4 DISABLED	09:00 AM	TUE	1	1	00:00	NO
#5 DISABLED	09:00 AM	TUE	1	1	00:00	NO

In the example above, exercise event #1 is enabled. Exercise runs will start at 7:30 AM. The first exercise run will occur on the second SATurday of the month; the second exercise run will occur on the fourth SATurday. The generator set(s) will run for 45 minutes. Load will not be transferred during the exercise runs.

Key

Entry

Display

Description



#1 ENABLED ? NO'

YES would show that an exercise "event" is enabled. An "event" can include up to two exercise periods, within part of the timeframe of the schedule.



STRT TM 00:00 AM '

Shows time that exercise period will start. Default start time is 9:00 AM.



DAY OF WEEK TUE '

Shows first day of "event" when system is to exercise. Default factory setting is TUESday.



1ST OCCUR # (1--5)'

Shows for first exercise run of "event."



2ND OCCUR # (1--5)'

Shows occurrence # of day, for second exercise run of "event."



RUN HR:MN 0:00 '

Shows length of run time set for each exercise event.



LD TRANS YES '

YES shows that load will be transferred to the emergency source during the exercise run. NO would show that load will not transfer during the exercise run.



#2 ENABLED ? NO'

"Events" 2 through 5 will have setting choices displayed, same as for event #1 described above.

OFF Mode— continued

Key Entry Display Description

 14- -DAY MODE ' ' Indicates exercise schedule type selected.

 CALENDAR ? NO ' '  14 DAY ? YES ' '  7 DAY ? NO ' '

Shows that 14-day mode has been selected.

The **14-day mode** allows up to 5 events, with 1, or 2, exercise runs each, in a 14-day (Sunday-to-Saturday) period. Each exercise run may be scheduled for a particular day of week 1 or week 2 in the 14-day period. The current week will show in Index 4, if the 14-day mode has been selected.

The following table shows the relationship among exercise events, start times, selected days for each exercise run, week of the 14-day period, the time that the generator set (emergency source) is to run and whether, or not, transfer switch is to transfer load to the emergency source.

14 Day Mode Summary						
EXERCISE EVENT	START TIME	DAY OF WEEK		WEEK 1 OR 2	RUN TIME HR:MN	LOAD TRANSFER
		1ST	2ND			
#1 ENABLED	07:30 AM	WED	SAT	2	00:45	NO
#2 DISABLED	09:00 AM	TUE	TUE	1	00:00	NO
#3 DISABLED	09:00 AM	TUE	TUE	1	00:00	NO
#4 DISABLED	09:00 AM	TUE	TUE	1	00:00	NO
#5 DISABLED	09:00 AM	TUE	TUE	1	00:00	NO









In the example above, exercise event #1 is enabled. Exercise runs will start at 7:30 AM. The first exercise run will occur on WEDnesday of week 2; the second exercise run will occur on SATurday of week 2. The generator set(s) will run for 45 minutes. Load will not be transferred during the exercise runs.

 #1 ENABLED ? NO ' ' YES would show that an exercise "event" is set to occur. An "event" can include up to two exercise periods, within part of the timeframe of the selected schedule.

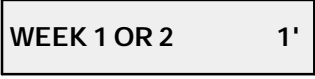
 STRT TM 00:00 AM ' ' Shows time that exercise period will start.

 1ST DAY TUE ' ' Shows day for first exercise run of "event."

Off/monitor Mode

Key Entry	Display	Description
		Shows day for second exercise run of "event."
		Shows week of 14-day period, for "event." See Index 4 for current week of 14-day period.
		Shows length of run time set for each exercise event.
		YES shows that load will be transferred to the emergency source during the exercise run. NO would show that load will not transfer during the exercise run.
		"Events" 2 through 5 will have setting choices displayed, same as for event #1 described above.

OFF Mode— continued

Key Entry Display Description

 7--DAY MODE ' ' Indicates exercise schedule type selected.

The 7-day mode allows up to 5 events, with 1, or 2, exercise runs each, in 7-day, Sunday-Saturday, period.

The following table shows the relationship among exercise events, start times, selected days for each exercise run, the time that the generator set (emergency source) is to run and whether, or not, transfer switch is to transfer load to the emergency source.

 CALENDAR ? NO'  14 DAY ? NO '  7 DAY ? YES'

Shows that 7-day mode has been selected.

7 Day Mode Summary					
EXERCISE EVENT	START TIME	DAY OF WEEK		RUN TIME HR:MN	LOAD TRANSFER
		1ST	2ND		
#1 ENABLED	07:30 AM	WED	SAT	00:45	NO
#2 DISABLED	09:00 AM	TUE	TUE	00:00	NO
#3 DISABLED	09:00 AM	TUE	TUE	00:00	NO
#4 DISABLED	09:00 AM	TUE	TUE	00:00	NO
#5 DISABLED	09:00 AM	TUE	TUE	00:00	NO

In the example above, exercise event #1 is enabled. Exercise runs will start at 7:30 AM. The first exercise run will occur on WEDnesday. The second exercise run will occur on SATurday. The generator set(s) will run for 45 minutes. Load will not be transferred during the exercise runs.

 #1 ENABLED ? NO' YES would show that an exercise "event" is enabled An "event" can include upto two exercise periods, within part of the time frame of the selected schedule (calendar, 14-day, 7-day).





 STRT TM 00:00 AM ' Shows time that exercise period will start.

 1ST DAY TUE ' Shows day for first exercise run of "event."

 2ND DAY TUE ' Shows day for second exercise run of "event."



 RUN HR:MN 0:00 ' Shows length of run time set for each exercise event.

Off/monitor Mode



Key Entry	Display	Description
		YES shows that load will be transferred to the emergency source during the exercise run. NO would show that load will not transfer during the exercise run.
		"Events" 2 through 5 will have setting choices displayed, same as for event #1 described above.



OFF Mode— continued

The following (generator set) engine start sequence may be used with any plant exerciser mode, or with the plant exerciser option disabled.

Key Entry	Display	Description
		Display shows that the generator set has not (NO), or has (YES), been signaled to run for a one-time exercise. This submenu feature allows the generator set to be run for a set time (up to 72 hours), in order to keep it (emergency source) available for the set time.



Note: All choices for the engine-start submenu will reset to NO/00:00 after the Engine-Start sequence you have set up has completed timing.

		Shows the amount of time that the generator set is to run during the engine-start period.
---	---	---

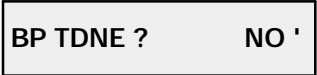
		YES would show that the transfer switch will transfer load during the engine-start period. "NO" shows that load will not be transferred to the generator set during the engine-start period.
---	---	--

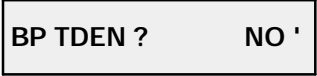
		YES would show that the normal-to-emergency time delay is to be bypassed when the generator set is started in the Engine-Start mode. NO shows that the normal-to-emergency time delay will not be bypassed.
---	---	---

		YES would show that the emergency-to-normal time delay is to be bypassed when returning to normal from the Engine Start mode. NO shows that emergency-to-normal time delay will not be bypassed.
---	---	--

		Shows the amount of time (hours and minutes) left in the exercise on Engine Start period.
---	---	---

		Allows a new index number to be entered.
---	---	--

Note: To stop the exercise timer during an exercise run, press **EXER STOP** key. Pressing the EXER STOP key will zero out the remaining exercise time. The generator set will continue to run through its timed cool-down cycle.

Off/monitor Mode

Key Entry



Display

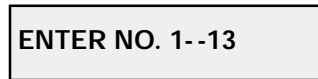
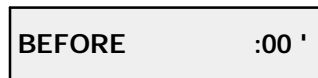
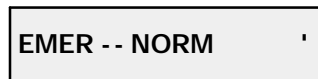
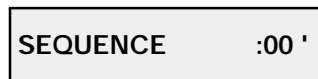
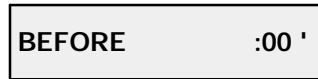
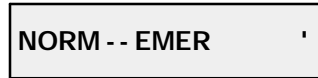
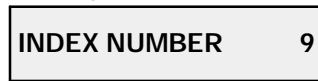

Description

Load Shed Settings— Index 9

Selection title, load shed times to be shown in minutes and seconds before and after transfer. See Appendix IV for standard and extended setting ranges. The transfer switch **must** be equipped with a load-shed circuit board (option) for load-shed settings to be effective.

Scan across for **normal-to-emergency load shed settings**.

Shows time that loads are shed, in minutes:seconds, after normal-to-emergency time delay. All 9 load blocks will be shed at one time.

Shows time, in minutes:seconds, after normal-to-emergency transfer that load(s) are to remain shed.

Shows time between individual sequenced load returns, in minutes:seconds, after a normal-to-emergency transfer. If sequence time is 00:00, all 9 load control relays will energize to return load simultaneously. With a sequence time set, relays 1 up through 9 will operate in sequence. Up to 9 loads may be controlled by sequence.

Shows the number of loads (up to 9) to be controlled in sequence by load control relays 1-9.

Scan across for **emergency-to-normal load shed settings**.

Shows time that loads are shed, in minutes:seconds, before emergency-to-normal time delay that load(s) are to remain shed. All load blocks will be shed..

Shows time after emergency-to-normal transfer, in minutes:seconds, that loads will remain shed.











Shows time between individual sequenced load returns, in minutes:seconds, after an emergency-to-normal transfer. If sequence is 00:00, all 9 load shed relays will energize to return load simultaneously. With a sequence time set, relays 1 up through 9 will operate in sequence. Up to 9 loads may be controlled by sequence.

Shows number of loads (up to 9) to be controlled in sequence by relays 1-9.

Allows a new index number to be entered.

Key Entry	Display	Description
1 FRI	0 INDEX NUMBER 10	Source History— Index 10
MENU ↓	SOURCE HISTORY	Selection shows failure type and summary of source failures (four most recent).
MENU ↓	RECORD #1 '	Scan across for description of most recent failure.
MENU →	EMER UNDER FREQ	Describes source and type of failure. See Appendix II for a list of Source History messages.
MENU →	DATE 00--00--00 '	Month, date, and year of failure.
MENU →	TIME 00:00 AM(PM)	Time of day of failure.
MENU ↓	RECORD #2 (3,4) '	Scan across for descriptions of failures 2, 3, 4-- second-most recent, third-most recent, fourth-most recent.
MENU ↓	OUTAGE #1 00 :00	Shows time elapsed during most-recent source outage or fault (hours:minutes for Record #1 only). Resets to zero after 24 hours.
RESET MENU	ENTER NO. 1--13	Allows a new index number to be entered.

Off/monitor Mode

Key Entry	Display	Description
 	INDEX NUMBER 11	
	CONTROL OPTIONS	Installed Control Options— Index 11 Sub-menu for enabled/disabled control options/features. These are shunt-enabled and cannot be enabled or disabled from the keypad.
	INPHASE MON YES	Shows inphase monitor enabled (YES), or disabled (NO).
	PHA SEQ/LOSS YES	Shows a source phase sequence relay enabled (YES), or disabled (NO). Transfer switch contactor lug connections must be properly phased in order for this option to function.
	NORM & EMER YES	Shows normal and emergency, over and under, voltage and frequency sensing enabled (YES), or disabled (NO).
	PLANT EXERC YES	Shows generator set/system exerciser enabled (YES), or disabled (NO). The generator set may still be exercised by using an engine-start sequence, even if the plant exerciser option is disabled.
	TD EXTENDED YES	Shows extended time delay enabled (YES), or disabled (NO). See Appendix IV for standard ranges. Extended time delays may be set up to 99 minutes.
	MAN OVERRIDE YES	Shows manual overrides enabled (YES), or disabled (NO). Enabled manual override (YES) allows automatic transfer to an available source, when a connected source fails. Transfer time delays will be bypassed. Disabled manual override (NO) will wait for manual operation and will not automatically seek an available source.
	ENTER NO. 1--13	Allows a new index number to be entered.

OFF Mode—continued

Key Entry	Display	Description
1 FRI	2 SAT	INDEX NUMBER 12
MENU ↓	CALIBRATION	Voltage Sensing Calibration— Index 12 Sub-menu for switch/system calibration settings. These are factory settings that will not have to be changed unless a main logic control circuit board has been replaced.
MENU ↓	N- -AUTO- -ZERO ?	Arrow down to the next screen. Calibration will be covered under "LOCAL" programming mode.
	For Single Phase	
MENU ↓	N- -VOLT VAC 000	Will show normal source voltage calibration setting. VAC for 1-phase; line-to-line VAC for 3-phase.
	For 3-phase	
MENU ↓	N- -PH A- -B VAC 000	Normal phase A-B voltage calibration
MENU ↓	N- -PH B- -C VAC 000	Normal phase B-C voltage calibration
MENU ↓	N- -PH A- -C VAC 000	Normal phase A-C voltage calibration
MENU ↓	E- -AUTO- -ZERO ?	Arrow down to the next screen. Calibration will be covered under "LOCAL" programming mode.
	For Single Phase	
MENU ↓	E- -VOLT VAC 000	Will show emergency source voltage calibration setting. GAIN for 1-phase; line-to-line for 3-phase.
	For 3-phase	
MENU ↓	E- -PH A- -B VAC 000	Emergency phase A-B voltage calibration
MENU ↓	E- -PH B- -C VAC 000	Emergency phase B-C voltage calibration
MENU ↓	E- -PH A- -C VAC 000	Emergency phase A-C voltage calibration
RESET MENU	ENTER NO. 1- -13	Allows a new index number to be entered.

Off/monitor Mode

Key Entry	Display	Description
1 FRI	3 SUN	INDEX NUMBER 13
MENU ↓	REMOTE CONTROL	Remote Control & Monitoring Settings— Index 13 Sub-menu for remote control settings. Communications may be enabled for one of the following single or network connection types.
MENU ↓	ON--LINE? YES/NO	Shows whether or not a PC can be connected for remote monitoring and programming.
MENU ↓	LOCAL? YES/NO	Shows whether or not PC can be connected with a Local Single Connection .
MENU ↓	LAN? YES/NO '	Shows whether or not PC can be connected through a Local Area Network (LAN) .
MENU →	ADDRESS (#) '	LAN address number for the transfer switch (1-128).
MENU ↓	REMOTE? YES/NO '	Shows whether or not PC can be connected through a Remote, Single Connection .
MENU →	SYS. ID 0000	Password, up to six digits.
MENU ↓	REMLAN? YES/NO '	Shows whether or not PC can be connected through a Remote Local Area Network (LAN) connection.
MENU →	SYS. ID 0000	Password, up to six digits.
MENU ↓	BAUD RATE 9600	Baud rate for the modem(s), or data connection used to connect the remote computer(s) to the transfer switch. 9600 is the default setting. Choices are 2400, 4800, 9600.
RESET MENU	ENTER NO. 1--13	Allows a new index number to be entered.















This completes the Off Mode overview.

Notes

Local/programming Mode

Local Mode

With the programming mode key switch in the LOCAL position, transfer switch control and plant exerciser settings can be made using the keypad. This section will guide you through setting procedures.

Key Entry	Display	Description
	ENTER INDEX. 1--13	Allows a new index number to be entered.
	INDEX NUMBER 3	
	RECORDS -- TOTAL	TOTAL records since factory setup, cannot be reset Push down arrow until display reads RECORDS -- RESET
	RECORDS -- RESET	
	RESET RECORD ?	If you want to reset records to zero, do the next step. If not, press RESET MENU, or menu down.
	RECORD RESET ? YES	Asks you if you want to reset records to zero.
	ENTRY ACCEPTED	Shows that resettable records have been reset to zero.
	RESET 0- -00- -00	Shows date of record reset.
	NOT NRM HRS 0	Hours with the transfer switch in the emergency position since last record reset
	EMER HRS 0	Hours with the emergency source available since last record reset, including exercise periods.
	OPER DAYS 0	Days of operation since last record reset
	TRANSFER # 0	Number of transfers since last record reset
	ENTER INDEX 1--13	
	STORE SET POINTS	<i>Do this after making any switch settings. The display shows that setpoints are stored in semi-permanent memory.</i>

Local Mode— continued

Key
Entry

Display

Description

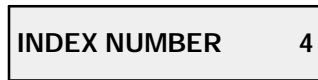

Clock & Calendar— Index 4

The following clock-calendar settings should be made when the transfer switch is first installed and energized. "SET TIME AND DATE" may appear if power to the transfer switch is lost for more than 10 seconds. The System Alert lamp may also flash. If this is the case, use the following procedure.

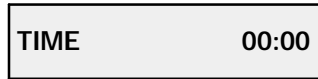

To set time of day, press digit keys for hours:minutes and press AM, or PM, to set correct time.

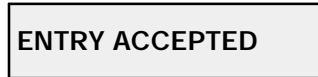

Shows that clock has been set. Seconds will reset to zero.



To set date, press digit keys for month, day and year. Display will show new date setting.



Shows that date has been set. Day, and week of month are automatically set when you set the date.

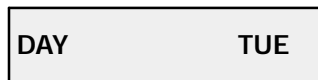

Current day of week



The number that appears (1-5) relates to the number of times that a given day occurs in the current month. For instance, if the current day is TUESday, this screen example shows that the current day is the first Tuesday of the month. The control uses these numbers in the calendar exercise mode.













If 14-day exerciser mode has been selected, this additional screen will show week 1 or 2 of the current 2-week (14-day) period.













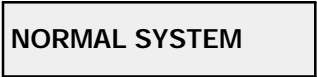

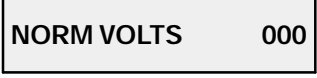





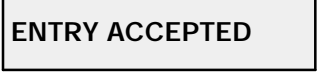

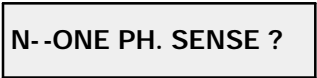

Do this after making any switch settings. The display shows that setpoints are stored in semi-permanent memory.

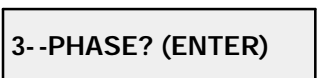
Local/programming Mode

Key Entry	Display	Description
	INDEX NUMBER 5	Time Delays— Index 5 See Appendix IV for setting ranges.
	TIME DELAY MN:SE	Time delays are entered in Minutes:Seconds
	TDES 00:00	Time Delay Engine Start. To set time delay press digit keys to get new setting.
	ENTRY ACCEPTED	Shows that new setting has been made.
	TDNE 00:00	Normal-to-Emergency Time Delay. To set time delay press digit keys to get new setting.
	ENTRY ACCEPTED	Shows that new setting has been made.
	TDEN 00:00	Emergency-to-Normal Time Delay. To set time delay press digit keys to get new setting.
	ENTRY ACCEPTED	Shows that new setting has been made.
	TDEC 00:00	Engine Cool-Down Time Delay. To set time delay press digit keys to get new setting.
	ENTRY ACCEPTED	Shows that new setting has been made.
	ENTER INDEX 1--13	Shows that new setting has been made.
	STORE SET POINTS	<i>Do this after making any switch settings. The display shows that setpoints are stored in semi-permanent memory.</i>

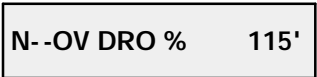

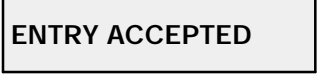





Local Mode—continued

Key Entry	Display	Description
		Normal Source Voltage and Frequency, Set Points—Index 6 See Appendix IV for setting ranges. These settings are critical, as they control transfer switch operation.
		Settings give reference points for starting transfer sequences. Dropout (DRO) points are those at which the source is unacceptable. Pickup (PKU) points are those at which the source is acceptable.
		To set normal-source/system <i>rated</i> voltage, press digit keys to get new setting. This setting MUST match system voltage!
	 	Shows that control accepts the new setting, or shows that attempted setting is out of possible range. See Appendix IV for setting ranges.
		To set normal system <i>rated</i> frequency, press digit keys to get new setting. This setting MUST match system frequency!
	 	Shows that new setting has been made, or shows that attempted setting is out of possible range.
		If normal-source sensing is to be on one phase (A-C) only, arrow down to the next choice. If normal-source sensing is to be 3-phase, press NO.
		
		Press ENTER to make choice.
		Note: Settings may only be changed as a percentage, not voltage or frequency.
		Shows dropout setting as % of normal-source <i>rated</i> voltage. Press digit keys for a new setting (if option 34-J is enabled).
		Shows that control accepts the new setting, or

Local/programming Mode

Key Entry	Display	Description
	RANGE ERROR	shows that attempted setting is out of possible range.
MENU →	N- -OV DRO V 000	Shows normal over voltage dropout setting in Volts (if option 34-J is enabled).
MENU ↓	N- -OV PKU % 000'	Shows pickup setting as % of normal-source <i>rated</i> voltage. Press digit keys for a new setting (if option 34-J is enabled).
ENTER ↵	ENTRY ACCEPTED	Shows that new setting has been made, or
	RANGE ERROR	shows that attempted setting is out of possible range.
MENU ↓	N- -UV PKU % 00'	Shows pickup setting as % for normal-source <i>rated</i> voltage. Press digit keys for a new setting.
ENTER ↵	ENTRY ACCEPTED	Shows that new setting has been made, or
	PICKUP ADJUSTED	shows that related pickup setting will adjust to hold 2% minimum difference, or
	RANGE ERROR	shows that attempted setting is out of possible range.
MENU ↓	N- -UV DRO % 00'	Shows dropout setting as % of normal-source <i>rated</i> voltage. Press digit keys for a new setting.
ENTER ↵	ENTRY ACCEPTED	Shows that control accepts new setting, or
	PICKUP ADJUSTED	shows that related pickup setting will adjust to hold 2% minimum difference, or
	RANGE ERROR	shows that attempted setting is out of possible range.
MENU ↓	N- -OF DRO % 000'	Shows dropout setting as % of normal-source <i>rated</i> frequency. Press digit keys for a new setting (if option 34-J is enabled).
ENTER ↵	ENTRY ACCEPTED	Shows that control accepts new setting, or
	PICKUP ADJUSTED	shows that related pickup setting will adjust to hold 2% minimum difference, or
	RANGE ERROR	shows that attempted setting is out of possible range.









Local Mode—continued

Key Entry	Display	Description
	N- -OF PKU % 000'	Shows pickup setting as % of normal-source <i>rated</i> frequency. Press digit keys for a new setting (if option 34-J is enabled).
	ENTRY ACCEPTED	Shows that control accepts new setting, or shows that related pickup setting will adjust to hold 2% minimum difference, or shows that attempted setting is out of possible range.
	PICKUP ADJUSTED	
	RANGE ERROR	
	N- -UF PKU % 00'	Shows pickup setting as % of normal-source <i>rated</i> frequency. Press digit keys for a new setting.
	ENTRY ACCEPTED	Shows that control accepts new setting, or Shows that related pickup setting will adjust to hold 2% minimum difference, or shows that attempted setting is out of possible range.
	PICKUP ADJUSTED	
	RANGE ERROR	
	N- -UF DRO % 00'	Shows dropout setting as % of normal-source <i>rated</i> frequency. Press digit keys for a new setting.
	ENTRY ACCEPTED	Shows that control accepts new setting, or shows that related pickup setting will adjust to hold 2% minimum difference, or shows that attempted setting is out of possible range.
	PICKUP ADJUSTED	
	RANGE ERROR	
	ENTER NO. 1--13	
	STORE SETPOINTS	<i>Do this after making any switch settings. The display shows that setpoints are stored in semi-permanent memory.</i>









Local/programming Mode

Key Entry	Display	Description
	INDEX NUMBER 7	
	EMERGENCY SYSTEM	
	EMER VOLTS 000	Settings give reference points for starting transfer sequences. Dropout (DRO) points are those at which the source is unacceptable. Pickup (PKU) points are those at which the source is acceptable.
	ENTRY ACCEPTED	To set for emergency-source system <i>rated</i> voltage, press digit keys for a new setting. This setting must match emergency source's voltage.
	RANGE ERROR	Shows that control accepts new setting, or shows that attempted setting is out of possible range.
	EMER HERTZ 00	
	ENTRY ACCEPTED	Shows emergency-source <i>rated</i> frequency. Press digit keys for a new setting.
	RANGE ERROR	Shows that control accepts new setting, or shows that attempted setting is out of possible range.
	ENTRY ACCEPTED	Shows that control accepts new setting, or
	RANGE ERROR	shows that attempted setting is out of possible range.
	E- -ONE PH. SENSE ?	Shows that control accepts new setting, or shows that attempted setting is out of possible range.
	E- -3 PHASE SENSE?	If emergency-source sensing is to be on one phase (A-C) only, arrow down to the next choice. If emergency-source sensing is to be 3-phase, press NO.
	3- -PHASE? (ENTER)	
	ENTRY ACCEPTED	Press ENTER to make choice.
	E- -OV DRO % 115	
		Shows dropout setting as % of emergency-source <i>rated</i> voltage. Press digit keys for a new setting (if option 34-J is enabled).

Local Mode— continued

Key Entry	Display	Description	
	ENTRY ACCEPTED	Shows that control accepts new setting, or	
	RANGE ERROR		shows that attempted setting is out of possible range.
	E- -OV DRO V 000	ShowsemergencyovervoltagedropoutsettinginVolts (if option 34-J is enabled). Note: Settings may only be changed as percentages, not voltage or frequency.	
	E- -OV PKU % 000	Shows pickup setting as % of emergency-source <i>rated</i> voltage. Press digit keys for a new setting (if option 34-J is enabled).	
	ENTRY ACCEPTED	Shows that control accepts new setting, or	
	RANGE ERROR		shows that attempted setting is out of possible range.
	E- -UV PKU % 00	Shows pickup setting as % of emergency-source <i>rated</i> voltage. Press digit keys for a new setting.	
	ENTRY ACCEPTED	Shows that control accepts new setting, or	
	PICKUP ADJUSTED		shows that related pickup setting will adjust to hold 2% minimum difference, or
	RANGE ERROR		shows that attempted setting is out of possible range.
	E- -UV DRO % 00	Shows dropout setting as % of emergency-source <i>rated</i> voltage. Press digit keys for a new setting.	
	ENTRY ACCEPTED	Shows that control accepts new setting, or	
	PICKUP ADJUSTED		shows that related pickup setting will adjust to hold 2% minimum difference, or
	RANGE ERROR		shows that attempted setting is out of possible range.
	E- -OF DRO % 000	Shows dropout setting as % of emergency-source <i>rated</i> frequency. Press digit keys for a new setting (if option 34-J is enabled).	

Local/programming Mode

Key Entry	Display	Description	
	ENTRY ACCEPTED	Shows that control accepts new setting, or	
	PICKUP ADJUSTED		shows that related pickup setting will adjust to hold 2% minimum difference, or
	RANGE ERROR		
	E- -OF PKU % 000	Shows pickup setting as % of emergency-source <i>rated</i> frequency. Press digit keys for a new setting (if option 34-J is enabled).	
	ENTRY ACCEPTED	Shows that control accepts new setting, or	
	PICKUP ADJUSTED		shows that related pickup setting will adjust to hold 2% minimum difference, or
	RANGE ERROR		
	E- -UF PKU % 00	Shows pickup setting as % of emergency-source <i>rated</i> frequency. Press digit keys for a new setting.	
	ENTRY ACCEPTED	Shows that control accepts new setting, or	
	PICKUP ADJUSTED		shows that related pickup setting will adjust to hold 2% minimum difference, or
	RANGE ERROR		
	E- -UF DRO% 00	Shows dropout setting as % of emergency-source <i>rated</i> frequency. Press digit keys for a new setting.	
	ENTRY ACCEPTED	Shows that control accepts new setting, or	
	PICKUP ADJUSTED		shows that related pickup setting will adjust to hold 2% minimum difference, or
	RANGE ERROR		
	ENTER NO. 1--13		
	STORE SETPOINTS		

Do this after making any switch settings. The display shows that setpoints are stored in semi-permanent memory.

Local Mode—continued

Key Entry

Display

Description

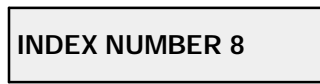

Plant Exerciser Settings— Index 8



Plant exerciser must be enabled in order for settings to be made. Check Index 11, Control Options. Note that system will be set to exercise when events are enabled.



YES or NO shows choice of exercise schedule type. Press the YES key to change the schedule type (other choices will change to NO).

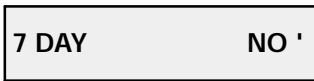
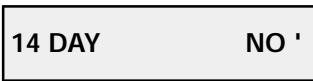

Shows **calendar mode** has been selected.

The **calendar mode** allows up to 5 events, with 1, or 2, exercise occurrences each. The calendar date for each occurrence is automatically set according to the date setting entered in Index 4. This is a “true calendar,” that “knows” the occurrences of days in any month. Relationships of calendar days and dates to occurrence days are illustrated below. Occurrence numbers for days in a typical month are shown in shaded columns. If a day occurrence number of 5 is entered, the exercise run may not occur every month. So, avoid using days with an occurrence number of 5, if at all possible.

SUN	MON	TUE	WED	THU	FRI	SAT
↓	↓	↓	↓	↓	↓	↓
		1	2	3	4	5
		1	1	1	1	1
6	7	8	9	10	11	12
1	1	2	2	2	2	2
13	14	15	16	17	18	19
2	2	3	3	3	3	3
20	21	22	23	24	25	26
3	3	4	4	4	4	4
27	28	29	30	31		
4	4	5	5	5		

Local/programming Mode

Calendar Mode Setup

EXERCISE EVENT	START TIME	DAY OF WEEK	Exercise Run		RUN TIME HR:MN	LOAD TRANSFER
			#1	#2		
#1 ENABLED E	07:30 AM 07:30 AM	SAT SAT	2 2	4 4	00:45 00:45	NO
#2 DISABLED D	09:00 AM 09:00 AM	TUE TUE	1 1	1 1	00:00 00:00	NO
#3 DISABLED D	09:00 AM 09:00 AM	TUE TUE	1 1	1 1	00:00 00:00	NO
#4 DISABLED D	09:00 AM 09:00 AM	TUE TUE	1 1	1 1	00:00 00:00	NO
#5 DISABLED D	09:00 AM 09:00 AM	TUE TUE	1 1	1 1	00:00 00:00	NO

In the example above, exercise event #1 is enabled. Exercise runs will start at 7:30 AM. The first exercise run will occur on the second SATurday of the month; the second exercise run will occur on the fourth SATurday. The generator set(s) will run for 45 minutes. Load will not be transferred during the exercise runs.

Key

Entry

Display

Description



ENTRY ACCEPTED

Shows that control accepts entry.

NOTE: Changing exercise mode will reset all to defaults; previous settings will be lost!

If selecting calendar YES, you may schedule up to 5 "events", on up to 7 different days, 2 exercises for each of 5 weeks.



#1 ENABLED ? NO '

Shows "event" #1 disabled.



ENTRY ACCEPTED



#1 ENABLED ? YES '

Shows "event" #1 enabled.



STRT TM 0:00 AM

Shows time of day for exercise start. Press digit and AM/PM keys for a new setting. Default start time is 9:00 AM.



ENTRY ACCEPTED

Shows that control accepts entry.



DAY OF WEEK TUE'













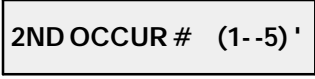

Shows day of week for event. Press day key for a new setting. Default is TUE.

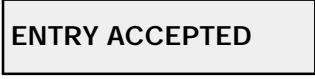

ENTRY ACCEPTED

Shows that control accepts entry.

Local Mode—continued

Key Entry	Display	Description
		Shows occurrence number of day (1- -5) for exercise #1 of event. Press digit key (1- -5) for a new setting. If a day occurrence number of 5 is entered, the exercise run may not occur every month. So, avoid using days with an occurrence number of 5, if at all possible.
		Shows that control accepts entry.
		Shows occurrence number of day (1- -5) for exercise #2 of event. Press digit key (1- -5) for a new setting. If a day occurrence number of 5 is entered, the exercise run may not occur every month. So, avoid using days with an occurrence number of 5, if at all possible.
		Shows that control accepts entry.
		Shows length of time for exercise period, in hours and minutes. Press digit keys for a new setting.
		Shows that control accepts entry.
		YES shows that load will be transferred to the emergency source during the exercise run. NO would show that load will not transfer during the exercise run. This cannot be changed using the keypad.
		Steps may be followed to set the desired number of exercise runs for events #2 through #5, same as for event #1 described above.

Note: To stop the exercise timer during an exercise run, press **EXER STOP** key. Pressing the EXER STOP key will zero out the remaining exercise time. The generator set will continue to run through its timed cool-down cycle.

Local/programming Mode

Key Entry

Display

Description

7 YES	14 DAY ?	YES '	MENU →	7 DAY	NO '	MENU →	CALENDAR	NO '
-----------------	----------	-------	-----------	-------	------	-----------	----------	------

Shows **14-day exercise schedule** has been selected. If selecting 14-day, you may schedule up to 5 events, up to 5 events, with 1, or 2, exercise runs each, in a 14-day (Sunday-to-Saturday) period. Each exercise run may be scheduled for a particular day of week 1 or week 2 in the 14-day period. The current week will show in Index 4, if the 14-day mode has been selected.



ENTRY ACCEPTED

Shows that control accepts entry.

NOTE: Changing exercise mode will reset all to defaults; previous settings will be lost!

The following table shows the relationship among exercise events, start times, selected days for each exercise run, week of the 14-day period, the time that the generator set (emergency source) is to run and whether, or not, transfer switch is to transfer load to the emergency source.

14 Day Mode Setup							
EXERCISE EVENT	START TIME	DAY #1	OF WEEK #2	WEEK 1 OR 2	RUN TIME HR:MN	LOAD TRANSFER	
#1 ENABLED	07:30 AM	WED	SAT	2	00:45	NO	
E	07:30 AM	WED	SAT	2	00:45		
#2 DISABLED	09:00 AM	TUE	TUE	1	00:00	NO	
D	09:00 AM	TUE	TUE	1	00:00		
#3 DISABLED	09:00 AM	TUE	TUE	1	00:00	NO	
D	09:00 AM	TUE	TUE	1	00:00		
#4 DISABLED	09:00 AM	TUE	TUE	1	00:00	NO	
D	09:00 AM	TUE	TUE	1	00:00		
#5 DISABLED	09:00 AM	TUE	TUE	1	00:00	NO	
D	09:00 AM	TUE	TUE	1	00:00		

In the example above, exercise event #1 is enabled. Exercise runs will start at 7:30 AM. The first exercise run will occur on WEDnesday of week 2; the second exercise run will occur on SATurday of week 2. The generator set(s) will run for 45 minutes. Load will not be transferred during the exercise runs.



#1 ENABLED ? NO'

Shows event #1 not enabled.



ENTRY ACCEPTED

Shows that control accepts entry.

#1 ENABLED ? YES '

Shows event #1 enabled.



STRT TM 0:00 AM









Shows time of day for exercise start. Press digit and AM/PM keys for a new setting. Default is 9:00 AM.



ENTRY ACCEPTED

Shows that control accepts entry.

Local Mode—continued

Key Entry	Display	Description
	1ST DAY TUE '	Shows day of week for exercise #1 of event. Press a day key for a new setting. Default is TUE.
	2ND DAY TUE '	Shows day of week for exercise #2 of event. Press a day key for a new setting. Default is TUE.
	ENTRY ACCEPTED	Shows that control accepts entry.
	WEEK 1 OR 2 1 '	Shows week of the two-week period for event 1 to be scheduled. Press digit key 1 or 2 for a new setting.
	ENTRY ACCEPTED	Shows that control accepts entry.
	RUN HR:MN 0:00 '	Shows length of time for exercise period, in hours and minutes. Press digit keys for a new setting.
	ENTRY ACCEPTED	Shows that control accepts entry.
	LD TRANS YES '	YES shows that load will be transferred to the emergency source during the exercise run. NO would show that load will not transfer during the exercise run.
	#2 ENABLED '	Steps may be followed to set the desired number of exercise runs for events #2 through #5, same as for event #1 described above.

Note: To stop the exercise timer during an exercise run, press **EXER STOP** key. Pressing the EXER STOP key will zero out the remaining exercise time. The generator set will continue to run through its timed cool-down cycle.

Local/programming Mode

Key Entry Display Description

7 YES	7 DAY ? YES '	MENU →	14 DAY NO '	MENU →	CALENDAR NO '
-----------------	------------------------------------	------------------	----------------------------------	------------------	------------------------------------

Shows that **7-day exercise schedule** has been selected. If selecting 7-day, you may schedule up to 5 "events" on up to 7 days, with up to 2 exercise runs per event, in a Sunday-Saturday period.

ENTER ↵	ENTRY ACCEPTED
-------------------	----------------

Shows that control accepts entry.

NOTE: Changing exercise mode will reset all to defaults; previous settings will be lost!

The following table shows the relationship among exercise events, start times, selected days for each exercise run, the time that the generator set (emergency source) is to run and whether, or not, transfer switch is to transfer load to the emergency source.

7 Day Mode Setup						
EXERCISE EVENT	START TIME	DAY 1ST	OF WEEK 2ND	RUN TIME HR:MN	LOAD TRANSFER	
#1 ENABLED E	07:30 AM 07:30 AM	WED	SAT	00:45 00:45	NO	
#2 DISABLED D	09:00 AM 09:00 AM	TUE	TUE	00:00 00:00	NO	
#3 DISABLED D	09:00 AM 09:00 AM	TUE	TUE	00:00 00:00	NO	
#4 DISABLED D	09:00 AM 09:00 AM	TUE	TUE	00:00 00:00	NO	
#5 DISABLED D	09:00 AM 09:00 AM	TUE	TUE	00:00 00:00	NO	

In the example above, exercise event #1 is enabled. Exercise runs will start at 7:30 AM. The first exercise run will occur on WEDnesday. The second exercise run will occur on SATurday. The generator set(s) will run for 45 minutes. Load will not be transferred during the exercise runs.

Note

The 7-day exercise schedule may also be used as a daily peak-shaving schedule.

Key Entry Display Description

MENU ↓	#1 ENABLED ? NO '
------------------	-------------------

Shows event #1 not enabled.

7 YES	ENTER ↵	ENTRY ACCEPTED
-----------------	-------------------	----------------

Shows that control accepts entry.

MENU →	STRT TM 0:00 AM '
------------------	--

Shows time of day for exercise start. Press digit keys and AM or PM key for a new setting. Default is 9:00 AM.

ENTER ↵	ENTRY ACCEPTED
-------------------	----------------

Shows that control accepts entry.

Local Mode—continued

Key Entry	Display	Description
MENU →	1ST DAY TUE'	Shows day of week for exercise #1 of event. Press a day key for a new day. Default is TUE.
ENTER ↵	ENTRY ACCEPTED	Shows that control accepts entry.
MENU →	2ND DAY TUE'	Shows day of week for exercise #2 of event. Press a day key for a new day. Default is TUE.
ENTER ↵	ENTRY ACCEPTED	Shows that control accepts entry.
MENU →	RUN HR:MN 0:00'	Shows length of time for exercise period, in hours and minutes. Press digit keys for a new setting.
ENTER ↵	ENTRY ACCEPTED	Shows that control accepts entry.
MENU →	LD TRANS YES'	YES shows that load will be transferred to the emergency source during the exercise run. NO would show that load will not transfer during the exercise run.
MENU ↓	#2 ENABLED NO'	Steps may be followed to set the desired number of exercise runs for events #2 through #5, same as for event #1 described above.

Note: To stop the generator set during an exercise run, press **EXER STOP** key. Pressing the EXER STOP key will zero out the remaining exercise time. The generator set will continue to run through its timed cool-down cycle.

Local/programming Mode

Key Entry

Display

Description



ENGINE START ? NO '

The following (generator set) engine start sequence may be used with any plant exerciser mode, or with the plant exerciser option disabled.

This sub-menu allows you to start the generator set, to have it run for a set period of time. This could be used to make sure that the emergency source is running and available for an anticipated outage, or to manually start the engine for an interruptible rate situation. You must enter all settings before the generator set can run.

Note: All choices for the engine-start submenu will reset to NO/00:00 after the Engine-Start sequence you have set up has completed timing.



RUN HR:MN :00 '

Shows length of engine-run time. Use digit keys to enter a setting (72 hours maximum).



ENTRY ACCEPTED

Shows that control accepts entry.



LD TRANS ? NO '

If you want load to transfer to the emergency source during the engine run, press YES and ENTER.



ENTRY ACCEPTED

Shows that control accepts entry.



BP TDNE ? NO '

If you entered NO as a load-transfer choice, skip this choice. If you entered YES as a load-transfer choice, entering YES here will bypass the normal-to-emergency time delay when load transfers.



ENTRY ACCEPTED

Shows that control accepts entry.



BP TDEN ? NO '

If you entered NO as a load-transfer choice, skip this choice. If you entered YES as a load-transfer choice, entering YES here will bypass the emergency-to-normal time delay when load transfers.



ENTRY ACCEPTED

Shows that control accepts entry.



ENGINE START ? NO '

Entering YES here will start the generator set.



ENTRY ACCEPTED

Shows that engine-start and/or transfer sequence has started.



COUNTDOWN :00

Shows the hours and minutes left of the preset engine run, or exercise time.



ENTER NO. 1--13

Local/programming Mode

Key Entry	Display
1 FRI	INDEX NUMBER 12
2 SAT	
MENU ↓	CALIBRATION

Description

Voltage Sensing Calibration— Index 12

Sub-menu for setting base levels for source phase voltages, and/or gain (single-phase only). For meters, source voltages should be read with an accurate voltmeter when calibrating voltage levels.

Note

Meter calibration is factory set. Meter calibration should only be necessary if system voltage changes, or if control has been replaced. Start the generator set(s)/emergency source, and adjust voltage and frequency as necessary to ensure that emergency source voltage and frequency will be acceptable. If necessary, go to Index 7 and set the control for 1-phase or 3-phase sensing, as required.

MENU ↓	
MENU ↓	
MENU ↓	E- -AUTO- -ZERO ?

Choice is to zero out emergency source voltmeter. If it's necessary to calibrate the emergency source voltmeter, make sure that the emergency source is de-energized or disconnected (open the emergency source circuit breaker). Press YES.

ENTER ↩	ENTRY ACCEPTED
------------	----------------

Shows that control accepts entry.

MENU ↓	E- -VOLT VAC 0
-----------	----------------

Shows emergency-source voltage (for single-phase, A-C) at zero, or

MENU ↓	E- -PH A- -B VAC 0
-----------	--------------------

or

MENU ↓	E- -PH B- -C VAC 0
-----------	--------------------

or, for 3-phase.













MENU ↓	E- -PH A- -C VAC 0
-----------	--------------------

MENU ↓	E- -VOLT VAC 0
-----------	----------------

Connect a 1%-accurate, or better, voltmeter to transfer switch emergency (for single phase, A-C) lugs A&C (single phase), or lugs shown by menu choice for 3-phase. Start the generator set and/or close the emergency-source circuit breaker. Press digit keys to enter voltage read on the voltmeter for each phase.

	E- -PH A- -B VAC 0
--	--------------------

Local Mode—continued

Key Entry	Display	Description
	E--PH B--C VAC 0	Shows that control accepts entry. If calibrating a single-phase switch, calibration is complete. Go to "N- -AUTO- -ZERO", following. If calibrating a 3-phase switch, press the menu-down key and repeat calibration steps for all 3 phases.
	E--PH A--C VAC 0	
	ENTRY ACCEPTED	
	N--AUTO--ZERO ?	Choice is to zero out the normal source voltmeter. If it's necessary to calibrate the normal source voltmeter, open the normal-source circuit breaker. Put the transfer switch in the emergency position.
		
		
	ENTRY ACCEPTED	Shows that control accepts entry.
	N--VOLT VAC 0 (for single-phase A- -C)	Shows normal-source voltage at zero. Connect an accurate voltmeter to transfer switch normal lugs A & C (single-phase), or lugs shown by menu choice for 3-phase. Close the normal-source circuit breaker.
	N--PH A--B VAC 0	Press digit keys to enter voltage read on voltmeter, for each phase.
	N--PH B--C VAC 0	
	N--PH A--C VAC 0	
	ENTRY ACCEPTED	Shows that control accepts entry. Display should show same voltages as voltmeter.
	ENTER INDEX 1--13	<i>Do this after making any switch settings. The display shows that setpoints are stored in semi-permanent memory.</i>
	STORE SET POINTS	

Local/programming Mode

Key Entry	Display
1 FRI	INDEX NUMBER 13
3 SUN	
MENU ↓	REMOTE CONTROL
MENU ↓	ON--LINE ? YES
MENU ↓	LOCAL ? NO
MENU ↓	LAN ? NO'
MENU →	ADDRESS 1
ENTER ↵	ENTRY ACCEPTED
MENU ↓	REMOTE ? NO'
MENU →	SYS. ID 0000
MENU ↓	REMLAN ? NO'
MENU →	SYS. ID 0000
ENTER ↵	ENTRY ACCEPTED

Description

RemoteControl & Monitoring Settings— Index 13

Sub-menu for enabling control and monitoring by a computer and M340 Monitor software.

Press NO and ENTER if remote access is to be denied. Otherwise, go to the next step. This does not change other settings.

Press YES and ENTER if computer is cabled directly to COM port (see Main Menu, Program Configuration, in M340 monitor software manual).

Press YES and ENTER if computer is connected to control through an ATS **Local Area Network**.

Press digit keys to enter LAN address number for the transfer switch (1-128). Use one address number per transfer switch, and keep numbers consecutive. This is necessary for the software to call up the desired transfer switch.

Shows that control accepts entry.

Press YES and ENTER if computer is connected to control through a **Remote Single Connection** (modem-to-modem).











Press up to 6 digit keys and ENTER to create a password for the particular transfer switch. Press YES and ENTER.

Press YES and ENTER if computer is connected through a **Remote Local Area Network**.

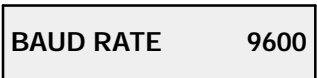
Press up to 6 digit keys to create a password for the particular transfer switch network. Press YES and ENTER to enter the password.

Shows that control accepts entry.

Local Mode— continued

Key Entry	Display	Description
		Press digit keys to enter LAN address number for the transfer switch (1-128). Use one address number per transfer switch, and keep numbers consecutive. This is necessary for the software to call up the desired transfer switch.
		Shows that control accepts entry.
		Press digit keys to enter the baud rate for the modem(s) used to connect the remote computer(s) to the transfer switch. This setting <i>Must</i> match the baud rate of modems used, and M340 Monitor software program configuration. 9600 is the default setting. Choices are 2400, 4800, 9600.
		Shows that control accepts entry.
		
		<i>Do this after making any switch settings. The display shows that setpoints are stored in semi-permanent memory.</i>

This completes the Local/Keypad programming and set-up procedure.

Microprocessor-Controlled Transfer Logic

Here is a set of explanations for various logic sequences programmed in the M 340 transfer switch control. Listed are possible conditions that provide input, followed by resulting outputs. See the flow chart at the end of this section.

j = input condition

J = resulting output

j With the contactor in the normal position,

j all timers stopped,

j the normal source fails.

J The engine-start time delay will begin timing.

j With the contactor in the normal position,

j all other timers stopped,

j the normal-source fails and then returns.

J The engine-start time delay will reset.

j With the contactor in the normal position,

j all other timers stopped,

j the normal-source fails,

j the engine-start time delay completes timing.

J The engine-start relay will de-energize, signaling the generator set to start.

j With the contactor in the normal position,

j all other timers stopped,

j the normal source fails,

j the engine-start time delay completes timing,

j the normal source returns before the engine starts.

J The timed engine cool-down cycle will start.

j With the contactor in the normal position,

j all other timers stopped,

j the normal source fails,

j the engine-start time delay completes timing,

j the emergency source becomes available.

J The normal-to-emergency time delay will start timing.

j With the contactor in the normal position,

j all other timers stopped,

j the normal source fails,

j the engine-start time delay completes timing,

j the emergency source becomes available and the normal source returns.

J The normal-to-emergency time delay will reset,

J The timed engine cool-down cycle will start.

Microprocessor-Controlled Transfer Logic- - continued

- j **With the contactor in the normal position and all other timers stopped,**
- j **the normal source fails,**
- j **the engine-start time delay completes timing,**
- j **the emergency source fails before the normal-to-emergency time delay completes timing.**
- J The normal-to-emergency time delay will reset.

- j **With the contactor in the normal position,**
- j **all other timers stopped,**
- j **the normal source fails,**
- j **the engine-start time delay completes timing,**
- j **the emergency source becomes available,**
- j **the normal-to-emergency time delay completes timing.**
- J The contactor will transfer to the emergency position.

- j **With the contactor in the normal position,**
- j **all other timers stopped,**
- j **the normal source fails,**
- j **the engine-start time delay completes timing,**
- j **the emergency source becomes available,**
- j **the normal-to-emergency time delay completes timing,**
- j **the normal source returns before transfer because load shedding prevents transfer.**
- J The timed engine cool-down cycle will start.

- j **With the contactor in the normal position,**
- j **all other timers stopped,**
- j **the normal source fails,**
- j **the engine-start time delay completes timing,**
- j **the emergency source becomes available,**
- j **the normal-to-emergency time delay completes timing.**
- J The contactor will transfer to the emergency position,
- J The emergency relay will de-energize.

- j **With the contactor in the emergency position,**
- j **the emergency source available,**
- j **the normal source returns.**
- J The emergency-to-normal time delay will start timing.

- j **If the normal source fails before the emergency-to-normal time delay completes timing**
- J The emergency-to-normal time delay will reset.

- J The engine start End light will go out.

- J The normal-to-emergency End light will go out.

- j **With the contactor in the emergency position,**
- j **the emergency source available,**
- j **the normal source returns,**
- j **the emergency-to-normal time delay is timing,**
- j **the emergency source fails.**
- J The contactor will transfer to the normal position.

- j **With the contactor in the emergency position,**
- j **the emergency source available,**
- j **the normal source returns,**
- j **the emergency-to-normal time delay completes timing.**
- J The contactor will transfer to the normal position.

- j **With the emergency source available,**
- j **the emergency-to-normal time delay completes timing,**
- j **the contactor transfers to the normal position.**
- J The normal relay will de-energize,
- J The engine-cooldown time delay will start timing.

- j **With the normal source available,**
- j **the contactor in the normal position,**
- j **the engine-cooldown time delay is timing,**
- j **the normal source fails.**
- J The normal-to-emergency time delay will start timing.

- j **With the normal source available,**
- j **the contactor in the normal position**
- J The engine-start relay will energize after the engine-cooldown time delay completes timing, signaling the generator set to shut down.

Microprocessor-Controlled Transfer Logic-- continued

Microprocessor-Controlled Transfer Logic

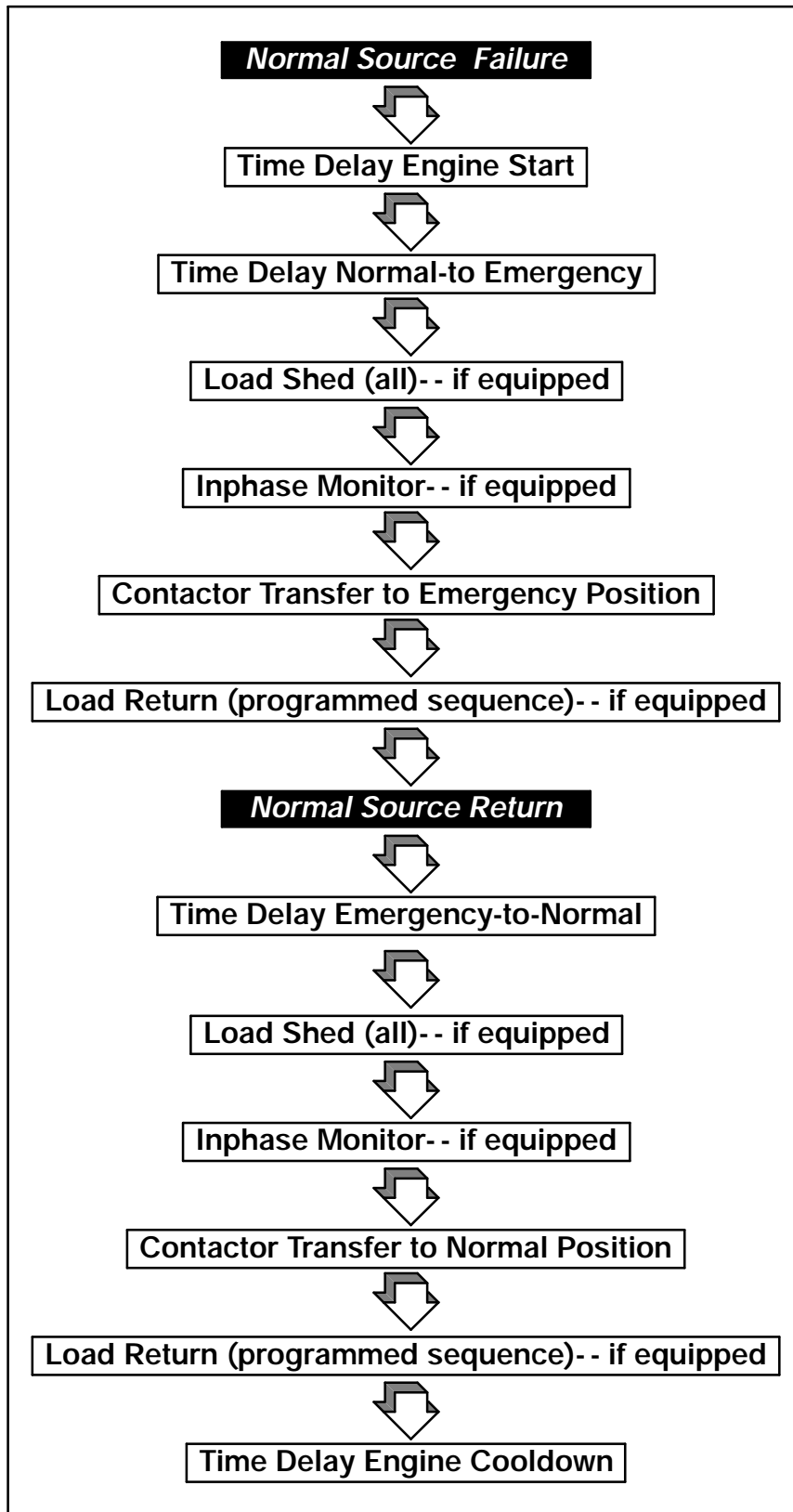

Menu Dynamics

LCD displays that you see are part of a dynamic menu program. Three factors effect some of the index menus you will see in the LCD display. They are:

D Programming Mode

Remote-Off-Local

D Control Options installed

Shown in Index 11

D Index Choices

When in the Local mode.

The following logic sequence display "maps" show contents of various indexes that are effected by factors described above.

Index 1— Normal Voltage & Frequency Meters

Single-phase sensing selected under Index 6.

"Phase sequence, if enabled under Index 11, will have no effect on control operation.

NORM VOLT & FREQ	
NORM VOLTAGE 000	MENU → IN- -PHASE VAC 000
N- -FREQ HZ 00.0	

Three-phase sensing selected under Index 6, and "Phase sequence," under Index 11 not enabled.

NORM VOLT & FREQ	
N- -PH A- -B VAC 000	
N- -PH B- -C VAC 000	
N- -PH A- -C VAC 000	MENU → IN- -PHASE VAC 000
N- -FREQ HZ 00.0	

Three-phase sensing selected under Index 6, and "Phase sequence," (option 34-Z) under Index 11 enabled.

NORM VOLT & FREQ	
N- -PH A- -B VAC 000	
N- -PH B- -C VAC 000	
N- -PH A- -C VAC 000	MENU → IN- -PHASE VAC 000
N- -FREQ HZ 00.0	
N- -PHA SEQ A- -B- -C	

All voltage readings are based on calibrations under Index 12. Voltage and frequency readings are from the system bus. They are compared to entries made in Index 6 to determine normal-source availability.

Phase Sequence is independent of other indexes. A phase sequence loss will be indicated by "B-A-C" and will cause the normal source to be unavailable.

Index 2— Emergency Voltage & Frequency Meters

Single-phase sensing selected under Index 7.

“Phase sequence,” if enabled under Index 11, will have no effect on control operation.

EMER VOLT & FREQ

EMER VOLTAGE 000

E--FREQ HZ 00.0

Three-phase sensing selected under Index 7, and “Phase sequence,” under Index 11 not enabled.

EMER VOLT & FREQ

E--PH A--B VAC 000

E--PH B--C VAC 000

E--PH A--C VAC 000

E--FREQ HZ 00.0

Three-phase sensing selected under Index 7, and “Phase sequence,” (option 34-Z) under Index 11 enabled.

EMER VOLT & FREQ

E--PH A--B VAC 000

E--PH B--C VAC 000

E--PH A--C VAC 000

E--FREQ HZ 00.0

E--PHA SEQ A--B--C

All voltage readings are based on calibrations under Index 12. Voltage and frequency readings are from the system bus. They are compared to entries made in Index 7 to determine emergency-source availability.

Phase Sequencer is independent of other indexes. A phase sequence loss will be indicated by “B-A-C” and will cause the normal source to be unavailable.

Index 3—Operational Records

Reset allowed in the Local programming mode, last exercise will show only with Plant Exerciser enabled (option 23-C, D, G).

RECORDS -- TOTAL		Since factory setup
NOT NRM HRS 0000		Total hours with normal source unacceptable
EMER HRS 0000		Total hours in emergency position, including exercise periods with load transfer
OPER DAYS 0000		Total days that control has been energized, since factory setup
TRANSFER # 0000		Total number of transfers, in either direction
RECORDS -- RESET ' 	MENU →	RESET RECORD ? entry made in local programming mode.
RESET 00--00--00		Date of last record reset
NOT NRM HRS 0000		Hours with normal source unacceptable since last record reset
EMER HRS 0000		Hours in emergency position since last record reset, including exercise periods with load transfer.
OPER DAYS 000		Days of operation since last record reset
TRANSFER # 0000		Number of transfers since last record reset
LAST EXERCISE ' 	MENU →	DATE 00--00--00 will show only if Plant Exerciser is enabled.

Index 4— Clock & Calendar

Screens in this index can take entries in the Local programming mode.

TIME	00:00 AM/PM	Setting made in Local programming mode.
DATE	00- -00- -00	Setting made in Local programming mode.
DAY	TUE	Sets automatically, according to Date entered.
DAY OCCURS #	1	Sets automatically, according to Date entered.
14- -DAY TMR	WK 1	Will show only if Plant Exerciser is enabled and 14-day exerciser mode is selected.

Index 5— Time Delays

Time Delays are adjustable in the Local programming mode. See Appendix IV for default settings and allowable ranges.

TIME DELAY	MN:SE	
TDES	00:00	Engine Start Time Delay
TDNE	00:00	Normal-to Emergency transfer Time Delay
TDEN	00:00	Emergency-to Normal transfer Time Delay
TDEC	00:00	Engine Cool Down time
TD EXTENDED	YES	If this screen shows in Index 11, maximum time setting is 99 minutes.

Index 6— Normal Voltage & Frequency Set Points

Normal-source pickup (PKU) and dropout (DRO) settings with normal & emergency over and under voltage/frequency sensing *not enabled* (Index 11).

NORMAL SYSTEM		
NORM VOLTS	000	Setting made in Local programming mode.
NORM HERTZ	00.0	
N- -3 PH. SENSE?		Choice made in Local programming mode.
	OR	
		N- -ONE PH. SENSE?
N- -UV PKU %	00'	MENU → N- -UV PKU V 000'
N- -UV DRO %	00'	MENU → N- -UV DRO V 000'

LCD Display Maps

Normal-source pickup (PKU) and dropout (DRO) settings with normal & emergency over and under voltage/frequency sensing (option 34-J) *enabled* (Index 11).

NORMAL SYSTEM

NORM VOLTS 000

Setting made in Local programming mode.

NORM HERTZ 00.0

Setting made in Local programming mode.

N- -3 PH. SENSE?

OR

N- -ONE PH. SENSE?

Selected in Local or Remote mode.

N- -OV DRO % 000'

MENU
→

N- -OV DRO V 000'

Setting made in Local programming mode.

N- -OV PKU % 000'

MENU
→

N- -OV PKU V 000'

Setting made in Local programming mode.

N- -UV PKU % 00'

MENU
→

N- -UV PKU V 000'

Setting made in Local programming mode.

N- -UV DRO % 00'

MENU
→

N- -UV DRO V 000'

Setting made in Local programming mode.

N- -OF DRO % 00'

MENU
→

N- -OF DRO HZ 00.0'

Setting made in Local programming mode.

N- -OF PKU % 00'

MENU
→

N- -OF PKU HZ 00.0'

Setting made in Local programming mode.

N- -UF DRO % 00'

MENU
→

N- -UF DRO HZ 00.0'

Setting made in Local programming mode.

Selecting three-phase or single-phase effects the displays that you will see in Index 1 and Index 12 Calibration.

Dropout (DRO) settings must be at least 2 % different than pickup (PKU) settings. Dropout settings will have priority over pickup settings. That is, if a dropout setting is entered that is within 2% of a pickup setting, the pickup setting will be automatically adjusted to 2% difference from the dropout setting.

The normal source will be considered available when bus voltage and frequency are within the pickup settings for at least a half second, and phases are in proper sequence (if phase sequence protection is enabled).

The normal source will be considered unavailable when bus voltage and frequency are outside of the dropout settings for at least a half second.

Index 7— Emergency Voltage & Frequency Settings & Trip Points

Emergency-source pickup (PKU) and dropout (DRO) settings with normal & emergency over and under voltage/frequency sensing *not enabled* (Index 11).

EMERGENCY SYSTEM			
EMER VOLTS	000		Setting made in Local programming mode.
EMER HERTZ	00.0		Setting made in Local programming mode.
E--3 PH. SENSE?		OR	E--ONE PH. SENSE?
			Selected in Local programming mode.
E--UV PKU %	00'	MENU →	E--UV PKU V 000'
			Setting made in Local programming mode.
E--UV DRO %	00'	MENU →	E--UV DRO V 000'
			Setting made in Local programming mode.
E--UF PKU %	00'	MENU →	E--UF PKU HZ 00.0'
			Setting made in Local programming mode.
E--UF DRO %	00'	MENU →	E--UF DRO HZ 00.0'
			Setting made in Local programming mode.

LCD Display Maps

Normal-source pickup (PKU) and dropout (DRO) settings with normal & emergency over and under voltage/frequency sensing (option 34-J) *enabled* (Index 11).

EMERGENCY SYSTEM			
EMER VOLTS	000		Setting made in Local programming mode.
EMER HERTZ	00.0		Setting made in Local programming mode.
E- -3 PH. SENSE?		OR	E- -ONE PH. SENSE?
			Selected in Local programming mode.
N- -3 PH. SENSE?		OR	N- -ONE PH. SENSE?
			Selected in Local programming mode.
E- -OV DRO %	000'	MENU →	E- -OV DRO V 000'
			Setting made in Local programming mode.
E- -OV PKU %	000'	MENU →	E- -OV PKU V 000'
			Setting made in Local programming mode.
E- -UV PKU %	00'	MENU →	E- -UV PKU V 000'
			Setting made in Local programming mode.
E- -UV DRO %	00'	MENU →	E- -UV DRO V 000'
			Setting made in Local programming mode.
E- -OF DRO %	00'	MENU →	E- -OF DRO HZ 00.0'
			Setting made in Local programming mode.
E- -OF PKU %	00'	MENU →	E- -OF PKU HZ 00.0'
			Setting made in Local programming mode.
E- -UF PKU %	00'	MENU →	E- -UF PKU HZ 00.0'
			Setting made in Local programming mode.
E- -UF DRO %	00'	MENU →	E- -UF DRO HZ 00.0'
			Setting made in Local programming mode.

Selecting three-phase or single-phase effects the displays that you will see in Index 2 and Index 12 Calibration. The emergency source will be considered available when bus voltage and frequency are within the pickup settings for at least a half second, and phases are in proper sequence (if phase sequence protection is enabled). The emergency source will be considered unavailable when bus voltage and frequency are outside of the dropout settings for at least a half second.

Index 10— Source History

Index shows failure type and summary of source failures (four most recent).

SOURCE HISTORY			
RECORD #1 ' MENU →	EMER UNDER FREQ MENU →	DATE 00--00--00 ' MENU →	
TIME 00:00 AM(PM) MENU ↓			
OUTAGE #1 00 :00	Hours:Minutes elapsed during most-recent outage		

Index 11— Installed Options

Installed options enabled by a control board programming shunt.

"YES" shows option enabled; "NO," not enabled.

CONTROL OPTIONS		
INPHASE MON YES		Option 34-A
PHA SEQ/LOSS YES		Option 34-Z
NORM & EMER YES		Normal and emergency, over and under, voltage and frequency sensing. Option 34-J
PLANT EXERC YES		Option 23-C, D, G
TD EXTENDED YES		Maximum time delays extended to 99 minutes. Option 100-B
MAN OVERRIDE YES		Option 29, must always be enabled.

Index 12— Voltage Calibration Settings

For single-phase

CALIBRATION

N--AUTO--ZERO ?

Will zero normal voltmeter in Local programming mode.

N--VOLT VAC 000

Enter phase voltage in Local programming mode.

E--AUTO--ZERO ?

Will zero emergency voltmeter in Local programming mode.

E--VOLT VAC 000

Enter phase voltage in Local programming mode.

For three-phase

CALIBRATION

N--AUTO--ZERO ?

Will zero normal voltmeter in Local programming mode.

N--PH A--B VAC 000

Enter phase voltage in Local programming mode.

N--PH B--C VAC 000

Enter phase voltage in Local programming mode.

N--PH A--C VAC 000

Enter phase voltage in Local programming mode.

E--AUTO--ZERO ?

Will zero emergency voltmeter in Local programming mode.

E--PH A--B VAC 000

Enter phase voltage in Local programming mode.

E--PH B--C VAC 000

Enter phase voltage in Local programming mode.

E--PH A--C VAC 000

Enter phase voltage in Local programming mode.

Notes

Appendix I, General Message Codes

The following messages may appear on the LCD display, in response to various key entries. The message will flash for three seconds.

RANGE ERROR shows that attempted entry is outside of allowable numeric range.

ENTRY ACCEPTED shows that the control accepts the entry.

CHECK KEY SWITCH shows that a setting or set-up entry has been attempted with the programming mode switch in the OFF or REMOTE position.

SET TIME & DATE will show that time and day (Index Number 4) need to be set.

PICKUP ADJUSTED shows that a setting has been entered and the related pick-up or drop-out setting has been automatically adjusted to maintain the required 2% difference between related settings.

DISABLED shows that the particular option is not enabled by a main circuit board jumper.

STORE SET-POINTS shows that control settings are stored in EEPROM. Pressing RESET MENU and ENTER after entering settings will store set-points.

Appendix II, Source History Message Summary

Three Phase

N- -OVVOLT PH A- -B
N- -OVVOLT PH B- -C
N- -OVVOLT PH A- -C
N- -UNVOLT PH A- -B
N- -UNVOLT PH B- -C
N- -UNVOLT PH A- -C
N- -OVER FREQ
N- -UNDER FREQ
N- -PHASE LOSS
E- -OVVOLT PH A- -B
E- -OVVOLT PH B- -C
E- -OVVOLT PH A- -C
E- -UNVOLT PH A- -B
E- -UNVOLT PH B- -C
E- -UNVOLT PH A- -C
E- -OVER FREQ
E- -UNDER FREQ
E- -PHASE LOSS

Single Phase

NORM OVER VOLT
NORM UNDER VOLT
NORM OVER FREQ
NORM UNDER FREQ
EMER OVER VOLT
EMER UNDER VOLT
EMER OVER FREQ
EMER UNDER FREQ

Appendix III, System Alert Message Summary

AUX- -SWITCH FAULT	shows contactor limit switch fault.
DBL AUX- -SW FAULT	shows contactor limit switch fault.
TRANSFER HANG	shows contactor transfer time too long or failure to transfer.
POWER- -DOWN ERROR	shows internal controller fault.
RAM ERROR	shows internal controller fault.
MEMORY ERROR	shows internal controller fault.
MANUAL TRANSFER	shows controller is ready to accept input from manual transfer pushbuttons (if equipped).
FAULT #1	shows annunciation of fault signal from a remote source, such as an engine condition switch, customer chosen and connected.
FAULT #2	shows annunciation of fault signal from a remote source, such as an engine condition switch, customer chosen and connected.

Appendix IV, Setting Ranges

Time Delays (index 5)	Standard Range	Maximum with Extended Time Delay	Factory Setting
Minutes:Seconds			
Time Delay Engine Start (TDES)	0-6 seconds;	99:00	5 seconds
Time Delay Normal to Emergency (TDNE)	0-5 minutes;	99:00	5 seconds
Time Delay Emergency to Normal (TDEN)	0-30 minutes;	99:00	5 minutes
Time Delay Engine Cooldown (TDEC)	0-30 minutes;	99:00	5 minutes

Normal Voltage/Frequency Settings and Trip Points (index 6)	Standard Range	Factory Setting
Normal Volts	105-600	
Normal Hz	48-62	
Normal Overvoltage Dropout	105-135%	115%
Normal Overvoltage Pickup	100-130%	110%
Normal Undervoltage Pickup	75-100%	90%
Normal Undervoltage Dropout	70-95%	85%
Normal Overfrequency Dropout	105-135%	115%
Normal Overfrequency Pickup	100-130%	110%
Normal Underfrequency Pickup	85-100%	90%
Normal Underfrequency Dropout	80-95%	85%

Emergency Voltage/Frequency Settings and Trip Points (index 7)	Standard Range	Factory Setting
Emergency Volts	105-600	
Emergency Hz	48-62	
Emergency Overvoltage Dropout	105-135%	115%
Emergency Overvoltage Pickup	100-130%	110%
Emergency Undervoltage Pickup	75-100%	90%
Emergency Undervoltage Dropout	70-95%	85%
Emergency Overfrequency Dropout	105-135%	115%
Emergency Overfrequency Pickup	100-130%	110%
Emergency Underfrequency Pickup	85-100%	90%
Emergency Underfrequency Dropout	80-95%	85%

Plant Exerciser (index 8)	Factory Setting
Mode	7-day
Run Hours 0-4:00 Hours:Minutes (Engine Run)	
Run Hours 0-72:00 Hours:Minutes, returns to 00:00 after timeout	

Load Shed (index 9)	Standard Range	Maximum with Extended Time Delay	Factory Setting
Minutes:Seconds			
Before	0-60 seconds;	99:00	00:00
After	0-5 seconds;	99:00	00:00
Sequence	0-5 seconds;	99:00	00:00
Loads Return 1-9			9

Appendix V, Local/Remote/Network Communications Installation

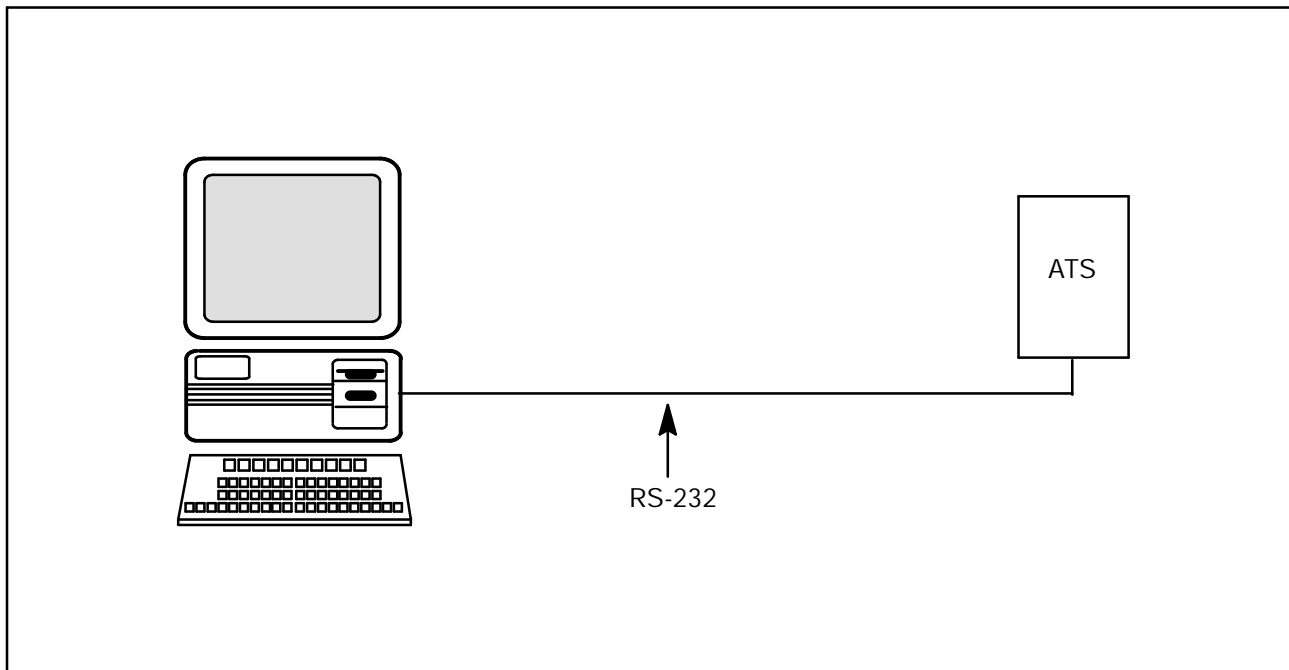

Local Single Connection, up to 50 feet (15.24 metres)

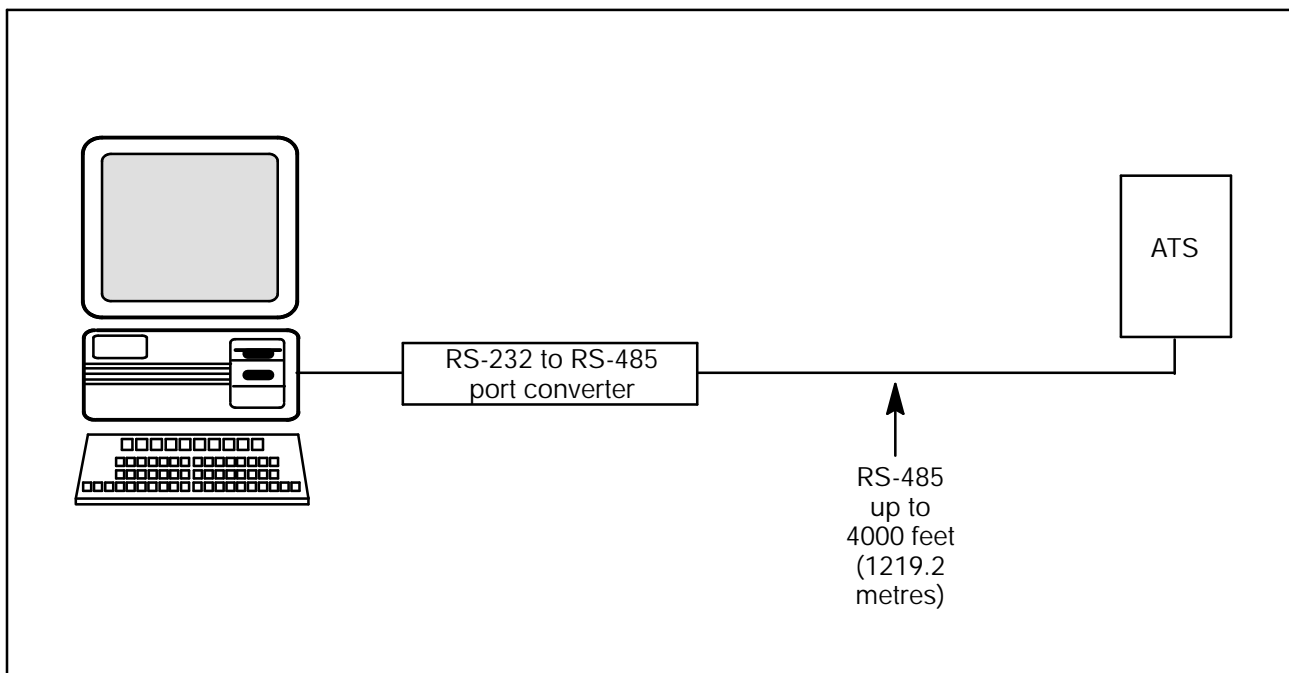

Local Single Connection, up to 4000 feet (15.24 to 1219.2 metres)

Appendix V, continued

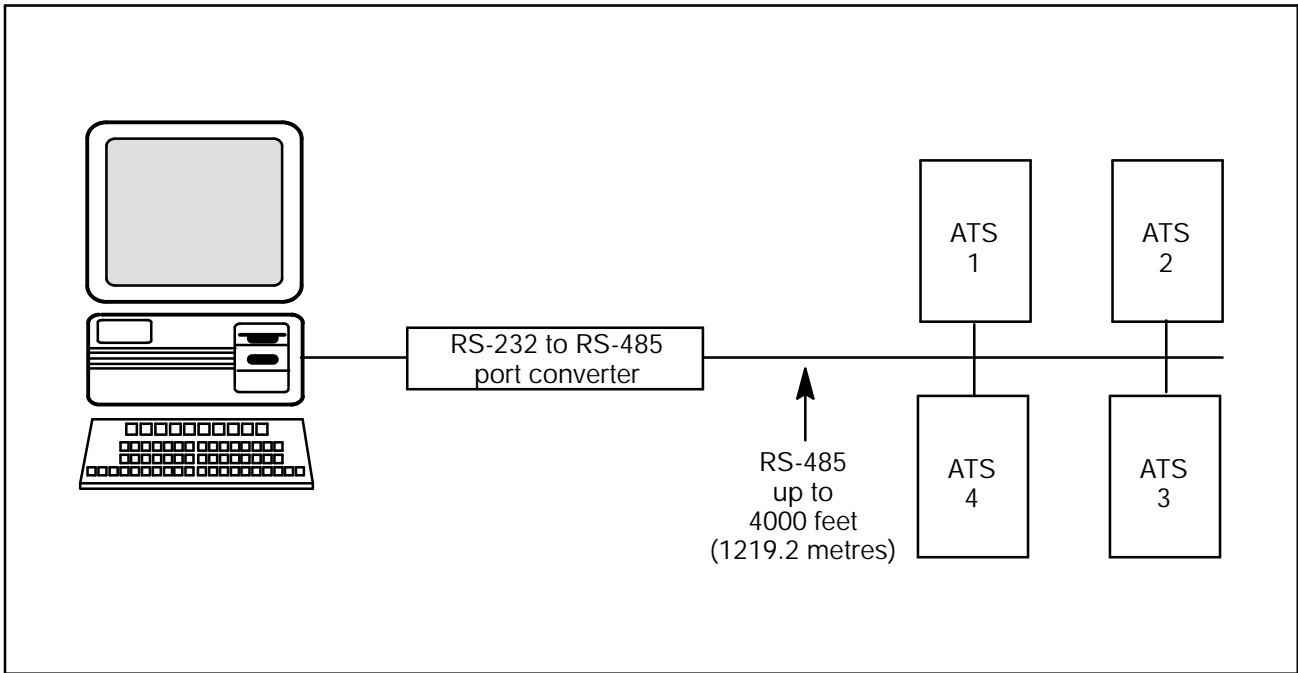

Local Area Network

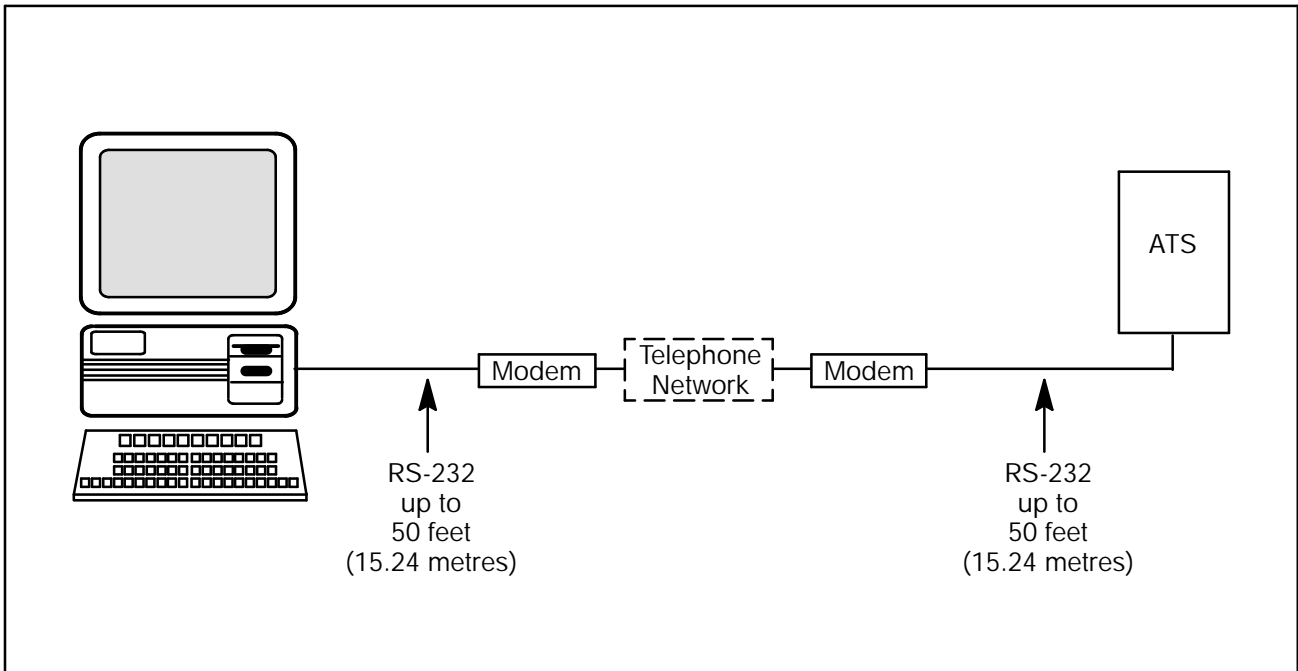

Remote Single Connection

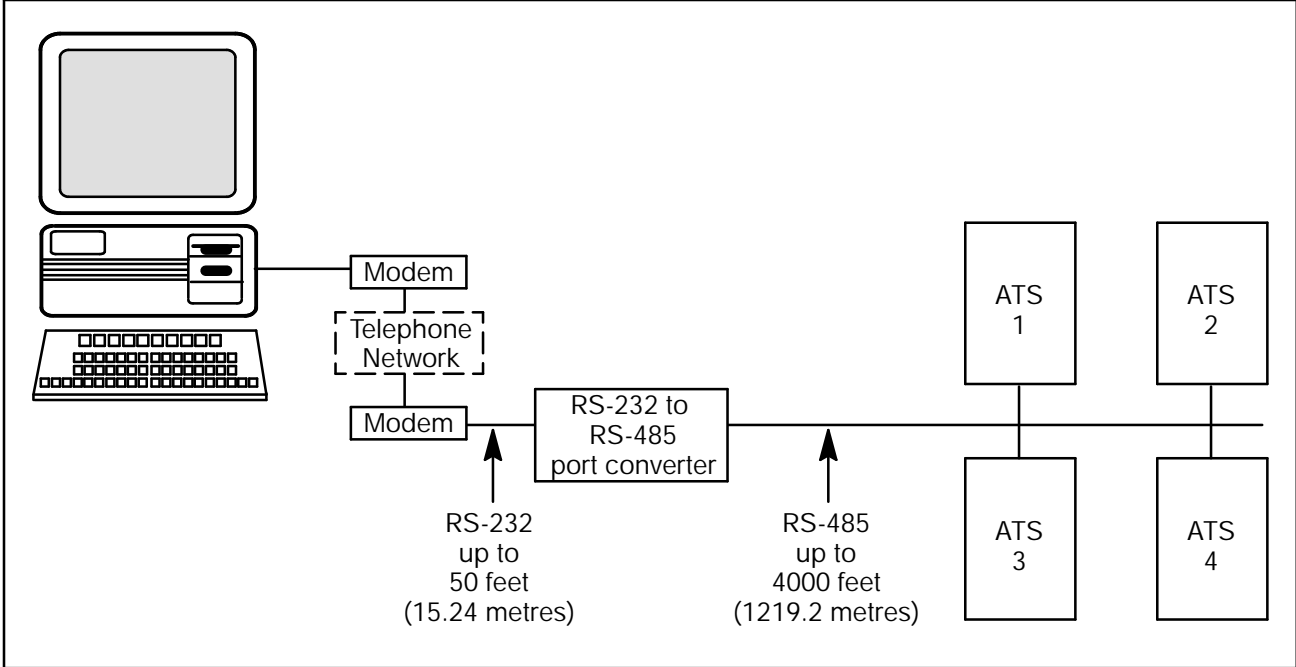

Remote Area Network

Notes

Index

A

Accessory Active, 2
 Area Protection, 2
 Inphase Monitor, 2
 Load Shed, 2
 Plant Exerciser, 2

Alarm Switch, 3

Auto-Inhibit Switch, 3

B

Bypass
 E-N Time Delay, 3
 N-E Time Delay, 3

C

Calibration, 5, 26, 66
 Setup, 47

Contactor, position LED, 1

Control Options, 5, 25, 65

Control Switches, 3

D

Date, 5, 10, 59
 setting, 30

Day, 5, 10, 59

Day Occurs, 10, 30, 59

E

Emergency Source, set points, 35

Emergency Source Settings, 14, 57, 62

Emergency System, 5

Emergency Voltage & Frequency, 5, 8, 70

Exer Stop Key, 3

L

LED Indicators, 1

Load Shed, 5
 Settings, 23, 64, 70
 Setup, 46

N

Normal System, 5

Normal Source, set points, 32

Normal Source Settings, 12, 56, 60

Normal Voltage & Frequency, 5, 7, 70

P

Plant Exerciser, 5
 engine start mode, 22

Settings, 16, 64, 70
 14-day mode, 18
 7-day mode, 20
 Calendar Mode, 16

Setup, 38
 14-day mode, 41
 7-day mode, 43
 calendar mode, 38
 engine-start mode, 45

Programming Mode Switch, 2, 7
 Local, 2, 29
 Off, 2, 7
 Remote, 2

R

Records, 5, 9, 58
 resetting, 29

Remote Control, 5, 27, 67
 local area network, 27, 72
 local area network setup, 49
 local single connection, 27, 71
 remote local area network, 27, 73
 remote local area network setup, 49
 remote single connection, 27, 72
 remote single connection setup, 49
 Setup, 49

S

Source, LED, 1

Source History, 5, 24, 65, 69

System Status, 2
 Not in Automatic, 2
 Program Mode Not in Off, 2
 System Alert, 2, 69

T

Test Pushbutton, 3

Time, 5, 10, 59
 setting, 30

Time Delays, Emergency to Normal, 2, 52

Time Delays, 2, 5, 11, 59, 70
 Engine Start, 2, 51
 Engine-Cooldown, 2, 51
 Normal to Emergency, 2, 51, 53
 setting, 31
 emergency-to-normal, 31
 engine cooldown, 31
 engine start, 31
 normal-to-emergency, 31

Transfer Mode Selector Switch, 3

Transfer Mode Selector Switch
 Auto Transfer Position, 3
 Manual Position, 3

TP-5569 1/92b

E Kohler Co., 1992. All rights reserved.

KOHLER[®] POWER SYSTEMS

KOHLER CO. Kohler, Wisconsin 53044
Phone 920-565-3381, Web site www.kohlergenerators.com
Fax 920-459-1646 (U.S.A. Sales), Fax 920-459-1614 (International)
For the nearest sales and service outlet in U.S.A. and Canada
Phone 1-800-544-2444

Kohler Power Systems
Asia Pacific Headquarters
7 Jurong Pier Road
Singapore 619159
Phone (65)264-6422, Fax (65)264-6455