

Service and Parts

Automatic Transfer Switches

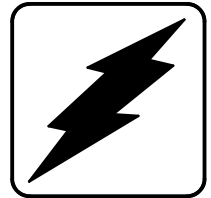

Models:

MMS

MNS

Contactors:

40-4000 Amperes

KOHLER[®]
POWER SYSTEMS

ISO 9001
KOHLER
GENERATORS
INTERNATIONALLY REGISTERED
U.S.A. Plant ISO Registered

TP-5666 1/95c

Table of Contents

SUBJECT	PAGE	SUBJECT	PAGE
Safety Precautions and Instructions	I	Section 6. Disassembly/Reassembly	6-1
Introduction	i	Introduction	6-1
List of Related Manuals	i	Contactor Removal	
Service Assistance	i	40-1250 Ampere ATS Units	6-1
Notes	ii	Contactor Installation	
		40-1250 Ampere ATS Units	6-2
Section 1. Specifications	1-1	Contactor Removal	
Purpose of Switch	1-1	1600-4000 Ampere ATS Units	6-2
Components of Switch	1-1	Contactor Installation	
Ratings	1-3	1600-4000 Ampere ATS Units	6-3
Interpreting a Transfer Switch Part Number ..	1-4	Contactor Component Removal	
Specifications	1-5	and Installation	6-4
Standard Features	1-5	Mechanical Interlock Removal	
Contactor Ratings	1-5	40-160 Ampere ATS Units	6-4
		Mechanical Interlock Installation	
Section 2. Operation	2-1	40-160 Ampere ATS Units	6-5
Switches and Indicators	2-1	Mechanical Interlock Removal	
Automatic Operation	2-1	250-1250 Ampere ATS Units	6-5
Initial Settings	2-1	Mechanical Interlock Installation	
Automatic Operation Procedures	2-1	250-1250 Ampere ATS Units	6-6
Manual Operation	2-2	Mechanical Interlock Removal	
Units with 40–160 Ampere Ratings	2-2	1600-4000 Ampere ATS Units	6-6
Units with 250–1250 Ampere Ratings	2-3	Mechanical Interlock Installation	
Units with 1600–4000 Ampere Ratings	2-5	1600-4000 Ampere ATS Units	6-7
Sequence of Operation	2-7	Motor Operator Removal	
Normal Source Failure	2-7	40-160 Ampere ATS Units	6-8
Normal Source Restoration	2-7	Motor Operator Installation	
Accessories	2-8	40-160 Ampere ATS Units	6-9
Time Delay Off	2-8	Motor Operator Removal	
Other Accessories	2-8	250-1250 Ampere ATS Units	6-9
		Motor Operator Installation	
Section 3. General Maintenance	3-1	250-1250 Ampere ATS Units	6-10
		Auxiliary Switch Removal	
Section 4. Troubleshooting	4-1	40-1250 Ampere ATS Units	6-11
Troubleshooting Table	4-1	Auxiliary Switch Installation	
		40-1250 Ampere ATS Units	6-11
Section 5. Accessory Testing			
and Adjustment	5-1	Section 7. Service Parts	7-1
Programmed Transition	5-1	Introduction	7-1
Other Accessories	5-1	Using Parts Lists	7-1
		Finding Parts Information	7-1
		Leads	7-1
		Appendix A. Glossary of Abbreviations ..	A-1

Safety Precautions and Instructions

A transfer switch, like any other electromechanical device, can pose potential dangers to life and limb if improperly maintained or imprudently operated. The best way to prevent accidents is to be aware of the potential dangers and to always use good common sense. In the interest of safety, some general precautions relating to operating of a transfer switch follow. Below are some general precautions relating to the operation of a transfer switch. **SAVE THESE INSTRUCTIONS.**



DANGER

Danger indicates the presence of a hazard that will cause severe personal injury, death, or substantial property damage if the danger is ignored.



WARNING

Warning indicates the presence of a hazard that can cause severe personal injury, death, or substantial property damage if the warning is ignored.



CAUTION

Caution indicates the presence of a hazard that will or can cause minor personal injury or property damage if the caution is ignored.

NOTE

Note communicates installation, operation, or maintenance information that is important but not hazard related.

Safety decals are affixed to the transfer switch in prominent places to advise the operator or service technician of potential hazards. The decals are reproduced here to improve operator recognition. For a further explanation of decal information, refer to the safety precautions throughout this manual. Before operating or servicing the transfer switch, be sure you understand the messages of these decals. Replace decals if missing or damaged.

Accidental Starting



**Accidental starting.
Can cause severe injury or death.**

Disconnect battery cables before working on generator set (negative lead first and reconnect it last).

Accidental starting can cause severe injury or death. Turn generator set master switch to OFF position, disconnect power to battery charger, and remove battery cables (remove negative lead first and reconnect it last) to disable generator set before working on any equipment connected to generator set. The generator set can be started by automatic transfer switch or remote start/stop switch unless these precautions are followed.

Battery

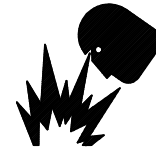

**Sulfuric acid in batteries.
Can cause severe injury or death.**

Use protective goggles and clothes. Battery acid can cause permanent damage to eyes, burn skin, and eat holes in clothing.

Explosion can cause severe injury or death. Battery gases can cause an explosion. Do not smoke or permit flame or spark to occur near a battery at any time, particularly when it is being charged. Avoid contacting terminals with tools, etc., to prevent burns and sparks that could cause an explosion. Remove wristwatch, rings, and any other jewelry before handling battery. Never connect negative (-) battery cable to positive (+) connection terminal of starter solenoid. Do not test battery condition by shorting terminals together. Sparks could ignite battery gases or fuel vapors. Ventilate any compartment containing batteries to prevent accumulation of explosive gases. To avoid sparks, do not disturb battery charger connections while battery is being changed. Always turn battery charger off before disconnecting battery connections. Remove negative lead first and reconnect it last when disconnecting battery.

Hazardous Voltage/ Electrical Shock

600 Volt and Above

⚠ DANGER

<p>Hazardous voltage. Will cause severe injury or death.</p> <p>Do not open enclosure until all power sources are disconnected.</p>

(600 Volt and above)

⚠ DANGER

<p>Hazardous voltage. Will cause severe injury or death.</p> <p>Disconnect power sources before servicing. Barrier must be installed after adjustments, maintenance, or servicing.</p>

(600 Volt and above)

Under 600 Volt

⚠ WARNING

<p>Hazardous voltage. Can cause severe injury or death.</p> <p>Disconnect power sources before servicing. Barrier must be installed after adjustments, maintenance, or servicing.</p>

(under 600 Volt)

⚠ WARNING

<p>Hazardous voltage. Can cause severe injury or death.</p> <p>Do not open enclosure until all power sources are disconnected.</p>

(under 600 Volt)

Hazardous voltage can cause severe injury or death. Short circuits can cause bodily injury and/or equipment damage. Do not contact electrical connections with tools or jewelry while adjustments are made. Remove wristwatch, rings, and jewelry that can cause short circuits.

Hazardous voltage can cause severe injury or death. Whenever electricity is present, there is the hazard of electrocution. Open main circuit breaker on all power sources before servicing equipment. Electrically ground the generator set and electrical circuits when in use. Never come into contact with electrical leads or appliances when standing in water or on wet ground, as the chance of electrocution is increased under such conditions.

Hazardous voltage can cause severe injury or death. To prevent the possibility of electrical shock, de-energize the normal power source to be connected to the transfer switch before making any line or auxiliary connections.

Hazardous voltage can cause severe injury or death. Disconnect inner panel harness at in-line connector. This will de-energize circuit board and logic circuitry, but allow transfer switch to continue to supply utility power to necessary lighting and equipment. Hazardous voltage will exist if any accessories mounted to inner panel are NOT wired through the inner panel harness and de-energized by in-line connector separation. Such accessories are at line voltage.

Notes

Charge only lead-acid or nickel-cadmium batteries with battery charger.

Charger Damage! Connect battery charger only to a battery with the same DC voltage as the battery charger output rating.

Hardware Damage! Transfer switch may use both American standard and metric hardware. Use the correct size tools to prevent rounding of bolt heads and nuts.

When replacing hardware, do not substitute with inferior grade hardware. Screws and nuts are available in different hardness ratings. American Standard hardware uses a series of markings and metric hardware uses a numeric system to indicate hardness. Check markings on bolt head and nuts for identification.

Introduction

This manual covers the operation, troubleshooting, repair, and service parts for the power conversion units that use 40-4000 ampere molded-case switches and molded-case circuit breakers power conversion units.

Read through this manual and carefully follow all procedures and safety precautions to ensure proper transfer switch operation and to avoid bodily injury. Keep this manual with the transfer switch for future reference.

Service requirements are minimal but are very important to the safe and reliable operation of the transfer switch; therefore, inspect associated parts often. It is recommended that an authorized service distributor perform required service to keep the switch in top condition.

All information found in this publication is based on data available at time of printing. The manufacturer reserves the right to make changes to this literature and the products represented at any time without notice and without incurring obligation.

List of Related Manuals

The power conversion units covered in this manual are part of a family of related devices. Separate service and parts manuals are available for each group within the overall family. Be sure this manual is the correct manual for the automatic transfer switch.

A logic controller is included in each automatic transfer switch. There are three types of logic controllers and each type is covered in a separate service and parts manual. Available logic controllers and the related manual numbers are as follows:

Controller	Service/ Parts Manual
Controller E33+	TP-5670
Controller S340+	TP-5671
Controller M340+	TP-5672

Service Assistance

For service or information, consult the yellow pages of the telephone directory under the heading GENERATORS– ELECTRIC for the Authorized Kohler Service Distributor/Dealer.

KOHLER CO., Kohler, Wisconsin 53044
Phone 414-565-3381
Fax 414-459-1646 (North American Sales)
414-459-1614 (International Sales)
For Sales and Service in U.S.A. and Canada
Phone 1-800-544-2444

In communications regarding the automatic transfer switch, please include the PART and SERIAL numbers provided on the nameplate attached to the transfer switch. Enter the numbers in the spaces provided below. This information will enable the authorized Kohler service distributor/dealer to supply the correct part or information for your particular model.

Part No. _____

Serial No. _____

Notes

Section 1. Specifications

Purpose of Switch

An automatic transfer switch (ATS) transfers critical electrical loads from a normal (preferred) source of electrical power to an emergency (standby) source. This transfer occurs automatically when the normal source voltage fails, or is substantially reduced, and the emergency source's voltage has reached an acceptable level.

Upon normal source failure, the automatic transfer switch controller signals the generator set(s) to start and transfer to the emergency source. The automatic transfer switch controller continuously senses for an acceptable normal source and will retransfer the load to the normal source after it has been restored to an acceptable level. After retransfer of the load, the generator set start signal is removed and the generator set(s) is allowed to shut down.

Components of Switch

A typical automatic transfer switch includes the power switching device and the logic controller to perform power monitoring and transfer sequencing tasks. See Figure 1-1. An interface board is also included to match the controller inputs/outputs to the levels required by a specific switching device.

Models in this manual use a power switching device made of two multi-pole, molded-case, toggle-operated switches or circuit breakers. Each switch or circuit breaker is equipped with a motor operator to allow automatic operation. The two switches or circuit breakers are mechanically and electrically interlocked to avoid conditions where both switches or circuit breakers are closed at the same time. With this feature it is possible to select one power source to feed the load without crosscoupling that power source to the other power source.

The three functional units that make up the automatic transfer switch are mounted in an enclosure with a hinged front door. The controller mounts on the back of the front door so its controls and indicators are available to an operator. A signal cable with in-line connectors to facilitate component replacement and door removal connects the controller to the interface board and the switching devices.

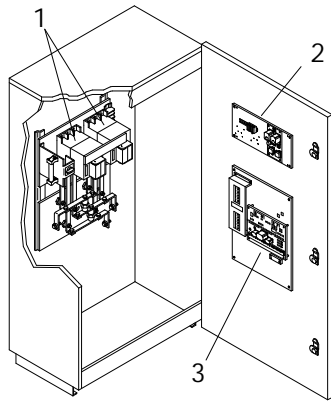

**Typical 400-1250 Ampere
Automatic Transfer Switch**

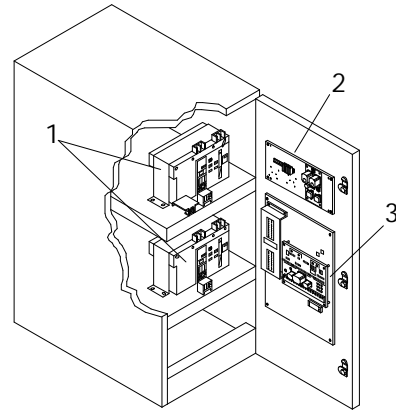

**Typical 1600-4000 Ampere
Automatic Transfer Switch**

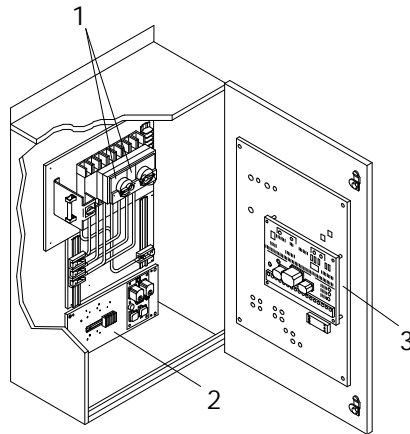

**Typical 40-160 Ampere
Automatic Transfer Switch**

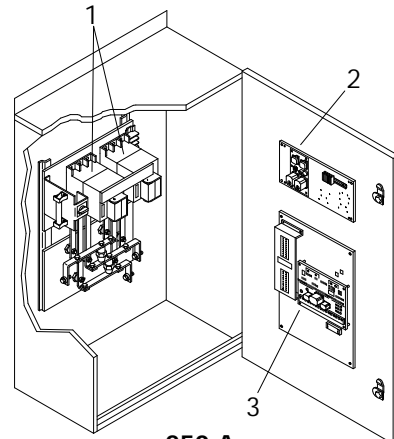

**250 Ampere
Automatic Transfer Switch**

566612

- 1. Switching Device
- 2. Interface Panel

- 3. Logic Controller

Figure 1-1. Transfer Switch Components

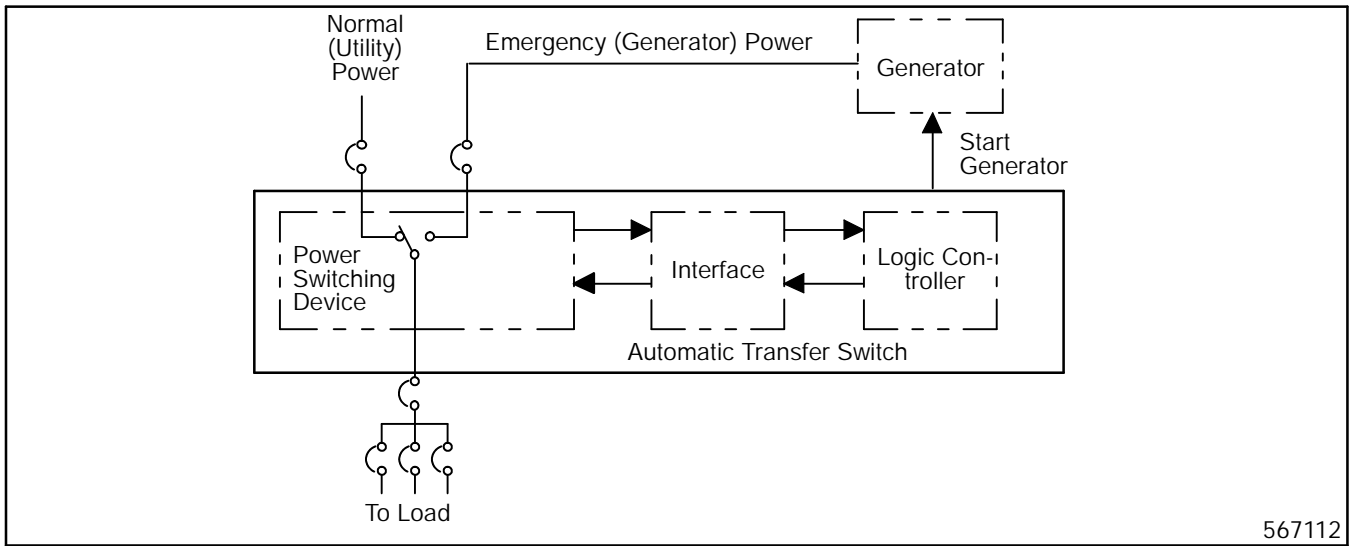

Figure 1-2. Basic Transfer Switch Block Diagram

Ratings

A nameplate is attached to the automatic transfer switch enclosure. See Figure 1-3. The nameplate label includes a factory part number. This number provides characteristics and rating information pertinent to installation and operation. Copy the part number into the blank spaces provided in the Service Assistance and then use the tables in Figure 1-4 to interpret the part number.

NOTE

Also copy the part number and serial number from the nameplate into the spaces provided in the **Service Assistance** Section of the Introduction for use when requesting service or parts.

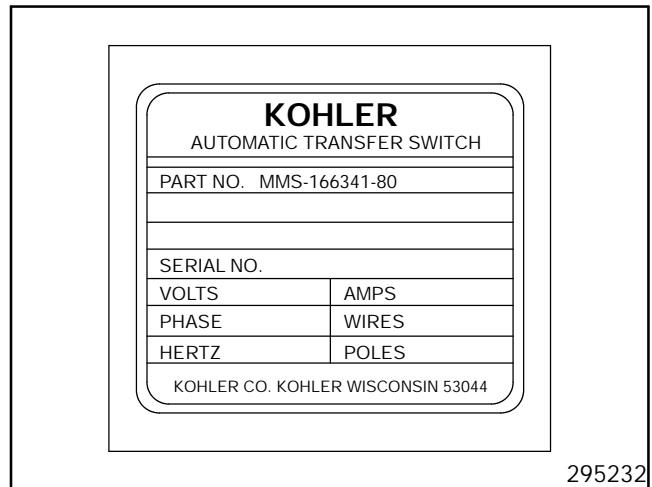
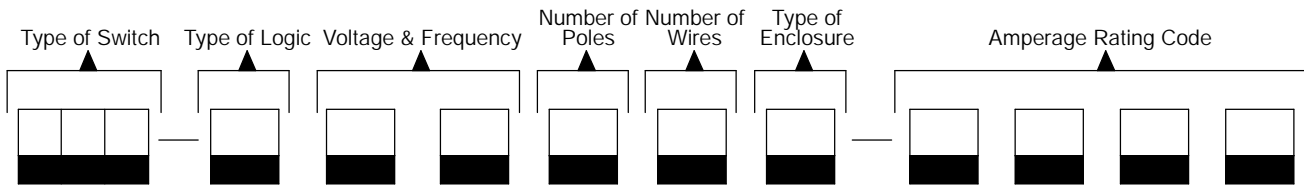

Figure 1-3. Transfer Switch Nameplate

295232

Transfer Switch Part Number Key

Record the transfer switch part number in the boxes below. The transfer switch part number defines characteristics and ratings explained in the accompanying following key.



Kohler Part Number Key

This chart explains the Kohler transfer switch part numbering system. The sample part number shown is for a standard molded-case switch with S340+ logic rated at 480 volts, 60 hertz, 3-phase, 3-pole, and 4 wires in a NEMA 1 enclosure with an amperage rating of 80 amperes.

SAMPLE PART NUMBER

MMS-166341-0080

Classification of Power Switch

M: Switch or Circuit Breaker

Type of Power Switch

M: Molded-Case Circuit Breaker

N: Molded-Case Switch (no protection)

Type of Switch

S: Standard

Type of Logic

1: S340+

2: E33+

3: S340+ with programmed transition

4: E33+ with programmed transition

5: M340+

6: M340+ with programmed transition

Voltage Code

60: 600 Volt, 60 Hz

66: 480 Volt, 60 Hz

62: 120 Volt, 60 Hz

68: 208 Volt, 60 Hz

63: 220 Volt, 50 Hz

71: 380 Volt, 50/60 Hz

64: 240 Volt, 60 Hz

Number of Poles

2: 2 pole, 1 phase (MM_, MN_, TE_, TL_, devices will be supplied with 3 poles)

3: 3 pole, 3 phase

6: 4 pole, fully rated switched poles (no overlapping neutral)

Number of Wires

2: 2 wire

3: 3 wire

4: 4 wire

Enclosure

1: NEMA type 1

Amperes

Available sizes vary with the type of switch.

56641

Figure 1-4. Transfer Switch Part Number Key

Specifications

The following specifications are for the circuit breaker/switch power conversion units. See the respective logic controller manual for its specifications.

Standard Features

- D Integrates with M340+ logic
- D Integrates with E33+, S340+, and M340+ Logic
- D 3- or 4-pole configuration (fully rated)
- D Available in NEMA type 1 enclosure
- D Available to 660 vac, 50 or 60 Hz
- D Rated from 40 to 4000 amps at 104°F (40_C)
- D Power breakers and switches used on 1600 ampere and above
- D Breaking capacity to 85 kVA at 220/240 volts
- D Available with short circuit and overload protection or as a molded-case switch with no overload protection
- D Switches and circuit breakers electrically or manually operated
- D Switches and circuit breakers electrically and mechanically interlocked
- D Available with programmed transition function
- D Rated per IEC standards. See Figure 1-5
- D Includes indication of circuit breaker position
- D Maintenance-free design suitable for use in all climates

Transfer Switch Rating (Amps)	Rated Operational Voltage	Rated Ultimate Breaking Capacity AC (kA rms)* according to IEC 947.2 (P1 according to IEC 157-1)					Rated Admissible Short-Time Current	
		220/240V	380/415V	440V	500V	660/690V	kA (rms)	time (sec)
40	690	85	25	20	14	8		
80	690	85	25	20	14	8		
100	690	85	25	20	14	8		
160	690	85	25	22	14	8		
250	690	85	35	30	15	8		
400	690	85	35	30	15	10	6	0.1
630	690	85	35	30	15	10	9	0.1
800	690	85	50	42	40	25	12	1.0
1000	690	85	50	42	40	25	12	1.0
1250	690	85	50	42	40	25	12	1.0
1600	690	40	40	40	40	40	40	1.0
2000	690	55	55	55	55	55	55	1.0
2500	690	55	55	55	55	55	55	1.0
3000	690	75	75	75	75	75	75	1.0
4000	690	75	75	75	75	75	75	1.0

*Defined for a power factor of:
 0.5 if 8 < kA rms < 10
 0.25 if 20 < kA rms < 50
 0.3 if 10 < kA rms < 20
 0.2 if kA rms > 50

Figure 1-5. Contactor Ratings

Section 2. Operation

Switches and Indicators

The switches and indicators on an automatic transfer switch are specified based on the logic controller used in the transfer switches. For details on this subject, refer to

the appropriate controller operation and installation manual. See **List of Related Manuals** in the Introduction.

Automatic Operation

Initial Settings

Before turning on the power for the first time or when returning from manual operation to automatic operation, manually operate the automatic transfer switch to select the normal power source. See **Manual Operation** below. Then continue as follows:

- D Units with ratings of 40-160 amperes.** See Figure 2-1. Place the slide switch on each switch or circuit breaker in the AUTO position. Locate the control switch in the upper left corner of the switch mounting plate. Turn the control switch to the ON position to connect the controller to the motor operators.
- D Units with ratings of 250-1250 Amperes.** See Figure 2-2. Close the plastic door on the front of each switch. Locate the control switch in the upper left corner of the switch mounting plate. Turn the control switch to the ON position to connect the controller to the motor operators.

- D Units with ratings of 1600-4000 amperes.** See Figure 2-3. Turn control switch to the on position to connect motor operators to controller.

Automatic Operation Procedures

NOTE

Circuit breaker switching devices will trip open automatically in the event of a short circuit. When this occurs, clear the short circuit. Then manually operate the switch to select the desired power source as described in Manual Operation above. To return to automatic operation after resetting a tripped circuit breaker, complete the Initial Settings described above.

Automatic operation is a function of the controller installed in the unit. For automatic operation details and procedures, refer to the appropriate controller operation and installation manual. See **List of Related Manuals** in the Introduction.

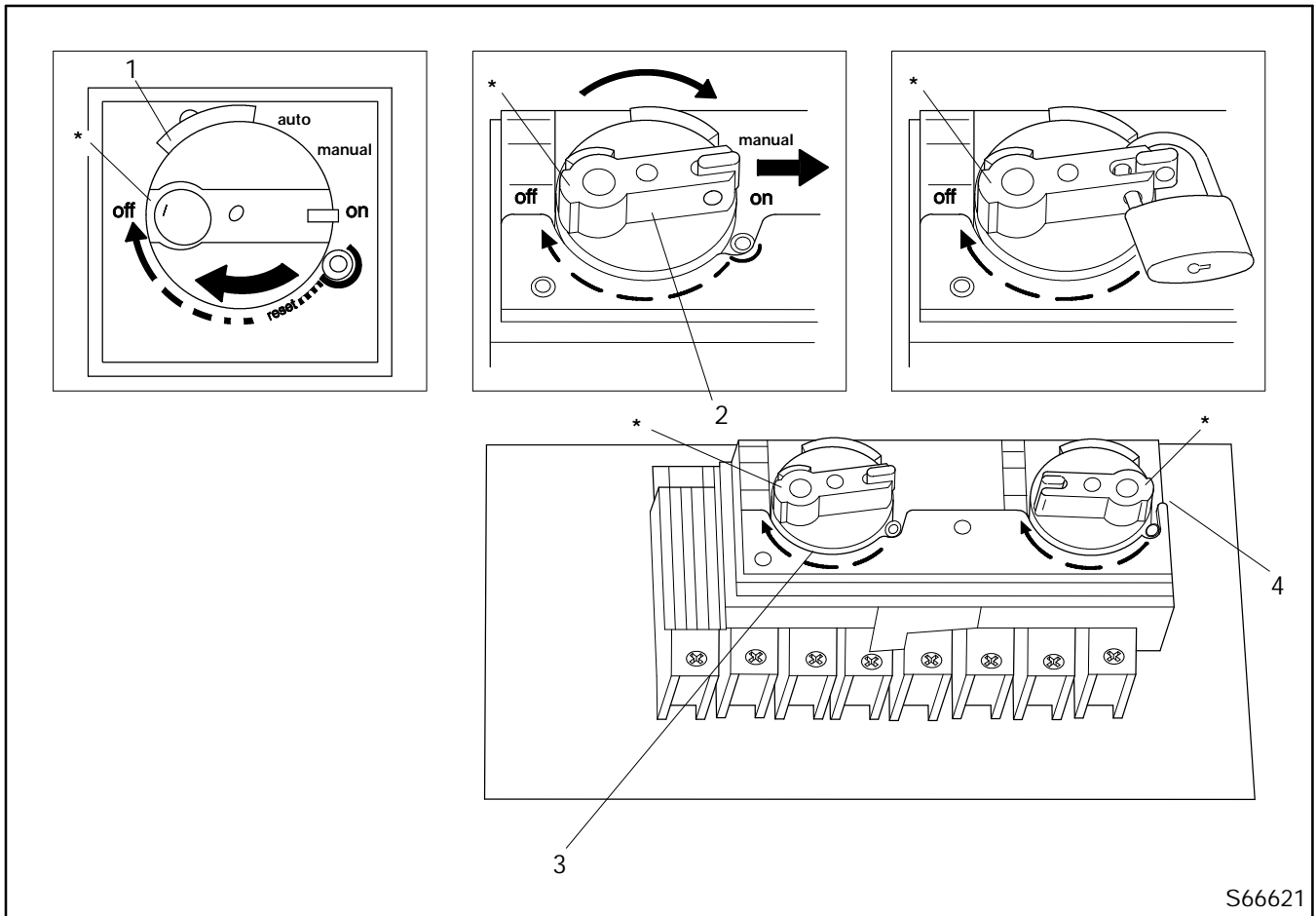

*Rotate rounded end of switch handle to ON/OFF position as required.

- 1. Slide Switch
- 2. Switch Handle

- 3. Normal Switch/Circuit Breaker
- 4. Standby Switch/Circuit Breaker

Figure 2-1. Automatic Transfer Switch (40-160 Ampere) Operation

Manual Operation

Manually operate the automatic transfer switch when the controller fails or when testing/troubleshooting the unit. Because the switches differ slightly, separate procedures are provided for: units with 40-160 ampere ratings, units with 250-1250 ampere ratings, and units with 1600-4000 ampere ratings.

Units with 40-160 Ampere Ratings

Manual operation of these units is as follows (see Figure 2-1):

1. Set control switch in upper left corner of the switch-mounting plate to OFF to disconnect motor operators from controller.

NOTE

Mechanical interlocks prevent both switches or circuit breakers from being in the on position simultaneously. To set one switch or circuit breaker to ON, the other switch or circuit breaker must first be set to OFF.



2. To operate a switch or circuit breaker, first set its slide switch to manual. Then rotate the switch handle clockwise to the desired position.

NOTE

Lock switches/circuit breakers in the OFF position as shown in Figure 2-1.

Units with 250-1250 Ampere Ratings

Manually operate these units as follows (see Figure 2-2):

 DANGER

Hazardous voltage. Will cause severe injury or death. Disconnect power sources before servicing. Barrier must be installed after adjustments, maintenance, or servicing.

(600 Volt and above)

1. Set control switch in upper left corner of switch mounting plate to OFF.

NOTE

Mechanical interlocks prevent both switches or circuit breakers from being in the on position simultaneously. To set one switch or circuit breaker to ON, the other switch or circuit breaker must first be set to OFF.

2. Open plastic door over front of switch or circuit breaker. Opening the door disconnects the motor operator from the controller.
3. Slide the switch lever to the desired position as shown in detail Figure 2-2.

NOTE

Padlock switches/circuit breakers in the OFF position as shown in Figure 2-2.

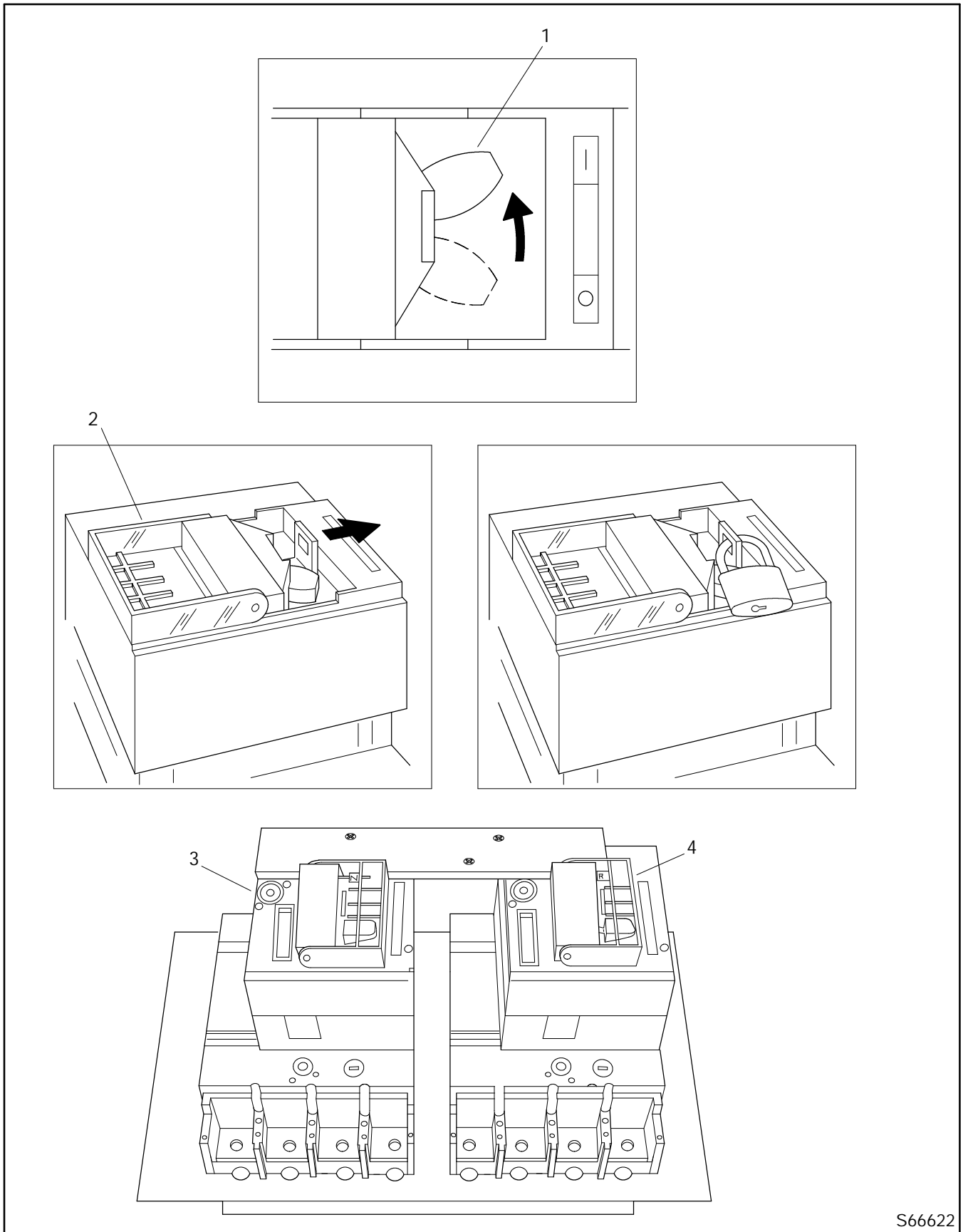

S66622



- 1. Lever
- 2. Door

- 3. Normal Switch/Circuit Breaker
- 4. Standby Switch/Circuit Breaker

Figure 2-2. Automatic Transfer Switch (250-1250 Ampere) Operation

Units with 1600-4000 Ampere Ratings

Manually operate these units as follows (see Figure 2-3):

 DANGER

Hazardous voltage. Will cause severe injury or death. Disconnect power sources before servicing. Barrier must be installed after adjustments, maintenance, or servicing.

(600 Volt and above)

1. Set control switch to OFF (0) to disconnect motor operators from controller.

NOTE

Mechanical interlocks prevent both switches or circuit breakers from being in the on position simultaneously. To set one switch or circuit breaker to ON, the other switch or circuit breaker must first be set to OFF

2. Operate the circuit breaker/switch handle as shown in Figure 2-3 up to seven times to tension the circuit breaker/switch operating spring. Indicator shows charged.
3. Press the button (1 for ON or 0 for OFF) for the desired position of the switch/circuit breaker. The spring drives the switch/circuit breaker to the desired position.

NOTE

Lock the switches/circuit breakers in the off position as shown in of Figure 2-3.

To manually change to the normal position

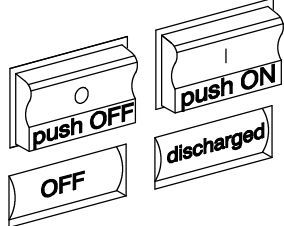
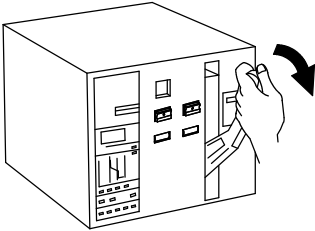
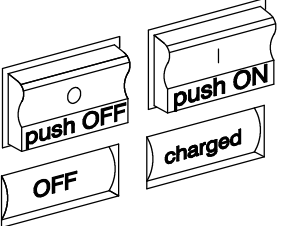
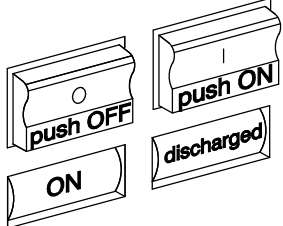
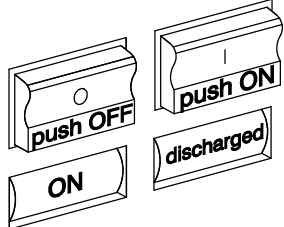
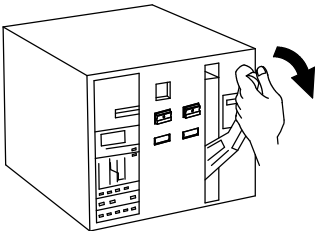
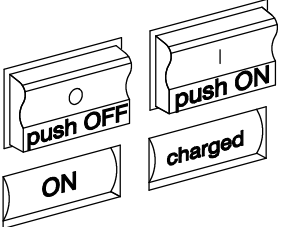
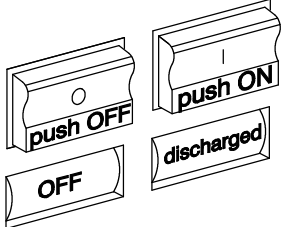
STARTING CONDITION	OPERATE HANDLE	SPRING CHARGED	PRESS BUTTON (1 OR 0) TO OPERATE
 <p>OFF - Discharged</p>		 <p>OFF - Charged</p>	 <p>ON - Discharged</p>
 <p>ON - Discharged</p>		 <p>ON - Charged</p>	 <p>OFF - Discharged</p>

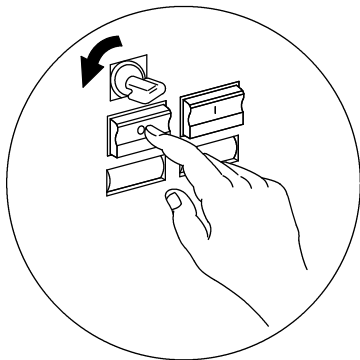
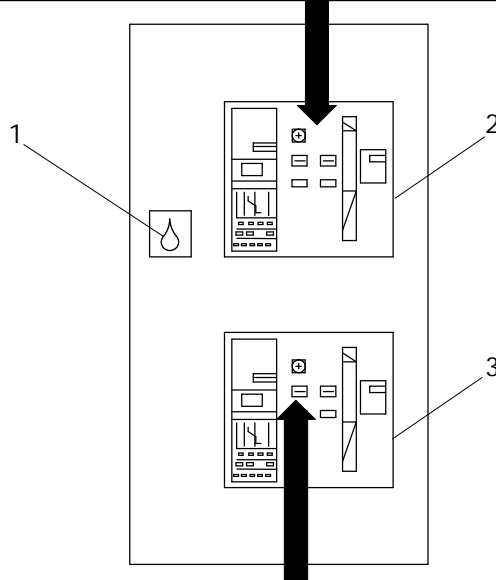

Press 0 and turn key.

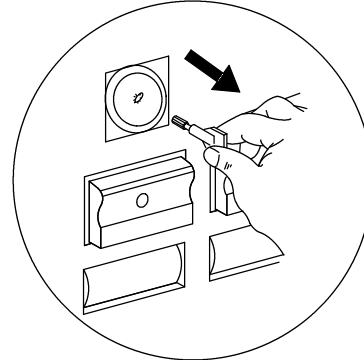

Remove key.

56622

1. Control Switch
2. Normal Switch/Circuit Breaker

3. Standby Switch/Circuit Breaker

Figure 2-3. Manual Operation

Sequence of Operation

Operation of the typical automatic transfer switch is in two separate sequences: (1) failure of normal power and the resulting transfer to emergency power and (2) restoration of normal power and the resulting transfer back to normal power. A brief description of both sequences is below. Note that accessories described later in this manual or in the applicable logic controller operation and installation manual may affect these sequences. In addition, for more specific details on circuit operation including time delays, refer to the applicable controller operation and installation manual. See **List of Related Manuals** in the Introduction.

Normal Source Failure

Monitors within the controller detect failure of normal power, whether it is loss or deterioration of one or more phases. The monitor that detects the failure starts a time delay called Time Delay Engine Start (TDES). If power is restored before the time delay expires, the controller issues a signal to start the standby (emergency) power generator. This time delay scheme prevents unnecessary starting of the generator during short power interruptions.

A second set of monitors within the controller checks the status of the emergency power. When the emergency (generator) voltage and frequency are at nameplate rating, these monitors start a timing delay called Time Delay Normal to Emergency (TDNE). The time delay provides the generator output time to stabilize, the controller issues a signal to the transfer switch motor operators to remove normal power and then connect emergency power to the load.

Once the load is switched, the transfer switch remains in the emergency position, supplying power to the load from the emergency source until normal power is restored.

Normal Source Restoration

Restoration of normal power automatically begins a sequence that transfers the load back to the normal

power source. The monitors within the controller continue to check the status of the normal power even when the load is operating from emergency power. These monitors start a time delay called Time Delay Emergency to Normal (TDEN) when they detect a stable condition of the normal power. If normal power fails before the time delay expires, the time delay is reset. This timing period ensures that normal power stabilizes before reconnecting to the load.

If the normal power remains stable and the time delay expires, the controller issues signals to the transfer switch motor operators to remove emergency power and reconnect normal power to the load. The controller starts a timer, called Time Delay Engine Cooldown (TDEC) simultaneous with the power transfer. After this time delay expires, the generator engine stops.

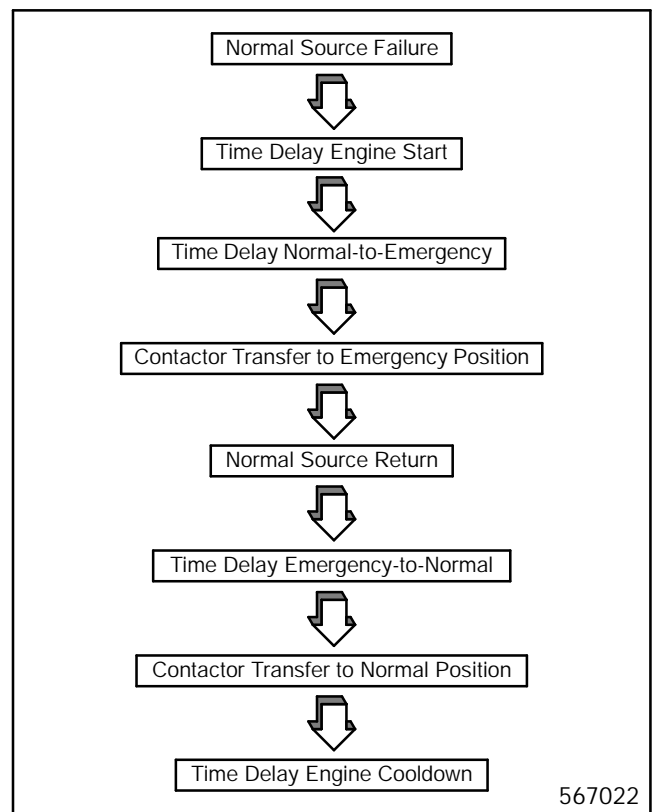

Figure 2-4. Logic Board Operation

Accessories

Time Delay Off

The Time Delay Off accessory consists of two timing relays that plug into the interface board. See Figure 2-5. However, when the ATS is equipped with an M340+ M340+ controller, the accessory is programmed into the controller's microprocessor. If the transfer switch has a time delay off accessory, power transfers from normal to emergency or emergency to normal power sources in three steps:

1. The switch for the previously connected power source opens.
2. A delay period, adjustable from 2 to 40 seconds, allows residual voltage in the load circuit to decay.
3. The switch or circuit breaker for the new power source closes.

Other Accessories

With the exception of the Time Delay Off accessory, all accessories are controller accessories. For controller accessory information and procedures, refer to the appropriate controller manual. See **List of Related Manuals** in the Introduction.

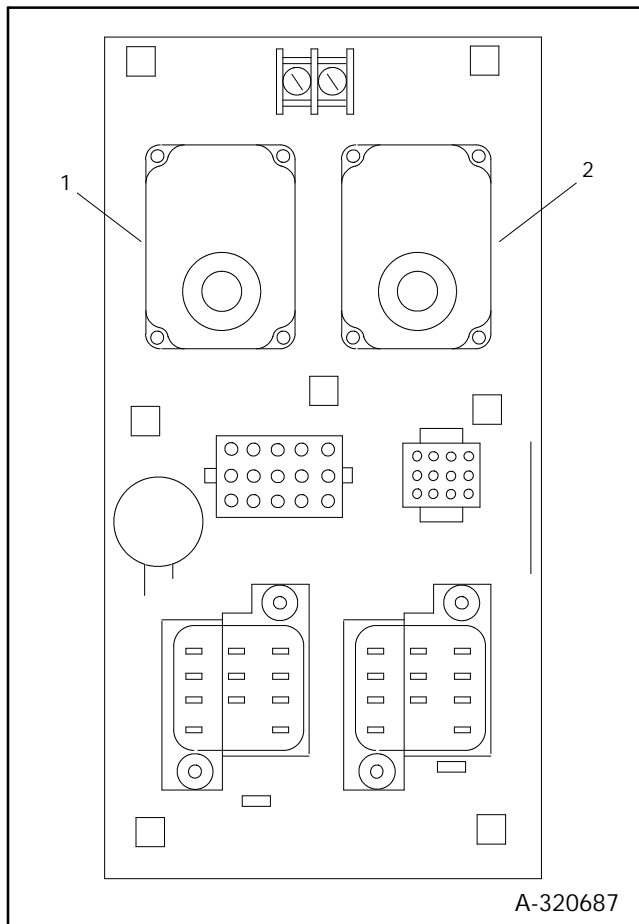

1. K3 (TDON)

2. K4 (TDOE)

Figure 2-5. Interface Board with Time Delay Relays

Section 3. General Maintenance

Reasonable preventive maintenance will ensure high reliability and long life for the automatic transfer switch. Follow all applicable local codes and standards, and keep a log book for scheduled maintenance and repairs.

Operate Transfer Switch at Least Once a Month. Use the test switch to check the electrical operation of the transfer switch. The test switch simulates failure of the normal source. Service is interrupted only during the actual transfer of the load. It is recommended that an actual load be connected while transfer takes place.

Keep Automatic Transfer Switch Clean. During installation, protect the switch from construction grit and metal chips. Once each year, with the control panel cover in place, brush and vacuum away any excessive dust accumulation.

Maintain Transfer Switch Lubrication. The transfer switch was lubricated at the factory. Under normal

operating conditions the transfer switch requires no further lubrication.

Inspect Main Current-Carrying Contacts. Once each year, de-energize all sources, and remove barriers to check condition of contact material. Replace switch or circuit breaker contactor unit when contacts are pitted or excessively worn .

Torquing of Contactor Lug Set Screws. Torque set screws to spec when installing in the ATS. Check torque every six months. When using an aluminum conductor, apply joint compound to conductors. Check contactor lugs after tightening and wipe off excess joint compound.

Effect of Ambient Temperature and Humidity Conditions. Operate the contactor in an ambient temperature of 32° to 104° F (0° to 40° C). Contact the manufacturer if operating the contactor in a higher or lower ambient temperature. Humidity can vary from 5 to 95% without affecting operation.

Section 4. Troubleshooting

This section provides troubleshooting procedures for mechanical failures of the switching device. The applicable Logic Controller Service Manual covers troubleshooting of the electrical functions of the switching device as well as the overall operation of the automatic transfer switch. See **List of Related Manuals** in the Introduction of this manual.

Troubleshooting Table

Use the following table to troubleshoot problems. The table includes troubleshooting information for a specific automatic transfer switch problem. Included in this information is a list of possible causes of the problem, the recommended remedy for each possible cause, and a reference to detailed information or procedures for the remedy.

Only authorized service dealers should perform repairs. Improper repairs by unqualified personnel can lead to additional failures.

Problem	Possible Cause	Corrective Action	Reference
Mechanical interlocks jam, preventing normal closure of a contactor	Interlock(s) misaligned	Realign interlock(s)	Section 6. Contactor Component Removal and Installation
	Interlock(s) damaged	Replace interlock(s)	Section 6. Contactor Component Removal and Installation
	Contactor defective	Replace contactor	Section 6. Contactor Removal and Contactor Installation
Mechanical interlocks fail to prevent simultaneous closure of both contactors	Interlock(s) misaligned	Realign interlock(s)	Section 6. Contactor Component Removal and Installation
	Interlock(s) damaged	Replace interlock(s)	Section 6. Contactor Component Removal and Installation
	Contactor interlock shaft defective	Replace contactor	Section 6. Contactor Removal and Contactor Installation

Problem	Possible Cause	Corrective Action	Reference
A 40-1250 ampere contactor fails to attain or hold a setting	Logic control defective	Troubleshoot/replace logic control	Logic control manual and/or Section 1, List of Related Manuals, in this manual
	Mechanical interlock interference	Check/fix mechanical interlock	Section 5. Mechanical interlocks jam, preventing normal closure of a contactor
	Contactors motor operator defective	Replace motor operator	Section 6. Contactor Component Removal and Installation
	Contactors auxiliary switch defective	Replace auxiliary switch	Section 6. Contactor Component Removal and Installation
	Contactors defective	Replace contactor	Section 6. Contactor Removal, 40-1250 Amperes, and Contactor Installation, 40-1250 Amperes
A 1600-4000 ampere contactor fails to attain or hold a setting	Logic control defective	Troubleshoot/replace logic control	Logic control manual and/or Section 1, List of Related Manuals, in this manual
	Mechanical interlock interference	Check/fix mechanical interlock	Section 5. Mechanical interlocks jam, preventing normal closure of a contactor
	Contactors defective	Replace contactor	Section 6. Contactor Removal, 1600-4000 Amperes, and Contactor Installation, 1600-4000 Amperes
A contactor circuit breaker trips	Load excessive or shorted	Correct load problem	None
	Contactors circuit breaker defective	Replace contactor	Section 6. Contactor Removal and Contactor Installation

Section 5. Accessory Testing and Adjustment



Programmed Transition

NOTE

This section does not apply to ATS utilizing the microprocessor logic control. The microprocessor controls the programmed transition function. Standard c-form relays replace the timing relays and do not require adjustment. See TP-5664 for operational details.

There are two separate timing relays used, K4 (TDOE) and K3 (TDON). K4 produces the time delay for the normal to emergency power transfer; K3 produces the time delay for the emergency to normal power transfer. Each relay has a separate adjustment. To make an adjustment, proceed as follows:

1. Disconnect both the normal and emergency power sources.

 DANGER

Hazardous voltage. Will cause severe injury or death.
Disconnect power sources before servicing. Barrier must be installed after adjustments, maintenance, or servicing.

(600 Volt and above)

Hazardous voltage can cause severe injury or death. Whenever electricity is present, there is the hazard of electrocution. Open main circuit breaker on all power sources before servicing equipment. Electrically ground the generator set and electrical circuits when in use. Never come into contact with electrical leads or appliances when standing in water or on wet ground, as the chance of electrocution is increased under such conditions.

2. Open the ATS door.

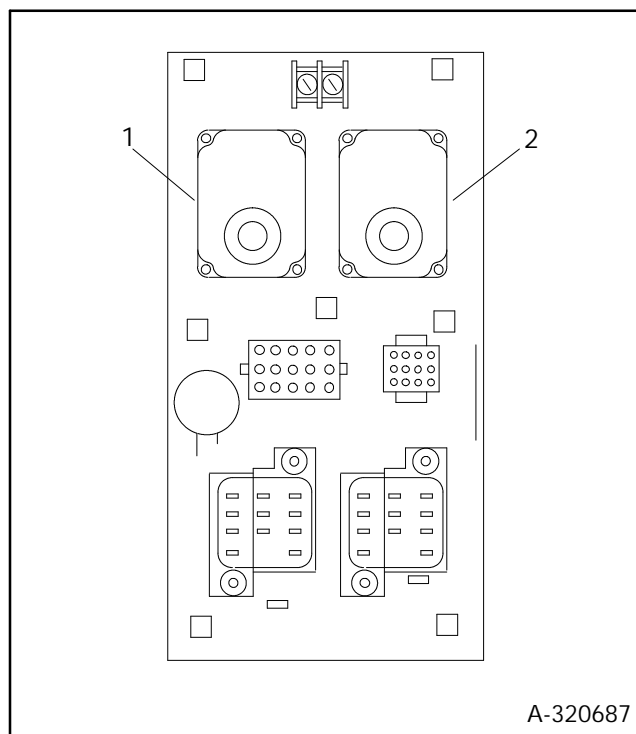
3. Locate the appropriate relay on the interface board. See Figure 5-1.
4. Insert a screwdriver into the adjustment slot of the adjustment screw, visible through the cover of the relay. Turn the adjustment screw to the desired time delay period.
5. Close the enclosure door.
6. Reconnect the normal and emergency power source.
7. Operate the automatic transfer switch automatically and check the time delay off period to ensure that it is properly adjusted.



1. K3 (TDON)

2. K4 (TDOE)

Figure 5-1. Interface Board with Programmed Transition Relays



Other Accessories

All other accessories for this automatic transfer switch are controller accessories. For controller accessory information and procedures, refer to the appropriate controller manual. See **List of Related Manuals** in the Introduction.

Section 6. Disassembly/Reassembly

Introduction



This section provides instructions for disassembly and reassembly of the switching devices. Use these instructions when it is necessary to replace parts within the switching devices.

 DANGER

Hazardous voltage. Will cause severe injury or death.
Do not open enclosure until all power sources are disconnected.

(600 Volt and above)

Hazardous voltage can cause severe injury or death. To prevent the possibility of electrical shock, de-energize the normal power source to be connected to the transfer switch before making any line or auxiliary connections.

Hazardous voltage can cause severe injury or death. De-energize both normal and emergency power sources before proceeding. Move generator set master switch on controller to OFF position and disconnect battery negative (-) before working on transfer switch! Turn the transfer switch selector switch to the OFF position.

 DANGER

Hazardous voltage. Will cause severe injury or death.
Disconnect power sources before servicing. Barrier must be installed after adjustments, maintenance, or servicing.

(600 Volt and above)

Hazardous voltage can cause severe injury or death. Whenever electricity is present, there is the hazard of electrocution. Open main circuit breaker on all power sources before servicing equipment. Electrically ground the generator set and electrical circuits when in use. Never come into contact with electrical leads or appliances when standing in water or on wet ground, as the chance of electrocution is increased under such conditions.

Contactor Removal 40-1250 Ampere ATS Units

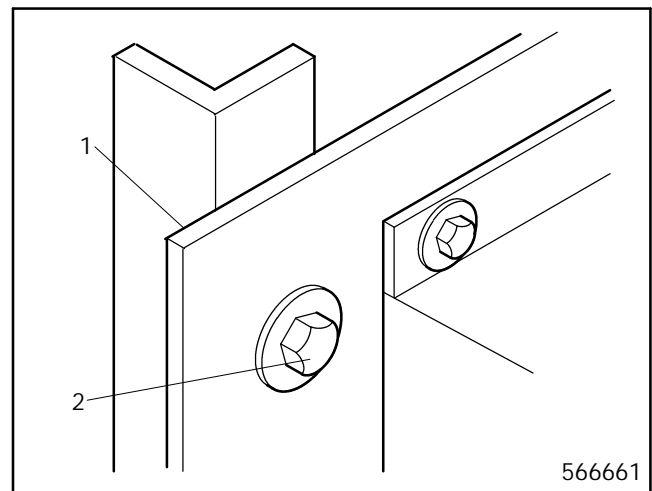
1. Disconnect both the normal and emergency power sources.
2. Open the ATS door.
3. Disconnect the normal and emergency power source connections from the contactor terminals.
4. Disconnect the load connection bus bars from both contactors.
5. Disconnect P1 of the contactor assembly harness from P1 of the logic control harness.
6. Remove the screws and washers. Lift the entire contactor assembly out of the ATS enclosure. See Figure 6-1.



1 Contactor Assembly 2 Screw and Washer

**Figure 6-1. Contactor Assembly Removal,
40-1250 Ampere ATS Units**

7. Place the contactor assembly on a work bench.
8. Remove the mechanical interlock from the contactors. See Mechanical Interlock Removal 40-160 Ampere ATS Units or Mechanical Interlock Removal 250-1250 Ampere ATS Units under Contactor Component Removal and Installation later in this section.
9. Remove the motor operator from the contactor. See Motor Operator Removal 40-160 Ampere ATS Units or Motor Operator Removal 250-1250 Ampere ATS Units under Contactor Component Removal and Installation later in this section.
10. Mark the outline of the circuit breaker/switch frame on the panel with a scribe or marker.
11. From the rear of the panel, remove the hardware that secures the circuit breaker/switch frame to the panel.
12. Separate the circuit breaker/switch frame from the panel.

Contactor Installation 40-1250 Ampere ATS Units

1. Place the circuit breaker/switch frame on the panel in the position marked during the removal phase.
2. From the rear of the panel, install the hardware to secure the circuit breaker/switch frame to the panel.
3. Install the motor operator on the contactor. See Motor Operator Installation 40-160 Ampere ATS Units or Motor Operator Installation 250-1250 Ampere ATS Units under Contactor Component Removal and Installation later in this section.
4. Install the mechanical interlock between the two circuit breakers or switches. See Mechanical Interlock Installation 40-160 Ampere ATS Units or Mechanical Interlock Installation 250-1250 Ampere ATS Units under Contactor Component Removal and Installation later in this section.

5. Position the entire contactor assembly in place on the mounting rails within the ATS enclosure and install the screws and lock washers to secure the contactor assembly.
6. Connect P1 of the contactor assembly harness to P1 of the logic control harness.
7. Install and reconnect the load bus bars to the load terminals of the contactor assembly's circuit breakers or switches.
8. Reconnect the normal and emergency power source leads to the contactor assembly's circuit breakers or switches.
9. Close the front panel of the enclosure.
10. Return the ATS to normal operation.

Contactor Removal 1600-4000 Ampere ATS Units

1. Turn off the normal and emergency power sources.
2. Open the front door of the ATS enclosure.
3. Disconnect the normal and emergency power source connections from the contactor terminals.
4. Disconnect the load connections from the contactor terminals.
5. Tag and disconnect the wiring harness leads from the contactor. See Figure 6-2.

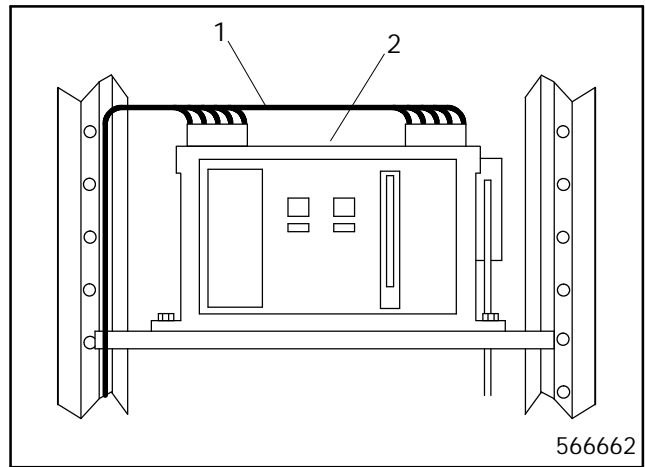

1. Wire Harness 2. Contactor

**Figure 6-2. Harness Leads from Contactor,
1600-4000 Ampere ATS Units**

6. Remove the mechanical interlock. See Mechanical Interlock Removal 1600-4000 Ampere ATS Units under Contactor Component Removal and Installation later in this section.
7. Remove the hardware that secures the contactor in place. See Figure 6-3.

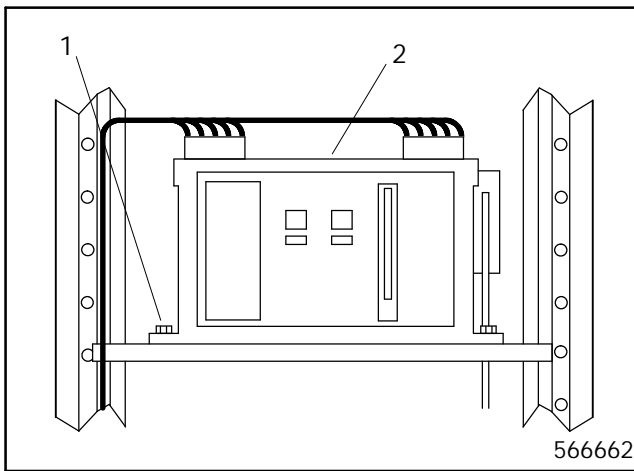

1. Mounting Hardware 2. Contactor

**Figure 6-3. Contactor Removal from Shelf,
1600-4000 Ampere ATS Units**

8. Remove the contactor from the enclosure.

Contactor Installation 1600-4000 Ampere ATS Units

1. Slide the contactor onto the shelf within the ATS enclosure.
2. Install the hardware to secure the contactor in place.
3. Install the mechanical interlock. See Mechanical Interlock Installation 1600-4000 Ampere ATS Units under Contactor Component Removal and Installation later in this section.
4. Reconnect the contactor wiring harness leads to the contactor.
5. Reconnect the load bus bars to the contactor terminals.
6. Reconnect the normal and emergency bus bars to the contactor terminals.
7. Close the front door of the ATS.
8. Return the ATS to normal operation. See Automatic Operation in the operation section of this manual.

Contactor Component Removal and Installation

Mechanical Interlock Removal 40-160 Ampere ATS Units

1. Turn off normal and emergency power sources and open the front panel of the ATS enclosure.
2. Remove three screws and lift cover off mechanical interlock. See Figure 6-4.

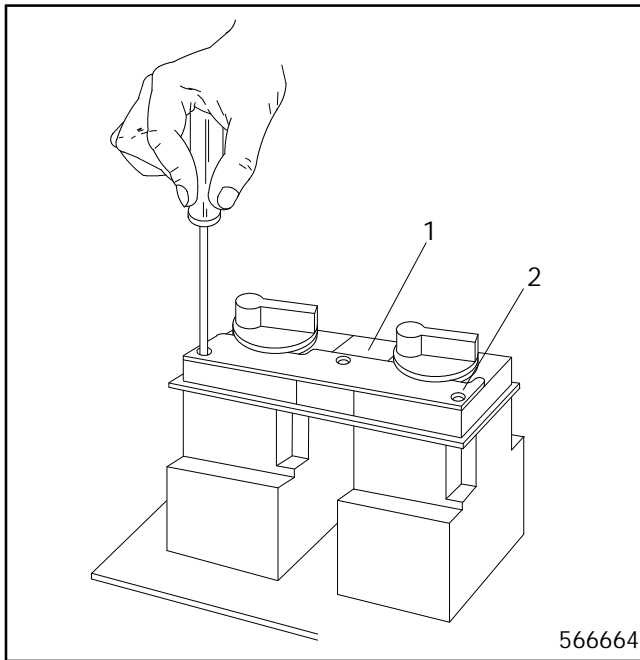

1. Cover
2. Screw

Figure 6-4. Mechanical Interlock Cover Removal, 40-160 Ampere ATS Units

3. Remove four screws and slide the mechanical interlock off the contactors. See Figure 6-5.

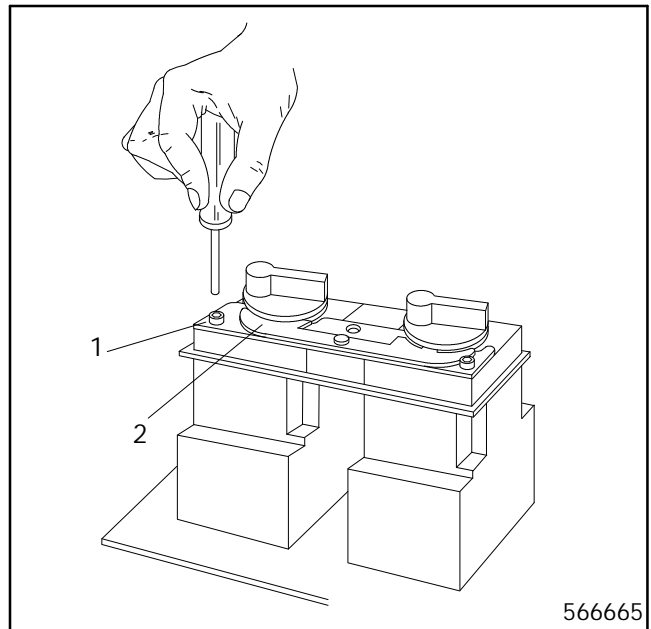

1. Screw
2. Mechanical Interlock

Figure 6-5. Mechanical Interlock Removal, 40-160 Ampere ATS Units

4. Remove the mechanical interlock pivot plate from the space between the two contactors. See Figure 6-6.

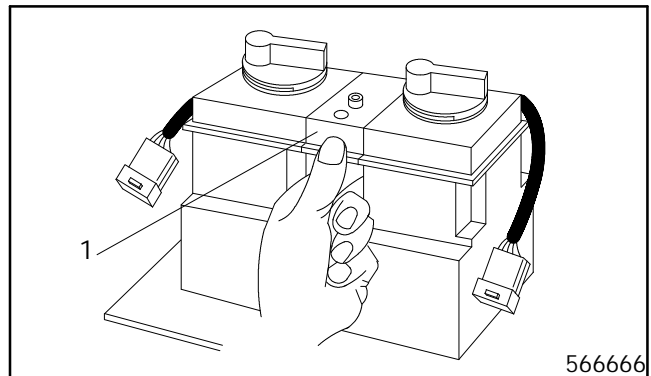

1. Pivot Plate

Figure 6-6. Mechanical Interlock Pivot Plate Removal, 40-160 Ampere ATS Units

Mechanical Interlock Installation 40-160 Ampere ATS Units

1. Install the mechanical interlock pivot plate in the space between the two contactors.
2. Install the mechanical interlock, engaging the interlock into the grooves on one contactor at a time. See Figure 6-7.

NOTE

To engage the interlock in both contactors, at least one contactor must be set to OFF. See Manual Operation in Section 2.

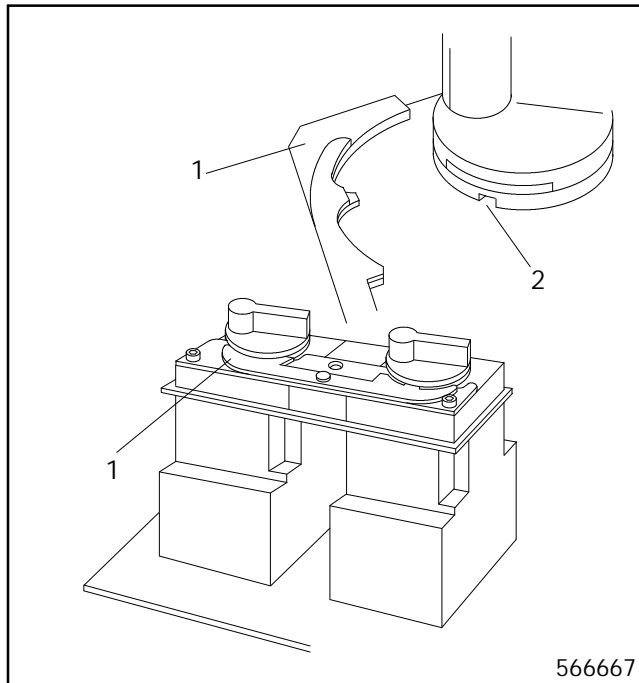

1. Mechanical Interlock 2. Groove

**Figure 6-7. Engaging Mechanical Interlock,
40-160 Ampere ATS Units**

3. Install the four screws to secure the mechanical interlock in place on the contactors. Tighten the screws to a torque of 13.3 pound-inches (1.5 Nm).
4. Place the cover on the mechanical interlock. Install the three screws to secure the cover in place. Tighten the screws to a torque of 8.8 pound-inches (1 Nm).
5. Return the ATS to normal operation.

Mechanical Interlock Removal 250-1250 Ampere ATS Units

1. Turn off normal and emergency power sources and open the front panel of the ATS enclosure.
2. Remove four screws and lift the cover off the mechanical interlock. See Figure 6-8.

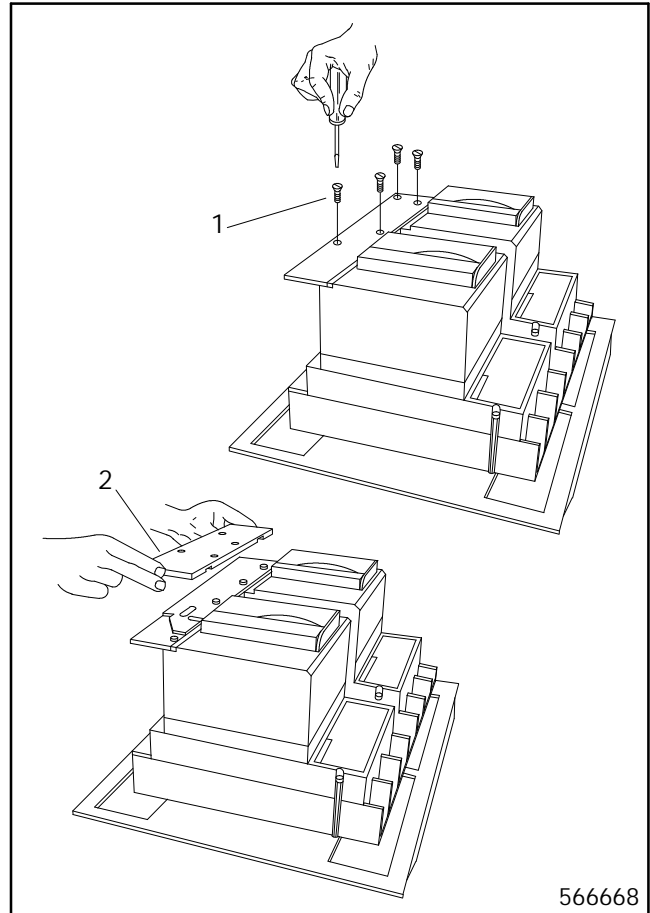

1. Screw 2. Cover

**Figure 6-8. Mechanical Interlock Cover Removal,
250-1250 Ampere ATS Units**

- Remove four screws and flat washers and slide the mechanical interlock off both contactors. See Figure 6-9.

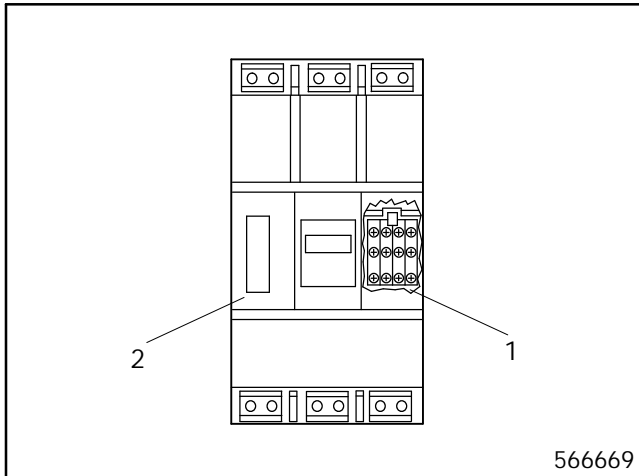

- Auxiliary Switch
- Cover

**Figure 6-9. Mechanical Interlock Removal,
250-1250 Ampere ATS Units**

Mechanical Interlock Installation 250-1250 Ampere ATS Units

- Carefully engage the mechanical interlock with the interlock control arms of the two contactors. See Figure 6-10.

NOTE

To engage the interlock in both contactors, at least one contactor must be set to OFF. See Manual Operation in Section 2.

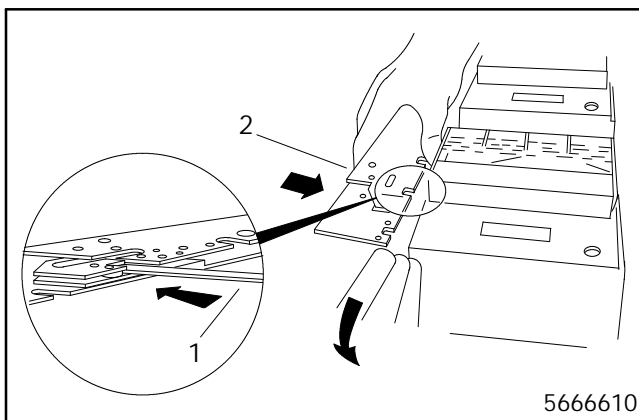

- Interlock Control Arm
- Mechanical Interlock

**Figure 6-10. Mechanical Interlock Installation,
250-1250 Ampere ATS Units**

- Install the four screws and flat washers to secure the mechanical interlock in place. Tighten the screws to a torque of 31 pound-inches (3.5 Nm).
- Slide knob in center of mechanical interlock fully to the left. When released, knob should return to center position. Repeat process, sliding knob fully to the right. If knob fails to return to center position after being moved to the left or right, check and correct part alignments.
- Place cover on mechanical interlock. Install the four screws to secure the cover in place.
- Return the ATS to normal operation.

Mechanical Interlock Removal 1600-4000 Ampere ATS Units

- Turn off normal and emergency power sources and open the front panel of the ATS enclosure.
- Loosen the set screw in the mechanical interlock collar. Then slide the rod out of the collar and also off the peg at the other end of the rod. See Figure 6-11.

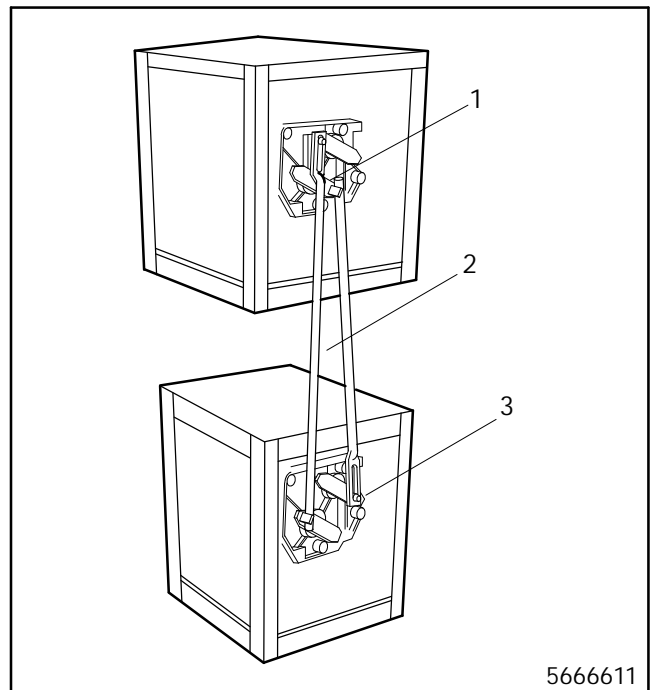

- Collar
- Rod
- Peg

Figure 6-11. Mechanical Interlock Rod Removal

- Repeat step 2 to remove other mechanical interlock rod.
- Remove screws and nuts and separate mechanical interlock plate from side of circuit breaker or switch.

NOTE

When removing mechanical interlock plate, remove front cover of circuit breaker or switch as needed for access to screws/nuts.

- If removal of mechanical interlock plate from other circuit breaker or switch is necessary, repeat step 4.

**Mechanical Interlock Installation
1600-4000 Ampere ATS Units**

- Place mechanical interlock plate on right side of circuit breaker or switch, matching pegs on rear of plate with mating holes in circuit breaker or switch. Then install nuts and screws to secure plate to side of circuit breaker or switch. See Figure 6-12.

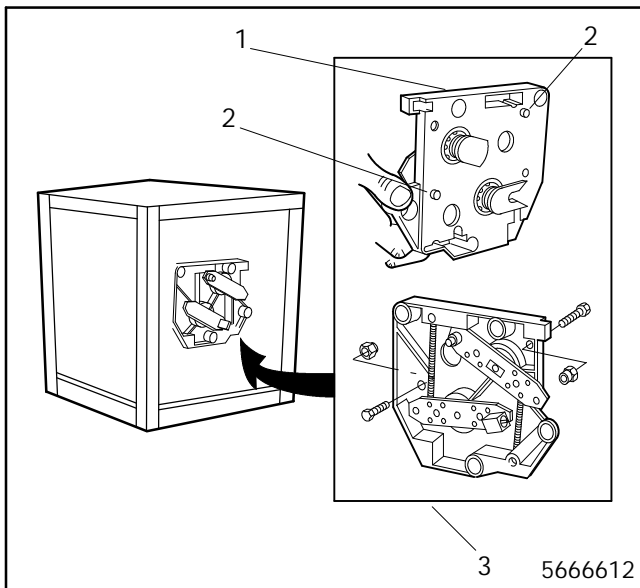

- Plate
- Peg
- Circuit Breaker/Switch

Figure 6-12. Installing Mechanical Interlock Plate

- Repeat step 1, to install other mechanical interlock plate on remaining circuit breaker or switch.
- If new rods are being installed, use a hacksaw to trim the rods to the same length as the previous rods.

NOTE

If previous rod broke, measure distances between attaching points on the two mechanical interlock plates. Cut the rod so the distance from the trimmed end to the far end of the slot on the other end of the rod is 0.375 inch (10 mm) longer than the distance between the two attaching points. See Figure 6-13.

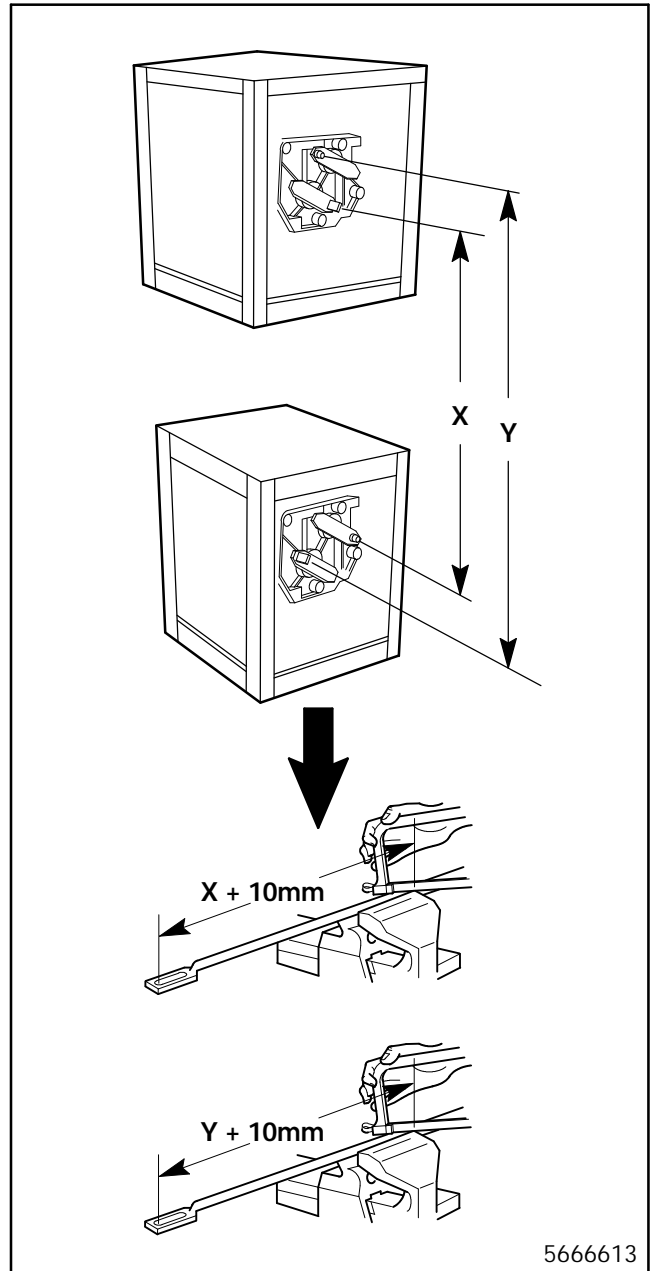

Figure 6-13. Mechanical Interlock Rod Trimming

4. Install the end of the rod with the round cross-section through the collar on one mechanical interlock plate and the slot on the other end of the rod over the peg on the other mechanical interlock plate. Pull the round cross-section end of the rod through the collar until the peg is at the far end of the slot. Then tighten the setscrew to secure the rod to the collar.

NOTE

To install the interlock rods, at least one contactor must be set to OFF. See Manual Operation in Section 2.

5. Repeat step 4 to install remaining mechanical interlock rod.
6. Return the ATS to normal operation. See Automatic Operation in the operation section of this manual

Motor Operator Removal 40-160 Ampere ATS Units

1. Turn off normal and emergency power sources and open the front panel of the ATS enclosure.
2. Remove mechanical interlock. See Mechanical Interlock Removal, 40-160 Ampere ATS Units earlier in this section.
3. Disconnect the motor operator plug. See Figure 6-14.

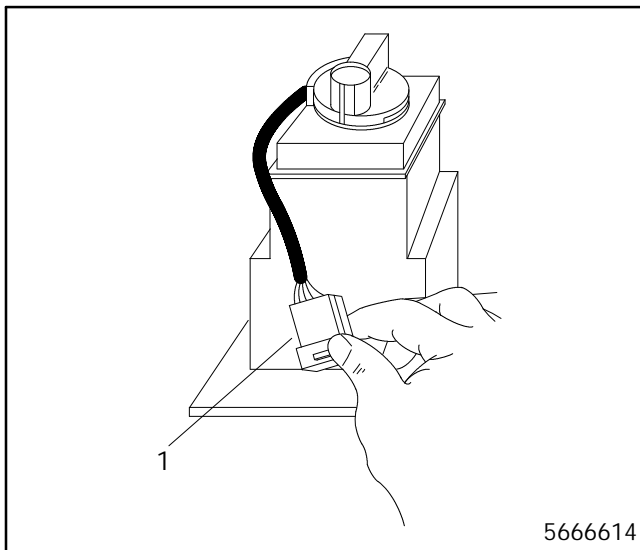

1. Plug

**Figure 6-14. Motor Operator Disconnection,
40-160 Ampere ATS Units**

4. Operate the motor operator slide switch and remove the screw that secures the motor operator cover. See Figure 6-15.

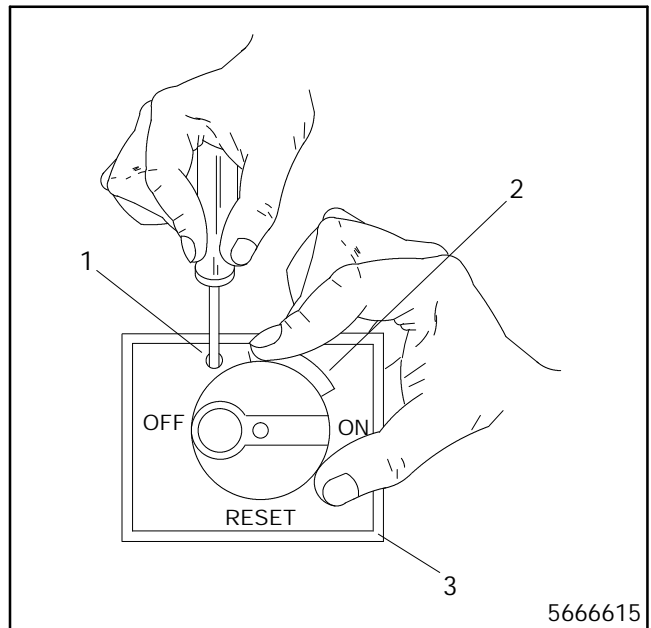

1. Screw
2. Slide Switch
3. Cover

**Figure 6-15. Motor Operator Cover Release,
40-160 Ampere ATS Units**

5. Swing the motor operator cover to its fully open position. See Figure 6-16.

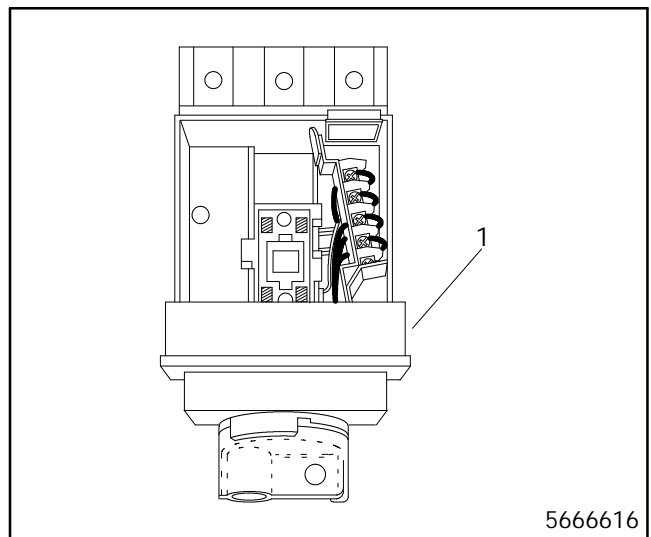

1. Motor operator

**Figure 6-16. Open Motor Operator Cover,
40-160 Ampere ATS Units**

6. Fold terminal block out of the way. Remove two screws and lift the motor operator off the circuit breaker/switch frame. See Figure 6-17.

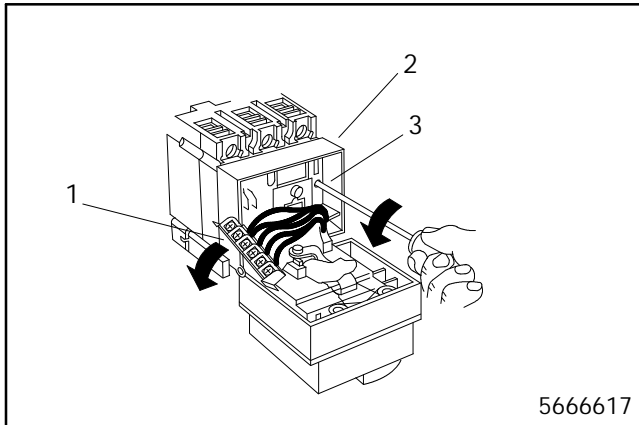

1. Terminal Block
2. Motor Operator
3. Screw

**Figure 6-17. Motor Operator Removal,
40-160 Ampere ATS Units**

Motor Operator Installation 40-160 Ampere ATS Units

1. Place the motor operator on the circuit breaker/switch frame.
2. Open the front cover of the motor operator and install the two screws to secure the motor operator to the circuit breaker/switch frame.
3. Reposition the terminal block and close the front cover of the motor operator.
4. Operate the slide switch and install the screw to secure the front cover in place. Tighten the screw to a torque of 13.3 pound-inches (1.5 Nm).
5. Reconnect the motor operator plug to the contactor assembly harness.
6. Reinstall the mechanical interlock. See Mechanical Interlock Installation, 40-160 Ampere ATS Units earlier in this section.

Motor Operator Removal 250-1250 Ampere ATS Units

1. Turn off normal and emergency power sources and open the front panel of the ATS enclosure.
2. Remove the mechanical interlock. See Mechanical Interlock Removal, 40-160 Ampere ATS Units earlier in this section.
3. Remove the two screws that secure the motor operator cover. See Figure 6-18.

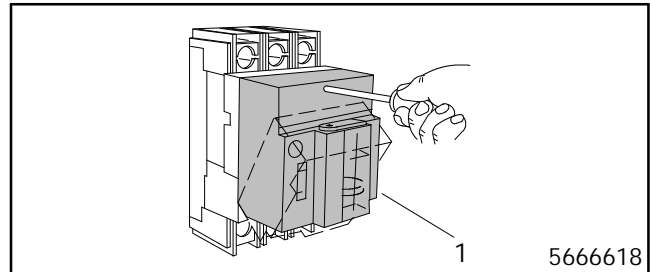

1. Motor Operator Cover

**Figure 6-18. Motor Operator Cover Release,
250-1250 Ampere ATS Units**

4. Disconnect the motor operator harness plug from the contactor harness. Then swing the cover open. See Figure 6-19.

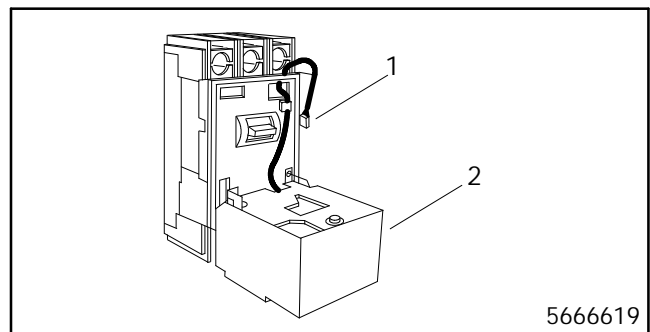

1. Motor Operator Plug
2. Motor Operator Cover

**Figure 6-19. Open Motor Operator Cover,
250-1250 Ampere ATS Units**

- Remove the two screws and lift the motor operator off the circuit breaker/switch frame. See Figure 6-20.

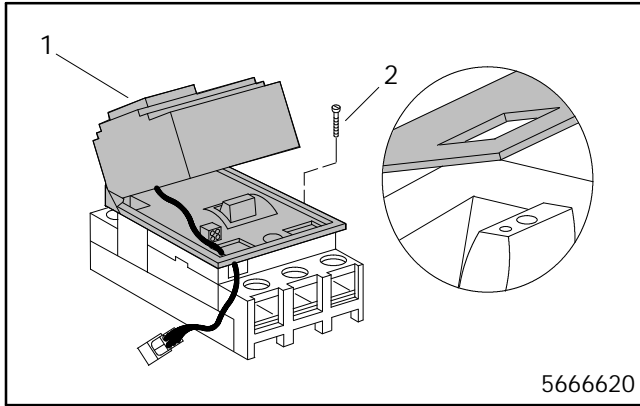

- Motor Operator
- Screw

**Figure 6-20. Motor Operator Removal,
250-1250 Ampere ATS Units**

- If the motor operator is to be replaced, remove and save the interlock control arm. See Figure 6-21.

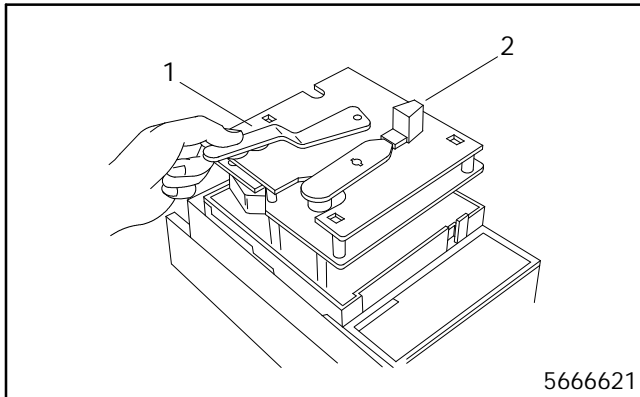

- Interlock Control Arm
- Manual Operator

**Figure 6-21. Interlock Control Arm Removal,
250-1250 Ampere ATS Units**

Motor Operator Installation 250-1250 Ampere ATS Units

- When installing a new motor operator, install the interlock control arm saved from the previous motor operator. See Figure 6-22.

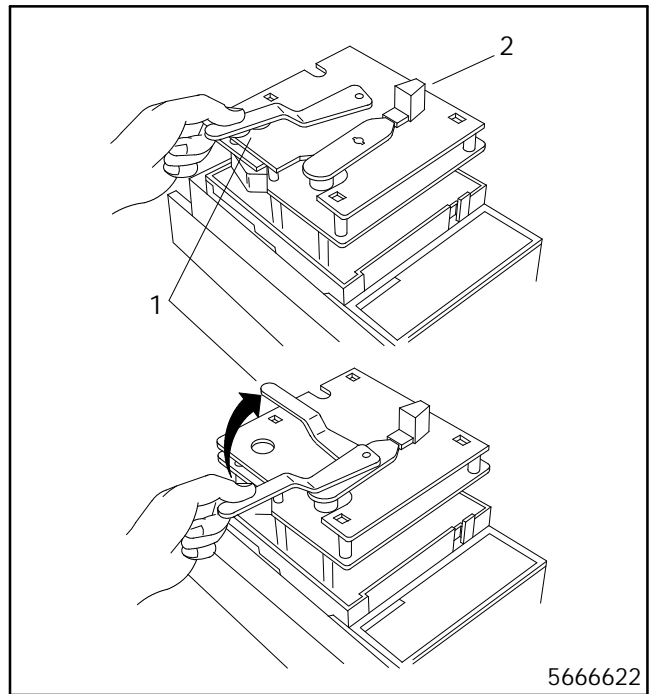

- Interlock Control Arm
- Manual Operator

Figure 6-22. Install Interlock Control Arm

- Place the motor operator on the circuit breaker/switch frame.
- Open the front cover of the motor operator and install the two screws to secure the motor operator to the circuit breaker/switch frame.
- After ensuring that the motor operator harness is properly routed, close the front cover of the motor operator.

5. Install the two screws to secure the front cover in place.
6. Reconnect the motor operator harness plug to the contactor assembly harness.
7. Reinstall the mechanical interlock. See **Mechanical Interlock Installation, 250-1250 Ampere ATS Units** earlier in this section.

Auxiliary Switch Removal 40-1250 Ampere ATS Units

1. Turn off normal and emergency power sources and open the front panel of the ATS enclosure.
2. Remove the mechanical interlock. See Mechanical Interlock Removal, 40-160 Ampere ATS Units or Mechanical Interlock Removal, 250-1250 Ampere ATS Units earlier in this section.
3. Remove the motor operator. See Motor Operator Removal, 40-160 Ampere ATS Units or Motor Operator Removal, 250-1250 Ampere ATS Units earlier in this section.
4. Loosen and remove the cover from the circuit breaker/switch frame. See Figure 6-23, 6-24, or 6-25.

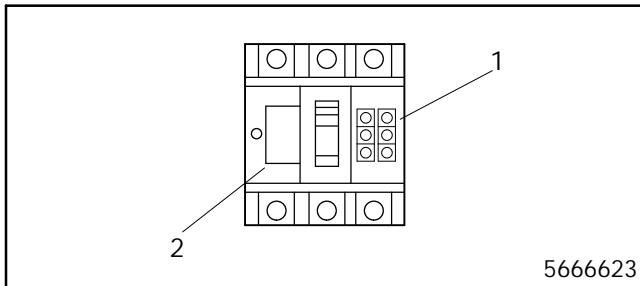

1. Auxiliary Switch 2. Cover

**Figure 6-23. Auxiliary Switch Removal,
40-160 Ampere ATS Units**

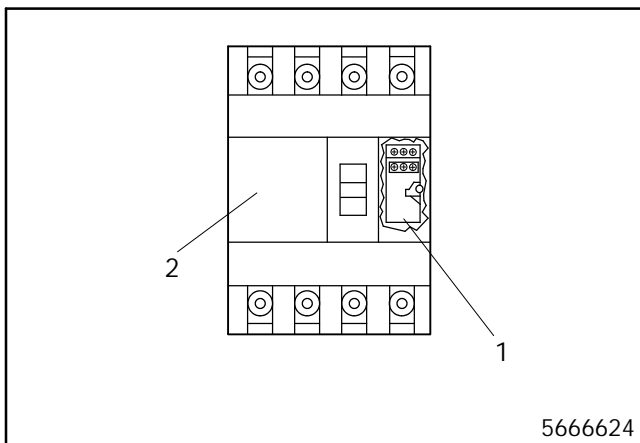

1. Auxiliary Switch 2. Cover

**Figure 6-24. Auxiliary Switch Removal,
250 Ampere ATS Units**

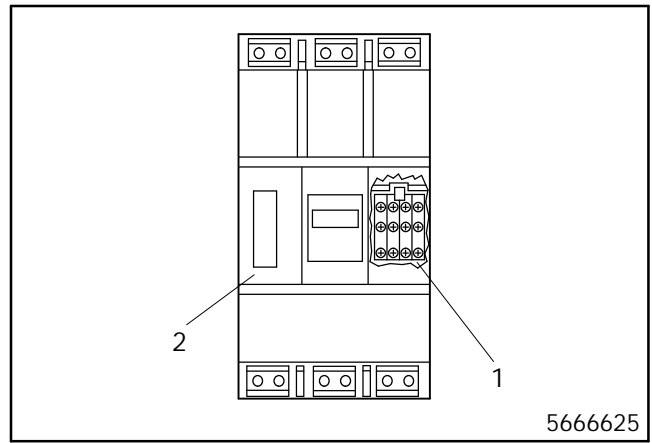

1. Auxiliary Switch 2. Cover

**Figure 6-25. Auxiliary Switch Removal,
400-1250 Ampere ATS Units**

5. Note routing and connections of auxiliary switch. Then disconnect and remove the auxiliary switch.

Auxiliary Switch Installation 40-1250 Ampere ATS Units

1. Place auxiliary switch into circuit breaker/switch frame. Route and reconnect switch leads to same points noted during removal.
2. Install the cover on the circuit breaker/switch frame.
3. Install the motor operator. See Motor Operator Installation, 40-160 Ampere ATS Units or Motor Operator Installation, 250-1250 Ampere ATS Units earlier in this section.
4. Install the mechanical interlock. See Mechanical Interlock Installation, 40-160 Ampere ATS Units or Mechanical Interlock Installation, 250-1250 Ampere ATS Units earlier in this section.

Section 7. Service Parts

Introduction

Use this section to locate and identify service parts for the 40-4000 ampere models of the automatic transfer switches that use molded-case switches and molded-case circuit breakers as the power conversion unit. The part numbers of the automatic transfer switches covered by the parts lists in this section will begin with TES- or TLS-MMS-MNS-.

This section does not include nonserviceable parts of the automatic transfer switch or any parts of the logic controller within the automatic transfer switch. A separate service and parts manual is provided for each logic controller model. To locate and identify logic controller parts, refer to the List of Related Manuals in the Introduction for the name and number of the service and parts manual for the applicable logic controller.

Using Parts Lists

Finding Parts Information

1. Use the illustration on page 7-2 to determine the description of parts group.
Example: An enclosed door hinge needs replacement. It is part of the enclosure.
2. Use the list on page 7-2 to locate the illustration identified in step 1.
Example: Turn to the **Enclosures** illustration on page 7-3.

NOTE

Some items have more than one illustration. In this case, pick the illustration that corresponds to the ATS rating.

3. Locate the part in the illustration.
Example: The door hinge is item 4.
4. Find the item number in the associated parts list on the same or facing page.
Example: Find number 4 in the **Item** column.
5. Use the remaining columns of the parts list to find the official part name and part number.
Example: The name in the **Description** column for item 4 is "Hinge." The number in the **Part Number** columns for both sets of ratings for item 4 is 294749-BLK. The number 2 or 3 in parentheses () preceding the **Part Number** indicates the quantity of the item.

NOTE

If there is no number in parentheses preceding the Part Number, the quantity of that item is one (1).

Leads

Most leads are included with the appropriate wiring harness. Otherwise fabricate a replacement lead using the same type of standard copper wire (gauge, color, length). Add terminals and lead designations at each end of the new lead.

Automatic Transfer Switch

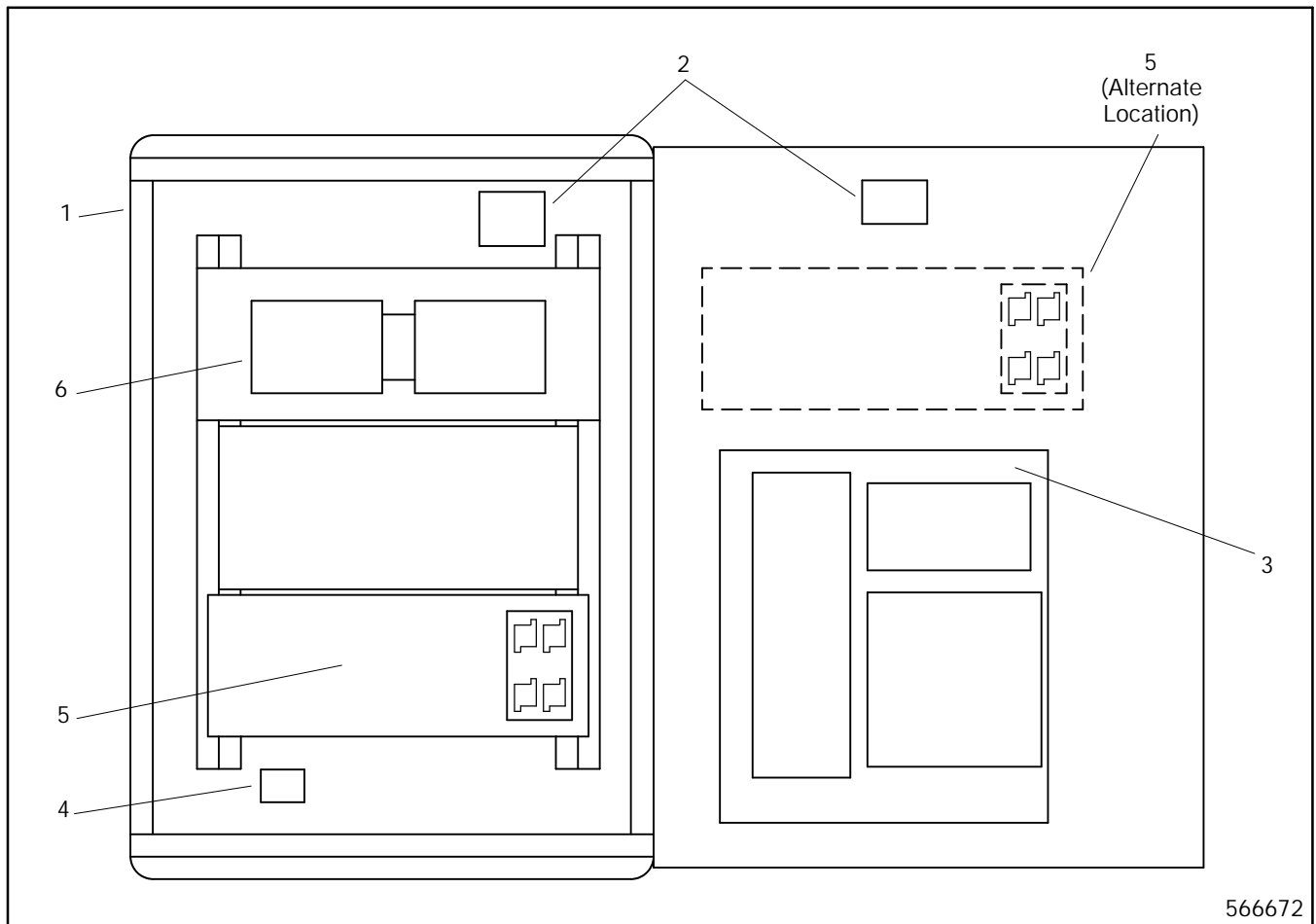

Item	Group Description	For further break-down, see
1	Enclosure	Enclosures , pages 7-3, 7-4, or 7-5
2	Decals	Decals , page 7-6
3	Logic Controller	Appropriate logic controller manual
4	Neutral Lug (Optional)	Neutral Lugs , pages 7-7, 7-8, or 7-9
5	Interface Panel Assembly	Interface Panel Assemblies (See Table to Right)
6	Contractor Assembly	Contractor Assemblies , pages 7-13 thru 7-34

ATS Rating Data		Interface Panel Assembly
Amps	Volts	
40-160	120	Type A (Page 10)
	208	Type B (Page 11)
	220-416	Type A (Page 10)
250-1200	480-600	Type B (Page 11)
	120-480	Type A (Page 10)
	600	Type C (Page 12)
1600-4000	Any	Type C (Page 12)

Enclosures

40-250 Amps

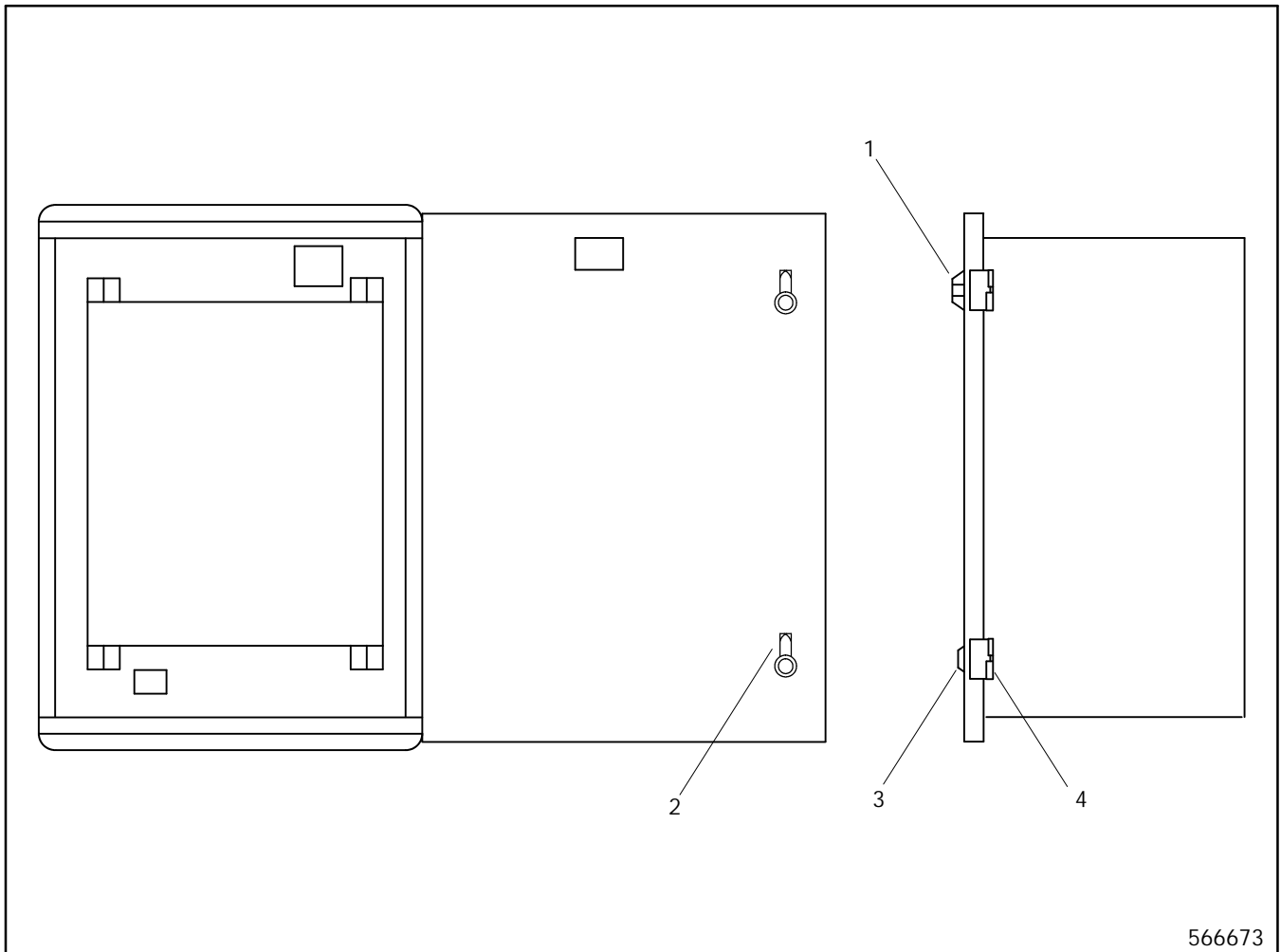

Item	Description	Part Number	
		40/80/100/160 Amp	250 Amp
1	Handle, latch	320822	320822
2	Cam	(2) 320824	(2) 320824
3	Latch	320823	320823
4	Hinge	(2) 294749-BLK	(3) 294749-BLK

Enclosures

400-1200 Amps

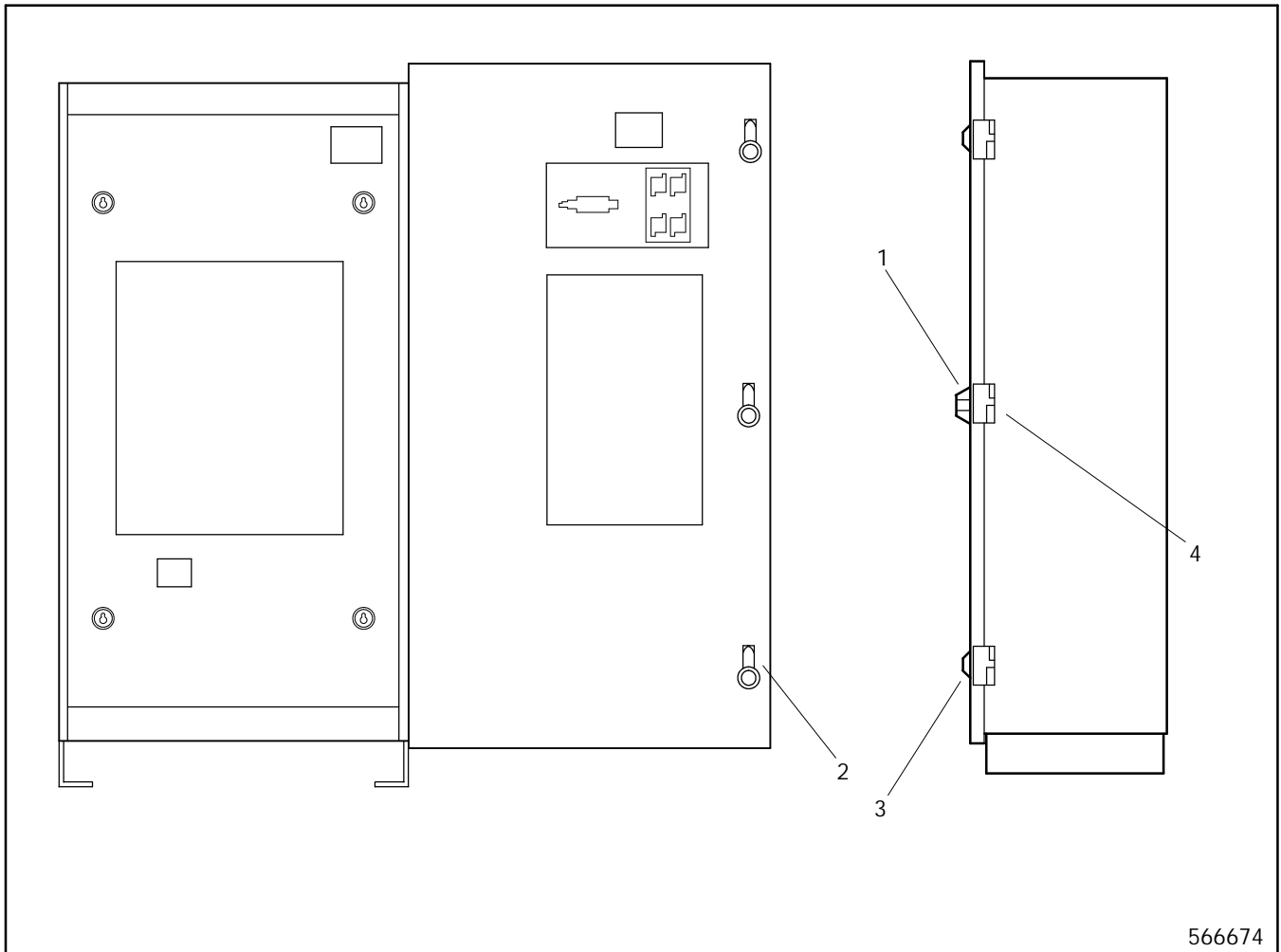

Item	Description	Part Number 400-1200 Amp
1	Handle, latch	320822
2	Cam	(3) 320824
3	Latch	(2) 320823
4	Hinge	(3) 294749-BLK

Enclosures

1600-4000 Amps

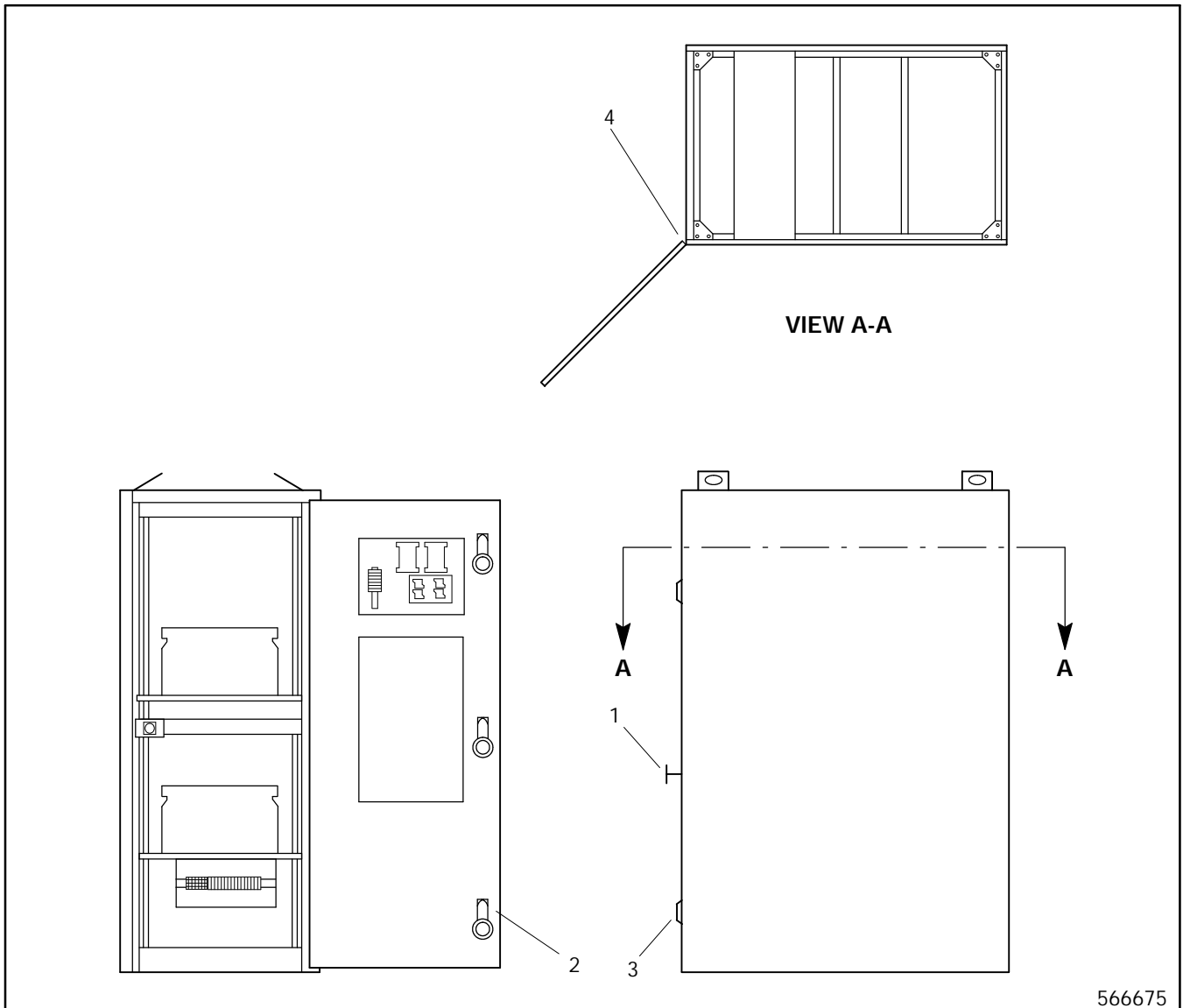

Item	Description	Part Number 1600-4000 Amp
------	-------------	------------------------------

1	Handle, latch	320821
2	Cam	(3) 320824
3	Latch	320823
4	Hinge	(4) 297600

Decals

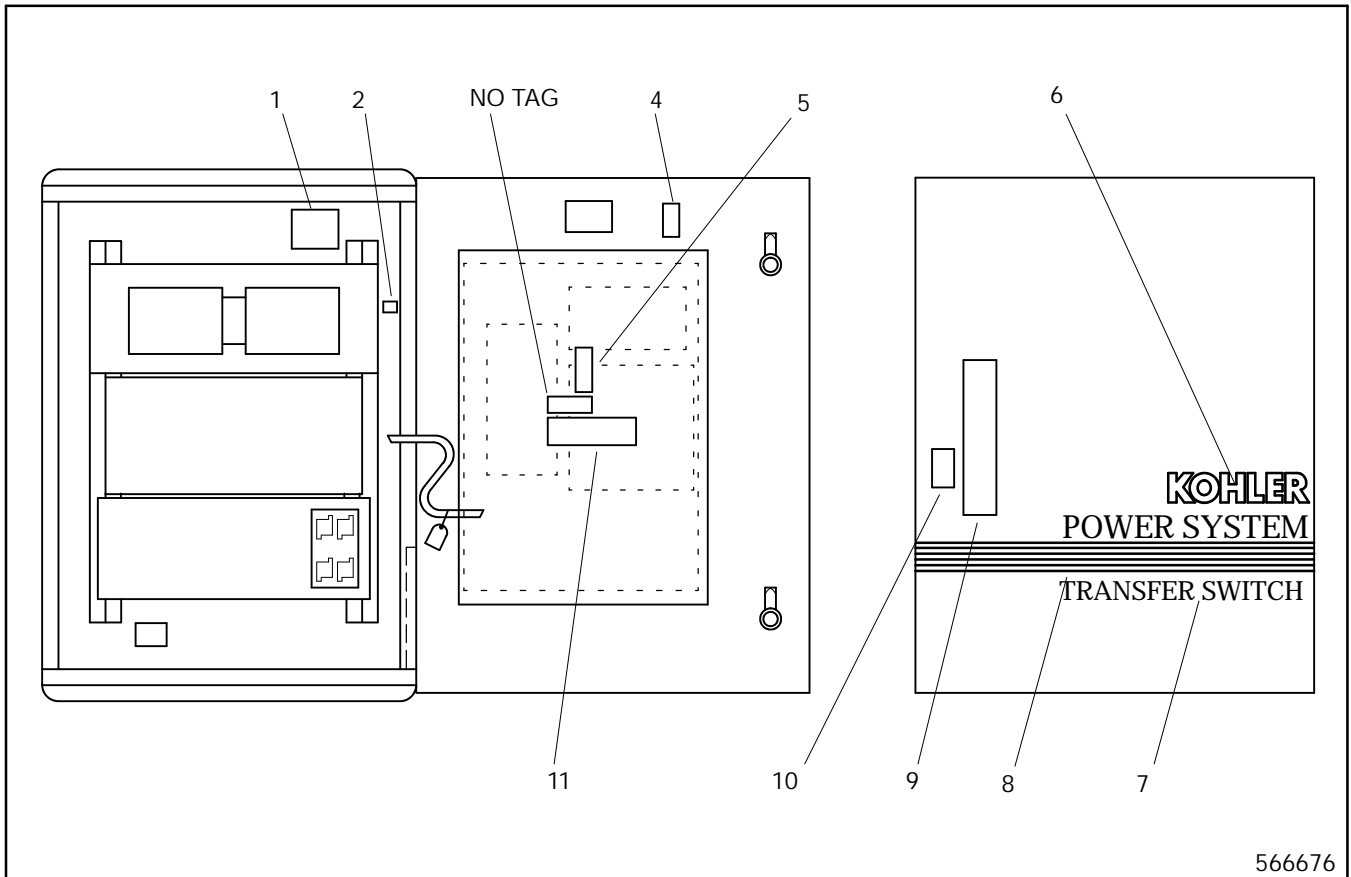

566676

Item	Description	Part Number	
		E33+/S340+ Logic	M340+ Logic
1	Decal, notice	294414	294414
2	Decal, engine start	321026	321026
3	Decal	295933	N/A
4	Decal, 1-800 number	224233	224223
5	Decal, warning	294328	294328
6	Decal, "Kohler Power System"	X-6246-3	X-6246-3
7	Decal, "Transfer Switch"	273746	273746
8	Decal, gold stripes	X-6232-2	X-6232-2
9	Decal, instruction	320834	320834
10	Decal, danger	294520	294520
11	Decal, ATS	295261	294523

Neutral Lugs

40-160 Amps

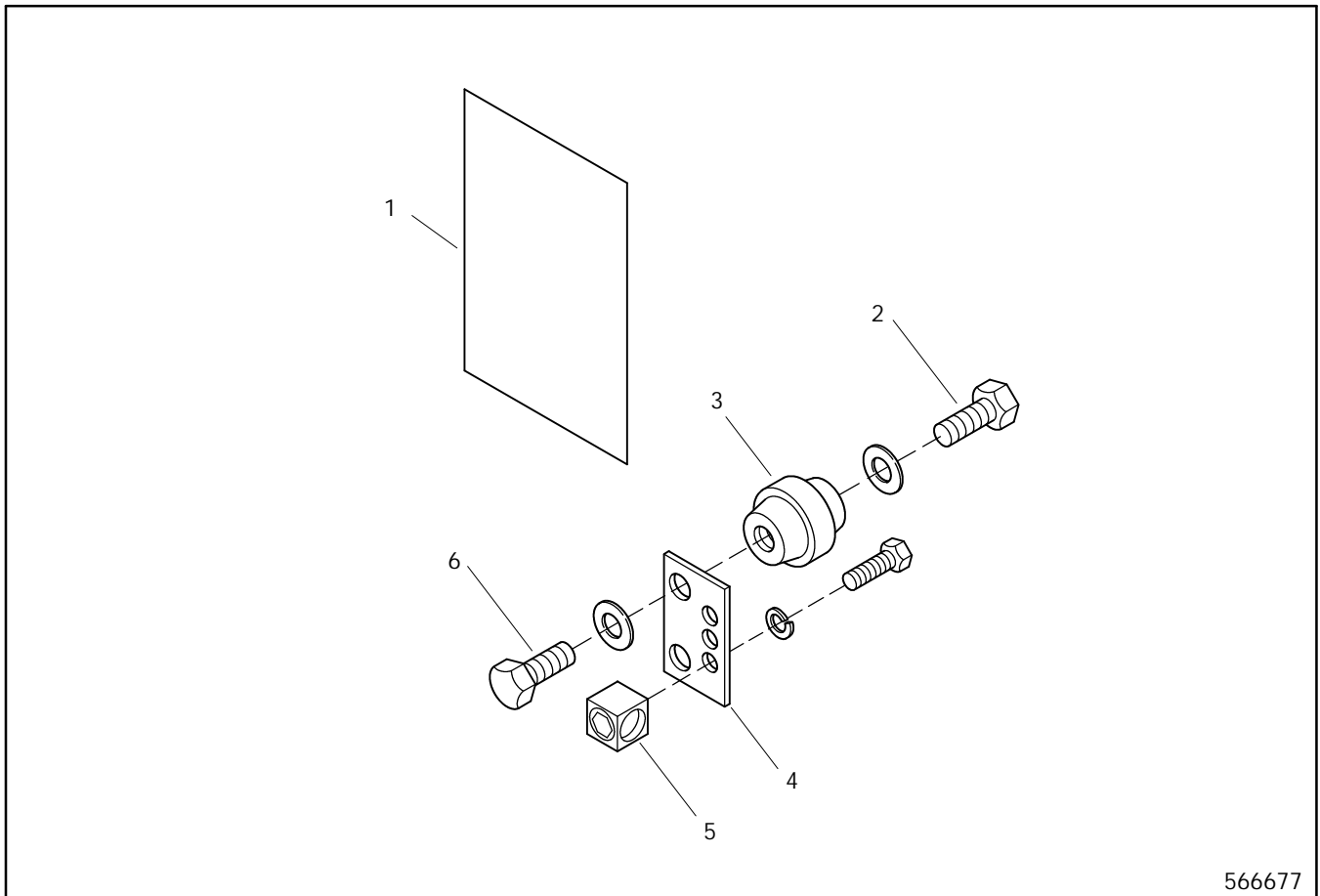

566677

Item	Description	Part Number	
		40-100 Amp	160 Amp
1	Decal	297556	297556
2	Screw	(2) X-6238-2	(2) X-6238-2
3	Insulator, standoff	(2) 233568	(2) 233568
4	Bracket, mounting	321015	321016
5	Lug terminal	(3) X-6238-2	(3) 297712
6	Screw	(2) X-6238-10	(2) X-6238-10

Neutral Lugs

630-1200 Amps

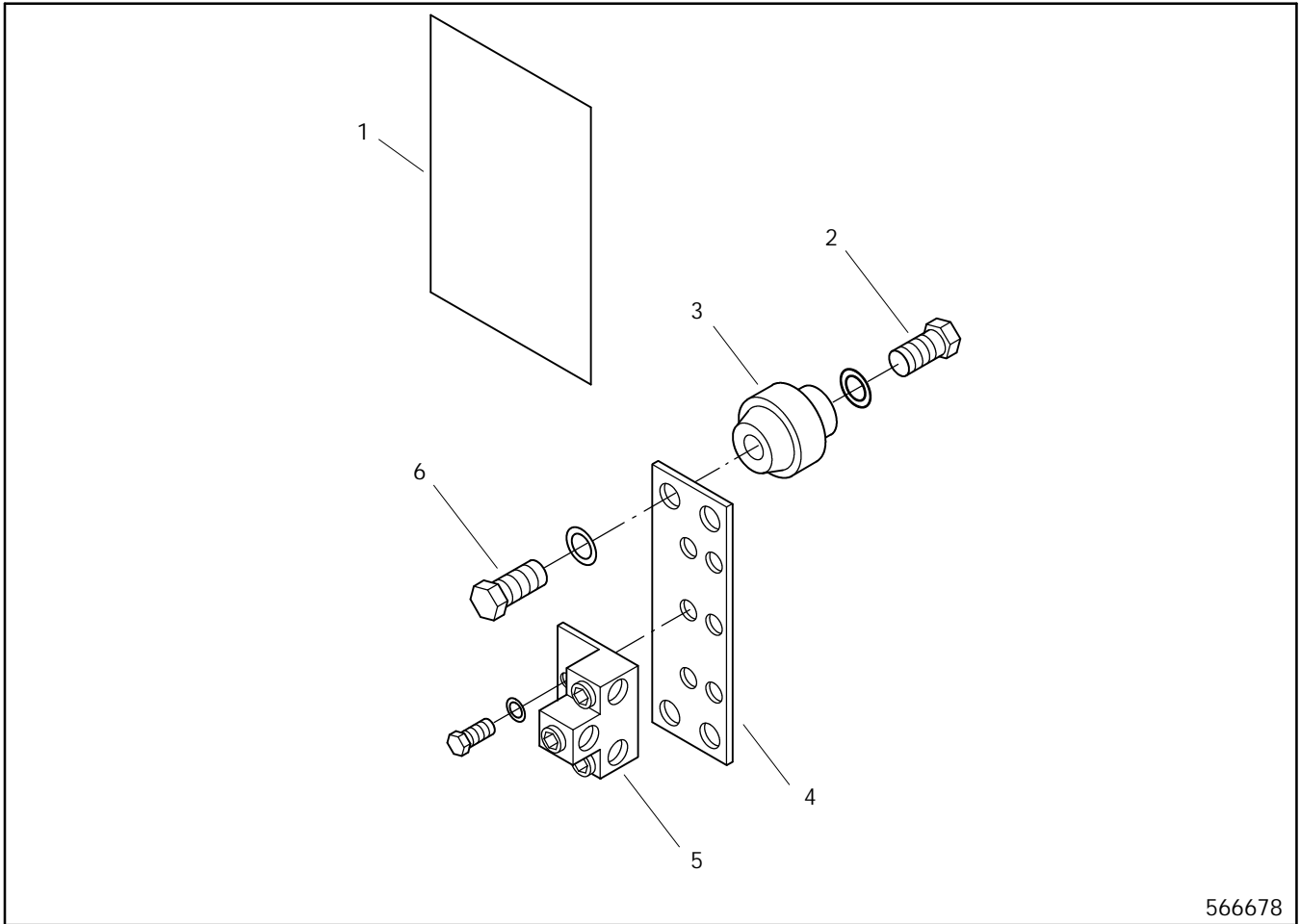

566678

Item	Description	Part Number	
		630/800 Amp	1000/1200 Amp
1	Decal	297556	297556
2	Screw	(4) X-6238-2	(4) X-6238-2
3	Insulator, standoff	(4) 233568	(4) 233568
4	Bracket, mounting	320948	320948
5	Lug terminal	(3) 295296	(3) 297582
6	Screw	(4) X-6238-10	(4) X-6238-10

Neutral Lugs

250-400 Amps

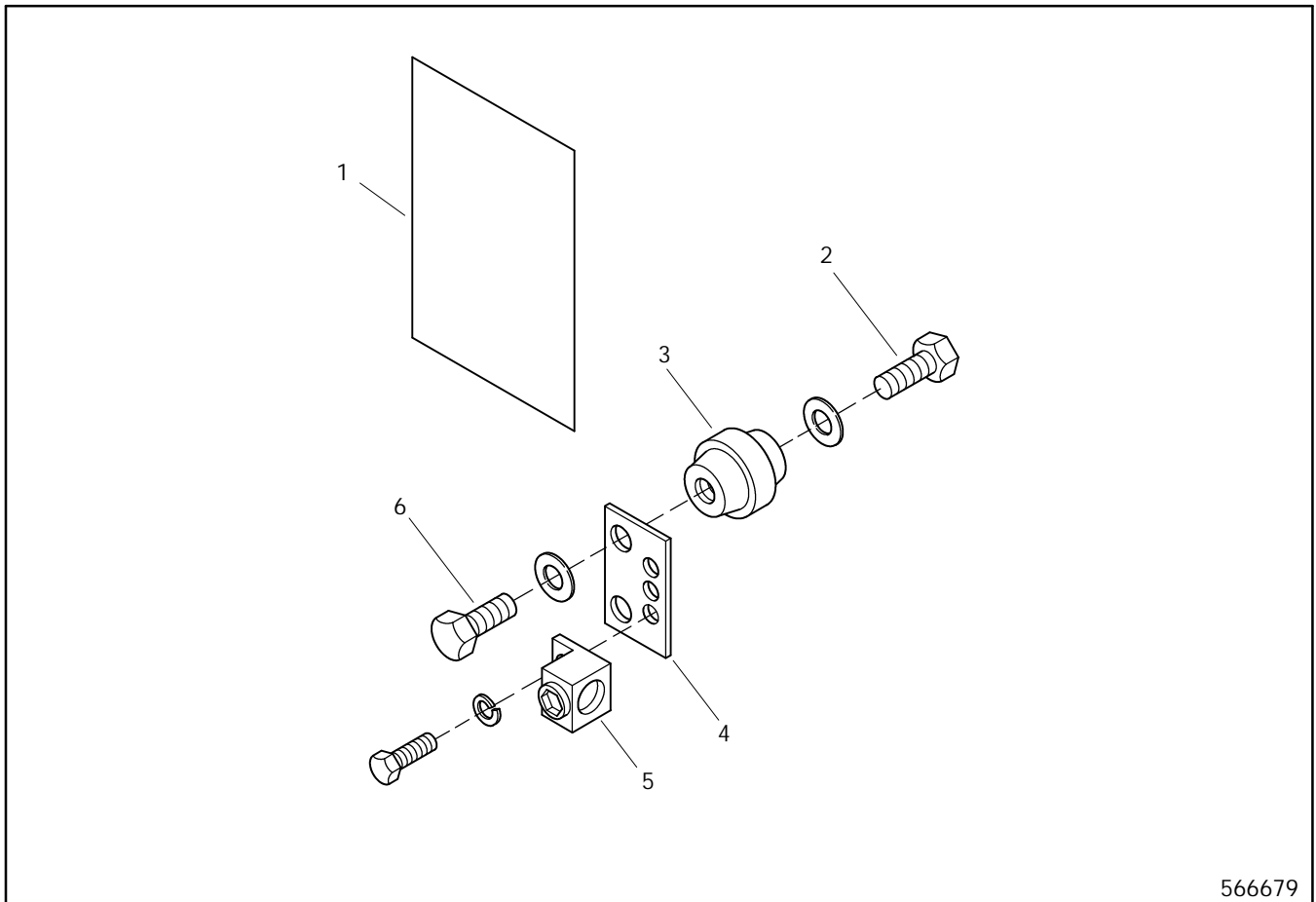

Item	Description	Part Number	
		250 Amp	400 Amp
1	Decal	297556	297556
2	Screw	(3) X-6207-5	(3) X-6207-9
3	Insulator, standoff	(2) 233568	(4) 233568
4	Bracket, mounting	320909	320947
5	Lug terminal	(2) X-6238-2	(4) X-6238-2
6	Screw	(2) X-6238-10	(4) X-6238-10

Interface Panel Assemblies

Type A

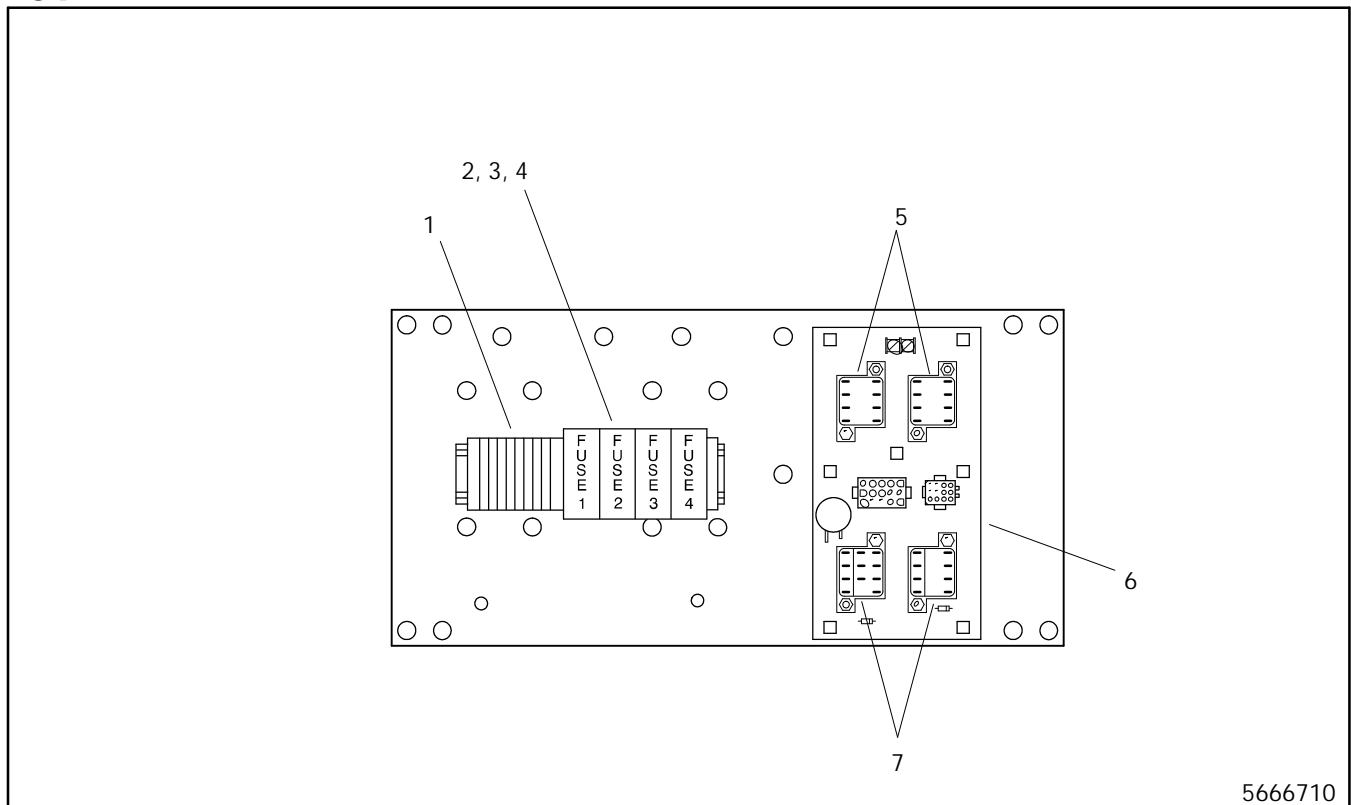

5666710

Item	Description	Part Number
1	Terminal	(4) 321021
2	Block, fuse	X-6129-8
3	Puller, safety	(4) X-6129-9
4	Fuse	(4) X-6135-6
5	Relay, Time Delay	(2) 320695
6	Interface Board Assembly	A-320687
7	Relay	(2) 295318

Interface Panel Assemblies

Type B

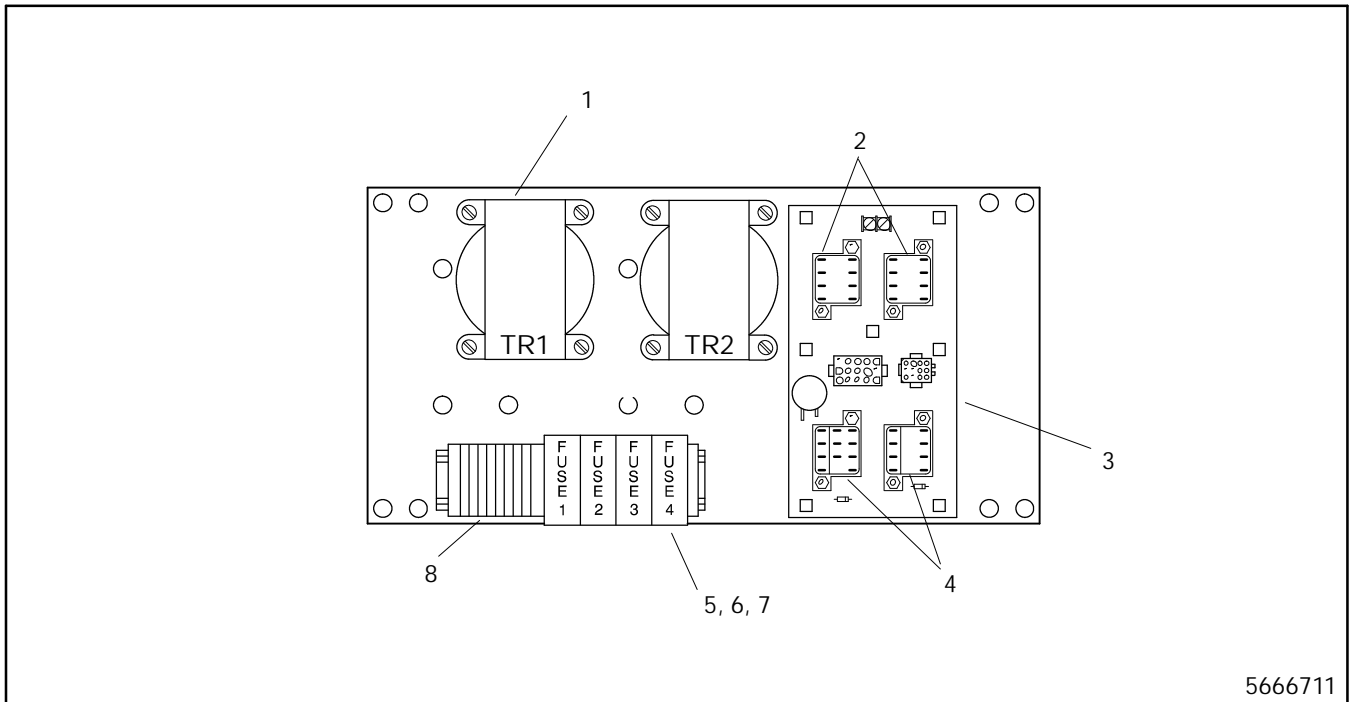

5666711

Item	Description	Part Number
1	Transformer	See Table At Right
2	Relay, Time Delay	(2) 320695
3	Interface Board Assembly	A-320687
4	Relay	(2) 295318
5	Block, fuse	X-6129-8
6	Puller, safety	(4) X-6129-9
7	Fuse	(4) X-6135-6
8	Terminal	(4) 321021

ATS Rated Voltage	Transformer Part Number
208	330855
380	330880
480	330857
600	330858

Interface Panel Assemblies

Type C

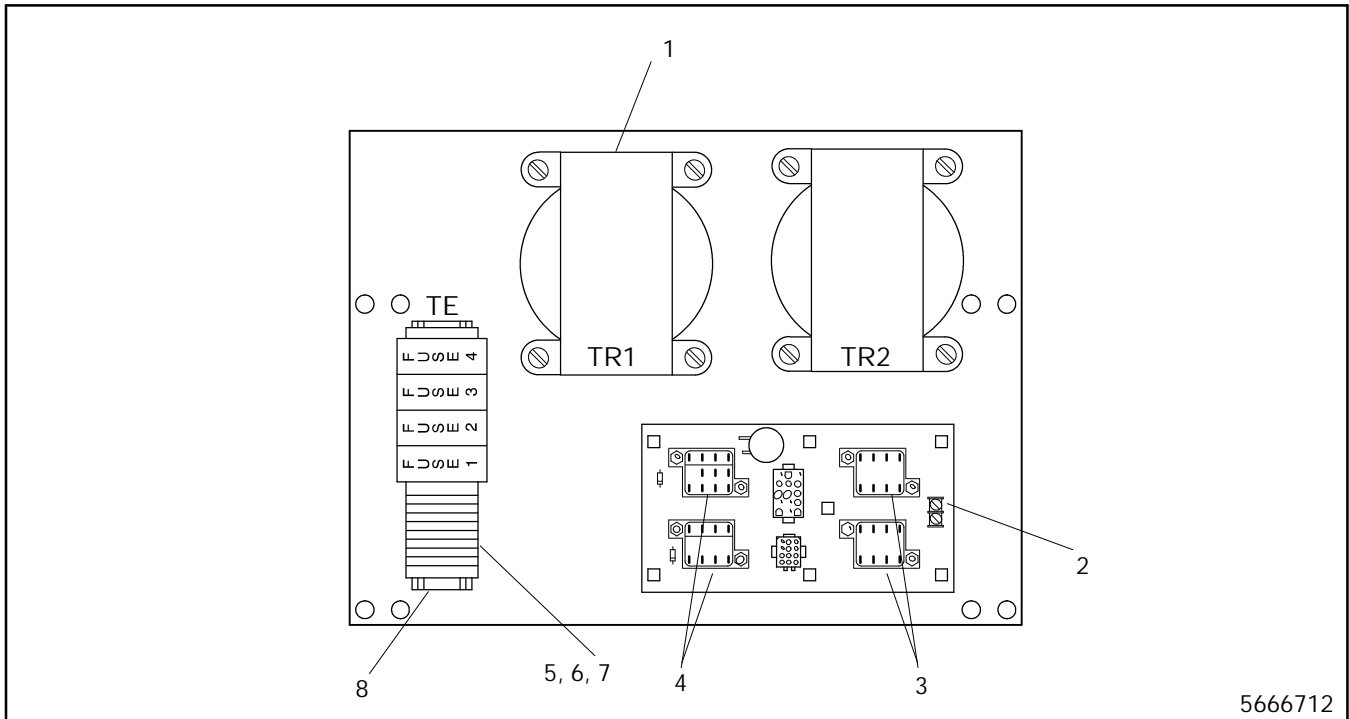

5666712

Item	Description	Part Number
1	Transformer	See Table At Right
2	Interface Board Assembly	A-320687
3	Relay, Time Delay	(2) 320695
4	Relay	(2) 295318
5	Block, fuse	X-6129-8
6	Puller, safety	(4) X-6129-9
7	Fuse	(4) X-6135-6
8	Terminal	(4) 321021

ATS Rated Voltage	Transformer Part Number
120	321188
208	321187
220/240	None
380	321186
416	321185
480	321184
600	321183

Contactors Assemblies

40 Amps, 3-Poles

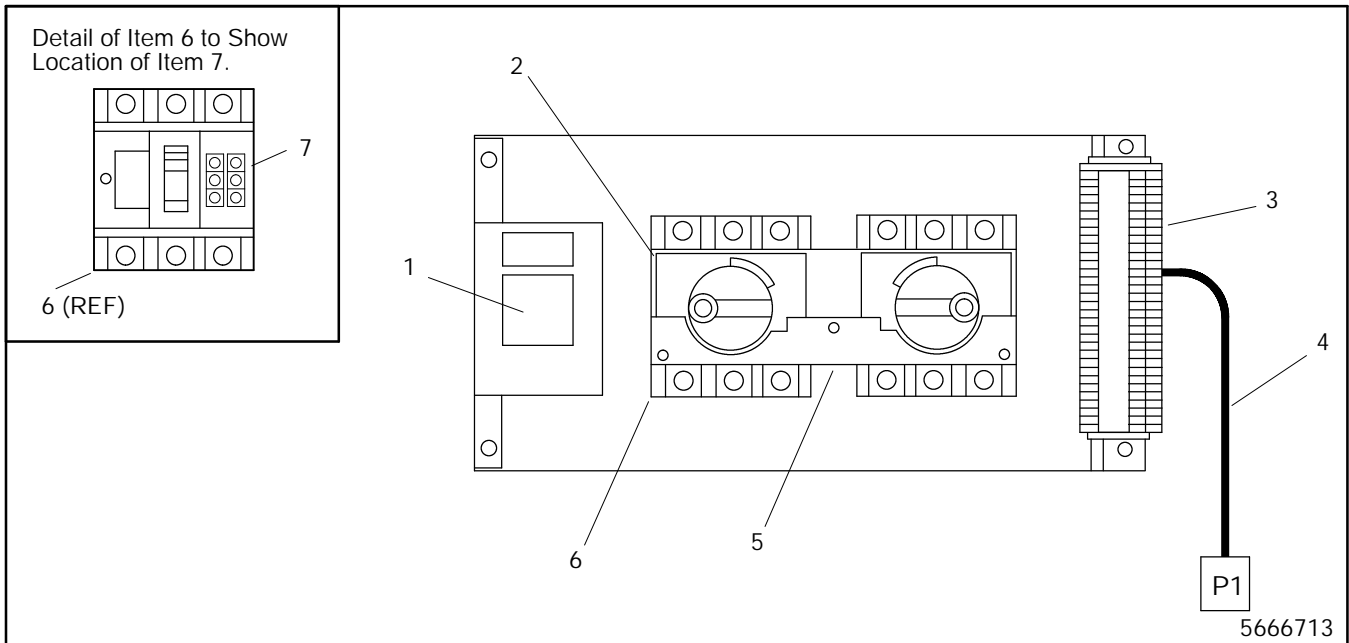

Item	Description	Part Number
1	Switch, 2-position, 4-pole	X-6108-41
2	Operator, motor	See Table to Right
3	Block, terminal	(34) 321021
4	Harness	320986
5	Interlock, mechanical	X-6311-3
6	Frame, circuit breaker	(2) A-330290
7	Switch, auxiliary	(2) X-6315-11

ATS Rating Data		Motor Operator (Item 2) Part Number
Volts	Hz	
110/127	50	X-6309-1
110/127	60	X-6309-5
208	60	X-6309-5
220/240	50	X-6309-2
220/240	60	X-6309-6
380/415	50	X-6309-3
440	50	X-6309-4
440	60	X-6309-3
480	60	X-6309-6
600	60	X-6309-6

Contactors Assemblies

40 Amps, 4-Poles

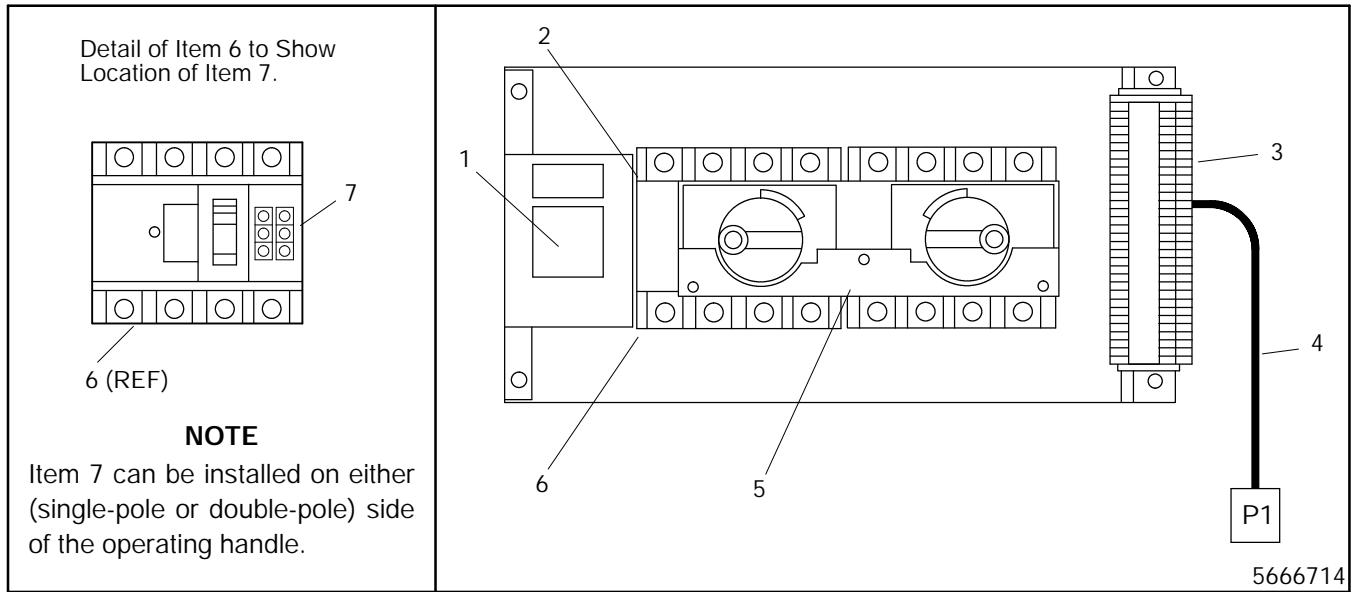

Item	Description	Part Number
1	Switch, 2-position, 4-pole	X-6108-41
2	Operator, motor	See Table to Right
3	Block, terminal	(34) 321021
4	Harness	320986
5	Interlock, mechanical	X-6311-3
6	Frame, circuit breaker	(2) A-330300
7	Switch, auxiliary	(2) X-6315-11

ATS Rating Data		Motor Operator (Item 2) Part Number
Volts	Hz	
110/127	50	X-6309-1
110/127	60	X-6309-5
208	60	X-6309-5
220/240	50	X-6309-2
220/240	60	X-6309-6
380/415	50	X-6309-3
440	50	X-6309-4
440	60	X-6309-3
480	60	X-6309-6
600	60	X-6309-6

Contactors Assemblies

80 Amps, 3-Poles

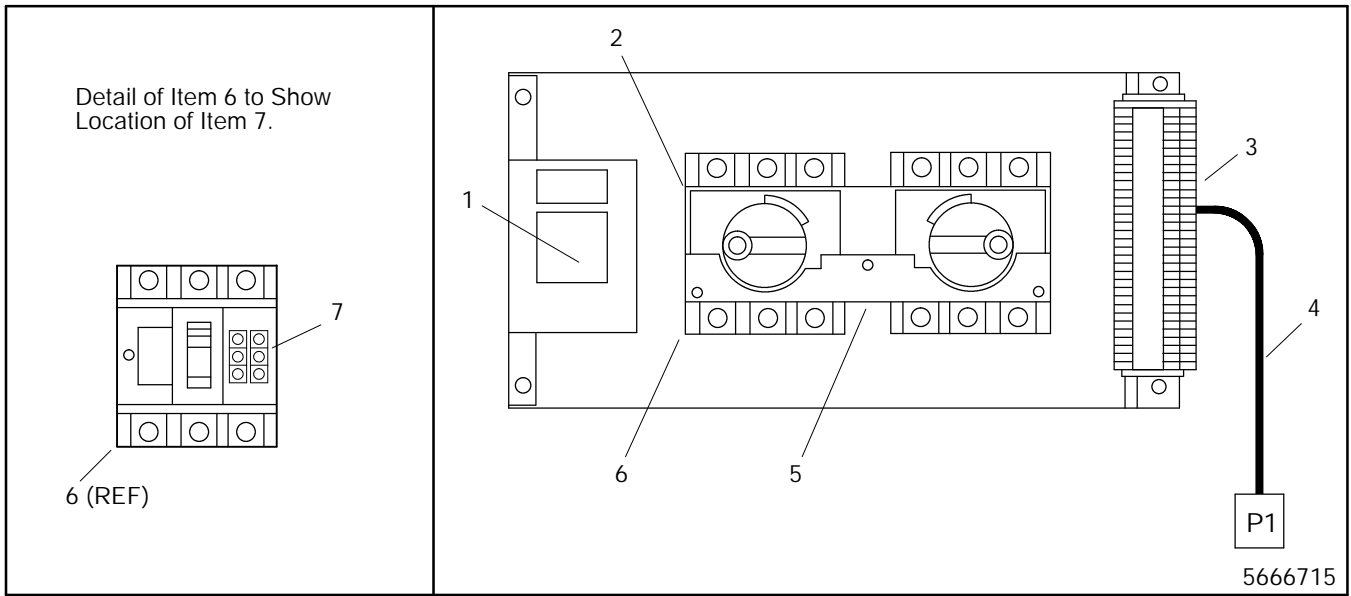

Item	Description	Part Number
1	Switch, 2-position, 4-pole	X-6108-41
2	Operator, motor	See Table to Right
3	Block, terminal	(34) 321021
4	Harness	320986
5	Interlock, mechanical	X-6311-3
6	Frame, circuit breaker	(2) A-330291
7	Switch, auxiliary	(2) X-6315-11

ATS Rating Data		Motor Operator (Item 2) Part Number
Volts	Hz	
110/127	50	X-6309-1
110/127	60	X-6309-5
208	60	X-6309-5
220/240	50	X-6309-2
220/240	60	X-6309-6
380/415	50	X-6309-3
440	50	X-6309-4
440	60	X-6309-3
480	60	X-6309-6
600	60	X-6309-6

Contactors Assemblies

80 Amps, 4-Poles

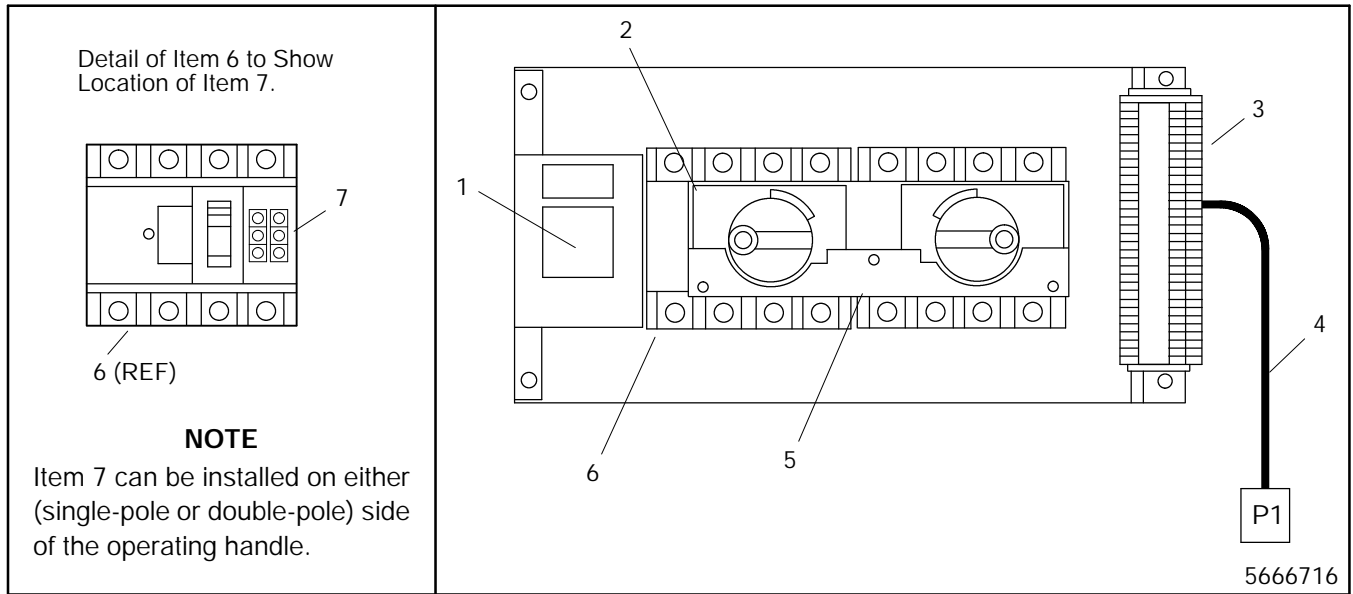

Item	Description	Part Number
1	Switch, 2-position, 4-pole	X-6108-41
2	Operator, motor	See Table to Right
3	Block, terminal	(34) 321021
4	Harness	320986
5	Interlock, mechanical	X-6311-3
6	Frame, circuit breaker	(2) A-330301
7	Switch, auxiliary	(2) X-6315-11

ATS Rating Data		Motor Operator (Item 2) Part Number
Volts	Hz	
110/127	50	X-6309-1
110/127	60	X-6309-5
208	60	X-6309-5
220/240	50	X-6309-2
220/240	60	X-6309-6
380/415	50	X-6309-3
440	50	X-6309-4
440	60	X-6309-3
480	60	X-6309-6
600	60	X-6309-6

Contactors Assemblies

100 Amps, 3-Poles

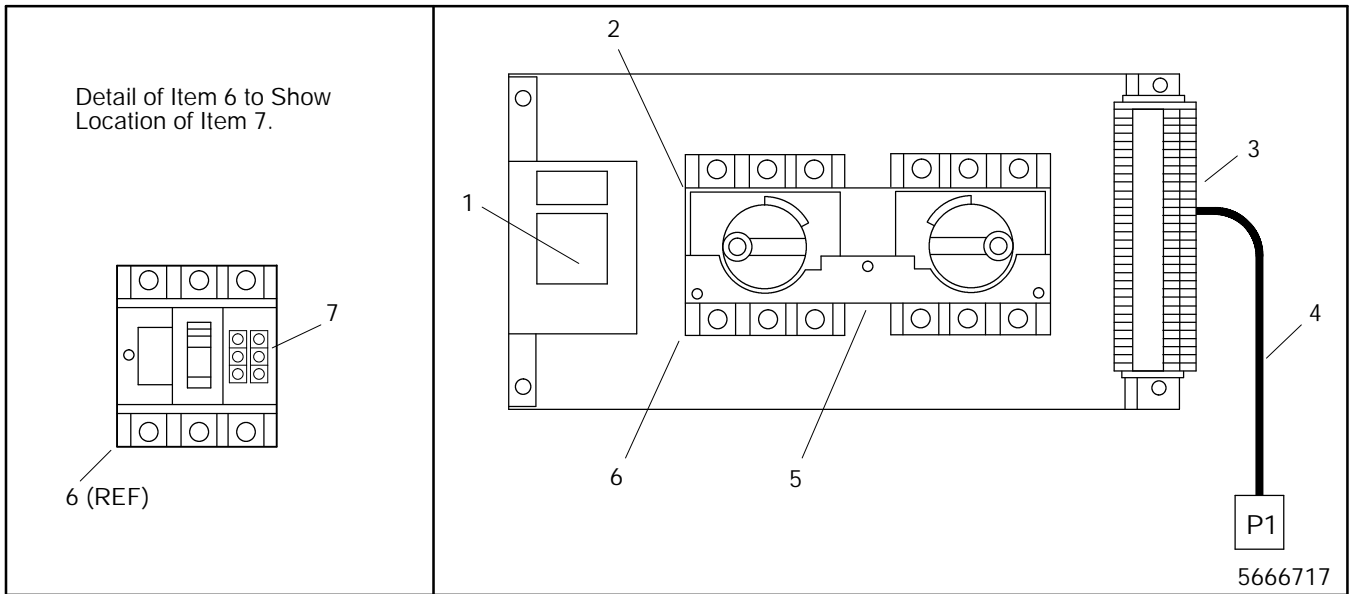

Item	Description	Part Number	
		Circuit Breaker	Switch ATS
1	Switch, 2-position, 4-pole	X-6108-41	X-6108-41
2	Operator, motor	See Table to Right	See Table to Right
3	Block, terminal	(34) 321021	(34) 321021
4	Harness	320986	320986
5	Interlock, mechanical	X-6311-3	X-6311-3
6	Frame	(2) A-330292	(2) A-330155
7	Switch, auxiliary	(2) X-6315-11	(2) X-6315-11

ATS Rating Data		Motor Operator (Item 2) Part Number
Volts	Hz	
110/127	50	X-6309-1
110/127	60	X-6309-5
208	60	X-6309-5
220/240	50	X-6309-2
220/240	60	X-6309-6
380/415	50	X-6309-3
440	50	X-6309-4
440	60	X-6309-3
480	60	X-6309-6
600	60	X-6309-6

Contactors Assemblies

100 Amps, 4-Poles

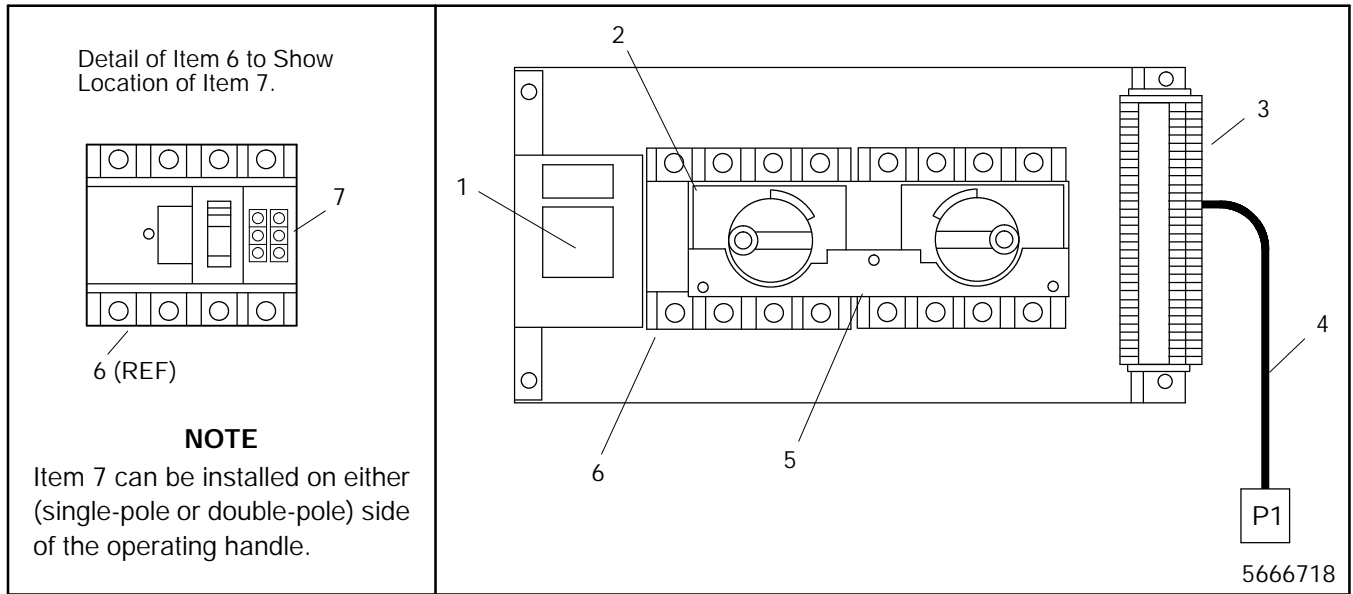

Item	Description	Part Number	
		Circuit Breaker	Switch ATS
1	Switch, 2-position, 4-pole	X-6108-41	X-6108-41
2	Operator, motor	See Table to Right	See Table to Right
3	Block, terminal	(34) 321021	(34) 321021
4	Harness	320986	320986
5	Interlock, mechanical	X-6311-3	X-6311-3
6	Frame	(2) A-330292	(2) A-330155
7	Switch, auxiliary	(2) X-6315-11	(2) X-6315-11

ATS Rating Data		Motor Operator (Item 2) Part Number
Volts	Hz	
110/127	50	X-6309-1
110/127	60	X-6309-5
208	60	X-6309-5
220/240	50	X-6309-2
220/240	60	X-6309-6
380/415	50	X-6309-3
440	50	X-6309-4
440	60	X-6309-3
480	60	X-6309-6
600	60	X-6309-6

Contactors Assemblies

160 Amps, 3-Poles

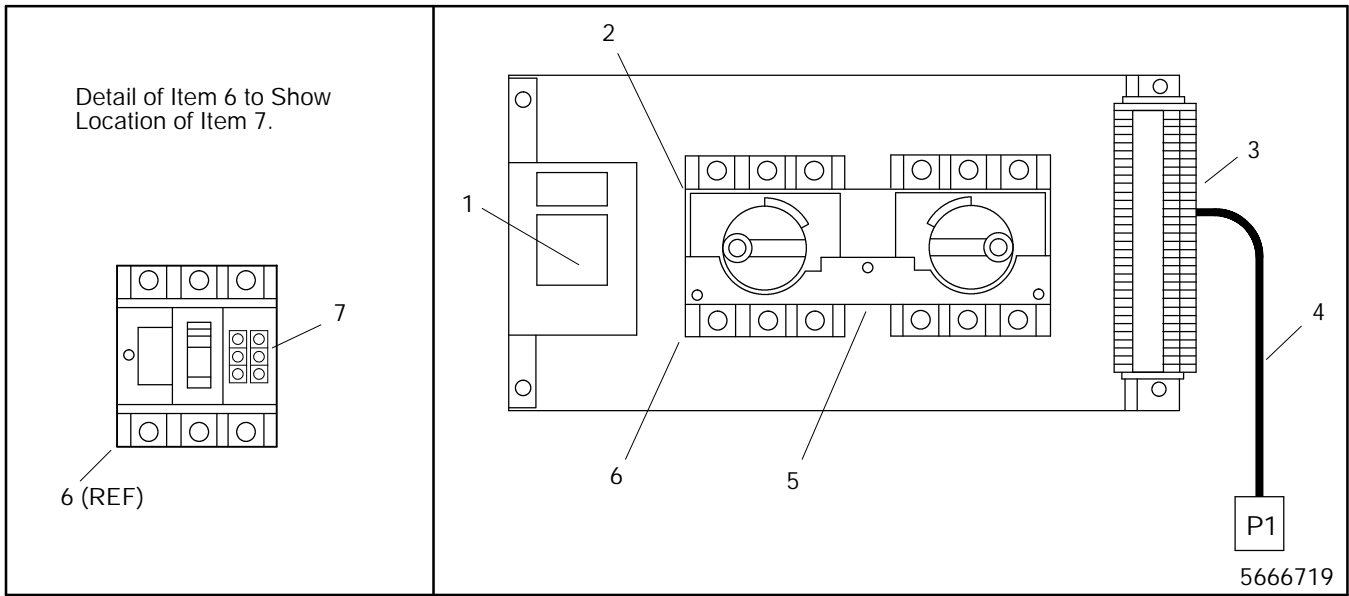

Item	Description	Part Number	
		Circuit Breaker	Switch ATS
1	Switch, 2-position, 4-pole	X-6108-41	X-6108-41
2	Operator, motor	See Table to Right	See Table to Right
3	Block, terminal	(34) 321021	(34) 321021
4	Harness	320986	320986
5	Interlock, mechanical	X-6311-3	X-6311-3
6	Frame	(2) A-330293	(2) A-330156
7	Switch, auxiliary	(2) X-6315-12	(2) X-6315-12

ATS Rating Data		Motor Operator (Item 2) Part Number
Volts	Hz	
110/127	50	X-6309-7
110/127	60	X-6309-10
208	60	X-6309-10
220/240	50	X-6309-8
220/240	60	X-6309-11
380/415	50	X-6309-9
440	50	X-6309-18
440	60	X-6309-11
480	60	X-6309-11
600	60	X-6309-11

Contactors Assemblies

160 Amps, 4-Poles

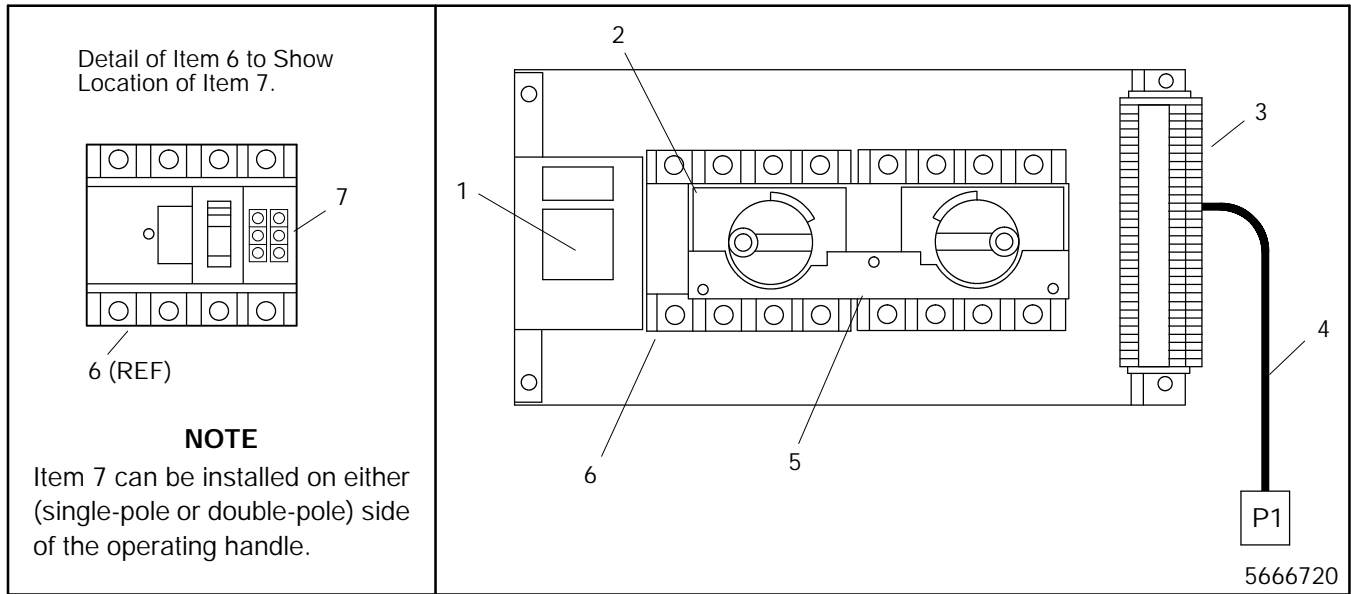

Item	Description	Part Number	
		Circuit Breaker	Switch ATS
1	Switch, 2-position, 4-pole	X-6108-41	X-6108-41
2	Operator, motor	See Table to Right	See Table to Right
3	Block, terminal	(34) 321021	(34) 321021
4	Harness	320986	320986
5	Interlock, mechanical	X-6311-3	X-6311-3
6	Frame	(2) A-330303	(2) A-330175
7	Switch, auxiliary	(2) X-6315-12	(2) X-6315-12

ATS Rating Data		Motor Operator (Item 2) Part Number
Volts	Hz	
110/127	50	X-6309-7
110/127	60	X-6309-10
208	60	X-6309-10
220/240	50	X-6309-8
220/240	60	X-6309-11
380/415	50	X-6309-9
440	50	X-6309-18
440	60	X-6309-11
480	60	X-6309-11
600	60	X-6309-11

Contactors Assemblies

250 Amps, 3-Poles

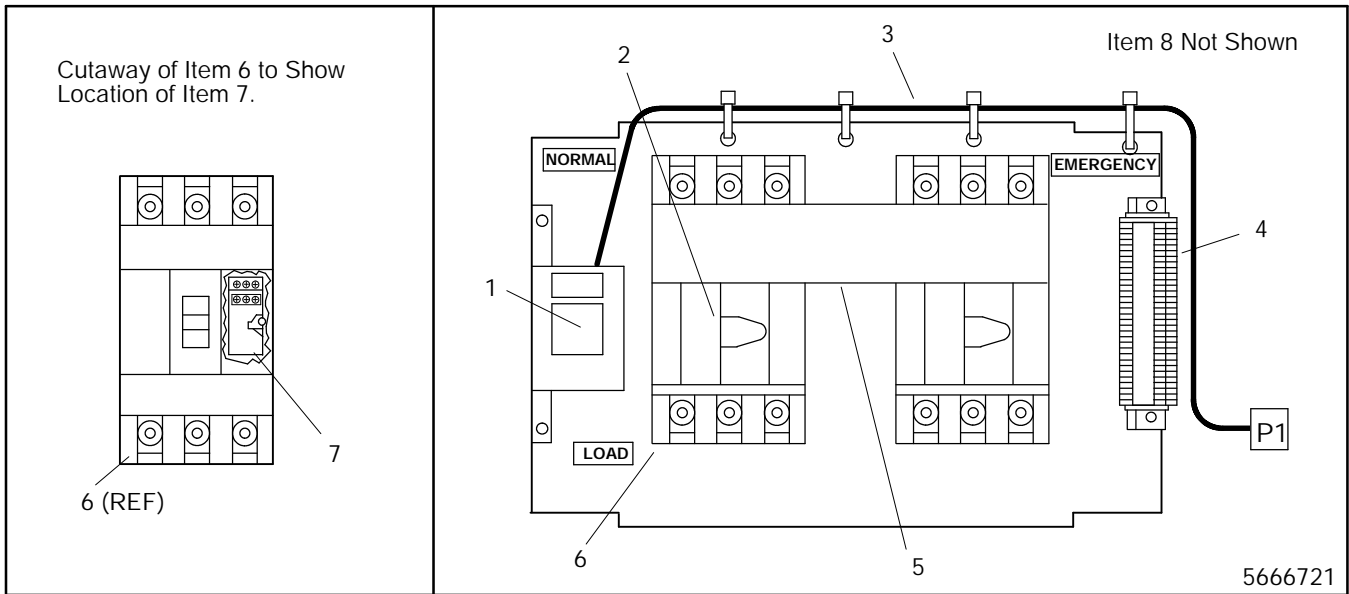

Item	Description	Part Number	
		Circuit Breaker	Switch ATS
1	Switch, 2-position, 4-pole	X-6108-41	X-6108-41
2	Operator, motor	See Table to Right	See Table to Right
3	Harness	321179	321179
4	Block, terminal	(34) 321021	(34) 321021
5	Interlock, mechanical	X-6311-4	X-6311-4
6	Frame	(2) A-330294	(2) A-330157
7	Switch, auxiliary	(2) X-6315-12	(2) X-6315-12
8	Resistor	See Table to Right	See Table to Right

ATS Rating Data		Motor Operator (Item 2) Part Number	Resistor (Item 8) Part Number
Volts	Hz		
110/127	50/60	X-6309-12	N/A
208	50/60	X-6309-13	N/A
220/240	50/60	X-6309-13	N/A
380/415	50/60	X-6309-13	330852
440/480	50/60	X-6309-13	330853
600	60	X-6309-13	N/A

Contactors Assemblies

250 Amps, 4-Poles

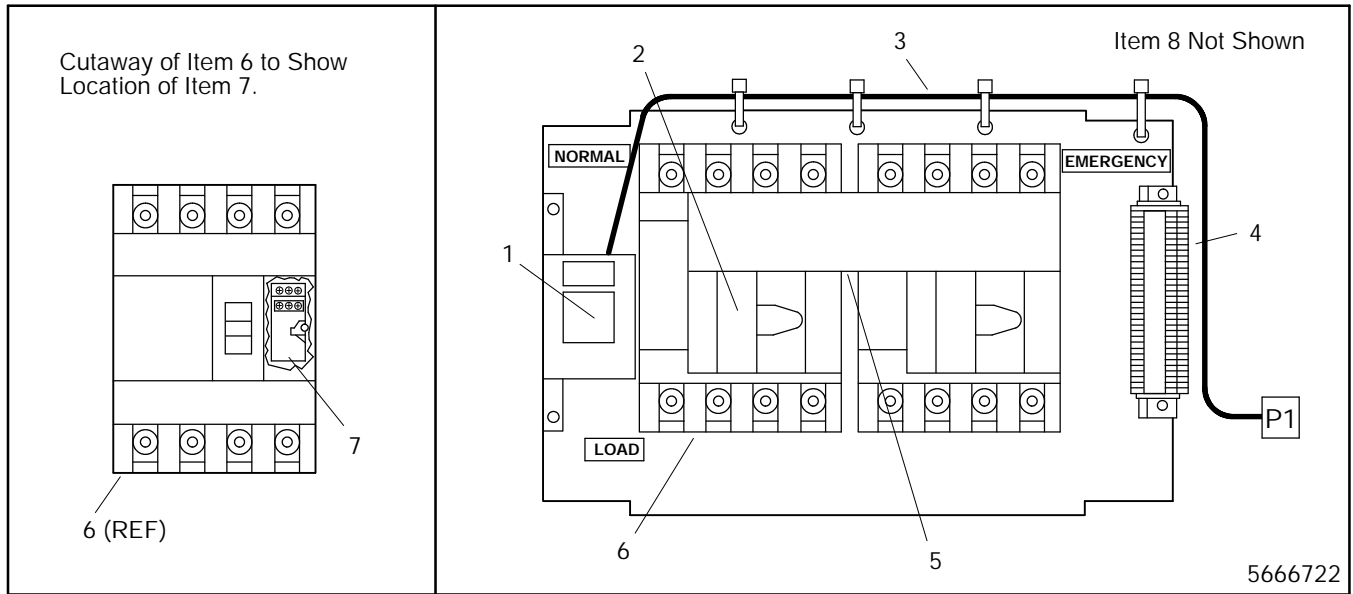

Item	Description	Part Number	
		Circuit Breaker	Switch ATS
1	Switch, 2-position, 4-pole	X-6108-41	X-6108-41
2	Operator, motor	See Table to Right	See Table to Right
3	Harness	321179	321179
4	Block, terminal	(34) 321021	(34) 321021
5	Interlock, mechanical	X-6311-4	X-6311-4
6	Frame	(2) A-330304	(2) A-330169
7	Switch, auxiliary	(2) X-6315-12	(2) X-6315-12
8	Resistor	See Table to Right	See Table to Right

ATS Rating Data		Motor Operator (Item 2) Part Number	Resistor (Item 8) Part Number
Volts	Hz		
110/127	50/60	X-6309-12	N/A
208	50/60	X-6309-13	N/A
220/240	50/60	X-6309-13	N/A
380/415	50/60	X-6309-13	330852
440/480	50/60	X-6309-13	330853
600	60	X-6309-13	N/A

Contactors Assemblies

400 Amps, 3-Poles

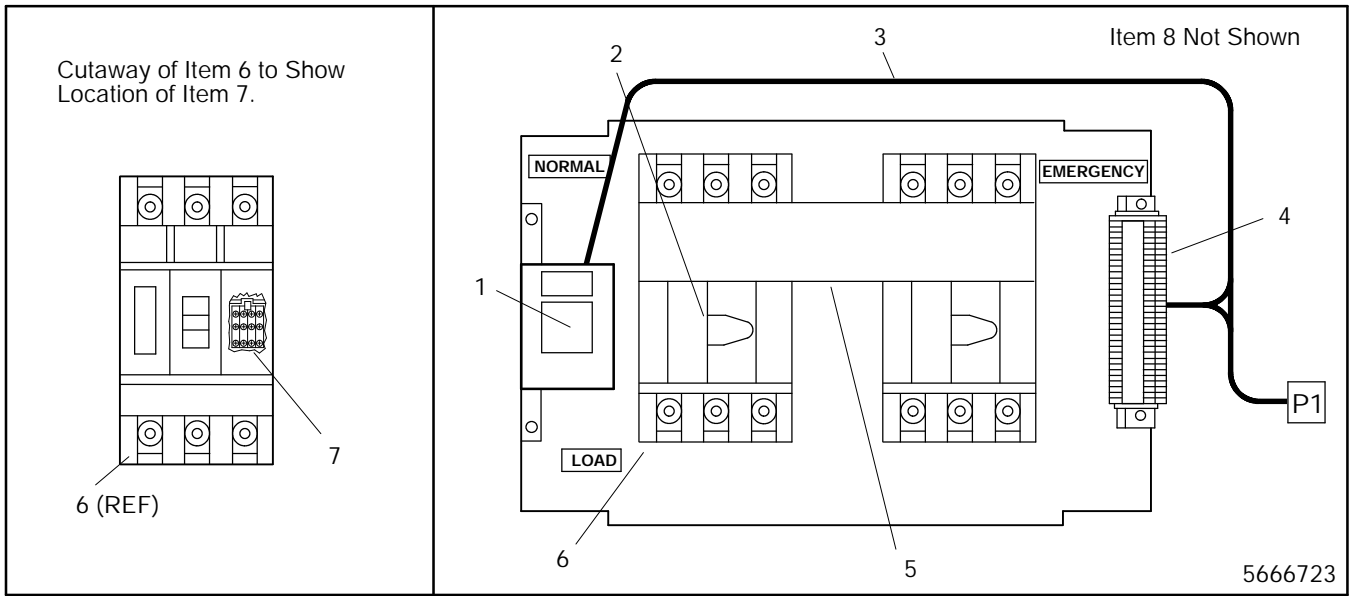

Item	Description	Part Number	
		Circuit Breaker	Switch ATS
1	Switch, 2-position, 4-pole	X-6108-41	X-6108-41
2	Operator, motor	See Table to Right	See Table to Right
3	Harness	321179	321179
4	Block, terminal	(34) 321021	(34) 321021
5	Interlock, mechanical	X-6311-2	X-6311-2
6	Frame	(2) A-330304	(2) A-330169
7	Switch, auxiliary	(2) X-6315-13	(2) X-6315-13
8	Resistor	See Table to Right	See Table to Right

ATS Rating Data		Motor Operator (Item 2) Part Number	Resistor (Item 8) Part Number
Volts	Hz		
110/127	50/60	X-6309-14	N/A
208	50/60	X-6309-15	N/A
220/240	50/60	X-6309-15	N/A
380/415	50/60	X-6309-15	330852
440/480	50/60	X-6309-15	330853
600	60	X-6309-15	N/A

Contactors Assemblies

400 Amps, 4-Poles

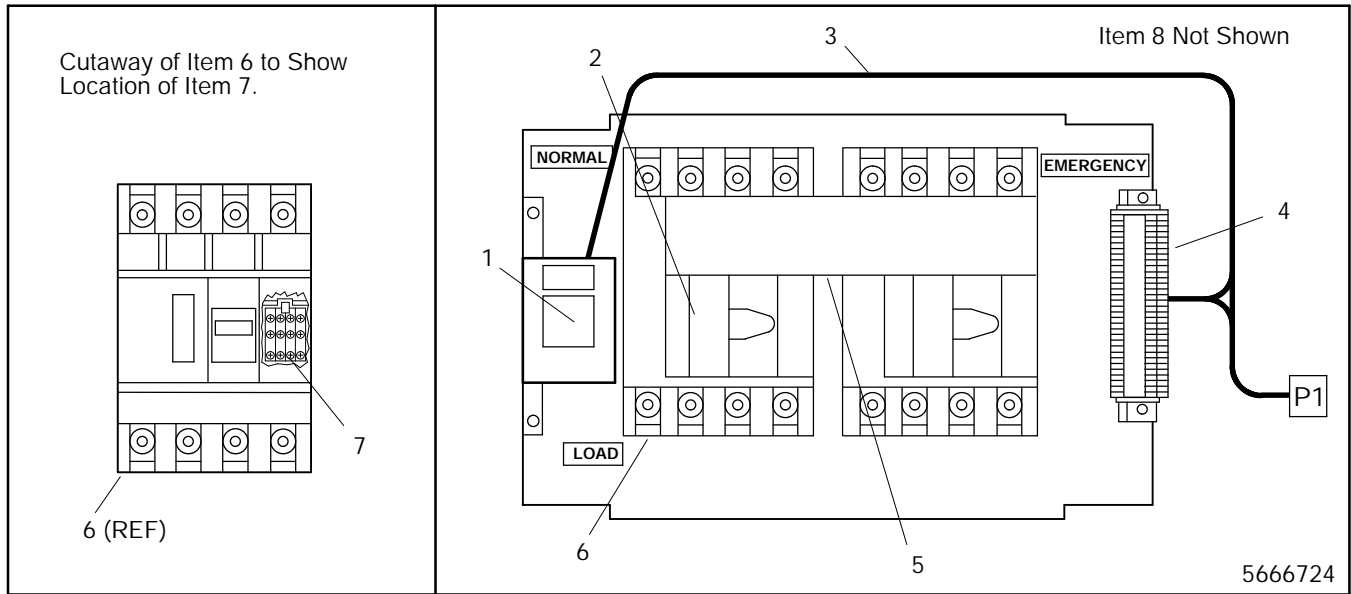

Item	Description	Part Number	
		Circuit Breaker	Switch ATS
1	Switch, 2-position, 4-pole	X-6108-41	X-6108-41
2	Operator, motor	See Table to Right	See Table to Right
3	Harness	321179	321179
4	Block, terminal	(34) 321021	(34) 321021
5	Interlock, mechanical	X-6311-2	X-6311-2
6	Frame	(2) A-330305	(2) A-330170
7	Switch, auxiliary	(2) X-6315-13	(2) X-6315-13
8	Resistor	See Table to Right	See Table to Right

ATS Rating Data		Motor Operator (Item 2) Part Number	Resistor (Item 8) Part Number
Volts	Hz		
110/127	50/60	X-6309-14	N/A
208	50/60	X-6309-15	N/A
220/240	50/60	X-6309-15	N/A
380/415	50/60	X-6309-15	330852
440/480	50/60	X-6309-15	330853
600	60	X-6309-15	N/A

Contactors Assemblies

630 Amps, 3-Poles

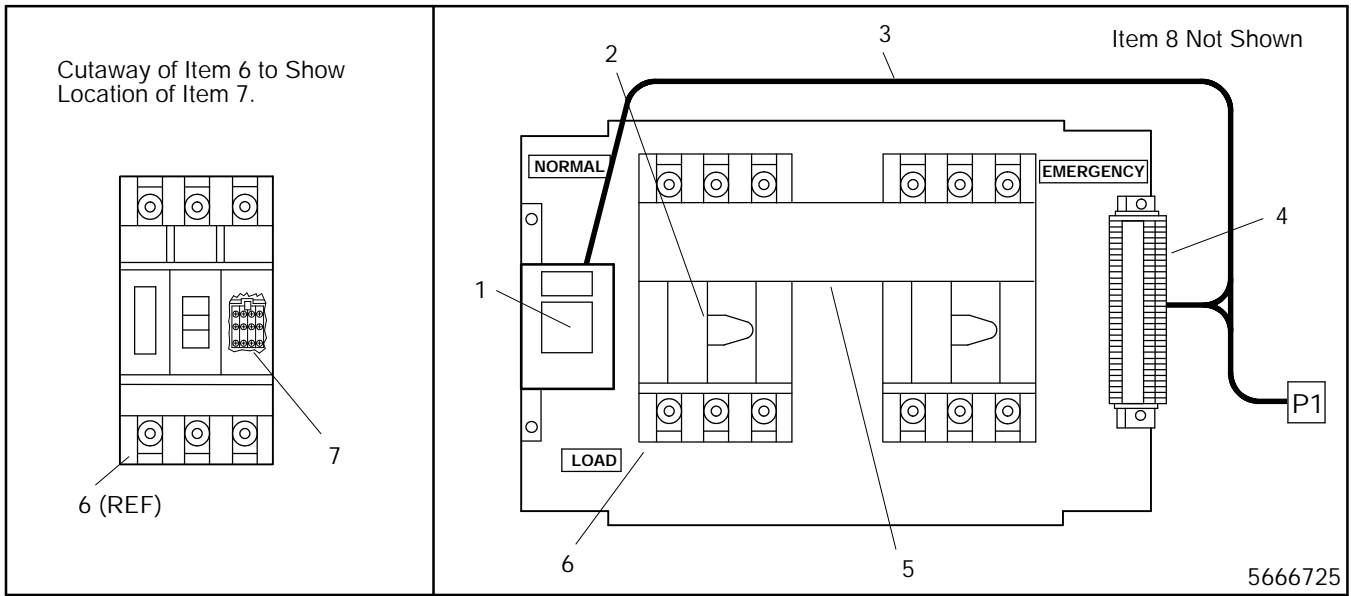

Item	Description	Part Number	
		Circuit Breaker	Switch ATS
1	Switch, 2-position, 4-pole	X-6108-41	X-6108-41
2	Operator, motor	See Table to Right	See Table to Right
3	Block, terminal	(34) 321021	(34) 321021
4	Harness	321179	321179
5	Interlock, mechanical	X-6311-4	X-6311-4
6	Frame	(2) A-330304	(2) A-330169
7	Switch, auxiliary	(2) X-6315-12	(2) X-6315-12
8	Resistor	See Table to Right	See Table to Right

ATS Rating Data		Motor Operator (Item 2) Part Number	Resistor (Item 8) Part Number
Volts	Hz		
110/127	50/60	X-6309-14	N/A
208	50/60	X-6309-15	N/A
220/240	50/60	X-6309-15	N/A
380/415	50/60	X-6309-15	330852
440/480	50/60	X-6309-15	330853
600	60	X-6309-15	N/A

5666725

Contactors Assemblies

630 Amps, 4-Poles

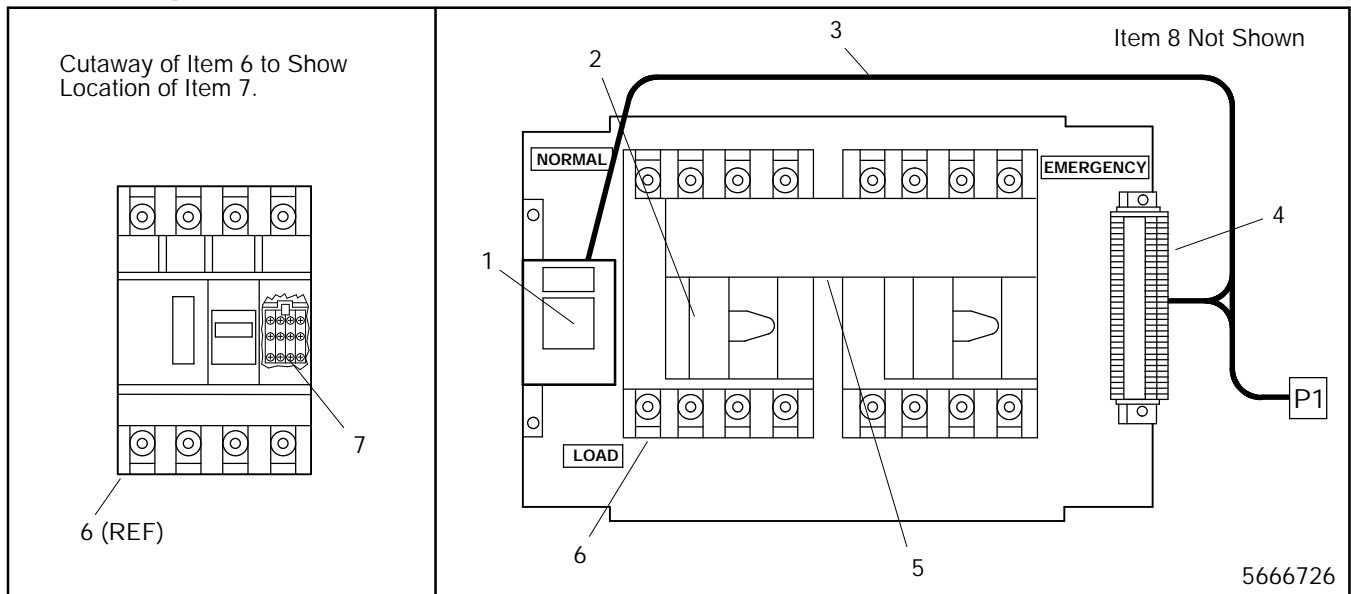

Item	Description	Part Number	
		Circuit Breaker	Switch ATS
1	Switch, 2-position, 4-pole	X-6108-41	X-6108-41
2	Operator, motor	See Table to Right	See Table to Right
3	Harness	321179	321179
4	Block, terminal	(34) 321021	(34) 321021
5	Interlock, mechanical	X-6311-2	X-6311-2
6	Frame	(2) A-330306	(2) A-330171
7	Switch, auxiliary	(2) X-6315-13	(2) X-6315-13
8	Resistor	See Table to Right	See Table to Right

ATS Rating Data		Motor Operator (Item 2) Part Number	Resistor (Item 8) Part Number
Volts	Hz		
110/127	50/60	X-6309-14	N/A
208	50/60	X-6309-15	N/A
220/240	50/60	X-6309-15	N/A
380/415	50/60	X-6309-15	330852
440/480	50/60	X-6309-15	330853
600	60	X-6309-15	N/A

Contactors Assemblies

800 Amps, 3-Poles

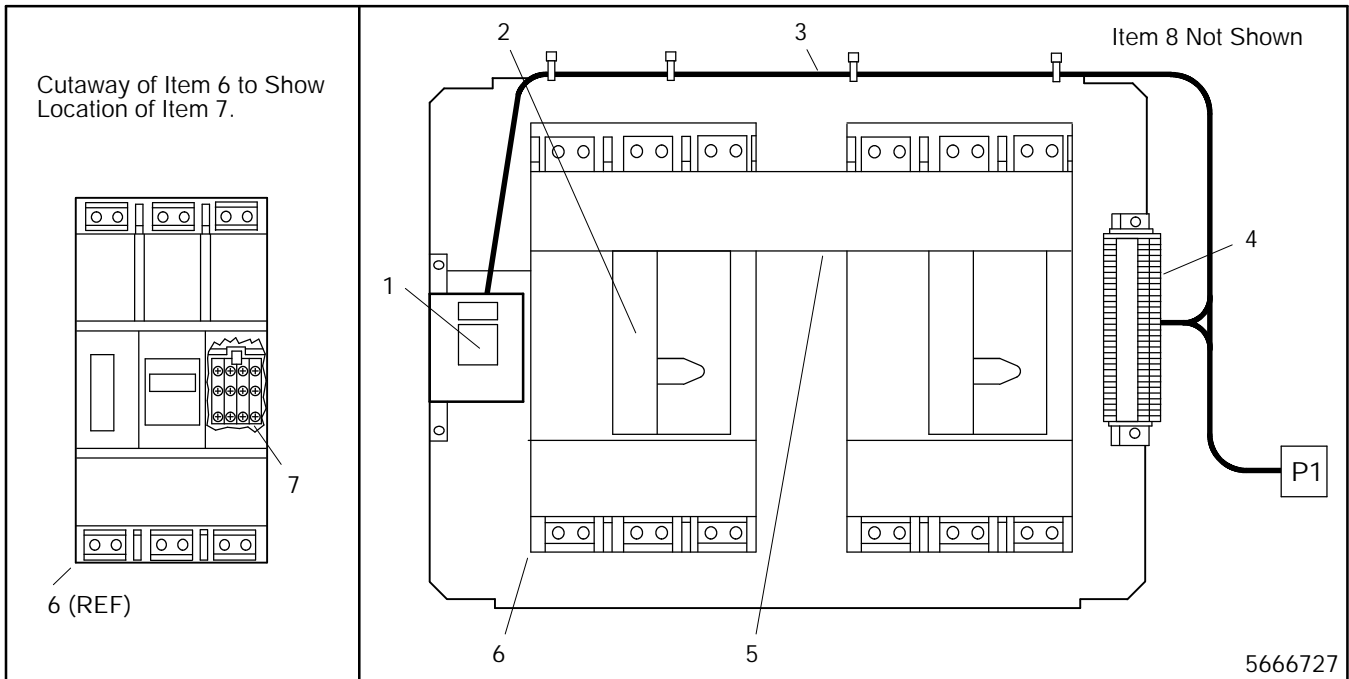

Item	Description	Part Number	
		Circuit Breaker	Switch ATS
1	Switch, 2-position, 4-pole	X-6108-41	X-6108-41
2	Operator, motor	See Table to Right	See Table to Right
3	Harness	321179	321179
4	Block, terminal	(34) 321021	(34) 321021
5	Interlock, mechanical	X-6311-4	X-6311-4
6	Frame	(2) A-330304	(2) A-330169
7	Switch, auxiliary	(2) X-6315-12	(2) X-6315-12
8	Resistor	See Table to Right	See Table to Right

ATS Rating Data		Motor Operator (Item 2) Part Number	Resistor (Item 8) Part Number
Volts	Hz		
110/127	50/60	X-6309-16	N/A
208	50/60	X-6309-17	N/A
220/240	50/60	X-6309-17	N/A
380/415	50/60	X-6309-17	330852
440/480	50/60	X-6309-17	330853
600	60	X-6309-17	N/A

Contactors Assemblies

800 Amps, 4-Poles

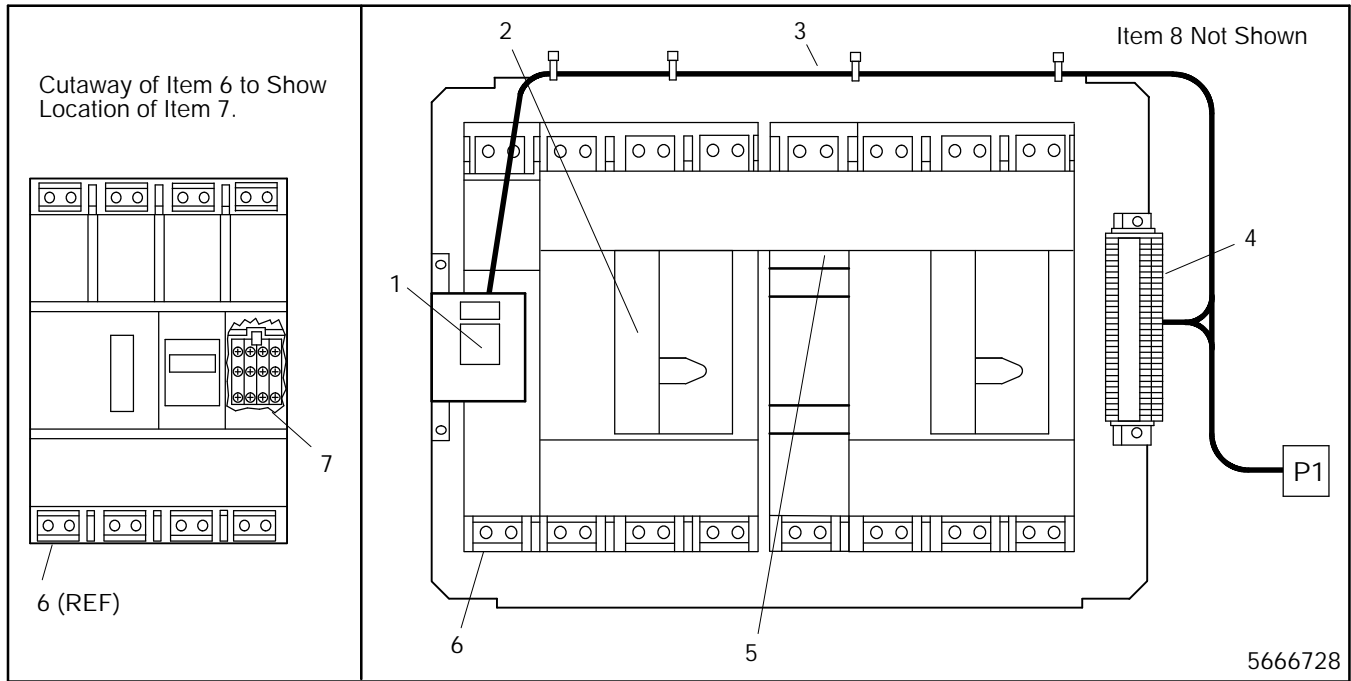

Item	Description	Part Number	
		Circuit Breaker	Switch ATS
1	Switch, 2-position, 4-pole	X-6108-41	X-6108-41
2	Operator, motor	See Table to Right	See Table to Right
3	Harness	321178	321178
4	Block, terminal	(34) 321021	(34) 321021
5	Interlock, mechanical	X-6311-1	X-6311-1
6	Frame	(2) A-330307	(2) A-330172
7	Switch, auxiliary	(2) X-6315-13	(2) X-6315-13
8	Resistor	See Table to Right	See Table to Right

ATS Rating Data		Motor Operator (Item 2) Part Number	Resistor (Item 8) Part Number
Volts	Hz		
110/127	50/60	X-6309-16	N/A
208	50/60	X-6309-17	N/A
220/240	50/60	X-6309-17	N/A
380/415	50/60	X-6309-17	330852
440/480	50/60	X-6309-17	330853
600	60	X-6309-17	N/A

Contactors Assemblies

1000 Amps, 3-Poles

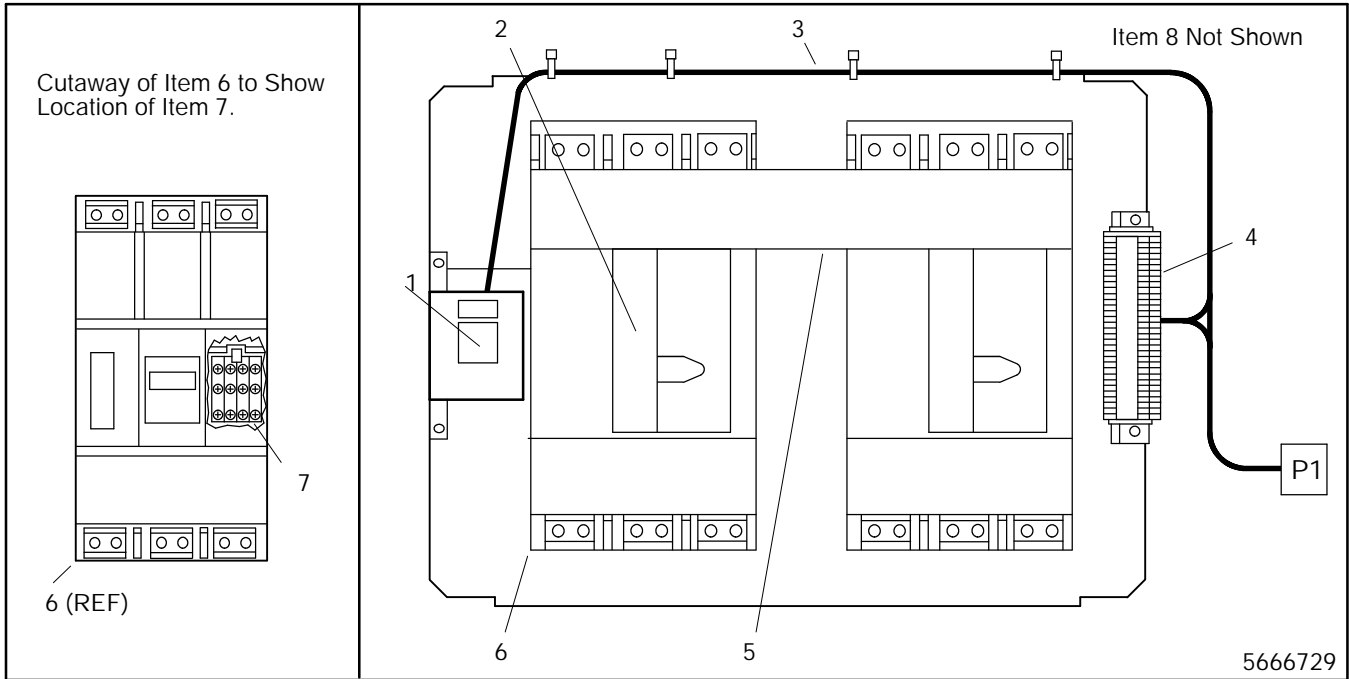

Item	Description	Part Number	
		Circuit Breaker	Switch ATS
1	Switch, 2-position, 4-pole	X-6108-41	X-6108-41
2	Operator, motor	See Table to Right	See Table to Right
3	Harness	321178	321178
4	Block, terminal	(34) 321021	(34) 321021
5	Interlock, mechanical	X-6311-1	X-6311-1
6	Frame	(2) A-330298	(2) A-330161
7	Switch, auxiliary	(2) X-6315-13	(2) X-6315-13
8	Resistor	See Table to Right	See Table to Right

ATS Rating Data		Motor Operator (Item 2) Part Number	Resistor (Item 8) Part Number
Volts	Hz		
110/127	50/60	X-6309-16	N/A
208	50/60	X-6309-17	N/A
220/240	50/60	X-6309-17	N/A
380/415	50/60	X-6309-17	330852
440/480	50/60	X-6309-17	330853
600	60	X-6309-17	N/A

Contactors Assemblies

1000 Amps, 4-Poles

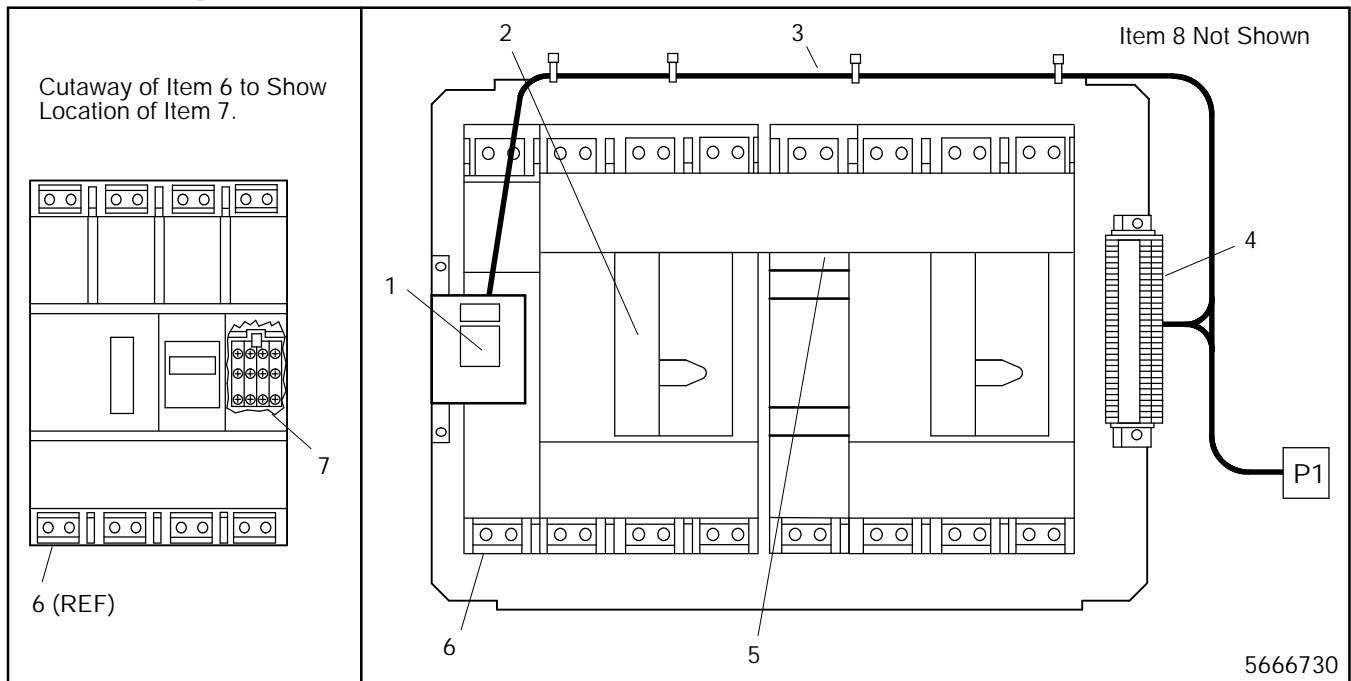

Item	Description	Part Number	
		Circuit Breaker	Switch ATS
1	Switch, 2-position, 4-pole	X-6108-41	X-6108-41
2	Operator, motor	See Table to Right	See Table to Right
3	Harness	321178	321178
4	Block, terminal	(34) 321021	(34) 321021
5	Interlock, mechanical	X-6311-1	X-6311-1
6	Frame	(2) A-330308	(2) A-330173
7	Switch, auxiliary	(2) X-6315-13	(2) X-6315-13
8	Resistor	See Table to Right	See Table to Right

ATS Rating Data		Motor Operator (Item 2) Part Number	Resistor (Item 8) Part Number
Volts	Hz		
110/127	50/60	X-6309-16	N/A
208	50/60	X-6309-17	N/A
220/240	50/60	X-6309-17	N/A
380/415	50/60	X-6309-17	330852
440/480	50/60	X-6309-17	330853
600	60	X-6309-17	N/A

Contactors Assemblies

1250 Amps, 3-Poles

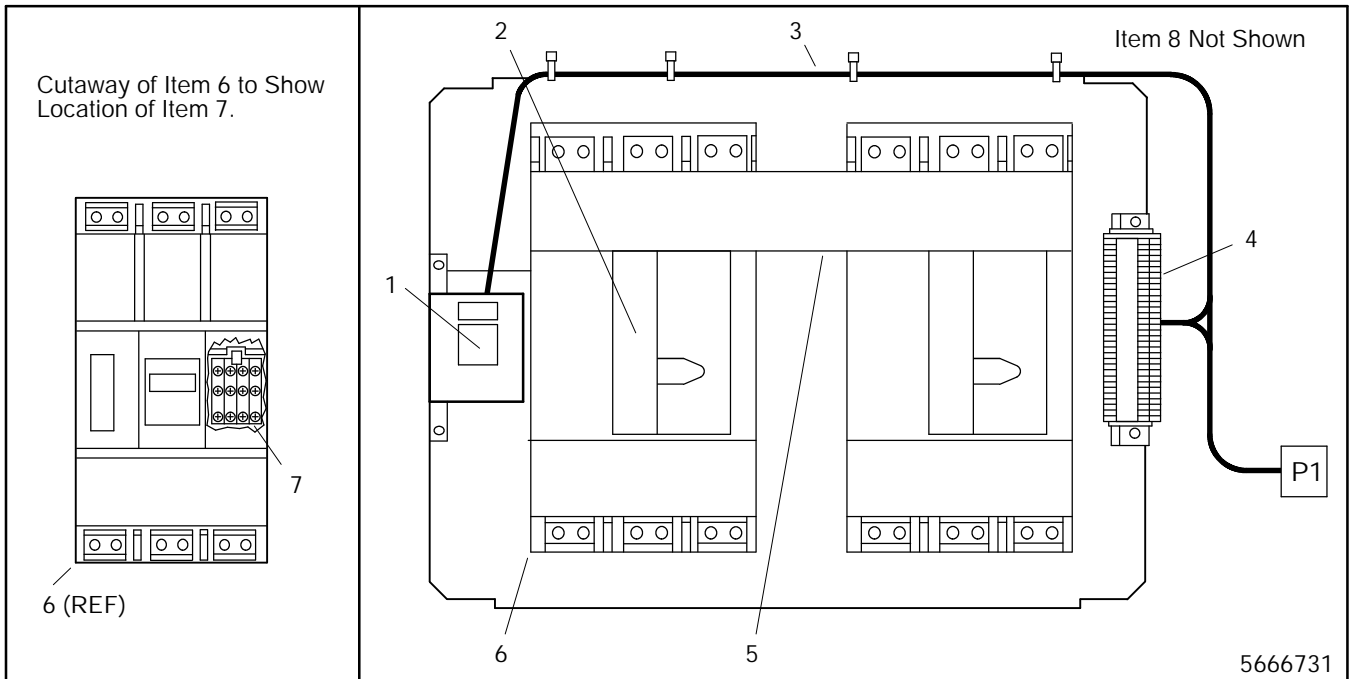

Item	Description	Part Number	
		Circuit Breaker	Switch ATS
1	Switch, 2-position, 4-pole	X-6108-41	X-6108-41
2	Operator, motor	See Table to Right	See Table to Right
3	Harness	321178	321178
4	Block, terminal	(34) 321021	(34) 321021
5	Interlock, mechanical	X-6311-1	X-6311-1
6	Frame	(2) A-330299	(2) A-330161
7	Switch, auxiliary	(2) X-6315-13	(2) X-6315-13
8	Resistor	See Table to Right	See Table to Right

ATS Rating Data		Motor Operator (Item 2) Part Number	Resistor (Item 8) Part Number
Volts	Hz		
110/127	50/60	X-6309-16	N/A
208	50/60	X-6309-17	N/A
220/240	50/60	X-6309-17	N/A
380/415	50/60	X-6309-17	330852
440/480	50/60	X-6309-17	330853
600	60	X-6309-17	N/A

Contactors Assemblies

1250 Amps, 4-Poles

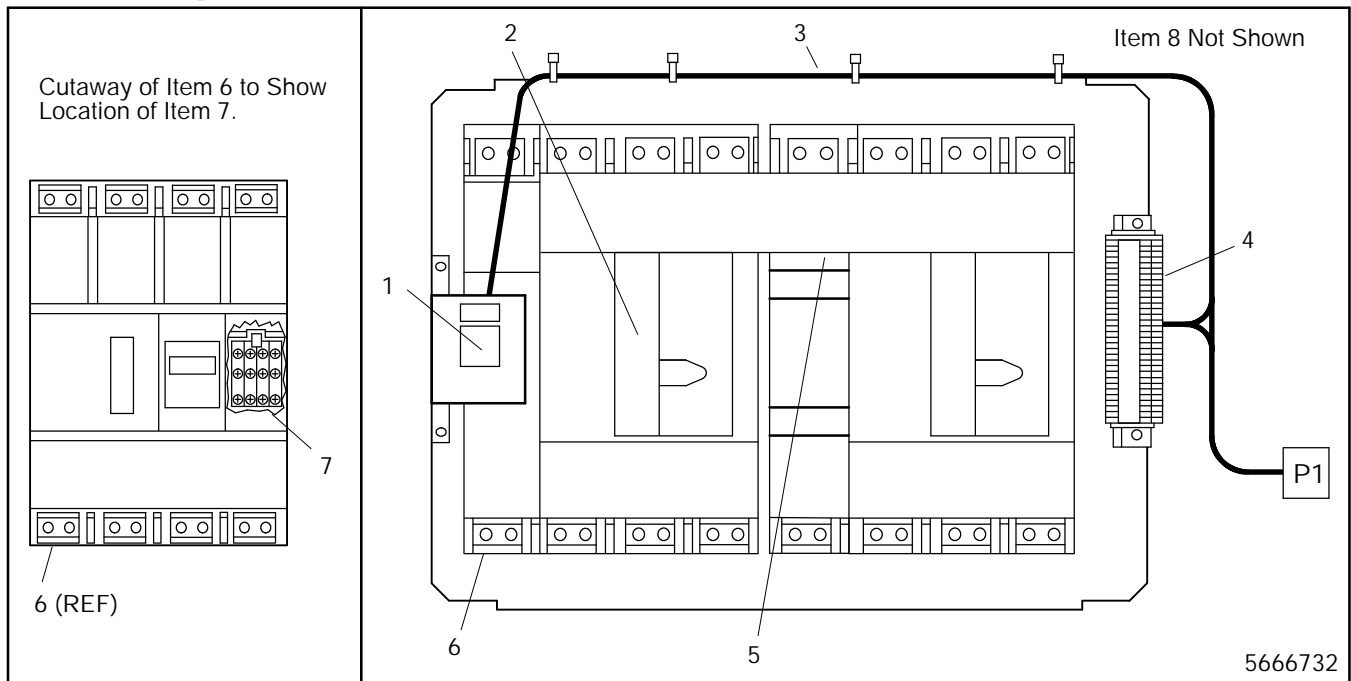

Item	Description	Part Number	
		Circuit Breaker	Switch ATS
1	Switch, 2-position, 4-pole	X-6108-41	X-6108-41
2	Operator, motor	See Table to Right	See Table to Right
3	Harness	321178	321178
4	Block, terminal	(34) 321021	(34) 321021
5	Interlock, mechanical	X-6311-1	X-6311-1
6	Frame	(2) A-330309	(2) A-330173
7	Switch, auxiliary	(2) X-6315-13	(2) X-6315-13
8	Resistor	See Table to Right	See Table to Right

ATS Rating Data		Motor Operator (Item 2) Part Number	Resistor (Item 8) Part Number
Volts	Hz		
110/127	50/60	X-6309-16	N/A
208	50/60	X-6309-17	N/A
220/240	50/60	X-6309-17	N/A
380/415	50/60	X-6309-17	330852
440/480	50/60	X-6309-17	330853
600	60	X-6309-17	N/A

Contactors Assemblies

1600-4000 Amps, 3-Poles

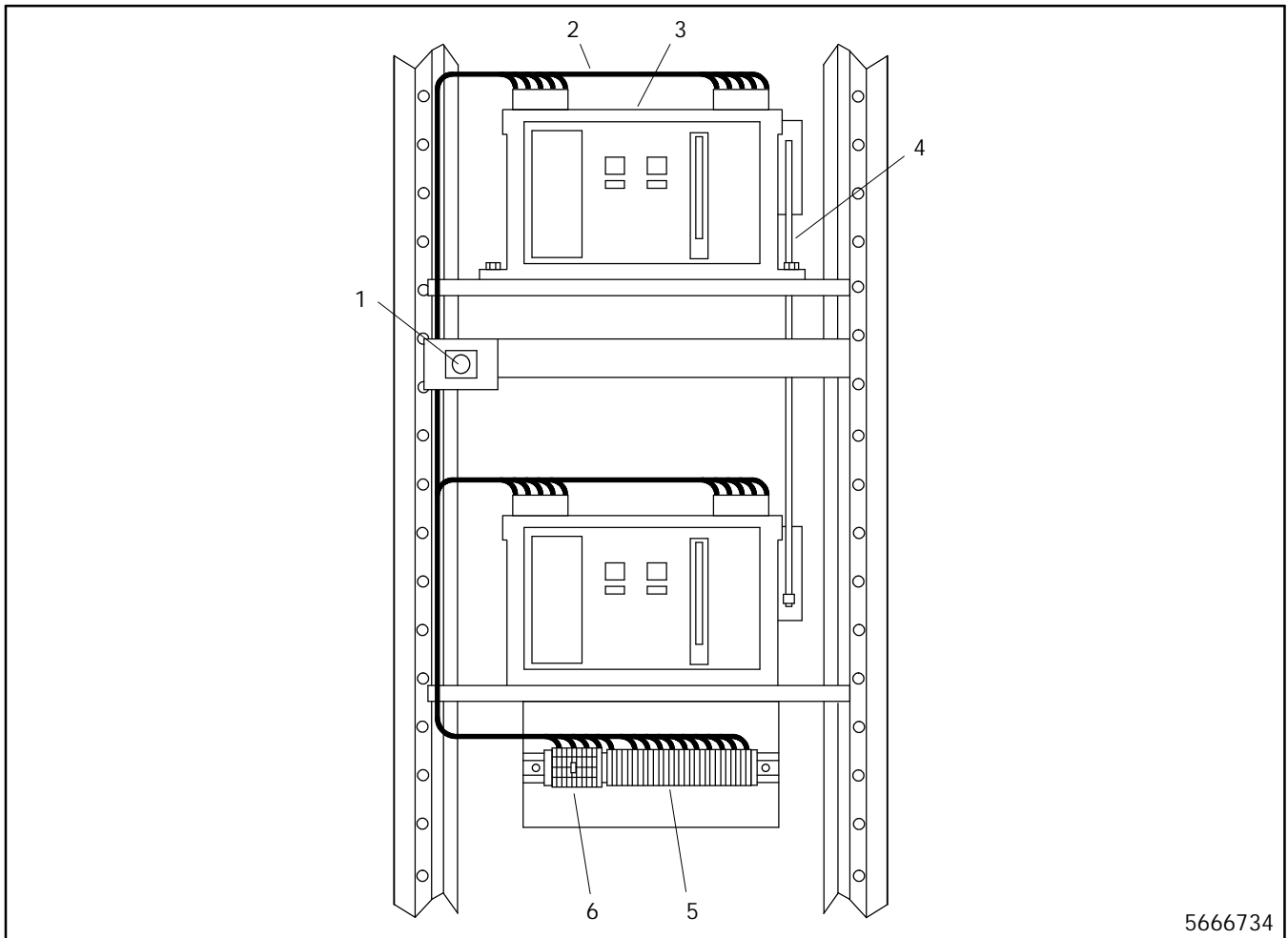

5666734

Item	Description	Part Number	
		Circuit Breaker	Switch ATS
1	Switch, 2-position, 4-pole	X-6108-41	X-6108-41
2	Harness	321248	321248
3	Frame	See Table to Right	See Table to Right
4	Interlock, mechanical	330869	330869
5	Block, terminal	(37) 321021	(37) 321021
6	Relay Control	(2) 321133	(2) 321133

Power Circuit Breaker (Item 3) Part Number	Power Switch (Item 3) Part Number
330859	330870
330860	330871
330861	330872
330862	330873
330863	330874

Contactors Assemblies

1600-4000 Amps, 4-Poles

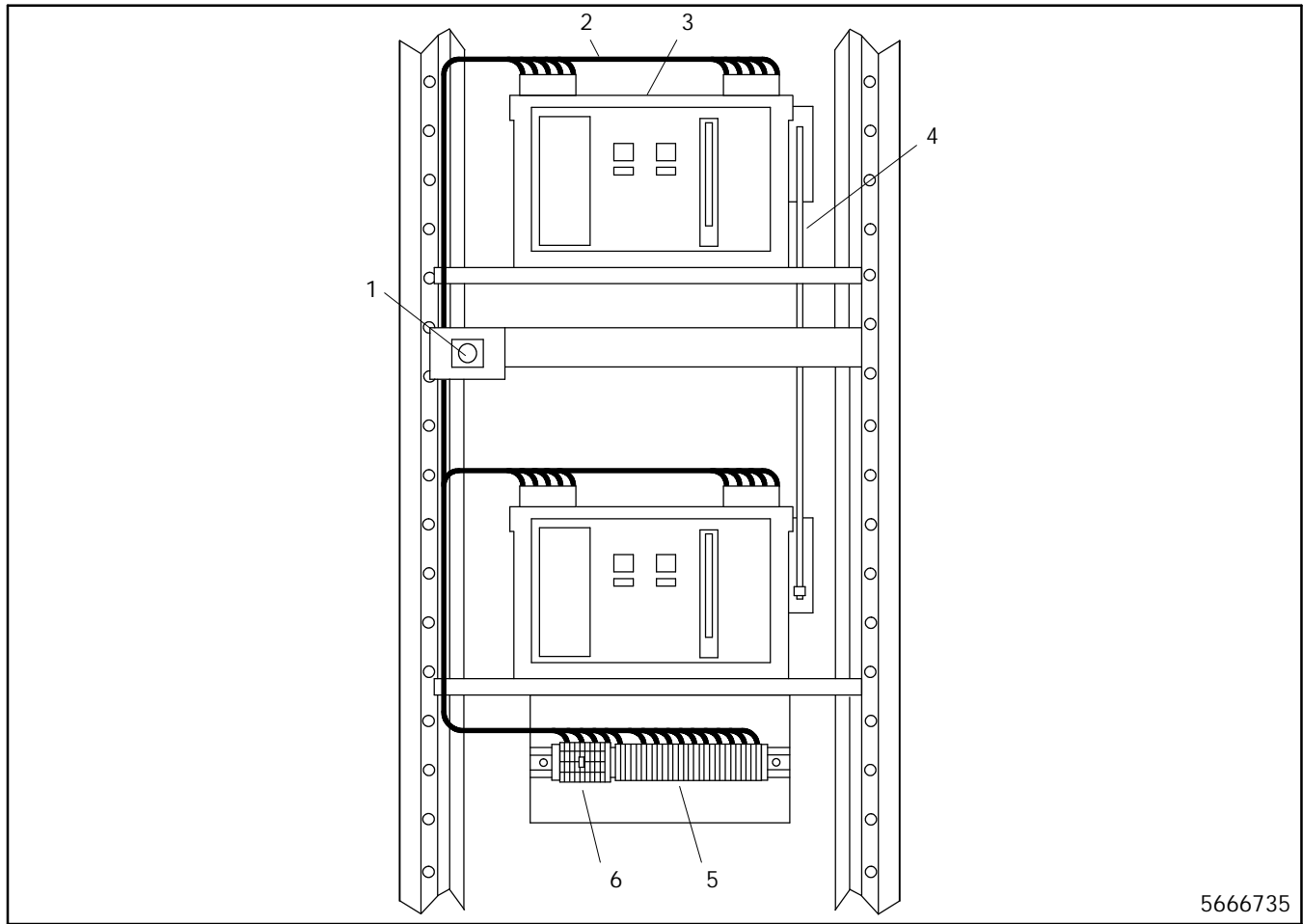

5666735

Item	Description	Part Number	
		Circuit Breaker	Switch ATS
1	Switch, 2-position, 4-pole	X-6108-41	X-6108-41
2	Harness	321248	321248
3	Circuit Breaker, Power	See Table to Right	See Table to Right
4	Interlock, mechanical	330869	330869
5	Block, terminal	(37) 321021	(37) 321021
6	Relay Control	(2) 321133	(2) 321133

Power Circuit Breaker (Item 3) Part Number	Power Switch (Item 3) Part Number
330864	330875
330865	330876
330865	330876
330867	330876
330868	330879

Appendix A. Glossary of Abbreviations

Abbreviations are used throughout this manual. Normally in the text they will appear in complete form with the abbreviation following in parenthesis the first

time they are used. After that they will appear in the abbreviated form. The commonly used abbreviations are shown below.

Abbreviation	Description	Abbreviation	Description
AC	alternating current	dept.	department
AHWT	anticipatory high water temp.	dia.	diameter
ALOP	anticipatory low oil pressure	e.g.	example given
AM	amplitude modulation	EMI	electromagnetic interference
Amp	ampere	etc.	etcetera, (and so forth)
Amps	amperes	ext.	external
ANSI	American National Standard Institute	°F	Fahrenheit degree
API	American Petroleum Institute	fl. oz.	fluid ounce, fluid ounces
approx.	approximate, approximately	FM	frequency modulation
A/R	as required, as requested	fs	full scale
A/S	as supplied, as stated, as suggested	ft.	foot, feet
ASA	American Standards Association	ft. lbs.	foot pound, foot pounds
assy.	assembly	ga.	gauge
ASTM	American Society for Testing Materials	gal., gals.	gallon, gallons
ATDC	after top dead center	gal./hr.	gallons per hour
ATS	automatic transfer switch	gph	gallons per hour
aux.	auxiliary	gpm	gallons per minute
AWG	American Wire Gauge	gr.	grade
AWM	appliance wiring material	grd.	ground
bhp	brake horsepower	HCHT	high cylinder head temperature
bmep	brake mean effective power	HET	high exhaust temperature
Btu	British thermal unit	Hg	mercury (element)
°C	Celsius degree	H ₂ O	water
cc	cubic centimeter	hp	horsepower
CCA	cold cranking Amps.	hr, hrs	hour
CEC	Canadian Electrical Code	HWT	high water temperature
cfh	cubic feet per hour	Hz	hertz (cycles per second)
cfm	cubic feet per minute	ID	inside diameter
CID	cubic inch displacement	in.	inch(es)
cm	centimeter, centimeters	inc.	incorporated
cmm	cubic meters per minute	in. lbs.	inch pounds
co.	company	int.	internal
cont'd.	continued	int.-ext.	internal-external
C.S.A.	Canadian Standards Association	ISO	International Standards Organization
cu. in.	cubic inch, cubic inches	J	joule, joules
cyl.	cylinder	JIS	Japanese Industry Standard
dBA	decibels	kg	kilogram, kilograms
DC	direct current	kg/cm ²	kilograms per square centimeter
DCR	direct current resistance	kgm	kilogram meter(s)
deg.	degree	km	kilometer, kilometers

Abbreviation	Description
kPa	kiloPascal, kiloPascals
kph	kilometers per hour
kV	kilovolt
kVA	kilovolt amperes
kW	kilowatt, kilowatts
kWH	kilowatt hour
L	liter, liters
LxWxH	length x width x height
LED, LEDs	light emitting diode
lb., lbs.	pound, pounds
L/hr.	liter per hour, liters per hour
L/min.	liter(s) per minutes
LOP	low oil pressure
LP	liquefied petroleum
LWT	low water temperature
m	meter, meters
m ³	cubic meter, cubic meters
max.	maximum
MCM	one thousand circular mils.
mi.	mile, miles
mil	one one-thousandth of an inch
min.	minimum
mJ	millijoule, millijoules
MJ	mega joule, mega joules
mm	millimeter, millimeters
m ³ /min	cubic meters per minute
MPa	megaPascal
mph	miles per hour
MS	military standard
mW	milliwatt, milliwatts
MW	megawatt, megawatts
N/A	not available
NEC	National Electrical Code
NEMA	National Electrical Manufacturers Association
NFPA	National Fire Protection Association
Nm	Newton meter, Newton meters
no., nos.	number, numbers
NPT	National Standard taper pipe

Abbreviation	Description
	thread per general use
N/R	not required
OC	overcrank
OD	outside diameter
OEM	original equipment manufacturer
OS	overspeed, oversize
OV	overvoltage
oz.	ounce, ounces
PF	power factor
pot.	potentiometer
ppm	parts per million
psi	pounds per square inch
pt., pts.	pint, pints
qt., qts.	quart, quarts
qty.	quantity
ref.	reference
RFI	radio frequency interference
rms	root mean square
rpm	revolutions per inch
SAE	Society of Automotive Engineers
sec.	second, seconds
SCR	silicon controlled rectifier
spec, specs	specification
sq.	square
sq. cm	square centimeters
sq. in.	square inch, square inches
tach	tachometer
TDC	top dead center
temp.	temperature
TIF	telephone influence factor
turbo	turbocharger
UNC	Unified coarse thread (was NC)
UNF	Unified fine thread (was NF)
UL	Underwriter's Laboratories, Inc.
US	undersize
V	volt, volts
VAC	Volts alternating current
VDC	volts direct current
W	watt, watts

KOHLER[®] POWER SYSTEMS

KOHLER CO. Kohler, Wisconsin 53044
Phone 414-565-3381, Web site www.kohlergenerators.com
Fax 414-459-1646 (U.S.A. Sales), Fax 414-459-1614 (International)
After July 26, 1997, use area code 920 instead of 414
For the nearest sales and service outlet in U.S.A. and Canada
Phone 1-800-544-2444

Kohler Power Systems
Asia Pacific Headquarters
7 Jurong Pier Road
Singapore 619159
Phone (65)264-6422, Fax (65)264-6455

TP-5666 1/95c

© Kohler Co., 1995. All rights reserved.