

Service and Parts

Automatic Transfer Switches

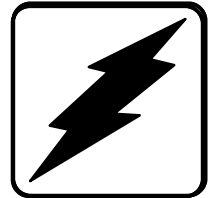

Models:

TES

TLS

Power Switching Devices:

Electrically Held Contactor
Mechanically Held Contactor

25 to 400 Amperes

KOHLER[®]
POWER SYSTEMS

ISO 9001
KOHLER
GENERATORS
INTERNATIONALLY REGISTERED
U.S.A. Plant ISO Registered

TP-5667 9/96b

Table of Contents

SUBJECT	PAGE	SUBJECT	PAGE
Safety Precautions and Instructions	I	Section 6. Reassembly/Disassembly	6-1
Introduction	i	Introduction	6-1
List of Related Manuals	i	Contact Removal	6-1
Service Assistance	i	Contact Installation	6-2
Section 1. Specifications	1-1	Component Removal and Installation	
Purpose of Switch	1-1	25-80 Amp Contactors	6-3
Components of Switch	1-1	Mechanical Interlock Removal	6-3
Nameplate	1-2	Mechanical Interlock Installation	6-3
Interpreting a Transfer Switch Part Number	1-3	Auxiliary Switch Removal	6-3
Standard Features	1-4	Auxiliary Switch Installation	6-4
Contact Ratings	1-4	Mechanical Latch Removal	6-4
Section 2. Operation	2-1	Mechanical Latch Installation	6-5
Switches and Indicators	2-1	Coil Removal	6-5
Automatic Operation	2-1	Coil Installation	6-5
Manual Operation	2-1	Component Removal and Installation	
Sequence of Operation	2-3	145-400 Amp Contactors	6-5
Normal Source Failure	2-3	Mechanical Interlock Removal	6-5
Normal Source Restoration	2-3	Mechanical Interlock Installation	6-6
Accessories	2-4	Auxiliary Switch Removal	6-6
Time Delay Off	2-4	Auxiliary Switch Installation	6-6
Other Accessories	2-4	Coil Removal	6-7
Section 3. General Maintenance	3-1	Coil Installation	6-7
Section 4. Troubleshooting	4-1	Contact Set Removal	6-7
Troubleshooting Tables	4-1	Contact Set Installation	6-8
Section 5. Accessory Testing and Adjustment 5-1		Section 7. Service Parts	7-1
Programmed Transition	5-1	Introduction	7-1
Other Accessories	5-1	Using Parts Lists	7-1
		Finding Parts Information	7-1
		Leads	7-1
		Appendix A. Glossary of Abbreviations	A-1

Safety Precautions and Instructions

A transfer switch, like any other electromechanical device, can pose potential dangers to life and limb if improperly maintained or operated. The best way to prevent accidents is to be aware of potential dangers and act safely. Please read and follow the safety precautions and instructions below to prevent harm to yourself and others. This manual contains several types of safety precautions and instructions which are explained below. **SAVE THESE INSTRUCTIONS.**

DANGER

Danger indicates the presence of a hazard that will cause severe personal injury, death, or substantial property damage.

WARNING

Warning indicates the presence of a hazard that can cause severe personal injury, death, or substantial property damage.

CAUTION

Caution indicates the presence of a hazard that will or can cause minor personal injury or property damage.

NOTICE

Notice communicates installation, operation, or maintenance information that is important but not hazard related.

Safety decals affixed to the generator set in prominent places advise the operator or service technician of potential hazards and how to act safely. The decals are reproduced in this publication to improve operator recognition. Replace missing or damaged decals.

Safety decals affixed to the transfer switch in prominent places advise the operator or service technician of potential hazards and how to act safely. The decals are reproduced here to improve operator recognition. Replace missing or damaged decals.

Accidental Starting



Accidental starting.
Can cause severe injury or death.

Disconnect battery cables before working on generator set (disconnect negative lead first and reconnect it last).

Disabling generator set. Accidental starting can cause severe injury or death. Turn generator set master switch to OFF position, disconnect power to battery charger, and remove battery cables (remove negative lead first and reconnect it last) to disable generator set before working on the generator set or connected equipment. The generator set can be started by an automatic transfer switch or remote start/stop switch unless these precautions are followed.

Battery

WARNING



**Sulfuric acid in batteries.
Can cause severe injury or death.**

Use protective goggles and clothes. Battery acid can cause permanent damage to eyes, burn skin, and eat holes in clothing.

WARNING



**Explosion.
Can cause severe injury or death. Relays in
battery charger cause arcs or sparks.**

Locate battery in a well-ventilated area. Isolate battery charger from explosive fumes.

Battery acid. Sulfuric acid in batteries can cause severe injury or death. Sulfuric acid in battery can cause permanent damage to eyes, burn skin, and eat holes in clothing. Always wear splash-proof safety goggles when working near the battery. If battery acid is splashed in the eyes or on skin, immediately flush the affected area for 15 minutes with large quantities of clean water. Seek immediate medical aid in the case of eye contact. Never add acid to a battery after placing the battery in service, as this may result in hazardous spattering of battery acid.

Battery acid. Sulfuric acid in batteries can cause severe injury or death. Sulfuric acid in battery can cause permanent damage to eyes, burn skin, and eat holes in clothing. Always wear splash-proof safety goggles when working around the battery. If battery acid is splashed in the eyes or on skin, immediately flush the affected area with large quantities of clean water. Continue flushing with water until emergency help arrives. Seek immediate medical aid. Never add acid to a battery after placing the battery in service, as this may result in hazardous spattering of battery acid.

Battery gases. Explosion can cause severe injury or death. Battery gases can cause an explosion. Do not smoke or permit flame or spark to occur near a battery at any time, particularly when it is charging. Avoid touching terminals with tools, etc., to prevent burns and sparks that could cause an explosion. Remove wristwatch, rings, and any other jewelry before handling battery. Never connect negative (-) battery cable to positive (+) connection terminal of starter solenoid. Do not test battery condition by shorting terminals together. Sparks could ignite battery gases or fuel vapors. Ventilate any compartment containing batteries to prevent accumulation of explosive gases. To avoid sparks, do not disturb battery charger connections while battery is being charged. Always turn battery charger off before disconnecting battery connections. Remove negative lead first and reconnect it last when disconnecting battery.

Hazardous Voltage/ Electrical Shock

⚠ DANGER

<p>Hazardous voltage. Will cause severe injury or death.</p> <p>Disconnect all power sources before opening enclosure.</p>

(600 Volt and above)

⚠ DANGER

<p>Hazardous voltage. Will cause severe injury or death.</p> <p>Disconnect power sources before servicing. Install barrier after adjustments, maintenance, or servicing.</p>

(600 Volt and above)

⚠ WARNING

<p>Hazardous voltage. Can cause severe injury or death.</p> <p>Disconnect power sources before servicing. Install barrier after adjustments, maintenance, or service.</p>

(under 600 Volt)

⚠ WARNING

<p>Hazardous voltage. Can cause severe injury or death.</p> <p>Disconnect all power sources before opening enclosure.</p>

(under 600 Volt)

Grounding generator set. Hazardous voltage can cause severe injury or death. Electrocutation is possible whenever electricity is present. Open main circuit breakers of all power sources before servicing equipment. Configure the installation to electrically ground the generator set and electrical circuits when in use. Never contact electrical leads or appliances when standing in water or on wet ground, as the chance of electrocution is increased under such conditions.

Short circuits. Hazardous voltage can cause severe injury or death. Short circuits can cause bodily injury and/or equipment damage. Do not contact electrical connections with tools or jewelry while adjustments are made. Remove wristwatch, rings, and jewelry before servicing equipment.

Installing accessories to transformer assembly. Hazardous voltage can cause severe injury or death. To prevent the possibility of electrical shock, disconnect harness plug before installing any accessories which will be connected to transformer assembly primary terminals 76, 77, 78, and 79. Terminals are at line voltage!
(Models with S340, S340+, 340, R340, and R33 controls only.)

Installing accessories to transformer assembly. Hazardous voltage can cause severe injury or death. To prevent the possibility of electrical shock, disconnect harness plug before installing any accessories which will be connected to transformer assembly primary terminals on microprocessor logic models. Terminals are at line voltage!

Making line or auxiliary connections. Hazardous voltage can cause severe injury or death. To prevent the possibility of electrical shock, de-energize the normal power source before making any line or auxiliary connections.

Servicing transfer switch. Hazardous voltage can cause severe injury or death. De-energize both normal and emergency power sources before proceeding. Move generator set master switch on controller to OFF position and disconnect battery negative (-) before working on transfer switch! Turn the transfer switch selector switch to the OFF position.

Servicing transfer inner panel. Hazardous voltage can cause severe injury or death. Disconnect inner panel harness at inline connector. This will de-energize circuit board and logic circuitry but allow transfer switch to continue to supply utility power to necessary lighting and equipment. Hazardous voltage exists for any accessories mounted to inner panel which are NOT wired through the inner panel harness and de-energized by inline connector separation. Such accessories are at line voltage.

Heavy Equipment

⚠ WARNING

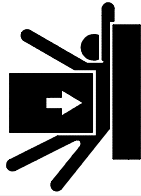

**Unbalanced weight.
Improper lift can cause severe injury or death
and/or equipment damage.**

Use adequate lifting capacity.
Never leave transfer switch standing upright
unless it is securely bolted in place or stabilized.

Notes

NOTE

Hardware damage! Transfer switch may use both American standard and metric hardware. Use the correct size tools to prevent rounding of bolt heads and nuts.

NOTE

When replacing hardware, do not substitute with inferior grade hardware. Screws and nuts are available in different hardness ratings. American Standard hardware uses a series of markings and metric hardware uses a numeric system to indicate hardness. Check markings on bolt head and nuts for identification.

NOTE

Improper operator handle usage! Use the manual operator handle provided on the transfer switch for maintenance purposes only. Return the transfer switch to the normal position. Remove manual operator handle (if used) and store it on the transfer switch in the place provided when service is completed.

NOTE

Perform voltage checks in the order given to avoid damaging the switch.

NOTE

These battery chargers are designed strictly for use in this transfer switch and conform with UL and CSA listing requirements where specified. Do not use battery charger before reading instructions.

NOTE

Connect source and load phases as indicated by the markings and drawings. Improper connections may cause short circuits or cause phase-sensitive load devices to malfunction or operate in reverse.

NOTE

Charger Damage! Connect battery charger only to a battery with the same DC voltage as the battery charger output rating.

NOTE

Foreign material contamination! Cover transfer switch during installation to keep dirt, grit, metal drill chips, etc., out of components. Cover solenoid mechanism during installation. After installation, use manual operating handle to position contactor to ensure that it operates freely. Do not use a screwdriver to force contactor mechanism.

Introduction

This manual covers the operation, troubleshooting, repair, and service parts for the power conversion units that use 25 to 400 ampere electrically held or mechanically held power switching devices.

Read through this manual and carefully follow all procedures and safety precautions to ensure proper transfer switch operation and to avoid bodily injury. Keep this manual with the transfer switch for future reference.

Service requirements are minimal but are very important to the safe and reliable operation of the transfer switch; therefore, inspect associated parts often. It is recommended that an authorized service distributor perform required servicing to keep the switch in top condition.

All information found in this publication is based on data available at time of print. The manufacturer reserves the right to make changes to this literature and the products represented at any time without notice and without incurring obligation.

List of Related Manuals

The group of power conversion units covered in this manual is part of a family of related devices. Separate service and parts manuals are available for each group within the overall family. Be sure this manual is the correct manual for the automatic transfer switch.

A logic controller is included in each automatic transfer switch. There are three types of logic controllers and each type is covered in a separate service and parts manual. Available logic controllers and the related manual numbers are as follows:

Logic Controller (Type)	Service/ Parts Manual
E33+ (solid-state)	TP-5670
S340+ (solid-state)	TP-5671
M340+ (microprocessor)	TP-5672

Service Assistance

For service or information, consult the yellow pages of the telephone directory under the heading GENERATORS—ELECTRIC for the Authorized Kohler Service Distributor/Dealer.

KOHLER CO., Kohler, Wisconsin 53044
Phone 920-565-3381
Fax 920-459-1646 (North American Sales)
920-459-1614 (International Sales)

For Sales and Service in U.S.A. and Canada
Phone 1-800-544-2444

In communications regarding the automatic transfer switch, please include the PART and SERIAL numbers provided on the nameplate attached to the transfer switch. Enter the numbers in the spaces provided below. This information will enable the authorized Kohler service distributor/dealer to supply the correct part or information for your particular model.

Part No. _____

Serial No. _____

Notes

Section 1. Specifications

Purpose of Switch

An automatic transfer switch (ATS) is a device that transfers critical electrical loads from a normal (preferred) source of electrical power to an emergency (standby) source. This transfer occurs automatically when the normal source voltage fails, or is substantially reduced, and the emergency source voltage reaches an acceptable level.

Upon normal source failure, the automatic transfer switch controller signals the generator set(s) to start and transfer to the emergency source. The automatic transfer switch controller continuously senses for an acceptable normal source and retransfers the load to the normal source after it is restored to an acceptable level. After retransfer of the load, the ATS removes the generator set start signal and allows the generator set(s) to shut down.

Components of Switch

A typical automatic transfer switch includes the power switching device and the logic controller to perform power monitoring and transfer sequencing tasks. See Figure 1-1. An interface board is also included to match the controller inputs/outputs to the levels required by a specific switching device.

hinged front door. The controller mounts on the back of the front door so its controls and indicators are available to an operator. A signal cable with in-line connectors to facilitate component replacement and door removal connects the controller to the interface board and the switching devices. See Figure 1-2

The three functional units that make up the automatic transfer switch are mounted in an enclosure with a

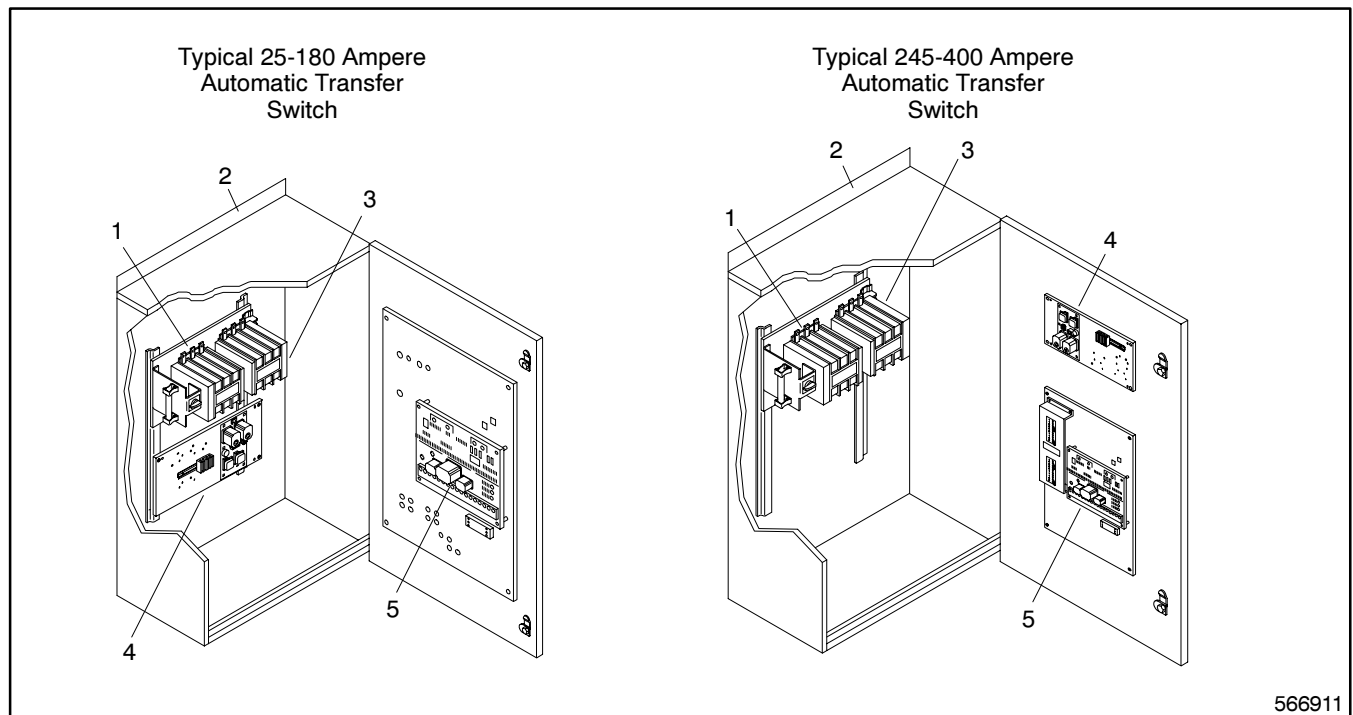

566911

1. Normal power contactor
2. Mounting flange
3. Standby power contactor

4. Interface panel
5. Logic controller

Figure 1-1. Transfer Switch Components

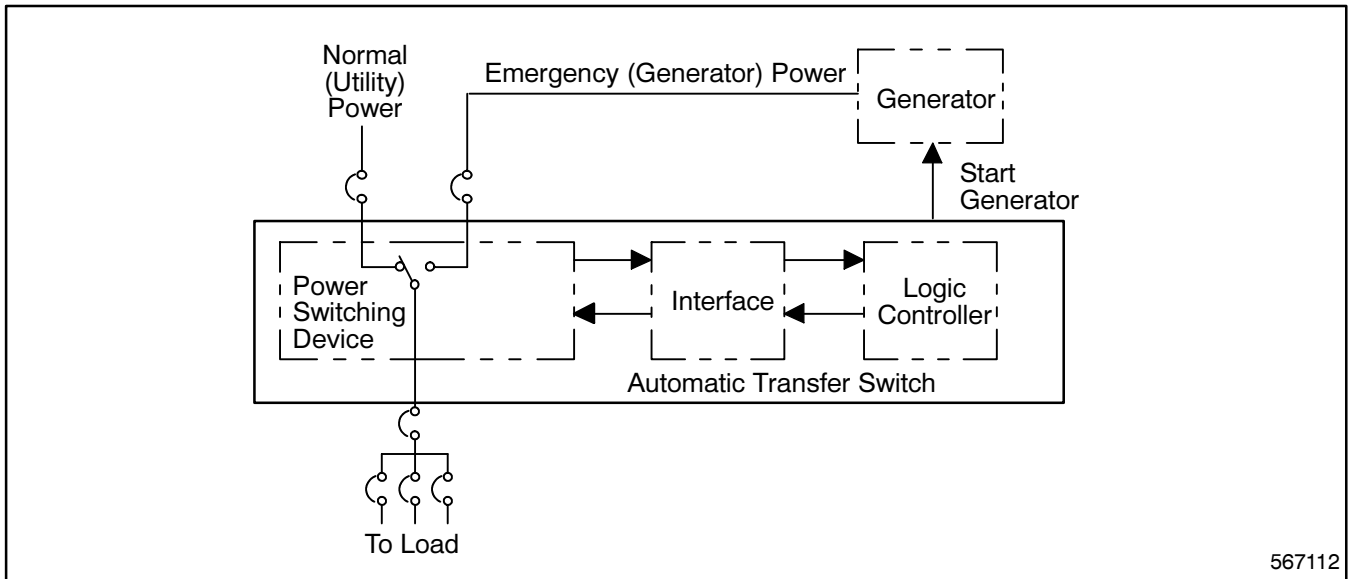

Figure 1-2. Basic Transfer Switch Block Diagram

Nameplate

A nameplate affixed to the ATS enclosure identifies the switch. See Figure 1-3. The nameplate label includes a factory part number coded to provide characteristic and rating information that affects installation and operation. Copy the part number into the blank spaces provided in Figure 1-4 and then use the charts in Figure 1-4 to interpret the part number.

NOTE

Also copy the part number and serial number from the nameplate into the spaces provided in the **Service Assistance** Section of the Introduction for use when requesting service or parts.

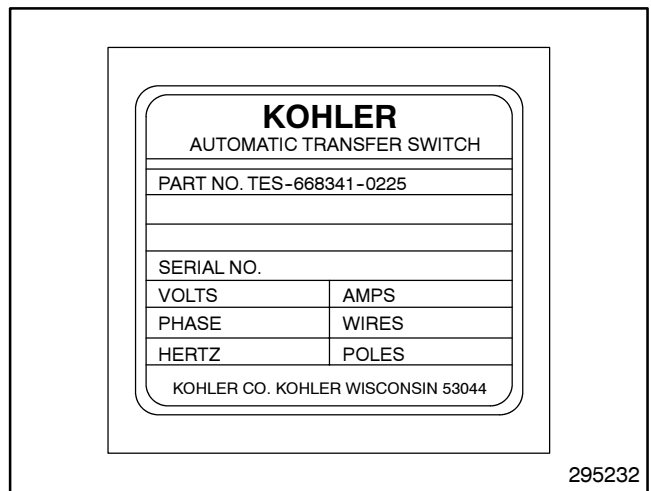
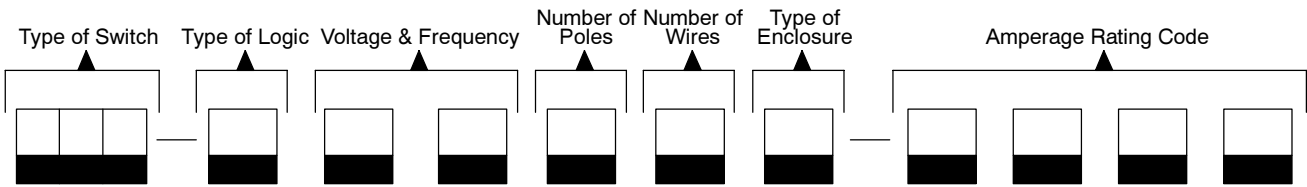

Figure 1-3. Transfer Switch Nameplate

Interpreting a Transfer Switch Part Number

Record the transfer switch part number in the boxes below. The transfer switch part number defines characteristics and ratings as explained in the accompanying chart.



Kohler® Part Number Key

This chart explains the Kohler® transfer switch part numbering code system. The sample part number shown is for an electrically held contactor with M340+ logic rated at 480 volts, 60 hertz, 3-phase, 3-pole, and 4 wires in a NEMA 1 enclosure with an amperage rating of 80 amperes.

SAMPLE PART NUMBER

TES-566341-0080

Classification of Power Switch

T: Electrically or Mechanically Held

Type of Power Switch

E: Electrically Held Contactor
L: Mechanically Held Contactor

Type of Switch

S: Standard

Type of Logic Controller

1: S340+
2: E33+
3: S340+ with programmed transition
4: E33+ with programmed transition
5: M340+
6: M340+ with programmed transition

Voltage Code

60: 600 Volt, 60 Hz 66: 480 Volt, 60 Hz
62: 120 Volt, 60 Hz 68: 208 Volt, 60 Hz
63: 220 Volt, 50 Hz 71: 380 Volt, 50/60 Hz
64: 240 Volt, 60 Hz 73: 416 Volt, 50 Hz.

Number of Poles

3: 3 pole, 3 phase
6: 4 pole, fully rated switched poles (no overlapping neutral)

Number of Wires

3: 3 wire
4: 4 wire

Enclosure

1: NEMA type 1

Amperes

Numbers indicate the current rating of the switch.

Figure 1-4. Transfer Switch Model Description

Standard Features

Specifications for automatic transfer switches covered by this manual are listed below:

- Provided as a complete automatic transfer switch with E33+, S340+ (solid state logic), or M340+ (microprocessor logic) controller in a NEMA Type 1 enclosure
- Meets IEC standards
- Can be turned off manually
- Three-pole and four-pole models
- Four pole fully rated (no overlapping neutral)
- Program Transition function available
- Switch amperage ratings from 25 to 400 amperes
- Contactor operational voltage rated at 1000 vac
- Contactor characteristics summarized in Figure 1-5 and Figure 1-6

Contactor Ratings

Transfer Switch Rating (Amps)*		Rated Insulation Voltage	Making Capacity (Amps)†	Breaking Capacity (Amps)‡				Short-Term Current Rating‡ (Started cold, no current flow for 15 minutes at a temperature of 104°F (40°C))						
				220-440V	500V	660V	1000V	For 1 sec	For 5 sec	For 10 sec	For 30 sec	For 1 min	For 3 min	For 10 min
AC-1‡	AC-3§													
40	25	600	450	450	400	180		380	290	240	155	120	80	50
50	32	600	550	550	450	180		430	340	260	175	138	92	60
80	65	600	1000	1000	1000	630		900	660	520	340	260	175	110
110	80	600	1100	1100	1000	640		990	800	640	420	320	210	135
200	145	1000	1300	1300	1100	900	400	1100	1100	1100	640	520	400	320
270	180	1000	2100	1800	1600	1200	600	1500	1500	1500	920	740	500	400
350	245	1000	2450	2450	2200	1750	800	2200	2200	2200	1230	950	620	480
500	400	1000	4500	4000	3500	3000	1200	3600	3600	3600	2400	1700	1200	1000

*All switches included in this table have a dry air operating temperature range of +23° to +131°F (-5° to +55°C).
†Per IEC 947-4
‡IEC 947-4 Category AC-1 Ratings apply to all types of AC loads with a power factor of 0.95 or greater.
§IEC 947-4 Category AC-3 Ratings apply to inductive loads typically between 0.0 and 1.0 power factor.

Figure 1-5. Characteristic Summary of Electrically and Mechanically Held Contactors

Transfer Switch Rating (Amps)*		Rated Insulation Voltage	Making Capacity (Amps)†	Breaking Capacity (Amps)‡				Short-Term Current Rating‡ (Started cold, no current flow for 15 minutes at a temperature of 104°F (40°C))						
				220-440V	500V	660V	1000V	For 1 sec	For 5 sec	For 10 sec	For 30 sec	For 1 min	For 3 min	For 10 min
AC-1‡	AC-3§													
200	145	1000	1500	1500	1200	1000	450	1200	1200	1200	700	600	450	350
270	180	1000	1800	1800	1600	1150	600	1500	1500	1500	920	740	500	400
350	245	1000	2450	2450	2200	1750	800	2200	2200	2200	1230	950	620	480
500	400	1000	4000	4000	3500	3000	1200	3600	3600	3600	2400	1700	1200	1000

*All switches included in this table have a dry air operating temperature range of +5° to +185°F (-15° to +70°C).
†Per IEC 158-1
‡IEC 947-4 Category AC-1 Ratings apply to all types of AC loads with a power factor of 0.95 or greater.
§IEC 947-4 Category AC-3 Ratings apply to inductive loads typically between 0.0 and 1.0 power factor.

Figure 1-6. Characteristic Summary of Magnetically Held Contactors

Section 2. Operation

Switches and Indicators



The switches and indicators on the automatic transfer switch are determined by the controller used in that switch. For details on this subject, refer to the appropriate controller operation and installation manual. See **List of Related Manuals** in the introduction.

Automatic Operation

Automatic operation is a function of the controller installed in the unit. For all details and procedures for both initialization and automatic operation, refer to the appropriate controller operation and installation manual. See **List of Related Manuals** in the introduction.

Manual Operation

Manual operation of the transfer switch, which is limited to opening of the contactors, is of use when the controller fails or when testing/troubleshooting the unit. However, those transfer switches that are electrically held are not capable of manual operation. To open contactors of a mechanically or magnetically held switch, proceed as follows:

 DANGER

Hazardous voltage. Will cause severe injury or death. Disconnect power sources before servicing. Install barrier after adjustments, maintenance, or servicing.

(600 Volt and above)

1. Disconnect both normal and emergency power sources.
2. Open the enclosure door of the automatic transfer switch.
3. For a mechanically held switch, press the orange button on the switch cover to open contactors. See Figure 2-1. For a magnetically held switch, insert the manual operation lever, located on the inner panel, into the hole on side of switch to open the contactors. See Figure 2-2.
4. Shut the enclosure door.

NOTE

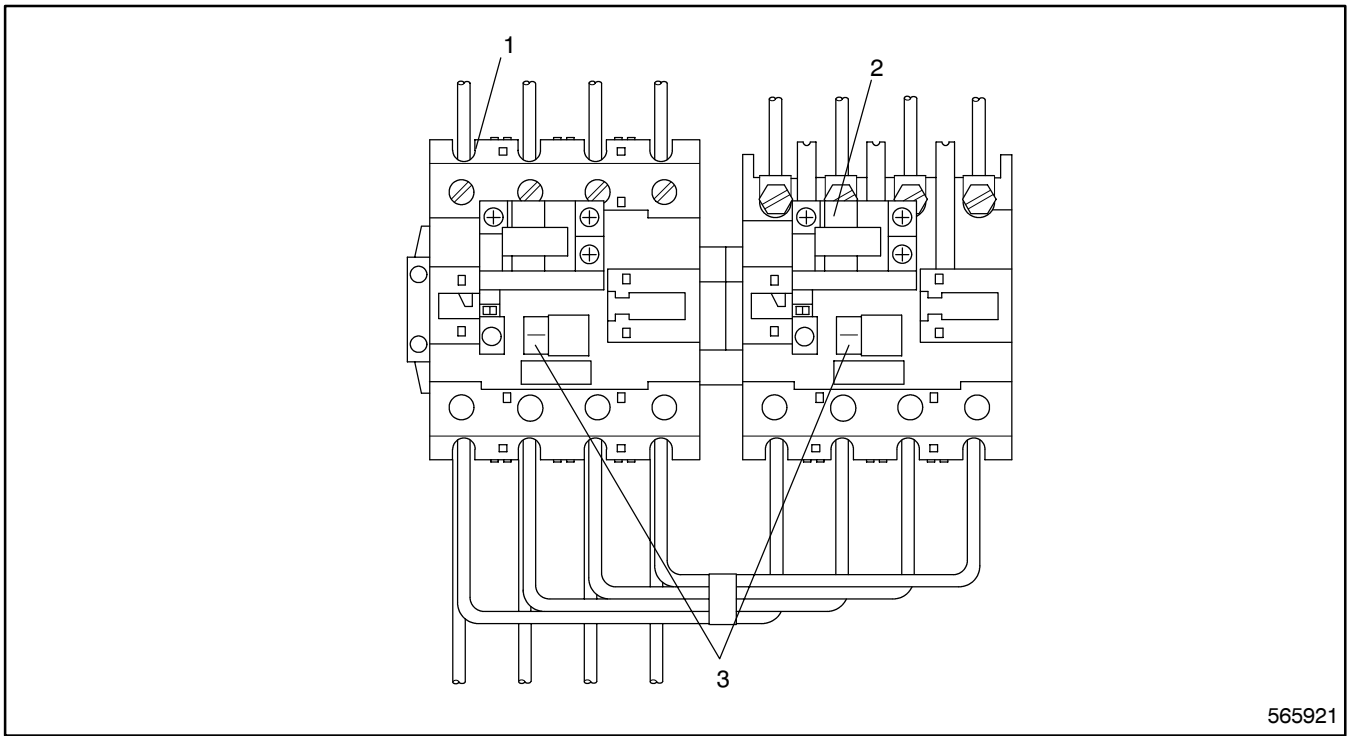
The logic controller may cause the switch to operate and close the contactors again when the power source(s) is (are) restored.



565921

- 1. Normal contactor
- 2. Standby (emergency) contactor
- 3. Orange button

Figure 2-1. Mechanically Held Automatic Transfer Switch Operation

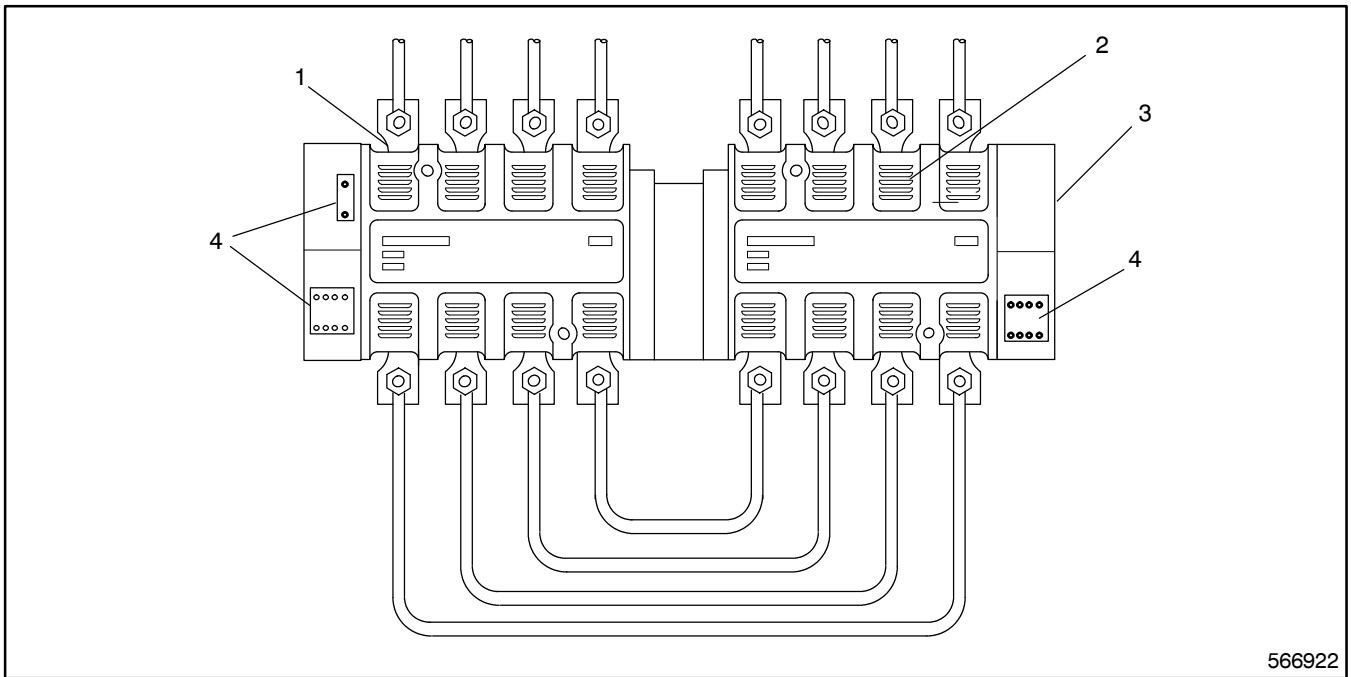

566922

- 1. Normal contactor
- 2. Standby (emergency) contactor
- 3. Manual operate lever hole
- 4. Auxiliary contacts

Figure 2-2. Magnetically Held Automatic Transfer Switch Operation

Sequence of Operation

Operation of the typical automatic transfer switch is divided into two separate sequences: (1) failure of normal power and the resulting transfer to emergency power and (2) restoration of normal power and the resulting transfer back to normal power. A brief description of both sequences is provided below. Note that these sequences may be affected by accessories described later in this section of this manual or in the applicable logic controller service and parts manual. In addition, for more specific details on circuit operation including time delays, refer to the applicable controller service and parts manual. See **List of Related Manuals** earlier in the Introduction.

Normal Source Failure

Failure of normal power, either loss or deterioration of one or more phases, is detected by monitors within the controller. The monitor that detects the failure starts a time delay, called Time Delay Engine Start (TDES). If power is restored before the time delay expires, the timer is reset. If the failure persists and the time delay expires, the controller issues a signal to start the standby (emergency) power generator. This time delay scheme is used to prevent unnecessary starting of the generator set during short power interruptions.

A second set of monitors within the controller checks the status of the emergency power. When the voltage and frequency of the emergency (generator set) power is within an acceptable range, these monitors start a timing cycle, called Time Delay Normal to Emergency (TDNE). At the end of the timing cycle, which is provided to allow the generator outputs to stabilize, the controller issues a signal to the transfer switch to remove normal power and connect emergency power to the load.

Once the transfer is complete, the transfer switch remains in the emergency position, supplying power to the load from the emergency source until normal power is restored.

Normal Source Restoration

Restoration of normal power automatically begins a sequence that transfers the load back to the normal power source. The monitors within the controller continue to check the status of normal power, even when the load is operating on emergency power. When these monitors detect a stable condition of the normal power, a time delay called Time Delay Emergency to Normal (TDEN) is started. If the normal power fails again before the time delay expires, the time delay is reset. This timing period is included to ensure that the normal power is stabilized before it is reconnected to the load.

If the normal power remains acceptable and the time delay expires, the controller issues signals to the transfer switch to remove emergency power and reconnect normal power to the load. Simultaneously with the power transfer, the controller starts a timer called Time Delay Engine Cooldown (TDEC). After this time delay expires, the generator engine is stopped.

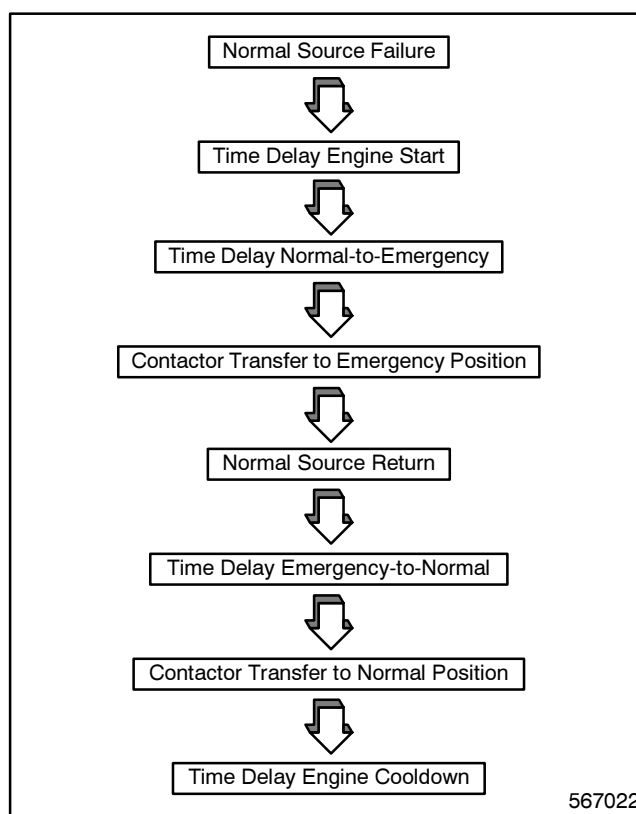

Figure 2-3. Logic Board Operation

Accessories

Time Delay Off

The Time Delay Off accessory consists of two timing relays that plug into the interface board. See Figure 2-4. However, when the ATS is equipped with an MATS+M340+ controller, the accessory is programmed into the controller's microprocessor. If the ATS has a time delay off accessory, it transfers power from normal to emergency or emergency to normal sources in three steps:

1. The switch for the previously connected power source opens.
2. There is a delay period, adjustable from 2 to 40 seconds, to allow residual voltage in the load circuit to decay.
3. The switch or circuit breaker for the new power source closes.

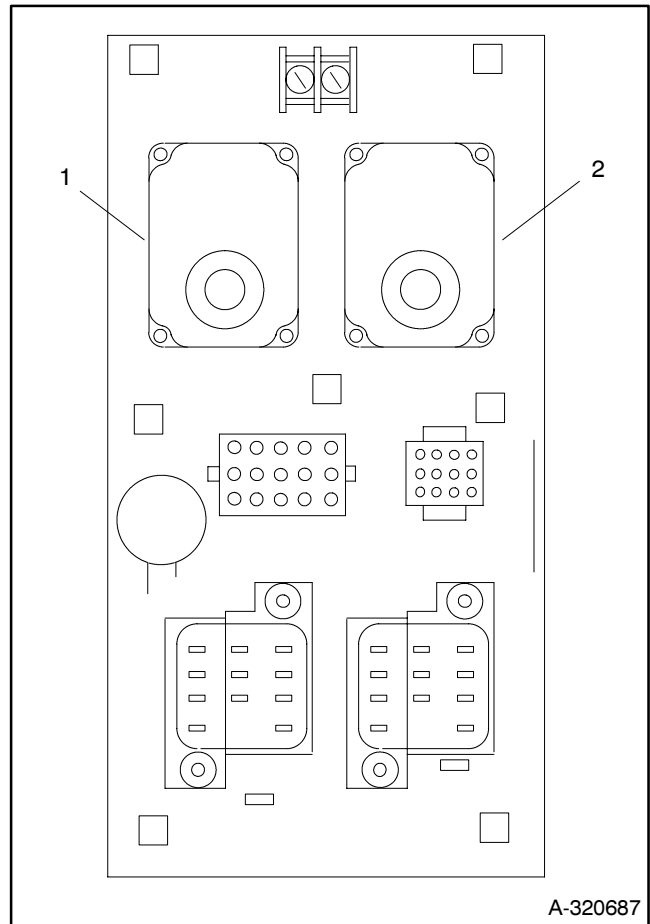

1. K3 (TDON)
2. K4 (TDOE)

Figure 2-4. Interface Board with Time Delay Relays

Other Accessories

With the exception of the Time Delay off accessory, all other accessories are controller accessories. For controller accessory information and procedures, refer to the appropriate controller manual. See **List of Related Manuals** in the Introduction.

Section 3. General Maintenance

Reasonable care in preventive maintenance will ensure high reliability and long life for the automatic transfer switch. Follow all applicable local codes and standards and keep a log book for scheduled maintenance and repairs.

Operate Transfer Switch at Least Once a Month

Use the test switch to check the electrical operation of the transfer switch. Because the test switch only simulates failure of the normal source, service is interrupted only during the actual transfer of the load. It is recommended that a load be connected while transfer takes place.

Keep Automatic Transfer Switch Clean



During installation, protect the switch from construction grit and metal chips. Once each year, with the cover on the control panel, brush and vacuum away any dust accumulation.

Inspect Main Current-Carrying Contacts

Once each year, de-energize all sources and remove barriers to check condition of contact material. Replace switch or circuit breaker contactor unit when contacts are pitted or worn.

NOTE

Never replace a single contact in a contactor. Always replace all of the contacts at the same time.

 DANGER

<p>Hazardous voltage. Will cause severe injury or death.</p> <p>Disconnect power sources before servicing. Install barrier after adjustments, maintenance, or servicing.</p>

(600 Volt and above)

Grounding generator set. Hazardous voltage can cause severe injury or death. Electrocution is possible whenever electricity is present. Open main circuit breakers of all power sources before servicing equipment. Configure the installation to electrically ground the generator set and electrical circuits when in use. Never contact electrical leads or appliances when standing in water or on wet ground, as the chance of electrocution is increased under such conditions.

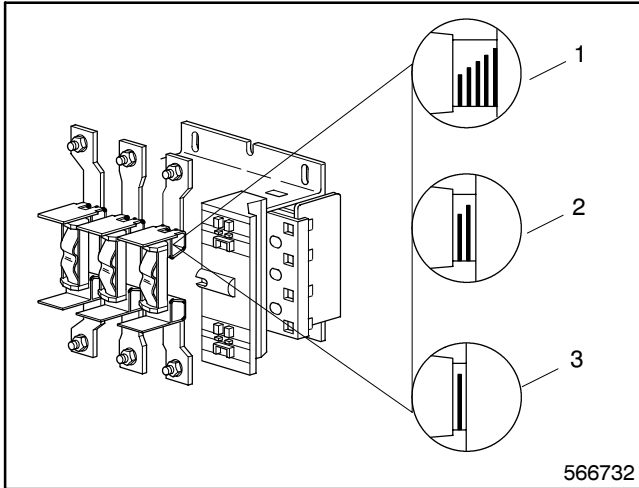
On all electrically held units, lines marked on the contacts serve as wear indicators. See Figure 3-1. To view these wear indicators, loosen the quarter-turn fasteners and slide the cover off the contactor assembly. When a wear indicator has less than two lines left, the contacts should be replaced. After inspection, reinstall the cover and tighten the quarter-turn fasteners before returning the ATS to normal operation.



1. New
2. 50% worn
3. Needs replacement

Figure 3-1. Line Wear Indicator

Torquing of Contactor Lug Set Screws

Set screws must be torqued to specs when installed and should be checked every six months. When aluminum conductor is used, apply joint compound to conductor. After tightening, check contactor lugs for joint compound and wipe off excess.

Effect of Ambient Temperature and Humidity Conditions

The contactor should be operated in an ambient temperature of 32° to 104° F (0° to 40° C). Contact the manufacturer if the contactor will be operated in a higher or lower ambient temperature. Humidity can vary from 5 to 95% without affecting operation.

Section 4. Troubleshooting

This section provides troubleshooting procedures for mechanical failures of the switching device. Troubleshooting of the electrical functions of the switching device as well as the overall operation of the automatic transfer switch is covered in the applicable logic controller service and parts manual. See **List of Related Manuals** in the Introduction of this manual.

Troubleshooting Tables

Use the following table to troubleshoot problems. The table includes troubleshooting information for a specific automatic transfer switch problem. Included in this information is a list of possible causes of the problem, the recommended remedy for each possible cause, and a reference to detailed information or procedures for the remedy.

It is recommended that repairs be accomplished only by an authorized service dealer. Improper repairs by unqualified personnel can lead to additional failures.

Problem	Possible Cause	Corrective Action	Reference
Mechanical interlocks jam, preventing normal closure of a contactor.	Interlock(s) misaligned	Realign interlock(s).	None
	Interlock(s) damaged	Replace interlock(s).	Section 6—Component Removal and Installation
	Contactor defective	Replace contactor.	Section 6—Contactor Removal and Contactor Installation
Mechanical interlocks fail to prevent simultaneous closure of both contactors.	Interlock(s) misaligned	Realign interlock(s).	None
	Interlock(s) damaged	Replace interlock(s).	Section 6—Component Removal and Installation
	Contactor interlock shaft defective	Replace contactor.	Section 6—Contactor Removal and Contactor Installation
A mechanically held (25-80 ampere) contactor fails to hold a closed setting.	Mechanical interlock interference	Check/fix mechanical interlock.	Section 6—Component Removal and Installation
	Contactor's mechanical latch defective	Replace mechanical latch.	Section 6—Component Removal and Installation
	Contactor defective	Replace contactor.	Section 6—Contactor Removal and Contactor Installation
A magnetically held (145-400 ampere) contactor fails to hold a closed setting.	Mechanical interlock interference	Check/fix mechanical interlock.	Section 6—Contactor Removal and Contactor Installation
	Contactor defective	Replace contactor.	Section 6—Contactor Removal and Contactor Installation
A magnetically held (145-400 ampere) contactor fails to manually open or close.	Mechanical interlock interference	Check/fix mechanical interlock.	Section 6—Component Removal and Installation
	Manual operator damaged	Replace auxiliary switch.	Section 6—Component Removal and Installation
	Contactor defective	Replace contactor.	Section 6—Contactor Removal and Contactor Installation

Notes

Section 5. Accessory Testing and Adjustment



Programmed Transition

NOTE

For ATs utilizing the M340+ logic control, DO NOT use this section. The programmed transition function is accomplished within the microprocessor. The timing relays are replaced with standard c-form relays and require no relay adjustments. See publication TP-5664, M340+ Operation and Installation Manual, for operational details.

Two separate timing relays are used. One relay, K4 (TDOE), produces the time delay neutral for the normal to emergency power transfer. The other relay, K3 (TDON), produces the time delay for the emergency to normal power transfer. Each relay has a separate adjustment. To make the adjustment, proceed as follows:

1. Disconnect both the normal and emergency power sources.

 DANGER

Hazardous voltage. Will cause severe injury or death.
Disconnect power sources before servicing. Install barrier after adjustments, maintenance, or servicing.

(600 Volt and above)

Grounding generator set. Hazardous voltage can cause severe injury or death. Electrocutation is possible whenever electricity is present. Open main circuit breakers of all power sources before servicing equipment. Configure the installation to electrically ground the generator set and electrical circuits when in use. Never contact electrical leads or appliances when standing in water or on wet ground, as the chance of electrocution is increased under such conditions.

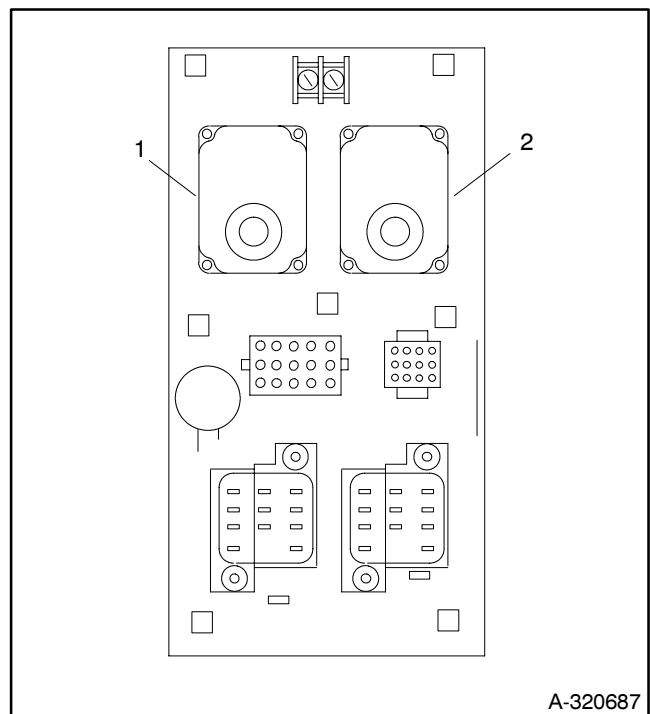
2. Open the enclosure door of automatic transfer switch.
3. Locate the appropriate relay on the interface board. See Figure 5-1.
4. The time delay adjustment screw is visible through the cover of the relay. Use a screwdriver inserted through the adjustment slot to manually adjust the time delay period.
5. Shut the enclosure door.
6. Reconnect the normal and emergency power sources.
7. Operate the automatic transfer switch automatically and check the time delay off period to ensure that it is properly adjusted.



1. K3 (TDON)
2. K4 (TDOE)

Figure 5-1. Interface Board with Time Delay Neutral Relays

Other Accessories

All other accessories for this automatic transfer switch are controller accessories. For controller accessory information and procedures, refer to the appropriate controller manual. See **List of Related Manuals** in the Introduction.

Notes

Section 6. Reassembly/Disassembly

Introduction

This section provides instructions for disassembly and reassembly of the switching devices. Use these instructions when it is necessary to replace parts within the switching devices.

⚠ DANGER

Hazardous voltage. Will cause severe injury or death.
Disconnect all power sources before opening enclosure.

(600 Volt and above)

Making line or auxiliary connections. Hazardous voltage can cause severe injury or death. To prevent the possibility of electrical shock, de-energize the normal power source before making any line or auxiliary connections.

Servicing transfer switch. Hazardous voltage can cause severe injury or death. De-energize both normal and emergency power sources before proceeding. Move generator set master switch on controller to OFF position and disconnect battery negative (-) before working on transfer switch! Turn the transfer switch selector switch to the OFF position.

⚠ DANGER

Hazardous voltage. Will cause severe injury or death.
Disconnect power sources before servicing. Install barrier after adjustments, maintenance, or servicing.

(600 Volt and above)

Grounding generator set. Hazardous voltage can cause severe injury or death. Electrocutation is possible whenever electricity is present. Open main circuit breakers of all power sources before servicing equipment. Configure the installation to electrically ground the generator set and electrical circuits when in use. Never contact electrical leads or appliances when standing in water or on wet ground, as the chance of electrocution is increased under such conditions.

Contactors Removal

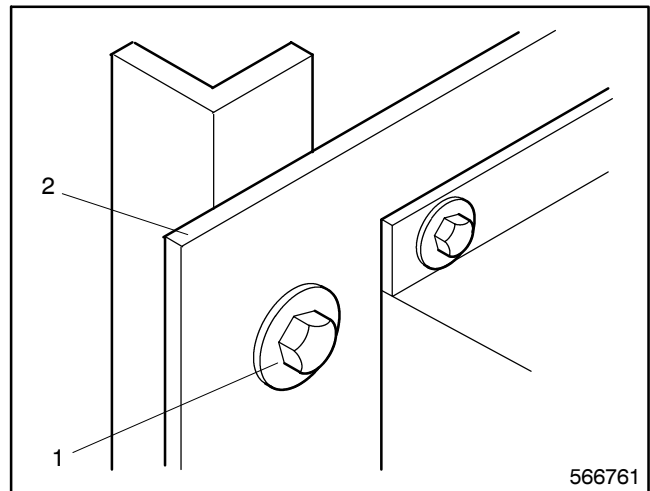
1. Disconnect both the normal and emergency power sources.
2. Open the enclosure door of the ATS.
3. Disconnect the normal and emergency power sources and load connections from the contactor terminals.
4. Disconnect P1 of the contactor assembly harness from P1 of the logic control harness.
5. Remove the screws and flat washers. Lift the switch panel out of the enclosure. See Figure 6-1.



1. Screw and washer
2. Contactor assembly

Figure 6-1. Switch Panel (Upper Left)

6. Place the contactor assembly on a work bench.
7. Remove the tie bars between the load connection lugs of the two contactors.
8. Disconnect wiring harness from auxiliary switch and contactor coil.
9. Remove screws and separate the contactor from the contactor assembly panel. See Figure 6-2.

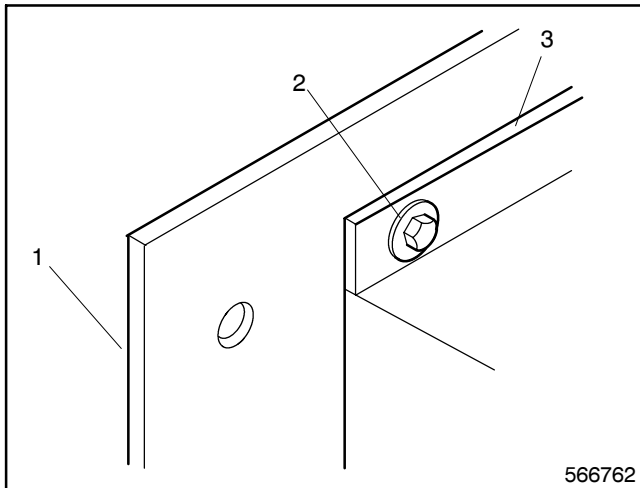

1. Panel
2. Screw
3. Contactor

Figure 6-2. Contactor Assembly Removal

10. Remove the mechanical interlock from the contactor. See **Mechanical Interlock Removal, 25-80 Ampere Contactors or 115-400 Ampere Contactors, Component Removal and Installation.**
11. Remove the auxiliary switch from the contactor. See **Auxiliary Switch Removal, 25-80 Ampere Contactors or 115-400 Ampere Contactors, Component Removal and Installation.**
12. On 25-80 ampere mechanically held contactors, remove the mechanical latch. See **Mechanical Latch Removal, 25-80 Ampere Contactors, Component Removal and Installation.**

Contactor Installation

1. On 25-80 ampere mechanically held contactors, install the mechanical latch. See **Mechanical Latch Installation, 25-80 Ampere Contactors, Component Removal and Installation.**
2. Install the auxiliary switch on the contactor. See **Auxiliary Switch Installation, 25-80 Ampere Contactors or 145-400 Ampere Contactors, Component Removal and Installation.**

3. Install the mechanical interlock on the contactor assembly. See **Mechanical Interlock Installation, 25-80 Ampere Contactors or 145-400 Ampere Contactors, Component Removal and Installation.**
4. Place the contactor assembly onto the switch plate and mate the mechanical interlocks. Install and tighten the screws to secure the contactor assembly in place.
5. Reconnect the contactor's auxiliary switch and coil to the main harness assembly. See wiring diagram in Section 7.
6. Reinstall the tie bars between the load connectors of the two contactor assemblies.
7. Place the switch panel back into the enclosure. Install the screws and flat washers to secure the switch panel in place.
8. Reconnect P1 of the switching device panel harness to P1 of the logic control and interface panel harness.

WARNING



**Hazardous voltage.
Can cause severe injury or death.**

Disconnect power sources before servicing. Install barrier after adjustments, maintenance, or service.

(under 600 Volt)

Making line or auxiliary connections. Hazardous voltage can cause severe injury or death. To prevent the possibility of electrical shock, de-energize the normal power source before making any line or auxiliary connections.

Servicing transfer switch. Hazardous voltage can cause severe injury or death. De-energize both normal and emergency power sources before proceeding. Move generator set master switch on controller to OFF position and disconnect battery negative (-) before working on transfer switch! Turn the transfer switch selector switch to the OFF position.

9. Reconnect the power source and load connections to the contactor terminals.
10. Shut the enclosure door.
11. Return the ATS to normal operation.

Component Removal and Installation—25-80 Amp Contactors

Mechanical Interlock Removal

1. Remove one contactor from the contactor assembly panel. See **Contactor Removal**, steps 1 through 9, earlier in this section.
2. Remove mechanical interlock from other contactor. See Figure 6-3.

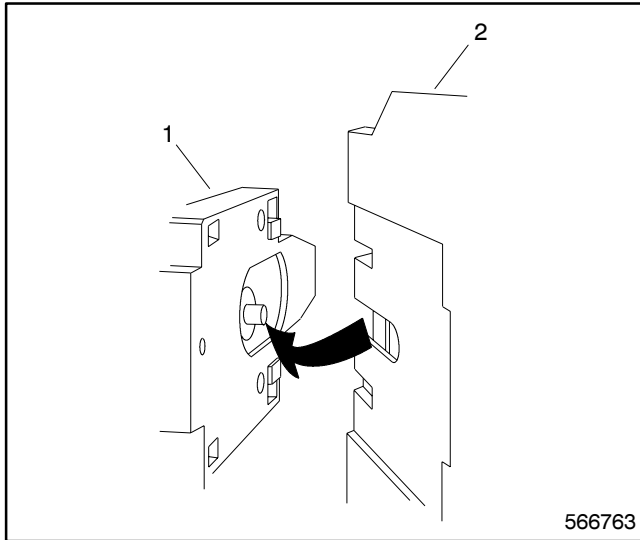

1. Interlock
2. Contactor

Figure 6-3. Mechanical Interlock Removal (25-80 Ampere Contactors)

Mechanical Interlock Installation

1. Engage tab of mechanical interlock into slot of contactor that is still attached to contactor assembly panel. See Figure 6-4.
2. Install other contactor, mating its slot with tab on mechanical interlock, on contactor assembly panel.
3. Complete installation of the contactor. See **Contactor Installation**, steps 4 through 8 earlier in this section.

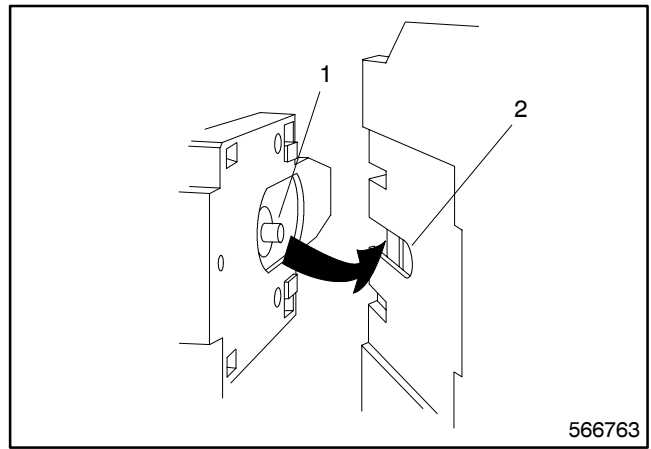

1. Tab
2. Slot

Figure 6-4. Mechanical Interlock Installation (25-80 Ampere Contactors)

Auxiliary Switch Removal

1. Disconnect the wire harness from the auxiliary switch.
2. If the contactor is electrically held, release the lock and slide the auxiliary switch up and off the contactor. See Figure 6-5.

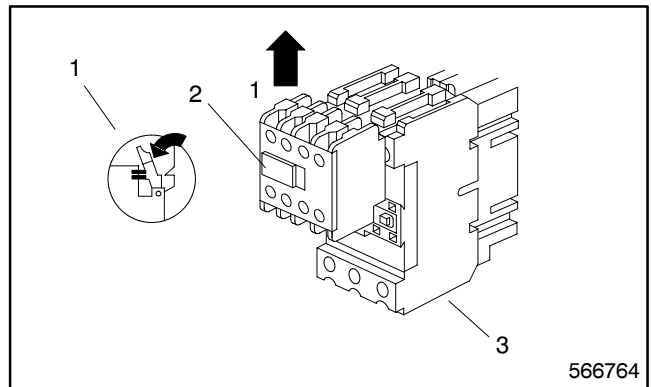

1. Lock
2. Auxiliary switch
3. Contactor

Figure 6-5. Auxiliary Switch Removal (25-80 Ampere Electrically Held Contactors)

3. If the contactor is mechanically held, lift the yellow tab and rotate the auxiliary switch down and to the side. See Figure 6-6.

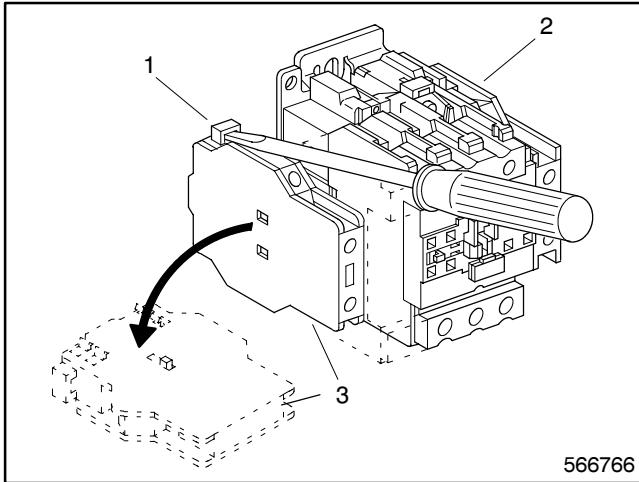

1. Tab
2. Contactor
3. Auxiliary switch

**Figure 6-6. Auxiliary Switch Removal
(25-80 Ampere Mechanically Held Contactors)**

Auxiliary Switch Installation

1. If the contactor is electrically held, slide auxiliary switch into slots of contactor and slide down until lock clicks. See Figure 6-7.

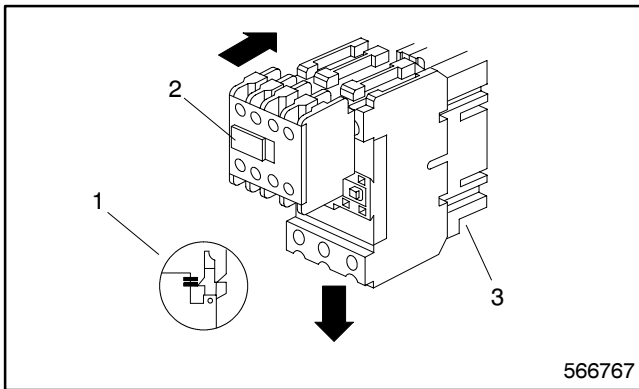

1. Lock
2. Auxiliary switch
3. Contactor

**Figure 6-7. Auxiliary Switch Installation
(25-80 Ampere Electrically Held Contactors)**

2. If the contactor is mechanically held, press auxiliary switch tabs into mating slots on contactor. See Figure 6-8.

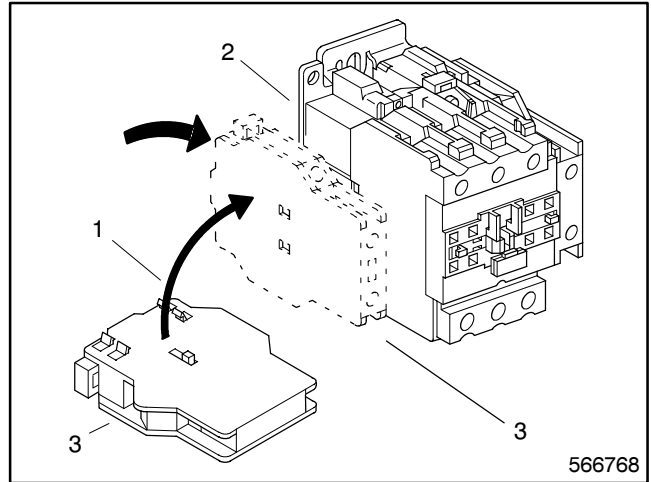

1. Tab
2. Contactor
3. Auxiliary switch

**Figure 6-8. Auxiliary Switch Installation
(25-80 Ampere Mechanically Held Contactors)**

3. Reconnect wire harness leads to auxiliary switch.

Mechanical Latch Removal

1. Release mechanical latch lock. See Figure 6-9.

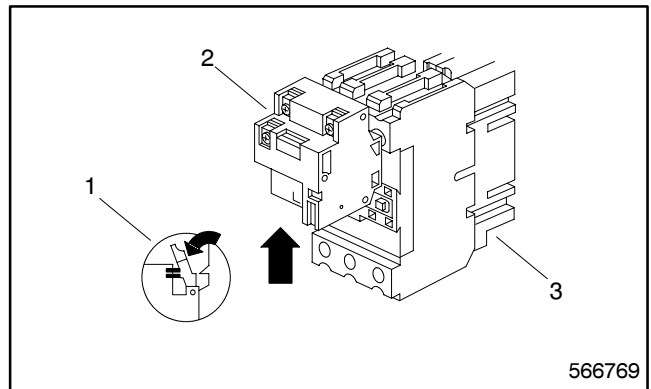

1. Lock
2. Latch
3. Contactor

**Figure 6-9. Mechanical Latch Removal
(25-80 Ampere Contactors)**

2. Slide mechanical latch up and off contactor.

Mechanical Latch Installation

1. Align ribs on back of mechanical latch with slots in contactor face.
2. Slide mechanical latch downward until lock clicks. See Figure 6-10.

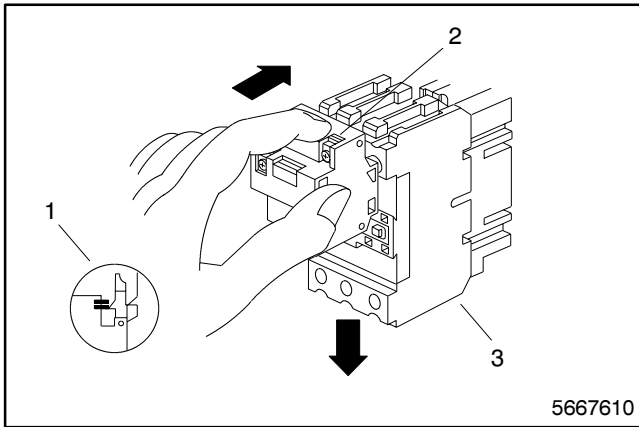

1. Lock
2. Latch
3. Contactor

**Figure 6-10. Mechanical Latch Installation
(25-80 Ampere Contactors)**

Coil Removal

1. Disconnect power source and load leads from contactor terminals.
2. Disconnect leads between load terminals of the two contactors.
3. Disconnect wire harness leads from auxiliary switch.
4. Loosen screws and remove contact assembly from contactor base. See Figure 6-11.

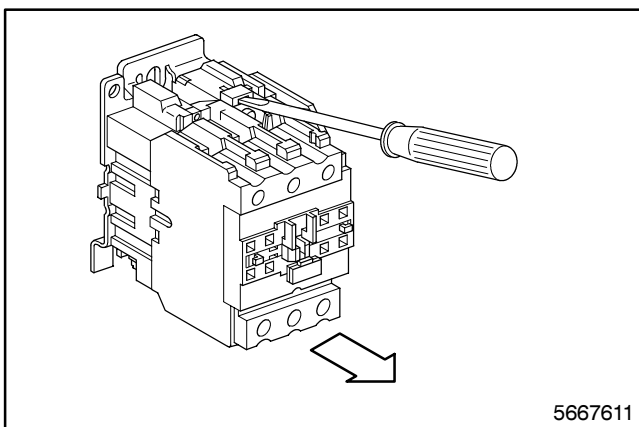

**Figure 6-11. Contact Assembly Removal
(25-80 Ampere Contactors)**

5. Loosen screws and disconnect wire harness leads from the coil.
6. Remove the coil from the contactor base. See Figure 6-12.

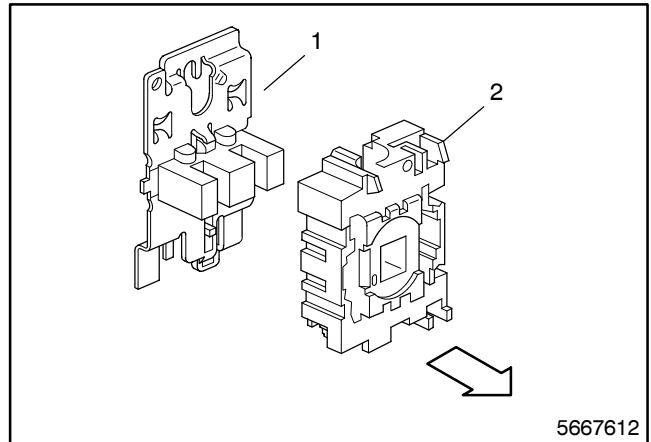

1. Contactor base
2. Coil

**Figure 6-12. Coil Removal
(25-80 Ampere Contactors)**

Coil Installation

1. Install the coil in the contactor base.
2. Reconnect wire harness leads to coil and tighten screws.
3. Install contact assembly on contactor base and tighten screws.
4. Reconnect wire harness leads to auxiliary switch.
5. Reconnect leads between load terminals of the two contactors.
6. Reconnect load and power source leads to contactor terminals.

Component Removal and Installation—145-400 Amp Contactors

Mechanical Interlock Removal

1. Remove one contactor from the contactor assembly panel. See **Contactors Removal**, steps 1 through 9, earlier in this section.

2. Remove capscrew and washer. See Figure 6-13.

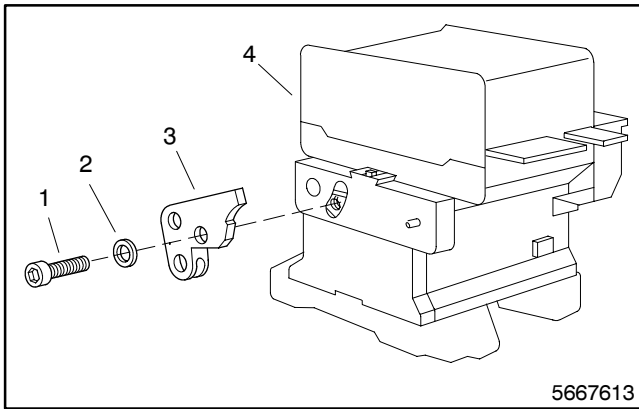

1. Capscrew
2. Washer
3. Interlock
4. Contactor

**Figure 6-13. Mechanical Interlock Removal
(145-400 Ampere Contactors)**

3. Separate mechanical interlock from contactor.

Mechanical Interlock Installation

1. Install mechanical interlock on contactor. See Figure 6-14.

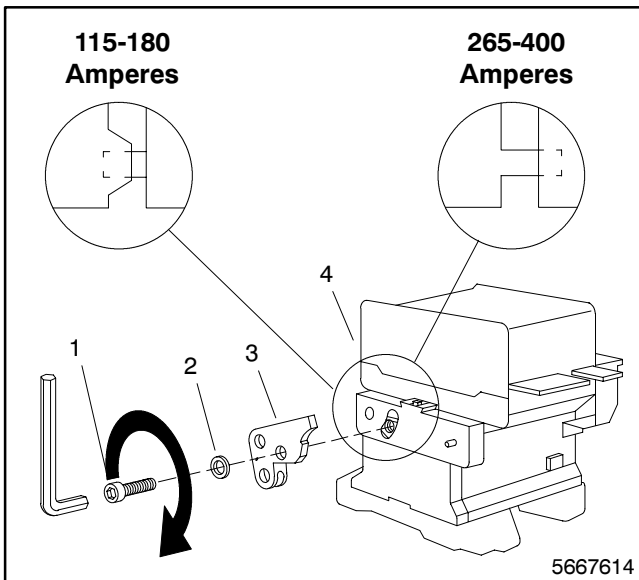

1. Capscrew
2. Washer
3. Interlock
4. Contactor

**Figure 6-14. Mechanical Interlock Installation
(145-400 Ampere Contactors)**

2. Install washer and capscrew. Torque capscrew to 40 in. lbs. (4.5 Nm).
3. Install previously removed contactor on contactor assembly panel. See **Contactors Installation**, steps 4 through 8, earlier in this section.

NOTE

Use L-wrench or manual operator to align mechanical interlocks on the two contactors during contactor installation.

Auxiliary Switch Removal

1. Disconnect wiring harness from auxiliary switch.
2. Lift mounting tab. See Figure 6-15.

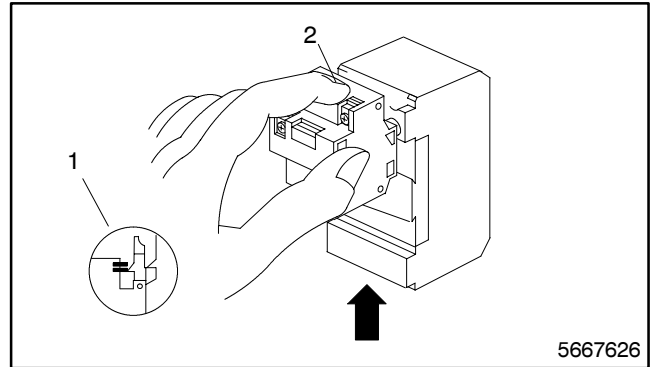

1. Mounting tab
2. Auxiliary switch

**Figure 6-15. Auxiliary Switch Removal
(145-400 Ampere Contactors)**

3. Slide the auxiliary switch up until the auxiliary switch can be removed.

Auxiliary Switch Installation

1. Engage auxiliary switch on mounting tab. See Figure 6-16.

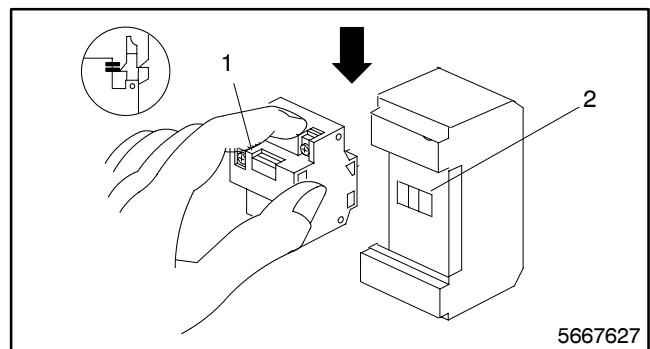

1. Auxiliary switch
2. Mounting tab

**Figure 6-16. Auxiliary Switch Installation (145-400
Ampere Contactors)**

2. Push the auxiliary switch downward until the mounting tab engages switch and clicks into place.
3. Reconnect wiring harness leads to auxiliary switch.

Coil Removal

1. Disconnect wiring harness from coil.
2. Press downward on contactor portion of latch. See Figure 6-17.

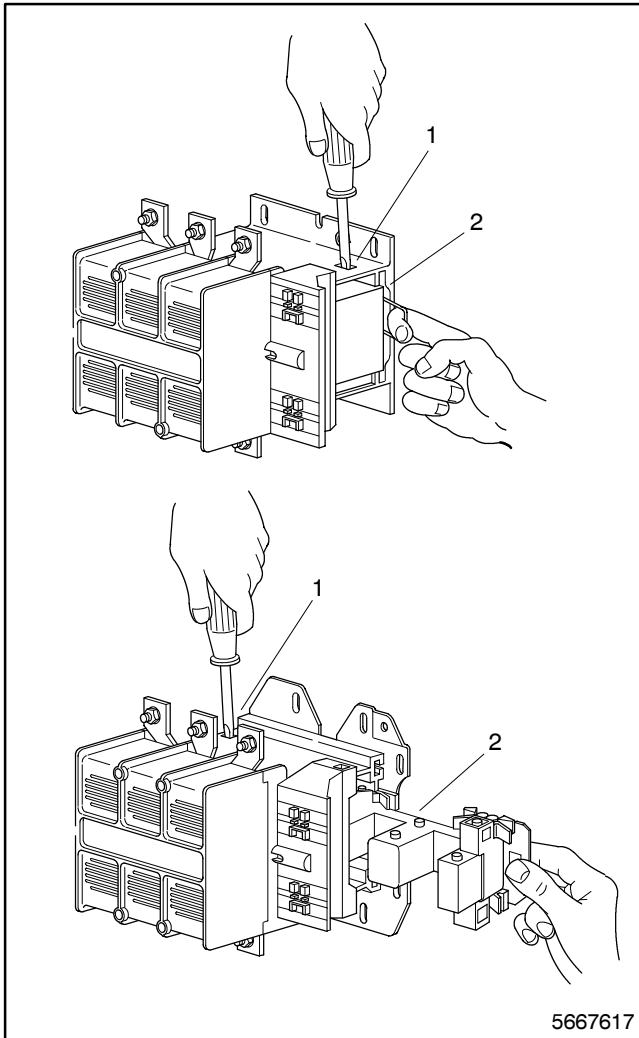

1. Latch
2. Coil

**Figure 6-17. Coil Removal
(145-400 Ampere Contactors)**

3. Pull coil from contactor body.

Coil Installation

1. Press downward on coil portion of latch. See Figure 6-18.
2. Slide coil into contactor body until latch engages.
3. Reconnect wiring harness to coil.

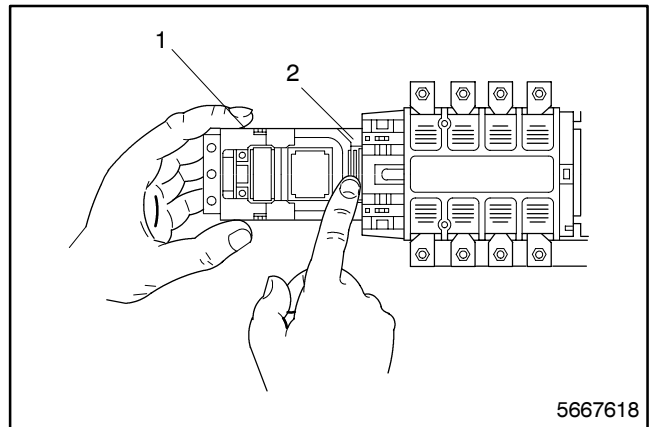

1. Coil
2. Latch

**Figure 6-18. Coil Installation
(145-400 Ampere Contactors)**

Contact Set Removal

1. Loosen captive quarter-turn fasteners and remove contactor cover.
2. If contactor is rated at 400 amperes, pull pole outward, locate and remove retaining pin, and then remove and discard pole. See Figure 6-19.

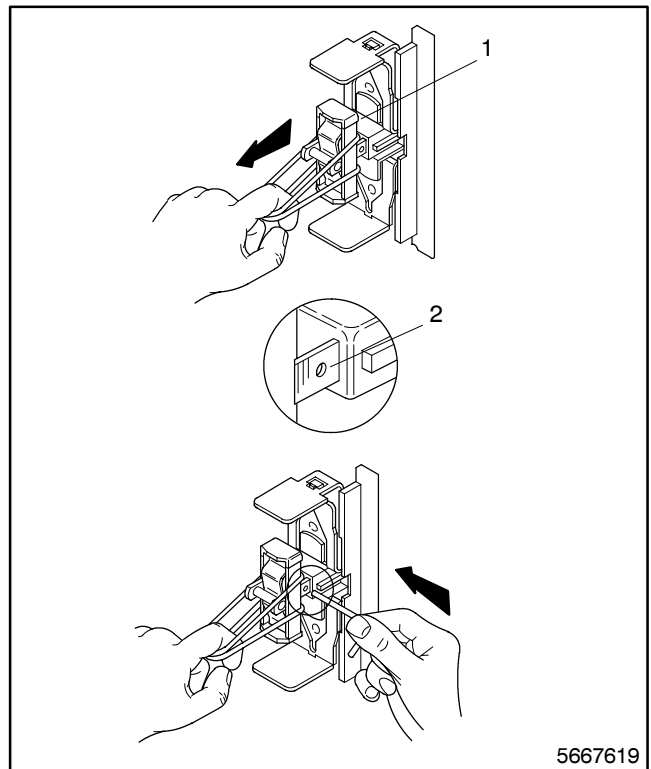

1. Pole
2. Retaining clip

**Figure 6-19. Contact Pole Removal
(400 Ampere Contactors)**

3. If contactor is not rated at 400 amperes, remove pole (Figure 6-20) as follows:

- a. Push and hold lower portion of pole inward.
- b. Press top of pole downward into retaining clip.
- c. Rotate lower portion of pole outward and remove and discard pole.

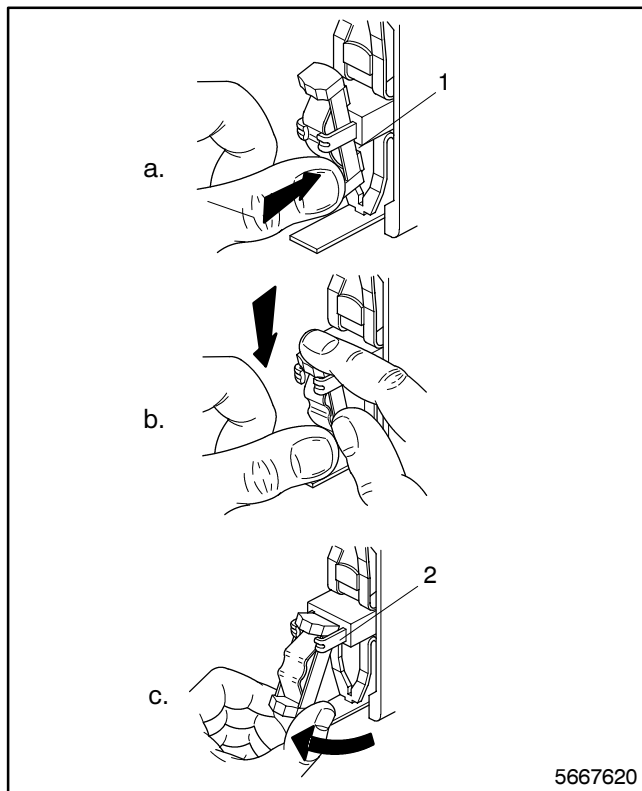

1. Pole
2. Retaining clip

**Figure 6-20. Contact Pole Removal
(145/150/180/245 Ampere Contactors)**

4. Using L-wrench, loosen screw and remove and discard upper contact. See Figure 6-21.
5. Repeating step 4, remove and discard lower contact.

6. Repeating steps 2 through 5, remove and discard remaining poles and contacts.

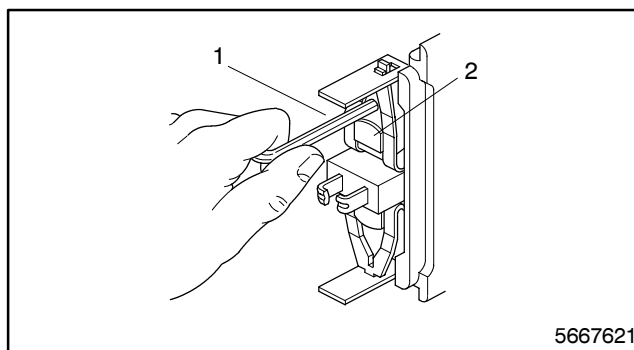

1. L-wrench
2. Contact

**Figure 6-21. Contact Removal
(145-400 Ampere Contactors)**

Contact Set Installation

1. Install new contact. See Figure 6-22. Tighten contact screw to torque given in Figure 6-23.

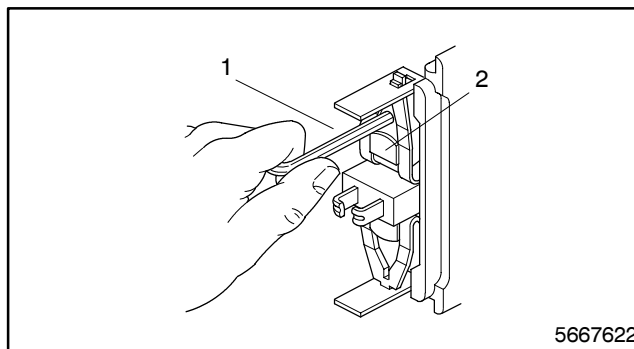

1. L-wrench
2. Contact

**Figure 6-22. Contact Installation
(145-400 Ampere Contactors)**

Ampere Rating	Torque	
	Nm	Lb. in.
145/150	3.6	32
180	6.6	58
245/265	6.6	58
400	10	88

Figure 6-23. Contact Screw Torque Values (145-400 Ampere Contactors)

2. Repeat step 1 to install new contacts for remainder of the contact set.
3. If contactor is rated at 400 amperes, slide pole into pole retainer, install rear retaining pin, and then install front retaining pin. See Figure 6-24.

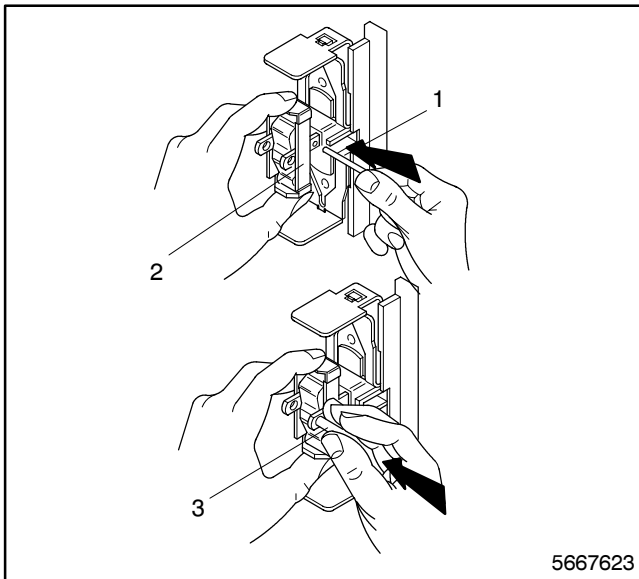

1. Rear retaining pin
2. Pole
3. Front retaining clip

Figure 6-24. Contact Pole Installation (400 Ampere Contactors)

4. If contactor is not rated at 400 amperes, insert top portion of pole into retaining clip, rotate bottom portion of pole inward, and then press pole upward until pole is centered in retaining clip. See Figure 6-25.

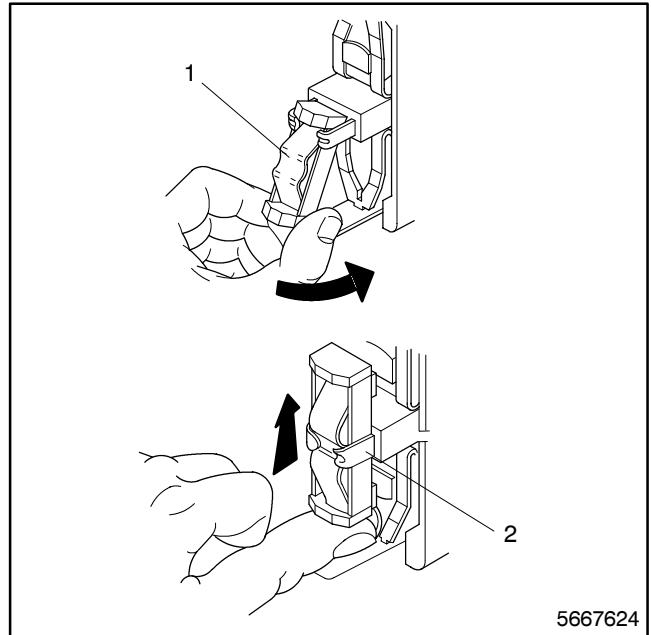

1. Pole
2. Retaining clip

Figure 6-25. Contact Pole Installation (145/150/180/245 Ampere Contactors)

5. Repeat step 3 or 4 to install new poles for remainder of the contact set.
6. Energize coil and check operation of contacts.
7. Install contactor cover, tightening captive quarter-turn fasteners to secure cover in place.

Notes

Section 7. Service Parts

Introduction

Use this section to locate and identify service parts for the 25-400 ampere models of the automatic transfer switches that use electrically held or mechanically held contactors as the power conversion unit. The part numbers of the automatic transfer switches covered by the parts lists in this section begin with TES- or TLS-.

This section does not include nonserviceable parts of the automatic transfer switch or any parts of the logic controller within the automatic transfer switch. A separate service and parts manual is provided for each logic controller model. To locate and identify logic controller parts, refer to the **List of Related Manuals** in the Introduction for the name and number of the service and parts manual for the applicable logic controller.

Using Parts Lists

Finding Parts Information

Use the following steps to locate the required parts in the parts lists.

1. Use the illustration on page 7-2 to determine the group that lists the required part.

Example: An enclosed door hinge is needed. It is part of the enclosure.

2. Use the list on page 7-2 to locate the illustration identified in step 1.

Example: Turn to the **Enclosures** illustration on page 7-3.

NOTE

Some items have more than one illustration. In this case, be sure to refer to the illustration that corresponds to the ATS rating.

3. Locate the required part in the illustration.

Example: The door hinge is labeled item 4.

4. Find the item number in the associated parts list on the same or facing page.

Example: Find number 4 in the **Item** column.

5. Use the remaining columns of the parts list to find the part name and part number.

Example: The name listed in the **Description** column for item 4 is "Hinge." The number listed in the **Part Number** columns for both sets of ratings given for item 4 is 294749-BLK. The number 2 or 3 in parentheses () at the end of the entry in the **Part Number** columns indicates the quantity of the item used.

NOTE

If there is no number in parentheses at the end of the listing in the Part Number column, the quantity of that item is one (1).

Leads

Most leads are available with the appropriate wiring harness. Otherwise, fabricate a replacement lead using the same type of standard copper wire (gauge, color, length) with the terminals and lead designations at each end of the new lead.

Automatic Transfer Switch

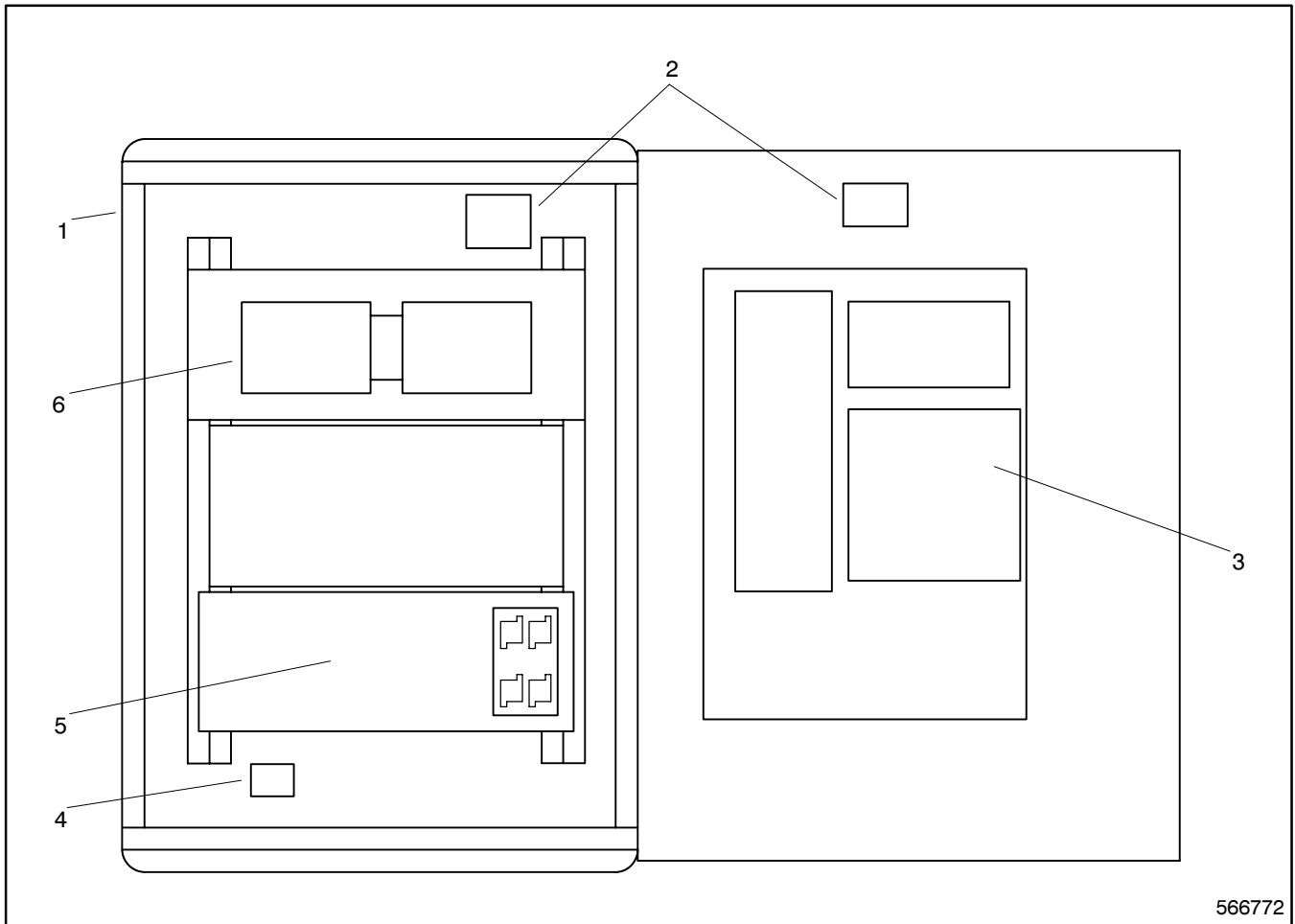

Item	Description	Parts breakdown page
1	Enclosure	Enclosures , page 7-3
2	Decals	Decals , page 7-4
3	Logic Controller	Appropriate logic controller manual
4	Neutral Lug (Optional)	Neutral Lugs , pages 7-5 and 7-6
5	Interface Panel Assembly	Interface Panel Assemblies , page 7-7, 7-8, see table to the right
6	Contactor Assembly	Contactor Assemblies , pages 7-9 thru 7-68

ATS Rating Data		Interface Panel Assembly
Amps	Volts	
25-400	110-380	A
25-80	480-600	A
145-400	480-600	B

Enclosures

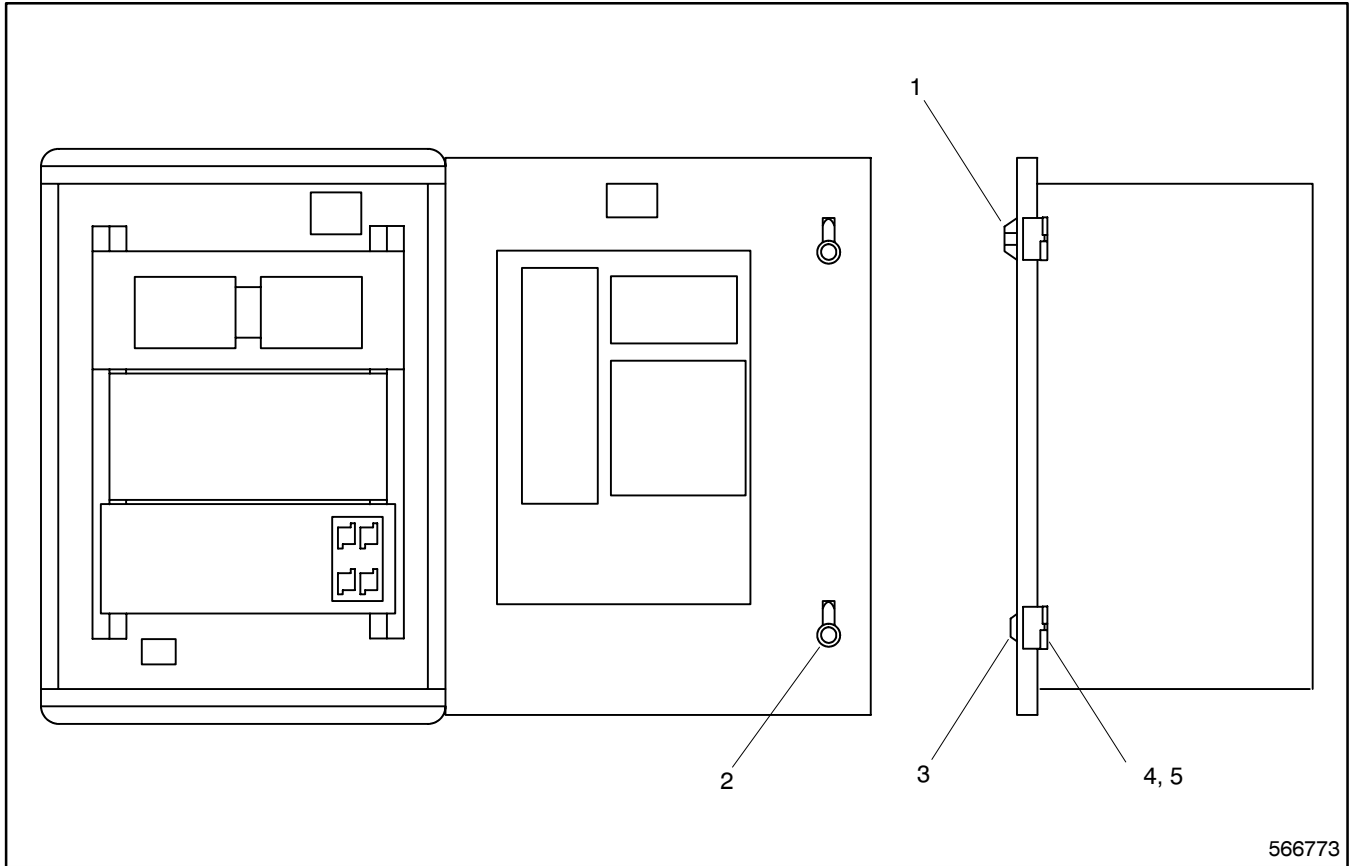

566773

Item	Description	Part Number	
		25/32/65/80/ 145/150/180 Amp	245/265/400 Amp
1	Handle, latch	320822	320822
2	Cam	320824 (2)	320824 (2)
3	Latch	320823	320823
4	Hinge	294749-BLK (2)	294749-BLK (3)
5	Screw	295098 (4)	295098 (6)

Decals

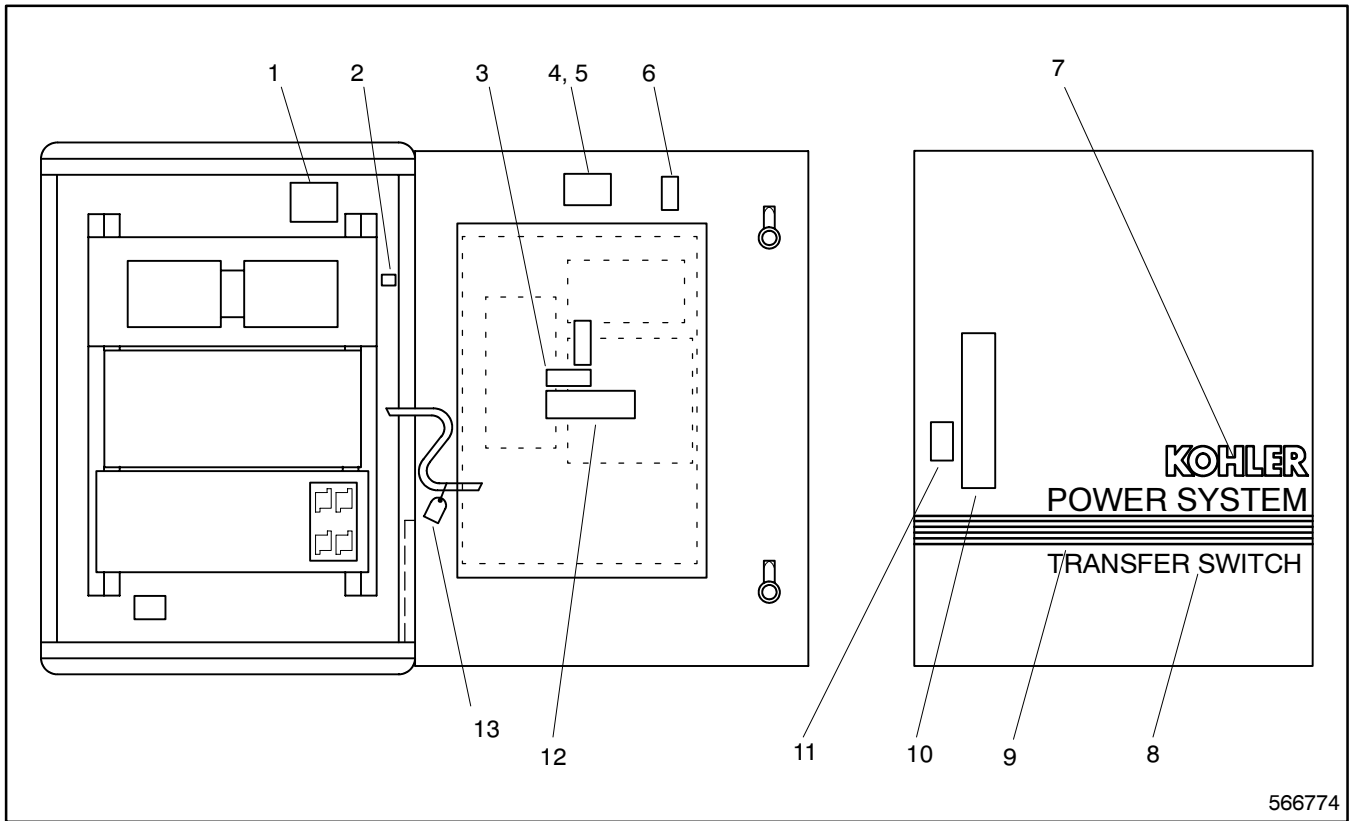

566774

Item	Description	Part Number	
		E33+/ S340+ Logic	M340+ Logic
1	Decal, notice	294414	294414
2	Decal, engine start	321026	321026
3	Decal	295933	N/A
4	Decal, nameplate	295232	295232
5	Decal, serial number	295392	295392
6	Decal, 1-800 number	224233	224233
7	Decal, "Kohler Power System"	X-6246-3	X-6246-3
8	Decal, "Transfer Switch"	273746	273746
9	Decal, gold stripes	X-6232-2	X-6232-2
10	Decal, instruction	See Table	See Table
11	Decal, danger	294520	294520
12	Decal, ATS	295261	294523
13	Tag, hanging	297949	297949

Neutral Lugs

25-180 Amps

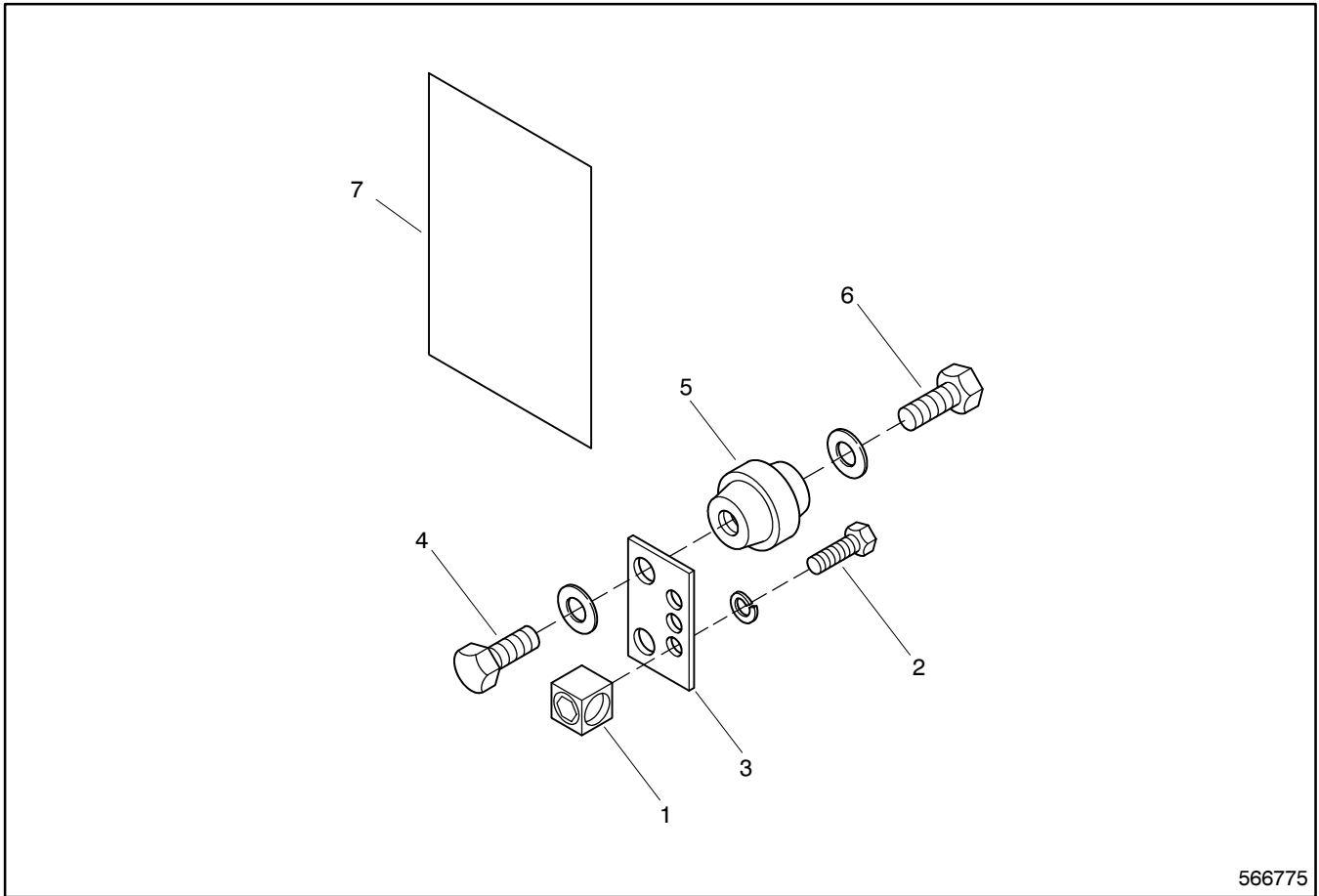

566775

Item	Description	Part Number	
		25/32/65/80 Amp	145/150/180 Amp
1	Lug terminal	295303 (3)	297712 (3)
2	Screw, H.C.	X-97-11 (3)	X-465-6 (3)
3	Bracket, mounting	321015	321016
4	Screw	X-6238-10 (2)	X-6238-10 (2)
5	Insulator, standoff	233568 (2)	233568 (2)
6	Screw	X-6238-2 (2)	X-6238-2 (2)
7	Decal	297556	297556

Neutral Lugs

245-400 Amps

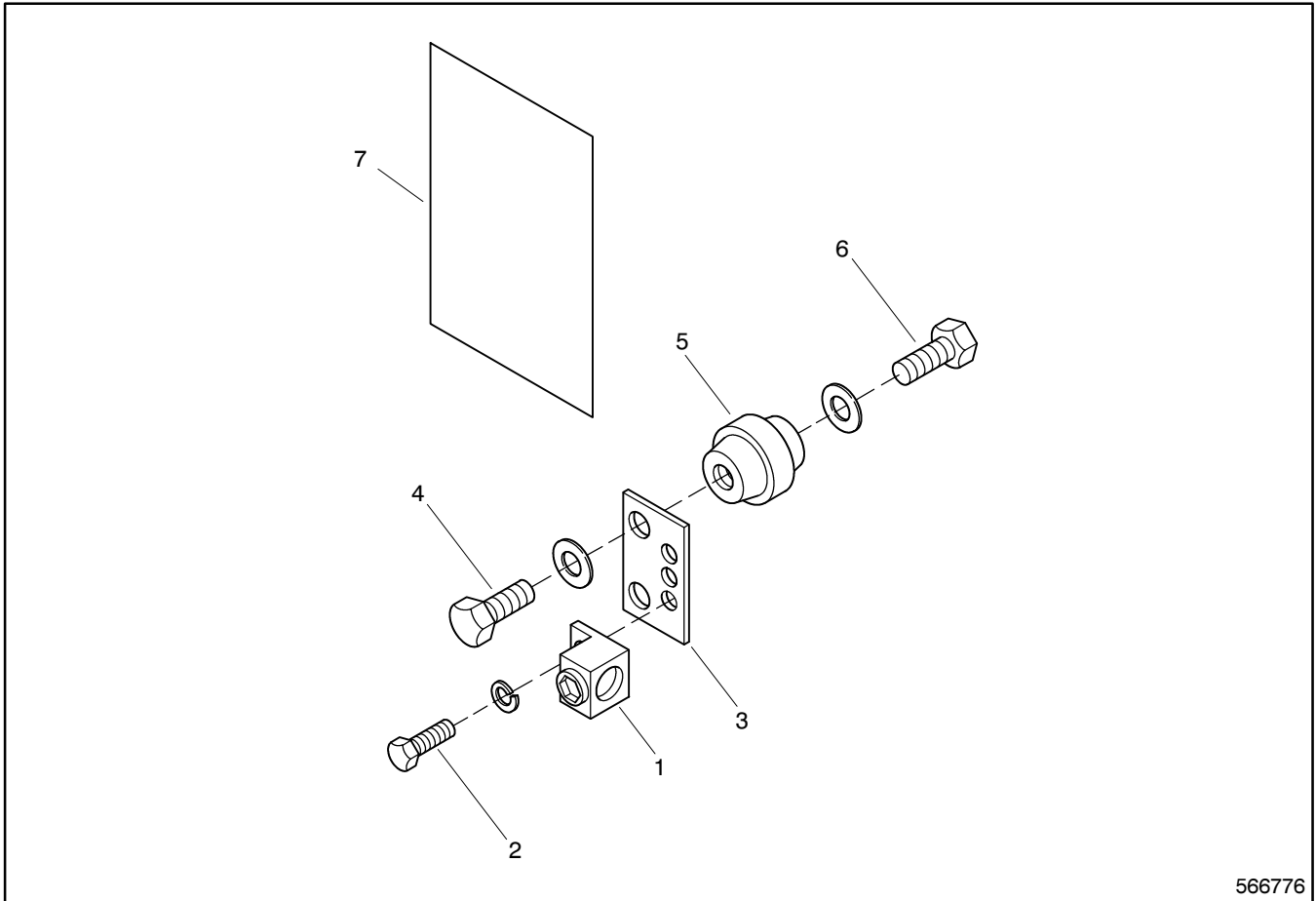

566776

Item	Description	Part Number	
		245/265 Amp	400 Amp
1	Lug terminal	X-6207-5 (3)	X-6207-9 (3)
2	Screw, H.C.	#3/8-16 (3)	#3/8-16 (3)
3	Bracket, mounting	320909	320909
4	Screw	X-6238-10 (2)	X-6238-10 (2)
5	Insulator, standoff	233568 (2)	233568 (2)
6	Screw	X-6238-2 (2)	X-6238-2 (2)
7	Decal	297556	297556

Interface Panel Assemblies

Type A

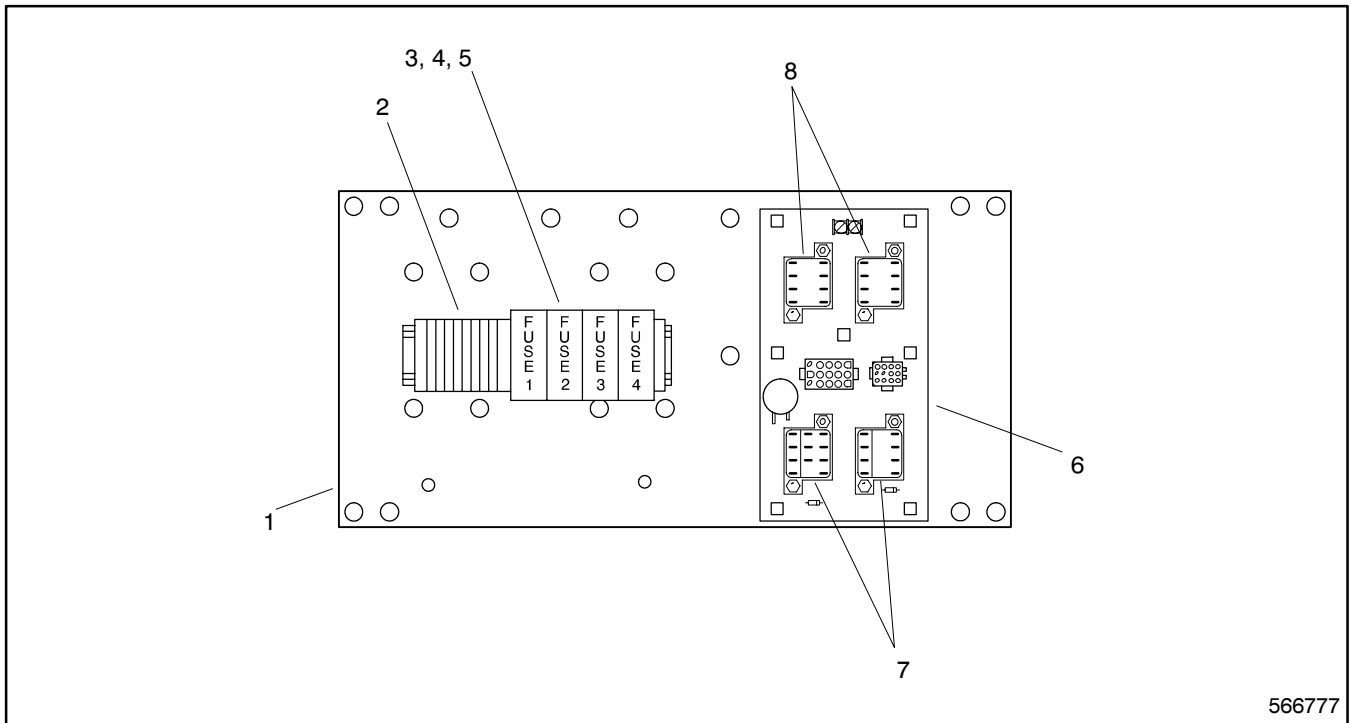

566777

Item	Description	Part Number
1	Panel, interface	320737
2	Terminal	321021 (8)
3	Block, fuse	X-6129-8
4	Puller, safety	X-6129-9 (4)
5	Fuse	X-6129-6 (4)
6	Interface Board Assembly	A-320687
7	Relay	395318 (2)
8	Relay, Time Delay	320695 (2)

Interface Panel Assemblies

Type B

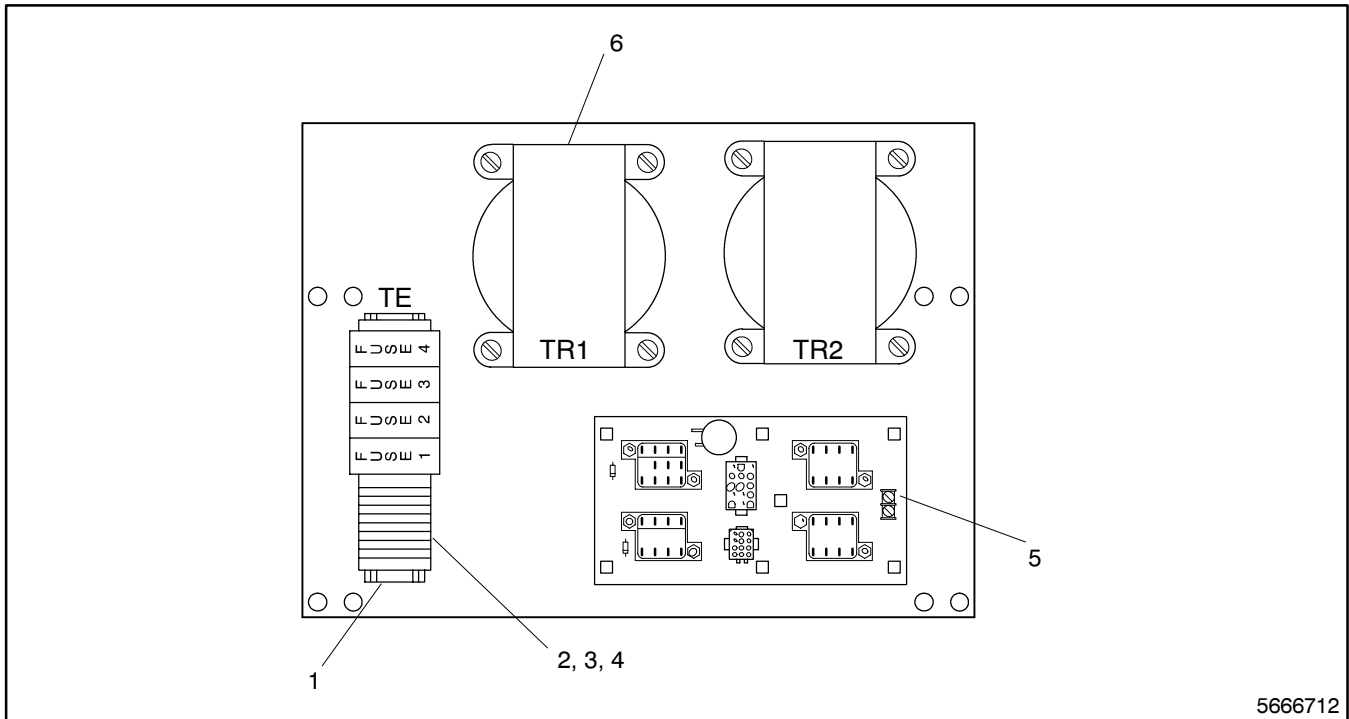

5666712

Item	Description	Part Number
1	Terminal	321021 (4)
2	Block, fuse	X-6129-8
3	Puller, safety	X-6129-9 (4)
4	Fuse	X-6135-6 (4)
5	Interface Board Assembly	A-320687
6	Transformer	See Table At Right
7	Relay, Time Delay	320695 (2)
8	Relay	295318 (2)

ATS Rating Data		Transformer Part Number
Amps	Volts	
145-400	600	346999
145-400	208	353001
145-400	480	353002

Contactor Assemblies

25 Amps, 4-Poles, Electrically Held

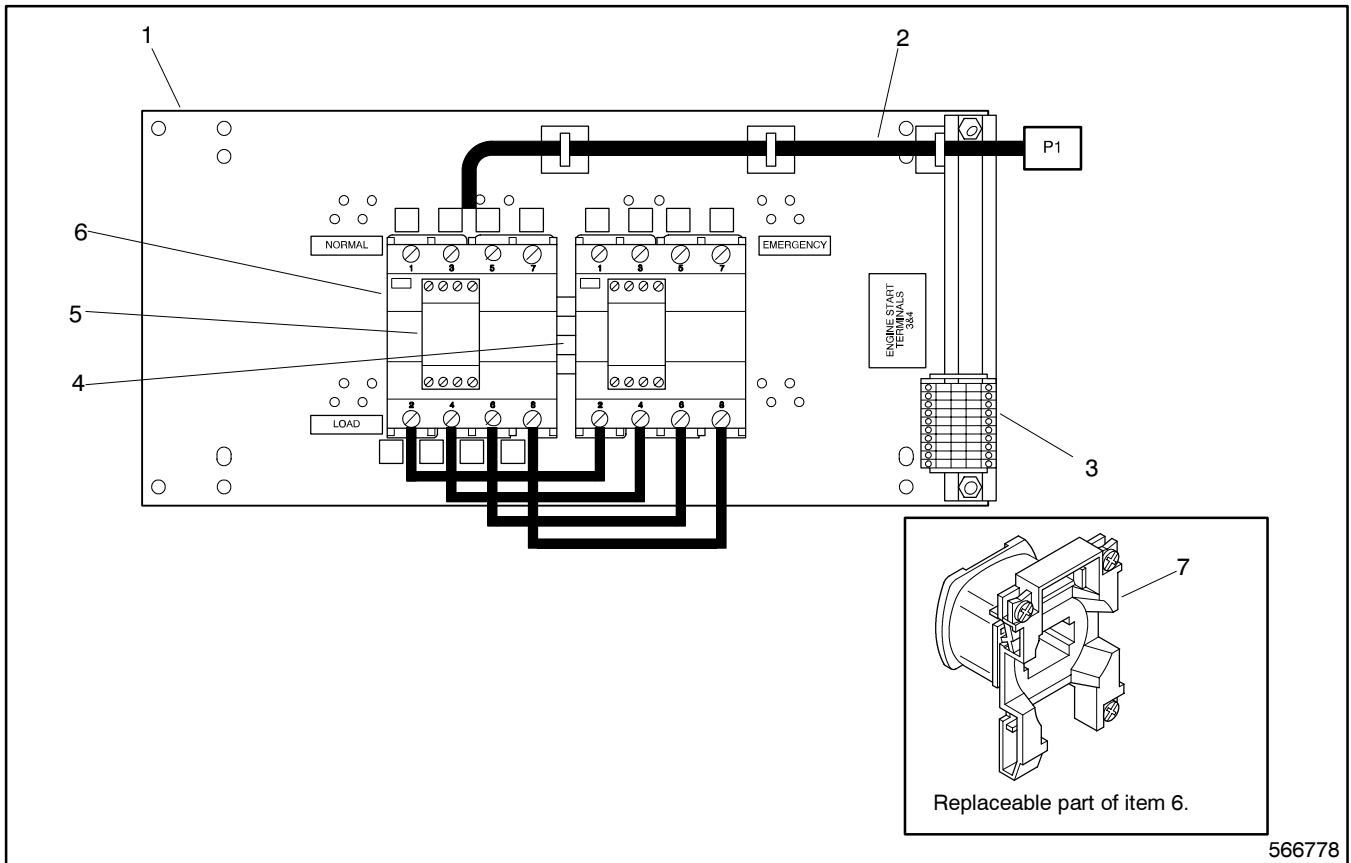

Item	Description	Part Number
1	Plate	320708
2	Harness	320965
3	Block, terminal	321021 (10)
4	Interlock, mechanical	X-6312-1 (2)
5	Switch, auxiliary	X-6315-4 (2)
6	Contactor	See Table
7	Coil	See Table

ATS Rating Data		Part Number	
Volts	Hz	Contactor (Item 6)	Coil (Item 7)
110	50/60	A-330258	X-6316-1
120	60	A-330259	X-6316-2
208	60	A-330260	X-6316-3
220	50/60	A-330261	X-6316-4
240	50/60	A-330266	X-6316-8
380	50/60	A-330263	X-6316-5
415	50/60	A-330262	X-6316-54
440	50/60	A-330264	X-6316-6
480	60	A-330265	X-6316-7
600	60	A-330267	X-6316-9

Contactor Assemblies

25 Amps, 4-Poles, Mechanically Held

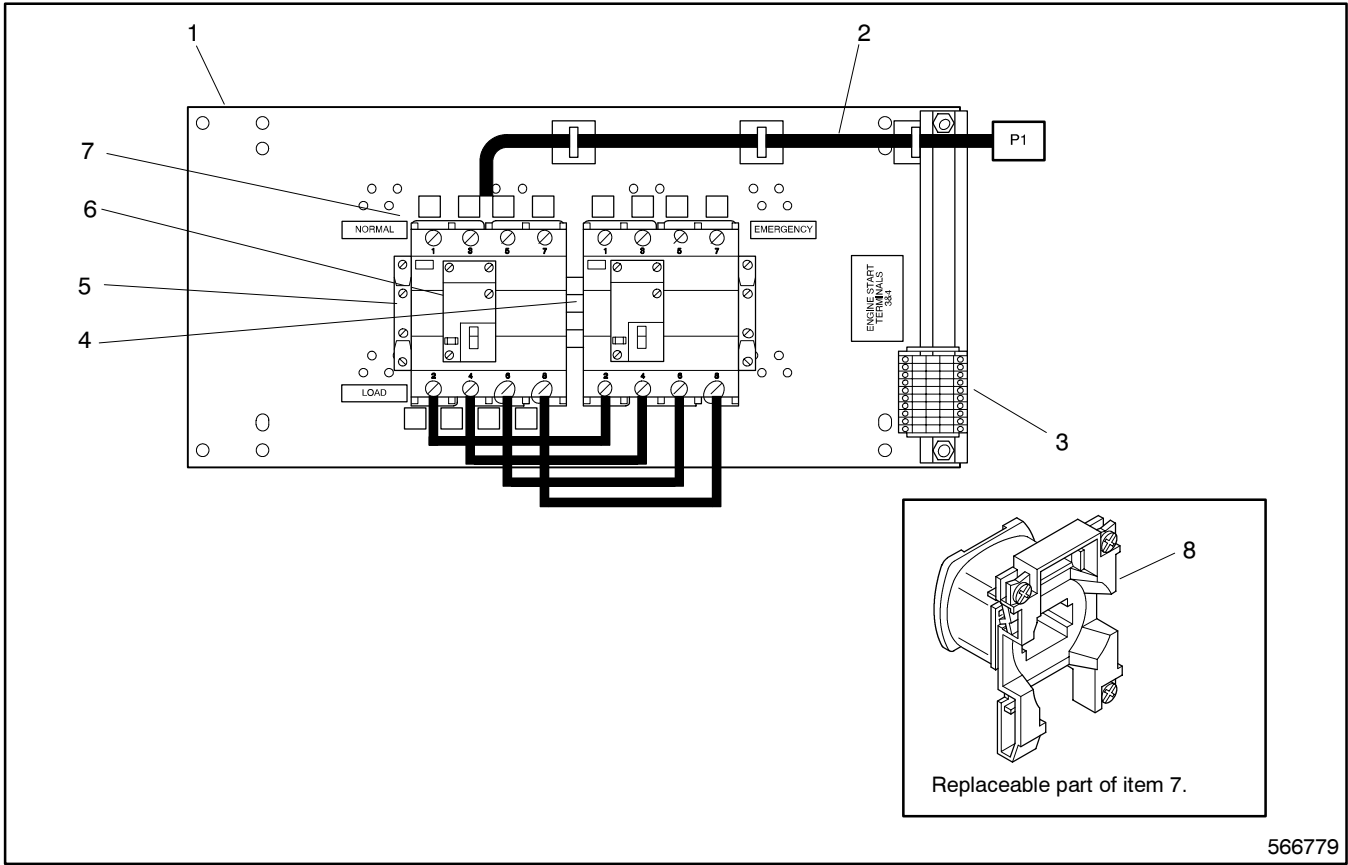

566779

Item	Description	Part Number
1	Plate	320708
2	Harness	320969
3	Block, terminal	321021 (10)
4	Interlock, mechanical	X-6312-1 (2)
5	Switch, auxiliary	X-6315-2 (2)
6	Latch, mechanical	See Table (2)
7	Contactor	See Table (2)
8	Coil	See Table

ATS Rating Data		Part Number		
Volts	Hz	Latch, mechanical (Item 6)	Contactor (Item 7)	Coil (Item 8)
110	50/60	X-6314-11	A-330258	X-6316-1
120	60	X-6314-12	A-330259	X-6316-2
208	60	X-6314-13	A-330260	X-6316-3
220	50/60	X-6314-14	A-330261	X-6316-4
240	50/60	X-6314-19	A-330266	X-6316-8
380	50/60	X-6314-16	A-330263	X-6316-5
415	50/60	X-6314-15	A-330262	X-6316-53
440	50/60	X-6314-17	A-330264	X-6316-6
480	60	X-6314-18	A-330265	X-6316-7
600	60	X-6314-20	A-330267	X-6316-9

Contactors Assemblies

32 Amps, 3-Poles, Electrically Held

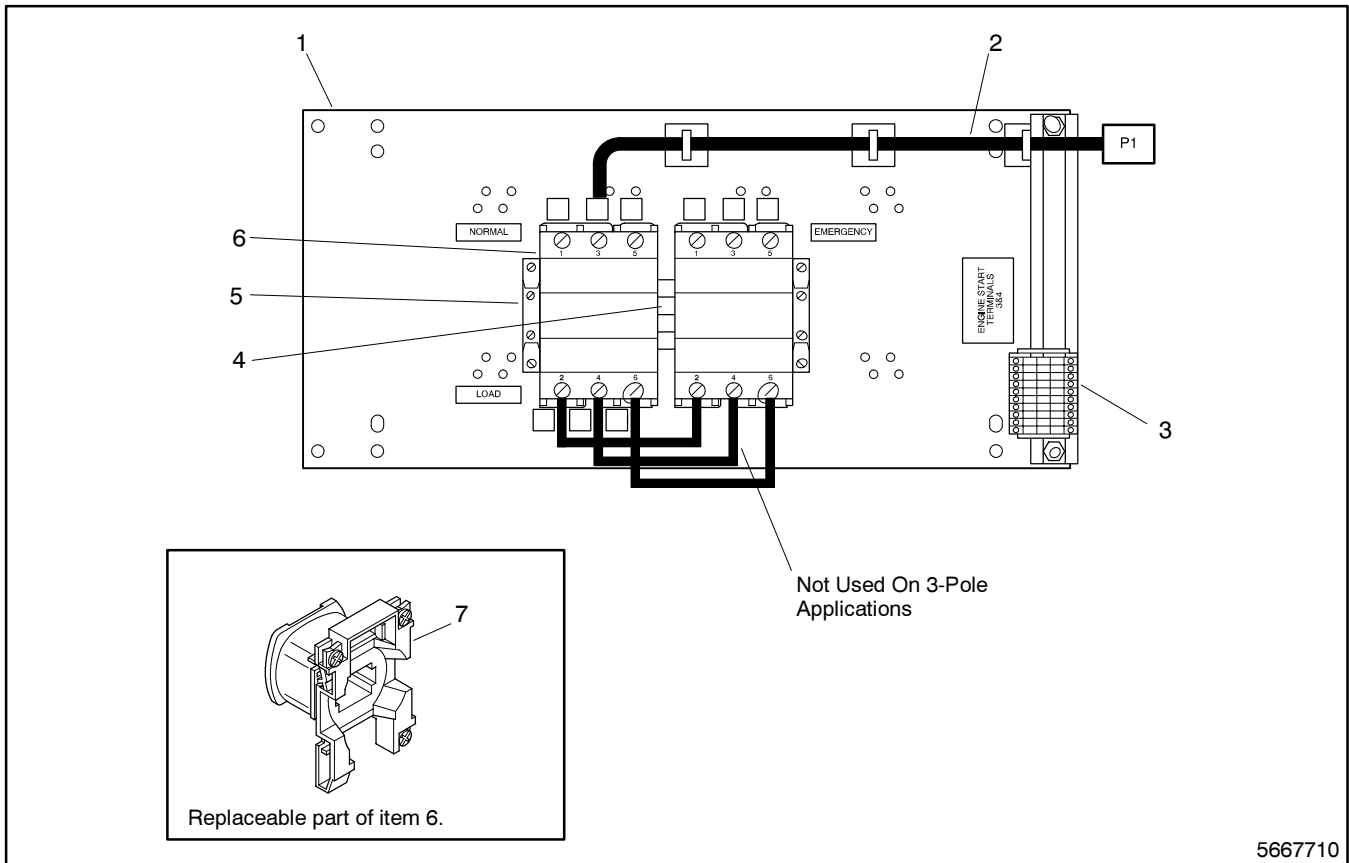

Item	Description	Part Number
1	Plate	320708
2	Harness	320963
3	Block, terminal	321021 (8)
4	Interlock, mechanical	X-6312-1 (2)
5	Switch, auxiliary	X-6315-2 (2)
6	Contactors	See Table
7	Coil	See Table

ATS Rating Data		Part Number	
Volts	Hz	Contactors (Item 6)	Coil (Item 7)
110	50/60	A-330204	X-6316-1
120	60	A-330205	X-6316-2
208	60	A-330206	X-6316-3
220	50/60	A-330207	X-6316-4
240	50/60	A-330212	X-6316-8
380	50/60	A-330209	X-6316-5
415	50/60	A-330208	X-6316-53
440	50/60	A-330210	X-6316-6
480	60	A-330211	X-6316-7
600	60	A-330213	X-6316-9

Contactor Assemblies

32 Amps, 3-Poles, Mechanically Held

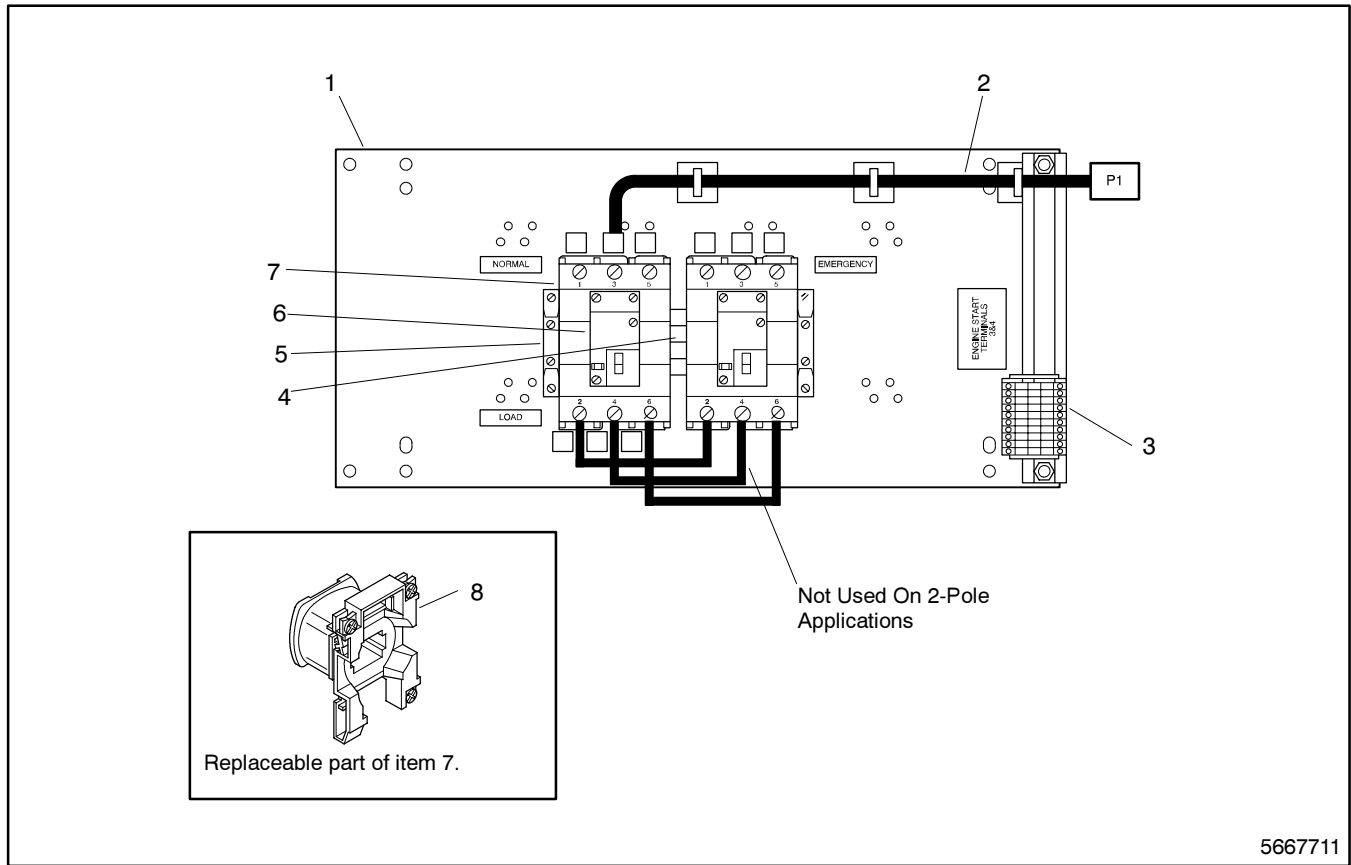

5667711

Item	Description	Part Number
1	Plate	320708
2	Harness	320967
3	Block, terminal	321021 (8)
4	Interlock, mechanical	X-6312-1 (2)
5	Switch, auxiliary	X-6315-2 (2)
6	Latch, mechanical	See Table (2)
7	Contactor	See Table (2)
8	Coil	See Table

ATS Rating Data		Part Number		
Volts	Hz	Latch, mechanical (Item 6)	Contactor (Item 7)	Coil (Item 8)
110	50/60	X-6314-11	A-330204	X-6316-1
120	60	X-6314-12	A-330205	X-6316-2
208	60	X-6314-13	A-330206	X-6316-3
220	50/60	X-6314-14	A-330207	X-6316-4
240	50/60	X-6314-19	A-330212	X-6316-8
380	50/60	X-6314-16	A-330209	X-6316-5
415	50/60	X-6314-15	A-330208	X-6316-53
440	50/60	X-6314-17	A-330210	X-6316-6
480	60	X-6314-18	A-330211	X-6316-7
600	60	X-6314-20	A-330213	X-6316-9

Contactors Assemblies

65 Amps, 3-Poles, Electrically Held

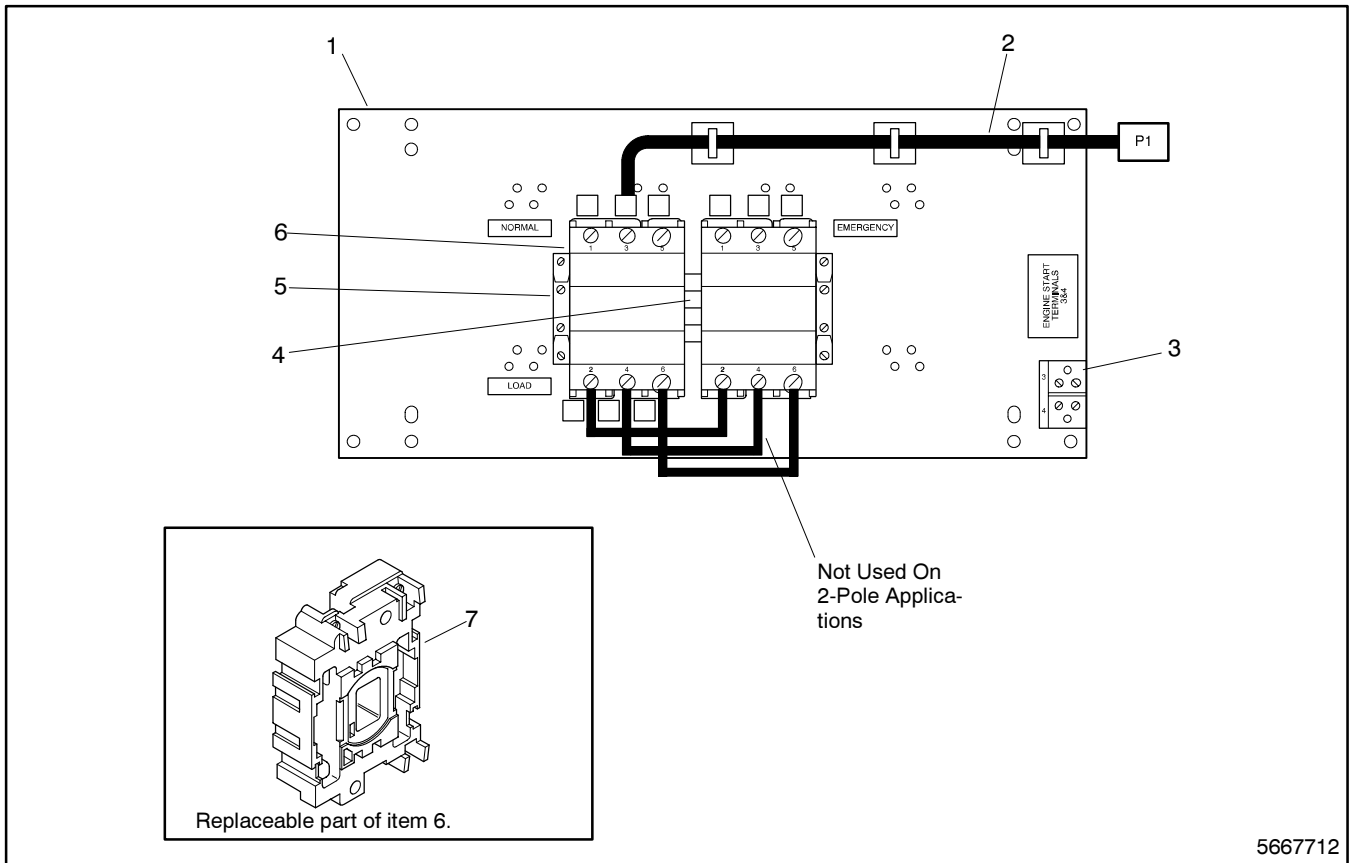

Item	Description	Part Number
1	Plate	320708
2	Harness	320964
3	Block, terminal	X-405-2
4	Interlock, mechanical	X-6312-2 (2)
5	Switch, auxiliary	X-6315-2 (2)
6	Contactors	See Table
7	Coil	See Table

ATS Rating Data		Part Number	
Volts	Hz	Contactors (Item 6)	Coil (Item 7)
110	50/60	A-330214	X-6316-10
120	60	A-330215	X-6316-11
208	60	A-330216	X-6316-12
220	50/60	A-330217	X-6316-13
240	50/60	A-330222	X-6316-17
380	50/60	A-330219	X-6316-14
415	50/60	A-330218	X-6316-52
440	50/60	A-330220	X-6316-15
480	60	A-330221	X-6316-16
600	60	A-330223	X-6316-18

Contactor Assemblies

65 Amps, 3-Poles, Mechanically Held

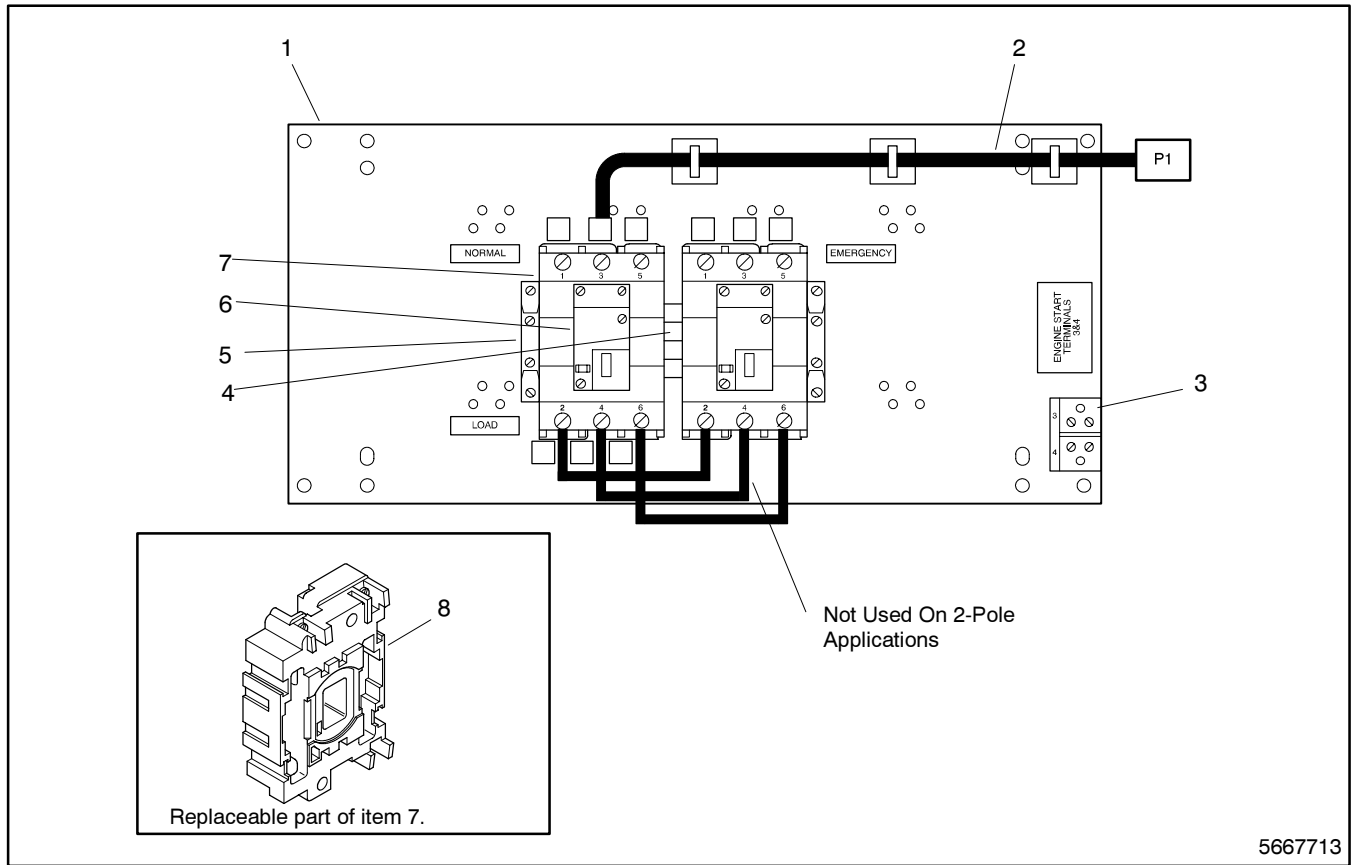

Item	Description	Part Number
1	Plate	320708
2	Harness	320968
3	Block, terminal	X-405-2
4	Interlock, mechanical	X-6312-2 (2)
5	Switch, auxiliary	X-6315-2 (2)
6	Latch, mechanical	See Table
7	Contactor	See Table
8	Coil	See Table

ATS Rating Data		Part Number		
Volts	Hz	Latch, mechanical (Item 6)	Contactor (Item 7)	Coil (Item 8)
110	50/60	X-6314-11	A-330214	X-6316-10
120	60	X-6314-12	A-330215	X-6316-11
208	60	X-6314-13	A-330216	X-6316-12
220	50/60	X-6314-14	A-330217	X-6316-13
240	50/60	X-6314-19	A-330222	X-6316-17
380	50/60	X-6314-16	A-330219	X-6316-14
415	50/60	X-6314-15	A-330218	X-6316-52
440	50/60	X-6314-17	A-330220	X-6316-15
480	60	X-6314-18	A-330221	X-6316-16
600	60	X-6314-20	A-330223	X-6316-18

Contactors Assemblies

65 Amps, 4-Poles, Electrically Held

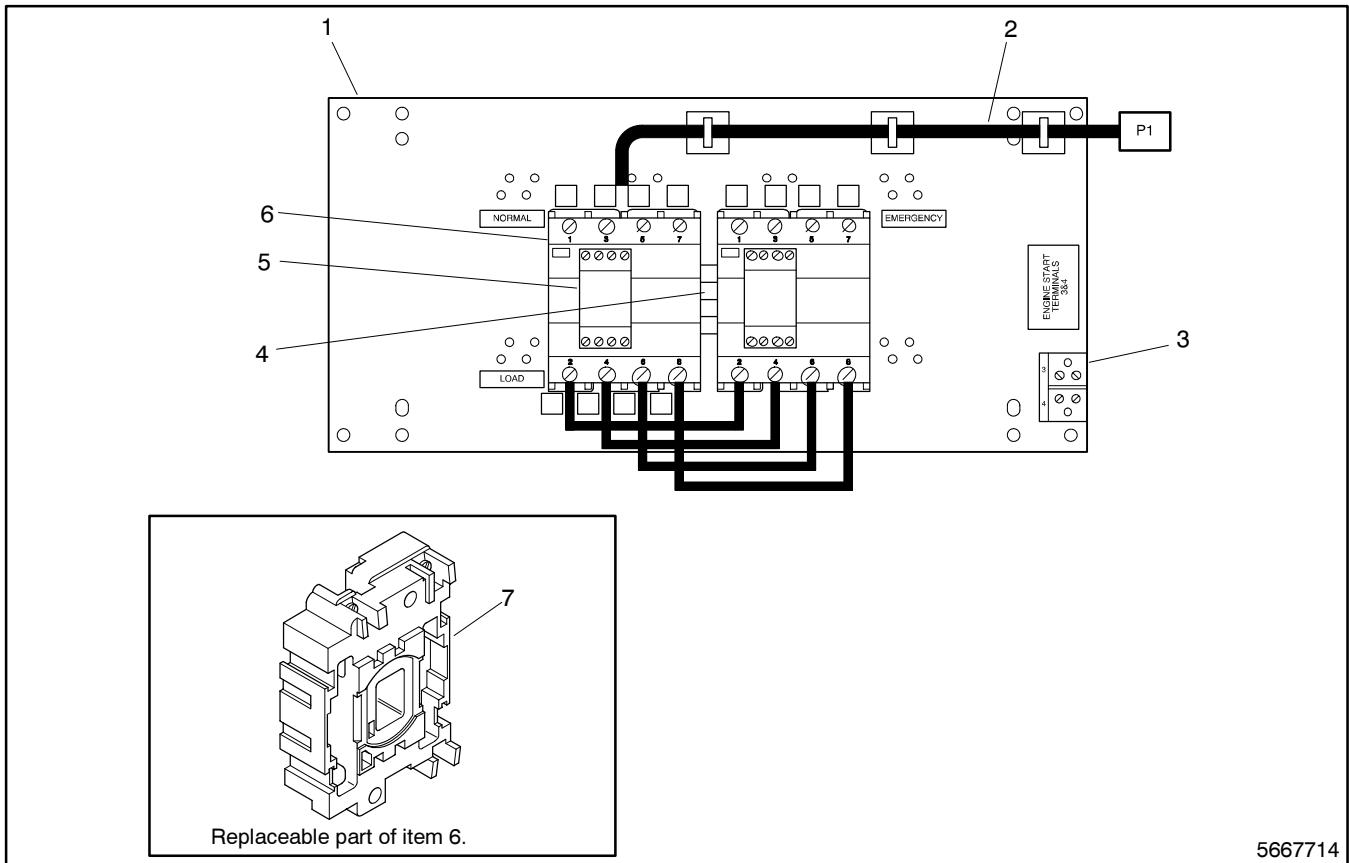

Item	Description	Part Number
1	Plate	320708
2	Harness	320966
3	Block, terminal	X-405-2
4	Interlock, mechanical	X-6312-2 (2)
5	Switch, auxiliary	X-6315-4 (2)
6	Contactors	See Table
7	Coil	See Table

ATS Rating Data		Part Number	
Volts	Hz	Contactors (Item 6)	Coil (Item 7)
110	50/60	A-330268	X-6316-10
120	60	A-330269	X-6316-11
208	60	A-330270	X-6316-12
220	50/60	A-330271	X-6316-13
240	50/60	A-330276	X-6316-17
380	50/60	A-330273	X-6316-14
415	50/60	A-330272	X-6316-52
440	50/60	A-330274	X-6316-15
480	60	A-330275	X-6316-16
600	60	A-330277	X-6316-18

Contactor Assemblies

65 Amps, 4-Poles, Mechanically Held

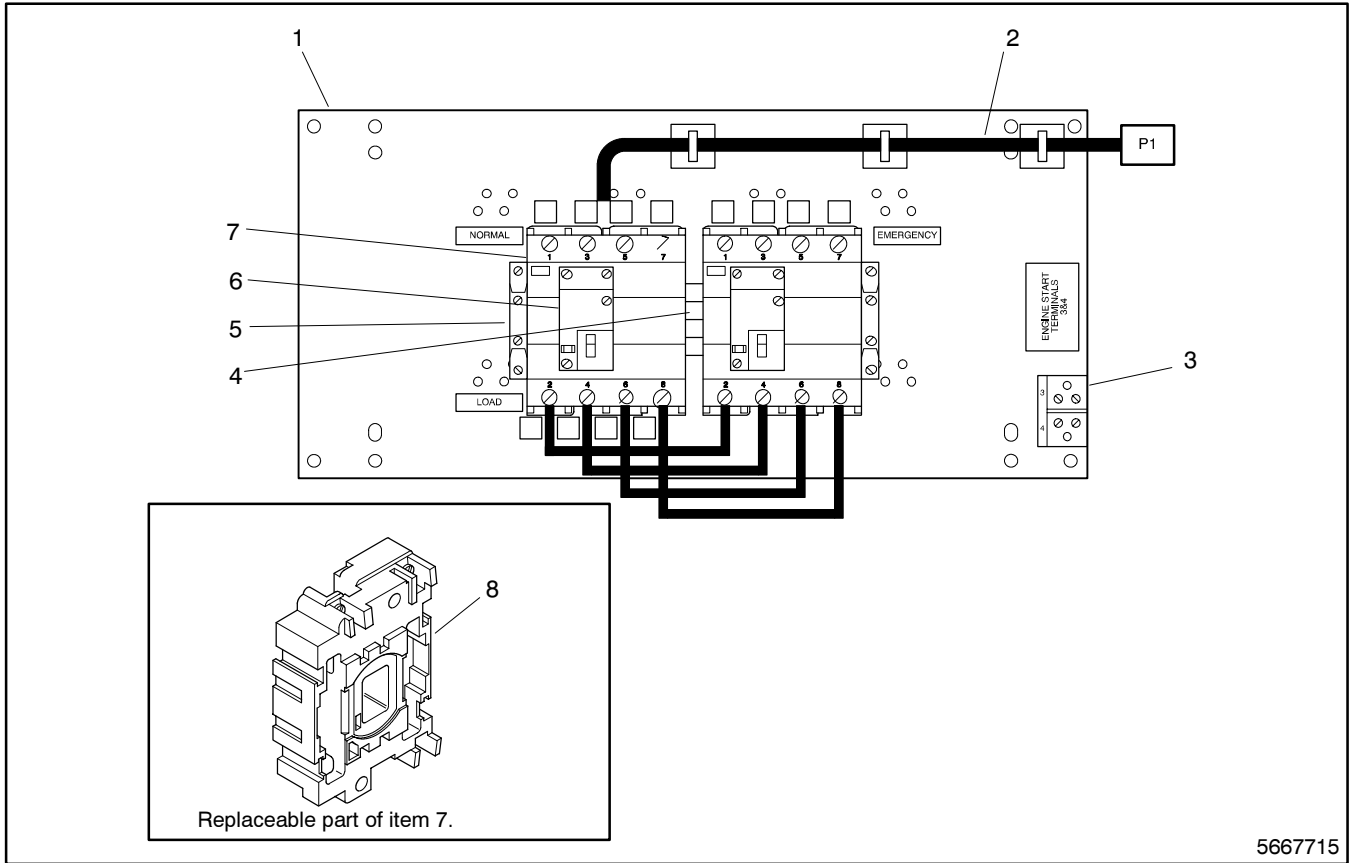

5667715

Item	Description	Part Number
1	Plate	320708
2	Harness	320970
3	Block, terminal	X-405-2
4	Interlock, mechanical	X-6312-2 (2)
5	Switch, auxiliary	X-6315-2 (2)
6	Latch, mechanical	See Table
7	Contactor	See Table
8	Coil	See Table

ATS Rating Data		Part Number		
Volts	Hz	Latch, mechanical (Item 6)	Contactor (Item 7)	Coil (Item 8)
110	50/60	X-6314-11	A-330268	X-6316-10
120	60	X-6314-12	A-330269	X-6316-11
208	60	X-6314-13	A-330270	X-6316-12
220	50/60	X-6314-14	A-330271	X-6316-13
240	50/60	X-6314-19	A-330276	X-6316-17
380	50/60	X-6314-16	A-330273	X-6316-14
415	50/60	X-6314-15	A-330272	X-6316-52
440	50/60	X-6314-17	A-330274	X-6316-15
480	60	X-6314-18	A-330275	X-6316-16
600	60	X-6314-20	A-330277	X-6316-18

Contactor Assemblies

80 Amps, 3-Poles, Electrically Held

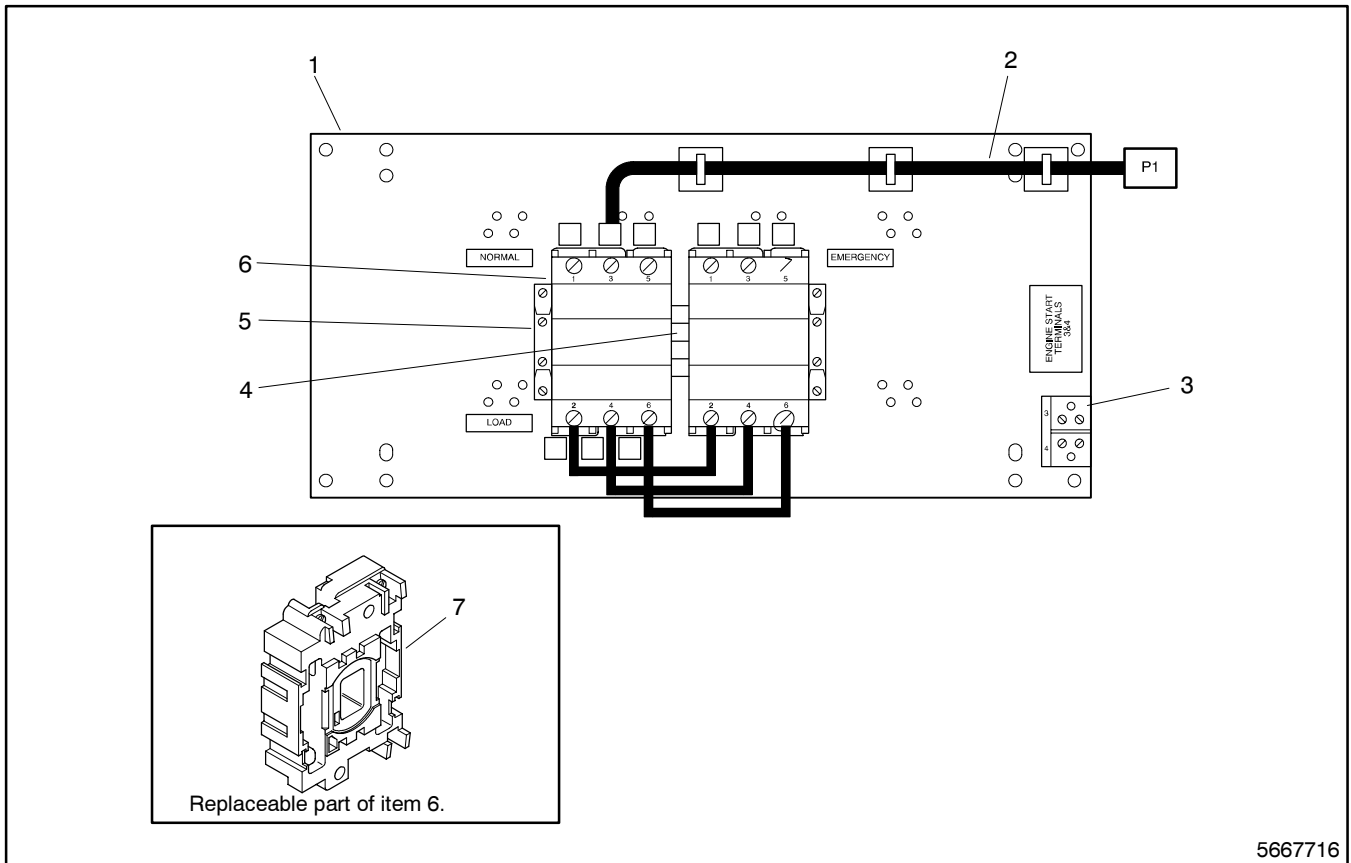

5667716

Item	Description	Part Number
1	Plate	320708
2	Harness	320964
3	Block, terminal	X-405-2
4	Interlock, mechanical	X-6312-2 (2)
5	Switch, auxiliary	X-6315-2 (2)
6	Contactors	See Table
7	Coil	See Table

ATS Rating Data		Part Number	
Volts	Hz	Contactors (Item 6)	Coil (Item 7)
110	50/60	A-330224	X-6316-10
120	60	A-330225	X-6316-11
208	60	A-330226	X-6316-12
220	50/60	A-330227	X-6316-13
240	50/60	A-330232	X-6316-17
380	50/60	A-330229	X-6316-14
415	50/60	A-330228	X-6316-52
440	50/60	A-330230	X-6316-15
480	60	A-330231	X-6316-16
600	60	A-330233	X-6316-18

Contactor Assemblies

80 Amps, 3-Poles, Mechanically Held

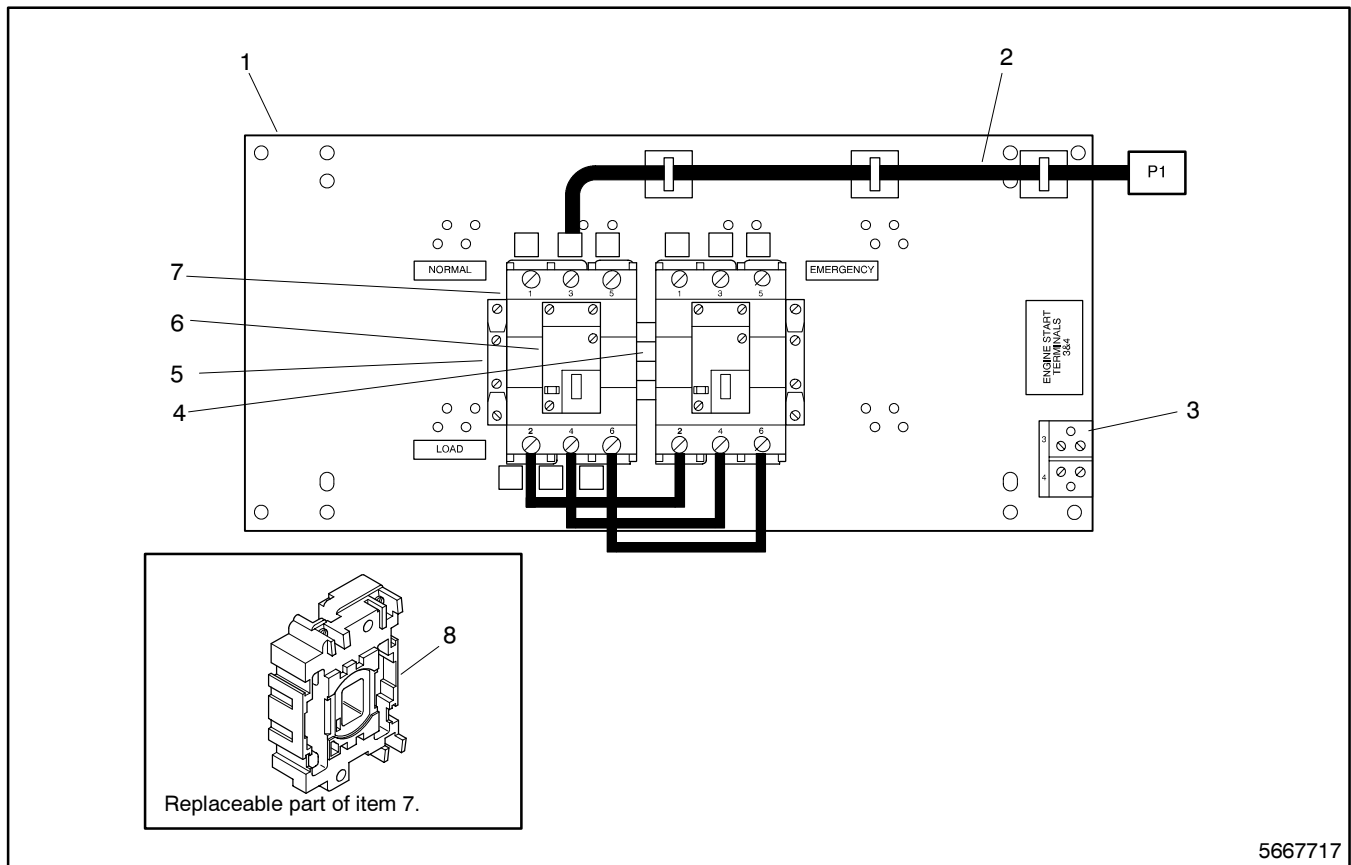

5667717

Item	Description	Part Number
1	Plate	320708
2	Harness	320968
3	Block, terminal	X-405-2
4	Interlock, mechanical	X-6312-2 (2)
5	Switch, auxiliary	X-6315-2 (2)
6	Latch, mechanical	See Table
7	Contactor	See Table
8	Coil	See Table

ATS Rating Data		Part Number		
Volts	Hz	Latch, mechanical (Item 6)	Contactor (Item 7)	Coil (Item 8)
110	50/60	X-6314-21	A-330224	X-6316-10
120	60	X-6314-22	A-330225	X-6316-11
208	60	X-6314-23	A-330226	X-6316-12
220	50/60	X-6314-24	A-330227	X-6316-13
240	50/60	X-6314-29	A-330232	X-6316-17
380	50/60	X-6314-26	A-330229	X-6316-14
415	50/60	X-6314-25	A-330228	X-6316-52
440	50/60	X-6314-27	A-330230	X-6316-15
480	60	X-6314-28	A-330231	X-6316-16
600	60	X-6314-30	A-330233	X-6316-18

Contactor Assemblies

80 Amps, 4-Poles, Electrically Held

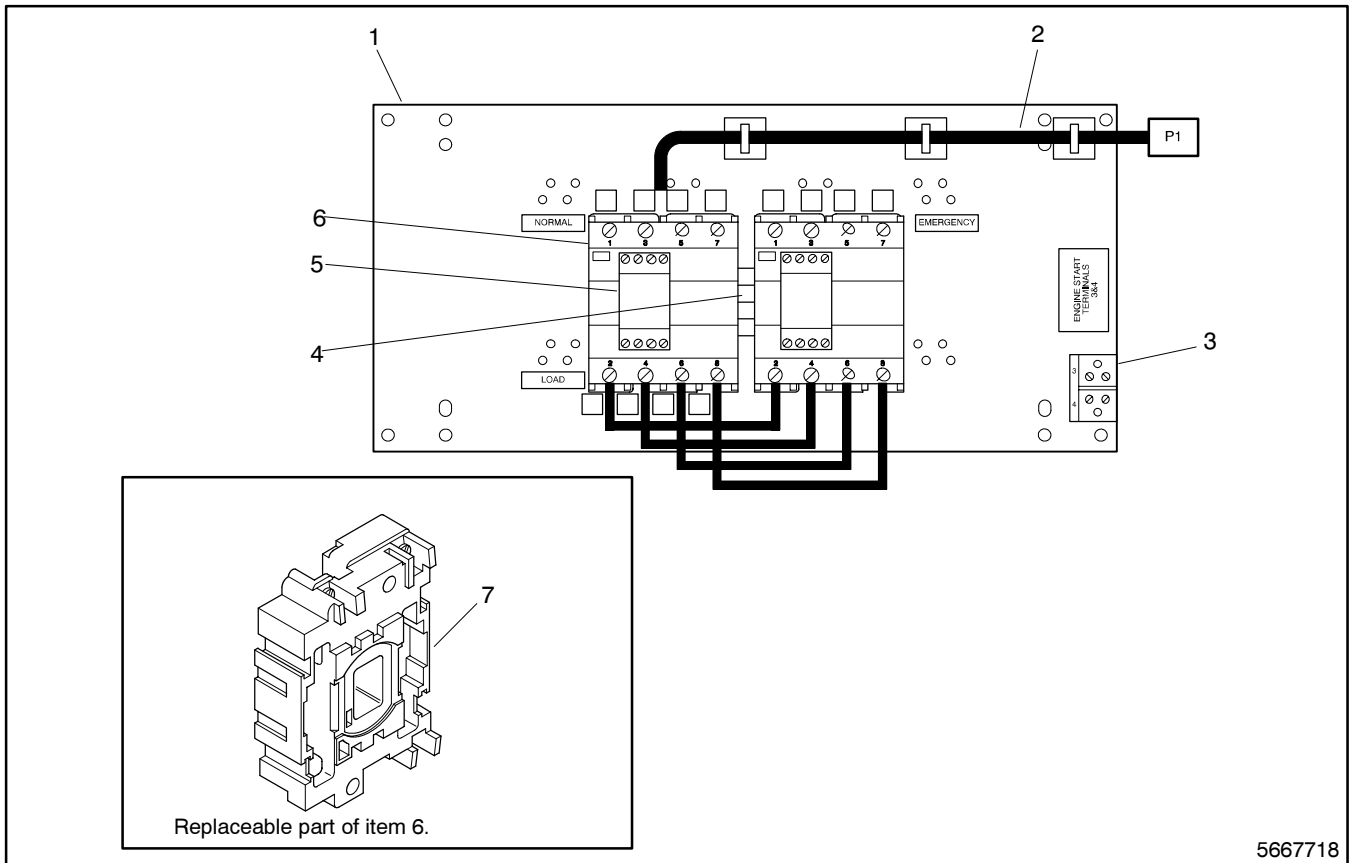

Item	Description	Part Number
1	Plate	320708
2	Harness	320966
3	Block, terminal	X-405-2
4	Interlock, mechanical	X-6312-2 (2)
5	Switch, auxiliary	X-6315-4 (2)
6	Contactors	See Table
7	Coil	See Table

ATS Rating Data		Part Number	
Volts	Hz	Contactors (Item 6)	Coil (Item 7)
110	50/60	A-330278	X-6316-10
120	60	A-330279	X-6316-11
208	60	A-330280	X-6316-12
220	50/60	A-330281	X-6316-13
240	50/60	A-330286	X-6316-17
380	50/60	A-330283	X-6316-14
415	50/60	A-330282	X-6316-52
440	50/60	A-330284	X-6316-15
480	60	A-330285	X-6316-16
600	60	A-330287	X-6316-18

Contactor Assemblies

80 Amps, 4-Poles, Mechanically Held

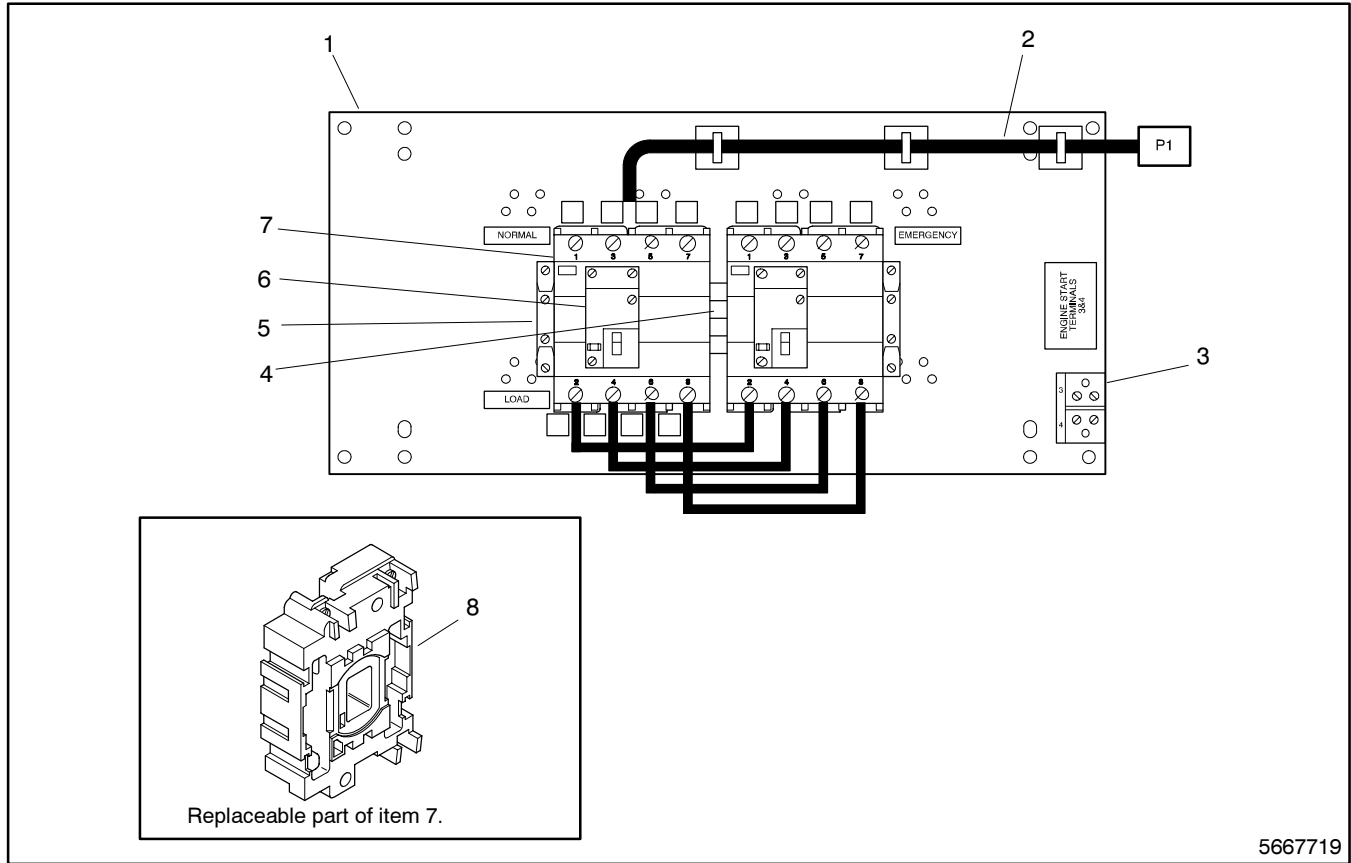

5667719

Item	Description	Part Number
1	Plate	320708
2	Harness	320970
3	Block, terminal	X-405-2
4	Interlock, mechanical	X-6312-2 (2)
5	Switch, auxiliary	X-6315-2 (2)
6	Latch, mechanical	See Table
7	Contactor	See Table
8	Coil	See Table

ATS Rating Data		Part Number		
Volts	Hz	Latch, mechanical (Item 6)	Contactor (Item 7)	Coil (Item 8)
110	50/60	X-6314-21	A-330278	X-6316-10
120	60	X-6314-22	A-330279	X-6316-11
208	60	X-6314-23	A-330280	X-6316-12
220	50/60	X-6314-24	A-330281	X-6316-13
240	50/60	X-6314-29	A-330286	X-6316-17
380	50/60	X-6314-26	A-330283	X-6316-14
415	50/60	X-6314-25	A-330282	X-6316-52
440	50/60	X-6314-27	A-330284	X-6316-15
480	60	X-6314-28	A-330285	X-6316-16
600	60	X-6314-30	A-330287	X-6316-18

Contactor Assemblies

145 Amps, 3-Poles, Magnetically Held

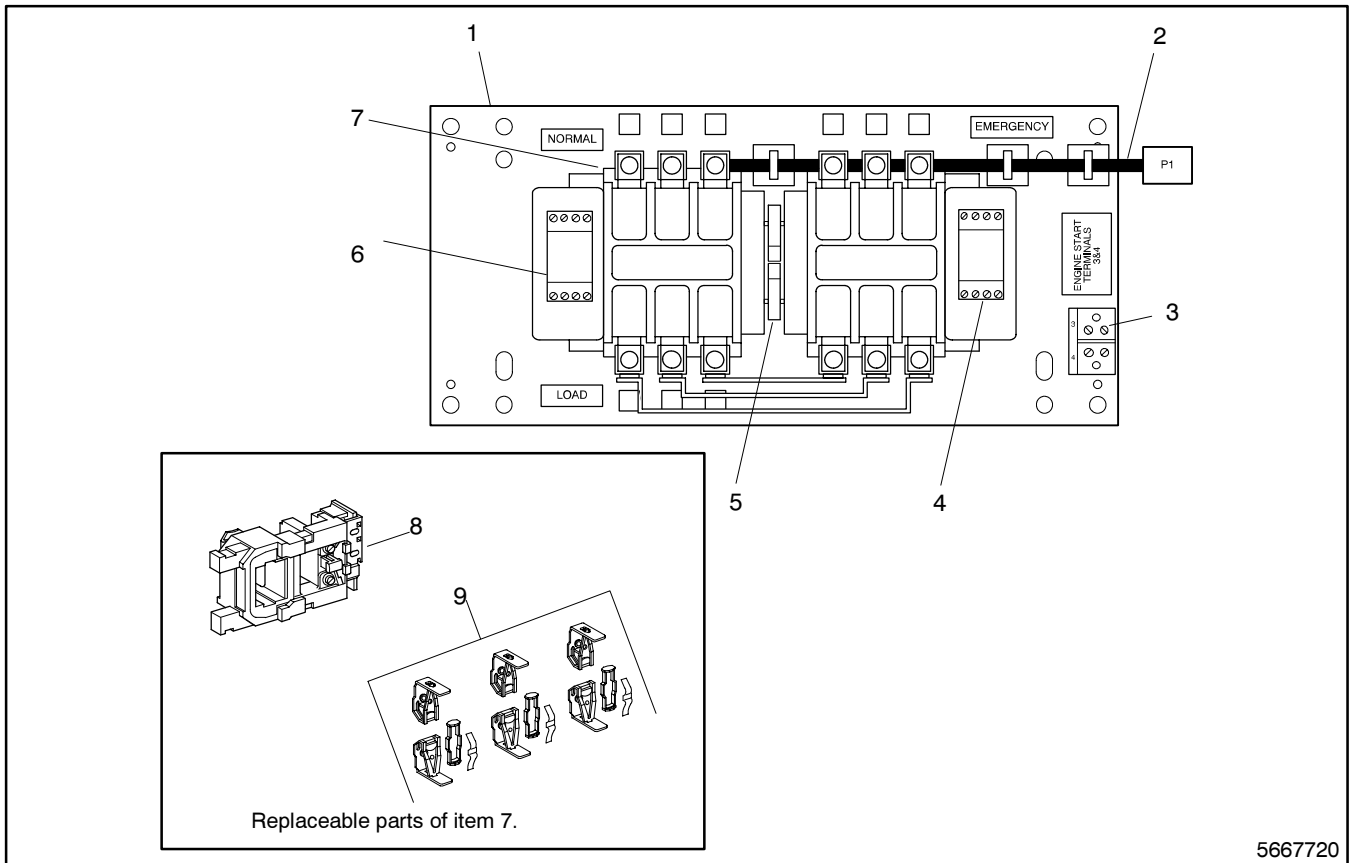

Item	Description	Part Number
1	Plate	320708
2	Harness	320977
3	Block, terminal	X-405-2
4	Switch, auxiliary	X-6315-3
5	Interlock, mechanical	X-6312-7 (2)
6	Switch, auxiliary	X-6315-5 (2)
7	Contactor	See Table
8	Coil	See Table
9	Contact Set	346076

ATS Rating Data		Part Number	
Volts	Hz	Contactor (Item 7)	Coil (Item 8)
110	50/60	A-346951	346084
127	50/60	A-346952	346085
208	50/60	A-346952	346086
220	50/60	A-346953	346086
240	50/60	A-346956	346087
380	50/60	A-346955	346088
415	50/60	A-346954	346089
440/480	50/60	A-346956	346086
600	50/60	A-346952	346086

Contactor Assemblies

145 Amps, 4-Poles, Magnetically Held

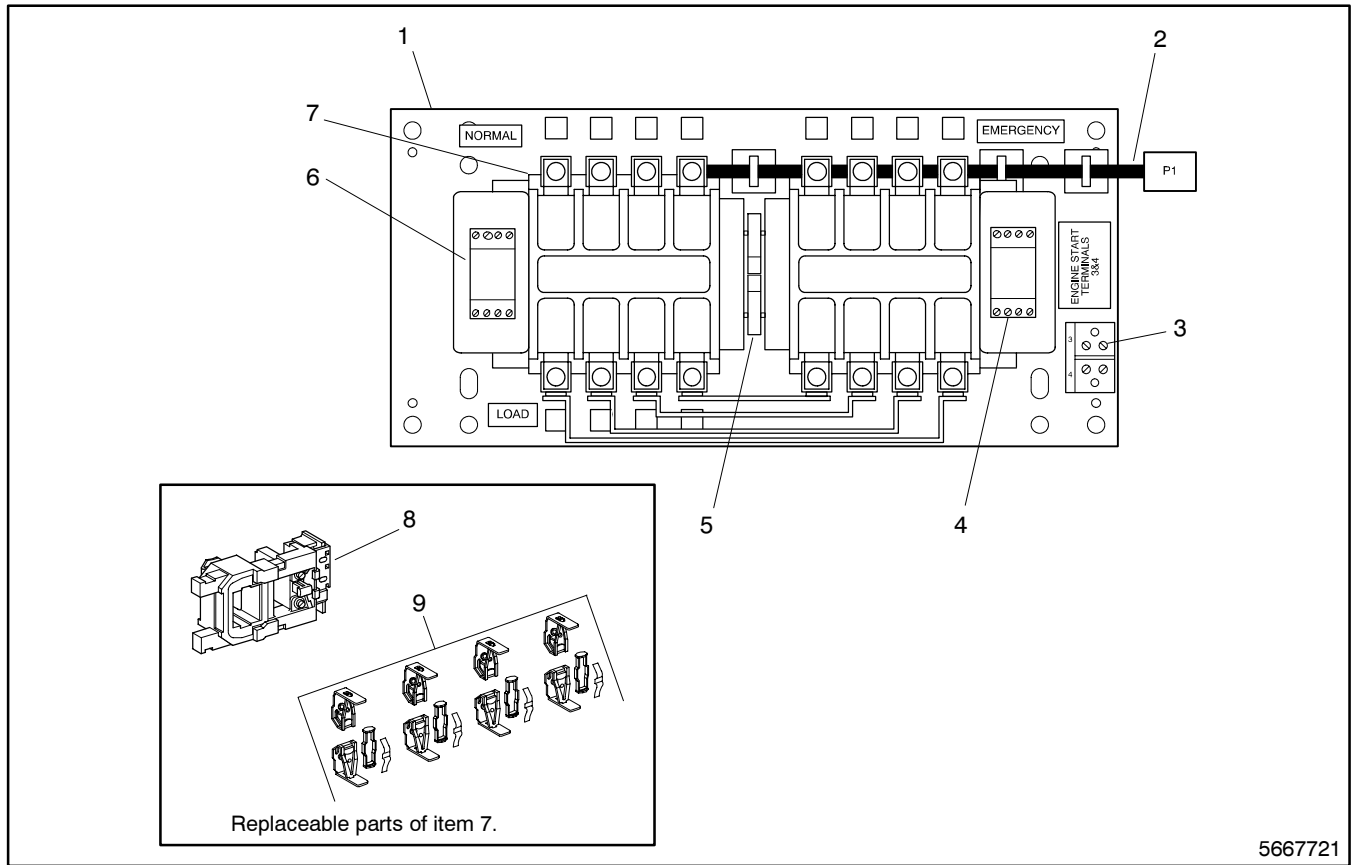

5667721

Item	Description	Part Number
1	Plate	320708
2	Harness	320977
3	Block, terminal	X-405-2
4	Switch, auxiliary	X-6315-5
5	Interlock, mechanical	X-6312-7 (2)
6	Switch, auxiliary	X-6315-3 (2)
7	Contactor	See Table
8	Coil	See Table
9	Contact Set	346080

ATS Rating Data		Part Number	
Volts	Hz	Contactor (Item 7)	Coil (Item 8)
110	50/60	A-346975	346084
127	50/60	A-346976	346085
208	50/60	A-346976	346086
220	50/60	A-346977	346086
240	50/60	A-346980	346087
380	50/60	A-346980	346088
415	50/60	A-346978	346089
440/480	50/60	A-346980	346086
600	50/60	A-346976	346086

Contactor Assemblies

145 Amps, 3-Poles, Electrically Held

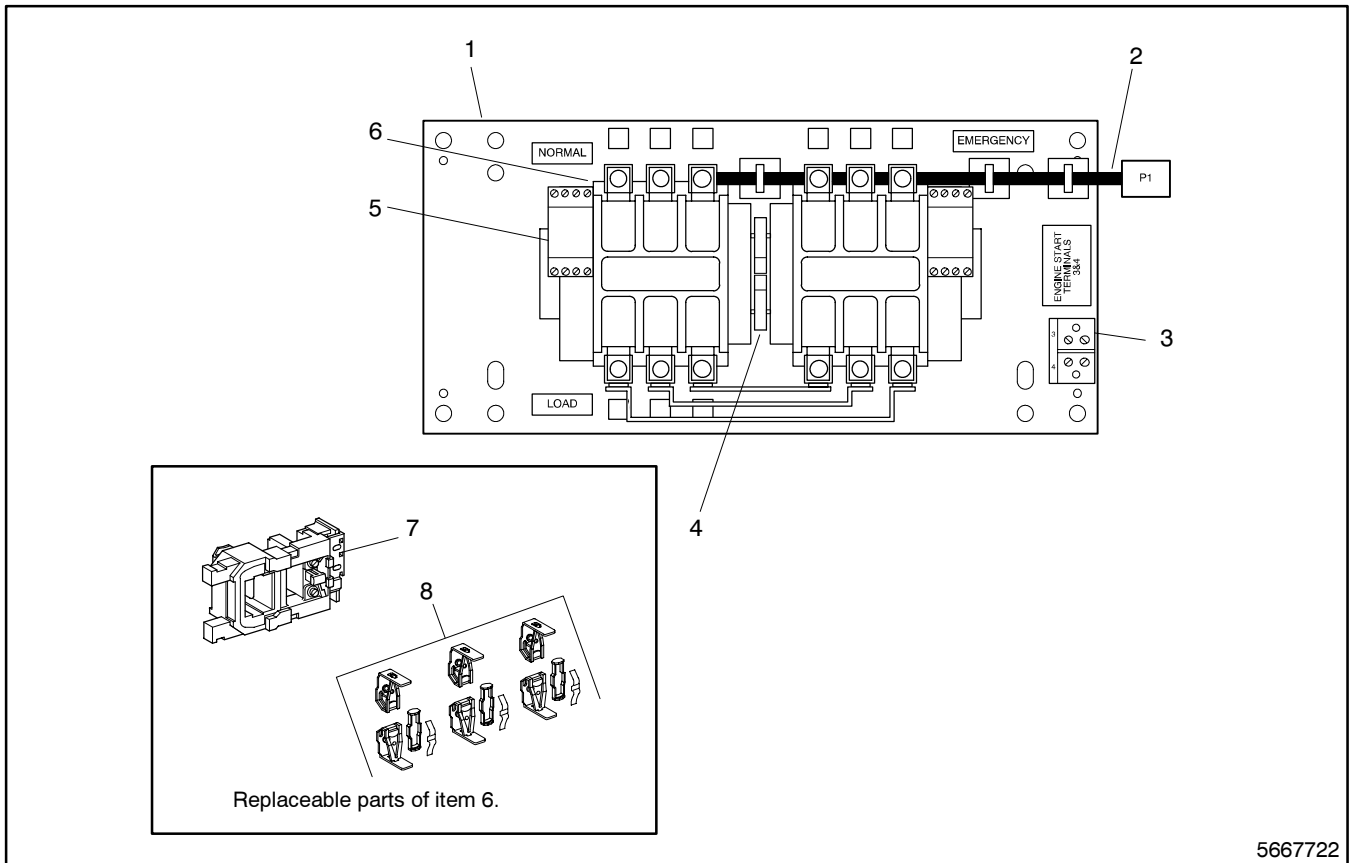

Item	Description	Part Number
1	Plate	320708
2	Harness	320975
3	Block, terminal	X-405-2
4	Interlock, mechanical	X-6312-7 (2)
5	Switch, auxiliary	X-6315-4 (2)
6	Contactor	See Table
7	Coil	See Table
8	Contact Set	346076

ATS Rating Data		Part Number	
Volts	Hz	Contactor (Item 6)	Coil (Item 7)
110	50	A-330311	X-6316-20
120	60	A-330311	X-6316-19
208	60	A-330311	X-6316-21
220	50	A-330311	X-6316-23
240	60	A-330311	X-6316-22
380	50	A-330311	X-6316-24
415/440	50	A-330311	X-6316-25
480	60	A-330311	X-6316-24
600	60	A-330311	X-6316-26

Contactor Assemblies

145 Amps, 4-Poles, Electrically Held

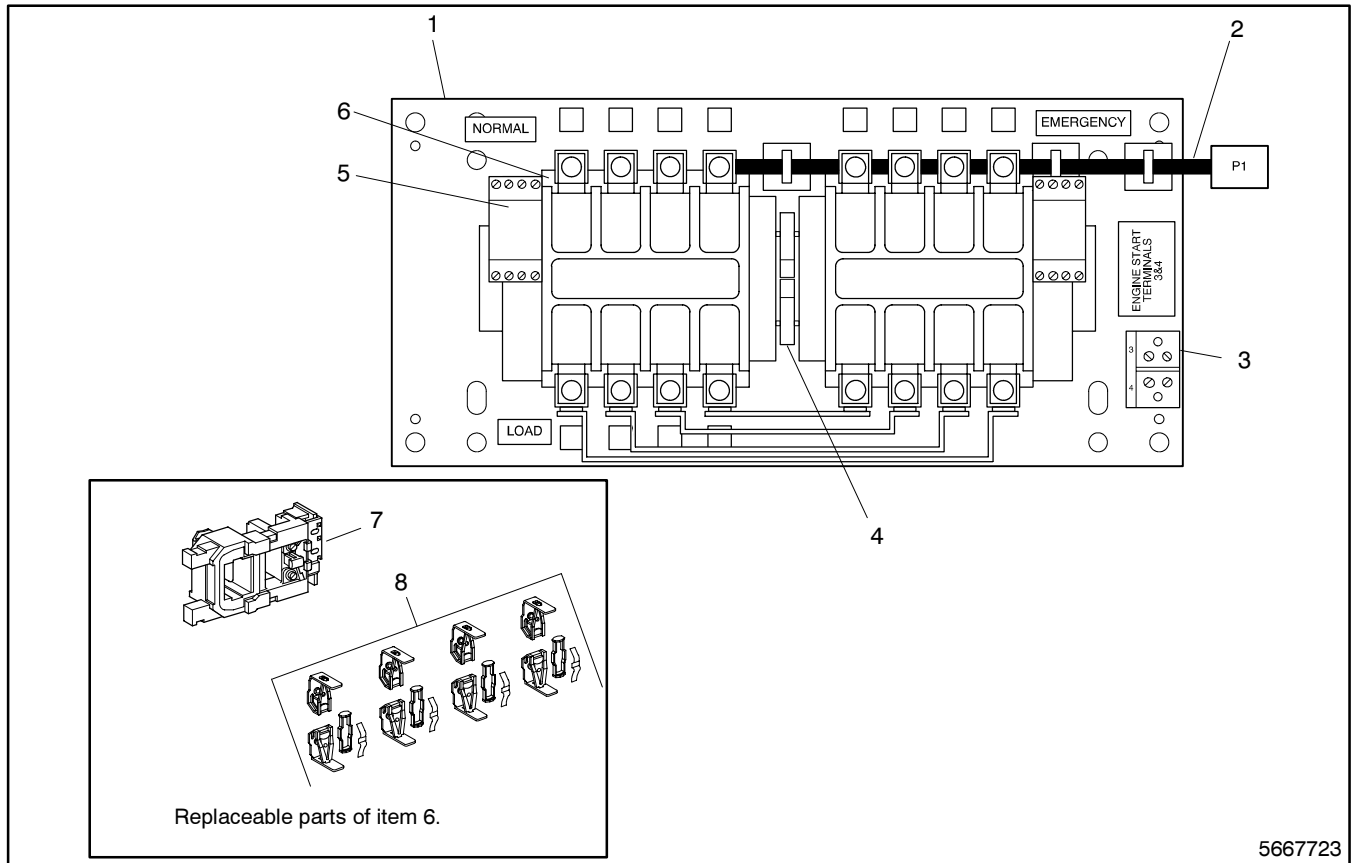

5667723

Item	Description	Part Number
1	Plate	320708
2	Harness	320975
3	Block, terminal	X-405-2
4	Interlock, mechanical	X-6312-7 (2)
5	Switch, auxiliary	X-6315-4 (2)
6	Contactor	See Table
7	Coil	See Table
8	Contact Set	346080

ATS Rating Data		Part Number	
Volts	Hz	Contactor (Item 6)	Coil (Item 7)
110	50	A-330316	X-6316-20
120	60	A-330316	X-6316-19
208	60	A-330316	X-6316-21
220	50	A-330316	X-6316-23
240	60	A-330316	X-6316-22
380	50	A-330316	X-6316-24
415/440	50	A-330316	X-6316-25
480	60	A-330316	X-6316-24
600	60	A-330316	X-6316-26

Contactor Assemblies

180 Amps, 3-Poles, Electrically Held

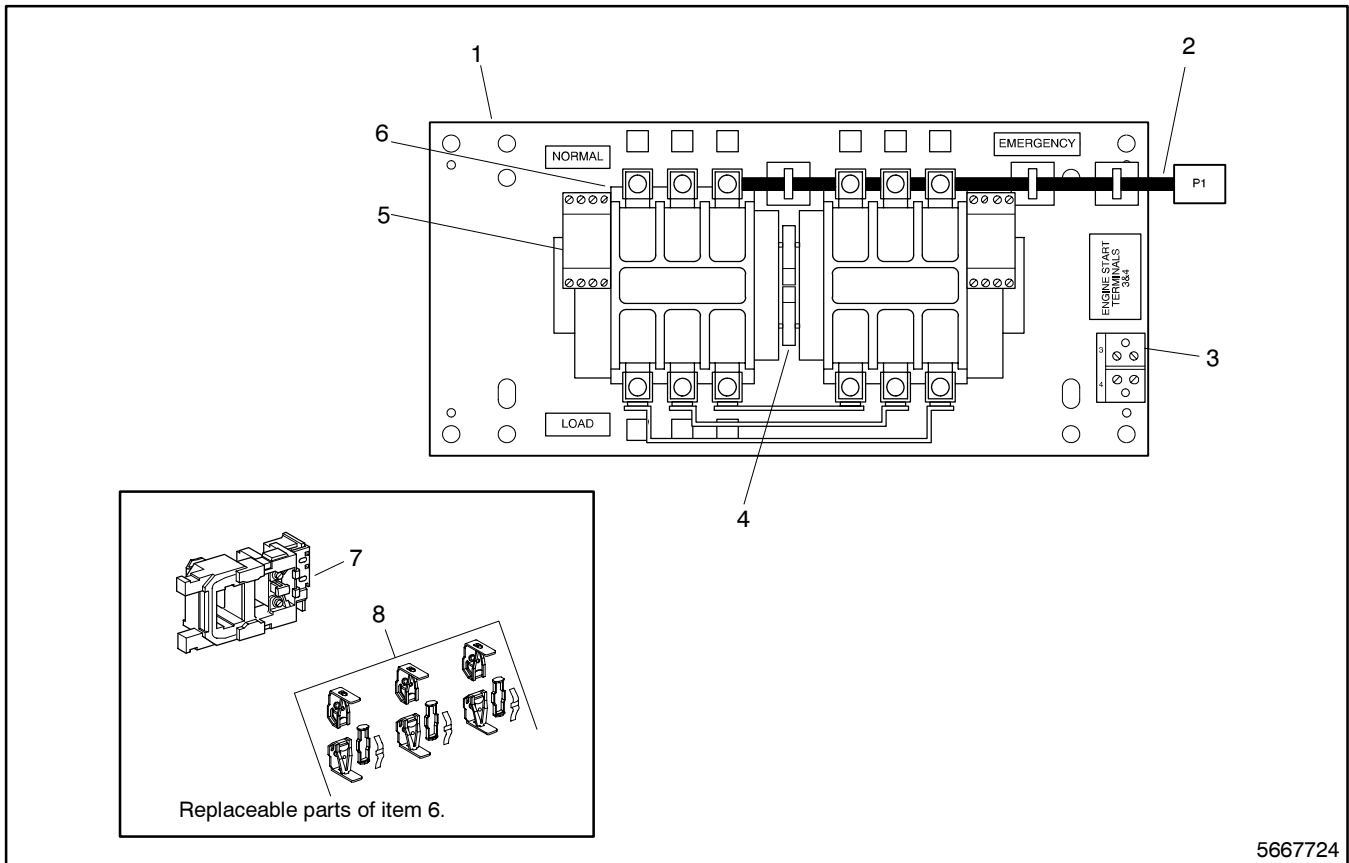

Item	Description	Part Number
1	Plate	320708
2	Harness	320975
3	Block, terminal	X-405-2
4	Interlock, mechanical	X-6312-4 (2)
5	Switch, auxiliary	X-6315-4 (2)
6	Contactor	See Table
7	Coil	See Table
8	Contact Set	346077

ATS Rating Data		Part Number	
Volts	Hz	Contactor (Item 6)	Coil (Item 7)
110	50	A-330312	X-6316-28
120	60	A-330312	X-6316-27
208	60	A-330312	X-6316-29
220	50	A-330312	X-6316-31
240	60	A-330312	X-6316-30
380	50	A-330312	X-6316-32
415/440	50	A-330312	X-6316-33
480	60	A-330312	X-6316-32
600	60	A-330312	X-6316-35

Contactor Assemblies

180 Amps, 3-Poles, Magnetically Held

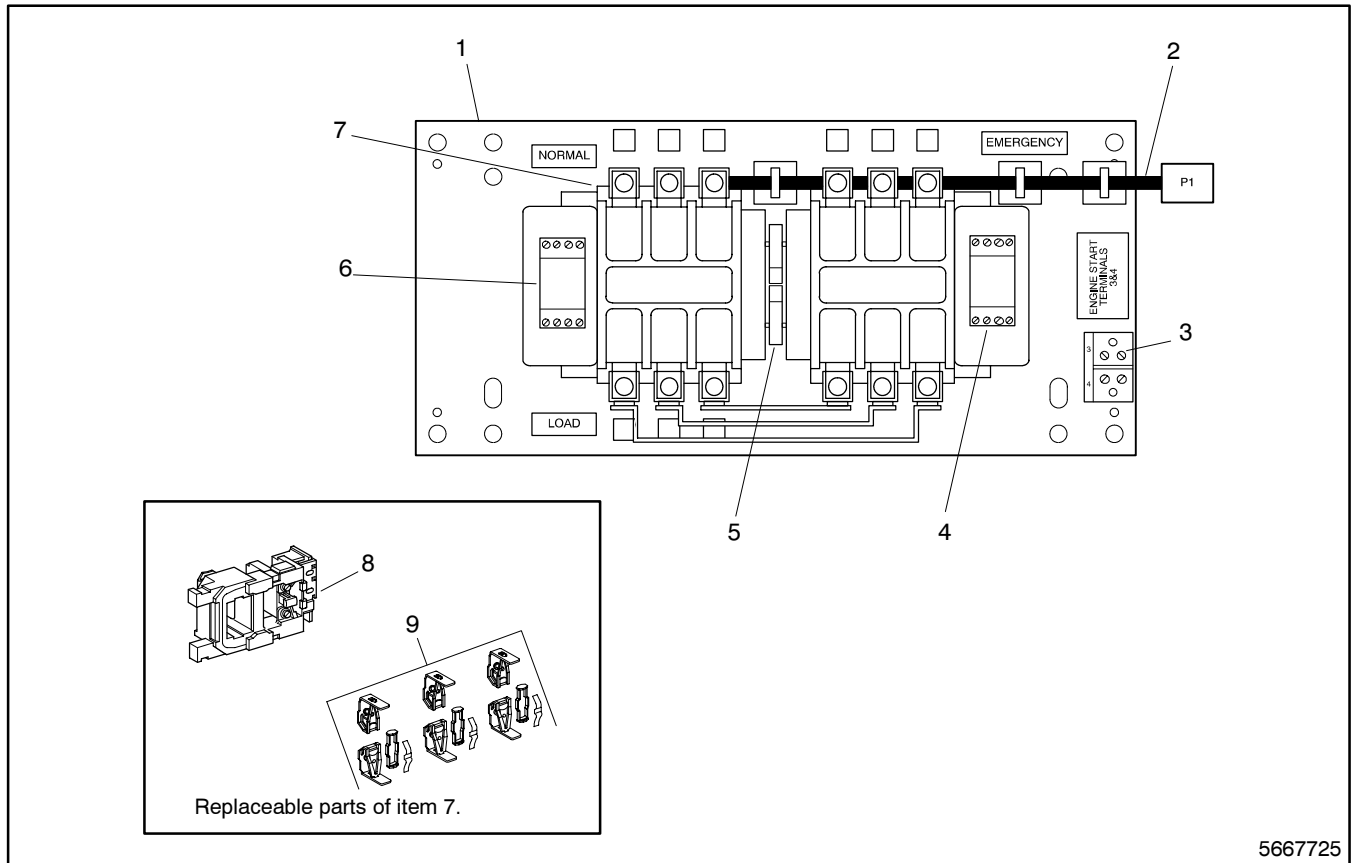

Item	Description	Part Number
1	Plate	320708
2	Harness	320977
3	Block, terminal	X-405-2
4	Switch, auxiliary	X-6315-5
5	Interlock, mechanical	X-6312-4 (2)
6	Switch, auxiliary	X-6315-3 (2)
7	Contactor	See Table
8	Coil	See Table
9	Contact Set	346077

ATS Rating Data		Part Number	
Volts	Hz	Contactor (Item 7)	Coil (Item 8)
110	50/60	A-346957	346090
127	50/60	A-346958	346091
208	50/60	A-346958	346092
220	50/60	A-346959	346092
240	50/60	A-346962	346093
380	50/60	A-346961	346094
415	50/60	A-346960	346095
440/480	50/60	A-346962	346093
600	50/60	A-346958	346093

Contactor Assemblies

180 Amps, 4-Poles, Electrically Held

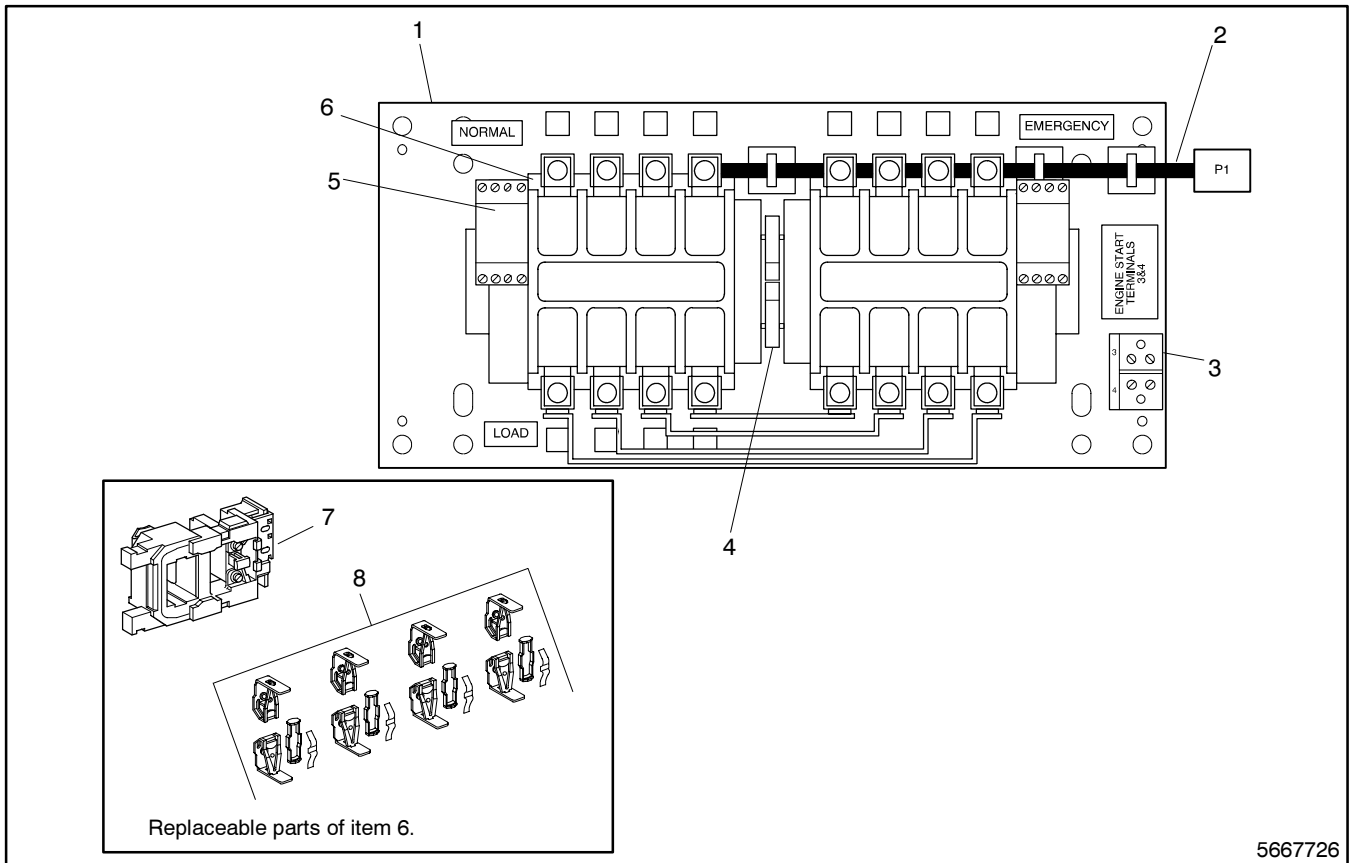

Item	Description	Part Number
1	Plate	320708
2	Harness	320975
3	Block, terminal	X-405-2
4	Interlock, mechanical	X-6312-4 (2)
5	Switch, auxiliary	X-6315-4 (2)
6	Contactor	See Table
7	Coil	See Table
8	Contact Set	346081

ATS Rating Data		Part Number	
Volts	Hz	Contactor (Item 6)	Coil (Item 8)
110	50	A-330317	X-6316-28
120	60	A-330317	X-6316-27
208	60	A-330317	X-6316-29
220	50	A-330317	X-6316-31
240	60	A-330317	X-6316-30
380	50	A-330317	X-6316-32
415/440	50	A-330317	X-6316-33
480	60	A-330317	X-6316-32
600	60	A-330317	X-6316-35

Contactor Assemblies

180 Amps, 4-Poles, Magnetically Held

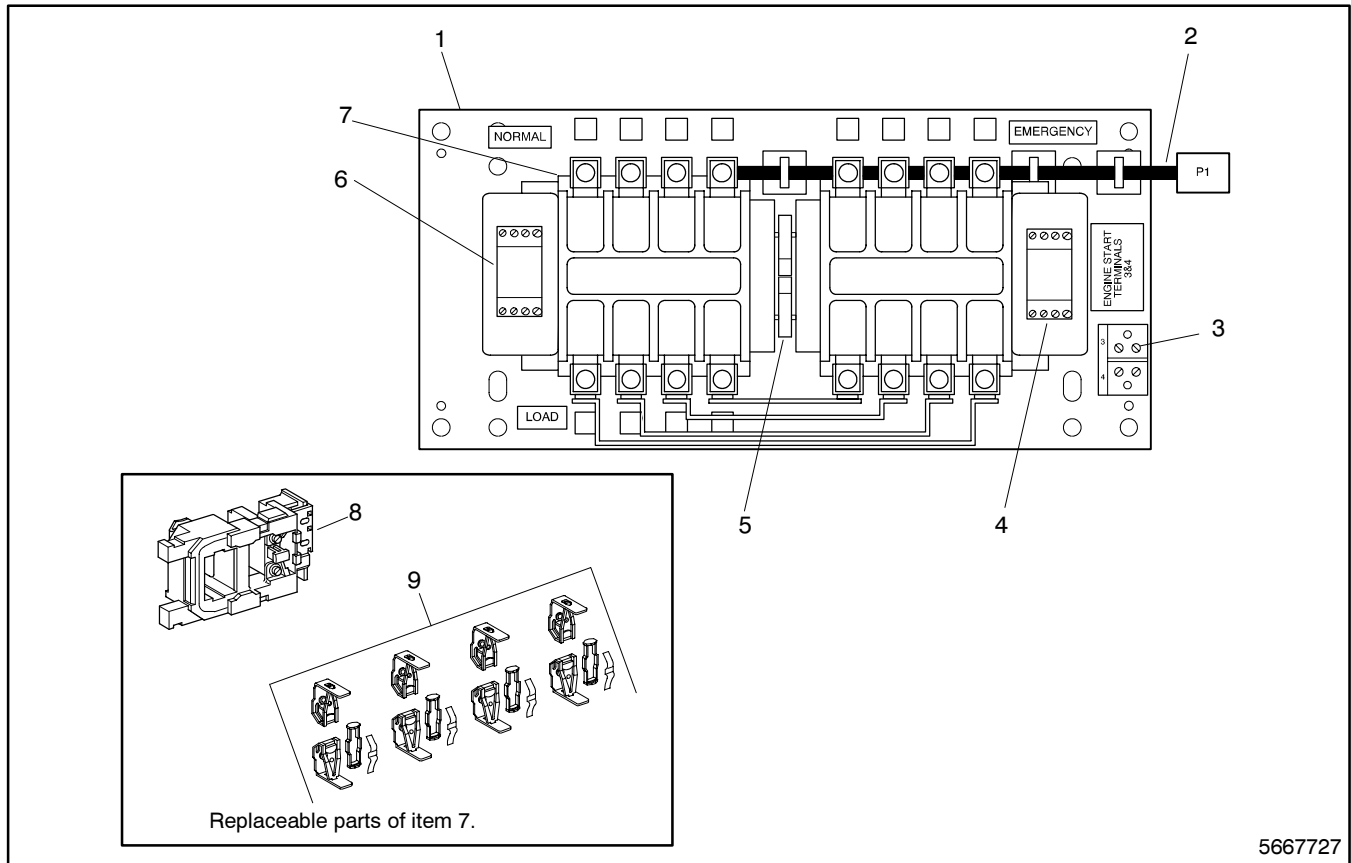

5667727

Item	Description	Part Number
1	Plate	320708
2	Harness	320977
3	Block, terminal	X-405-2
4	Switch, auxiliary	X-6315-5
5	Interlock, mechanical	X-6312-4 (2)
6	Switch, auxiliary	X-6315-3 (2)
7	Contactor	See Table
8	Coil	See Table
9	Contact Set	346081

ATS Rating Data		Part Number	
Volts	Hz	Contactor (Item 6)	Coil (Item 8)
110	50/60	A-346981	346090
127	50/60	A-346982	346091
208	50/60	A-346982	346092
220	50/60	A-346983	346092
240	50/60	A-346986	346093
380	50/60	A-346985	346094
415	50/60	A-346984	346095
440/480	50/60	A-346986	346093
600	50/60	A-346982	346093

Contactors Assemblies

245 Amps, 3-Poles, Magnetically Held

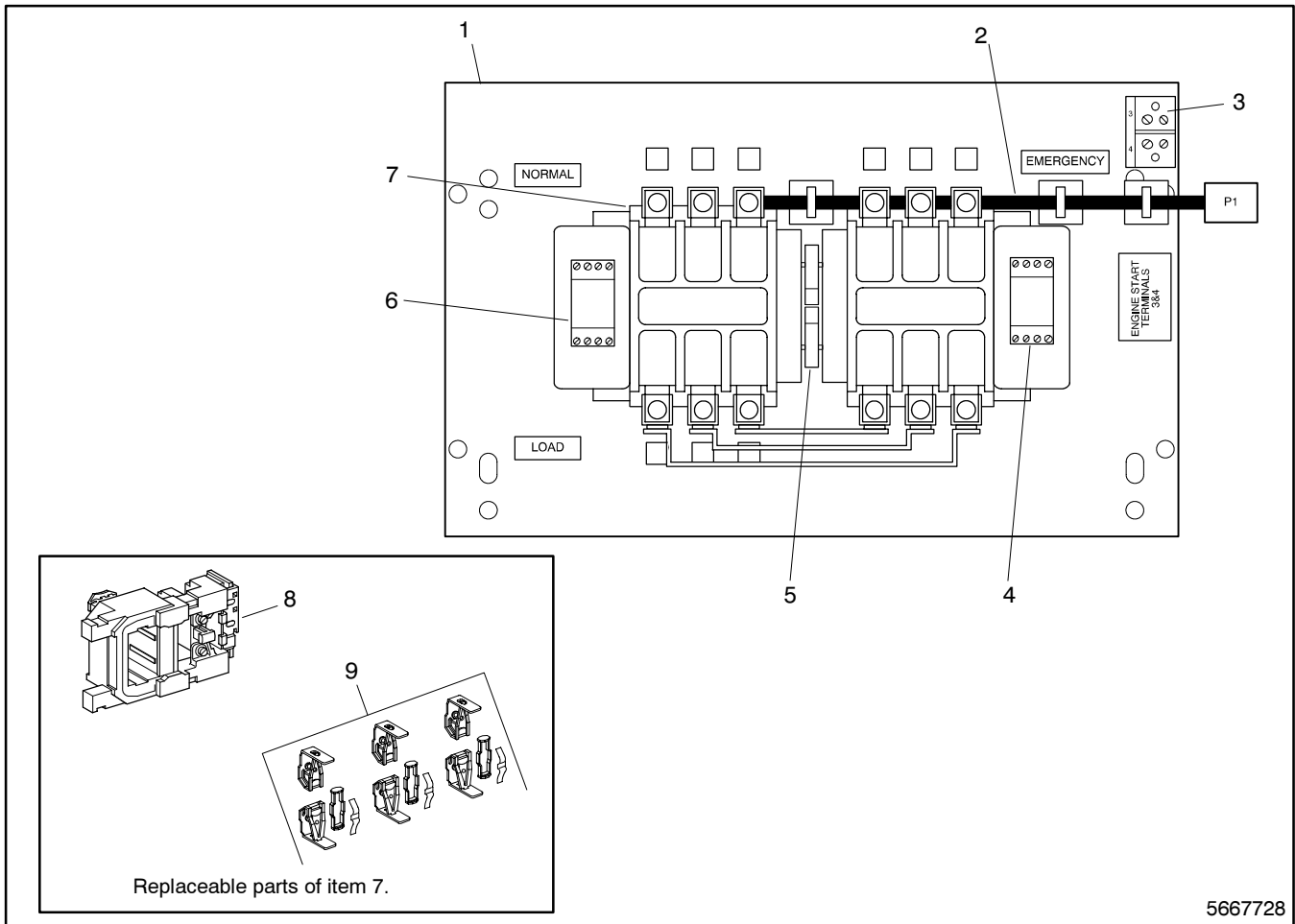

Item	Description	Part Number
1	Plate	320709
2	Harness	320978
3	Block, terminal	X-405-2
4	Switch, auxiliary	X-6315-5
5	Interlock, mechanical	X-6312-6 (2)
6	Switch, auxiliary	X-6315-3 (2)
7	Contactors	See Table
8	Coil	See Table
9	Contact Set	346078

ATS Rating Data		Part Number	
Volts	Hz	Contactors (Item 7)	Coil (Item 8)
110	50/60	A-346963	346096
127	50/60	A-346964	346097
208	50/60	A-346964	346098
220	50/60	A-346965	346098
240	50/60	A-346968	346099
380	50/60	A-346967	346100
415	50/60	A-346966	346101
440/480	50/60	A-346968	346099
600	50/60	A-346964	346099

Contactor Assemblies

245 Amps, 4-Poles, Magnetically Held

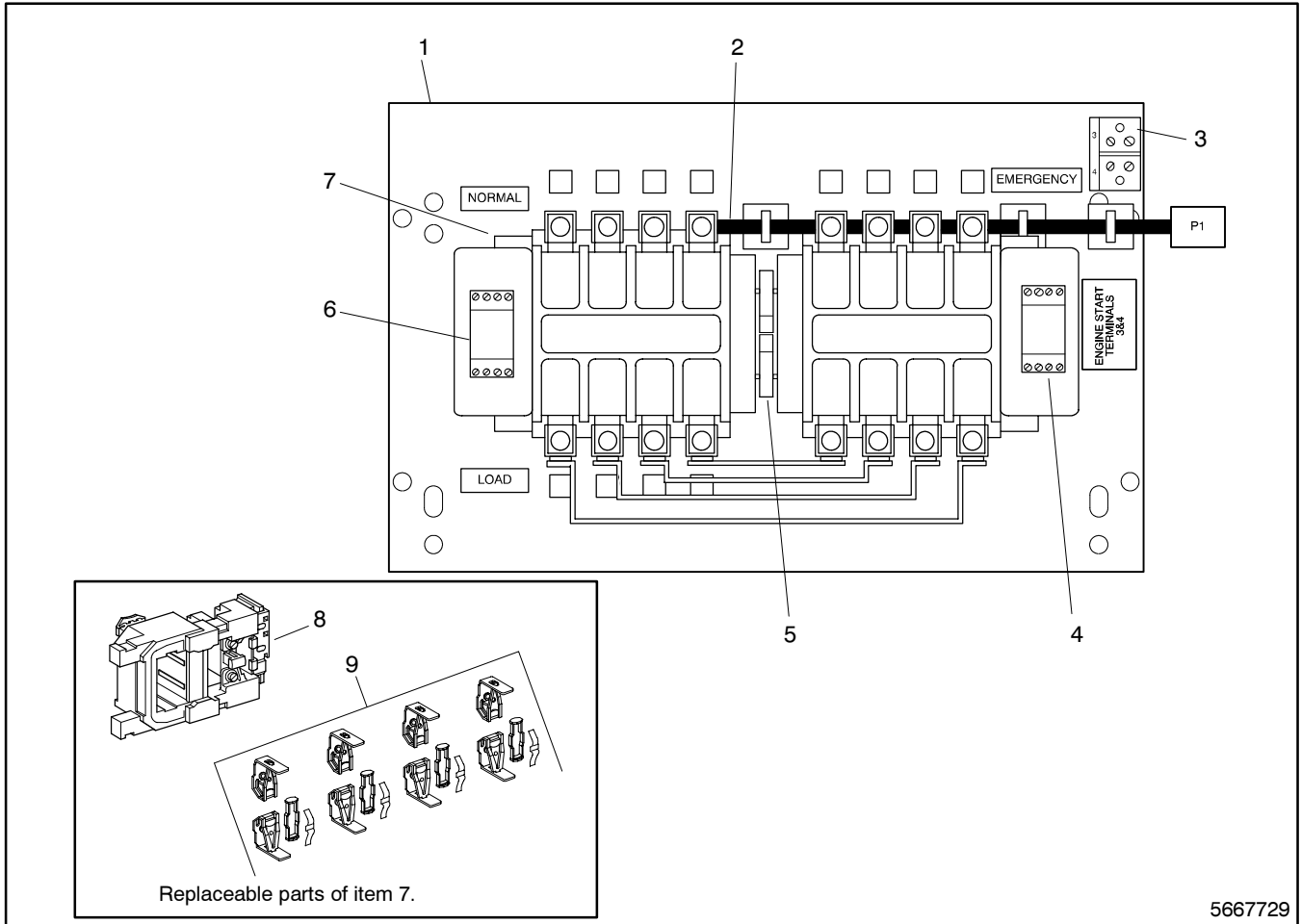

Item	Description	Part Number
1	Plate	320709
2	Harness	320978
3	Block, terminal	X-405-2
4	Switch, auxiliary	X-6315-5
5	Interlock, mechanical	X-6312-6 (2)
6	Switch, auxiliary	X-6315-3 (2)
7	Contactor	See Table
8	Coil	See Table
9	Contact Set	346082

ATS Rating Data		Part Number	
Volts	Hz	Contactor (Item 7)	Coil (Item 8)
110	50/60	A-346987	346096
127	50/60	A-346988	346097
208	50/60	A-346988	346098
220	50/60	A-346989	346098
240	50/60	A-346992	346099
380	50/60	A-346991	346100
415	50/60	A-346990	346101
440/480	50/60	A-346992	346099
600	50/60	A-346988	346099

Contactor Assemblies

245 Amps, 3-Poles, Electrically Held

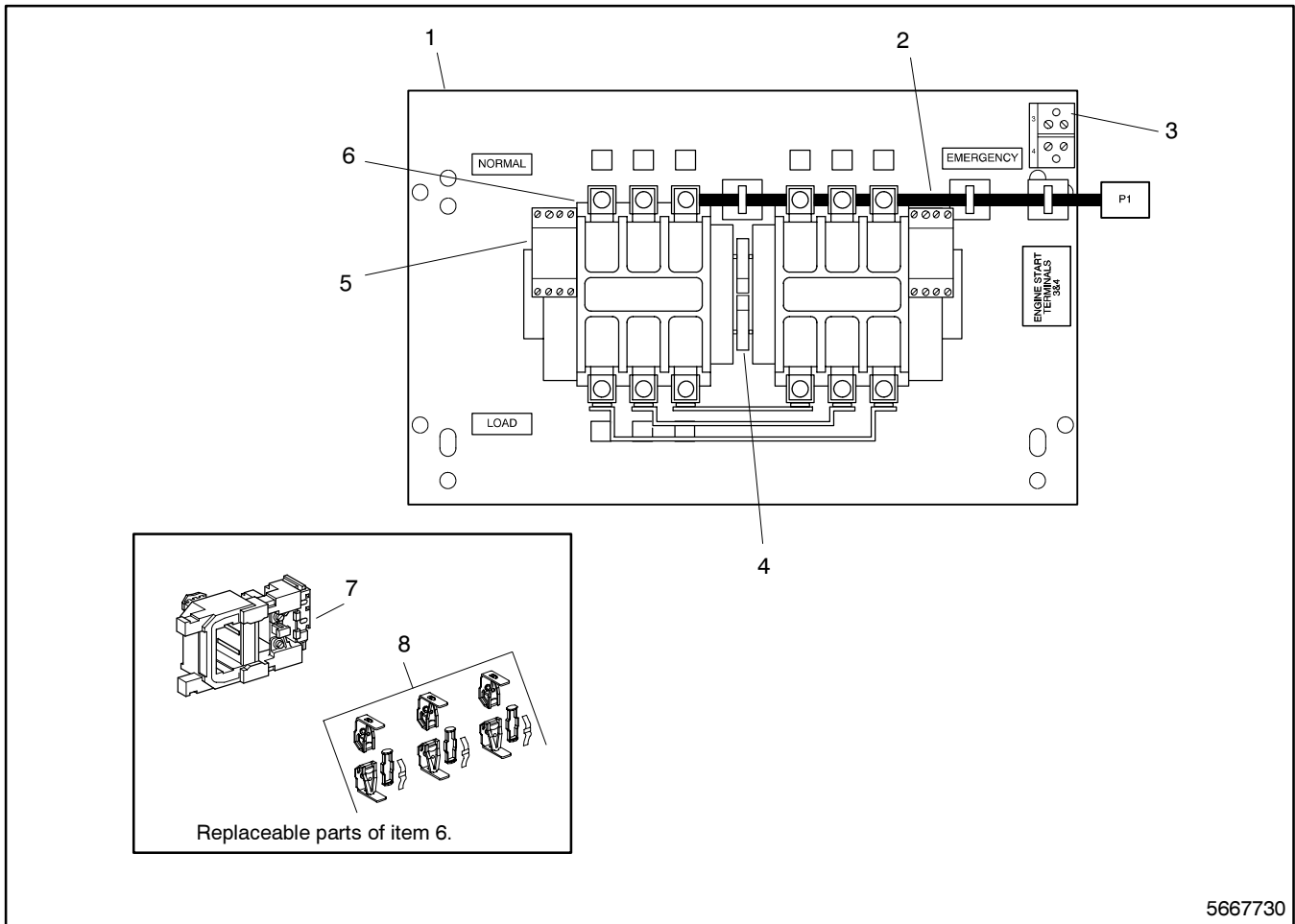

Item	Description	Part Number
1	Plate	320709
2	Harness	320976
3	Block, terminal	X-405-2
4	Interlock, mechanical	X-6312-6 (2)
5	Switch, auxiliary	X-6315-4 (2)
6	Contactor	See Table
7	Coil	See Table
8	Contact Set	346078

ATS Rating Data		Part Number	
Volts	Hz	Contactor (Item 6)	Coil (Item 7)
110	50	A-330313	X-6316-36
120	60	A-330313	X-6316-36
208	60	A-330313	X-6316-38
220	50	A-330313	X-6316-39
240	60	A-330313	X-6316-39
380	50	A-330313	X-6316-41
415/440	50	A-330313	X-6316-42
480	60	A-330313	X-6316-41
600	60	A-330313	X-6316-43

Contactor Assemblies

245 Amps, 4-Poles, Electrically Held

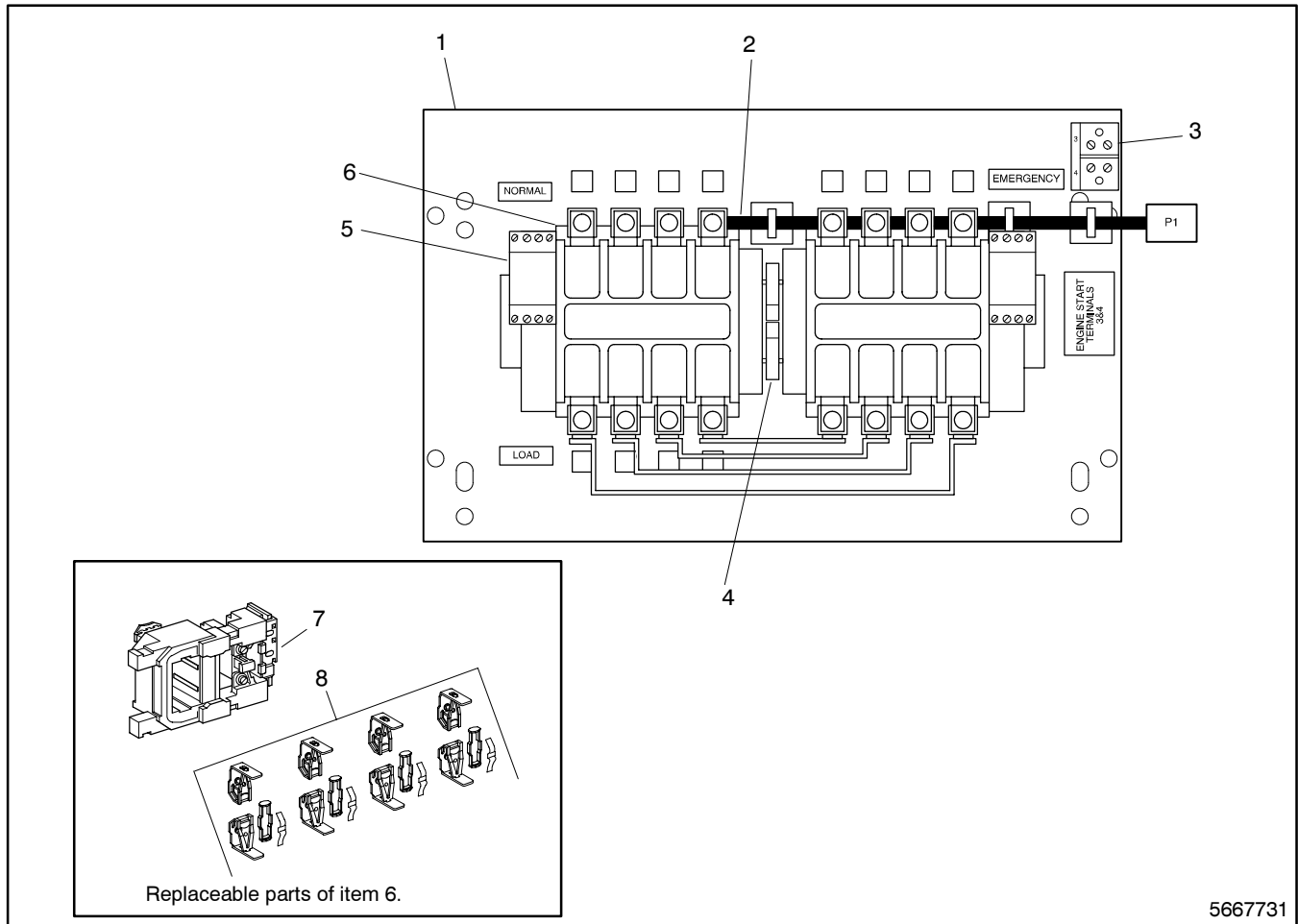

5667731

Item	Description	Part Number
1	Plate	320709
2	Harness	320976
3	Block, terminal	X-405-2
4	Interlock, mechanical	X-6312-6 (2)
5	Switch, auxiliary	X-6315-4 (2)
6	Contactor	See Table
7	Coil	See Table
8	Contact Set	346082

ATS Rating Data		Part Number	
Volts	Hz	Contactor (Item 6)	Coil (Item 7)
110	50	A-330318	X-6316-36
120	60	A-330318	X-6316-36
208	60	A-330318	X-6316-38
220	50	A-330318	X-6316-39
240	60	A-330318	X-6316-39
380	50	A-330318	X-6316-41
415/440	50	A-330318	X-6316-42
480	60	A-330318	X-6316-41
600	60	A-330318	X-6316-43

Contactors Assemblies

400 Amps, 3-Poles, Electrically Held

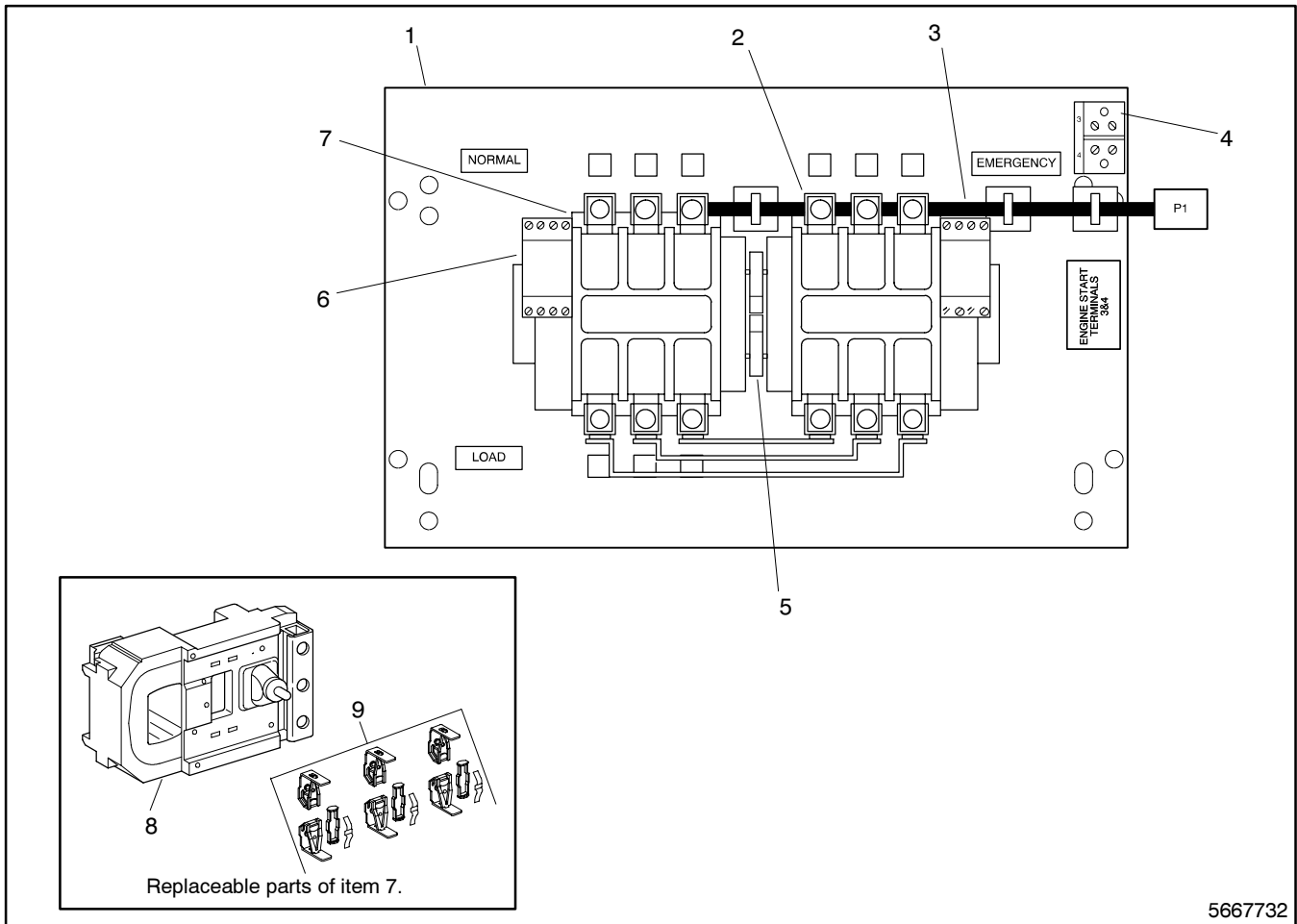

5667732

Item	Description	Part Number
1	Plate	320709
2	Lug	330176 (9)
3	Harness	320976
4	Block, terminal	X-405-2
5	Interlock, mechanical	X-6312-6 (2)
6	Switch, auxiliary	X-6315-4 (2)
7	Contactors	See Table
8	Coil	See Table
9	Contact Set	346079

ATS Rating Data		Part Number	
Volts	Hz	Contactors (Item 7)	Coil (Item 8)
110	50	A-330314	X-6316-45
120	60	A-330314	X-6316-44
208	60	A-330314	X-6316-46
220	50	A-330314	X-6316-48
240	60	A-330314	X-6316-47
380	50	A-330314	X-6316-49
415/440	50	A-330314	X-6316-50
480	60	A-330314	X-6316-49
600	60	A-330314	X-6316-51

Contactor Assemblies

400 Amps, 3-Poles, Magnetically Held

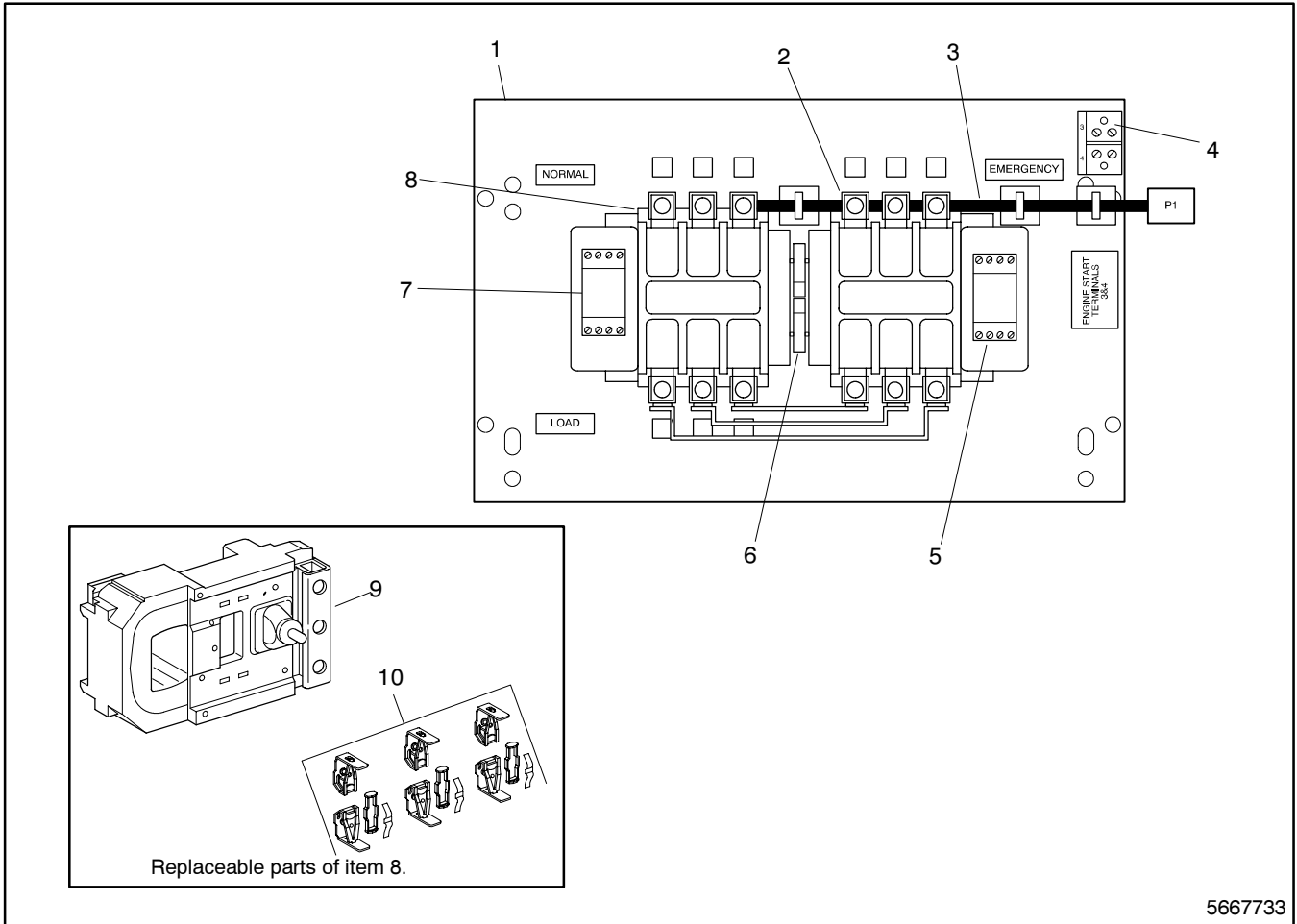

Item	Description	Part Number
1	Plate	320709
2	Lug	330176 (9)
3	Harness	320978
4	Block, terminal	X-405-2
5	Switch, auxiliary	X-6315-5
6	Interlock, mechanical	X-6312-6 (2)
7	Switch, auxiliary	X-6315-3 (2)
8	Contactor	See Table
9	Coil	See Table
10	Contact Set	346079

ATS Rating Data		Part Number	
Volts	Hz	Contactor (Item 8)	Coil (Item 9)
110	50/60	A-346969	346102
127	50/60	A-346970	346103
208	50/60	A-346970	346104
220	50/60	A-346971	346104
240	50/60	A-346974	346105
380	50/60	A-346973	346106
415	50/60	A-346972	346107
440/480	50/60	A-346974	346105
600	50/60	A-346970	346105

Contactor Assemblies

400 Amps, 4-Poles, Electrically Held

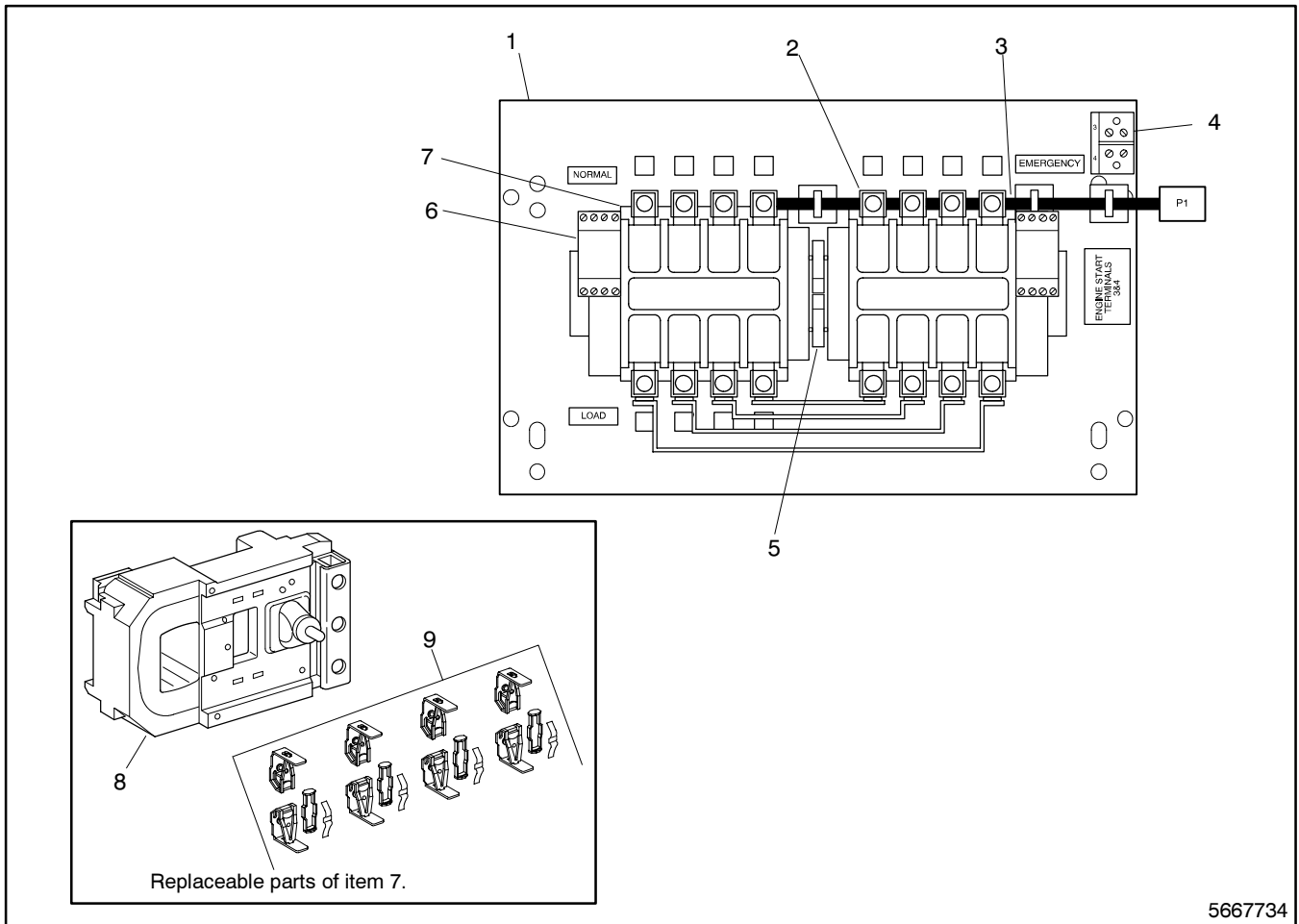

5667734

Item	Description	Part Number
1	Plate	320709
2	Lug	330176 (12)
3	Harness	320976
4	Block, terminal	X-405-2
5	Interlock, mechanical	X-6312-6 (2)
6	Switch, auxiliary	X-6315-4 (2)
7	Contactor	See Table
8	Coil	See Table
9	Contact Set	346083

ATS Rating Data		Part Number	
Volts	Hz	Contactor (Item 7)	Coil (Item 8)
110	50	A-330319	X-6316-45
120	60	A-330319	X-6316-44
208	60	A-330319	X-6316-46
220	50	A-330319	X-6316-48
240	60	A-330319	X-6316-47
380	50	A-330319	X-6316-49
415/440	50	A-330319	X-6316-50
480	60	A-330319	X-6316-49
600	60	A-330319	X-6316-51

Contactor Assemblies

400 Amps, 4-Poles, Magnetically Held

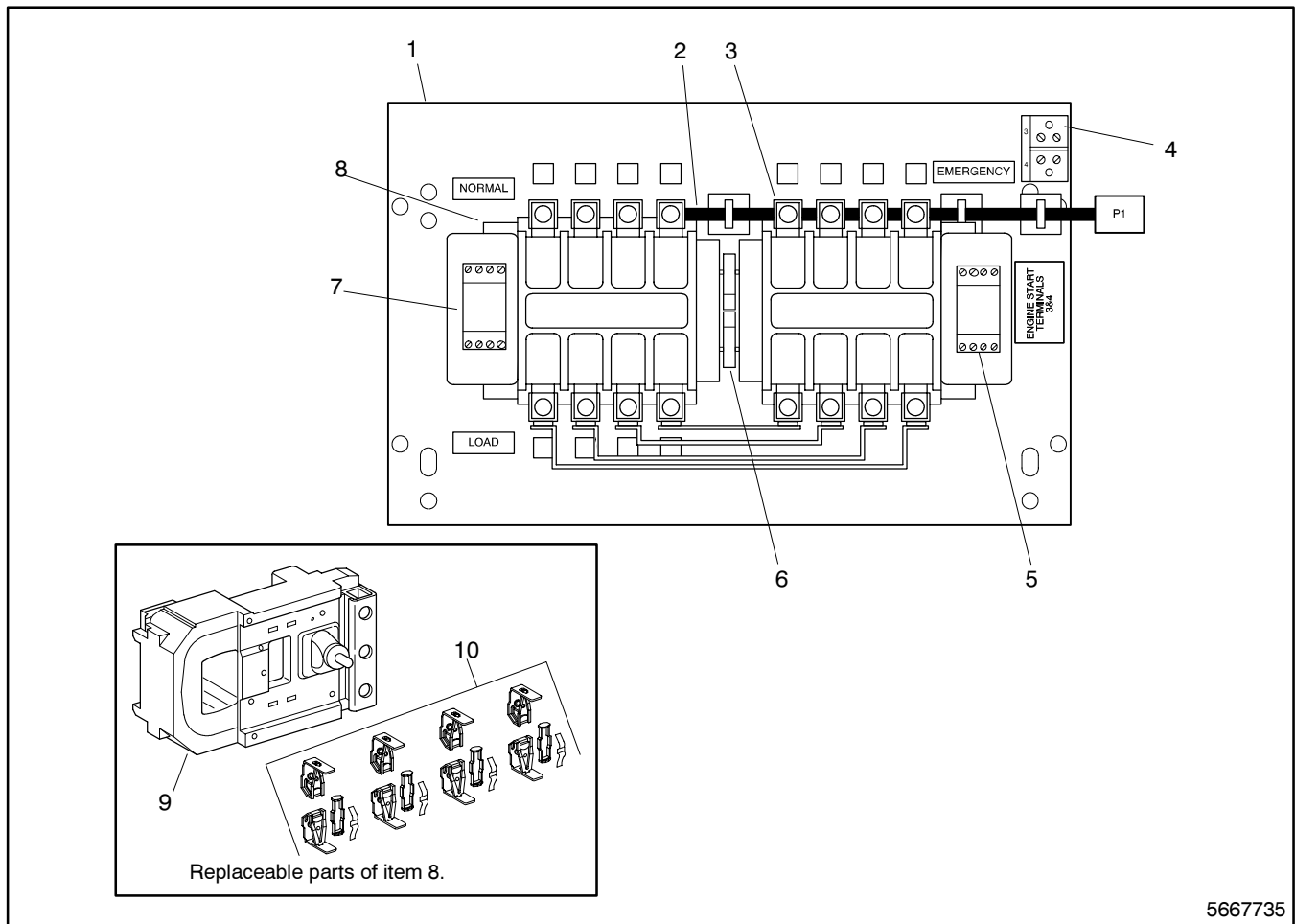

Item	Description	Part Number
1	Plate	320709
2	Harness	320978
3	Lug	330176 (12)
4	Block, terminal	X-405-2
5	Switch, auxiliary	X-6315-5
6	Interlock, mechanical	X-6312-6 (2)
7	Switch, auxiliary	X-6315-3 (2)
8	Contactor	See Table
9	Coil	See Table
10	Contact Set	346083

ATS Rating Data		Part Number	
Volts	Hz	Contactor (Item 8)	Coil (Item 9)
110	50/60	A-346993	346102
127	50/60	A-346994	346103
208	50/60	A-346994	346104
220	50/60	A-346995	346104
240	50/60	A-346998	346105
380	50/60	A-346997	346106
415	50/60	A-346996	346107
440/480	50/60	A-346998	346105
600	50/60	A-346994	346105

Appendix A. Glossary of Abbreviations

Abbreviations are used throughout this manual. Normally they will appear in the text in complete form with the abbreviation following in parentheses the first time they are used. After that they will appear in the

abbreviated form. The commonly used abbreviations are shown below. Some items may not apply to this application.

Abbreviation	Description
ABDC	after bottom dead center
AC	alternating current
AISI	American Iron and Steel Institute
AHWT	anticipatory high water temp.
ALOP	anticipatory low oil pressure
AM	amplitude modulation
amp	ampere
amps	amperes
ANSI	American National Standard Institute
API	American Petroleum Institute
approx.	approximate, approximately
A/R	as required, as requested
A/S	as supplied, as stated, as suggested
ASA	American Standards Association (former name of ANSI)
ASME	American Society of Mechanical Engineers
assy.	assembly
ASTM	American Society for Testing Materials
ATDC	after dead top center
aux.	auxiliary
A/V	audio-visual
AWG	American Wire Gage
AWM	appliance wiring material
BBDC	before bottom dead center
BDC	before dead center
BHP	brake horsepower
bmep	brake mean effective power
BTDC	before top dead center
Btu	British thermal unit
°C	Celsius degree
cc	cubic centimeter
CCA	cold cranking amps
CEC	Canadian Electrical Code
cfh	cubic feet per hour
cfm	cubic feet per minute
CID	cubic inch displacement
cm	centimeter, centimeters
cmm	cubic meters per minute
co.	company
cont'd.	continued
CPVC	chloropoly vinyl chloride
CRT	cathode ray tube
CSA	Canadian Standards Association
CT	current transformer
cu. in.	cubic inch (es)

Abbreviation	Description
CWC	city-water cooled
cyl.	cylinder
dB	decibel
dBA	decibels (A weighted)
DC	direct current
DCR	direct current resistance
deg.	degree
dept.	department
dia.	diameter
DIN	Deutsches Institut fur Normung e. V. (also Deutsche Industrie Normenausschuss)
e.g.	example given
EIA	Electronic Industries Association
EMI	electromagnetic interference
EPA	Environmental Protection Agency
etc.	et cetera (and so forth)
ext.	external
°F	Fahrenheit degree
fl. oz.	fluid ounce(s)
FM	frequency modulation
ft.	foot, feet
ft. lbs.	foot pound(s)
fs	full scale
ga.	gauge (meters wire size)
gal./gals.	gallon, gallons
gph	gallons per hour
gpm	gallons per minute
gr.	grade
grd.	ground
HCHT	high cylinder head temperature
HET	high exhaust temperature
Hg.	mercury (element)
H ₂ O	water
HP	horsepower
hr, hrs	hour, hours
HWT	high water temperature
Hz	hertz (cycles per second)
ID	inside diameter
IEEE	Institute of Electrical and Electronic Engineers
in.	inch, inches
inc.	incorporated
in. lbs.	inch pounds
int.	internal
int.-ext.	internal-external

Abbreviation	Description
ISO	International Standards Organization
J	joule, joules
JIS	Japanese Industry Standard
kg	kilogram, kilograms
kg/cm ²	kilograms per square centimeter
kgm	kilogram meter(s)
kJ	kilojoules (btu cal)
km	kilometer, kilometers
kPa	kiloPascal, kiloPascals
kph	kilometers per hour
kV	kilovolt
kVA	kilovolt amperes
kW	kilowatt, kilowatts
kWH	kilowatt hour
L	liter, liters
LxWxH	length x width x height
LED(s)	light emitting diode(s)
lb., lbs.	pound, pounds
L/hr.	liter per hour, liters per hour
L/min.	liter(s) per minute
LOP	low oil pressure
LP	liquified petroleum
LWT	low water temperature
m	meter, meters
m ³	cubic meter, cubic meters
max.	maximum
MCM	one thousand circular mils.
meggar	megohmmeter
MHz	megahertz
mi.	mile, miles
mil	one one-thousandth of an inch
min.	minimum
min	minutes
misc.	miscellaneous
mJ	milli joule(s)
MJ	mega joule(s)
mm	millimeter
m ³ /min	cubic meters per minute
MPa	megaPascal
mpg	miles per gallon
mph	miles per hour
MS	military standard
mW	milliwatt(s)
MW	megawatt(s)
N/A	not available
NBS	National Bureau of Standards
N.C.	normally closed
NEC	National Electrical Code
NEMA	National Electrical Manufacturers Association
NFPA	National Fire Protection Association
Nm	Newton meter(s)
N.O.	normally open

Abbreviation	Description
no., nos.	number, numbers
NPT	National Standard taper pipe thread per general use
N/R	not required
OC	overcrank
OD	outside diameter
OEM	original equipment manufacturer
OS	overspeed
O/S	oversize
OSHA	Occupational Safety and Health Act
OV	overvoltage
oz.	ounce, ounces
PF	power factor
PMG	permanent magnet generator
pot	potentiometer
ppm	parts per million
psi	pounds per square inch
pt., pts.	pint, pints
PVC	polyvinyl chloride
qt., qts.	quart, quarts
qty.	quantity
ref.	reference
RFI	radio frequency interference
r.h.m.	round-head machine (screw)
rms	root means square
RPM	revolutions per minute
RTV	room temperature vulcanization
RV	recreational vehicle
SAE	Society of Automotive Engineers
SCR	silicon controlled rectifier
sec.	second, seconds
spec, specs	specification
sq.	square
sq. cm.	square centimeters
sq. in.	square inch(es)
tach	tachometer
TDC	top dead center
tech. pub.	technical publications
temp.	temperature
TIF	telephone influence factor
TP, TPs	technical publications
turbo	turbocharger
UHF	ultrahigh frequency
UNC	Unified coarse thread (was NC)
UNF	Unified fine thread (was NF)
UL	Underwriter's Laboratories, Inc.
U/S	undersize
U.S.A.	United States of America
V	volt, volts
vac	volts alternating current
vdc	volts direct current
VHF	very high frequency
W	watt, watts

TP-5667 9/96b

© Kohler Co., 1996. All rights reserved.

KOHLER[®] POWER SYSTEMS

KOHLER CO. Kohler, Wisconsin 53044
Phone 920-565-3381, Web site www.kohlergenerators.com
Fax 920-459-1646 (U.S.A. Sales), Fax 920-459-1614 (International)
For the nearest sales and service outlet in U.S.A. and Canada
Phone 1-800-544-2444

Kohler[®] Power Systems
Asia Pacific Headquarters
7 Jurong Pier Road
Singapore 619159
Phone (65)264-6422, Fax (65)264-6455