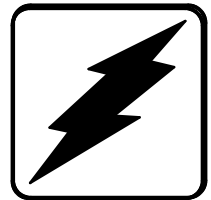


# Service and Parts

## Automatic Transfer Switches



Models:

**M340+**

Logic:

Microprocessor

**KOHLER**<sup>®</sup>  
POWER SYSTEMS

**ISO 9001**  
**KOHLER**  
GENERATORS  
INTERNATIONALLY REGISTERED  
U.S.A. Plant ISO Registered

TP-5672 11/95d

# Table of Contents

SUBJECT	PAGE	SUBJECT	PAGE
<b>Safety Precautions and Instructions</b> .....	<b>i</b>	Area Protection .....	4-20
<b>Introduction</b> .....	<b>i</b>	Shunt Jumper-Controlled Options .....	4-21
List of Related Manuals .....	<b>i</b>	Inphase Monitor .....	4-23
<b>Service Assistance</b> .....	<b>i</b>	Source Monitors .....	4-24
 		Plant Exerciser .....	4-27
<b>Section 1. Specifications</b> .....	<b>1-1</b>	Time Delays .....	4-32
Purpose of Switch .....	1-1	Manual Override .....	4-33
Components of Switch .....	1-1	Off Delays .....	4-34
Ratings .....	1-2	 	
Interpreting a Transfer Switch Part Number .....	1-3	<b>Section 5. Accessory Troubleshooting</b> .....	<b>5-1</b>
Specifications .....	1-4	Optional Accessories .....	5-2
Standard Features .....	1-4	Emergency Source Three-Phase Phase Option ..	5-2
Shunt-Jumper-Controlled Accessories .....	1-5	Test Switches .....	5-4
Optional Features .....	1-5	Time Delay Override Option .....	5-10
 		Preferred Source Switch .....	5-14
<b>Section 2. Operation</b> .....	<b>2-1</b>	Relay Auxiliary Dry Contacts .....	5-15
LED Indicators .....	2-1	Main Shaft Auxiliary Dry Contacts .....	5-22
Control Switches and Indicators .....	2-2	Meters .....	5-23
Sequence of Operation .....	2-3	Battery Charger .....	5-47
Normal Source Failure .....	2-3	Manual Operation Switches .....	5-54
Normal Source Restoration .....	2-4	Load Shedding Contacts .....	5-63
Sequence of Operation Programmed Transition ..	2-6	Remote Communication– RS/232 Or RS/485 ..	5-65
Normal Source Failure .....	2-6	 	
Normal Source Restoration .....	2-7	<b>Section 6. Service Parts</b> .....	<b>6-1</b>
To Disconnect The P1 Plug .....	2-9	Introduction .....	6-1
Electrical Operation Test .....	2-9	Inner Panel .....	6-2
 		Accessories .....	6-5
<b>Section 3. Troubleshooting Guide</b> .....	<b>3-1</b>	Time Delay .....	6-5
 		Source monitors .....	6-5
<b>Section 4. Controller Troubleshooting</b> .....	<b>4-1</b>	Test Switches .....	6-5
Power to the System .....	4-2	Time Delay Override Switches .....	6-5
Keypad And Status Panel .....	4-3	Preferred-Source Switches .....	6-5
Normal Source Voltage and Frequency .....	4-6	Auxiliary Contacts– Relay .....	6-5
Emergency Source Voltage and Frequency .....	4-9	Auxiliary Contacts– Main Shaft .....	6-5
System-Status, Not-In-Automatic Error .....	4-11	Meters .....	6-6
System-Status, System-Alert .....	4-12	Plant Exercisers .....	6-11
Contactor Position Fault Error Messages .....	4-12	Battery Chargers .....	6-11
Transfer Hang Error Message .....	4-12	Source Monitors– Normal and Emergency .....	6-12
Power-Down Error Message .....	4-12	Load-Shed Contacts .....	6-12
RAM Or Memory Error Message .....	4-13	Time Delays .....	6-12
Manual Transfer Message .....	4-13	 	
Manual-to-Off Transfer Message .....	4-13	<b>Appendix A. Glossary of Abbreviations</b> .....	<b>A-1</b>
Fault #1 Or Fault #2 Message .....	4-14	 	
Programming Mode Not-In-Off .....	4-15	<b>Appendix B. General Controller Information</b> ..	<b>B-1</b>
Engine Operates When it Should Not .....	4-16	 	
Engine Will Not Start .....	4-18	<b>Appendix C. Commonly Used Accessories</b> ..	<b>C-1</b>

# Safety Precautions and Instructions

A transfer switch, like any other electromechanical device, can pose potential dangers to life and limb if improperly maintained or imprudently operated. The best way to prevent accidents is to be aware of the potential dangers and to always use good common sense. Below are some general precautions relating to the operation of a transfer switch. This manual contains several types of safety precautions which are explained below. **SAVE THESE INSTRUCTIONS.**

## **DANGER**

Danger indicates the presence of a hazard that will cause severe personal injury, death, or substantial property damage if the danger is ignored.

## **WARNING**

Warning indicates the presence of a hazard that can cause severe personal injury, death, or substantial property damage if the warning is ignored.

## **CAUTION**

Caution indicates the presence of a hazard that will or can cause minor personal injury or property damage if the caution is ignored.

## **NOTE**

Note communicates installation, operation, or maintenance information that is important but not hazard related.

Safety decals are affixed to the generator set in prominent places to advise the operator or service technician of potential hazards. The decals are reproduced here to improve operator recognition. For a further explanation of decal information, refer to the safety precautions throughout this manual. Before operating or servicing the generator set, be sure you understand the messages of these decals. Replace decals if missing or damaged.

Safety decals are affixed to the transfer switch in prominent places to advise the operator or service technician of potential hazards. The decals are reproduced here to improve operator recognition. For a further explanation of decal information, refer to the safety precautions throughout this manual. Before operating or servicing the transfer switch, be sure you understand the messages of these decals. Replace decals if missing or damaged.

# Accidental Starting

---



**Accidental starting.  
Can cause severe injury or death.**

Disconnect battery cables before working on generator set (negative lead first and reconnect it last).

---

**Accidental starting can cause severe injury or death.** Turn generator set master switch to OFF position, disconnect power to battery charger, and remove battery cables (remove negative lead first and reconnect it last) to disable generator set before working on any equipment connected to generator set. The generator set can be started by automatic transfer switch or remote start/stop switch unless these precautions are followed.

# Battery

## WARNING



**Sulfuric acid in batteries.  
Can cause severe injury or death.**

Use protective goggles and clothes. Battery acid can cause permanent damage to eyes, burn skin, and eat holes in clothing.

## WARNING



**Explosion.  
Can cause severe injury or death. Relays in  
battery charger cause arcs or sparks.**


Locate in a well-ventilated area. Keep explosive fumes away.


**Sulfuric acid in batteries can cause severe injury or death.** Sulfuric acid in battery can cause permanent damage to eyes, burn skin, and eat holes in clothing. Always wear splash-proof safety goggles when working around the battery. If battery electrolyte is splashed in the eyes or on skin, immediately flush the affected area for 15 minutes with large quantities of clean water. Seek immediate medical aid in the case of eye contact. Never add acid to a battery once the battery has been placed in service. This may result in hazardous spattering of electrolyte.


**Sulfuric acid in batteries can cause severe injury or death.** Sulfuric acid in battery can cause permanent damage to eyes, burn skin, and eat holes in clothing. Always wear splash-proof safety goggles when working around the battery. If battery electrolyte is splashed in the eyes or on skin, immediately flush the affected area with large quantities of clean water. Continue flushing with water until emergency help arrives. Seek immediate medical aid in the case of eye contact. Never add acid to a battery once the battery has been placed in service. This may result in hazardous spattering of electrolyte.


**Explosion can cause severe injury or death.** Battery gases can cause an explosion. Do not smoke or permit flame or spark to occur near a battery at any time, particularly when it is being charged. Avoid contacting terminals with tools, etc., to prevent burns and sparks that could cause an explosion. Remove wristwatch, rings, and any other jewelry before handling battery. Never connect negative (-) battery cable to positive (+) connection terminal of starter solenoid. Do not test battery condition by shorting terminals together. Sparks could ignite battery gases or fuel vapors. Ventilate any compartment containing batteries to prevent accumulation of explosive gases. To avoid sparks, do not disturb battery charger connections while battery is being changed. Always turn battery charger off before disconnecting battery connections. Remove negative lead first and reconnect it last when disconnecting battery.

# Hazardous Voltage/ Electrical Shock

<b>⚠ DANGER</b>

<p><b>Hazardous voltage.</b> <b>Will cause severe injury or death.</b></p> <p>Do not open enclosure until all power sources are disconnected.</p> <p><i>(600 Volt and above)</i></p>

<b>⚠ DANGER</b>

<p><b>Hazardous voltage.</b> <b>Will cause severe injury or death.</b></p> <p>Disconnect power sources before servicing. Barrier must be installed after adjustments, maintenance, or servicing.</p> <p><i>(600 Volt and above)</i></p>

<b>⚠ WARNING</b>

<p><b>Hazardous voltage.</b> <b>Can cause severe injury or death.</b></p> <p>Disconnect power sources before servicing. Barrier must be installed after adjustments, maintenance, or servicing.</p> <p><i>(under 600 Volt)</i></p>

<b>⚠ WARNING</b>

<p><b>Hazardous voltage.</b> <b>Can cause severe injury or death.</b></p> <p>Do not open enclosure until all power sources are disconnected.</p> <p><i>(under 600 Volt)</i></p>

**Hazardous voltage can cause severe injury or death.** Whenever electricity is present, there is the hazard of electrocution. Open main circuit breaker on all power sources before servicing equipment. Electrically ground the generator set and electrical circuits when in use. Never come into contact with electrical leads or appliances when standing in water or on wet ground, as the chance of electrocution is increased under such conditions.

**Hazardous voltage can cause severe injury or death.** Short circuits can cause bodily injury and/or equipment damage. Do not contact electrical connections with tools or jewelry while adjustments are made. Remove wristwatch, rings, and jewelry that can cause short circuits.

**Hazardous voltage can cause severe injury or death.** To prevent the possibility of electrical shock, disconnect harness plug before installing any accessories involving connection to transformer assembly primary terminals 76, 77, 78, and 79. Terminals are at line voltage!  
*(S340, R340, and R33 models only.)*

**Hazardous voltage can cause severe injury or death.** To prevent the possibility of electrical shock, disconnect harness plug before installing any accessories involving connection to transformer assembly primary terminals on microprocessor logic models. Terminals are at line voltage!

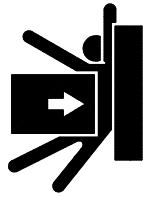
**Hazardous voltage can cause severe injury or death.** To prevent the possibility of electrical shock, de-energize the normal power source to be connected to the transfer switch before making any line or auxiliary connections.

**Hazardous voltage can cause severe injury or death.** De-energize both normal and emergency power sources before proceeding. Move generator set master switch on controller to OFF position and disconnect battery negative (-) before working on transfer switch! Turn the transfer switch selector switch to the OFF position.

**Hazardous voltage can cause severe injury or death.** Disconnect inner panel harness at in-line connector. This will de-energize circuit board and logic circuitry, but allow transfer switch to continue to supply utility power to necessary lighting and equipment. Hazardous voltage will exist if any accessories mounted to inner panel are NOT wired through the inner panel harness and de-energized by in-line connector separation. Such accessories are at line voltage.

# Heavy Equipment

**⚠ WARNING**



**Unbalanced weight.  
Improper lift can cause severe injury or death  
and/or equipment damage.**

Use adequate lifting capacity.  
Never leave transfer switch standing upright  
unless it is securely bolted in place or stabilized.

# Notes

## NOTE

**Hardware Damage!** Transfer switch may use both American standard and metric hardware. Use the correct size tools to prevent rounding of bolt heads and nuts.

## NOTE

**When replacing hardware, do not substitute with inferior grade hardware.** Screws and nuts are available in different hardness ratings. American Standard hardware uses a series of markings and metric hardware uses a numeric system to indicate hardness. Check markings on bolt head and nuts for identification.

## NOTE

A manual operator handle is provided on the transfer switch for maintenance purposes only. Return the transfer switch to the normal position. Remove manual operator handle (if used) and store it on the transfer switch in the place provided when service is completed.

## NOTE

Perform voltage checks in the order given to avoid damaging the switch.

## NOTE

These battery chargers are designed strictly for use in this transfer switch and conform with UL and CSA listing requirements where specified. Do not use battery charger before reading instructions.

## NOTE

Connect source and load phases as indicated by the markings and drawings. Improper connections may cause short circuits and can cause phase-sensitive load devices to run in reverse or prevent load devices from functioning.

## NOTE

**Charger Damage!** Connect battery charger only to a battery with the same DC voltage as the battery charger output rating.

## NOTE

Cover transfer switch during installation to keep dirt, grit, metal drill chips, etc., out of components. Cover solenoid mechanism during installation. After installation, use manual operating handle to position contactor to ensure that it operates freely. Do not use a screwdriver to force contactor mechanism.

# Introduction

This manual covers the operation, troubleshooting, repair, and service parts for the M340+ microprocessor logic controller.

Read through this manual and carefully follow all procedures and safety precautions to ensure proper transfer switch operation and to avoid bodily injury. Keep this manual with the transfer switch for future reference.

Service requirements are minimal but are very important to the safe and reliable operation of the transfer switch; therefore, inspect associated parts often. It is recommended that an authorized service distributor perform required servicing to keep the switch in top condition.

All information found in this publication is based on data available at time of printing. The manufacturer reserves the right to make changes to this literature and the products represented at any time without notice and without incurring obligation.

## List of Related Manuals

The logic controller covered in this manual is part of a family of related devices. Separate service and parts manuals are available for each group within the overall family. Be sure this manual is the correct manual for the automatic transfer switch.

A power conversion unit is included in each automatic transfer switch. There are three types of power conversion units and each type is covered in a separate service and parts manual. Available power conversion units and the related manual numbers are as follows:

<b>Power Switch Device</b>	<b>Service/ Parts Manual</b>
Mechanically held or electrically held contactors	TP-5667
Molded-case circuit breakers or switch	TP-5666
Standard contactor, programmed transition, and Bypass-Isolation	TP-5668

## Service Assistance

For sales and service in the U.S.A. and Canada check the yellow pages of the telephone directory under the heading GENERATORS– ELECTRIC for an authorized service distributor/dealer or call 1-800-544-2444.

KOHLER CO., Kohler, Wisconsin 53044 U.S.A.

Phone: 920-565-3381

Fax: 920-459-1646 (U.S.A. Sales)  
920-459-1614 (International)

To ensure supply of correct parts or information, make note of the following identification numbers in the spaces provided:

### PART NUMBER AND SERIAL NUMBER

Part and serial numbers are provided on the nameplate attached to the transfer switch.

Part No. \_\_\_\_\_

Serial No. \_\_\_\_\_

# Notes

# Section 1. Specifications

## Purpose of Switch

An automatic transfer switch (ATS) is a device used for transferring critical electrical loads from a normal (preferred) source of electrical power to an emergency (standby) source. This transfer occurs automatically when the normal source voltage fails, or is substantially reduced, and the emergency source's voltage has reached an acceptable level.

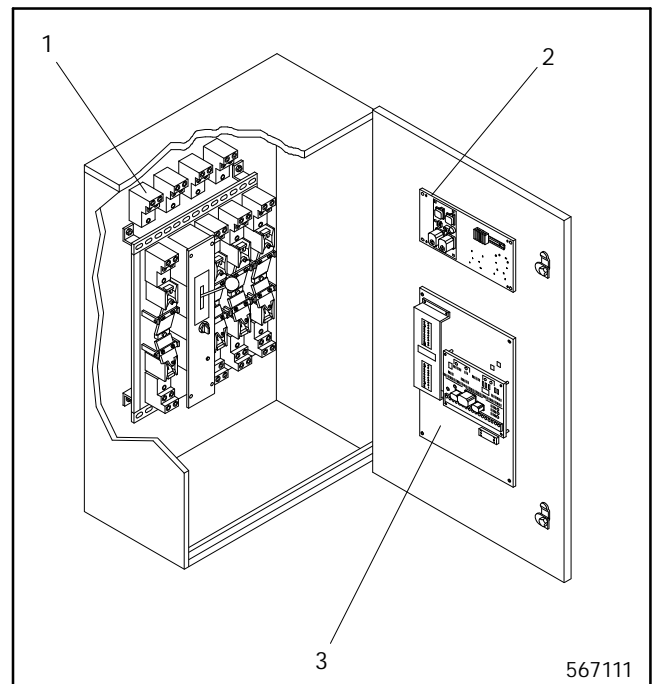
Upon normal source failure, the automatic transfer switch controller signals the generator set(s) to start and

transfer to the emergency source. The automatic transfer switch controller continuously senses for an acceptable normal source and will retransfer the load to the normal source after it has been restored to an acceptable level. After retransfer of the load, the generator set start signal is removed and the generator set(s) is allowed to shut down.

## Components of Switch

A typical automatic transfer switch includes the actual power switching device and the logic controller to perform power monitoring and transfer sequencing tasks. See Figure 1-1. An interface board is also included to match the controller inputs/outputs to the levels required by a specific switching device.

The three functional units that make up the automatic transfer switch are mounted in an enclosure with a hinged front door. The controller mounts on the back of the front door so its controls and indicators are available to an operator. A signal cable with in-line connectors to facilitate component replacement and door removal connects the controller to the interface board and the switching devices.



1. Power Conversion Unit
2. Interface Panel
3. Logic Controller

**Figure 1-1. Transfer Switch Components**

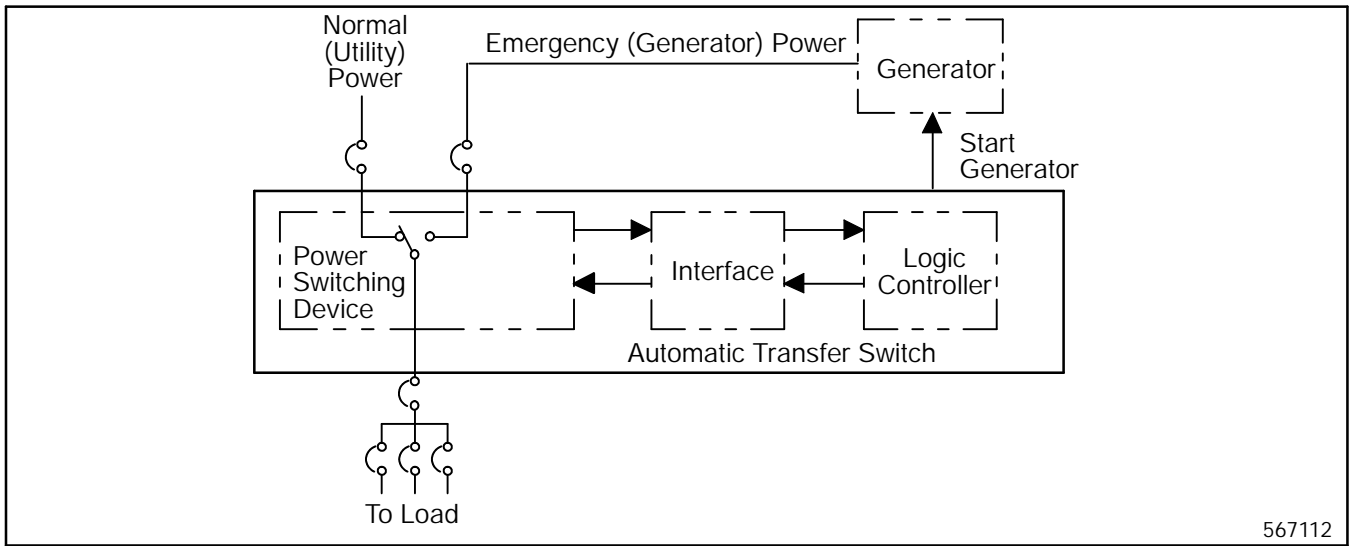


Figure 1-2. Basic Transfer Switch Block Diagram

## Ratings

A nameplate is attached to the automatic transfer switch enclosure. See Figure 1-3. The nameplate label includes a factory part number coded to provide characteristic and rating information that affects installation and operation. Copy the part number into the blank spaces provided in the introduction and then use the charts in Figure 1-4 to interpret the part number.

### NOTE

Also copy the part number and serial number from the nameplate into the spaces provided in the **Service Assistance** Section of the Introduction for use when requesting service or parts.

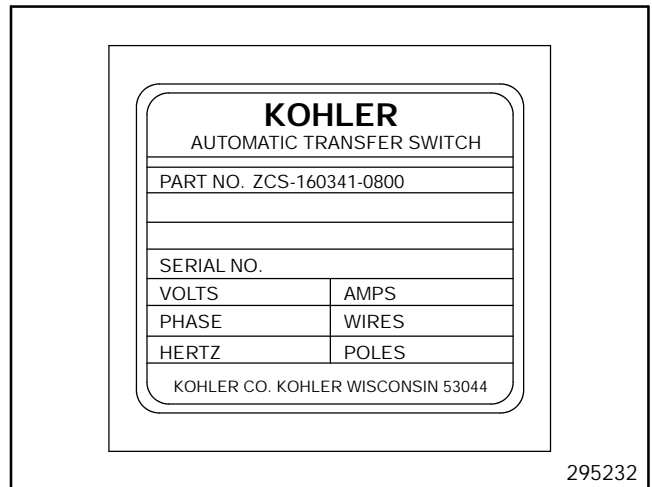
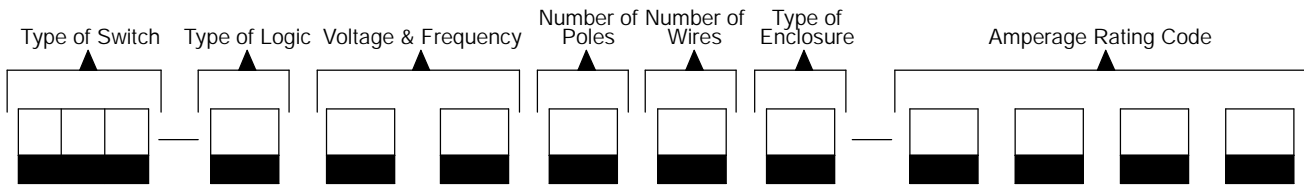


Figure 1-3. Transfer Switch Nameplate

# Interpreting a Transfer Switch Part Number

Record the transfer switch part number in the boxes below. The transfer switch part number defines characteristics and ratings as explained in the accompanying chart.



## Kohler Part Number Key

This chart explains the Kohler transfer switch part numbering code system. The sample part number shown is for a standard molded-case switch with M340+ logic rated at 480 volts, 60 hertz, 3-phase, 3-pole, and 4 wires in a NEMA 1 enclosure with an amperage rating of 80 amperes.

## SAMPLE PART NUMBER

**MNS-566341-0080**

### Classification of Power Switch

M: Switch or Circuit Breaker  
T: Electrically & Mechanically Held  
Z: Contactor Style

### Type of Power Switch

C: Contactor  
E: Electrically Held Contactor  
L: Mechanically Held Contactor  
M: Molded-Case Circuit Breaker  
N: Molded-Case Switch (no protection)

### Type of Switch

S: Standard  
B: Bypass

### Type of Logic

5: M340+  
6: M340+ with programmed transition

### Voltage Code

60: 600 Volt, 60 Hz	66: 480 Volt, 60 Hz
62: 120 Volt, 60 Hz	68: 208 Volt, 60 Hz
63: 220 Volt, 50 Hz	71: 380 Volt, 50/60 Hz
64: 240 Volt, 60 Hz	

### Number of Poles

2: 2 pole, 1 phase (MM\_, MN\_, TE\_, TL\_, devices will be supplied with 3 poles)  
3: 3 pole, 3 phase  
6: 4 pole, fully rated switched poles (no overlapping neutral)

### Number of Wires

2: 2 wire  
3: 3 wire  
4: 4 wire

### Enclosure

1: NEMA type 1

### Amperes

Available sizes vary with the type of switch.

Figure 1-4. Transfer Switch Model Description

# Specifications

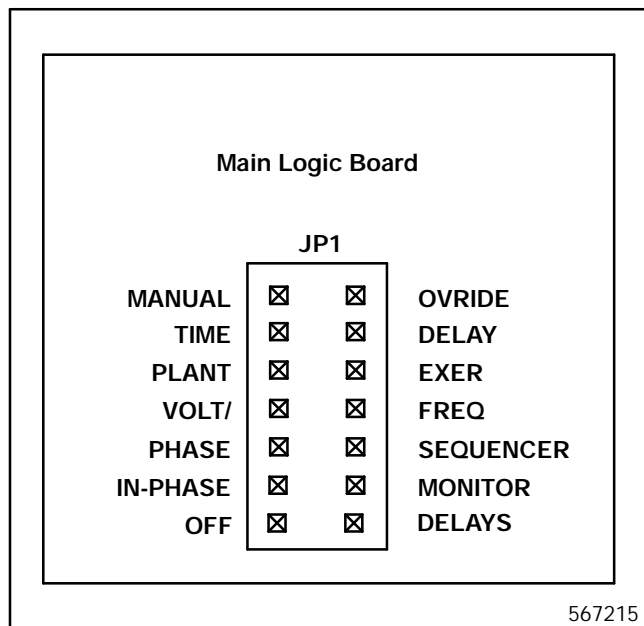
The specifications listed below are for the M340+ logic controller. See the respective power switching device manual for its specifications.

## Standard Features

- D Normal source voltage sensing adjustable from 75% to 130% of normal for pickup and from 70% to 135% for dropout; provides monitoring line-to-line for all phases of 3-phase switches.
- D TDNE (Time Delay Normal-to-Emergency) adjustable 0 to 5 minutes.
- D TDES (Time Delay Engine Start) adjustable from 0 to 6 seconds.
- D TDEN (Time Delay Emergency-to-Normal) adjustable 0 to 30 minutes.
- D Program Transition (Center off)– time delay during transfer with neither source connected to the load. Adjustable 0 to 2 minutes.
- D LCD digital voltmeter.
- D LCD digital running time meter.
- D LCD digital transfer counter.
- D LCD digital frequency meter.
- D Status panel with keypad data entry.
- D Area protection with override.
- D TDEC (Time Delay Engine Cooldown) adjustable from 0 to 30 minutes.
- D Generator engine start contacts.
- D Indicators for switch position– normal and emergency.
- D Indicators for source available– normal and emergency.
- D Lamp test switch, momentary.
- D Underfrequency sensing– one phase emergency source only.

## Shunt-Jumper-Controlled Accessories

Enable or disable shunt-jumper-controlled accessories by altering socket JP1 on the main logic board. See Figure 1-5. All shunt-jumper features are disabled from the factory unless the function was ordered at the time of purchase. But features can be enabled after factory delivery by adding jumpers to the JP1 socket.



**Figure 1-5. Logic Board Accessory Programming Shunts**

- D Manual Override.** Enabling manual override allows automatic transfer to an available source when the connected source fails. Transfer time delays will be bypassed. Disabling manual override causes the logic board to wait for manual operation. The logic board will not automatically seek the available source.
- D Inphase Monitor.** Abnormal inrush currents from switching between two live power sources can damage motors and related equipment. The purpose of the inphase monitor is to minimize abnormal inrush currents to equipment when the ATS transfers from one source to a new power source. The inphase monitor samples a single phase of one source and compares it to a single phase of the other source. When the two voltages are within the desired phase angle and approaching a zero phase angle difference, the inphase monitor signals the transfer switch to

operate. The transfer may be from utility to generator, from generator to generator, or utility to utility.

### NOTE

This option is available only on contactor type, nonprogrammed transition switches. If the contactor is not of this type, then the controller will not allow this option to be enabled. Enable this accessory by installing the INPHASE MONITOR jumper on the controller's main logic board.

- D Phase Rotation and Anti-Single Phasing.** This function provides source monitoring for both the normal and emergency sources. The feature includes phase rotation (A B C only) and anti-single phase protection. This option must be used in conjunction with accessory DD-05-K in order to provide source monitoring on the emergency side. Enable this accessory by installing the PHASE SEQUENCER jumper on the controller's main logic board.
- D Normal and Emergency Source Sensing.** This function provides overvoltage sensing on all phases of the normal source, over/underfrequency sensing on one phase of the normal source, overvoltage sensing on one phase of the emergency source, and overfrequency sensing on one phase of the emergency source. Enable this accessory by installing the VOLT/FREQ jumper on the controller's main logic board.
- D Plant Exerciser.** This function enables a no-load plant exerciser. User has a choice of 7-day, 14-day, or calendar-based exercise modes. Enable this accessory by installing the PLANT EXER jumper on the controller's main logic board.
- D Extended Time Delay.** This function extends the time delay to 99 minutes for TDNE, TDES, TDEN, TDOE, TDON, and TDEC. Enable this accessory by installing the TIME DELAY jumper on the controller's main logic board.
- D Off Position Time Delay.** This function enables the time delay during transfer when neither source is connected to the load. Enable this accessory by installing the OFF DELAYS jumper on the controller's main logic board.

## Optional Accessories

See Appendix C for details of optional accessories. The nameplate includes a list of the accessories selected. See Figure 1-3.

# Section 2. Operation

## Control Switches and Indicators

Various optional control switches and indicator lamps may be present on the transfer switch door depending

on the options chosen. See Figure 2-1 for LED, Switch, and Key locations.

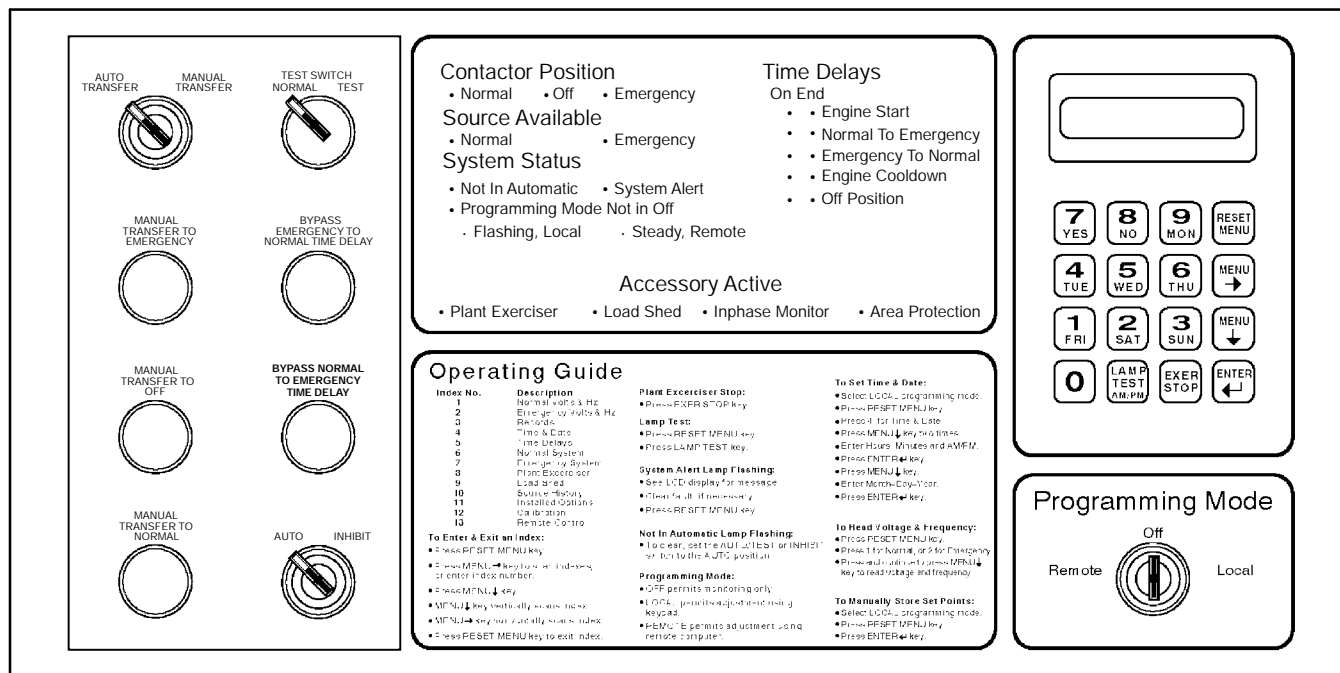


Figure 2-1. Front Panel

## LED Indicators

**Contactor Position.** LEDs indicate transfer switch position– NORMAL (green), EMERGENCY (red), or OFF (yellow).

**Source Available.** LEDs indicate source with acceptable voltage and frequency– Normal (green) and/or Emergency (red).

## System Status

**Not in Automatic (red).** LED flashes to indicate that Test switch is actuated, or Auto/Manual switch is in the Manual position.

**System Alert (red).** LED flashes to indicate possible problem with contactor or logic operation. System alert will also flash if any fault signals are received from the generator set.

**Programming Mode Not in Off (yellow).** LED flashes to indicate that programming switch is in the LOCAL position. A steady, nonflashing light indicates that the programming switch is in the REMOTE position.

## Time Delays

**Engine Start** (If emergency source is a generator set). ON LED indicates that engine-start time delay is timing. END LED indicates that the engine has been signaled to start.

**Normal to Emergency.** ON LED indicates that the normal-to-emergency time delay is timing. END LED indicates that the time delay has completed timing.

**Emergency to Normal.** ON LED indicates that the emergency to normal time delay is timing. END LED indicates that the time delay has completed timing.

**Engine Cooldown.** ON LED indicates that the generator set engine cooldown timer is timing. END LED illuminates until the engine has shut down.

**Off Position.** ON LED indicates that the time delay off position is timing. END LED indicates that the time delay has completed timing.

## Accessory Active

**Plant Exerciser.** Plant exerciser LED indicates that the system is in the exerciser mode.

**Load Shed.** Load shed LED indicates that programmed load shedding is active.

**Inphase Monitor** (available on ZC type power switches only). Inphase monitor LED indicates that the sources are being monitored for phase relationship to allow inphase transfer. The inphase monitor will permit

transfer from emergency to normal and normal to emergency when sources are near synchronization.

### NOTE

When a programmed transition switch is ordered, the inphase monitor option is disabled by the microprocessor.

**Area Protection.** Area protection LED indicates that the controller is in the area protection mode. The generator will be signaled to START and the contactor will transfer to the emergency position and remain there while in area protection.

## Programming Mode Switch

### NOTE

The programming mode switch keys should be kept in a safe place to prevent unwanted tampering with the transfer switch control. Do *not* leave the programming switch in the LOCAL position with the transfer switch unattended.

**Remote.** Allows both status monitoring and setting of the transfer switch controls by a connected personal computer.

**Off.** Transfer switch status settings and power source may be monitored from the local LCD display or connected computers.

**Local.** Allows both status monitoring and setting of transfer switch control from the microprocessor's LCD display and keypad.

## Control Switches

**Test Switch (Standard).** Move the test switch to the TEST position to simulate a normal source outage. Not-in-Automatic system status light will flash.

**Bypass N-E Time Delay Pushbutton Switch (Option).** If the bypass normal-to-emergency time delay pushbutton is pressed when normal-to-emergency time delay is on, time delay will end.

**Bypass E-N Time Delay Pushbutton Switch (Option).** If the bypass normal-to-emergency time delay pushbutton is pressed, when emergency-to-normal time delay is on, time delay will end.

**Manual Transfer to Emergency Switch (Option).** When the transfer switch control is in the manual mode of operation and manual to emergency is required, press the manual transfer-to-emergency pushbutton to

cause the transfer switch to transfer to the emergency position.

**Manual Transfer to Off Switch (Option).** When the transfer switch control is in the manual mode of operation and manual to off is required, press the manual transfer-to-emergency pushbutton to cause the transfer switch to transfer to the off position.

**Manual Transfer to Normal Switch (Option).** When the transfer switch control is in the manual mode of operation and manual to normal is required, press the manual transfer-to-emergency pushbutton to cause the transfer switch to transfer to the normal position.

**Auto/Inhibit Switch (Option).** If the auto/inhibit switch is in the AUTO position, the transfer switch will operate normally. If the switch is in the Inhibit position, the transfer switch will not transfer under any conditions.

# Sequence of Operation

This section describes the correct operation of a microprocessor-controlled transfer switch.

## Sequence of Operation Standard Switch

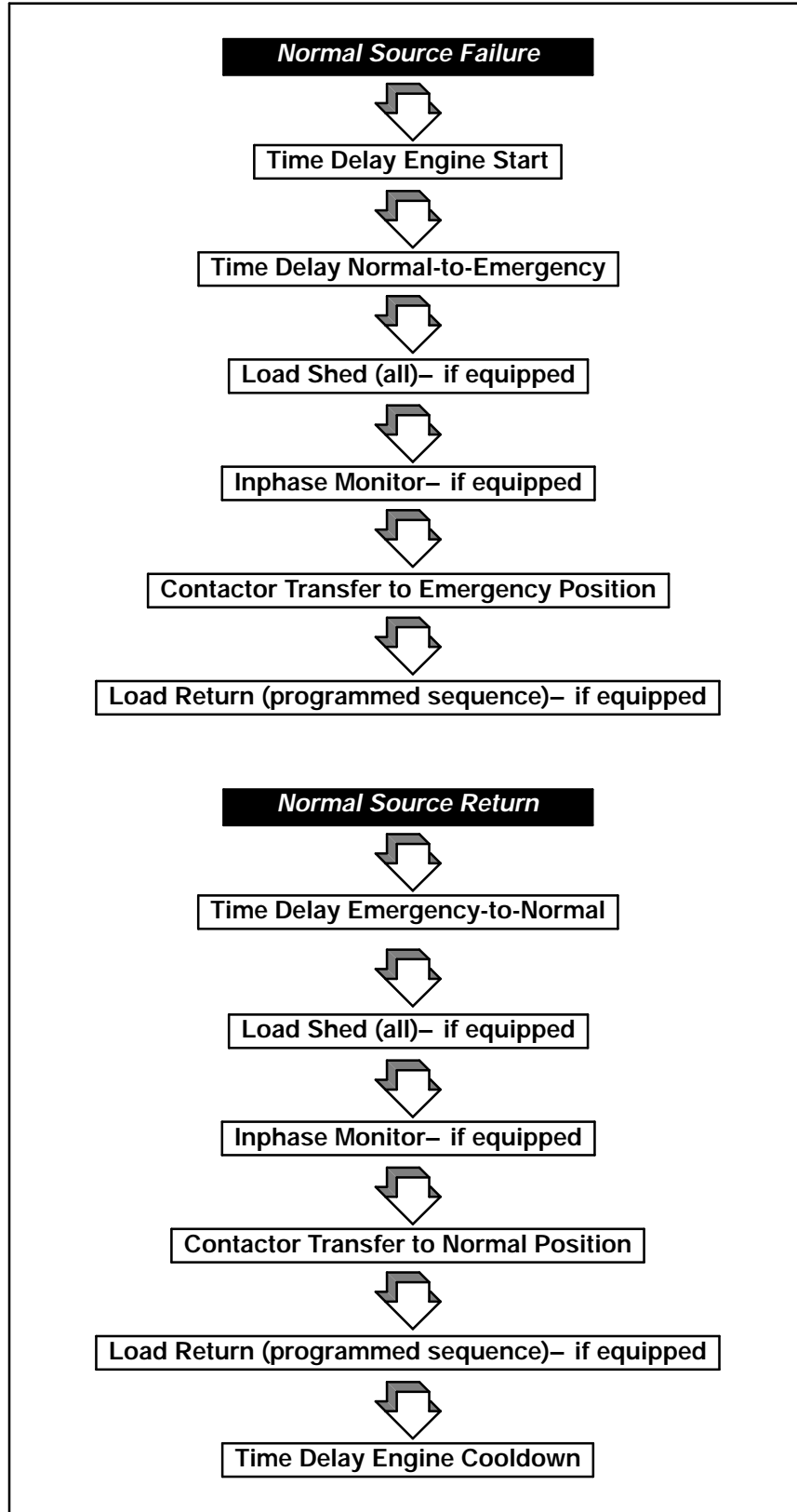
### When the Normal Source Fails

1. The source-available normal LED turns off.
2. The time-delay-engine-start ON LED illuminates to indicate the engine-start-time-delay is timing.
3. The time-delay-engine-start END LED illuminates to indicate the engine has been signaled to start.
4. The source-available emergency LED illuminates.
5. The time-delay normal-to-emergency ON LED illuminates to indicate the normal-to-emergency time delay is timing.
6. The time-delay normal-to-emergency END LED illuminates to indicate the time delay has completed timing.
7. The load-shed LED illuminates at the same time all loads to be shed are disconnected from the switch (if equipped with load-shed option).
8. The inphase monitor LED illuminates (if equipped with inphase monitor option on ZC type power switches only). The controller monitors the two voltages to make sure they are at a desired phase angle and approaching zero phase angle difference.
9. The contactor transfers to the emergency position after the load-shed time-before-transfer timer has completed timing. The contactor-position normal LED turns off and the contactor-position emergency LED illuminates. The inphase monitor LED turns off.
10. After the load-shed time-after-transfer timer has completed timing, the selected loads for the emergency source are now returned to the switch. The load-shed LED turns off (if equipped with load-shed option).

## When the Normal Source Returns

1. The source-available, normal LED illuminates.
2. The time-delay emergency-to-normal ON LED illuminates to indicate the emergency-to-normal time delay is timing.
3. The time-delay emergency-to-normal END LED illuminates to indicate the time delay has completed timing.
4. The load-shed LED illuminates at the same time all loads to be shed are disconnected from the switch (if equipped with load-shed option).
5. The inphase monitor LED illuminates (if equipped with load-shed option).
6. The contactor transfers to the normal position after the load-shed time-before-transfer timer has completed timing. The contactor-position emergency LED turns off and the contactor-position normal LED illuminates.
7. After the load-shed time-after-transfer timer has completed timing, the selected loads for the normal source are returned to the switch. The load-shed LED turns off (if equipped with load-shed options).
8. The time-delay engine-cooldown ON LED illuminates to indicate the generator set engine cooldown timer is timing.
9. The time-delay engine-cooldown END LED stays illuminated until the generator has shut down.
10. The source-available, emergency LED turns off.

# Microprocessor-Controlled Transfer Logic Standard Switch



# Sequence of Operation Programmed Transition Switch

## When the Normal Source Fails

### NOTE

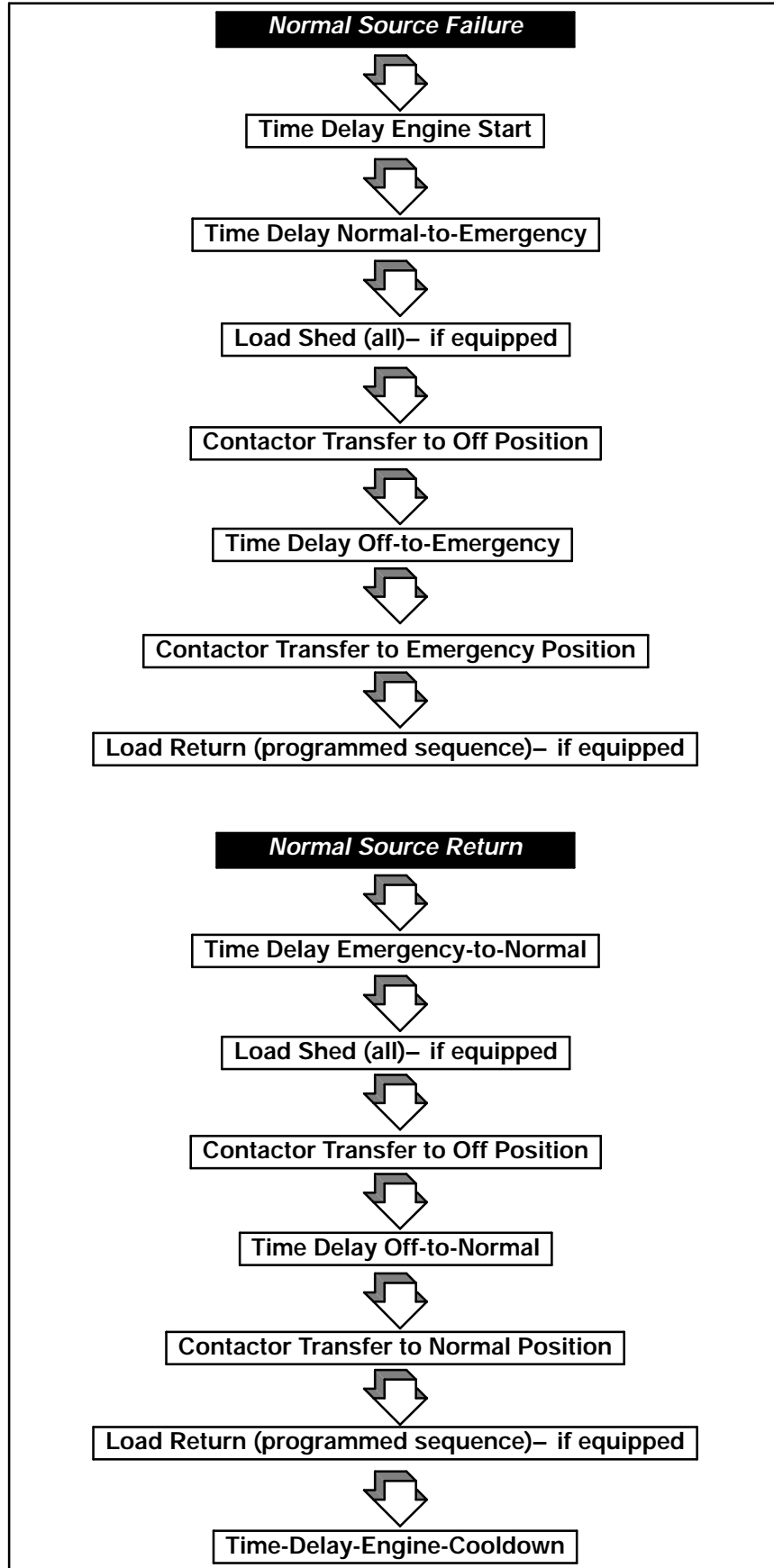
When a programmed transition switch is ordered, the inphase monitor option is disabled by the microprocessor.

1. The source-available, normal LED turns off.
2. The time-delay-engine-start ON LED illuminates to indicate the engine-start-time-delay is timing.
3. The time-delay-engine-start END LED illuminates to indicate the engine has been signaled to start.
4. The source-available emergency LED illuminates after the generator is at rated voltage and frequency.
5. The time-delay normal-to-emergency ON LED illuminates to indicate the normal-to-emergency time delay is timing.
6. The time-delay normal-to-emergency END LED illuminates to indicate the time delay has completed timing.
7. The load-shed LED illuminates at the same time all loads to be shed are disconnected from the switch (if equipped with load-shed option).
8. After the load-shed time-before-transfer timer has completed timing, the contactor transfers to the Off position. The contactor-position normal LED turns off and the contactor-position Off LED illuminates.
9. The time-delay-off-position ON LED illuminates to indicate the Off position time delay is timing.
10. The time-delay-off-position END LED illuminates to indicate the time delay has completed timing.
11. The contactor transfers to the emergency position. The contactor-position Off LED turns off and the contactor-position emergency LED illuminates.
12. After the load-shed time-after-transfer timer completes timing, the selected loads for the emergency source are returned to the switch. The load-shed LED turns off (if equipped with load-shed option).

## When the Normal Source Returns

1. The source-available, normal LED illuminates.
2. The time-delay emergency-to-normal ON LED illuminates to indicate the emergency-to-normal time delay is timing.
3. The time-delay emergency-to-normal END LED illuminates to indicate the time delay has completed timing.
4. The load-shed LED illuminates at the same time all loads to be shed are disconnected from the switch (if equipped with load-shed option).
5. After the load-shed time-before-transfer timer has completed timing, the contactor transfers to the Off position. The contactor-position emergency LED turns off and the contactor-position Off LED illuminates.
6. The time-delay off-position ON LED illuminates to indicate the off-position-time-delay is timing.
7. The time-delay off-position END LED illuminates to indicate the time delay has completed timing.
8. The contactor transfers to the normal position. The contactor-position OFF LED turns off and the contactor-position normal LED illuminates.
9. After the load-shed time-after-transfer timer has completed timing, the selected loads for the normal source are returned to the switch. The load-shed LED turns off (if equipped with load-shed option).
10. The time-delay-engine-cooldown ON LED illuminates to indicate the generator set engine cooldown timer is timing.
11. The time-delay-engine-cooldown END LED stays illuminated until the generator has shut down.
12. The source-available emergency LED turns off.

# Microprocessor-Controlled Transfer Logic Programmed Transition Switch



## To Disconnect The P1 Plug

1. If the transfer switch is in the normal position, open the emergency-source circuit breaker.
2. If the transfer switch is in the emergency position, open the normal-source circuit breaker.
3. Separate the in-line disconnect plug by grasping and squeezing the plug. Do NOT pull on the wires.

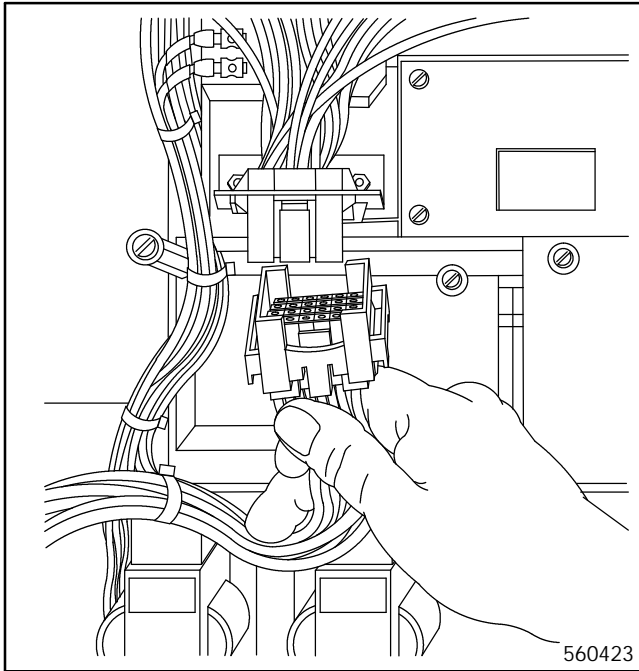


Figure 2-2. In-Line Disconnect Plug

## To Reconnect The P1 Plug

- 1 Engage the in-line disconnect plug by grasping the connectors and pressing them together. See Figure 2-2.
- 2 If the transfer switch is in the normal position, place the generator set start switch in the AUTO position. Then close the emergency-source circuit breaker.
3. If the transfer switch is in the emergency position, close the normal-source circuit breaker. The load will automatically retransfer to the normal source, if

it is available, after a time delay. For immediate retransfer, open and then reclose the emergency-source circuit breaker. Place the generator set start switch in the AUTO position.

## Electrical Operation Test

Place the transfer switch in the NORMAL position. Use the following procedure to check the electrical operation of the automatic transfer switch:

1. Press and hold the test pushbutton for 15 seconds. See Figure 2-1.
2. The generator set should start and run after the time delay engine start (TDES) completed timing.
3. The transfer switch will transfer to the emergency position. The transfer occurs after the normal-to-emergency time delay (TDNE) has completed timing.
4. Release the test pushbutton. The transfer switch retransfers to normal after the emergency-to-normal time delay.
5. Time delay engine cooldown (TDEC) allows the engine to continue running for an unloaded running time. The transfer switch TDEC will complete timing before any TDEC function in the generator set controller begins timing.
6. Close load circuit breaker(s) when loads may be safely energized.

### NOTE

Connecting the transfer switch in-line disconnect plugs (P1) together when the generator controller's master switch is in the AUTO position causes the generator set to IMMEDIATELY start and run until the generator set controller's cooldown timer completes timing.

This completes functional tests of the transfer switch. Leave the AUTO/MANUAL switch in the AUTO TRANSFER position.

# Section 3. Troubleshooting Guide

For location of pushbuttons, switches, LEDs, and keys referred to in this section, see Figure 2-1. Refer to Figure 3-1 as a guide to troubleshooting problems with

the microprocessor logic controller. Refer to Figure 3-2 as guide to troubleshooting problems with the microprocessor accessories.

Problem	Refer to Section 4– Controller Troubleshooting
None of the LEDs are on and the LCD is blank	Power to the system
Pressing a key on the keypad does not supply the appropriate response	Keypad and status panel
Every LED does not turn on and every character block on the LCD does not blacken	Keypad and status panel
The normal source should be available but the Source-Available, Normal LED is not on	Source-available, normal error
The emergency source should be available but the Source-Available, Emergency LED is not on	Source-available, emergency error
The Automatic/Test pushbutton is pressed, the Automatic/Inhibit switch (option DD-09) is set to Inhibit, or the Automatic-Transfer key switch (option DD-29) is set to manual, but the System-Status, Not-In-Automatic LED is not flashing	System-status, not-in-automatic error
The System-Status, System-Alert LED is flashing; check the LCD for a message	System-status, system-Alert error
The LCD displays Auxiliary-Switch Fault or Double Auxiliary-Switch fault message	Auxiliary-switch fault or double auxiliary-switch fault error message
The LCD displays Transfer Hang error message	Transfer hang error message
The LCD displays Power-Down error message	Power-down error message
The LCD displays RAM or Memory error message	RAM or memory error message
The Programming-Mode-Not-In-Off LED is flashing	Programming-mode-not-in-off
The engine operates when it should not be operating	Engine operates when it should not
The engine should start	Engine will not start
One of the control options is not working (the control options include the inphase monitor, source-phase-sequence, normal/emergency voltage/frequency sensing, plant exerciser, extended time delay, and manual override)	Shunt-jumpered controlled options

**Figure 3-1. Microprocessor logic controller troubleshooting chart**

<b>Problem</b>	<b>Refer to Section 5– Accessory Troubleshooting</b>
Controller will not sense three-phase emergency voltage	Phase sequencer, accessory DD-05
The generator set does not start when the test switch is in the engine start position	Test switch, accessory DD-06 and DD-07
The generator set does not start when the test switch is in the test position	Test switch, accessory DD-06 and DD-07
The normal-to-emergency time delay pushbutton does not work	Time delay override, accessory DD-08
The emergency-to-normal time delay pushbutton does not work	Time delay override, accessory DD-08
The auxiliary dry contacts relay boards do not operate	Relay auxiliary dry contacts, accessory DD-14
The analog meters are not working	Meters, accessory DD-18
The battery charger is not working	Battery charger, accessory DD-24
The manual transfer to emergency source does not work	Manual operation switches, accessory DD-29
The manual transfer to normal source does not work	Manual operation switches, accessory DD-29
The manual transfer to off does not work	Manual operation switches, accessory DD-29
The auto/manual switch does not work in the manual position	Manual operation switches, accessory DD-29
The auto/manual switch does not work in the auto position	Manual operation switches, accessory DD-29
The load shed contacts do not work	Load-shed contacts, accessory DD-35
Problems with remote communication exist	Remote communication– RS/232 or RS/485, accessory DD-51

**Figure 3-2. Accessory troubleshooting chart**

# Section 4. Controller Troubleshooting

The following section will assist in solving common problems with the M340+ controller. Note any optional accessories that may have been furnished on this switch

and review their operation in section 5– Accessory Troubleshooting.

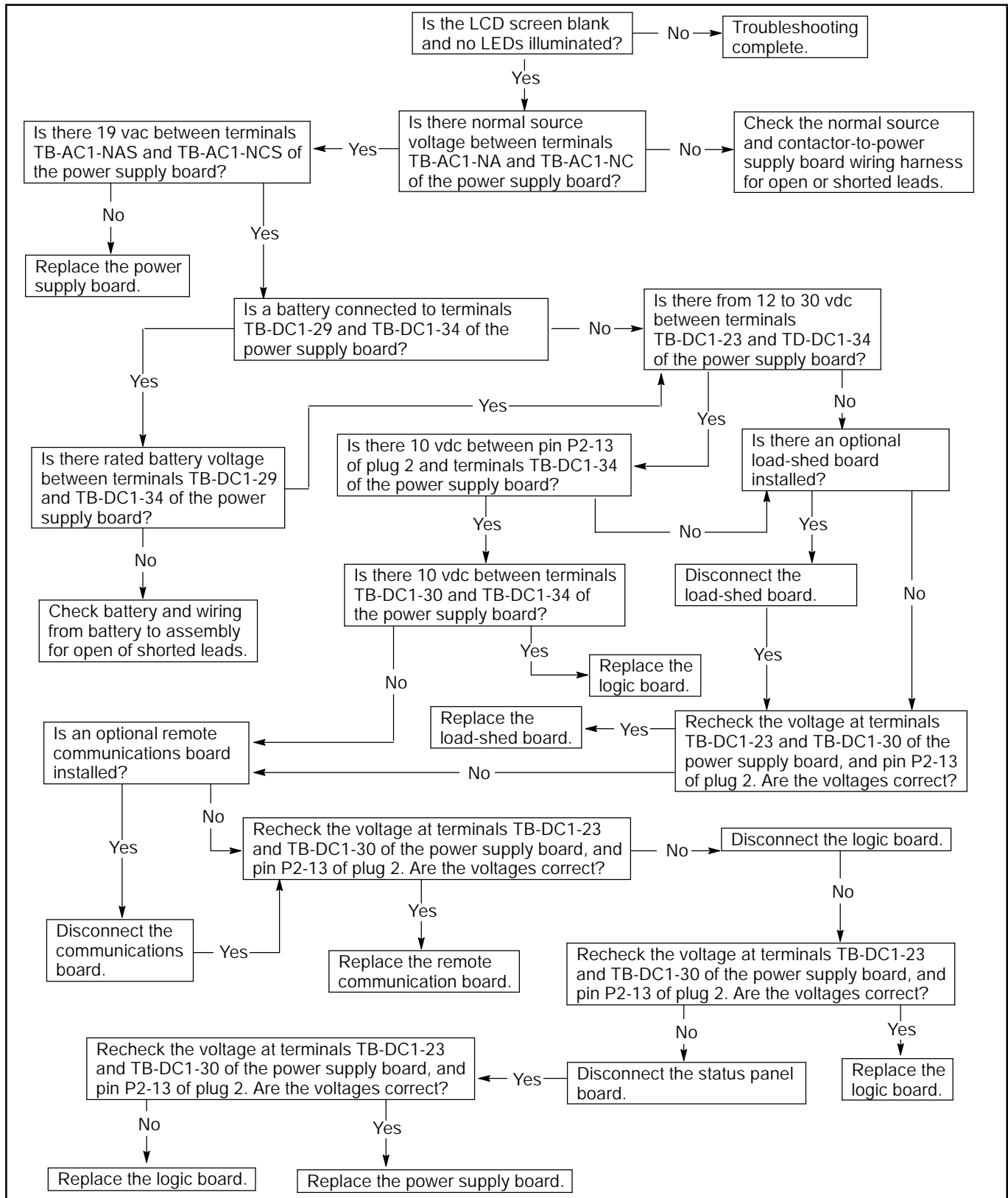


Figure 4-1. Troubleshooting– Power to the system

# Power to the System

If there is a problem with the logic board, the first step is to check the status panel. If no LEDs on the status panel are illuminated and the liquid crystal display (LCD) is blank, check the power to the system by performing the following steps. See Figure 4-1 for the Power to the System troubleshooting flowchart. See Appendix B Figure B-4 for location of power supply board components referred to in this section. See Appendix B Figure B-6 for location and description of P2 ribbon cable pins. See Appendix B Figure B-9 for location of main logic board components referred to in this section.

1. Using a voltmeter, connect one test lead to TB-AC1-NA. Connect the other test lead to TB-AC1-NC. If the voltmeter does not read the expected normal source voltage, check the normal source and the contactor-to-assembly harness, P1.
2. If the normal source voltage is present, connect one test lead to TB-AC1-NAS and the other test lead to TB-AC1-NCS. If the voltmeter does not read approximately 19 volts AC, the secondary normal source voltage, check that the transformer is wired correctly. If the transformer is wired correctly and the voltmeter still does not read 19 volts AC, disconnect transformer secondary wires and retest transformer secondary voltage to determine if the transformer or the logic board assembly is at fault.
3. If both the normal source voltage and the secondary normal source voltage are present, connect one test lead to TB-AC1-EA and the other test lead to TB-AC1-EC. If the voltmeter does not read the expected emergency source voltage, check the emergency source and the contactor-to-assembly harness, P1.
4. If the emergency source voltage is present, connect one test lead to TB-AC1-EAS and the other test lead to TB-AC1-ECS. If the voltmeter does not read approximately 19 volts AC, the expected secondary emergency source voltage, check that the transformer is wired correctly. If the transformer is wired correctly and the voltmeter still does not read 19 volts AC, disconnect transformer secondary wires and retest transformer secondary voltage to determine if the transformer or the logic board assembly is at fault.
5. If the emergency source, normal source, and transformers are all working properly, and the battery back-up option is used, connect the positive test lead to TB-DC1-29 and the negative test lead to TB-DC1-34. If the voltmeter does not read between 12 and 30 volts DC, expected battery voltage, check the battery-to-assembly wires and the battery.

6. Connect the positive test lead to TB-DC1-23, and the negative test lead to TB-DC1-34. If the voltmeter does not read between approximately 12 and 30 volts DC, check if an accessory is connected to TB-DC1-23. If there is an accessory connected to TB-DC1-23, disconnect it. If the voltmeter still does not read between 12 and 30 volts DC, perform step 9.

## NOTE

When taking a voltage or resistance measurement at a ribbon cable pin, do not disconnect the ribbon cable from the board. Use a needle point probe to take the readings from the holes on the top side of the ribbon cable connector.

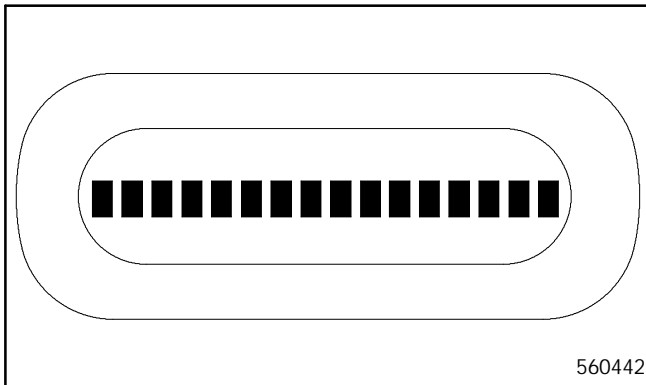
7. Connect the positive test lead to P2-13, and the negative test lead to TB-DC1-34. If the voltmeter does not read approximately 10 volts DC, perform step 9. See Appendix B Figure 6 for location of P2 ribbon cable pins.
8. Connect the positive test lead to TB-DC1-30 and the negative test lead to TB-DC1-34. If the voltmeter does not read approximately 10 volts DC, perform step 9.
9. If each of the measurements taken in steps 6, 7, and 8 was correct, this step may be skipped.
  - a. Disconnect the main logic board ribbon cable from P2, and recheck the voltages in steps 6, 7, and 8. If the voltage readings in steps 6, 7, and 8 are now correct, the main logic board is defective. Replace the logic board assembly.
  - b. If the logic board is equipped with a load shed board, disconnect the load shed ribbon cable from P10 on the main logic board, and recheck the voltages in steps 6, 7, and 8. If the voltage readings in steps 6, 7, and 8 are now correct, replace the Load Shed board.
  - c. If the logic board is equipped with a remote communications board, disconnect the remote communications ribbon cable from P12 on the main logic board, and recheck the voltages in steps 6, 7, and 8. If the voltage readings in steps 6, 7, and 8 are now correct, replace the remote communications board.
  - d. Disconnect the status panel ribbon cable from P4, and recheck the voltages in steps 6, 7, and 8. If the voltage readings in steps 6, 7, and 8 are now correct, the status panel is defective. Replace the logic board assembly.
  - e. If the voltages measured in steps 6, 7, and 8 were never correct, replace the power supply board.

# Keypad And Status Panel

For location of pushbuttons, switches, LEDs, and keys referred to in this section, see Figure 2-1.

1. Test the keypad by pressing a key and checking the response. If the response is correct, repeat this step until satisfied that there is not a problem with the keypad. If the response is ever incorrect, the keypad is defective. Replace the logic board assembly.
2. Press the LAMP TEST key on the keypad.
3. If after pressing the LAMP TEST key some LEDs on the display panel are on, but at least one LED is not on, the status panel is defective. Replace the logic board assembly.
4. If after pressing the LAMP TEST key some of the character blocks on the LCD appear black, but at least one character block is not black, the status panel is defective. Replace the logic board assembly.

5. If after pressing the LAMP TEST key no LEDs are on, and the character blocks in the LCD are black, verify that there is power to the system by performing the steps outlined in Section 4– Power To The System. Check the P2 and P4 ribbon cable connections by performing the following steps. See Appendix B Figure B-9 for location of ribbon cables and other power supply board components referred to in this section.
  - a. Disconnect all power sources.
  - b. Wait 30 seconds.
  - c. Being careful not to bend or break any of the pins, remove both P2 and P4 ribbon cable connectors.
  - d. Inspect the pins on the P2 and P4 ribbon cable connectors.
  - e. If pins are bent, carefully bend them back. If pins are broken, replace the ribbon cable connector.
  - f. Carefully reconnect P2 and P4 ribbon cable connector.
  - g. If the problem still exists, replace the logic board assembly.



**Figure 4-2. The M340+ LCD display during a lamp test**

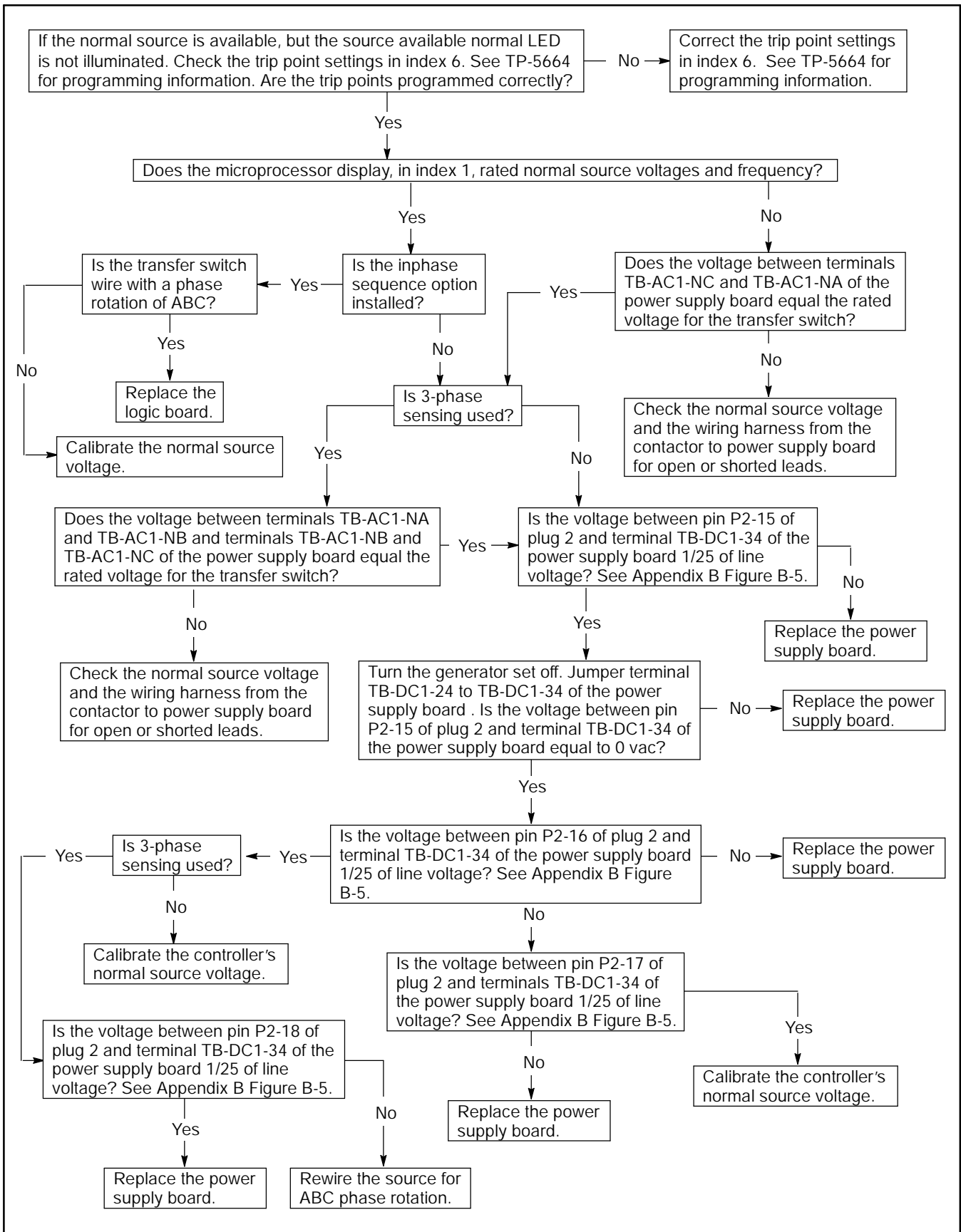


Figure 4-3. Troubleshooting– Source-available, normal error

For location of pushbuttons, switches, LEDs, and keys referred to in this section, see Figure 2-1.

This section covers the condition in which the normal source is available but the Source-Available, Normal LED is not on.

The first item to check is the trip-point settings. The trip-point settings can be found in Index 6 in the program menu. See Figure 4-4 for recommended trip-point settings. The trip-points do not need to exactly match the recommended trip-point settings for proper operation. However, if the trip-point settings in Index 6 are too high or too low, problems could occur. If the trip-point settings are too high or too low, correct them. Then enter normal source voltage and normal source frequency, and store the set points.

Trip Point	Setting Limits	Normal Source Factory Setting
Overtoltage Dropout	105% - 135%	115%
Overtoltage Pickup	100% - 130%	110%
Undervoltage Pickup	75% - 100%	90%
Undervoltage Dropout	70% - 95%	85%
Overfrequency Dropout	105% - 135%	115%
Overfrequency Pickup	100% - 130%	110%
Underfrequency Pickup	85% - 100%	90%
Underfrequency Dropout	80% - 95%	85%

**Figure 4-4. Normal source voltage trip point setting limits and factory settings**

Next check Index 1 in the program menu for correct normal source voltage and frequency reading. If the voltage and frequency values in Index 1 match the voltage and frequency values in Index 6, perform the following steps.

1. Check if the phase sequence option is installed. If there is a jumper across JP1-5, the phase sequence option is installed.
2. If the phase sequence option is installed, press the MENU arrow down key to check the phase sequence in Index 1. **Utility power must be phased ABC.**
3. If the normal source is single-phase, verify in Menu Index 6 that single-phase sensing was selected. A single-phase source must be sensed as a single-phase source.
4. If the source is available, the phase sequencing is correct, the sensing is correct, and the Source-Available, Normal LED is still not on, check the P2 ribbon cable connector.
  - a. Remove all power sources.
  - b. Wait for 30 seconds.
  - c. Making sure not to bend or break any of the pins, remove the P2 ribbon cable connector.
  - d. Inspect the pins on the P2 ribbon cable connector.
  - e. If any of the pins are bent, carefully bend them back. If any of the pins are broken, the ribbon cable connector is defective. Replace the ribbon cable connector.
  - f. Carefully, reconnect P2 ribbon cable connector.
5. If the Source-Available, Normal LED is still not illuminated, the status panel is defective. Replace the logic board assembly. If a value in Index 1 is incorrect, see steps below.

# Incorrect Normal Source Voltage And Frequency Values

See Appendix B, Figure B-9 for location of TB-AC1 and other power supply board components referred to in this section.

1. If the system is single-phase, use a voltmeter to measure the normal source voltage by connecting one test lead to TB-AC1-NA and the other test lead to TB-AC1-NC. Note the voltmeter reading.
2. If the system is three-phase, use a voltmeter to measure the normal source voltage by connecting one test lead to TB-AC1-NA and the other test lead to TB-AC1-NB. Note the voltmeter reading. Connect one test lead to TB-AC1-NB and the other test lead to TB-AC1-NC. Note the voltmeter reading.
3. If the voltmeter did not display the normal source voltage in step 1 or step 2, check the normal source and the contactor-to-assembly harness, P1.
4. If the voltage reading(s) in step 1 or step 2 did not match the value(s) displayed in Index 1, check the power supply board by performing the following four steps.

## NOTE

When taking a voltage or resistance measurement at a ribbon cable pin, do not disconnect the ribbon cable from the board. Use a needle point probe to take the readings from the holes on the top side of the ribbon cable connector.

- a. Check the Test LED on the power supply board. If the Test LED is not on, install a jumper between TB-DC1-24 and TB-DC1-34. If the Test LED comes on when the jumper is installed, check the Automatic/Test pushbutton and the connected accessories.
- b. Using a voltmeter, connect one test lead to P2-15 and the other test lead to TB-DC1-34. See Appendix B, Figure B-9 for location of P2 ribbon cable connector. The voltmeter should read approximately 1/25 of the line voltage. See Appendix B, Figure B-5 for values. Turn the generator off. See Appendix B, Figure B-9 for location of P2 ribbon cable pins.
- c. Connect one test lead to P2-16 and the other to TB-DC1-34. The voltmeter should read approximately 1/25 of the line voltage. See Appendix B, Figure B-5.
- d. If the system is three-phase, connect one test lead to P2-17 and the other to TB-DC1-34. The voltmeter should read approximately 1/25 of the line voltage. See Appendix B, Figure B-5.

- e. If the system is three-phase, connect one test lead to P2-18 and the other to TB-DC1-34. The voltmeter should read approximately 1/25 of the line voltage. See Appendix B, Figure B-5.
  - f. Remove power from the logic board. Disconnect the P2 ribbon cable connector. Recheck the P2 points on the power supply board in steps 4a, 4b, 4c, and 4d. If the voltage readings are now correct, either an accessory or the logic board main logic board is bad.
5. If any of the voltage readings in step four were incorrect, replace the power supply board. If all of the voltage readings in step four were correct, calibrate the normal source voltage.

## Calibrate Logic Board Normal Three-Phase Source Voltage

1. Press the Automatic/Test pushbutton to start the generator and to transfer the load to the generator.
2. Disconnect the incoming normal power to the transfer switch by removing the line fuses, the in-line disconnect plug, or the incoming circuit breaker.
3. Verify that the normal source voltage is zero. Using a voltmeter connect one test lead to TB-AC1-NA and one test lead to TB-AC1-NC. The voltmeter should read 0 volts AC. Connect one voltmeter test lead to TB-AC1-NA and the other test lead to TB-AC1-NB. The voltmeter should read 0 volts AC. Connect one voltmeter test lead to TB-AC1-NB and the other test lead to TB-AC1-NC. The voltmeter should read 0 volts AC.
4. If the normal source is three-phase, it can be sensed as either single-phase or three-phase depending on what the application requires. In Menu Index 6 choose the appropriate sensing method: single-phase sensing or three-phase sensing.

## NOTE

When calibrating either the normal source or emergency source, never auto-zero the source unless it is zero volts. If source voltage is present and the YES key is pressed and entered at the AUTO-ZERO message, the logic board will always read the system voltage as zero volts.

5. Using the menu in Index 12, arrow down to N-AUTO-ZERO? and press the YES key and the ENTER key.
6. Observe the ENTRY ACCEPTED message on the LCD.

7. When the message on the LCD again reads, N-AUTO-ZERO?, restore the normal power source.

8. If single-phase sensing is used, perform this step. Press the MENU Arrow Down key so the LCD reads N-VOLT VAC. If the value displayed on the LCD after N-VOLT VAC is not between 60% and 80% of the system voltage, replace the logic board assembly. If the value is between 60% and 80% of the system voltage, measure the normal system voltage by connecting one test lead of a voltmeter to TB-AC1-NA and the other test lead to TB-AC1-NC. Enter the measured value at the LCD message N-VOLT VAC. Press the ENTER key and observe the ENTRY ACCEPTED message on the LCD.

9. If three-phase sensing is used, perform this step. Press the MENU Arrow Down key so the LCD reads N-PH A-C VAC. If the values displayed on the LCD after N-PH A-C VAC, N-PH A-B VAC, or N-PH B-C VAC are not between 60% and 80% of the system voltage, replace the logic board assembly. If the values are between 60% and 80% of the system voltage, measure and enter the normal system voltage by performing the next three steps.

a. Connect one test lead of a voltmeter to TB-AC1-NA. Connect the other test lead to TB-AC1-NB. Enter the measured value at the LCD message N-PH A-B VAC. Press the ENTER key. Observe the ENTRY ACCEPTED message on the LCD. Press the MENU arrow down key.

b. Connect one test lead to TB-AC1-NB, and connect the other test lead to TB-AC1-NC. Enter the measured value at the LCD message N-PH B-C VAC. Press the ENTER key. Observe the ENTRY ACCEPTED message on the LCD. Press the MENU arrow down key.

c. Connect one test lead to TB-AC1-NA, and connect the other test lead to TB-AC1-NC. Enter the measured value at the LCD message N-PH A-C VAC. Press the ENTER key. Observe the ENTRY ACCEPTED message on the LCD. Press the MENU arrow down key.

10. Press the RESET MENU key and then the ENTER key to store the set points.

#### **NOTE**

If the system will not calibrate, replace the logic board assembly.

## **Calibrate Logic Board Normal Single-Phase Source**

#### **NOTE**

When calibrating either the normal source or emergency source, never auto-zero the source unless it is zero volts. If source voltage is present and the YES key is pressed and entered at the AUTO-ZERO message, the logic board will always read the system voltage as zero volts.

1. Using the menu in Index 12, arrow down to N-AUTO-ZERO?. Press the YES key and the ENTER key.

2. Observe the ENTRY ACCEPTED message on the LCD.

3. When the message on the LCD again reads, N-AUTO-ZERO?, restore the normal power source.

4. Press the MENU Arrow Down key so the LCD reads N-VOLT VAC. If the value displayed on the LCD after N-VOLT VAC is not between 60% and 80% of the system voltage, replace the logic board assembly. If the value is between 60% and 80% of the system voltage, measure the normal system voltage by connecting one test lead of a voltmeter to TB-AC1-NA and the other test lead to TB-AC1-NC. Enter the measured value at the LCD message N-VOLT VAC. Press the ENTER key and observe the ENTRY ACCEPTED message on the LCD.

5. Press the RESET MENU key and then the ENTER key to store the set points.

#### **NOTE**

If the system will not calibrate, replace the logic board assembly.

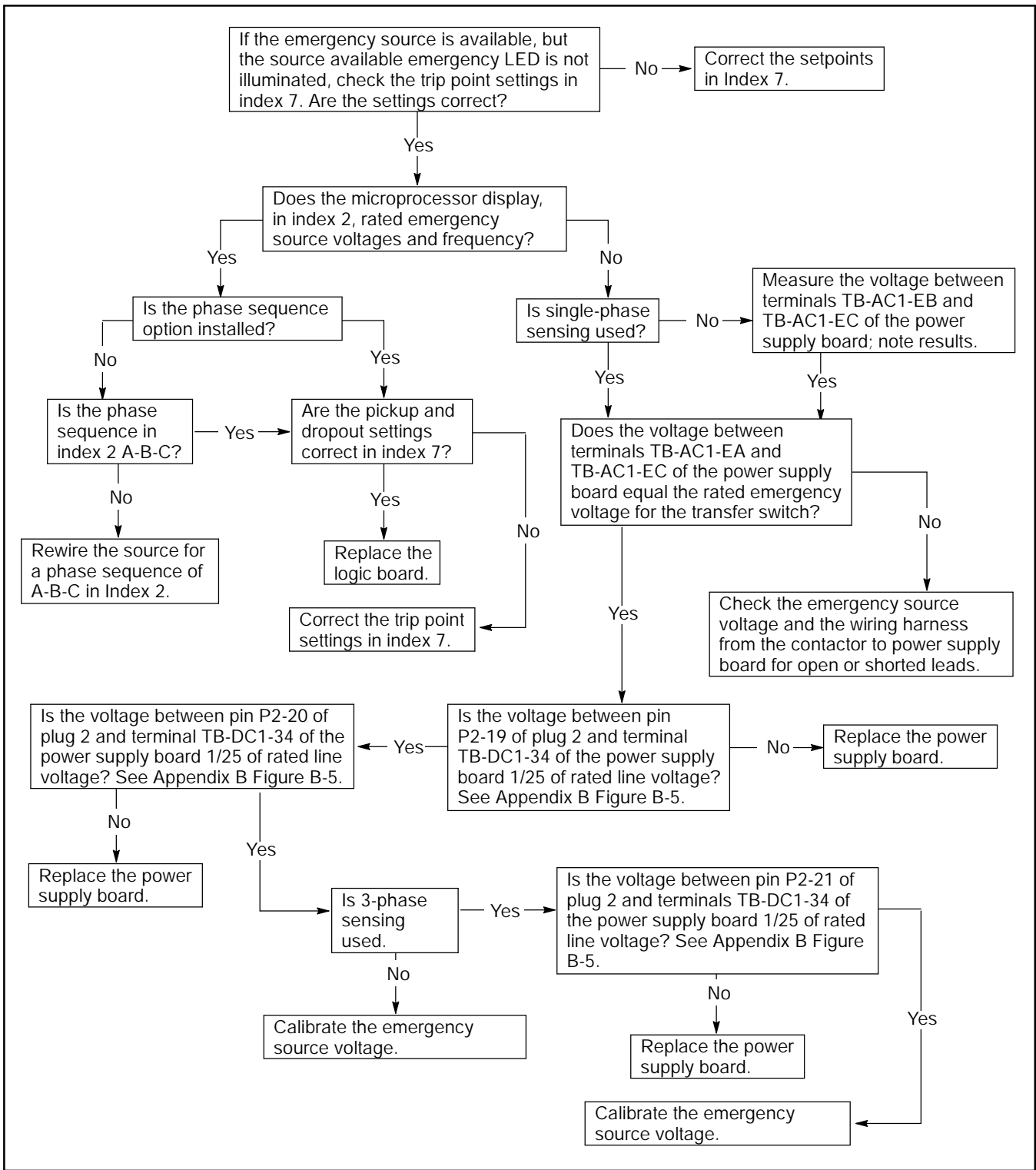


Figure 4-5. Troubleshooting– Source-available, emergency error

For location of pushbuttons, switches, LEDs, and keys referred to in this section, see Figure 2-1.

This section covers the condition in which the emergency source is available but the Source-Available, Emergency LED is not on.

The first item to check is the trip-point settings. The trip-point settings can be found in Index 7 in the program menu. The recommended trip-point settings are in Figure 4-6. If the trip points in Index 7 are too high or too low, change them. Enter emergency source voltage and emergency source frequency. Store the set points.

Trip Point	Setting Limits	Emergency Source Factory Setting
Overtoltage Dropout	105% - 135%	115%
Overtoltage Pickup	100% - 130%	110%
Undervoltage Pickup	75% - 100%	90%
Undervoltage Dropout	70% - 95%	85%
Overfrequency Dropout	105% - 135%	115%
Overfrequency Pickup	100% - 130%	110%
Underfrequency Pickup	85% - 100%	90%
Underfrequency Dropout	80% - 95%	85%

**Figure 4-6. Emergency source voltage trip point Setting Limits And Factory Settings**

## Incorrect Emergency Source Voltage and Frequency Values

1. Use a voltmeter to measure the emergency source voltage by connecting one test lead to TB-AC1-EA and the other test lead to TB-AC1-EC. Note the voltmeter reading. See Appendix B Figure B-9 for location of TB-AC1 and other power supply board components referred to in this section.
2. If the system is three-phase and three phase sensing or phase rotation is desired, the option DD-05-K must be installed. If it is installed, use a voltmeter to measure the emergency source voltage by connecting one test lead to TB-AC1-EA and the other test lead to TB-AC1-EB. Note the voltmeter reading. Connect one test lead to TB-AC1-EB and the other test lead to TB-AC1-EC. Note the voltmeter reading.
3. If the voltmeter did not display the expected emergency source voltage in step 1 or step 2, check

Next check Index 2 of the program menu for correct emergency source voltage and frequency reading. If the values in Index 2 are correct, perform the following steps.

1. Check if the phase sequence option DD-05-K is installed. If accessory DD-05-K is installed and there is a jumper across JP1-5, the phase sequence option is installed.
2. If the phase sequence option is installed, press the MENU arrow down key to check the phase sequence in Index 1. **Emergency power must be phased ABC.**
3. Check Menu Index 7 to verify proper sensing. A single phase source should use single phase sensing. If the source is three-phase and three phase sensing is desired, the three-phase sensing option, DD-05-K, must be installed. If this option is not installed, single-phase sensing must be used.

If the source is available, the values in Index 2 are correct, the phase sequence is correct, and the phase sensing is correct, but the Source-Available, Emergency LED is still not on, the status panel is bad. Replace the logic board assembly.

If a value in Index 2 is incorrect, perform the steps below.

- the emergency source and the contactor to assembly harness, P1.
4. If the voltage reading(s) in step 1 or step 2 did not match the value(s) displayed in Index 2, check the power supply board by performing the following steps.

### NOTE

When taking a voltage or resistance measurement at a ribbon cable pin, do not disconnect the ribbon cable from the board. Use a needle point probe to take the readings from the holes on the top side of the ribbon cable connector.

See Appendix B Figure B-6 for location and description of P2 ribbon cable pins.

- a. Using a voltmeter, connect one test lead to P2-19 and the other to TB-DC1-34. The

voltmeter should read approximately 1/25 of the line voltage. See Appendix B, Figure B-5.

- b. If the system is three-phase and the three-phase-sensing option is installed, connect one test lead to P2-20 and the other to TB-DC1-34. The voltmeter should read approximately 1/25 of the line voltage. See Appendix B, Figure B-5.
  - c. If the system is three-phase and the three-phase-sensing option is installed, connect one test lead to P2-21 and the other to TB-DC1-34. The voltmeter should read approximately 1/25 of the line voltage. See Appendix B, Figure B-5.
  - d. Remove Power from the logic board. Disconnect the P2 ribbon cable connector. Recheck the P2 points on the power supply board in steps 4a, 4b, and 4c. If the voltage readings taken in steps 4a, 4b, and 4c are now correct, either an accessory or the main logic board is bad.
5. If any of the voltage readings in step 4 were incorrect, replace the power supply board. If all of the voltage readings in step 4 were correct, calibrate the logic board emergency source voltage by performing the steps below.

## **Calibrate The Logic Board Emergency Source Voltage**

1. Three-phases sources can be sensed as either three-phase or single-phase. However, to have three-phase sensing the three-phase-sensing option DD-05-K must be installed. If the three-phase sensing option is installed and three-phase sensing is desired choose emergency three-phase sensing in Menu Index 7.
2. If the emergency source is single-phase, or the option DD-05 is not installed, the emergency source can only be sensed as single-phase. In Menu Index 7 choose single-phase sensing.

### **NOTE**

When calibrating either the normal source or emergency source, never auto-zero the source unless it is zero volts. If source voltage is present, and the YES key is pressed and entered at the AUTO-ZERO message, the logic board will always read the system voltage as zero volts.

3. Read this step completely before performing it. Using the menu in Index 12 of the program menu, press the YES key when the E-AUTO-ZERO? message appears. Do not press the ENTER key afterwards.

4. Disconnect the emergency power source.
5. Press the ENTER key.
6. Observe the ENTRY ACCEPTED message on the LCD.
7. When the message on the LCD again reads, E-AUTO-ZERO?, reconnect the emergency power source.
8. Press the MENU Arrow Down key.

### **Single-Phase Sensing**

9. If single-phase sensing is used, perform this step. If the value displayed on the LCD after E-VOLT VAC is not between 60% and 80% of the system voltage, replace the logic board assembly. If the value is between 60% and 80% of the system voltage, measure the emergency system voltage. Measure the emergency system voltage by connecting one test lead of a voltmeter to TB-AC1-EA. Connect the other test lead to TB-AC1-EC. Enter the measured value at the LCD message E-VOLT VAC. Press the ENTER key.

### **Three-Phase Sensing**

10. If the emergency source is three phase and three-phase sensing is desired, the three-phase-sensing option DD-05-K must be installed. If the option is installed and three-phase sensing is used, perform this step. If the value displayed on the LCD after E-PH A-C VAC, E-PH A-B VAC, and E-PH B-C VAC is not between 60% and 80% of the system voltage, replace the logic board assembly. If the value is between 60% and 80% of the system voltage, measure the emergency system voltage by performing the following three steps.
  - a. Connect one test lead of a voltmeter to TB-AC1-EA. Connect the other test lead to TB-AC1-EB. Enter the measured value at the LCD message E-PH A-B VAC. Press the ENTER key. Press the MENU arrow down key.
  - b. Connect one test lead to TB-AC1-EB, and connect the other test lead to TB-AC1-EC. Enter the measured value at the LCD message E-PH B-C VAC. Press the ENTER key. Press the MENU arrow down key.
  - c. Connect one test lead to TB-AC1-EA, and connect the other test lead to TB-AC1-EC. Enter the measured value at the LCD message E-PH A-C VAC. Press the ENTER key.
11. Press the RESET MENU key and then the ENTER key to store the setpoints.

### **NOTE**

If the system will not calibrate, replace the logic board assembly.

## System-Status, Not-In-Automatic Error

For location of pushbuttons, switches, LEDs, and keys referred to in this section, see Figure 2-1.

### NOTE

Pressing the Automatic/Test pushbutton will cause the generator set to start and run.

The System-Status, Not-In-Automatic LED should flash if the Automatic/Test pushbutton is pressed, if the Automatic/Inhibit key switch is in the Inhibit position, or if the Automatic-Transfer/Manual-Transfer key switch is in the Manual position. If one of these conditions is true, but the System-Status, Not-In-Automatic LED is not flashing, perform the following steps.

- a. Press the LAMP TEST key. If the System-Status, Not-In-Automatic LED does not turn on, the status panel is defective. Replace the logic board assembly.
- b. Connect TB-DC1-9 to TB-DC1-34. If the System-Status, Not-In-Automatic LED is not flashing, connect P2-6 to TB-DC1-34. If the System-Status, Not-In-Automatic LED is now flashing, replace the power supply board. If the System-Status, Not-In-Automatic LED is not flashing when P2-6 is grounded, perform step 4. See Appendix B, Figure B-9 for location of the P2 ribbon cable and other power supply board components referred to in this section. See Appendix B, Figure B-6 for location and

description of P2 ribbon cable pins. See Figure 4-7 for the System-Status, Not-In-Automatic LED wiring diagram.

- c. If the System-Status, Not-In-Automatic LED is not flashing when P2-6 is grounded, remove the connection from P2-6 to TB-DC1-34, and check the P2 ribbon cable connection by performing the following steps.
  - d. Remove all power sources.
  - e. Wait for 30 seconds.
  - f. Making sure not to bend or break any of the pins, remove the P2 ribbon cable connector.
  - g. Inspect the pins on the P2 ribbon cable connector. Specifically check P2-6.
  - h. If any of the pins are bent, carefully bend them back. If any of the pins are broken, the ribbon cable connector is defective. Replace the ribbon cable connector.
  - i. Carefully reconnect P2 ribbon cable connector.
12. If the System-Status, Not-In-Automatic LED is still not flashing, check the continuity of the P2 ribbon cable connector. Disconnect the P2 ribbon cable connector from both the power supply board and from the main logic board. Using an ohmmeter, place one test lead on the power supply board side of P2-6, and place the other test lead on the main logic board side of P2-6. If the resistance is high indicating a lack of continuity, replace the ribbon cable connector. If the resistance is low indicating continuity, replace the logic board assembly.

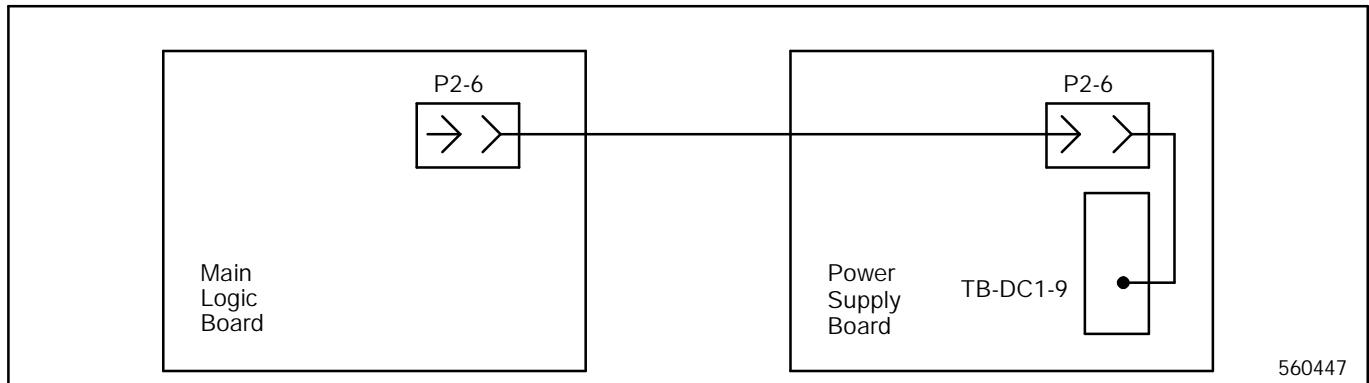


Figure 4-7. Wiring Diagram– System-status, not-in-automatic LED

## System-Status, System-Alert

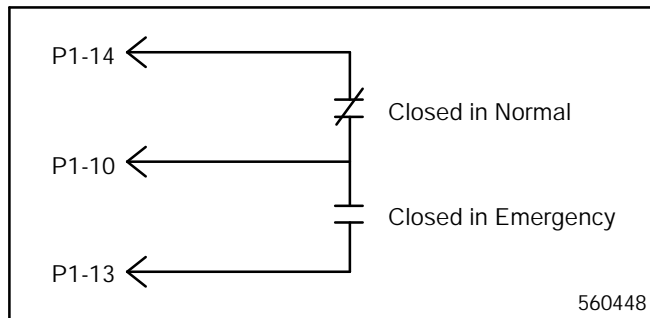
For location of pushbuttons, switches, LEDs, and keys referred to in this section, see Figure 2-1.

If the System-Status, System-Alert LED is flashing, check the LCD for an error message. If the System-Status, System-Alert LED is flashing, but no error message appears on the LCD, the status panel is defective. Replace the logic board assembly.

The following sections will cover the different error messages encountered when the System-Status, System-Alert LED is flashing.

### Contactor Position Fault Error Messages

The auxiliary-switch (AUX-SWITCH) fault error occurs when the position of the contactor does not match the position that the logic controller last placed the contactor in. The double auxiliary-switch (DBL AUX-SW) fault error occurs when two contactor positions are detected simultaneously. If either of these error messages appears on the LCD, perform the following steps. See Figure 4-8.



**Figure 4-8. Wiring Diagram– Auxiliary-switch fault and double auxiliary-switch fault error message**

Check the continuity of the contactor by performing the following three steps:

1. Disconnect the 24-pin plug to the logic controller assembly.
2. While the contactor is in the NORMAL position, connect one test lead of an ohmmeter to the contactor side of P1-12. Connect the other test lead to the contactor side of P1-4. Note the resistance.

3. While the contactor is in the EMERGENCY position, connect one test lead of an ohmmeter to the contactor side of P1-16. Connect the other test lead to the contactor side of P1-8. Note the resistance.

4. If the resistance in either case was high, there is an open circuit. Verify correct wiring.

5. Check the auxiliary switches on the contactor.

The following steps check proper operation of the controller.

6. Connect the positive lead of a 12-24 volt DC power source to TB-DC1-29. Connect the negative lead of the power source to TB-DC1-34. See Appendix B Figure B-9 for location of TB-DC1 and other power supply board components referred to in this section.

7. Connect P1-12 to P1-4. Press the RESET MENU key. If the Contactor-Position, Normal LED is not on, or if the System-Status, System-Alert LED is still on, replace the power supply board.

8. Connect P1-16 to P1-8. Press the RESET MENU key. If the Contactor-Position, Emergency LED is not on, or if the System-Status, System-Alert LED is still on, replace the power supply board.

### Transfer Hang Error Message

A Transfer Hang error occurs when the controller issues a transfer command, but a transfer is not detected.

If TRANSFER HANG ERROR appears on the LCD, check for a binding contactor and check the contactor bridge rectifier. See the Contactor Service Manual.

### Power-Down Error Message

A POWER-DOWN ERROR indicates there was a loss of AC power for a period of time. If the POWER-DOWN ERROR message does not appear regularly on the LCD, press the RESET MENU key, and set the time and the date. Press the RESET MENU key and then the ENTER key to store the setpoints. If the POWER-DOWN ERROR message does appear regularly on the LCD, perform the following two steps.

1. If the ambient temperature is less than 20 degrees Fahrenheit, install a battery backup on the logic board.

---

## **⚠ WARNING**



### **Sulfuric acid in batteries. Can cause severe injury or death.**

Use protective goggles and clothes. Battery acid can cause permanent damage to eyes, burn skin, and eat holes in clothing.

---

**Sulfuric acid in batteries can cause severe injury or death.** Sulfuric acid in battery can cause permanent damage to eyes, burn skin, and eat holes in clothing. Always wear splash-proof safety goggles when working around the battery. If battery electrolyte is splashed in the eyes or on skin, immediately flush the affected area for 15 minutes with large quantities of clean water. Seek immediate medical aid in the case of eye contact. Never add acid to a battery once the battery has been placed in service. This may result in hazardous spattering of electrolyte.

### **NOTE**

When taking a voltage or resistance measurement at a ribbon cable pin, do not disconnect the ribbon cable from the board. Use a needle point probe to take the readings from the holes on the top side of the ribbon cable connector.

- a. Check the voltage at P2-13. Using a voltmeter, connect the positive test lead to P2-13. Connect the negative test lead to TB-DC1-34. See Appendix B, Figure B-6 for location and description of P2 ribbon cable pins. Carefully

remove the power source by disconnecting the in-line disconnect plug. Leave the power source disconnected for six seconds. After six seconds note the voltmeter reading.

- b. If the voltage is less than six volts, replace the power supply board.
- c. If the voltage is greater than six volts, replace the logic board assembly.

## **RAM Or Memory Error Message**

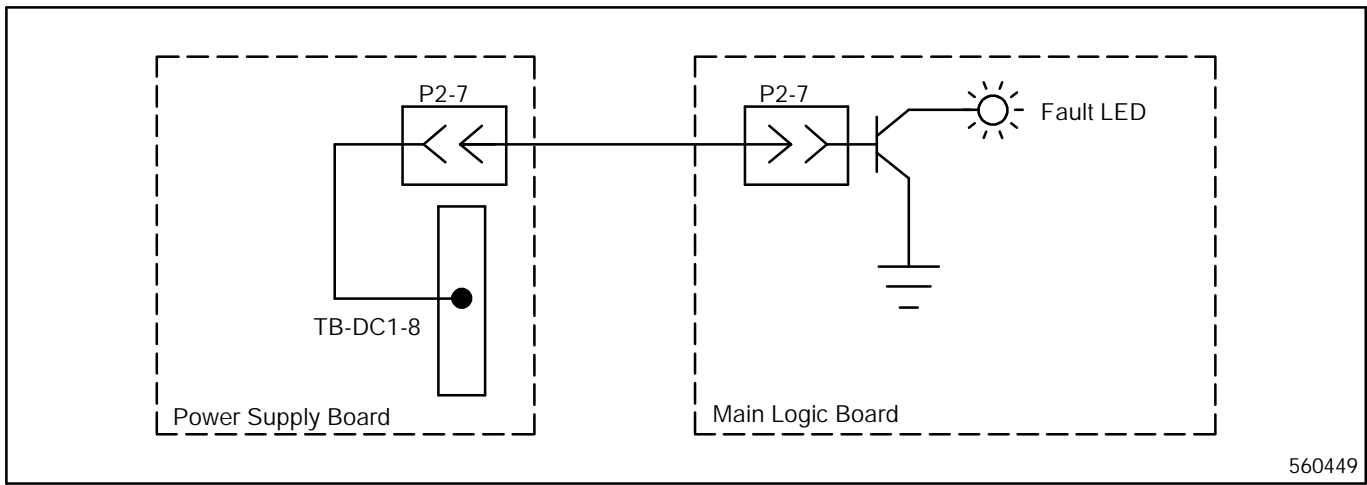
If either a RAM ERROR or a MEMORY ERROR message appear on the LCD, power down the logic board for at least 30 seconds. Replace power to the logic board. If either the RAM ERROR or MEMORY ERROR message still appear on the LCD, the main logic board is defective. Replace the logic board assembly.

## **Manual Transfer Message**

The MANUAL TRANSFER message will appear on the LCD when a transfer to the emergency source or to the normal source is desired but the logic board is in the manual mode. When this message appears press the appropriate pushbutton: Manual Transfer-to-Emergency or Manual Transfer-to-Normal. If automatic transfer is desired instead of manual transfer, place the automatic/manual transfer switch in the automatic position.

## **Manual-to-Off Transfer Message**

The MANUAL TO OFF message will appear on the LCD when three conditions are met: 1) The transfer switch is in either the emergency or normal position, 2) the logic controller is in manual mode, and 3) the off position time delay is enabled. When this message appears press the MANUAL-TO-OFF pushbutton.



560449

**Figure 4-9. Wiring Diagram– Fault #1 or Fault #2 message**

## Fault #1 Or Fault #2 Message

The external fault function can be used to identify a problem with the emergency power system, or a support device of the emergency power system. A dry relay contact can be used to signal a fault, such as a Ten Relay Dry Contact Kit, sold as an accessory with the generator set.

**NOTE:** The contact kit must be a dry contact, the logic controller supplies its own voltage source.

The fault messages are used to monitor accessory components. A fault message appears on the LCD when an accessory is grounding the pin to which it is connected. See Figure 4-9.

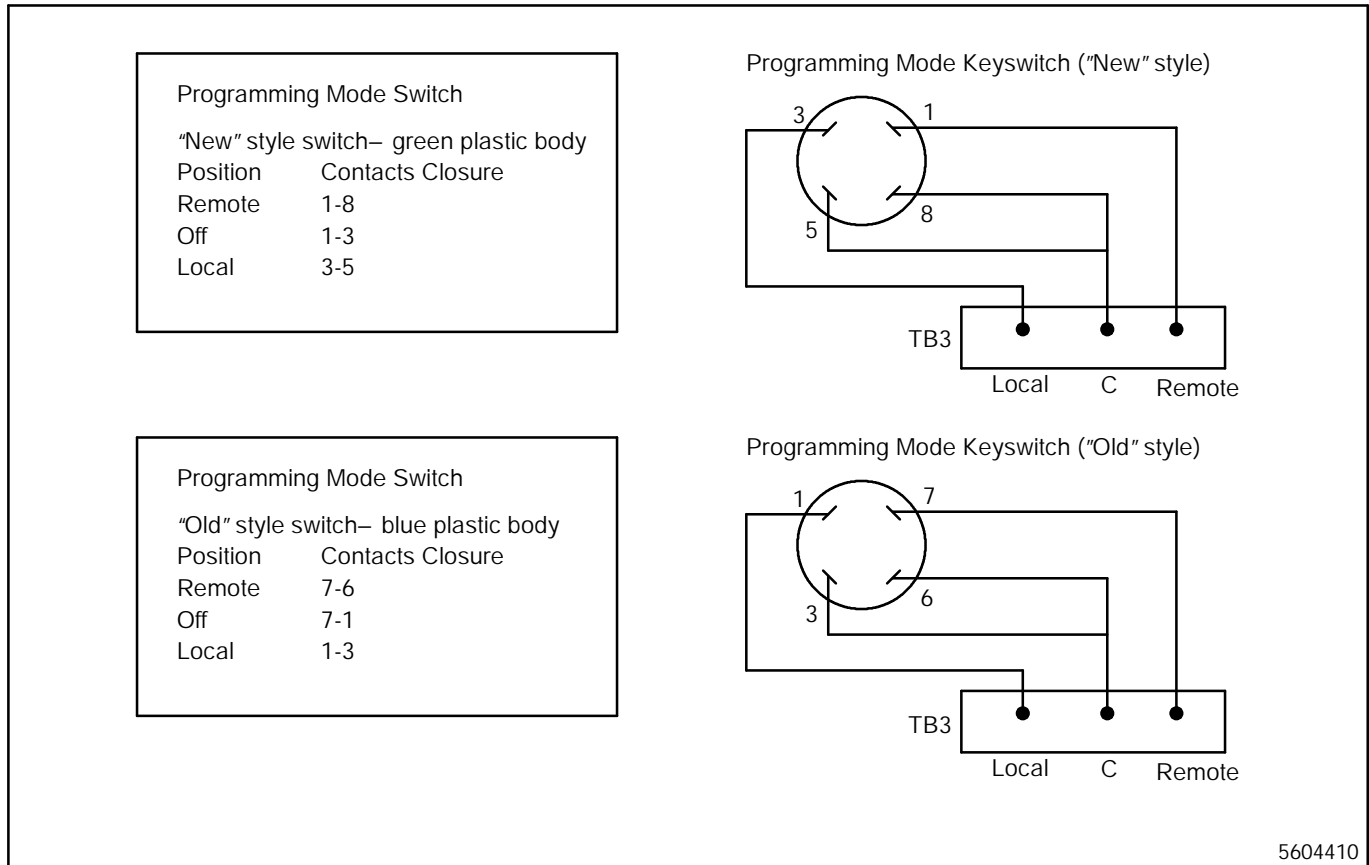
1. If a FAULT #1 message appears on the LCD, check TB-DC1-8.
  - a. If there is an accessory connected to TB-DC1-8, disconnect the accessory. Press the RESET MENU key. If the message disappears, the logic board is performing correctly. The FAULT #1 message is caused by the connected accessory.
  - b. If there is not an accessory connected to TB-DC1-8, remove power from the logic board and disconnect the P2 ribbon cable connector from the power supply board. Using an ohmmeter, connect one test lead to P2-7 on the power supply board. Connect the other test lead to TB-DC1-34. If the resistance is low, replace the power supply board. If the resistance is high, replace the logic board assembly.
2. If a FAULT #2 message appears on the LCD, check TB-DC1-11.
  - a. If there is an accessory connected to TB-DC1-11, disconnect the accessory. If the message disappears, then the logic board is performing correctly.
  - b. If there is not an accessory connected to TB-DC1-11, remove power from the logic board and disconnect the P2 ribbon cable connector from the power supply board. Using an ohmmeter, connect one test lead to P2-8 on the power supply board. Connect the other test lead to TB-DC1-34. If the resistance is low, replace the power supply board. If the resistance is high, replace the logic board assembly.

# Programming Mode Not-In-Off

For location of pushbuttons, switches, LEDs, and keys referred to in this section, see Figure 2-1.

The Programming Mode Not-In-Off LED signals the status of the Programming-Mode key switch. The three programming modes are Remote, Off, and Local. When the Programming-Mode key is set to Local programming mode, the Programming Mode Not-In-Off LED should be flashing. When the Programming-Mode key is set to

Remote programming mode, the Programming Mode Not-In-Off LED should be on steadily. When the Programming-Mode key is set to Off, the Programming Mode Not-In-Off LED should be off. See Figure 4-10. If any of these cases are not true, check the Programming-Mode key switch for proper wiring and operation. If the problem still exists, replace the logic board assembly.



**Figure 4-10. Wiring Diagram— Programming Mode Keyswitch**

# Engine Operates When it Should Not

If the engine continues to operate after the logic controller removes the start signal, check the power supply board Start LED and perform the following procedure. For location of the Start LED and other power supply board components referred to in this section, see Figure 2-1.

1. If the Start LED is on, disconnect the engine from the contactor by removing wires number 3 and number 4 from the engine.
  - a. If the engine continues to run when wires 3 and 4 are disconnected from the engine, wait the period of time equal to the engine cooldown to ensure that the generator set is not just in the cooldown mode. If the engine continues to run, check the generator set and the generator set wiring.
  - b. If the engine stops running when wires 3 and 4 are disconnected from the engine, remove the P1 harness from the power supply board.
    - (1) If the engine continues to run when the P1 harness is disconnected, there is a contactor problem. See the Contactor Service Manual.
    - (2) If the engine stops running when the P1 harness is disconnected, reconnect the P1 wire harness. Check the continuity between TB-DC1-22 and TB-DC1-21. Using an ohmmeter, connect one test lead to TB-DC1-22. Connect the other test lead to TB-DC1-21. If the resistance is high indicating lack of continuity, replace the power supply board. If the resistance is low indicating continuity, disconnect any accessories connected to TB-DC1-21 or to TB-DC1-22. If the engine stops running after the accessories are disconnected, check the accessories by referring to Unit 3. If the engine continues to run after the accessories are disconnected, replace the power supply board.
2. If the Start LED is off, check the voltage at TB-DC1-23. Using a voltmeter, connect one test lead to TB-DC1-23, and connect the other test lead to TB-DC1-34. If the voltmeter does not read approximately 19 volts AC, see Section 4– Power To The System. If the voltmeter does read approximately 19 volts AC, connect P4-1 to TB-DC1-34.
  - a. If the Start LED still does not light when P4-1 is grounded, replace the power supply board.
  - b. If the Start LED lights when P4-1 is grounded, check the Normal-Source-Available LED. If the Normal-Source-Available LED is on, replace the logic board assembly. If the Normal-Source-Available LED is not on, see Source-Available Normal Error.

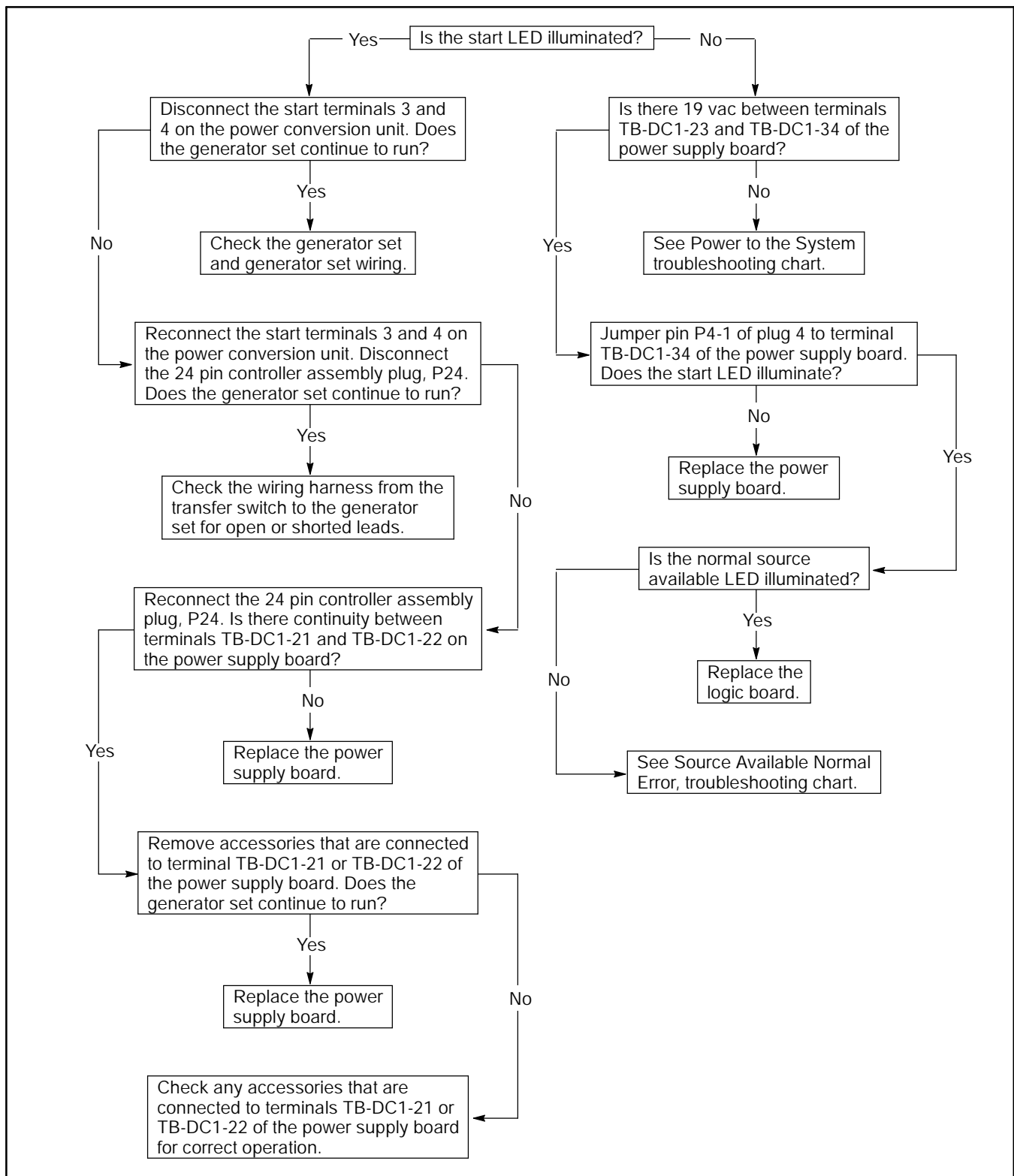


Figure 4-11. Troubleshooting– Engine operates when it should not.

# Engine Will Not Start

If the engine will not operate, check the power supply board START LED and perform the following procedure. For location of the START LED and other power supply board components referred to in this section, see Appendix B, Figure B-10.

1. If the START LED is off, jumper engine start terminals 3 and 4 on the contactor assembly.
  - a. If the unit does not start when engine start terminals 3 and 4 are jumpered, check the generator set and the generator set wiring.
  - b. If the unit starts when the engine start terminals 3 and 4 are jumpered, remove the jumper between engine start terminals 3 and 4. Jumper TB-DC1-21 and TB-DC1-22.
    - (1) If the engine starts when TB-DC1-21 and TB-DC1-22 are jumpered, replace the power supply board.
    - (2) If the engine does not start when TB-DC1-21 and TB-DC1-22 are jumpered,

check if there is a jumper between TB-DC1-22 and TB-DC1-31. If there is not a jumper, add one. If the engine still does not start when TB-DC1-21 and TB-DC1-22 are jumpered, replace the power supply board.

## NOTE

When taking a voltage or resistance measurement at a ribbon cable pin, do not disconnect the ribbon cable from the board. Use a needle point probe to take the readings from the holes on the top side of the ribbon cable connector.

2. If the START LED is on, using a voltmeter, connect the positive test lead to P4-1. Connect the negative test lead to TB-DC1-34.
  - a. If the voltmeter reading is low (about 1 volt), the status panel is defective. Replace the logic board assembly.
  - b. If the voltmeter reading is high (about 10 volts), replace the power supply board.

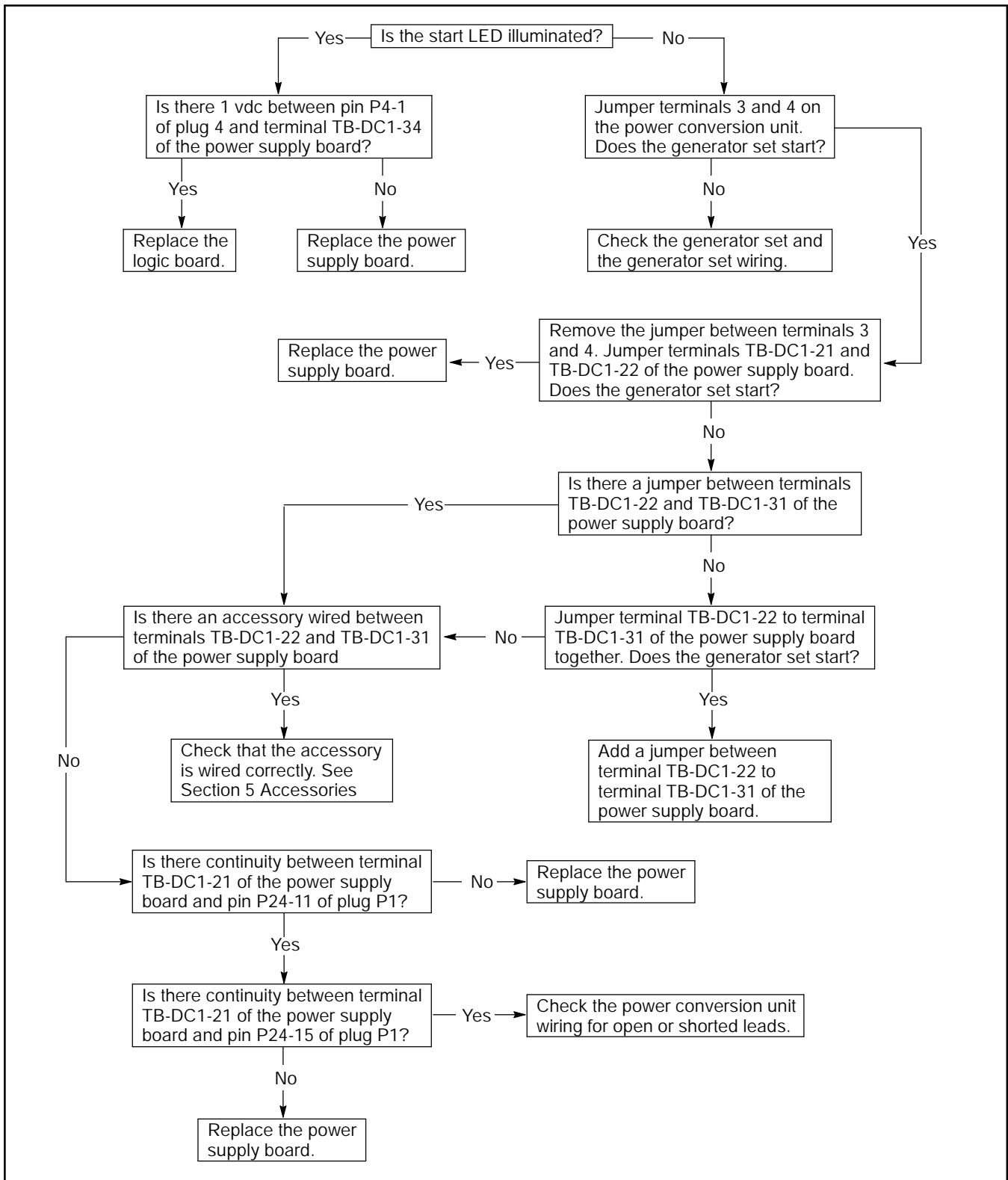


Figure 4-12. Troubleshooting– Engine will not start.

# Area Protection

Area Protection turns on the emergency source when a loss of normal power is expected because of an approaching storm or for some other reason. Area Protection allows the user to transfer to the emergency source.

If the Area-Protection LED is on and area protection is not active, perform the following steps.

1. Connect TB-DC1-6 to TB-DC1-34.

2. If the Area-Protection LED does not turn off after grounding TB-DC1-6, connect P2-5 to ground. If the Area-Protection LED does not turn off, replace the power supply board. If the Area-Protection LED still does not turn off, replace the logic board assembly.
3. If the Area-Protection LED does turn off after grounding TB-DC1-6, check the wiring for an open circuit to TB-DC1-6 and the connection at TB-DC1-6.

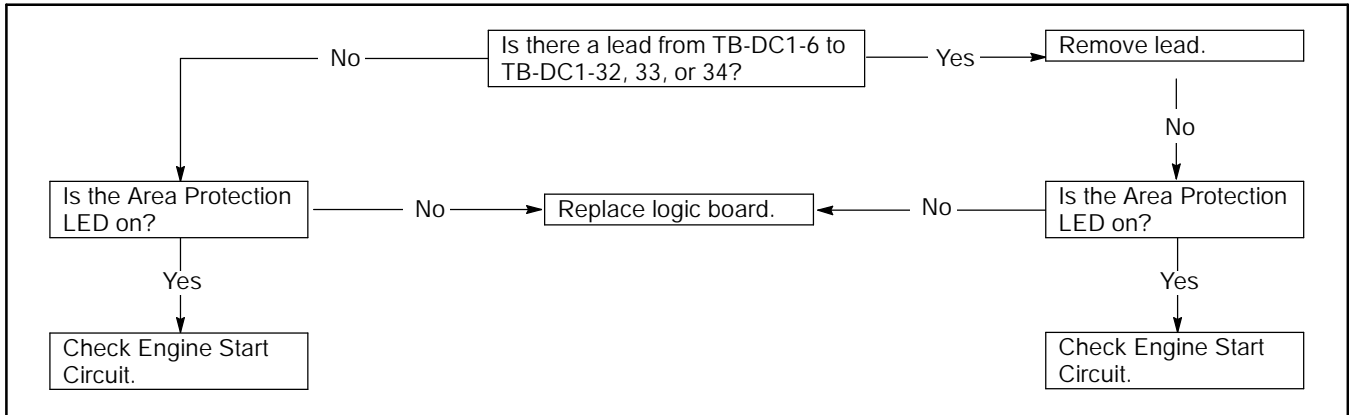


Figure 4-13. Troubleshooting– Area protection does not turn on

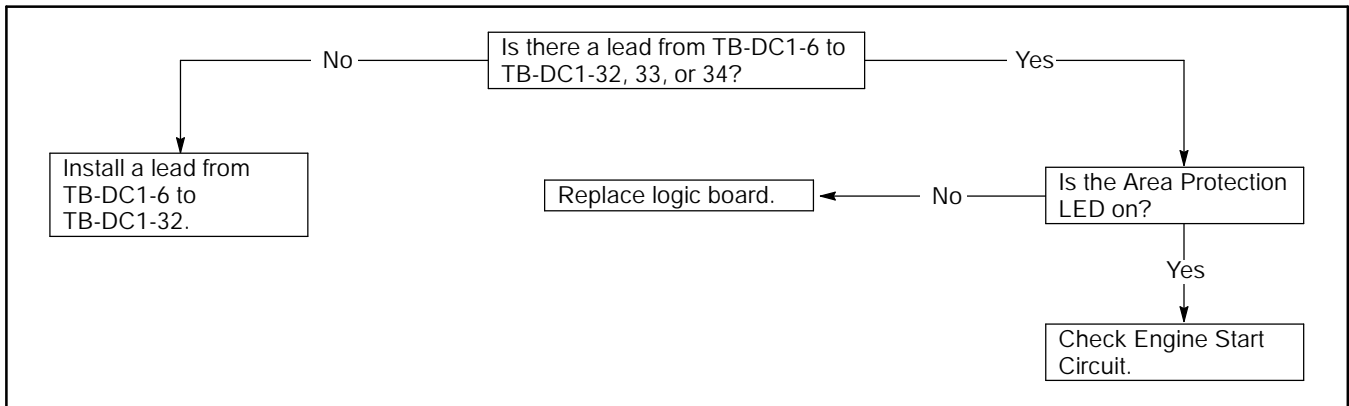


Figure 4-14. Troubleshooting– Area protection does not turn off

# Shunt Jumper-Controlled Options

Jumpers installed in the shunt-jumper socket JP1 on the main logic board control the following options.

- D Extended Time Delays– DD-100-B
- D Plant Exerciser– DD-23-C, DD-23-D, and DD-23-G
- D Voltage/Frequency Sensing– DD-34-J
- D Phase Sequencer– DD-34-Z and DD-05-K
- D In-phase Monitor– DD-34-A
- D Off Delays

See Appendix B Figure B-9 to locate JP1. See Figure 4-15 to locate option shunt jumper locations on JP1. Programming Index 11 displays installed control options status as enabled or disabled. Figure 4-16 describes the options in Index 11.

### To add/remove shunt-jumper controlled options:

1. Add/remove shunt-jumpers across the terminals next to the name of the option on JP1 and shown in Figure 4-15. Do not remove the MANUAL OVERRIDE jumper.
2. Go to Index 20 and press Menu Down and look for OPTIONS LOCK? NO. If the question does not appear, the options are locked. Go to step 3. Otherwise, lock the options:
  - a. Answer the question with YES then ENTER. The controller briefly displays ENTRY ACCEPTED.
  - b. Press RESET MENU and then ENTER to store the setpoints. The controller briefly displays STORE SET-POINTS. The options will remain locked when the controller powers back up the next time.

3. Power down the controller by disconnecting the inline disconnect plug P1.
4. Wait a minimum of 1 minute then reconnect plug P1 to power up the controller.
5. Check Index 11. YES should appear only after the Index 11 listing of all options with installed shunt jumpers.

To troubleshoot shunt jumper-controlled options see Figure 4-17 or Figure 4-18.

### NOTE

When the options are not locked the controller does not check JP1 upon powerup to determine option status, but rather reads the setpoints stored before power was interrupted.

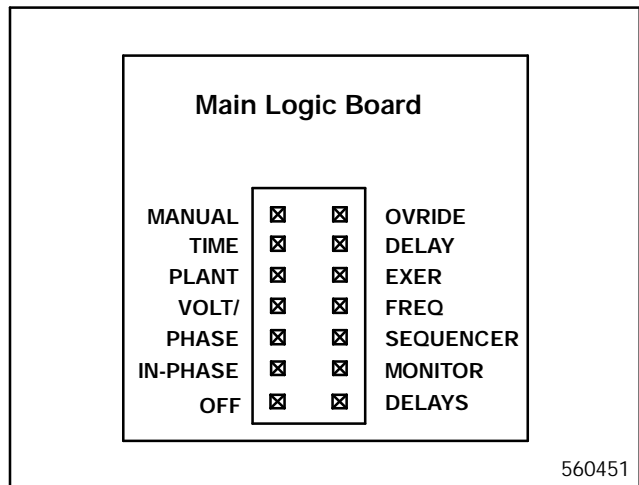
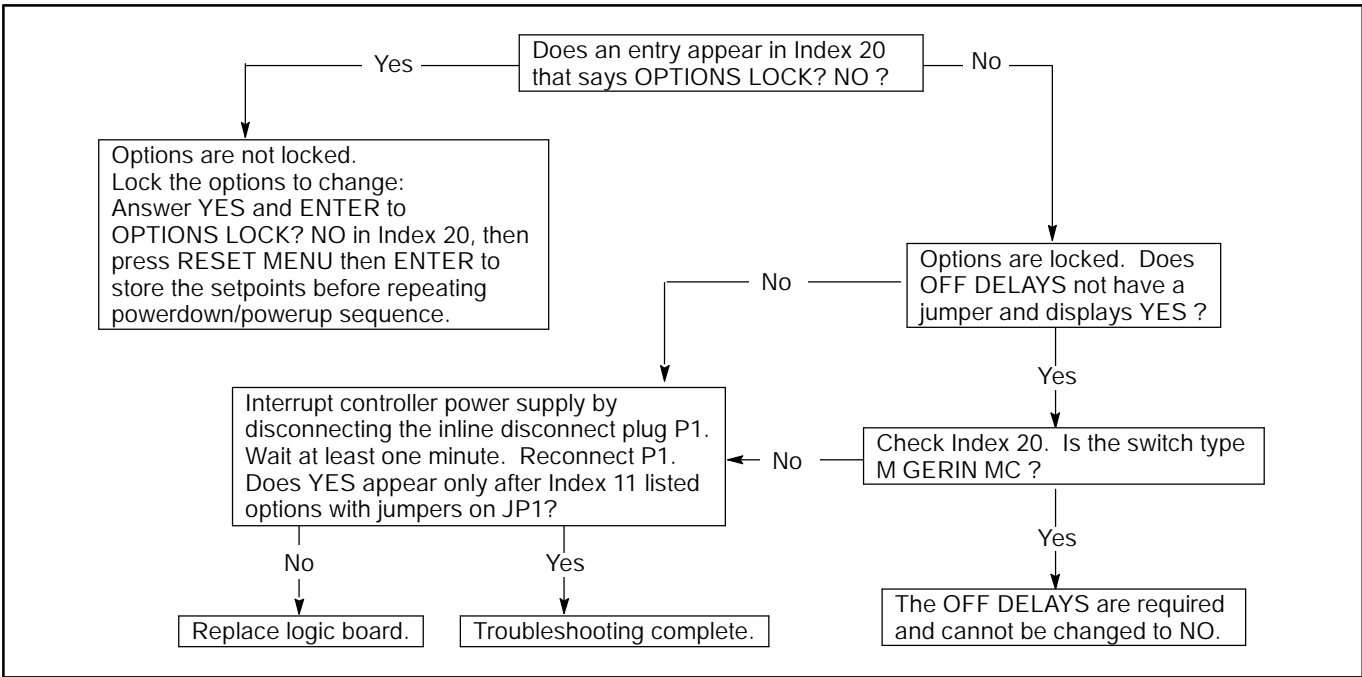


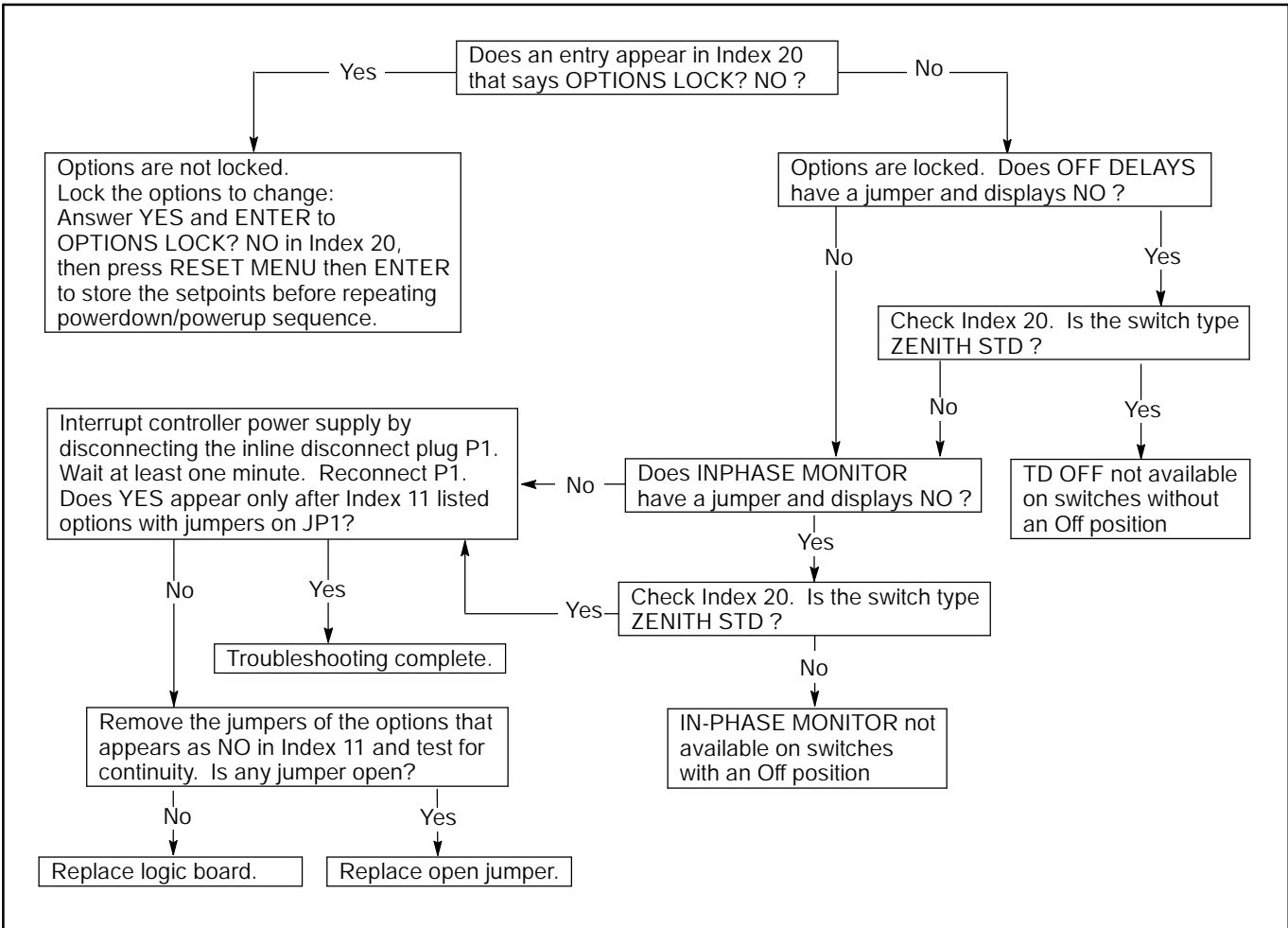
Figure 4-15. Shunt-jumper socket JP1

Control Option	Description
INPHASE MON	Shows Inphase Monitor enabled (Yes) or disabled (No).
PHA SEQ/LOSS	Shows Source-Phase-Sequence enabled (YES) or disabled (NO). (Transfer Switch contactor lug connections must be properly phased ABC in order for the source to be acceptable).
NORM & EMER	Shows sensing enabled (YES) or disabled (NO) of overvoltage, undervoltage, overfrequency, underfrequency for both the normal source and the emergency source.
PLANT EXER	Shows generator set/system exerciser enabled (YES) or disabled (NO).
TD EXTENDED	Shows extended time delay enabled (YES) or disabled (NO).
MAN OVERRIDE	Shows manual override enabled (YES) or disabled (NO). Enabled manual override (YES) allows automatic transfer to an available source when connected source fails. Transfer time delays will be bypassed. Disabled manual override (NO) causes the logic board to wait for manual operation. The logic board will not automatically seek available source.
OFF DELAYS	Shows time delay off to normal and off to emergency are enabled (YES) or disabled (NO).

Figure 4-16. The installed control options as they appear on the LCD



**Figure 4-17. Troubleshooting– YES appears in Index 11 when a jumper for that option is not installed**



**Figure 4-18. Troubleshooting– NO appears in Index 11 when a jumper for that option is installed**

# Inphase Monitor

Motors and related equipment can be damaged by abnormal inrush currents when switched between two live power sources. The purpose of the Inphase Monitor, DD-34-A, is to minimize abnormal inrush currents to equipment when the equipment is connected to a new power source. The Inphase Monitor samples a single phase of one source and compares it to a single phase of another source. When the two voltages are within the desired phase angle and approaching zero phase angle difference, the Inphase Monitor signals the transfer switch to operate. The transfer may be from utility to generator, from generator to generator, or from utility to

utility. To enable this option, the IN-PHASE MONITOR jumper must be installed on the main logic board. See Figure 4-15.

## NOTE

The generator set should run 0.5 Hz faster than the utility source. Inphase Monitor can be enabled only on transfer switches with power conversion units without an *Off* position like ZENITH STD.

Figure 4-19 shows a wiring diagram for this option. See Figure 4-20 for troubleshooting this option.

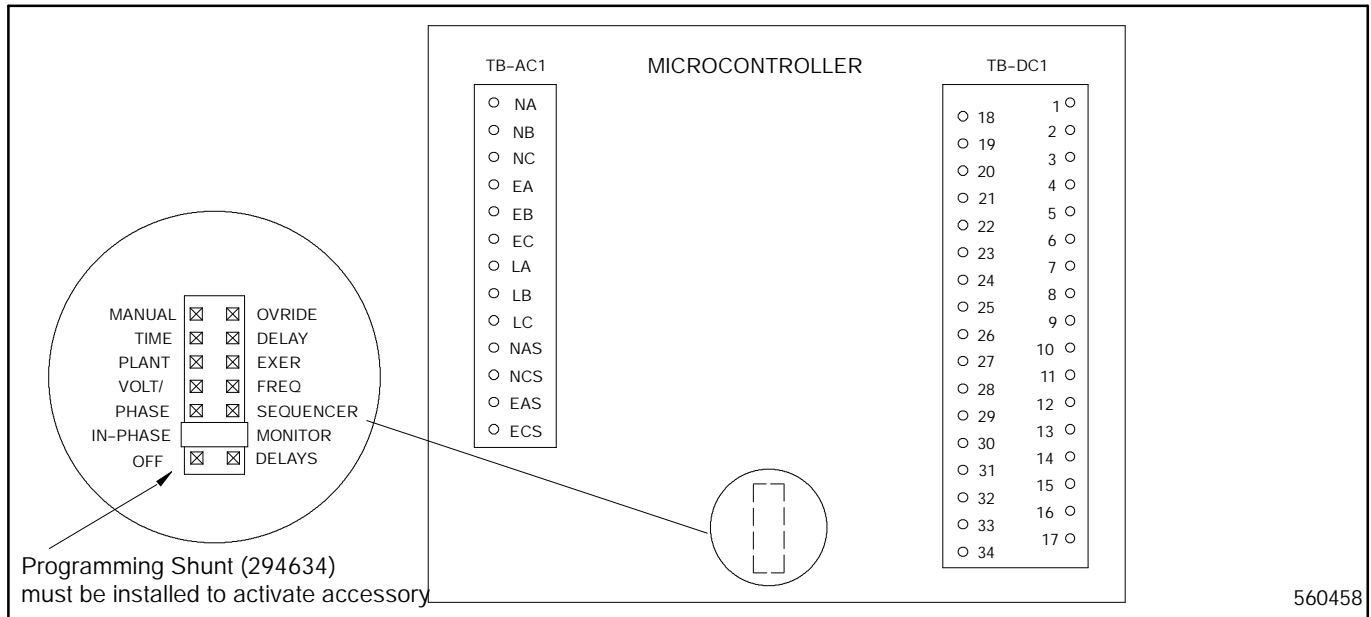


Figure 4-19. Wiring Diagram– Inphase monitor, option DD-34-A

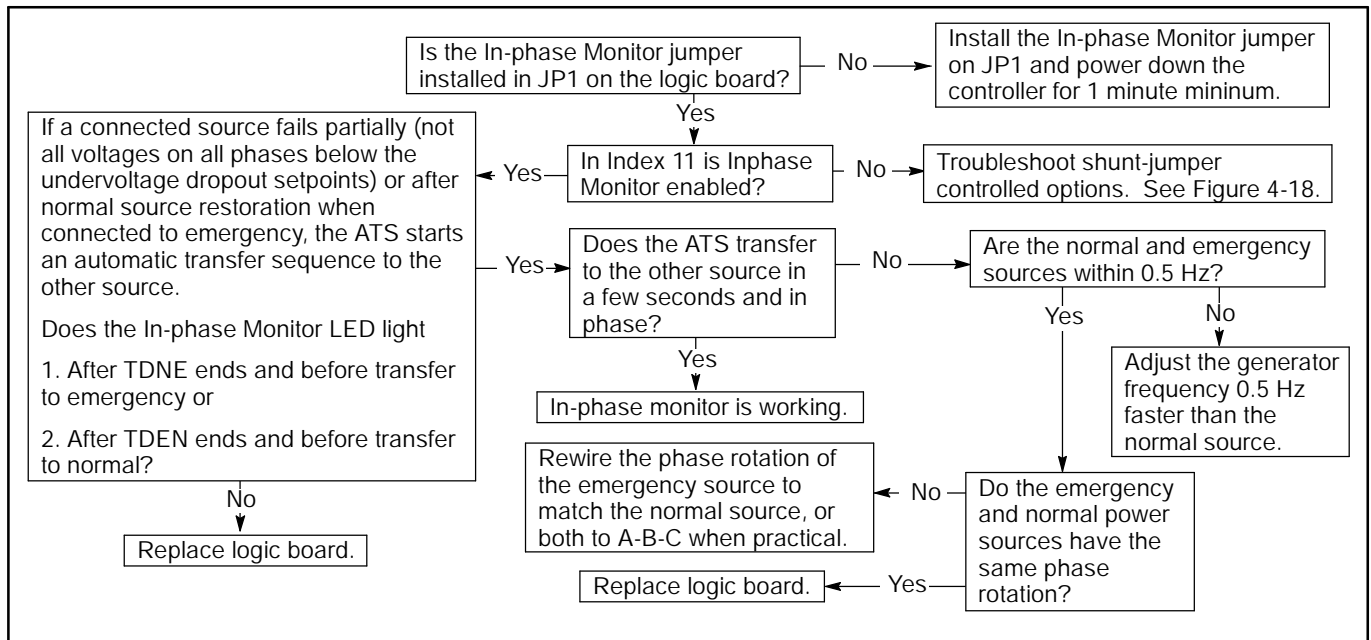


Figure 4-20. Troubleshooting– Inphase monitor, does not work

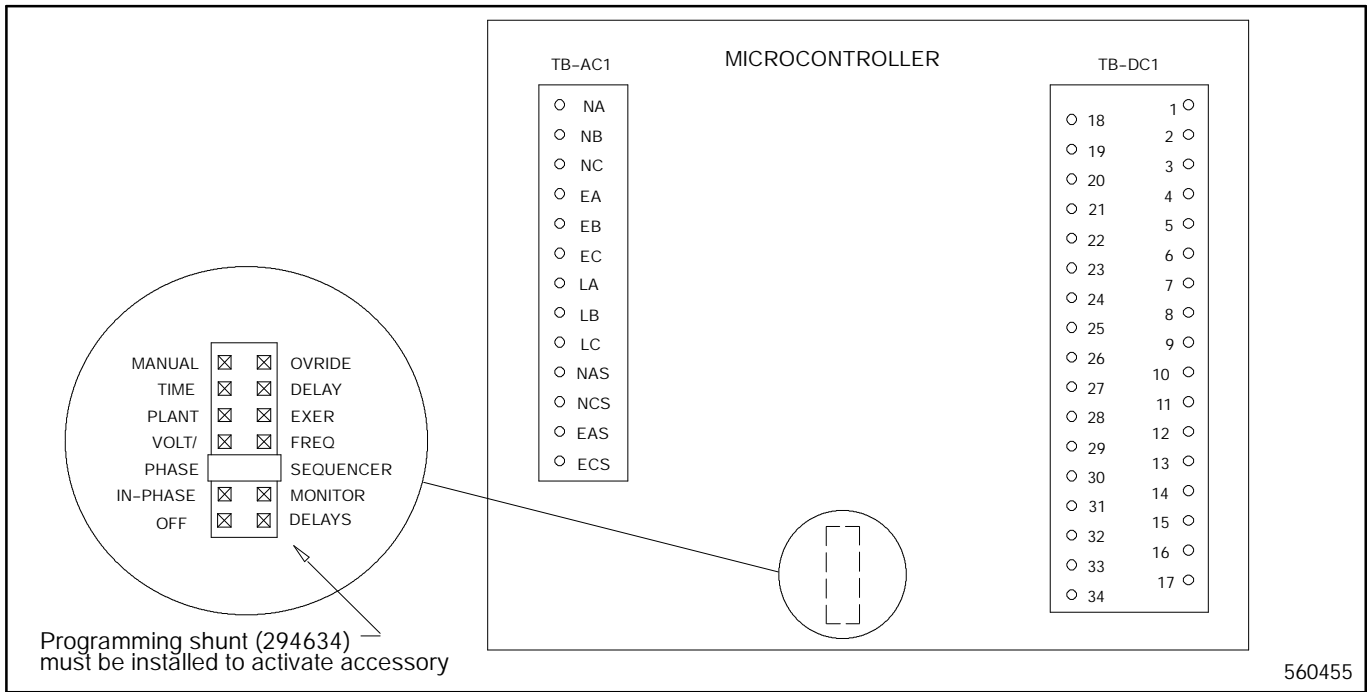
# Source Monitors

The Source Monitor Phase Sequencer accessory DD-34-Z provides source monitoring for both the normal and emergency sources. The features include phase rotation and anti-single phasing protection. This option must be used in conjunction with DD-05-K in order to provide three-phase source monitoring on the emergency side. This accessory needs to be enabled by installing the PHASE SEQUENCER jumper on the main logic board. See Figure 4-15. A wiring diagram for this option is in Figure 4-21.

The Voltage/Frequency Sensing accessory, DD-34-J, provides source monitoring for both the normal and emergency sources. This accessory senses an overvoltage condition for all normal source phases, an over/underfrequency condition on one normal source phase, and an overfrequency and overvoltage condition

on one emergency source phase. This accessory is enabled by installing the VOLT/FREQ jumper on the main logic board. See Figure 4-15. See Appendix B, Figure B-4 for the emergency source voltage trip point setting limits and factory settings. A wiring diagram for this accessory is in Figure 4-22.

The three-phase emergency source sensing accessory DD-05-K provides source monitoring for the emergency source. The features include overfrequency sensing for one phase of the emergency source and over/undervoltage sensing for all three phases of the emergency source. This accessory needs to be enabled by installing the PHASE SEQUENCER jumper on the main logic board. See Figure 4-15. Figure 5-3 shows a wiring diagram for this option.



**Figure 4-21. Wiring Diagram– Source monitor phase sequence, option DD-34-Z**

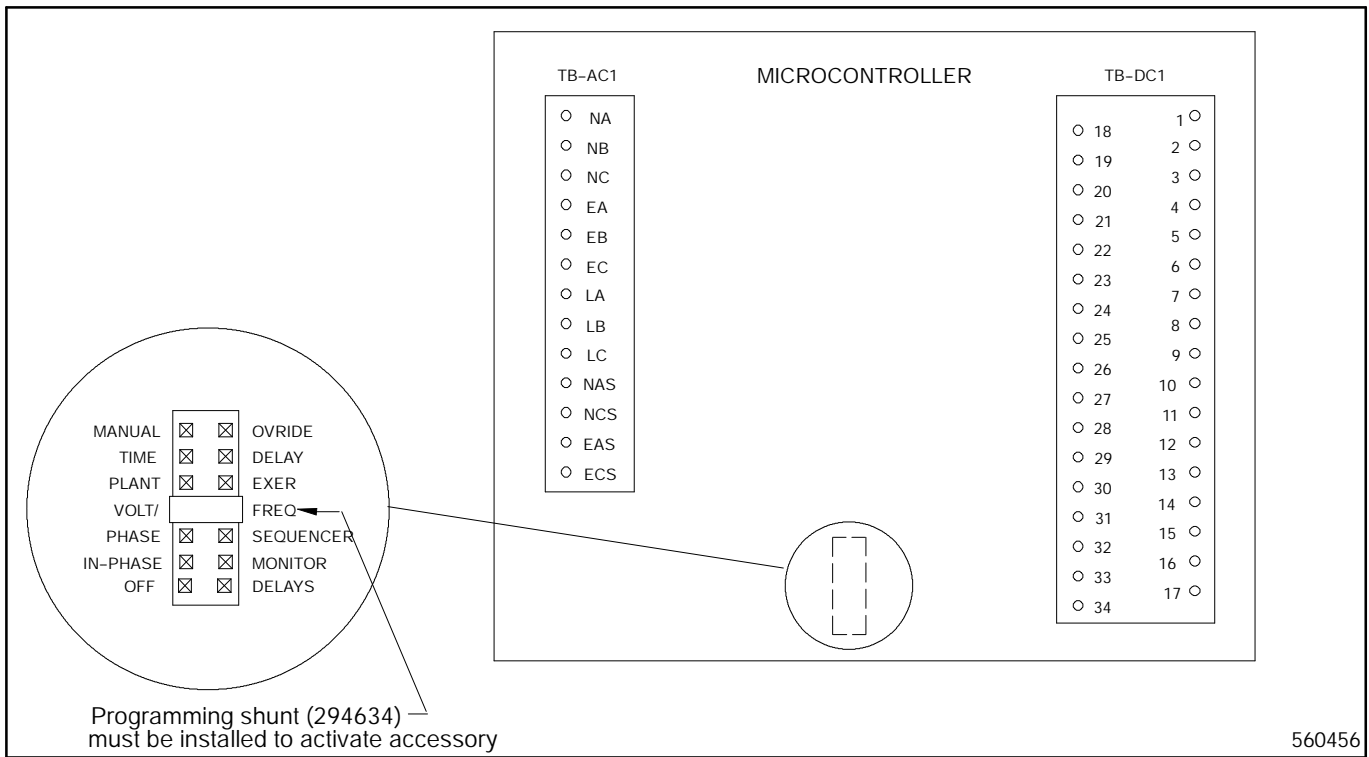


Figure 4-22. Wiring Diagram– Voltage/Frequency Sensing, option DD-34-J

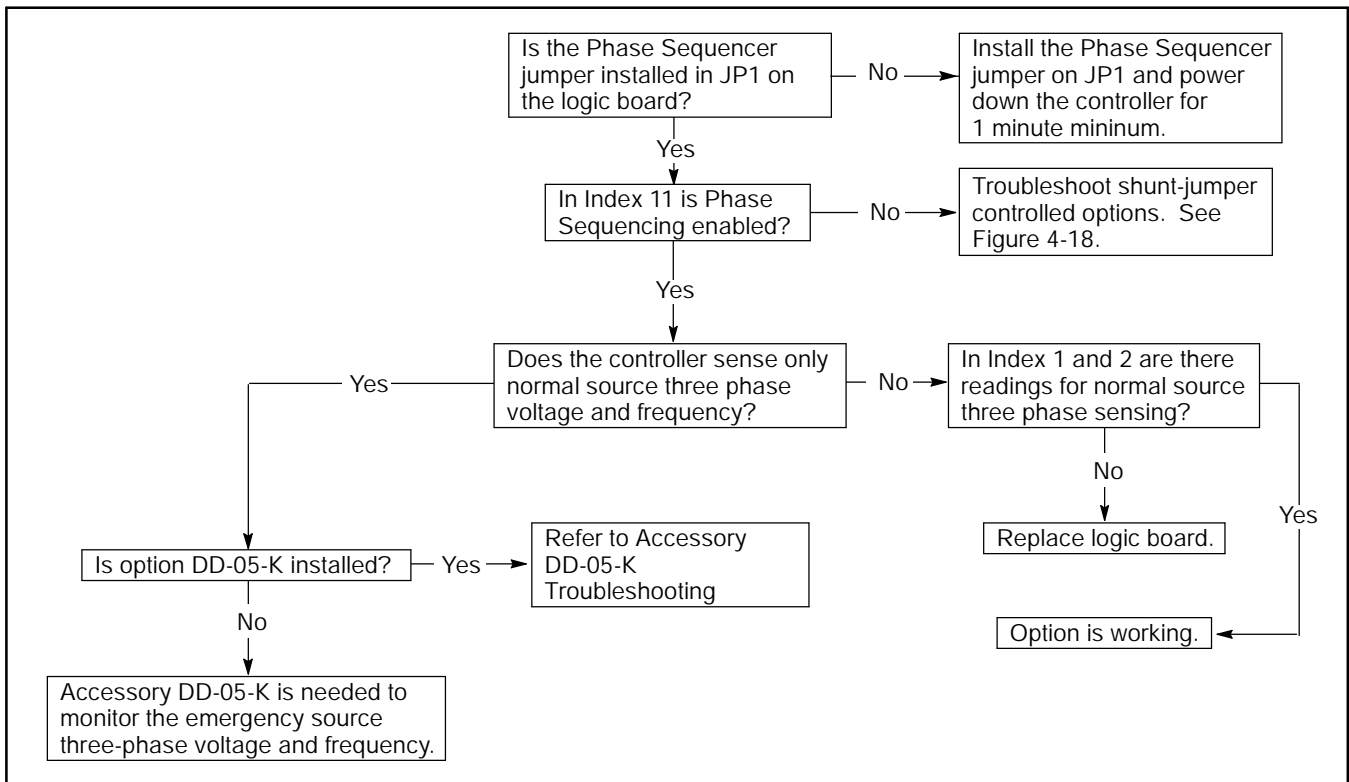


Figure 4-23. Troubleshooting– Source monitor phase sequencer does not work

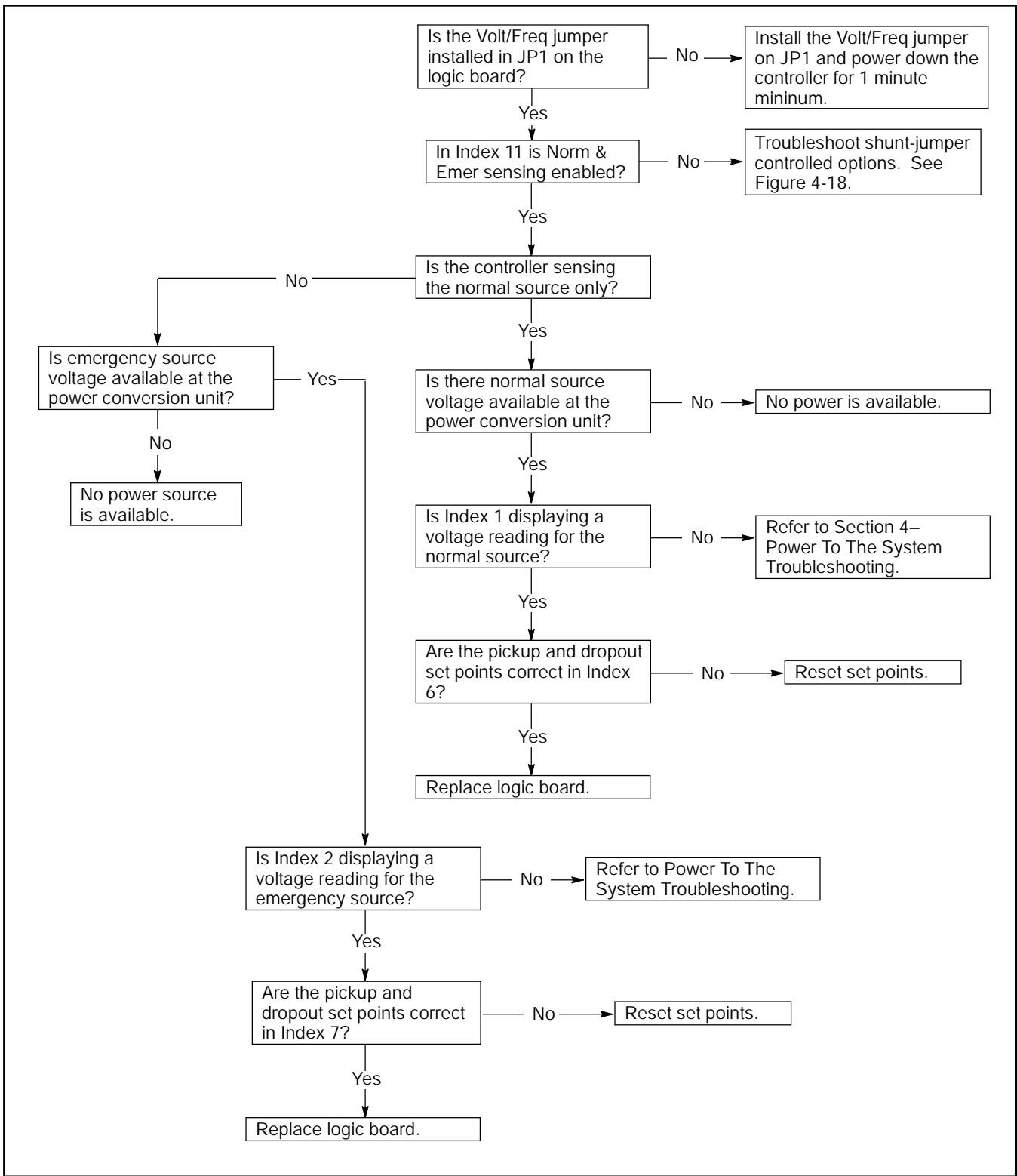


Figure 4-24. Troubleshooting– Voltage and frequency sensing does not work

# Plant Exerciser

The Plant Exerciser is an accessory which periodically tests the emergency source for proper operation. To enable this option, the PLANT EXER jumper must be installed on the logic board. See Figure 4-15. The accessory is available in three different variations.

- D DD-23-C. Allows test of the engine generator set only. The generator set will start and run under no load.
- D DD-23-D. Allows a complete test of the emergency source. The exerciser simulates a loss of normal power. The generator set starts and the transfer switch transfers the load to the generator set.
- D DD-23-G. Allows the customer to choose between DD-23-C and DD-23-D with a Load/No Load selector switch.

Option DD-23-C (no-load exerciser) and DD-23-D (load exerciser) are wired differently. In order to enable DD-23-D, TB-DC1-10 must be jumpered to TB-DC1-32. See Figure 3-1 or 3-2.

The plant exerciser is programmed in Index 8. The following information is needed to program the plant exerciser.

- D Start time
- D Day of the week
- D Run time in hours and minutes
- D Week of the month (Calendar Mode Only)

Enter the information and enable the event to operate the plant exerciser.

If the plant exerciser is programmed and functioning, the Accessory Active, Plant Exerciser LED lights whenever the plant exerciser is operating.

The Plant Exerciser uses three different modes.

- D 7 Day. The timer looks at only 7 days at one time
- D 14 Day. The timer looks at 14 days at a time
- D Calendar. The timer looks at a true calendar for each month.

See Figure 4-27 through Figure 4-30 for troubleshooting flowcharts for these options.

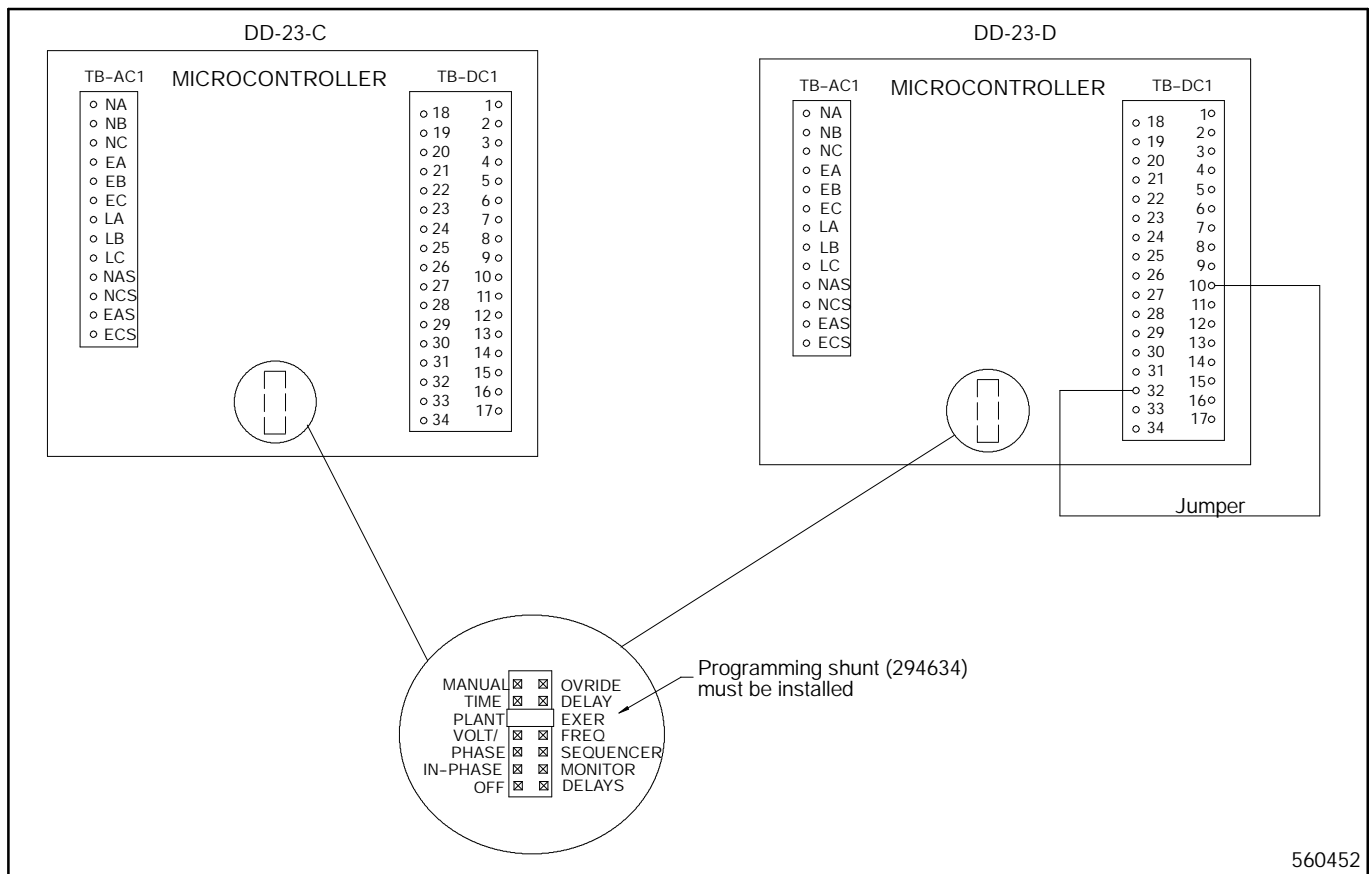


Figure 4-25. Wiring Diagram– Plant exerciser, option DD-23-C and DD-23-D

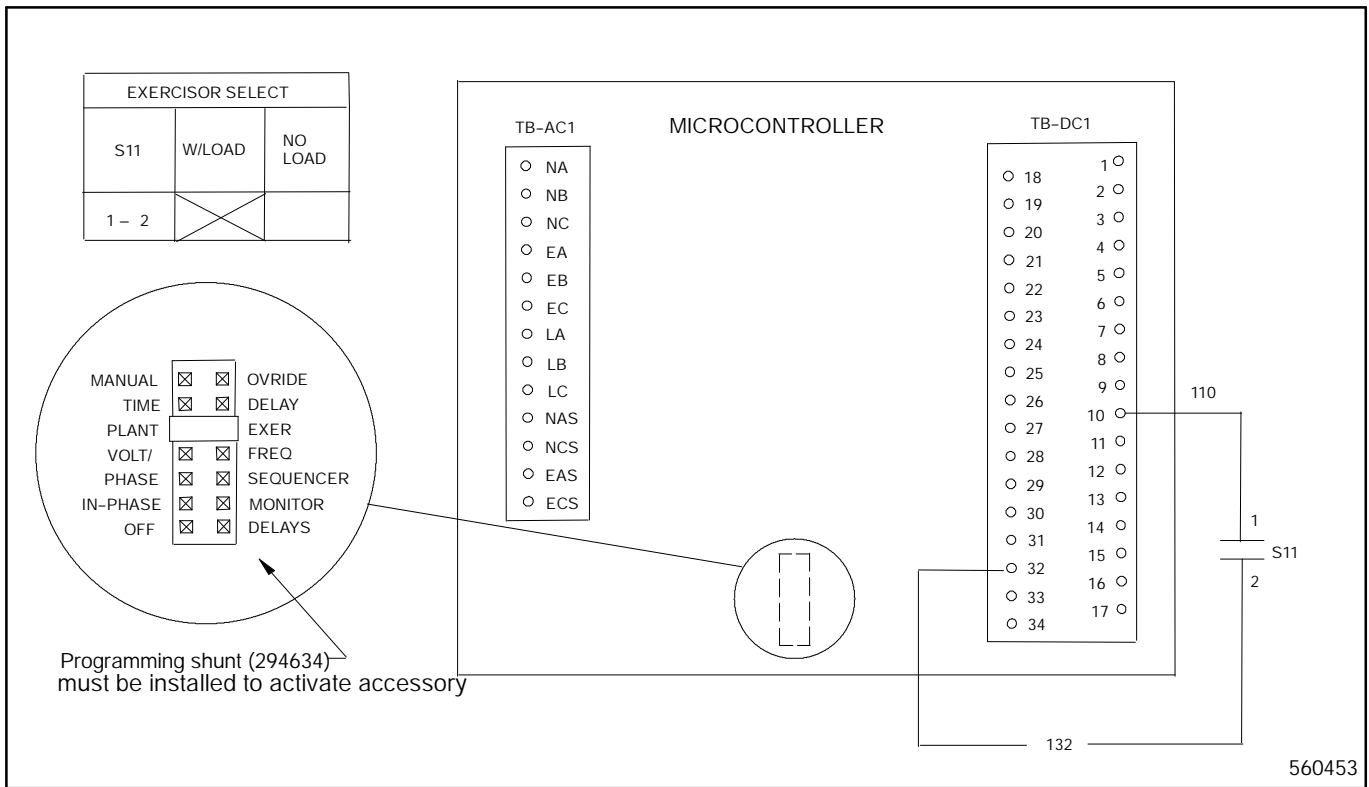


Figure 4-26. Wiring Diagram– Plant exerciser, option DD-23-G

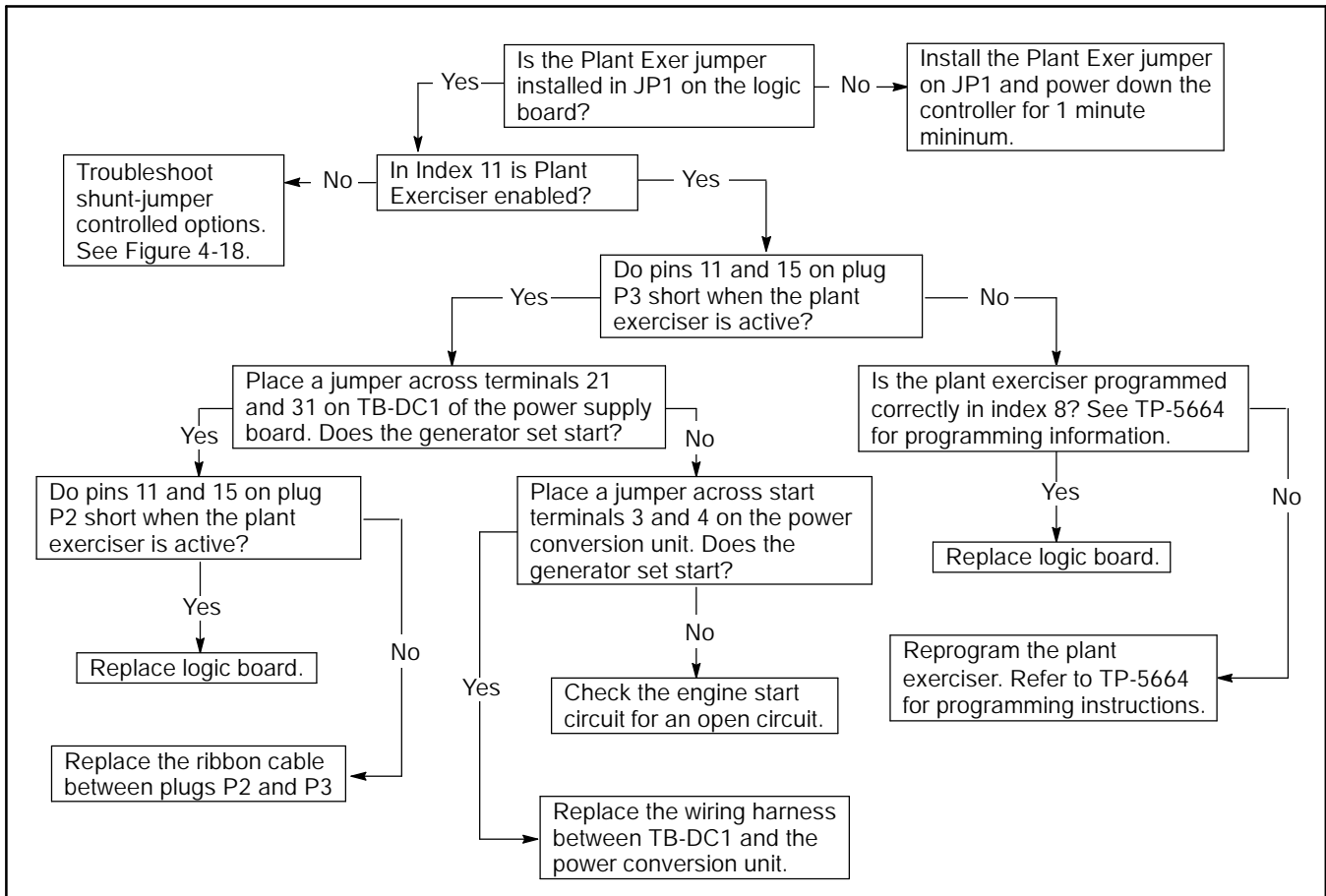


Figure 4-27. Troubleshooting– Accessory 23-C, plant exerciser, does not work

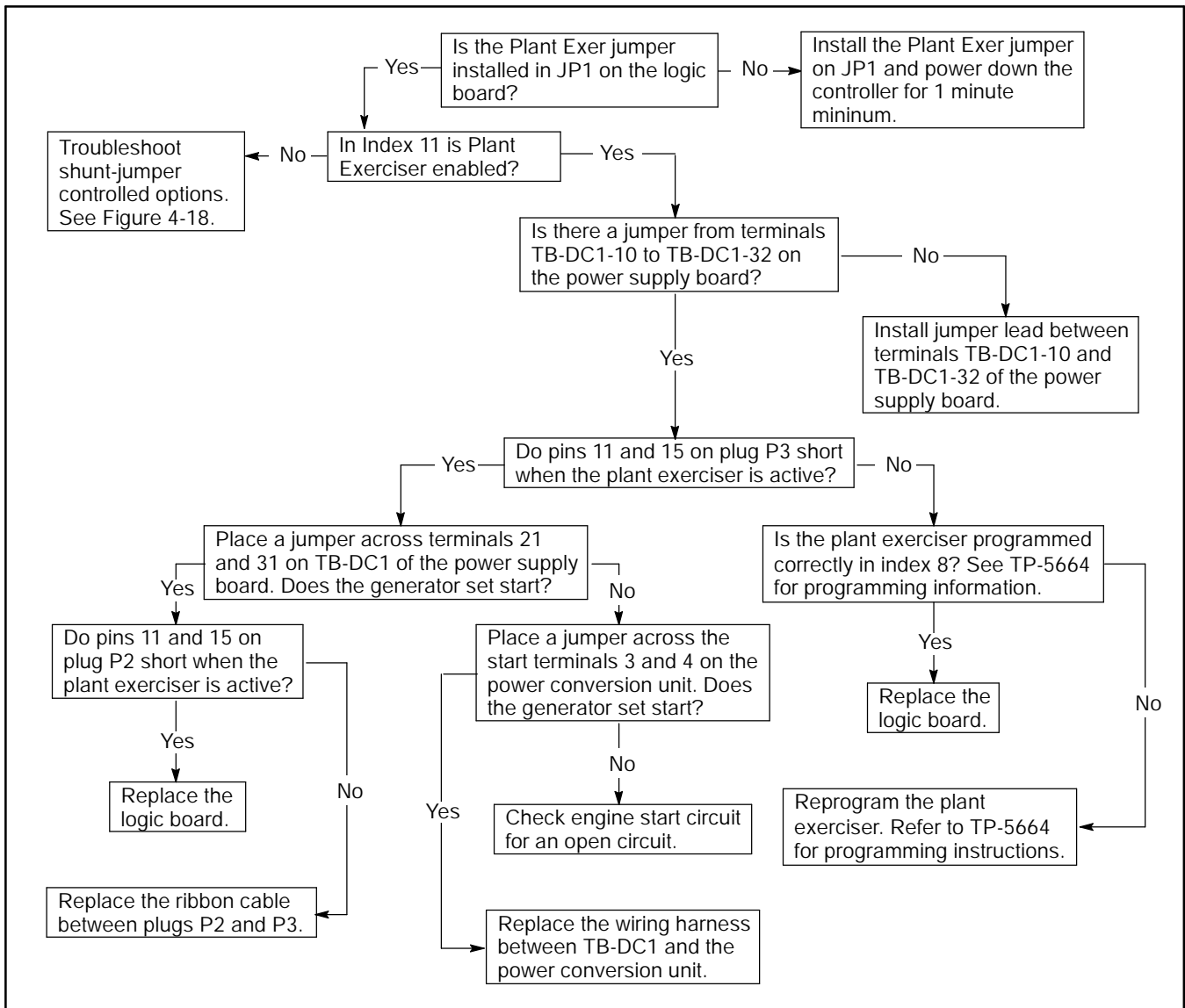


Figure 4-28. Troubleshooting– Accessory 23-D, plant exerciser does not work

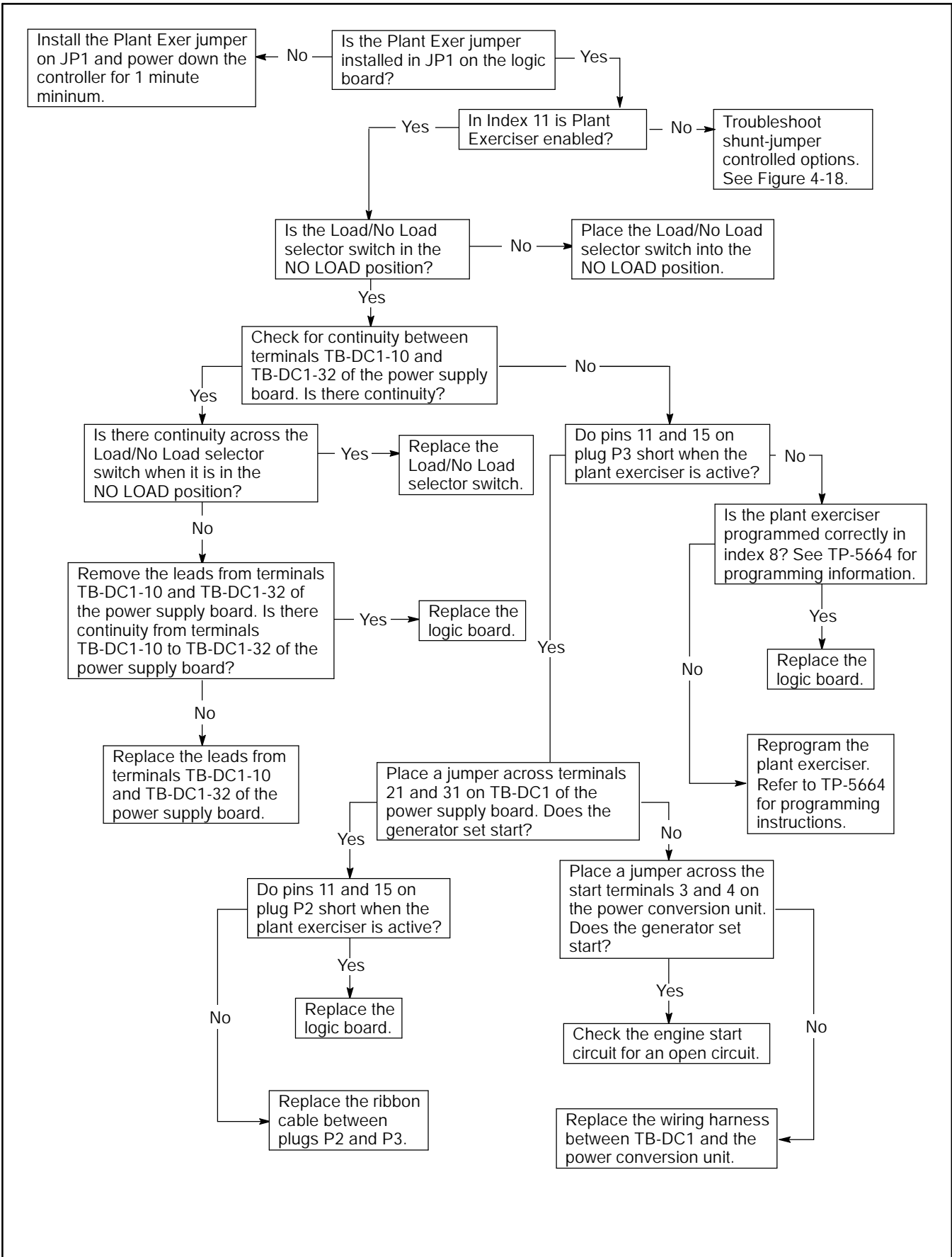


Figure 4-29. Troubleshooting– Accessory 23-G, plant exerciser, does not work (unloaded exercise)

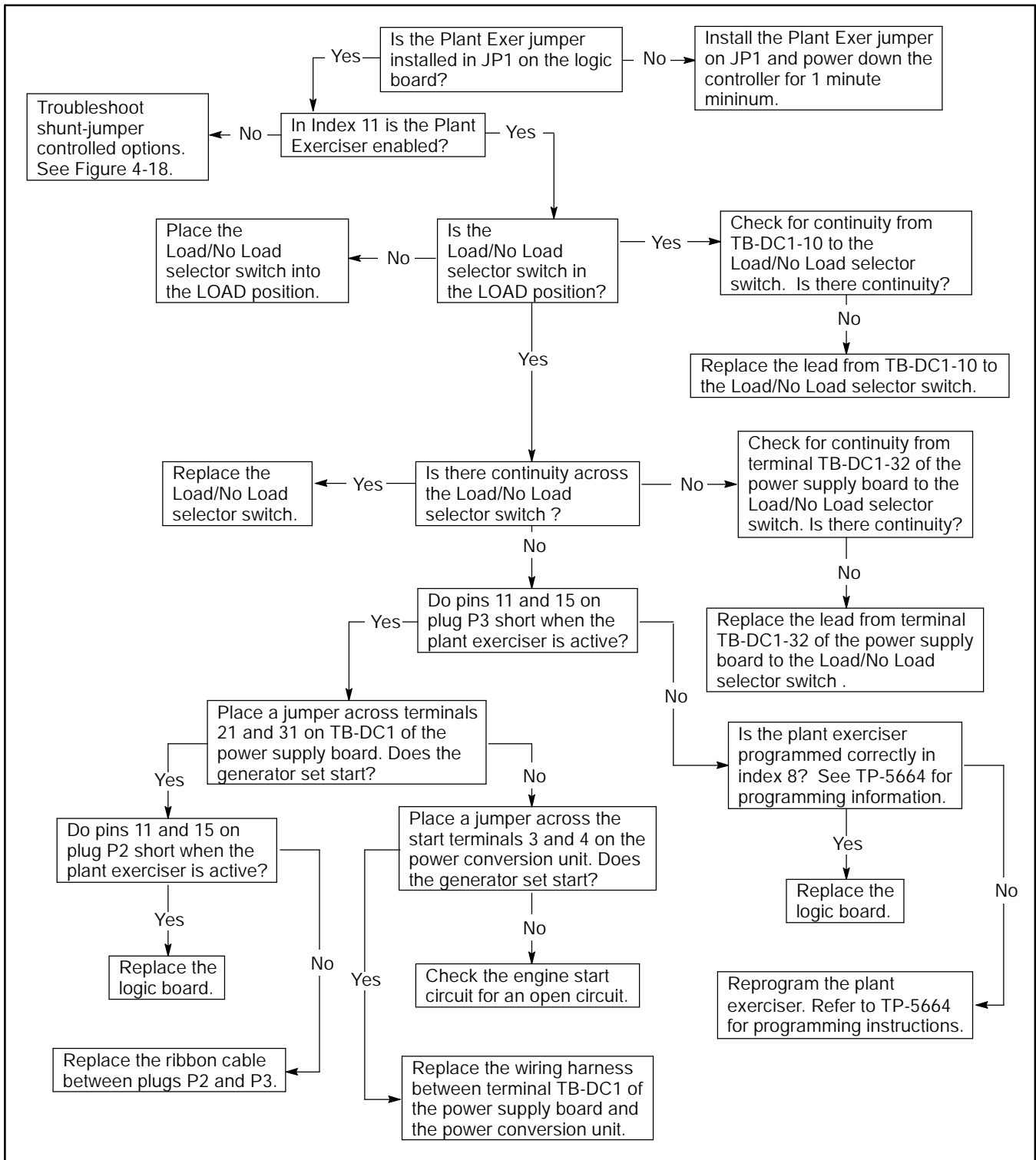


Figure 4-30. Troubleshooting– Accessory 23-G, plant exerciser, does not work (loaded exercise)

# Time Delays

**D** DD-100-B. This accessory allows all time delays to be adjusted from 0 to 99 minutes.

Time Delay accessory DD-100-B increases all of the time delays up to 99 minutes. The time delays are used for transfer from normal to emergency, transfer from emergency to normal, engine start, engine cooldown, and load-shed sequence. The TIME DELAY jumper

must be installed on the main logic board to increase the adjustable range of standard time delays up to 99 minutes. See Figure 4-15. To extend TDES time delays an external 12-32 vdc power supply is required. See Figure 4-15. Time delays are adjustable from either the front panel keypad or from a remote computer. See Figure 4-31 for a troubleshooting chart for this option.

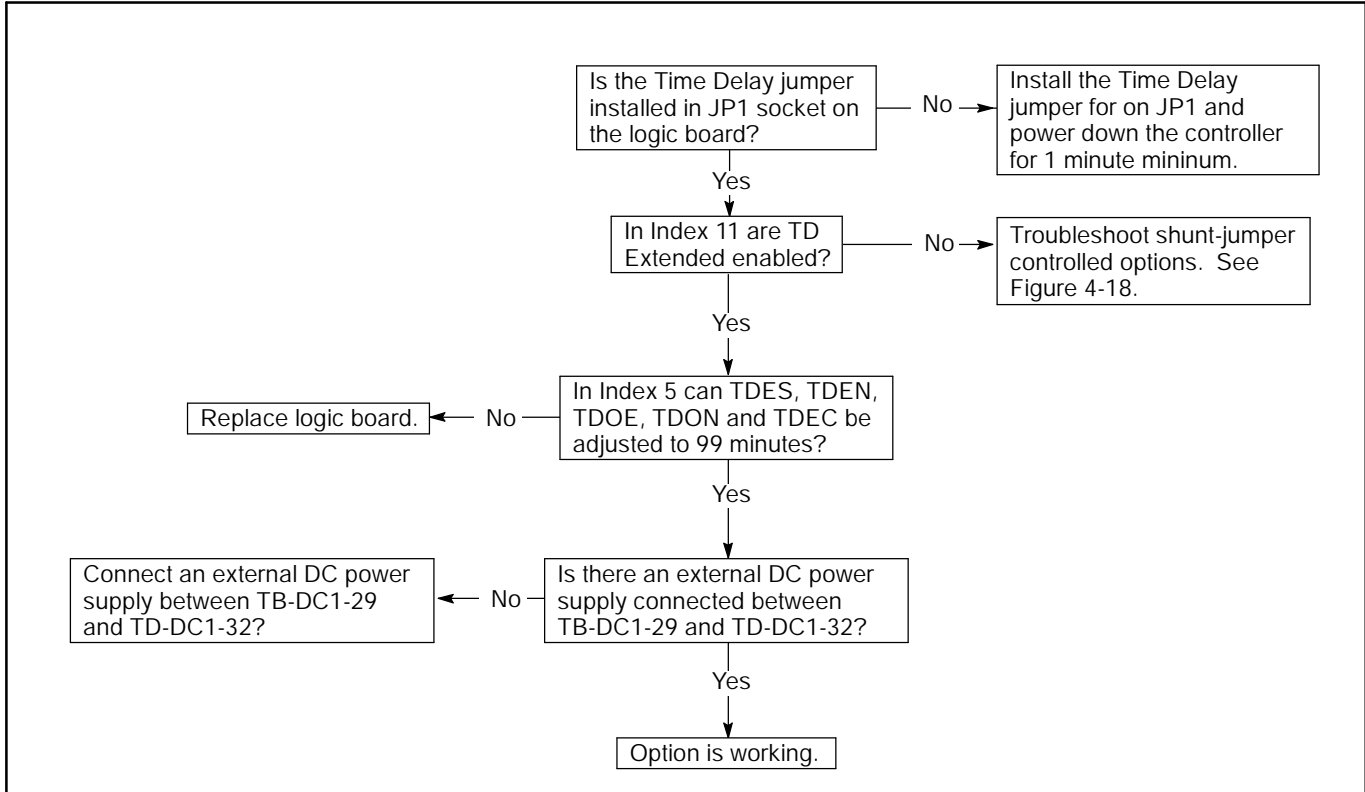


Figure 4-31. Troubleshooting– Extended time delays do not work

# Manual Override

It is important that the MANUAL OVRIDE jumper always be in place on the main logic board. See Figure 4-15. Do not remove it!

See Figure 4-32 for a troubleshooting flowchart for this option.

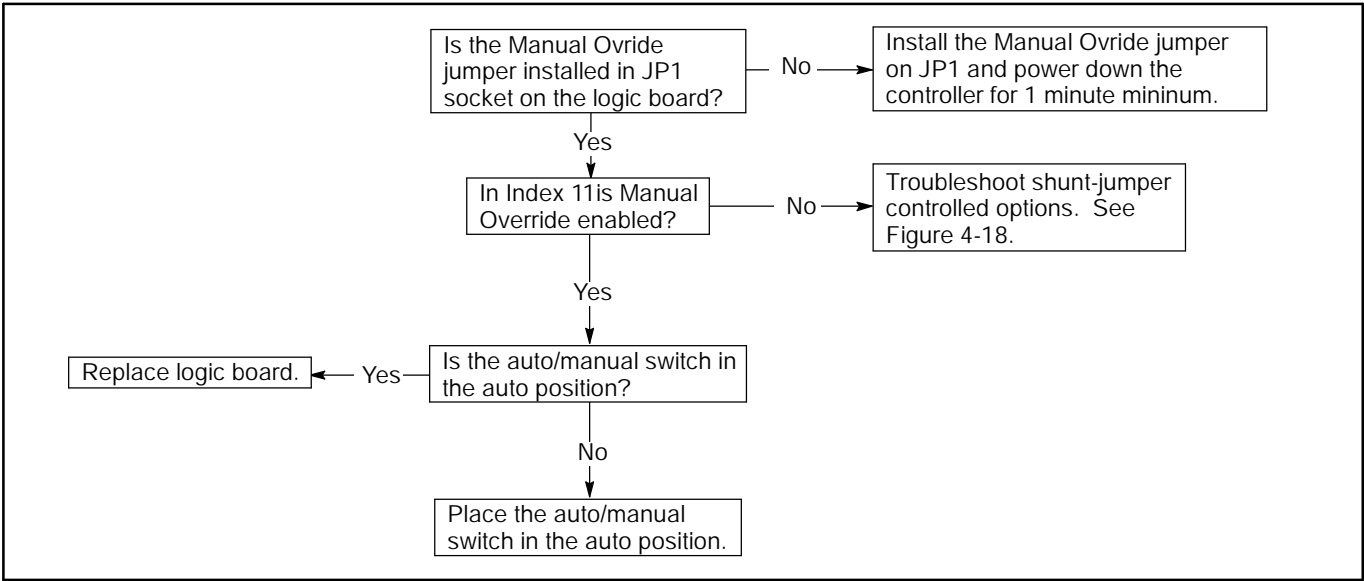


Figure 4-32. Troubleshooting– Switch does not automatically transfer

## Off Delays

The Off position time delay allows an off position power conversion unit to stop for a defined period of time in the off position. A unique time delay can be programmed for an off-to-normal transfer and an off-to-emergency transfer. This off delay can be used to allow motor loads to come to rest before being reenergized. The OFF DELAYS jumper must be installed on the logic board. See Figure 4-15. Off delays cannot be enabled on a switch type that does not have an *Off* position like ZENITH STD and the jumper has no effect. On all power

conversion units with an *Off* position except the MM and MN, the off delays can be set to zero. On the MM and MN power conversion units the minimum off delay is one second.

If the Off Delays jumper is not installed, install the Off Delay jumper on JP1 and power down the controller for 1 minute minimum.

If the jumper is installed, check Index 11 to see if the Off Delays option is enabled. If not enabled, see Figure 4-18 to troubleshoot shunt-jumper controlled options.

# Section 5. Accessory Troubleshooting

This section contains a brief description, wiring diagrams, and troubleshooting flowcharts for many of the logic board accessories.

Refer to Appendix C for a comprehensive list of

commonly used accessories.

See Figure 5-1 for the relationship between the microprocessor main functions and the affect that certain accessories can have on those functions.

Options with DD- Prefix	Option Description	Accessory Affects			
		Transfer Normal to Emergency	Transfer Emergency to Normal	Engine Start	Engine Shutdown
Shunt Jumper-Controlled Options					
23-C	Plant Exerciser			X	X
34-A	Inphase Monitor	X	X		
34-J	Voltage Sensing	X	X		
34-Z	Phase Rotation	X	X		
100-B	Extended Time Delays	X	X	X	X
Other Options					
05-K	Emergency Source Sensing	X	X	X	
06-F	Two Position Test Switch	X	X	X	X
06-N	Three Position Test Switch	X	X	X	X
06-P	Three Position Test Switch	X	X	X	X
07-D	Four Position Test Switch	X	X	X	X
08-C	E-to-N Time Delay Override Switch		X		
08-D	N-to-E Time Delay Override Switch	X			
23-D	Plant Exerciser	X	X	X	X
23-G	Plant Exerciser	X	X	X	X
24-XX-A,B	Battery Charger			X	
29-P	Manual Transfer-Both Directions	X	X		
29-R	Manual Transfer-Both Directions, Key	X	X		
29-S	Manual Transfer-E-to-N		X		
29-T	Manual Transfer-E-to-N, Key		X		
29-U	Manual Transfer-Both Directions with Auto/Manual switch	X	X		
29-V	Manual Transfer-Both Directions with Auto/Manual Switch, Key	X	X		
29-W	Manual Transfer-E-to-N with Auto/Manual Switch		X		
29-X	Manual Transfer-E-to-N with Auto/Manual Switch, Key		X		
35-N	Load Shed	X	X		

Figure 5-1. Accessory Troubleshooting Grid

# Optional Accessories

## Three-Phase Emergency Source Sensing Accessory, DD-05-K

The three-phase emergency source sensing accessory DD-05-K provides source monitoring for the emergency source. The accessory includes over/undervoltage

sensing for all three phases of the emergency source. Refer to Figure 5-2 for the troubleshooting flowchart.

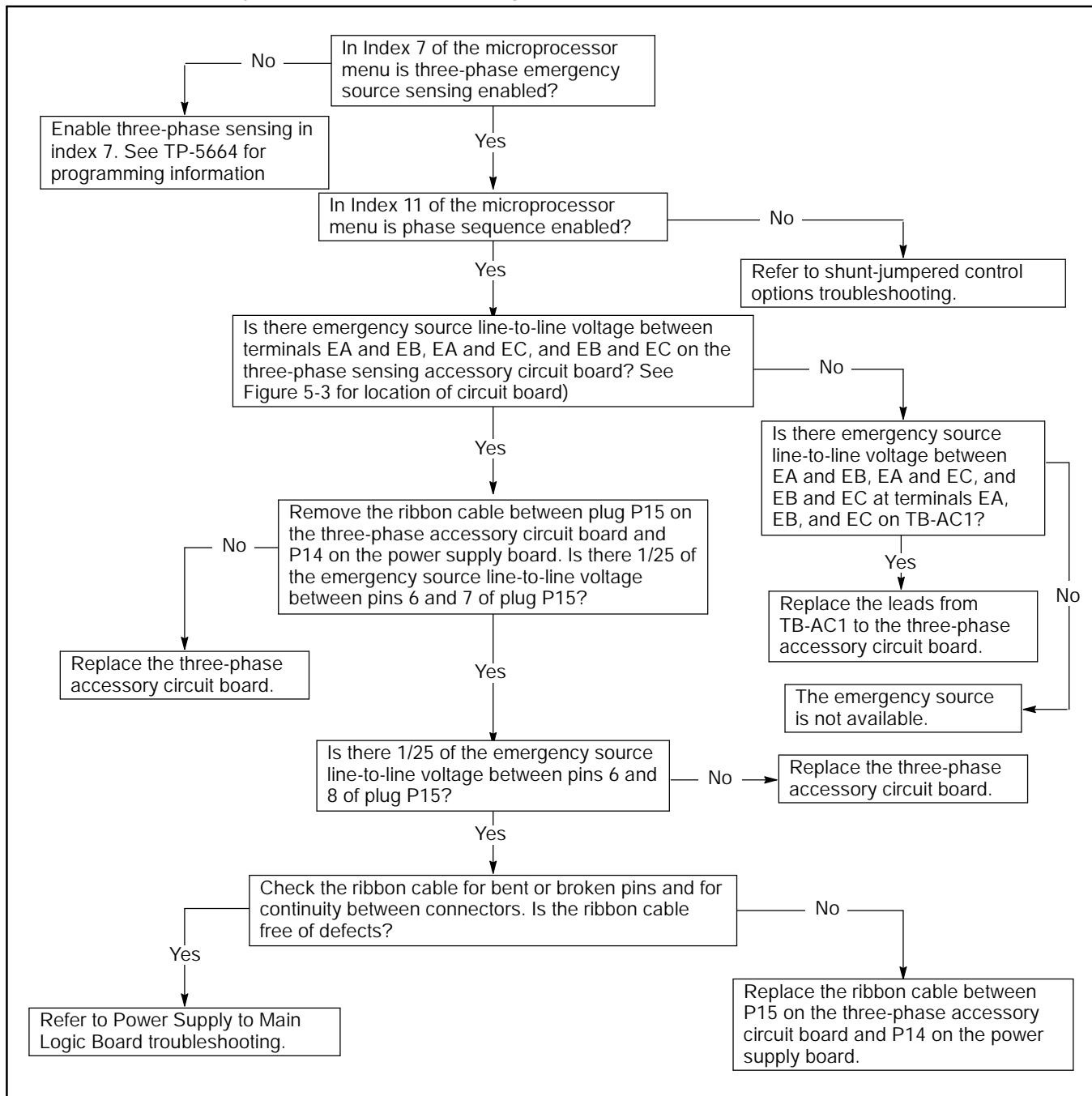
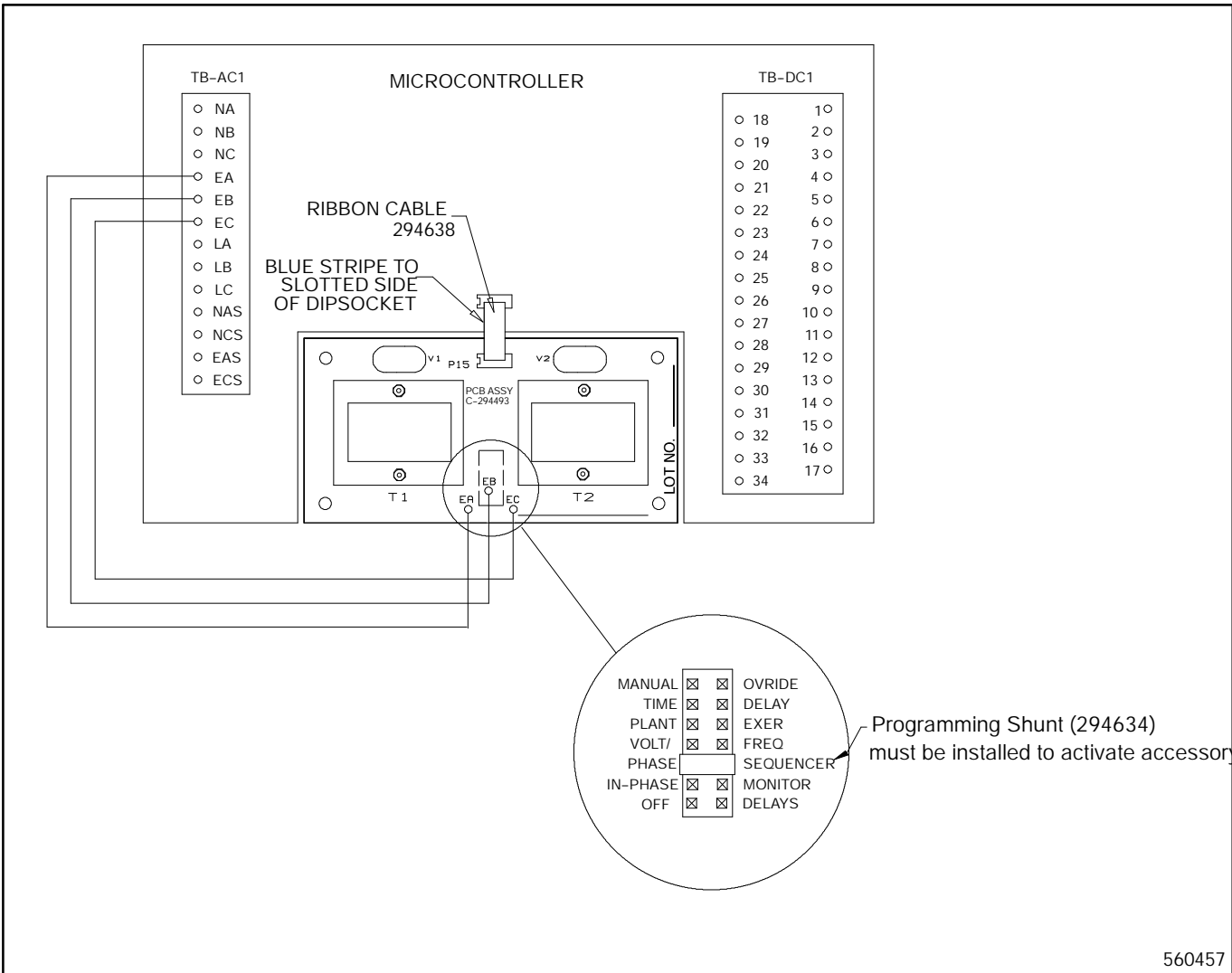


Figure 5-2. Troubleshooting– Controller will not sense three-phase emergency voltage



560457

Figure 5-3. Wiring Diagram– Three-phase emergency source sensing, Option DD-05-K

# Test Switches

Refer to Figure 5-4 for wiring diagram for the Test switch. Refer to Figure 5-5 through Figure 5-10 for the troubleshooting flowcharts.

## Description Of The Automatic/Test Switch Accessories

The two-position test switch is described below:

- D DD-06-F.** Momentary, key-operated Automatic/Test switch simulates a normal source failure.

The system operates automatically with switch in the automatic position. The test position simulates a normal source failure.

The three-position test switches are described below:

- D DD-06-N.** Momentary Test/Automatic/Engine-Start switch

- D DD-06-P.** Momentary, key-operated Test/Automatic/Engine-Start switch

The system operates automatically with switch in the automatic position. The test position simulates a normal source failure. The engine-start position starts the generator set.

The four-position test switch is described below:

- D DD-07-D.** Maintained rotary style Test/Automatic/Off/Engine-Start switch.

The system operates automatically with switch in the automatic position. The test position simulates a normal source failure. The off position prevents transfer switch operation. The engine-start position starts the generator set.

## Troubleshooting The Automatic/Test Switch Accessory

### NOTE

Pressing the Automatic/Test pushbutton causes the generator set to start and run.

Press the Automatic/Test pushbutton for 15 seconds.

1. If the power supply board Test LED does not illuminate, connect TB-DC1-24 to TB-DC1-34. If the Test LED illuminates when TB-DC1-24 is grounded, check the Automatic/Test pushbutton and the wiring from the Automatic/Test pushbutton to the power supply board. If the Test LED does not illuminate when TB-DC1-24 is grounded, replace the power supply board.

### NOTE

When taking a voltage or resistance measurement at a ribbon cable pin, do not disconnect the ribbon cable from the board. Use a needle point probe to take the readings from the holes on the top side of the ribbon cable connector.

2. If the power supply board Test LED turns on when the Automatic/Test pushbutton is pressed, check the Not-In-Automatic LED. If the Not-In-Automatic LED does not turn on when the Automatic/Test pushbutton is pressed, connect TB-DC1-9 to TB-DC1-34.

- a. If the Not-In-Automatic LED does not turn on when TB-DC1-9 is grounded, check the P2 ribbon cable connection by performing the following steps.

(1) Disconnect TB-DC1-9 from TB-DC1-34.

(2) Remove all power sources.

(3) Wait for 30 seconds.

(4) Making sure not to bend or break any of the pins, remove the P2 ribbon cable connector.

(5) Inspect the pins on the P2 ribbon cable connector.

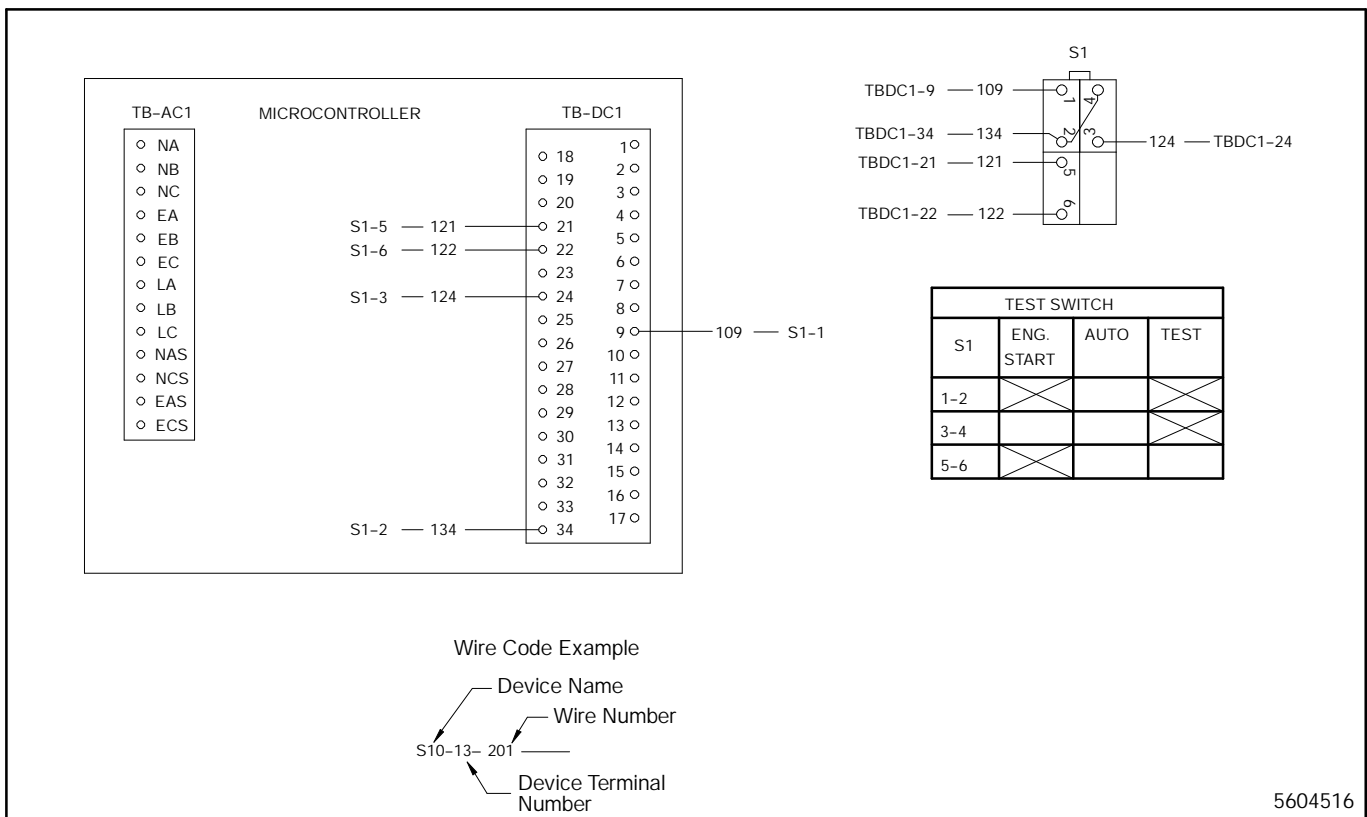
(6) If any of the pins are bent, carefully bend them back. If any of the pins are broken, the ribbon cable connector is defective. Replace the ribbon cable.

(7) Carefully reconnect P2 ribbon cable connector.

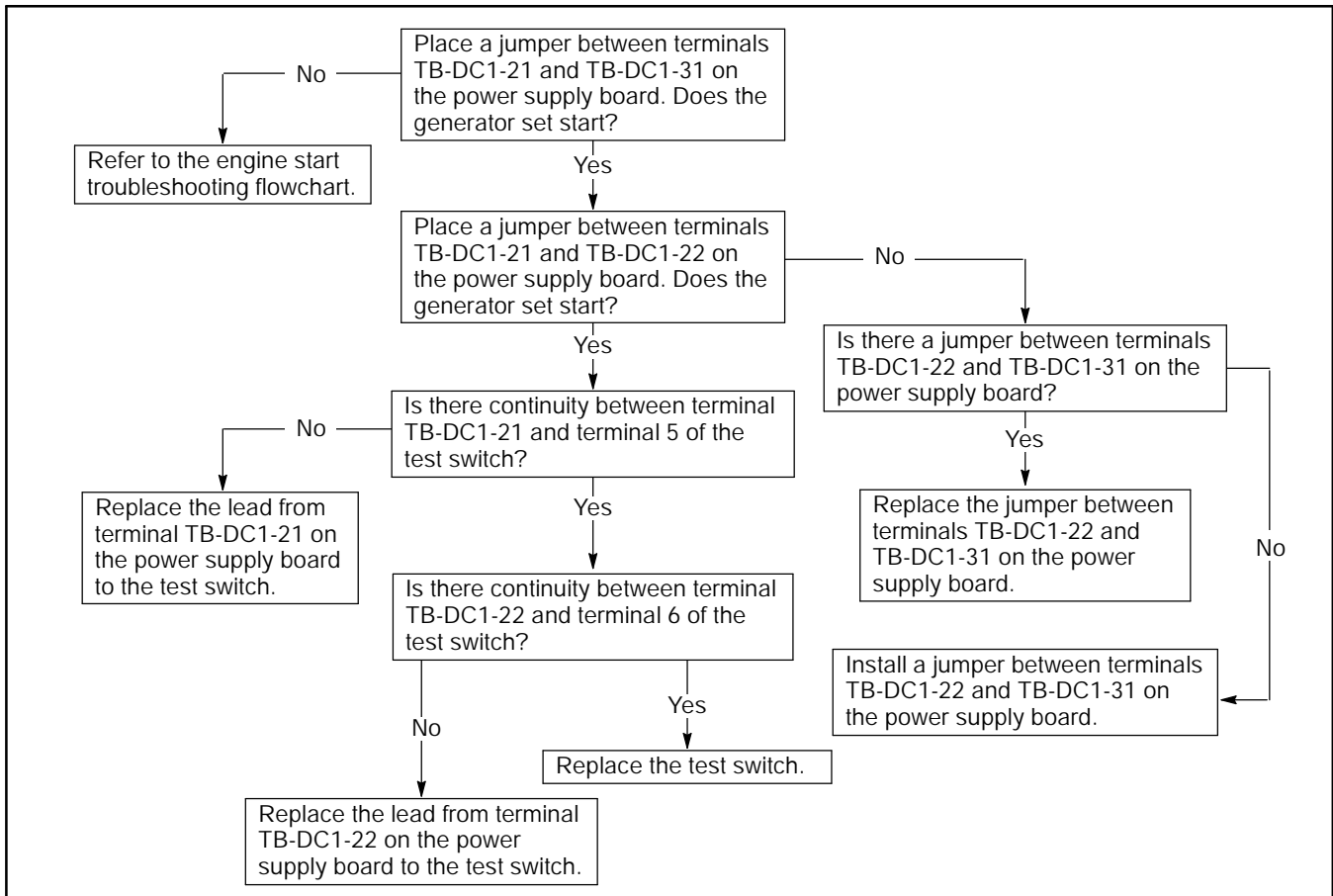
(8) If the Not-In-Automatic LED still does not turn on when TB-DC1-9 is grounded, replace the logic board assembly.

- b. If the Not-In-Automatic LED turns on when TB-DC1-9 is grounded but not when the Automatic/Test pushbutton is pressed, check the Automatic/Test pushbutton and the wiring from the Automatic/Test pushbutton to the power supply board.

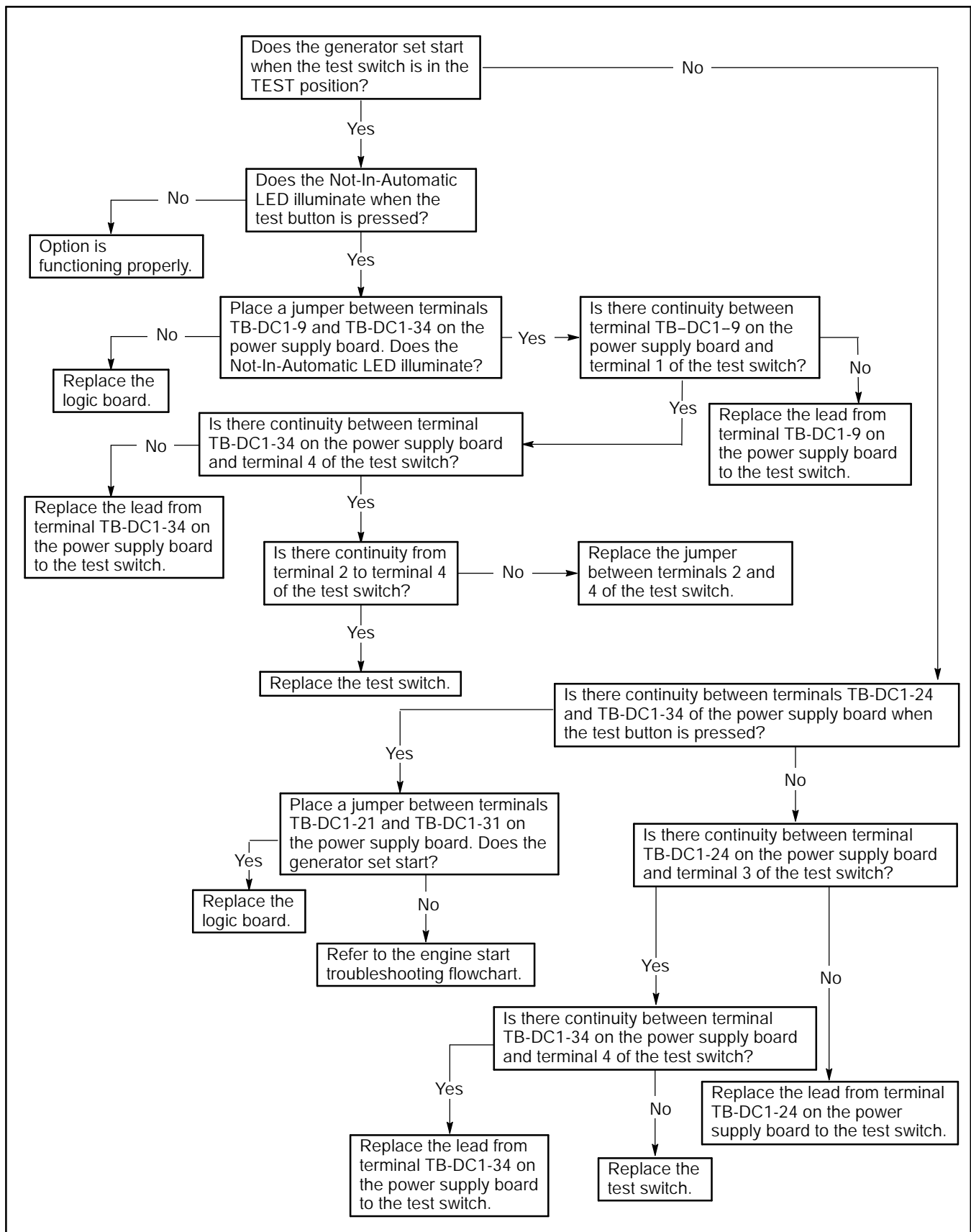
3. If the power supply board Test LED and the Not-In-Automatic LED both turn on when the Automatic/Test pushbutton is pressed, but the engine does not start, check the power supply board Start LED. If the Start LED is not on, see Section 4, Engine Will Not Start. If the Start LED does come on, replace the power supply board.



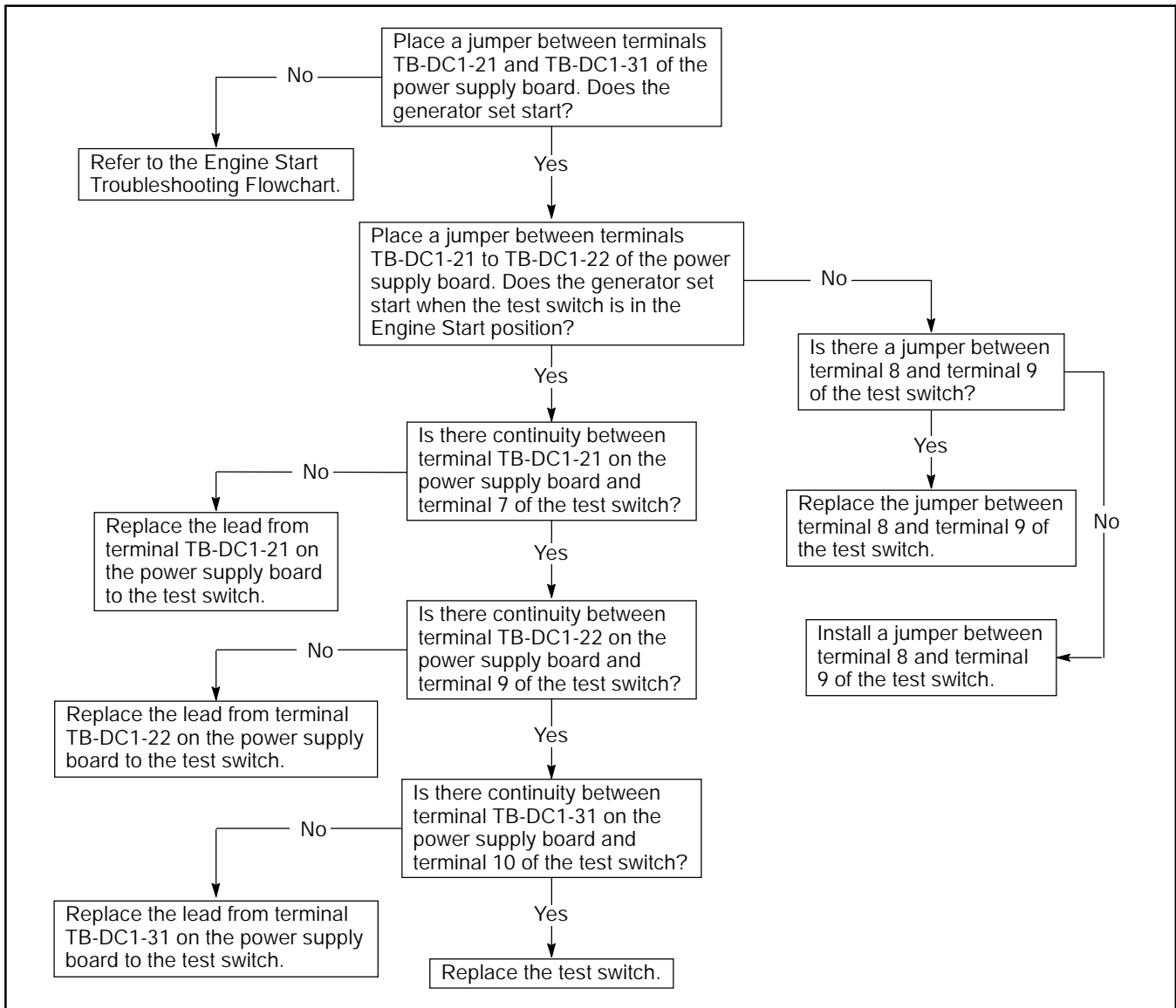
**Figure 5-4. Wiring Diagram– Test switches, Options DD-06-N, -P, -R, -T**



**Figure 5-5. Troubleshooting– Test switches, Options DD-06-N, -P switch does not start the generator set when switch is in the engine start position**



**Figure 5-6. Troubleshooting– Test switches, Options DD-06-N, -P switch does not start the generator set when the test switch is in the Test position**



**Figure 5-7. Troubleshooting– Test switches, Option DD-07-D switch does not start the generator set when in the engine start position**

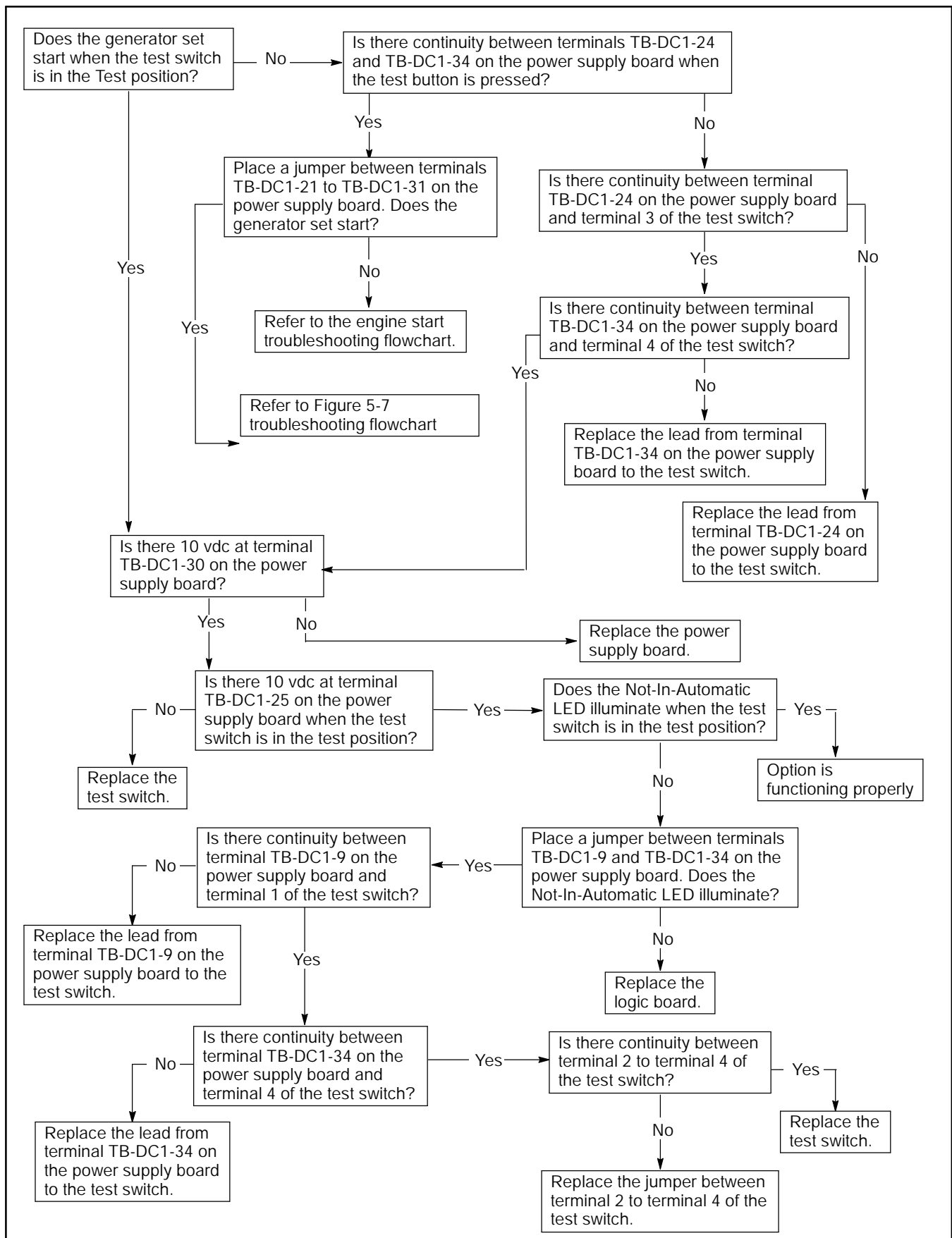
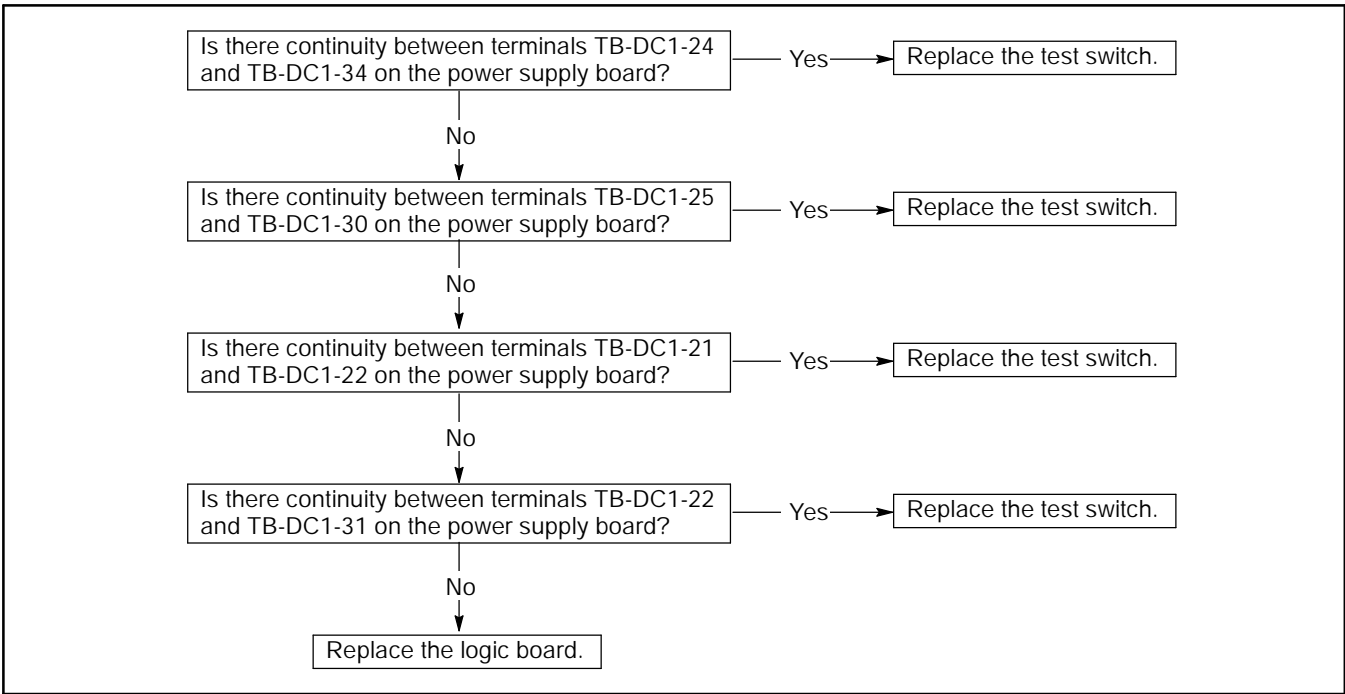
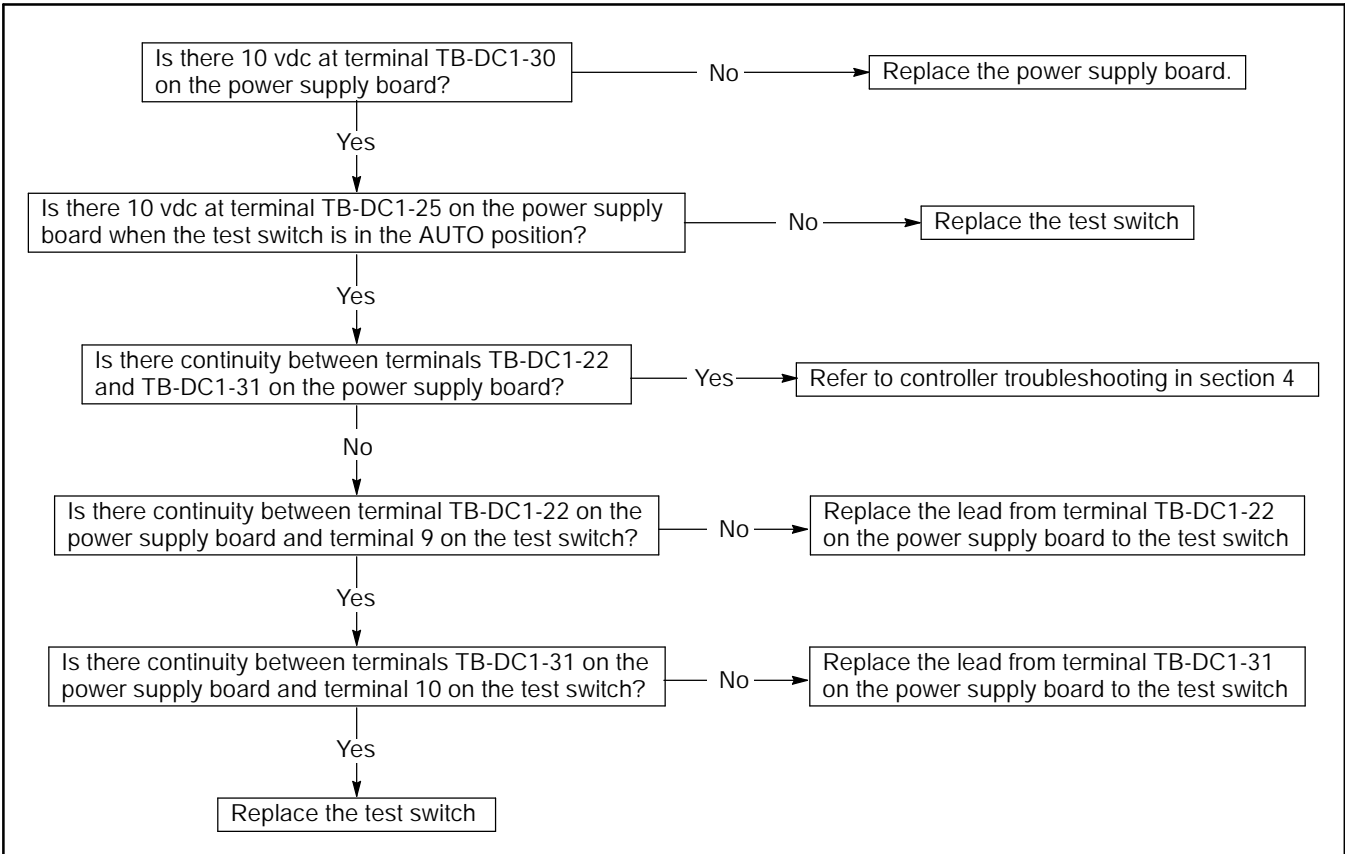


Figure 5-8. Troubleshooting– Test switches, Option DD-07-D switch does go into Test mode



**Figure 5-9. Troubleshooting– Transfer switch operates when Option DD-07-D test switch is in the Off position**



**Figure 5-10. Troubleshooting– Transfer switch will not operate when Option DD-07-D test switch is in the Auto position**

# Time Delay Override Accessory

The Time Delay Override Accessory allows the user to manually override the emergency-to-normal or normal-to-emergency time delay. When the pushbutton is pressed the corresponding transfer occurs immediately. The two different Time Delay Override accessories are listed below.

- D **DD-08-C.** Emergency to normal time delay override pushbutton
- D **DD-08-D.** Normal to emergency time delay override pushbutton

Wiring diagrams for these two accessories are in Figure 5-11 and Figure 5-12. Refer to Figure 5-13 and Figure 5-14 for troubleshooting flowcharts.

## Troubleshooting The Bypass Normal-To-Emergency Time Delay Pushbutton

This section covers the steps to take to verify that the Bypass Normal-to-Emergency Time Delay pushbutton will override the normal-to-emergency time delay.

### NOTE

Pressing the Bypass Normal-to-Emergency Time Delay pushbutton causes the generator set to start and run.

First ensure through the software that a minimum 5-second normal-to-emergency time delay is set. Next,

make sure that the emergency source is available. Initiate a normal-to-emergency time delay by removing the normal source, and then press the Bypass Normal-to- Emergency Time Delay pushbutton.

If after pressing the Bypass Normal-to-Emergency Time Delay pushbutton the normal-to-emergency time delay is not bypassed, connect TB-DC1-3 to TB-DC1-34.

1. If grounding TB-DC1-3 causes the normal-to-emergency time delay to be bypassed but the Bypass Normal-to-Emergency Time Delay pushbutton is not operating, check the Bypass Normal-to-Emergency Time Delay pushbutton and the wiring to the Bypass Normal-to-Emergency Time Delay pushbutton.
2. If after grounding TB-DC1-3 the normal-to-emergency time delay is not bypassed, check the continuity between P2-3 and TB-DC1-3.
  - a. Remove power from the logic board.
  - b. Disconnect the P2 ribbon cable connector from the power supply board.
  - c. Using an ohmmeter, connect one test lead to P2-3 on the power supply board. Connect the other test lead to TB-DC1-3. If there is an open circuit, replace the power supply board. If the resistance is low, the main logic board is bad. Replace the logic board assembly.

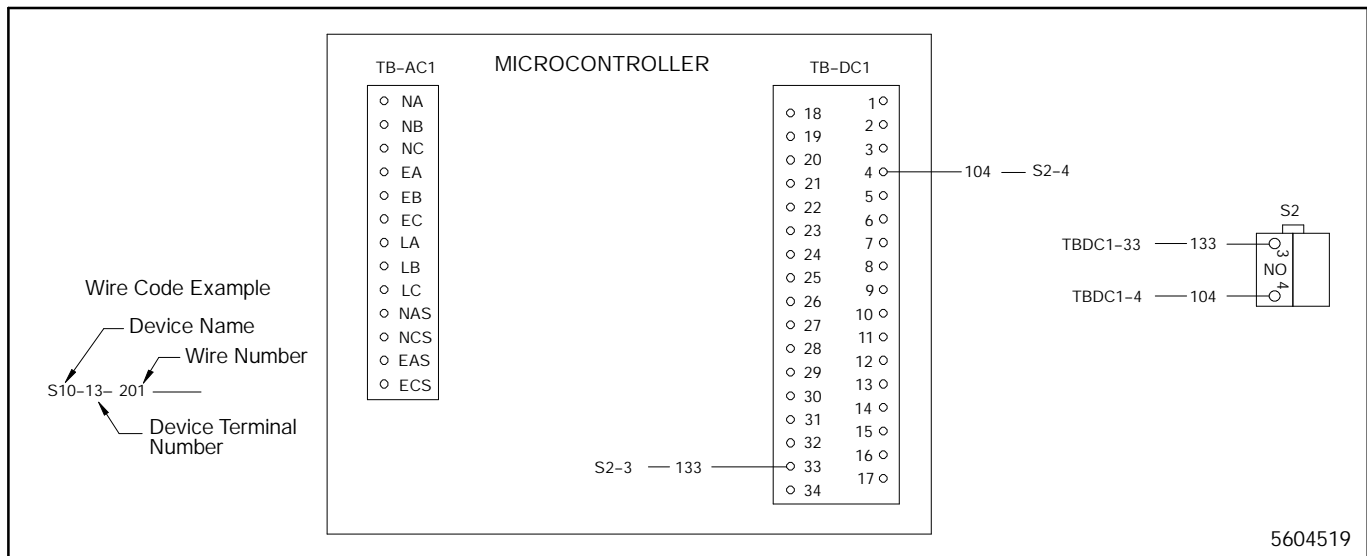
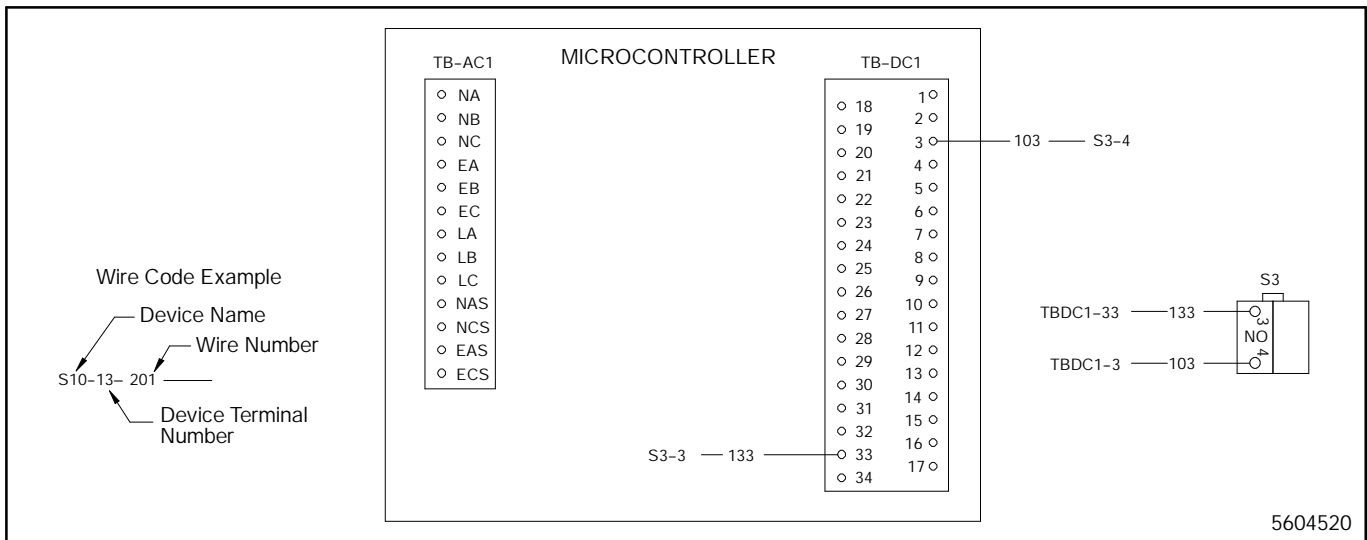


Figure 5-11. Wiring Diagram– Time Delay Override, Option DD-08-C



**Figure 5-12. Wiring Diagram– Time Delay Override, Option DD-08-D**

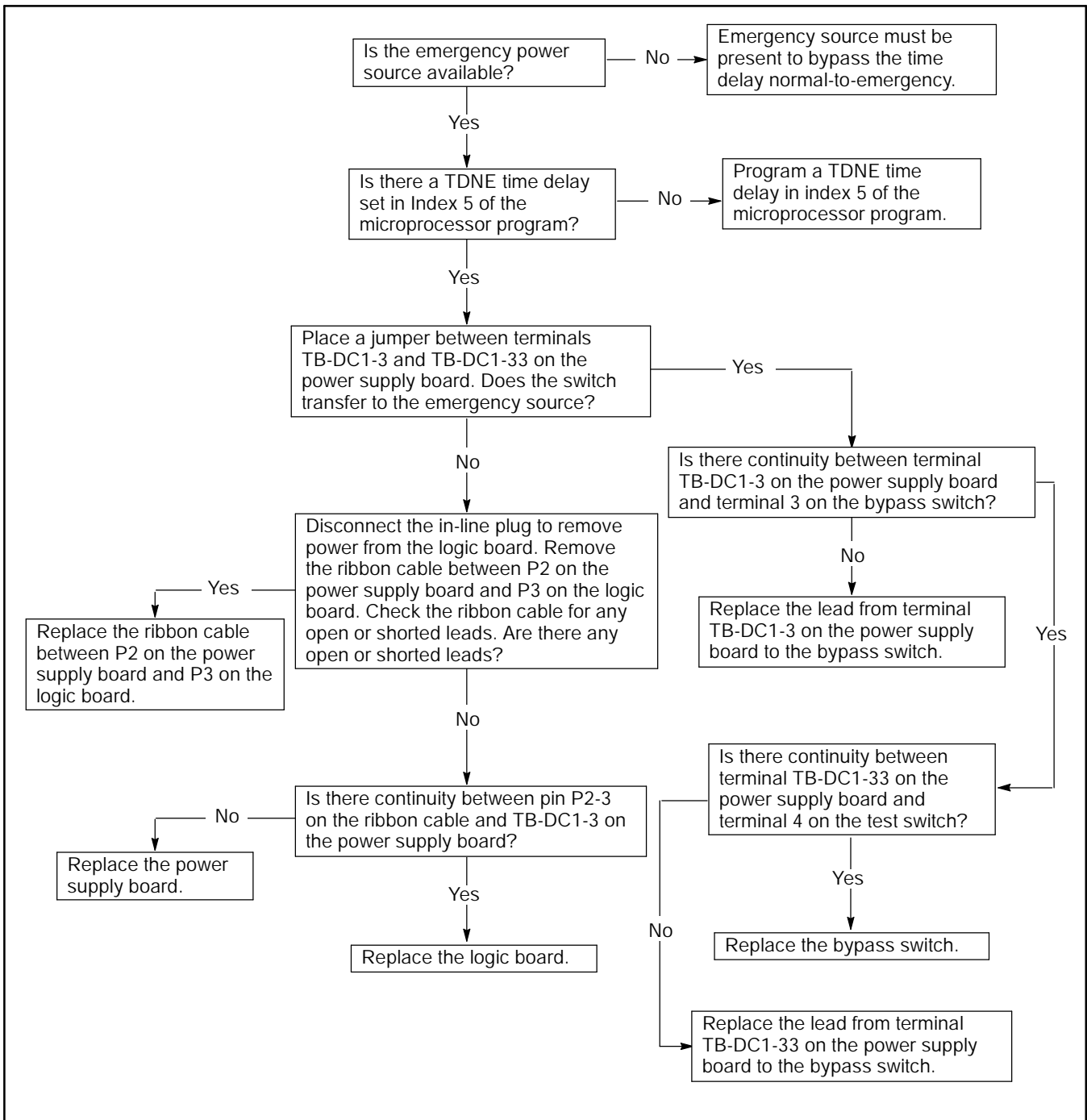
### Troubleshooting The Bypass Emergency-To-Normal Time Delay Pushbutton

This section covers the steps to take to verify that pressing the Bypass Emergency-To-Normal Time Delay pushbutton will override the emergency-to-normal time delay.

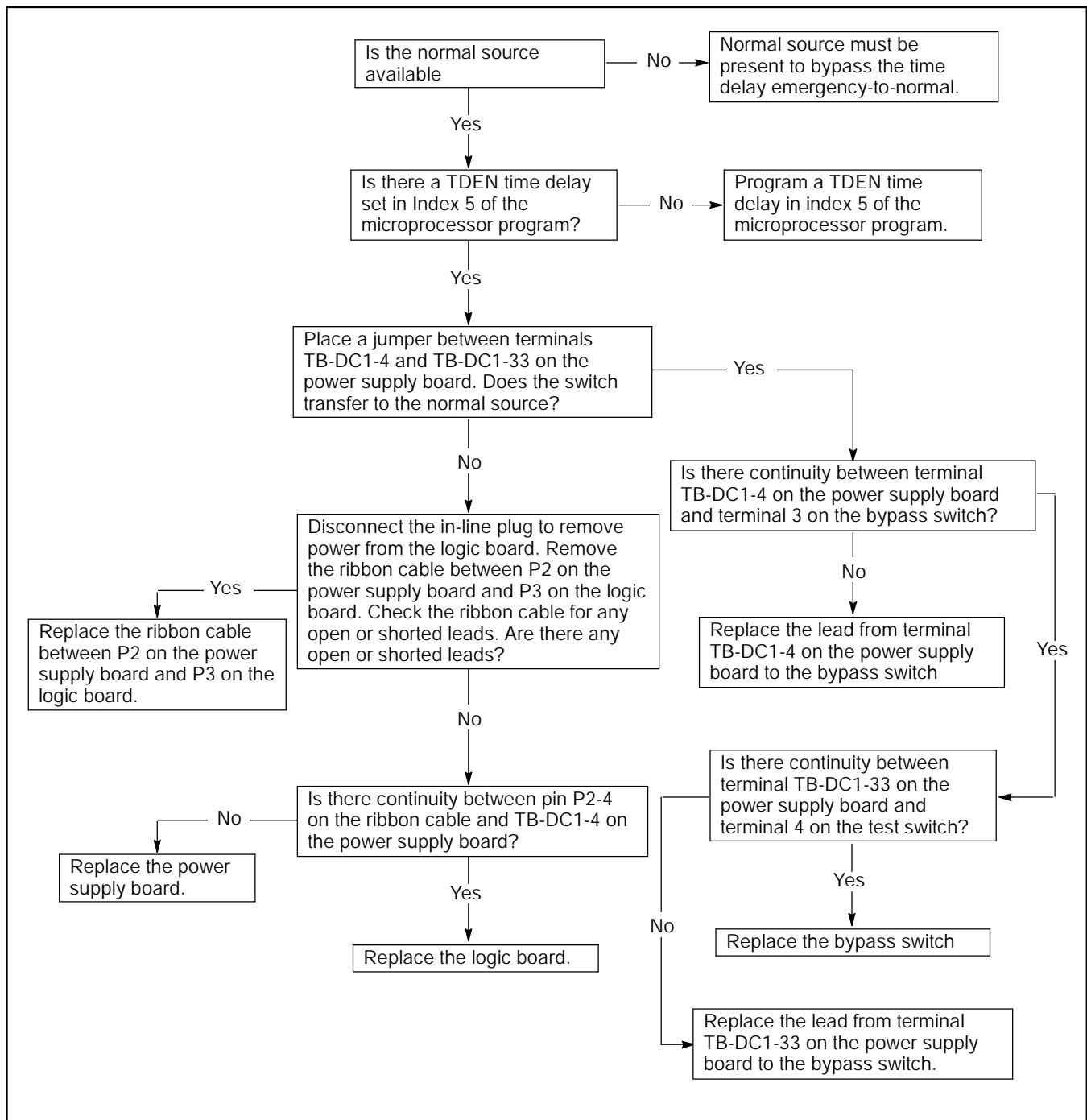
First ensure through the software that a 10 second emergency-to-normal time delay is set. While the emergency source is being used, initiate an emergency-to-normal time delay by restoring the normal source. Then press the Bypass Emergency-to-Normal Time Delay pushbutton.

If after pressing the Bypass Emergency-to-Normal Time Delay pushbutton the emergency-to-normal time delay is not bypassed, connect TB-DC1-4 to TB-DC1-34.

1. If grounding TB-DC1-4 causes the emergency-to-normal time delay to be bypassed but the Bypass Emergency-to-Normal Time Delay pushbutton is not operating, check the Bypass Emergency-To-Normal Time Delay pushbutton and the wiring to the Bypass Emergency-To-Normal Time Delay pushbutton.
2. If after grounding TB-DC1-4 the emergency-to-normal time delay is not bypassed, check the continuity between P2-4 and TB-DC1-4.
  - a. Remove power from the logic board.
  - b. Disconnect the P2 ribbon cable connector from the power supply board.
  - c. Using an ohmmeter, connect one test lead to P2-4 on the power supply board. Connect the other test lead to TB-DC1-4. If there is an open circuit, replace the power supply board. If the resistance is low, the main logic board is bad. Replace the logic board assembly.



**Figure 5-13. Troubleshooting– Option DD-08-C, Normal-to-emergency time delay pushbutton does not work**



**Figure 5-14. Troubleshooting– Option DD-08-D, Emergency-to-normal time delay pushbutton does not work**

# Preferred Source Switch

Preferred source switch option DD-10-D provides a means to select which of two generator sets will be used

when the emergency source fails. See Figure 5-15 for a wiring diagram for DD-10-D.

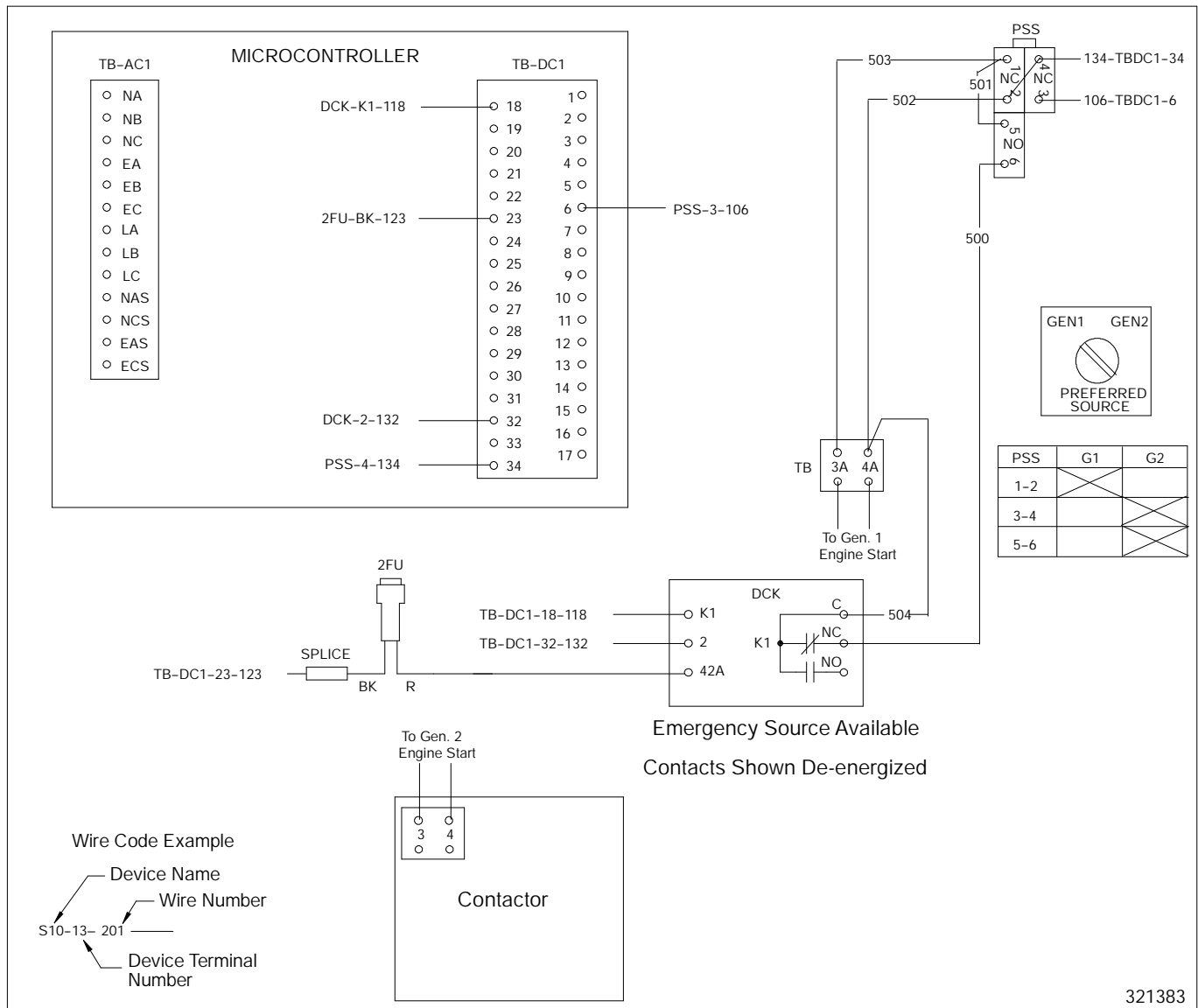


Figure 5-15. Wiring Diagram– Preferred source switch, Option DD-10-D

# Relay Auxiliary Dry Contacts

Auxiliary Dry Contacts option DD-14-G provides ten contacts for remote indication. The contacts are rated at 10 amperes and 125 volts AC. This accessory indicates normal and emergency contactor positions, normal and emergency source availability, control not in automatic,

program mode not in off, and system alert. DD-14-G can be fitted to a transfer switch alone or with up to two additional auxiliary dry contact accessories. Figure 5-16 contains a wiring diagram for DD-14-G.

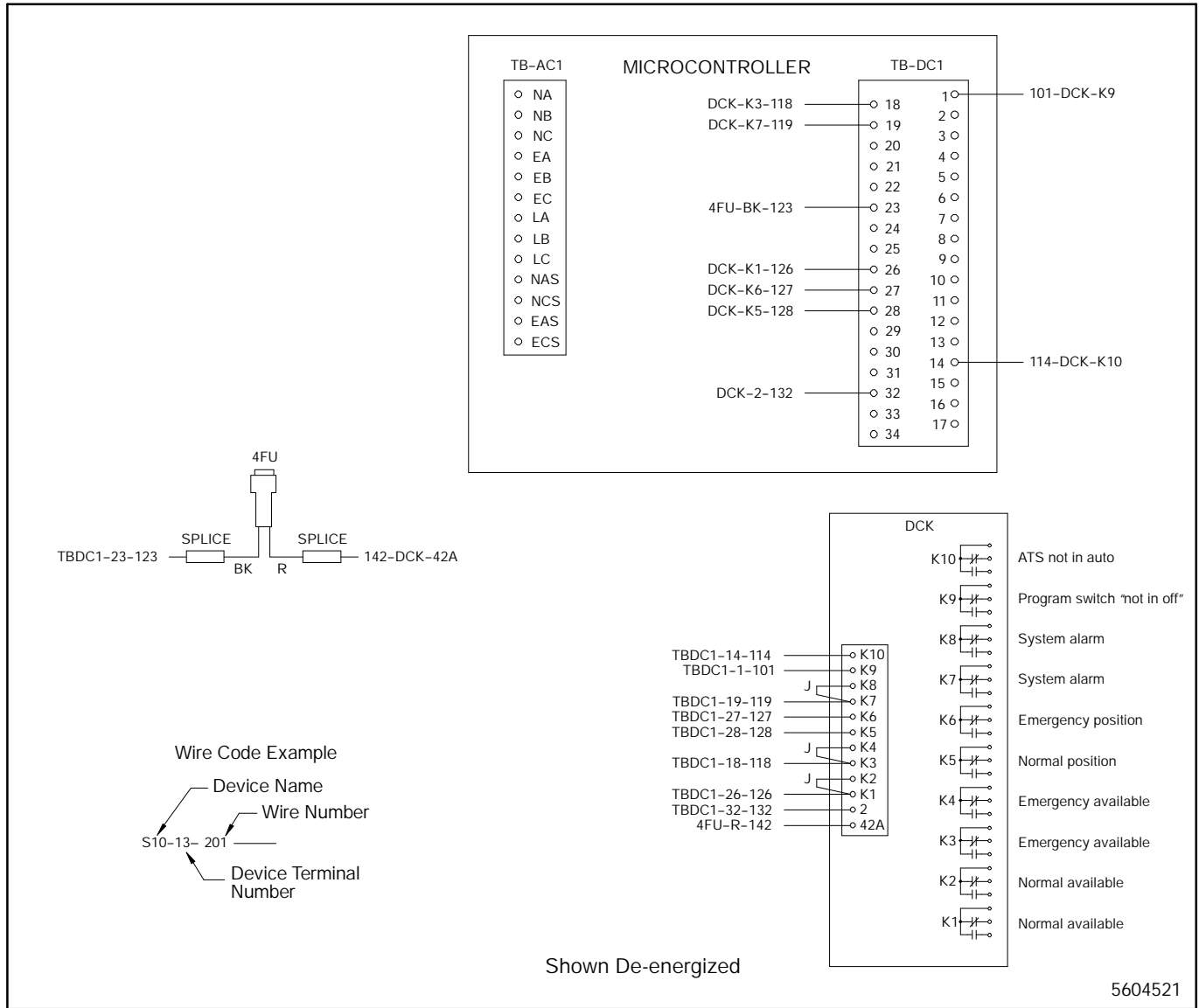


Figure 5-16. Wiring Diagram– Option DD-14-G, Auxiliary Dry Contacts

Additional auxiliary dry contact accessories are described below. Wiring diagrams for these accessories are in Figure 5-17 to Figure 5-24. Refer to Figure 5-25 for the troubleshooting flowchart.

- D DD-14-H. Single-contact kit for remote indication. This option is rated for 10 amps and for 120 volts AC. It is used to indicate the normal contactor position.
- D DD-14-J. Single-contact kit for remote indication. This option is rated for 10 amps and for 120 volts AC. It is used to indicate the emergency contactor position.
- D DD-14-K. Single-contact kit for remote indication. This option is rated for 10 amps and for 120 volts AC. It is used to indicate normal source availability.
- D DD-14-L. Single-contact kit for remote indication. This option is rated for 10 amps and for 120 volts AC. It is used to indicate emergency source availability.
- D DD-14-M. Single-contact kit for remote indication. This option is rated for 10 amps and for 120 volts AC. It is used to indicate whether the Automatic/Manual selector switch is not in the Automatic position.
- D DD-14-N. Single-contact kit for remote indication. This option is rated for 10 amps and for 120 volts AC. It is used to indicate whether the programming mode switch is not in the Off position.
- D DD-14-P. Single-contact kit for remote indication. This option is rated for 10 amps and for 120 volts AC. It is used to indicate a system alert condition.
- D DD-14-R. Single-contact kit for remote indication. This option is rated for 10 amps and for 120 volts AC. It is used for load bank control. Relay energizes when the plant exersier is active and the contractor does not transfer.

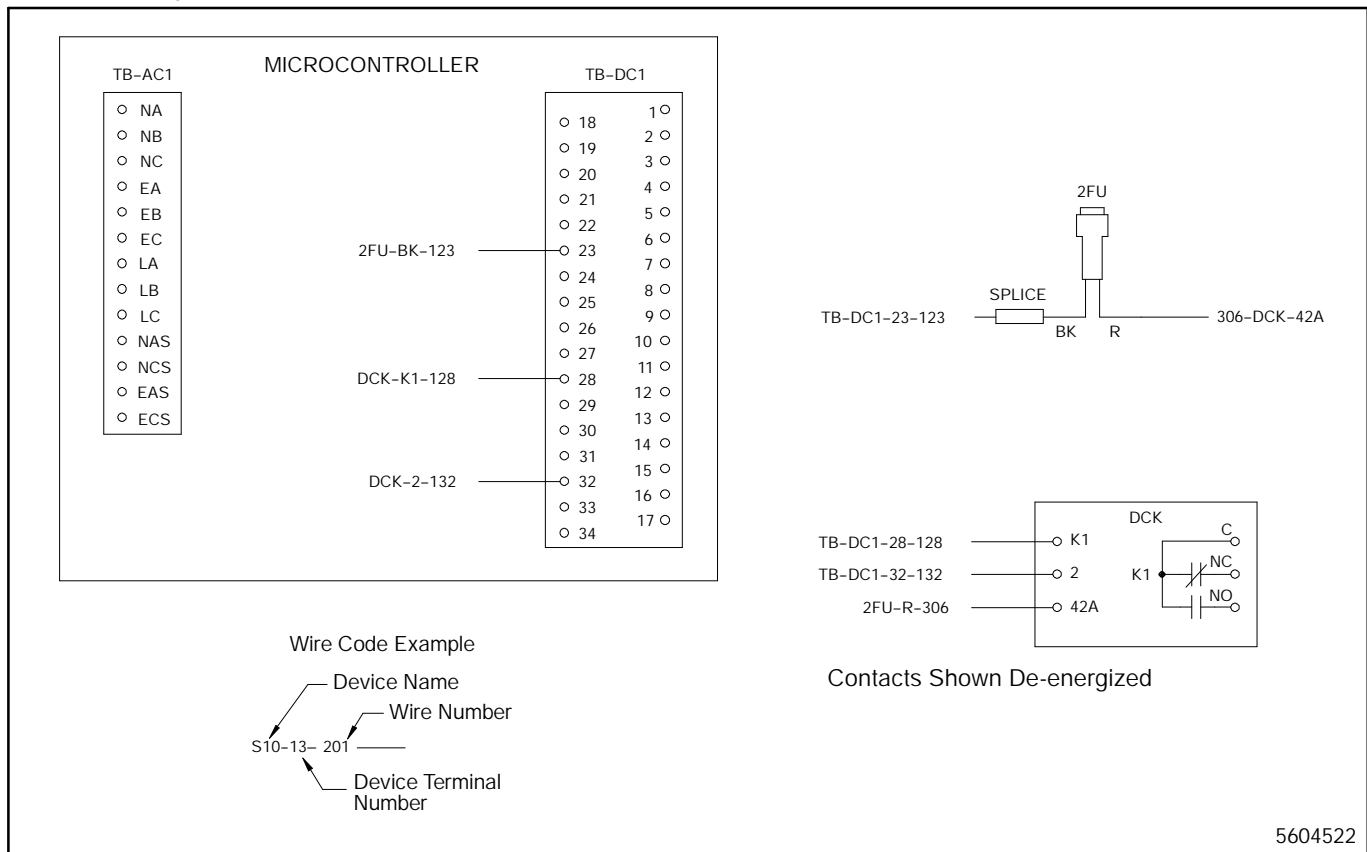


Figure 5-17. Wiring Diagram– Option DD-14-H, Auxiliary dry contacts

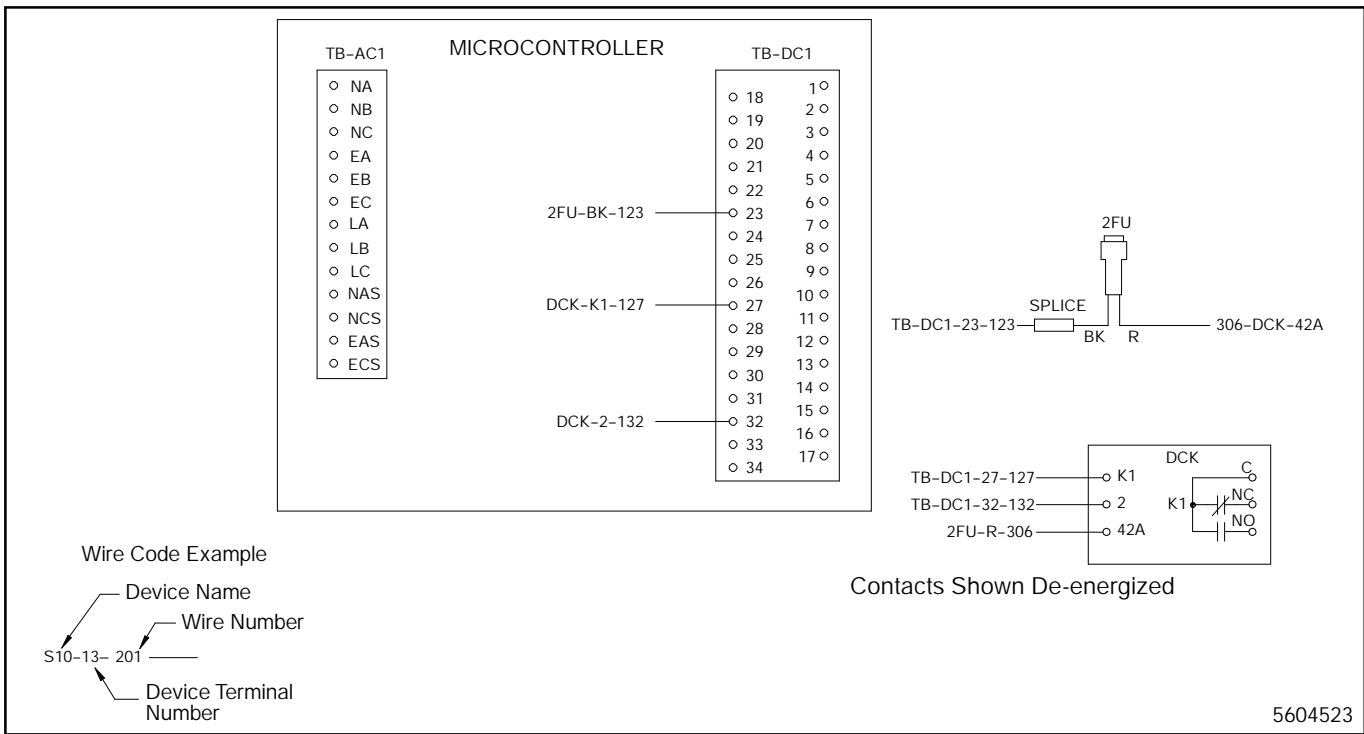


Figure 5-18. Wiring Diagram– Option DD-14-J, Auxiliary dry contacts

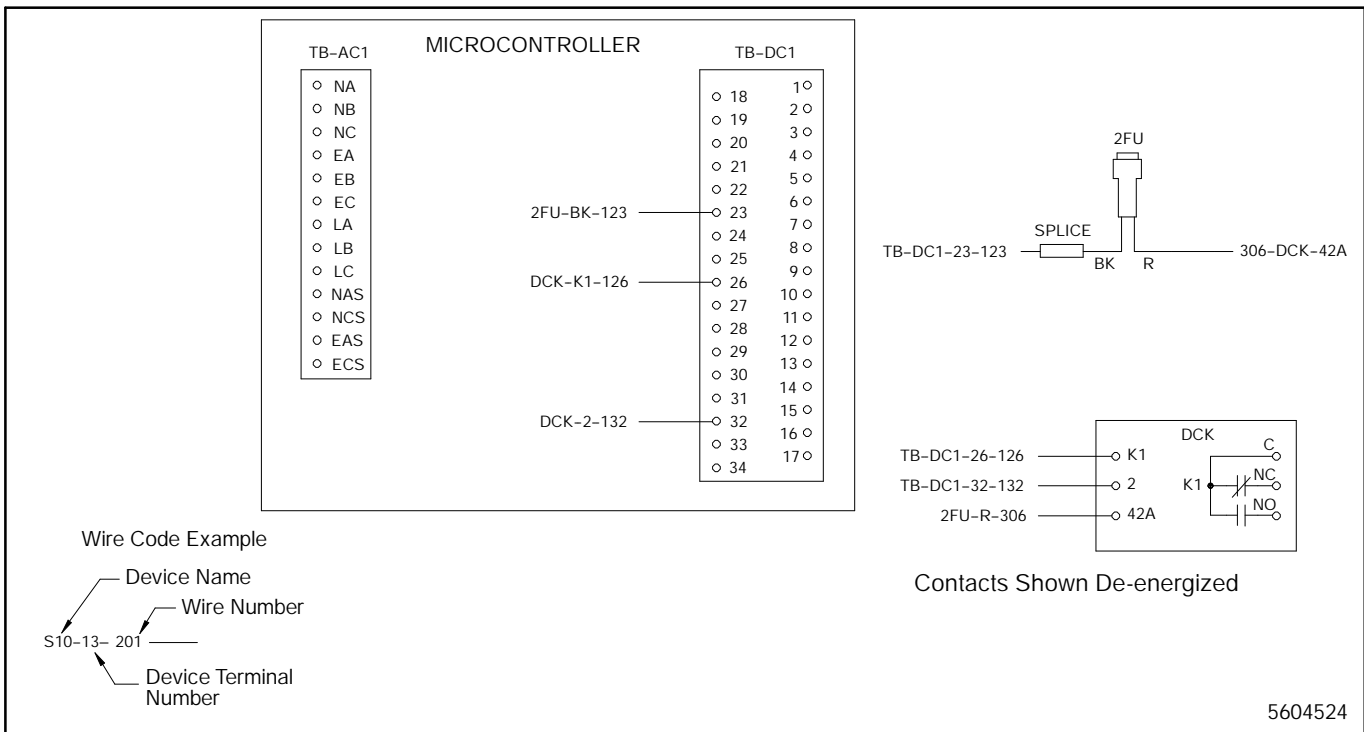
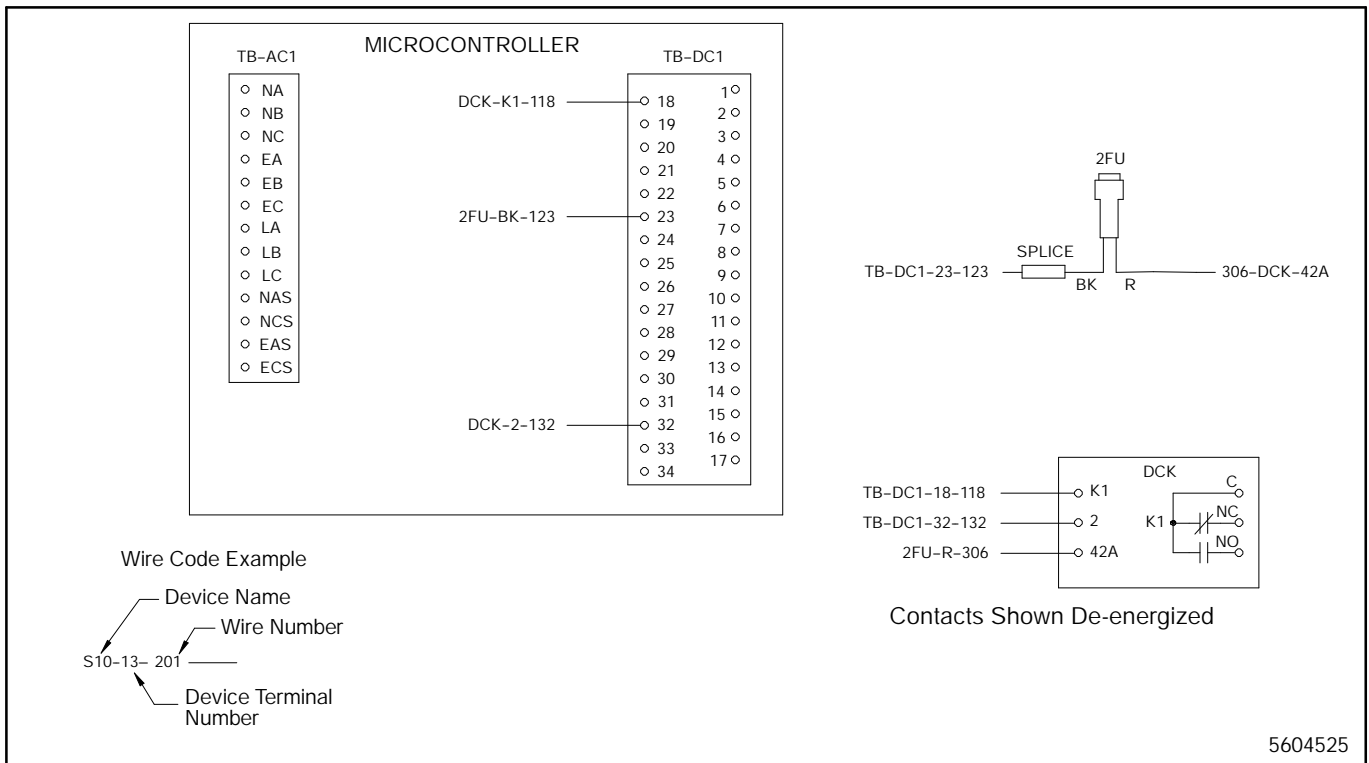
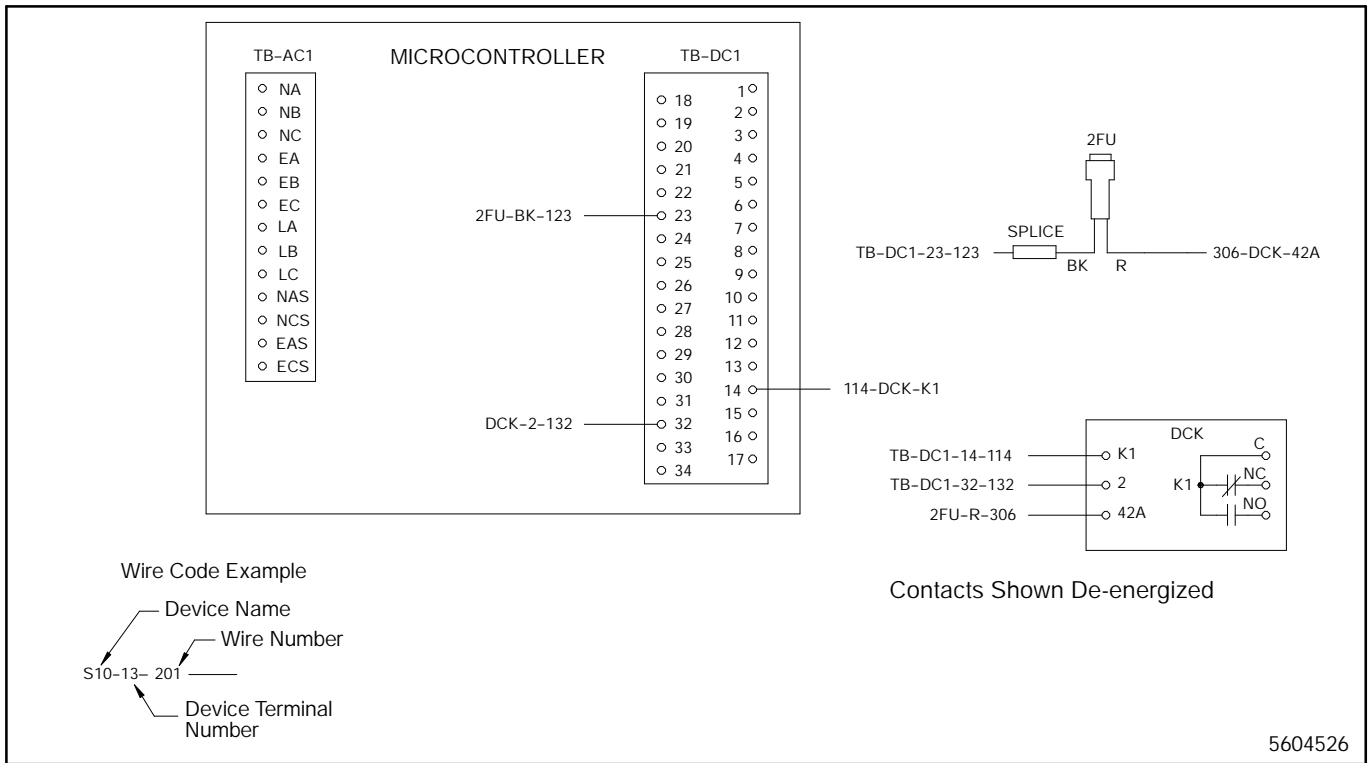


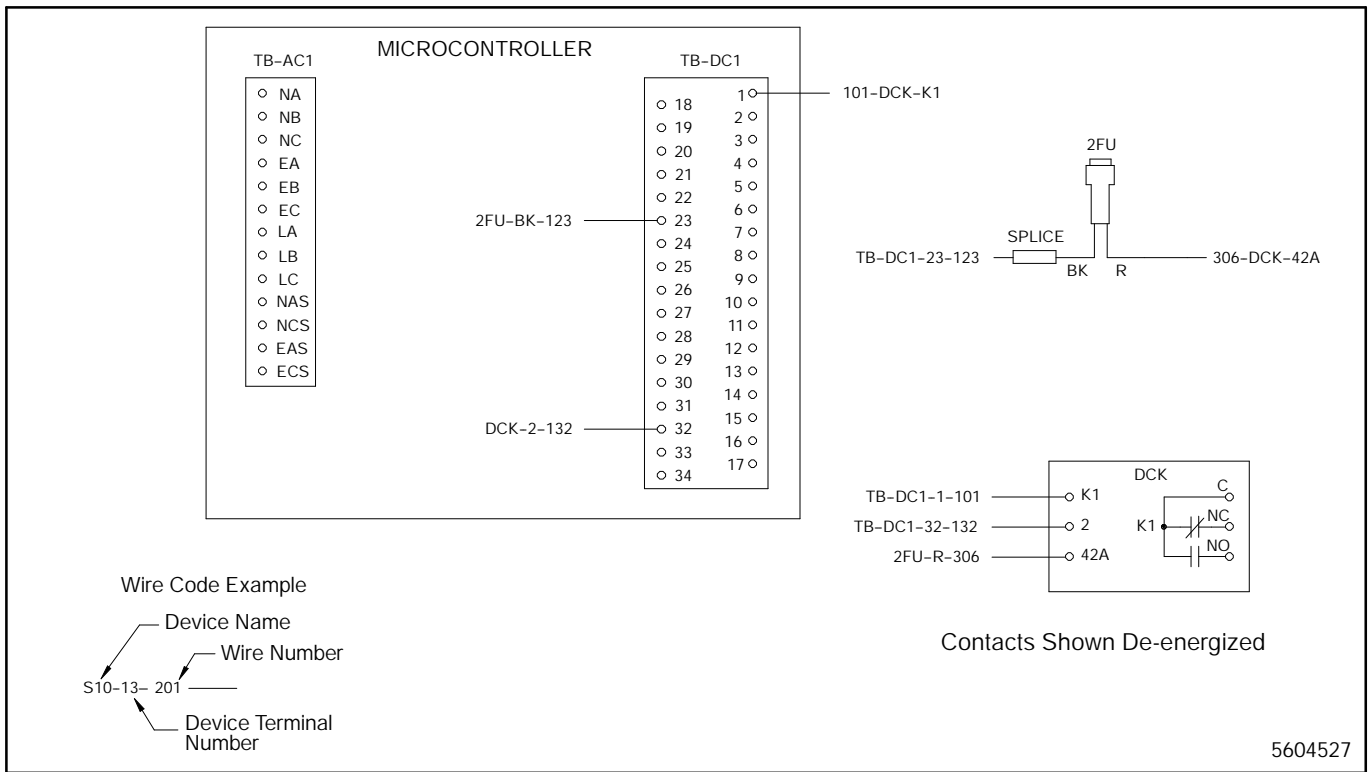
Figure 5-19. Wiring Diagram– Option DD-14-K, Auxiliary dry contacts



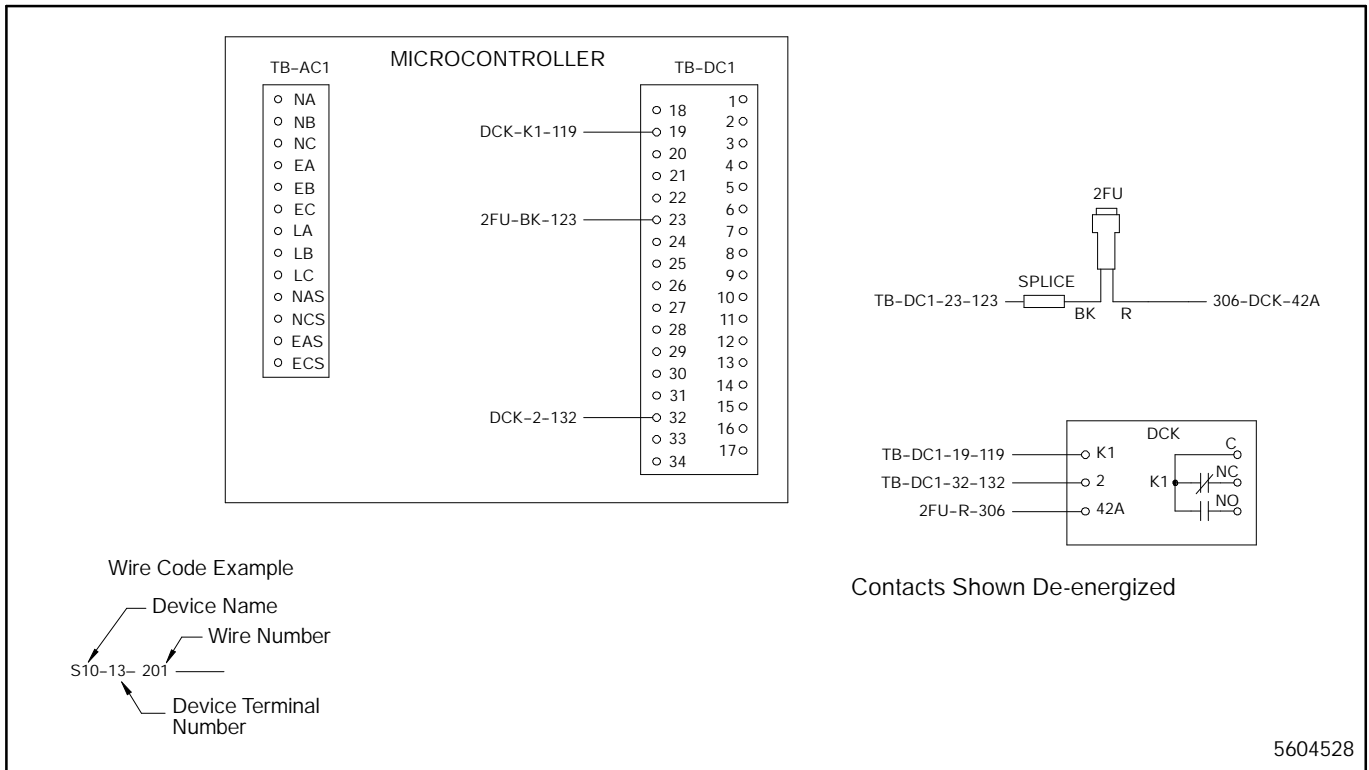
**Figure 5-20. Wiring Diagram– Option DD-14-L, Auxiliary dry contacts**



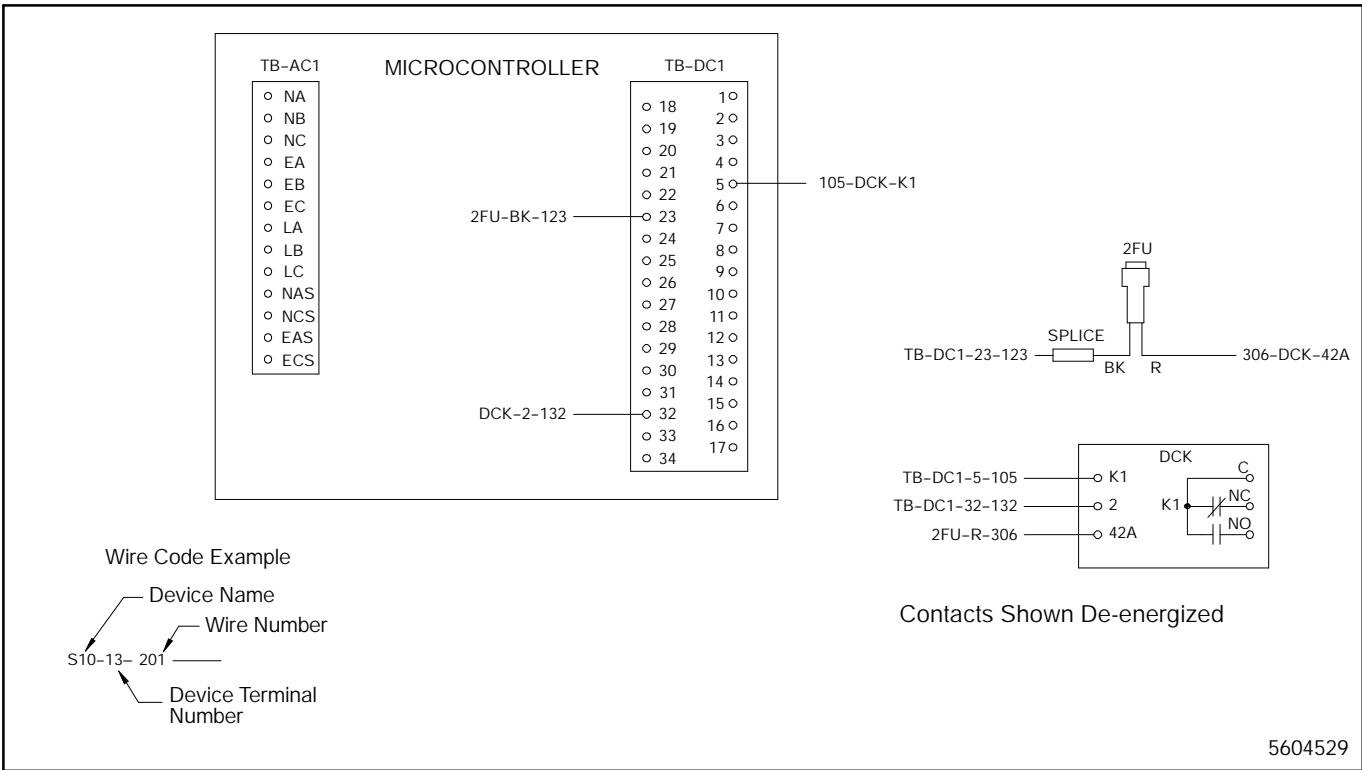
**Figure 5-21. Wiring Diagram– Option DD-14-M, Auxiliary dry contacts**



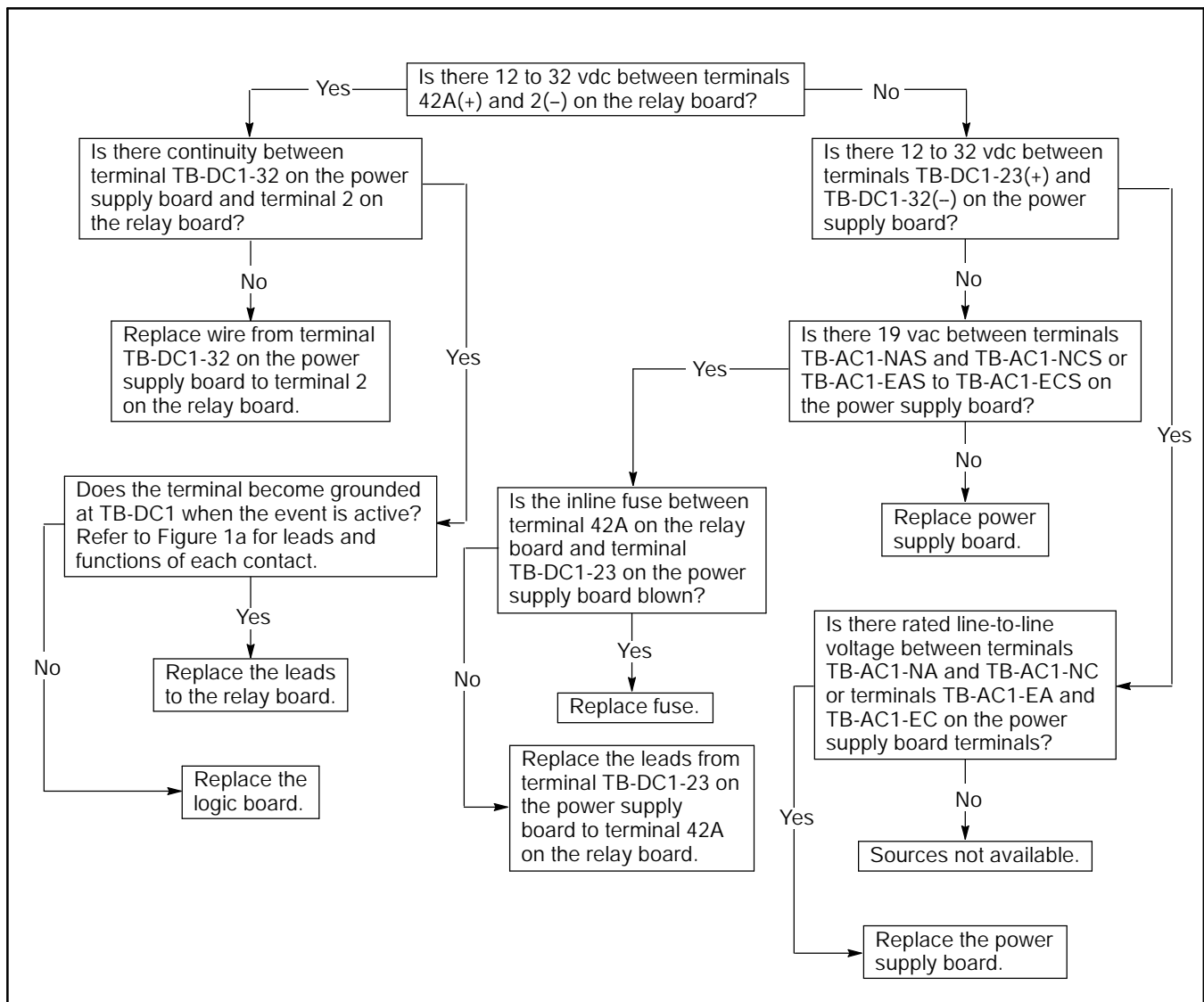
**Figure 5-22. Wiring Diagram– Option DD-14-N, Auxiliary dry contacts**



**Figure 5-23. Wiring Diagram– Option DD-14-P, Auxiliary dry contacts**



**Figure 5-24. Wiring Diagram– Option DD-14-R, Auxiliary dry contacts**



**Figure 5-25. Troubleshooting– Option DD-14, Auxiliary dry contacts relay boards do not operate**

Make sure that the function you are testing is available, energized the Test switch must not be in the Auto position, i.e., ATS Not-In-Auto relay K10. For this relay to be

Terminal number for ten-relay board	Terminal number for single-relay boards	Description	Terminal Number
K1	K1	Normal Source Available	TB-DC1-32
K2	K1	Normal Source Available	TB-DC1-26
K3	K1	Emergency Source Available	TB-DC1-18
K4	K1	Emergency Source Available	TB-DC1-18
K5	K1	Contactor in the Normal position	TB-DC1-28
K6	K1	Contactor in the Emergency position	TB-DC1-27
K7	K1	System Alarm	TB-DC1-19
K8	K1	System Alarm	TB-DC1-19
K9	K1	Program switch not in the Off position	TB-DC1-1
K10	K1	Test switch not in the Auto position	TB-DC1-14

**Figure 5-26. Option DD-14 Terminal Description**

# Main Shaft Auxiliary Dry Contacts

One main shaft auxiliary dry contact, option DD-15-A, is supplied standard on 600 volt class transfer switches. DD-15-A is mounted on the transfer switch. The location of the auxiliary contacts varies according to the ampere size and type of power conversion unit. One set of auxiliary contacts is closed when the transfer switch is connected to the normal source. One set is closed when the transfer switch is connected to the emergency source. Refer to the power conversion unit service

manual for troubleshooting.

Additional accessory DD-15 contacts available are described below.

- D DD-15-E.** This accessory has one additional contact which is closed when the transfer switch is connected to the normal source.
- D DD-15-F.** This accessory has one additional contact which is closed when the transfer switch is connected to the emergency source.

# Meters

Option 18 provides an analog meter to measure various parameters including voltage, current, and frequency. Figure 5-27 contains a wiring diagram for option DD-18-G. Figure 5-33 contains a troubleshooting flowchart for option DD-18-G. Figure 1b through Figure 5-32 contain wiring diagrams for option DD-18-J.

Troubleshooting flowcharts for option DD-18-J begin with Figure 5-36 and conclude with Figure 5-52.

- D **DD-18-G.** Analog frequency meter with fuse.
- D **DD-18-J.** Analog voltmeter and ammeter with fuses.

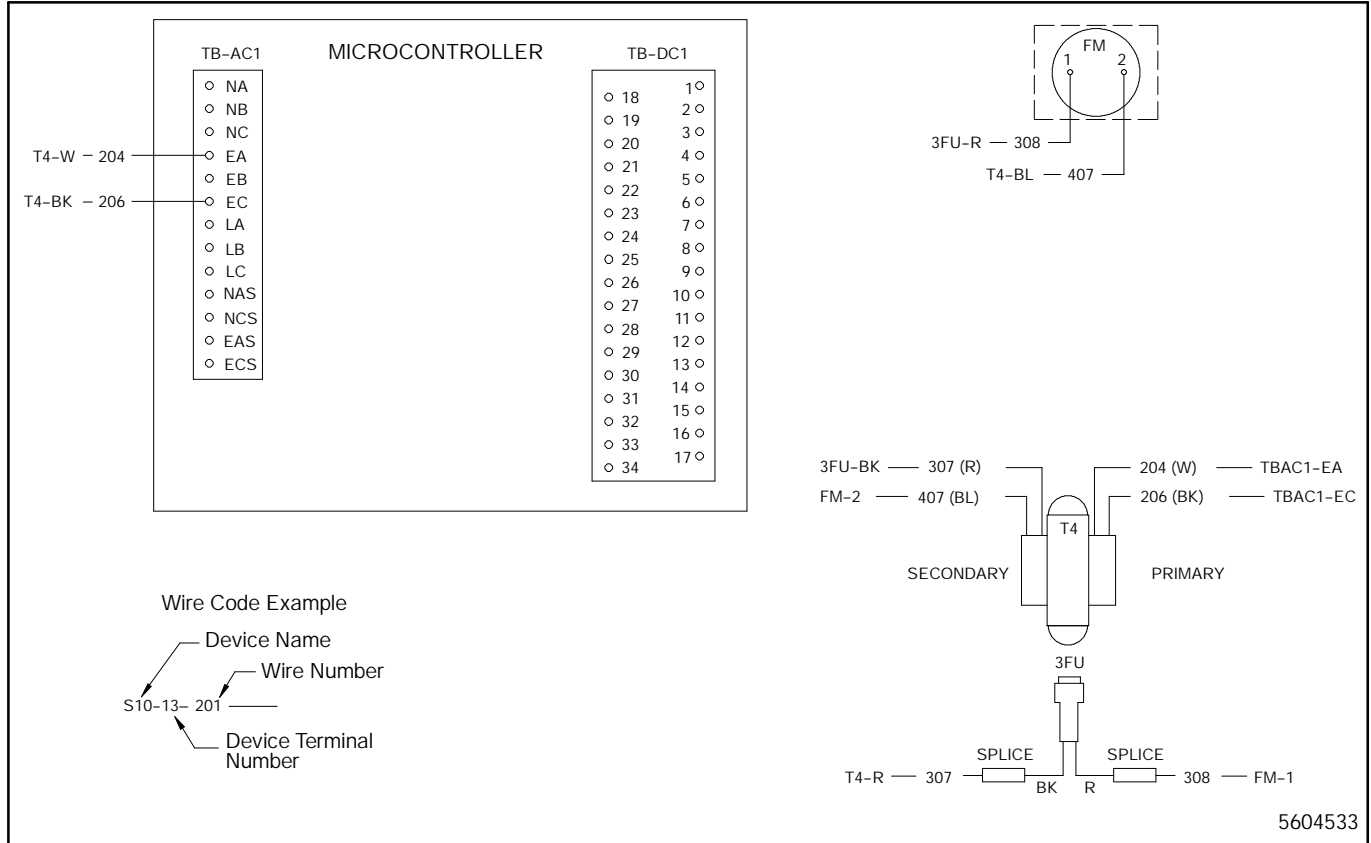
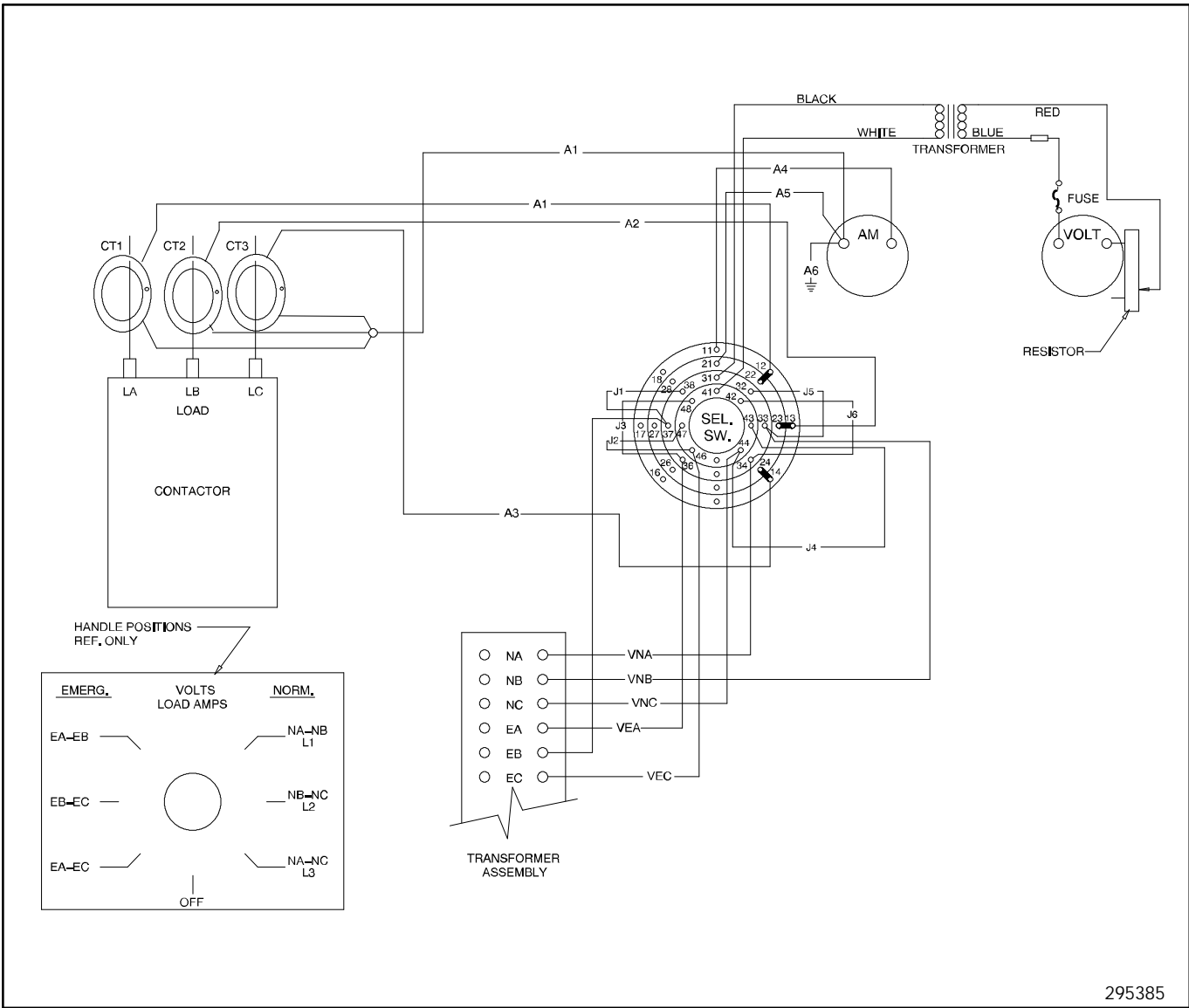
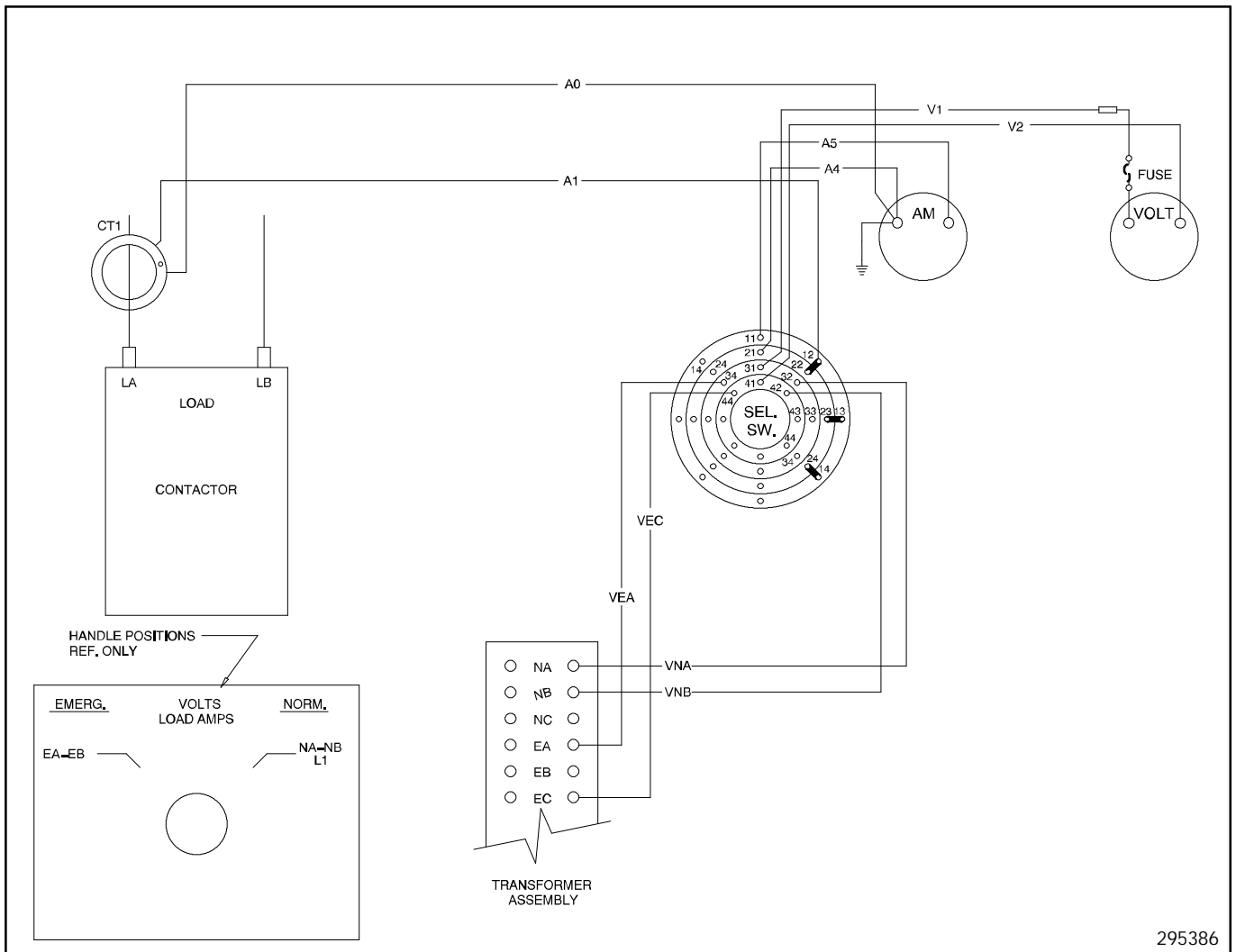


Figure 5-27. Wiring Diagram– Option DD-18-G, Analog frequency meter



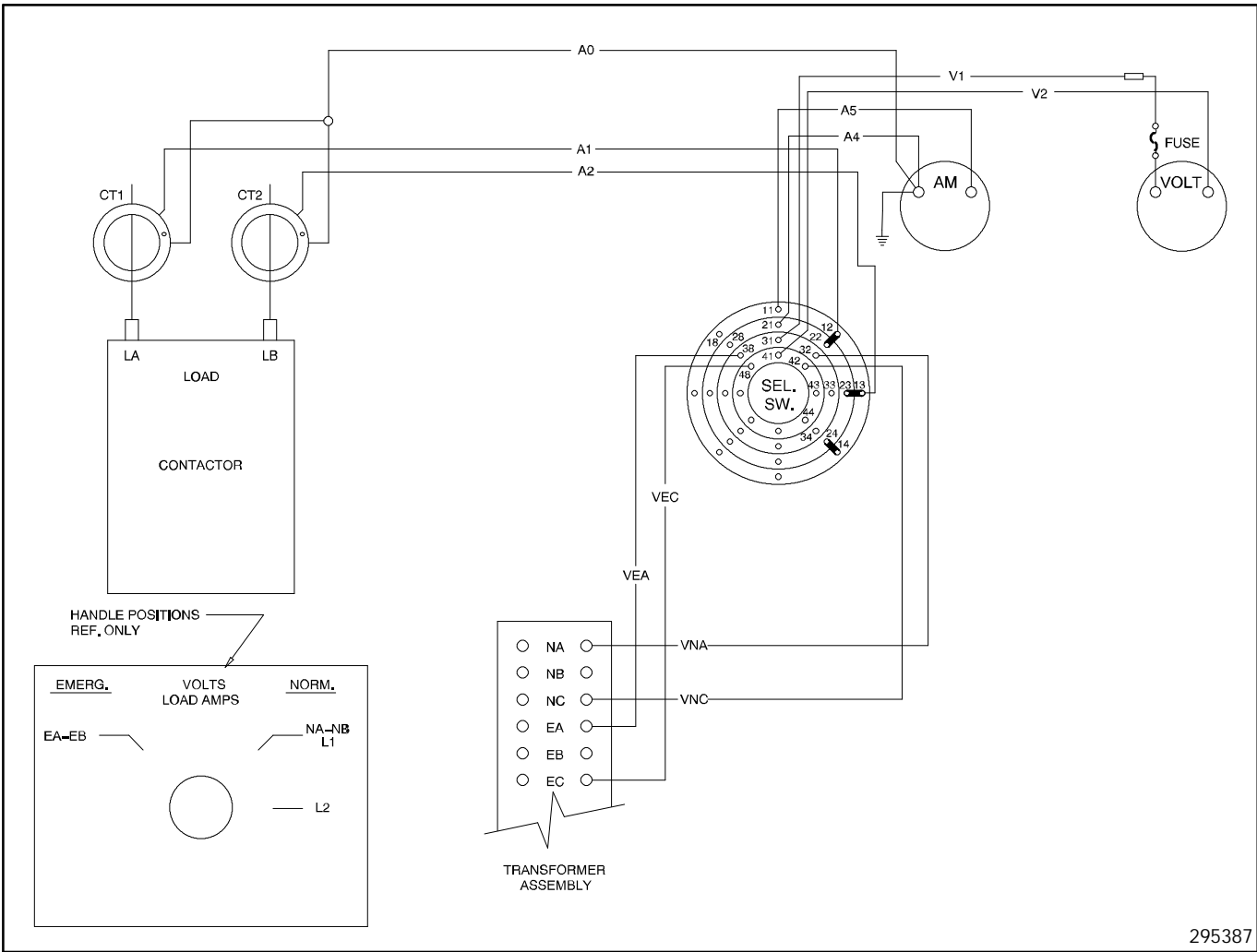
295385

Figure 5-28. Wiring Diagram– Option DD-18-J, Analog Volt and Amp Meter



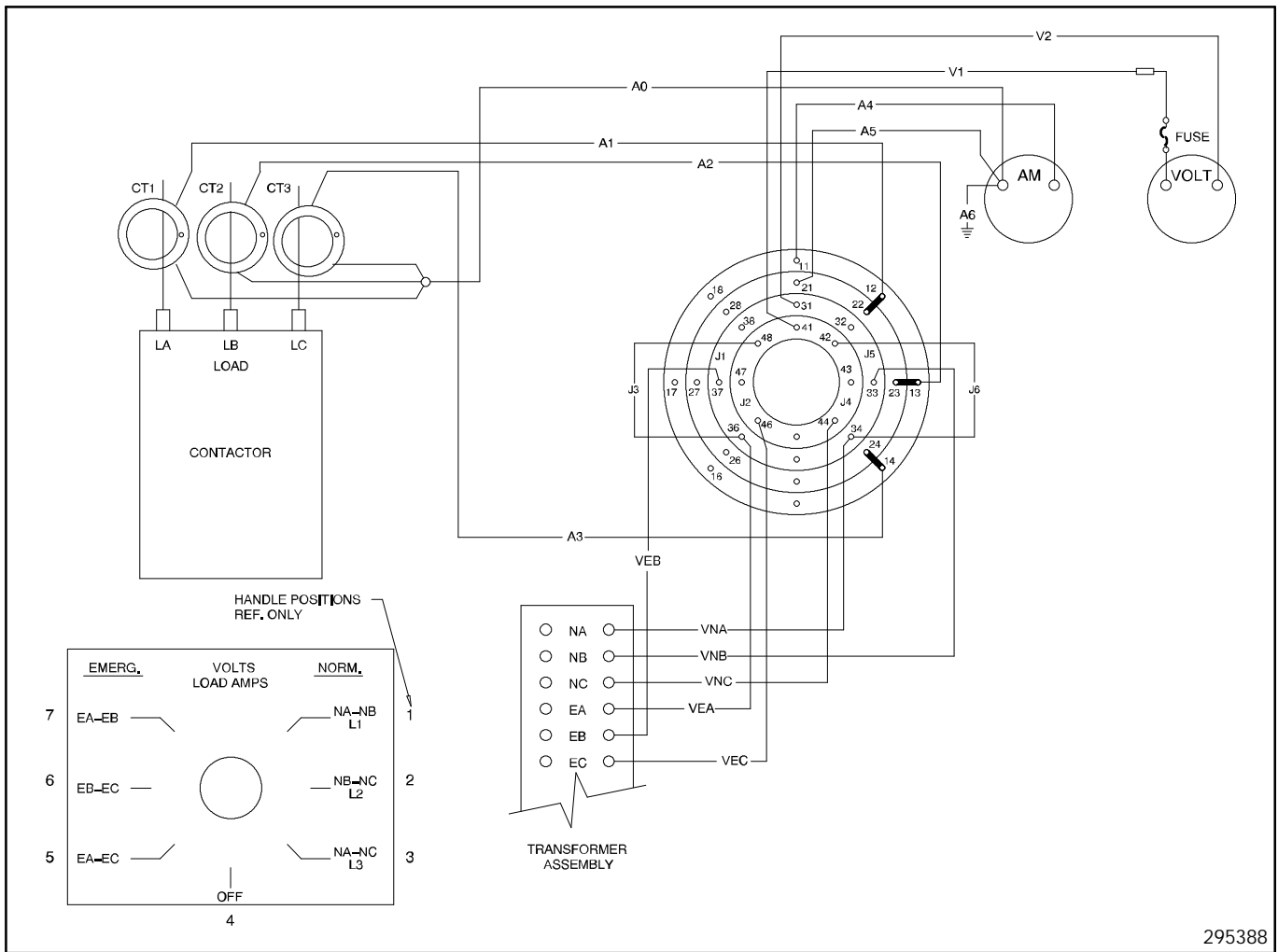
295386

Figure 5-29. Wiring Diagram– Option DD-18-J, Analog Volt and Amp Meter



295387

Figure 5-30. Wiring Diagram– Option DD-18-J, Analog Volt and Amp Meter



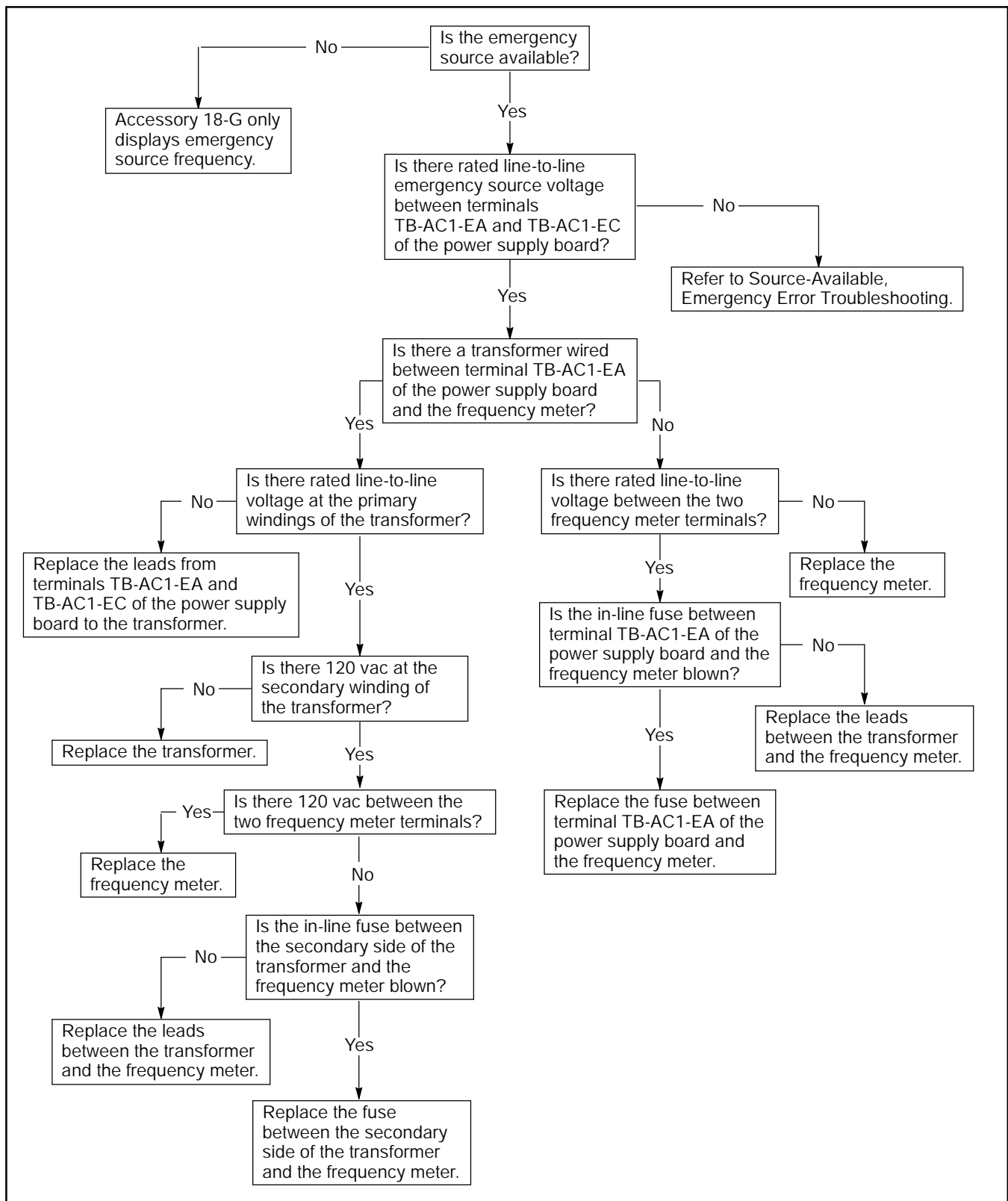
295388

Figure 5-31. Wiring Diagram– Option DD-18-J, Analog Volt and Amp Meter

CONTACTS	HANDLE POSITIONS										
	AMMETER	VOLTMETER		OFF	1	2	3	4	5	6	7
11 12	31 32	41 42		X							
11 13	31 33	41 43			X						
11 14	31 34	41 44				X					
11 15	31 35	41 45					X				
11 16	31 36	41 46						X			
11 17	31 37	41 47							X		
11 18	31 38	41 48								X	
21 22			X	X	X	X	X	X	X	X	X
21 23			X	X		X	X	X	X	X	X
21 24			X	X	X		X	X	X	X	X
21 25			X	X	X	X		X	X	X	
21 26			X	X	X	X	X		X	X	
21 27			X	X	X	X	X	X	X		X
21 28			X	X	X	X	X	X	X	X	

295388

Figure 5-32. Wiring Diagram– Option DD-18-J, Analog Volt and Amp Meter



**Figure 5-33. Troubleshooting– Option DD-18-G, Meter will not display frequency**

Use the following table to find the troubleshooting flowchart for Option DD-18-J Current and Voltage meters. Locate the DD-18-J accessory that is used on your transfer switch in the left column. The flowchart number for troubleshooting the voltmeter is in the center column and the flowchart for troubleshooting the ammeter is in the right column.

Options with DD-18-Prefix	Voltmeter Troubleshooting	Ammeter Troubleshooting Flowchart
JA1	Figure 5-36	Figure 5-37
JA2	Figure 5-40 to Figure 5-45	Figure 5-46
JA3	Figure 5-36	Figure 5-37
JA4	Figure 5-38	Figure 5-39
JA5	Figure 5-40 to Figure 5-45	Figure 5-46
JA8	Figure 5-47 to Figure 5-52	Figure 5-46
JA9	Figure 5-47 to Figure 5-52	Figure 5-46
JA10	Figure 5-47 to Figure 5-52	Figure 5-46
JB1	Figure 5-36	Figure 5-37
JB2	Figure 5-40 to Figure 5-45	Figure 5-46
JB3	Figure 5-36	Figure 5-37
JB4	Figure 5-38	Figure 5-39
JB5	Figure 5-40 to Figure 5-45	Figure 5-46
JB6	Figure 5-47 to Figure 5-52	Figure 5-46
JB8	Figure 5-47 to Figure 5-52	Figure 5-46
JB9	Figure 5-47 to Figure 5-52	Figure 5-46
JB10	Figure 5-47 to Figure 5-52	Figure 5-46
JC1	Figure 5-36	Figure 5-37
JC2	Figure 5-40 to Figure 5-45	Figure 5-46
JC3	Figure 5-36	Figure 5-37
JC4	Figure 5-38	Figure 5-39
JC5	Figure 5-40 to Figure 5-45	Figure 5-46
JC8	Figure 5-47 to Figure 5-52	Figure 5-46
JC9	Figure 5-47 to Figure 5-52	Figure 5-46
JC10	Figure 5-47 to Figure 5-52	Figure 5-46
JD1	Figure 5-36	Figure 5-37
JD2	Figure 5-40 to Figure 5-45	Figure 5-46
JD3	Figure 5-36	Figure 5-37
JD4	Figure 5-38	Figure 5-39

Options with DD-18-Prefix	Voltmeter Troubleshooting	Ammeter Troubleshooting Flowchart
JD5	Figure 5-40 to Figure 5-45	Figure 5-46
JD8	Figure 5-47 to Figure 5-52	Figure 5-46
JD9	Figure 5-47 to Figure 5-52	Figure 5-46
JD10	Figure 5-47 to Figure 5-52	Figure 5-46
JE1	Figure 5-36	Figure 5-37
JE2	Figure 5-40 to Figure 5-45	Figure 5-46
JE3	Figure 5-36	Figure 5-37
JE4	Figure 5-38	Figure 5-39
JE5	Figure 5-40 to Figure 5-45	Figure 5-46
JE8	Figure 5-47 to Figure 5-52	Figure 5-46
JE9	Figure 5-47 to Figure 5-52	Figure 5-46
JE10	Figure 5-47 to Figure 5-52	Figure 5-46
JF1	Figure 5-36	Figure 5-37
JF2	Figure 5-40 to Figure 5-45	Figure 5-46
JF3	Figure 5-36	Figure 5-37
JF4	Figure 5-38	Figure 5-39
JF5	Figure 5-40 to Figure 5-45	Figure 5-46
JF6	Figure 5-47 to Figure 5-52	Figure 5-46
JF8	Figure 5-47 to Figure 5-52	Figure 5-46
JF9	Figure 5-47 to Figure 5-52	Figure 5-46
JF10	Figure 5-47 to Figure 5-52	Figure 5-46
JG1	Figure 5-36	Figure 5-37
JG2	Figure 5-40 to Figure 5-45	Figure 5-46
JG3	Figure 5-36	Figure 5-37
JG4	Figure 5-38	Figure 5-39
JG5	Figure 5-40 to Figure 5-45	Figure 5-46
JG8	Figure 5-47 to Figure 5-52	Figure 5-46
JG9	Figure 5-47 to Figure 5-52	Figure 5-46
JG10	Figure 5-47 to Figure 5-52	Figure 5-46
JH1	Figure 5-36	Figure 5-37
JH2	Figure 5-40 to Figure 5-45	Figure 5-46
JH3	Figure 5-36	Figure 5-37
JH4	Figure 5-38	Figure 5-39
JH5	Figure 5-40 to Figure 5-45	Figure 5-46
JH6	Figure 5-47 to Figure 5-52	Figure 5-46
JH8	Figure 5-47 to Figure 5-52	Figure 5-46
JH9	Figure 5-47 to Figure 5-52	Figure 5-46
JH10	Figure 5-47 to Figure 5-52	Figure 5-46

**Figure 5-34. Option DD-18, analog meters troubleshooting table**

Option 18-JXXX, analog meters	Turn ratio of transformer
JA1-5, JA8-10	30-5
JB1-6, JB8-10	75-5
JC1-5, JC8-10	100-5
JD1-5, JD8-10	150-5
JE1-5, JE8-10	300-5
JF1-6, JF8-10	400-5
JG1-5, JG8-10	600-5
JH1-5, JH8-10	800-5

**Figure 5-35. Transformer Turn Ratio**



NOTE: The ammeter reads load currents. The source selector switch must be in the NORM. NA-NBL1 position to read the load current.

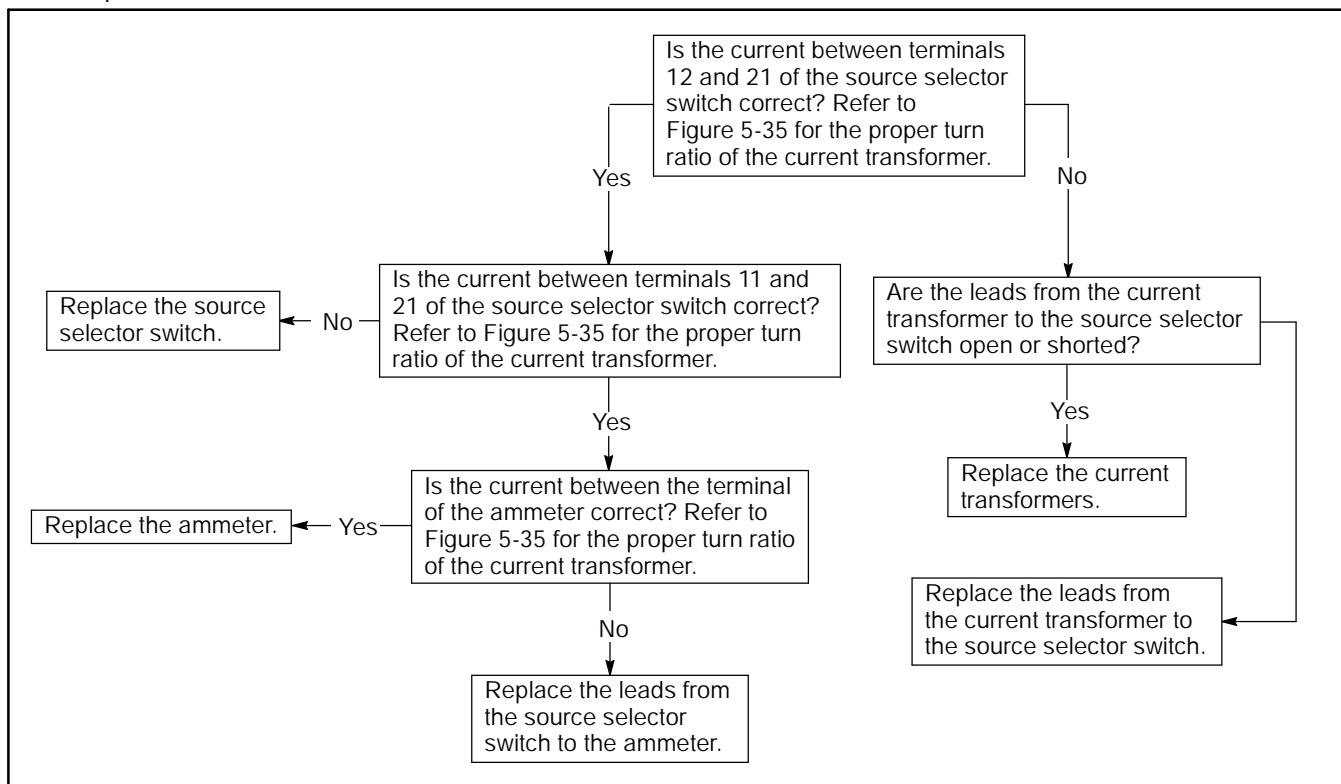
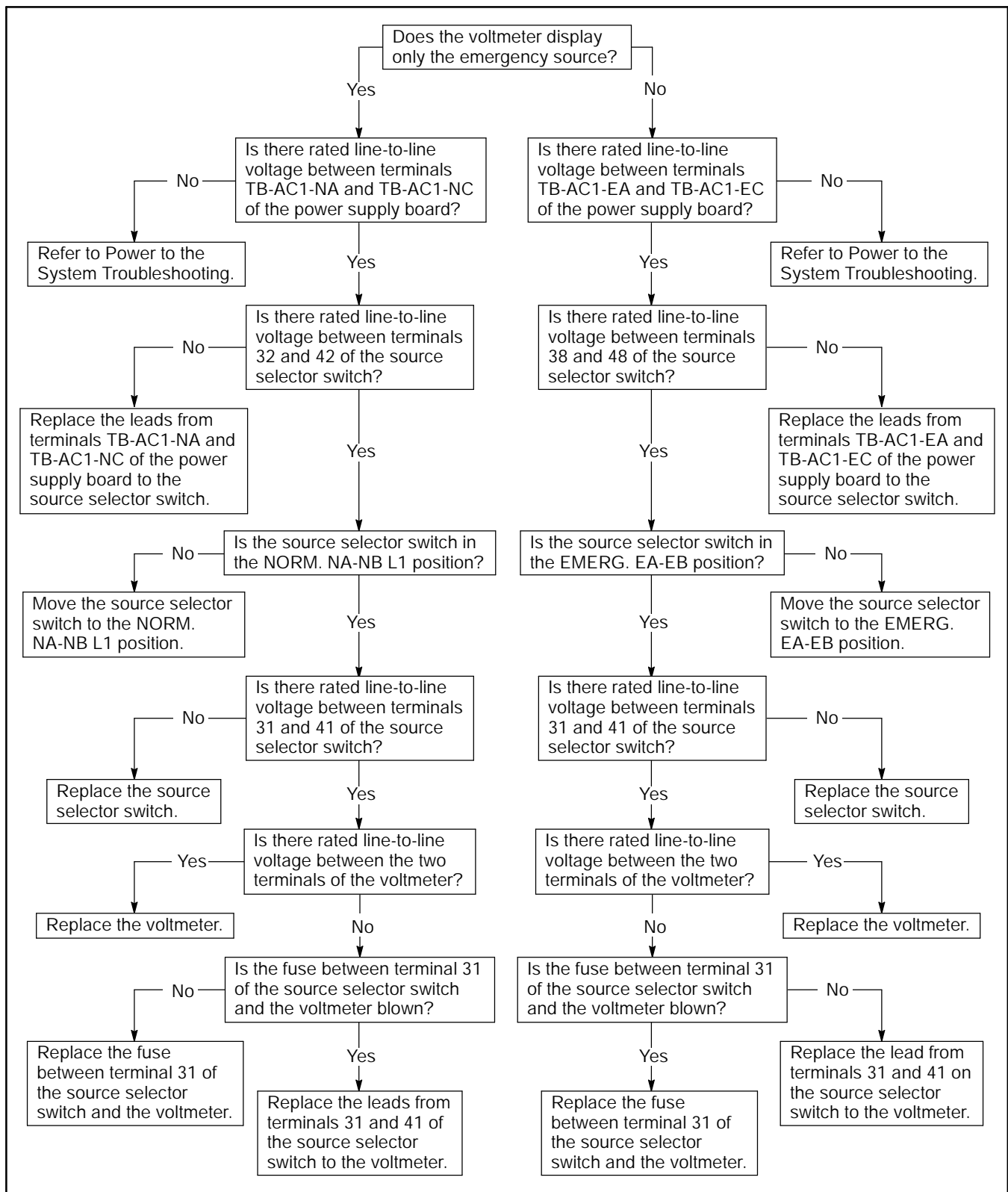


Figure 5-37. Troubleshooting– Option DD-18-J, Ammeter is not functioning



**Figure 5-38. Troubleshooting– Option DD-18-J, Voltmeter is not functioning**

NOTE: The ammeter reads the load current. The source selector switch must be in the NORM. NA-NBL1 or L2 position to read the load current.

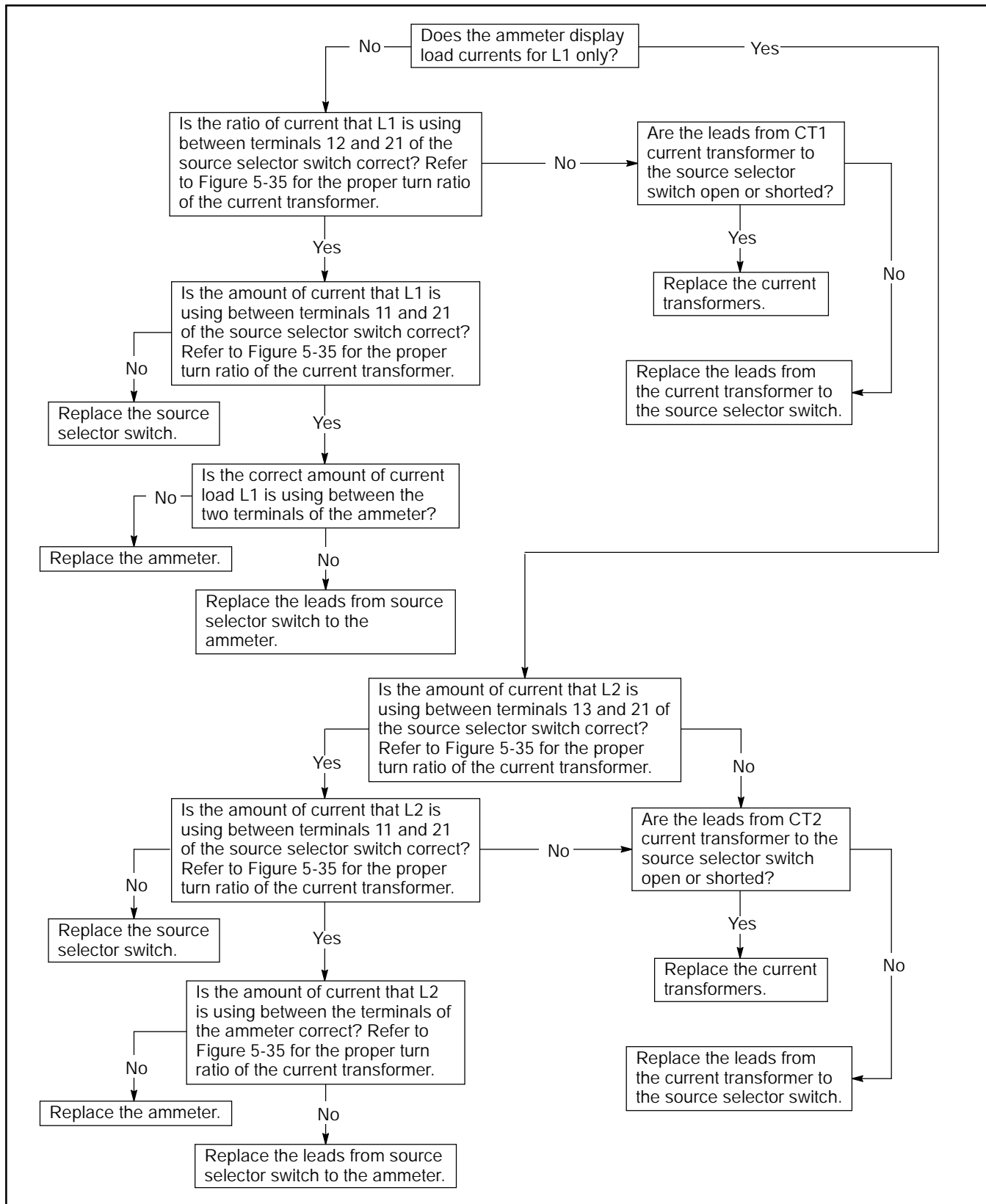
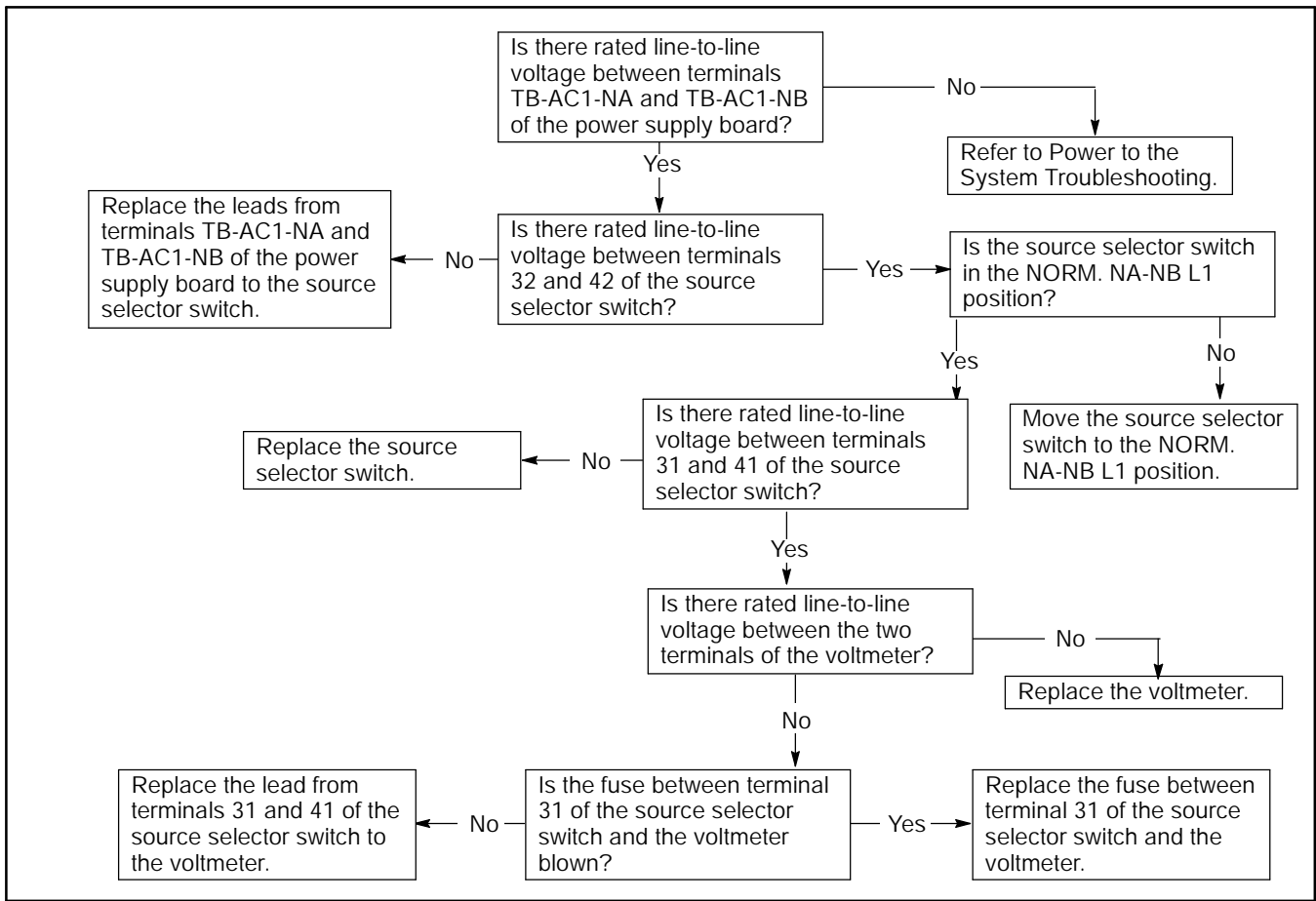
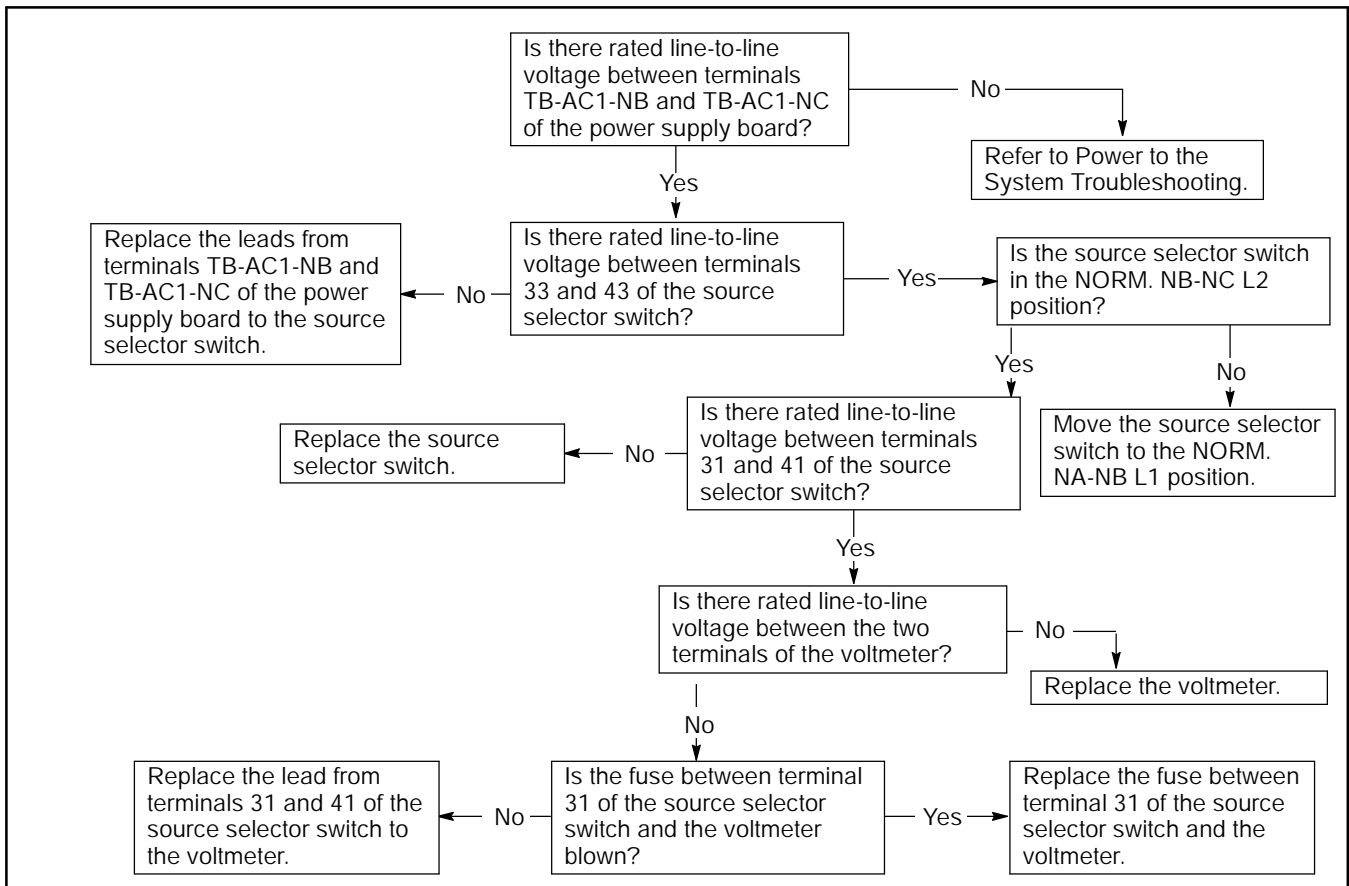


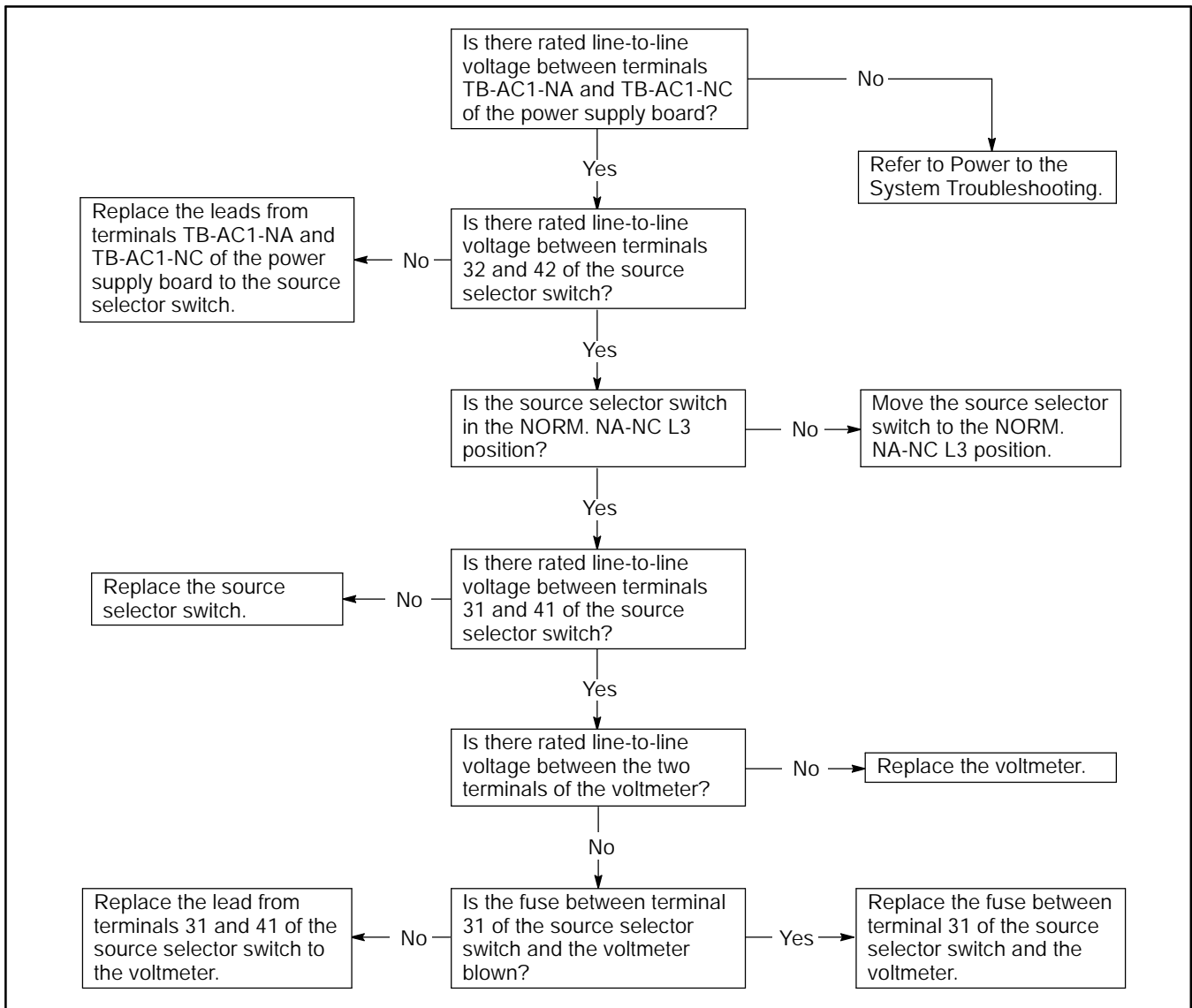
Figure 5-39. Troubleshooting– Option DD-18-J, Ammeter is not functioning



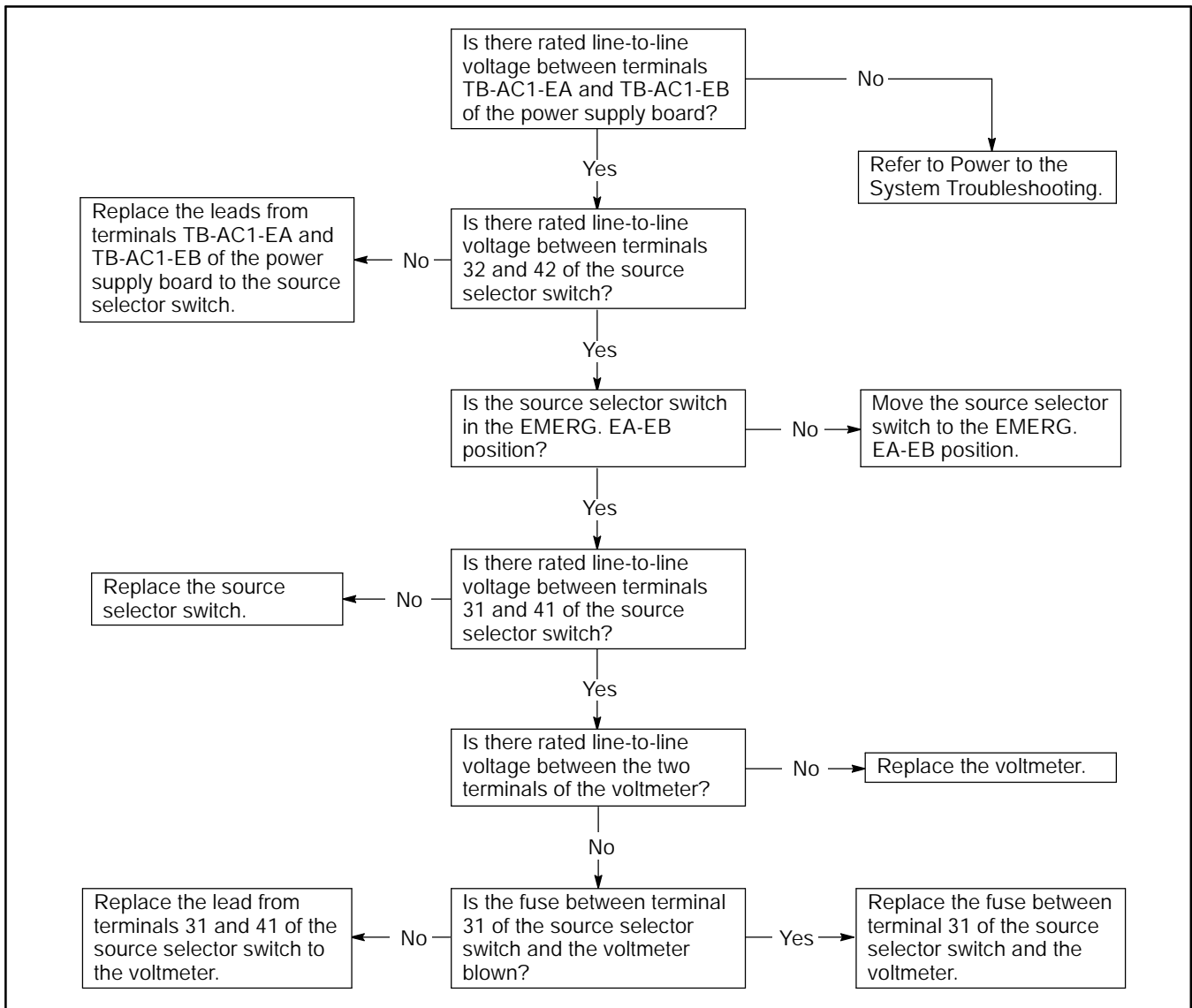
**Figure 5-40. Troubleshooting– Option DD-18-J, Voltmeter does not read NA-NB voltage**



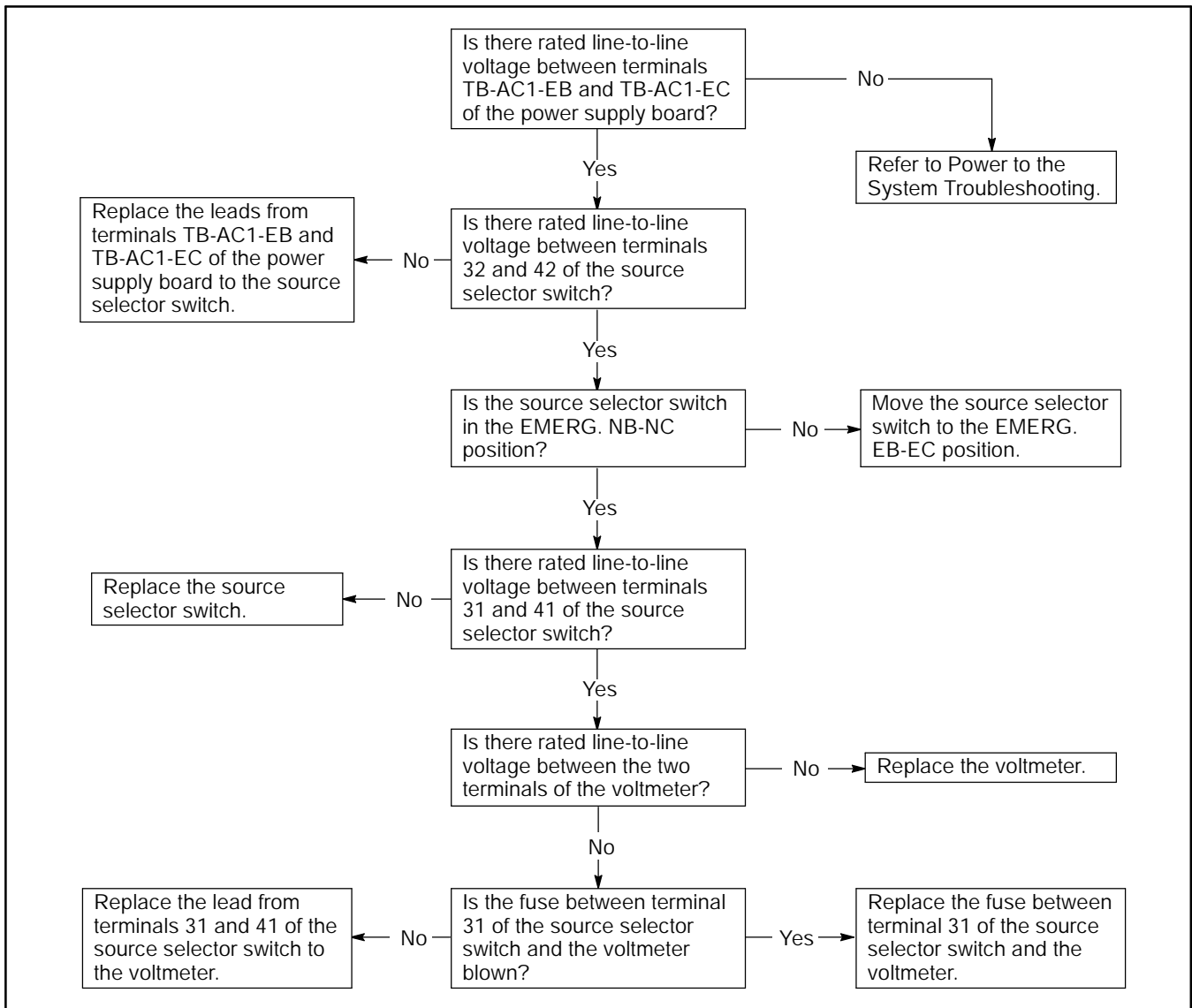
**Figure 5-41. Troubleshooting– Option DD-18-J, Voltmeter does not read NB-NC voltage**



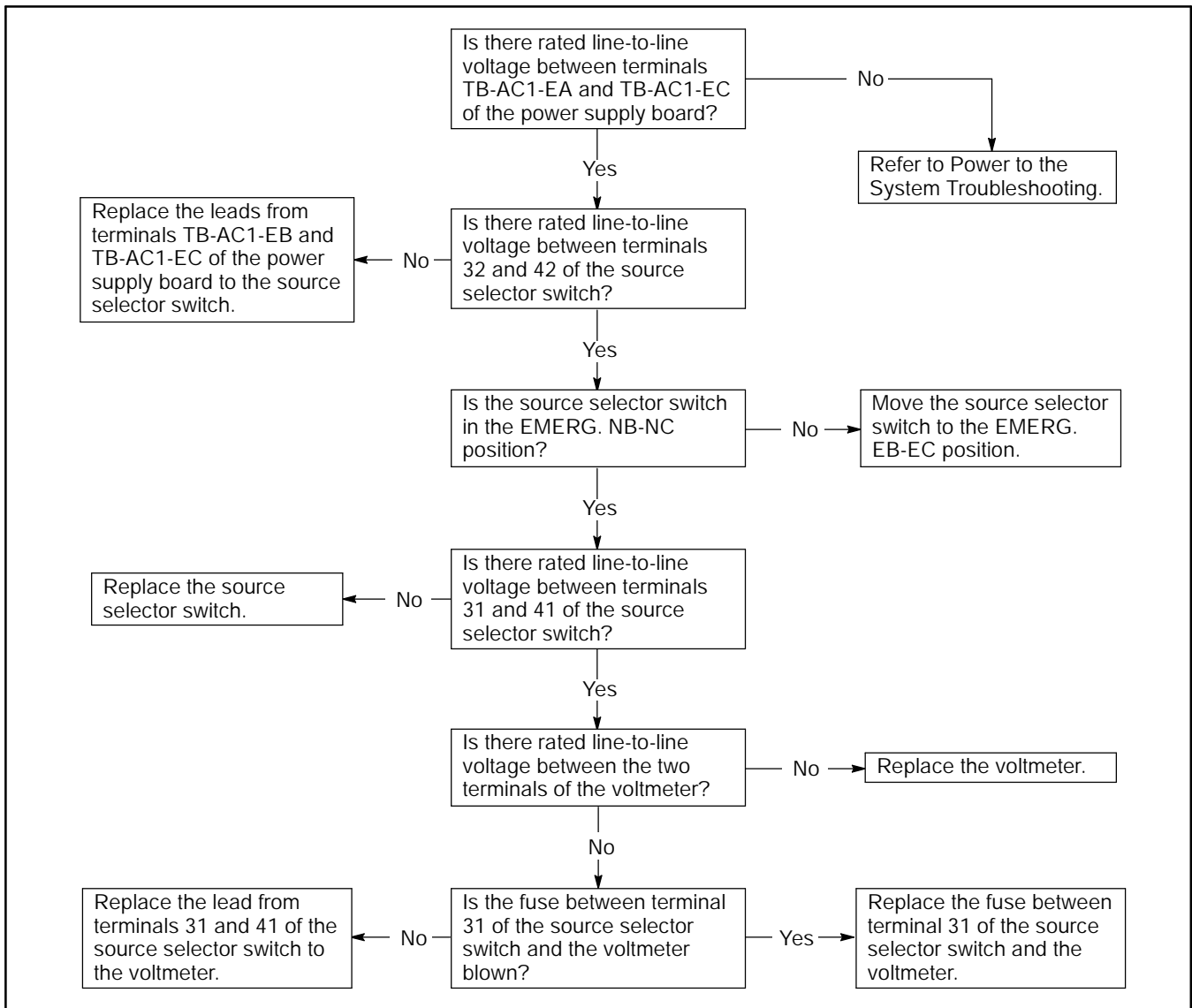
**Figure 5-42. Troubleshooting– Option DD-18-J, Voltmeter does not read NA-NC voltage**



**Figure 5-43. Troubleshooting– Option DD-18-J, Voltmeter does not read EA-EB voltage**



**Figure 5-44. Troubleshooting– Option DD-18-J, Voltmeter does not read EB-EC voltage**



**Figure 5-45. Troubleshooting– Option DD-18-J, Voltmeter does not read EA-EC voltage**

NOTE: The ammeter reads load currents. The Source selector switch must be in the NORM. NA-NB, NB-NC, or NA-NC to read loads L1, L2, or L3.

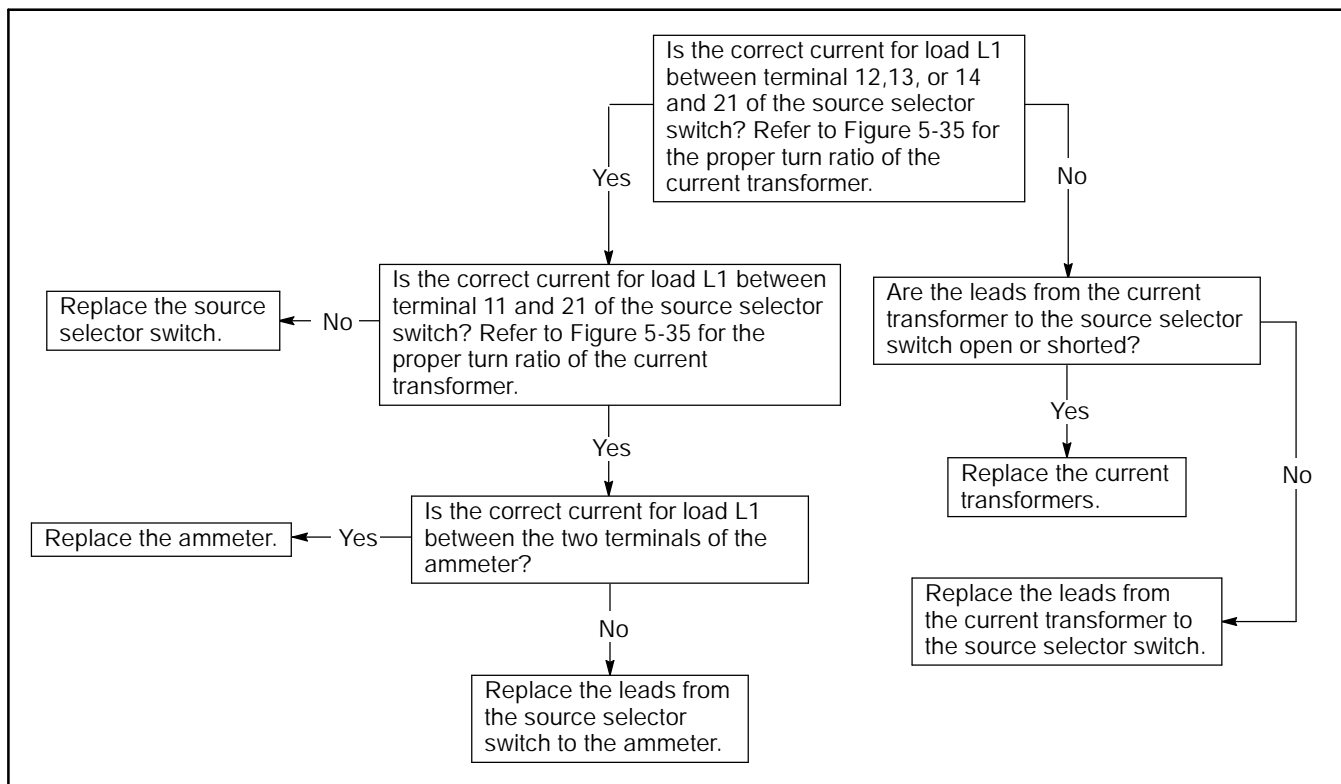


Figure 5-46. Troubleshooting– Option DD-18-J, Ammeter Does not read load for L1

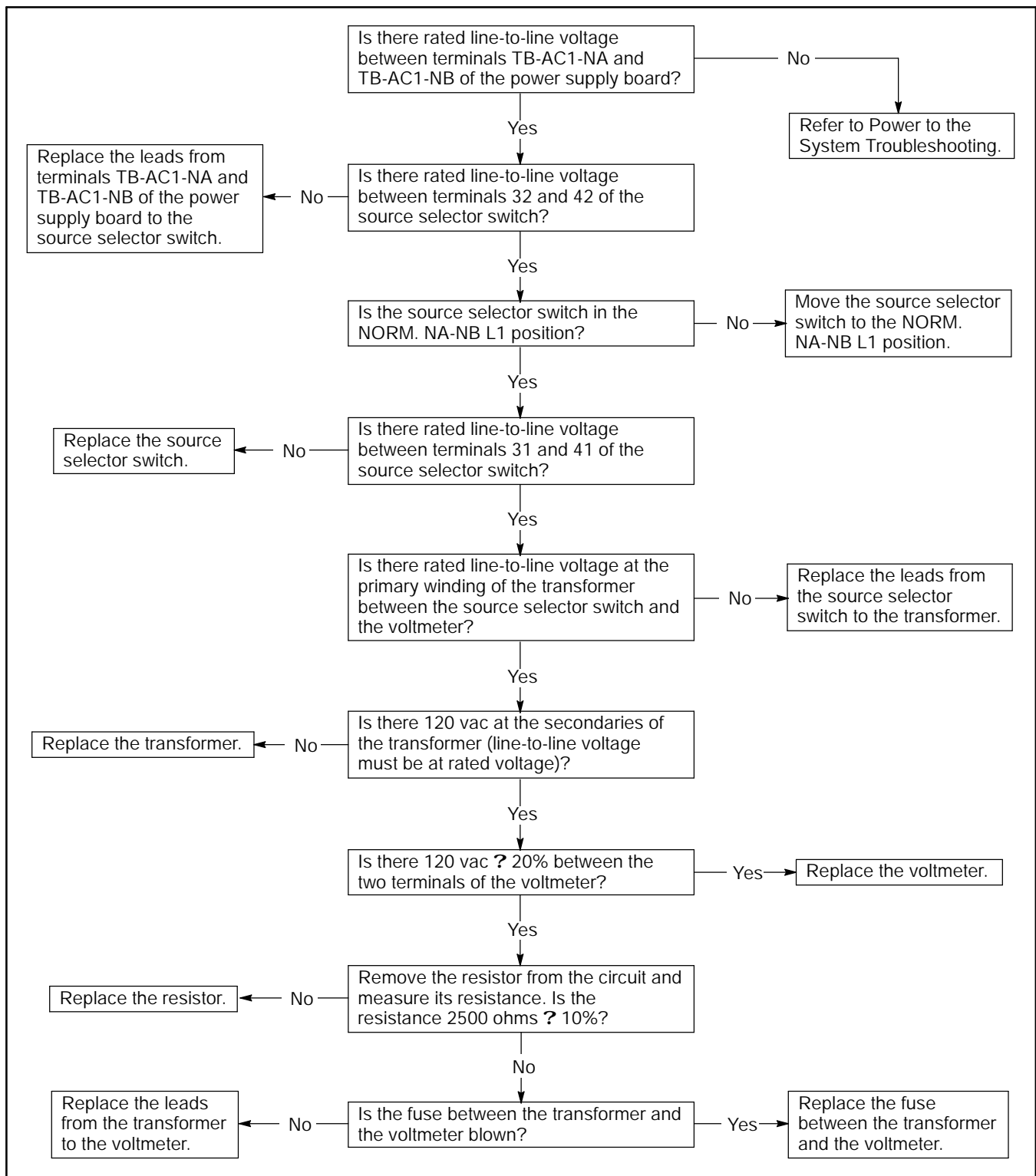


Figure 5-47. Troubleshooting– Option DD-18-J, Voltmeter does not read NA-NB voltage

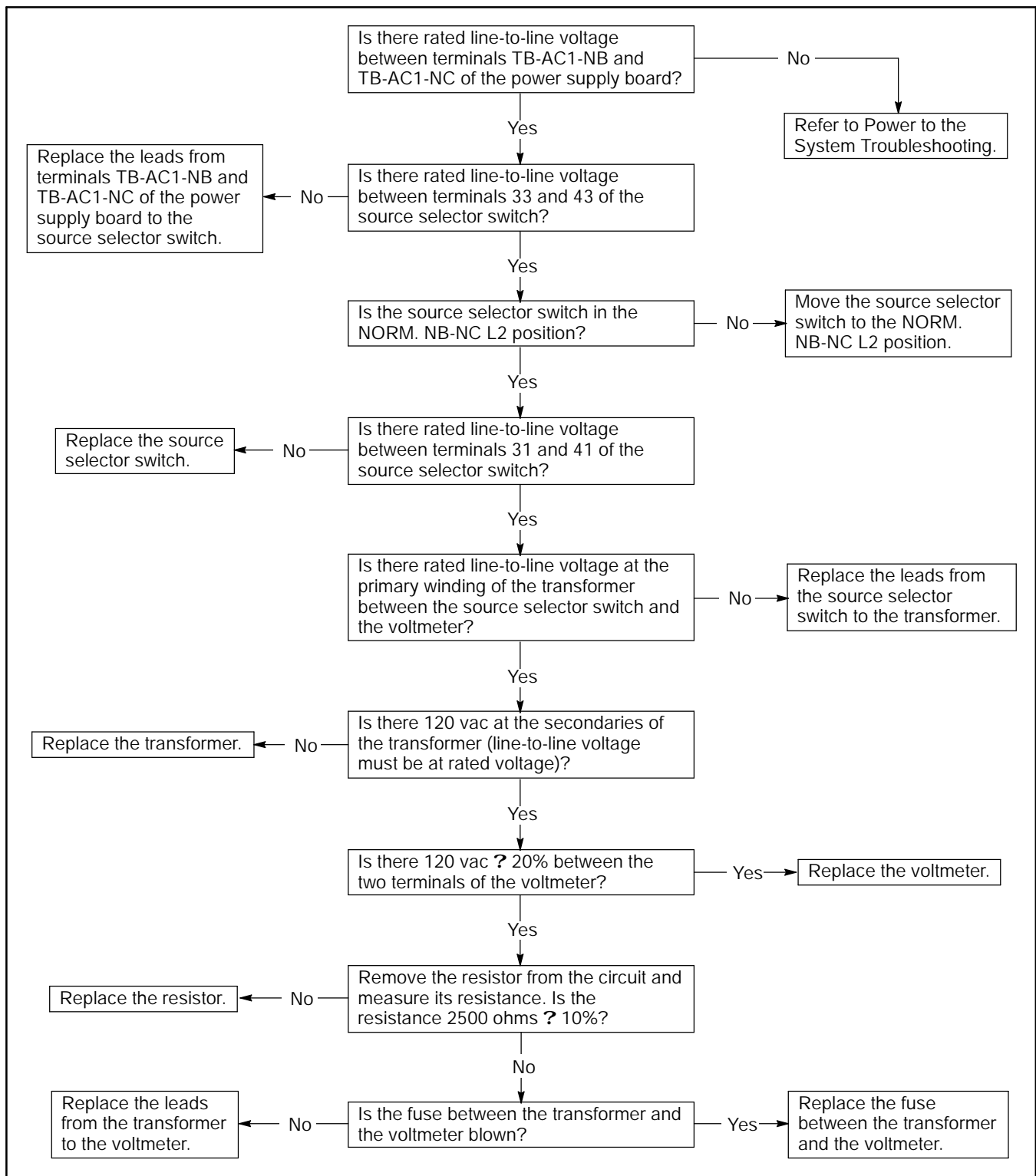


Figure 5-48. Troubleshooting– Option DD-18-J, Voltmeter does not read NA-NC voltage

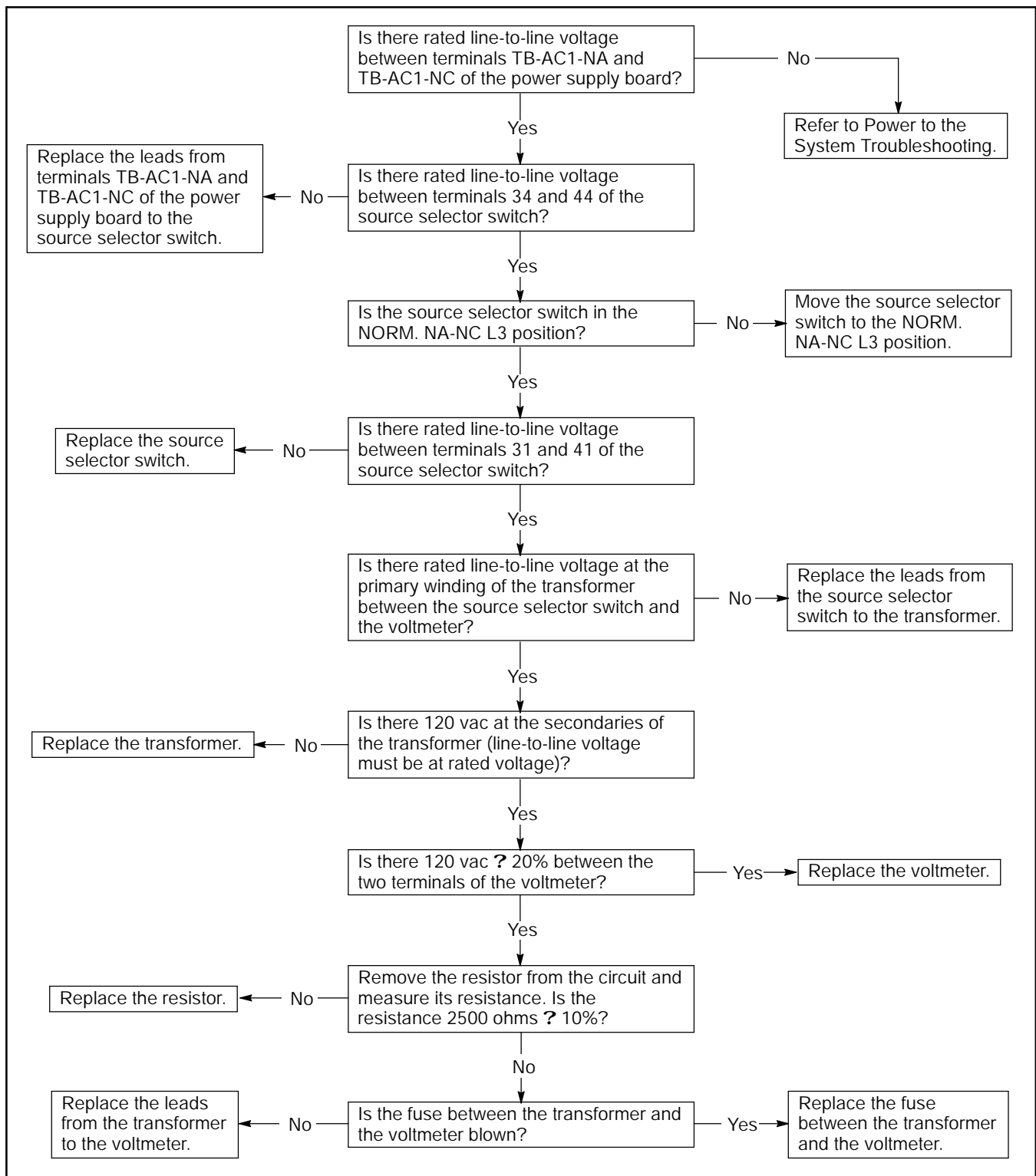


Figure 5-49. Troubleshooting– Option DD-18-J, Voltmeter does not read NA-NC voltage

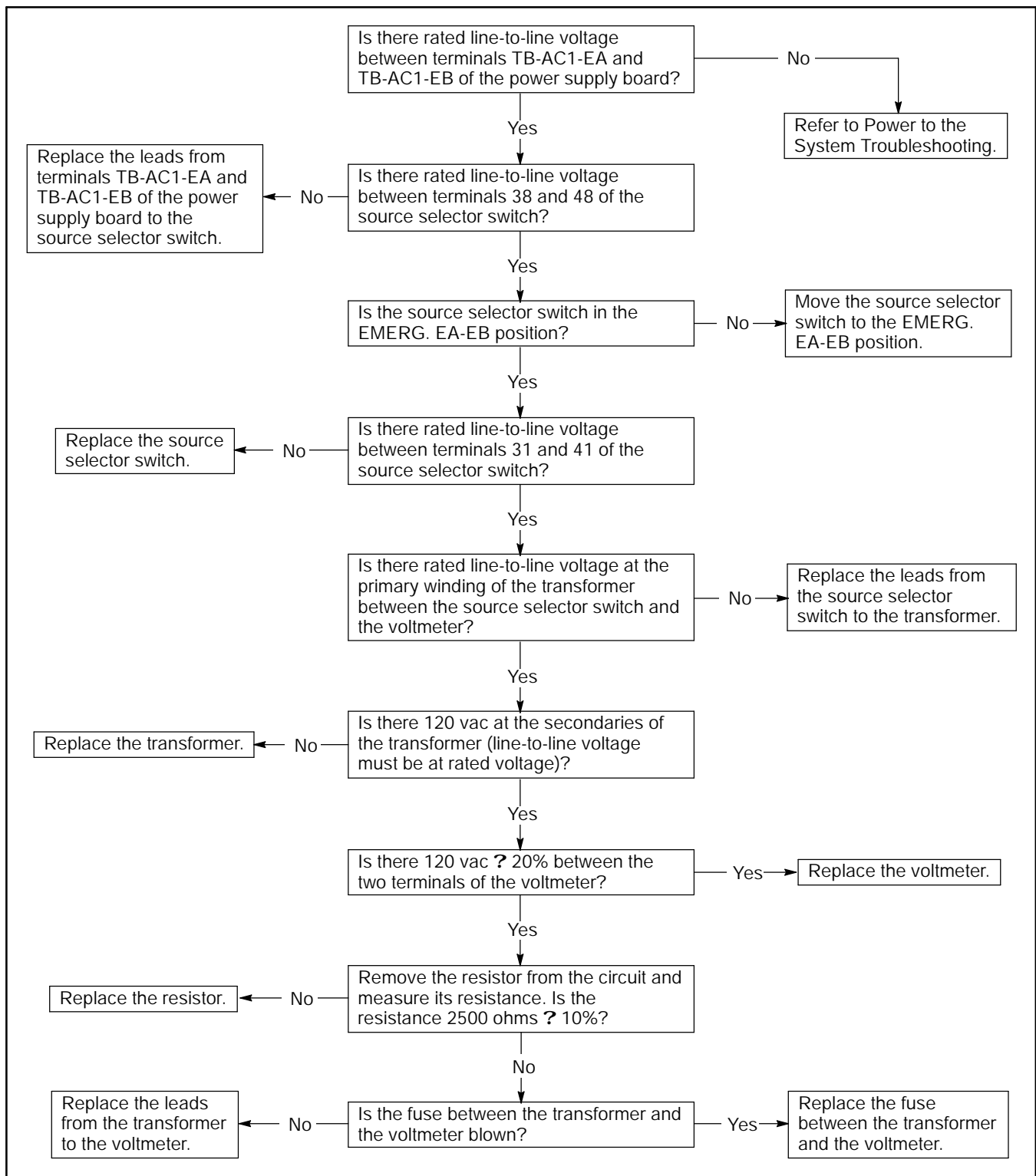


Figure 5-50. Troubleshooting– Option DD-18-J, Voltmeter does not read EA-EB voltage

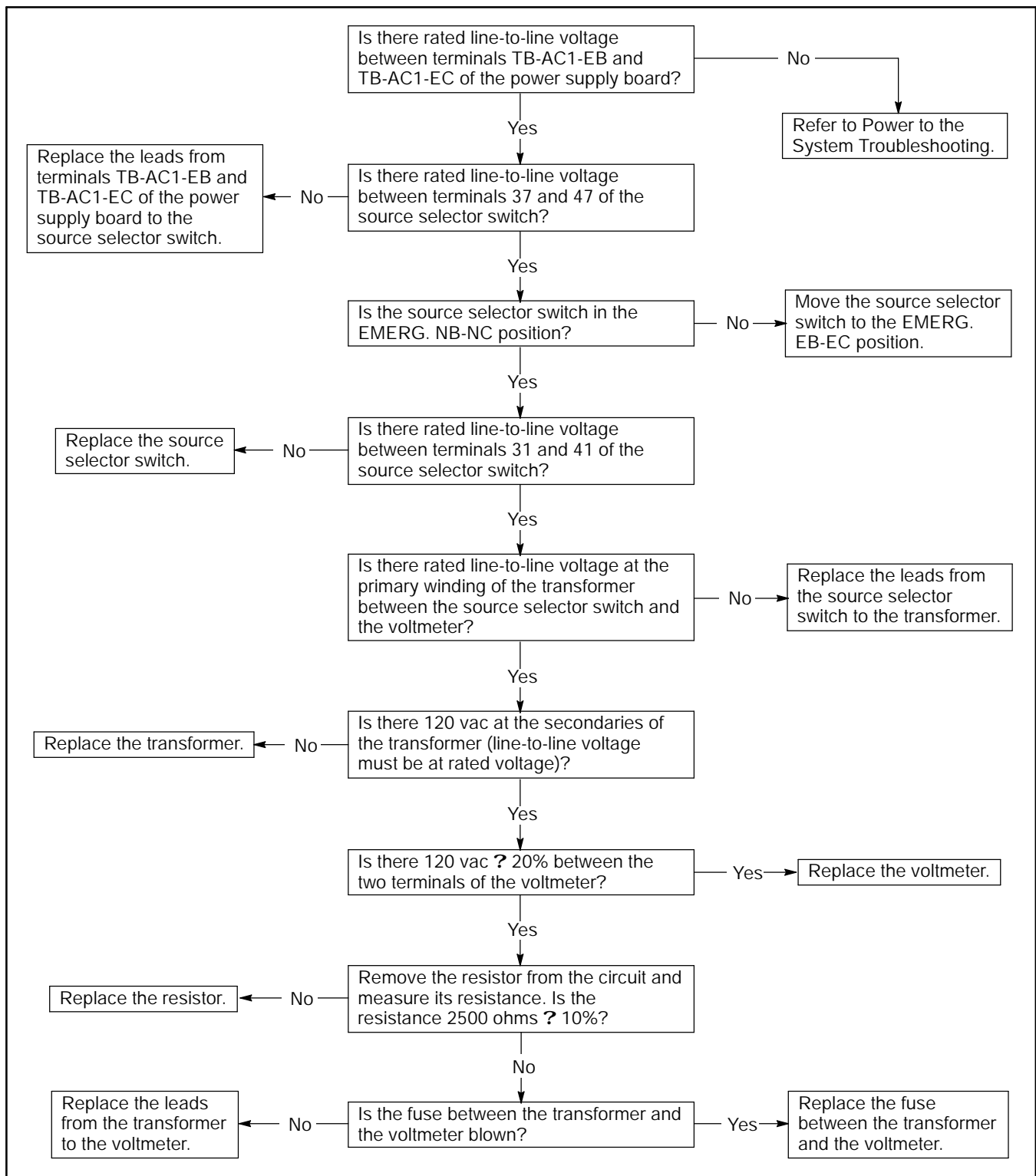


Figure 5-51. Troubleshooting– Option DD-18-J, Voltmeter does not read EB-EC voltage

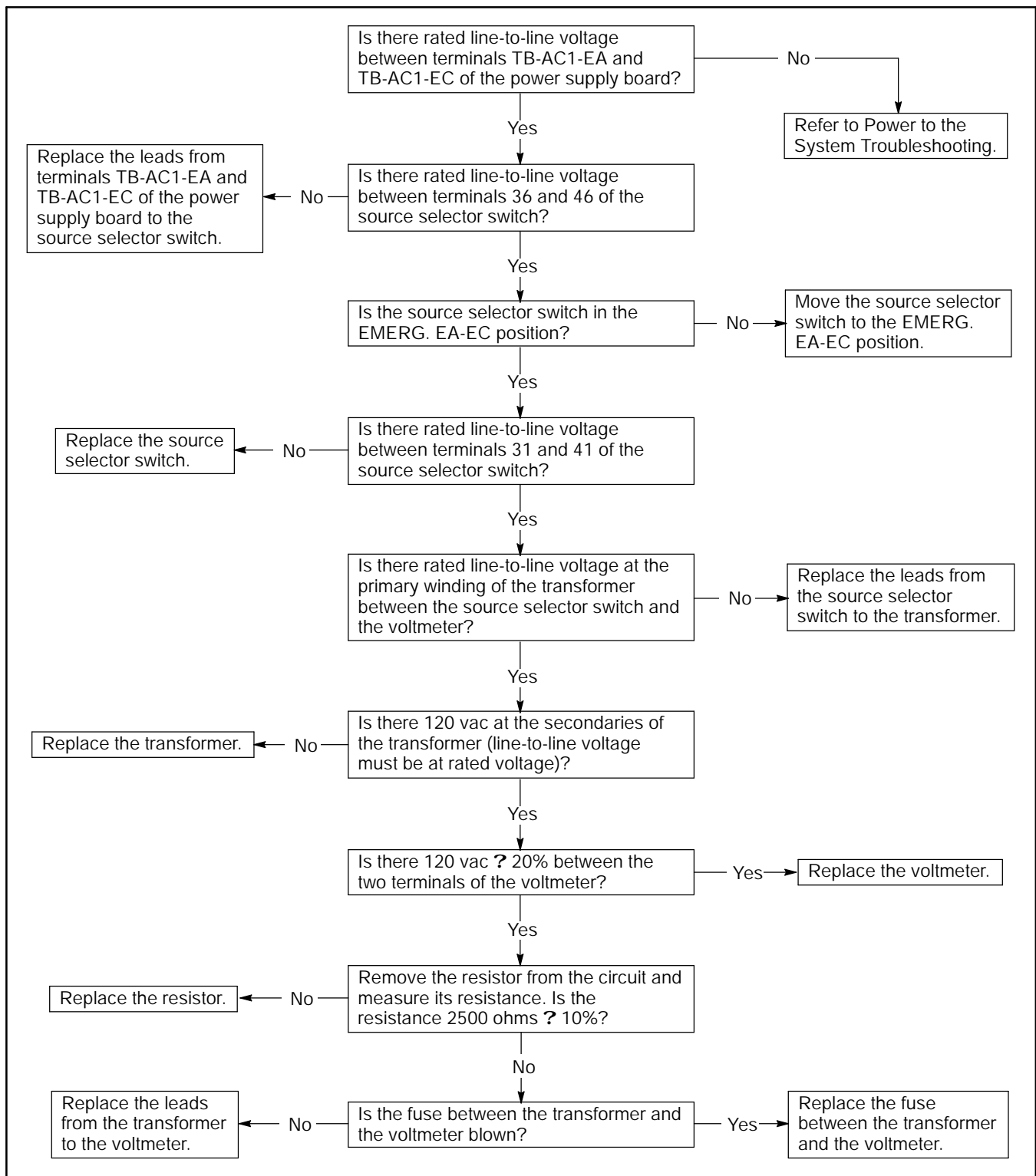


Figure 5-52. Troubleshooting– Option DD-18-J, Voltmeter does not read EA-EC voltage

# Battery Charger

Option DD-24 is an automatic adjustable float battery charger. The battery charger is mounted below the main circuit board on the enclosure door.

The automatic battery charger is designed to charge and maintain lead-acid and nickel-cadmium automotive-type batteries in a fully charged state without manual intervention. The charger output provided by the power transformer is controlled by the circuit board. The control board provides the charger with current-limiting, AC line compensation, reverse-polarity protection, ambient-temperature compensation, and constant voltage charging mode. The control circuit board continuously monitors the battery and load conditions to maintain the battery's proper charge. Refer to Figure 5-53 for component identification. The chargers are factory adjusted to maintain the battery at the proper float voltages. The 12-volt charger will maintain a lead-acid (6-cell) battery without adjustment. The 24-volt charger will maintain a lead-acid (12-cell) battery without adjustment. Refer to Figure 5-54 through Figure 5-58 for wiring diagrams. See Figure 5-59 for battery charger connection. and Figure 5-60 for the troubleshooting table.

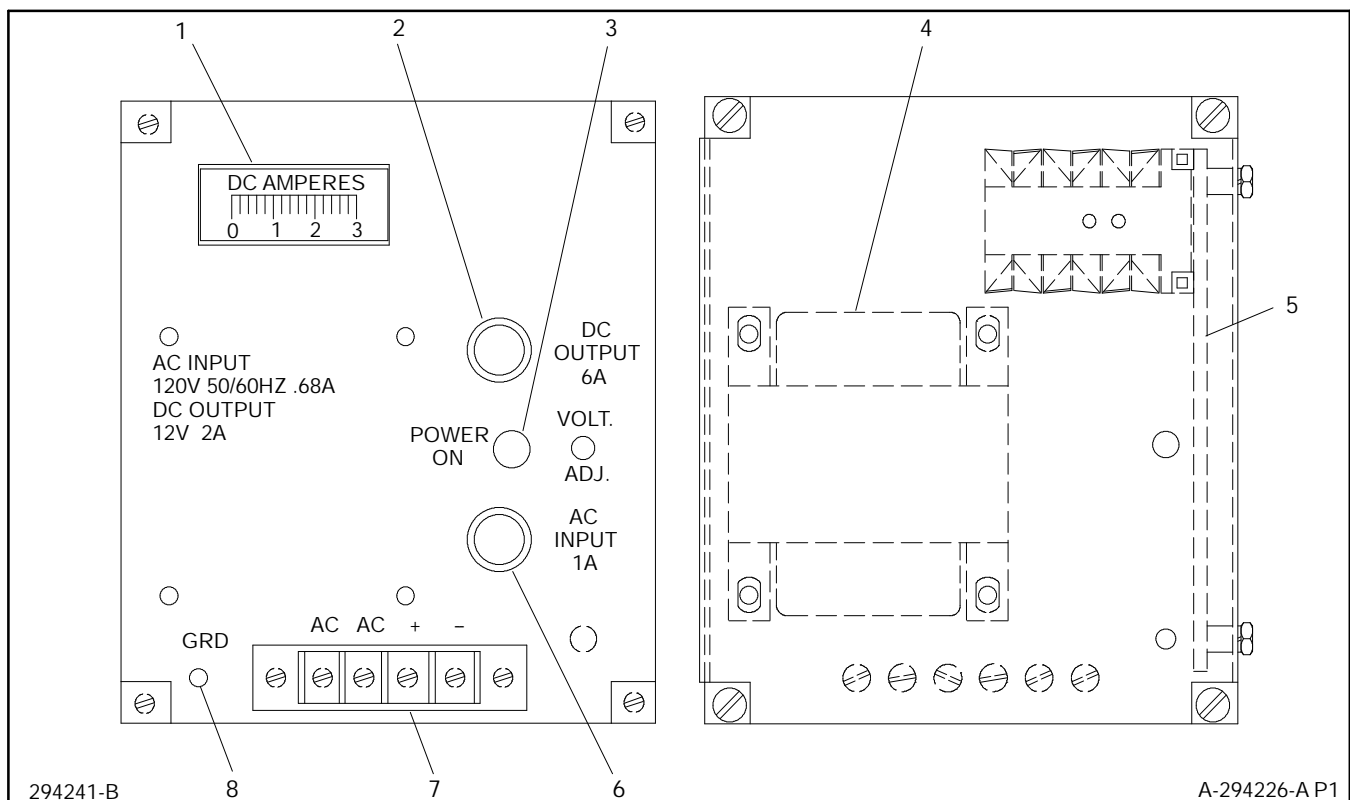
## **⚠ WARNING**



**Sulfuric acid in batteries.  
Can cause severe injury or death.**

Use protective goggles and clothes. Battery acid can cause permanent damage to eyes, burn skin, and eat holes in clothing.

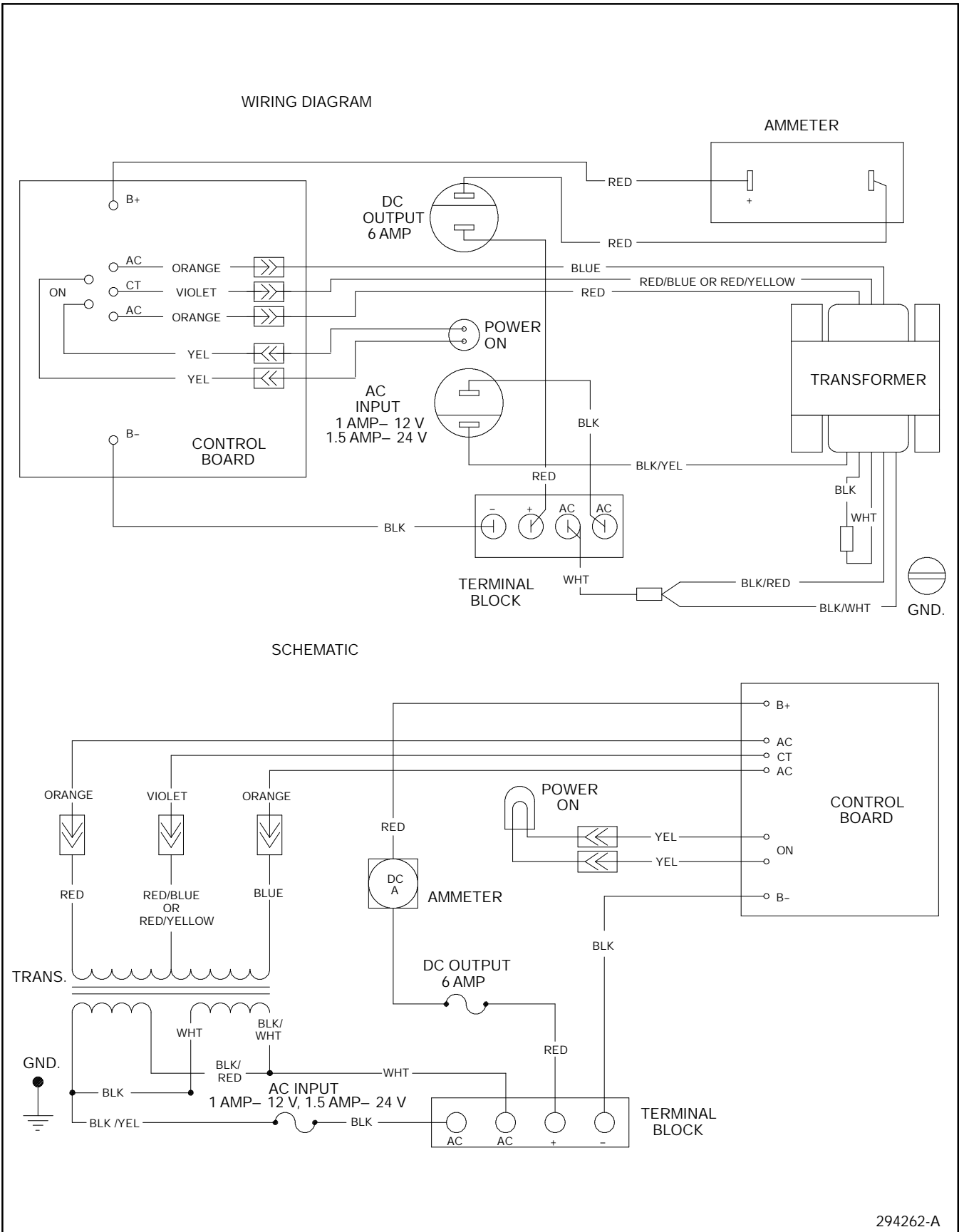
**Sulfuric acid in batteries can cause severe injury or death.** Sulfuric acid in battery can cause permanent damage to eyes, burn skin, and eat holes in clothing. Always wear splash-proof safety goggles when working around the battery. If battery electrolyte is splashed in the eyes or on skin, immediately flush the affected area for 15 minutes with large quantities of clean water. Seek immediate medical aid in the case of eye contact. Never add acid to a battery once the battery has been placed in service. This may result in hazardous spattering of electrolyte.



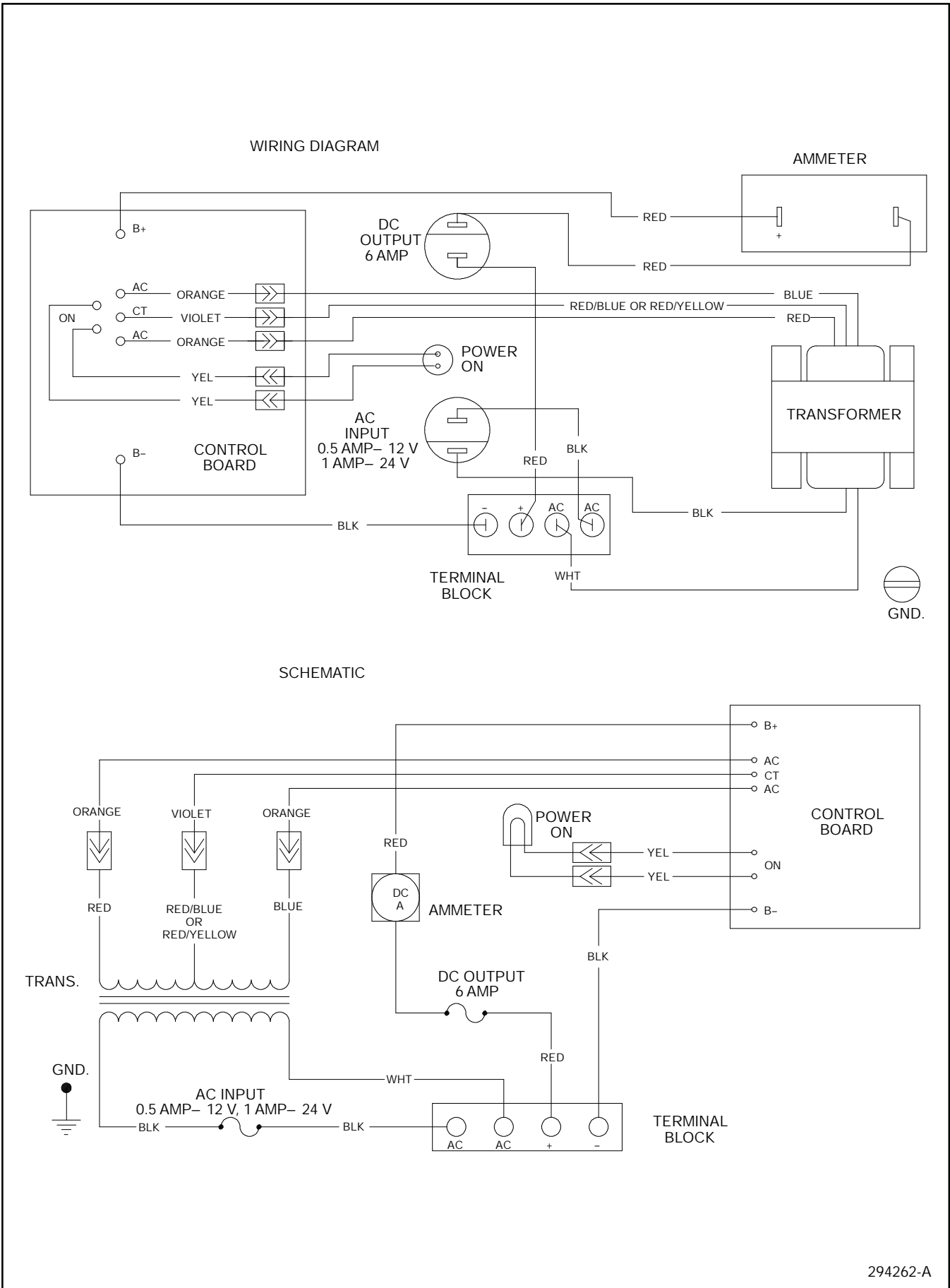
1. DC Ammeter
2. DC Output Fuse
3. "Power On" Lamp
4. Transformer

5. Main Circuit Board Assembly
6. AC Input Fuse
7. Terminal Block
8. Ground Terminal (AC)

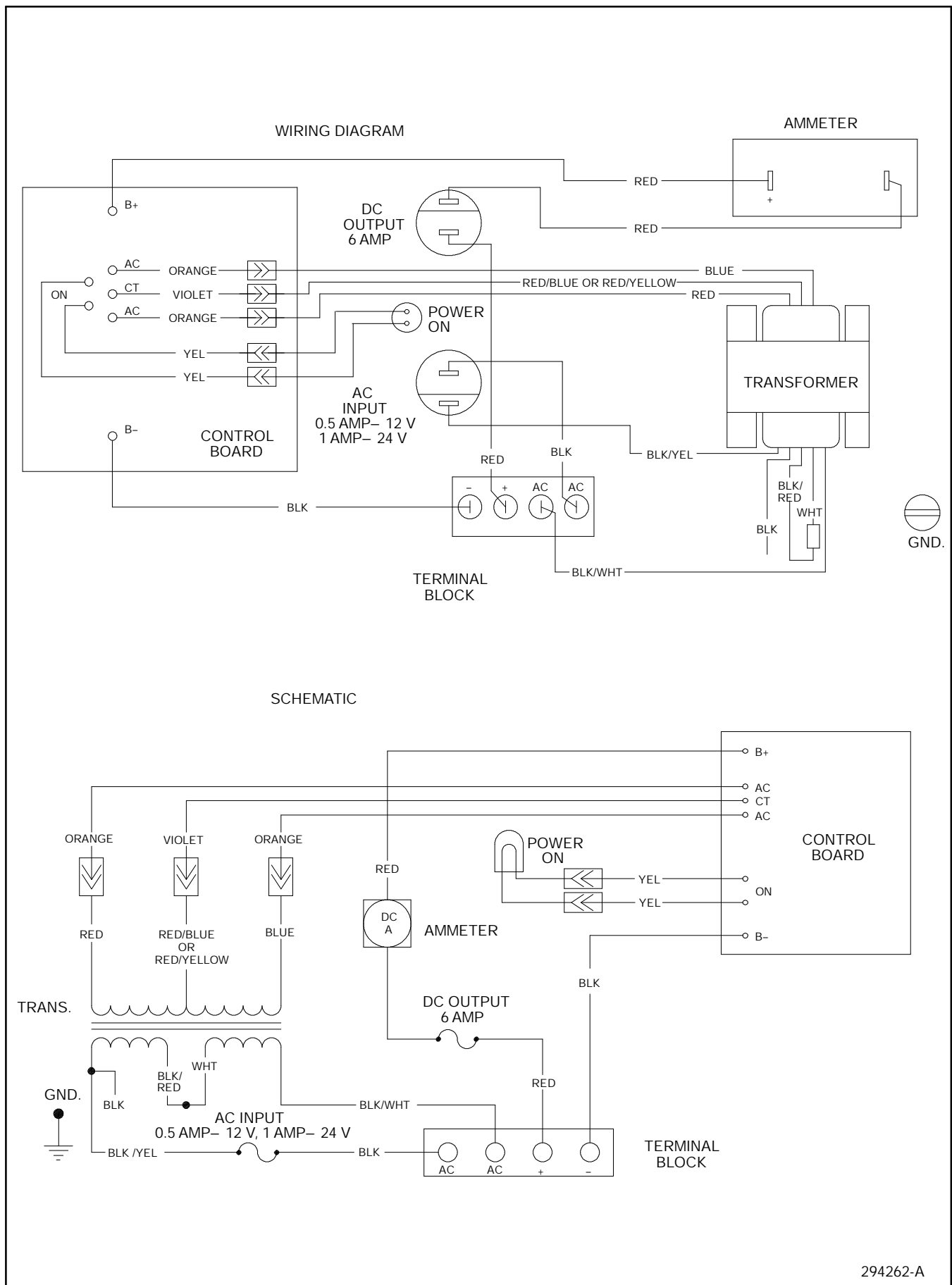
**Figure 5-53. Battery Charger Components**



**Figure 5-54. Wiring Diagram– Option DD-24, Battery Charger 120-volt input**

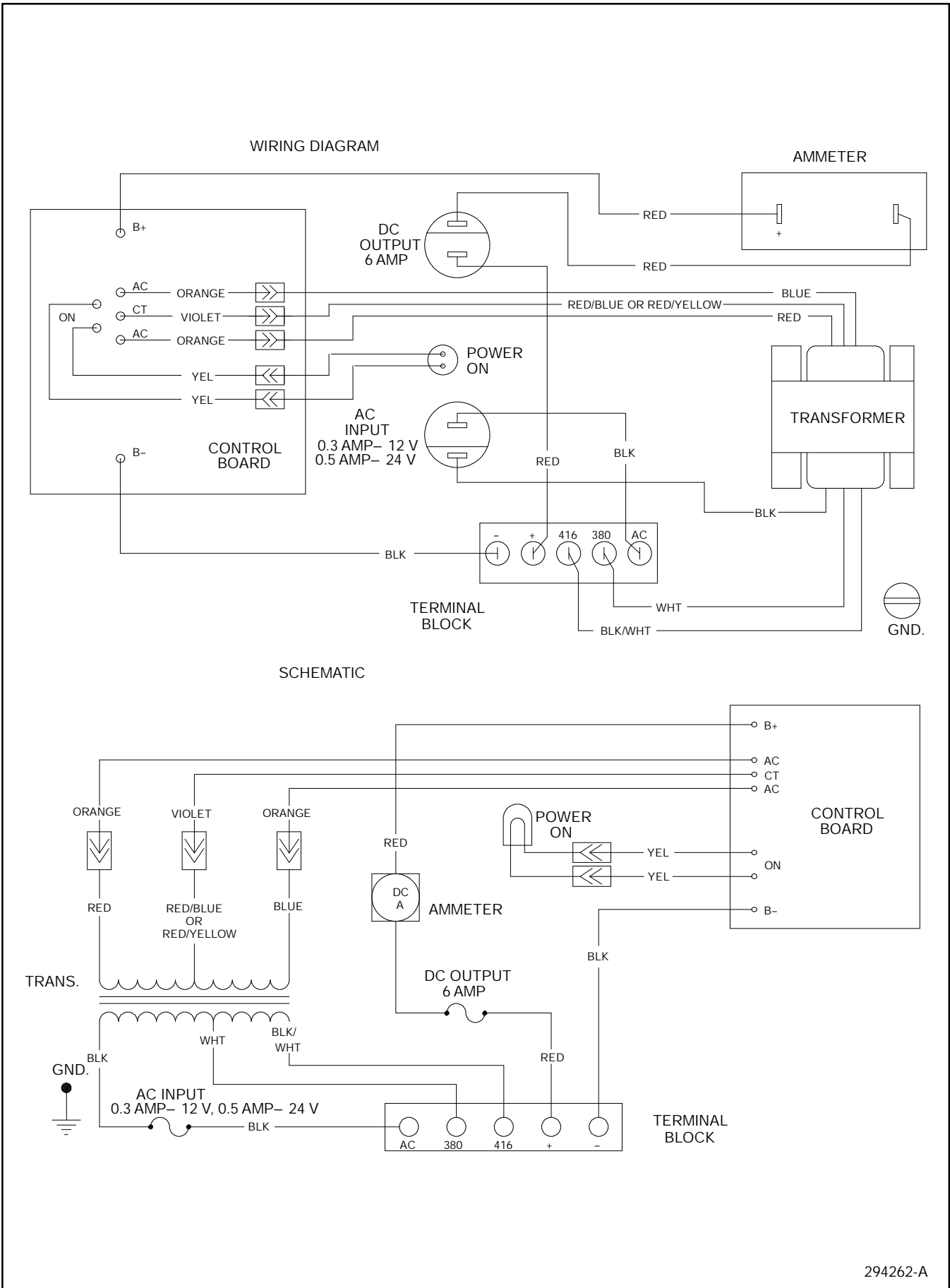


**Figure 5-55. Wiring Diagram– Option DD-24, Battery Charger 220-volt input**

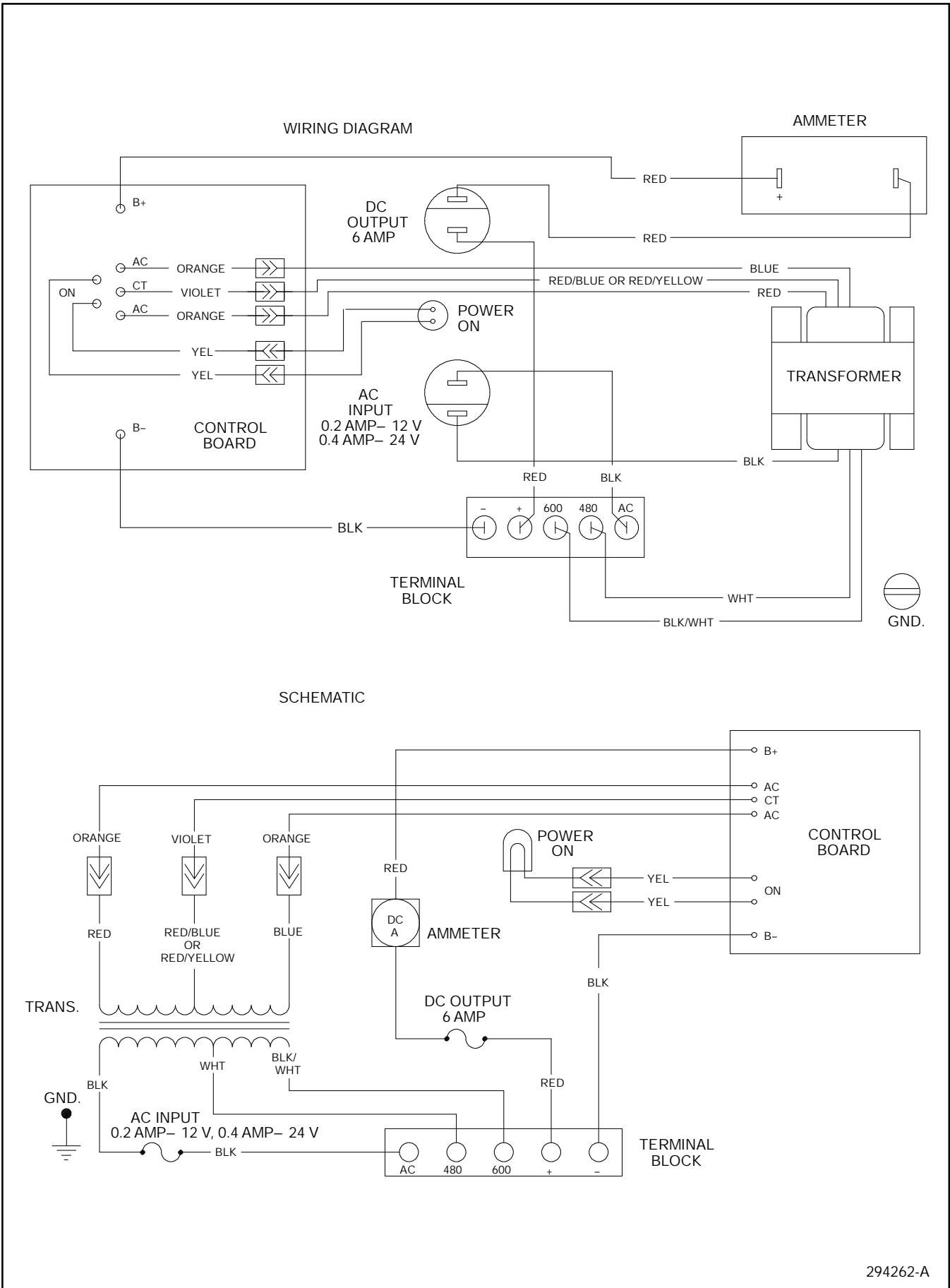


294262-A

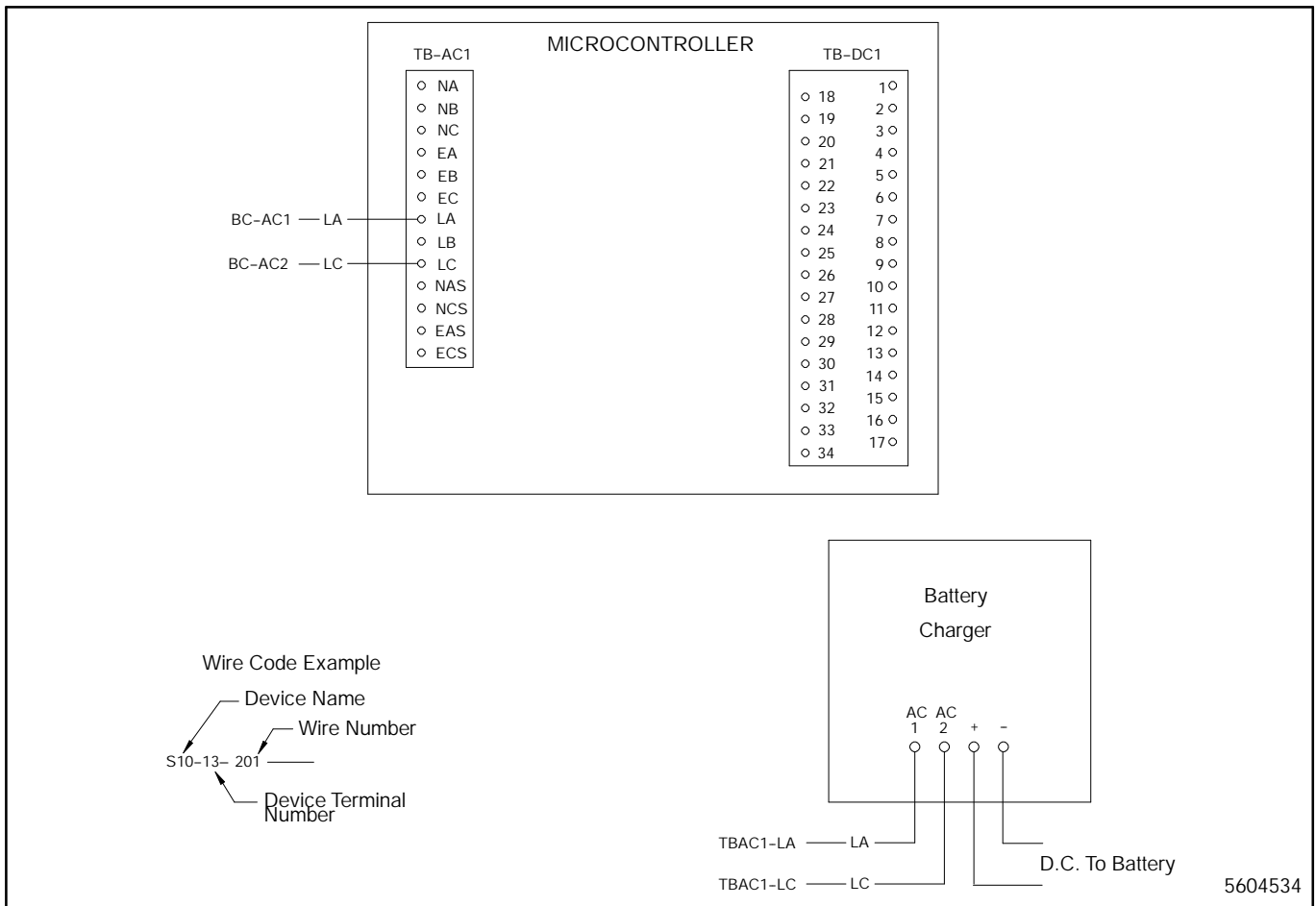
Figure 5-56. Wiring Diagram– Option DD-24, Battery Charger 240-volt input



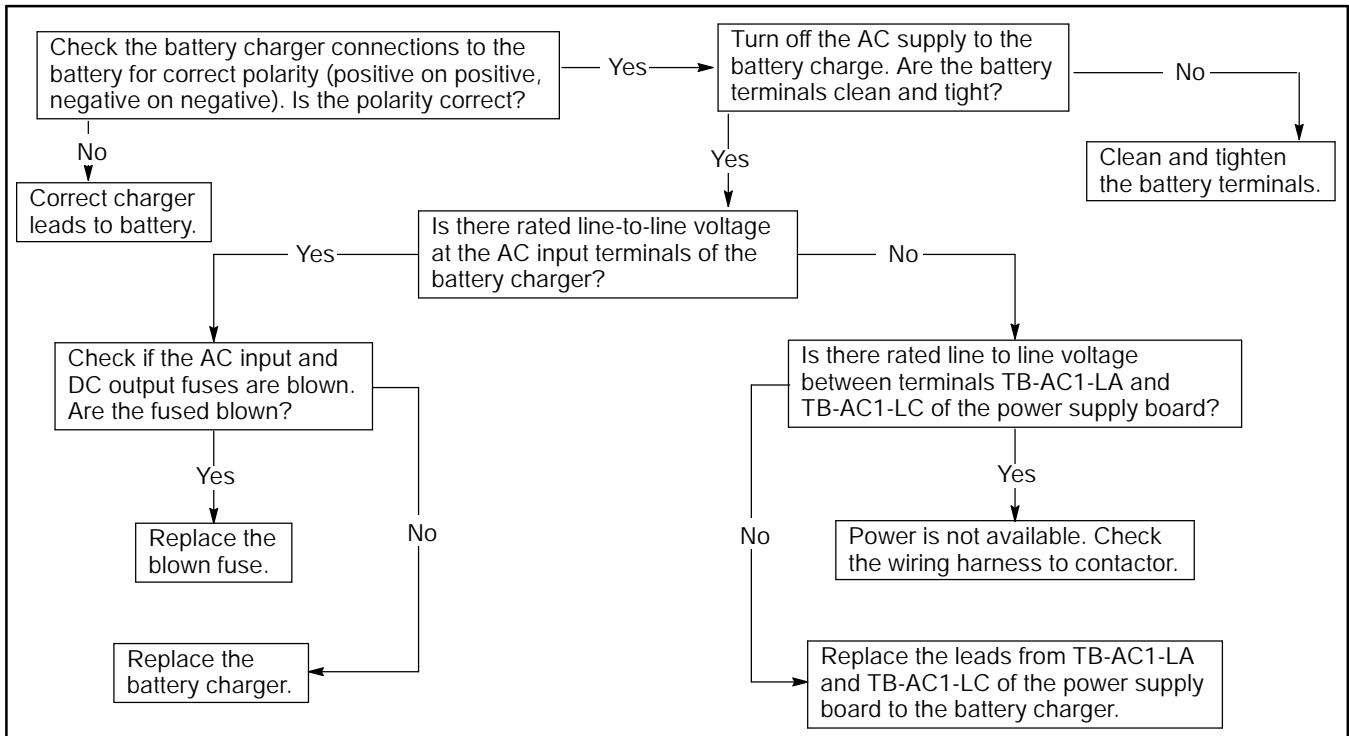
**Figure 5-57. Wiring Diagram– Option DD-24, Battery Charger 380/416-volt input**



**Figure 5-58. Wiring Diagram– Option DD-24, Battery Charger 480/600-volt input**



**Figure 5-59. Wiring Diagram– Option DD-24-A and DD-24-B, Battery charger**



**Figure 5-60. Troubleshooting– Option DD-24-A and DD-24-B, No ammeter reading on battery charger**

# Manual Operation Switches

## Description of the Manual Operation Switches

The accessory DD-29 allows manual operation of the transfer switch. DD-29 includes an override circuit which will cause the transfer switch to automatically transfer to the alternate power source if the connected source fails. See Figure 5-61 to Figure 5-64 for wiring diagrams for this option.

- D DD-29-P.** Momentary contact buttons for manual transfer in both directions.
- D DD-29-R.** Momentary contact key-operated switches for manual transfer in both directions.
- D DD-29-S.** A momentary contact button for manual transfer from emergency to normal.
- D DD-29-T.** A momentary contact key-operated switch for manual transfer from emergency to normal.
- D DD-29-U.** Momentary contact buttons for manual transfer in both directions and an Automatic/Manual selector switch.
- D DD-29-V.** A momentary contact key-operated switch for manual transfer in both directions and an Automatic/Manual selector switch.
- D DD-29-W.** A momentary contact button for manual transfer from emergency to normal and an Automatic/Manual selector switch.
- D DD-29-X.** A key-operated switch for manual transfer from emergency to normal and an Automatic/Manual selector switch.
- D DD-29-Y.** A Pushbutton switch for manual transfer from emergency or normal to off position.

## Troubleshooting the Standard Power Conversion Unit Automatic-Transfer/Manual-Transfer Switch

If the Automatic-Transfer/Manual-Transfer switch is in the Manual position, the following events will occur.

When the normal source fails:

1. The Source-Available, Normal LED turns off.
2. The Time-Delay, Engine-Start-On LED illuminates indicating the engine start time delay is timing.
3. The Time-Delay, Engine-Start-End LED illuminates indicating the engine has been signaled to start.
4. The Source-Available, Emergency LED turns on.
5. The System-Status, System-Alert LED flashes.
6. The LCD displays the MANUAL TRANSFER message. Push the Manual Transfer-To-Emergency Pushbutton. The contactor transfers to the emergency position. The Contactor-Position, Normal LED turns off, and the Contactor-Position, Emergency LED turns on. If the Manual Override jumper is installed the transfer will occur automatically.

When the normal source returns:

1. The Source-Available, Normal LED illuminates.
2. The Time-Delay, Emergency-To-Normal-On LED illuminates indicating the emergency-to-normal time delay is timing.
3. The Time-Delay, Emergency-To-Normal-End LED illuminates indicating the time delay has completed timing.
4. The System-Status, System-Alert LED flashes and the LCD shows the MANUAL TRANSFER message.
5. Push the Manual-Transfer-To-Normal Pushbutton. The contactor transfers to the normal position.
6. The Time-Delay, Engine-Cooldown-On LED illuminates showing that the generator set engine cooldown timer is timing.
7. The Time-Delay, Engine-Cooldown-End LED illuminates momentarily as the engine is signaled to shut down.
8. The Source-Available, Emergency LED turns off.

When the Automatic-Transfer/Manual-Transfer key switch is in the Manual position, the Not-In-Automatic LED illuminates. When the system is in the Manual mode and is waiting to be transferred to a new power source after all the time-delays have completed timing, the System-Alert LED illuminates and MANUAL TRANSFER appears on the LCD.

If the system is waiting to be transferred to a new power source while in the Manual mode, but the System-Status, System-Alert LED does not illuminate and MANUAL TRANSFER does not appear on the LCD, connect TB-DC1-20 to TB-DC1-34.

- a. If after grounding TB-DC1-20 the System-Status, System-Alert LED illuminates and MANUAL TRANSFER appears on the LCD while the system is waiting in the Manual mode to be transferred to a new power source, verify that the Automatic-Transfer/Manual-Transfer key switch is in the Manual Transfer position and check the wiring to the Automatic-Transfer/Manual-Transfer key switch for an open.
- b. If after grounding TB-DC1-20, the System-Status, System-Alert LED does not illuminate and MANUAL TRANSFER does not appear on the LCD while the system is waiting in the Manual mode to be transferred to a new power source, check the P2 ribbon cable connection to the main logic board by performing the following steps.
  - (1) Remove all power sources.
  - (2) Wait for 30 seconds.
  - (3) Making sure not to bend or break any of the pins, remove the P2 ribbon cable connector.
  - (4) Inspect the pins on the P2 ribbon cable connector.
  - (5) If pins are bent, carefully bend them back. If pins are broken, the ribbon cable connector is defective. Replace the ribbon cable connector.
  - (6) Carefully reconnect P2 ribbon cable connector.

If the P2 ribbon cable connection is good, connect P2-24 to TB-DC1-34. If the System-Status, System-Alert LED is illuminated when P2-24 is grounded, but not when TB-DC1-20 is grounded, replace the power supply board. If the System-Status, System Alert LED does not illuminate when P2-24 is grounded, Replace the logic board assembly.

## **Troubleshooting the Off Position Automatic-Transfer/Manual-Transfer Key Switch**

If the Automatic-Transfer/Manual-Transfer key switch is in the Manual position, the following events occur.

When the normal source fails:

1. The Source-Available, Normal LED turns off.
2. The Time-Delay, Engine-Start-On LED illuminates indicating the engine start time delay is timing.
3. The Time-Delay, Engine-Start-End LED illuminates indicating the engine has been signaled to start.
4. The Source-Available, Emergency LED illuminates.
5. The System-Status, System-Alert LED flashes.
6. The LCD displays the MANUAL TO OFF message. Press the Manual-Transfer-To-Off Pushbutton. The contactor transfers to the off position. The Contactor-Position, Normal LED turns off, and the Contactor-Position, Off LED illuminates.
7. When the Off time delay times out the LCD displays MANUAL TRANSFER. Push the manual transfer to emergency pushbutton. The contactor transfers to the emergency position. The Off Position LED turns off and the emergency position LED illuminates.

When the normal source returns:

1. The Source-Available, Normal illuminates.
2. The Time-Delay, Emergency-To-Normal-On LED illuminates indicating the emergency-to-normal time delay is timing.
3. The Time-Delay, Emergency-To-Normal-End LED illuminates indicating the time delay has completed timing.
4. The System-Status, System-Alert LED flashes and the LCD shows the MANUAL TO OFF message.
5. Press the Manual-Transfer-To-Off Pushbutton. The contactor transfers to the Off position.
6. When the Off time delay times out the LCD displays MANUAL TRANSFER. Press the manual transfer to normal pushbutton. The contactor will transfer to the normal position. The Off Position LED turns off and the normal position LED illuminates.
7. The Time-Delay, Engine-Cooldown-On LED illuminates showing that the generator set engine cooldown timer is timing.
8. The Time-Delay, Engine-Cooldown-End LED illuminates momentarily as the engine is signaled to shut down.
9. The Source-Available, Emergency LED turns off.

When the Automatic-Transfer/Manual-Transfer key switch is in the Manual position, the Not-In-Automatic LED illuminates. When the system is in the Manual mode and is waiting to be transferred to a new power source after all the time delays have completed timing, the System-Alert LED illuminates and MANUAL TRANSFER or MANUAL TO OFF appears on the LCD.

If the system is waiting to be transferred to a new power source while in the Manual mode, but the System-Status, System-Alert LED does not illuminate and MANUAL TRANSFER or MANUAL TO OFF does not appear on the LCD, connect TB-DC1-20 to TB-DC1-34.

- a. If after grounding TB-DC1-20 the System-Status, System-Alert LED illuminates and MANUAL TRANSFER or MANUAL TO OFF appears on the LCD when the system is waiting in the Manual mode to be transferred to a new power source, Verify that the Automatic-Transfer/Manual-Transfer key switch is in the Manual Transfer position and check the wiring to the Automatic-Transfer/Manual-Transfer key switch for an open.
- b. If after grounding TB-DC1-20, the System-Status, System-Alert LED does not illuminate and MANUAL TRANSFER does not appear on the LCD while the system is waiting in the Manual mode to be transferred to a new power source, check the P2 ribbon cable connection to the main logic board by performing the following steps.
  - (1) Remove all power sources.
  - (2) Wait 30 seconds.
  - (3) Making sure not to bend or break any of the pins, remove the P2 ribbon cable connector.
  - (4) Inspect the pins of the P2 ribbon cable connector.
  - (5) If any pins are bent, carefully bend them back. If any pins are broken, the ribbon cable connector is defective. Replace the ribbon cable connector.
  - (6) Carefully reconnect P2 ribbon cable connector.

If the P2 ribbon cable connection is good, connect P2-24 to TB-DC1-34. If the System-Status, System-Alert LED illuminates when P2-24 is grounded, but does not illuminate when TB-DC1-20 is grounded, replace the power supply board. If the System-Status, System Alert LED does not illuminate when P2-24 is grounded, the main logic board is defective. Replace the logic board assembly.

### **Troubleshooting The Manual Transfer-To-Emergency Source Pushbutton**

When the Automatic-Transfer/Manual-Transfer key switch is in the Manual position and the system is waiting to be transferred to the emergency power source, the user should press the Manual Transfer-to-Emergency Source pushbutton.

If the Manual Transfer-To-Emergency Source pushbutton is not operating, connect TB-DC1-7 to TB-DC1-34.

1. Check the Manual Transfer-to-Emergency Source pushbutton and the wires for an open circuit if both of the following are true:
  - a. Grounding TB-DC1-7 causes a transfer to the emergency source when the system is in the Manual mode and waiting to be transferred to the emergency source and
  - b. Pressing the Manual Transfer-To-Emergency Source pushbutton does not transfer the power conversion unit to the emergency source.
2. If grounding TB-DC1-7 does not cause a transfer to the emergency source when the system is in the Manual mode and waiting to be transferred to the emergency source, check the continuity between P2-1 and TB-DC1-7 following the steps below:
  - a. Remove power from the logic board.
  - b. Disconnect the P2 ribbon cable connector from the power supply board.
  - c. Using an ohmmeter, connect one test lead to P2-1 on the power supply board. Connect the other test lead to TB-DC1-7. If there is an open circuit, replace the power supply board. If the resistance is low, the main logic board is bad. Replace the logic board assembly.

## Troubleshooting The Manual Transfer-To-Normal Source Pushbutton

If the Manual Transfer-to-Normal Source pushbutton is not operating, connect TB-DC1-2 to TB-DC1-34.

1. If grounding TB-DC1-2 causes a transfer to the normal source when the system is in the Manual mode and is waiting to be transferred to the normal source but the Manual Transfer-To-Normal Source pushbutton is not operating, check the Manual Transfer-to-Normal Source pushbutton and the wiring to the Manual Transfer-to-Normal Source pushbutton.
2. If grounding TB-DC1-2 does not cause a transfer to the normal source when the system is in the Manual mode and is waiting to be transferred to the normal source, check the continuity between P2-2 and TB-DC1-2.
  - a. Remove power from the logic board.
  - b. Disconnect the P2 ribbon cable connector from the power supply board.
  - c. Using an ohmmeter, connect one test lead to P2-2 on the power supply board. Connect the other test lead to TB-DC1-2. If there is an open circuit, replace the power supply board. If the resistance is low, the main logic board is bad. Replace the logic board assembly.

## Troubleshooting The Manual Transfer-To-Off Pushbutton

If the Manual Transfer-to-Off pushbutton is not operating, connect TB-DC1-12 to TB-DC1-34.

1. If grounding TB-DC1-12 causes a transfer to the off position when the system is in the Manual mode and is waiting to be transferred to the off position but the Manual Transfer-To-Off pushbutton is not operating, check the Manual Transfer-to-Off pushbutton and the wiring to the Manual Transfer-to-Off pushbutton.
2. If grounding TB-DC1-12 does not cause a transfer to the normal source when the system is in the Manual mode and is waiting to be transferred to the normal source, check the continuity between P2-11 and TB-DC1-12.
  - a. Remove power from the logic board.
  - b. Disconnect the P2 ribbon cable connector from the power supply board.
  - c. Using an ohmmeter, connect one test lead to P2-11 on the power supply board. Connect the other test lead to TB-DC1-12. If there is an open circuit, replace the power supply board. If the resistance is low, the main logic board is bad. Replace the logic board assembly.

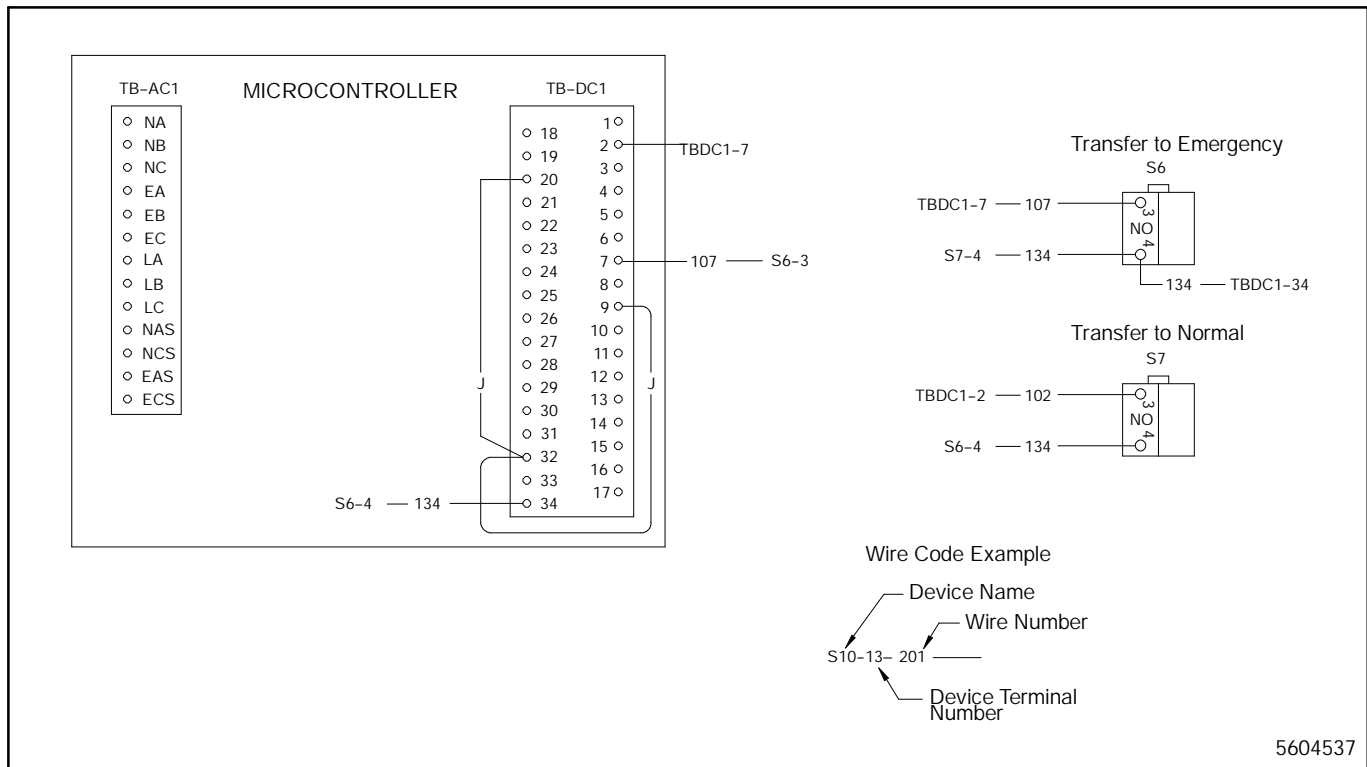
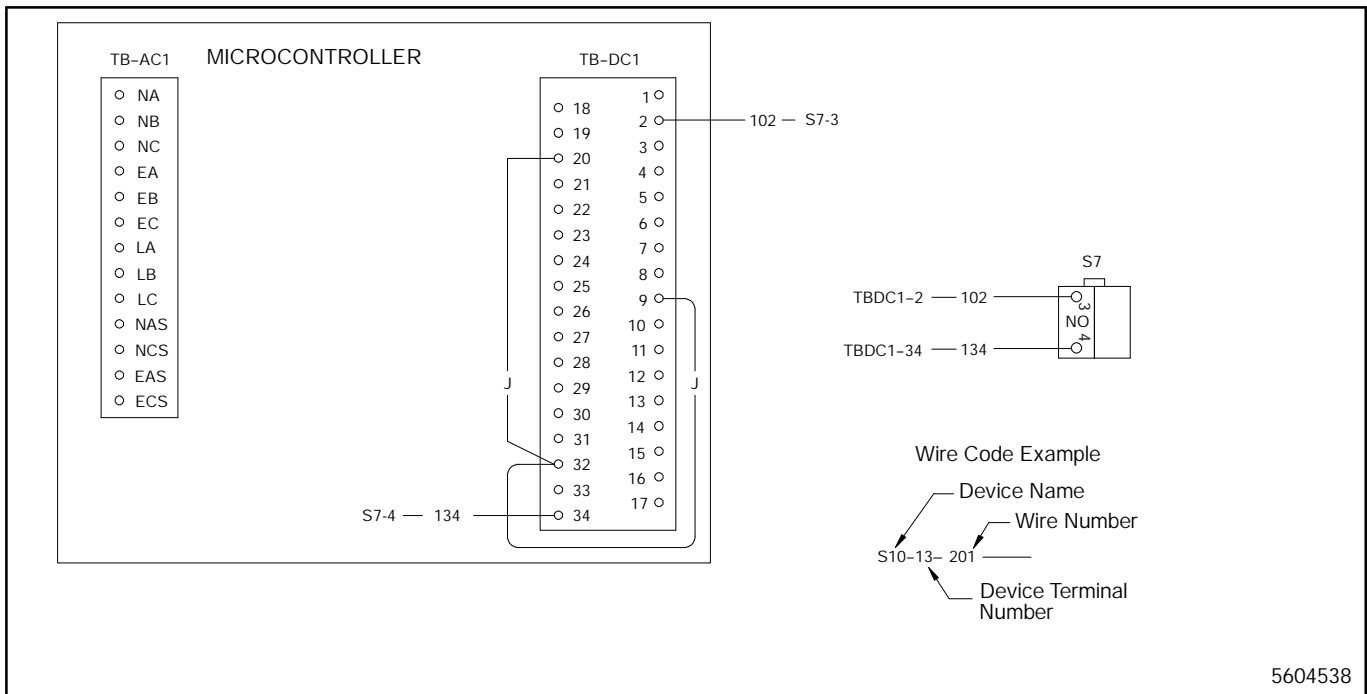
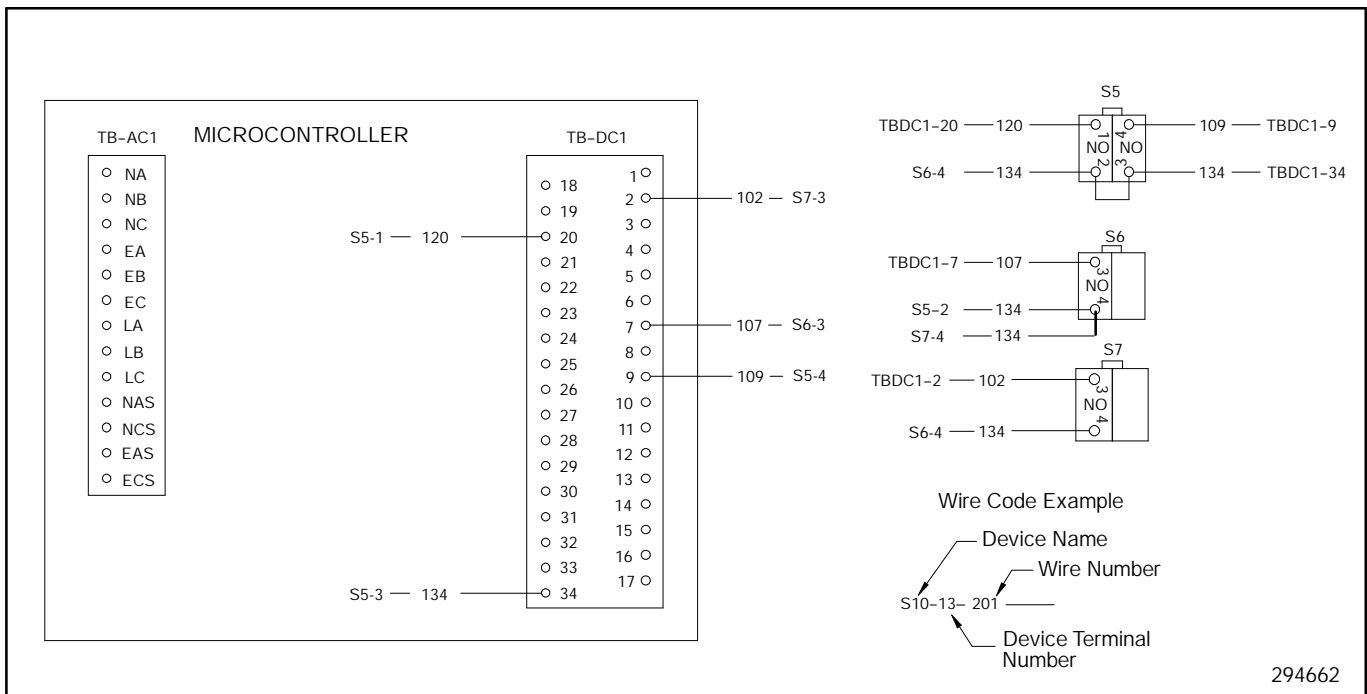


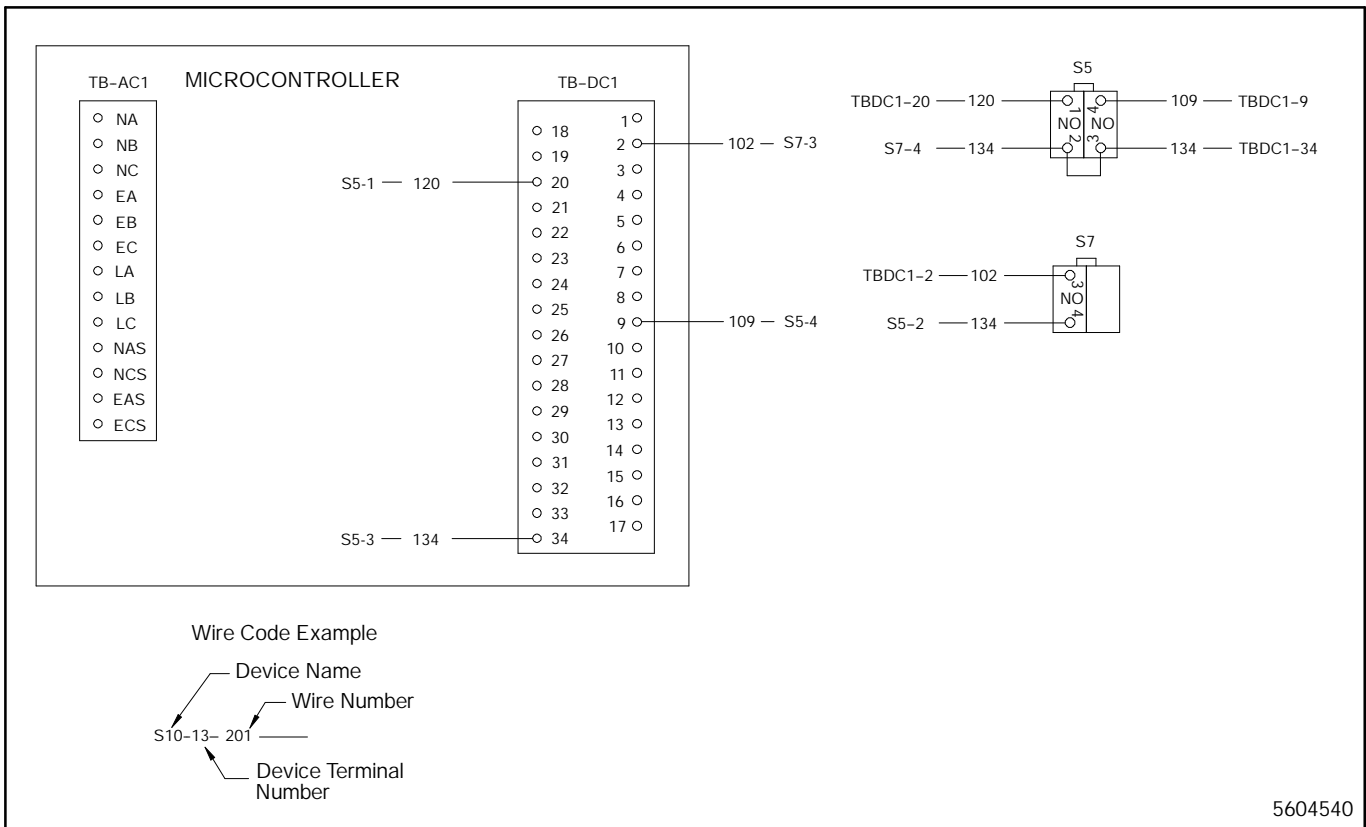
Figure 5-61. Wiring Diagram– Option DD-29-P and DD-29-R, Manual operation switches



**Figure 5-62. Wiring Diagram— Option DD-29-S and DD-29-T, Manual operation switches**



**Figure 5-63. Wiring Diagram— Option DD-29-U and DD-29-V, Manual operation switches**



5604540

Figure 5-64. Wiring Diagram– Option DD-29-W and DD-29-X, Manual operation switches

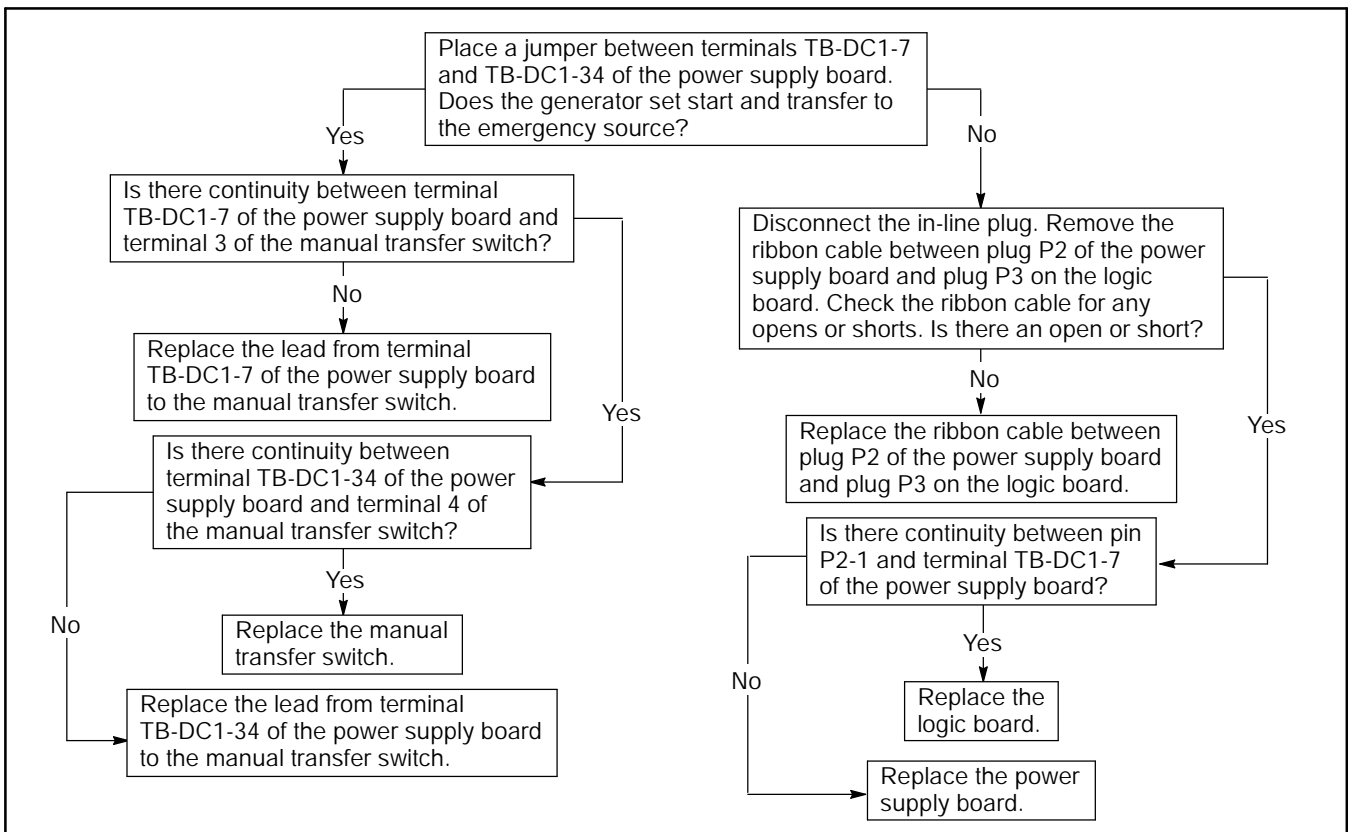
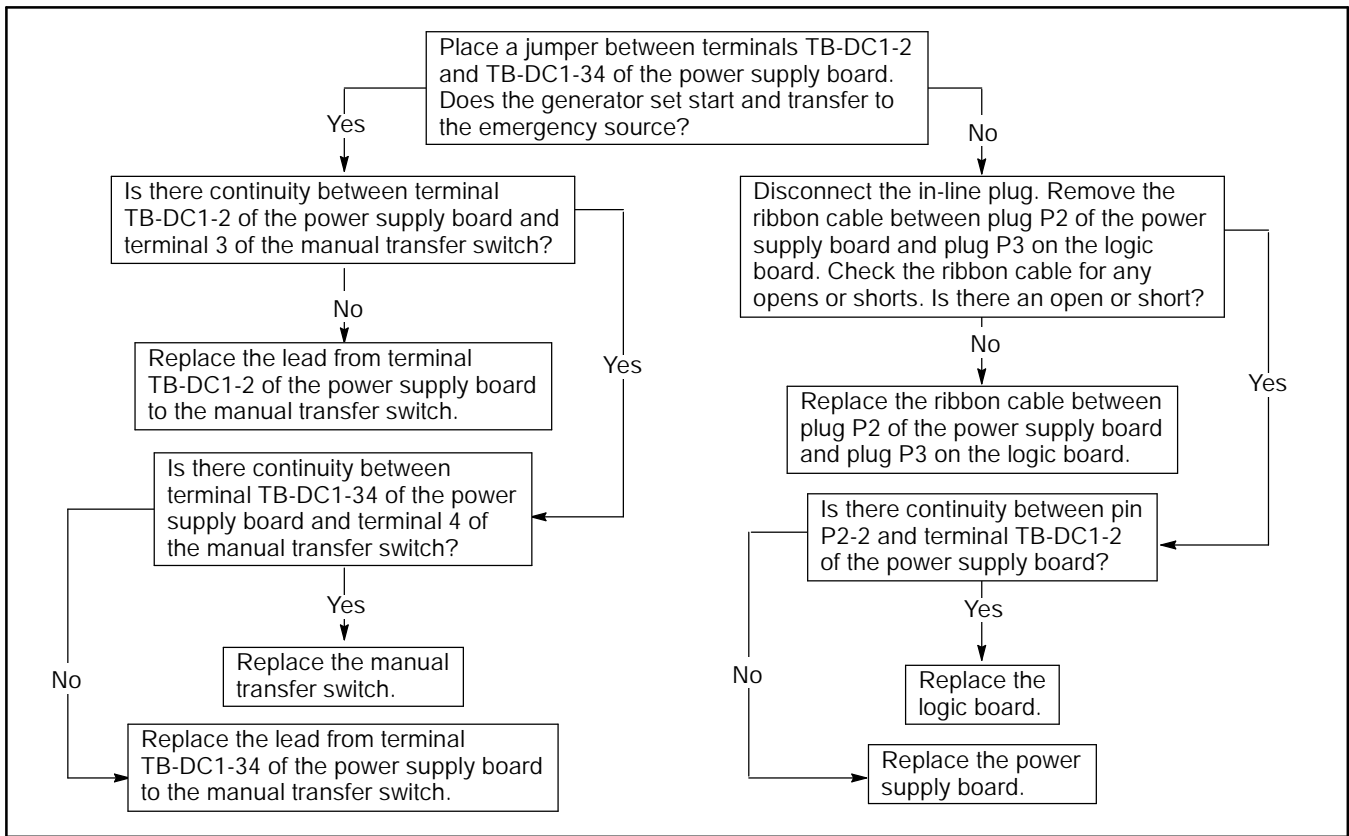
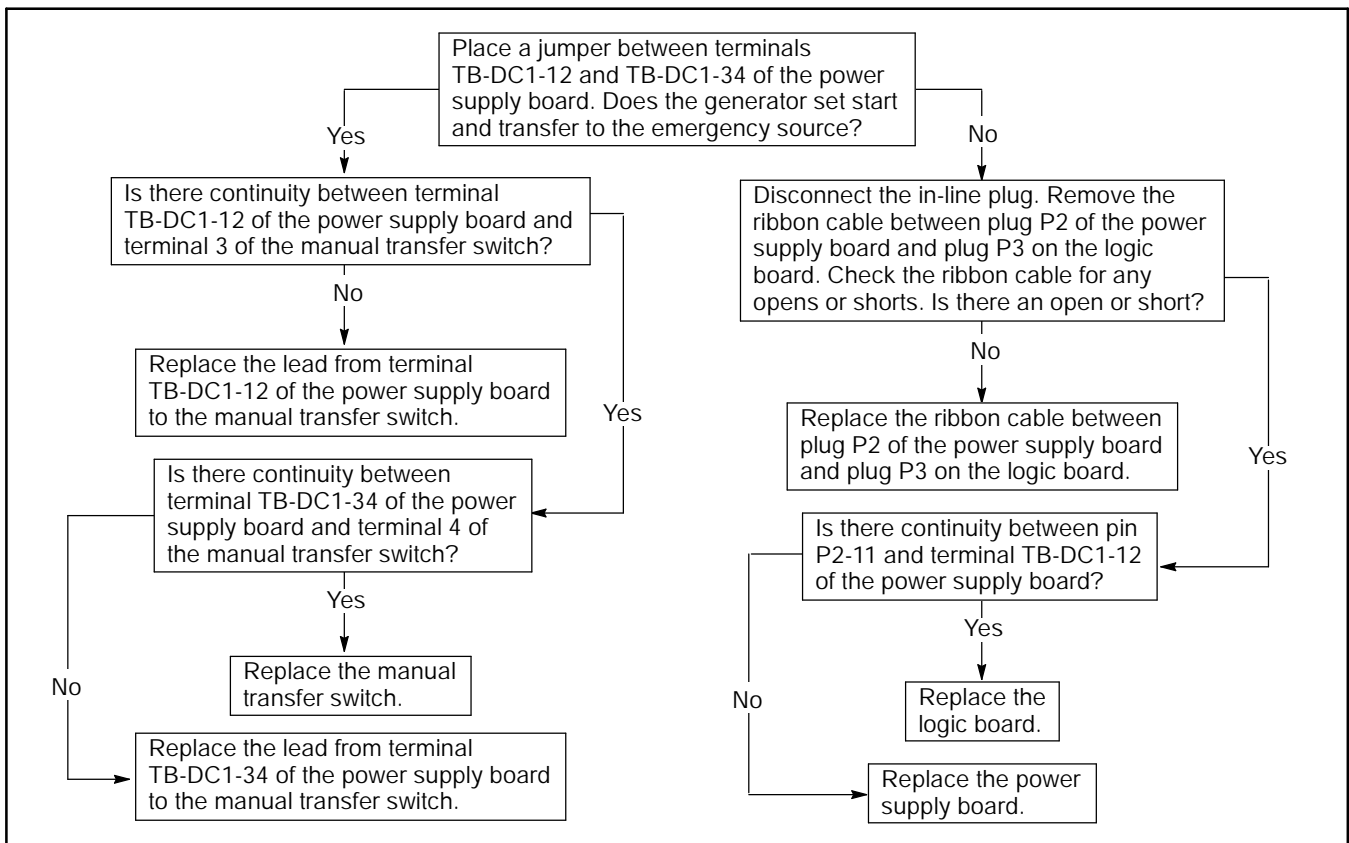


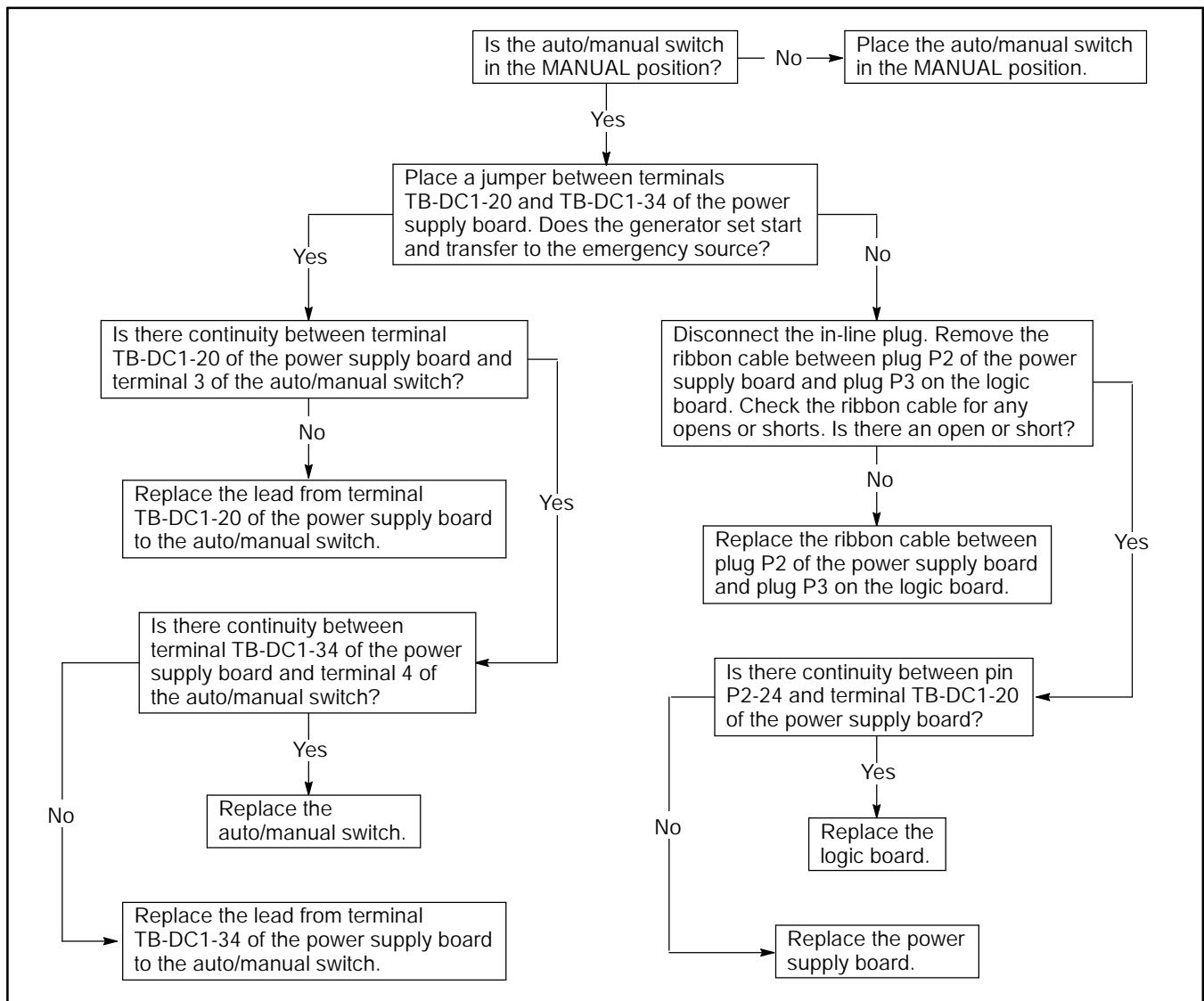
Figure 5-65. Troubleshooting– Option DD-29-P and DD-29-R, Manual transfer to emergency source does not work



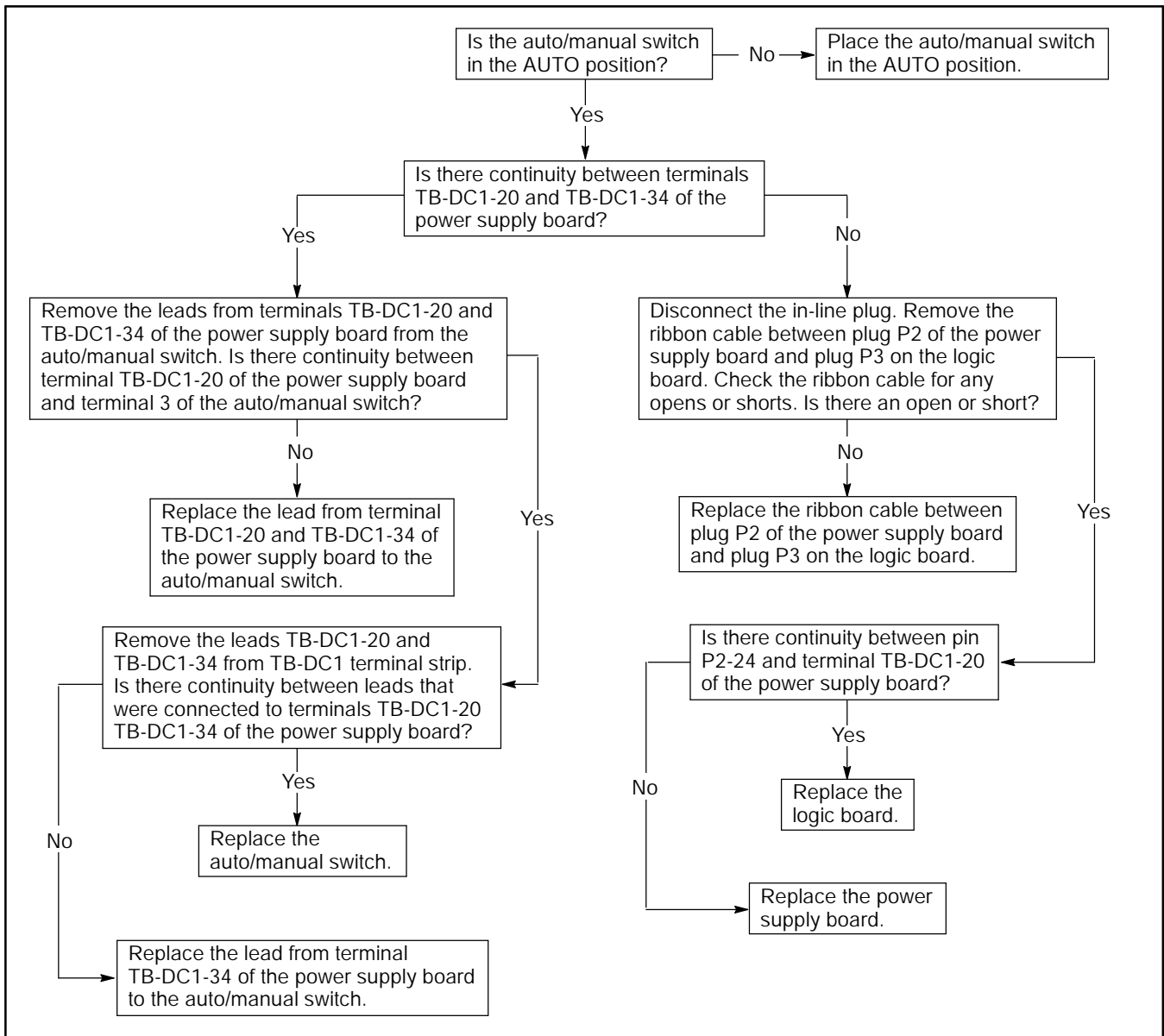
**Figure 5-66. Troubleshooting— Option DD-29-P and DD-29-R, Manual transfer to normal source does not work**



**Figure 5-67. Troubleshooting— Option DD-29-Y, Manual transfer to off does not work**



**Figure 5-68. Troubleshooting– Option DD-29-U, -V, -W, and -X, Auto/Manual switch does not work in the manual position**



**Figure 5-69. Troubleshooting– Option DD-29-U, -V, -W, and -X, Auto/Manual switch does not work in the auto position**

# Load-Shedding Contacts

The load-shedding contacts accessory, DD-35-N, allows the user to control the number of loads as well as the which loads will receive power. This accessory can transfer from zero to nine isolated form C contacts before and after the transfer switch transfers from either normal source to emergency source or from emergency source to normal source. The contacts can be either transferred in a block or transferred sequentially in either direction. The exact contacts to transfer are user programmable.

The time delays before transfer and the sequence interval time delays are individually adjustable. Settings may be made from the front panel keypad or from a remote computer. The first relay to energize is K1 and the last relay to energize is K10

See Figure 5-70 for the load-shedding contact option wiring diagram and Figure 5-71 for the troubleshooting flowchart.

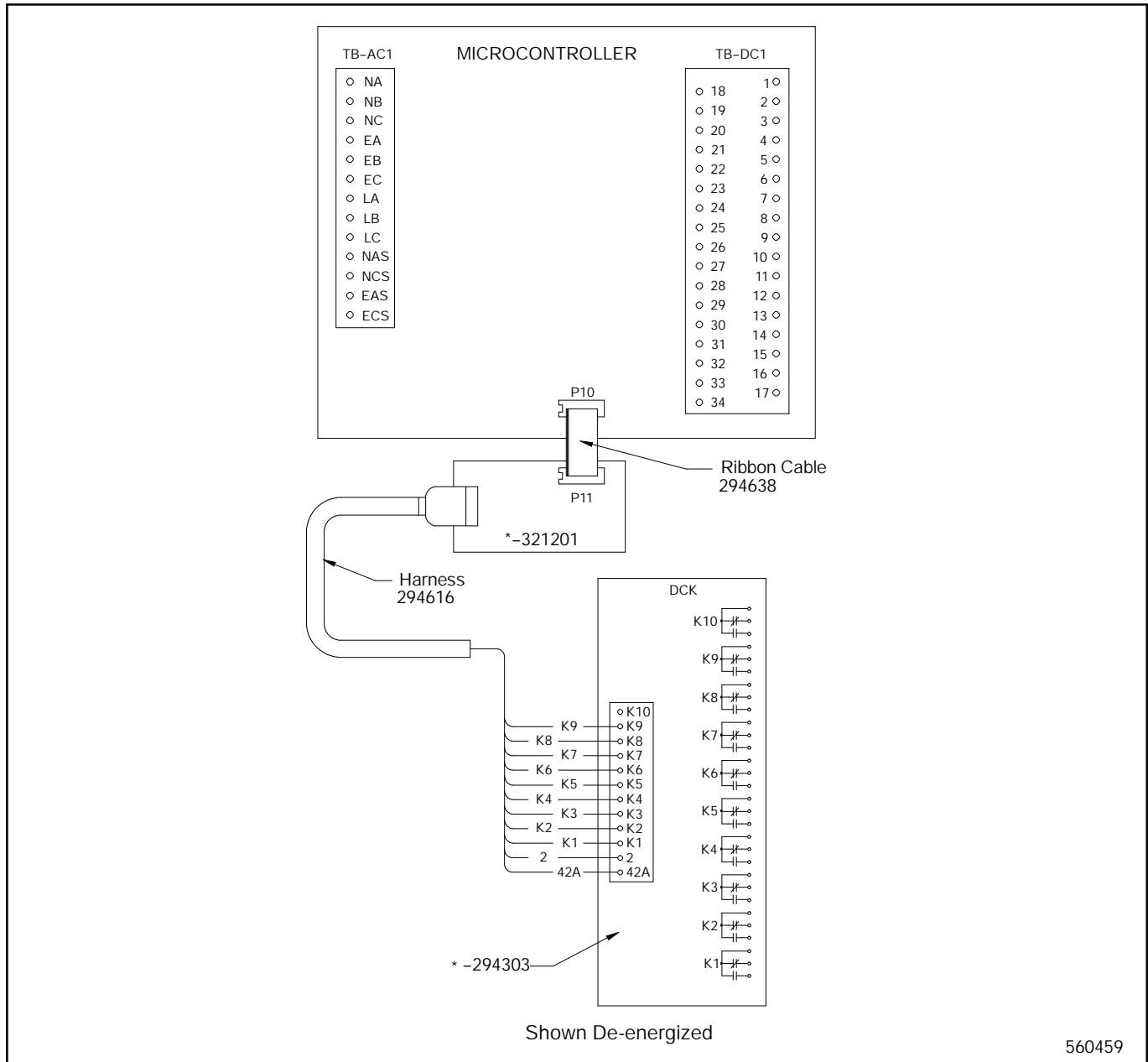


Figure 5-70. Wiring Diagram– Option KD-35-N, Load-shedding contacts

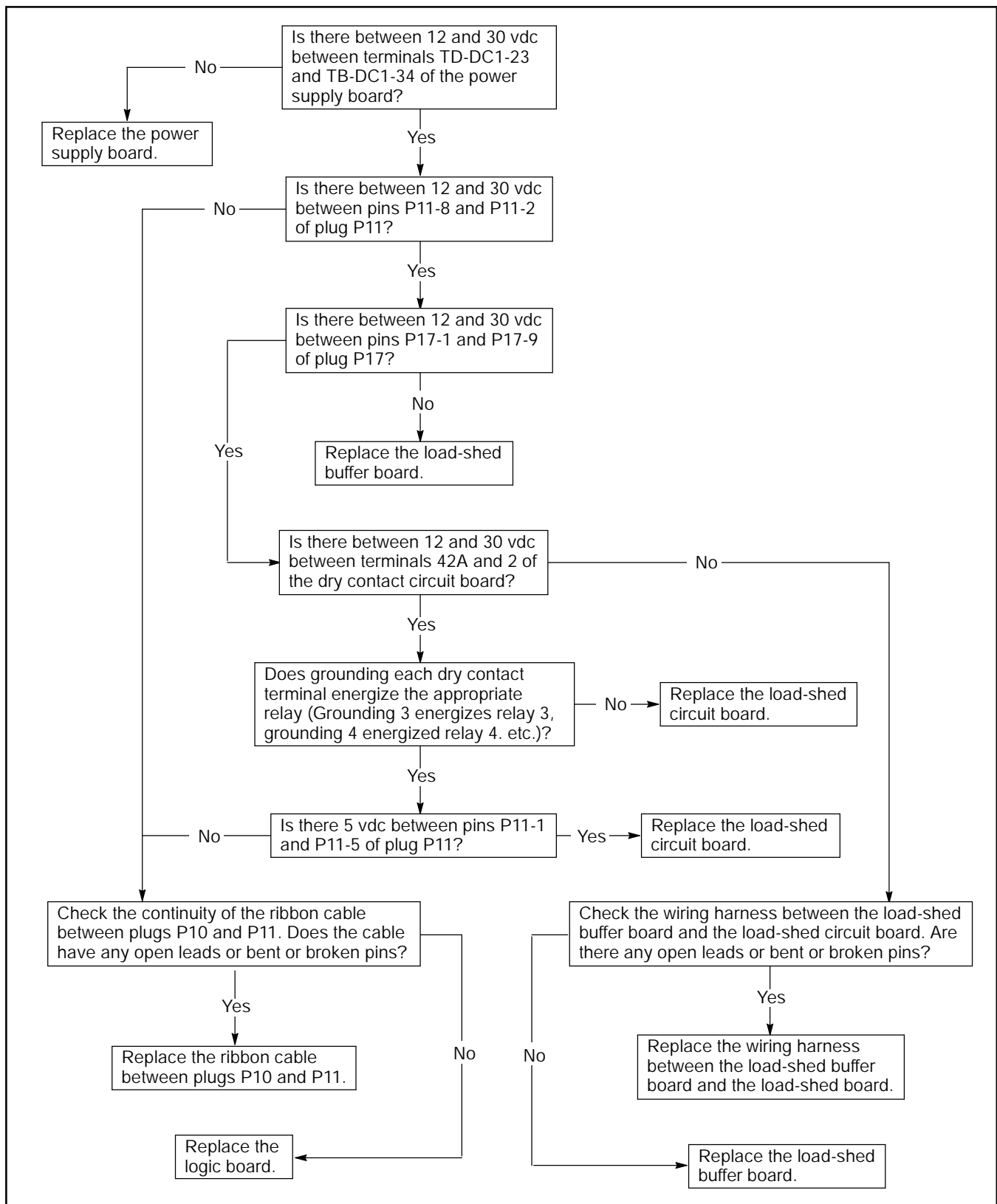


Figure 5-71. Troubleshooting– Option DD-35-N, Load-shedding contacts

# Remote Communication– RS/232 Or RS/485

For location of pushbuttons, switches, LEDs, and keys referred to in this section, see Figure 2-1.

- D **DD-51-A.** This accessory provides an automatic transfer switch RS-485 port adapter board for direct or LAN connection
- D **DD-51-B.** This accessory provides an automatic transfer switch RS-232 port adapter board for modem connection

If problems exist communicating with the logic board from a remote location check the Remote Control submenu. If problems persist, check the hardware.

## Remote Control Submenu

1. Press the RESET MENU key. Press digit keys 1, 3 to obtain the Remote Control submenu. Press the MENU Arrow Down key to scroll through and check the different options. Figure 5-72 below explains each of the options and what the proper response should be depending on the hardware used.

	Description
ON-LINE	Press YES and ENTER to allow remote access.
LOCAL	Press YES and ENTER if a personal computer is cabled directly to the logic board transfer switch COM port (See Main Menu, Program Configuration in the logic board Monitor Software manual).
REMOTE	Press YES and ENTER if a personal computer is connected through a Remote Single Connection (modem-to-modem).
LAN	Press YES and ENTER if there is more than one logic board transfer switch connected directly to one computer.
REMLAN	Press YES and ENTER if a personal computer accesses an Automatic transfer Switch Local Area Network through a modem.

**Figure 5-72. Explanation Of Remote Control Submenu Options And Responses**

2. If YES was entered at the REMOTE message, check the Options Locked submenu by performing the following steps.
  - a. Press the RESET MENU key.
  - b. Press digit keys 2,0 to obtain the Options Locked submenu.
  - c. Press the Arrow Down key until the LCD reads, CLOCK #. Write down the Clock # displayed on the LCD.
  - d. Press the Arrow Right key. Enter the Clock number which was just written down. Press the ENTER key.

Return to the Remote Control submenu. At the REMOTE message press the MENU Arrow Right key. The LCD should read SYS ID. Press up to six digit keys and ENTER to create a password for the transfer switch. Make sure that the ID entered at the keypad is the same ID used in the logic board Monitor software program.

3. If YES was entered at the LAN message, press the MENU Arrow Right key at the LAN message. The LCD should read ADDRESS. Press the digit keys to enter the Local Area Network address number for the transfer switch. The address number must be between 1 and 128. Use one address number per transfer switch, keeping the numbers consecutive. This is necessary in order for the software to call up the desired transfer switch. Make sure that the address entered at the keypad is the same address used in the logic board Monitor software program.
4. If YES was entered at the REMLAN message, perform the following step.
  - a. Press the MENU Arrow Right key at the REMLAN message. The LCD should read SYS ID. Press up to six digit keys and press ENTER to create a password for the transfer switch.
  - b. Press the MENU Arrow Right key at the SYS ID message. The LCD should read ADDRESS. Press the digit keys to enter the Local Area Network address number for the transfer switch. The address number must be between 1 and 128. Use one address number per transfer switch, keeping the numbers consecutive. This is necessary in order for the software to call up the desired transfer switch. Make sure that the address and system ID entered at the keypad is the same address used in the logic board Monitor software program.
5. Verify the correct baud rate setting by performing the following step.
  - a. Scroll through Index 13 using the MENU Arrow Down key to the BAUD RATE option.
  - b. Press the digit keys to enter the baud rate for the modems used to connect the remote computer(s) to the transfer switch. This setting must match the baud rate of the modems used. This setting must also match the logic board Monitor software program configuration. The default setting is 9600. The choices are 2400, 4800, and 9600.
  - c. Press ENTER.
6. Press the RESET MENU key. Press the digit keys 2, 0 to obtain the Options Locked submenu. Press the Arrow Down key until the LCD displays OPTIONS

LOCKED. Press the YES key and then the ENTER key.

7. Press the RESET MENU key, and then press the ENTER key to store the setpoints.

### Remote Communication Hardware

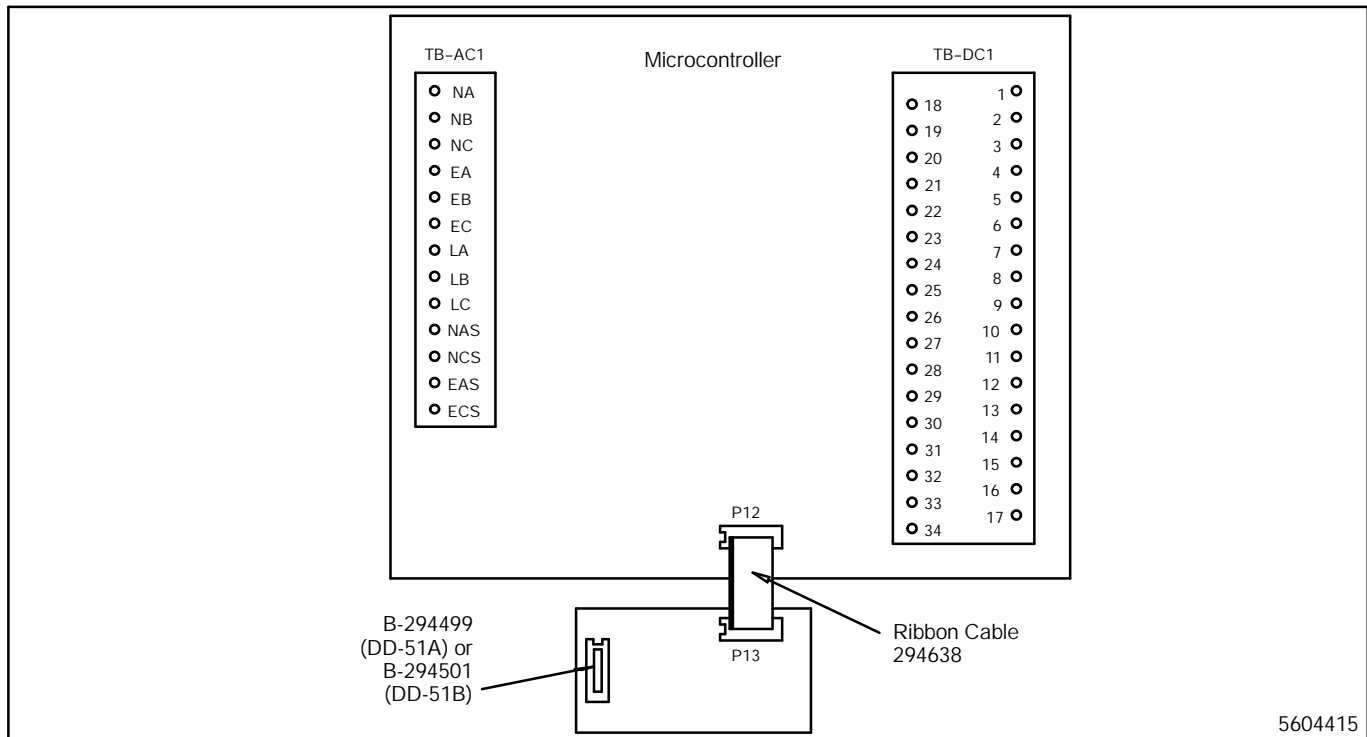
1. Check the voltage at P13-1 on the Remote Communication board. See Figure 5-73. Using a voltmeter, connect the positive test lead to P13-1 on the Remote Communication board. Connect the negative test lead to P13-6. The voltmeter should read five volts DC.
  - a. If the voltmeter reads approximately zero volts DC, check the P13 ribbon cable connection to the main logic board by performing the following procedure.
  - b. Remove all power sources.
  - c. Wait 30 seconds.
  - d. Making sure not to bend or break any of the pins, remove the P13 ribbon cable connector.
  - e. Inspect ribbon cable connector pin P13-1.
  - f. If any pins are bent, carefully bend them back. If any pins are broken, replace the ribbon cable connector.
  - g. Carefully reconnect P13 ribbon cable connector.

2. If the voltmeter reads approximately five volts DC, check the voltage at P13-7 on the Remote Communication board. Using a voltmeter, connect the positive test lead to P13-7. Connect the negative test lead to P13-6. The voltmeter should read approximately ten volts DC.
  - a. If the voltmeter reads zero volts DC at P13-7, check the P13 ribbon cable connection to the main logic board by performing the following steps.
  - b. Remove all power sources.
  - c. Wait 30 seconds.
  - d. Making sure not to bend or break any of the pins, remove the P13 ribbon cable connector.
  - e. Inspect the ribbon cable connector pin P13-7.
  - f. If any pins are bent, carefully bend them back. If any pins are broken, replace the ribbon cable connector.
  - g. Carefully reconnect P13 ribbon cable connector.

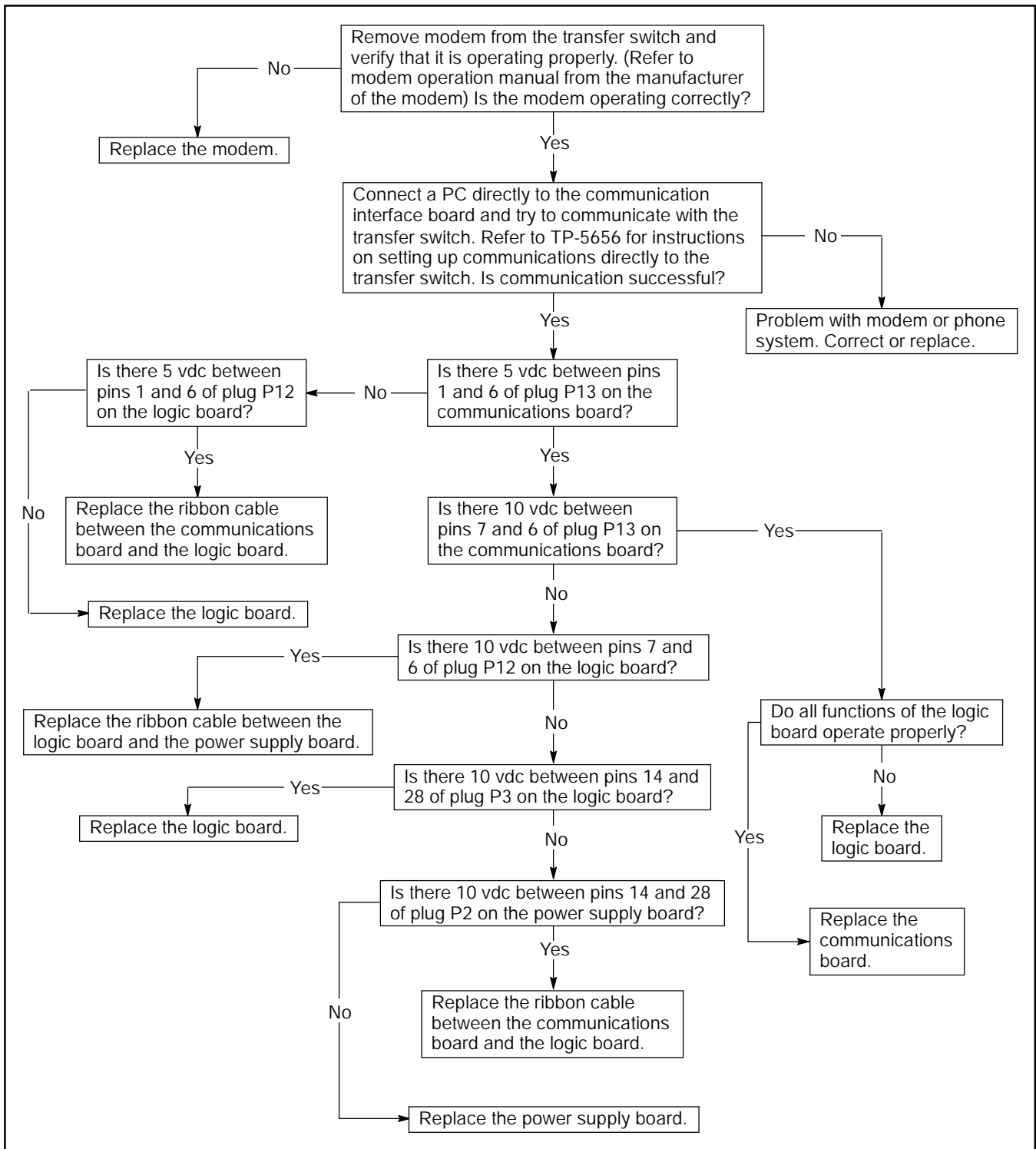
If the P13 ribbon cable is good, but the DC voltage at pin P13-7 is still zero, the main logic board is defective. Replace the logic board assembly.

Accessory DD-51 allows connection to an IBM-compatible personal computer for remote transfer switch monitoring. See Figure 5-73 for a wiring diagram for this accessory and Figure 5-74 for the troubleshooting flowchart.

If the P13 ribbon cable is good, but the DC voltage at pin P13-1 is still zero, the main logic board is defective. Replace the logic board assembly.



**Figure 5-73. Wiring Diagram– Option DD-51-A and DD-51-B, Remote communications board**



**Figure 5-74. Troubleshooting– Option DD-51-A and DD-51-B, Remote communication is not functioning properly**

# Section 6. Service Parts

## Introduction

Use this section to locate and identify service parts for the models of the automatic transfer switches that use microprocessor logic. The part numbers of the automatic transfer switches covered by the parts listed in this section begin with a 5 or a 6.

This section does not include nonserviceable parts of the automatic transfer switch or any parts of the power conversion unit within the automatic transfer switch. A separate service and parts manual is provided for each power conversion model. Refer to the List of Related Manuals in the Introduction of this manual for the name and number of the service and parts manual for the applicable power conversion unit.

## Using Parts Lists

### Finding Parts Information

1. Determine the parts needed.

Example: The micro-controller assembly needs to be replaced.

2. Use the illustration on Figure 6-1 to locate the number of the part that needs to be replaced.

Example: The micro-controller assembly is callout number 1.

3. Use the parts list to find the factory part name and part number.

Example: The name in the **Description** column for item 1 is micro-controller assembly  
The part number in the **Part Number** column for item 1 is 346061.

### Leads

Most leads are included with the wiring harness. For lead replacement, fabricate a lead using the same type of standard copper wire (gauge, color, length). Add terminals and lead designations at each end of the new lead.

# Inner Panel

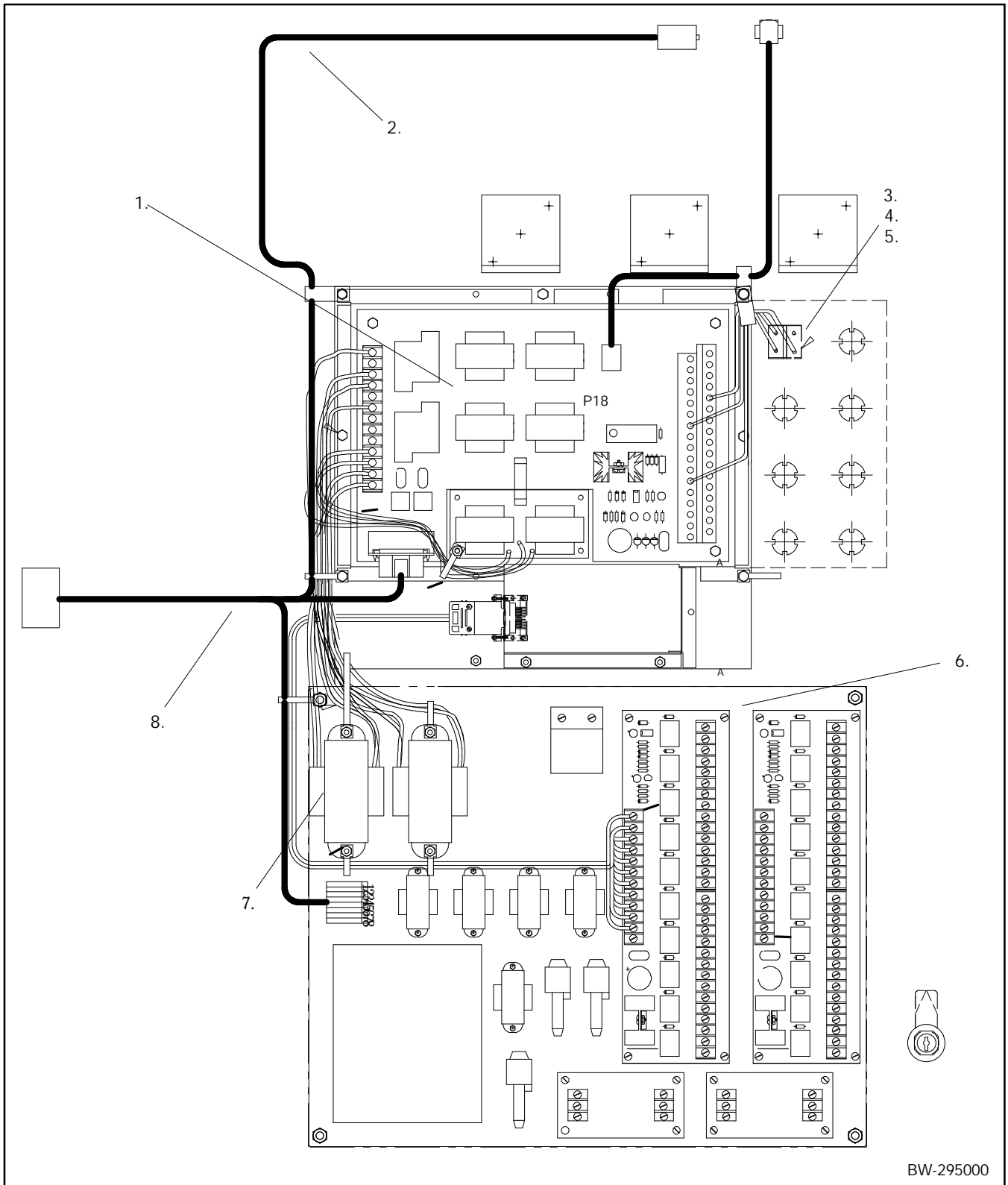
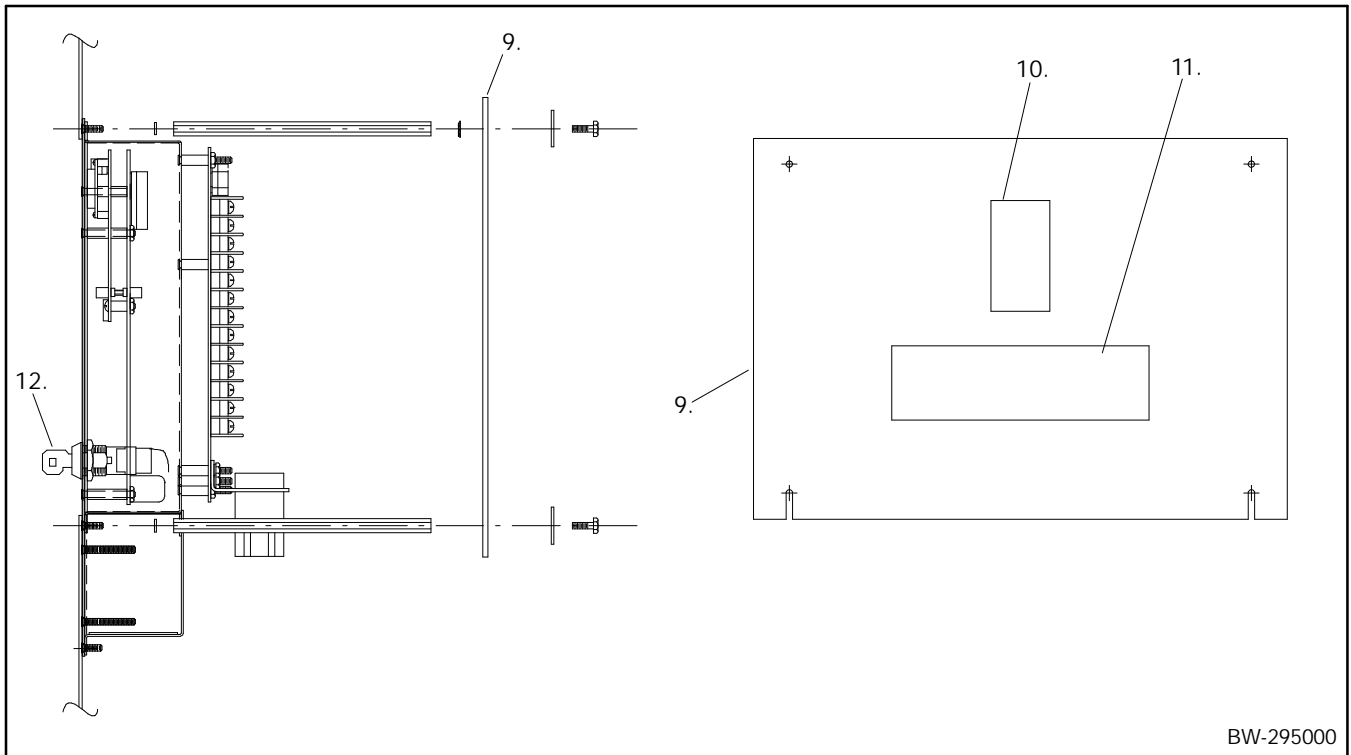


Figure 6-1. Microprocessor inner panel assembly



BW-295000

**Figure 6-2. Micro-controller assembly**

Item	Qty.	Description Variation	Part No.
1.	1	Micro-controller assembly	346061
2.	1	Logic to interface harness	See Figure 6-4
3.	1	Contact Assembly	298049
4.	1	Block, contact	294651
5.	1	Switch, pushbutton	294653
6.	1	Pannel, inner	294741
7.	2	Transformers	See Figure 6-3

Item	Qty.	Description Variation	Part No.
8.	1	Logic to power conversion unit harness	See Figure 6-4
9.	1	Guard	294860
10.	1	Decal, hazardous voltage	294328
11.	1	Decal, "This transfer..."	294523
12.	1	Key, replacement (6792)	296292
		Key, replacement (6375)	296293
		Key, replacement (PL976)	296294
		Key, replacement (XX6286)	296295

Switch Voltage	Item 7. Transformer
110	294644
120	294593
190	294645
208	294594
220	294646
240	294595
380	294596
416	294597
480	294598
600	294599

**Figure 6-3. Item 7– Transformer Part Numbers, See Figure 6-1 for illustration**

Switch Amps	Switch Description	Item 2. Logic to Interface	Item 8. Logic/Interface to Power Conversion Unit
<b>TES, TLS</b>			
25-180	standard and programmed transition	320957	321089
265-400	standard and programmed transition	320960	321327
<b>MNS, MMS</b>			
40-160	standard and programmed transition	320957	321313
250-4000	standard and programmed transition	320960	321326
<b>ZCS</b>			
150-4000	standard and programmed transition	320960	321089
<b>ZCB</b>			
100-400	standard	321456	321460
100-400	programmed transition	321456	321457
600-1200	standard and programmed transition	321456	321458
1600-3000	standard	320960	321465
1600-3000	programmed transition	320960	321468

**Figure 6-4. Wiring Harness Part Numbers, See Figure 6-1 for illustration**

# M340+ Accessories

## Time Delay

Accessory	Description	Part Number
02-F	Relay, Time Delay	295974

## Source Monitors

Accessory	Description	Part Number
5-K	Circuit Board, 3 phase Cable Assembly, Ribbon Shunt, Programming	C-294493 294638 294634

## Test Switches

Accessory	Description	Part Number
6-F	Switch, Pushbutton Switch, 2-Position Decal, Auto/Test	294653 294656 294689
6-N	Block, Contact Switch, Pushbutton Decal Switch, 3-Position Contact Assembly	294653 294653 294685 294691 298049
6-P	Block, Contact Switch, Pushbutton Decal Switch, 3-Position Contact Assembly	294651 294653 294685 294692 298049

## Test Switch

Accessory	Description	Part Number
07-D	Decal Block, Contact Switch, Pushbutton Switch, 4 Position Contact Assembly	294686 294651 294653 294695 298049

## Time Delay Override Switches

Accessory	Description	Part Number
8-C	Switch, Pushbutton Contact Assembly	294653 298049
8-D	Switch, Pushbutton Contact Assembly	294653 298049

## Preferred-Source Switches

Accessory	Description	Part Number
10-D	Fuse, Lamp Block, Contact Block, Contact Switch, Operator Contact Assembly	239179 294651 294652 298039 298047

## Auxiliary Contacts– Relay

Accessory	Description	Part Number
14-C	Relay Socket, Relay Tab, Identification Clamp, Relay Hold Down	295254 295034 201620-157 295189
14-D	Relay Socket, Relay Tab, Identification Clamp, Relay Hold Down	295254 295034 201620-158 295189
14-G	Circuit Board,10 Relay Jumper (3) Holder, Fuse Fuse, Lamp	D-294303 X-6048-2 239050 239179
14-H	Circuit Board,1 Relay Holder, Fuse Fuse, Lamp	C-294301 239050 239179
14-J	Circuit Board,1 Relay Holder, Fuse Fuse, Lamp	C-294301 239050 239179
14-K	Circuit Board,1 Relay Holder, Fuse Fuse, Lamp	C-294301 239050 239179
14-L	Circuit Board,1 Relay Holder, Fuse Fuse, Lamp	C-294301 239050 239179
14-M	Circuit Board,1 Relay Holder, Fuse Fuse, Lamp	C-294301 239050 239179
14-N	Circuit Board,1 Relay Holder, Fuse Fuse, Lamp	C-294301 239050 239179
14-P	Circuit Board,1 Relay Holder, Fuse Fuse, Lamp	C-294301 239050 239179
14-R	Circuit Board,1 Relay Holder, Fuse Fuse, Lamp	C-294301 239050 239179

## Auxiliary Contacts– Main Shaft

Accessory	Description	Part Number
15-E	Contact, Auxiliary	295166
15-F	Contact, Auxiliary Insulator, Plate	295166 297275

# Accessories

## Meters

Accessory	Description	Part Number
18-GA	Insulink (3) Fuse, 2 Amp Meter, Frequency	X-367-3 239049 295069
18-GB	Insulink (3) Fuse, 2 Amp Meter, Frequency	X-367-3 239049 295348
18-GC	Insulink (3) Fuse, 2 Amp Meter, Frequency	X-367-3 239049 295348
18-GD	Insulink (3) Fuse, 2 Amp Meter, Frequency Transformer	X-367-3 239049 295069 295300
18-GE	Insulink (3) Fuse, 2 Amp Meter, Frequency Transformer	X-367-3 239049 295069 295301
18-GF	Insulink (3) Fuse, 2 Amp Meter, Frequency Transformer	X-367-3 239049 295069 295302
18-GG	Insulink (3) Fuse, 2 Amp Meter, Frequency Transformer	X-367-3 239049 295069 295299
18-JA-1	Insulink (2) Fuse, 2 Amp Switch, Selector Nameplate Voltmeter, AC Transformer Ammeter	X-367-3 239049 283638 295343 295344 295019 295336
18-JA2	Insulink (2) Fuse, 2 Amp Switch, Selector Nameplate Voltmeter, AC Transformer (3) Ammeter	X-367-3 239049 283638 294704 295011 295019 295336
18-JA3	Insulink (2) Fuse, 2 Amp Switch, Selector Nameplate Voltmeter, AC Transformer Ammeter	X-367-3 239049 294700 294702 295011 295019 295336
18-JA4	Insulink (2) Insulink Fuse, 2 Amp Switch, Selector Nameplate Voltmeter, AC Transformer (2) Ammeter	X-367-4 X-367-3 239049 294701 294703 295011 295019 295336

Accessory	Description	Part Number
18-JA5	Insulink (2) Fuse, 2 Amp Switch, Selector Nameplate Voltmeter, AC Transformer (2) Ammeter	X-367-3 239049 283638 294704 295011 295019 295336
18-JA8	Insulink (3) Fuse, 2 Amp Switch, Selector Nameplate Voltmeter, AC Transformer Transformer Ammeter Resistor	X-367-3 239049 294700 294702 295014 295019 295302 295336 295396
18-JA9	Insulink (3) Fuse, 2 Amp Switch, Selector Nameplate Voltmeter, AC Transformer Transformer Ammeter Resistor	X-367-3 239049 283638 294704 295014 295019 295302 295336 295396
18-JA-10	Insulink (2) Fuse, 2 Amp Switch, Selector Nameplate Voltmeter, AC Transformer Ammeter Resistor	X-367-3 239049 283638 295343 295344 295019 295336 295396
18-JB1	Insulink (3) Fuse, 2 Amp Transformer Switch, Selector Nameplate Ammeter Voltmeter	X-367-3 239049 246884 294700 294702 295337 295344
18-JB-2	Insulink (2) Fuse, 2 Amp Transformer (3) Switch, Selector Nameplate Ammeter Voltmeter	X-367-3 239049 246884 283638 295342 295337 295011
18-JB-3	Insulink Fuse, 2 Amp Transformer (3) Switch, Selector Nameplate Ammeter Voltmeter	X-367-3 239049 246884 283638 295343 295337 295011
18-JB4	Insulink Fuse, 2 Amp Transformer (2) Switch, Selector Nameplate Ammeter Voltmeter	X-367-3 239049 246884 283638 295341 295011 295337

## Meters (continued)

Accessory	Description	Part Number
18-JB5	Insulink (2) Fuse, 2 Amp Transformer (3) Switch, Selector Nameplate Ammeter Voltmeter	X-367-3 239049 246884 283638 295342 295337 295011
18-JB6	Insulink Fuse, 2 Amp Transformer (3) Transformer Switch, Selector Nameplate Ammeter Voltmeter	X-367-3 239049 246884 295302 283638 295342 295337 295014
18-JB8	Insulink Fuse, 2 Amp Transformer Switch, Selector Nameplate Transformer Ammeter Voltmeter Resistor	X-367-3 239049 246884 283638 295343 295302 295337 295014 295396
18-JB9	Insulink Fuse, 2 Amp Transformer (3) Switch, Selector Nameplate Transformer Ammeter Voltmeter Resistor	X-367-3 239049 246884 283638 295342 295302 295337 295014 295396
18-JB10	Insulink (2) Fuse, 2 Amp Transformer (3) Switch, Selector Nameplate Transformer Ammeter Voltmeter Resistor	X-367-3 239049 246884 283638 295342 245299 295337 295017 295396
18-JC1	Insulink Fuse, 2 Amp Transformer Switch, Selector Nameplate Ammeter Voltmeter	X-367-3 239049 246885 283638 295343 295338 295344
18-JC2	Insulink Fuse, 2 Amp Transformer (3) Switch, Selector Nameplate Ammeter Voltmeter	X-367-3 239049 246885 283638 295342 295338 295011
18-JC3	Insulink Fuse, 2 Amp Transformer Switch, Selector Nameplate Ammeter Voltmeter	X-367-3 239049 246885 283638 295343 295338 295011
18-JC4	Insulink Fuse, 2 Amp Transformer (2) Switch, Selector Nameplate Ammeter Voltmeter	X-367-3 239049 246885 283638 295341 295338 295011

Accessory	Description	Part Number
18-JC5	Insulink Fuse, 2 Amp Transformer (3) Switch, Selector Nameplate Ammeter Voltmeter	X-367-3 239049 246885 283638 295342 295338 295011
18-JC8	Insulink Fuse, 2 Amp Transformer Transformer Switch, Selector Nameplate Ammeter Voltmeter	X-367-3 239049 246885 295302 283638 295343 295338 295014
18-JC9	Insulink Fuse, 2 Amp Transformer (3) Switch, Selector Nameplate Transformer Ammeter Voltmeter Resistor	X-367-3 239049 246885 283638 295342 295302 295338 295014 295396
18-JC10	Insulink Fuse, 2 Amp Transformer (3) Switch, Selector Nameplate Transformer Ammeter Voltmeter Resistor	X-367-3 239049 246885 283638 295342 295299 295338 295017 295396
18-JD1	Insulink Fuse, 2 Amp Transformer Switch, Selector Nameplate Ammeter Voltmeter	X-367-3 239049 246886 283638 295343 295337 295344
18-JD2	Insulink Fuse, 2 Amp Transformer (3) Switch, Selector Nameplate Ammeter Voltmeter	X-367-3 239049 246886 283638 295342 295337 295011
18-JD3	Insulink Fuse, 2 Amp Transformer Switch, Selector Nameplate Ammeter Voltmeter	X-367-3 239049 246886 283638 295343 295337 295011
18-JD4	Insulink Fuse, 2 Amp Transformer (2) Switch, Selector Nameplate Ammeter Voltmeter	X-367-3 239049 246886 283638 295341 295337 295011
18-JD5	Insulink Fuse, 2 Amp Transformer (3) Switch, Selector Nameplate Ammeter Voltmeter	X-367-3 239049 246886 283638 295342 295337 295011

## Meters (continued)

Accessory	Description	Part Number
18-JD8	Insulink Fuse, 2 Amp Transformer Switch, Selector Nameplate Ammeter Voltmeter Transformer Resistor	X-367-3 239049 246886 283638 295343 295337 295014 295302 295396
18-JD9	Insulink Fuse, 2 Amp Transformer (3) Switch, Selector Nameplate Ammeter Voltmeter Transformer Resistor	X-367-3 239049 246886 283638 295342 295337 295014 295302 295396
18-JD10	Insulink Fuse, 2 Amp Transformer (3) Switch, Selector Nameplate Transformer Ammeter Voltmeter Resistor	X-367-3 239049 246886 283638 295342 295299 295337 295017 295396
18-JE1	Insulink Fuse, 2 Amp Transformer Switch, Selector Nameplate Ammeter Voltmeter	X-367-3 239049 246889 283638 295343 295339 295344
18-JE2	Insulink Fuse, 2 Amp Transformer (3) Switch, Selector Nameplate Ammeter Voltmeter	X-367-3 239049 246889 283638 295342 295339 295011
18-JE3	Insulink Fuse, 2 Amp Transformer Switch, Selector Nameplate Ammeter Voltmeter	X-367-3 239049 246889 283638 295343 295339 295011
18-JE4	Insulink Fuse, 2 Amp Transformer Switch, Selector Nameplate Ammeter Voltmeter	X-367-3 239049 246889 283638 295341 295339 295011
18-JE5	Insulink Fuse, 2 Amp Transformer (3) Switch, Selector Nameplate Ammeter Voltmeter	X-367-3 239049 246889 283638 295342 295339 295011

Accessory	Description	Part Number
18-JE8	Insulink Fuse, 2 Amp Transformer Switch, Selector Nameplate Ammeter Voltmeter Transformer Resistor	X-367-3 239049 246889 283638 295343 295339 295014 295302 295396
18-JE9	Insulink Fuse, 2 Amp Transformer (3) Switch, Selector Nameplate Ammeter Voltmeter Transformer Resistor	X-367-3 239049 246889 283638 295342 295339 295014 295302 295396
18-JE10	Insulink Fuse, 2 Amp Transformer (3) Switch, Selector Nameplate Ammeter Voltmeter Transformer Resistor	X-367-3 239049 246889 283638 295342 295339 295017 295299 295396
18-JF1	Insulink Fuse, 2 Amp Transformer Switch, Selector Nameplate Ammeter Voltmeter	X-367-3 239049 248874 283638 295343 295340 295344
18-JF2	Insulink Fuse, 2 Amp Transformer (3) Switch, Selector Nameplate Ammeter Voltmeter	X-367-3 239049 248874 283638 295342 295340 295011
18-JF3	Insulink Fuse, 2 Amp Transformer Switch, Selector Nameplate Ammeter Voltmeter	X-367-3 239049 248874 283638 295343 295340 295011
18-JF4	Insulink Fuse, 2 Amp Transformer (2) Switch, Selector Nameplate Ammeter Voltmeter	X-367-3 239049 248874 283638 295341 295340 295011
18-JF5	Insulink Fuse, 2 Amp Transformer (3) Switch, Selector Nameplate Ammeter Voltmeter	X-367-3 239049 248874 283638 295342 295340 295011
18-JF6	Insulink Fuse, 2 Amp Transformer (3) Switch, Selector Nameplate Ammeter Voltmeter Resistor	X-367-3 239049 248874 283638 295342 295340 295014 295396

## Meters (continued)

Accessory	Description	Part Number
18-JF8	Insulink Fuse, 2 Amp Transformer Switch, Selector Nameplate Ammeter Voltmeter Transformer Resistor	X-367-3 239049 248874 283638 295343 295340 295014 295302 295396
18-JF9	Insulink Fuse, 2 Amp Transformer Switch, Selector Nameplate Ammeter Voltmeter Transformer Resistor	X-367-3 239049 248874 283638 295342 295340 295014 295302 295396
18-JF10	Insulink Fuse, 2 Amp Transformer (3) Switch, Selector Nameplate Ammeter Voltmeter Transformer Resistor	X-367-3 239049 248874 283638 295342 295340 295017 295299 295396
18-JG1	Insulink Fuse, 2 Amp Transformer Switch, Selector Nameplate Ammeter Voltmeter	X-367-3 239049 297148 283638 295343 295339 295344
18-JG2	Insulink Fuse, 2 Amp Transformer (3) Switch, Selector Nameplate Ammeter Voltmeter	X-367-3 239049 297148 283638 295342 295339 295011
18-JG3	Insulink Fuse, 2 Amp Transformer Switch, Selector Nameplate Ammeter Voltmeter	X-367-3 239049 297148 283638 295343 295339 295011
18-JG4	Insulink Fuse, 2 Amp Transformer (2) Switch, Selector Nameplate Ammeter Voltmeter	X-367-3 239049 297148 283638 295341 295339 295011
18-JG5	Insulink Fuse, 2 Amp Transformer (3) Switch, Selector Nameplate Ammeter Voltmeter	X-367-3 239049 297148 283638 295342 295339 295011

Accessory	Description	Part Number
18-JG8	Insulink Fuse, 2 Amp Transformer Switch, Selector Nameplate Ammeter Voltmeter Transformer Resistor	X-367-3 239049 295302 283638 295343 295339 295014 297148 295396
18-JG9	Insulink Fuse, 2 Amp Transformer Switch, Selector Nameplate Ammeter Voltmeter Transformer (3) Resistor	X-367-3 239049 295302 283638 295342 295339 295014 297148 295396
18-JG10	Insulink Fuse, 2 Amp Transformer Switch, Selector Nameplate Ammeter Voltmeter Transformer (3) Resistor	X-367-3 239049 295299 283638 295342 295339 295017 297148 295396
18-JH1	Insulink Fuse, 2 Amp Transformer Switch, Selector Nameplate Ammeter Voltmeter	X-367-3 239049 297149 283638 295343 295340 295344
18-JH2	Insulink Fuse, 2 Amp Transformer (3) Switch, Selector Nameplate Ammeter Voltmeter	X-367-3 239049 297149 283638 295342 295340 295011
18-JH3	Insulink Fuse, 2 Amp Transformer Switch, Selector Nameplate Ammeter Voltmeter	X-367-3 239049 297149 283638 295343 295340 295011
18-JH4	Insulink Fuse, 2 Amp Transformer (2) Switch, Selector Nameplate Ammeter Voltmeter	X-367-3 239049 297149 283638 295341 295340 295011
18-JH5	Insulink Fuse, 2 Amp Transformer (3) Switch, Selector Nameplate Ammeter Voltmeter	X-367-3 239049 297149 283638 295342 295340 295011
18-JH8	Insulink Fuse, 2 Amp Transformer Switch, Selector Nameplate Ammeter Voltmeter Transformer Resistor	X-367-3 239049 295302 283638 295343 295340 295014 297149 295396

## Meters (continued)

Accessory	Description	Part Number
18-JH9	Insulink Fuse, 2 Amp Transformer Switch, Selector Nameplate Ammeter Voltmeter Transformer (3) Resistor	X-367-3 239049 295302 283638 295342 295340 295014 297149 295396
18-JH10	Insulink Fuse, 2 Amp Transformer Switch, Selector Nameplate Ammeter Voltmeter Transformer (3) Resistor	X-367-3 239049 295299 283638 295342 295340 295017 297149 295396
18-JK2	Insulink Fuse, 2 Amp Switch, Selector Nameplate Ammeter Voltmeter Transformer (3)	X-367-3 239049 283699 295704 282958 295011 291546
18-JK6	Insulink Fuse, 2 Amp Switch, Selector Nameplate Ammeter Voltmeter Transformer (3) Transformer	X-367-3 239049 283699 295704 282958 295014 291546 295300
18-JK9	Insulink Fuse, 2 Amp Transformer Switch, Selector Nameplate Ammeter Voltmeter Transformer (3) Resistor	X-367-3 239049 295302 283638 295342 282958 295014 291546 295396
18-JL2	Insulink Fuse, 2 Amp Switch, Selector Nameplate Ammeter Voltmeter Transformer (3)	X-367-3 239049 283638 295342 282959 295011 291547
18-JL9	Insulink Fuse, 2 Amp Transformer Switch, Selector Nameplate Ammeter Voltmeter Transformer (3) Resistor	X-367-3 239049 295302 283638 295342 282959 295014 291547 295396

18-JM2	Insulink Fuse, 2 Amp Switch, Selector Nameplate Ammeter Voltmeter Transformer (3)	X-367-3 239049 283638 295342 282960 295011 291548
18-JM9	Insulink Fuse, 2 Amp Transformer Switch, Selector Nameplate Ammeter Voltmeter Transformer (3) Resistor	X-367-3 239049 295302 283638 295342 282960 295014 291548 295396
18-JN2	Insulink Fuse, 2 Amp Switch, Selector Nameplate Ammeter Voltmeter Transformer (3)	X-367-3 239049 283638 295342 282959 295011 297675
18-JN9	Insulink Fuse, 2 Amp Transformer Switch, Selector Nameplate Ammeter Voltmeter Transformer (3) Resistor	X-367-3 239049 295302 283638 295342 282959 295014 297675 295396
18-JP2	Insulink Fuse, 2 Amp Switch, Selector Nameplate Ammeter Voltmeter Transformer (3)	X-367-3 239049 283638 295342 282960 295011 297676
18-JP9	Insulink Fuse, 2 Amp Transformer Switch, Selector Nameplate Ammeter Voltmeter Transformer (3) Resistor	X-367-3 239049 295302 283638 295342 282960 295014 297676 295396

## Plant Exercisers

Accessory	Description	Part Number
23-TA	Clock, Time	294541
23-TB	Clock, Time Transformer	294541 295354
23-TC	Clock, Time Transformer	294541 295355
23-TD	Clock, Time Transformer	294541 295301
23-TE	Clock, Time Transformer	294541 295302
23-TF	Clock, Time Transformer	294541 295299
23-UA	Clock, Time	294541
23-UB	Clock, Time Transformer	294541 295354
23-UC	Clock, Time Transformer	294541 295355
23-UD	Clock, Time Transformer	294541 295301
23-UE	Clock, Time Transformer	294541 295302
23-UF	Clock, Time Transformer	294541 295299
23-VA	Clock, Time Switch, Selector	294541 295322
23-VA3	Clock, Time Switch, Operator Block, Contact Block, Contact Contact, Assembly	294541 298039 298051 298052 298054
23-VB	Clock, Time Transformer Switch, Selector	294541 295354 295322
23-VB3	Clock, Time Transformer Switch, Operator Block, Contact Block, Contact Contact, Assembly	294541 295354 298039 298051 298052 298054

Accessory	Description	Part Number
23-VC	Clock, Time Transformer Switch, Selector	294541 295355 295322
23-VC3	Clock, Time Transformer Switch, Operator Block, Contact Block, Contact Contact, Assembly	294541 295355 298039 298051 298052 298054
23-VD	Clock, Time Transformer Switch, Selector	294541 295301 295322
23-VD3	Clock, Time Transformer Switch, Operator Block, Contact Block, Contact Contact, Assembly	294541 295301 298039 298051 298052 298054
23-VE	Clock, Time Transformer Switch, Selector	294541 295302 295322
23-VE3	Clock, Time Transformer Switch, Operator Block, Contact Block, Contact Contact, Assembly	294541 295302 298039 298051 298052 298054
23-VF	Clock, Time Transformer Switch, Selector	294541 295299 295322
23-VF3	Clock, Time Transformer Switch, Operator Block, Contact Block, Contact Contact, Assembly	294541 295299 298039 298051 298052 298054

## Battery Chargers

Accessory	Description	Part Number
24-60A	Charger Assembly, Battery Fuse, 6.0 amp Fuse, 0.2 amp	A-294236 226520 226527
24-60B	Charger Assembly, Battery Fuse, 6.0 amp Fuse, 0.4 amp	A-294237 226520 226528
24-62A	Charger Assembly, Battery Fuse, 6.0 amp Fuse, 1.0 amp	A-294226 226520 226525
24-62B	Charger Assembly, Battery Fuse, 6.0 amp Fuse, 1.5 amp	A-294227 226520 291207
24-63A	Charger Assembly, Battery Fuse, 6.0 amp Fuse, 0.5 amp	A-294230 226520 226521
24-63B	Charger Assembly, Battery Fuse, 6.0 amp Fuse, 1.0 amp	A-294231 226520 226525
24-64A	Charger Assembly, Battery Fuse, 6.0 amp Fuse, 0.5 amp	A-294232 226520 226521
24-64B	Charger Assembly, Battery Fuse, 6.0 amp Fuse, 1.0 amp	A-294233 226520 226525
24-66A	Charger Assembly, Battery Fuse, 6.0 amp Fuse, 0.2 amp	A-294236 226520 226527
24-66B	Charger Assembly, Battery Fuse, 6.0 amp Fuse, 0.4 amp	A-294237 226520 226528
24-68A	Charger Assembly, Battery Fuse, 1.0 Fuse,	A-294229 226525 239298
24-68B	Charger Assembly, Battery Fuse, 1.0 Fuse	A-294229 226525 239298
24-71A	Charger Assembly, Battery Fuse, 6.0 amp Fuse, 0.3 amp	A-294234 226520 226526
24-71B	Charger Assembly, Battery Fuse, 6.0 amp Fuse, 0.5 amp	A-294235 226520 294552
24-73A	Charger Assembly, Battery Fuse, 6.0 amp Fuse, 0.3 amp	A-294234 226520 226526
24-73B	Charger Assembly, Battery Fuse, 6.0 amp Fuse, 0.5 amp	A-294235 226520 294552

## Manual Switch Operation

Accessory	Description	Part Number
29-P	Switch, Pushbutton (2) Contact Assembly (2)	294653 298049
29-R	Switch, 2 Position (2) Decal Contact Assembly (2)	294656 294688 298049
29-S	Switch, Pushbutton Contact Assembly	294653 298049
29-T	Switch, 2 Position Decal Contact Assembly	294656 294687 298049
29-U	Switch, Pushbutton (2) Switch, 2-Position Contact Assembly (3)	294653 294654 298049
29-V	Switch, Pushbutton (2) Switch, 2-Position Contact Assembly (3)	294653 294655 298049
29-W	Switch, Pushbutton Switch, 2-Position Contact Assembly (2)	294653 294654 298049
29-X	Switch, Pushbutton Switch, 2-Position Switch, Operator	294653 294655 298039

## Source Monitors– Normal & Emergency

Accessory	Description	Part Number
34-A	Shunt, Programming	294634
34-J	Shunt, Programming	294634
34-Z	Shunt, Programming	294634

## Load-Shedding Contacts

Accessory	Description	Part Number
35-N	Circuit Board, Load Shed Circuit Board, 10 Relay Harness, Wiring Cable Assembly, Ribbon Box, Cover	C-294495 D-294303 294616 294638 294719

## Time Delays

Accessory	Description	Part Number
100-B	Shunt, Programming	294634

## Remote Connections

Accessory	Description	Part Number
PA-320798	Software, host computer	294862
PA-294863	Converter Assembly Resistor 120 ohm Cable, RS-232 Connector	A-320302 X-6058-27 294981 294988
PA-294864	Cable, RS-232 Modem Connector	294981 294986 294988

# Appendix A. Glossary of Abbreviations

Abbreviations are used throughout this manual. Normally they will appear in the text in complete form with the abbreviation following in parentheses the first time they are used. After that they will appear in the

abbreviated form. The commonly used abbreviations are shown below. Some items may not apply to this application.

Abbreviation	Description
ABDC	after bottom dead center
AC	alternating current
AISI	American Iron and Steel Institute
AHWT	anticipatory high water temp.
ALOP	anticipatory low oil pressure
AM	amplitude modulation
amp	ampere
amps	amperes
ANSI	American National Standard Institute
API	American Petroleum Institute
approx.	approximate, approximately
A/R	as required, as requested
A/S	as supplied, as stated, as suggested
ASA	American Standards Association (former name of ANSI)
ASME	American Society of Mechanical Engineers
assy.	assembly
ASTM	American Society for Testing Materials
ATDC	after dead top center
aux.	auxiliary
A/V	audio-visual
AWG	American Wire Gage
AWM	appliance wiring material
BBDC	before bottom dead center
BDC	before dead center
BHP	brake horsepower
bmep	brake mean effective power
BTDC	before top dead center
Btu	British thermal unit
$^{\circ}\text{C}$	Celsius degree
cc	cubic centimeter
CCA	cold cranking amps
CEC	Canadian Electrical Code
cfh	cubic feet per hour
cfm	cubic feet per minute
CID	cubic inch displacement
cm	centimeter, centimeters
cmm	cubic meters per minute
co.	company
cont'd.	continued
CPVC	chloropoly vinyl chloride
CRT	cathode ray tube
CSA	Canadian Standards Association
CT	current transformer
cu. in.	cubic inch (es)

Abbreviation	Description
CWC	city-water cooled
cyl.	cylinder
dB	decibel
dBA	decibels (A weighted)
DC	direct current
DCR	direct current resistance
deg.	degree
dept.	department
dia.	diameter
DIN	Deutsches Institut fur Normung e. V. (also Deutsche Industrie Normenausschuss)
e.g.	example given
EIA	Electronic Industries Association
EMI	electromagnetic interference
EPA	Environmental Protection Agency
etc.	etcetera, (and so forth)
ext.	external
$^{\circ}\text{F}$	Fahrenheit degree
fl. oz.	fluid ounce(s)
FM	frequency modulation
ft.	foot, feet
ft. lbs.	foot pound(s)
fs	full scale
ga.	gauge (meters wire size)
gal./gals.	gallon, gallons
gph	gallons per hour
gpm	gallons per minute
gr.	grade
grd.	ground
HCHT	high cylinder head temperature
HET	high exhaust temperature
Hg.	mercury (element)
H <sub>2</sub> O	water
HP	horsepower
hr, hrs	hour, hours
HWT	high water temperature
Hz	hertz (cycles per second)
ID	inside diameter
IEEE	Institute of Electrical and Electronic Engineers
in.	inch, inches
inc.	incorporated
in. lbs.	inch pounds
int.	internal
int.-ext.	internal-external

<b>Abbreviation</b>	<b>Description</b>
ISO	International Standards Organization
J	joule, joules
JIS	Japanese Industry Standard
kg	kilogram, kilograms
kg/cm <sup>2</sup>	kilograms per square centimeter
kgm	kilogram meter(s)
kJ	kilojoules (btu cal)
km	kilometer, kilometers
kPa	kiloPascal, kiloPascals
kph	kilometers per hour
kV	kilovolt
kVA	kilovolt amperes
kW	kilowatt, kilowatts
kWH	kilowatt hour
L	liter, liters
LxWxH	length x width x height
LED(s)	light emitting diode(s)
lb., lbs.	pound, pounds
L/hr.	liter per hour, liters per hour
L/min.	liter(s) per minute
LOP	low oil pressure
LP	liquified petroleum
LWT	low water temperature
m	meter, meters
m <sup>3</sup>	cubic meter, cubic meters
max.	maximum
MCM	one thousand circular mils.
meggar	megohmmeter
MHz	megahertz
mi.	mile, miles
mil	one one-thousandth of an inch
min.	minimum
misc.	miscellaneous
mJ	milli joule(s)
MJ	mega joule(s)
mm	millimeter
m <sup>3</sup> /min	cubic meters per minute
MPa	megaPascal
mpg	miles per gallon
mph	miles per hour
MS	military standard
mW	milliwatt(s)
MW	megawatt(s)
N/A	not available
NBS	National Bureau of Standards
N.C.	normally closed
NEC	National Electrical Code
NEMA	National Electrical Manufacturers Association
NFPA	National Fire Protection Association
Nm	Newton meter(s)
N.O.	normally open
no., nos.	number, numbers

<b>Abbreviation</b>	<b>Description</b>
NPT	National Standard taper pipe thread per general use
N/R	not required
OC	overcrank
OD	outside diameter
OEM	original equipment manufacturer
OS	overspeed
O/S	oversize
OSHA	Occupational Safety and Health Act
OV	overvoltage
oz.	ounce, ounces
PF	power factor
PMG	permanent magnet generator
pot	potentiometer
ppm	parts per million
psi	pounds per square inch
pt., pts.	pint, pints
PVC	polyvinyl chloride
qt., qts.	quart, quarts
qty.	quantity
ref.	reference
RFI	radio frequency interference
r.h.m.	round-head machine (screw)
rms	root means square
RPM	revolutions per minute
RTV	room temperature vulcanization
RV	recreational vehicle
SAE	Society of Automotive Engineers
SCR	silicon controlled rectifier
sec.	second, seconds
spec, specs	specification
sq.	square
sq. cm.	square centimeters
sq. in.	square inch(es)
tach	tachometer
TDC	top dead center
tech. pub.	technical publications
temp.	temperature
TIF	telephone influence factor
TP, TPs	technical publications
turbo	turbocharger
UHF	ultrahigh frequency
UNC	Unified coarse thread (was NC)
UNF	Unified fine thread (was NF)
UL	Underwriter's Laboratories, Inc.
U/S	undersize
U.S.A.	United States of America
V	volt, volts
vac	volts alternating current
vdc	volts direct current
VHF	very high frequency
W	watt, watts

# Appendix B

## General Controller Information

TB-DC1 Terminal No.	Input/ Output*	TB-DC1 Terminal Name	TB-DC1 Terminal Description
1	OUTPUT	Programming-Mode-Not-In-Off	If the programming-mode key is not in the off position, terminal 1 is grounded.
2	INPUT	Manual Transfer to Normal	If terminal 2 is grounded, a manual-transfer-to-normal-source occurs.
3	INPUT	Bypass Normal-To-Emergency Time Delay	If terminal 3 is grounded, the normal-to-emergency time delay is bypassed.
4	INPUT	Bypass Emergency-to-Normal Time Delay	If terminal 4 is grounded, the emergency-to-normal time delay is bypassed.
5	OUTPUT	Load Bank Control	If the plant exerciser is set to no load and is active, the load bank control is on. Terminal 5 is grounded.
6	INPUT	Area-Protection	If terminal 6 is not grounded, the area-protection mode is active.
7	INPUT	Manual Transfer to Emergency	If terminal 7 is grounded, a manual transfer to emergency occurs.
8	INPUT	Fault 1	If terminal 8 is grounded, the fault 1 message appears on the LCD.
9	INPUT	Not-In-Automatic	If terminal 9 is grounded, the not-in-automatic LED flashes.
10	INPUT	Exercise At No Load/Full Load	If terminal 10 is grounded, the generator set runs loaded during the plant exercise.
11	INPUT	Fault 2	If terminal 11 is grounded, the fault 2 message appears on the LCD.
12	INPUT	Manual Transfer to Off	If terminal 12 is grounded, a manual transfer to off occurs.
13	N/A	Reserved	Reserved
14	OUTPUT	Not-In-Automatic	If the logic board is not in the automatic mode, terminal 14 is grounded.
15	N/A	Reserved	Reserved
16	N/A	Reserved	Reserved
17	OUTPUT	Off Position Relay	If the contactor is in the Off position, then terminal 17 is grounded.

\*Use Dry Contact Kit for external annunciation to custom equipment.

**Figure B-1. Power supply board TB-DC1 terminal numbers, names, and descriptions**

TB-DC1 Terminal No.	Input/ Output*	TB-DC1 Terminal Name	TB-DC1 Terminal Description
18	OUTPUT	Emergency Source	If the emergency source is available, terminal 18 is grounded.
19	OUTPUT	System Alert	If there is a system-status system alert, terminal 19 is grounded.
20	INPUT	Automatic/Manual	If terminal 20 is grounded, the logic board is in the manual mode. The transfer switch is then under the control of the manual transfer pushbuttons.
21	OUTPUT	Engine Start Terminal 3	Connects to generator set engine start terminal 3.
22	OUTPUT	Remote Start/Stop Relay	Terminal 22 is connected to K2, normally closed contact.
23	OUTPUT	Unregulated DC Power	Terminal 23 is an output voltage source to the optional dry contact kit, DD-14.
24	INPUT	K1 Test Relay Control	Grounding terminal 24 energizes the test relay which simulates a normal source failure.
25	INPUT	Normal Relay/ Emergency Relay/ Off-to-Normal Relay Off-to-Emergency Relay	Terminal 25 supplies 10 volts DC to the transfer control relays. The power is supplied from terminal 30.
26	OUTPUT	Normal Source	If the normal source is available, terminal 26 is grounded.
27	OUTPUT	Emergency-Position Relay	If the contactor is in the emergency position, terminal 27 is grounded.
28	OUTPUT	Normal-Position Relay	If the contactor is in the normal position, terminal 28 is grounded.
29	INPUT	Battery	Input for external 12 to 30 volt DC controller power supply.
30	OUTPUT	Regulated DC Power Supply	Regulated 10 volts DC from the controller power supply.
31	OUTPUT	Engine Start Terminal 4	Connected to P1-15.
32	N/A	Ground	Ground
33	N/A	Ground	Ground
34	N/A	Ground	Ground

\*Use Dry Contact Kit for external annunciation to custom equipment.

**Figure B-1. Power supply board TB-DC1 terminal numbers, names, and descriptions– continued**

Label	TB-AC1 Terminal Name	TB-AC1 Terminal Name
NA	Normal Phase A P1-5	Normal Phase A voltage is connected from the contactor to terminal NA through P1-5.
NB	Normal Phase B P1-1	Normal Phase B voltage is connected from the contactor to terminal NB through P1-1.
NC	Normal Phase C P1-2	Normal Phase C voltage is connected from the contactor to terminal NC through P1-2.
EA	Emergency Phase A P1-21	Emergency Phase A voltage is connected from the contactor to terminal EA through P1-21.
EB	Emergency Phase B P1-17	Emergency Phase B voltage is connected from the contactor to terminal EB through P1-17.
EC	Emergency Phase C P1-13	Emergency Phase C voltage is connected from the contactor to terminal EC through P1-13.
LA	Load Phase A P1-23	Contactor load voltage– Phase A from P1-23.
LB	N/A	N/A
LC	Load Phase C P1-24	Contactor load voltage– Phase C from P1-24.
NAS	Normal Rectified #1 Input to DC power supply from NT1 transformer	There is approximately 19 volts AC between NAS and NCS.
NCS	Normal Rectified #2 Input to DC power supply from NT1 transformer	There is approximately 19 volts AC between NAS and NCS.
EAS	Emergency Rectified #1 Input to DC power supply from ET1 transformer	There is approximately 19 volts AC between EAS and ECS.
ECS	Emergency Rectified #1 Input to DC power supply from ET1 transformer	There is approximately 19 volts AC between EAS and ECS.

**Figure B-2. Power supply board TB-AC1 terminal labels, names, and descriptions**

Pin	P1-J1 Contactor-transformer Pin Names
1	Normal Phase B.
2	Normal Phase C.
3	N/A
4	Normal contactor position auxiliary contact common.
5	Normal Phase A.
6	N/A
7	N/A
8	Emergency contactor position auxiliary contact common.
9	N/A
10	N/A
11	Engine start contact 3.
12	Normal contactor position auxiliary contact normally open.
13	Emergency Phase C.
14	N/A
15	Engine start contact 4
16	Emergency contactor position auxiliary contact normally open.
17	Emergency Phase B for sensing.
18	N/A
19	N/A
20	N/A
21	Emergency Phase A
22	N/A
23	Load Phase A
24	Load Phase C

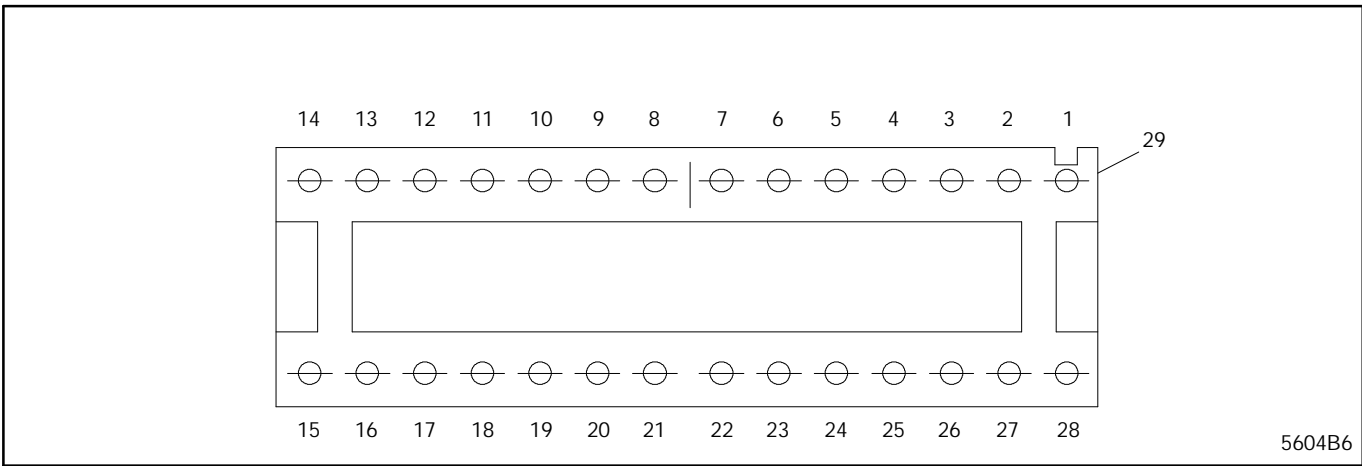
**Figure B-3. P1-J1 contactor to power supply board harness pin numbers and pin names**

Trip Point	Setting Limits	Emergency Source Factory Settings
Overtoltage Dropout	115%-135%	115%
Overtoltage Pickup	110%-130%	110%
Undervoltage Pickup	75%-100%	90%
Undervoltage Dropout	70%-95%	85%
Overfrequency Dropout	105%-135%	115%
Overfrequency Pickup	100%-130%	110%
Underfrequency Pickup	85%-100%	90%
Underfrequency Dropout	80%-95%	85%

**Figure B-4. Emergency source voltage trip point setting limits and factory settings**

Line Voltage (Volts)	1/25 Of Line Voltage (Volts)
120	4.8
208	8.3
240	9.6
480	19.2
600	24.0

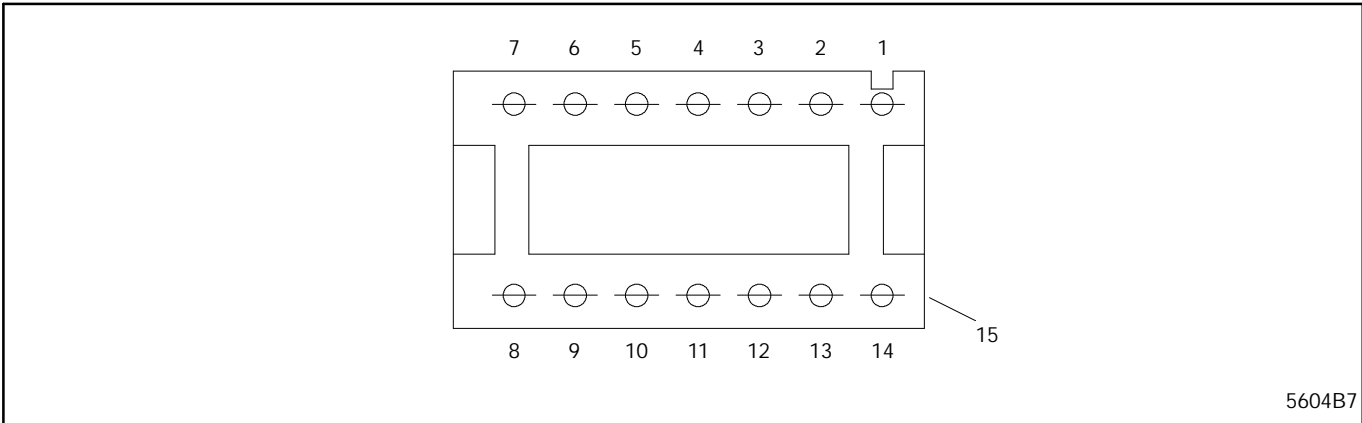
**Figure B-5. 1/25 of the line voltage**



5604B6

- |  |   |
|--|---|
| 1. Manual transfer to emergency, input           | 16. Normal phase AC inphase monitor     |
| 2. Manual transfer to normal, input              | 17. Normal phase BC                     |
| 3. Normal to emergency time-delay bypass, input  | 18. Normal phase AB                     |
| 4. Emergency to normal time-delay bypass, input  | 19. Emergency phase AC                  |
| 5. Area protection, input                        | 20. Emergency phase BC                  |
| 6. Not-in-automatic indicator, input             | 21. Emergency phase AB                  |
| 7. Fault #1, input                               | 22. Normal contactor position, input    |
| 8. Fault #2, input                               | 23. Emergency Contactor Position, Input |
| 9. Plant exerciser load/no load option           | 24. Automatic/manual, input             |
| 10. Reserved                                     | 25. +13 DC volts: load-shed relays      |
| 11. Manual transfer to off, input                | 26. N/A                                 |
| 12. N/A  | 27. Load-shed dry contact board ground  |
| 13. +10 dc volts: main logic and lcd             | 28. Ground                              |
| 14. +10 dc volts: leds and remote communications | 29. Ribbon cable connector notch        |
| 15. Normal phase AC                              |   |

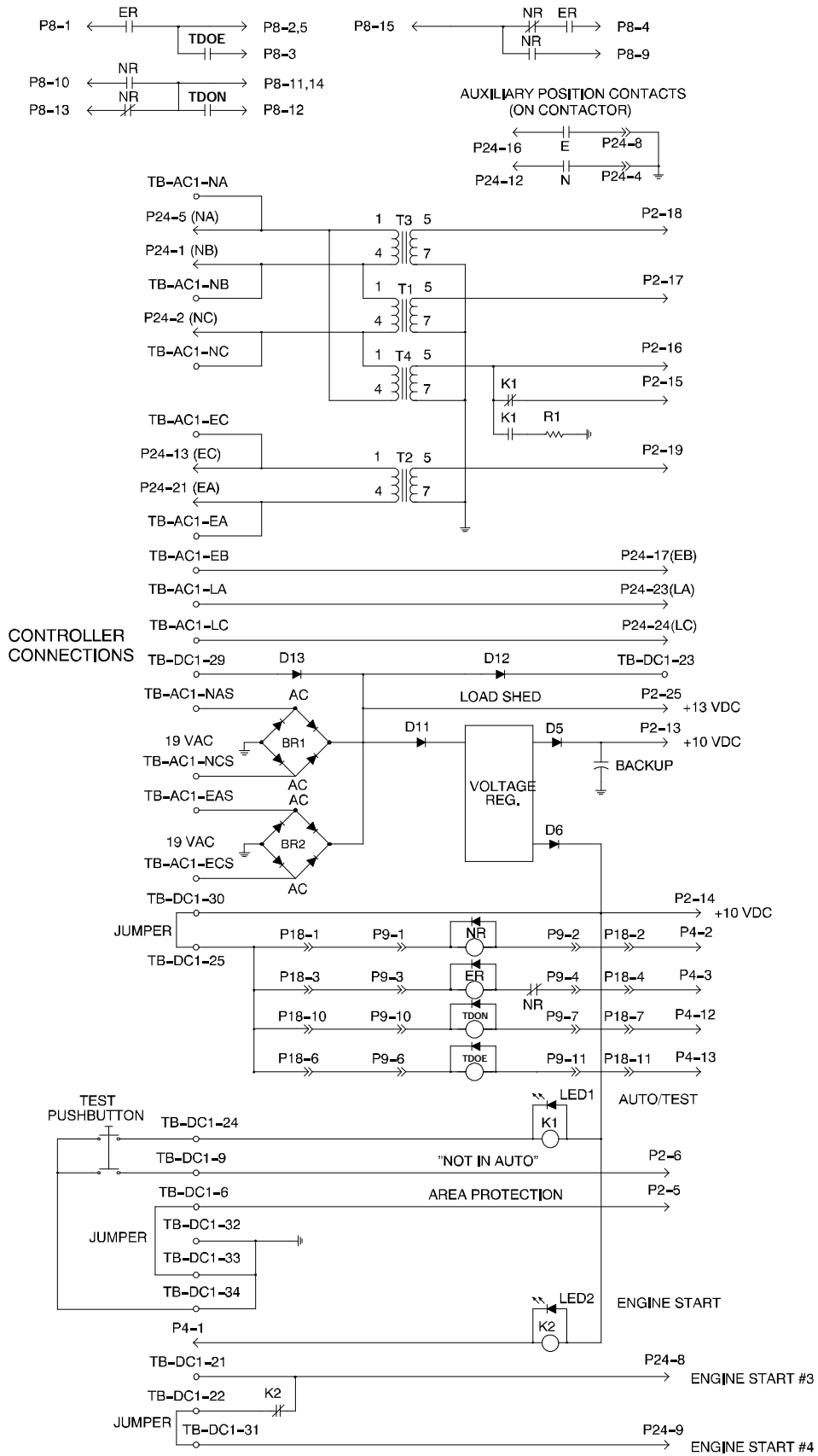
**Figure B-6. P2 Ribbon cable connector pin layout with reference to the connector notch.**



5604B7

- |   |  |
|---|--|
| 1. Engine-start relay                           | 9. Programming switch not-in-off dry       |
| 2. Normal relay                                 | 10. Load-bank-control dry contact kit      |
| 3. Emergency relay                              | 11. Normal contactor position dry contact  |
| 4. Emergency-contactor-position dry contact kit | 12. Off-to-emergency relay                 |
| 5. Normal-source-available dry contact kit      | 13. Off-to-normal relay                    |
| 6. Emergency-source-available dry contact kit   | 14. Off contactor position dry contact kit |
| 7. System-fault-indicator dry contact kit       | 15. Ribbon cable connector notch           |
| 8. Not-in-automatic dry contact kit             |  |

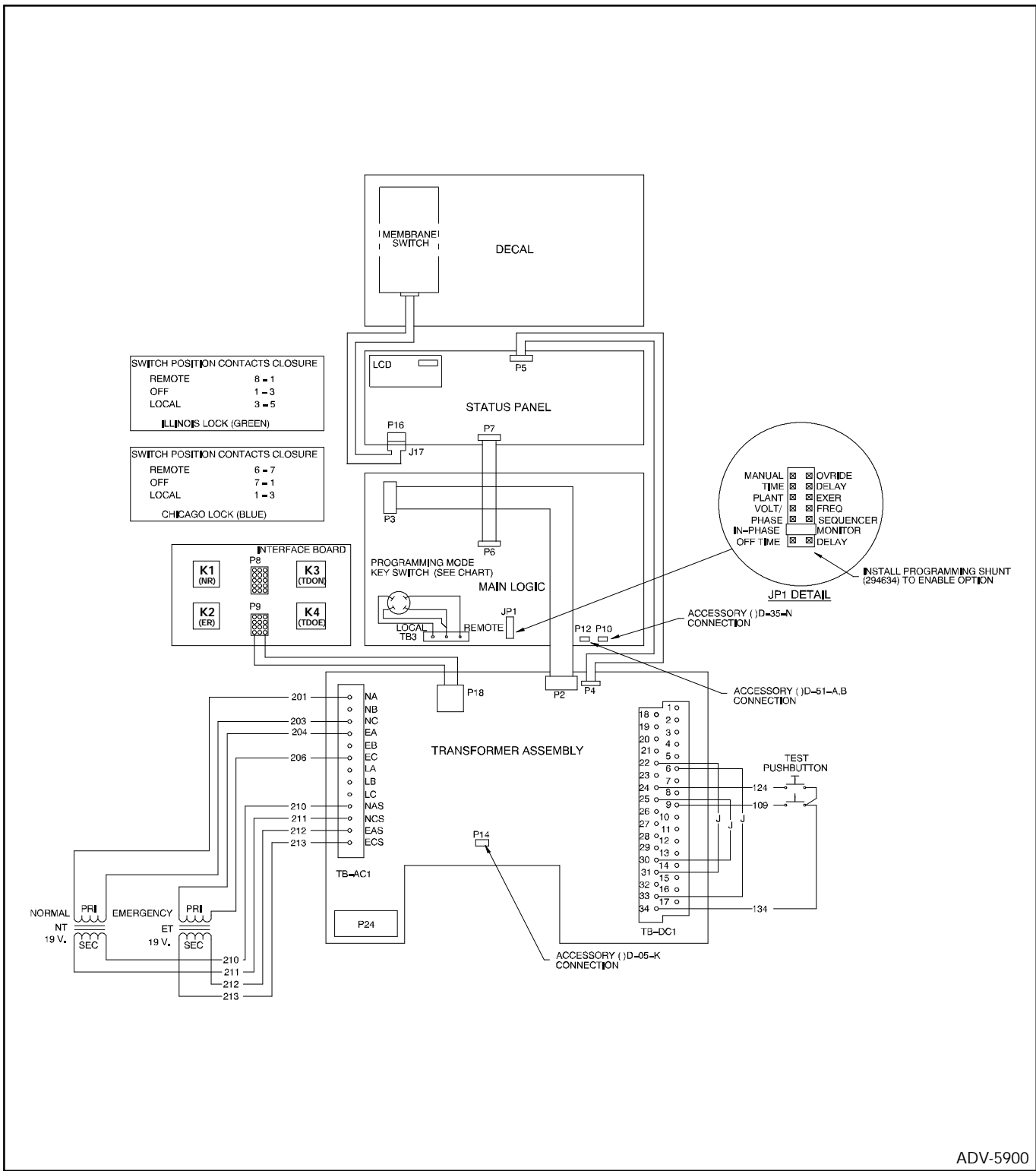
**Figure B-7. P4 Ribbon cable connector pin layout with reference to the connector notch.**



Shown with no power present in normal position.

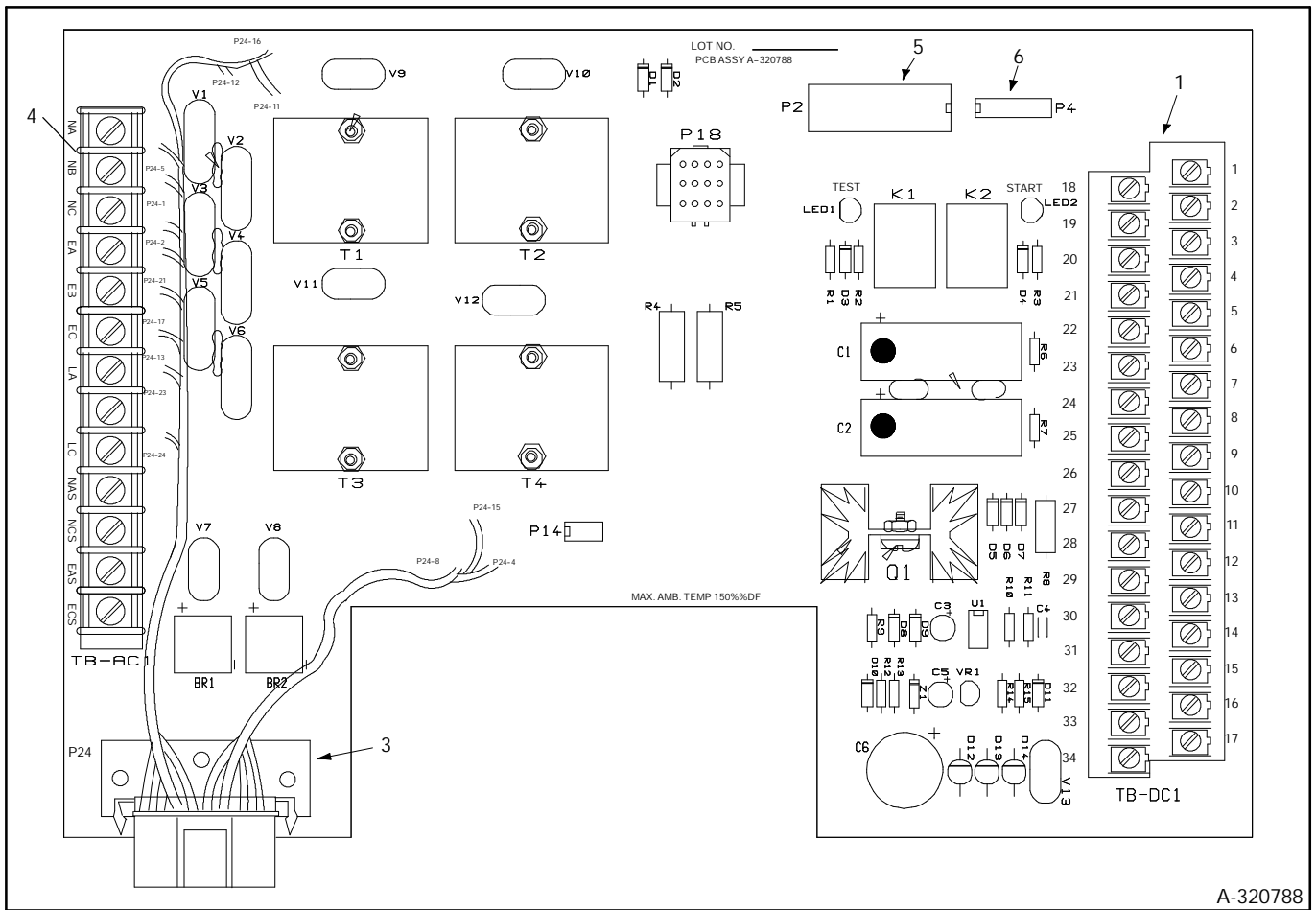
ADV-5900

Figure B-8. Logic board schematic diagram

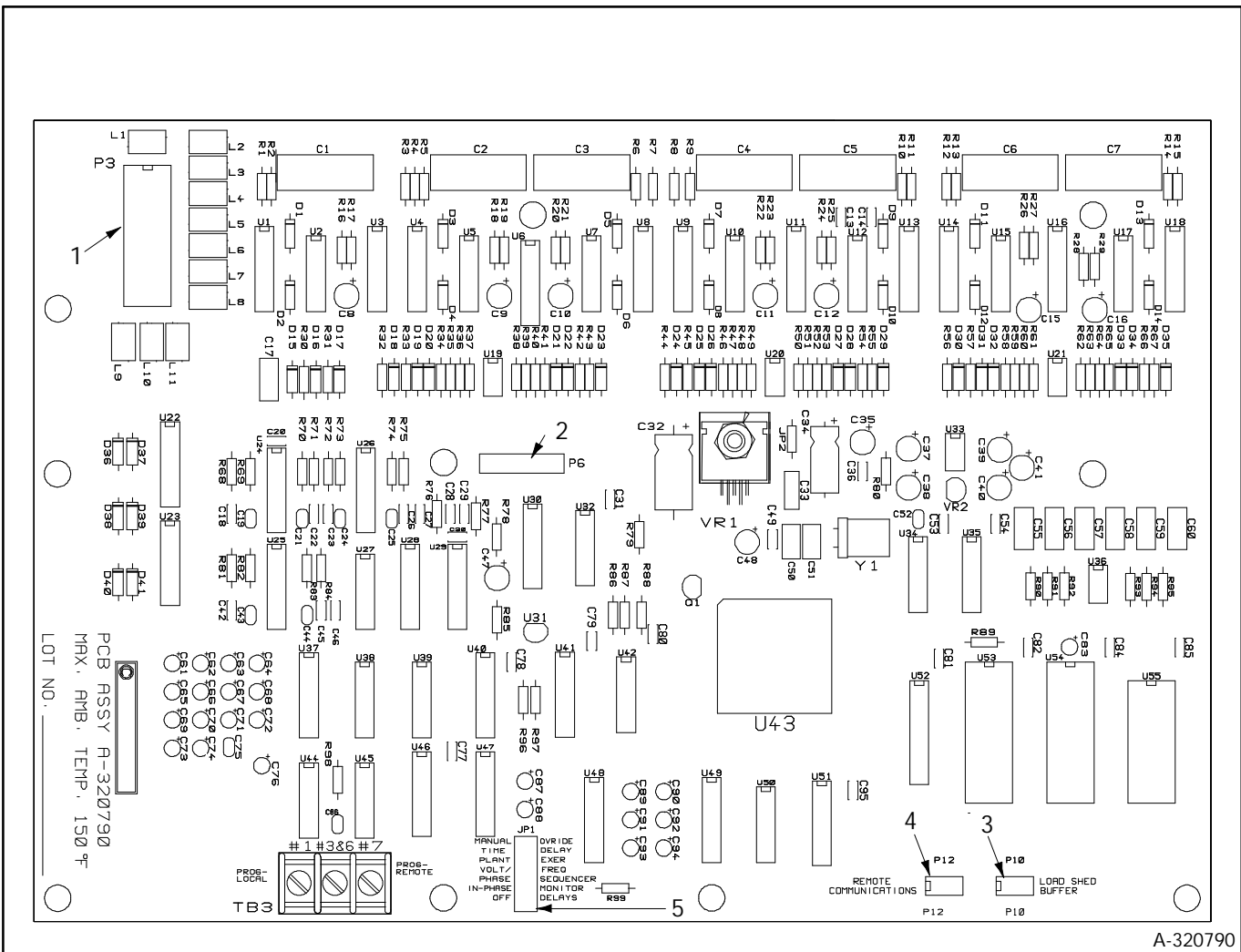


ADV-5900

Figure B-9. Logic board schematic diagram



**Figure B-10. Power supply board**



A-320790

- 1. P3 power supply board ribbon cable connector
- 2. P6 status panel ribbon cable connector
- 3. P10 load-shed buffer ribbon cable connector
- 4. P12 remote communications ribbon cable connector
- 5. JP1

Figure B-11. Main logic board



**Battery Charger**

- DD-24-XX A Solid State, 2-amp. float, 12 volt
  - DD-24-XX B Solid State, 2-amp. float, 24 volt
- XX-Same voltage code as the automatic transfer switch

**Manual Switch Operation with Override Circuit**

- DD-29-P Switch operation enables transfer in both directions, momentary contacts
- DD-29-R Switch operation enables transfer in both directions, momentary contact, key-operated
- DD-29-S Switch operation enables transfer from emergency to normal, momentary
- DD-29-T Switch operation enables transfer from emergency to normal, momentary, key-operated
- DD-29-U Switch operation enables transfer in both directions with auto/manual selector switch
- DD-29-V Switch operation enables transfer in both directions with auto/manual selector switch, key-operated
- DD-29-W Switch operation enables transfer emergency to normal with auto/manual selector switch
- DD-29-X Switch operation enables transfer emergency to normal with auto/manual selector switch, key-operated

**Load-Shedding Contacts**

- DD-35-N Load sequencer, transfers from one to nine isolated form-C contacts before (adj. 0-60 sec.) and after (adj. 0-5 sec.) switch transfer in either direction. The contacts can be transferred in a block or sequentially in either direction. The sequence interval time delay is adjustable from 0 to 5 seconds.

**Transient Voltage Suppression**

- DD-38 Lightning Arrestors

**Remote Communication**

- DD-51-A ATS RS-485 Port adapter board for direct or LAN connection
- DD-51-B ATS RS-232 Port adapter board for modem connection
- PA-320798 M340+ Monitor software kit for PC operation
- PA-294863 PC adapter kit, RS-232 to RS-485 port converter
- PA-294864 External modem for PC, includes 10-foot RS-232 cable
- PA-294865 External modem for M340+ ATS, includes 10' RS-232 cable
- PA-294911 ATS adapter kit, RS-232 to RS-485 port converter
- PA-294992 PC cable for direct connection

**Miscellaneous**

- 2.5-foot extender harness for intelligence circuit
- 5-foot extender harness for intelligence circuit
- 10-foot extender harness for intelligence circuit
- 20-foot extender harness for intelligence circuit
- PA-294869 Shunt jumpers for accessories— quantity 6

**Literature**

- G11-56 M340+ Specification Sheet
- TP-5664 Operation and Installation Manual
- TP-5656 M340+ Software Manual
- TP-5672 M340+ Service and Parts Manual

**TP-5672 11/95d**

E Kohler Co., 1995. All rights reserved.

# **KOHLER**<sup>®</sup> POWER SYSTEMS

KOHLER CO. Kohler, Wisconsin 53044  
Phone 920-565-3381, Web site [www.kohlergenerators.com](http://www.kohlergenerators.com)  
Fax 920-459-1646 (U.S.A. Sales), Fax 920-459-1614 (International)  
For the nearest sales and service outlet in U.S.A. and Canada  
Phone 1-800-544-2444

Kohler Power Systems  
Asia Pacific Headquarters  
7 Jurong Pier Road  
Singapore 619159  
Phone (65)264-6422, Fax (65)264-6455