

Service and Parts

Automatic Transfer Switches

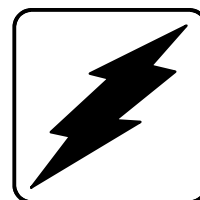

Models:

MMT, MNT

Power Switching Device:
Molded-Case Circuit Breakers
Molded-Case Switches

40-1250 Amperes

ISO 9001
KOHLER
GENERATORS
INTERNATIONALLY REGISTERED

KOHLER[®]
POWER SYSTEMS

TP-5974 11/99

Table of Contents

Safety Precautions and Instructions	i	6.4 Mechanical Interlock Removal and Installation, 800–1250 Amp Models	33
Introduction	I	6.4.1 Mechanical Interlock Removal, 800–1250 Amp Models	33
List of Related Materials	I	6.4.2 Mechanical Interlock Installation, 800–1250 Amp Models	34
Service Assistance	II	6.5 Mechanical Interlock Tests	35
Service Information	II	6.5.1 40–630 Amp Models	35
Product Information	II	6.5.2 800–1250 Amp Models	37
Section 1. Specifications	1	6.6 Motor Operator Removal and Installation	38
1.1 Purpose	1	6.6.1 Motor Operator Removal, 40–630 Amp Models	38
1.2 Components	1	6.6.2 Motor Operator Installation, 40–630 Amp Models	39
1.3 Nameplate	2	6.6.3 Motor Operator Removal, 800–1250 Amp Models	39
1.4 Model Number Code	3	6.6.4 Motor Operator Installation, 800–1250 Amp Models	40
1.5 Standard Features	4	6.7 Circuit Breaker/Switch Removal and Installation	42
1.6 Weights and Dimensions	4	6.7.1 Circuit Breaker/Switch Removal, 40–1250 Amp Models	42
1.7 Ratings	5	6.7.2 Circuit Breaker/Switch Installation, 40–1250 Amp Models	43
1.8 Application Data	6	6.8 Auxiliary Switch Replacement	44
Section 2. Operation	7	6.8.1 Auxiliary Switch Removal, 40–630 Amp Models	44
2.1 Startup	7	6.8.2 Auxiliary Switch Installation, 40–630 Amp Models	45
2.2 Operation Sequence	8	6.8.3 Auxiliary Switch Removal, 800–1250 Amp Models	45
2.2.1 Transfer to the Emergency Source ...	8	6.8.4 Auxiliary Switch Installation, 800–1250 Amp Models	46
2.2.2 Transfer to the Normal Source	8	6.9 Wire Harness Replacement	47
2.3 Manual Operation	9	6.10 Load Bus Replacement	50
2.3.1 40–630 Amp Models	9	6.11 Lug Replacement	51
2.3.2 800–1250 Amp Models	12	6.11.1 Source Lug Replacement	51
2.4 Resetting Tripped Circuit Breakers	13	6.11.2 Load Lug Replacement	52
Section 3. Scheduled Maintenance	15	6.12 Voltage Take-Off Replacement	53
3.1 Inspection and Service	16	6.13 Phase Separator Replacement	53
3.1.1 General Inspection	16	Section 7. Diagrams and Drawings	55
3.1.2 Other Inspections and Service	17	Section 8. Service Parts	67
3.2 Testing	17	8.1 Finding Parts Information	67
3.2.1 Weekly Generator Set Exercise	17	8.2 Leads	67
3.2.2 Monthly Automatic Operation Test ...	17	8.3 Automatic Transfer Switch	68
3.3 Service Schedule	18	8.4 Enclosures	69
Section 4. Troubleshooting	19	8.5 Decals	70
4.1 Troubleshooting Charts	20	8.6 Interface Panel Assembly	71
4.2 Checking Control System Operation	22	8.7 Interface Board	72
4.2.1 Initial Checks	22	8.8 Neutral Lugs	73
4.2.2 Transfer to the Emergency Source ...	23	8.9 Load Bus Assembly	76
4.2.3 Transfer to the Normal Source	25	8.10 Power Switch Assemblies	77
Section 5. Accessory Testing and Adjustment	27	Appendix A. Abbreviations	A-1
5.1 Programmed Transition	27	Appendix B. Common Hardware Application Guidelines	A-3
5.1.1 Description	27		
5.1.2 Adjustment	28		
5.2 Other Accessories	28		
Section 6. Service Part Replacement	29		
6.1 Introduction	29		
6.2 Before and After Service	31		
6.3 Power Switching Device Removal and Installation	31		
6.3.1 Power Switching Device Removal, 40–1250 Amp Models	31		
6.3.2 Power Switching Device Installation, 40–1250 Amp Models	32		

Appendix C. General Torque Specifications . . A-4
**Appendix D. Common Hardware
Identification A-5**
Appendix E. Common Hardware List A-6

Safety Precautions and Instructions

Electromechanical equipment, including generator sets, transfer switches, switchgear, and accessories, can cause bodily harm and pose life-threatening danger when improperly installed, operated, or maintained. To prevent accidents be aware of potential dangers and act safely. Read and follow all safety precautions and instructions. **SAVE THESE INSTRUCTIONS.**

This manual has several types of safety precautions and instructions: Danger, Warning, Caution, and Notice.

DANGER

Danger indicates the presence of a hazard that **will cause severe personal injury, death, or substantial property damage.**

WARNING

Warning indicates the presence of a hazard that **can cause severe personal injury, death, or substantial property damage.**

CAUTION

Caution indicates the presence of a hazard that **will or can cause minor personal injury or property damage.**

NOTICE

Notice communicates installation, operation, or maintenance information that is safety related but not hazard related.

Safety decals affixed to the equipment in prominent places alert the operator or service technician to potential hazards and explain how to act safely. The decals are shown throughout this publication to improve operator recognition. Replace missing or damaged decals.

Accidental Starting

WARNING

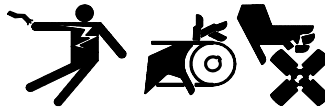

**Accidental starting.
Can cause severe injury or death.**

Disconnect the battery cables before working on the generator set. Remove the negative (-) lead first when disconnecting the battery. Reconnect the negative (-) lead last when reconnecting the battery.

Disabling the generator set. Accidental starting can cause severe injury or death. Before working on the generator set or connected equipment, disable the generator set as follows: (1) Move the generator set master switch to the OFF position. (2) Disconnect the power to the battery charger. (3) Remove the battery cables, negative (-) lead first. Reconnect the negative (-) lead last when reconnecting the battery. Follow these precautions to prevent starting of the generator set by an automatic transfer switch, remote start/stop switch, or engine start command from a remote computer.

Battery

WARNING



**Sulfuric acid in batteries.
Can cause severe injury or death.**

Wear protective goggles and clothing. Battery acid may cause blindness and burn skin.

Battery acid. Sulfuric acid in batteries can cause severe injury or death. Sulfuric acid in the battery can cause blindness and burn skin. Always wear splashproof safety goggles when working near the battery. If battery acid splashes in the eyes or on the skin, immediately flush the affected area for 15 minutes with large quantities of clean water. Seek immediate medical aid in the case of eye contact. Never add acid to a battery after placing the battery in service, as this may result in hazardous spattering of battery acid.

WARNING



**Explosion.
Can cause severe injury or death.
Relays in the battery charger
cause arcs or sparks.**

Locate the battery in a well-ventilated area. Isolate the battery charger from explosive fumes.

Battery gases. Explosion can cause severe injury or death. Battery gases can cause an explosion. Do not smoke or permit flames or sparks to occur near a battery at any time, particularly when it is charging. To prevent burns and sparks that could cause an explosion, avoid touching the battery terminals with tools or other metal objects. Remove wristwatch, rings, and other jewelry before handling the battery. Never connect the negative (-) battery cable to the positive (+) connection terminal of the starter solenoid. Do not test the battery condition by shorting the terminals together. Sparks could ignite the battery gases or fuel vapors. Ventilate the compartments containing batteries to prevent accumulation of explosive gases. To avoid sparks, do not disturb the battery charger connections while the battery is charging. Always turn the battery charger off before disconnecting the battery connections. Remove the negative (-) lead first when disconnecting the battery. Reconnect the negative (-) lead last when reconnecting the battery.

Hazardous Voltage/ Electrical Shock

⚠ WARNING

<p>Hazardous voltage. Can cause severe injury or death.</p> <p>Disconnect all power sources before servicing. Install the barrier after adjustments, maintenance, or servicing.</p>

(600 volts and under)

⚠ WARNING

<p>Hazardous voltage. Can cause severe injury or death.</p> <p>Disconnect all power sources before opening the enclosure.</p>

(600 volts and under)

⚠ WARNING

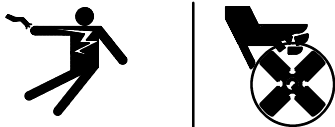
<p>Hazardous voltage. Can cause severe injury or death.</p> <p>Only authorized personnel should open the enclosure.</p>

(600 volts and under)

⚠ WARNING

<p>Hazardous voltage. Moving rotor. Can cause severe injury or death.</p> <p>Operate the generator set only when all guards and electrical enclosures are in place.</p>

Grounding electrical equipment. Hazardous voltage can cause severe injury or death. Electrocutation is possible whenever electricity is present. Open the main circuit breakers of all power sources before servicing the equipment. Configure the installation to electrically ground the generator set, transfer switch, and related equipment and electrical circuits to comply with applicable codes and standards. Never contact electrical leads or appliances when standing in water or on wet ground because these conditions increase the risk of electrocution.

Hazardous voltage can cause severe injury or death. To prevent electrical shock disconnect the harness plug before installing accessories that will be connected to transformer assembly primary terminals 76, 77, 78, and 79. Terminals are at line voltage. *(Models with E33+, S340, S340+, 340, R340, and R33 controls only)*

Installing accessories to the transformer assembly. Hazardous voltage can cause severe injury or death. To prevent electrical shock disconnect the harness plug before installing accessories that will be connected to the transformer assembly primary terminals on microprocessor logic models. Terminals are at line voltage.

Making line or auxiliary connections. Hazardous voltage can cause severe injury or death. To prevent electrical shock deenergize the normal power source before making any line or auxiliary connections.

Servicing the transfer switch. Hazardous voltage can cause severe injury or death. Deenergize all power sources before servicing. Open the main circuit breakers of all transfer switch power sources and disable all generator sets as follows: (1) Move all generator set master controller switches to the OFF position. (2) Disconnect power to all battery chargers. (3) Disconnect all battery cables, negative (-) leads first. Reconnect negative (-) leads last when reconnecting the battery cables after servicing. Follow these precautions to prevent the starting of generator sets by an automatic transfer switch, remote start/stop switch, or engine start command from a remote computer. Before servicing any components inside the enclosure: (1) Remove rings, wristwatch, and jewelry. (2) Stand on a dry, approved electrically insulated mat. (3) Test circuits with a voltmeter to verify that they are deenergized.

Servicing the transfer switch controls and accessories within the enclosure. Hazardous voltage can cause severe injury or death. Disconnect the transfer switch controls at the inline connector to deenergize the circuit boards and logic circuitry but allow the transfer switch to continue to supply power to the load. Disconnect all power sources to accessories that are mounted within the enclosure but are not wired through the controls and deenergized by inline connector separation. Test circuits with a voltmeter to verify that they are deenergized before servicing.

Testing live electrical circuits. Hazardous voltage or current can cause severe injury or death. Have trained and qualified personnel take diagnostic measurements of live circuits. Use adequately rated test equipment with electrically insulated probes and follow the instructions of the test equipment manufacturer when performing voltage tests. Observe the following precautions when performing voltage tests: (1) Remove rings, wristwatch, and jewelry. (2) Stand on a dry, approved electrically insulated mat. (3) Do not touch the enclosure or components inside the enclosure. (4) Be prepared for the system to operate automatically.



(600 volts and under)

Heavy Equipment

⚠ WARNING

Unbalanced weight. Improper lifting can cause severe injury or death and equipment damage.
Use adequate lifting capacity. Never leave the transfer switch standing upright unless it is securely bolted in place or stabilized.

Moving Parts

⚠ WARNING	
	
Hazardous voltage. Moving rotor. Can cause severe injury or death.	
Operate the generator set only when all guards and electrical enclosures are in place.	

Notice

NOTICE

Hardware damage. The transfer switch may use both American Standard and metric hardware. Use the correct size tools to prevent rounding of the bolt heads and nuts.

NOTICE

When replacing hardware, do not substitute with inferior grade hardware. Screws and nuts are available in different hardness ratings. To indicate hardness, American Standard hardware uses a series of markings, and metric hardware uses a numeric system. Check the markings on the bolt heads and nuts for identification.

NOTICE

Foreign material contamination. Cover the transfer switch during installation to keep dirt, grit, metal drill chips, and other debris out of the components. Cover the solenoid mechanism during installation. After installation, use the manual operating handle to cycle the contactor to verify that it operates freely. Do not use a screwdriver to force the contactor mechanism.

NOTICE

Electrostatic discharge damage. Electrostatic discharge (ESD) damages electronic circuit boards. Prevent electrostatic discharge damage by wearing an approved grounding wrist strap when handling electronic circuit boards or integrated circuits. An approved grounding wrist strap provides a high resistance (about 1 megohm), *not a direct short*, to ground.

This manual provides power switch troubleshooting, service, and parts information for Kohler® model MMT/MNT automatic transfer switches (ATS) that use a pair of 40- to 1250-ampere molded-case circuit breakers or switches as the power switching device.

Information in this publication represents data available at the time of print. Kohler Co. reserves the right to change this literature and the products represented without notice and without any obligation or liability whatsoever.

Read this manual and carefully follow all procedures and safety precautions to ensure proper equipment operation and to avoid bodily injury. Read and follow the Safety Precautions and Instructions section at the beginning of this manual. Keep this manual with the equipment for future reference.

The equipment service requirements are very important to safe and efficient operation. Inspect parts often and perform required service at the prescribed intervals. Obtain service from an authorized service distributor/dealer to keep equipment in top condition.

x:in:002:002

List of Related Materials

This manual provides service and parts information for the transfer switch's power switching device. A separate manual covers service and parts for the electrical controls. These two manuals provide the complete service instructions and parts information for the automatic transfer switch (ATS).

The transfer switch model number shows which types of power switching device and electrical controls are installed on the automatic transfer switch. Use the chart in Section 1 of this manual to decode the transfer switch model number printed on the nameplate. Verify that the transfer switch's power switching device matches the model shown on the front cover of this manual before proceeding with service or repairs.

A separate manual covers operation and installation for the transfer switch power switching device. The following table shows the operation and installation manual part number:

Models (Power Switching Device)	Operation/Installation Manual
MMT/MNT (Circuit Breaker/Switch)	TP-5973

Three types of electrical controls are available with the transfer switch described in this manual. The following tables list the available controls and the related manual part numbers.

Electrical Controls (Type)	Operation/Installation Manual
E33+ (Solid State)	TP-5662
S340+ (Solid State)	TP-5663
M340+ (Microprocessor)	TP-5664

Electrical Controls (Type)	Service/Parts Manual
E33+ (Solid State)	TP-5670
S340+ (Solid State)	TP-5671
M340+ (Microprocessor)	TP-5672

A personal computer and software can monitor and control transfer switches with microprocessor electrical controls and communication accessories. The following table lists the available manuals and part numbers for remote monitoring and control communication software and controller communication kits.

Communication Item	Operation/Installation Manual
Remote Monitoring and Control Communication Software DOS Win 95/98/NT	TP-5823 TP-5972
Communications Kits	TT-847

Service Assistance

Service Information

Please contact a local authorized distributor/dealer for sales, service, or other information about Kohler Generator Division products.

To locate a local authorized distributor/dealer inside the U.S.A. and Canada

- Look on the product or in the information included with the product
- Consult the Yellow Pages under the heading Generators—Electric
- Visit the Kohler Generator Division web site at www.kohlergenerators.com
- Call 1-800-544-2444

To locate a local authorized distributor/dealer outside the U.S.A. and Canada

- Look on the product or in the information included with the product
- Consult the telephone directory under the heading Generators—Electric
- Visit the Kohler Generator Division web site at www.kohlergenerators.com
- Contact the nearest regional office

Africa, Europe, Middle East

London Regional Office
Langley, Slough, England
Phone: (44) 1753-580-771
Fax: (44) 1753-580-036

Australia

Australia Regional Office
Queensland, Australia
Phone: (617) 3893-0061
Fax: (617) 3893-0072

China

China Regional Office
Shanghai, People's Republic of China
Phone: (86) 21-6482 1252
Fax: (86) 21-6482 1255

India, Bangladesh, Sri Lanka

India Regional Office
Bangalore, India
Phone: (91) 80-2284270
(91) 80-2284279
Fax: (91) 80-2284286

Japan

Japan Regional Office
Tokyo, Japan
Phone: (813) 3440-4515
Fax: (813) 3440-2727

Latin America

Latin America Regional Office
Lakeland, Florida, U.S.A.
Phone: (941) 619-7568
Fax: (941) 701-7131

South East Asia

Singapore Regional Office
Singapore, Republic of Singapore
Phone: (65) 264-6422
Fax: (65) 264-6455

Product Information

Product identification numbers determine service parts. Record the product identification numbers in the spaces below immediately after unpacking the products so that the numbers are readily available for future reference. Record field-installed kit numbers after installing the kits.

Transfer Switch Identification Numbers

Record the product identification numbers from the transfer switch nameplate.

Model Number _____

Serial Number _____

Accessory Number	Accessory Description
_____	_____
_____	_____
_____	_____
_____	_____
_____	_____
_____	_____
_____	_____
_____	_____
_____	_____
_____	_____

Section 1. Specifications

1.1 Purpose

An automatic transfer switch (ATS) transfers electrical loads from a normal (preferred) source of electrical power to an emergency (standby or replacement) source when the normal source fails to maintain acceptable voltage and/or frequency levels.

When the normal source fails, the ATS signals the generator set to start. When the emergency source reaches a minimum voltage and/or frequency level, the ATS transfers the load from the normal source to the emergency source. The ATS continuously senses the normal source and transfers the load back to the normal source when the normal source returns and stabilizes. After transfer of the load back to the normal source, the ATS removes the generator set start signal, allowing the generator set to shut down.

1.2 Components

The automatic transfer switch (ATS) documented in this manual contains several components. See Figure 1-1. The power switching device connects the load to the normal or emergency source of power. The electrical controls monitor the power sources, control the power switching device, and signal the generator to start when needed. Controls and indicators mounted on the door allow the operator to control the ATS operation and obtain system status information. The wire harness connects the controller to the power switching device using inline connectors to allow easy removal of the door for service.

Controls and indicators mounted on the door are determined by the electrical controls and installed accessories. The nameplate on the inside of the enclosure door shows the model number and lists the installed accessories. Use the chart in Section 1.4 to determine the type of electrical controls installed on the transfer switch. For control and accessory details see the operation and installation manual for the electrical controls. See the List of Related Materials in the Introduction section of this manual for the manual number.

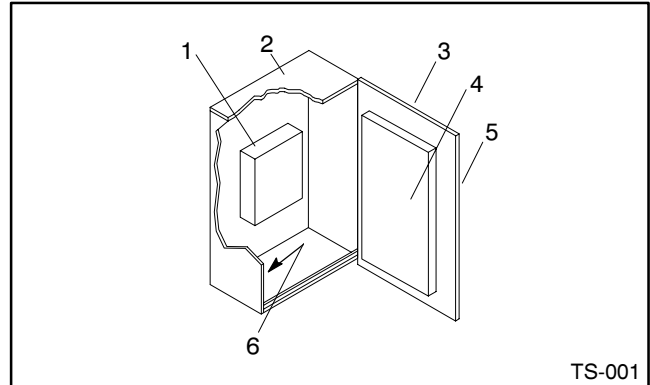

1. Power switching device
2. Enclosure
3. Enclosure door
4. Inner panel control circuitry
5. Controls and indicators (mounted on enclosure door)
6. Neutral lug (location may vary)

Figure 1-1. Typical Transfer Switch Components

The power switching device uses two motor-operated circuit breakers or switches. See Figure 1-2. Mechanical and electrical interlocks on the power switching device prevent the simultaneous closing of both circuit breakers/switches. Interlocking ensures load servicing without cross-coupling of power sources. The transfer switch also includes a provision for manual operation in emergency nonpowered conditions.

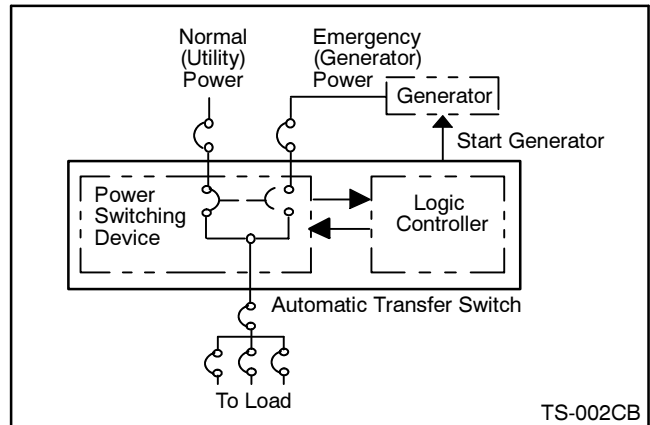
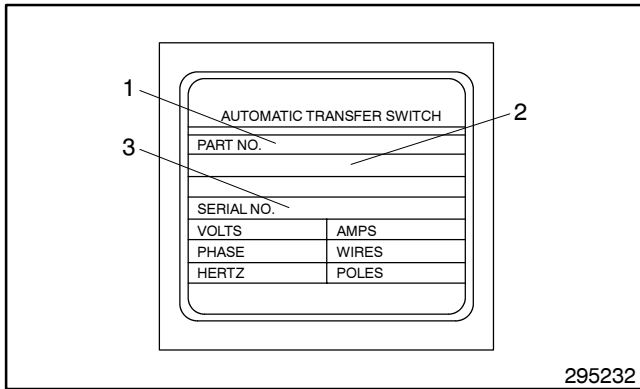

Figure 1-2. Typical ATS Block Diagram

1.3 Nameplate

A nameplate attached to the ATS enclosure door includes a model number, a serial number, ratings, and other information that may be needed for service or to order parts. See Figure 1-3 or Figure 1-4.

Copy the model number, serial number, and accessory information from the nameplate into the spaces provided in the Service Assistance section in this manual for use when requesting service or parts. Copy the model number into the blank spaces provided in Section 1.4 and then use the chart to interpret the model number code.



1. Model number
2. Factory-installed accessory numbers
3. Serial number

Figure 1-3. Transfer Switch Nameplate (used before April 8, 1999)

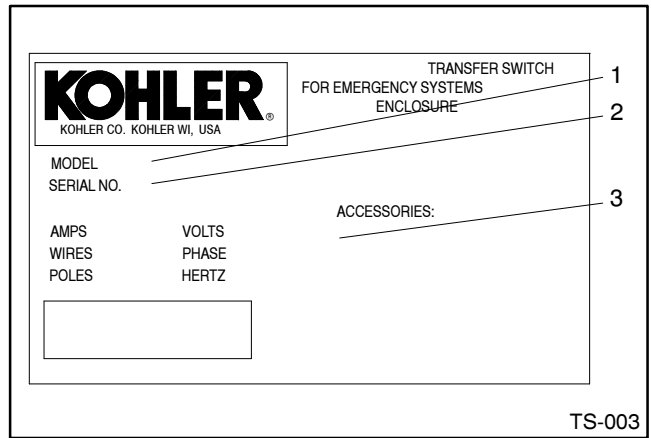

1. Model number
2. Serial number
3. Factory-installed accessory numbers

Figure 1-4. Transfer Switch Nameplate (used after April 8, 1999)

1.4 Model Number Code

Use the chart below to record and interpret the transfer switch model number.

Record the transfer switch model number in the boxes below. The transfer switch model number defines characteristics and ratings as explained in the accompanying chart.

Type of Switch	Type of Logic	Voltage & Frequency		Number of Poles	Number of Wires	Type of Enclosure	Amperage Rating Code				

Kohler® Model Number Key
 This chart explains the Kohler® transfer switch model number code. The sample model number shown is for a molded-case switch with E33+ logic rated at 480 volts, 60 hertz, 3 phases, 3 poles, and 4 wires in a NEMA type 1 enclosure with a switch rating of 250 amperes. Not all possible combinations are available.

SAMPLE MODEL NUMBER
MNT-266341-0250

Transfer Switch Family M: Model M ATS	
Type of Power Switch M: Molded-Case Circuit Breaker N: Molded-Case Switch (No Protection)	
Frame T: 40-1250 Amperes	
Type of Electrical Controls (Logic Controller) 1: S340+ 2: E33+ 3: S340+ with Programmed Transition 4: E33+ with Programmed Transition 5: M340+ 6: M340+ with Programmed Transition	
Voltage Code 60: 600 Volt, 60 Hz 66: 480 Volt, 60 Hz 62: 120 Volt, 60 Hz 68: 208 Volt, 60 Hz 63: 220 Volt, 50 Hz 71: 380 Volt, 50 Hz 64: 240 Volt, 60 Hz 72: 380 Volt, 60 Hz Other voltages may be available.	
Number of Poles 3: 3 Pole, 3 Phase 4: 3 Pole, 1 Phase (also used for 2-pole, 1-phase applications) 6: 4 Pole, 3 Phase (fully rated poles, no overlapping neutral)	
Number of Wires 2: 2 Wire 3: 3 Wire 4: 4 Wire	
Enclosure 1 = NEMA type 1	
Amperes Numbers indicate switch rating in amperes.	

Figure 1-5. Transfer Switch Model Number

1.5 Standard Features

The standard features of the MMT/MNT power switching device are listed below. Refer to the E33+, S340+, or M340+ electrical controls operation and installation manual for electrical controls specifications. See the List of Related Materials in the Introduction for the manual numbers.

- Rated per IEC 947-2 and IEC 947-3 standards
- Current ratings from 40 to 1250 amps at 40°C
- Fast five-cycle open/close operation on 40 to 630 amp circuit breakers/switches
- Provided with 3 or 4 fully rated poles; two-pole configurations also available
- Available with molded-case circuit breaker (short circuit and overload protection) or molded-case switch (no overload protection) power switching devices
- Available to 600 VAC, 50 or 60 Hz
- Provided in a NEMA type 1 enclosure
- Available with E33+, S340+, or M340+ controls
- Indication of circuit breaker/switch position provided

- Power switching devices electrically or manually operated, electrically and mechanically interlocked
- Available with a programmed transition function to disconnect the load from both sources during switching. See the controls operation and installation manual for details.
- Ambient operating temperature range from – 5° to 60°C
- Ambient storage temperature range from – 55° to 100°C
- Humidity range from 5% to 95% noncondensing

1.6 Weights and Dimensions

Figure 1-6 shows the enclosure dimensions and weights of the complete automatic transfer switches in NEMA type 1 enclosures.

Switch Rating (amps)	Weight lbs. (kg)	Dimensions, H x W x D in. (mm)
40, 80, 100, 160, 250	206 (93)	39 x 27 x 19 (991 x 686 x 483)
400, 630	314 (142)	51 x 33 x 21 (1295 x 838 x 533)
800, 1000, 1250	610 (277)	58 x 41 x 22 (1470 x 1040 x 559)

Figure 1-6. ATS Weights and Dimensions

1.7 Ratings

Figure 1-7 gives ratings for the circuit breaker/switch power switching devices according to IEC 947-2 and IEC 947-3 standards.

Switch Rating (amps)	Circuit Breaker Ultimate Breaking Capacity (Icu) * (kA rms) AC 50/60 Hz					Admissible Short-time Current (Icw) *			
						Circuit Breakers		Switches	
	220/240 V	380/415 V	440 V	500 V	660/690 V	kA (rms)	Time (sec)	kA (rms)	Time (sec)
40	85	25	25	18	8	—	—	—	—
80	85	25	25	18	8	—	—	—	—
100	85	25	25	18	8	—	—	1.8	1.0
160	85	36	35	30	8	—	—	2.5	1.0
250	85	36	35	30	8	—	—	3.5	1.0
400	85	45	42	30	10	—	—	5.0	1.0
630	85	45	42	30	10	—	—	6.0	1.0
800	85	50	42	40	25	12	1.0	10.0	1.0
1000	85	50	42	40	25	12	1.0	15.0	1.0
1250	85	50	42	40	25	12	1.0	15.0	1.0

*Icw and circuit breaker Icu ratings according to IEC 947-2 and IEC 947-3

Figure 1-7. Ratings

High temperatures affect the maximum service currents for circuit breakers and switches. For temperatures above 40°C, decrease the service currents to the values shown in Figure 1-8.

Switch Type	Switch Rating (amps)	Maximum Service Current (amps)			
		45°C	50°C	55°C	60°C
Molded-case circuit breaker	40	39	38	37	36
	80	78	76	74	72
	100	97	95	92	90
	160	156	152	147	144
	250	244	238	231	225
	400	400	400	390	380
	630	615	600	585	570
	800	790	780	770	760
	1000	975	950	925	900
	1250	1200	1150	1100	1050
Molded-case switch	100	100	100	100	100
	160	160	160	160	160
	250	250	250	237	237
	400	400	400	390	380
	630	615	600	585	570
	800	790	780	770	760
	1000	975	950	925	900
	1250	1200	1150	1100	1050

Figure 1-8. Temperature Derating

For altitudes above 2000 meters, multiply the power switching device current rating by the factor shown in Figure 1-9. Apply the temperature derating shown in Figure 1-8, if applicable, before applying the altitude derating.

Altitude (m)	Maximum Operational Voltage	Current Derating Factor *
2000	690	1.00
3000	550	0.96
4000	480	0.93
5000	420	0.90

*Multiply the current rating by this factor after applying the temperature derating.

Figure 1-9. Altitude Derating

1.8 Application Data

See Figure 1-10 for application data including the wire sizes and tightening torques for transfer switch source and load connections.

Connections	Switch Rating (amps)	Strip Length in. (mm)	Range of Wire Sizes, Copper or Aluminum		Tightening Torque ft. lbs. (Nm)	Cables per Pole
			AWG/MCM	mm ²		
Normal and emergency source connections	40-160	0.8 (20)	#16 to #6 AWG #4 to 3/0 AWG	1.5-16 25-95	9 (12) 15 (20)	1 1
	250	0.8 (20)	#6 to #2 AWG #1 AWG to 350 MCM	16-35 50-185	15 (20) 19 (26)	1 1
	400	0.8 (20)	#2 AWG to 600 MCM	35-300	23 (31)	1
	630	1.2 (30)*	3/0 AWG to 500 MCM	85-240	23 (31)	1 or 2
	800	1.5 (38)*	2/0 AWG to 350 MCM	70-185	23 (31)	1 to 3
	1000-1250	1.5 (38)*	2/0 AWG to 500 MCM	70-240	31 (42)	1 to 4
Load connections	40	0.8 (20)	#6 to 2/0 AWG	16-70	15 (20)	1
	80-250	0.8 (20)	#6 AWG to 350 MCM	16-185	25 (34)	1
	400	0.8 (20)	#2 AWG to 600 MCM	35-300	23 (31)	1
	630	1.2 (30)*	3/0 AWG to 500 MCM	85-240	23 (31)	1 or 2
	800	1.5 (38)*	2/0 AWG to 350 MCM	70-185	23 (31)	1 to 3
	1000-1250	1.5 (38)*	2/0 AWG to 500 MCM	70-240	31 (42)	1 to 4

*Terminal lug front holes. For rear holes, 2.25 in. (58 mm)

Figure 1-10. Application Data

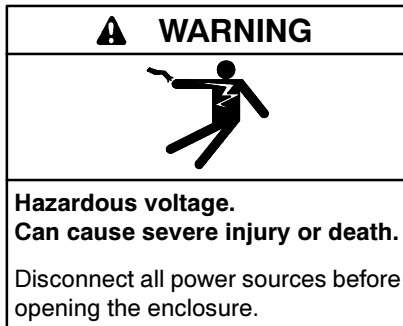

(600 volts and under)

Have an authorized distributor/dealer perform preventive maintenance on the transfer switch at regular intervals. See Section 3 for preventive maintenance.

DO NOT ENERGIZE THE SWITCH when any wear, damage, deterioration, or malfunction of the transfer switch or its components is evident or suspected. Call an authorized distributor/dealer to inspect and service the transfer switch.

2.1 Startup

Do not use this section for initial startup. Follow the instructions in the installation sections of the operation and installation manuals for the ATS power switching device and electrical controls. See the List of Related Materials in the Introduction section of this manual for manual numbers.

Use this section after power sources to the transfer switch have been disconnected for maintenance or service of the standby system. Follow this procedure to energize the transfer switch and prepare it for automatic operation.

Startup Procedure

1. Move the generator set master switch to the OFF position to prevent the generator set from starting.
2. Disconnect all power sources to the transfer switch by opening the circuit breakers or switches leading to the transfer switch.
3. Open the enclosure door and check that the wire harnesses for the power switching device and the controller are connected together at the inline plugs. See Figure 6-29 or Figure 6-30.
4. Set the transfer switch circuit breakers/switches to select the normal source and to operate automatically. See Section 2.3—Manual Operation.
5. Close and lock the transfer switch enclosure door. Tighten the screws securing the enclosure door in place.
6. Prepare the generator set for operation. Check the oil level, coolant level, fuel supply, batteries, and items specified by the generator set installation or operation checklist or manual.
7. Move the generator set master switch to the AUTO position. The generator set should start.
8. When the loads can be safely energized, reapply power sources to the transfer switch by closing the circuit breakers or switches.

NOTE

When power is initially applied to the transfer switch, the engine start contacts remain closed. The generator set runs until time delay engine cooldown (TDEC), if equipped, ends.

9. Perform an automatic operation test. Refer to the electrical controls operation and installation manual for the automatic test procedure.

Refer to the electrical controls operation and installation manual for other setup and startup procedures.

2.2 Operation Sequence

The ATS electrical controls or accessories detect whether a power source is acceptable, has failed, or has been restored. A power source is acceptable when the voltage and frequency on all sensed phases remain within a preset range. Failure of a power source occurs when the voltage and/or frequency on one or more sensed phases fall outside of the acceptable range. A power source is restored when the voltage and/or frequency return to acceptable levels after failing.

Automatic transfer switches typically operate in two sequences:

- Transfer to the emergency power source when the normal source fails.
- Transfer back to the normal power source after the normal source is restored.

The following sections explain these sequences of operation. Optional accessories can change the sequence of operation. See the electrical controls operation and installation manual for specifications on time delays, voltage and frequency limits, control adjustments, and accessory information.

2.2.1 Transfer to the Emergency Source

When the normal power source fails, the controller starts the time delay engine start (TDES) timer. TDES prevents unnecessary generator set startup during short normal power interruptions. If the normal power source is restored before TDES ends, the controller resets the timer. If the normal power failure persists and TDES ends, the controller issues a signal to start the

emergency generator set to produce the emergency power source.

After signaling the generator set to start, the controller monitors the emergency power source. When the controller determines that the emergency (generator set) power source is acceptable, it starts the time delay normal to emergency (TDNE) timer. TDNE allows the emergency power source to stabilize before the ATS transfers the load. When TDNE ends, the controller signals the transfer switch to connect the load to the emergency source.

After load transfer, the switch remains in the emergency position, supplying emergency source power to the load until normal power source restoration and stabilization occur.

2.2.2 Transfer to the Normal Source

After normal power source restoration, the controller starts the time delay emergency to normal (TDEN) timer. If the normal power source fails before TDEN ends, the timer resets. TDEN ensures normal power source stabilization before load reconnection.

When the controller determines that the normal power source has maintained an acceptable level and TDEN ends, the controller signals the transfer switch to reconnect the load to the normal source.

After load transfer, the switch mechanically latches in the normal position and the controller starts the time delay engine cooldown (TDEC) timer. TDEC allows the generator set to run unloaded and cool down before shutdown. When TDEC expires, the controller signals the generator set to shut down.

2.3 Manual Operation

Manually operate the power switching device to prepare the transfer switch for automatic operation, to reset a tripped circuit breaker, or to test or troubleshoot the unit.

Power-switching devices with 40–630 ampere ratings have different operating procedures than devices with 800–1250 ampere ratings. The following procedures explain how to manually operate both devices.

WARNING

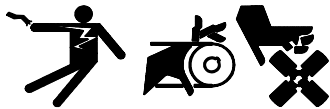

Accidental starting. Can cause severe injury or death.

Disconnect the battery cables before working on the generator set. Remove the negative (-) lead first when disconnecting the battery. Reconnect the negative (-) lead last when reconnecting the battery.

Disabling the generator set. Accidental starting can cause severe injury or death. Before working on the generator set or connected equipment, disable the generator set as follows: (1) Move the generator set master switch to the OFF position. (2) Disconnect the power to the battery charger. (3) Remove the battery cables, negative (-) lead first. Reconnect the negative (-) lead last when reconnecting the battery. Follow these precautions to prevent starting of the generator set by an automatic transfer switch, remote start/stop switch, or engine start command from a remote computer.

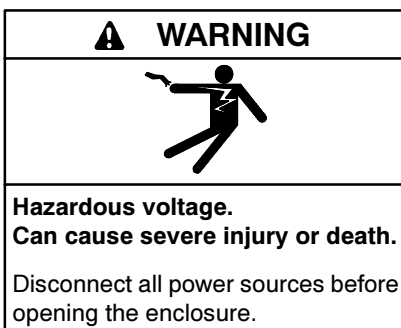

(600 volts and under)

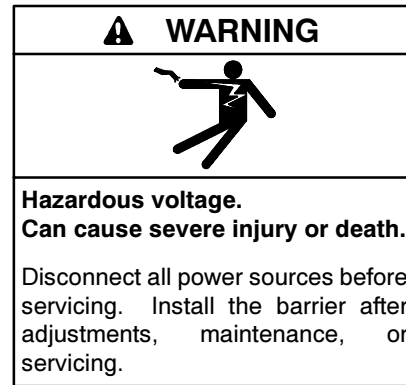

(600 volts and under)

Servicing the transfer switch. Hazardous voltage can cause severe injury or death. Deenergize all power sources before servicing. Open the main circuit breakers of all transfer switch power sources and disable all generator sets as follows: (1) Move all generator set master controller switches to the OFF position. (2) Disconnect power to all battery chargers. (3) Disconnect all battery cables, negative (-) leads first. Reconnect negative (-) leads last when reconnecting the battery cables after servicing. Follow these precautions to prevent the starting of generator sets by an automatic transfer switch, remote start/stop switch, or engine start command from a remote computer. Before servicing any components inside the enclosure: (1) Remove rings, wristwatch, and jewelry. (2) Stand on a dry, approved electrically insulated mat. (3) Test circuits with a voltmeter to verify that they are deenergized.

NOTE

A current overload will cause circuit breakers to trip (open). *Identify and correct the cause of the overload before resetting the tripped circuit breaker.*

NOTE

Mechanical interlocks allow only one switch or circuit breaker to be closed at any time. Before turning one circuit breaker/switch on, set the other circuit breaker/switch to the OFF position.

2.3.1 40–630 Amp Models

Figure 2-1 shows the normal and emergency circuit breakers/switches. The emergency source circuit breaker/switch is also labeled R for replacement power

source. Models rated from 40 through 630 amps use the motor operator shown in Figure 2-2 to open and close the circuit breaker. Use the following procedure to operate these units manually.

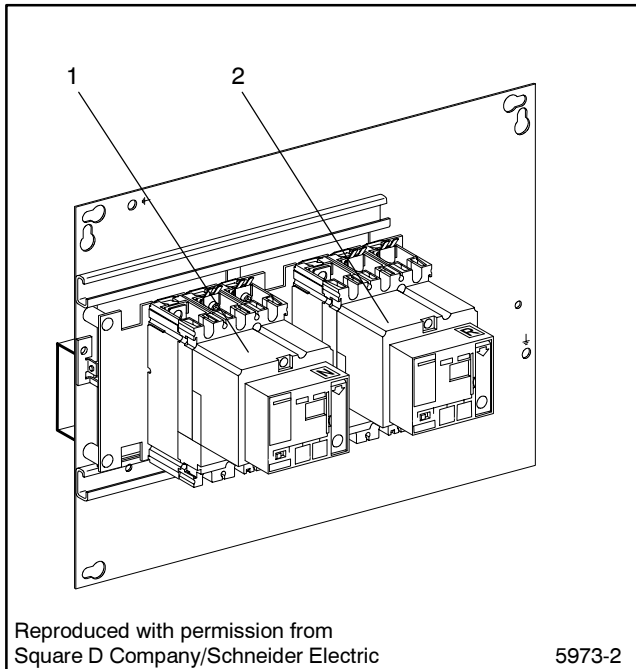

Reproduced with permission from Square D Company/Schneider Electric 5973-2

1. Normal circuit breaker/switch
2. Emergency circuit breaker/switch

Figure 2-1. Normal and Emergency Circuit Breakers/Switches, 40-630 Amp Models

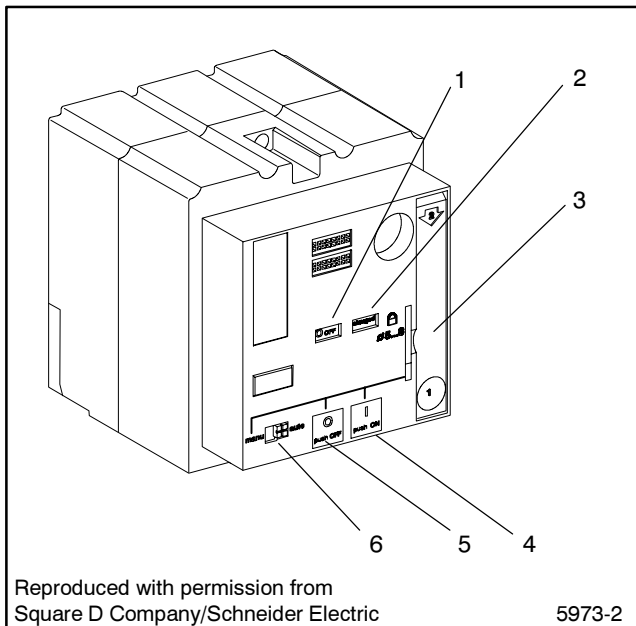

Reproduced with permission from Square D Company/Schneider Electric 5973-2

1. ON/OFF indicator
2. Charged/discharged indicator
3. Mechanical charge lever
4. ON button
5. OFF button
6. Automatic/manual slide switch

Figure 2-2. Motor Operator, 40-630 Amp Models

Manual Operation Procedure, 40-630 Amp Models

1. Prevent the emergency power source generator set from starting as follows:
 - a. Move the generator set master switch to the OFF position.
 - b. Disconnect power to the generator set battery charger, if installed.
 - c. Remove the generator set engine start battery cables, negative (-) leads first.
2. Disconnect or turn off *BOTH* the normal and emergency power sources before opening the enclosure door. Use a voltmeter with sufficient voltage rating and electrically-insulated probes to verify that the power is off.
3. Set both automatic/manual slide switches on the motor operators to the MANU position.
4. Press the OFF buttons on both motor operators. Check the ON/OFF indicators on both motor operators to verify that both are OFF.

NOTE

A circuit breaker/switch must have its motor operator charged electrically or mechanically in order to close (turn on).

5. Charge the motor operator for the normal or emergency circuit breaker/switch, if it is not already charged, by pulling down on the charge lever 7 or 8 times until the charged/discharged indicator changes from DISCHARGED to CHARGED. See Figure 2-3.

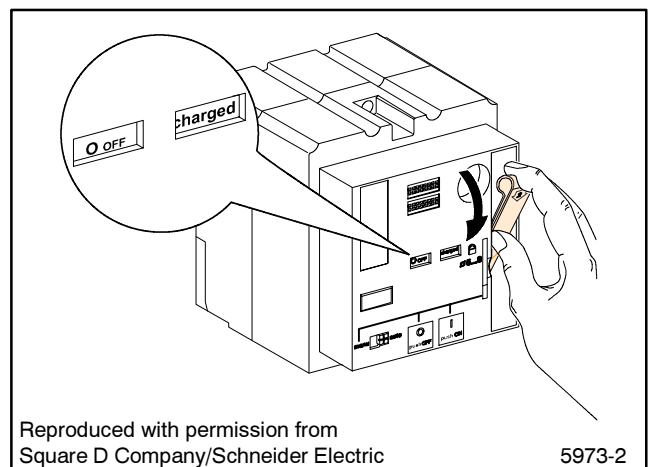

Reproduced with permission from Square D Company/Schneider Electric 5973-2

Figure 2-3. Motor Operator Manual Charging, 40-630 Amp Models

6. Press the ON button to close the desired circuit breaker/switch. The indicators will change to ON and DISCHARGED. Mechanical interlocks allow only one circuit breaker/switch to be set to the ON position at any time.
7. Turn the emergency source circuit breaker/switch OFF and the normal source circuit breaker/switch ON before returning the power switching device to automatic operation.
8. Set the automatic/manual slide switches on both motor operators to the AUTO position to return to automatic operation.
9. Close and lock the enclosure door before reapplying power. Tighten the screws that secure the enclosure door.
10. Reconnect the generator set battery cables, negative (-) leads last; reconnect power to the generator set battery charger, if installed; and move the generator set master switch to the AUTO (automatic) position. The generator may start and run until the time delay engine cooldown (TDEC) expires.

Locking Procedure, 40-630 Amp Models

Circuit breakers/switches can be padlocked in the OFF position as shown in Figure 2-4.

1. Pull out the locking tab while pressing the OFF button. See Figure 2-4.
2. Insert from 1 to 3 padlocks.

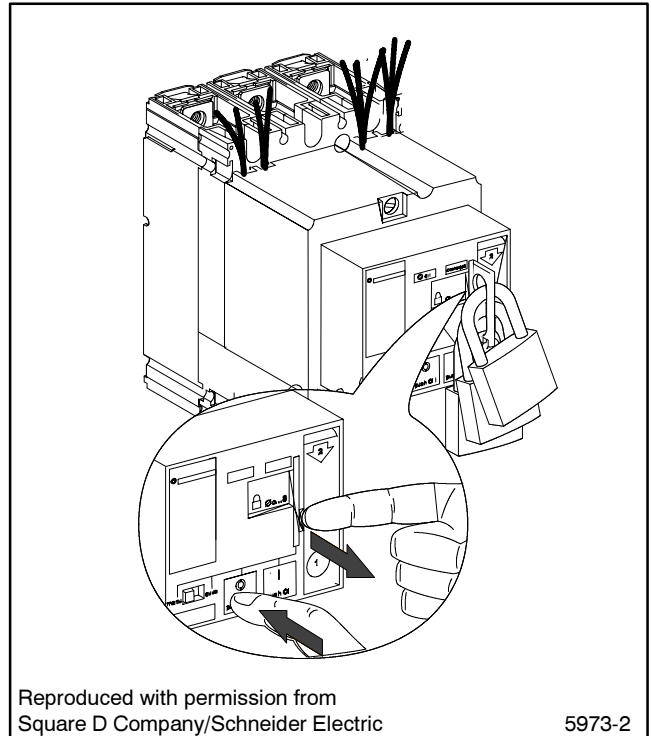

Figure 2-4. Locking Procedure, 40-630 Amp Models

2.3.2 800-1250 Amp Models

Figure 2-5 shows the normal and emergency source circuit breakers/switches. The emergency source circuit breaker/switch is also labeled R for replacement power source. Manually operate these models as described in the following procedure.

Manual Operation Procedure, 800-1250 Amp Models

1. Prevent the emergency power source generator set from starting as follows:
 - a. Move the generator set master switch to the OFF position.
 - b. Disconnect power to the generator set battery charger, if installed.
 - c. Remove the generator set engine start battery cables, negative (-) leads first.
2. Disconnect or turn off **BOTH** the normal and emergency power sources before opening the enclosure door. Check circuits with a voltmeter to verify that the power is off.
3. Open the plastic doors on the normal and emergency circuit breakers/switches to prevent controller circuitry from operating the circuit breakers/switches and to allow access to the motor operator lever.
4. Slide the switch lever on the desired circuit breaker/switch to the ON (1) position. See Figure 2-5. Mechanical interlocks allow only one circuit breaker/switch to be set to the ON position at any time.
5. Turn the emergency power circuit breaker/switch OFF and the normal power circuit breaker/switch ON before returning to automatic operation.
6. Close the plastic doors over both circuit breakers/switches to return to automatic operation.
7. Close and lock the enclosure door. Tighten the screws that secure the enclosure door.
8. Reconnect the power supplies to the transfer switch.
9. Reconnect the generator set battery cables, negative (-) leads last; reconnect power to the generator set battery charger, if installed; and move the generator set master switch to the AUTO (automatic) position. The generator set may start and run until the time delay engine cooldown (TDEC) expires.

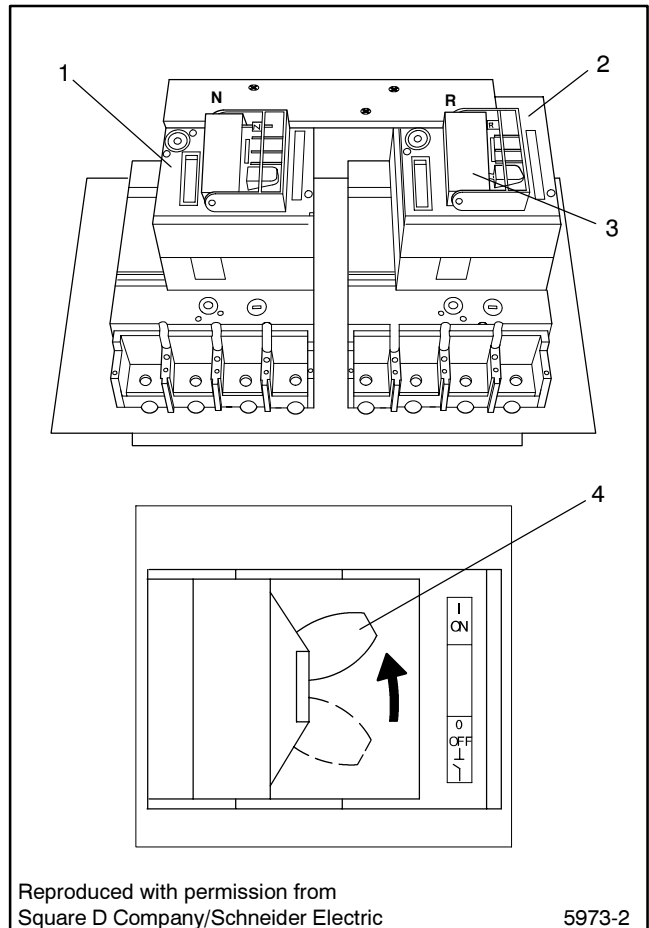

1. Normal circuit breaker/switch
2. Emergency circuit breaker/switch
3. Plastic door
4. Lever

Figure 2-5. Manual Operation, 800-1250 Amp Models

Locking Procedure, 800-1250 Amp Models

Circuit breakers/switches can be padlocked in the OFF position as shown in Figure 2-6.

1. Move the circuit breaker/switch handle to the OFF (0) position.
2. Pull out the locking tab as shown in Figure 2-6.
3. Insert a padlock as shown in Figure 2-6.

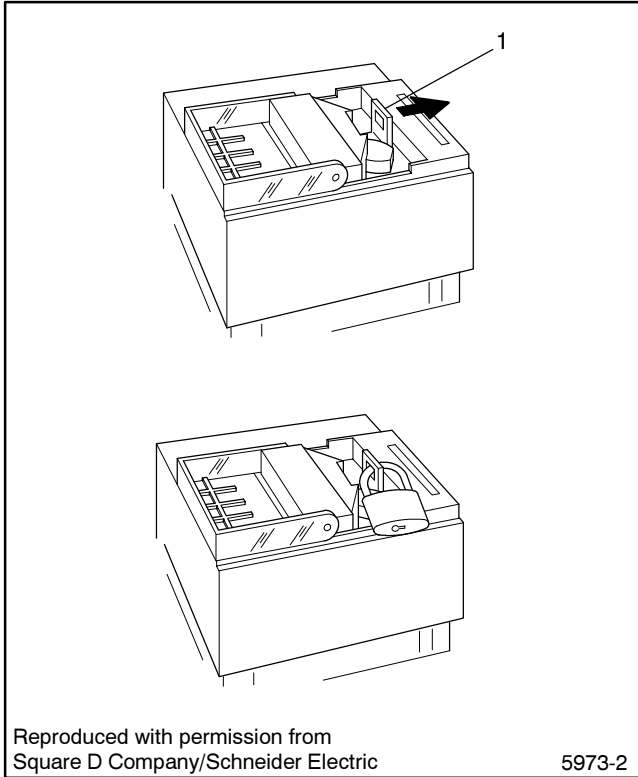

1. Locking tab

Figure 2-6. Locking Procedure, 800-1250 Amp Models

2.4 Resetting Tripped Circuit Breakers

A current overload will automatically trip (open) the circuit breakers on model MMT transfer switches. The ON/OFF indicator on the front of 40-630 amp motor operators displays OFF when the circuit breaker is tripped. On 800-1250 amp models, the motor operator lever on a tripped circuit breaker stops in the center position. Identify and correct the cause of the overload before resetting the circuit breaker. Turn off or disconnect all power sources and check circuits with a voltmeter to verify that the power is off before opening the enclosure. Follow the manual operation procedure in Section 2.3—Manual Operation to reset the tripped circuit breaker. Then select the desired power source.

To return to automatic operation after resetting a tripped circuit breaker, turn the normal circuit breaker on and set both circuit breakers for automatic operation. Close and lock the enclosure door. Tighten the screws that secure the enclosure door before reconnecting the power sources.

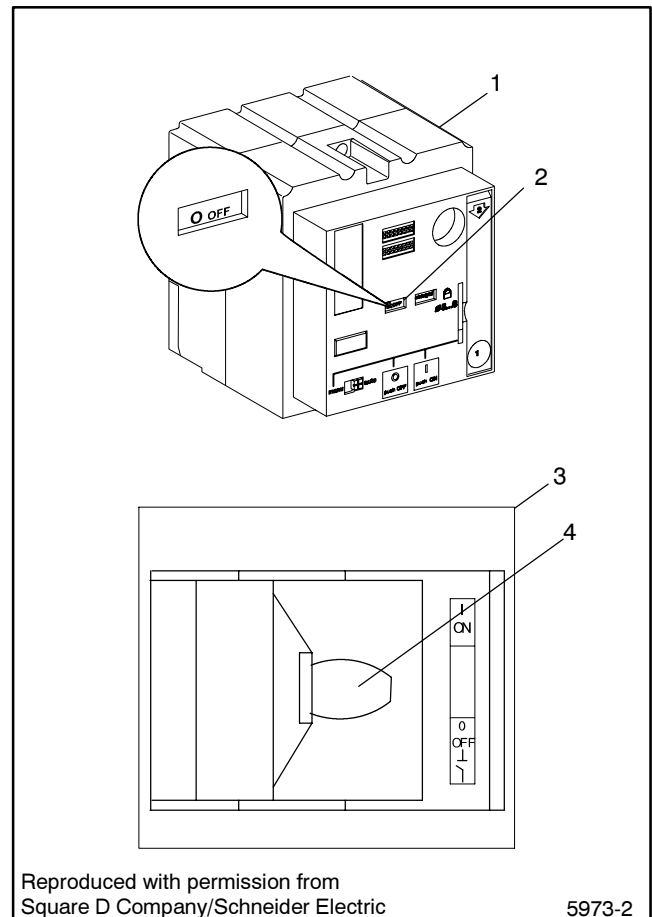

1. Typical 40-630 amp circuit breaker
2. ON/OFF display
3. Typical 800-1250 amp circuit breaker
4. Lever

Figure 2-7. Tripped Circuit Breakers

Notes

Section 3. Scheduled Maintenance

Scheduled preventive maintenance ensures safe and reliable operation and extends the life of the transfer switch. Preventive maintenance includes periodic testing, cleaning, inspection, and replacement of worn or missing components. A local authorized distributor/dealer can provide complete preventive maintenance and services to keep the transfer switch in top condition.

Read this entire section carefully before attempting any maintenance or service. Unless otherwise specified, have maintenance or service performed by trained and qualified personnel who follow all applicable codes and standards.

Keep records of all maintenance and service.

Replace all barriers and close and lock the enclosure door after maintenance or service and before reapplying power. Tighten the screws securing the enclosure door in place.

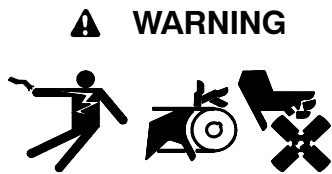

Accidental starting.
Can cause severe injury or death.

Disconnect the battery cables before working on the generator set. Remove the negative (-) lead first when disconnecting the battery. Reconnect the negative (-) lead last when reconnecting the battery.

Disabling the generator set. Accidental starting can cause severe injury or death. Before working on the generator set or connected equipment, disable the generator set as follows: (1) Move the generator set master switch to the OFF position. (2) Disconnect the power to the battery charger. (3) Remove the battery cables, negative (-) lead first. Reconnect the negative (-) lead last when reconnecting the battery. Follow these precautions to prevent starting of the generator set by an automatic transfer switch, remote start/stop switch, or engine start command from a remote computer.

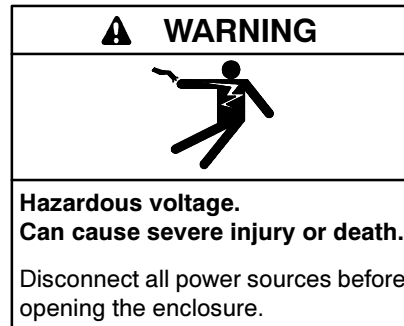

Hazardous voltage.
Can cause severe injury or death.

Disconnect all power sources before opening the enclosure.

(600 volts and under)

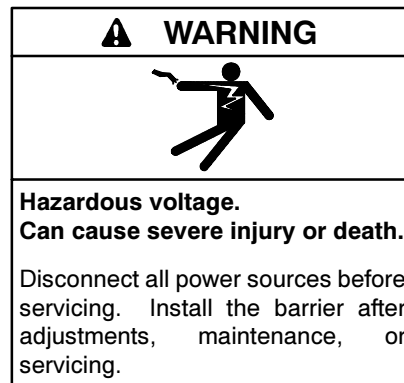

Hazardous voltage.
Can cause severe injury or death.

Disconnect all power sources before servicing. Install the barrier after adjustments, maintenance, or servicing.

(600 volts and under)

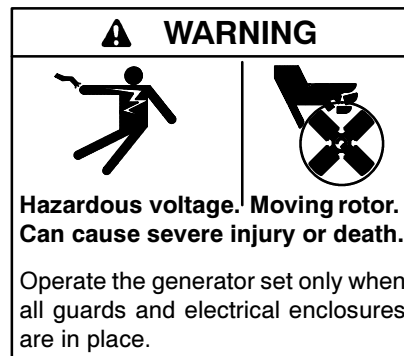

Hazardous voltage. Moving rotor.
Can cause severe injury or death.

Operate the generator set only when all guards and electrical enclosures are in place.

Grounding electrical equipment. Hazardous voltage can cause severe injury or death. Electrocutation is possible whenever electricity is present. Open the main circuit breakers of all power sources before servicing the equipment. Configure the installation to electrically ground the generator set, transfer switch, and related equipment and electrical circuits to comply with applicable codes and standards. Never contact electrical leads or appliances when standing in water or on wet ground because these conditions increase the risk of electrocution.

Servicing the transfer switch. Hazardous voltage can cause severe injury or death. Deenergize all power sources before servicing. Open the main circuit breakers of all transfer switch power sources and disable all generator sets as follows: (1) Move all generator set master controller switches to the OFF position. (2) Disconnect power to all battery chargers. (3) Disconnect all battery cables, negative (-) leads first. Reconnect negative (-) leads last when reconnecting the battery cables after servicing. Follow these precautions to prevent the starting of generator sets by an automatic transfer switch, remote start/stop switch, or engine start command from a remote computer. Before servicing any components inside the enclosure: (1) Remove rings, wristwatch, and jewelry. (2) Stand on a dry, approved electrically insulated mat. (3) Test circuits with a voltmeter to verify that they are deenergized.

Servicing the transfer switch controls and accessories within the enclosure. Hazardous voltage can cause severe injury or death. Disconnect the transfer switch controls at the inline connector to deenergize the circuit boards and logic circuitry but allow the transfer switch to continue to supply power to the load. Disconnect all power sources to accessories that are mounted within the enclosure but are not wired through the controls and deenergized by inline connector separation. Test circuits with a voltmeter to verify that they are deenergized before servicing.

NOTICE

Hardware damage. The transfer switch may use both American Standard and metric hardware. Use the correct size tools to prevent rounding of the bolt heads and nuts.

NOTICE

When replacing hardware, do not substitute with inferior grade hardware. Screws and nuts are available in different hardness ratings. To indicate hardness, American Standard hardware uses a series of markings, and metric hardware uses a numeric system. Check the markings on the bolt heads and nuts for identification.

NOTICE

Electrostatic discharge damage. Electrostatic discharge (ESD) damages electronic circuit boards. Prevent electrostatic discharge damage by wearing an approved grounding wrist strap when handling electronic circuit boards or integrated circuits. An approved grounding wrist strap provides a high resistance (about 1 megohm), *not a direct short*, to ground.

3.1 Inspection and Service

Contact an authorized distributor/dealer to inspect and service the transfer switch when wear, damage, deterioration, or malfunction of the transfer switch or its components is evident or suspected.

3.1.1 General Inspection

External Inspection. Keep the transfer switch clean and in good condition by performing a weekly external inspection of the transfer switch. Look for signs of vibration, leakage, extreme temperatures, contamination, or deterioration. Remove dirt, dust or other contaminants from the transfer switch external components or the enclosure with a vacuum cleaner or by wiping with a dry cloth or brush. *Do not use compressed air to clean the switch because it can cause debris to lodge in components and damage the transfer switch.* Replace worn, missing, or broken components with manufacturer-recommended replacement parts. Tighten loose hardware.

Internal Inspection. Disconnect all power sources before opening the transfer switch enclosure door. Use a voltmeter to verify that the power is off. Inspect the internal components monthly or when vibration, leakage, extreme temperatures, contamination, or deterioration noticed during an external inspection may have affected internal components.

Contact an authorized distributor/dealer to inspect and service the transfer switch if any of the following conditions exist inside the transfer switch enclosure.

- Accumulations of dirt, dust, moisture, or contaminants
- Signs of corrosion
- Worn, missing, or broken components
- Loose hardware
- Wire or cable insulation deterioration, cuts, or abrasions
- Signs of overheating or loose connections: discoloration of metal, melted plastic, or a burning odor
- Other evidence of wear, damage, or malfunction of the transfer switch or its components

Replace all barriers and close and lock the enclosure door after service or maintenance and before reapplying power. Tighten the screws securing the enclosure door in place.

3.1.2 Other Inspections and Service

Have an authorized distributor/dealer perform maintenance and service that ensures the safe and reliable operation of the transfer switch. See Section 3.3—Service Schedule for the recommended maintenance items and service intervals.

Have an authorized distributor/dealer repair or replace components inside the transfer switch enclosure with manufacturer-recommended replacement parts. Do not adjust or repair factory-sealed molded-case circuit breakers/switches.

The factory lubricates the operating mechanisms of molded-case circuit breakers/switches. Under normal conditions, the circuit breakers/switches require no further lubrication.

3.2 Testing

3.2.1 Weekly Generator Set Exercise

Use a plant exerciser or manual test to start and run the generator set under load once a week to maximize the reliability of the emergency power system. See the controller operation and installation manual for the procedure to exercise the generator set. See the List of Related Materials in the Introduction for the controller manual number.

3.2.2 Monthly Automatic Operation Test

Test the transfer switch's automatic control system monthly. See the electrical controls operation and installation manual for the test procedure. Verify that the expected sequence of operations occurs as the switch transfers the load to the emergency source when a normal source failure occurs or is simulated. Observe the indicator lamps on the transfer switch to check their operation. Listen for unusual or excessive noise during operation. When the switch transfers the load to the emergency source, end the test and verify that the expected sequence of operations occurs as the transfer switch retransfers to the available normal source and signals the generator set to shut down after a cooldown period.

3.3 Service Schedule

Follow the service schedule below for the recommended service intervals. Have all service performed by an authorized distributor/dealer except for items marked with an X.

System Component or Procedure	See Section	Visually Inspect	Check	Change	Clean	Test	Interval
ELECTRICAL SYSTEM							
Check for signs of overheating or loose connections: discoloration of metal, melted plastic, or a burning odor.	3.1.1	X	X				M
Check wires and cables for deterioration, cuts, or or abrasion. Repair or replace damaged wiring.	3.1.1	X					M
	3.1.2	D	D	D, R			Q
Tighten source, load, and control cable connections and bus bars to specifications.	1.8, 3.1.1, 6.10, C		D				A
Check the operation of the mechanical interlocks. Replace the entire power switching device assembly on 40-630 amp units if the interlocks fail to operate. Repair or replace the interlocks on 800-1250 amp units.	2.3, 6.3, 6.4		D	D, R			A
Test wire and cable insulation for electrical breakdown.	3.1.2			D, R		D	Every 3 Years
Test calibration of voltage-sensing circuitry and setpoints. Recalibrate circuitry if necessary.	3.1.2, C			D		D	Every 5 Years
CONTROL SYSTEM							
Exercise the generator set under load.	3.2.1, C					X	W
Test the transfer switch's automatic control system.	3.2.2, C	X				X	M
Test indicator lamps and LEDs and remote control circuits for operation.	C	X	D	D, R		D	A
GENERAL EQUIPMENT CONDITION							
Inspect the outside of the transfer switch for any condition of vibration, leakage, extreme temperature, contamination, or deterioration.*	3.1.1	X			X		W
Check that all external hardware is in place, tightened, and not badly worn. Replace worn or damaged hardware.	3.1.1	X	X	X			W
Inspect the inside of the transfer switch for any condition of vibration, leakage, extreme temperature, contamination, or deterioration.*	3.1.1	X	X		D		S
	3.1.2	D	D		D		A
Check that all internal hardware is in place, tightened, and not badly worn. Replace worn or damaged hardware.	3.1.2, 1.8, 6.10	X	D	D, R			A
<p>* Service more frequently if operated in dusty or dirty areas.</p> <p>See Section Read these sections carefully for additional information before attempting maintenance or service.</p> <p>Visually Inspect Examine these items visually.</p> <p>Check Requires physical contact with or movement of system components, or the use of nonvisual indications.</p> <p>Change May require replacement of components depending upon the severity of the problem.</p> <p>Clean Remove accumulations of dirt and contaminants from external transfer switch's components or enclosure with a vacuum cleaner or by wiping with a dry cloth or brush. <i>Do not use compressed air to clean the switch because it can cause debris to lodge in the components and cause damage.</i></p> <p>Test May require tools, equipment, or training available only through an authorized distributor/dealer.</p> <p>C See the transfer switch electrical controls operation and installation manual for the procedure.</p> <p>D Have service performed by an authorized distributor/dealer.</p> <p>X Operator action.</p> <p>R May require replacement of components.</p>							<p>W=Weekly</p> <p>M=Monthly</p> <p>Q=Quarterly</p> <p>S=Semi-annually</p> <p>A=Annually</p>



Section 4. Troubleshooting



This section contains power switching device troubleshooting, diagnostic, and repair information. Refer to the electrical controls service manual for the electrical controls troubleshooting, diagnostics, and repair information. See the List of Related Materials in the Introduction of this manual for the controls manual numbers.

Have trained and qualified personnel service the transfer switch. Verify that repairs comply with all applicable codes and standards. Maintain a record of repairs and adjustments made on the equipment.

Use the following chart to diagnose and correct common problems. First check for simple causes such as an open circuit breaker, loose or corroded connections, or damaged wiring. The chart includes a list of common problems, possible causes of the problem, recommended corrective actions, and references to detailed information or repair procedures.

The flowcharts in this section give step-by-step procedures for troubleshooting electrical problems.

 WARNING

Hazardous voltage. Can cause severe injury or death. Disconnect all power sources before opening the enclosure. <i>(600 volts and under)</i>

 WARNING

Hazardous voltage. Can cause severe injury or death. Disconnect all power sources before servicing. Install the barrier after adjustments, maintenance, or servicing. <i>(600 volts and under)</i>

(600 volts and under)

Servicing the transfer switch. Hazardous voltage can cause severe injury or death. Deenergize all power sources before servicing. Open the main circuit breakers of all transfer switch power sources and disable all generator sets as follows: (1) Move all generator set master controller switches to the OFF position. (2) Disconnect power to all battery chargers. (3) Disconnect all battery cables, negative (-) leads first. Reconnect negative (-) leads last when reconnecting the battery cables after servicing. Follow these precautions to prevent the starting of generator sets by an automatic transfer switch, remote start/stop switch, or engine start command from a remote computer. Before servicing any components inside the enclosure: (1) Remove rings, wristwatch, and jewelry. (2) Stand on a dry, approved electrically insulated mat. (3) Test circuits with a voltmeter to verify that they are deenergized.

Servicing the transfer switch controls and accessories within the enclosure. Hazardous voltage can cause severe injury or death. Disconnect the transfer switch controls at the inline connector to deenergize the circuit boards and logic circuitry but allow the transfer switch to continue to supply power to the load. Disconnect all power sources to accessories that are mounted within the enclosure but are not wired through the controls and deenergized by inline connector separation. Test circuits with a voltmeter to verify that they are deenergized before servicing.

Making line or auxiliary connections. Hazardous voltage can cause severe injury or death. To prevent electrical shock deenergize the normal power source before making any line or auxiliary connections.

Testing live electrical circuits. Hazardous voltage or current can cause severe injury or death. Have trained and qualified personnel take diagnostic measurements of live circuits. Use adequately rated test equipment with electrically insulated probes and follow the instructions of the test equipment manufacturer when performing voltage tests. Observe the following precautions when performing voltage tests: (1) Remove rings, wristwatch, and jewelry. (2) Stand on a dry, approved electrically insulated mat. (3) Do not touch the enclosure or components inside the enclosure. (4) Be prepared for the system to operate automatically.
(600 volts and under)

NOTICE

Hardware damage. The transfer switch may use both American Standard and metric hardware. Use the correct size tools to prevent rounding of the bolt heads and nuts.

NOTICE

When replacing hardware, do not substitute with inferior grade hardware. Screws and nuts are available in different hardness ratings. To indicate hardness, American Standard hardware uses a series of markings, and metric hardware uses a numeric system. Check the markings on the bolt heads and nuts for identification.

NOTICE

Electrostatic discharge damage. Electrostatic discharge (ESD) damages electronic circuit boards. Prevent electrostatic discharge damage by wearing an approved grounding wrist strap when handling electronic circuit boards or integrated circuits. An approved grounding wrist strap provides a high resistance (about 1 megohm), *not a direct short*, to ground.

4.1 Troubleshooting Charts

Problem	Possible Cause	Corrective Action	Reference
Circuit breaker trips off.	Load excessive or shorted	Correct load problem and reset circuit breaker.	Section 2.4—Resetting Tripped Circuit Breakers
	Factory-adjusted trip points tampered with	Replace circuit breaker if factory seal is broken. Do not attempt to readjust trip points.	Section 6.7—Circuit Breaker/Switch Removal and Installation
	Circuit breaker defective	Replace circuit breaker.	Section 6.7—Circuit Breaker/Switch Removal and Installation
Circuit breaker/switch fails to turn on or off.	Auto/Manual switch on a circuit breaker/switch in the Manu position	Place both Auto/Manual switches into the Auto position.	Section 2.3—Manual Operation
	Upstream circuit breaker tripped or open	Determine cause of trip and correct before resetting circuit breaker. Close upstream circuit breakers. Check for voltage at the transfer switch source terminal lugs.	Section 4.2.1—Initial Checks
	Transfer switch circuit breaker tripped	Determine cause of trip and correct before resetting circuit breaker.	Circuit breaker trips off, this chart; Section 2.4—Resetting Tripped Circuit Breakers
	Control circuit failure	Check control circuit operation.	Section 4.2—Verifying Control System Operation; transfer switch electrical controls manuals
	Transfer switch control settings incorrect	Check transfer switch and generator set controller settings.	Transfer switch electrical controls manuals or generator set operation and service manuals
	Time delays excessive	Check transfer switch and generator set controller settings.	Transfer switch electrical controls manuals or generator set operation and service manuals
	Mechanical binding	Perform a complete manual operation and mechanical interlock test. Refer to mechanical problems below, then verify control circuit operation.	Section 6.5—Mechanical Interlock Tests

Problem	Possible Cause	Corrective Action	Reference
Circuit breaker fails to turn on or off, cont'd.	Mechanical interlock interference	40–630 A units: replace power switching device assembly.	Section 6.3—Power Switching Device Removal and Installation
		800–1250 A units only: check/fix mechanical interlock.	Section 6.4—Mechanical Interlock Removal and Installation, 800–1250 Ampere Units
	Mechanical interlock auxiliary switch defective	40–630 A units: Check/replace SDE auxiliary switch.	Section 6.8—Auxiliary Switch Replacement
		800–1250 A units: Replace circuit breaker/switch.	Section 6.7—Circuit Breaker/Switch Removal and Installation
	Circuit breaker/switch defective	Replace circuit breaker/switch.	Section 6.7—Circuit Breaker/Switch Removal and Installation
Generator set engine does not start.	Time delays excessive	Check transfer switch and generator set controller settings.	Transfer switch electrical controls manuals or generator set operation and service manuals.
	Control circuit failure	Check control circuit operation.	Section 4.2—Verifying Control System Operation; transfer switch electrical controls manuals
Mechanical interlocks jam.	800–1250 A units only: interlock(s) misaligned	800–1250 A units only: realign interlock(s).	Section 6.4—Mechanical Interlock Removal and Installation, 800–1250 Ampere Units
	Interlock(s) damaged	40–630 A units: replace power switching device assembly.	Section 6.3—Power Switching Device Removal and Installation
		800–1250 A units only: replace interlock(s).	Section 6.4—Mechanical Interlock Removal and Installation, 800–1250 Ampere Units
	Circuit breaker/switch defective	Replace circuit breaker/switch.	Section 6.7—Circuit Breaker/Switch Removal and Installation

4.2 Checking Control System Operation

This section explains the operation of the power switching device and explains how to troubleshoot the power switching device electrical circuits. Section 7 contains the power switching device electrical schematic diagrams. Refer to the electrical controls manuals for more information about the operation of the controls.

Each circuit breaker/switch requires specific input signals to function correctly. The controller opens and closes various relays in the system to cause transfers. Control signals may not be available for a number of reasons—loose or corroded connections, damaged wiring, a blown fuse, a defective relay or auxiliary switch, or other controller faults.

If the problem could be caused by an overcurrent fault condition in the control circuit (a blown fuse or open switch or relay contact), check for short circuits in that

part of the circuit before and after replacing the defective component to locate all defective components. For example, a blown fuse may indicate a defective motor operator and/or a binding mechanism. Replacing the fuse may restore operation temporarily, but the unit may fail again later. Find and correct the cause of the failure before returning the unit to service.

NOTE

Check for loose connections before replacing parts.

4.2.1 Initial Checks

Check terminal lugs NA-NC and EA-EC for line voltage. The circuit breaker/switch units cannot operate automatically without power.

Check for line voltage between P1-33 and P1-22 (NA) or P1-33 and P1-8 (EA). The circuit breaker/switch units are both fed at terminals A1 from P1-33 and require line voltage to operate.

When the controller's off-to-emergency time delay ends, a contact on the TDOE relay closes and powers P1-3 to signal transfer to the emergency source. See Figure 4-2. Check for line voltage at pin P1-3 after the time delays have expired. If line voltage is not present at P1-3, the problem is located on the controller.

An electrical interlock contact (SDE or CV) on the normal circuit breaker/switch closes to allow the emergency circuit breaker/switch to operate when the normal circuit breaker/switch is open and reset. Check for voltage at terminal A2 on the emergency circuit breaker/switch to verify that the electrical interlock is working correctly. If voltage is not present, replace the

SDE auxiliary switch on the normal circuit breaker/switch on 40–630 amp models. Replace the entire motor operator assembly on the normal circuit breaker/switch on 800–1250 amp models. See Section 6.6—Motor Operator Removal and Installation or Section 6.8—Auxiliary Switch Replacement.

If the emergency circuit breaker/switch fails to close when the normal circuit breaker is off and there is voltage between terminals A1 and A2 on the emergency circuit breaker/switch, replace the motor operator on the emergency circuit breaker/switch. See Section 6.6—Motor Operator Removal and Installation.

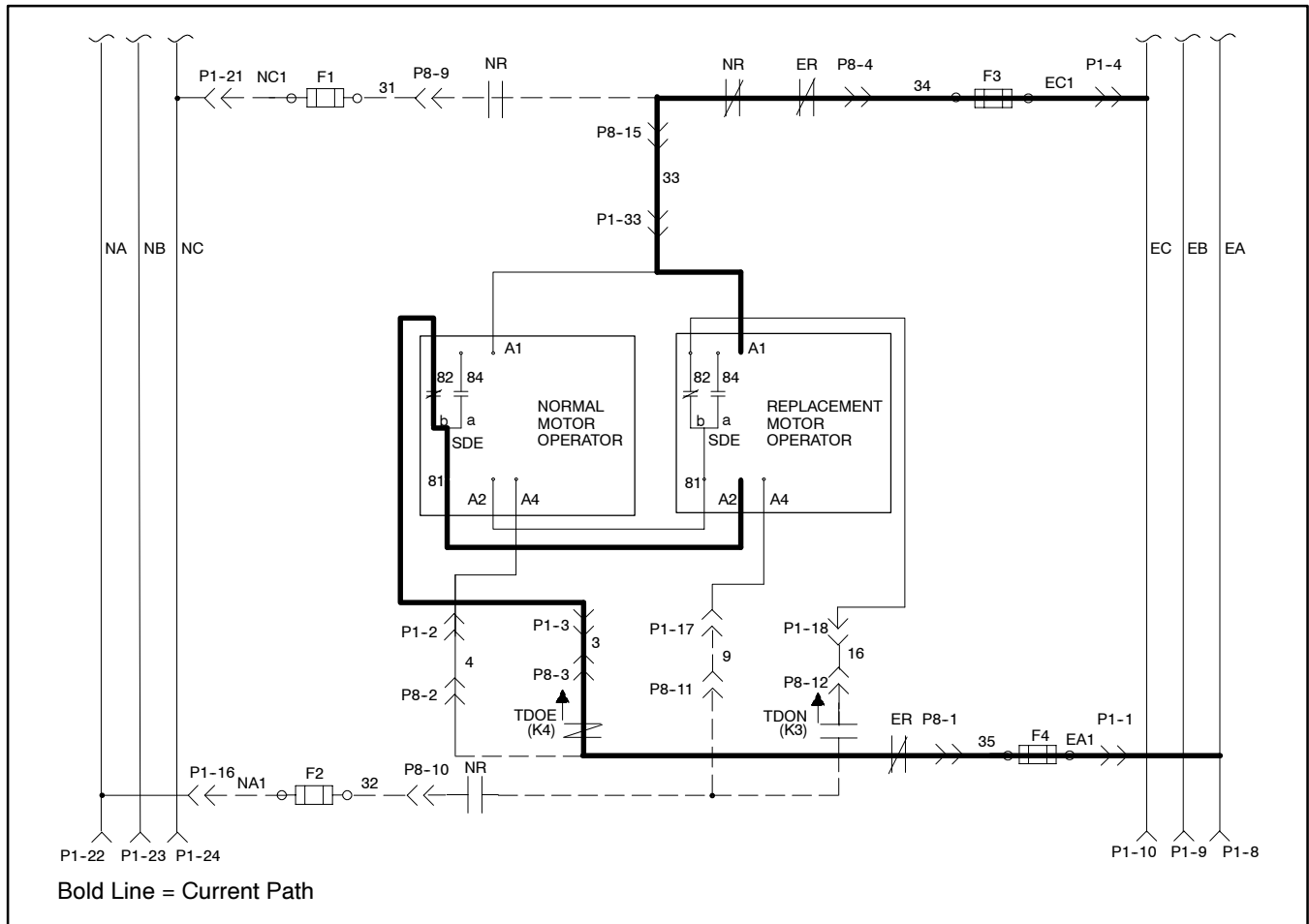

Figure 4-2. Emergency Circuit Breaker/Switch Closed

4.2.3 Transfer to the Normal Source

When the normal source is restored and the controller time delay TDEN ends, the NR relay energizes, completing the connection from terminal NC to both circuit breakers/switches at the A1 terminals and opening the circuit connecting to terminal EC. See Figure 4-3.

Check for line voltage at pin P1-33. If line voltage is not present, refer to the controller service manual to troubleshoot components in this area (NR relay contact, F1 fuse).

The controller also closes an NR relay contact that powers pin P1-17 which is connected to terminal A4 on the emergency circuit breaker/switch. Check for line

voltage at terminal A4 on the emergency circuit breaker/switch. If line voltage is not present at terminal A4, the emergency circuit breaker will not open and therefore the normal circuit breaker/switch cannot close. Refer to the controller service manual to troubleshoot components in this area (NR relay contact, F2 fuse).

If line voltage is present at P1-17 but the emergency circuit breaker/switch is not opening, verify that the Auto/Manual switch on the circuit breaker/switch is in the Auto position and the circuit breaker is not tripped. If the emergency circuit breaker/switch is still not opening, replace the motor operator on the emergency circuit breaker/switch. See Section 6.6—Motor Operator Removal and Installation.

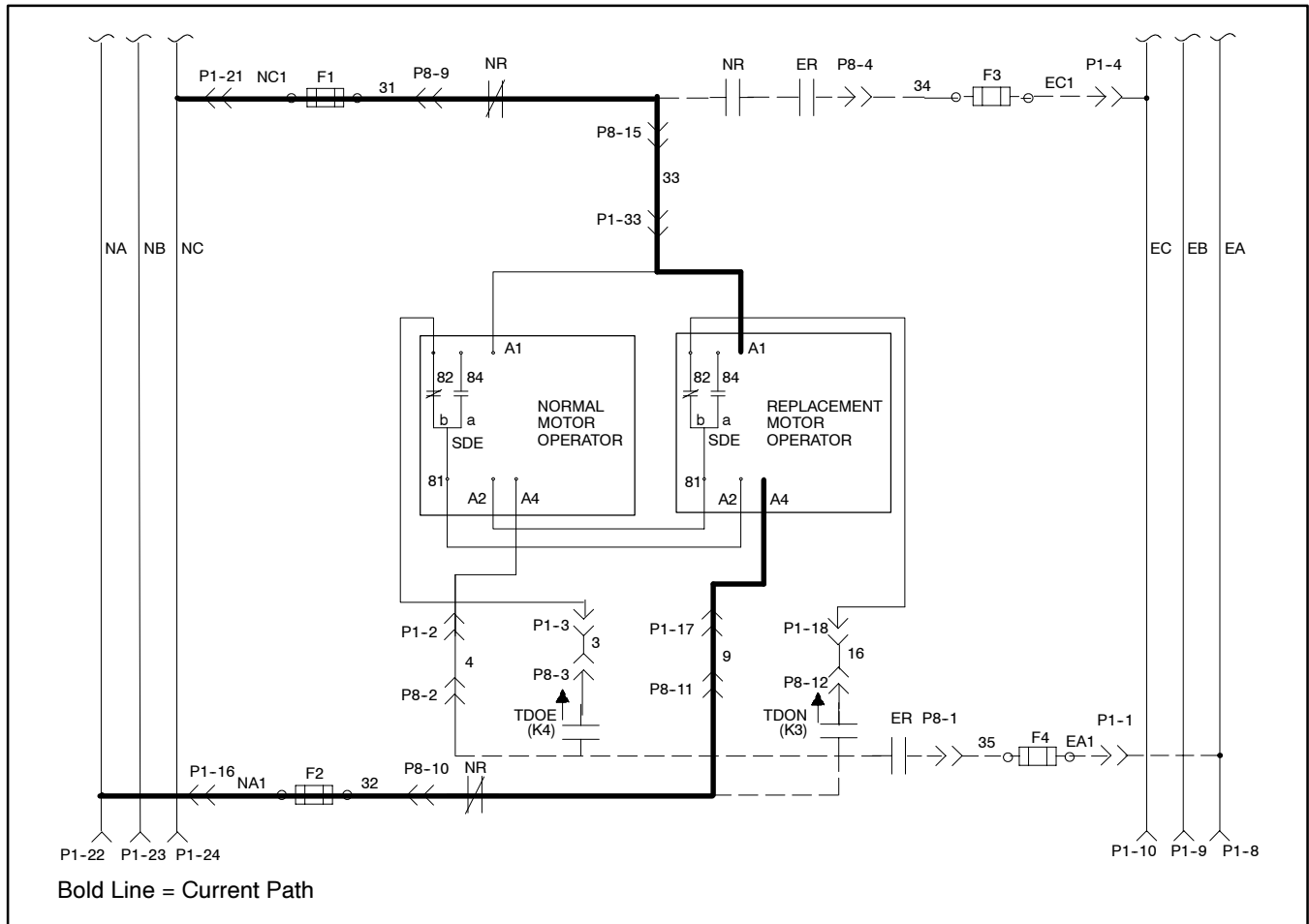

Figure 4-3. Normal Source Restored and Emergency Circuit Breaker/Switch Open

When the controller's off-to-normal time delay ends, a contact on the TDON relay closes and powers P1-18 to signal transfer to the normal source. See Figure 4-4. Check for line voltage at pin P1-18 after the time delays expire. If line voltage is not present at P1-18, the problem is located on the controller.

An electrical interlock contact (SDE or CV) on the emergency circuit breaker/switch closes to allow the normal circuit breaker/switch to operate when the emergency circuit breaker/switch is open and reset. Check for voltage at terminal A2 on the normal circuit breaker/switch to verify that the electrical interlock is working correctly. If voltage is not present, replace the

SDE auxiliary switch on the emergency circuit breaker/switch on 40–630 amp models. Replace the entire motor operator assembly on the emergency circuit breaker/switch on 800–1250 amp models. See Section 6.6—Motor Operator Removal and Installation or Section 6.8—Auxiliary Switch Replacement.

If the normal circuit breaker/switch fails to close when the emergency circuit breaker is off and there is voltage between terminals A1 and A2 on the normal circuit breaker/switch, replace the motor operator on the normal circuit breaker/switch. See Section 6.6—Motor Operator Removal and Installation.

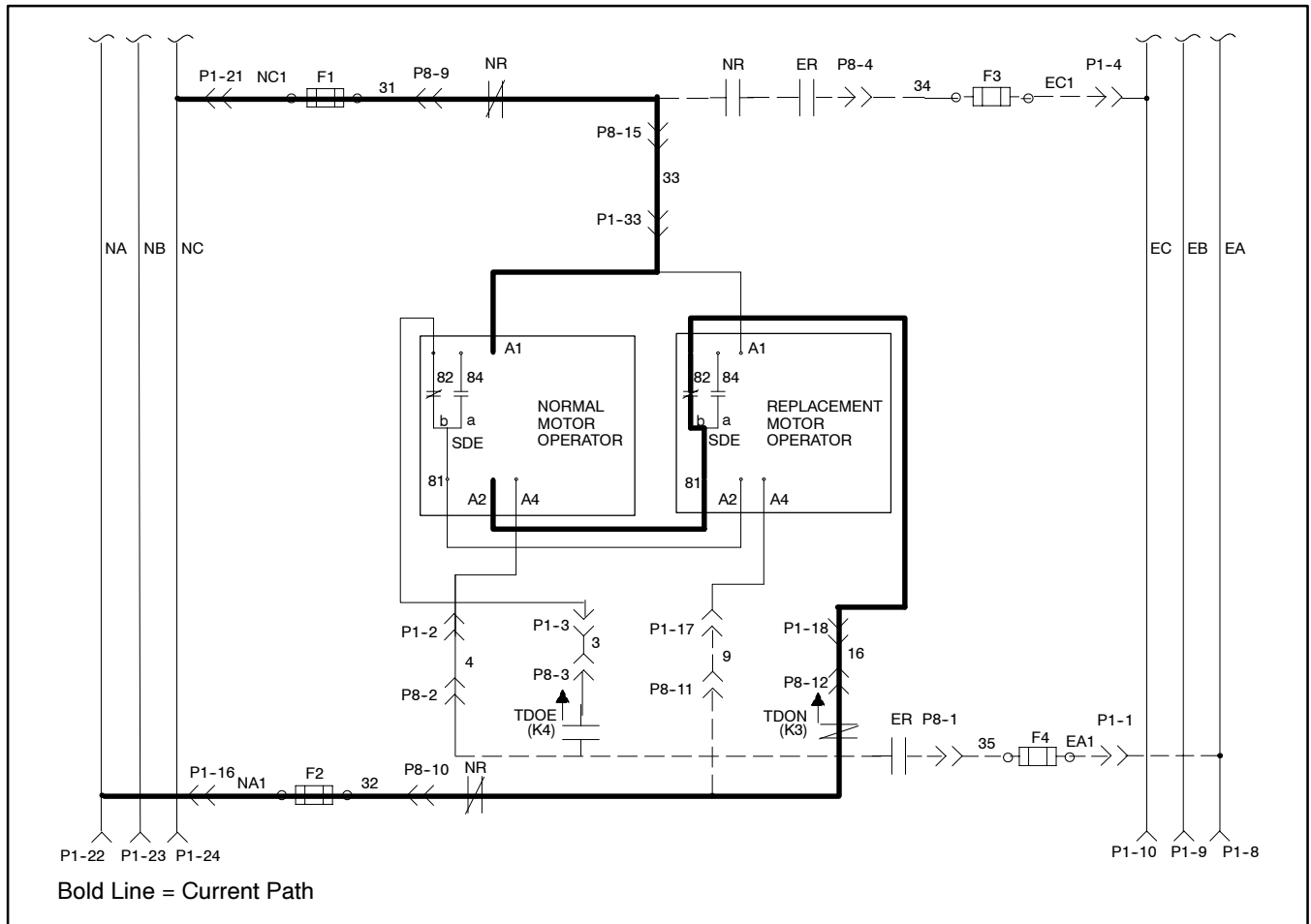

Figure 4-4. Normal Circuit Breaker/Switch Closed

Section 5. Accessory Testing and Adjustment

5.1 Programmed Transition

The programmed transition accessory provides an adjustable time delay off during load transfer. The load is disconnected from the sources during the time delay.

NOTE

For automatic transfer switches utilizing the M340+ logic control, the programmed transition function is accomplished within the microprocessor and therefore no timing relays are required. See manual number TP-5664 for operational details. *Do not* use this section.

5.1.1 Description

The programmed transition accessory consists of two timing relays that plug into the interface board. See Figure 5-1 for an illustration of the interface board. See the drawing in Section 8.3 for the location of the interface board. The time delay off to emergency (TDOE) relay produces the time delay during the normal to emergency power transfer and begins timing when the time delay normal to emergency (TDNE) expires. The time delay off to normal (TDON) relay produces the time delay during the emergency to normal power transfer and begins timing when the time delay emergency to normal (TDEN) expires.

When these relays are mounted on the interface board, power will transfer from the normal to the emergency power source or from the emergency to the normal power source in the following sequence:

1. The switch or circuit breaker for the previously connected power source opens.
2. A time delay, adjustable from 2 to 40 seconds, allows residual voltage in the load circuit to decay.
3. The switch or circuit breaker for the new power source closes.

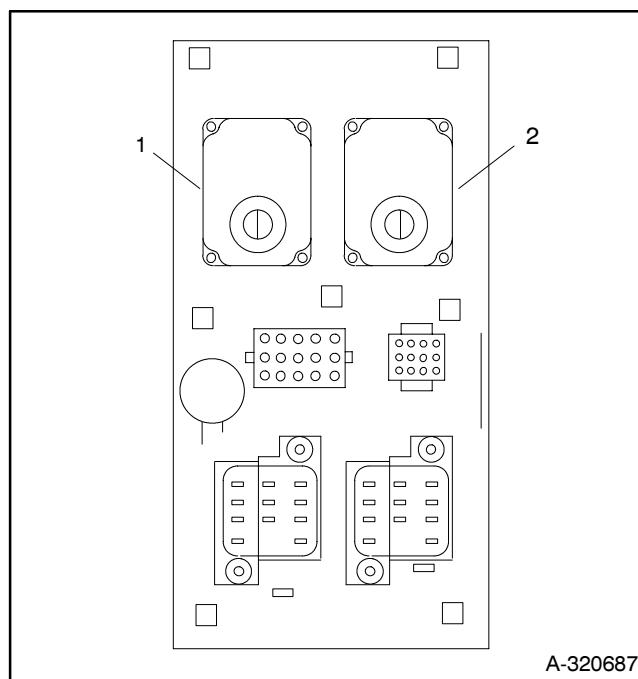

1. K3 (TDON)
2. K4 (TDOE)

Figure 5-1. Interface Board with Programmed Transition Timing Relays

5.1.2 Adjustment

Each relay has a separate adjustment. Adjust each relay according to the following procedure.

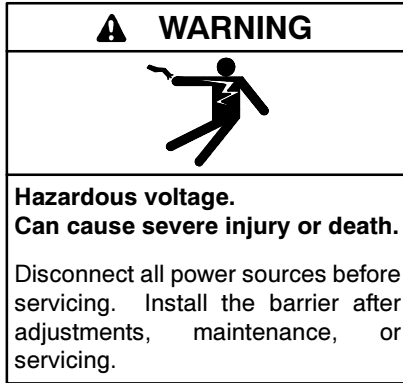

(600 volts and under)

Timing Relay Adjustment Procedure:

1. Disconnect all power sources before opening the enclosure door.
2. Locate the TDOE or TDON relay on the interface board inside the enclosure. See Figure 5-1.

3. Insert a screwdriver into the slot of the adjustment screw visible through the cover of the relay. Turn the adjustment screw until the slot points to the desired time delay.
4. Close and lock the enclosure door. Tighten the screw(s) securing the door in place.
5. Reconnect the power sources.
6. Operate the transfer switch automatically and check the length of the time delay to verify that it is properly adjusted.

5.2 Other Accessories

Most other accessories are controller accessories. For controller accessory information and procedures, refer to the operation and installation manual for the controller type specified by the model number shown on the transfer switch nameplate. See the List of Related Materials in the Introduction for the manual numbers.

Section 6. Service Part Replacement

6.1 Introduction

This section provides instructions for replacing power switching device parts.

WARNING

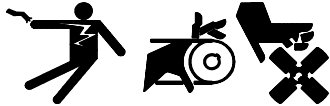

Accidental starting.
Can cause severe injury or death.

Disconnect the battery cables before working on the generator set. Remove the negative (-) lead first when disconnecting the battery. Reconnect the negative (-) lead last when reconnecting the battery.

Disabling the generator set. Accidental starting can cause severe injury or death. Before working on the generator set or connected equipment, disable the generator set as follows: (1) Move the generator set master switch to the OFF position. (2) Disconnect the power to the battery charger. (3) Remove the battery cables, negative (-) lead first. Reconnect the negative (-) lead last when reconnecting the battery. Follow these precautions to prevent starting of the generator set by an automatic transfer switch, remote start/stop switch, or engine start command from a remote computer.

WARNING



Hazardous voltage.
Can cause severe injury or death.

Disconnect all power sources before opening the enclosure.

(600 volts and under)

WARNING



Hazardous voltage.
Can cause severe injury or death.

Disconnect all power sources before servicing. Install the barrier after adjustments, maintenance, or servicing.

(600 volts and under)

WARNING



Hazardous voltage.
Can cause severe injury or death.

Only authorized personnel should open the enclosure.



(600 volts and under)

Servicing the transfer switch. Hazardous voltage can cause severe injury or death. Deenergize all power sources before servicing. Open the main circuit breakers of all transfer switch power sources and disable all generator sets as follows: (1) Move all generator set master controller switches to the OFF position. (2) Disconnect power to all battery chargers. (3) Disconnect all battery cables, negative (-) leads first. Reconnect negative (-) leads last when reconnecting the battery cables after servicing. Follow these precautions to prevent the starting of generator sets by an automatic transfer switch, remote start/stop switch, or engine start command from a remote computer. Before servicing any components inside the enclosure: (1) Remove rings, wristwatch, and jewelry. (2) Stand on a dry, approved electrically insulated mat. (3) Test circuits with a voltmeter to verify that they are deenergized.

Testing live electrical circuits. Hazardous voltage or current can cause severe injury or death. Have trained and qualified personnel take diagnostic measurements of live circuits. Use adequately rated test equipment with electrically insulated probes and follow the instructions of the test equipment manufacturer when performing voltage tests. Observe the following precautions when performing voltage tests: (1) Remove rings, wristwatch, and jewelry. (2) Stand on a dry, approved electrically insulated mat. (3) Do not touch the enclosure or components inside the enclosure. (4) Be prepared for the system to operate automatically.
(600 volts and under)

Making line or auxiliary connections. Hazardous voltage can cause severe injury or death. To prevent electrical shock deenergize the normal power source before making any line or auxiliary connections.

Servicing the transfer switch controls and accessories within the enclosure. Hazardous voltage can cause severe injury or death. Disconnect the transfer switch controls at the inline connector to deenergize the circuit boards and logic circuitry but allow the transfer switch to continue to supply power to the load. Disconnect all power sources to accessories that are mounted within the enclosure but are not wired through the controls and deenergized by inline connector separation. Test circuits with a voltmeter to verify that they are deenergized before servicing.

 WARNING

<p>Unbalanced weight. Improper lifting can cause severe injury or death and equipment damage.</p> <p>Use adequate lifting capacity. Never leave the transfer switch standing upright unless it is securely bolted in place or stabilized.</p>

NOTICE

Electrostatic discharge damage. Electrostatic discharge (ESD) damages electronic circuit boards. Prevent electrostatic discharge damage by wearing an approved grounding wrist strap when handling electronic circuit boards or integrated circuits. An approved grounding wrist strap provides a high resistance (about 1 megohm), *not a direct short*, to ground.

NOTICE

Hardware damage. The transfer switch may use both American Standard and metric hardware. Use the correct size tools to prevent rounding of the bolt heads and nuts.

NOTICE

When replacing hardware, do not substitute with inferior grade hardware. Screws and nuts are available in different hardness ratings. To indicate hardness, American Standard hardware uses a series of markings, and metric hardware uses a numeric system. Check the markings on the bolt heads and nuts for identification.

6.2 Before and After Service

Before Service. Before servicing power switching device components inside the ATS enclosure, disconnect all power sources and disable the generator set to prevent accidental starting.

1. Prevent the emergency power source generator set from starting:
 - a. Move the generator set master switch to the OFF position.
 - b. Disconnect power to the generator set battery charger, if installed.
 - c. Remove the generator set engine start battery cables, negative (-) leads first.
2. Disconnect or turn off *BOTH* the normal and emergency power sources before opening the enclosure door.
3. Check circuits with a voltmeter to verify that the power is off before servicing components inside the enclosure.

After Service. Follow these instructions to return the equipment to a safe operating condition and verify that the ATS is working properly.

1. Reinstall all barriers.
2. Check the operation of the mechanical interlocks using the mechanical interlock tests described in Section 6.5 of this manual.
3. Use the Startup Procedure in Section 2, Operation, to return the system to operation.

6.3 Power Switching Device Removal and Installation

For most repairs, it is not necessary to remove the entire power switching device assembly from the ATS enclosure. Use these instructions for all models if it is necessary to replace the entire power switching device assembly. On 800-1250 amp models, remove the power switching device assembly from the ATS enclosure to remove and replace the circuit breakers/switches. Figure 6-1 and Figure 6-2 show typical power switching device assemblies.

6.3.1 Power Switching Device Removal, 40-1250 Amp Models

1. Disable the generator set and disconnect all power sources as described in section 6.2 before opening the ATS enclosure.
2. Disconnect the inline plug (P1) of the circuit breaker/switch assembly wire harness from the electrical control wire harness.
3. Disconnect the normal and emergency power source connections from the circuit breaker/switch source lugs.
4. Disconnect the load conductors from the lugs on the load bus bars (40-630 amp models) or load bus assembly (800-1250 amp models).
5. Remove the load bus assembly from 800-1250 amp power switching devices.
6. Remove the nuts and washers that attach the assembly mounting rails to the back wall of the enclosure. See Figure 6-2 for the locations of the nuts and washers. Lift the entire assembly out of the ATS enclosure and place it on a workbench or table.
7. If a new power switching device is being installed, remove the top and bottom mounting rails and use them to mount the new assembly.

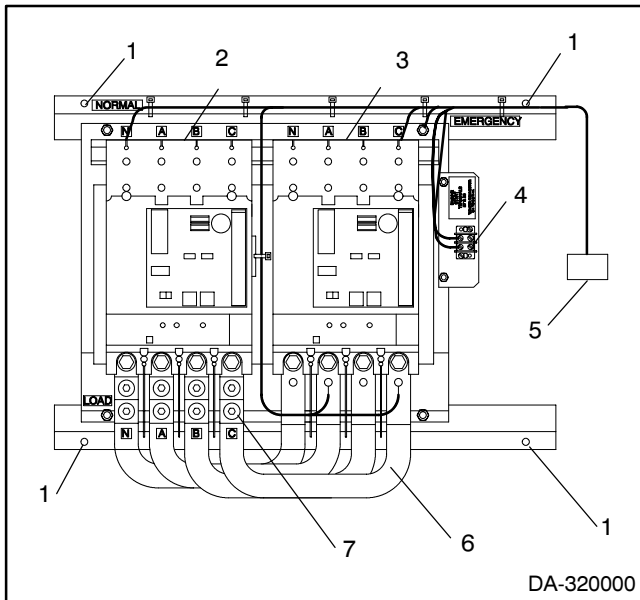

1. Nuts and washers
2. Normal source connecting lugs
3. Emergency source connecting lugs
4. Engine start terminals
5. Inline plug, P1
6. Load bus bars
7. Load connecting lugs

Figure 6-1. Typical Power Switching Device Assembly, 40-630 Amp Models

6.3.2 Power Switching Device Installation, 40-1250 Amp Models

1. Bolt the mounting rails onto the new power switching device.
2. Position the entire power switching device assembly in place inside the ATS enclosure and install the screws and lock washers to secure the assembly.
3. Install the load bus on 800-1250 amp models and tighten the bolts to 37 ft. lbs. (50 Nm).
4. Connect the power source and load conductors to the lugs. Tighten the connections to the torques shown in Figure 1-10 in Section 1.8 of this manual.
5. Check the voltages and the phase rotation using the voltage check procedure in the operation and installation manual for the power switching device.
6. Connect the inline plug (P1) of the circuit breaker/switch assembly wire harness to P1 of the electrical control wire harness.
7. Follow the instructions in Section 6.2 to return the equipment to a safe operating condition and verify that the ATS is working properly.

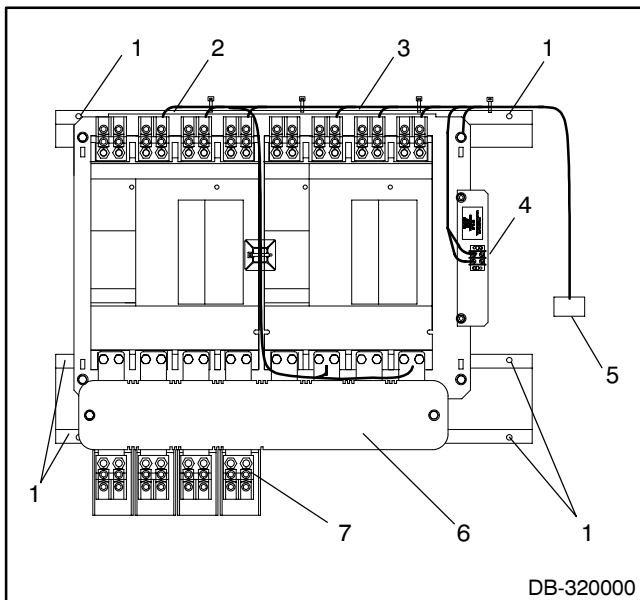

1. Nuts and washers
2. Normal source connecting lugs
3. Emergency source connecting lugs
4. Engine start terminals
5. Inline plug, P1
6. Load bus
7. Load connecting lugs

Figure 6-2. Typical Power Switching Device Assembly, 800-1250 Amp Models

6.4 Mechanical Interlock Removal and Installation, 800-1250 Amp Models

Remove the mechanical interlocks on 800-1250 amp models to obtain access to the motor operator, circuit breaker/switch, or auxiliary switches.

NOTE

Do not remove or repair the mechanical interlocks on 40-630 amp models.

6.4.1 Mechanical Interlock Removal, 800-1250 Amp Models

1. Disable the generator set and disconnect all power sources as described in section 6.2. Open the ATS enclosure.
2. Set one or both circuit breakers/switches to the OFF position. See Manual Operation in Section 2.3.
3. Remove four screws and lift the cover off the mechanical interlock. See Figure 6-3.
4. Remove four screws and flat washers and slide the mechanical interlock off both circuit breakers/switches. See Figure 6-3.

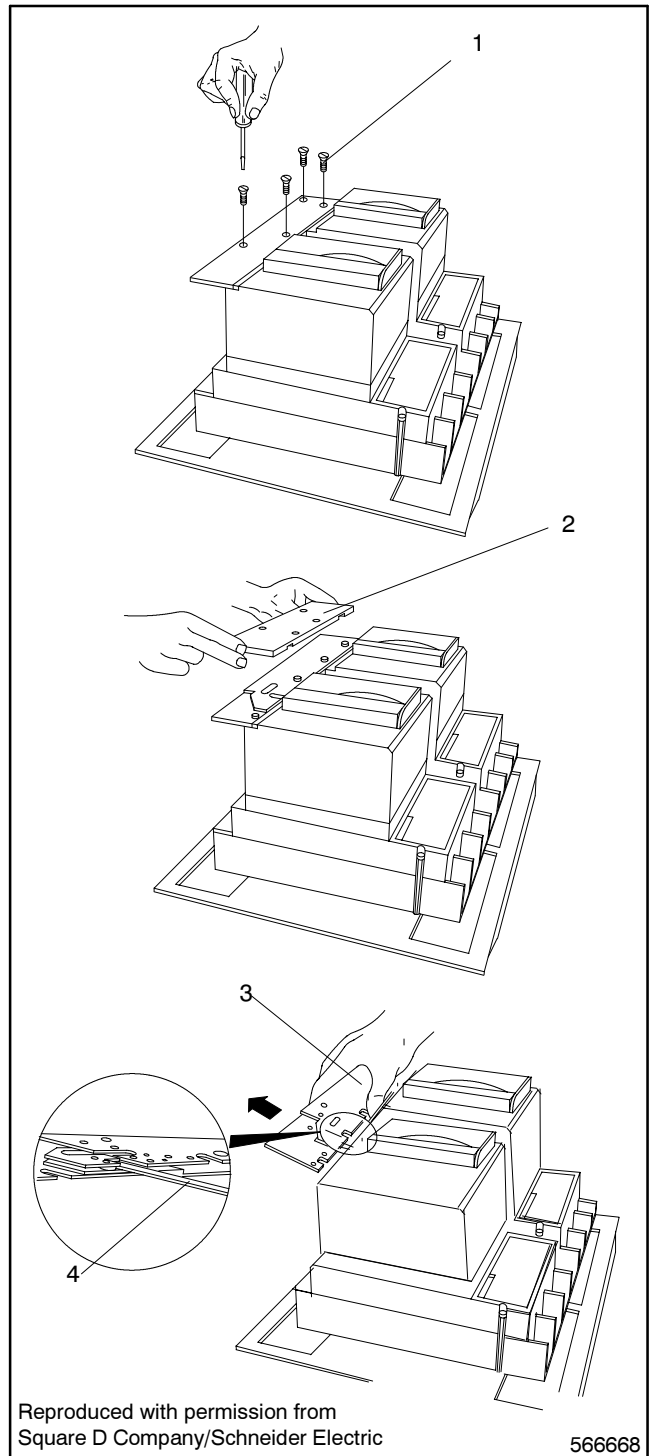

1. Screw
2. Cover
3. Mechanical interlock
4. Interlock control arm

Figure 6-3. Mechanical Interlock Removal, 800-1250 Amp Models

6.4.2 Mechanical Interlock Installation, 800–1250 Amp Models

1. Use a screwdriver to carefully guide the interlock control arms of the two circuit breakers/switches into the mechanical interlock. See Figure 6-4.

NOTE

To align both interlock control arms with the mechanical interlock, at least one circuit breaker/switch must be set to the OFF position. See Manual Operation in Section 2.3.

2. Install the four screws and flat washers to secure the mechanical interlock in place. Tighten the screws to 31 in. lbs.(3.5 Nm).
3. To check the alignment of the mechanical interlocks, slide the knob in center of the mechanical interlock as far to the left as possible, and release it. When released, the knob should return to the center position. Then slide the knob as far to the right as possible, and release it. If the knob fails to return to the center position after being moved to the left or right, check and correct the alignment of the parts.

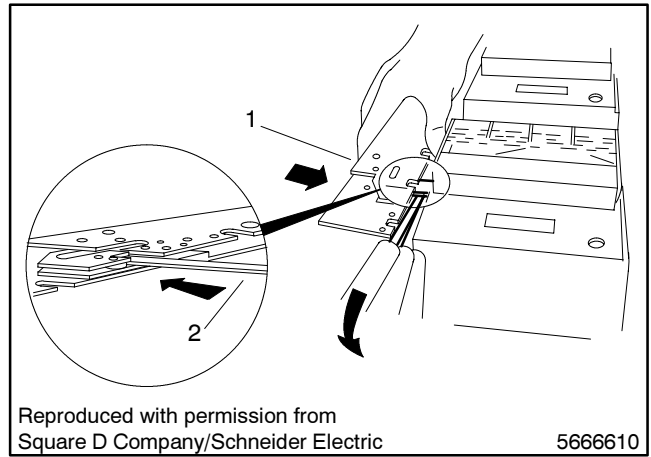

1. Mechanical interlock
2. Interlock control arm

Figure 6-4. Mechanical Interlock Installation, 800–1250 Amp Models

4. Place the cover on the mechanical interlock. Install the four screws to secure the cover in place.
5. Test the operation of the mechanical interlocks. See Section 6.5 for the test procedure.
6. Return the transfer switch to operation as described in Section 6.2.

6.5 Mechanical Interlock Tests

Test the operation of the mechanical interlocks after repairing or replacing the circuit breakers or switches, and after repairing or replacing the mechanical interlocks on the 800–1250 amp models. Use the following procedure to verify that the mechanical interlocks allow only one circuit breaker/switch to be ON (closed) at any time.

6.5.1 40–630 Amp Models

Start this test with both circuit breakers/switches off and the motor operator mechanisms on both circuit breakers/switches initially charged. The test procedure is illustrated in Figure 6-5.

NOTE

Do not remove or repair the mechanical interlocks on 40–630 amp models.

NOTE

A circuit breaker/switch must have its motor operator charged electrically or mechanically to allow it to close (turn ON). Manually charge the motor operator by pulling down on the charge lever 7 or 8 times until the indicator changes from DISCHARGED to CHARGED.

Mechanical Interlock Test Procedure, 40–630 Amp Models:

1. Disable the generator set and disconnect all power sources as described in section 6.2 before opening the ATS enclosure.
2. Set the automatic/manual slide switches on the circuit breakers/switches to the MANU position. See steps 1 and 2 of Figure 6-5.
3. Push the ON button (labeled 1 push ON) on the normal (N) circuit breaker/switch. The circuit breaker closes (turns on). See step 3 of Figure 6-5. The indicators on the circuit breaker/switch change from 0 OFF to 1 ON and from CHARGED to DISCHARGED.
4. Push the ON button on the emergency circuit breaker/switch (also labeled R for replacement) to verify that this circuit breaker/switch does *not* close

when the normal circuit breaker/switch is closed. See step 4 of Figure 6-5. The circuit breaker discharges. The indicators on the emergency circuit breaker/switch change from CHARGED to DISCHARGED but stay 0 OFF.

5. Push the OFF button on the normal (N) circuit breaker/switch. The circuit breaker/switch opens (turns off). The indicator changes to 0 OFF.
6. Manually charge the motor operators on both circuit breakers/switches by pulling down on the mechanical charge levers repeatedly until the messages shown on both devices change from DISCHARGED to CHARGED.
7. Push the ON button on the emergency (R) circuit breaker/switch. The circuit breaker closes. See step 7 of Figure 6-5. The indicator on the circuit breaker/switch changes from CHARGED to DISCHARGED.
8. Push the ON button on the normal (N) circuit breaker/switch to verify that this circuit breaker/switch does *not* close when the emergency (R) circuit breaker/switch is closed. See step 8 of Figure 6-5. The circuit breaker/switch discharges. The indicators on the normal circuit breaker/switch stay 0 OFF and change from CHARGED to DISCHARGED.
9. Push the OFF button on the emergency (R) circuit breaker/switch. The circuit breaker disconnects the load from the emergency (replacement) source. See step 9 of Figure 6-5. Both circuit breakers/switches are now OFF (open) and DISCHARGED.
10. To return to the normal source, manually charge the motor operator on the normal (N) circuit breaker/switch. Press the ON pushbutton to close the normal circuit breaker/switch.
11. To return to automatic operation, set the slide switches shown in steps 1 and 2 of Figure 6-5 to the AUTO position.
12. Follow the instructions in section 6.2 to return the ATS to operation.

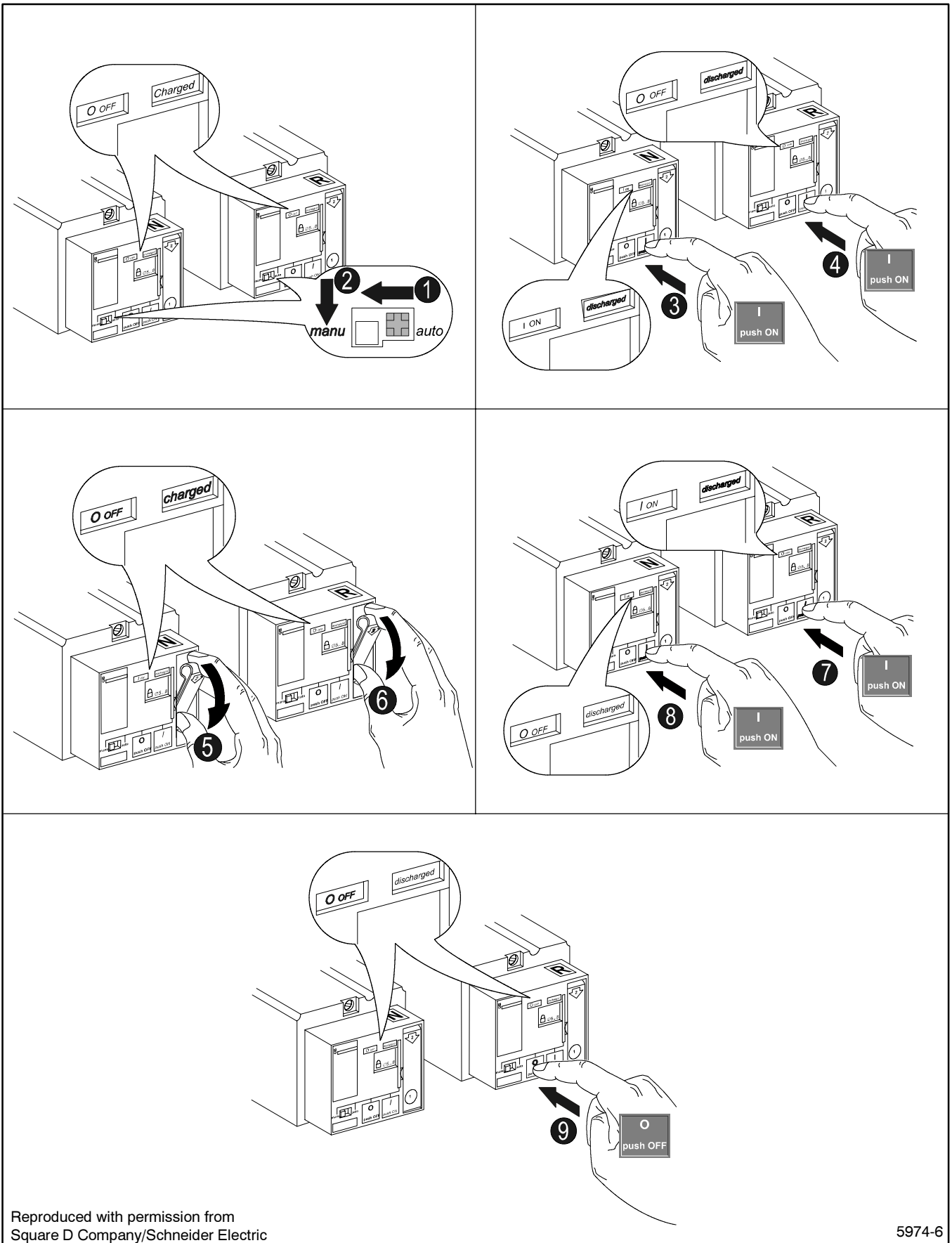

Reproduced with permission from
Square D Company/Schneider Electric

5974-6

Figure 6-5. Mechanical Interlock Test, 40-630 Amps

6.5.2 800-1250 Amp Models

These models use the motor operator shown in Figure 6-6. The emergency circuit breaker/switch is also labeled R for replacement power.

Mechanical Interlock Test Procedure, 800-1250 A Models:

1. Disable the generator set and disconnect all power sources as described in section 6.2 before opening the ATS enclosure.
2. Open the plastic doors over the front of the circuit breakers/switches. Opening the plastic doors disables the motor operators and prevents automatic operation. See Detail A of Figure 6-6 for the location of the normal (N) and emergency (R) power circuit breakers/switches.
3. Slide the switch lever on the normal (N) circuit breaker/switch to the ON position. See Detail B of Figure 6-6. Verify that the emergency (R) circuit breaker/switch cannot be set to the ON position when the normal circuit breaker/switch is ON.
4. Slide the switch lever on the normal (N) circuit breaker/switch to the OFF position.
5. Slide the switch lever on the emergency circuit breaker/switch to the ON position. See Detail B of Figure 6-6. Verify that the normal power circuit breaker/switch cannot be set to the ON position when the emergency circuit breaker/switch is ON.
6. Set the emergency power circuit breaker/switch to the OFF position and the normal power circuit breaker/switch to the ON position before returning to automatic operation.
7. Close the plastic doors over both circuit breakers/switches to return to automatic operation.
8. Return the ATS to operation following the instructions in section 6.2.

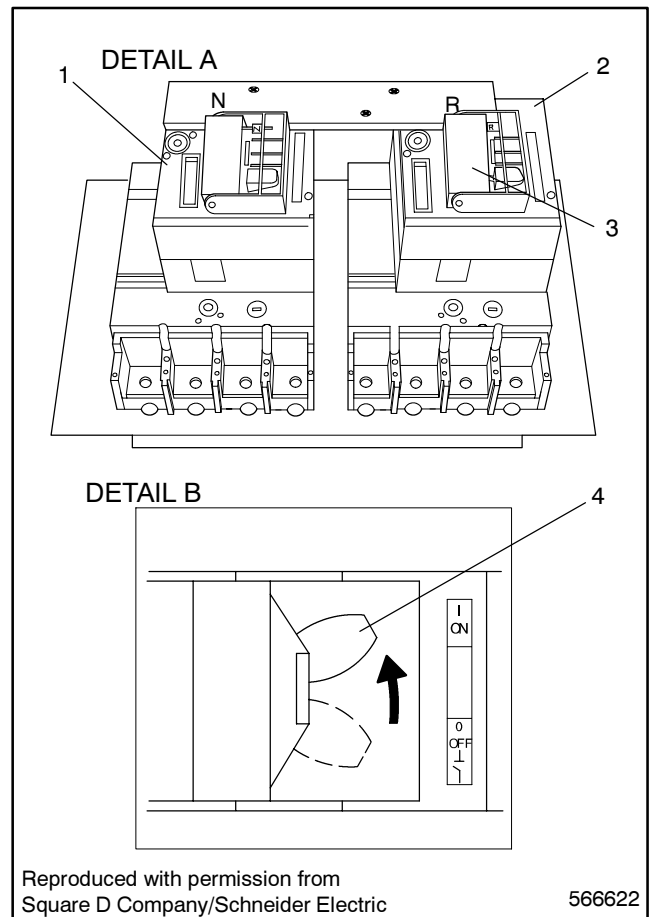

1. Normal switch/circuit breaker
2. Emergency (replacement) switch/circuit breaker
3. Plastic door
4. Lever

Figure 6-6. Automatic Transfer Switch Operation, 800-1250 Amp Models

6.6 Motor Operator Removal and Installation

This section contains instructions for the removal and installation of the power switching device motor operators. Separate procedures are given for 40–630 amp models and 800–1250 amp models.

6.6.1 Motor Operator Removal, 40–630 Amp Models

1. Turn off the normal and emergency power sources and disable the generator set as described in Section 6.2. Open the door of the ATS enclosure.
2. Disconnect the wire harness inline plug, P1.
3. Loosen the release screw on the motor operator. See Figure 6-7.

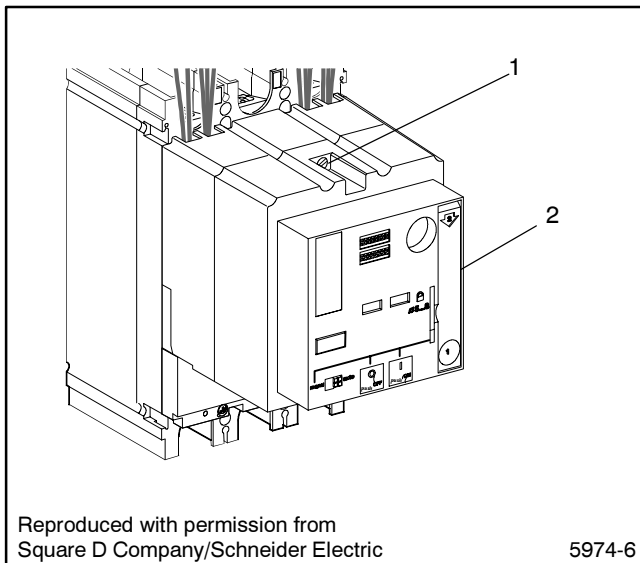

1. Release screw
2. Mechanical charge lever

**Figure 6-7. Motor Operator,
40–630 Amp Models**

4. Swing the motor operator down to its fully open position. See Figure 6-8.
5. Make a note of the connections at the bottom right corner of the motor operator. Disconnect these leads. See Figure 6-8.

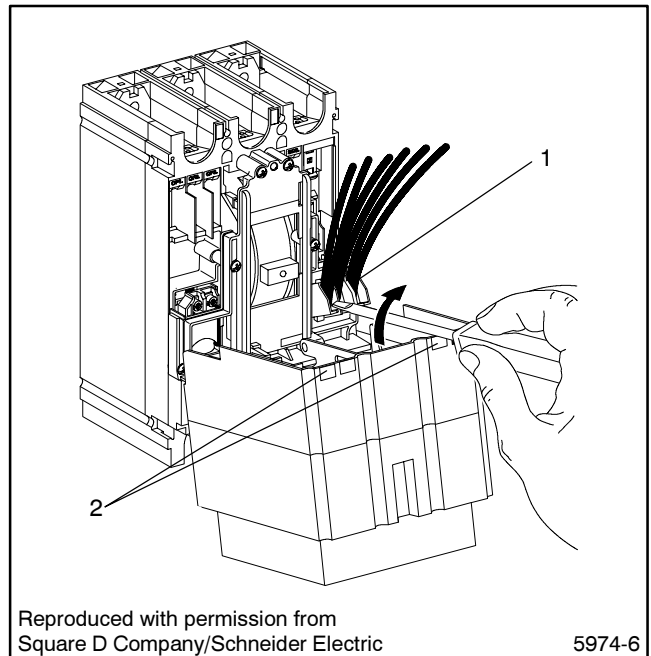

1. Motor operator connections
2. Knock-out plugs

**Figure 6-8. Motor Operator Connections,
40–630 Amp Models**

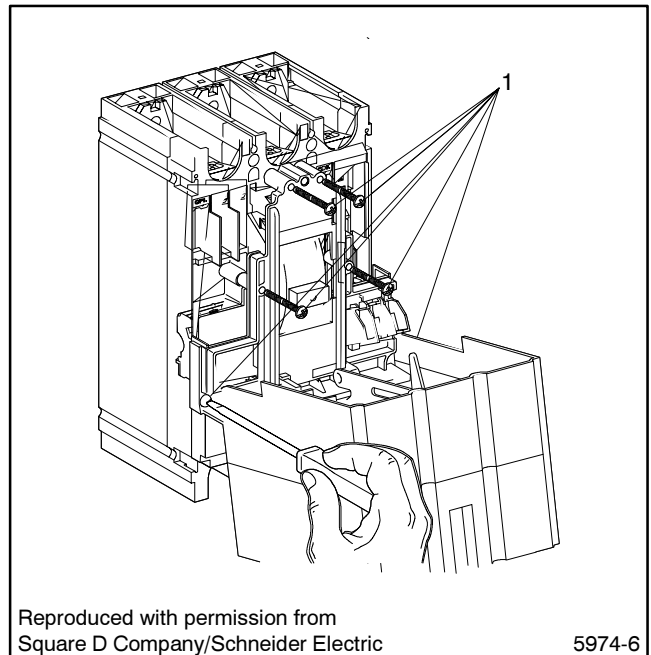

1. Mounting screws

**Figure 6-9. Motor Operator Mounting Screws,
400–630 Amp Models**

6. Remove the mounting screws that secure the motor operator to the circuit breaker/switch. The 40–250 amp models use four mounting screws; 400–630 amp models use six. The screw locations are shown in Figure 6-9. Remove the motor operator.

6.6.2 Motor Operator Installation, 40–630 Amp Models

1. Place the motor operator on the circuit breaker/switch frame.
2. Swing the motor operator down to its open position and install the four screws to secure the motor operator to the circuit breaker/switch frame.
3. Reconnect the leads to the terminals on the lower right corner of the motor operator. The motor operator connections are shown in Section 6.9.
4. Use pliers to remove the knock-out plugs in the cover when installing a new motor operator. Close the motor operator, being careful to guide all leads through the openings. If the motor operator does not close easily, operate the mechanical charge lever until the motor operator mechanism lines up with the circuit breaker/switch handle. The location of the charge lever is shown in Figure 6-7.
5. Tighten the screw securing the motor operator in place to 13.3 in. lbs. (1.5 Nm).
6. Reconnect the wire harness inline plugs.
7. Return the transfer switch to operation as described in Section 6.2.

6.6.3 Motor Operator Removal, 800–1250 Amp Models

Although the illustrations in this section show the motor operator in the horizontal position, it is not necessary to remove the circuit breaker/switch assembly from the ATS enclosure for these procedures.

1. Turn off the normal and emergency power sources and disable the generator set as described in Section 6.2 . Open the enclosure door.
2. Remove the mechanical interlock. See Section 6.4—Mechanical Interlock Removal and Installation, 800–1250 Amp models.
3. Use a slotted screwdriver to rotate the four corner fasteners that secure the motor operator cover in place counterclockwise 1/4 turn. Remove the cover. See Figure 6-10.

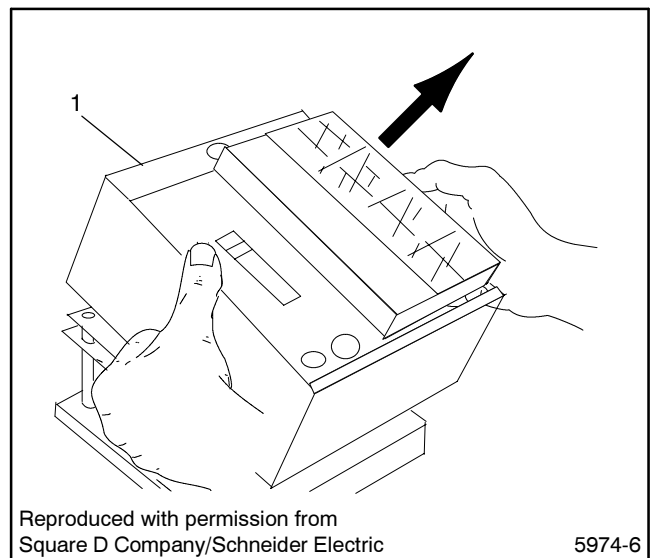

1. Motor operator cover

Figure 6-10. Motor Operator Cover, 800–1250 Amp Models

- If the motor operator is to be replaced, remove and save the interlock control arm to reinstall later. Rotate the arm counterclockwise to the position shown in Figure 6-11 to remove it.

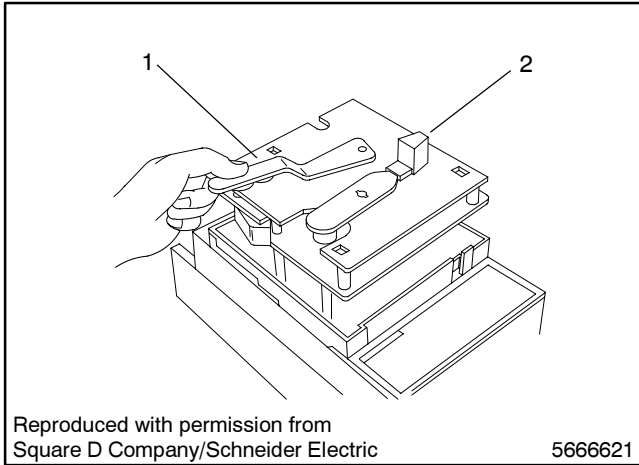

- Interlock control arm
- Manual operator

Figure 6-11. Interlock Control Arm Removal, 800-1250 Amp Models

- Loosen the screw that holds the motor operator in place. Swing the motor operator down to its fully open position. See Figure 6-12.

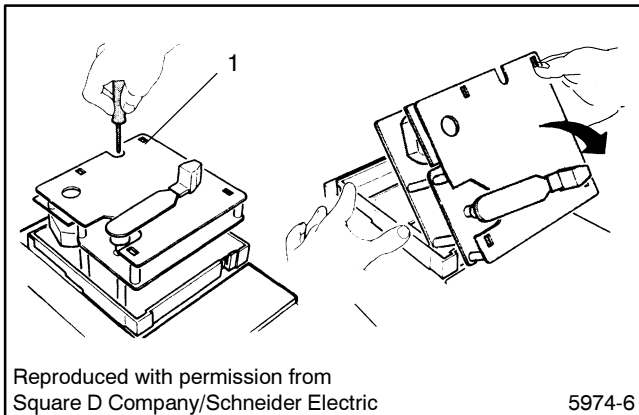

- Screw

Figure 6-12. Motor Operator Release, 800-1250 Amp Models

- Remove the plastic cover over the terminal blocks. Note the connections and then disconnect the wire harness leads from terminal blocks A1 through B4, 151, and 152.
- Remove the six screws holding the motor operator onto the circuit breaker/switch frame. Remove the motor operator.

6.6.4 Motor Operator Installation, 800-1250 Amp Models

- Place the motor operator on the circuit breaker/switch frame. Guide the wire harness leads through the openings in the motor operator.
- Install the six screws to secure the motor operator to the circuit breaker/switch frame.
- Connect the wire harness leads to terminals A1 through B4, 151, and 152. The wire harness connections are shown in Section 6.9. Install the plastic cover over the terminal blocks.
- Close the motor operator and install the screw to secure the motor operator in place. If the motor operator does not close easily, operate the motor operator handle until the slot lines up with the circuit breaker/switch handle. See Figure 6-13.

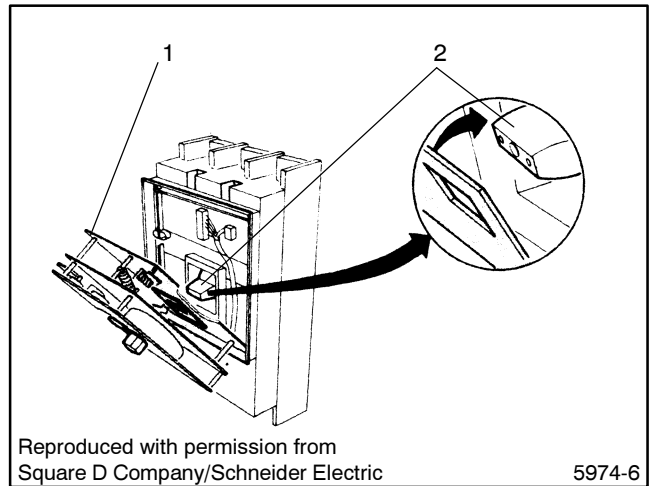

- Motor operator
- Circuit breaker/switch handle

Figure 6-13. Motor Operator Installation, 800-1250 Amp Models

- Install the interlock control arm saved from the previous motor operator. See Figure 6-14.

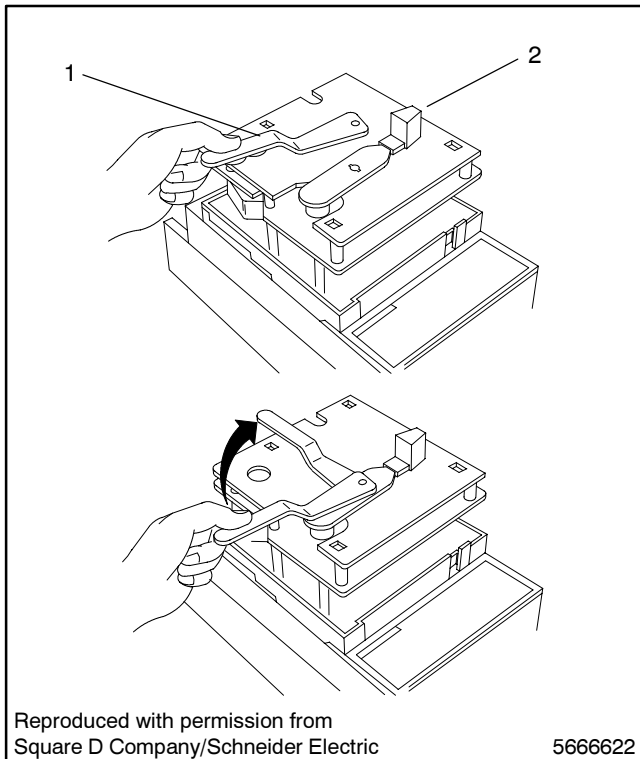

1. Interlock control arm
2. Manual operator

Figure 6-14. Install Interlock Control Arm

6. Replace the motor operator cover, guiding the interlock control arm through the opening in the top of the cover. Use a slotted screwdriver to push in and rotate the four fasteners 1/4 turn clockwise to secure the cover.
7. Reinstall the mechanical interlock. See Section 6.4.2—Mechanical Interlock Installation, 800–1250 Amp Models.
8. Close the plastic door over the motor operator handle.
9. Reconnect the wire harness inline plugs.
10. Return the transfer switch to operation as described in Section 6.2.

6.7 Circuit Breaker/Switch Removal and Installation

6.7.1 Circuit Breaker/Switch Removal, 40-1250 Amp Models

1. Disable the generator set and disconnect all power sources as described in section 6.2 before opening the ATS enclosure.
2. Disconnect the inline plug (P1) of the circuit breaker/switch assembly wire harness from P1 of the electrical control wire harness.
3. Disconnect the load conductors and remove the load bus bars (40-630 amp models) or load bus assembly (800-1250 amp models).
4. Follow steps 4a and 4b for 800-1250 amp models only. For 40-630 amp models, proceed to step 5.
 - a. Remove the power switching device assembly from the enclosure as described in Section 6.3—Power Switching Device Removal and Installation. Place the assembly on a workbench.
 - b. Remove the mechanical interlock from the 800-1250 amp models only. See Section 6.4.1—Mechanical Interlock Removal, 800-1250 Amp Models.
5. Open the motor operator cover and remove the auxiliary switches if they will be reused. See Section 6.8 for the locations of the auxiliary switches and instructions for removing them.
6. Disconnect the wire harness and remove the motor operator from the circuit breaker/switch as described in Section 6.6—Motor Operator Removal and Installation.
7. Mark the outline of the circuit breaker/switch on the panel with a scribe or marker.
8. Remove the mounting screws that secure the circuit breaker/switch to the back plate. On 800-1250 amp models, remove the hardware from the back of the plate. Figure 6-15 and Figure 6-16 show the locations of the mounting screws.

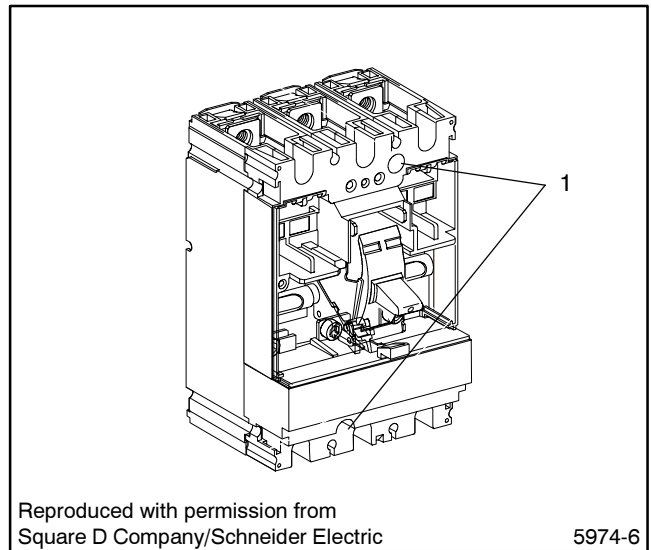

1. Mounting screws

Figure 6-15. Circuit Breaker Mounting Screw Locations, 40-250 Amps

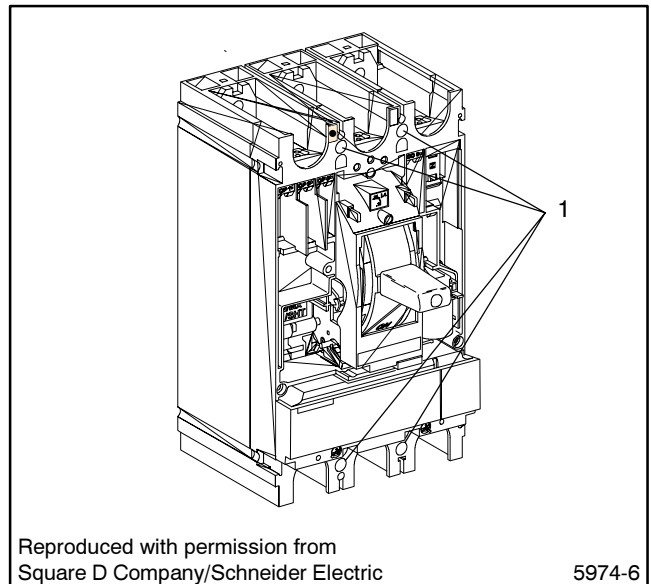

1. Mounting screws

Figure 6-16. Circuit Breaker Mounting Screw Locations, 400-630 Amps

9. Pull the circuit breaker/switch straight off the back plate, guiding the striker mechanism on the back of 40–630 amp circuit breakers/switches through the slot in the back plate. See Figure 6-17. Figure 6-18 shows the circuit breakers/switches and motor operators removed from the back plate.

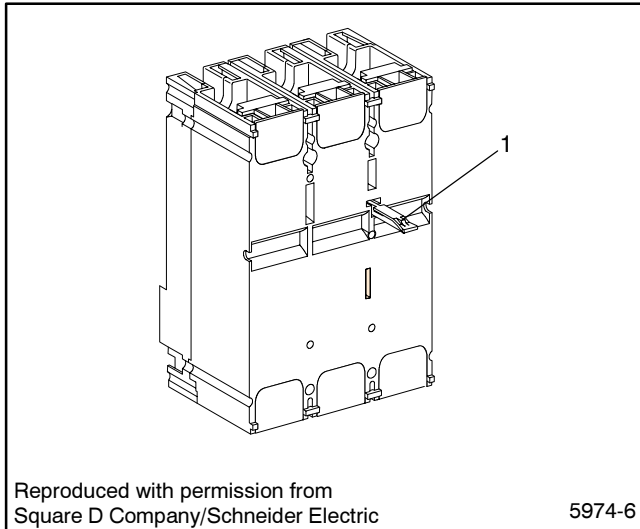

1. Striker mechanism

Figure 6-17. Striker Mechanism (Back View of Circuit Breaker)

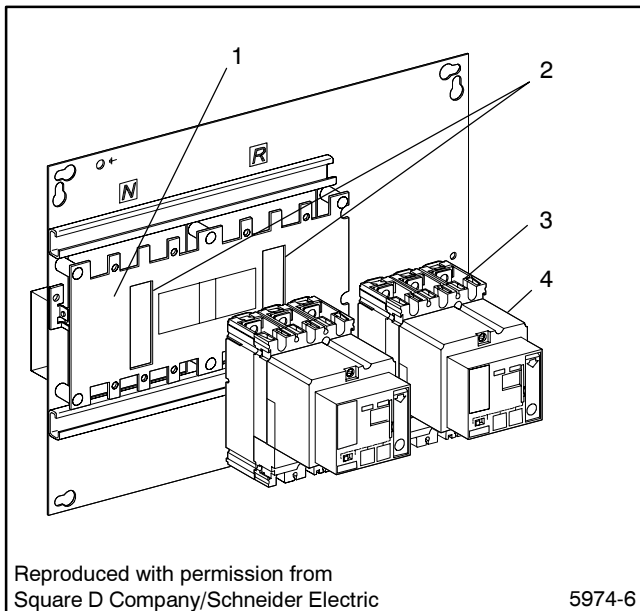

1. Back plate
2. Slots
3. Circuit breaker
4. Motor operator

Figure 6-18. Typical Power Switching Device Assembly, 40-630 Amps

6.7.2 Circuit Breaker/Switch Installation, 40–1250 Amp Models

1. Place the circuit breaker/switch on the panel in the position marked during the removal phase. Guide the striker mechanism on the back of 40–630 amp circuit breakers/switches through the slot in the back plate.
2. Install the hardware to secure the circuit breaker/switch to the back plate. On the 800–1250 amp models, attach and tighten the hardware on the back of the plate.
3. Reinstall the auxiliary switches. See Section 6.8 for auxiliary switch locations.
4. Install the motor operator on the circuit breaker/switch and reconnect the wire harness. See Section 6.6—Motor Operator Removal and Installation and Section 6.9—Wire Harness Replacement.
5. Install the mechanical interlock between the two circuit breakers or switches on the 800–1250 amp models. See Section 6.4.2—Mechanical Interlock Installation, 800–1250 Amp Models.
6. Install the load bus bars (40–630 amp models) or load bus assembly (800–1250 amp models).
7. Connect the load conductors. Tighten to the torques given in Section 1.8.
8. Connect the inline plug (P1) of the circuit breaker/switch assembly wire harness to P1 of the electrical control wire harness.
9. Test the operation of the circuit breakers/switches and mechanical interlocks using the manual test procedures described in Section 6.5 of this manual.
10. Return the ATS to operation following the instructions in section 6.2.

6.8 Auxiliary Switch Replacement

Figure 6-19, Figure 6-20, and Figure 6-22 show the locations of the auxiliary switches for the different circuit breakers/switches.

6.8.1 Auxiliary Switch Removal, 40-630 Amp Models

1. Disable the generator set and disconnect power sources as described in section 6.2 before opening the ATS enclosure.
2. Turn off the normal and emergency power sources and open the front panel of the ATS enclosure.
3. Remove the screws holding the motor operator in place and swing the hinged motor operator down to the fully open position.
4. Note the connections and then disconnect the leads to the auxiliary switch. Figure 6-19 and Figure 6-20 show the locations of the auxiliary switches.

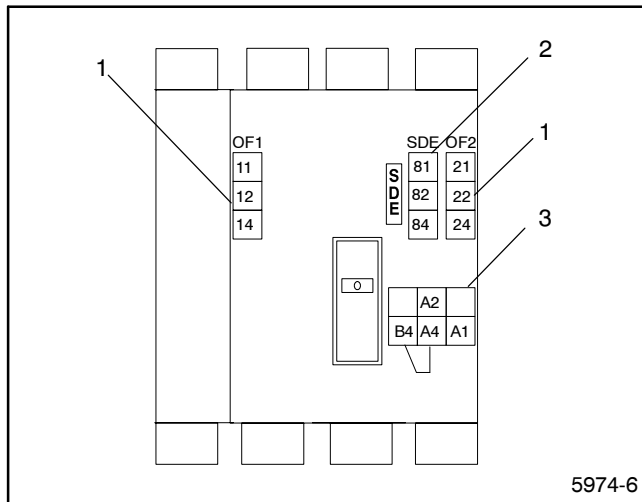

1. OF (open/closed) auxiliary switches
2. SDE (fault indication) auxiliary switch
3. Motor operator connections

Figure 6-19. Auxiliary Switch Locations, 40-250 Amp Models

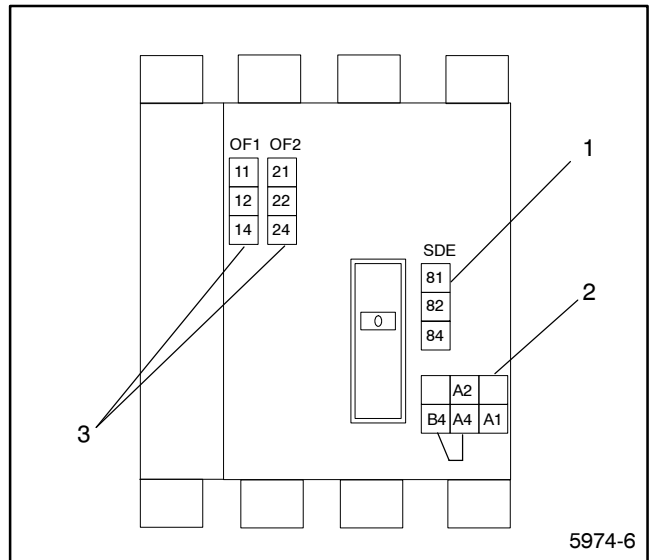

1. SDE (fault indication) auxiliary switch
2. Motor operator connections
3. OF (open/closed) auxiliary switches

Figure 6-20. Auxiliary Switch Location, 400-630 Amp Models

5. Insert a screwdriver at the top of the auxiliary switch as shown in Figure 6-21. Raise the handle of the screwdriver to push down on the spring clip on the top of the auxiliary switch and push the switch out of the socket.

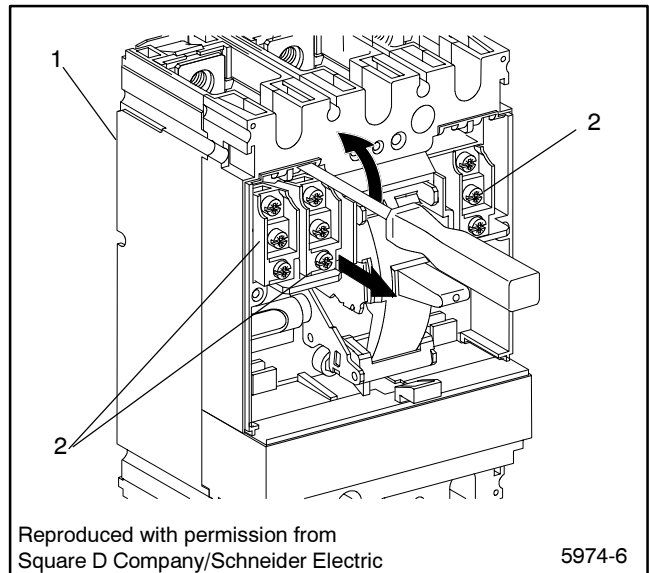

Reproduced with permission from Square D Company/Schneider Electric

5974-6

1. Circuit breaker
2. Auxiliary switches

Figure 6-21. Auxiliary Switch Removal, 40-630 Amp Models

6.8.2 Auxiliary Switch Installation, 40–630 Amp Models

1. Install the auxiliary switch with the spring clip on the top. Push the auxiliary switch into the socket in the circuit breaker/switch.
2. Reconnect the switch leads to the same terminals noted during removal. See Section 6.9 for the auxiliary switch connection diagrams. Tighten the connections to 10 in. lbs. (1.2 Nm).
3. Close the motor operator, being careful to guide all leads through the openings in the cover.
4. Install the screws at the top and bottom of the motor operator to hold it in place. Tighten the screws to 18 in. lbs. (2 Nm).
5. Return the ATS to operation following the instructions in section 6.2.

6.8.3 Auxiliary Switch Removal, 800–1250 Amp Models

1. Disable the generator set and disconnect power sources as described in section 6.2 before opening the ATS enclosure.
2. Turn off the normal and emergency power sources and open the front panel of the ATS enclosure.
3. Remove the mechanical interlock. See Section 6.4—Mechanical Interlock Removal and Installation, 800–1250 Amp models.
4. Use a slotted screwdriver to rotate the four fasteners that secure the motor operator cover in place counterclockwise 1/4 turn. Remove the cover. See Figure 6-10.
5. Remove one screw and swing the motor operator down to the fully open position.
6. Note the connections and then disconnect the leads to the auxiliary switch. Figure 6-22 shows the location of the auxiliary switches.

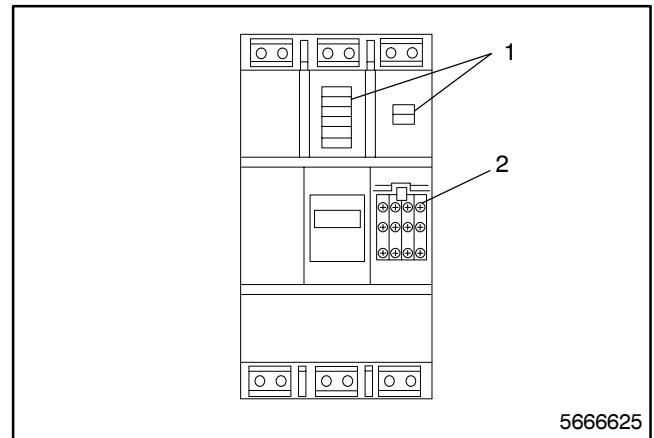

1. Motor operator terminal blocks
2. Auxiliary switches

**Figure 6-22. Auxiliary Switch Location,
800–1250 Amp Models**

7. Use a screwdriver to push up on the spring clip at the top of the auxiliary switch terminal block and remove the auxiliary switches.

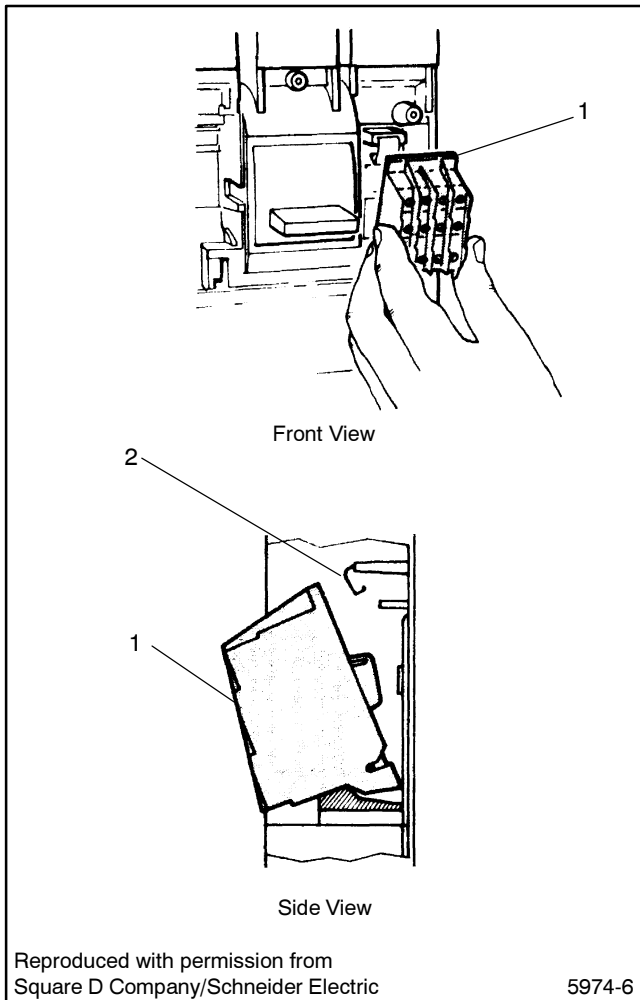

Reproduced with permission from
Square D Company/Schneider Electric

5974-6

1. Auxiliary switches
2. Spring clip

**Figure 6-23. Auxiliary Switches,
800-1250 Amp Models**

6.8.4 Auxiliary Switch Installation, 800-1250 Amp Models

1. Push the new auxiliary switch terminal block into place. See Figure 6-22 .
2. Reconnect the switch leads to the same terminals noted during removal. See Section 6.9 for the auxiliary switch connection diagrams. Tighten the connections to 10 in. lbs. (1.2 Nm).
3. Close the motor operator, being careful to guide all leads through the openings. Tighten the screw to secure the motor operator in place.
4. Replace the motor operator cover. Push in and rotate the four fasteners 1/4 turn clockwise to secure the cover.
5. Install the mechanical interlock between the two circuit breakers or switches. See Section 6.4.2—Mechanical Interlock Installation, 800-1250 Amp Models.
6. Return the ATS to operation following the instructions in section 6.2.

6.9 Wire Harness Replacement

Disconnect the old wire harness and reconnect the new harness one lead at a time to ensure that the new leads are connected to the correct terminals. Figure 6-24 and Figure 6-25 show the inline plug (P1) pin assignments and the wire harness labels. See Figure 6-26, Figure 6-27, and Figure 6-28 for the terminal locations.

1. Disable the generator set and disconnect power sources as described in section 6.2 before opening the ATS enclosure.
2. Disconnect the inline plugs that connect the wire harnesses for the power switching device and the controls together.
3. Disconnect the leads to the voltage take-offs on the source and load connections, and connect the new wire harness leads. Use a crimping tool to tighten the connectors.
4. Disconnect the leads to the engine start terminals and connect the new leads labeled 57 and 58. Tighten the engine start terminals to 4-5 in. lbs. (0.4-0.6 Nm).
5. Open the motor operator cover for access to the auxiliary switch and motor operator connections. Tighten the new auxiliary switch and motor operator connections to 10 in. lbs. (1.2 Nm).
6. Close the motor operator, guiding all leads through the openings in the cover. Tighten the screw securing the motor operator cover in place to 18 in. lbs. (2 Nm).
7. Reconnect the wire harness inline plugs.
8. Return the ATS to operation following the instructions in section 6.2.

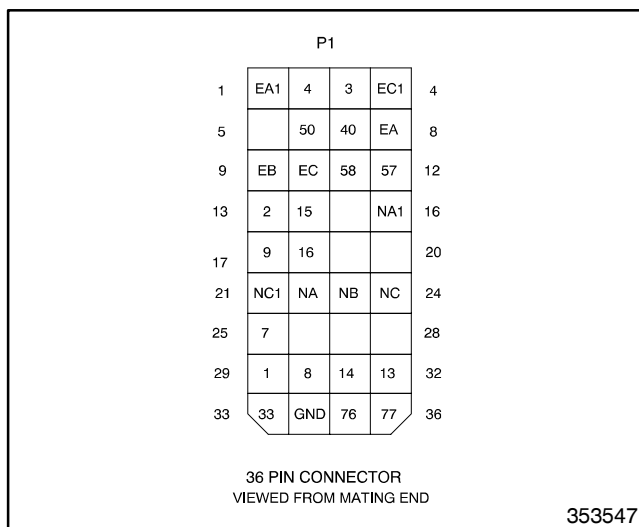

Figure 6-24. Inline Plug (P1) Pin Assignments

P1 Pins	Terminal	Wire Label
1	EA1	EA1
2	MOA4 N	4
3	SDE82 N*	3
4	EC1	EC1
5	—	—
6	OF12 N	50
7	OF12 E	40
8	EA	EA
9	EB	EB
10	EC	EC
11	58	58
12	57	57
13	OF11 N	2
14	OF11 E	15
15	—	—
16	NA1	NA1
17	MOA4 E	9
18	SDE82 E*	16
19	—	—
20	—	—
21	NC1	NC1
22	NA	NA
23	NB	NB
24	NC	NC
25	OF22 N	7
26	—	—
27	—	—
28	—	—
29	OF21 N	1
30	OF24 N	8
31	OF21 E	14
32	OF24 E	13
33	MOA1 N	33
34	GND	GND
35	LA	76
36	LC	77

*SDE152 on the 800-1250 amp models

Figure 6-25. P1 Pins and Wire Labels, 40-1250 Amp Models

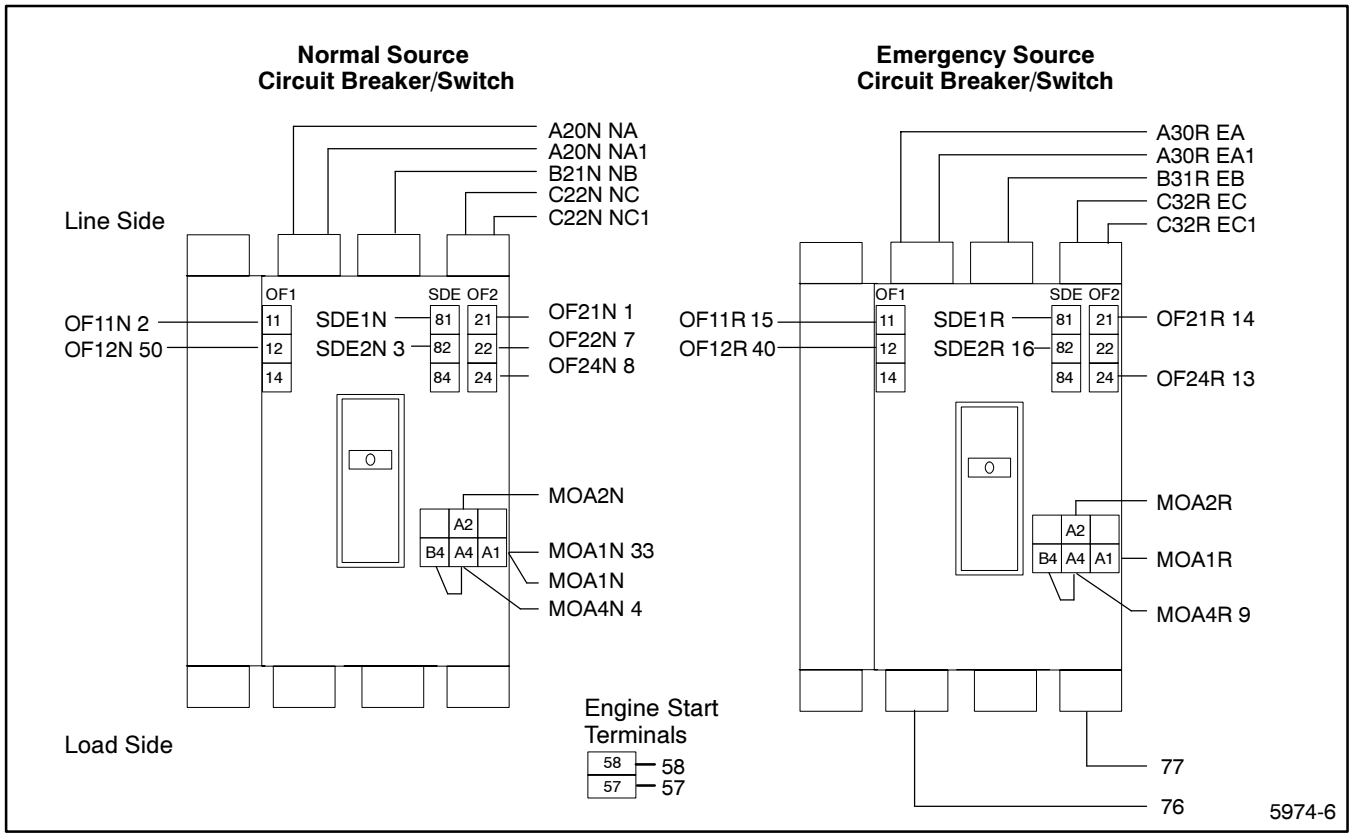

Figure 6-26. Wire Harness Connections, 40-250 amp Models

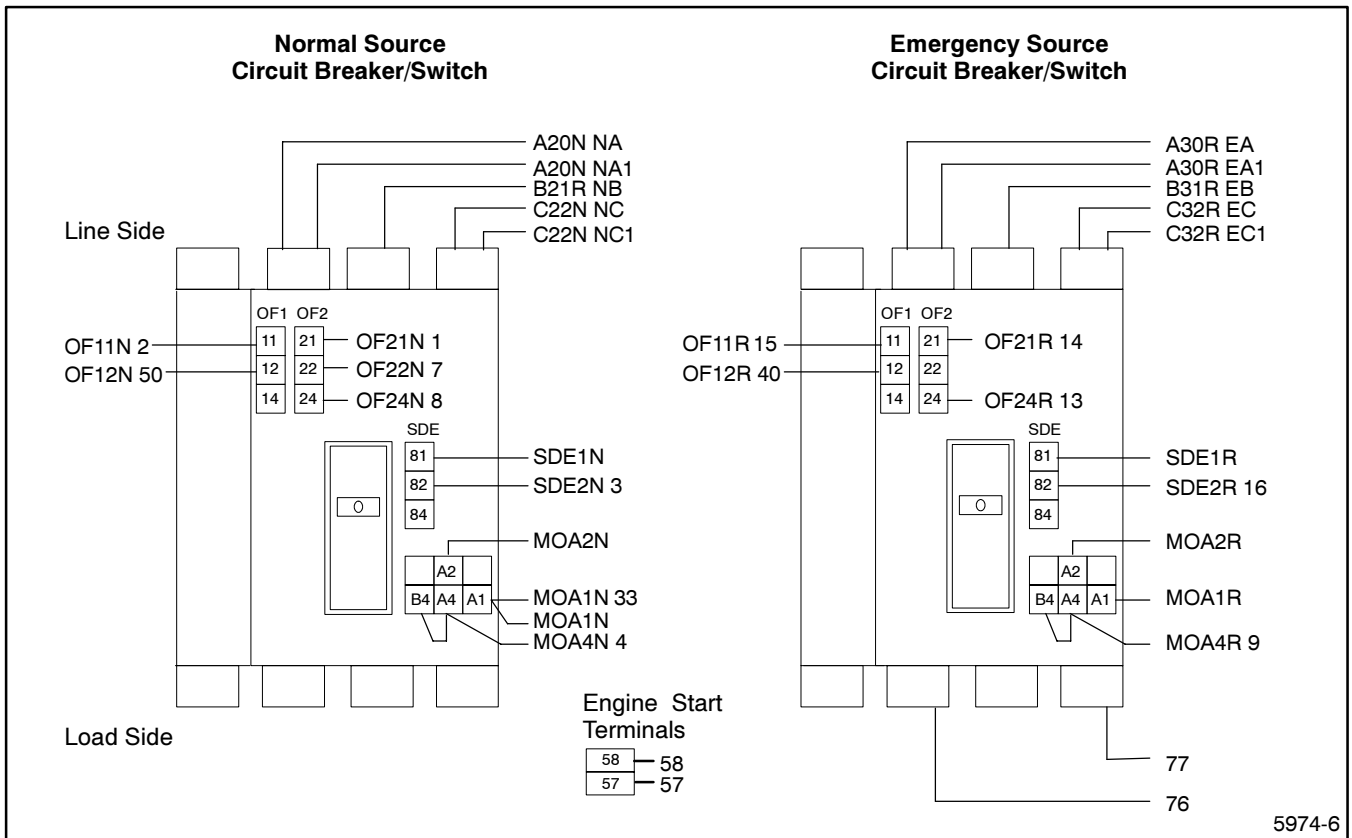

Figure 6-27. Wire Harness Connections, 400-630 amp Models

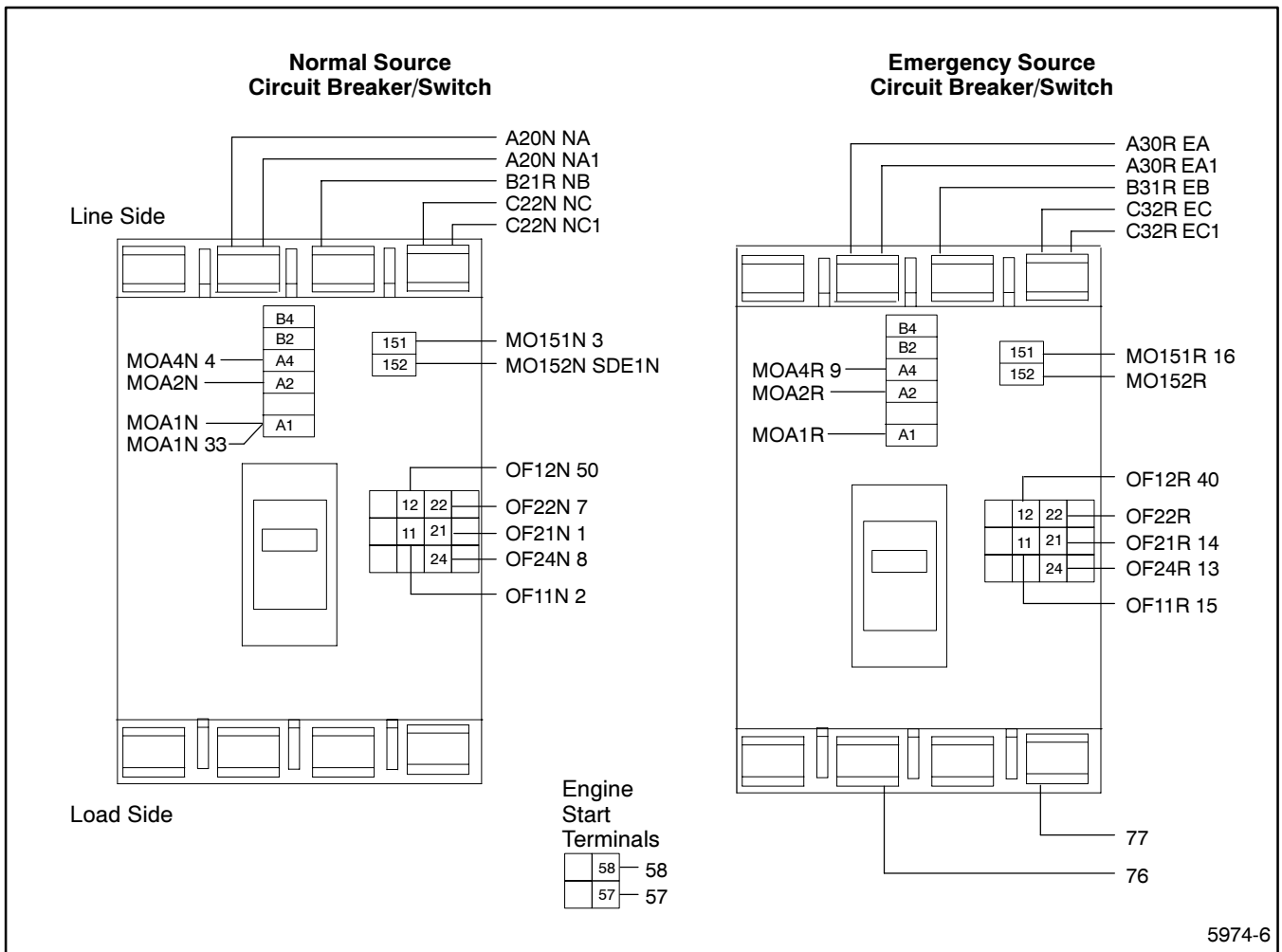
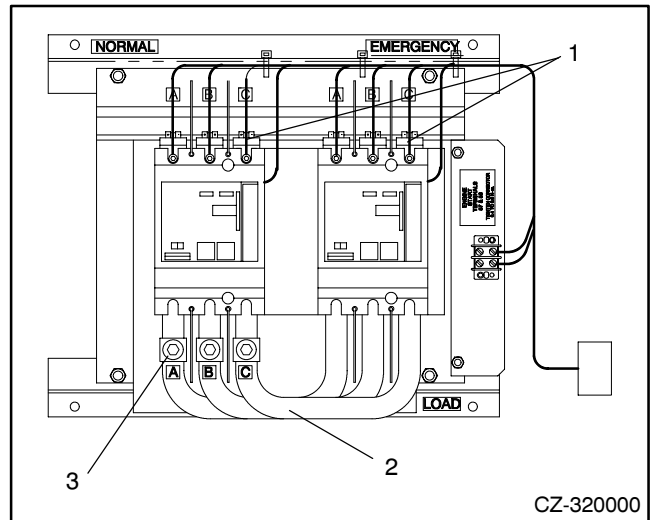

Figure 6-28. Wire Harness Connections, 800-1250 amp Models

6.10 Load Bus Replacement

Figure 6-29 shows the load bus bars used on 40–630 amp models. Figure 6-30 shows the load bus assembly used on 800–1250 amp models.

1. Disable the generator set and disconnect power sources as described in section 6.2 before opening the ATS enclosure.
2. Disconnect the load conductors.
3. Remove the load lugs and set them aside to be reinstalled later. See section 6.11.2 for instructions for removing the lugs.
4. Disconnect the load bus bars or load bus assembly from the circuit breakers/switches.
5. Reconnect the new bus bars or assembly and tighten all bolts to the torque shown in Figure 6-31.
6. Install the load lugs. See section 6.11.2 for instructions for installing and tightening the lugs.
7. Connect the load conductors. Tighten to the torques given in Section 1.8.
8. Return the ATS to operation following the instructions in section 6.2.



1. Source lugs
2. Load bus bars
3. Load lugs

Figure 6-29. Typical Circuit Breaker/Switch Assembly, 40-630 Amp Models

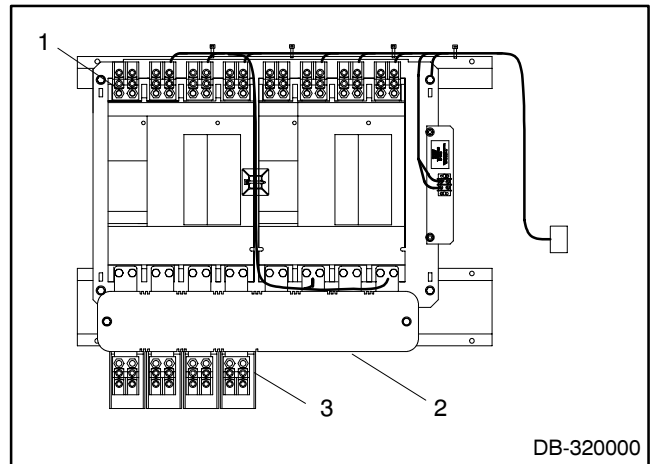

1. Source lugs
2. Load bus
3. Load lugs

Figure 6-30. Typical Circuit Breaker/Switch Assembly, 800-1250 Amp Models

Circuit Breaker/ Switch Size (amps)	Bolt Size	Tightening Torque ft. lbs. (Nm)
40-100	M6	7 (10)
160-250	M8	11 (15)
400-630	M10	37 (50)
800-1250	M10 nut	37 (50)

Figure 6-31. Load Bus Bolt Sizes and Torques

6.11 Lug Replacement

The locations of the lugs are shown in Figure 6-29 and Figure 6-30 of Section 6.10.

6.11.1 Source Lug Replacement

1. Disable the generator set and disconnect power sources as described in section 6.2 before opening the ATS enclosure.
2. Loosen the cable tightening screw and disconnect the power cables from the lug.
3. The procedure for replacing the lug varies for different models.
 - a. **40-250 Amp Models.** See Figure 6-32 or Figure 6-33. Insert a screwdriver into the slot to pry the plastic cover off. Remove the plastic cover and the lug.
 - b. **400-630 Amp Models.** See Figure 6-34. Remove the cable tightening screw from the lower hole (back connection) of the lug. Insert a hex key (Allen wrench) through the threaded hole to loosen and remove the screw that holds the lug in place. Remove the lug.
 - c. **800-1250 Amp Models.** See Figure 6-35. Remove the two sets of nuts and bolts securing the lug to the circuit breaker/switch and remove the lug.

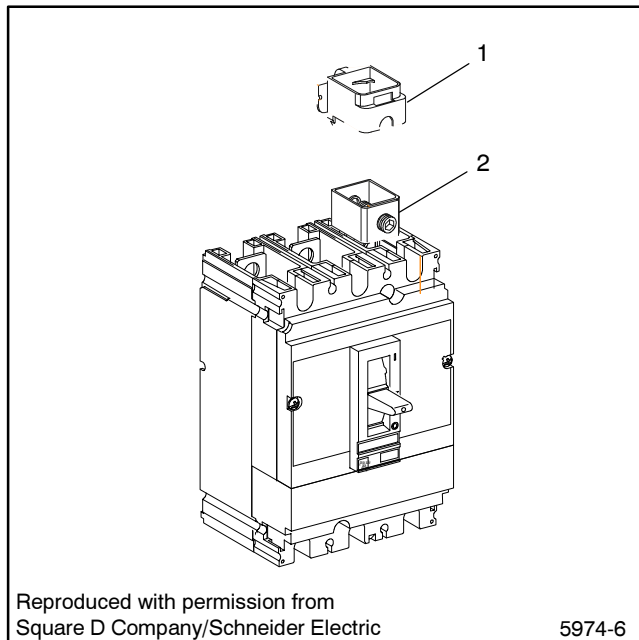

1. Plastic cover
2. Lug

Figure 6-32. Source Lugs, 40-160 Amp Models

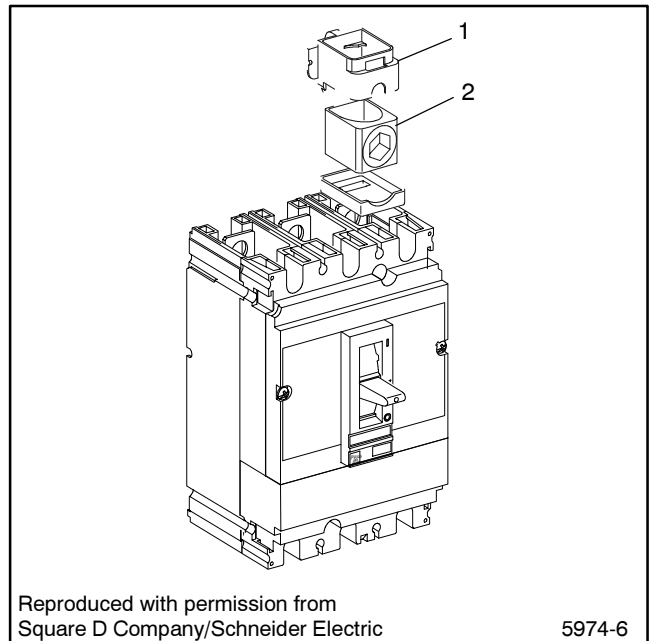

1. Plastic cover
2. Lug

Figure 6-33. Source Lugs, 250 Amp Models

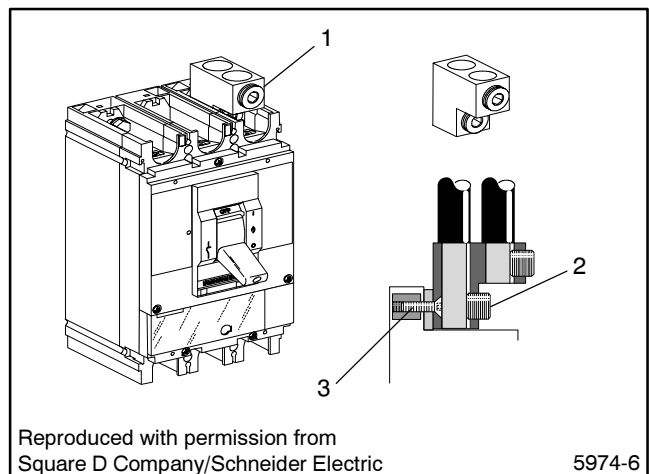

1. Lug
2. Cable tightening screw
3. Lug screw

Figure 6-34. Source Lugs, 400-630 Amp Models

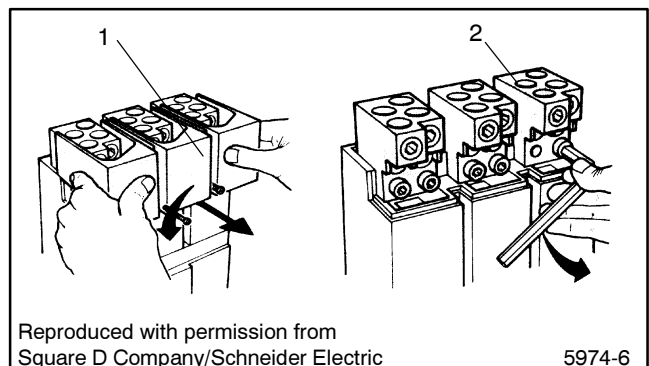

1. Plastic cover
2. Lug

Figure 6-35. Source Lugs, 800-1250 Amp Models

4. Install the new lug and and tighten the screws (400-1250 amp models only) to the torque shown in Figure 6-36.

Circuit Breaker/Switch Size Amps	Lug Screw Tightening Torque, ft. lbs. (Nm)
400-630	27 (37)
800-1250	37 (50)

Figure 6-36. Lug Screw Tightening Torques

5. Reconnect the source cables and tighten to the torques shown in Figure 1-10 in Section 1.8 of this manual.
6. Replace the plastic covers.
7. Return the ATS to operation following the instructions in section 6.2.

6.11.2 Load Lug Replacement

1. Disable the generator set and disconnect power sources as described in section 6.2 before opening the ATS enclosure.
2. Disconnect the cables from the lug.
3. The procedure for replacing the lug varies for different models.
4. **40-630 Amp Models.** See Figure 6-37.
 - a. Remove the cable tightening screw from the lower hole (back connection) of the lug.
 - b. Insert a hex key (Allen wrench) through the threaded hole to loosen and remove the screw that holds the lug in place. Remove the lug.

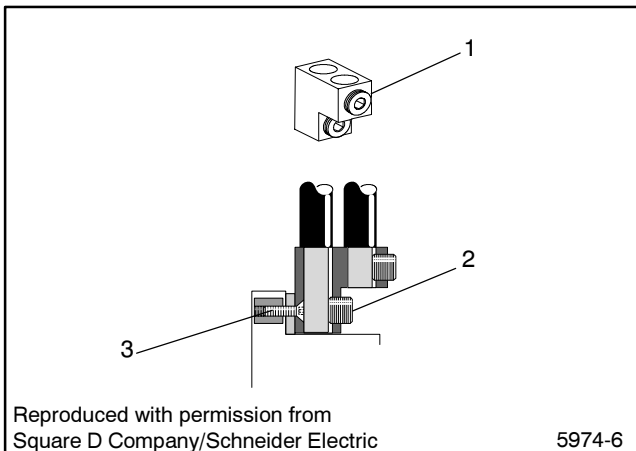

1. Lug
2. Cable tightening screw
3. Lug screw

Figure 6-37. Load Lugs, 40-630 Amp Models

5. **800-1250 Amp Models.** See Figure 6-38. Remove the two sets of nuts and bolts securing the lug to the circuit breaker/switch. Remove the lug.

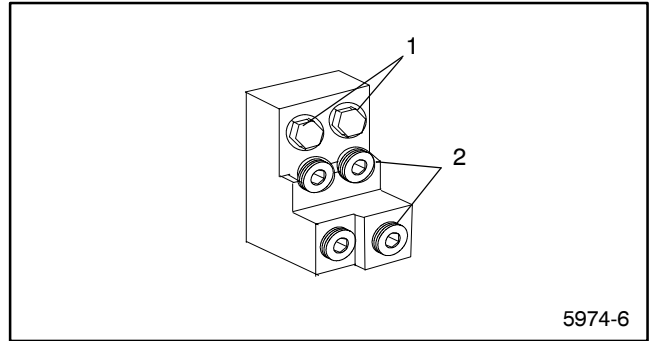

1. Lug bolts
2. Cable tightening screws

Figure 6-38. Load Lugs, 800-1250 Amp Models

6. Install the new lug and and tighten the screws to the torque shown in Figure 6-36.
7. Reconnect the source cables and tighten to the torques shown in Figure 1-10 in Section 1.8 of this manual.
8. Return the ATS to operation following the instructions in section 6.2.

6.12 Voltage Take-Off Replacement

1. Disable the generator set and disconnect power sources as described in section 6.2 before opening the ATS enclosure.
2. Remove the plastic cover plate and lug as described in Section 6.11.
3. Remove the screw securing the voltage take-off to the back of the lug. See Figure 6-39.
4. Attach the new voltage take-off and tighten the screw to 9 in. lbs. (1 Nm).
5. Replace the lug and plastic cover as described in Section 6.11.
6. Return the ATS to operation following the instructions in section 6.2.

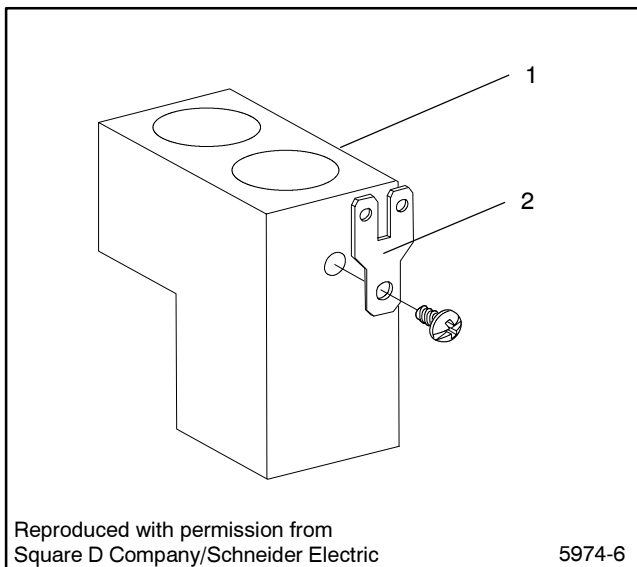

1. Lug
2. Voltage take-off

Figure 6-39. Voltage Take-offs

6.13 Phase Separator Replacement

The phase separators slide into place as shown in Figure 6-40.

1. Disable the generator set and disconnect power sources as described in section 6.2 before opening the ATS enclosure.
2. Remove the old phase separator by pulling it forward and then off.
3. Slide the new phase separator into place as shown in Figure 6-40.
4. Return the ATS to operation following the instructions in section 6.2.

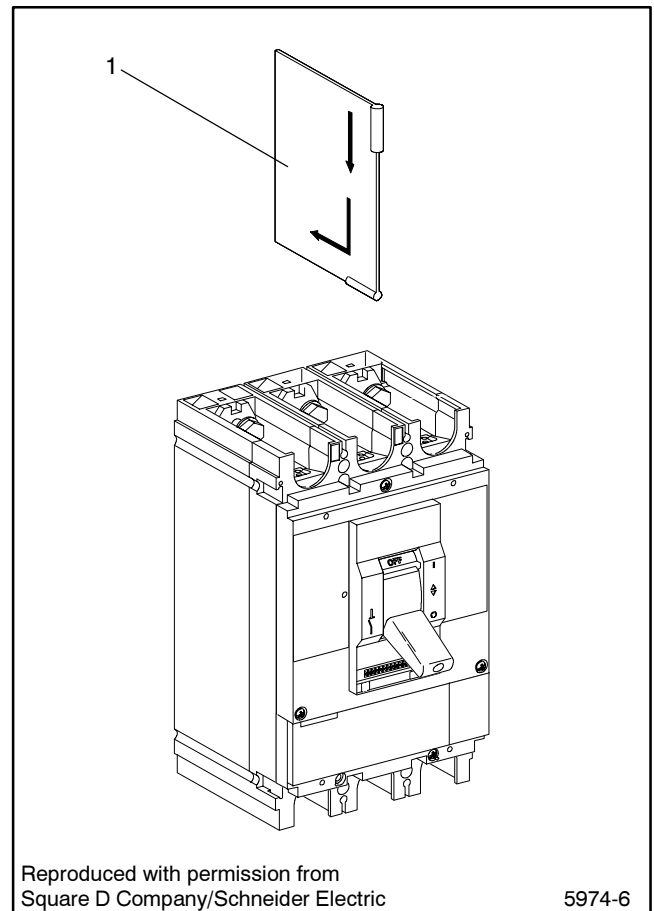

1. Phase separator

Figure 6-40. Phase Separators

Notes

Section 7. Diagrams and Drawings

Diagram or Drawing	Drawing Number	Page
Interconnection Diagrams		
Power Switching Interconnection	353547-A	57
E33+ Logic Interconnection	353551-A	58
S340+ Logic Interconnection	353553-	59
M340+ Logic Interconnection	353549-	60
Schematic Diagrams		
Power Switching Device, 40–250 Amps	353548-	61
Power Switching Device, 400–630 Amps	353538-	62
Power Switching Device, 800–1250 Amps	353539-	63
E33+ Logic Controls	353552-	64
S340+ Logic Controls	353554-	65
M340+ Logic Controls	353550-	66

Notes

- LEGEND**
- E - EMERGENCY
 - L - LOAD
 - N - NORMAL
 - P - PLUG
 - TE - TERMINAL BLOCK ON TRANSFER SWITCH PANEL
 - ▲ - CUSTOMER CONNECTIONS

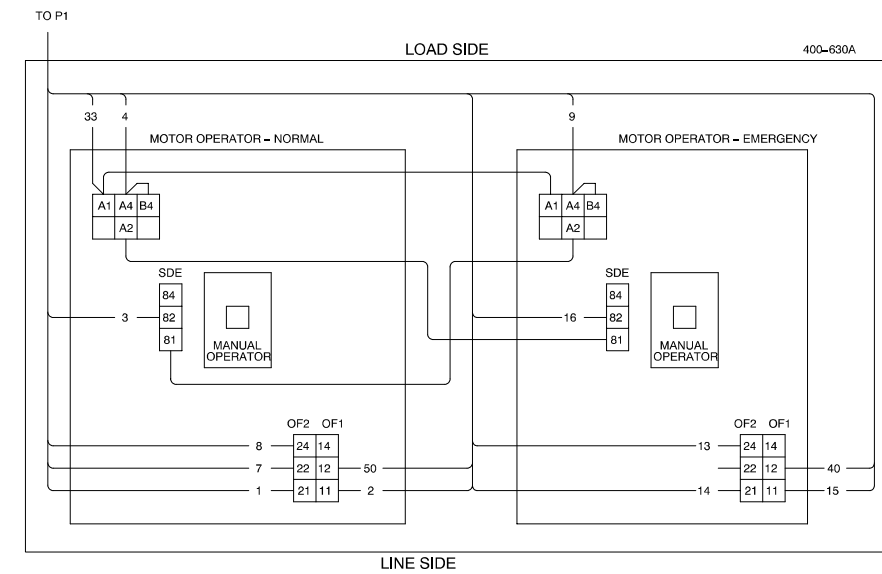
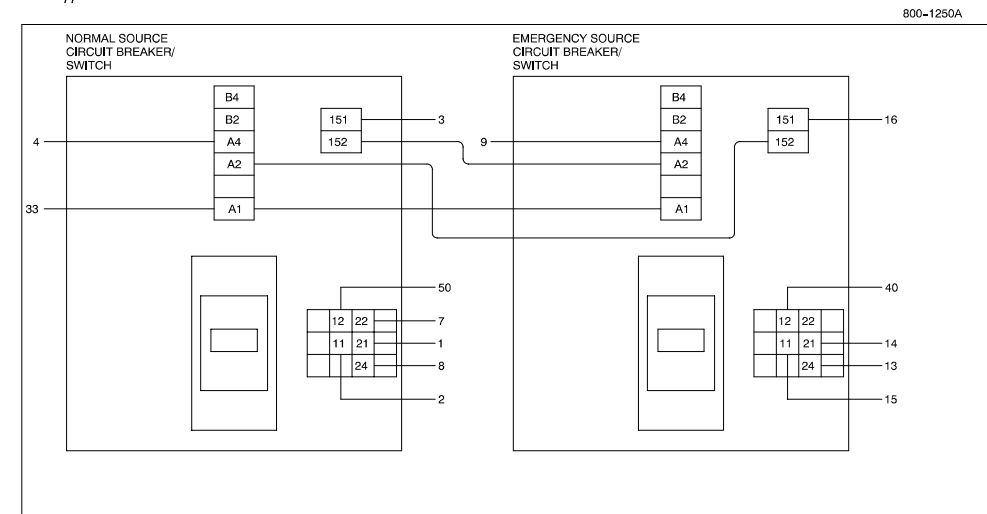
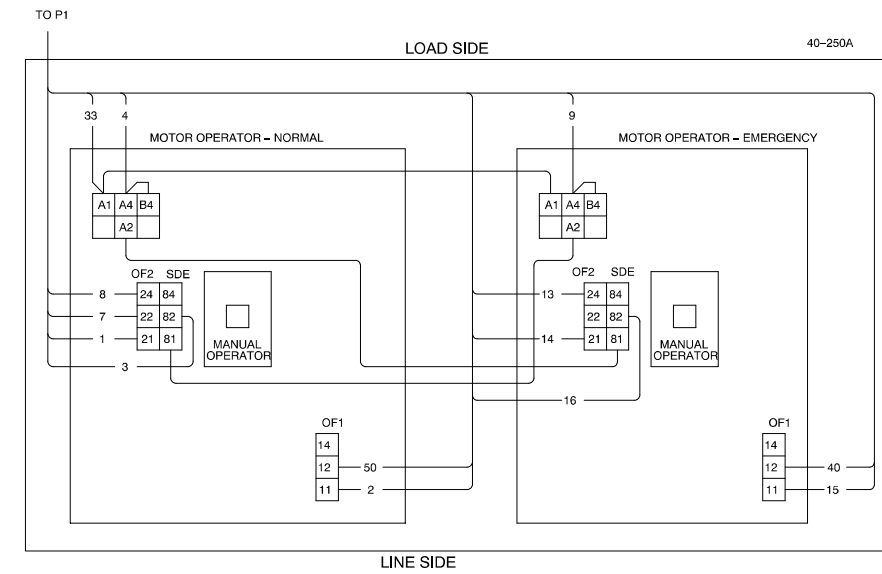
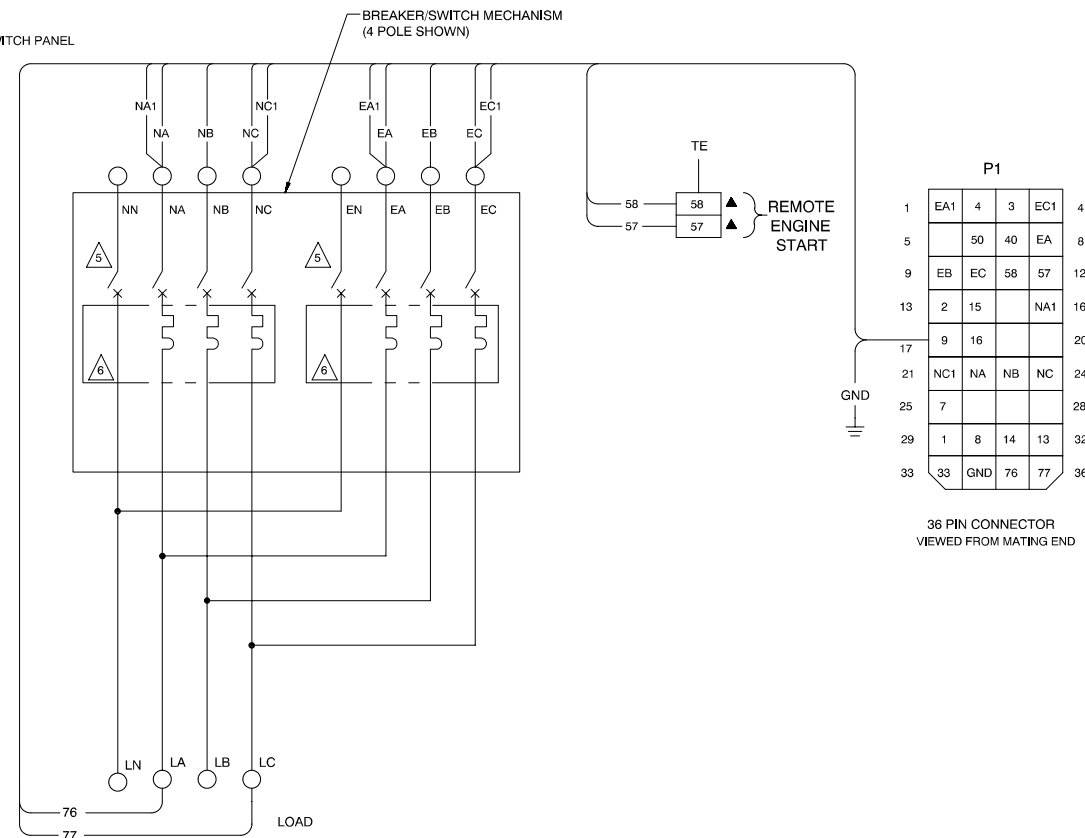

- NOTES:**
1. SWITCH SHOWN DE-ENERGIZED AND NOT CONNECTED TO EITHER SOURCE
 2. REFER TO OPERATORS MANUAL PRIOR TO INSTALLATION AND OPERATION OF THE SWITCH.
 3. PLUG AND SOCKET WIRE NUMBERS MATCH WHEN PLUGGED TOGETHER
ALL PLUGS AND SOCKETS VIEWED FROM MATING SIDE
 4. 3 POLE MECHANISM SUPPLIED ON 2 POLE APPLICATION.
 5. SWITCHED NEUTRAL (4 POLE) MECHANISMS ONLY.
 6. AUTOMATIC CIRCUIT BREAKER TRIPS.

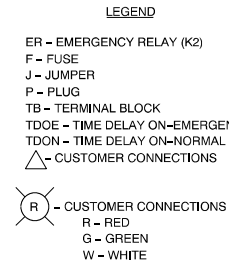
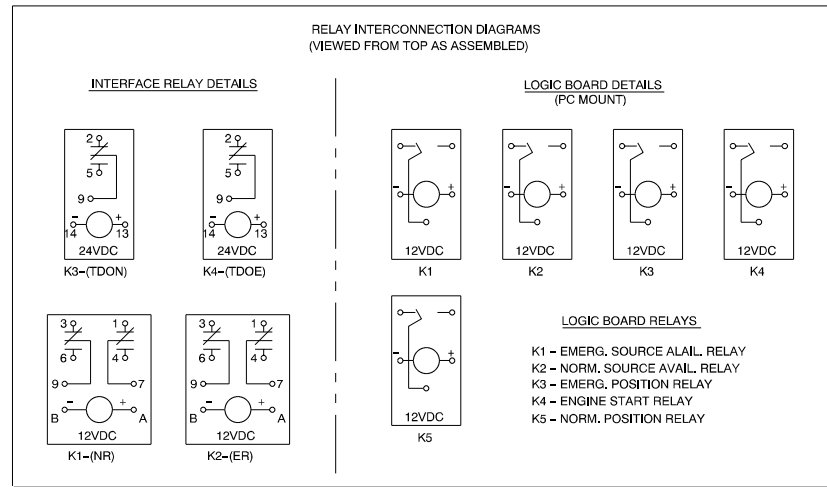

- NOTES:**
- REFER TO OPERATORS MANUAL PRIOR TO INSTALLATION AND OPERATION OF THE SWITCH.
 - PLUG AND SOCKET WIRE NUMBERS MATCH WHEN PLUGGED TOGETHER. ALL PLUGS AND SOCKETS VIEWED FROM MATING SURFACE.
 - P1 - PIN 25 WIRE #7 FROM TRANSFER SWITCH DOES NOT HAVE A RESPECTIVE MATING PIN OR WIRE.
 - REMOVE JUMPERS JP1, JP2, JP3, & JP4 ON LOGIC BOARD WHEN USING VOLTAGE SENSING ABOVE 240 VAC.
 - REMOVE JUMPER JP5 ON LOGIC BOARD FOR 3Ø SENSING.
 - P4 WIRE HARNESS CONTAINS SPARE WIRES ES3, ES4, EX, NX.

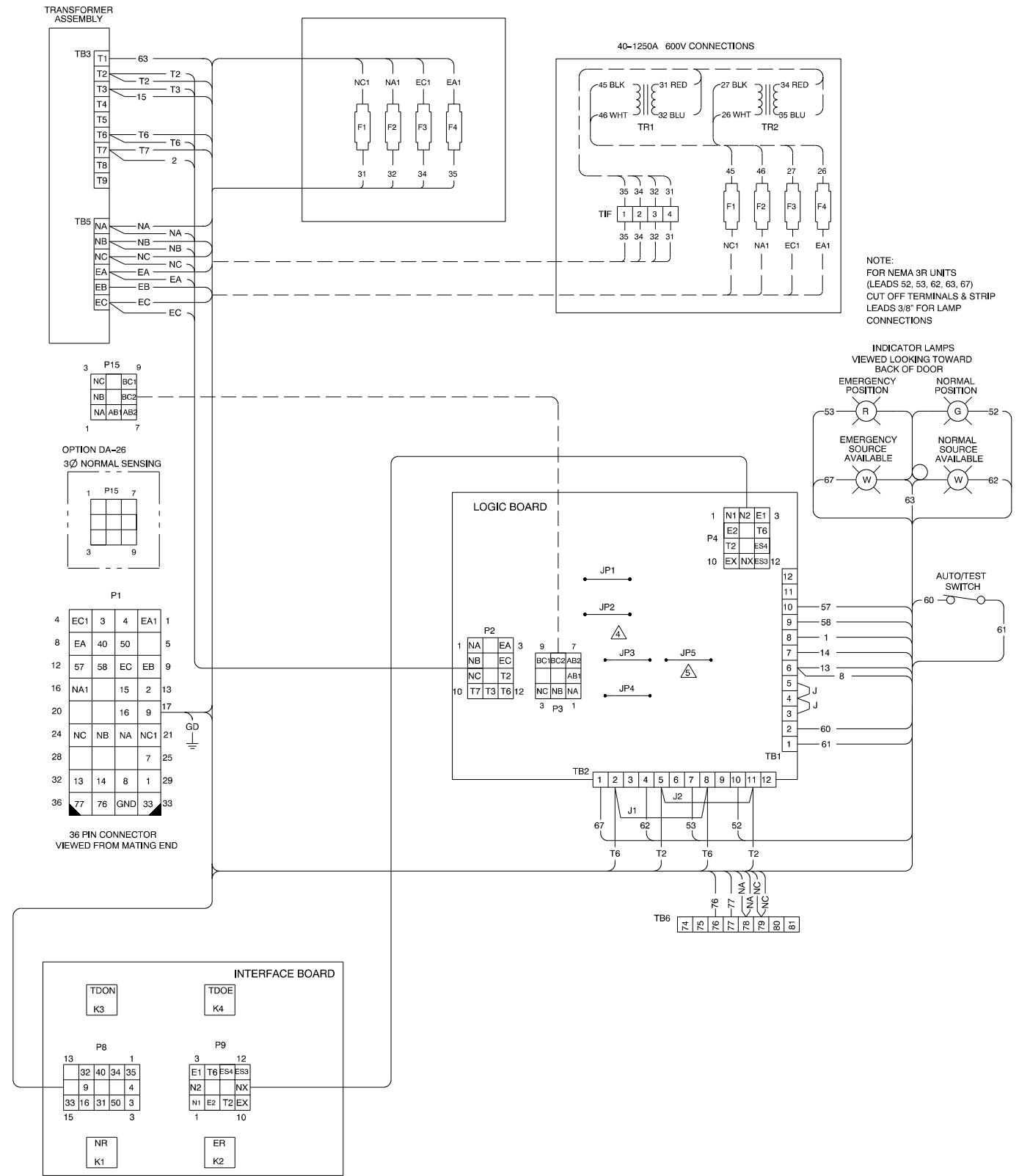

TRANSFORMER ASSEMBLY 40-1250A 110, 120, 220, 240, 380, 416, 440, 480V CONNECTIONS

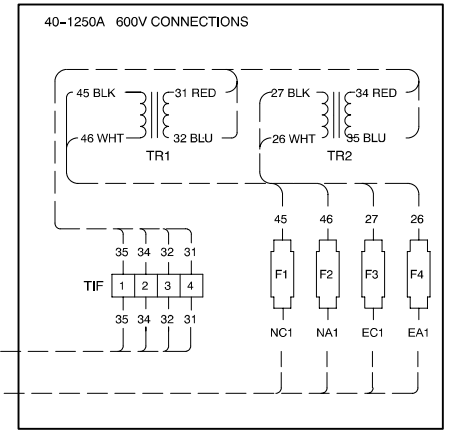
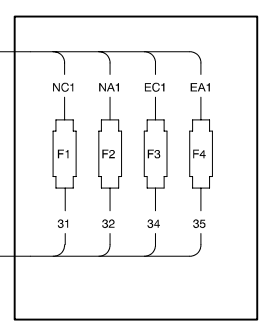
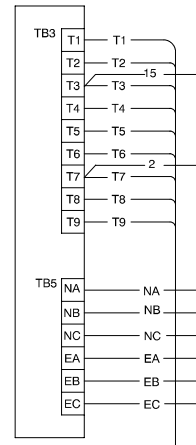

NOTE:
FOR NEMA 3R UNITS
(LEADS 8, 13, 62, 63, 67)
CUT OFF TERMINALS & STRIP
LEADS 3/8" FOR LAMP
CONNECTIONS

INDICATOR LAMPS
VIEWED LOOKING TOWARD BACK OF DOOR

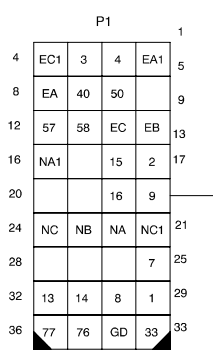
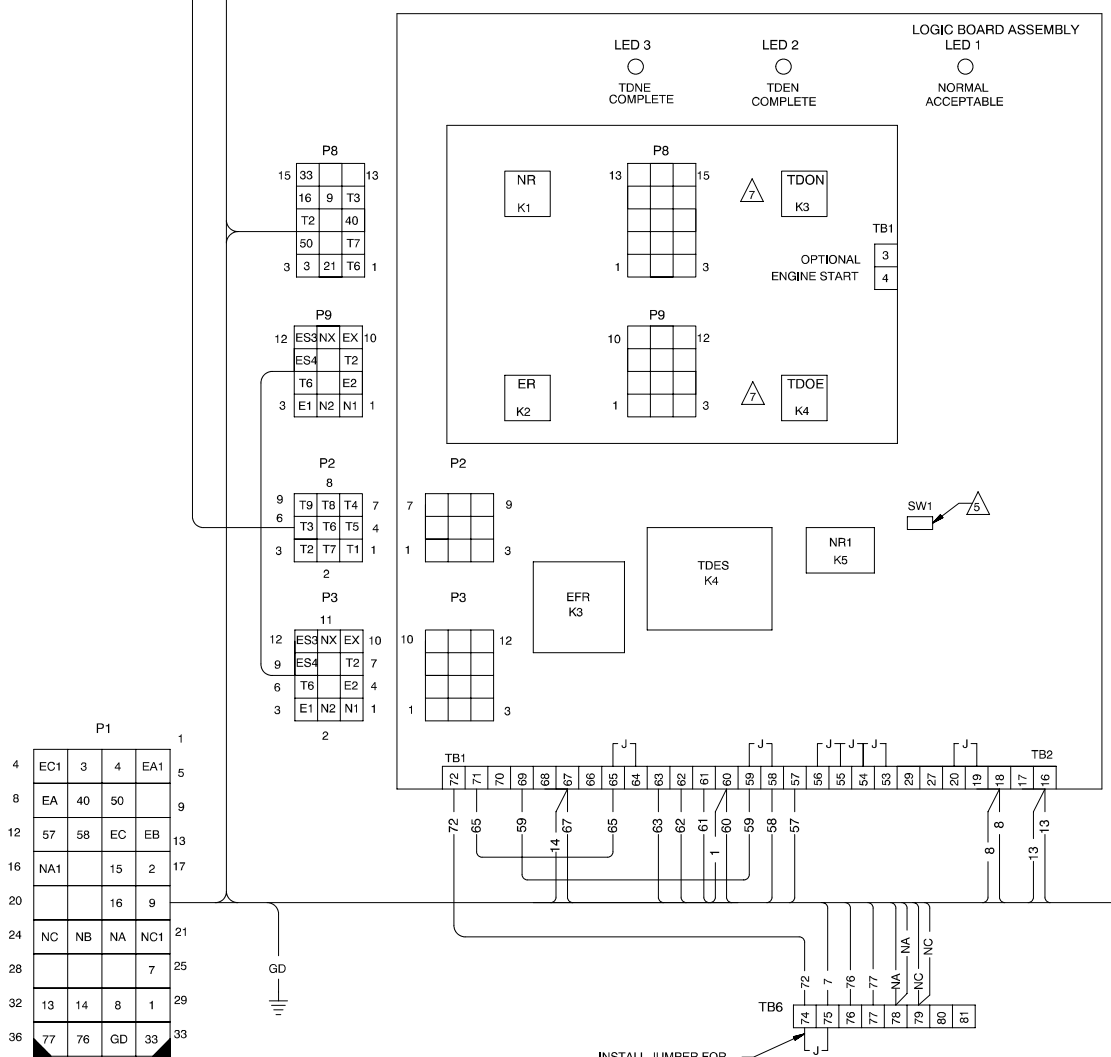
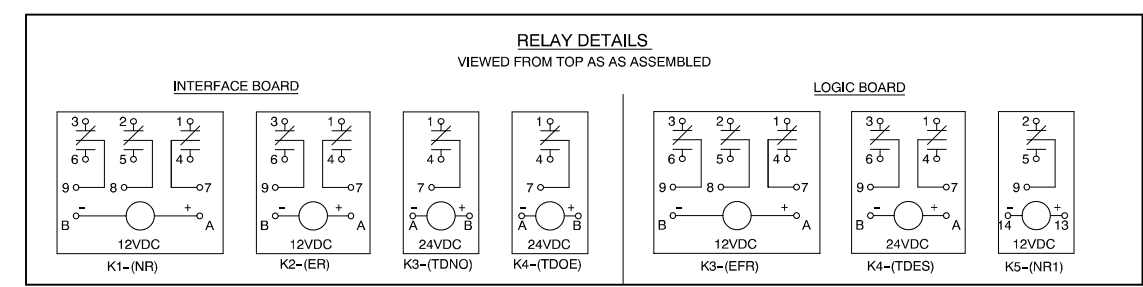
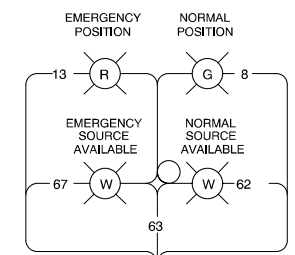

INSTALL JUMPER FOR AUTOMATIC RETRANSFER

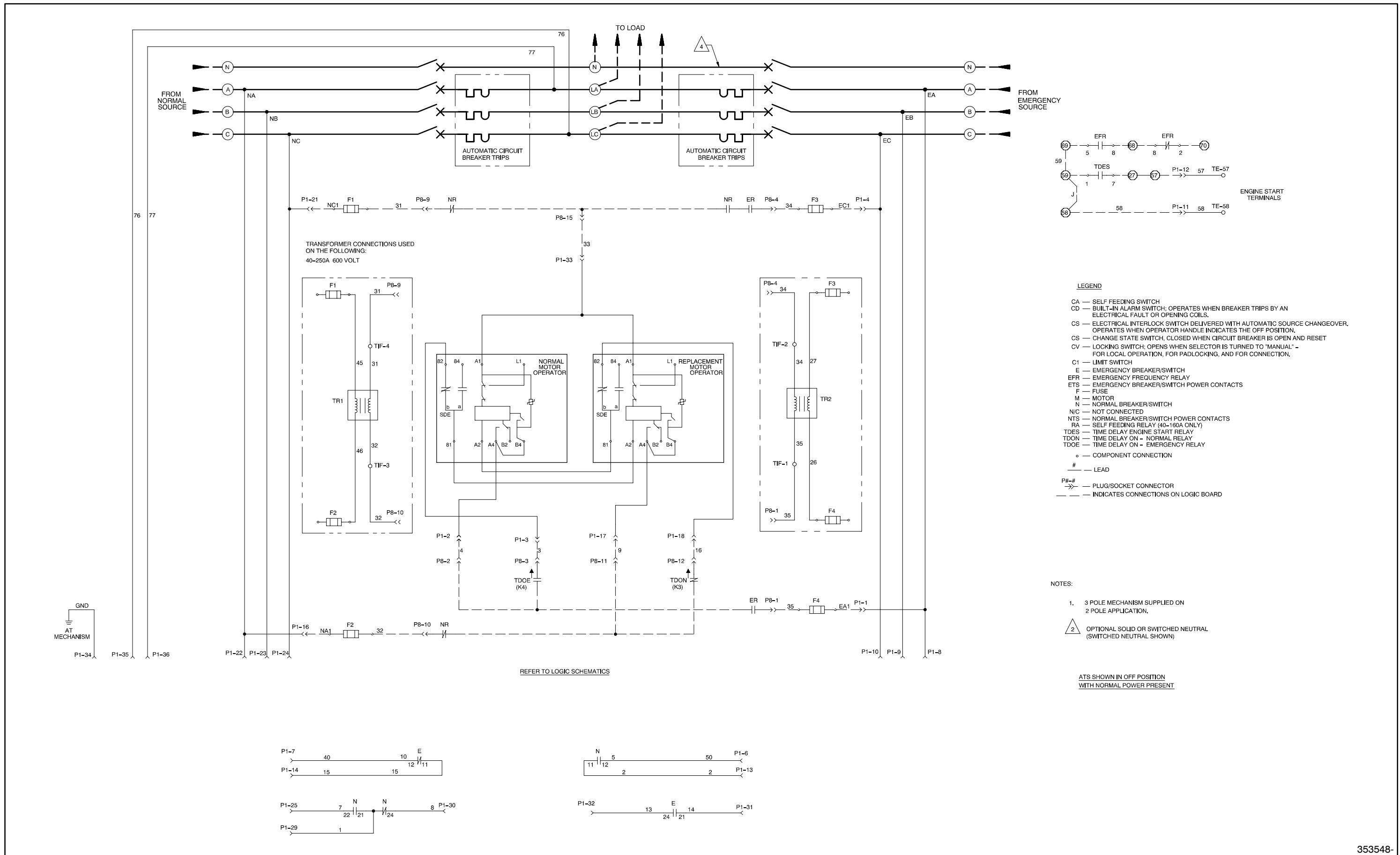

353548-

Schematic Diagram, Power Switching Device, 40-250 Amps, 353548-

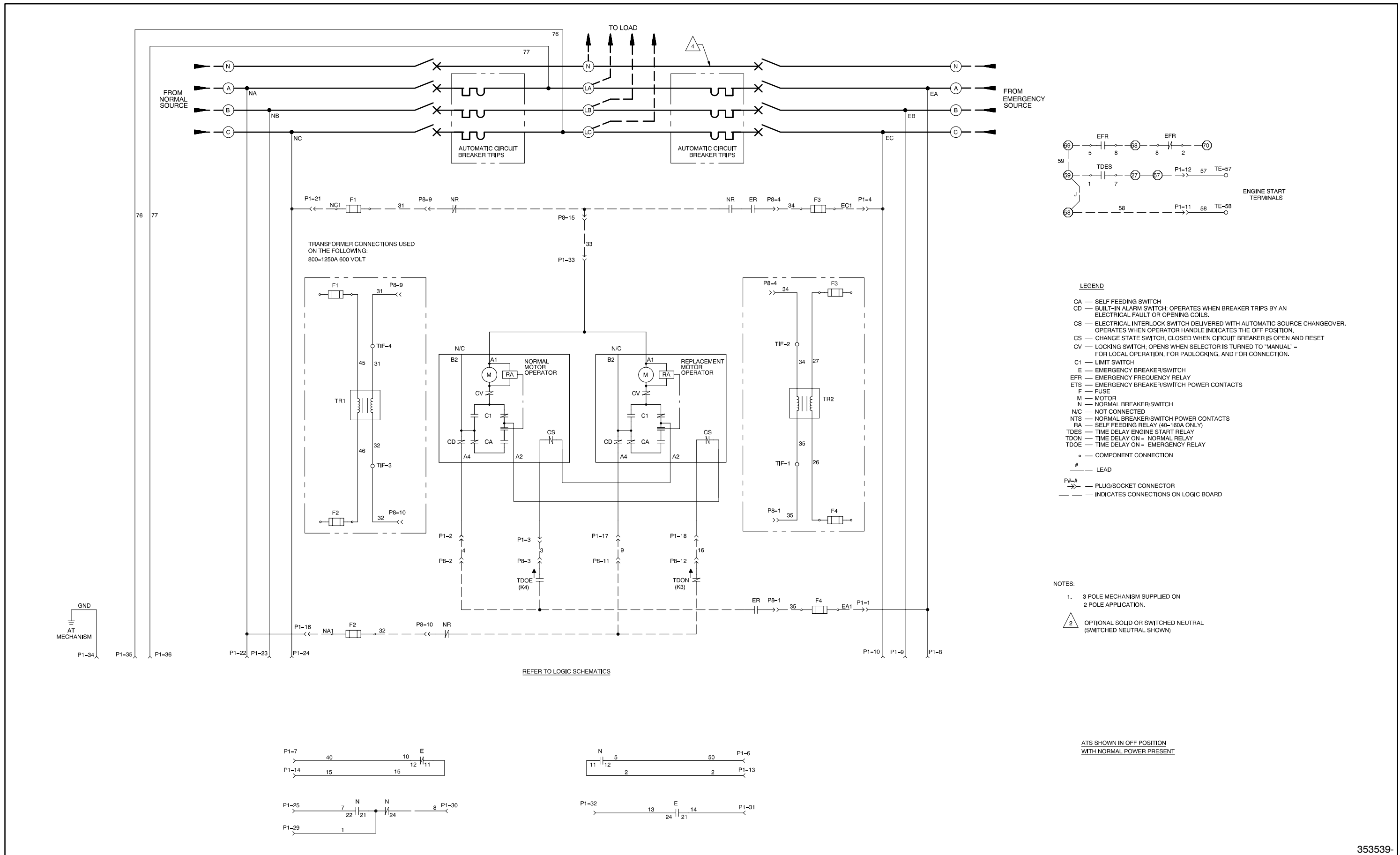

Schematic Diagram, Power Switching Device, 800-1250 Amps, 353539-

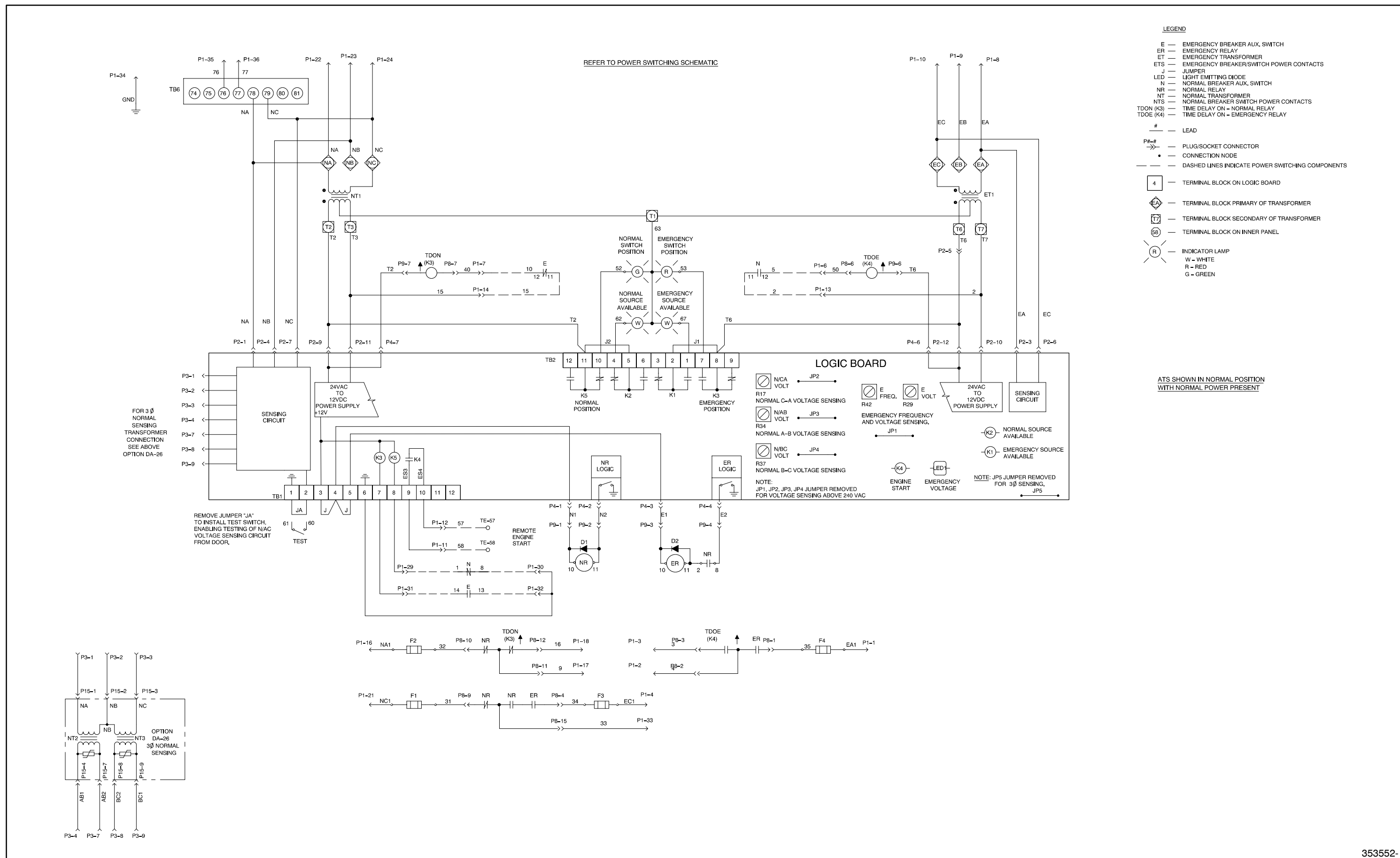

Schematic Diagram, E33+ Logic, 353552-

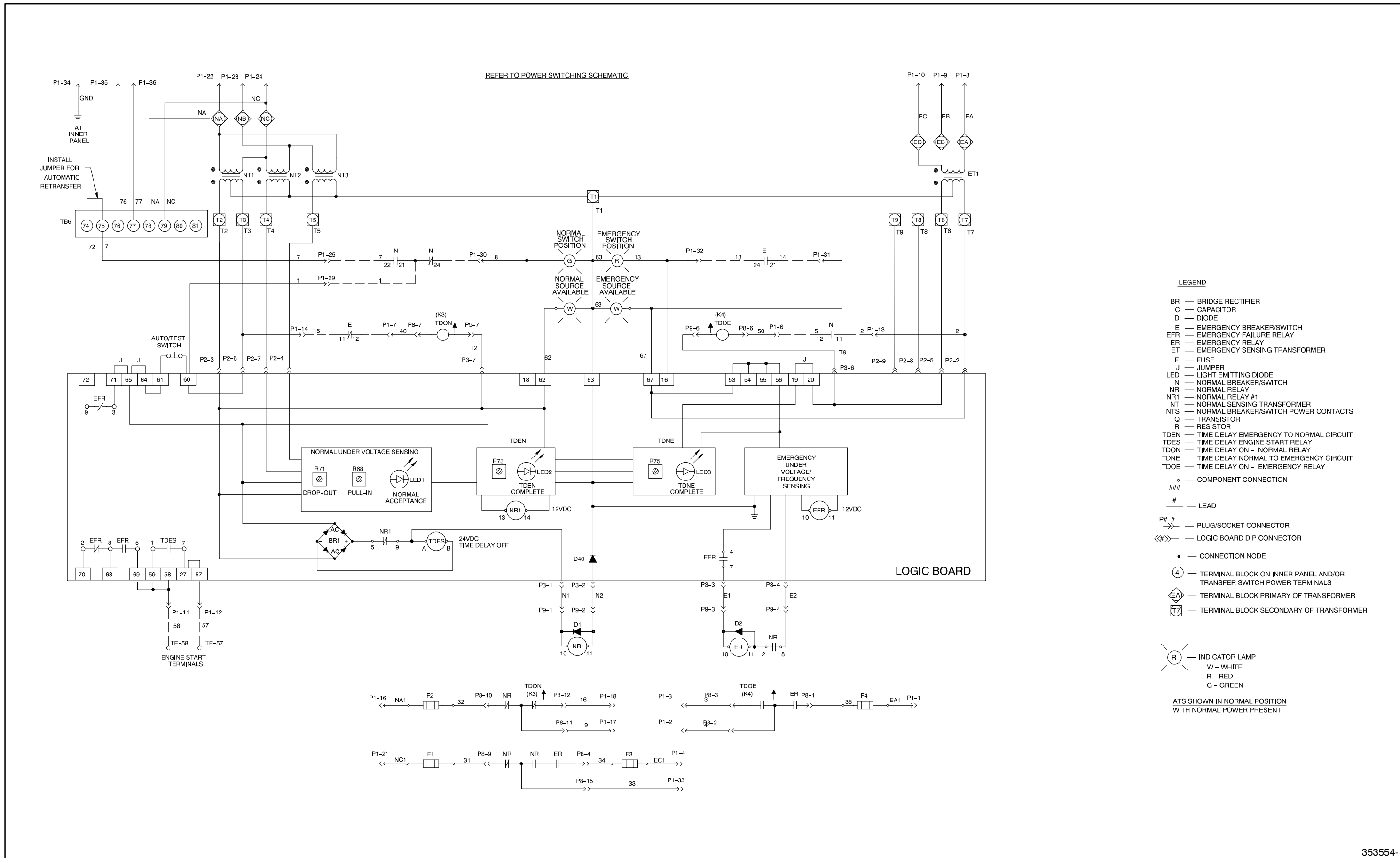

Schematic Diagram, S340+ Logic, 353554-

353554-

REFER TO POWER SWITCHING SCHEMATIC

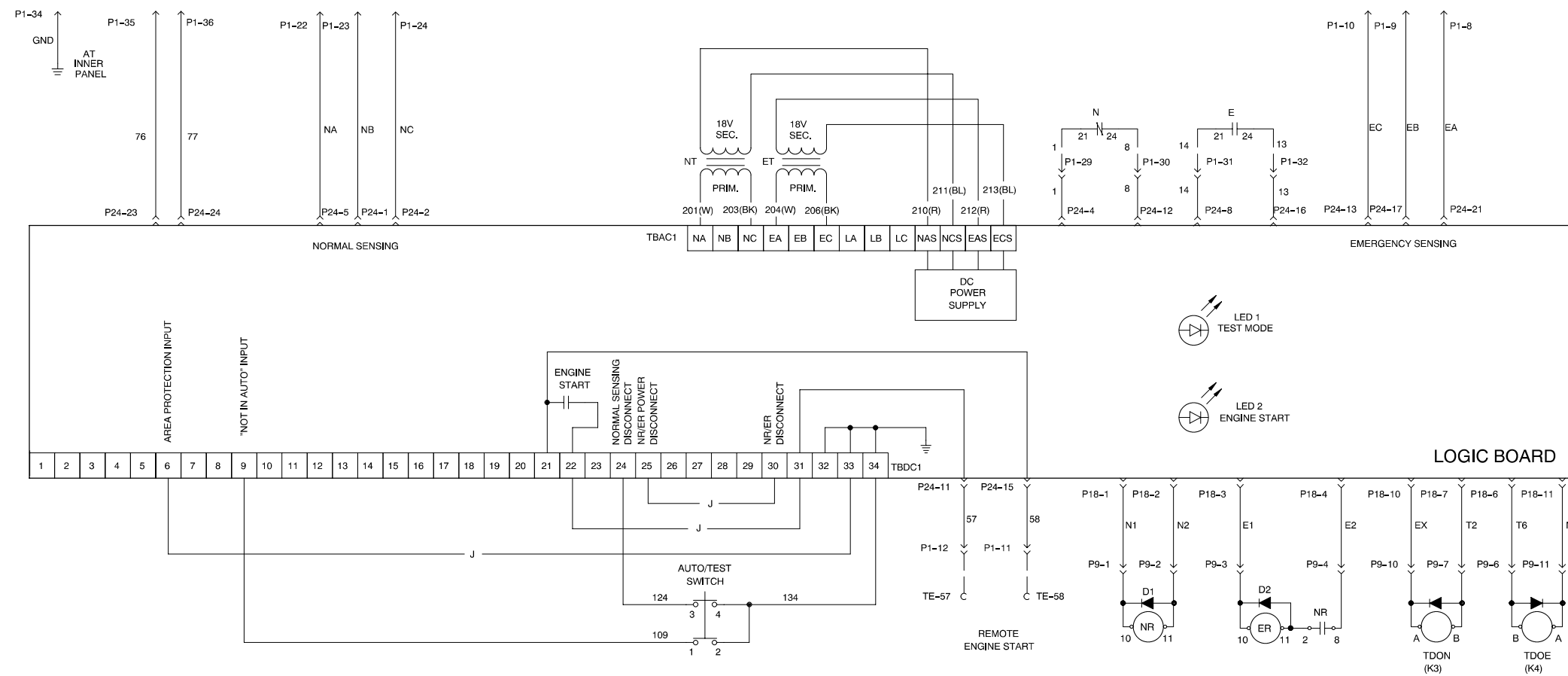

- LEGEND**
- CS(E) — EMERGENCY CHANGE STATE SWITCH
 - CS(N) — NORMAL CHANGE STATE SWITCH
 - DS — DISCONNECT SWITCH
 - E — EMERGENCY BREAKER AUX. SWITCH
 - ER — EMERGENCY RELAY
 - ET — EMERGENCY TRANSFORMER
 - ETS — EMERGENCY BREAKER/SWITCH POWER CONTACTS
 - F — FUSE
 - J — JUMPER
 - LED — LIGHT EMITTING DIODE
 - N — NORMAL BREAKER AUX. SWITCH
 - NR — NORMAL RELAY
 - NT — NORMAL TRANSFORMER 1, 2, 3
 - NTS — NORMAL BREAKER SWITCH POWER CONTACTS
 - TDON (K3) — DELAY TO NORMAL RELAY
 - TDOE (K4) — DELAY TO EMERGENCY RELAY
 - TR — INTERFACE TRANSFORMER
- # — LEAD
- P#-# — PLUG/SOCKET CONNECTOR
- o — COMPONENT CONNECTION
- — DASHED LINES INDICATE POWER SWITCHING COMPONENTS

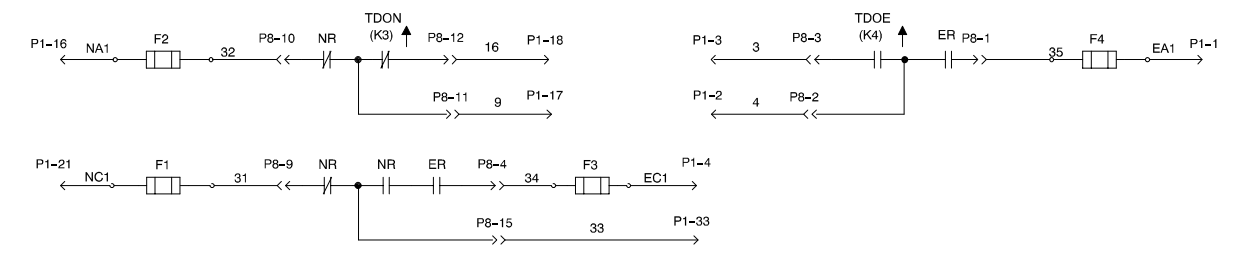

ATS SHOWN IN NORMAL POSITION WITH NORMAL POWER PRESENT

Schematic Diagram, M340+ Logic, 353550-

Section 8. Service Parts

Use this section to locate and identify service parts for the automatic transfer switches covered by this manual.

This section does not include nonserviceable parts of the automatic transfer switch or any parts of the electrical controller within the automatic transfer switch. A separate service and parts manual is provided for each electrical controller model. To locate and identify controller parts, refer to the List of Related Manuals in the Introduction for the name and number of the service and parts manual for the applicable controller.

8.1 Finding Parts Information

1. Use the illustration on page 68 to determine the description of the parts group. Use the table below the illustration to find the page number of the parts list.
Example: A motor operator needs replacement. It is part of the power switch assembly. Power switch assemblies are shown on pages 77 through 96.
2. Use the chart in Section 1 of this manual to decode the ATS model number. Determine whether the ATS uses circuit breakers or switches, the voltage rating, current rating, and number of poles of the transfer switch. Find the power switch assembly that corresponds to the current rating and number of poles.
Example: The ATS model number is MMT-168341-0630. The ATS uses circuit breakers in the power switching device. The voltage rating is 208 volts, the current rating is 630 amps, and there are 3 poles. The corresponding power switch assembly parts list is on page 89.

3. Locate the part in the illustration.
Example: The motor operator is item 2 in the illustration on page 89.
4. Find the item number in the associated parts list table on the same page and read the description.
Example: Find number 2 in the Item column. The description is "operator, motor."
5. Find the part number in the circuit breaker column for model MMT transfer switches or the switch column for model MNT transfer switches. The part number column may contain a reference to another table.
Example: Item 2 in the circuit breaker column shows a reference to the second table on the same page.
6. Find the voltage rating in the second table and read the part number in the motor operator column.
Example: The voltage rating is 208 volts, and the motor operator part number is X-6309-26.
7. Check the item quantity. The number in parentheses () before the part number indicates the quantity. If there is no number in parentheses with the part number, the quantity is one (1).
Example: The number 2 in parentheses preceding the part number shows that two motor operators are used on the power switch assembly.

8.2 Leads

For leads not included in the wiring harness, fabricate replacement leads using the same type of wire as the old leads. Add terminals and lead markers at each end of the new lead.

8.3 Automatic Transfer Switch

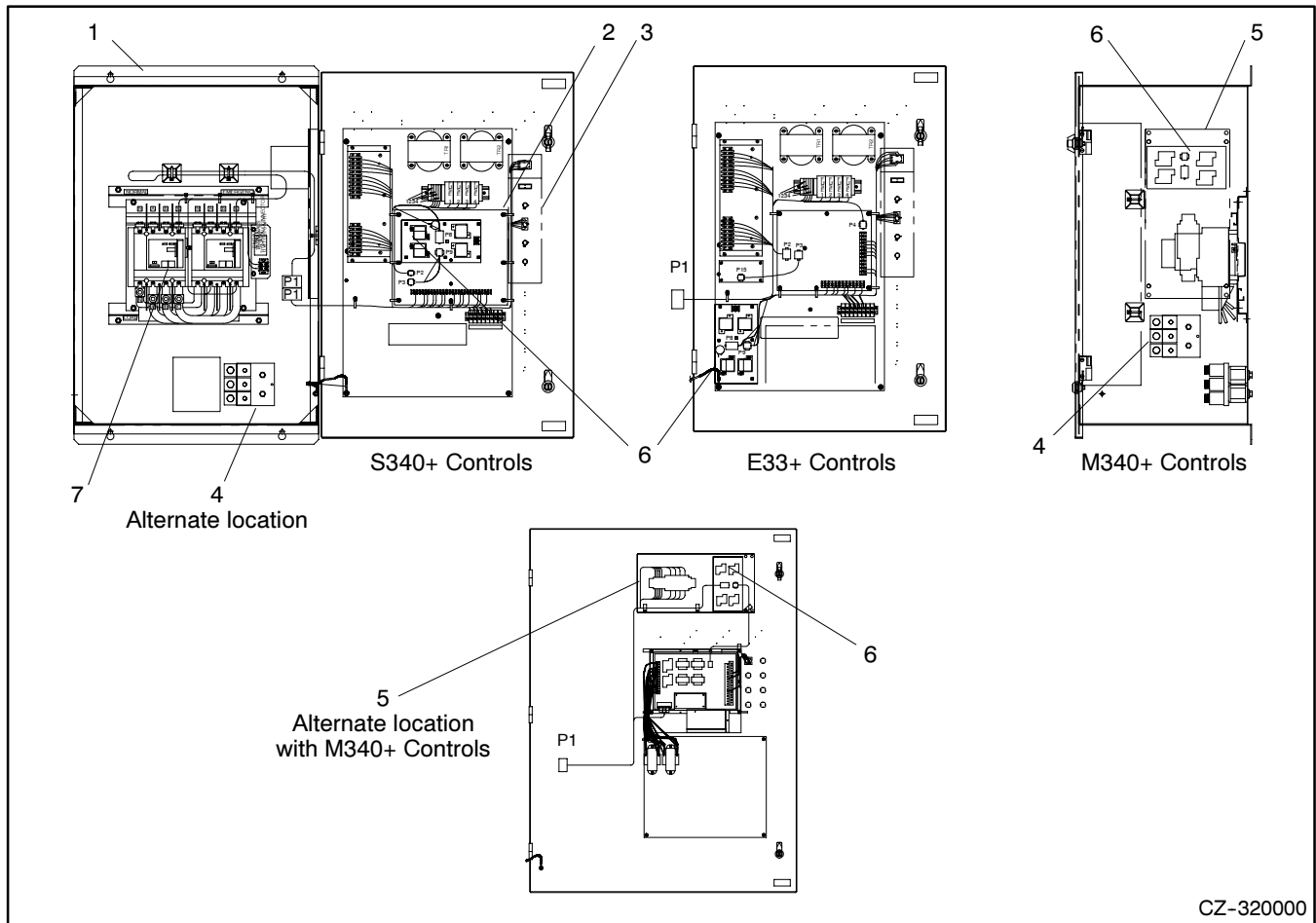

CZ-320000

Item	Group Description	Parts List Location
1	Enclosure	Enclosures , page 69
2	Electrical Controls	Electrical controls manual
3	Decals	Decals , page 70
4	Neutral Lug (Optional)	Neutral Lugs , pages 73-75
5	Interface Panel Assembly (M340+ controls only)	Interface Panel Assembly , page 71
6	Interface Board	Interface Board , page 72
7	Power Switching Device Assembly (100 amp, 4-pole model shown)	Power Switch Assemblies , pages 77-96

8.4 Enclosures

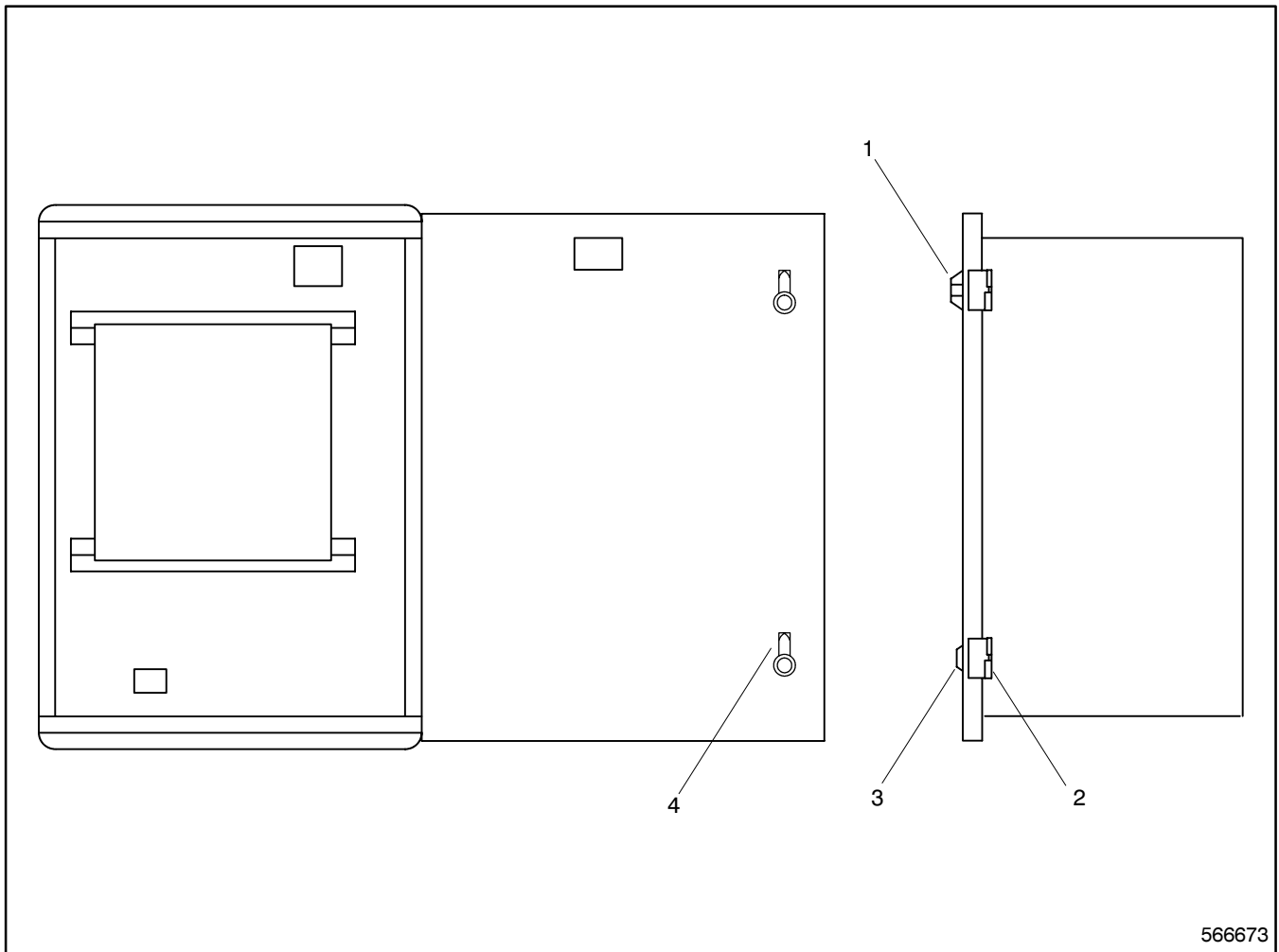

566673

Item	Description	Part Number
1	Handle, latch	320822
2	Hinge	(2) 294749-BLK
3	Latch	320823
4	Cam	(2) 320824

8.5 Decals

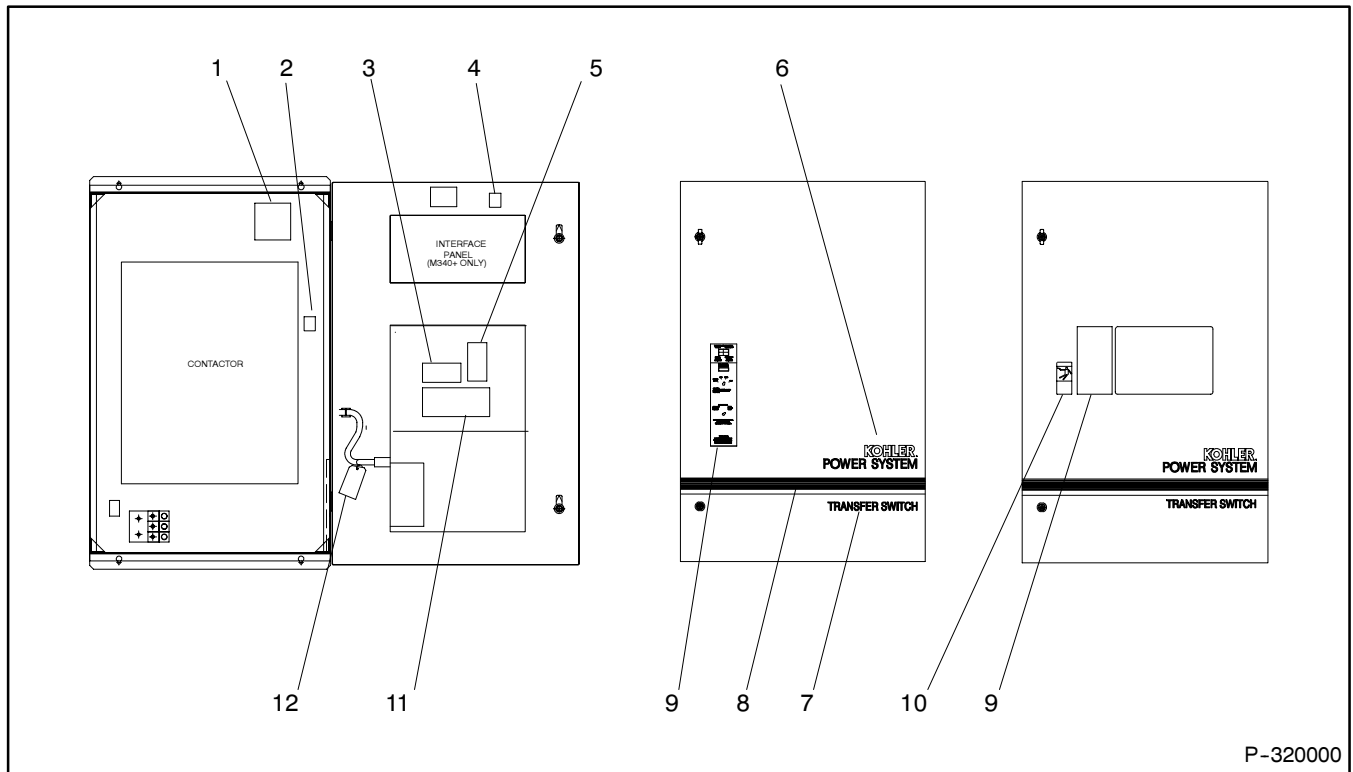

P-320000

Item	Description	Part Number		
		E33+ Logic	S340+ Logic	M340+ Logic
1	Decal, notice	294414	294414	294414
2	Decal, engine start	321026	321026	321026
3	Decal, mounting	295933	295933	NA
4	Decal, 1-800 number	224233	224233	224223
5	Decal, warning	294328	294328	294328
6	Decal, "Kohler® Power System"	See table below	See table below	See table below
7	Decal, "Transfer Switch"	273746	273746	273746
8	Decal, gold stripes	See table below	See table below	See table below
9	Decal, instruction	321159	320834	321077
10	Decal, danger	294520	294520	294520
11	Decal, ATS	295261	295261	294523
12	Tag, hanging	297949	297949	297949

Item	Description	Part Number	
		40-250 Amp ATS	400-1250 Amp ATS
6	Decal, "Kohler® Power System"	X-6246-3	X-6232-2
8	Decal, gold stripes	X-6246-4	X-6232-3

8.6 Interface Panel Assembly

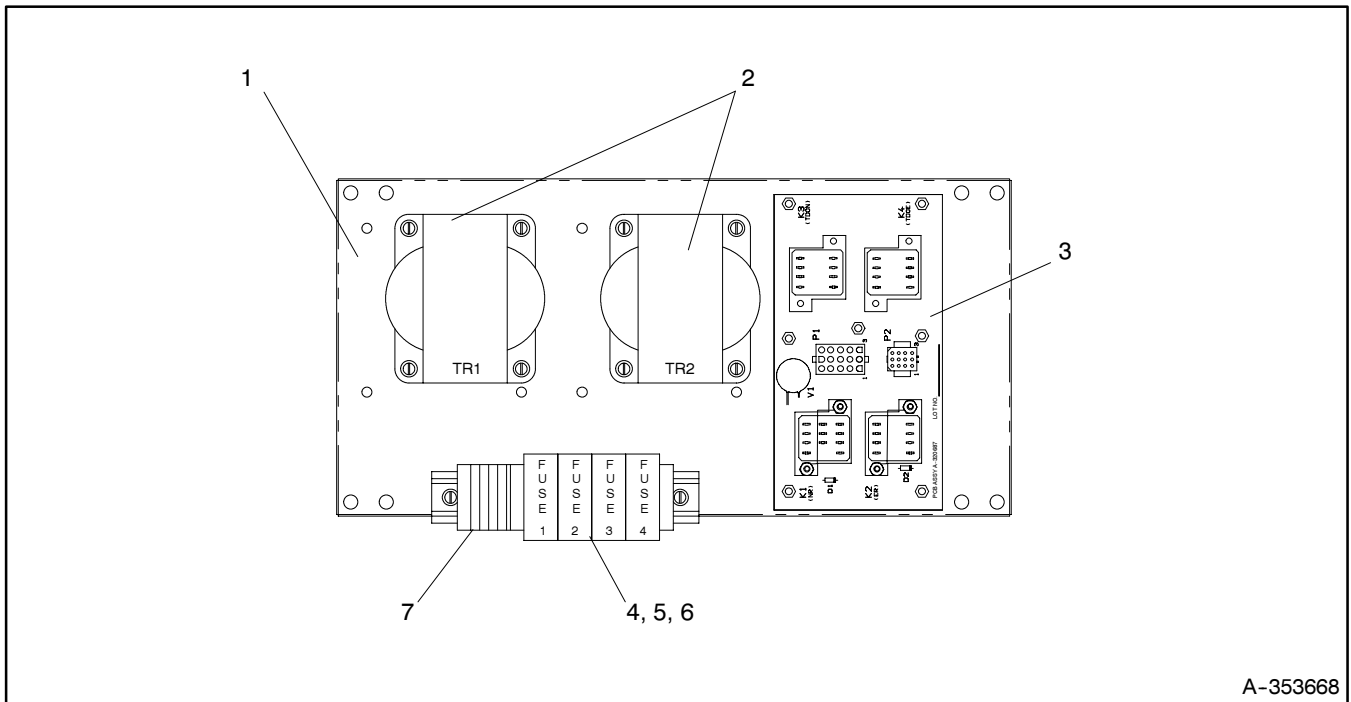

A-353668

Item	Description	Part Number
1	Interface Panel Assembly	See table below
2	Transformer	See table below
3	Interface Board	A-320687
4	Block, fuse	X-6129-8
5	Puller, safety	(4) X-6129-9
6	Fuse	(4) X-6135-6
7	Terminal	(4) 321021

ATS Rating		Interface Panel Assembly	Transformer
Current (amps)	Voltage		
40-630	120-480	A-353669	—
	600	A-353668	330858
800-1250	208	GM10108	321187
	220-480	A-353669	—
	600	A-353670	321183

8.7 Interface Board

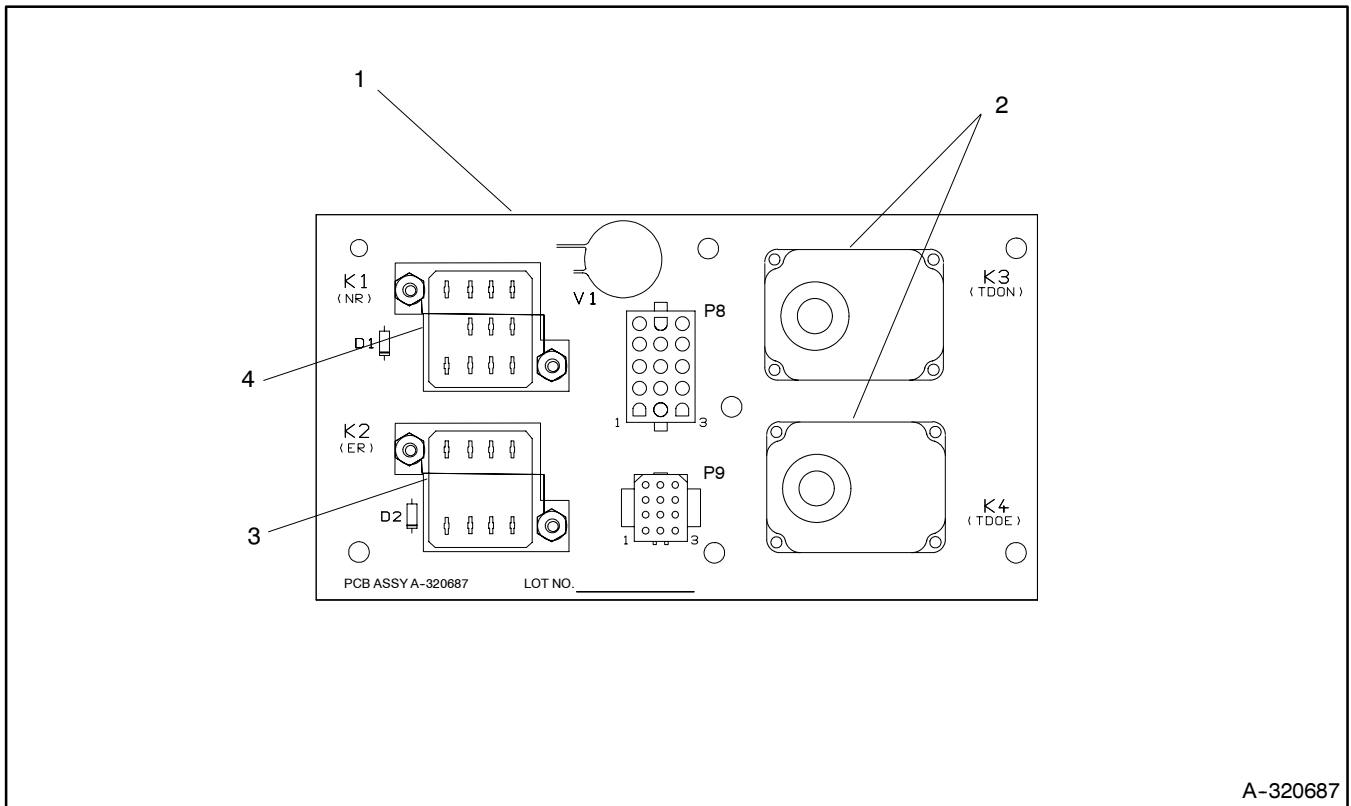

A-320687

Item	Description	Part Number
1	Interface Board	A-320687
2	Relay, Time Delay	(2) 320695
3	Relay, K2 (ER)	294571
4	Relay, K1 (NR)	320889

8.8 Neutral Lugs

40–160 Amps

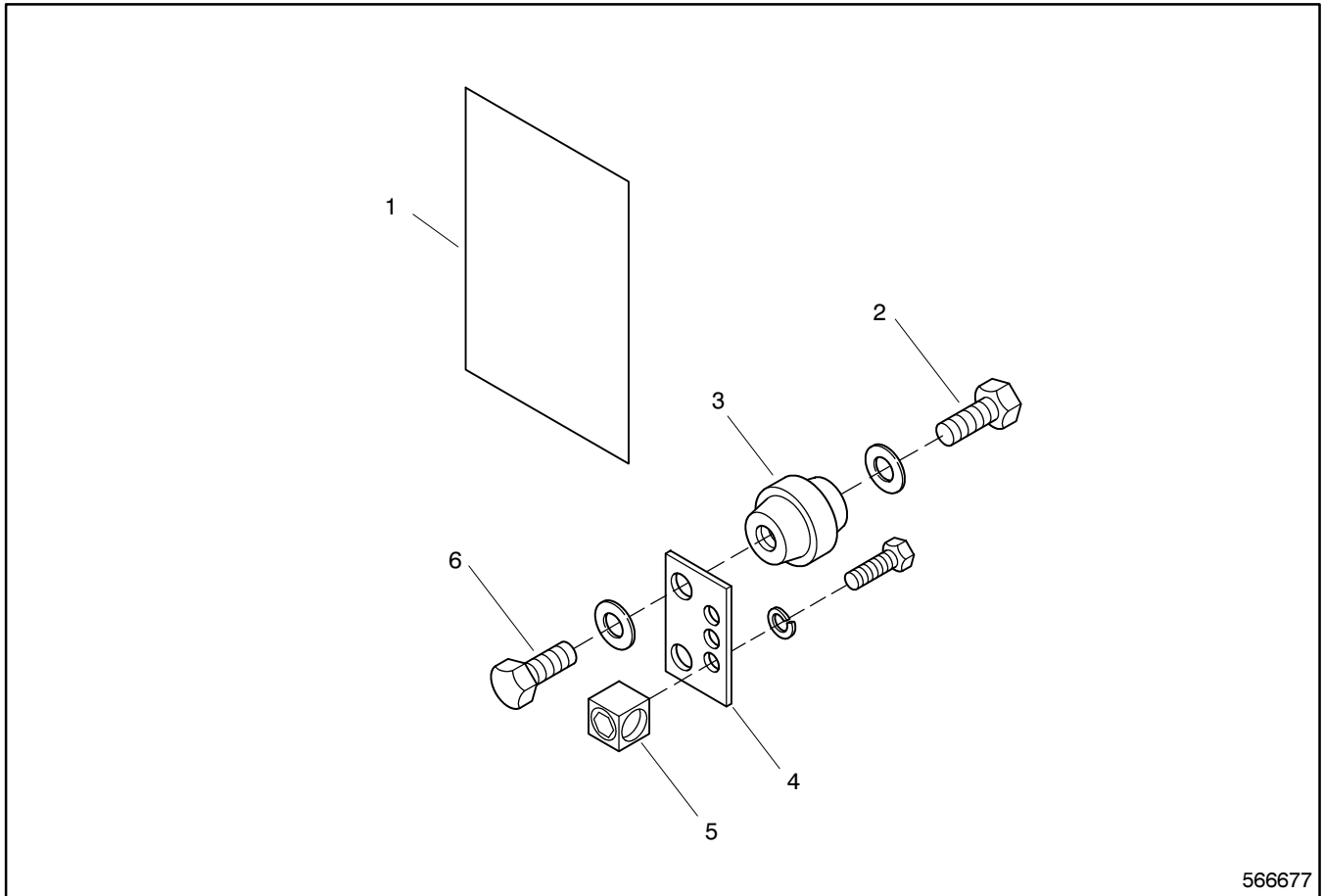

566677

Item	Description	Part Number	
		40–100 Amp	160 Amp
1	Decal, torque	297556	297556
2	Screw, 1/4-20 x 0.38	(2) X-465-17	(2) X-465-17
3	Insulator, standoff	(2) 233269	(2) 233269
4	Bracket, mounting	295304	297713
5	Lug terminal	(3) 295303	(3) 297712
6	Screw, 1/4-20 x 0.5	(2) X-465-6	(2) X-465-6

Neutral Lugs

250–400 Amps

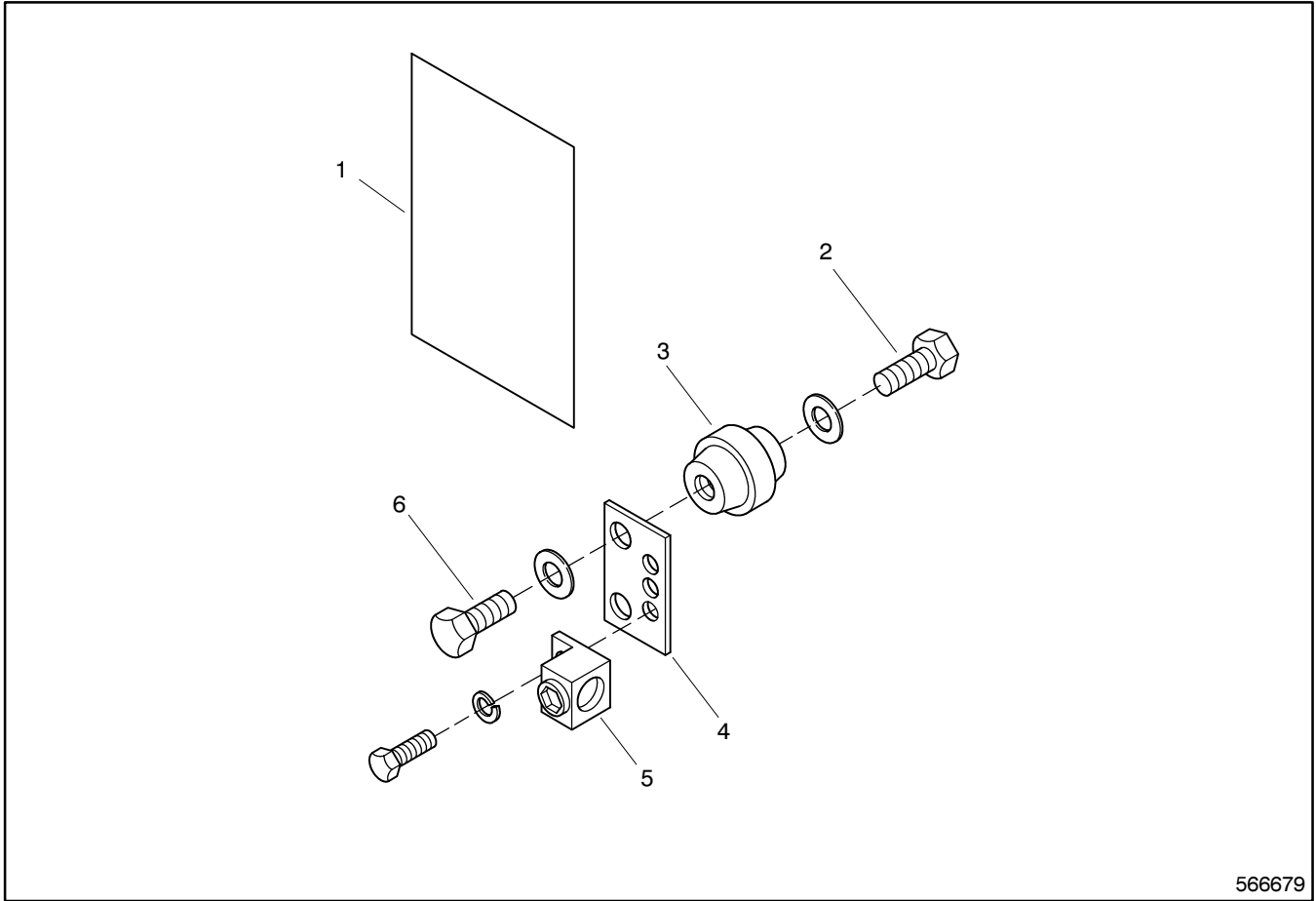

566679

Item	Description	Part Number	
		250 Amp	400 Amp
1	Decal, torque	297556	297556
2	Screw, 3/8-16 x 0.62	(3) X-6238-2	(3) X-6238-2
3	Insulator, standoff	(2) 233568	(4) 233568
4	Bracket, mounting	294362	294359
5	Lug terminal	(2) X-6207-5	(4) X-6207-9
6	Screw, 3/8-16 x 0.75	(2) X-6238-10	(4) X-6238-10

Neutral Lugs

630 Amps

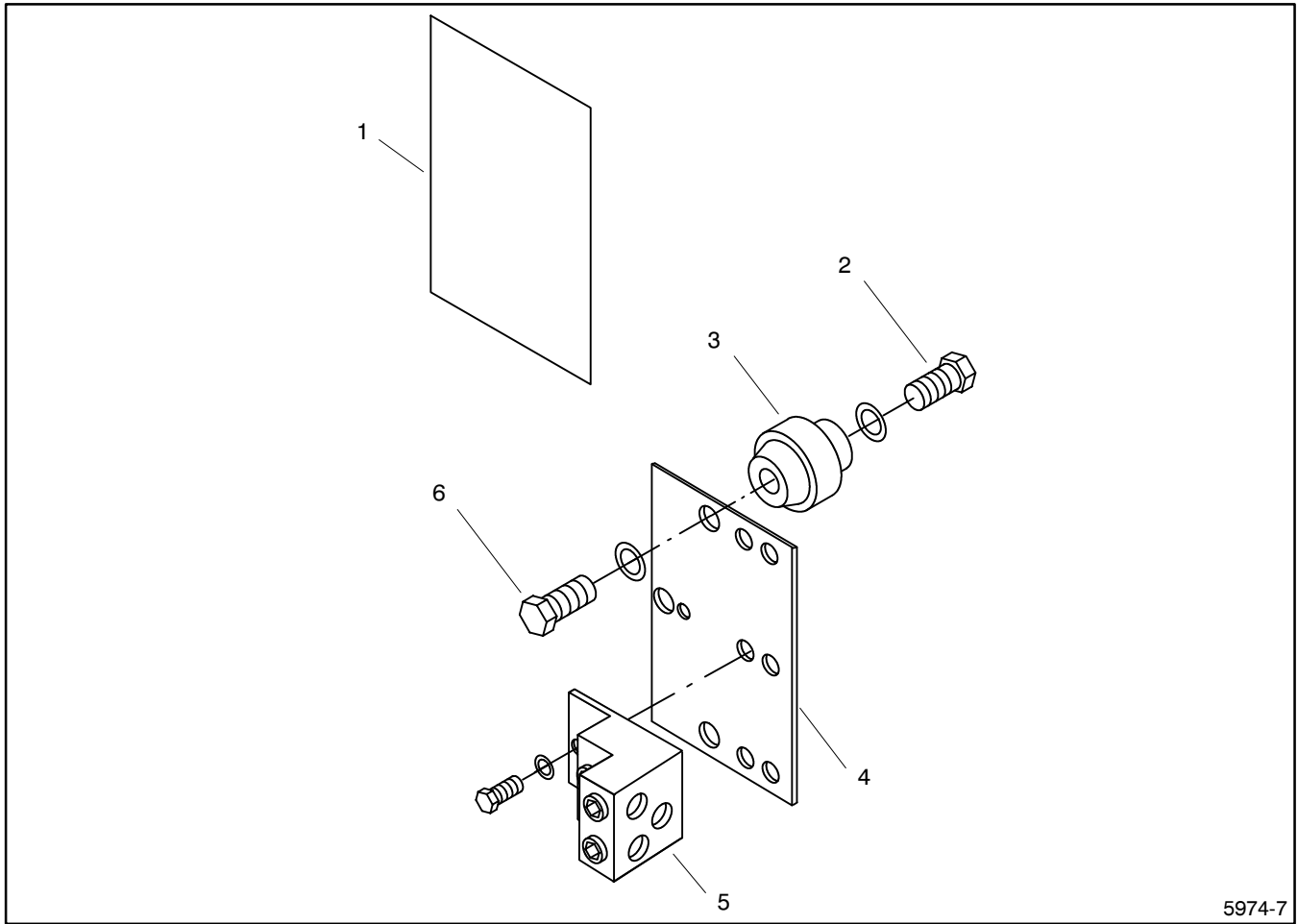

5974-7

Item	Description	Part Number
1	Decal, torque	297556
2	Screw, 3/8-16 x 0.75	(4) X-6238-2
3	Insulator, standoff	(4) 233568
4	Bracket, mounting	295298
5	Lug terminal	(3) 295296

8.9 Load Bus Assembly

800-1250 Amps, 3 and 4 Poles

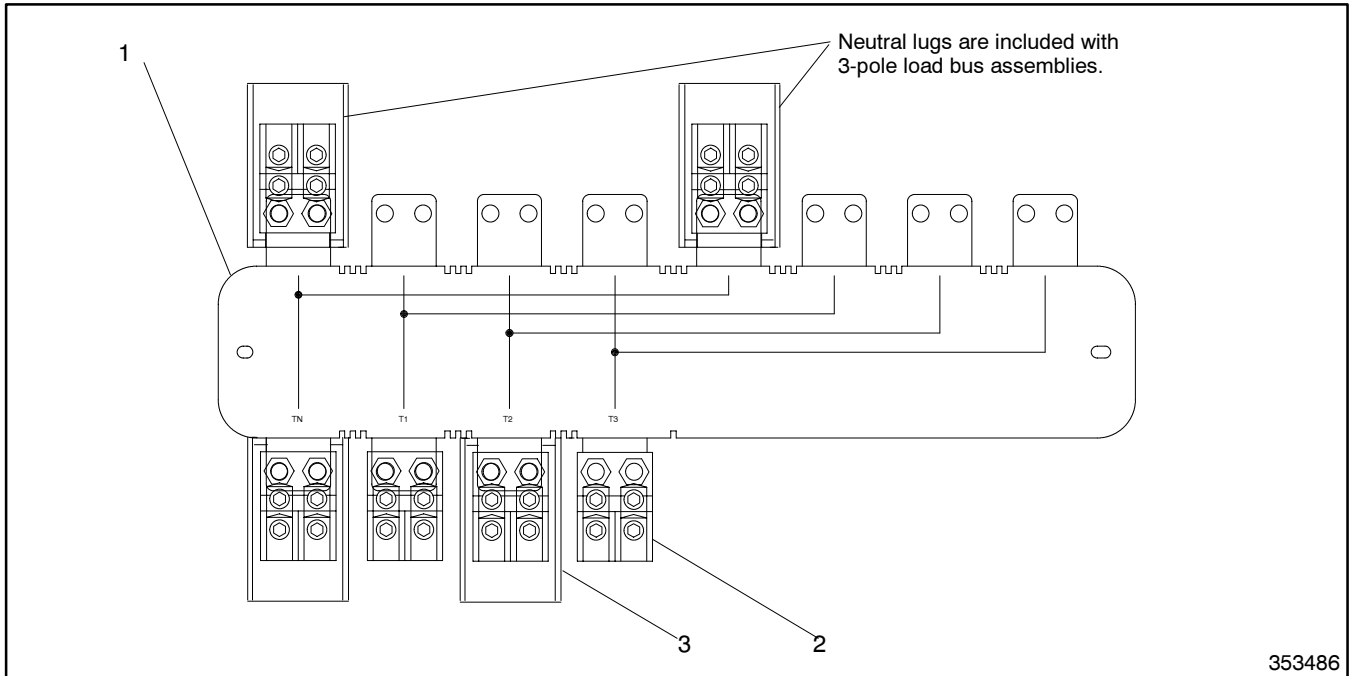

Item	Description	Part Number
1	Load bus assembly	353486
2	Load lug	362455
3	Phase barrier	362456

8.10 Power Switch Assemblies

40 Amps, 3 Poles

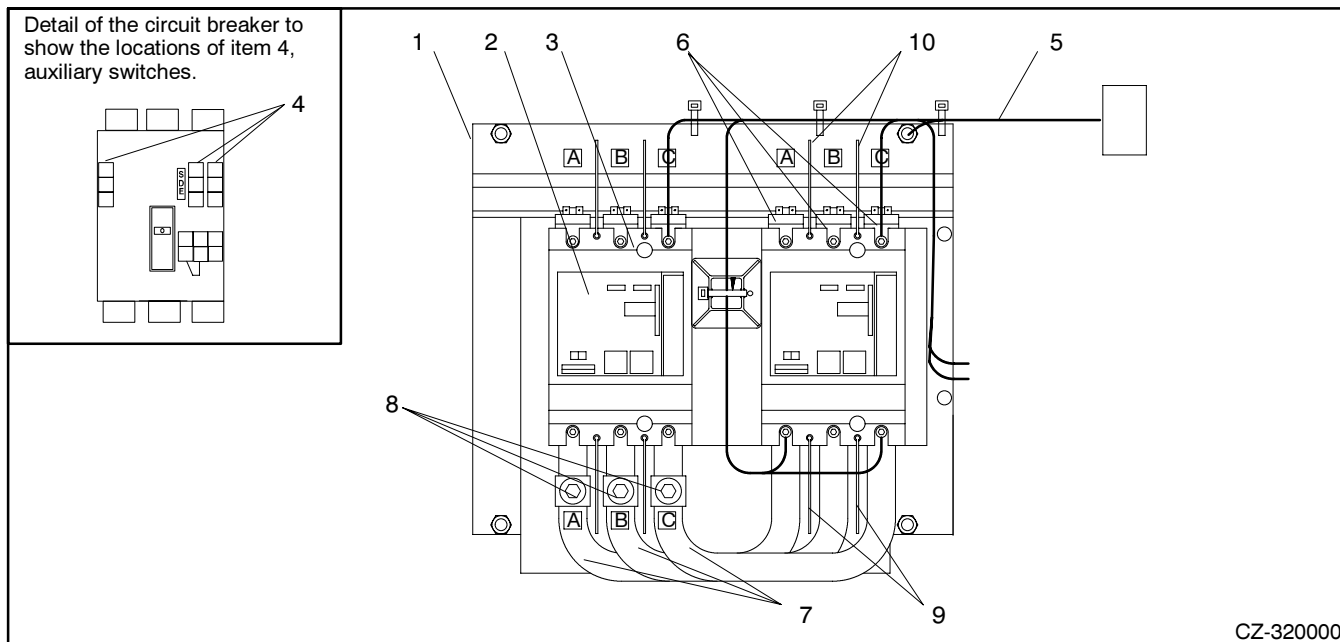

Item	Description	Part Number
1	Assembly, power switch	See table below
2	Operator, motor	See table below
3	Circuit breaker	(2) A-353512
4	Switch, auxiliary	(3) X-6315-14
5	Harness, wiring	353540
6	Lugs, line side (set of 3)	(2) 353579
7	Load bus bars (set of 3)	353587
8	Load lugs (set of 3)	353592
9	Phase barrier, load	353596
10	Phase barrier, line (set of 6)	362328
11	Voltage taps, (not shown)	(3) 362329

ATS Rating, Volts	Power Switch Assembly (Item 1)	Motor Operator (Item 2)
110/127	A-353229	(2) X-6309-19
208/220/240/277	A-353230	(2) X-6309-20
380/415/440/480	A-353231	(2) X-6309-21
600	A-353230	(2) X-6309-20

Power Switch Assemblies

40 Amps, 4 Poles

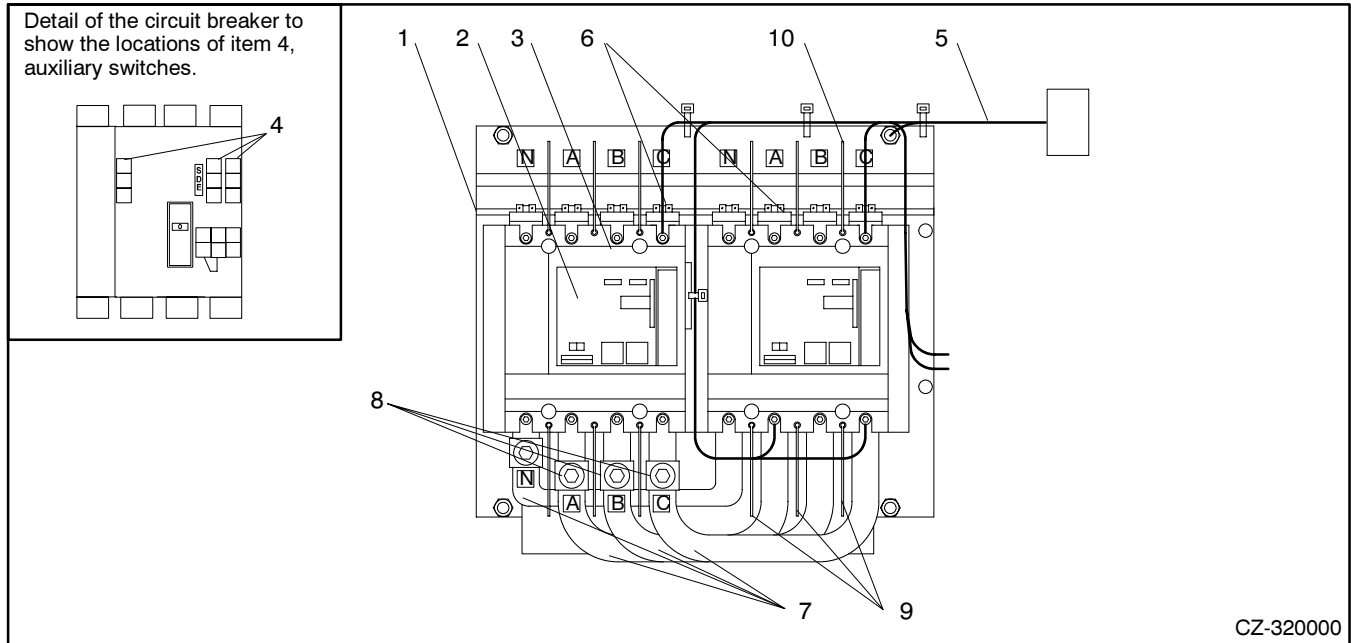

Item	Description	Part Number
1	Assembly, power switch	See table below
2	Operator, motor	See table below
3	Circuit breaker	(2) A-353519
4	Switch, auxiliary	(3) X-6315-14
5	Harness, wiring	353540
6	Lugs, line side (set of 4)	(2) 353583
7	Load bus bars (set of 4)	353590
8	Load lugs (set of 4)	362326
9	Phase barrier, load	353596
10	Phase barrier, line (set of 6)	362328
11	Voltage taps (not shown)	(3) 362329

ATS Rating, Volts	Power Switch Assembly (Item 1)	Motor Operator (Item 2)
110/127	A-353253	(2) X-6309-19
208/220/240/277	A-353254	(2) X-6309-20
380/415/440/480	A-353255	(2) X-6309-21
600	A-353254	(2) X-6309-20

Power Switch Assemblies

80 Amps, 3 Poles

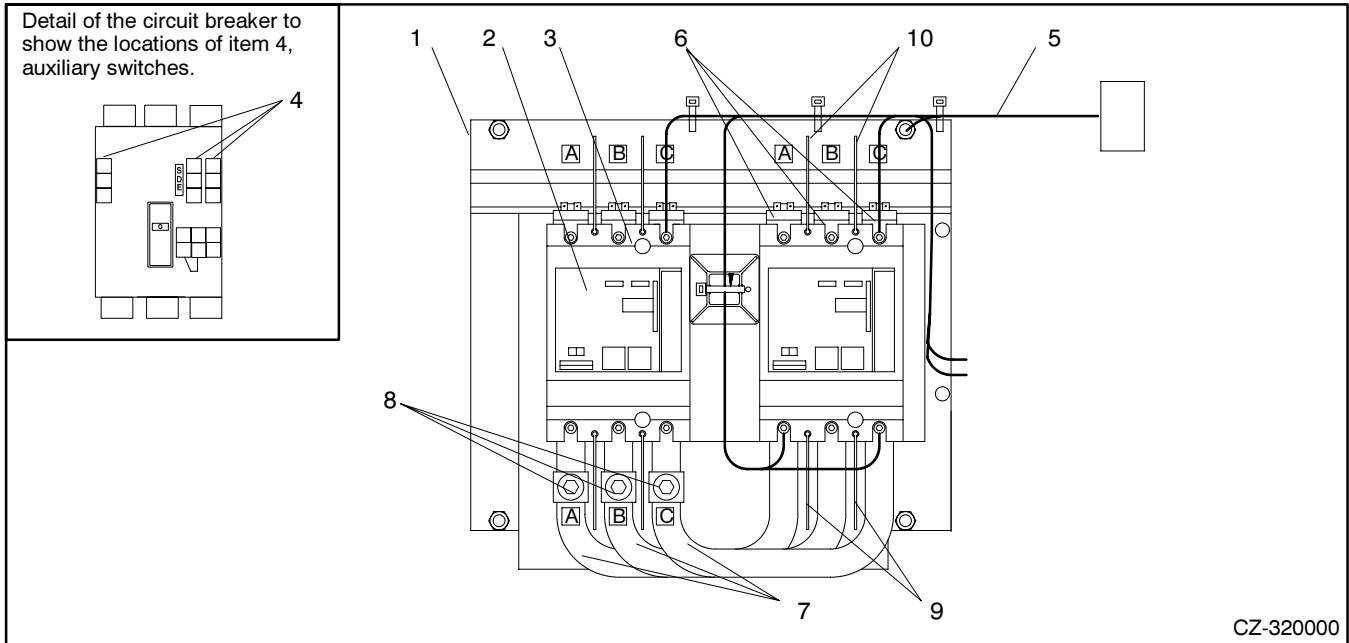

Item	Description	Part Number
1	Assembly, power switch	See table below
2	Operator, motor	See table below
3	Circuit breaker	(2) A-353513
4	Switch, auxiliary	(3) X-6315-14
5	Harness, wiring	353540
6	Lugs, line side (set of 3)	(2) 353579
7	Load bus bars (set of 3)	353587
8	Load lugs (set of 3)	353589
9	Phase barrier, load	353596
10	Phase barrier, line (set of 6)	362328
11	Voltage taps, (not shown)	(3) 362329

ATS Rating Data	Power Switch Assembly (Item 1)	Motor Operator (Item 2)
110/127	A-353232	(2) X-6309-19
208/220/240/277	A-353233	(2) X-6309-20
380/415/440/480	A-353234	(2) X-6309-21
600	A-353233	(2) X-6309-20

Power Switch Assemblies

80 Amps, 4 Poles

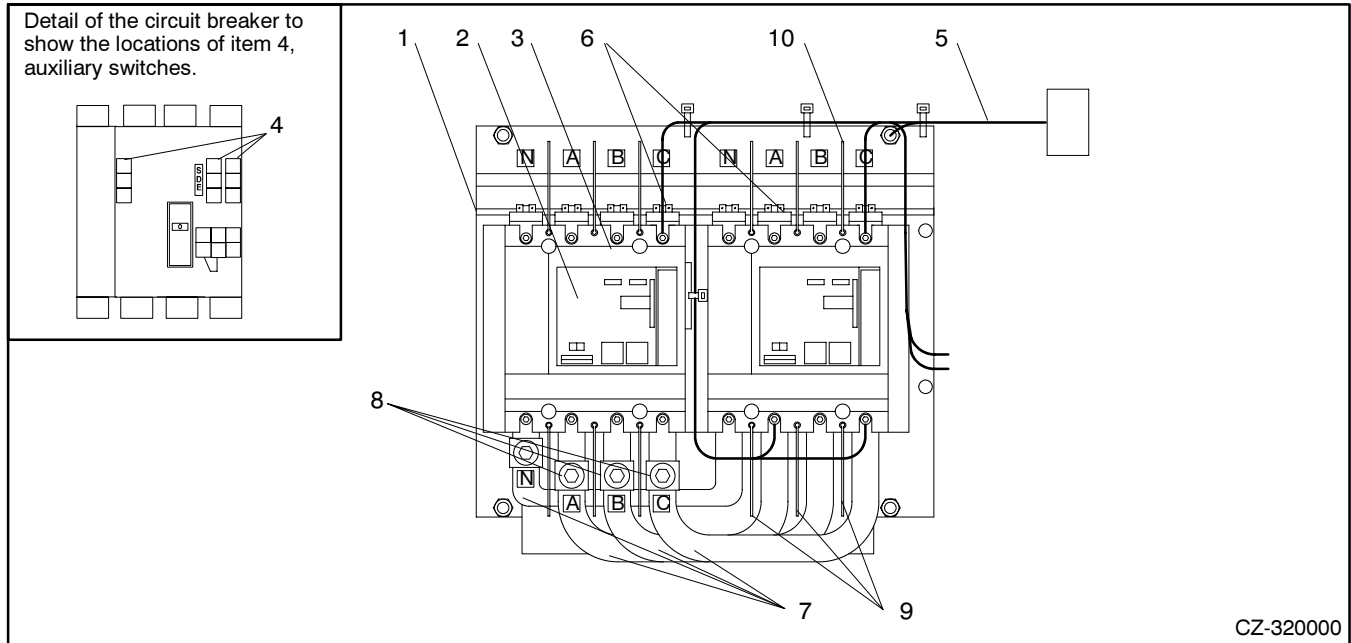

Item	Description	Part Number
1	Assembly, power switch	See table below
2	Operator, motor	See table below
3	Circuit breaker/switch	(2) A-353520
4	Switch, auxiliary	(3) X-6315-14
5	Harness, wiring	353540
6	Line lugs (set of 4)	(2) 353583
7	Load bus bars (set of 4)	353590
8	Load lugs (set of 4)	362326
9	Phase barriers, load	353596
10	Phase barriers, line (set of 6)	362328
11	Voltage taps, (not shown)	(3) 362329

ATS Rating, Volts	Power Switch Assembly (Item 1)	Motor Operator (Item 2)
110/127	A-353256	(2) X-6309-19
208/220/240/277	A-353257	(2) X-6309-20
380/415/440/480	A-353258	(2) X-6309-21
600	A-353257	(2) X-6309-20

Power Switch Assemblies

100 Amps, 3 Poles

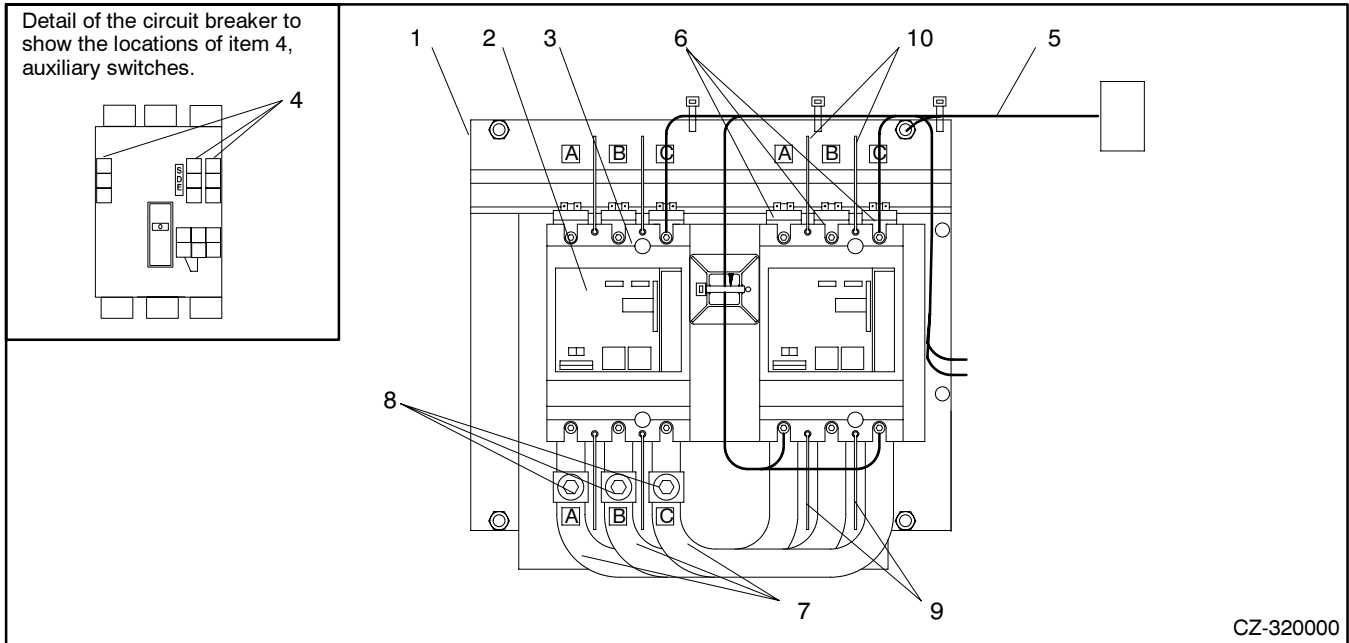

Item	Description	Part Number	
		Circuit Breaker	Switch
1	Assembly, power switch	See table below	See table below
2	Operator, motor	See table below	See table below
3	Circuit breaker/switch	(2) A-353514	(2) A-353502
4	Switch, auxiliary	(3) X-6315-14	(3) X-6315-14
5	Harness, wiring	353540	353540
6	Line lugs (set of 3)	(2) 353579	(2) 353579
7	Load bus bars (set of 3)	353587	353587
8	Load lugs (set of 3)	353589	353589
9	Phase barrier, load	353596	353596
10	Phase barrier, line (set of 6)	362328	362328
11	Voltage taps, (not shown)	(3) 362329	(3) 362329

ATS Rating, Volts	Power Switch Assembly (Item 1)		Motor Operator (Item 2)
	Circuit Breaker	Switch	
110/127	A-353235	A-353195	(2) X-6309-19
208/220/240/277	A-353236	A-353196	(2) X-6309-20
380/415/440/480	A-353237	A-353197	(2) X-6309-21
600	A-353236	A-353196	(2) X-6309-20

Power Switch Assemblies

100 Amps, 4 Poles

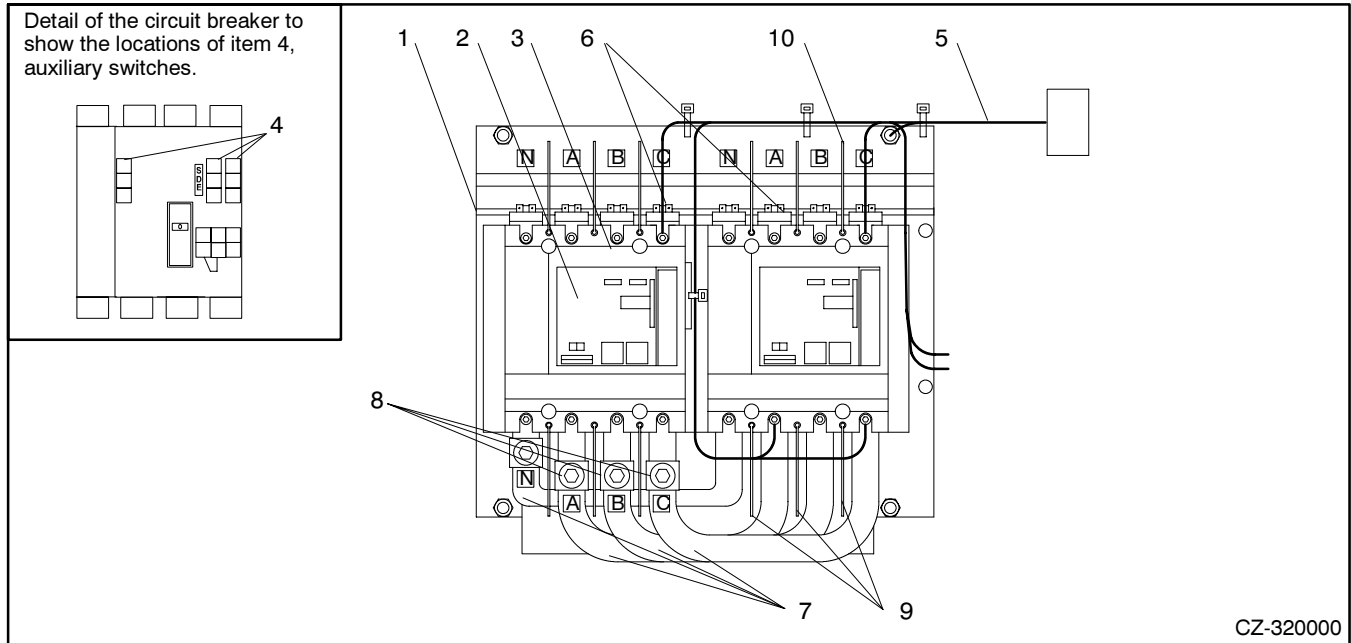

Item	Description	Part Number	
		Circuit Breaker	Switch
1	Assembly, power switch	See table below	See table below
2	Operator, motor	See table below	See table below
3	Circuit breaker/switch	(2) A-353521	(2) A-353507
4	Switch, auxiliary	(3) X-6315-14	(3) X-6315-14
5	Harness, wiring	353540	353540
6	Line lugs (set of 4)	(2) 353579	(2) 353579
7	Load bus bars (set of 4)	353587	353587
8	Load lugs (set of 4)	353589	353589
9	Phase barriers, load	353596	353596
10	Phase barriers, line (set of 6)	362328	362328
11	Voltage taps (not shown)	(3) 362329	(3) 362329

ATS Rating, Volts	Power Switch Assembly (Item 1)		Motor Operator (Item 2)
	Circuit Breaker	Switch	
110/127	A-353259	A-353212	(2) X-6309-19
208/220/240/277	A-353260	A-353213	(2) X-6309-20
380/415/440/480	A-353261	A-353214	(2) X-6309-21
600	A-353260	A-353213	(2) X-6309-20

Power Switch Assemblies

160 Amps, 3 Poles

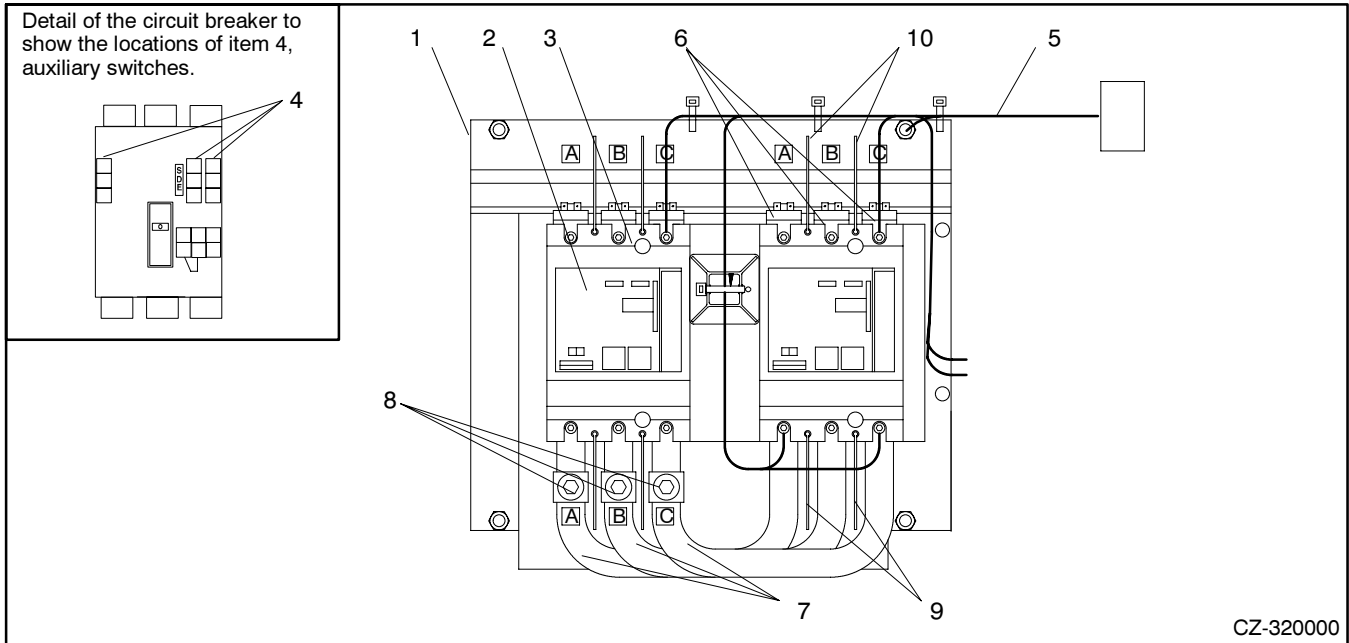

Item	Description	Part Number	
		Circuit Breaker	Switch
1	Assembly, power switch	See table below	See table below
2	Operator, motor	See table below	See table below
3	Circuit breaker/switch	(2) A-353515	(2) A-353503
4	Switch, auxiliary	(3) X-6315-14	(3) X-6315-14
5	Harness, wiring	353540	353540
6	Line lugs (set of 3)	(2) 353579	(2) 353579
7	Load bus bars (set of 3)	353587	353587
8	Load lugs (set of 3)	353589	353589
9	Phase barrier, load	353596	353596
10	Phase barrier, line (set of 6)	362328	362328
11	Voltage taps (not shown)	(3) 362329	(3) 362329

ATS Rating, Volts	Power Switch Assembly (Item 1)		Motor Operator (Item 2)
	Circuit Breaker	Switch	
110/127	A-353238	A-353198	(2) X-6309-19
208/220/240/277	A-353239	A-353199	(2) X-6309-20
380/415/440/480	A-353240	A-353200	(2) X-6309-21
600	A-353239	A-353199	(2) X-6309-20

Power Switch Assemblies

160 Amps, 4 Poles

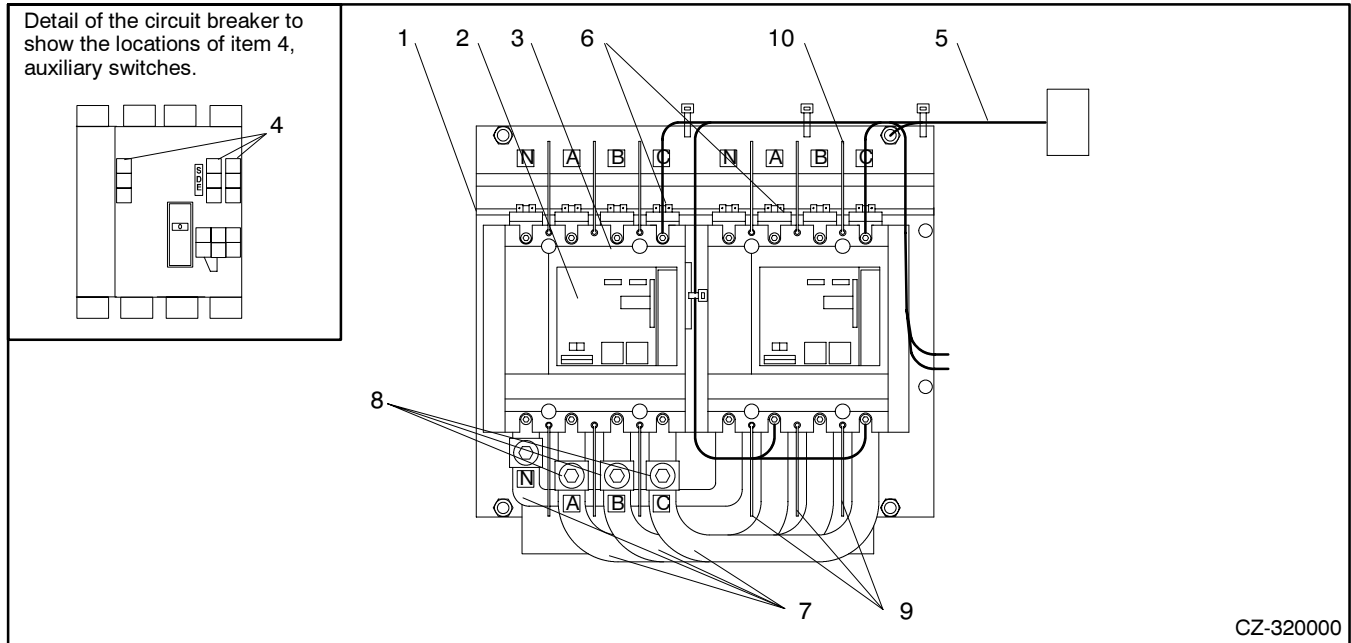

Item	Description	Part Number	
		Circuit Breaker	Switch
1	Assembly, power switch	See table below	See table below
2	Operator, motor	See table below	See table below
3	Circuit breaker/switch	(2) A-353522	(2) A-353508
4	Switch, auxiliary	(3) X-6315-14	(3) X-6315-14
5	Harness, wiring	353540	353540
6	Line lugs (set of 4)	(2) 353579	(2) 353579
7	Load bus bars (set of 4)	353587	353587
8	Load lugs (set of 4)	353589	353589
9	Phase barriers, load	362328	362328
10	Phase barriers, line (set of 6)	353596	353596
11	Voltage taps (not shown)	(3) 362329	(3) 362329

ATS Rating, Volts	Power Switch Assembly (Item 1)		Motor Operator (Item 2)
	Circuit Breaker	Switch	
110/127	A-353262	A-353215	(2) X-6309-19
208/220/240/277	A-353263	A-353216	(2) X-6309-20
380/415/440/480	A-353264	A-353217	(2) X-6309-21
600	A-353263	A-353216	(2) X-6309-20

Power Switch Assemblies

250 Amps, 3 Poles

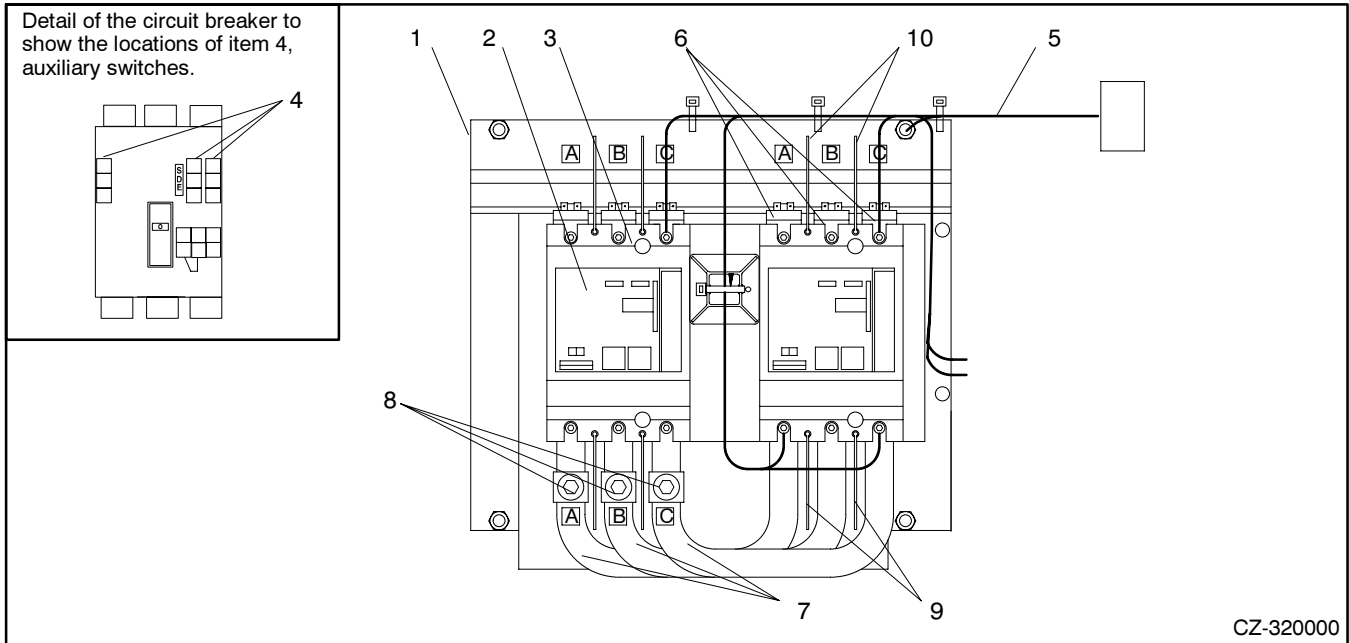

Item	Description	Part Number	
		Circuit Breaker	Switch
1	Assembly, power switch	See table below	See table below
2	Operator, motor	See table below	See table below
3	Circuit breaker/switch	(2) A-353516	(2) A-353504
4	Switch, auxiliary	(3) X-6315-14	(3) X-6315-14
5	Harness, wiring	353540	353540
6	Line lugs (set of 3)	(2) 353580	(2) 353580
7	Load bus bars (set of 3)	353587	353587
8	Load lugs (set of 3)	353589	353589
9	Phase barrier, line (set of 6)	362328	362328
10	Phase barrier, load	353596	353596
11	Voltage taps, line (not shown)	(2) 362329	(2) 362329
12	Voltage taps, load (not shown)	353586	353586

ATS Rating, Volts	Power Switch Assembly (Item 1)		Motor Operator (Item 2)
	Circuit Breaker	Switch	
110/127	A-353241	A-353201	(2) X-6309-22
208/220/240/277	A-353242	A-353202	(2) X-6309-23
380/415/440/480	A-353243	A-353203	(2) X-6309-24
600	A-353242	A-353202	(2) X-6309-23

Power Switch Assemblies

250 Amps, 4 Poles

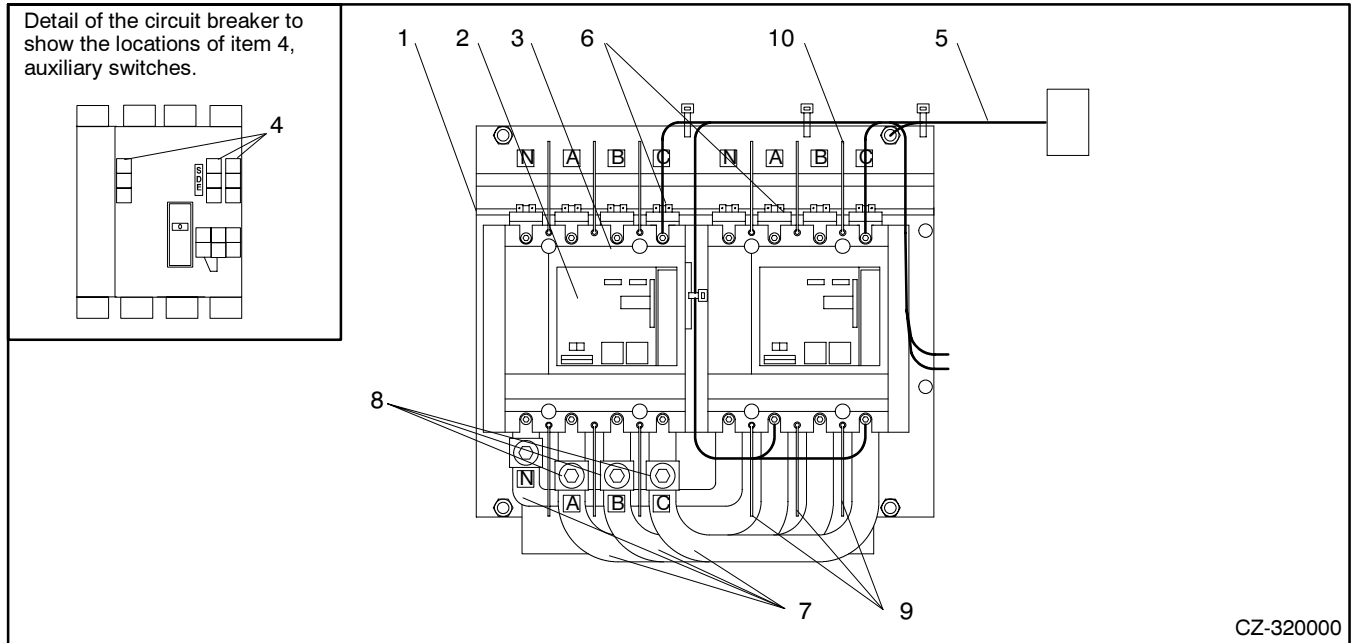

Item	Description	Part Number	
		Circuit Breaker	Switch
1	Assembly, power switch	See table below	See table below
2	Operator, motor	See table below	See table below
3	Circuit breaker/switch	(2) A-353523	(2) A-353509
4	Switch, auxiliary	(3) X-6315-14	(3) X-6315-14
5	Harness, wiring	353540	353540
6	Line lugs (set of 4)	(2) 353584	(2) 353584
7	Load bus bars (set of 4)	353590	353590
8	Load lugs (set of 4)	362327	362326
9	Phase barriers, line (set of 6)	362328	362328
10	Phase barriers, load	353596	353596
11	Voltage taps, line (not shown)	(2) 362329	(2) 362329
12	Voltage taps, load (not shown)	353586	353586

ATS Rating, Volts	Power Switch Assembly (Item 1)		Motor Operator (Item 2)
	Circuit Breaker	Switch	
110/127	A-353265	A-353218	(2) X-6309-22
208/220/240/277	A-353266	A-353219	(2) X-6309-23
380/415/440/480	A-353267	A-353220	(2) X-6309-24
600	A-353266	A-353219	(2) X-6309-23

Power Switch Assemblies

400 Amps, 3 Poles

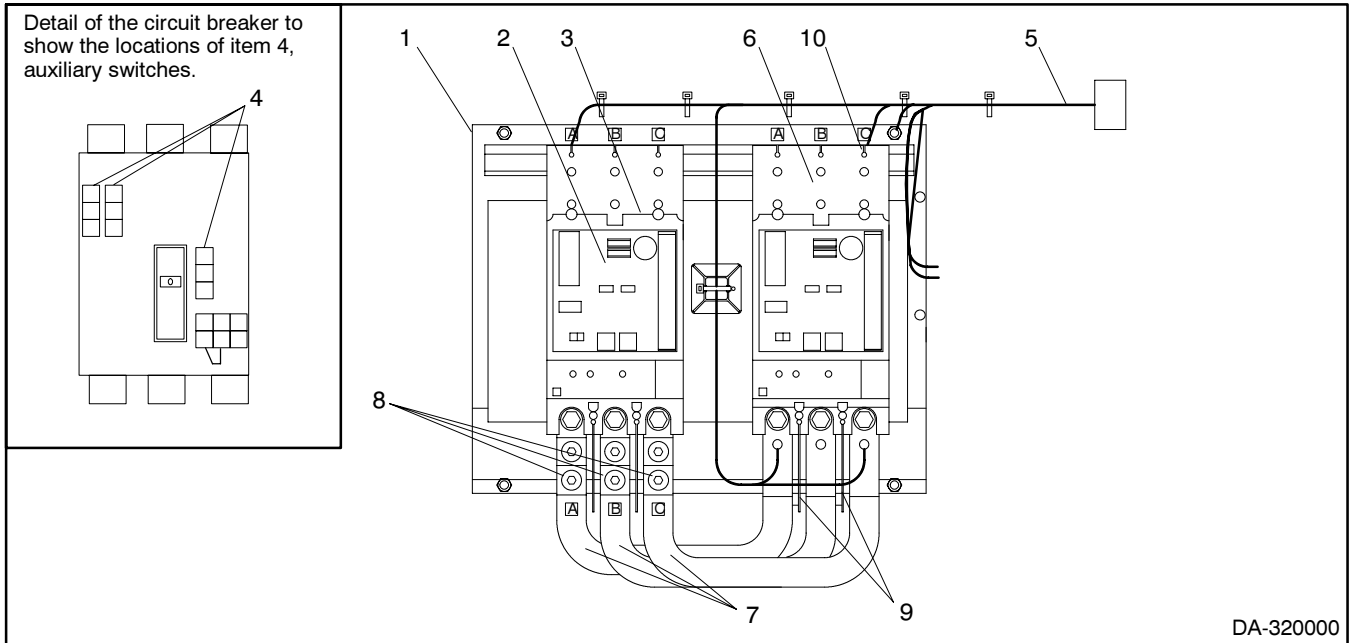

Item	Description	Part Number	
		Circuit Breaker	Switch
1	Assembly, power switch	See table below	See table below
2	Operator, motor	See table below	See table below
3	Circuit breaker/switch	(2) A-353517	(2) A-353505
4	Switch, auxiliary	(2) X-6315-14	(2) X-6315-14
5	Harness, wiring	353541	353541
6	Line lugs (set of 3)	(2) 353581	(2) 353581
7	Load bus bars (set of 3)	353588	353588
8	Load lugs (set of 3)	353581	353581
9	Phase barrier, load	353596	353596
10	Phase barrier, line (set of 6)	362328	362328
11	Voltage taps (not shown)	(3) 353586	(3) 353586

ATS Rating, Volts	Power Switch Assembly (Item 1)		Motor Operator (Item 2)
	Circuit Breaker	Switch	
110/127	A-353245	A-353204	(2) X-6309-25
208/220/240/277	A-353246	A-353205	(2) X-6309-26
380/415	A-353247	A-353206	(2) X-6309-27
440/480	A-353248	A-353207	(2) X-6309-28
600	A-353246	A-353205	(2) X-6309-26

Power Switch Assemblies

400 Amps, 4 Poles

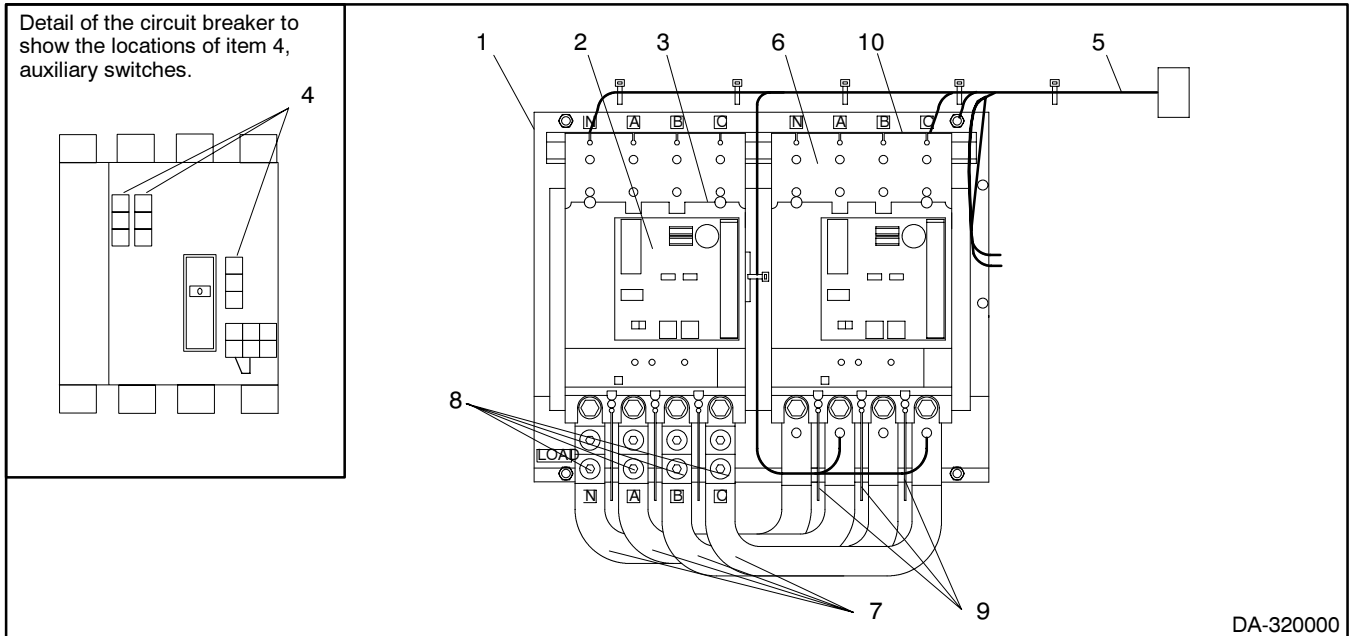

Item	Description	Part Number	
		Circuit Breaker	Switch
1	Assembly, power switch	See table below	See table below
2	Operator, motor	See table below	See table below
3	Circuit breaker/switch	(2) A-353524	(2) A-353510
4	Switch, auxiliary	(2) X-6315-14	(2) X-6315-14
5	Harness, wiring	353541	353541
6	Line lugs (set of 4)	(2) 353585	(2) 353585
7	Load bus bars (set of 4)	353591	353591
8	Load lugs (set of 4)	353585	353585
9	Phase barrier, load	353596	353596
10	Phase barrier, line (set of 6)	362328	362328
11	Voltage taps (not shown)	(3) 353586	(3) 353586

ATS Rating, Volts	Power Switch Assembly (Item 1)		Motor Operator (Item 2)
	Circuit Breaker	Switch	
110/127	A-353269	A-353221	(2) X-6309-25
208/220/240/277	A-353270	A-353222	(2) X-6309-26
380/415	A-353271	A-353223	(2) X-6309-27
440/480	A-353272	A-353224	(2) X-6309-28
600	A-353270	A-353222	(2) X-6309-26

Power Switch Assemblies

630 Amps, 3 Poles

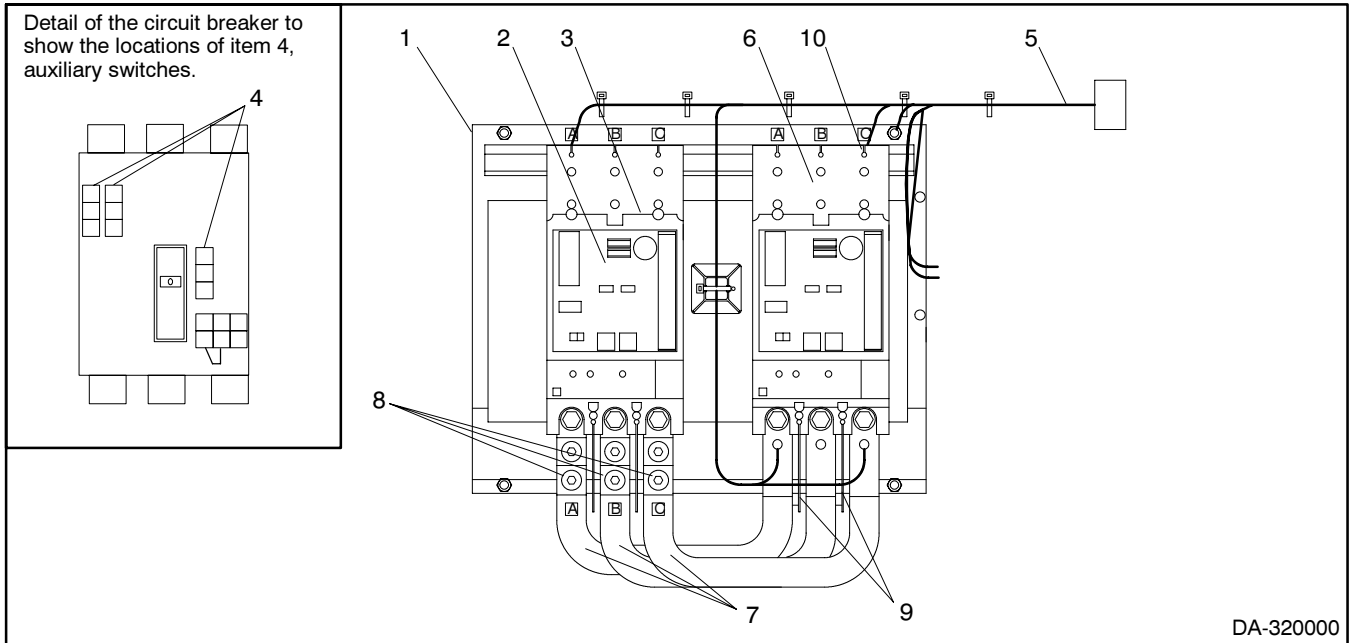

Item	Description	Part Number	
		Circuit Breaker	Switch
1	Assembly, power switch	See table below	See table below
2	Operator, motor	See table below	See table below
3	Circuit breaker/switch	(2) A-353518	(2) A-353506
4	Switch, auxiliary	(2) X-6315-14	(2) X-6315-14
5	Harness, wiring	353541	353541
6	Line lugs (set of 3)	(2) 353582	(2) 353581
7	Load bus bars (set of 3)	353588	353588
8	Load lugs (set of 3)	353582	353581
9	Phase barrier, load	353596	353596
10	Phase barrier, line (set of 6)	362328	362328
11	Voltage taps (not shown)	(3) 353586	(3) 353586

ATS Rating, Volts	Power Switch Assembly (Item 1)		Motor Operator (Item 2)
	Circuit Breaker	Switch	
110/127	A-353249	A-353208	(2) X-6309-29
208/220/240/277	A-353250	A-353209	(2) X-6309-30
380/415	A-353251	A-353210	(2) X-6309-31
440/480	A-353252	A-353211	(2) X-6309-32
600	A-353250	A-353209	(2) X-6309-30

Power Switch Assemblies

630 Amps, 4 Poles

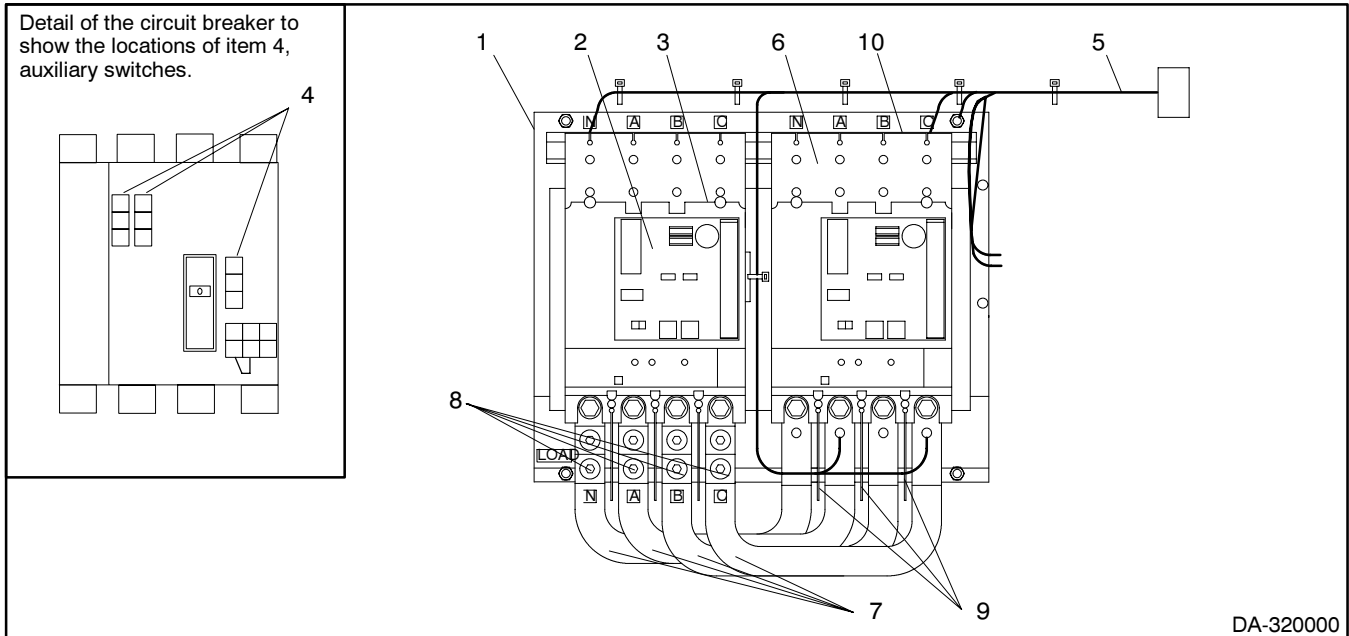

Item	Description	Part Number	
		Circuit Breaker	Switch
1	Assembly, power switch	See table below	See table below
2	Operator, motor	See table below	See table below
3	Circuit breaker/switch	(2) A-353545	(2) A-353511
4	Switch, auxiliary	(2) X-6315-14	(2) X-6315-14
5	Harness, wiring	353541	353541
6	Line lugs (set of 4)	(2) 353595	(2) 353595
7	Load bus bars (set of 4)	353591	353591
8	Load lugs (set of 4)	353595	353595
9	Phase barrier, load	353596	353596
10	Phase barrier, line (set of 6)	362328	362328
11	Voltage taps (not shown)	(3) 353586	(3) 353586

ATS Rating, Volts	Power Switch Assembly (Item 1)		Motor Operator (Item 2)
	Circuit Breaker	Switch	
110/127	A-353273	A-353225	(2) X-6309-29
208/220/240/277	A-353274	A-353226	(2) X-6309-30
380/415	A-353275	A-353227	(2) X-6309-31
440/480	A-353276	A-353228	(2) X-6309-32
600	A-353274	A-353226	(2) X-6309-30

Power Switch Assemblies

800 Amps, 3 Poles

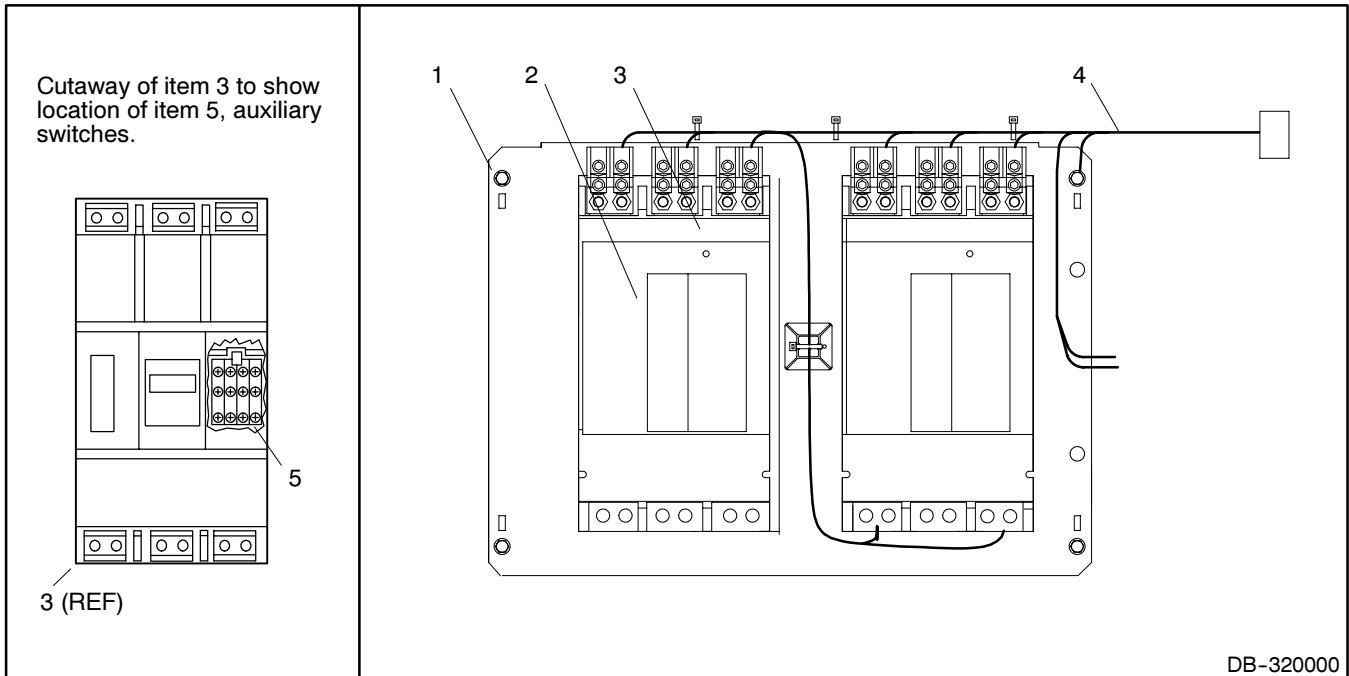

Item	Description	Part Number	
		Circuit Breaker	Switch
1	Assembly, power switch	See table below	See table below
2	Operator, motor	See table below	See table below
3	Circuit breaker/switch	(2) A-330297	(2) A-353506
4	Harness, wiring	353542	353542
5	Switch, auxiliary	(2) X-6315-13	(2) X-6315-13
6	Interlocks, mechanical (not shown)	X-6311-1	X-6311-1

ATS Rating, Volts	Power Switch Assembly (Item 1)		Motor Operator (Item 2)
	Circuit Breaker	Switch	
208/220/240	A-330647	A-330779	(2) X-6309-17
380/415	A-330648	A-330780	(2) X-6309-29
440/480	A-330649	A-330781	(2) X-6309-30
600	A-330647	A-330779	(2) X-6309-17

Power Switch Assemblies

800 Amps, 4 Poles

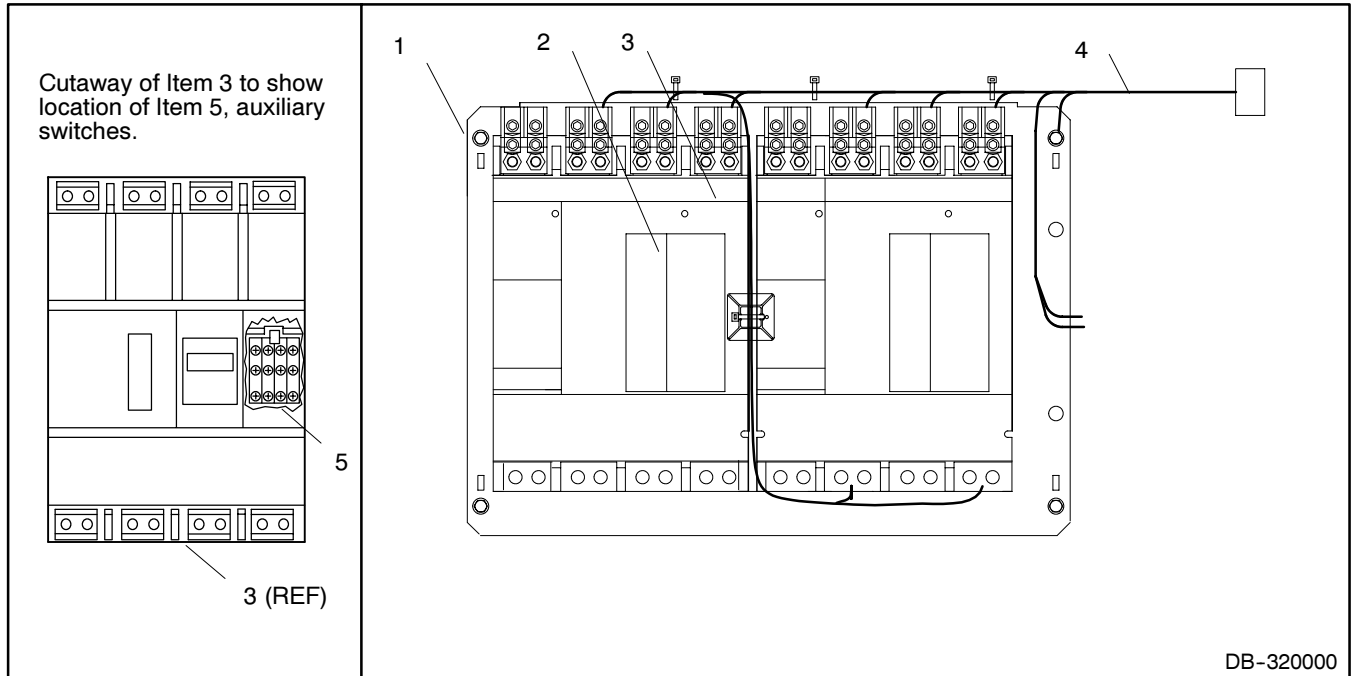

Item	Description	Part Number	
		Circuit Breaker	Switch
1	Assembly, power switch	See table below	See table below
2	Operator, motor	See table below	See table below
3	Circuit breaker/switch	A-330307	A-330172
4	Harness, wiring	353542	353542
5	Switch, auxiliary	X-6315-13	X-6315-13
6	Interlocks, mechanical (not shown)	X-6311-1	X-6311-1

ATS Rating, Volts	Power Switch Assembly (Item 1)		Motor Operator (Item 2)
	Circuit Breaker	Switch	
208/220/240	A-330717	A-330835	(2) X-6309-17
380/415	A-330718	A-330836	(2) X-6309-29
440/480	A-330719	A-330837	(2) X-6309-30
600	A-330717	A-330835	(2) X-6309-17

Power Switch Assemblies

1000 Amps, 3 Poles

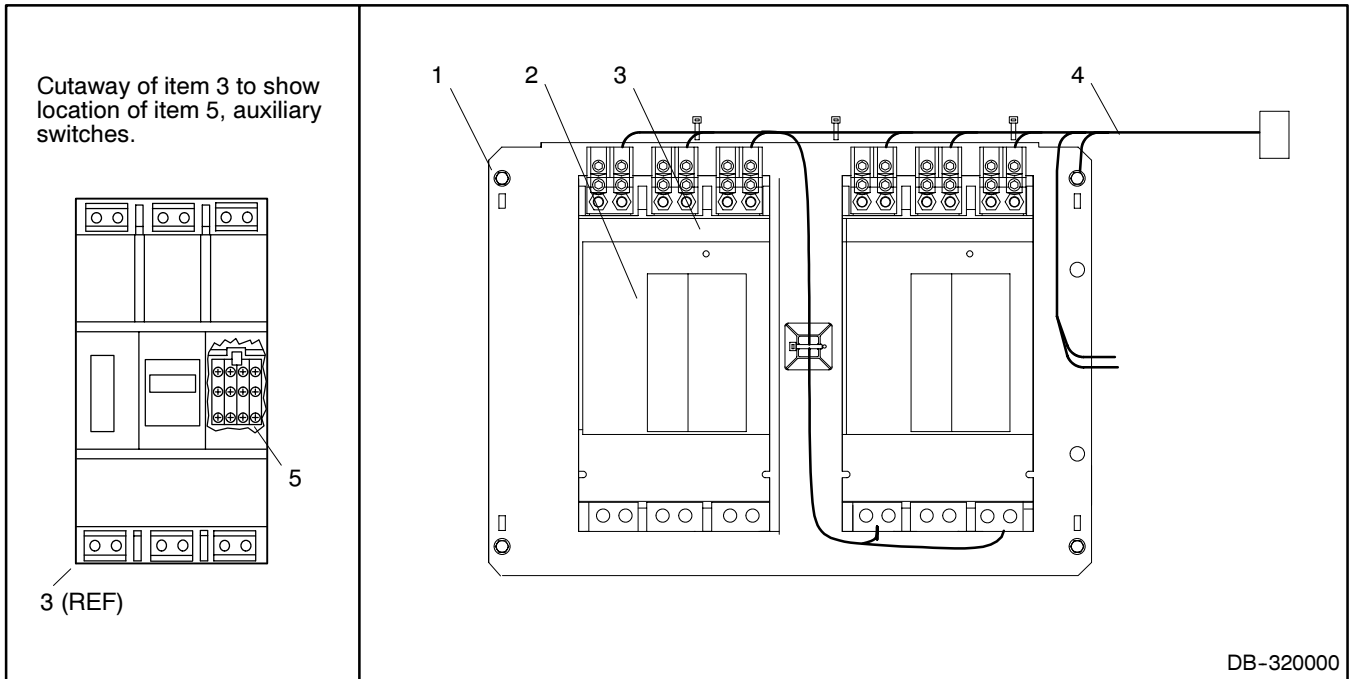

Item	Description	Part Number	
		Circuit Breaker	Switch
1	Assembly, power switch	See table below	See table below
2	Operator, motor	See table below	See table below
3	Circuit breaker/switch	A-330298	A-330161
4	Harness, wiring	353542	353542
5	Switch, auxiliary	X-6315-13	X-6315-13
6	Interlocks, mechanical (not shown)	X-6311-1	X-6311-1

ATS Rating, Volts	Power Switch Assembly (Item 1)		Motor Operator (Item 2)
	Circuit Breaker	Switch	
208/220/240	A-330652	A-330785	(2) X-6309-17
380/415	A-330653	A-330786	(2) X-6309-29
440/480	A-330654	A-330787	(2) X-6309-30
600	A-330652	A-330785	(2) X-6309-17

Power Switch Assemblies

1000 Amps, 4 Poles

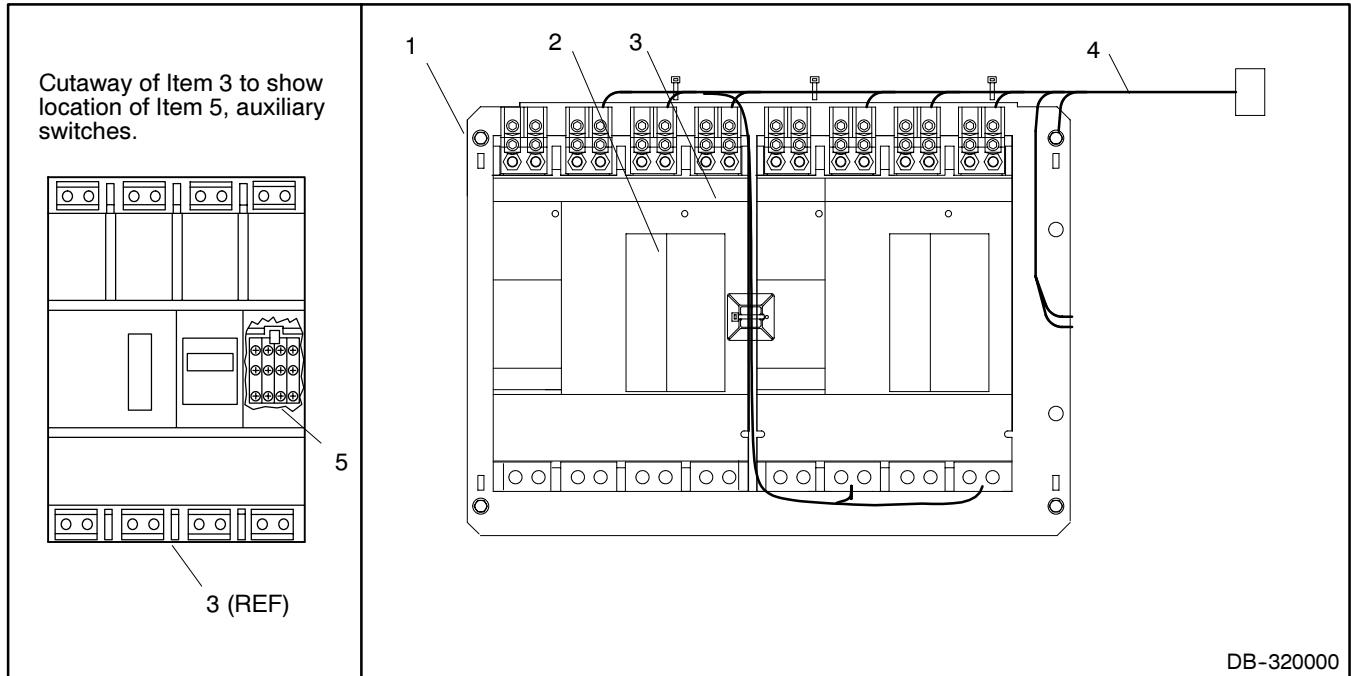

Item	Description	Part Number	
		Circuit Breaker	Switch
1	Assembly, power switch	See table below	See table below
2	Operator, motor	See table below	See table below
3	Circuit breaker/switch	A-330308	A-330173
4	Harness, wiring	353542	353542
5	Switch, auxiliary	X-6315-13	X-6315-13
6	Interlocks, mechanical (not shown)	X-6311-1	X-6311-1

ATS Rating, Volts	Power Switch Assembly (Item 1)		Motor Operator (Item 2)
	Circuit Breaker	Switch	
208/220/240	A-330722	A-330841	(2) X-6309-17
380/415	A-330723	A-330842	(2) X-6309-29
440/480	A-330724	A-330843	(2) X-6309-30
600	A-330722	A-330841	(2) X-6309-17

Power Switch Assemblies

1250 Amps, 3 Poles

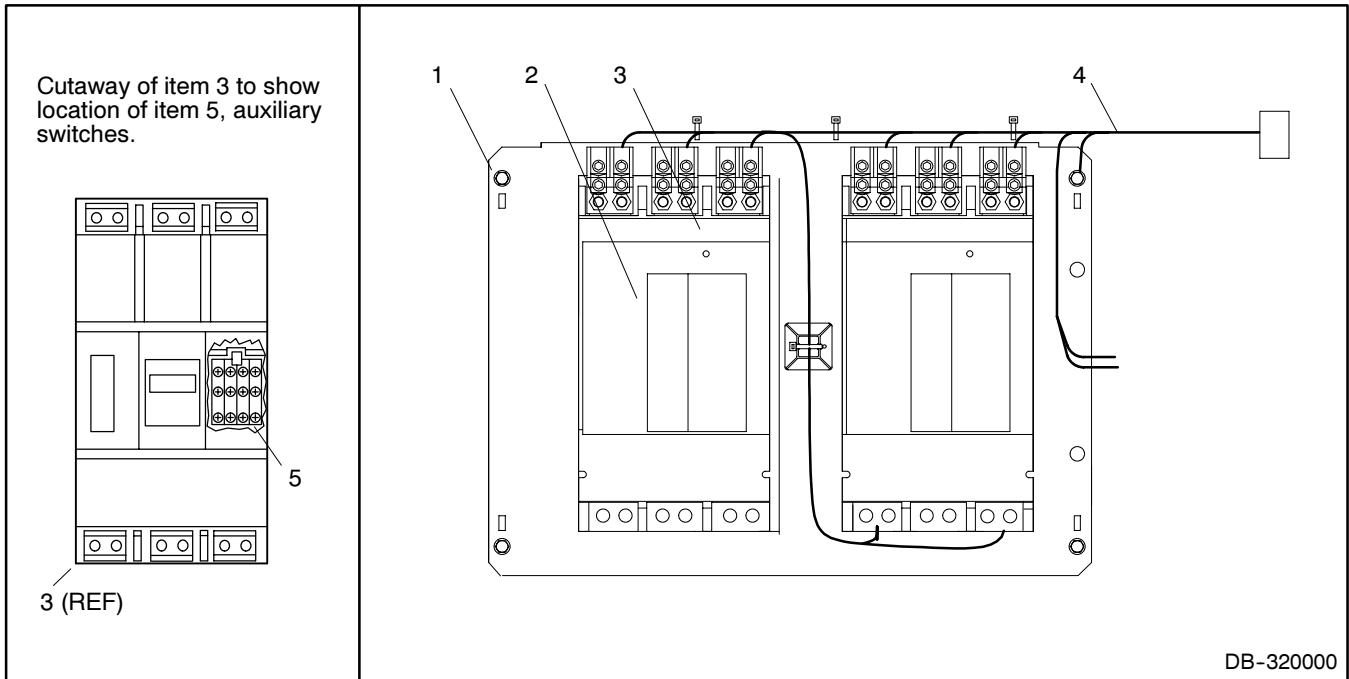

Item	Description	Part Number	
		Circuit Breaker	Switch
1	Assembly, power switch	See table below	See table below
2	Operator, motor	See table below	See table below
3	Circuit breaker/switch	A-330299	A-330161
4	Harness, wiring	353542	353542
5	Switch, auxiliary	X-6315-13	X-6315-13
6	Interlocks, mechanical (not shown)	X-6311-1	X-6311-1

ATS Rating, Volts	Power Switch Assembly (Item 1)		Motor Operator (Item 2)
	Circuit Breaker	Switch	
208/220/240	A-330657	A-330791	(2) X-6309-17
380/415	A-330658	A-330792	(2) X-6309-29
440/480	A-330659	A-330793	(2) X-6309-30
600	A-330657	A-330791	(2) X-6309-17

Power Switch Assemblies

1250 Amps, 4 Poles

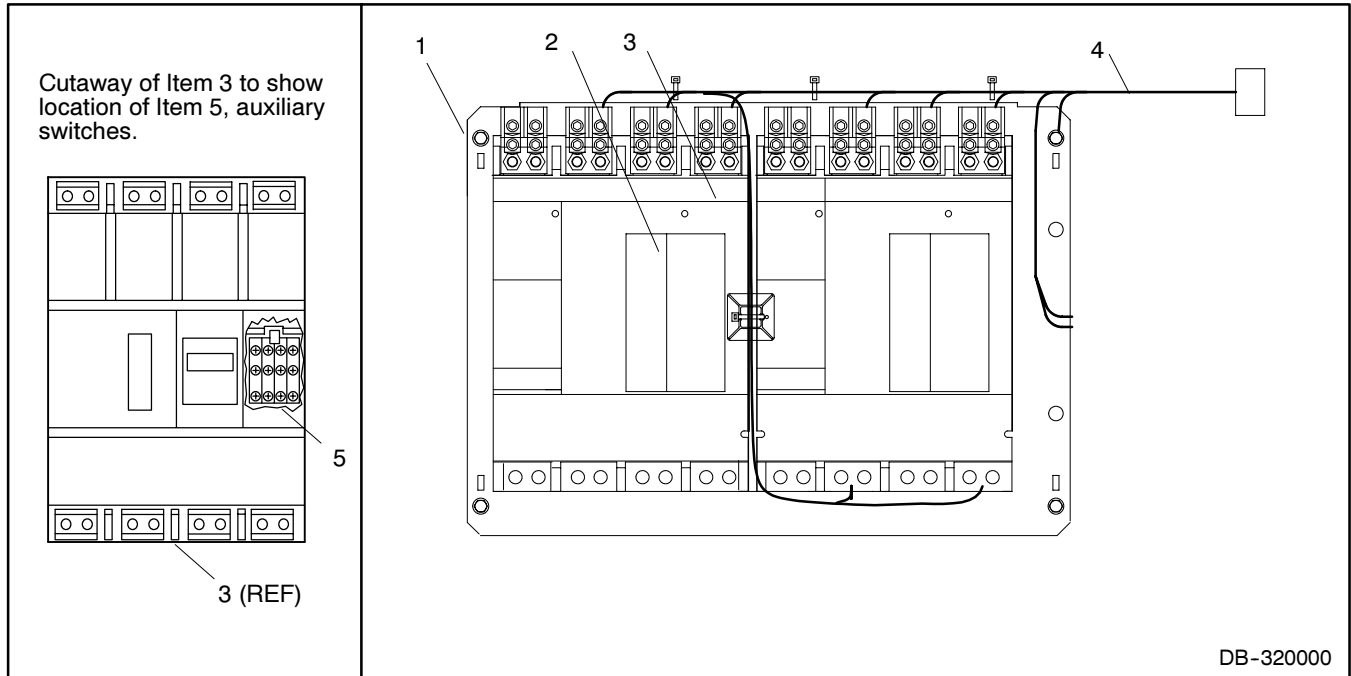

Item	Description	Part Number	
		Circuit Breaker	Switch
1	Assembly, power switch	See table below	See table below
2	Operator, motor	See table below	See table below
3	Circuit breaker/switch	A-330309	A-330173
4	Harness, wiring	353542	353542
5	Switch, auxiliary	X-6315-13	X-6315-13
6	Interlocks, mechanical (not shown)	X-6311-1	X-6311-1

ATS Rating, Volts	Power Switch Assembly (Item 1)		Motor Operator (Item 2)
	Circuit Breaker	Switch	
208/220/240	A-330727	A-330847	(2) X-6309-17
380/415	A-330728	A-330848	(2) X-6309-29
440/480	A-330729	A-330849	(2) X-6309-30
600	A-330727	A-330847	(2) X-6309-17

Appendix A. Abbreviations

The following list contains abbreviations that may appear in this publication.

A, amp	ampere	CG	center of gravity	F	Fahrenheit, female
ABDC	after bottom dead center	CID	cubic inch displacement	fglass.	fiberglass
AC	alternating current	CL	centerline	FHM	flat head machine (screw)
A/D	analog to digital	cm	centimeter	fl. oz.	fluid ounce
ADC	analog to digital converter	cmm	cubic meters per minute	flex.	flexible
adj.	adjust, adjustment	CMOS	complementary metal oxide substrate (semiconductor)	freq.	frequency
ADV	advertising dimensional drawing			FS	full scale
AHWT	anticipatory high water temperature	cogen.	cogeneration	ft.	foot, feet
AISI	American Iron and Steel Institute	COM	communications (port)	ft. lbs.	foot pounds (torque)
ALOP	anticipatory low oil pressure	conn.	connection	ft./min.	feet per minute
alt.	alternator	cont.	continued	g	gram
Al	aluminum	CPVC	chlorinated polyvinyl chloride	ga.	gauge (meters, wire size)
ANSI	American National Standards Institute (formerly American Standards Association, ASA)	crit.	critical	gal.	gallon
		CRT	cathode ray tube	gen.	generator
AO	anticipatory only	CSA	Canadian Standards Association	genset	generator set
API	American Petroleum Institute	CT	current transformer	GFI	ground fault interrupter
approx.	approximate, approximately	Cu	copper	gnd.	ground
AR	as required, as requested	cu. in.	cubic inch	gov.	governor
AS	as supplied, as stated, as suggested	cw.	clockwise	gph	gallons per hour
ASE	American Society of Engineers	CWC	city water-cooled	gpm	gallons per minute
ASME	American Society of Mechanical Engineers	cyl.	cylinder	gr.	grade, gross
assy.	assembly	D/A	digital to analog	gr. wt.	gross weight
ASTM	American Society for Testing Materials	DAC	digital to analog converter	H x W x D	height by width by depth
ATDC	after top dead center	dB	decibel	HC	hex cap
ATS	automatic transfer switch	dBA	decibel (A weighted)	HCHT	high cylinder head temperature
auto.	automatic	DC	direct current	HD	heavy duty
aux.	auxiliary	DCR	direct current resistance	HET	high exhaust temperature
A/V	audio/visual	deg., °	degree	hex	hexagon
avg.	average	dept.	department	Hg	mercury (element)
AVR	automatic voltage regulator	dia.	diameter	HH	hex head
AWG	American Wire Gauge	DI/EO	dual inlet/end outlet	HHC	hex head cap
AWM	appliance wiring material	DIN	Deutsches Institut fur Normung e. V. (also Deutsche Industrie Normenausschuss)	HP	horsepower
bat.	battery	DIP	dual inline package	hr.	hour
BBDC	before bottom dead center	DPDT	double-pole, double-throw	HS	heat shrink
BC	battery charger, battery charging	DPST	double-pole, single-throw	hsg.	housing
BCA	battery charging alternator	DS	disconnect switch	HVAC	heating, ventilation, and air conditioning
BCI	Battery Council International	DVR	digital voltage regulator	HWT	high water temperature
BDC	before dead center	E, emer.	emergency (power source)	Hz	hertz (cycles per second)
BHP	brake horsepower	EDI	electronic data interchange	IC	integrated circuit
blk.	black (paint color), block (engine)	EFR	emergency frequency relay for example (<i>exempli gratia</i>)	ID	inside diameter, identification
blk. htr.	block heater	e.g.	for example (<i>exempli gratia</i>)	IEC	International Electrotechnical Commission
BMEP	brake mean effective pressure	EG	electronic governor	IEEE	Institute of Electrical and Electronics Engineers
bps	bits per second	EGSA	Electrical Generating Systems Association	IMS	improved motor starting
br.	brass	EIA	Electronic Industries Association	in.	inch
BTDC	before top dead center	EI/EO	end inlet/end outlet	in. H ₂ O	inches of water
Btu	British thermal unit	EMI	electromagnetic interference	in. Hg	inches of mercury
Btu/min.	British thermal units per minute	emiss.	emission	in. lbs.	inch pounds
C	Celsius, centigrade	eng.	engine	Inc.	incorporated
cal.	calorie	EPA	Environmental Protection Agency	ind.	industrial
CARB	California Air Resources Board	EPS	emergency power system	int.	internal
CB	circuit breaker	ER	emergency relay	int./ext.	internal/external
cc	cubic centimeter	ES	engineering special, engineered special	I/O	input/output
CCA	cold cranking amps	ESD	electrostatic discharge	IP	iron pipe
ccw.	counterclockwise	est.	estimated	ISO	International Organization for Standardization
CEC	Canadian Electrical Code	E-Stop	emergency stop	J	joule
cfh	cubic feet per hour	etc.	et cetera (and so forth)	JIS	Japanese Industry Standard
cfm	cubic feet per minute	exh.	exhaust	k	kilo (1000)
		ext.	external	K	kelvin
				kA	kiloampere
				KB	kilobyte (2 ¹⁰ bytes)
				kg	kilogram

kg/cm ²	kilograms per square centimeter	mW	milliwatt	rnd.	round
kgm	kilogram-meter	μF	microfarad	ROM	read only memory
kg/m ³	kilograms per cubic meter	N, norm.	normal (power source)	rot.	rotate, rotating
kHz	kilohertz	NA	not available, not applicable	rpm	revolutions per minute
kJ	kilojoule	nat. gas	natural gas	RS	right side
km	kilometer	NBS	National Bureau of Standards	RTV	room temperature vulcanization
kOhm, kΩ	kilo-ohm	NC	normally closed	SAE	Society of Automotive Engineers
kPa	kilopascal	NEC	National Electrical Code	scfm	standard cubic feet per minute
kph	kilometers per hour	NEMA	National Electrical Manufacturers Association	SCR	silicon controlled rectifier
kV	kilovolt	NFPA	National Fire Protection Association	s, sec.	second
kVA	kilovolt ampere	Nm	newton meter	SI	<i>Systeme international d'unites</i> , International System of Units
kVAR	kilovolt ampere reactive	NO	normally open	SI/EO	side in/end out
kW	kilowatt	no., nos.	number, numbers	sil.	silencer
kWh	kilowatt-hour	NPS	National Pipe, Straight	SN	serial number
kWm	kilowatt mechanical	NPSC	National Pipe, Straight-coupling	SPDT	single-pole, double-throw
L	liter	NPT	National Standard taper pipe thread per general use	SPST	single-pole, single-throw
LAN	local area network	NPTF	National Pipe, Taper-Fine	spec, specs	specification(s)
L x W x H	length by width by height	NR	not required, normal relay	sq.	square
lb.	pound	ns	nanosecond	sq. cm	square centimeter
lbm/ft ³	pounds mass per cubic feet	O/C	overcrank	sq. in.	square inch
LCB	line circuit breaker	OD	outside diameter	SS	stainless steel
LCD	liquid crystal display	OEM	original equipment manufacturer	std.	standard
ld. shd.	load shed	O/F	overfrequency	stl.	steel
LED	light emitting diode	opt.	option, optional	tach.	tachometer
Lph	liters per hour	O/S	oversize, overspeed	TD	time delay
Lpm	liters per minute	OSHA	Occupational Safety and Health Administration	TDC	top dead center
LOP	low oil pressure	O/V	overvoltage	TDEC	time delay engine cooldown
LP	liquefied petroleum	oz.	ounce	TDEN	time delay emergency to normal
LPG	liquefied petroleum gas	oz.	ounce	TDES	time delay engine start
LS	left side	p., pp.	page, pages	TDNE	time delay normal to emergency
L _{wa}	sound power level, A weighted	PA	packed accessory	TDOE	time delay off to emergency
LWL	low water level	PC	personal computer	TDON	time delay off to normal
LWT	low water temperature	PCB	printed circuit board	temp.	temperature
m	meter, milli (1/1000)	pF	picofarad	term.	terminal
M	mega (10 ⁶ when used with SI units), male	PF	power factor	TIF	telephone influence factor
m ³	cubic meter	ph.	phase	TIR	total indicator reading
m ³ /min.	cubic meters per minute	PHC	Phillips head crimplite (screw)	tol.	tolerance
mA	milliampere	PHH	Phillips hex head (screw)	turbo.	turbocharger
man.	manual	PHM	pan head machine (screw)	typ.	typical (same in multiple locations)
max.	maximum	PLC	programmable logic control	U/F	underfrequency
MB	megabyte (2 ²⁰ bytes)	PMG	permanent magnet generator	UHF	ultrahigh frequency
MCM	one thousand circular mils	pot	potentiometer, potential	UL	Underwriter's Laboratories, Inc.
meggar	megohmmeter	ppm	parts per million	UNC	unified coarse thread (was NC)
MHz	megahertz	PROM	programmable read only memory	UNF	unified fine thread (was NF)
mi.	mile	psi	pounds per square inch	univ.	universal
mil	one one-thousandth of an inch	pt.	pint	U/S	undersize, underspeed
min.	minimum, minute	PTC	positive temperature coefficient	UV	ultraviolet
misc.	miscellaneous	PTO	power takeoff	U/V	undervoltage
MJ	megajoule	PVC	polyvinyl chloride	V	volt
mJ	millijoule	qt.	quart	VAC	volts alternating current
mm	millimeter	qty.	quantity	VAR	voltampere reactive
mOhm, mΩ	milliohm	R	replacement (emergency) power source	VDC	volts direct current
MOhm, MΩ	megohm	rad.	radiator, radius	VFD	vacuum fluorescent display
MOV	metal oxide varistor	RAM	random access memory	VGA	video graphics adapter
MPa	megapascal	RDO	relay driver output	VHF	very high frequency
mpg	miles per gallon	ref.	reference	W	watt
mph	miles per hour	rem.	remote	WCR	withstand and closing rating
MS	military standard	RFI	radio frequency interference	w/	with
m/sec.	meters per second	RH	round head	w/o	without
MTBF	mean time between failure	RHM	round head machine (screw)	wt.	weight
MTBO	mean time between overhauls	rly.	relay	xfrm	transformer
mtg.	mounting	rms	root mean square		
MW	megawatt				

Appendix B. Common Hardware Application Guidelines

Use the information below and on the following pages to identify proper fastening techniques when no specific reference for reassembly is made.

Bolt/Screw Length: When bolt/screw length is not given, use Figure 1 as a guide. As a general rule, a minimum length of one thread beyond the nut and a maximum length of 1/2 the bolt/screw diameter beyond the nut is the preferred method.

Washers and Nuts: Use split lock washers as a bolt locking device where specified. Use SAE flat washers with whiz nuts, spiralock nuts, or standard nuts and preloading (torque) of the bolt in all other applications.

See General Torque Specifications and other torque specifications in the service literature.

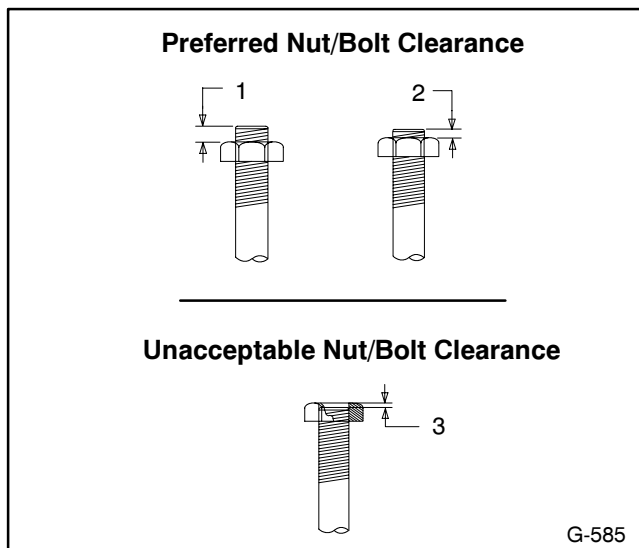

1. 1/2 of Bolt Diameter
2. Min. 1 Full Thread Beyond Top of Nut
3. Below Top of Nut

Figure 1. Acceptable Bolt Lengths

Steps for common hardware application:

1. Determine entry hole type: round or slotted.
2. Determine exit hole type: fixed female thread (weld nut), round, or slotted.

For round and slotted exit holes, determine if hardware is greater than 1/2 inch in diameter, or 1/2 inch in diameter or less. Hardware that is *greater than 1/2 inch* in diameter takes a standard nut and SAE washer. Hardware *1/2 inch or less* in diameter can take a properly torqued whiz nut or spiralock nut. See the diagram below.

3. Follow these SAE washer rules after determining exit hole type:
 - a. Always use a washer between hardware and a slot.
 - b. Always use a washer under a nut (see 2 above for exception).
 - c. Use a washer under a bolt when the female thread is fixed (weld nut).
4. Refer to the diagram below, which depicts the preceding hardware configuration possibilities.

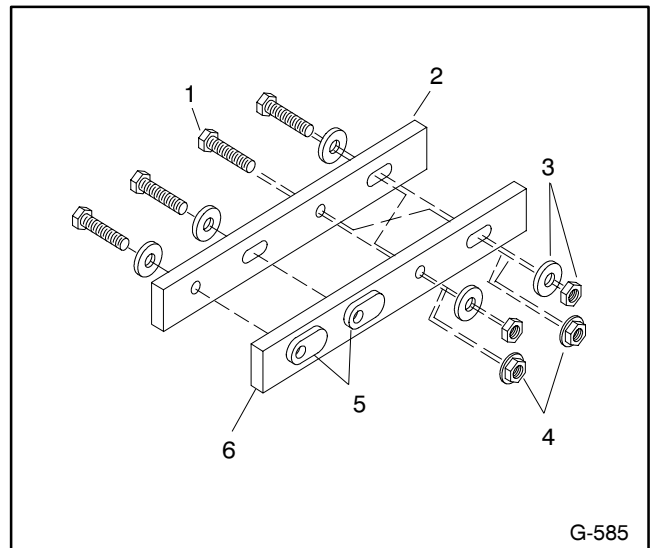

1. Cap screw
2. Entry hole types
3. Standard nut and SAE washer
4. Whiz nut or spiralock: up to 1/2" dia. hardware
5. Weld nuts: above 1/2" dia. hardware
6. Exit hole types

Figure 2. Acceptable Hardware Combinations

Appendix C. General Torque Specifications

Use the following torque specifications when service literature instructions give no specific torque values. The charts list values for new plated, zinc phosphate, or

oiled threads. Increase values by 15% for nonplated threads. All torque values are +0%/-10%.















American Standard Fasteners Torque Specifications











Size	Torque Measurement	Assembled into Cast Iron or Steel			Assembled into Aluminum
		Grade 2	Grade 5	Grade 8	Grade 2 or 5
8-32	in. lbs. (Nm)	16 (1.8)	20 (2.3)	—	16 (1.8)
10-24	in. lbs. (Nm)	26 (2.9)	32 (3.6)	—	26 (2.9)
10-32	in. lbs. (Nm)	26 (2.9)	32 (3.6)	—	26 (2.9)
1/4-20	in. lbs. (Nm)	60 (6.8)	96 (10.8)	132 (14.9)	60 (6.8)
1/4-28	in. lbs. (Nm)	72 (8.1)	108 (12.2)	144 (16.3)	72 (8.1)
5/16-18	in. lbs. (Nm)	120 (13.6)	192 (21.7)	264 (29.8)	120 (13.6)
5/16-24	in. lbs. (Nm)	132 (14.9)	204 (23.1)	288 (32.5)	132 (14.9)
3/8-16	ft. lbs. (Nm)	18 (24)	28 (38)	39 (53)	18 (24)
3/8-24	ft. lbs. (Nm)	20 (27)	31 (42)	44 (60)	20 (27)
7/16-14	ft. lbs. (Nm)	29 (39)	44 (60)	63 (85)	—
7/16-20	ft. lbs. (Nm)	32 (43)	50 (68)	70 (95)	—
1/2-13	ft. lbs. (Nm)	44 (60)	68 (92)	96 (130)	—
1/2-20	ft. lbs. (Nm)	49 (66)	76 (103)	108 (146)	—
9/16-12	ft. lbs. (Nm)	60 (81)	98 (133)	138 (187)	—
9/16-18	ft. lbs. (Nm)	67 (91)	109 (148)	154 (209)	—
5/8-11	ft. lbs. (Nm)	83 (113)	135 (183)	191 (259)	—
5/8-18	ft. lbs. (Nm)	94 (128)	153 (208)	216 (293)	—
3/4-10	ft. lbs. (Nm)	147 (199)	240 (325)	338 (458)	—
3/4-16	ft. lbs. (Nm)	164 (222)	268 (363)	378 (513)	—
1-8	ft. lbs. (Nm)	191 (259)	532 (721)	818 (1109)	—
1-12	ft. lbs. (Nm)	209 (283)	582 (789)	895 (1214)	—





Metric Fasteners Torque Specifications, Measured in ft. lbs. (Nm)

Size (mm)	Assembled into Cast Iron or Steel			Assembled into Aluminum
	Grade 5.8	Grade 8.8	Grade 10.9	Grade 5.8 or 8.8
M6 x 1.00	4 (5.6)	7 (9.9)	10 (14)	4 (5.6)
M8 x 1.25	10 (13.6)	18 (25)	26 (35)	10 (13.6)
M8 x 1.00	16 (21)	18 (25)	26 (35)	16 (21)
M10 x 1.50	20 (27)	35 (49)	50 (68)	20 (27)
M10 x 1.25	29 (39)	35 (49)	50 (68)	29 (39)
M12 x 1.75	35 (47)	61 (83)	86 (117)	—
M12 x 1.50	48 (65)	65 (88)	92 (125)	—
M14 x 2.00	55 (74)	97 (132)	136 (185)	—
M14 x 1.50	74 (100)	103 (140)	142 (192)	—
M16 x 2.00	85 (115)	148 (200)	210 (285)	—
M16 x 1.50	104 (141)	155 (210)	218 (295)	—
M18 x 2.50	114 (155)	203 (275)	288 (390)	—
M18 x 1.50	145 (196)	225 (305)	315 (425)	—

Appendix D. Common Hardware Identification

Screw/Bolts/Studs	
Head Styles	
Hex Head or Machine Head	
Hex Head or Machine Head with Washer	
Flat Head (FHM)	
Round Head (RHM)	
Pan Head	
Hex Socket Head Cap or Allen™ Head Cap	
Hex Socket Head or Allen™ Head Shoulder Bolt	
Sheet Metal Screw	
Stud	
Drive Styles	
Hex	
Hex and Slotted	
Phillips®	
Slotted	
Hex Socket	

Nuts	
Nut Styles	
Hex Head	
Lock or Elastic	
Square	
Cap or Acorn	
Wing	
Washers	
Washer Styles	
Plain	
Split Lock or Spring	
Spring or Wave	
External Tooth Lock	
Internal Tooth Lock	
Internal-External Tooth Lock	

Hardness Grades	
American Standard	
Grade 2	
Grade 5	
Grade 8	
Grade 8/9 (Hex Socket Head)	
Metric	
Number stamped on hardware; 5.8 shown	

Allen™ head screw is a trademark of Holo-Krome Co.

Phillips® screw is a registered trademark of Phillips Screw Company.

Sample Dimensions

American Standard (Screws, Bolts, Studs, and Nuts)

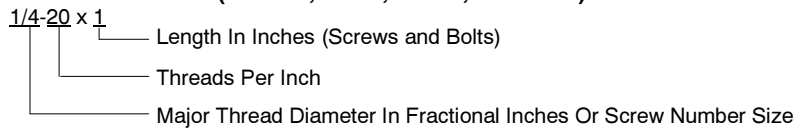

Metric (Screws, Bolts, Studs, and Nuts)

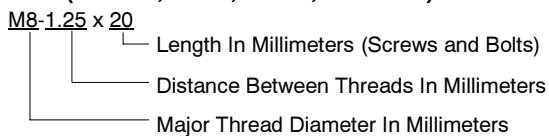

Plain Washers

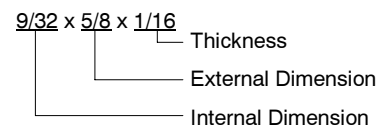

Lock Washers

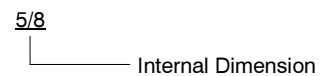

Appendix E. Common Hardware List

The Common Hardware List lists part numbers and dimensions for common hardware items.

American Standard

Part No.	Dimensions	Part No.	Dimensions	Part No.	Dimensions	Type
Hex Head Bolts (Grade 5)						
X-465-17	1/4-20 x .38	X-6238-14	3/8-24 x .75	X-6009-1	1-8	Standard
X-465-6	1/4-20 x .50	X-6238-16	3/8-24 x 1.25	X-6210-3	6-32	Whiz
X-465-2	1/4-20 x .62	X-6238-21	3/8-24 x 4.00	X-6210-4	8-32	Whiz
X-465-16	1/4-20 x .75	X-6238-22	3/8-24 x 4.50	X-6210-5	10-24	Whiz
X-465-18	1/4-20 x .88	X-6024-5	7/16-14 x .75	X-6210-1	10-32	Whiz
X-465-7	1/4-20 x 1.00	X-6024-2	7/16-14 x 1.00	X-6210-2	1/4-20	Spiralock
X-465-8	1/4-20 x 1.25	X-6024-8	7/16-14 x 1.25	X-6210-6	1/4-28	Spiralock
X-465-9	1/4-20 x 1.50	X-6024-3	7/16-14 x 1.50	X-6210-7	5/16-18	Spiralock
X-465-10	1/4-20 x 1.75	X-6024-4	7/16-14 x 2.00	X-6210-8	5/16-24	Spiralock
X-465-11	1/4-20 x 2.00	X-6024-11	7/16-14 x 2.75	X-6210-9	3/8-16	Spiralock
X-465-12	1/4-20 x 2.25	X-6024-12	7/16-14 x 6.50	X-6210-10	3/8-24	Spiralock
X-465-14	1/4-20 x 2.75	X-129-15	1/2-13 x .75	X-6210-11	7/16-14	Spiralock
X-465-21	1/4-20 x 5.00	X-129-17	1/2-13 x 1.00	X-6210-12	1/2-13	Spiralock
X-465-25	1/4-28 x .38	X-129-18	1/2-13 x 1.25	X-6210-15	7/16-20	Spiralock
X-465-20	1/4-28 x 1.00	X-129-19	1/2-13 x 1.50	X-6210-14		Spiralock
X-125-33	5/16-18 x .50	X-129-20	1/2-13 x 1.75	X-85-3	5/8-11	Standard
X-125-23	5/16-18 x .62	X-129-21	1/2-13 x 2.00	X-88-12	3/4-10	Standard
X-125-3	5/16-18 x .75	X-129-22	1/2-13 x 2.25	X-89-2	1/2-20	Standard
X-125-31	5/16-18 x .88	X-129-23	1/2-13 x 2.50			
X-125-5	5/16-18 x 1.00	X-129-24	1/2-13 x 2.75			
X-125-24	5/16-18 x 1.25	X-129-25	1/2-13 x 3.00			
X-125-34	5/16-18 x 1.50	X-129-27	1/2-13 x 3.50			
X-125-25	5/16-18 x 1.75	X-129-29	1/2-13 x 4.00			
X-125-26	5/16-18 x 2.00	X-129-30	1/2-13 x 4.50			
230578	5/16-18 x 2.25	X-463-9	1/2-13 x 5.50			
X-125-29	5/16-18 x 2.50	X-129-44	1/2-13 x 6.00			
X-125-27	5/16-18 x 2.75	X-129-51	1/2-20 x .75			
X-125-28	5/16-18 x 3.00	X-129-45	1/2-20 x 1.25			
X-125-22	5/16-18 x 4.50	X-129-52	1/2-20 x 1.50			
X-125-32	5/16-18 x 5.00	X-6021-3	5/8-11 x 1.00			
X-125-35	5/16-18 x 5.50	X-6021-4	5/8-11 x 1.25			
X-125-36	5/16-18 x 6.00	X-6021-2	5/8-11 x 1.50			
X-125-40	5/16-18 x 6.50	X-6021-1	5/8-11 x 1.75			
X-125-43	5/16-24 x 1.75	273049	5/8-11 x 2.00			
X-125-44	5/16-24 x 2.50	X-6021-5	5/8-11 x 2.25			
X-125-30	5/16-24 x .75	X-6021-6	5/8-11 x 2.50			
X-125-39	5/16-24 x 2.00	X-6021-7	5/8-11 x 2.75			
X-125-38	5/16-24 x 2.75	X-6021-12	5/8-11 x 3.75			
X-6238-2	3/8-16 x .62	X-6021-11	5/8-11 x 4.50			
X-6238-10	3/8-16 x .75	X-6021-10	5/8-11 x 6.00			
X-6238-3	3/8-16 x .88	X-6021-9	5/8-18 x 2.50			
X-6238-11	3/8-16 x 1.00	X-6239-1	3/4-10 x 1.00			
X-6238-4	3/8-16 x 1.25	X-6239-8	3/4-10 x 1.25			
X-6238-5	3/8-16 x 1.50	X-6239-2	3/4-10 x 1.50			
X-6238-1	3/8-16 x 1.75	X-6239-3	3/4-10 x 2.00			
X-6238-6	3/8-16 x 2.00	X-6239-4	3/4-10 x 2.50			
X-6238-17	3/8-16 x 2.25	X-6239-5	3/4-10 x 3.00			
X-6238-7	3/8-16 x 2.50	X-6239-6	3/4-10 x 3.50			
X-6238-8	3/8-16 x 2.75	X-792-1	1-8 x 2.25			
X-6238-9	3/8-16 x 3.00	X-792-5	1-8 x 3.00			
X-6238-19	3/8-16 x 3.25	X-792-8	1-8 x 5.00			
X-6238-12	3/8-16 x 3.50					
X-6238-20	3/8-16 x 3.75					
X-6238-13	3/8-16 x 4.50					
X-6238-18	3/8-16 x 5.50					
X-6238-25	3/8-16 x 6.50					

Washers

Part No.	ID	OD	Thick.	Bolt/ Screw
X-25-46	.125	.250	.022	#4
X-25-9	.156	.375	.049	#6
X-25-48	.188	.438	.049	#8
X-25-36	.219	.500	.049	#10
X-25-40	.281	.625	.065	1/4
X-25-85	.344	.687	.065	5/16
X-25-37	.406	.812	.065	3/8
X-25-34	.469	.922	.065	7/16
X-25-26	.531	1.062	.095	1/2
X-25-15	.656	1.312	.095	5/8
X-25-29	.812	1.469	.134	3/4
X-25-127	1.062	2.000	.134	1

Metric

Hex head bolts are hardness grade 8.8 unless noted.

Part No.	Dimensions	Part No.	Dimensions	Part No.	Dimensions	Type		
Hex Head Bolts (partial thread)			Hex Head Bolts (full thread)			Hex Nuts		
M931-06040-60	M6-1.00 x 40	M933-04006-60	M4-0.70 x 6	M934-03-50	M3-0.50	Standard		
M931-06055-60	M6-1.00 x 55	M933-05050-60	M5-0.80 x 50	M934-04-50	M4-0.70	Standard		
M931-06060-60	M6-1.00 x 60	M933-06010-60	M6-1.00 x 10	M934-05-50	M5-0.80	Standard		
M931-06070-60	M6-1.00 x 70	M933-06014-60	M6-1.00 x 14	M982-05-80	M5-0.80	Elastic Stop		
M931-06075-60	M6-1.00 x 75	M933-06016-60	M6-1.00 x 16	M6923-06-80	M6-1.00	Spiralock		
M931-06090-60	M6-1.00 x 90	M933-06020-60	M6-1.00 x 20	M934-06-64	M6-1.00	Std. (green)		
M931-08035-60	M8-1.25 x 35	M933-06025-60	M6-1.00 x 25	M982-06-80	M6-1.00	Elastic Stop		
M931-08040-60	M8-1.25 x 40	M933-06040-60	M6-1.00 x 40	M6923-08-80	M8-1.25	Spiralock		
M931-08040-82	M8-1.25 x 40*	M933-06050-60	M6-1.00 x 50	M934-08-60	M8-1.25	Standard		
M931-08045-60	M8-1.25 x 45	M933-08016-60	M8-1.25 x 16	M982-08-80	M8-1.25	Elastic Stop		
M931-08050-60	M8-1.25 x 50	M933-08020-60	M8-1.25 x 20	M6923-10-80	M10-1.50	Spiralock		
M931-08055-82	M8-1.25 x 55*	M933-08025-60	M8-1.25 x 25	M982-10-80	M10-1.50	Elastic Stop		
M931-08060-60	M8-1.25 x 60	M933-08030-60	M8-1.25 x 30	M6923-12-80	M12-1.75	Spiralock		
M931-08070-60	M8-1.25 x 70	M933-10012-60	M10-1.50 x 12	M982-12-80	M12-1.75	Elastic Stop		
M931-08070-82	M8-1.25 x 70*	M961-10020-60	M10-1.25 x 20	M982-14-80	M14-2.00	Elastic Stop		
M931-08075-60	M8-1.25 x 75	M933-10020-60	M10-1.50 x 20	M6923-16-80	M16-2.00	Spiralock		
M931-08080-60	M8-1.25 x 80	M933-10025-60	M10-1.50 x 25	M982-16-80	M16-2.00	Elastic Stop		
M931-08090-60	M8-1.25 x 90	M933-10030-60	M10-1.50 x 30	M982-18-80	M18-2.50	Elastic Stop		
M931-08095-60	M8-1.25 x 95	M933-10030-82	M10-1.50 x 30*	M934-20-80	M20-2.50	Standard		
M931-08100-60	M8-1.25 x 100	M961-10035-60	M10-1.25 x 35	M982-20-80	M20-2.50	Elastic Stop		
M931-10040-60	M10-1.50 x 40	M933-10035-60	M10-1.50 x 35	M934-22-80	M22-2.50	Standard		
M931-10045-60	M10-1.50 x 45	M933-12016-60	M12-1.75 x 16	M982-22-80	M22-2.50	Elastic Stop		
M931-10050-60	M10-1.50 x 50	M933-12020-60	M12-1.75 x 20	M934-24-80	M24-3.00	Standard		
M931-10055-60	M10-1.50 x 55	M933-12025-60	M12-1.75 x 25	M982-24-80	M24-3.00	Elastic Stop		
M931-10060-60	M10-1.50 x 60	M933-12025-82	M12-1.75 x 25*	Washers				
M931-10065-60	M10-1.50 x 65	M933-12030-60	M12-1.75 x 30	Part No.	ID	OD	Bolt/ Thick. Screw	
M931-10070-60	M10-1.50 x 70	M933-12040-60	M12-1.75 x 40	M125A-03-80	3.2	7.0	0.5 M3	
M931-10080-60	M10-1.50 x 80	M933-12040-82	M12-1.75 x 40*	M125A-04-80	4.3	9.0	0.8 M4	
M931-10090-60	M10-1.50 x 90	M961-14025-60	M14-1.50 x 25	M125A-05-80	5.3	10.0	1.0 M5	
M931-10100-60	M10-1.50 x 100	M933-14025-60	M14-2.00 x 25	M125A-06-80	6.4	12.0	1.6 M6	
M931-12045-60	M12-1.75 x 45	M961-16025-60	M16-1.50 x 25	M125A-08-80	8.4	16.0	1.6 M8	
M931-12050-60	M12-1.75 x 50	M933-16025-60	M16-2.00 x 25	M125A-10-80	10.5	20.0	2.0 M10	
M931-12055-60	M12-1.75 x 55	M933-16030-82	M16-2.00 x 30*	M125A-12-80	13.0	24.0	2.5 M12	
M931-12060-60	M12-1.75 x 60	M933-16035-60	M16-2.00 x 35	M125A-14-80	15.0	28.0	2.5 M14	
M931-12065-60	M12-1.75 x 65	M933-16040-60	M16-2.00 x 40	M125A-16-80	17.0	30.0	3.0 M16	
M931-12080-60	M12-1.75 x 80	M933-16050-60	M16-2.00 x 50	M125A-18-80	19.0	34.0	3.0 M18	
M931-12090-60	M12-1.75 x 90	M933-16050-82	M16-2.00 x 50*	M125A-20-80	21.0	37.0	3.0 M20	
M931-12100-60	M12-1.75 x 100	M933-16060-60	M16-2.00 x 60	M125A-24-80	25.0	44.0	4.0 M24	
M931-12110-60	M12-1.75 x 110	M933-18050-60	M18-2.50 x 50	Pan Head Machine Screws				
M931-16090-60	M16-2.00 x 90	M933-18060-60	M18-2.50 x 60	M7985A-03010-20	M3-0.50 x 10			
M931-20065-60	M20-2.50 x 65	Flat Head Machine Screws						
M931-20120-60	M20-2.50 x 120	M7985A-03012-20	M3-0.50 x 12	M7985A-04020-20	M4-0.70 x 20			
M931-20160-60	M20-2.50 x 160	M7985A-05010-20	M5-0.80 x 10	M7985A-05012-20	M5-0.80 x 12			
M931-22090-60	M22-2.50 x 90	M7985A-05016-20	M5-0.80 x 16					
M931-22120-60	M22-2.50 x 120							
M931-22160-60	M22-2.50 x 160							
M931-24090-60	M24-3.00 x 90							
M931-24120-60	M24-3.00 x 120							
M931-24160-60	M24-3.00 x 160							

* This metric hex bolt's hardness is grade 10.9.

KOHLER[®] POWER SYSTEMS

KOHLER CO. Kohler, Wisconsin 53044
Phone 920-565-3381, Web site www.kohlergenerators.com
Fax 920-459-1646 (U.S.A. Sales), Fax 920-459-1614 (International)
For the nearest sales and service outlet in U.S.A. and Canada
Phone 1-800-544-2444

Kohler[®] Power Systems
Asia Pacific Headquarters
7 Jurong Pier Road
Singapore 619159
Phone (65)264-6422, Fax (65)264-6455

TP-5974 11/99

© Kohler Co., 1999. All rights reserved.