

# Installation

## Industrial Generator Sets

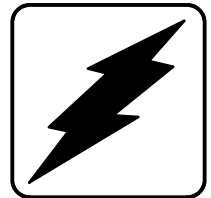

Models:

**20-2000 kW**

**KOHLER**<sup>®</sup>  
POWER SYSTEMS

TP-5700 7/93c



# Table of Contents

<b>Product Identification Information</b> .....	<b>Inside front cover</b>
<b>Safety Precautions and Instructions</b> .....	<b>I</b>
<b>Introduction</b> .....	<b>i</b>
<b>Service Assistance</b> .....	<b>i</b>
<b>Section 1 General</b> .....	<b>1</b>
<b>Section 2 Load and Transport</b> .....	<b>3</b>
2.1 Lifting the Generator Set .....	3
2.1.1 Weather Housing .....	5
2.1.2 Sound Shield .....	5
2.1.3 Subbase Fuel Tank .....	5
2.2 Transporting the Generator Set .....	5
<b>Section 3 Location</b> .....	<b>7</b>
3.1 Location Factors .....	7
3.2 Weight .....	7
3.3 Mounting .....	8
3.4 Vibration Isolation .....	9
<b>Section 4 Air Requirements</b> .....	<b>11</b>
4.1 General .....	11
4.2 Air-Cooled Generators .....	12
4.3 Forced Air .....	13
4.4 Air-Vac Cooling System .....	14
4.5 Air Vent .....	15
4.6 Liquid-Cooled Models .....	16
4.7 Unit-Mounted Radiator Cooling .....	16
4.8 Remote Radiator Cooling .....	17
4.9 City Water Cooling .....	18
4.10 Cooling Tower .....	18
4.11 Block Heaters .....	20
4.12 Recommended Coolant .....	20
<b>Section 5 Exhaust System</b> .....	<b>21</b>
5.1 Flexible Section .....	22
5.2 Condensation Trap .....	22
5.3 Piping .....	22
5.4 Double-Sleeve Thimbles .....	23
<b>Section 6 Fuel Systems</b> .....	<b>25</b>
6.1 Diesel Fuel Systems .....	25
6.2 Main Fuel Tank .....	26
6.3 Fuel Lines .....	27
6.4 Transfer Tanks .....	27
6.5 Auxiliary Fuel Pumps .....	28
6.6 Gasoline Fuel Systems .....	29
6.7 Natural or LP Gas Fuel Systems .....	30
6.8 Flexible Connector .....	32
6.9 Gas Piping .....	32
6.10 Fuel Regulators .....	32
6.11 LP Gas Fuel Characteristics .....	33
6.12 Vapor Withdrawal Systems .....	33
6.13 Liquid Withdrawal Systems .....	33
6.14 Dual Systems (Natural and LP Gas) .....	33
6.15 Natural Gas .....	34
6.16 Combination Gas-Gasoline .....	34

# Table of Contents, continued

---

<b>Section 7 Electrical Requirements</b> .....	<b>35</b>
7.1 Batteries .....	35
7.2 Electrical Connections .....	36
7.3 Load Lead Connections .....	36
7.4 Terminal Connector Torque .....	37
7.5 Automatic Transfer Switches .....	38
7.6 Control Connections .....	38
7.7 Remote Annunciator .....	38
7.8 Audiovisual Alarm .....	38
7.9 Remote Emergency Stop Switch .....	39
7.10 Dry Contact Kit .....	39
7.11 Wiring .....	39
<b>Appendix A Abbreviations</b> .....	<b>A-1</b>

# Safety Precautions and Instructions

IMPORTANT SAFETY INSTRUCTIONS. Electromechanical equipment, including generator sets, transfer switches, switchgear, and accessories, can cause bodily harm and pose life-threatening danger when improperly installed, operated, or maintained. To prevent accidents be aware of potential dangers and act safely. Read and follow all safety precautions and instructions. **SAVE THESE INSTRUCTIONS.**

This manual has several types of safety precautions and instructions: Danger, Warning, Caution, and Notice.

## DANGER

Danger indicates the presence of a hazard that **will cause severe personal injury, death, or substantial property damage.**

## WARNING

Warning indicates the presence of a hazard that **can cause severe personal injury, death, or substantial property damage.**

## CAUTION

Caution indicates the presence of a hazard that **will or can cause minor personal injury or property damage.**

## NOTE

Notice communicates installation, operation, or maintenance information that is safety related but not hazard related.

Safety decals affixed to the equipment in prominent places alert the operator or service technician to potential hazards and explain how to act safely. The decals are shown throughout this publication to improve operator recognition. Replace missing or damaged decals.

## Accidental Starting

### WARNING

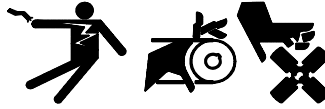

#### **Accidental starting. Can cause severe injury or death.**

Disconnect the battery cables before working on the generator set. Remove the negative (-) lead first when disconnecting the battery. Reconnect the negative (-) lead last when reconnecting the battery.

**Disabling the generator set. Accidental starting can cause severe injury or death.** Before working on the generator set or connected equipment, disable the generator set as follows: (1) Move the generator set master switch to the OFF position. (2) Disconnect the power to the battery charger. (3) Remove the battery cables, negative (-) lead first. Reconnect the negative (-) lead last when reconnecting the battery. Follow these precautions to prevent starting of the generator set by an automatic transfer switch, remote start/stop switch, or engine start command from a remote computer.

## Battery

### WARNING



#### **Sulfuric acid in batteries. Can cause severe injury or death.**

Wear protective goggles and clothing. Battery acid may cause blindness and burn skin.

### WARNING



#### **Explosion. Can cause severe injury or death. Relays in the battery charger cause arcs or sparks.**

Locate the battery in a well-ventilated area. Isolate the battery charger from explosive fumes.

**Battery gases. Explosion can cause severe injury or death.** Battery gases can cause an explosion. Do not smoke or permit flames or sparks to occur near a battery at any time, particularly when it is charging. Do not dispose of a battery in a fire. To prevent burns and sparks that could cause an explosion, avoid touching the battery terminals with tools or other metal objects. Remove wristwatch, rings, and other jewelry before servicing the equipment. Discharge static electricity from your body before touching batteries by first touching a grounded metal surface away from the battery. To avoid sparks, do not disturb the battery charger connections while the battery is charging. Always turn the battery charger off before disconnecting the battery connections. Ventilate the compartments containing batteries to prevent accumulation of explosive gases.

**Battery electrolyte is a diluted sulfuric acid. Battery acid can cause severe injury or death.** Battery acid can cause blindness and burn skin. Always wear splashproof safety goggles, rubber gloves, and boots when servicing the battery. Do not open a sealed battery or mutilate the battery case. If battery acid splashes in the eyes or on the skin, immediately flush the affected area for 15 minutes with large quantities of clean water. Seek immediate medical aid in the case of eye contact. Never add acid to a battery after placing the battery in service, as this may result in hazardous spattering of battery acid.

**Battery short circuits. Explosion can cause severe injury or death.**

Short circuits can cause bodily injury and/or equipment damage. Disconnect the battery before generator set installation or maintenance. Remove wristwatch, rings, and other jewelry before servicing the equipment. Use tools with insulated handles. Remove the negative (-) lead first when disconnecting the battery. Reconnect the negative (-) lead last when reconnecting the battery. Never connect the negative (-) battery cable to the positive (+) connection terminal of the starter solenoid. Do not test the battery condition by shorting the terminals together.

**Battery acid cleanup. Battery acid can cause severe injury or death.**

Battery acid is electrically conductive and corrosive. Add 500 g (1 lb.) of bicarbonate of soda (baking soda) to a container with 4 L (1 gal.) of water and mix the neutralizing solution. Pour the neutralizing solution on the spilled battery acid and continue to add the neutralizing solution to the spilled battery acid until all evidence of a chemical reaction (foaming) has ceased. Flush the resulting liquid with water and dry the area.

## Engine Backfire/Flash Fire

<b>⚠ WARNING</b>

<b>Fire.</b> <b>Can cause severe injury or death.</b>
Do not smoke or permit flames or sparks near fuels or the fuel system.

**Servicing the fuel system. A flash fire can cause severe injury or death.**

Do not smoke or permit flames or sparks near the carburetor, fuel line, fuel filter, fuel pump, or other potential sources of spilled fuels or fuel vapors. Catch fuels in an approved container when removing the fuel line or carburetor.

**Servicing the air cleaner. A sudden backfire can cause severe injury or death.** Do not operate the generator set with the air cleaner removed.

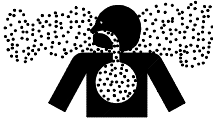
## Exhaust System

<b>⚠ WARNING</b>

<b>Carbon monoxide.</b> <b>Can cause severe nausea, fainting, or death.</b>
The exhaust system must be leakproof and routinely inspected.

**Copper tubing exhaust systems. Carbon monoxide can cause severe nausea, fainting, or death.** Do not use copper tubing in diesel exhaust systems. Sulfur in diesel exhaust causes rapid deterioration of copper tubing exhaust systems, resulting in exhaust leakage.

**Generator set operation. Carbon monoxide can cause severe nausea, fainting, or death.** Carbon monoxide is an odorless, colorless, tasteless, nonirritating gas that can cause death if inhaled for even a short time. Avoid breathing exhaust fumes when working on or near the generator set. Never operate the generator set inside a building unless the exhaust gas is piped safely outside. Never operate the generator set where exhaust gas could accumulate and seep back inside a potentially occupied building.

**Carbon monoxide symptoms. Carbon monoxide can cause severe nausea, fainting, or death.** Carbon monoxide is a poisonous gas present in exhaust gases. Carbon monoxide poisoning symptoms include but are not limited to the following:

- Light-headedness, dizziness
- Physical fatigue, weakness in joints and muscles
- Sleepiness, mental fatigue, inability to concentrate or speak clearly, blurred vision
- Stomachache, vomiting, nausea

If experiencing any of these symptoms and carbon monoxide poisoning is possible, seek fresh air immediately and remain active. Do not sit, lie down, or fall asleep. Alert others to the possibility of carbon monoxide poisoning. Seek medical attention if the condition of affected persons does not improve within minutes of breathing fresh air.

## Fuel System

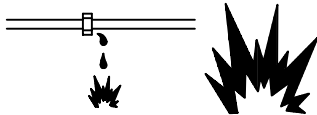
<b>⚠ WARNING</b>

<b>Explosive fuel vapors.</b> <b>Can cause severe injury or death.</b>
Use extreme care when handling, storing, and using fuels.

**Draining the fuel system. Explosive fuel vapors can cause severe injury or death.** Spilled fuel can cause an explosion. Use a container to catch fuel when draining the fuel system. Wipe up spilled fuel after draining the system.

**LP liquid withdrawal fuel leaks. Explosive fuel vapors can cause severe injury or death.** Fuel leakage can cause an explosion. Check the LP liquid withdrawal gas fuel system for leakage by using a soap and water solution with the fuel system test pressurized to at least 90 psi (621 kPa). Do not use a soap solution containing either ammonia or chlorine because both prevent bubble formation. A successful test depends on the ability of the solution to bubble.

**The fuel system. Explosive fuel vapors can cause severe injury or death.** Vaporized fuels are highly explosive. Use extreme care when handling and storing fuels. Store fuels in a well-ventilated area away from spark-producing equipment and out of the reach of children. Never add fuel to the tank while the engine is running because spilled fuel may ignite on contact with hot parts or from sparks. Do not smoke or permit flames or sparks to occur near sources of spilled fuel or fuel vapors. Keep the fuel lines and connections tight and in good condition. Do not replace flexible fuel lines with rigid lines. Use flexible sections to avoid fuel line breakage caused by vibration. Do not operate the generator set in the presence of fuel leaks, fuel accumulation, or sparks. Repair fuel systems before resuming generator set operation.

**Explosive fuel vapors can cause severe injury or death.** Take additional precautions when using the following fuels:

**Gasoline**—Store gasoline only in approved red containers clearly marked GASOLINE.

**Propane (LP)**—Adequate ventilation is mandatory. Because propane is heavier than air, install propane gas detectors low in a room. Inspect the detectors per the manufacturer's instructions.

**Natural Gas**—Adequate ventilation is mandatory. Because natural gas rises, install natural gas detectors high in a room. Inspect the detectors per the manufacturer's instructions.

**Fuel tanks. Explosive fuel vapors can cause severe injury or death.** Gasoline and other volatile fuels stored in day tanks or subbase fuel tanks can cause an explosion. Store only diesel fuel in tanks.

**Gas fuel leaks. Explosive fuel vapors can cause severe injury or death.** Fuel leakage can cause an explosion. Check the LP vapor gas or natural gas fuel system for leakage by using a soap and water solution with the fuel system test pressurized to 6–8 ounces per square inch (10–14 inches water column). Do not use a soap solution containing either ammonia or chlorine because both prevent bubble formation. A successful test depends on the ability of the solution to bubble.

## Hazardous Noise

**CAUTION**



**Hazardous noise.  
Can cause hearing loss.**

Never operate the generator set without a muffler or with a faulty exhaust system.

## Hazardous Voltage/ Electrical Shock

**DANGER**



**Hazardous voltage.  
Will cause severe injury or death.**

Disconnect all power sources before opening the enclosure.

*(over 600 volts)*

**DANGER**



**Hazardous voltage.  
Will cause severe injury or death.**

Disconnect all power sources before servicing. Install the barrier after adjustments, maintenance, or servicing.

*(over 600 volts)*

**WARNING**



**Hazardous voltage.  
Can cause severe injury or death.**

Disconnect all power sources before servicing. Install the barrier after adjustments, maintenance, or servicing.

*(600 volts and under)*

**WARNING**



**Hazardous voltage.  
Can cause severe injury or death.**

Disconnect all power sources before opening the enclosure.

*(600 volts and under)*

**WARNING**



**Hazardous voltage. Moving rotor.  
Can cause severe injury or death.**

Operate the generator set only when all guards and electrical enclosures are in place.

<b>⚠ WARNING</b>

<p><b>Hazardous voltage. Backfeed to the utility system can cause property damage, severe injury, or death.</b></p> <p>If the generator set is used for standby power, install an automatic transfer switch to prevent inadvertent interconnection of standby and normal sources of supply.</p>

**Grounding electrical equipment. Hazardous voltage can cause severe injury or death.** Electrocutation is possible whenever electricity is present. Open the main circuit breakers of all power sources before servicing the equipment. Configure the installation to electrically ground the generator set, transfer switch, and related equipment and electrical circuits to comply with applicable codes and standards. Never contact electrical leads or appliances when standing in water or on wet ground because these conditions increase the risk of electrocution.

**Installing the battery charger. Hazardous voltage can cause severe injury or death.** An ungrounded battery charger may cause electrical shock. Connect the battery charger enclosure to the ground of a permanent wiring system. As an alternative, install an equipment grounding conductor with circuit conductors and connect it to the equipment grounding terminal or the lead on the battery charger. Install the battery charger as prescribed in the equipment manual. Install the battery charger in compliance with local codes and ordinances.

**Connecting the battery and the battery charger. Hazardous voltage can cause severe injury or death.** Reconnect the battery correctly, positive to positive and negative to negative, to avoid electrical shock and damage to the battery charger and battery(ies). Have a qualified electrician install the battery(ies).

**Servicing the day tank. Hazardous voltage can cause severe injury or death.** Service the day tank electrical control module (ECM) as prescribed in the equipment manual. Disconnect the power to the day tank before servicing. Press the day tank ECM OFF pushbutton to disconnect the power. Notice that line voltage is still present within the ECM when the POWER ON light is lit. Ensure that the generator set and day tank are electrically grounded. Do not operate the day tank when standing in water or on wet ground because these conditions increase the risk of electrocution.

**Short circuits. Hazardous voltage/current can cause severe injury or death.** Short circuits can cause bodily injury and/or equipment damage. Do not contact electrical connections with tools or jewelry while making adjustments or repairs. Remove wristwatch, rings, and jewelry before servicing the equipment.

**Engine block heater. Hazardous voltage can cause severe injury or death.** The engine block heater can cause electrical shock. Remove the engine block heater plug from the electrical outlet before working on the block heater electrical connections.

**Electrical backfeed to the utility. Hazardous backfeed voltage can cause severe injury or death.** Install a transfer switch in standby power installations to prevent the connection of standby and other sources of power. Electrical backfeed into a utility electrical system can cause serious injury or death to utility personnel working on power lines.

**Installing accessories to the transformer assembly. Hazardous voltage can cause severe injury or death.** To prevent electrical shock disconnect the harness plug before installing accessories that will be connected to transformer assembly primary terminals 76, 77, 78, and 79. Terminals are at line voltage. *(Models with E33+, S340, S340+, 340, R340, and R33 controls only)*

**Installing accessories to the transformer assembly. Hazardous voltage can cause severe injury or death.** To prevent electrical shock disconnect the harness plug before installing accessories that will be connected to the transformer assembly primary terminals on microprocessor logic models. Terminals are at line voltage.

**Making line or auxiliary connections. Hazardous voltage can cause severe injury or death.** To prevent electrical shock deenergize the normal power source before making any line or auxiliary connections.

**Servicing the transfer switch. Hazardous voltage can cause severe injury or death.** Deenergize all power sources before servicing. Open the main circuit breakers of all transfer switch power sources and disable all generator sets as follows: (1) Move all generator set master controller switches to the OFF position. (2) Disconnect power to all battery chargers. (3) Disconnect all battery cables, negative (-) leads first. Reconnect negative (-) leads last when reconnecting the battery cables after servicing. Follow these precautions to prevent the starting of generator sets by an automatic transfer switch, remote start/stop switch, or engine start command from a remote computer. Before servicing any components inside the enclosure: (1) Remove rings, wristwatch, and jewelry. (2) Stand on a dry, approved electrically insulated mat. (3) Test circuits with a voltmeter to verify that they are deenergized.

Servicing the transfer switch controls and accessories within the enclosure. Hazardous voltage can cause severe injury or death. Disconnect the transfer switch controls at the inline connector to deenergize the circuit boards and logic circuitry but allow the transfer switch to continue to supply power to the load. Disconnect all power sources to accessories that are mounted within the enclosure but are not wired through the controls and deenergized by inline connector separation. Test circuits with a voltmeter to verify that they are deenergized before servicing.

## Heavy Equipment

<b>⚠ WARNING</b>

<p><b>Unbalanced weight. Improper lifting can cause severe injury or death and equipment damage.</b></p> <p>Do not use lifting eyes. Lift the generator set using lifting bars inserted through the lifting holes on the skid.</p>

<b>⚠ WARNING</b>

<p><b>Unbalanced weight. Improper lifting can cause severe injury or death and equipment damage.</b></p> <p>Use adequate lifting capacity. Never leave the transfer switch standing upright unless it is securely bolted in place or stabilized.</p>

## Hot Parts



<b>⚠ WARNING</b>

<p><b>Hot coolant and steam. Can cause severe injury or death.</b></p> <p>Before removing the pressure cap, stop the generator set and allow it to cool. Then loosen the pressure cap to relieve pressure.</p>

<b>⚠ WARNING</b>

<p><b>Hot engine and exhaust system. Can cause severe injury or death.</b></p> <p>Do not work on the generator set until it cools.</p>

**Servicing the exhaust system. Hot parts can cause severe injury or death.** Do not touch hot engine parts. The engine and exhaust system components become extremely hot during operation.

**Checking the coolant level. Hot coolant can cause severe injury or death.** Allow the engine to cool. Release pressure from the cooling system before removing the pressure cap. To release pressure, cover the pressure cap with a thick cloth and then slowly turn the cap counterclockwise to the first stop. Remove the cap after pressure has been completely released and the engine has cooled. Check the coolant level at the tank if the generator set has a coolant recovery tank.

## Moving Parts

<b>⚠ WARNING</b>	
	
<p><b>Hazardous voltage. Moving rotor. Can cause severe injury or death.</b></p> <p>Operate the generator set only when all guards and electrical enclosures are in place.</p>	

<b>⚠ WARNING</b>

<p><b>Rotating parts. Can cause severe injury or death.</b></p> <p>Operate the generator set only when all guards, screens, and covers are in place.</p>

**Servicing the generator set when it is operating. Exposed moving parts can cause severe injury or death.** Keep hands, feet, hair, clothing, and test leads away from the belts and pulleys when the generator set is running. Replace guards, screens, and covers before operating the generator set.

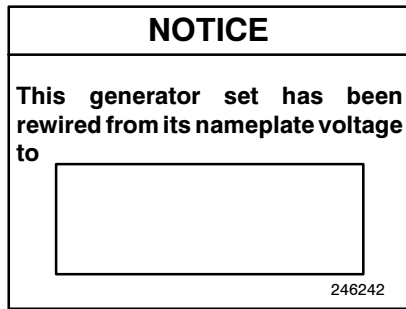
## Notice



### NOTICE

**Voltage reconnection.** Affix a notice to the generator set after reconnecting the set to a voltage different from the voltage on the nameplate. Order voltage reconnection decal 246242 from an authorized service distributor/dealer.

### NOTICE

**Hardware damage.** The engine and generator set may use both American Standard and metric hardware. Use the correct size tools to prevent rounding of the bolt heads and nuts.

### NOTICE

**Hardware damage.** The transfer switch may use both American Standard and metric hardware. Use the correct size tools to prevent rounding of the bolt heads and nuts.

### NOTICE

**When replacing hardware, do not substitute with inferior grade hardware.** Screws and nuts are available in different hardness ratings. To indicate hardness, American Standard hardware uses a series of markings, and metric hardware uses a numeric system. Check the markings on the bolt heads and nuts for identification.

### NOTICE

**Canadian installations only.** For standby service connect the output of the generator set to a suitably rated transfer switch in accordance with Canadian Electrical Code, Part 1.

This manual provides installation instructions for 20-2000 kW generator sets. Operation manuals and wiring diagram manuals are available separately.

x:in:001:001

Information in this publication represents data available at the time of print. Kohler Co. reserves the right to change this publication and the products represented without notice and without any obligation or liability whatsoever.

Read this manual and carefully follow all procedures and safety precautions to ensure proper equipment operation and to avoid bodily injury. Read and follow the Safety Precautions and Instructions section at the beginning of this manual. Keep this manual with the equipment for future reference.

x:in:001:002:a

---

## Service Assistance

---

Please contact a local authorized distributor/dealer for sales, service, or other information about Kohler Co. Generator Division products.

- Look on the product or in the information included with the product
- Consult the Yellow Pages under the heading Generators—Electric
- Visit the Kohler Co. Generator Division web site at [www.kohlergenerators.com](http://www.kohlergenerators.com)
- Inside the USA and Canada, call 1-800-544-2444
- Outside the USA and Canada, call the nearest regional office

### **Africa, Europe, Middle East**

London Regional Office  
Langley, Slough, England  
Phone: (44) 1753-580-771  
Fax: (44) 1753-580-036

### **Australia**

Australia Regional Office  
Queensland, Australia  
Phone: (617) 3893-0061  
Fax: (617) 3893-0072

### **China**

China Regional Office  
Shanghai, People's Republic of China  
Phone: (86) 21-6482 1252  
Fax: (86) 21-6482 1255

### **India, Bangladesh, Sri Lanka**

India Regional Office  
Bangalore, India  
Phone: (91) 80-2284270  
(91) 80-2284279  
Fax: (91) 80-2284286

### **Japan**

Japan Regional Office  
Tokyo, Japan  
Phone: (813) 3440-4515  
Fax: (813) 3440-2727

### **Latin America**

Latin America Regional Office  
Lakeland, Florida, USA  
Phone: (941) 619-7568  
Fax: (941) 701-7131

### **South East Asia**

Singapore Regional Office  
Singapore, Republic of Singapore  
Phone: (65) 264-6422  
Fax: (65) 264-6455

X:in:008:001



# Section 1 General

---

Industrial power systems give years of dependable service if installed using the guidelines provided in this manual and in applicable codes. Incorrect installation can cause continuing problems. Figure 1-1 illustrates a typical installation.

Your authorized generator set distributor/dealer may also provide advice about or assistance with your installation.

This manual references several organizations and their codes that provide installation requirements and guidelines such as the National Fire Protection Association (NFPA) and Underwriter's Laboratories Inc. (UL).

- NFPA 54 National Fuel Gas Code
- NFPA 70 National Electrical Code®; the National Electrical Code is a registered trademark of the NFPA

- NFPA 99 Standard for Health Care Facilities
- NFPA 101 Life Safety Code
- NFPA 110 Emergency and Standby Power Systems
- UL-486A The Standard for Wire Connectors and Soldering Lugs for Use with Copper Conductors
- UL-486B The Standard for Wire Connectors for Use with Aluminum Conductors
- UL-486E Equipment Wiring Terminals for Use with Aluminum and/or Copper Conductors
- UL-2200 Stationary Engine Generator Assemblies

These organizations provide information specifically for US installations. Installers must comply with their respective national and local codes.

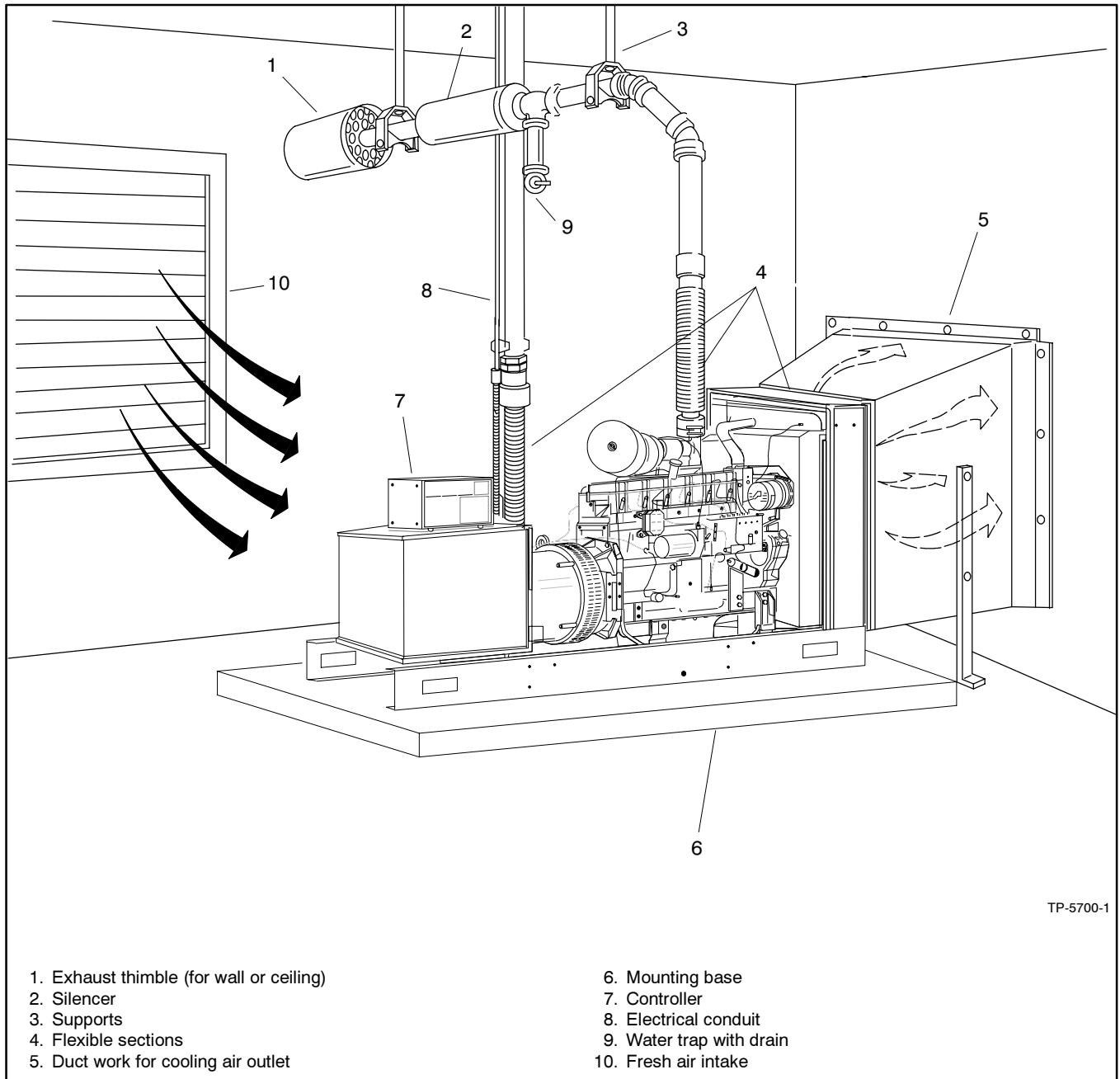

TP-5700-1

**Figure 1-1** Typical Stationary-Duty Generator Set Installation

## Section 2 Load and Transport

---

To ensure personal safety while preventing damage to the product, we strongly recommend the following guidelines be observed when loading and transporting standby generator sets. Due to the different designs, dimensions and weights of the generators involved, specific instructions for each model are not provided. However, these guidelines are applicable to the full standby line (although minor procedural changes may be necessary between sets). It is the responsibility of the dealer/distributor to see that generator loading and transport be performed within the framework of these guidelines. Obviously, prepackaged (crated) sets may be exempt from certain aspects of this section. (Prepackaged generators generally are loaded in their containers with the aid of lift trucks.)

### 2.1 Lifting the Generator Set

- **Do not lift the generator set by the lifting eyes attached to the engine and/or alternator.** These lifting eyes are only used during generator assembly and are not capable of supporting the entire weight of the generator. The mounting skid of each standby generator set includes four holes for attaching the lifting device. These holes are strategically placed to avoid damage to generator components by lifting cables and to maintain balance during lifting. In some cases, it may be necessary to remove protruding generator components (air cleaner, shrouding) to avoid damage by lifting cables.

- A four-point lifting method is necessary to lift the generator set.** To maintain generator balance during lifting, the lifting apparatus must utilize the four skid lifting holes mentioned in the previous paragraph. One method of lifting standby generators uses an apparatus of hooks and cables joined at a single rigging point. See Figure 2-2. The use of spreader bars is necessary with this method to avoid damage to the set during the lifting procedure. The spreader bars should be slightly wider than the generator skid so the set is not damaged by lifting cables and only vertical force is applied to the skid while lifting. The generators may also be lifted by placing bars through the skid lifting holes and attaching hooks to the ends of the bars. See Figure 2-1. Be sure the bars are properly sized for the weight of the generator set. Precautions must be taken to prevent the lifting hooks from sliding off the ends of the bars. Spreader bars may be necessary with this arrangement if lifting cables are in contact with the set. A specially designed lifting fixture is often used to lift the larger standby generators. The fixture usually includes adjustable cables to adapt to different size generators and to compensate for unit imbalance. See Figure 2-3. In all cases, be sure the components of the lifting device (cables, chains, bars) are properly sized for the weight of the generator set.

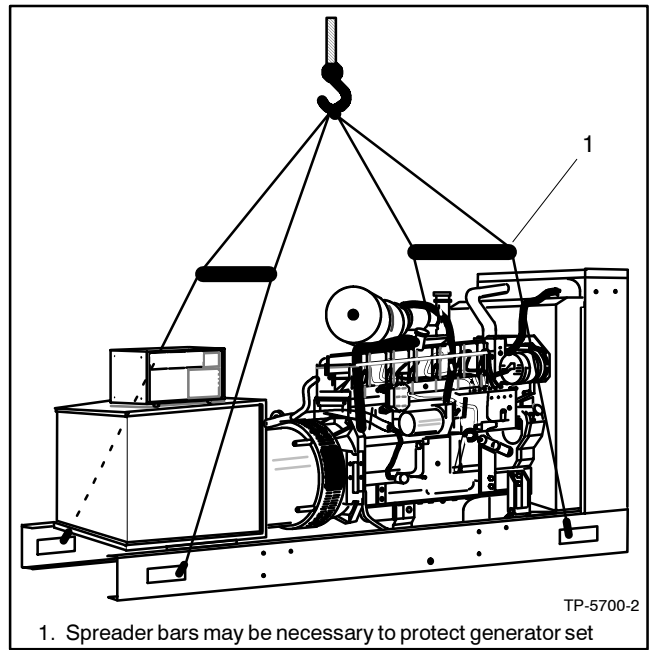

**Figure 2-2** Generator Set with Lifting Hooks in Skid

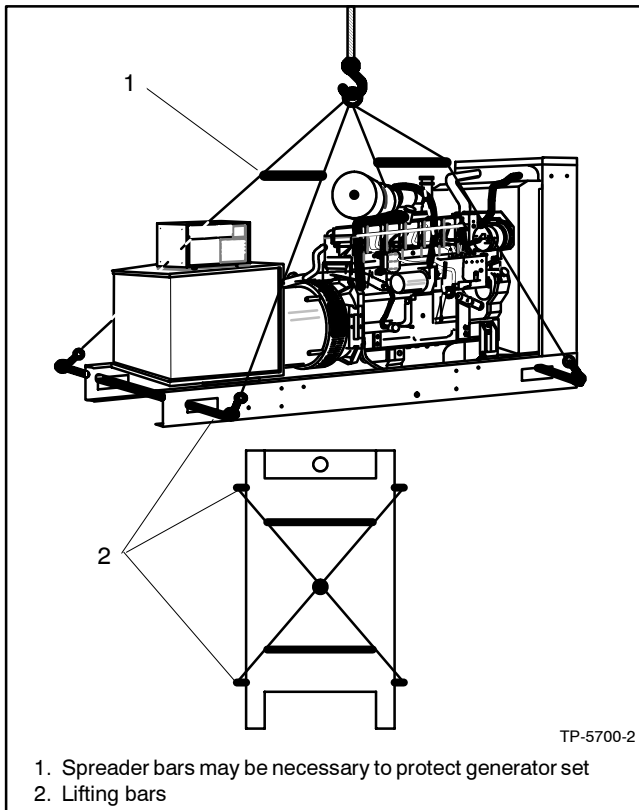

**Figure 2-1** Generator Set with Lifting Bars in Skid

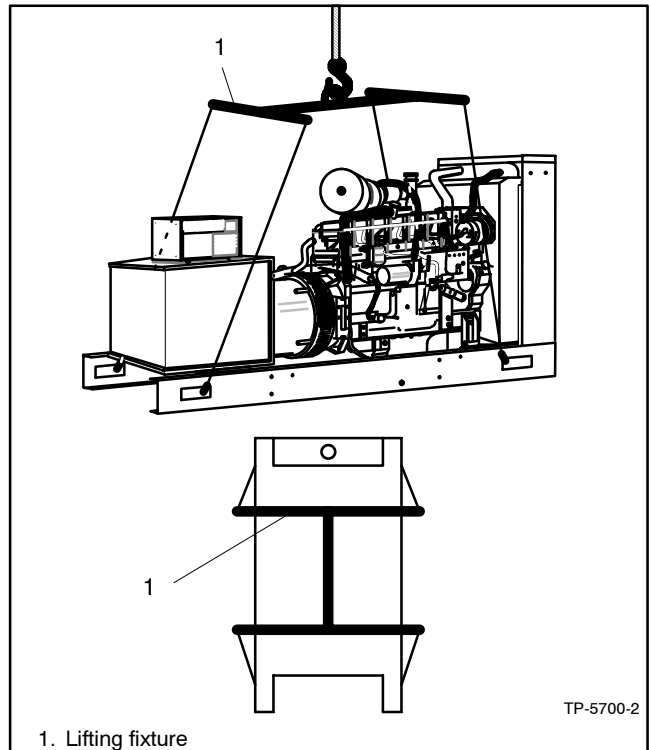

**Figure 2-3** Generator Set with Lifting Fixture

- **Do not attach lifting hooks to outside reinforcing plate on skid.** Attach lifting hooks to skid exactly as shown in Figure 2-4. This method utilizes the strongest portion of the mounting skid and also prevents the lifting hooks from slipping. Generators without skid reinforcing plates can be raised with lift hooks on the inside or outside of the skid.

The following information pertains to lifting a generator set with subbase fuel tank, weather housing, and/or sound shield.

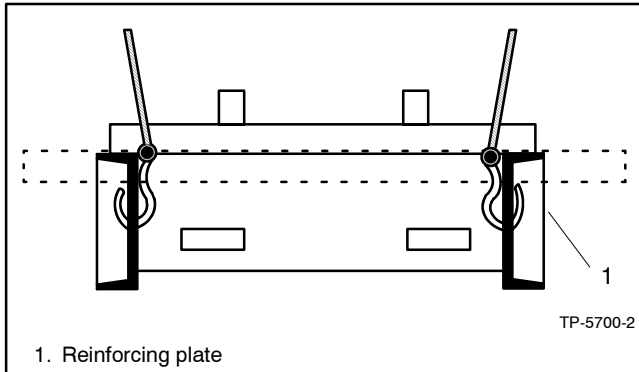

**Figure 2-4** Lifting Hook Placement (above 1000 kW)

### 2.1.1 Weather Housing

Lift the weather housing and generator set together as one unit using the generator set guidelines.

### 2.1.2 Sound Shield

If the generator set has an installed sound shield and subbase fuel tank the assembly can be lifted as one unit provided the subbase fuel tank has lifting eyes installed and meets the criteria of subbase fuel tank paragraph 2. In all other cases, remove the sound shield per the following paragraphs.

*Remove the sound shield, if installed, from the generator set before lifting the generator set. The sound shield attaching bolts may be hidden by the sound shield insulation. To locate the hardware carefully lift the sound insulation near the skid.*

*Remove the wood skid before lifting the sound shield using the eye bolts. Use the sound shield eye bolts, if equipped, to lift only the sound shield.*

Reinstall the sound shield after lifting and mounting the generator set.

### 2.1.3 Subbase Fuel Tank

The lifting contractor determines the type and suitability of the subbase fuel tank lifting device. Lift the subbase fuel tank as one unit if shipped separately from the generator set. Use lifting eyes if equipped on subbase fuel tank; otherwise, use chains or cables to lift the subbase fuel tank. If using lifting straps, protect the strap from sharp fuel tank edges.

Lift the generator set (up to 400 kW) and subbase fuel tank together provided the fuel tank is empty and the subbase fuel tank does not extend beyond the perimeter of the generator set skid.

In all other cases, remove the mounting hardware and wiring between the the generator set and subbase fuel tank. Lift the generator set and subbase fuel tank separately. It is not necessary to drain fuel tank when lifting just the fuel tank.

## 2.2 Transporting the Generator Set

- **The transporting vehicle/trailer must be sized for the dimension and weight of the generator set.** Consult the set dimensional drawing or contact the factory for information (weight, dimensions) pertinent to planning transport. The overall height of a generator set in transit (including vehicle/trailer) must not exceed 13.5 ft. (4.1 m) unless special hauling permits are obtained (check Federal, State, and local laws prior to transporting). Larger units (above 1000 kW) should be transported on low-boy-type trailers with a deck height of 25 in. (635 mm) or less to meet clearance requirements. Large (unboxed) generators with radiators should be loaded with the radiator facing the rear to reduce wind resistance while in transit. Radiators with free-wheeling fans must have the fan secured to prevent rotation that might introduce flying objects to the radiator core or fan blades.
- **Be sure the generator set is securely fastened to the vehicle/trailer and covered with a tarpaulin.** Even the heaviest of units is capable of movement during shipment unless properly secured. Fasten the set to the vehicle/trailer bed with properly sized chain routed through the mounting holes of the skid. Use chain tighteners to remove slack from the mounting chain. Cover the entire unit with a heavy-duty tarpaulin and secure tarpaulin to the generator or trailer.

# Notes

### 3.1 Location Factors

Location is the key to a proper installation. The following sections will deal with the factors to consider in a proper installation. Before final plans are made for locating a generator set, the following questions should be raised concerning the set and the proposed site.

1. Is the **structure strong** enough to support the set and related equipment such as fuel storage tanks, batteries and radiators?
2. Can **vibration** be effectively isolated and dampened to reduce noise and prevent damage?
3. Is the **area clean**, dry and not subject to flooding?
4. Is the **area large enough** to provide easy access for servicing and repair?
5. Can **adequate ventilation** be attained in the area with a minimum amount of ductwork?
6. Can **exhaust gases** be expelled safely out of and away from the structure and other buildings?
7. Will an adequate **supply of fuel** be available to sustain operation during emergencies?
8. Will fuel **tank location** be within the vertical lift capabilities of the fuel pump?

The location of the generator set must:

- Meet applicable fire rating codes and standards.
- Position the generator set over a noncombustible surface. If the mounting surface directly under or near the generator set is porous or deteriorates from exposure to engine fluids, construct a containment pan for spilled fuel, oil, coolant, and battery electrolyte. Do not allow accumulation of combustible materials under the generator set.

### 3.2 Weight

The weight of the generator set will determine the type of construction at the site. Most sets are mounted on concrete at ground level. Some, however, are located on upper levels of steel, concrete or wood construction.

The generator's weight will determine how strong this construction should be. Generator weights can be found in the specification sheet for your particular model. Be sure that the weight of accessory items is added to the total requirements. This is especially important in upper story or roof installations.

### 3.3 Mounting

Typical mounting surface details and dimensions are shown in Figure 3-1. The recommended mounting surface is a concrete mounting pad. This must be a level surface as shown in Figure 3-2, or raised pads as shown in Figure 3-3 and Figure 3-4.

The advantage of the arrangement shown in Figure 3-3 is that the engine oil can be drained more conveniently. An oil drain piped to the side of the mounting base is usually available as an accessory from the manufacturer. If there is not sufficient clearance below the oil outlet for a pan large enough to hold the full engine oil capacity, it will be necessary to use a pump whenever oil is changed.

The double-pedestal arrangement shown in Figure 3-4 has the advantage of providing more working room under the engine without raising the engine or generator set off its mountings. With either arrangement, the mounting pad should extend six inches (15 cm) beyond the mounting base dimensions. When using the double-pedestal arrangement, the pedestals should extend at least six inches (15 cm) back from the location of the front engine mount and six inches (15 cm) toward the engine from the generator mounting point. A minimum of 18 inches (46 cm) between the generator and any adjacent walls or other obstructions should be maintained for ease of servicing.

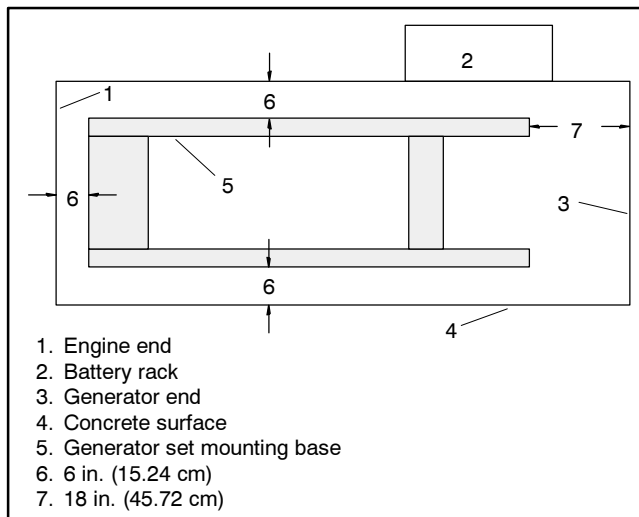

**Figure 3-1** Mounting Surface Detail

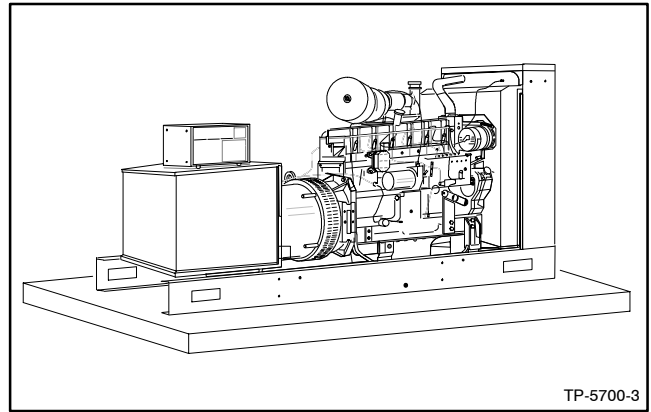

**Figure 3-2** Single-Pad Mounting

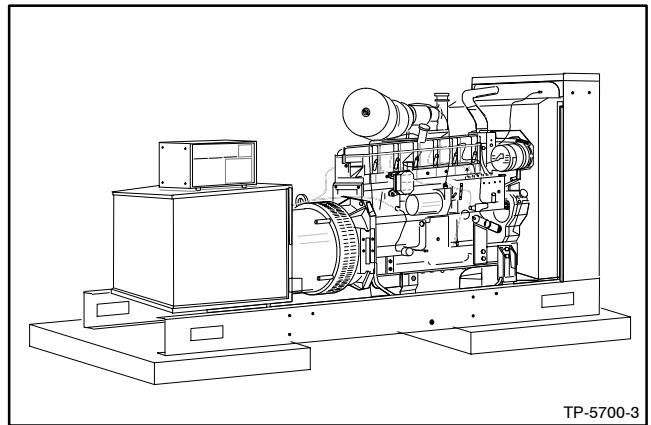

**Figure 3-3** Dual-Pad Mounting

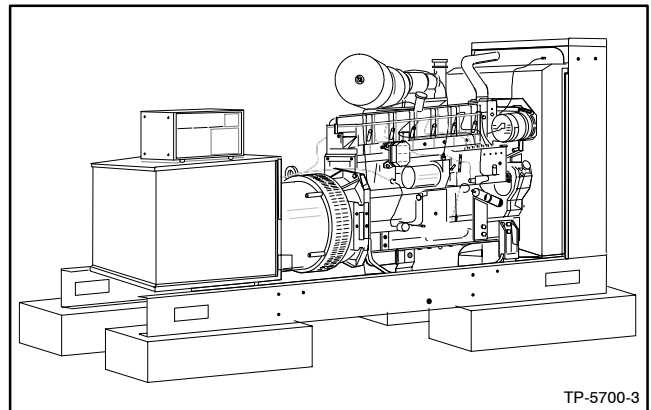

**Figure 3-4** Four-Pad Mounting

The composition of the mounting pad should follow standard practice for the required loading. Common specifications call for 2500-3000 psi (176-211 kg/cm<sup>2</sup>) concrete reinforced with eight-gauge wire mesh or number 6 reinforcing bars on 12-inch (30-cm) centers. The total weight of the mounting pad should be at least equal to the weight of the generator set (a density of 150 lbs. per cubic foot [68.4 kg per 0.03 m<sup>3</sup>] for concrete can be used for this calculation). Suggested concrete mixture by volume is 1:2:3 parts of cement, sand, and aggregate. A layer of 8-10 inches (21-26 cm) of sand or gravel should surround the pad for proper support and isolation of a pad located at or below grade. All generator sets should be anchored to concrete with bolts buried in the surface of the pad. Expansion-type anchors are not acceptable.

**Note:** Always refer to the dimensional drawings for the generator and accessories when considering placement of conduits and fuel lines. Dimensions are provided on these drawings for rough-ins and stub-ups of electrical and fuel connections.

### 3.4 Vibration Isolation

Mounting bases for generator sets 30kW and larger are typically made from “I” or “C” section fabricated steel with a width of 2-3 inches per channel. Length varies with the size of the unit, resulting in a static load on the mounting base of 10-25 psi (0.703-1.758 kg/cm<sup>2</sup>) if the total bottom surface of the channel is in contact with the mounting base. All generator sets should have vibration isolation between the engine-generator and skid or mounting base. See Figure 3-5. This may consist of neoprene or combination spring and neoprene isolators between the engine-generator and skid, or spring-type mounts between the skid and mounting pad. An advantage of factory-installed mounts between the engine-generator and the skid is that engine-generator alignment is not affected by stress induced in handling, shipment, or mounting on an uneven surface. A less rigid skid may be used, reducing weight and installation time. All connections between the generator and mounting base such as conduits, fuel lines, exhaust piping, etc., must have flexible sections to prevent breakage and isolate vibration to the generator set.

Generator sets 350 kW and larger are usually mounted directly to a structural steel base. For these units, the manufacturer’s recommended vibration isolators should be installed between the base and mounting pad. Because of the reduced mounting surface area of these individual mounts, the static load on the mounting surface will increase to the range of 50-100 psi (3.515-7.03 kg/cm<sup>2</sup>).

The vibration isolation efficiency of neoprene pad-type mounts is approximately 90%. When installed at or below grade, this degree of isolation will prevent transmission of objectionable vibration to the surrounding structure. Spring-type isolators can be expected to provide isolation efficiency of 98%. This type of mount may be desirable for above-grade installations.

In some critical applications where the generator set is installed above grade or where earthquake-proof mounts are specified, it may be necessary to install spring-type vibration isolators under the generator set mounting base. Check state and local codes for such requirements. Accessory vibration mounts should be installed at the locations of the standard predrilled mounting holes.

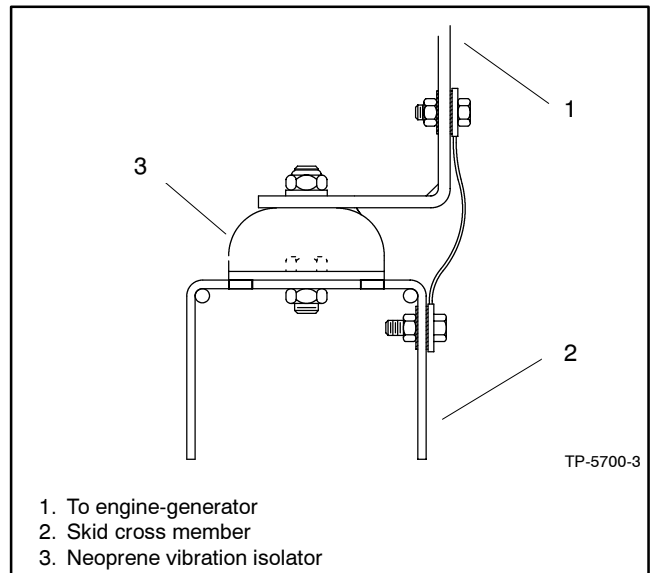

**Figure 3-5** Neoprene-Type Integral Vibration Isolators

# Notes

## Section 4 Air Requirements

### 4.1 General

An ample flow of clean, cool air is required to support combustion and dissipate heat. Approximately 70% of the heat value of fuel consumed by an engine will be rejected to the cooling system and exhaust.

**Battery compartment ventilation.** To prevent the accumulation of explosive gases, ventilate compartments containing batteries.

If a generator set is to be located in a building or enclosure, make certain that adequate air intake and air outlet openings are provided. If air flow provided by the engine-generator cooling fan is not sufficient to prevent excessive temperatures, other means such as ductwork and/or ventilating fans will have to be used to provide adequate air flow. If an exhaust fan is used, (Figure 4-1 and Figure 4-2) check the fan's capacity in cubic feet (cubic meters) per minute. Follow the fan manufacturer's recommendations to determine the size of the inlet and outlet openings.

In certain cold climate applications, controlled recirculation may be used as a means of heat recovery; however, special equipment such as thermostatically activated louvers and fans are needed to prevent engine and engine room overheating. The uncontrolled recirculation of heated air within an enclosure must be prevented. Otherwise, the temperature in the enclosure quickly rises to a point where efficient cooling is no longer possible. With a properly designed ventilation system, a sufficient temperature differential is not hard to maintain—even on the hottest days. Make certain air inlets and outlets cannot be blocked by snow. Air inlets and outlets should also be kept clean and unobstructed at all times. The direction of the prevailing wind should be considered when positioning outlets. If wind velocity is considerable, it tends to cancel the effects of the engine or exhaust fan. When strong prevailing winds are anticipated, face the air inlet into the wind and the outlet in the opposite direction. See Section 4.6, Liquid-Cooled Models, for additional suggestions.

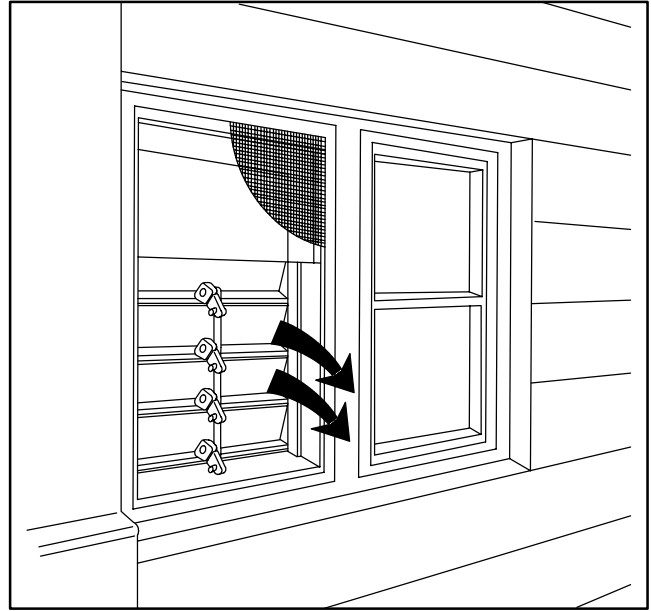

**Figure 4-1** Exhaust Fan-Operated Louvers (fan not shown)

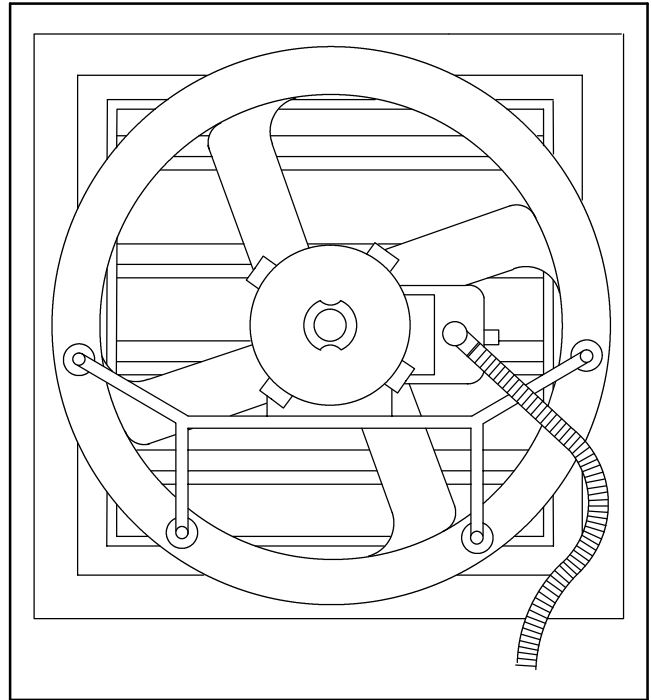

**Figure 4-2** Fans Required On Some Installations

In many installations it may be desirable to install louvers in the inlet and outlet openings. Louvers may be either stationary or movable. In areas of great temperature variation, it is often best to install movable louvers that can be thermostatically adjusted to regulate air flow and room temperature. See Figure 4-3 and Figure 4-4.

If the set is to be installed in an atmosphere highly contaminated with impurities such as dust, chaff, etc., it may be necessary to install a filter in the inlet opening. Furnace-type filters have been very satisfactory. Again, a certain amount of air flow is lost that must be compensated for by increasing the size of the opening.

The following are minimum air inlet and outlet recommendations:

1. If **louvers** are used, the size of the opening should be increased approximately 50%.
2. If **window screening** is used, the opening should be increased approximately 80%.
3. If **furnace filters** are used, the opening should be increased 120%.

## 4.2 Air-Cooled Generators

Air-cooled generator sets are available with three basic types of air cooling systems that are discussed separately on the following pages. For air-cooled models 4 kW and smaller, size the air inlet and outlet openings at least 1 square foot (0.092 m<sup>2</sup>). For larger sets determine inlet and outlet size on the basis of 0.25 square feet (0.023 m<sup>2</sup>) for each 1000 watts of capacity. A 5000-watt set, for example, requires inlets and outlets of 1.25 square feet (0.115 m<sup>2</sup>) each:

$$0.25 \text{ cu. ft.} \times 5 \text{ kW} = 1.25 \text{ cu. ft.}$$
$$(0.023 \text{ m}^2 \times 5 \text{ kW} = 0.115 \text{ m}^2)$$

Air requirements are listed in each model's specification sheet. Remember to increase the size of openings for louvers, screens, filters, etc. as described earlier in this section.

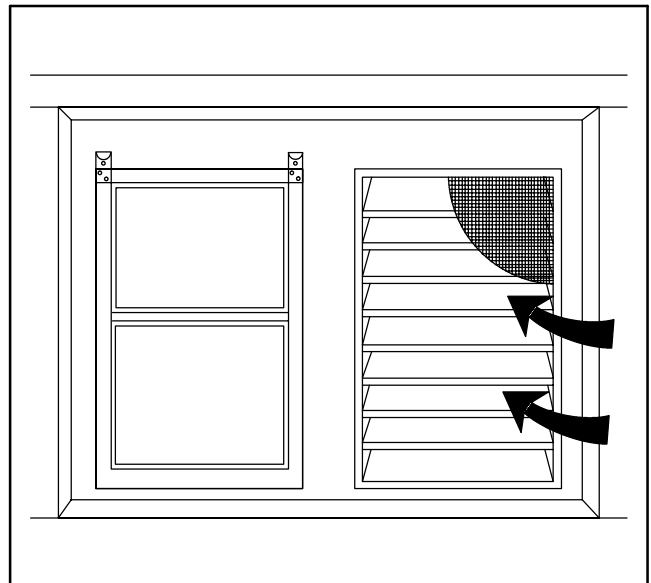

**Figure 4-3** Stationary Louvers for Air Inlet

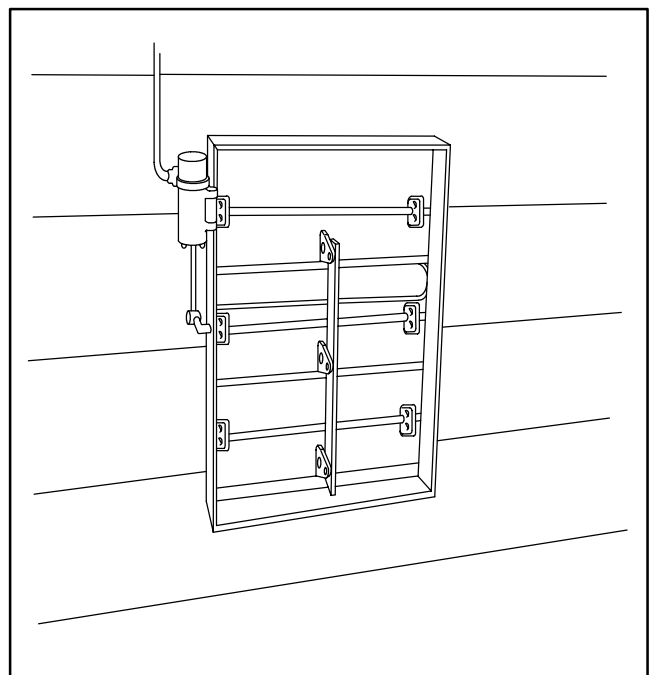
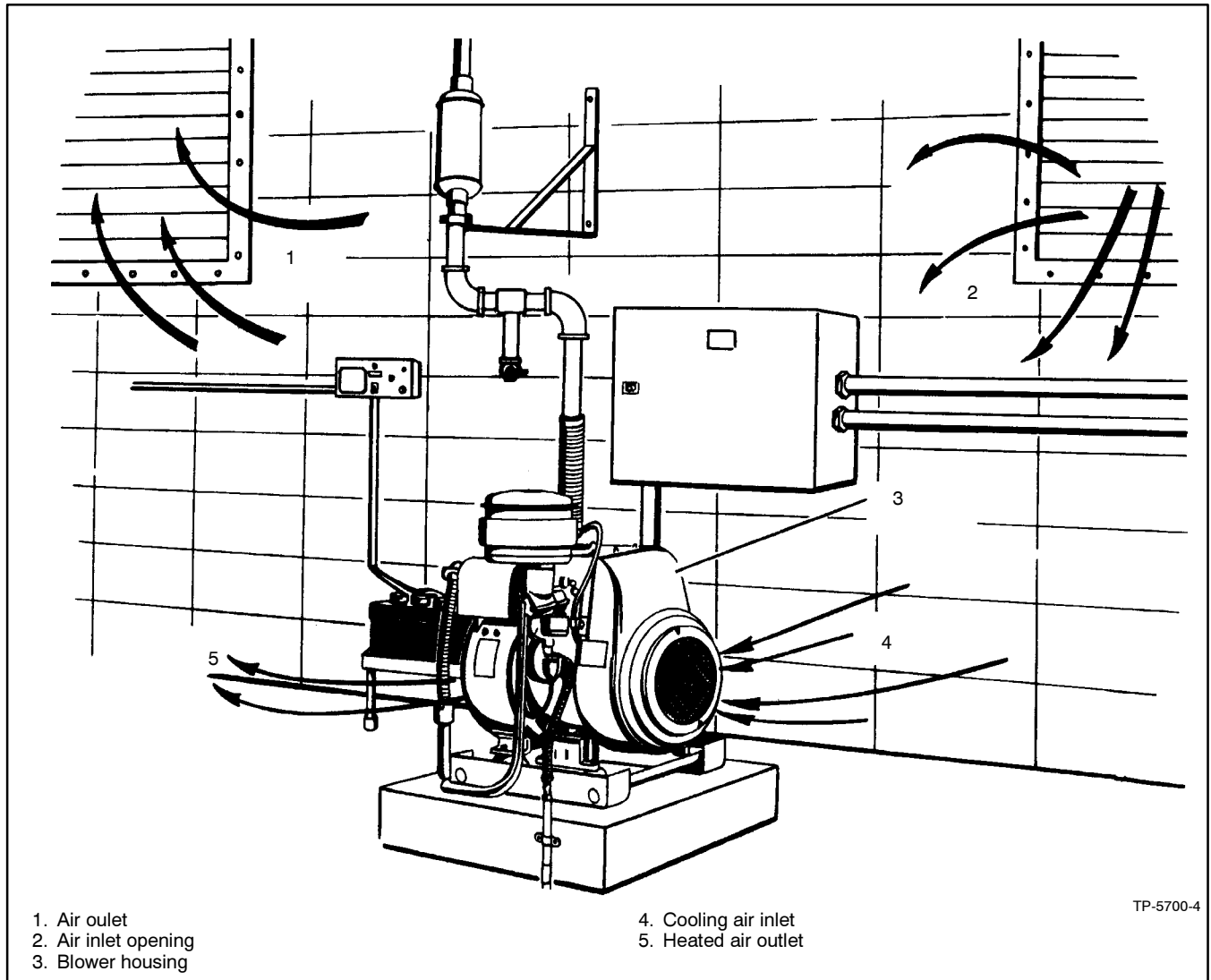

**Figure 4-4** Movable Louvers For Air Inlet

### 4.3 Forced Air

With the forced-air system, cooling air is drawn in through the front of the engine, circulated around finned areas of the cylinder block and head, then ejected

toward the rear or generator end of the set. This system is best suited to wide-open, well-ventilated areas. It is not recommended for confined areas unless intake and/or exhaust fans are used to achieve the required air circulation. See Figure 4-5.



**Figure 4-5** Standard Forced-Air Cooling System

## 4.4 Air-Vac™ Cooling System

The air flow direction with the Air-Vac™ system is the opposite of the conventional forced air cooling system. Use the Air-Vac™ system in confined areas since it includes a blower scroll which easily connects to the ductwork. For duct dimensions refer to the dimensional drawing for your model. With Air-Vac™ cooling, air is drawn across the generator end of the unit, into the

finned areas, and then out into the scroll located at the front of the engine. The heated air is forced through ductwork to the outside of the building. See Figure 4-6.

**Note:** Order Air-Vac™ cooling systems factory installed since major components of the engine are affected making it difficult and uneconomical to install at a later time.

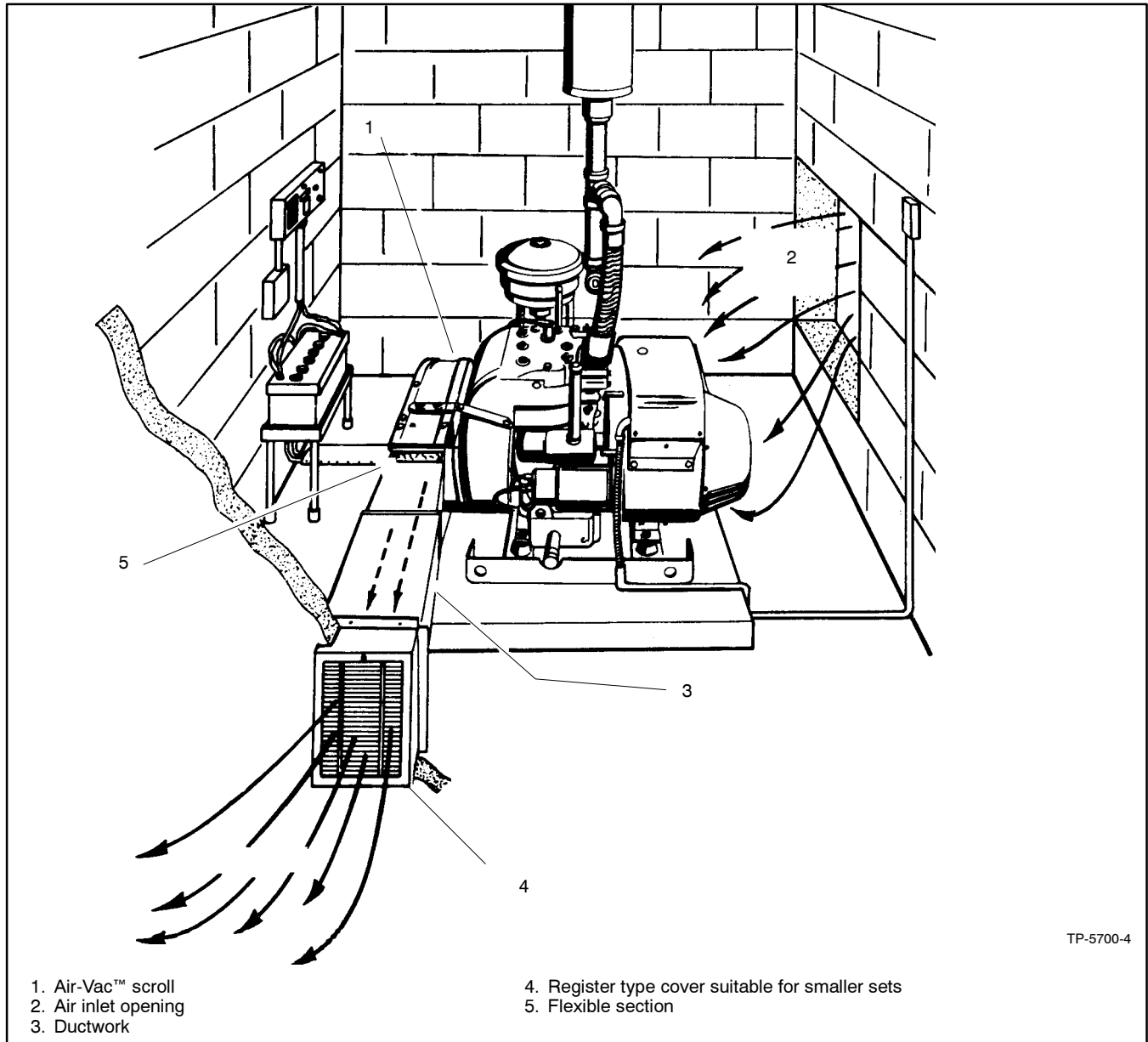

**Figure 4-6** Air-Vac™ Cooling System

## 4.5 Air Vent

The air vent system is used on some air-cooled gas and has been used on some diesel models. It includes special ductwork which directs the flow of heated air to the outlet at the top or side of the engine. The air vent air flow is not reversed as it is with the Air-Vac™ system. Choose top or side outlet of the engine. Additional

ductwork connects to the engine ductwork carrying the heated air outside. For duct dimensions, refer to the dimensional drawing for the particular unit. This system is also efficient in maintaining consistent operating temperatures in confined areas. See Figure 4-7.

**Note:** Air vent requires very little engine modification making it practical for field installation.

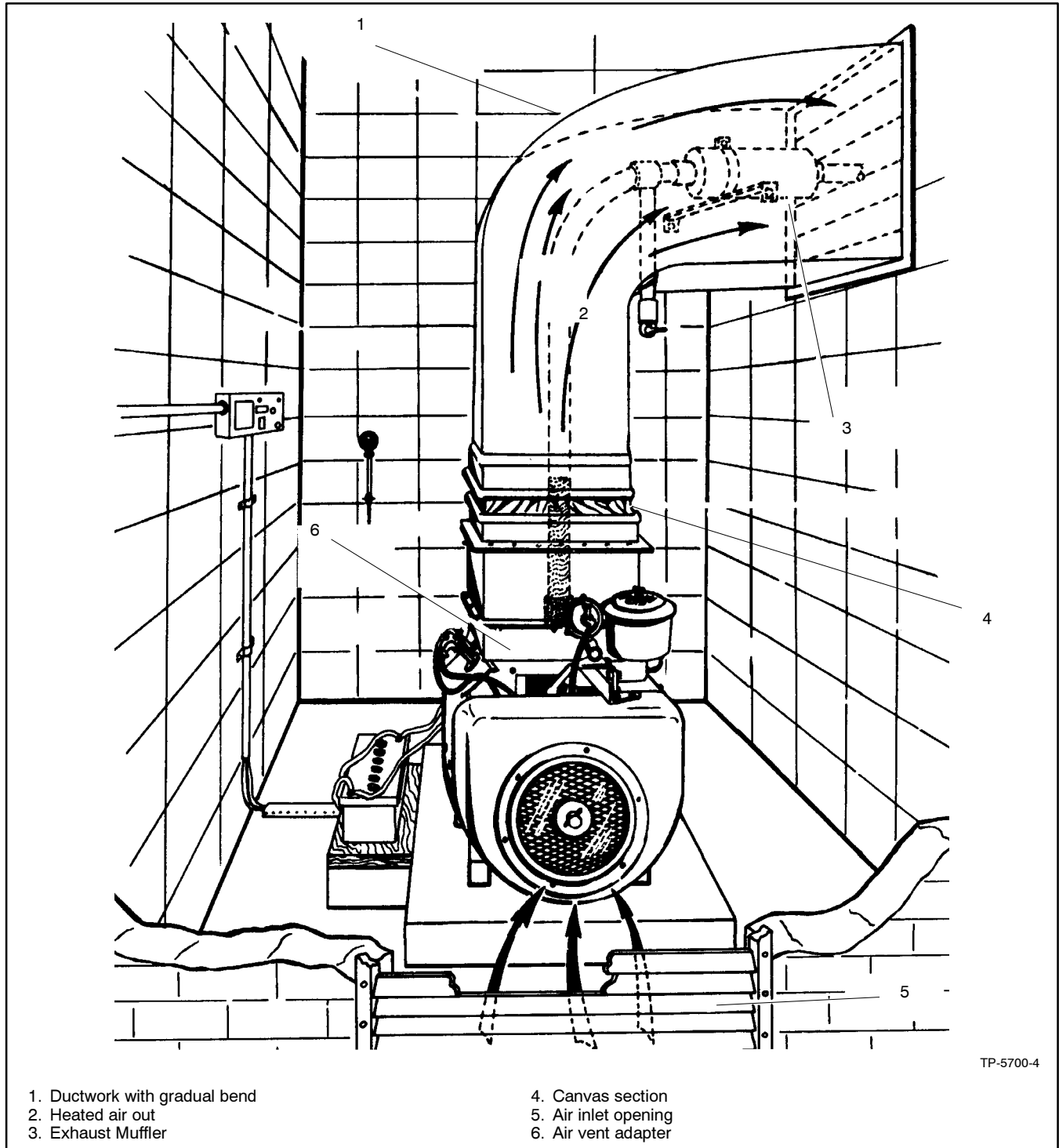

**Figure 4-7** Air Vent Cooling System using an Air-Cooled Generator Set

## 4.6 Liquid-Cooled Models

The three most common liquid cooling systems used for generator sets are unit-mounted radiator, city water, and remote radiator cooling. Since each involves somewhat different installation considerations, they will be discussed separately.

## 4.7 Unit-Mounted Radiator Cooling

This is the most common cooling system used for engine-driven generator sets 20 kW and larger. The major system components are an engine-driven fan and circulating water pump, a radiator, and a thermostat. The pump circulates water through the engine until it reaches operating temperature. Then the engine thermostat opens and allows circulation through the radiator. It can also close, restricting the flow as necessary to prevent overcooling. The fan blows air from the engine side of the radiator across the cooling surface as shown in Figure 4-8.

Cooling air flow can be reversed by using a suction fan, but this is generally not recommended because it may interfere with generator cooling air flow, which moves in the same direction as the engine's standard pusher fan. Also, a suction fan would result in higher temperature combustion air being drawn into the air cleaner, reducing the maximum engine power available.

Whenever a generator set is installed inside a building or enclosure, the radiator air should be ducted outside the room or enclosure. A typical arrangement is shown in Figure 4-8. Ductwork should be as short, straight, and unobstructed as possible. Static pressure restrictions of more than 1/2 inch (1.3 cm) water column on the radiator outlet or inlet air will reduce air flow to the point of limiting maximum power and/or ambient temperature that causes overheating.

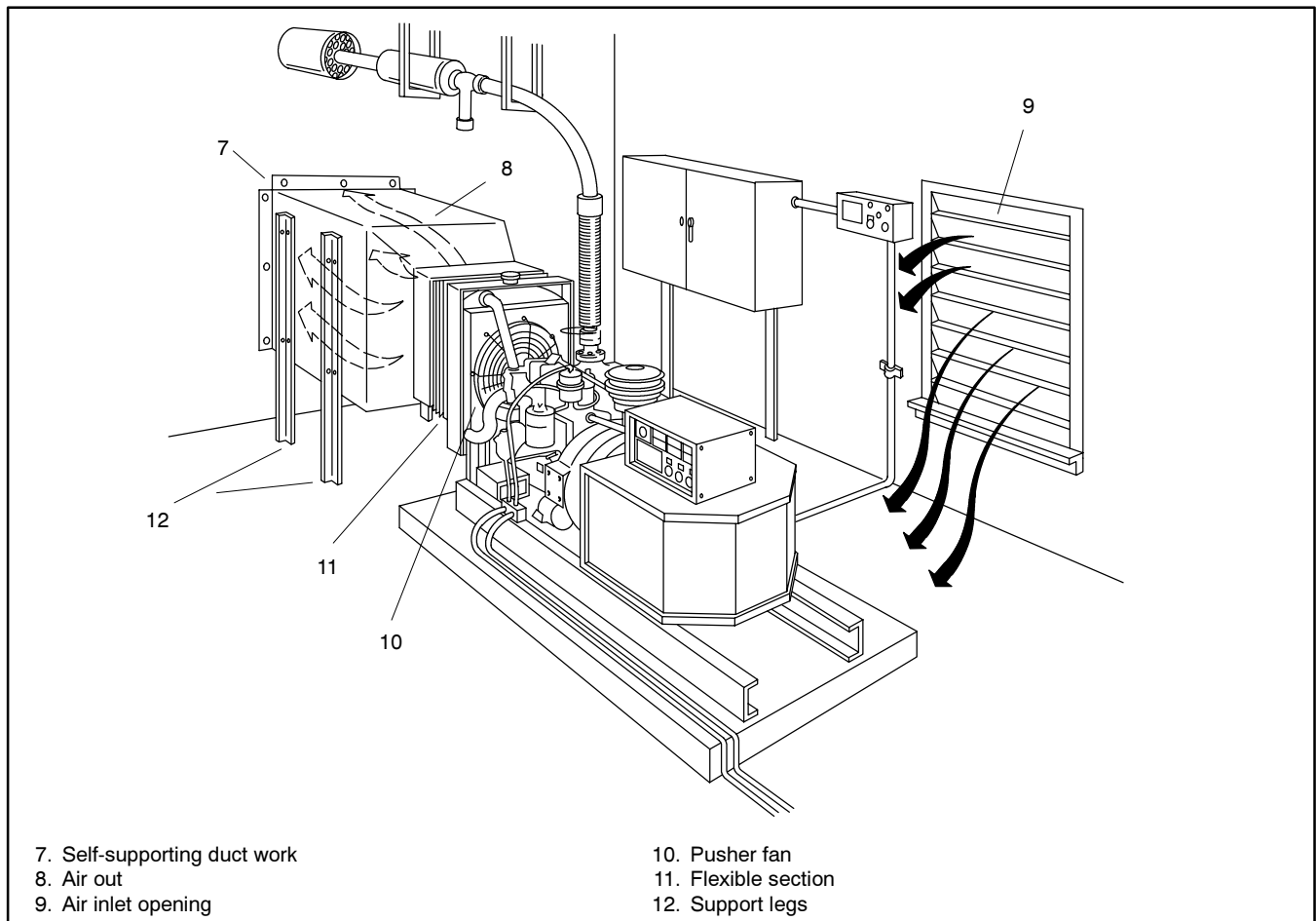

**Figure 4-8** Radiator-Cooled Generator Set Installation

The connection from the radiator duct flange to the ductwork should be heavy canvas, silicone or similar flexible material to prevent noise and vibration transmission. Sheet metal ductwork should be self-supporting. In general, the outlet duct should have an unrestricted area 150% greater than that enclosed by the radiator duct flange. The inlet air opening should be at least as large as the outlet but preferably 50% larger. If screens, louvers or filters are used, openings should be increased in size according to the recommendations given in the "Air Requirements, General" section. Ductwork should be designed to allow ease of service in the event the radiator would have to be removed.

Air inlet and outlet locations should be chosen to prevent air recirculation inside or outside the enclosure. Consideration should also be given to prevailing winds, facing inlets into the expected winds and outlets on the downwind side where possible. Inlets and outlets should be located where they will not be blocked by accumulated snow or any other obstruction. Keep in mind that the exhaust air of larger units is both high-volume and high velocity. It may be accompanied by a high sound level and should be directed away from areas that may be occupied by people or animals.

Be sure to design any temperature controlling louvers so that inlet air is not restricted to the point that pressure inside the building is reduced. Low pressure can cause pilot lights on gas fired appliances to be extinguished or problems with the building ventilation system.

Bringing large quantities of winter air into a building can waste building heat and even result in frozen water pipes in normally heated spaces. An arrangement as shown in Figure 4-9 using thermostatic controls can eliminate such problems and allow recovery of engine heat to supplement the building heating system. For cold outdoor ambients, louvers to the exterior would be closed, with those to the interior open. Controls would be set to reverse the condition for warm outdoor temperatures.

## 4.8 Remote Radiator Cooling

If the generator set is located in an area into which it is difficult to bring the volume of air required to cool the radiator, such as a basement, a remote radiator can be mounted outside the building. See Figure 4-10.

The top of the remote radiator must be at the highest point in the system to function properly. The fan motor is connected to the generator output and will run when the generator is operating. The radiators can be set up for either horizontal or vertical air discharge.

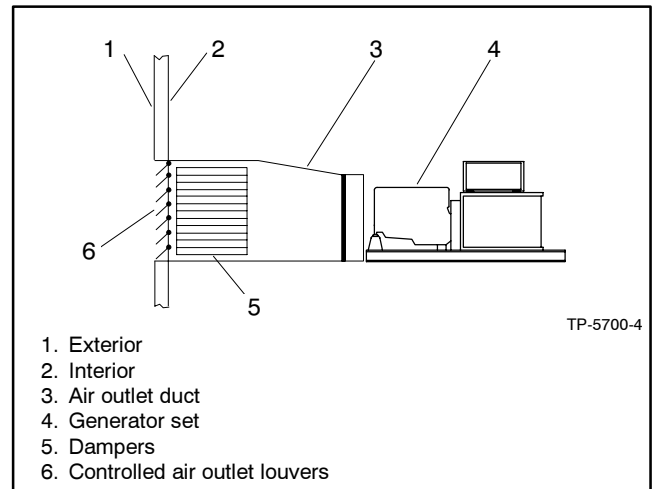

Figure 4-9 Air Control Louvers

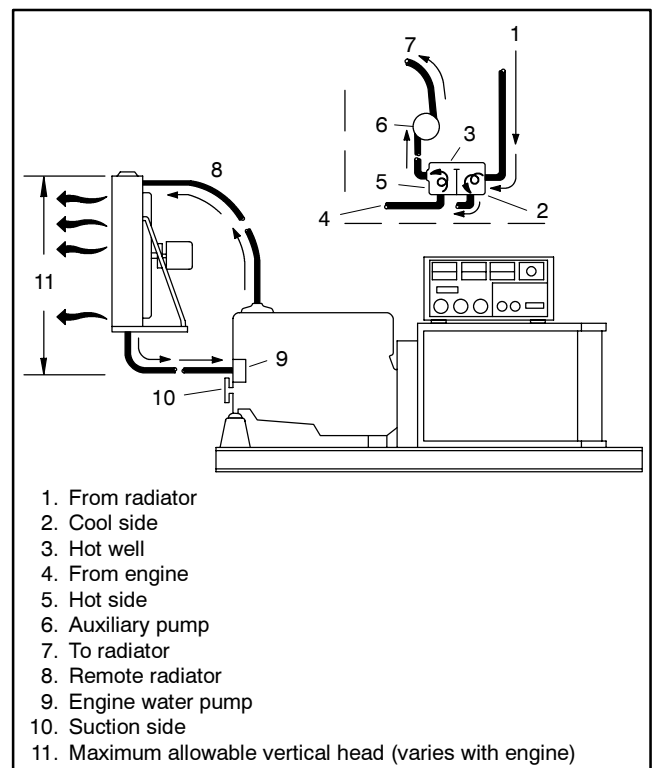

Figure 4-10 Schematic Diagram of Remote Radiator System

The engine water pump can be used to circulate water through the remote radiator providing that the vertical distance from the engine water pump does not exceed the engine manufacturer's recommendations. The allowable static head may range from 17-50 feet (5.2-15.2 m). Consult the Specification Sheet for the unit. This is important because greater height will result in excessive head pressure on engine components, causing problems such as leaking water pump seals. The piping between the engine and remote radiator must be sized for a maximum of 2 psi (0.141 kg/cm<sup>2</sup>) pressure drop at the rated flow of the engine water pump. A vent line from the engine to the radiator may be necessary to purge air from the cooling system.

When either horizontal or vertical distances exceed the above limitations, a hot well tank or heat exchanger and auxiliary circulating pump as shown in Figure 4-10 should be used. The circulating pump should always be wired in parallel with the remote radiator fan so that both will operate whenever the generator set operates.

Heated water is forced by the engine pump into the "hot" side and then is drawn off by the auxiliary pump and forced into the radiator. After circulating through the radiator, coolant flows back to the cold side of the well where it is removed by the engine water pump. Head pressures are thus isolated from the engine. Pressure can also be isolated by installing a heat exchanger between the engine and remote radiator.

With the radiator at a remote location, it is easily overlooked each time the generator is serviced. For this reason, low water alarms, or automatic "make-up" controls are often included in these systems. Antifreeze is required if the radiator is subject to freezing temperatures.

Shutoff valves should be located between the engine and cooling system to allow for isolation of both systems. This will eliminate the need to drain the entire system during service.

To determine radiator size and air requirements check the Specification Sheet for your model. The amount of air required to ventilate the generator set room or enclosure determines the size of the air inlet and outlet—a ventilating fan is usually necessary as generator heat loss as well as engine heat loss must be dissipated.

## 4.9 City Water Cooling

These systems utilizes city water and heat exchangers for cooling and are similar to remote radiator systems in

that they require less cooling air than unit-mounted radiator systems. Refer to Figure 4-11 for a view of some of the elements of a typical installation.

The heat exchanger the effects of city water (lime deposits, corrosion) to one side of a heat exchanger which is relatively easy to clean or replace, while engine coolant circulates in a closed system similar to a radiator system.

It allows better control of engine temperature, permits the use of antifreeze and coolant conditioners, and is suited to the use of an engine block heater as a starting aid.

Water inlet and outlet connections are mounted on the generator set skid and isolated from engine vibration by flexible sections. If the generator set is vibration-mounted to the skid and the skid is bolted directly to the mounting base, no additional flexible sections are needed between connection points on the skid and city water lines. If the generator set skid is mounted to the base with vibration isolators, flexible sections must be used between connection points on the skid and city water lines.

A solenoid valve mounted at the inlet connection point automatically opens upon start-up of the generator set, providing water under pressure from city mains for engine cooling. This valve automatically closes when the unit shuts down. Be sure that the solenoid valve is located upstream of the supply flexible connection. An additional customer-supplied valve may be used ahead of the entire system to manually shut off city water when servicing the generator.

## 4.10 Cooling Tower

In warm, dry climates, a cooling tower may be a suitable source of generator set cooling water. A typical system is shown in Figure 4-12. This is a variation of the city water cooling with heat exchanger. The engine system usually includes the engine water pump, a heat exchanger, a surge tank, and the water jacket of the engine. The raw water system consists of the cooling tower, a raw water pump, and the tube portion of the heat exchanger. Raw water is circulated through the heat exchanger tubes to absorb heat from the engine system which is circulated around the surrounding shell of the heat exchanger. The heated raw water is directed into a pipe at the top of the cooling tower and sprayed down into the tower to cool by evaporation. Since some water is constantly being lost by evaporation, the system must include provision for "make up" water.

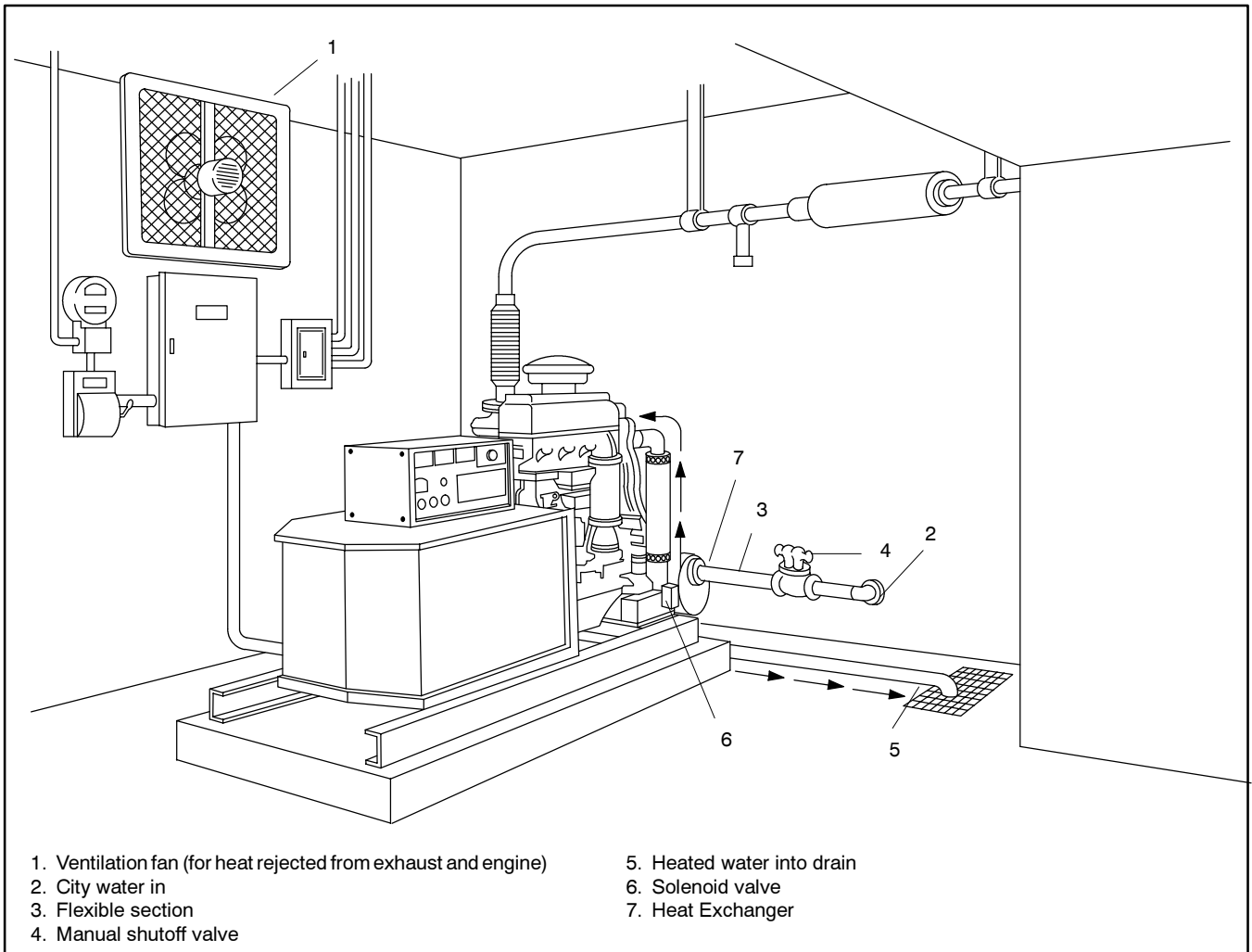

**Figure 4-11** Installation Using City Water Cooling System with Heat Exchanger

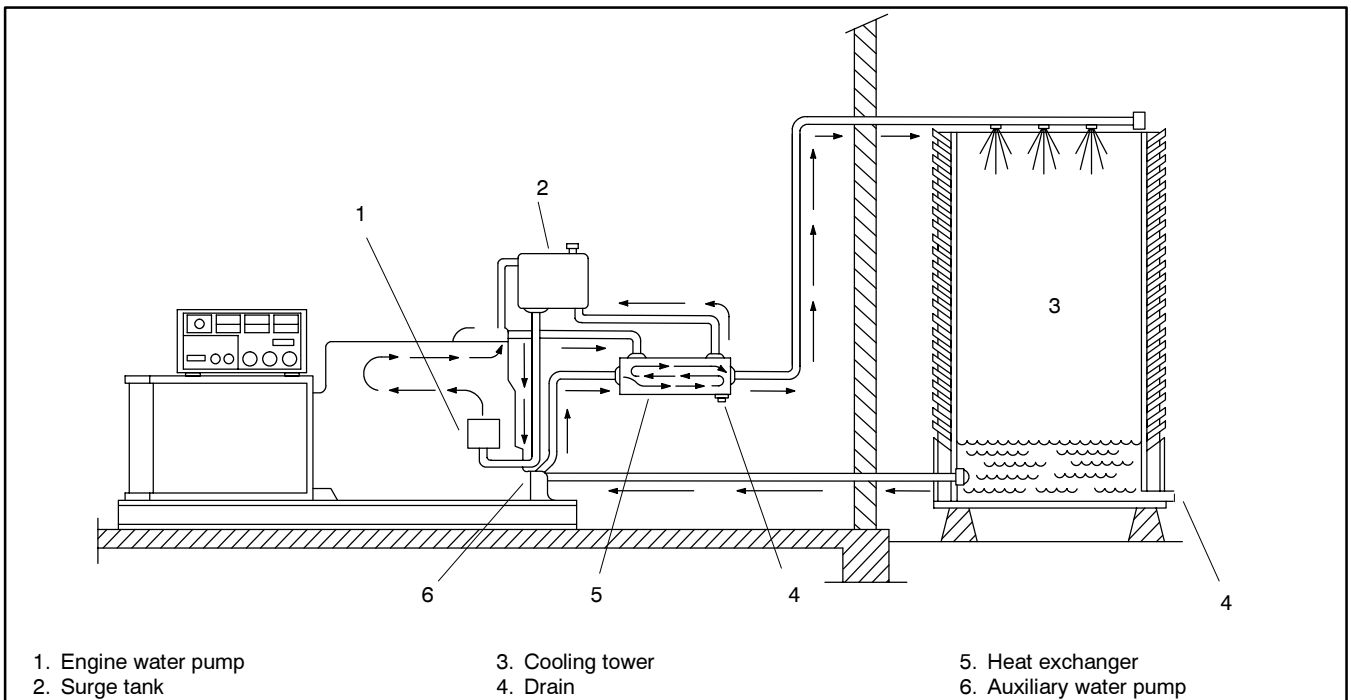

**Figure 4-12** Cooling Tower System

## 4.11 Block Heaters

Block heaters are recommended on all standby applications where the generator is subject to temperatures below 60° F (16°C) and are available as installed accessories on all generator sets. The block heater should be connected to a source of power, which is determined by the particular size and type of heater.

**Note: BLOCK HEATER DAMAGE!** Do not energize block heater until engine block is filled with coolant and the generator set is run to remove trapped air. Otherwise, block heater failure will result. Unplug block heater prior to draining cooling system.

## 4.12 Recommended Coolant

Antifreeze/coolant protection will be required for most applications. This must be performed prior to startup of generator set and energizing block heater(s).

A solution of 50% ethylene glycol and 50% clean, softened water is recommended to provide freezing protection to -34°F (-37°C) and boiling protection to 256 °F (129 °C). A 50/50 solution will also inhibit rust and corrosion. Follow the engine manufacturer's recommendations when available.

For most diesel engines, an additional inhibitor additive is required to prevent cavitation erosion. Refer to the engine operation manual for inhibitor section and concentration level recommendations.

## Section 5 Exhaust System

Proper installation of the exhaust system is essential to obtain satisfactory performance from a generator set. The most important factor is that the installed system must not exceed the engine manufacturer's maximum exhaust back pressure limit. Any exhaust back pressure will limit the maximum power available from the engine. Excessive back pressure may cause serious engine damage.

Excessive back pressure usually results from one or a combination of the following:

- Exhaust pipe diameter too small
- Exhaust pipe too long
- Too many sharp bends in the exhaust system
- Too small an exhaust silencer or incorrect silencer design

Figure 5-1 and Figure 5-2 show the general arrangement of recommended exhaust systems.

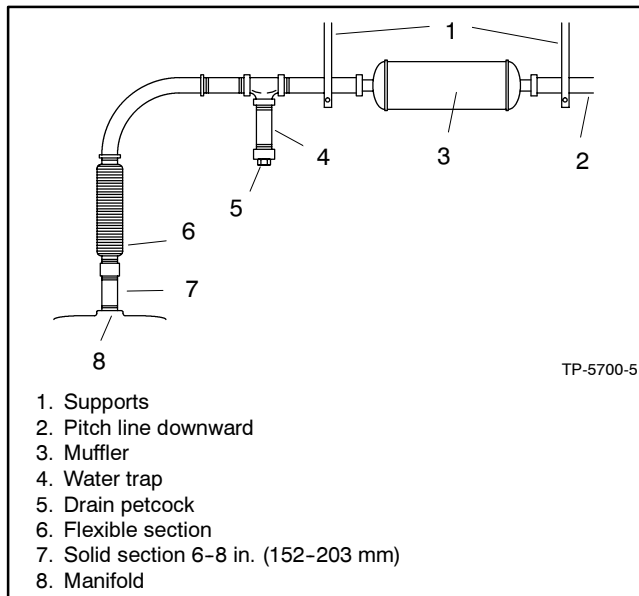

**Figure 5-1** Exhaust System, End Inlet Silencer

Exhaust lines should be as short and straight as possible. Schedule 40 black iron pipe is the recommended material. Where possible, sweep elbows with a radius of at least three times the pipe diameter should be used.

The exhaust outlet must be located in a manner that will prevent exhaust fumes from entering a building or enclosure.

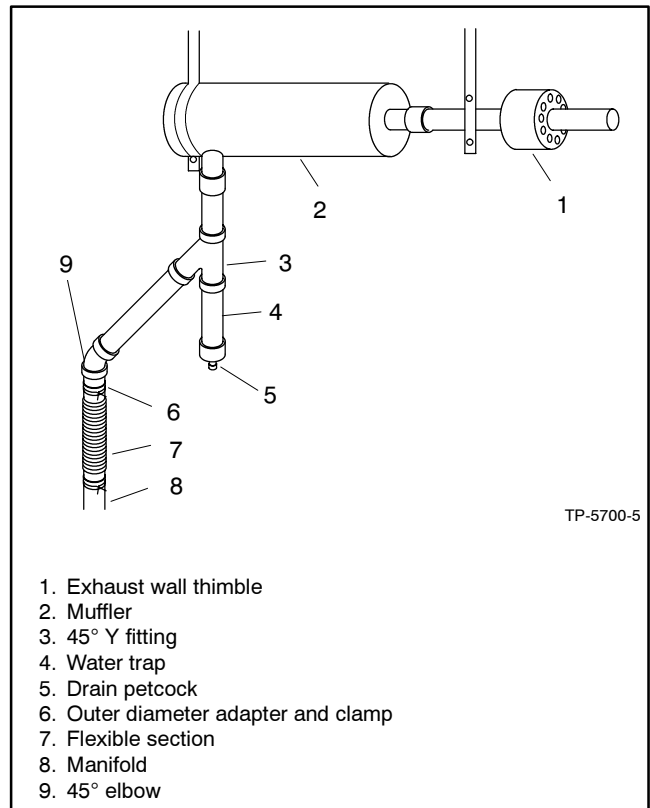

**Figure 5-2** Exhaust System, Side Inlet Silencer

## 5.1 Flexible Section

A section of flexible exhaust line should be installed within 2 feet (51 mm) of the engine exhaust outlet. This limits the stress on the engine exhaust manifold or turbocharger resulting from engine motion on its vibration mounts and temperature-induced changes in pipe dimensions. Never allow the engine manifold or turbocharger to support the silencer or exhaust piping weight. The flexible section should be at least 12 inches (305 mm) long.

Where threaded flexible exhaust connectors are used, a 6-8 inch (152-203 mm) length of pipe should separate them from the exhaust manifold. This will serve to reduce the temperature of the flexible connection and extend its life. It also makes it easier to remove the flexible section, if necessary, without putting excessive strain on the engine manifold.

The flexible section should not be bent or used to make up for misalignment between the engine exhaust and the exhaust piping. Since typical exhaust temperatures range from 800°F (427°C) to over 1200°F (649°C) for some engines, seamless stainless steel should be used for the flexible section.

## 5.2 Condensation Trap

A Y- or tee-type condensation trap with a drain plug or petcock should be installed between the engine and exhaust silencer as shown in Figure 5-3. This will prevent condensed moisture in the engine exhaust from draining into the engine when it is shut down. The trap should be drained of collected moisture periodically.

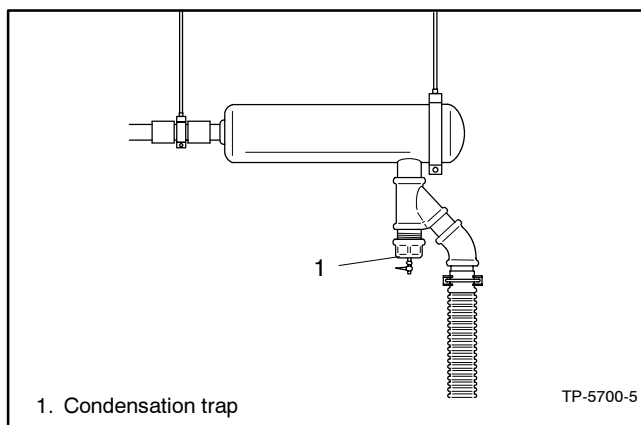

**Figure 5-3** Condensation Trap

## 5.3 Piping

Exhaust piping should conform to all applicable codes. In general, exhaust temperatures will be less than 1000°F (538°C) measured at the engine exhaust outlet, except for infrequent brief periods, and standards for low heat appliances will apply. For units with exhaust temperatures below 1000°F (538°C), exhaust piping should be routed a minimum of 18 inches (457 mm) from any combustible materials. If exhaust temperatures will exceed 1000°F (538°C), the minimum distance should be 36 inches (914 mm).

The heat rejected by exhaust piping, and consequently the amount of ventilating air required, can be substantially reduced by insulating exhaust piping with suitable high-temperature insulation. Exhaust temperatures are given on each generator model's specification sheet.

Placement of exhaust silencer and piping should consider location of combustible materials. If location of exhaust cannot avoid these concerns, use a regular maintenance routine to remove combustible materials. Combustible materials include building materials as well as natural surroundings. Keep dry field grass, foliage, and combustible landscaping material whether or not seasonal a safe distance from the exhaust system.

## 5.4 Double-Sleeve Thimbles

If the exhaust pipe should need to pass through a wall or roof, an exhaust thimble must be used to prevent exhaust pipe heat from being transmitted to the combustible material. Construction details for a typical double-sleeve thimble to be used where exhaust piping passes through a combustible roof or wall are shown in Figure 5-4. They are usually fabricated at a local sheet metal shop to the specifications furnished by the installation engineer.

The thimbles should be constructed so that they extend at least 10 inches (25.40 cm) both ways from the surface of the wall or roof. Holes are provided at both ends to allow cooling air to circulate through the thimble. If screening is used on the outer end to keep birds, rodents, etc., from entering the thimble, make sure that the mesh is large enough so that it doesn't impair air circulation through the thimble. If the exhaust pipe must exit through a roof, a rain shield must be included above the thimble as shown in Figure 5-4. The rain cap as shown on the end of the exhaust pipe is recommended only in areas not subject to freezing temperatures. In an area where freezing is common, extend the exhaust piping well beyond the roof and use a gradual "U" bend at the end to direct the exhaust outlet downward which will keep rain, snow, etc., out of the pipe. The outlet of the pipe should be far enough from the roof to prevent ignition of the roof material from hot exhaust.

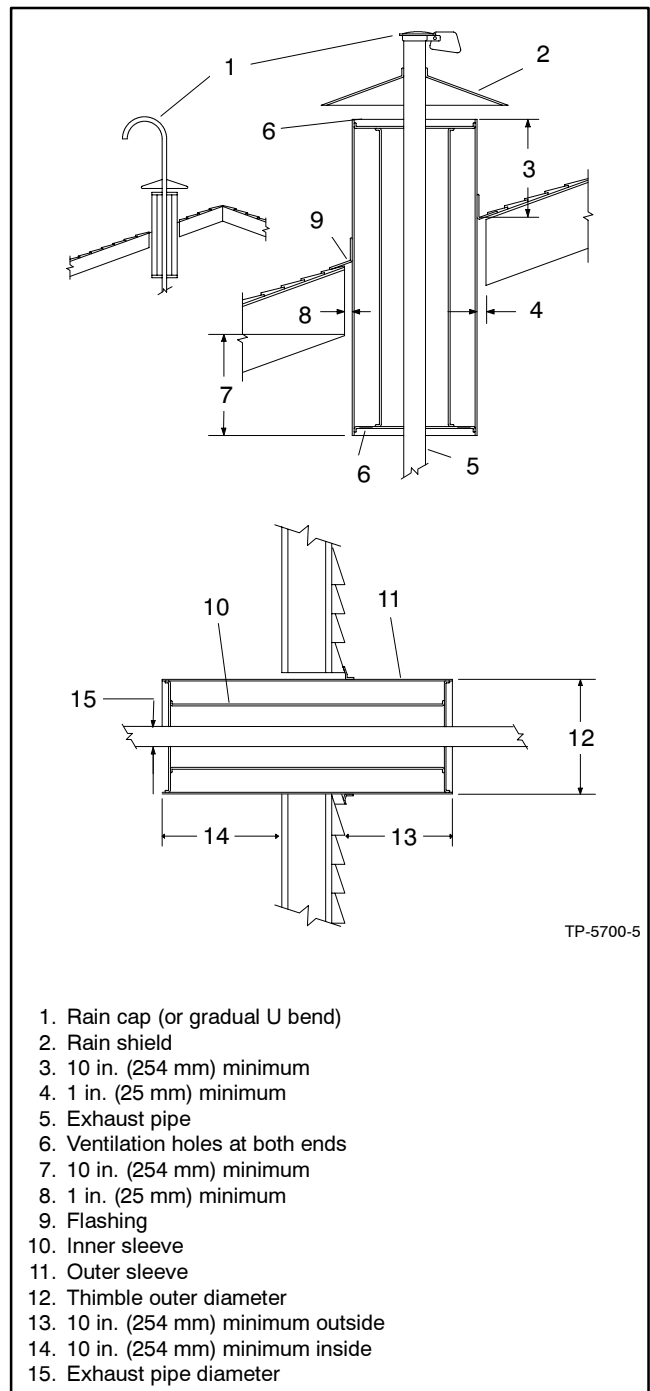

**Figure 5-4** Double-Sleeved Thimbles and Rain Cap

# Notes

## Section 6 Fuel Systems

When planning an installation, check state and local regulations regarding fuel storage and handling. Piping and fuel system components must conform to these regulations.

### 6.1 Diesel Fuel Systems

Since diesel fuel is less volatile than gas or gasoline, it may be considered safer fuel from the standpoint of storage and handling. This is often reflected in less stringent regulations for placement of tanks. In some locations, main tanks of considerable size are permitted inside the building or enclosure; however, local regulations must be checked before planning the installation.

The main components of a typical diesel fuel system are a main fuel storage tank, fuel lines, transfer tank, and auxiliary fuel pump. See Figure 6-1.

Fuel storage tanks may be located above ground indoors or outdoors, or buried underground. “Base-mounted” or “subbase” tanks are commonly used. This is a tank that is contained in a base that the generator is mounted on. See Figure 6-2.

Fuel filters and sediment drains must be easily accessible for regular and frequent service. Cleanliness of the fuel is especially important on diesel engines which have easily clogged, precision fuel injectors and pumps. Black iron pipe or steel tubing must be used for diesel fuel systems—galvanized tanks and piping must not be used since the diesel fuel will react chemically with them to produce flaking which will quickly clog filters or causes failure of the fuel pump or injectors. All flexible lines must be of the type approved for diesel fuels.

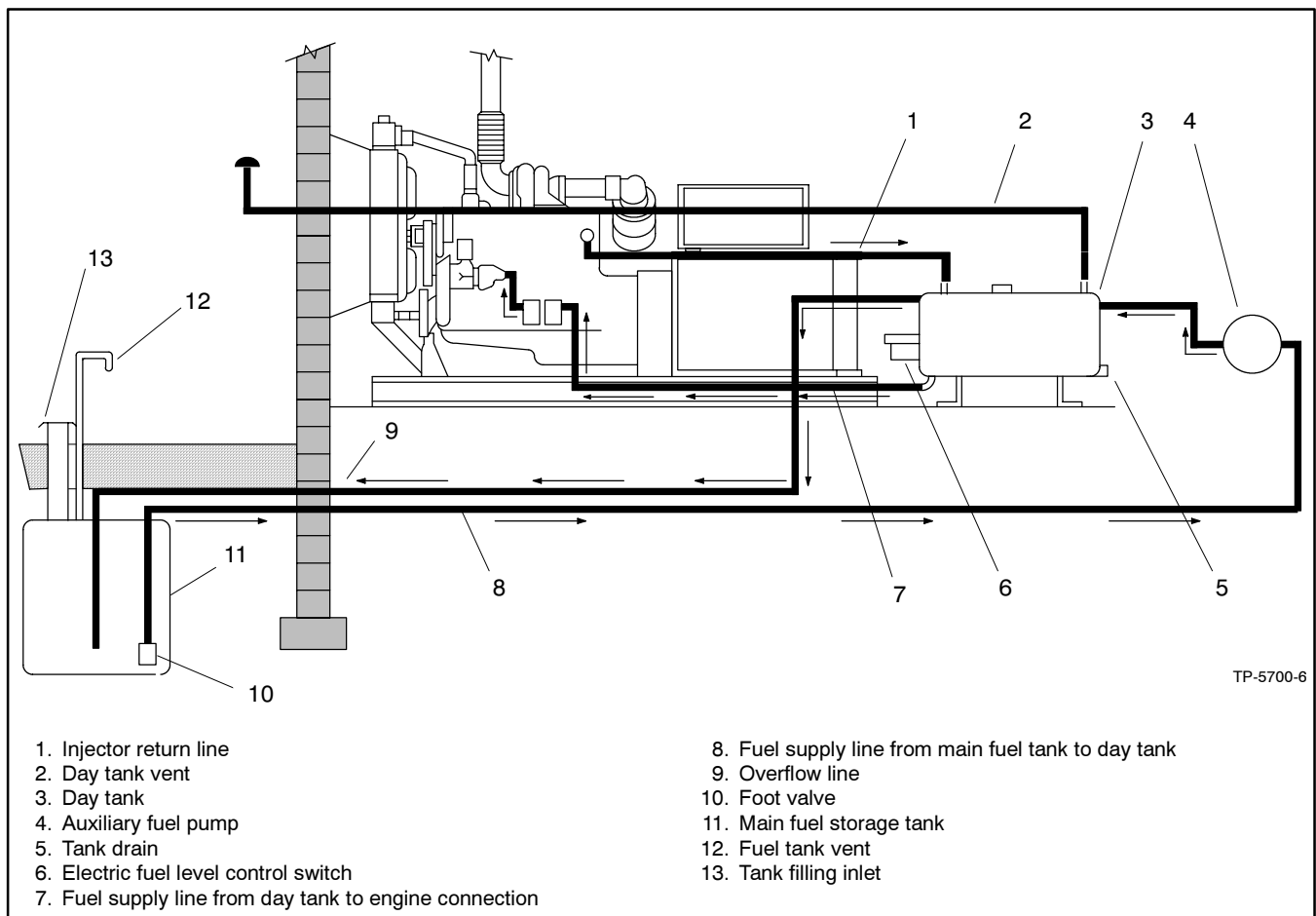

**Figure 6-1** Diesel Fuel System

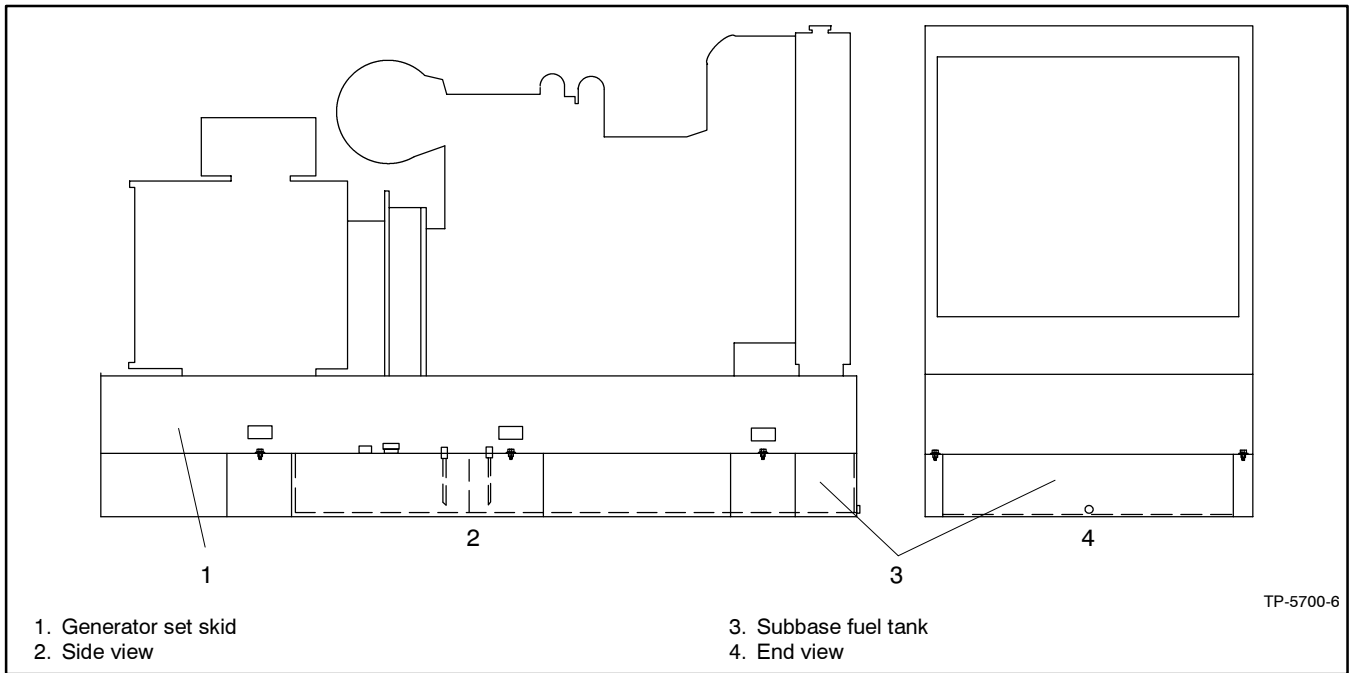

**Figure 6-2** Subbase Fuel Tank

## 6.2 Main Fuel Tank

All main tanks should be vented so that air and other gases can escape to the atmosphere. The vent must prevent dust, dirt, and moisture from entering the tank. Return lines should be spaced as far away from the pick-up or fuel dip tube as possible. If this is not done, air bubbles could be drawn into the fuel supply line and cause erratic engine operation. Also, fuel returning from the engine will be warmed from passing through the engine. This returning fuel, if hot enough, can cause a reduction in the power of the engine. At least 5% capacity should be allowed in a diesel main tank for expansion of the fuel. If the main tank is to be located overhead, a fuel shutoff solenoid should be used to prevent hydraulic lock or tank overflowing due to excessive pressures caused by static head of fuel.

Codes requiring standby power often specify minimum on-site fuel supply. Such requirements are included in NFPA 70, National Electrical Code; and NFPA 99, Standard for Health Care Facilities. Diesel fuel will deteriorate if stored for more than a year, so the tank should not be oversized to the point that its contents cannot be used in one year of regular exercising. If there are no applicable code requirements, a tank sized for eight hours operation at rated load is suggested. Refer to the specification sheet for fuel consumption data.

Most diesel engines will operate satisfactorily on #2 domestic burner oil as furnished in most parts of the United States. The engine can be supplied from the same tank used for heating oil if both use the same fuel. This is desirable both because of the cost savings and

the added advantage that fuel will be used and replaced regularly, ensuring a fresh fuel supply for the engine. Dual usage of the fuel can be done provided the fuel oil meets the engine manufacturer's minimum requirements for such properties as wax point, pour point, and cetane number. These factors influence cold weather starting and power output of the engine/generator. Where more than one engine or an engine and another appliance(s) are fueled from the same main tank, each engine should have its own supply line.

## 6.3 Fuel Lines

Fuel lines should be constructed of Schedule 40 black iron pipe or copper tubing. Galvanized pipe, fittings, or tanks should never be used with diesel fuel systems. The fuel will react chemically with the galvanized coating, causing it to peel and clog fuel filters and damage fuel injection components.

Fuel line sizes should be the minimum required to deliver the volume necessary to the equipment within an acceptable pressure drop—1 psi (0.07 kg/cm<sup>2</sup>). The use of excessively large piping increases the chance that air will be introduced into the system, and that fuel pumps will be damaged by operating dry when priming the system.

Flexible connections must be used wherever there may be relative motion between piping and supplied equipment. Always use flexible lines at the engine connections. These should be a minimum of six inches (15.3 cm) long.

Diesel engines require at least two fuel lines: one supply and at least one return from the fuel injectors. More fuel is delivered to the injectors than the engine will use and the excess must be returned to a transfer tank or the main storage tank. Fuel return lines should be at least the size of the supply lines. They should be unrestricted, as short as possible, and allow gravity return of fuel to the storage tanks.

In some installations it may be difficult or inconvenient to route return lines so that fuel will flow by gravity. Before designing a system which will have any head of fuel on the return lines, the details should be approved by the engine supplier. Serious problems with engine hydraulic lock or uncontrollable overspeeding will result from any return fuel line restriction on some diesel fuel systems.

## 6.4 Transfer Tanks

The term “transfer tank” and “day tank” are often used interchangeably. Both are used to ensure engine starting in the minimum possible time after a power failure by means of a quantity of fuel stored in a tank adjacent to the engine. This allows the engine fuel transfer pump to easily draw fuel when starting and provides a convenient location to connect injector return lines. Standard tanks are available in sizes from 5-275 gallons (19-1040 L) with or without integral electric fuel transfer pumps. They can also be provided with fuel level gauges, manual priming pumps, float switches for pump control, float valves, rupture basins and low level alarms. A float switch controlled solenoid anti-siphon valve or a float valve should be used whenever there is a possibility of siphoning fuel from the main storage tank, or when the fuel level in the main tank may be above the level of the transfer tank inlet. Engines are subject to derating for fuel temperature above 100°F and are subject to damage if operated with fuel temperature above 140°F. A day tank sized for two hours fuel consumption should prevent excessive fuel heating by fuel returned from the engine. If smaller day tanks are used, the engine supplier may recommend routing engine fuel return lines to the main storage, or installation of a fuel cooler. See Figure 6-3.

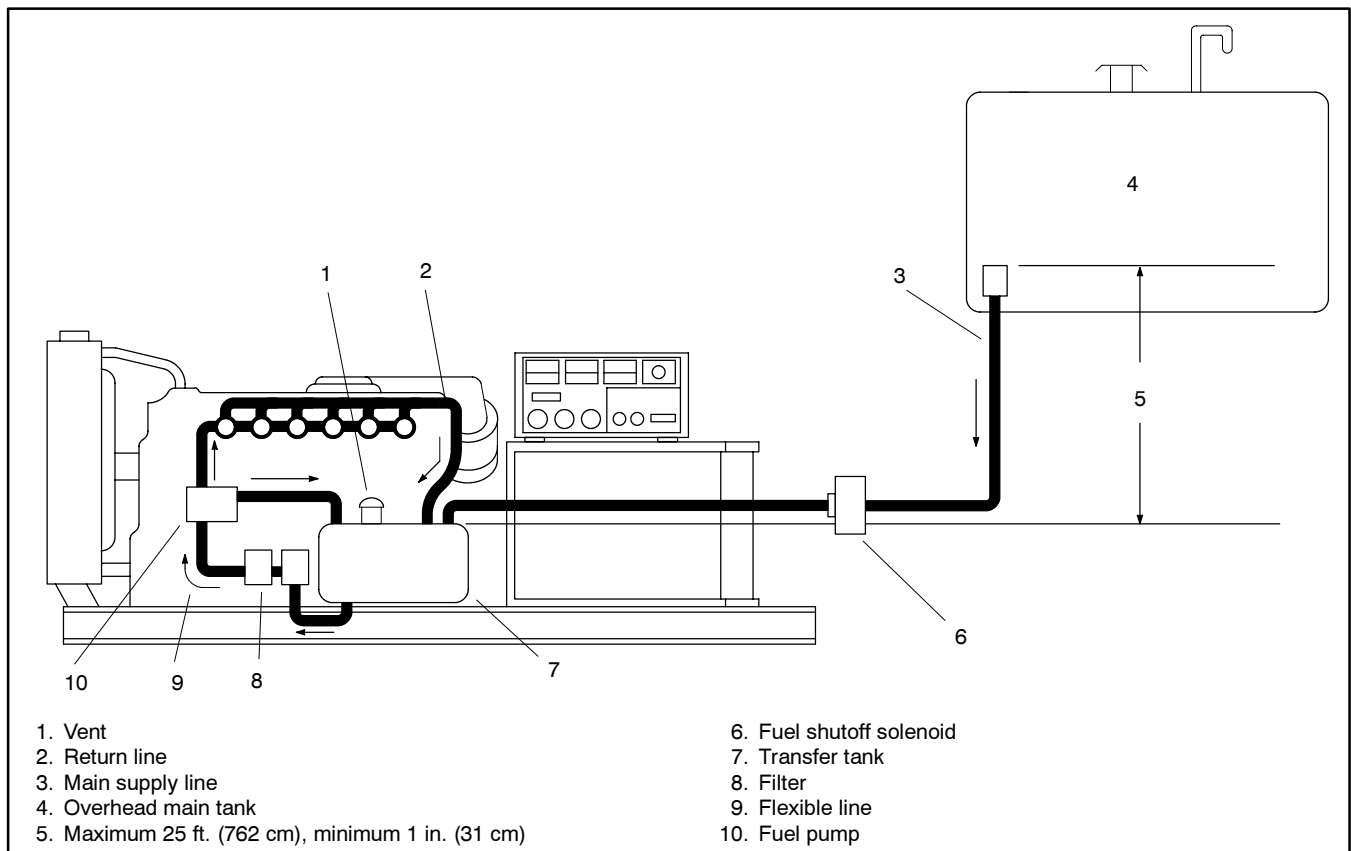

**Figure 6-3** Diesel Fuel System with Overhead Main Tank and Transfer Tank

## 6.5 Auxiliary Fuel Pumps

Engine-driven fuel transfer pumps usually develop a maximum of 7 psi (48 kPa) pressure and have a lift capacity of 4-6 feet (1.2-1.8 m). Even if the engine pump can draw fuel a greater distance, a more reliable system results if a transfer tank and/or auxiliary pump are used when the vertical lift exceeds three feet or fuel must be drawn horizontally more than 20 feet (6.1 m).

On engines using less than ten gallons (38 L) of fuel per hour (approximately 100 kW or less), an electric fuel transfer pump powered by the engine starting battery can be installed in series with the engine-driven transfer pump. Best results are obtained when the electric pump is located near the fuel tank rather than near the engine.

Where fuel must be lifted 6 feet (1.8 m) or more, or long horizontal runs are involved, an electric motor driven positive displacement pump should be used with a transfer tank and float switch. The power supply for the

pump should always be from the load side of the transfer switch for maximum reliability. Such pumps typically are capable of lifting fuel 18 feet (5.5 m) or drawing it horizontally up to 200 feet (61 m).

Where vertical or horizontal runs exceed these limits, the pump should be remote mounted adjacent to the fuel storage tank. When so located, these pumps can push fuel over 1,000 feet (305 m) horizontally or more than 100 feet (30.5 m) vertically and deliver adequate fuel for generator sets up to 2000 kW. Positive displacement pumps should never be connected directly to an engine; a transfer tank and float switch should always be used so the engine fuel system is not subjected to excessive fuel pressures.

A check valve or shutoff solenoid valve (wired into the engine ignition) can be used to help keep the fuel line primed. If such a valve is included in the system, it should be installed on the outlet side of the auxiliary fuel pump to minimize inlet restriction.

## 6.6 Gasoline Fuel Systems

Due to code restrictions which do not allow storage of more than one gallon (3.8 L) of gasoline inside a building, gasoline fuel systems are usually limited to housed generator sets installed outdoors or portable trailer-mounted units.

Gasoline will deteriorate if stored for more than six months, so storage tank size should be kept to the minimum required by code. Engine fuel pumps usually will lift fuel up to four feet (1.20 m) or draw it horizontally up to 20 feet (6.01 m). Auxiliary electric pumps powered by the engine starting-battery can be connected in series with the engine pump. See Figure 6-4. Auxiliary pump pressure should be limited to approximately 5 psi (34.5 kPa). If the auxiliary pump is located at the fuel tank, horizontal and vertical distance limits of approximately twice those for a lone engine pump are practical.

Fuel supply lines should be Schedule 40 black iron pipe, steel tubing, or copper tubing. Galvanized pipe and fittings are not recommended. Line size should be kept to the minimum necessary for the required flow.

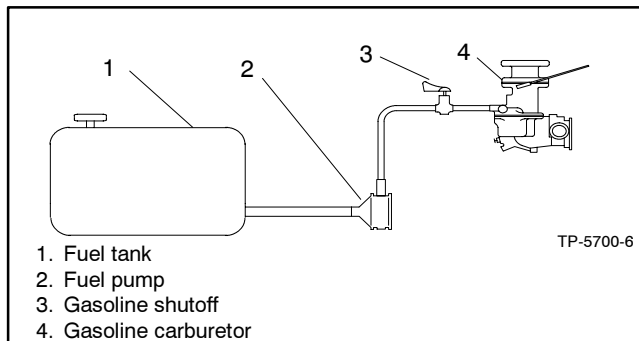
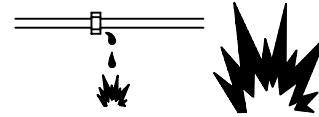

**Figure 6-4** Gasoline Fuel System

Flexible connections at least six inches (15.3 cm) in length should be used between stationary piping and the engine fuel inlet connection.

---

### **⚠ WARNING**



**Explosive fuel vapors.  
Can cause severe injury or death.**

Use extreme care when handling, storing, and using fuels.

---

Combination natural gas-gasoline fuel systems are sometimes used with gasoline as a standby fuel to meet code requirements for on-site fuel supply. Such systems are not recommended unless the engine will be operated on gasoline often enough to ensure that fuel does not deteriorate and the carburetor will not be disabled by accumulated gum and fuel deposits.

If a fuel storage tank is located above the engine, an anti-siphon fuel solenoid valve or air bleed hole in the fuel tank dip tube (near the top of the tube inside the tank) should be used to prevent siphoning.

## 6.7 Natural or LP Gas Fuel Systems

Natural and LP (liquefied petroleum) gas fuel systems should be designed and installed in accordance with the requirements of NFPA 54, National Fuel Gas Code, and all applicable local codes. Various types of gas fuel systems are available as follows:

- LP Gas Vapor (Figure 6-5 and Figure 6-6)
- LP Gas-Liquid Withdrawal (Figure 6-7)
- Combination Natural Gas and LP Gas (Figure 6-8 and Figure 6-9)
- Natural Gas (Figure 6-10)
- Combination LP Gas or Natural Gas and Gasoline (Figure 6-11)

The engine-mounted components of all these systems are similar and usually include a carburetor, secondary gas regulator, electric gas fuel solenoid shutoff valve, and flexible fuel connector.

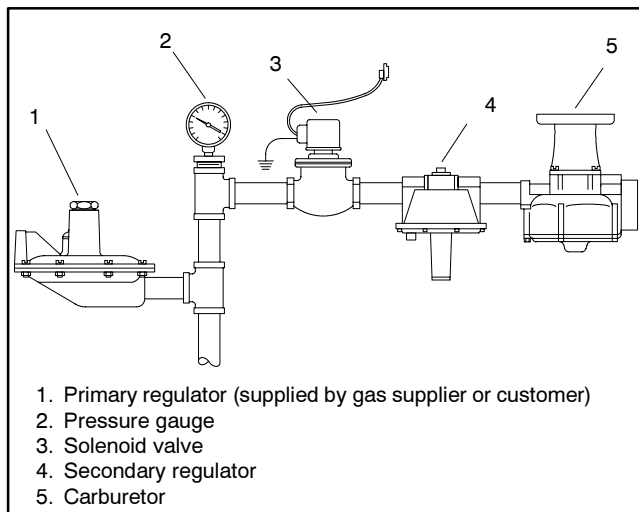

**Figure 6-5** LP Gas Vapor Fuel System

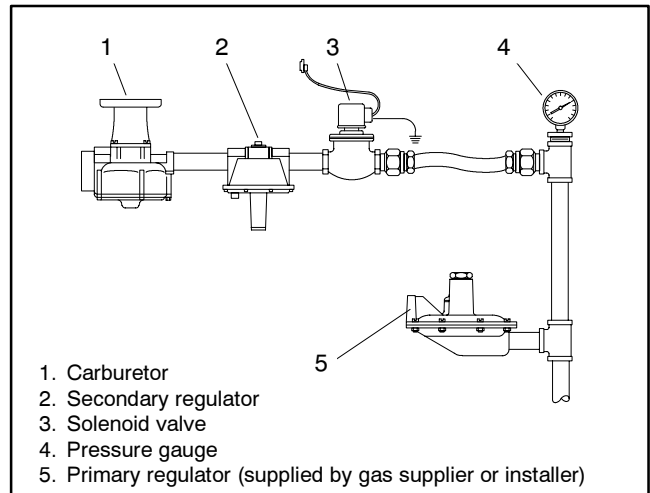

**Figure 6-6** Typical LP Gas Vapor-Withdrawal System

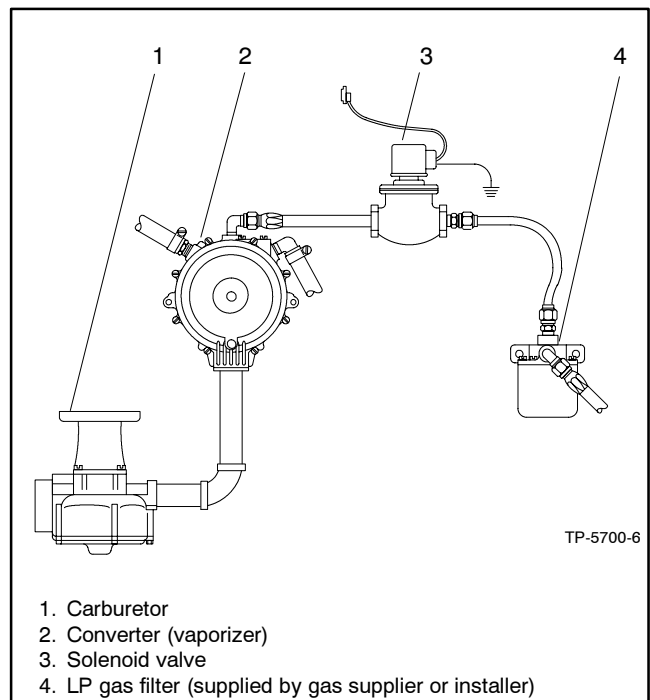

**Figure 6-7** LP Gas Liquid Withdrawal System

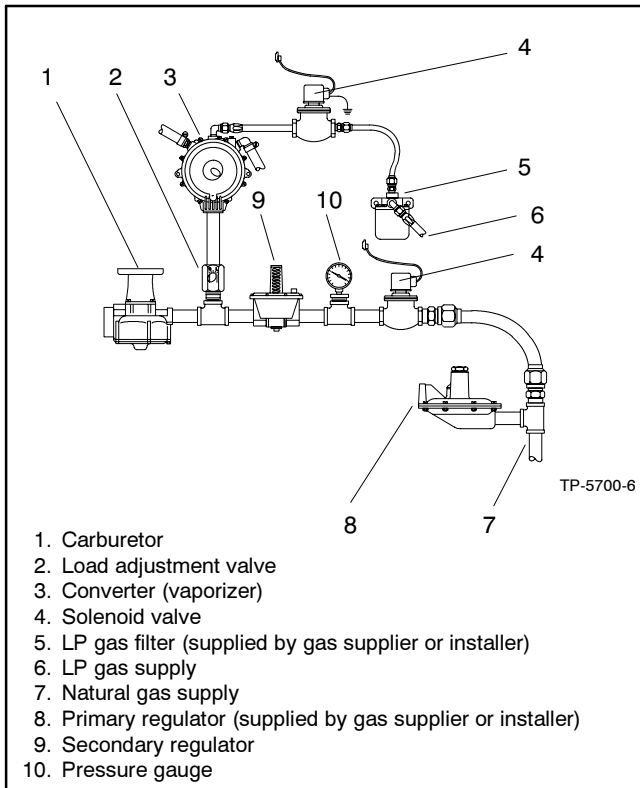

**Figure 6-8** Natural Gas and LP Gas System, Liquid Withdrawal

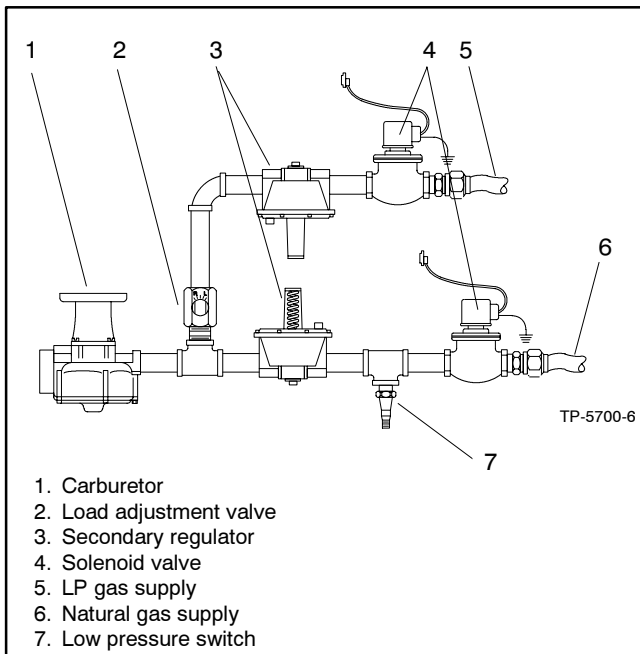

**Figure 6-9** Natural Gas and LP Gas System, Vapor Withdrawal

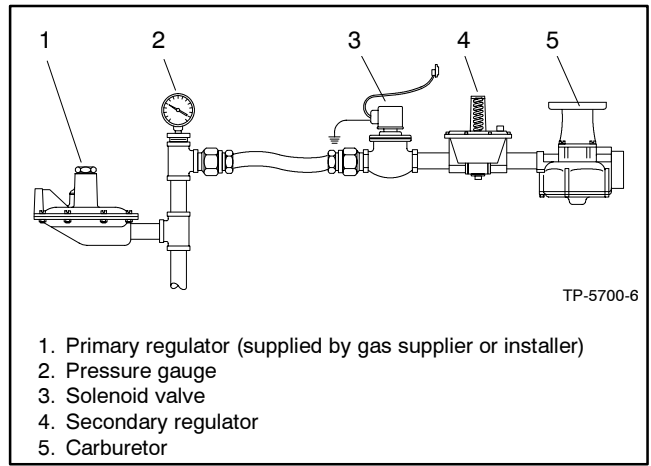

**Figure 6-10** Natural Gas Fuel System

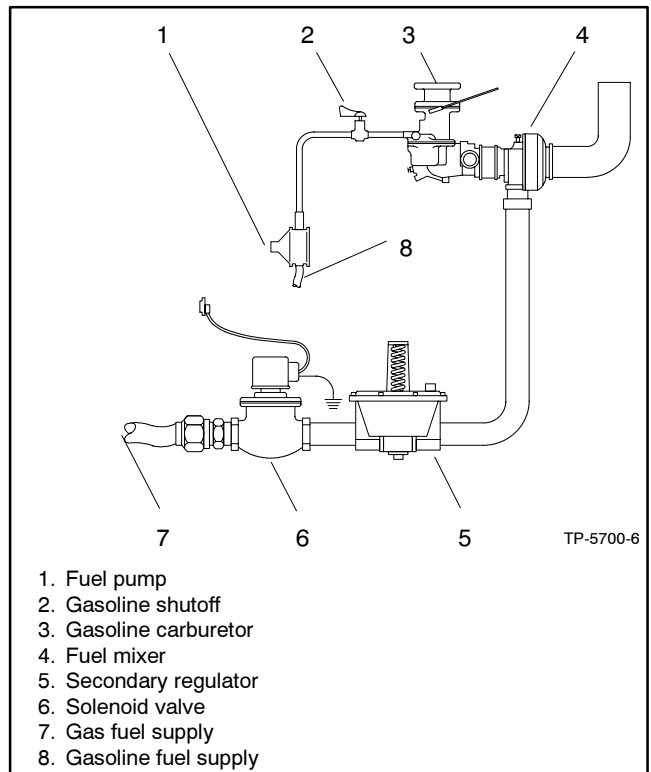

**Figure 6-11** Combination Gas/Gasoline Fuel System

## 6.8 Flexible Connector

An approved flexible connector should always be used between stationary gas piping and the engine-mounted fuel system components. It should be at least six inches (15.3 cm) long or as recommended by the generator supplier based upon engine specifications.

## 6.9 Gas Piping

Gas piping should be Schedule 40 black iron pipe. Copper tubing may be used if the fuel does not contain hydrogen sulfide or other ingredients which will react chemically with copper. Fuel piping should never be used to ground electrical equipment. Piping should be sized according to the requirements of the equipment to be operated. Refer to the dimensional drawing for detailed information on your unit. In addition to the actual fuel consumption, the following factors must be considered:

- Pressure loss due to length of pipe
- Pressure loss due to other appliances on the same fuel supply
- Pressure loss due to number of fittings

## 6.10 Fuel Regulators

Fuel regulators are compatible with both natural gas and LP gas. When used with natural gas the spring and retainer are installed. The spring and retainer are usually removed from the fuel regulator when used with LP gas. Refer to the appropriate generator set operation manual and/or decal on the unit for specific information regarding spring/retainer usage.

Gas fuels may require the fuel regulator to be mounted in a given position. The fuel regulator will function properly with the fuel regulator pointing downward for both natural gas and LP gas. The fuel regulator may be positioned so that it is pointing upward for use with natural gas only.

Two regulators are used in the typical gaseous fuel system:

- **Primary Regulator**—This regulator provides initial control of the gas from the fuel supply. The primary regulator reduces line pressures to allowable inlet pressures for the secondary regulators on the system. This regulator would drop high pressure from a tank or transmission line to a low pressure, typically 4-6 ounces per square inch (1.7-2.6 kPa) or 7-11 inches (178-279 mm) of water column. This regulator is not usually supplied with the generator set, as conditions that dictate the type used vary depending on the method in which the fuel is supplied.
- **Secondary Regulator**—This low-pressure type regulator is mounted on the engine and is designed for a maximum inlet pressure of six ounces per square inch (2.6 kPa) or 11 inches (279 mm) of water column. The engine will operate satisfactorily at four ounces per square inch (1.7 kPa) or 7 inches (179 mm) of water column or less, but lower pressures may result in poor response to load changes or lack of power where the primary regulator is not near the engine.

Although regulators are designed to close and shut off fuel when the engine stops, a solenoid valve should be located ahead of the regulator and the flexible fuel connector to prevent the accumulation of an explosive mixture of gas and air, should either the flexible connection or regulator develop a leak. The generator set installer normally wires the solenoid valve to the engine starting controls so it will open (with battery power) when the engine cranks or runs.

Some fuel regulators have provisions to install a pressure gauge to test inlet and outlet pressures. If none are available, install pipe tees in the fuel line to serve this purpose and use pipe plugs on any unused openings.

## 6.11 LP Gas Fuel Characteristics

LP gas is supplied as a liquid in pressure tanks. It is easily adaptable to stationary applications where complete independence of an outside fuel supply is required. Since LP gas does not deteriorate in long periods of storage as gasoline is known to do, a large supply of fuel can be kept on hand indefinitely for operation during emergency conditions.

LP gas is propane, butane, or a mixture of the two gases. The ratio of butane to propane is especially important when a large outdoor tank is used—a fuel supplier may fill the tank in the warm summer months with a mixture composed mainly of butane; however, this mixture may not provide sufficient vaporized pressure at extremely cold temperatures to start and operate the engine. A local fuel supplier is likely to be the best source of information on what size tank will be necessary to provide adequate fuel vapor.

Since LP gas is supplied in pressurized tanks in liquid form, it must be converted to a vapor state before being introduced into the carburetor. There are 31.26 cubic feet (0.88 m<sup>3</sup>) of butane gas in each gallon (3.78 L) of liquid, and 36.39 cubic feet (1.03 m<sup>3</sup>) of propane in each gallon of liquid. See the individual generator spec sheets for fuel consumption at different loads, and contact your fuel supplier for information regarding tank sizes and fuel mixtures.

## 6.12 Vapor Withdrawal Systems

The liquid level in LP gas tanks must not exceed 90% of the tank capacity. Generally, 10 to 20 percent of capacity is allowed for expansion of the gas from a liquid to a vapor state. A vapor withdrawal system utilizes vapor forming in the space above the liquid. Temperature of the air surrounding the tank must be high enough to sustain adequate vaporization of the liquid fuel. In the colder climates, an independent heat source may be necessary to supplement natural vaporization within the tank. Fuel can be withdrawn in liquid form and vaporized in an electrically heated, engine water jacket-heated, or LP gas-heated vaporizer. Straight butane gas has little or no vaporization pressure in temperatures below +40°F (4°C). Even at +70°F (21°C) the pressure is only approximately 18 psi (124 kPa). Some primary regulators will not operate if tank pressure drops below +30 psi (207 kPa) while others operate at incoming pressures as low as to 3-5 psi (20.7-34.5 kPa). The fuel mixture and its vaporization pressure at the anticipated

temperatures influence the selection of regulatory equipment. The components of the vapor withdrawal system used in a typical stationary application are shown in Figure 6-5 and Figure 6-6.

## 6.13 Liquid Withdrawal Systems

Liquid withdrawal fuel systems can be supplied for generator sets but are not recommended for automatic standby service. With these systems, high-pressure LP at 150-200 psi (1034-1379 kPa) is piped to the engine in liquid form. A combination of converters (vaporizers) and regulators can then reduce the gas to acceptable pressures. In Figure 6-7, a converter (combination of vaporizer, primary, and secondary regulators) changes the liquid to vapor using heat from the engine cooling system. In such a system, for a short period after start-up, there may be problems vaporizing enough fuel for an engine running under load. The engine, which supplies heat to the converter (vaporizer), needs time to warm sufficiently to allow the converter to vaporize enough fuel to supply the engine.

Many areas have codes prohibiting gas fuel at more than 5 psi (34.5 kPa) inside of buildings. This might preclude the use of a liquid withdrawal system. In order to meet codes, converters are sometimes located outside of the building that houses the generator set. This can cause start-up problems because the great length of pipe between the converter and the carburetor does not allow sufficient heat buildup and heat retention.

## 6.14 Dual Systems (Natural and LP Gas)

In many applications, natural gas is the main fuel and LP gas is used as the emergency fuel when natural gas is not available.

The dual fuel system in common use offers automatic changeover from one fuel to the other. This is accomplished by the use of two separate regulators and solenoid valves. A pressure switch placed on the primary source of fuel closes with a drop in pressure and energizes a relay which closes the primary fuel solenoid and opens the secondary or emergency fuel solenoid. To ensure proper carburetion upon changeover to LP gas, a separate LP gas load adjustment is located in-line between the secondary regulator and the carburetor. See Figure 6-8 and Figure 6-9.

## 6.15 Natural Gas

Natural gas is in a vapor state as supplied from the utility. This fuel system, therefore, consists of the same basic components and is used in the same general sequence as LP gas systems. When the heating content of the fuel falls below 1000 BTU, as it does with manufactured sewage and some natural gas fuels, the set will not produce rated power.

The primary regulator may or may not be furnished by the supplier. It is the responsibility of the supplier to insure that sufficient pressure is present at all times to operate the primary regulator. Installation, repair, and alteration to gas piping should be undertaken only by the supplier or with supplier's permission. Piping should never be used to ground any electrical apparatus. The piping should be rigidly mounted but protected against damage from vibration. Where flexible connections are needed use only fuel line approved for gas fuels. See Figure 6-10.

## 6.16 Combination Gas-Gasoline

Most engines, especially the smaller models, will operate successfully on gas or gasoline without extensive modification or complicated mechanical changeover. With a combination gas-gasoline fuel system, changeover involves only a few simple steps.

These systems normally utilize a gaseous fuel as the primary fuel with gasoline for emergency operation. In some areas natural gas is available at reduced cost on an "interrupted service" basis. In some cases a by-product gas is the primary fuel, but it may at times be unavailable. Continued operation is assured under these conditions by switching over to gasoline. The changeover is done manually at the generator set.

Either a combination gas-gasoline carburetor or a gasoline carburetor with a gas adapter is used. Natural or LP gas can be used with these carburetor combinations.

With the exception of the carburetor and addition of a gas adapter, the combination gas-gasoline systems utilize the same basic components as those in the natural and LP gas systems. See Figure 6-11.

## Section 7 Electrical Requirements

Before installing the generator set, provide for electrical connections through conduit to the transfer switch and other accessories for the generator set. Carefully install the selected generator set accessories. Route wiring to the generator set through flexible connections. Comply with all applicable codes when installing a wiring system.

**AC circuit protection.** All AC circuits must include fuse or circuit breaker protection. Select a circuit breaker for up to 125% of the rated generator set output current. The circuit breaker must open all ungrounded connectors.

### 7.1 Batteries

Batteries should be located in a clean, dry area. Position them so that the caps are readily accessible for checking the electrolyte level. Keep batteries out of areas subject to high temperatures. Locate them close to the set to keep cables short and thus insure maximum output. Several types of battery racks are used throughout the product line—be sure to refer to the submittal drawings for your unit. Figure 7-1 shows a typical battery system.

Starting batteries are usually lead-acid type sized according to the engine manufacturer's recommendation for a particular ambient temperature and required cranking time. Recommended cranking periods are specified in NFPA 110. It allows a single 45-second cranking cycle for generator sets below 20 kW. For larger models, three 15-second crank cycles separated by 15-second rests are required. The battery industry rating standard most commonly used to specify batteries is the cold-cranking ampere rating. Refer to the unit's specification sheet for battery cold-cranking ampere rating.

Nickel cadmium batteries are sometimes used for standby generator sets because of their long life (20 years). This is offset by their high initial cost, larger space requirements, and special charging requirements. Conventional lead-acid batteries have proven satisfactory for the majority of generator set applications.

Batteries are charged by engine-driven, battery charging alternators whenever the generator set operates. These systems are normally capable of charge rates of 30 amperes or more and can restore the charge used in a normal cranking cycle within a short period of operation. When the engine is not operating, a very low charge rate from an AC-powered battery

charger is sufficient to maintain the batteries fully charged. These chargers may be automatic or manual with a high charge rate of 2 amperes and a trickle charge rate up to 300 milliamperes. They can be separate, self-contained units or built into the automatic transfer switch. Due to the low maximum charge rate, they are not well suited to restoring fully discharged batteries. Automatic float chargers with high charge rates of 10 amperes or more are available if full recovery capability independent of the engine-driven charging system is required.

The most common reason for the failure of an emergency generator set to start when needed is starting battery failure. Two common causes of battery failure are: a manual charge rate set too low to maintain the battery, or a manual charge rate set too high, which results in loss of battery electrolyte. For this reason, automatic float chargers, which vary the charge rate in response to battery condition, are strongly recommended over manual types.

For large engines using two starters, either one bank of batteries and chargers for both starters, or separate battery systems may be used. The latter system is preferable since it reduces the chance of one component's failure making the entire system inoperative.

**Battery cables.** A UL-2200 listed generator set requires battery cables with positive (+) lead boots. Factory-supplied and optional battery cables include positive (+) lead boots. When battery cables are not factory-supplied, source battery cables with positive (+) lead boots for UL-2200 compliance.

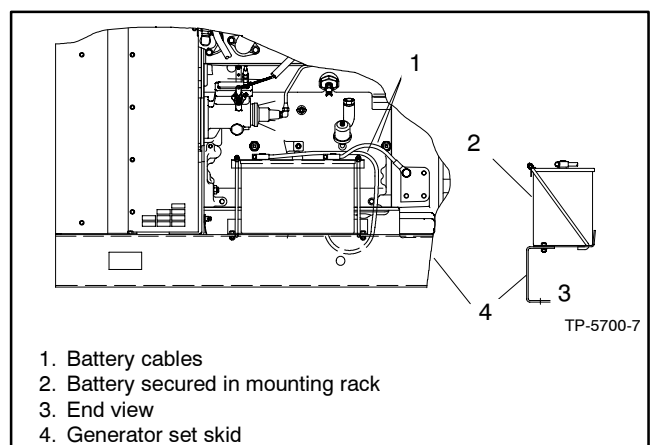

**Figure 7-1** Typical Battery System, Side View

## 7.2 Electrical Connections

Several electrical connections must be made between the generator set and other components of the system for proper operation. Because of the large number of accessories and possible combinations, this manual does not address specific applications. Refer to the submittal catalog accessory drawings and wiring diagrams for connection and location. Most field-installed accessory kits include installation instructions.

For customer-supplied wiring, select the wire temperature rating in Figure 7-2 based upon the following criteria:

- Select row 1, 2, 3, or 4 if the circuit rating is 110 amperes or less or requires #1 AWG (42.4 mm<sup>2</sup>) or smaller conductors.
- Select row 3 or 4 if the circuit rating is greater than 110 amperes or requires #1 AWG (42.4 mm<sup>2</sup>) or larger conductors.

Comply with applicable national and local codes when installing a wiring system.

Row	Temp. Rating	Copper (Cu) Only	Cu/Aluminum (Al) Combinations	Al Only
1	60°C (140°F) or 75°C (167°F)	Use No. * AWG, 60°C wire or use No. * AWG, 75°C wire	Use 60°C wire, either No. * AWG Cu, or No. * AWG Al or use 75°C wire, either No. * AWG Cu or No. * AWG Al	Use 60°C wire, No. * AWG or use 75°C wire, No. * AWG
2	60°C (140°F)	Use No. * AWG, 60°C wire	Use 60°C wire, either No. * AWG Cu or No. * AWG Al	Use 60°C wire, No. * AWG
3	75°C (167°F)	Use No. *† AWG, 75°C wire	Use 75°C wire, either No. *† AWG Cu or No. *† AWG Al	Use 75°C wire, No.*† AWG
4	90°C (194°F)	Use No. *† AWG, 90°C wire	Use 90°C wire, either No. *† AWG Cu or No. *† AWG Al	Use 90°C wire, No.*† AWG

\* The wire size for 60°C (140°F) wire is not required to be included in the marking. If included, the wire size is based on ampacities for the wire given in Table 310-16 of the National Electrical Code®, in ANSI/NFPA 70, and on 115% of the maximum current that the circuit carries under rated conditions. The National Electrical Code® is a registered trademark of the National Fire Protection Association, Inc.

† Use the larger of the following conductors: the same size conductor as that used for the temperature test or one selected using the guidelines in the preceding footnote.

**Figure 7-2** Terminal Markings for Various Temperature Ratings and Conductors

## 7.3 Load Lead Connections

Load leads being brought into the generator can enter in a number of different areas. On generators 300 kW and below the most commonly used is the bottom entry, where conduit is “stubbed up” into the junction box from below. Other methods include flexible conduit roughed into the sides or top of the junction box. When using this method, be sure not to block the front or rear of the controller, as doing so will prevent access to it for service purposes. See Figure 7-3.

On generators larger than 300 kW, a junction box is mounted on the rear of the generator. Larger sets may have oversize junction boxes supplied as an option or to accommodate buss bar connections. Consult the dimensional drawing on your unit for detailed information.

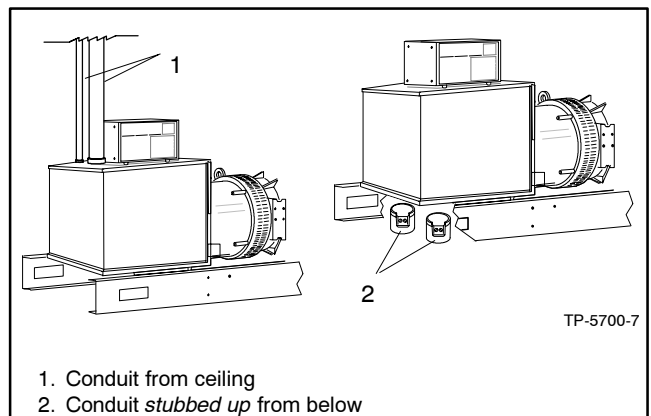

**Figure 7-3** Typical Load Lead Connection

## 7.4 Terminal Connector Torque

Use the torque values shown in Figure 7-4 or Figure 7-5 for terminal connectors. Refer to UL-486A, UL-486B, and UL-486E for information on terminal connectors for aluminum and/or copper conductors. See Section 7.2, Electrical Connections, for information on the temperature rating of customer-supplied wire. Comply

with applicable national and local codes when installing a wiring system.

**Note:** If a connector has a clamp screw such as a slotted, hexagonal head screw with more than one means of tightening, test the connector using both applicable torque values provided in Figure 7-4.

Wire Size for Unit Connection	Tightening Torque, Nm (in. lb.)			
	Slot Head 4.7 mm (No. 10) or Larger*		Hexagonal Head—External Drive Socket Wrench	
AWG, kcmil (mm <sup>2</sup> )	Slot Width <1.2 mm (0.047 in.) Slot Length <6.4 mm (0.25 in.)	Slot Width >1.2 mm (0.047 in.) Slot Length >6.4 mm (0.25 in.)	Split-Bolt Connectors	Other Connections
18-10 (0.82-5.3)	2.3 (20)	4.0 (35)	9.0 (80)	8.5 (75)
8 (8.4)	2.8 (25)	4.5 (40)	9.0 (80)	8.5 (75)
6-4 (13.3-21.2)	4.0 (35)	5.1 (45)	18.6 (165)	12.4 (110)
3 (26.7)	4.0 (35)	5.6 (50)	31.1 (275)	16.9 (150)
2 (33.6)	4.5 (40)	5.6 (50)	31.1 (275)	16.9 (150)
1 (42.4)	—	5.6 (50)	31.1 (275)	16.9 (150)
1/0-2/0 (53.5-67.4)	—	5.6 (50)	43.5 (385)	20.3 (180)
3/0-4/0 (85.0-107.2)	—	5.6 (50)	56.5 (500)	28.2 (250)
250-350 (127-177)	—	5.6 (50)	73.4 (650)	36.7 (325)
400 (203)	—	5.6 (50)	93.2 (825)	36.7 (325)
500 (253)	—	5.6 (50)	93.2 (825)	42.4 (375)
600-750 (304-380)	—	5.6 (50)	113.0 (1000)	42.4 (375)
800-1000 (406-508)	—	5.6 (50)	124.3 (1100)	56.5 (500)
1250-2000 (635-1016)	—	—	124.3 (1100)	67.8 (600)

\* For values of slot width or length not corresponding to those specified, select the largest torque value associated with the conductor size. Slot width is the nominal design value. Slot length is to be measured at the bottom of the slot.

**Note:** If a connector has a clamp screw such as a slotted, hexagonal head screw with more than one means of tightening, test the connector using both applicable torque values.

**Figure 7-4** Tightening Torque for Screw-Type Pressure Wire Connectors

Socket Size Across Flats, mm (in.)	Tightening Torque, Nm (in. lb.)
3.2 (1/8)	5.1 (45)
4.0 (5/32)	11.4 (100)
4.8 (3/16)	13.8 (120)
5.6 (7/32)	17.0 (150)
6.4 (1/4)	22.6 (200)
7.9 (5/16)	31.1 (275)
9.5 (3/8)	42.4 (375)
12.7 (1/2)	56.5 (500)
14.3 (9/16)	67.8 (600)

**Note:** For values of slot width or length not corresponding to those specified, select the largest torque value associated with the conductor size. Slot width is the nominal design value. Slot length is to be measured at the bottom of the slot.

**Figure 7-5** Tightening Torque for Pressure Wire Connectors with Internal-Drive Socket-Head Screws

## 7.5 Automatic Transfer Switches

A typical standby system has at least one automatic transfer switch connected to the generator set output to automatically transfer the electrical load to the generator set if the normal source fails. When normal power returns, the switch transfers the load back to the normal power source and then signals the generator set to stop.

The transfer switch uses a set of contacts to signal the engine/generator to start. These contacts are terminals 3 and 4 on the generator set controller terminal strip or controller connection terminal strip (if used) inside the junction box. When the normal source fails and the generator set master switch is in the AUTO position, the transfer switch contacts close to start the generator set.

The location of the transfer switch contacts is usually near the contactor with an engine start decal to identify the correct terminals. The terminals are identified as 3 and 4 (or 57 and 58). Do not connect to terminals 57 and 58 on the inner panel circuit board. Connection must be at the contactor location. Verify the correct engine start terminals using the transfer switch wiring diagrams before making connections.

## 7.6 Control Connections

Most standby generators can be equipped with a myriad of optional equipment that will have to be connected to other components in the system. These accessories will enable the generator set to meet standards for local and national codes, or specific requirements of the customer's installation. A few of the more common accessories and their functions are listed on the following pages.

## 7.7 Remote Annunciator

The remote annunciator allows monitoring of the standby power system from a location remote from the generator set. Individual lamps identifying fault shutdowns and/or prealarms are located on the remote annunciator, along with an alarm horn and silence switch. There are both surface- and flush-mount models available. The remote annunciator is typically located in an area that is monitored on a full-time basis. This allows the operator to be aware of any alarm conditions when they occur without having to be physically present at the generator set. See Figure 7-6.

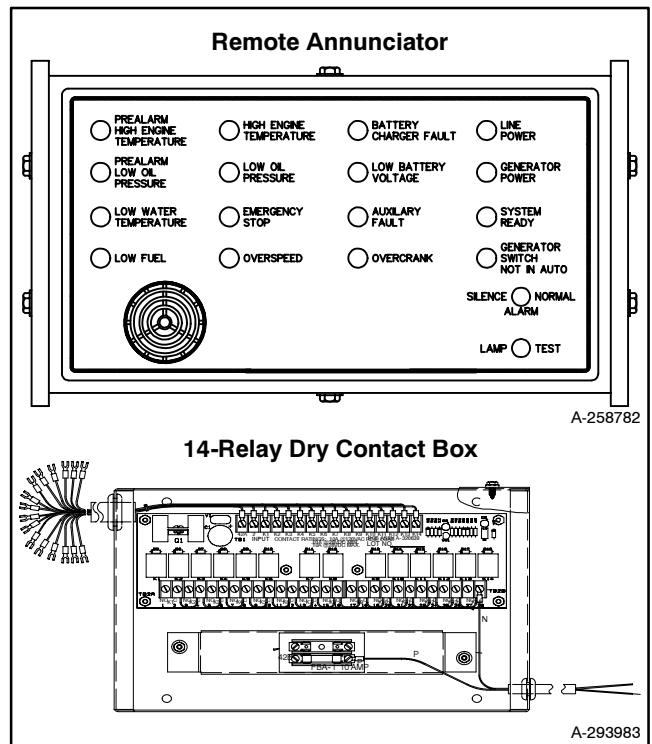

**Figure 7-6** Remote Annunciator with 14-Relay Dry Contact Kit

## 7.8 Audiovisual Alarm

The audiovisual alarm warns the operator of a fault shutdown or prealarm condition at a remote location. See Figure 7-7.

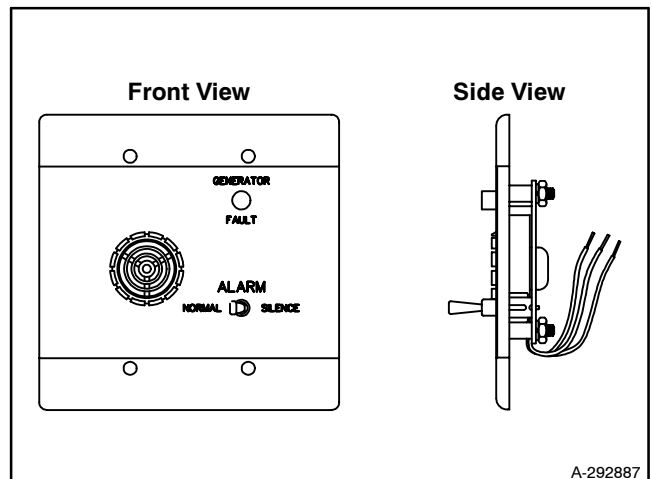

**Figure 7-7** Audiovisual Alarm

## 7.9 Remote Emergency Stop Switch

The emergency stop switch allows immediate shutdown of the generator from a remote location. If the emergency stop switch is activated, the emergency stop lamp on the generator controller lights and the unit shuts down immediately. The generator cannot be restarted until the emergency stop switch is reset. See Figure 7-8.

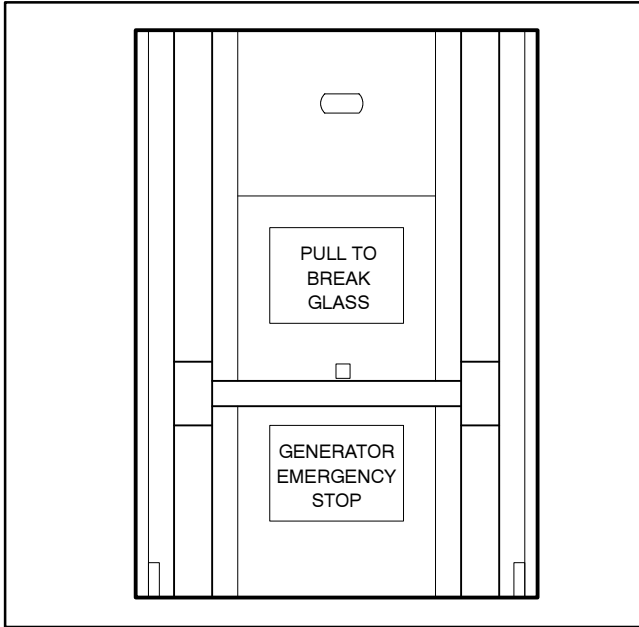

**Figure 7-8** Remote Emergency Stop Switch

## 7.10 Dry Contact Kit

The dry contact kit allows monitoring of the standby system and/or the ability to activate accessories from a remote location. Customer- provided warning devices (lamps, horns, etc.) can be connected to any of the generator controller's alarm/indication outputs, allowing the user to "customize" an alarm system to their needs.

## 7.11 Wiring

Connections between the components of a standby generator system differ based on the type of equipment used, options, and installation. Figure 8-6 on the following page gives examples of the possible options and wire connections necessary to make a standby system operational. You should always refer to the wiring diagram for details regarding wire sizing, location, and number.

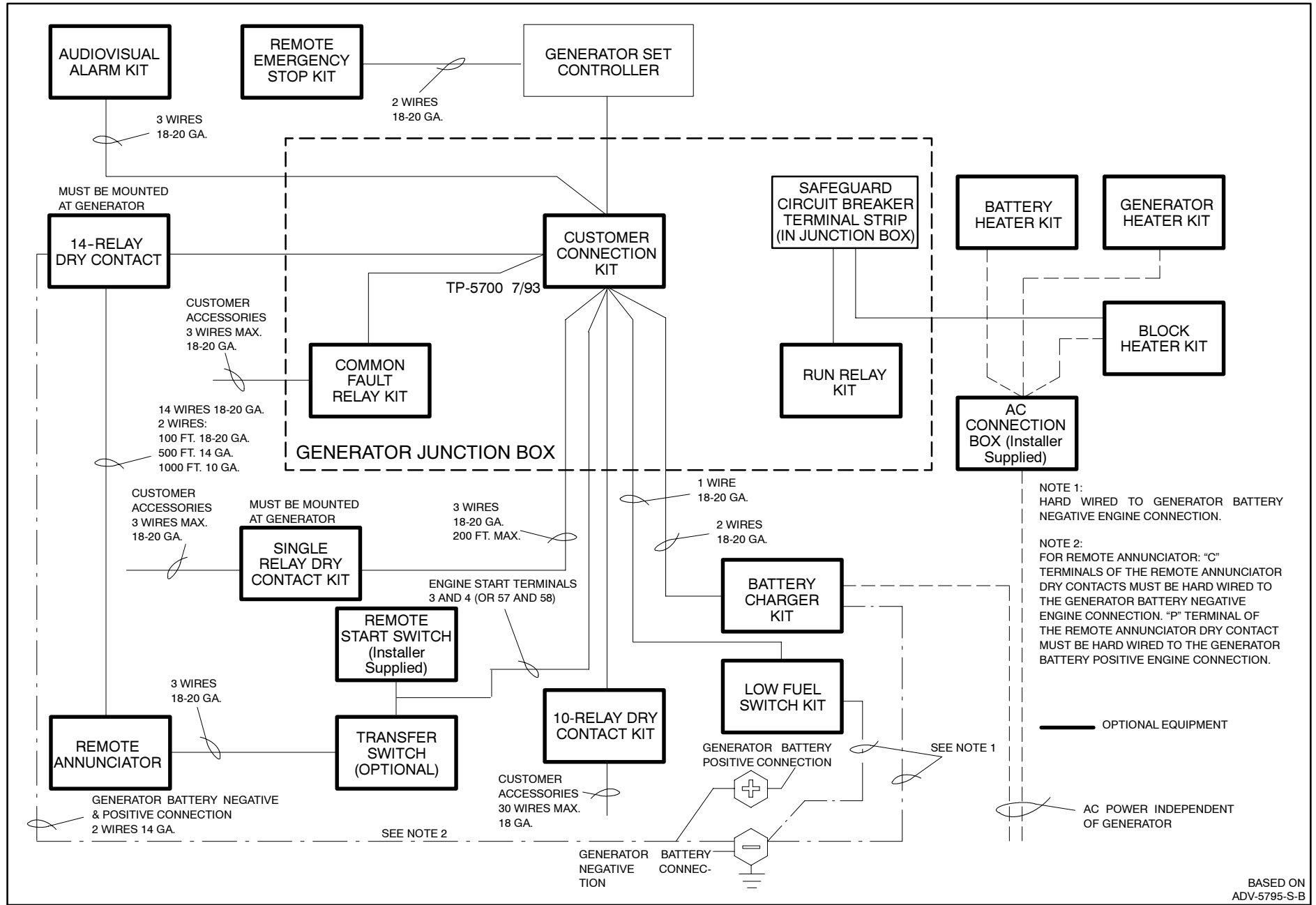

Figure 7-9 Generator Set Connections, Typical

BASED ON  
ADV-5795-S-B

# Appendix A Abbreviations

The following list contains abbreviations that may appear in this publication.

A, amp	ampere	CG	center of gravity	fglass.	fiberglass
ABDC	after bottom dead center	CID	cubic inch displacement	FHM	flat head machine (screw)
AC	alternating current	CL	centerline	fl. oz.	fluid ounce
A/D	analog to digital	cm	centimeter	flex.	flexible
ADC	analog to digital converter	CMOS	complementary metal oxide substrate (semiconductor)	freq.	frequency
adj.	adjust, adjustment			FS	full scale
ADV	advertising dimensional drawing	cogen.	cogeneration	ft.	foot, feet
AHWT	anticipatory high water temperature	Com	communications (port)	ft. lbs.	foot pounds (torque)
AISI	American Iron and Steel Institute	conn.	connection	ft./min.	feet per minute
ALOP	anticipatory low oil pressure	cont.	continued	g	gram
alt.	alternator	CPVC	chlorinated polyvinyl chloride	ga.	gauge (meters, wire size)
Al	aluminum	crit.	critical	gal.	gallon
ANSI	American National Standards Institute (formerly American Standards Association, ASA)	CRT	cathode ray tube	gen.	generator
		CSA	Canadian Standards Association	genset	generator set
AO	anticipatory only	CT	current transformer	GFI	ground fault interrupter
API	American Petroleum Institute	Cu	copper	GND, ⊕	ground
approx.	approximate, approximately	cu. in.	cubic inch	gov.	governor
AR	as required, as requested	cw.	clockwise	gph	gallons per hour
AS	as supplied, as stated, as suggested	CWC	city water-cooled	gpm	gallons per minute
ASE	American Society of Engineers	cyl.	cylinder	gr.	grade, gross
ASME	American Society of Mechanical Engineers	D/A	digital to analog	GRD	equipment ground
assy.	assembly	DAC	digital to analog converter	gr. wt.	gross weight
ASTM	American Society for Testing Materials	dB	decibel	H x W x D	height by width by depth
ATDC	after top dead center	dBA	decibel (A weighted)	HC	hex cap
ATS	automatic transfer switch	DC	direct current	HCHT	high cylinder head temperature
auto.	automatic	DCR	direct current resistance	HD	heavy duty
aux.	auxiliary	deg., °	degree	HET	high exhaust temperature
A/V	audiovisual	dept.	department	hex	hexagon
avg.	average	dia.	diameter	Hg	mercury (element)
AVR	automatic voltage regulator	DI/EO	dual inlet/end outlet	HH	hex head
AWG	American Wire Gauge	DIN	Deutsches Institut für Normung e. V. (also Deutsche Industrie Normenausschuss)	HHC	hex head cap
AWM	appliance wiring material			HP	horsepower
bat.	battery	DIP	dual inline package	hr.	hour
BBDC	before bottom dead center	DPDT	double-pole, double-throw	HS	heat shrink
BC	battery charger, battery charging	DPST	double-pole, single-throw	hsg.	housing
BCA	battery charging alternator	DS	disconnect switch	HVAC	heating, ventilation, and air conditioning
BCI	Battery Council International	DVR	digital voltage regulator	HWT	high water temperature
BDC	before dead center	E, emer.	emergency (power source)	Hz	hertz (cycles per second)
BHP	brake horsepower	EDI	electronic data interchange	IC	integrated circuit
blk.	black (paint color), block (engine)	EFR	emergency frequency relay	ID	inside diameter, identification
blk. htr.	block heater	e.g.	for example ( <i>exempli gratia</i> )	IEC	International Electrotechnical Commission
BMEP	brake mean effective pressure	EG	electronic governor	IEEE	Institute of Electrical and Electronics Engineers
bps	bits per second	EGSA	Electrical Generating Systems Association	IMS	improved motor starting
br.	brass	EIA	Electronic Industries Association	in.	inch
BTDC	before top dead center	EI/EO	end inlet/end outlet	in. H <sub>2</sub> O	inches of water
Btu	British thermal unit	EMI	electromagnetic interference	in. Hg	inches of mercury
Btu/min.	British thermal units per minute	emiss.	emission	in. lbs.	inch pounds
C	Celsius, centigrade	eng.	engine	Inc.	incorporated
cal.	calorie	EPA	Environmental Protection Agency	ind.	industrial
CARB	California Air Resources Board	EPS	emergency power system	int.	internal
CB	circuit breaker	ER	emergency relay	int./ext.	internal/external
cc	cubic centimeter	ES	engineering special, engineered special	I/O	input/output
CCA	cold cranking amps	ESD	electrostatic discharge	IP	iron pipe
ccw.	counterclockwise	est.	estimated	ISO	International Organization for Standardization
CEC	Canadian Electrical Code	E-Stop	emergency stop	J	joule
cfh	cubic feet per hour	etc.	et cetera (and so forth)	JIS	Japanese Industry Standard
cfm	cubic feet per minute	exh.	exhaust	k	kilo (1000)
		ext.	external	K	kelvin
		F	Fahrenheit, female	KA	kiloampere
				KB	kilobyte (2 <sup>10</sup> bytes)

kg	kilogram	MW	megawatt	rms	root mean square
kg/cm <sup>2</sup>	kilograms per square centimeter	mW	milliwatt	rnd.	round
kgm	kilogram-meter	μF	microfarad	ROM	read only memory
kg/m <sup>3</sup>	kilograms per cubic meter	N, norm.	normal (power source)	rot.	rotate, rotating
kHz	kilohertz	NA	not available, not applicable	rpm	revolutions per minute
kJ	kilojoule	nat. gas	natural gas	RS	right side
km	kilometer	NBS	National Bureau of Standards	RTV	room temperature vulcanization
kOhm, kΩ	kilo-ohm	NC	normally closed	SAE	Society of Automotive Engineers
kPa	kilopascal	NEC	National Electrical Code	scfm	standard cubic feet per minute
kph	kilometers per hour	NEMA	National Electrical Manufacturers Association	SCR	silicon controlled rectifier
kV	kilovolt	NFPA	National Fire Protection Association	s, sec.	second
kVA	kilovolt ampere	Nm	newton meter	SI	<i>Système international d'unites</i> , International System of Units
kVAR	kilovolt ampere reactive	NO	normally open	SI/EO	side in/end out
kW	kilowatt	no., nos.	number, numbers	sil.	silencer
kWh	kilowatt-hour	NPS	National Pipe, Straight	SN	serial number
kWm	kilowatt mechanical	NPSC	National Pipe, Straight-coupling	SPDT	single-pole, double-throw
L	liter	NPT	National Standard taper pipe thread per general use	SPST	single-pole, single-throw
LAN	local area network	NPTF	National Pipe, Taper-Fine	spec, specs	specification(s)
L x W x H	length by width by height	NR	not required, normal relay	sq.	square
lb.	pound, pounds	ns	nanosecond	sq. cm	square centimeter
lbm/ft <sup>3</sup>	pounds mass per cubic feet	OC	overcrank	sq. in.	square inch
LCB	line circuit breaker	OD	outside diameter	SS	stainless steel
LCD	liquid crystal display	OEM	original equipment manufacturer	std.	standard
ld. shd.	load shed	OF	overfrequency	stl.	steel
LED	light emitting diode	opt.	option, optional	tach.	tachometer
Lph	liters per hour	OS	oversize, overspeed	TD	time delay
Lpm	liters per minute	OSHA	Occupational Safety and Health Administration	TDC	top dead center
LOP	low oil pressure	OV	overvoltage	TDEC	time delay engine cooldown
LP	liquefied petroleum	oz.	ounce	TDEN	time delay emergency to normal
LPG	liquefied petroleum gas	p., pp.	page, pages	TDES	time delay engine start
LS	left side	PC	personal computer	TDNE	time delay normal to emergency
L <sub>wa</sub>	sound power level, A weighted	PCB	printed circuit board	TDOE	time delay off to emergency
LWL	low water level	pF	picofarad	TDON	time delay off to normal
LWT	low water temperature	PF	power factor	temp.	temperature
m	meter, milli (1/1000)	ph., ∅	phase	term.	terminal
M	mega (10 <sup>6</sup> when used with SI units), male	PHC	Phillips head crimptite (screw)	TIF	telephone influence factor
m <sup>3</sup>	cubic meter	PHH	Phillips hex head (screw)	TIR	total indicator reading
m <sup>3</sup> /min.	cubic meters per minute	PHM	pan head machine (screw)	tol.	tolerance
mA	milliampere	PLC	programmable logic control	turbo.	turbocharger
man.	manual	PMG	permanent-magnet generator	typ.	typical (same in multiple locations)
max.	maximum	pot	potentiometer, potential	UF	underfrequency
MB	megabyte (2 <sup>20</sup> bytes)	ppm	parts per million	UHF	ultrahigh frequency
MCM	one thousand circular mils	PROM	programmable read-only memory	UL	Underwriter's Laboratories, Inc.
MCCB	molded-case circuit breaker	psi	pounds per square inch	UNC	unified coarse thread (was NC)
meggar	megohmmeter	pt.	pint	UNF	unified fine thread (was NF)
MHz	megahertz	PTC	positive temperature coefficient	univ.	universal
mi.	mile	PTO	power takeoff	US	undersize, underspeed
mil	one one-thousandth of an inch	PVC	polyvinyl chloride	UV	ultraviolet, undervoltage
min.	minimum, minute	qt.	quart	V	volt
misc.	miscellaneous	qty.	quantity	VAC	volts alternating current
MJ	megajoule	R	replacement (emergency) power source	VAR	voltampere reactive
mJ	millijoule	rad.	radiator, radius	VDC	volts direct current
mm	millimeter	RAM	random access memory	VFD	vacuum fluorescent display
mOhm, mΩ	milliohm	RDO	relay driver output	VGA	video graphics adapter
MOhm, MΩ	megohm	ref.	reference	VHF	very high frequency
MOV	metal oxide varistor	rem.	remote	W	watt
MPa	megapascal	RFI	radio frequency interference	WCR	withstand and closing rating
mpg	miles per gallon	RH	round head	w/	with
mph	miles per hour	RHM	round head machine (screw)	w/o	without
MS	military standard	rly.	relay	wt.	weight
m/sec.	meters per second			xfrm	transformer
MTBF	mean time between failure				
MTBO	mean time between overhauls				
mtg.	mounting				



**TP-5700 7/93c**

© 1993, 2001 by Kohler Co. All rights reserved.

# **KOHLER**<sup>®</sup> POWER SYSTEMS

KOHLER CO. Kohler, Wisconsin 53044  
Phone 920-565-3381, Web site [www.kohlergenerators.com](http://www.kohlergenerators.com)  
Fax 920-459-1646 (U.S.A. Sales), Fax 920-459-1614 (International)  
For the nearest sales and service outlet in U.S.A. and Canada  
Phone 1-800-544-2444

Kohler Power Systems  
Asia Pacific Headquarters  
7 Jurong Pier Road  
Singapore 619159  
Phone (65)264-6422, Fax (65)264-6455