

Operation

Industrial Generator Sets

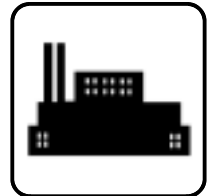

Models:

20-2000 kW

Controllers:

Decision-Maker™ 3+, 16-Light

Decision-Maker™ 3+, 7-Light

Decision-Maker™ 3, 16-Light

Decision-Maker™ 3, 6-Light

Manual Paralleling

Decision-Maker™ 1

Manual

Engine Gauge Box for Paralleling Switchgear



KOHLER[®]
POWER SYSTEMS

TP-5750 7/00g

Table of Contents

Product Identification Information	Inside front cover
Safety Precautions and Instructions	1
Introduction	i
Service Assistance	i
Section 1 Specifications	1
1.1 Introduction	1
1.2 Specifications, 20-300 kW	1
1.3 Specifications, 350-2000 kW	2
1.4 Accessories	2
1.4.1 Controller Connection Kit	2
1.4.2 Remote Annunciator Kit	2
1.4.3 Single-Relay Dry Contact Kit	3
1.4.4 Dry Contact Kits	3
1.4.5 Audiovisual Alarm	4
1.4.6 Safeguard Breaker	4
1.4.7 Line Circuit Breaker	4
1.4.8 Run Relay Kit	4
1.4.9 Remote Emergency Stop Kit	5
1.4.10 FASTCHECK Diagnostic Tester	5
1.4.11 Accessory and Prime Power Terminal Strip Connections	6
Section 2 Operation	9
2.1 Prestart Checklist	9
2.2 Generator Set Exercising	9
2.3 Microprocessor Controllers	10
2.3.1 Microprocessor Controller Features	10
2.3.2 Normal Operation	17
2.3.3 Prime Power Mode Operation (Decision-Maker 3+ Controller)	17
2.3.4 Emergency Stopping	18
2.3.5 Fault Shutdowns	19
2.3.6 Controller Resetting After a Fault Shutdown	19
2.4 Manual Paralleling Controller	20
2.4.1 Manual Paralleling Controller Features	20
2.4.2 Single Generator Set Operation	21
2.4.3 Paralleling Setup and Test	21
2.4.4 Load Disconnection from Paralleled Generator Sets	22
2.5 Expanded Decision-Maker 1 Controller	23
2.5.1 Controls and Indicators	23
2.5.2 Generator Set Starting	24
2.5.3 Generator Set Stopping	24
2.5.4 Fault Shutdowns	24
2.5.5 Controller Resetting After a Fault Shutdown	24
2.6 Standard Decision-Maker 1 Controller with Engine Gauges	25
2.6.1 Controls and Indicators	25
2.6.2 Generator Set Starting	25
2.6.3 Generator Set Stopping	25
2.6.4 Fault Shutdowns	26
2.6.5 Controller Resetting After a Fault Shutdown	26
2.7 Standard Decision-Maker 1 Controller	26
2.7.1 Controls and Indicators	27
2.7.2 Generator Set Starting	27
2.7.3 Generator Set Stopping	27
2.7.4 Fault Shutdowns	27
2.7.5 Controller Resetting After a Fault Shutdown	28
2.8 Manual Controller	28
2.8.1 Controls and Indicators	29
2.8.2 Generator Set Starting	29

Table of Contents, continued

2.8.3	Generator Set Stopping	29
2.8.4	Fault Shutdowns	30
2.9	Paralleling Engine Gauge Box Controller (Switchgear)	30
Section 3	Scheduled Maintenance	33
3.1	Generator Service	33
3.2	Engine Service	33
3.3	Service Schedule	34
3.4	Generator Bearing Service	36
3.4.1	20–300 kW Models	36
3.4.2	350–2000 kW Models with Single- Bearing Generator	36
3.4.3	1250–2000 kW Model with Two- Bearing Generator	36
3.5	Diesel Fuel Systems	36
3.5.1	Bleeding Air from the Fuel System	36
3.5.2	Subbase Fuel Day Tank Electronic Control Module (ECM)	37
3.5.3	Subbase Inner Fuel Tank Alarm	38
3.6	Gas/Gasoline Fuel Systems	39
3.6.1	Gaseous Fuel System Concept	39
3.6.2	LP Liquid Withdrawal Fuel System Concept	39
3.6.3	LP Gas/Natural Gas Conversion for Straight Gas Fuel System	39
3.6.4	Fuel System Changeover Kits	40
3.6.5	Carburetor Adjustment	41
3.6.6	Fuel System Maintenance	41
3.7	Turbocharger Maintenance on Ford-Powered Models	41
3.7.1	Oil Type Recommendations	41
3.7.2	Turbocharger Oil Prime Procedure	42
3.7.3	Turbocharger Maintenance	42
3.8	Cooling System	42
3.8.1	Coolant Level Check	43
3.8.2	Cooling System Component Inspection	43
3.8.3	Cooling System Drainage Procedure	43
3.8.4	Cooling System Flush and Clean Procedure	43
3.8.5	Cooling System Refilling Procedure	44
3.9	Radiator Expansion Joint Loosening—Initial Setup Only	44
3.10	Fan Bearing Lubrication	45
3.11	Battery	46
3.11.1	Cleaning	47
3.11.2	Electrolyte Level Inspection	48
3.11.3	Specific Gravity Check	48
3.11.4	Charging	49
3.12	Detroit Diesel Engine Control (DDEC) System	49
3.12.1	DDEC Features	49
3.12.2	DDEC Engine Diagnostics	49
3.13	Deutz Engine Control System	50
3.14	Storage Procedure	50
3.14.1	Lubricating System	50
3.14.2	Cooling System	50
3.14.3	Fuel System	50
3.14.4	Internal Engine Components (Gas/Gasoline-Fueled Engines)	51
3.14.5	Exterior	51
3.14.6	Battery	51
Section 4	Troubleshooting	53
Section 5	Generator Set Reconnection	57
5.1	Voltage Reconnection	57
5.2	Overvoltage Shutdown Adjustment	59
5.2.1	Decision-Maker 3+ Controller	59
5.2.2	Decision-Maker 3 Controller	60
Appendix A	Abbreviations	A-1

Safety Precautions and Instructions

IMPORTANT SAFETY INSTRUCTIONS. Electromechanical equipment, including generator sets, transfer switches, switchgear, and accessories, can cause bodily harm and pose life-threatening danger when improperly installed, operated, or maintained. To prevent accidents be aware of potential dangers and act safely. Read and follow all safety precautions and instructions. **SAVE THESE INSTRUCTIONS.**

This manual has several types of safety precautions and instructions: Danger, Warning, Caution, and Notice.

DANGER

Danger indicates the presence of a hazard that **will cause severe personal injury, death, or substantial property damage.**

WARNING

Warning indicates the presence of a hazard that **can cause severe personal injury, death, or substantial property damage.**

CAUTION

Caution indicates the presence of a hazard that **will or can cause minor personal injury or property damage.**

NOTICE

Notice communicates installation, operation, or maintenance information that is safety related but not hazard related.

Safety decals affixed to the equipment in prominent places alert the operator or service technician to potential hazards and explain how to act safely. The decals are shown throughout this publication to improve operator recognition. Replace missing or damaged decals.

Accidental Starting

WARNING

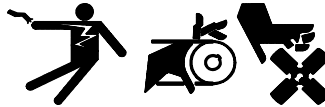

Accidental starting.
Can cause severe injury or death.

Disconnect the battery cables before working on the generator set. Remove the negative (-) lead first when disconnecting the battery. Reconnect the negative (-) lead last when reconnecting the battery.

Disabling the generator set. Accidental starting can cause severe injury or death. Before working on the generator set or connected equipment, disable the generator set as follows: (1) Move the generator set master switch to the OFF position. (2) Disconnect the power to the battery charger. (3) Remove the battery cables, negative (-) lead first. Reconnect the negative (-) lead last when reconnecting the battery. Follow these precautions to prevent starting of the generator set by an automatic transfer switch, remote start/stop switch, or engine start command from a remote computer.

Battery

WARNING



Sulfuric acid in batteries.
Can cause severe injury or death.

Wear protective goggles and clothing. Battery acid may cause blindness and burn skin.

WARNING



Explosion.
Can cause severe injury or death.
Relays in the battery charger cause arcs or sparks.

Locate the battery in a well-ventilated area. Isolate the battery charger from explosive fumes.



Battery electrolyte is a diluted sulfuric acid. Battery acid can cause severe injury or death. Battery acid can cause blindness and burn skin. Always wear splashproof safety goggles, rubber gloves, and boots when servicing the battery. Do not open a sealed battery or mutilate the battery case. If battery acid splashes in the eyes or on the skin, immediately flush the affected area for 15 minutes with large quantities of clean water. Seek immediate medical aid in the case of eye contact. Never add acid to a battery after placing the battery in service, as this may result in hazardous spattering of battery acid.

Battery acid cleanup. Battery acid can cause severe injury or death. Battery acid is electrically conductive and corrosive. Add 500 g (1 lb.) of bicarbonate of soda (baking soda) to a container with 4 L (1 gal.) of water and mix the neutralizing solution. Pour the neutralizing solution on the spilled battery acid and continue to add the neutralizing solution to the spilled battery acid until all evidence of a chemical reaction (foaming) has ceased. Flush the resulting liquid with water and dry the area.

Battery gases. Explosion can cause severe injury or death. Battery gases can cause an explosion. Do not smoke or permit flames or sparks to occur near a battery at any time, particularly when it is charging. Do not dispose of a battery in a fire. To prevent burns and sparks that could cause an explosion, avoid touching the battery terminals with tools or other metal objects. Remove all jewelry before servicing the equipment. Discharge static electricity from your body before touching batteries by first touching a grounded metal surface away from the battery. To avoid sparks, do not disturb the battery charger connections while the battery is charging. Always turn the battery charger off before disconnecting the battery connections. Ventilate the compartments containing batteries to prevent accumulation of explosive gases.

Battery short circuits. Explosion can cause severe injury or death. Short circuits can cause bodily injury and/or equipment damage. Disconnect the battery before generator set installation or maintenance. Remove all jewelry before servicing the equipment. Use tools with insulated handles. Remove the negative (-) lead first when disconnecting the battery. Reconnect the negative (-) lead last when reconnecting the battery. Never connect the negative (-) battery cable to the positive (+) connection terminal of the starter solenoid. Do not test the battery condition by shorting the terminals together.

Engine Backfire/Flash Fire

 WARNING

<p>Fire. Can cause severe injury or death.</p> <p>Do not smoke or permit flames or sparks near fuels or the fuel system.</p>

Servicing the fuel system. A flash fire can cause severe injury or death. Do not smoke or permit flames or sparks near the carburetor, fuel line, fuel filter, fuel pump, or other potential sources of spilled fuels or fuel vapors. Catch fuels in an approved container when removing the fuel line or carburetor.

Servicing the air cleaner. A sudden backfire can cause severe injury or death. Do not operate the generator set with the air cleaner removed.

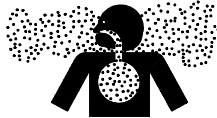
Exhaust System

 WARNING

<p>Carbon monoxide. Can cause severe nausea, fainting, or death.</p> <p>The exhaust system must be leakproof and routinely inspected.</p>



Generator set operation. Carbon monoxide can cause severe nausea, fainting, or death. Carbon monoxide is an odorless, colorless, tasteless, nonirritating gas that can cause death if inhaled for even a short time. Avoid breathing exhaust fumes when working on or near the generator set. Never operate the generator set inside a building unless the exhaust gas is piped safely outside. Never operate the generator set where exhaust gas

could accumulate and seep back inside a potentially occupied building.

Carbon monoxide symptoms. Carbon monoxide can cause severe nausea, fainting, or death. Carbon monoxide is a poisonous gas present in exhaust gases. Carbon monoxide poisoning symptoms include but are not limited to the following:

- Light-headedness, dizziness
 - Physical fatigue, weakness in joints and muscles
 - Sleepiness, mental fatigue, inability to concentrate or speak clearly, blurred vision
 - Stomachache, vomiting, nausea
- If experiencing any of these symptoms and carbon monoxide poisoning is possible, seek fresh air immediately and remain active. Do not sit, lie down, or fall asleep. Alert others to the possibility of carbon monoxide poisoning. Seek medical attention if the condition of affected persons does not improve within minutes of breathing fresh air.

Fuel System

 WARNING

<p>Explosive fuel vapors. Can cause severe injury or death.</p> <p>Use extreme care when handling, storing, and using fuels.</p>

The fuel system. Explosive fuel vapors can cause severe injury or death. Vaporized fuels are highly explosive. Use extreme care when handling and storing fuels. Store fuels in a well-ventilated area away from spark-producing equipment and out of the reach of children. Never add fuel to the tank while the engine is running because spilled fuel may ignite on contact with hot parts or from sparks. Do not smoke or permit flames or sparks to occur near sources of spilled fuel or fuel vapors. Keep the fuel lines

and connections tight and in good condition. Do not replace flexible fuel lines with rigid lines. Use flexible sections to avoid fuel line breakage caused by vibration. Do not operate the generator set in the presence of fuel leaks, fuel accumulation, or sparks. Repair fuel systems before resuming generator set operation.

Explosive fuel vapors can cause severe injury or death. Take additional precautions when using the following fuels:

Propane (LP)—Adequate ventilation is mandatory. Because propane is heavier than air, install propane gas detectors low in a room. Inspect the detectors per the manufacturer's instructions.

Natural Gas—Adequate ventilation is mandatory. Because natural gas rises, install natural gas detectors high in a room. Inspect the detectors per the manufacturer's instructions.

Gas fuel leaks. Explosive fuel vapors can cause severe injury or death. Fuel leakage can cause an explosion. Check the LP vapor gas or natural gas fuel system for leakage by using a soap and water solution with the fuel system test pressurized to 6–8 ounces per square inch (10–14 inches water column). Do not use a soap solution containing either ammonia or chlorine because both prevent bubble formation. A successful test depends on the ability of the solution to bubble.

LP liquid withdrawal fuel leaks. Explosive fuel vapors can cause severe injury or death. Fuel leakage can cause an explosion. Check the LP liquid withdrawal gas fuel system for leakage by using a soap and water solution with the fuel system test pressurized to at least 90 psi (621 kPa). Do not use a soap solution containing either ammonia or chlorine because both prevent bubble formation. A successful test depends on the ability of the solution to bubble.

Hazardous Noise

CAUTION



Hazardous noise. Can cause hearing loss.

Never operate the generator set without a muffler or with a faulty exhaust system.

Engine noise. Hazardous noise can cause hearing loss. Generator sets not equipped with sound enclosures can produce noise levels greater than 105 dBA. Prolonged exposure to noise levels greater than 85 dBA can cause permanent hearing loss. Wear hearing protection when near an operating generator set.

Hazardous Voltage/ Electrical Shock

DANGER



Hazardous voltage. Will cause severe injury or death.

Disconnect all power sources before opening the enclosure.

(over 600 volts)

WARNING

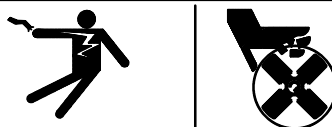

Hazardous voltage. Moving rotor. Can cause severe injury or death.

Operate the generator set only when all guards and electrical enclosures are in place.

WARNING



Hazardous voltage. Backfeed to the utility system can cause property damage, severe injury, or death.

If the generator set is used for standby power, install an automatic transfer switch to prevent inadvertent interconnection of standby and normal sources of supply.

Grounding electrical equipment. Hazardous voltage can cause severe injury or death. Electrocutation is possible whenever electricity is present. Open the main circuit breakers of all power sources before servicing the equipment. Configure the installation to electrically ground the generator set, transfer switch, and related equipment and electrical circuits to comply with applicable codes and standards. Never contact electrical leads or appliances when standing in water or on wet ground because these conditions increase the risk of electrocution.

Disconnecting the electrical load. Hazardous voltage can cause severe injury or death. Disconnect the generator set from the load by opening the line circuit breaker or by disconnecting the generator set output leads from the transfer switch and heavily taping the ends of the leads. High voltage transferred to the load during testing may cause personal injury and equipment damage. Do not use the safeguard circuit breaker in place of the line circuit breaker. The safeguard circuit breaker does not disconnect the generator set from the load.

High voltage test. Hazardous voltage can cause severe injury or death. Follow the instructions of the test equipment manufacturer when performing high-voltage tests on the rotor or stator. An improper test procedure can damage equipment or lead to generator set failure.

Installing the battery charger. Hazardous voltage can cause severe injury or death. An ungrounded battery charger may cause electrical shock. Connect the battery charger enclosure to the ground of a permanent wiring system. As an alternative, install an equipment grounding conductor with circuit conductors and connect it to the equipment grounding terminal or the lead on the battery charger. Install the battery charger as prescribed in the equipment manual. Install the battery charger in compliance with local codes and ordinances.



Connecting the battery and the battery charger. Hazardous voltage can cause severe injury or death. Reconnect the battery correctly, positive to positive and negative to negative, to avoid electrical shock and damage to the battery charger and battery(ies). Have a qualified electrician install the battery(ies).

Short circuits. Hazardous voltage/current can cause severe injury or death. Short circuits can cause bodily injury and/or equipment damage. Do not contact electrical connections with tools or jewelry while making adjustments or repairs. Remove all jewelry before servicing the equipment.



Testing the voltage regulator. Hazardous voltage can cause severe injury or death. High voltage is present at the voltage regulator heat sink. To prevent electrical shock do not touch the voltage regulator heat sink when testing the voltage regulator. *(PowerBoost™, PowerBoost™ III, and PowerBoost™ V voltage regulator models only)*

Electrical backfeed to the utility. Hazardous backfeed voltage can cause severe injury or death. Install a transfer switch in standby power installations to prevent the connection of standby and other sources of power. Electrical backfeed into a utility electrical system can cause severe injury or death to utility personnel working on power lines.

Heavy Equipment

 WARNING

<p>Unbalanced weight. Improper lifting can cause severe injury or death and equipment damage.</p> <p>Do not use lifting eyes. Lift the generator set using lifting bars inserted through the lifting holes on the skid.</p>

Hot Parts

 WARNING

<p>Hot engine and exhaust system. Can cause severe injury or death.</p> <p>Do not work on the generator set until it cools.</p>

Servicing the generator. Hot parts can cause severe injury or death. Avoid touching the generator set field or exciter armature. When shorted, the generator set field and exciter armature become hot enough to cause severe burns.

Servicing the exhaust system. Hot parts can cause severe injury or death. Do not touch hot engine parts. The engine and exhaust system components become extremely hot during operation.

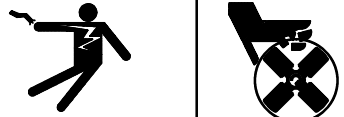
Moving Parts

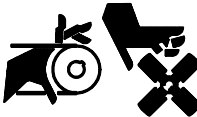
 WARNING

<p>Hazardous voltage. Moving rotor. Can cause severe injury or death.</p> <p>Operate the generator set only when all guards and electrical enclosures are in place.</p>

 WARNING

<p>Rotating parts. Can cause severe injury or death.</p> <p>Operate the generator set only when all guards, screens, and covers are in place.</p>

Tightening the hardware. Flying projectiles can cause severe injury or death. Loose hardware can cause the hardware or pulley to release from the generator set engine and can cause personal injury. Retorque all crankshaft and rotor hardware after servicing. Do not loosen the crankshaft hardware or rotor throbolt when making adjustments or servicing the generator set. Rotate the crankshaft manually in a clockwise direction only. Turning the crankshaft bolt or rotor throbolt counterclockwise can loosen the hardware.

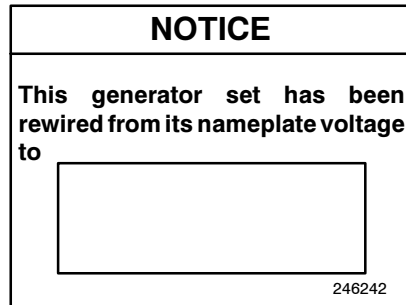
Servicing the generator set when it is operating. Exposed moving parts can cause severe injury or death. Keep hands, feet, hair, clothing, and test leads away from the belts and pulleys when the generator set is running. Replace guards, screens, and covers before operating the generator set.

Notice



NOTICE

Voltage reconnection. Affix a notice to the generator set after reconnecting the set to a voltage different from the voltage on the nameplate. Order voltage reconnection decal 246242 from an authorized service distributor/dealer.

NOTICE

Hardware damage. The engine and generator set may use both American Standard and metric hardware. Use the correct size tools to prevent rounding of the bolt heads and nuts.

NOTICE

When replacing hardware, do not substitute with inferior grade hardware. Screws and nuts are available in different hardness ratings. To indicate hardness, American Standard hardware uses a series of markings, and metric hardware uses a numeric system. Check the markings on the bolt heads and nuts for identification.

NOTICE

Canadian installations only. For standby service connect the output of the generator set to a suitably rated transfer switch in accordance with Canadian Electrical Code, Part 1.

Notes

This manual provides operation instructions for 20–2000 kW generator sets equipped with the following controllers:

- Microprocessor Controller, Decision-Maker™ 3+
- Microprocessor Controller, Decision-Maker™ 3
- Manual Paralleling Controller
- Decision-Maker™ 1
- Manual Controller
- Engine Gauge Box for Paralleling Switchgear

Wiring diagram manuals are available separately.

Refer to the engine operation manual for generator set engine scheduled maintenance information.

xin:001:001

This manual may be used for models not listed on the front cover.

Information in this publication represents data available at the time of print. Kohler Co. reserves the right to change this publication and the products represented without notice and without any obligation or liability whatsoever.

Read this manual and carefully follow all procedures and safety precautions to ensure proper equipment operation and to avoid bodily injury. Read and follow the Safety Precautions and Instructions section at the beginning of this manual. Keep this manual with the equipment for future reference.

The equipment service requirements are very important to safe and efficient operation. Inspect the parts often and perform required service at the prescribed intervals. Maintenance work must be performed by appropriately skilled and suitably-trained maintenance personnel familiar with generator set operation and service.

xin:001:002:a

Service Assistance

Please contact a local authorized distributor/dealer for sales, service, or other information about Kohler Co. Generator Division products.

- Look on the product or in the information included with the product
- Consult the Yellow Pages under the heading Generators—Electric
- Visit the Kohler Co. Generator Division web site at www.kohlergenerators.com
- Inside the U.S.A. and Canada, call 1-800-544-2444
- Outside the U.S.A. and Canada, call the nearest regional office

Africa, Europe, Middle East

London Regional Office
Langley, Slough, England
Phone: (44) 1753-580-771
Fax: (44) 1753-580-036

Australia

Australia Regional Office
Queensland, Australia
Phone: (617) 3893-0061
Fax: (617) 3893-0072

China

China Regional Office
Shanghai, People's Republic of China
Phone: (86) 21-6482 1252
Fax: (86) 21-6482 1255

India, Bangladesh, Sri Lanka

India Regional Office
Bangalore, India
Phone: (91) 80-2284270
(91) 80-2284279
Fax: (91) 80-2284286

Japan

Japan Regional Office
Tokyo, Japan
Phone: (813) 3440-4515
Fax: (813) 3440-2727

Latin America

Latin America Regional Office
Lakeland, Florida, U.S.A.
Phone: (941) 619-7568
Fax: (941) 701-7131

South East Asia

Singapore Regional Office
Singapore, Republic of Singapore
Phone: (65) 264-6422
Fax: (65) 264-6455

Xin:008:001

Notes

Section 1 Specifications

1.1 Introduction

The specification sheets for each generator set provide specific generator and engine information. Refer to the respective specification sheet for data not supplied in this manual. Consult the generator set service manual, installation manual, engine operation manual, and engine service manual for additional specifications.

1.2 Specifications, 20-300 kW

The generator set is a 4-pole, rotating-field unit with a brushless, permanent-magnet-generator (PMG) excitation system. The generator set excitation system uses a permanent-magnet exciter with a silicon-controlled rectifier (SCR) assembly that controls the amount of DC current supplied to the generator field. The voltage regulator sends a signal to the SCR assembly through an optical coupling. The voltage regulator bases the signal on engine speed and generator output voltage. The signal turns a stationary light-emitting diode (LED) on or off. The LED is mounted on the end bracket opposite a photo transistor board that rotates on the shaft. The photo transistor receives the signal from the LED and signals the SCR assembly to turn on or off. See Figure 1-1.

PMG generator sets offer the following advantages:

- Voltage recovery time several times faster than the conventionally wound field brushless generator sets because the inductance of the exciter field has no affect.
- Better recovery characteristics than static-excited generators because the system doesn't draw excitation power from the generator output voltage.
- The inherent ability to support short-circuit current and allow system coordination for tripping downstream branch circuit breakers.

The PMG exciter system delivers the required level of exciter current to the main field within 0.05 seconds of a load change.

For the duration of a short circuit in the load circuit(s), the output voltage drops and the amperage momentarily rises to 600-1000% of the generator set's rated current.

The SCR assembly sends full exciter power to the main field and the generator sustains up to 300% of rated current. Sustained high current trips correspondingly or rated load circuit fuses/breakers. The safeguard breaker kit collapses the generator set's main field during a sustained heavy overload or short circuit.

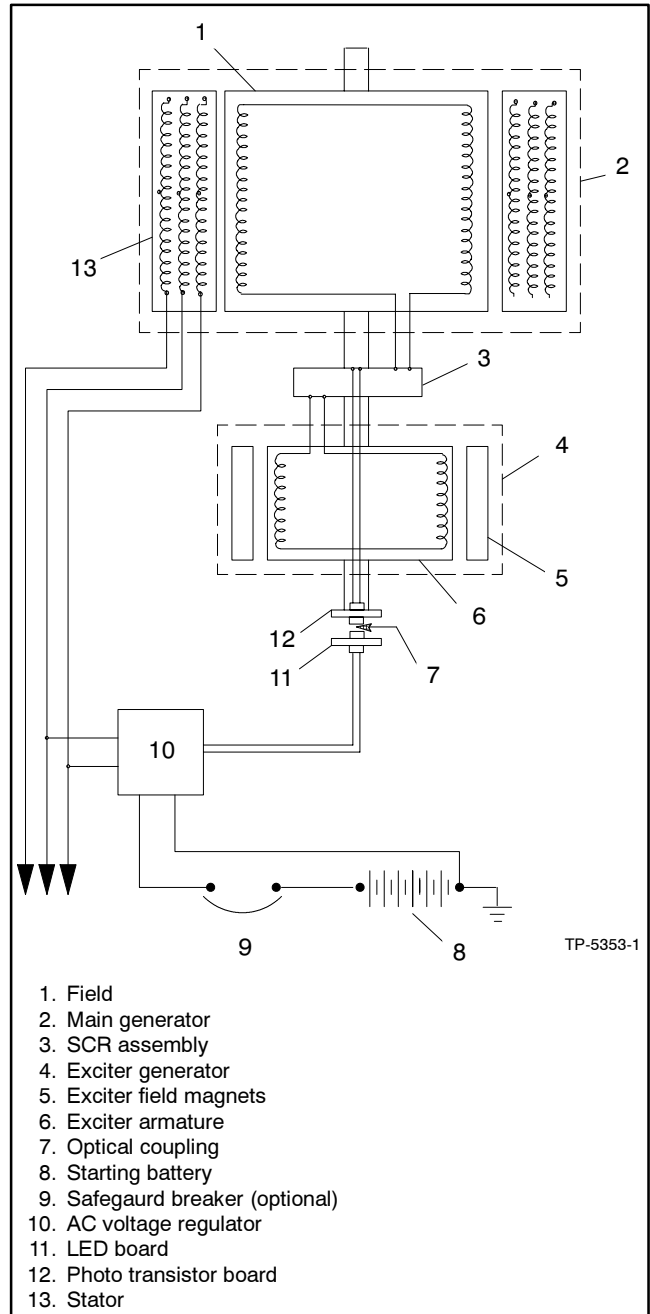

Figure 1-1 Alternator (20-300 kW)

1.3 Specifications, 350–2000 kW

The 4-pole, rotating-field generator set has a brushless, permanent-magnet-generator (PMG) excitation system. The PMG system provides up to 300% short-circuit excitation current at 60 Hz (approximately 275% at 50 Hz) for a minimum of 10 seconds to allow selective circuit breaker tripping. The solid-state voltage regulator is PMG-powered, maintenance free, and encapsulated for moisture protection. The voltage regulator provides $\pm 0.25\%$ no-load to full-load voltage regulation, adjustable volts/Hz, underspeed protection, 3-phase RMS sensing, and over excitation protection.

Earlier models use the PM100 voltage regulator with analog design. Later models use the digital DVR2000 voltage regulator.

1.4 Accessories

The manufacturer offers several accessories to finalize installation, to add convenience to operation and service, and to comply with state and local codes. Accessories vary with each generator set model and controller. Accessories are available factory-installed or shipped loose. Obtain the most current information by contacting your local authorized service distributor/dealer. The accessories described in Sections 1.4.1 through 1.4.11 were available at the time of print.

Note: The accessories with the (M) notation are available only on models with microprocessor controllers.

1.4.1 Controller Connection Kit (M)

The controller connection kit allows easy connection of controller accessories without accessing the controller terminal strip. The kit uses a 165-cm (65-in.) wiring harness to link the controller terminal strip(s) with a remote terminal strip. With the exception of a few terminals the remote terminal strip is identical to that of the controller. Connect all accessories except the emergency stop kit to the connection kit terminal strip.

1.4.2 Remote Annunciator Kit (M)

A remote annunciator provides convenient monitoring of the generator set's condition from a remote location. See Figure 1-2. The remote annunciator includes an alarm horn, alarm silence switch, lamp test, and the same lamp indicators (except air damper and auxiliary prealarm) as the microprocessor controller, plus the following lamps:

Line Power lamp illuminates to indicate that the commercial utility is the power source.

Generator Power lamp illuminates to indicate that the generator set is the power source.

Early models used a 10-relay dry contact box.

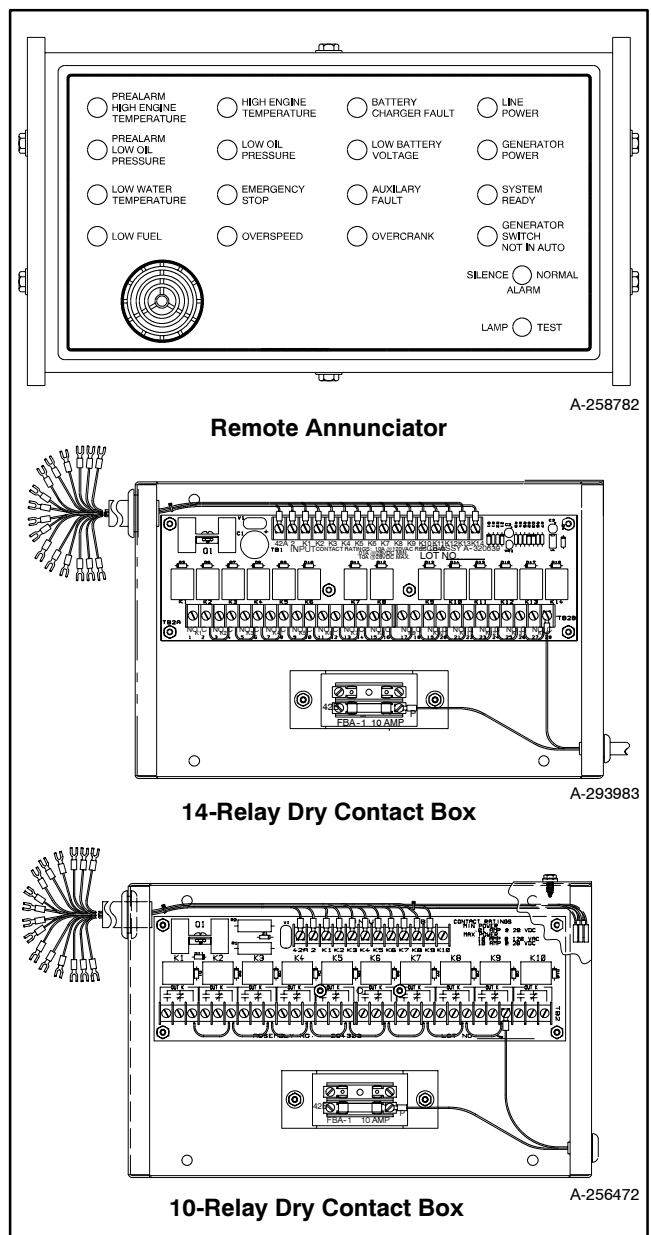

Figure 1-2 Remote Annunciator with 14- or 10-Relay Dry Contact Box

1.4.3 Single-Relay Dry Contact Kit (M)

The single-relay dry contact kit uses one set of contacts to trigger customer-provided warning devices if a fault condition occurs. Connect any controller fault output connection from the TB1 terminal strip to the single-relay kit. Use the single-relay dry contact kit as a common fault relay for signaling any of the following common fault conditions:

- Emergency Stop
- Auxiliary
- Overspeed
- Low Oil Pressure
- High Engine Temperature

Connect a maximum of three dry contact kits to a single controller output. See Figure 1-3.

1.4.4 Dry Contact Kits (M)

Dry contact kits allow monitoring of the standby system and provide the ability to activate warning devices and other customer-provided accessories. Available kits include 10 or 20 sets of relay contacts for connecting customer-provided devices to desired generator set functions. Twenty-relay kits can be used on 450 kW and larger generator sets.

Warning devices (lamp and/or audible alarms) and other accessories typically connect to the controller output connections listed below. A total of three dry contact kits may connect to a specific output connection on the controller. Figure 1-4 shows some typical dry contact kits mounted on an assembly panel for 450 kW and larger generator sets.

Typical 10-relay contact kit output connections include:

- Overspeed
- Overcrank
- High engine temperature
- Low oil pressure
- Low water temperature
- Auxiliary fault
- Air damper (if equipped)
- Anticipatory high engine temperature
- Anticipatory low oil pressure
- Emergency stop

Additional connections available with the 20-relay kits include:

- Battery charger fault
- Low battery voltage
- Low fuel level
- Engine trouble
- Not in AUTO
- System ready
- Common fault
- Overcrank
- Crank terminate
- Cooldown

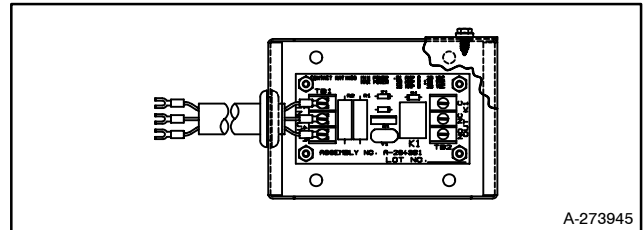

Figure 1-3 Single-Relay Dry Contact Kit

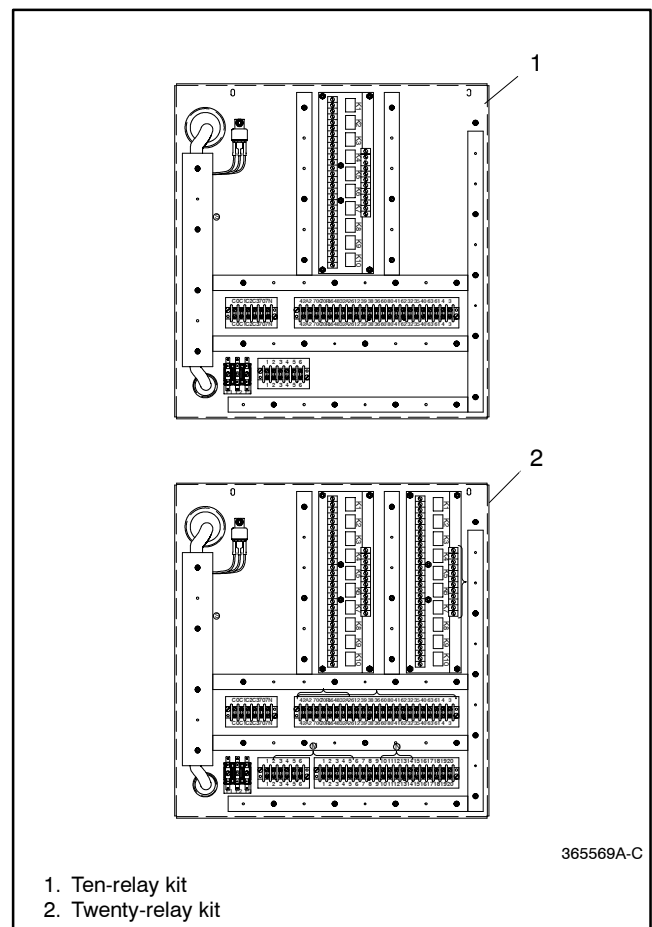

Figure 1-4 Dry Contact Kits (shown mounted on an assembly panel for 450 kW and larger generator sets)

1.4.5 Audiovisual Alarm (M)

An audiovisual alarm warns the operator of fault shutdowns and prealarm conditions (except battery charger fault and low battery voltage) from a remote location. Audiovisual alarms include an alarm horn, an alarm silence switch, and a common fault lamp. See Figure 1-5.

Note: Use the audiovisual alarm with a dry contact kit.

1.4.6 Safeguard Breaker

The safeguard breaker senses output current on each generator phase and shuts off the AC voltage regulator if a sustained overload or short circuit occurs. It is not a line circuit breaker and does not disconnect the generator set from the load. See Figure 1-6.

1.4.7 Line Circuit Breaker

The line circuit breaker interrupts generator output if an overload or short circuit occurs. Use the line circuit breaker to manually disconnect the generator set from the load during generator set service. See Figure 1-7.

1.4.8 Run Relay Kit

The run relay kit includes three sets of contacts that energize only during generator set operation. The run relay kit can control air intake louvers, radiator louvers, alarms, and other signaling. See Figure 1-8.

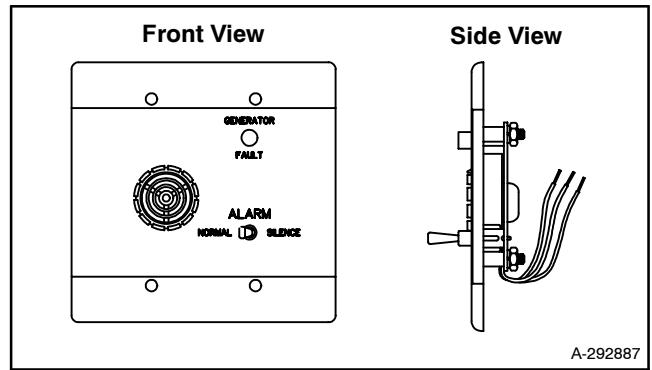

Figure 1-5 Audiovisual Alarm

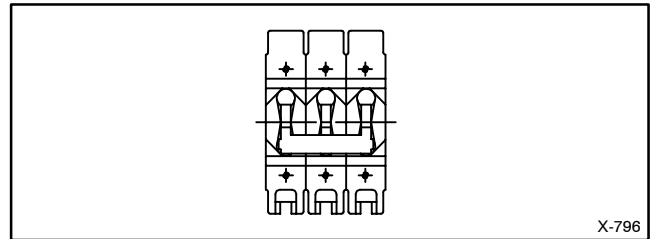

Figure 1-6 Safeguard Breaker

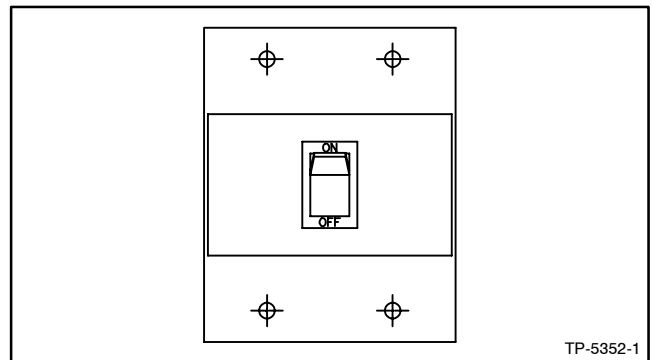

Figure 1-7 Line Circuit Breaker

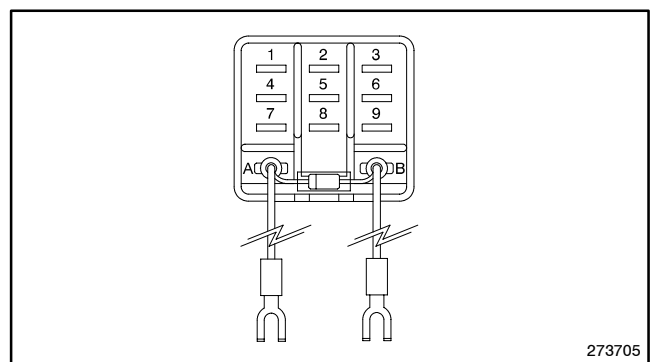

Figure 1-8 Run Relay Kit

1.4.9 Remote Emergency Stop Kit (M)

The emergency stop kit shuts down the generator set from a remote location in an emergency. See Figure 1-9. Activating the emergency stop switch lights the EMERGENCY STOP lamp and shuts down the unit. Before restarting the generator set, reset the emergency stop switch by replacing the glass piece and reset the generator set by placing the master switch in the OFF/RESET position. The switch holds a single replacement glass piece, which is available as a service part.

1.4.10 FASTCHECK Diagnostic Tester (M)

The FASTCHECK® diagnostic tester simulates engine operation to identify faults in the controller and engine circuitry. Use the FASTCHECK® when troubleshooting startup problems or to test and troubleshoot the controller when it is removed from the generator set. Perform tests without starting the generator set. FASTCHECK® functions are listed below; refer to Figure 1-10 to identify LEDs and switches.

LEDs on the FASTCHECK® illuminate to indicate the energizing of the following circuits:

- AC Voltage Regulator
- Battery Connection (correct polarity)
- Engine Ignition (gas/gasoline)
- Engine Crank
- Engine Antidieseling
- Engine Malfunction Alarm and/or Alarm Shutdown
- Fuel Solenoid (diesel)

Switches on the FASTCHECK® simulate the following:

- Anticipatory High Engine Coolant Temperature
- Anticipatory Low Engine Oil Pressure
- Engine Crank
- Engine Overspeed
- Engine Running
- High Engine Coolant Temperature
- Low Engine Coolant Temperature
- Low Engine Oil Pressure
- Low Fuel

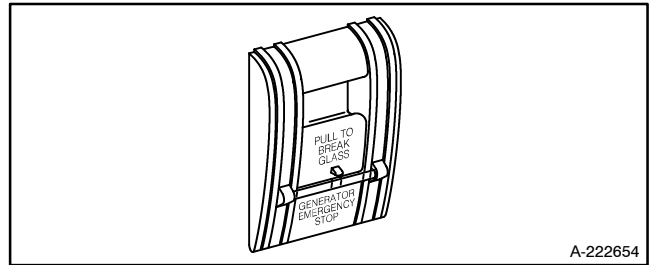

Figure 1-9 Emergency Stop Kit

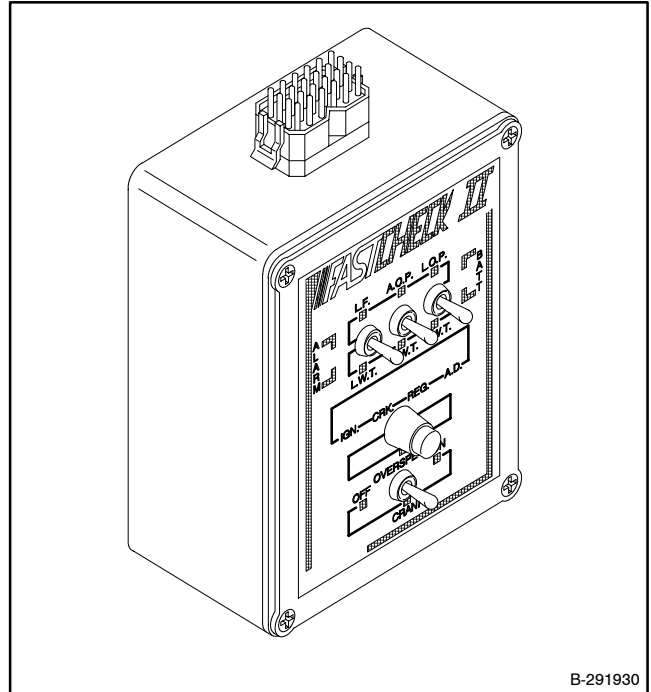

Figure 1-10 FASTCHECK® Diagnostic Tester

1.4.11 Accessory and Prime Power Terminal Strip Connections (M)

The microprocessor controller circuit board has a terminal strip(s) for easy connection of generator set accessories. Do not connect accessories directly to the controller terminal strip. Connect accessories to either a single-relay dry contact kit or ten-relay dry contact kit. Connect the dry contact kit(s) to the controller terminal strip or controller connection kit (if used). Connect alarms, battery chargers, remote switches, and other accessories to the dry contact kit relay(s) using 18- or 20-gauge stranded wire up to 305 m (1000 ft.) long.

The Decision-Maker™ 3 controller has the TB1 terminal strip on the controller circuit board. The Decision-Maker™ 3+ controller has two terminal strips, TB1 and TB2, on the controller circuit board, and prime power choices are made on TB2. See Figure 1-11 or Figure 1-12 for controller configurations. See Figure 1-13 and Figure 1-14 for Decision-Maker™ 3+ controller terminal strip identification. See Figure 1-15 for Decision-Maker™ 3 controller terminal strip identification.

Lower the controller circuit board panel until it is lying flat when connecting the dry contact kits to the controller TB1 terminal strip. Route dry contact relay leads through the controller grommet and guide loops to the circuit board terminal strip. Place the controller circuit board panel flat to ensure adequate slack in the dry contact relay leads. For specific information on accessory connections refer to the accessory wiring diagrams in the Wiring Diagram Manual and the instruction sheet accompanying the kit.

Note: Not all terminals are used for all generator sets (see appropriate wiring diagrams for specific generator set models).

Note: To use the prime power mode, use jumpers to connect TB2-1P to TB2-2P, TB2-3P to TB2-4P, and TB2-3 to TB2-4. To deactivate the prime power mode, remove these jumpers.

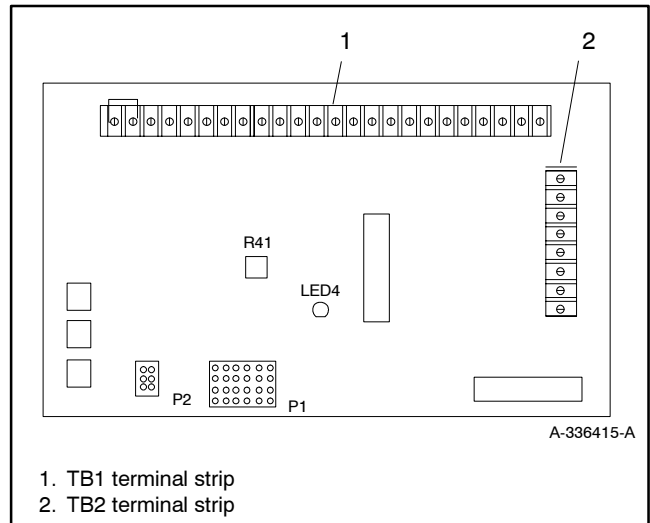

Figure 1-11 TB1 and TB2 Terminal Strips on the Decision-Maker™ 3+ Controller

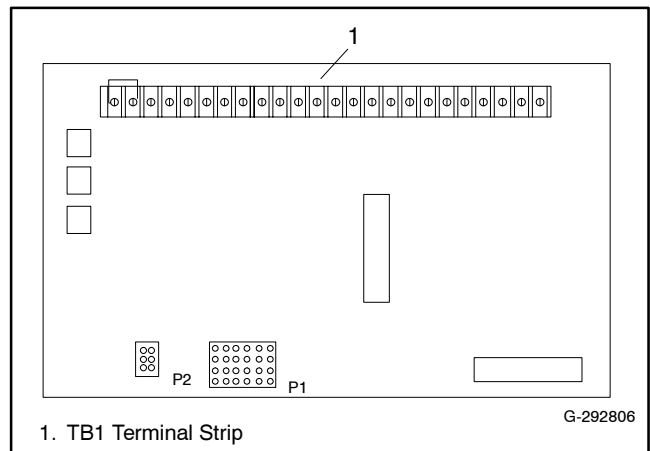

Figure 1-12 TB1 Terminal Strip on the Decision-Maker™ 3 Controller

Terminal	Purpose
1P	Prime power operation.
2P	Prime power operation.
3	Remote start ground. Connect transfer switch or remote start switch to TB2-3 and TB2-4.
3P	Prime power operation.
4	Remote start. Connect transfer switch or remote start switch to TB2-3 and TB2-4.
4P	Prime power operation.
9	Crank mode selection (open: cyclic crank, ground: continuous crank). Connect TB2-9 to TB2-9A for continuous cranking; leave TB2-9 open cyclic cranking; see starting instructions in Section 2, Operation.
9A	Crank mode ground.

Figure 1-13 Decision-Maker™ 3+ Controller TB2 Terminal Strip

Terminal	Purpose
1	Ground. Emergency stop relay (K4). Connect emergency stop across terminals TB1-1 and 1A. *
1A	Emergency stop relay (K4) coil; negative side. Connect emergency stop across terminals TB1-1 and 1A. *
2	Ground terminal.
12	Overcrank (OC) signal. †
26	Auxiliary (AUX) signal. †
32	Common fault/prealarm line 1. audiovisual alarm or common fault relay activated by OC, 12; AUX, 26; LWT, 35; HET, 36; LOP, 38; OS, 39; AHET, 40; ALOP, 41; and LF, 63 faults.
32A	Common fault/prealarm line 2. audiovisual alarm or common fault relay activated by AUX, 26; HET, 36; LOP, 38; OS, 39; and ES, 48 faults.
35	Low water temperature (LWT) signal.
36	High engine temperature (HET) signal. †
38	Low oil pressure (LOP) signal. †
39	Overspeed (OS) signal. †
40	Anticipatory high engine temperature (AHET) signal. †
41	Anticipatory low oil pressure (ALOP) signal. †
42A	Battery voltage (fuse #1 protected). Accessory power supply; Customer may also provide separate accessory power source.
48	Emergency stop (ES) signal. †
56	Air damper (AD) switch (if equipped). Standard on all 200–2000 kW Detroit Diesel powered models.
60	System ready signal. †
61	Battery charger fault. Connect battery charger alarm contact to TB1-61 to activate fault lamp (active low) (if used).
62	Low battery volts. Connect battery charger alarm contact to TB1-62 to activate fault lamp (active low) (if used).
63	Low fuel (LF) fault. Connect fuel level sensor to TB1-63 to activate fault lamp (active low) (if used).
70C	Generator in cool down mode signal.
70R	Generator in running mode signal.
80	Not in auto signal. †
* Connect jumper across terminals 1 and 1A if emergency stop switch is not used.	
† Use a remote annunciator and/or audiovisual alarm kit as an indicator with a dry contact kit connected to controller terminal strip TB1.	

Figure 1-14 Decision-Maker™ 3+ Controller TB1 Terminal Strip

Terminal	Purpose
1	Ground. Emergency stop relay (K4). Connect emergency stop across terminals TB1-1 and 1A. *
1A	Emergency stop relay (K4) coil, negative side. Connect emergency stop across terminals TB1-1 and 1A. *
2	Ground terminal.
3	Remote start ground. Connect transfer switch or remote start switch to TB1-3 and TB1-4.
4	Remote start. Connect transfer switch or remote start switch to TB1-3 and TB1-4.
9	Crank mode selection (open: cyclic crank, ground: continuous crank). Connect TB1-9 to TB1-9A for continuous cranking; leave TB1-9 open for cyclic cranking; see Section 2.3.2, Starting.
12	Overcrank (OC) signal. †
26	Auxiliary (AUX) signal. †
32	Common fault/prealarm line 1. audiovisual alarm or common fault relay activated by OC, 12; AUX, 26; LWT, 35; HET, 36; LOP, 38; OS, 39; AHET, 40; ALOP, 41; and LF, 63 faults.
35	Low water temperature (LWT) signal.
36	High engine temperature (HET) signal. †
38	Low oil pressure (LOP) signal. †
39	Overspeed (OS) signal. †
40	Anticipatory high engine temperature (AHET) signal. †
41	Anticipatory low oil pressure (ALOP) signal. †
42A	Battery voltage (fuse #1 protected). Accessory power supply. Customer may also provide separate accessory power source.
48	Emergency stop (ES) signal. †
56	Air damper switch (if equipped). Standard on 200–2000 kW Detroit Diesel-powered models.
60	System ready signal. †
61	Battery charger fault. Connect battery charger alarm contact to TB1-61 to activate fault lamp (active low) (if used).
62	Low battery volts. Connect battery charger alarm contact to TB1-62 to activate fault lamp (active low) (if used).
63	Low fuel (LF) fault. Connect fuel level sensor to TB1-63 to activate fault lamp (active low) (if used).
80	Not in auto signal. †
* Connect jumper across terminals 1 and 1A if emergency stop switch is not used.	
† Use a remote annunciator and/or audiovisual alarm kit as an indicator with a dry contact kit connected to controller terminal strip TB1.	

Figure 1-15 Decision-Maker™ 3 Controller TB1 Terminal Strip

Notes

2.1 Prestart Checklist

To ensure continued satisfactory operation, perform the following checks or inspections before or at each startup, as designated, and at the intervals specified in the service schedule. In addition, some checks require verification after the unit starts.

Air Cleaner. Check for a clean and installed air cleaner element to prevent unfiltered air from entering the engine.

Battery. Check for tight battery connections. Consult the battery manufacturer's instructions regarding battery care and maintenance.

Coolant Level. Check the coolant level according to the cooling system maintenance information.

Note: On 20–40 kW generator sets with Deutz oil-cooled engines, the low water temperature and low coolant level fault lamps are not used because these engines do not have water-cooled systems.

Note: Block heater damage. The block heater will fail if the energized heater element is not immersed in coolant. Fill the cooling system before turning on the block heater. Run the engine until it is warm, and refill the radiator to purge the air from the system before energizing the block heater.

Drive Belts. Check the belt condition and tension of the radiator fan, water pump, and battery charging alternator belt(s).

Exhaust System. Check for exhaust leaks and blockages. Check the silencer and piping condition and check for tight exhaust system connections.

Inspect the exhaust system components (exhaust manifold, exhaust line, flexible exhaust, clamps, silencer, and outlet pipe) for cracks, leaks, and corrosion.

- Check for corroded or broken metal parts and replace them as needed.

- Check for loose, corroded, or missing clamps and hangers. Tighten or replace the exhaust clamps and/or hangers as needed.
- Check that the exhaust outlet is unobstructed.
- Visually inspect for exhaust leaks (*blowby*). Check for carbon or soot residue on exhaust components. Carbon and soot residue indicates an exhaust leak. Seal leaks as needed.

Fuel Level. Check the fuel level and fill the tank(s) regularly to ensure adequate fuel supply.

Lamp Test. Press the lamp test button, if equipped, to verify that all controller LEDs illuminate.

Oil Level. Maintain the oil level at or near, not over, the full mark on the dipstick. Keep the oil level in the mechanical governor, if equipped, at or near the full level.

Operating Area. Check for obstructions that could block the flow of cooling air. Keep the air intake area clean. Do not leave rags, tools, or debris on or near the generator set.

2.2 Generator Set Exercising

Operate the generator set under load once each week for one hour. Perform the exercise in the presence of an operator if the generator set does not have a programmed exercise mode or an automatic transfer switch with an exercise option.

During the exercise period apply a minimum of 35% load based on the nameplate standby rating, unless otherwise instructed in the engine operation manual.

The operator should perform all of the prestart checks before starting the exercise procedure. Start the generator set according to the starting procedure in the controller section of this manual. While the generator set is operating, listen for a smooth-running engine and visually inspect the generator set for fluid or exhaust leaks.

x:op:001:005

2.3 Microprocessor Controllers

The Decision-Maker™ 3+ and Decision-Maker™ 3 microprocessor controllers are available in standard and oversize meterbox versions. The oversized meterbox has space for additional meters and gauges such as a wattmeter, tachometer, or oil temperature gauge.

The Decision-Maker™ 3+ and Decision-Maker™ 3 microprocessor controllers are similar in appearance and function except as noted. The Decision-Maker™ 3+ controller can operate in either the normal mode or the prime power mode. The prime power mode allows reduced controller current draw in applications without a battery charger, minimizing battery drain by the controller circuitry. See Section 2.3.3, Prime Power Mode Operation, for more information.

Microprocessor controllers have several annunciator panel versions. Figure 2-1 shows the 16-light (level 1) controller, and Figure 2-2 shows the 7-light (level 2) model. The 6-light (level 2) controller is similar to the 7-light microprocessor controller. For identification and an explanation of lamp functions, see the corresponding illustration and the following descriptions.

Note: Some installations use modified 16-light microprocessor controllers with switchgear applications. These nonstandard controllers may have remote start and no time delay for engine cooldown circuitry. Consult the switchgear literature for configuration and function.

2.3.1 Microprocessor Controller Features

Microprocessor controller features include annunciator panel lamps, analog meters, switches and controls, and fuses and terminal strips. The following paragraphs describe the features.

Annunciator Panel Lamps

Figure 2-3 lists the annunciator lamps included on each controller and describes the lamp functions.

Note: The air damper lamp functions only on air damper-equipped engines. The engine air damper (air box) is available on some 200–2000 kW generator sets using Detroit Diesel Series 71, 92, and 149 engines. The air damper is an optional accessory on generator sets with serial numbers above 376029.

Note: On 20–40 kW generator sets with Deutz oil-cooled engines the low water temperature and low coolant level fault lamps are not used because these engines do not have water-cooled systems.

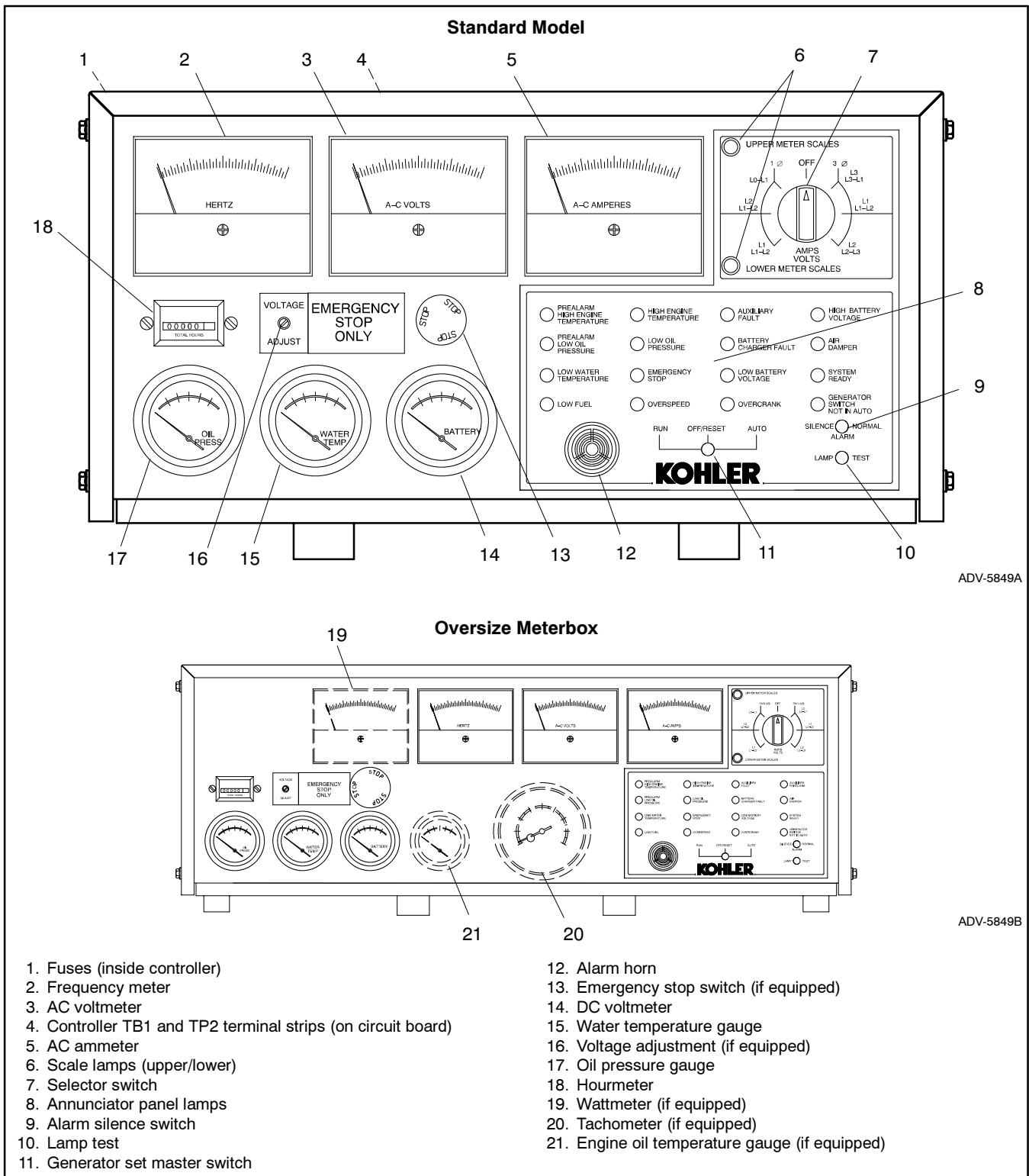

Figure 2-1 16-Light Microprocessor Controller (Standard and Oversize Meterbox Models)

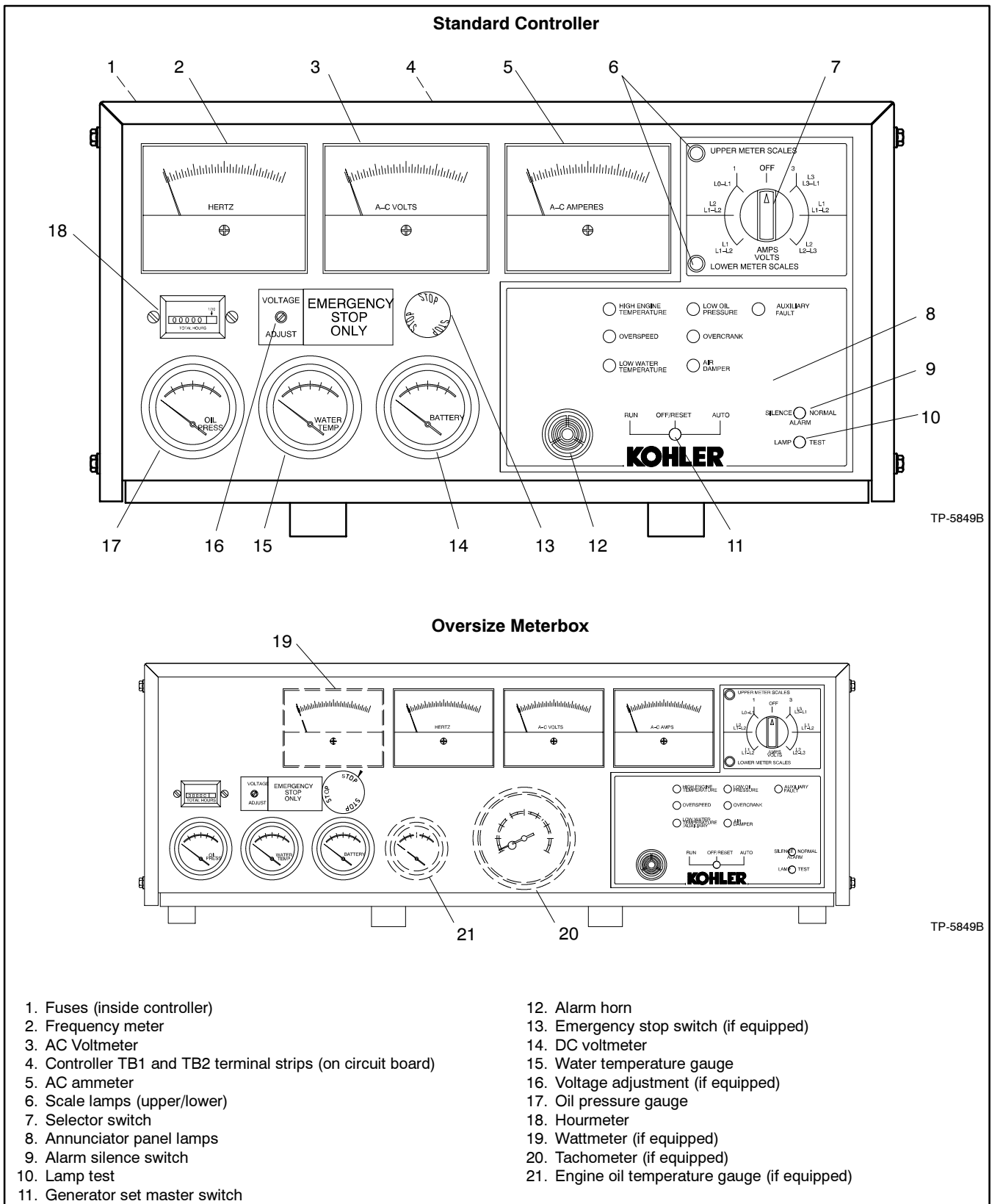

Figure 2-2 7-Light Microprocessor Controller (Standard and Oversize Meterbox Models)

Note: 6-Light Microprocessor Controller is similar except where noted.

Lamp	Description	16-Light	7-Light	6-Light
Air damper	Lights after an emergency stop, overspeed fault, or overvoltage fault to indicate that the engine air damper is closed. The lamp remains lit until the air damper is manually reset. See Section 2.3.4, Emergency Stopping.	X	X	X
Auxiliary fault	Flashes or lights upon fault detection. The 16-light and 7-light controllers have an auxiliary fault lamp and the 6-light controller has a low engine temperature/auxiliary fault lamp. Figure 2-4 describes auxiliary fault conditions.	X	X	X
High engine temperature	Lights if the engine has shut down because of high engine temperature. The shutdown occurs 5 seconds after the engine reaches temperature shutdown range.	X	X	X
Low oil pressure	Lamp lights if the generator set shuts down because of insufficient oil pressure.	X	X	X
Overspeed	Lamp lights if the generator set shuts down because the governed frequency on 50 and 60 Hz models exceeds 70 Hz (2100 rpm).	X	X	X
Overcrank	Cranking stops and the lamp lights if the engine does not start after 45 seconds of continuous cranking or 75 seconds of cyclic cranking. See Section 2.3.2, Normal Operation. Cranking stops and the overcrank lamp lights after 15 seconds if the starter or engine does not turn (locked rotor). The overcrank lamp flashes if the speed sensor signal is absent for longer than one second.	X	X	X
Low water temperature	Lights if water temperature approaches the shutdown range. This lamp requires an optional prealarm sender kit in order to function. The lamp does not light on 20–40 kW engines that have oil-cooled systems.	X	X	
Auxiliary prealarm	Activated by customer-provided sensing devices. This lamp was replaced by a high battery voltage lamp in later models.	X		
Battery charger fault	Lights if the battery charger malfunctions. This lamp requires an optional battery charger.	X		
Emergency stop	Lights and the generator set shuts down if the optional emergency stop switch is energized either locally or from a remote location. This lamp requires an optional emergency stop switch in order to function. The local emergency stop switch is standard on 200–2000 kW models with Detroit Diesel Engines.	X		
Generator switch not in auto	Lights when the generator set master switch is in the RUN or OFF/RESET position.	X		
High battery voltage	Lights if the battery voltage rises above preset level. An optional battery charger is required for the lamp to function. The high battery voltage lamp replaced the auxiliary prealarm lamp on later models.	X		
Low battery voltage	Lights if the battery voltage drops below a preset level. This lamp requires an optional battery charger in order for the lamp to function.	X		
Low fuel	Lights if the fuel level in tank approaches empty. This lamp requires a low fuel sensor in the fuel tank in order to function. On gas-fueled systems, this lamp lights if the gas line pressure drops below a preset level.	X		
Prealarm high engine temperature	Lights if the engine temperature approaches the shutdown range. This lamp requires an optional prealarm sender kit.	X		
Prealarm low oil pressure	Lights if the engine oil pressure approaches the shutdown range. This lamp requires an optional prealarm sender kit in order to function.	X		
System ready	Lights when the generator set master switch is in the AUTO position and the system senses no faults. Indicates that the generator set is ready for operation.	X		

Figure 2-3 Annunciator Panel Lamps

Auxiliary Fault Lamps

The auxiliary fault lamps flash or light continuously to indicate different conditions. Figure 2-4 describes the auxiliary fault lamp conditions.

Generator Condition	Lamp Illumination		Controller		
	Flashing	Continuous	16-Light	7-Light	6-Light
No AC Output. Lamp flashes if the controller senses no AC output with the unit running (except during first 10 seconds after startup). When the controller senses AC output, the flashing stops and the lamp is unlit. Does not require manual reset.	X		X	X	X
Low Battery Voltage. Lamp flashes if the battery power was reconnected or was low and then was restored while the generator set master switch was in the RUN or AUTO position. A battery that is weak or undersized for the application may cause this fault condition. Place the generator set master switch in the OFF/RESET position to clear this fault.	X		X	X	X
Emergency Stop Switch Reset. Lamp lights if the optional emergency stop switch is reset while the generator set master switch is in the AUTO or RUN position. Place the generator set master switch in the OFF/RESET position to clear this fault.		X	X	X	X
Emergency Stop Switch Energized. Lamp lights and the engine shuts down if the optional emergency stop switch is energized either locally or from a remote location. Requires an optional emergency stop switch for the lamp to function. The local emergency stop switch is standard on Detroit Diesel-equipped 200-2000 kW generator sets.		X		X	X
Auxiliary Delay Shutdown. Lamp lights and the engine shuts down 5 seconds after high oil temperature (P1-13), low coolant level (P1-10, Decision-Maker™ 3+ or P1-14, Decision-Maker™ 3), or auxiliary delay shutdown (P1-15) faults (if equipped) occur. These fault conditions are inhibited during the first 30 seconds after crank disconnect.		X	X	X	X
Overvoltage Shutdown. Lamp lights and the engine shuts down immediately if an overvoltage condition arises (if equipped with overvoltage shutdown kit). The overvoltage shutdown is standard with the Decision-Maker™ 3+ controller.		X	X	X	X
Auxiliary Immediate Shutdown. Lamp lights and the engine shuts down if activated by customer-supplied sensing devices connected to auxiliary immediate shutdown ports (P1-17 and P1-18).		X	X	X	X
Low Water Temperature. Lamp lights if the engine water temperature approaches the critical range. Requires an optional prealarm sender kit for the lamp to function. The lamp does not light on 20-40 kW engines that do not have water-cooled systems.		X			X

Figure 2-4 Auxiliary Fault Lamp Operation

Analog Meters and Gauges

Figure 2-5 describes the meters and gauges located on microprocessor controllers.

Switches and Controls

Figure 2-6 describes the switches and controls located on microprocessor controllers.

Note: Manual paralleling controller models use a different type of voltage adjustment potentiometer. See Section 2.4, Manual Paralleling Controller, and Section 2.4.3, Paralleling Setup and Test, for additional information.

Name	Description
AC voltmeter	Meter displays the AC output voltage. Use the selector switch to choose the output lead circuits.
AC ammeter	Meter displays the AC output amperage. Use the selector switch to choose the phase currents.
DC voltmeter	Meter displays the voltage of the starting battery(ies).
Engine oil temperature, if equipped	Meter displays the engine oil temperature.
Frequency meter	Meter displays the frequency (Hz) of the generator set output.
Hourmeter	Hourmeter records the generator set total operating hours for reference in maintenance scheduling.
Oil pressure gauge	Gauge measures the engine oil pressure.
Scale lamps (upper/lower)	Lamps indicate which AC voltmeter and/or ammeter scales to read.
Tachometer, if equipped	Meter displays the engine speed (rpm).
Water temperature gauge, if equipped	Gauge displays the engine coolant temperature. Note: The 20–40 kW models with Deutz oil-cooled engines substitute an engine oil temperature gauge for the water temperature gauge.
Wattmeter, if equipped	Meter displays the generator output in kilowatts. Use the selector switch to choose output lead circuits. Note: Manual paralleling controllers use the wattmeter. See Section 2.4, Manual Paralleling Controller, for additional information.

Figure 2-5 Analog Meters and Gauges

Name	Description
Alarm horn	Horn sounds if any fault or prealarm condition exists (except emergency stop, battery charger fault, or low battery voltage). Place the generator set master switch in the AUTO position before silencing the alarm horn. See controller resetting procedure in Section 2.3.6.
Alarm silence switch	Switch disconnects the alarm during service. Place the generator set master switch in the AUTO position before silencing the alarm horn. To avoid reactivating the alarm horn, restore all alarm horn switches (controller, remote annunciator, and audiovisual alarm) to their normal positions after correcting the fault. See controller resetting procedure in Section 2.3.6.
Emergency stop switch	Switch (if equipped) immediately shuts down the generator set in emergency situations. Reset the emergency stop switch after shutdown by rotating the switch clockwise. Use the emergency stop switch for emergency shutdowns only. Use the generator set master switch for normal shutdowns. The local emergency stop switch is standard on Detroit Diesel-equipped 200–2000 kW generator sets.
Generator set master switch	Switch functions as the controller reset and generator set operation switch. Refer to Section 2.3.2, Normal Operation, Section 2.3.3, Prime Power Mode Operation, and Section 2.3.6, Controller Resetting After a Fault Shutdown.
Lamp test switch	Switch displays the controller indicator lamps.
Selector switch	Switch selects the generator set output circuits to measure. When switched to a position with three circuit labels, the meters display the amperage on the lead shown in the upper label and the voltage between the two leads shown in the lower label. The AC ammeter and voltmeter function only with the switch in the ON position.
Voltage adjustment potentiometer, if equipped	Potentiometer fine tunes ($\pm 5\%$) the generator set output voltage. Used with 20–300 kW models only. The voltage adjustment on 350–2000 kW models is located in the generator junction box.

Figure 2-6 Switches and Controls

Fuses

The fuses listed in Figure 2-7 protect the generator set circuitry.

Terminal Strips

Decision-Maker™ 3+ Controller. Two terminal strips are mounted on the Decision-Maker™ 3+ controller circuit board. See Figure 2-8 and Figure 2-9. Refer to Section 2.3.3, Prime Power Mode Operation, for information on enabling the prime power mode.

Decision-Maker™ 3 Controller. One terminal strip is mounted on the Decision-Maker™ 3 controller circuit board. See Figure 2-10 and Figure 2-11.

The controller is factory-set for cyclic cranking. To change to the continuous cranking mode on the Decision-Maker™ 3+ controller, install a jumper between circuit board terminals TB2-9 and TB2-9A. On the Decision-Maker™ 3 controller, install a jumper between TB1-2 and TB1-9. To return to cyclic cranking, remove the jumpers.

Fuse	Description
F1	3-amp remote annunciator fuse protects the dry contact kit (if equipped).
F2	3-amp controller fuse protects the controller circuit board, speed sensor, and lamp circuit board.
F3	15-amp engine and accessories fuse protects engine/starting circuitry and accessories.

Figure 2-7 Controller Fuses

Terminal Strip	Description
TB1	Terminal strip for connecting generator set accessories such as an emergency stop switch, a remote start/stop switch, audiovisual alarms, etc. Refer to the wiring diagrams for information on connecting accessories to the TB1 terminal strip.
TB2	Terminal strip for selecting the crank mode (cyclic or continuous), remote start/stop switch inputs, and prime power mode.

Figure 2-8 Decision-Maker™ 3+ Controller Terminal Strips

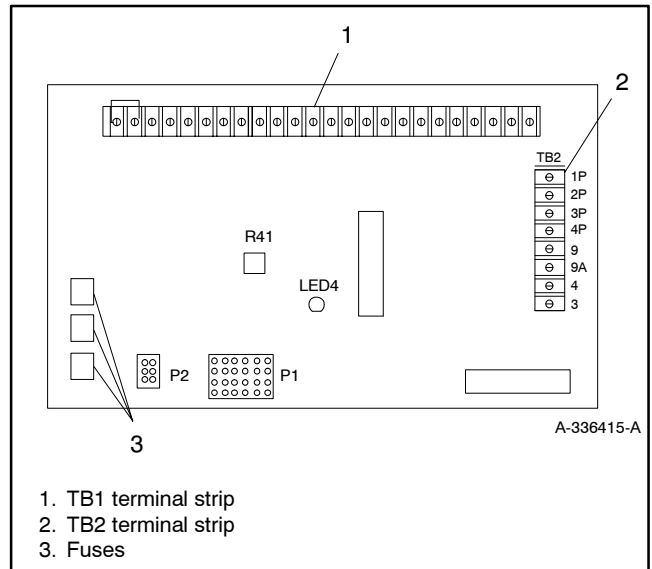

Figure 2-9 Decision-Maker™ 3+ Controller Circuit Board

Terminal Strip	Description
TB1	Terminal strip for selecting the crank mode and connecting generator set accessories such as an emergency stop switch, a remote start/stop switch, audiovisual alarms, etc. Refer to the wiring diagrams for additional information on connecting accessories to the TB1 terminal strip.

Figure 2-10 Decision-Maker™ 3 Controller Terminal Strips

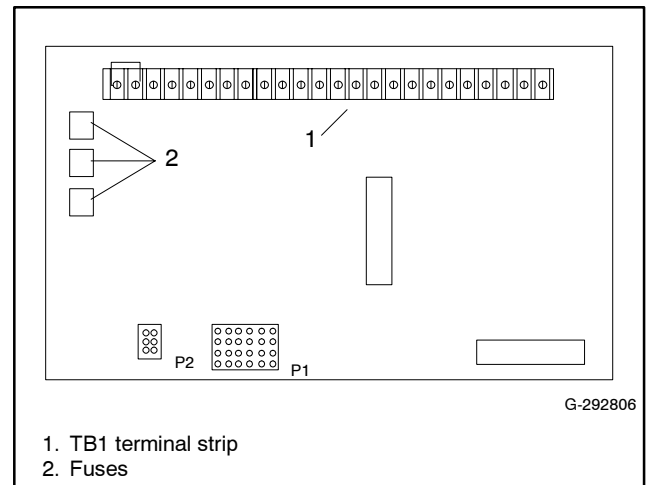

Figure 2-11 Decision-Maker™ 3 Controller Circuit Board

2.3.2 Normal Operation

Local Starting. Move the generator set master switch to the RUN position to start the generator set at the controller.

Note: The alarm horn sounds and the Not in Auto lamp lights when the generator set master switch is not in the AUTO position.

Note: The transient start/stop function of the microprocessor controller prevents accidental cranking of the rotating engine. If the generator set master switch is momentarily placed in the OFF/RESET position and then is returned to the RUN position, the generator set slows to 249 rpm and recranks before returning to rated speed.

Automatic Starting. Move the generator set master switch to the AUTO position to allow startup by an automatic transfer switch or a remote start/stop switch. Refer to the wiring diagrams for remote switch connection information.

The engine cranks up to 45 seconds continuously or 75 seconds cyclically (crank 15 seconds, rest 15 seconds, crank 15 seconds, etc.) before shutting down on an overcrank fault. Select the cyclic or continuous cranking mode on the controller circuit board terminal strip using the instructions in Section 2.3.1, Microprocessor Controller Features.

Stopping. Run the generator set without load for 5 minutes to ensure adequate engine cooldown. To stop the generator set, place the generator set master switch in the OFF/RESET position and wait until the generator set stops completely.

Note: The generator set continues to run during a 5-minute cooldown cycle if a remote switch or automatic transfer switch signals the engine to stop.

2.3.3 Prime Power Mode Operation (Decision-Maker 3+ Controller)

The Decision-Maker™ 3+ controller can operate in either the normal mode or the prime power mode. In prime power mode, the controller draws less current, minimizing the battery drain. Consider using the prime power mode for installations that do not have a battery charger.

Moving the generator set master switch to the OFF/RESET position disables all controller functions. Moving the generator set master switch to the AUTO position restores controller functions.

Enabling and Disabling the Prime Power Mode.

Enable the prime power mode by connecting jumpers across the following terminals on terminal strip TB2 on the controller circuit board:

- TB2-1P and TB2-2P
- TB2-3P and TB2-4P
- TB2-3 and TB2-4

See Figure 2-9. Remove the jumpers listed above to disable the prime power mode.

Prime Power Starting. The prime power mode provides local starting only at the controller. When the generator set master switch is in the OFF/RESET position, the controller functions are inoperative. Move the generator set master switch to the AUTO position to start the generator set. Do not start the generator set with the master switch in the RUN position because the alarm horn will sound.

Note: Move the generator set master switch to the AUTO position to return controller functions to normal.

Prime Power Stopping. Move the generator set master switch to the OFF/RESET position to stop the generator set and power down the controller.

Note: The controller functions are inoperative when the generator set master switch is in the OFF/RESET position.

2.3.4 Emergency Stopping

Activate the controller emergency stop switch, if equipped, or the optional remote emergency stop switch for immediate shutdown.

Use the emergency stop switch(es) for emergency shutdowns only. Use the generator set master switch for normal shutdowns.

The unit shuts down and the controller emergency stop lamp lights if an operator activates either the local or remote emergency stop switch. The 6- and 7-light controllers do not have separate emergency stop lamps. The auxiliary or low water temperature lamp illuminates to indicate an emergency stop on these models. See Figure 2-12. On some 200-2000 kW generator sets equipped with Detroit Diesel Series 71, 92, and 149 engines, both the air damper and emergency stop lamps light when an operator activates the emergency stop switch.

Use the following procedure to restart the generator set after shutdown by an emergency stop switch. Refer to Section 2.3.6, Controller Resetting After a Fault Shutdown, to restart the generator set following a fault shutdown.

Emergency Stop Switch Resetting Procedure

1. Investigate the cause of the emergency stop and correct the circuit or wiring problem(s).
2. If the remote emergency stop switch was activated, reset the switch by replacing the glass piece. If the controller-mounted emergency stop switch (if equipped) was activated, reset the controller emergency stop switch by rotating the switch clockwise until it springs back to its original position.

Note: The controller auxiliary fault lamp lights if the generator set master switch is in the RUN or AUTO position during the resetting procedure.

3. If the controller air damper lamp is lit, reset the engine air damper by rotating the air damper lever until the air damper light goes out. See Figure 2-13.

Note: The air damper lamp functions only on air damper-equipped engines. The engine air damper (air box) is available on some 200-2000 kW generator sets using Detroit Diesel Series 71, 92, and 149 engines. Generator sets with serial numbers above 376029 do not offer the air damper as standard equipment.

4. Toggle the generator set master switch to the OFF/RESET position and then to the RUN or AUTO position to restart the generator set. The generator set does not crank until the resetting procedure is completed.

Lamp	16-Light	7-Light	6-Light
Emergency Stop	X		
Auxiliary		X	
Low Water Temperature/ Auxiliary			X

Figure 2-12 Controller Lamp Indicating an Emergency Stop Condition

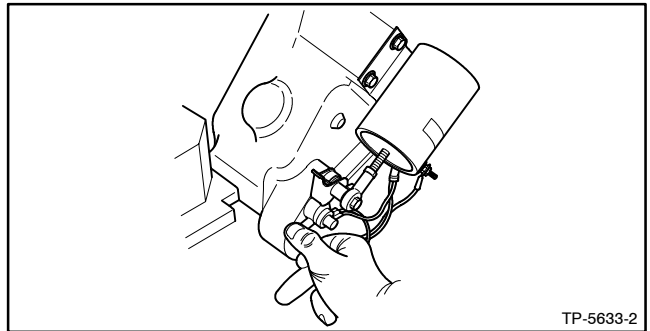

Figure 2-13 Air Damper Lever (Detroit Diesel)

2.3.5 Fault Shutdowns

The generator set shuts down automatically under the fault conditions listed in Figure 2-14.

2.3.6 Controller Resetting After a Fault Shutdown

Use the following procedure to restart the generator set after a fault shutdown. Refer to Section 2.3.4, Emergency Stopping, to reset the generator set after an emergency stop.

1. Move the controller alarm horn switch to the SILENCE position. If equipped, the audiovisual annunciator alarm horn and lamp are activated. Move the audiovisual annunciator alarm switch to SILENCE to stop the alarm horn. The audiovisual annunciator lamp stays lit.
2. Disconnect the generator set from the load by using the line circuit breaker or the automatic transfer switch.
3. Correct the cause of fault shutdown. See the Safety Precautions section of this manual before proceeding.
4. Start the generator set by moving the generator set master switch to the OFF/RESET position and then to the RUN position. If equipped, the audiovisual annunciator alarm horn sounds and lamp goes out.
5. Verify that the cause of the shutdown was corrected by test operating the generator set.
6. Reconnect the generator set to the load by using the line circuit breaker or the automatic transfer switch.

Note: Place the generator set master switch in the AUTO position before silencing the alarm horn.
7. Move the generator set master switch to the AUTO position for startup by remote transfer switch or remote start/stop switch. If equipped, move the audiovisual annunciator alarm switch to NORMAL.
8. Move the controller alarm horn switch to the NORMAL position.

Fault	Description
High engine temperature	The high engine temperature shutdown shuts down the unit 5 seconds after a fault. The shutdown does not function during the first 30 seconds following startup. Note: Water-cooled engines only. The high temperature shutdown functions only when the coolant level is in the operating range.
Low coolant level, if equipped	The low coolant level shutdown shuts down the unit 5 seconds after the fault. The shutdown does not function during the first 30 seconds following startup. The lamp does not function on 20–40 kW models with Deutz oil-cooled engines.
Low oil pressure	The low oil pressure shutdown shuts down the unit 5 seconds after fault detection. The shutdown does not function during the first 30 seconds following startup. Note: The low oil pressure shutdown does not protect against low oil level. Check the oil level at the engine.
Overcrank	Overcrank shuts down the unit after 45 seconds of continuous cranking. Shutdown occurs after 75 seconds of cyclic cranking (crank 15 seconds, reset 15 seconds, crank 15 seconds, etc., for a total of 75 seconds). Shutdown occurs after 15 seconds if the engine or starter does not turn (locked rotor). Note: The controller has an automatic restart function. The generator set attempts to restart if the engine speed drops below 390 rpm (output frequency of 13 Hz). Continued low engine speed causes an overcrank fault condition.
Overspeed	Overspeed shuts down the unit immediately when governed frequency on 50 and 60 Hz models exceeds 70 Hz (2100 rpm).
Overvoltage, if equipped	Overvoltage shuts down the unit and lights the auxiliary lamp when voltage is at least 15% over the nominal voltage for longer than 2 seconds. The overvoltage shutdown is standard on Decision-Maker™ 3+ controllers. Note: Overvoltage can damage sensitive equipment in less than 1 second. Provide separate overvoltage protection for online equipment requiring faster shutdowns.

Figure 2-14 Fault Shutdowns

2.4 Manual Paralleling Controller

The manual paralleling controller provides an economical means of paralleling two or more generator sets. An oversized controller box mounted on the generator set holds the synchronizer controls. When two generator sets operate in parallel, the manual paralleling controller divides the total load between the generator sets in proportion to their power ratings.

The manual paralleling controller parallels generator sets that meet all of the following criteria. The generator sets must:

- Be built by the same manufacturer
- Belong to similar generator set families (that is, 20–300 kW or 350–2000 kW)
- Use the same rotor pitch, electronic governor, and voltage regulator
- Include an electronic governor, reactive droop compensator, and shunt-trip circuit breaker

Before using the manual paralleling controller, have a qualified technician perform the reactive droop compensation adjustment and test, load sharing module setup, and reverse power relay test procedures in Section 2.4.3.

The manual paralleling controller operates either a single generator set or multiple generator sets in parallel. See the operation procedures for details.

Parallel two or more generator sets if the load is expected to be greater than the full-load rating of one generator set. Use the procedures in Section 2.4.3 to parallel two or more generator sets.

Note: To avoid a reverse-power condition, do not parallel two or more generator sets without load. Reverse power can shut down one of the generator sets. If the load is less than 10% of the full-load rating of the first generator set, shut down the additional generator sets.

2.4.1 Manual Paralleling Controller Features

The manual paralleling controller has all the features of the 16-light microprocessor controller described in Section 2.3 plus additional features used for manual paralleling. For generator controller features and operation procedures, see Section 2.3, Microprocessor Controllers. For identification of the features unique to the manual paralleling controller and an explanation of their functions, refer to Figure 2-15 and Figure 2-16.

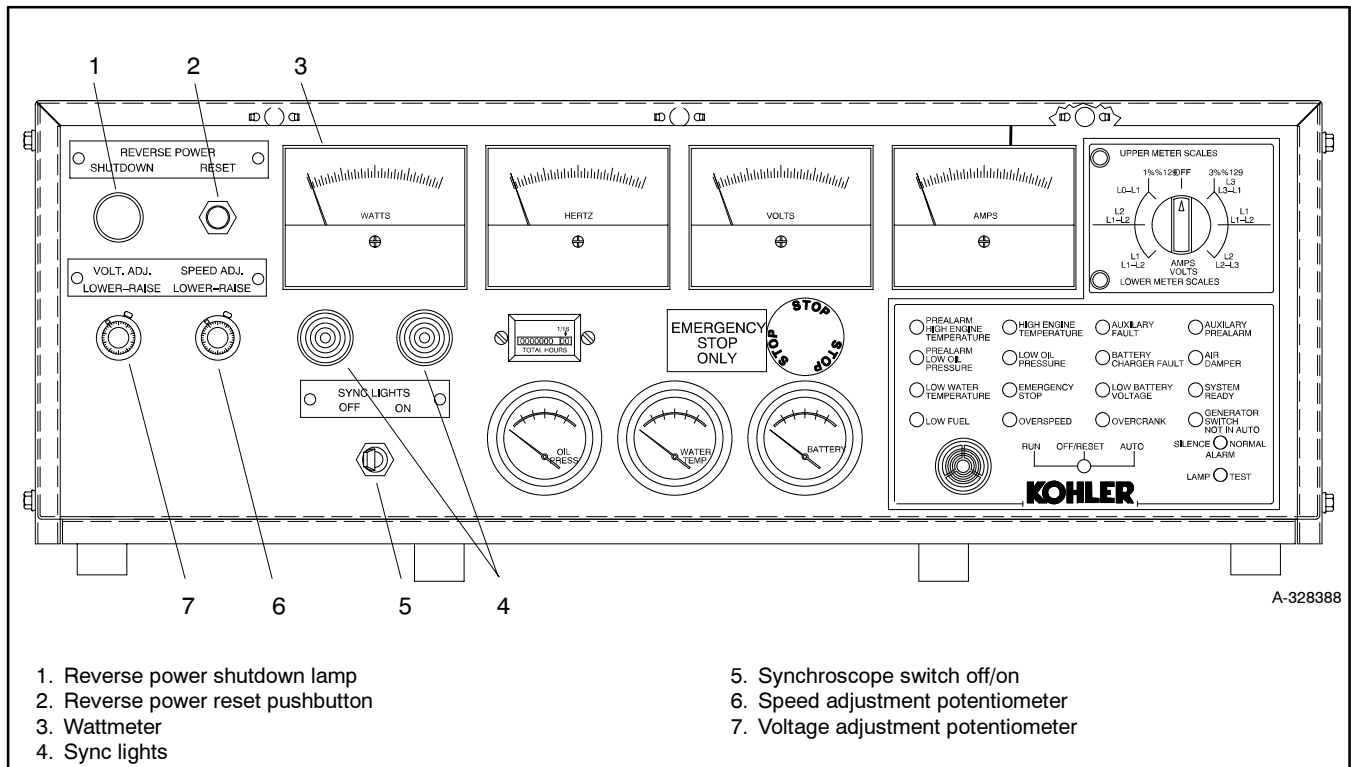

Figure 2-15 Manual Paralleling Controller

Name	Description
Microprocessor controller features	Controller contains all the features of the microprocessor controller described in Section 2.3.
Reverse power shutdown lamp	Lamp lights when a reverse power shutdown occurs.
Sync lights	Lights are used for the manual paralleling operation.
Wattmeter	Wattmeter measures output in kilowatts from the output leads selected with the selector switch.
Reverse power reset pushbutton	Pushbutton resets the reverse power shutdown circuit.
Speed adjustment potentiometer	Potentiometer adjusts the generator set frequency.
Synchroscope switch (OFF/ON)	Switch controls the operation of the synchroscope (sync) lights.
Voltage adjustment potentiometer	Potentiometer adjusts the generator set output voltage.

Figure 2-16 Manual Paralleling Controller Features

2.4.2 Single Generator Set Operation

Start the first generator set as described in Section 2.3.2, Normal Operation. When the generator set reaches rated voltage and frequency, close the circuit breaker to the load. The first generator set can operate from no-load to full-load rating.

2.4.3 Paralleling Setup and Test

The manual paralleling controller setup and test procedures include the reactive droop compensation adjustment setup, paralleling the generator sets, the load-sharing module setup, and the reverse-power relay test. Perform the reactive droop compensation adjustment setup on all of the generator sets before attempting the paralleling procedure. After these setup and test procedures, the system requires no further adjustment unless components have been altered or replaced.

Reactive Droop Compensation Adjustment Procedure

To adjust the reactive droop compensation on 350–1600 kW generator sets, refer to TP-5579, Digital Voltage Regulator manual..

Perform the following procedure to test and adjust the reactive droop compensator for 20–300 kW generator sets. Read the entire procedure before beginning.

1. Set the generator set master switch to the OFF/RESET position.
2. Set the reactive droop rheostat at minimum (full counterclockwise position).
3. Move the voltage-sensing lead inside the controller from terminal V7 to terminal V9.
4. Start the generator set and adjust the voltage to the rated system voltage using the voltage-adjusting potentiometer.
5. Check the droop compensation on each generator set as follows:
 - a. With the first generator set operating at the rated speed and voltage, apply a resistive load (1.0 power factor) until rated current is obtained.
 - b. Adjust the reactive droop rheostat to achieve a 6%–8% droop in voltage.
6. Remove the load from the generator set.
7. Shut down the generator set by placing the generator set master switch in the OFF/RESET position.
8. Move the voltage-sensing lead inside the controller from terminal V9 to terminal V7.

Repeat steps 1–7 for additional generator sets.

After completing the reactive droop compensation adjustment on all of the generator sets, use the following procedure to parallel the generator sets.

Note: To avoid a reverse-power condition, do not parallel two or more generator sets without load. Reverse power can shut down one of the generator sets. If the load is less than 10% of the full-load rating of the first generator set, shut down the additional generator sets.

Paralleling Procedure

1. Start the first generator set as described in Local Starting in Section 2.3.2
2. When the generator set reaches rated voltage and frequency, close the circuit breaker to the load.
3. When the load is approximately 80% of the maximum rated load for the first generator set, start an additional generator set.
4. When the incoming generator set reaches rated voltage and frequency, place the sync-light switch in the ON position.
5. Use the speed potentiometer to adjust the frequency of the incoming generator set until the sync-lights darken from brightest to fully dark in a minimum of 20 seconds.
6. After the sync-lights are dark for a minimum of 2 seconds, close the incoming generator set circuit breaker.
7. Observe the wattmeters of the paralleled generator sets. Adjust the speed potentiometer of the second generator set to share the load proportionally with the first generator set.

Repeat the above procedure to parallel additional generator sets.

Reactive Droop Compensation Test

After paralleling the generator sets, use the following procedure to ensure that the generator sets are sharing the reactive load.

1. Check the wattmeters to verify that each generator set is carrying equal kW load or a load proportional to its capacity. If the loads are incorrect, adjust and recheck the governor throttle control to balance loading. The engine speed determines the load-sharing ability.
2. With the load balanced, check the ammeters to verify that the current is proportional to the generator set capacities. If the currents are incorrect, adjust the reactive droop rheostat to reduce the highest reading.

Load-Sharing Module Setup Procedure

Use the following procedure to calibrate the load-sharing module for a 3% droop.

1. With the droop adjustment potentiometer in the fully counterclockwise position, calibrate the 8000

governor as described in TP-5739, DYNA 8000 Technical Manual.

2. Set the no-load speed to the rated frequency.
3. Adjust the AC line voltage for rated value.
4. Start the first generator set and apply 100% load.
5. While monitoring the frequency, adjust the droop set potentiometer clockwise to achieve 3% droop.
6. Unload the generator set and repeat steps 1–4 on the remaining generator sets.
7. After adjusting the generator sets for equal droop, parallel the generator sets. See the procedure for paralleling generator sets.
8. If the governors are unstable when the generator sets are paralleled, repeat steps 4–7 and gradually increase the percentage of droop until stable.

Note: If there is unequal loading of the phases, the droop is not linear but the units share the load proportionally.

Reverse-Power Relay Test Procedure

Perform the following steps to test the reverse-power relay. Read the entire procedure before beginning.

1. Start the generator set and adjust the voltage to the rated system voltage using the voltage-adjustment potentiometer.
2. Close the generator set's circuit breaker.
3. Press the PUSH TO TEST switch on the reverse-power relay module. The generator set's circuit breaker opens and the reverse-power relay shutdown lamp lights.
4. Press the reverse-power reset button to reset the relay.

Repeat steps 1–4 for any additional generator sets.

2.4.4 Load Disconnection from Paralleled Generator Sets

Disconnect a generator set when the total system load drops to less than 50% of the lowest single generator set rating. Open the circuit breaker of the desired generator set to remove it from the load. Allow the generator set to run unloaded for a minimum 5-minute cooldown period, then place the engine control switch in the OFF/RESET position to shut down the generator set.

2.5 Expanded Decision-Maker 1 Controller

For identification of the expanded controller's indicators and controls and their functions, refer to Figure 2-17.

2.5.1 Controls and Indicators

Figure 2-18 and Figure 2-19 describe the controls and indicators located on the controller.

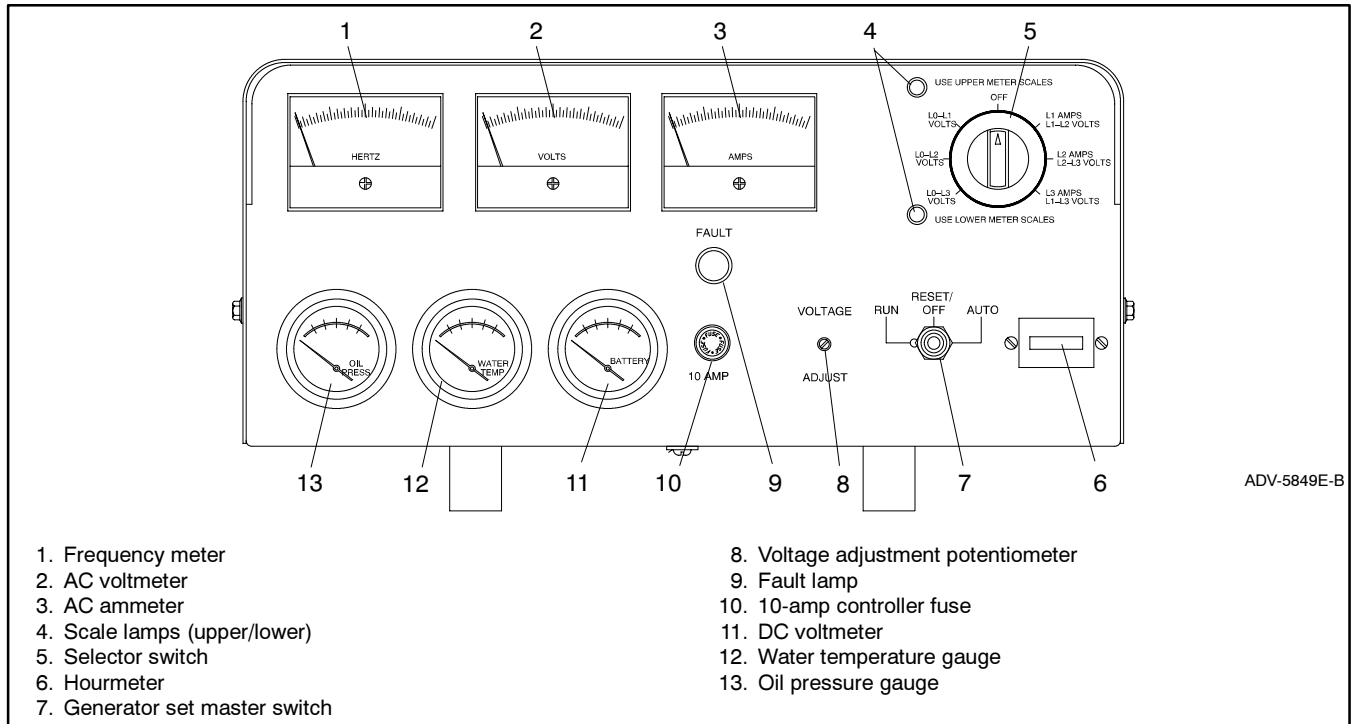

Figure 2-17 Expanded Decision-Maker™ 1 Controller

x:op:002:001

Item	Description
AC ammeter	Meter displays the AC output amperage. Use the selector switch to choose the phase currents.
AC voltmeter	Meter displays the AC output voltage. Use the selector switch to choose the output lead circuits.
DC voltmeter	Meter displays the voltage of the starting battery(ies).
Fault lamp	Lamp illuminates during engine shutdown if the engine shuts down because of one of the following faults: high engine temperature, low water level, low oil pressure, overcrank, or overspeed. See Section 2.5.4, Fault Shutdowns, for additional shutdown information.
Frequency meter	Meter displays the frequency (Hz) of the generator set output.
Generator set master switch	Switch functions as the controller reset and generator set operation switch.

Figure 2-18 Controls and Indicators

Item	Description
Hourmeter	Hourmeter records the generator set total operating hours for reference in maintenance scheduling.
Oil pressure gauge	Gauge displays the engine oil pressure.
Scale lamps (upper/lower)	Lamps indicate which AC voltmeter and/or ammeter scales to read.
Selector switch	Switch selects the generator set output circuits to measure. When switched to a position with three circuit labels, the meters display the amperage on the lead shown in the upper label and the voltage between the two leads shown in the lower label. The AC ammeter and voltmeter function only with the switch in the ON position.
Voltage adjustment potentiometer	Potentiometer fine tunes ($\pm 5\%$) the generator set output voltage.
Water temperature gauge	Gauge displays the engine coolant temperature.
10-amp controller fuse	Fuse protects the controller circuitry from short circuits and overloads.

Figure 2-19 Controls and Indicators, continued

2.5.2 Generator Set Starting

Local Starting. Move the generator set to the RUN position to immediately start the generator set.

Automatic Starting. Move the generator set master switch to the AUTO position to allow startup by the automatic transfer switch or the remote start/stop switch connected to controller terminals TB1-3 and TB1-4.

Note: The controller allows up to 30 seconds of continuous cranking before overcrank shutdown occurs.

2.5.3 Generator Set Stopping

Local Stopping

1. Run the generator set at no load for 5 minutes to ensure adequate engine cooldown.
2. Move the generator set master switch to the OFF/RESET position. The engine stops.

Automatic Stopping

1. The automatic transfer switch (ATS) or other device disconnects the load from the generator set.
2. The generator set continues to run for a preset time if the ATS is equipped with an engine cooldown time delay.
3. The ATS opens the connection between controller terminals TB1-3 and TB1-4. The generator set shuts down if the generator set master switch is in the AUTO position.

2.5.4 Fault Shutdowns

The generator set shuts down automatically under the fault conditions shown in Figure 2-20 and cannot be restarted until the fault condition is corrected. The generator set shutdown switches automatically reset when the problem is corrected. Reset the controller after a fault shutdown.

The fault lamp does not stay lit after the generator set shuts down on a fault condition.

2.5.5 Controller Resetting After a Fault Shutdown

Use the following procedure to restart the generator set after a fault shutdown.

1. Disconnect the generator set from the load using the line circuit breaker or automatic transfer switch. See the Safety Precautions at the beginning of this section before proceeding.
2. Correct the cause of the fault shutdown. See the Safety Precautions at the beginning of this section before proceeding.
3. Start the generator set by moving the generator set master switch to RESET/OFF and then to RUN.
4. Verify that the cause of the shutdown has been corrected by test operating the generator set.
5. Reconnect the generator set to the load using the line circuit breaker or automatic transfer switch.
6. Move the generator set master switch to the AUTO position for startup by remote transfer switch or remote start/stop switch.

Fault	Description
High engine temperature	Shutdown occurs 5 seconds after the fault. The high engine temperature shutdown does not function during the first 5 seconds after startup. Note: The high temperature shutdown functions only when the coolant level is in the operating range.
Low coolant level	Shutdown occurs 5 seconds after the fault. The low coolant level shutdown does not function during the first 5 seconds after startup.
Low oil pressure	Shutdown occurs 5 seconds after the fault. The low oil pressure shutdown does not function during the first 5 seconds after startup. Note: The low oil pressure shutdown does not protect against low oil level. Check the oil level at the engine.
Overcrank	Shutdown occurs after 30 seconds of continuous cranking. Shutdown occurs 30 seconds after startup if there is no AC output.
Overspeed	Shutdown occurs immediately when the governed frequency on the 50 and 60 Hz models exceeds 70 Hz.

Figure 2-20 Fault Shutdowns

2.6 Standard Decision-Maker 1 Controller with Engine Gauges

For identification of the standard controller's engine gauges and controls and their functions, refer to Figure 2-21.

2.6.1 Controls and Indicators

Figure 2-22 describes the controls and indicators located on the controller.

2.6.2 Generator Set Starting

Local Starting (Nonautomatic). Move the generator set master switch to the RUN position to start the generator set.

Automatic Starting. Move the generator set master switch to the AUTO position to allow startup by the automatic transfer switch or remote start/stop switch (connected to controller terminals TB1-3 and TB1-4).

Note: The controller allows up to 30 seconds of continuous cranking before the overcrank shutdown occurs.

2.6.3 Generator Set Stopping

Cooldown. Run the generator set at no load for 5 minutes to ensure adequate engine cooldown.

Local Stopping. Move the generator set master switch to the OFF/RESET position. The engine stops.

Automatic Stopping. The automatic transfer switch or other device disconnects the load from the generator set and opens the connection between controller terminals TB1-3 and TB1-4. The generator set shuts down if the generator set master switch is in the AUTO position.

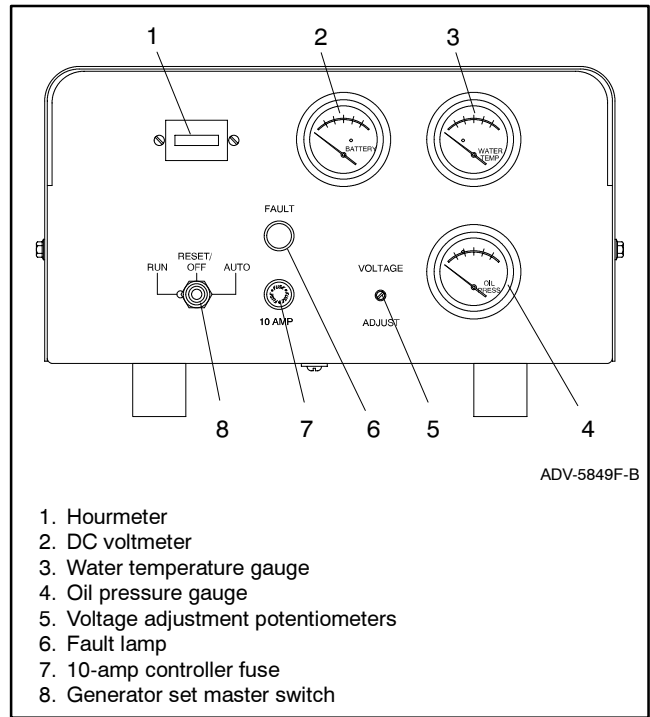

Figure 2-21 Standard Decision-Maker™ 1 Controller with Engine Gauges

Item	Description
AC voltmeter	Meter displays the voltage of the starting battery(ies).
Fault lamp	Lamp illuminates during engine shutdown if the engine shuts down because of one of the following faults: high engine temperature, low water level, low oil pressure, overcrank, or overspeed. See Section 2.6.4, Fault Shutdowns, for additional shutdown information.
Generator set master switch	Switch functions as the controller reset and generator set operation switch.
Hourmeter	Hourmeter records the generator set total operating hours for reference in maintenance scheduling.
Oil pressure gauge	Gauge displays the engine oil pressure.
Voltage adjustment potentiometer	Potentiometer fine tunes ($\pm 5\%$) the generator set output voltage.
Water temperature gauge	Gauge displays the engine coolant temperature.
10-amp controller fuse	Fuse protects the controller circuitry from short circuits and overloads.

Figure 2-22 Controls and Indicators

2.6.4 Fault Shutdowns

The generator set shuts down automatically under the fault conditions shown in Figure 2-23 and cannot be restarted until the fault condition is corrected. The generator set shutdown switches automatically reset when the problem is corrected. Reset the controller after a fault shutdown.

2.6.5 Controller Resetting After a Fault Shutdown

Use the following procedure to restart the generator set after a fault shutdown.

1. Disconnect the generator set from the load using the line circuit breaker or automatic transfer switch. See the Safety Precautions at the beginning of this section before proceeding.

Fault	Description
High engine temperature	Shutdown occurs 5 seconds after the fault. The high engine temperature shutdown does not function during the first 5 seconds after startup. Note: The high temperature shutdown functions only when the coolant level is in the operating range.
Low coolant level	Shutdown occurs 5 seconds after the fault. The low coolant level shutdown does not function during the first 5 seconds after startup.
Low oil pressure	Shutdown occurs 5 seconds after the fault. The low oil pressure shutdown does not function during the first 5 seconds after startup. Note: The low oil pressure shutdown does not protect against low oil level. Check the oil level at the engine.
Overcrank	Shutdown occurs after 30 seconds of continuous cranking. Shutdown occurs 30 seconds after startup if there is no AC output.
Overspeed	Shutdown occurs immediately when the governed frequency on 50 and 60 Hz models exceeds 70 Hz.

Figure 2-23 Fault Shutdowns

2. Correct the cause of the fault shutdown. See the Safety Precautions at the beginning of this section before proceeding.
3. Start the generator set by moving the generator set master switch to RESET/OFF and then to RUN.
4. Verify that the cause of the shutdown has been corrected by test operating the generator set.
5. Reconnect the generator set to the load using the line circuit breaker or automatic transfer switch.
6. Move the generator set master switch to the AUTO position for startup by remote transfer switch or remote start/stop switch.

2.7 Standard Decision-Maker 1 Controller

For identification of the standard basic controller's indicators and controls and their functions, refer to Figure 2-24.

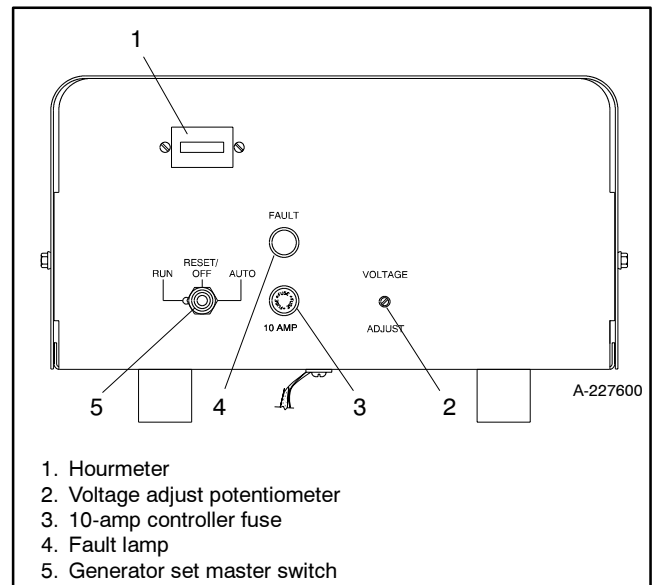

Figure 2-24 Standard Decision-Maker™ 1 Controller

x.op:004:001

2.7.1 Controls and Indicators

Figure 2-25 describes the controls and indicators located on the controller.

2.7.2 Generator Set Starting

Local Starting. Move the generator set master switch to the RUN position to immediately start the generator set.

Automatic Starting. Move the generator set master switch to the AUTO position to allow startup by the automatic transfer switch or the remote start/stop switch (connected to controller terminals TB1-3 and TB1-4).

Note: The controller allows up to 30 seconds of continuous cranking before the overcrank shutdown occurs.

2.7.3 Generator Set Stopping

Cooldown. Run the generator set at no load for 5 minutes to ensure adequate engine cooldown.

Local Stopping. Move the generator set master switch to the OFF/RESET position. The engine stops.

Automatic Stopping. The automatic transfer switch or other device disconnects the load from the generator set and opens the connection between controller terminals TB1-3 and TB1-4. The generator set shuts down if the generator set master switch is in the AUTO position.

2.7.4 Fault Shutdowns

The generator set shuts down automatically under the fault conditions shown in Figure 2-26 and cannot be restarted until the fault condition is corrected. The generator set shutdown switches automatically reset when the problem is corrected. Reset the controller after a fault shutdown.

Item	Description
Fault lamp	Lamp illuminates during engine shutdown if the engine shuts down because of one of the following faults: high engine temperature, low water level, low oil pressure, overcrank, or overspeed. See Section 2.7.4, Fault Shutdowns, for additional shutdown information.
Generator set master switch	Switch functions as the controller reset and generator operation switch.
Hourmeter	Hourmeter records the generator set total operating hours for reference in maintenance scheduling.
Voltage adjust potentiometer	Potentiometer fine tunes ($\pm 5\%$) generator output voltage.
10-amp controller fuse	Fuse protects the controller circuitry from short circuits and overloads.

Figure 2-25 Controls and Indicators

Fault	Description
High engine temperature	Shutdown occurs 5 seconds after the fault. The high engine temperature shutdown does not function during the first 5 seconds after startup. Note: The high temperature shutdown functions only when the coolant level is in the operating range.
Low coolant level	Shutdown occurs 5 seconds after the fault. Low coolant level shutdown does not function during the first 5 seconds after startup.
Low oil pressure	Shutdown occurs 5 seconds after the fault. Low oil pressure shutdown does not function during the first 5 seconds after startup. Note: The low oil pressure shutdown does not protect against low oil level. Check the oil level at the engine.
Overcrank	Shutdown occurs after 30 seconds of continuous cranking. Shutdown occurs 30 seconds after startup if there is no AC output.
Overspeed	Shutdown occurs immediately when the governed frequency on 50 and 60 Hz models exceeds 70 Hz.

Figure 2-26 Fault Shutdowns

2.7.5 Controller Resetting After a Fault Shutdown

Use the following procedure to restart the generator set after a fault shutdown.

1. Disconnect the generator set from the load using the line circuit breaker or automatic transfer switch. See the Safety Precautions at the beginning of this section before proceeding.
2. Correct the cause of the fault shutdown. See the Safety Precautions at the beginning of this section before proceeding.
3. Start the generator set by moving the generator set master switch to RESET/OFF and then to RUN.

4. Verify that the cause of the shutdown has been corrected by test operating the generator set.
5. Reconnect the generator set to the load using the line circuit breaker or automatic transfer switch.
6. Move the generator set master switch to the AUTO position for startup by remote transfer switch or remote start/stop switch.

2.8 Manual Controller

Use the manual controller for manual (nonautomatic) prime power applications operation. For identification and explanation of manual controller components, refer to Figure 2-27 and Section 2.8.1.

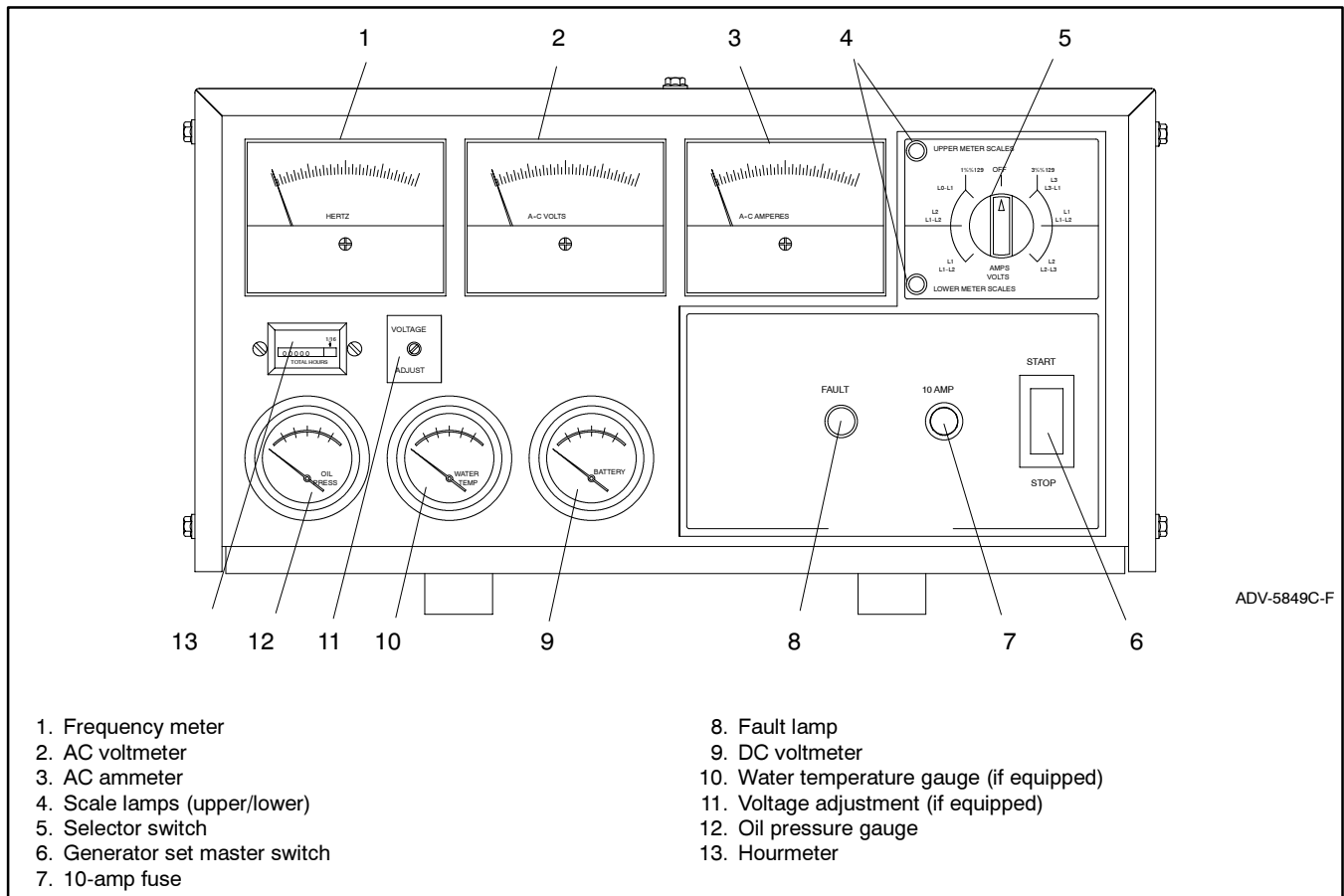

Figure 2-27 Manual Controller

2.8.1 Controls and Indicators

Figure 2-28 describes the controls and indicators located on the controller.

2.8.2 Generator Set Starting

Place and hold the controller or remote start/stop switch in the START position until the engine is running, then release. If the engine fails to start after cranking for 5–10 seconds, release the switch. Wait 60 seconds to allow the engine to stop cranking completely and cool down before the next start attempt.

Note: Do not crank the engine continuously for longer than 10 seconds. If the engine does not start, allow a 60-second cooldown period between cranking attempts. If the unit fails to start after three attempts, contact an authorized service distributor/dealer for repair. Failure to follow these guidelines may result in starter-motor burnout.

2.8.3 Generator Set Stopping

Run the generator set at no load for 5 minutes to ensure adequate engine cooldown.

To stop the generator set, place the controller start/stop switch or remote start/stop switch in the STOP position and wait until the generator set stops completely.

Item	Description
AC voltmeter	Meter displays the AC output voltage. Use the selector switch to choose the output lead circuits.
AC ammeter	Meter displays the AC output current in amps. Use the selector switch to choose the phase currents.
DC voltmeter	Meter displays the voltage of the starting battery(ies).
Fault lamp	Lamp illuminates during engine shutdown if the engine shuts down because of one of the following faults: high engine temperature, low water level, low oil pressure, or overspeed. See Section 2.8.4, Fault Shutdowns, for additional shutdown information.
Frequency meter	Meter displays the frequency (Hz) of the generator set output.
Engine oil temperature, if equipped	Meter displays the engine oil temperature. Note: The 20–40 kW models substitute an engine oil temperature gauge for the water temperature gauge.
Generator set master switch	Switch functions as the controller reset and generator set operation switch.
Hourmeter	Hourmeter records the generator set total operating hours for reference in maintenance scheduling.
Oil pressure gauge	Gauge displays the engine oil pressure.
Scale lamps (upper/lower)	Lamps indicate which AC voltmeter and/or ammeter scales to read.
Selector switch	Switch selects the generator set output circuits to measure. When switched to a position with three circuit labels, the ammeter measures current on the upper lead and the voltmeter measures voltage between the lower two leads. The AC ammeter and voltmeter do not register with the switch in the OFF position. The labels 1Ø and 3Ø indicate single-phase and three-phase voltage/current respectively.
Voltage adjustment potentiometer	Potentiometer fine tunes ($\pm 5\%$) the generator set output voltage. Note: Used with 20–300 kW models only; 300–2000 kW models have the voltage adjustment located in the generator junction box.
Water temperature gauge	Gauge displays the engine coolant temperature.
10-amp controller fuse	Fuse protects the controller circuitry from short circuits and overloads.

Figure 2-28 Controls and Indicators

2.8.4 Fault Shutdowns

The generator set shuts down automatically under the fault conditions shown in Figure 2-29 and cannot be restarted until the fault condition is corrected. The generator set shutdown switches automatically reset when the problem is corrected or the generator set cools (if overheating was the problem).

Note: The fault lamp does not stay lit after the unit shuts down on a fault condition.

Fault	Description
High engine temperature	Shutdown occurs 5 seconds after the fault. The high engine temperature shutdown does not function during the first 5 seconds after startup. Note: Water-cooled engines only. The high temperature shutdown functions only when the coolant level is in the operating range.
Low coolant level	Shutdown occurs 5 seconds after the fault. Low coolant level shutdown does not function during the first 5 seconds after startup.
Low oil pressure	Shutdown occurs 5 seconds after the fault. Low oil pressure shutdown does not function during the first 5 seconds after startup. Note: The low oil pressure shutdown does not protect against low oil level. Check the oil level at the engine.
Overspeed	Shutdown occurs immediately when the governed frequency on 50 and 60 Hz models exceeds 70 Hz.
AC interlock	Shutdown occurs when the start/stop switch is released if there is no AC output.

Figure 2-29 Fault Shutdowns

2.9 Paralleling Engine Gauge Box Controller (Switchgear)

The paralleling engine gauge box provides the connectors and terminal strips needed to connect the generator set to switchgear-mounted controls. Each generator set in the paralleling system requires an engine gauge box. Some engine gauge box models include an emergency stop switch; the engine gauge box contains no other operating controls. The switchgear contains the generator set operating controls.

A connection plug connects the generator set governor, crank relays, safety shutdown switches (high water temperature, low oil pressure, and low coolant level), and gauge senders to gauge box terminal strips. The appropriate terminals on the terminal strips are then hard-wired to the switchgear controls.

Controller Features

The gauge box also includes an electronic speed switch with overspeed and crank outputs. For identification and explanation of paralleling meter box components, refer to Figure 2-30 and Figure 2-31.

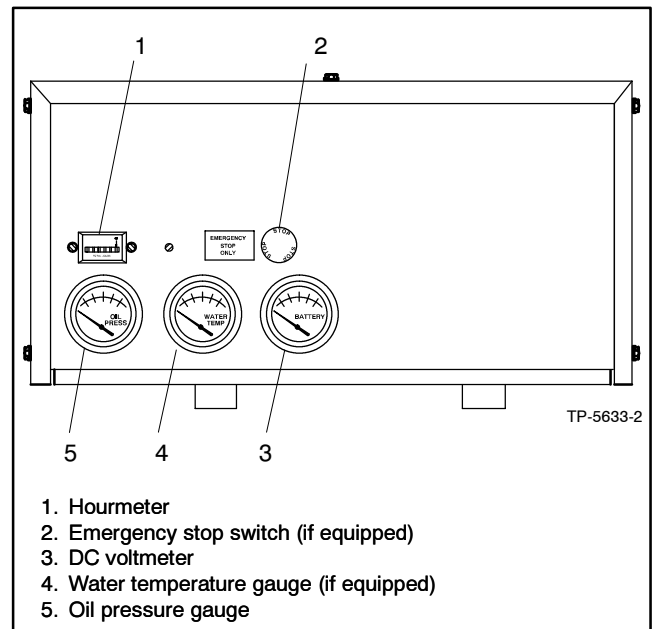

Figure 2-30 Paralleling Engine Gauge Box Controller (Switchgear)

Feature	Description
Connection plug	Use the plug to connect the wiring harness from the generator set governor control, crank relays, safety shutdown switches, and gauge senders to the gauge box terminal strips.
DC voltmeter	Meter displays the voltage of the starting battery(ies).
Gauge box terminal strips	Use the terminal strips to connect the switchgear control wiring to the generator set governor control, crank relays, safety shutdown switches, gauge senders, etc.
Hourmeter	Hourmeter records the generator set total operating hours for reference in maintenance scheduling.
Oil pressure gauge	Gauge displays the engine oil pressure.
Electronic speed switch	Switch signals the switchgear engine control logic to disconnect the starter motor after startup or to shut down the system if an overspeed fault occurs. The speed switch settings for crank and overspeed are adjustable.
Emergency stop switch, if equipped	Switch Immediately shuts down the generator set in emergency situations. Reset the emergency stop switch after shutdown by rotating the switch clockwise. Use the emergency stop switch for emergency shutdowns only. Use the generator set master switch for normal shutdowns. The local emergency stop switch is standard on Detroit Diesel engine-powered 200-2000 kW generator sets.
Water temperature gauge	Gauge displays the engine coolant temperature.

Figure 2-31 Paralleling Engine Gauge Box Controller Features (Switchgear)

Notes

Section 3 Scheduled Maintenance

Under normal operating conditions, the generator's alternator requires no normal service. Consult the prestart checklist in Section 2.1 for a list of routine checks.

3.1 Generator Service

When operating the generator set under dusty or dirty conditions, use dry compressed air to blow dust out of the generator while the generator set is running. Direct the stream of air through openings in the generator set end bracket.

3.2 Engine Service

Perform engine service at the intervals specified in the engine manufacturer's service literature. Contact an authorized service distributor/dealer to obtain service literature.

Note: Have maintenance work, including battery service, performed by appropriately skilled and suitably trained maintenance personnel familiar with generator set operation and service.

⚠ WARNING

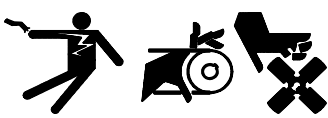

**Accidental starting.
Can cause severe injury or death.**

Disconnect the battery cables before working on the generator set. Remove the negative (-) lead first when disconnecting the battery. Reconnect the negative (-) lead last when reconnecting the battery.

Disabling the generator set. Accidental starting can cause severe injury or death. Before working on the generator set or connected equipment, disable the generator set as follows: (1) Move the generator set master switch to the OFF position. (2) Disconnect the power to the battery charger. (3) Remove the battery cables, negative (-) lead first. Reconnect the negative (-) lead last when reconnecting the battery. Follow these precautions to prevent starting of the generator set by an automatic transfer switch, remote start/stop switch, or engine start command from a remote computer.

⚠ WARNING



**Hot engine and exhaust system.
Can cause severe injury or death.**

Do not work on the generator set until it cools.

Servicing the exhaust system. Hot parts can cause severe injury or death. Do not touch hot engine parts. The engine and exhaust system components become extremely hot during operation.

⚠ WARNING

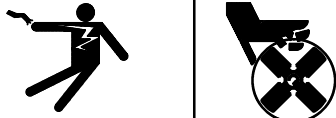

**Hazardous voltage. Moving rotor.
Can cause severe injury or death.**

Operate the generator set only when all guards and electrical enclosures are in place.

Servicing the generator set when it is operating. Exposed moving parts can cause severe injury or death. Keep hands, feet, hair, clothing, and test leads away from the belts and pulleys when the generator set is running. Replace guards, screens, and covers before operating the generator set.

3.3 Service Schedule

System—Component	Action					Interval
	Visually Inspect	Check	Change	Clean	Test	
Fuel						
Day tank level	X	X				Weekly
Flexible lines and connections	X		X			Weekly
Fuel level switch	X				X	Weekly
Main tank supply level		X				Weekly
Solenoid valve operation	X				X	Weekly
Transfer pump operation	X				X	Weekly
Water in system, remove		•		•		Weekly
Filter(s)			•			Quarterly
Gasoline supply			X			Six Months
Fuel piping	X					Yearly
Tank vents and return lines for obstructions		X				Yearly
Lubrication						
Oil level	•	•				Weekly
Crankcase breather	•		•			Quarterly
Change oil			•			50 Hours or Yearly
Replace filter(s)*			•			50 Hours or Yearly
Cooling						
Air cleaner to room/enclosure		X				Weekly
Block heater operation		X				Weekly
Coolant level	•	•				Weekly
Flexible hoses and connectors	X	X				Weekly
Water pump(s)	•					Weekly
Fan and alternator belts	•	•	X			Monthly
Coolant temperature protection level					•	Six Months
Air ducts, louvers		X		X		Yearly
Coolant			•			Yearly
Heat exchanger				X		Yearly
Louver motors and controls	X			X	X	Yearly
Radiator exterior				X		Yearly
Water supply to heat exchanger		X				Yearly
Exhaust Line						
Drain condensate trap		X				Weekly
Leakage	X	X				Weekly
Insulation, fire hazards	X					Quarterly
Flexible connector(s)	X					Six Months
Excessive back pressure					X	Yearly
Hangers and supports	X					Yearly
DC Electrical System						
Battery charger operation, charge rate	X					Monthly
Battery electrolyte level		X				Monthly
Battery specific gravity, charge state					X	Monthly
Recharge after engine start		X				Monthly
Remove corrosion, clean and dry battery and rack	X			X		Monthly
Clean and tighten battery terminals	X	X				Quarterly
Tighten DC electrical connections		X				Six Months
<p>• Follow procedures and frequencies indicated in the engine manufacturer's maintenance manual. If not indicated, follow this service schedule. Some items may not apply to all generator sets.</p> <p>X Action</p> <p>* Service more frequently if operated in dusty areas.</p>						

Service Schedule, continued

System—Component	Action					Interval
	Visually Inspect	Check	Change	Clean	Test	
AC Electrical System						
Controller lamp test	X				R	Weekly
General Inspection	X					Weekly
Circuit breakers, fuses†	X	X	X	X	X	Monthly
Wire abrasions where subject to motion	X	X				Quarterly
Safety and alarm operation		X			X	Six Months
Tighten control and power wiring connections		X				Yearly
Transfer switch main contacts†	X			X		Yearly
Voltage-sensing device/relay adjustment†		•			•	Yearly
Wire-cable insulation breakdown	X				X	3 Years or 500 Hours
Engine and Mounting						
General inspection	•					Weekly
Governor operation, lubricate moving parts	•	•				Monthly
Air cleaner service		•	•			Six Months
Choke, carburetor adjustment		•				Six Months
Governor oil (mechanical governor only)		•				Yearly
Ignition components	•			•		Yearly
Injector pump and injector flow rate, pressure, spray pattern		•			•	Yearly
Valve clearance		•				3 Years or 500 Hours
Bolt torque		•			•	3 Years or 500 Hours
Remote Control System, etc.						
Compartment condition	X			X		Weekly
Remote control					X	Monthly
Run generator set					X	Monthly
Generator						
General inspection	X					Weekly
Rotor and stator	X			X		Yearly
Bearing condition	X	X	X			Yearly
Exciter	X	X		X		Yearly
Voltage regulator	X	X		X		Yearly
Measure and record resistance readings of windings with insulation tester (Megger, with SCR assembly or rectifier disconnected)					X	Yearly
Blow dust out of generator*	X			•		2 Years or 300 Hours
General Condition of Equipment						
Any condition of vibration, leakage, noise, temperature, or deterioration	X	X		X		Weekly
Ensure that system is set for automatic operation	X					Weekly
Interior of equipment room or outdoor weather housing	X			X		Weekly
<p>• Follow procedures and frequencies indicated in the engine manufacturer's maintenance manual. If not indicated, follow this service schedule. Some items may not apply to all generator sets.</p> <p>X Action.</p> <p>* Service more frequently if operated in dusty areas.</p> <p>† Do not break manufacturer's seals or internally inspect these devices.</p>						

3.4 Generator Bearing Service

Have an authorized service distributor/dealer perform generator service.

3.4.1 20–300 kW Models

Replace the end bracket bearing every 10,000 hours of operation in standby and prime power applications. Service the bearing more frequently if the annual inspection indicates excessive rotor end play or bearing damage. Replace the tolerance ring, if equipped, following end bracket removal. The sealed end bracket bearing requires no additional lubrication.

3.4.2 350–2000 kW Models with Single-Bearing Generator

The generator bearing requires lubrication at intervals specified in the generator technical manual. Use Chevron SRI or equivalent antifriction, high-quality grease with a lubrication temperature range of -30° to $+175^{\circ}\text{C}$ (-22° to $+350^{\circ}\text{F}$).

3.4.3 1250–2000 kW Model with Two-Bearing Generator

Refer to the generator service manual for bearing maintenance information.

3.5 Diesel Fuel Systems

3.5.1 Bleeding Air from the Fuel System

Bleed air from the fuel system after fuel system maintenance, such as replacing the fuel filter(s) using the hand prime pump kit, when equipped. The hand prime fuel pump eliminates the need for cranking the engine to bleed air from the fuel system.

Note: Bleed air from the fuel system according to the engine manufacturer's instructions. Trapped air in the fuel system causes difficult starting and/or erratic engine operation.

Note: Correct any fuel leaks encountered during the priming procedure.

1. Place the fuel valves in the fuel system prime position. Close the fuel valve located between the pipe tee and the engine. Open the fuel valves on each side of the fuel prime pump. See Figure 3-1.

Note: The illustration shows a generator set without a fuel/water separator. The valve location and position for a generator set equipped with a fuel/water separator is similar.

2. Loosen the bleed screw at the engine. Refer to the engine operation manual for location of the bleed screw(s). The bleed screw allows air to be expelled from the fuel system when the hand prime pump is operated.
3. Rotate the hand prime pump handle counterclockwise until fuel flows from the bleed screw. Stop pumping.
4. Tighten the bleed screw. Wipe up any fuel leakage.
5. Place the fuel valves in the normal operation position. Open the fuel valve located between the pipe tee and the engine. Close the fuel valves on each side of the fuel prime pump.

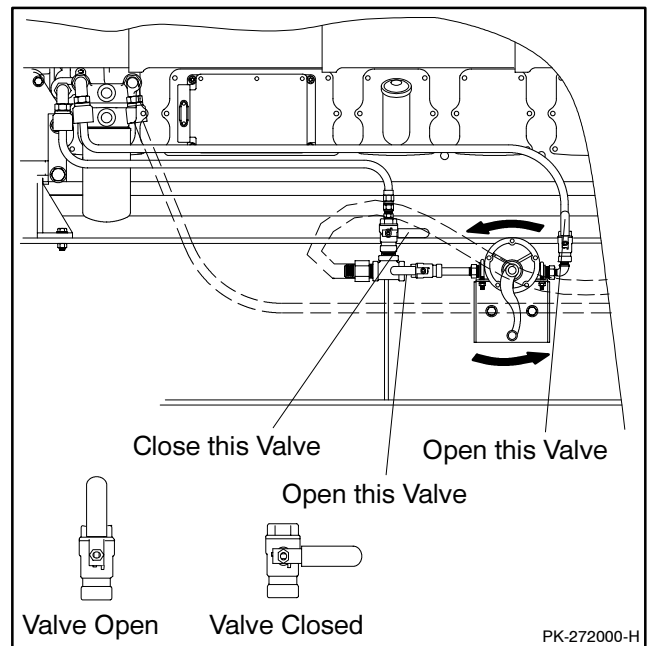

Figure 3-1 Hand Prime Pump with Valve Positions for Fuel Priming (Generator Set Without a Fuel/Water Separator Shown)

3.5.2 Subbase Fuel Day Tank Electronic Control Module (ECM)

With an electronic control module (ECM), the optional subbase diesel fuel tank functions as a day tank. Following are operating information and features of the ECM. See Figure 3-2 for the ECM front panel layout.

Servicing the day tank. Hazardous voltage can cause severe injury or death. Service the day tank electrical control module (ECM) as prescribed in the equipment manual. Disconnect the power to the day tank before servicing. Press the day tank ECM OFF pushbutton to disconnect the power. Notice that line voltage is still present within the ECM when the POWER ON light is lit. Ensure that the generator set and day tank are electrically grounded. Do not operate the day tank when standing in water or on wet ground because these conditions increase the risk of electrocution.

ECM General Function

The ECM controls a pump/motor that maintains the day tank fuel level. The ECM motor relay is connected to the pump/motor. The ECM starts the pump when the fuel level drops to 87% of full and stops the pump when the day tank is full.

ECM Function Indicator LEDs

Two LEDs on the front panel indicate ECM operation. See Figure 3-2 for the locations of the LEDs. Figure 3-3 describes the LED functions.

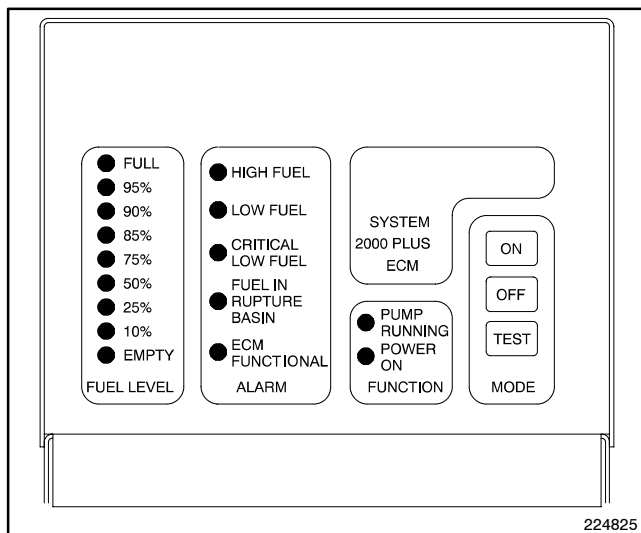

Figure 3-2 ECM Front Panel Layout

Function	Description
Power On	LED lights to indicate that power is applied to the ECM.
Pump Running	LED lights when the pump starts.

Figure 3-3 ECM Function Indicator LEDs

Level Sensor

An electronic analog float gauge located below the ECM on the mounting bracket determines the day tank fuel level. Nine LEDs on the ECM indicate the day tank fuel level from full to empty.

ECM Mode

The ECM has three pushbutton switches for normal operation and one internal test button. See Figure 3-4.

ECM Alarms

The ECM has five standard alarm conditions indicated locally by LEDs and remotely by relays. Figure 3-5 describes the five alarm conditions. Make customer connections to the normally open and normally closed relay contacts provided.

Pushbutton	Description
Off	Pushbutton disables the ECM for routine maintenance to the tank system.
On	Pushbutton activates the ECM after the OFF pushbutton is depressed. On power-up after a power outage, the ECM automatically turns on.
Test	Pushbutton lights front panel LEDs for 3 seconds and activates the pump/motor for as long as the pushbutton is depressed. The alarm relays maintain their original positions.
Internal test	Pushbutton (located inside the ECM) tests each alarm LED and remote annunciation relay in sequential order (high fuel to ECM functional).

Figure 3-4 ECM Pushbuttons

Alarm	Description
High fuel	Alarm activates at 106% of normal fuel level.
Low fuel	Alarm activates at 62% of normal fuel level. The alarm provides time to respond to a potential problem before a low fuel shutdown occurs.
Critical low fuel (engine shutdown)	Alarm activates at 6% of normal fuel level to warn the operator to shut down the generator set before fuel runs out.
Fuel in rupture basin, if equipped	Alarm activates when the ECM detects fuel in the rupture basin.
ECM functional	Alarm activates to indicate a problem with the ECM operation. Note: The ECM functional alarm relay activates a customer-installed alarm when the relay deenergizes.

Figure 3-5 ECM Alarms

3.5.3 Subbase Inner Fuel Tank Alarm

This kit provides for both audible and visual alarm from a location remote from the generator set if a leak is detected in the inner fuel tank of the double-wall subbase fuel tanks. See Figure 3-6. If the inner tank is leaking, a sensor installed in the outer tank sends an electrical signal to the alarm plate when the sensor becomes immersed in the fuel collecting in the outer tank. If a leak is detected, the alarm horn will sound and the fault lamp will light. The alarm horn is quieted by moving the alarm switch to the SILENCE position; the alarm lamp remains lit until the fault is corrected. See Figure 3-7 for troubleshooting information.

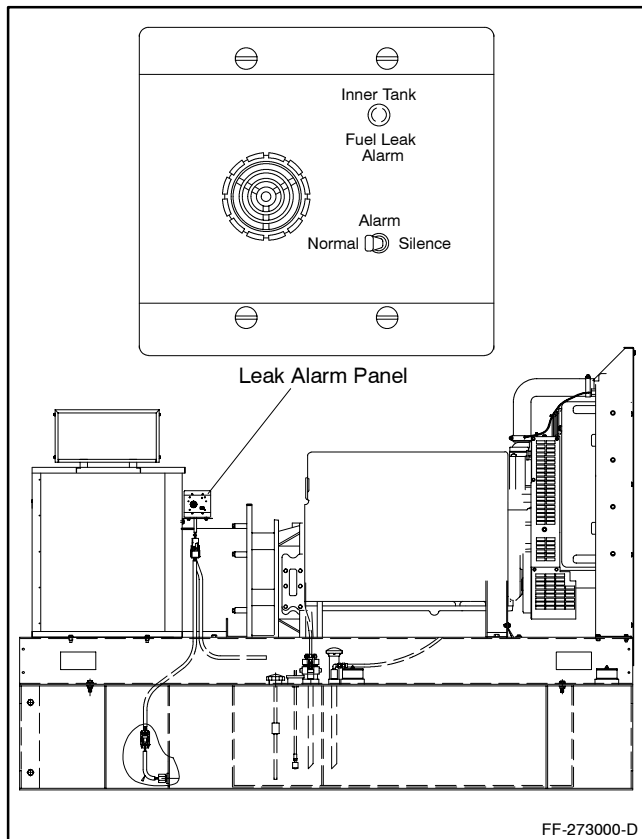

Figure 3-6 Inner Fuel Tank Leak Alarm (20-300 kW Model Shown)

Resetting Procedure

Use the following procedure to reset the alarm after a fault alarm.

1. Move alarm switch to the SILENCE position to stop alarm horn. Lamp will remain lit.
2. Disconnect generator set from load with line circuit breaker or automatic transfer switch.
3. Repair or replace the inner fuel tank.
4. Move generator master switch to the OFF/RESET position and then to the RUN position for startup. Alarm horn sounds and lamp goes out.
5. Reconnect generator to load via line circuit breaker or automatic transfer switch.
6. Move generator master switch to the AUTO position for startup by remote transfer switch or remote start/stop switch. Move alarm switch to the NORMAL position.

Alarm Switch Position	Float Switch Position	Observation
Normal	Open	The alarm horn and the lamp are not energized.
Normal	Closed	The alarm horn and lamp activate when a fuel leak occurs. If the alarm switch is moved to the silence position the lamp stays on until the fuel leak fault is corrected.
Silence	Open	The alarm horn sounds to alert the user that the alarm horn switch is not in the normal position and that the alarm horn will not sound should a fuel leak occur.

Figure 3-7 Inner Fuel Tank Leak Alarm Troubleshooting

3.6 Gas/Gasoline Fuel Systems

This section describes fuel systems that are not covered in the engine operation manual or engine service manual.

3.6.1 Gaseous Fuel System Concept

The gaseous fuel system uses a fuel valve with a solenoid to control the fuel flow to the fuel regulator. The generator-mounted regulator reduces the fuel pressure as fuel passes to the carburetor. See Figure 3-8. The carburetor/mixer controls the ratio of fuel to air under varying load and speed conditions. Because the carburetor receives fuel in a gaseous state, it does not have to vaporize the fuel. When switching from natural gas to LP gas or LP gas to natural gas, verify that the electronic governor maintains the rated engine speed (1800 rpm at 60 Hz or 1500 rpm at 50 Hz). If the engine speed is incorrect, refer to the generator service manual for the governor adjustment procedure.

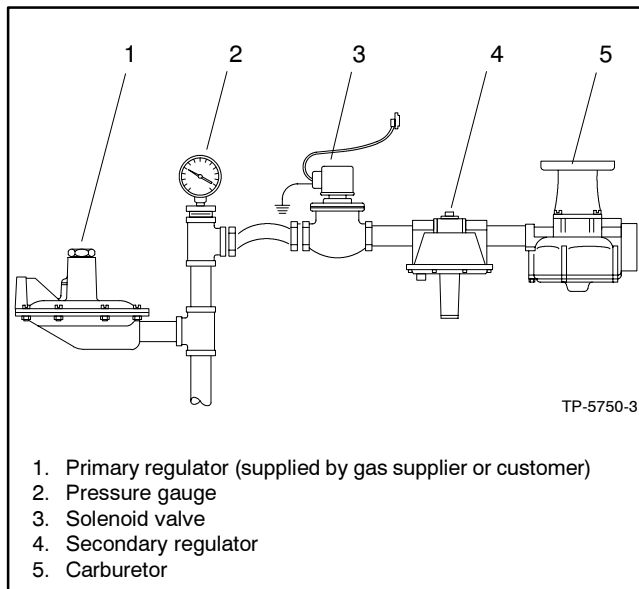

Figure 3-8 Fuel Regulator and Valve, Typical

3.6.2 LP Liquid Withdrawal Fuel System Concept

With the LP liquid withdrawal fuel system, pressurized liquid LP fuel passes from the tank to a vaporizer. The

vaporizer converts the liquid fuel to gas before sending it to the carburetor. The system also includes a fuel valve that shuts off the fuel flow when the engine stops. Contact an authorized service distributor/dealer for availability.

3.6.3 LP Gas/Natural Gas Conversion for Straight Gas Fuel System

Most models operate on either LP gas or natural gas fuel by performing the fuel conversion procedure. Some models require a different fuel kit when changing gas fuels. Consult your local generator distributor/dealer for additional information.

Fuel conversion may decrease generator set output and affect exhaust emissions. Consult your local generator distributor/dealer for additional information.

Fuel Conversion Procedure

When converting the generator set to operate with LP gas, remove the internal spring from the secondary regulator. Install the spring to operate the generator set on natural gas.

Note: Not all fuel regulators require spring and retainer removal for fuel conversion. A hang tag on the fuel regulator identifies the conversion procedure.

LP Fuel Conversion Procedure

Use the following steps to remove the internal spring from the fuel regulator:

1. Remove the fuel regulator cover plug. See Figure 3-9.
2. Remove the adjustment screw and spring from the fuel regulator. Save the adjustment screw and spring for possible conversion back to natural gas.
3. Reinstall the cover plug.

Natural Gas Fuel Conversion Procedure

Use the following steps to convert the generator set to natural gas:

1. Remove the fuel regulator cover plug. See Figure 3-9.
2. Replace the spring and adjustment screw.
3. Connect a manometer to check the fuel supply pressure on the carburetor side of the regulator. The recommended fuel supply pressures are shown in Figure 3-10 and on the generator set spec sheet.
4. Adjust the fuel supply pressure with the generator set running at full load. Rotate the adjustment screw on the fuel regulator until the pressure indicated by the manometer matches the specified pressure. Use the lower pressure value if the generator set still provides good response and full power. Lower-than-specified pressures may result in poor response to load changes or lack of power.
5. Reinstall the cover plug.

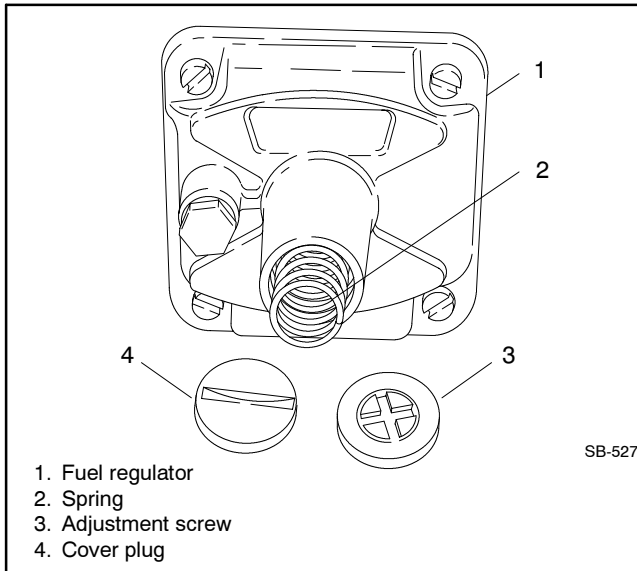

Figure 3-9 Fuel Regulator, Typical

3.6.4 Fuel System Changeover Kits

Automatic Changeover

A changeover fuel system kit provides automatic changeover from natural gas to LP gas vapor or from LP gas vapor to natural gas. The primary and backup fuels each have a secondary fuel regulator and a fuel valve. Typically, the primary fuel is natural gas; the backup fuel is LP gas vapor. When the generator set starts, the primary fuel valve opens and the backup fuel valve closes. The primary fuel line has a vacuum switch in series with a relay connected to the start/run circuit. When the primary fuel pressure drops below 0.6 kPa (1.4 oz./in.²) or 6.4 cm (2.5 in.) water column, a relay opens the backup fuel valve and closes the primary fuel valve. When the primary fuel pressure rises above 0.6 kPa (1.4 oz./in.²) or 6.4 cm (2.5 in.) water column, the generator set uses the primary fuel. Contact an authorized service distributor/dealer for kit availability.

Manual Changeover

A manual changeover fuel system allows manual changeover from gasoline to natural gas or LP gas, or from natural gas or LP gas to gasoline. Typically, the combination system uses gas as the primary, preferred fuel and gasoline in emergencies. If the primary fuel is unavailable (an empty fuel tank or fuel supply disruption), the system uses gasoline. A toggle switch on the generator set controls the fuel choice and energizes either a fuel solenoid and electric fuel pump for gasoline or a fuel valve for gas. Pull out the control cable for gasoline and push in the control cable for gas.

Generator Set Model	Engine	Fuel Supply Pressure	
		kPa (oz./in. ²)	Water Column, cm (in.)
20-100 kW	Ford	1.7-27.4 (4-6)	18-28 (7-11)
30-125 kW	GM	1.7-27.4 (4-6)	18-28 (7-11)
115/135 kW	Cummins	3.5 (8)	36 (14)
135-180 kW	Detroit Diesel Series 50	1.2-5 (2.9-11.6)	13-51 (5-20)
200-275 kW	Detroit Diesel Series 60	1.2-5 (2.9-11.6)	13-51 (5-20)

Figure 3-10 Recommended Fuel Supply Pressures

3.6.5 Carburetor Adjustment

Before adjusting the carburetor, verify that the engine compression and the ignition system meet specifications. Do not adjust the carburetor to compensate for other engine disorders. If the engine speed is incorrect, adjust the electronic governor to achieve 1800 rpm (at 60 Hz) or 1500 rpm (at 50 Hz). Adjust the carburetor if governor adjustment alone does not result in the desired engine speed.

Adjusting the carburetor affects the engine fuel mixture. Routine carburetor adjustment is not necessary. However, if the carburetor is removed or tampered with, the carburetor may require adjustment to achieve optimum engine performance. Some engines have sealed carburetors that are not adjustable.

Gasoline Carburetor Adjustment

Refer to the engine operation manual or engine service manual for gasoline carburetor adjustment information.

Gaseous Carburetor (Fuel Mixer) Adjustment Procedure

Use the following procedure to adjust the carburetor (fuel mixer).

1. Start the generator set and run it at approximately half load.
2. Adjust the engine fuel mixture screw (Figure 3-11) until the engine runs smoothly.
3. Apply varying loads and readjust the carburetor as necessary to achieve smooth engine performance at all load levels.
4. Stop the generator set.

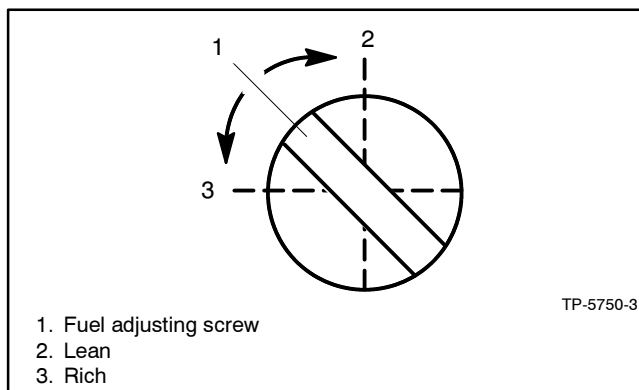

Figure 3-11 Fuel Mixture Adjustment, Typical

3.6.6 Fuel System Maintenance

Gasoline Models

Clean or replace the fuel filter at the specified interval. Service the filters more frequently if the engine runs roughly, as a clogged fuel filter can cause rough engine operation. Some models use a disposable inline fuel filter, which must be replaced. Other models have a fuel pump with an integral fuel filter that requires cleaning at the specified interval.

Gaseous Models

This fuel system requires no regular maintenance.

3.7 Turbocharger Maintenance on Ford-Powered Models

The oil recommendations, turbocharger oil priming, and turbocharger maintenance procedures are for Ford-powered 30 (with LSG-423 engine), 80, and 100 kW models with turbochargers not described or explained in the engine operation manual. Use the following turbocharger maintenance information for the above-listed models.

3.7.1 Oil Type Recommendations

The engine and generator manufacturers' engine oil viscosity recommendations for engines used in generator applications differ from the recommendations for engines used in other applications. Use oil that has a minimum rating of (API) classification SH/CD, SG/CD, SH/CC, or SG/CC to ensure long life and minimal engine wear. See Figure 3-12 for oil viscosity selection for the Ford-powered models listed above.

For Air Temperatures Consistently Above	Use Viscosity
0°C (32°F)	20W50 or 10W40
-23°C (-10°F)	10W40 or 10W50

Figure 3-12 Oil Viscosity Selection

3.7.2 Turbocharger Oil Prime Procedure

After changing the engine lube oil, use the following procedure to prime the turbocharger bearing to prevent premature turbocharger bearing wear.

1. Place the generator set master switch in the OFF/RESET position.
2. Disconnect the wire between the ignition coil and the distributor at the distributor terminal. Connect a jumper wire from the ignition coil lead to the engine block.

Note: Electronic Ignition Damage. Ground the ignition coil to the engine block to prevent electronic ignition system damage.

3. Place an oil-collection container under the oil drain line. Disconnect the turbocharger oil drain line at the engine connection.
4. Place the generator set master switch in the RUN position to crank the engine until fresh oil flows from the turbocharger oil drain line.

Note: Starter Damage. Do not crank the engine continuously for longer than 10 seconds. Allow a 60-second cooldown period between cranking cycles to prevent starter motor and/or starter solenoid failure caused by overheating.

5. Place the generator set master switch in the OFF/RESET position.
6. Reconnect the turbocharger oil drain line at the engine connection.
7. Remove the jumper wire and reconnect the ignition coil wire to the distributor.
8. Place the generator set master switch in the RUN position, run the generator set for a few minutes, and check for oil leaks at the turbocharger drain line connection. Stop the generator set.
9. Check the oil level. Add oil to bring the level up to the full mark. Consult the engine operation manual for oil capacity.
10. Wipe up spilled oil and dispose of rags in a fireproof container.

3.7.3 Turbocharger Maintenance

See Figure 3-13 for the turbocharger maintenance service schedule.

Service	500 Hours or 6 Months	1000 Hours	2000 Hours
Check for abnormal turbo rotor noise during operation (e.g., high frequency pitch) and check for oil leakage at the turbocharger.	X		
Check turbo rotor shaft for wear (end play and radial tolerances).		X	
Overhaul turbocharger.*			X
Change lube oil. Change lube oil filter. Change air filter.	Refer to engine operation manual.		
* Have service performed by an authorized distributor/dealer.			

Figure 3-13 Turbocharger Maintenance Service Schedule

3.8 Cooling System

The cooling system maintenance information applies to radiator-cooled models and city-water-cooled (heat exchanger) models. The cooling systems function similarly even though they use different components. Radiator-cooled models have a radiator with a pressure cap and coolant recovery tank. City-water-cooled models have a heat exchanger and an expansion/surge tank with a pressure cap.

Note: The 20–40 kW Deutz engine-powered generator sets are oil cooled and therefore do not have a water cooling system.

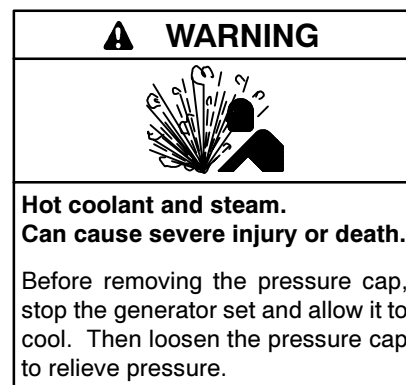

Checking the coolant level. Hot coolant can cause severe injury or death. Allow the engine to cool. Release pressure from the cooling system before removing the pressure cap. To release pressure, cover the pressure cap with a thick cloth and then slowly turn the cap counterclockwise to the first stop. Remove the cap after pressure has been completely released and the engine has cooled. Check the coolant level at the tank if the generator set has a coolant recovery tank.

Note: Engine damage. Bleed the air from the cooling system to prevent overheating and subsequent engine damage.

Note: Block heater damage. The block heater will fail if the energized heater element is not immersed in coolant. Fill the cooling system before turning on the block heater. Run the engine until it is warm, and refill the radiator to purge the air from the system before energizing the block heater.

3.8.1 Coolant Level Check

Check the coolant level in the coolant recovery tank, if equipped. Maintain the coolant level between the high and low marks.

Note: Periodically check the coolant level by removing the pressure cap. Do not rely solely on the level in the coolant recovery tank. Add fresh coolant until the level is just below the overflow tube opening of the filler neck.

3.8.2 Cooling System Component Inspection

To prevent generator shutdown or damage caused by overheating:

- Keep the cooling air inlets clean and unobstructed.
- Inspect the radiator's exterior for obstructions. Remove dirt and foreign material using a soft brush or cloth to avoid damaging the radiator fins.
- Check the hoses and connections for leaks. Replace any cracked, frayed, or spongy hoses.
- Check the condition and tension of the radiator fan and water pump belt(s). Follow the belt tension procedure in this manual and/or the engine operation manual.

- Check the pressure cap seal and replace a cracked or deteriorated cap. Remove dirt and other debris from the pressure cap and filler neck. The pressure cap raises the boiling point of the coolant, enabling higher operating temperatures. Replace a leaking pressure cap with one rated for the same pressure. The pressure cap rating usually appears on the pressure cap.

x:sm:003:003

3.8.3 Cooling System Drainage Procedure

For optimum protection, drain, flush, and refill the cooling system at the intervals listed in the service schedule.

Note: Dispose of all waste materials (oil, fuel, coolant, filters, and gaskets) in an environmentally safe manner.

1. Deenergize the block heater, if equipped.
2. Remove the pressure cap to allow the entire system to drain and prevent air pockets from restricting coolant flow through the engine block.
3. Open the radiator and/or engine block coolant drain valve(s) and allow the system to drain.
4. If the inside of the radiator has mineral deposits or the used coolant contains dirt or grease, refer to Section 3.8.4, Cooling System Flush and Clean Procedure. If the cooling system does not have mineral deposits, go to Section 3.8.5, Cooling System Refilling Procedure.

x:sm:003:004

3.8.4 Cooling System Flush and Clean Procedure

Use the instructions in the engine operation manual when available to flush and clean the cooling system. Otherwise, use the following procedure and the cooling system cleaner manufacturer's instructions.

1. Flush the cooling system with clean water.
2. If the inside of the radiator still has mineral deposits, use a radiator cleaner to remove the remaining deposits following the manufacturer's instructions.
3. Drain, clean, and flush the coolant recovery tank.

x:sm:003:005

3.8.5 Cooling System Refilling Procedure

See the generator set spec sheet for coolant capacity.

Note: Do not add coolant to a hot engine. Adding coolant to a hot engine can cause the cylinder block or cylinder head to crack. Wait until the engine has cooled.

1. Remove the pressure cap.
2. Close the radiator and/or engine block coolant drain valve(s) and tighten the cooling system hose clamps.
3. Open the air-bleed petcocks, if equipped. Close the air-bleed petcocks when coolant begins to flow from them.
4. Add coolant additives or water pump lubricants according to the engine manufacturer's recommendations in the engine operation manual.
5. Fill the cooling system with the recommended coolant/antifreeze mixture of 50% ethylene glycol and 50% clean, softened water to inhibit rust/corrosion and prevent freezing.

Note: A coolant solution of 50% ethylene glycol provides freezing protection to -37°C (-34°F) and overheating protection to 129°C (265°F). A coolant solution containing less than 50% ethylene glycol may not provide adequate freezing and overheating protection. A coolant solution containing more than 50% ethylene glycol can cause engine or component damage. Do not use alcohol or methanol antifreeze or mix them with the specified coolant. Refer to the engine operation manual for recommendations regarding the coolant mixture to use in extreme temperatures.

6. Replace the pressure cap.
7. Fill the coolant recovery tank to the low mark.
8. Operate the generator set until the thermostat opens when the upper cooling system hose warms.
9. Stop the engine and allow it to cool.

10. Remove the pressure cap.
11. Add coolant to bring the coolant level to just below the overflow tube opening of the filler neck.
12. Replace the pressure cap.
13. Maintain the coolant level in the coolant recovery tank between the high and low marks.

Note: Air pockets often form in the engine water jacket when the coolant system is refilled. Check the coolant level in the coolant recovery tank after each generator set operation and add coolant as necessary until the coolant level stabilizes. Then check the coolant at the interval specified in the service schedule.

14. Reenergize the block heater, if equipped.

x:sm:003:006

3.9 Radiator Expansion Joint Loosening—Initial Setup Only

Loosen the radiator expansion joint nuts on 1200–2000 kW generator sets that have radiators manufactured by Young Radiator Company. Expansion joints located on each side of the radiator permit differential thermal expansion of the radiator tank. The factory tightens the 12 expansion joint nuts before generator set shipment. Loosen the expansion joint nuts one full turn before running the generator set. See Figure 3-14.

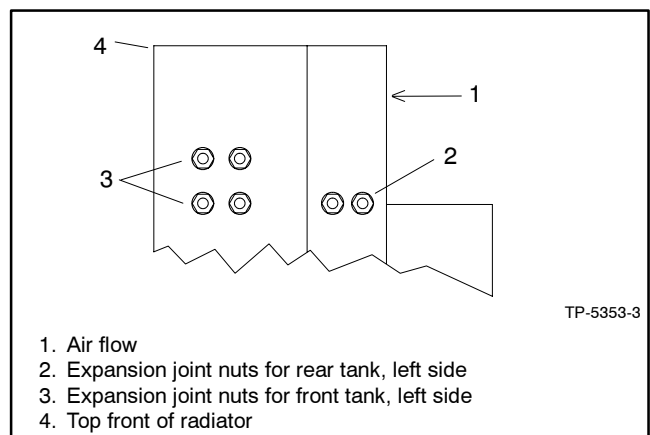

Figure 3-14 Expansion Joint Nuts, Top Left Side of Radiator, Typical

3.10 Fan Bearing Lubrication

The following procedure applies only to 1200–2000 kW generator sets. Lubricate the radiator fan shaft and idler shaft bearings at every engine oil change to avoid bearing damage. Lubricate the bearings every 200 hours of operation when the generator set runs in ambient temperatures below 29°C (85°F) or when the generator set runs in a dusty and/or humid environment.

Lubrication and Drive Belt Adjustment Procedure

Lubricate the fan shaft and idler shaft bearings with a lithium-complex base, multi-purpose grease with antirust, antifoam, and extreme-pressure additives having a minimum dropping point of 204°C (400°F). Use Mobil Mobilith AW2 NLGI Grade 2 or equivalent.

1. Place the generator set master switch in the OFF/RESET position.
2. Disconnect the generator set engine starting battery(ies), negative (-) lead first, and disconnect power to the battery charger.
3. Remove the belt guards to expose the fan shaft and idler shaft bearings.
4. Inject grease into the two bearings on the fan shaft block and the two bearings on the idler shaft block using a grease gun until a 3–6 mm (0.13–0.25 in.) grease column shows at the bearing pressure relief port. See Figure 3-15.

Note: The fan shaft and idler shaft bearings have pressure relief ports to prevent bearing damage caused by overlubrication.

5. Remove excess grease from the bearing pressure relief ports.
6. Inspect the fan drive belt and replace if it is damaged or worn. Check the fan belt tension using a poly V-belt tension gauge and adjust the tension, if necessary. See Figure 3-16.
7. Reinstall the belt guards using the original hardware.

8. Reconnect the generator set engine starting battery(ies), negative (-) lead last.
9. Test run the generator set for a few minutes and listen for belt noise (squeal) indicating a slipping belt. Stop the generator set.

If the belt slips after the belt tension procedure, clean the pulley surfaces and repeat the belt tension procedure. If slippage continues, replace the fan belt.

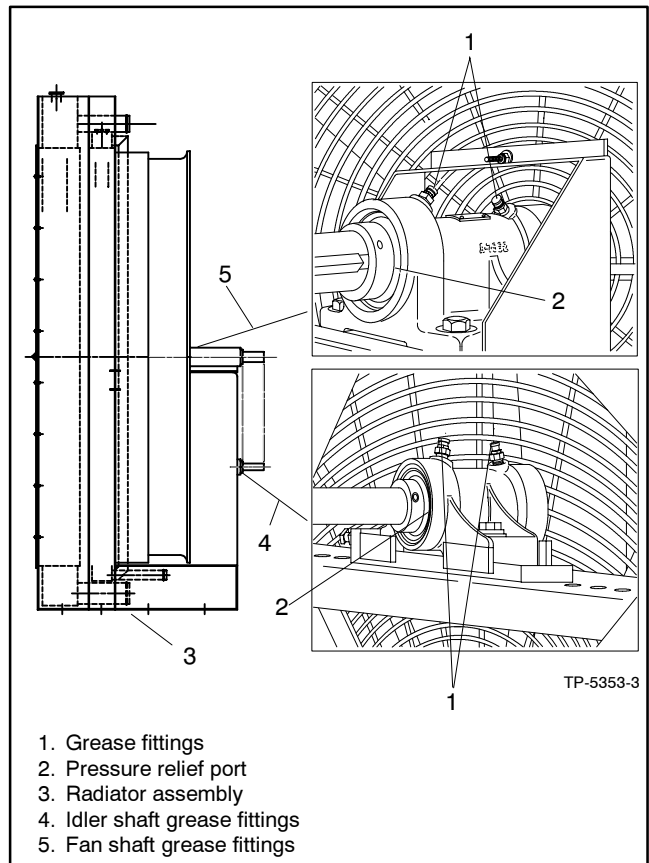

Figure 3-15 Radiator Fan Bearings and Pressure Relief Ports, Typical

Generator Set Model	New Belt, N (lbf.)	Used Belt,* N (lbf.)
1200-2000 kW	2450-2890 (550-650)	1650-1910 (370-430)

* A belt is considered used after 50 hours of service.

Figure 3-16 Poly V-Belt Tension Specifications

3.11 Battery

WARNING



**Sulfuric acid in batteries.
Can cause severe injury or death.**

Wear protective goggles and clothing. Battery acid may cause blindness and burn skin.

Battery gases. Explosion can cause severe injury or death. Battery gases can cause an explosion. Do not smoke or permit flames or sparks to occur near a battery at any time, particularly when it is charging. Do not dispose of a battery in a fire. To prevent burns and sparks that could cause an explosion, avoid touching the battery terminals with tools or other metal objects. Remove all jewelry before servicing the equipment. Discharge static electricity from your body before touching batteries by first touching a grounded metal surface away from the battery. To avoid sparks, do not disturb the battery charger connections while the battery is charging. Always turn the battery charger off before disconnecting the battery connections. Ventilate the compartments containing batteries to prevent accumulation of explosive gases.

Battery short circuits. Explosion can cause severe injury or death. Short circuits can cause bodily injury and/or equipment damage. Disconnect the battery before generator set installation or maintenance. Remove all jewelry before servicing the equipment. Use tools with insulated handles. Remove the negative (-) lead first when disconnecting the battery. Reconnect the negative (-) lead last when reconnecting the battery. Never connect the negative (-) battery cable to the positive (+) connection terminal of the starter solenoid. Do not test the battery condition by shorting the terminals together.

Battery electrolyte is a diluted sulfuric acid. Battery acid can cause severe injury or death. Battery acid can cause blindness and burn skin. Always wear splashproof safety goggles, rubber gloves, and boots when servicing the battery. Do not open a sealed battery or mutilate the battery case. If battery acid splashes in the eyes or on the skin, immediately flush the affected area for 15 minutes with large quantities of clean water. Seek immediate medical aid in the case of eye contact. Never add acid to a battery after placing the battery in service, as this may result in hazardous spattering of battery acid.

Battery acid cleanup. Battery acid can cause severe injury or death. Battery acid is electrically conductive and corrosive. Add 500 g (1 lb.) of bicarbonate of soda (baking soda) to a container with 4 L (1 gal.) of water and mix the neutralizing solution. Pour the neutralizing solution on the spilled battery acid and continue to add the neutralizing solution to the spilled battery acid until all evidence of a chemical reaction (foaming) has ceased. Flush the resulting liquid with water and dry the area.

Refer to this section for general battery information and maintenance. All generator set models use a negative ground with a 12-volt or 24-volt engine electrical system. Consult the generator set nameplate for the engine electrical system voltage. Consult the generator spec sheet for battery capacity recommendations for replacement purposes. The wiring diagrams provide battery connection information. See Figure 3-17, Figure 3-18, and Figure 3-19 for typical battery connections, including multiple battery configurations.

3.11.1 Cleaning

Clean the battery and cables and tighten the battery terminals according to the service schedule recommendations. Clean the battery by wiping it with a damp cloth. Keep the electrical connections dry and tight.

If corrosion exists, disconnect the cables from the battery and remove the corrosion with a wire brush. Clean the battery and cables with a solution of baking soda and water. Do not allow the cleaning solution to enter battery cells. Flush the battery and cables with clean water and wipe the battery with a dry cloth.

After reconnecting the battery cables, coat the terminals with petroleum jelly, silicon grease, or other nonconductive grease.

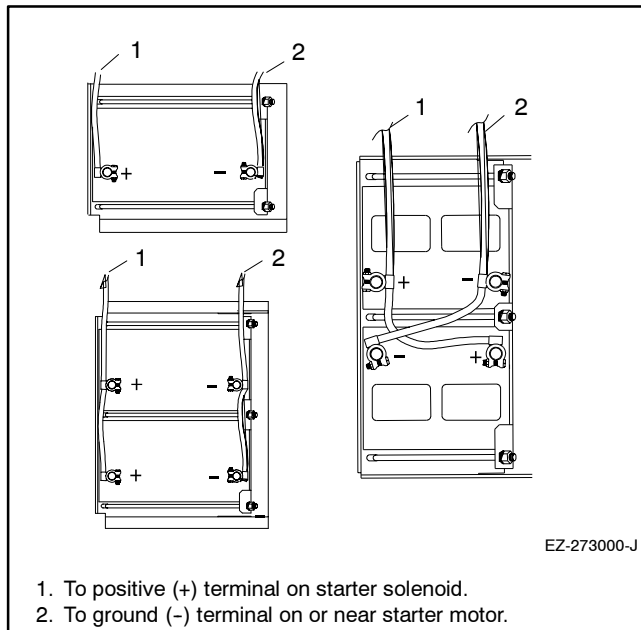

Figure 3-17 12-Volt Engine Electrical System Single Starter Motor Typical Battery Connection

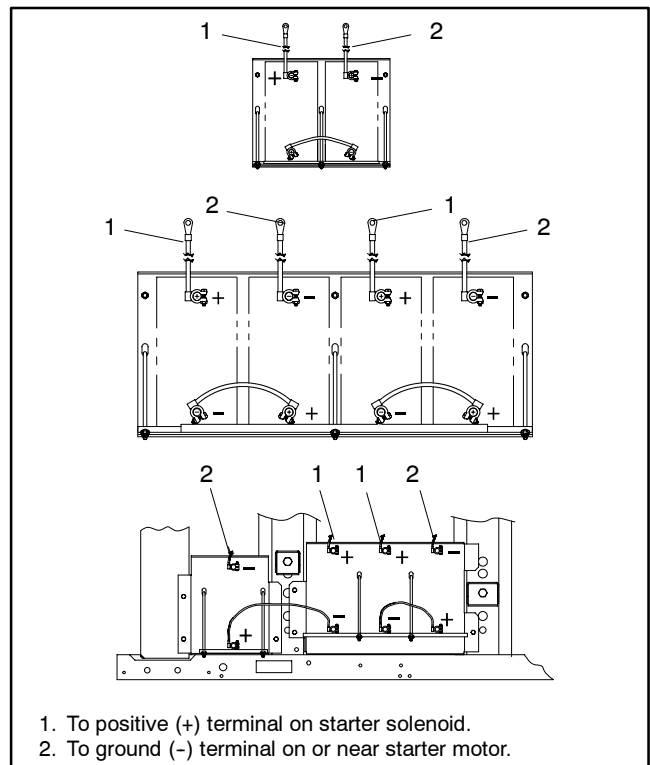

Figure 3-18 24-Volt Engine Electrical System Single Starter Motor Typical Battery Connection

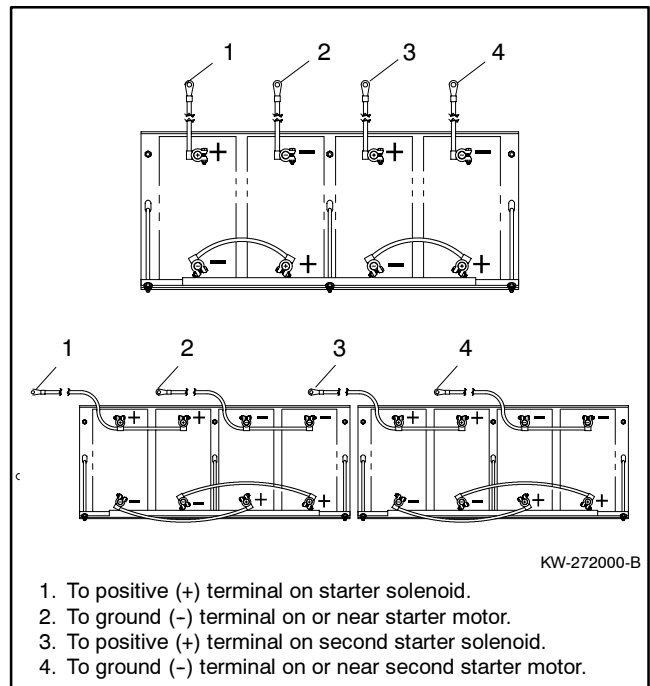

Figure 3-19 24-Volt Engine Electrical System Dual Starter Motors Typical Battery Connections

3.11.2 Electrolyte Level Inspection

Check the electrolyte level and specific gravity of batteries that have filler caps. Maintenance-free batteries do not require electrolyte level checking or specific gravity testing.

Check the electrolyte level before each startup. Remove the filler caps and verify that the electrolyte level reaches the bottom of each filler hole. See Figure 3-20. Refill as necessary with distilled water or clean tap water. Do not add fresh electrolyte. Tighten the filler caps. After adding water during freezing temperatures, run the generator set 20–30 minutes to mix the electrolyte and the water to prevent battery damage from freezing.

3.11.3 Specific Gravity Check

Use a battery hydrometer to check the specific gravity of the electrolyte in each battery cell of batteries with filler caps. Holding the hydrometer vertically, read the number on the glass bulb at the top of the electrolyte level or the number adjacent to the pointer. If the hydrometer used does not have a correction table, consult Figure 3-21. Determine the specific gravity and electrolyte temperature of the battery cells. Locate the temperature in Figure 3-21 and correct the specific gravity by the amount shown. The battery is fully charged if the specific gravity is 1.260 at an electrolyte temperature of 26.7°C (80°F). Maintain the specific gravities between cells within ±0.01 of each other. Charge the battery if the specific gravity is below 1.215 at an electrolyte temperature of 26.7°C (80°F).

Note: Some battery testers have four or five beads in a test tube. Draw electrolyte into the tube as with the battery hydrometer described in this section. Use the tester manufacturer’s instructions. Figure 3-22 shows typical test results.

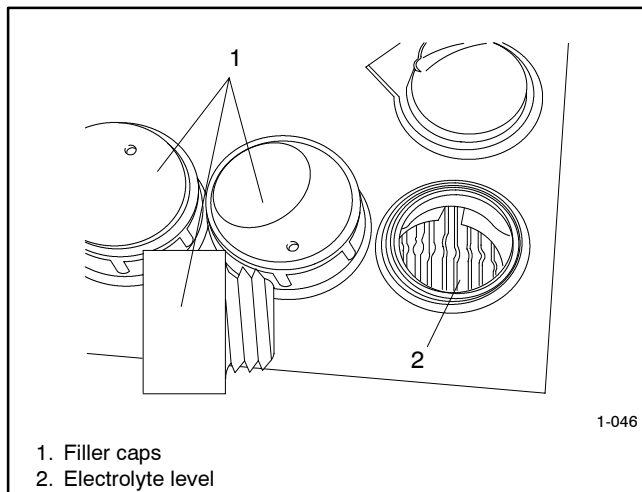

Figure 3-20 Battery Electrolyte Level Inspection

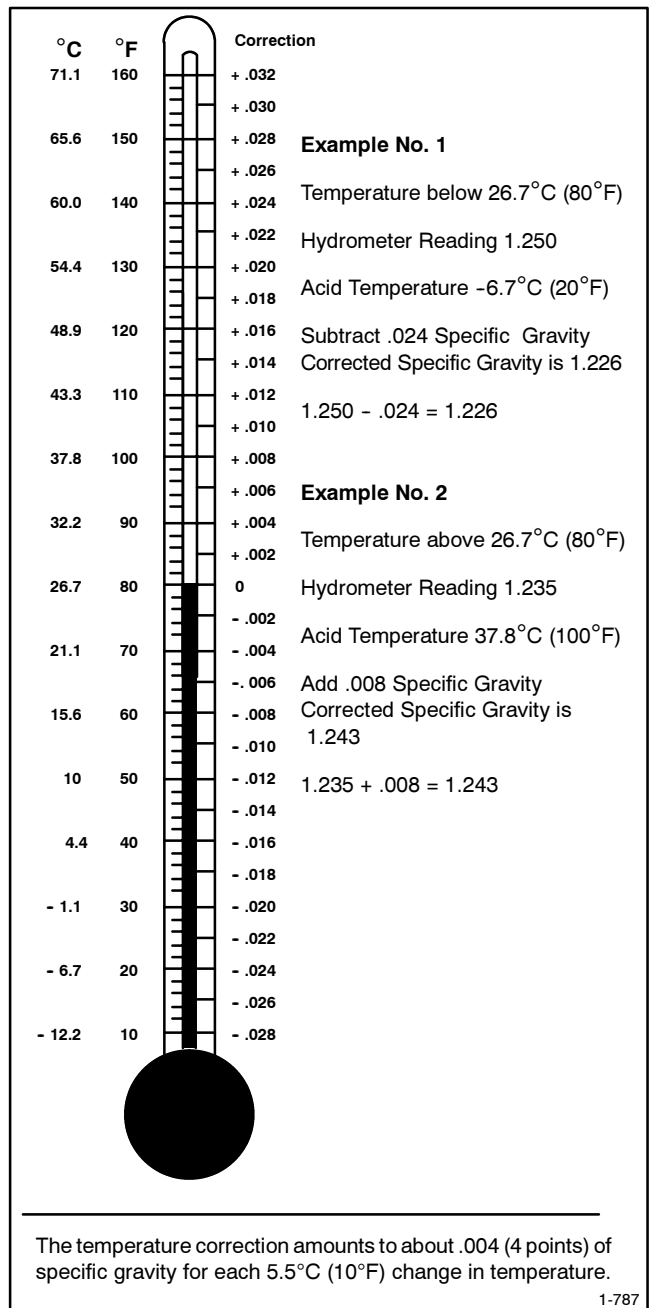

Figure 3-21 Specific Gravity Temperature Correction

Number of Floating Beads	Battery Condition
5	Overcharged
4	Fully charged
3	A good charge
1 or 2	A low charge
0	A dead battery

Figure 3-22 Bead-Type Test Interpretation

3.11.4 Charging

Use a battery charger to maintain a fully charged battery when the generator set is used in a standby application. The engine battery-charging alternator charges the battery only while the generator set is running.

Note: If the generator set is in a temporary prime power application in which the generator set has periods of inactivity, the controller circuitry may drain the battery. If there is no power source for a battery charger, place the controller in the prime power mode, if equipped, or disconnect the battery from the generator set.

3.12 Detroit Diesel Engine Control (DDEC) System

Some generator sets equipped with Detroit Diesel engines use a DDEC system. Access the DDEC control box inside the generator set junction box to retrieve codes when performing routine maintenance or troubleshooting the engine.

Use the following data for informational purposes only. Consult the engine operation manual or engine service manual for complete information regarding DDEC operation and troubleshooting. Contact an authorized service distributor/dealer for service or diagnostic equipment.

3.12.1 DDEC Features

The DDEC system optimizes control of critical engine functions and protects against serious engine damage resulting from conditions such as the following:

- Low coolant level
- Low coolant pressure
- High coolant temperature
- Low oil pressure
- High oil temperature

The major components of the DDEC system include the engine control module (ECM), engine sensors, and control box, which is located in the generator set junction box.

3.12.2 DDEC Engine Diagnostics

The DDEC engine protection system monitors engine sensors and electronic components and recognizes system malfunctions. Critical faults light the check engine (CEL) and stop engine (SEL) lamps on the

control box. ECM memory software logs malfunction codes. Consult the engine operation manual or engine service manual to identify the stored failure code. See Figure 3-23 for the DDEC control box features.

Access the stored codes in one of three ways:

- Place the switch in the DIAGNOSTIC REQUEST position. The CEL or SEL flashes to identify the failure.
- Use a hand-held diagnostic data reader (DDR). Place the switch in the DIAGNOSTIC DATA READER position. Plug the DDR into the control box. The DDR displays the stored failure codes.
- Use a personal computer software package with a translator to access stored codes. Follow the instructions provided with the software.

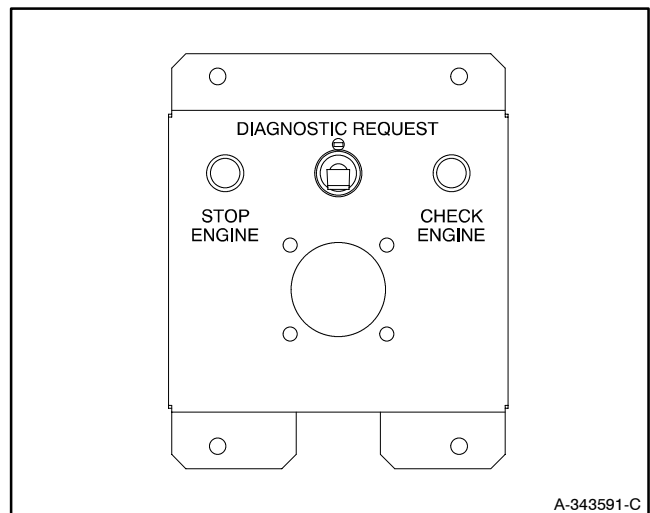

Figure 3-23 DDEC Control Box

Code Types

Active code. A code flashing on the SEL lamp indicates a fault currently exists.

Inactive code. A code flashing on the CEL lamp indicates a previous fault occurrence. The ECM memory stores inactive codes with time/date identification and the following information:

- First occurrence of each diagnostic code in engine operating hours.
- Last occurrence of each diagnostic code in engine operating hours.
- Total time in seconds that the diagnostic code was active.

3.13 Deutz Engine Control System

Some generator sets equipped with Deutz engines use an engine control system. Access the control box inside the generator set junction box to retrieve codes when performing routine maintenance or troubleshooting engine.

Use the following data for general informational purposes only. See the Engine Service Manual for complete information regarding operation and troubleshooting. Contact an authorized service distributor/dealer for service or diagnostic equipment.

Deutz Engine Control Features

The Deutz engine control is an advanced-technology, electronic engine control system. The system optimizes control of critical engine functions and provides protection against serious engine damage.

The major components include the electronic control module (ECM), engine sensors, and control box located in the generator set junction box. See Figure 3-24 for the Deutz control box features.

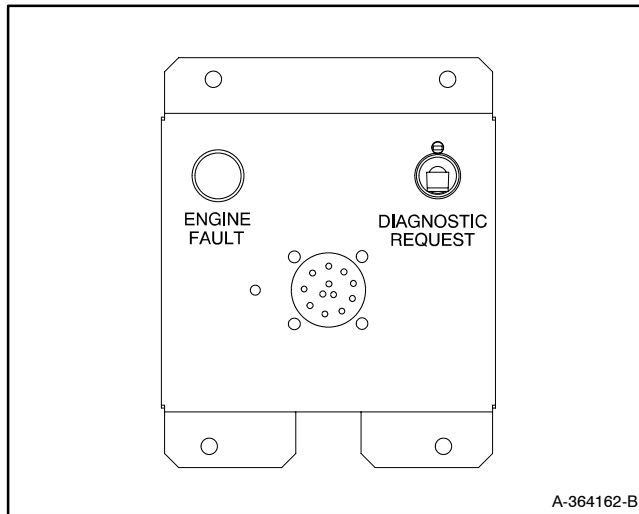

Figure 3-24 Deutz Control Box

3.14 Storage Procedure

Perform the following storage procedure before taking a generator set out of service for three months or longer. Follow the engine manufacturer's recommendations, if available, for fuel system and internal engine component storage.

x.sm:002:001

3.14.1 Lubricating System

Prepare the engine lubricating system for storage as follows:

1. Run the generator set for a minimum of 30 minutes to bring it to normal operating temperature.
2. Stop the generator set.
3. With the engine still warm, drain the oil from the crankcase.
4. Remove and replace the oil filter.
5. Refill the crankcase with oil suited to the climate.
6. Run the generator set for two minutes to distribute the clean oil.
7. Stop the generator set.
8. Check the oil level and adjust, if needed.

x.sm:002:002

3.14.2 Cooling System

Prepare the cooling system for storage as follows:

1. Check the coolant freeze protection using a coolant tester.
2. Add or replace coolant as necessary to ensure adequate freezing protection. Use the guidelines included in the engine operation manual.
3. Run the generator set for 30 minutes to redistribute added coolant.

x.sm:002:003

3.14.3 Fuel System

Prepare the fuel system for storage as follows:

Diesel-Fueled Engines

1. Fill the fuel tank with #2 diesel fuel.
2. Condition the fuel system with compatible additives to control microbial growth.
3. Change the fuel filter/separator and bleed the fuel system. See the engine owner's manual.

Gasoline-Fueled Engines

1. Add stabilizer to the fuel system. Follow the manufacturer's recommended procedure.
2. Run the generator set for 15 minutes to ensure that the stabilized fuel reaches the carburetor.
3. Place the generator set master switch in the OFF/RESET position.
4. Close the fuel valve.

Gas-Fueled Engines

1. Start the generator set.
2. With the generator set running, shut off the gas supply.
3. Run the generator set until the engine stops.
4. Place the generator set master switch in the OFF/RESET position.

3.14.4 Internal Engine Components (Gas/Gasoline-Fueled Engines)

If you have access to a fogging agent or SAE 10 oil prepare the pistons and cylinders for storage as follows:

1. While the engine is running, spray a fogging agent or SAE 10 engine oil into the air intake for about two minutes until the engine stops.
2. Place the generator set master switch in the OFF/RESET position.

If a fogging agent is not available perform the following:

1. Remove the spark plugs.
2. Pour 15 cc (0.5 oz.) of engine oil into each spark plug hole.

Ignition System Damage. Refer to the engine operation manual for ignition system precautions before cranking the engine while the spark plug wires are disconnected.

3. Toggle the generator set master switch to crank the engine two or three revolutions to lubricate the cylinders.
4. Reinstall the spark plugs and torque them to specifications.

x:sm:002:005

3.14.5 Exterior

1. Clean the exterior surface of the generator set.
2. Seal all engine openings except for the air intake with nonabsorbent adhesive tape.
3. To prevent impurities from entering the air intake and to allow moisture to escape from the engine, secure a cloth over the air intake.
4. Mask electrical connections.
5. Spread a light film of oil over unpainted metallic surfaces to inhibit rust and corrosion.

x:sm:002:006

3.14.6 Battery

Perform battery storage after all other storage procedures.

1. Place the generator set master switch in the OFF/RESET position.
2. Disconnect the battery(ies), negative (-) lead first.
3. Clean the battery. Refer to Section 3.11.1 for the battery cleaning procedure.
4. Place the battery in a cool, dry location.
5. Connect the battery to a float/equalize battery charger or charge it monthly with a trickle battery charger. Refer to the battery charger manufacturer's recommendations.

Maintain a full charge to extend battery life.

x:sm:002:007

Notes

Section 4 Troubleshooting

This section contains generator set troubleshooting, diagnostic, and repair information.

Use the chart on the following page to diagnose and correct common problems. First check for simple causes such as a dead engine starting battery or an open circuit breaker. The chart includes a list of common problems, possible causes of the problem, recommended corrective actions, and references to detailed information or repair procedures.

Maintain a record of repairs and adjustments performed on the equipment. If the procedures in this manual do not explain how to correct the problem, contact an authorized distributor/dealer. Use the record to help describe the problem and repairs or adjustments made to the equipment.

x:gt:001:002a:

Trouble Symptoms										Probable Causes	Recommended Actions	Section or Publication Reference*
Does not crank	Cranks but does not start	Starts hard	No or low output voltage	Stops suddenly	Lacks power	Overheats	Low oil pressure	High fuel consumption	Excessive or abnormal noise			
Controller												
x	x									Controller circuit board(s) inoperative	Replace the controller circuit board.	Gen. S/M
				x						Controller fault	Troubleshoot the controller.†	Gen. S/M
x	x			x						Controller fuse blown	Replace the blown controller fuse. If the fuse blows again, troubleshoot the controller.†	Section 2, W/D
x										Controller master switch inoperative	Replace the controller master switch.	—
x										Controller master switch in the OFF/RESET position	Move the controller master switch to the RUN or AUTO position.	Section 2
x										Engine start circuit open	Move the controller master switch to the RUN position to test the generator set. Troubleshoot the auto start circuit and time delays.	Section 2, W/D, Gen. I/M, S/M ATS O/M, S/M
Cooling System												
						x		x		Air openings clogged	Clean the air openings.	—
						x				Coolant level low	Restore the coolant to normal operating level.	Section 3
						x				Cooling water pump inoperative	Tighten or replace the belt. Replace the water pump.	Eng. O/M or S/M
				x						High temperature shutdown	Allow the engine to cool down. Then troubleshoot the cooling system.	Sec. 3, Eng. O/M
				x						Low coolant level shutdown, if equipped	Restore the coolant to normal operating level.	Section 3
						x				Thermostat inoperative	Replace the thermostat.	Eng. S/M
Electrical System (DC circuits)												
x	x									Battery connections loose, corroded, or incorrect	Verify that the battery connections are correct, clean, and tight.	Section 3
x	x									Battery weak or dead	Recharge or replace the battery. The spec sheet provides recommended battery CCA rating.	Section 3, S/S
x	x									Starter/starter solenoid inoperative	Replace the starter or starter solenoid.	Eng. S/M
x				x						Engine harness connector(s) not locked tight	Disconnect the engine harness connector(s) then reconnect it to the controller.	W/D
				x						High water temperature switch inoperative	Replace the inoperative switch.	Gen. S/M or W/D
				x						Fault shutdown	Reset the fault switches and troubleshoot the controller.	Section 2
				x						High exhaust temperature switch inoperative	Replace the inoperative switch.	Gen. S/M or W/D
* Sec./Section—numbered section of this manual; ATS—Automatic Transfer Switch; Eng.—Engine; Gen.—Generator Set; I/M—Installation Manual; O/M—Operation Manual; S/M—Service Manual; S/S—Spec Sheet; W/D—Wiring Diagram Manual												
† Have an authorized service distributor/dealer perform this service.												

Trouble Symptoms										Probable Causes	Recommended Actions	Section or Publication Reference*
Does not crank	Cranks but does not start	Starts hard	No or low output voltage	Stops suddenly	Lacks power	Overheats	Low oil pressure	High fuel consumption	Excessive or abnormal noise			
Engine												
	x	x			x			x		Air cleaner clogged	Clean or replace the filter element.	Eng. O/M
	x	x				x		x	x	Compression weak	Check the compression. †	Eng. S/M
			x		x	x		x	x	Engine overload	Reduce the electrical load. See the generator set spec sheet for wattage specifications.	S/S
									x	Exhaust system leak	Inspect the exhaust system. Replace the inoperative exhaust system components. †	I/M
									x	Exhaust system not securely installed	Inspect the exhaust system. Tighten the loose exhaust system components. †	I/M
		x	x		x			x		Governor inoperative	Adjust the governor. †	Gen. S/M
					x				x	Valve clearance incorrect	Adjust the valves. †	Eng. S/M
									x	Vibration excessive	Tighten all loose hardware.	—
	x	x			x					Ignition system inoperative (gas/gasoline only)	Check the ignition system (spark plugs, spark plug wires, etc.).	Eng. O/M
Fuel System												
	x	x			x					Air in fuel system (diesel only)	Bleed the diesel fuel system.	Eng. O/M
	x	x								Ether canister empty or system inoperative, if equipped (diesel only)	Replace or repair the ether starting system.	Eng. O/M
	x			x						Fuel tank empty or fuel valve shut off	Add fuel and move the fuel valve to the ON position.	—
	x				x			x		Fuel feed or injection pump inoperative (diesel only)	Rebuild or replace the injection pump. †	Eng. S/M
	x	x			x					Fuel or fuel injectors dirty or faulty (diesel only)	Clean, test, and/or replace the inoperative fuel injector. †	Eng. S/M
	x	x		x	x					Fuel filter restriction	Clean or replace the fuel filter.	Eng. O/M
	x									Fuel solenoid inoperative	Troubleshoot the fuel solenoid. †	Eng. S/M
	x				x					Fuel pressure insufficient (gas only)	Check the fuel supply and valves. †	S/S, Gen. O/M
	x	x			x			x		Fuel injection timing out of adjustment (diesel only)	Adjust the fuel injection timing. †	Eng. S/M
<p>* Sec./Section—numbered section of this manual; ATS—Automatic Transfer Switch; Eng.—Engine; Gen.—Generator Set; I/M—Installation Manual; O/M—Operation Manual; S/M—Service Manual; S/S—Spec Sheet; W/D—Wiring Diagram Manual</p> <p>† Have an authorized service distributor/dealer perform this service.</p>												

Trouble Symptoms										Probable Causes	Recommended Actions	Section or Publication Reference*
Does not crank	Cranks but does not start	Starts hard	No or low output voltage	Stops suddenly	Lacks power	Overheats	Low oil pressure	High fuel consumption	Excessive or abnormal noise			
Generator												
			x							AC output circuit breaker open	Reset the breaker and check for AC voltage at the generator side of the circuit breaker.	—
x										Transfer switch test switch in the OFF position	Move the transfer switch test switch to the AUTO position.	ATS O/M
			x							Transfer switch fails to transfer load	Move the ATS test switch to the AUTO position. Troubleshoot the transfer circuit and time delays.	ATS O/M, S/M
			x							Wiring, terminals, or pin in the exciter field open	Check for continuity.	Gen. S/M, W/D
			x							Main field (rotor) inoperative (open or grounded)	Test and/or replace the rotor.†	Gen. S/M
			x							Stator inoperative (open or grounded)	Test and/or replace the stator.†	Gen. S/M
									x	Vibration excessive	Tighten loose components.†	—
			x	x						Voltage regulator digital settings incorrect (digital controller only)	Adjust the voltage regulator.	Sec. 2, Menu 11
			x	x						Voltage regulator inoperative	Replace the voltage regulator fuse. If the fuse blows again, troubleshoot the voltage regulator.	Gen. S/M
			x	x						Voltage regulator out of adjustment	Adjust the voltage regulator.	Gen. S/M
Lube System												
	x	x					x		x	Crankcase oil type incorrect for ambient temperature	Change the oil. Use oil with a viscosity suitable for the operating climate.	Eng. O/M
						x	x		x	Oil level low	Restore the oil level. Inspect the generator set for oil leaks.	Eng. O/M
				x						Low oil pressure shutdown	Check the oil level.	Eng. O/M
<p>* Sec./Section—numbered section of this manual; ATS—Automatic Transfer Switch; Eng.—Engine; Gen.—Generator Set; I/M—Installation Manual; O/M—Operation Manual; S/M—Service Manual; S/S—Spec Sheet; W/D—Wiring Diagram Manual</p> <p>† Have an authorized service distributor/dealer perform this service.</p>												

Section 5 Generator Set Reconnection

5.1 Voltage Reconnection

To change the voltage of 12-lead generator sets, use the following voltage reconnection procedure. Adjust the governor and voltage regulator for frequency changes. Consult the generator set service manual for frequency adjustment information.

Voltage reconnection. Affix a notice to the generator set after reconnecting the set to a voltage different from the voltage on the nameplate. Order voltage reconnection decal 246242 from an authorized service distributor/dealer.

Equipment damage. Verify that the voltage ratings of the transfer switch, line circuit breakers, and other accessories match the selected line voltage.

⚠ WARNING

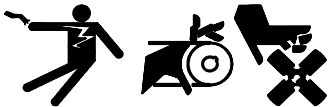

**Accidental starting.
Can cause severe injury or death.**

Disconnect the battery cables before working on the generator set. Remove the negative (-) lead first when disconnecting the battery. Reconnect the negative (-) lead last when reconnecting the battery.

Disabling the generator set. Accidental starting can cause severe injury or death. Before working on the generator set or equipment connected to the set, disable the generator set as follows: (1) Turn the generator set master switch and switchgear engine control switch to the OFF position. (2) Disconnect the power to the battery charger. (3) Remove the battery cables, negative (-) lead first. Reconnect the negative (-) lead last when reconnecting the battery. Follow these precautions to prevent the starting of the generator set by an automatic transfer switch or a remote start/stop switch.

Disabling the generator set. Accidental starting can cause severe injury or death. Before working on the generator set or connected equipment, disable the generator set as follows: (1) Move the generator set master switch to the OFF position. (2) Disconnect the power to the battery charger. (3) Remove the battery cables, negative (-) lead first. Reconnect the negative (-) lead last when reconnecting the battery. Follow these precautions to prevent starting of the generator set by an automatic transfer switch, remote start/stop switch, or engine start command from a remote computer.

⚠ WARNING

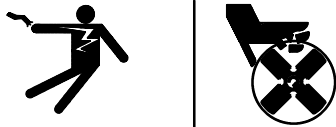

**Hazardous voltage. Moving rotor.
Can cause severe injury or death.**

Operate the generator set only when all guards and electrical enclosures are in place.

Short circuits. Hazardous voltage/current can cause severe injury or death. Short circuits can cause bodily injury and/or equipment damage. Do not contact electrical connections with tools or jewelry while making adjustments or repairs. Remove all jewelry before servicing the equipment.

Reconnect the generator set stator leads to change the output phase or voltage. Refer to the following procedure and the connection schematics in Figure 5-5 or Figure 5-6. Follow the safety precautions at the front of this manual and in the text and observe National Electrical Code (NEC) guidelines.

Voltage Reconnection Procedure

1. Place the generator set master switch in the OFF/RESET position.
2. Disconnect the generator set engine starting battery, negative (-) lead first. Disconnect power to the battery charger (if equipped).
3. Use Figure 5-5 or Figure 5-6 to determine the generator set voltage configuration. Note the original voltage and reconnect as needed. Route leads through current transformers (CTs) and connect them according to the diagram for desired phase and voltage.

Note: Position current transformers CT1, CT2, and CT3 with the dot or HI side toward the generator set.

Note: Only generator sets equipped with AC meter controllers and/or safeguard circuit breakers require CTs.

4. If the controller has meters, remove the controller cover and reposition the meter scale lamp jumper (see Figure 5-1) to match the position for desired voltage (shown in Figure 5-5 or Figure 5-6). Replace the controller cover.

5. The overvoltage shutdown is standard on Decision-Maker™ 3+ controllers and optional on Decision-Maker™ 3 controllers. A circuit board mounted to the back of the Decision-Maker™ 3 controller frequency meter indicates the presence of an overvoltage shutdown kit.

- a. If the generator set has a Decision-Maker™ 3 without overvoltage shutdown, go to step 6.
- b. The 139/240 volt (low wye) and 277/480 volt (high wye), 3-phase, 4-wire, 60 Hz configurations use different overvoltage shutdown settings than all other configurations. Recalibrate the overvoltage shutdown if the reconnection changes the voltage to or from one of these configurations. See Section 5.2, Overvoltage Shutdown Adjustment. Do not recalibrate the overvoltage adjustment for other voltage changes.

6. If the controller has meters, set the phase selector switch to the L1-L2 position (1-phase or 3-phase depending on generator set connection). Connect a voltmeter across leads L1 and L2 if the controller has no meters.

7. Reconnect the starting battery, negative (-) lead last. Place the generator set master switch in the RUN position to start the generator set. Check the voltmeter to verify that the voltage changed to the desired value.

- a. 20–300 kW Models: Adjust the voltage with the voltage adjustment potentiometer on the generator set controller front panel or switchgear. See Figure 5-2.
- b. 350–2000 kW Models: Adjust the voltage with the voltage adjustment potentiometer on the voltage regulator or switchgear. Use the applicable technical manual for voltage regulator adjustment.

8. Stop the generator set after completing the voltage adjustment. Replace the controller cover.

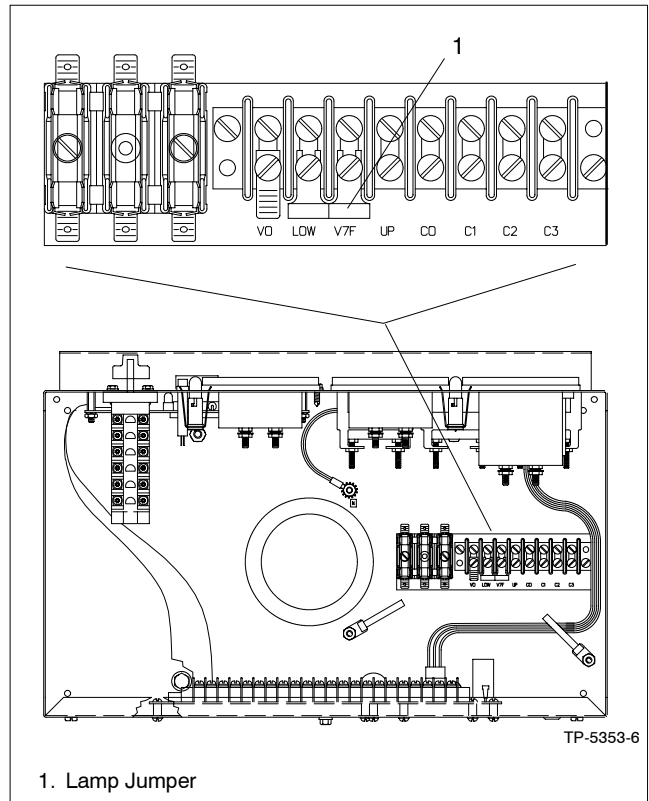

Figure 5-1 Meter Scale Lamp Jumper

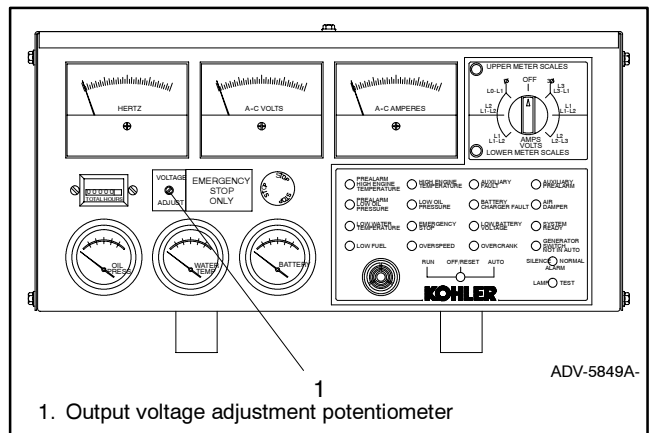

Figure 5-2 Voltage Adjustment

5.2 Overvoltage Shutdown Adjustment

The overvoltage shutdown is standard on Decision-Maker™ 3+ controllers and optional on Decision-Maker™ 3 controllers. A circuit board mounted to the back of the Decision-Maker™ 3 controller frequency meter indicates the presence of an overvoltage shutdown kit.

The 139/240 volt (low wye) and 277/480 volt (high wye), 3-phase, 4-wire, 60 Hz configurations use different overvoltage shutdown settings than all other configurations. Recalibrate the overvoltage shutdown if the reconnection changes the voltage to or from one of these configurations. Do not recalibrate the overvoltage adjustment for other voltage changes.

5.2.1 Decision-Maker 3+ Controller

Disconnecting the electrical load. Hazardous voltage can cause severe injury or death. Disconnect the generator set from the load by opening the line circuit breaker or by disconnecting the generator set output leads from the transfer switch and heavily taping the ends of the leads. High voltage transferred to the load during testing may cause personal injury and equipment damage. Do not use the safeguard circuit breaker in place of the line circuit breaker. The safeguard circuit breaker does not disconnect the generator set from the load.

Short circuits. Hazardous voltage/current can cause severe injury or death. Short circuits can cause bodily injury and/or equipment damage. Do not contact electrical connections with tools or jewelry while making adjustments or repairs. Remove all jewelry before servicing the equipment.

Procedure

1. Disconnect the generator set engine starting battery, negative (-) lead first. Disconnect power to the battery charger (if equipped).
2. With the generator set idle, open the output line circuit breaker to disconnect the load from the generator set.
3. Remove the controller cover.
4. Wrap the shaft of an insulated-handle screwdriver with electrical tape. Turn the overvoltage potentiometer (R41) on the main circuit board fully clockwise. See Figure 5-3.
5. Connect a digital AC voltmeter (or other highly accurate voltmeter) to terminals V0 and V7 on the controller terminal block. See Figure 5-1.

6. Reconnect the battery, negative (-) lead last.
7. Start the generator set by placing the generator set master switch in the RUN position.
8. Adjust the output voltage to 115% of the nominal output voltage by adjusting the potentiometer described in a or b. If the voltage configuration is 139/240 volts (low wye) or 277/480 volts (high wye), 3-phase, 4-wire, 60 Hz, adjust to produce approximately 160 volts across V0 and V7. For all other voltages, adjust to produce approximately 140 volts across V0 and V7.
 - a. 20–300 kW Models: Adjust the output voltage with the voltage adjustment potentiometer on the generator set controller front panel or switchgear. See Figure 5-2.
 - b. 350–2000 kW Models: Adjust the output voltage with the voltage adjustment potentiometer on the voltage regulator or switchgear. Use the applicable technical manual for voltage regulator adjustment.
9. Use the wrapped screwdriver to slowly rotate the overvoltage adjustment potentiometer (R41) counterclockwise until red LED4 lights. See Figure 5-3. The generator set should shut down on overvoltage fault in approximately 2 seconds.

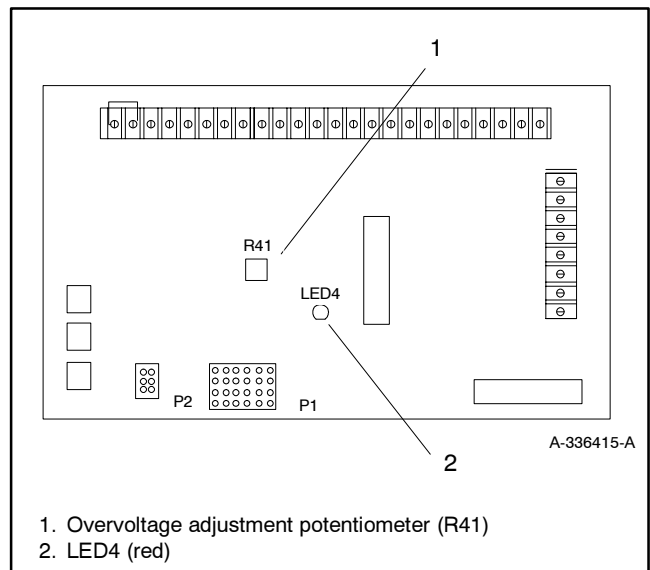

Figure 5-3 Overvoltage Shutdown Adjustment on Main Circuit Board

10. Turn the voltage adjustment potentiometer counterclockwise to reduce output voltage. Restart the generator set. Slowly increase voltage and verify the shutdown setting by observing the voltmeter and noting when red LED4 lights. The generator set should shut down on overvoltage fault in approximately 2 seconds. If shutdown voltage is not within tolerance, repeat the calibration output procedure; otherwise, continue to step 11.
11. Turn the voltage adjustment potentiometer counterclockwise to reduce output voltage. Restart the generator set. Readjust the generator set output to the nominal voltage.
12. Stop the generator set by placing the generator set master switch in the OFF/RESET position. Seal the overvoltage adjustment potentiometer (R41) with RTV sealant or equivalent. Replace the controller cover.

5.2.2 Decision-Maker 3 Controller

Disconnecting the electrical load. Hazardous voltage can cause severe injury or death. Disconnect the generator set from the load by opening the line circuit breaker or by disconnecting the generator set output leads from the transfer switch and heavily taping the ends of the leads. High voltage transferred to the load during testing may cause personal injury and equipment damage. Do not use the safeguard circuit breaker in place of the line circuit breaker. The safeguard circuit breaker does not disconnect the generator set from the load.

Short circuits. Hazardous voltage/current can cause severe injury or death. Short circuits can cause bodily injury and/or equipment damage. Do not contact electrical connections with tools or jewelry while making adjustments or repairs. Remove all jewelry before servicing the equipment.

Procedure

1. With the generator set idle, open the output line circuit breaker to disconnect the load from the generator set.
2. Remove the controller cover.
3. Check for the J1 jumper on the overvoltage circuit board. Install the J1 jumper if the generator set is connected for 139/240 volts (low wye) or 277/480 volts (high wye) 3-phase, 4-wire, 60 Hz. Remove the J1 jumper for all other voltages. See Figure 5-4.
4. Replace the cover.

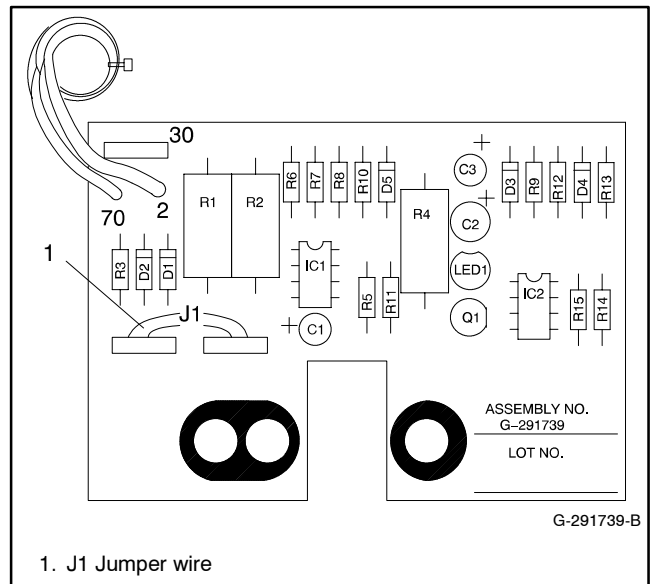
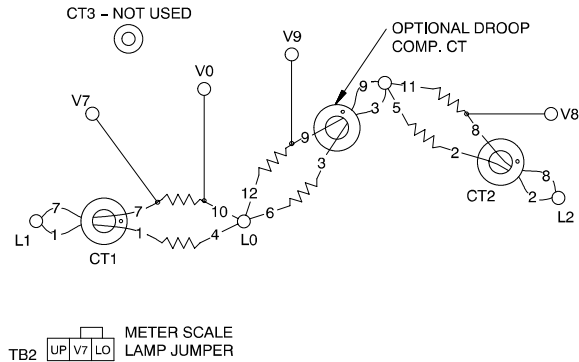

Figure 5-4 Overvoltage Shutdown Adjustment (Circuit Board Kit on Frequency Meter)

12 LEAD ALTERNATOR, 3 WIRE, SINGLE PHASE

60 HZ: 100/200V
 60 HZ: 120/240V
 50 HZ: 100/200V
 50 HZ: 110/220V

SOME SETS NOT RATED FOR SINGLE PHASE - SEE MANUALS



12 LEAD ALTERNATOR, 4 WIRE, DELTA

60 HZ: 120/240V
 50 HZ: 110/220V

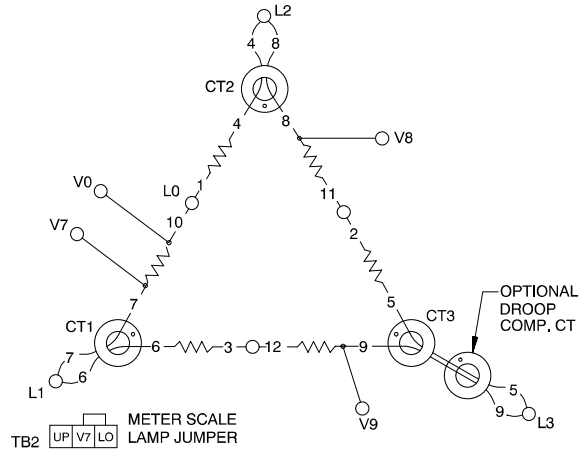

12 LEAD ALTERNATOR, 4 WIRE, LOW WYE

60 HZ: 120/208V
 60 HZ: 127/220V
 60 HZ: 139/240V
 50 HZ: 110/190V
 50 HZ: 115/200V
 50 HZ: 120/208V

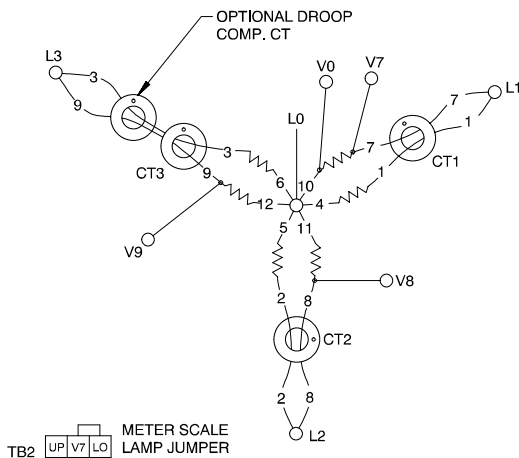

12 LEAD ALTERNATOR, 4 WIRE, HI WYE

60 HZ: 220/380V
 60 HZ: 240/416V
 60 HZ: 277/480V
 50 HZ: 220/380V
 50 HZ: 230/400V
 50 HZ: 240/416V

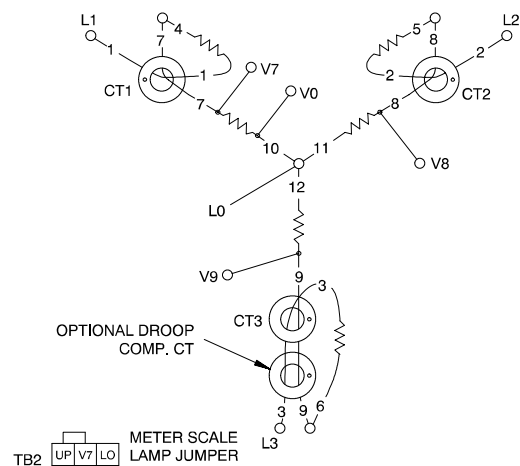

Reconnection Notes

Note: Position the current transformers with the dot or HI side CT mark toward the generator set. Some generator sets have no current transformers.

Note: Phase Rotation: A = L1, B = L2, and C = L3.

Note: All 12-lead generator sets are reconnectable. The 6-lead, 600-volt generator set is not reconnectable. Some specially wound stators made for a single voltage are also not reconnectable.

Note: (600-volt models only) Use 1 turn of the output lead through the current transformer on 6-lead, 600-volt stators. Some stators may have two turns of the output lead through the current transformer. Continue using the original factory two-turn current transformer wiring system.

6 LEAD ALTERNATOR, 4 WIRE, WYE

60 HZ: 347/600V

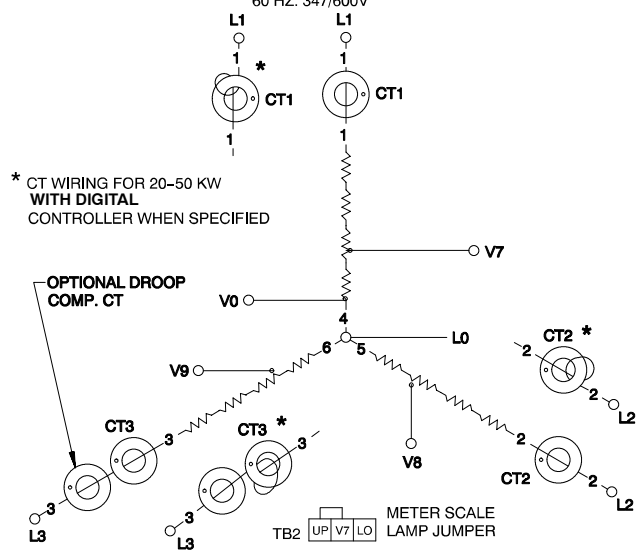

ADV-5875A-DI

Figure 5-5 Generator Set Reconnections, 20-300 kW Models

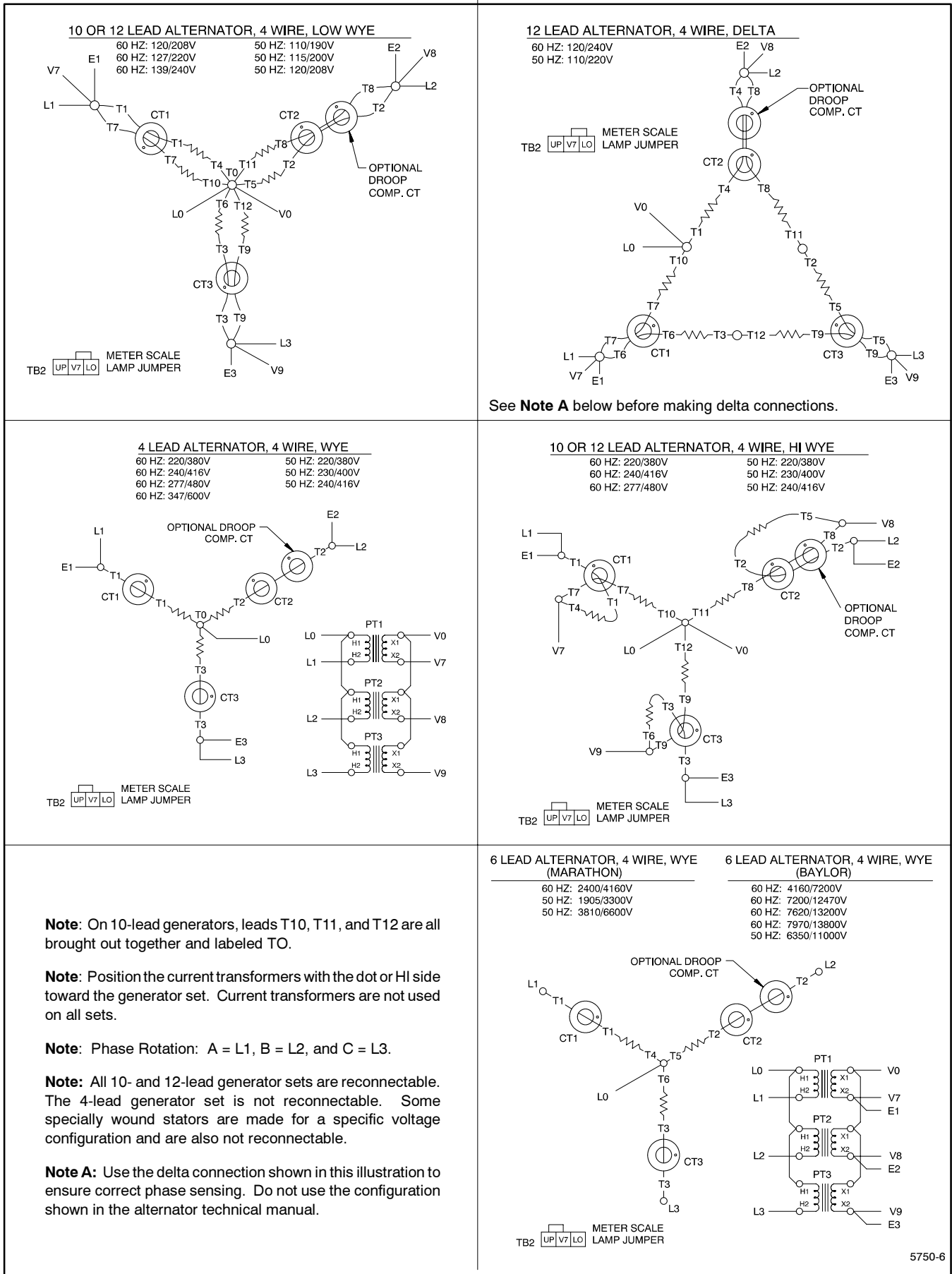

Figure 5-6 Generator Set Reconnections, 350–2000 kW Models

Appendix A Abbreviations

The following list contains abbreviations that may appear in this publication.

A, amp	ampere	CG	center of gravity	fglass.	fiberglass
ABDC	after bottom dead center	CID	cubic inch displacement	FHM	flat head machine (screw)
AC	alternating current	CL	centerline	fl. oz.	fluid ounce
A/D	analog to digital	cm	centimeter	flex.	flexible
ADC	analog to digital converter	CMOS	complementary metal oxide substrate (semiconductor)	freq.	frequency
adj.	adjust, adjustment			FS	full scale
ADV	advertising dimensional drawing	cogen.	cogeneration	ft.	foot, feet
AHWT	anticipatory high water temperature	Com	communications (port)	ft. lbs.	foot pounds (torque)
AISI	American Iron and Steel Institute	conn.	connection	ft./min.	feet per minute
ALOP	anticipatory low oil pressure	cont.	continued	g	gram
alt.	alternator	CPVC	chlorinated polyvinyl chloride	ga.	gauge (meters, wire size)
Al	aluminum	crit.	critical	gal.	gallon
ANSI	American National Standards Institute (formerly American Standards Association, ASA)	CRT	cathode ray tube	gen.	generator
		CSA	Canadian Standards Association	genset	generator set
AO	anticipatory only	CT	current transformer	GFI	ground fault interrupter
API	American Petroleum Institute	Cu	copper	GND, ⊕	ground
approx.	approximate, approximately	cu. in.	cubic inch	gov.	governor
AR	as required, as requested	cw.	clockwise	gph	gallons per hour
AS	as supplied, as stated, as suggested	CWC	city water-cooled	gpm	gallons per minute
ASE	American Society of Engineers	cyl.	cylinder	gr.	grade, gross
ASME	American Society of Mechanical Engineers	D/A	digital to analog	GRD	equipment ground
assy.	assembly	DAC	digital to analog converter	gr. wt.	gross weight
ASTM	American Society for Testing Materials	dB	decibel	H x W x D	height by width by depth
ATDC	after top dead center	dBA	decibel (A weighted)	HC	hex cap
ATS	automatic transfer switch	DC	direct current	HCHT	high cylinder head temperature
auto.	automatic	DCR	direct current resistance	HD	heavy duty
aux.	auxiliary	deg., °	degree	HET	high exhaust temperature
A/V	audiovisual	dept.	department	hex	hexagon
avg.	average	dia.	diameter	Hg	mercury (element)
AVR	automatic voltage regulator	DI/EO	dual inlet/end outlet	HH	hex head
AWG	American Wire Gauge	DIN	Deutsches Institut für Normung e. V. (also Deutsche Industrie Normenausschuss)	HHC	hex head cap
AWM	appliance wiring material			HP	horsepower
bat.	battery	DIP	dual inline package	hr.	hour
BBDC	before bottom dead center	DPDT	double-pole, double-throw	HS	heat shrink
BC	battery charger, battery charging	DPST	double-pole, single-throw	hsg.	housing
BCA	battery charging alternator	DS	disconnect switch	HVAC	heating, ventilation, and air conditioning
BCI	Battery Council International	DVR	digital voltage regulator	HWT	high water temperature
BDC	before dead center	E, emer.	emergency (power source)	Hz	hertz (cycles per second)
BHP	brake horsepower	EDI	electronic data interchange	IC	integrated circuit
blk.	black (paint color), block (engine)	EFR	emergency frequency relay	ID	inside diameter, identification
blk. htr.	block heater	e.g.	for example (<i>exempli gratia</i>)	IEC	International Electrotechnical Commission
BMEP	brake mean effective pressure	EG	electronic governor	IEEE	Institute of Electrical and Electronics Engineers
bps	bits per second	EGSA	Electrical Generating Systems Association	IMS	improved motor starting
br.	brass	EIA	Electronic Industries Association	in.	inch
BTDC	before top dead center	EI/EO	end inlet/end outlet	in. H ₂ O	inches of water
Btu	British thermal unit	EMI	electromagnetic interference	in. Hg	inches of mercury
Btu/min.	British thermal units per minute	emiss.	emission	in. lbs.	inch pounds
C	Celsius, centigrade	eng.	engine	Inc.	incorporated
cal.	calorie	EPA	Environmental Protection Agency	ind.	industrial
CARB	California Air Resources Board	EPS	emergency power system	int.	internal
CB	circuit breaker	ER	emergency relay	int./ext.	internal/external
cc	cubic centimeter	ES	engineering special, engineered special	I/O	input/output
CCA	cold cranking amps	ESD	electrostatic discharge	IP	iron pipe
ccw.	counterclockwise	est.	estimated	ISO	International Organization for Standardization
CEC	Canadian Electrical Code	E-Stop	emergency stop	J	joule
cfh	cubic feet per hour	etc.	et cetera (and so forth)	JIS	Japanese Industry Standard
cfm	cubic feet per minute	exh.	exhaust	k	kilo (1000)
		ext.	external	K	kelvin
		F	Fahrenheit, female	KA	kiloampere
				KB	kilobyte (2 ¹⁰ bytes)

kg	kilogram	MW	megawatt	rms	root mean square
kg/cm ²	kilograms per square centimeter	mW	milliwatt	rnd.	round
kgm	kilogram-meter	μF	microfarad	ROM	read only memory
kg/m ³	kilograms per cubic meter	N, norm.	normal (power source)	rot.	rotate, rotating
kHz	kilohertz	NA	not available, not applicable	rpm	revolutions per minute
kJ	kilojoule	nat. gas	natural gas	RS	right side
km	kilometer	NBS	National Bureau of Standards	RTV	room temperature vulcanization
kOhm, kΩ	kilo-ohm	NC	normally closed	SAE	Society of Automotive Engineers
kPa	kilopascal	NEC	National Electrical Code	scfm	standard cubic feet per minute
kph	kilometers per hour	NEMA	National Electrical Manufacturers Association	SCR	silicon controlled rectifier
kV	kilovolt	NFPA	National Fire Protection Association	s, sec.	second
kVA	kilovolt ampere	Nm	newton meter	SI	<i>Système international d'unites</i> , International System of Units
kVAR	kilovolt ampere reactive	NO	normally open	SI/EO	side in/end out
kW	kilowatt	no., nos.	number, numbers	sil.	silencer
kWh	kilowatt-hour	NPS	National Pipe, Straight	SN	serial number
kWm	kilowatt mechanical	NPSC	National Pipe, Straight-coupling	SPDT	single-pole, double-throw
L	liter	NPT	National Standard taper pipe thread per general use	SPST	single-pole, single-throw
LAN	local area network	NPTF	National Pipe, Taper-Fine	spec, specs	specification(s)
L x W x H	length by width by height	NR	not required, normal relay	sq.	square
lb.	pound, pounds	ns	nanosecond	sq. cm	square centimeter
lbm/ft ³	pounds mass per cubic feet	OC	overcrank	sq. in.	square inch
LCB	line circuit breaker	OD	outside diameter	SS	stainless steel
LCD	liquid crystal display	OEM	original equipment manufacturer	std.	standard
ld. shd.	load shed	OF	overfrequency	stl.	steel
LED	light emitting diode	opt.	option, optional	tach.	tachometer
Lph	liters per hour	OS	oversize, overspeed	TD	time delay
Lpm	liters per minute	OSHA	Occupational Safety and Health Administration	TDC	top dead center
LOP	low oil pressure	OV	overvoltage	TDEC	time delay engine cooldown
LP	liquefied petroleum	oz.	ounce	TDEN	time delay emergency to normal
LPG	liquefied petroleum gas	p., pp.	page, pages	TDES	time delay engine start
LS	left side	PC	personal computer	TDNE	time delay normal to emergency
L _{wa}	sound power level, A weighted	PCB	printed circuit board	TDOE	time delay off to emergency
LWL	low water level	pF	picofarad	TDON	time delay off to normal
LWT	low water temperature	PF	power factor	temp.	temperature
m	meter, milli (1/1000)	ph., ∅	phase	term.	terminal
M	mega (10 ⁶ when used with SI units), male	PHC	Phillips head crimptite (screw)	TIF	telephone influence factor
m ³	cubic meter	PHH	Phillips hex head (screw)	TIR	total indicator reading
m ³ /min.	cubic meters per minute	PHM	pan head machine (screw)	tol.	tolerance
mA	milliampere	PLC	programmable logic control	turbo.	turbocharger
man.	manual	PMG	permanent-magnet generator	typ.	typical (same in multiple locations)
max.	maximum	pot	potentiometer, potential	UF	underfrequency
MB	megabyte (2 ²⁰ bytes)	ppm	parts per million	UHF	ultrahigh frequency
MCM	one thousand circular mils	PROM	programmable read-only memory	UL	Underwriter's Laboratories, Inc.
MCCB	molded-case circuit breaker	psi	pounds per square inch	UNC	unified coarse thread (was NC)
meggar	megohmmeter	pt.	pint	UNF	unified fine thread (was NF)
MHz	megahertz	PTC	positive temperature coefficient	univ.	universal
mi.	mile	PTO	power takeoff	US	undersize, underspeed
mil	one one-thousandth of an inch	PVC	polyvinyl chloride	UV	ultraviolet, undervoltage
min.	minimum, minute	qt.	quart	V	volt
misc.	miscellaneous	qty.	quantity	VAC	volts alternating current
MJ	megajoule	R	replacement (emergency) power source	VAR	voltampere reactive
mJ	millijoule	rad.	radiator, radius	VDC	volts direct current
mm	millimeter	RAM	random access memory	VFD	vacuum fluorescent display
mOhm, mΩ	milliohm	RDO	relay driver output	VGA	video graphics adapter
MOhm, MΩ	megohm	ref.	reference	VHF	very high frequency
MOV	metal oxide varistor	rem.	remote	W	watt
MPa	megapascal	RFI	radio frequency interference	WCR	withstand and closing rating
mpg	miles per gallon	RH	round head	w/	with
mph	miles per hour	RHM	round head machine (screw)	w/o	without
MS	military standard	rly.	relay	wt.	weight
m/sec.	meters per second			xfrm	transformer
MTBF	mean time between failure				
MTBO	mean time between overhauls				
mtg.	mounting				

TP-5750 7/00g

© 1995, 1999, 2000, 2001 by Kohler Co. All rights reserved.

KOHLER[®] POWER SYSTEMS

KOHLER CO. Kohler, Wisconsin 53044
Phone 920-565-3381, Web site www.kohlergenerators.com
Fax 920-459-1646 (U.S.A. Sales), Fax 920-459-1614 (International)
For the nearest sales and service outlet in U.S.A. and Canada
Phone 1-800-544-2444

Kohler Power Systems
Asia Pacific Headquarters
7 Jurong Pier Road
Singapore 619159
Phone (65)264-6422, Fax (65)264-6455