

# Operation

## Industrial Generator Sets

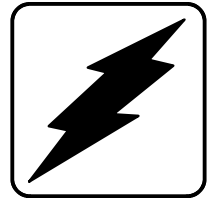

Models:

**20-2000 kW**

Controllers:

Decision-Maker™ 340

**KOHLER**<sup>®</sup>  
POWER SYSTEMS

**ISO 9001**  
**KOHLER**  
GENERATORS  
INTERNATIONALLY REGISTERED

TP-5829 2/97d



# Table of Contents

---

<b>Product Identification Information</b> .....	<b>Inside front cover</b>
<b>Safety Precautions and Instructions</b> .....	<b>I</b>
<b>Introduction</b> .....	<b>i</b>
<b>Service Assistance</b> .....	<b>ii</b>
<b>Section 1 Specifications and Features</b> .....	<b>1</b>
1.1 Introduction .....	1
1.2 Digital Controller Features .....	1
1.2.1 Annunciator Panel Lamps .....	2
1.2.2 Digital Display and Keypad .....	3
1.2.3 Switches and Controls .....	3
1.2.4 Controller Circuit Boards .....	4
1.2.5 Fuses .....	4
1.2.6 Terminal Strips .....	5
1.2.7 Communication Port .....	5
1.3 Controller Logic Specifications .....	6
<b>Section 2 Operation</b> .....	<b>9</b>
2.1 Prestart Checklist .....	9
2.2 Exercising the Generator Set .....	9
2.3 Digital Controller Operation .....	10
2.3.1 Starting .....	10
2.3.2 Stopping .....	10
2.3.3 Resetting Emergency Stop Switch .....	11
2.3.4 System Ready Lamp .....	11
2.3.5 System Warning .....	11
2.3.6 System Shutdown .....	13
2.3.7 Controller Resetting Procedure .....	15
2.4 Menu List Summary .....	15
2.5 Reviewing the Digital Display .....	20
2.5.1 Keypad Operation .....	20
2.5.2 Display Messages .....	21
2.6 Monitoring and Programming Setup .....	21
2.6.1 Personal Computer (PC) Communications .....	22
2.7 Local Programming Mode Off .....	24
2.7.1 Menu 1—Generator Output .....	25
2.7.2 Menu 2—Operational Records .....	26
2.7.3 Menu 3—Time & Date .....	28
2.7.4 Menu 4—Time Delays .....	29
2.7.5 Menu 5—User-Defined Functions .....	31
2.7.6 Menu 6—Generator System .....	35
2.7.7 Menu 7—Engine Status .....	37
2.7.8 Menu 8—Source History .....	38
2.7.9 Menu 9—Calibration .....	39
2.7.10 Menu 10—Remote Control .....	40

# Table of Contents, continued

---

2.8	Local Programming Mode On	42
2.8.1	Menu 1—Generator Output	43
2.8.2	Menu 2—Operational Records	44
2.8.3	Menu 3—Time & Date	46
2.8.4	Menu 4—Time Delays	47
2.8.5	Menu 5—User-Defined Functions	49
2.8.6	Menu 6—Generator System	54
2.8.7	Menu 7—Engine Status	57
2.8.8	Menu 8—Source History	59
2.8.9	Menu 9—Calibration	60
2.8.10	Menu 10—Remote Control	62
2.8.11	Menu 11—Programming Mode	65
<b>Section 3 Scheduled Maintenance</b>		<b>69</b>
3.1	Generator Service	69
3.2	Engine Service	69
3.3	Service Schedule	70
3.4	Generator Bearing	72
3.4.1	20-300 kW Models	72
3.4.2	350-2000 kW Models with Single- Bearing Generator	72
3.4.3	2000 kW Models with Two-Bearing Generator	72
3.5	Gas/Gasoline Fuel Systems	72
3.5.1	Gaseous Fuel System Concept	72
3.5.2	LP Liquid Withdrawal Fuel System Concept	72
3.5.3	LP Gas/Natural Gas Conversion for Straight Gas Fuel System	72
3.5.4	Fuel System Changeover Kits	73
3.5.5	Carburetor Adjustment	74
3.5.6	Fuel System Maintenance	74
3.6	Turbocharger Maintenance on Ford-Powered Models	74
3.6.1	Oil Type Recommendations	75
3.6.2	Turbocharger Oil Prime Procedure	75
3.6.3	Turbocharger Maintenance	75
3.7	Radiator Expansion Joint Loosening—Initial Setup Only	76
3.8	Fan Bearing Lubrication	76
3.9	Battery	77
3.9.1	Cleaning	78
3.9.2	Electrolyte Level Inspection	78
3.9.3	Specific Gravity Check	79
3.9.4	Charging	80
3.10	Detroit Diesel Engine Control (DDEC) System	80
3.10.1	DDEC Features	80
3.10.2	DDEC Engine Diagnostics	80
3.11	Deutz Engine Control System	81
3.12	Storage Procedure	81
3.12.1	Lubricating System	81
3.12.2	Cooling System	81
3.12.3	Fuel System	81
3.12.4	Internal Engine Components (Gas/Gasoline-Fueled Engines)	81
3.12.5	Exterior	82
3.12.6	Battery	82

## Table of Contents, continued

---

<b>Section 4 General Troubleshooting</b> .....	<b>83</b>
<b>Section 5 Generator Reconnection</b> .....	<b>85</b>
5.1 Voltage Reconnection .....	85
5.1.1 Introduction .....	85
5.1.2 Voltage Reconnection Procedure .....	86
<b>Section 6 Accessories</b> .....	<b>89</b>
6.1 Accessories .....	89
6.1.1 Audiovisual Alarm Kit .....	90
6.1.2 Common Failure Relay Kit .....	90
6.1.3 Controller (Customer) Connection Kit .....	91
6.1.4 Engine Prealarm Kit .....	92
6.1.5 Float/Equalize Battery Charger Kit with Alarm Option .....	93
6.1.6 Prime Power Switch Kit .....	94
6.1.7 Remote Annunciator Kit .....	94
6.1.8 Remote Emergency Stop Kit .....	96
6.1.9 Remote Reset Feature .....	97
6.1.10 Remote Speed Adjustment Potentiometer Kit .....	97
6.1.11 Run Relay Kit .....	98
6.1.12 Single-Relay Dry Contact Kit .....	98
6.1.13 Ten-Relay Dry Contact Kit .....	99
6.1.14 Voltage Adjustment Feature with Digital Voltage Regulator .....	100
6.2 Accessory and Prime Power Terminal Strip Connections .....	101
<b>Appendix A Abbreviations</b> .....	<b>A-1</b>
<b>Appendix B User-Defined Settings</b> .....	<b>A-3</b>

# Safety Precautions and Instructions

IMPORTANT SAFETY INSTRUCTIONS. Electromechanical equipment, including generator sets, transfer switches, switchgear, and accessories, can cause bodily harm and pose life-threatening danger when improperly installed, operated, or maintained. To prevent accidents be aware of potential dangers and act safely. Read and follow all safety precautions and instructions. **SAVE THESE INSTRUCTIONS.**

This manual has several types of safety precautions and instructions: Danger, Warning, Caution, and Notice.

## DANGER

Danger indicates the presence of a hazard that **will cause severe personal injury, death, or substantial property damage.**

## WARNING

Warning indicates the presence of a hazard that **can cause severe personal injury, death, or substantial property damage.**

## CAUTION

Caution indicates the presence of a hazard that **will or can cause minor personal injury or property damage.**

## NOTICE

Notice communicates installation, operation, or maintenance information that is safety related but not hazard related.

Safety decals affixed to the equipment in prominent places alert the operator or service technician to potential hazards and explain how to act safely. The decals are shown throughout this publication to improve operator recognition. Replace missing or damaged decals.

## Accidental Starting

### WARNING

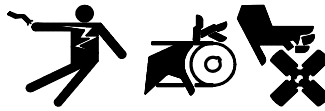

#### **Accidental starting. Can cause severe injury or death.**

Disconnect the battery cables before working on the generator set. Remove the negative (-) lead first when disconnecting the battery. Reconnect the negative (-) lead last when reconnecting the battery.

**Disabling the generator set. Accidental starting can cause severe injury or death.** Before working on the generator set or connected equipment, disable the generator set as follows: (1) Move the generator set master switch to the OFF position. (2) Disconnect the power to the battery charger. (3) Remove the battery cables, negative (-) lead first. Reconnect the negative (-) lead last when reconnecting the battery. Follow these precautions to prevent starting of the generator set by an automatic transfer switch, remote start/stop switch, or engine start command from a remote computer.

## Battery

### WARNING



#### **Sulfuric acid in batteries. Can cause severe injury or death.**

Wear protective goggles and clothing. Battery acid may cause blindness and burn skin.

### WARNING



#### **Explosion. Can cause severe injury or death. Relays in the battery charger cause arcs or sparks.**

Locate the battery in a well-ventilated area. Isolate the battery charger from explosive fumes.

**Battery electrolyte is a diluted sulfuric acid. Battery acid can cause severe injury or death.** Battery acid can cause blindness and burn skin. Always wear splashproof safety goggles, rubber gloves, and boots when servicing the battery. Do not open a sealed battery or mutilate the battery case. If battery acid splashes in the eyes or on the skin, immediately flush the affected area for 15 minutes with large quantities of clean water. Seek immediate medical aid in the case of eye contact. Never add acid to a battery after placing the battery in service, as this may result in hazardous spattering of battery acid.

**Battery gases. Explosion can cause severe injury or death.** Battery gases can cause an explosion. Do not smoke or permit flames or sparks to occur near a battery at any time, particularly when it is charging. Do not dispose of a battery in a fire. To prevent burns and sparks that could cause an explosion, avoid touching the battery terminals with tools or other metal objects. Remove wristwatch, rings, and other jewelry before servicing the equipment. Discharge static electricity from your body before touching batteries by first touching a grounded metal surface away from the battery. To avoid sparks, do not disturb the battery charger connections while the battery is charging. Always turn the battery charger off before disconnecting the battery connections. Ventilate the compartments containing batteries to prevent accumulation of explosive gases.

## Engine Backfire/Flash Fire

<b>⚠ WARNING</b>

<b>Fire.</b> <b>Can cause severe injury or death.</b>  Do not smoke or permit flames or sparks near fuels or the fuel system.

**Servicing the fuel system. A flash fire can cause severe injury or death.** Do not smoke or permit flames or sparks near the carburetor, fuel line, fuel filter, fuel pump, or other potential sources of spilled fuels or fuel vapors. Catch fuels in an approved container when removing the fuel line or carburetor.

**Servicing the air cleaner. A sudden backfire can cause severe injury or death.** Do not operate the generator set with the air cleaner removed.

**Combustible materials. A fire can cause severe injury or death.** Generator set engine fuels and fuel vapors are flammable and explosive. Handle these materials carefully to minimize the risk of fire or explosion. Equip the compartment or nearby area with a fully charged fire extinguisher. Select a fire extinguisher rated ABC or BC for electrical fires or as recommended by the local fire code or an authorized agency. Train all personnel on fire extinguisher operation and fire prevention procedures.

## Exhaust System

<b>⚠ WARNING</b>

<b>Carbon monoxide.</b> <b>Can cause severe nausea, fainting, or death.</b>  The exhaust system must be leakproof and routinely inspected.

**Generator set operation. Carbon monoxide can cause severe nausea, fainting, or death.** Carbon monoxide is an odorless, colorless, tasteless, nonirritating gas that can cause death if inhaled for even a short time. Avoid breathing exhaust fumes when working on or near the generator set. Never operate the generator set inside a building unless the exhaust gas is piped safely outside. Never operate the generator set where exhaust gas could accumulate and seep back inside a potentially occupied building.

**Carbon monoxide symptoms. Carbon monoxide can cause severe nausea, fainting, or death.** Carbon monoxide is a poisonous gas present in exhaust gases. Carbon monoxide poisoning symptoms include but are not limited to the following:

- Light-headedness, dizziness
- Physical fatigue, weakness in joints and muscles
- Sleepiness, mental fatigue, inability to concentrate or speak clearly, blurred vision
- Stomachache, vomiting, nausea

If experiencing any of these symptoms and carbon monoxide poisoning is possible, seek fresh air immediately and remain active. Do not sit, lie down, or fall asleep. Alert others to the possibility of carbon monoxide poisoning. Seek medical attention if the condition of affected persons does not improve within minutes of breathing fresh air.

**Copper tubing exhaust systems. Carbon monoxide can cause severe nausea, fainting, or death.** Do not use copper tubing in diesel exhaust systems. Sulfur in diesel exhaust causes rapid deterioration of copper tubing exhaust systems, resulting in exhaust leakage.

## Fuel System

---

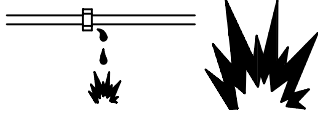
<b>⚠ WARNING</b>

<b>Explosive fuel vapors.</b> <b>Can cause severe injury or death.</b>  Use extreme care when handling, storing, and using fuels.

---

**The fuel system. Explosive fuel vapors can cause severe injury or death.** Vaporized fuels are highly explosive. Use extreme care when handling and storing fuels. Store fuels in a well-ventilated area away from spark-producing equipment and out of the reach of children. Never add fuel to the tank while the engine is running because spilled fuel may ignite on contact with hot parts or from sparks. Do not smoke or permit flames or sparks to occur near sources of spilled fuel or fuel vapors. Keep the fuel lines and connections tight and in good condition. Do not replace flexible fuel lines with rigid lines. Use flexible sections to avoid fuel line breakage caused by vibration. Do not operate the generator set in the presence of fuel leaks, fuel accumulation, or sparks. Repair fuel systems before resuming generator set operation.

**Explosive fuel vapors can cause severe injury or death.** Take additional precautions when using the following fuels:

**Gasoline**—Store gasoline only in approved red containers clearly marked GASOLINE.

**Propane (LP)**—Adequate ventilation is mandatory. Because propane is heavier than air, install propane gas detectors low in a room. Inspect the detectors per the manufacturer's instructions.

**Natural Gas**—Adequate ventilation is mandatory. Because natural gas rises, install natural gas detectors high in a room. Inspect the detectors per the manufacturer's instructions.

**Fuel tanks. Explosive fuel vapors can cause severe injury or death.** Gasoline and other volatile fuels stored in day tanks or subbase fuel tanks can cause an explosion. Store only diesel fuel in tanks.

**Draining the fuel system. Explosive fuel vapors can cause severe injury or death.** Spilled fuel can cause an explosion. Use a container to catch fuel when draining the fuel system. Wipe up spilled fuel after draining the system.

**Gas fuel leaks. Explosive fuel vapors can cause severe injury or death.** Fuel leakage can cause an explosion. Check the LP vapor gas or natural gas fuel system for leakage by using a soap and water solution with the fuel system test pressurized to 6–8 ounces per square inch (10–14 inches water column). Do not use a soap solution containing either ammonia or chlorine because both prevent bubble formation. A successful test depends on the ability of the solution to bubble.

**LP liquid withdrawal fuel leaks. Explosive fuel vapors can cause severe injury or death.** Fuel leakage can cause an explosion. Check the LP liquid withdrawal gas fuel system for leakage by using a soap and water solution with the fuel system test pressurized to at least 90 psi (621 kPa). Do not use a soap solution containing either ammonia or chlorine because both prevent bubble formation. A successful test depends on the ability of the solution to bubble.

## Hazardous Noise

**CAUTION**



**Hazardous noise. Can cause hearing loss.**

Never operate the generator set without a muffler or with a faulty exhaust system.

**Engine noise. Hazardous noise can cause hearing loss.** Generator sets not equipped with sound enclosures can produce noise levels greater than 105 dBA. Prolonged exposure to noise levels greater than 85 dBA can cause permanent hearing loss. Wear hearing protection when near an operating generator set.

## Hazardous Voltage/ Electrical Shock

<b>⚠ DANGER</b>

<b>Hazardous voltage. Will cause severe injury or death.</b> Disconnect all power sources before opening the enclosure.

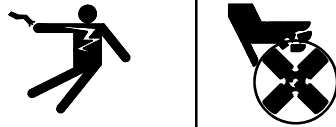
*(over 600 volts)*

<b>⚠ WARNING</b>

<b>Hazardous voltage. Moving rotor. Can cause severe injury or death.</b> Operate the generator set only when all guards and electrical enclosures are in place.

<b>⚠ WARNING</b>

<b>Hazardous voltage. Backfeed to the utility system can cause property damage, severe injury, or death.</b> If the generator set is used for standby power, install an automatic transfer switch to prevent inadvertent interconnection of standby and normal sources of supply.

**Grounding electrical equipment. Hazardous voltage can cause severe injury or death.** Electrocutation is possible whenever electricity is present. Open the main circuit breakers of all power sources before servicing the equipment. Configure the installation to electrically ground the generator set, transfer switch, and related equipment and electrical circuits to comply with applicable codes and standards. Never contact electrical leads or appliances when standing in water or on wet ground because these conditions increase the risk of electrocution.

**Disconnecting the electrical load. Hazardous voltage can cause severe injury or death.** Disconnect the generator set from the load by opening the line circuit breaker or by disconnecting the generator set output leads from the transfer switch and heavily taping the ends of the leads. High voltage transferred to the load during testing may cause personal injury and equipment damage. Do not use the safeguard circuit breaker in place of the line circuit breaker. The safeguard circuit breaker does not disconnect the generator set from the load.

**High voltage test. Hazardous voltage can cause severe injury or death.** Follow the instructions of the test equipment manufacturer when performing high-voltage tests on the rotor or stator. An improper test procedure can damage equipment or lead to generator set failure.

**Testing the photo transistor circuit board. Hazardous voltage can cause severe injury or death.** When the end cover is removed, do not expose the photo transistor circuit board mounted on the generator set end bracket to any external light source, as exposure to light causes high voltage. Keep foreign sources of light away from the photo transistor circuit board during testing. Place black electrical tape over the LED on the circuit board before starting the generator set.

**Installing the photo transistor circuit board. Hazardous voltage can cause severe injury or death.** Ensure that the foil side of the photo transistor circuit board, the end of the shaft, and the threaded holes are clean and free of metal particles and chips. Metal debris may short-circuit the photo transistor circuit board and cause hazardous voltage in the generator set. Do not reconnect the generator set to the load until the AC voltmeter shows the correct output.

**Connecting the SCR assembly. Hazardous voltage can cause severe injury or death.** Connect leads C and E to the corresponding terminals of the one-piece SCR assembly. The SCR assembly will turn full on and cause hazardous output voltage if the leads are connected in reverse or if the C (red) lead is grounded.  
*(One-piece SCR models only. Does not apply to current split activator models.)*

**Installing the battery charger. Hazardous voltage can cause severe injury or death.** An ungrounded battery charger may cause electrical shock. Connect the battery charger enclosure to the ground of a permanent wiring system. As an alternative, install an equipment grounding conductor with circuit conductors and connect it to the equipment grounding terminal or the lead on the battery charger. Install the battery charger as prescribed in the equipment manual. Install the battery charger in compliance with local codes and ordinances.

**Connecting the battery and the battery charger. Hazardous voltage can cause severe injury or death.** Reconnect the battery correctly, positive to positive and negative to negative, to avoid electrical shock and damage to the battery charger and battery(ies). Have a qualified electrician install the battery(ies).

**Servicing the day tank. Hazardous voltage can cause severe injury or death.** Service the day tank electrical control module (ECM) as prescribed in the equipment manual. Disconnect the power to the day tank before servicing. Press the day tank ECM OFF pushbutton to disconnect the power. Notice that line voltage is still present within the ECM when the POWER ON light is lit. Ensure that the generator set and day tank are electrically grounded. Do not operate the day tank when standing in water or on wet ground because these conditions increase the risk of electrocution.

**Short circuits. Hazardous voltage/current can cause severe injury or death.** Short circuits can cause bodily injury and/or equipment damage. Do not contact electrical connections with tools or jewelry while making adjustments or repairs. Remove wristwatch, rings, and jewelry before servicing the equipment.

**Testing the voltage regulator. Hazardous voltage can cause severe injury or death.** High voltage is present at the voltage regulator heat sink. To prevent electrical shock do not touch the voltage regulator heat sink when testing the voltage regulator.  
*(PowerBoost™, PowerBoost™ III, and PowerBoost™ V voltage regulator models only)*

**Engine block heater. Hazardous voltage can cause severe injury or death.** The engine block heater can cause electrical shock. Remove the engine block heater plug from the electrical outlet before working on the block heater electrical connections.

**Handling the capacitor. Hazardous voltage can cause severe injury or death.** Electrical shock results from touching the charged capacitor terminals. Discharge the capacitor by shorting the terminals together.  
*(Capacitor-excited models only)*

**Electrical backfeed to the utility. Hazardous backfeed voltage can cause severe injury or death.** Install a transfer switch in standby power installations to prevent the connection of standby and other sources of power. Electrical backfeed into a utility electrical system can cause serious injury or death to utility personnel working on power lines.

**Testing live electrical circuits. Hazardous voltage or current can cause severe injury or death.** Have trained and qualified personnel take diagnostic measurements of live circuits. Use adequately rated test equipment with electrically insulated probes and follow the instructions of the test equipment manufacturer when performing voltage tests. Observe the following precautions when performing voltage tests: (1) Remove rings, wristwatch, and jewelry. (2) Stand on a dry, approved electrically insulated mat. (3) Do not touch the enclosure or components inside the enclosure. (4) Be prepared for the system to operate automatically.  
*(600 volts and under)*

## Heavy Equipment

<b>⚠ WARNING</b>

<b>Unbalanced weight. Improper lifting can cause severe injury or death and equipment damage.</b> Do not use lifting eyes. Lift the generator set using lifting bars inserted through the lifting holes on the skid.

## Hot Parts

<b>⚠ WARNING</b>

<b>Hot coolant and steam.</b> <b>Can cause severe injury or death.</b>
Before removing the pressure cap, stop the generator set and allow it to cool. Then loosen the pressure cap to relieve pressure.

<b>⚠ WARNING</b>

<b>Hot engine and exhaust system.</b> <b>Can cause severe injury or death.</b>
Do not work on the generator set until it cools.



**Servicing the generator. Hot parts can cause severe injury or death.** Avoid touching the generator set field or exciter armature. When shorted, the generator set field and exciter armature become hot enough to cause severe burns.

**Checking the coolant level. Hot coolant can cause severe injury or death.** Allow the engine to cool. Release pressure from the cooling system before removing the pressure cap. To release pressure, cover the pressure cap with a thick cloth and then slowly turn the cap counterclockwise to the first stop. Remove the cap after pressure has been completely released and the engine has cooled. Check the coolant level at the tank if the generator set has a coolant recovery tank.

**Servicing the exhaust system. Hot parts can cause severe injury or death.** Do not touch hot engine parts. The engine and exhaust system components become extremely hot during operation.

**Combustible materials. Fire can cause severe injury or death.** A hot exhaust system can ignite adjacent combustible materials. Do not locate electrical wiring, fuel lines, or combustible materials above the exhaust muffler. Exercise caution when parking your vehicle to prevent the exhaust system and hot exhaust gases from starting grass fires.

## Moving Parts

<b>⚠ WARNING</b>	
	
<b>Hazardous voltage. Moving rotor.</b> <b>Can cause severe injury or death.</b>	
Operate the generator set only when all guards and electrical enclosures are in place.	

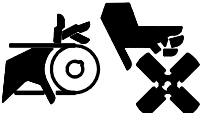
<b>⚠ WARNING</b>

<b>Rotating parts.</b> <b>Can cause severe injury or death.</b>
Operate the generator set only when all guards, screens, and covers are in place.

**Tightening the hardware. Flying projectiles can cause severe injury or death.** Loose hardware can cause the hardware or pulley to release from the generator set engine and can cause personal injury. Retorque all crankshaft and rotor hardware after servicing. Do not loosen the crankshaft hardware or rotor thribolt when making adjustments or servicing the generator set. Rotate the crankshaft manually in a clockwise direction only. Turning the crankshaft bolt or rotor thribolt counterclockwise can loosen the hardware.

**Servicing the generator set when it is operating. Exposed moving parts can cause severe injury or death.** Keep hands, feet, hair, clothing, and test leads away from the belts and pulleys when the generator set is running. Replace guards, screens, and covers before operating the generator set.

## Notice

<b>NOTICE</b>
<b>This generator set has been rewired from its nameplate voltage to</b>

246242

### NOTICE

**Voltage reconnection.** Affix a notice to the generator set after reconnecting the set to a voltage different from the voltage on the nameplate. Order voltage reconnection decal 246242 from an authorized service distributor/dealer.

### NOTICE

**Hardware damage.** The engine and generator set may use both American Standard and metric hardware. Use the correct size tools to prevent rounding of the bolt heads and nuts.

### NOTICE

**When replacing hardware, do not substitute with inferior grade hardware.** Screws and nuts are available in different hardness ratings. To indicate hardness, American Standard hardware uses a series of markings, and metric hardware uses a numeric system. Check the markings on the bolt heads and nuts for identification.

### NOTICE

**Canadian installations only.** For standby service connect the output of the generator set to a suitably rated transfer switch in accordance with Canadian Electrical Code, Part 1.

# Notes

This manual provides operation instructions for 20–2000 kW generator sets equipped with the following controller:

- Decision-Maker™ 340

Wiring diagram manuals are available separately.

Refer to the engine operation manual for generator set engine scheduled maintenance information.

x:in:001:001

This manual may be used for models not listed on the front cover.

Information in this publication represents data available at the time of print. Kohler Co. reserves the right to change this publication and the products represented without notice and without any obligation or liability whatsoever.

Read this manual and carefully follow all procedures and safety precautions to ensure proper equipment operation and to avoid bodily injury. Read and follow the Safety Precautions and Instructions section at the beginning of this manual. Keep this manual with the equipment for future reference.

The equipment service requirements are very important to safe and efficient operation. Inspect the parts often and perform required service at the prescribed intervals. Maintenance work must be performed by appropriately skilled and suitably-trained maintenance personnel familiar with generator set operation and service.

x:in:001:002:a

## List of Related Materials

Separate literature contains communication and software information not provided in this manual. The following table lists the available literature part numbers.

<b>Communication and Software Manual Description</b>	<b>Literature Part Number</b>
Communications Spec Sheet	G6-38
Decision-Maker™ 340 Controller Spec Sheet	G6-34
Decision-Maker™ 340 Software Operation Manual	TP-5823
Generator Set/Controller Wiring Diagram Manual	Contact your Distributor/Dealer
KBUS Communication Kits Installation	TT-1283
Modbus Interface Module	G6-43
Monitor II Software Operation/Installation Manual	TP-5972

# Service Assistance

---

Please contact a local authorized distributor/dealer for sales, service, or other information about Kohler Co. Generator Division products.

- Look on the product or in the information included with the product
- Consult the Yellow Pages under the heading Generators—Electric
- Visit the Kohler Co. Generator Division web site at [www.kohlergenerators.com](http://www.kohlergenerators.com)
- Inside the U.S.A. and Canada, call 1-800-544-2444
- Outside the U.S.A. and Canada, call the nearest regional office

## **Africa, Europe, Middle East**

London Regional Office  
Langley, Slough, England  
Phone: (44) 1753-580-771  
Fax: (44) 1753-580-036

## **Australia**

Australia Regional Office  
Queensland, Australia  
Phone: (617) 3893-0061  
Fax: (617) 3893-0072

## **China**

China Regional Office  
Shanghai, People's Republic of China  
Phone: (86) 21-6482 1252  
Fax: (86) 21-6482 1255

## **India, Bangladesh, Sri Lanka**

India Regional Office  
Bangalore, India  
Phone: (91) 80-2284270  
(91) 80-2284279  
Fax: (91) 80-2284286

## **Japan**

Japan Regional Office  
Tokyo, Japan  
Phone: (813) 3440-4515  
Fax: (813) 3440-2727

## **Latin America**

Latin America Regional Office  
Lakeland, Florida, U.S.A.  
Phone: (941) 619-7568  
Fax: (941) 701-7131

## **South East Asia**

Singapore Regional Office  
Singapore, Republic of Singapore  
Phone: (65) 264-6422  
Fax: (65) 264-6455

Xin:008:001

# Section 1 Specifications and Features

## 1.1 Introduction

The spec sheets for each generator set provide specific generator and engine information. The controller spec sheet provides specifications particular to each controller. Refer to the respective spec sheet for data not supplied in this manual. Consult the generator set service manual, installation manual, engine operation manual, and engine service manual for additional specifications.

## 1.2 Digital Controller Features

The digital controller features include the annunciator panel lamps, digital display and keypad, switches and

controls, and fuses and terminal strip. Each of these topics is covered in the following paragraphs.

**Note:** Press any key on the keypad to turn on the controller panel lights and display. The panel lights and display turn off 5 minutes after the last keypad entry.

**Note:** See Prime Power Mode under Section 1.2.6, Terminal Strips, if no display appears and the keypad is not functional. Refer to Section 6.1.6, Prime Power Switch Kit, for switch positions and function.

See Figure 1-1 for an illustration of the controller front panel and the following paragraphs for controller features.

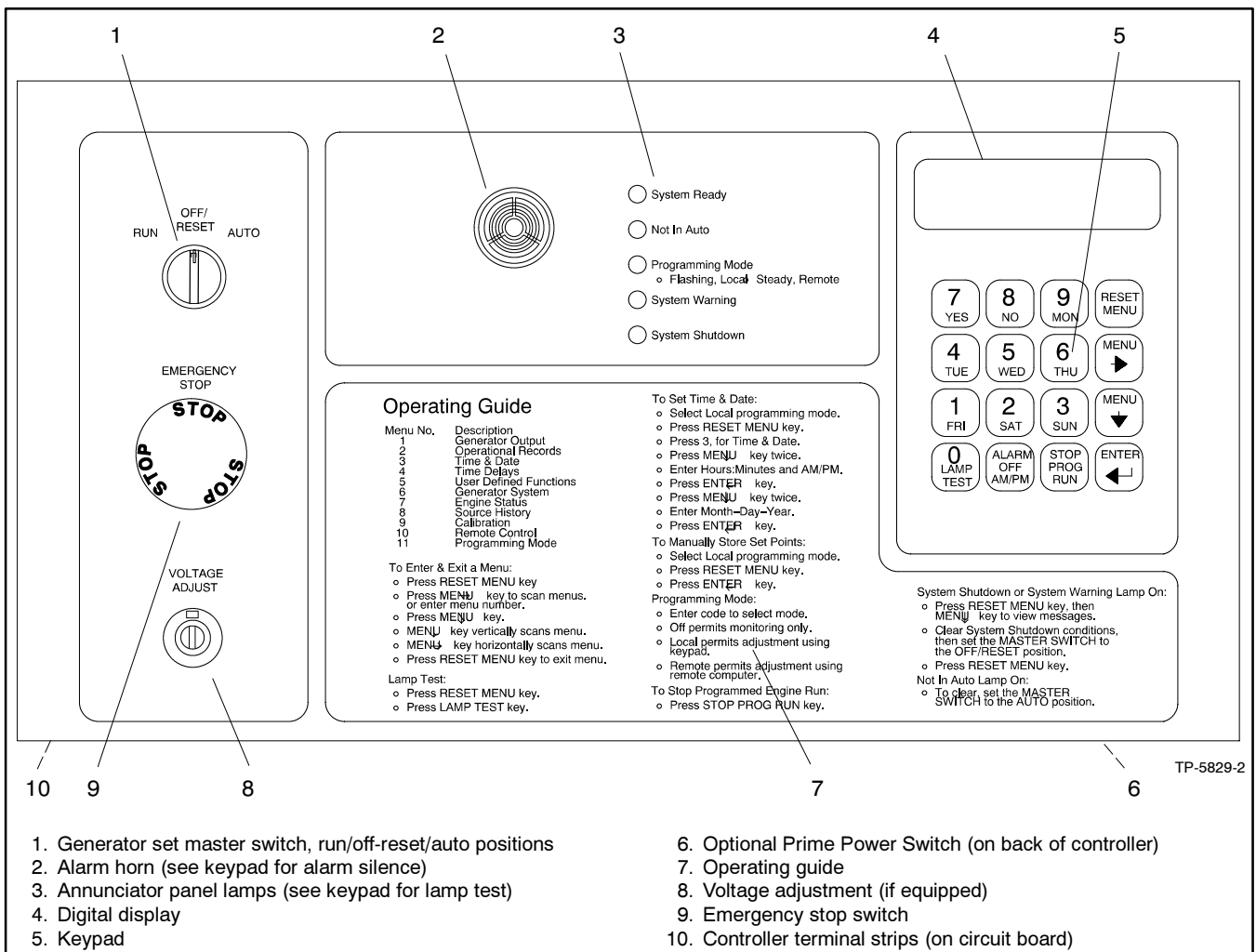

Figure 1-1 Digital Controller

## 1.2.1 Annunciator Panel Lamps

Five annunciator panel lamps provide an immediate visual reference for generator set status. See Figure 1-2.

**System Ready.** Green lamp illuminates when generator set master switch is in AUTO position and the system senses no faults.

**Not in Auto (NIA).** Yellow lamp illuminates when generator set master switch is not in the AUTO position.

**Programming Mode.** Yellow lamp in flashing mode indicates local programming selection or “steady on” for remote programming mode.

**Note:** Additional information for the programming mode lamp function and access to the local or remote programming mode are found in Section 2.8.11, Operation, Local Programming Mode On, Menu 11—Programming Mode.

**System Warning.** Yellow lamp identifies an existing fault condition but does not shutdown the generator set. A continuing system warning fault condition may cause a system shutdown if the source is not corrected.

The following conditions cause a system warning:

- Customer auxiliary warnings 1-4
- Ground fault detected
- Generator switch not in auto
- Emergency power system supplying load
- Speed sensor fault
- Load shed
- Overcurrent
- Low battery voltage
- Battery charger fault
- High battery voltage
- Weak battery
- Low fuel
- High coolant temperature
- Low oil pressure
- Low coolant temperature
- Coolant temperature signal loss
- Oil pressure signal loss

See Section 2.3.5, Operation, System Warning, for definitions of the items listed above.

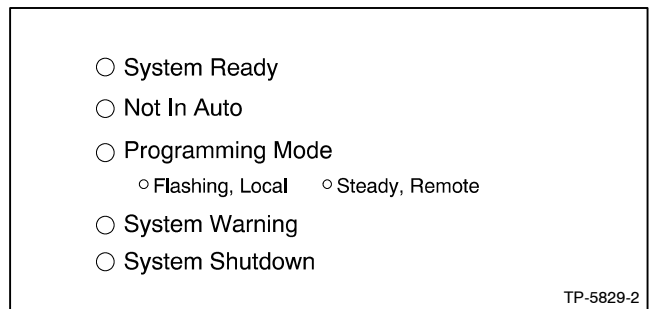

**Figure 1-2** Annunciator Panel Lamps

**System Shutdown.** Red lamp identifies that the generator set has shut down because of a fault condition. A system shutdown may follow a system warning condition.

The following conditions cause a system shutdown:

- Low oil pressure
- High coolant temperature
- Overcrank
- Locked rotor
- Overspeed
- Emergency stop
- Overvoltage
- Undervoltage
- Underfrequency
- Overfrequency
- Low coolant level
- High oil temperature
- Customer auxiliary shutdowns 1-4
- Internal fault
- Master switch in off/reset position

See Section 2.3.6, Operation, System Shutdown, for definitions of the items listed above.

## 1.2.2 Digital Display and Keypad

See Figure 1-3 for illustration of the digital display and keypad.

**Note:** Press any key on the keypad to turn on the controller panel lights and display. The panel lights and display turn off 5 minutes after the last keypad entry.

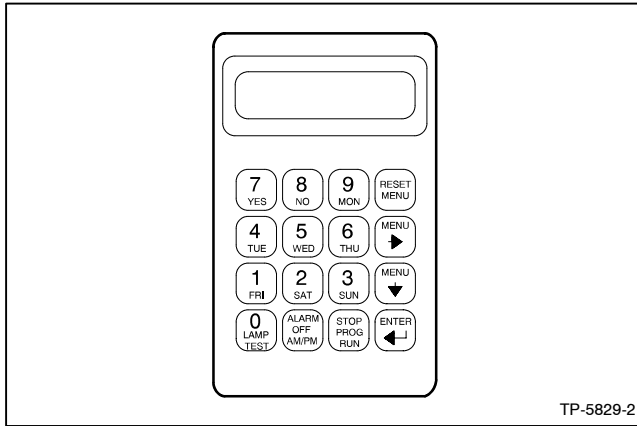

**Figure 1-3** Digital Display and Keypad

### Digital Display

The two-line vacuum fluorescent display provides generator set and engine condition information.

### Generator Output Displays

**AC Amps** displays generator output current. Each line of three-phase models is available.

**AC Volts** displays generator output voltages. All line-to-neutral and line-to-line voltages are available.

**Frequency** displays frequency (Hz) of generator output voltage.

**Hourmeter** displays generator set operating hours loaded and unloaded for reference in scheduling maintenance.

**Watts** displays total kilowatt loading.

### Engine Displays

**DC Volts** displays voltage of starting battery(ies).

**Oil Pressure** displays engine oil pressure.

**Tachometer** displays engine speed (rpm).

**Water Temperature** displays engine coolant temperature.

### Keypad

The 16-button keypad provides information access and local programming capability.

## 1.2.3 Switches and Controls

See Figure 1-4 and Figure 1-5 for switches and controls.

**Note:** Find additional switches and controls in Section 2.5.1, Operation, Reviewing the Digital Display, Keypad Operation.

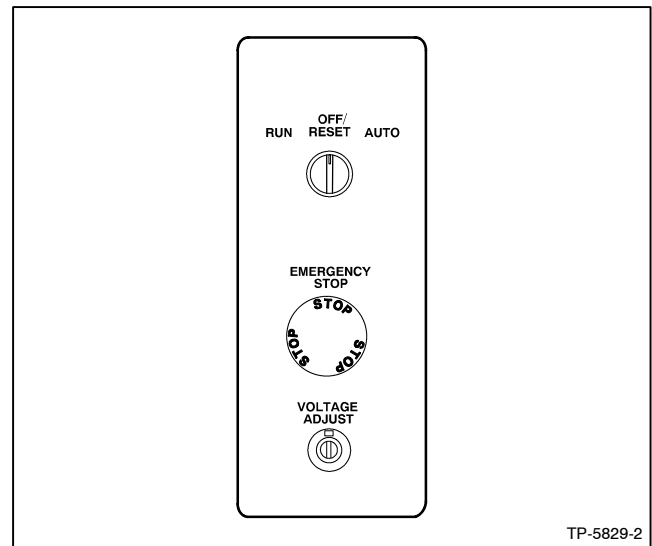

**Figure 1-4** Switches and Adjustment Potentiometer

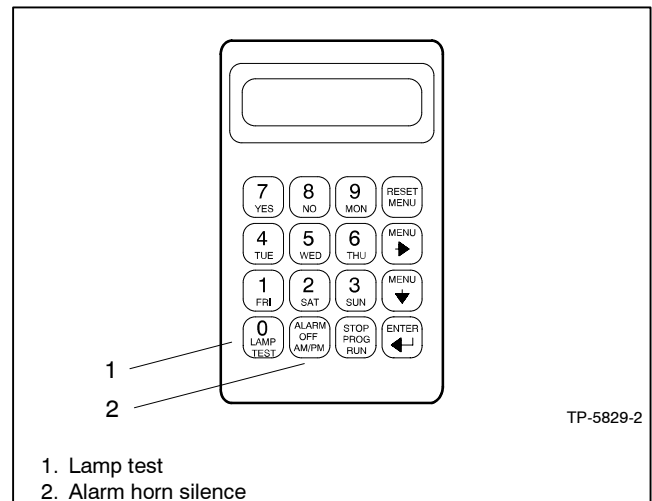

**Figure 1-5** Keypad Switches

**Alarm Horn.** Horn sounds if certain shutdown or warning conditions exist. See Section 1.3, Control Logic Specifications, for specific items. Place generator set master switch in the AUTO position before silencing alarm horn. Alarm horn cannot be silenced unless the master switch is in the AUTO position. See Section 2.3.7, Controller Resetting Procedure.

**Alarm Silence.** Keypad switch silences alarm during service. Place generator set master switch in the AUTO position before silencing alarm horn. Restore alarm horn switches at all locations including those on remote annunciator and audio/visual alarm kits to normal position after correcting fault shutdown to avoid reactivating alarm horn. See Section 2.3.7, Controller Resetting Procedure.

**Emergency Stop.** Switch instantly shuts down the generator set in emergency situations. Reset emergency stop switch after shutdown by rotating switch clockwise. *Use the emergency stop switch for emergency shutdowns only.* Use the generator set master switch for normal shutdowns.

**Generator Set Master Switch (Run/Off-Reset/Auto).** Switch functions as controller reset and generator operation switch. Refer to Section 2.3 for starting, stopping, and controller resetting procedures.

**Lamp Test.** Keypad switch tests the controller indicator lamps, horn, and display.

**Voltage Adjustment Potentiometer, if equipped.** Fine adjustment ( $\pm 5\%$ ) for generator output voltage. Used with 20–300 kW models only.

**Note:** Adjust voltage  $\pm 10\%$  on 350–2000 kW models using the keypad. See Section 2.8.1, Local Programming Mode On, Menu 1—Generator Output, for complete information.

## 1.2.4 Controller Circuit Boards

The controller has several circuit boards and an optional communication circuit board. See Figure 1-6.

**Communication Circuit Board (optional).** Board provides PC communication locally (direct) or remotely (modem) using RS-232 or RS-485 connectors.

**Indicator Circuit Board.** Circuit board includes the LED status lamps and alarm horn.

**Input Conditioning Circuit Board.** Board connects between the main logic and interconnection circuit boards.

**Interconnection Circuit Board.** Board provides the terminal strips for connecting the customer connection and/or dry contact kits.

**Keypad and Digital Display Circuit Boards.** Boards feature the keypad and digital display to monitor generator set functions.

**Main Logic (Microprocessor) Circuit Board.** Board has the controller logic and three fuses (F1, F2, and F3).

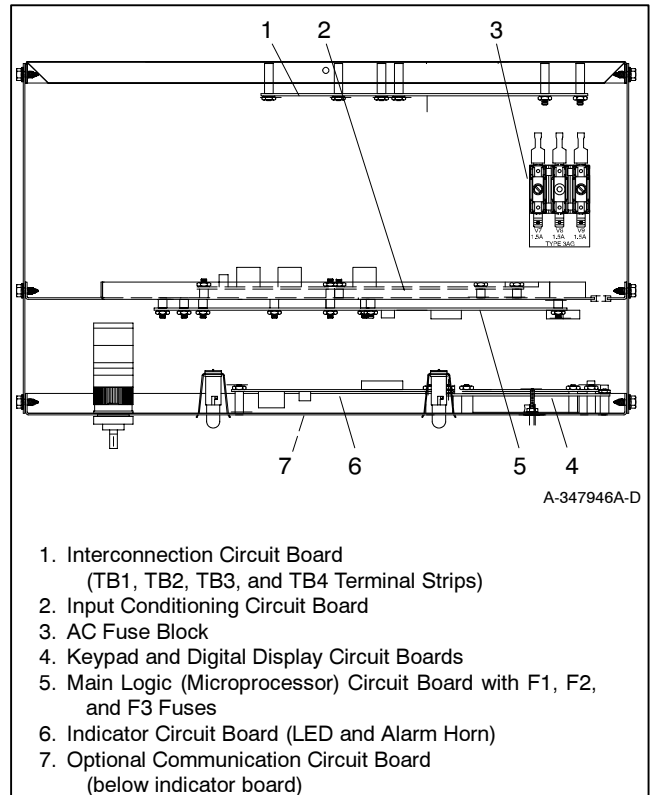

**Figure 1-6** Controller Circuit Boards and Fuses, Controller Top View

## 1.2.5 Fuses

**AC Circuit Fuses (TB6).** Fuses are located inside controller. See Figure 1-6.

- **1.5-Amp (V7).** Fuse protects L1 input to interconnection circuit board.
- **1.5-Amp (V8).** Fuse protects L2 input to interconnection circuit board.
- **1.5-Amp (V9).** Fuse protects L3 input to interconnection circuit board.

**DC Circuit Fuses.** Fuses are located on the controller main logic circuit board.

- **3-Amp Remote Annunciator (F1).** Fuse protects dry contact kit if equipped.
- **3-Amp Controller (F2).** Fuse protects controller circuitry.
- **15-Amp Engine and Accessories (F3).** Fuse protects engine/starting circuitry and accessories.

## 1.2.6 Terminal Strips

Terminal Strips are located on the Interconnection Circuit Board. These terminal strips provide various external input and output connections. See Section 6, Accessories.

**Note:** Do not directly connect accessories to the controller terminal strip. Doing so may damage the controller. Connect all accessories to either a single-relay dry contact kit or a ten-relay dry contact kit.

**TB1 Output Connection Terminal Strip.** TB1 provides relay driver outputs such as engine warning and shutdowns, voltage regulator adjustments, and other functions.

**TB2 Input Connection Terminal Strip.** TB2 provides input connections such as prime power mode, battery charger fault, low fuel, and remote reset ground fault.

**TB3 Input Connection Terminal Strip.** TB3 provides input connections such as remote start, emergency stop (e-stop), engine gauge senders, and auxiliary connections.

**TB4 AC Input Connection Terminal Strip.** TB4 provides connection to generator set output for sensing voltage and current.

Figure 1-7 shows locations of the terminal strips on the controller interconnection circuit board. See Section 6.2, Accessory and Prime Power Terminal Strip Connections, for specific terminal identification information. Refer to the wiring diagrams for additional information on connecting accessories to the terminal strips.

## 1.2.7 Communication Port

The main logic circuit board contains a communication port for either an RS-232 or RS-485 communication module kit. See Figure 1-8. Refer to the list of related literature in the introduction section for corresponding communication installation information.

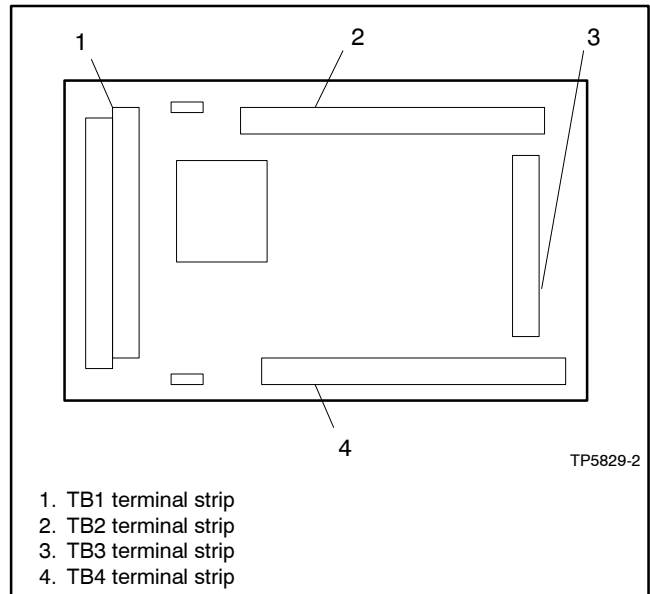

**Figure 1-7** Interconnection Circuit Board Terminal Strips, Circuit Board Top View

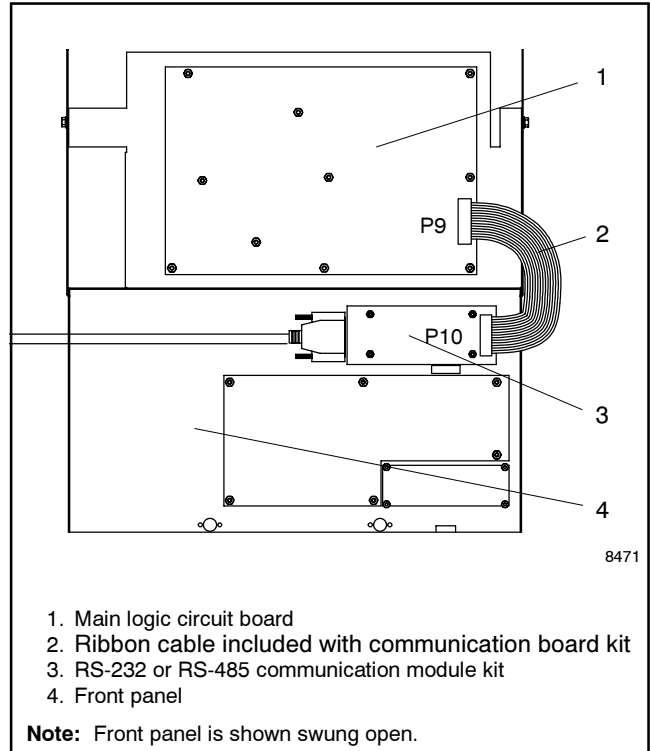

**Figure 1-8** Main Logic Circuit Board Communication Port

### 1.3 Controller Logic Specifications

The Controller Logic Specifications is an overview of the various features and functions of the controller. Certain

features are only operational when optional accessories are specified. See Section 2, Operation, for details.

Condition or Fault and Menu Location for Changes	Digital Display	Alarm Horn	Relay Driver Output (RDO)*	Panel Lamp	Range Setting	Default Selection	Inhibit Time Delay† (sec.)	Time Delay (sec.)
Access Code (Password) (see Menu 11)						0 (zero)		
Air Damper (if used) (see Menu 5)	Air Damper	On	RDO-5	Shutdown				
Battery Charger Fault (see Menu 5)	Battery Charger Fault	Off	Std.	Warning				
Cyclic Cranking (see Menu 4)		Off			1-6 crank cycles 1-60 sec. crank 1-60 sec. pause	3 15 sec. 15 sec.		
Coolant Temperature Signal Loss (see Menu 5)	No Temp Gauge Signal	Off	User Defined	Warning			30	
Customer Auxiliary 1-4 Shutdown or Warning (see Menus 4 and 5)	Auxiliary 1-4	On	User Defined	Shutdown or Warning		30 sec. inhibit, 5 sec. delay	0-60‡	0-60
Defined Common Fault (see Menu 5)	Defined Common Fault		RDO-2	Shutdown or Warning				
Emergency Power System Supplying Load (see Menu 5)	EPS Supplying Load	Off	RDO-8	Warning		5% of line current		
Emergency Stop Shutdown (see Menu 5)	Emergency Stop	Off	Std.	Shutdown				
Generator Running (see Menu 5)		Off	RDO-3					
Ground Fault Detected (see Menu 5)	Ground Fault	On	User Defined	Warning				
High Battery Voltage (see Menu 5 and 6)	High Battery Voltage	Off	RDO-10	Warning	14.5-16.5 (12V) 29-33 (24V)	16 (12V) 32 (24V)		10
High Coolant Temperature Shutdown (see Menu 5)	High Coolant Temperature	On	Std.	Shutdown			30	5
High Coolant Temperature Warning (see Menu 5)	High Coolant Temperature Warning	On	Std.	Warning			30	
High Oil Temperature Shutdown (see Menu 5)	High Oil Temperature	On	User Defined	Shutdown			30	5
Internal Fault Shutdown (see Menu 5)	Internal Fault	On	User Defined	Shutdown				
kW Overload (see Load Shed)								
Load Shed (see Menu 5)	Load Shed KW Overload	Off	User Defined	Warning		100% of kW Rating		5
	Load Shed Underfrequency	Off	User Defined	Warning		59, (60 Hz) 49, (50 Hz)		5
Locked Rotor Shutdown (see Menu 5)	Locked Rotor	On	User Defined	Shutdown				
Low AC Output (see Menu 5)	Low AC Output	Off	User Defined	Warning			10	
Low Battery Voltage (see Menu 5 and 6)	Low Battery Voltage	Off	Std.	Warning	10-12.5 (12V) 20-25 (24V)	12 (12V) 24 (24V)		10
Low Coolant Level Shutdown (see Menu 5)	Low Coolant Level	On	RDO-7	Shutdown			30	5

\* RDO-1-10 represent user-defined default selections.

† Inhibited time delay is the time delay period after crank disconnect.

‡ If auxiliary input inhibit time is set to 0 seconds, the auxiliary input is active at all times and not dependent on time delay engine start (TDES).

Condition or Fault and Menu Location for Changes	Digital Display	Alarm Horn	Relay Driver Output (RDO)*	Panel Lamp	Range Setting	Default Selection	Inhibit Time Delay† (sec.)	Time Delay (sec.)
Low Coolant Temperature (see Menu 5)	Low Coolant Temperature	On	Std.	Warning				
Low Fuel (see Menu 5)	Low Fuel	On	Std.	Warning				
Low Oil Pressure Shutdown (see Menu 5)	Low Oil Pressure	On	Std.	Shutdown			30	5
Low Oil Pressure Warning (see Menu 5)	Low Oil Pressure Warning	On	Std.	Warning			30	
Master Switch Open	Master Switch Open	On		Shutdown				
NFPA Common Alarm (see Menu 5)	NFPA Common Alarm		RDO-1	Shutdown or Warning				
Not In Auto (Generator Switch) (see Menu 5)	Not In Auto	On	Std.	Not In Auto				
Overcrank Shutdown (see Menu 5)	Overcrank	On	Std.	Shutdown				
Overcurrent (see Menu 5)	Overcurrent	On	User Defined	Warning		110%		10
Overfrequency Shutdown (see Menus 5 and 6)	Overfrequency	On	User Defined	Shutdown	102% - 140%	140% Std. 103% FAA		10
Overspeed Shutdown (see Menus 5 and 6)	Overspeed	On	Std.	Shutdown	65-70 (60 Hz) 55-70 (50 Hz)	70 (60 Hz) 70 (50 Hz)		0.25
Oil Pressure Signal Loss (see Menu 5)	No Oil Gauge Signal	Off	User Defined	Warning			30	
Overvoltage Shutdown (see Menus 5 and 6)	Overvoltage	On	RDO-6	Shutdown	105% - 135%	115% 2-sec time delay		2-10
Password (Access Code)						0 (zero)		
Speed Sensor Fault (see Menu 5)	Speed Sensor Fault	On	RDO-9	Warning				
Starting Aid Function (see Menus 4 and 5)			User Defined		0-10 sec.			
System Ready		Off	Std.	System Ready				
Time Delay Engine Cooldown (TDEC) (see Menu 4)		Off	RDO-4		00:00-10:00 min:sec	5:00		
Time Delay Engine Start (TDES) (see Menu 4)		Off	User Defined		00:00-5:00 min:sec	00:01		
Underfrequency Shutdown (see Menus 5 and 6)	Underfrequency	On	User Defined	Shutdown	80% - 95%	90%		10
Undervoltage Shutdown (see Menus 5 and 6)	Undervoltage	On	User Defined	Shutdown	70% - 95%	85% 10-sec time delay		5-30
Weak Battery (see Menu 5)	Weak Battery	Off	User Defined	Warning		60%		2

\* RDO-1-10 represent user-defined default selections.

† Inhibited time delay is the time delay period after crank disconnect.

‡ If auxiliary input inhibit time is set to 0 seconds, the auxiliary input is active at all times and not dependent on time delay engine start (TDES).

# Notes

### 2.1 Prestart Checklist

To ensure continued satisfactory operation perform the following checks or inspections before or at each startup, as designated, and at the intervals specified in the service schedule. In addition, some checks require verification after the unit starts.

**Air Cleaner.** Check for a clean and installed air cleaner element to prevent unfiltered air from entering the engine.

**Air Inlets.** Check for clean and unobstructed air inlets.

**Battery.** Check for tight battery connections. Consult the battery manufacturer's instructions regarding battery care and maintenance.

**Controller.** After energizing the controller using the prime power switch or reconnecting the battery, set the controller time and date. See Section 2.8.3, Local Programming Mode On, Menu 3—Time & Date.

**Coolant Level.** Check the coolant level according to the cooling system maintenance information.

**Note: Block heater damage.** The block heater will fail if the energized heater element is not immersed in coolant. Fill the cooling system before turning on the block heater. Run the engine until it is warm, and refill the radiator to purge the air from the system before energizing the block heater.

**Drive Belts.** Check the belt condition and tension of the radiator fan, water pump, and battery charging alternator belt(s).

**Exhaust System.** Check for exhaust leaks and blockages. Check the silencer and piping condition and check for tight exhaust system connections.

Inspect the exhaust system components (exhaust manifold, exhaust line, flexible exhaust, clamps, silencer, and outlet pipe) for cracks, leaks, and corrosion.

- Check for corroded or broken metal parts and replace them as needed.
- Check for loose, corroded, or missing clamps and hangers. Tighten or replace the exhaust clamps and/or hangers as needed.
- Check that the exhaust outlet is unobstructed.
- Visually inspect for exhaust leaks (*blowby*). Check for carbon or soot residue on exhaust components. Carbon and soot residue indicates an exhaust leak. Seal leaks as needed.

**Fuel Level.** Check the fuel level and keep the tank(s) full to ensure adequate fuel supply.

**Oil Level.** Maintain the oil level at or near, not over, the full mark on the dipstick. Keep the oil level in the mechanical governor, if equipped, at or near the full level.

**Operating Area.** Check for obstructions that could block the flow of cooling air. Keep the air intake area clean. Do not leave rags, tools, or debris on or near the generator set.

x:op:001:002:a

### 2.2 Exercising the Generator Set

Operate the generator set under load once each week for one hour. Perform the exercise in the presence of an operator if the generator set does not have a programmed exercise mode or an automatic transfer switch with an exercise option.

During the exercise period apply a minimum of 35% load based on the nameplate standby rating, unless otherwise instructed in the engine operation manual.

The operator should perform all of the prestart checks before starting the exercise procedure. Start the generator set according to the starting procedure in the controller section of this manual. While the generator set is operating, listen for a smooth-running engine and visually inspect the generator set for fluid or exhaust leaks.

x:op:001:005

## 2.3 Digital Controller Operation

### 2.3.1 Starting

#### Local Starting

Move the generator set master switch to the RUN position to start the generator set at the controller.

**Note:** The alarm horn sounds and the Not-In-Auto lamp lights whenever the generator set master switch is not in the AUTO position.

**Note:** The transient start/stop function of the controller prevents accidental cranking of the rotating engine. The generator set slows to 249 rpm and recranks before returning to rated speed if the generator set master switch is momentarily placed in the OFF/RESET position and then returned to RUN.

#### Auto Starting

Move the generator set master switch to the AUTO position to allow startup by automatic transfer switch or remote start/stop switch (connected to controller terminals 3 and 4).

Terminals 3 and 4 connect to an open crank cycle circuit which, when closed by an external source, automatically starts the generator set crank cycle.

**Note:** The controller provides programmable cyclic cranking up to 60 seconds of cranking and up to 60 seconds rest with up to 6 cycles. The default setting is 15 seconds cranking and 15 seconds rest for 3 cycles. Make cyclic cranking adjustments using the keypad. See Section 2.8.4, Local Programming Mode On, Menu 4—Time Delays.

#### Prime Power Mode

The digital controller has an optional prime power mode of operation. The prime power mode requires installation of an optional prime power switch kit. See Section 6, Accessories, for instructions on how to install the optional prime power switch kit. The prime power switch kit prevents engine starting battery drain when the generator set is shut down and no external battery charging is available.

Move the prime power switch located on the back of the controller to the CONTROLLER ON position *and* set the controller time and date before attempting to start the generator set. When the prime power mode is off, all controller functions including the digital display, LEDs, and alarm horn are operative.

**Note:** After energizing the controller using the prime power switch, set the controller time and date. See Section 2.8.3, Local Programming Mode On, Menu 3—Time & Date.

Stop the generator set using the stopping procedures in Section 2.3.2 before placing the generator set in the prime power mode. Move the prime power switch located on the back of the controller to the CONTROLLER OFF position. When the generator set is in the prime power mode, all controller functions including the digital display, LEDs, alarm horn, and communications are inoperative.

### 2.3.2 Stopping

#### Normal Stopping

Run generator set without load for five minutes to ensure adequate engine cooldown.

The controller has a programmable cooldown timer which functions only when the master switch is in the AUTO position. To stop the generator set, place the generator set master switch in the OFF/RESET position and wait until generator set comes to a complete stop.

**Note:** The generator set continues running during the cooldown cycle if a remote switch or automatic transfer switch signals the engine to stop.

#### Emergency Stopping

Use the controller emergency stop switch or optional remote emergency stop for immediate shutdown.

The emergency stop switch bypasses the time delay engine cooldown and causes an immediate shutdown.

**Note:** Use the emergency stop switch(es) for emergency shutdowns only. Use the generator set master switch for normal shutdowns.

The controller system shutdown lamp lights and the unit shuts down if the local or remote emergency stop switch activates.

### 2.3.3 Resetting Emergency Stop Switch

Use the following procedure to reset the generator set after shutdown by a local or remote emergency stop switch. Refer to Section 2.3.7, Controller Resetting Procedure, to restart the generator set following a fault shutdown.

1. Place generator set master switch in OFF/RESET position.
2. Investigate cause of emergency stop and correct.
3. Reset optional remote emergency stop switch by replacing glass piece, if equipped. Reset controller emergency stop switch by rotating switch clockwise until switch springs back to original position.
4. Reset air damper, if equipped, on engine by rotating air damper lever. See Figure 2-1.

**Note:** The engine air damper (air box) feature is available on some 200–2000 kW generator sets using 2-cycle Detroit Diesel Series 71, 92, and 149 engines.

5. After resetting all faults using the Controller Resetting Procedure, toggle generator set master switch to RUN or AUTO to restart generator set. The generator set will not crank until the resetting procedure is completed.

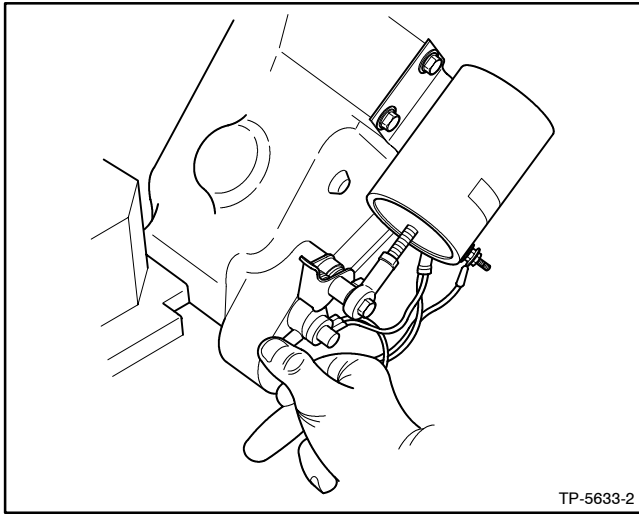

**Figure 2-1** Air Damper Lever on Detroit Diesel-Powered Models, if equipped (typical)

### 2.3.4 System Ready Lamp

**System Ready.** Green lamp illuminates when generator set master switch is in AUTO position and the system has no fault conditions.

### 2.3.5 System Warning

The yellow warning lamp illuminates indicating a fault but does not shut down the generator set under the following conditions. In some cases the alarm horn will also sound. See Section 2.3.7, Controller Resetting Procedure, for resetting a system warning.

If system warning lamp is on and no message is displayed, press Reset Menu and the menu down ↓ key to view messages.

If the system warning continues, it may cause a system shutdown.

Keypad switch disconnects alarm during service. Place generator set master switch in the AUTO position before silencing alarm horn. Alarm horn cannot be silenced unless the master switch is in the AUTO position.

**Note:** Text shown in *italics* represents digital display messages.

**Customer Auxiliary Warning.** Lamp illuminates and alarm horn sounds if signalled by auxiliary inputs 1–4. Customer can define up to four inputs as shutdowns or warnings. The local display shows *auxiliary 1–4* when activated.

Using the remote communications package, the user can label the auxiliary 1–4 functions with an identifying name. The controller receives this warning information and displays the selected name instead of *auxiliary 1–4*.

**Ground Fault Detected.** Lamp illuminates and alarm horn sounds if signalled by a user-supplied ground fault detector. Local display shows *ground fault*.

**Generator Switch Not in Auto.** Lamp illuminates and alarm horn sounds when generator set master switch is in RUN or OFF/RESET position. Local display shows master switch *not in auto*.

**Emergency Power System Supplying Load.** Lamp illuminates when the generator set supplies more than 5% of the rated standby output current. Local display shows *EPS supplying load*.

**Speed Sensor Fault.** Lamp illuminates and alarm horn sounds when speed signal is absent for 1 second while the generator set is running. Local display shows *speed sensor fault*. This warning lamp remains on until the user places the master switch in the OFF/RESET position.

**Load Shed.** Lamp illuminates when generator set total kW load exceeds 100% of the standby rating for more than 5 seconds. If the load shed alarm occurs and resets more than 2 times in 1 minute, the load shed warning lamp latches and remains on until the generator set shuts off. Local display shows *load shed with kW overload* at the next lower display level. Use the menu down ↓ key to review display.

If the generator set frequency drops to less than 59 Hz. on a 60 Hz. system or 49 Hz. on a 50 Hz. system for more than 5 seconds, the local display shows *load shed with underfrequency* at the next lower display level. Use the menu down ↓ key to review display. If the load shed alarm occurs and resets more than 2 times in 1 minute, the load shed warning lamp latches and remains on until the generator set shuts off.

**Overcurrent.** Lamp illuminates and alarm horn sounds when the generator set supplies more than 110% of the rated standby output current for more than 10 seconds. Local display shows *overcurrent*.

**Low Battery Voltage.** Lamp illuminates if battery voltage drops below preset level for more than 10 seconds. Local display shows *low battery voltage*. Low battery voltage specs follow. See Figure 2-2.

Engine Electrical System Voltage	Low Battery Voltage Range	Low Battery Voltage Default Setting
12	10-12.5	12
24	20-25	24

**Figure 2-2** Low Battery Voltage Specs

The low battery voltage feature monitors the battery and battery charging system in the generator set operating and off modes. Low battery voltage warning is inhibited during the crank cycle.

**Battery Charger Fault.** Lamp illuminates if battery charger malfunctions. Requires optional battery charger with malfunction output for lamp to function. Local display shows *battery charger fault*.

**High Battery Voltage** Lamp illuminates if battery voltage rises above the preset level for more than 10 seconds. Local display shows *high battery voltage*. High battery voltage specs follow. See Figure 2-3.

Engine Electrical System Voltage	High Battery Voltage Range	High Battery Voltage Default Setting
12	14.5-16.5	16
24	29-33	32

**Figure 2-3** High Battery Voltage Specs

The high battery voltage feature monitors the battery and battery charging system in the generator set operating and off modes.

**Weak Battery.** Lamp illuminates if battery voltage is below 60% of the nominal voltage (12 VDC or 24 VDC) for more than 2 seconds during the crank cycle. Local display shows *weak battery*.

**Low Fuel (Level or Pressure).** Lamp illuminates and alarm horns sounds when fuel tank level approaches empty on gasoline or diesel models or low fuel pressure occurs on gaseous fueled models. Requires optional low fuel switch for lamp to function. Local display shows *low fuel*.

**Low AC Output.** Lamp illuminates if nominal generator set AC output voltage is not detected after crank disconnect. Low AC output is inhibited for 10 seconds after crank disconnect. Local display shows *low AC output*.

**High Coolant Temperature (Warning).** Lamp illuminates and alarm horn sounds if engine coolant temperature approaches shutdown range. Requires optional prealarm sender kit for lamp to function. Local display shows *high coolant temperature warning*.

**Low Oil Pressure (Warning).** Lamp illuminates and alarm horn sounds when engine oil pressure approaches shutdown range. Requires optional prealarm sender kit for lamp to function. Local display shows *low oil pressure warning*.

**Low Coolant Temperature.** Lamp illuminates and alarm horn sounds when engine coolant temperature is low. Requires optional prealarm sender kit for lamp to function. Local display shows *low coolant temperature*.

**Coolant Temperature Gauge Signal Loss.** Lamp illuminates when the engine coolant temperature sender circuit is open. Local display shows *no temp gauge signal*.

**Oil Pressure Gauge Signal Loss.** Lamp illuminates when the engine oil pressure sender circuit is open. Local display shows *no oil gauge signal*.

### 2.3.6 System Shutdown

The red lamp illuminates, the alarm horn sounds, and the unit shuts down to indicate a fault shutdown under the following conditions. See Section 2.3.7, Controller Resetting Procedure, for resetting a system shutdown.

**Note:** Keypad switch disconnects alarm during service. Place the generator set master switch in the AUTO position before silencing alarm horn. Alarm horn cannot be silenced unless the master switch is in the AUTO position.

**Note:** Text shown in *italics* represents digital display messages.

**Low Oil Pressure.** Lamp illuminates if unit shuts down because of low oil pressure. Shutdown occurs 5 seconds after engine reaches pressure shutdown range. Low oil pressure shutdown is inhibited during first 30 seconds after startup. Local display shows *low oil pressure*.

**High Coolant Temperature.** Lamp illuminates when unit shuts down because of high engine coolant temperature. Shutdown occurs 5 seconds after engine reaches temperature shutdown range. High engine temperature shutdown does not function during first 30 seconds after startup. Local display shows *high coolant temperature*.

**Note:** The high engine temperature shutdown switch and low coolant level switch function independently of each other. Low coolant level may not activate the high engine temperature switch.

**Overcrank.** Lamp illuminates and cranking stops when unit does not start within the defined cranking period. Local display shows *overcrank*. See Section 2.3.1, Auto Starting, and Section 1, Specifications, for cyclic crank specs.

**Note:** The controller is equipped with an automatic restart function. If while running the engine speed drops below 13 Hz (390 rpm), the unit attempts to recrank. The unit then follows the cyclic cranking cycle and, if the engine fails to start, will shut down on an overcrank fault condition.

**Locked Rotor.** After initiating engine cranking and if none of the speed sensing inputs shows engine rotation during the first 5 seconds of the crank cycle, the ignition and crank circuits turn off for 5 seconds and the cycle repeats. If at the end of the second cycle of 5 seconds of cranking and the condition still exists, the unit shuts down. Local display shows *locked rotor*.

**Overspeed.** Lamp illuminates and unit shuts down immediately when the governed frequency on 50 and 60 Hz models exceeds the overspeed setting for 0.25 seconds. Local display shows *overspeed*. Overspeed specs follow. See Figure 2-4.

Generator Set Frequency Hz	Overspeed Range Hz	Overspeed Default Setting Hz
60	65-70	70
50	55-70	70

**Figure 2-4** Overspeed Specs

**Emergency Stop.** Lamp illuminates and unit shuts down when local or optional remote emergency stop switch activates. Local display shows *emergency stop*.

**Overvoltage.** Lamp illuminates and unit shuts down when the overvoltage setting exceeds the time delay period. Local display shows *overvoltage*. Overvoltage specs follow. See Figure 2-5.

Overvoltage Setting Range	Time Delay Range	Overvoltage Default Setting
105%-135% of nominal	2-10 sec.	115% at 2 sec.

**Figure 2-5** Overvoltage Specs

**Note:** Overvoltage can damage sensitive equipment in less than one second. Install separate overvoltage protection on on-line equipment requiring faster than 2 second shutdowns.

**Undervoltage.** Lamp illuminates and unit shuts down when the voltage falls below the undervoltage setting for the time delay period. Local display shows *undervoltage*. Undervoltage specs follow. See Figure 2-6.

Undervoltage Setting Range	Time Delay Range	Undervoltage Default Setting
70%–95% of nominal	5–30 sec.	85% of nominal at 10 sec.

**Figure 2-6** Undervoltage Specs

**Underfrequency.** Lamp illuminates and unit shuts down when the frequency is below the underfrequency setting. Local display shows *underfrequency*. See Figure 2-7.

Underfrequency Setting Range	Time Delay Range	Underfrequency Default Setting
80%–95% of nominal	10 sec.	90% of nominal

**Figure 2-7** Underfrequency Specs

**Low Coolant Level.** Lamp illuminates and unit shuts down because of low coolant level. Shutdown occurs 5 seconds after low coolant level is detected. Low coolant level shutdown is inhibited during first 30 seconds after startup. Local display shows *low coolant level*.

**Note:** The high engine temperature shutdown switch and low coolant level switch function independently of each other. Low coolant level may not activate the high engine temperature switch.

**High Oil Temperature.** Lamp illuminates and unit shuts down because of high engine oil temperature. Shutdown occurs 5 seconds after engine oil reaches temperature shutdown range. High engine oil temperature shutdown is inhibited during first 30 seconds after startup. Optional high oil temperature switch required for lamp to function. Local display shows *high oil temperature*.

**Customer Auxiliary.** Lamp illuminates and unit shuts down if signalled by auxiliary contact(s) 1–4. Customer can define up to four inputs for shutdowns or warnings. When using customer auxiliary as a shutdown, the local display shows *auxiliary 1–4*.

When using customer auxiliary as a shutdown, the customer can define the following:

- Delay time after crank disconnect (inhibit time)
- Delay time before shutdown

When used as a shutdown:

- Auxiliaries 1 and 2 are latching shutdowns. Reset by placing the master switch in the OFF/RESET position.
- Auxiliaries 3 and 4 are non-latching shutdowns and are reset when the input is no longer grounded.

Using the remote communications package, the user can label the auxiliary 1–4 functions with identifying names. The controller receives this shutdown information and displays the selected name instead of auxiliary shutdown number.

**Internal Fault.** Lamp illuminates and unit shuts down when internal diagnostic test detects a controller malfunction. Local display shows *internal fault*.

**Master Switch Open.** Lamp illuminates and unit shuts down when master switch is in the open position. Local display shows *master switch open*.

### 2.3.7 Controller Resetting Procedure (Following System Shutdown or Warning)

Use the following procedure to restart the generator set after a system shutdown or warning. Refer to Section 2.3.3, Resetting Emergency Stop Switch, to reset the generator set after an emergency stop.

1. Silence the alarm horn by pressing the alarm off key. If equipped, A/V annunciator alarm horn and lamp activate. Move A/V annunciator alarm switch to SILENCE to stop alarm horn. A/V annunciator lamp stays lit.
2. Disconnect generator set from load with line circuit breaker or automatic transfer switch.
3. Correct the cause of the fault shutdown or warning. See Safety Precautions and Instructions section of this manual before proceeding.
4. Start generator set by moving the generator set master switch to OFF/RESET and then to the RUN position. If equipped, A/V annunciator alarm horn sounds and the lamp turns off.
5. Test operate the generator set to verify that the cause of the shutdown has been corrected.
6. Reconnect generator to load via line circuit breaker or automatic transfer switch.

7. Move generator set master switch to AUTO position for startup by remote transfer switch or remote start/stop switch. If equipped, move A/V annunciator alarm switch to the NORMAL position.

**Note:** Place generator set master switch in the AUTO position before silencing alarm horn.

## 2.4 Menu List Summary

See the Menu List section on the following pages. Use the Menu List after reading and understanding the features of the keypad. Details of each menu selection appear immediately after the overview in two different operating modes—Local Programming Mode Off and Local Programming Mode On.

The information in the Menu List boxes represents the digital display data. Some digital display data represents actual data and may not be identical to your display due to application differences. The arrows connecting the boxes represent use of the arrow down ↓ key or arrow right → key to access the next menu.

The arrows within the boxes inform the user that additional submenus are available using the arrow right → key.

# Menu List

## Menu 1

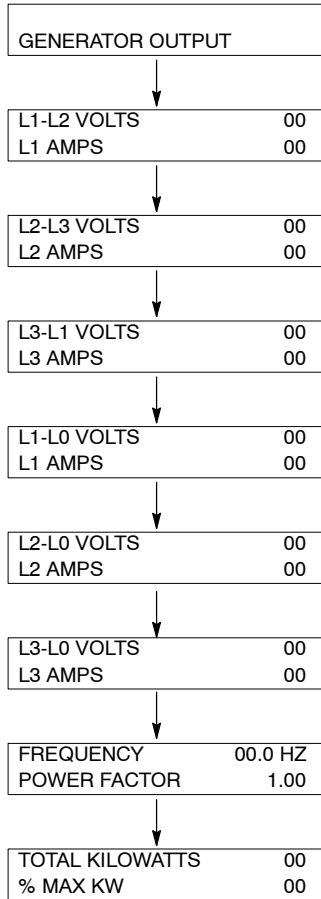

## Menu 2

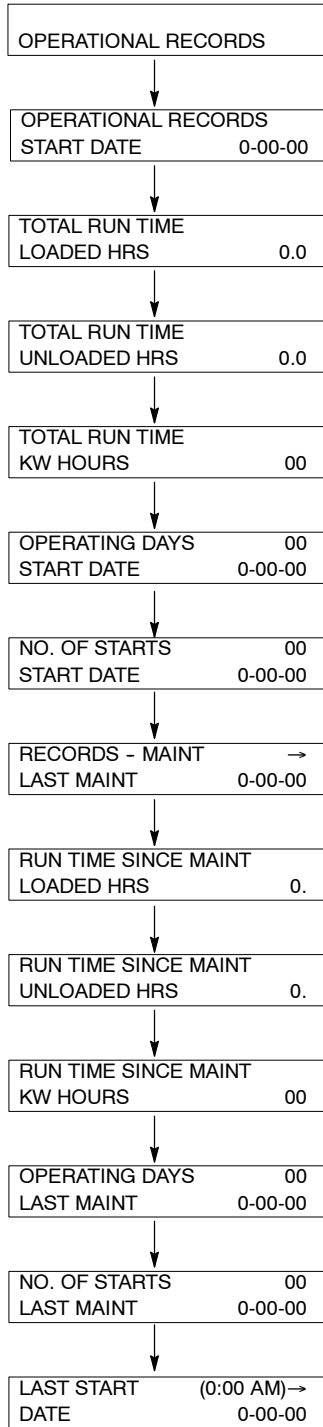

## Menu 3

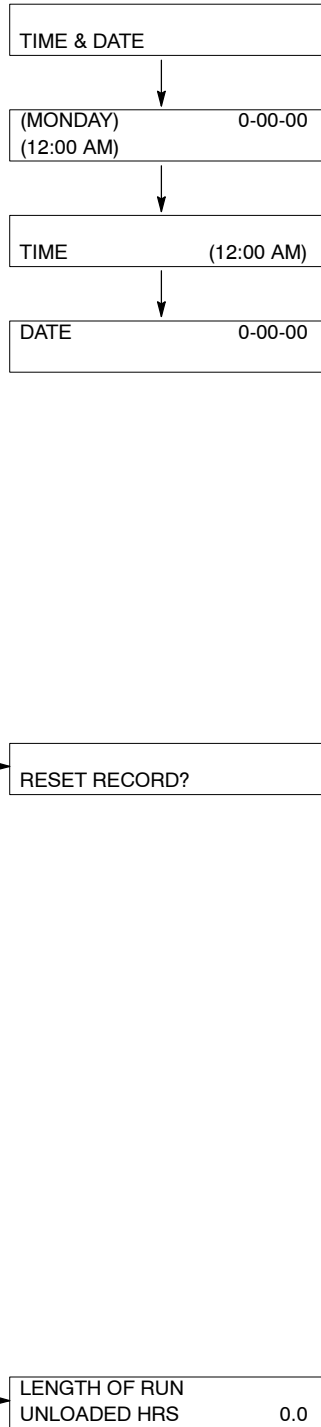

## Menu 4

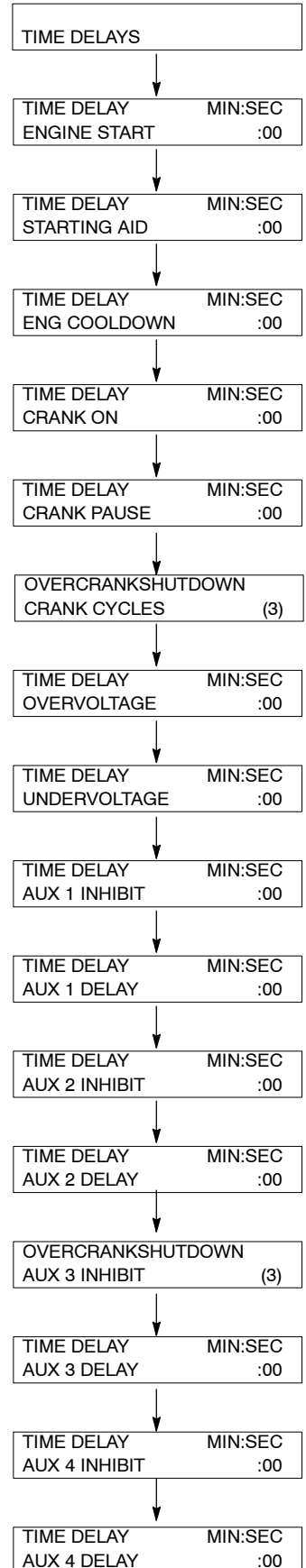

# Menu List, continued

## Menu 5

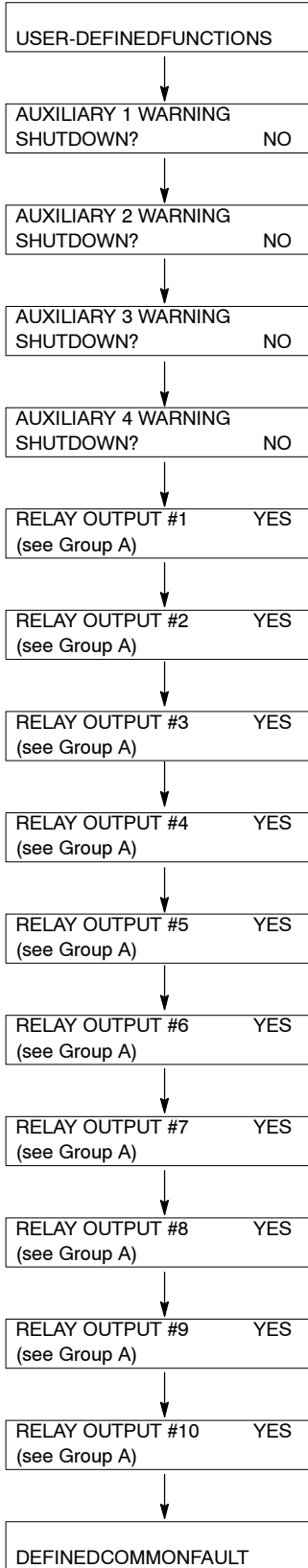

## Menu 6

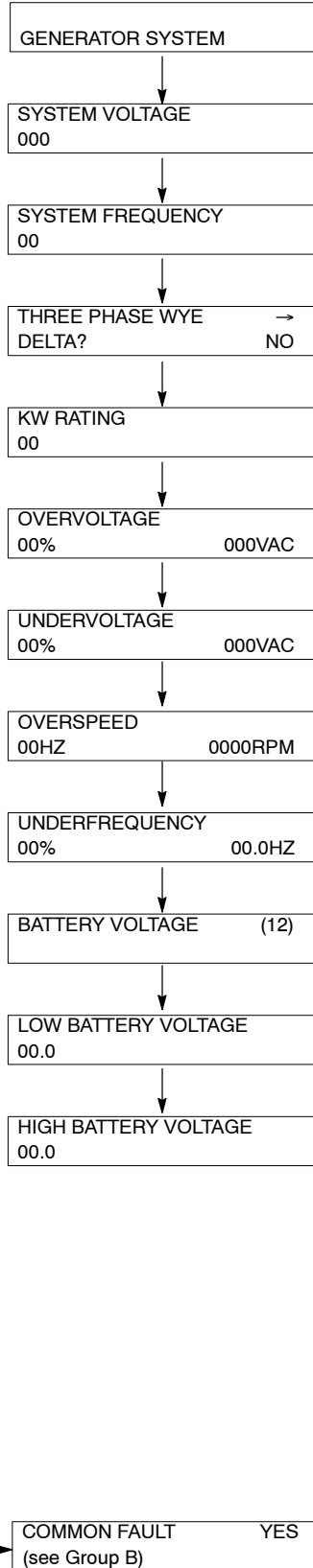

**Group B**  
**For defined common fault, choose from the following 44 selections:**

- AIR DAMPER
- OVERVOLTAGE
- UNDERVOLTAGE
- UNDERFREQ SHUTDOWN
- LOW COOLANT LEVEL
- HIGH OIL TEMPERATURE
- AUXILIARY 1
- AUXILIARY 2
- AUXILIARY 3
- AUXILIARY 4
- LOCKED ROTOR
- INTERNAL ERROR
- EPS SUPPLYING LOAD
- SPEED SENSOR FAULT
- LOAD SHED
- KW OVERLOAD
- UNDERFREQ WARNING
- HIGH BATTERY VOLTAGE
- NO TEMP GAUGE SIGNAL
- NO OIL GAUGE SIGNAL
- GRND FAULT DETECTED
- OVERCURRENT
- ENG COOLDOWN
- ENGINE START
- GENERATOR RUNNING
- NFPA 110 COMM ALARM
- STARTING AID
- LOW OIL PRESSURE
- HIGH COOLANT TEMP
- OVERCRANK
- OVERSPEED
- EMERGENCY STOP
- NOT IN AUTO
- SYSTEM READY
- LOW BATTERY VOLTAGE
- BATT CHARGER FAULT
- LOW FUEL
- HIGH TEMP WARNING
- LOW OIL PRES WARNING
- LOW COOLANT TEMP
- WEAK BATTERY
- LOAD SHED UNDERFREQ
- LOAD SHED EXCESS KW
- LOW AC OUTPUT

**Group A**  
**For relay outputs 1-10, choose one from the following 30 selections:**

- DEFINED COMMON FAULT
- AIR DAMPER
- OVERVOLTAGE
- UNDERVOLTAGE
- UNDERFREQ SHUTDOWN
- LOW COOLANT LEVEL
- HIGH OIL TEMPERATURE
- AUXILIARY 1
- AUXILIARY 2
- AUXILIARY 3
- AUXILIARY 4
- LOCKED ROTOR
- INTERNAL ERROR
- EPS SUPPLYING LOAD
- SPEED SENSOR FAULT
- LOAD SHED
- KW OVERLOAD
- UNDERFREQ WARNING
- HIGH BATTERY VOLTAGE
- NO TEMP GAUGE SIGNAL
- NO OIL GAUGE SIGNAL
- GRND FAULT DETECTED
- OVERCURRENT
- ENG COOLDOWN
- ENGINE START
- GENERATOR RUNNING
- NFPA 110 COMM ALARM
- STARTING AID
- WEAK BATTERY
- LOW AC OUTPUT

# Menu List, continued

## Menu 7

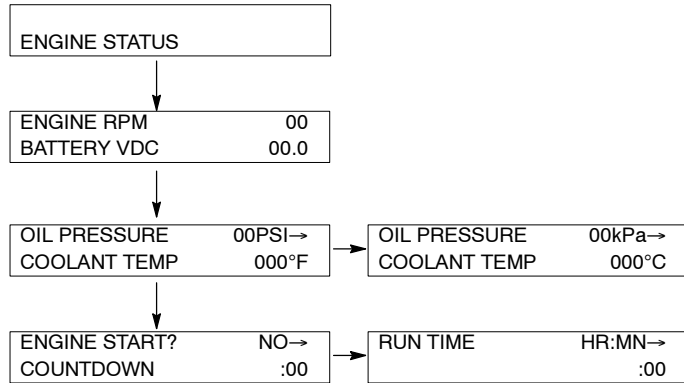

## Menu 8

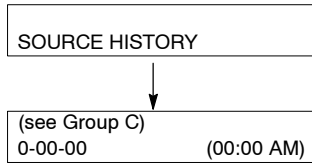

### Group C The 28 fault warning and shutdowns include the following:

- AIR DAMPER
- UNDERFREQ SHUTDOWN
- LOW COOLANT LEVEL
- HIGH OIL TEMPERATURE
- AUXILIARY 1
- AUXILIARY 2
- AUXILIARY 3
- AUXILIARY 4
- LOCKED ROTOR
- INTERNAL ERROR
- LOW OIL PRESSURE
- HIGH COOLANT TEMP
- OVERCRANK
- OVERSPEED
- EMERGENCY STOP
- OVERVOLTAGE L1-L2
- OVERVOLTAGE L2-L3
- OVERVOLTAGE L3-L1
- OVERVOLTAGE L1-L0
- OVERVOLTAGE L2-L0
- OVERVOLTAGE L3-L0
- UNDERVOLTAGE L1-L2
- UNDERVOLTAGE L2-L3
- UNDERVOLTAGE L3-L1
- UNDERVOLTAGE L1-L0
- UNDERVOLTAGE L2-L0
- UNDERVOLTAGE L3-L0
- MASTER SWITCH OPEN

## Menu 9

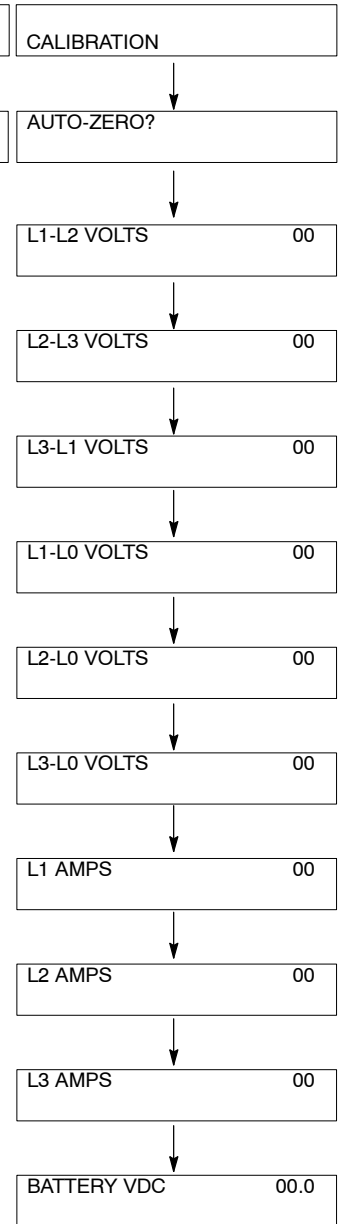

## Menu List, continued

### Menu 10

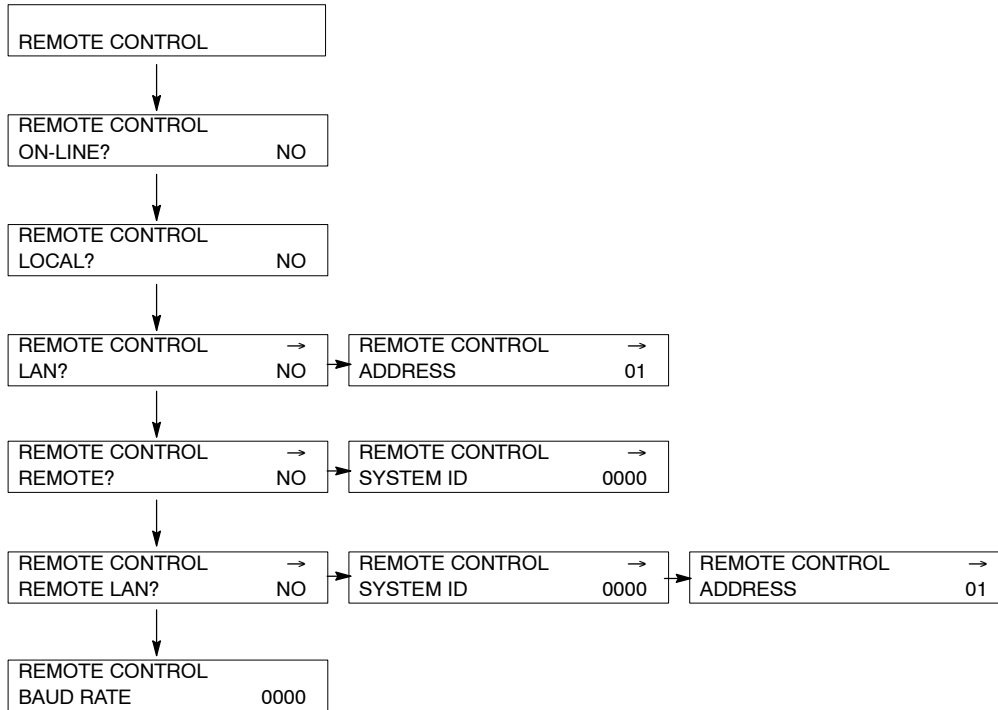

### Menu 11

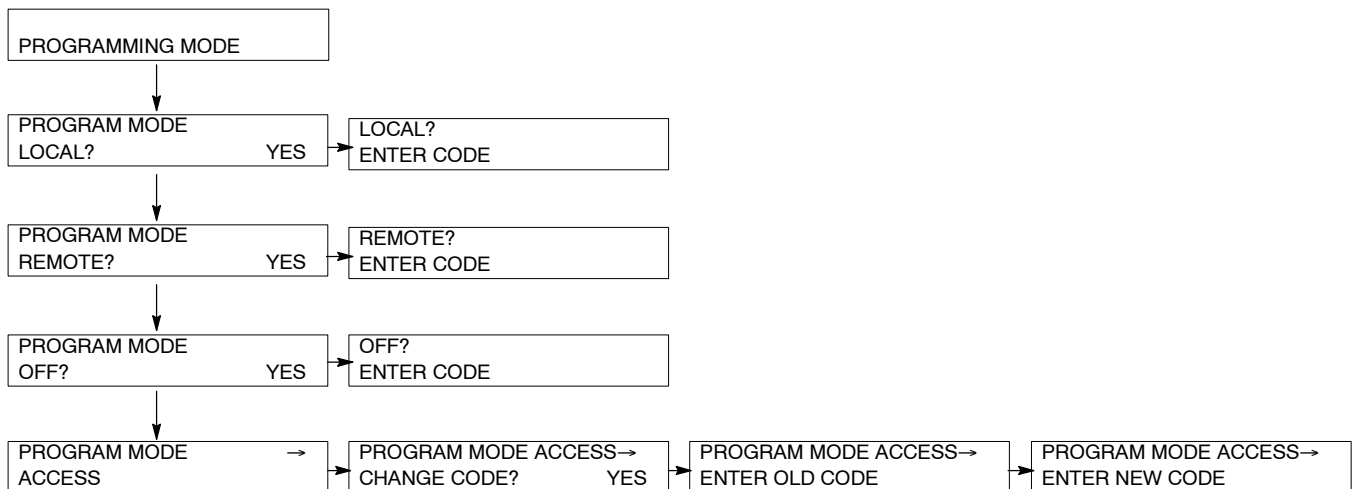

## 2.5 Reviewing the Digital Display

The user interacts with the digital controller by a keypad and digital display. Use the keypad to access the generator set informational data and preset settings. This review section shows how to access the data. Instructions on how to change information is found in Local Programming Mode On in Section 2.8. See Figure 2-8 for illustration of the digital display and keypad.

**Note:** After energizing the controller using the prime power switch or reconnecting the battery, set the controller time and date. See Section 2.8.3, Local Programming Mode On, Menu 3—Time & Date.

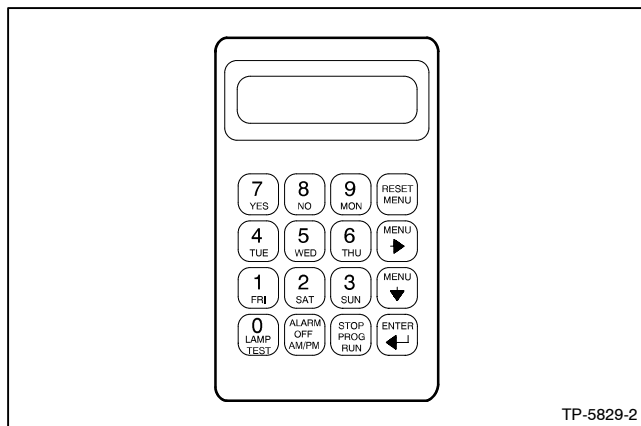

**Figure 2-8** Digital Display and Keypad

Pressing any key on the keypad activates the controller panel display. The panel lamps and display turns off 5 minutes after the last keypad entry.

### 2.5.1 Keypad Operation

Use the keypad to input information into the controller. Some of the keys have two functions. Key functions include the following.

**Number keys.** If the controller asks a question requiring a numeric answer, the controller accepts a keypad number and ignores the secondary function of the key.

**Number key secondary function.** If the controller asks a question requiring a nonnumeric answer (yes, no, weekday, a.m./p.m., etc.), the controller accepts the secondary key function and ignores the numeric value of the key.

**Menu down ↓ key.** The controller software consists of layered menus of data or programming steps. Use the menu down ↓ key to navigate through the menu layers. Press the menu down ↓ key repeatedly to return the the opening menu.

**Note:** Pressing the menu down ↓ key locks the user into the layers of that main menu. Press the reset menu key to access other main menus.

**Menu right → key.** Use the menu right → key to scroll the main menus. Within the layers of each main menu several horizontal information displays or programming steps may appear. The display contains an arrow in the right-hand corner when there is a horizontal layer. Pressing the menu right → key when no arrow is present does not affect the program.

**Reset menu key.** The reset menu key takes the program back to the beginning or resets an incorrect keypad entry. Use the reset menu key to exit a menu or any layers within that menu.

**Enter ↵ key.** Use the enter ↵ key to input information on the display into the controller memory.

**Lamp test key.** Press the lamp test key to check that the status lamps illuminate and clear the digital display. Press the reset menu key before pressing the lamp test key.

**Alarm off key.** Use the alarm off key to disconnect the horn during service. Place generator set master switch in the AUTO position before silencing alarm horn. Alarm horn cannot be silenced unless the master switch is in the AUTO position. See Section 2.3, Digital Controller Operation, Switches and Controls, for more information on turning the alarm horn off.

**Stop prog run key.** Use the stop prog run key to end the generator set programmed exercise run in Menu 7—Engine Status. The generator set shuts down after the time-delay for engine cooldown period elapses. The stop prog run key does not affect the programmed transfer switch exercise function.

## 2.5.2 Display Messages

**Arrow down ↓ display.** Directs the user to the next menu within the same main menu. Menu loop; press the down arrow key to navigate to the next menu.

**Arrow right → display.** Directs the user to the next menu. Menu loop; press the right arrow key to the next menu.

**Question mark ? display.** The control firmware asks a question; answer the question by pressing the yes/no, digit, day, or am/pm key.

**Code error.** If this message appears, the entered information is not within the required parameters. Press Reset Menu and rekey information.

**Entry accepted.** This message appears for several seconds after pressing the Enter key during the programming mode. The display then reverts back to the previous display with the new data shown.

## 2.6 Monitoring and Programming Setup

Access the controller system in several ways using Menu 10—Remote Control and Menu 11—Programming Mode. The user can monitor the controller system without data changes or monitor using programmed control. Use the controller keypad and display or a personal computer with optional software to monitor and/or program. Access the controller system

with a personal computer using local (direct) or remote (modem) systems.

While this manual focuses on access through the controller, it includes access using a personal computer for initial connection.

There are six basic configurations for data monitoring and programming. See Figure 2-9.

Other combinations of data review are possible but perform programming from a single location. Figure 2-10 for the Monitoring and Programming Matrix provides a brief description of the settings of Menu 10 and Menu 11 based on user-selected operating mode.

Initially setup the access configurations at the controller using the keypad and digital display. Go to Section 2.8, Local Programming Mode On, and set the desired selection in Menu 10—Remote Control and Menu 11—Programming Mode before accessing data.

User Activity	Access Source
Monitor only	Controller
Monitor and Program	Controller
Monitor only	Direct PC
Monitor and Program	Direct PC
Monitor only	PC via Telephone Lines
Monitor and Program	PC via Telephone Lines

**Figure 2-9** Monitoring and Programming Configurations

User Operating Mode Selection		Menu 10—Remote Control Settings			Menu 11—Programming Mode		
User Activity	Access Source	On Line?	Local?	Remote?	Programming Mode Off?	Local Programming Mode?	Remote Programming Mode?
Monitor only	Controller	No	No	No	Yes	No	No
Monitor and Program	Controller	No	No	No	No	Yes	No
Monitor only	Direct PC	Yes	Yes	No	Yes	No	No
Monitor and Program	Direct PC	Yes	Yes	No	No	No	Yes
Monitor only	PC via Telephone Lines	Yes	No	Yes	Yes	No	No
Monitor and Program	PC via Telephone Lines	Yes	No	Yes	No	No	Yes

**Figure 2-10** Monitoring and Programming Matrix

## 2.6.1 Personal Computer (PC) Communications

There are four ways to communicate with a PC and the generator set and/or transfer switch devices. The PC connections require optional software, communication modules in the generator set controller and/or transfer switch, and possibly other hardware. See Software Operation Manual for details. Contact your authorized distributor/dealer for availability.

### Local Single Connection

A PC connects directly to the COM port of the communication module with an RS-232 cable when PC is within 15 m (50 ft.) from the device or RS-485 cable where the PC is up to 1220 m (4000 ft.) from the device. See Figure 2-11 or Figure 2-12.

### Local Area Network (LAN)

A PC connects directly to the device's local area network. A LAN is a system which connects more than one device to a single PC. Acceptable devices include Decision-Maker™ 340 controller, M340 transfer switch control, and M340+ transfer switch control. See Figure 2-13.

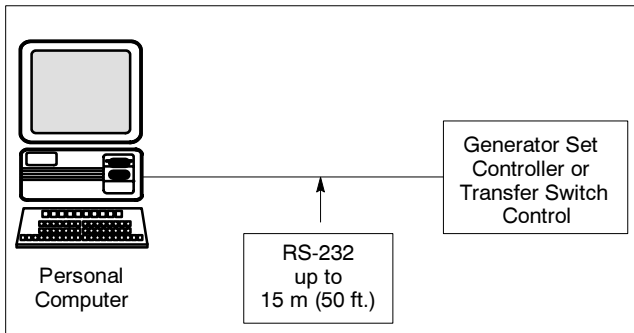

**Figure 2-11** Local Single Connection, up to 15 m (50 ft.)

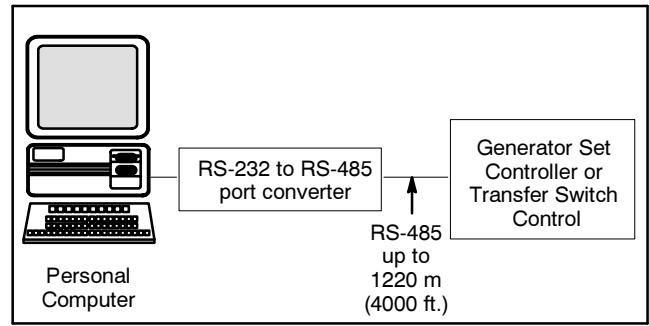

**Figure 2-12** Local Single Connection, up to 1220 m (4000 ft.)

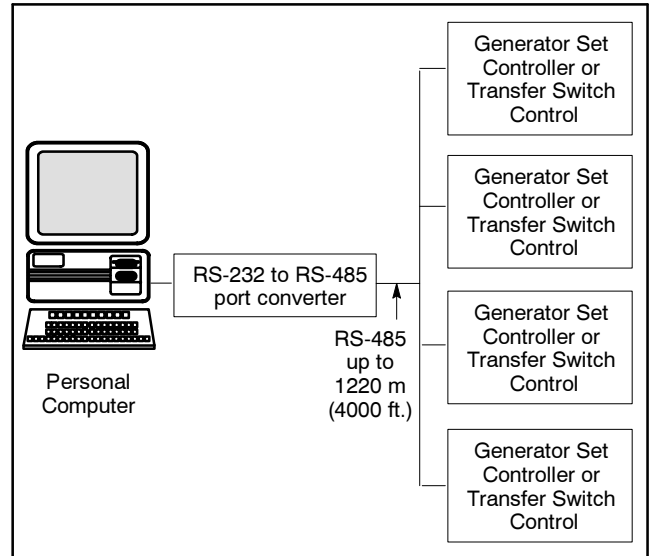

**Figure 2-13** Local Area Network

### Remote Single Connection

A PC connects to a modem and a single device connects a modem. The PC communicates to the device via a telephone network. Locate the PC anywhere a telephone line is available. See Figure 2-14.

### Remote Area Network

A PC connects to a modem. The devices connect to a LAN network. The PC communicates to the devices via a telephone network that is interfaced to the LAN network. Acceptable devices include Decision-Maker™340 controller, M340 transfer switch control, and M340+ transfer switch control. Locate the PC anywhere a telephone line is available. See Figure 2-15.

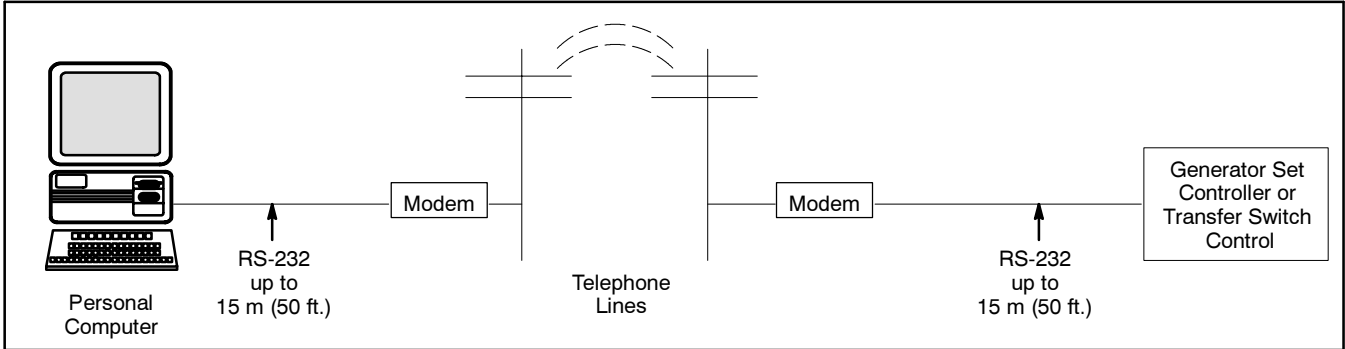

Figure 2-14 Remote Single Connection

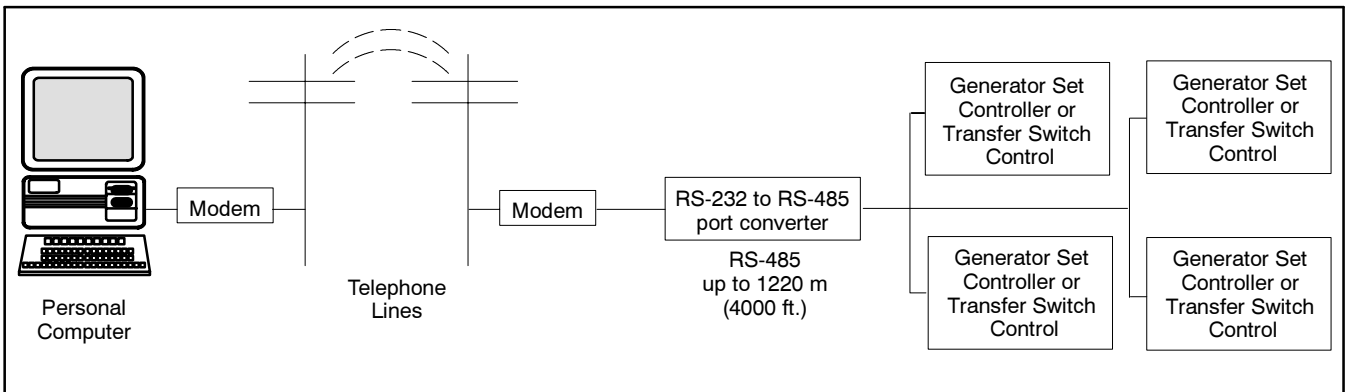

Figure 2-15 Remote Area Network

## 2.7 Local Programming Mode Off

Use the Local Program Mode Off section to review data when no programming is necessary. Review all generator set controller data with the programming mode off.

See Section 1, Specifications, to review set point ranges and default settings.

User must enable programming mode to edit display and/or files. See Menu 11—Programming Mode and Programming Mode On section for more information.















**Note:** Press any key on the keypad to activate the controller panel display. The panel display turns off 5 minutes after the last keypad entry.

**Note:** Press the Reset Menu key to clear the error messages

## 2.7.1 Menu 1—Generator Output

Menu 1 provides generator output data including line-to-line and line-to-neutral voltages, current, frequency, power factor, total kilowatts, and percent of maximum kW displays. Menu 1 displays three-phase voltage and current readings when applicable.

Use Menu 1 to access the voltage regulator sensing calibration across L1 and L2 for 350–2000 kW models with digital voltage regulators. Enable local programming mode to edit DVR voltage regulator adjustments.

Key Entry	Display	Description
	ENTER NO. 1-11	Input a menu number.
	MENU NUMBER 1	Displays menu number.
	GENERATOR OUTPUT	Displays menu name.
	L1-L2 VOLTS 00 L1 AMPS 00	Displays L1-L2 volts and L1 amps.
	L1-L2 VOLTS 00 INCREASE VOLTAGE ?	Gives the user the option to fine adjust voltage on 350–2000 kW models with the DVR remote voltage adjust option connected. User must enable local programming mode to change DVR voltage regulator adjustments.
	L1-L2 VOLTS 00 DECREASE VOLTAGE ?	Gives the user the option to fine adjust voltage on 350–2000 kW models with the DVR remote voltage adjust option connected. User must enable local programming mode to change DVR voltage regulator adjustments.
	L1-L2 VOLTS 00 L1 AMPS 00	Returns user to L1-L2 volts and L1 amps menu.
	L2-L3 VOLTS 00 L2 AMPS 00	Displays L2-L3 volts and L2 amps (three-phase models only).
	L3-L1 VOLTS 00 L3 AMPS 00	Displays L3-L1 volts and L3 amps (three-phase models only).
	L1-L0 VOLTS 00 L1 AMPS 00	Displays L1-L0 volts and L1 amps.
	L2-L0 VOLTS 00 L2 AMPS 00	Displays L2-L0 volts and L2 amps.
	L3-L0 VOLTS 00 L3 AMPS 00	Displays L3-L0 volts and L3 amps (three-phase models only).
	FREQUENCY 00.0 HZ POWER FACTOR 1.00	Displays frequency and power factor.
	TOTAL KILOWATTS 00 % MAX KW 00	Displays total kilowatts and percent of maximum standby kilowatts available from generator set.
	GENERATOR OUTPUT	Returns user to Menu 1—Generator Output.

## 2.7.2 Menu 2—Operational Records

Menu 2 provides generator set operational records including operation start date, last logged maintenance, total run time loaded and unloaded, run time since last maintenance, number of starts, number of running days, etc.

The user must reset the date after performing maintenance to keep records accurate. Enable programming mode to edit display and/or files.

Key Entry	Display	Description
RESET MENU	ENTER NO. 1-11	Input a menu number.
2 SAT	MENU NUMBER 2	Displays menu number.
MENU ▼	OPERATIONAL RECORDS	Displays menu name.
MENU ▼	OPERATIONAL RECORDS START DATE 0-00-00	Displays date generator set was placed in service.
MENU ▼	TOTAL RUN TIME LOADED HRS 0.0	Displays number of hours which generator set operated with load applied.
MENU ▼	TOTAL RUN TIME UNLOADED HRS 0.0	Displays numbers of hours which generator set operated without load applied.
MENU ▼	TOTAL RUN TIME KW HOURS 00	Displays number of kilowatts hours.
MENU ▼	OPERATING DAYS 00 START DATE 0-00-00	Displays number of operating days and date since generator set installation.
MENU ▼	NO. OF STARTS 00 START DATE 0-00-00	Displays number of generator set starts and date when generator set started operating.
MENU ▼	RECORDS—MAINT → LAST MAINT 0-00-00	Displays date of last logged maintenance.
MENU ▶	RESET RECORD?	Gives user option to reset last maintenance date. <b>Note:</b> User must enable programming mode to edit display and/or files.
MENU ▶	RECORDS—MAINT → LAST MAINT 0-00-00	Returns user to Records Maintenance menu. If Yes was entered on previous menu, current date appears as last maintenance date.
MENU ▼	RUN TIME SINCE MAINT LOADED HRS 0.	Displays number of hours which generator set operated with load applied.
MENU ▼	RUN TIME SINCE MAINT UNLOADED HRS 0.	Displays number of hours which generator set operated without load applied.
MENU ▼	RUN TIME SINCE MAINT KW HOURS 00	Displays number of kW hours since last logged maintenance.







## Menu 2—Operational Records, continued

Key Entry	Display	Description
MENU ▼	OPERATING DAYS 00 LAST MAINT 0-00-00	Displays number of operating days and date of last logged maintenance.
MENU ▼	NO. OF STARTS 00 LAST MAINT 0-00-00	Displays number of generator set starts and date of last logged maintenance.
MENU ▼	LAST START (0:00 AM)→ DATE 0-00-00	Displays time and date when generator set last operated.
MENU ▶	LENGTH OF RUN UNLOADED HRS 0.0	Displays number of hours which generator set operated without load applied.
MENU ▶	LAST START (0:00 AM)→ DATE 0-00-00	Returns user to Last Start menu.
MENU ▼	OPERATIONAL RECORDS	Returns user to Menu 2—Operational Records.

### 2.7.3 Menu 3—Time & Date

Menu 3 sets the clock time and date and internal calendar. The controller uses set time to determine exercise run time. Time and date are valid only if

controller power (starting battery) is connected. User must enable programming mode to edit display and/or files.















Key Entry	Display	Description
	<input type="text" value="ENTER NO. 1-11"/>	Input a menu number.
	<input type="text" value="MENU NUMBER 3"/>	Displays menu number.
	<input type="text" value="TIME &amp; DATE"/>	Displays menu name.
	<input type="text" value="(MONDAY) 0-00-00&lt;br/&gt;(12:00 AM)"/>	Displays day of the week, month-day-year, and time of day.
	<input type="text" value="TIME (12:00 AM)"/>	Displays time of day.
	<input type="text" value="DATE 0-00-00"/>	Displays month-day-year date.
	<input type="text" value="MENU NUMBER 3&lt;br/&gt;TIME &amp; DATE"/>	Returns user to Menu 3—Time & Date.

## 2.7.4 Menu 4—Time Delays







Menu 4 displays the cyclic cranking, various engine related starting and shutdown features, and auxiliary shutdown and inhibit time delays. Enable programming mode to edit display and/or files.

**Note:** If auxiliary input inhibit time is set to 0 seconds, the auxiliary input is active at all times and not dependent on time delay engine start (TDES).

**Note: Code error.** If *code error* message appears, the entered information is not within the required parameters. Press Reset Menu and rekey information.

Key Entry	Display	Description
	ENTER NO. 1-11	Input a menu number.
	MENU NUMBER 4	Displays menu number.
	TIME DELAYS	Displays menu name.
	TIME DELAY            MIN:SEC ENGINE START            :00	Displays engine start time delay in minutes:seconds.
	TIME DELAY            MIN:SEC STARTING AID            :00	Displays engine starting aid time delay in minutes:seconds.
	TIME DELAY            MIN:SEC ENG COOLDOWN            :00	Displays engine cooldown time delay in minutes:seconds.
	TIME DELAY            MIN:SEC CRANK ON                :00	Displays engine cyclic cranking on time in minutes:seconds.
	TIME DELAY            MIN:SEC CRANK PAUSE            :00	Displays engine cyclic cranking off time in minutes:seconds.
	OVERCRANKSHUTDOWN CRANK CYCLES            (3)	Displays engine crank cycles before shutdown.
	TIME DELAY            MIN:SEC OVERVOLTAGE            :00	Displays overvoltage time delay shutdown in minutes:seconds.
	TIME DELAY            MIN:SEC UNDERVOLTAGE            :00	Displays undervoltage time delay shutdown in minutes:seconds.
	TIME DELAY            MIN:SEC AUX 1 INHIBIT            :00	Displays auxiliary 1 inhibit time delay in minutes:seconds. Inhibit time delay is time period after engine starting and before time delay begins.
	TIME DELAY            MIN:SEC AUX 1 DELAY            :00	Displays auxiliary 1 shutdown time delay in minutes:seconds. Delay is time period after signal is received and before warning or shutdown fault occurs.
	TIME DELAY            MIN:SEC AUX 2 INHIBIT            :00	Displays auxiliary 2 inhibit time delay in minutes:seconds. Inhibit time delay is time period after engine starting and before time delay begins.







## Menu 4—Time Delays, continued

Key Entry	Display	Description				
	<table border="1"> <tr> <td>TIME DELAY</td> <td>MIN:SEC</td> </tr> <tr> <td>AUX 2 DELAY</td> <td>:00</td> </tr> </table>	TIME DELAY	MIN:SEC	AUX 2 DELAY	:00	Displays auxiliary 2 shutdown time delay in minutes:seconds. Delay is time period after signal is received and before warning or shutdown fault occurs.
TIME DELAY	MIN:SEC					
AUX 2 DELAY	:00					
	<table border="1"> <tr> <td>TIME DELAY</td> <td>MIN:SEC</td> </tr> <tr> <td>AUX 3 INHIBIT</td> <td>(3)</td> </tr> </table>	TIME DELAY	MIN:SEC	AUX 3 INHIBIT	(3)	Displays auxiliary 3 inhibit time delay in minutes:seconds. Inhibit time delay is time period after engine starting and before time delay begins.
TIME DELAY	MIN:SEC					
AUX 3 INHIBIT	(3)					
	<table border="1"> <tr> <td>TIME DELAY</td> <td>MIN:SEC</td> </tr> <tr> <td>AUX 3 DELAY</td> <td>:00</td> </tr> </table>	TIME DELAY	MIN:SEC	AUX 3 DELAY	:00	Displays auxiliary 3 shutdown time delay in minutes:seconds. Delay is time period after signal is received and before warning or shutdown fault occurs.
TIME DELAY	MIN:SEC					
AUX 3 DELAY	:00					
	<table border="1"> <tr> <td>TIME DELAY</td> <td>MIN:SEC</td> </tr> <tr> <td>AUX 4 INHIBIT</td> <td>:00</td> </tr> </table>	TIME DELAY	MIN:SEC	AUX 4 INHIBIT	:00	Displays auxiliary 4 inhibit time delay in minutes:seconds. Inhibit time delay is time period after engine starting and before time delay begins.
TIME DELAY	MIN:SEC					
AUX 4 INHIBIT	:00					
	<table border="1"> <tr> <td>TIME DELAY</td> <td>MIN:SEC</td> </tr> <tr> <td>AUX 4 DELAY</td> <td>:00</td> </tr> </table>	TIME DELAY	MIN:SEC	AUX 4 DELAY	:00	Displays auxiliary 4 shutdown time delay in minutes:seconds. Delay is time period after signal is received and before warning or shutdown fault occurs.
TIME DELAY	MIN:SEC					
AUX 4 DELAY	:00					
	<table border="1"> <tr> <td>TIME DELAYS</td> </tr> </table>	TIME DELAYS	Returns user to Menu 4—Time Delays.			
TIME DELAYS						

### 2.7.5 Menu 5—User-Defined Functions

Menu 5 provides user options for auxiliary shutdowns and warnings 1-4 and relay driver outputs (RDO) 1-10. Menu 5 also defines common fault inputs. Enable programming mode to edit display and/or files.









**Note: Code error.** When *code error* message appears, the entered information is not within the required parameters. Press Reset Menu and rekey information.

Key Entry	Display	Description
	<input type="text" value="ENTER NO. 1-11"/>	Input a menu number.
	<input type="text" value="MENU NUMBER 5"/>	Displays menu number.
	<input type="text" value="USER-DEFINED FUNCTIONS"/>	Displays menu name.
	<input type="text" value="AUXILIARY 1 WARNING SHUTDOWN? NO"/>	Displays to the user if auxiliary 1 causes a shutdown condition. Yes causes Auxiliary 1 to signal a fault shutdown. No causes Auxiliary 1 to signal a fault warning.
	<input type="text" value="AUXILIARY 2 WARNING SHUTDOWN? NO"/>	Displays to the user if auxiliary 2 causes a shutdown condition. Yes causes Auxiliary 2 to signal a fault shutdown. No causes Auxiliary 2 to signal a fault warning.
	<input type="text" value="AUXILIARY 3 WARNING SHUTDOWN? NO"/>	Displays to the user if auxiliary 3 causes a shutdown condition. Yes causes Auxiliary 3 to signal a fault shutdown. No causes Auxiliary 3 to signal a fault warning.
	<input type="text" value="AUXILIARY 4 WARNING SHUTDOWN? NO"/>	Displays to the user if auxiliary 4 causes a shutdown condition. Yes causes Auxiliary 4 to signal a fault shutdown. No causes Auxiliary 4 to signal a fault warning.





## Menu 5—User-Defined Functions, continued

Key Entry	Display	Description
	RELAY OUTPUT #1 (see Group A)	YES  Identifies signal source for relay output #1.
	<p><b>Group A</b>  <b>For relay outputs 1-10, choose one from the following 31 selections:</b>            DEFINED COMMON FAULT            AIR DAMPER            OVERVOLTAGE            UNDERVOLTAGE            UNDERFREQ SHUTDOWN            LOW COOLANT LEVEL            HIGH OIL TEMPERATURE            AUXILIARY 1            AUXILIARY 2            AUXILIARY 3            AUXILIARY 4            LOCKED ROTOR            INTERNAL ERROR            EPS SUPPLYING LOAD            SPEED SENSOR FAULT            LOAD SHED            KW OVERLOAD            UNDERFREQ WARNING            HIGH BATTERY VOLTAGE            NO TEMP GAUGE SIGNAL            NO OIL GAUGE SIGNAL            GRND FAULT DETECTED            OVERCURRENT            ENG COOLDOWN            ENGINE START            GENERATOR RUNNING            NFPA 110 COMM ALARM*            STARTING AID            WEAK BATTERY            LOW AC OUTPUT            OVERFREQUENCY</p>	<p><b>Note:</b> Menu 5 describes and provides selection of Defined Common Fault components</p> <p><b>Note:</b> Components of NFPA-110 Common Alarm include the 14 items listed below. The user cannot edit NFPA-110 Common Alarm items.</p> <p><b>*NFPA-110 Common Alarm 14 items include the following:</b>            OVERCRANK            LOW COOLANT TEMPERATURE            HIGH COOLANT TEMPERATURE WARNING            HIGH COOLANT TEMPERATURE            LOW OIL PRESSURE WARNING            LOW OIL PRESSURE            OVERSPEED            LOW FUEL            NOT IN AUTO            BATTERY CHARGER FAULT            LOW BATTERY VOLTAGE            AIR DAMPER            EPS SUPPLYING LOAD            HIGH BATTERY VOLTAGE</p>

## Menu 5—User-Defined Functions, continued

Key Entry	Display	Description
		Identifies signal source for relay outputs #2-10. See Relay Output #1 for Group A selections.
	RELAY OUTPUT #2 YES (see Group A)	
	RELAY OUTPUT #3 YES (see Group A)	
	RELAY OUTPUT #4 YES (see Group A)	
	RELAY OUTPUT #5 YES (see Group A)	
	RELAY OUTPUT #6 YES (see Group A)	
	RELAY OUTPUT #7 YES (see Group A)	
	RELAY OUTPUT #8 YES (see Group A)	
	RELAY OUTPUT #9 YES (see Group A)	
	RELAY OUTPUT #10 YES (see Group A)	













## Menu 5—User-Defined Functions, continued

Key Entry	Display	Description	
	DEFINEDCOMMONFAULT →	Provides user entry to defined common fault selections.	
	COMMON FAULT NO (see Group B)	Gives user previously selected items for defined common fault group. Press Menu Down ↓ key to continue to the next selection (repeat as necessary).	
	<p><b>Group B</b>  <b>For defined common fault, choose from the following 45 selections:</b>            AIR DAMPER*            OVERVOLTAGE            UNDERVOLTAGE            UNDERFREQ SHUTDOWN            LOW COOLANT LEVEL            HIGH OIL TEMPERATURE            AUXILIARY 1            AUXILIARY 2            AUXILIARY 3            AUXILIARY 4            LOCKED ROTOR            INTERNAL ERROR            EPS SUPPLYING LOAD*            SPEED SENSOR FAULT            LOAD SHED            KW OVERLOAD            UNDERFREQ WARNING            HIGH BATTERY VOLTAGE*            NO TEMP GAUGE SIGNAL            NO OIL GAUGE SIGNAL            GRND FAULT DETECTED</p>	<p>OVERCURRENT            ENG COOLDOWN            ENGINE START            GENERATOR RUNNING            NFPA 110 COMM ALARM            (see *NOTE)            STARTING AID            LOW OIL PRESSURE*            HIGH COOLANT TEMP*            OVERCRANK*            OVERSPEED*            EMERGENCY STOP            NOT IN AUTO*            SYSTEM READY            LOW BATTERY VOLTAGE*            BATT CHARGER FAULT*            LOW FUEL*            HIGH TEMP WARNING*            LOW OIL PRES WARNING*            LOW COOLANT TEMP*            WEAK BATTERY            LOAD SHED UNDERFREQ            LOAD SHED EXCESS KW            LOW AC OUTPUT            OVERFREQUENCY</p>	<p><b>Note:</b> Components of NFPA-110 Common Alarm include the 14 items marked by an asterisk (*). The user cannot edit NFPA-110 Common Alarm items.</p>
	DEFINEDCOMMONFAULT →	Returns user to beginning of defined common fault selections.	
	USER-DEFINED FUNCTIONS	Returns user to Menu 5—User-Defined Functions	







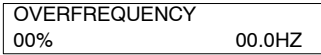

## 2.7.6 Menu 6—Generator System

Menu 6 contains factory-preset generator set voltage and frequency data. Enter corresponding data if the generator set requires voltage reconnection and/or frequency adjustment. It is imperative that the user enter correct data because these settings trigger all related shutdowns. Enable programming mode to edit display and/or files.

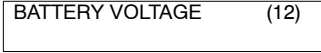
**Note:** The user defines the data shown in Menu 6. It is NOT data measured by the controller and associated sensing devices. The user defines these values for purposes of calibrating the control.

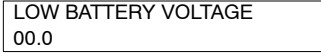
Key Entry	Display	Description
	ENTER NO. 1-11	Input a menu number.
	MENU NUMBER 6	Displays menu number.
	GENERATOR SYSTEM	Displays menu name.
	SYSTEM VOLTAGE 000	Displays system voltage as entered data.
	SYSTEM FREQUENCY 00	Displays system frequency as entered data.
	THREE-PHASE WYE → DELTA? NO	Displays to the user if voltage configuration is wired for a wye connection as entered data.
	<b>OR</b>	
	THREE-PHASE DELTA → WYE? NO	Displays to the user if voltage configuration is wired for a delta connection as entered data.
	SINGLE-PHASE? NO	Displays to the user if voltage configuration is wired for three-phase as entered data.
	<b>OR</b>	
	THREE-PHASE? NO	Displays to the user if voltage configuration is wired for single-phase as entered data.
	THREE-PHASE WYE → DELTA? NO	Returns user to three-phase wye/delta menu. <b>Note:</b> Display sample may differ depending upon previous entries.
	KW RATING 00	Displays generator set kW rating as entered data.
	OVERVOLTAGE 00% 000VAC	Displays overvoltage setting.
	UNDERVOLTAGE 00% 000VAC	Displays undervoltage setting.
	OVERSPEED 00HZ 0000RPM	Displays overspeed setting.
	UNDERFREQUENCY 00% 00.0HZ	Displays underfrequency setting.

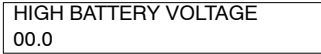
## Menu 6—Generator System, continued

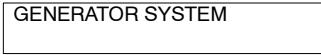









Key Entry	Display	Description
		Displays overfrequency setting.
		Displays battery voltage setting as entered data.
		Displays low battery voltage setting as entered data.
		Displays high battery voltage setting as entered data.
		Returns user to Menu 6—Generator System.

## 2.7.7 Menu 7—Engine Status

Menu 7 provides user with engine status, operating data, and time delay to start and run time. Enable programming mode to edit display and/or files.





**Code error.** If *code error* message appears, the entered information is not within the required parameters. Press Reset Menu and rekey information.

**Note:** Use STOP PROG RUN key to stop generator set Engine Start program.

Key Entry	Display	Description
	<input type="text" value="ENTER NO. 1-11"/>	Input a menu number.
	<input type="text" value="MENU NUMBER 7"/>	Displays menu number.
	<input type="text" value="ENGINE STATUS"/>	Displays menu name.
	<input type="text" value="ENGINE RPM 00&lt;br/&gt;BATTERY VDC 00.0"/>	Displays engine rpm and engine starting battery voltage.
	<input type="text" value="OIL PRESSURE 00PSI→&lt;br/&gt;COOLANT TEMP 000°F"/>	Displays engine oil pressure in psi and engine coolant temperature in °F.
	<input type="text" value="OIL PRESSURE 00kPa→&lt;br/&gt;COOLANT TEMP 000°C"/>	Displays engine oil pressure in kPa and engine coolant temperature in °C.
	<input type="text" value="OIL PRESSURE 00PSI→&lt;br/&gt;COOLANT TEMP 000°F"/>	Returns user to Engine Oil Pressure in psi and engine Coolant Temperature in °F menu.
	<input type="text" value="ENGINE START? NO→&lt;br/&gt;COUNTDOWN :00"/>	Gives user option to start generator set using run time feature.
	<input type="text" value="RUN TIME HR:MN→&lt;br/&gt;:00"/>	Allows user to enter programmed run time. User must enable programming mode to edit display and/or files.
	<input type="text" value="ENGINE START? NO→&lt;br/&gt;COUNTDOWN :00"/>	Returns user to Engine Start?—Countdown menu.
	<input type="text" value="ENGINE STATUS"/>	Returns user to Menu 7—Engine Status.

## 2.7.8 Menu 8—Source History

Menu 8 indicates the source of a generator set shutdown or warning. Multiple faults may simultaneously exist. Correct each fault before attempting to restart the generator set.















Key Entry	Display	Description
	<input type="text" value="ENTER NO. 1-11"/>	Input a menu number.
	<input type="text" value="MENU NUMBER 8"/>	Displays menu number.
	<input type="text" value="SOURCE HISTORY"/>	Displays menu name.
	<input type="text" value="(see Group C)&lt;br/&gt;0-00-00 (00:00 AM)"/>	Menu lists up to 4 fault descriptions with date and time of fault. Press Menu Down ↓ key to continue. See System Warning or System Shutdown at the beginning of Section 2 for fault definitions.
	<p><b>Group C</b>  <b>The 28 fault warning and shutdowns include the following:</b>            AIR DAMPER            UNDERFREQ SHUTDOWN            LOW COOLANT LEVEL            HIGH OIL TEMPERATURE            AUXILIARY 1            AUXILIARY 2            AUXILIARY 3            AUXILIARY 4            LOCKED ROTOR            INTERNAL ERROR            LOW OIL PRESSURE            HIGH COOLANT TEMP            OVERCRANK            OVERSPEED            EMERGENCY STOP            OVERVOLTAGE L1-L2            OVERVOLTAGE L2-L3            OVERVOLTAGE L3-L1            OVERVOLTAGE L1-L0            OVERVOLTAGE L2-L0            OVERVOLTAGE L3-L0            UNDERVOLTAGE L1-L2            UNDERVOLTAGE L2-L3            UNDERVOLTAGE L3-L1            UNDERVOLTAGE L1-L0            UNDERVOLTAGE L2-L0            UNDERVOLTAGE L3-L0            MASTER SWITCH OPEN</p>	
	<input type="text" value="SOURCE HISTORY"/>	Returns user to Menu 8—Source History.

## 2.7.9 Menu 9—Calibration

Menu 9 provides calibration of the voltage sensing logic. Changing system voltage or replacing the main logic control circuit board requires calibration adjustment. Enable programming mode to edit display and/or files.

Adjust the generator set voltage at the controller voltage adjustment or using Menu 1 with digital voltage regulators. Adjust the frequency at the generator set governor before making calibration adjustments.

Connect a meter with a minimum accuracy of 1% to output leads to calibrate the voltage-sensing logic.











Key Entry	Display	Description
	<input type="text" value="ENTER NO. 1-11"/>	Input a menu number.
	<input type="text" value="MENU NUMBER 9"/>	Displays menu number.
	<input type="text" value="CALIBRATION"/>	Displays menu name.
	<input type="text" value="AUTO-ZERO?"/>	Gives user the option to calibrate the voltage and current inputs for zero input signals. <b>Note:</b> Perform this programming function only when the generator set is NOT running.
	<input type="text" value="L1-L2 VOLTS 00"/>	Displays user-measured and entered voltage for calibration procedure (single-phase and three-phase models).
	<input type="text" value="L2-L3 VOLTS 00"/>	Displays user-measured and entered voltage for calibration procedure (three-phase models only).
	<input type="text" value="L3-L1 VOLTS 00"/>	Displays user-measured and entered voltage for calibration procedure (three-phase models only).
	<input type="text" value="L1-L0 VOLTS 00"/>	Displays user-measured and entered voltage for calibration procedure (single- and three-phase models).
	<input type="text" value="L2-L0 VOLTS 00"/>	Displays user-measured and entered voltage for calibration procedure (single- and three-phase models).
	<input type="text" value="L3-L0 VOLTS 00"/>	Displays user-measured and entered voltage for calibration procedure (three-phase models only).
	<input type="text" value="L1 AMPS 00"/>	Displays user-measured and entered current for calibration procedure (single- and three-phase models).
	<input type="text" value="L2 AMPS 00"/>	Displays user-measured and entered current for calibration procedure (single- and three-phase models).
	<input type="text" value="L3 AMPS 00"/>	Displays user-measured and entered current for calibration procedure (three-phase models).
	<input type="text" value="BATTERY VDC 00.0"/>	Displays user-measured battery voltage for calibration procedure.
	<input type="text" value="CALIBRATION"/>	Returns user to Menu 9—Calibration.

## 2.7.10 Menu 10—Remote Control

Menu 10 provides local or remote access to the control logic and displays. Use the LAN (local area network) to gain remote access to multiple devices/addresses. Enable *remote* programming mode to edit display and/or files in this menu.

Use the Software Operation Manual when accessing this menu, programming from a remote location, and determining address and system identification information.

**Note A:** There are four PC remote control choices: local, LAN, remote, and remote LAN. Entering Yes to one remote control choice changes the other three choices to No. Yes menus are highlighted in the following instructions. The dashed lines separate the four control choices.

Key Entry	Display	Description
	ENTER NO. 1-11	Input a menu number.
 	MENU NUMBER 10	Displays menu number.
	REMOTE CONTROL	Displays menu name.
	REMOTE CONTROL ON-LINE? NO	Displays user choice to deactivate the option for accessing the control using a PC connection.
<b>OR</b>		
	REMOTE CONTROL ON-LINE? YES	Displays user choice to activate the option for accessing the control using a PC connection.
<hr style="border-top: 1px dashed black;"/>		
<b>Local Control</b>		
	REMOTE CONTROL LOCAL? NO	Displays user choice to deactivate a local (direct) PC connection.
<b>OR</b>		
	REMOTE CONTROL LOCAL? YES	Displays user choice to activate a local (direct) PC connection to a single control. See Note A.
<hr style="border-top: 1px dashed black;"/>		
<b>Local LAN Control</b>		
	REMOTE CONTROL LAN? NO	Displays user choice to deactivate LAN connection.
<b>OR</b>		
	REMOTE CONTROL LAN? YES	Displays user choice to activate a local area network (LAN) of controls and transfer switches with a local (direct) connected PC. See Note A.
	REMOTE CONTROL ADDRESS 01	Indicates address of device 1-128.
	REMOTE CONTROL LAN? YES	Returns user to remote control—LAN? menu.

## Menu 10—Remote Control, continued

Key Entry	Display	Description
<b>Remote Control</b>		
MENU ▼	REMOTE CONTROL → REMOTE? NO	Indicates no remote (modem) PC connection with a single device.
<b>OR</b>		
MENU ▼	REMOTE CONTROL → REMOTE? YES	Indicates a remote (modem) PC connection. See Note A.
MENU ▶	REMOTE CONTROL → SYSTEM ID 0000	Requires user to enter system ID for remote control access during remote programming mode. The system ID is a password. The user must use the same password for all devices at a site.
MENU ▶	REMOTE CONTROL → REMOTE? YES	Returns user to remote control—REMOTE? menu.
<b>Remote LAN Control</b>		
MENU ▼	REMOTE CONTROL → REMOTE LAN? NO	Indicates no remote LAN connection.
<b>OR</b>		
MENU ▼	REMOTE CONTROL → REMOTE LAN? YES	Indicates a remote (modem) PC connection with a network of devices at the site. See Note A.
MENU ▶	REMOTE CONTROL → SYSTEM ID 0000	Requires user to enter system ID of remote LAN for remote control access during remote programming mode. The system ID is a password. The user must use the same password for all devices at a site.
MENU ▶	REMOTE CONTROL → ADDRESS 01	Indicates address of device.
MENU ▶	REMOTE CONTROL → REMOTE LAN? YES	Returns user to remote control—REMOTE LAN? menu.
MENU ▼	REMOTE CONTROL BAUD RATE 0000	Indicates active baud rate. User must enter a baud rate for all on-line devices.
MENU ▼	REMOTE CONTROL	Returns user to Menu 10—Remote Control.

## 2.8 Local Programming Mode On

The Local Programming Mode On section explains how to program the generator set controller logic. Each menu contains a step-by-step procedure for programming the various logic groups. See Section 1, Specifications for setting ranges and default settings.

Please read and understand the entire Local Programming Mode On section before attempting any programming. The factory settings are adjustable and inadvertent changes can occur without full understanding of the logic features and functions.

The programming feature alters stored settings and changes characteristics of the logic. Do not operate the controller with the program mode on unless there is a need to edit program logic or clear stored data. Limit programming responsibilities to individuals with training and authority.

Use the Local Program Mode Off mode to view generator set operation data and review previously programmed information. Use Section 2.7, Local Program Mode Off, to review data when no programming is necessary.

**Note:** Use the generator set controller to initially set up remote programming. Remote programming cannot be accessed from a PC unless the controller is first set for remote programming using Menu 11.

















**Note:** Press any key on the keypad to activate the controller panel display. The panel display turns off 5 minutes after the last keypad entry.

**Note:** Press the Reset Menu key to clear the Error display.

## 2.8.1 Menu 1—Generator Output

Menu 1 provides generator output data including line-to-line and line-to-neutral voltages, current, frequency, power factor, total kilowatts, and percent of maximum kW. Logic displays three-phase voltage and current readings when applicable.

Use the first menu to access the voltage regulator sensing calibration across L1 and L2 for 350–2000 kW models with digital voltage regulators.

Key Entry	Display	Description
	ENTER NO. 1-11	Input a menu number.
	MENU NUMBER 1	Displays menu number.
	GENERATOR OUTPUT	Displays menu name.
	L1-L2 VOLTS 00 L1 AMPS 00	Displays L1-L2 volts and L1 amps.
	L1-L2 VOLTS 00 INCREASE VOLTAGE ?	Gives the user the option to fine adjust voltage on 350-2000 kW models with the DVR remote voltage adjust option connected. When required, use Yes key to increase volts. <b>Note:</b> Models below 350 kW have a voltage adjustment potentiometer on controller.
	L1-L2 VOLTS 00 INCREASE VOLTAGE ?	Increases voltage. Press Yes key as necessary to reach required voltage.
	L1-L2 VOLTS 00 DECREASE VOLTAGE ?	Gives the user the option to fine adjust voltage on 350-2000 kW models. When required, use Yes key to decrease volts.
	L1-L2 VOLTS 00 DECREASE VOLTAGE ?	Decreases voltage. Press Yes key as necessary to reach required voltage.
	L1-L2 VOLTS 00 L1 AMPS 00	Returns user to L1-L2 volts and L1 amps menu.
	L2-L3 VOLTS 00 L2 AMPS 00	Displays L2-L3 volts and L2 amps (three-phase models only).
	L3-L1 VOLTS 00 L3 AMPS 00	Displays L3-L1 volts and L3 amps (three-phase models only).
	L1-L0 VOLTS 00 L1 AMPS 00	Displays L1-L0 volts and L1 amps.
	L2-L0 VOLTS 00 L2 AMPS 00	Displays L2-L0 volts and L2 amps.
	L3-L0 VOLTS 00 L3 AMPS 00	Displays L3-L0 volts and L3 amps (three-phase models only).
	FREQUENCY 00.0 HZ POWER FACTOR 1.00	Displays frequency and power factor.
	TOTAL KILOWATTS 00 % MAX KW 00	Displays total kilowatts and percent of maximum standby kilowatts available from generator set.
	GENERATOR OUTPUT	Returns user to Menu 1—Generator Output.

## 2.8.2 Menu 2—Operational Records

Menu 2 provides generator set operational records including operation start date, last logged maintenance, total run time loaded and unloaded, run time since last

maintenance, number of starts, number of running days, etc. The user must reset the date after performing maintenance to keep records accurate.

Key Entry	Display	Description
RESET MENU	ENTER NO. 1-11	Input a menu number.
2 SAT	MENU NUMBER 2	Displays menu number.
MENU ▼	OPERATIONAL RECORDS	Displays menu name.
MENU ▼	OPERATIONAL RECORDS START DATE 0-00-00	Displays date generator set was placed in service.
MENU ▼	TOTAL RUN TIME LOADED HRS 0.0	Displays number of hours which generator set operated with load applied.
MENU ▼	TOTAL RUN TIME UNLOADED HRS 0.0	Displays numbers of hours which generator set operated without load applied.
MENU ▼	TOTAL RUN TIME KW HOURS 00	Displays number of kilowatt hours.
MENU ▼	OPERATING DAYS 00 START DATE 0-00-00	Displays number of operating days and date since generator set installation.
MENU ▼	NO. OF STARTS 00 START DATE 0-00-00	Displays number of generator set starts and date when generator set started operating.
MENU ▼	RECORDS—MAINT → LAST MAINT 0-00-00	Displays date of last logged maintenance.
MENU ▶	RESET RECORD?	Gives user option to reset last maintenance date.
8 NO	RESET RECORD? NO	Enter No to keep the previously logged date.
<b>AND</b>		
ENTER ↩	RESET RECORD? NO	Confirms entry.
<b>OR</b>		
7 YES	RESET RECORD? YES	Enter Yes to reset to the current date.
<b>AND</b>		
ENTER ↩	RESET RECORD? NO	Confirms entry.
MENU ▶	RECORDS—MAINT → LAST MAINT 0-00-00	Returns user to Records Maintenance menu. If Yes was entered on previous menu, current date appears as last maintenance date.
MENU ▼	RUN TIME SINCE MAINT LOADED HRS 0.	Displays number of hours which generator set operated with load applied.









## Menu 2—Operational Records, continued

Key Entry	Display	Description
MENU ▼	RUN TIME SINCE MAINT UNLOADED HRS 0.	Displays number of hours which generator set operated without load applied.
MENU ▼	RUN TIME SINCE MAINT KW HOURS 00	Displays number of kW hours since last logged maintenance.
MENU ▼	OPERATING DAYS 00 LAST MAINT 0-00-00	Displays number of operating days and date of last logged maintenance.
MENU ▼	NO. OF STARTS 00 LAST MAINT 0-00-00	Displays number of generator set starts and date of last logged maintenance.
MENU ▼	LAST START (0:00 AM)→ DATE 0-00-00	Displays time and date when generator set last operated.
MENU ▶	LENGTH OF RUN UNLOADED HRS 0.0	Displays number of hours which generator set operated without load applied.
MENU ▶	LAST START (0:00 AM)→ DATE 0-00-00	Returns user to Last Start menu.
MENU ▼	OPERATIONAL RECORDS	Returns user to Menu 2—Operational Records.

### 2.8.3 Menu 3—Time & Date

Menu 3 sets the clock time and date and internal calendar. The controller uses set time to determine

exercise run time. Time and date are valid only when controller power (starting battery) is connected.

Key Entry	Display	Description
	<input type="text" value="ENTER NO. 1-11"/>	Input a menu number.
	<input type="text" value="MENU NUMBER 3"/>	Displays menu number.
	<input type="text" value="TIME &amp; DATE"/>	Displays menu name.
	<input type="text" value="(MONDAY) 0-00-00&lt;br/&gt;(12:00 AM)"/>	Displays day of the week, month-day-year, and time of day.
	<input type="text" value="TIME (12:00 AM)"/>	Displays time of day. When required, use numeric and am/pm keys to set time and press Enter key.
	<input type="text" value="TIME (12:00 AM)"/>	Displays corrected time of day.
	<input type="text" value="DATE 0-00-00"/>	Displays month-day-year date. When required, use numeric keys to set month-day-year date and press Enter key.
	<input type="text" value="DATE 0-00-00"/>	Displays corrected month-day-year date.
	<input type="text" value="TIME &amp; DATE"/>	Returns user to Menu 3—Time & Date.

















## 2.8.4 Menu 4—Time Delays

**Code error.** When *code error* message appears, the entered information is not within the required parameters. Press Reset Menu and rekey information.

**Note:** Menu 4 sets the cyclic cranking, various engine-related starting and shutdown features,

and auxiliary shutdown and inhibit time delays. Enter all time delays in minutes and seconds.

**Note:** If auxiliary input inhibit time is set to 0 seconds, the auxiliary input is active at all times and not dependent on time delay engine start (TDES).

Key Entry	Display	Description
	ENTER NO. 1-11	Input a menu number.
	MENU NUMBER 4	Displays menu number.
	TIME DELAYS	Displays menu name.
	TIME DELAY            MIN:SEC ENGINE START            :00	Displays engine start time delay in minutes:seconds. When required, use numeric keys to set new time delay and press Enter key.
	TIME DELAY            MIN:SEC ENGINE START            :00	Displays corrected engine start time delay.
	TIME DELAY            MIN:SEC STARTING AID            :00	Displays engine starting aid time delay in minutes:seconds. When required, use numeric keys to set new time delay and press Enter key.
	TIME DELAY            MIN:SEC STARTING AID            :00	Displays corrected engine starting aid time delay.
	TIME DELAY            MIN:SEC ENG COOLDOWN            :00	Displays engine cooldown time delay in minutes:seconds. When required, use numeric keys to set new time delay and press Enter key.
	TIME DELAY            MIN:SEC ENG COOLDOWN            :00	Displays corrected engine cooldown time delay.
	TIME DELAY            MIN:SEC CRANK ON            :00	Displays engine cyclic cranking "on" time in minutes:seconds. When required, use numeric keys to set new time delay and press Enter key.
	TIME DELAY            MIN:SEC CRANK ON            :00	Displays corrected engine cyclic cranking "on" time.
	TIME DELAY            MIN:SEC CRANK PAUSE            :00	Displays engine cyclic cranking "off" time in minutes:seconds. When required, use numeric keys to set new time delay and press Enter key.
	TIME DELAY            MIN:SEC CRANK PAUSE            :00	Displays corrected engine cyclic cranking "off" time.
	OVERCRANKSHUTDOWN CRANK CYCLES            (3)	Displays engine crank cycles before shutdown. When required, use numeric keys to set new quantity and press Enter key.
	OVERCRANKSHUTDOWN CRANK CYCLES            (3)	Displays corrected engine crank cycles before shutdown.
	TIME DELAY            MIN:SEC OVERVOLTAGE            :00	Displays overvoltage time delay shutdown in minutes:seconds. When required, use numeric keys to set new time delay and press Enter key.
	TIME DELAY            MIN:SEC OVERVOLTAGE            :00	Displays corrected overvoltage time delay shutdown.

## Menu 4—Time Delays, continued

Key Entry	Display	Description
	TIME DELAY      MIN:SEC UNDERVOLTAGE      :00	Displays undervoltage time delay shutdown in minutes:seconds. When required, use numeric keys to change time delay and press Enter key.
	TIME DELAY      MIN:SEC UNDERVOLTAGE      :00	Displays corrected undervoltage time delay shutdown.
	TIME DELAY      MIN:SEC AUX 1 INHIBIT      :00	Displays auxiliary 1 inhibit time delay in minutes:seconds. Inhibit time delay is time period after engine starting and before time delay begins. When required, use numeric keys to set new time delay and press Enter key.
	TIME DELAY      MIN:SEC AUX 1 INHIBIT      :00	Displays corrected auxiliary 1 inhibit time delay.
	TIME DELAY      MIN:SEC AUX 1 DELAY      :00	Displays auxiliary 1 shutdown time delay in minutes:seconds. Delay is time period after signal is received and before fault (warning or shutdown) occurs. When required, use numeric keys to set new time delay and press Enter key.
	TIME DELAY      MIN:SEC AUX 1 DELAY      :00	Displays corrected auxiliary 1 time delay.
	TIME DELAY      MIN:SEC AUX 2 INHIBIT      :00	Displays auxiliary 2 inhibit time delay in minutes:seconds. Inhibit time delay is time period after engine starting and before time delay begins. When required, use numeric keys to set new time delay and press Enter key.
	TIME DELAY      MIN:SEC AUX 2 INHIBIT      :00	Displays corrected auxiliary 2 inhibit time delay.
	TIME DELAY      MIN:SEC AUX 2 DELAY      :00	Displays auxiliary 2 shutdown time delay in minutes:seconds. Delay is time period after signal is received and before fault (warning or shutdown) occurs. When required, use numeric keys to set new time delay and press Enter key.
	TIME DELAY      MIN:SEC AUX 2 DELAY      :00	Displays corrected auxiliary 2 time delay.
	TIME DELAY      MIN:SEC AUX 3 INHIBIT      (3)	Displays auxiliary 3 inhibit time delay in minutes:seconds. Inhibit time delay is time period after engine starting and before time delay begins. When required, use numeric keys to set new time delay and press Enter key.
	TIME DELAY      MIN:SEC AUX 3 INHIBIT      (3)	Displays corrected auxiliary 3 inhibit time delay.
	TIME DELAY      MIN:SEC AUX 3 DELAY      :00	Displays auxiliary 3 shutdown time delay in minutes:seconds. Delay is time period after signal is received and before fault (warning or shutdown) occurs. When required, use numeric keys to set new time delay and press Enter key.
	TIME DELAY      MIN:SEC AUX 3 DELAY      :00	Displays corrected auxiliary 3 time delay.
	TIME DELAY      MIN:SEC AUX 4 INHIBIT      :00	Displays auxiliary 4 inhibit time delay in minutes:seconds. Inhibit time delay is time period after engine starting and before time delay begins. When required, use numeric keys to set new time delay and press Enter key.
	TIME DELAY      MIN:SEC AUX 4 INHIBIT      :00	Displays corrected auxiliary 4 inhibit time delay.
	TIME DELAY      MIN:SEC AUX 4 DELAY      :00	Displays auxiliary 4 shutdown time delay in minutes:seconds. Delay is time period after signal is received and before fault (warning or shutdown) occurs. When required, use numeric keys to set new time delay and press Enter key.
	TIME DELAY      MIN:SEC AUX 4 DELAY      :00	Displays corrected auxiliary 4 time delay.
	TIME DELAYS	Returns user to Menu 4—Time Delays.

## 2.8.5 Menu 5—User-Defined Functions

Menu 5 provides user options for auxiliary shutdowns and warnings 1-4 and relay driver outputs (RDO) 1-10. Menu 5 also defines common fault inputs. For Menu 5 enter yes/no questions or a fault description.

**Note: Code error.** When *code error* message appears, the entered information is not within the required parameters. Press Reset Menu and rekey information.

When used as a shutdown





- Auxiliaries 1 and 2 are latching shutdowns and are reset by placing the master switch in the OFF/RESET position.
- Auxiliaries 3 and 4 are non-latching shutdowns and are reset when the input is no longer grounded.

Key Entry	Display	Description
RESET MENU	ENTER NO. 1-11	Input a menu number.
5 WED	MENU NUMBER 5	Displays menu number.
MENU ▼	USER-DEFINED FUNCTIONS	Displays menu name.
MENU ▼	AUXILIARY 1 WARNING SHUTDOWN? NO	Asks the user if auxiliary 1 should cause a shutdown condition.
7 YES	AUXILIARY 1 WARNING SHUTDOWN? YES	Entering Yes causes Auxiliary 1 to signal a fault shutdown.
ENTER ←	<b>AND</b> AUXILIARY 1 WARNING SHUTDOWN? YES	Confirms entry.
8 NO	<b>OR</b> AUXILIARY 1 WARNING SHUTDOWN? NO	Entering No causes Auxiliary 1 to signal a fault warning.
ENTER ←	<b>AND</b> AUXILIARY 1 WARNING SHUTDOWN? NO	Confirms entry.
MENU ▼	AUXILIARY 2 WARNING SHUTDOWN? NO	Asks the user if auxiliary 2 should cause a shutdown condition.
7 YES	AUXILIARY 2 WARNING SHUTDOWN? YES	Entering Yes causes Auxiliary 2 to signal a fault shutdown.
ENTER ←	<b>AND</b> AUXILIARY 2 WARNING SHUTDOWN? YES	Confirms entry.
8 NO	<b>OR</b> AUXILIARY 2 WARNING SHUTDOWN? NO	Entering No causes Auxiliary 2 to signal a fault warning.
ENTER ←	<b>AND</b> AUXILIARY 2 WARNING SHUTDOWN? NO	Confirms entry.
MENU ▼	AUXILIARY 3 WARNING SHUTDOWN? NO	Asks the user if auxiliary 3 should cause a shutdown condition.









## Menu 5—User-Defined Functions, continued

Key Entry	Display	Description
7 YES	AUXILIARY 3 WARNING SHUTDOWN? YES	Entering Yes causes Auxiliary 3 to signal a fault shutdown.
	<b>AND</b>	
ENTER ←	AUXILIARY 3 WARNING SHUTDOWN? YES	Confirms entry.
	<b>OR</b>	
8 NO	AUXILIARY 3 WARNING SHUTDOWN? NO	Entering No causes Auxiliary 3 to signal a fault warning.
	<b>AND</b>	
ENTER ←	AUXILIARY 3 WARNING SHUTDOWN? NO	Confirms entry.
MENU ▼	AUXILIARY 4 WARNING SHUTDOWN? NO	Asks the user if auxiliary 4 should cause a shutdown condition.
7 YES	AUXILIARY 4 WARNING SHUTDOWN? YES	Entering Yes causes Auxiliary 4 to signal a fault shutdown.
	<b>AND</b>	
ENTER ←	AUXILIARY 4 WARNING SHUTDOWN? YES	Confirms entry.
	<b>OR</b>	
8 NO	AUXILIARY 4 WARNING SHUTDOWN? NO	Entering No causes Auxiliary 4 to signal a fault warning.
	<b>AND</b>	
ENTER ←	AUXILIARY 4 WARNING SHUTDOWN? NO	Confirms entry.









## Menu 5—User-Defined Functions, continued

Key Entry	Display	Description
	RELAY OUTPUT #1 YES (see Group A)	Identifies signal source for relay output #1. When required, press Menu Right → key and edit selection by choosing 1 of 30 selections.
	RELAY OUTPUT #1 NO (see Group A)	Continue to press Menu Right → key until desired relay output selection is displayed. Press Yes key to select desired relay output. <b>Note:</b> Menu 5 describes and provides selection of Defined Common Fault components. <b>Note:</b> Components of NFPA-110 Common Alarm include the 14 items listed below. The user cannot change NFPA-110 Common Alarm items.
	<p><b>Group A</b>  <b>For relay outputs 1-10, choose one from the following 31 selections:</b>            DEFINED COMMON FAULT            AIR DAMPER            OVERVOLTAGE            UNDERVOLTAGE            UNDERFREQ SHUTDOWN            LOW COOLANT LEVEL            HIGH OIL TEMPERATURE            AUXILIARY 1            AUXILIARY 2            AUXILIARY 3            AUXILIARY 4            LOCKED ROTOR            INTERNAL ERROR            EPS SUPPLYING LOAD            SPEED SENSOR FAULT            LOAD SHED            KW OVERLOAD            UNDERFREQ WARNING            HIGH BATTERY VOLTAGE            NO TEMP GAUGE SIGNAL            NO OIL GAUGE SIGNAL            GRND FAULT DETECTED            OVERCURRENT            ENG COOLDOWN            ENGINE START            GENERATOR RUNNING            NFPA 110 COMM ALARM*            STARTING AID            WEAK BATTERY            LOW AC OUTPUT            OVERFREQUENCY</p>	<p><b>*NFPA-110 Common Alarm 14 items include the following:</b>            OVERCRANK            LOW COOLANT TEMPERATURE            HIGH COOLANT TEMPERATURE WARNING            HIGH COOLANT TEMPERATURE            LOW OIL PRESSURE WARNING            LOW OIL PRESSURE            OVERSPEED            LOW FUEL            NOT IN AUTO            BATTERY CHARGER FAULT            LOW BATTERY VOLTAGE            AIR DAMPER            EPS SUPPLYING LOAD            HIGH BATTERY VOLTAGE</p>
	RELAY OUTPUT #1 YES (see Group A)	Entering Yes selects displayed relay output.
	<b>AND</b>	
	RELAY OUTPUT #1 YES (see Group A)	Confirms entry. <b>Note:</b> After pressing the Yes and Enter keys, any previous Yes selection defaults to No.

## Menu 5—User-Defined Functions, continued

Key Entry	Display	Description
		Identifies signal source for relay outputs #2-10. When required, press Menu Right → key and edit selection by choosing 1 of 30 selections. See Relay Output #1 instructions for complete procedure and Group A.
	RELAY OUTPUT #2 YES (see Group A)	
	RELAY OUTPUT #3 YES (see Group A)	
	RELAY OUTPUT #4 YES (see Group A)	
	RELAY OUTPUT #5 YES (see Group A)	
	RELAY OUTPUT #6 YES (see Group A)	
	RELAY OUTPUT #7 YES (see Group A)	
	RELAY OUTPUT #8 YES (see Group A)	
	RELAY OUTPUT #9 YES (see Group A)	
	RELAY OUTPUT #10 YES (see Group A)	

## Menu 5—User-Defined Functions, continued

Key Entry	Display	Description	
	DEFINEDCOMMONFAULT →	Provides user entry to defined common fault selections.	
	COMMON FAULT NO (see Group B)	Gives user option to add or delete selection from defined common fault group. Press Menu Down key ↓ to continue to the next selection (repeat as necessary).	
	COMMON FAULT YES (see Group B)	Entering Yes adds selection to the defined common fault group.	
	COMMON FAULT YES (see Group B)	Confirms entry.	
	COMMON FAULT NO (see Group B)	Entering No deletes selection from the defined common fault group.	
	COMMON FAULT NO (see Group B)	Confirms entry.	
	<p><b>Group B</b>  <b>For defined common fault, choose from the following 45 selections</b></p> <ul style="list-style-type: none"> <li>AIR DAMPER*</li> <li>OVERVOLTAGE</li> <li>UNDERVOLTAGE</li> <li>UNDERFREQ SHUTDOWN</li> <li>LOW COOLANT LEVEL</li> <li>HIGH OIL TEMPERATURE</li> <li>AUXILIARY 1</li> <li>AUXILIARY 2</li> <li>AUXILIARY 3</li> <li>AUXILIARY 4</li> <li>LOCKED ROTOR</li> <li>INTERNAL ERROR</li> <li>EPS SUPPLYING LOAD*</li> <li>SPEED SENSOR FAULT</li> <li>LOAD SHED</li> <li>KW OVERLOAD</li> <li>UNDERFREQ WARNING</li> <li>HIGH BATTERY VOLTAGE*</li> <li>NO TEMP GAUGE SIGNAL</li> <li>NO OIL GAUGE SIGNAL</li> <li>GRND FAULT DETECTED</li> </ul>	<p>OVERCURRENT  ENG COOLDOWN  ENGINE START  GENERATOR RUNNING  NFPA 110 COMM ALARM  (see <b>Note</b>)  STARTING AID  LOW OIL PRESSURE*  HIGH COOLANT TEMP*  OVERCRANK*  OVERSPEED*  EMERGENCY STOP  NOT IN AUTO*  SYSTEM READY  LOW BATTERY VOLTAGE*  BATT CHARGER FAULT*  LOW FUEL*  HIGH TEMP WARNING*  LOW OIL PRES WARNING*  LOW COOLANT TEMP*  WEAK BATTERY  LOAD SHED UNDERFREQ  LOAD SHED EXCESS KW  LOW AC OUTPUT  OVERFREQUENCY</p>	<p><b>Note:</b> Components of NFPA-110 Common Alarm include the 14 items marked by an asterisk (*). The user cannot change NFPA-110 Common Alarm items.</p>
	DEFINEDCOMMONFAULT →	Returns user to beginning of defined common fault selections.	
	USER-DEFINED FUNCTIONS	Returns user to Menu 5—User-Defined Functions.	

## 2.8.6 Menu 6—Generator System

Menu 6 contains factory-preset generator set voltage and frequency data. Enter corresponding data if the generator set requires voltage reconnection and/or frequency adjustment. It is imperative that the user enter correct data because these settings trigger all related shutdowns.







**Note:** The user defines the data shown in Menu 6. It is NOT data measured by the controller and associated sensing devices. The user defines these values for purposes of calibrating the control.

Key Entry	Display	Description
RESET MENU	ENTER NO. 1-11	Input a menu number.
6 THU	MENU NUMBER 6	Displays menu number.
MENU ↓	GENERATOR SYSTEM	Displays menu name.
MENU ↓	SYSTEM VOLTAGE 000	Displays system voltage as entered data. When required, use numeric keys to set new value. Press Enter key.
ENTER ↵	SYSTEM VOLTAGE 000	Displays corrected system voltage.
MENU ↓	SYSTEM FREQUENCY 00	Displays system frequency as entered data. When required, use the numeric keys to set new value. Press Enter key.
ENTER ↵	SYSTEM FREQUENCY 00	Displays corrected system frequency.
MENU ↓	THREE-PHASE WYE → DELTA? NO	Displays to the user if voltage configuration is wired for a wye connection as entered data. When required, use yes key to choose delta connection.
<b>OR</b>		
MENU ↓	THREE-PHASE DELTA → WYE? NO	Displays to the user if voltage configuration is wired for a delta connection as entered data. When required, use Yes key to choose wye connection.
7 YES	THREE-PHASE WYE → DELTA? YES	Enter Yes to change voltage configuration to a delta connection.
<b>AND</b>		
ENTER ↵	THREE-PHASE WYE → DELTA? YES	Displays corrected system phase configuration.
<b>OR</b>		
7 YES	THREE-PHASE DELTA → WYE? YES	Enter Yes to change voltage configuration to a wye connection.
<b>AND</b>		
ENTER ↵	THREE-PHASE DELTA → WYE? YES	Displays corrected system phase configuration.
MENU →	SINGLE-PHASE? NO	Displays voltage configuration is wired for three-phase as entered data. When required, use yes key to choose single-phase.
<b>OR</b>		
MENU →	THREE-PHASE? NO	Displays voltage configuration is wired for single-phase as entered data. When required, use yes key to choose three-phase.

## Menu 6—Generator System, continued

Key Entry	Display	Description
	SINGLE-PHASE? YES	Enter Yes to change voltage configuration to single-phase
	<b>AND</b>	
	THREE-PHASE? NO	Displays corrected system phase configuration.
	<b>OR</b>	
	THREE-PHASE? YES	Enter Yes to change voltage configuration to three-phase.
	<b>AND</b>	
	SINGLE-PHASE? NO	Displays selected system phase configuration.
	THREE-PHASE WYE → DELTA? NO	Returns user to three-phase wye/delta menu. <b>Note:</b> Display sample may differ depending upon previous entries.
	KW RATING 00	Displays generator set kW rating as entered data. When required, use the numeric keys to set new value. Press Enter key.
	KW RATING 00	Displays corrected system kilowatt rating.
	OVERVOLTAGE 00% 000VAC	Displays overvoltage setting. When required, use the numeric keys to set new value. Press Enter key.
	OVERVOLTAGE 00% 000VAC	Displays corrected overvoltage setting.
	UNDERVOLTAGE 00% 000VAC	Displays undervoltage setting. When required, use the numeric keys to set new value. Press Enter key.
	UNDERVOLTAGE 00% 000VAC	Displays corrected undervoltage setting.
	OVERSPEED 00HZ 0000RPM	Displays overspeed setting. When required, use the numeric keys to set new value. Press Enter key.
	OVERSPEED 00HZ 0000RPM	Displays corrected overspeed setting.
	UNDERFREQUENCY 00% 00.0HZ	Displays underfrequency setting. When required, use the numeric keys to set new value. Press Enter key.
	UNDERFREQUENCY 00% 00.0HZ	Displays corrected underfrequency setting.
	OVERFREQUENCY 00% 00.0HZ	Displays overfrequency setting. When required, use the numeric keys to set new value. Press Enter key.
	OVERFREQUENCY 00% 00.0HZ	Displays corrected underfrequency setting.

## Menu 6—Generator System, continued













Key Entry	Display	Description
	BATTERY VOLTAGE (12)	Displays battery voltage setting as entered data. When required, use the numeric keys to set new value. Press Enter key.
	BATTERY VOLTAGE (12)	Displays corrected battery voltage setting.
	LOW BATTERY VOLTAGE 00.0	Displays low battery voltage setting as entered data. When required, use the numeric keys to set new value. Press Enter key.
	LOW BATTERY VOLTAGE 00.0	Displays corrected low battery voltage setting.
	HIGH BATTERY VOLTAGE 00.0	Displays high battery voltage setting as entered data. When required, use the numeric keys to set new value. Press Enter key.
	HIGH BATTERY VOLTAGE 00.0	Displays corrected high battery voltage setting.
	GENERATOR SYSTEM	Returns user to Menu 6—Generator System.

## 2.8.7 Menu 7—Engine Status



Menu 7 provides user with engine status, operating data, and time delay to start and run time.

**Note: Code error.** When *code error* message appears, the entered information is not within the required parameters. Press Reset Menu and rekey information.

**Note:** Use STOP PROG RUN key to stop generator set Engine Start program.





Key Entry	Display	Description
	ENTER NO. 1-11	Input a menu number.
	MENU NUMBER 7	Displays menu number.
	ENGINE STATUS	Displays menu name.
	ENGINE RPM 00 BATTERY VDC 00.0	Displays engine rpm and engine starting battery voltage.
	OIL PRESSURE 00PSI→ COOLANT TEMP 000°F	Displays engine oil pressure in psi and engine coolant temperature in °F.
	OIL PRESSURE 00kPa→ COOLANT TEMP 000°C	Displays engine oil pressure in kPa and engine coolant temperature in °C.
	OIL PRESSURE 00PSI→ COOLANT TEMP 000°F	Returns user to Engine Oil Pressure in psi and engine Coolant Temperature in °F menu.
	ENGINE START? NO→ COUNTDOWN :00	Gives user option to start generator set using run time feature.
	RUN TIME HR:MN→ :00	Allows user to enter programmed run time.
	RUN TIME HR:MN→ :00	Use numeric keys to enter desired programmed run time.
	<b>AND</b>	
	RUN TIME HR:MN→ :00	Confirms entry.
	ENGINE START? NO→ COUNTDOWN :00	Returns user to Engine Start?—Countdown menu.
	ENGINE START? NO→ COUNTDOWN :00	Use numeric keys to enter desired engine start countdown time.
	<b>AND</b>	
	ENGINE START? NO→ COUNTDOWN :00	Confirms entry.

## Menu 7—Engine Status, continued

Key Entry	Display	Description
	<div style="border: 1px solid black; padding: 2px; display: inline-block;">           ENGINE START?    YES→            COUNTDOWN        :00         </div> <p style="text-align: center;"><b>AND</b></p>	Entering Yes starts generator set timed run after countdown period is completed.
	<div style="border: 1px solid black; padding: 2px; display: inline-block;">           ENGINE START?    YES→            COUNTDOWN        :00         </div>	Confirms entry. <b>Note:</b> Use STOP PROG RUN key to stop generator set programmed run.
	<div style="border: 1px solid black; padding: 2px; display: inline-block;">           ENGINE STATUS         </div>	Returns user to Menu 7—Engine Status.

## 2.8.8 Menu 8—Source History

Menu 8 indicates the source of a generator set shutdown or warning. Multiple faults may simultaneously exist. Correct each fault before attempting to restart the generator set.















Key Entry	Display	Description
	<input type="text" value="ENTER NO. 1-11"/>	Input a menu number.
	<input type="text" value="MENU NUMBER 8"/>	Displays menu number.
	<input type="text" value="SOURCE HISTORY"/>	Displays menu name.
	(see Group C) 0-00-00 (00:00 AM)	Menu lists up to 4 fault descriptions with date and time of fault. Press Menu Down ↓ key to continue. See Section 2.3.5, System Warning, or Section 2.3.6, System Shutdown, at the beginning of Section 2 for fault definitions.
<p><b>Group C</b>  <b>Fault warning and shutdowns include the following:</b>            AIR DAMPER            UNDERFREQ SHUTDOWN            LOW COOLANT LEVEL            HIGH OIL TEMPERATURE            AUXILIARY 1            AUXILIARY 2            AUXILIARY 3            AUXILIARY 4            LOCKED ROTOR            INTERNAL ERROR            LOW OIL PRESSURE            HIGH COOLANT TEMP            OVERCRANK            OVERSPEED            EMERGENCY STOP            OVERVOLTAGE L1-L2            OVERVOLTAGE L2-L3            OVERVOLTAGE L3-L1            OVERVOLTAGE L1-L0            OVERVOLTAGE L2-L0            OVERVOLTAGE L3-L0            UNDERVOLTAGE L1-L2            UNDERVOLTAGE L2-L3            UNDERVOLTAGE L3-L1            UNDERVOLTAGE L1-L0            UNDERVOLTAGE L2-L0            UNDERVOLTAGE L3-L0            MASTER SWITCH OPEN</p>		
	<input type="text" value="SOURCE HISTORY"/>	Returns user to Menu 8—Source History.

## 2.8.9 Menu 9—Calibration















Menu 9 provides calibration of the voltage sensing logic. Changing system voltage or replacing the main logic control circuit board requires calibration adjustment. Enable programming mode to edit display and/or files.

Adjust the generator set voltage at the controller voltage adjustment or using Menu 1 with digital voltage regulators. Adjust the frequency at the generator set governor before making calibration adjustments.

Connect a meter with a minimum accuracy of 1% to output leads to calibrate the voltage-sensing logic.

Key Entry	Display	Description
	ENTER NO. 1-11	Input a menu number.
	MENU NUMBER 9	Displays menu number.
	CALIBRATION	Displays menu name.
	AUTO-ZERO?	Gives user the option to calibrate the voltage and current inputs for zero input signals. <b>Note:</b> Perform this programming function only when the generator set is NOT running.
	AUTO-ZERO? YES	Entering Yes activates the auto-zero feature.
	AND AUTO-ZERO? YES	Confirms entry.
	OR AUTO-ZERO? NO	Entering No prevents the auto-zero feature.
	AND AUTO-ZERO? NO	Confirms entry.
	L1-L2 VOLTS 00	Measure generator set output voltage for single-phase and three-phase models between L1-L2 using a voltmeter and enter result using numeric keys. <b>Note:</b> Generator set must be running for the following steps.
	AND L1-L2 VOLTS 00	Confirms entry.
	L2-L3 VOLTS 00	Measure generator set output voltage for three-phase models between L2-L3 using a voltmeter and enter result using numeric keys.
	AND L2-L3 VOLTS 00	Confirms entry.
	L3-L1 VOLTS 00	Measure generator set output voltage for three-phase models between L3-L1 using a voltmeter and enter result using numeric keys.
	AND L3-L1 VOLTS 00	Confirms entry.

## Menu 9—Calibration, continued

Key Entry	Display	Description
	L1-L0 VOLTS 00	Measure generator set output voltage for single-phase and three-phase models between L1-L0 using a voltmeter and enter result using numeric keys.
	<b>AND</b>	
	L1-L0 VOLTS 00	Confirms entry.
	L2-L0 VOLTS 00	Measure generator set output voltage for single-phase and three-phase models between L1-L0 using a voltmeter and enter result using numeric keys.
	<b>AND</b>	
	L2-L0 VOLTS 00	Confirms entry.
	L3-L0 VOLTS 00	Measure generator set output voltage for three-phase models between L3-L0 using a voltmeter and enter result using numeric keys.
	<b>AND</b>	
	L3-L0 VOLTS 00	Confirms entry.
	L1 AMPS 00	Measure generator set output current for single-phase and three-phase models at L1 using AC ammeter and enter result using numeric keys.
	<b>AND</b>	
	L1 AMPS 00	Confirms entry.
	L2 AMPS 00	Measure generator set output current for single-phase and three-phase models at L2 using AC ammeter and enter result using numeric keys.
	<b>AND</b>	
	L2 AMPS 00	Confirms entry.
	L3 AMPS 00	Measure generator set output current for three-phase models at L3 using AC ammeter and enter result using numeric keys.
	<b>AND</b>	
	L3 AMPS 00	Confirms entry.
	BATTERY VDC 00.0	Measure generator set battery voltage and enter result using numeric keys.
	<b>AND</b>	
	BATTERY VDC 00.0	Confirms entry.
	CALIBRATION	Returns user to Menu 9—Calibration.

## 2.8.10 Menu 10—Remote Control













Menu 10 provides local or remote access to the control logic and displays. Use the LAN (local area network) to gain remote access to multiple devices/addresses.

Use the Software Operation Manual when accessing this menu, programming from a remote location, and determining address and system identification information.

**Note A:** There are four PC remote control choices: local, LAN, remote, and remote LAN. Entering Yes to one remote control choice changes the other three choices to No. Yes menus are highlighted in the following instructions. The dashed lines separate the four control choices.

Key Entry	Display	Description
	ENTER NO. 1-11	Input a menu number.
	MENU NUMBER 10	Displays menu number.
	REMOTE CONTROL	Displays menu name.
	REMOTE CONTROL ON-LINE? NO	Gives the user the option for accessing the control using a PC connection.
	REMOTE CONTROL ON-LINE? NO	Enter No to disable the on-line PC connection feature. Access is available only through the keypad and digital display.
<b>AND</b>		
	REMOTE CONTROL ON-LINE? NO	Confirms entry.
<b>OR</b>		
	REMOTE CONTROL ON-LINE? YES	Enter Yes to enable the on-line PC connection. This entry establishes the first step for a PC connection.
<b>AND</b>		
	REMOTE CONTROL ON-LINE? YES	Confirms entry.
<hr style="border-top: 1px dashed black;"/>		
<b>Local Control</b>		
	REMOTE CONTROL LOCAL? NO	Indicates no local (direct) PC connection.
	REMOTE CONTROL LOCAL? YES	Enter Yes to enable the local (direct) PC connection to a single control. See <b>Note A</b> .
<b>AND</b>		
	REMOTE CONTROL LOCAL? YES	Confirms entry.

## Menu 10—Remote Control, continued

Key Entry	Display	Description
<b>Local LAN Control</b>		
	<div style="border: 1px solid black; padding: 2px;">           REMOTE CONTROL →            LAN? NO         </div>	Indicates no LAN connection.
	<div style="border: 1px solid black; padding: 2px;">           REMOTE CONTROL →            LAN? YES         </div>	Enter Yes to enable a local area network (LAN) of controls and transfer switches with a local (direct) connected PC. See <b>Note A</b> .
<b>AND</b>		
	<div style="border: 1px solid black; padding: 2px;">           REMOTE CONTROL →            LAN? YES         </div>	Confirms entry.
	<div style="border: 1px solid black; padding: 2px;">           REMOTE CONTROL →            ADDRESS 01         </div>	Indicates address of device.
	<div style="border: 1px solid black; padding: 2px;">           REMOTE CONTROL →            ADDRESS 01         </div>	Use numeric keys to enter desired address 1-128. Use one address number per unit and use consecutive numbers. Individual addresses are necessary for the software to call up the desired unit.
<b>AND</b>		
	<div style="border: 1px solid black; padding: 2px;">           REMOTE CONTROL →            ADDRESS 01         </div>	Confirms entry.
	<div style="border: 1px solid black; padding: 2px;">           REMOTE CONTROL →            LAN? YES         </div>	Returns user to remote control—LAN? menu.
<b>Remote Control</b>		
	<div style="border: 1px solid black; padding: 2px;">           REMOTE CONTROL →            REMOTE? NO         </div>	Indicates no remote (modem) PC connection with a single device.
	<div style="border: 1px solid black; padding: 2px;">           REMOTE CONTROL →            REMOTE? YES         </div>	Enter Yes to enable a remote (modem) PC connection. See <b>Note A</b> .
<b>AND</b>		
	<div style="border: 1px solid black; padding: 2px;">           REMOTE CONTROL →            REMOTE? YES         </div>	Confirms entry.
	<div style="border: 1px solid black; padding: 2px;">           REMOTE CONTROL →            SYSTEM ID 0000         </div>	Enter system ID of device. The system ID is a type of password. The user must use the same system ID as utilized within the PC control software.
	<div style="border: 1px solid black; padding: 2px;">           REMOTE CONTROL →            SYSTEM ID 0000         </div>	Use numeric keys to enter desired system ID.
<b>AND</b>		
	<div style="border: 1px solid black; padding: 2px;">           REMOTE CONTROL →            SYSTEM ID 0000         </div>	Confirms entry.
	<div style="border: 1px solid black; padding: 2px;">           REMOTE CONTROL →            REMOTE? YES         </div>	Returns user to remote control—REMOTE? menu.

## Menu 10—Remote Control, continued

Key Entry	Display	Description
<b>Remote LAN Control</b>		
MENU ▼	REMOTE CONTROL → REMOTE LAN? NO	Indicates no remote LAN connection.
7 YES	REMOTE CONTROL → REMOTE LAN? YES	Enter Yes to enable a remote (modem) PC connection with a network of devices at the site. See <b>Note A</b> .
<b>AND</b>		
ENTER ↵	REMOTE CONTROL → REMOTE LAN? YES	Confirms entry.
MENU ▶	REMOTE CONTROL → SYSTEM ID 0000	Enter system ID of remote LAN. The system ID is a password. The user must use the same password for all devices at a site.
	REMOTE CONTROL → SYSTEM ID 0000	Use numeric keys to enter desired system ID.
<b>AND</b>		
ENTER ↵	REMOTE CONTROL → SYSTEM ID 0000	Confirms entry.
MENU ▶	REMOTE CONTROL → ADDRESS 01	Indicates address of device.
	REMOTE CONTROL → ADDRESS 01	Use numeric keys to enter desired address.
<b>AND</b>		
ENTER ↵	REMOTE CONTROL → ADDRESS 01	Confirms entry.
MENU ▶	REMOTE CONTROL → REMOTE LAN? YES	Returns user to remote control—REMOTE LAN? menu.
<hr/>		
MENU ▼	REMOTE CONTROL BAUD RATE 0000	Indicates current baud rate. User must enter a baud rate for all on-line devices.
	REMOTE CONTROL BAUD RATE 0000	Use numeric keys to enter appropriate baud rate—2400, 4800, 9600. This selection must match the baud rate of the companion modem (if used) and software program configuration. The default setting is 9600.
<b>AND</b>		
ENTER ↵	REMOTE CONTROL BAUD RATE 0000	Confirms entry.
MENU ▼	REMOTE CONTROL	Returns user to Menu 10—Remote Control menu.

## 2.8.11 Menu 11—Programming Mode

Menu 11 provides local or remote access to the programming function. User enters a password to access the programming mode.

**Note:** Log into the *local* programming mode to edit the programming access code. **The factory default access code is the number 0.**

**Note:** Menu 11 to change the access code. Record the new number and give the access code to only authorized individuals. Should the controller logic not accept the access code or if the new code number is lost, contact your local authorized distributor/dealer for password information.

**Note B:** The user chooses one of three programming modes:









local—using the controller keypad

remote—using a PC









off—no programming is permitted

Enter Yes to one mode to change the other two choices to No. Yes menus are highlighted in the following instructions.









**Note:** Use the generator set controller to initially set up remote programming. Remote programming cannot be accessed from a PC unless the controller is first set for remote programming using Menu 11.

Key Entry	Display	Description
	<input type="text" value="ENTER NO. 1-11"/>	Input a menu number.
 	<input type="text" value="MENU NUMBER 11"/>	Displays menu number.
	<input type="text" value="PROGRAMMING MODE"/>	Displays menu name. Choose from three programming modes—local, remote, or off. See <b>Note B</b> . Press Menu Down ↓ key to access desired mode.
<hr style="border-top: 1px dashed black;"/>		
<b>Local Programming</b>		
	<input type="text" value="PROGRAM MODE LOCAL? NO"/>	Gives user the option for local programming mode.
	<input type="text" value="PROGRAM MODE LOCAL? YES"/>	Enter Yes to select local program mode. See <b>Note B</b> .
<b>AND</b>		
	<input type="text" value="PROGRAM MODE LOCAL? YES"/>	Confirms entry.
	<input type="text" value="LOCAL? ENTER CODE"/>	Enter access code. The access code is a password. Use numeric keys to enter access code (6 digits maximum).
	<input type="text" value="LOCAL? ENTER CODE"/>	
<b>AND</b>		
	<input type="text" value="LOCAL? ENTER CODE"/>	Confirms entry.
	<input type="text" value="PROGRAM MODE LOCAL? YES"/>	Returns user to Program Mode—Local? menu.

## Menu 11—Programming Mode, continued

Key Entry	Display	Description
<b>Remote Programming</b>		
	PROGRAM MODE REMOTE? NO	Gives user the option for remote programming mode.
	PROGRAM MODE REMOTE? YES	Enter Yes to select remote program mode. See <b>Note B</b> .
<b>AND</b>		
	PROGRAM MODE REMOTE? YES	Confirms entry.
	REMOTE? ENTER CODE	Enter access code. The access code is a password.
	REMOTE? ENTER CODE	Use numeric keys to enter access code (6 digits maximum).
<b>AND</b>		
	REMOTE? ENTER CODE	Confirms entry.
	PROGRAM MODE REMOTE? YES	Returns user to Program Mode—Remote? menu.
<b>Programming Off</b>		
	PROGRAM MODE OFF? NO	Gives user the option for programming off mode.
	PROGRAM MODE OFF? YES	Enter Yes to select programming off mode. See <b>Note B</b> .
<b>AND</b>		
	PROGRAM MODE OFF? YES	Confirms entry.
	OFF? ENTER CODE	Enter access code. The access code is a password. Use numeric keys to enter access code (6 digits maximum).
	OFF? ENTER CODE	Confirms entry.
<b>AND</b>		
	OFF? ENTER CODE	Returns user to Program Mode—Off? menu.
	PROGRAM MODE OFF? YES	

## Menu 11—Programming Mode, continued

Key Entry	Display	Description
	PROGRAM MODE ACCESS →	Gives user option to change programming access code.
	PROGRAM MODE ACCESS → C HANGE CODE? NO	Allows user to change programming access code. <b>Note:</b> User must be logged in the <i>local</i> programming mode to change the programming access code.
	PROGRAM MODE ACCESS → C HANGE CODE? YES	Enter Yes to change the programming access code.
<b>AND</b>		
	PROGRAM MODE ACCESS → CHANGE CODE? YES	Confirms entry.
	PROGRAM MODE ACCESS → ENTER OLD CODE	Requires user to enter current access code.
	PROGRAM MODE ACCESS → ENTER OLD CODE	Use numeric keys to enter access code (6 digits maximum).
<b>AND</b>		
	PROGRAM MODE ACCESS → ENTER OLD CODE	Confirms entry.
	PROGRAM MODE ACCESS → ENTER NEW CODE	Requires user to enter new access code.
	PROGRAM MODE ACCESS → ENTER NEW CODE	Use numeric keys to enter new access code (6 digits maximum).
<b>AND</b>		
	PROGRAM MODE ACCESS → ENTER NEW CODE	Confirms entry.
	PROGRAM MODE ACCESS →	Returns user to Program mode—Access menu.
	PROGRAMMING MODE	Returns user to Menu 11—Programming Mode.

# Notes

## Section 3 Scheduled Maintenance

Under normal operating conditions, the generator's alternator requires no normal service. Consult the prestart checklist in Section 2.1 for a list of routine checks.

### 3.1 Generator Service

When operating the generator set under dusty or dirty conditions, use dry compressed air to blow dust out of the generator while the generator set is running. Direct the stream of air through openings in the generator set end bracket.

### 3.2 Engine Service

Perform engine service at the intervals specified in the engine manufacturer's service literature. Contact an authorized service distributor/dealer to obtain service literature.

**Note:** Have maintenance work, including battery service, performed by appropriately skilled and suitably trained maintenance personnel familiar with generator set operation and service.

---

**⚠ WARNING**

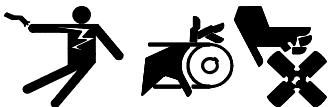

**Accidental starting.  
Can cause severe injury or death.**

Disconnect the battery cables before working on the generator set. Remove the negative (-) lead first when disconnecting the battery. Reconnect the negative (-) lead last when reconnecting the battery.

---

**Disabling the generator set. Accidental starting can cause severe injury or death.** Before working on the generator set or connected equipment, disable the generator set as follows: (1) Move the generator set master switch to the OFF position. (2) Disconnect the power to the battery charger. (3) Remove the battery cables, negative (-) lead first. Reconnect the negative (-) lead last when reconnecting the battery. Follow these precautions to prevent starting of the generator set by an automatic transfer switch, remote start/stop switch, or engine start command from a remote computer.

**⚠ WARNING**



**Hot engine and exhaust system.  
Can cause severe injury or death.**

Do not work on the generator set until it cools.

**Servicing the exhaust system. Hot parts can cause severe injury or death.** Do not touch hot engine parts. The engine and exhaust system components become extremely hot during operation.

**⚠ WARNING**

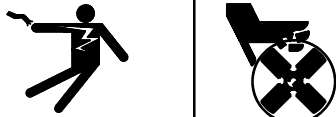

**Hazardous voltage. Moving rotor.  
Can cause severe injury or death.**

Operate the generator set only when all guards and electrical enclosures are in place.

**Servicing the generator set when it is operating. Exposed moving parts can cause severe injury or death.** Keep hands, feet, hair, clothing, and test leads away from the belts and pulleys when the generator set is running. Replace guards, screens, and covers before operating the generator set.

### 3.3 Service Schedule

System—Component	Action					Interval
	Visually Inspect	Check	Change	Clean	Test	
<b>FUEL</b>						
Day tank level	X	X				Weekly
Flexible lines and connections	X		R			Weekly
Fuel level switch	X				X	Weekly
Main tank supply level		X				Weekly
Solenoid valve operation	X				X	Weekly
Transfer pump operation	X				X	Weekly
Water in system, remove		•		•		Weekly
Filter(s)			•			Quarterly
Gasoline supply			R			Six Months
Fuel piping	X					Yearly
Tank vents and return lines for obstructions		X				Yearly
<b>LUBRICATION</b>						
Oil level	•	•				Weekly
Crankcase breather	•		•			Quarterly
Change oil			•			50 Hours or Yearly
Replace filter(s)*			•			50 Hours or Yearly
<b>COOLING</b>						
Air cleaner to room/enclosure		X				Weekly
Block heater operation		X				Weekly
Coolant level	•	•				Weekly
Flexible hoses and connectors	X	X				Weekly
Water pump(s)	•					Weekly
Fan and alternator belts	•	•	R			Monthly
Coolant temperature protection level					•	Six Months
Air ducts, louvers		X		X		Yearly
Coolant			•			Yearly
Heat exchanger				X		Yearly
Louver motors and controls	X			X	X	Yearly
Radiator exterior				X		Yearly
Water supply to heat exchanger		X				Yearly
<b>EXHAUST LINE</b>						
Drain condensate trap		X				Weekly
Leakage	X	X				Weekly
Insulation, fire hazards	X					Quarterly
Flexible connector(s)	X					Six Months
Excessive back pressure					X	Yearly
Hangers and supports	X					Yearly
<b>DC ELECTRICAL SYSTEM</b>						
Battery charger operation, charge rate	X					Monthly
Battery electrolyte level		X				Monthly
Battery specific gravity, charge state					X	Monthly
Recharge after engine start		X				Monthly
Remove corrosion, clean and dry battery and rack	X			X		Monthly
Clean and tighten battery terminals	X	X				Quarterly
Tighten DC electrical connections		X				Six Months
<p>X Action  R Replace as necessary  • Follow procedures and frequencies indicated in the engine manufacturer's maintenance manual. If not indicated, follow this service schedule. Some items may not pertain to specific generator sets.  * Service more frequently if operated in dusty areas.  † Do not break manufacturer's seals or internally inspect these devices.</p>						

System—Component	Action					Interval
	Visually Inspect	Check	Change	Clean	Test	
<b>AC ELECTRICAL SYSTEM</b>						
Controller lamp test	X				R	Weekly
General Inspection	X					Weekly
Circuit breakers, fuses†	X	X	R	X	X	Monthly
Wire abrasions where subject to motion	X	X				Quarterly
Safety and alarm operation		X			X	Six Months
Tighten control and power wiring connections		X				Yearly
Transfer switch main contacts†	X			X		Yearly
Voltage-sensing device/relay adjustment†		●			●	Yearly
Wire-cable insulation breakdown	X				X	3 Years or 500 Hours
<b>ENGINE AND MOUNTING</b>						
General inspection	●					Weekly
Governor operation, lubricate moving parts	●	●				Monthly
Air cleaner service		●	●			Six Months
Choke, carburetor adjustment		●				Six Months
Governor oil (mechanical gov. only)		●				Yearly
Ignition components	●			●		Yearly
Injector pump and injector flow rate, pressure, spray pattern		●			●	Yearly
Valve clearance		●				3 Years or 500 Hours
Bolt torque		●			●	3 Years or 500 Hours
<b>REMOTE CONTROL SYSTEM, ETC.</b>						
Compartment condition	X			X		Weekly
Remote control					X	Monthly
Run generator set					X	Monthly
<b>GENERATOR</b>						
General inspection	X					Weekly
Rotor and stator	X			X		Yearly
Bearing condition	X	X	R			Yearly
Exciter	X	X		X		Yearly
Voltage regulator	X	X		X		Yearly
Measure and record resistance readings of windings with insulation tester (Megger with SCR assembly or rectifier disconnected)					X	Yearly
Blow dust out of generator*	X			●		2 Years or 300 Hours
<b>GENERAL CONDITION OF EQUIPMENT</b>						
Any condition of vibration, leakage, noise, temperature, or deterioration	X	X		X		Weekly
Ensure that system is set for automatic operation	X					Weekly
Interior of equipment room or outdoor weather housing	X			X		Weekly
X Action R Replace as necessary ● Follow procedures and frequencies indicated in the engine manufacturer's maintenance manual. If not indicated, follow this service schedule. Some items may not pertain to specific generator sets. * Service more frequently if operated in dusty areas. † Do not break manufacturer's seals or internally inspect these devices.						

## 3.4 Generator Bearing

Have an authorized service distributor/dealer perform generator service.

### 3.4.1 20–300 kW Models

Replace the end bracket bearing every 10,000 hours of operation in standby and prime power applications. Service the bearing more frequently if the annual inspection indicates excessive rotor end play or bearing damage. Replace the tolerance ring, if equipped, following end bracket is removed. The sealed end bracket bearing requires no additional lubrication.

### 3.4.2 350–2000 kW Models with Single-Bearing Generator

The generator bearing requires lubrication at intervals specified in the generator technical manual. Use Chevron SRI or equivalent antifriction, high-quality grease with a lubrication temperature range of  $-30^{\circ}$  to  $+175^{\circ}$  C ( $-22^{\circ}$  to  $+350^{\circ}$  F).

### 3.4.3 2000 kW Models with Two-Bearing Generator

Refer to the generator technical manual for bearing maintenance information.

## 3.5 Gas/Gasoline Fuel Systems

This section describes fuel systems that are not covered in the engine operation manual or engine service manual.

### 3.5.1 Gaseous Fuel System Concept

The gaseous fuel system uses a fuel valve with a solenoid to control the fuel flow to the fuel regulator. The generator-mounted regulator reduces the fuel pressure as fuel passes to the carburetor. See Figure 3-1. The carburetor/mixer controls the ratio of fuel to air under varying load and speed conditions. Because the carburetor receives fuel in a gaseous state, it does not have to vaporize the fuel. When switching from natural gas to LP gas or LP gas to natural gas, verify that the

electronic governor maintains the rated engine speed (1800 rpm at 60 Hz or 1500 rpm at 50 Hz). If the engine speed is incorrect, refer to generator service manual for the governor adjustment procedure.

### 3.5.2 LP Liquid Withdrawal Fuel System Concept

With the LP liquid withdrawal fuel system, pressurized liquid LP fuel passes from the tank to a vaporizer. The vaporizer converts the liquid fuel to gas before sending it to the carburetor. The system also includes a fuel valve that shuts off the fuel flow when the engine stops. Contact an authorized service distributor/dealer for availability.

### 3.5.3 LP Gas/Natural Gas Conversion for Straight Gas Fuel System

By performing the fuel conversion, the 20, 30 (with CSG-649 engine only), 50, 60, 70, 80, and 100 kW generator sets operate on LP gas or natural gas fuel. The 35 and 45 kW models require different fuel kits when changing gas fuels. Consult your local generator distributor/dealer for additional information.

Fuel conversion may decrease generator set output and affect exhaust emissions. Consult your local generator distributor/dealer for additional information.

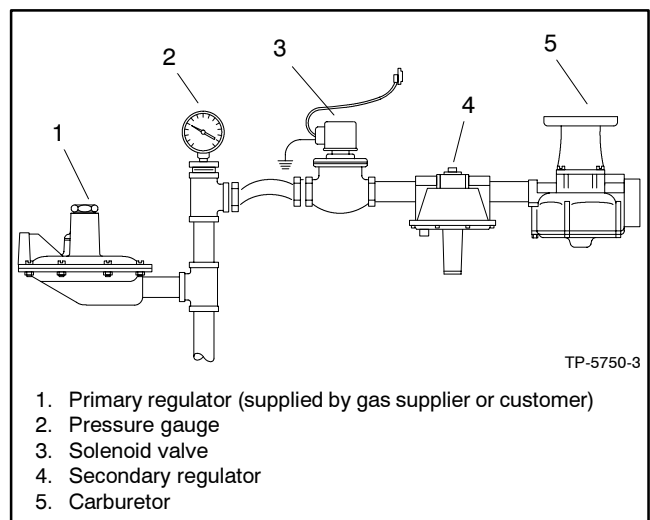

**Figure 3-1** Fuel Regulator and Valve, Typical

## Fuel Conversion Procedure

To convert the generator set to operate with LP gas, remove the internal spring from the secondary regulator. Install the spring to operate the generator set on natural gas.

**Note:** Not all fuel regulators require spring and retainer removal for fuel conversion. A hang tag on the fuel regulator identifies the conversion procedure.

Use the following steps to remove the internal spring from the gas regulator:

1. Remove the retainer and spring. Save the regulator spring and retainer for possible conversion back to natural gas.
2. Reinstall the retaining screw.

Use the following steps to convert the generator set to natural gas:

1. Remove the retaining screw from the regulator. See Figure 3-2.
2. Install the spring and retainer, and replace the retaining screw.
3. Use a manometer to check the fuel supply pressure on the carburetor side of the regulator.

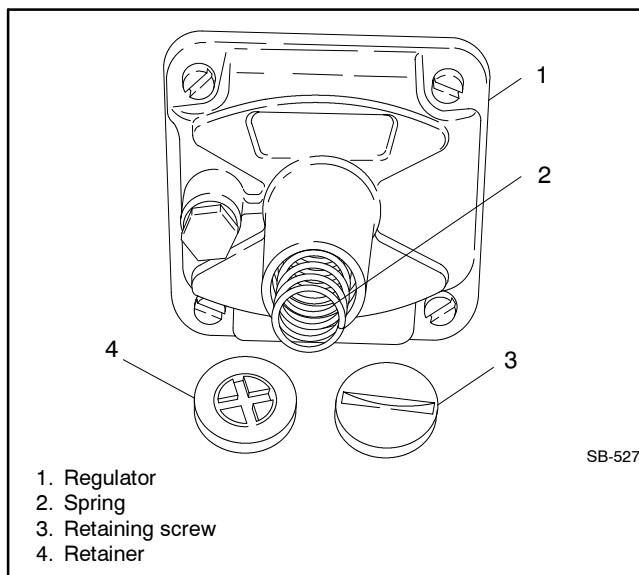

**Figure 3-2** Regulator Spring and Retainer, Typical

4. With the generator set running at full load, rotate the spring retainer on the regulator to adjust the fuel supply pressure. The recommended fuel supply pressures are shown in Figure 3-3 and on the generator set spec sheet. Use the lower pressure value if the generator set still provides good response and full power. Lower-than-specified pressures may cause poor response to load changes or lack of power.

Generator Set Model	Engine	Fuel Supply Pressure	
		kPa (oz./in. <sup>2</sup> )	Water Column, cm (in.)
20-100 kW	Ford	1.7-27.4 (4-6)	18-28 (7-11)
30-100 kW	GM	1.7-27.4 (4-6)	18-28 (7-11)
115/135 kW	Cummins	3.5 (8)	36 (14)
135-180 kW	Detroit Diesel Series 50	1.2-5 (2.9-11.6)	13-51 (5-20)
200-275 kW	Detroit Diesel Series 60	1.2-5 (2.9-11.6)	13-51 (5-20)

**Figure 3-3** Recommended Fuel Supply Pressures

## 3.5.4 Fuel System Changeover Kits

### Automatic Changeover

A changeover fuel system kit provides automatic changeover from natural gas to LP gas vapor or from LP gas vapor to natural gas. The primary and backup fuels each have a secondary fuel regulator and a fuel valve. Contact an authorized service distributor/dealer for kit availability.

Typically, the primary fuel is natural gas; the backup fuel is LP gas vapor. When the generator set starts, the primary fuel valve opens and the backup fuel valve closes. The primary fuel line has a vacuum switch in series with a relay connected to the start/run circuit. When the primary fuel pressure drops below 0.6 kPa (1.4 oz./in.<sup>2</sup>) or 6.4 cm (2.5 in.) water column, a relay opens the backup fuel valve and closes the primary fuel valve. When the primary fuel pressure rises above 0.6 kPa (1.4 oz./in.<sup>2</sup>) or 6.4 cm (2.5 in.) water column, the generator set uses the primary fuel.

## Manual Changeover

A manual changeover fuel system allows manual changeover from gasoline to natural gas or LP gas, or from natural gas or LP gas to gasoline. Typically, the combination system uses gas as the primary, preferred fuel and gasoline in emergencies. If the primary fuel is unavailable (an empty fuel tank or fuel supply disruption), the system uses gasoline.

A toggle switch on the generator set controls the fuel choice and energizes either a fuel solenoid and electric fuel pump for gasoline or a fuel valve for gas. Pull out the control cable for gasoline and push in the control cable for gas.

### 3.5.5 Carburetor Adjustment

Adjusting the carburetor changes the engine fuel mixture. Routine carburetor adjustment is not necessary. However, if the carburetor is removed or tampered with, the carburetor may require adjustment to achieve optimum engine performance. Some engines have sealed carburetors that are not adjustable.

Do not adjust the carburetor to compensate for other engine disorders. Before adjusting the carburetor, verify that the engine compression and the ignition system meet specifications. If the engine speed is incorrect, adjust the electronic governor to achieve 1800 rpm (at 60 Hz) or 1500 rpm (at 50 Hz). Adjust the carburetor if governor adjustment alone does not result in the desired engine speed.

#### Gasoline Models

Consult the engine operation manual or engine service manual for gasoline carburetor adjustment information.

#### Gaseous Models

Use the following procedure to adjust the carburetor.

1. Start the generator set and run it at approximately half load.
2. Adjust the engine fuel mixture screw (Figure 3-4) until the engine runs smoothly.
3. Apply varying loads and readjust the carburetor as necessary to achieve smooth engine performance at all load levels.
4. Stop the generator set.

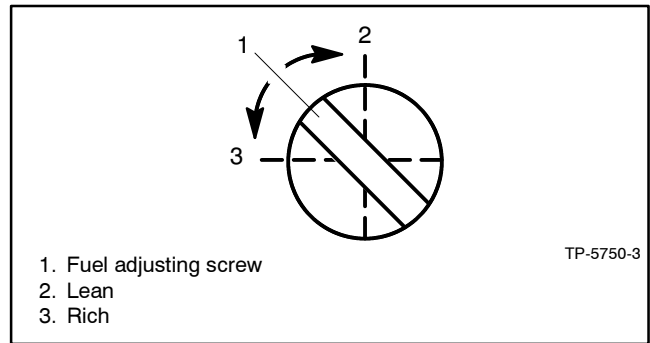

**Figure 3-4** Fuel Mixture Adjustment, Typical

## 3.5.6 Fuel System Maintenance

### Gasoline Models

Clean or replace the fuel filter at the specified interval. Service the filter more frequently if the engine runs roughly, because a clogged fuel filter can cause rough engine operation. Some models use a disposable inline fuel filter that must be replaced. Other models have a fuel pump with an integral fuel filter that requires cleaning at the specified interval.

### Gaseous Models

Some models use a disposable inline fuel filter. Inspect and replace the fuel filter at the intervals shown in the service schedule.

## 3.6 Turbocharger Maintenance on Ford-Powered Models

The oil recommendations, turbocharger oil priming, and turbocharger maintenance procedures are for Ford-powered 30 (with LSG-423 engine), 80, and 100 kW models with turbochargers not described or explained in the engine operation manual. Use the following turbocharger maintenance information for the above-listed models.

### 3.6.1 Oil Type Recommendations

The engine and generator manufacturers' engine oil viscosity recommendations for engines used in generator applications differ from the recommendations for engines used in other applications. Use oil that has a minimum rating of (API) classification SH/CD, SG/CD, SH/CC, or SG/CC to ensure long life and minimal engine wear. See Figure 3-5 for oil viscosity selection for the Ford-powered models listed above.

For Air Temperatures Consistently Above	Use Viscosity
0°C (32°F)	20W50 or 10W40
-23°C (-10°F)	10W40 or 10W50

**Figure 3-5** Oil Viscosity Selection

### 3.6.2 Turbocharger Oil Prime Procedure

After changing the engine lube oil, use the following procedure to prime the turbocharger bearing to prevent premature turbocharger bearing wear.

1. Place the generator set master switch in the OFF/RESET position.
2. Disconnect the wire between the ignition coil and the distributor at the distributor terminal. Connect a jumper wire from the ignition coil lead to the engine block.
 

**Note: Electronic Ignition Damage.** Ground the ignition coil to the engine block to prevent electronic ignition system damage.
3. Place an oil-collection container under the oil drain line. Disconnect the turbocharger oil drain line at the engine connection.
4. Place the generator set master switch in the RUN position to crank the engine until fresh oil flows from the turbocharger oil drain line.

**Note: Starter Damage.** Do not crank the engine continuously for longer than 10 seconds. Allow a 60-second cooldown period between cranking cycles to prevent starter motor and/or starter solenoid failure caused by overheating.

5. Place the generator set master switch in the OFF/RESET position.
6. Reconnect the turbocharger oil drain line at the engine connection.
7. Remove the jumper wire and reconnect the ignition coil wire to the distributor.
8. Place the generator set master switch in the RUN position, run the generator set for a few minutes, and check for oil leaks at the turbocharger drain line connection. Stop the generator set.
9. Check the oil level. Add oil to bring the level up to the full mark. Consult the engine operation manual for oil capacity.
10. Wipe up spilled oil and dispose of rags in a fireproof container.

### 3.6.3 Turbocharger Maintenance

See Figure 3-6 for the turbocharger maintenance service schedule.

Service	500 Hours or 6 Months	1000 Hours	2000 Hours
Check for abnormal turbo rotor noise during operation (e.g., high frequency pitch) and check for oil leakage at the turbocharger.	X		
Check turbo rotor shaft for wear (end play and radial tolerances).		X	
Overhaul turbocharger.*			X
Change lube oil. Change lube oil filter. Change air filter.	Refer to engine operation manual.		
* Have service performed by an authorized distributor/dealer.			

**Figure 3-6** Turbocharger Maintenance Service Schedule

### 3.7 Radiator Expansion Joint Loosening—Initial Setup Only

Loosen the radiator expansion joint nuts on 1200–2000 kW generator sets that have radiators manufactured by Young Radiator Company. Expansion joints located on each side of the radiator permit differential thermal expansion of the radiator tank. The factory tightens the 12 expansion joint nuts before generator set shipment. Loosen the expansion joint nuts one full turn before running the generator set. See Figure 3-7.

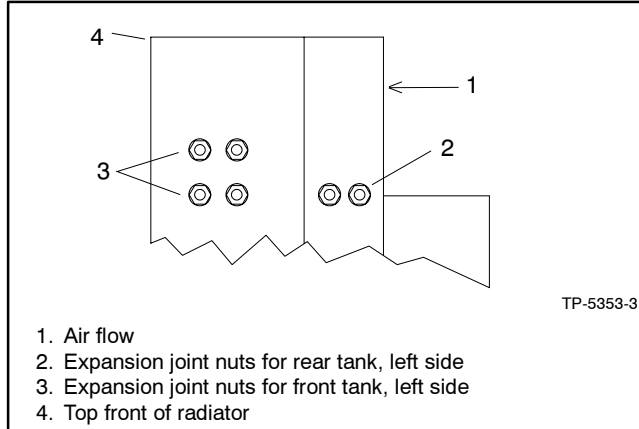

**Figure 3-7** Expansion Joint Nuts, Top Left Side of Radiator, Typical

### 3.8 Fan Bearing Lubrication

The following procedure applies to 1200–2000 kW generator sets with DDC engines. Lubricate the radiator fan shaft and idler shaft bearings at every engine oil change to avoid bearing damage. Lubricate the bearings every 200 hours of operation when the generator set runs in ambient temperatures below 29°C (85°F) or when the generator set runs in a dusty or humid environment.

Lubricate the fan shaft and idler shaft bearings with a lithium-complex base, multi-purpose grease with antirust, antifoam, extreme-pressure additives, and a minimum dropping point of 204°C (400°F). Use Mobil Mobilith AW2 NLGI Grade 2 or equivalent.

#### Lubrication and Drive Belt Tension Adjustment Procedure

1. Place the generator set master switch in the OFF/RESET position.

2. Disconnect the generator set engine starting battery(ies), negative (-) lead first, and disconnect power to the battery charger.
3. Remove the belt guards to expose the fan shaft and idler shaft bearings.
4. Use a grease gun to inject grease into the two bearings on the fan shaft block and the two bearings on the idler shaft block until a 3–6 mm (0.13–0.25 in.) grease column shows at the bearing pressure relief port. See Figure 3-8.

**Note:** The fan shaft and idler shaft bearings have pressure relief ports to prevent bearing damage from over lubrication.

5. Remove excess grease from the bearing pressure relief ports.

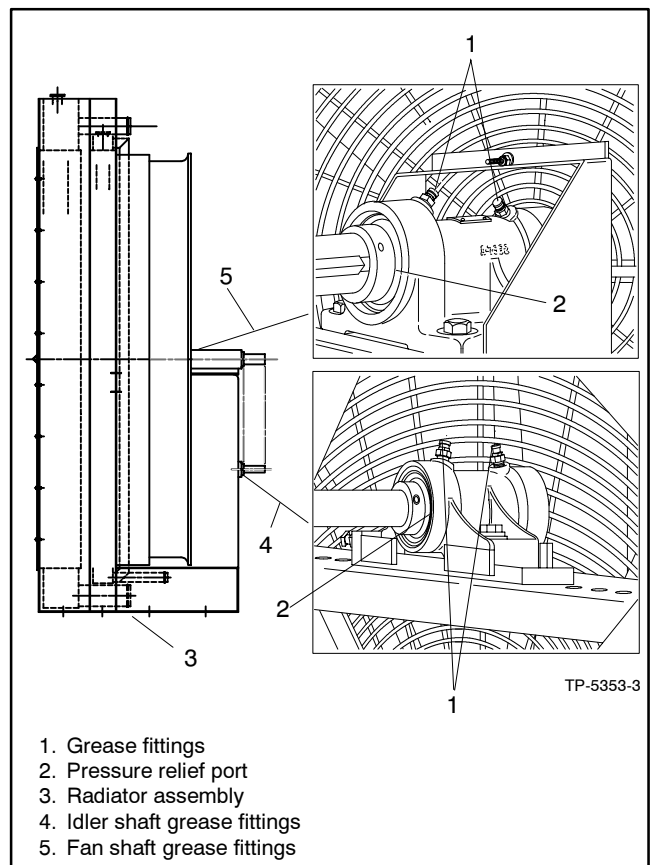

**Figure 3-8** Radiator Fan Bearings and Pressure Relief Ports, Typical

6. Inspect the fan drive belt and replace if it is damaged or worn. Check the fan belt tension using a poly V-belt tension gauge and adjust the tension, if necessary. See Figure 3-9.
7. Reinstall the belt guards using the original hardware.
8. Reconnect the generator set engine starting battery(ies), negative (-) lead last.
9. Test run the generator set for a few minutes and listen for belt noise (squeal) indicating a slipping belt. Stop the generator set.

Generator Set Model	New Belt, N (lbf.)	Used Belt*, N (lbf.)
1200-2000 kW	2450-2890 (550-650)	1650-1910 (370-430)

\* A belt is considered used after 50 hours of service.

**Figure 3-9** Fan Belt Tension

If belt slippage occurs after the belt tension procedure, clean the pulley surfaces and repeat the belt tension procedure. If slippage continues, replace the fan belt.

### 3.9 Battery

#### **⚠ WARNING**



**Sulfuric acid in batteries.  
Can cause severe injury or death.**

Wear protective goggles and clothing. Battery acid may cause blindness and burn skin.

**Battery gases. Explosion can cause severe injury or death.** Battery gases can cause an explosion. Do not smoke or permit flames or sparks to occur near a battery at any time, particularly when it is charging. Do not dispose of a battery in a fire. To prevent burns and sparks that could cause an explosion, avoid touching the battery terminals with tools or other metal objects. Remove wristwatch, rings, and other jewelry before servicing the equipment. Discharge static

electricity from your body before touching batteries by first touching a grounded metal surface away from the battery. To avoid sparks, do not disturb the battery charger connections while the battery is charging. Always turn the battery charger off before disconnecting the battery connections. Ventilate the compartments containing batteries to prevent accumulation of explosive gases.

**Battery short circuits. Explosion can cause severe injury or death.** Short circuits can cause bodily injury and/or equipment damage. Disconnect the battery before generator set installation or maintenance. Remove wristwatch, rings, and other jewelry before servicing the equipment. Use tools with insulated handles. Remove the negative (-) lead first when disconnecting the battery. Reconnect the negative (-) lead last when reconnecting the battery. Never connect the negative (-) battery cable to the positive (+) connection terminal of the starter solenoid. Do not test the battery condition by shorting the terminals together.

**Battery electrolyte is a diluted sulfuric acid. Battery acid can cause severe injury or death.** Battery acid can cause blindness and burn skin. Always wear splashproof safety goggles, rubber gloves, and boots when servicing the battery. Do not open a sealed battery or mutilate the battery case. If battery acid splashes in the eyes or on the skin, immediately flush the affected area for 15 minutes with large quantities of clean water. Seek immediate medical aid in the case of eye contact. Never add acid to a battery after placing the battery in service, as this may result in hazardous spattering of battery acid.

**Battery acid cleanup. Battery acid can cause severe injury or death.** Battery acid is electrically conductive and corrosive. Add 500 g (1 lb.) of bicarbonate of soda (baking soda) to a container with 4 L (1 gal.) of water and mix the neutralizing solution. Pour the neutralizing solution on the spilled battery acid and continue to add the neutralizing solution to the spilled battery acid until all evidence of a chemical reaction (foaming) has ceased. Flush the resulting liquid with water and dry the area.

Refer to this section for general battery information and maintenance. All generator set models use a negative ground with a 12-volt or 24-volt engine electrical system. Consult the generator set nameplate for engine electrical system voltage. Consult the generator spec sheet for battery capacity recommendations for replacement purposes. Wiring diagrams provide battery connection information. See Figure 3-10, Figure 3-11, and Figure 3-12 for typical battery connections, including multiple battery configurations.

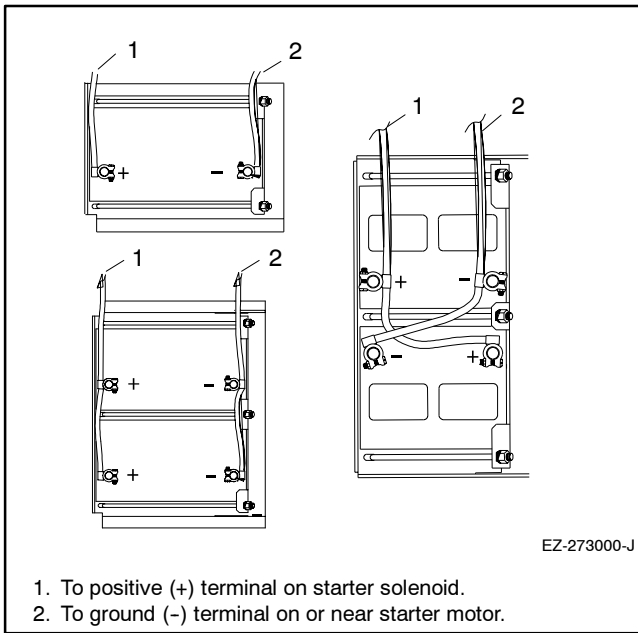

**Figure 3-10** 12-Volt Engine Electrical System with Single Starter Motor Typical Battery Connections

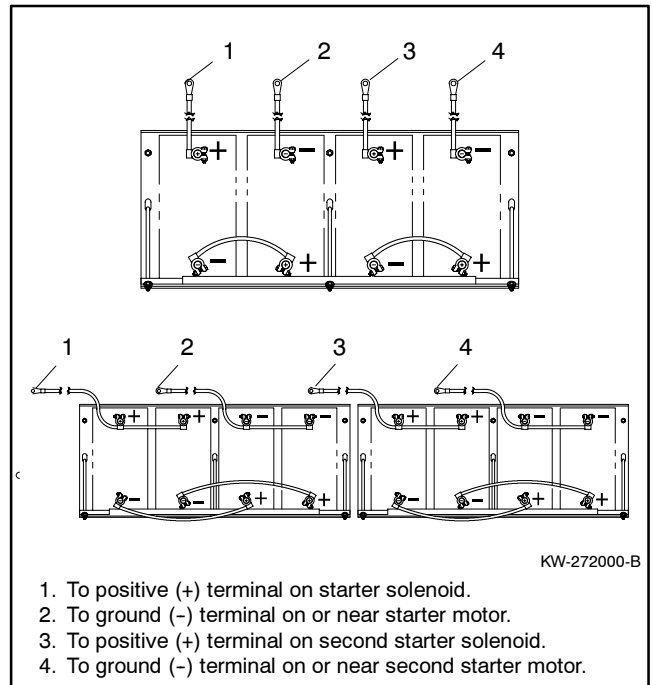

**Figure 3-12** 24-Volt Engine Electrical System with Dual Starter Motors Typical Battery Connections

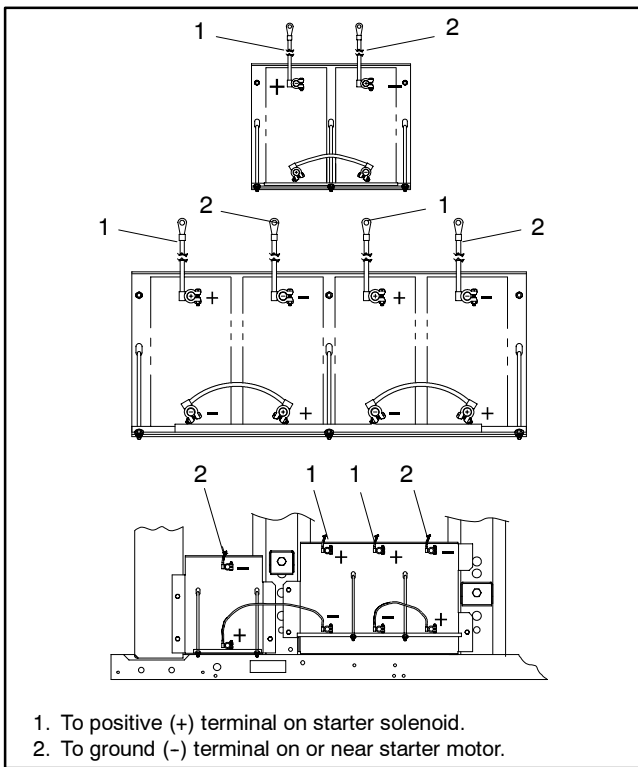

**Figure 3-11** 24-Volt Engine Electrical System with Single Starter Motor Typical Battery Connections

### 3.9.1 Cleaning

Clean the battery and cables and tighten battery terminals according to the service schedule recommendations. Clean the battery by wiping it with a damp cloth. Keep the electrical connections dry and tight.

To remove corrosion, disconnect the cables from the battery and remove the corrosion with a wire brush. Clean the battery and cables with a solution of baking soda and water. Do not allow the cleaning solution to enter battery cells. Flush the battery and cables with clean water and wipe the battery with a dry cloth.

After reconnecting the battery cables, coat the terminals with petroleum jelly, silicon grease, or other nonconductive grease.

### 3.9.2 Electrolyte Level Inspection

Check the electrolyte level and specific gravity of batteries that have filler caps. Maintenance-free

batteries do not require electrolyte level checking or specific gravity testing.

Check the electrolyte level before each startup. Remove the filler caps and verify that the electrolyte level reaches the bottom of each filler hole. See Figure 3-13. Refill as necessary with distilled water or clean tap water. Do not add fresh electrolyte. Tighten the filler caps. After adding water during freezing temperatures, run the generator set 20–30 minutes to mix the electrolyte and the water to prevent battery damage from freezing.

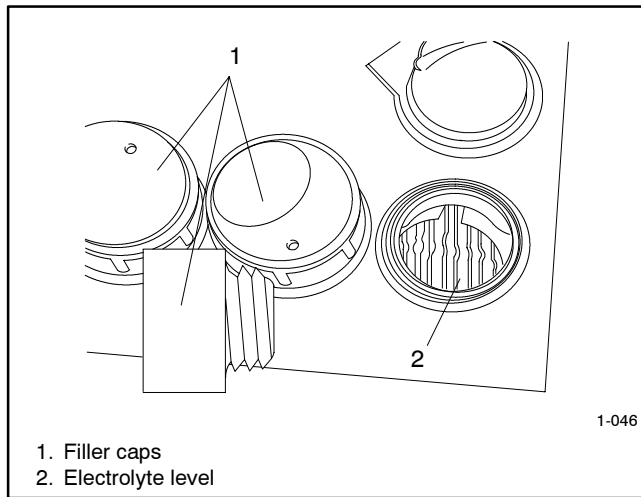

**Figure 3-13** Battery Electrolyte Level Inspection

### 3.9.3 Specific Gravity Check

**Note:** Some battery testers have four or five beads in a test tube. Draw electrolyte into the tube as with the battery hydrometer described in this section. Use the tester manufacturer’s instructions. Figure 3-14 shows typical test results.

Use a battery hydrometer to check the specific gravity of the electrolyte in each battery cell of batteries with filler caps. Holding the hydrometer vertically, read the number on the glass bulb at the top of the electrolyte level or the number adjacent to the pointer. If the hydrometer used does not have a correction table, consult Figure 3-15. Determine the specific gravity and electrolyte temperature of the battery cells. Locate the temperature in Figure 3-15 and correct the specific gravity by the amount shown. The battery is fully charged if the specific gravity is 1.260 at an electrolyte temperature of 26.7°C (80°F). Maintain the specific gravities between cells within ±0.01 of each other. Charge the battery if the specific gravity is below 1.215 at an electrolyte temperature of 26.7°C (80°F).

Number of Floating Beads	Battery Condition
5	Overcharged
4	Fully charged
3	A good charge
1 or 2	A low charge
0	A dead battery

**Figure 3-14** Bead-Type Test Interpretation

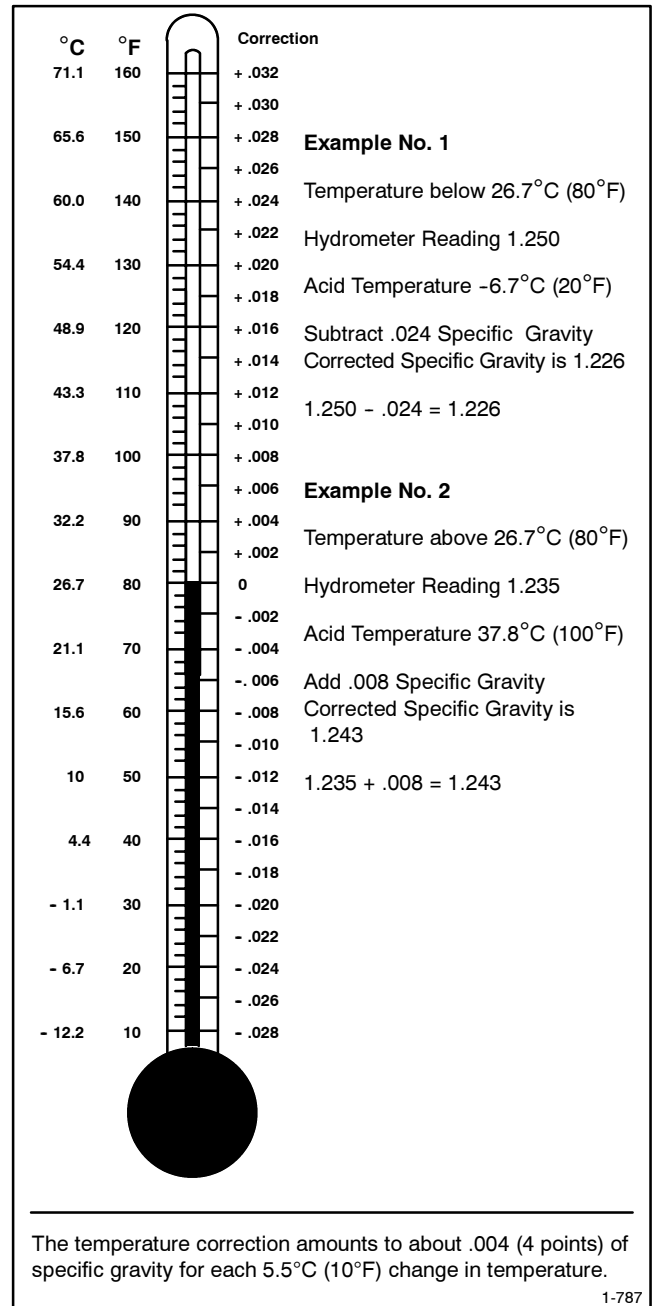

**Figure 3-15** Specific Gravity Temperature Correction

### 3.9.4 Charging

Use a battery charger to maintain a fully charged battery when the generator set is used in a standby application. The engine battery-charging alternator charges the battery only while the generator set is running.

**Note:** If the generator set is in a temporary prime power application in which the generator set has periods of inactivity, the controller circuitry may drain the battery. If there is no power source for a battery charger, place the controller in the prime power mode, if equipped, or disconnect the battery from the generator set.

## 3.10 Detroit Diesel Engine Control (DDEC) System

Some generator sets equipped with Detroit Diesel engines use a DDEC system. Access the DDEC control box inside the generator set junction box to retrieve codes when performing routine maintenance or troubleshooting engine.

Use the following data for informational purposes only. Consult the engine operation manual or engine service manual for complete information regarding DDEC operation and troubleshooting. Contact an authorized service distributor/dealer for service or diagnostic equipment.

### 3.10.1 DDEC Features

The DDEC system optimizes control of critical engine functions and protects against serious engine damage resulting from conditions such as the following:

- Low coolant level
- Low coolant pressure
- High coolant temperature
- Low oil pressure
- High oil temperature

The major components of the DDEC system include the engine electronic control module (ECM), engine sensors, and control box located in the generator set junction box.

### 3.10.2 DDEC Engine Diagnostics

The DDEC engine protection system monitors engine sensors and electronic components and recognizes system malfunctions. Critical faults light the check engine (CEL) and stop engine (SEL) lamps on the control box. The ECM memory software logs

malfunction codes. Consult the engine operation manual or engine service manual to identify the stored failure code.. See Figure 3-16 for DDEC control box features.

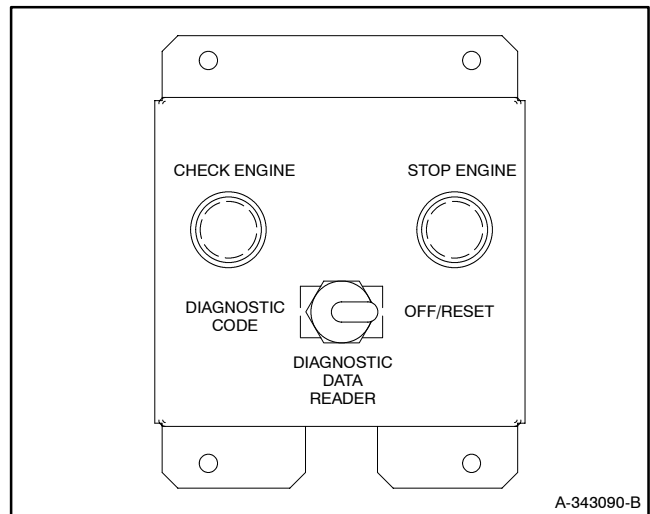

**Figure 3-16** DDEC Control Box

Access the stored codes in one of three ways:

- Place the switch in the DIAGNOSTIC CODE position. The CEL or SEL flashes to identify the failure.
- Use a hand-held diagnostic data reader (DDR). Place the switch in the DIAGNOSTIC DATA READER position. Plug the DDR into the control box. The DDR displays the stored failure codes.
- Use a personal computer software package with a translator to access stored codes. Follow the instructions provided with the software.

### Code Types

**Active code.** A code flashing on the SEL lamp indicates a fault currently exists.

**Inactive code.** A code flashing on the CEL lamp indicates a previous fault occurrence. The ECM memory stores inactive codes with time/date identification and the following information:

- First occurrence of each diagnostic code in engine operating hours.
- Last occurrence of each diagnostic code in engine operating hours.
- Total time in seconds that the diagnostic code was active.

### 3.11 Deutz Engine Control System

Some generator sets equipped with Deutz engines use an engine control system. Access the control box inside the generator set junction box to retrieve codes when performing routine maintenance or troubleshooting engine.

Use the following data for general informational purposes only. See the Engine Service Manual for complete information regarding operation and troubleshooting. Contact an authorized service distributor/dealer for service or diagnostic equipment.

The Deutz engine control is an advanced-technology, electronic engine control system. The system optimizes control of critical engine functions and provides protection against serious engine damage.

The major components include the engine electronic control module (ECM), engine sensors, and control box located in the generator set junction box. See Figure 3-17 for the Deutz control box features.

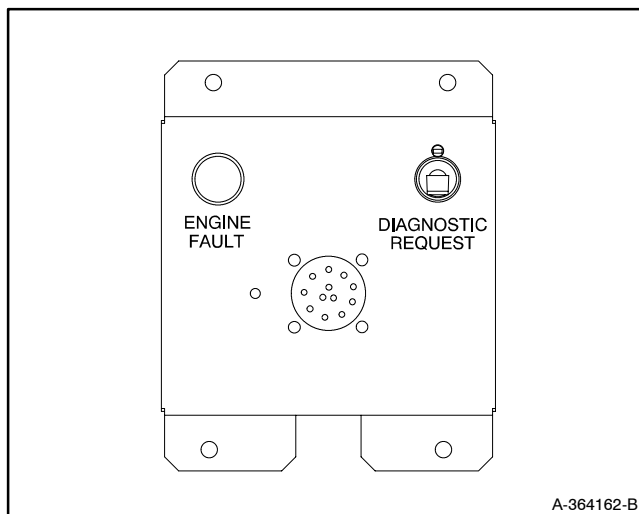

Figure 3-17 Deutz Control Box

### 3.12 Storage Procedure

Perform the following storage procedure before taking a generator set out of service for three months or longer. Follow the engine manufacturer's recommendations, if available, for fuel system and internal engine component storage.

x:sm:002:001

#### 3.12.1 Lubricating System

Prepare the engine lubricating system for storage as follows:

1. Run the generator set for a minimum of 30 minutes to bring it to normal operating temperature.
2. Stop the generator set.
3. With the engine still warm, drain the oil from the crankcase.
4. Remove and replace the oil filter.
5. Refill the crankcase with oil suited to the climate.
6. Run the generator set for two minutes to distribute the clean oil.
7. Stop the generator set.
8. Check the oil level and adjust, if needed.

x:sm:002:002

#### 3.12.2 Cooling System

Prepare the cooling system for storage as follows:

1. Check the coolant freeze protection using a coolant tester.
2. Add or replace coolant as necessary to ensure adequate freezing protection. Use the guidelines included in the engine operation manual.
3. Run the generator set for 30 minutes to redistribute added coolant.

x:sm:002:003

#### 3.12.3 Fuel System

Prepare the fuel system for storage as follows:

##### Gasoline-Fueled Engines

1. Add stabilizer to the fuel system. Follow the manufacturer's recommended procedure.
2. Run the generator set for 15 minutes to ensure that the stabilized fuel reaches the carburetor.
3. Place the generator set master switch in the OFF/RESET position.
4. Close the fuel valve.

##### Gas-Fueled Engines

1. Start the generator set.
2. With the generator set running, shut off the gas supply.

3. Run the generator set until the engine stops.
4. Place the generator set master switch in the OFF/RESET position.

### 3.12.4 Internal Engine Components (Gas/Gasoline-Fueled Engines)

If you have access to a fogging agent or SAE 10 oil prepare the pistons and cylinders for storage as follows:

1. While the engine is running, spray a fogging agent or SAE 10 engine oil into the air intake for about two minutes until the engine stops.
2. Place the generator set master switch in the OFF/RESET position.

If a fogging agent is not available perform the following:

1. Remove the spark plugs.
2. Pour 15 cc (0.5 oz.) of engine oil into each spark plug hole.

**Ignition System Damage.** Refer to the engine operation manual for ignition system precautions before cranking the engine while the spark plug wires are disconnected.

3. Toggle the generator set master switch to crank the engine two or three revolutions to lubricate the cylinders.
4. Reinstall the spark plugs and torque them to specifications.

x.sm:002:005

### 3.12.5 Exterior

1. Clean the exterior surface of the generator set.
2. Seal all engine openings except for the air intake with nonabsorbent adhesive tape.
3. To prevent impurities from entering the air intake and to allow moisture to escape from the engine, secure a cloth over the air intake.
4. Mask electrical connections.
5. Spread a light film of oil over unpainted metallic surfaces to inhibit rust and corrosion.

x.sm:002:006

### 3.12.6 Battery

Perform battery storage after all other storage procedures.

1. Place the generator set master switch in the OFF/RESET position.
2. Disconnect the battery(ies), negative (-) lead first.
3. Clean the battery. Refer to Section 3.9.1 for the battery cleaning procedure.
4. Place the battery in a cool, dry location.
5. Connect the battery to a float/equalize battery charger or charge it monthly with a trickle battery charger. Refer to the battery charger manufacturer's recommendations.

Maintain a full charge to extend battery life.

x.sm:002:007

## Section 4 General Troubleshooting

This section contains generator set troubleshooting, diagnostic, and repair information.

Use the following chart to diagnose and correct common problems. First check for simple causes such as a dead engine starting battery or an open circuit breaker. The chart includes a list of common problems, possible causes of the problem, recommended corrective actions, and references to detailed information or repair procedures.

Maintain a record of repairs and adjustments performed on the equipment. If the procedures in this manual do not explain how to correct the problem, contact an authorized distributor/dealer. Use the record to help describe the problem and repairs or adjustments made to the equipment.

x:gt:001:002a:

Problem	Possible Cause	Corrective Action
Controller display is blank	5-minute time delay for inactive use	Press any key
	Prime power mode	Place prime power switch to Controller On position
	Weak or dead battery	Recharge or replace; check charger operation
	Reversed or poor battery connections	Check connections
	Fuse blown in controller	Replace fuse
	Controller malfunction	Contact an authorized service distributor
Unit will not crank	Weak or dead battery	Recharge or replace; check charger operation
	Reversed or poor battery connections	Check connections
	Fuse blown in controller	Replace fuse
	Emergency stop switch activated (local or remote)	See Resetting Emergency Stop Switches
	Fault shutdown	Correct fault and reset controller
	Generator master switch in OFF position (attempting start-up from remote switch)	Move generator master switch to AUTO position
Unit cranks but will not start	Improper fuel	Replace fuel
	No fuel	Add fuel; check fuel control circuit
	Air in fuel system (diesel models)	Bleed air from system
	Defective ignition system (gas/gasoline models)	Check ignition system (spark plugs, spark plug wires, etc.)
	Air cleaner clogged	Clean or replace filter element
	Overcrank shutdown	Reset; if overcrank fault reoccurs, check DDEC engine controls (if so equipped). See Section 3, Scheduled Maintenance, Detroit Diesel Engine Control (DDEC) System and/or contact an authorized service distributor
No AC output	Line circuit breaker or safeguard breaker (if equipped) in the OFF position	Return circuit breaker to the ON position
	Generator problem such as defective voltage regulator or other internal fault	Contact an authorized service distributor
Low output or excessive drop in voltage	Unit overloaded	Reduce load
	Engine speed too low	Contact an authorized service distributor
	Faulty voltage rheostat or voltage regulator	Contact an authorized service distributor

<b>Problem</b>	<b>Possible Cause</b>	<b>Corrective Action</b>
Unit stops suddenly	Low oil pressure shutdown	Check oil level (if low, check for leaks)
	High temperature shutdown	Check for cooling air restrictions or poor belt tension
	Low coolant level shutdown	Check coolant level (if low, check for leaks); see Safety Precautions and Instructions Section
	Out of fuel	Add fuel
	Overcrank shutdown	Reset; if overcrank fault reoccurs, check DDEC engine controls (if so equipped). See Section 3, Scheduled Maintenance, Detroit Diesel Engine Control (DDEC) System and/or contact an authorized service distributor
	Fuse blown in controller	Replace fuse; if fuse blows again contact an authorized service distributor
	Engine malfunction	Contact an authorized service distributor
	Overspeed shutdown	Reset; if unit overspeeds, contact an authorized service distributor
	High oil temperature shutdown	Check oil level and type. If shutdown reoccurs, contact an authorized service distributor
	Overvoltage shutdown	Contact an authorized service distributor
	Generator master switch in OFF/RESET position	Move switch to RUN or AUTO position
	Emergency stop switch activated (local or remote)	See Resetting Emergency Stop Switches

# Section 5 Generator Reconnection

## 5.1 Voltage Reconnection

### 5.1.1 Introduction

Use the following voltage reconnection procedure to change the voltage of 10- and 12-lead generator sets. Consult the generator set service manual for frequency and governor adjustment information.

**Note:** Electronic engine controls prevent generator set frequency conversion on some models. Refer to the respective generator set spec sheet or contact your authorized distributor/dealer for applicable models.

Refer to 5.1.2 Voltage Reconnection Procedure and the connection schematics. Follow the safety precautions at the front of this manual and in the procedure text and observe National Electrical Code (NEC) guidelines.

#### NOTICE

**Voltage reconnection.** Affix a notice to the generator set after reconnecting the set to a voltage different from the voltage on the nameplate. Order voltage reconnection decal 246242 from an authorized service distributor/dealer.

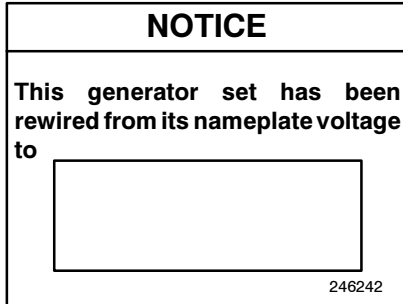

**Note: Equipment damage.** Verify that the voltage ratings of the transfer switch, line circuit breakers, and other accessories match the desired line voltage.

#### ⚠ WARNING

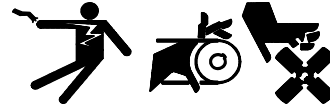

**Accidental starting.**  
**Can cause severe injury or death.**

Disconnect the battery cables before working on the generator set. Remove the negative (-) lead first when disconnecting the battery. Reconnect the negative (-) lead last when reconnecting the battery.

**Disabling the generator set. Accidental starting can cause severe injury or death.** Before working on the generator set or connected equipment, disable the generator set as follows: (1) Move the generator set master switch to the OFF position. (2) Disconnect the power to the battery charger. (3) Remove the battery cables, negative (-) lead first. Reconnect the negative (-) lead last when reconnecting the battery. Follow these precautions to prevent starting of the generator set by an automatic transfer switch, remote start/stop switch, or engine start command from a remote computer.

#### ⚠ WARNING



**Hazardous voltage. Moving rotor.**  
**Can cause severe injury or death.**

Operate the generator set only when all guards and electrical enclosures are in place.

**Grounding electrical equipment. Hazardous voltage can cause severe injury or death.** Electrocutation is possible whenever electricity is present. Open the main circuit breakers of all power sources before servicing the equipment. Configure the installation to electrically ground the generator set, transfer switch, and related equipment and electrical circuits to comply with applicable codes and standards. Never contact electrical leads or appliances when standing in water or on wet ground because these conditions increase the risk of electrocution.

**Short circuits. Hazardous voltage/current can cause severe injury or death.** Short circuits can cause bodily injury and/or equipment damage. Do not contact electrical connections with tools or jewelry while making adjustments or repairs. Remove wristwatch, rings, and jewelry before servicing the equipment.

x:gr:001:001

### 5.1.2 Voltage Reconnection Procedure

1. Place the generator set master switch in the OFF/RESET position.
2. Disconnect the generator set engine starting battery, negative (-) lead first. Disconnect power to the battery charger (if equipped).
3. Use Figure 5-2 or Figure 5-3 to determine the generator set voltage configuration. Note the original voltage and reconnect as needed. Route leads through current transformers (CTs) and connect them according to the diagram for desired phase and voltage.

**Note:** Position the current transformers with the dot or HI side CT marking toward the generator set.

**Note:** Only generator sets equipped with AC meter controllers and/or safeguard circuit breakers require CTs.

4. Reconnect battery, negative lead last.
5. Go to Menu 11—Programming Mode and access Program Mode—Local. See Section 2.8, Local Programming Mode On, Section 2.8.11, Menu 11—Programming Mode, for the complete procedure.

6. Go to Menu 6—Generator System and update the voltage information. See Section 2.8, Local Programming Mode On, Section 2.8.6, Menu 6—Generator System for complete procedure.
7. Go to Menu 9—Calibration and perform the calibration procedure. Section 2.8, Local Programming Mode On, Section 2.8.9, Menu 9—Calibration for complete procedure.
8. Move the generator set master switch to the RUN position to start the generator set.
9. Check voltage display for selected voltage. See Section 2.8.1, Menu 1—Generator Output, for access to voltage data.
10. Stop the generator set after completing voltage adjustment. Replace controller cover.

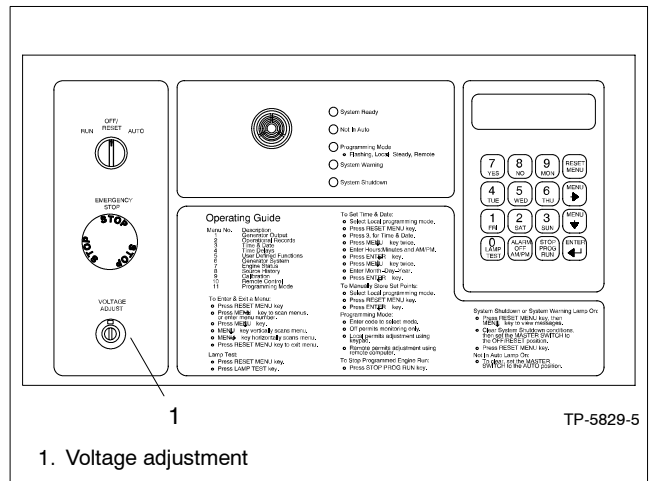

**Figure 5-1** Voltage Adjustment

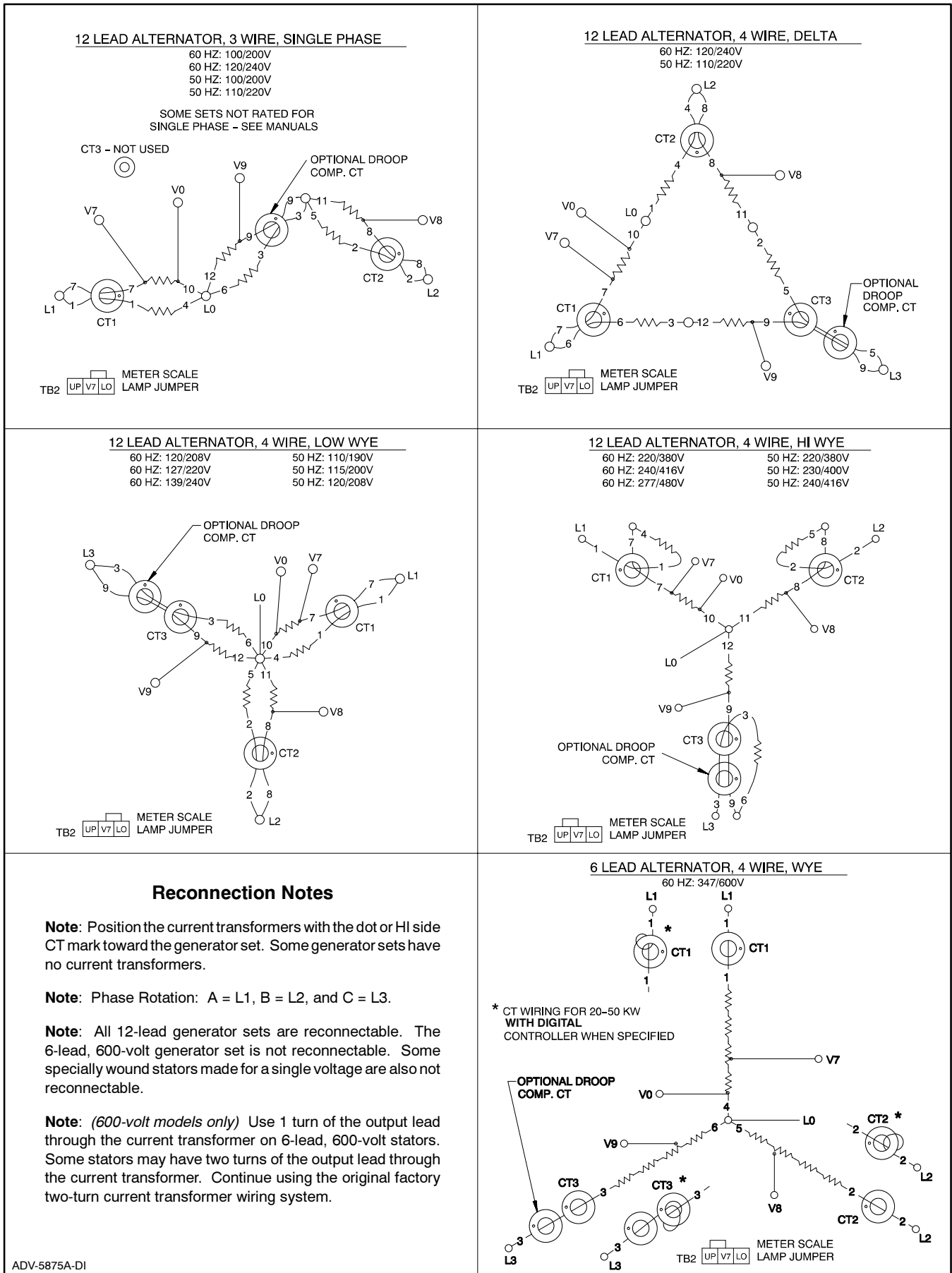

**Figure 5-2** Generator Set Reconnections, 20-300 kW Models

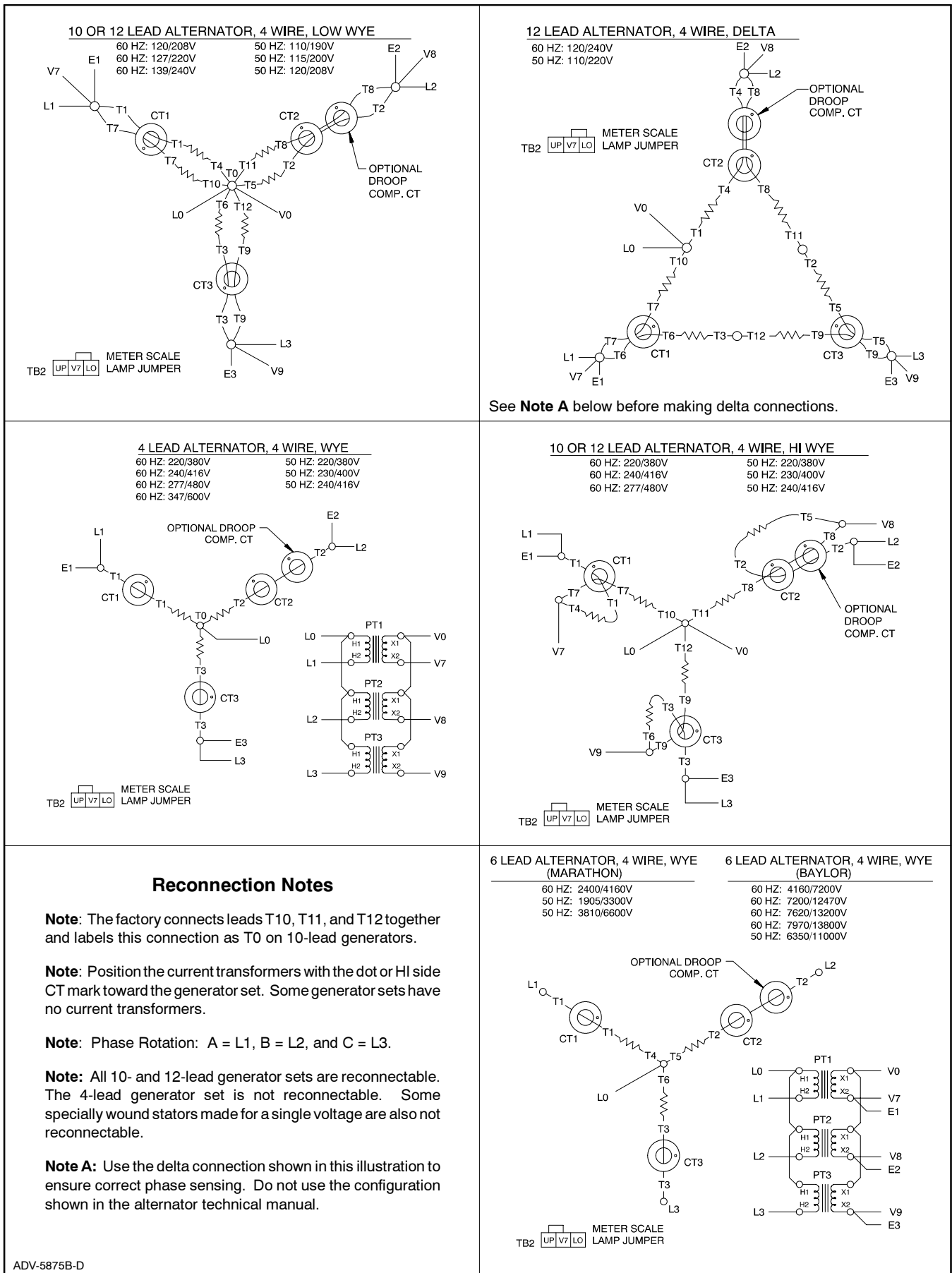

Figure 5-3 Generator Set Reconnections, 350–2000 kW Models

### 6.1 Accessories

Several accessories help finalize installation, add convenience to operation and service, and establish state and local code compliance.

Accessories vary with each generator set model and controller. Select factory-installed and/or shipped-loose accessories. See the matrix in Figure 6-1 for a list of available kits. Kit and installation instruction part numbers change. Obtain the most current accessory information from your local authorized service distributor/dealer.

This section illustrates several accessories available at the time of print of this publication. Accessory kits generally include installation instructions. See the wiring diagrams manual for electrical connections not shown in this section. See the installation instructions supplied with the kit for information on kit mounting location.

The instruction provided with the accessory kit supersedes these instructions where there are differences. In general, run AC and DC wiring in separate conduit. Observe all applicable national, state, and local electrical codes during accessory installation.

Kit Description	Kit Part No.	Installation Instruction
Audiovisual Alarm	PA-292856	TT-639
Common Failure Relay (Terminal 32A)	PA-347274	TT-1068
Controller (Customer) Connection	PA-328911 or PA-347428	TT-1070
Engine Prealarm (prealarm low oil pressure, prealarm high water temperature, and low water temperature) Some kits used on gaseous-fueled models include the low fuel pressure switch.	Multiple kits based on engine model number and generator set model number.	Multiple TTs
Float/Equalize Battery Charger (with alarms)	PAD-292863 (12 volt) or PAD-292865 (24 volt)	TT-680
Prime Power Switch	PA-354395	TT-1155
Remote Annunciator (16-light panel)	PA-293991	TT-1023
Remote Emergency Stop	PA-293906	TT-940
Remote Speed Adjustment Potentiometer (requires electronic governor)	PA-273768	TT-774
Run Relay	PA-273743 (12 volt) or PA-273744 (24 volt)	TT-700
Single-Relay Dry Contact	PA-273912	TT-722
Ten-Relay Dry Contact	PA-273913	TT-723
Voltage Adjustment (with digital voltage regulator)	No kit required. Use customer-supplied leads.	See Accessory Wiring Diagram 354246
Remote Reset Feature	No kit required. Use customer-supplied leads.	See Accessory, Section 6.1.9

**Figure 6-1** Optional Accessories for Digital Controller

### 6.1.1 Audiovisual Alarm Kit

An audiovisual alarm warns the operator at a remote location of fault shutdowns and prealarm conditions. Audiovisual alarms include alarm horn, alarm silence switch, and common fault lamp. See Figure 6-2 and Figure 6-4. See Section 6.2, Accessory and Prime Power Terminal Strip Connections, for terminal identification.

**Note:** Use the audiovisual alarm with a dry contact kit.

### 6.1.2 Common Failure Relay Kit

The common failure relay kit provides one set of contacts to trigger customer-provided warning devices if a fault occurs. The common failure relay faults are user defined with up to 44 selections available. See Section 2, Operation, Menu 5—User Defined Functions for faults available for this function. The factory default settings are:

- Emergency Stop
- High Engine Temperature
- Low Oil Pressure
- Overcrank
- Overspeed

Connect up to three defined common fault relay kits to the controller output. See Figure 6-3 and Figure 6-5. See Section 6.2, Accessory and Prime Power Terminal Strip Connections, for terminal identification.

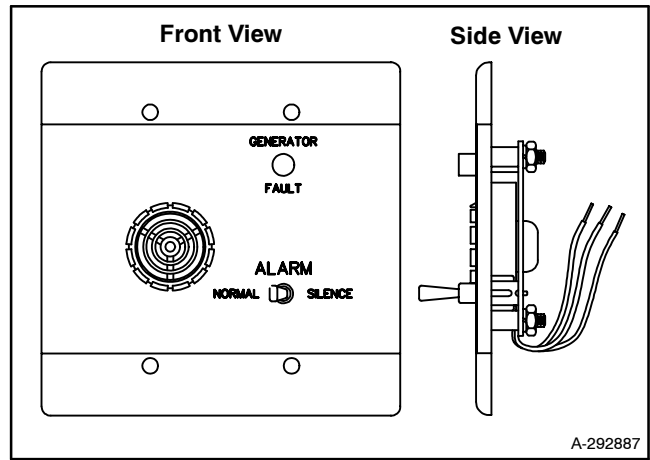

**Figure 6-2** Audiovisual Alarm

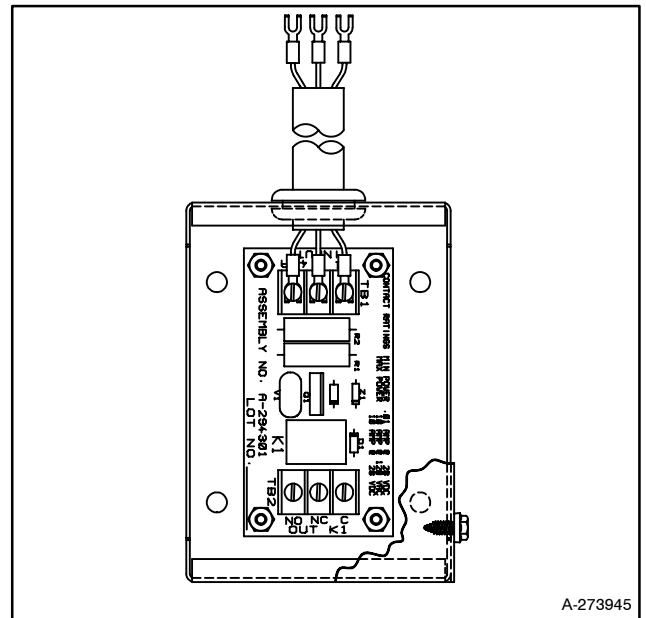

**Figure 6-3** Common Failure Relay Kit

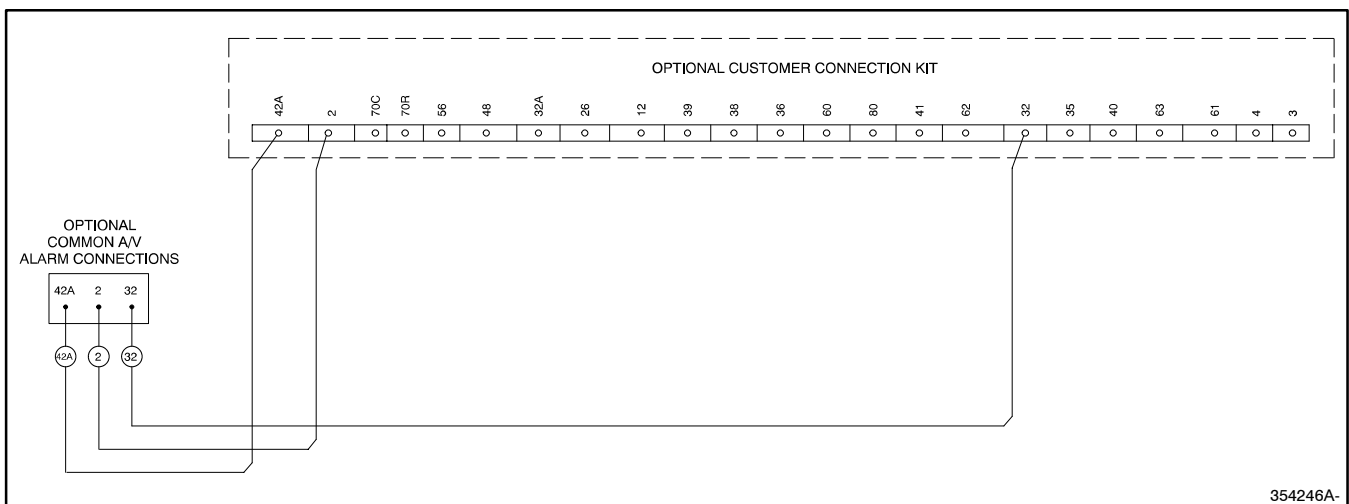

**Figure 6-4** Audiovisual Alarm Connections

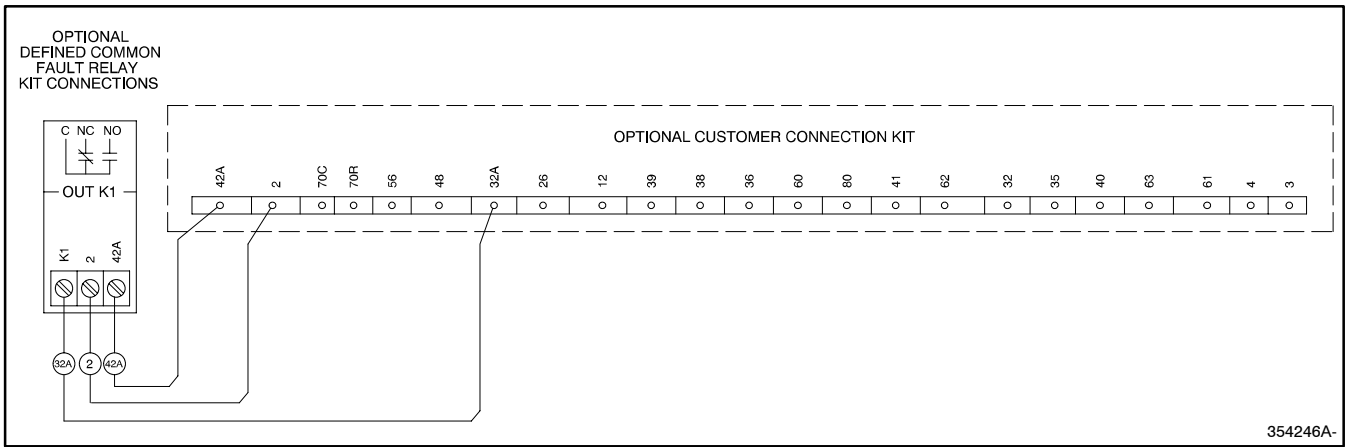
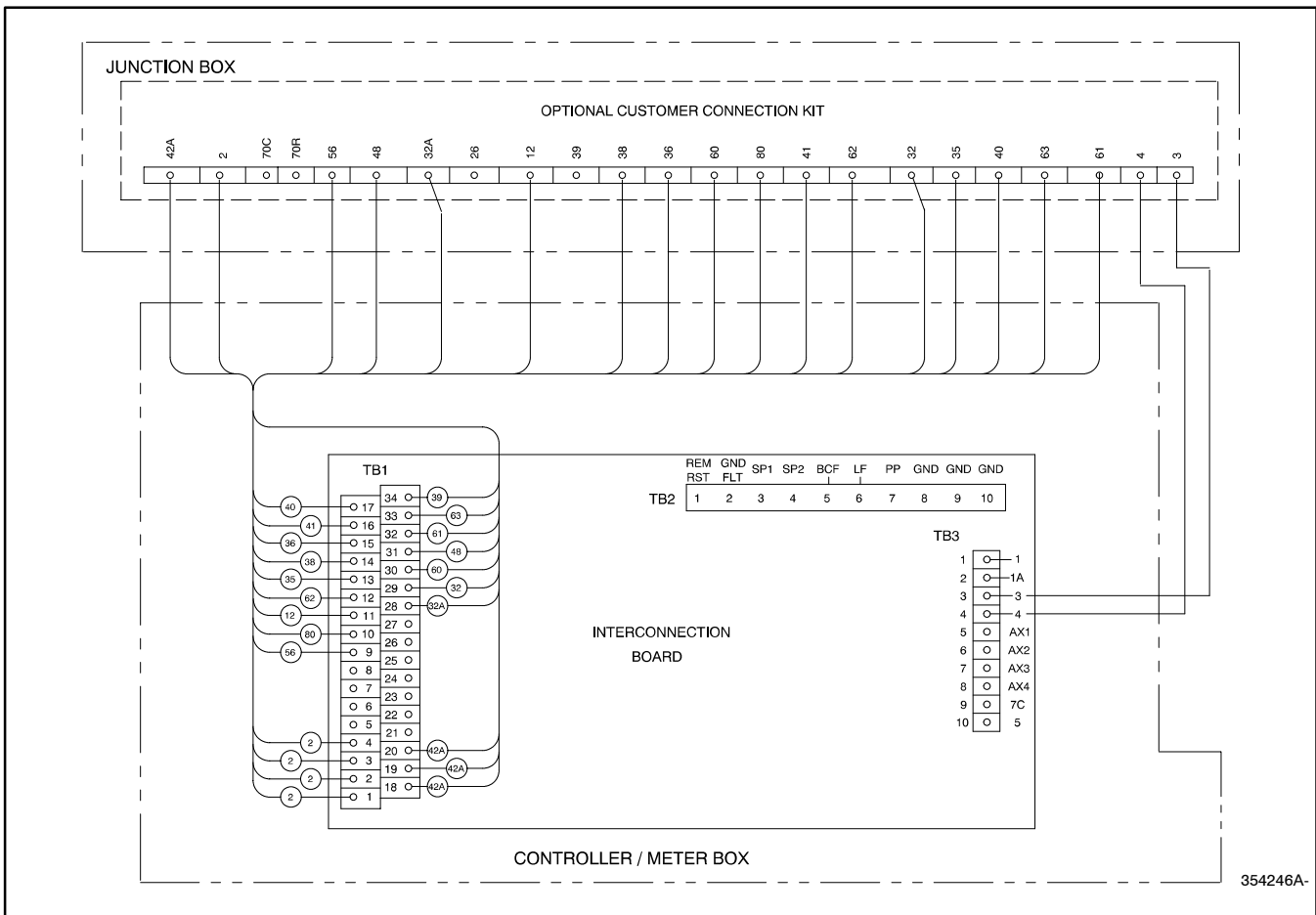

**Figure 6-5** Common Failure Relay Kit Connections

### 6.1.3 Controller (Customer) Connection Kit

The controller connection kit allows easy connection of controller accessories without accessing the controller terminal strip. The kit uses a 165-cm (65-in.) wiring harness to link the controller terminal strip(s) with a

remote terminal strip. With the exception of a few terminals, the remote terminal strip has the same terminals as in the controller. Connect all accessories (except the emergency stop kit) to the connection kit terminal strip. See Figure 6-6. See Section 6.2, Accessory and Prime Power Terminal Strip Connections, for terminal identification.

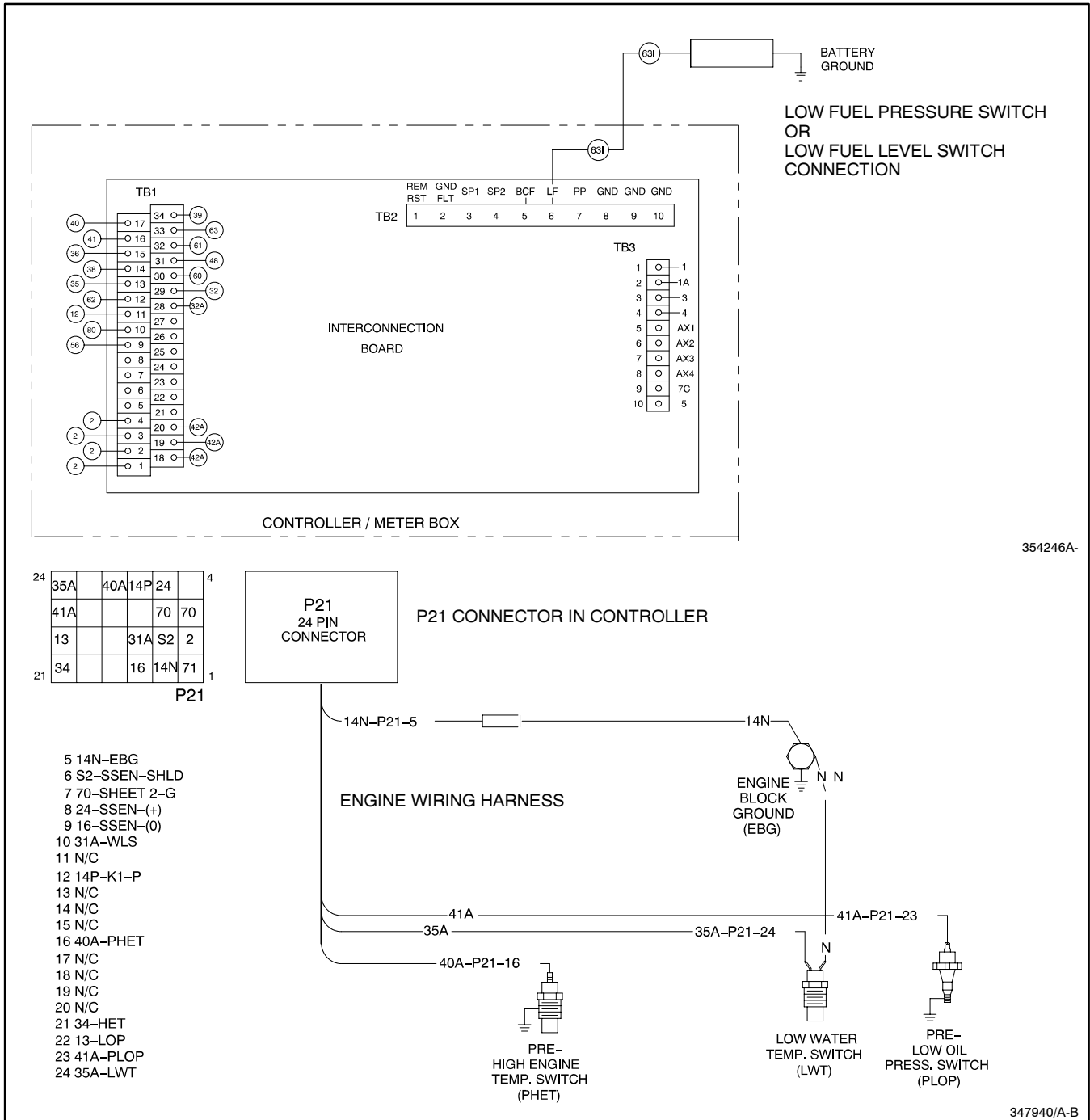

**Figure 6-6** Controller (Customer) Connection Kit

## 6.1.4 Engine Prealarm Kit

The engine prealarm kit provides engine switches for prealarm low oil pressure, prealarm high water temperature, and low water temperature. Kit components and hardware vary with engine model. Some kits for gaseous-fueled models include a low fuel pressure switch. The low fuel *pressure* switch connects to the same terminals as the low fuel *level* switch on diesel- or gasoline-fueled models. See Figure 6-7. See Section 6.2, Accessory and Prime Power Terminal Strip Connections, for terminal identification.

**Note:** The main tank or the transfer/day tank includes the low fuel level switch. The fuel tank supplier typically provides the low fuel level switch. The engine prealarm kit does not include the low fuel level switch although this section illustrates the electrical connection.



**Figure 6-7** Engine Prealarm Kit Connections, Typical

### 6.1.5 Float/Equalize Battery Charger Kit with Alarm Option

The float/equalize battery charger with alarm option provides battery charging to the engine starting battery(ies) and connects to the controller for fault detection. Battery chargers for 12 or 24 volt models are available as a generator set accessory. See Figure 6-8 and Figure 6-9. See Section 6.2, Accessory and Prime Power Terminal Strip Connections, for terminal identification.

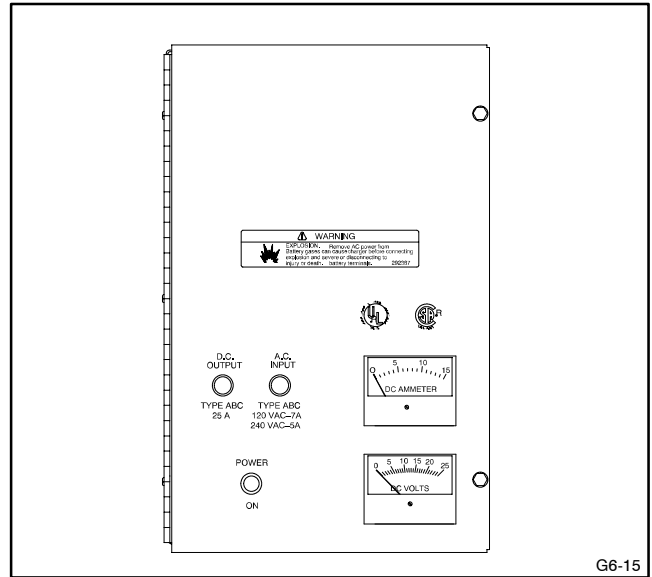

Figure 6-8 Float/Equalize Battery Charger

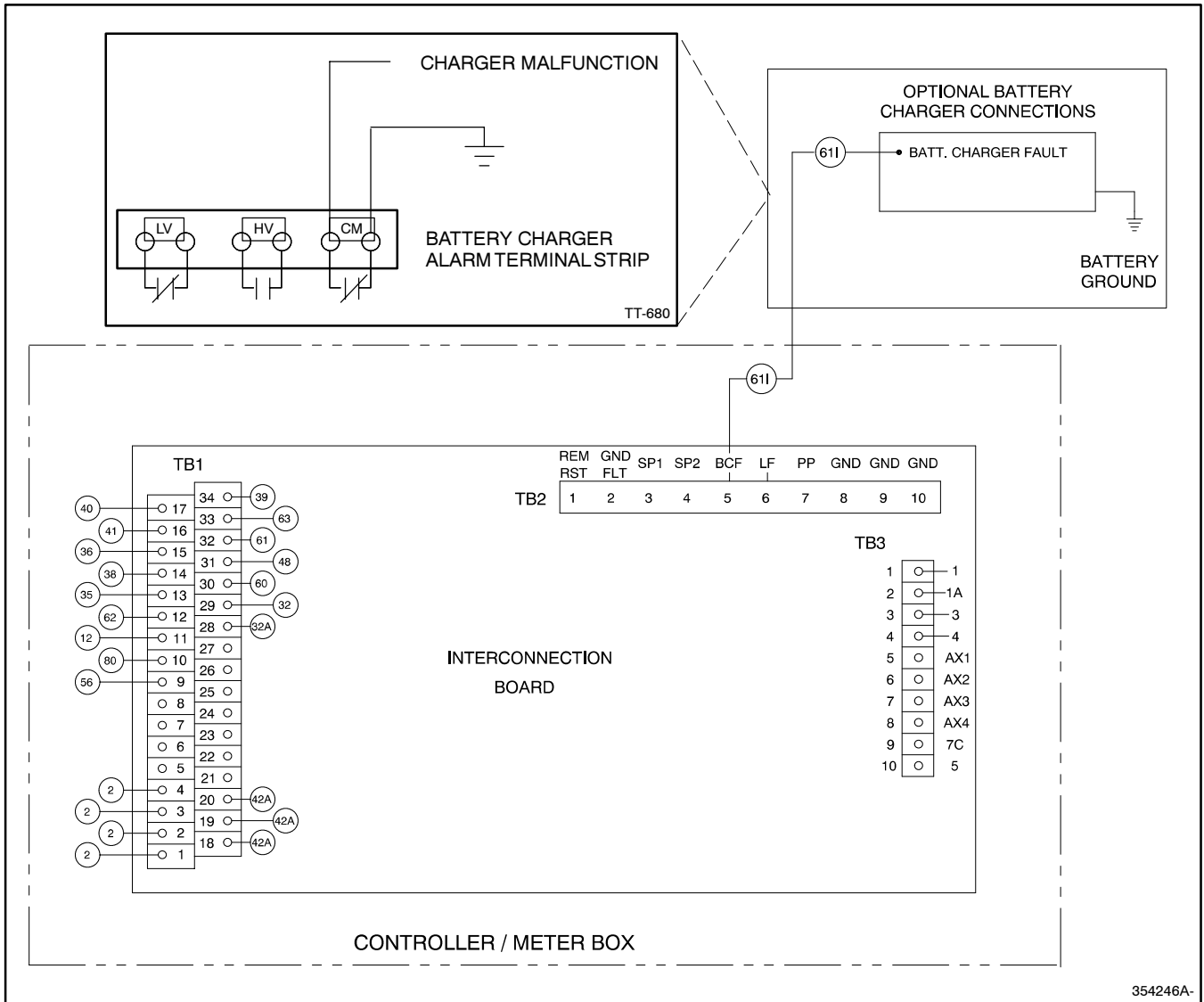

Figure 6-9 Float/Equalize Battery Charger Connections

### 6.1.6 Prime Power Switch Kit

The prime power switch kit prevents battery drain during generator set non-operation periods and without battery charging. See Figure 6-10.

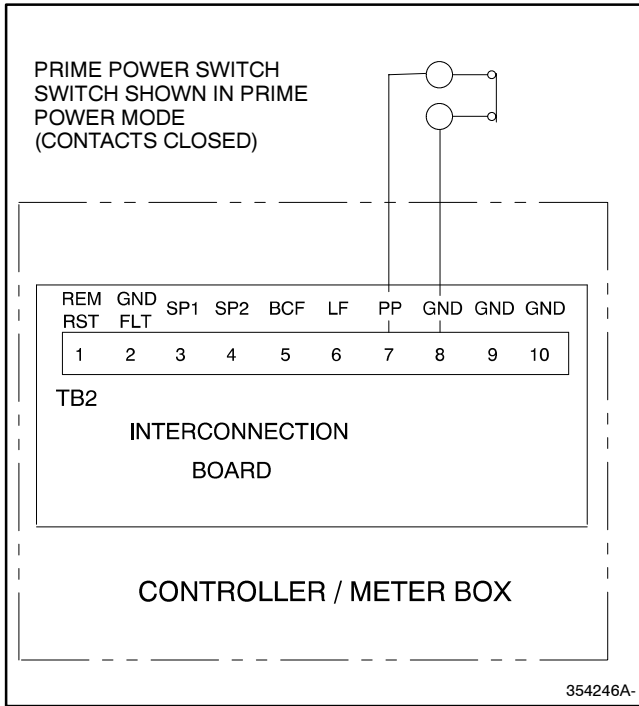

Figure 6-10 Prime Power Switch Connections

Stop the generator set using the stopping procedures in Section 2.3.2, Stopping, before placing the generator set in the prime power mode. Move the prime power switch located on the back of the controller to the CONTROLLER OFF position. The controller including the digital display, LEDs, and alarm horn does not function when the generator set is in the prime power mode.

Move the prime power switch located on the back of the controller to the CONTROLLER ON position and reset the controller time and date before attempting to start the generator set.

See Section 6.2, Accessory and Prime Power Terminal Strip Connections, for terminal identification.

### 6.1.7 Remote Annunciator Kit

A remote annunciator monitors the generator set's condition from a location remote of the generator set. See Figure 6-11. Remote annunciator includes alarm horn, alarm silence switch, lamp test, and lamp indicators similar to the digital controller, plus the following:

**Line Power.** Lamp illuminates to indicate power source is commercial utility.

**Generator Power.** Lamp illuminates to indicate power source is generator set.

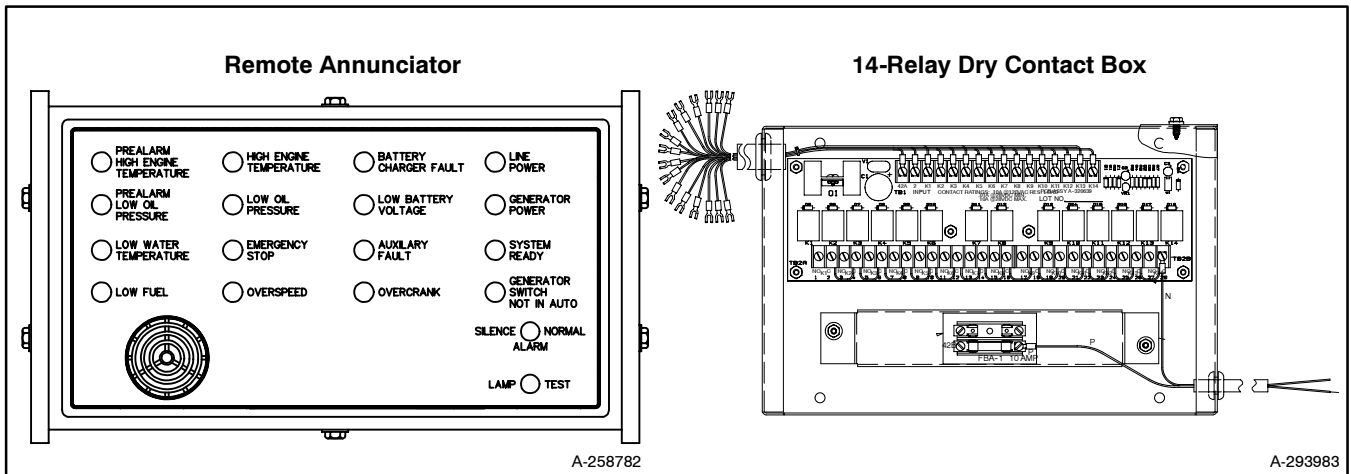
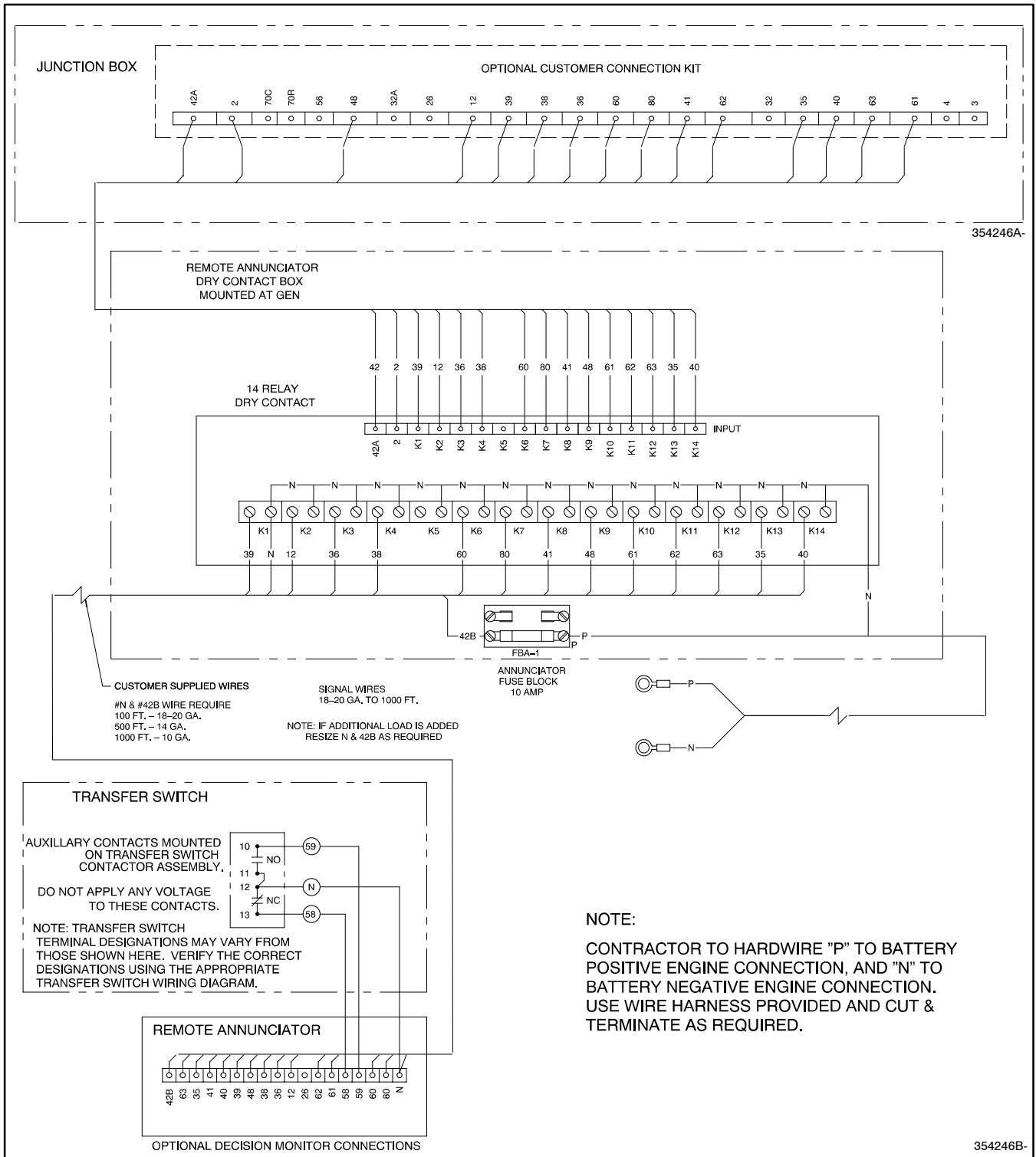

Figure 6-11 Remote Annunciator with 14-Relay Dry Contact Kit



**Figure 6-12** Remote Annunciator with 14-Relay Dry Contact Kit Connections

### 6.1.8 Remote Emergency Stop Kit

The emergency stop kit allows immediate shutdown of the generator set from a remote location. See Figure 6-13 and Figure 6-14. If the emergency stop switch activates, the EMERGENCY STOP lamp lights and the unit shuts down. Before attempting to restart the generator set, reset the emergency stop switch (by replacing glass piece) and reset the generator set by placing the master switch in the OFF/RESET position. Use the single glass piece located inside the switch for replacement and order additional glass pieces as service parts. Reset the engine air damper switch if equipped on 200–2000 kW models with 2-cycle Detroit Diesel engines. See Section 2.3.3, Resetting Emergency Stop Switch. See Section 6.2, Accessory and Prime Power Terminal Strip Connections, for terminal identifications.

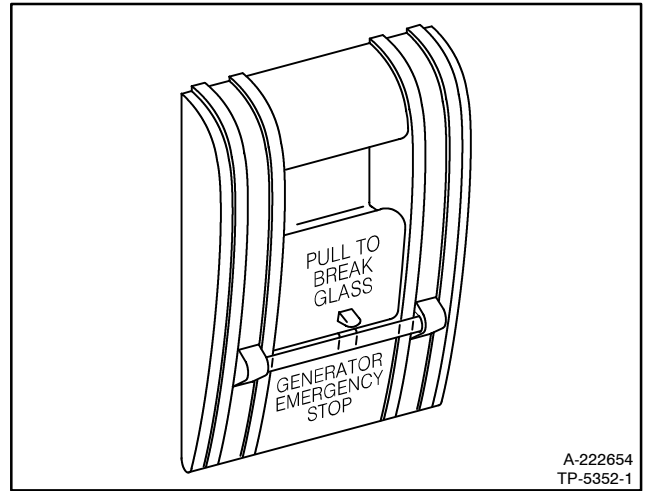

Figure 6-13 Emergency Stop Kit

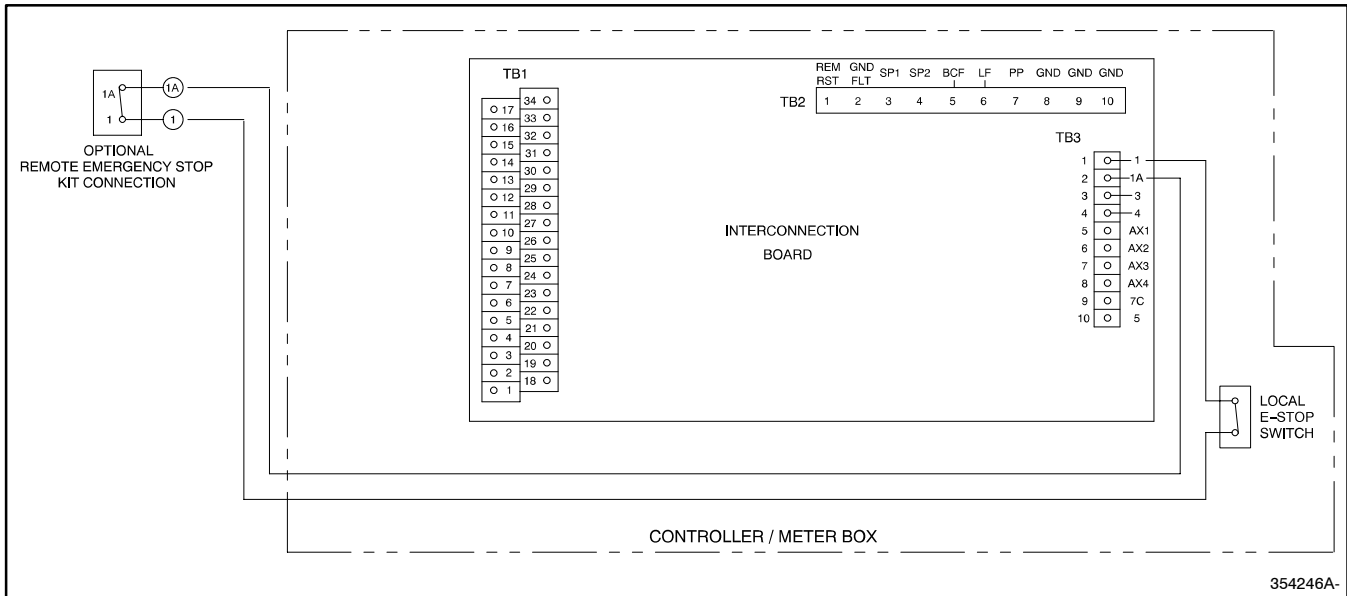

Figure 6-14 Remote Emergency Stop Kit Connections

### 6.1.9 Remote Reset Feature

The remote reset switch provides generator set resetting after a fault shutdown at a remote location. See Figure 6-15. Press and hold the switch for 2-3 seconds and release.

Switch Rating
125 volts AC maximum 15 amps minimum

Wiring Recommendation	
Gauge	mm (ft.)
18-20	30.5 (100)
14	153 (500)
10	305 (1000)

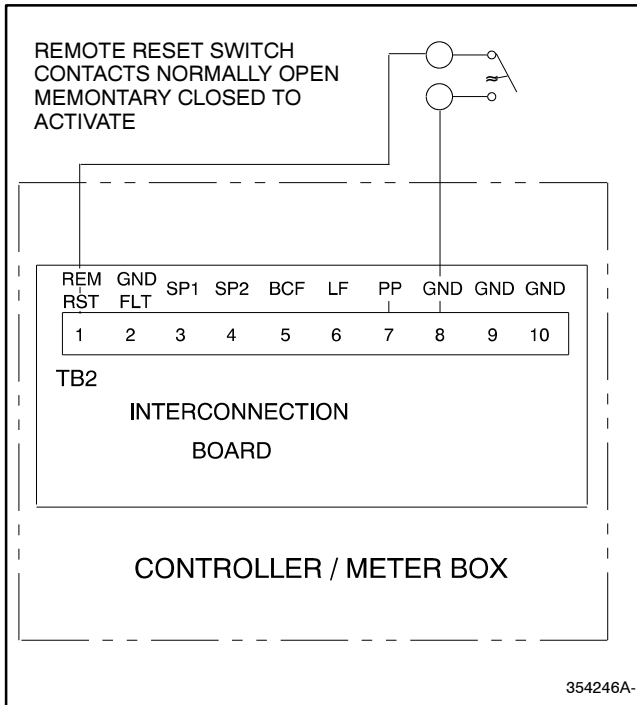

Figure 6-15 Remote Reset Switch Connections

### 6.1.10 Remote Speed Adjustment Potentiometer Kit

The remote speed adjustment potentiometer kit provides controller-mounted engine speed adjustment. The speed adjustment range is approximately  $\pm 5\%$ . Some applications locate this potentiometer with the switchgear. This kit requires an electronic governor on the generator set. See Figure 6-16. See Section 6.2, Accessory and Prime Power Terminal Strip Connections, for terminal identifications.

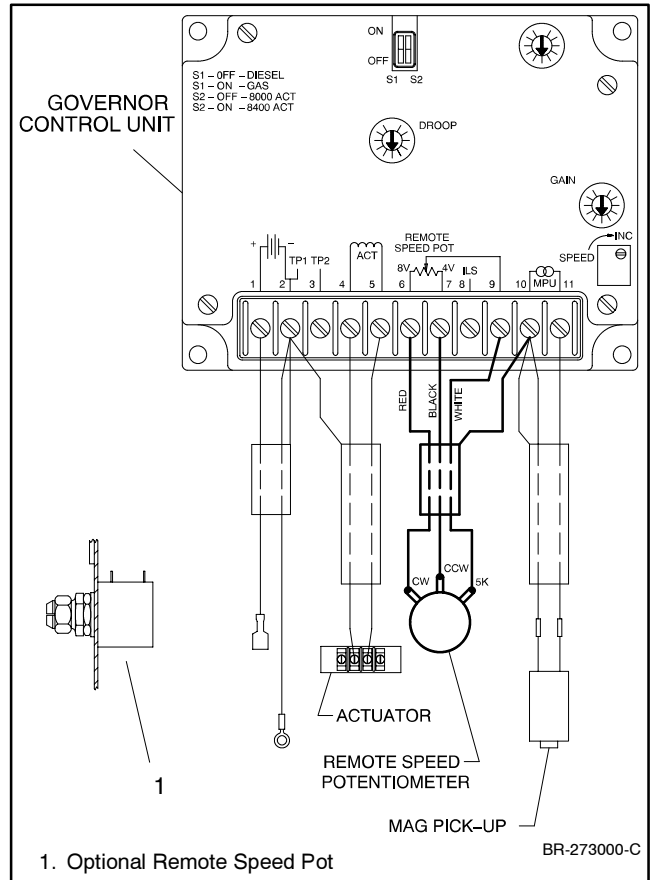

Figure 6-16 Remote Speed Adjustment Potentiometer Connection, Typical

### 6.1.11 Run Relay Kit

The run relay kit energizes only when the generator set runs. Typically the run relay kit controls air intake and/or radiator louvers or uses the kit for alarms and other signalling devices. See Figure 6-17 and Figure 6-18.

### 6.1.12 Single-Relay Dry Contact Kit

The single-relay dry contact kit uses one set of contacts to trigger customer-provided warning devices when a fault condition occurs. Any controller fault output (from TB1 terminal strip) can connect to the single-relay kit.

A total of three dry contact kits may connect to a single controller output. See Figure 6-19 and Figure 6-20. See Section 6.2, Accessory and Prime Power Terminal Strip Connections, for terminal identifications.

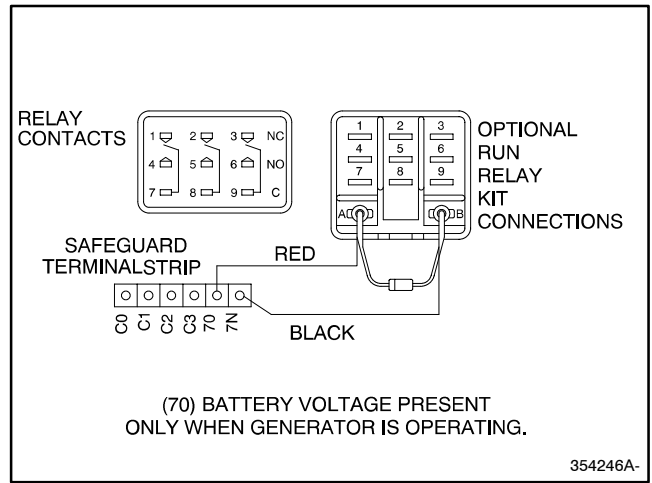

Figure 6-18 Run Relay Connections

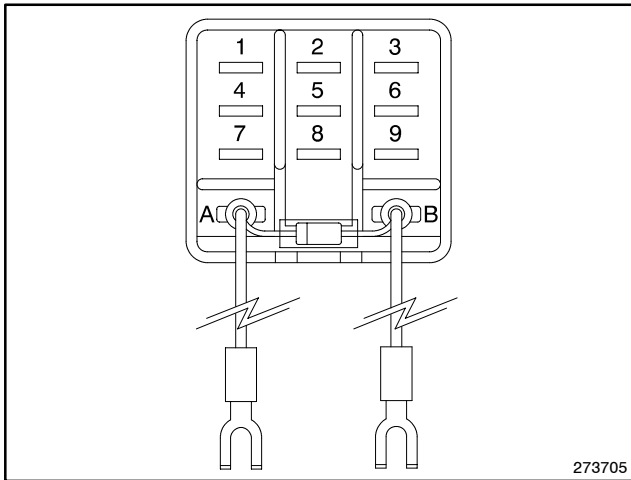

Figure 6-17 Run Relay Kit

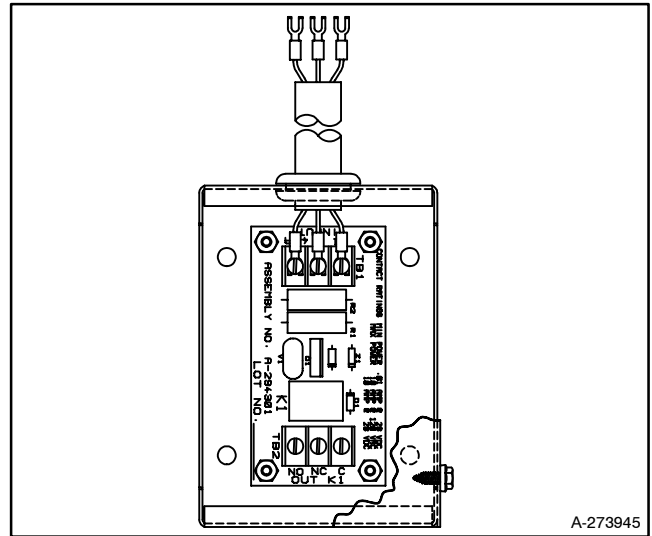

Figure 6-19 Single-Relay Dry Contact Kit

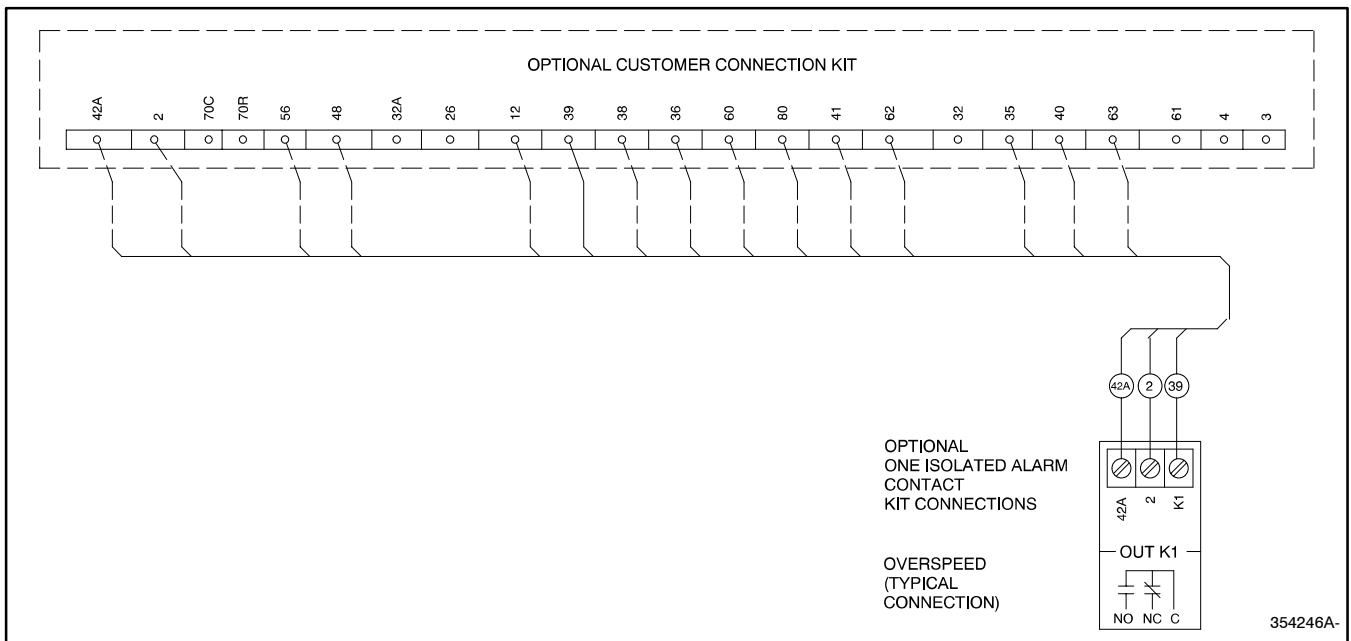

Figure 6-20 Single-Relay Dry Contact Kit Connections

### 6.1.13 Ten-Relay Dry Contact Kit

The ten-relay dry contact kit allows monitoring of the standby system and/or the ability to activate accessories such as derangement panels. The kit includes ten sets of relay contacts for connection of customer-provided devices to desired generator functions. Connect warning devices (lamps and/or audible alarms) and other accessories to the controller outputs listed below. Connect a total of three dry contact kits to a controller output. Refer to Figure 6-21 for an internal view of the contact kit. See Figure 6-22 for electrical connections.

- Overspeed
- Overcrank
- High Engine Temperature
- Low Oil Pressure
- Low Water Temperature
- Low Battery Voltage
- Air Damper (if equipped)
- Prealarm High Engine Temperature
- Prealarm Low Oil Pressure
- Emergency Stop

See Section 6.2, Accessory and Prime Power Terminal Strip Connections, for terminal identifications.

Typical contact kit output connections include the following:

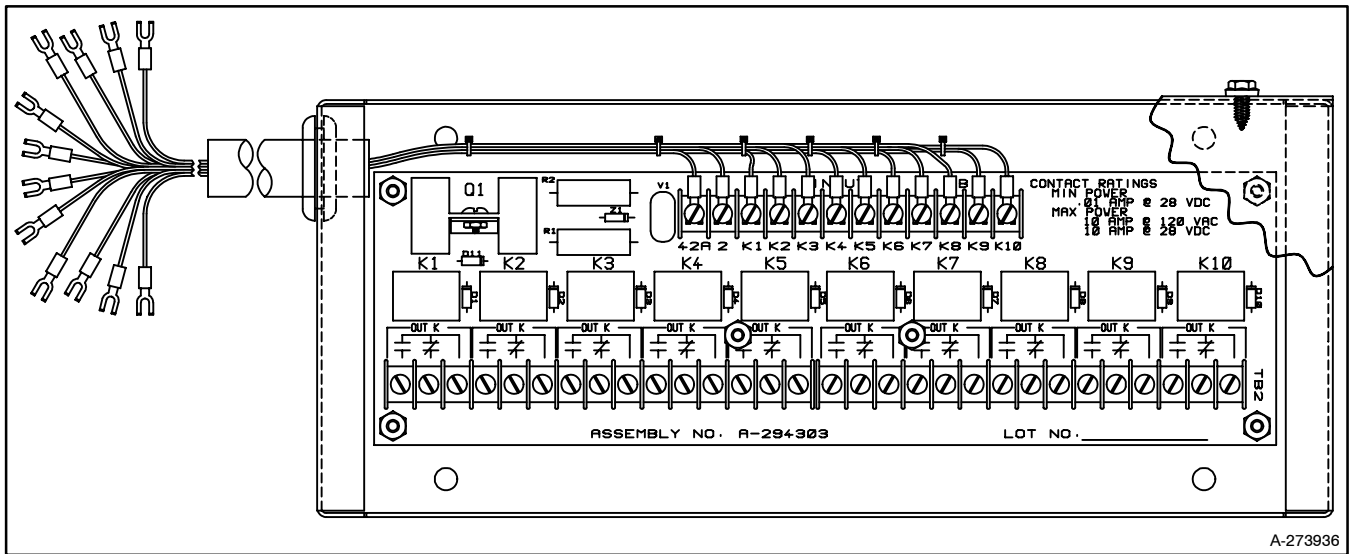

Figure 6-21 Ten-Relay Dry Contact Kit

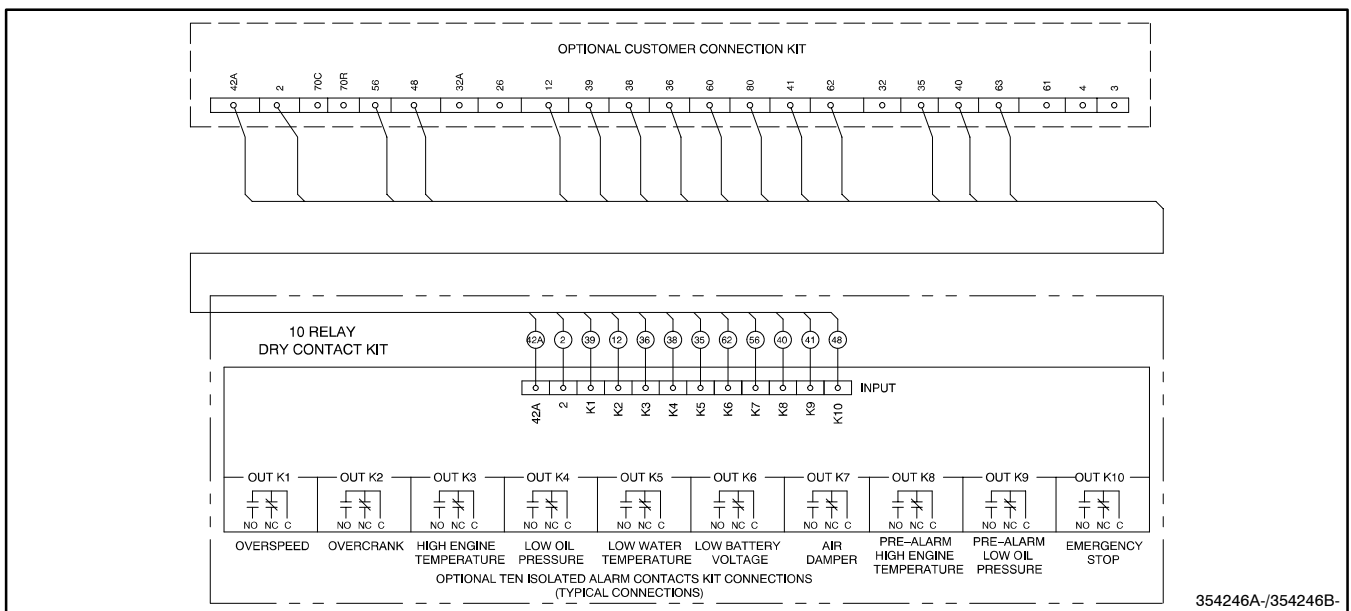
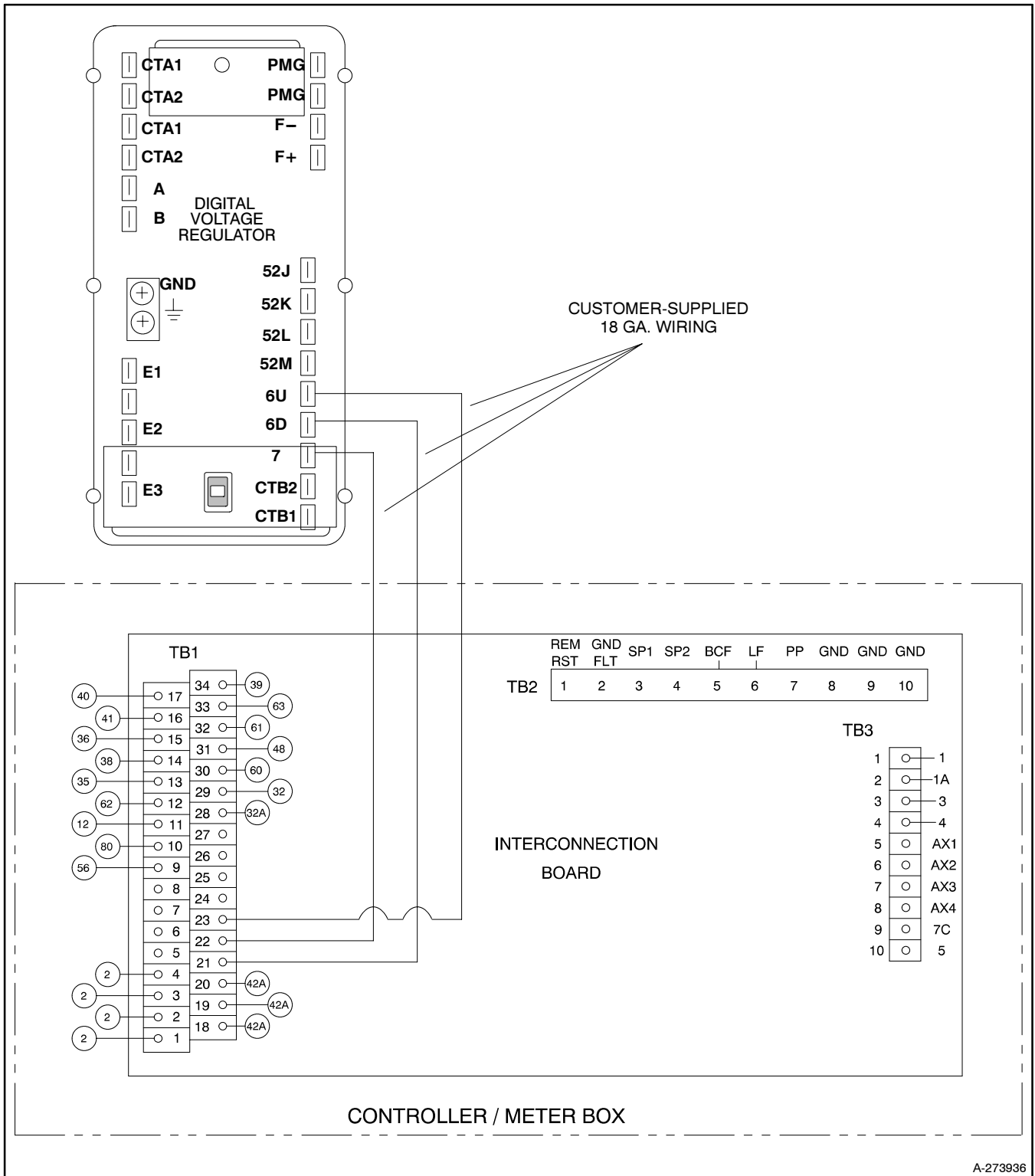

Figure 6-22 Ten-Relay Dry Contact Kit Connections

### 6.1.14 Voltage Adjustment Feature with Digital Voltage Regulator

The voltage adjustment feature provides remote fine adjustment of  $\pm 10\%$  of generator output voltage. Generator sets 350-2000 kW use digital voltage

regulators. Connect the voltage adjustment feature using customer-supplied 18 ga. leads between the digital voltage regulator and the digital controller. See Figure 6-23. See Section 6.2, Accessory and Prime Power Terminal Strip Connections, for terminal identifications.



**Figure 6-23** Voltage Adjustment with Digital Voltage Regulator Connections

## 6.2 Accessory and Prime Power Terminal Strip Connections

The digital controller contains circuit boards equipped with terminal strip(s) for easy connection of generator set accessories. Do not directly connect accessories to the controller terminal strip. Connect all accessories to a single-relay dry contact kit or ten-relay dry contact kit. Connect the dry contact kit(s) to the controller terminal

strip or controller connection kit (if used). Connect alarms, battery chargers, remote switches, and other accessories to the dry contact kit relay(s) using 18- or 20-gauge stranded wire up to 305 m (1000 ft.).

For specific information on accessory connections, refer to the accessory wiring diagrams in the Wiring Diagram Manual and the instruction sheet accompanying the kit. See Figure 6-24 through Figure 6-28.

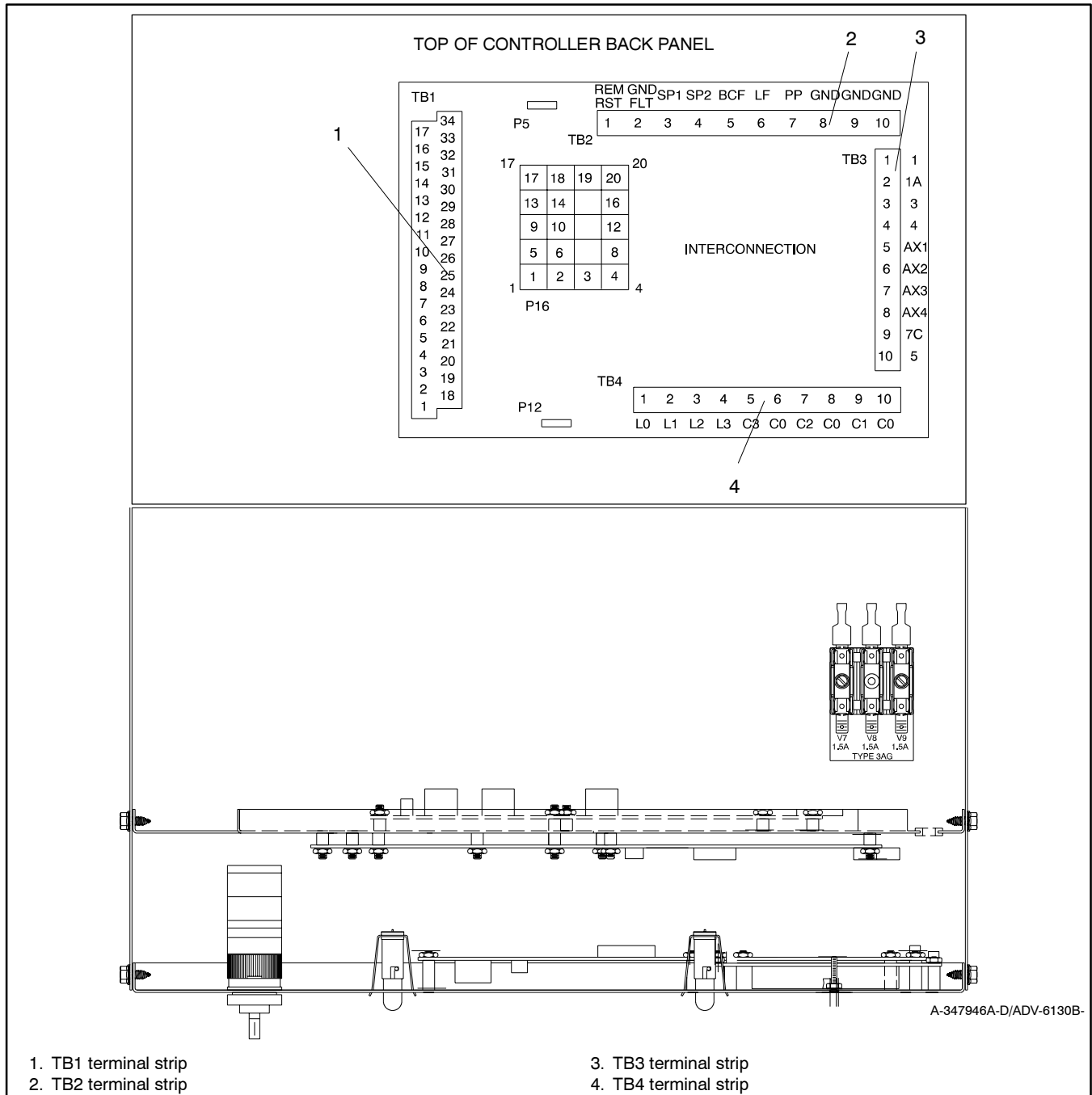

**Figure 6-24** Terminal Strips on Controller Interconnection Circuit Board (Controller Back Panel Folded Down)

Terminal	Description
1	Engine ground (-)
2	Engine ground (-)
3	Engine ground (-)
4	Engine ground (-)
5	Panel lamp output
6	Relay driver output (RDO)—10
7	Relay driver output (RDO)—9
8	Relay driver output (RDO)—7
9	Relay driver output (RDO)—5
10	Not in auto relay output (80)
11	Overcrank relay output (12)
12	Low battery voltage relay output
13	Low coolant temperature relay output (35)
14	Low oil pressure relay output (38)
15	High coolant temperature relay output (36)
16	Low oil pressure warning relay output (41)
17	High coolant temperature warning relay output (40)
18	42A battery voltage (+)—accessory power supply
19	42A battery voltage (+)—accessory power supply
20	42A battery voltage (+)—accessory power supply
21	Digital voltage regulator (DVR) adjustment down
22	Digital voltage regulator (DVR) adjustment common
23	Digital voltage regulator (DVR) adjustment up
24	Relay driver output (RDO)—8
25	Relay driver output (RDO)—6
26	Relay driver output (RDO)—4
27	Relay driver output (RDO)—3
28	Relay driver output (RDO)—2
29	Relay driver output (RDO)—1
30	System ready relay output (60)
31	Emergency stop relay output (48)
32	Battery charger fault relay output (61)
33	Low fuel relay output
34	Overspeed relay output (39)

NOTE: RDO outputs are active low, battery voltage (-).  
\* Connect to ground to activate.

**Figure 6-25** TB1 Terminal Strip Output Connections

Terminal	Description
REM RST	Remote reset*
GND FLT	Ground fault*
SP1	Not used
SP2	Not used
BCF	Battery charger fault*
LF	Low fuel*
PP	Prime power mode*
GND	Engine ground
GND	Engine ground
GND	Engine ground

\* Connect to ground to activate.

**Figure 6-26** TB2 Terminal Strip Input Connections

Terminal	Description
1	Emergency stop ground
1A	Emergency stop
3	Remote start
4	Remote start
AX1	Auxiliary 1*
AX2	Auxiliary 2*
AX3	Auxiliary 3*
AX4	Auxiliary 4*
7C	Oil pressure
5	Coolant temperature

\* Connect to ground to activate.

**Figure 6-27** TB3 Terminal Strip Input Connections

Terminal	Description
L0	L0 (V0)
L1	L1 (V7)
L2	L2 (V8)
L3	L3 (V9)
—	Not used
C3	C3
C2	C2
C1	C1
C0	C0

**Figure 6-28** TB4 Terminal Strip AC Input Connections

# Appendix A Abbreviations

The following list contains abbreviations that may appear in this publication.

A, amp	ampere	cfm	cubic feet per minute	exh.	exhaust
ABDC	after bottom dead center	CG	center of gravity	ext.	external
AC	alternating current	CID	cubic inch displacement	F	Fahrenheit, female
A/D	analog to digital	CL	centerline	fglass.	fiberglass
ADC	analog to digital converter	cm	centimeter	FHM	flat head machine (screw)
adj.	adjust, adjustment	cmm	cubic meters per minute	fl. oz.	fluid ounce
ADV	advertising dimensional drawing	CMOS	complementary metal oxide substrate (semiconductor)	flex.	flexible
AHWT	anticipatory high water temperature	cogen.	cogeneration	freq.	frequency
AISI	American Iron and Steel Institute	COM	communications (port)	FS	full scale
ALOP	anticipatory low oil pressure	conn.	connection	ft.	foot, feet
alt.	alternator	cont.	continued	ft. lbs.	foot pounds (torque)
Al	aluminum	CPVC	chlorinated polyvinyl chloride	ft./min.	feet per minute
ANSI	American National Standards Institute (formerly American Standards Association, ASA)	crit.	critical	g	gram
AO	anticipatory only	CRT	cathode ray tube	ga.	gauge (meters, wire size)
API	American Petroleum Institute	CSA	Canadian Standards Association	gal.	gallon
approx.	approximate, approximately	CT	current transformer	gen.	generator
AR	as required, as requested	Cu	copper	genset	generator set
AS	as supplied, as stated, as suggested	cu. in.	cubic inch	GFI	ground fault interrupter
ASE	American Society of Engineers	cw.	clockwise	gnd.	ground
ASME	American Society of Mechanical Engineers	CWC	city water-cooled	gov.	governor
assy.	assembly	cyl.	cylinder	gph	gallons per hour
ASTM	American Society for Testing Materials	D/A	digital to analog	gpm	gallons per minute
ATDC	after top dead center	DAC	digital to analog converter	gr.	grade, gross
ATS	automatic transfer switch	dB	decibel	gr. wt.	gross weight
auto.	automatic	dBA	decibel (A weighted)	H x W x D	height by width by depth
aux.	auxiliary	DC	direct current	HC	hex cap
A/V	audiovisual	DCR	direct current resistance	HCHT	high cylinder head temperature
avg.	average	deg., °	degree	HD	heavy duty
AVR	automatic voltage regulator	dept.	department	HET	high exhaust temperature
AWG	American Wire Gauge	dia.	diameter	hex	hexagon
AWM	appliance wiring material	DI/EO	dual inlet/end outlet	Hg	mercury (element)
bat.	battery	DIN	Deutsches Institut für Normung e. V. (also Deutsche Industrie Normenausschuss)	HH	hex head
BBDC	before bottom dead center	DIP	dual inline package	HHC	hex head cap
BC	battery charger, battery charging	DPDT	double-pole, double-throw	HP	horsepower
BCA	battery charging alternator	DPST	double-pole, single-throw	hr.	hour
BCI	Battery Council International	DS	disconnect switch	HS	heat shrink
BDC	before dead center	DVR	digital voltage regulator	hsg.	housing
BHP	brake horsepower	E, emer.	emergency (power source)	HVAC	heating, ventilation, and air conditioning
blk.	black (paint color), block (engine)	EDI	electronic data interchange	HWT	high water temperature
blk. htr.	block heater	EFR	emergency frequency relay	Hz	hertz (cycles per second)
BMEP	brake mean effective pressure	e.g.	for example ( <i>exempli gratia</i> )	IC	integrated circuit
bps	bits per second	EG	electronic governor	ID	inside diameter, identification
br.	brass	EGSA	Electrical Generating Systems Association	IEC	International Electrotechnical Commission
BTDC	before top dead center	EIA	Electronic Industries Association	IEEE	Institute of Electrical and Electronics Engineers
Btu	British thermal unit	EI/EO	end inlet/end outlet	IMS	improved motor starting
Btu/min.	British thermal units per minute	EMI	electromagnetic interference	in.	inch
C	Celsius, centigrade	emiss.	emission	in. H <sub>2</sub> O	inches of water
cal.	calorie	eng.	engine	in. Hg	inches of mercury
CARB	California Air Resources Board	EPA	Environmental Protection Agency	in. lbs.	inch pounds
CB	circuit breaker	EPS	emergency power system	Inc.	incorporated
cc	cubic centimeter	ER	emergency relay	ind.	industrial
CCA	cold cranking amps	ES	engineering special, engineered special	int.	internal
ccw.	counterclockwise	ESD	electrostatic discharge	int./ext.	internal/external
CEC	Canadian Electrical Code	est.	estimated	I/O	input/output
cfh	cubic feet per hour	E-Stop	emergency stop	IP	iron pipe
		etc.	et cetera (and so forth)	ISO	International Organization for Standardization
				J	joule
				JIS	Japanese Industry Standard
				k	kilo (1000)
				K	kelvin

kA	kiloampere	mtg.	mounting	rms	root mean square
KB	kilobyte (2 <sup>10</sup> bytes)	MW	megawatt	rnd.	round
kg	kilogram	mW	milliwatt	ROM	read only memory
kg/cm <sup>2</sup>	kilograms per square centimeter	μF	microfarad	rot.	rotate, rotating
kgm	kilogram-meter	N, norm.	normal (power source)	rpm	revolutions per minute
kg/m <sup>3</sup>	kilograms per cubic meter	NA	not available, not applicable	RS	right side
kHz	kilohertz	nat. gas	natural gas	RTV	room temperature vulcanization
kJ	kilojoule	NBS	National Bureau of Standards	SAE	Society of Automotive Engineers
km	kilometer	NC	normally closed	scfm	standard cubic feet per minute
kOhm, kΩ	kilo-ohm	NEC	National Electrical Code	SCR	silicon controlled rectifier
kPa	kilopascal	NEMA	National Electrical Manufacturers Association	s, sec.	second
kph	kilometers per hour	NFPA	National Fire Protection Association	SI	<i>Système international d'unites</i> , International System of Units
kV	kilovolt	Nm	newton meter	SI/EO	side in/end out
kVA	kilovolt ampere	NO	normally open	sil.	silencer
kVAR	kilovolt ampere reactive	no., nos.	number, numbers	SN	serial number
kW	kilowatt	NPS	National Pipe, Straight	SPDT	single-pole, double-throw
kWh	kilowatt-hour	NPSC	National Pipe, Straight-coupling	SPST	single-pole, single-throw
kWm	kilowatt mechanical	NPT	National Standard taper pipe thread per general use	spec, specs	specification(s)
L	liter	NPTF	National Pipe, Taper-Fine	sq.	square
LAN	local area network	NR	not required, normal relay	sq. cm	square centimeter
L x W x H	length by width by height	ns	nanosecond	sq. in.	square inch
lb.	pound	O/C	overcrank	SS	stainless steel
lbm/ft <sup>3</sup>	pounds mass per cubic feet	OD	outside diameter	std.	standard
LCB	line circuit breaker	OEM	original equipment manufacturer	stl.	steel
LCD	liquid crystal display	O/F	overfrequency	tach.	tachometer
ld. shd.	load shed	opt.	option, optional	TD	time delay
LED	light emitting diode	O/S	oversize, overspeed	TDC	top dead center
Lph	liters per hour	OSHA	Occupational Safety and Health Administration	TDEC	time delay engine cooldown
Lpm	liters per minute	O/V	overvoltage	TDEN	time delay emergency to normal
LOP	low oil pressure	oz.	ounce	TDES	time delay engine start
LP	liquefied petroleum	p., pp.	page, pages	TDNE	time delay normal to emergency
LPG	liquefied petroleum gas	PA	packed accessory	TDOE	time delay off to emergency
LS	left side	PC	personal computer	TDON	time delay off to normal
L <sub>wa</sub>	sound power level, A weighted	PCB	printed circuit board	temp.	temperature
LWL	low water level	pF	picofarad	term.	terminal
LWT	low water temperature	PF	power factor	TIF	telephone influence factor
m	meter, milli (1/1000)	ph.	phase	TIR	total indicator reading
M	mega (10 <sup>6</sup> when used with SI units), male	PHC	Phillips head crimplite (screw)	tol.	tolerance
m <sup>3</sup>	cubic meter	PHH	Phillips hex head (screw)	turbo.	turbocharger
m <sup>3</sup> /min.	cubic meters per minute	PHM	pan head machine (screw)	typ.	typical (same in multiple locations)
mA	milliampere	PLC	programmable logic control	U/F	underfrequency
man.	manual	PMG	permanent magnet generator	UHF	ultrahigh frequency
max.	maximum	pot	potentiometer, potential	UL	Underwriter's Laboratories, Inc.
MB	megabyte (2 <sup>20</sup> bytes)	ppm	parts per million	UNC	unified coarse thread (was NC)
MCM	one thousand circular mils	PROM	programmable read only memory	UNF	unified fine thread (was NF)
meggar	megohmmeter	psi	pounds per square inch	univ.	universal
MHz	megahertz	pt.	pint	U/S	undersize, underspeed
mi.	mile	PTC	positive temperature coefficient	UV	ultraviolet
mil	one one-thousandth of an inch	PTO	power takeoff	U/V	undervoltage
min.	minimum, minute	PVC	polyvinyl chloride	V	volt
misc.	miscellaneous	qt.	quart	VAC	volts alternating current
MJ	megajoule	qty.	quantity	VAR	voltampere reactive
mJ	millijoule	R	replacement (emergency) power source	VDC	volts direct current
mm	millimeter	rad.	radiator, radius	VFD	vacuum fluorescent display
mOhm, mΩ	milliohm	RAM	random access memory	VGA	video graphics adapter
MOhm, MΩ	megohm	RDO	relay driver output	VHF	very high frequency
MOV	metal oxide varistor	ref.	reference	W	watt
MPa	megapascal	rem.	remote	WCR	withstand and closing rating
mpg	miles per gallon	RFI	radio frequency interference	w/	with
mph	miles per hour	RH	round head	w/o	without
MS	military standard	RHM	round head machine (screw)	wt.	weight
m/sec.	meters per second	rly.	relay	xfmr	transformer
MTBF	mean time between failure				
MTBO	mean time between overhauls				

## Appendix B User-Defined Settings

Use the table below to record user-defined settings during the generator set controller setup and calibration. The controller default settings and ranges provide

guidelines. The table contains all faults with ranges and time delays including items which do not have adjustments.

Status or Fault	Refer to Menu	Digital Display	Relay Driver Output (RDO)	Range Setting	Default Selection	Inhibit Time Delay* (sec.)	Time Delay (sec.)	User-Defined Settings
Access Code (Password)	11				0 (zero)			
Cyclic Cranking	4			1-6 crank cycles 1-60 sec. crank 1-60 sec. pause	3 15 sec. 15 sec.			
Coolant Temperature Signal Loss	5	No Temp Gauge Signal	User Defined			30		
Customer Auxiliary 1-4 Shutdown or Warning	4, 5	Auxiliary 1-4	User Defined		30 sec. inhibit, 5 sec. delay	0-60 <sup>†</sup>	0-60	Not adjustable
Emergency Power System Supplying Load	5	EPS Supplying Load	RDO—8		5% of line current			
High Battery Voltage	5, 6	High Battery Voltage	RDO—10	14.5-16.5 (12V) 29-33 (24V)	16 (12V) 32 (24V)		10	
High Coolant Temperature Shutdown	5	High Coolant Temperature	Std.			30	5	Not adjustable
High Coolant Temperature Warning	5	High Coolant Temperature Warning	Std.			30		Not adjustable
High Oil Temperature Shutdown	5	High Oil Temperature	User Defined			30	5	Not adjustable
kW Overload (Load Shed)								
Load Shed	5	Load Shed KW Overload	User Defined		100% of kW Rating		5	
		Load Shed Underfrequency	User Defined		59, (60 Hz) 49, (50 Hz)		5	
Low AC Output	5	Low AC Output	User Defined			10		
Low Battery Voltage	5, 6	Low Battery Voltage	Std.	10-12.5 (12V) 20-25 (24V)	12 (12V) 24 (24V)		10	
Low Coolant Level Shutdown	5	Low Coolant Level	RDO—7			30	5	Not adjustable
Low Oil Pressure Shutdown	5	Low Oil Pressure	Std.			30	5	Not adjustable
Low Oil Pressure Warning	5	Low Oil Pressure Warning	Std.			30		Not adjustable
Overcrank Shutdown	5	Overcrank	Std.					
Overcurrent	5	Overcurrent	User Defined		110%		10	
Overfrequency Shutdown	5, 6	Overfrequency	User Defined	102%-140%	140% Std. 103% FAA		10	
Overspeed Shutdown	5, 6	Overspeed	Std.	65-70 (60 Hz) 55-70 (50 Hz)	70 (60 Hz) 70 (50 Hz)		0.25	

\* Inhibited time delay is the time delay period after crank disconnect.

Status or Fault	Refer to Menu	Digital Display	Relay Driver Output (RDO)	Range Setting	Default Selection	Inhibit Time Delay* (sec.)	Time Delay (sec.)	User-Defined Settings
Oil Pressure Signal Loss	5	No Oil Gauge Signal	User Defined			30		Not adjustable
Overvoltage Shutdown	5, 6	Overvoltage	RDO—6	105%-135%	115% 2-sec time delay		2-10	
Password (Access Code)					0 (zero)			
Starting Aid Function	4, 5		User Defined	0-10 sec.				
Time Delay Engine Cooldown (TDEC)	4		RDO—4	00:00-10:00 min:sec	5:00			
Time Delay Engine Start (TDES)	4		User Defined	00:00-5:00 min:sec	00:01			
Underfrequency Shutdown	5, 6	Underfrequency	User Defined	80%-95%	90%		10	
Undervoltage Shutdown	5, 6	Undervoltage	User Defined	70%-95%	85% 10-sec time delay		5-30	
Weak Battery	5	Weak Battery	User Defined		60%		2	

\* Inhibited time delay is the time delay period after crank disconnect.

**TP-5829 2/97d**

© Kohler Co., 1996, 1997, 1998, 1999, 2000. All rights reserved.

# **KOHLER**<sup>®</sup> POWER SYSTEMS

KOHLER CO. Kohler, Wisconsin 53044  
Phone 920-565-3381, Web site [www.kohlergenerators.com](http://www.kohlergenerators.com)  
Fax 920-459-1646 (U.S.A. Sales), Fax 920-459-1614 (International)  
For the nearest sales and service outlet in U.S.A. and Canada  
Phone 1-800-544-2444

Kohler<sup>®</sup> Power Systems  
Asia Pacific Headquarters  
7 Jurong Pier Road  
Singapore 619159  
Phone (65)264-6422, Fax (65)264-6455