

Operation

Commercial Generator Sets

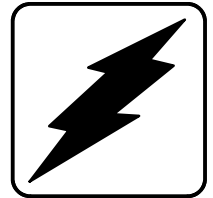

Models:

ALPHA-5 (36 VDC)
ALPHA-5 (48 VDC)

ISO 9001
KOHLER
GENERATORS
INTERNATIONALLY REGISTERED

KOHLER[®]
POWER SYSTEMS

TP-6076 3/00a

California Proposition 65

 WARNING

Engine exhaust from this product contains chemicals known to the State of California to cause cancer, birth defects, or other reproductive harm.

Table of Contents

Safety Precautions and Instructions	I	Section 3. Scheduled Maintenance	11
Introduction	i	3.1 Routine Maintenance	11
Maintenance and Service Parts	i	3.2 Service Schedule	11
Service Assistance	ii	3.3 Service Access	13
Section 1. Specifications	1	3.4 Lubrication System	14
1.1 System Description	1	3.4.1 Oil Check	14
1.2 Generator Set Functional Description	1	3.4.2 Engine Oil Recommendation	14
1.3 Specifications	1	3.4.3 Oil Change Procedure	14
1.3.1 Generator Set Specifications	1	3.4.4 Low Oil Pressure Shutdown	15
1.3.2 Engine Specifications	2	3.5 Air Cleaner Element and Precleaner	16
1.3.3 Generator Specifications	3	3.5.1 Precleaner Service	16
1.4 Service Views	4	3.5.2 Paper Element Service	17
Section 2. Operation	5	3.6 Fuel System	17
2.1 Prestart Checklist	5	3.7 Battery	18
2.2 Exercising the Generator Set	5	3.8 Ignition System	19
2.3 Controller Operation	6	3.8.1 Ignition System Description	19
2.3.1 Control Connections	6	3.8.2 Spark Plug	19
2.3.2 Remote Start/Stop Connections	7	3.9 Cooling System	19
2.3.3 Starting the Generator Set	8	3.10 Electronic Governor	19
2.3.4 Stopping the Generator Set	8	3.11 Exhaust System	20
2.3.5 Status Indicators	8	3.12 Alternator Service	20
2.3.6 Fault Shutdowns	9	Section 4. Troubleshooting	21
2.3.7 Control Resetting Procedure (Following Fault Shutdown)	9	Section 5. Diagrams and Drawings	23
2.4 Circuit Protection	9	Appendix A Abbreviations	A-1

Safety Precautions and Instructions

IMPORTANT SAFETY INSTRUCTIONS. Electromechanical equipment, including generator sets and accessories, can cause bodily harm and pose life-threatening danger when improperly installed, operated, or maintained. To prevent accidents be aware of potential dangers and act safely. Read and follow all safety precautions and instructions. **SAVE THESE INSTRUCTIONS.**

This manual has several types of safety precautions and instructions: Danger, Warning, Caution, and Notice.

DANGER

Danger indicates the presence of a hazard that **will cause severe personal injury, death, or substantial property damage.**

WARNING

Warning indicates the presence of a hazard that **can cause severe personal injury, death, or substantial property damage.**

CAUTION

Caution indicates the presence of a hazard that **will or can cause minor personal injury or property damage.**

NOTICE

Notice communicates installation, operation, or maintenance information that is safety related but not hazard related.

Safety decals affixed to the equipment in prominent places alert the operator or service technician to potential hazards and explain how to act safely. The decals are shown throughout this publication to improve operator recognition. Replace missing or damaged decals.

Accidental Starting

WARNING

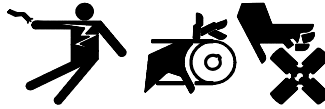

Accidental starting.
Can cause severe injury or death.

Disconnect the battery cables before working on the generator set. Remove the negative (-) lead first when disconnecting the battery. Reconnect the negative (-) lead last when reconnecting the battery.

Disabling the generator set. **Accidental starting can cause severe injury or death.** Before working on the generator set or connected equipment, disable the generator set as follows: (1) Move the generator set master switch to the OFF position. (2) Disconnect the power to the battery charger. (3) Remove the battery cables, negative (-) lead first. Reconnect the negative (-) lead last when reconnecting the battery. Follow these precautions to prevent starting of the generator set by an automatic transfer switch, remote start/stop switch, or engine start command from a remote computer.

Battery

WARNING



Sulfuric acid in batteries.
Can cause severe injury or death.

Wear protective goggles and clothing. Battery acid may cause blindness and burn skin.

WARNING



Explosion.
Can cause severe injury or death.
Relays in the battery charger cause arcs or sparks.

Locate the battery in a well-ventilated area. Isolate the battery charger from explosive fumes.

Battery electrolyte is a diluted sulfuric acid. Battery acid can cause severe injury or death. Battery acid can cause blindness and burn skin. Always wear splashproof safety goggles, rubber gloves, and boots when servicing the battery. Do not open a sealed battery or mutilate the battery case. If battery acid splashes in the eyes or on the skin, immediately flush the affected area for 15 minutes with large quantities of clean water. Seek immediate medical aid in the case of eye contact. Never add acid to a battery after placing the battery in service, as this may result in hazardous spattering of battery acid.

Battery gases. Explosion can cause severe injury or death. Battery gases can cause an explosion. Do not smoke or permit flames or sparks to occur near a battery at any time, particularly when it is charging. Do not dispose of a battery in a fire. To prevent burns and sparks that could cause an explosion, avoid touching the battery terminals with tools or other metal objects. Remove wristwatch, rings, and other jewelry before servicing the equipment. Discharge static electricity from your body before touching batteries by first touching a grounded metal surface away from the battery. To avoid sparks, do not disturb the battery charger connections while the battery is charging. Always turn the battery charger off before disconnecting the battery connections. Ventilate the compartments containing batteries to prevent accumulation of explosive gases.

Engine Backfire/Flash Fire

⚠ WARNING

<p>Fire. Can cause severe injury or death.</p> <p>Do not smoke or permit flames or sparks near fuels or the fuel system.</p>

Servicing the air cleaner. A sudden backfire can cause severe injury or death. Do not operate the generator set with the air cleaner removed.

Combustible materials. A fire can cause severe injury or death. Generator set engine fuels and fuel vapors are flammable and explosive. Handle these materials carefully to minimize the risk of fire or explosion. Equip the compartment or nearby area with a fully charged fire extinguisher. Select a fire extinguisher rated ABC or BC for electrical fires or as recommended by the local fire code or an authorized agency. Train all personnel on fire extinguisher operation and fire prevention procedures.

Exhaust System

⚠ WARNING

<p>Carbon monoxide. Can cause severe nausea, fainting, or death.</p> <p>The exhaust system must be leakproof and routinely inspected.</p>

Generator set operation. Carbon monoxide can cause severe nausea, fainting, or death. Carbon monoxide is an odorless, colorless, tasteless, nonirritating gas that can cause death if inhaled for even a short time. Avoid breathing exhaust fumes when working on or near the generator set. Never operate the generator set inside a building unless the exhaust gas is piped safely outside. Never operate the generator set where exhaust gas could accumulate and seep back inside a potentially occupied building.

Carbon monoxide symptoms. Carbon monoxide can cause severe nausea, fainting, or death. Carbon monoxide is a poisonous gas present in exhaust gases. Carbon monoxide poisoning symptoms include but are not limited to the following:

- Light-headedness, dizziness
 - Physical fatigue, weakness in joints and muscles
 - Sleepiness, mental fatigue, inability to concentrate or speak clearly, blurred vision
 - Stomachache, vomiting, nausea
- If experiencing any of these symptoms and carbon monoxide poisoning is possible, seek fresh air immediately and remain active. Do not sit, lie down, or fall asleep. Alert others to the possibility of carbon monoxide poisoning. Seek medical attention if the condition of affected persons does not improve within minutes of breathing fresh air.

Fuel System



⚠ WARNING

<p>Explosive fuel vapors. Can cause severe injury or death.</p> <p>Use extreme care when handling, storing, and using fuels.</p>

Gas fuel leaks. Explosive fuel vapors can cause severe injury or death. Fuel leakage can cause an explosion. Check the LP vapor gas or natural gas fuel system for leakage by using a soap and water solution with the fuel system test pressurized to 6-8 ounces per square inch (10-14 inches water column). Do not use a soap solution containing either ammonia or chlorine because both prevent bubble formation. A successful test depends on the ability of the solution to bubble.

Hazardous Noise

⚠ CAUTION

<p>Hazardous noise. Can cause hearing loss.</p> <p>Never operate the generator set without a muffler or with a faulty exhaust system.</p>

Hazardous Voltage/ Electrical Shock

⚠ WARNING	
	
Hazardous voltage. Moving rotor. Can cause severe injury or death.	
Operate the generator set only when all guards and electrical enclosures are in place.	

Grounding electrical equipment. Hazardous voltage can cause severe injury or death. Electrocutation is possible whenever electricity is present. Open the main circuit breakers of all power sources before servicing the equipment. Configure the installation to electrically ground the generator set and related equipment and electrical circuits to comply with applicable codes and standards. Never contact electrical leads or appliances when standing in water or on wet ground because these conditions increase the risk of electrocution.

Connecting the battery and the battery charger. Hazardous voltage can cause severe injury or death. Reconnect the battery correctly, positive to positive and negative to negative, to avoid electrical shock and damage to the battery charger and battery(ies). Have a qualified electrician install the battery(ies).



Short circuits. Hazardous voltage/current can cause severe injury or death. Short circuits can cause bodily injury and/or equipment damage. Do not contact electrical connections with tools or jewelry while making adjustments or repairs. Remove wristwatch, rings, and jewelry before servicing the equipment.

Hot Parts

⚠ WARNING	
	
Hot engine and exhaust system. Can cause severe injury or death.	
Do not work on the generator set until it cools.	

Servicing the exhaust system. Hot parts can cause severe injury or death. Do not touch hot engine parts. The engine and exhaust system components become extremely hot during operation.

Moving Parts

⚠ WARNING	
	
Rotating parts. Can cause severe injury or death.	
Operate the generator set only when all guards, screens, and covers are in place.	

Servicing the generator set when it is operating. Exposed moving parts can cause severe injury or death. Keep hands, feet, hair, clothing, and test leads away from the belts and pulleys when the generator set is running. Replace guards, screens, and covers before operating the generator set.

Notice

NOTICE

Hardware damage. The engine and generator set may use both American Standard and metric hardware. Use the correct size tools to prevent rounding of the bolt heads and nuts.

NOTICE

When replacing hardware, do not substitute with inferior grade hardware. Screws and nuts are available in different hardness ratings. To indicate hardness, American Standard hardware uses a series of markings, and metric hardware uses a numeric system. Check the markings on the bolt heads and nuts for identification.

Notes

This manual provides operation instructions for model ALPHA-5 generator sets equipped with microprocessor-based controls.

Information in this publication represents data available at the time of print. The manufacturer reserves the right to change this publication and the products represented without notice and without any obligation or liability whatsoever.

Read this manual and carefully follow all procedures and safety precautions to ensure proper equipment operation and to avoid bodily injury. Read and follow the Safety Precautions and Instructions section at the beginning of this manual. Keep this manual with the equipment for future reference.

The equipment service requirements are very important to safe and efficient operation. Inspect the parts often and perform required service at the prescribed intervals. Obtain service from an authorized service distributor/dealer to keep equipment in top condition.

California Emission Certification

An engine or generator set with the following identification label is certified for operation in the state of California.

IMPORTANT ENGINE INFORMATION
THIS ENGINE MEETS EMISSION
REGULATIONS FOR U.S. EPA PH1
SMALL ENGINES AND 2000-2001
CALIFORNIA SI SORES *

DISPLACEMENT:
FAMILY: -
BUILD DATE:

REFER TO OWNERS MANUAL FOR
SAFETY, MAINTENANCE SPECS AND
ADJUSTMENTS. FOR SALES AND
SERVICE IN US/CANADA CALL:
1-800-544-2444

THIS ENGINE IS CERTIFIED TO OPERATE
ON -

KOHLER
POWER SYSTEMS

*Spark-Ignited Small Off-Road Engines

This engine/generator is certified to operate using natural gas or propane fuel.

This engine is certified with engine modifications made by the generator set manufacturer.

Maintenance and Service Parts

Figure 1 lists some routine maintenance and service parts for your generator set. Obtain a complete list of maintenance and service parts from your authorized generator distributor/dealer.

Part Description	Part Number
Air Cleaner Foam Element	12 083 07
Air Cleaner Paper Element	12 083 15
Exhaust gasket	12 041 03
Fuse, 150 amp (48 volt)	337123
Fuse, 200 amp (36 volt)	GM13492
Oil Filter	12 050 01
Spark Plug	24 132 03

Figure 1 Maintenance and Service Parts

Section 1. Specifications

1.1 System Description

The ALPHA-5 generator set provides reliable backup DC power to cable TV systems or telecommunication sites in place of, or in addition to, batteries. The ALPHA-5 is available in both 36 volt DC and 48 volt DC models. The generator set nameplate lists the unit's rated voltage.

The system batteries provide power at 36 or 48 volts. When power fails, the control system signals the generator set to start. The generator set provides DC power for continued or reserve operation of the system.

The ALPHA-5 generator set has both local and remote annunciation and control capabilities. The unit runs on natural gas or LP vapor.

1.2 Generator Set Functional Description

The ALPHA-5 generator set system consists of the generator set (engine and generator) and the control system. The generator set provides regulated DC voltage to the telecommunications power system. The control system provides complete control of the engine

and generator, accepts remote control commands, and delivers local and remote annunciation of unit status. Internal control functions include start and stop logic, fault monitoring, unit voltage control, engine speed governing, and local LEDs for fault annunciation. Status indicators include low oil pressure, high temperature, overspeed, overcrank, and engine running.

Under very light loads, the generator set operates at low speed. As loads increase, the control system maintains constant generator output voltage by increasing the generator set engine speed (RPM).

The Kohler CV14 engine drives a direct-connected, variable-speed, 3-phase, voltage-specific generator to produce high-frequency AC power. A 3-phase, full-wave rectifier in the control system rectifies the output to produce low-ripple, unfiltered DC power. The DC inline fuse provides protection for downstream devices in case of overload.

1.3 Specifications

The following tables contain generator set, engine, and alternator specifications. Refer to the scheduled maintenance section for service details.

1.3.1 Generator Set Specifications

	36 VDC	48 VDC
Manufacturer	Kohler	
Dimensions, L x W x H, mm (in.)	495 x 380 x 514 mm (19.5 x 15 x 20.24 in.)	
Weight, Dry	68 kg (150 lb.)	
Rated kW*	5	
Rated Voltage (after rectifier)	39	52
Rated Amps	128	96

* Derate approximately 3.5% per 300 m (1000 ft.) over 600 m (2000 ft.) above sea level. Derate 1% for each 5.5°C (10°F) increase in temperature above 49°C (120°F).

1.3.2 Engine Specifications

Item	Specification
Manufacturer	Kohler
Make/Model	CV14
Cycle	4
Compression Ratio	8.5:1
Displacement	398 cc (24.3 cu. in.)
Rated Horsepower (using natural gas fuel)	10.5 HP
Engine Speed	2800-3600 rpm
Bore	87 mm (3.43 in.)
Stroke	67 mm (2.64 in.)
Valve Train	Overhead Valve
Valve Material: Intake Exhaust	Steel Stellite® Face
Number of Cylinders	1
Cylinder Block Material	Aluminum w/Cast Iron Liners
Cylinder Head Material	Aluminum
Piston Rings	2 Compression, 1 Oil
Crankshaft Material	Heat Treated, Ductile Iron Casting
Bearings, Number & Type	2, Replaceable Sleeve
Governor	Electronic
Starter Motor	Electric, Solenoid Shift
Lubrication System	Full Pressure
Oil Capacity (with filter and cooler)	2.0 L (2.1 qt.)
Oil Type (summer/winter)	Synthetic 5W-30
Oil Pressure	172-241 kPa (25-35 psi)
Low Oil Pressure	13.8-34.5 kPa (2-5 psi)
Fuel Type	Natural Gas or Propane
Fuel Pressure	1.7 to 2.7 kPa (7 to 11 in. water column)
Fuel Consumption at 5 kW: Natural Gas, 1000 Btu/ft. ³	2.3 m ³ /hr. (80 cfh)
Propane, 2516 Btu/ft. ³	1.1 m ³ /hr. (40 cfh) 2.1 kg/hr. (4.66 lb./hr.) 4.2 Lph (1.1 gph)
Battery Voltage	12 VDC
Battery Ground	Negative
Battery Recommendation (minimum)	425 CCA at -18°C (0°F) or 85 amp-hour capacity standby gel cell
Spark Plug Type (Kohler Part No.)	24 132 03
Spark Plug Gap	0.75 mm (0.030 in.)
Spark Plug Tightening Torque, Nm (ft. lb.)	24.4-29.8 Nm (18-22 ft. lb.)
Ignition System	Battery/Coil
Cooling System	Integrated Air Cooling
High Engine Temperature	152°C (305°F)

1.3.3 Generator Specifications

Item	36 VDC	48 VDC
Stator Resistance	0.014 ohms	0.024 ohms
Stator Type	3-Phase, 3-Lead, Ungrounded	
Excitation Method (rotor)	Permanent-Magnet, Brushless	
Coupling Type	Direct-to-Engine	
Insulation (stator)	Class 155, Epoxy Varnish, Vacuum-Impregnated	
Winding Material	Copper	

1.4 Service Views

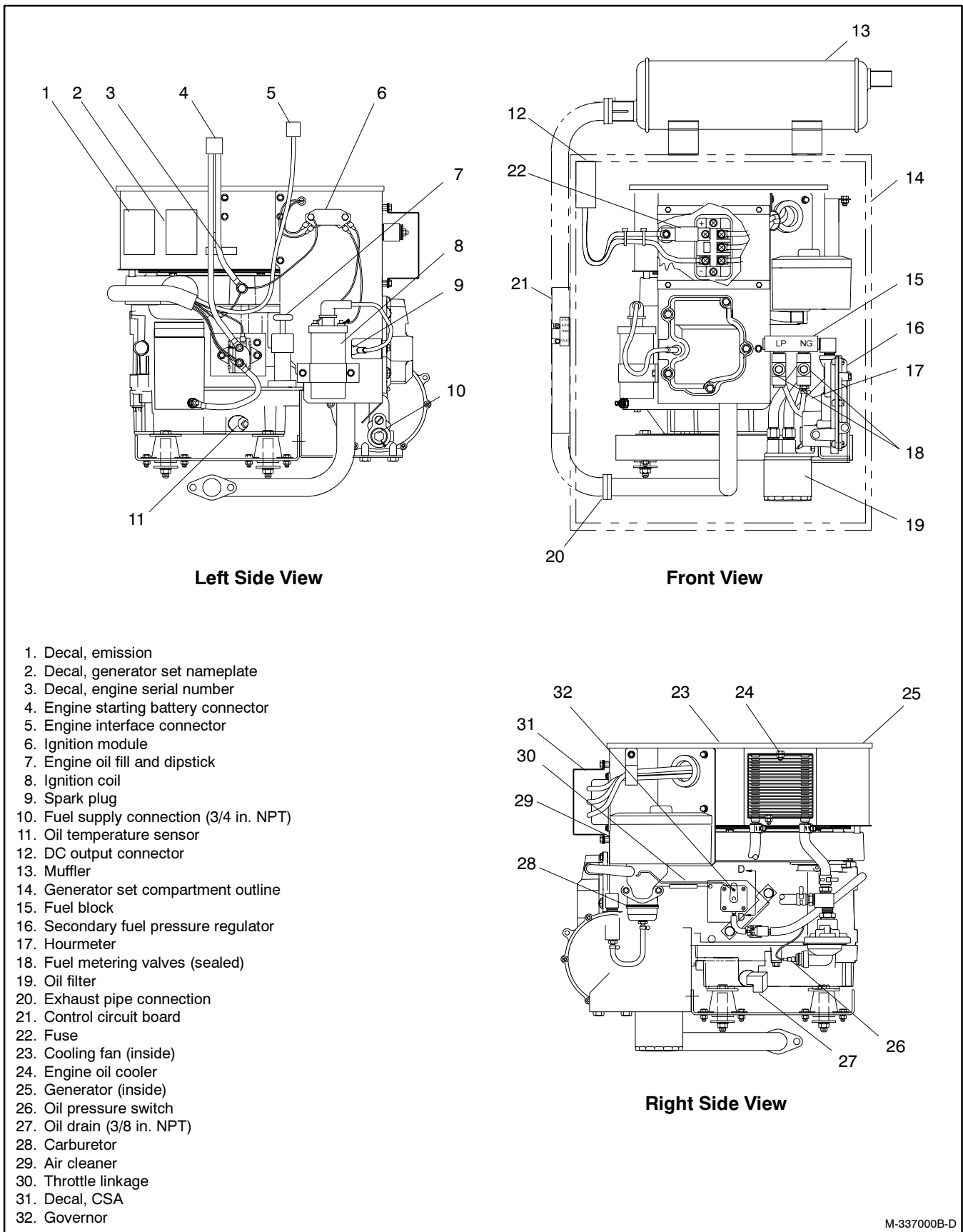
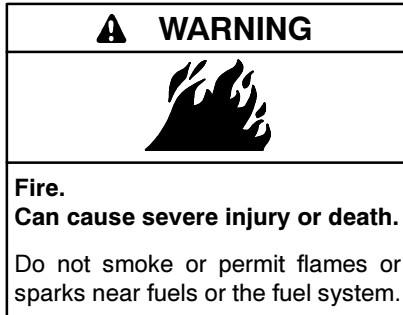

Figure 1-1 ALPHA-5 Service Views



Combustible materials. A fire can cause severe injury or death. Generator set engine fuels and fuel vapors are flammable and explosive. Handle these materials carefully to minimize the risk of fire or explosion. Equip the compartment or nearby area with a fully charged fire extinguisher. Select a fire extinguisher rated ABC or BC for electrical fires or as recommended by the local fire code or an authorized agency. Train all personnel on fire extinguisher operation and fire prevention procedures.

CAUTION



Hazardous noise.
Can cause hearing loss.

Never operate the generator set without a muffler or with a faulty exhaust system.

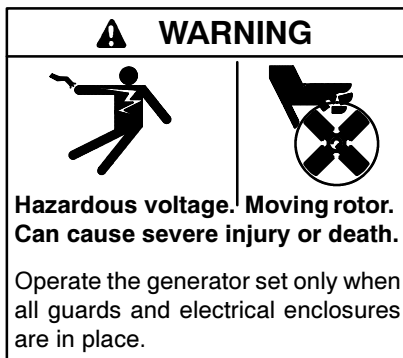

2.1 Prestart Checklist

To ensure satisfactory operation perform the following checks or inspections before or at each startup, as designated, and at the intervals specified in the service schedule. Some checks require verification after the unit starts.

Air Cleaner. Check for a clean and installed air cleaner element to prevent unfiltered air from entering the engine.

Air Inlets and Outlets. Check for clean and unobstructed cabinet air inlets and outlets. Check for obstructions that could block the flow of cooling air. Keep the air intake area clean. Do not leave rags, tools, or debris on or near the generator set.

Battery. Check for clean and tight battery connections. Consult the battery manufacturer's instructions regarding battery care and maintenance.

Exhaust System. Check for exhaust leaks and blockages. Check the silencer and piping condition and check for tight exhaust system connections.

Inspect the exhaust system components (exhaust manifold, exhaust line, flexible exhaust, clamps, silencer, and outlet pipe) for cracks, leaks, and corrosion.

- Check for corroded or broken metal parts and replace them as needed.
- Check for loose, corroded, or missing clamps and hangers. Tighten or replace the exhaust clamps and/or hangers as needed.
- Check that the exhaust outlet is unobstructed.
- Visually inspect for exhaust leaks. Check for carbon or soot residue on exhaust components. Carbon and soot residue indicates an exhaust leak. Replace or repair leaking parts as needed.

Oil Level. Maintain the oil level at or near, not over, the full mark on the dipstick.

2.2 Exercising the Generator Set

Operate the generator set under load at least monthly for one hour with an operator present.

The operator should perform all of the prestart checks before starting the exercise procedure. Start the generator set according to the starting procedure in the controller section of this manual. While the generator set is operating, listen for a smooth-running engine and visually inspect the generator set for fluid or exhaust leaks.

x.op:001:005

2.3 Controller Operation

Microprocessor-based controls provide complete control of the engine and generator. The control system accepts remote control inputs for generator start and run and delivers local and remote annunciation of unit status. Internal functions of the controls include start and stop logic, fault monitoring, generator voltage and engine speed governing, and fault annunciation through local LEDs.

A three-position generator set master switch on the control board allows local or remote control of the generator set. The RUN and STOP positions provide local control of the generator set. The STOP position also resets controller faults. The AUTO position allows a remote device to start and stop the generator set. See Section 2.3.2 for remote start/stop connection information.

Note: Set the generator set master switch to the AUTO position to allow remote control of the generator set.

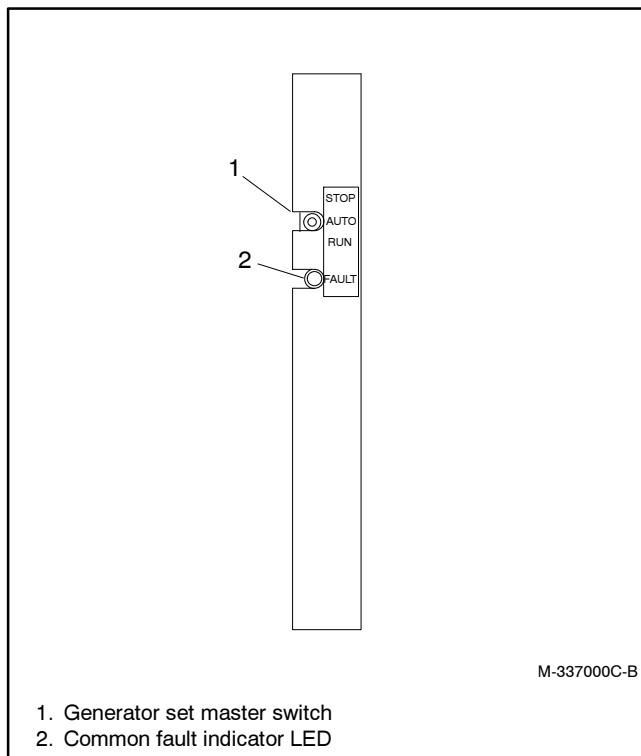

Figure 2-1 Generator Set Controls

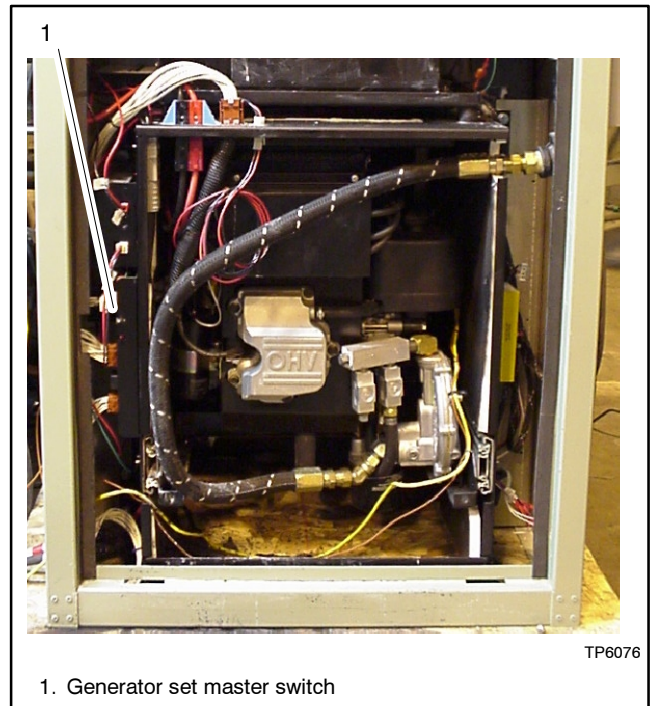

Figure 2-2 Generator Set Master Switch Location

2.3.1 Control Connections

Wiring harnesses connect the generator set control board to the remote controls and the engine. Figure 2-3 shows the wiring harness connections to the control board. Figure 2-4 and Figure 2-6 show the connector pins. Figure 2-5 defines the abbreviations used in the pin diagrams. Refer to the wiring diagrams in Section 5 for more information.

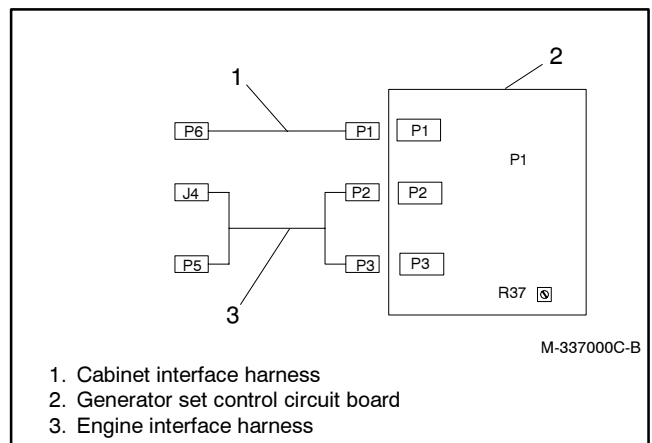

Figure 2-3 Generator Set Control Connections

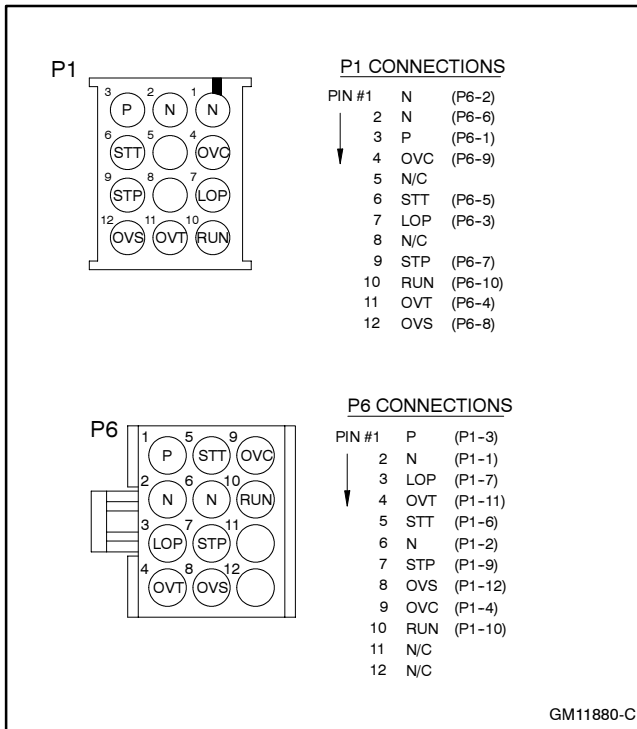

Figure 2-4 Cabinet Interface Harness Connectors

Abbreviation	Definition
N	Ground
OVC	Overcrank
N/C	Not connected
STT	Start
LOP	Low oil pressure
STP	Stop
OVT	Overtemperature
OVS	Overspeed
DCP	DC positive
DCN	DC negative
AC1	Speed sensing
AC2	Speed sensing
M1	Throttle control
M2	Throttle control
M3	Throttle control
M4	Throttle control
P	Positive
70	Crank
71	Run

Figure 2-5 Pin Abbreviations

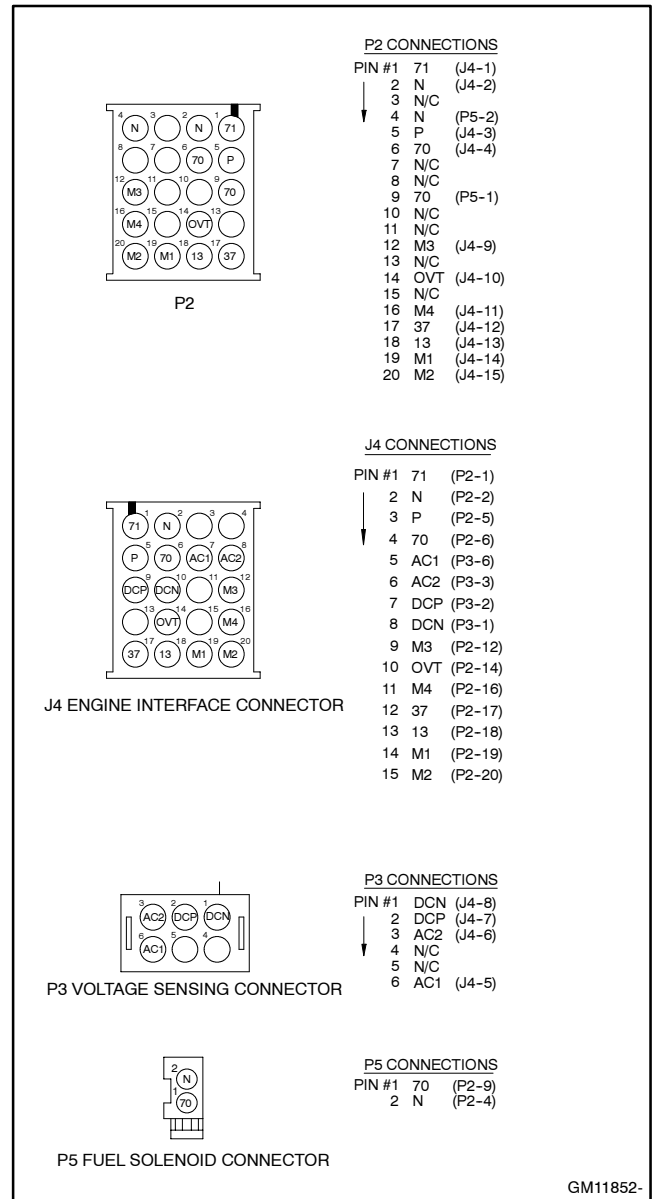

Figure 2-6 Engine Interface Harness Connectors

2.3.2 Remote Start/Stop Connections

To operate the generator set from a remote location, use a three-wire start/stop switch connected to P6 of the cabinet interface harness. To start the generator set, open a contact between pins 6 and 7 and close a contact between pins 5 and 6 of connector P6 (see Figure 2-4). Close the contact between pins 6 and 7 to stop the generator set. Set the generator set master switch to the AUTO position for remote operation.

2.3.3 Starting the Generator Set

The following procedures describe the actions required to start the generator set.

Local Starting. Move the generator set master switch to the RUN position to immediately start the generator set.

Remote Starting. Move the generator set master switch to the AUTO position to allow startup by the remote start/stop contacts. See Section 2.3.2 for the remote start/stop switch connections.

Note: The control board provides up to 70 seconds of cyclic cranking before overcrank shutdown occurs.

2.3.4 Stopping the Generator Set

The following procedures describe the actions required to stop the generator set.

Local Stopping. Move the generator set master switch to the STOP position. The generator set stops immediately.

Remote Stopping. Close a remote contact between pins 6 and 7 of connector P6 of the cabinet interface harness. The generator set shuts down regardless of the generator set master switch position.

2.3.5 Status Indicators

Eight LEDs on the generator set control board provide system status and fault annunciation. LEDs indicate the status or fault shutdowns listed in Figure 2-7. Figure 2-1 shows the LED locations.

LED	Indicates	Remote Annunciation
1	Overspeed shutdown	Yes
2	Overtemperature shutdown	Yes
3	Engine running status indicator	Yes
4	Low oil pressure fault shutdown	Yes
5	Overcrank shutdown	Yes
6	Ignition energized	No
7	Cranking energized	No
8	Common fault indicator	No

Figure 2-7 Control Board LEDs

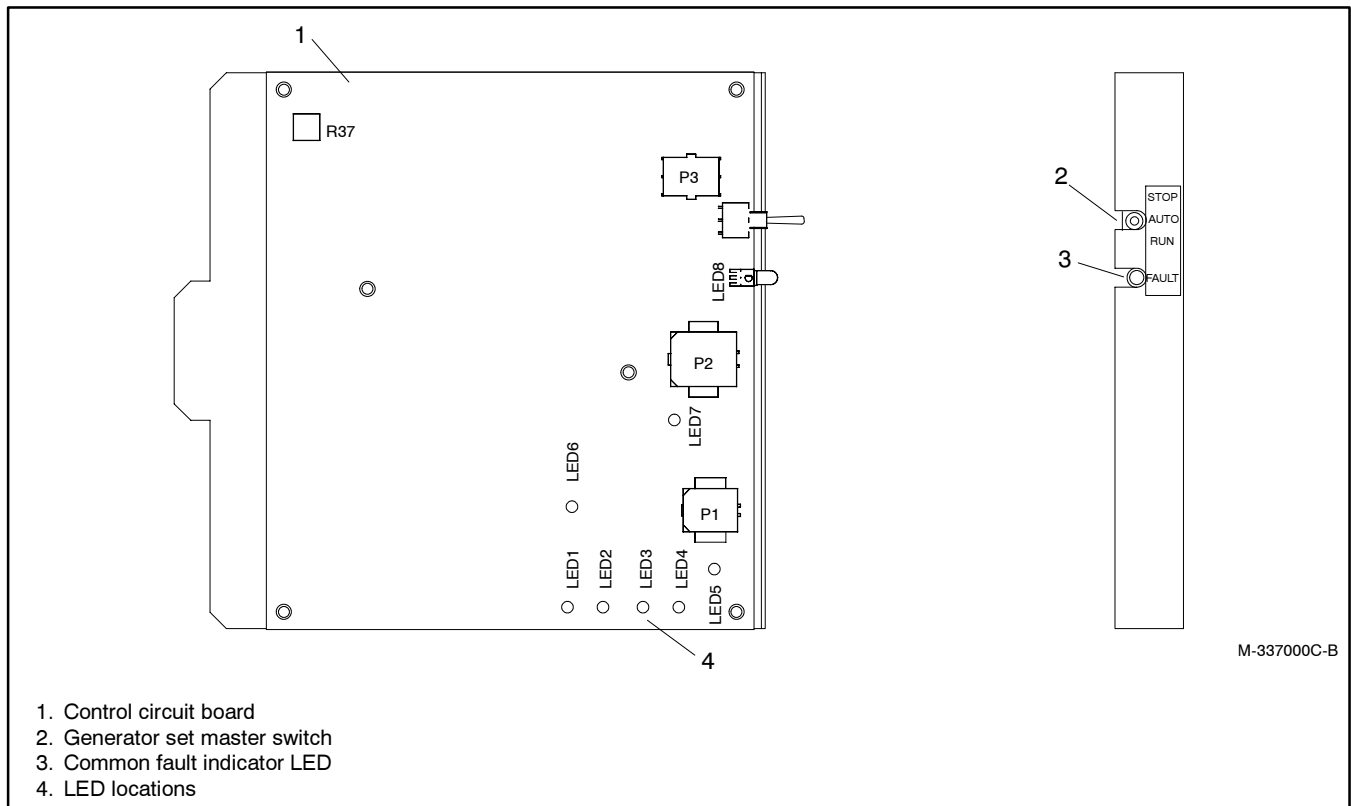

Figure 2-8 Control Board LEDs

2.3.6 Fault Shutdowns

The generator set shuts down automatically under the fault conditions listed in Figure 2-9 and cannot be restarted until the controls are reset. Reset the controller by placing either the remote control switch or the generator set master switch in the STOP position. The high engine temperature fault automatically resets when the generator set cools.

Fault	Description
High engine temperature	Shuts down 5 seconds after the fault. When the engine cools, the fault clears and allows the generator set to be started without resetting the controller. The high engine temperature shutdown does not function during the first 30 seconds after startup.
Low oil pressure	Shuts down 5 seconds after the fault. The low oil pressure shutdown does not function during the first 30 seconds after startup. NOTE: The low oil pressure shutdown does not protect against low oil level.
Overcrank	Shuts down after 70 seconds of cyclic cranking. The factory sets the circuit board for three starting attempts: crank 20 sec., rest 5 sec., crank 20 sec., rest 5 sec., crank 20 sec., overcrank fault. Overcrank shutdown also occurs in the case of a locked rotor. Shuts down 1 second after the fault is detected.
Overspeed	Shuts down immediately if the engine speed exceeds 3750 RPM.

Figure 2-9 Fault Shutdowns

2.3.7 Control Resetting Procedure (Following Fault Shutdown)

Use the following procedure to restart the generator set after a fault shutdown. Set either the remote control switch or the generator set master switch to the STOP position to reset the controls.

1. Move either the generator set master switch or the remote switch to the STOP position.
2. Correct the cause of the fault shutdown. See the safety precautions at the beginning of this section before proceeding.
3. Start the generator set locally by moving the generator set master switch to the RUN position, or move the master switch to the AUTO position and start the generator set using the remote start switch. Run the generator set to verify that the cause of the shutdown has been corrected.
4. Move the generator set master switch to the STOP position to stop the generator set.
5. Move the generator set master switch to the AUTO position to return to standby operation.

2.4 Circuit Protection

A DC line limiter (fuse) interrupts the generator output in the event of a 50% overload or a short circuit in the wiring between the generator and the load. Replace the line limiter if it blows. See Maintenance and Service Parts in the Introduction of this manual for the fuse part number.

Notes

Section 3. Scheduled Maintenance

WARNING

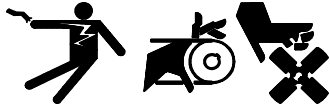

Accidental starting.
Can cause severe injury or death.

Disconnect the battery cables before working on the generator set. Remove the negative (-) lead first when disconnecting the battery. Reconnect the negative (-) lead last when reconnecting the battery.

Disabling the generator set. Accidental starting can cause severe injury or death. Before working on the generator set or connected equipment, disable the generator set as follows: (1) Move the generator set master switch to the OFF position. (2) Disconnect the power to the battery charger. (3) Remove the battery cables, negative (-) lead first. Reconnect the negative (-) lead last when reconnecting the battery. Follow these precautions to prevent starting of the generator set by an automatic transfer switch, remote start/stop switch, or engine start command from a remote computer.

WARNING



Hot engine and exhaust system.
Can cause severe injury or death.

Do not work on the generator set until it cools.

Servicing the exhaust system. Hot parts can cause severe injury or death. Do not touch hot engine parts. The engine and exhaust system components become extremely hot during operation.

WARNING

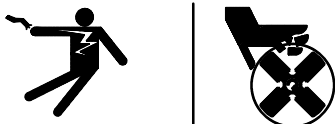

Hazardous voltage. Moving rotor.
Can cause severe injury or death.

Operate the generator set only when all guards and electrical enclosures are in place.

Grounding electrical equipment. Hazardous voltage can cause severe injury or death. Electrocutation is possible whenever electricity is present. Open the main circuit breakers of all power sources before servicing the equipment. Configure the installation to electrically ground the generator set and related equipment and electrical circuits to comply with applicable codes and standards. Never contact electrical leads or appliances when standing in water or on wet ground because these conditions increase the risk of electrocution.

Servicing the generator set when it is operating. Exposed moving parts can cause severe injury or death. Keep hands, feet, hair, clothing, and test leads away from the belts and pulleys when the generator set is running. Replace guards, screens, and covers before operating the generator set.

3.1 Routine Maintenance

Refer to the following service schedule and the hourmeter located on the generator set to schedule routine maintenance. Perform maintenance on each item in the service schedule at the designated interval for the life of the generator set. Service units subject to extreme weather, long operating hours, or dusty or dirty conditions more frequently.

Generator set service. Have an authorized Kohler service distributor/dealer perform all generator set service. See the Safety Precautions and Instructions at the beginning of this manual before attempting to service or repair the generator set.

Engine service. Perform generator set engine service at the intervals specified by the service schedule in this section. For additional information contact an authorized Kohler service distributor/dealer to obtain engine service literature.

Generator service. Refer to the service schedule for items that require maintenance.

Tools. Tools and instruments used to perform some maintenance are not generally available to the generator set owner. It is recommended that service requiring special tools be performed by an authorized distributor/dealer.

3.2 Service Schedule

Perform the service listed in Figure 3-1 at the designated intervals for the life of the generator set. Refer to the service views in Section 1.4 for system component locations.

System Component or Procedure	See Section	Procedure					Frequency
		Visually Inspect	Check	Change	Clean	Test	
FUEL	3.6						
Inspect flexible lines and connections. Replace cracked or spongy hoses. *		X		R			Q
Check the main LP tank supply level, if used.			X				M
Inspect fuel piping for damage or corrosion.		X					Y
LUBRICATION	3.4						
Check the oil level.	3.4.1	X	X				M or before use
Change the oil and replace the oil filter.	3.4.2, 3.4.3			R			Y or 100 hrs.
COOLING	3.9						
Check that air ducts and louvers are clean and unobstructed.		X	X		X		M or before use
EXHAUST SYSTEM	3.11						
Check for leakage. Carbon or soot residue indicates a leak. Repair leaks.		X	X	R			Y
Check for fire hazards.		X	X		X		Y
Check for loose or broken hangers and supports. Tighten or replace as needed.		X	X	R			Y
BATTERY							
Check battery charger operation and charge rate (if equipped).	Battery charger manual	X	X				M
Clean and tighten battery terminals.	3.7	X	X		X		Y
ELECTRICAL SYSTEM							
Inspect wiring and components for visible wear or damage.		X					Q
Check for abrasions where wiring is subject to motion.		X	X				S
ENGINE AND MOUNTING							
Inspect for visible wear or damage.		X					M
Inspect the air cleaner element; replace it if necessary.*	3.5	X		R			Y or 500 hrs.
Clean and oil the foam precleaner.	3.5.1				X		100
Inspect the spark plug; replace if necessary.*	3.8.2	X		R			Y or 500 hrs.
CONTROL SYSTEM							
Check remote control operation.	Controller manufacturer's instructions.					X	M
GENERATOR SET							
Check items listed in the Prestart Checklist.	2.1	X					M
Exercise the generator set.	2.2					X	M
GENERAL CONDITION OF EQUIPMENT							
Check for signs of vibration, leakage, excessive noise, extreme temperature, or deterioration.		X	X		X		M
Inspect and clean the cabinet interior.		X			X		Q
* Contact your local distributor/dealer for parts or service.		X Action R Replace as necessary					W=Weekly M=Monthly Q=Quarterly S=Six Months Y=Yearly

Figure 3-1 Service Schedule

3.3 Service Access

Use the following procedure to gain access to the generator set for maintenance or service. See Figure 3-3 and Figure 3-2.

Note: Allow the exhaust system to cool before disconnecting the exhaust pipe. Inspect the exhaust gasket and replace it if necessary when reassembling the exhaust system. See the list of routine service parts in the Introduction of this manual for the gasket part number.



Figure 3-2 Generator Set Installed in the Cabinet

Generator Set Service Access

1. Remove the front door of the cabinet.
2. Place the generator set master switch in the STOP position.
3. Remove the front panel from the generator set compartment.
4. Disconnect the generator set battery harness, engine wiring harness, and load leads at the quick-disconnect plugs.
5. Turn off the fuel supply at the upstream valve and disconnect the fuel line on the right side of the cabinet. See Figure 3-2.
6. Disconnect the engine exhaust pipe at the location show in Figure 3-3.
7. Grasp the generator tray at the sides and pull the generator set forward.

Return the generator set to normal operation using the following procedure.

Return to Operation

1. Verify that the generator set master switch is in the STOP position.
2. Slide the generator set back into the cabinet.
3. Install the exhaust gasket and reconnect the exhaust pipe.
4. Reconnect the fuel line.

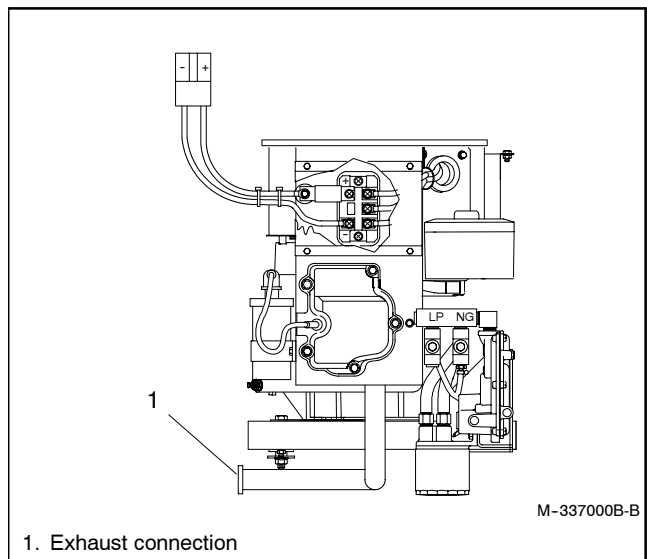

Figure 3-3 Exhaust Connection

5. Reconnect the engine wiring harness, load leads, and battery harness.
6. Reconnect the generator set engine battery harness.
7. Move the generator set master switch to the AUTO position to return the generator set to standby service.
8. Reinstall the generator set compartment front panel.
9. Reinstall the cabinet door.

3.4 Lubrication System

See the service schedule in Section 3.2 for oil change and oil filter replacement intervals. See Figure 3-4 for the oil drain, oil check, oil fill, and oil filter locations. The list of routine service parts in the Introduction of this manual shows the oil filter part number.

3.4.1 Oil Check

The generator set is shipped with oil. Before operating a new generator set check the engine oil in the crankcase. See Figure 3-4. Verify that the oil level is at the F mark on the dipstick. See Section 3.4.2 for engine oil recommendations.

Do not check the oil level when operating the generator set. To obtain the most accurate oil level reading, shut down the generator set and wait several minutes before checking the oil .

3.4.2 Engine Oil Recommendation

The generator set manufacturer recommends API (American Petroleum Institute) Service Class SG or SH 5W-30 synthetic oil.

3.4.3 Oil Change Procedure

Allow the oil to cool to a safe temperature before changing.

1. Follow the instructions in Section 3.3 to access the generator set oil drain plug, filter, and fill tube. See Figure 3-4.
2. Drain the oil.
 - a. Place an oil collection container below the oil drain and remove the oil drain plug.

- b. Allow the engine oil to drain completely.
 - c. Replace the oil drain plug.
3. Replace the oil filter.
 - a. Place an oil collection container below the oil filter.
 - b. Remove the oil filter by rotating it counterclockwise with an oil filter wrench.
 - c. Clean the gasket sealing surface of the oil filter adapter.
 - d. Apply a light coat of clean oil to the rubber seal of the new oil filter.
 - e. Install the new oil filter following the instructions provided with the filter. Hand-tighten the filter.

Note: Dispose of all waste materials (engine oil, fuel, filter, etc.) in an environmentally safe manner.

4. Fill with oil.
 - a. Remove the oil fill cap and fill the engine to the F mark on the dipstick. The engine oil capacity is 2.0 L (2.1 qt.). See Section 3.4.2 for oil selection.
 - b. Reinstall the dipstick and the oil fill cap.
5. Slide the generator set back into the cabinet and reconnect the exhaust pipe and wiring harnesses as described in Section 3.3. Do not replace the compartment front panel.
6. Check for leaks.
 - a. Start and run the generator set to allow the oil pressure to reach the operating range.
 - b. Check for oil leaks around the oil filter and oil drain plug.
 - c. Stop the generator set and recheck the oil level. Tighten the oil filter to stop any leaks. Add oil to bring the level up to the F mark on the dipstick.
7. Replace the generator set compartment front panel.
8. Move the generator set master switch to the AUTO position to return the unit to standby service.
9. Reinstall the cabinet door.

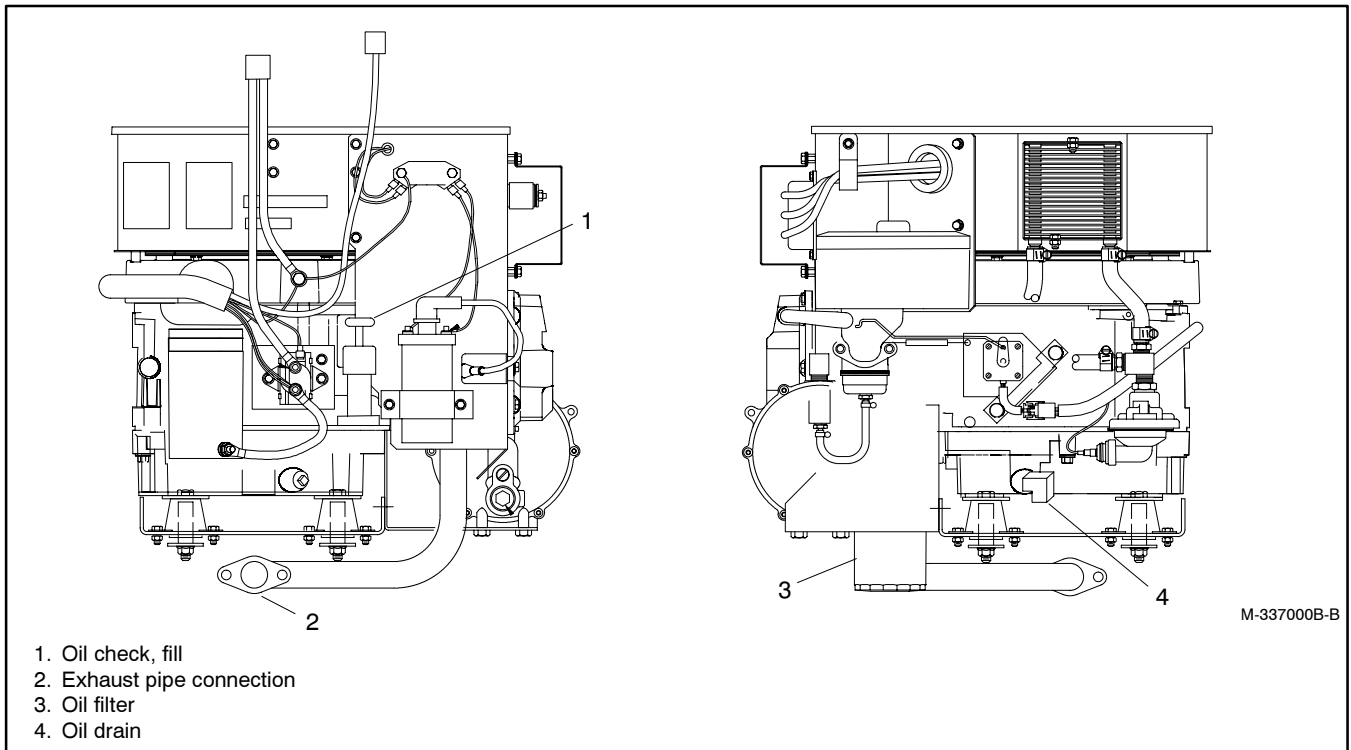

Figure 3-4 Lubrication System

3.4.4 Low Oil Pressure Shutdown

The low oil pressure shutdown feature protects the engine against internal damage if the oil pressure drops below a safe operating level because of oil pump failure

or other malfunction. This shutdown feature does not protect against damage caused by operating with the oil level below the safe range—it is not a low oil level shutdown. Check the oil level regularly and add oil as needed.

3.5 Air Cleaner Element and Precleaner

The engine has a replaceable high-density paper air cleaner element with an oiled-foam precleaner. See Figure 3-5. Refer to the service views in Section 1.4 for the air cleaner location.

Check for a buildup of dirt and debris around the air cleaner system. Keep this area clean.

Note: Operating the engine with loose or damaged air cleaner components could allow unfiltered air into the engine causing premature wear and failure.

3.5.1 Precleaner Service

Wash and reoil the precleaner at the intervals shown in the service schedule. Wash and reoil the precleaner more often if the generator set operates in extremely dusty or dirty conditions.

1. Follow the instructions in Section 3.3 to access the air cleaner.
2. Loosen the cover retaining knob and remove the cover. Remove the precleaner from the paper element. Wash the precleaner in warm water with detergent. Rinse the precleaner thoroughly until all traces of detergent are eliminated. Squeeze out excess water (do not wring). Allow the precleaner to air dry.
3. Saturate the precleaner with new engine oil. Squeeze out all of the excess oil.
4. Reinstall the precleaner over the paper element.
5. Reinstall the air cleaner cover. Secure the cover with the cover retaining knob.
6. Follow the instructions in Section 3.3 to return the generator set to service.

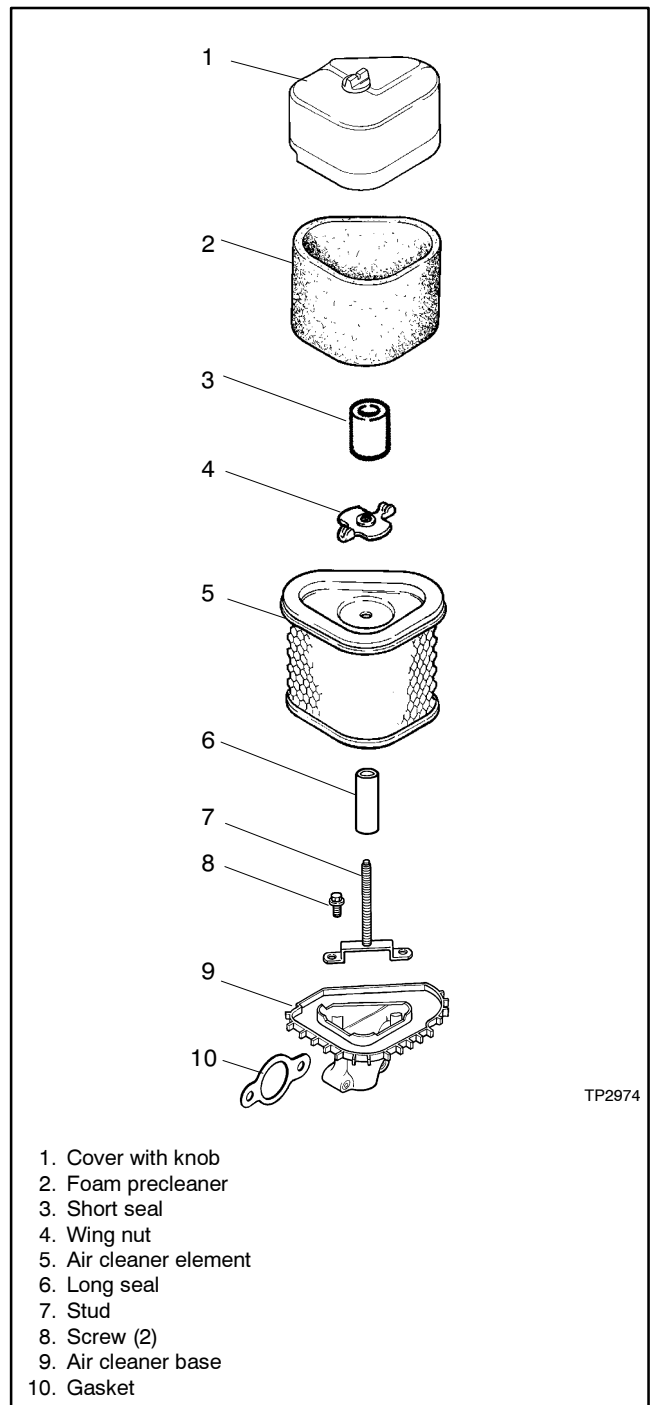

Figure 3-5 Air Cleaner Components

3.5.2 Paper Element Service

Replace the paper element at the intervals specified in the service schedule. Replace the paper element more often if the generator set operates in extremely dusty or dirty conditions. Refer to Maintenance and Service Parts in the Introduction section of this manual for replacement part numbers.

1. Follow the instructions in Section 3.3 to access the air cleaner.
2. Loosen the cover retaining knob and remove the cover.
3. Remove the short seal, wing nut, and paper element with precleaner.
4. Remove the precleaner from the paper element.

Note: Do not wash the paper element or clean it with pressurized air, as this will damage the element.

5. Replace the paper element if it is dirty, bent, or damaged.
6. Check the air cleaner base. Make sure it is secure and not bent or damaged. Remove any loose dirt or debris from the air cleaner base. Wipe the base carefully so that no dirt drops into the intake throat.
7. Replace all damaged air cleaner components. Check the condition of the rubber seals and replace them if necessary.
8. Clean and oil the precleaner as described in Section 3.5.1.
9. Reinstall the paper element, precleaner, and wing nut. Replace the short seal and the air cleaner cover. Secure the cover with the cover retaining knob.
10. Follow the instructions in Section 3.3 to return the generator set to service.

3.6 Fuel System

⚠ WARNING

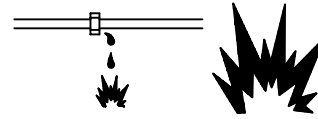

**Explosive fuel vapors.
Can cause severe injury or death.**

Use extreme care when handling, storing, and using fuels.

A fuel solenoid valve turns the fuel supply to the fuel pressure regulator on and off. The regulator then reduces fuel pressure for delivery to the fuel metering (fuel mixture adjustment) valve. The fuel flows from the metering valve to the carburetor in a gaseous state. The carburetor mixes the fuel with intake air for consumption by the engine.

Two fuel metering valves allow field-conversion between natural gas and LP vapor. The fuel metering valves are factory-sealed to comply with applicable emission standards and to provide the best possible hot and cold starting. Do not adjust the fuel metering valves.

Have the fuel conversion procedure performed by trained and qualified personnel.

The manufacturer ships the generator set with the fuel system set for natural gas. To convert to LP gas, use the following procedure to move the fuel line from the natural gas inlet port to the LP inlet port in the fuel block (or from the LP inlet to the natural gas inlet to convert from LP to natural gas). See Figure 3-6 for the LP and natural gas fuel connection and fuel block locations. Also see the service views in Section 1.4.

Fuel Conversion Procedure

1. Remove the cabinet front door and the generator compartment front panel to access the fuel system.
2. Disconnect the battery at the quick-disconnect plug.
3. Turn off the fuel supply by closing the upstream valve outside of the cabinet.
4. Remove the hose clamp and fuel line hose from the fuel inlet.
5. Remove the hose fitting from the natural gas (or LP) inlet in the fuel metering valve.
6. Remove the plug from the LP (or natural gas) metering valve. Clean the plug with a dry cloth or brush, apply fresh pipe sealant, and install it into the natural gas (or LP) inlet.
7. Clean the hose fitting with a dry cloth or brush, apply fresh pipe sealant, and install it into the LP (or natural gas) metering valve inlet. Do not adjust the fuel metering valves.
8. Slide the hose onto the hose fitting and secure it with the clamp.
9. Turn on the fuel supply and check for leaks using a gas leak detector.
10. Reconnect the battery harness.
11. Install the generator compartment front panel. Set the generator set master switch to the AUTO position to return the generator set to standby service.
12. Replace the cabinet door.

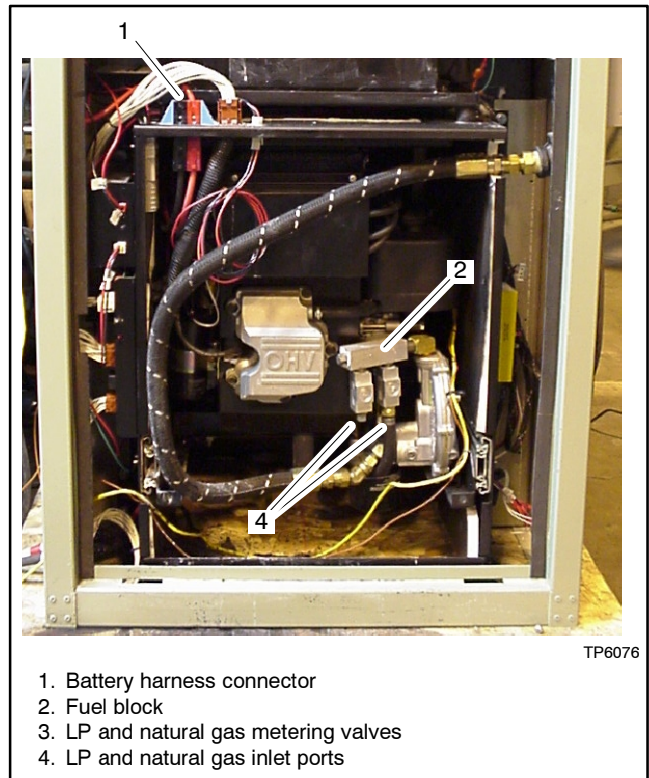

Figure 3-6 Fuel System Conversion

3.7 Battery

Use a 12-volt battery with a minimum rating of 425 cold cranking amps at -18°C (0°F) or a gel-electrolyte battery with a minimum standby capacity of 85 amp-hours. The wiring diagrams in Section 5 show the battery connections. The generator set uses a negative ground system. Make sure that the battery is connected correctly and the terminals are tight.

Note: The generator set will not start and circuit board damage may result if the battery is connected in reverse.

Generator sets that are not used regularly require an external battery charger to keep the starting battery fully charged. Observe the battery polarity when connecting the battery charger.

Refer to the cabinet manufacturer's Operation and Maintenance Manual for battery maintenance instructions.

3.8 Ignition System

3.8.1 Ignition System Description

The generator set uses a battery-powered coil ignition system. Ignition system components include the ignition module, ignition coil, wiring, and spark plug. See the service views in Section 1.4 for ignition system component locations.

Maintain the spark plug using the instructions in Section 3.8.2. The other ignition system components do not require routine maintenance.

3.8.2 Spark Plug

Reset the spark plug gap or replace the plug with a new plug if necessary. Replace the plug at the intervals shown in the service schedule, Figure 3-1.

1. Clean the area around the base of the spark plug to keep dirt and debris out of the engine.
2. Remove the spark plug and check its condition. Verify that the insulator is a light tan or gray color. Replace the spark plug if the insulator is discolored, the plug is coated with deposits, or the electrodes are pitted or worn.
3. Check the spark plug gap using a wire feeler gauge. Adjust the gap to 0.76 mm (0.030 in.) by carefully bending the ground electrode. See Figure 3-7 and Figure 3-8.

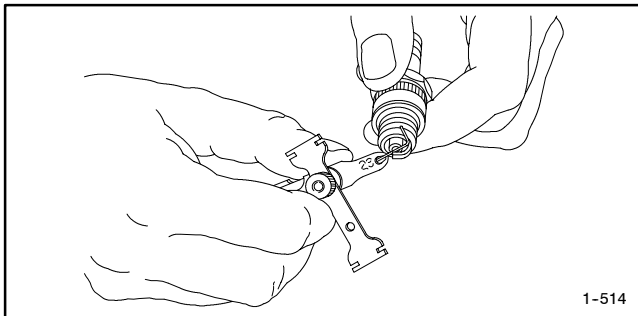

Figure 3-7 Checking the Spark Plug Gap

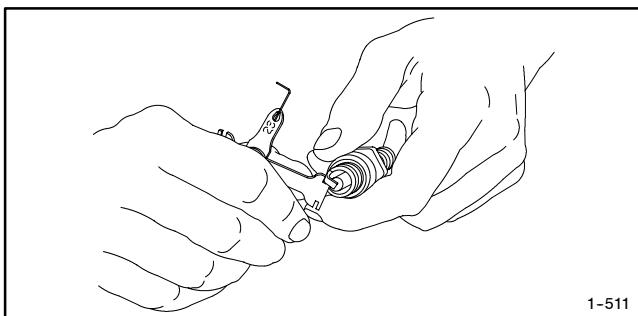

Figure 3-8 Adjusting the Spark Plug Gap

3.9 Cooling System

The air inlet and outlet vents are located near the top of the cabinet. To prevent generator set damage caused by overheating, keep the housing cooling inlets and outlets clean and unobstructed at all times.

Note: Do not block the generator set cooling air inlet or mount other equipment above it. Overheating and severe generator damage may occur.

Figure 3-9 shows the flow of air through and around the generator set. Ducts inside the cabinet, which are not shown in this figure, direct the flow of cooling air. The generator fan draws cooling air through the opening in the back of the cabinet. The air flows into the alternator at the top of the unit and down over the engine. The air then flows up over the exhaust piping and muffler, mixes with the engine exhaust, and discharges at the cabinet outlet in the front of the cabinet.

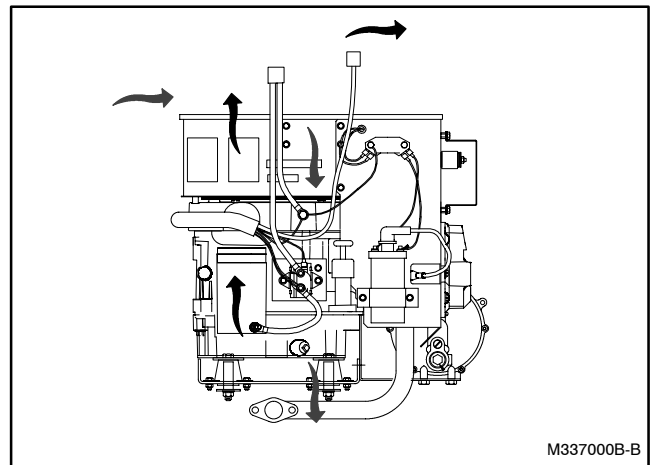

Figure 3-9 Cooling Air Flow

3.10 Electronic Governor

The governor system consists of an electronic governor control and an electromechanical actuator. The system regulates engine speed to achieve specified DC output voltage. The generator supplies a speed signal to the governor control unit in the form of AC electrical pulses. The control unit compares the frequency of these pulses to a preset reference in the speed command and provides a control signal to the actuator. The actuator controls the carburetor and hence the engine speed.

Note: Do not touch or move the throttle linkage between the actuator and carburetor while the engine is running. Manually increasing the engine speed (RPM) can raise the output voltage high enough to damage the generator and connected equipment.

3.11 Exhaust System

Remove all combustible materials from the exhaust location. Combustible materials include building materials as well as natural surroundings. Keep dry field grass, foliage, and combustible landscaping material away from the exhaust outlet.

Periodically inspect the exhaust system components (exhaust manifold, exhaust line, flexible exhaust, clamps, silencer, and outlet pipe) for cracks and corrosion.

- Check for corroded or broken metal parts and replace as needed.
- Check for loose, corroded, or missing clamps and hangers. Tighten or replace clamps and/or hangers as needed.
- Check for and remove loose insulation in the exhaust duct.
- Check that the exhaust outlet is clear.

3.12 Alternator Service

Under normal operating conditions, routine alternator maintenance is not required.

Section 4. Troubleshooting

This section contains generator set troubleshooting, diagnostic, and repair information.

Use the following chart to diagnose and correct common problems. First check for simple causes such as a dead engine starting battery or a blown fuse. The chart includes a list of common problems, possible causes of the problem, and recommended corrective actions.

If the procedures in this manual do not explain how to correct the problem, contact an authorized distributor/dealer. Maintain a record of repairs and adjustments performed on the equipment. Use the record to help describe the problem and repairs or adjustments made to the equipment.

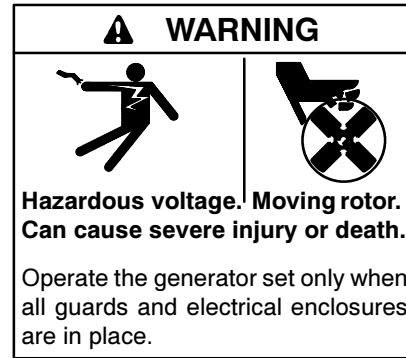

Grounding electrical equipment. Hazardous voltage can cause severe injury or death. Electrocutation is possible whenever electricity is present. Open the main circuit breakers of all power sources before servicing the equipment. Configure the installation to electrically ground the generator set and related equipment and electrical circuits to comply with applicable codes and standards. Never contact electrical leads or appliances when standing in water or on wet ground because these conditions increase the risk of electrocution.

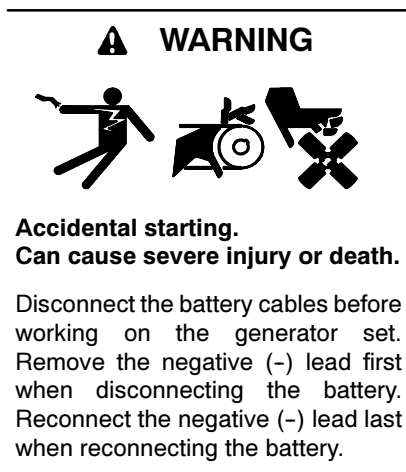

Disabling the generator set. Accidental starting can cause severe injury or death. Before working on the generator set or connected equipment, disable the generator set as follows: (1) Move the generator set master switch to the OFF position. (2) Disconnect the power to the battery charger. (3) Remove the battery cables, negative (-) lead first. Reconnect the negative (-) lead last when reconnecting the battery. Follow these precautions to prevent starting of the generator set by an automatic transfer switch, remote start/stop switch, or engine start command from a remote computer.

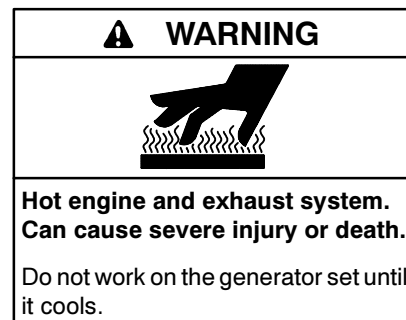

Servicing the exhaust system. Hot parts can cause severe injury or death. Do not touch hot engine parts. The engine and exhaust system components become extremely hot during operation.

Problem	Possible Cause	Corrective Action
The generator set does not crank.	Weak or dead battery Reversed or poor battery connections Generator set master switch in STOP position	Recharge or replace; check battery charger operation. Check the battery charger. Check the connections. Move the master switch to the RUN position.
The generator set cranks but does not start, starts hard, lacks power, or operates erratically.	Clogged air cleaner Weak or dead battery Poor battery connection Loose spark plug wire connection Faulty spark plug Engine malfunction	Clean and/or replace the air cleaner. Recharge or replace the battery. Clean and tighten the battery connections. Check the spark plug wires. Check, clean, regap, or replace the spark plug as described in Section 3.8.2. Contact the distributor/dealer.
No DC output.	DC output fuse blown Faulty rectifier Faulty stator winding	Correct the cause of the blown fuse. Replace the fuse. Contact the distributor/dealer. Contact the distributor/dealer.
Low output or excessive drop in voltage.	Overloaded generator set Engine running at reduced speed Incorrect voltage adjustment Rotor or stator problem	Reduce the load. Check the fuel supply. Contact the distributor/dealer. Contact the distributor/dealer. Contact the distributor/dealer.
The generator set stops suddenly.	Low oil pressure shutdown Out of fuel Overcrank shutdown Overspeed shutdown Overtemperature shutdown Engine malfunction	Check the oil level. Check the fuel supply. Reset the controller. If the overcrank fault occurs again, contact the distributor/dealer. Reset the controller. If the overspeed fault occurs again, contact the distributor/dealer. Allow the unit to cool. Verify that the air inlet and outlet openings are clear. Reset the controller. If the overtemperature fault occurs again, contact the distributor/dealer. Contact the distributor/dealer.
The unit overheats.	Air openings clogged Air cleaner clogged	Clean the air intake and outlet openings. Clean or replace the air cleaner element.

Figure 4-1 General Troubleshooting Chart

Section 5. Diagrams and Drawings

Diagram or Drawing	Drawing Number	Page
Enclosure Dimensions Drawings		
Dimension Drawing	ADV-6535	24
Schematic Diagrams		
Wiring Diagram	GM11880-C	25
Schematic	ADV-6536-B	26

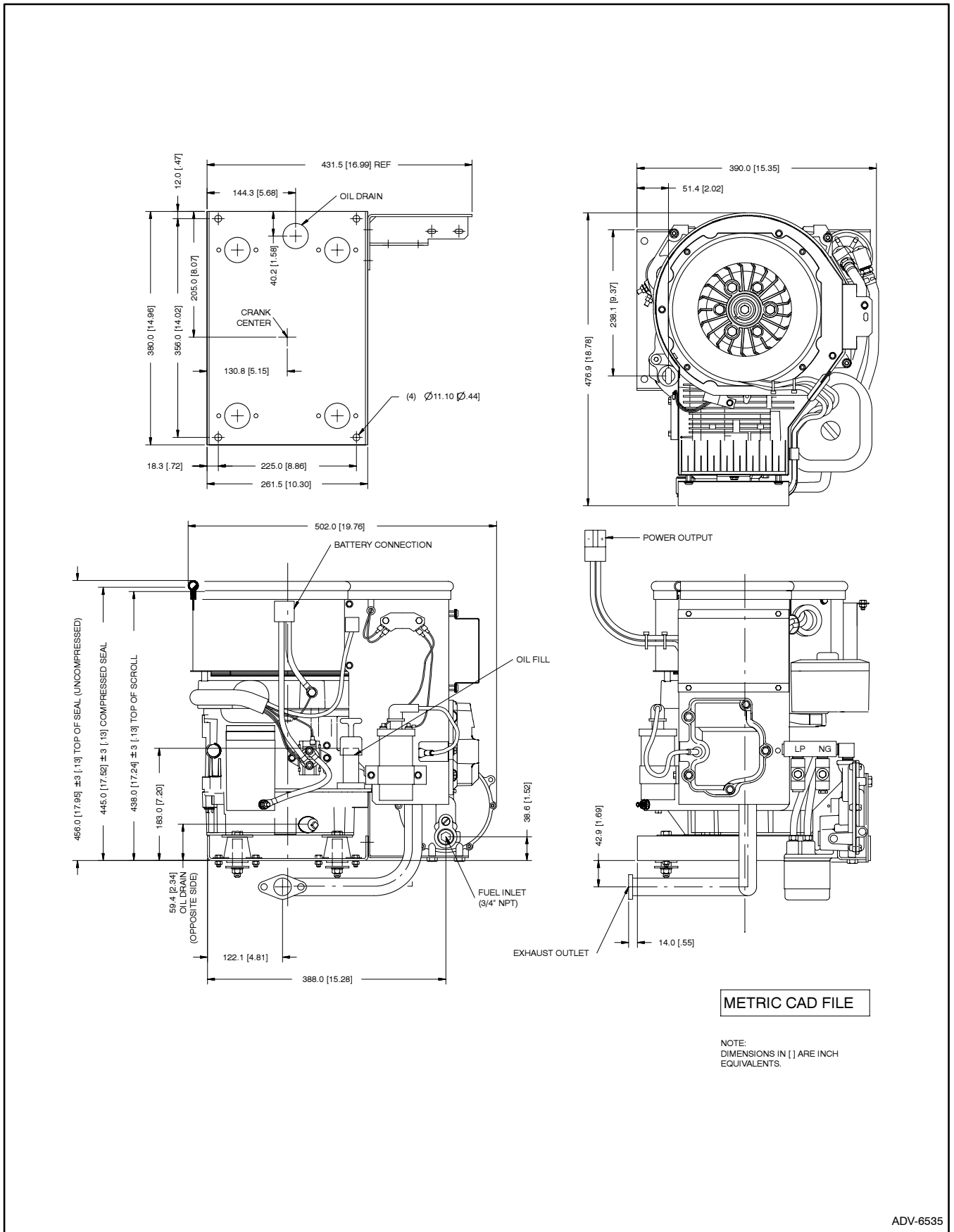

ADV-6535

Figure 5-1 Dimension Drawing, ADV-6535

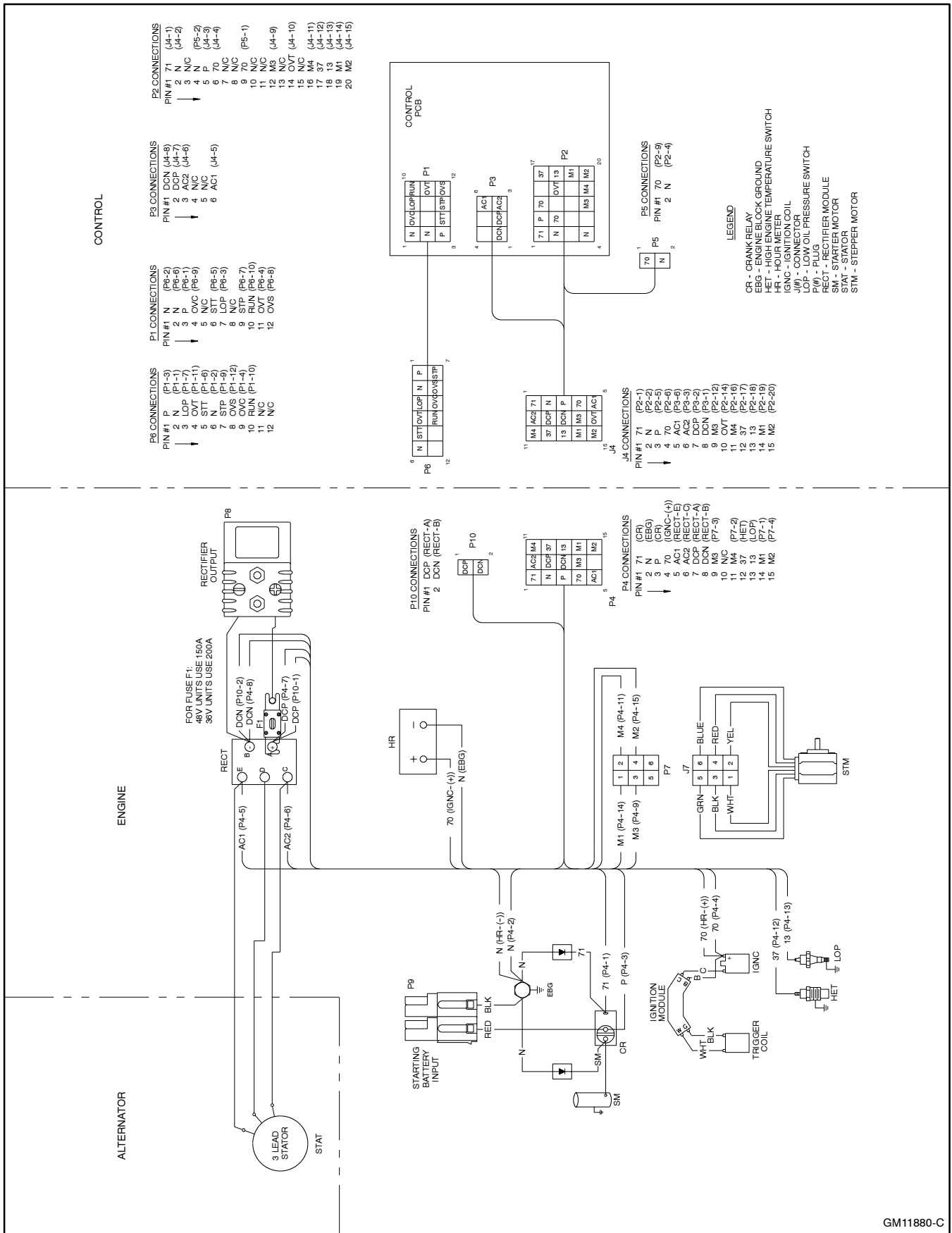

Figure 5-2 Wiring Diagram, GM11880-C

Appendix A Abbreviations

The following list contains abbreviations that may appear in this publication.

A, amp	ampere	CG	center of gravity	F	Fahrenheit, female
ABDC	after bottom dead center	CID	cubic inch displacement	fglass.	fiberglass
AC	alternating current	CL	centerline	FHM	flat head machine (screw)
A/D	analog to digital	cm	centimeter	fl. oz.	fluid ounce
ADC	analog to digital converter	cmm	cubic meters per minute	flex.	flexible
adj.	adjust, adjustment	CMOS	complementary metal oxide substrate (semiconductor)	freq.	frequency
ADV	advertising dimensional drawing			FS	full scale
AHWT	anticipatory high water temperature	cogen.	cogeneration	ft.	foot, feet
AISI	American Iron and Steel Institute	COM	communications (port)	ft. lbs.	foot pounds (torque)
ALOP	anticipatory low oil pressure	conn.	connection	ft./min.	feet per minute
alt.	alternator	cont.	continued	g	gram
Al	aluminum	CPVC	chlorinated polyvinyl chloride	ga.	gauge (meters, wire size)
ANSI	American National Standards Institute (formerly American Standards Association, ASA)	crit.	critical	gal.	gallon
		CRT	cathode ray tube	gen.	generator
AO	anticipatory only	CSA	Canadian Standards Association	genset	generator set
API	American Petroleum Institute	CT	current transformer	GFI	ground fault interrupter
approx.	approximate, approximately	Cu	copper	gnd.	ground
AR	as required, as requested	cu. in.	cubic inch	gov.	governor
AS	as supplied, as stated, as suggested	cw.	clockwise	gph	gallons per hour
ASE	American Society of Engineers	CWC	city water-cooled	gpm	gallons per minute
ASME	American Society of Mechanical Engineers	cyl.	cylinder	gr.	grade, gross
assy.	assembly	D/A	digital to analog	gr. wt.	gross weight
ASTM	American Society for Testing Materials	DAC	digital to analog converter	H x W x D	height by width by depth
ATDC	after top dead center	dB	decibel	HC	hex cap
ATS	automatic transfer switch	dBA	decibel (A weighted)	HCHT	high cylinder head temperature
auto.	automatic	DC	direct current	HD	heavy duty
aux.	auxiliary	DCR	direct current resistance	HET	high exhaust temperature
A/V	audio/visual	deg., °	degree	hex	hexagon
avg.	average	dept.	department	Hg	mercury (element)
AVR	automatic voltage regulator	dia.	diameter	HH	hex head
AWG	American Wire Gauge	DI/EO	dual inlet/end outlet	HHC	hex head cap
AWM	appliance wiring material	DIN	Deutsches Institut fur Normung e. V. (also Deutsche Industrie Normenausschuss)	HP	horsepower
bat.	battery	DIP	dual inline package	hr.	hour
BBDC	before bottom dead center	DPDT	double-pole, double-throw	HS	heat shrink
BC	battery charger, battery charging	DPST	double-pole, single-throw	hsg.	housing
BCA	battery charging alternator	DS	disconnect switch	HVAC	heating, ventilation, and air conditioning
BCI	Battery Council International	DVR	digital voltage regulator	HWT	high water temperature
BDC	before dead center	E, emer.	emergency (power source)	Hz	hertz (cycles per second)
BHP	brake horsepower	EDI	electronic data interchange	IC	integrated circuit
blk.	black (paint color), block (engine)	EFR	emergency frequency relay for example (<i>exempli gratia</i>)	ID	inside diameter, identification
blk. htr.	block heater	EG	electronic governor	IEC	International Electrotechnical Commission
BMEP	brake mean effective pressure	EGSA	Electrical Generating Systems Association	IEEE	Institute of Electrical and Electronics Engineers
bps	bits per second	EIA	Electronic Industries Association	IMS	improved motor starting
br.	brass	EI/EO	end inlet/end outlet	in.	inch
BTDC	before top dead center	EMI	electromagnetic interference	in. H ₂ O	inches of water
Btu	British thermal unit	emiss.	emission	in. Hg	inches of mercury
Btu/min.	British thermal units per minute	eng.	engine	in. lbs.	inch pounds
C	Celsius, centigrade	EPA	Environmental Protection Agency	Inc.	incorporated
cal.	calorie	EPS	emergency power system	ind.	industrial
CARB	California Air Resources Board	ER	emergency relay	int.	internal
CB	circuit breaker	ES	engineering special, engineered special	int./ext.	internal/external
cc	cubic centimeter	ESD	electrostatic discharge	I/O	input/output
CCA	cold cranking amps	est.	estimated	IP	iron pipe
ccw.	counterclockwise	E-Stop	emergency stop	ISO	International Organization for Standardization
CEC	Canadian Electrical Code	etc.	et cetera (and so forth)	J	joule
cfh	cubic feet per hour	exh.	exhaust	JIS	Japanese Industry Standard
cfm	cubic feet per minute	ext.	external	k	kilo (1000)

kg/cm ²	kilograms per square centimeter	mW	milliwatt	rnd.	round
kgm	kilogram-meter	μF	microfarad	ROM	read only memory
kg/m ³	kilograms per cubic meter	N, norm.	normal (power source)	rot.	rotate, rotating
kHz	kilohertz	NA	not available, not applicable	rpm	revolutions per minute
kJ	kilojoule	nat. gas	natural gas	RS	right side
km	kilometer	NBS	National Bureau of Standards	RTV	room temperature vulcanization
kOhm, kΩ	kilo-ohm	NC	normally closed	SAE	Society of Automotive Engineers
kPa	kilopascal	NEC	National Electrical Code	scfm	standard cubic feet per minute
kph	kilometers per hour	NEMA	National Electrical Manufacturers Association	SCR	silicon controlled rectifier
kV	kilovolt	NFPA	National Fire Protection Association	s, sec.	second
kVA	kilovolt ampere	Nm	newton meter	SI	<i>Systeme international d'unites</i> , International System of Units
kVAR	kilovolt ampere reactive	NO	normally open	SI/EO	side in/end out
kW	kilowatt	no., nos.	number, numbers	sil.	silencer
kWh	kilowatt-hour	NPS	National Pipe, Straight	SN	serial number
kWm	kilowatt mechanical	NPSC	National Pipe, Straight-coupling	SPDT	single-pole, double-throw
L	liter	NPT	National Standard taper pipe thread per general use	SPST	single-pole, single-throw
LAN	local area network	NPTF	National Pipe, Taper-Fine	spec, specs	specification(s)
L x W x H	length by width by height	NR	not required, normal relay	sq.	square
lb.	pound	ns	nanosecond	sq. cm	square centimeter
lbm/ft ³	pounds mass per cubic feet	O/C	overcrank	sq. in.	square inch
LCB	line circuit breaker	OD	outside diameter	SS	stainless steel
LCD	liquid crystal display	OEM	original equipment manufacturer	std.	standard
ld. shd.	load shed	O/F	overfrequency	stl.	steel
LED	light emitting diode	opt.	option, optional	tach.	tachometer
Lph	liters per hour	O/S	oversize, overspeed	TD	time delay
Lpm	liters per minute	OSHA	Occupational Safety and Health Administration	TDC	top dead center
LOP	low oil pressure	O/V	overvoltage	TDEC	time delay engine cooldown
LP	liquefied petroleum	oz.	ounce	TDEN	time delay emergency to normal
LPG	liquefied petroleum gas	oz.	ounce	TDES	time delay engine start
LS	left side	p., pp.	page, pages	TDNE	time delay normal to emergency
L _{wa}	sound power level, A weighted	PA	packed accessory	TDOE	time delay off to emergency
LWL	low water level	PC	personal computer	TDON	time delay off to normal
LWT	low water temperature	PCB	printed circuit board	temp.	temperature
m	meter, milli (1/1000)	pF	picofarad	term.	terminal
M	mega (10 ⁶ when used with SI units), male	PF	power factor	TIF	telephone influence factor
m ³	cubic meter	ph.	phase	TIR	total indicator reading
m ³ /min.	cubic meters per minute	PHC	Phillips head crimptite (screw)	tol.	tolerance
mA	milliampere	PHH	Phillips hex head (screw)	turbo.	turbocharger
man.	manual	PHM	pan head machine (screw)	typ.	typical (same in multiple locations)
max.	maximum	PLC	programmable logic control	U/F	underfrequency
MB	megabyte (2 ²⁰ bytes)	PMG	permanent magnet generator	UHF	ultrahigh frequency
MCM	one thousand circular mils	pot	potentiometer, potential	UL	Underwriter's Laboratories, Inc.
meggar	megohmmeter	ppm	parts per million	UNC	unified coarse thread (was NC)
MHz	megahertz	PROM	programmable read only memory	UNF	unified fine thread (was NF)
mi.	mile	psi	pounds per square inch	univ.	universal
mil	one one-thousandth of an inch	pt.	pint	U/S	undersize, underspeed
min.	minimum, minute	PTC	positive temperature coefficient	UV	ultraviolet
misc.	miscellaneous	PTO	power takeoff	U/V	undervoltage
MJ	megajoule	PVC	polyvinyl chloride	V	volt
mJ	millijoule	qt.	quart	VAC	volts alternating current
mm	millimeter	qty.	quantity	VAR	voltampere reactive
mOhm, mΩ	milliohm	R	replacement (emergency) power source	VDC	volts direct current
MOhm, MΩ	megohm	rad.	radiator, radius	VFD	vacuum fluorescent display
MOV	metal oxide varistor	RAM	random access memory	VGA	video graphics adapter
MPa	megapascal	RDO	relay driver output	VHF	very high frequency
mpg	miles per gallon	ref.	reference	W	watt
mph	miles per hour	rem.	remote	WCR	withstand and closing rating
MS	military standard	RFI	radio frequency interference	w/	with
m/sec.	meters per second	RH	round head	w/o	without
MTBF	mean time between failure	RHM	round head machine (screw)	wt.	weight
MTBO	mean time between overhauls	rly.	relay	xfrm	transformer
mtg.	mounting	rms	root mean square		
MW	megawatt				

TP-6076 3/00a

© Kohler Co., 2000. All rights reserved.

KOHLER[®] POWER SYSTEMS

KOHLER CO. Kohler, Wisconsin 53044
Phone 920-565-3381, Web site www.kohlergenerators.com
Fax 920-459-1646 (U.S.A. Sales), Fax 920-459-1614 (International)
For the nearest sales and service outlet in U.S.A. and Canada
Phone 1-800-544-2444

Kohler[®] Power Systems
Asia Pacific Headquarters
7 Jurong Pier Road
Singapore 619159
Phone (65)264-6422, Fax (65)264-6455