

Operation

Industrial Generator Sets

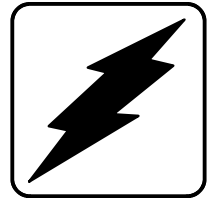

Models:

20-2000 kW

Controllers:

Decision-Maker™ 550

KOHLER[®]
POWER SYSTEMS

ISO 9001
KOHLER
GENERATORS
INTERNATIONALLY REGISTERED

TP-6083 6/01

California Proposition 65

 WARNING

Engine exhaust from this product contains chemicals known to the State of California to cause cancer, birth defects, or other reproductive harm.

Product Identification Information

Product identification numbers determine service parts. Record the product identification numbers in the spaces below immediately after unpacking the products so that the numbers are readily available for future reference. Record field-installed kit numbers after installing the kits.

Generator Set Identification Numbers

Record the product identification numbers from the generator set nameplate(s).

Model Designation _____

Specification Number _____

Serial Number _____

Accessory Number	Accessory Description
_____	_____
_____	_____
_____	_____
_____	_____
_____	_____
_____	_____
_____	_____
_____	_____
_____	_____
_____	_____
_____	_____
_____	_____
_____	_____
_____	_____
_____	_____
_____	_____
_____	_____
_____	_____
_____	_____
_____	_____
_____	_____
_____	_____

Engine Identification

Record the product identification information from the engine nameplate.

Manufacturer _____

Model Designation _____

Serial Number _____

Table of Contents

Product Identification Information	Inside Front Cover
Safety Precautions and Instructions	I
Introduction	i
Service Assistance	ii
Section 1 Specifications and Features	1
1.1 Introduction	1
1.2 Controller Features	1
1.2.1 Annunciator Lamps	2
1.2.2 Digital Display and Keypad	3
1.2.3 Switches and Controls	5
1.2.4 Controller Circuit Boards	6
1.2.5 Fuses	6
1.2.6 Terminal Strips and Connectors	7
1.2.7 Circuit Board Interconnections for Calibration Procedure	7
1.2.8 Communication Ports	8
1.3 Controller Logic Specifications	8
1.3.1 Status Event and Fault Specifications	9
1.3.2 Voltage Regulator and Calibration Specifications*	11
1.3.3 Voltage Regulator Adjustments	12
Section 2 Operation	13
2.1 Prestart Checklist	13
2.2 Exercising the Generator Set	13
2.3 Controller Operation	14
2.3.1 Starting	14
2.3.2 Stopping	15
2.3.3 Emergency Stop Switch Reset Procedure	15
2.3.4 System Ready Lamp	15
2.3.5 System Warning Lamp	16
2.3.6 System Shutdown Lamp	18
2.3.7 Controller Reset Procedure (Following System Shutdown or Warning)	20
2.4 Menu List Summary	20
2.5 Digital Display Messages	24
2.6 Reviewing the Digital Display	25
2.6.1 Keypad Operation	25
2.6.2 Auto-Scroll Function	25
2.6.3 Request and Error Messages	26
2.7 Monitoring and Programming Setup	27
2.7.1 Personal Computer (PC) Communications	28
2.7.2 Modbus Communications	29
2.8 Reviewing the Menu Displays	30
2.8.1 Menu 1—Generator Monitoring	31
2.8.2 Menu 2—Engine Monitoring	32
2.8.3 Menu 3—Analog Monitoring	33
2.8.4 Menu 4—Operational Records	34
2.8.5 Menu 5—Event History	35
2.8.6 Menu 6—Time and Date	35
2.8.7 Menu 7—Generator System	36
2.8.8 Menu 8—Time Delays	37
2.8.9 Menu 9—Input Setup	38
2.8.10 Menu 10—Output Setup	39
2.8.11 Menu 11—Voltage Regulator	41
2.8.12 Menu 12—Calibration	42
2.8.13 Menu 13—Communications	43
2.8.14 Menu 14—Programming Mode	44

Table of Contents, continued

2.9	Local Programming Mode On	45
2.9.1	Menu 1—Generator Monitoring	46
2.9.2	Menu 2—Engine Monitoring	49
2.9.3	Menu 3—Analog Monitoring	51
2.9.4	Menu 4—Operational Records	52
2.9.5	Menu 5—Event History	54
2.9.6	Menu 6—Time and Date	55
2.9.7	Menu 7—Generator System	56
2.9.8	Menu 8—Time Delays	61
2.9.9	Menu 9—Input Setup	63
2.9.10	Menu 10—Output Setup	68
2.9.11	Menu 11—Voltage Regulator	78
2.9.12	Menu 12—Calibration	83
2.9.13	Menu 13—Communications	86
2.9.14	Menu 14—Programming Mode	90
Section 3 Scheduled Maintenance		93
3.1	Generator Service	93
3.2	Engine Service	93
3.3	Service Schedule	94
3.4	Generator Bearing Service	96
3.4.1	20–300 kW Models	96
3.4.2	350–2000 kW Models with Single-Bearing Generator	96
3.4.3	1250–2000 kW Models with Two-Bearing Generator	96
3.5	Diesel Fuel Systems	96
3.5.1	Bleeding Air from the Fuel System	96
3.5.2	Subbase Fuel Day Tank Electronic Control Module (ECM)	97
3.5.3	Subbase Inner Fuel Tank Alarm	98
3.6	Gas/Gasoline Fuel Systems	98
3.6.1	Gaseous Fuel System Concept	98
3.6.2	LP Liquid Withdrawal Fuel System Concept	99
3.6.3	LP Gas/Natural Gas Conversion for Straight Gas Fuel System	99
3.6.4	Fuel System Changeover Kits	100
3.6.5	Carburetor Adjustment	100
3.6.6	Fuel System Maintenance	101
3.7	Cooling System	101
3.7.1	Coolant Level Check	102
3.7.2	Cooling System Component Inspection	102
3.7.3	Procedure to Drain the Cooling System	102
3.7.4	Procedure to Flush and Clean the Cooling System	102
3.7.5	Procedure to Refill the Cooling System	103
3.8	Radiator Expansion Joint Loosening—Initial Setup Only	103
3.9	Fan Bearing Lubrication	104
3.10	Battery	105
3.10.1	Cleaning	106
3.10.2	Electrolyte Level Inspection	107
3.10.3	Specific Gravity Check	107
3.10.4	Charging	108
3.11	Detroit Diesel Engine Control (DDEC) System	108
3.11.1	DDEC Features	108
3.11.2	DDEC Engine Diagnostics	108
3.12	Deutz Engine Control System	109

Table of Contents, continued

3.13	Storage Procedure	109
3.13.1	Lubricating System	109
3.13.2	Cooling System	110
3.13.3	Fuel System	110
3.13.4	Internal Engine Components (Gas/Gasoline-Fueled Engines)	110
3.13.5	Exterior	110
3.13.6	Battery	110
Section 4 General Troubleshooting		111
Section 5 Generator Reconnection		115
5.1	Introduction	115
5.2	Voltage Reconnection Procedure	116
Section 6 Accessories		119
6.1	Accessories and Connections	119
6.1.1	Audiovisual Alarm Kit	120
6.1.2	Common Failure Relay Kit	120
6.1.3	Controller (Customer) Connection Kit	120
6.1.4	Float/Equalize Battery Charger Kit with Alarm Option	122
6.1.5	Idle (Speed) Mode Feature	122
6.1.6	Low Fuel (Level or Pressure) Switch	122
6.1.7	Prime Power Switch Kit	123
6.1.8	Remote Annunciator Kit	123
6.1.9	Remote Emergency Stop Kit	125
6.1.10	Remote Reset Feature	125
6.1.11	Remote Speed Adjustment Potentiometer Kit (non-ECM models)	126
6.1.12	Run Relay Kit	126
6.1.13	Single-Relay Dry Contact Kit	127
6.1.14	Ten-Relay Dry Contact Kit	127
6.2	Accessory Connections	129
Appendix A Abbreviations		A-1
Appendix B User-Defined Settings		A-3
Appendix C Voltage Regulator Definitions and Adjustments		A-5

Safety Precautions and Instructions

IMPORTANT SAFETY INSTRUCTIONS. Electromechanical equipment, including generator sets, transfer switches, switchgear, and accessories, can cause bodily harm and pose life-threatening danger when improperly installed, operated, or maintained. To prevent accidents be aware of potential dangers and act safely. Read and follow all safety precautions and instructions. **SAVE THESE INSTRUCTIONS.**

This manual has several types of safety precautions and instructions: Danger, Warning, Caution, and Notice.

DANGER

Danger indicates the presence of a hazard that **will cause severe personal injury, death, or substantial property damage.**

WARNING

Warning indicates the presence of a hazard that **can cause severe personal injury, death, or substantial property damage.**

CAUTION

Caution indicates the presence of a hazard that **will or can cause minor personal injury or property damage.**

NOTICE

Notice communicates installation, operation, or maintenance information that is safety related but not hazard related.

Safety decals affixed to the equipment in prominent places alert the operator or service technician to potential hazards and explain how to act safely. The decals are shown throughout this publication to improve operator recognition. Replace missing or damaged decals.

Accidental Starting

WARNING

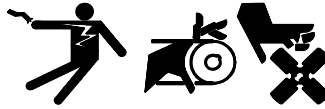

**Accidental starting.
Can cause severe injury or death.**

Disconnect the battery cables before working on the generator set. Remove the negative (-) lead first when disconnecting the battery. Reconnect the negative (-) lead last when reconnecting the battery.

Disabling the generator set. Accidental starting can cause severe injury or death. Before working on the generator set or connected equipment, disable the generator set as follows: (1) Move the generator set master switch to the OFF position. (2) Disconnect the power to the battery charger. (3) Remove the battery cables, negative (-) lead first. Reconnect the negative (-) lead last when reconnecting the battery. Follow these precautions to prevent starting of the generator set by an automatic transfer switch, remote start/stop switch, or engine start command from a remote computer.

Battery

WARNING



**Sulfuric acid in batteries.
Can cause severe injury or death.**

Wear protective goggles and clothing. Battery acid may cause blindness and burn skin.

WARNING



**Explosion.
Can cause severe injury or death. Relays in the battery charger cause arcs or sparks.**

Locate the battery in a well-ventilated area. Isolate the battery charger from explosive fumes.

Battery electrolyte is a diluted sulfuric acid. Battery acid can cause severe injury or death. Battery acid can cause blindness and burn skin. Always wear splashproof safety goggles, rubber gloves, and boots when servicing the battery. Do not open a sealed battery or mutilate the battery case. If battery acid splashes in the eyes or on the skin, immediately flush the affected area for 15 minutes with large quantities of clean water. Seek immediate medical aid in the case of eye contact. Never add acid to a battery after placing the battery in service, as this may result in hazardous spattering of battery acid.

Battery gases. Explosion can cause severe injury or death. Battery gases can cause an explosion. Do not smoke or permit flames or sparks to occur near a battery at any time, particularly when it is charging. Do not dispose of a battery in a fire. To prevent burns and sparks that could cause an explosion, avoid touching the battery terminals with tools or other metal objects. Remove all jewelry before servicing the equipment. Discharge static electricity from your body before touching batteries by first touching a grounded metal surface away from the battery. To avoid sparks, do not disturb the battery charger connections while the battery is charging. Always turn the battery charger off before disconnecting the battery connections. Ventilate the compartments containing batteries to prevent accumulation of explosive gases.

Engine Backfire/Flash Fire

⚠ WARNING

<p>Fire. Can cause severe injury or death.</p> <p>Do not smoke or permit flames or sparks near fuels or the fuel system.</p>

Servicing the fuel system. A flash fire can cause severe injury or death. Do not smoke or permit flames or sparks near the carburetor, fuel line, fuel filter, fuel pump, or other potential sources of spilled fuels or fuel vapors. Catch fuels in an approved container when removing the fuel line or carburetor.

Servicing the air cleaner. A sudden backfire can cause severe injury or death. Do not operate the generator set with the air cleaner removed.

Combustible materials. A fire can cause severe injury or death. Generator set engine fuels and fuel vapors are flammable and explosive. Handle these materials carefully to minimize the risk of fire or explosion. Equip the compartment or nearby area with a fully charged fire extinguisher. Select a fire extinguisher rated ABC or BC for electrical fires or as recommended by the local fire code or an authorized agency. Train all personnel on fire extinguisher operation and fire prevention procedures.

Exhaust System

⚠ WARNING

<p>Carbon monoxide. Can cause severe nausea, fainting, or death.</p> <p>The exhaust system must be leakproof and routinely inspected.</p>

Generator set operation. Carbon monoxide can cause severe nausea, fainting, or death. Carbon monoxide is an odorless, colorless, tasteless, nonirritating gas that can cause death if inhaled for even a short time. Avoid breathing exhaust fumes when working on or near the generator set. Never operate the generator set inside a building unless the exhaust gas is piped safely outside. Never operate the generator set where exhaust gas could accumulate and seep back inside a potentially occupied building.

Carbon monoxide symptoms. Carbon monoxide can cause severe nausea, fainting, or death. Carbon monoxide is a poisonous gas present in exhaust gases. Carbon monoxide poisoning symptoms include but are not limited to the following:

- Light-headedness, dizziness
- Physical fatigue, weakness in joints and muscles
- Sleepiness, mental fatigue, inability to concentrate or speak clearly, blurred vision
- Stomachache, vomiting, nausea

If experiencing any of these symptoms and carbon monoxide poisoning is possible, seek fresh air immediately and remain active. Do not sit, lie down, or fall asleep. Alert others to the possibility of carbon monoxide poisoning. Seek medical attention if the condition of affected persons does not improve within minutes of breathing fresh air.

Copper tubing exhaust systems. Carbon monoxide can cause severe nausea, fainting, or death. Do not use copper tubing in diesel exhaust systems. Sulfur in diesel exhaust causes rapid deterioration of copper tubing exhaust systems, resulting in exhaust leakage.

Fuel System

WARNING

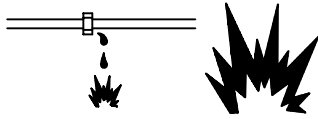

Explosive fuel vapors.
Can cause severe injury or death.

Use extreme care when handling, storing, and using fuels.

The fuel system. Explosive fuel vapors can cause severe injury or death. Vaporized fuels are highly explosive. Use extreme care when handling and storing fuels. Store fuels in a well-ventilated area away from spark-producing equipment and out of the reach of children. Never add fuel to the tank while the engine is running because spilled fuel may ignite on contact with hot parts or from sparks. Do not smoke or permit flames or sparks to occur near sources of spilled fuel or fuel vapors. Keep the fuel lines and connections tight and in good condition. Do not replace flexible fuel lines with rigid lines. Use flexible sections to avoid fuel line breakage caused by vibration. Do not operate the generator set in the presence of fuel leaks, fuel accumulation, or sparks. Repair fuel systems before resuming generator set operation.

Explosive fuel vapors can cause severe injury or death. Take additional precautions when using the following fuels:

Gasoline—Store gasoline only in approved red containers clearly marked GASOLINE.

Propane (LP)—Adequate ventilation is mandatory. Because propane is heavier than air, install propane gas detectors low in a room. Inspect the detectors per the manufacturer's instructions.

Natural Gas—Adequate ventilation is mandatory. Because natural gas rises, install natural gas detectors high in a room. Inspect the detectors per the manufacturer's instructions.

Fuel tanks. Explosive fuel vapors can cause severe injury or death. Gasoline and other volatile fuels stored in day tanks or subbase fuel tanks can cause an explosion. Store only diesel fuel in tanks.

Draining the fuel system. Explosive fuel vapors can cause severe injury or death. Spilled fuel can cause an explosion. Use a container to catch fuel when draining the fuel system. Wipe up spilled fuel after draining the system.

Gas fuel leaks. Explosive fuel vapors can cause severe injury or death. Fuel leakage can cause an explosion. Check the LP vapor gas or natural gas fuel system for leakage by using a soap and water solution with the fuel system test pressurized to 6–8 ounces per square inch (10–14 inches water column). Do not use a soap solution containing either ammonia or chlorine because both prevent bubble formation. A successful test depends on the ability of the solution to bubble.

LP liquid withdrawal fuel leaks. Explosive fuel vapors can cause severe injury or death. Fuel leakage can cause an explosion. Check the LP liquid withdrawal gas fuel system for leakage by using a soap and water solution with the fuel system test pressurized to at least 90 psi (621 kPa). Do not use a soap solution containing either ammonia or chlorine because both prevent bubble formation. A successful test depends on the ability of the solution to bubble.

Hazardous Noise

CAUTION



Hazardous noise.
Can cause hearing loss.

Never operate the generator set without a muffler or with a faulty exhaust system.

Engine noise. Hazardous noise can cause hearing loss. Generator sets not equipped with sound enclosures can produce noise levels greater than 105 dBA. Prolonged exposure to noise levels greater than 85 dBA can cause permanent hearing loss. Wear hearing protection when near an operating generator set.

Hazardous Voltage/ Electrical Shock

DANGER



Hazardous voltage.
Will cause severe injury or death.

Disconnect all power sources before opening the enclosure.

(over 600 volts)

WARNING



Hazardous voltage. Moving rotor.
Can cause severe injury or death.

Operate the generator set only when all guards and electrical enclosures are in place.

WARNING



Hazardous voltage.
Backfeed to the utility system can cause property damage, severe injury, or death.

If the generator set is used for standby power, install an automatic transfer switch to prevent inadvertent interconnection of standby and normal sources of supply.

Grounding electrical equipment. Hazardous voltage can cause severe injury or death. Electrocutation is possible whenever electricity is present. Open the main circuit breakers of all power sources before servicing the equipment. Configure the installation to electrically ground the generator set, transfer switch, and related equipment and electrical circuits to comply with applicable codes and standards. Never contact electrical leads or appliances when standing in water or on wet ground because these conditions increase the risk of electrocution.

Disconnecting the electrical load. Hazardous voltage can cause severe injury or death. Disconnect the generator set from the load by opening the line circuit breaker or by disconnecting the generator set output leads from the transfer switch and heavily taping the ends of the leads. High voltage transferred to the load during testing may cause personal injury and equipment damage. Do not use the safeguard circuit breaker in place of the line circuit breaker. The safeguard circuit breaker does not disconnect the generator set from the load.

High voltage test. Hazardous voltage can cause severe injury or death. Follow the instructions of the test equipment manufacturer when performing high-voltage tests on the rotor or stator. An improper test procedure can damage equipment or lead to generator set failure.

Testing the photo transistor circuit board. Hazardous voltage can cause severe injury or death. When the end cover is removed, do not expose the photo transistor circuit board mounted on the generator set end bracket to any external light source, as exposure to light causes high voltage. Keep foreign sources of light away from the photo transistor circuit board during testing. Place black electrical tape over the LED on the circuit board before starting the generator set.

Installing the photo transistor circuit board. Hazardous voltage can cause severe injury or death. Ensure that the foil side of the photo transistor circuit board, the end of the shaft, and the threaded holes are clean and free of metal particles and chips. Metal debris may short-circuit the photo transistor circuit board and cause hazardous voltage in the generator set. Do not reconnect the generator set to the load until the AC voltmeter shows the correct output.

Connecting the SCR assembly. Hazardous voltage can cause severe injury or death. Connect leads C and E to the corresponding terminals of the one-piece SCR assembly. The SCR assembly will turn full on and cause hazardous output voltage if the leads are connected in reverse or if the C (red) lead is grounded. *(One-piece SCR models only. Does not apply to current split activator models.)*

Installing the battery charger. Hazardous voltage can cause severe injury or death. An ungrounded battery charger may cause electrical shock. Connect the battery charger enclosure to the ground of a permanent wiring system. As an alternative, install an equipment grounding conductor with circuit conductors and connect it to the equipment grounding terminal or the lead on the battery charger. Install the battery charger as prescribed in the equipment manual. Install the battery charger in compliance with local codes and ordinances.

Connecting the battery and the battery charger. Hazardous voltage can cause severe injury or death. Reconnect the battery correctly, positive to positive and negative to negative, to avoid electrical shock and damage to the battery charger and battery(ies). Have a qualified electrician install the battery(ies).

Servicing the day tank. Hazardous voltage can cause severe injury or death. Service the day tank electrical control module (ECM) as prescribed in the equipment manual. Disconnect the power to the day tank before servicing. Press the day tank ECM OFF pushbutton to disconnect the power. Notice that line voltage is still present within the ECM when the POWER ON light is lit. Ensure that the generator set and day tank are electrically grounded. Do not operate the day tank when standing in water or on wet ground because these conditions increase the risk of electrocution.

Short circuits. Hazardous voltage/current can cause severe injury or death. Short circuits can cause bodily injury and/or equipment damage. Do not contact electrical connections with tools or jewelry while making adjustments or repairs. Remove all jewelry before servicing the equipment.

Testing the voltage regulator. Hazardous voltage can cause severe injury or death. High voltage is present at the voltage regulator heat sink. To prevent electrical shock do not touch the voltage regulator heat sink when testing the voltage regulator. *(PowerBoost™, PowerBoost™ III, and PowerBoost™ V voltage regulator models only)*

Engine block heater. Hazardous voltage can cause severe injury or death. The engine block heater can cause electrical shock. Remove the engine block heater plug from the electrical outlet before working on the block heater electrical connections.

Handling the capacitor. Hazardous voltage can cause severe injury or death. Electrical shock results from touching the charged capacitor terminals. Discharge the capacitor by shorting the terminals together. *(Capacitor-excited models only)*

Electrical backfeed to the utility. Hazardous backfeed voltage can cause severe injury or death. Install a transfer switch in standby power installations to prevent the connection of standby and other sources of power. Electrical backfeed into a utility electrical system can cause severe injury or death to utility personnel working on power lines.

Testing live electrical circuits. Hazardous voltage or current can cause severe injury or death. Have trained and qualified personnel take diagnostic measurements of live circuits. Use adequately rated test equipment with electrically insulated probes and follow the instructions of the test equipment manufacturer when performing voltage tests. Observe the following precautions when performing voltage tests: (1) Remove all jewelry. (2) Stand on a dry, approved electrically insulated mat. (3) Do not touch the enclosure or components inside the enclosure. (4) Be prepared for the system to operate automatically. (600 volts and under)

Heavy Equipment

⚠ WARNING

<p>Unbalanced weight. Improper lifting can cause severe injury or death and equipment damage.</p> <p>Do not use lifting eyes. Lift the generator set using lifting bars inserted through the lifting holes on the skid.</p>

Hot Parts

⚠ WARNING

<p>Hot coolant and steam. Can cause severe injury or death.</p> <p>Before removing the pressure cap, stop the generator set and allow it to cool. Then loosen the pressure cap to relieve pressure.</p>

⚠ WARNING

<p>Hot engine and exhaust system. Can cause severe injury or death.</p> <p>Do not work on the generator set until it cools.</p>

Servicing the generator. Hot parts can cause severe injury or death. Avoid touching the generator set field or exciter armature. When shorted, the generator set field and exciter armature become hot enough to cause severe burns.

Checking the coolant level. Hot coolant can cause severe injury or death. Allow the engine to cool. Release pressure from the cooling system before removing the pressure cap. To release pressure, cover the pressure cap with a thick cloth and then slowly turn the cap counterclockwise to the first stop. Remove the cap after pressure has been completely released and the engine has cooled. Check the coolant level at the tank if the generator set has a coolant recovery tank.

Servicing the exhaust system. Hot parts can cause severe injury or death. Do not touch hot engine parts. The engine and exhaust system components become extremely hot during operation.

Combustible materials. Fire can cause severe injury or death. A hot exhaust system can ignite adjacent combustible materials. Do not locate electrical wiring, fuel lines, or combustible materials above the exhaust muffler. Exercise caution when parking your vehicle to prevent the exhaust system and hot exhaust gases from starting grass fires.

Moving Parts

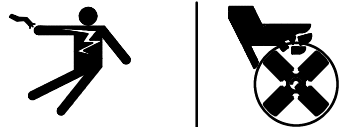
⚠ WARNING

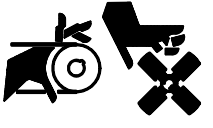
<p>Hazardous voltage. Moving rotor. Can cause severe injury or death.</p> <p>Operate the generator set only when all guards and electrical enclosures are in place.</p>

⚠ WARNING

<p>Rotating parts. Can cause severe injury or death.</p> <p>Operate the generator set only when all guards, screens, and covers are in place.</p>

⚠ WARNING

<p>Airborne particles. Can cause severe injury or blindness.</p> <p>Wear protective goggles and clothing when using power tools, hand tools, or compressed air.</p>

Tightening the hardware. Flying projectiles can cause severe injury or death. Loose hardware can cause the hardware or pulley to release from the generator set engine and can cause personal injury. Retorque all crankshaft and rotor hardware after servicing. Do not loosen the crankshaft hardware or rotor throbolt when making adjustments or servicing the generator set. Rotate the crankshaft manually in a clockwise direction only. Turning the crankshaft bolt or rotor throbolt counterclockwise can loosen the hardware.

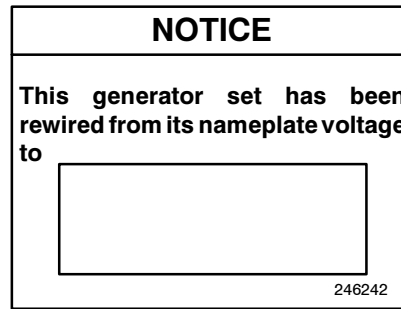
Servicing the generator set when it is operating. Exposed moving parts can cause severe injury or death. Keep hands, feet, hair, clothing, and test leads away from the belts and pulleys when the generator set is running. Replace guards, screens, and covers before operating the generator set.

Notice



NOTICE

Voltage reconnection. Affix a notice to the generator set after reconnecting the set to a voltage different from the voltage on the nameplate. Order voltage reconnection decal 246242 from an authorized service distributor/dealer.

NOTICE

Hardware damage. The engine and generator set may use both American Standard and metric hardware. Use the correct size tools to prevent rounding of the bolt heads and nuts.

NOTICE

When replacing hardware, do not substitute with inferior grade hardware. Screws and nuts are available in different hardness ratings. To indicate hardness, American Standard hardware uses a series of markings, and metric hardware uses a numeric system. Check the markings on the bolt heads and nuts for identification.

NOTICE

Canadian installations only. For standby service connect the output of the generator set to a suitably rated transfer switch in accordance with Canadian Electrical Code, Part 1.

This manual provides operation instructions for 20–2000 kW generator sets equipped with the following controller:

- Decision-Maker™ 550

Wiring diagram manuals are available separately.

Refer to the engine operation manual for generator set engine scheduled maintenance information.

x:in:001:001

This manual may be used for models not listed on the front cover.

Information in this publication represents data available at the time of print. Kohler Co. reserves the right to change this publication and the products represented without notice and without any obligation or liability whatsoever.

Read this manual and carefully follow all procedures and safety precautions to ensure proper equipment operation and to avoid bodily injury. Read and follow the Safety Precautions and Instructions section at the beginning of this manual. Keep this manual with the equipment for future reference.

The equipment service requirements are very important to safe and efficient operation. Inspect the parts often and perform required service at the prescribed intervals. Maintenance work must be performed by appropriately skilled and suitably-trained maintenance personnel familiar with generator set operation and service.

x:in:001:002:a

The disc supplied with this generator set is a backup copy of the generator set personality program containing data specific to the engine and alternator. The engine and alternator data was preprogrammed in the controller at the factory and no further use of the disc should be necessary. Typically, your authorized distributor stores this disc for possible future use such as controller replacement or other circumstances requiring a backup.

List of Related Materials

Separate literature contains communication and software information not provided in this manual. The following table lists the available literature part numbers.

Communication and Software Manual Description	Literature Part Number
550 Controller Spec Sheet	G6-46
Generator Set/Controller Wiring Diagram Manual	Multiple Part Numbers Contact your Distributor/Dealer
550 Communications Spec Sheet	G6-50
KBUS Communications Spec Sheet	G6-38
Monitor II Software Operation/Installation Manual	TP-5972
Modbus Communication Operation/Installation Manual	TP-6113
Program Loader Software Installation	TT-1285
KBUS Communication Kits Installation	TT-1283

Service Assistance

Please contact a local authorized distributor/dealer for sales, service, or other information about Kohler Co. Generator Division products.

- Look on the product or in the information included with the product
- Consult the Yellow Pages under the heading Generators—Electric
- Visit the Kohler Co. Generator Division web site at www.kohlergenerators.com
- Inside the U.S.A. and Canada, call 1-800-544-2444
- Outside the U.S.A. and Canada, call the nearest regional office

Africa, Europe, Middle East

London Regional Office
Langley, Slough, England
Phone: (44) 1753-580-771
Fax: (44) 1753-580-036

Australia

Australia Regional Office
Queensland, Australia
Phone: (617) 3893-0061
Fax: (617) 3893-0072

China

China Regional Office
Shanghai, People's Republic of China
Phone: (86) 21-6482 1252
Fax: (86) 21-6482 1255

India, Bangladesh, Sri Lanka

India Regional Office
Bangalore, India
Phone: (91) 80-2284270
(91) 80-2284279
Fax: (91) 80-2284286

Japan

Japan Regional Office
Tokyo, Japan
Phone: (813) 3440-4515
Fax: (813) 3440-2727

Latin America

Latin America Regional Office
Lakeland, Florida, U.S.A.
Phone: (941) 619-7568
Fax: (941) 701-7131

South East Asia

Singapore Regional Office
Singapore, Republic of Singapore
Phone: (65) 264-6422
Fax: (65) 264-6455

Xin:008:001

Section 1 Specifications and Features

1.1 Introduction

The spec sheets for each generator set provide model specific generator and engine information. The controller spec sheet provides specifications for this controller. Refer to the respective spec sheet for data not supplied in this manual. Consult the generator set service manual, installation manual, engine operation manual, and engine service manual for additional specifications.

1.2 Controller Features

The controller features include the annunciator lamps, digital display and keypad, switches and controls, and fuses and terminal strip. The following paragraphs detail the features by general topics.

The controller features, accessories, and menu displays depend upon the engine electronic control module

(ECM) setup and features. Controller features apply to generator set models with ECM and non-ECM engines unless otherwise noted.

Note: Press any key on the keypad to turn on the controller lights and display. The lights and display turn off 5 minutes after the last keypad entry.

Note: There are two operating modes: prime power or standby. The operating mode selection alters the displays involving generator set ratings. Change this setting using Menu 14—Programming Mode Menu and Menu 7—Generator System Menu.

Note: Measurements display in metric or English. See Menu 7—Generator System.

See Figure 1-1 for an illustration of the controller front panel.

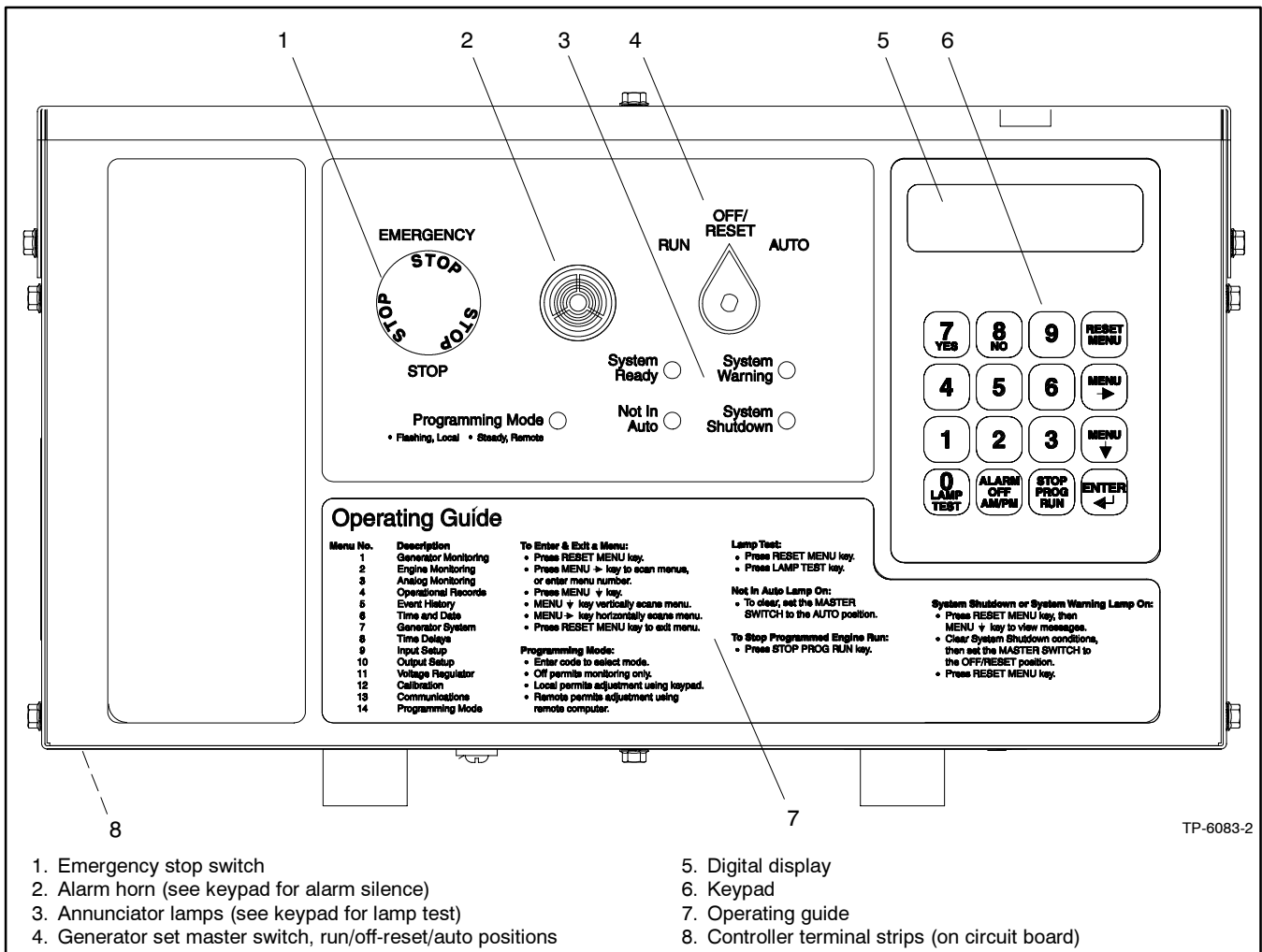

Figure 1-1 Controller

1.2.1 Annunciator Lamps

Five annunciator lamps provide visual generator set status. See Figure 1-2.

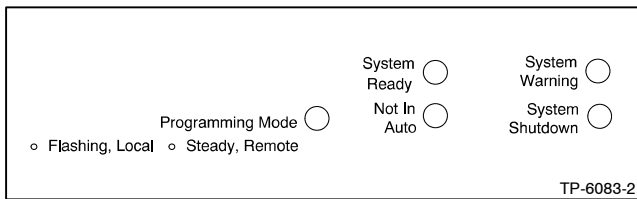

Figure 1-2 Annunciator Lamps

System Ready. Green lamp illuminates when the generator set master switch is in the AUTO (automatic start) position and the system senses no faults. The unit is ready to start.

Not in Auto (NIA). Yellow lamp illuminates when the generator set master switch is not in the AUTO (automatic start) position.

Programming Mode. Yellow programming lamp indicates the user selected programming mode. See Figure 1-3.

Programming Lamp	Programming Mode Selection
Lamp Flashing	Local Programming
Lamp Steady On	Remote Programming
Lamp Off	Programming Disabled

Figure 1-3 Programming Lamp Mode

Note: Find additional information for the programming mode lamp function and access to the local or remote programming modes in Section 2.9, Local Programming Mode On, Menu 14—Programming Mode.

System Warning. Yellow lamp identifies an existing fault condition that does not shut down the generator set. A continuing system warning fault condition may cause a system shutdown. Correct all system warnings as soon as practical.

See Section 2.3.5, System Warning Lamp, for definitions of the items listed.

The following conditions cause a system warning:

- Engine functions:
 - High battery voltage
 - High coolant temperature
 - Low battery voltage
 - Low coolant temperature
 - Low fuel (level or pressure)*
 - Low oil pressure
 - Speed sensor fault
 - Starting aid (status)
 - Weak battery
- General functions:
 - Auxiliary—Analog up to 7 inputs each with a high and low programmable warning level
 - NOTE:** Non-ECM models have 5 programmable warnings
 - Auxiliary—Digital up to 21 programmable warnings
 - Battery charger fault*
 - Emergency power system (EPS) supplying load
 - Engine cooldown delay
 - Engine start delay
 - Load shed kW overload
 - Load shed underfrequency
 - Master switch not in AUTO (automatic start) position
 - NFPA-110 fault (National Fire Protection Association)
 - System ready (status)
- Generator functions:
 - AC sensing loss
 - Generator running (status)
 - Ground fault*
 - Overcurrent

* Requires optional input sensors.

System Shutdown. Red lamp indicates that the generator set has shut down because of a fault condition. Unit will not start without resetting controller, see Section 2.3.7, Controller Reset Procedure.

See Section 2.3.6, System Shutdown Lamp, for definitions of the items listed.

The following conditions cause a system shutdown:

- Engine functions:
 - Air damper closed (status), if equipped
 - Coolant temperature signal loss
 - High coolant temperature
 - High oil temperature
 - Low coolant level
 - Low oil pressure
 - Oil pressure signal loss
 - Overcrank
 - Overspeed
- General functions:
 - Auxiliary—Analog up to 7 inputs each with a high and low programmable shutdown level
NOTE: Non-ECM models have 5 programmable shutdowns
 - Auxiliary—Digital up to 21 programmable shutdowns
 - ECM communications loss (ECM models only)
 - Emergency stop
 - Internal fault
 - Master switch in OFF/RESET position
 - Master switch error
 - Master switch open
 - NFPA 110 fault
- Generator functions:
 - AC output overvoltage
 - AC output undervoltage
 - Alternator protection against overload and short circuits
 - Field overvoltage (M4, M5, or M7 alternator only)
 - Locked rotor (failed to crank)
 - Overfrequency
 - Underfrequency

1.2.2 Digital Display and Keypad

Figure 1-4 illustrates the digital display and keypad.

Note: Press any key on the keypad to turn on the controller lights and display. The lights and display turn off 5 minutes after the last keypad entry.

The 2-line vacuum fluorescent display provides generator set and engine condition information.

The 16-button keypad gives the user information access and local programming capability.

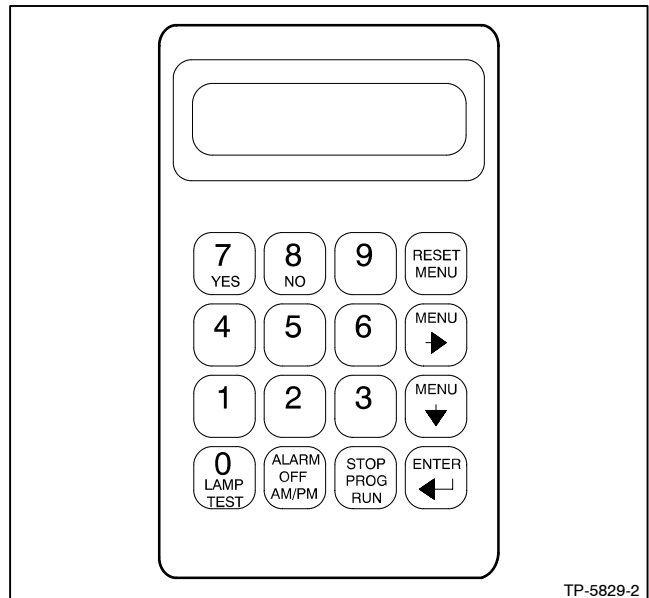

Figure 1-4 Digital Display and Keypad

Keypad Functions

Alarm (horn) off key silences the alarm horn at the operator's discretion. Place the generator set master switch in the AUTO position before silencing the alarm horn. See Section 2.3.7, Controller Reset Procedure, and Section 1.2.3, Switches and Controls.

AM/PM key provides time of day data entries when programming.

Enter ↵ **key** provides confirmation entry when selecting menu or programming.

Lamp test key tests the controller indicator lamps, horn, and digital display. See Section 1.2.3, Switches and Controls.

Menu down ↓ **key** provides navigation within menus when necessary.

Menu right → **key** provides navigation within menus when necessary.

Numeric 0-9 keys provide numeric data entries when selecting menus or programming.

Reset menu key exits a menu, clears incorrect entries, and cancels the auto-scroll feature.

Stop prog (program) run key allows the user to stop any previously programmed generator set run sequence. See Section 1.2.3, Switches and Controls.

Yes/No keys provides data answer entries when programming.

Generator Output Displays

AC Amps displays the generator output current. The display shows each line of 3-phase models.

AC Volts displays the generator output voltages. The display shows all line-to-neutral and line-to-line voltage combinations.

Alternator duty level displays the actual load kW divided by the nameplate kW rating as a percentage.

Frequency displays the frequency (Hz) of generator output voltage.

Hourmeter displays the generator set operating hours loaded and unloaded for reference in scheduling maintenance.

KVA displays the total and individual L1, L2, and L3 kVA.

KVAR displays the total and individual L1, L2, and L3 kVAR.

Power factor displays the leading/lagging L1, L2, L3, and total power factor.

Watts displays the total and individual L1, L2, L3 kilowatts.

Engine Displays

Some engine displays are available with selected generator set engines using engine electronic control modules (ECM) only. The controller display shows N/A (not available) for items that are unavailable. See the controller spec sheet for applicable generator set models.

Ambient Temperature displays the generator set area ambient temperature.

Coolant Level displays the engine coolant level.

Coolant Pressure displays the engine coolant pressure.

Coolant Temperature displays the engine coolant temperature.

Crankcase Pressure displays the engine crankcase pressure.

DC Volts displays the voltage of starting battery(ies).

Fuel Pressure displays the fuel supply pressure.

Fuel Rate displays the calculated fuel consumption rate based on fuel injector outputs.

Fuel Temperature displays the fuel supply temperature.

Oil Level displays the engine oil level as a percent of full capacity.

Oil Pressure displays the engine oil pressure.

Oil Temperature displays the engine oil temperature.

RPM (Tachometer) displays the engine speed.

Used Last Run displays the accumulated amount of fuel used since last reset by the engine DDEC reader.

Operational Record Displays

The operational record displays events since last reset. See Section 2.9.4, Menu 4—Operational Records, for resetting procedure.

Engine Start Countdown displays the time remaining before the next generator set startup.

Event History displays up to 100 stored system events including status, warnings, and shutdowns.

Last Start Date displays the date when the generator set last operated.

Number of Starts displays the total number of generator set startup events.

Number of Starts (Since) Last Maintenance displays the total number of generator set startup events since the last maintenance date.

Operating Days (Since) Last Maintenance displays the total number of days of operation since the last maintenance date. A counted day of operation can be 1-24 hours.

Run Time displays the total loaded hours, total unloaded hours, and total kW hours.

Run Time Since Maintenance displays the total loaded hours, total unloaded hours, and total kW hours.

Time Delay Displays

The time delays are user adjustable. See Section 2.9.8, Menu 8—Time Delays, for time delay adjustments. See Section 1.3.1, Status Event and Fault Specifications, for range and default settings.

Crank On/Crank Pause displays the time allocated for generator set crank on and crank pause in minutes:seconds.

Engine Cooldown displays the time delay for engine cooldown while the master switch is in the AUTO or RUN positions and not in the idle mode.

Engine Start displays the time delay before the generator set starts while the master switch is in AUTO or RUN positions.

Overcrank Shutdown (Number of) Crank Cycles displays the number of unsuccessful crank cycles (crank on/crank pause) before the generator set shuts down on an overcrank fault.

Overvoltage displays the time delay before the generator set shuts down because of an overvoltage condition.

Starting Aid displays the engine starting aid activation time.

Undervoltage displays the time delay before the generator set shuts down because of an undervoltage condition.

1.2.3 Switches and Controls

See Figure 1-5 and Figure 1-6 for switches and controls.

Note: Find additional switches and controls in Section 2.6.1, Keypad Operation.

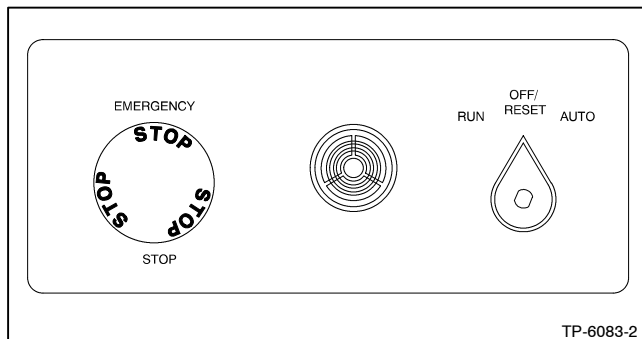

Figure 1-5 Switches and Alarm Horn

Alarm Horn. The alarm horn alerts the operator or other attendants that a shutdown or warning condition exists. See Section 1.3, Controller Logic Specifications, for conditions. Place the generator set master switch in the AUTO position before silencing the alarm horn. The alarm horn cannot be silenced unless the generator set master switch is in the AUTO position. See Section 2.3.7, Controller Reset Procedure.

Alarm (Horn) Off. The keypad switch silences the alarm horn at the operator's discretion. Place the generator set master switch in the AUTO position before silencing the alarm horn. Restore alarm horn switches at all locations including those on remote annunciator and audiovisual alarm kits to the normal position after correcting the fault shutdown to avoid reactivating the alarm horn. See Section 2.3.7, Controller Reset Procedure.

Emergency Stop. The operator-activated switch immediately shuts down the generator set in emergency situations. Reset the emergency stop switch after shutdown by pulling the switch knob outward. *Use the emergency stop switch for emergency shutdowns only.* Use the generator set master switch for normal shutdowns.

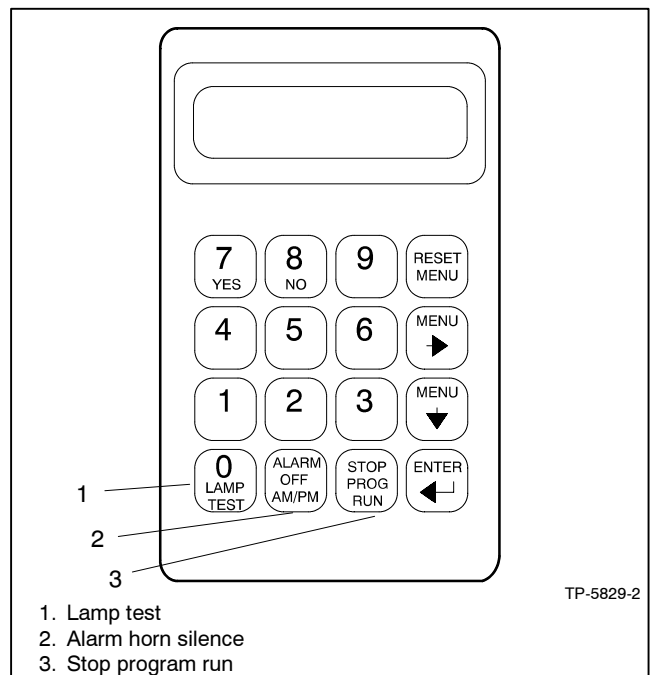

Figure 1-6 Keypad Switches

Generator Set Master Switch (Run/Off-Reset/Auto). This switch resets the controller fault lamps and start/stops the generator set. Refer to Section 2.3.1, Starting, Section 2.3.2, Stopping, and Section 2.3.3, Emergency Stop Switch Reset Procedure.

Lamp Test. Keypad switch tests the controller indicator lamps, horn, and digital display. Press the reset menu key before pressing the lamp test key.

Stop Prog (Program) Run. Keypad switch allows the user to stop any previously programmed generator set run sequence.

1.2.4 Controller Circuit Boards

The controller has five circuit boards—indicator, interconnection, keypad, digital display, and main logic/communication. See Figure 1-7 for circuit board locations.

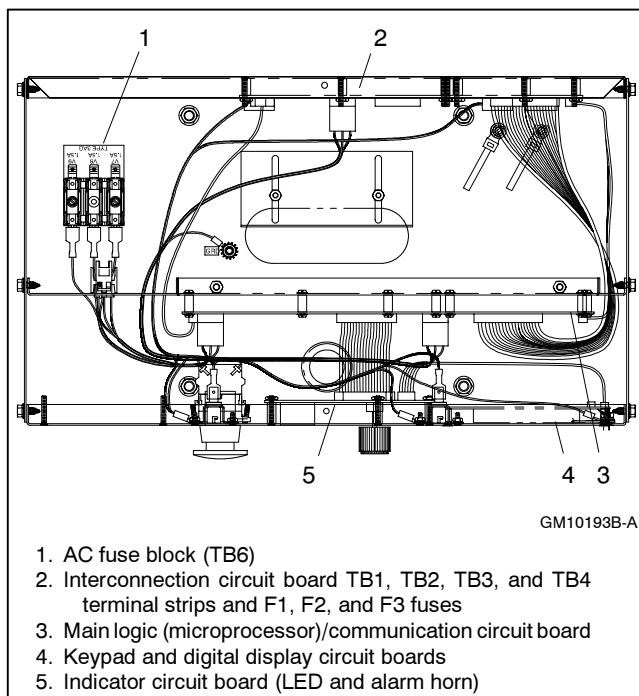

Figure 1-7 Controller Circuit Boards and Fuses (Controller Top View)

Indicator Circuit Board includes the LED status lamps and alarm horn.

Interconnection Circuit Board provides the terminal strips to connect the customer connection and/or dry contact kits and three fuses (F1, F2, and F3).

Keypad Circuit Board provides the keypad to navigate the generator set displays and enter data.

Digital Display Circuit Board provides the digital display for monitoring the generator set functions and output values.

Main Logic (Microprocessor)/Communication Circuit Board provides the controller operation logic and provides PC communication locally (direct) or remotely (via modem) using RS-232 or RS-485 connectors.

1.2.5 Fuses

AC Circuit Fuses (TB6). Fuses are located inside the controller. See Figure 1-7.

- **1.5-Amp (V7)** fuse protects L1 sensing input to interconnection circuit board.
- **1.5-Amp (V8)** fuse protects L2 sensing input to interconnection circuit board.
- **1.5-Amp (V9)** fuse protects L3 sensing input to interconnection circuit board.

DC Circuit Fuses fuses are located on the controller interconnection circuit board.

- **5-Amp Remote Annunciator (F1)** fuse protects the dry contact kit if equipped and the controller panel lamps.
- **5-Amp Controller (F2)** fuse protects the controller circuitry.
- **15-Amp Engine and Accessories (F3)** fuse protects the engine/starting circuitry and accessories.

1.2.6 Terminal Strips and Connectors

Terminal strips and connectors for inputs and outputs are located on the interconnection circuit board. See Section 6, Accessories.

TB1 Input Connection Terminal Strip provides input connections for remote start and emergency stop (E-Stop).

TB2 Analog Input Connection Terminal Strip provides analog input connections, including non-ECM sensor connections.

TB3 Accessory Power Output Connection Terminal Strips provides a generator set power supply for factory use.

TB4 Digital Input Connection Terminal Strips connect external devices (engine ECM and user supplied) to the generator set digital inputs.

P23 Connector connects the interconnection circuit board to the (customer) connection terminal strip (connector P25) inside the junction box.

Figure 1-8 shows locations of the terminal strips on the controller interconnection circuit board. See Section 6.2, Accessory and Connections, for specific terminal identification information. Refer to the wiring diagrams for additional information on connecting accessories to the terminal strips.

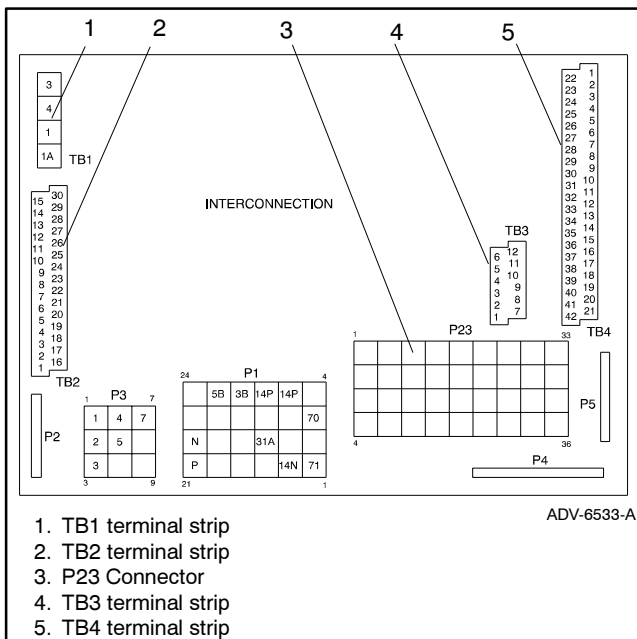

Figure 1-8 Interconnection Circuit Board Terminal Strips and Connectors

1.2.7 Circuit Board Interconnections for Calibration Procedure

The interconnection circuit board shown in Figure 1-9 contains a ribbon connector that requires disconnection during the calibration procedure in Menu 12—Calibration. Disconnect ribbon connector P2 prior to zeroing out (resetting) the auxiliary analog inputs.

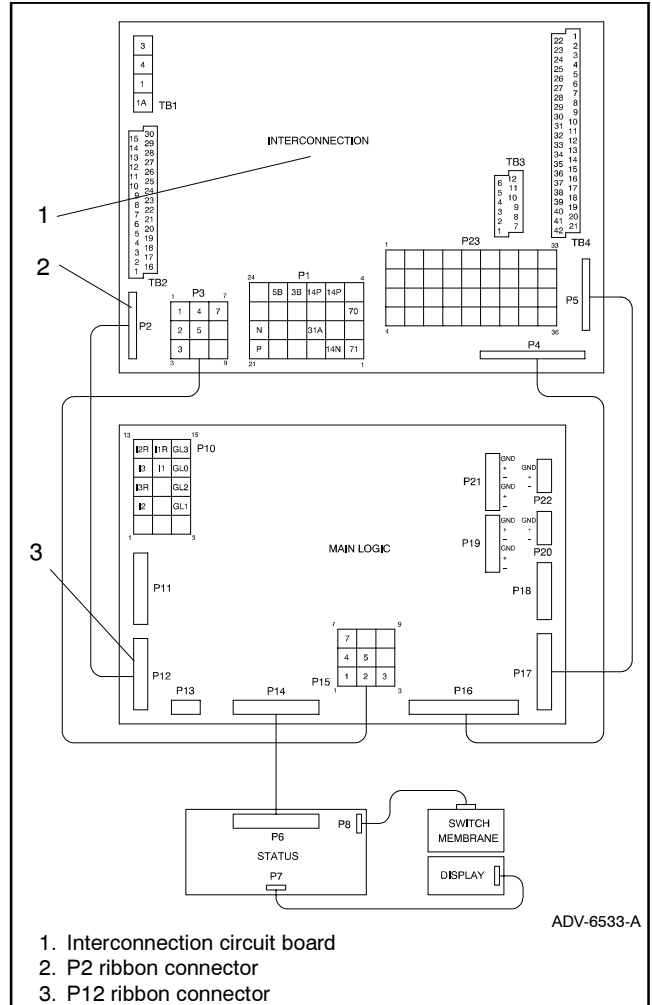

Figure 1-9 Interconnection Circuit Board Ribbon Connector P2 (Top View of Circuit Board)

1.2.8 Communication Ports

The main logic circuit board contains several communication ports for KBUS and Modbus connections. See Figure 1-10. Refer to the List of Related Materials in the Introduction section for corresponding communication installation information.

1.3 Controller Logic Specifications

The Controller Logic Specifications section is an overview of the various features and functions of the controller. Certain features function only when optional accessories are connected. See Section 2, Operation, for details.

The default selection time delays and relay driver outputs (RDOs) are factory set and adjustable with the programming mode on. Some data entries require using a PC in the Remote Programming mode. See the Software Operation Manual for details.

Inhibit Time Delay. The inhibit time delay is the time period following crank disconnect during which the generator set stabilizes and the controller does not detect the fault or status events. Select the desired inhibit time delay from 0 to 60 seconds.

Time Delay (Shutdown or Warning). The time delay follows the inhibit time delay. The time delay is the time period between when the controller first detects the fault or status event and the controller warning or shutdown lamp illuminates. The delay prevents any nuisance alarms. Select the desired time delay from 0 to 60 seconds.

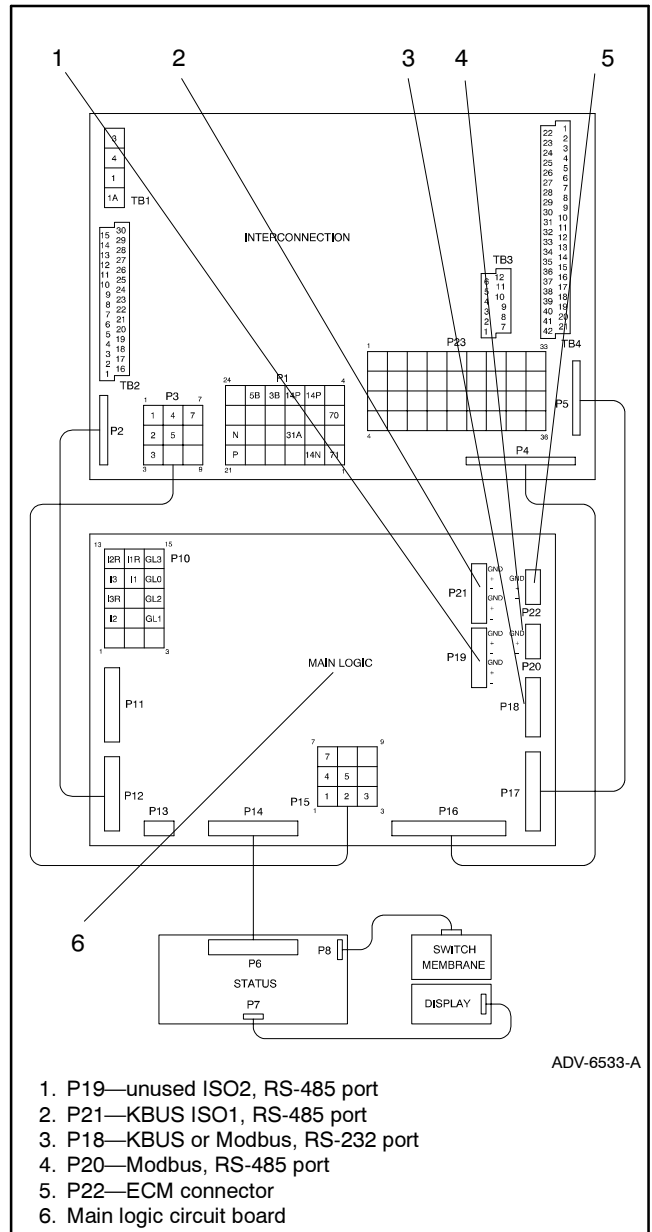

Figure 1-10 Main Logic Circuit Board Communication Ports (Top View of Circuit Board)

1.3.1 Status Event and Fault Specifications

Status Event or Fault	Refer to Menu	Digital Display	Relay Driver Output (RDO)	Alarm Horn	Lamp	Range Setting	Default Selection	Inhibit Time Delay (sec.)	Time Delay (sec.)
AC Sensing Loss	10	AC Sensing Loss	RDO-25	On	Warning				
Access Code (password)	14						0 (zero)		
Air Damper Indicator (if used) Digital Aux. Input 20	10	Air Damper Indicator	RDO-23 (lead 56)	On	Shutdown		0 sec. inhibit, 0 sec. delay		
Alternator Protection	10	Alternator Protection		On	Shutdown				
Battery Charger Fault, Digital Aux. Input 1	10	Battery Charger Fault	RDO-11 (lead 61)	Off	Warning		0 sec. inhibit, 0 sec. delay		
Battle Switch (see Fault Shutdown Override Switch)	9	Battle Switch		Off	Warning				
Analog Aux. Inputs 1-7	9	User-Defined A1-A7		On	Shutdown or Warning	Default Values with Warning Enabled: HI warning 90% LO warning 10% HI shutdown 100% LO shutdown 1%	30 sec. inhibit, 5 sec. delay	0-60	0-60
Analog Aux. Input 1 (non-ECM only)	9	Coolant Temp		On	Shutdown or Warning	Default Values with Warning Enabled: HI/LO warning and HI/LO shutdown are all engine dependent	30 sec. inhibit, 0 sec. delay	0-60	0-60
Analog Aux. Input 2 (non-ECM only)	9	Oil Pressure		On	Shutdown or Warning	Default Values with Warning Enabled: HI/LO warning and HI/LO shutdown are all engine dependent (255 psi max.)	30 sec. inhibit, 0 sec. delay warning, 5 sec. delay shutdown	0-60	0-60
Digital Aux. Input 1-21	9	User-Defined D1-D21		On	Shutdown or Warning		30 sec. inhibit, 5 sec. delay	0-60	0-60
Cyclic Cranking	8			Off		1-6 crank cycles 1-60 sec. crank on 1-60 sec. pause	3 15 sec. 15 sec.		
Defined Common Faults	10	Defined Common Fault	RDO-18 (lead 32A)	On	Shutdown or Warning	Default shutdowns include: Emergency stop High coolant temp Low oil pressure Overcrank Overspeed	30 sec. inhibit, 5 sec. delay	0-60	0-60
EEPROM Write Failure	10	EEPROM Write Failure		On					
Engine Cooldown (see Time Delay-)									
Engine Start (see Time Delay-)									
EPS (Emergency Power System) Supplying Load	10	EPS Supplying Load	RDO-22	Off			5% of rated line current		
Emergency Stop Shutdown	10	Emergency Stop	RDO-14 (lead 48)	Off	Shutdown				
Fault Shutdown Override Switch	9	Battle Switch		Off	Warning				
Field Overvoltage Digital Aux. Input 4 (M4, M5, or M7 alternator only)	9	Field Overvoltage		On	Shutdown		1 sec. inhibit, 15 sec. delay		

Status Event and Fault Specifications, continued

Status Events or Fault	Refer to Menu	Digital Display	Relay Driver Output (RDO)	Alarm Horn	Lamp	Range Setting	Default Selection	Inhibit Time Delay (sec.)	Time Delay (sec.)
Generator Running	10		RDO-15 (lead 70R)	Off					
Ground Fault Detected	10	Ground Fault		On	Warning				
High Battery Voltage	10	High Battery Voltage	RDO-13	Off	Warning	14.5-16.5 V (12 V) 29-33 V (24 V)	16 V (12 V) 32 V (24 V)		10
High Coolant Temperature Shutdown	10	Hi Cool Temp Shutdown	RDO-03 (lead 36)	On	Shutdown			30	5
High Coolant Temperature Warning	10	Hi Cool Temp Warning	RDO-06 (lead 40)	On	Warning			30	
High Oil Temperature Shutdown	10	Hi Oil Temp Shutdown		On	Shutdown			30	5
Idle (speed) Mode Function Digital Aux. Input 21	10	Idle Mode Active	RDO-21	Off	Warning		0 sec. inhibit, 60 sec. delay		0-600
Internal Fault Shutdown	10	Internal Fault		On	Shutdown				
kW Overload (see Load Shed)									
Load Shed kW Overload	10	Load Shed KW Over	RDO-30	Off	Warning		100% of kW Rating		5
Load Shed Underfrequency	10	Load Shed Under Frequency	RDO-31	Off	Warning		59 Hz with (60 Hz) 49 Hz with (50 Hz)		5
Locked Rotor Shutdown	10	Locked Rotor		On	Shutdown				
Loss of ECM Communication	10	Loss of ECM Comm	RDO-26	On	Shutdown				4
Low Battery Voltage	10	Low Battery Voltage	RDO-12 (lead 62)	Off	Warning	10-12.5 V (12 V) 20-25 V (24 V)	12 V (12 V) 24 V (24 V)		10
Low Coolant Level	10	Low Coolant Level	RDO-19	On	Shutdown			30	5
Low Coolant Temperature, Digital Aux. Input 3 (ECM)	10	Low Coolant Temp	RDO-05 (lead 35)	On	Warning		0 sec. inhibit, 0 sec. delay		
Low Fuel, Digital Aux. Input 2	10	Low Fuel	RDO-08 (lead 63)	On	Warning		0 sec. inhibit, 0 sec. delay		
(Low) Oil Pressure Shutdown	10	Oil Pressure Shutdown	RDO-04 (lead 38)	On	Shutdown			30	5
(Low) Oil Pressure Warning	10	Oil Pressure Warning	RDO-07 (lead 41)	On	Warning			30	
Master Not In Auto (generator switch)	10	Not In Auto	RDO-09 (lead 80)	On	Not In Auto				
Master Switch Error	10	Master Switch Error		On	Shutdown				
Master Switch Open	10	Master Switch Open		On	Shutdown				
NFPA 110 Fault	10	NFPA 110 Fault	RDO-10 (lead 32)	On	Shutdown or Warning				
No Coolant Temperature Signal	10	No Cool Temp Signal		Off	Shutdown			30	4
No Oil Pressure Signal	10	No Oil Pressure Signal		Off	Shutdown			30	4

Status Event and Fault Specifications, continued

status events or Fault	Refer to Menu	Digital Display	Relay Driver Output (RDO)	Alarm Horn	Lamp	Range Setting	Default Selection	Inhibit Time Delay (sec.)	Time Delay (sec.)
Overcrank Shutdown	8	Over Crank	RDO-02 (lead 12)	On	Shutdown	0-6 Cycles	3 Cycles		
Overcurrent	10	Over Current		On	Warning		110%		10
Overfrequency Shutdown	7, 10	Over Frequency	RDO-28	On	Shutdown	102%-140%	140% Std. 103% FAA		10
Overspeed Shutdown	7, 10	Over Speed	RDO-01 (lead 39)	On	Shutdown	65-70 Hz (60 Hz) 55-70 Hz (50 Hz)	70 (60 Hz) 60 (50 Hz)		0.25
Overvoltage Shutdown	7, 8, 10	Over Voltage	RDO-20 (lead 26)	On	Shutdown	105%-135%	115% 2-sec time delay		2-10
Password (see Access Code)									
Speed Sensor Fault	10	Speed Sensor Fault	RDO-24	On	Warning				
Starting Aid (see Time Delay Starting Aid)									
System Ready	10		RDO-17 (lead 60)	Off	System Ready				
Time Delay Engine Cooldown (TDEC)	8, 10		RDO-16 (lead 70C)	Off		00:00-10:00 min:sec	5:00		
Time Delay Engine Start (TDES)	8, 10			Off		00:00-5:00 min:sec	00:01		
Time Delay Starting Aid	8, 10			Off		0-10 sec.			
Underfrequency	7, 10	Under Frequency	RDO-29	On	Shutdown or Warning	80%-95%	90%		10
Undervoltage Shutdown	7, 8, 10	Under Voltage	RDO-27	On	Shutdown	70%-95%	85% 10-sec time delay		5-30
Weak Battery	10	Weak Battery		Off	Warning		60%		2

1.3.2 Voltage Regulator and Calibration Specifications*

Calibration	Refer to Menu	Digital Display	Range Setting	Default Selection
Underfrequency Unload Slope	11	Slope	0-10% of rated voltage volts per cycle	2 volts per cycle
PF Adjust Control	11	PF Adj.	0.7 to 1.0 leading 0.6 to 1.0 lagging	0.8 lagging
Reactive Droop	11	Voltage Droop	0-10% of system voltage	4% of system voltage
Underfrequency Unload or Frequency Setpoint	11	Frequency Setpoint	40 to 70 Hz	1 Hz below system frequency (ECM) 2 Hz below system frequency (non-ECM)
VAR Control	11	kVAR Adj.	0 to rated kVAR generating 0 to 35% of rated kVAR absorbing	0
Voltage Adjustment	11	Volt Adj.	±20% of system voltage	System voltage

* The controller-to-alternator interface circuit board was temporarily unavailable on early units. As a result, 350-2000 kW generator sets are equipped with a Marathon DVR 2000 voltage regulator and not the internal controller voltage regulator. Refer to the Marathon voltage regulator technical manual for specifications and all adjustments.

1.3.3 Voltage Regulator Adjustments

The descriptions of the voltage regulator adjustments and features follow. See Appendix C, Voltage Regulator Definitions and Adjustments, for additional information.

Underfrequency Unload Slope. This setting determines how much the voltage drops during an underfrequency condition. Typically, applying a large electrical load causes a dip in engine speed and underfrequency. The voltage regulator reduces voltage, allowing engine speed recovery. The volts-per-Hz setting determines the *amount of voltage drop*.

Power Factor (PF) Adjust Control. Power factor adjust controls the generator reactive load. The PF adjustment controls the excitation level for maintaining the PF setting. The PF adjust control setting determines the *reactive current (VARs) amount in relation to the real current (watts)* as regulated by the load-sharing module.

Power is the cosine of the electrical angle between current and voltage. The cosine function is positive for angles between -90 degrees (lagging) and $+90$ degrees (leading). This adjustment requires the user to determine whether the current leads (positive angle) or lags (negative angle) the voltage.

Reactive Droop. Reactive droop compensation provides reactive current flow adjustment in the generator during generator-to-generator paralleling applications. Reactive droop reduces excitation levels with increasing reactive current. A reduced excitation level removes generator reactive current or generates VARs, improving stability.

Enter the gain setting as a *percentage of system voltage causing output voltage drop* when full-rated load with 0.8 power factor is applied. Any loads less than full load force voltage drop by the ratio of reactive volt-amps (VARs) to rated VARs.

Underfrequency Unload or Frequency Setpoint.

This adjustment affects the voltage droop (volts per Hz) when load is applied and underfrequency occurs. The underfrequency unload setting defines the *setpoint where underfrequency starts*. Any frequency below the setpoint causes the voltage to drop and engine speed to recover according to the underfrequency unload slope setting.

Engine speed recovery depends upon characteristics such as engine make, fuel type, load types, and operating conditions. The underfrequency unload setting best matches engine speed recovery characteristics to the application.

VAR Control. VAR control provides *reactive current flow adjustment* in the generator during generator-to-utility paralleling applications. The controller displays the total kVAR generator load while running in parallel with the utility.

The utility supply, not the controller, determines terminal voltage. Engine fueling determines real power measured in watts using load sharing module control.

Voltage Adjustment. The voltage adjustment allows the customer to *enter the desired generator set output level*. This regulated level setting is the average of the three line-to-neutral voltages in wye configurations or L1-to-L2 in single phase and delta configurations.

Submenus display the individual line-to-line voltages. These voltages are relevant in unbalanced load conditions. The voltage adjust setpoint can be changed to accommodate an important phase in an unbalanced system.

2.1 Prestart Checklist

To ensure continued satisfactory operation perform the following checks or inspections before or at each startup, as designated, and at the intervals specified in the service schedule. In addition, some checks require verification after the unit starts.

Air Cleaner. Check for a clean and installed air cleaner element to prevent unfiltered air from entering the engine.

Air Inlets. Check for clean and unobstructed air inlets.

Battery. Check for tight battery connections. Consult the battery manufacturer's instructions regarding battery care and maintenance.

Controller. After reconnecting the battery, set the controller time and date. See Section 2, Menu 14—Programming Mode On and Menu 6—Time and Date.

Coolant Level. Check the coolant level according to the cooling system maintenance information.

Note: Block heater damage. The block heater will fail if the energized heater element is not immersed in coolant. Fill the cooling system before turning on the block heater. Run the engine until it is warm, and refill the radiator to purge the air from the system before energizing the block heater.

Drive Belts. Check the belt condition and tension of the radiator fan, water pump, and battery charging alternator belt(s).

Exhaust System. Check for exhaust leaks and blockages. Check the silencer and piping condition and check for tight exhaust system connections.

Inspect the exhaust system components (exhaust manifold, exhaust line, flexible exhaust, clamps, silencer, and outlet pipe) for cracks, leaks, and corrosion.

- Check for corroded or broken metal parts and replace them as needed.
- Check for loose, corroded, or missing clamps and hangers. Tighten or replace the exhaust clamps and/or hangers as needed.
- Check that the exhaust outlet is unobstructed.
- Visually inspect for exhaust leaks (*blowby*). Check for carbon or soot residue on exhaust components. Carbon and soot residue indicates an exhaust leak. Seal leaks as needed.

Fuel Level. Check the fuel level and keep the tank(s) full to ensure adequate fuel supply.

Oil Level. Maintain the oil level at or near, not over, the full mark on the dipstick.

Operating Area. Check for obstructions that could block the flow of cooling air. Keep the air intake area clean. Do not leave rags, tools, or debris on or near the generator set.

2.2 Exercising the Generator Set

Operate the generator set under load once each week for one hour. Perform the exercise in the presence of an operator when the generator set does not have a programmed exercise mode or an automatic transfer switch with an exercise option.

During the exercise period apply a minimum of 35% load based on the nameplate standby rating, unless otherwise instructed in the engine operation manual.

The operator should perform all of the prestart checks before starting the exercise procedure. Start the generator set according to the starting procedure in Section 2.3, Controller Operation. While the generator set is operating, listen for a smooth-running engine and visually inspect the generator set for fluid or exhaust leaks.

x:op:001:005

2.3 Controller Operation

2.3.1 Starting

Local Starting

Move the generator set master switch to the RUN position to start the generator set at the controller.

Note: The alarm horn sounds and the Not-In-Auto lamp lights whenever the generator set master switch is not in the AUTO position.

Note: The transient start/stop function of the controller prevents accidental cranking of the rotating engine. The generator set stops and recranks when the generator set master switch is momentarily placed in the OFF/RESET position and then returned to RUN.

Auto Starting

Move the generator set master switch to the AUTO position to allow startup by the automatic transfer switch or remote start/stop switch (connected to controller terminals 3 and 4).

Terminals 3 and 4 connect to a circuit that automatically starts the generator set crank cycle when an external source closes the circuit.

Note: The controller provides up to 60 seconds of programmable cyclic cranking and up to 60 seconds rest with up to 6 cycles. The default setting is 15 seconds cranking and 15 seconds rest for 3 cycles. Make cyclic cranking adjustments using the keypad. See Section 2.9.14, Menu 14—Programming Mode, and Section 2.9.8, Menu 8—Time Delays.

Idle (Speed) Mode Warmup and Cooldown Function

The idle (speed) mode function provides the ability to start and run the engine at reduced speed for a selectable time period (0–10 minutes) during warmup. See Section 6.1.5, Idle (Speed) Mode Feature, for installation information.

The controller will override the idle speed mode when the engine reaches the preprogrammed engine warm-up temperature before the idle mode times out.

The idle function also provides engine cooldown at idle speed. The controller overrides the idle speed mode when the engine reaches the preprogrammed engine cooldown temperature before the idle mode times out.

During the idle (speed) mode the controller continues to monitor critical engine parameters such as oil pressure, coolant temperature, and engine speed. The voltage regulator, thermal protection feature, and AC metering are disabled in the idle speed mode.

The controller overrides the idle speed function when the generator set is signaled to start while in the AUTO position. This override provides emergency generator set power in the event of a utility power failure. When the utility power returns and the generator set is signaled to stop, the generator set continues to run for the duration of the idle mode period when the idle mode is active. When the idle mode is not active, the generator set will shut down in the normal stopping mode including time delays.

See Menu 9—Input Setup to activate the idle speed function as a user-defined digital input. The idle speed feature requires an ECM-equipped engine with the idle speed function.

Run Time Feature

The run time feature allows the user to set up the generator set to run unassisted and automatically return to the standby mode. The user does not need to wait for the exercise period (run time) to conclude in order to place the unit back in the standby mode. See Menu 4—Operational Records for setup of this feature.

With the run time enabled, the generator set will begin to crank and run based on the run time period and all previously established time delays from Menu 8—Time Delays.

Generator set connected to an automatic transfer switch. Should a utility power failure occur while the unit is in the run time mode, the controller will bypass the run time mode and function in the standby (backup) mode. When the utility power returns, the generator set continues to run for the duration of the run time period when not timed out.

Note: Press the STOP PROG RUN key, when necessary, to stop the generator set when it is in the run time mode.

Prime Power Switch

The digital controller has an optional prime power mode of operation. The prime power mode requires installation of an optional prime power switch kit. See Section 6, Accessories for instructions on how to install the optional prime power switch kit. The prime power switch kit prevents engine starting battery drain when the generator set is shut down and no external battery charging is available.

Move the prime power switch located on the back of the controller to the CONTROLLER ON position and set the controller time and date before attempting to start the generator set. When the prime power mode is off, all controller functions including the digital display, LEDs, and alarm horn are operative.

Note: After energizing the controller using the prime power switch, set the controller time and date. See Section 2.9.6, Menu 6—Time and Date.

Stop the generator set using the stopping procedures in 2.3.2 before placing the generator set in the prime power mode. Move the prime power switch located on the back of the controller to the CONTROLLER OFF position. When the generator set is in the prime power mode, all controller functions including the digital display, LEDs, alarm horn, and communications are inoperative.

2.3.2 Stopping

Normal Stopping

Run the generator set without load for 5 minutes to ensure adequate engine cooldown.

The controller has a programmable cooldown timer that functions only when the master switch is in the AUTO position. To stop the generator set, place the generator set master switch in the OFF/RESET position and wait until the generator set comes to a complete stop.

Note: The cooldown cycle times out before the generator set stops when a remote switch or automatic transfer switch initiates the generator set start/stop sequence.

Emergency Stopping

Use the controller emergency stop switch or optional remote emergency stop for immediate shutdown.

The emergency stop switch bypasses the time delay engine cooldown and immediately shuts down the generator set.

Note: Use the emergency stop switch(es) for emergency shutdowns only. Use the generator set master switch for normal shutdowns.

The controller system shutdown lamp lights and the unit shuts down when the local or remote emergency stop switch activates.

Battle Switch/Fault Shutdown Override Switch

The *battle* switch function forces the system to ignore normal fault shutdowns such as low oil pressure and high engine temperature. The battle switch does not override the emergency stop and overspeed shutdown. When the battle switch function is enabled the generator set continues to run regardless of shutdown signals where potential engine/generator damage can occur.

When this input is enabled the yellow warning lamp illuminates and stored warning/shutdown events that are ignored continue to log in Menu 5—Event History.

See Section 2.9.9, Menu 9—Input Setup, for information on how to enable the battle switch feature.

2.3.3 Emergency Stop Switch Reset Procedure

Use the following procedure to reset the generator set after shutdown by a local or remote emergency stop switch. Refer to Section 2.3.7, Controller Reset Procedure, to restart the generator set following a fault shutdown.

1. Place the generator set master switch in the OFF/RESET position.
2. Investigate and correct the cause of the emergency stop.
3. Reset the optional remote emergency stop switch by replacing the glass piece, when equipped. Additional glass rods are available as a service part. Reset the controller emergency stop switch by pulling the switch knob outward.
4. After resetting all faults using the Controller Reset Procedure, toggle the generator set master switch to RUN or AUTO to restart the generator set. The generator set will not crank until the reset procedure completes.

2.3.4 System Ready Lamp

System Ready. The green lamp illuminates when the generator set master switch is in the AUTO position and the system has no fault conditions.

2.3.5 System Warning Lamp

The yellow warning lamp illuminates indicating a fault or status event but does not shut down the generator set under the following conditions. In some cases the alarm horn also sounds. See Section 2.3.7, Controller Reset Procedure, for instructions on resetting a system warning.

When the system warning lamp is on and no message displays, press the Reset Menu and the menu down ↓ key to view messages. When the system warning continues, it may lead to a fault and cause a system shutdown.

Use the Alarm Off keypad switch to silence the alarm horn at the operator's discretion. Place the generator set master switch in the AUTO position before silencing the alarm horn. The alarm horn cannot be silenced unless the master switch is in the AUTO position.

Note: Text shown in *italics* in this manual represents digital display messages.

AC Sensing Loss. The lamp illuminates when the controller does not detect nominal generator set AC output voltage after crank disconnect. The local display shows *AC sensing loss*.

Battery Charger Fault. The lamp illuminates when the battery charger malfunctions. This fault feature requires an optional battery charger with a malfunction output for the lamp to function. Local display shows *battery charger fault*.

Customer Auxiliary (Warning). The lamp illuminates and the alarm horn sounds when an auxiliary digital or analog inputs signals the controller. The customer can define inputs as shutdowns or warnings. The local display shows *digital input 1-21 or analog input 1-7*.

Using the remote communications package, the user can label the auxiliary functions. The controller displays the selected name instead of *digital input 1-21 or analog input 1-7*.

EEPROM Write Failure. The lamp illuminates and the alarm horn sounds when the control logic detects a data save error. The local display shows *EEPROM write failure*.

Emergency Power System (EPS) Supplying Load.

The lamp illuminates when the generator set supplies more than 5% of the rated standby output current. The local display shows *EPS supplying load*.

Generator Switch Not in Auto. The lamp illuminates and the alarm horn sounds when the generator set master switch is in the RUN or OFF/RESET position. The local display shows master switch *not in auto*.

Ground Fault Detected. The lamp illuminates and the alarm horn sounds when a user-supplied ground fault detector signals the controller. The local display shows *ground fault*.

High Battery Voltage. The lamp illuminates when the battery voltage rises above the preset level for more than 10 seconds. The local display shows *high battery voltage*. Figure 2-1 shows high battery voltage specifications. The high battery voltage feature monitors the battery and battery charging system in the generator set operating and off modes.

Engine Electrical System Voltage	High Battery Voltage Range	High Battery Voltage Default Setting
12	14.5-16.5	16
24	29-33	32

Figure 2-1 High Battery Voltage Specs

High Coolant Temperature Warning. The lamp illuminates and the alarm horn sounds when the engine coolant temperature approaches the shutdown range. The local display shows *high coolant temperature warning*.

Load Shed. The lamp illuminates when the generator set's total kW load exceeds the programmed level for more than the load shed time. When the load shed alarm sounds and resets more than twice in 1 minute, the load shed warning lamp circuit latches and remains on until the generator set shuts off. The local display shows *load shed kW over*.

When the generator set frequency drops to less than 59 Hz on a 60 Hz system or 49 Hz on a 50 Hz system for more than 5 seconds, the local display shows *load shed under freq*. When the load shed alarm sounds and resets more than twice in 1 minute, the load shed warning lamp latches and remains on until the generator set shuts down.

Low Battery Voltage. The lamp illuminates when the battery voltage drops below a preset level for more than 10 seconds. The local display shows *low battery voltage*. See Figure 2-2 for low battery voltage specifications.

The low battery voltage feature monitors the battery and battery charging system in the generator set operating and off modes. The controller logic inhibits the low battery voltage warning during the crank cycle.

Low Coolant Temperature. The lamp illuminates and the alarm horn sounds when the engine coolant temperature is low. The local display shows *low coolant temperature*.

Low Fuel (Level or Pressure). The lamp illuminates and the alarm horn sounds when the fuel tank level on gasoline or diesel models approaches empty or low fuel pressure on gaseous fueled models occurs. This fault requires an optional low fuel switch for the lamp to function. The local display shows *low fuel*.

(Low) Oil Pressure Warning. The lamp illuminates and the alarm horn sounds when the engine oil pressure approaches the shutdown range. The local display shows *oil press warning*.

Master Switch in OFF/RESET Position. The lamp illuminates and the alarm horn sounds when the master switch is placed in the OFF/RESET position. The local display shows *master not in auto*.

Engine Electrical System Voltage	Low Battery Voltage Range	Low Battery Voltage Default Setting
12	10-12.5	12
24	20-25	24

Figure 2-2 Low Battery Voltage Specs

NFPA 110 Fault. The lamp illuminates and the alarm horn sounds when NFPA 110 faults signal the controller. The local display shows *NFPA 110 fault*. The NFPA 110 faults include:

- Air damper indicator
- Battery charger fault
- EPS supplying load
- High battery voltage
- High coolant temperature warning
- High coolant temperature shutdown
- Low battery voltage
- Low coolant level
- Low coolant temperature warning
- Low fuel (level or pressure)
- Low oil pressure warning
- Low oil pressure shutdown
- Master switch not in auto
- Overcrank
- Overspeed

Overcurrent. The lamp illuminates and the alarm horn sounds when the generator set supplies more than 110% of the rated standby output current for more than 10 seconds. The local display shows *overcurrent*.

Speed Sensor Fault. The lamp illuminates and the alarm horn sounds when the speed signal is absent for one second while the generator set runs. The local display shows *speed sensor fault*. This warning lamp remains on until the operator places the master switch in the OFF/RESET position.

Underfrequency. The lamp illuminates and the alarm horn sounds when the frequency falls below the underfrequency setting. The local display shows *underfrequency*. See Figure 2-3.

Weak Battery. The lamp illuminates when the battery voltage falls below 60% of the nominal voltage (12 VDC or 24 VDC) for more than 2 seconds during the crank cycle. The local display shows *weak battery*.

Underfrequency Setting Range	Time Delay Range	Underfrequency Default Setting
80%-95% of nominal	10 sec.	90% of nominal

Figure 2-3 Underfrequency Specs

2.3.6 System Shutdown Lamp

The red lamp illuminates, the alarm horn sounds, and the unit shuts down to indicate a fault shutdown under the following conditions. See Section 2.3.7, Controller Reset Procedure, for information on resetting a system shutdown.

Use the Alarm Off keypad switch to silence the alarm horn at the operator's discretion. Place the generator set master switch in the AUTO position before silencing the alarm horn. The alarm horn will not stop sounding unless the master switch is in the AUTO position.

Note: The text shown in *italics* represents digital display messages.

Air Damper Indicator. The lamp illuminates and the unit shuts down when signaled by a closed air damper circuit. The local display shows *air damper indicator*.

Alternator Protection. The lamp illuminates and the unit shuts down because of an alternator overload or short circuit. The local display shows *altrntr protect sdwn*.

Customer Auxiliary (Shutdown). The lamp illuminates and the unit shuts down when an auxiliary digital or analog input signals the controller. The customer can define inputs as shutdowns or warnings. The local display shows *digital input 1-21 or analog input 1-7* when activated.

Using the remote communications package, the user can label the auxiliary functions. The controller displays the selected name instead of *digital input 1-21 or analog input 1-7*.

Emergency Stop. The lamp illuminates and the unit shuts down when the local or optional remote emergency stop switch activates. The local display shows *emergency stop*.

High Coolant Temperature Shutdown. The lamp illuminates and the unit shuts down because of high engine coolant temperature. The shutdown occurs 5 seconds after the engine reaches the temperature shutdown range. The high engine temperature shutdown does not function during the first 30 seconds after startup. The local display shows *high cool temp shutdwn*.

Note: The high engine temperature shutdown function and the low coolant level shutdown function are independent. A low coolant level condition may not activate the high engine temperature switch.

High Oil Temperature. The lamp illuminates and the unit shuts down because of high engine oil temperature. The shutdown occurs 5 seconds after the engine oil reaches the temperature shutdown range. The high engine oil temperature shutdown does not function during the first 30 seconds after startup. The local display shows *high oil temp*.

Internal Fault. The lamp illuminates and the unit shuts down when the internal diagnostic test detects a controller malfunction. The local display shows *internal fault*.

Locked Rotor. If none of the speed sensing inputs show engine rotation within 5 seconds of initiating engine cranking, the ignition and crank circuits turn off for 5 seconds and the cycle repeats. The unit shuts down after the second cycle of 5 seconds of cranking. The local display shows *locked rotor*.

Loss of ECM Communications. The lamp illuminates and the unit shuts down when the ECM communication link is disrupted. The local display shows *loss of ECM comm*.

Low Coolant Level. The lamp illuminates and the unit shuts down because of low coolant level. Shutdown occurs 5 seconds after the controller detects low coolant level. The low coolant level shutdown does not function during first the 30 seconds after startup. The local display shows *low coolant level*.

Note: The high engine temperature shutdown function and the low coolant level shutdown function are independent of each other. A low coolant level condition may not activate the high engine temperature switch.

(Low) Oil Pressure Shutdown. The lamp illuminates when the unit shuts down because of low oil pressure. The shutdown occurs 5 seconds after the engine pressure reaches the shutdown range. The low oil pressure shutdown does not function during first the 30 seconds after startup. The local display shows *(low) oil press shutdown*.

Master Switch Error. The lamp illuminates and unit the shuts down when the controller detects a fault in the master switch position or circuit. The local display shows *master switch error*.

Master Switch Open. The lamp illuminates and the unit shuts down when the controller detects an open circuit in the master switch circuit. The local display shows *master switch open*.

NFPA 110 Fault. The lamp illuminates and the unit shuts down when NFPA 110 faults signal the controller. The local display shows *NFPA 110 fault*. See Section 2.4, Menu List Summary, Menu 10—Output Setup, for the NFPA 110 list.

No Coolant Temperature Signal. The lamp illuminates and the unit shuts down when the engine coolant temperature sender circuit is open. The local display shows *no cool temp signal*.

No Oil Pressure Signal. The lamp illuminates and the unit shuts down when the engine oil pressure sender circuit is open. The local display shows *no oil press signal*.

Overcrank. The lamp illuminates and cranking stops when the unit does not start within the defined cranking period. The local display shows *overcrank*. See Section 2.3.1, Auto Starting, and Section 1, Specifications and Features, for cyclic crank specifications.

Note: The controller is equipped with an automatic restart function. When speed drops below 13 Hz (390 rpm) while the engine is running, the unit attempts to recrank. The unit then follows the cyclic cranking cycle and, when the engine fails to start, will shut down on an overcrank fault condition.

Overfrequency. The lamp illuminates and the unit shuts down when the frequency is above the overfrequency setting. The local display shows *overfrequency*. See Figure 2-4.

Overfrequency Setting Range	Time Delay	Overfrequency Default Setting
102% -140% of nominal	10 sec.	140% of nominal

Figure 2-4 Overfrequency Specs

Overspeed. The lamp illuminates and the unit shuts down immediately when the governed frequency on 50 and 60 Hz models exceeds the overspeed setting for 0.25 seconds. The local display shows *overspeed*. See Figure 2-5 for overspeed specs.

Generator Set Frequency Hz	Overspeed Range Hz	Overspeed Default Setting Hz
60	65-70	70
50	55-70	60

Figure 2-5 Overspeed Specs

Overvoltage. The lamp illuminates and the unit shuts down when the overvoltage setting exceeds the overvoltage setting for the time delay period. The local display shows *overvoltage*. Overvoltage specifications follow. See Figure 2-6.

Note: Overvoltage can damage sensitive equipment in less than one second. Install separate overvoltage protection on online equipment requiring faster than 2-second shutdown.

Overvoltage Setting Range	Time Delay Range	Overvoltage Default Setting
105% -135% of nominal	2-10 sec.	115% at 2 sec.

Figure 2-6 Overvoltage Specs

Underfrequency. The lamp illuminates and the unit shuts down when the frequency falls below the underfrequency setting. The local display shows *underfrequency*. See Figure 2-7.

Underfrequency Setting Range	Time Delay	Underfrequency Default Setting
80%–95% of nominal	10 sec.	90% of nominal

Figure 2-7 Underfrequency Specs

Undervoltage. The lamp illuminates and the unit shuts down when the voltage falls below the undervoltage setting for the time delay period. The local display shows *undervoltage*. Undervoltage specifications follow. See Figure 2-8.

Undervoltage Setting Range	Time Delay Range	Undervoltage Default Setting
70%–95% of nominal	5–30 sec.	85% of nominal at 10 sec.

Figure 2-8 Undervoltage Specs

2.3.7 Controller Reset Procedure (Following System Shutdown or Warning)

Use the following procedure to restart the generator set after a system shutdown or to clear a warning lamp condition. This procedure includes the resetting of the optional remote annunciator and the audiovisual alarm.

Refer to Section 2.3.3, Emergency Stop Switch Reset Procedure, to reset the generator set after an emergency stop.

1. Move the generator set master switch to the AUTO position, if not already done.
2. Silence the controller alarm horn by pressing the alarm off key.

When equipped, the optional remote annunciator and/or audiovisual alarm horn and lamp activate. Move the alarm switch to the SILENCE position to stop the alarm horn. The lamp stays lit.

3. Disconnect the generator set load using the line circuit breaker or automatic transfer switch.
4. Correct the cause of the fault shutdown or warning. See Safety Precautions and Instructions section of this manual before proceeding.

5. Start the generator set by moving the generator set master switch to the OFF/RESET position and then to the RUN position.

When equipped, the remote annunciator and/or audiovisual alarm horn sounds when the alarm switch is in the NORMAL position. When necessary, move the alarm switch to the SILENCE position to stop the alarm horn. The lamp turns off.

6. Test operate the generator set verifying correction of the shutdown cause.
7. Move the generator set master switch to the OFF/RESET position to stop the generator set.
8. Move the generator set master switch to the AUTO position.
9. Silence the controller alarm horn by pressing the alarm off key.
10. Reconnect the generator set load via the line circuit breaker or automatic transfer switch.
11. Move the generator set master switch to the AUTO position for startup by the remote transfer switch or the remote start/stop switch.

When equipped, move the remote annunciator and/or audiovisual alarm switch to the NORMAL position.

2.4 Menu List Summary

Use the Menu List Summary section on the following pages after reading and understanding the features of the keypad. See Section 1.2.2, Digital Display and Keypad.

The Menu List Summary provides a quick reference to the digital display data. Some digital display data may not be identical to your display due to generator set application differences. The closed bullet items represent main level data and the open bullet items are sub-level data.

Section 2.8, Reviewing the Menu Displays, provides a digital display menu overview and explains the navigation using the down and right arrow keys.

Section 2.9, Local Programming Mode On, contains the keystroke details of each menu when programming.

Menu List Summary

Menu 1 Generator Monitoring	Menu 2 Engine Monitoring	Menu 4 Operational Records	Menu 7 Generator System
<p>Volts & Amps</p> <ul style="list-style-type: none"> ● L1-L2 Volts L1 Amps ● L2-L3 Volts L2 Amps (3 phase) ● L3-L1 Volts L3 Amps (3 phase) ● L1-L0 Volts L1 Amps ● L2-L0 Volts L2 Amps ● L3-L0 Volts L3 Amps (3 phase) ● Frequency ● L1-L2 Volts L2 Amps (1 phase) <p>V & A Summary</p> <ul style="list-style-type: none"> ● V L1-L2, L2-L3, L3-L1 (3 phase) ● V L1-L0, L2-L0, L3-L0 (3 phase) ● A L1, L2, L3 (3 phase) ● V L1-L2, L1-L0, L2-L0 (1 phase) ● A L1, L2 (1 phase) <p>Power kW</p> <ul style="list-style-type: none"> ● Total kW Power Factor ● L1 kW Power Factor ● L2 kW Power Factor ● L3 kW Power Factor (3 phase) ● Total kW % of Rated kW <p>Power kVAR</p> <ul style="list-style-type: none"> ● Total kVAR Absorbing/Generating ● L1 kVAR Absorbing/Generating ● L2 kVAR Absorbing/Generating ● L3 kVAR Absorbing/Generating (3 phase) <p>Power kVA</p> <ul style="list-style-type: none"> ● Total kVA ● L1 kVA ● L2 kVA ● L3 kVA (3 phase) 	<p>Engine Monitoring Basic</p> <ul style="list-style-type: none"> ● Oil Pressure Coolant Temperature ● Engine RPM Local Battery VDC <p>Engine Monitoring Detailed (ECM equipped engines only)</p> <p>Engine Fuel</p> <ul style="list-style-type: none"> ● Fuel Pressure Fuel Temperature ● Fuel Rate ● Used Last Run <p>Engine Coolant</p> <ul style="list-style-type: none"> ● Coolant Pressure Coolant Temperature (ECM and non-ECM engines) ● Coolant Level <p>Engine Oil</p> <ul style="list-style-type: none"> ● Oil Pressure (ECM and non-ECM engines) Oil Temperature ● Oil Level ● Crackcase Pressure <p>Engine Misc</p> <ul style="list-style-type: none"> ● ECM Battery VDC Ambient Temperature ● Engine Model No. ● Engine Serial No. ● Unit No. ECM S/N 	<ul style="list-style-type: none"> ● Factory Test Date ● Total Run Time ● Total Run Time Loaded Hours ● Total Run Time Unloaded Hours ● Total Run Time kW Hours ● No. of Starts ● Engine Start Countdown <ul style="list-style-type: none"> ○ Run Time ● Records-Maintenance <ul style="list-style-type: none"> ○ Reset Records ● Run Time Since Maintenance Total Hours ● Run Time Since Maintenance Loaded Hours ● Run Time Since Maintenance Unloaded Hours ● Run Time Since Maintenance kW Hours ● Operating Days Last Maintenance ● No. of Starts Last Maintenance ● Last Start Date ● Length of Run (Un)loaded Hours 	<ul style="list-style-type: none"> ● Operating Mode <ul style="list-style-type: none"> ○ Standby Y/N ○ Prime Power N/Y ● System Voltage Line-Line ● System Frequency ● Phase <ul style="list-style-type: none"> ○ 3-Phase Delta Y/N ○ 3-Phase WYE N/Y ○ 1-Phase N/Y ● kW Rating ● Rated Current ● Load Shed Output <ul style="list-style-type: none"> ○ Time Delay ● Overvoltage <ul style="list-style-type: none"> ○ Time Delay ● Undervoltage <ul style="list-style-type: none"> ○ Time Delay ● Overfrequency ● Underfrequency ● Overspeed ● Battery Voltage <ul style="list-style-type: none"> ○ 12 VDC Y/N ○ 24 VDC N/Y ● Low Battery Voltage ● High Battery Voltage ● Metric Units Y/N ● Set NFPA-110 Defaults Y/N
	<p>Menu 3 Analog Monitoring</p> <ul style="list-style-type: none"> ● Local Batt VDC ● Analog 01 to 07 (user-defined descriptions) (Scroll through 1-7 user-defined descriptions with ECM engines) (Scroll through 3-7 user-defined descriptions with non-ECM engines where 01 is coolant temperature and 02 is oil pressure) 	<p>Menu 5 Event History</p> <ul style="list-style-type: none"> ● (Message Text) ● (Scroll through up to 100 stored events) <p>Menu 6 Time and Date</p> <ul style="list-style-type: none"> ● Time 00:00 AM/PM ● Date 	<p>Menu 8 Time Delays</p> <ul style="list-style-type: none"> ● Time Delay Engine Start ● Time Delay Starting Aid ● Time Delay Crank On ● Time Delay Crank Pause ● Time Delay Eng. Cooldown ● Overcrank Shutdown Crank Cycles ● Time Delay Overvoltage ● Time Delay Undervoltage ● Time Delay Load Shed kW

Menu List Summary, continued

Menu 9 Input Setup	Menu 9 Input Setup, cont.	Menu 10 Output Setup, cont.	Menu 10 Output Setup, cont.
<p>Setup Digital Auxiliary Inputs</p> <ul style="list-style-type: none"> • Digital Input (Scroll through up to 21 user defined desc) • Digital Input Message Text Y/N, see Group A <p>Group A The preprogrammed selections include the following:</p> <p>Warning Shutdown Type A Shutdown Type B Voltage Raise Voltage Lower VAR PF Mode Remote Shutdown Remote Reset Air Damper Low Fuel Field Overvoltage Idle Mode Active (ECM engines only) Battle Switch Ground Fault Bat Chgr Fault Hi Oil Temperature Low Coolant Level Low Coolant Temperature (Not user selectable) <ul style="list-style-type: none"> • Digital Input Enable Y/N • Digital Input Inhibit Time • Digital Input Delay Time </p>	<p>Setup Analog Auxiliary Inputs</p> <ul style="list-style-type: none"> • Analog Input (Scroll through 1-7 user-defined descriptions with ECM engines) (Scroll through 3-7 user-defined descriptions with non-ECM engines) • Analog Input Warning Enabled Y/N • Analog Input Shutdown Enabled Y/N • Analog Input Inhibit Time 0-60 Sec. • Analog Input Warning Delay Time 0-60 Sec. • Analog Input Shutdown Delay Time 0-60 Sec. • Analog Input Low Shutdown Value • Analog Input Low Warning Value • Analog Input High Warning Value • Analog Input High Shutdown Value <p>Menu 10 Output Setup</p> <p>Defined Common Fault</p> <ul style="list-style-type: none"> • Defined Common Fault (Y/N for a <i>single</i> defined common fault) Scroll through status and fault choices from: <ul style="list-style-type: none"> ○ System events, see Group B (except Defined Common Fault) ○ 21 digital inputs D01-D21 ○ 7 analog inputs A01-A07 	<p>Relay Driver Outputs (RDOs)</p> <ul style="list-style-type: none"> • RDOs (Y/N) (Scroll through up to 31 status and fault choices from: <ul style="list-style-type: none"> ○ System events, see Group B ○ 21 digital inputs D01-D21 ○ 7 analog inputs A01-A07 <p>Group B The system events include the following:</p> <p>Emergency Stop Over Speed Over Crank Hi Cool Temp Shutdown Oil Pressure Shutdown Low Coolant Temperature (non-ECM engines) Low Fuel Hi Cool Temp Warning Oil Pressure Warning Master Not in Auto NFPA 110 Fault*</p> <p>Low Battery Voltage High Battery Voltage Battery Charger Fault System Ready Loss of ECM Comm (ECM engines) No Oil Pressure Signal Hi Oil Temperature No Cool Temperature Signal Low Coolant Level Speed Sensor Fault Locked Rotor Master Switch Error Master Switch Open Master Switch to Off AC Sensing Loss Over Voltage Under Voltage Weak Battery Over Frequency Under Frequency</p>	<p>Group B, continued</p> <p>Load Shed kW Over Load Shed Under Freq Over Current EPS Supplying Load Internal Fault Delay Engine Cooldown Delay Engine Start Starting Aid Generator Running Air Damper Control Ground Fault EEPROM Write Failure Critical Overvoltage Alternator Protection SDWN Air Damper Indicator Defined Common Fault (RDO only) SCRDOs 1-4 (Software Controlled RDOs)</p> <p>*NFPA-110 Fault The 15 NFPA-110 Common Fault Alarms include the following:</p> <p>Overspeed Overcrank High Coolant Temperature Shutdown Oil Pressure Shutdown Low Coolant Temperature High Coolant Temperature Warning Oil Pressure Warning Low Fuel Master Not In Auto Battery Charger Fault Low Battery Voltage High Battery Voltage Low Coolant Level EPS Supplying Load Air Damper Indicator</p>

Menu List Summary, continued

Menu 10 Output Setup, cont.	Menu 12 Calibration	Menu 13 Communications	Menu 14 Programming Mode
<p>Digital Inputs</p> <ul style="list-style-type: none"> Common Fault Y/N (Scroll through up to 21 user-defined descriptions shown as D01 to D21) <p>Analog Inputs</p> <ul style="list-style-type: none"> Common Fault Y/N (Scroll through up to 7 user-defined descriptions shown as A01 to A07) (ECM engines) Common Fault Y/N (Scroll through up to 5 user-defined descriptions shown as A03 to A07) (non-ECM engines) Low Warning High Warning Low Shutdown High Shutdown 	<p>Scale AC Analog Inputs</p> <ul style="list-style-type: none"> Gen L1-L0 V Calibration Reference Gen L2-L0 V Calibration Reference Gen L3-L0 V (3 phase) Calibration Reference Gen L1 Amps Calibration Reference Gen L2 Amps Calibration Reference Gen L3 Amps (3 phase) Calibration Reference Restore Defaults? Y/N <p>Scale Aux. Analog Inputs</p> <ul style="list-style-type: none"> Zero Aux. Analog Inputs (Scroll through additional analog auxiliary inputs 1–7 with ECM engines) (Scroll through additional analog auxiliary inputs 3–7 with non-ECM engines) Analog 01 Scale Value 1 <ul style="list-style-type: none"> Scale 1 V Scale 2 V Analog 01 Scale Value 2 <ul style="list-style-type: none"> Scale 1 V Scale 2 V 	<p>Protocol KBUS</p> <ul style="list-style-type: none"> KBUS Online Y/N Connection Type (User-defined) <ul style="list-style-type: none"> Local Single Y/N Local LAN Y/N Local LAN Conv Y/N Remote Single Y/N Remote LAN Y/N Remote LAN Conv Y/N Primary Port (User-defined) <ul style="list-style-type: none"> RS-232 Y/N RS-485 ISO1 Y/N Address (LAN Connections) System ID (Remote Connections) BAUD Rate (User-defined) <ul style="list-style-type: none"> BAUD Rate 1200 2400 9600 	<ul style="list-style-type: none"> Programming Mode <ul style="list-style-type: none"> Local? Y/N Remote? Y/N Off? Y/N Programming Mode Change, Access Code <ul style="list-style-type: none"> Enter Old Code Enter New Code
<p>Menu 11 Voltage Regulator</p>			
<p>AVG L-L V Volt ADJ</p> <ul style="list-style-type: none"> L1-L2 Volts L2-L3 Volts (3 phase) L3-L1 Volts (3 phase) <p>Under Freq. Unload Enabled N/Y</p> <ul style="list-style-type: none"> Frequency Setpoint (Cut-In Point) Slope Volts-Per-Cycle <p>Reactive Droop Enabled N/Y</p> <ul style="list-style-type: none"> 0.8 PF Rated Load Voltage Droop <p>VAR Control Enabled N/Y</p> <ul style="list-style-type: none"> Total kVAR (Running) kVAR Adj Generating/Absorbing Y/N <p>PF Control Enabled N/Y</p> <ul style="list-style-type: none"> Average PF PF Adjustment Lagging/Leading Y/N 		<p>Protocol Modbus</p> <ul style="list-style-type: none"> Modbus Online N/Y Connection Type (User-defined) <ul style="list-style-type: none"> Single Y/N Convertor Y/N Primary Port <ul style="list-style-type: none"> RS-485 RS-232 Address BAUD Rate (User-defined) <ul style="list-style-type: none"> 9600 19200 	

2.5 Digital Display Messages

Throughout this manual there are examples of the display text. In some cases, the message words and phrases are abbreviated or shortened to accommodate

the 40-character display. See Figure 2-9 for a full description of the system event display messages.

Display Message	Description
A01 through A07	Analog auxiliary input 01 through 07
AC SENSING LOSS	AC sensing loss
AIR DAMPER CONTROL	Air damper control
AIR DAMPER INDICATOR	Air damper indicator
ALTRNTR PROTECT SDWN	Alternator protection shutdown
BATTERY CHRGR FAULT	Battery charger fault
BATTLESWITCH	Battle Switch (fault shutdown override switch)
CRITICAL OVERVOLTAGE	Critical overvoltage
D01 through D21	Digital auxiliary input 01 through 21
DEFINED COMMON FAULT	Defined common fault (do not use for common fault)
DELAY ENG COOLDOWN	Time delay engine cooldown (TDEC) timing
DELAY ENG START	Time delay engine start (TDES) timing
EEPROM WRITE FAILURE	EEPROM write failure
EMERGENCY STOP	Emergency stop
EPS SUPPLYING LOAD	Emergency power system supplying load
GENERATOR RUNNING	Generator running
GROUND FAULT	Ground fault detected
HI COOL TEMP WARNING	High coolant temperature warning
HI COOL TEMP SHUTDOWN	High coolant temperature shutdown
HI OIL TEMP	High oil temperature shutdown
HIGH BATTERY VOLTAGE	High battery voltage
INTERNAL FAULT	Internal fault
LOAD SHED KW OVER	Load shed kW overload
LOAD SHED UNDER FREQ	Load shed underfrequency
LOCKED ROTOR	Locked rotor
LOSS OF ECM COMM	Engine control module communications loss (ECM models only)
LOW BATTERY VOLTAGE	Low battery voltage
LOW COOLANT LEVEL	Low coolant level
LOW COOLANT TEMP	Low coolant temperature
LOW FUEL	Low fuel level (gasoline or diesel) or pressure (gas)
MASTER SWITCH ERROR	Master switch error
MASTER SWITCH TO OFF	Master switch in the OFF position (User must move master switch to OFF position)
MASTER NOT IN AUTO	Master switch not in the AUTO position
MASTER SWITCH OPEN	Master switch open
NFPA 110 FAULT	NFPA 110 common fault
NO COOL TEMP SIGNAL	Coolant temperature signal loss
NO OIL PRESS SIGNAL	Oil pressure signal loss
OIL PRESS SHUTDOWN	Oil pressure shutdown
OIL PRESS WARNING	Oil pressure warning
OVER CRANK	Overcrank shutdown
OVER CURRENT	Overcurrent warning
OVER FREQUENCY	Overfrequency shutdown
OVER SPEED	Overspeed shutdown
OVER VOLTAGE	Overvoltage shutdown
SPEED SENSOR FAULT	Speed sensor fault
STARTING AID	Starting aid status
S'WARE CONTROLLED #1 through #4	Software controlled #1 through #4 (RDO only)
SYSTEM READY	System ready
UNDER FREQUENCY	Underfrequency shutdown
UNDER VOLTAGE	Undervoltage
WEAK BATTERY	Weak battery

Figure 2-9 System Events Display Message List

2.6 Reviewing the Digital Display

The user interacts with the controller with a keypad and digital display. Use the keypad to access the generator set informational data and preset settings. This review section shows how to access the data. See Section 2.9, Local Programming Mode On, for instructions on how to change the information. See Figure 2-10 for an illustration of the digital display and keypad.

Note: After energizing the controller by reconnecting the battery, set the controller time and date. See Section 2.9.6, Local Programming Mode On, Menu 6—Time and Date.

Pressing any key on the keypad activates the controller panel display. The panel lamps and display turn off 5 minutes after the last keypad entry.

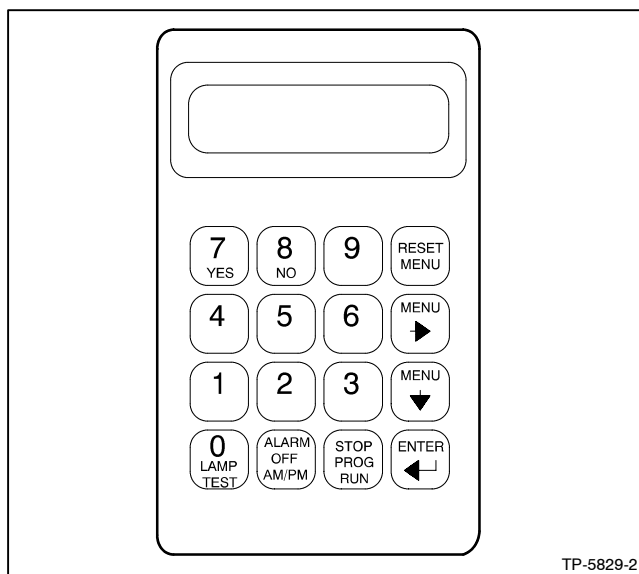

Figure 2-10 Digital Display and Keypad

2.6.1 Keypad Operation

Use the keypad to input information into the controller. Some of the keys have two functions. The following gives keypad definitions and functions.

Alarm (Horn) Off Key. Press the alarm off key to silence the horn at the user's discretion. Place the generator set master switch in the AUTO position before silencing the alarm horn. The alarm horn cannot be silenced unless the master switch is in the AUTO position. See Section 2.3.7, Controller Reset Procedure, for more information on turning the alarm horn off.

AM/PM Key. When the controller asks a question during programming requiring a nonnumeric answer (am or pm), the controller accepts the secondary key function and ignores the numeric value of the key.

Enter ↵ Key. Press the enter ↵ key to confirm the entered information on the display when selecting menus or programming.

Lamp Test Key. Press the lamp test key to check that the status and fault lamps illuminate, the horn sounds, and the digital display clears. Press the reset menu key before pressing the lamp test key.

Menu Down ↓ Key. The controller displays consist of menus with data levels or programming steps. Use the menu down ↓ key to navigate through the menu levels.

Note: Pressing the menu down ↓ key locks the user into the levels of that main menu. Press the reset menu key to access other main menus.

Menu Right → Key. Press the menu right → key to scroll through sub-levels of each main menu. The display contains an arrow in the right-hand corner when there is a sub-level. Pressing the menu right → key when no arrow is present moves to the next submenu header. Press the menu right → key prior to entering decimal values when required.

Numeric 0-9 Keys. Press the numeric keys when selecting menus or entering numeric values during programming. The controller ignores the secondary function of the key (yes, no, etc.) when numeric values are valid.

Reset Menu Key. The reset menu key exits a menu, clears incorrect entries, and cancels the auto-scroll function. Press the reset menu key to exit a menu or any layer within that menu.

Stop Prog Run Key. Press the stop prog run key to end the generator set programmed exercise run created in Menu 4—Operational Records. The generator set shuts down after the time delay for engine cooldown ends. The stop prog run key does not affect the programmed transfer switch exercise function.

Yes/No Keys. When the controller asks a question during programming requiring a nonnumeric answer (yes or no), the controller accepts the secondary key function and ignores the numeric value of the key.

2.6.2 Auto-Scroll Function

The auto-scroll function continuously shows voltage and current data from Menu 1—Generator Monitoring, V & A Summary without the need to press the down arrow for each display.

For auto-scroll function press ENTER at the V & A Summary menu. Press the Reset Menu key or Menu Right → key to stop the auto-scroll function.

2.6.3 Request and Error Messages

Request Messages

Display messages require additional data, confirm the previous entry or require time to process as described below.

Entry Accepted appears for several seconds after pressing the Enter key during the programming mode. The display then shows the new data.

Reset Complete indicates the user:

- Reset the maintenance records or
- Restored the AC analog inputs to the default settings.

Right Arrow → directs the user to the next menu. Menu loop; press the right arrow key to the next menu.

Setup Complete indicates the completion of the analog input setup.

(Question) ? asked by the control firmware; answer the question by pressing the yes/no, numeric digit, or am/pm key.

Wait for System Reset (6 Sec) appears while the EEPROM initializes.

Error Messages

When an error message appears, the entered information is not within the allowable parameters set by the control firmware or is not permitted as described below. In cases where the data was outside the parameters, press the Reset Menu key and enter the corrected information.

Access Denied appears when the user attempts to:

- Enter data prohibited by the master switch position,
- Enter data prohibited by the generator set state, or
- Enable the LDD (load disturbance detection).

Access Denied Idle Mode Active appears when the user attempts to modify the voltage regulator setup while the idle mode is active.

Alarm Active appears when the user attempts to modify an active digital input. See Menu 9—Input Setup.

Cannot Change (because the) NFPA is Enabled appears when the user attempts to modify an RDO setting that is a NFPA 110 default requirement.

Cannot Change Preset appears when the user attempts to change the preset factory digital input or input parameter.

Entry Unacceptable appears when the user attempts an invalid input to the voltage regulator setup.

Func(Function) Used by (RDO) XX Reassign? appears when the user attempts to assign an RDO to a function already assigned.

Invalid Code appears when the user attempts to enter:

- An invalid access code for programming mode setup, or
- An invalid access code for setup unlock.

No Input Assigned appears when the user attempts to assign any of the following system faults to an RDO where the digital input is not defined. See digital input scale requirements in Menu 12—Calibration.

- Air damper indicator
- Battery charger fault
- Ground fault
- High oil temperature shutdown
- Low coolant level
- Low fuel

Not in Local Program Mode appears when the user attempts to program using the keypad when the programming mode is set for remote or off.

Output in Use appears when the user attempts to modify or reassign an active RDO.

Port in Use appears when the user attempts to use an already assigned communications port.

Range Error appears when the user attempts to enter:

- A numeric input that is not within the required parameters of system settings, time delays, addresses, etc.
- An invalid analog or digital input number or date/time.

Setpoint Values Cannot be Equal appears when the user attempts to enter the same value for both setpoints during the analog input calibration.

2.7 Monitoring and Programming Setup

The user can access the controller data with the controller keypad and display or a PC (personal computer) with optional software to monitor and/or program. Access the controller system with a PC using local (direct) or remote (modem) systems. Refer to the Introduction, List of Related Materials for related software literature. See Menu 13—Communications.

The user can access the controller data while in the programming mode off or programming mode on. See Menu 14—Programming Mode.

While this manual focuses on data access and programming through the controller keypad and display, some data entries require input using a PC for initial setup. The PC entries typically include alpha characters such as digital input descriptions. The individual menus

in Section 2.9, Local Programming Mode On, indicate where data requires entry using a PC.

There are six basic configurations for data monitoring and programming using three access source options. See Figure 2-11.

Other combinations of data monitoring and programming are possible but require programming from a single location. Figure 2-11, Monitoring and Programming Configurations, briefly describes the settings of Menu 13—Communications and Menu 14—Programming Mode based on user-selected operating mode.

Use the keypad and digital display to setup the access configurations the first time. Go to Section 2.9, Local Programming Mode On, and set the desired selection in Menu 13—Communication and Menu 14—Programming Mode before accessing data.

User Operating Mode Selection		Menu 13—Communications Settings			Menu 14—Programming Mode		
User Activity	Access Source	On Line?	Local LAN?	Remote Single or LAN?	Programming Mode Off?	Local Programming Mode?	Remote Programming Mode?
Monitor only	Controller	No	No	No	Yes	No	No
	Direct PC	Yes	Yes	No	Yes	No	No
	PC via Telephone Lines	Yes	No	Yes	Yes	No	No
Monitor and Program	Controller	No	No	No	No	Yes	No
	Direct PC	Yes	Yes	No	No	No	Yes
	PC via Telephone Lines	Yes	No	Yes	No	No	Yes

Figure 2-11 Monitoring and Programming Configurations

2.7.1 Personal Computer (PC) Communications

There are four ways to communicate between a PC and the generator set and/or transfer switch devices using KBUS communication protocol. The PC connections require optional software and possibly other hardware, communication modules in the generator set controller and/or transfer switch. See the Software Operation Manual for details. Contact your authorized distributor/dealer for availability.

Local Single Connection

A PC connects to the COM port of the controller module using an RS-232 cable when the PC is within 15 m (50 ft.) of the device or an RS-485 cable when the PC is within 1220 m (4000 ft.) of the device. See Figure 2-12 or Figure 2-13.

Local Area Network (LAN)

A PC connects to the device's LAN. A LAN is a system that connects more than one device to a single PC. Acceptable devices include Decision-Maker™ 550 controller, Decision-Maker™ 340 controller, M340 transfer switch control, M340+ transfer switch control, and PM340 power monitor. See Figure 2-14.

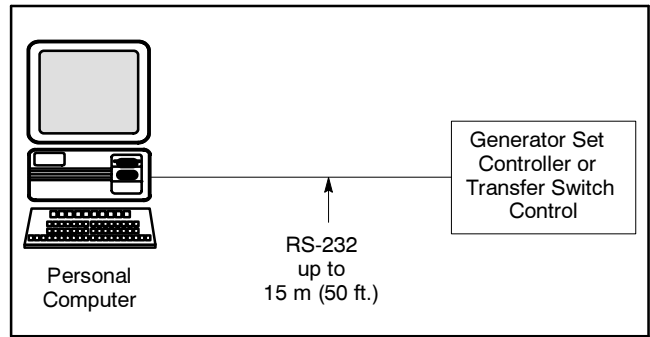

Figure 2-12 Local Single Connection, up to 15 m (50 ft.)

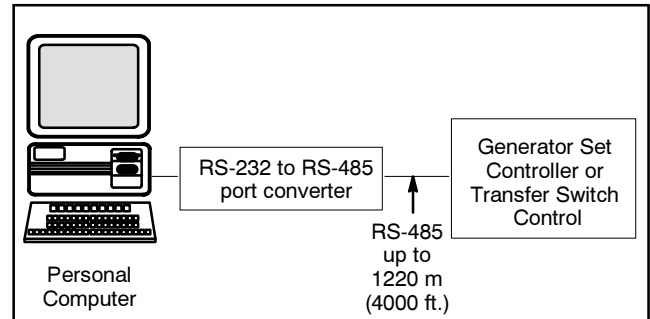

Figure 2-13 Local Single Connection, up to 1220 m (4000 ft.)

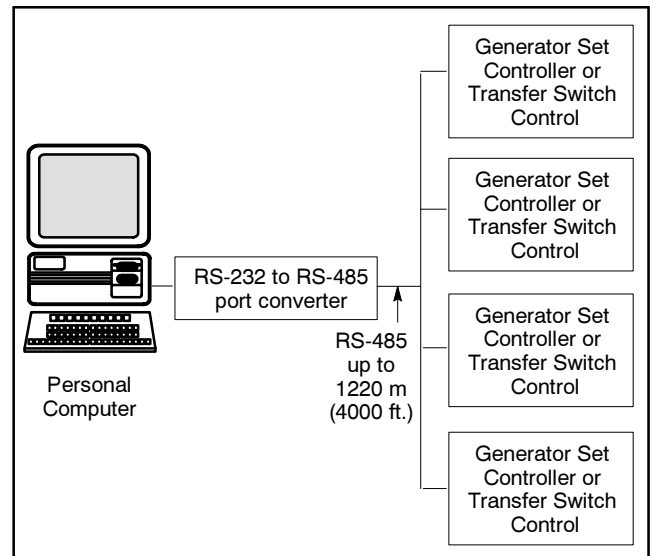

Figure 2-14 Local Area Network

Remote Single Connection

A modem connects a PC to a single device. The PC communicates with the device via a telephone network. Locate the PC anywhere a telephone line is available. See Figure 2-16.

Remote Area Network

A PC connects to a modem. The devices connect to a LAN network. The PC communicates to the devices via a telephone network that is interfaced to the LAN network. Acceptable devices include Decision-Maker™ 550 controller, Decision-Maker™ 340 controller, M340 transfer switch control, M340+ transfer switch control, and PM340 power monitor. Locate the PC anywhere a telephone line is available. See Figure 2-17.

2.7.2 Modbus Communications

The controller communicates using Modbus® as a slave connection with the Modbus® master initiating the communication. The controller interrogates system and alternator parameters and diagnostic information. In addition, the controller accepts information to alter controller parameters including generator set starting and stopping. See Figure 2-15. Refer to the List of Related Materials for available Modbus® literature.

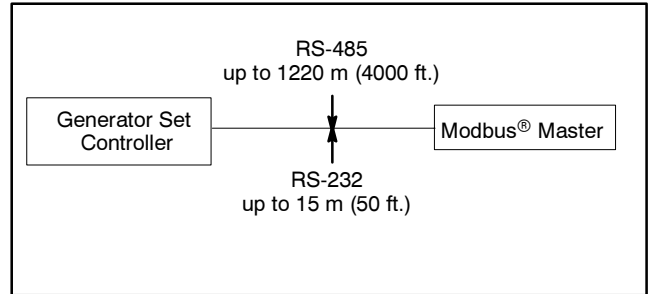

Figure 2-15 Modbus® Connections

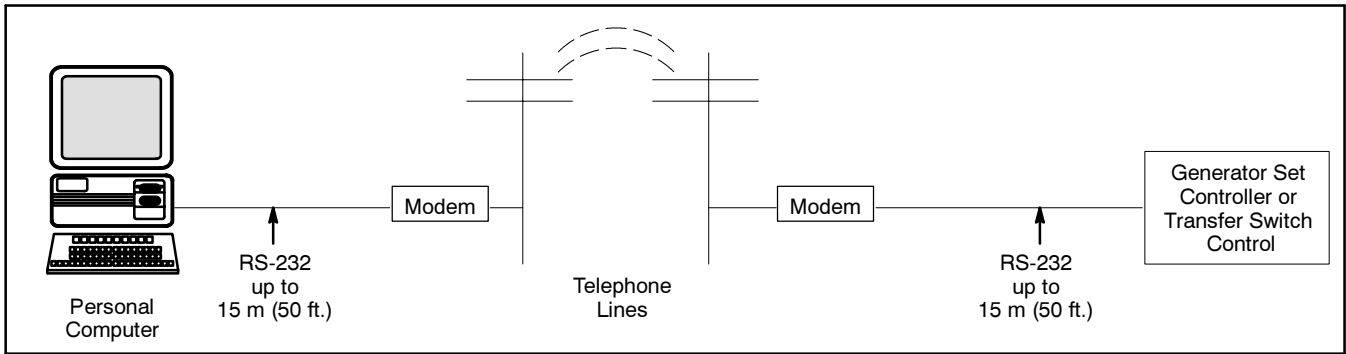

Figure 2-16 Remote Single Connection

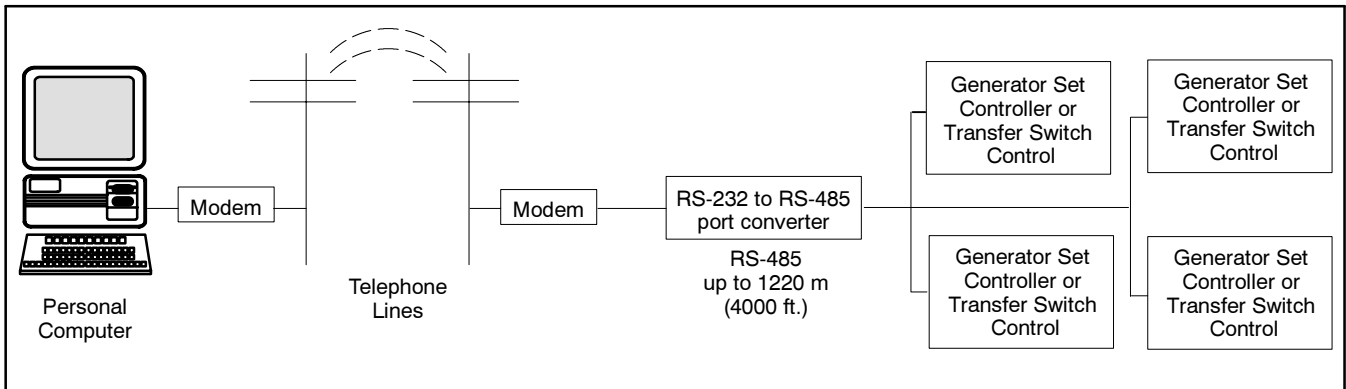

Figure 2-17 Remote Area Network

Modbus® is a registered trademark of Schneider Electric.

2.8 Reviewing the Menu Displays

Use this section to review generator set controller data while in the programming off mode.

Press the Reset key, enter the desired menu number key(s), and then press the Enter key. Use the down arrow and right arrow keys for navigation.

See Section 1, Specifications and Features, to review set point ranges and default settings for comparison to the actual setup.

The user must enable the programming mode to edit the display. See Menu 14—Programming Mode and Section 2.9, Local Programming Mode On, for more information.

Note: Press any key on the keypad to activate the controller panel display. The panel display turns off 5 minutes after the last keypad entry.

Note: Press the Reset Menu key to clear error messages.

Note: Press the Menu Right → key prior to entering decimal values where necessary.

Menus displaying the # symbol represent one of the following data types:

- System-calculated data
- System-measured data
- User-entered data

Menus displaying the ? symbol require the user to enter data.

Menus displaying the * symbol represent access code or password type entries. Actual key entry does not display.

See Section 2.6.3, Request and Error Messages, for error display messages and explanations while navigating the menus.

2.8.1 Menu 1—Generator Monitoring

Menu 1 displays generator output data including line-to-line and line-to-neutral voltages, current, frequency, power factor, total kilowatts, percent of maximum kW, total kVA, and total kVAR. Menu 1 displays three-phase voltage and current readings when applicable.

All menu displays apply to both single-phase and three-phase voltages unless otherwise noted as (1 PH) or (3 PH) on the menu overview. The phase designation does not appear in the controller menu displays.

Note: For the auto-scroll function, press ENTER at V & A Summary menu. Press the Reset Menu key or Menu Right → key to stop the auto-scroll function.

Note: Pressing a right arrow key from any submenu moves to the next submenu header.

Menu 1 Overview

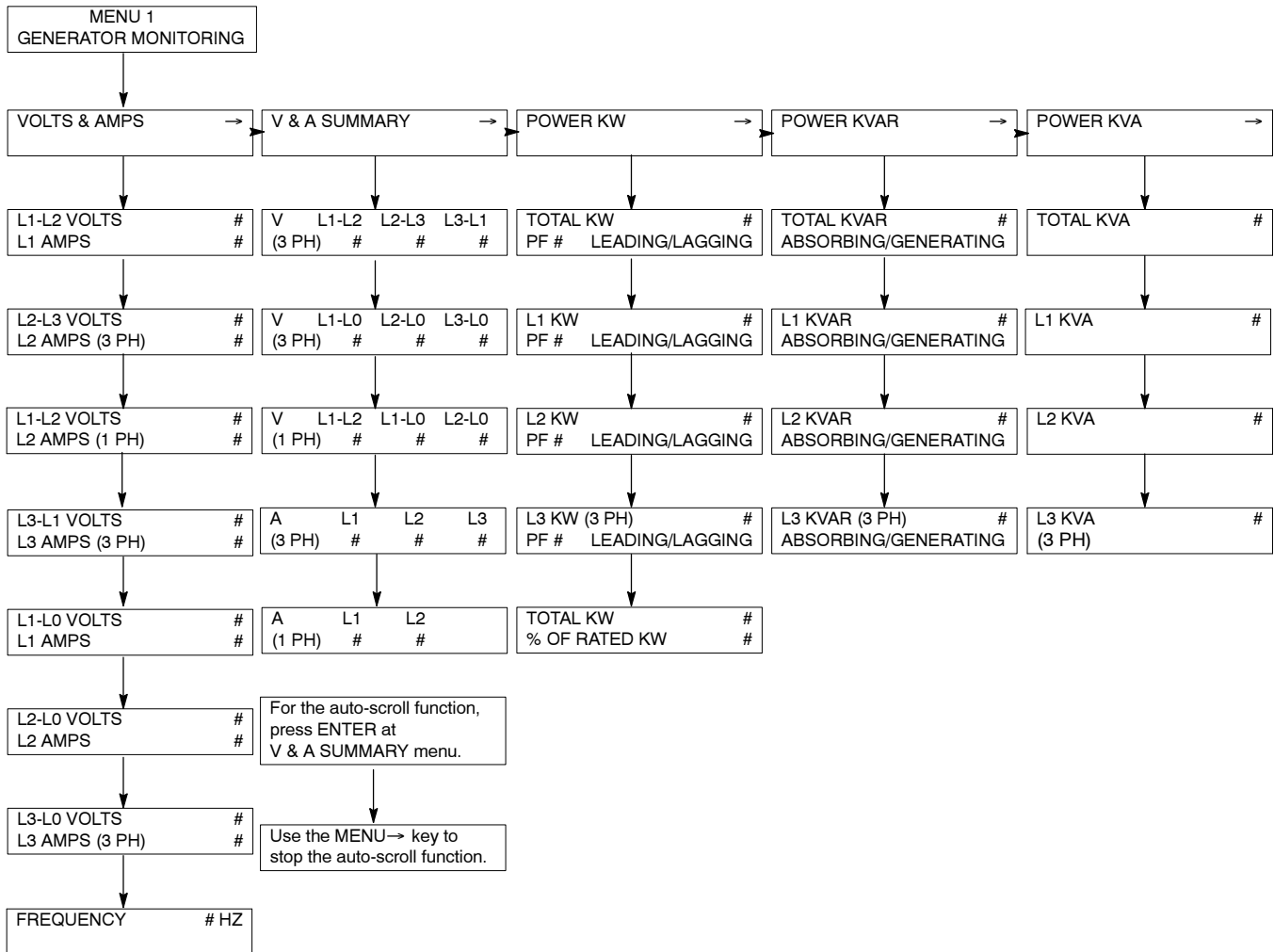

2.8.2 Menu 2—Engine Monitoring

Menu 2 displays engine operating data including oil pressure and temperature, coolant pressure and temperature, fuel pressure and temperature, engine rpm, and battery voltage. The detailed engine monitoring feature functions only with an ECM-equipped engine.

Note: A right arrow from any submenu moves to the next submenu header.

Menu 2 Overview

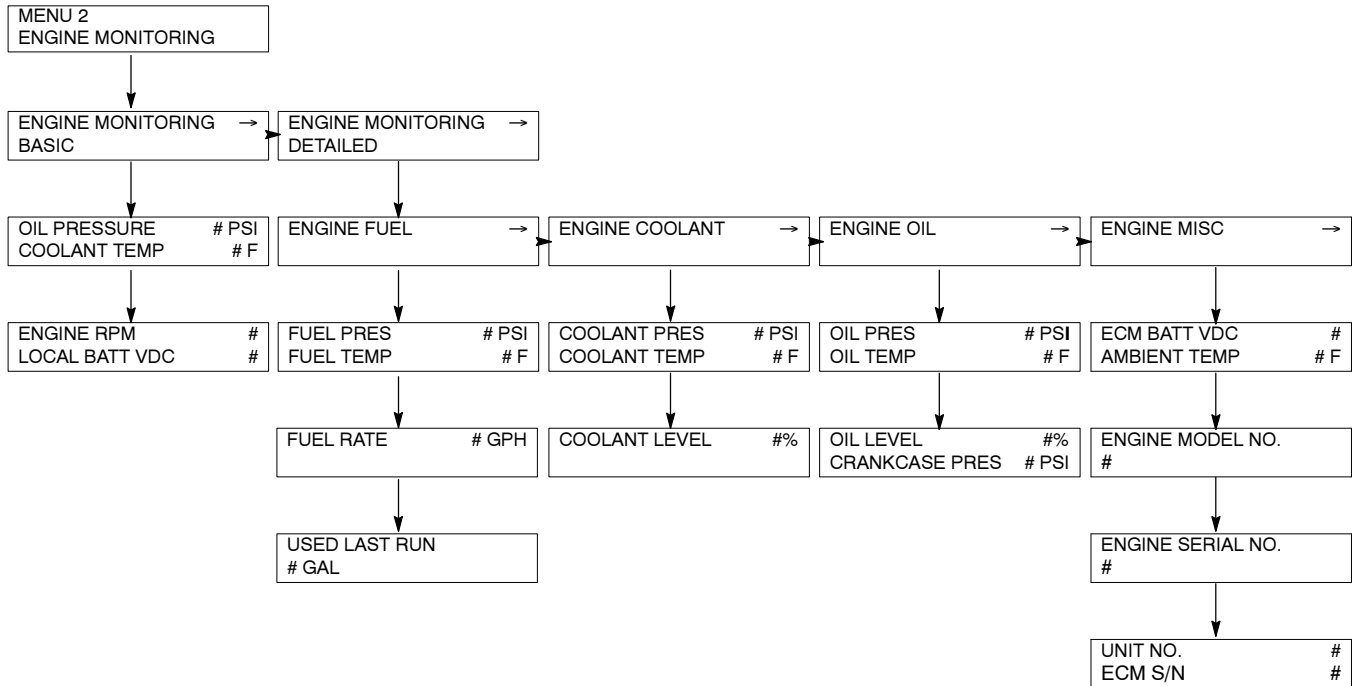

2.8.3 Menu 3—Analog Monitoring

Menu 3 displays battery voltage and up to 7 user-defined analog items dependant upon the generator system.

The *User Defined Desc* display refers to a description entered into the controller using the PC software. This description remains as the display for future review until changed by the PC software user. The display has 20 characters maximum.

Note: If the analog display shows O/R (out of range), no input is connected.

Note: ECM engines have user-defined analog inputs 01–07. Non-ECM engines have user-defined analog inputs 03–07 where analog inputs 01 and 02 are reserved for engine oil pressure and coolant temperature displays.

Menu 3 Overview

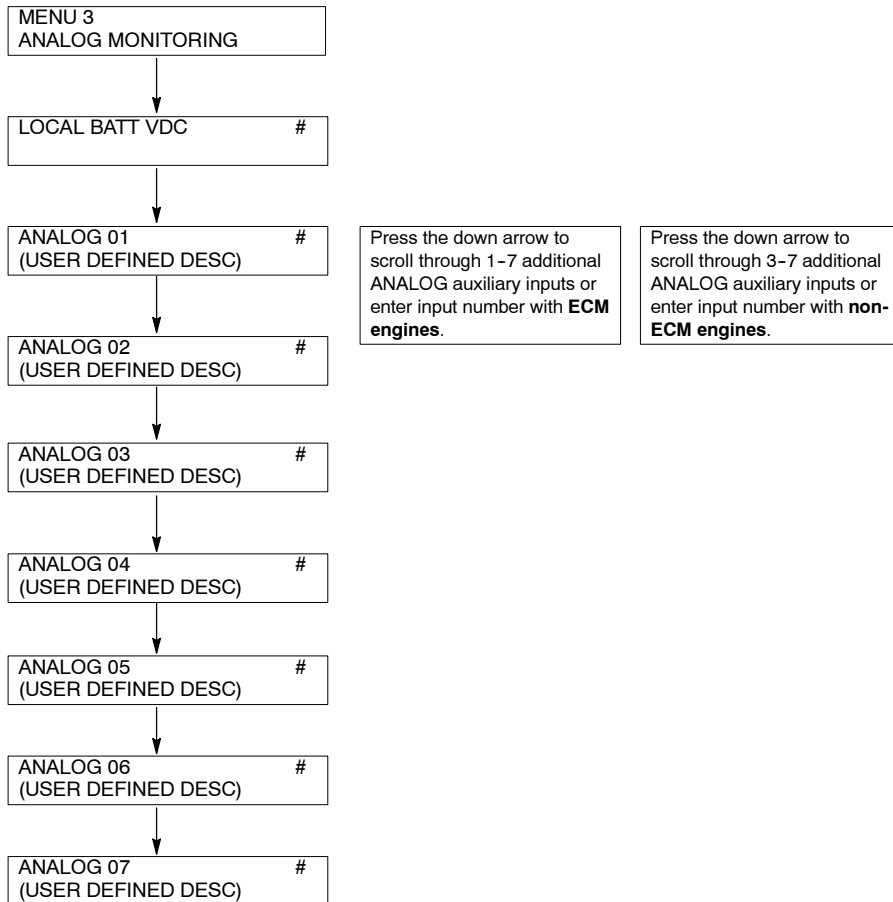

2.8.4 Menu 4—Operational Records

Menu 4 displays the generator set's operating record including operating start date, last logged maintenance, total run time loaded and unloaded, run time since last maintenance, number of starts, and number of days the unit ran.

After performing maintenance enter yes to reset records reflecting the current day. The user must enable the programming mode to edit the display.

Menu 4 Overview

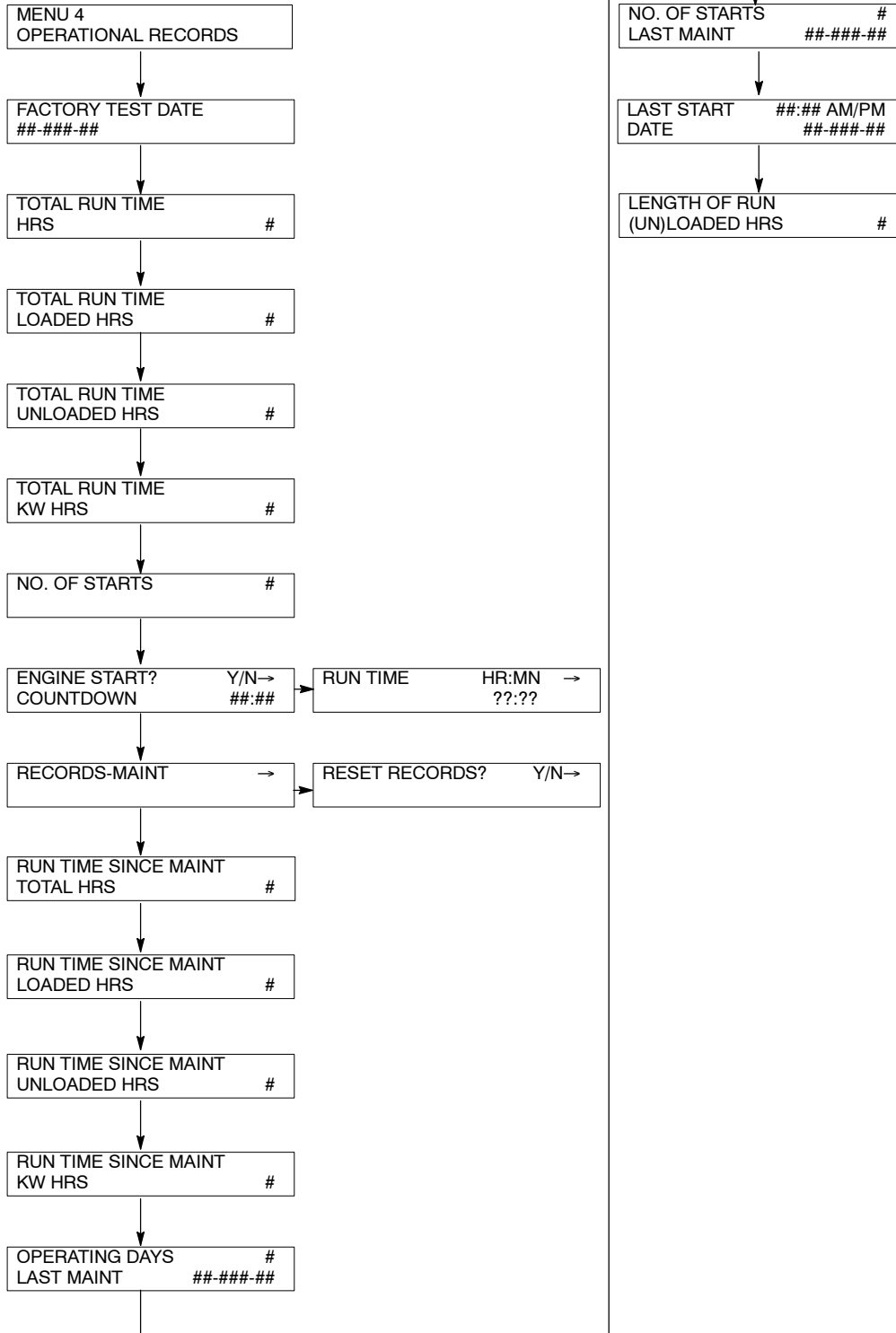

2.8.5 Menu 5—Event History

Menu 5 stores and displays the times and dates of up to 100 stored warning and shutdown events. See Menu 10—Output Setup for a list of possible events.

Menu 5 Overview

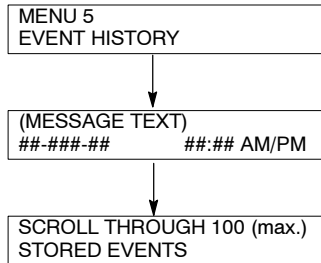

2.8.6 Menu 6—Time and Date

Menu 6 sets the clock time and date and internal calendar. The controller uses the set clock time to determine exercise run time and event records. The time and date are valid as long as the controller power (starting battery) remains connected.

The user must enable the programming mode to edit the display.

Menu 6 Overview

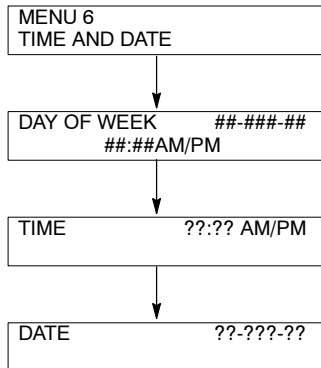

2.8.7 Menu 7—Generator System

Menu 7 displays factory-preset generator set voltage and frequency data. Enter the new voltage and/or frequency data when the generator set requires voltage reconnection and/or frequency adjustment. It is imperative that the user enter the correct data because these settings trigger all related shutdowns.

The user must enable the programming mode to edit the display.

Note: The user defines the data shown in Menu 7. It is NOT data measured by the controller and associated sensing devices. The user defines these values for purposes of calibrating the control.

Note: Press the Menu Right → key prior to entering decimal values where necessary.

Menu 7 Overview

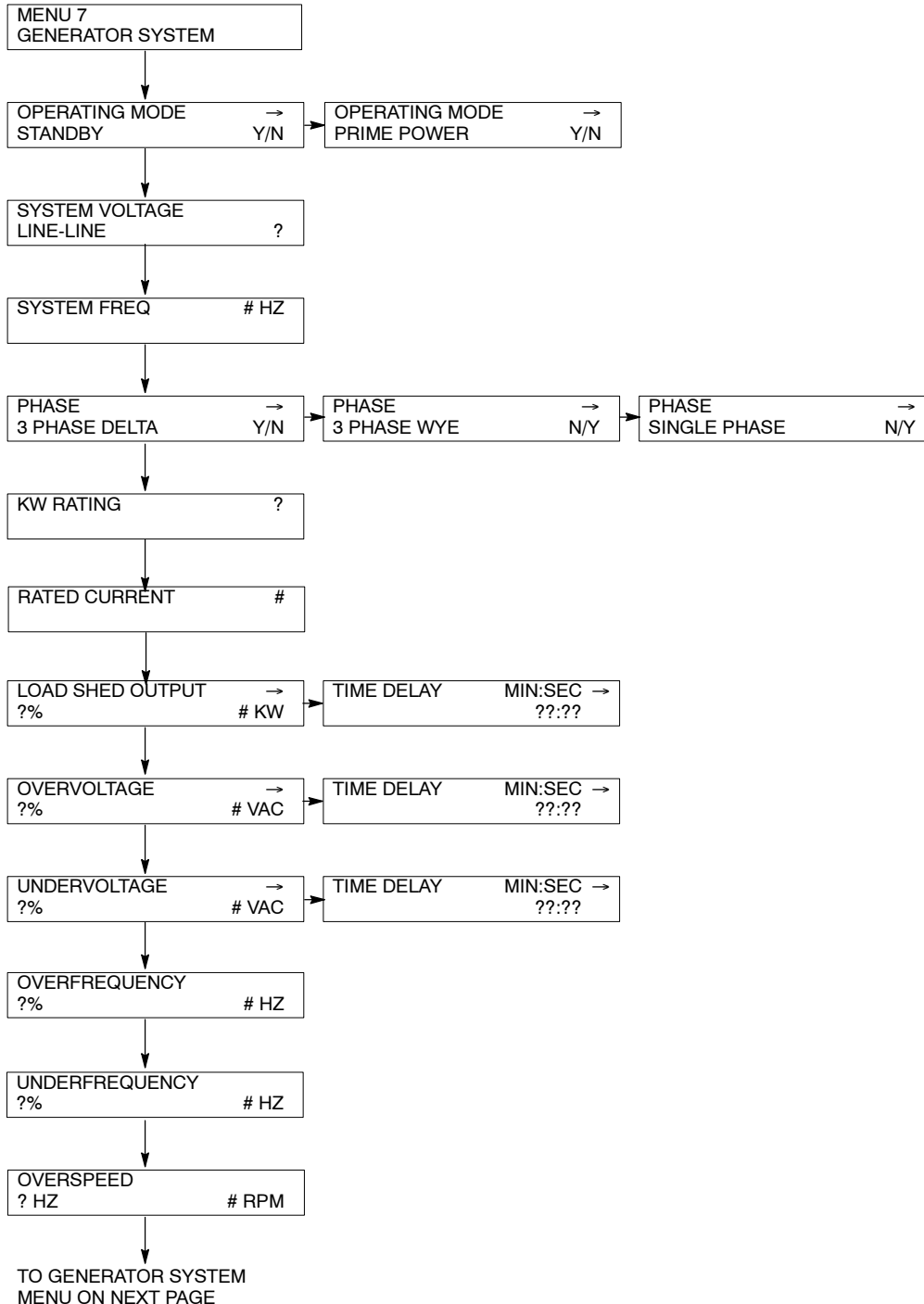

Menu 7—Generator System, continued

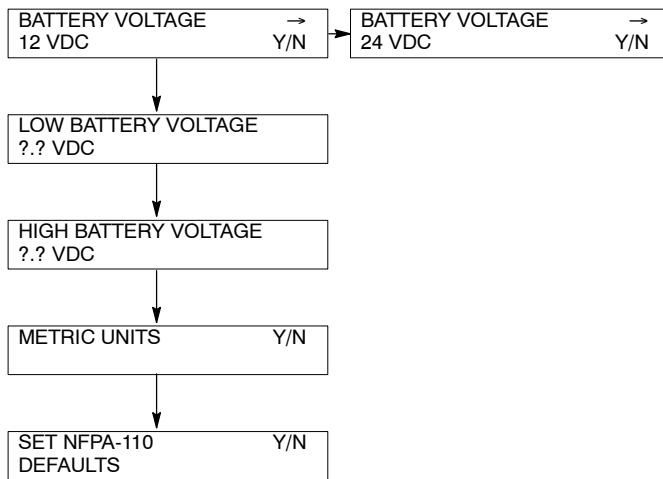

2.8.8 Menu 8—Time Delays

Menu 8 displays the cyclic cranking cycles, various engine related starting and shutdown features, and auxiliary shutdown and inhibit time delays.

The user must enable the programming mode to edit the display.

Menu 8 Overview

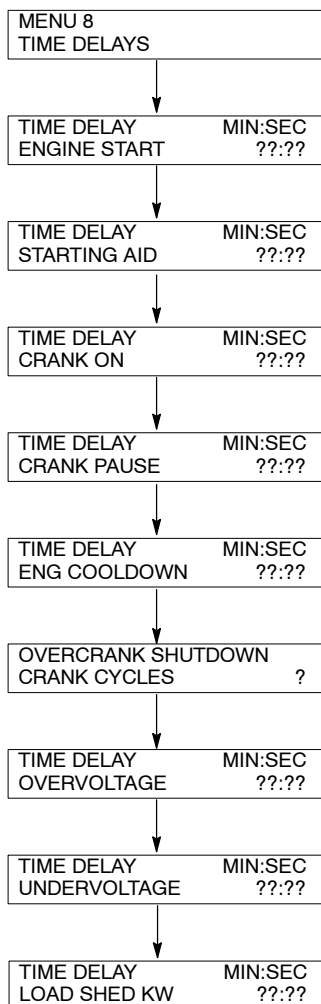

2.8.9 Menu 9—Input Setup

Menu 9 displays the setup of user-defined digital and analog warning and shutdown inputs. These inputs provide a multitude of choices for configuring customized auxiliary inputs.

The user must enable the programming mode to edit the display.

Note: Press the down arrow to move to the start of the next input setup.

Note: ECM engines have user-defined analog inputs 01-07. Non-ECM engines have user-defined analog inputs 03-07 where analog inputs 01 and 02 are reserved for engine coolant temperature and oil pressure displays.

Digital and Analog Inputs. After the user selects input, enter the following choices or values—enabled (yes/no), inhibit time (min.:sec.), and delay time (min.:sec.).

- **Enabled.** This menu entry enables the input. The previous yes/no selection does not activate the input. **Analog inputs** have separate warning and shutdown enabled choices.
- **Inhibit Time Delay.** The inhibit time delay is the time period following crank disconnect during which the generator set stabilizes and the controller does not detect the fault or status event. The inhibit time delay range is from 0 to 60 seconds.

- **Time Delay (shutdown or warning).** The time delay follows the inhibit time delay. The time delay is the time period between when the controller first detects the fault or status event and the controller warning or shutdown lamp illuminates. The delay prevents any nuisance alarms. The time delay range is from 0 to 60 seconds.

Additional Analog Input Entries. The analog input selection typically requires entering four values—low warning, high warning, low shutdown, and high shutdown.

Battle Switch/Fault Shutdown Override Switch. The *battle* switch function forces the system to ignore normal fault shutdowns such as low oil pressure and high engine temperature. The battle switch does not override the emergency stop and overspeed shutdown. When the battle switch function is enabled the generator set continues to run regardless of shutdown signals where potential engine/generator damage can occur.

When this input is enabled the yellow warning lamp illuminates and stored warning/shutdown events that are ignored continue to log in Menu 5—Event History.

Shutdown Type A and Shutdown Type B. Choose **shutdown type A** for standard shutdown where red lamp illuminates and alarm horn sounds. Choose **shutdown type B** for shutdown where air damper indicator RDO-23 energizes for two seconds, red lamp illuminates, and alarm horn sounds.

Menu 9 Overview

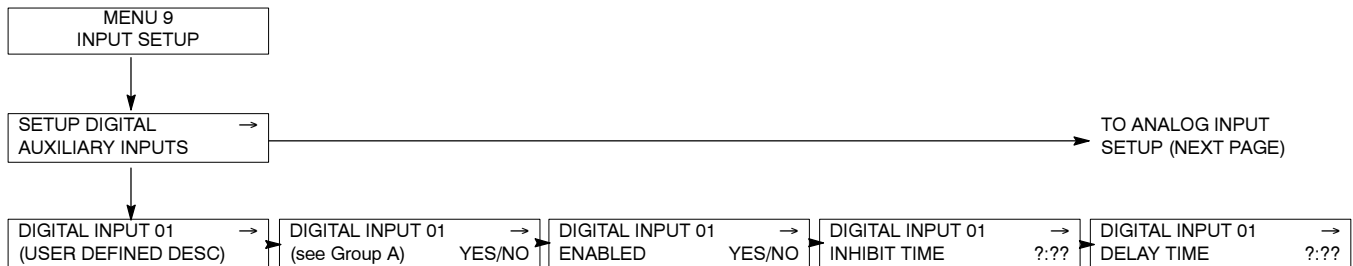

Press the down arrow to scroll through additional DIGITAL auxiliary inputs 1-21 or enter the input number.

Group A
The preprogrammed selections include the following:

WARNING	Y/N
SHUTDOWN TYPE A	Y/N
SHUTDOWN TYPE B	Y/N
VOLTAGE RAISE	Y/N
VOLTAGE LOWER	Y/N
VAR PF MODE	Y/N
REMOTE SHUTDOWN	Y/N
REMOTE RESET	Y/N

Group A, continued

AIR DAMPER	Y/N
LOW FUEL	Y/N
FIELD OVERVOLTAGE	Y/N
IDLE MODE ACTIVE	Y/N
(ECM engine only)	
BATTLE SWITCH	Y/N
GROUND FAULT	Y/N
BAT CHGR FAULT	Y/N
Hi OIL TEMP	Y/N
LOW COOLANT LEVEL	Y/N
LOW COOLANT TEMP	Y/N
(not user selectable)	

Menu 9—Input Setup, continued

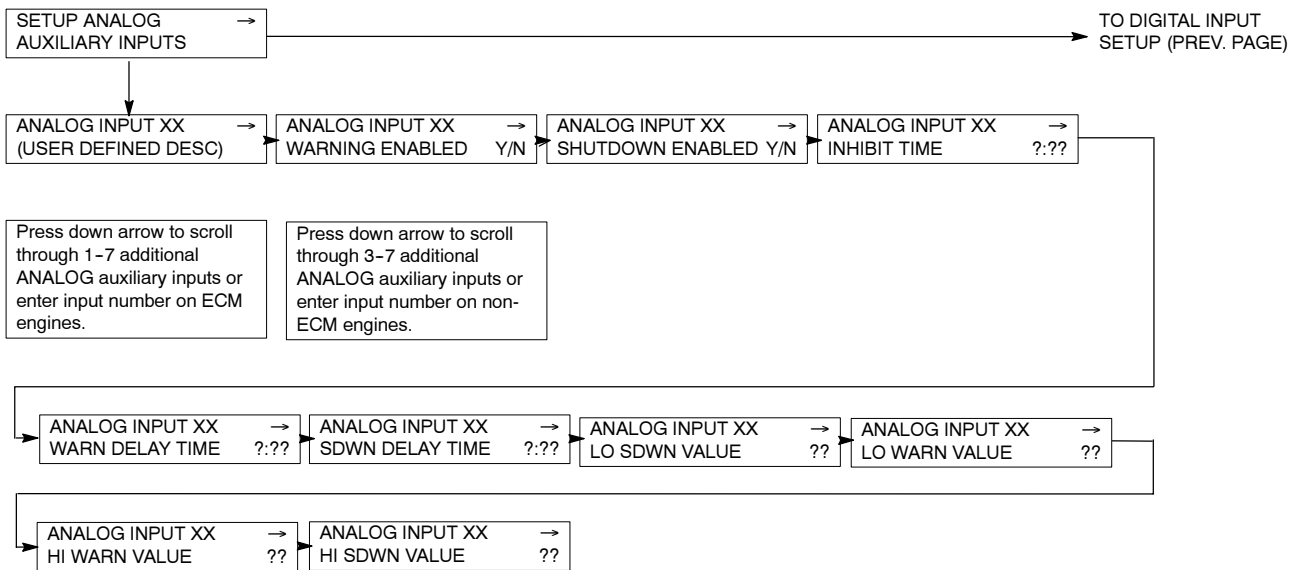

2.8.10 Menu 10—Output Setup

Menu 10 displays the setup of user-defined system, digital, and analog status and fault outputs and relay driver outputs (RDO) 1–31. These RDO outputs provide a multitude of choices for configuring customized auxiliary outputs. Additional individual outputs are available for monitoring, diagnostics, and control functions.

The user must enable the programming mode to edit the display.

Note: Some data require entry using a PC in the Remote Programming mode. See the Software Operation Manual for details.

Common Faults

The user can program a single fault comprised of faults from 3 common fault programs—system, digital, and analog faults.

Up to 46 user-defined *system* status events and faults are available. See Group B on the following pages for specific descriptions. The NFPA-110 faults are part of the *system* fault program and are comprised of 15 individual faults shown on the next page.

The user can select up to 21 user-defined *digital* status events and faults designated as D01 to D21. Each of the 21 status events and faults are assignable as shutdowns or warnings.

The user can select up to 7 user-defined *analog* status events and faults designated as A01 to A07. Each of the 7 status events and faults are assignable as shutdowns or warnings with high or low settings for a total of up to 7 status events and fault functions.

Relay Driver Outputs (RDOs)

Up to 31 *RDOs* are available using the system, digital, and analog status events and faults. RDOs provide only the driver. The contact relays that interface with other equipment are optional.

Note: *Func(tion) Used By (RDO) XX Reassign?* error message appears when the user attempts to duplicate an existing RDO selection.

Note: *Cannot Change NFPA is Enabled.* error message appears when the user attempts to modify RDO setting defaulted as NFPA 110 requirement.

Menu 10 Overview

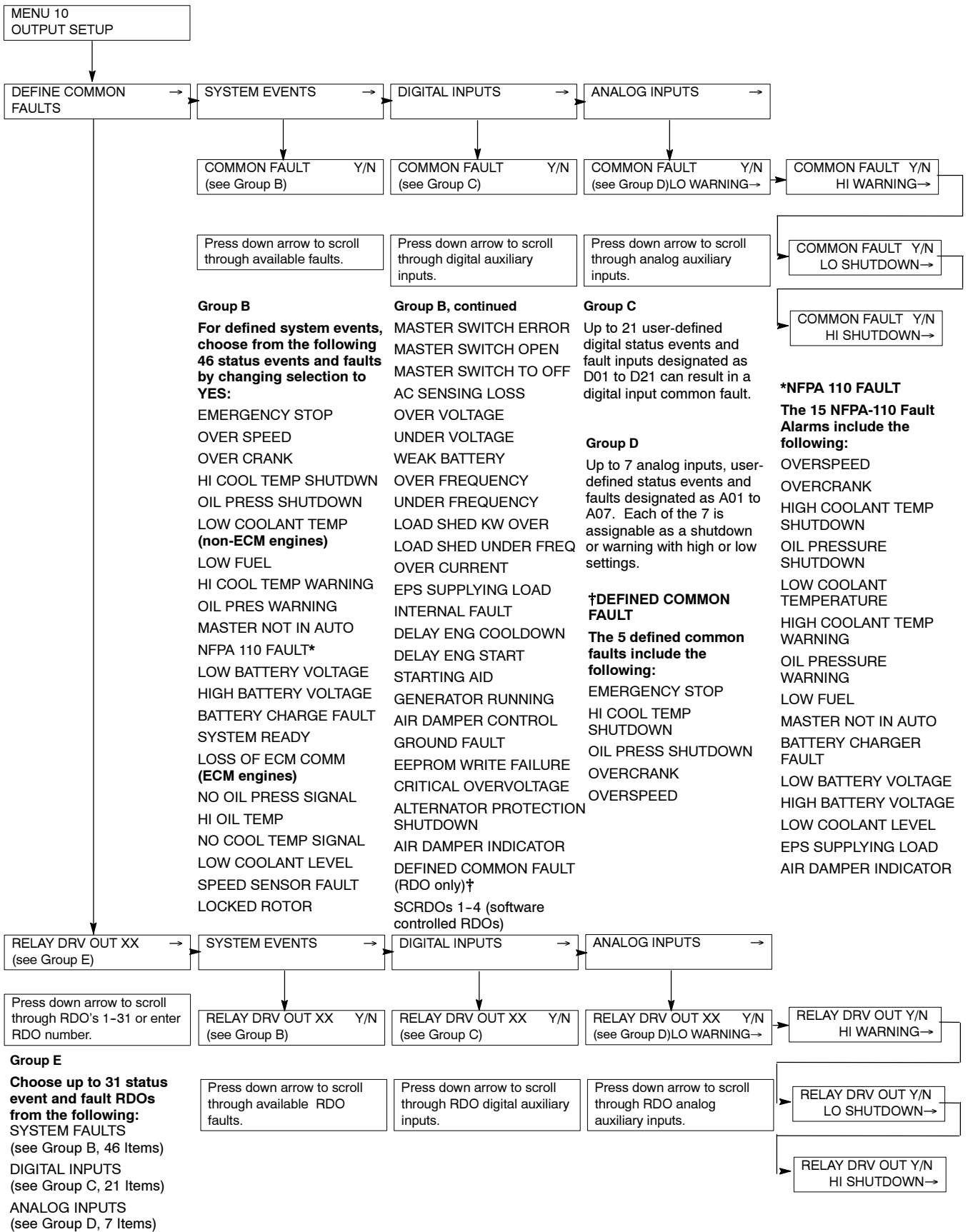

2.8.11 Menu 11—Voltage Regulator

Menu 11 displays setup of the voltage regulator functions including line-to-line voltages, underfrequency unloading (volts per Hz), reactive droop, power factor, and kVAR adjustments.

Adjust the frequency at the generator set's governor before making voltage regulator adjustments.

The user must enable the programming mode to edit the display.

Note: Press the Menu Right → key prior to entering decimal values where necessary.

Menu 11 Overview

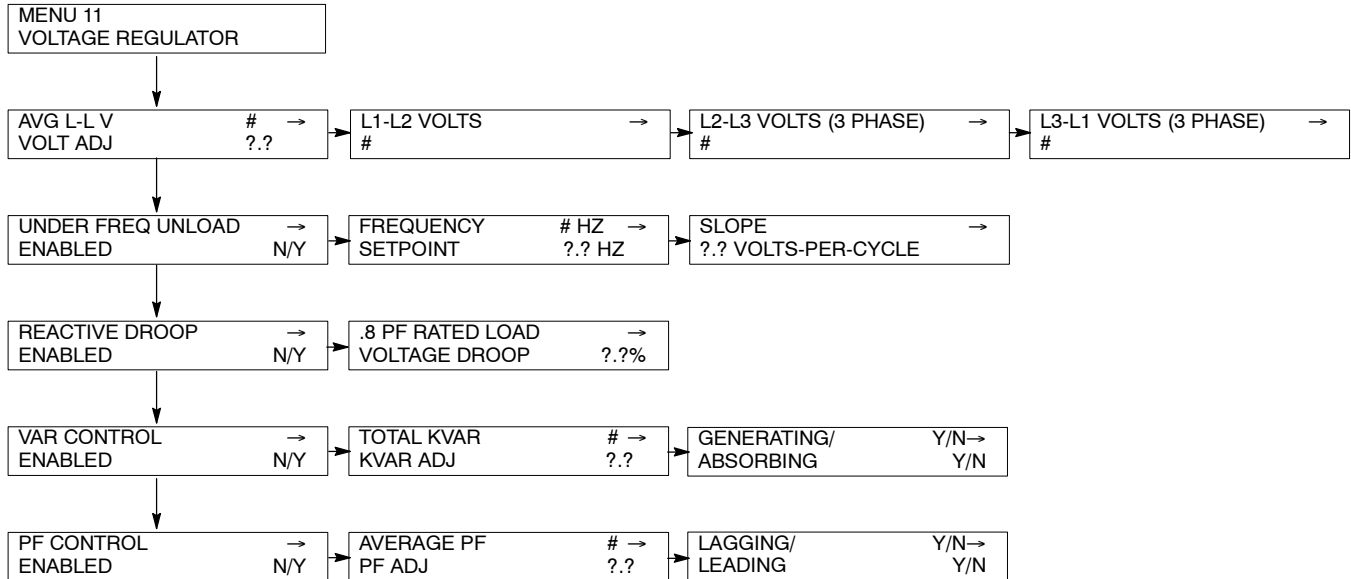

2.8.12 Menu 12—Calibration

Menu 12 provides calibration of the voltage sensing logic and displays. Changing the system voltage or replacing the main logic control circuit board requires calibration adjustment.

The user must enable the programming mode to edit the display.

Connect a meter with a minimum accuracy of $\pm 1\%$ to the output leads to calibrate the voltage-sensing logic. Configure the generator set controller for the system operating configuration using Menu 7—Generator System. If the generator set has a digital voltage

regulator, adjust the generator set voltage using Menu 11—Voltage Regulator. Adjust the frequency at the generator set governor before making calibration adjustments.

Note: Press the Menu Right → key prior to entering decimal values where necessary.

Note: ECM engines have user-defined analog inputs A01–A07. Non-ECM engines have user-defined analog inputs A03–A07 where analog inputs 01 and 02 are reserved for engine oil pressure and coolant temperature displays.

Menu 12 Overview

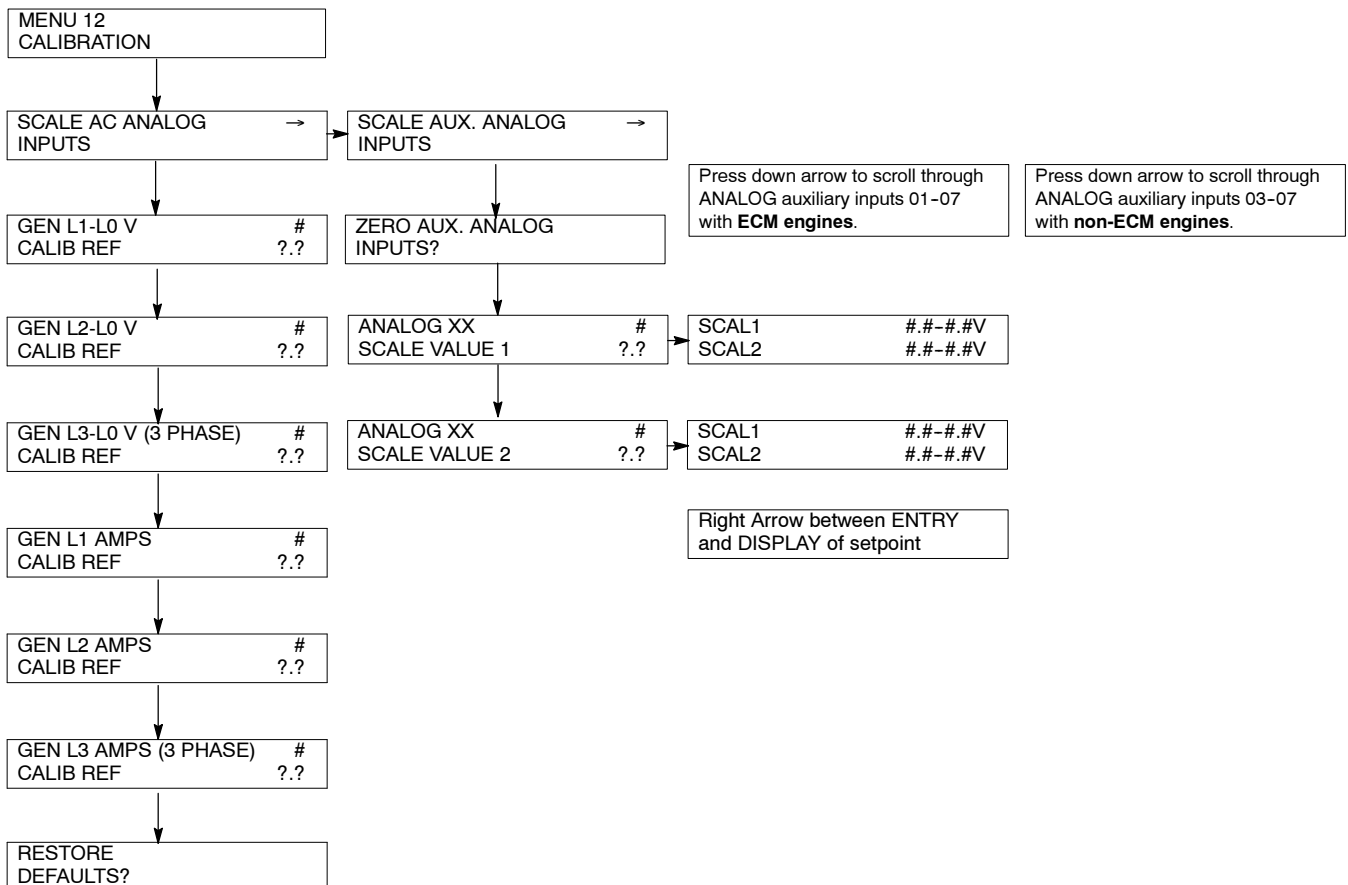

2.8.13 Menu 13—Communications

Menu 13 provides local or remote access to the control logic.

Use the LAN (local area network) to gain remote access to multiple devices/addresses. Enable the *local* programming mode to edit the display using the keypad

and digital display or the *remote* programming mode to edit the display using a PC. Use the Software Operation Manual when accessing this menu, programming from a remote location, and determining address and system identification information.

Menu 13 Overview

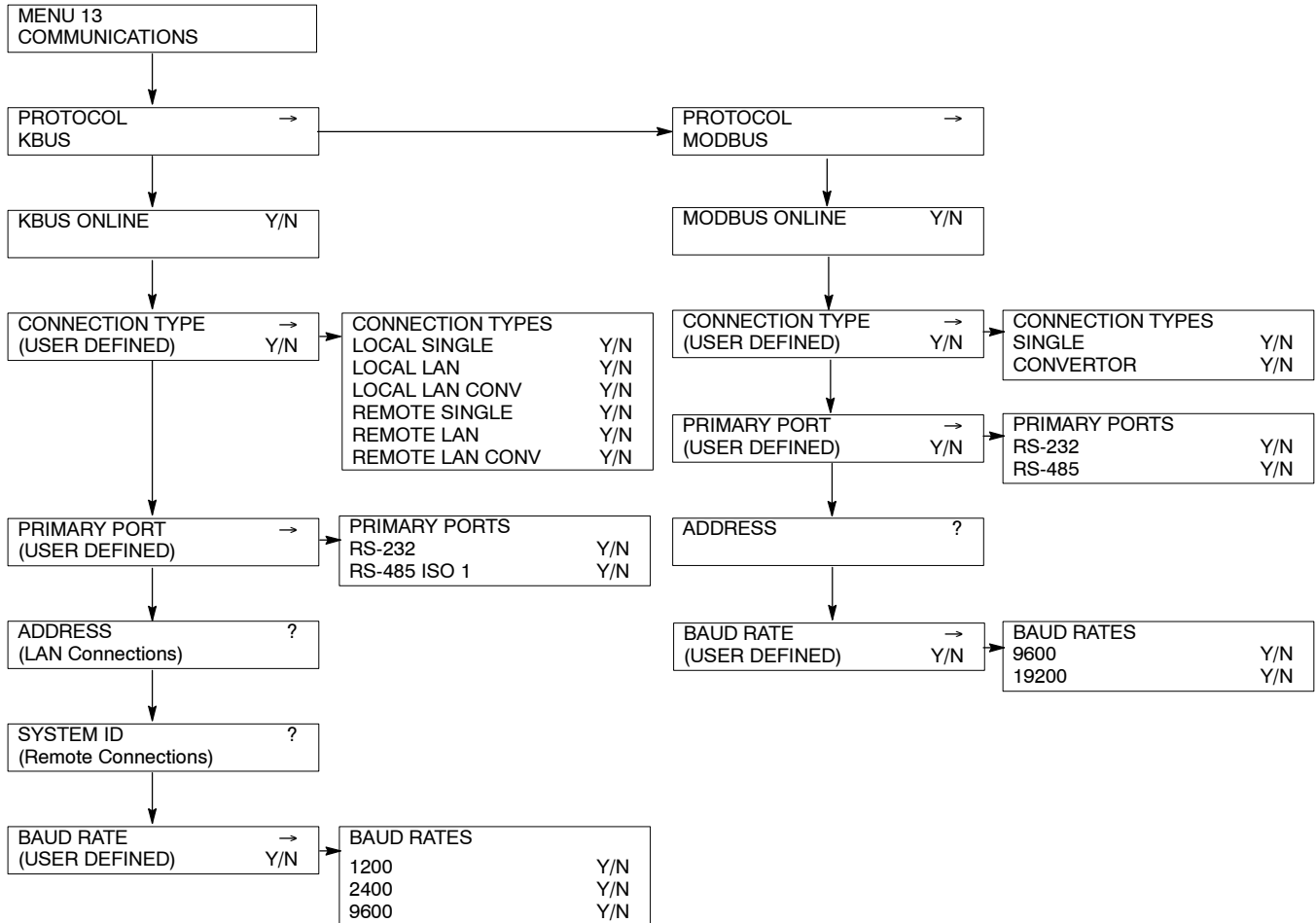

2.8.14 Menu 14—Programming Mode

Menu 14 provides local or remote access to the programming function. The user enters a password to access the programming mode.

Note: Log into the *local* programming mode to edit the programming access code. *The factory default access code is the number 0.*

Use Menu 14 to change the access code. Record the new number and give the access code only to authorized individuals. Should the controller logic not accept the access code or if the new code number is lost, contact your local authorized distributor/dealer for password information.

The user chooses one of three programming modes:

- local—using the controller keypad
- remote—using a PC
- off—no programming is permitted

Note: Use the generator set controller to initially set up remote programming. Remote programming cannot be accessed from a PC unless the controller is first set for remote programming using Menu 14.

Menu 14 Overview

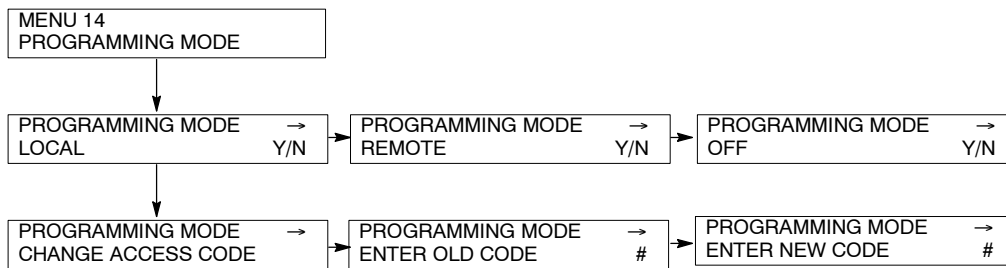

2.9 Local Programming Mode On

The Local Programming Mode On section explains how to program the generator set controller logic. Each menu contains a step-by-step procedure for programming the various logic groups. See Section 1, Specifications, for setting ranges and default settings.

Please read and understand the entire Local Programming Mode On section before attempting any programming. The factory settings are adjustable and programming without full understanding of the logic features and functions can cause inadvertent changes.

Refer to Menu 14—Programming Mode for information regarding menu programming activation. After completing the programming always *place the controller back in the Programming Mode Off position* to prevent inadvertent program changes.

The programming feature alters stored settings and changes characteristics of the logic. Do not operate the controller with the program mode on unless there is a need to edit program logic or clear stored data. Limit programming responsibilities to individuals with training and authority.

The product application requires expertise in the design and programming of control systems. Only qualified personnel should program, install, alter, and apply this product.

Use Section 2.8, Reviewing the Menu Displays, to view the generator set operation data and review previously programmed information and to review the data when no programming is necessary.

Menus displaying the # symbol represent one of the following data types:

- System-calculated data
- System-measured data
- User-entered data

Menus displaying the ? symbol require the user to enter data.

Menus displaying the * symbol represent access code or password type entries. Actual key entry does not display.

See Section 2.6.3, Request and Error Messages, for error display messages and explanations while navigating through the menus.

All menu displays apply to both single-phase and three-phase voltages unless otherwise noted as (1 PH) or (3 PH) on the menu overview. The phase designation does not appear in the actual menu displays.

Note: Place the generator set master switch in the OFF/RESET position when using the programming mode on.

Note: Use the generator set controller to initially set up the remote programming. Set the controller for remote programming using Menu 14 and remote communication using Menu 13 before attempting remote programming.

Note: Press any key on the keypad to activate the controller panel display. The panel display turns off 5 minutes after the last keypad entry.

Note: Press the Reset Menu key to clear the Error display.

Note: Press the Menu Right → key prior to entering decimal values where necessary.

2.9.1 Menu 1—Generator Monitoring

















Menu 1 provides generator output data including line-to-line and line-to-neutral voltages, current, frequency, power factor, total kilowatts, percent of maximum kW, total kVA and total kVAR displays. Menu 1 displays three-phase voltage and current readings when applicable.

Note: For the auto-scroll function, press ENTER at the V & A Summary menu. Press the Reset Menu key or Menu Right → key to stop the auto-scroll function.

Note: A right arrow from any submenu moves to the next submenu header.

Menu 1—Generator Monitoring

Menu 1 Displays with Key Entries

Key Entry	Display	Description
	ENTER MENU NO. 1-14	Input a menu number.
	MAIN MENU NUMBER 1	Press the Enter key.
	MENU 1 GENERATOR MONITORING	Displays the menu number and name.
	VOLTS & AMPS →	Displays the volts and amps heading.
	L1-L2 VOLTS # L1 AMPS #	Displays L1 and L2 volts and L1 amps.
	L2-L3 VOLTS # L2 AMPS #	Displays L2 and L3 volts and L2 amps. (3 ph. only)
	L1-L2 VOLTS # L2 AMPS #	Displays L1 and L2 volts and L2 amps. (1 ph. only)
	L3-L1 VOLTS # L3 AMPS #	Displays L3 and L1 volts and L3 amps. (3 ph. only)
	L1-L0 VOLTS # L1 AMPS #	Displays L1-L0 volts and L1 amps.
	L2-L0 VOLTS # L2 AMPS #	Displays L2 and L0 volts and L2 amps.
	L3-L0 VOLTS # L3 AMPS #	Displays L3-L0 volts and L3 amps. (3 ph. only)
	FREQUENCY # HZ	Displays the frequency.
	MENU 1 GENERATOR MONITORING	Returns the user to the menu number and name.
	VOLTS & AMPS →	Returns the user to volts and amps heading.
	V & A SUMMARY →	Displays the volts and amps summary heading.
	V L1-L2 L2-L3 L3-L1 # # #	Displays L1-L2, L2-L3, and L3-L1 volts. (3 ph. only)









Menu 1—Generator Monitoring, continued

Menu 1 Displays with Key Entries

Key Entry	Display	Description
MENU ▼	V L1-L0 L2-L0 L3-L0 # # #	Displays L1-L0, L2-L0, and L3-L0 volts. (3 ph. only)
MENU ▼	V L1-L2 L1-L0 L2-L0 # # #	Displays L1-L2, L1-L0, and L2-L0 volts. (1 ph. only)
MENU ▼	A L1 L2 L3 # # #	Displays L1, L2, and L3 amps. (3 ph. only)
MENU ▼	A L1 L2 # #	Displays L1 and L2 amps. (1 ph. only)
MENU ▼	V & A SUMMARY →	Returns the user to the volts and amps summary heading.
MENU ▶	POWER KW →	Displays the power kilowatt heading.
MENU ▼	TOTAL KW # PF # LEADING/LAGGING	Displays total kilowatts and leading or lagging power factor.
MENU ▼	L1 KW # PF # LEADING/LAGGING	Displays total L1 kilowatts and leading or lagging power factor.
MENU ▼	L2 KW # PF # LEADING/LAGGING	Displays total L2 kilowatts and leading or lagging power factor.
MENU ▼	L3 KW # PF # LEADING/LAGGING	Displays total L3 kilowatts and leading or lagging power factor. (3 ph. only)
MENU ▼	TOTAL KW # % OF RATED KW #	Displays the total kW and percent of rated kilowatts.
MENU ▼	POWER KW →	Returns the user to the power kilowatt heading.
MENU ▶	POWER KVAR →	Displays the power kVAR heading.
MENU ▼	TOTAL KVAR # ABSORBING/GENERATING	Displays total kVAR, absorbing or generating.
MENU ▼	L1 KVAR # ABSORBING/GENERATING	Displays L1 kVAR, absorbing or generating.
MENU ▼	L2 KVAR # ABSORBING/GENERATING	Displays L2 kVAR, absorbing or generating.
MENU ▼	L3 KVAR # ABSORBING/GENERATING	Displays L3 kVAR, absorbing or generating. (3 ph. only)
MENU ▼	POWER KVAR →	Returns the user to power kVAR heading.
MENU ▶	POWER KVA →	Displays the power kVA heading.

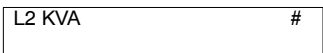
Menu 1—Generator Monitoring, continued

Menu 1 Displays with Key Entries

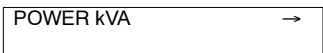
Key Entry	Display	Description
		Displays total kVA.
		Displays L1 kVA.
		Displays L2 kVA.
		Displays L3 kVA. (3 ph. only)
		Returns the user to power kVA heading.

















2.9.2 Menu 2—Engine Monitoring

Menu 2 provides engine operating data including oil pressure and temperature, coolant pressure and temperature, fuel pressure and temperature, engine rpm, and battery voltage. The detailed engine monitoring feature requires an ECM-equipped engine.

Note: A right arrow from any submenu moves to the next submenu header.













Menu 2—Engine Monitoring, continued

Menu 2 Displays with Key Entries

Key Entry	Display	Description
	ENTER MENU NO. 1-14	Input a menu number.
	MAIN MENU NUMBER 2	Press the Enter key.
	MENU 2 ENGINE MONITORING	Displays the menu number and name.
	ENGINE MONITORING → BASIC	Displays the basic engine monitoring heading.
	OIL PRESSURE # PSI COOLANT TEMP # F	Displays oil pressure and coolant temperature.
	ENGINE RPM # LOCAL BATT VDC #	Displays engine rpm and local battery VDC.
	MENU 2 ENGINE MONITORING	Returns the user to the menu number and name.
	ENGINE MONITORING → BASIC	Returns the user to basic engine monitoring heading.
	ENGINE MONITORING → DETAILED	Displays the detailed engine monitoring heading. Note: The detailed engine monitoring feature requires an ECM-equipped engine.
	ENGINE FUEL →	Displays the engine fuel subheading.
	FUEL PRES # PSI FUEL TEMP # F	Displays the fuel pressure and fuel temperature.
	FUEL RATE # GPH	Displays the fuel rate per hour.
	USED LAST RUN # GAL	Displays the amount of fuel used during the last run.
	ENGINE MONITORING → DETAILED	Returns the user to the detailed engine monitoring heading.
	ENGINE FUEL →	Displays the engine fuel subheading.
	ENGINE COOLANT →	Displays the engine coolant subheading.

Menu 2—Engine Monitoring, continued

Menu 2 Displays with Key Entries

Key Entry	Display	Description
	COOLANT PRES # PSI COOLANT TEMP # F	Displays the coolant pressure and coolant temperature.
	COOLANT LEVEL #%	Displays the coolant level as a percent of full capacity.
	ENGINE COOLANT →	Returns the user to engine coolant subheading.
	ENGINE OIL →	Displays the engine oil subheading.
	OIL PRES # PSI OIL TEMP # F	Displays the oil pressure and oil temperature.
	OIL LEVEL #% CRANKCASE PRES # PSI	Displays the oil level as a percent of full capacity and crankcase pressure.
	ENGINE OIL →	Returns the user to engine oil subheading.
	ENGINE MISC →	Displays the miscellaneous engine subheading.
	ECM BATT VDC # AMBIENT TEMP # F	Displays the engine ECM battery VDC and ambient temperature.
	ENGINE MODEL NO. #	Displays the engine model number.
	ENGINE SERIAL NO. #	Displays the engine serial number.
	UNIT NO. # ECM S/N #	Displays the unit number and ECM serial number.
	ENGINE MISC →	Returns the user to the miscellaneous engine subheading.

2.9.3 Menu 3—Analog Monitoring

Menu 3 provides the battery voltage and up to 7 user-defined analog monitoring items dependent upon the generator system.











The *User Defined Desc* display refers to a description entered into the controller using the PC software. This description remains as the display for future review until changed by the PC software user. The display has 20 characters maximum.

Note: If the analog display shows O/R (out of range), no input is connected.

Note: Some data require entry using a PC in the Remote Programming mode. See the Software Operation Manual for details.

Note: ECM engines have user-defined analog inputs A01–A07. Non-ECM engines have user-defined analog inputs A03–A07 where analog inputs 01 and 02 are reserved for the engine coolant temperature and oil pressure displays.

Menu 3—Analog Monitoring Menu 3 Displays with Key Entries

Key Entry	Display	Description
	ENTER MENU NO. 1-14	Input a menu number.
	MAIN MENU NUMBER 3	Press the Enter key.
	MENU 3 ANALOG MONITORING	Displays the menu number and name.
	LOCAL BATT VDC #	Displays the local battery VDC.
	ANALOG 01 (USER DEFINED DESC) #	Displays analog 01 and the user-defined description. Note: ECM engines have inputs 01–07 and non-ECM engines have inputs 03–07.
	ANALOG 02 (USER DEFINED DESC) #	Displays analog 02 and the user defined description.
	ANALOG 03 (USER DEFINED DESC) #	Displays analog 03 and the user-defined description.
	ANALOG 04 (USER DEFINED DESC) #	Displays analog 04 and the user-defined description.
	ANALOG 05 (USER DEFINED DESC) #	Displays analog 05 and the user-defined description.
	ANALOG 06 (USER DEFINED DESC) #	Displays analog 06 end the user-defined description.
	ANALOG 07 (USER DEFINED DESC) #	Displays analog 07 and the user-defined description.

2.9.4 Menu 4—Operational Records

Menu 4 provides the generator set operational records including the operating start date, last logged maintenance, total run time loaded and unloaded, run time since the last maintenance, number of starts, and number of running days.

Run Time Feature. This menu provides the ability to run the generator set for a designated time. After the run time elapses the generator set shuts down and functions in the standby mode. **Generator set connected to an automatic transfer switch.** Should a utility power failure occur while the unit is in the run time













mode, the controller bypasses the run time mode and functions in the standby (backup) mode. If the utility power returns, the generator set continues to run for the duration of the run time period if not timed out.

Note: Press the STOP PROG RUN key to stop the generator set when in the run time mode, if necessary.

After performing maintenance enter yes to reset records reflecting the current day. The user must enable the programming mode to edit the display.

Menu 4—Operational Records

Menu 4 Displays with Key Entries

Key Entry	Display	Description
	ENTER MENU NO. 1-14	Input a menu number.
	MAIN MENU NUMBER 4	Press the Enter key.
	MENU 4 OPERATIONAL RECORDS	Displays the menu number and name.
	FACTORY TEST DATE ##-###-##	Displays the factory test date (day-month-year).
	TOTAL RUN TIME HRS #	Displays the total run time (hours:minutes).
	TOTAL RUN TIME LOADED HRS #	Displays the total run time for loaded hours.
	TOTAL RUN TIME UNLOADED HRS #	Displays the total run time for unloaded hours.
	TOTAL RUN TIME KW HRS #	Displays the total run time in kW hours.
	NO. OF STARTS #	Displays the number of engine starts.
	ENGINE START? Y/N→ COUNTDOWN ##:##	Displays the start and countdown subheading.
	RUN TIME HR:MN→ ??:??	Displays the run time (hours:minutes) feature. When required, use the numeric keys to enter the selected run time (hours:minutes) and press the Enter key.
	RUN TIME HR:MN→ ##:##	Confirms entry and displays the selected run time (hours:minutes). The generator set will start after activation. Note: Activate the generator set run time feature by pressing the Yes and Enter keys. See the following steps.
	ENGINE START? Y/N→ COUNTDOWN ##:##	Returns the user to the start and countdown subheading. Enter Yes to start the generator set.

Menu 4—Operational Records, continued

Menu 4 Displays with Key Entries







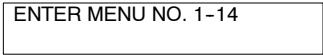

Key Entry	Display	Description
	ENGINE START? YES→ COUNTDOWN ##:##	Press the Enter key.
	RUN TIME HR:MN→ ##:##	Confirms the entry. The generator set will begin cranking and run based on the run time (hours:minutes) period and all previously established time (hours:minutes) delays from Menu 8—Time Delays. Note: Press the STOP PROG RUN key to stop the generator set when in the run time mode, if necessary.
	RECORDS MAINT →	Displays the records maintenance subheading.
	RESET RECORDS? →	Displays the reset records option. After performing maintenance or when required, enter Yes to reset.
	RESET RECORDS? YES→	Enter Yes to reset to the current date and press the Enter key.
	RESET RECORDS? YES→	Confirms the entry.
	RECORDS MAINT →	Returns the user to records maintenance subheading.
	RUN TIME SINCE MAINT TOTAL HRS #	Displays the run time since the last maintenance with total hours.
	RUN TIME SINCE MAINT LOADED HRS #	Displays the run time since last the maintenance with loaded hours.
	RUN TIME SINCE MAINT UNLOADED HRS #	Displays the run time since the last maintenance with unloaded hours.
	RUN TIME SINCE MAINT KW HRS #	Displays the run time since the last maintenance in kW hours.
	OPERATING DAYS # LAST MAINT ###-###-##	Displays the operating days since the last maintenance.
	NO. OF STARTS # LAST MAINT ##-###-##	Displays the number of starts since the last maintenance date (day-month-year).
	LAST START ##:## AM/PM DATE ##-###-##	Displays last the start time (hours:minutes) and date (day-month-year).
	LENGTH OF RUN (UN)LOADED HRS #	Displays the length of last run in (un)loaded hours.
	MENU 4 OPERATIONAL RECORDS	Returns the user to the operational records heading.

2.9.5 Menu 5—Event History

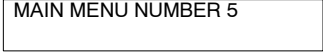
Menu 5 provides up to 100 stored warning and shutdown events that are day and time dated. See Menu 10—Output Setup for a list of possible events.

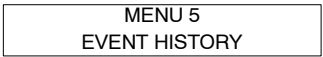
Menu 5—Event History

Menu 5 Displays with Key Entries

Key Entry	Display	Description
		Input a menu number.
		Press the Enter key.
		Displays the menu number and name.
		Displays the message text, date (day-month-year) and time (hours:minutes). Scroll through up to 100 stored events. See Section 2.3.5, System Warning Lamp, for fault descriptions.
		Returns the user to event history heading.









2.9.6 Menu 6—Time and Date

Menu 6 sets the clock time and date and internal calendar. The controller uses set time for determining the exercise run time and event records. The time and date are valid only if the controller power (starting battery) remains connected.

The user must enable the programming mode to edit the display.

Menu 6—Time and Date

Menu 6 Displays with Key Entries

Key Entry	Display	Description
	ENTER MENU NO. 1-14	Input a menu number.
	MAIN MENU NUMBER 6	Press the Enter key.
	MENU 6 TIME AND DATE	Displays the menu number and name.
	DAY OF WEEK ##-##-## ###:## AM/PM	Displays the day of the week, date (day-month-year), and time (hours:minutes).
	TIME ??:?? AM/PM	Displays the time (hours:minutes) of day entry. When required, use the numeric and am/pm keys to set the time (hours:minutes) of day and press the Enter key.
	DAY OF WEEK ##-##-## ###:## AM/PM	Displays the corrected time (hours:minutes) of day.
	DATE ??-??-??	Displays the date (day-month-year) entry. When required, use the numeric keys to set the day of the month.
	AND	
	DATE ??-??-??	Use the Menu Right → key to select the month .
	AND	
	DATE ??-??-??	Use the numeric keys to set the two-digit year and press the Enter key.
	AND	
	DAY OF WEEK ##-##-## ###:## AM/PM	Displays the corrected date (day- month-year).

2.9.7 Menu 7—Generator System

Menu 7 contains the factory-preset generator set voltage and frequency data. Enter the corresponding data if the generator set requires voltage reconnection and/or frequency adjustment. It is imperative that the user enter the correct data because these settings trigger all related shutdowns.

The user must enable the programming mode to edit the display.

See Section 2.6.3, Request and Error Messages, for error display messages and explanations while navigating the menus.

Note: The user defines the data shown in Menu 7. It is NOT data measured by the controller and associated sensing devices. The user defines these values for purposes of calibrating the control.

Note: Press the Menu Right → key prior to entering decimal values where necessary.

Menu 7—Generator System

Menu 7 Displays with Key Entries

Key Entry	Display	Description
	ENTER MENU NO. 1-14	Input a menu number.
	MAIN MENU NUMBER 7	Press the Enter key.
	MENU 7 GENERATOR SYSTEM	Displays the menu number and name.
	OPERATING MODE → (see note) YES	Displays the operating mode selection. Note: The display sample may differ depending upon previous entries. The previously selected operating mode appears first, either standby or prime power.
	OPERATING MODE → STANDBY NO	Displays the optional operating mode selection. When required, enter YES for standby operating mode. Note: This display indicates the <i>generator set application</i> .
	OPERATING MODE → STANDBY YES	Enter YES to change the operating mode selection to standby and press the Enter key.
	OPERATING MODE → STANDBY YES	Confirms the entry.
OR		
	OPERATING MODE → PRIME POWER NO	Displays the optional operating mode selection. When required, enter YES for the prime power operating mode. Note: This display indicates the <i>generator set application</i> .
	OPERATING MODE → PRIME POWER YES	Enter YES to change the operating mode selection to prime power and press the Enter key.
	OPERATING MODE → PRIME POWER YES	Confirms the entry.
	SYSTEM VOLTAGE LINE-LINE ?	Displays the line-to-line system voltage as entered data. When required, use the numeric keys to set new value. Press the Enter key.
	SYSTEM VOLTAGE LINE-LINE #	Displays the corrected line-to-line system voltage.
	SYSTEM FREQ # HZ	Displays the system frequency as entered data. When required, use the numeric keys to set the new value. Press the Enter key.













Menu 7—Generator System, continued

Menu 7 Displays with Key Entries

Key Entry	Display	Description
	SYSTEM FREQ # HZ	Displays the corrected system frequency.
	PHASE (see note) → YES	Displays the phase configuration selection. Note: The display sample may differ depending upon previous entries. The user-selected phase appears first, either wye, delta, or single phase.
	PHASE 3 PHASE DELTA → NO	Displays the optional phase configuration selection. When required, use the YES key to choose the delta phase configuration.
	PHASE 3 PHASE DELTA → YES	Enter YES to change the phase configuration to a delta phase configuration and press the Enter key.
	PHASE 3 PHASE DELTA → YES	Confirms the entry.
OR		
	PHASE 3 PHASE WYE → NO	Displays the optional phase configuration selection. When required, use the YES key to choose the wye phase configuration.
	PHASE 3 PHASE WYE → YES	Enter YES to change the phase configuration to a wye phase configuration and press the Enter key.
	PHASE 3 PHASE WYE → YES	Confirms the entry.
OR		
	PHASE SINGLE-PHASE → NO	Displays the optional phase configuration selection. When required, use YES key to choose the single-phase configuration.
	PHASE SINGLE-PHASE → YES	Enter YES to change the phase configuration to a single-phase configuration and press the Enter key.
	PHASE SINGLE-PHASE → YES	Confirms the entry.
	KW RATING ?	Displays the generator set kW rating as entered data. When required, use the numeric keys to set the new value. Press the Enter key.
	KW RATING #	Displays the corrected system kilowatt rating.
	RATED CURRENT #	Displays the generator set rated current as entered data. Note: This is a read-only display.
	LOAD SHED OUTPUT → ?% # KW	Displays the load shed output setting. When required, use the numeric keys to set the new value. Press the Enter key.
	LOAD SHED OUTPUT → #% # KW	Displays the corrected load shed output setting.
	TIME DELAY MIN:SEC → ?:??	Displays the load shed time (minutes:seconds) delay setting. When required, use the numeric keys to set the new value. Press the Enter key.
	TIME DELAY MIN:SEC → ##:##	Displays the corrected load shed time (minutes:seconds) delay setting.
	LOAD SHED OUTPUT → #% # KW	Returns the user to the load shed output setting.

Menu 7—Generator System, continued

Menu 7 Displays with Key Entries

Key Entry	Display	Description
	OVERVOLTAGE → ?% # VAC	Displays the overvoltage setting. When required, use the numeric keys to set the new value. Press the Enter key.
	OVERVOLTAGE → #% # VAC	Displays the corrected overvoltage setting.
	TIME DELAY MIN:SEC → ??:??	Displays the overvoltage time (minutes:seconds) delay setting. When required, use the numeric keys to set the new value. Press the Enter key.
	TIME DELAY MIN:SEC → ##:##	Displays the corrected overvoltage time (minutes:seconds) delay setting.
	OVERVOLTAGE → #% # VAC	Returns the user to the overvoltage setting.
<hr style="border-top: 1px dashed black;"/>		
	UNDERVOLTAGE → ?% # VAC	Displays the undervoltage setting. When required, use the numeric keys to set the new value. Press the Enter key.
	UNDERVOLTAGE → #% # VAC	Displays the corrected undervoltage setting.
	TIME DELAY MIN:SEC → ??:??	Displays the undervoltage time (minutes:seconds) delay setting. When required, use the numeric keys to set the new value. Press the Enter key.
	TIME DELAY MIN:SEC → ##:##	Displays the corrected overvoltage time (minutes:seconds) delay setting.
	UNDERVOLTAGE → #% # VAC	Returns the user to the undervoltage setting.
<hr style="border-top: 1px dashed black;"/>		
	OVERFREQUENCY → ?% # HZ	Displays the overfrequency setting. When required, use the numeric keys to set the new value. Press the Enter key.
	OVERFREQUENCY → #% # HZ	Displays the corrected overfrequency setting.
	UNDERFREQUENCY → ?% # HZ	Displays the underfrequency setting. When required, use the numeric keys to set the new value. Press the Enter key.
	UNDERFREQUENCY → #% # HZ	Displays the corrected underfrequency setting.
	OVERSPEED → ? HZ # RPM	Displays the overspeed setting. When required, use the numeric keys to set the new value. Press the Enter key.
	OVERSPEED → # HZ # RPM	Displays the corrected overspeed setting.

Menu 7—Generator System, continued

Menu 7 Displays with Key Entries

Key Entry	Display	Description
MENU ↓	BATTERY VOLTAGE (see note) → YES	Displays the battery voltage selection. Note: The display sample may differ depending upon previous entries. The user-selected battery voltage appears first, either 12 VDC or 24 VDC.
MENU →	BATTERY VOLTAGE 12 VDC → NO	Displays the 12 VDC battery voltage selection. When required, use the YES key to choose the 12 VDC battery voltage.
7 YES	BATTERY VOLTAGE 12 VDC → YES	Enter YES to change the battery voltage to 12 VDC and press the Enter key.
ENTER ↵	BATTERY VOLTAGE 12 VDC → YES	Confirms the entry.
OR		
MENU →	BATTERY VOLTAGE 24 VDC → NO	Displays the 24 VDC battery voltage selection. When required, use the YES key to choose the 24 VDC battery voltage.
7 YES	BATTERY VOLTAGE 24 VDC → YES	Enter YES to change the battery voltage to 24 VDC and press the Enter key.
ENTER ↵	BATTERY VOLTAGE 24 VDC → YES	Confirms the entry.
AND		
MENU ↓	LOW BATTERY VOLTAGE ?.? VDC	Displays the low battery voltage setting. When required, use the numeric keys to set the new value. Press the Menu Right → key prior to entering the decimal value.
MENU →	LOW BATTERY VOLTAGE ?.? VDC	Use the numeric keys to enter the <i>decimal</i> value. Press the Enter key.
ENTER ↵	LOW BATTERY VOLTAGE #.# VDC	Displays the corrected low battery voltage setting.
MENU ↓	HIGH BATTERY VOLTAGE ?.? VDC	Displays the high battery voltage setting. When required, use the numeric keys to set the new value. Press the Menu Right → key prior to entering the decimal value.
MENU →	HIGH BATTERY VOLTAGE ?.? VDC	Use the numeric keys to enter the <i>decimal</i> value. Press the Enter key.
ENTER ↵	HIGH BATTERY VOLTAGE #.# VDC	Displays the corrected high battery voltage setting.
AND		
MENU ↓	METRIC UNITS Y/N	Displays the metric units selection.
7 YES	METRIC UNITS YES	Enter YES to change to metric displays and press the Enter key.
ENTER ↵	METRIC UNITS YES	Confirms the entry.
OR		
8 NO	METRIC UNITS NO	Enter NO to change to English displays and press the Enter key.
ENTER ↵	METRIC UNITS NO	Confirms the entry.

Menu 7—Generator System, continued

Menu 7 Displays with Key Entries

Key Entry	Display	Description
MENU ▼	SET NFPA-110 DEFAULTS Y/N	Displays the NFPA 110 default selection. Note: See Menu 10—Output Setup, Overview for a list of the NFPA-110 faults.
7 YES	SET NFPA-110 DEFAULTS YES	Enter YES to select the NFPA 110 default selection and press the Enter key.
ENTER ↵	SET NFPA-110 DEFAULTS YES	Confirms the entry.
OR		
8 NO	SET NFPA-110 DEFAULTS NO	Enter NO to deselect the NFPA 110 default selection and press the Enter key.
ENTER ↵	SET NFPA-110 DEFAULTS NO	Confirms the entry.
MENU ▼	MENU 7 GENERATOR SYSTEM	Returns the user to the generator system heading.















2.9.8 Menu 8—Time Delays

Menu 8 displays the various time delays for cyclic cranking and other engine-related starting and shutdown features.

The user must enable the programming mode to edit the display.







Menu 8—Time Delays

Menu 8 Displays with Key Entries

Key Entry	Display	Description
	ENTER MENU NO. 1-14	Input a menu number.
	MAIN MENU NUMBER 8	Press the Enter key.
	MENU 8 TIME DELAYS	Displays the menu number and name.
	TIME DELAY MIN:SEC ENGINE START ??:??	Displays the engine start time delay in minutes:seconds. When required, use the numeric keys to set the new value. Press the Enter key.
	TIME DELAY MIN:SEC ENGINE START ##:##	Displays the corrected engine start time (minutes:seconds) delay setting.
	TIME DELAY MIN:SEC STARTING AID ??:??	Displays the starting aid time delay in minutes:seconds. When required, use the numeric keys to set the new value. Press the Enter key.
	TIME DELAY MIN:SEC STARTING AID ##:##	Displays the corrected starting aid time (minutes:seconds) delay setting.
	TIME DELAY MIN:SEC CRANK ON ??:??	Displays the crank on time delay in minutes:seconds. When required, use the numeric keys to set the new value. Press the Enter key.
	TIME DELAY MIN:SEC CRANK ON ##:##	Displays the corrected crank on time (minutes:seconds) delay setting.
	TIME DELAY MIN:SEC CRANK PAUSE ??:??	Displays the crank pause time delay in minutes:seconds. When required, use the numeric keys to set the new value. Press the Enter key.
	TIME DELAY MIN:SEC CRANK PAUSE ##:##	Displays the corrected crank pause time (minutes:seconds) delay setting.
	TIME DELAY MIN:SEC ENG COOLDOWN ??:??	Displays the engine cooldown time delay in minutes:seconds. When required, use the numeric keys to set the new value. Press the Enter key.
	TIME DELAY MIN:SEC ENG COOLDOWN ##:##	Displays the corrected engine cooldown time (minutes:seconds) delay setting.
	OVERCRANK SHUTDOWN CRANK CYCLES ?	Displays the engine crank cycles before overcrank shutdown. When required, use the numeric keys to set the new value. Press the Enter key.
	OVERCRANK SHUTDOWN CRANK CYCLES #	Displays the corrected engine crank cycles before overcrank shutdown setting.

Menu 8—Time Delays, continued

Menu 8 Displays with Key Entries

Key Entry	Display	Description				
	<table border="1"> <tr> <td>TIME DELAY</td> <td>MIN:SEC</td> </tr> <tr> <td>OVERVOLTAGE</td> <td>??:??</td> </tr> </table>	TIME DELAY	MIN:SEC	OVERVOLTAGE	??:??	Displays the overvoltage time delay in minutes:seconds. When required, use the numeric keys to set the new value. Press the Enter key.
TIME DELAY	MIN:SEC					
OVERVOLTAGE	??:??					
	<table border="1"> <tr> <td>TIME DELAY</td> <td>MIN:SEC</td> </tr> <tr> <td>OVERVOLTAGE</td> <td>##:##</td> </tr> </table>	TIME DELAY	MIN:SEC	OVERVOLTAGE	##:##	Displays the corrected overvoltage time (minutes:seconds) delay setting.
TIME DELAY	MIN:SEC					
OVERVOLTAGE	##:##					
	<table border="1"> <tr> <td>TIME DELAY</td> <td>MIN:SEC</td> </tr> <tr> <td>UNDERVOLTAGE</td> <td>??:??</td> </tr> </table>	TIME DELAY	MIN:SEC	UNDERVOLTAGE	??:??	Displays the undervoltage time delay in minutes:seconds. When required, use the numeric keys to set the new value. Press the Enter key.
TIME DELAY	MIN:SEC					
UNDERVOLTAGE	??:??					
	<table border="1"> <tr> <td>TIME DELAY</td> <td>MIN:SEC</td> </tr> <tr> <td>UNDERVOLTAGE</td> <td>##:##</td> </tr> </table>	TIME DELAY	MIN:SEC	UNDERVOLTAGE	##:##	Displays the corrected undervoltage time (minutes:seconds) delay setting.
TIME DELAY	MIN:SEC					
UNDERVOLTAGE	##:##					
	<table border="1"> <tr> <td>TIME DELAY</td> <td>MIN:SEC</td> </tr> <tr> <td>LOAD SHED KW</td> <td>??:??</td> </tr> </table>	TIME DELAY	MIN:SEC	LOAD SHED KW	??:??	Displays the load shed time delay in minutes:seconds. When required, use the numeric keys to set the new value. Press the Enter key.
TIME DELAY	MIN:SEC					
LOAD SHED KW	??:??					
	<table border="1"> <tr> <td>TIME DELAY</td> <td>MIN:SEC</td> </tr> <tr> <td>LOAD SHED KW</td> <td>##:##</td> </tr> </table>	TIME DELAY	MIN:SEC	LOAD SHED KW	##:##	Displays the corrected load shed time (minutes:seconds) delay setting.
TIME DELAY	MIN:SEC					
LOAD SHED KW	##:##					
	<table border="1"> <tr> <td>MENU 8</td> </tr> <tr> <td>TIME DELAYS</td> </tr> </table>	MENU 8	TIME DELAYS	Returns the user to the time delays heading.		
MENU 8						
TIME DELAYS						

2.9.9 Menu 9—Input Setup

Menu 9 provides the setup of user-defined digital and analog warning and shutdown inputs. These inputs provide a multitude of choices for configuring customized auxiliary inputs.

The user must enable the programming mode to edit the display.

Note: Press the down arrow to move to the start of the next input setup.

Note: The user must scale the analog input value in order to calculate the low/high warning and shutdown analog values based on a 0-5 VDC scale. See Menu 12—Calibration.

Note: If the ALARM ACTIVE message appears, the selected input has an active fault preventing the enabled choice change from yes to no. The LED display indicates whether the fault is a warning or shutdown. Correct the fault condition before attempting the keypad entry.

Note: ECM engines have user-defined analog inputs A01–A07. Non-ECM engines have user-defined analog inputs A03–A07 where analog inputs A01 and A02 are reserved for the engine coolant temperature and oil pressure displays.

Note: Some data requires entry by a PC in the Remote Programming mode. See the Software Operation Manual for details.

Digital and Analog Inputs. After the user selects the input, the setup requires entering the following choices or values: enabled (yes/no), inhibit time, and delay time.

- **Enabled.** This menu entry enables the input. The previous yes/no selection does not activate the input. **Digital inputs** have three tier groups: the selection group (25 total), the chosen group (up to 21 total), and the enabled group (up to 21 total based on the chosen group). **Analog inputs** have separate warning and shutdown enabled choices.
- **Inhibit Time Delay.** The inhibit time delay is the time period following crank disconnect during which the generator set stabilizes and the controller does not detect fault or status events. The inhibit time delay range is from 0 to 60 seconds.
- **Time Delay (Shutdown or Warning).** The time delay follows the inhibit time delay. The time delay is the time period between the controller fault or status event detection and the controller warning or shutdown lamp illumination. The delay prevents any nuisance alarms. The time delay range is from 0 to 60 seconds.

Analog Input Values. The analog input selection typically requires entering four values: low warning, high warning, low shutdown, and high shutdown. The analog values and time delays affect how and when the controller reacts. See Figure 2-18. The user must set both the high and low levels so the unit will not inadvertently trigger the adjacent high or low value to cause a warning or shutdown fault.

Each analog input has the following nine features:

- One warning enabled and one shutdown enabled
- One inhibit time period
- One warning delay and one shutdown delay
- Two warning levels and two shutdown levels

Analog Values	Time after Crank Disconnect		
	Inhibit Time Period →	Time Delay Period →	Time Delay Complete
High shutdown value is above the high warning value	The controller <i>does not</i> view the analog input signal value	The controller <i>does</i> view the analog input signal value and the <i>time delay begins</i>	High shutdown function
High warning value is above the acceptable value			High warning function
Acceptable analog value			System ready status
Low warning value is below the acceptable value			Low warning function
Low shutdown value is below the low warning value			Low shutdown function

Figure 2-18 Analog Input Logistics

Battle Switch/Fault Shutdown Override Switch. The *battle* switch function forces the system to ignore normal fault shutdowns such as low oil pressure and high engine temperature. The battle switch does not override the emergency stop and overspeed shutdown. When the battle switch function is enabled the generator set continues to run regardless of shutdown signals where potential engine/generator damage can occur.

When this input is enabled the yellow warning lamp illuminates and stored warning/shutdown events that are ignored continue to log in Menu 5— Event History.

Shutdown Type A and Shutdown Type B. Choose **shutdown type A** for standard shutdown where red lamp illuminates and alarm horn sounds. Choose **shutdown type B** for shutdown where air damper indicator RDO-23 energizes for two seconds, red lamp illuminates, and alarm horn sounds.

Menu 9—Input Setup

Menu 9 Displays with Key Entries

Key Entry	Display	Description																																										
	ENTER MENU NO. 1-14	Input a menu number.																																										
	MAIN MENU NUMBER 9	Press the Enter key.																																										
	MENU 9 INPUT SETUP	Displays the menu number and name.																																										
	SETUP DIGITAL AUXILIARY INPUTS →	Displays the setup of digital auxiliary inputs heading.																																										
	DIGITAL INPUT 01 (USER DEFINED DESC) →	Displays the digital input 01 with the user-defined description. Note: Press the down arrow to move to the start of the next input setup.																																										
	DIGITAL INPUT 01 → (see Group A) YES/NO	Identifies the signal source for digital input 01. Use the menu down ↓ key to select the digital input.																																										
	<p>Group A The preprogrammed selections include the following:</p> <table border="0"> <tr><td>WARNING</td><td>Y/N</td></tr> <tr><td>SHUTDOWN TYPE A</td><td>Y/N</td></tr> <tr><td>SHUTDOWN TYPE B</td><td>Y/N</td></tr> <tr><td>VOLTAGE RAISE</td><td>Y/N</td></tr> <tr><td>VOLTAGE LOWER</td><td>Y/N</td></tr> <tr><td>VAR PF MODE</td><td>Y/N</td></tr> <tr><td>REMOTE SHUTDOWN</td><td>Y/N</td></tr> <tr><td>REMOTE RESET</td><td>Y/N</td></tr> <tr><td>AIR DAMPER</td><td>Y/N</td></tr> <tr><td>LOW FUEL</td><td>Y/N</td></tr> </table>	WARNING	Y/N	SHUTDOWN TYPE A	Y/N	SHUTDOWN TYPE B	Y/N	VOLTAGE RAISE	Y/N	VOLTAGE LOWER	Y/N	VAR PF MODE	Y/N	REMOTE SHUTDOWN	Y/N	REMOTE RESET	Y/N	AIR DAMPER	Y/N	LOW FUEL	Y/N	<p>Group A, continued</p> <table border="0"> <tr><td>FIELD OVERVOLTAGE</td><td>Y/N</td></tr> <tr><td>IDLE MODE ACTIVE</td><td>Y/N</td></tr> <tr><td colspan="2">(ECM engine only)</td></tr> <tr><td>BATTLE SWITCH</td><td>Y/N</td></tr> <tr><td colspan="2">(see Battle Switch/Fault Shutdown Override Switch on the previous page.)</td></tr> <tr><td>GROUND FAULT</td><td>Y/N</td></tr> <tr><td>BAT CHGR FAULT</td><td>Y/N</td></tr> <tr><td>HI OIL TEMP</td><td>Y/N</td></tr> <tr><td>LOW COOLANT LVL</td><td>Y/N</td></tr> <tr><td>LOW COOLANT TEMP</td><td>Y/N</td></tr> <tr><td colspan="2">(not user selectable)</td></tr> </table>	FIELD OVERVOLTAGE	Y/N	IDLE MODE ACTIVE	Y/N	(ECM engine only)		BATTLE SWITCH	Y/N	(see Battle Switch/Fault Shutdown Override Switch on the previous page.)		GROUND FAULT	Y/N	BAT CHGR FAULT	Y/N	HI OIL TEMP	Y/N	LOW COOLANT LVL	Y/N	LOW COOLANT TEMP	Y/N	(not user selectable)	
WARNING	Y/N																																											
SHUTDOWN TYPE A	Y/N																																											
SHUTDOWN TYPE B	Y/N																																											
VOLTAGE RAISE	Y/N																																											
VOLTAGE LOWER	Y/N																																											
VAR PF MODE	Y/N																																											
REMOTE SHUTDOWN	Y/N																																											
REMOTE RESET	Y/N																																											
AIR DAMPER	Y/N																																											
LOW FUEL	Y/N																																											
FIELD OVERVOLTAGE	Y/N																																											
IDLE MODE ACTIVE	Y/N																																											
(ECM engine only)																																												
BATTLE SWITCH	Y/N																																											
(see Battle Switch/Fault Shutdown Override Switch on the previous page.)																																												
GROUND FAULT	Y/N																																											
BAT CHGR FAULT	Y/N																																											
HI OIL TEMP	Y/N																																											
LOW COOLANT LVL	Y/N																																											
LOW COOLANT TEMP	Y/N																																											
(not user selectable)																																												
	DIGITAL INPUT 01 → ENABLED YES/NO	Displays the digital input 01, enabled yes or no selection.																																										
<hr style="border-top: 1px dashed black;"/>																																												
	DIGITAL INPUT 01 → ENABLED NO	Entering YES enables digital input 01.																																										
	DIGITAL INPUT 01 → ENABLED YES	Press the Enter key.																																										
	DIGITAL INPUT 01 → ENABLED YES	Confirms the entry.																																										
<hr style="border-top: 1px dashed black;"/>																																												
	<p style="text-align: center;">OR</p> DIGITAL INPUT 01 → ENABLED YES	Entering NO disables digital input 01.																																										
	DIGITAL INPUT 01 → ENABLED NO	Press the Enter key.																																										
	DIGITAL INPUT 01 → ENABLED NO	Confirms the entry.																																										

Menu 9—Input Setup, continued

Menu 9 Displays with Key Entries

Key Entry	Display	Description
	DIGITAL INPUT 01 INHIBIT TIME → ?::??	Displays the digital input 01 inhibit time (minutes:seconds) setting. When required, use the numeric keys to set the new values. Press the Enter key.
	DIGITAL INPUT 01 INHIBIT TIME → #::##	Displays the corrected inhibit time (minutes:seconds) setting.
	DIGITAL INPUT 01 DELAY TIME → ?::??	Displays the digital input 01 delay time (minutes:seconds) setting. When required, use the numeric keys to set the new values. Press the Enter key.
	DIGITAL INPUT 01 DELAY TIME → #::##	Displays the corrected delay time (minutes:seconds) setting.
	DIGITAL INPUT 01 (USER DEFINED DESC) →	Returns the user to digital input 01.
	DIGITAL INPUT XX (USER DEFINED DESC) →	Displays digital inputs 02 to 21. Note: Press the down arrow to scroll through additional digital auxiliary inputs or enter the input number. Note: Press the right arrow at each digital auxiliary input to enable the selection, inhibit time setting, and delay time setting. See Digital Input 01 instructions for complete procedure and Group A selections.
	MENU 9 INPUT SETUP	Returns the user to the menu number and name.
	SETUP DIGITAL AUXILIARY INPUTS →	Returns the user to setup digital auxiliary inputs.
	SETUP ANALOG AUXILIARY INPUTS →	Displays the setup of analog auxiliary inputs heading.
	ANALOG INPUT 01 (USER DEFINED DESC) →	Displays the analog input 01 with user-defined description. Note: ECM engines have inputs 01-07 and non-ECM engines have inputs 03-07. Note: Press the down arrow to move to the start of the next input setup.
	ANALOG INPUT 01 WARNING ENABLED → Y/N	Displays the analog input 01, warning enabled yes or no selection.

	ANALOG INPUT 01 WARNING ENABLED → NO	Entering YES enables the warning analog input 01.
	ANALOG INPUT 01 WARNING ENABLED → YES	Press the Enter key.
	AND ANALOG INPUT 01 WARNING ENABLED → YES	Confirms the entry.

	OR ANALOG INPUT 01 WARNING ENABLED → YES	Entering NO disables the warning analog input 01.
	ANALOG INPUT 01 WARNING ENABLED → NO	Press the Enter key.
	AND ANALOG INPUT 01 WARNING ENABLED → NO	Confirms the entry.













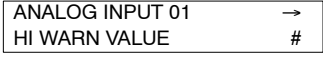

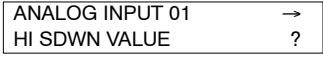
Menu 9—Input Setup, continued

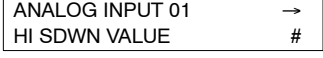
Menu 9 Displays with Key Entries

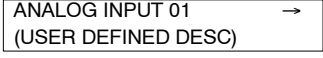
Key Entry	Display	Description
MENU ▶	ANALOG INPUT 01 SHUTDOWN ENABLED → Y/N	Displays the analog input 01, shutdown enabled selection.
7 YES	ANALOG INPUT 01 SHUTDOWN ENABLED → NO	Entering YES enables the shutdown analog input 01.
ENTER ↵	ANALOG INPUT 01 SHUTDOWN ENABLED → YES	Press the Enter key.
ENTER ↵	AND ANALOG INPUT 01 SHUTDOWN ENABLED → YES	Confirms the entry.
8 NO	OR ANALOG INPUT 01 SHUTDOWN ENABLED → YES	Entering NO disables the shutdown analog input 01.
ENTER ↵	ANALOG INPUT 01 SHUTDOWN ENABLED → NO	Press the Enter key.
ENTER ↵	AND ANALOG INPUT 01 SHUTDOWN ENABLED → NO	Confirms the entry.
MENU ▶	ANALOG INPUT 01 INHIBIT TIME → ?:??	Displays the analog input 01, inhibit time (minutes:seconds) setting. When required, use the numeric keys to set the new values. Press the Enter key.
ENTER ↵	ANALOG INPUT 01 INHIBIT TIME → #:#	Displays the corrected inhibit time (minutes:seconds) setting.
MENU ▶	ANALOG INPUT 01 WARN DELAY TIME → ?:??	Displays the analog input 01, warning time (minutes:seconds) delay setting. When required, use the numeric keys to set the new values. Press the Enter key.
ENTER ↵	ANALOG INPUT 01 WARN DELAY TIME → #:#	Displays the corrected warning time (minutes:seconds) delay setting.
MENU ▶	ANALOG INPUT 01 SDWN DELAY TIME → ?:??	Displays the analog input 01, shutdown time (minutes:seconds) delay setting. When required, use the numeric keys to set the new values. Press the Enter key.
ENTER ↵	ANALOG INPUT 01 SDWN DELAY TIME → #:#	Displays the corrected shutdown time (minutes:seconds) delay setting.
MENU ▶	ANALOG INPUT 01 LO SDWN VALUE → ?	Displays the analog input 01, low shutdown value. When required, use the numeric keys to set the new values. Press the Enter key. Note: The user must scale the analog input value in order to calculate the low/high warning and shutdown values based on a 0-5 VDC scale. See Menu 12—Calibration.
ENTER ↵	ANALOG INPUT 01 LO SDWN VALUE → #	Displays the corrected low shutdown value.
MENU ▶	ANALOG INPUT 01 LO WARN VALUE → ?	Displays the analog input 01, low warning value. When required, use the numeric keys to set the new values. Press the Enter key. Note: The user must scale the analog input value in order to calculate the low/high warning and shutdown values based on a 0-5 VDC scale. See Menu 12—Calibration.
ENTER ↵	ANALOG INPUT 01 LO WARN VALUE → #	Displays the corrected low warning value.

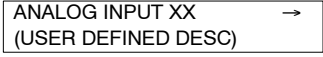
Menu 9—Input Setup, continued

Menu 9 Displays with Key Entries

Key Entry	Display	Description
		Displays the analog input 01, high warning value. When required, use the numeric keys to set the new values. Press the Enter key. Note: The user must scale the analog input value in order to calculate the low/high warning and shutdown values based on a 0-5 VDC scale. See Menu 12—Calibration.
		Displays the corrected high warning value.
		Displays the analog input 01, high shutdown value. When required, use the numeric keys to set the new values. Press the Enter key. Note: The user must scale the analog input value in order to calculate the low/high warning and shutdown values based on a 0-5 VDC scale. See Menu 12—Calibration.
		Displays the corrected high shutdown value.
		Returns the user to analog input 01.
		Displays analog inputs A02 to A07. Note: Press the down arrow to scroll through additional analog auxiliary inputs or enter the input number. Note: ECM engines have inputs A01–A07 and non-ECM engines have inputs A03–A07. Note: Press the right arrow at each analog auxiliary input for the following selections and settings: <ul style="list-style-type: none"> Warning enabled Shutdown enabled Inhibit time Warning delay time Shutdown delay time Low shutdown value Low warning value High warning value High shutdown value See the Analog Input 01 instructions for the complete procedure.
		Returns the user to the setup analog auxiliary input heading.
		Returns the user to the setup digital auxiliary input heading.

2.9.10 Menu 10—Output Setup

Menu 10 provides setup of the user-defined system, digital and analog status and fault outputs, and relay driver outputs (RDO) 1–31. These outputs provide a multitude of choices for configuring customized auxiliary outputs. Additional individual outputs are available for monitoring, diagnostic, and control functions.

The user must enable the programming mode to edit the display.

Note: Some data require entry using a PC in the Remote Programming mode. See the Software Operation Manual for details.

Common Faults

The user can program a single fault comprised of status and fault events from 3 common fault programs—system, digital, and analog faults.

Up to 46 user-defined *system* status and fault events are available. See Group B on the following pages for specific descriptions. The NFPA-110 faults are part of the *system* fault program and are comprised of 15 individual faults shown on the next page.

Up to 21 user-defined *digital* status and fault events designated as D01 to D21 are available. Each of the 21 status events and faults are assignable as shutdowns or warnings.

Up to 7 user-defined *analog* status events and faults designated as A01 to A07 are available. Each of the 7 status events and faults are assignable as shutdowns or warnings with high or low settings for a total of up to 7 status events and fault functions.

Relay Driver Outputs (RDOs)

Up to 31 *RDOs* are available using the system, digital, and analog status events and faults. RDOs provide only the relay driver, not the relay. The contact relays that interface with other equipment are user supplied.

Note: *Func(Function) Used by (RDO) XX Reassign?* appears when the user attempts to assign an RDO to a function already assigned.

Note: *Cannot Change (because the) NFPA is Enabled* appears when the user attempts to modify an RDO setting that is a NFPA 110 default requirement.

Software Controlled RDOs (SCRDOs)

The SCRDO is set up and enabled using the keypad or PC. See the Software Operation Manual when reactivating the SCRDO. The user can deactivate an SCRDO at the controller. The user cannot reactivate the SCRDO at the controller. The procedure to deactivate the SCRDO appears at the end of Menu 10—Output Setup, Displays with Entry Keys—Deactivating the SCRDO. The user must enable the programming mode to edit the display.

Menu 10—Output Setup

Menu 10 Displays with Key Entries

Key Entry	Display	Description
RESET MENU	ENTER MENU NO. 1-14	Input a menu number.
1 0 LAMP TEST	MAIN MENU NUMBER 10	Press the Enter key.
ENTER	MENU 10 OUTPUT SETUP	Displays the menu number and name.
MENU	DEFINE COMMON FAULTS →	Displays the common faults heading.
MENU	SYSTEM EVENTS →	Displays the system events heading.
MENU	COMMON FAULT Y/N (see Group B)	Gives the user the option to add or delete the selection from the defined system events group. Press the Menu Down key to continue to the next selection (repeat as necessary).
	COMMON FAULT NO (see Group B)	Entering YES adds the selection to the defined system event group.
7 YES	COMMON FAULT YES (see Group B)	Press the Enter key.
ENTER	COMMON FAULT YES (see Group B)	Confirms the entry.
	OR COMMON FAULT YES (see Group B)	Entering NO removes the selection from the defined system event group.
8 NO	COMMON FAULT NO (see Group B)	Press the Enter key.
ENTER	COMMON FAULT NO (see Group B)	Confirms the entry.
	Group B For defined system events, choose from the following 46 status events and faults by changing selection to YES: EMERGENCY STOP OVER SPEED OVER CRANK HI COOL TEMP SHUTDOWN OIL PRESS SHUTDOWN LOW COOLANT TEMP (non-ECM engines) LOW FUEL HI COOL TEMP WARNING OIL PRES WARNING MASTER NOT IN AUTO NFPA 110 FAULT (see Menu 10 overview for list) LOW BATTERY VOLTAGE HIGH BATTERY VOLTAGE BATTERY CHARGE FAULT	Group B, continued SYSTEM READY LOSS OF ECM COMM (ECM engines) NO OIL PRESS SIGNAL HI OIL TEMP NO COOL TEMP SIGNAL LOW COOLANT LEVEL SPEED SENSOR FAULT LOCKED ROTOR MASTER SWITCH ERROR MASTER SWITCH OPEN MASTER SWITCH TO OFF AC SENSING LOSS OVER VOLTAGE UNDER VOLTAGE WEAK BATTERY OVER FREQUENCY UNDER FREQUENCY LOAD SHED KW OVER
		Group B, continued LOAD SHED UNDER FREQ OVER CURRENT EPS SUPPLYING LOAD INTERNAL FAULT DELAY ENG COOLDOWN DELAY ENG START STARTING AID GENERATOR RUNNING AIR DAMPER CONTROL GROUND FAULT EEPROM WRITE FAILURE CRITICAL OVERVOLTAGE ALTERNATOR PROTECTION SHUTDOWN AIR DAMPER INDICATOR DEFINED COMMON FAULT (RDO only) SCRDOs 1-4 (software controlled RDOs)

Menu 10—Output Setup, continued

Menu 10 Displays with Key Entries

Key Entry	Display	Description
	DIGITAL INPUTS →	Displays the digital inputs heading.
	COMMON FAULT Y/N Dxx (see Group C)	Gives the user the option to add or delete selection from the defined digital faults starting with D01. Note: Press the Menu Down key to continue to the next selection D02-D21 (repeat as necessary).
	COMMON FAULT NO Dxx (see Group C)	Entering YES adds the selection to the defined digital fault group.
	COMMON FAULT YES Dxx (see Group C)	Press the Enter key.
	COMMON FAULT YES Dxx (see Group C)	Confirms the entry.
OR		
	COMMON FAULT YES Dxx (see Group C)	Entering NO removes the selection from the defined digital fault group.
	COMMON FAULT NO Dxx (see Group C)	Press the Enter key.
	COMMON FAULT NO Dxx (see Group C)	Confirms the entry.
<p>Group C Up to 21 PC user-defined digital status and fault inputs designated as D01 to D21 can result in a digital input common fault.</p>		
	ANALOG INPUTS →	Displays the analog inputs heading.
	COMMON FAULT Y/N Axx(see Group D)LO WARNING→	Gives the user the option to add or delete selection from the defined analog faults starting with A01. Note: Press the Menu Down key to continue to the next selection A02-A07 (repeat as necessary).
<p>Group D Up to 7 analog inputs, PC user-defined status events and faults designated as A01 to A07. Each of the 7 is assignable as a shutdown or warning with high and low settings.</p>		

Menu 10—Output Setup, continued

Menu 10 Displays with Key Entries

Key Entry	Display	Description
	<div style="border: 1px solid black; padding: 2px;"> COMMON FAULT Y/N A01 LO WARNING→ </div>	Indicates whether the previously user-defined analog output was selected (yes or no) as a low warning fault.
	<hr style="border-top: 1px dashed black;"/> <div style="border: 1px solid black; padding: 2px;"> COMMON FAULT NO A01 LO WARNING→ </div>	Entering YES adds the low warning selection to the defined analog fault group.
7 YES	<div style="border: 1px solid black; padding: 2px;"> COMMON FAULT YES A01 LO WARNING→ </div>	Press the Enter key.
ENTER ↵	<div style="border: 1px solid black; padding: 2px;"> COMMON FAULT YES A01 LO WARNING→ </div>	Confirms the entry.
	<hr style="border-top: 1px dashed black;"/> <p style="text-align: center;">OR</p> <div style="border: 1px solid black; padding: 2px;"> COMMON FAULT YES A01 LO WARNING→ </div>	Entering NO removes the low warning selection from the defined analog fault group.
8 NO	<div style="border: 1px solid black; padding: 2px;"> COMMON FAULT NO A01 LO WARNING→ </div>	Press the Enter key.
ENTER ↵	<div style="border: 1px solid black; padding: 2px;"> COMMON FAULT NO A01 LO WARNING→ </div>	Confirms the entry.
	<hr style="border-top: 1px dashed black;"/> <div style="border: 1px solid black; padding: 2px;"> COMMON FAULT Y/N A01 HI WARNING→ </div>	Indicates whether the previously user-defined analog output was selected (yes or no) as a high warning fault.
	<hr style="border-top: 1px dashed black;"/> <div style="border: 1px solid black; padding: 2px;"> COMMON FAULT NO A01 HI WARNING→ </div>	Entering YES adds the high warning selection to the defined analog fault group.
7 YES	<div style="border: 1px solid black; padding: 2px;"> COMMON FAULT YES A01 HI WARNING→ </div>	Press the Enter key.
ENTER ↵	<div style="border: 1px solid black; padding: 2px;"> COMMON FAULT YES A01 HI WARNING→ </div>	Confirms the entry.
	<hr style="border-top: 1px dashed black;"/> <p style="text-align: center;">OR</p> <div style="border: 1px solid black; padding: 2px;"> COMMON FAULT YES A01 HI WARNING→ </div>	Entering NO removes the high warning selection from the defined analog fault group.
8 NO	<div style="border: 1px solid black; padding: 2px;"> COMMON FAULT NO A01 HI WARNING→ </div>	Press the Enter key.
ENTER ↵	<div style="border: 1px solid black; padding: 2px;"> COMMON FAULT NO A01 HI WARNING→ </div>	Confirms the entry.

Menu 10—Output Setup, continued

Menu 10 Displays with Key Entries

Key Entry	Display	Description
MENU →	COMMON FAULT Y/N A01 LO SHUTDOWN→	Indicates whether the previously user-defined analog output was selected (yes or no) as a low shutdown fault.
7 YES	COMMON FAULT NO A01 LO SHUTDOWN→	Entering YES adds the low shutdown selection to the defined analog fault group.
ENTER ↵	COMMON FAULT YES A01 LO SHUTDOWN→	Press the Enter key.
ENTER ↵	COMMON FAULT YES A01 LO SHUTDOWN→	Confirms the entry.
OR		
8 NO	COMMON FAULT YES A01 LO SHUTDOWN→	Entering NO removes the low shutdown selection from the defined analog fault group.
ENTER ↵	COMMON FAULT NO A01 LO SHUTDOWN→	Press the Enter key.
ENTER ↵	COMMON FAULT NO A01 LO SHUTDOWN→	Confirms the entry.
OR		
MENU →	COMMON FAULT Y/N A01 HI SHUTDOWN→	Indicates whether the previously user-defined analog output was selected (yes or no) as a high shutdown fault.
7 YES	COMMON FAULT NO A01 HI SHUTDOWN→	Entering YES adds the high shutdown selection to the defined analog fault group.
ENTER ↵	COMMON FAULT YES A01 HI SHUTDOWN→	Press the Enter key.
ENTER ↵	COMMON FAULT YES A01 HI SHUTDOWN→	Confirms the entry.
OR		
8 NO	COMMON FAULT YES A01 HI SHUTDOWN→	Entering NO removes the high shutdown selection from the defined analog fault group.
ENTER ↵	COMMON FAULT NO A01 HI SHUTDOWN→	Press the Enter key.
ENTER ↵	COMMON FAULT NO A01 HI SHUTDOWN→	Confirms the entry.
MENU →	COMMON FAULT Y/N A01 LO WARNING→	Returns the user to common fault (analog inputs) heading. Press the Menu Down key to continue to the next selection A02-A07 (repeat as necessary).
MENU ↓	COMMON FAULT Y/N Axx(see Group D)LO WARNING→	Gives the user the option to add or delete selection from the next defined analog fault. Note: Use the A01 common fault analog input setup procedure shown above for A02-A07. To go 

Group D

Up to 7 analog inputs, PC user-defined status events and faults designated as A01 to A07. Each of the 7 is assignable as a shutdown or warning with high and low settings.







Menu 10—Output Setup, continued

Menu 10 Displays with Key Entries

Key Entry	Display	Description		
	ANALOG INPUTS →	Returns the user to analog inputs heading.		
	DEFINE COMMON FAULTS →	Returns the user to the define common faults heading.		
©	RELAY DRV OUT 01 (user defined) →	Gives the user previously selected items for relay driver outputs (RDO) starting with 01. Note: Press the down arrow to continue to the next relay driver output 02-31 or enter the RDO number. Note: The RDO can be assigned from the SYSTEM EVENTS, DIGITAL INPUTS, or ANALOG INPUTS groups. The start of each of these groups are highlighted on the following pages.		
	SYSTEM EVENTS →	Displays the system events heading.		
<hr style="border-top: 1px dashed black;"/>				
	RELAY DRV OUT 01 Y/N (see Group B)	Gives the user the option to assign a system event to an RDO. Press the Menu Down key to continue to the next selection (repeat as necessary).		
	RELAY DRV OUT 01 NO (see Group B)	Entering YES adds the selection to the RDO group. Note: <i>Func(Function) Used by (RDO) XX Reassign?</i> appears when the user attempts to assign an RDO to a function already assigned. Note: <i>Cannot Change (because the) NFPA is Enabled</i> appears when the user attempts to modify the RDO setting that is a NFPA 110 default requirement.		
	RELAY DRV OUT 01 YES (see Group B)	Press the Enter key.		
	RELAY DRV OUT 01 YES (see Group B)	Confirms the entry.		
	<p>Group B For defined system events, choose from the following 46 status events and faults by changing selection to YES:</p> <p>EMERGENCY STOP OVER SPEED OVER CRANK HI COOL TEMP SHUTDWN OIL PRESS SHUTDOWN LOW COOLANT TEMP (non-ECM engines) LOW FUEL HI COOL TEMP WARNING OIL PRES WARNING MASTER NOT IN AUTO NFPA 110 FAULT* LOW BATTERY VOLTAGE HIGH BATTERY VOLTAGE BATTERY CHARGE FAULT SYSTEM READY LOSS OF ECM COMM (ECM engines) NO OIL PRESS SIGNAL HI OIL TEMP NO COOL TEMP SIGNAL LOW COOLANT LEVEL SPEED SENSOR FAULT LOCKED ROTOR</p>	<p>Group B, continued</p> <p>MASTER SWITCH ERROR MASTER SWITCH OPEN MASTER SWITCH TO OFF AC SENSING LOSS OVER VOLTAGE UNDER VOLTAGE WEAK BATTERY OVER FREQUENCY UNDER FREQUENCY LOAD SHED KW OVER LOAD SHED UNDER FREQ OVER CURRENT EPS SUPPLYING LOAD INTERNAL FAULT DELAY ENG COOLDOWN DELAY ENG START STARTING AID GENERATOR RUNNING AIR DAMPER INDICATOR GROUND FAULT EEPROM WRITE FAILURE CRITICAL OVERVOLTAGE ALTERNATOR PROTECTION SHUTDOWN DEFINED COMMON FAULT (RDO only)† SCRDOs 1-4 (software controlled RDOs)</p>	<p>*NFPA 110 FAULT The 15 NFPA-110 Fault Alarms include the following:</p> <p>OVERSPEED OVERCRANK HIGH COOLANT TEMP SHUTDOWN OIL PRESSURE SHUTDOWN LOW COOLANT TEMPERATURE HIGH COOLANT TEMP WARNING OIL PRESSURE WARNING LOW FUEL MASTER NOT IN AUTO BATTERY CHARGER FAULT LOW BATTERY VOLTAGE HIGH BATTERY VOLTAGE LOW COOLANT LEVEL EPS SUPPLYING LOAD AIR DAMPER INDICATOR</p>	<p>†DEFINED COMMON FAULT The 5 defined common faults include the following:</p> <p>EMERGENCY STOP HI COOL TEMP SHUTDOWN OIL PRESS SHUTDOWN OVERCRANK OVERSPEED</p>

Menu 10—Output Setup, continued

Menu 10 Displays with Key Entries

Key Entry	Display	Description
	DIGITAL INPUTS →	Displays the digital inputs heading.
	RELAY DRV OUT 01 Y/N Dxx (see Group C)	Gives the user the option to assign a digital input to an RDO starting with D01. Press the Menu Down key to continue to the next selection D02-D21 (repeat as necessary). Note: <i>Func(Function) Used by (RDO) XX Reassign?</i> appears when the user attempts to assign an RDO to a function already assigned.
<hr/>		
	RELAY DRV OUT 01 NO Dxx (see Group C)	Entering YES adds the selection to the RDO group. Note: <i>Func(Function) Used by (RDO) XX Reassign?</i> appears when the user attempts to assign an RDO to a function already assigned. Note: <i>Cannot Change (because the) NFPA is Enabled</i> appears when the user attempts to modify the RDO setting that is a NFPA 110 default requirement.
	RELAY DRV OUT 01 YES Dxx (see Group C)	Press the Enter key.
	RELAY DRV OUT 01 YES Dxx (see Group C)	Confirms the entry.
	Group C Up to user-defined digital status and fault inputs designated as D01 to D21 can result in a digital input common fault.	
<hr/>		
	ANALOG INPUTS →	Displays the analog inputs heading.
	RELAY DRV OUT 01 Y/N Axx(see Group D)LO WARNING→	Gives the user the option to assign an analog input to an RDO starting with A01. Note: Press the Menu Down key to continue to the next selection A02-A07 (repeat as necessary).
	Group D Up to 7 analog inputs, user-defined status events and faults designated as A01 to A07. Each of the 7 is assignable as a shutdown or warning with high or low settings.	
<hr/>		

Menu 10—Output Setup, continued

Menu 10 Displays with Key Entries

Key Entry	Display	Description
MENU ▶	RELAY DRV OUT 01 Y/N A01 LO WARNING→	Indicates whether the previously user-defined analog RDO was selected (yes or no) as a low warning fault.
7 YES	RELAY DRV OUT 01 NO A01 LO WARNING→	Entering YES adds the low warning selection to the defined analog RDO group.
ENTER ↵	RELAY DRV OUT 01 YES A01 LO WARNING→	Press the Enter key.
ENTER ↵	RELAY DRV OUT 01 YES A01 LO WARNING→	Confirms the entry.
OR		
8 NO	RELAY DRV OUT 01 YES A01 LO WARNING→	Entering NO removes the low warning selection from the defined analog RDO group.
ENTER ↵	RELAY DRV OUT 01 NO A01 LO WARNING→	Press the Enter key.
ENTER ↵	RELAY DRV OUT 01 NO A01 LO WARNING→	Confirms the entry.
MENU ▶	RELAY DRV OUT 01 Y/N A01 HI WARNING→	Indicates whether the previously user-defined analog RDO was selected (yes or no) as a high warning fault.
7 YES	RELAY DRV OUT 01 NO A01 HI WARNING→	Entering YES adds the high warning selection to the defined analog RDO group.
ENTER ↵	RELAY DRV OUT 01 YES A01 HI WARNING→	Press the Enter key.
ENTER ↵	RELAY DRV OUT 01 YES A01 HI WARNING→	Confirms the entry.
OR		
8 NO	RELAY DRV OUT 01 YES A01 HI WARNING→	Entering NO removes the high warning selection from the defined analog RDO group.
ENTER ↵	RELAY DRV OUT 01 NO A01 HI WARNING→	Press the Enter key.
ENTER ↵	RELAY DRV OUT 01 NO A01 HI WARNING→	Confirms the entry.

Menu 10—Output Setup, continued

Menu 10 Displays with Key Entries

Key Entry	Display	Description
MENU ▶	RELAY DRV OUT 01 Y/N A01 LO SHUTDOWN→	Indicates whether the previously user-defined analog RDO was selected (yes or no) as a low shutdown fault.
7 YES	RELAY DRV OUT 01 NO A01 LO SHUTDOWN→	Entering YES adds the low shutdown selection to the defined analog RDO group.
ENTER ↵	RELAY DRV OUT 01 YES A01 LO SHUTDOWN→	Press the Enter key.
ENTER ↵	RELAY DRV OUT 01 YES A01 LO SHUTDOWN→	Confirms the entry.
OR		
8 NO	RELAY DRV OUT 01 YES A01 LO SHUTDOWN→	Entering NO removes the low shutdown selection from the defined analog RDO group.
ENTER ↵	RELAY DRV OUT 01 NO A01 LO SHUTDOWN→	Press the Enter key.
ENTER ↵	RELAY DRV OUT 01 NO A01 LO SHUTDOWN→	Confirms the entry.
MENU ▶	RELAY DRV OUT 01 Y/N A01 HI SHUTDOWN→	Indicates whether the previously user-defined analog RDO was selected (yes or no) as a high shutdown fault.
7 YES	RELAY DRV OUT 01 NO A01 HI SHUTDOWN→	Entering YES adds the high shutdown selection to the defined analog RDO group.
ENTER ↵	RELAY DRV OUT 01 YES A01 HI SHUTDOWN→	Press the Enter key.
ENTER ↵	RELAY DRV OUT 01 YES A01 HI SHUTDOWN→	Confirms the entry.
OR		
8 NO	RELAY DRV OUT 01 YES A01 HI SHUTDOWN→	Entering NO removes the high shutdown selection from the defined analog RDO group.
ENTER ↵	RELAY DRV OUT 01 NO A01 HI SHUTDOWN→	Press the Enter key.
ENTER ↵	RELAY DRV OUT 01 NO A01 HI SHUTDOWN→	Confirms the entry.
MENU ▶	RELAY DRV OUT 01 Y/N A01 LO WARNING→	Returns the user to the analog RDO (analog inputs) heading. Press the Menu Down key to continue to the next selection A02-A07 (repeat as necessary).
MENU ▼	RELAY DRV OUT 01 Y/N Axx(see Group D)LO WARNING→	Gives the user the option to add or delete a selection for the next analog RDO. Note: Use the A01 analog RDO setup procedure shown above for A02-A07. Go to B
MENU ▼	ANALOG INPUTS →	Returns the user to the analog inputs heading. Press the Menu Right key.
MENU ▶	RELAY DRV OUT 01 → (user defined)	Returns the user to the RDO 01 heading.
MENU ▼	RELAY DRV OUT XX → (user defined)	Gives the user the option to add or delete a selection for the next RDO. Note: Use the RDO 01 setup procedure shown above for RDOs 02-31. Go to C

Menu 10—Output Setup, continued

Menu 10 Displays with Key Entries— Deactivating the SCRDO

Key Entry	Display	Description
RESET MENU	ENTER MENU NO. 1-14	Input a menu number.
1 0 LAMP TEST	MAIN MENU NUMBER 10	Press the Enter key.
ENTER	MENU 10 OUTPUT SETUP	Displays the menu number and name
MENU	DEFINE COMMON FAULTS →	Displays the common faults heading.
MENU	RELAY DRV OUT XX S'WARE CONTROLLED #X →	Gives the user previously selected items for the relay driver outputs (RDO). Press the down arrow to scroll through relay driver outputs 1-31 or enter the RDO number. Locate the SCRDO display.
MENU	DEACTIVATE RDO? →	When required (SCRDO is currently active), enter the YES key to deactivate the SCRDO.
7 YES	DEACTIVATE RDO? YES →	Press the Enter key.
ENTER	RELAY DRV OUT XX S'WARE CONTROLLED #X →	

2.9.11 Menu 11—Voltage Regulator

Menu 11 provides the setup of the voltage regulator functions including the line-to-line voltages, underfrequency unloading (volts per Hz), reactive droop, power factor, and kVAR adjustments. See Section 1.3.3, Voltage Regulator Adjustments, and Appendix C, Voltage Regulator Definitions and Adjustments, for additional information.

The user must enable the programming mode to edit the display.

Note: Press the Menu Right → key prior to entering the decimal values where necessary.

Note: **350–2000 kW models only**, see 1.3.2 Voltage Regulator and Calibration Specifications regarding the use of the Marathon DVR 2000 voltage regulator.

Menu 11—Voltage Regulator Menu 11 Displays with Key Entries

Key Entry	Display	Description
	ENTER MENU NO. 1-14	Input a menu number.
	MAIN MENU NUMBER 11	Press the Enter key.
	MENU 11 VOLTAGE REGULATOR	Displays the menu number and name.
<hr style="border-top: 1px dashed black;"/>		
	AVG L-L V # → VOLT ADJ ??	Displays the average line-to-line volts and voltage adjustment. Enter the desired nominal voltage using the numeric keys. Press the Menu Right → key prior to entering the decimal value.
	AND	
	AVG L-L V # → VOLT ADJ ??	Use the numeric keys to enter the <i>decimal</i> value. Press the Enter key.
	AVG L-L V # → VOLT ADJ ##	Confirms the entry.
<hr style="border-top: 1px dashed black;"/>		
	L1-L2 VOLTS → #	Displays L1-L2 volts.
	L2-L3 VOLTS → #	Displays L2-L3 volts (3 phase only).
	L3-L1 VOLTS → #	Displays L3-L1 volts (3 phase only).
	AVG L-L V # → VOLT ADJ #	Returns the user to the average line-to-line volts and voltage adjustment heading.
	UNDER FREQ UNLOAD → ENABLED N/Y	Displays the under frequency (volts per Hz) unloading (yes or no) selection.
<hr style="border-top: 1px dashed black;"/>		
	→ UNDER FREQ UNLOAD → ENABLED NO	Entering YES enables the underfrequency unloading feature.
	UNDER FREQ UNLOAD → ENABLED YES	Press the Enter key.
	UNDER FREQ UNLOAD → ENABLED YES	Confirms the entry.

Menu 11—Voltage Regulator

Menu 11 Displays with Key Entries

Key Entry	Display	Description
	OR	
	<div style="border: 1px solid black; padding: 2px; display: inline-block;"> UNDER FREQ UNLOAD → ENABLED YES </div>	Entering NO disables the underfrequency unloading feature.
8 NO	<div style="border: 1px solid black; padding: 2px; display: inline-block;"> UNDER FREQ UNLOAD → ENABLED NO </div>	Press the Enter key.
ENTER ↵	<div style="border: 1px solid black; padding: 2px; display: inline-block;"> UNDER FREQ UNLOAD → ENABLED NO </div>	Confirms the entry.
MENU →	<div style="border: 1px solid black; padding: 2px; display: inline-block;"> FREQUENCY # HZ → SETPOINT ?? HZ </div>	Displays the operating frequency and underfrequency unloading cut-in point. Enter the desired underfrequency cut-in point using the numeric keys. Press the Menu Right → key prior to entering the decimal value.
	AND	
MENU →	<div style="border: 1px solid black; padding: 2px; display: inline-block;"> FREQUENCY # HZ → SETPOINT ?? HZ </div>	Use the numeric keys to enter the <i>decimal</i> value. Press the Enter key.
ENTER ↵	<div style="border: 1px solid black; padding: 2px; display: inline-block;"> FREQUENCY # HZ → SETPOINT ## HZ </div>	Confirms the entry.
MENU →	<div style="border: 1px solid black; padding: 2px; display: inline-block;"> SLOPE → ?? VOLTS-PER-CYCLE </div>	Displays the underfrequency unloading slope (volts-per-cycle). Enter the desired underfrequency unloading slope using the numeric keys. Press the Menu Right → key prior to entering the decimal value.
	AND	
MENU →	<div style="border: 1px solid black; padding: 2px; display: inline-block;"> SLOPE → ?? VOLTS-PER-CYCLE </div>	Use the numeric keys to enter the <i>decimal</i> value. Press the Enter key.
ENTER ↵	<div style="border: 1px solid black; padding: 2px; display: inline-block;"> SLOPE → ## VOLTS-PER-CYCLE </div>	Confirms the entry.
MENU →	<div style="border: 1px solid black; padding: 2px; display: inline-block;"> UNDER FREQ UNLOAD → ENABLED N/Y </div>	Returns the user to the underfrequency unloading heading.
MENU ↓	<div style="border: 1px solid black; padding: 2px; display: inline-block;"> REACTIVE DROOP → ENABLED N/Y </div>	Displays the reactive droop selection (yes or no).
	OR	
	<div style="border: 1px solid black; padding: 2px; display: inline-block;"> REACTIVE DROOP → ENABLED NO </div>	Entering YES enables the reactive droop feature.
7 YES	<div style="border: 1px solid black; padding: 2px; display: inline-block;"> REACTIVE DROOP → ENABLED YES </div>	Press the Enter key.
ENTER ↵	<div style="border: 1px solid black; padding: 2px; display: inline-block;"> REACTIVE DROOP → ENABLED YES </div>	Confirms the entry.
	OR	
	<div style="border: 1px solid black; padding: 2px; display: inline-block;"> REACTIVE DROOP → ENABLED YES </div>	Entering NO disables the reactive droop feature.
8 NO	<div style="border: 1px solid black; padding: 2px; display: inline-block;"> REACTIVE DROOP → ENABLED NO </div>	Press the Enter key.
ENTER ↵	<div style="border: 1px solid black; padding: 2px; display: inline-block;"> REACTIVE DROOP → ENABLED NO </div>	Confirms the entry.

Menu 11—Voltage Regulator, continued

Menu 11 Displays with Key Entries

Key Entry	Display	Description
MENU →	.8 PF RATED LOAD VOLTAGE DROOP ??.?%	Displays the reactive (voltage) droop as a percentage of the rated voltage at rated load. When required, enter the desired reactive droop using the numeric keys. Press the Menu Right → key prior to entering the decimal value.
MENU →	AND .8 PF RATED LOAD VOLTAGE DROOP ??.?%	Use the numeric keys to enter the <i>decimal</i> value. Press the Enter key.
ENTER ↵	.8 PF RATED LOAD VOLTAGE DROOP #.##%	Confirms the entry.
<hr/>		
MENU →	REACTIVE DROOP ENABLED N/Y	Returns the user to reactive droop selection heading.
MENU ↓	VAR CONTROL ENABLED N/Y	Displays the VAR control selection (yes or no).
<hr/>		
7 YES	VAR CONTROL ENABLED NO	Entering YES enables the VAR control feature. Note: A YES entry disables the PF control if previously activated.
ENTER ↵	VAR CONTROL ENABLED YES	Press the Enter key.
ENTER ↵	VAR CONTROL ENABLED YES	Confirms the entry.
<hr/>		
OR		
8 NO	VAR CONTROL ENABLED NO	Entering NO disables the VAR control feature.
ENTER ↵	VAR CONTROL ENABLED NO	Press the Enter key.
ENTER ↵	VAR CONTROL ENABLED NO	Confirms the entry.
<hr/>		
MENU →	TOTAL KVAR # → KVAR ADJ ??.	Displays total kVAR (running) and kVAR adjustment settings. Enter the desired kVAR adjustment using the numeric keys. Press the Menu Right → key prior to entering the decimal value.
MENU →	AND TOTAL KVAR # → KVAR ADJ ??.	Use the numeric keys to enter the <i>decimal</i> value. Press the Enter key.
ENTER ↵	TOTAL KVAR # → KVAR ADJ #.##	Confirms the entry.
<hr/>		
MENU →	GENERATING/ ABSORBING N/Y →	Displays the generating <i>or</i> absorbing kVAR selection. Note: The display sample may differ depending upon the previous entries. The generating selection is the factory default setting.
<hr/>		
OR		
→		
GENERATING YES →		
Displays the generating kVAR selection. When required, use the NO key to choose absorbing kVAR.		
8 NO	GENERATING NO →	Press the Enter key.
ENTER ↵	ABSORBING YES →	Confirms the entry.

Menu 11—Voltage Regulator, continued

Menu 11 Displays with Key Entries

Key Entry	Display	Description
	OR	
	<div style="border: 1px solid black; padding: 2px; display: inline-block;"> ABSORBING YES → </div>	Displays the absorbing kVAR selection. When required, use the NO key to choose generating kVAR.
8 NO	<div style="border: 1px solid black; padding: 2px; display: inline-block;"> ABSORBING NO → </div>	Press the Enter key.
ENTER	<div style="border: 1px solid black; padding: 2px; display: inline-block;"> GENERATING YES → </div>	Confirms the entry.
MENU	<div style="border: 1px solid black; padding: 2px; display: inline-block;"> VAR CONTROL ENABLED N/Y → </div>	Returns the user to VAR control selection heading.
MENU	<div style="border: 1px solid black; padding: 2px; display: inline-block;"> PF CONTROL ENABLED N/Y → </div>	Displays the power factor control selection (yes or no).
	<div style="border: 1px solid black; padding: 2px; display: inline-block;"> PF CONTROL ENABLED NO → </div>	Entering YES enables the power factor control feature. Note: A YES entry disables the kVAR control if previously activated.
7 YES	<div style="border: 1px solid black; padding: 2px; display: inline-block;"> PF CONTROL ENABLED YES → </div>	Press the Enter key.
ENTER	<div style="border: 1px solid black; padding: 2px; display: inline-block;"> PF CONTROL ENABLED YES → </div>	Confirms the entry.
	OR	
	<div style="border: 1px solid black; padding: 2px; display: inline-block;"> PF CONTROL ENABLED YES → </div>	Entering NO disables the power factor control feature.
8 NO	<div style="border: 1px solid black; padding: 2px; display: inline-block;"> PF CONTROL ENABLED NO → </div>	Press the Enter key.
ENTER	<div style="border: 1px solid black; padding: 2px; display: inline-block;"> PF CONTROL ENABLED NO → </div>	Confirms the entry.
MENU	<div style="border: 1px solid black; padding: 2px; display: inline-block;"> AVERAGE PF # → PF ADJ ?? → </div>	Displays the average power factor and power factor adjustment settings. Enter the desired kVAR adjustment using the numeric keys. Press the Menu Right → key prior to entering the decimal value.
MENU	AND	
	<div style="border: 1px solid black; padding: 2px; display: inline-block;"> AVERAGE PF # → PF ADJ ?? → </div>	Use the numeric keys to enter the <i>decimal</i> value. Press the Enter key.
ENTER	<div style="border: 1px solid black; padding: 2px; display: inline-block;"> AVERAGE PF # → PF ADJ ## → </div>	Confirms the entry.
MENU	<div style="border: 1px solid black; padding: 2px; display: inline-block;"> LAGGING/ LEADING N/Y → </div>	Displays the lagging <i>or</i> leading PF selection. Note: The display sample may differ depending upon the previous entries. The lagging selection is the factory default setting.
	<div style="border: 1px solid black; padding: 2px; display: inline-block;"> LAGGING YES → </div>	Displays the lagging PF selection. When required, use the NO key to choose leading PF.
8 NO	<div style="border: 1px solid black; padding: 2px; display: inline-block;"> LAGGING NO → </div>	Press the Enter key.
ENTER	<div style="border: 1px solid black; padding: 2px; display: inline-block;"> LEADING YES → </div>	Confirms the entry.

Menu 11—Voltage Regulator, continued

Menu 11 Displays with Key Entries

Key Entry	Display	Description
	OR	
	LEADING YES →	Displays the leading PF selection. When required, use the NO key to choose lagging PF.
8 NO	LEADING NO →	Press the Enter key.
ENTER ←	LAGGING YES →	Confirms the entry.
<hr style="border-top: 1px dashed black;"/>		
MENU →	PF CONTROL → ENABLED N/Y	Returns the user to the power factor control selection heading.

2.9.12 Menu 12—Calibration

Menu 12 provides the calibration of the voltage and current sensing logic. Changing the system voltage or replacing the main logic control circuit board requires a calibration adjustment.

The user must enable the programming mode to edit the display.

Connect a meter with a minimum accuracy of $\pm 1\%$ to the generator set output leads to calibrate the voltage-sensing logic. Configure the generator set controller for the system operating configuration using Menu 7—Generator System. Adjust the generator set voltage using Menu 11—Voltage Regulator, when

required and adjust the frequency at the generator set governor before making calibration adjustments.











Note: The user must scale the analog input value in order to calculate the low/high warning and shutdown analog values based on a 0–5 VDC scale.

Note: ECM engines have user-defined analog inputs 01–07. Non-ECM engines have user-defined analog inputs 03–07 where analog inputs 01 and 02 are reserved for engine coolant temperature and oil pressure displays.

Note: Press the Menu Right \rightarrow key prior to entering decimal values where necessary.















Menu 12—Calibration

Menu 12 Displays with Key Entries

Key Entry	Display	Description
	ENTER MENU NO. 1-14	Input a menu number.
 	MAIN MENU NUMBER 12	Press the Enter key.
	MENU 12 CALIBRATION	Displays the menu number and name.
	SCALE AC ANALOG INPUTS	Displays the scale AC analog inputs heading.
	GEN L1-L0 V # CALIB REF ??	Measure the generator set output voltage for single and three-phase models between L1-L0 using a voltmeter and enter the result using the numeric keys. Press the Menu Right \rightarrow key prior to entering the decimal value. Note: The generator set must be running for the following steps.
	AND GEN L1-L0 V # CALIB REF ??	Use the numeric keys to enter the <i>decimal</i> value. Press the Enter key.
	GEN L1-L0 V # CALIB REF ##	Confirms the entry.
	GEN L2-L0 V # CALIB REF ??	Measure the generator set output voltage for three-phase models between L2-L0 using a voltmeter and enter the result using the numeric keys. Press the Menu Right \rightarrow key prior to entering the decimal value.
	AND GEN L2-L0 V # CALIB REF ??	Use the numeric keys to enter the <i>decimal</i> value. Press the Enter key.
	GEN L2-L0 V # CALIB REF ##	Confirms the entry.













Menu 12—Calibration, continued

Menu 12 Displays with Key Entries

Key Entry	Display	Description
	<div style="border: 1px solid black; padding: 2px;"> GEN L3-L0 V # CALIB REF ??. </div>	Three-Phase Models only. Measure the generator set output voltage for three-phase models between L3-L0 using a voltmeter and enter the result using the numeric keys. Press the Menu Right → key prior to entering the decimal value.
	AND	
	<div style="border: 1px solid black; padding: 2px;"> GEN L3-L0 V # CALIB REF ??. </div>	Use the numeric keys to enter the <i>decimal</i> value. Press the Enter key.
	<div style="border: 1px solid black; padding: 2px;"> GEN L3-L0 V # CALIB REF # </div>	Confirms the entry.
	<div style="border: 1px solid black; padding: 2px;"> GEN L1 AMPS # CALIB REF ??. </div>	Measure the generator set output current for single- and three-phase models at L1 using an AC ammeter and enter the result using the numeric keys. Press the Menu Right → key prior to entering the decimal value.
	AND	
	<div style="border: 1px solid black; padding: 2px;"> GEN L1 AMPS # CALIB REF ??. </div>	Use the numeric keys to enter the <i>decimal</i> value. Press the Enter key.
	<div style="border: 1px solid black; padding: 2px;"> GEN L1 AMPS # CALIB REF # </div>	Confirms the entry.
	<div style="border: 1px solid black; padding: 2px;"> GEN L2 AMPS # CALIB REF ??. </div>	Measure the generator set output current for three-phase models at L2 using an AC ammeter and enter the result using the numeric keys. Press the Menu Right → key prior to entering the decimal value.
	AND	
	<div style="border: 1px solid black; padding: 2px;"> GEN L2 AMPS # CALIB REF ??. </div>	Use the numeric keys to enter the <i>decimal</i> value. Press the Enter key.
	<div style="border: 1px solid black; padding: 2px;"> GEN L2 AMPS # CALIB REF # </div>	Confirms the entry.
	<div style="border: 1px solid black; padding: 2px;"> GEN L3 AMPS # CALIB REF ??. </div>	Three-Phase Models only. Measure the generator set output current for three-phase models at L3 using an AC ammeter and enter the result using the numeric keys. Press the Menu Right → key prior to entering the decimal value.
	AND	
	<div style="border: 1px solid black; padding: 2px;"> GEN L3 AMPS # CALIB REF ??. </div>	Use the numeric keys to enter the <i>decimal</i> value. Press the Enter key.
	<div style="border: 1px solid black; padding: 2px;"> GEN L3 AMPS # CALIB REF # </div>	Confirms the entry.
	<div style="border: 1px solid black; padding: 2px;"> RESTORE DEFAULTS? </div>	Displays the restore defaults selection (yes or no).
	<div style="border: 1px solid black; padding: 2px;"> RESTORE DEFAULTS? YES </div>	When required, enter YES to activate the restore calibration defaults setting. Press the Enter key. Note: Entering Yes will delete all of the previously entered voltage and current data based on system voltage and kW and restore the calibration default settings.
	<div style="border: 1px solid black; padding: 2px;"> RESTORE DEFAULTS? YES </div>	Confirms the entry.

Menu 12—Calibration, continued

Menu 12 Displays with Key Entries

Key Entry	Display	Description
	MENU 12 CALIBRATION	Returns the user to the menu number and name.
	SCALE AC ANALOG INPUTS →	Returns the user to the scale AC analog inputs heading.
	SCALE AUX. ANALOG INPUTS →	Displays the scale auxiliary analog inputs heading.
	ZERO AUX. ANALOG INPUTS?	Gives the user the option to calibrate the auxiliary analog inputs for zero input signals. Note: ECM engines have inputs A01–A07 and non-ECM engines have inputs A03–A07.
	ZERO AUX. ANALOG INPUTS? YES	When required, enter YES to activate the auto-zero auxiliary analog inputs feature. Press the Enter key.
	ZERO AUX. ANALOG INPUTS? YES	Confirms the entry.
	ANALOG 01 # SCALE VALUE 1 ?	Displays the analog 01 and scale value 1 settings. Use the numeric keys to enter the minimum value based on the previously calculated 5 VDC analog input value. Note: There is no calibration available on analogs inputs 01 and 02 with <i>non-ECM engines</i> .
	SCAL 1 #-#. #V SCAL 2 #-#. #V	Note: Press the Menu Right → key to review both the scale value 1 and scale value 2 settings any time during the setup procedure.
	ANALOG 01 # SCALE VALUE 2 ?	Displays analog 01 and scale value 2 settings. Use the numeric keys to enter the maximum value based on the previously calculated 5 VDC analog value.
	SCALE AUX. ANALOG INPUTS →	Returns the user to the scale auxiliary analog inputs heading.
	ZERO AUX. ANALOG INPUTS?	Press the down arrow to go to the desired analog XX.
	ANALOG XX # SCALE VALUE 1 ?	Displays scale auxiliary analog inputs 01 to 07. Note: Press the down arrow to scroll through the additional analog auxiliary inputs 02–07. Note: Press the down arrow to scroll through the additional analog scale value 1 and value 2 for each analog selection. Note: Press the right arrow at each analog auxiliary input that provides display of the scale 1 and scale 2 voltage settings.

2.9.13 Menu 13—Communications

Menu 13 enables communication with the controller for monitoring or controlling the generator set. KBUS allows a variety of connection types while Modbus® follows Modbus® RTU protocols. Use the LAN (local area network) to gain remote access to multiple devices/addresses. Use the KBUS enable *local* programming mode to edit displays in this menu. Use the Software Operation Manual when accessing this

menu, programming from a remote location, and determining address and system identification information.

The user must enable the programming mode to edit the display.

Modbus® is a registered trademark of Schneider Electric.

Menu 13—Communications

Menu 13 Displays with Key Entries















Key Entry	Display	Description
RESET MENU	ENTER MENU NO. 1-14	Input a menu number.
1 3	MAIN MENU NUMBER 13	Press the Enter key.
ENTER	MENU 13 COMMUNICATIONS	Displays the menu number and name.
MENU	PROTOCOL → KBUS	Displays the KBUS protocol heading.
MENU	KBUS ONLINE Y/N	Displays the KBUS online selection.

	KBUS ONLINE NO	Entering YES activates the online KBUS selection.
7 YES	KBUS ONLINE YES	Press the Enter key.
ENTER	KBUS ONLINE YES	Confirms the entry.

OR		
	KBUS ONLINE YES	Entering NO deactivates the online KBUS selection.
8 NO	KBUS ONLINE NO	Press the Enter key.
ENTER	KBUS ONLINE NO	Confirms the entry.

Menu 13—Communications, continued

Menu 13 Displays with Key Entries

Key Entry	Display	Description
	<div style="border: 1px solid black; padding: 5px;"> CONNECTION TYPE → (USER DEFINED) Y/N </div>	Displays the user-defined connection type. Press the Down arrow key if the correct connection type is displayed. If the desired connection type is not displayed, press the Right arrow key until the desired connection type appears.
	<div style="border: 1px solid black; padding: 5px;"> CONNECTION TYPES LOCAL SINGLE Y/N LOCAL LAN N/Y LOCAL LAN CONV N/Y REMOTE SINGLE N/Y REMOTE LAN N/Y REMOTE LAN CONV N/Y </div>	Entering YES selects the connection type shown. Note: Selecting one connection type deselects any previously selected choice.
<hr style="border-top: 1px dashed black;"/>		
	<div style="border: 1px solid black; padding: 5px;"> CONNECTION TYPE → (USER DEFINED) YES </div>	Press the Enter key.
	<div style="border: 1px solid black; padding: 5px;"> CONNECTION TYPE → (USER DEFINED) YES </div>	Confirms the entry.
<hr style="border-top: 1px dashed black;"/>		
	<div style="border: 1px solid black; padding: 5px;"> PRIMARY PORT → (USER DEFINED) Y/N </div>	Displays the user-defined primary port subheading. Press the Down arrow key if the correct primary port type is displayed. If the desired primary port type is not displayed, press the Right arrow key until the desired primary port type appears.
	<div style="border: 1px solid black; padding: 5px;"> PRIMARY PORTS RS-232 Y/N RS-485 ISO 1 N/Y </div>	Entering YES selects the primary port shown. Note: Selecting one primary port deselects any previously selected choice.
<hr style="border-top: 1px dashed black;"/>		
	<div style="border: 1px solid black; padding: 5px;"> PRIMARY PORT → (USER DEFINED) YES </div>	Press the Enter key.
	<div style="border: 1px solid black; padding: 5px;"> PRIMARY PORT → (USER DEFINED) YES </div>	Confirms the entry.
<hr style="border-top: 1px dashed black;"/>		
	<div style="border: 1px solid black; padding: 5px;"> ADDRESS ? (LAN Connections) </div>	Displays the LAN connection address number. Use the numeric keys to enter the desired address 1-128. Use one address number per unit and use consecutive numbers. Individual addresses are necessary for the software to call up the desired unit.
	<div style="border: 1px solid black; padding: 5px;"> ADDRESS # (LAN Connections) </div>	Confirms the entry.
	<div style="border: 1px solid black; padding: 5px;"> SYSTEM ID ? (Remote Connections) </div>	Displays the system ID request. Use the numeric keys to enter the required system ID of remote connections. The system ID is a password. The user must use the same password for all devices at a site.
	<div style="border: 1px solid black; padding: 5px;"> SYSTEM ID # (Remote Connections) </div>	Confirms the entry.
	<div style="border: 1px solid black; padding: 5px;"> BAUD RATE → (USER DEFINED) Y/N </div>	Displays the user-defined baud rate selection. Press the Down arrow key if the correct baud rate is displayed. If the desired baud rate is not displayed, press the Right arrow key until the desired baud rate appears.
	<div style="border: 1px solid black; padding: 5px;"> BAUD RATES 1200 Y/N 2400 N/Y 9600 N/Y </div>	Entering YES selects the baud rate shown. Note: Selecting one baud rate deselects any previously selected choice.

Menu 13—Communications, continued

Menu 13 Displays with Key Entries

Key Entry	Display	Description
	BAUD RATE (USER DEFINED) → YES	Press the Enter key.
	BAUD RATE (USER DEFINED) → YES	Confirms the entry.
	MENU 13 COMMUNICATIONS	Returns the user to the menu number and name.
	PROTOCOL KBUS →	Returns the user to kBUS protocol heading.
	PROTOCOL MODBUS →	Displays the Modbus protocol heading.
	MODBUS ONLINE Y/N	Displays the Modbus online selection (yes or no).
	MODBUS ONLINE NO	Entering YES activates the online Modbus selection.
	MODBUS ONLINE YES	Press the Enter key.
	MODBUS ONLINE YES	Confirms the entry.
	OR MODBUS ONLINE YES	Entering NO de-activates the online Modbus selection.
	MODBUS ONLINE NO	Press the Enter key.
	MODBUS ONLINE NO	Confirms the entry.
	CONNECTION TYPE (USER DEFINED) → Y/N	Displays the user-defined connection types. Press the Down arrow key if the correct connection type is displayed. If the desired connection type is not displayed, press the Right arrow key until the desired connection type appears.
	CONNECTION TYPES SINGLE Y/N CONVERTOR N/Y	Entering YES selects the connection type shown. Choices are a single or RS-232 to RS-485 convertor. Note: Selecting one connection type deselects any previously selected choice.
	CONNECTION TYPE (USER DEFINED) → YES	Press the Enter key.
	CONNECTION TYPE (USER DEFINED) → YES	Confirms the entry.
	PRIMARY PORT (USER DEFINED) → Y/N	Displays the user-defined primary ports. Press the Down arrow if the correct primary port is displayed. If the desired primary port is not displayed, press the Right arrow key until the desired primary port appears.
	PRIMARY PORTS RS-232 Y/N RS-485 N/Y	Entering YES selects the primary port shown. Note: Selecting one primary port deselects any previously selected choice.

Menu 13—Communications, continued

Menu 13 Displays with Key Entries

Key Entry	Display	Description
	PRIMARY PORT (USER DEFINED) → YES	Press the Enter key.
	PRIMARY PORT (USER DEFINED) → YES	Confirms the entry.
	ADDRESS ?	Displays the address number. Use the numeric keys to enter the desired address 1-128. Use one address number per unit and use consecutive numbers. Individual addresses are necessary for the software to call up the desired unit.
	ADDRESS #	Confirms the entry.
	BAUD RATE (USER DEFINED) → Y/N	Displays the user-defined baud rate. Press the Down arrow key if the correct baud rate is displayed. If the desired baud rate is not displayed, press the Right arrow key until the desired baud rate appears.
	BAUD RATES 9600 N/Y 19200 N/Y	Entering YES selects the baud rate shown. Note: Selecting one baud rate deselects any previously selected choice.
	BAUD RATE (USER DEFINED) → YES	Press the Enter key.
	BAUD RATE (USER DEFINED) → YES	Confirms the entry.
	PROTOCOL MODBUS →	Returns the user to Modbus protocol heading.

2.9.14 Menu 14—Programming Mode

Menu 14 allows altering controller data either locally using the keypad or remotely using a PC or other device.

The user must enter a password (access code) to enable the programming mode.

Local Programming. Local programming is data alteration using the controller keypad and display.

Remote Programming. Remote programming is data alteration using devices connected to a communication port using KBUS or Modbus®.

Note: Log into the *local* programming mode to edit the programming access code. *The factory default access code is the number 0.*

Use Menu 14 to change the access code. Record the new number and give the access code to authorized individuals only. Should the controller logic not accept the access code or if the new code number is lost, contact your local authorized distributor/dealer for password information.

The user chooses one of three programming modes:

- Local—using the controller keypad
- Remote—using a PC
- Off—no programming is permitted

Enter Yes to one mode to change the other two choices to No.

Note: Use the generator set controller to initially set up remote programming. Remote programming is not allowed from a PC unless the controller is first set for remote programming using Menu 14.

Note: After completing the programming always *place the controller back in the Programming Mode Off position* to prevent inadvertent program changes.

Modbus® is a registered trademark of Schneider Electric.

Menu 14—Programming Mode

Menu 14 Displays with Key Entries

Key Entry	Display	Description
	ENTER MENU NO. 1-14	Input a menu number.
	MAIN MENU NUMBER 14	Press the Enter key.
	MENU 14 PROGRAMMING MODE	Displays the menu number and name.
	PROGRAMMING MODE → (USER DEFINED) Y/N	Displays the user-defined programming mode. Press the Down arrow key if the correct programming mode is displayed. If the desired programming mode is not displayed, press the Right arrow key until the desired programming mode appears.
	PROGRAMMING MODES OFF Y/N LOCAL N/Y REMOTE N/Y	Entering YES selects the programming mode shown. Note: Selecting one programming mode deselects any previously selected choice.
<hr/>		
	PROGRAMMING MODE → (USER DEFINED) YES	Press the Enter key.
	PROGRAMMING MODE ENTER CODE *	Changing the programming mode requires entering the access code. Enter the access code and press the Enter key. Note: The factory default access code is the number 0.
	PROGRAMMING MODE → (USER DEFINED) YES	Confirms the entry.
<hr/>		
	PROGRAMMING MODE → CHANGE ACCESS CODE	Displays the programming mode and changes the access code. Press the Down arrow key if you do not wish to change the access code. To change the access code, press the Right arrow key.
<hr/>		
	PROGRAMMING MODE ENTER OLD CODE *	Enter the old access code and press the Enter key.
	PROGRAMMING MODE ENTER NEW CODE *	Enter the new access code and press the Enter key.
	PROGRAMMING MODE → CHANGE ACCESS CODE	Confirms the entry.
<hr/>		
	MENU 14 PROGRAMMING MODE	Returns the user to the programming mode heading.

Notes

Section 3 Scheduled Maintenance

Under normal operating conditions, the generator set's alternator requires no normal service. Consult Section 2.1, Prestart Checklist, for a list of routine checks.

3.1 Generator Service

When operating the generator set under dusty or dirty conditions, use dry compressed air to blow dust out of the generator while the generator set is running. Direct the stream of air through openings in the generator set end bracket.

3.2 Engine Service

Perform engine service at the intervals specified in the engine manufacturer's service literature. Contact an authorized service distributor/dealer to obtain service literature.

Note: Have maintenance work, including battery service, performed by appropriately skilled and suitably trained maintenance personnel familiar with generator set operation and service.

Disabling the generator set. Accidental starting can cause severe injury or death. Before working on the generator set or connected equipment, disable the generator set as follows: (1) Move the generator set master switch to the OFF position. (2) Disconnect the power to the battery charger. (3) Remove the battery cables, negative (-) lead first. Reconnect the negative (-) lead last when reconnecting the battery. Follow these precautions to prevent starting of the generator set by an automatic transfer switch, remote start/stop switch, or engine start command from a remote computer.

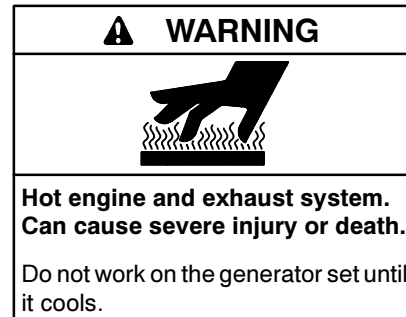

Servicing the exhaust system. Hot parts can cause severe injury or death. Do not touch hot engine parts. The engine and exhaust system components become extremely hot during operation.

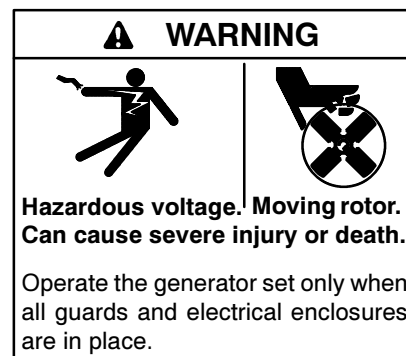
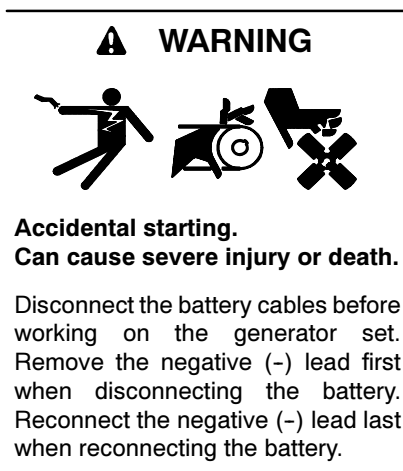

Exposed moving parts can cause severe injury or death. Keep hands, feet, hair, and clothing away from belts and pulleys when unit is running. Replace guards, covers, and screens before operating generator set.

3.3 Service Schedule

System—Component	Action					Interval
	Visually Inspect	Check	Change	Clean	Test	
Fuel System						
Day tank level	X	X				Weekly
Flexible lines and connections	X		X			Weekly
Fuel level switch	X				X	Weekly
Main tank supply level		X				Weekly
Solenoid valve operation	X				X	Weekly
Transfer pump operation	X				X	Weekly
Water in system, remove		•		•		Weekly
Filter(s)			•			Quarterly
Gasoline supply			X			Six Months
Fuel piping	X					Yearly
Tank vents and return lines for obstructions		X				Yearly
Lubrication System						
Oil level	•	•				Weekly
Crankcase breather	•		•			Quarterly
Change oil			•			50 Hours or Yearly
Replace filter(s)*			•			50 Hours or Yearly
Cooling System						
Air cleaner to room/enclosure		X				Weekly
Block heater operation		X				Weekly
Coolant level	•	•				Weekly
Flexible hoses and connectors	X	X				Weekly
Water pump(s)	•					Weekly
Fan and alternator belts	•	•	X			Monthly
Coolant temperature protection level					•	Six Months
Air ducts, louvers		X		X		Yearly
Coolant			•			Yearly
Heat exchanger				X		Yearly
Louver motors and controls	X			X	X	Yearly
Radiator exterior				X		Yearly
Water supply to heat exchanger		X				Yearly
Exhaust System						
Drain condensate trap		X				Weekly
Leakage	X	X				Weekly
Insulation, fire hazards	X					Quarterly
Flexible connector(s)	X					Six Months
Excessive back pressure					X	Yearly
Hangers and supports	X					Yearly
DC Electrical System						
Battery charger operation, charge rate	X					Monthly
Battery electrolyte level		X				Monthly
Battery specific gravity, charge state					X	Monthly
Recharge after engine start		X				Monthly
Remove corrosion, clean and dry battery and rack	X			X		Monthly
Clean and tighten battery terminals	X	X				Quarterly
Tighten DC electrical connections		X				Six Months
<p>• Follow procedures and frequencies indicated in the engine manufacturer's maintenance manual. If not indicated, follow this service schedule. Some items may not apply to all generator sets.</p> <p>X Action</p> <p>* Service more frequently if operated in dusty areas.</p>						

Service Schedule, continued

System—Component	Action					Interval
	Visually Inspect	Check	Change	Clean	Test	
AC Electrical System						
Controller lamp test	X				R	Weekly
General Inspection	X					Weekly
Circuit breakers, fuses†	X	X	X	X	X	Monthly
Wire abrasions where subject to motion	X	X				Quarterly
Safety and alarm operation		X			X	Six Months
Tighten control and power wiring connections		X				Yearly
Transfer switch main contacts†	X			X		Yearly
Voltage-sensing device/relay adjustment†		•			•	Yearly
Wire-cable insulation breakdown	X				X	3 Years or 500 Hours
Engine and Mounting						
General inspection	•					Weekly
Governor operation, lubricate moving parts	•	•				Monthly
Air cleaner service		•	•			Six Months
Choke, carburetor adjustment		•				Six Months
Governor oil (mechanical governor only)		•				Yearly
Ignition components	•			•		Yearly
Injector pump and injector flow rate, pressure, spray pattern		•			•	Yearly
Valve clearance		•				3 Years or 500 Hours
Bolt torque		•			•	3 Years or 500 Hours
Remote Control System, etc.						
Compartment condition	X			X		Weekly
Remote control					X	Monthly
Run generator set					X	Monthly
Generator						
General inspection	X					Weekly
Rotor and stator	X			X		Yearly
Bearing condition	X	X	X			Yearly
Exciter	X	X		X		Yearly
Voltage regulator	X	X		X		Yearly
Measure and record resistance readings of windings with insulation tester (Megger, with SCR assembly or rectifier disconnected)					X	Yearly
Blow dust out of generator*	X			•		2 Years or 300 Hours
General Condition of Equipment						
Any condition of vibration, leakage, noise, temperature, or deterioration	X	X		X		Weekly
Ensure that system is set for automatic operation	X					Weekly
Interior of equipment room or outdoor weather housing	X			X		Weekly
<p>• Follow procedures and frequencies indicated in the engine manufacturer's maintenance manual. If not indicated, follow this service schedule. Some items may not apply to all generator sets.</p> <p>R Replace as necessary.</p> <p>X Action.</p> <p>* Service more frequently if operated in dusty areas.</p> <p>† Do not break manufacturer's seals or internally inspect these devices.</p>						

3.4 Generator Bearing Service

Have an authorized service distributor/dealer perform generator service.

3.4.1 20–300 kW Models

Replace the end bracket bearing every 10,000 hours of operation in standby and prime power applications. Service the bearing more frequently if the annual inspection indicates excessive rotor end play or bearing damage. Replace the tolerance ring, if equipped, following end bracket removal. The sealed end bracket bearing requires no additional lubrication.

3.4.2 350–2000 kW Models with Single-Bearing Generator

The generator bearing requires lubrication at intervals specified in the generator technical manual. Use Chevron SRI or equivalent antifriction, high-quality grease with a lubrication temperature range of -30° to $+175^{\circ}\text{C}$ (-22° to $+350^{\circ}\text{F}$).

3.4.3 1250–2000 kW Models with Two-Bearing Generator

Refer to the generator service manual for bearing maintenance information.

3.5 Diesel Fuel Systems

3.5.1 Bleeding Air from the Fuel System

Bleed air from the fuel system after fuel system maintenance, such as replacing the fuel filter(s) using the hand prime pump kit, when equipped. The hand prime fuel pump eliminates the need for cranking the engine to bleed air from the fuel system.

Note: Bleed air from the fuel system according to the engine manufacturer's instructions. Trapped air in the fuel system causes difficult starting and/or erratic engine operation.

Note: Correct any fuel leaks encountered during the priming procedure.

1. Place the fuel valves in the fuel system prime position. Close the fuel valve located between the pipe tee and the engine. Open the fuel valves on each side of the fuel prime pump. See Figure 3-1.

Note: The illustration shows a generator set without a fuel/water separator. The valve location and position for a generator set equipped with a fuel/water separator is similar.

2. Loosen the bleed screw at the engine. Refer to the engine operation manual for location of the bleed screw(s). The bleed screw allows air to be expelled from the fuel system when the hand prime pump is operated.
3. Rotate the hand prime pump handle counterclockwise until fuel flows from the bleed screw. Stop pumping.
4. Tighten the bleed screw. Wipe up any fuel leakage.
5. Place the fuel valves in the normal operation position. Open the fuel valve located between the pipe tee and the engine. Close the fuel valves on each side of the fuel prime pump.

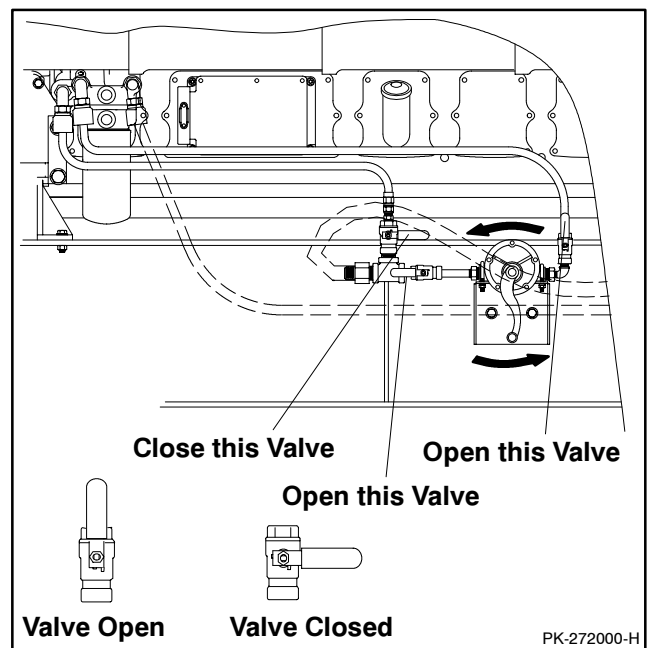

Figure 3-1 Hand Prime Pump with Valve Positions for Fuel Priming (Generator Set Without a Fuel/Water Separator Shown)

3.5.2 Subbase Fuel Day Tank Electronic Control Module (ECM)

With an electronic control module (ECM), the optional subbase diesel fuel tank functions as a day tank. Following are operating information and features of the ECM. See Figure 3-2 for the ECM front panel layout.

Servicing the day tank. Hazardous voltage can cause severe injury or death. Service the day tank electrical control module (ECM) as prescribed in the equipment manual. Disconnect the power to the day tank before servicing. Press the day tank ECM OFF pushbutton to disconnect the power. Notice that line voltage is still present within the ECM when the POWER ON light is lit. Ensure that the generator set and day tank are electrically grounded. Do not operate the day tank when standing in water or on wet ground because these conditions increase the risk of electrocution.

ECM General Function

The ECM controls a pump/motor that maintains the day tank fuel level. The ECM motor relay is connected to the pump/motor. The ECM starts the pump when the fuel level drops to 87% of full and stops the pump when the day tank is full.

ECM Function Indicator LEDs

Two LEDs on the front panel indicate ECM operation. See Figure 3-2 for the locations of the LEDs. Figure 3-3 describes the LED functions.

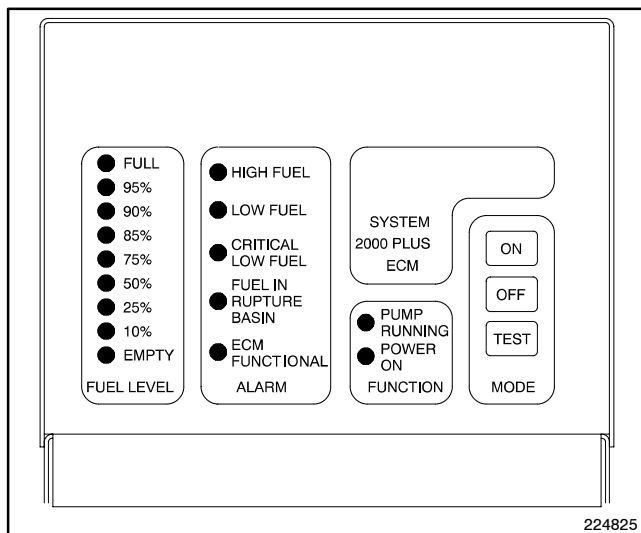

Figure 3-2 ECM Front Panel Layout

Function	Description
Power On	LED lights to indicate that power is applied to the ECM.
Pump Running	LED lights when the pump starts.

Figure 3-3 ECM Function Indicator LEDs

Level Sensor

An electronic analog float gauge located below the ECM on the mounting bracket determines the day tank fuel level. Nine LEDs on the ECM indicate the day tank fuel level from full to empty.

ECM Mode

The ECM has three pushbutton switches for normal operation and one internal test button. See Figure 3-4.

ECM Alarms

The ECM has five standard alarm conditions indicated locally by LEDs and remotely by relays. Figure 3-5 describes the five alarm conditions. Make customer connections to the normally open and normally closed relay contacts provided.

Pushbutton	Description
Off	Pushbutton disables the ECM for routine maintenance to the tank system.
On	Pushbutton activates the ECM after the OFF pushbutton is depressed. On power-up after a power outage, the ECM automatically turns on.
Test	Pushbutton lights front panel LEDs for 3 seconds and activates the pump/motor for as long as the pushbutton is depressed. The alarm relays maintain their original positions.
Internal test	Pushbutton (located inside the ECM) tests each alarm LED and remote annunciation relay in sequential order (high fuel to ECM functional).

Figure 3-4 ECM Pushbuttons

Alarm	Description
High fuel	Alarm activates at 106% of normal fuel level.
Low fuel	Alarm activates at 62% of normal fuel level. The alarm provides time to respond to a potential problem before a low fuel shutdown occurs.
Critical low fuel (engine shutdown)	Alarm activates at 6% of normal fuel level to warn the operator to shut down the generator set before fuel runs out.
Fuel in rupture basin, if equipped	Alarm activates when the ECM detects fuel in the rupture basin.
ECM functional	Alarm activates to indicate a problem with the ECM operation. Note: The ECM functional alarm relay activates a customer-installed alarm when the relay deenergizes.

Figure 3-5 ECM Alarms

3.5.3 Subbase Inner Fuel Tank Alarm

This kit provides for both audible and visual alarm from a location remote from the generator set if a leak is detected in the inner fuel tank of the double-wall subbase fuel tanks. See Figure 3-6. If the inner tank is leaking, a sensor installed in the outer tank sends an electrical signal to the alarm plate when the sensor becomes immersed in the fuel collecting in the outer tank. If a leak is detected, the alarm horn will sound and the fault lamp will light. The alarm horn is quieted by moving the alarm switch to the SILENCE position; the alarm lamp remains lit until the fault is corrected. See Figure 3-7 for troubleshooting information.

Resetting Procedure

Use the following procedure to reset the alarm after a fault alarm.

1. Move alarm switch to the SILENCE position to stop alarm horn. Lamp will remain lit.
2. Disconnect generator set from load with line circuit breaker or automatic transfer switch.

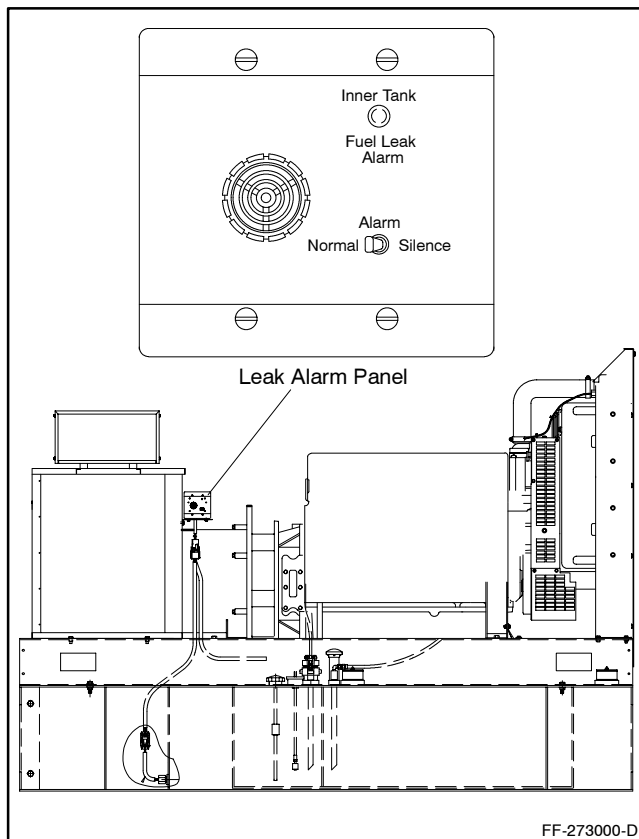

Figure 3-6 Inner Fuel Tank Leak Alarm (20-300 kW Model Shown)

3. Repair or replace the inner fuel tank.
4. Move generator master switch to the OFF/RESET position and then to the RUN position for startup. Alarm horn sounds and lamp goes out.
5. Reconnect generator to load via line circuit breaker or automatic transfer switch.
6. Move generator master switch to the AUTO position for startup by remote transfer switch or remote start/stop switch. Move alarm switch to the NORMAL position.

3.6 Gas/Gasoline Fuel Systems

This section describes fuel systems that are not covered in the engine operation manual or engine service manual.

3.6.1 Gaseous Fuel System Concept

The gaseous fuel system uses a fuel valve with a solenoid to control the fuel flow to the fuel regulator. The generator-mounted regulator reduces the fuel pressure as fuel passes to the carburetor. See Figure 3-8. The carburetor/mixer controls the ratio of fuel to air under varying load and speed conditions. Because the carburetor receives fuel in a gaseous state, it does not have to vaporize the fuel. When switching from natural gas to LP gas or LP gas to natural gas, verify that the electronic governor maintains the rated engine speed (1800 rpm at 60 Hz or 1500 rpm at 50 Hz). If the engine speed is incorrect, refer to the generator service manual for the governor adjustment procedure.

Alarm Switch Position	Float Switch Position	Observation
Normal	Open	The alarm horn and the lamp are not energized.
Normal	Closed	The alarm horn and lamp activate when a fuel leak occurs. If the alarm switch is moved to the silence position the lamp stays on until the fuel leak fault is corrected.
Silence	Open	The alarm horn sounds to alert the user that the alarm horn switch is not in the normal position and that the alarm horn will not sound should a fuel leak occur.

Figure 3-7 Inner Fuel Tank Leak Alarm Troubleshooting

3.6.2 LP Liquid Withdrawal Fuel System Concept

With the LP liquid withdrawal fuel system, pressurized liquid LP fuel passes from the tank to a vaporizer. The vaporizer converts the liquid fuel to gas before sending it to the carburetor. The system also includes a fuel valve that shuts off the fuel flow when the engine stops. Contact an authorized service distributor/dealer for availability.

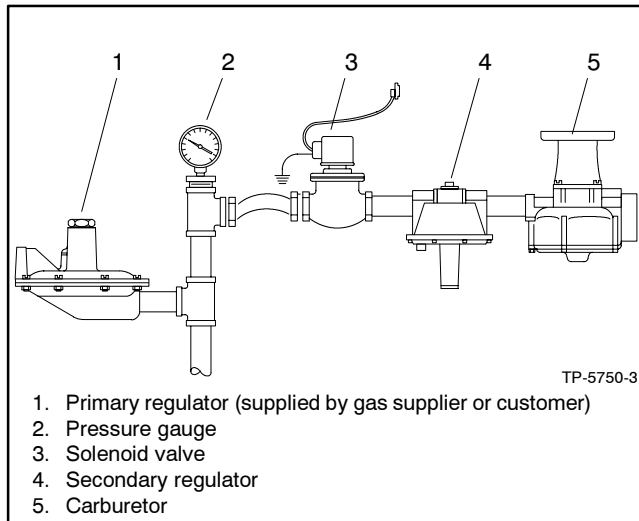

Figure 3-8 Fuel Regulator and Valve, Typical

3.6.3 LP Gas/Natural Gas Conversion for Straight Gas Fuel System

Most models operate on either LP gas or natural gas fuel by performing the fuel conversion procedure. Some models require a different fuel kit when changing gas fuels. Consult your local generator distributor/dealer for additional information.

Fuel conversion may decrease generator set output and affect exhaust emissions. Consult your local generator distributor/dealer for additional information.

Fuel Conversion Procedure

When converting the generator set to operate with LP gas, remove the internal spring from the secondary regulator. Install the spring to operate the generator set on natural gas.

Note: Not all fuel regulators require spring and retainer removal for fuel conversion. A hang tag on the fuel regulator identifies the conversion procedure.

LP Fuel Conversion Procedure

Use the following steps to remove the internal spring from the fuel regulator:

1. Remove the fuel regulator cover plug. See Figure 3-9.
2. Remove the adjustment screw and spring from the fuel regulator. Save the adjustment screw and spring for possible conversion back to natural gas.
3. Reinstall the cover plug.

Natural Gas Fuel Conversion Procedure

Use the following steps to convert the generator set to natural gas:

1. Remove the fuel regulator cover plug. See Figure 3-9.
2. Replace the spring and adjustment screw.

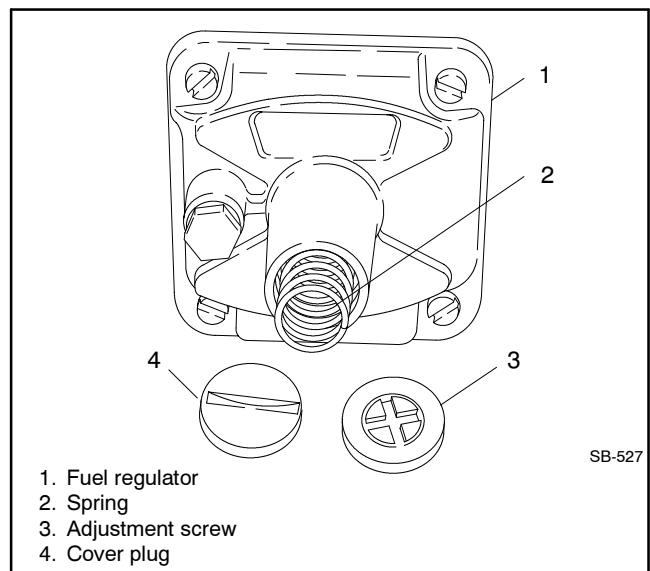

Figure 3-9 Fuel Regulator, Typical

3. Connect a manometer to check the fuel supply pressure on the carburetor side of the regulator. The recommended fuel supply pressures are shown in Figure 3-10 and on the generator set spec sheet.
4. Adjust the fuel supply pressure with the generator set running at full load. Rotate the adjustment screw on the fuel regulator until the pressure indicated by the manometer matches the specified pressure. Use the lower pressure value if the generator set still provides good response and full power. Lower-than-specified pressures may result in poor response to load changes or lack of power.
5. Reinstall the cover plug.

3.6.4 Fuel System Changeover Kits

Automatic Changeover

A changeover fuel system kit provides automatic changeover from natural gas to LP gas vapor or from LP gas vapor to natural gas. The primary and backup fuels each have a secondary fuel regulator and a fuel valve. Typically, the primary fuel is natural gas; the backup fuel is LP gas vapor. When the generator set starts, the primary fuel valve opens and the backup fuel valve closes. The primary fuel line has a vacuum switch in series with a relay connected to the start/run circuit. When the primary fuel pressure drops below 0.6 kPa (1.4 oz./in.²) or 6.4 cm (2.5 in.) water column, a relay opens the backup fuel valve and closes the primary fuel valve. When the primary fuel pressure rises above 0.6 kPa (1.4 oz./in.²) or 6.4 cm (2.5 in.) water column, the generator set uses the primary fuel. Contact an authorized service distributor/dealer for kit availability.

Generator Set Model	Engine	Fuel Supply Pressure	
		kPa (oz./in. ²)	Water Column, cm (in.)
20-100 kW	Ford	1.7-27.4 (4-6)	18-28 (7-11)
30-100 kW	GM	1.7-27.4 (4-6)	18-28 (7-11)
115/135 kW	Cummins	3.5 (8)	36 (14)
135-180 kW	Detroit Diesel Series 50	1.2-5 (2.9-11.6)	13-51 (5-20)
200-275 kW	Detroit Diesel Series 60	1.2-5 (2.9-11.6)	13-51 (5-20)

Figure 3-10 Recommended Fuel Supply Pressures

Manual Changeover

A manual changeover fuel system allows manual changeover from gasoline to natural gas or LP gas, or from natural gas or LP gas to gasoline. Typically, the combination system uses gas as the primary, preferred fuel and gasoline in emergencies. If the primary fuel is unavailable (an empty fuel tank or fuel supply disruption), the system uses gasoline. A toggle switch on the generator set controls the fuel choice and energizes either a fuel solenoid and electric fuel pump for gasoline or a fuel valve for gas. Pull out the control cable for gasoline and push in the control cable for gas.

3.6.5 Carburetor Adjustment

Before adjusting the carburetor, verify that the engine compression and the ignition system meet specifications. Do not adjust the carburetor to compensate for other engine disorders. If the engine speed is incorrect, adjust the electronic governor to achieve 1800 rpm (at 60 Hz) or 1500 rpm (at 50 Hz). Adjust the carburetor if governor adjustment alone does not result in the desired engine speed.

Adjusting the carburetor affects the engine fuel mixture. Routine carburetor adjustment is not necessary. However, if the carburetor is removed or tampered with, the carburetor may require adjustment to achieve optimum engine performance. Some engines have sealed carburetors that are not adjustable.

Gasoline Carburetor Adjustment

Refer to the engine operation manual or engine service manual for gasoline carburetor adjustment information.

Gaseous Carburetor (Fuel Mixer) Adjustment Procedure

Use the following procedure to adjust the carburetor (fuel mixer).

1. Start the generator set and run it at approximately half load.
2. Adjust the engine fuel mixture screw (Figure 3-11) until the engine runs smoothly.
3. Apply varying loads and readjust the carburetor as necessary to achieve smooth engine performance at all load levels.
4. Stop the generator set.

3.6.6 Fuel System Maintenance

Gasoline Models

Clean or replace the fuel filter at the specified interval. Service the filters more frequently if the engine runs roughly, as a clogged fuel filter can cause rough engine operation. Some models use a disposable inline fuel filter, which must be replaced. Other models have a fuel pump with an integral fuel filter that requires cleaning at the specified interval.

Gaseous Models

This fuel system requires no regular maintenance.

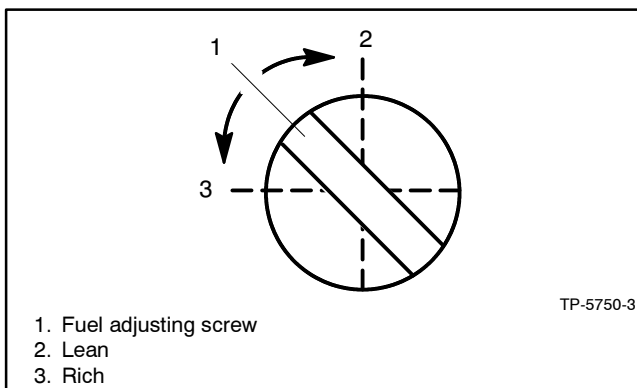
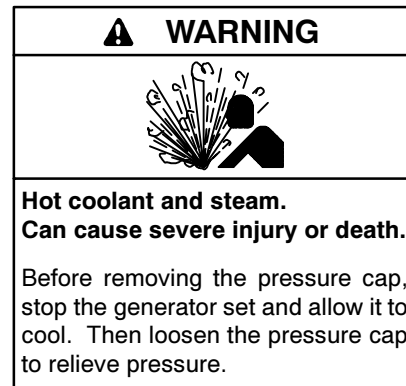

Figure 3-11 Fuel Mixture Adjustment, Typical

3.7 Cooling System

The cooling system maintenance information applies to radiator-cooled models and city-water-cooled (heat exchanger) models. The cooling systems function similarly even though they use different components. Radiator-cooled models have a radiator with a pressure cap and coolant recovery tank. City-water-cooled models have a heat exchanger and an expansion/surge tank with a pressure cap.

Note: The 20–40 kW Deutz engine-powered generator sets are oil cooled and therefore do not have a water cooling system.



Checking the coolant level. Hot coolant can cause severe injury or death. Allow the engine to cool. Release pressure from the cooling system before removing the pressure cap. To release pressure, cover the pressure cap with a thick cloth and then slowly turn the cap counterclockwise to the first stop. Remove the cap after pressure has been completely released and the engine has cooled. Check the coolant level at the tank if the generator set has a coolant recovery tank.

Note: Engine damage. Bleed the air from the cooling system to prevent overheating and subsequent engine damage.

Note: Block heater damage. The block heater will fail if the energized heater element is not immersed in coolant. Fill the cooling system before turning on the block heater. Run the engine until it is warm, and refill the radiator to purge the air from the system before energizing the block heater.

3.7.1 Coolant Level Check

Check the coolant level in the coolant recovery tank. Maintain the coolant level between the high and low marks.

Note: Periodically check the coolant level by removing the pressure cap. Do not rely solely on the level in the coolant recovery tank. Add fresh coolant until the level is just below the overflow tube opening of the filler neck.

3.7.2 Cooling System Component Inspection

To prevent generator shutdown or damage caused by overheating:

- Keep the cooling air inlets clean and unobstructed.
- Inspect the radiator's exterior for obstructions. Remove dirt and foreign material using a soft brush or cloth to avoid damaging the radiator fins.
- Check the hoses and connections for leaks. Replace any cracked, frayed, or spongy hoses.
- Check the condition and tension of the radiator fan and water pump belt(s). Follow the belt tension procedure in this manual and/or the engine operation manual.
- Check the pressure cap seal and replace a cracked or deteriorated cap. Remove dirt and other debris from the pressure cap and filler neck. The pressure cap raises the boiling point of the coolant, enabling higher operating temperatures. Replace a leaking pressure cap with one rated for the same pressure. The pressure cap rating usually appears on the pressure cap.

x:sm:003:003

3.7.3 Procedure to Drain the Cooling System

For optimum protection, drain, flush, and refill the cooling system at the intervals listed in the service schedule.

Note: Dispose of all waste materials (oil, fuel, coolant, filters, and gaskets) in an environmentally safe manner.

1. Deenergize the block heater, if equipped.
2. Remove the pressure cap to allow the entire system to drain and prevent air pockets from restricting coolant flow through the engine block.
3. Open the radiator and/or engine block coolant drain valve(s) and allow the system to drain.
4. If the inside of the radiator has mineral deposits or the used coolant contains dirt or grease, refer to Section 3.7.4, Procedure to Flush and Clean the Cooling System. If the cooling system does not have mineral deposits, go to Section 3.7.5, Procedure to Refill the Cooling System.

x:sm:003:004

3.7.4 Procedure to Flush and Clean the Cooling System

Use the instructions in the engine operation manual when available to flush and clean the cooling system. Otherwise, use the following procedure and the cooling system cleaner manufacturer's instructions.

1. Flush the cooling system with clean water.
2. If the inside of the radiator still has mineral deposits, use a radiator cleaner to remove the remaining deposits following the manufacturer's instructions.
3. Drain, clean, and flush the coolant recovery tank.

x:sm:003:005

3.7.5 Procedure to Refill the Cooling System

See the generator set spec sheet for coolant capacity.

Note: Do not add coolant to a hot engine. Adding coolant to a hot engine can cause the cylinder block or cylinder head to crack. Wait until the engine has cooled.

1. Remove the pressure cap.
2. Close the radiator and/or engine block coolant drain valve(s) and tighten the cooling system hose clamps.
3. Open the air-bleed petcocks, if equipped. Close the air-bleed petcocks when coolant begins to flow from them.
4. Add coolant additives or water pump lubricants according to the engine manufacturer's recommendations in the engine operation manual.
5. Fill the cooling system with the recommended coolant/antifreeze mixture of 50% ethylene glycol and 50% clean, softened water to inhibit rust/corrosion and prevent freezing.

Note: A coolant solution of 50% ethylene glycol provides freezing protection to -37°C (-34°F) and overheating protection to 129°C (265°F). A coolant solution containing less than 50% ethylene glycol may not provide adequate freezing and overheating protection. A coolant solution containing more than 50% ethylene glycol can cause engine or component damage. Do not use alcohol or methanol antifreeze or mix them with the specified coolant. Refer to the engine operation manual for recommendations regarding the coolant mixture to use in extreme temperatures.

6. Replace the pressure cap.
7. Fill the coolant recovery tank to the low mark.
8. Operate the generator set until the thermostat opens when the upper cooling system hose warms.
9. Stop the engine and allow it to cool.

10. Remove the pressure cap.
11. Add coolant to bring the coolant level to just below the overflow tube opening of the filler neck.
12. Replace the pressure cap.
13. Maintain the coolant level in the coolant recovery tank between the high and low marks.

Note: Air pockets often form in the engine water jacket when the coolant system is refilled. Check the coolant level in the coolant recovery tank after each generator set operation and add coolant as necessary until the coolant level stabilizes. Then check the coolant at the interval specified in the service schedule.

14. Reenergize the block heater, if equipped.

x:sm:003:006

3.8 Radiator Expansion Joint Loosening—Initial Setup Only

Loosen the radiator expansion joint nuts on 1200–2000 kW generator sets that have radiators manufactured by Young Radiator Company. Expansion joints located on each side of the radiator permit differential thermal expansion of the radiator tank. The factory tightens the 12 expansion joint nuts before generator set shipment. Loosen the expansion joint nuts one full turn before running the generator set. See Figure 3-12.

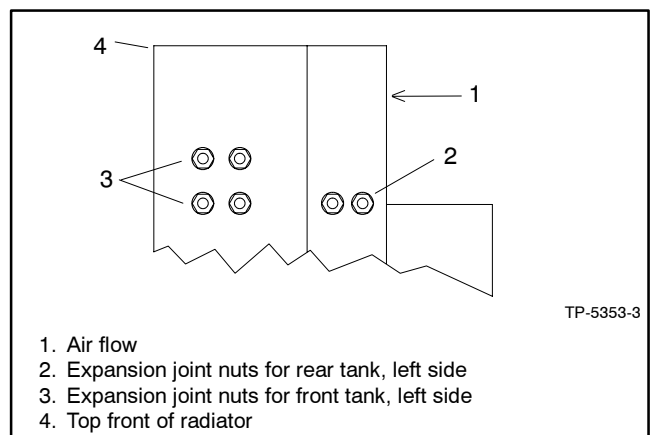

Figure 3-12 Expansion Joint Nuts, Top Left Side of Radiator, Typical

3.9 Fan Bearing Lubrication

The following procedure applies only to 1200–2000 kW generator sets. Lubricate the radiator fan shaft and idler shaft bearings at every engine oil change to avoid bearing damage. Lubricate the bearings every 200 hours of operation when the generator set runs in ambient temperatures below 29°C (85°F) or when the generator set runs in a dusty and/or humid environment.

Lubrication and Drive Belt Adjustment Procedure

Lubricate the fan shaft and idler shaft bearings with a lithium-complex base, multi-purpose grease with antirust, antifoam, and extreme-pressure additives having a minimum dropping point of 204°C (400°F). Use Mobil Mobilith AW2 NLGI Grade 2 or equivalent.

1. Place the generator set master switch in the OFF/RESET position.
2. Disconnect the generator set engine starting battery(ies), negative (-) lead first, and disconnect power to the battery charger.
3. Remove the belt guards to expose the fan shaft and idler shaft bearings.
4. Inject grease into the two bearings on the fan shaft block and the two bearings on the idler shaft block using a grease gun until a 3–6 mm (0.13–0.25 in.) grease column shows at the bearing pressure relief port. See Figure 3-13.

Note: The fan shaft and idler shaft bearings have pressure relief ports to prevent bearing damage caused by overlubrication.

5. Remove excess grease from the bearing pressure relief ports.
6. Inspect the fan drive belt and replace if it is damaged or worn. Check the fan belt tension using a poly V-belt tension gauge and adjust the tension, if necessary. See Figure 3-14.
7. Reinstall the belt guards using the original hardware.

8. Reconnect the generator set engine starting battery(ies), negative (-) lead last.
9. Test run the generator set for a few minutes and listen for belt noise (squeal) indicating a slipping belt. Stop the generator set.

If the belt slips after the belt tension procedure, clean the pulley surfaces and repeat the belt tension procedure. If slippage continues, replace the fan belt.

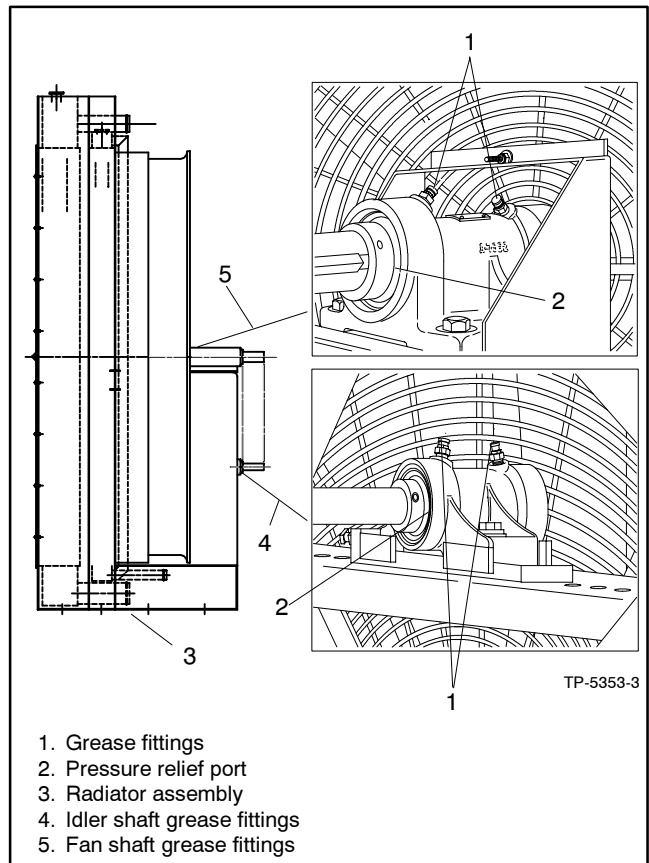

Figure 3-13 Radiator Fan Bearings and Pressure Relief Ports, Typical

Generator Set Model	New Belt, N (lbf.)	Used Belt*, N (lbf.)
1200-2000 kW	2450-2890 (550-650)	1650-1910 (370-430)

* A belt is considered used after 50 hours of service.

Figure 3-14 Poly V-Belt Tension Specifications

3.10 Battery

WARNING



**Sulfuric acid in batteries.
Can cause severe injury or death.**

Wear protective goggles and clothing. Battery acid may cause blindness and burn skin.

Battery gases. Explosion can cause severe injury or death. Battery gases can cause an explosion. Do not smoke or permit flames or sparks to occur near a battery at any time, particularly when it is charging. Do not dispose of a battery in a fire. To prevent burns and sparks that could cause an explosion, avoid touching the battery terminals with tools or other metal objects. Remove all jewelry before servicing the equipment. Discharge static electricity from your body before touching batteries by first touching a grounded metal surface away from the battery. To avoid sparks, do not disturb the battery charger connections while the battery is charging. Always turn the battery charger off before disconnecting the battery connections. Ventilate the compartments containing batteries to prevent accumulation of explosive gases.

Battery short circuits. Explosion can cause severe injury or death. Short circuits can cause bodily injury and/or equipment damage. Disconnect the battery before generator set installation or maintenance. Remove all jewelry before servicing the equipment. Use tools with insulated handles. Remove the negative (-) lead first when disconnecting the

battery. Reconnect the negative (-) lead last when reconnecting the battery. Never connect the negative (-) battery cable to the positive (+) connection terminal of the starter solenoid. Do not test the battery condition by shorting the terminals together.

Battery electrolyte is a diluted sulfuric acid. Battery acid can cause severe injury or death. Battery acid can cause blindness and burn skin. Always wear splashproof safety goggles, rubber gloves, and boots when servicing the battery. Do not open a sealed battery or mutilate the battery case. If battery acid splashes in the eyes or on the skin, immediately flush the affected area for 15 minutes with large quantities of clean water. Seek immediate medical aid in the case of eye contact. Never add acid to a battery after placing the battery in service, as this may result in hazardous spattering of battery acid.

Battery acid cleanup. Battery acid can cause severe injury or death. Battery acid is electrically conductive and corrosive. Add 500 g (1 lb.) of bicarbonate of soda (baking soda) to a container with 4 L (1 gal.) of water and mix the neutralizing solution. Pour the neutralizing solution on the spilled battery acid and continue to add the neutralizing solution to the spilled battery acid until all evidence of a chemical reaction (foaming) has ceased. Flush the resulting liquid with water and dry the area.

Refer to this section for general battery information and maintenance. All generator set models use a negative ground with a 12-volt or 24-volt engine electrical system. Consult the generator set nameplate for the engine electrical system voltage. Consult the generator spec sheet for battery capacity recommendations for replacement purposes. The wiring diagrams provide battery connection information. See Figure 3-15, Figure 3-16, and Figure 3-17 for typical battery connections, including multiple battery configurations.

3.10.1 Cleaning

Clean the battery and cables and tighten the battery terminals according to the service schedule recommendations. Clean the battery by wiping it with a damp cloth. Keep the electrical connections dry and tight.

If corrosion exists, disconnect the cables from the battery and remove the corrosion with a wire brush. Clean the battery and cables with a solution of baking soda and water. Do not allow the cleaning solution to enter battery cells. Flush the battery and cables with clean water and wipe the battery with a dry cloth.

After reconnecting the battery cables, coat the terminals with petroleum jelly, silicon grease, or other nonconductive grease.

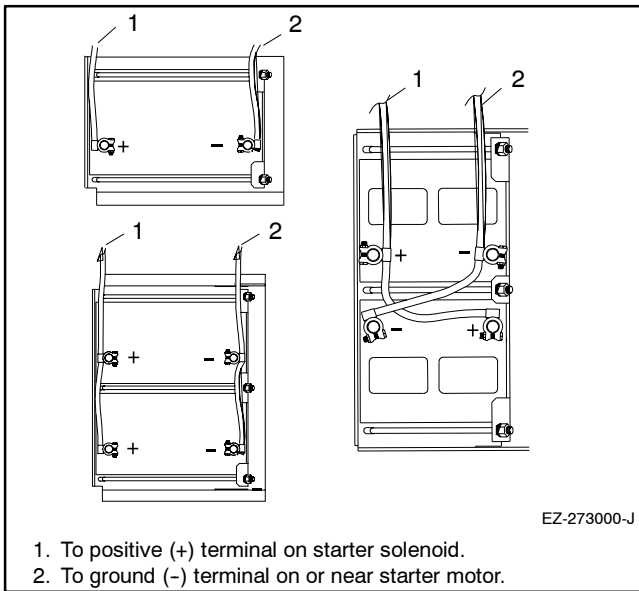

Figure 3-15 12-Volt Engine Electrical System Single Starter Motor Typical Battery Connection

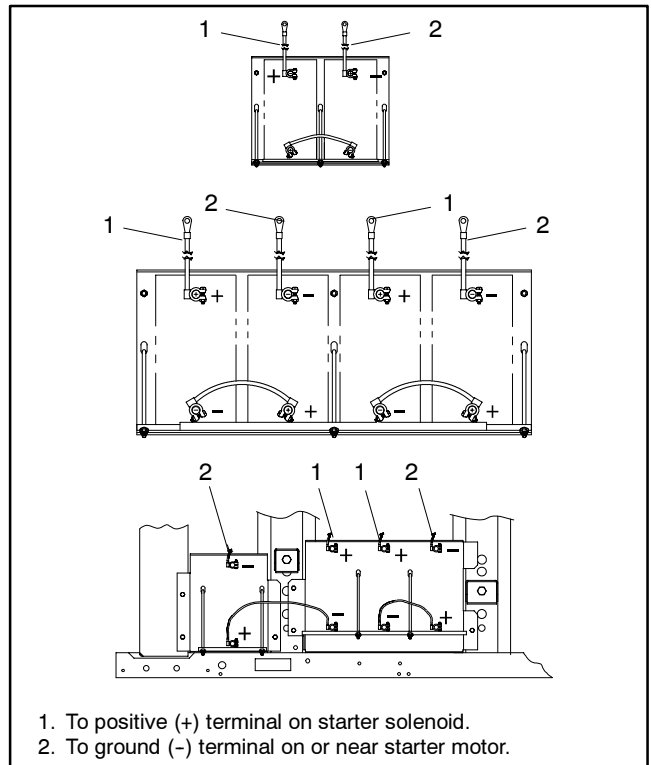

Figure 3-16 24-Volt Engine Electrical System Single Starter Motor Typical Battery Connection

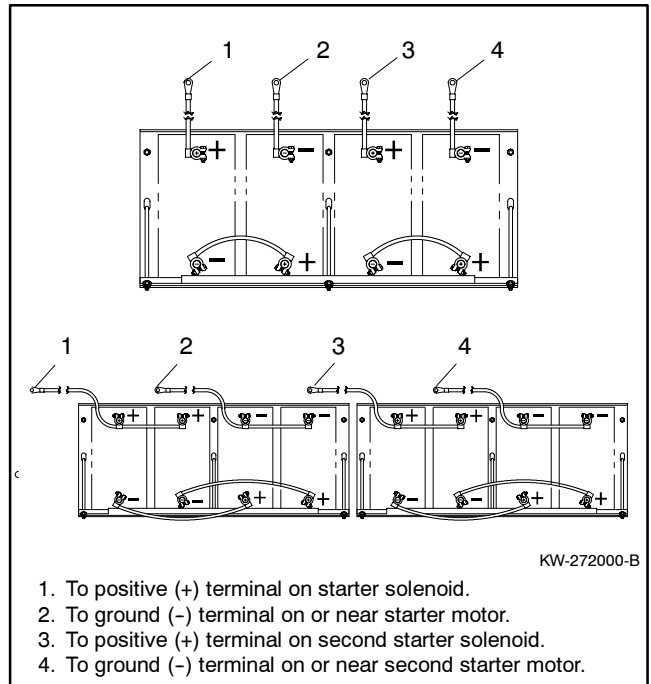

Figure 3-17 24-Volt Engine Electrical System Dual Starter Motors Typical Battery Connections

3.10.2 Electrolyte Level Inspection

Check the electrolyte level and specific gravity of batteries that have filler caps. Maintenance-free batteries do not require electrolyte level checking or specific gravity testing.

Check the electrolyte level before each startup. Remove the filler caps and verify that the electrolyte level reaches the bottom of each filler hole. See Figure 3-18. Refill as necessary with distilled water or clean tap water. Do not add fresh electrolyte. Tighten the filler caps. After adding water during freezing temperatures, run the generator set 20–30 minutes to mix the electrolyte and the water to prevent battery damage from freezing.

3.10.3 Specific Gravity Check

Use a battery hydrometer to check the specific gravity of the electrolyte in each battery cell of batteries with filler caps. Holding the hydrometer vertically, read the number on the glass bulb at the top of the electrolyte level or the number adjacent to the pointer. If the hydrometer used does not have a correction table, consult Figure 3-19. Determine the specific gravity and electrolyte temperature of the battery cells. Locate the temperature in Figure 3-19 and correct the specific gravity by the amount shown. The battery is fully charged if the specific gravity is 1.260 at an electrolyte temperature of 26.7°C (80°F). Maintain the specific gravities between cells within ±0.01 of each other. Charge the battery if the specific gravity is below 1.215 at an electrolyte temperature of 26.7°C (80°F).

Note: Some battery testers have four or five beads in a test tube. Draw electrolyte into the tube as with the battery hydrometer described in this section or use the manufacturer’s instructions. Use Figure 3-20 to interpret typical test results.

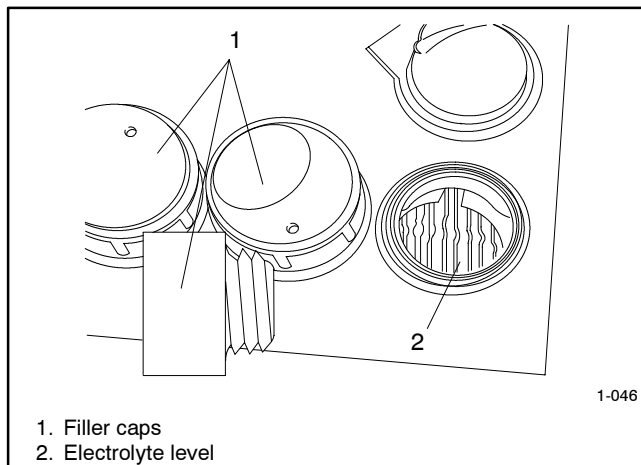

Figure 3-18 Battery Electrolyte Level Inspection

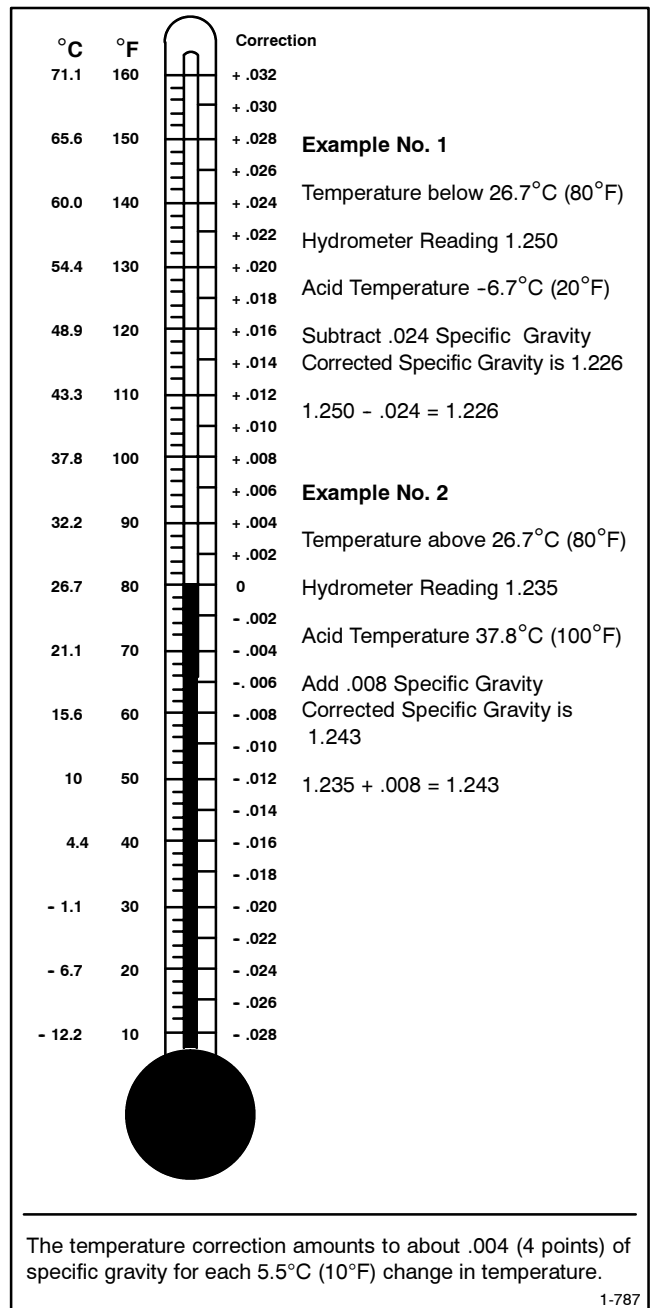

Figure 3-19 Specific Gravity Temperature Correction

Number of Floating Beads	Battery Condition
5	Overcharged
4	Fully charged
3	A good charge
1 or 2	A low charge
0	A dead battery

Figure 3-20 Bead-Type Test Interpretation

3.10.4 Charging

Use a battery charger to maintain a fully charged battery when the generator set is used in a standby application. The engine battery-charging alternator charges the battery while the generator set is running.

Note: If the generator set is in a temporary prime power application in which the generator set has periods of inactivity, the controller circuitry may drain the battery. If there is no power source for a battery charger, place the controller in the prime power mode, if equipped, or disconnect the battery from the generator set.

3.11 Detroit Diesel Engine Control (DDEC) System

Some generator sets equipped with Detroit Diesel engines use a DDEC system. Access the DDEC control box inside the generator set junction box to retrieve codes when performing routine maintenance or troubleshooting the engine.

Use the following data for informational purposes only. Consult the engine operation manual or engine service manual for complete information regarding DDEC operation and troubleshooting. Contact an authorized service distributor/dealer for service or diagnostic equipment.

3.11.1 DDEC Features

The DDEC system optimizes control of critical engine functions and protects against serious engine damage resulting from conditions such as the following:

- Low coolant level
- Low coolant pressure
- High coolant temperature
- Low oil pressure
- High oil temperature

The major components of the DDEC system include the electronic control module (ECM), engine sensors, and control box, which is located in the generator set junction box.

3.11.2 DDEC Engine Diagnostics

The DDEC engine protection system monitors engine sensors and electronic components and recognizes system malfunctions. Critical faults light the check engine (CEL) and stop engine (SEL) lamps on the control box. ECM memory software logs malfunction codes. Consult the engine operation manual or engine service manual to identify the stored failure code. See Figure 3-21 for the DDEC control box features.

Access the stored codes in one of three ways:

- Place the switch in the DIAGNOSTIC REQUEST position. The CEL or SEL flashes to identify the failure.
- Use a hand-held diagnostic data reader (DDR). Place the switch in the DIAGNOSTIC DATA READER position. Plug the DDR into the control box. The DDR displays the stored failure codes.
- Use a personal computer software package with a translator to access stored codes. Follow the instructions provided with the software.

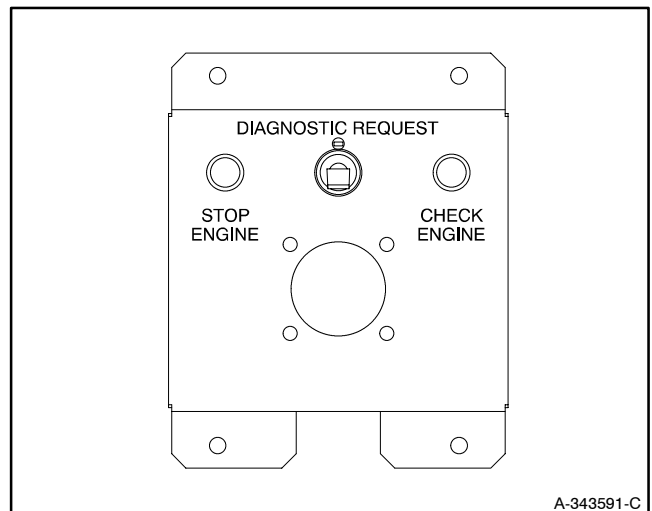

Figure 3-21 DDEC Control Box

Code Types

Active code. A code flashing on the SEL lamp indicates a fault currently exists.

Inactive code. A code flashing on the CEL lamp indicates a previous fault occurrence. The ECM memory stores inactive codes with time/date identification and the following information:

- First occurrence of each diagnostic code in engine operating hours.
- Last occurrence of each diagnostic code in engine operating hours.
- Total time in seconds that the diagnostic code was active.

3.12 Deutz Engine Control System

Some generator sets equipped with Deutz engines use an engine control system. Access the control box inside the generator set junction box to retrieve codes when performing routine maintenance or troubleshooting engine.

Use the following data for general informational purposes only. See the Engine Service Manual for complete information regarding operation and troubleshooting. Contact an authorized service distributor/dealer for service or diagnostic equipment.

Deutz Engine Control Features

The Deutz engine control is an advanced-technology, electronic engine control system. The system optimizes control of critical engine functions and provides protection against serious engine damage.

The major components include the engine control module (EMR), engine sensors, and control box located in the generator set junction box. See Figure 3-22 for the Deutz control box features.

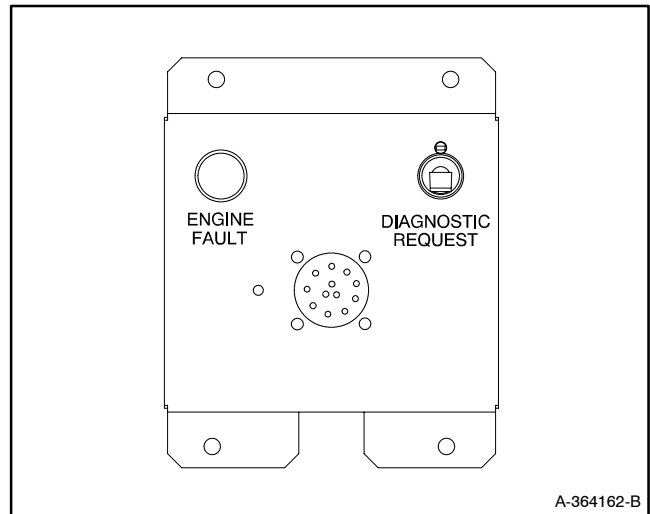

Figure 3-22 Deutz Control Box

3.13 Storage Procedure

Perform the following storage procedure before taking a generator set out of service for three months or longer. Follow the engine manufacturer's recommendations, if available, for fuel system and internal engine component storage.

x.sm:002:001

3.13.1 Lubricating System

Prepare the engine lubricating system for storage as follows:

1. Run the generator set for a minimum of 30 minutes to bring it to normal operating temperature.
2. Stop the generator set.
3. With the engine still warm, drain the oil from the crankcase.
4. Remove and replace the oil filter.
5. Refill the crankcase with oil suited to the climate.
6. Run the generator set for two minutes to distribute the clean oil.
7. Stop the generator set.
8. Check the oil level and adjust, if needed.

x.sm:002:002

3.13.2 Cooling System

Prepare the cooling system for storage as follows:

1. Check the coolant freeze protection using a coolant tester.
2. Add or replace coolant as necessary to ensure adequate freezing protection. Use the guidelines included in the engine operation manual.
3. Run the generator set for 30 minutes to redistribute added coolant.

x.sm:002:003

3.13.3 Fuel System

Prepare the fuel system for storage as follows:

Diesel-Fueled Engines

1. Fill the fuel tank with #2 diesel fuel.
2. Condition the fuel system with compatible additives to control microbial growth.
3. Change the fuel filter/separator and bleed the fuel system. See the engine owner's manual.

Gasoline-Fueled Engines

1. Add stabilizer to the fuel system. Follow the manufacturer's recommended procedure.
2. Run the generator set for 15 minutes to ensure that the stabilized fuel reaches the carburetor.

Gas-Fueled Engines

1. Start the generator set.
2. With the generator set running, shut off the gas supply.
3. Run the generator set until the engine stops.
4. Place the generator set master switch in the OFF/RESET position.

3.13.4 Internal Engine Components (Gas/Gasoline-Fueled Engines)

If you have access to a fogging agent or SAE 10 oil prepare the pistons and cylinders for storage as follows:

1. While the engine is running, spray a fogging agent or SAE 10 engine oil into the air intake for about two minutes until the engine stops.
2. Place the generator set master switch in the OFF/RESET position.

If a fogging agent is not available perform the following:

1. Remove the spark plugs.
2. Pour 15 cc (0.5 oz.) of engine oil into each spark plug hole.

Ignition System Damage. Refer to the engine operation manual for ignition system precautions before cranking the engine while the spark plug wires are disconnected.

3. Toggle the generator set master switch to crank the engine two or three revolutions to lubricate the cylinders.
4. Reinstall the spark plugs and torque them to specifications.

x.sm:002:005

3.13.5 Exterior

1. Clean the exterior surface of the generator set.
2. Seal all engine openings except for the air intake with nonabsorbent adhesive tape.
3. To prevent impurities from entering the air intake and to allow moisture to escape from the engine, secure a cloth over the air intake.
4. Mask electrical connections.
5. Spread a light film of oil over unpainted metallic surfaces to inhibit rust and corrosion.

x.sm:002:006

3.13.6 Battery

Perform battery storage after all other storage procedures.

1. Place the generator set master switch in the OFF/RESET position.
2. Disconnect the battery(ies), negative (-) lead first.
3. Clean the battery. Refer to Section 3.10.1 for the battery cleaning procedure.
4. Place the battery in a cool, dry location.
5. Connect the battery to a float/equalize battery charger or charge it monthly with a trickle battery charger. Refer to the battery charger manufacturer's recommendations.

Maintain a full charge to extend battery life.

x.sm:002:007

Section 4 General Troubleshooting

This section contains generator set troubleshooting, diagnostic, and repair information.

Use the following charts to diagnose and correct common problems. First check for simple causes such as a dead engine starting battery or an open circuit breaker. The charts include a list of common problems, possible causes of the problem, recommended corrective actions, and references to detailed information or repair procedures.

Maintain a record of repairs and adjustments performed on the equipment. If the procedures in this manual do not explain how to correct the problem, contact an authorized distributor/dealer. Use the record to help describe the problem and repairs or adjustments made to the equipment.

x:gt:001:002a:

Battle Switch/Fault Shutdown Override Switch. The *battle* switch function forces the system to ignore normal fault shutdowns such as low oil pressure and high engine temperature. The battle switch does not override the emergency stop and overspeed shutdown. When the battle switch function is enabled, the generator set continues to run regardless of shutdown signals where potential engine/generator damage can occur.

When this input is enabled, the yellow warning lamp illuminates and stored warning/shutdown events that are ignored continue to log in Menu 5— Event History.

See Section 2.9.9, Menu 9—Input Setup, for information on how to enable the battle switch feature.

Trouble Symptoms										Probable Causes	Recommended Actions	Section or Publication Reference*
Does not crank	Cranks but does not start	Starts hard	No or low output voltage	Stops suddenly	Lacks power	Overheats	Low oil pressure	High fuel consumption	Excessive or abnormal noise			
Controller												
X	X									Controller circuit board(s) inoperative	Replace the controller circuit board.	Gen. S/M
				X						Controller fault	Troubleshoot the controller. †	Gen. S/M
X	X			X						Controller fuse blown	Replace the blown controller fuse. If the fuse blows again, troubleshoot the controller. †	Section 2, W/D
X										Controller master switch inoperative	Replace the controller master switch.	—
X										Controller master switch in the OFF/RESET position	Move the controller master switch to the RUN or AUTO position.	Section 2
X										Engine start circuit open	Move the controller master switch to the RUN position to test the generator set. Troubleshoot the auto start circuit and time delays.	Section 2, W/D, Gen. I/M, S/M ATS O/M, S/M
Cooling System												
						X		X		Air openings clogged	Clean the air openings.	—
						X		X		Coolant level low	Restore the coolant to normal operating level.	Section 3
						X		X		Cooling water pump inoperative	Tighten or replace the belt. Replace the water pump.	Eng. O/M or S/M
				X						High temperature shutdown	Allow the engine to cool down. Then troubleshoot the cooling system.	Sec. 3, Eng. O/M
				X						Low coolant level shutdown, if equipped	Restore the coolant to normal operating level.	Section 3
						X				Thermostat inoperative	Replace the thermostat.	Eng. S/M
Electrical System (DC circuits)												
X	X									Battery connections loose, corroded, or incorrect	Verify that the battery connections are correct, clean, and tight.	Section 3
X	X									Battery weak or dead	Recharge or replace the battery. The spec sheet provides recommended battery CCA rating.	Section 3, S/S
X	X									Starter/starter solenoid inoperative	Replace the starter or starter solenoid.	Eng. S/M
X				X						Engine harness connector(s) not locked tight	Disconnect the engine harness connector(s) then reconnect it to the controller.	W/D
				X						High water temperature switch inoperative	Replace the inoperative switch.	Gen. S/M or W/D
				X						Fault shutdown	Reset the fault switches and troubleshoot the controller.	Section 2
				X						High exhaust temperature switch inoperative	Replace the inoperative switch.	Gen. S/M or W/D

* Sec./Section—numbered section of this manual; ATS—Automatic Transfer Switch; Eng.—Engine; Gen.—Generator Set; I/M—Installation Manual; O/M—Operation Manual; S/M—Service Manual; S/S—Spec Sheet; W/D—Wiring Diagram Manual

† Have an authorized service distributor/dealer perform this service.

Trouble Symptoms										Probable Causes	Recommended Actions	Section or Publication Reference*
Does not crank	Cranks but does not start	Starts hard	No or low output voltage	Stops suddenly	Lacks power	Overheats	Low oil pressure	High fuel consumption	Excessive or abnormal noise			
Engine												
	x	x			x			x		Air cleaner clogged	Clean or replace the filter element.	Eng. O/M
	x	x				x		x	x	Compression weak	Check the compression. †	Eng. S/M
			x		x	x		x	x	Engine overload	Reduce the electrical load. See the generator set spec sheet for wattage specifications.	S/S
									x	Exhaust system leak	Inspect the exhaust system. Replace the inoperative exhaust system components. †	I/M
									x	Exhaust system not securely installed	Inspect the exhaust system. Tighten the loose exhaust system components. †	I/M
		x			x			x		Governor inoperative	Adjust the governor. †	Gen. S/M
			x		x				x	Valve clearance incorrect	Adjust the valves. †	Eng. S/M
									x	Vibration excessive	Tighten all loose hardware.	—
	x				x					Ignition system inoperative (gas/gasoline only)	Check the ignition system (spark plugs, spark plug wires, etc.).	Eng. O/M
Fuel System												
	x	x			x					Air in fuel system (diesel only)	Bleed the diesel fuel system.	Eng. O/M
	x	x								Ether canister empty or system inoperative, if equipped (diesel only)	Replace or repair the ether starting system.	Eng. O/M
	x			x						Fuel tank empty or fuel valve shut off	Add fuel and move the fuel valve to the ON position.	—
	x				x			x		Fuel feed or injection pump inoperative (diesel only)	Rebuild or replace the injection pump. †	Eng. S/M
	x	x			x					Fuel or fuel injectors dirty or faulty (diesel only)	Clean, test, and/or replace the inoperative fuel injector. †	Eng. S/M
	x	x		x	x					Fuel filter restriction	Clean or replace the fuel filter.	Eng. O/M
	x									Fuel solenoid inoperative	Troubleshoot the fuel solenoid. †	Eng. S/M
	x				x					Fuel pressure insufficient (gas only)	Check the fuel supply and valves. †	S/S, Gen. O/M
	x	x			x			x		Fuel injection timing out of adjustment (diesel only)	Adjust the fuel injection timing. †	Eng. S/M

* Sec./Section—numbered section of this manual; ATS—Automatic Transfer Switch; Eng.—Engine; Gen.—Generator Set; I/M—Installation Manual; O/M—Operation Manual; S/M—Service Manual; S/S—Spec Sheet; W/D—Wiring Diagram Manual

† Have an authorized service distributor/dealer perform this service.

Trouble Symptoms										Probable Causes	Recommended Actions	Section or Publication Reference*
Does not crank	Cranks but does not start	Starts hard	No or low output voltage	Stops suddenly	Lacks power	Overheats	Low oil pressure	High fuel consumption	Excessive or abnormal noise			
Generator												
			x							AC output circuit breaker open	Reset the breaker and check for AC voltage at the generator side of the circuit breaker.	—
x										Transfer switch test switch in the OFF position	Move the transfer switch test switch to the AUTO position.	ATS O/M
			x							Transfer switch fails to transfer load	Move the ATS test switch to the AUTO position. Troubleshoot the transfer circuit and time delays.	ATS O/M, S/M
			x							Wiring, terminals, or pin in the exciter field open	Check for continuity.	Gen. S/M, W/D
			x							Main field (rotor) inoperative (open or grounded)	Test and/or replace the rotor. †	Gen. S/M
			x							Stator inoperative (open or grounded)	Test and/or replace the stator. †	Gen. S/M
									x	Vibration excessive	Tighten loose components. †	—
			x	x						Voltage regulator digital settings incorrect (digital controller only)	Adjust the voltage regulator.	Sec. 2, Menu 11
			x	x						Voltage regulator inoperative	Replace the voltage regulator fuse, if the fuse blows again, troubleshoot the voltage regulator.	Gen. S/M
			x	x						Voltage regulator out of adjustment	Adjust the voltage regulator.	Gen. S/M
Lube System												
	x	x					x		x	Crankcase oil type incorrect for ambient temperature	Change the oil. Use oil with a viscosity suitable for the operating climate.	Eng. O/M
						x	x		x	Oil level low	Restore the oil level. Inspect the generator set for oil leaks.	Eng. O/M
				x						Low oil pressure shutdown	Check the oil level.	Eng. O/M

* Sec./Section—numbered section of this manual; ATS—Automatic Transfer Switch; Eng.—Engine; Gen.—Generator Set; I/M—Installation Manual; O/M—Operation Manual; S/M—Service Manual; S/S—Spec Sheet; W/D—Wiring Diagram Manual

† Have an authorized service distributor/dealer perform this service.

bp #

Section 5 Generator Reconnection

5.1 Introduction

Use the following voltage reconnection procedure to change the voltage of 10- and 12-lead generator sets. Frequency changes require voltage regulator *and* governor adjustments. Consult the generator set service manual for frequency adjustment information.

Refer to the following procedure and the connection schematics. Follow the safety precautions at the front of this manual and in the procedure text and observe National Electrical Code (NEC) guidelines.

NOTICE

Voltage reconnection. Affix a notice to the generator set after reconnecting the set to a voltage different from the voltage on the nameplate. Order voltage reconnection decal 246242 from an authorized service distributor/dealer.

Note: Equipment damage. Verify that the voltage ratings of the transfer switch, line circuit breakers, and other accessories match the selected line voltage.

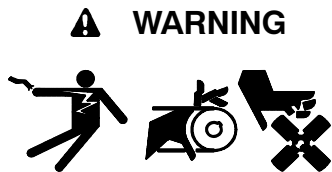

Accidental starting.
Can cause severe injury or death.

Disconnect the battery cables before working on the generator set. Remove the negative (-) lead first when disconnecting the battery. Reconnect the negative (-) lead last when reconnecting the battery.

Disabling the generator set. Accidental starting can cause severe injury or death. Before working on the generator set or equipment connected to the set, disable the generator set as follows: (1) Turn the generator set master switch and switchgear engine control switch to the OFF position. (2) Disconnect the power to the battery charger. (3) Remove the battery cables, negative (-) lead first. Reconnect the negative (-) lead last when reconnecting the battery. Follow these precautions to prevent the starting of the generator set by an automatic transfer switch or a remote start/stop switch.

Disabling the generator set. Accidental starting can cause severe injury or death. Before working on the generator set or connected equipment, disable the generator set as follows: (1) Move the generator set master switch to the OFF position. (2) Disconnect the power to the battery charger. (3) Remove the battery cables, negative (-) lead first. Reconnect the negative (-) lead last when reconnecting the battery. Follow these precautions to prevent starting of the generator set by an automatic transfer switch, remote start/stop switch, or engine start command from a remote computer.

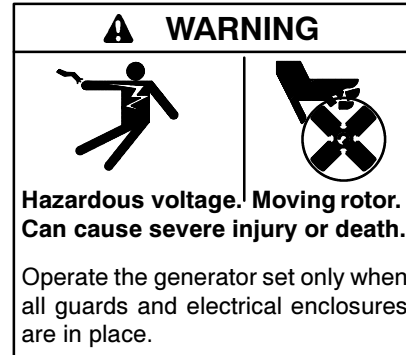

Grounding electrical equipment. Hazardous voltage can cause severe injury or death. Electrocutation is possible whenever electricity is present. Open the main circuit breakers of all power sources before servicing the equipment. Configure the installation to electrically ground the generator set, transfer switch, and related equipment and electrical circuits to comply with applicable codes and standards. Never contact electrical leads or appliances when standing in water or on wet ground because these conditions increase the risk of electrocution.

Short circuits. Hazardous voltage/current can cause severe injury or death. Short circuits can cause bodily injury and/or equipment damage. Do not contact electrical connections with tools or jewelry while making adjustments or repairs. Remove all jewelry before servicing the equipment.

5.2 Voltage Reconnection Procedure

1. Place the generator set master switch in the OFF/RESET position.
2. Disconnect the generator set engine starting battery, negative (-) lead first. Disconnect power to the battery charger (if equipped).
3. Use Figure 5-1 or Figure 5-2 to determine the generator set voltage configuration. Note the original voltage and reconnect as needed. Route leads through current transformers (CTs) and connect them according to the diagram for the desired phase and voltage.

Note: Position current transformers CT1, CT2, and CT3 with the dot or HI side CT marking toward the generator set.
4. Reconnect the battery, negative lead last.
5. Go to Menu 14—Programming Mode and select the Program Mode—Local. See Section 2.9.14, Menu 14—Programming Mode, for the complete procedure.
6. Go to Menu 7—Generator System and update the voltage information. See Section 2.9.7, Menu 7—Generator System, for the complete procedure.
7. Go to Menu 12—Calibration and perform the calibration procedure. See Section 2.9.12, Menu 12—Calibration, for the complete procedure.
8. Go to Menu 11—Voltage Regulator and perform the voltage regulator setup procedure. See Section 2.9.11, Menu 11—Voltage Regulator, for the complete procedure.
9. Move the generator set master switch to the RUN position to start the generator set. Check the digital display for correct voltages using Menu 1—Generator Monitoring.
10. Move the generator set master switch to the OFF/RESET position to stop the generator set after completing the voltage adjustments.
11. Replace the controller cover.
12. Place the generator set master switch in the AUTO or RUN position.

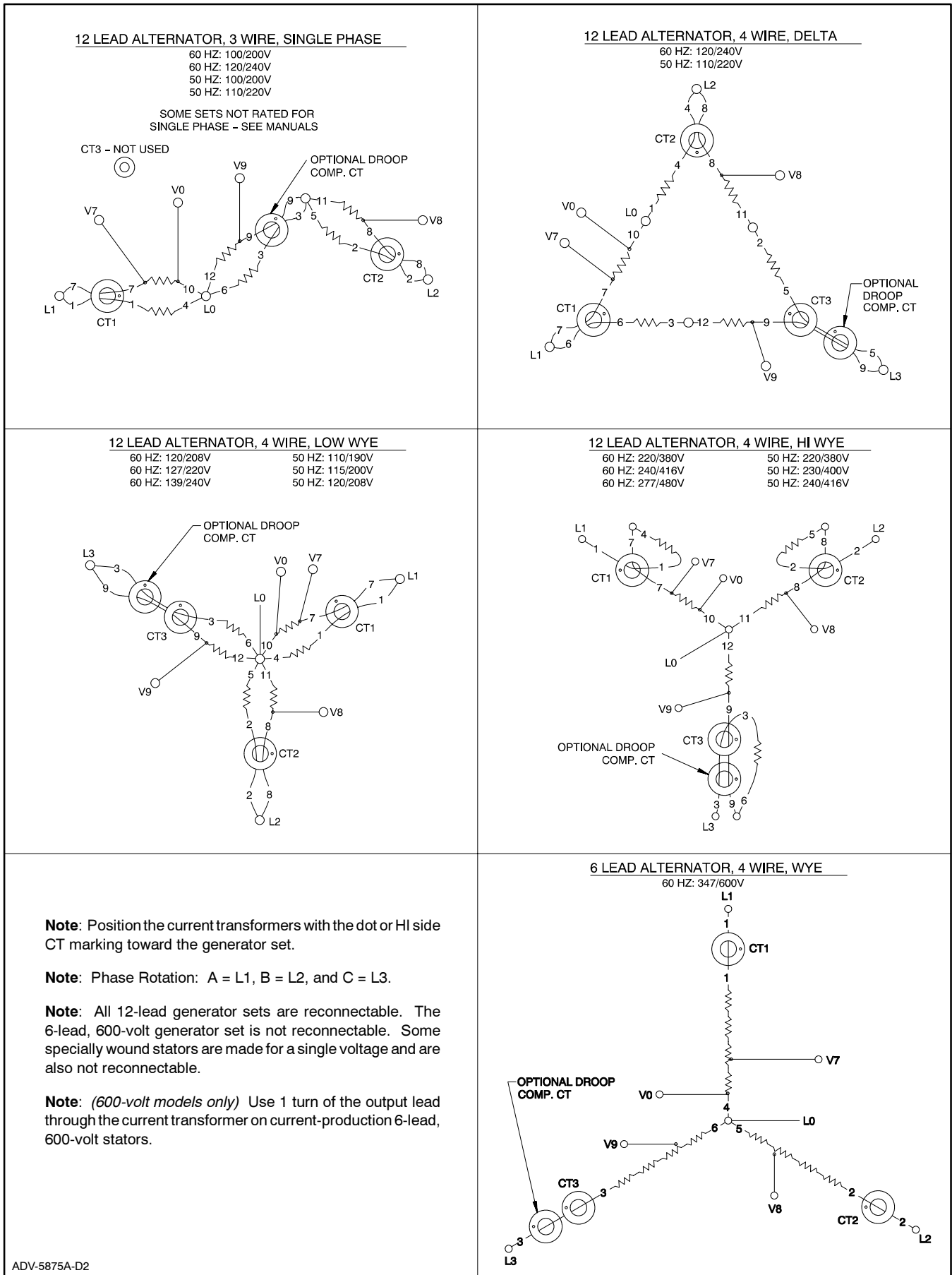

Figure 5-1 Generator Set Reconnections, 20-300 kW Models

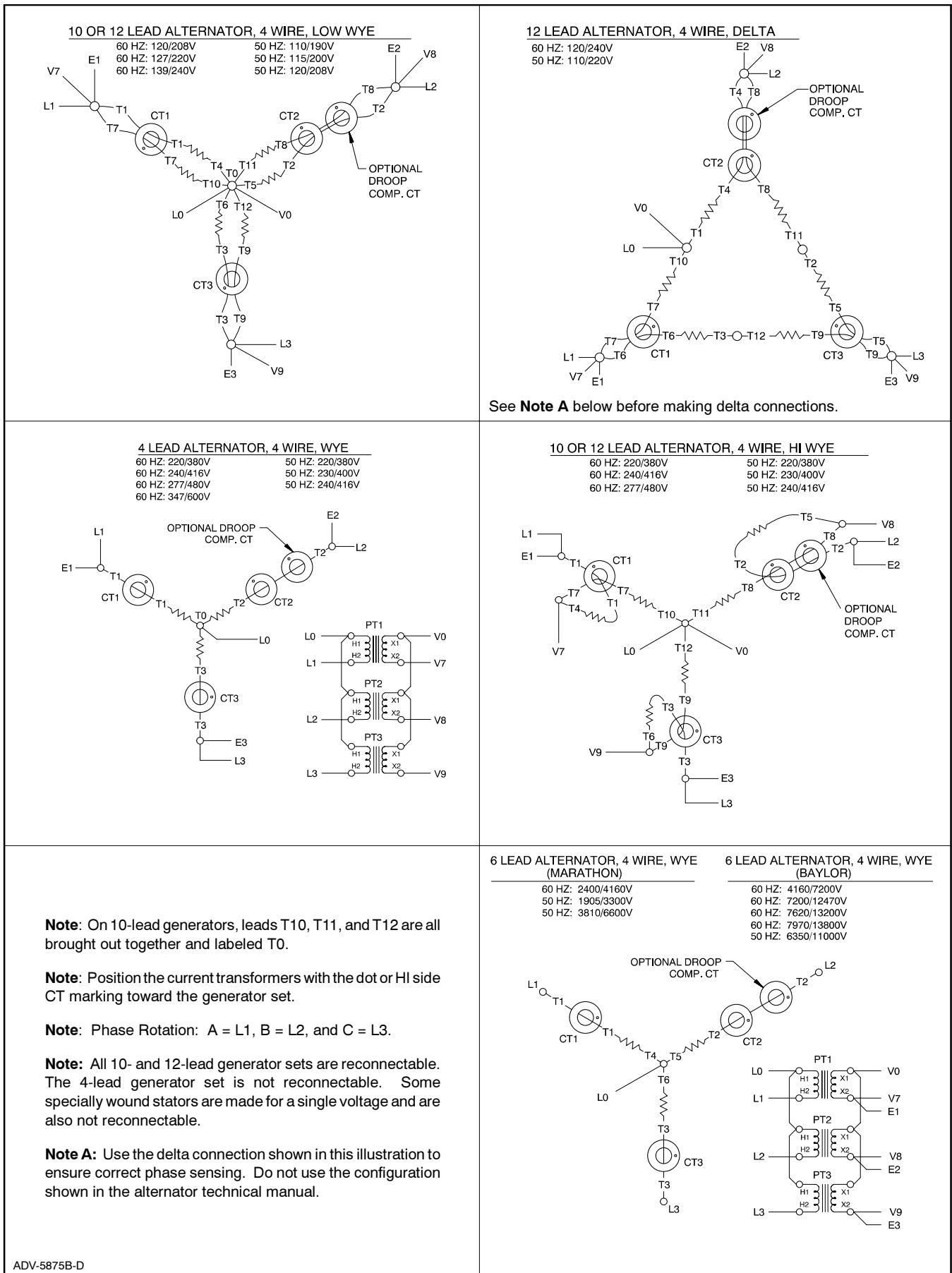

Figure 5-2 Generator Set Reconnections, 350–2000 kW Models

6.1 Accessories and Connections

Several accessories help finalize installation, add convenience to operation and service, and establish state and local code compliance.

Accessories vary with each generator set model and controller. Select factory-installed and/or shipped-loose accessories. See the matrix in Figure 6-1 for a list of available kits. Kit and installation instruction part numbers change. Obtain the most current accessory information from your local authorized service distributor/dealer.

This section illustrates several accessories available at the time of print of this publication. Accessory kits generally include installation instructions. See the Wiring Diagrams Manual for electrical connections not shown in this section. See the installation instructions and drawings supplied with the kit for information on the kit mounting location.

The instructions provided with the accessory kit supersede these instructions where there are differences. In general, run AC and DC wiring in separate conduit. Use shielded cable for all analog inputs. Observe all applicable national, state, and local electrical codes during accessory installation.

Kit Description	Kit Part Nos.	Installation Instruction
Audiovisual Alarm	GM17070-KP1, GM17070-KP2, GM17070-KP3	TT-1300
Common Failure Relay (Terminal 32A)	GM17028-KP2, GM17032-KP2, 365569-KP14	TT-1301
Controller (Customer) Connection	GM17028-KP1, GM17032-KP1	TT-1302
Float/Equalize Battery Charger (with alarms)	PAD-292863 (12 volt), PAD-292865 (24 volt)	TT-680
Idle (Speed) Mode Feature	No kit required. Use customer-supplied switch and leads.	See Section 6.1.5, Idle (Speed) Mode Feature
Key Switch	New	New
Low Fuel (Level) Switch	Multiple kits based on generator set subbase fuel tank or day tank selection. Note: The main fuel tank may include this switch as provided by the fuel tank supplier.	Multiple TTs or contact main fuel tank supplier.
Low Fuel (Pressure) Switch	Multiple kits based on generator set model number.	Multiple TTs
Prime Power Switch	GM20652-KP1	New
Remote Annunciator (16-light panel)	GM17071-KP1, GM17071-KP2, GM17071-KP3	TT-1303
Remote Emergency Stop	PA-293906	New
Remote Reset Feature	No kit required. Use customer-supplied switch and leads.	See Section 6.1.10, Remote Reset Feature
Remote Speed Adjustment Potentiometer (requires electronic governor) Non-ECM models only	PA-273768	TT-774
Run Relay	PA-273743 (12 volt), PA-273744 (24 volt), 365569-KA8 (24 volt)	New
Single-Relay Dry Contact	GM17068-KP1, GM17068-KP2, 365569-KP9	TT-1304
Ten-Relay Dry Contact	GM17069-KP1, GM17069-KP2, 365569-KP10	TT-1305

Figure 6-1 Optional Accessories

6.1.1 Audiovisual Alarm Kit

An audiovisual alarm warns the operator at a remote location of fault shutdowns and prealarm conditions. Audiovisual alarms include an alarm horn, an alarm silence switch, and common fault lamp. See Figure 6-2 and Figure 6-4. See Section 6.2, Accessory Connections, for terminal identification.

Note: Use the audiovisual alarm with a dry contact kit.

6.1.2 Common Failure Relay Kit

The common failure relay kit provides one set of contacts to trigger customer-provided warning devices if a fault occurs. The common failure relay faults are user-defined. See Section 2, Operation, Menu 10—Output Setup, for status and faults available for this function.

Connect up to three common failure relay kits to the controller output. See Figure 6-3 and Figure 6-5. See Section 6.2, Accessory Connections, for terminal identification.

6.1.3 Controller (Customer) Connection Kit

The controller connection kit allows easy connection of controller accessories without accessing the controller terminal strip. The supplied wiring harness connects controller connector P23 and terminal strips TB1-3 and TB1-4 to the controller connection kit connector P25 and terminal strips TB6, TB7, TB8, and TB9. Connect all accessories (except the emergency stop kit) to the customer connection kit terminal strips. See Figure 6-6.

See Section 6.2, Accessory Connections, for terminal identification.

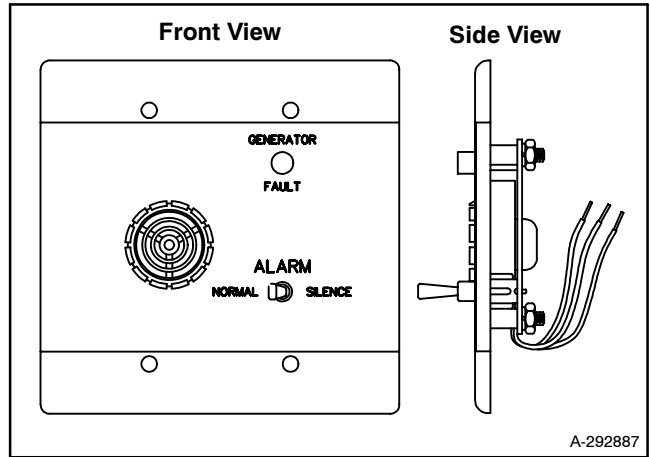

Figure 6-2 Audiovisual Alarm

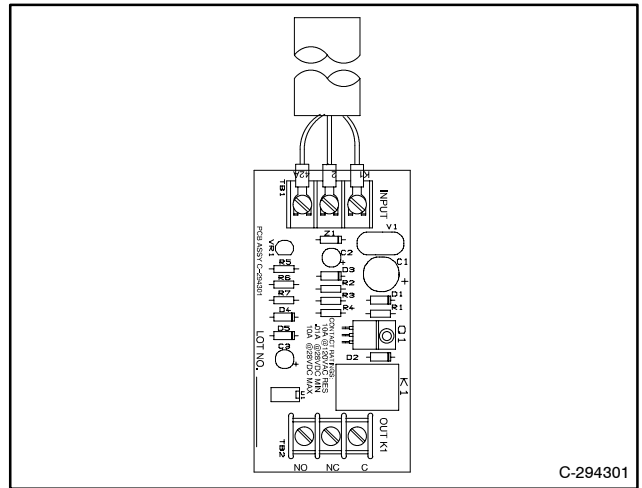

Figure 6-3 Common Failure Relay Kit

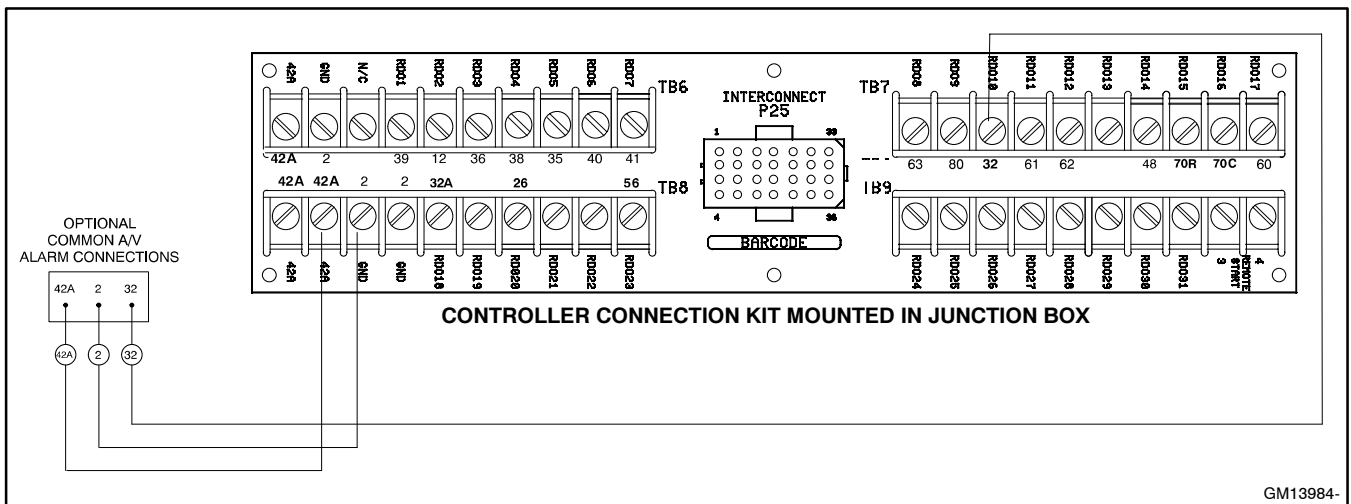
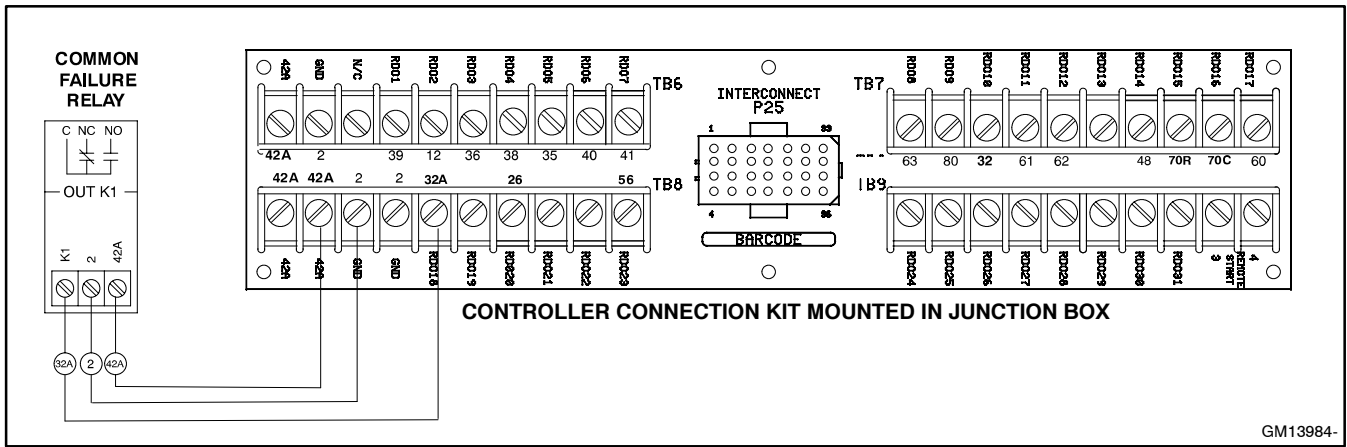
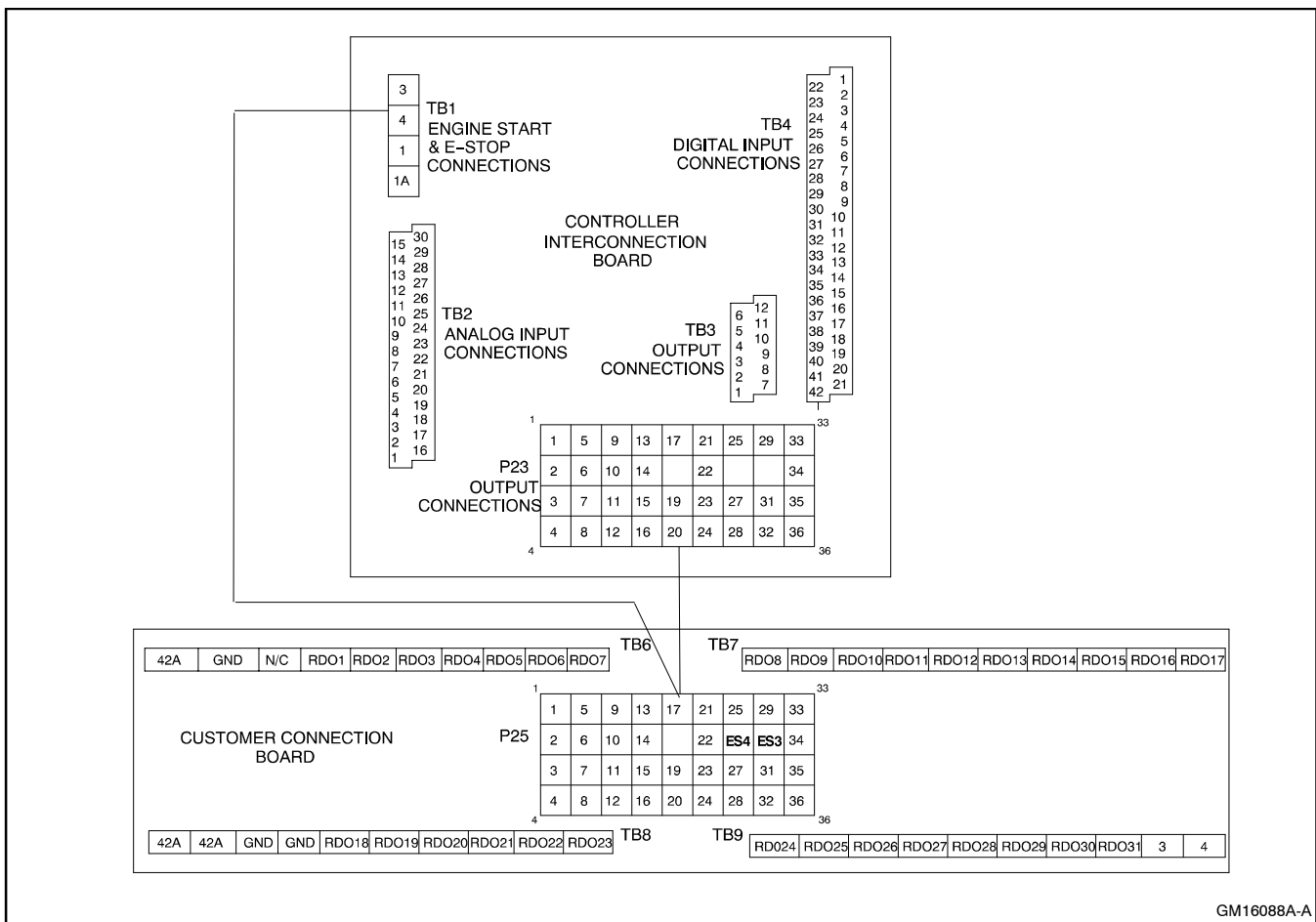

Figure 6-4 Audiovisual Alarm Connections



GM13984-

Figure 6-5 Common Failure Relay Kit Connections



GM16088A-A

Figure 6-6 Controller (Customer) Connection Kit

6.1.4 Float/Equalize Battery Charger Kit with Alarm Option

The float/equalize battery charger with alarm option provides battery charging to the engine starting battery(ies) and connects to the controller for fault detection. Battery chargers for 12- or 24-volt models are available as a generator set accessory. See Figure 6-9. See Section 6.2, Accessory Connections, for terminal identification.

6.1.5 Idle (Speed) Mode Feature

The idle (speed) mode feature provides the ability to start and run the engine at idle (reduced) speed for a selectable time period (0-10 minutes) during warm-up. The controller will override the idle speed mode if the engine reaches the preprogrammed engine warmed-up temperature before the idle mode times out. See Figure 6-7 for user-supplied switch connection.

6.1.6 Low Fuel (Level or Pressure) Switch

Some gaseous-fueled models offer a low fuel pressure switch. The low fuel pressure switch connects to the same terminal as the low fuel level switch on diesel- or gasoline-fueled models. See Figure 6-8. See Section 6.2, Accessory Connections, for terminal identification.

Note: The main tank or the transfer/day tank includes the low fuel level switch. The fuel tank supplier typically provides the low fuel level switch.

Wiring Recommendation	
Gauge	mm (ft.)
18-20	30.5 (100)
14	153 (500)
10	305 (1000)

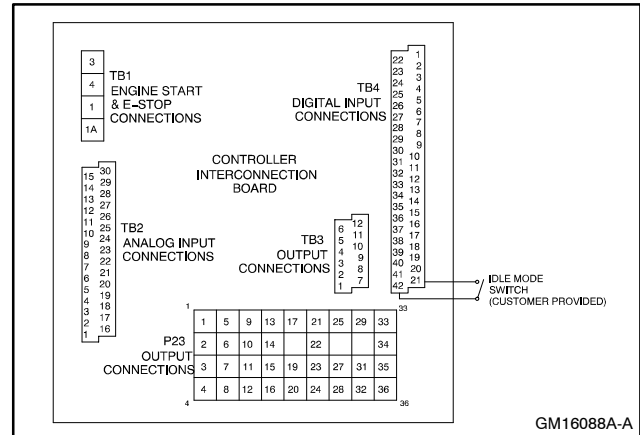

Figure 6-7 Idle (Speed) Mode Switch

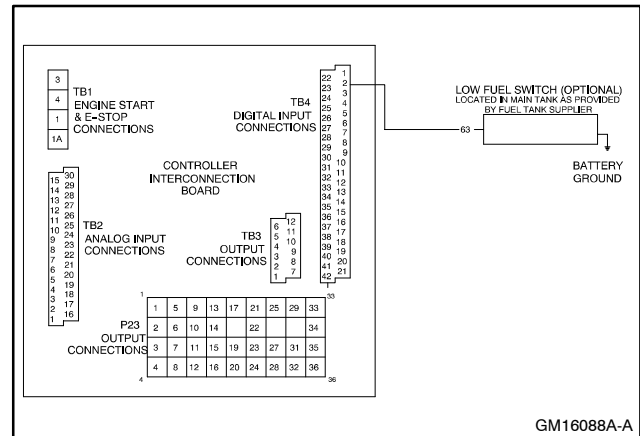

Figure 6-8 Low Fuel Switch (Level or Pressure)

Switch Rating
12 volts DC minimum
0.5 amp minimum

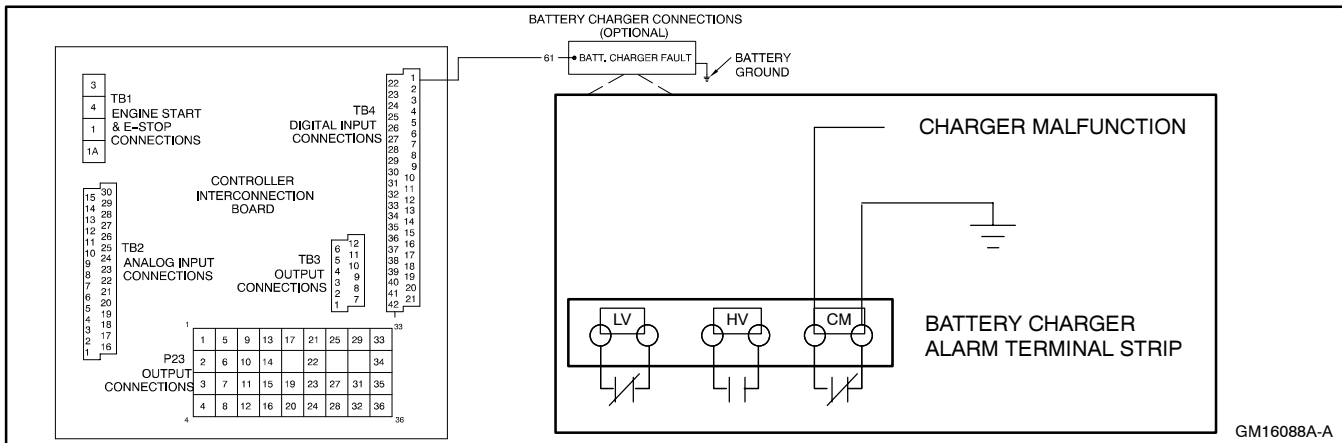

Figure 6-9 Float/Equalize Battery Charger Connections

6.1.7 Prime Power Switch Kit

The prime power switch kit prevents battery drain during generator set non-operation periods and without battery charging.

Stop the generator set using the stopping procedures in Section 2.3.2, Stopping, before placing the generator set in the prime power mode. Move the prime power switch located on the back of the controller to the CONTROLLER OFF position. The controller including the digital display, LEDs, and alarm horn does not function when the generator set is in the prime power mode.

Move the prime power switch located on the back of the controller to the CONTROLLER ON position and reset the controller time and date before attempting to start the generator set.

6.1.8 Remote Annunciator Kit

A remote annunciator monitors the generator set's condition from a location remote of the generator set. See Figure 6-10. The remote annunciator includes an alarm horn, an alarm silence switch, a lamp test, and lamp indicators similar to the digital controller, plus the following:

Line Power. Lamp illuminates to indicate the power source is a commercial utility.

Generator Power. Lamp illuminates to indicate the power source is the generator set.

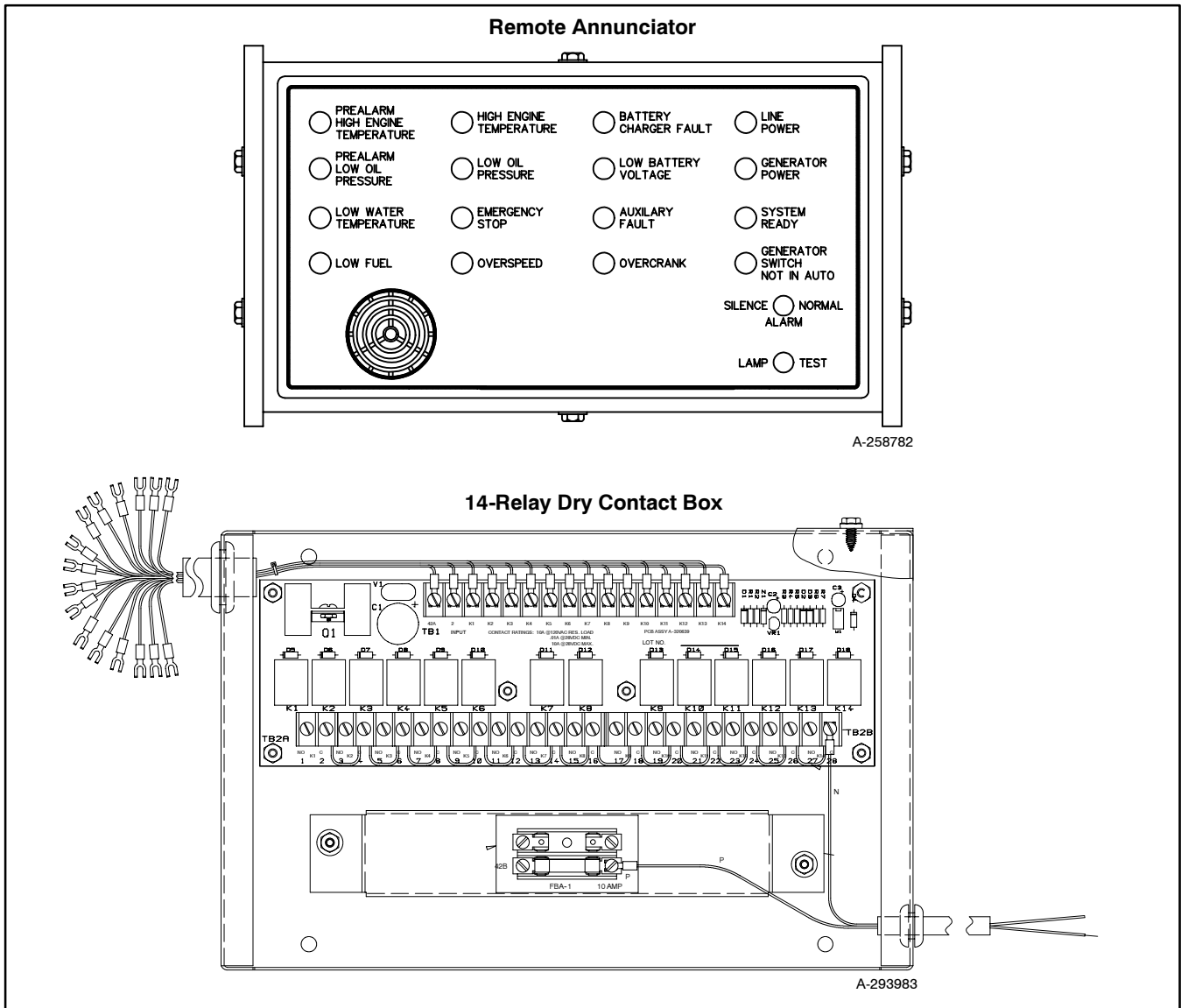

Figure 6-10 Remote Annunciator with 14-Relay Dry Contact Kit

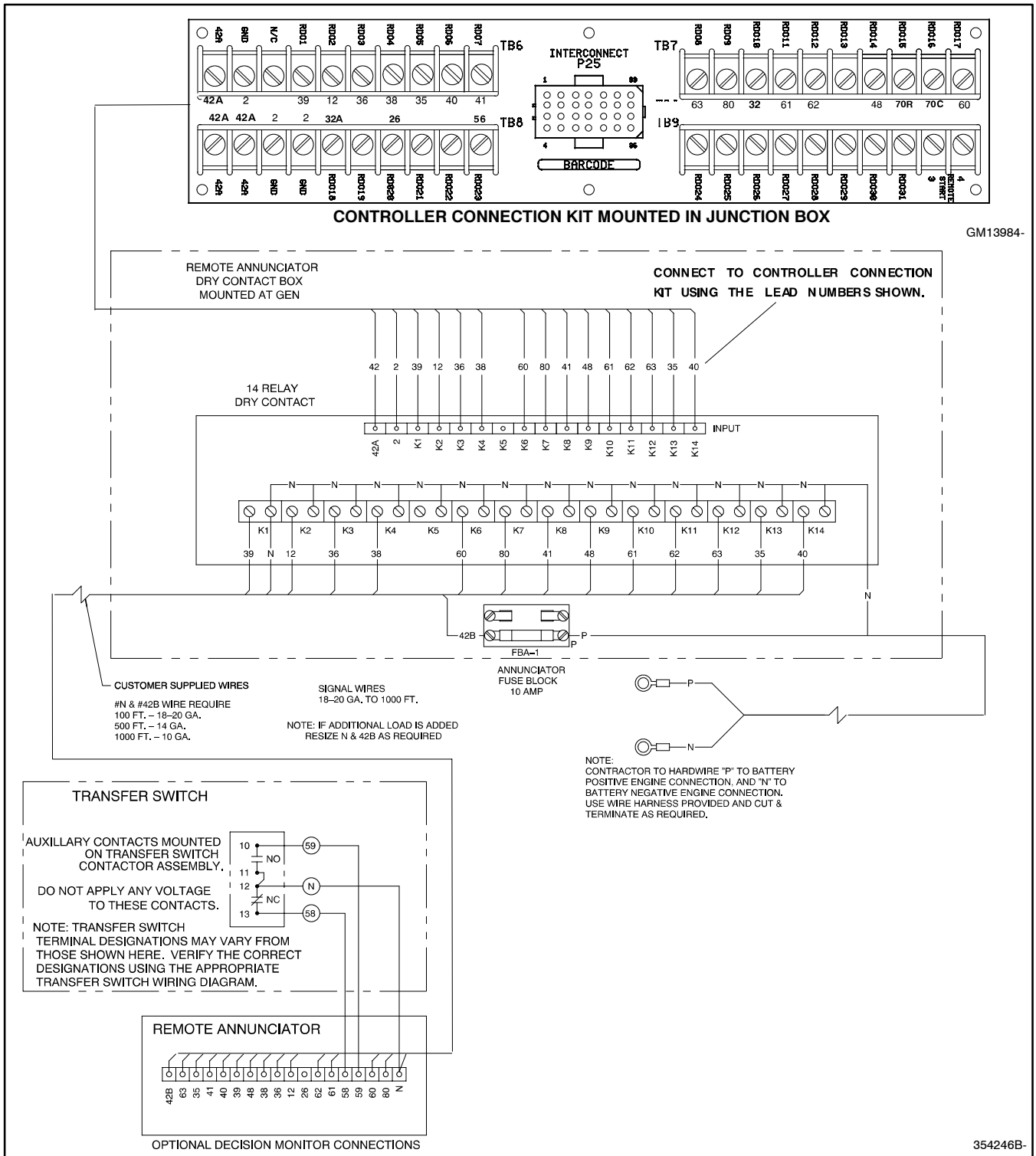

Figure 6-11 Remote Annunciator with 14-Relay Dry Contact Kit Connections

6.1.9 Remote Emergency Stop Kit

The emergency stop kit allows immediate shutdown of the generator set from a remote location. See Figure 6-12 and Figure 6-13. If the emergency stop switch activates, the EMERGENCY STOP lamp lights and the unit shuts down. Before attempting to restart the generator set, reset the emergency stop switch (by replacing the glass piece) and reset the generator set by placing the master switch in the OFF/RESET position.

Use the single glass piece located inside the switch for replacement and order additional glass pieces as service parts. See Section 2.3.3, Emergency Stop Switch Reset Procedure. See Section 6.2, Accessory Connections, for terminal identifications.

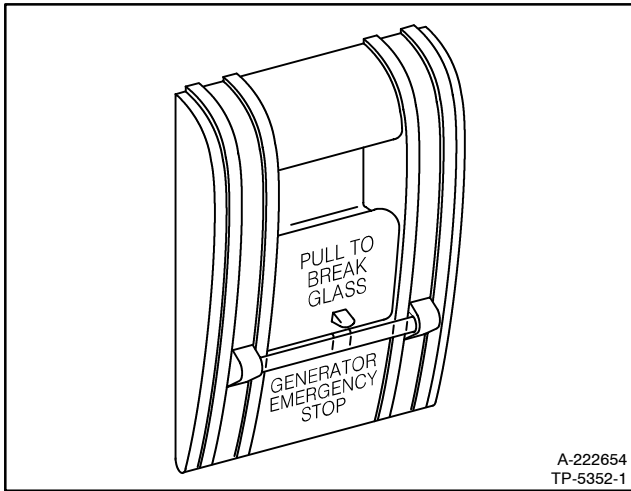

Figure 6-12 Emergency Stop Kit

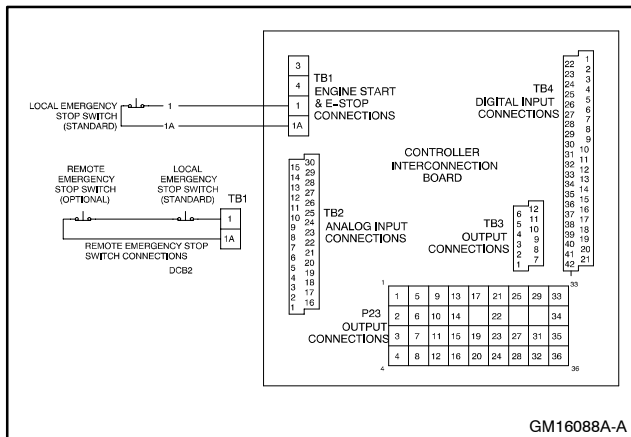

Figure 6-13 Remote Emergency Stop Kit Connections

6.1.10 Remote Reset Feature

The remote reset switch provides generator set resetting after a fault shutdown at a remote location. See Figure 6-14 for user-supplied switch connection.

Press and hold the switch for 2-3 seconds and release to reset the generator set controller.

Switch Rating
12 volts DC minimum 1 amp minimum

Wiring Recommendation	
Gauge	mm (ft.)
18-20	30.5 (100)
14	153 (500)
10	305 (1000)

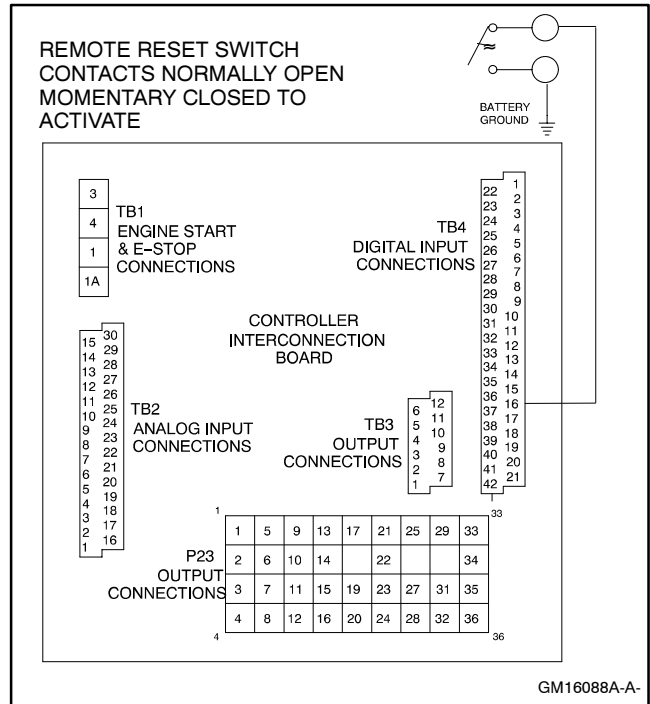

Figure 6-14 Remote Reset Switch Connections

6.1.11 Remote Speed Adjustment Potentiometer Kit (non-ECM models)

The remote speed adjustment potentiometer kit provides controller-mounted engine speed adjustment. The adjustment range is approximately $\pm 5\%$. Some applications locate this potentiometer with the switchgear. This kit requires an electronic governor on the generator set. See Figure 6-15. See Section 6.2, Accessory Connections, for terminal identifications.

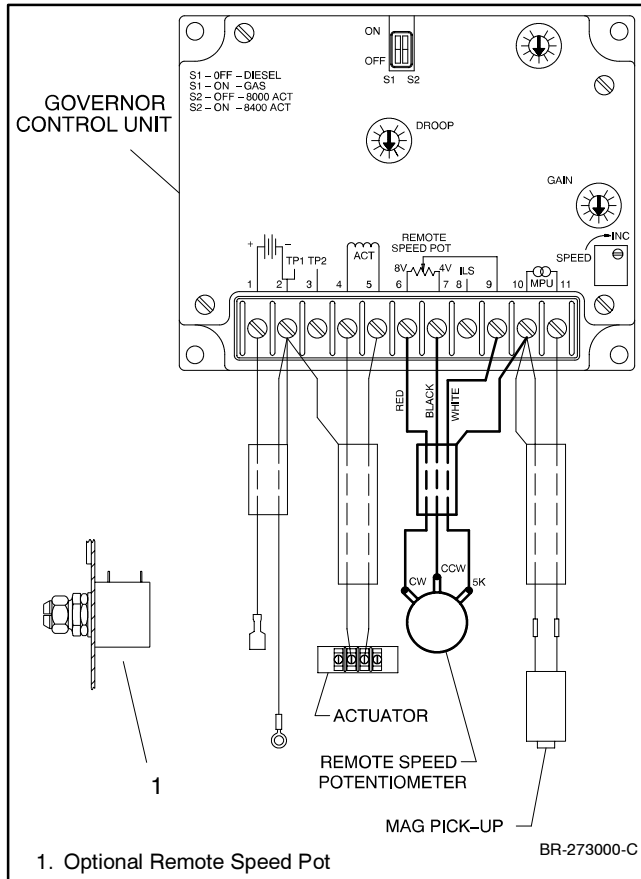

Figure 6-15 Remote Speed Adjustment Potentiometer Connection, Typical

6.1.12 Run Relay Kit

The run relay kit energizes only when the generator set runs. Use the run relay kit to control air intake and radiator louvers, alarms, and/or other signalling devices. See Figure 6-16 and Figure 6-17.

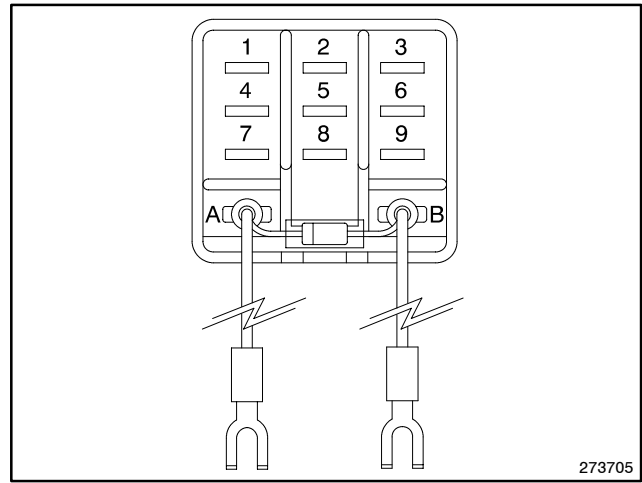

Figure 6-16 Run Relay Kit

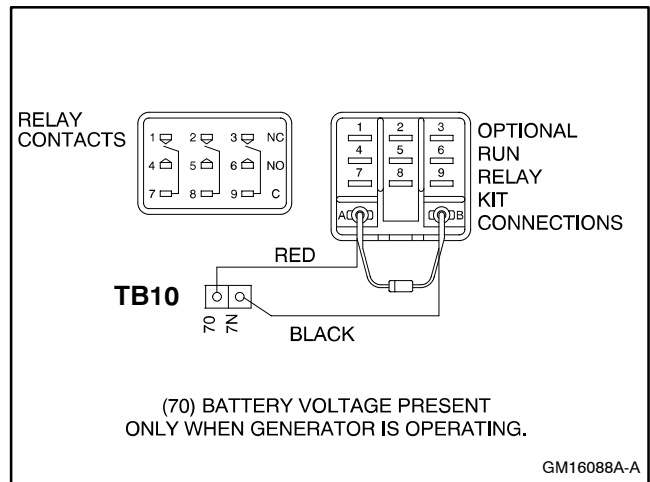

Figure 6-17 Run Relay Connections

6.1.13 Single-Relay Dry Contact Kit

The single-relay dry contact kit uses one set of contacts to trigger customer-provided warning devices when a fault condition occurs. Any controller fault output from the controller connection terminal strip can connect to the single-relay kit.

A total of three dry contact kits may connect to a single controller output. See Figure 6-18 and Figure 6-19. See Section 6.2, Accessory Connections, for terminal identifications.

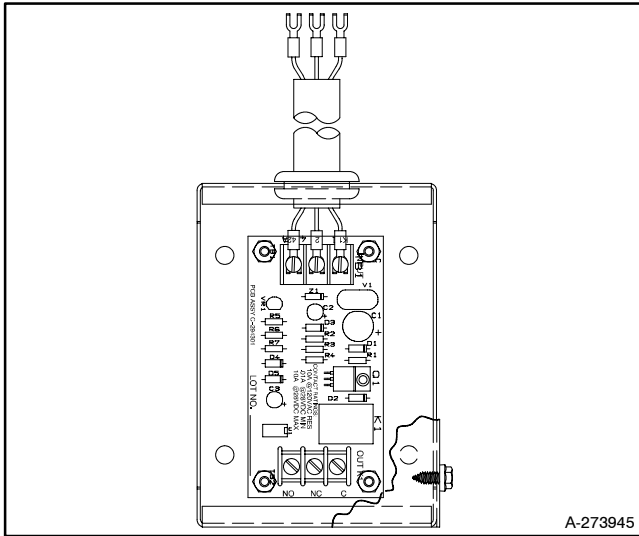

Figure 6-18 Single-Relay Dry Contact Kit

6.1.14 Ten-Relay Dry Contact Kit

The ten-relay dry contact kit allows monitoring of the standby system and/or provides the ability to activate accessories such as derangement panels. The kit includes ten sets of relay contacts for connection of customer-provided devices to desired generator functions. Connect warning devices (lamps and/or audible alarms) and other accessories to the controller outputs. Connect a total of three dry contact kits to a controller output. Refer to Figure 6-20 for an internal view of the contact kit. See Figure 6-21 for electrical connections.

See Section 6.2, Accessory Connections, for terminal identifications.

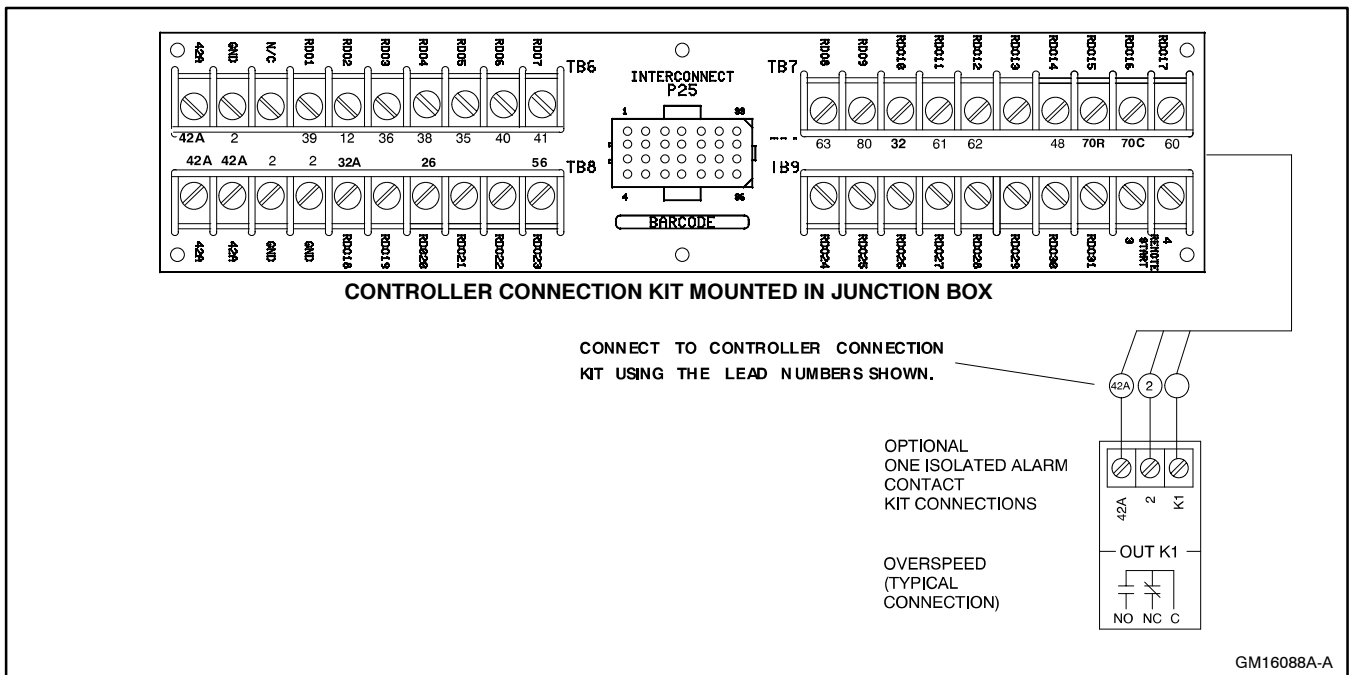

Figure 6-19 Single-Relay Dry Contact Kit Connections

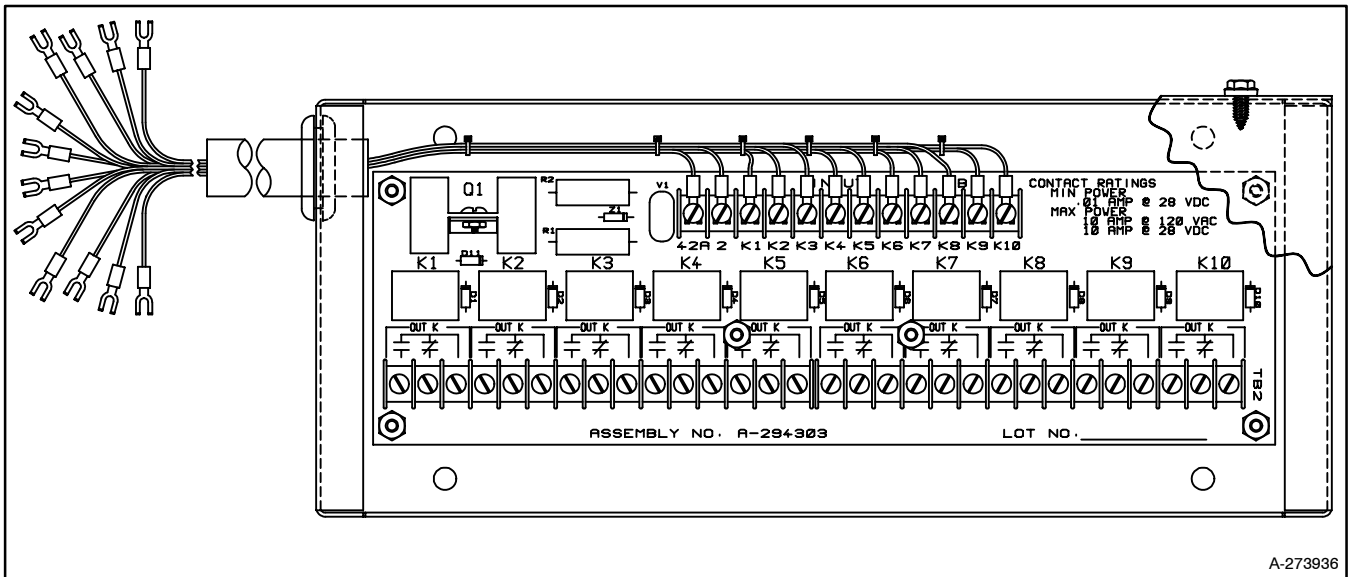

Figure 6-20 Ten-Relay Dry Contact Kit

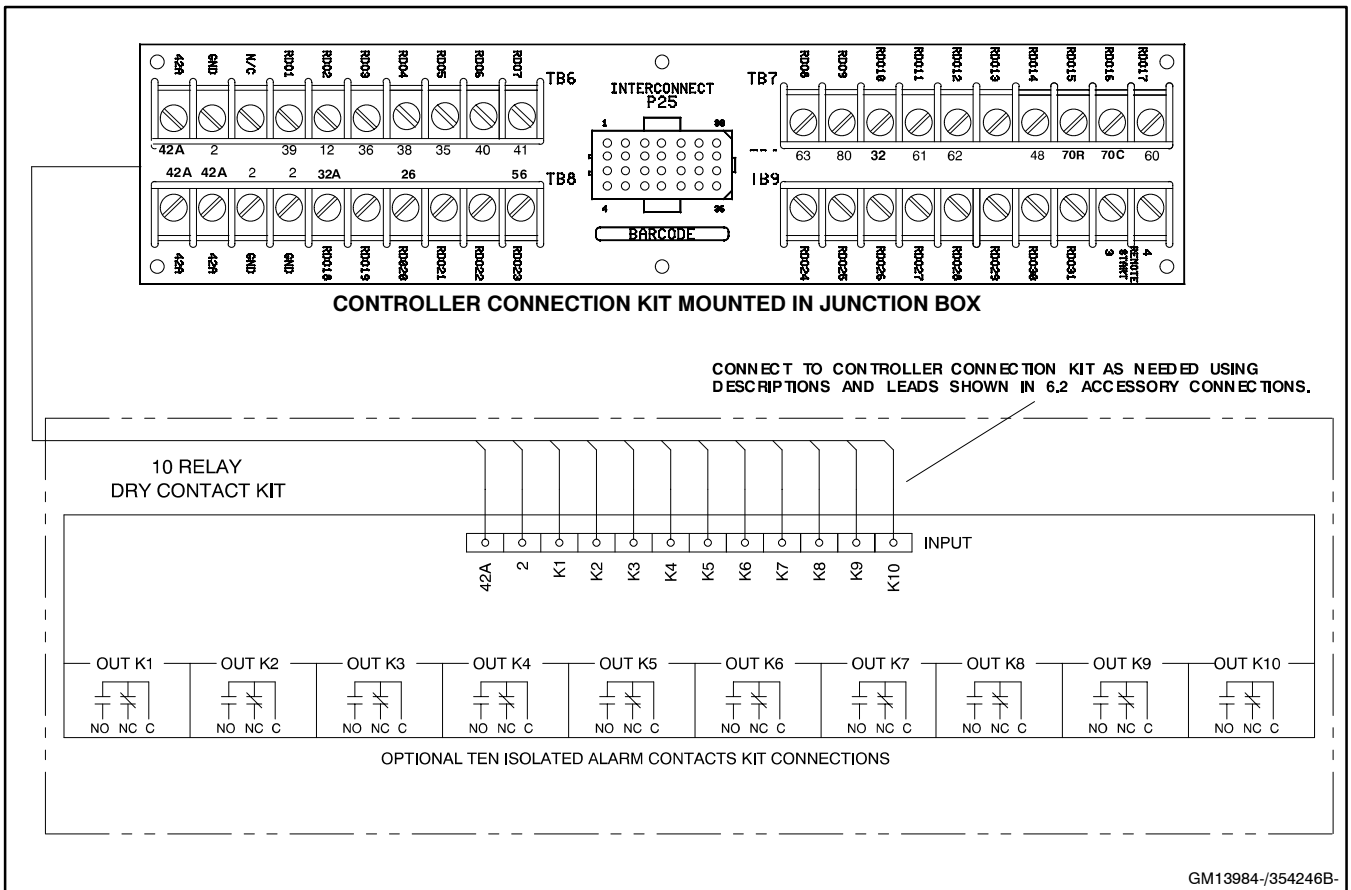

Figure 6-21 Ten-Relay Dry Contact Kit Connections

6.2 Accessory Connections

The digital controller contains circuit boards equipped with terminal strip(s) for easy connection of generator set accessories. Do not connect accessories directly to the controller terminal strip. Connect all accessories to a single-relay dry contact kit or ten-relay dry contact kit. Connect the dry contact kit(s) to the controller connection kit. Connect alarms, battery chargers, remote switches, and other accessories to the dry

contact kit relay(s) using 18- or 20-gauge stranded wire up to 305 m (1000 ft.).

For specific information on accessory connections, refer to the accessory wiring diagrams in the Wiring Diagram Manual and the instruction sheet accompanying the kit. See Figure 6-22 and Figure 6-23 for controller interconnection circuit board connections. See Figure 6-24 and Figure 6-25 for controller (customer) connection kit connections.

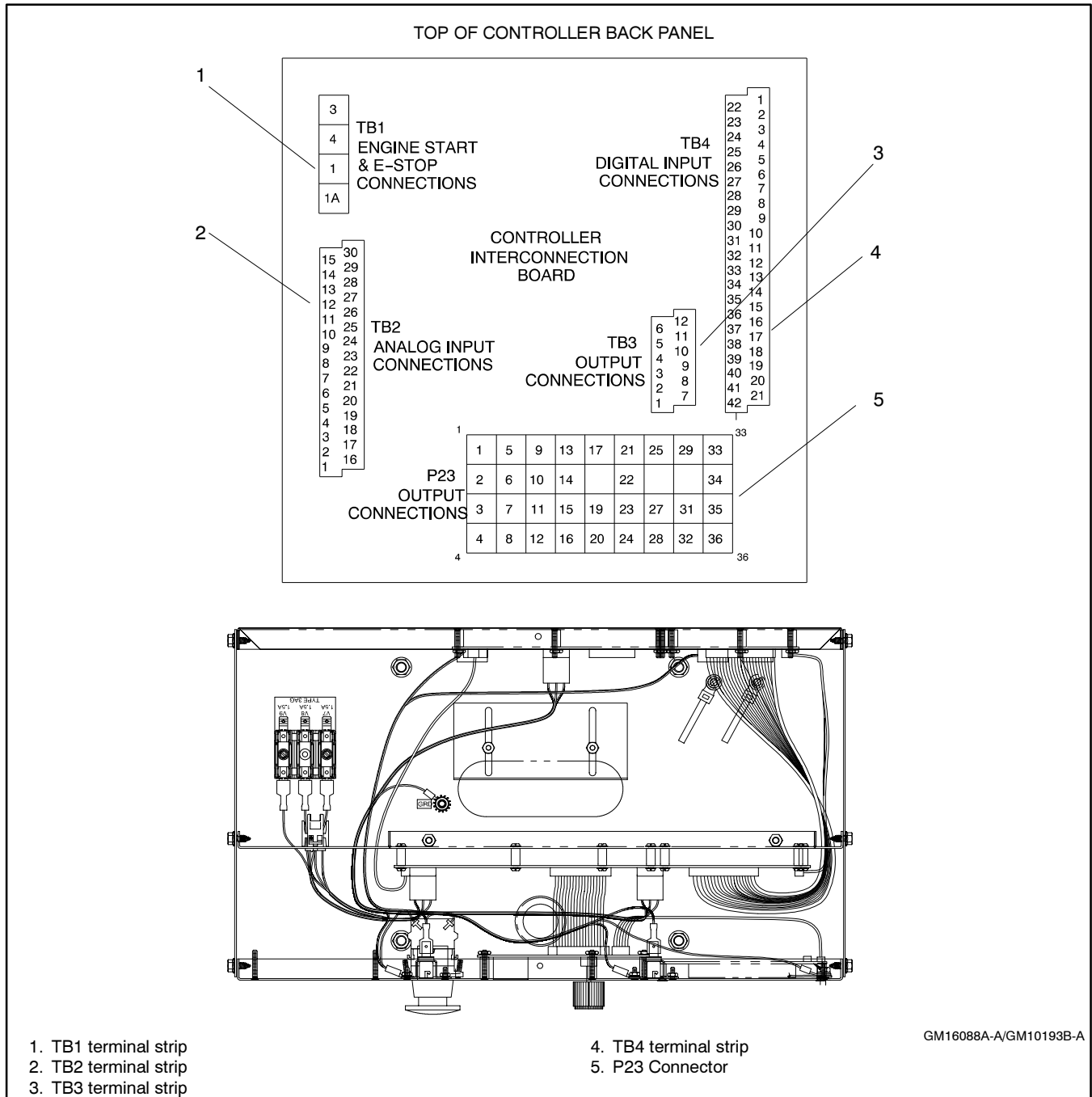

Figure 6-22 Terminal Strips on Controller Interconnection Circuit Board (Controller Back Panel Folded Down)

TB1 Terminal Strip—Engine Start and Emergency Stop Connections

Term.	Description
1	Emergency stop ground
1A	Emergency stop
3	Remote start
4	Remote start

TB2 Terminal Strip—Analog Input Connections

Term.	Description
1	ACH1 (CTS) Signal (non-ECM)
2	ACH1 (CTS) Supply (non-ECM)
3	ACH2 (OPS) Signal (non-ECM)
4	ACH2 (OPS) Supply (non-ECM)
5	ACH3 Signal
6	ACH3 Supply
7	ACH4 Signal
8	ACH4 Supply
9	ACH5 Signal
10	ACH5 Supply
11	ACH6 Signal
12	ACH6 Supply
13	ACH7 Signal
14	ACH7 Supply
15	N/C
16	ACH1 (CTS) Return (non-ECM)
17	ACH1 (CTS) Shield ground (non-ECM)
18	ACH2 (OPS) Return (non-ECM)
19	ACH2 (OPS) Shield ground (non-ECM)
20	ACH3 Return
21	ACH3 Shield ground
22	ACH4 Return
23	ACH4 Shield ground
24	ACH5 Return
25	ACH5 Shield ground
26	ACH6 Return
27	ACH6 Shield ground
28	ACH7 Return
29	ACH7 Shield ground
30	N/C

TB3 Terminal Strip—Accessory Power Output Connections

Term.	Description
1	+12 VDC (OEM use only)
2	+12 VDC (OEM use only)
3	+12 VDC (OEM use only)
4	Fused battery (+) (42A) (5 Amp)
5	Fused battery (+) (42A) (5 Amp)
6	Fused battery (+) (42A) (5 Amp)
7	Battery (-)
8	Battery (-)
9	Battery (-)
10	Battery (-)
11	Battery (-)
12	Panel lamp output

TB4 Terminal Strip—Input Factory Connections

Term.	Description
1	DCH1 Battery charger fault
2	DCH2 Low fuel
3	DCH3 Low coolant temp. with ECM models or warning default with non-ECM models
4	DCH4 Field overvoltage with M4/M5/M7 alternators or warning default with non-M4/M5/M7 alternators
5	DCH5 Warning
6	DCH6 Warning
7	DCH7 Warning
8	DCH8 Warning
9	DCH9 Warning
10	DCH10 Warning
11	DCH11 Warning
12	DCH12 Warning
13	DCH13 Warning
14	DCH14 Low coolant level with 50-100ROZK models or warning default with all models except 50-100ROZK
15	DCH15 Remote shutdown
16	DCH16 Remote reset
17	DCH17 VAR PF mode
18	DCH18 Voltage lower
19	DCH19 Voltage raise
20	DCH20 Air damper
21	DCH21 Idle mode functional with ECM-equipped engines only
22	DCH1 Return
23	DCH2 Return
24	DCH3 Return
25	DCH4 Return
26	DCH5 Return
27	DCH6 Return
28	DCH7 Return
29	DCH8 Return
30	DCH9 Return
31	DCH10 Return
32	DCH11 Return
33	DCH12 Return
34	DCH13 Return
35	DCH14 Return
36	DCH15 Return
37	DCH16 Return
38	DCH17 Return
39	DCH18 Return
40	DCH19 Return
41	DCH20 Return
42	DCH21 Return

Note: TB4-1 through TB4-21 are customer definable with factory defaults listed. Terminals TB4-3, TB4-4, TB4-14, and TB4-21 have different functions depending upon the generator set configuration. See comments above. See Menu 9—Input Setup for changing inputs.

Figure 6-23 Controller Terminal Strip Identification

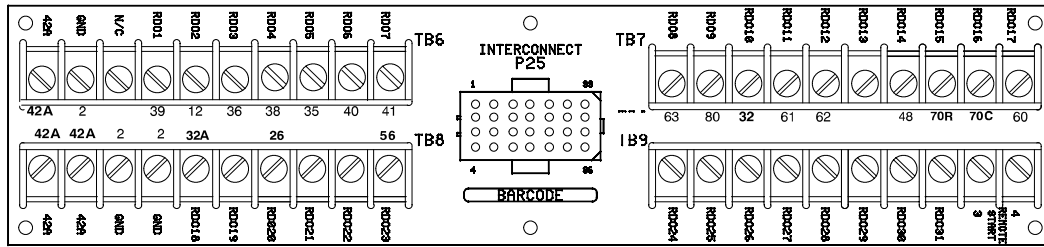

GM13984-

Figure 6-24 Terminal Strips TB6, TB7, TB8, and TB9 on the Controller Connection Kit in the Junction Box

TB6 Terminal Strip—RDOs 1-7

Term.	Description
42A	Battery (+)
GND	Battery (-)
N/C	
RDO1	Overspeed (39)
RDO2	Overcrank (12)
RDO3	High coolant temperature shutdown (36)
RDO4	Low oil pressure shutdown (38)
RDO5	Low coolant temperature (35)
RDO6	High coolant temperature warning (40)
RDO7	Low oil pressure warning (41)

TB7 Terminal Strip—RDOs 8-17

Term.	Description
RDO8	Low fuel (63)
RDO9	Master switch not in auto (80)
RDO10	NFPA 110 common alarm (32)*
RDO11	Battery charger fault (61)
RDO12	Low battery voltage (62)
RDO13	High battery voltage
RDO14	Emergency stop (48)
RDO15	Generator running (70R)
RDO16	Time delay engine cooldown (TDEC) (70C)
RDO17	System ready (60)

TB8 Terminal Strip—RDOs 18-23

Term.	Description
42A	Battery (+)
42A	Battery (+)
2	Battery (-)
2	Battery (-)
RDO18	Defined common fault (32A)
RDO19	Low coolant level
RDO20	Overvoltage (26)
RDO21	Idle mode
RDO22	EPS supplying load
RDO23	Air damper indicator (56)

TB9 Terminal Strip—RDOs 24-31

Term.	Description
RDO24	Speed sensor fault
RDO25	Loss of AC sensing
RDO26	ECM loss of communication
RDO27	Undervoltage
RDO28	Overfrequency
RDO29	Underfrequency
RDO30	Load shed kW overload
RDO31	Load shed underfrequency
3	Remote start
4	Remote start

Note: RDO-1 through RDO-31 are customer definable with the following factory defaults: emergency stop, high coolant temperature, low oil pressure, overcrank, and overspeed

***NFPA-110 common alarm faults include:**

- Air damper indicator
- Battery charger fault
- EPS supplying load
- High battery voltage
- High coolant temperature warning
- High coolant temperature shutdown
- Low battery voltage
- Low coolant level
- Low coolant temperature warning
- Low fuel (level or pressure)
- Low oil pressure warning
- Low oil pressure shutdown
- Master switch not in auto
- Overcrank
- Overspeed

Figure 6-25 Controller (Customer) Connection Kit Terminal Strip Identification with Relay Driver Outputs (RDOs)

Notes

Appendix A Abbreviations

The following list contains abbreviations that may appear in this publication.

A, amp	ampere	CG	center of gravity	fglass.	fiberglass
ABDC	after bottom dead center	CID	cubic inch displacement	FHM	flat head machine (screw)
AC	alternating current	CL	centerline	fl. oz.	fluid ounce
A/D	analog to digital	cm	centimeter	flex.	flexible
ADC	analog to digital converter	CMOS	complementary metal oxide substrate (semiconductor)	freq.	frequency
adj.	adjust, adjustment			FS	full scale
ADV	advertising dimensional drawing	cogen.	cogeneration	ft.	foot, feet
AHWT	anticipatory high water temperature	Com	communications (port)	ft. lbs.	foot pounds (torque)
AISI	American Iron and Steel Institute	conn.	connection	ft./min.	feet per minute
ALOP	anticipatory low oil pressure	cont.	continued	g	gram
alt.	alternator	CPVC	chlorinated polyvinyl chloride	ga.	gauge (meters, wire size)
Al	aluminum	crit.	critical	gal.	gallon
ANSI	American National Standards Institute (formerly American Standards Association, ASA)	CRT	cathode ray tube	gen.	generator
		CSA	Canadian Standards Association	genset	generator set
AO	anticipatory only	CT	current transformer	GFI	ground fault interrupter
API	American Petroleum Institute	Cu	copper	GND, ⊕	ground
approx.	approximate, approximately	cu. in.	cubic inch	gov.	governor
AR	as required, as requested	cw.	clockwise	gph	gallons per hour
AS	as supplied, as stated, as suggested	CWC	city water-cooled	gpm	gallons per minute
ASE	American Society of Engineers	cyl.	cylinder	gr.	grade, gross
ASME	American Society of Mechanical Engineers	D/A	digital to analog	GRD	equipment ground
assy.	assembly	DAC	digital to analog converter	gr. wt.	gross weight
ASTM	American Society for Testing Materials	dB	decibel	H x W x D	height by width by depth
ATDC	after top dead center	dBA	decibel (A weighted)	HC	hex cap
ATS	automatic transfer switch	DC	direct current	HCHT	high cylinder head temperature
auto.	automatic	DCR	direct current resistance	HD	heavy duty
aux.	auxiliary	deg., °	degree	HET	high exhaust temperature
A/V	audiovisual	dept.	department	hex	hexagon
avg.	average	dia.	diameter	Hg	mercury (element)
AVR	automatic voltage regulator	DI/EO	dual inlet/end outlet	HH	hex head
AWG	American Wire Gauge	DIN	Deutsches Institut fur Normung e. V. (also Deutsche Industrie Normenausschuss)	HHC	hex head cap
AWM	appliance wiring material			HP	horsepower
bat.	battery	DIP	dual inline package	hr.	hour
BBDC	before bottom dead center	DPDT	double-pole, double-throw	HS	heat shrink
BC	battery charger, battery charging	DPST	double-pole, single-throw	hsg.	housing
BCA	battery charging alternator	DS	disconnect switch	HVAC	heating, ventilation, and air conditioning
BCI	Battery Council International	DVR	digital voltage regulator	HWT	high water temperature
BDC	before dead center	E, emer.	emergency (power source)	Hz	hertz (cycles per second)
BHP	brake horsepower	EDI	electronic data interchange	IC	integrated circuit
blk.	black (paint color), block (engine)	EFR	emergency frequency relay	ID	inside diameter, identification
blk. htr.	block heater	e.g.	for example (<i>exempli gratia</i>)	IEC	International Electrotechnical Commission
BMEP	brake mean effective pressure	EG	electronic governor	IEEE	Institute of Electrical and Electronics Engineers
bps	bits per second	EGSA	Electrical Generating Systems Association	IMS	improved motor starting
br.	brass	EIA	Electronic Industries Association	in.	inch
BTDC	before top dead center	EI/EO	end inlet/end outlet	in. H ₂ O	inches of water
Btu	British thermal unit	EMI	electromagnetic interference	in. Hg	inches of mercury
Btu/min.	British thermal units per minute	emiss.	emission	in. lbs.	inch pounds
C	Celsius, centigrade	eng.	engine	Inc.	incorporated
cal.	calorie	EPA	Environmental Protection Agency	ind.	industrial
CARB	California Air Resources Board	EPS	emergency power system	int.	internal
CB	circuit breaker	ER	emergency relay	int./ext.	internal/external
cc	cubic centimeter	ES	engineering special, engineered special	I/O	input/output
CCA	cold cranking amps	ESD	electrostatic discharge	IP	iron pipe
ccw.	counterclockwise	est.	estimated	ISO	International Organization for Standardization
CEC	Canadian Electrical Code	E-Stop	emergency stop	J	joule
cfh	cubic feet per hour	etc.	et cetera (and so forth)	JIS	Japanese Industry Standard
cfm	cubic feet per minute	exh.	exhaust	k	kilo (1000)
		ext.	external	K	kelvin
		F	Fahrenheit, female	KA	kiloampere
				KB	kilobyte (2 ¹⁰ bytes)

kg	kilogram	MW	megawatt	rms	root mean square
kg/cm ²	kilograms per square centimeter	mW	milliwatt	rnd.	round
kgm	kilogram-meter	μF	microfarad	ROM	read only memory
kg/m ³	kilograms per cubic meter	N, norm.	normal (power source)	rot.	rotate, rotating
kHz	kilohertz	NA	not available, not applicable	rpm	revolutions per minute
kJ	kilojoule	nat. gas	natural gas	RS	right side
km	kilometer	NBS	National Bureau of Standards	RTV	room temperature vulcanization
kOhm, kΩ	kilo-ohm	NC	normally closed	SAE	Society of Automotive Engineers
kPa	kilopascal	NEC	National Electrical Code	scfm	standard cubic feet per minute
kph	kilometers per hour	NEMA	National Electrical Manufacturers Association	SCR	silicon controlled rectifier
kV	kilovolt	NFPA	National Fire Protection Association	s, sec.	second
kVA	kilovolt ampere	Nm	newton meter	SI	<i>Système international d'unites</i> , International System of Units
kVAR	kilovolt ampere reactive	NO	normally open	SI/EO	side in/end out
kW	kilowatt	no., nos.	number, numbers	sil.	silencer
kWh	kilowatt-hour	NPS	National Pipe, Straight	SN	serial number
kWm	kilowatt mechanical	NPSC	National Pipe, Straight-coupling	SPDT	single-pole, double-throw
L	liter	NPT	National Standard taper pipe thread per general use	SPST	single-pole, single-throw
LAN	local area network	NPTF	National Pipe, Taper-Fine	spec, specs	specification(s)
L x W x H	length by width by height	NR	not required, normal relay	sq.	square
lb.	pound, pounds	ns	nanosecond	sq. cm	square centimeter
lbm/ft ³	pounds mass per cubic feet	OC	overcrank	sq. in.	square inch
LCB	line circuit breaker	OD	outside diameter	SS	stainless steel
LCD	liquid crystal display	OEM	original equipment manufacturer	std.	standard
ld. shd.	load shed	OF	overfrequency	stl.	steel
LED	light emitting diode	opt.	option, optional	tach.	tachometer
Lph	liters per hour	OS	oversize, overspeed	TD	time delay
Lpm	liters per minute	OSHA	Occupational Safety and Health Administration	TDC	top dead center
LOP	low oil pressure	OV	overvoltage	TDEC	time delay engine cooldown
LP	liquefied petroleum	oz.	ounce	TDEN	time delay emergency to normal
LPG	liquefied petroleum gas	p., pp.	page, pages	TDES	time delay engine start
LS	left side	PC	personal computer	TDNE	time delay normal to emergency
L _{wa}	sound power level, A weighted	PCB	printed circuit board	TDOE	time delay off to emergency
LWL	low water level	pF	picofarad	TDON	time delay off to normal
LWT	low water temperature	PF	power factor	temp.	temperature
m	meter, milli (1/1000)	ph., ∅	phase	term.	terminal
M	mega (10 ⁶ when used with SI units), male	PHC	Phillips head crimptite (screw)	TIF	telephone influence factor
m ³	cubic meter	PHH	Phillips hex head (screw)	TIR	total indicator reading
m ³ /min.	cubic meters per minute	PHM	pan head machine (screw)	tol.	tolerance
mA	milliampere	PLC	programmable logic control	turbo.	turbocharger
man.	manual	PMG	permanent-magnet generator	typ.	typical (same in multiple locations)
max.	maximum	pot	potentiometer, potential	UF	underfrequency
MB	megabyte (2 ²⁰ bytes)	ppm	parts per million	UHF	ultrahigh frequency
MCM	one thousand circular mils	PROM	programmable read-only memory	UL	Underwriter's Laboratories, Inc.
MCCB	molded-case circuit breaker	psi	pounds per square inch	UNC	unified coarse thread (was NC)
meggar	megohmmeter	pt.	pint	UNF	unified fine thread (was NF)
MHz	megahertz	PTC	positive temperature coefficient	univ.	universal
mi.	mile	PTO	power takeoff	US	undersize, underspeed
mil	one one-thousandth of an inch	PVC	polyvinyl chloride	UV	ultraviolet, undervoltage
min.	minimum, minute	qt.	quart	V	volt
misc.	miscellaneous	qty.	quantity	VAC	volts alternating current
MJ	megajoule	R	replacement (emergency) power source	VAR	voltampere reactive
mJ	millijoule	rad.	radiator, radius	VDC	volts direct current
mm	millimeter	RAM	random access memory	VFD	vacuum fluorescent display
mOhm, mΩ	milliohm	RDO	relay driver output	VGA	video graphics adapter
MOhm, MΩ	megohm	ref.	reference	VHF	very high frequency
MOV	metal oxide varistor	rem.	remote	W	watt
MPa	megapascal	RFI	radio frequency interference	WCR	withstand and closing rating
mpg	miles per gallon	RH	round head	w/	with
mph	miles per hour	RHM	round head machine (screw)	w/o	without
MS	military standard	rly.	relay	wt.	weight
m/sec.	meters per second			xfrm	transformer
MTBF	mean time between failure				
MTBO	mean time between overhauls				
mtg.	mounting				

Appendix B User-Defined Settings

Use the table below to record user-defined settings during the generator set controller setup and calibration. The controller default settings and ranges provide

guidelines. The table contains all faults with ranges and time delays including items that do not have adjustments.

Status or Fault	Refer to Menu	Digital Display	Relay Driver Output (RDO)	Range Setting	Default Selection	Inhibit Time Delay* (sec.)	Time Delay (sec.)	User-Defined Settings
AC Sensing Loss	10	AC Sensing Loss	RDO-25					Not adjustable
Access Code (password)	14				0 (zero)			
Analog Aux. Inputs 1-7	9	User-Defined A1-A7		Default values with Warning Enabled: HI warning 90%, LO warning 10%, HI shutdown 100%, LO shutdown 1%	30 sec. inhibit, 5 sec. delay	0-60	0-60	
Analog Aux. Input 1	9	Coolant Temperature		Default values with Warning Enabled: HI/LO warning and HI/LO shutdown are all engine dependant	30 sec. inhibit, 0 sec. delay	0-60	0-60	
Analog Aux. Input 2	9	Oil Pressure		Default values with Warning Enabled: HI/LO warning and HI/LO shutdown are all engine dependant (255 psi max.)	30 sec. inhibit, 0 sec. delay warning, 5 sec. delay shutdown	0-60	0-60	
Cyclic Cranking	8			1-6 crank cycles 1-60 sec. crank on 1-60 sec. pause	3 cycles 15 sec. 15 sec.			
Defined Common Faults	10	User-Defined	RDO-18	Default shutdowns include: Emergency stop High coolant temp Low oil pressure Overcrank Overspeed	30 sec. inhibit, 5 sec. delay	0-60	0-60	
Digital Aux. Inputs 1-21	9	User-Defined D1-D21			30 sec. inhibit, 5 sec. delay	0-60	0-60	
EPS (Emergency Power System) Supplying Load	10	EPS Supplying Load	RDO-15		5% of rated line current			
High Battery Voltage	10	High Battery Voltage	RDO-13	14.5-16.5 (12V) 29-33 (24V)	16 (12V) 32 (24V)		10	
High Coolant Temperature Shutdown	10	Hi Cool Temp Shutdown	RDO-03			30	5	Not adjustable
High Coolant Temperature Warning	10	Hi Cool Temp Warning	RDO-06			30		Not adjustable
High Oil Temperature Shutdown	10	Hi Oil Temp Shutdown	RDO-17			30	5	Not adjustable
Idle Mode			RDO-21					
Load Shed kW Overload	10	Load Shed KW Over	RDO-30		100% of kW rating		5	

* Inhibited time delay is the time delay period after crank disconnect.

Status or Fault	Refer to Menu	Digital Display	Relay Driver Output (RDO)	Range Setting	Default Selection	Inhibit Time Delay* (sec.)	Time Delay (sec.)	User-Defined Settings
Load Shed Underfrequency	10	Load Shed Under Frequency	RDO-31		59, (60 Hz) 49, (50 Hz)		5	
Low Battery Voltage	10	Low Battery Voltage	RDO-12	10-12.5 (12V) 20-25 (24V)	12 (12V) 24 (24V)		10	
Low Coolant Level	10	Low Coolant Level	RDO-14			30	5	Not adjustable
(Low) Oil Pressure Shutdown	10	Oil Pressure Shutdown	RDO-04			30	5	Not adjustable
(Low) Oil Pressure Warning	10	Oil Pressure Warning	RDO-07			30		Not adjustable
No Coolant Temperature Signal	10	No Cool Temp Signal				30		Not adjustable
No Oil Pressure Signal	10	No Oil Pressure Signal				30		Not adjustable
Overcrank Shutdown	8	Over Crank	RDO-02	0-6 cycles	3 cycles			
Overcurrent	10	Over Current			110%		10	
Overfrequency Shutdown	7, 10	Over Frequency	RDO-28	102%-140%	140% std. 103% FAA		10	
Overspeed Shutdown	7, 10	Over Speed	RDO-01	65-70 (60 Hz) 55-70 (50 Hz)	70 (60 Hz) 60 (50 Hz)		0.25	
Overvoltage Shutdown	7, 8, 10	Over Voltage	RDO-20	105%-135%	115% 2-sec time delay		2-10	
Password (access code)	14				0 (zero)			See Access Code entry
Time Delay Engine Cooldown (TDEC)	8, 10		RDO-23	00:00-10:00 min:sec	5:00			
Time Delay Engine Start (TES)	8, 10			00:00-5:00 min:sec	00:01			
Time Delay Starting Aid	8, 10			0-10 sec.				
Underfrequency Shutdown	7, 10	Under Frequency	RDO-29	80%-95%	90%		10	
Undervoltage Shutdown	7, 8, 10	Under Voltage	RDO-27	70%-95%	85% 10-sec time delay		5-30	
Weak Battery	10	Weak Battery	RDO-26		60%		2	

* Inhibited time delay is the time delay period after crank disconnect.

Appendix C Voltage Regulator Definitions and Adjustments

The following **Definitions** and **Adjustment and Setting Specifications** are intended for users planning to adjust the voltage regulator beyond the default settings in order to customize the voltage regulator for a specific application.

This information is not intended to be a comprehensive explanation of all the terms mentioned. There are numerous documents available that define these terms more completely than described herein. Any user planning to change the generator set controller adjustment settings or to apply the generator set to these types of applications should understand these terms.

This appendix contains references to other sections of this manual. Please refer to these sections for further information and explanation.

Paralleling generator sets can be a complicated and dangerous exercise. Application programming must be performed by appropriately skilled and suitably-trained personnel.

Definitions

Underfrequency Unloading

Underfrequency unloading is a function used in the generator excitation control system to improve the overall generator set system (engine and alternator) response. In particular, underfrequency unloading relates to large-block load applications. When applied to engine-driven generators, large-block loads cause a subsequent transient torque load on the engine. This torque load can reduce the engine's speed below the normal operating point. Typically, the engine speed controller or governor will compensate for this by commanding an increase in fuel. If, however, the fuel system is inadequate to recover from a relatively large load, the speed may never recover. In these instances, other measures must be taken. This is where the underfrequency unloading occurs.

When the excitation control system detects a drop in the speed or electrical frequency below some predetermined point, the control system enters an unloading condition. This can be described as moving to a lower voltage regulation point. By reducing the output voltage of the alternator, the load on the generator set is, in effect, reduced. This can be shown

mathematically by Ohm's law, which states that power is equal to the voltage squared divided by the impedance. As the voltage is reduced, the power delivered by the alternator decreases by a squared relationship and since it is the power in the alternator that translates into engine torque, the engine load is also reduced.

By changing various parameters of this compensation technique, the controlling system can be tailored to match the performance capabilities of nearly any combination of engine and alternator. The point at which the unloading begins to act or how much unloading occurs can be adjusted to impact such things as maximum voltage droop, maximum speed droop, or time to recover. Some applications may not need any unloading and, in these cases, set the unloading parameter to disable the function. These parameters are further described below. An example is provided to help clarify the relationship between these parameters.

Underfrequency Unload Slope

Underfrequency unload slope is the term used to describe the amount that the voltage is reduced, per-cycle-per-second or per-hertz (Hz), when in an underfrequency condition. The slope or schedule is sometimes called the volts-per-hertz slope. When the electrical frequency drops below the cut-in point (see below), the excitation control system temporarily reduces the regulated voltage to reduce the subsequent torque on the engine. The amount that the control system reduces voltage is defined as the product or multiplication of the slope and the amount of frequency or speed below the cut-in point. For every Hz below the cut-in point, the control system reduces the line-to-line voltage by an amount equal to the slope.

Because each engine responds differently to the various loads encountered, the slope may be adjusted to improve the system response. If, when large loads are applied to the generator set, the engine speed drops below the acceptable limit (as determined by the particular loads applied), the slope may need to be increased. Increasing the slope will cause the voltage to droop more during load applications, consequently reducing the load torque on the engine and allowing the speed to increase. If, however, the voltage drops below an acceptable lower limit (as determined by the particular loads connected to the generator set), a lower slope may work better. The underfrequency unloading function may be disabled by setting the slope to zero.

Frequency Setpoint or Cut-In Point

The point at which the underfrequency unloading begins to take effect is adjustable, allowing the system to be tailored for each application. Because the characteristics of the engine have the largest effect on the system's performance, the engine's response should determine the unloading point. The unloading setpoint is the frequency below which the excitation control will reduce the voltage so that the engine may begin to recover.

The cut-in point, or frequency setpoint, should be set 0.5–1.0 Hz lower than the normal steady-state band of operation. If the engine normally operates within a very narrow range of speeds close to the nominal, a setpoint of 0.5 to 1.0 Hz below nominal should be suitable. If the engine normally operates over a wide range of speeds, the setpoint may need to be 2.0–3.0 Hz from the nominal. The underfrequency unloading function can be eliminated by setting the cut-in point below the minimum expected operating frequency.

Example

A 90 kW load is applied to a 100 kW, 60 Hz generator set driven by a turbocharged diesel engine with an electrical control module (ECM). The speed drops 10% and takes 20 seconds to recover to at least 59.5 Hz. The voltage, meanwhile, drops from 480 to 460 and recovers to 480 within 15 seconds. Therefore, some underfrequency unloading should be provided. A good starting point would be a frequency setpoint or cut-in of 59 Hz. A slope of 8 volts per-cycle-per-second is appropriate as well. If after these adjustments the speed recovers very quickly, in about 5 seconds, but the voltage drops below 440 volts, the slope should be reduced to 6 volts per cycle. More adjusting may be required to get the most desirable compromise between speed and voltage.

Three-Phase Sensing

Three-phase sensing describes how the excitation control or voltage regulator determines the condition of the generator output voltage. Early types of regulators sensed the voltage on just one phase of the alternator. Single-phase sensing is not uncommon today as most alternators are designed to produce balanced, equal voltage on all three phases. If the loads applied to the generator set including no load are equal and balanced, the output voltage on each phase will be nearly equal.

However, in some applications, individual phases may have unequal or unbalanced loads. In these cases, the output voltages will not be equal on each phase. In general, the phase with the greatest load will have the

lowest voltage while the phase with the least load will have the highest voltage. This is true regardless of the type of sensing used in the regulator system. A single-phase sensing excitation controller will keep the voltage of the sensed phase at the voltage adjustment value. A three-phase sensing system will average the three phases and hold the average to the adjustment setting. The average is the sum of the voltages of three phases divided by 3.

As stated above, three-phase sensing does not eliminate the unequal voltage phenomenon. Three-phase sensing balances the inequality of voltage between the phases to the desired value. In other words, if a system with unbalanced loads uses a single-phase control feedback, the voltage on the sensed phase would be at the setpoint while the other two phases would vary by their proportional loads. For example, if the sensed phase had rated load while the two other phases were only loaded at half the rated value, those two phases would have higher-than-rated voltage which may be undesirable. If a three-phase sensing feedback were utilized, the phase with rated load would be regulated to a voltage slightly below the rated voltage while the other two phases would be slightly above the rated voltage (but lower than in the previous case).

The line-to-line voltages and line-to-neutral voltages have a known relationship of the $\sqrt{3}$ (square root of 3):

$$V_{I-I} = V_{I-n} * \sqrt{3}$$

Where: V_{I-I} is the line-to-line voltage
 V_{I-n} is the line-to-neutral voltage

It is possible to regulate the line-to-line voltage by monitoring the line-to-neutral voltages. This is the method used by the 550 controller. The average of the line-to-neutral voltages is regulated (try to keep constant) to a value corresponding to the line-to-line voltage adjust setting. See Adjustment and Setting Specifications.

In a single-phase system, the average value of the two line-to-neutral voltages is held equal to the line-to-line voltage adjust setting divided by two. In a three-phase system, the line-to-line neutral voltage (average of three) is regulated to the voltage adjust setting divided by $\sqrt{3}$. Because these relationships ($1/\sqrt{3}$ in three phase or $1/2$ in single phase) may vary when the loading is severely unbalanced or nonlinear, the average of the line-to-line voltages may vary slightly from the actual setting. In some cases, it may be desirable to keep one phase at a particular value. Modify the voltage adjust setting higher or lower accordingly for any unique requirements for the particular application.

Reactive Droop

Reactive droop refers to another compensation technique used in excitation control systems. Reactive droop means that the generator set voltage droops with increasing reactive current. Although this sounds like an undesirable effect, it is quite beneficial in paralleling applications with multiple generator sets. Because the terminals of the generator set are connected to another generator set(s), the voltage at the terminals is not solely determined by either generator set's excitation. Rather, it is determined by the combination of the excitation level, the generated voltage, and the voltage drop across the armature impedance or armature reactance for each generator set.

Normally the generated voltage is higher than the voltage at the terminals because the generator set current causes a drop across the armature impedance. In a parallel application, the generated voltage of one generator set may be slightly higher than the generated voltage of another generator set. Differences in potential between the generator sets will cause current to flow into the lower voltage generator set and will also cause the generator sets to share the load current disproportionately. Both results are undesirable.

By introducing reactive droop, the reactive current can be better predicted and controlled. If the current is measured, the regulator/controller can adjust the excitation up or down accordingly, reducing excitation as more current is supplied or increasing excitation as the reactive current decreases. If all the parallel generator sets incorporate this type of compensation, the reactive current can be shared equally based on the proportional size of the generator sets. For an example, see below.

The stability and accuracy of this technique depends on several factors. Most important, the regulation point for each generator set must be equal. That is, each voltage adjust setting must be the equal to the other(s). This is a basic requirement prior to the actual paralleling connection. Also, the effects of the reactive current in each generator set must be compensated for individually, which requires an adjustable droop for each generator set. This adjustment happens to be the reactive droop adjust. The reactive droop adjust is quantified as the droop in voltage from the adjusted setting when full rated load with 0.8 power factor (PF) is applied. A droop setting of 4% voltage at full rated load is a recommended starting point. If the reactive current is not shared proportionately in each generator set, the respective droops may need adjustment. Adjust those generator sets that have proportionately higher current for more droop and those generator sets with lower reactive current for less droop. If the reactive current is

not stable in the system, adjust the droop lower in all generator sets.

As implied above, the reactive droop is not usually necessary in stand-alone applications. Therefore, some means of disabling the feature is provided. If the generator set will not be paralleled with other generator sets, the reactive droop feature should be disabled. A reactive droop setting of 0 will also effectively disable the reactive droop feature. It should be noted that disabling reactive droop applies strictly to the reactive current or volt-ampere-reactive (VAR) loading. Primarily, the fueling or speed governing system controls the real current which contributes to watts loading.

The gain of the reactive droop function is determined by the voltage droop setting. For most applications, a droop of 3%–5% of rated voltage at rated load at 0.8 PF is adequate. Prior to actually connecting the generator sets in parallel, test the droop by applying full rated load at 0.8 PF. The system is operating correctly if this test shows a reduction in voltage equal to the voltage droop setting. If the available load is less than full load, the correct voltage droop should be proportional to the applied VAR load as a fraction of the rated VAR output for the generator set. For instance, a 480-volt generator set with a voltage droop setting of 4% should drop 19.2 volts with full rated (0.8 PF) load applied (480×0.04) or 9.6 volts with half the rated load applied ($480 \times 0.04 / 2$).

When a generator set will be connected in parallel with the utility, VAR or PF control should be ENABLED. If there are multiple generator sets in parallel as well, then reactive droop should be ENABLED also.

Example

Two 100 kilowatt (kW) generator sets are paralleled to provide 150 kW of power at 0.8 PF and wired for a 277/480-volt wye system.

Total kVA load:

$$\text{kVA} = \text{kW} / \text{PF}$$

$$187.5 = 150 / 0.8$$

KVAR load:

$$\text{kVAR} = \text{kVA} * \sin (\text{acos} [\text{PF}])$$

$$112.5 = 187.5 * 0.6$$

Line current:

$$I = (\text{VA} / 3) / V_{L-N}$$

$$226 \text{ amps} = (187500 / 3 / 277)$$

Reactive current:

$$I = (\text{VAR} / 3) / V_{L-N}$$

$$135 \text{ amps} = (112500 / 3) / 277$$

Where: acos is arccosine or inverse cosine
 W is Watt
 L-N is line-to-neutral
 PF is power factor
 VA is volt-ampere
 k is kilo (= 1000)

Therefore, each generator set in this case should carry 113 amps per phase or half the 226 calculated line amps. The 113 amps includes 67.5 amps of reactive current half of the calculated reactive current of 135 amps. The reactive droop should be adjusted until each generator set carries equal reactive current. The load sharing control should be adjusted so that real current and/or watts are shared equally as well.

If one generator set is larger than the other, it should be adjusted to carry proportionate current. For this example, if a 150 kW generator set is paralleled to a 75 kW generator set, the larger generator set would carry 90 amps reactive ($135 * 2 / 3$) and the other would carry 45 amps reactive ($135 * 1 / 3$). Adjust the reactive droop based on the ratio of the actual measured currents, not the calculated values.

VAR Control

VAR control is analogous to the reactive droop function described above. It differs in that it applies to utility paralleling applications. Because the utility represents a nearly infinite bus, the voltage at the load terminals is not controlled at all by the generator set, and it is impossible to compare the ratio of the generator set current to the utility based on its rated output. In this situation, the excitation control changes from voltage feedback to VAR feedback. More specifically, the excitation is controlled to maintain a certain VAR output rather than a voltage output. This is called VAR control and again is used only in utility paralleling applications.

The VAR adjust can be set to any value within the generator set's rated capability. Because the VARs cause heating in the armature, any value beyond the generator set's rating could damage the alternator. In most cases, the generator set will be adjusted to generate VAR (lagging PF) but could absorb VARs (leading PF) as well. However, the VAR setting is maintained regardless of the relative PF. If the particular load requires more VARs than the generator set can provide, the excess is derived from the utility bus.

The term *rated VARs* is a bit obscure. In essence, it is a value derived from the rated kW of the generator set. For a typical standby rating, the full load of the generator set is defined to have 0.8 PF. This means that the kW load is eight-tenths of the VA load. As described earlier, the PF for a linear load may be calculated as the cosine of the angle between voltage and current. This relationship is based on the power triangle. Using this power triangle concept, it can be shown that the reactive power for a linear load is equal to the sine of the power angle. Then, using these trigonometric functions, it can be shown that for a PF of 0.8, the VARs are related similarly to the VA by a factor of 0.6. More explicitly, the power angle is equal to the inverse cosine (arccosine) of the PF. For a PF of 0.8, the power angle is 36.9 degrees (0.2 radians). The sine of this angle, sine (36.9 degrees) is 0.6. This is the factor for calculating rated VARs from the rated VA. The ratio of these two factors is 0.75 (0.6 / 0.8), which can be used to calculate rated VARs directly from the rated kW, VARs equals watts * 0.75.

When a generator set will be connected in parallel with the utility, VAR or PF control should be ENABLED. If multiple generator sets are in parallel as well, then reactive droop should be ENABLED also. Additionally, note that VAR control should be used only when the generator set is connected in parallel with the utility. Parallel connection with the utility requires the logical indication that the circuit breakers tying the generator set bus to the utility bus are closed. This indication is made by use of the programmable digital input for VAR/PF mode. If this input function is activated, the excitation control changes to the selected VAR or PF control. If the logical indicator is not present and the VAR or PF control is not enabled, the control will not switch to VAR or PF control. Because the active state for the digital input is a HI or open connection, the default for the digital input (VAR/PF Mode) is DISABLED (displays ENABLED NO). If the input is ENABLED by the user, it should be held low by a contact or jumper until the actual closing of the connecting circuit breaker(s). The proper control method, VAR or PF must be ENABLED within the regulator's configuration menu.

Power Factor Control

PF control is much like the VAR control above. PF control is used only when the generator set is paralleled to the utility grid. The difference is that the PF of the generator set current is held constant. The setting for the PF adjust determines the relationship of the current and voltage from the generator set. The PF is a term that defines the ratio of real watts to the volt-ampere (VA) product. For linear loads, a trigonometric relationship can describe the PF. The PF equals the cosine of the angle between the current and voltage. PF is further defined

as leading or lagging. That is to say, if the current lags the voltage (i.e., is later in time), the PF is lagging; if the current leads the voltage (i.e., is earlier in time), the PF is leading. Inductive loads have lagging PF while capacitive loads have leading PF. The current in a purely resistive load is in phase with the voltage (not leading or lagging) and the PF is 1.0 (cos. [0]).

Set the PF adjust according to the requirements of the application. When a generator set will be connected in parallel with the utility, VAR or PF control should be ENABLED. If there are multiple generator sets in parallel as well, then reactive droop should be ENABLED also. Additionally, note that PF control should be used only while the generator set is connected in parallel with the utility. Parallel connection with the utility requires the logical indication that the circuit breakers tying the generator set bus to the utility bus are closed. This indication is made by use of the programmable digital input for VAR/PF mode. If this input function is activated, the excitation control changes to the selected VAR or PF control. If the logical indicator is not present and the VAR or PF control is not enabled, the control will not switch to VAR or PF control. Because the active state for the digital input is a HI or open connection, the default for the digital input (VAR/PF mode) is DISABLED (displays ENABLED NO). If the input is ENABLED by the user, it should be held low by a contact or jumper until the actual closing of the connecting circuit breaker(s). The proper control method, VAR or PF must be ENABLED within the regulator's configuration menu.

Adjustment and Setting Specifications

Voltage Adjust

The voltage adjust is entered as the rated or otherwise desired line-to-line voltage. The average of the line-to-neutral voltages is then regulated to the corresponding value as previously described. The setting may be as fine as tenths of volts. The voltage adjust defaults to the rated system voltage whenever the system voltage is changed. The voltage adjust may be set to any value within 20% of the system voltage. The upper limit is 20% above the system voltage and the lower limit is 20% below the system voltage. If a value beyond these limits is entered, a RANGE ERROR message will be displayed.

As a reference, the present voltage adjust setting is displayed as well as the average value of the line-to-line voltages. The individual line-to-line voltages are also

displayed on the subsequent menu screens. This allows the user to monitor any one phase, if desired.

The voltage adjust setting may be changed by means other than the menu including user-defined digital input or remote communications. If voltage adjustment occurs, the new value will be displayed accordingly in the voltage adjust menu.

Underfrequency Unload Enable

The underfrequency unload enable menu is used to turn the underfrequency unload on or off. A YES entry will turn the feature on and the display will show ENABLED YES. A NO entry will turn the feature off and the display will show ENABLED NO. The underfrequency unload defaults to an enabled (ON) condition.

Frequency Setpoint

The frequency setpoint is the cut-in point for underfrequency unloading. At any operating frequency below the frequency setpoint, the output voltage will be reduced. The frequency may be entered with resolution to tenths of a Hz. The range of acceptable entries is 40 to 70 Hz. Any entry beyond these limits causes a RANGE ERROR display and the setting will not change. The default value is one cycle-per-second (or two for non-ECM engines) below the normal system frequency. The frequency setpoint changes to the default value if the system frequency changes. A setting of 40 Hz essentially disables the underfrequency unload feature because most engines do not normally drop to speeds this low, even during load applications.

Underfrequency Unload Slope

The slope determines how much voltage is reduced during an unloading condition. The line-to-line voltage is regulated to a value less than the voltage adjust setting by this amount for every cycle below the frequency setpoint. The voltage may be entered with resolution as fine as one-tenth of one volt. The default value is 2.0 volts per-cycle-per-second. A zero entry for the slope in effect turns the underfrequency unload feature off.

Reactive Droop Enable

This menu allows the user to enable the reactive droop feature. A YES entry turns the feature on and the display shows ENABLED YES. A NO entry turns the feature off and the display shows ENABLED NO. Reactive droop is intended to be used in a generator set-to-generator set paralleling application.

Voltage Droop

The amount of reactive droop is entered here. The droop is entered as a percentage of system voltage when a fully rated load at 0.8 PF is applied. The entry may be made with resolution as fine as one-tenth of one volt. This entry determines how much the voltage will droop when the alternator provides reactive current. The actual amount the voltage changes is equal to the voltage droop setting times the VAR load as a fraction of the rated VARs (at 0.8 PF). If the generator set were providing full rated load (at 0.8 PF), the expected voltage change would equal the voltage droop setting as a percentage of system voltage. A voltage droop setting of zero in effect disables the reactive droop feature. The default value is 4% droop at full rated load at 0.8 PF.

The present voltage droop setting is displayed for reference. The display may change if this value is changed via remote communication.

VAR Control Enable

In order for the VAR control function to operate, it must be enabled. Entering YES at this menu will turn the feature on. Because the function is designed to operate while the generator set is in parallel with the utility, VAR control also requires the proper indication that all tying circuit breakers are closed. This is done through the user-programmable digital inputs.

Because VAR control cannot be enabled at the same time that PF control is enabled, turning VAR control on (ENABLED) when PF control is enabled turns the PF control off (DISABLED).

KVAR Adjust

Using the kVAR adjust sets the desired operating value for the generator set's reactive load when the generator set operates in a utility paralleling application. The desired generator set load is entered directly as kVARs. The value entered may be as low as zero or as high as the rated value (rated kW x 0.75). Any entry beyond the rated value will not be accepted, and a RANGE ERROR message will be displayed.

The default value for kVAR adjust is zero. Each time the system's rated kW is changed, the kVAR adjust will revert to zero. The displayed kVAR setting may change if the kVAR setting is changed via other inputs.

Generating/Absorbing

While operating in the VAR control mode, the reactive load on the generator set may be specified to be out of GENERATING or into ABSORBING the generator set. Specifying the VAR type or direction is done through the GENERATING/ABSORBING menu. Because the normal flow of reactive current is out of the generator set, the default value is GENERATING. If ABSORBING is desired, a NO entry at this menu will change the control mode to ABSORBING. When ABSORBING is selected, another NO entry will revert the control mode back to GENERATING. It is assumed that this mode will not be changed when the generator set is running. Therefore, an attempt to change the mode while running will return a RANGE ERROR message. The generator set will need to be shut down in order to change this setting.

PF Adjust

Use the PF adjust to set the desired operating relationship for the generator set's output voltage and current when the generator set is connected in parallel with the utility. The excitation is regulated to maintain a PF equal to the entered value. The value entered may be as low as 0.7 for leading PFs or as low as 0.6 for lagging PFs. Any entries below these limits will cause a RANGE ERROR message to display.

The upper limit for PF adjust is 1.0 and the default value is 0.8 lagging. Each time the system's rated kW is changed, the PF adjust will revert to this default value. The PF adjust display setting may change if the PF adjust is changed via other inputs.

Lagging/Leading

It is possible to select either a leading or lagging PF for utility parallel applications. The selected mode is displayed. A NO entry switches the controller to use the other reference. Lagging/leading may only be changed while the generator set is not running. Because the most common mode of operation will be with a lagging PF, LAGGING is the default value. Because this mode should not be changed while the generator set is running, attempting to change this mode during operation will return a RANGE ERROR message. Always shut down the generator set to change the lagging/leading mode setting.

TP-6083 6/01

© 2001 by Kohler Co. All rights reserved.

KOHLER[®] POWER SYSTEMS

KOHLER CO. Kohler, Wisconsin 53044
Phone 920-565-3381, Web site www.kohlergenerators.com
Fax 920-459-1646 (U.S.A. Sales), Fax 920-459-1614 (International)
For the nearest sales and service outlet in U.S.A. and Canada
Phone 1-800-544-2444

Kohler Power Systems
Asia Pacific Headquarters
7 Jurong Pier Road
Singapore 619159
Phone (65)264-6422, Fax (65)264-6455