

Controller Setup and Application

Industrial Generator Sets

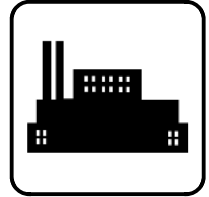

Models:

20-3250 kW

Controllers:

Decision-Maker® 550

ISO 9001
KOHLER
POWER SYSTEMS
NATIONALLY REGISTERED

KOHLER[®]
POWER SYSTEMS

TP-6140 10/01c

Table of Contents

Product Identification Information	2
Safety Precautions and Instructions	5
Introduction	9
List of Related Materials	9
Service Assistance	10
Section 1 Features and Operation Overview	11
1.1 Controller Overview	12
1.2 Controller Operation	12
1.2.1 Cooldown Mode	12
1.2.2 Idle (Speed) Mode (ECM equipped engines only)	12
1.3 Keypad	13
1.4 Controller Lights	14
1.5 Controller Circuit Boards	15
1.5.1 Main Logic Circuit Board	17
1.5.2 Interconnection Circuit Board	17
Section 2 Installation	19
2.1 ECM Communications	19
2.2 ECM Engines and Controller Displays	20
2.3 20–300 kW Voltage Regulator (Brushless Alternator with Brushless Exciter) ...	27
2.4 350–3250 kW Voltage Regulator (Brushless Alternator with Brushless Pilot Exciter)	28
2.5 Interface Board	28
2.6 Voltage Regulator Adjustment	29
2.6.1 Voltage Adjust	29
2.6.2 Underfrequency Unload Enable	29
2.6.3 Frequency Setpoint	30
2.6.4 Underfrequency Unload Slope	30
2.7 Paralleling Applications (Reactive Droop)	30
2.7.1 Reactive Droop Enable	30
2.7.2 Voltage Droop	30
2.8 Paralleling Applications with Utility	30
2.8.1 VAR Control Enable	30
2.8.2 KVAR Adjust	30
2.8.3 Generating/Absorbing	31
2.8.4 Power Factor Adjust	31
2.8.5 Lagging/Leading	31
2.9 Alternator Protection	31
2.10 Load Shed	31
2.11 Controller with Marathon DVR 2000 Voltage Regulator Substitution	32
Section 3 Wiring	35
3.1 Voltage and Current Inputs	35
3.2 Voltage Measurement	35
3.3 Current Measurement	35
3.4 Calibration: Voltage and Amperage (Menu 12)	36
3.5 Digital Inputs	37
3.5.1 Idle Mode Switch	37
3.5.2 Define Digital Inputs	38
3.5.3 TB1 Customer Connection	39
3.5.4 TB3 Accessory Output	39
3.5.5 TB2 Analog Inputs	39

Table of Contents, continued

3.6	Zeroing Auxiliary Analog Inputs	40
3.7	Analog Inputs (Calibration)	40
3.8	Alternative Calibration Method	41
3.9	Analog Input (Warning/ Shutdown)	42
3.10	Relay Driver Outputs (Menu 10)	43
3.10.1	NFPA Defaults	43
3.10.2	Common Fault	43
Section 4 Accessory Installations		45
4.1	Accessories and Connections	45
4.2	Controller (Customer) Connection Kit	48
4.3	Interconnect Circuit Board	49
Section 5 Communication		51
5.1	Factory Setup	51
5.2	Program Loader	51
5.3	Communications	51
5.4	Personal Computer Communications	52
5.5	Remote LAN Conversion	54
5.6	Modbus Communications	55
Section 6 Controller Replacement		57
6.1	Introduction	57
6.2	Installation	57
6.2.1	Requirements	57
6.2.2	Procedure	58
Appendix A Abbreviations		65
Appendix B Display Items for Reference		67
Appendix C Controller User-Defined Settings		68
Appendix D Relay Driver Output (RDO) Designations		70

Safety Precautions and Instructions

IMPORTANT SAFETY INSTRUCTIONS. Electromechanical equipment, including generator sets, transfer switches, switchgear, and accessories, can cause bodily harm and pose life-threatening danger when improperly installed, operated, or maintained. To prevent accidents be aware of potential dangers and act safely. Read and follow all safety precautions and instructions. **SAVE THESE INSTRUCTIONS.**

This manual has several types of safety precautions and instructions: Danger, Warning, Caution, and Notice.

DANGER

Danger indicates the presence of a hazard that **will cause severe personal injury, death, or substantial property damage.**

WARNING

Warning indicates the presence of a hazard that **can cause severe personal injury, death, or substantial property damage.**

CAUTION

Caution indicates the presence of a hazard that **will or can cause minor personal injury or property damage.**

NOTICE

Notice communicates installation, operation, or maintenance information that is safety related but not hazard related.

Safety decals affixed to the equipment in prominent places alert the operator or service technician to potential hazards and explain how to act safely. The decals are shown throughout this publication to improve operator recognition. Replace missing or damaged decals.

Accidental Starting

WARNING



**Accidental starting.
Can cause severe injury or death.**

Disconnect the battery cables before working on the generator set. Remove the negative (-) lead first when disconnecting the battery. Reconnect the negative (-) lead last when reconnecting the battery.

Disabling the generator set. Accidental starting can cause severe injury or death. Before working on the generator set or connected equipment, disable the generator set as follows: (1) Move the generator set master switch to the OFF position. (2) Disconnect the power to the battery charger. (3) Remove the battery cables, negative (-) lead first. Reconnect the negative (-) lead last when reconnecting the battery. Follow these precautions to prevent starting of the generator set by an automatic transfer switch, remote start/stop switch, or engine start command from a remote computer.

Battery

WARNING



**Sulfuric acid in batteries.
Can cause severe injury or death.**

Wear protective goggles and clothing. Battery acid may cause blindness and burn skin.

WARNING



**Explosion.
Can cause severe injury or death. Relays in the battery charger cause arcs or sparks.**

Locate the battery in a well-ventilated area. Isolate the battery charger from explosive fumes.

Battery electrolyte is a diluted sulfuric acid. Battery acid can cause severe injury or death. Battery acid can cause blindness and burn skin. Always wear splashproof safety goggles, rubber gloves, and boots when servicing the battery. Do not open a sealed battery or mutilate the battery case. If battery acid splashes in the eyes or on the skin, immediately flush the affected area for 15 minutes with large quantities of clean water. Seek immediate medical aid in the case of eye contact. Never add acid to a battery after placing the battery in service, as this may result in hazardous spattering of battery acid.

Battery acid cleanup. Battery acid can cause severe injury or death. Battery acid is electrically conductive and corrosive. Add 500 g (1 lb.) of bicarbonate of soda (baking soda) to a container with 4 L (1 gal.) of water and mix the neutralizing solution. Pour the neutralizing solution on the spilled battery acid and continue to add the neutralizing solution to the spilled battery acid until all evidence of a chemical reaction (foaming) has ceased. Flush the resulting liquid with water and dry the area.

Battery gases. Explosion can cause severe injury or death. Battery gases can cause an explosion. Do not smoke or permit flames or sparks to occur near a battery at any time, particularly when it is charging. Do not dispose of a battery in a fire. To prevent burns and sparks that could cause an explosion, avoid touching the battery terminals with tools or other metal objects. Remove all jewelry before servicing the equipment. Discharge static electricity from your body before touching batteries by first touching a grounded

metal surface away from the battery. To avoid sparks, do not disturb the battery charger connections while the battery is charging. Always turn the battery charger off before disconnecting the battery connections. Ventilate the compartments containing batteries to prevent accumulation of explosive gases.

Battery short circuits. Explosion can cause severe injury or death. Short circuits can cause bodily injury and/or equipment damage. Disconnect the battery before generator set installation or maintenance. Remove all jewelry before servicing the equipment. Use tools with insulated handles. Remove the negative (-) lead first when disconnecting the battery. Reconnect the negative (-) lead last when reconnecting the battery. Never connect the negative (-) battery cable to the positive (+) connection terminal of the starter solenoid. Do not test the battery condition by shorting the terminals together.

Engine Backfire/Flash Fire

⚠ WARNING

<p>Fire. Can cause severe injury or death.</p> <p>Do not smoke or permit flames or sparks near fuels or the fuel system.</p>

Combustible materials. A fire can cause severe injury or death. Generator set engine fuels and fuel vapors are flammable and explosive. Handle these materials carefully to minimize the risk of fire or explosion. Equip the compartment or nearby area with a fully charged fire extinguisher. Select a fire extinguisher rated ABC or BC for electrical fires or as recommended by the local fire code or an authorized agency. Train all personnel on fire extinguisher operation and fire prevention procedures.

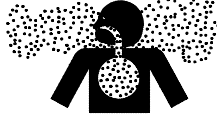
Exhaust System

⚠ WARNING

<p>Carbon monoxide. Can cause severe nausea, fainting, or death.</p> <p>The exhaust system must be leakproof and routinely inspected.</p>

Generator set operation. Carbon monoxide can cause severe nausea, fainting, or death. Carbon monoxide is an odorless, colorless, tasteless, nonirritating gas that can cause death if inhaled for even a short time. Avoid breathing exhaust fumes when working on or near the generator set. Never operate the generator set inside a building unless the exhaust gas is piped safely outside. Never operate the generator set where exhaust gas could accumulate and seep back inside a potentially occupied building.

Carbon monoxide symptoms. Carbon monoxide can cause severe nausea, fainting, or death. Carbon monoxide is a poisonous gas present in exhaust gases. Carbon monoxide is an odorless, colorless, tasteless, nonirritating gas that can cause death if inhaled for even a short time. Carbon monoxide poisoning symptoms include but are not limited to the following:

- Light-headedness, dizziness
- Physical fatigue, weakness in joints and muscles
- Sleepiness, mental fatigue, inability to concentrate or speak clearly, blurred vision
- Stomachache, vomiting, nausea

If experiencing any of these symptoms and carbon monoxide poisoning is possible, seek fresh air immediately and remain active. Do not sit, lie down, or fall asleep. Alert others to the possibility of carbon monoxide poisoning. Seek medical attention if the condition of affected persons does not improve within minutes of breathing fresh air.

Fuel System

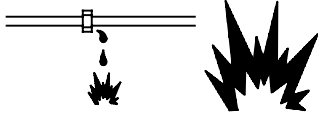
⚠ WARNING

<p>Explosive fuel vapors. Can cause severe injury or death.</p> <p>Use extreme care when handling, storing, and using fuels.</p>

The fuel system. Explosive fuel vapors can cause severe injury or death. Vaporized fuels are highly explosive. Use extreme care when handling and storing fuels. Store fuels in a well-ventilated area away from spark-producing equipment and out of the reach of children. Never add fuel to the tank while the engine is running because spilled fuel may ignite on contact with hot parts or from sparks. Do not smoke or permit flames or sparks to occur near sources of spilled fuel or fuel vapors. Keep the fuel lines and connections tight and in good condition. Do not replace flexible fuel lines with rigid lines. Use flexible sections to avoid fuel line breakage caused by vibration. Do not operate the generator set in the presence of fuel leaks, fuel accumulation, or sparks. Repair fuel systems before resuming generator set operation.

Explosive fuel vapors can cause severe injury or death. Take additional precautions when using the following fuels:

Gasoline—Store gasoline only in approved red containers clearly marked GASOLINE.

Propane (LP)—Adequate ventilation is mandatory. Because propane is heavier than air, install propane gas detectors low in a room. Inspect the detectors per the manufacturer's instructions.

Natural Gas—Adequate ventilation is mandatory. Because natural gas rises, install natural gas detectors high in a room. Inspect the detectors per the manufacturer's instructions.

Hazardous Noise

CAUTION



Hazardous noise.
Can cause hearing loss.

Never operate the generator set without a muffler or with a faulty exhaust system.

Engine noise. Hazardous noise can cause hearing loss. Generator sets not equipped with sound enclosures can produce noise levels greater than 105 dBA. Prolonged exposure to noise levels greater than 85 dBA can cause permanent hearing loss. Wear hearing protection when near an operating generator set.

Hazardous Voltage/Moving Parts

DANGER



Hazardous voltage.
Will cause severe injury or death.

Disconnect all power sources before opening the enclosure.

WARNING



Hazardous voltage. Moving parts.
Can cause severe injury or death.

Operate the generator set only when all guards and electrical enclosures are in place.

WARNING



Hazardous voltage.
Backfeed to the utility system can cause property damage, severe injury, or death.

If the generator set is used for standby power, install an automatic transfer switch to prevent inadvertent interconnection of standby and normal sources of supply.

Grounding electrical equipment. Hazardous voltage can cause severe injury or death. Electrocutation is possible whenever electricity is present. Ensure you comply with all applicable codes and standards. Electrically ground the generator set, transfer switch, and related equipment and electrical circuits. Turn off the main circuit breakers of all power sources before servicing the equipment. Never contact electrical leads or appliances when standing in water or on wet ground because these conditions increase the risk of electrocution.

Connecting the battery and the battery charger. Hazardous voltage can cause severe injury or death. Reconnect the battery correctly, positive to positive and negative to negative, to avoid electrical shock and damage to the battery charger and battery(ies). Have a qualified electrician install the battery(ies).

Short circuits. Hazardous voltage/current can cause severe injury or death. Short circuits can cause bodily injury and/or equipment damage. Do not contact electrical connections with tools or jewelry while making adjustments or repairs. Remove all jewelry before servicing the equipment.

Testing live electrical circuits. Hazardous voltage or current can cause severe injury or death. Have trained and qualified personnel take diagnostic measurements of live circuits. Use adequately rated test equipment with electrically insulated probes and follow the instructions of the test equipment manufacturer when performing voltage tests. Observe the following precautions when performing voltage tests: (1) Remove all jewelry. (2) Stand on a dry, approved electrically insulated mat. (3) Do not touch the enclosure or components inside the enclosure. (4) Be prepared for the system to operate automatically. (600 volts and under)

WARNING



Airborne particles.
Can cause severe injury or blindness.

Wear protective goggles and clothing when using power tools, hand tools, or compressed air.

Servicing the generator set when it is operating. Exposed moving parts can cause severe injury or death. Keep hands, feet, hair, clothing, and test leads away from the belts and pulleys when the generator set is running. Replace guards, screens, and covers before operating the generator set.

Hot Parts

WARNING



Hot coolant and steam.
Can cause severe injury or death.

Before removing the pressure cap, stop the generator set and allow it to cool. Then loosen the pressure cap to relieve pressure.

⚠ WARNING

Hot engine and exhaust system. Can cause severe injury or death.
Do not work on the generator set until it cools.

Servicing the alternator. Hot parts can cause severe injury or death.

Avoid touching the alternator field or exciter armature. When shorted, the alternator field and exciter armature become hot enough to cause severe burns.

Servicing the exhaust system. Hot parts can cause severe injury or death.

Do not touch hot engine parts. The engine and exhaust system components become extremely hot during operation.

Notice

NOTICE
This generator set has been rewired from its nameplate voltage to
<div style="border: 1px solid black; width: 150px; height: 40px; margin: 0 auto;"></div>
<small>246242</small>

NOTICE

Voltage reconnection. Affix a notice to the generator set after reconnecting the set to a voltage different from the voltage on the nameplate. Order voltage reconnection decal 246242 from an authorized service distributor/dealer.

This manual provides setup and application information for 20–3250 kW generator sets equipped with the following controller:

- Decision-Maker® 550

In addition, some diagnostic information is shown for selected components.

This manual may be used for models not listed on the front cover.

Information in this publication represents data available at the time of print. Kohler Co. reserves the right to change this publication and the products represented without notice and without any obligation or liability whatsoever.

Read this manual and carefully follow all procedures and safety precautions to ensure proper equipment operation and to avoid bodily injury. Read and follow the Safety Precautions and Instructions section at the beginning of this manual. Keep this manual with the equipment for future reference.

Generator set controller setup and diagnostic work must be performed by appropriately skilled and suitably trained personnel familiar with generator set operation and service.

The disk supplied with this generator set is a backup copy of the generator set personality program containing data specific to the engine and alternator. The engine and alternator data was preprogrammed in the controller at the factory and no further use of the disk should be necessary. Typically, your authorized distributor stores this disk for possible future use such as controller replacement or other circumstances requiring a backup.

List of Related Materials

Separate literature contains communication and software information not provided in this manual. The following table lists the available literature part numbers.

550 Controller Literature Description	Literature Part Number
550 Controller Spec Sheet	G6-46
550 Controller Generator Set Operation Manual	TP-6083 or TP-6200
Generator Set/Controller Wiring Diagram Manual	Multiple Part Numbers Contact your Distributor/Dealer
550 Communications Spec Sheet	G6-50
KBUS Communications Spec Sheet	G6-38
Monitor II Software Operation/Installation Manual	TP-5972
Modbus Communication Operation Manual	TP-6113
Program Loader Software Installation	TT-1285
Communication Kits Installation	TT-847

Service Assistance

For professional advice on generator set power requirements and conscientious service, please contact your nearest Kohler distributor or dealer.

- Consult the Yellow Pages under the heading Generators—Electric.
- Visit the Kohler Power Systems website at KohlerPower.com.
- Look at the labels and stickers on your Kohler product or review the appropriate literature or documents included with the product.
- Call toll free in the US and Canada 1-800-544-2444.
- Outside the US and Canada, call the nearest regional office.

Headquarters Europe, Middle East, Africa (EMEA)

Kohler Power Systems
3 rue de Brennus
93200 Saint Denis
France
Phone: (33) 1 49 178300
Fax: (33) 1 49 178301

Asia Pacific

Power Systems Asia Pacific Regional Office
Singapore, Republic of Singapore
Phone: (65) 6264-6422
Fax: (65) 6264-6455

China

North China Regional Office, Beijing
Phone: (86) 10 6518 7950
(86) 10 6518 7951
(86) 10 6518 7952
Fax: (86) 10 6518 7955

East China Regional Office, Shanghai
Phone: (86) 21 6288 0500
Fax: (86) 21 6288 0550

India, Bangladesh, Sri Lanka

India Regional Office
Bangalore, India
Phone: (91) 80 3366208
(91) 80 3366231
Fax: (91) 80 3315972

Japan, Korea

North Asia Regional Office
Tokyo, Japan
Phone: (813) 3440-4515
Fax: (813) 3440-2727

Latin America

Latin America Regional Office
Lakeland, Florida, USA
Phone: (863) 619-7568
Fax: (863) 701-7131

Section 1 Features and Operation Overview

The 550 controller, available on 20–3250 kW generator sets, meets the requirements of NFPA 99 and NFPA 110. The controller contains microprocessor-based logic and communicates with a personal computer (PC) individually or on a network when equipped with optional communication software products. The controller provides complete compatibility with select engine electronic control module (ECM) and non-ECM equipped generator set engines. Refer to Section 2.2, ECM Engines and Controller Displays, for identification of compatible ECM engines. All other engines, even if ECM equipped, are not compatible and considered non-ECM engines. The controller is compatible with 12- or 24-volt engine battery systems. See Figure 1-1.

The controller displays both engine and generator conditions as well as numerous system functions. The controller monitors engine and generator parameters

and displays and stores 100 system events. Optional menu-driven, Windows®-based PC software monitors engine and alternator parameters and also provides control capability. The controller supports the Modbus® remote terminal unit (RTU), an industry standard open communication protocol.

The 550 controller standard features include:

- Built-in digital voltage regulator.
- Inherent alternator protection including overload and short circuit matched to each alternator.
- User-programmable load shed function.
- Smart-starting idle mode for noncritical operation.
- Digital inputs, analog inputs, and digital outputs for system control.

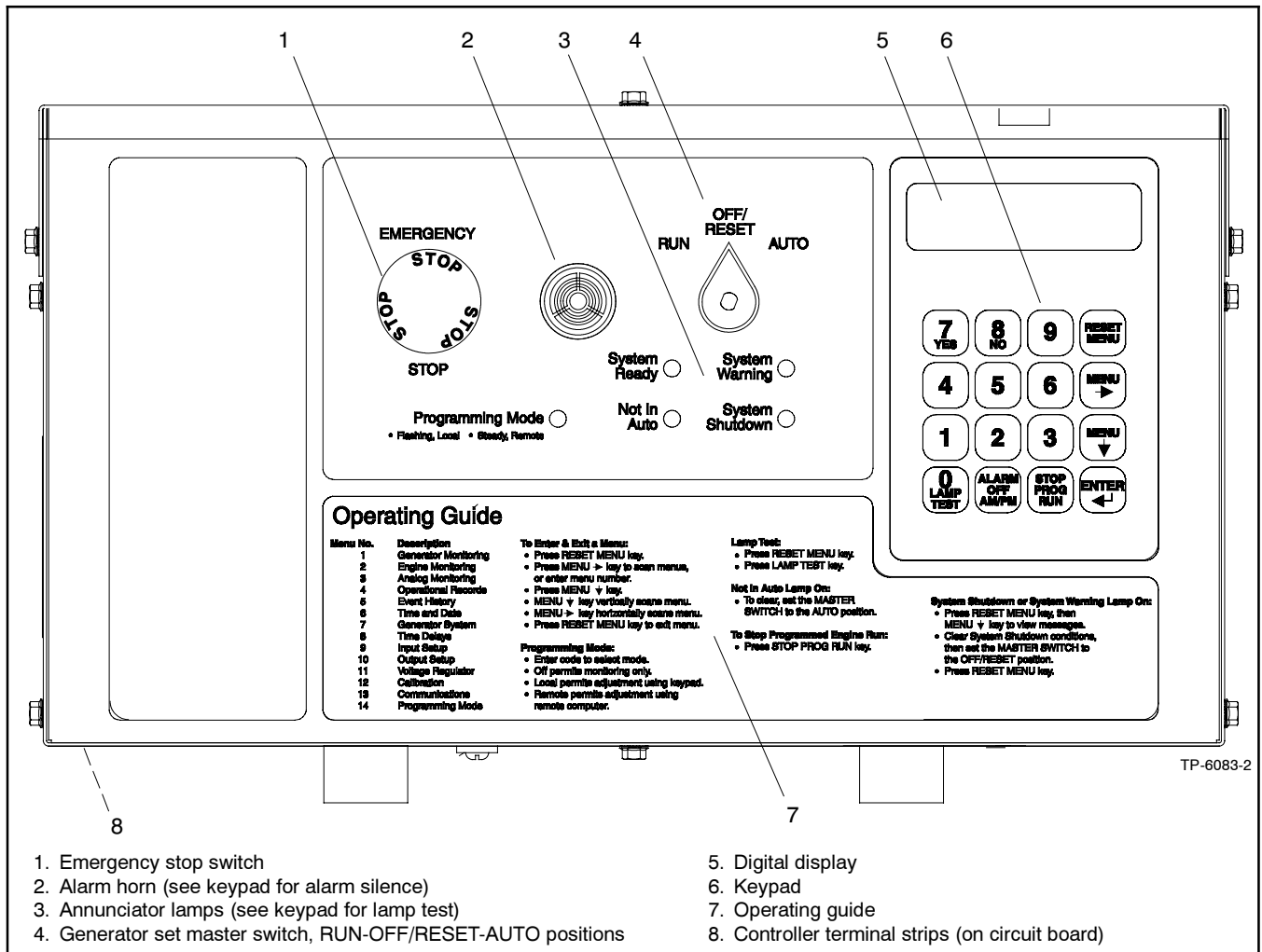

Figure 1-1 Controller Front View

1.1 Controller Overview

The 550 controller features a built-in voltage regulator to better match engine and generator performance. The 550 controller regulates voltage internally without using an external voltage regulator board.

Each controller/generator set is loaded with a unique, factory-loaded personality parameter file. The controller personality file is specific to the generator set application. The personality parameter file can be reinstalled at the installation site when required.

The controller circuit has a speed sensor and uses the voltage input as a secondary means of crank disconnect and overspeed. ECM equipped engines use the ECM speed signal as a basis for engine crank termination and overspeed shutdown. If the ECM signal circuit is interrupted, the engine shuts down.

No safeguard breaker option is required. The controller has overload and short circuit protection with the data built into the personality parameter file.

Communication is possible using the controller KBUS and Modbus® RS-232 and RS-485 connections.

The 550 controller engine harness is unique and not compatible with Decision-Maker 3+ or Decision-Maker 340 controller applications.

Engine sensors for oil and coolant are 3-wire types on non-ECM engines providing system integrity monitoring. ECM engines utilize ECM communications to provide engine faults and warnings. ECM engines utilize SAE J1939 serial communication to the 550 controller and allow information captured by the ECM to be used for controller system functions, eliminating redundant sensors on the engine. The engine monitoring menu or the monitoring software displays additional status information.

The 550 controller requires a customer connection kit when relay driver outputs are used for remote annunciation. Customer-specified analog inputs are provided with 0–5 VDC signals and/or digital inputs are available where the signal goes to chassis ground.

1.2 Controller Operation

The generator set master RUN-OFF/RESET-AUTO switch is a 3-position, rotary, selector switch. See Figure 1-2. The RUN position starts the generator set locally. The AUTO position starts and stops the generator set remotely. OFF stops the generator set without any time delay when operating locally in the RUN position. When the generator set shuts down due

to a fault, reset the control system by moving the selector to the center OFF/RESET position prior to a restart. Controllers are available with a key-operated switch.

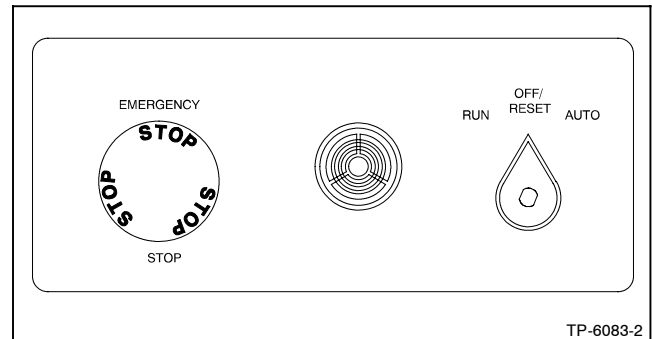

Figure 1-2 Switches and Alarm Horn

Pressing the emergency stop switch bypasses any time delays and provides an immediate engine shutdown when operating. The switch latches in the open position; pull the switch knob outward to reset it.

The alarm horn sounds whenever the selector switch is not in the AUTO position or a fault shutdown occurs. The alarm also sounds along with various warning indications. To silence the horn, place the generator set master switch in the AUTO position and depress the keypad alarm off button.

1.2.1 Cooldown Mode

The cooldown period is based on coolant temperature. The engine shuts down early if it reaches the engine cooldown temperature (which is part of the personality profile) before the engine cooldown time delay period times out. If the engine does not reach the defined engine warmed-up temperature before being put into the cooldown mode, it will shut down immediately.

1.2.2 Idle (Speed) Mode (ECM equipped engines only)

The idle (speed) mode function provides the ability to start and run the engine at idle (reduced) speed for a selectable time period (0–10 minutes) during warm up. The controller overrides the idle speed mode if the engine reaches the preprogrammed engine warmed-up temperature before the idle mode times out.

During the idle (speed) mode, the controller continues to monitor critical engine parameters such as oil pressure, coolant temperature, and engine speed. The voltage regulator, thermal protection feature, and AC metering are disabled in the idle speed mode.

Modbus® is a registered trademark of Schneider Electric

The controller overrides the idle speed function when the generator set is signaled to start while in the AUTO position. This override provides immediate emergency generator set power in the event of a utility power failure. When the utility power returns and the generator set is signaled to stop, the generator set will continue to run until the idle mode switch circuit is opened. If idle mode is not active, the generator set will enter a cooldown period as discussed earlier.

Use menu 9 to activate the idle speed function as a user-defined digital input. The idle speed feature requires an ECM-equipped engine with the idle speed function.

1.3 Keypad

Use the keypad to interact locally with the controller by accessing generator set data and preset settings. Program crank cycles and time delays under password control with the keypad. Pressing any key activates the controller panel display. The 2-line vacuum fluorescent display provides generator set and engine condition information. See Figure 1-3.

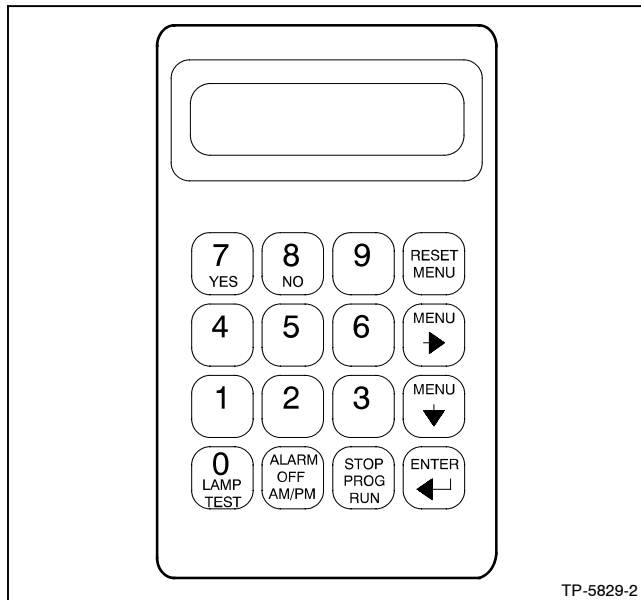

Figure 1-3 Digital Display and Keypad

The 14 available menus are listed in Figure 1-4. Additionally, menu 20 allows factory setup.

To enter a menu:

1. Clear the display by pressing RESET MENU.
2. Enter menu number 1-14.
3. Press ENTER.
4. Once in the menu, use the arrow keys to navigate.

Menu	Title	Function
1	Generator Monitoring	Provides generator set output data including line-to-line and line-to-neutral voltages, current, frequency, power factor (PF), kW, kVA, and kVAR.
2	Engine Monitoring	Provides engine operating data including oil pressure, coolant temperature, engine RPM, and battery voltage. Additional monitoring is available on ECM-equipped engines depending on the engine family selected.
3	Analog Monitoring	Provides battery voltage status and up to 7 user-defined analog monitoring inputs. On non-ECM engines, inputs 03-07 are available where analog inputs 01 and 02 are reserved for engine oil pressure and coolant temperature.
4	Operational Records	Provides generator set operational records including operating start date, last logged maintenance, total run time loaded and unloaded, run time since last maintenance, number of starts, and number of running days.
5	Event History	Provides up to 100 stored warning and shutdown events that are day and time dated.
6	Time and Date	Sets time, date, and internal calendar. Necessary for exercise run time and event records. The starting battery must remain connected for time and date to stay valid.
7	Generator System	Contains factory-preset generator set voltage and frequency data. Data may be changed if the unit is reconnected. Overvoltage, undervoltage, overfrequency, underfrequency, and overspeed settings are also located in menu 7.
8	Time Delays	Displays and sets up cycle cranking, start and shutdown functions, and auxiliary shutdown and inhibit time delays.
9	Input Setup	Provides setup of user-defined digital and analog warning and shutdown inputs. These inputs are dictated by the generator set application and are field-installed. There is a default for factory setup.
10	Output Setup	Provides setup of user-defined outputs.
11	Voltage Regulation	Provides voltage regulator function setup including line-to-line voltages, underfrequency unloading, reactive droop, PF, and kVAR adjustments.
12	Calibration	Provides voltage sensing logic calibration. Calibration is set at the factory. Recalibration is necessary only when the generator set is reconnected for an optional voltage or the controller is replaced.
13	Communications	Provides local or remote access to the control logic and displays by a PC or other system.
14	Programming Mode	Provides local or remote access to the programming function. The user enters a password to access the programming mode. Default password is 0. Monitoring is always allowed.

Figure 1-4 Menu Summary

1.4 Controller Lights

Five annunciator panel lamps, as shown in Figure 1-5 and described in Figure 1-6, provide an immediate visual indication of generator set status. Conditions causing a system warning are listed in Figure 1-7. Conditions causing a system shutdown are listed in Figure 1-8.

Note: Lists are dependent on engine alternator combination.

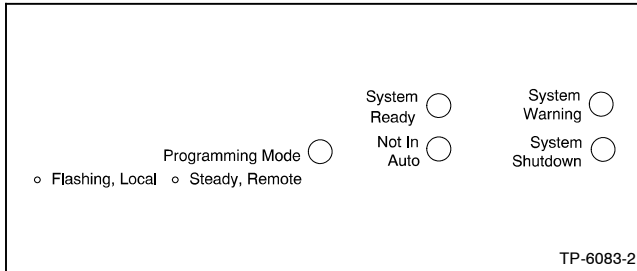

Figure 1-5 Annunciator Lamps

Lamp	Description
System Ready	Green lamp illuminates when the generator set master switch is in the AUTO position and the system senses no faults.
Not In Auto	Yellow lamp illuminates when the generator set master switch is not in the AUTO position.
Programming Mode	Yellow lamp in flashing mode indicates local programming selection, steady on mode for remote programming mode. No light indicates controller is in the off programming mode.
System Warning	Yellow lamp identifies an existing fault condition but does not shut down the generator set. A continuing system warning fault condition may cause a system shutdown if the source is not corrected.
System Shutdown	The red lamp identifies generator set shutdown because of a fault condition. A system shutdown may follow a system warning condition.

Figure 1-6 Annunciator Panel Lamps

Engine Functions	General Functions	Generator Functions
<ul style="list-style-type: none"> Coolant temperature signal loss High battery voltage High coolant temperature Low battery voltage Low coolant temperature Low fuel (level or pressure)* Low oil pressure Oil pressure signal loss Speed sensor fault Starting aid fault Weak battery 	<ul style="list-style-type: none"> Auxiliary-analog inputs (up to 7 programmable shutdowns or warnings) Auxiliary-digital inputs (up to 21 programmable shutdowns or warnings) Battery charger fault* Emergency power system (EPS) supplying load Engine cooldown delay Engine start delay Load shed kW overload Load shed underfrequency Master switch not in AUTO Master switch open NFPA 110 fault 	<ul style="list-style-type: none"> AC sensing loss Generator running Ground fault* Overcurrent
*Requires optional input sensors		

Figure 1-7 System Warning

Engine Functions	General Functions	Generator Functions
<ul style="list-style-type: none"> Air damper control fault, if equipped Air damper indicator fault, if equipped High coolant temperature High oil temperature Low coolant level Low oil pressure Overcrank Overspeed 	<ul style="list-style-type: none"> Auxiliary-analog inputs (up to 7 programmable shutdowns or warnings) Auxiliary-digital inputs (up to 21 programmable shutdowns or warnings) ECM communications loss Emergency stop Internal fault Master switch in off/reset position Master switch error Master switch open NFPA 110 fault 	<ul style="list-style-type: none"> Locked rotor (failed to crank) AC output overvoltage AC output undervoltage Field overvoltage Alternator protection, overloads, short circuits Overfrequency Underfrequency

Figure 1-8 System Shutdown

1.5 Controller Circuit Boards

The controller has five circuit boards as listed in Figure 1-9. See Figure 1-10, Figure 1-11, and Figure 1-12 for circuit board locations. See Figure 1-13 for controller connections.

Circuit Board	Description and Function
Indicator	Includes the LED status lamps and alarm horn.
Interconnection	Provides the terminal strips to connect the customer connection and/or dry contact kits and three fuses (F1, F2, and F3).
Keypad	Provides the keypad to navigate the generator set displays and enter data.
Digital Display	Provides the digital display for monitoring the generator set functions and output values.
Main Logic (Microprocessor)/Communication	Provides the controller operation logic and provides communication locally (direct) or remotely (via modem) using RS-232 or RS-485 connectors.

Figure 1-9 Controller Circuit Boards

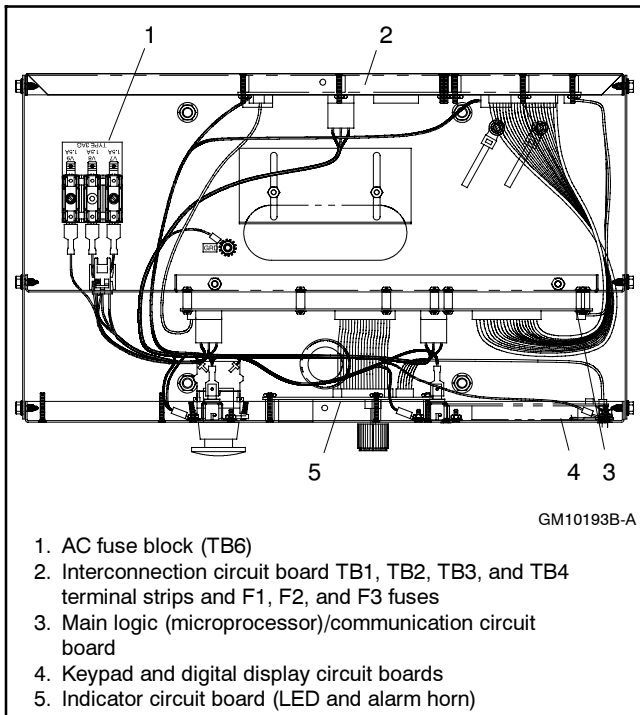

Figure 1-10 Controller Circuit Boards and Fuses (Controller Top View)

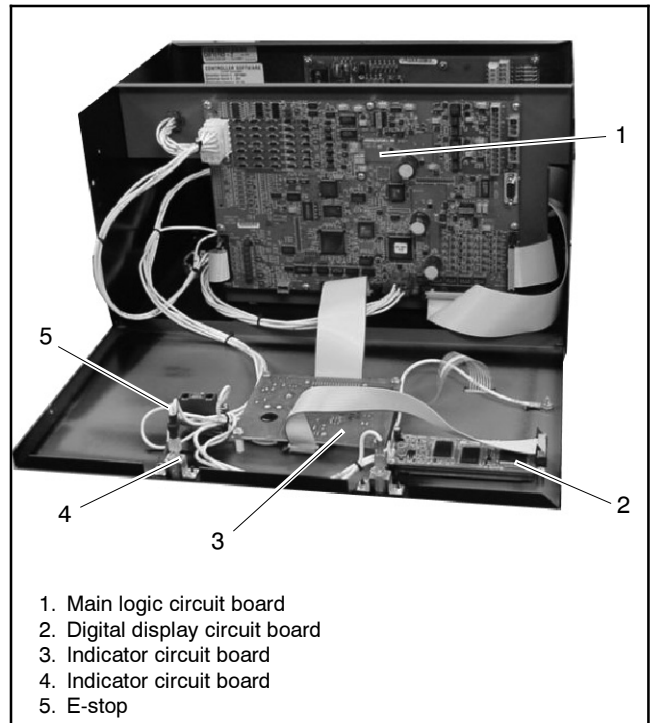

Figure 1-11 Front Panel Controller Layout

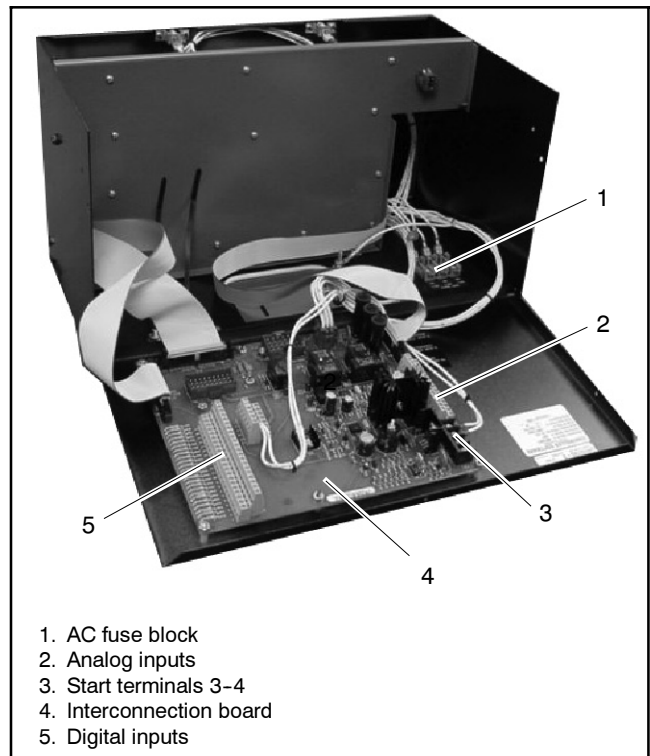

Figure 1-12 Back Panel Controller Layout

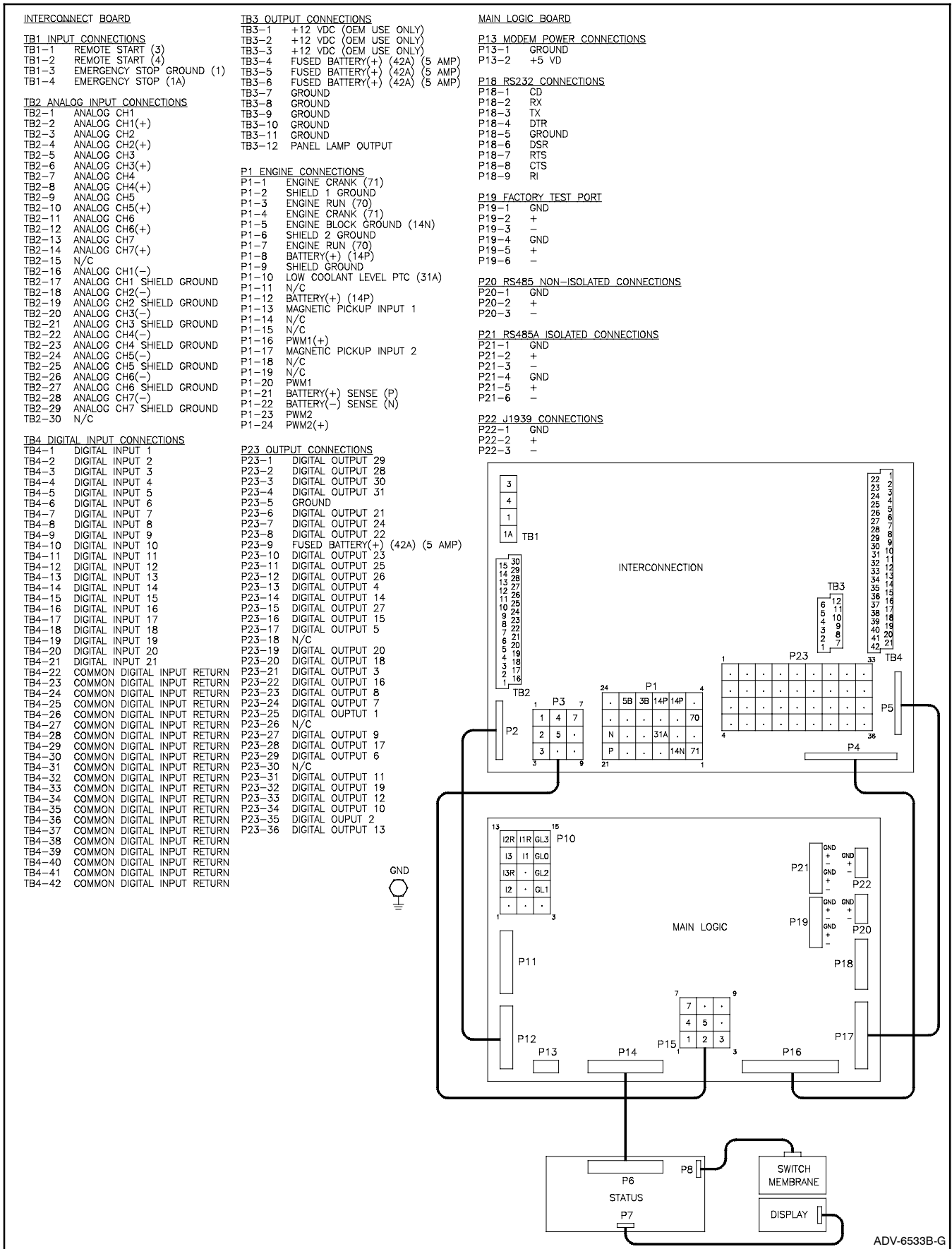

Figure 1-13 Controller Connections

1.5.1 Main Logic Circuit Board

The main logic circuit board is responsible for all microprocessor logic functions, remote communications, and display and keypad functions. See Figure 1-14.

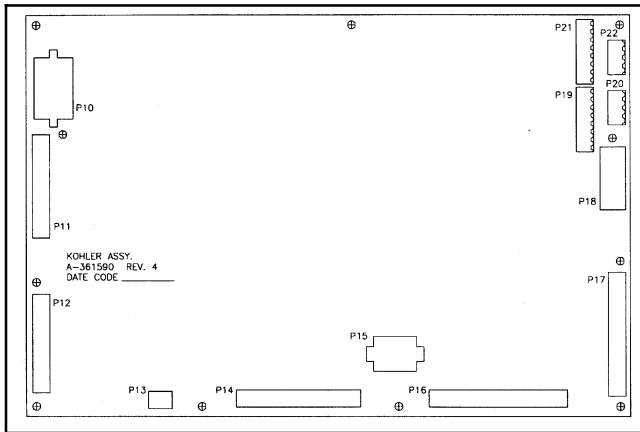

Figure 1-14 Main Logic Circuit Board

P10 Harness plug connection for the voltage and current inputs. The voltage inputs are from V7, V8, V9, and V0. The current inputs are from the CT burden resistor board.

P12 Ribbon cable connection from the interconnection board. This connection links the analog input terminal strip to the logic board.

P13 Modem power connection (future connection).

P14 Ribbon cable connection to the status board. This is the communications link for annunciation of alarms, digital display, and keypad.

P15 Harness connection from the interconnection board and power input to the main logic board.

P16 Ribbon cable connection for digital outputs from the main logic board.

P17 Ribbon cable connection for digital inputs. This connection links the interconnection board's digital input terminal strip to the main logic board.

P18 RS-232 communication connection for communication to a PC at a distance of 15 m (50 ft.) or less.

P20 RS-485 communication connection for Modbus® communications.

P21 RS-485 communication connection for communication to a PC for distances of 15–1220 m (50–4000 ft.). This connection is used for KBUS communications.

P19 RS-485 communication connection is a spare connection for factory use.

P22 SAE J1939 connector for communications with an ECM, when equipped.

1.5.2 Interconnection Circuit Board

The interconnection circuit provides the terminal strips to connect the customer connection and/or dry contact kits and three fuses (F1, F2, and F3). See Figure 1-15 and Figure 1-16.

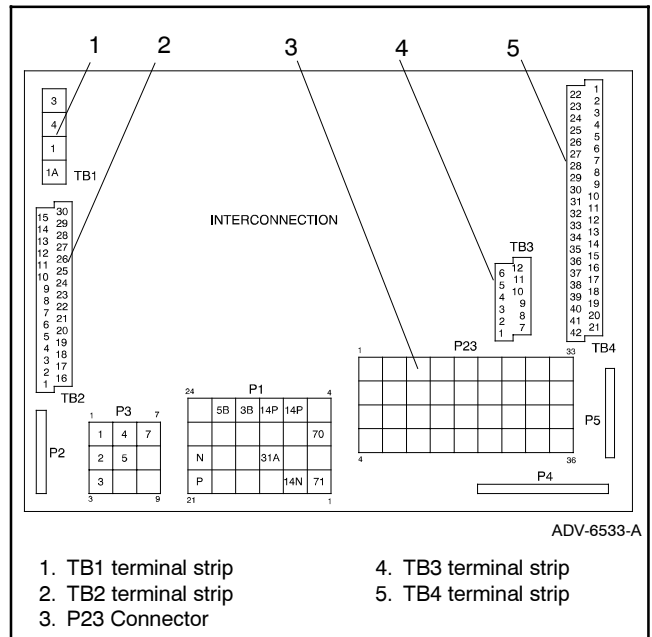

Figure 1-15 Interconnection Circuit Board Terminal Strips and Connectors

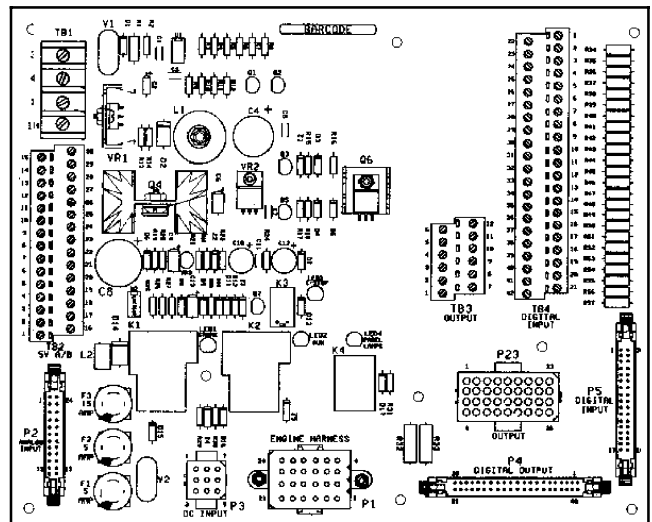

Figure 1-16 Interconnection Circuit Board

P1 Main engine harness connection.

P2 Ribbon cable connection used to link the analog inputs to the main logic board.

P3 Harness connection for the DC power input to the main logic board.

P4 Ribbon cable connection to the main logic board (used to link digital outputs from the main logic board).

P5 Ribbon cable connector that transfers the digital inputs to the main logic board.

P23 Output plug that transfers the digital output logic to the customer connection board.

TB1 Customer connection point for remote start (3-4) and emergency stop input (1-1A).

TB2 Customer connection point for the analog inputs.

TB3 Customer connection point for the DC control power.

TB4 Customer connection point for the digital inputs.

2.1 ECM Communications

The J1939 serial communication link accesses information from certain Detroit Diesel engines with DDEC ECMs. See Figure 2-1. The communication link provides access to DDEC data and is displayed in menu 2 of the 550 controller. The J1939 link also provides engine sensor data access eliminating redundant senders on the engine. If the J1939 communication link from the ECM to the 550 controller is lost, the generator set shuts down on a loss of ECM communication fault. See Figure 2-2.

Menu 2, Engine Monitoring, provides information about the various engine parameters while the generator set is either operational or shut down. Menu 2 is only an informational menu, and the user cannot set or change engine parameters.

Some available engine data is dependent on the engine family. As a result, some monitoring displays may not be available with a given engine.

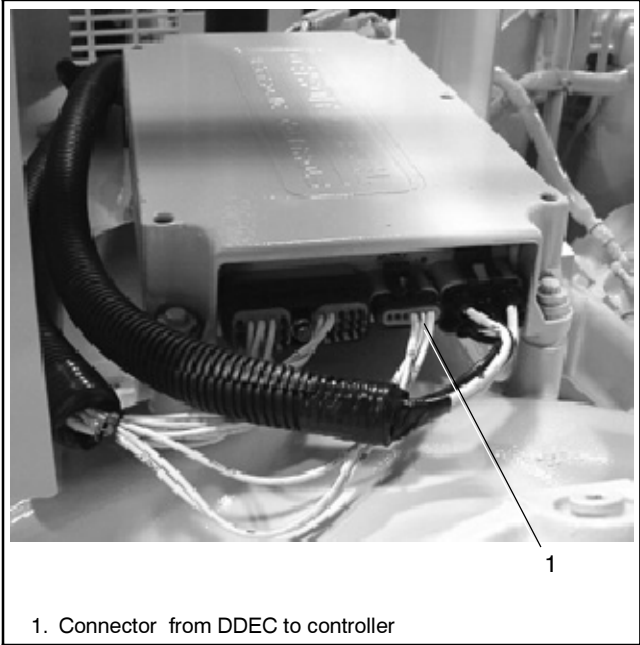

Figure 2-1 Detroit Diesel Engine DDEC Engine Control Module (ECM)

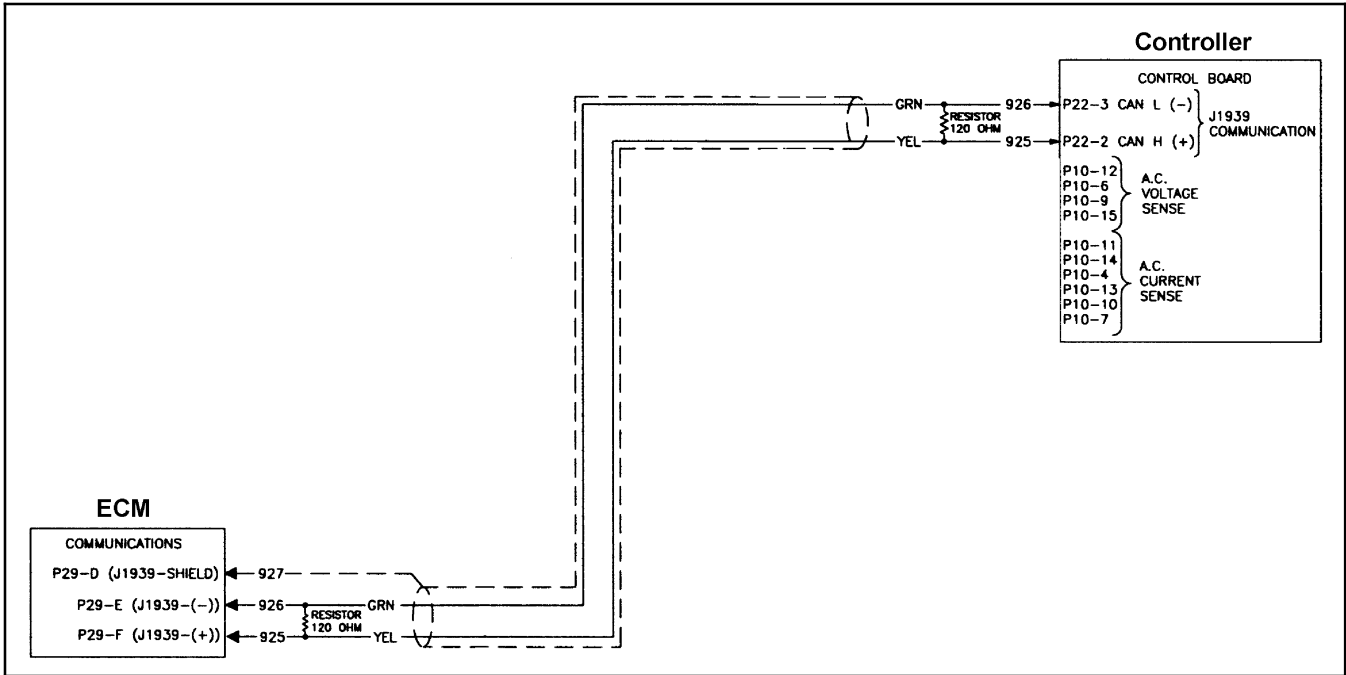

Figure 2-2 J1939 Communication Link Between Engine ECM and 550 Controller

2.2 ECM Engines and Controller Displays

Detroit Diesel series 60, 2000, and 4000 engines are ECM-equipped. The controller displays provided by each engine are listed in Figure 2-3. Figure 2-4 lists references to typical wiring schematics on the following pages.

Display	Generator Set Models		
	230-400 kW DDC Series 60 Diesel Engine	450-1000 kW DDC Series 2000 Engine	1250-2000 kW DDC Series 4000 Engine
Engine speed	X	X	X
Fuel pressure	#	X	X
Fuel temperature	X	X	X
Fuel consumption rate	X	X	X
Fuel used last run*	X	X	X
Coolant pressure	#	#	X
Coolant temperature	X	X	X
Oil pressure	X	X	X
Oil temperature	X	X	X
Crankcase pressure	#	#	X
Ambient temperature	X	X	X
ECM battery voltage	X	X	X
Engine model number	X	X	X
Engine serial number	X	X	X
Unit number	X	X	X
ECM serial number	X	X	X
Coolant level switch	#	#	#
Oil level switch	#	#	#

X Available display feature
 * Value must be reset using the DDEC reader
 # Not available at this time

Figure 2-3 Controller Displays for ECM-Equipped Engines

Wiring Schematic	Figure Number
ECM Equipped Engine and 200 kW Alternator	Figure 2-5
ECM Equipped Engine and 230-300 kW Alternator	Figure 2-6
ECM Equipped Engine and 350/400 kW Alternator	Figure 2-7
ECM Equipped Engine and 450-2000 kW Alternator	Figure 2-8
Non-ECM Equipped Engine and 20-300 kW Alternator	Figure 2-9
Non-ECM Equipped Engine and 350-2000 kW Alternator	Figure 2-10

Figure 2-4 Typical Wiring Schematics

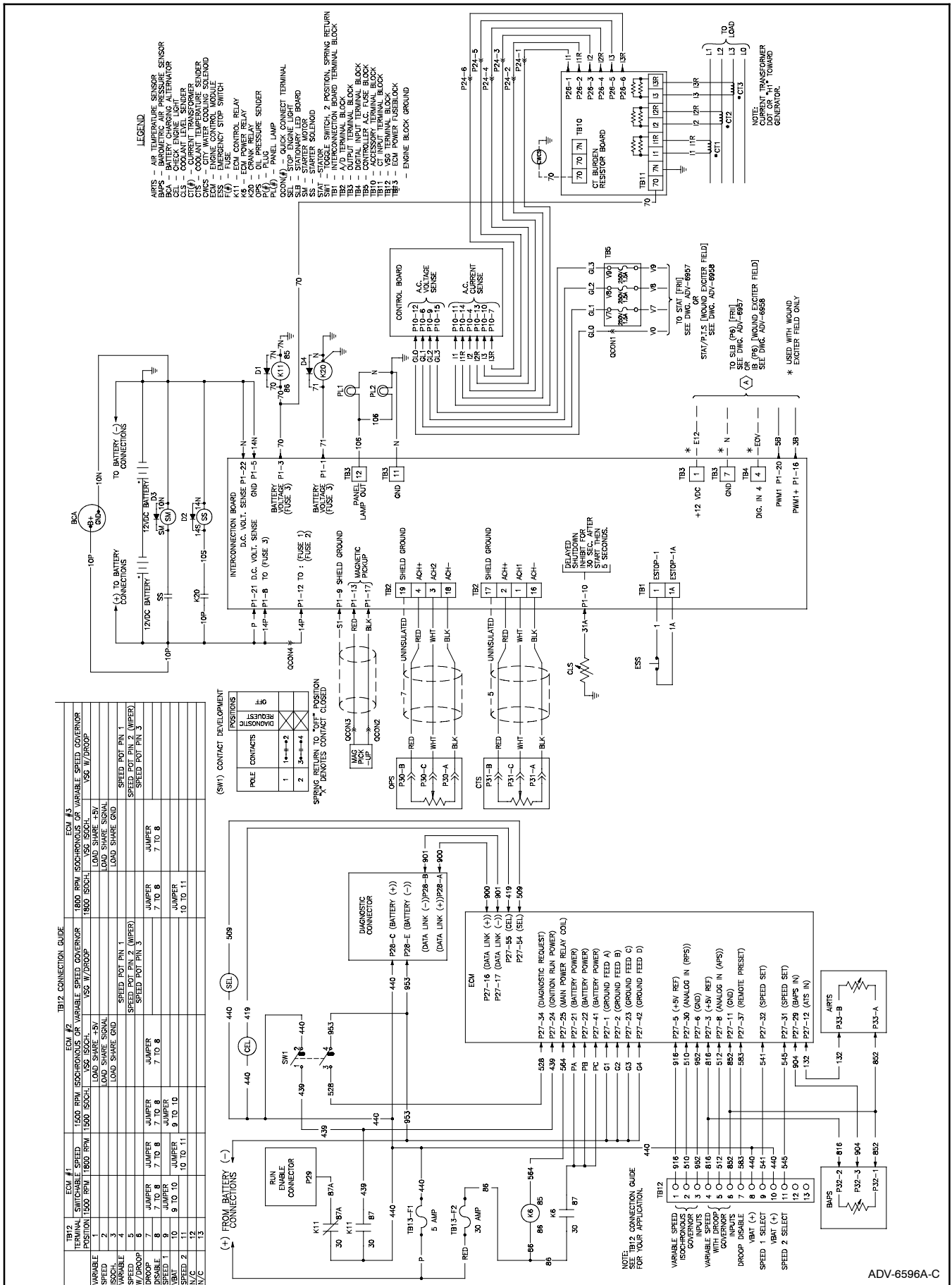

Figure 2-5 ECM Engine and 200 kW Alternator

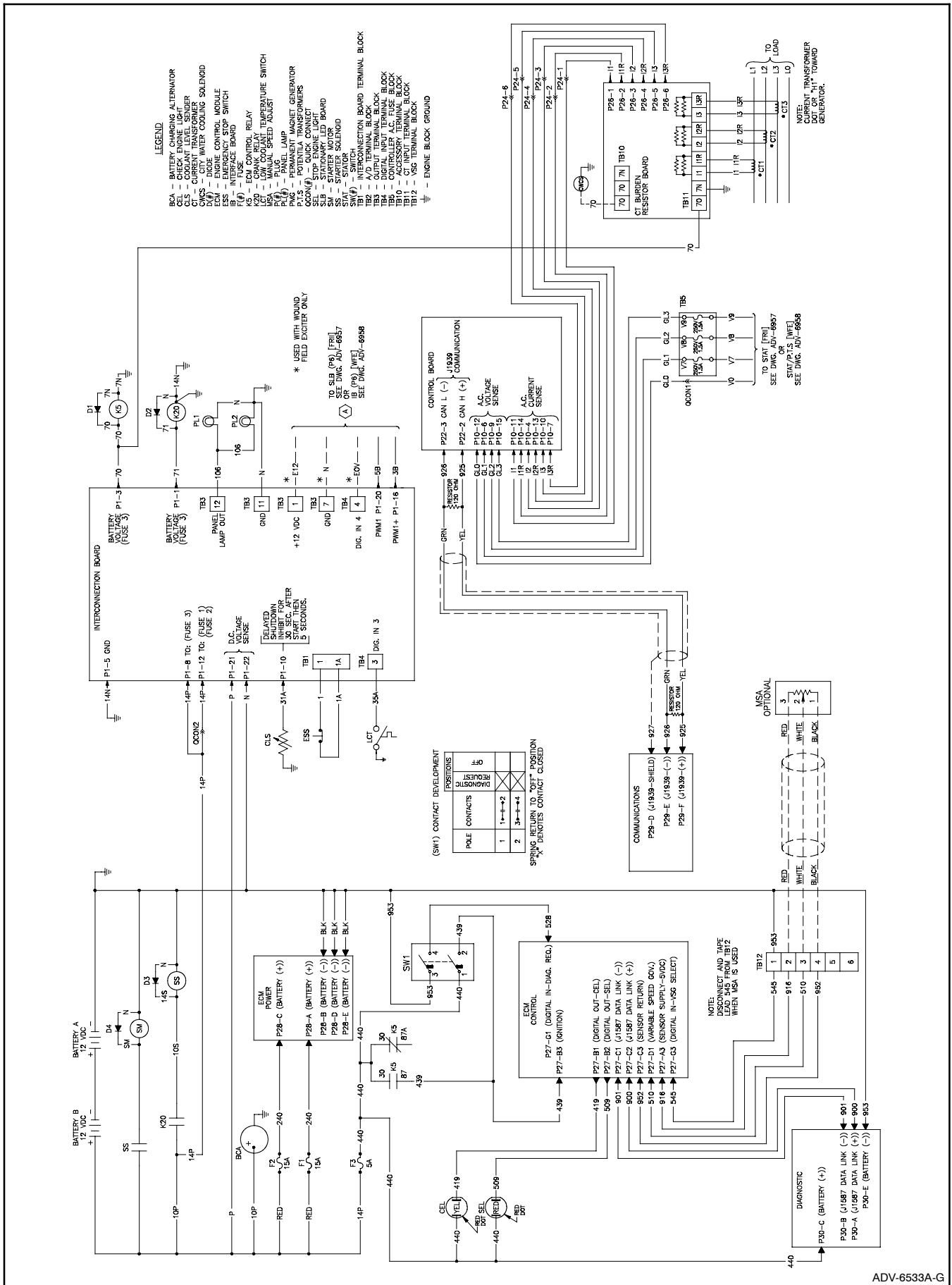

Figure 2-6 ECM Equipped Engine and 230-300 kW Alternator

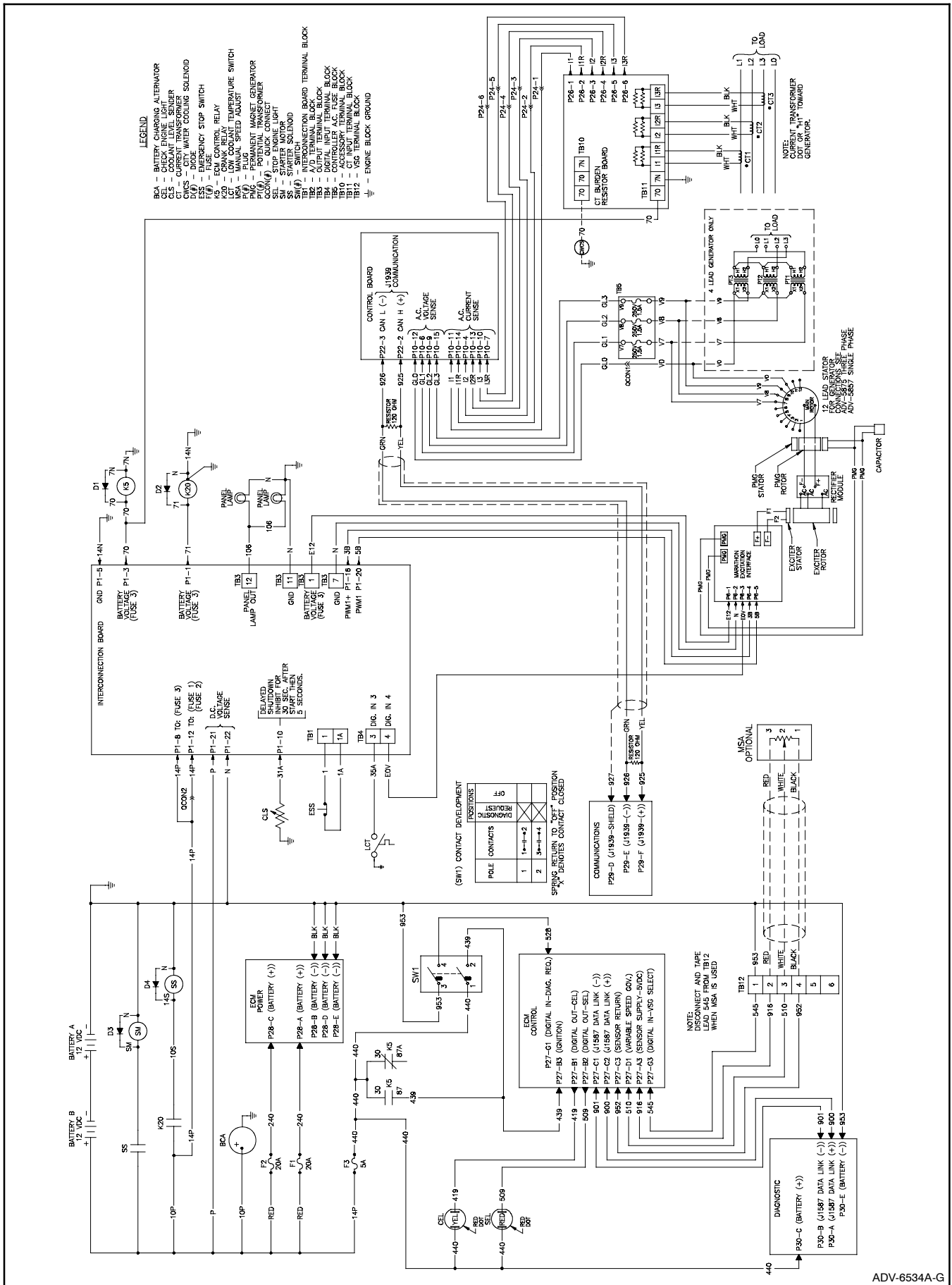

Figure 2-7 ECM Equipped Engine and 350/400 kW Alternator

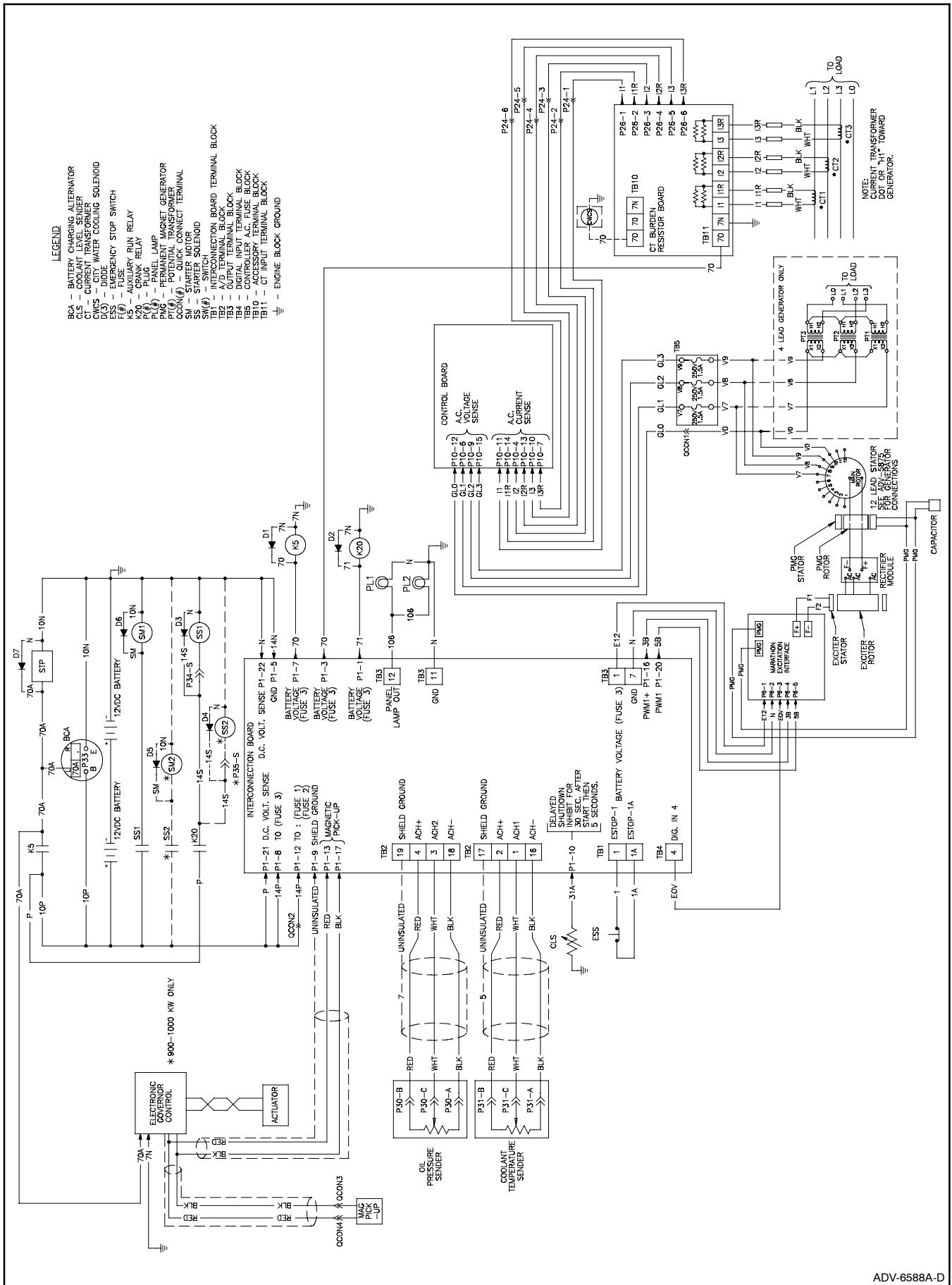

Figure 2-10 Non-ECM Engine and 350-2000 kW Alternator

2.3 20-300 kW Voltage Regulator (Brushless Alternator with Brushless Exciter)

The 550 controller voltage regulator provides $\pm 0.25\%$ regulation for single- or three-phase loading. See Figure 2-11. The three-phase voltage-sensing regulator is part of the main logic board software and is serviced as part of the complete controller.

Voltage regulation and stability controls are based on programmed parameters that are part of the 550 controller personality profile specific to the generator set application.

The regulator output is a pulse width modulation (PWM) signal. The PWM signal controls the current flow through the main rotor field, which in turn controls voltage supply at the alternator stator lead output. For any given load and alternator speed, the alternator output voltage is proportional to the regulator PWM signal level.

Menu 11 displays voltage regulator setup functions including line-to-line voltages, voltage adjustment, underfrequency unloading (volts per Hz), reactive droop, power factor (PF), and kVAR adjustments. Reactive droop, PF, and kVAR adjustments are required only when the generator set is used in paralleling applications.

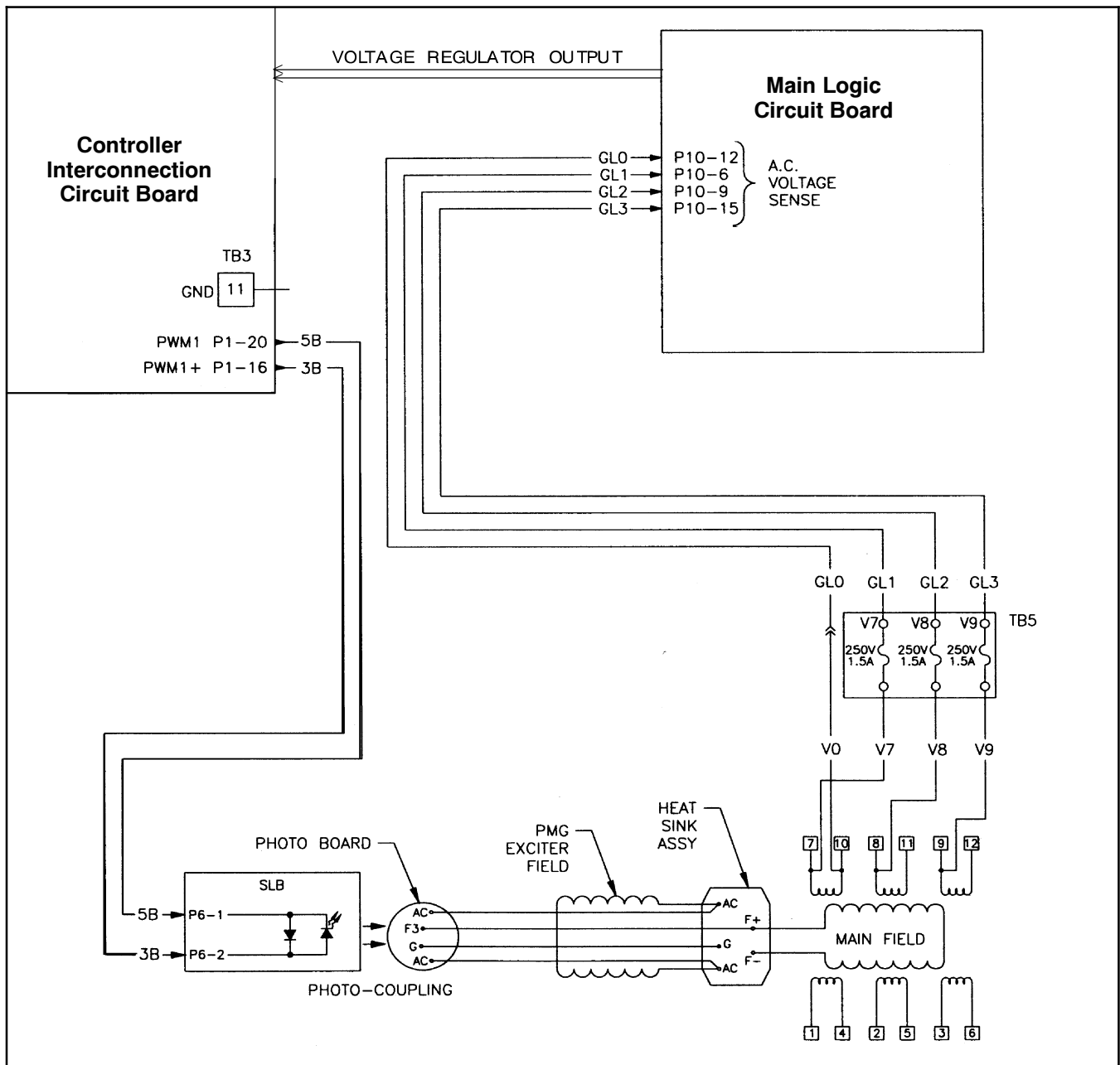

Figure 2-11 Main Logic Circuit Board and Controller Interconnection Circuit Board

2.4 350-3250 kW Voltage Regulator (Brushless Alternator with Brushless Pilot Exciter)

The three-phase voltage-sensing regulator is built into the main controller logic board. Additionally, an interface board excites the 350-3250 kW alternator. See Figure 2-12. Voltage and stability control is based on programmed parameters that are part of the 550 controller personality profile for the specific generator set application. These programmed parameters are not field-adjustable. The voltage regulator output (3B-5B) is a pulse width modulation (PWM) signal. This PWM signal triggers the interface board excitation circuit allowing for DC main rotor field excitation.

2.5 Interface Board

The interface board is required as part of the voltage regulation for 350-3250 kW alternators. The permanent magnet generator (PMG) input signal is rectified on the interface board. This rectified voltage provides the output stator excitation power.

The interface board requires battery voltage (12 or 24 volts) for control power. This power is fused with F3 located on the controller interconnect board. The overvoltage adjustment potentiometer controls the shutdown point for field overvoltage (EOV). The EOV output signal from the interface board is wired to interconnect board digital input 4. This input is defaulted for 350-3250 kW alternators to activate the field overvoltage shutdown (Marathon Over V). See Figure 2-13.

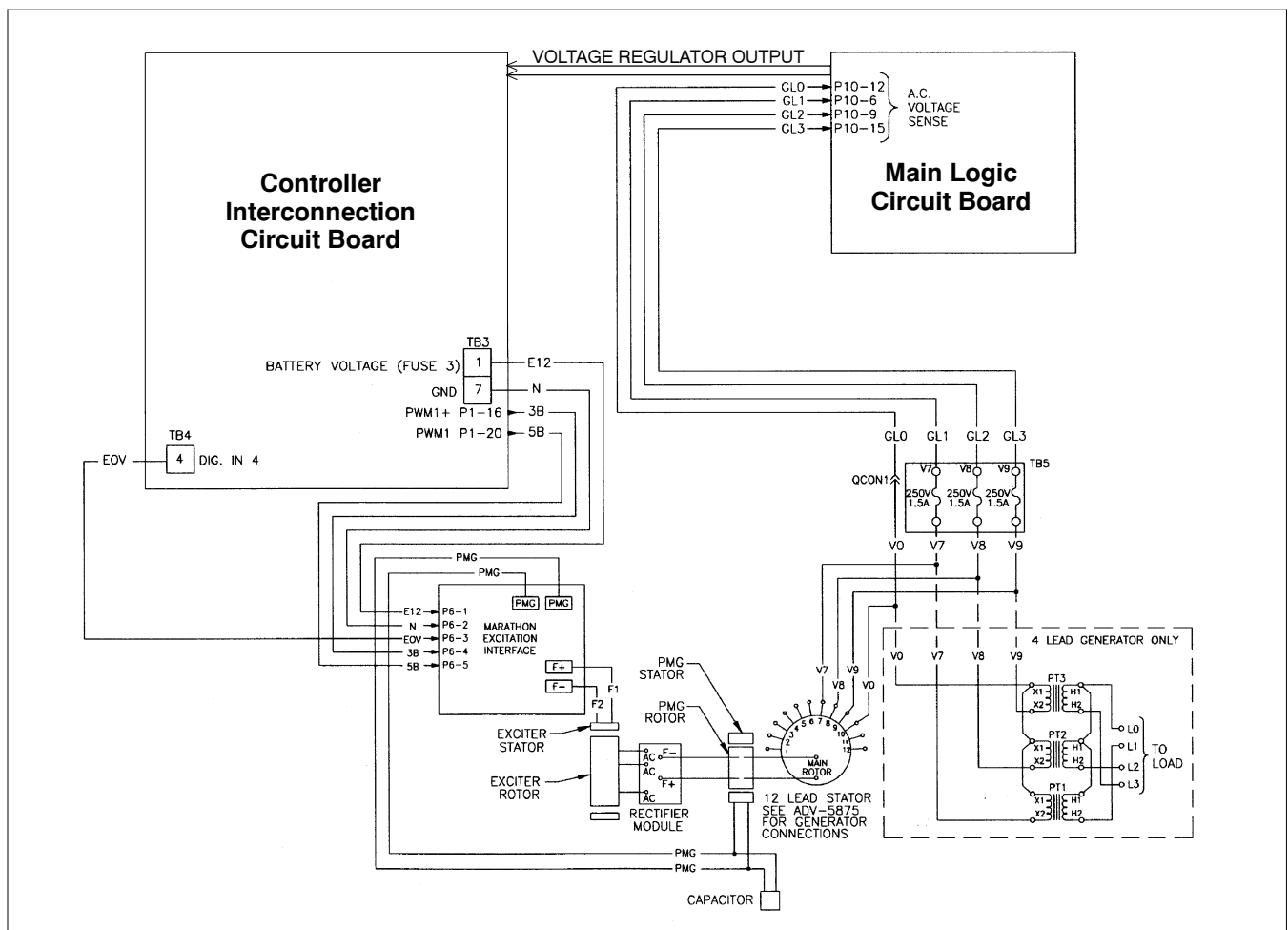

Figure 2-12 Main Logic Circuit Board and Controller Interconnection Circuit Board with 350-3250 kW Excitation Interface Circuit Board

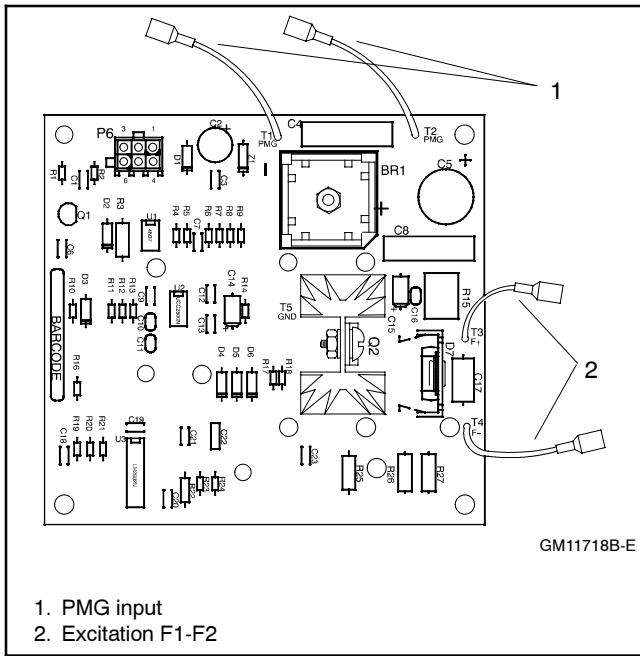

Figure 2-13 Interface Board

2.6 Voltage Regulator Adjustment

2.6.1 Voltage Adjust

The voltage adjust is entered as the rated or otherwise desired line-to-line voltage. See Figure 2-14. The average of the line-to-neutral voltages is then regulated to the corresponding value. The setting may be as precise as one tenth of a volt. The voltage adjustment

defaults to the rated system voltage. The voltage adjust may be set to any value within 20% of the system voltage. The upper limit is 20% above the system voltage, and the lower limit is 20% below the system voltage. If a value beyond these limits is entered, a RANGE ERROR message appears.

As a reference, the present voltage adjust setting is displayed as well as the average value of the line-to-line voltages. The individual line-to-line voltages are also displayed on the subsequent menu screens, allowing the user to monitor any one phase if desired. The voltage adjust setting may be changed by means other than the menu; i.e., digital input or communications. If this occurs, the new value displays accordingly in the voltage adjust menu.

2.6.2 Underfrequency Unload Enable

This menu turns the underfrequency unload on or off. A yes entry turns the feature on and the display shows ENABLED YES. A no entry turns the feature off and the display shows ENABLED NO. The underfrequency unload defaults to an enabled (ON) condition. Underfrequency unload lowers the output voltage when the frequency dips due to large loads.

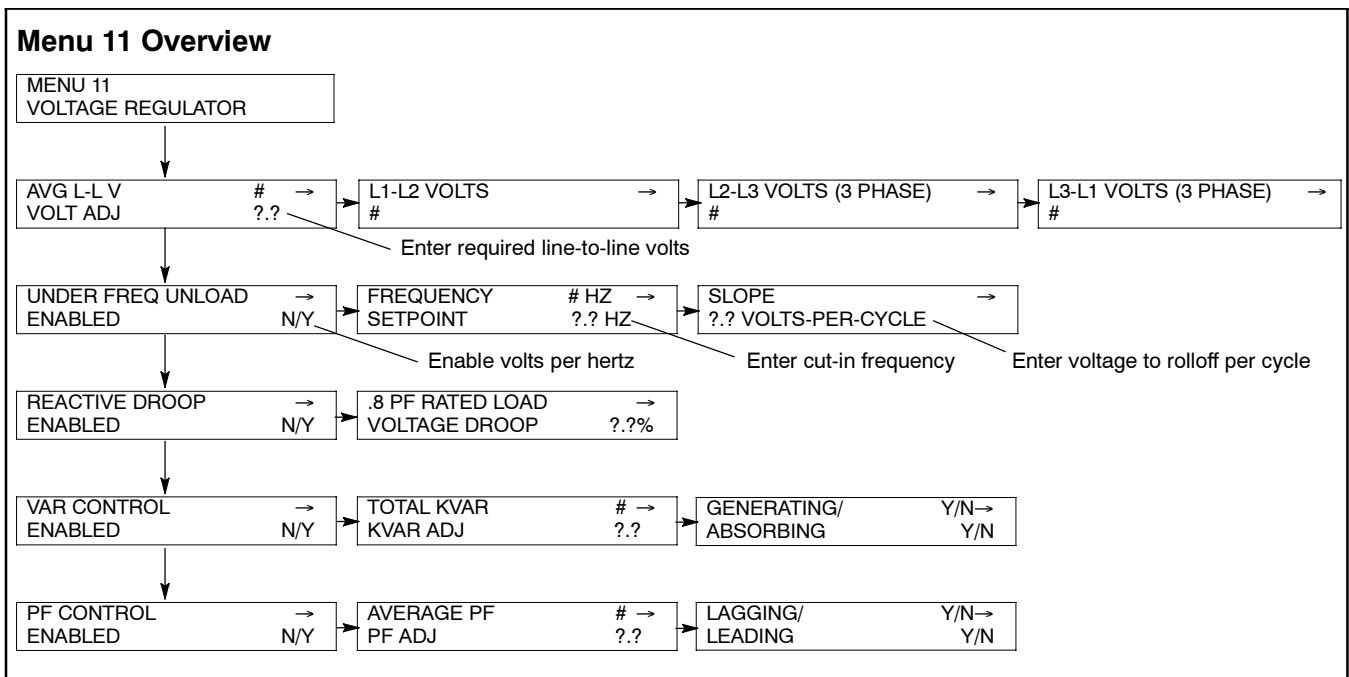

Figure 2-14 Menu 11, Voltage Regulator

2.6.3 Frequency Setpoint

Frequency setpoint is the cut-in point for the underfrequency unloading. At any operating frequency below this value, the output voltage is reduced. The frequency may be entered with resolution to tenths of a hertz. The range of acceptable entries is 40 to 70 Hz. Any entry beyond these limits will cause a RANGE ERROR display, and the setting will not change. The default value is 1 cycle per second (or 2 for non-ECM engines) below the system frequency normal. The frequency setpoint changes to the default value if the system frequency changes. A setting of 40 Hz will essentially disable the underfrequency unload feature because most engines will not normally drop to this low speed even during load applications.

2.6.4 Underfrequency Unload Slope

The slope determines how much the voltage is reduced during an unloading condition. The line-to-line voltage is regulated to a value less than the voltage adjust setting by this amount for every cycle below the frequency setpoint. The voltage may be entered with resolution as fine as one tenth of one volt. The default value is 2.0 volts/Hz. A zero entry for the slope will in effect turn the underfrequency unload feature OFF.

2.7 Paralleling Applications (Reactive Droop)

2.7.1 Reactive Droop Enable

This menu allows the user to ENABLE the reactive droop feature. A yes entry turns the feature on and the display shows ENABLED YES. A no entry turns the feature off and the display shows ENABLED NO. Use reactive droop in a generator set to generator set paralleling application.

2.7.2 Voltage Droop

The amount of reactive droop is entered as a percentage of system voltage when applying full rated load, at 0.8 PF. The entry is made as precise as one tenth of a volt. This entry determines how much the voltage droops when the alternator provides reactive current. The actual amount the voltage changes is equal to the voltage droop setting times the VAR load as a fraction of the rated VARs at 0.8 PF.

If the generator set provides full rated load at 0.8 PF, the expected voltage change equals the voltage droop setting as a percentage of system voltage. A voltage droop setting of zero will in effect disable the reactive droop feature. The default value is 4% droop at full rated load at 0.8 PF. The voltage droop setting is displayed for reference. As this value changes via the remote communications, the display setting changes.

2.8 Paralleling Applications with Utility

2.8.1 VAR Control Enable

In order for the VAR control function to operate, it must be enabled. Entering yes at this menu turns the feature on. Because the function is designed to operate while in parallel with the utility, it also requires the proper indication that all tying circuit breakers are closed. This is done through the user programmable digital inputs. Because VAR control cannot be enabled at the same time that PF control is enabled, the action of turning VAR Control on (ENABLED) turns the PF control off (DISABLED) if it was previously ENABLED.

To activate the VAR or PF modes, a digital input to TB-4 is required. This input should indicate the generator set is paralleled to the utility. After the digital input is grounded, the VAR or PF adjustment initiates.

Note: When the VAR control is enabled, the unit will not shut down when TB-4-17 is grounded.

2.8.2 KVAR Adjust

The KVAR adjustment is used to set the desired operating value for the generator set reactive load when in a utility paralleling application. Enter the desired generator set load directly as kVARs. The value entered may be as low as zero or as high as the rated value (rated kW x 0.75). Any entry beyond this will not be accepted and a RANGE ERROR message is displayed. The default value for KVAR adjust is zero. Any time the system rated kW is changed, the KVAR adjust will revert to this default value. Because the KVAR adjust may be changed via other inputs, the display setting changes.

2.8.3 Generating/Absorbing

While operating in the VAR control mode, the generator load may be specified to be out of (generating) or into (absorbing) the generator. Set through the generating/absorbing menu. Because the normal flow of reactive current is out of the generator, the default value for this setting is generating. If absorbing is desired, a NO entry at this menu will change the control mode to absorbing. When absorbing is selected, another NO entry will revert back to generating. It is assumed that this mode will not be changed when the generator set is running. Therefore, an attempt to change the mode while running will return a RANGE ERROR message. Shut down the generator set to change this setting.

2.8.4 Power Factor Adjust

Use the PF adjust to set the desired operating relationship for the generator set output and current when connected in parallel with the utility. The regulated excitation maintains a PF that is equal to the entered value. The value entered may be 0.7 for leading PFs to 0.6 for lagging PFs. Any entries outside these limits cause a RANGE ERROR message display. The default value for PF adjust is 0.8 lagging. Whenever the system rated kW changes, the PF adjustment reverts to the default value. If the PF adjustment is changed via other inputs, the display setting changes.

2.8.5 Lagging/Leading

It is possible to select either a leading or lagging PF for utility parallel applications. The controller displays the selected mode. A NO entry switches the controller to use the opposite relationship for regulation purposes. This may only be changed while the generator set is not running. Lagging is the default value because the most common mode of operation has a lagging PF.

2.9 Alternator Protection

Inherent alternator protection is part of the personality parameters program installed in the controller. The parameters program is specific to the alternator listed in menu 20 of the controller. The alternator part number is listed on the controller software label located inside the 550 controller. The programmed protection limits for the controller/alternator cannot be adjusted. When the alternator current output exceeds the programmed overload and short circuit limits, the generator set shuts down. The local display will read *altrntr protect sdwn* (alternator protection shutdown).

2.10 Load Shed

The load shed feature is based on either kW overload or underfrequency. See Figure 2-15.

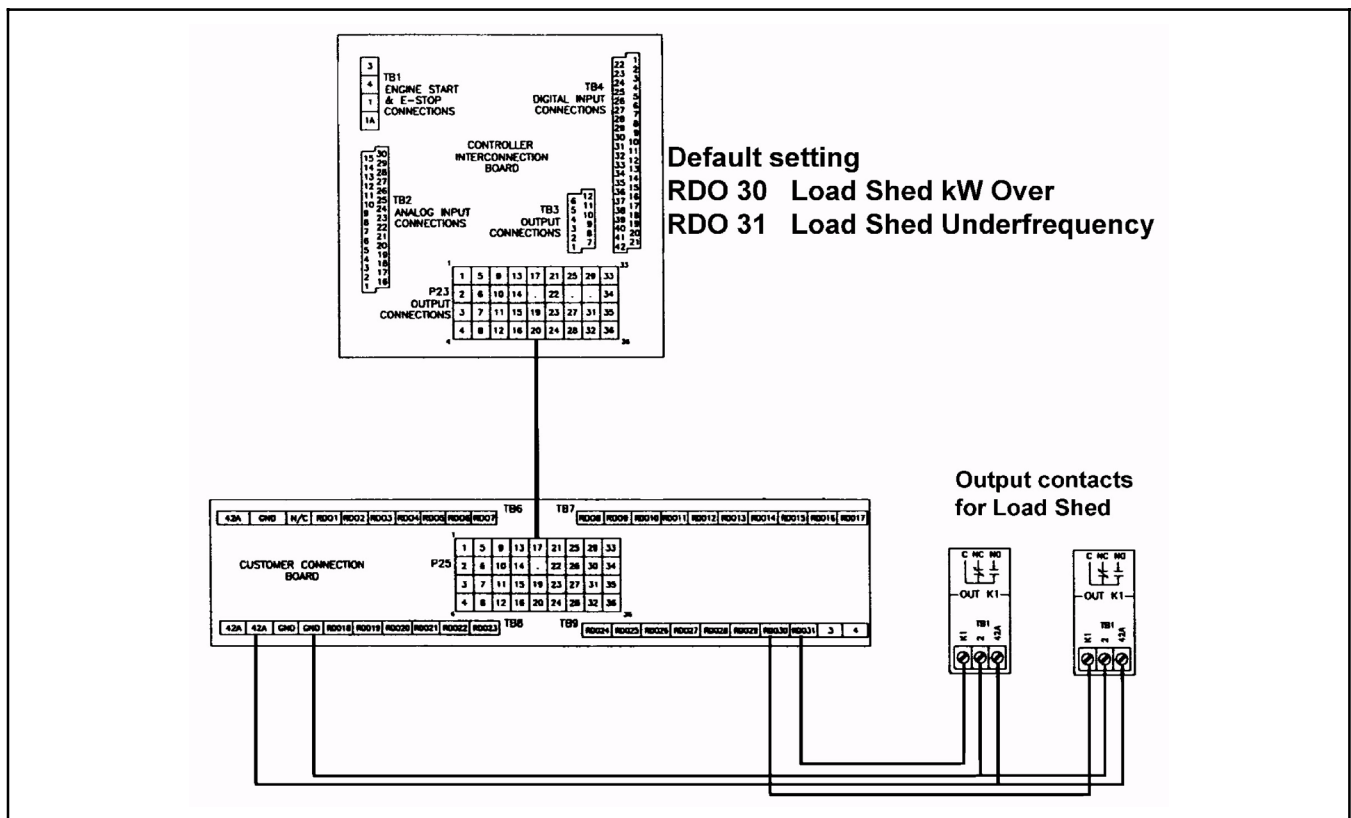

Figure 2-15 Load Shed Feature

If the generator set output exceeds the kW load shed limits defined in menu 7, a local warning for load shed kW over is displayed. This warning, defined as a relay driver output (RDO), trips a downstream circuit breaker allowing the excess load to be shed when the generator set is online. If the generator set output frequency drops to 59 Hz for 60 Hz operation or 49 Hz for 50 Hz operation, the controller displays a load shed underfrequency local warning. This warning can be programmed as an RDO to trip a circuit breaker allowing load shedding. The underfrequency setpoint is a fixed nonadjustable setting and is programmed with a 5-second time delay.

2.11 Controller with Marathon DVR 2000 Voltage Regulator Substitution

Certain early shipments of the 550 controller were equipped with the Marathon DVR2000 voltage regulator. Figure 2-16 shows the location of the DVR 2000 voltage regulator inside the junction box.

The internal 550 controller voltage regulator and the DVR2000 voltage regulator share most features. The following features, however, are not available with the DVR 2000 voltage regulator:

- Voltage regulator programming using the controller keypad. Make adjustments to the DVR 2000 voltage regulator at the voltage regulator. Remove the junction box cover to adjust the DVR 2000 voltage regulator.
- Voltage setting using the controller keypad.
- Volts/Hz display.

- VAR/power factor controller, display, and adjustment. This feature is available as an accessory; order part number PA-347165 or PA-347165-SD.
- Reactive droop controller, display, and adjustment.
- Engine idle mode capability using the controller (voltage regulator is deenergized).

The 550 controller spec sheet and operation manual provide only information regarding the controller voltage regulator. For information regarding the DVR 2000 voltage regulator, obtain TP-5579, Operation Manual, DVR 2000 Voltage Regulator.

Use Figure 2-17 for installation and troubleshooting of the electrical wiring system.

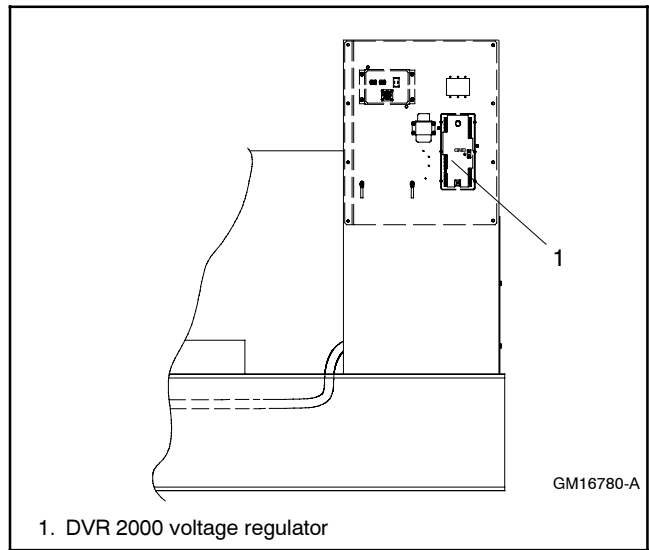

Figure 2-16 DVR 2000 Voltage Regulator Mounting Location

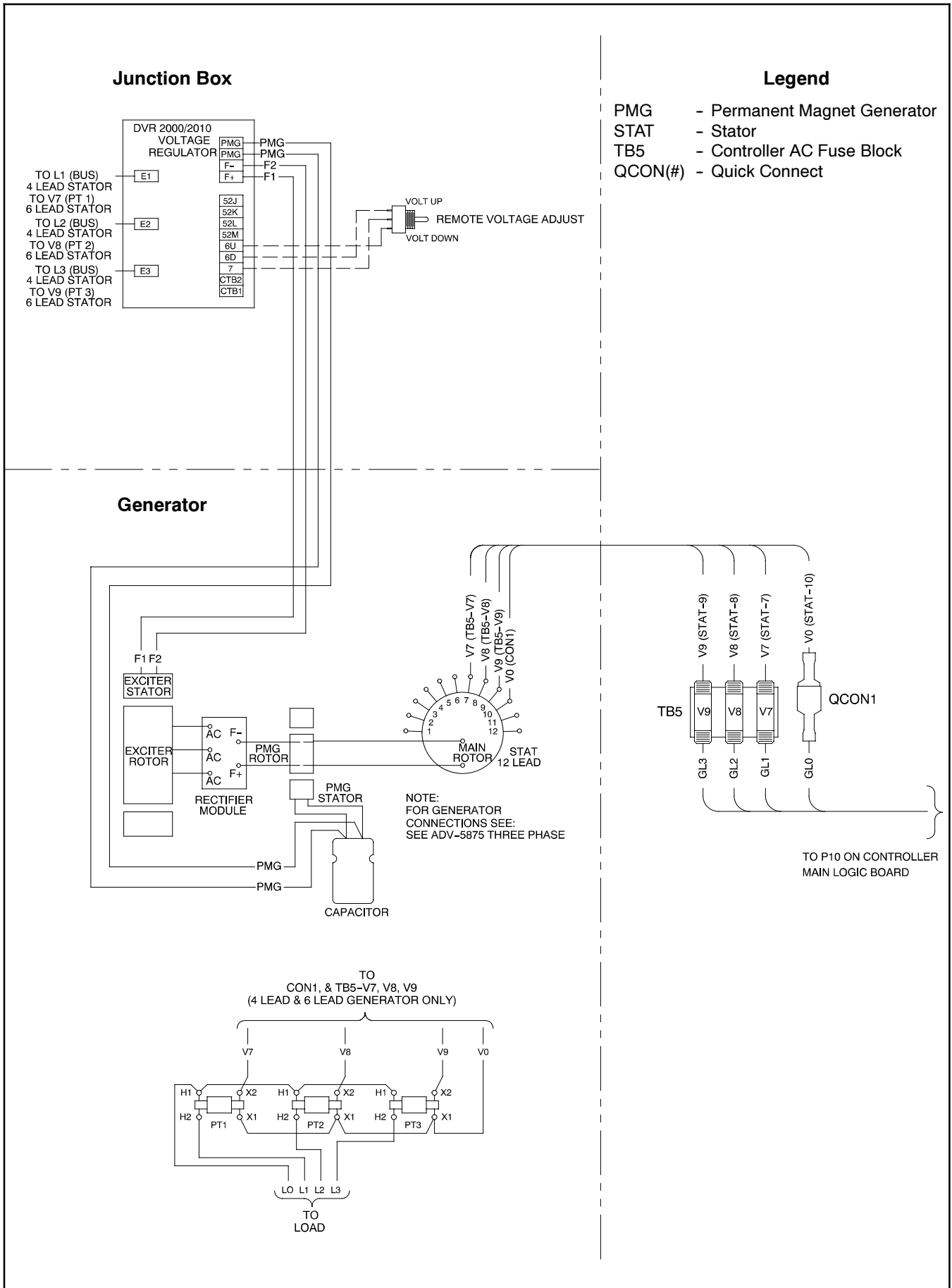

Figure 2-17 DVR 2000 Voltage Regulator/Alternator Interconnection Wiring Diagram, GM20500

Notes

3.1 Voltage and Current Inputs

Voltage and current inputs enter the controller at P10 of the main logic board. The inputs are required for metering calculations, voltage regulation, voltage and current protection, and secondary crank termination (non-ECM engines). See Figure 3-1.

3.2 Voltage Measurement

The voltage inputs are V7, V8, V9, and V0 and terminate at generator windings 7,8,9, and neutral for 10- and 12-lead alternators. For a 4-lead alternator, a transformer assembly is required to step down the voltage to input levels acceptable for the controller (240 volts and below). TB5 is a fuse block for voltage input protection. The fuse rating is 1.5 amps at 250 volts.

3.3 Current Measurement

For generator sets above 200 kW, a CT burden resistor board is included with the 550 controller application. The board is located in the junction box with wiring between the 550 controller and the CT burden resistor board. CTs with 0.5 amps secondary current are mounted in the junction box and wired to TB11. The CT burden resistor board converts the CT current input to a voltage output (P26) for the 550 controller main logic board. The current input and voltage output are proportional; i.e., the greater the current sensed, the higher the voltage output. Generator sets 20-200 kW utilize a CT with the resistor installed as part of the CT, so no burden resistor board is required.

Note: The CTs with 0.5 amp secondary outputs are unique to the 550 controllers.

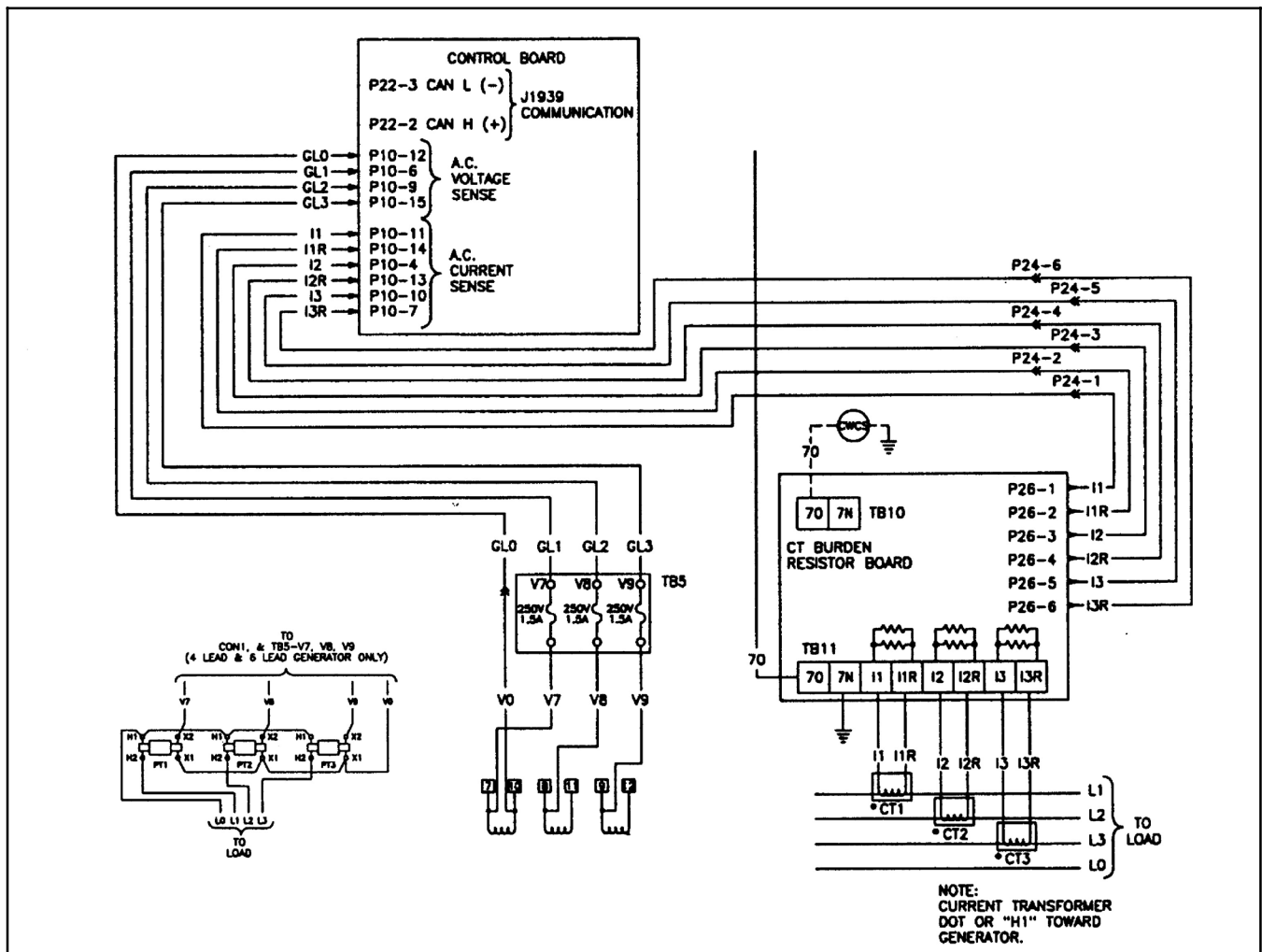

Figure 3-1 Voltage and Current Inputs

3.4 Calibration: Voltage and Amperage (Menu 12)

The 550 controller requires voltage and current sensing input calibration. See Figure 3-2. Calibration is initially done at the factory and typically requires no adjustment in the field. If, however, the system voltage is reprogrammed or the controller is replaced, calibration

is necessary. Controller calibration is based on readings taken from the generator output windings using a multimeter with a minimum accuracy of +/-1%. Voltage readings are taken from line-to-neutral and must be done for L1, L2, and L3, if required. Current measurement is based on readings taken with a handheld AC ammeter for L1, L2, and L3.

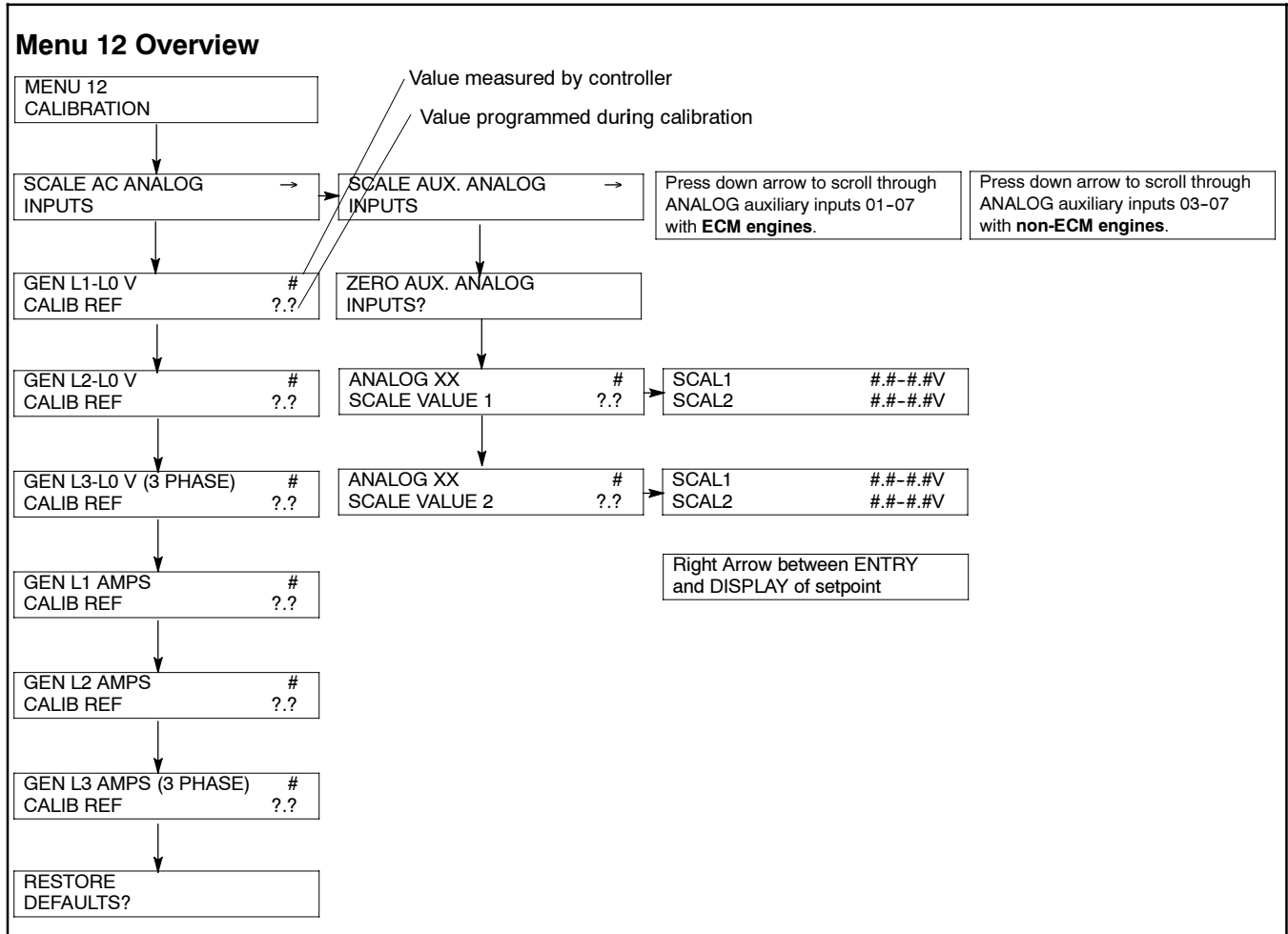

Figure 3-2 Menu 12, Calibration

3.5 Digital Inputs

Digital inputs are specific on-off inputs that monitor the external parameters. These inputs may come from a battery charger, switchgear, fuel tank, or other external devices. Inputs may be wired as a single-wire connection with the return wire going to battery ground (example: battery charger connection). Inputs can also be wired as a two-wire connection with the return ground going to TB4, 22-42 (example: idle mode switch). Inputs are based on the digital signal switching to battery ground or ground return of TB4 to initiate a controller action. Typically, the digital input signal switching is done with a relay dry contact and not with a powered contact. See Figure 3-3.

Factory programmed defaults for TB4 inputs 1 through 21 are as follows:

1. Battery Charger Fault
2. Low Fuel
3. Low Coolant Temperature
4. Excitation Overvoltage (Marathon alternator only)
5. Warning
6. Warning
7. Warning
8. Warning
9. Warning
10. Warning
11. Warning
12. Warning
13. Warning
14. Warning (all models except 50-100ROZK)
Low Coolant Level (50-100ROZK)
Note: All models, except 50-100ROZK use P1-10 as the low coolant level.
15. Remote Shutdown
16. Remote Reset
17. VAR PF Model
18. Voltage Lower
19. Voltage Raise
20. Air Damper
21. Idle Mode

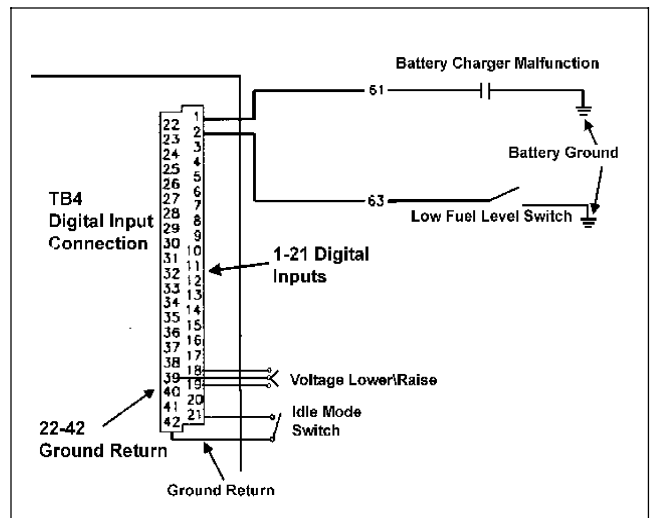

Figure 3-3 Digital Inputs

Each input (other than those predestined) can be programmed as a warning or a shutdown and also can have an inhibit and a delay time.

If the controller is programmed to meet NFPA 110 requirements (the NFPA 110 setting is found in menu 7), inputs 1, 2, and 20 are factory-defined and the user cannot change the preset function. If the controller is used with an ECM-equipped engine, digital input 3 (low coolant temperature) is predefined. If the controller is used in conjunction with the Marathon alternator, digital input 4 (MARATHON OVER V) is predefined. Both digital and analog input descriptions can be defined remotely with alphanumeric characters on the controller display. Define inputs as needed by using the communication software and programming inputs as desired.

3.5.1 Idle Mode Switch

The idle mode input function is only active on ECM-equipped engines. The idle speed function starts and runs the engine at idle during nonemergency operation. Closing the switch starts the generator set in idle mode, and the engine remains running at idle until the generator set reaches a predefined temperature or the idle timer is complete. When warmed-up temperature is reached, the engine is ramped to rated speed and remains running until the switch is opened. The alternator output is disabled during idle operation.

3.5.2 Define Digital Inputs

Menu 9 identifies the user-defined wired inputs to the TB4 terminal strip. See Figure 3-4. Menu 9 allows the user to customize the digital inputs for the application required. Program menu 9 at the controller keypad or from a PC using the Monitor II software. If programming with the controller keypad, select the digital input descriptions in menu 9. See Figure 3-5.

When an input is activated, the controller displays the active input D1–D21 (after the inhibit time and delay time have timed out). The user can also program a relay driver output (RDO) in menu 10 that corresponds to the digital input.

Input	Description
Warning	Horn sounds and customer auxiliary lamp lights
Shutdown Type A	Initiates shutdown removing power to ignition and crank
Shutdown Type B	Initiates shutdown similar to type A and activates the air damper RDO
Voltage Raise/Lower	Remote input to adjust voltage
VAR/PF Mode	Initiates VAR or power factor mode of voltage regulator (parallel with utility)
Remote Shutdown	Used for remote shutdown from switchgear
Remote Reset	Used to reset controller faults from remote location
Air Damper	Initiates air damper shutdown
Low Fuel	Warning for low fuel level or pressure
Marathon Over V	Field overvoltage shutdown (Marathon alternator)
Battle Switch	Overrides all warnings and shutdowns except overspeed and air damper
Idle Mode	ECM engines only; allows engine idle on startup and shutdown for programmed time
Ground Fault	Indicates ground fault (ground fault sensor required)
Bat Chgr Fault	Warns of battery charger malfunction
High Oil Temperature	Initiates high oil temperature shutdown
Low Coolant Level	Initiates low coolant level shutdown
Low Coolant Temp	Activates digital input 3 (only available when used with ECM engines)

Figure 3-4 Selection Group Digital Inputs

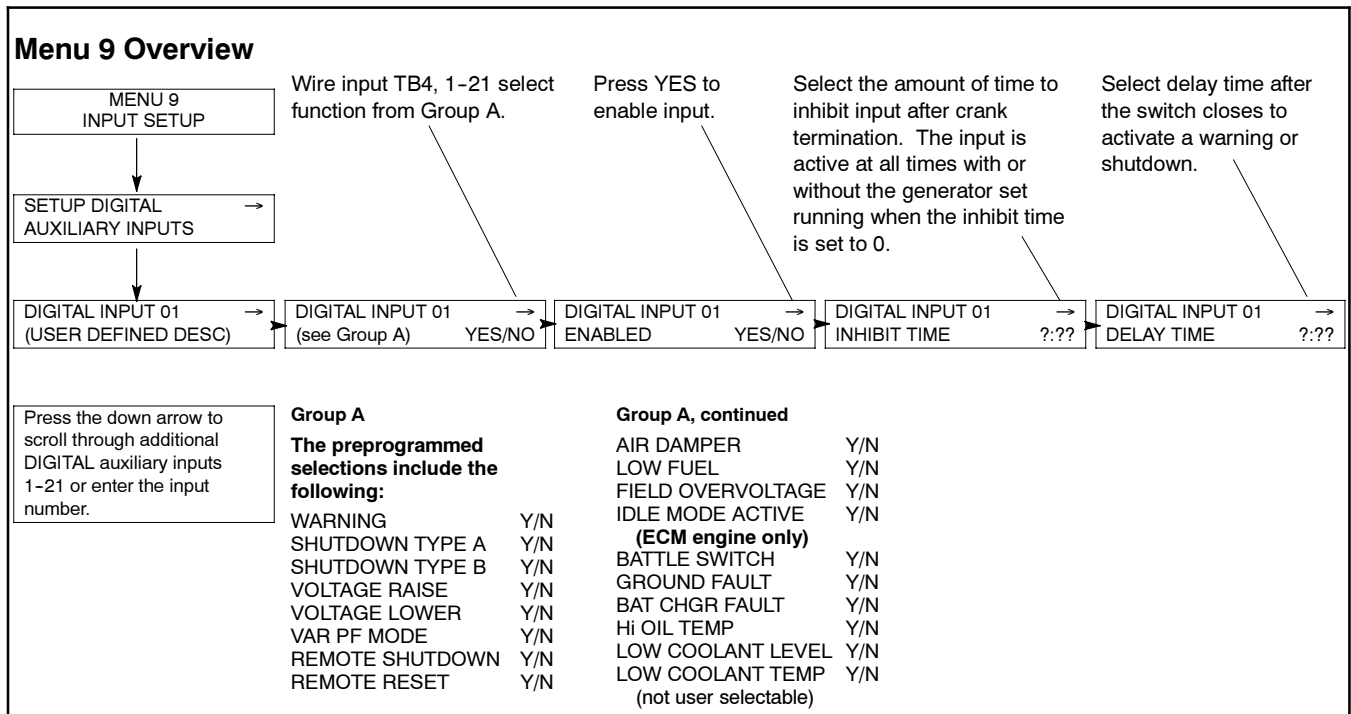

Figure 3-5 Menu 9, Input Setup (Programming of Digital Input 01 Shown, Repeat for Inputs 02-21 as needed)

3.5.3 TB1 Customer Connection

TB1 provides access to remote start inputs 3-4. See Figure 3-6. Contact closure on terminals 3-4 initiates an engine start sequence, provided the master control switch is in the auto position. Typical installation has the remote start wired to the automatic transfer switch.

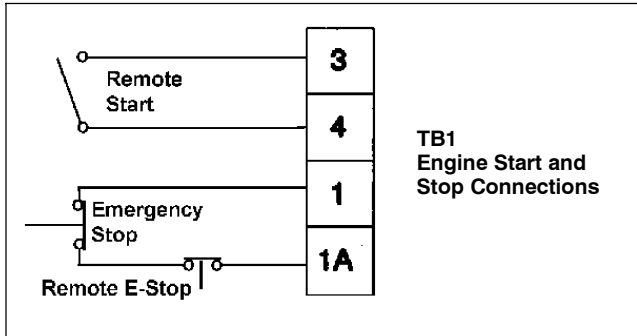

Figure 3-6 TB1 Engine Start/Stop Connections

Terminals 1-1A are used for the emergency stop switch. The switch is normally closed and opening causes an immediate engine shutdown. If adding remote E-stop switches, always use a series connection between switches.

3.5.4 TB3 Accessory Output

The TB3 output accessory terminal block provides connections for 12 VDC options that require a fused 5-amp power source. TB3 allows connection to 42A and battery ground. Terminal 42A is a fused 5-amp battery supply (fuse F1). See Figure 3-7.

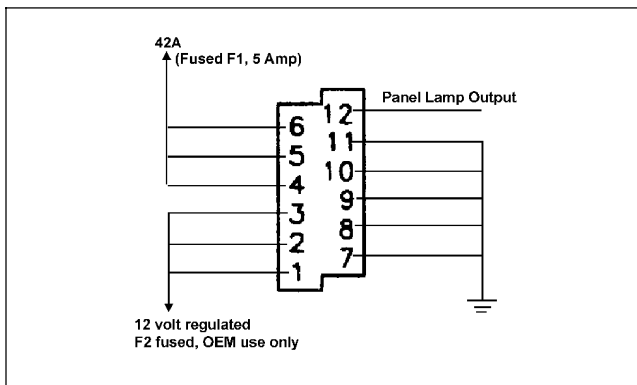

Figure 3-7 TB3 Fused 5-Amp Power Source

3.5.5 TB2 Analog Inputs

TB2 provides 0-5 VDC analog signal inputs for customer connections. The installer must scale and calibrate each analog input before the input value becomes a warning or shutdown trip point value. See Figure 3-8. Analog inputs 1-7 are available for user-defined applications on ECM-engine models. Non-ECM engines have analog inputs 3-7 available for optional applications, while inputs 1-2 are reserved for oil pressure and coolant temperature. On ECM engines, oil pressure and coolant temperature come from the ECM. Refer to Section 2.2, ECM Engines and Controller Displays, for identification of ECM engines.

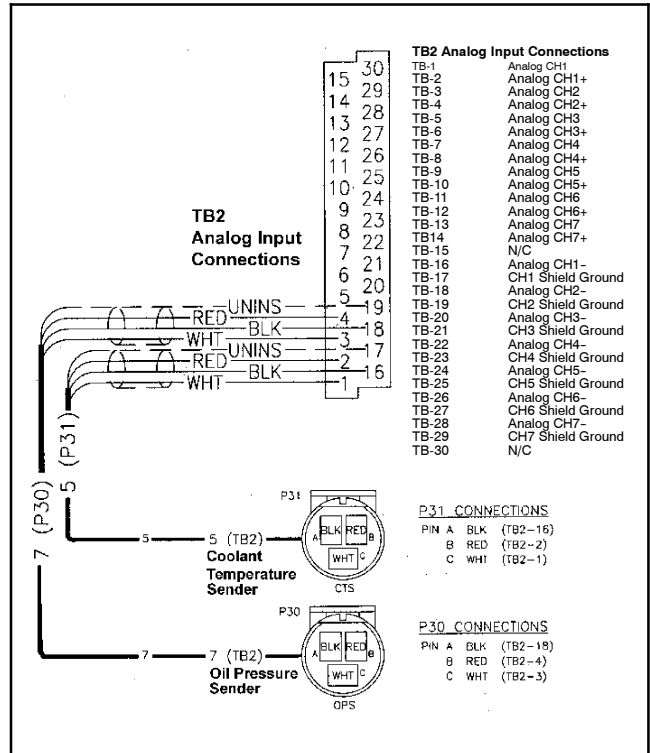

Figure 3-8 TB2 Analog Inputs

The oil pressure input is responsible for low oil pressure warning and shutdown functions and for the oil pressure value (menu 2). The coolant temperature sender is responsible for high coolant temperature warning and shutdown functions, low coolant temperature warning, and coolant temperature value (menu 2).

Analog inputs 1-2 for non-ECM units do not have access for adjustment or calibration. The oil pressure and coolant temperature parameters and calibration are part of the factory-installed personality program for the controller, and no further adjustment is necessary.

3.6 Zeroing Auxiliary Analog Inputs

In the calibration process for analog inputs (menu 12), the sender needs to be zeroed out. To accomplish this, disconnect the P2 ribbon cable prior to the zeroing out procedure. See Figure 3-9. After P2 has been disconnected, answer *yes* to the question ZERO AUX. ANALOG INPUTS? Then reconnect P2 connector to complete the sender calibration.

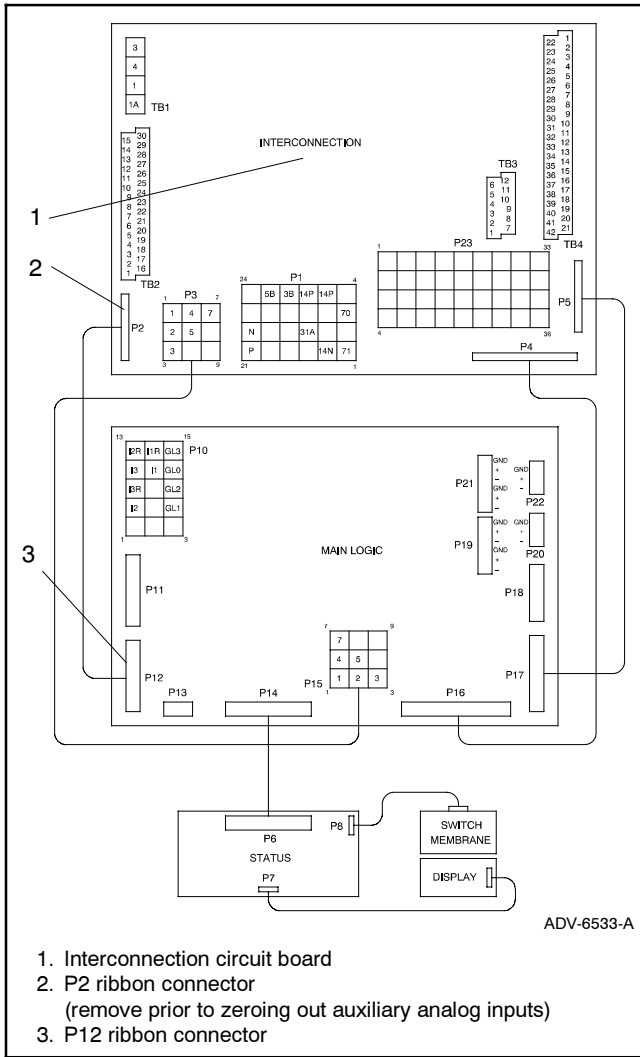

Figure 3-9 Interconnection Circuit Board Ribbon Connector P2 (Top View of Circuit Board)

3.7 Analog Inputs (Calibration)

Using the analog input requires a sender or device that is scaled based on a 0-5 VDC signal with a calibrated output. See Figure 3-10.

Example: Temperature Sender

.50 VDC @ 60°F
4.50 VDC @ 275°F

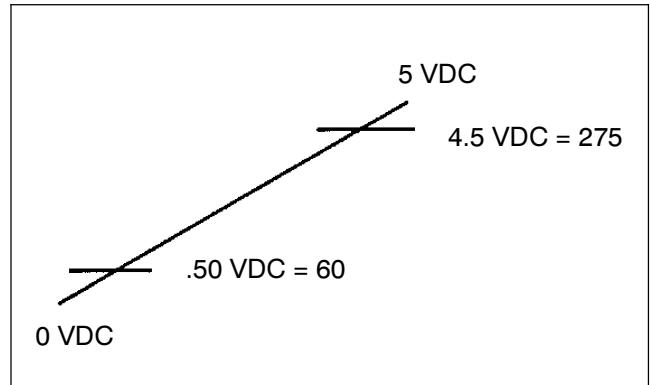

Figure 3-10 Analog Input Scale Values (sample)

Analog calibration is required; see menu 12. See Figure 3-11. To calibrate analog inputs, program two scale values to allow the controller to create a linear scale between the two values that represents the selected device.

To set scale value 1, program a scale value based on the sender output voltage. For example, if the sender device output is 0.50 VDC, the value represents 60°F (based on calibration data of temperature sender). To set scale value 2, increase the device output to 4.5 VDC and enter a value of 275 (representing 275°F). This completes the linear scale setup.

The acceptable scale range is 0 to 9999, giving a resolution of one part in 10,000.

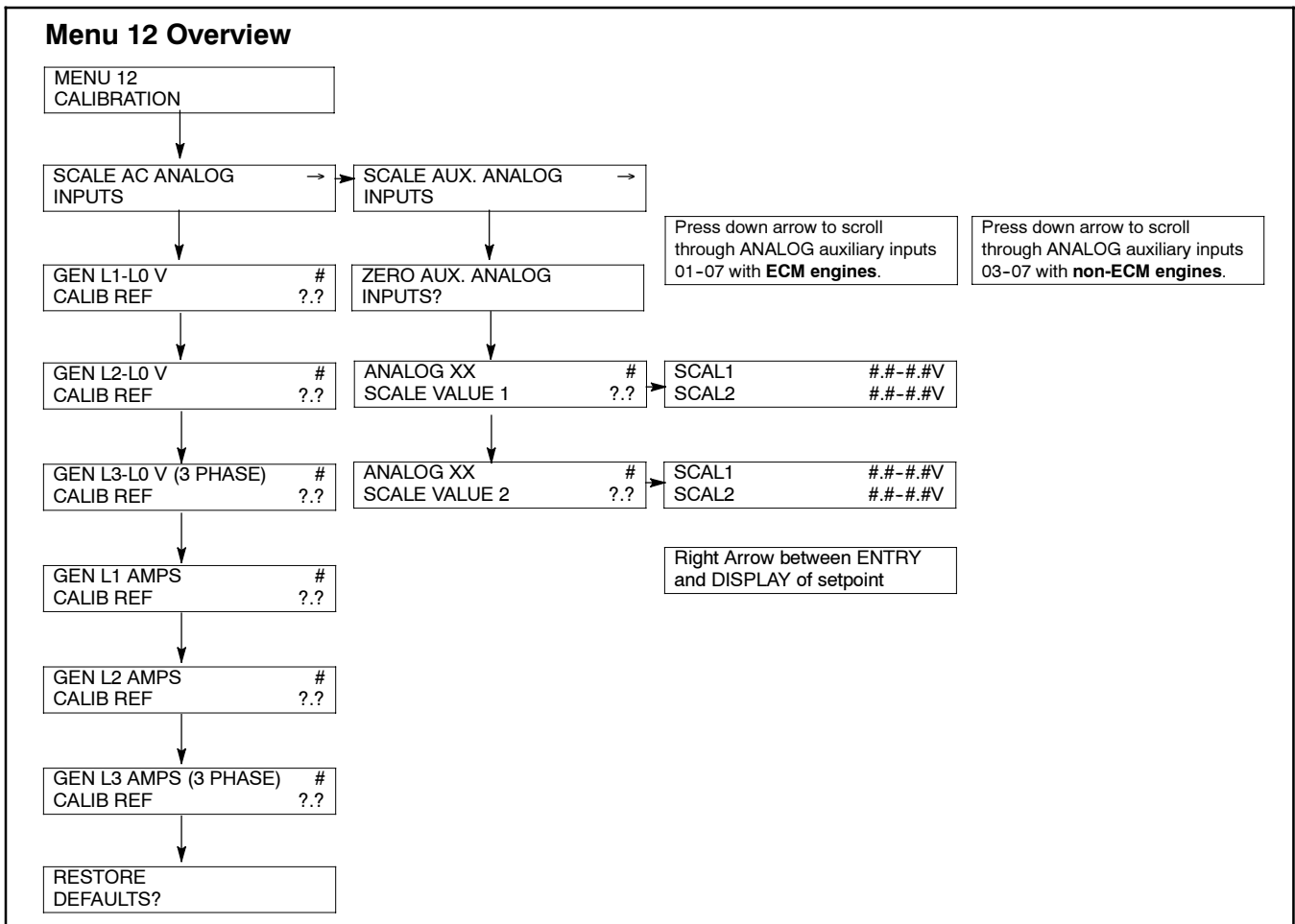

Figure 3-11 Menu 12, Calibration

3.8 Alternative Calibration Method

Substitute a potentiometer for the sender or device to calibrate the input values if it is difficult to adjust the sender output. Install a potentiometer in place of the three-wire sender to adjust the voltage between 0-5 VDC, and enter the calibrated values when the input value matches the known calibrated value. See Figure 3-12.

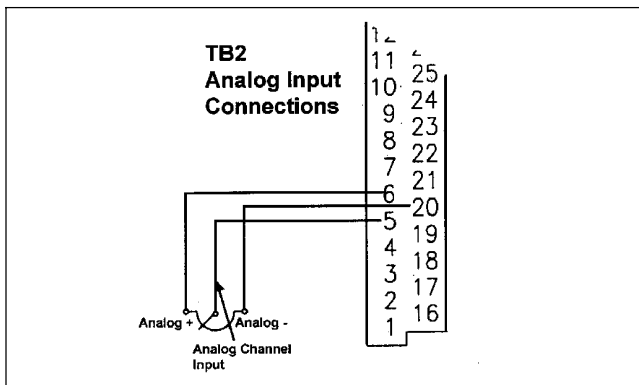

Figure 3-12 Potentiometer Connections on TB2

A 10-turn, 10 kOhm potentiometer is recommended for fine adjustment in calibration.

Note: Remember to zero auxiliary analog inputs before entering calibrated values.

Example: Temperature Sender

.50 VDC @ 60°F
4.50 VDC @ 275°F

1. Wire the potentiometer according to Figure 3-13.
2. Adjust the potentiometer for value 1 to read 0.5 volts and enter 60 for the known calibrated value.
3. Adjust the potentiometer for value 2 to read 4.5 volts and enter 275 for the known calibrated value.

3.9 Analog Input (Warning/Shutdown)

Define the analog input as a warning and/or shutdown device or the analog input can be used for data information purposes only. To program the desired function, the user defines variables in menu 9. This menu allows the user to define the analog input for the desired application.

Procedure to define an analog input as a warning and/or shutdown:

1. After entering the analog input in menu 9, enable or activate the input as a warning and/or shutdown. If neither is selected, the input displays data but no action is associated with the input. See Figure 3-13.

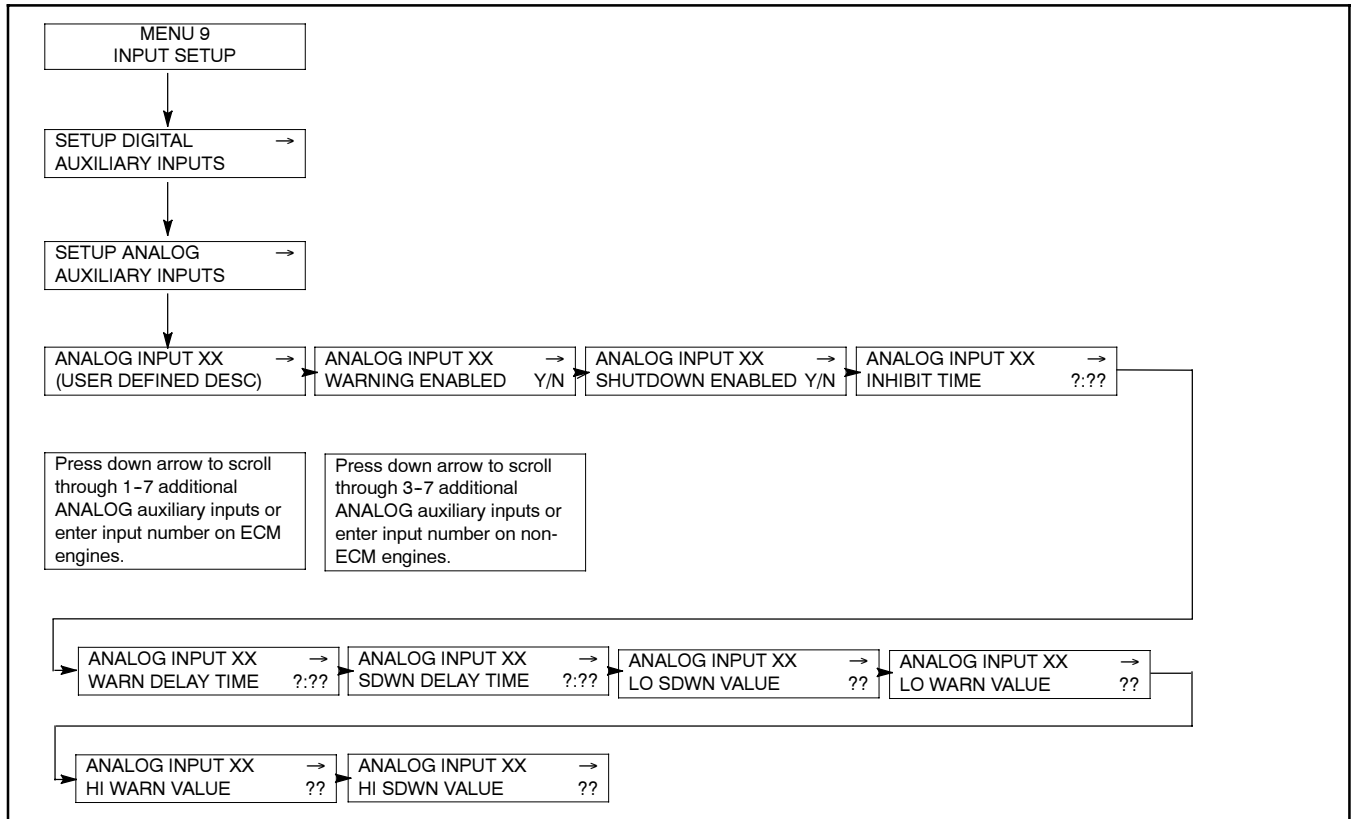

Figure 3-13 Menu 9, Input Setup

2. After the input is activated, program an inhibit time. This is a time delay preventing an action for a time (inhibit) after a crank disconnect. Typically this time is set at 30 seconds.

Note: To have the input *active* at all times, set the inhibit time to 0.

3. Program the delay time to function after the inhibit time delay has timed out. This time delay is the time period between when the controller first detects the fault and when the controller indicates a warning or shutdown. The fault must be present for the total delay time.
4. Enter values to initiate the controller action as a warning or shutdown. The operator determines the application values and enters the values based on the calibrated scale in menu 12. See Figure 3-14 for an example of warning and shutdown values.

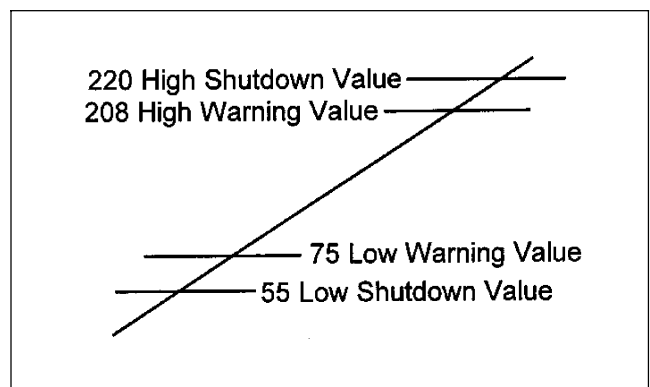

Figure 3-14 Setting Warning and Shutdown Values

3.10 Relay Driver Outputs (Menu 10)

Up to 31 RDOs are available to define using the system events, digital inputs, and analog inputs giving the user flexibility for control or remote annunciation. RDOs provide only the relay driver, not the relay. RDOs are used in conjunction with the customer connection kit and, typically, will drive all relay kits. Refer to Appendix D for RDO factory designations and user-defined designations.

3.10.1 NFPA Defaults

If the controller is programmed with NFPA enabled (menu 7), the controller will automatically define a number of RDOs as defaults, and the user cannot reset these defaults. If the user attempts to reassign the default, a message displays *Cannot Change NFPA is Enabled*.

3.10.2 Common Fault

The user can program the common faults (menu 10) from the list of system events, digital inputs, and analog inputs. To define a common fault, go through the submenus and enter yes to any items wanted as part of a common fault. Then designate an RDO (1-31) to drive the common fault relay output. See Figure 3-15.

A common fault acts as an *or* function. The output occurs when any one of the items occur, such as A or B or C, etc.

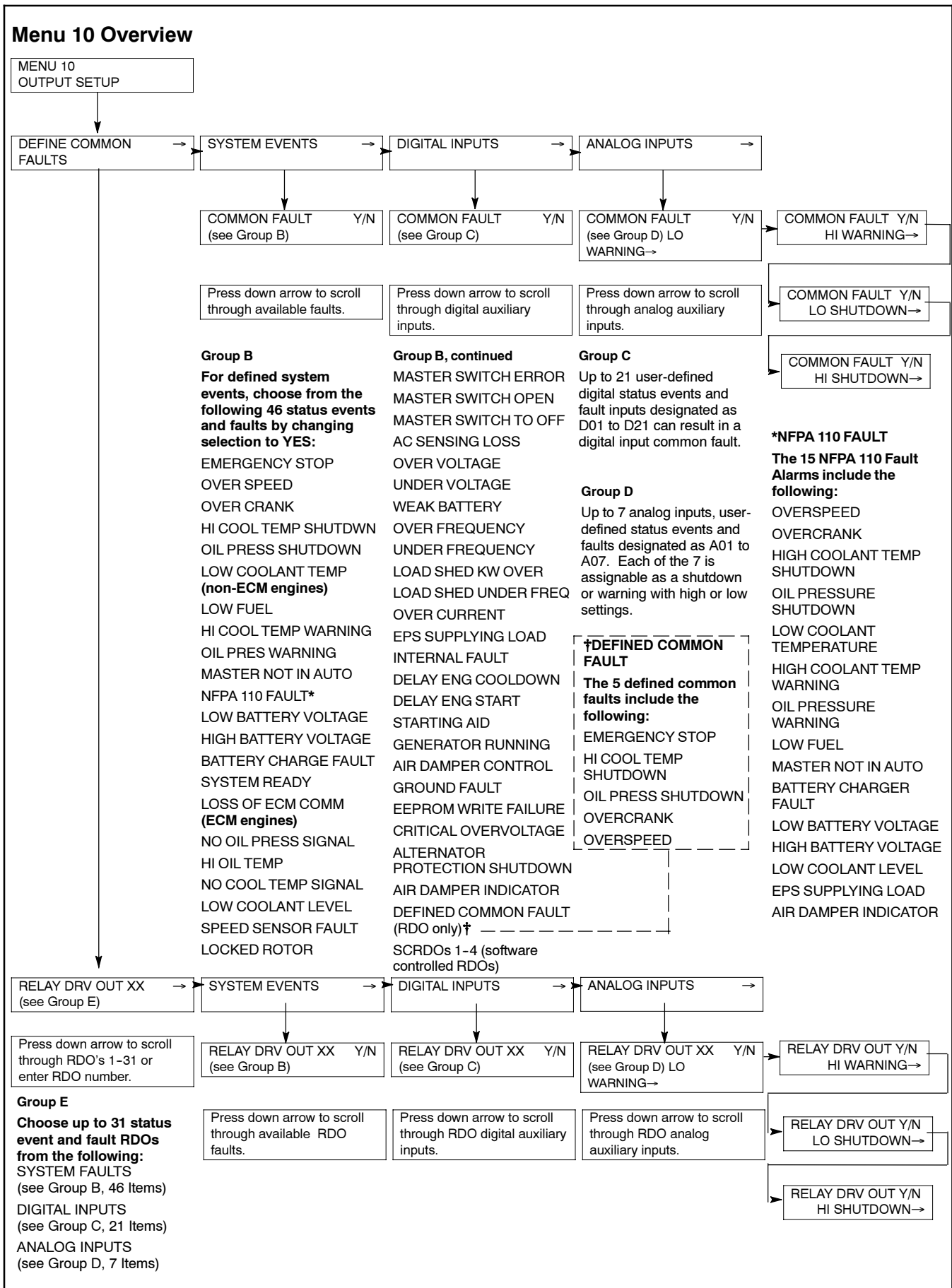

Figure 3-15 Menu 10, Output Setup

Section 4 Accessory Installations

4.1 Accessories and Connections

Several accessories help finalize installation, add convenience to operation and service, and establish state and local code compliance.

Accessories vary with each generator set model and controller. Select factory-installed and/or shipped-loose accessories. See Figure 4-1 for a list of available kits. Kit and installation instruction part numbers change. Obtain the most current accessory information from your local authorized service distributor/dealer.

This section describes several accessories available at the time of print of this publication. Accessory kits generally include installation instructions. See the wiring diagram manual for electrical connections not shown in this section. See the installation instructions and drawings supplied with the kit for information on the kit mounting location. See Figure 4-2 and Figure 4-3.

The instructions provided with the accessory kit supersede these instructions where there are differences. Always run AC and DC wiring in separate conduit. Use shielded cable for all analog inputs. Observe all applicable national and local electrical codes during accessory installation.

Kit Description	Kit Part Numbers	Installation Instructions
Audiovisual Alarm	GM17070-KP1, GM17070-KP2, GM17070-KP3	TT-1300
Battle Switch	New	New
Common Failure Relay (terminal 32A)	GM17028-KP2, GM17032-KP2, 365569-KP14	TT-1301
Controller (customer) Connection	GM17028-KP1, GM17032-KP1	TT-1302
Float/Equalize Battery Charger (with alarms)	PAD-292863 (12 volt), PAD-292865 (24 volt)	TT-680
Idle (speed) Mode Feature	No kit required. Use customer-supplied switch and leads.	See operation manual (idle mode feature)
Key Switch	New	New
Low Fuel (level) Switch	Multiple kits based on generator set subbase fuel tank or day tank selection. Note: The main fuel tank may include this switch as provided by the fuel tank supplier.	Multiple TTs or contact main fuel tank supplier.
Low Fuel (pressure) Switch	Multiple kits based on generator set model number.	Multiple TTs
Prime Power Switch	GM20652-KP1	New
Remote Annunciator (16-light panel)	GM17071-KP1, GM17071-KP2, GM17071-KP3	TT-1303
Remote Emergency Stop	PA-293906	New
Remote Reset Feature	No kit required. Use customer-supplied switch and leads.	See operation manual (remote reset feature)
Remote Speed Adjustment Potentiometer (requires electronic governor)(non-ECM models only)	PA-273768	TT-774
Run Relay	PA-273743 (12 volt), PA-273744 (24 volt), 365569-KA8 (24 volt)	New
Single-Relay Dry Contact	GM17068-KP1, GM17068-KP2, 365569-KP9	TT-1304
Ten-Relay Dry Contact	GM17069-KP1, GM17069-KP2, 365569-KP10	TT-1305
Twenty-Relay Dry Contact	365569-KA13	New

Figure 4-1 Optional Accessories

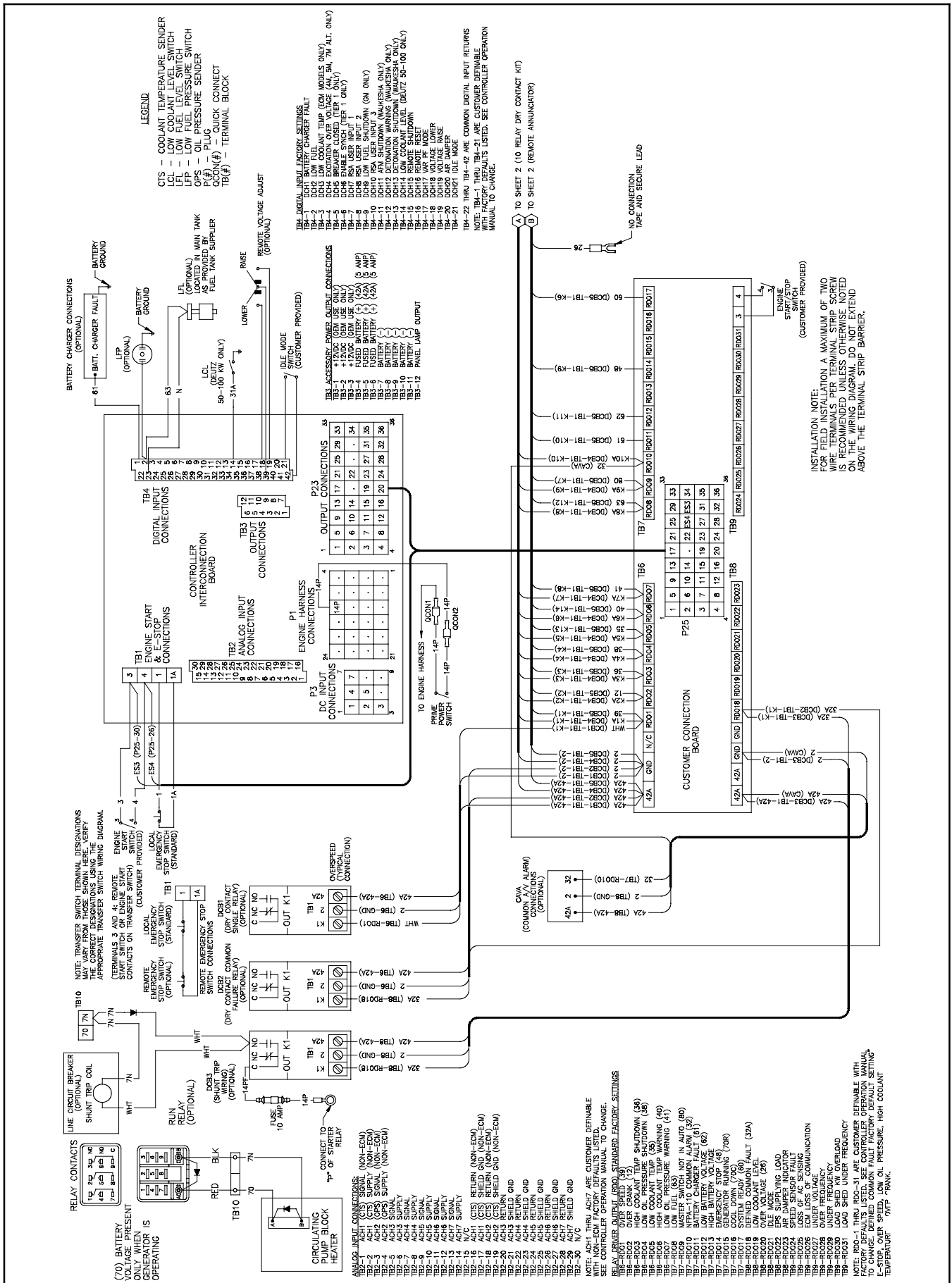
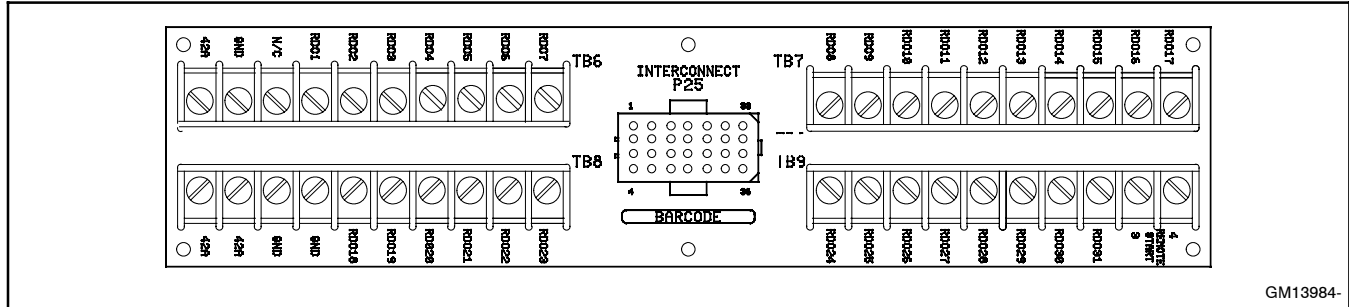

Figure 4-2 Accessory Connections, GM16088A-F

4.2 Controller (Customer) Connection Kit

A controller connection kit is required when a contact kit and/or the remote annunciator (NFPA remote audiovisual alarms) are specified.

The connection kit allows connection of accessories without opening the controller to make multiple terminal connections. The kit uses a wiring harness with plug connectors to link the controller's RDOs and power connections to a customer connection board for easy connection and identification of outputs. Remote start terminals are also accessible from the customer connection board. See Figure 4-4 and Figure 4-5.



GM13984-

Figure 4-4 Terminal Strips TB6, TB7, TB8, and TB9 on the Controller Connection Kit in the Junction Box

TB6 Terminal Strip—RDOs 1-7		TB9 Terminal Strip—RDOs 24-31	
Term.	Description	Term.	Description
42A	Battery (+)	RDO24	Speed sensor fault
GND	Battery (-)	RDO25	Loss of AC sensing
N/C		RDO26	ECM loss of communication
RDO1	Overspeed (39)	RDO27	Undervoltage
RDO2	Overcrank (12)	RDO28	Overfrequency
RDO3	High coolant temperature shutdown (36)	RDO29	Underfrequency
RDO4	Low oil pressure shutdown (38)	RDO30	Load shed kW overload
RDO5	Low coolant temperature (35)	RDO31	Load shed underfrequency
RDO6	High coolant temperature warning (40)	3	Remote start
RDO7	Low oil pressure warning (41)	4	Remote start
TB7 Terminal Strip—RDOs 8-17		Note: RDO-1 though RDO-31 are customer definable with the following factory defaults: emergency stop, high coolant temperature, low oil pressure, overcrank, and overspeed. Numbers in parentheses are the factory wire designations.	
Term.	Description	*NFPA 110 common alarm faults include:	
RDO8	Low fuel (63)	Air damper indicator	
RDO9	Master switch not in auto (80)	Battery charger fault	
RDO10	NFPA 110 common alarm (32)*	EPS supplying load	
RDO11	Battery charger fault (61)	High battery voltage	
RDO12	Low battery voltage (62)	High coolant temperature warning	
RDO13	High battery voltage	High coolant temperature shutdown	
RDO14	Emergency stop (48)	Low battery voltage	
RDO15	Generator running (70R)	Low coolant level	
RDO16	Time delay engine cooldown (TDEC) (70C)	Low coolant temperature warning	
RDO17	System ready (60)	Low fuel (level or pressure)	
TB8 Terminal Strip—RDOs 18-23		Low oil pressure warning	
Term.	Description	Low oil pressure shutdown	
42A	Battery (+)	Master switch not in auto	
42A	Battery (+)	Overcrank	
2	Battery (-)	Overspeed	
2	Battery (-)		
RDO18	Defined common fault (32A)		
RDO19	Low coolant level		
RDO20	Overvoltage (26)		
RDO21	Idle mode		
RDO22	EPS supplying load		
RDO23	Air damper indicator (56)		

Figure 4-5 Controller (Customer) Connection Kit Terminal Strip Identification with Factory-Assigned Relay Driver Outputs (RDOs)

4.3 Interconnect Circuit Board

The interconnect circuit board contains four control relays: K1 (crank), K2 (run), K3 (emergency stop), and K4 (panel lamps). Main circuit board logic controls the K1, K2, and K4 relays. The manual E-Stop switch located on the control panel controls the K3 relay. See Figure 4-6 and Figure 4-7.

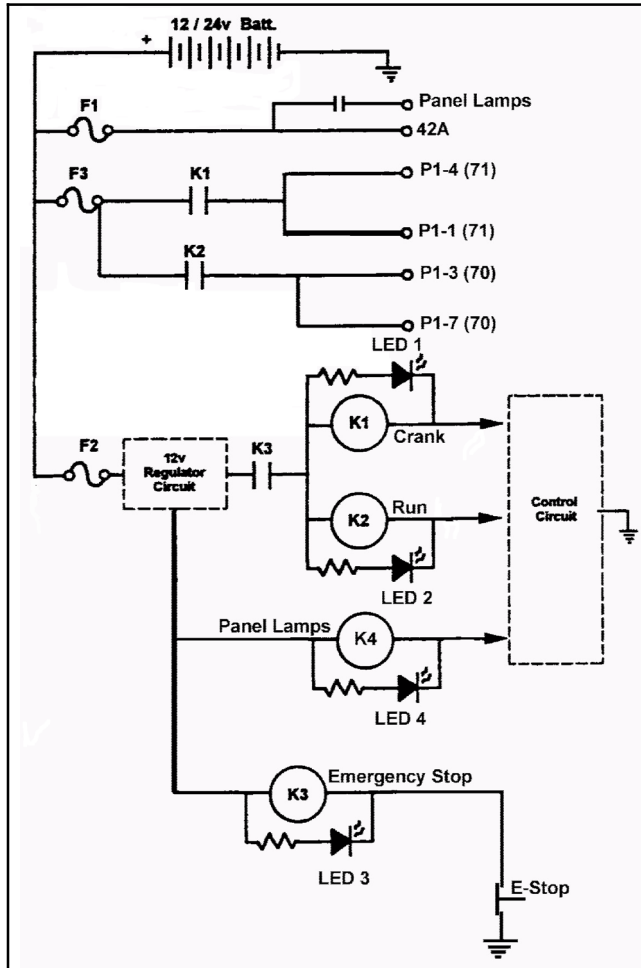

Figure 4-6 Interconnect Circuit Board Schematic

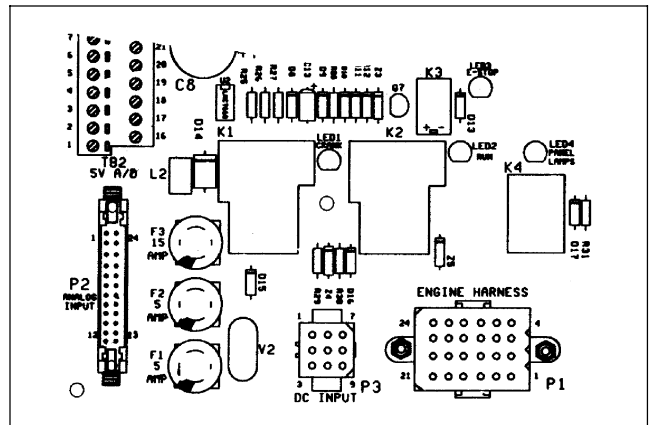

Figure 4-7 Interconnect Circuit Board Layout

K1 Relay. Energized only during the engine crank cycle. Wire 71 energizes when the K1 contact closes. LED 1 lights when power is supplied to the K1 relay coil.

K2 Relay. Energized during engine cranking cycle and normal engine running. The relay energizes when the control logic issues a start command. Wire 70 energizes when the K2 contacts close. LED 2 lights when power is supplied to the K2 relay coil.

K3 Relay. Energized at all times unless the emergency stop switch activates. When activated, the K3 contact opens, disabling power to the K1 and K2 relay coils.

K4 Relay. Energized when the main logic board turns on the panel lamps. Touch the keypad to turn on the light. The light turns off five minutes after the last keypad entry.

Three fuses mounted to the board protect the controller, customer accessories, and engine wiring.

F1 Fuse. Provides 5-amp circuit protection to 42A, which powers the customer-connected options and the panel lamps.

F2 Fuse. Provides 5-amp circuit protection for the controller's 12-volt regulator circuit, including K1, K2, K3, K4, and relay coils.

F3 Fuse. Provides 15-amp protection for the engine control circuit and other devices powered by wire 70 or wire 71.

Notes

5.1 Factory Setup

The controller is functional after the factory setup is complete. Both an application program and personality parameters are factory-entered into the 550 controller. The application program controls the controller operating functions.

The personality parameter files specify the controller characteristics to match the alternator and engine requirements for generator set operation. Parameters include alternator characteristics for current and voltage protection, voltage regulation, calibration for oil pressure and water temperature if required, specification number, and serial number. A backup disk containing the personality parameters file and application file is created at the factory. The literature package shipped with the generator set includes the backup disk.

5.2 Program Loader

Use the Program Loader to load the files from a PC to the controller when replacing the 550 controller or upgrading the application program or personality files. See Figure 5-1. This program allows the technician to access the files stored on the backup disk and download the files to non-volatile memory, overwriting the

controller's original program. Refer to TT-1285, the program loader software instructions, for installation and operation. If the disk is damaged or misplaced, a copy can be created by the manufacturer using the generator set serial number as reference.

5.3 Communications

The 550 controller's remote monitoring or programming is accomplished using the Monitor II communication software. The software is installed on a host PC, and a communication link (RS-232/RS485) is installed between the digital controller and the PC. The PC can then access data from the generator set controller. The software, under password control, also allows the operator to program the generator set remotely. Connect the host PC to the controller using the RS-232 for a single controller or RS-485 for multiple controllers. Access can also be made over phone lines with the addition of a modem.

The software package is a Windows®-based graphical user interface allowing the operator to build data windows specifically for their application. The software package also allows for multiple and simultaneous device displays when using a local area network. Refer to the software operation and installation manual when using the Monitor II software.

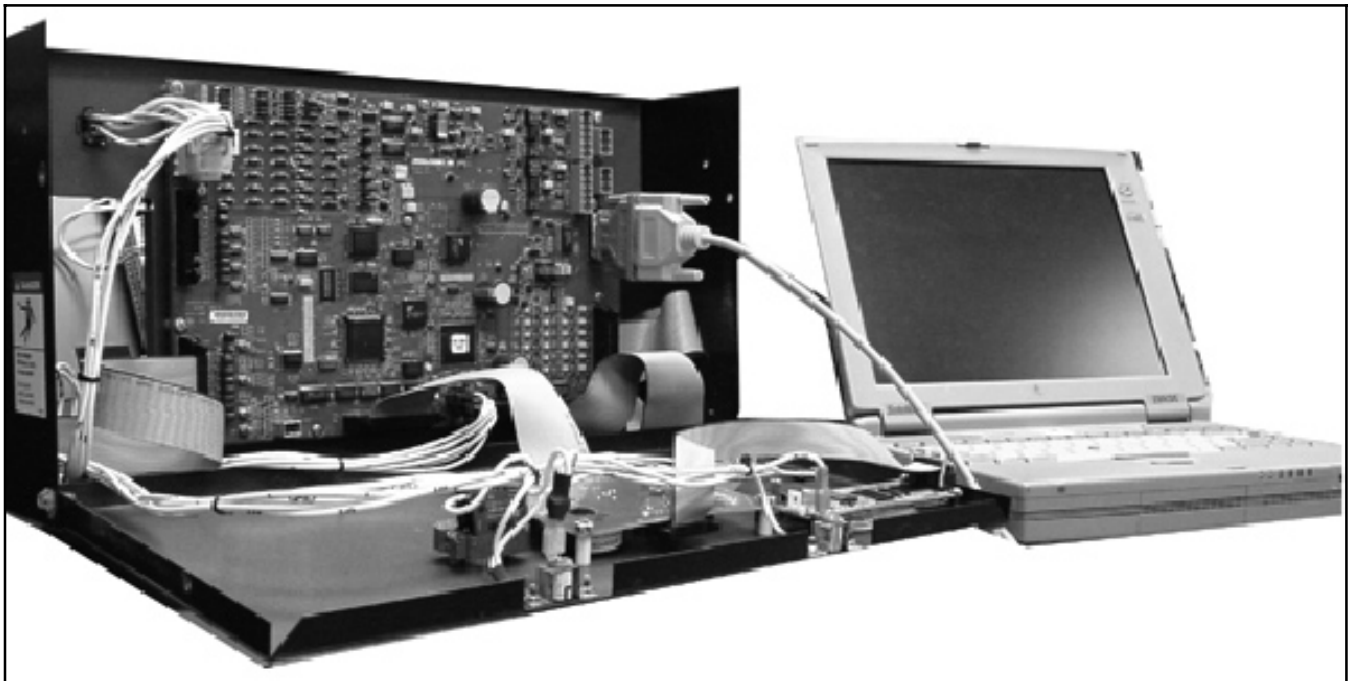

Figure 5-1 Program Loader Connections to the 550 Controller

Windows® is a registered trademark of Microsoft Corporation

5.4 Personal Computer Communications

Figure 5-2 identifies the four ways to communicate with a personal computer (PC) and the generator set using KBUS protocol, the generator set manufacturer's communication protocol. See Figure 5-3 and Figure 5-4.

Protocol	Description
Local Single Connection	A PC connects directly to the communication port with an RS-232 cable when the PC is within 15 m (50 ft.) of the device or RS-485* cable where the PC is up to 1220 m (4000 ft.) from the device. See Figure 5-5.
Local Area Network (LAN)	A PC connects directly to the device's local area network through an address (1-128). A LAN is a system that connects more than one device to a single PC. See Figure 5-6.
Remote Single Connection	A PC connects to a modem and a single device connects to a modem. The PC communicates to the device via a telephone network. Locate the PC anywhere a telephone line is available. See Figure 5-7.
Remote Area Network	A PC connects to a modem. The devices connect to a LAN network through a system ID and an address (1-128). The PC communicates to the devices via a telephone network that is interfaced to the LAN network. Locate the PC anywhere a telephone line is available. See Figure 5-8.

Figure 5-2 KBUS Communication Protocol

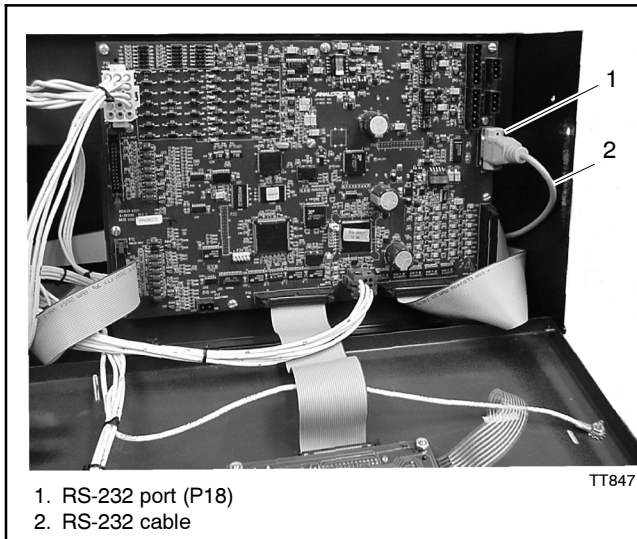

Figure 5-3 RS-232 Port Location and Connection for the 550 Generator Set Controller

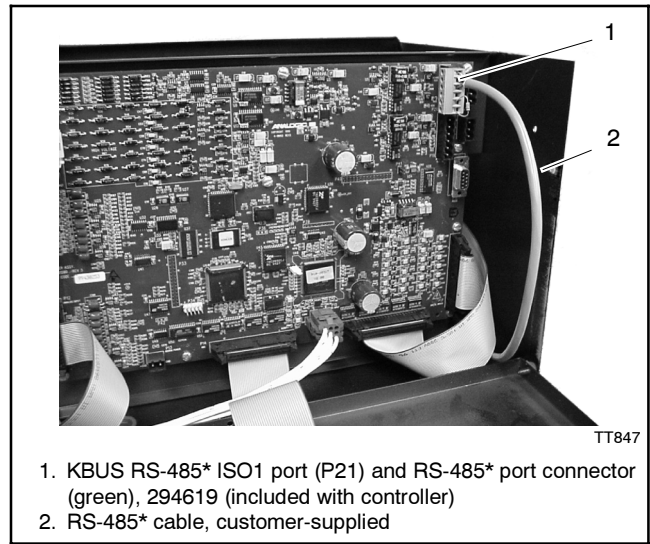

Figure 5-4 RS-485* KBUS Port Location and Connection for the 550 Generator Set Controller

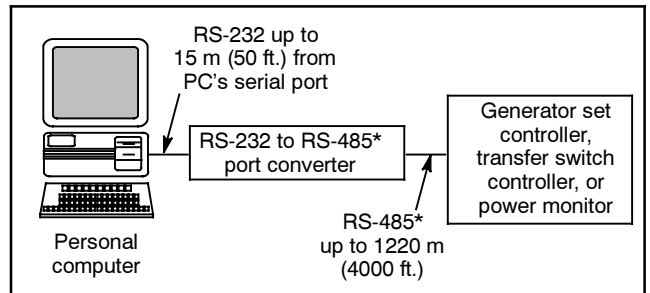

Figure 5-5 Local Single Connection, up to 1220 m (4000 ft.)

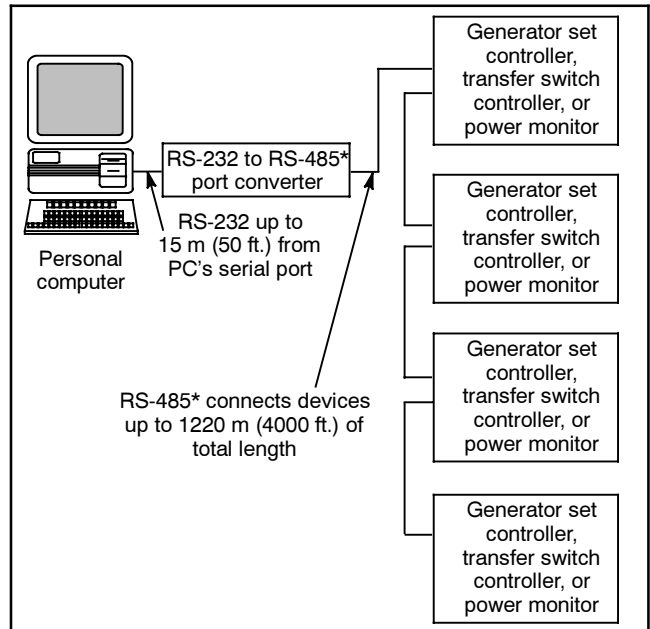

Figure 5-6 Local Area Network Connection, up to 128 Devices

* Belden #9841 or equivalent

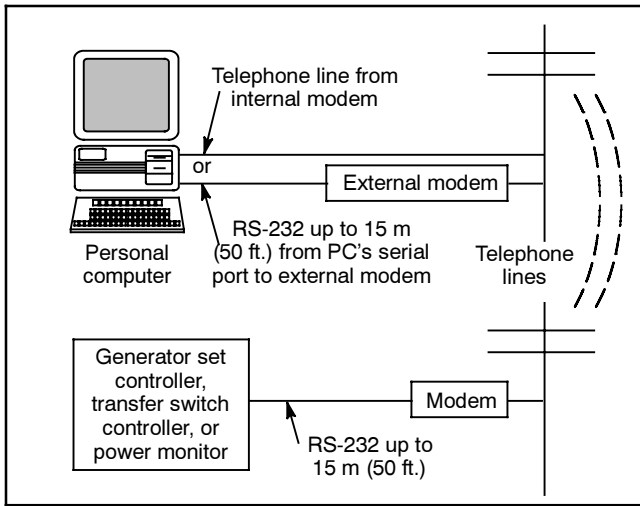

Figure 5-7 Remote Single Connection

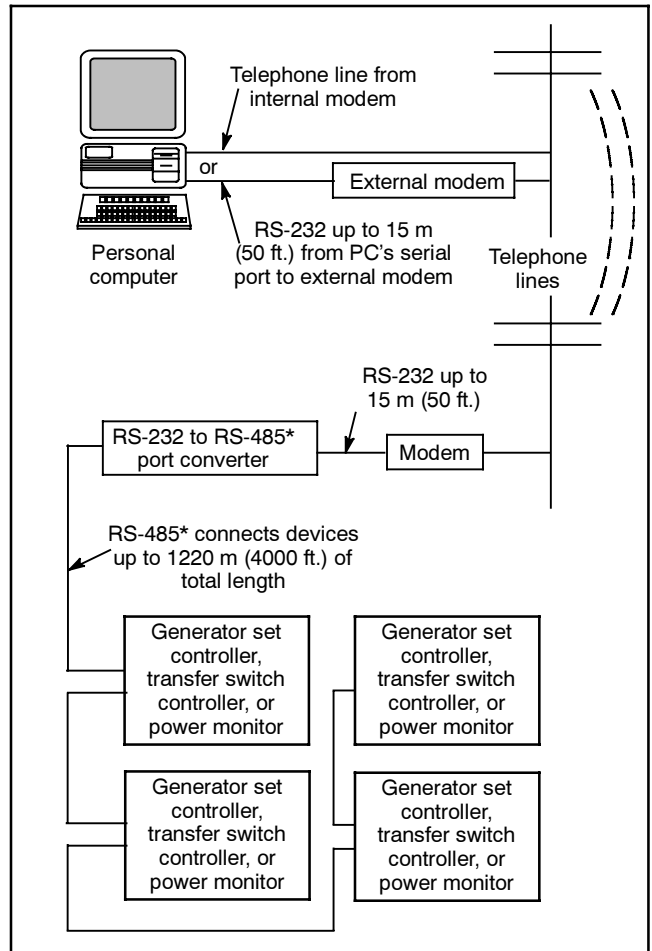

Figure 5-8 Remote Area Network Connection

* Belden #9841 or equivalent

5.5 Remote LAN Conversion

Use the 550 controller to convert RS-232 input signals from the PC to an RS-485* output for other network devices. This built-in converter eliminates the need for an external RS-232 to RS-485* converter. Use the 550 controller as a converter; connect the controller as the first device after the PC. Program (menu 13) them as either LOCAL LAN CONV or REMOTE LAN CONV depending on the application. See Figure 5-9 or Figure 5-10. To use the controller's built-in converter, the PC or modem connection must be within 15 m (50 ft.) of the 550 controller. If this distance is not possible, use the external RS-232 to RS-485* converter. LAN CONV sets the controller to convert the RS-232 signal to RS-485* output to other devices.

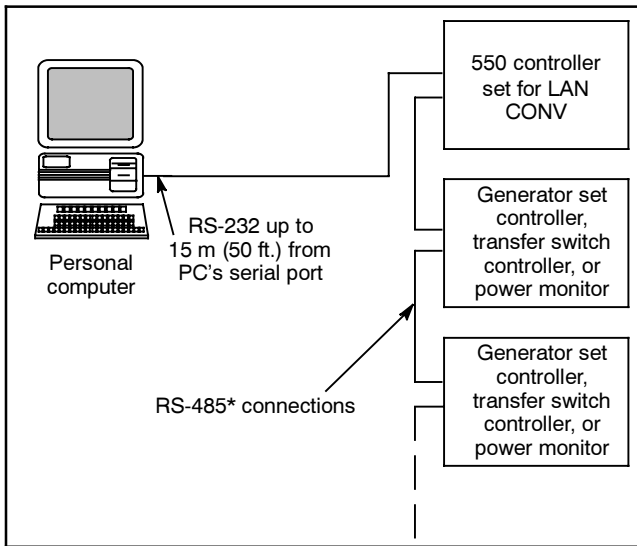

Figure 5-9 550 Controller LAN CONV Setting Converts a RS-232 PC Signal to a RS-485* Output to other Devices

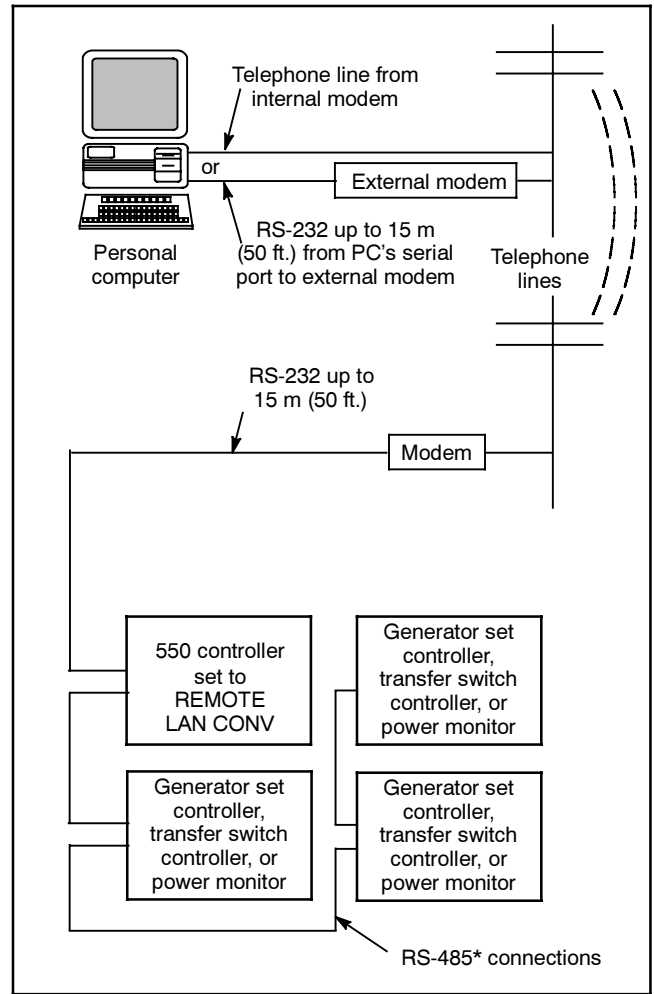

Figure 5-10 Remote Area Network Connection with a 550 Controller REMOTE LAN CONV Setting

* Belden #9841 or equivalent

5.6 Modbus Communications

Modbus® communications allow a host PC or Modbus master to obtain information from the generator set's 550 controller using Modbus communication protocol. See Figure 5-11. The Modbus protocol is viewed as an industry standard and was developed by the Modicon Corporation. The controller communicates using Modbus as a slave connection with the Modbus master initiating the communications. See See Figure 5-12. Modbus communications were developed so software applications other than Monitor II software can be used to gain access to 550 controller information. The Modbus master interrogates the controller system for alternator and engine parameters and also for diagnostic information. The controller also accepts data to alter controller parameters, including generator set start and stop functions.

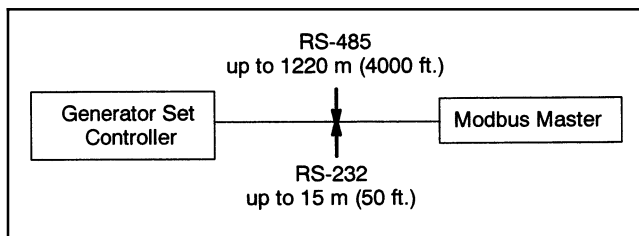

Figure 5-11 Generator Set Controller to Modbus Master Connections using RS-232 or RS-485*

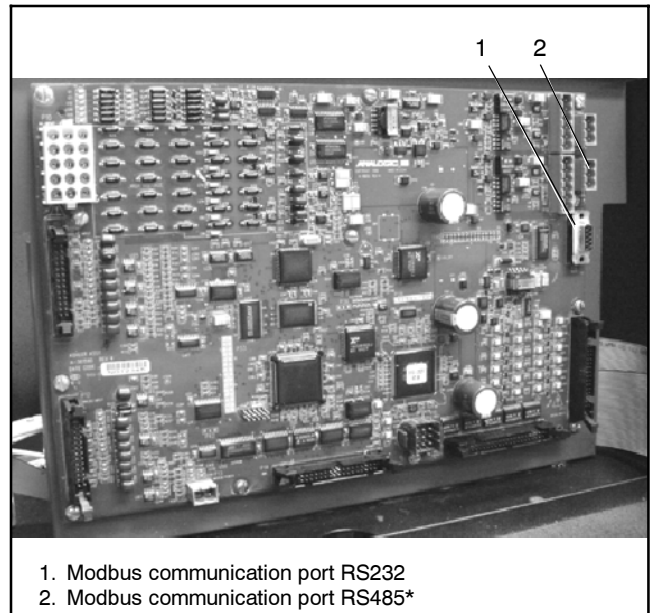

Figure 5-12 Main Logic Board

Modbus® is a registered trademark of Schneider Electric
* Belden #9841 or equivalent

Notes

Section 6 Controller Replacement

6.1 Introduction

The 550 controller service replacement kit is available to replace a non-functional 550 controller. Use the following procedure to install the replacement controller. See Figure 6-1 for typical controller identification.

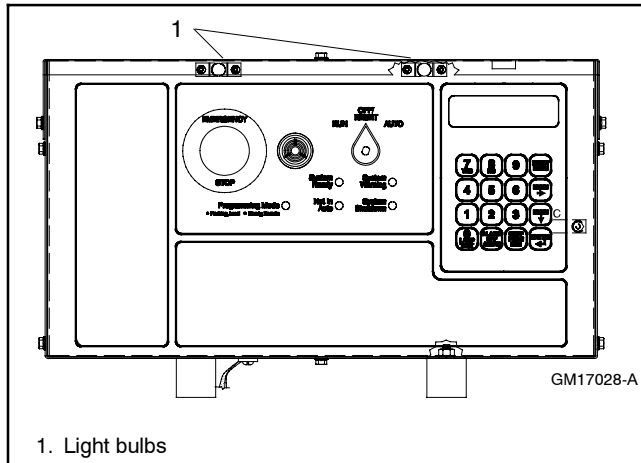

Figure 6-1 550 Controller Front Panel

When replacing the 550 controller, three files must be resident for the 550 controller to function.

- **Application program** contains the software that controls system operation. The application file is preprogrammed in the 550 controller at the factory.
- **Personality profile** is specific to the engine and alternator and is preprogrammed in the 550 controller at the factory. A backup disk of the personality profile is supplied with the literature packet. Typically, the distributor stores this disk for possible future use such as controller replacement or other circumstances requiring a backup.

Note: If the personality disk is *not* available, request a replacement from the manufacturer using the generator set serial number or order number.
- **User parameters** unique to an installation include timer values, setpoints, generator set data such as kW and voltage, and input/output selections. These parameters are typically set up for or by the installer at the time of installation. Created user parameters are typically documented and stored on the personality profile disk, a separate backup disk, or written in Appendix C in the 550 controller operation manual. See Appendix C of this manual for a copy of the Controller User-Defined Settings form.

Note: If the user parameters are included on the personality disk, the disk label should indicate Site Program—Yes.

Read the entire installation procedure and compare the kit parts with the parts list in this publication before beginning installation. Perform the steps in the order shown.

Always observe applicable local and national electrical codes.

Note: The following service kit procedure changes only the controller. If the generator set requires voltage reconnection and/or frequency adjustment, see the 550 controller operation manual TP-6083 for Software (Code) Version Prior to 2.10 and TP-6200 for Software (Code) Version 2.0 or higher.

6.2 Installation

6.2.1 Requirements

The following items are necessary PC requirements for installing the controller service replacement kits.

- Program loader kit GM17732 or GM17733. See the program loader kit instructions for additional items needed to complete the installation. The program loader kit includes the Monitor II software, version 2.2.5 or later.

Use the Monitor II software, version 2.2.5 or greater, to enter the user parameters from a backup disk and/or enter alphanumeric data. See the Monitor II software instructions for additional items.
- Null modem RS-232 cable with a 9-pin male plug on the controller end, part no. GM16657 or kits PA-294992 or PA-294992-SD.

6.2.2 Procedure

Observe the following safety precautions while installing the kit.

⚠ WARNING



Accidental starting.
Can cause severe injury or death.

Disconnect the battery cables before working on the generator set. Remove the negative (-) lead first when disconnecting the battery. Reconnect the negative (-) lead last when reconnecting the battery.

Disabling the generator set. Accidental starting can cause severe injury or death. Before working on the generator set or connected equipment, disable the generator set as follows: (1) Move the generator set master switch to the OFF position. (2) Disconnect the power to the battery charger. (3) Remove the battery cables, negative (-) lead first. Reconnect the negative (-) lead last when reconnecting the battery. Follow these precautions to prevent starting of the generator set by an automatic transfer switch, remote start/stop switch, or engine start command from a remote computer.

⚠ WARNING



Hazardous voltage. Moving parts.
Can cause severe injury or death.

Operate the generator set only when all guards and electrical enclosures are in place.

Grounding electrical equipment. Hazardous voltage can cause severe injury or death. Electrocutation is possible whenever electricity is present. Ensure you comply with all applicable codes and standards. Electrically ground the generator set, transfer switch, and related equipment and electrical circuits. Turn off the main circuit breakers of all power sources before servicing the equipment. Never contact electrical leads or appliances when standing in water or on wet ground because these conditions increase the risk of electrocution.

Connecting the battery and the battery charger. Hazardous voltage can cause severe injury or death. Reconnect the battery correctly, positive to positive and negative to negative, to avoid electrical shock and damage to the battery charger and battery(ies). Have a qualified electrician install the battery(ies).

Short circuits. Hazardous voltage/current can cause severe injury or death. Short circuits can cause bodily injury and/or equipment damage. Do not contact electrical connections with tools or jewelry while making adjustments or repairs. Remove all jewelry before servicing the equipment.

1. Acquire the user parameters.
 - a. Choose one of the following methods to retrieve the user parameters:
 - Backup disk. If a backup disk was previously made, obtain the parameters from this disk. If a disk was not previously made, create a backup if possible using the Monitor II software, version 2.2.5 or greater. The existing controller must function in order to create the file.
 - Paper form. Parameters should have been recorded on the User-Defined Settings form located in the 550 controller operation manual, Appendix C, or other similar form.
 - Controller menu. Manually review the controller menu displays if possible and enter the parameter information in the 550 controller operation manual, Appendix C, User-Defined Settings, form.
 - b. Save the user parameter data.
2. Acquire display data from the old controller for entry in the new controller.

Certain data cannot be stored on electronic media for archival purposes and must be entered using a PC or the controller keypad.

When possible, make note of the following data from the old controller for entry in the new controller. If the old controller is not functional, the installer *must* determine and document this information for entry later in this procedure. See Appendix C for the Controller User-Defined Settings form.

- a. From menu 7, Generator System
 - Metric Units, yes or no
- b. From menu 12, Calibration
 - Scale Aux. Analog Inputs. Repeat for each input 01-07
 - Analog 01, scale value 1
 - Analog 01, scale value 2

c. From menu 13, Communication

(1) Protocol KBUS

- KBUS online, yes or no
- Connection type
 - Local single, yes or no
 - Local LAN, yes or no
 - Local LAN conv, yes or no
 - Remote single, yes or no
 - Remote LAN, yes or no
 - Remote LAN conv, yes or no
- Primary port
 - RS-232, yes or no
 - RS-485 ISO1, yes or no
- Address (LAN connections)
- System ID (remote connections)
- BAUD rate
 - 1200
 - 2400
 - 9600

(2) Protocol Modbus

- Modbus online, yes or no
- Connection type
 - Single, yes or no
 - Convertor, yes or no
- Primary port
 - RS-485
 - RS-232
- Address
- BAUD rate
 - 9600
 - 19200

d. From menu 20, Factory Setup

- Final assembly date
- Final assembly clock number
- Model number
- Spec number
- Serial number

3. Acquire display data from the old controller for reference purposes.

When possible, write down the old controller display data in Appendix B. This data is not required for the new controller but may be needed for future reference. If the old controller is not functional, the information is no longer retrievable.

4. Remove the generator set from service.

- a. Place the generator set master switch in the OFF position.
- b. Disconnect power to battery charger, if equipped.

c. Disconnect the generator set engine starting battery(ies), negative (-) lead first.

5. Disconnect the existing 550 controller electrical connections.

- a. Remove the controller cover. If access to the interconnection circuit board on the rear panel and/or the main logic/communication circuit board on the front panel is difficult, partially disassemble the controller box. Remove the two controller panel top screws and center bottom screw and then loosen the bottom panel screw on each side to swing the controller panel down. See Figure 6-2.

Note: Clearly mark all disconnected leads from the 550 controller with tape to simplify reconnection.

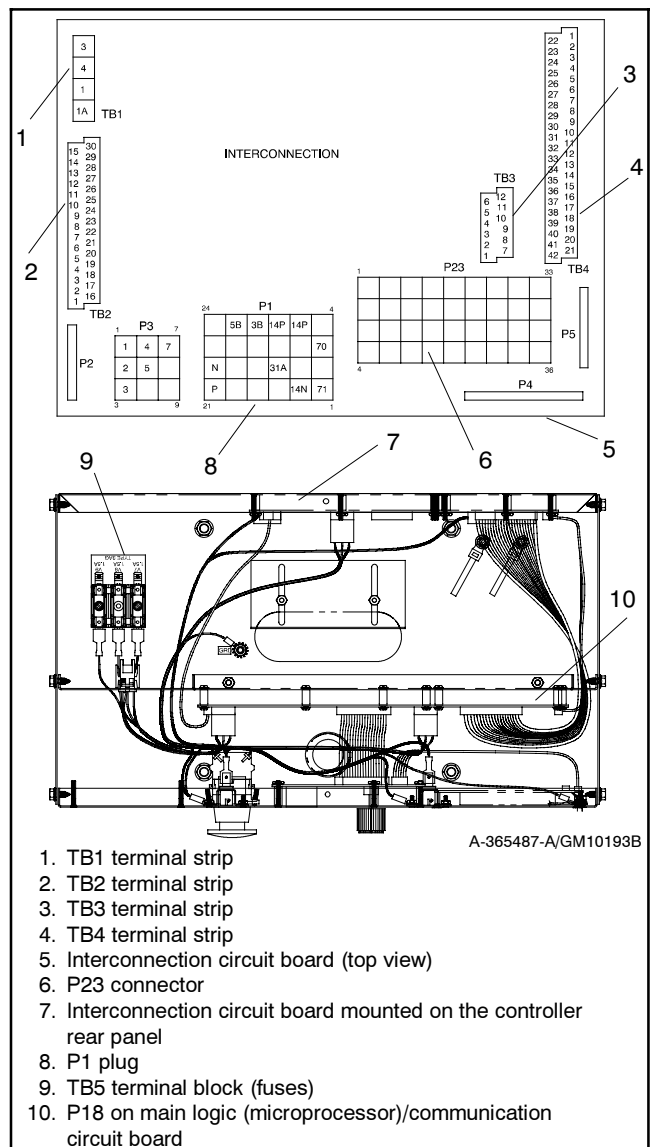

Figure 6-2 Disconnecting Controller Circuit Board External Wiring Connections

b. Disconnect the 550 controller harness leads. Listed below are some common leads and plugs that require removal or disconnection. Items below in **bold** are shown in Figure 6-2. These connections are typical and may not apply to all situations. See the corresponding wiring diagram found in the wiring diagrams manual.

- AC fuse terminal block **TB5** leads V7, V8, and V9
- All external connections to terminal strips **TB1, TB2, TB3, and TB4**
- CT/meter scale terminal block lead V0
- P24 connector to the CT burden resistor board
- Plug **P1** on the burden resistor board and the 350–3250 kW voltage regulator interface board
- Plug **P23** to the controller connection strip in the junction box
- Plug P22 to the engine wiring harness
- Plug **P18** communication connection
- Prime power kit
- Any other external leads to the controller

6. Remove the existing 550 controller.

- a. Remove the junction box panel(s) to gain access to the controller vibromount screws.
- b. Remove the four controller vibromount screws from underneath the junction box top panel.
- c. Lift off the existing 550 controller.

7. Install the replacement 550 controller.

- a. Place the replacement 550 controller on the junction box top panel holes.
- b. Align the 550 controller vibromounts with the mounting holes and install four screws.

c. Change the controller’s front display lamps, if required. See Figure 6-1 for location. See Figure 6-3 for lamp identification. The factory ships the 550 controller with 12-volt lamps. Replace the bulbs in the controller with the lamps provided in the replacement kit if the generator set has a 24-volt engine electrical system. Determine the engine electrical system voltage using the generator set nameplate information.

Lamp Part Number	Voltage	Bulb Part Number
255126	12	1892
283420	24	313

Figure 6-3 Lamp Identification

8. Connect the replacement 550 controller.

a. Remove the controller cover. If access to the interconnection circuit board on the rear panel and/or the communication circuit board on the front panel is difficult, partially disassemble the controller box. Remove the two controller panel top screws and center bottom screw and then loosen the bottom screw on each side to swing the controller panel down. See Figure 6-2.

b. Reconnect the controller wiring that was previously removed. See the corresponding wiring diagram found in the wiring diagrams manual. Listed below are some common leads and plugs that may require reconnection. These connections are typical and may not apply to all situations.

- AC fuse terminal block **TB5** leads V7, V8, and V9
- All external connections to terminal strips **TB1, TB2, TB3, and TB4**
- CT/meter scale terminal block lead V0
- P24 connector to the CT burden resistor board
- Plug **P1** on the burden resistor board and the 350–3250 kW voltage regulator interface board
- Plug **P23** to the controller connection strip in the junction box
- Plug P22 to the engine wiring harness
- Prime power kit
- Any other external leads to the controller

- c. Swing the rear controller panel up and replace and tighten the screws, as necessary.
 - d. Replace the junction box panel(s) and screws.
9. Restore power to the generator set.
- a. Check that the generator set master switch is in the OFF position.
 - b. Reconnect the generator set engine starting battery, negative (-) lead last.
 - c. Reconnect power to the battery charger, if equipped.
10. Install the program/data files.
- a. Connect the PC serial port to the controller RS-232 port using a null modem RS-232 cable with a 9-pin male plug on the controller end. See TT-1285 for details.
 - b. Install the Program Loader program into the PC using the procedure outlined in TT-1285.
 - c. Insert the personality profile backup disk and load the data. See TT-1285 for details.
11. Establish the controller identity in menu 20.

The controller displays the following error message: GENSET S/N WARNING.

This procedure includes instructions on how to unlock and lock the factory setup after entering menu 20. Use the down arrow key to go to the setup lock menu for determining the setup status.

Note: After completing the factory setup always return the controller to the setup lock position to prevent inadvertent program changes.

- a. Press the RESET MENU key on the controller keypad.

- b. Use the controller keypad to go to menu 14, Programming Mode, and select programming mode—local. Use the information from the 550 controller operation manual as necessary.

Note: The factory default access code is the number 0.

- c. Press the RESET MENU key on the controller keypad.
- d. Use the controller keypad to go to menu 20, Factory Setup. See Figure 6-4 for displays.
- e. Arrow down to the SETUP LOCK display.

If the SETUP LOCK display indicates YES, go to step f.

If the SETUP LOCK display indicates NO, go to step g.

- f. Unlock the setup.
 - (1) Arrow down to the FINAL ASSEMBLY, CLOCK NO. display. Record the clock number on the controller display.
 - (2) Arrow right to ENTER CODE display.
 - (3) Use the controller keypad to enter the clock number previously recorded.
 - (4) Press the ENTER key. Changes to menu 20, Factory Setup, are now possible.

- g. Initialize the EEPROM.
 - (1) Arrow down to the CODE VERSION display.
 - (2) Arrow right to the INITIALIZE EEPROM display.
 - (3) Press the YES key to initialize the EEPROM.
 - (4) Press the ENTER key.

- h. Wait for completion of the system reset (approx. 5–10 seconds).

- i. Go to menu 20, Factory Setup. See Figure 6-4 for displays.

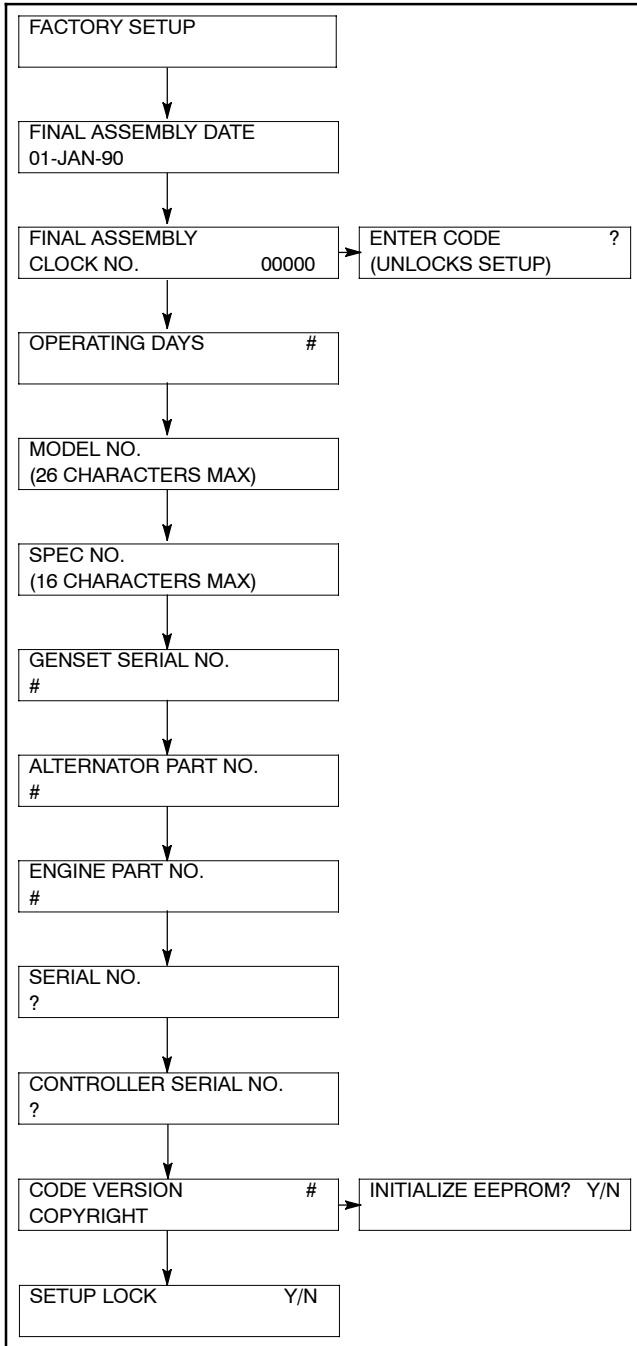

Figure 6-4 Menu 20, Factory Setup

- j. Change the final assembly date.
 - (1) Arrow down to the FINAL ASSEMBLY DATE display.
 - (2) Enter the final assembly date using the data recorded from the old controller. If data from the old controller is not available, keep the default setting.
 - (3) Press the ENTER key if making a new entry.

- k. Change the final assembly clock number.
 - (1) Arrow down to the FINAL ASSEMBLY CLOCK NO. display.
 - (2) Enter the final assembly clock number using the data recorded from the old controller. If data from the old controller is not available, keep the default setting.
 - (3) Press the ENTER key if making a new entry.

- l. Change the serial number.
 - (1) Arrow down to the SERIAL NO. display.
 - (2) Enter the serial number of the generator set using the data recorded from the old controller or as shown on the generator set nameplate. If the serial number is six digits, enter a *leading zero* to create a seven-digit serial number.
 - (3) Press the ENTER key. The GENSET S/N WARNING display no longer appears.

- 12. Perform the menu 13, Communications, entries.
 - a. Press the RESET MENU key on controller keypad.
 - b. Use the controller keypad to go to menu 13, Communications.
 - c. Complete the communication entries as necessary for remote programming. Use the information from the 550 controller operation manual as necessary. Use the information from the Monitor II software, version 2.2.5 or greater as necessary.

13. Perform the menu 14, Programming Mode, entries.
 - a. Press the RESET MENU key on controller keypad.
 - b. Use the controller keypad to go to menu 14, Programming Mode, and select programming mode—remote. Use the information from the Monitor II software, version 2.2.5 or greater.
14. Perform the menu 20, Factory Setup, entries using the Monitor II software generator info window. Use the information from the Monitor II software, version 2.2.5 or greater.
 - a. Change the model number.
 - (1) Go to the MODEL NO. display.
 - (2) Enter the model number using the data recorded from the old controller or as shown on the generator set nameplate.
 - b. Change the spec (specification) number.
 - (1) Go to the SPEC NO. display.
 - (2) Enter the spec number using the data recorded from the old controller or as shown on the generator set nameplate.
15. Perform the menu 14, Programming Mode, entries.
 - a. Press the RESET MENU key on the controller keypad.
 - b. Use the controller keypad to go to menu 14, Programming Mode and select programming mode—local. Use the information from the 550 controller operation manual as necessary.
16. Lock the menu 20, Factory Setup, entries.
 - a. Press the SETUP MENU key on the controller keypad.
 - b. Use the controller keypad to go to menu 20, Factory Setup.
 - c. Arrow down to the SETUP LOCK display.
 - d. Press the YES key to lock the setup and prevent alterations to menu 20, Factory Setup.
17. Enter the menu 6, Time and Date, settings.
 - a. Press the RESET MENU key on the controller keypad.
 - b. Use the controller keypad to go to menu 6, Time and Date. Use the information from the 550 controller operation manual as necessary to set the time and date.
18. Perform the menu 7, Generator System, entries for English or metric displays.
 - a. Press the RESET MENU key on the controller keypad.
 - b. Use the controller keypad to go to menu 7, Generator System. Use the information from the 550 controller operation manual as necessary to change Metric Unit, yes or no.
19. Perform the menu 12, Calibration, entries.
 - a. Press the RESET MENU key on the controller keypad.
 - b. Use the controller keypad to go to menu 12, Calibration. Use the information from the 550 controller operation manual as necessary to scale AC analog inputs.
 - c. With the information previously recorded from step 2b, scale the auxiliary analog inputs. Use the information from the 550 controller operation manual as necessary.
20. Perform the menu 14, Programming Mode, entries.
 - a. Press the RESET MENU key on the controller keypad.
 - b. Use the controller keypad to go to menu 14, Programming Mode.
 - Select programming mode—remote when adding user parameter from a backup disk or PC. Use the information from the Monitor II software, version 2.2.5 or greater.
 - Select programming mode—local for keypad entries. Use the information from the 550 controller operation manual as necessary.

21. Add the user parameters.

- a. Choose one of the following methods to load the user parameters.
 - Backup disk. Use a PC to load the data from the user parameter backup disk. Enable menu 14, Programming Mode—Remote. See the information from the Monitor II software manual.
 - Paper form. Use a PC to enter the user parameter data from the filled-out 550 controller operation manual, Appendix C, User-Defined Settings form or other similar form. Enable menu 14, Programming Mode—Remote. See the information supplied with the Monitor II software manual.
 - Controller menu. Use the controller keypad to manually enter the user parameter data from the filled-out 550 controller operation manual, Appendix C, User-Defined Settings form. Enable menu 14, Programming Mode—Local. Use the information from the 550 controller operation manual as necessary.
- b. Create a new user parameter data backup disk if any changes are made. See the Monitor II software manual.
- c. Disconnect the PC null modem RS-232 cable.
- d. Install the P18 communication connection, as necessary.
- e. Swing the front controller panel up and replace and tighten the screws, as necessary.
- f. Replace the controller cover and hardware. Tighten all controller screws.

22. Restore the generator set to service.

- a. Perform the menu 13, Communication, entries.
 - (1) Press the RESET MENU key on controller keypad.
 - (2) Use the controller keypad to go to menu 13, Communications.
 - (3) With the information previously recorded, complete the communication entries as necessary for the application. Use the information from the 550 controller operation manual as necessary.
- b. Perform the menu 14, Programming Mode entries.
 - (1) Press the RESET MENU key on controller keypad.
 - (2) Use the controller keypad to go to menu 14, Programming Mode.
 - (3) Change the entries for the application as necessary. Use the information from the 550 controller operation manual as necessary.
- c. The generator set system is now ready to function.
- d. Move the generator set master switch to AUTO for startup by remote transfer switch or remote start/stop switch.

Appendix A Abbreviations

The following list contains abbreviations that may appear in this publication.

A, amp	ampere	cfm	cubic feet per minute	est.	estimated
ABDC	after bottom dead center	CG	center of gravity	E-Stop	emergency stop
AC	alternating current	CID	cubic inch displacement	etc.	et cetera (and so forth)
A/D	analog to digital	CL	centerline	exh.	exhaust
ADC	advanced digital control; analog to digital converter	cm	centimeter	ext.	external
adj.	adjust, adjustment	CMOS	complementary metal oxide substrate (semiconductor)	F	Fahrenheit, female
ADV	advertising dimensional drawing	cogen.	cogeneration	fglass.	fiberglass
Ah	amp-hour	com	communications (port)	FHM	flat head machine (screw)
AHWT	anticipatory high water temperature	coml	commercial	fl. oz.	fluid ounce
AISI	American Iron and Steel Institute	Coml/Rec	Commercial/Recreational conn.	flex.	flexible
ALOP	anticipatory low oil pressure	cont.	connection	freq.	frequency
alt.	alternator	CPVC	chlorinated polyvinyl chloride	FS	full scale
Al	aluminum	crit.	critical	ft.	foot, feet
ANSI	American National Standards Institute (formerly American Standards Association, ASA)	CRT	cathode ray tube	ft. lb.	foot pounds (torque)
AO	anticipatory only	CSA	Canadian Standards Association	ft./min.	feet per minute
APDC	Air Pollution Control District	CT	current transformer	ftp	file transfer protocol
API	American Petroleum Institute	Cu	copper	g	gram
approx.	approximate, approximately	cUL	Canadian Underwriter's Laboratories	ga.	gauge (meters, wire size)
AQMD	Air Quality Management District	CUL	Canadian Underwriter's Laboratories	gal.	gallon
AR	as required, as requested	cu. in.	cubic inch	gen.	generator
AS	as supplied, as stated, as suggested	cw.	clockwise	genset	generator set
ASE	American Society of Engineers	CWC	city water-cooled	GFI	ground fault interrupter
ASME	American Society of Mechanical Engineers	cyl.	cylinder	GND, ⊕	ground
assy.	assembly	D/A	digital to analog	gov.	governor
ASTM	American Society for Testing Materials	DAC	digital to analog converter	gph	gallons per hour
ATDC	after top dead center	dB	decibel	gpm	gallons per minute
ATS	automatic transfer switch	dB(A)	decibel (A weighted)	gr.	grade, gross
auto.	automatic	DC	direct current	GRD	equipment ground
aux.	auxiliary	DCR	direct current resistance	gr. wt.	gross weight
avg.	average	deg., °	degree	H x W x D	height by width by depth
AVR	automatic voltage regulator	dept.	department	HC	hex cap
AWG	American Wire Gauge	DFMEA	Design Failure Mode and Effects Analysis	HCHT	high cylinder head temperature
AWM	appliance wiring material	dia.	diameter	HD	heavy duty
bat.	battery	DI/EO	dual inlet/end outlet	HET	high exhaust temp., high engine temp.
BBDC	before bottom dead center	DIN	Deutsches Institut für Normung e. V. (also Deutsche Industrie Normenausschuss)	hex	hexagon
BC	battery charger, battery charging	DIP	dual inline package	Hg	mercury (element)
BCA	battery charging alternator	DPDT	double-pole, double-throw	HH	hex head
BCI	Battery Council International	DPST	double-pole, single-throw	HHC	hex head cap
BDC	before dead center	DS	disconnect switch	HP	horsepower
BHP	brake horsepower	DVR	digital voltage regulator	hr.	hour
blk.	black (paint color), block (engine)	E, emer.	emergency (power source)	HS	heat shrink
blk. htr.	block heater	ECM	electronic control module, engine control module	hsg.	housing
BMEP	brake mean effective pressure	EDI	electronic data interchange	HVAC	heating, ventilation, and air conditioning
bps	bits per second	EFR	emergency frequency relay	HWT	high water temperature
br.	brass	e.g.	for example (<i>exempli gratia</i>)	Hz	hertz (cycles per second)
BTDC	before top dead center	EG	electronic governor	IC	integrated circuit
Btu	British thermal unit	EGSA	Electrical Generating Systems Association	ID	inside diameter, identification
Btu/min.	British thermal units per minute	EIA	Electronic Industries Association	IEC	International Electrotechnical Commission
C	Celsius, centigrade	EI/EO	end inlet/end outlet	IEEE	Institute of Electrical and Electronics Engineers
cal.	calorie	EMI	electromagnetic interference	IMS	improved motor starting
CAN	controller area network	emiss.	emission	in.	inch
CARB	California Air Resources Board	eng.	engine	in. H ₂ O	inches of water
CB	circuit breaker	EPA	Environmental Protection Agency	in. Hg	inches of mercury
cc	cubic centimeter	ES	engineering special, engineered special	in. lb.	inch pounds
CCA	cold cranking amps	ESD	electrostatic discharge	Inc.	incorporated
ccw.	counterclockwise			ind.	industrial
CEC	Canadian Electrical Code			int.	internal
cert.	certificate, certification, certified			int./ext.	internal/external
cfh	cubic feet per hour			I/O	input/output
				IP	iron pipe
				ISO	International Organization for Standardization
				J	joule
				JIS	Japanese Industry Standard

k	kilo (1000)	MTBO	mean time between overhauls	rms	root mean square
K	kelvin	mtg.	mounting	rnd.	round
kA	kiloampere	MTU	Motoren-und Turbinen-Union	ROM	read only memory
KB	kilobyte (2 ¹⁰ bytes)	MW	megawatt	rot.	rotate, rotating
KBus	Kohler communication protocol	mW	milliwatt	rpm	revolutions per minute
kg	kilogram	μF	microfarad	RS	right side
kg/cm ²	kilograms per square centimeter	N, norm.	normal (power source)	RTU	remote terminal unit
kgm	kilogram-meter	NA	not available, not applicable	RTV	room temperature vulcanization
kg/m ³	kilograms per cubic meter	nat. gas	natural gas	RW	read/write
kHz	kilohertz	NBS	National Bureau of Standards	SAE	Society of Automotive Engineers
kJ	kilojoule	NC	normally closed	scfm	standard cubic feet per minute
km	kilometer	NEC	National Electrical Code	SCR	silicon controlled rectifier
kOhm, kΩ	kilo-ohm	NEMA	National Electrical Manufacturers Association	s, sec.	second
kPa	kilopascal	NFPA	National Fire Protection Association	SI	<i>Systeme internationale d'unites</i> , International System of Units
kph	kilometers per hour	Nm	newton meter	SI/EO	side in/end out
kV	kilovolt	NO	normally open	sil.	silencer
kVA	kilovolt ampere	no., nos.	number, numbers	SN	serial number
kVAR	kilovolt ampere reactive	NPS	National Pipe, Straight	SNMP	simple network management protocol
kW	kilowatt	NPSC	National Pipe, Straight-coupling	SPDT	single-pole, double-throw
kWh	kilowatt-hour	NPT	National Standard taper pipe thread per general use	SPST	single-pole, single-throw
kWm	kilowatt mechanical	NPTF	National Pipe, Taper-Fine	spec	specification
kWth	kilowatt-thermal	NR	not required, normal relay	specs	specification(s)
L	liter	ns	nanosecond	sq.	square
LAN	local area network	OC	overcrank	sq. cm	square centimeter
L x W x H	length by width by height	OD	outside diameter	sq. in.	square inch
lb.	pound, pounds	OEM	original equipment manufacturer	SS	stainless steel
lbm/ft ³	pounds mass per cubic feet	OF	overfrequency	std.	standard
LCB	line circuit breaker	opt.	option, optional	stl.	steel
LCD	liquid crystal display	OS	oversize, overspeed	tach.	tachometer
ld. shd.	load shed	OSHA	Occupational Safety and Health Administration	TD	time delay
LED	light emitting diode	OV	overvoltage	TDC	top dead center
Lph	liters per hour	oz.	ounce	TDEC	time delay engine cooldown
Lpm	liters per minute	p., pp.	page, pages	TDEN	time delay emergency to normal
LOP	low oil pressure	PC	personal computer	TDES	time delay engine start
LP	liquefied petroleum	PCB	printed circuit board	TDNE	time delay normal to emergency
LPG	liquefied petroleum gas	pF	picofarad	TDOE	time delay off to emergency
LS	left side	PF	power factor	TDON	time delay off to normal
L _{wa}	sound power level, A weighted	ph., ∅	phase	temp.	temperature
LWL	low water level	PHC	Phillips® head Crimptite® (screw)	term.	terminal
LWT	low water temperature	PHH	Phillips® hex head (screw)	THD	total harmonic distortion
m	meter, milli (1/1000)	PHM	pan head machine (screw)	TIF	telephone influence factor
M	mega (10 ⁶ when used with SI units), male	PLC	programmable logic control	TIR	total indicator reading
m ³	cubic meter	PMG	permanent magnet generator	tol.	tolerance
m ³ /hr.	cubic meters per hour	pot	potentiometer, potential	turbo.	turbocharger
m ³ /min.	cubic meters per minute	ppm	parts per million	typ.	typical (same in multiple locations)
mA	milliampere	PROM	programmable read-only memory	UF	underfrequency
man.	manual	psi	pounds per square inch	UHF	ultrahigh frequency
max.	maximum	psig	pounds per square inch gauge	UL	Underwriter's Laboratories, Inc.
MB	megabyte (2 ²⁰ bytes)	pt.	pint	UNC	unified coarse thread (was NC)
MCCB	molded-case circuit breaker	PTC	positive temperature coefficient	UNF	unified fine thread (was NF)
MCM	one thousand circular mils	PTO	power takeoff	univ.	universal
megger	megohmmeter	PVC	polyvinyl chloride	US	undersize, underspeed
MHz	megahertz	qt.	quart, quarts	UV	ultraviolet, undervoltage
mi.	mile	qty.	quantity	V	volt
mil	one one-thousandth of an inch	R	replacement (emergency) power source	VAC	volts alternating current
min.	minimum, minute	rad.	radiator, radius	VAR	voltampere reactive
misc.	miscellaneous	RAM	random access memory	VDC	volts direct current
MJ	megajoule	RDO	relay driver output	VFD	vacuum fluorescent display
mJ	millijoule	ref.	reference	VGA	video graphics adapter
mm	millimeter	rem.	remote	VHF	very high frequency
mOhm, mΩ	milliohm	Res/Coml	Residential/Commercial	W	watt
MOhm, MΩ	megohm	RFI	radio frequency interference	WCR	withstand and closing rating
MOV	metal oxide varistor	RH	round head	w/	with
MPa	megapascal	RHM	round head machine (screw)	w/o	without
mpg	miles per gallon	rly.	relay	wt.	weight
mph	miles per hour			xfrm	transformer
MS	military standard				
ms	millisecond				
m/sec.	meters per second				
MTBF	mean time between failure				

Appendix B Display Items for Reference

Menu 4 Operational Records		Menu 5 Event History		
<ul style="list-style-type: none"> ● Factory Test Date ● Total Run Time ● Total Run Time Loaded Hours ● Total Run Time Unloaded Hours ● Total Run Time kW Hours ● No. of Starts ● Engine Start Countdown <ul style="list-style-type: none"> ○ Run Time ● Records-Maintenance <ul style="list-style-type: none"> ○ Reset Records ● Run Time Since Maintenance Total Hours ● Run Time Since Maintenance Loaded Hours ● Run Time Since Maintenance Unloaded Hours ● Run Time Since Maintenance kW Hours ● Operating Days Last Maintenance ● No. of Starts Last Maintenance ● Last Start Date ● Length of Run (Un)loaded Hours 		<ul style="list-style-type: none"> ● (Message Text) ● (Scroll through up to 100 stored events) 		
			Menu 20 Factory Setup	
			<ul style="list-style-type: none"> ● Final Assembly Date ● Final Assembly Clock No. ● Operating Days 	

Appendix C Controller User-Defined Settings

Use the table below to record user-defined settings during the generator set controller setup and calibration. The controller default settings and ranges provide

guidelines. The table contains all faults with ranges and time delays including items that do not have adjustments.

Status or Fault	Refer to Menu	Digital Display	Relay Driver Output (RDO)	Range Setting	Default Selection	Inhibit Time Delay* (sec.)	Time Delay (sec.)	User-Defined Settings
AC Sensing Loss	10	AC Sensing Loss	RDO-25					Not adjustable
Access Code (password)	14				0 (zero)			
Analog Aux. Inputs 1-7	9	User-Defined A1-A7		Default values with Warning Enabled: HI warning 90%, LO warning 10%, HI shutdown 100%, LO shutdown 1%	30 sec. inhibit, 5 sec. delay	0-60	0-60	
Analog Aux. Input 1	9	Coolant Temperature		Default values with Warning Enabled: HI/LO warning and HI/LO shutdown are all engine dependant	30 sec. inhibit, 0 sec. delay	0-60	0-60	
Analog Aux. Input 2	9	Oil Pressure		Default values with Warning Enabled: HI/LO warning and HI/LO shutdown are all engine dependant (255 psi max.)	30 sec. inhibit, 0 sec. delay warning, 5 sec. delay shutdown	0-60	0-60	
Cyclic Cranking	8			1-6 crank cycles 1-60 sec. crank on 1-60 sec. pause	3 cycles 15 sec. 15 sec.			
Defined Common Faults	10	User-Defined	RDO-18	Default shutdowns include: Emergency stop High coolant temp Low oil pressure Overcrank Overspeed	30 sec. inhibit, 5 sec. delay	0-60	0-60	
Digital Aux. Inputs 1-21	9	User-Defined D1-D21			30 sec. inhibit, 5 sec. delay	0-60	0-60	
EPS (Emergency Power System) Supplying Load	10	EPS Supplying Load	RDO-15		5% of rated line current			
High Battery Voltage	10	High Battery Voltage	RDO-13	14.5-16.5 (12V) 29-33 (24V)	16 (12V) 32 (24V)		10	
High Coolant Temperature Shutdown	10	Hi Cool Temp Shutdown	RDO-03			30	5	Not adjustable
High Coolant Temperature Warning	10	Hi Cool Temp Warning	RDO-06			30		Not adjustable
High Oil Temperature Shutdown	10	Hi Oil Temp Shutdown	RDO-17			30	5	Not adjustable

* Inhibited time delay is the time delay period after crank disconnect.

Status or Fault	Refer to Menu	Digital Display	Relay Driver Output (RDO)	Range Setting	Default Selection	Inhibit Time Delay* (sec.)	Time Delay (sec.)	User-Defined Settings
Idle (speed) Mode Function Digital Auz. Input 21	9	Idle Mode Active	RDO-21		0 sec. inhibit, 60 sec. delay		0-600	
Load Shed kW Overload	10	Load Shed KW Over	RDO-30		100% of kW rating		5	
Load Shed Underfrequency	10	Load Shed Under Frequency	RDO-31		59, (60 Hz) 49, (50 Hz)		5	
Low Battery Voltage	10	Low Battery Voltage	RDO-12	10-12.5 (12V) 20-25 (24V)	12 (12V) 24 (24V)		10	
Low Coolant Level	10	Low Coolant Level	RDO-14			30	5	Not adjustable
(Low) Oil Pressure Shutdown	10	Oil Pressure Shutdown	RDO-04			30	5	Not adjustable
(Low) Oil Pressure Warning	10	Oil Pressure Warning	RDO-07			30		Not adjustable
No Coolant Temperature Signal	10	No Cool Temp Signal				30		Not adjustable
No Oil Pressure Signal	10	No Oil Pressure Signal				30		Not adjustable
Overcrank Shutdown	8	Over Crank	RDO-02	0-6 cycles	3 cycles			
Overcurrent	10	Over Current			110%		10	
Overfrequency Shutdown	7, 10	Over Frequency	RDO-28	102%-140%	140% std. 103% FAA		10	
Overspeed Shutdown	7, 10	Over Speed	RDO-01	65-70 (60 Hz) 55-70 (50 Hz)	70 (60 Hz) 60 (50 Hz)		0.25	
Overvoltage Shutdown	7, 8, 10	Over Voltage	RDO-20	105%-135%	115% 2-sec time delay		2-10	
Password (access code)	14				0 (zero)			See Access Code entry
Time Delay Engine Cooldown (TDEC)	8, 10		RDO-23	00:00-10:00 min:sec	5:00			
Time Delay Engine Start (TDES)	8, 10			00:00-5:00 min:sec	00:01			
Time Delay Starting Aid	8, 10			0-10 sec.				
Underfrequency Shutdown	7, 10	Under Frequency	RDO-29	80%-95%	90%		10	
Undervoltage Shutdown	7, 8, 10	Under Voltage	RDO-27	70%-95%	85% 10-sec time delay		5-30	
Weak Battery	10	Weak Battery	RDO-26		60% of nominal		2	

* Inhibited time delay is the time delay period after crank disconnect.

Appendix D Relay Driver Output (RDO) Designations

Use the table below to record user-defined description changes to the individual RDO selections.

RDO Number	Factory Default RDO Designation	User-Defined RDO Designation
RDO1	Overspeed	
RDO2	Overcrank	
RDO3	High coolant temperature shutdown	
RDO4	Low oil pressure shutdown	
RDO5	Low coolant temperature	
RDO6	High coolant temperature	
RDO7	Low oil pressure warning	
RDO8	Low fuel	
RDO9	Master switch not in auto	
RDO10	NFPA 110 common alarm	
RDO11	Battery charger fault	
RDO12	Low battery voltage	
RDO13	High battery voltage	
RDO14	Emergency stop	
RDO15	Generator running	
RDO16	Time delay engine cooldown	
RDO17	System ready	
RDO18	Defined common fault	
RDO19	Low coolant level	
RDO20	Overvoltage	
RDO21	Idle mode	
RDO22	EPS supplying load	
RDO23	Air damper indicator	
RDO24	Speed sensor fault	
RDO25	Loss of AC sensing	
RDO26	ECM loss of communication	
RDO27	Undervoltage	
RDO28	Overfrequency	
RDO29	Underfrequency	
RDO30	Load shed kW overload	
RDO31	Load shed underfrequency	

TP-6140 10/01c

© 2001, 2008, 2010 by Kohler Co. All rights reserved.

KOHLER[®] POWER SYSTEMS

KOHLER CO. Kohler, Wisconsin 53044
Phone 920-457-4441, Fax 920-459-1646
For the nearest sales/service outlet in the
US and Canada, phone 1-800-544-2444
KohlerPower.com

Kohler Power Systems
Asia Pacific Headquarters
7 Jurong Pier Road
Singapore 619159
Phone (65) 264-6422, Fax (65) 264-6455