INSTALLATION INSTRUCTIONS

Original Issue Date: 7/95
 Model: 6-15ROY/ROZ
 Market: Industrial
 Subject: Double-Wall Subbase Fuel Tanks/Day Tanks

Double-wall subbase fuel tanks provide fuel storage immediately beneath the generator set where the engine fuel transfer pump easily draws fuel for starting and running. The subbase fuel tank also provides a convenient location to connect fuel injector return lines.

There are two types of double-wall subbase fuel tanks: secondary containment and closed-top diked. Double-wall fuel tanks are UL listed and have all vent fittings necessary to meet NFPA requirements.

Secondary Containment Double-Wall Subbase Fuel Tank

Diesel generator sets use an above-ground rectangular secondary containment fuel tank as a subbase fuel tank. The purpose of the outer tank is to contain liquids if a leak or rupture of the inner tank occurs. The inner tank is sealed inside the outer tank except for the necessary vents. The UL-listed secondary containment fuel tank has emergency relief vent fittings on the inner and outer tanks. The secondary containment subbase fuel tank allows for direct mounting of the generator set.

Closed-Top Diked Double-Wall Subbase Fuel Tank

The purpose of an integral steel dike is to contain fuel from an inner tank leak or rupture. The protected top of the diked tank prevents precipitation, debris, and/or other elements from entering the diked area. The top incorporates a vent negating the need for emergency venting of the secondary containment tank (outer tank). The UL listed, closed-top diked subbase fuel tank allows for direct mounting of the generator set.

Double-Wall Subbase Fuel Tank with Day Tank Option

For double-wall subbase day tank use, add float switch and transfer pump. Transfer pump specifications:

- ▷ Capable of lifting fuel a maximum of 17 ft. (5.2 m)
- ▷ 120-volt AC single phase
- ▷ 2 gpm (7.57 L/min)
- ▷ Motor-driven, 1/3 HP

⚠ WARNING



**Accidental starting.
Can cause severe injury or death.**

Disconnect battery cables before working on generator set. (Remove negative (-) lead first when disconnecting battery. Reconnect negative (-) lead last when reconnecting battery.)

Disabling generator set. Accidental starting can cause severe injury or death. Before working on the generator set or connected equipment, disable the generator set as follows: 1) Turn the generator set master switch to OFF position. 2) Disconnect power to battery charger. 3) Remove battery cables (remove negative (-) lead first). Reconnect negative (-) lead last when reconnecting battery. Follow these precautions to prevent starting of generator set by an automatic transfer switch or remote start/stop switch.

⚠ WARNING

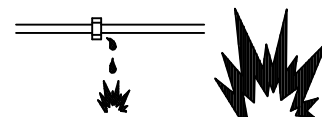

**Explosive fuel vapors.
Can cause severe injury or death.**

Use extreme care when handling, storing, and using fuels.

Fuel system. Explosive fuel vapors can cause severe injury or death. All fuels are highly explosive in a vapor state. Use extreme care when handling and storing fuels. Store fuel in a well-ventilated area away from spark-producing equipment and out of the reach of children. Never add fuel to the tank while the engine is running because spilled fuel may ignite on contact with hot parts or from spark. Do not smoke or permit flame or spark to occur near sources of spilled fuel or fuel vapors. Keep fuel lines and connections tight and in good condition. Do not replace flexible fuel lines with rigid lines. Use flexible sections to avoid breakage caused by vibration. Do not operate generator set in the presence of fuel leaks, fuel accumulation, or sparks. Repair systems before resuming generator set operation.

Fuel tanks. Explosive fuel vapors can cause severe injury or death. Gasoline and other volatile fuels stored in day tanks or subbase fuel tanks can cause an explosion. Store only diesel fuel in tanks.

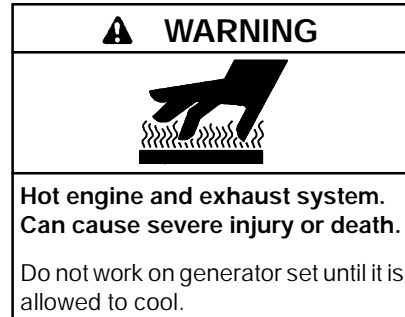
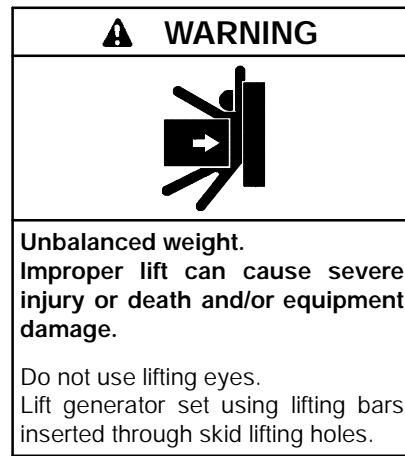
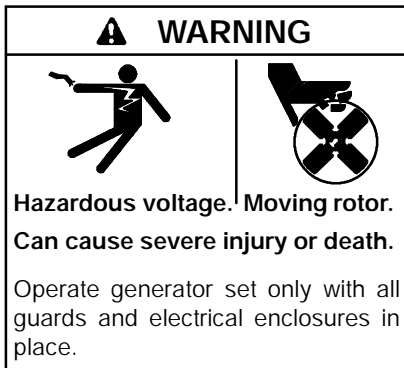

Servicing exhaust system. Hot parts can cause severe injury or death. Do not touch hot engine parts. An engine becomes hot while running and exhaust system components become extremely hot.

Grounding generator set. Hazardous voltage can cause severe injury or death. Electrocutation is possible whenever electricity is present. Open main circuit breakers of all power sources before servicing equipment. Configure the installation to electrically ground the generator set and electrical circuits when in use. Never contact electrical leads or appliances when standing in water or on wet ground, as the chance of electrocution increases under such conditions.

Servicing day tank. Hazardous voltage can cause severe injury or death. Service day tank Electrical Control Module (ECM) as prescribed in equipment manual. Disconnect power to day tank before servicing. Press the day tank ECM OFF pushbutton to disconnect power. Be aware that line voltage is still present within the ECM when the POWER ON light is lit. Be sure that generator set and day tank are electrically grounded. Do not operate day tank when standing in water or on wet ground as the chance of electrocution increases under such conditions.

Fuel Tank Kit/Part Numbers and Specifications

Fuel Tank Kit/Part Numbers

	Closed-Top Diked Fuel Tanks				Secondary Containment Fuel Tanks			
Fuel Tank Capacity Gallons (L)	Std. Fuel Tank Kit No.	Fuel Tank Part No. (included in kit)	Std. Fuel Tank w/Day Tank Option Kit No.	Fuel Tank Part No. (included in kit)	Std. Fuel Tank Kit No.	Fuel Tank Part No. (included in kit)	Std. Fuel Tank w/Day Tank Option Kit No.	Fuel Tank Part No. (included in kit)
6 ROY/ROZ								
25 (94.6)	224376	224375	224378	224377	224470	224469	224472	224471
35(132.5)	224380	224379			224474	224473		
10 ROY/ROZ								
25 (94.6)	224827	224826	224829	224828	224839	224838	224841	224840
35(132.5)	224831	224830			224843	224842		
15 ROY/ROZ								
25 (94.6)	224833	224832	224835	224834	224845	224844	224847	224846
35(132.5)	224837	224836			224849	224848		

Specifications

	Closed-Top Diked (CTD) and Secondary Containment (SC) Fuel Tank Specifications					
Fuel Tank Capacity Gallons (L)	Emergency Relief Vent Size in. (mm)	Fuel Tank Length in. (mm)	Fuel Tank Width in. (mm)	Fuel Tank Height in. (mm)	CTD Approx. Empty Fuel Tank Weight lbs. (kg)	SC Approx. Empty Fuel Tank Weight lbs. (kg)
6 ROY/ROZ						
25 (94.6)	2 (50.8)	53.5 (1358.9)	29.0 (736.6)	12.5 (318.0)	403 (183)	398 (181)
35(132.5)	2 (50.8)	53.5 (1358.9)	29.0 (736.6)	18.0 (457.0)	498 (226)	492 (223)
10 ROY/ROZ						
25 (94.6)	2 (50.8)	56.5 (1435.1)	29.0 (736.6)	12.5 (318.0)	414 (188)	409 (186)
35(132.5)	2 (50.8)	56.5 (1435.1)	29.0 (736.6)	18.0 (457.0)	511 (232)	505 (229)
15 ROY/ROZ						
25 (94.6)	2 (50.8)	63.0 (1600.2)	29.0 (736.6)	12.5 (318.0)	435 (197)	430 (195)
35(132.5)	2 (50.8)	63.0 (1600.2)	29.0 (736.6)	18.0 (457.0)	535 (243)	530 (240)

Standard Features

The following features are standard on all subbase fuel tanks.

2 in. NPT Lockable Fill Cap Kit with 2 in. (50.8 mm) Riser. Includes 2 in. NPT diameter, 2 in. NPT riser pipe with lockable cap. This kit allows for a convenient way to fill the tank.

Low Fuel Level Alarm Kit. Includes float switch and wiring to microprocessor controller. Alarm annunciates when tank fuel level reaches approximately 50%.

Normal Vent Kit with 5 in. (127 mm) Riser and Mushroom Cap. Includes 1 1/4 in. NPT, 5 in. NPT riser pipe, and matching mushroom cap for normal vent.

Accessories

Several accessories are available for double-wall subbase fuel tanks. Local, state, or federal codes and ordinances may require installation of one or more of the following kits. Contact local inspector or generator distributor to determine which accessories to install to comply with codes. See Figure 1 for double-wall subbase fuel tank features.

1/2 psi (3.4 kPa). Relief valve is fully open at 2 1/2 psi (17.2 kPa). Secondary containment tank requires two vents (inner tank and outer tank), and closed-top, diked tank requires one vent (inner tank).

Day Tank Control Modules

Day Tank Electronic Control Module (ECM). Includes 1/3 HP, 110/120 vac, 50/60 Hz, single-phase motor, 2 gpm (7.57 L/min) pump, float switch, leak alarm, electronic control module, and wiring. The ECM activates the pump when the tank fuel level reaches 50%. The ECM displays fuel level at Full, 95%, 90%, 85%, 75%, 50%, 25%, 10%, and Empty. ECM also displays high fuel, low fuel, critical low fuel, fuel in rupture basin, ECM functional, pump running, and power on. Kit requires either a 20- or 40-foot (6.1- or 12.2-m) wiring harness.

Day Tank Relay Control Module. Includes 1/3 HP, 110/120 vac, 50/60 Hz, single-phase motor, 2 gpm (7.57 L/min.) pump, float switch, relay control, and wiring. Use this kit with the double-wall subbase fuel tank kit with the day tank option. The motor and pump are controlled via the float switch through relays. The float switch activates the pump when the tank fuel level reaches 50%.

NOTE

Seal all unused fittings with steel pipe plugs. The plastic plugs in these fittings are for shipping and are not intended for permanent use. See available pipe plug kits.

Alarm Kits

Inner Tank Leak Alarm Kit. Includes one light, one horn remote annunciator panel, leak alarm switch, and wiring. Alarm indicates a need for tank replacement when the inner tank has leaked into the outer tank. Leak alarm is standard with the electronic control module

Cap Kits

Normal Vent Mushroom Cap Kit. Includes one 1 1/4 in. NPT mushroom cap for use on normal vent.

Vent Kits

Emergency Pressure Relief Vent Kit. Includes one emergency pressure relief valve which opens to relieve the internal tank pressure when the pressure exceeds

Pipe Plug Kits

Pipe Plug Kits. Kit includes one pipe plug. Plugs sized 1/2 in. NPT through 4 in. NPT are square head, and 5 in. NPT pipe plugs are slotted bar head. NPT pipe plugs are required for fittings where optional accessories are not required.

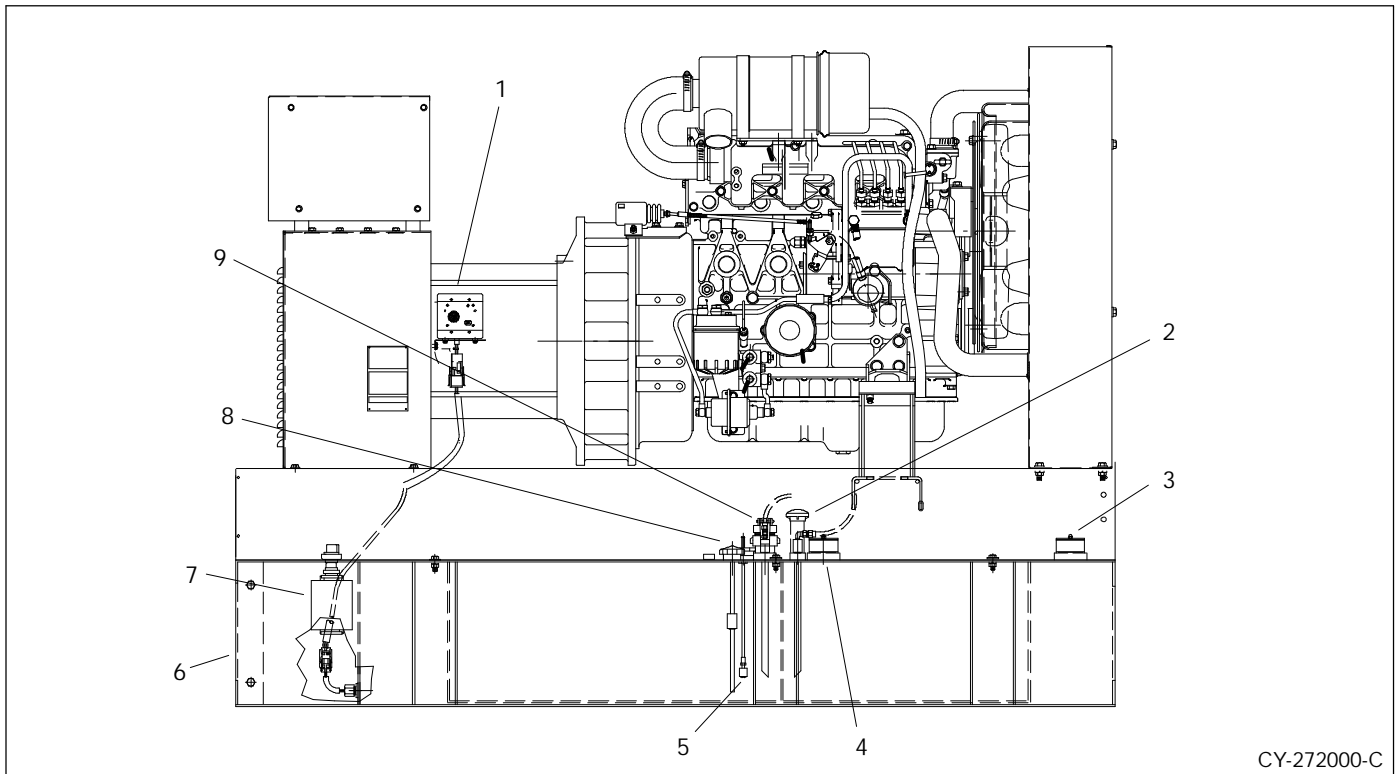

- 1. Inner tank-leak alarm kit
- 2. Normal vent kit with riser and mushroom cap
- 3. Outer tank emergency pressure relief vent kit
(secondary containment tank only)
- 4. Emergency pressure-relief vent kit
- 5. Low fuel level alarm kit
- 6. Removable end channel
- 7. Day tank kit
- 8. Mechanical fuel gauge (standard)
- 9. Lockable fill cap and riser kit

Figure 1. Double-Wall Subbase Fuel Tank Options

Kits	Part Number
Alarm Kits	
Inner Tank Leak Alarm	224805
Vent Kits	
Emergency Pressure Relief 2 in.	224678
Normal Vent	224686
Pipe Plug Kits	
1/2 in. (13 mm)	224666
1 in. (25 mm)	224667
2 in. (51 mm)	224668
3 in. (76 mm)	224669
4 in. (102 mm)	224670
5 in. (127 mm)	224671

Figure 2. Accessories

Installation

1. Disconnect engine starting battery, negative (-) lead first.
2. Calculate the weight of the generator set and accessories (including subbase fuel tank and fuel) to determine the strength of the mounting pad construction. Use current generator set spec sheet for data.

NOTE

Calculations to determine total weight of the tank and fuel:

Fuel weight = Tank capacity (gallons) x 7.3

Total weight of tank and fuel = Fuel weight + tank weight (see specifications chart)

Total weight of generator set with subbase tank = Total weight of tank and fuel + weight of generator set (see spec sheet)

3. Use current generator set spec sheet and subbase tank dimensional drawing to size mounting pad.

NOTE

The lifting contractor determines the type and suitability of the subbase fuel tank lifting device. Lift the subbase fuel tank as one unit if shipped separately from the generator set. Use lifting eyes if equipped on subbase fuel tank; otherwise, use chains or cables to lift the subbase fuel tank. If using lifting straps, protect the strap from sharp fuel tank edges.

Lift the generator set (up to 400 kW) and subbase fuel tank together provided the fuel tank is empty and the subbase fuel tank does not extend beyond the perimeter of the generator set skid.

In all other cases, remove the mounting hardware and wiring between the the generator set and subbase fuel tank. Lift the generator set and subbase fuel tank separately. It is not necessary to drain fuel tank when lifting just the fuel tank.

4. Attach the subbase fuel tank to the concrete using anchor bolts placed in the cement before it has set. Otherwise install anchors later by drilling holes in the concrete.
5. Size all hoist equipment accordingly. Hoist the generator set into place and bolt it to the subbase fuel tank. Use grade 5 minimum bolts and associated hardware when mounting hardware is not supplied in the kit. Torque all hardware using a value that corresponds to the hardware size.
6. Install emergency pressure relief vents as required. Secondary containment tanks require two vents (inner tank and outer tank) and closed-top, diked tanks require one vent (inner tank).
7. Connect low fuel level switch leads 63 and N according to the illustration in Figure 4. Use a connection kit (terminal strip) for easier connection and disconnection of generator accessories.

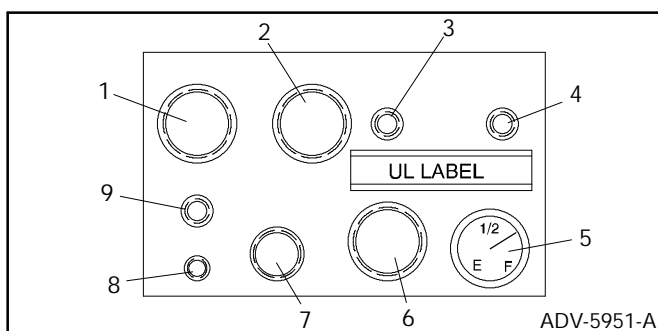

1. 3/8 in. NPT for day tank pump fill (day tank only)
2. 2 in. NPT for optional low fuel level alarm
3. 3/8 in. (9.5 mm) dip-tube fuel return and 3/8 in. (9.5 mm) to 1/4 in. (6.3 mm) reducer
4. 3/8 in. (9.5 mm) dip-tube fuel supply and 3/8 in. (9.5 mm) to 1/4 in. (6.3 mm) reducer
5. 2 in. (50.8 mm) mechanical fuel level gauge— standard
6. 1 1/4 in. NPT for optional normal vent and riser
7. 2 in. NPT fill for optional fuel cap and riser
8. 1/2 in. NPT for overflow— 2 gpm (7.57 L/min) pump maximum (day tank only)
9. 2 in. NPT for optional sensor/pump control float (day tank only)

Figure 3. Fuel Tank Fittings

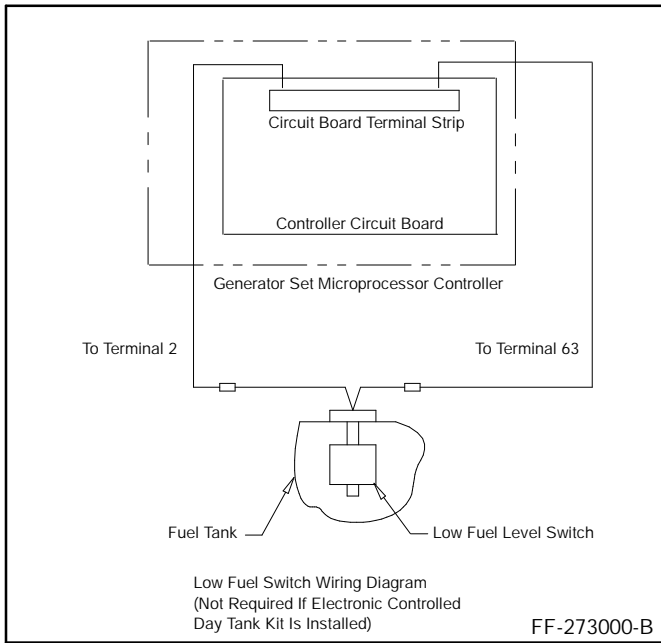

Figure 4. Low Fuel Switch Wiring Diagram

8. Install flexible fuel line kit. Refer to installation instructions provided with kit. Connect two lines, a supply line and return line, between the generator set and the subbase fuel tank.

9. If subbase day tank is required, install transfer pump kit, float and controls.

For day tank relay control module instructions proceed to step 12a. For day tank electronic control module instructions proceed to step 13. If subbase day tank is not required proceed to step 14.

NOTE

Controller box assembly shown at suggested mounting location only.

a. Remove cover plate from controller box assembly. Mount controller box assembly (A-224874) to skid using two screws (X-50-3), washers (X-25-36), and nuts (X-6210-5) supplied with the controller box assembly. Do not yet install cover plate. See Figure 5.

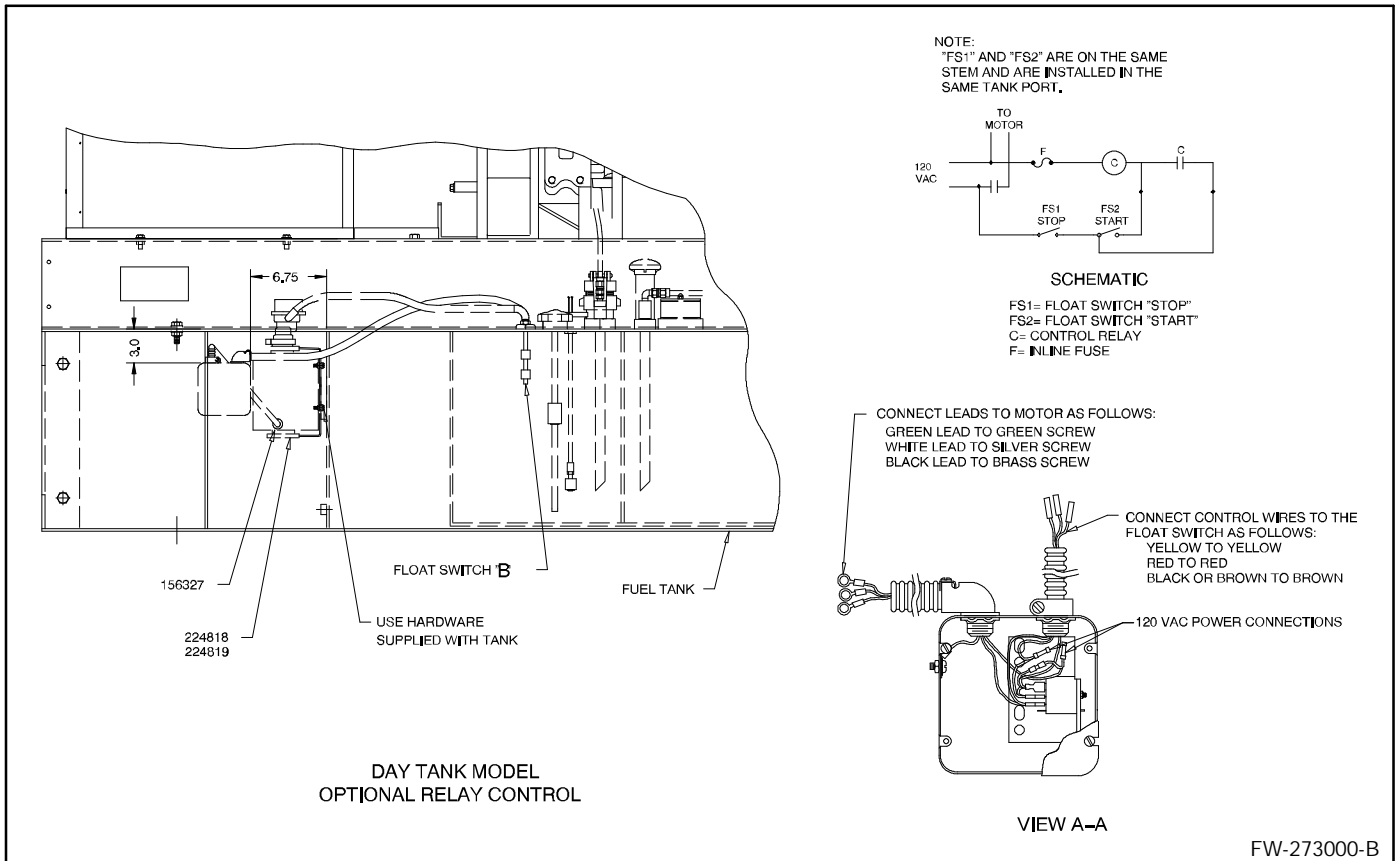

Figure 5. Relay Control Module

- b. Mount transfer pump assembly to skid using hardware supplied with the tank. See Figure 5.
- c. Remove 3/8 in. NPT pipe plug for fuel inlet connection at subbase fuel tank. See Figure 3. Pipe plug is not reused. Apply pipe sealant to male ends of 3/8 in. (9.5 mm) elbow hose connector (X-391-13), and install. Point elbow hose connector toward transfer pump assembly when final tightened.
- d. Apply pipe sealant to elbow hose connector (X-391-13) and install into transfer pump assembly outlet. Point elbow hose connector toward subbase fuel tank when final tightened.
- e. Slide hose clamps (X-426-10) over each end of flexible fuel line approximately 1 in. (25 mm), as required. Install fuel line to transfer pump assembly outlet and subbase tank inlet. Position hose clamps approximately 1/4 in. (6 mm) from fuel line end and tighten.
- f. Remove 2 in. NPT pipe plug for float switch (224869) installation. See Figure 3. Pipe plug is not reused. Apply pipe sealant to threads of float switch and install in subbase fuel tank.
- g. Connect float switch leads to controller as follows:
 - Yellow to Yellow
 - Red to Red
 - Black or Brown to Brown
- h. Install conduit connector (156327) to transfer pump assembly.
- i. Connect green, white, and black leads of controller box to transfer pump assembly. Remove electric motor access plate. Green lead connects to ground screw on frame. Refer to schematic on electric motor and motor wiring schematic shown in Figure 5 to make connections. Replace electric motor access plate.

NOTE

Electric motor rotation must be clockwise for transfer pump operation. Check motor schematic for correct rotation. If rotation is counterclockwise, motor operates, but transfer pump will not pump fuel.

- j. Make AC voltage connections to controller box assembly. Remove knockout and add conduit as necessary. Replace controller box cover.
- k. Leave circuit breaker connected to the transfer pump assembly power line open until external fuel tank is filled and all piping completed.
- l. Remove 3/4 in. NPT pipe plug for tank over fill return line. See Figure 3. Install 3/4 in. NPT 90 degree elbow fitting (not provided) and fuel overflow line (not provided) back to primary tank.

NOTE

To prevent overflow from the fill cap or normal vent, locate the return line lower than the fill cap.

- m. Upon completion of relay control module installation proceed to step 11.
10. If subbase day tank with electronic control module (ECM) is required proceed to step 10a.
- a. Remove 1/2 in. NPT pipe plug for leak alarm (224863) installation. Pipe plug is not reused. Apply pipe sealant to threads of leak alarm and install in subbase fuel tank. See Figure 6 for positioning and location.

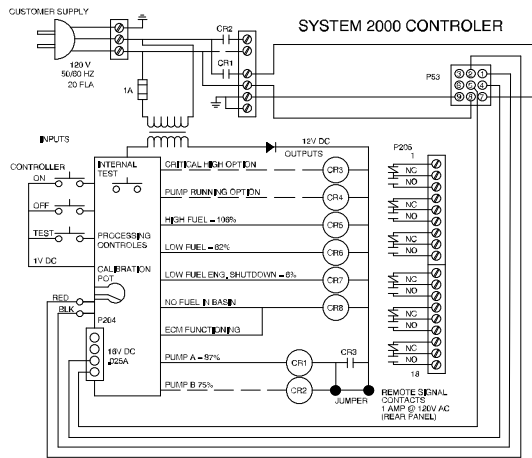

NOTES:
 1. RELAY IS ENERGIZED DURING NORMAL OPERATION.
 2. THE CONTROLLER CAN BE MOUNTED UP TO 40' AWAY FROM THE TANK & GAUGE USING EXTENSION HARNESS.

NOTE:
 FUEL SENSOR FLOAT SHOULD BE MOVED THROUGH ITS ENTIRE RANGE OF MOTION. ADJUST CALIBRATION POT SO ELECTRONIC CONTROL MODULE READS EMPTY TO FULL OVER THIS RANGE.

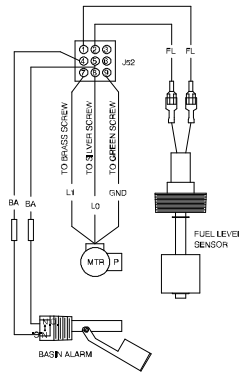
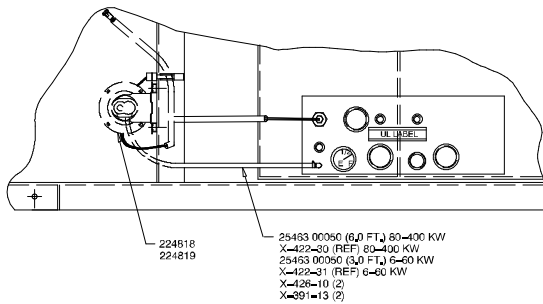

MOTOR WIRING DIAGRAM

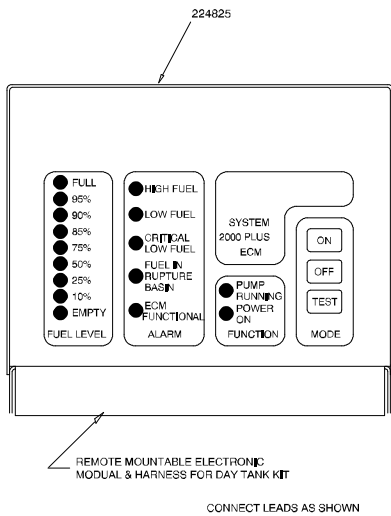

REMOTE MOUNTABLE ELECTRONIC MODULAR & HARNESS FOR DAY TANK KIT

CONNECT LEADS AS SHOWN

WIRING DIAGRAM

224884

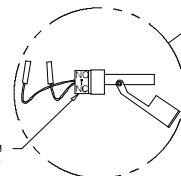

DAY TANK MODEL
 OPTIONAL ELECTRONIC CONTROL

224880 (6-60 KW)
 224881 (80-400 KW)

USE HARDWARE SUPPLIED WITH TANK

Figure 6. Electronic Control Module

- b. Mount transfer pump assembly to skid using hardware supplied with tank.
 - c. Remove 3/8 in. NPT pipe plug for fuel inlet connection at subbase fuel tank. Pipe plug is not reused. Apply pipe sealant to male end of 3/8 in. (9.5 mm) elbow hose connector (X-391-13) and install. Point elbow hose connector toward transfer pump assembly when final tightened.
 - d. Apply pipe sealant to elbow hose connector (X-391-13) and install into transfer pump assembly outlet. Point elbow hose connector toward subbase fuel tank when final tightened.
 - e. Slide hose clamps (X-426-10) over each end of flexible fuel line approximately 1 in. (25 mm), as required. Install fuel line (X-422-30) to transfer pump assembly outlet and subbase tank inlet. Position hose clamps approximately 0.25 in. (6 mm) from fuel line end and tighten.
 - f. Remove 2 in. NPT pipe plug for float sensor (224814) installation. See Figure 3. Pipe plug is not reused. Apply pipe sealant to threads of float sensor and install in subbase fuel tank.
 - g. Connect float level sensor, leak alarm, and electric motor to appropriate wiring harness (224880) leads. See Figure 6, Motor Wiring Diagram.
 - h. Connect ECM wiring harness (224884) to required ECM connections. See Figure 6. Mount ECM in desired location. Extension harness kit length may limit location of ECM.
 - i. Route wiring harness to control module. Connect mating end of extension harness to the ECM wiring harness and the day tank harness. See Figure 6.
 - j. Connect AC voltage to control module assembly.
 - k. Leave transfer pump circuit breaker open until external fuel tank is filled and all piping completed.
 - l. Remove 3/4 in. NPT pipe plug for tank over fill return line. Install 3/4 in. NPT 90 degree elbow fitting (not provided) and fuel overflow return line (not provided) back to primary tank. See Figure 3.
-

NOTE

To prevent overflow from the fill cap or normal vent, locate the return line lower than the fill cap.

- m. See Operation (ECM) for electronic control module operation.
-

NOTE

Seal all unused fittings with steel pipe plugs. The plastic plugs in these fittings are for shipping and are not intended for permanent use. See available pipe plug kits.

NOTE

Electric motor must rotate clockwise for transfer pump operation. Check motor schematic for correct rotation. If rotation is counterclockwise, motor operates, but transfer pump will not pump fuel.

- 11. Complete the remaining installation and start-up procedures as required by contractor/distributor.

Operation (ECM)

General

The electronic control module (ECM) maintains the fuel level of the day tank by controlling a pump/motor. The pump remains off at the normal fuel level and activates at 87% full. A pump running indicator LED lights when the pump activates. The motor relay is prewired to the pump/motor. Another function light on the ECM panel is the power ON. This LED lights when the power is applied to the ECM. Follow all safety precautions listed in the front of this manual.

Servicing day tank. Hazardous voltage can cause severe injury or death. Service day tank Electrical Control Module (ECM) as prescribed in equipment manual. Disconnect power to day tank before servicing. Press the day tank ECM OFF pushbutton to disconnect power. Be aware that line voltage is still present within the ECM when the POWER ON light is lit. Be sure that generator set and day tank are electrically grounded. Do not operate day tank when standing in water or on wet ground as the chance of electrocution increases under such conditions.

Level Sensor

An electronic analog float gauge located below the ECM on the mounting bracket determines the day tank fuel level. Nine LEDs on the ECM indicate the day tank fuel level from full to empty. See Figure 7 for front panel layout.

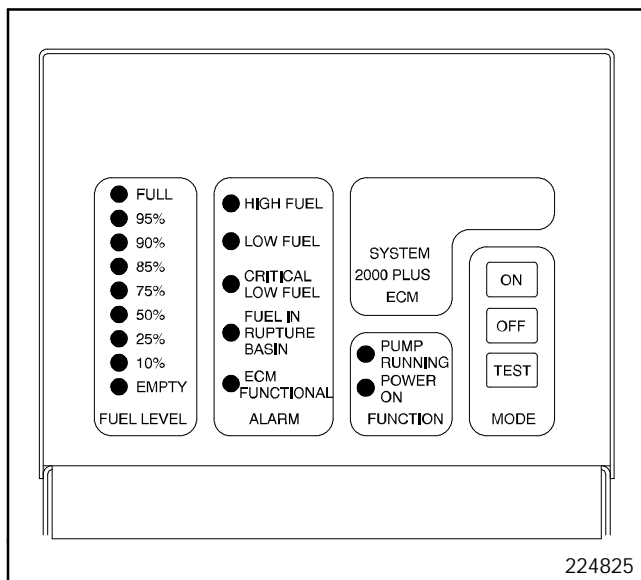

Figure 7. Front Panel Layout

Alarms

The ECM has five standard alarm conditions. An LED indicates alarms locally. A relay indicates alarms remotely. Normally open and normally closed contacts are provided on these relays for customer connections.

1. **High Fuel.** Alarm activates at 106% of normal fuel level.
2. **Low Fuel.** Alarm activates at 62% of normal fuel level. This enables reaction time to a potential problem before low fuel shutdown occurs.
3. **Critical Low Fuel (engine shutdown).** Alarm activates at 6% of normal fuel level. This enables the customer to shut down engine/generator before fuel runs out.
4. **Fuel In Rupture Basin.** If equipped with a rupture basin float switch, the ECM monitors whether fuel has leaked into the rupture basin.
5. **ECM Functional.** The ECM performs many internal checks to ensure correct operation.

Mode

There are three modes of operation on the ECM and one internal test button.

OFF. Pushbutton disables the ECM for routine maintenance to the tank system without disrupting the ECM.

NOTE

When ECM functional alarm relay de-energizes, it can activate a customer-installed alarm wired to this relay.

ON. Pushbutton activates the ECM after the OFF pushbutton is depressed. On any initial power-up condition (after a power outage), the ECM automatically turns on.

TEST. Pushbutton tests all front panel LEDs for 3 seconds and activates pump/motor for as long as the pushbutton is depressed. All alarm relays maintain their original positions.

INTERNAL TEST. Pushbutton (located inside ECM) tests each LED and remote annunciation relay in sequential order (high fuel to ECM functional).

Double-Wall Subbase Fuel Tank

Parts List		
Kits: PA-224376 to PA-224849		
Qty.	Description	Part Number
1	Tank, double-wall subbase fuel	(See Fuel Tank Kit/Part Numbers)
4	Screw, hex 1/2-13 x 1.50 in.	X-129-19
4	Washer, plain 0.531 x 1.062 x 0.095	X-25-26
4	Nut, whiz 1/2-13	X-6210-12

Day Tank Relay Controller

Parts List		
Kits: PA-224850		
Qty.	Description	Part Number
1	Connector, conduit elbow	156327
1	Motor	224818
1	Pump	224819
1	Switch, float	279746
2	Washer, plain 0.219 x 0.500 x 0.049	X-25-36
2	Connector, elbow	X-391-13
1	Hose	X-422-31
2	Clamp, hose	X-426-10
2	Screw, hex 10-24 x 0.750 in.	X-50-3
2	Nut, whiz 10-24	X-6210-5
1	Box, controller assembly	A-224874

Day Tank Electronic Controller

Parts List		
Kits: PA-224877		
Qty.	Description	Part Number
1	Sensor, float	224814
1	Motor	224818
1	Pump	224819
1	Module, control	224825
1	Switch, float	224863
1	Harness, day tank	224880
1	Harness, wiring	224884
2	Connector, elbow	X-391-13
1	Hose	X-422-31
2	Clamp, hose	X-426-10