

**INSTALLATION INSTRUCTIONS**

Original Issue Date: 4/01

Model: 20-2000 kW

Market: Industrial Generator Sets with the 550 Controller

Subject: Audiovisual Alarm Kits:  
GM17070-KP1, GM17070-KP2, and GM17070-KP3

**Introduction**

The audiovisual alarm signals fault conditions to the operator at a remote location. The audiovisual alarm kit includes an alarm horn, an alarm silence switch, and a single fault lamp. See Figure 1. If a fault (shutdown or warning) condition occurs, the alarm horn sounds and the fault lamp lights. Quiet the alarm horn by moving the alarm switch to SILENCE; the lamp remains lit until the fault is corrected. See Resetting section following. Mount the audiovisual alarm(s) in a location easily observable by the operating personnel at their work station.

Typically, the audiovisual alarm annunciates the NFPA-110 common alarm and connects to terminal 32. Alternatively, the user can select a single fault by connecting the signal lead (white) to any fault terminal.

**Note:** Connect up to three audiovisual alarm kits, dry contact kits, and/or remote annunciator kits in any combination.

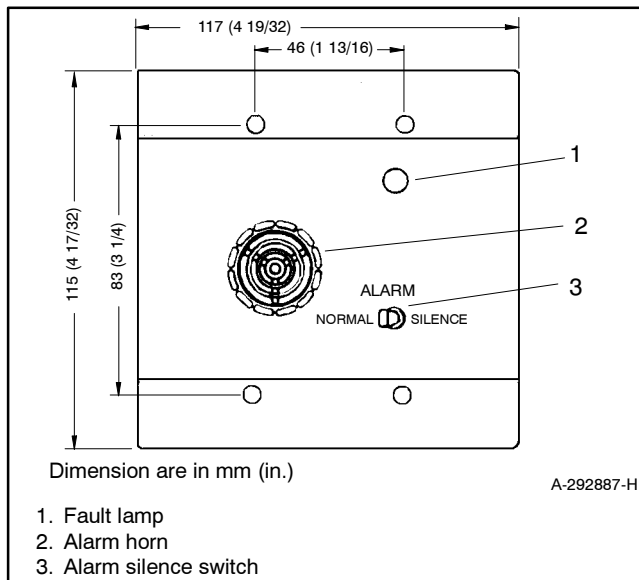

**Figure 1** Audiovisual Alarm Panel

Read the entire installation procedure and compare the kit parts with the parts list in this publication before beginning installation. Perform the steps in the order shown.

Observe applicable national and local electrical codes when installing the wiring system.

**Safety Precautions**

Observe the following safety precautions while installing the kit.

**⚠ WARNING**



**Accidental starting.  
Can cause severe injury or death.**

Disconnect the battery cables before working on the generator set. Remove the negative (-) lead first when disconnecting the battery. Reconnect the negative (-) lead last when reconnecting the battery.

**Disabling the generator set. Accidental starting can cause severe injury or death.** Before working on the generator set or connected equipment, disable the generator set as follows: (1) Move the generator set master switch to the OFF position. (2) Disconnect the power to the battery charger. (3) Remove the battery cables, negative (-) lead first. Reconnect the negative (-) lead last when reconnecting the battery. Follow these precautions to prevent starting of the generator set by an automatic transfer switch, remote start/stop switch, or engine start command from a remote computer.

# Installation Procedure

## 1. Remove the generator set from service.

- 1.1 Place the generator set master switch in the OFF position.
- 1.2 Disconnect the power to the battery charger, if equipped.
- 1.3 Disconnect the generator set engine starting battery(ies), negative (-) lead first.

## 2. Mount and connect the controller connection assembly.

### 2.1 GM17070-KP1 kit (20-300 kW)

- 2.1.1 Remove the junction box rear panel and hardware.
- 2.1.2 Attach the controller connection assembly (GM13984) to the junction box using six screws (X-51-3), spacers (X-712-9), and nuts (X-6210-4). Place the spacers between the controller connection assembly and the junction box bracket. See Figure 2 for the mounting location.
- 2.1.3 Plug the wiring connection harness (GM17033) into the controller connection assembly's P25 connector.
- 2.1.4 Proceed to step 2.4.

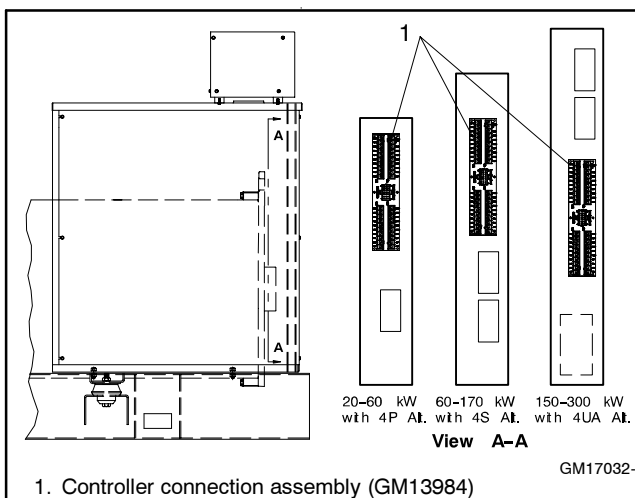

**Figure 2** Controller Connection Assembly Mounting Locations in Junction Box (20-300 kW)

### 2.2 GM17070-KP2 kit (350/400 kW)

- 2.2.1 Remove the junction box rear panel and hardware.
- 2.2.2 Remove the four screws attaching the controller to the junction box. See Figure 3.
- 2.2.3 Mark the drill hole locations where the terminal block bracket (347292) mounts to the junction box top panel using the dimensions given in Figure 3.
- 2.2.4 Move the controller away from the rear of the junction box in order to provide enough clearance to drill two 9 mm (0.344 in.) dia. holes in the top of the junction box.
- 2.2.5 Remove burrs from the drilled holes and cleanup all metal chips in the junction box.
- 2.2.6 Place the terminal block bracket (347292) on the underside of the junction box top panel with the bracket mounting holes visible from the rear of the junction box and mount using two screws (X-125-3) and nuts (X-6210-7). See Figure 3.
- 2.2.7 Reposition the controller over the junction box holes and install the four screws.

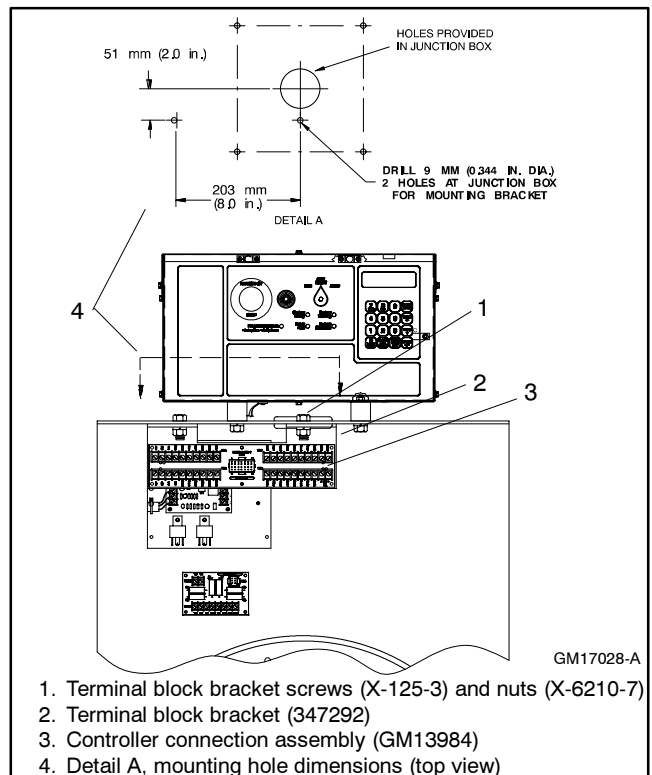

**Figure 3** Terminal Block Bracket and Controller Connection Assembly Mounting (350/400 kW)

2.2.8 Attach the controller connection assembly (GM13984) to the terminal block bracket using six screws (X-51-3), spacers (X-712-9), and nuts (X-70-12). Place the spacers between the controller connection assembly and the mounting bracket.

2.2.9 Plug the wiring connection harness (GM17029) into the controller connection assembly's P25 connector.

2.2.10 Proceed to step 2.4.

**2.3 GM17070-KP3 kit (450-2000 kW)**

2.3.1 Remove the junction box upper rear panel and hardware.

2.3.2 Remove the inner panel access door screws and swing open the access door.

2.3.3 Attach the controller connection assembly (GM13984) to the junction box inner panel studs using six spacers (X-712-9) and nuts (X-70-12). Place the spacers between the controller connection assembly and the mounting bracket. See Figure 4 for the mounting location.

2.3.4 Plug the wiring connection harness (GM16753) into the controller connection assembly's P25 connector.

2.3.5 Proceed to step 2.4.

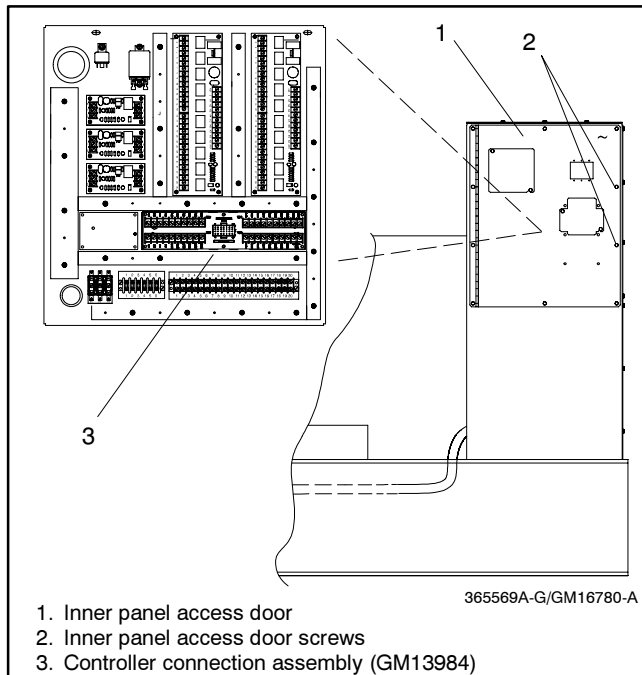

**Figure 4** Terminal Block Bracket Mounting in Junction Box (450-2000 kW)

2.4 Remove the controller cover and hardware.

2.5 Route the other end of the wiring connection harness (GM17029, GM17033, or GM16753) through the junction box port to the controller interconnection circuit board.

2.6 Plug the wiring harness connector into the interconnection circuit board's P23 connector. Connect lead ES3 to TB-1 terminal 3 and connect lead ES4 to TB-1 terminal 4. See Figure 5. If access to the interconnection circuit board is difficult, remove the two rear controller panel top screws and loosen the bottom screws to swing the rear controller panel down.

2.7 Swing the rear controller panel up and replace the screws, if previously removed. Replace the controller cover and hardware. Tighten all controller screws.

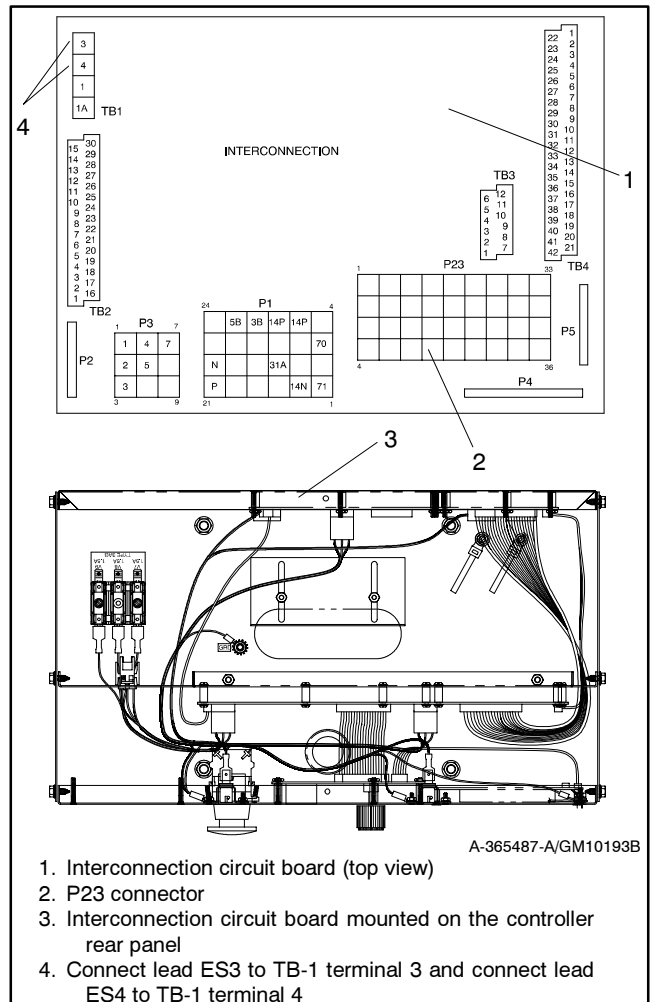

**Figure 5** Attaching Wiring Connection Harness to Controller Circuit Board

### 3. Mount and connect the audiovisual alarm panel assembly.

- 3.1 Mount a two-gang electrical box (not supplied) in a location selected for the audiovisual alarm(s). Mount the electrical box(es) flush with the surrounding wall surface. See Figure 6.
- 3.2 Supply three lengths of 18 gauge (minimum) stranded wire to make the audiovisual leads long enough to reach the controller connection assembly in the junction box (or to reach the controller terminal strip if the fault terminal is not available at the controller connection assembly). Use color-coded wire for easy identification. Make leads long enough to allow for walls, ductwork, and other obstructions. Use separate conduit for the audiovisual alarm leads.
- 3.3 Strip each end of the leads and connect to the audiovisual panel leads 2 (black), 32 (white), and 42A (red). Secure the wire connections with wire nuts (not supplied).

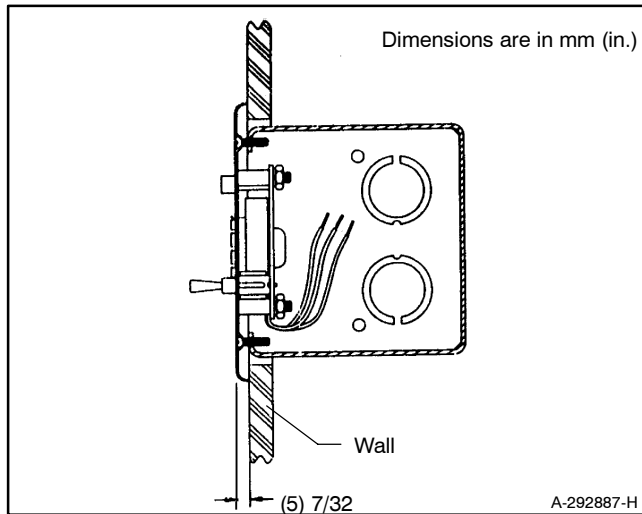

**Figure 6** Electrical Box Mounting

- 3.4 Attach the audiovisual panel to the electrical box with four machine screws (292828).
- 3.5 Route the three leads to the controller connection assembly in the generator set junction box. Cut leads to length, strip wire ends, crimp-on spade terminals (not supplied), and connect the leads to the screw terminals shown in Figure 7. Keep the audiovisual alarm leads away from the generator set output leads.

Typically, the audiovisual alarm connects to the NFPA-110 common alarm terminal 32. Alternatively, the user can select a single fault by connecting the signal lead (white) to any fault terminal. See Figure 8 and Figure 9 for alternate terminal connections.

- 3.6 **GM17070-KP3 kit only (450-2000 kW).** Swing the access door closed and install the screws.
- 3.7 Replace the junction box panel and hardware.

### 4. Restore the generator set to service.

- 4.1 Check that the generator set master switch is in the OFF position.
- 4.2 Reconnect the generator set engine starting battery, negative (-) lead last.
- 4.3 Reconnect power to the battery charger, if equipped.
- 4.4 Move the generator master switch to AUTO for startup by remote transfer switch or remote start/stop switch.
- 4.5 Move the audiovisual alarm switch to NORMAL. The audiovisual alarm lamp should not be lit. If the alarm horn sounds or the lamp remains lit, refer to section 5, Resetting the audio/visual alarm.

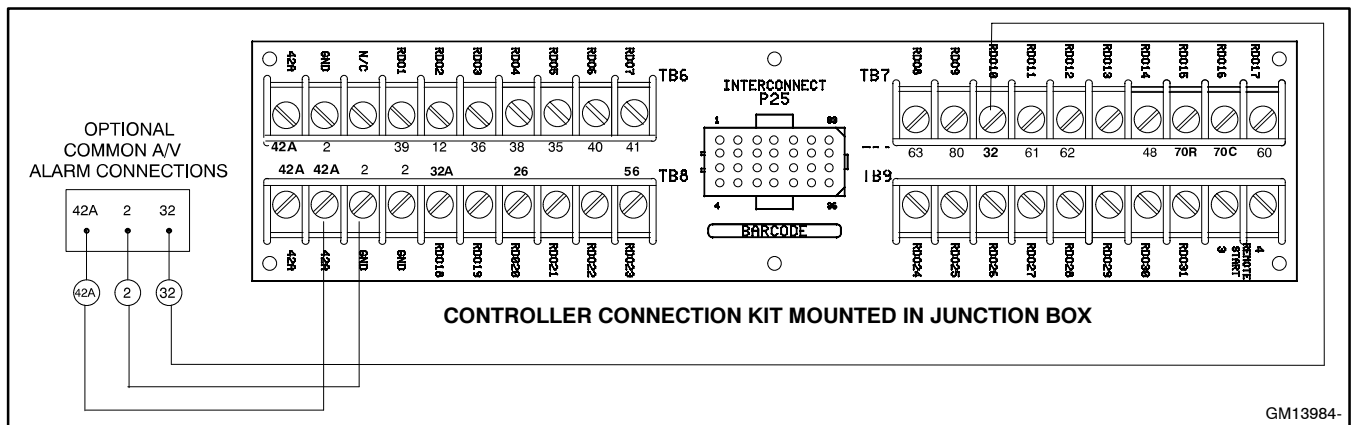

**Figure 7** Audiovisual Alarm Connections to the 550 Controller (Connection to Common Fault Terminal 32 Shown)

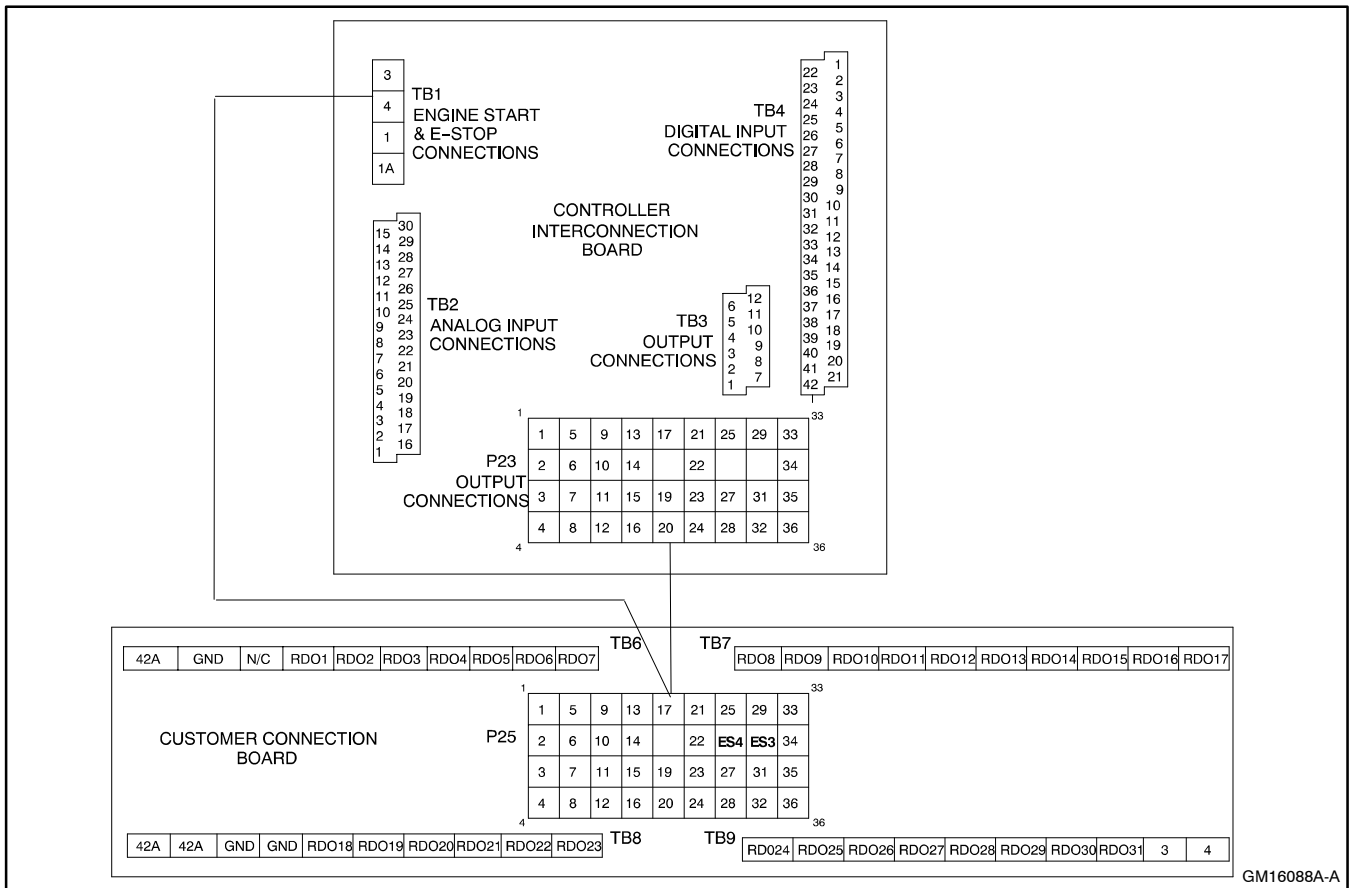

GM16088A-A

**Figure 8** Controller Connection Kit

<b>TB6 Terminal Strip—RDOs 1-7</b>		<b>TB9 Terminal Strip—RDOs 24-31</b>	
Term.	Description	Term.	Description
42A	Battery (+)	RDO24	Speed sensor fault
GND	Battery (-)	RDO25	Loss of AC sensing
N/C		RDO26	ECM loss of communication
RDO1	Overspeed (39)	RDO27	Undervoltage
RDO2	Overcrank (12)	RDO28	Overfrequency
RDO3	High coolant temperature shutdown (36)	RDO29	Underfrequency
RDO4	Low oil pressure shutdown (38)	RDO30	Load shed kW overload
RDO5	Low coolant temperature (35)	RDO31	Load shed underfrequency
RDO6	High coolant temperature warning (40)	3	Remote start
RDO7	Low oil pressure warning (41)	4	Remote start
<b>TB7 Terminal Strip—RDOs 8-17</b>		<b>NOTE:</b> RDO-1 through RDO-31 are customer definable with the following factory defaults: emergency stop, high coolant temperature, low oil pressure, overcrank, and overspeed	
Term.	Description	<b>*NFPA-110 common alarm faults include:</b>	
RDO8	Low fuel (63)	Air damper indicator	
RDO9	Master switch not in auto (80)	Battery charger fault	
RDO10	NFPA 110 common alarm (32)*	EPS supplying load	
RDO11	Battery charger fault (61)	High battery voltage	
RDO12	Low battery voltage (62)	High coolant temperature warning	
RDO13	High battery voltage	High coolant temperature shutdown	
RDO14	Emergency stop (48)	Low battery voltage	
RDO15	Generator running (70R)	Low coolant level	
RDO16	Time delay engine cooldown (TDEC) (70C)	Low coolant temperature warning	
RDO17	System ready (60)	Low fuel (level or pressure)	
<b>TB8 Terminal Strip—RDOs 18-23</b>		Low oil pressure warning	
Term.	Description	Low oil pressure shutdown	
42A	Battery (+)	Master switch not in auto	
42A	Battery (+)	Overcrank	
2	Battery (-)	Overspeed	
2	Battery (-)		
RDO18	Defined common fault (32A)		
RDO19	Low coolant level		
RDO20	Overvoltage (26)		
RDO21	Idle mode		
RDO22	EPS supplying load		
RDO23	Air damper indicator (56)		

**Figure 9** Controller Connection Kit Terminal Strip Identification with Relay Driver Outputs (RDOs)

## 5. Resetting the audiovisual alarm.

Use the following procedure to reset the controller and the audiovisual alarm after a fault alarm.

- 5.1 Press the ALARM OFF key on the controller keypad to silence the controller alarm horn.
- 5.2 Move the audiovisual alarm horn switch to SILENCE to stop the alarm horn. The audiovisual lamp remains lit.
- 5.3 Disconnect the generator set from the system load with the line circuit breaker or automatic transfer switch.
- 5.4 Correct the cause of the fault alarm (refer to the generator set service manual).
- 5.5 Move the generator set master switch to OFF/RESET position and then to the RUN position for startup. The audiovisual alarm horn and the controller alarm horn sound because the unit is not in the AUTO position.
- 5.6 Verify that the cause of the alarm has been corrected.
- 5.7 Reconnect the generator set to the system load via the line circuit breaker or automatic transfer switch.
- 5.8 Move the generator set master switch to the AUTO position for startup by remote transfer switch or the remote start/stop switch.
- 5.9 Move the audiovisual alarm horn switch to the NORMAL position.

## Parts List

### Audiovisual Alarm Kits

Kit: GM17070-KP1 (20-300 kW)		
Qty.	Description	Part Number
4	Screw, mounting	292828
1	Panel assembly, audiovisual alarm	A-292887
1	Connection assembly, controller	GM13984
1	Harness, wiring controller connection	GM17033
6	Screw, mounting	X-51-3
6	Spacer, 0.25 in OD x 0.5 in.	X-712-9
6	Nut, 8-32 whiz	X-6210-4

Kit: GM17070-KP2 (350/400 kW)		
Qty.	Description	Part Number
4	Screw, mounting	292828
1	Panel assembly, audiovisual alarm	A-292887
1	Bracket, terminal block	347292
1	Connection assembly, controller	GM13984
1	Harness, wiring controller connection	GM17029
6	Screw, mounting	X-51-3
2	Screw, 5/16-18 x 3/4 in.	X-125-3
6	Nut, 8-32 hex	X-70-12
2	Nut, 5/16-18 spiralock	X-6210-7
6	Spacer, 0.25 in OD x 0.5 in.	X-712-9

Kit: GM17070-KP3 (450-2000 kW)		
Qty.	Description	Part Number
4	Screw, mounting	292828
1	Panel assembly, audiovisual alarm	A-292887
1	Connection assembly, controller	GM13984
1	Harness, wiring controller connection	GM16753
6	Nut, 8-32 hex	X-70-12
6	Spacer, 0.25 in OD x 0.5 in.	X-712-9