INSTALLATION INSTRUCTIONS

Original Issue Date: 8/01

Model: 20-2000 kW

Market: Industrial Generator Sets

Subject: 550 Controller Service Replacement Kits:
GM20722-1, GM20722-1S, GM20722-2, and GM20722-2S

Introduction

The 550 controller service replacement kit is available to replace a non-functional 550 controller. Use the following procedure to install the replacement controller. See Figure 1 for typical controller identification. For features and operation of the 550 controller, see the operation manual in the literature kit.

When replacing the 550 controller, three files must be resident for the 550 controller to function.

- **Application program** contains the software that controls system operation. The application file is preprogrammed in the 550 controller at the factory.
- **Personality profile** is specific to the engine and alternator and is preprogrammed in the 550 controller at the factory. A backup disk of the personality profile is supplied with the literature packet. Typically, the distributor stores this disk for possible future use such as controller replacement or other circumstances requiring a backup.

Note: If the personality disk is NOT available, request a replacement from the manufacturer using the generator set serial number or order number.

- **User parameters** unique to an installation include timer values, setpoints, generator set data such as kW and voltage, and input/output selections. These parameters are typically set up for or by the installer at the time of installation. Created user parameters are typically documented and stored on the personality profile disk, a separate backup disk, or written in Appendix B, User-Defined Settings, in the 550 controller operation manual. **A copy of the User-Defined Settings form is included at the end of this document.**

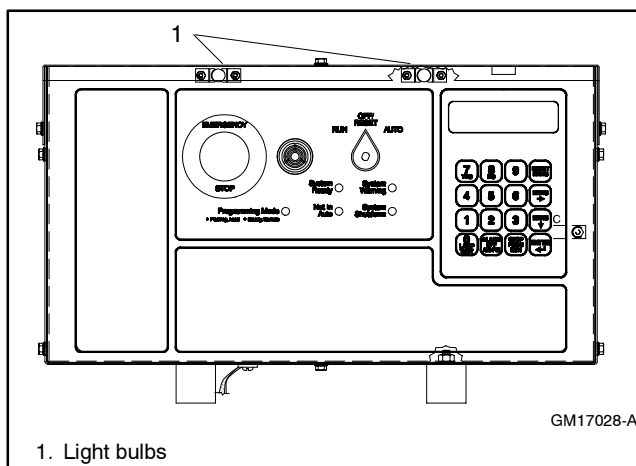

Figure 1 550 Controller Front Panel

Note: If the user parameters are included on the personality disk, the disk label should indicate Site Program—Yes.

Read the entire installation procedure and compare the kit parts with the parts list in this publication before beginning installation. Perform the steps in the order shown.

Always observe applicable local and national electrical codes.

Note: The following service kit procedure changes only the controller. If the generator set requires voltage reconnection and/or frequency adjustment, see the 550 controller operation manual (TP-6083 or MP-6083).

Installation Requirements

The following items are necessary PC requirements for installing the controller service replacement kits.

- Program loader kit GM17732 or GM17733. See the program loader kit instructions for additional items needed to complete the installation. The program loader kit includes the Monitor II software, version 2.2.5 or later.

Use the Monitor II software, version 2.2.5 or greater, to enter the user parameters from a backup disk and/or enter alpha-numeric data. See the Monitor II software instructions for additional items.

- Null modem RS-232 cable with a 9-pin male plug on the controller end, part no. GM16657 or kits PA-294992 or PA-294992-SD.

Safety Precautions

Observe the following safety precautions while installing the kit.

⚠ WARNING

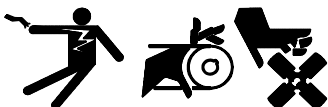

Accidental starting.
Can cause severe injury or death.

Disconnect the battery cables before working on the generator set. Remove the negative (-) lead first when disconnecting the battery. Reconnect the negative (-) lead last when reconnecting the battery.

Disabling the generator set. Accidental starting can cause severe injury or death. Before working on the generator set or connected equipment, disable the generator set as follows: (1) Move the generator set master switch to the OFF position. (2) Disconnect the power to the battery charger. (3) Remove the battery cables, negative (-) lead first. Reconnect the negative (-) lead last when reconnecting the battery. Follow these precautions to prevent starting of the generator set by an automatic transfer switch, remote start/stop switch, or engine start command from a remote computer.

⚠ WARNING

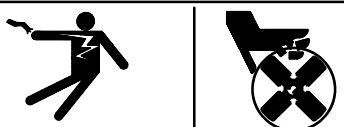

Hazardous voltage. Moving rotor.
Can cause severe injury or death.

Operate the generator set only when all guards and electrical enclosures are in place.

Grounding electrical equipment. Hazardous voltage can cause severe injury or death. Electrocutation is possible whenever electricity is present. Open the main circuit breakers of all power sources before servicing the equipment. Configure the installation to electrically ground the generator set and related equipment and electrical circuits to comply with applicable codes and standards. Never contact electrical leads or appliances when standing in water or on wet ground because these conditions increase the risk of electrocution.

Connecting the battery and the battery charger. Hazardous voltage can cause severe injury or death. Reconnect the battery correctly, positive to positive and negative to negative, to avoid electrical shock and damage to the battery charger and battery(ies). Have a qualified electrician install the battery(ies).

Short circuits. Hazardous voltage/current can cause severe injury or death. Short circuits can cause bodily injury and/or equipment damage. Do not contact electrical connections with tools or jewelry while making adjustments or repairs. Remove all jewelry before servicing the equipment.

Installation Procedure

1. Acquire the user parameters.

1.1 Choose one of the following methods to retrieve the user parameters:

- Backup disk. If a backup disk was previously made, obtain the parameters from this disk. If a disk was not previously made, create a backup if possible using the Monitor II software, version 2.2.5 or greater. The existing controller must function in order to create the file. If a disk is not available...
- Paper form. Parameters should have been recorded on the User-Defined Settings form located in Appendix B of the 550 controller operation manual or other similar form.
- Controller menu. Manually review the controller menu displays if possible and enter the parameter information in the 550 controller operation manual Appendix B, User-Defined Settings form.

1.2 Save the user parameter data for step 21.1.

2. Acquire display data from the old controller for entry in the new controller.

Certain data cannot be stored on electronic media for archival purposes and must be entered using a PC or the controller keypad.

When possible, make note of the following data from the old controller for entry in the new controller. If the old controller is not functional, the installer **must** determine and document this information for entry later in this procedure. See Appendix B for the Controller User-Defined Settings form.

2.1 From Menu 7, Generator System

2.1.1 Metric Units, yes or no

2.2 From Menu 12, Calibration

2.2.1 Scale Aux. Analog Inputs. Repeat for each input 01-07

- Analog 01, scale value 1
- Analog 01, scale value 2

2.3 From Menu 13, Communication

2.3.1 Protocol KBUS

- KBUS online, yes or no
- Connection type

- Local single, yes or no
- Local LAN, yes or no
- Local LAN conv, yes or no
- Remote single, yes or no
- Remote LAN, yes or no
- Remote LAN conv, yes or no

- Primary port
 - RS-232, yes or no
 - RS-485 ISO1, yes or no
- Address (LAN connections)
- System ID (remote connections)
- BAUD rate
 - 1200
 - 2400
 - 9600

2.3.2 Protocol Modbus

- Modbus online, yes or no
- Connection type
 - Single, yes or no
 - Convertor, yes or no
- Primary port
 - RS-485
 - RS-232
- Address
- BAUD rate
 - 9600
 - 19200

2.4 From Menu 20, Factory Setup

- Final assembly date
- Final assembly clock number
- Model number
- Spec number
- Serial number

3. Acquire display data from the old controller for reference purposes.

When possible, write down the old controller display data in Appendix A. This data is not required for the new controller but may be needed for future reference. If the old controller is not functional, the information is no longer retrievable.

4. Remove the generator set from service.

4.1 Place the generator set master switch in the OFF position.

4.2 Disconnect the power to the battery charger, if equipped.

4.3 Disconnect the generator set engine starting battery(ies), negative (-) lead first.

5. Disconnect the existing 550 controller electrical connections.

5.1 Remove the controller cover. If access to the interconnection circuit board on the rear panel and/or the main logic/communication circuit board on the front panel is difficult, partially disassemble the controller box. Remove the two controller panel top screws and center bottom screw and then loosen the bottom screw on each side to swing the controller panel down. See Figure 2.

Note: Clearly mark all disconnected leads from the 550 controller with tape to simplify reconnection.

5.2 Disconnect the 550 controller harness leads. Listed below are some common leads and plugs that require removal or disconnection. Items below in **bold** are shown in Figure 2. These connections are typical and may not apply to all situations. See the corresponding wiring diagram found in the wiring diagrams manual.

- AC fuse terminal block **TB5** leads V7, V8, and V9
- All external connections to terminal strips **TB1, TB2, TB3, and TB4**
- CT/meter scale terminal block lead V0
- P24 connector to the CT burden resistor board
- Plug **P1** on the burden resistor board and the Marathon excitation interface board
- Plug **P23** to the controller connection strip in the junction box
- Plug P22 to the engine wiring harness
- Plug **P18** communication connection
- Prime power kit
- Any other external leads to the controller

6. Remove the existing 550 controller.

- 6.1 Remove the junction box panel(s) to gain access to the controller vibromount screws.
- 6.2 Remove the four controller vibromount screws from underneath the junction box top panel.
- 6.3 Lift off the existing 550 controller.

7. Install the replacement 550 controller.

7.1 Place the replacement 550 controller on the junction box top panel holes.

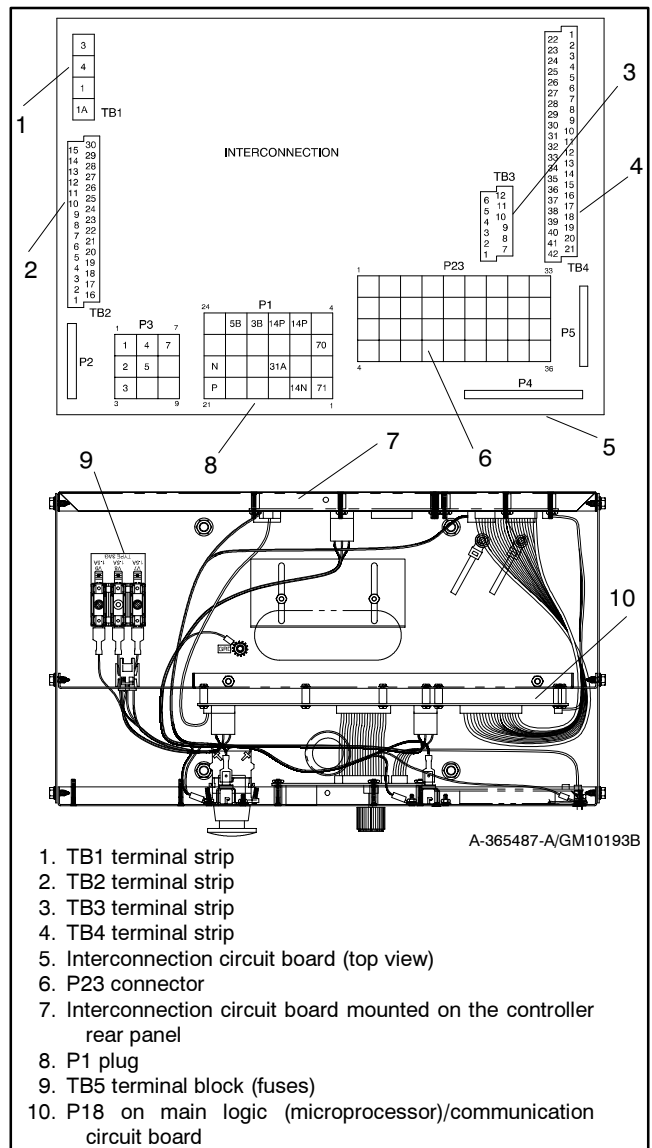

Figure 2 Disconnecting Controller Circuit Board External Wiring Connections

- 7.2 Align the 550 controller vibromounts with the mounting holes and install four screws.
- 7.3 Change the controller's front display lamps, if required. See Figure 1 for location. See Figure 3 for lamp identification. The factory ships the 550 controller with 12-volt lamps. Replace the bulbs in the controller with the lamps provided in the replacement kit if the generator set has a 24-volt engine electrical system. Determine the engine electrical system voltage using the generator set nameplate information.

Lamp Part No.	Voltage	Bulb Part Number
255126	12	1892
283420	24	313

Figure 3 Lamp Identification

8. Reconnect the existing 550 controller.

8.1 Remove the controller cover. If access to the interconnection circuit board on the rear panel and/or the communication circuit board on the front panel is difficult, partially disassemble the controller box. Remove the two controller panel top screws and center bottom screw and then loosen the bottom screw on each side to swing the controller panel down. See Figure 2.

8.2 Reconnect the controller wiring that was previously removed. See the corresponding wiring diagram found in the wiring diagrams manual. Listed below are some common leads and plugs that may require reconnection. These connections are typical and may not apply to all situations.

- AC fuse terminal block **TB5** leads V7, V8, and V9
- All external connections to terminal strips **TB1, TB2, TB3, and TB4**
- CT/meter scale terminal block lead V0
- P24 connector to the CT burden resistor board
- Plug **P1** on the burden resistor board and the Marathon excitation interface board
- Plug **P23** to the controller connection strip in the junction box
- Plug P22 to the engine wiring harness
- Prime power kit
- Any other external leads to the controller

8.3 Swing the rear controller panel up and replace and tighten the screws, as necessary.

8.4 Replace the junction box panel(s) and screws.

9. Restore power to the generator set.

9.1 Check that the generator set master switch is in the OFF position.

9.2 Reconnect the generator set engine starting battery, negative (-) lead last.

9.3 Reconnect power to the battery charger, if equipped.

10. Install the program/data files.

10.1 Connect the PC serial port to the controller RS-232 port using a null modem RS-232 cable with a 9-pin male plug on the controller end. See TT-1285 for details.

10.2 Install the Program Loader program into the PC using the procedure outlined in TT-1285.

10.3 Insert the personality profile backup disk and load the data. See TT-1285 for details.

11. Establish the controller identity in Menu 20.

The controller displays the following error message: GENSET S/N WARNING.

This procedure includes instructions on how to unlock and lock the factory setup after entering menu 20. Use the down arrow key to go to the setup lock menu for determining the setup status.

Note: After completing the factory setup always **return the controller to the setup lock position** to prevent inadvertent program changes.

11.1 Press the RESET MENU key on the controller keypad.

11.2 Use the controller keypad to go to Menu 14, Programming Mode, and select **programming mode—local**. Use the information from the 550 controller operation manual as necessary.

Note: The factory default access code is the number 0.

11.3 Press the RESET MENU key on the controller keypad.

11.4 Use the controller keypad to go to Menu 20, Factory Setup. See Figure 4 for displays.

11.5 Arrow down to the SETUP LOCK display.

If the SETUP LOCK display indicates YES, go to step 11.6.

If the SETUP LOCK display indicates NO, go to step 11.7.

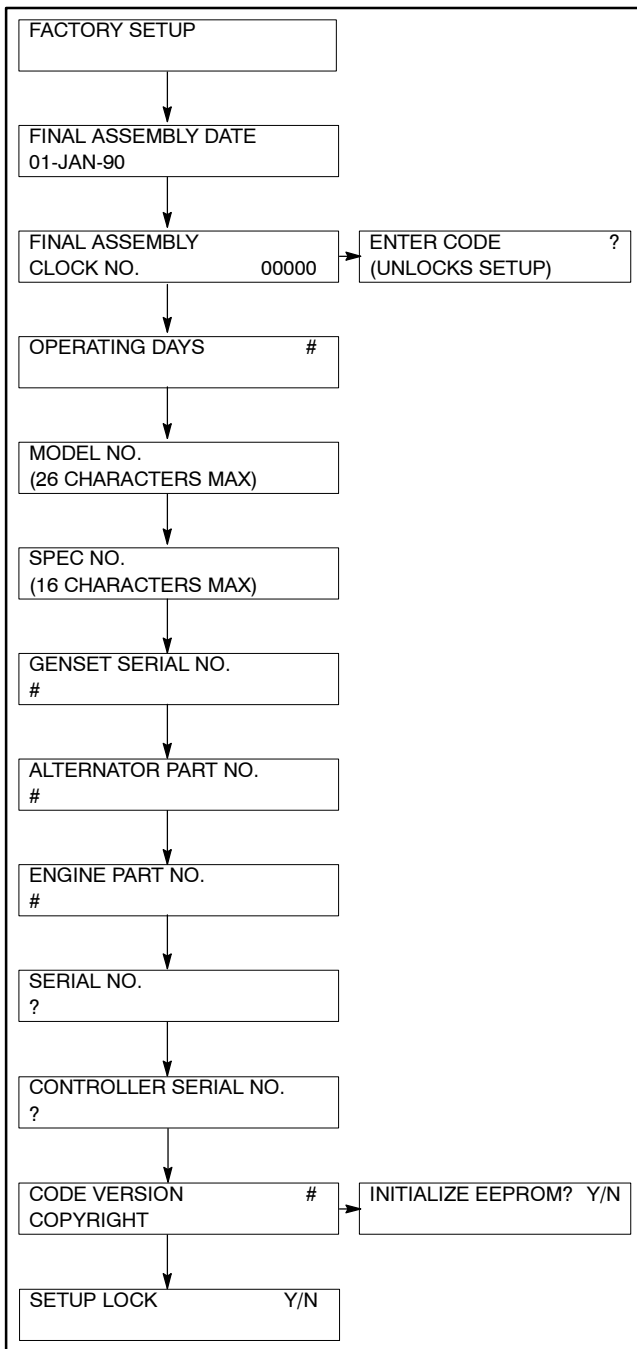

Figure 4 Menu 20, Factory Setup

11.6 Unlock the setup.

11.6.1 Arrow down to the FINAL ASSEMBLY, CLOCK NO. display. Record the clock number on the controller display.

11.6.2 Arrow right to ENTER CODE display.

11.6.3 Use the controller keypad to enter the clock number previously recorded.

11.6.4 Press the ENTER key. Changes to Menu 20, Factory Setup, are now possible.

11.7 Initialize the EEPROM.

11.7.1 Arrow down to the CODE VERSION display.

11.7.2 Arrow right to the INITIALIZE EEPROM display.

11.7.3 Press the YES key to initialize the EEPROM.

11.7.4 Press the ENTER key.

11.8 Press the RESET MENU key on the controller keypad and wait for completion of the system reset (approx. 5-10 seconds).

11.9 Go to Menu 20, Factory Setup. See Figure 4 for displays.

11.10 Change the final assembly date.

11.10.1 Arrow down to the FINAL ASSEMBLY DATE display.

11.10.2 Enter the final assembly date using the data recorded from the old controller, reference step 2.4. If data from the old controller is not available, keep the default setting.

11.10.3 Press the ENTER key if making a new entry.

11.11 Change the final assembly clock number.

11.11.1 Arrow down to the FINAL ASSEMBLY CLOCK NO. display.

11.11.2 Enter the final assembly clock number using the data recorded from the old controller. If data from the old controller is not available, keep the default setting.

11.11.3 Press the ENTER key if making a new entry.

11.12 Change the serial number.

11.12.1 Arrow down to the SERIAL NO. display.

11.12.2 Enter the serial number of the generator set using the data recorded from the old controller or as shown on the generator set nameplate. If the serial number is six digits, enter a *leading zero* for a seven-digit serial number.

11.12.3 Press the ENTER key. The GENSET S/N WARNING display no longer appears.

12. Perform the Menu 13, Communications entries.

12.1 Press the RESET MENU key on controller keypad.

12.2 Use the controller keypad to go to Menu 13, Communications.

12.3 Complete the communication entries as necessary for remote programming. Use the information from the 550 controller operation manual as necessary. Use the information from the Monitor II software, version 2.2.5 or greater as necessary.

13. Perform the Menu 14, Programming mode entries.

13.1 Press the RESET MENU key on controller keypad.

13.2 Use the controller keypad to go to Menu 14, Programming Mode, and select **programming mode—remote**. Use the information from the Monitor II software, version 2.2.5 or greater.

14. Perform the Menu 20, Factory Setup entries using the Generator Info window. Use the information from the Monitor II software, version 2.2.5 or greater.

14.1 Change the model number.

14.1.1 Go to the MODEL NO. display.

14.1.2 Enter the model number using the data recorded from the old controller or as shown on the generator set nameplate.

14.2 Change the spec (specification) number.

14.2.1 Go to the SPEC NO. display.

14.2.2 Enter the spec number using the data recorded from the old controller or as shown on the generator set nameplate.

15. Perform the Menu 14, Programming mode entries.

15.1 Press the RESET MENU key on the controller keypad.

15.2 Use the controller keypad to go to Menu 14, Programming Mode and select **programming mode—local**. Use the information from the 550 controller operation manual as necessary.

16. Lock the Menu 20, Factory Setup entries.

16.1 Press the SETUP MENU key on the controller keypad.

16.2 Use the controller keypad to go to Menu 20, Factory Setup.

16.3 Arrow down to the SETUP LOCK display.

16.4 Press the YES key to lock the setup and prevent alterations to Menu 20, Factory Setup.

17. Enter the Menu 6, Time and Date, settings.

17.1 Press the RESET MENU key on the controller keypad.

17.2 Use the controller keypad to go to Menu 6, Time and Date. Use the information from the 550 controller operation manual as necessary to set the time and date.

18. Perform the Menu 7, Generator System, entries for English or metric displays.

18.1 Press the RESET MENU key on the controller keypad.

18.2 Use the controller keypad to go to Menu 7, Generator System. Use the information from the 550 controller operation manual as necessary to change Metric Unit, yes or no.

19. Perform the Menu 12, Calibration, entries.

19.1 Press the RESET MENU key on the controller keypad.

19.2 Use the controller keypad to go to Menu 12, Calibration. Use the information from the 550 controller operation manual as necessary to scale AC analog inputs.

- 19.3 With the information previously recorded from step 2.2, complete the scale auxiliary analog inputs. Use the information from the 550 controller operation manual as necessary.
- 20. Perform the Menu 14, Programming Mode entries.**
- 20.1 Press the RESET MENU key on the controller keypad.
- 20.2 Use the controller keypad to go to Menu 14, Programming Mode.
- Select **programming mode—remote** when adding user parameter from a backup disk or PC. Use the information from the Monitor II software, version 2.2.5 or greater.
 - Select **programming mode—local** for keypad entries. Use the information from the 550 controller operation manual as necessary.
- 21. Add the user parameters.**
- 21.1 Choose one of the following methods to load the user parameters.
- Backup disk. Use a PC to load the data from the user parameter backup disk. Enable Menu 14, Programming Mode—Remote. See the information from the Monitor II software manual.
 - Paper form. Use a PC to enter the user parameter data from the filled-out 550 controller operation manual, Appendix B, User-Defined Settings form or other similar form. Enable Menu 14, Programming Mode—Remote. See the information supplied with the Monitor II software manual.
 - Controller menu. Use the controller keypad to manually enter the user parameter data from the filled-out 550 controller operation manual, Appendix B, User-Defined Settings form. Enable Menu 14, Programming Mode—Local. Use the information from the 550 controller operation manual as necessary.
- 21.2 Create a new user parameter data backup disk if any changes are made. See the Monitor II software manual.
- 21.3 Disconnect the PC null modem RS-232 cable.
- 21.4 Install the P18 communication connection, as necessary.
- 21.5 Swing the front controller panel up and replace and tighten the screws, as necessary.
- 21.6 Replace the controller cover and hardware. Tighten all controller screws.
- 22. Restore the generator set to service.**
- 22.1 Perform the Menu 13, Communication, entries.
- 22.1.1 Press the RESET MENU key on controller keypad.
- 22.1.2 Use the controller keypad to go to Menu 13, Communications.
- 22.1.3 With the information previously recorded from step 2.3, complete the communication entries as necessary for the application. Use the information from the 550 controller operation manual as necessary.
- 22.2 Perform the Menu 14, Programming Mode entries.
- 22.2.1 Press the RESET MENU key on controller keypad.
- 22.2.2 Use the controller keypad to go to Menu 14, Programming Mode.
- 22.2.3 Change the entries for the application as necessary.
- 22.3 The generator set system is now ready to function.
- 22.4 Move the generator set master switch to AUTO for startup by remote transfer switch or remote start/stop switch.

Parts List

550 Controller Service Replacement Kits

Kit: GM20722-1		
Qty.	Description	Part Number
1	Controller assembly with rotary switch and 12-volt lamps	GM10193-1
2	Lamps, 24-volt, no. 313	283420
1	Literature kit	GM20727-KP

Kit: GM20722-1S		
Qty.	Description	Part Number
1	Controller assembly with rotary switch and 12-volt lamps	GM10193-3
2	Lamps, 24-volt, no. 313	283420
1	Literature kit	GM20727-KPS

Kit: GM20722-2		
Qty.	Description	Part Number
1	Controller assembly with key switch and 12-volt lamps	GM10193-5
2	Lamps, 24-volt, no. 313	283420
1	Literature kit	GM20727-KP

Kit: GM20722-2S		
Qty.	Description	Part Number
1	Controller assembly with key switch and 12-volt lamps	GM10193-7
2	Lamps, 24-volt, no. 313	283420
1	Literature kit	GM20727-KPS

Appendix A Display Items for Reference

Menu 4 Operational Records		Menu 5 Event History		
<ul style="list-style-type: none"> ● Factory Test Date ● Total Run Time ● Total Run Time Loaded Hours ● Total Run Time Unloaded Hours ● Total Run Time kW Hours ● No. of Starts ● Engine Start Countdown <ul style="list-style-type: none"> ○ Run Time ● Records-Maintenance <ul style="list-style-type: none"> ○ Reset Records ● Run Time Since Maintenance Total Hours ● Run Time Since Maintenance Loaded Hours ● Run Time Since Maintenance Unloaded Hours ● Run Time Since Maintenance kW Hours ● Operating Days Last Maintenance ● No. of Starts Last Maintenance ● Last Start Date ● Length of Run (Un)loaded Hours 		<ul style="list-style-type: none"> ● (Message Text) ● (Scroll through up to 100 stored events) 		
			Menu 20 Factory Setup	
			<ul style="list-style-type: none"> ● Final Assembly Date ● Final Assembly Clock No. ● Operating Days 	

Appendix B Controller User-Defined Settings

Use the table below to record user-defined settings during the generator set controller setup and calibration. The controller default settings and ranges provide

guidelines. The table contains all faults with ranges and time delays including items that do not have adjustments.

Status or Fault	Refer to Menu	Digital Display	Relay Driver Output (RDO)	Range Setting	Default Selection	Inhibit Time Delay* (sec.)	Time Delay (sec.)	User-Defined Settings
AC Sensing Loss	10	AC Sensing Loss	RDO-25					Not adjustable
Access Code (password)	14				0 (zero)			
Analog Aux. Inputs 1-7	9	User-Defined A1-A7		Default values with Warning Enabled: HI warning 90%, LO warning 10%, HI shutdown 100%, LO shutdown 1%	30 sec. inhibit, 5 sec. delay	0-60	0-60	
Analog Aux. Input 1	9	Coolant Temperature		Default values with Warning Enabled: HI/LO warning and HI/LO shutdown are all engine dependant	30 sec. inhibit, 0 sec. delay	0-60	0-60	
Analog Aux. Input 2	9	Oil Pressure		Default values with Warning Enabled: HI/LO warning and HI/LO shutdown are all engine dependant (255 psi max.)	30 sec. inhibit, 0 sec. delay warning, 5 sec. delay shutdown	0-60	0-60	
Cyclic Cranking	8			1-6 crank cycles 1-60 sec. crank on 1-60 sec. pause	3 cycles 15 sec. 15 sec.			
Defined Common Faults	10	User-Defined	RDO-18	Default shutdowns include: Emergency stop High coolant temp Low oil pressure Overcrank Overspeed	30 sec. inhibit, 5 sec. delay	0-60	0-60	
Digital Aux. Inputs 1-21	9	User-Defined D1-D21			30 sec. inhibit, 5 sec. delay	0-60	0-60	
EPS (Emergency Power System) Supplying Load	10	EPS Supplying Load	RDO-15		5% of rated line current			
High Battery Voltage	10	High Battery Voltage	RDO-13	14.5-16.5 (12V) 29-33 (24V)	16 (12V) 32 (24V)		10	
High Coolant Temperature Shutdown	10	Hi Cool Temp Shutdown	RDO-03			30	5	Not adjustable
High Coolant Temperature Warning	10	Hi Cool Temp Warning	RDO-06			30		Not adjustable
High Oil Temperature Shutdown	10	Hi Oil Temp Shutdown	RDO-17			30	5	Not adjustable
Idle Mode			RDO-21					
Load Shed kW Overload	10	Load Shed KW Over	RDO-30		100% of kW rating		5	

* Inhibited time delay is the time delay period after crank disconnect.

Status or Fault	Refer to Menu	Digital Display	Relay Driver Output (RDO)	Range Setting	Default Selection	Inhibit Time Delay* (sec.)	Time Delay (sec.)	User-Defined Settings
Load Shed Underfrequency	10	Load Shed Under Frequency	RDO-31		59, (60 Hz) 49, (50 Hz)		5	
Low Battery Voltage	10	Low Battery Voltage	RDO-12	10-12.5 (12V) 20-25 (24V)	12 (12V) 24 (24V)		10	
Low Coolant Level	10	Low Coolant Level	RDO-14			30	5	Not adjustable
(Low) Oil Pressure Shutdown	10	Oil Pressure Shutdown	RDO-04			30	5	Not adjustable
(Low) Oil Pressure Warning	10	Oil Pressure Warning	RDO-07			30		Not adjustable
No Coolant Temperature Signal	10	No Cool Temp Signal				30		Not adjustable
No Oil Pressure Signal	10	No Oil Pressure Signal				30		Not adjustable
Overcrank Shutdown	8	Over Crank	RDO-02	0-6 cycles	3 cycles			
Overcurrent	10	Over Current			110%		10	
Overfrequency Shutdown	7, 10	Over Frequency	RDO-28	102%-140%	140% std. 103% FAA		10	
Overspeed Shutdown	7, 10	Over Speed	RDO-01	65-70 (60 Hz) 55-70 (50 Hz)	70 (60 Hz) 60 (50 Hz)		0.25	
Overvoltage Shutdown	7, 8, 10	Over Voltage	RDO-20	105%-135%	115% 2-sec time delay		2-10	
Password (access code)	14				0 (zero)			See Access Code entry
Time Delay Engine Cooldown (TDEC)	8, 10		RDO-23	00:00-10:00 min:sec	5:00			
Time Delay Engine Start (TES)	8, 10			00:00-5:00 min:sec	00:01			
Time Delay Starting Aid	8, 10			0-10 sec.				
Underfrequency Shutdown	7, 10	Under Frequency	RDO-29	80%-95%	90%		10	
Undervoltage Shutdown	7, 8, 10	Under Voltage	RDO-27	70%-95%	85% 10-sec time delay		5-30	
Weak Battery	10	Weak Battery	RDO-26		60%		2	

* Inhibited time delay is the time delay period after crank disconnect.