INSTALLATION INSTRUCTIONS

Original Issue Date: **9/89**

Model: **All**

Market: **Industrial**

Subject: **Float/Equalize Battery Charger Kits PAA-326766, PAA-326767, PAC-292862 to PAC-292865, PAD-292862 to PAD-292865, PAA-325332-SD to PAA-325335-SD, PAB-325332-SD to PAB-325335-SD**

Introduction

The automatic battery charger charges and maintains lead-acid and nickel-cadmium automotive-type batteries in a fully charged state without manual intervention. The circuit board controls a full-wave SCR circuit which rectifies battery charger output from the power transformer. The control board provides the charger with current-limiting, AC line compensation, reverse polarity protection, ambient temperature compensation, and two constant-voltage charging modes. The control circuit board continuously monitors the battery and load conditions to maintain the battery's state of charge. Refer to Figure 1 for component identification. The chargers are factory-adjusted to maintain the battery at established float and equalize voltages.

The battery chargers are factory-connected for 120-volt, 50 or 60 Hz input and capable of charging as follows:

12-Volt Charger	24-Volt Charger
Lead-acid battery (6-cell)	Lead-acid battery (12-cell)
Nickel-cadmium battery (9-cell)	Nickel-cadmium battery (18-cell)

Determine input voltage and type of battery(ies) to be charged. If input voltage is not 120-volt, 50/60 Hz, see Input Connections on page 5 for further information.

Safety Precautions

Observe the following safety precautions when installing the kit.

⚠ WARNING

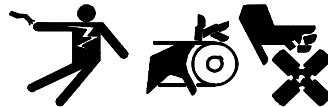

Accidental starting.
Can cause severe injury or death.

Disconnect the battery cables before working on the generator set. Remove the negative (-) lead first when disconnecting the battery. Reconnect the negative (-) lead last when reconnecting the battery.

Disabling the generator set. Accidental starting can cause severe injury or death. Before working on the generator set or connected equipment, disable the generator set as follows: (1) Move the generator set master switch to the OFF position. (2) Disconnect the power to the battery charger. (3) Remove the battery cables, negative (-) lead first. Reconnect the negative (-) lead last when reconnecting the battery. Follow these precautions to prevent starting of the generator set by an automatic transfer switch, remote start/stop switch, or engine start command from a remote computer.

⚠ WARNING



Sulfuric acid in batteries.
Can cause severe injury or death.

Wear protective goggles and clothing. Battery acid may cause blindness and burn skin.

⚠ WARNING

<p>Explosion. Can cause severe injury or death. Relays in the battery charger cause arcs or sparks.</p> <p>Locate the battery in a well-ventilated area. Isolate the battery charger from explosive fumes.</p>

Battery electrolyte is a diluted sulfuric acid. Battery acid can cause severe injury or death. Battery acid can cause blindness and burn skin. Always wear splashproof safety goggles, rubber gloves, and boots when servicing the battery. Do not open a sealed battery or mutilate the battery case. If battery acid splashes in the eyes or on the skin, immediately flush the affected area for 15 minutes with large quantities of clean water. Seek immediate medical aid in the case of eye contact. Never add acid to a battery after placing the battery in service, as this may result in hazardous spattering of battery acid.

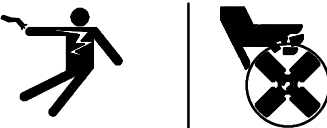
Battery gases. Explosion can cause severe injury or death. Battery gases can cause an explosion. Do not smoke or permit flames or sparks to occur near a battery at any time, particularly when it is charging. Do not dispose of a battery in a fire. To prevent burns and sparks that could cause an explosion, avoid touching the battery terminals with tools or other metal objects. Remove all jewelry before servicing the equipment. Discharge static electricity from your body before touching batteries by first touching a grounded metal surface away from the battery. To avoid sparks, do not disturb the battery charger connections while the battery is charging. Always turn the battery charger off before disconnecting the battery connections. Ventilate the compartments containing batteries to prevent accumulation of explosive gases.

⚠ WARNING

<p>Hazardous voltage. Moving rotor. Can cause severe injury or death.</p> <p>Operate the generator set only when all guards and electrical enclosures are in place.</p>

High voltage test. Hazardous voltage can cause severe injury or death. Follow the instructions of the test equipment manufacturer when performing high-voltage tests on the rotor or stator. An improper test procedure can damage equipment or lead to generator set failure.

Installing the battery charger. Hazardous voltage can cause severe injury or death. An ungrounded battery charger may cause electrical shock. Connect the battery charger enclosure to the ground of a permanent wiring system. As an alternative, install an equipment grounding conductor with circuit conductors and connect it to the equipment grounding terminal or the lead on the battery charger. Install the battery charger as prescribed in the equipment manual. Install the battery charger in compliance with local codes and ordinances.

Connecting the battery and the battery charger. Hazardous voltage can cause severe injury or death. Reconnect the battery correctly, positive to positive and negative to negative, to avoid electrical shock and damage to the battery charger and battery(ies). Have a qualified electrician install the battery(ies).

Short circuits. Hazardous voltage/current can cause severe injury or death. Short circuits can cause bodily injury and/or equipment damage. Do not contact electrical connections with tools or jewelry while making adjustments or repairs. Remove all jewelry before servicing the equipment.

⚠ WARNING

<p>Hazardous voltage. Moving rotor. Can cause severe injury or death.</p> <p>Operate the generator set only when all guards and electrical enclosures are in place.</p>

Servicing the generator set when it is operating. Exposed moving parts can cause severe injury or death. Keep hands, feet, hair, clothing, and test leads away from the belts and pulleys when the generator set is running. Replace guards, screens, and covers before operating the generator set.

NOTICE

Hardware damage. The engine and generator set may use both American Standard and metric hardware. Use the correct size tools to prevent rounding of the bolt heads and nuts.

NOTICE
<p>This is a positive terminal only. Do not attach negative (-) lead!</p>

Note: Charge only lead-acid or nickel-cadmium batteries with the battery charger.

Battery Charger Components

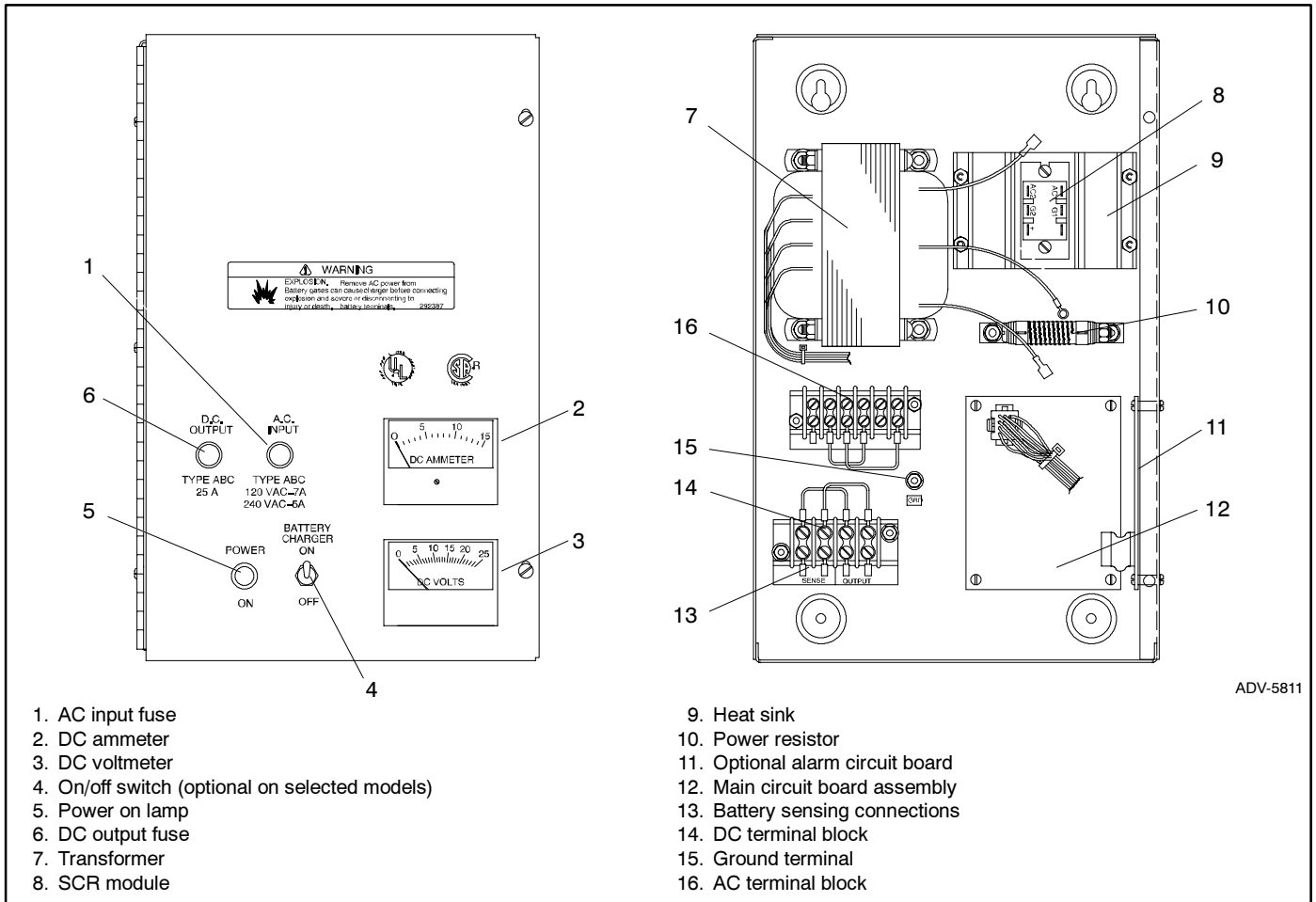

Figure 1 Battery Charger Components

Specifications

Model No.	Output Voltage	Output Amps.	Number of Cells		Voltage Regulation
			Lead-Acid	Nicad	
PAD-292862/PAC-292862	12	10	6	9	±1%
PAD-292863*/PAC-292863*	12	10	6	9	±1%
PAD-292864/PAC-292864	24	10	12	18	±1%
PAD-292865*/PAC-292865*	24	10	12	18	±1%
PAB-325332-SD/PAA-325332-SD	12	10	6	9	±1%
PAB-325333-SD*/PAA-325333-SD*	12	10	6	9	±1%
PAB-325334-SD/PAA-325334-SD	24	10	12	18	±1%
PAB-325335-SD*/PAA-325335-SD*	24	10	12	18	±1%
Weight:		11.8 kg (26 lb.)			
Dimensions, L x D x H:		267 x 148 x 413 mm (10.5 x 5.8 x 16.25 in.)			
* Includes optional alarm circuit board.					

Charger Voltage	Float Voltage	Equalize Voltage	Current Limit
12V	13V	14V	10A
24V	26V	28V	10A

Standard Accessories

Current Limiting

Current-limiting circuitry protects the battery charger from overload. This circuitry continuously monitors the battery charger output current and limits the current to 10-amps from full load to short circuit. Therefore, a crank disconnect is not required when the plant is exercised.

Reverse Polarity Protection

The reverse polarity protection circuit determines if battery charger connection is correct. If the polarity is reversed, the battery charger will not energize.

Automatic Float-to-Equalize Operation

After connecting the battery charger to the battery and applying AC power, the battery charger operates in the constant-current mode until the battery rises to the preset equalize level. At the preset equalize level, the battery charger switches to the constant voltage equalize mode until the current required to maintain this voltage drops to 5.5 amps. The battery charger then switches to the lower constant voltage float mode where the battery charger continues to operate until AC input power is lost or the current required to maintain the battery at the float voltage setting exceeds 6.5 amps.

Temperature Compensation

The battery charger provides temperature compensation of $-2\text{mv}/^{\circ}\text{C}$ per cell over the ambient temperature range of -40°C to 60°C (-40°F to 140°F). The temperature compensation feature automatically adjusts the float and equalize voltage settings to prevent overcharging the battery at high ambient temperatures and undercharging at low ambient temperatures.

Local and Remote Voltage Sensing

The battery charger has battery-sensing terminal block connections. If the battery charger output leads are longer than 4.6 m (15 ft.), disconnect the terminal block jumpers and separate sensing leads to the battery-sensing terminal block for battery monitoring (minimum wire size 18 ga.).

AC Input Fuse

The AC input fuse protects the power transformer from damage caused by short circuits. Ongoing vibration could also cause the fuse to open. Replace the fuse to return the charger to operation.

When changing input voltage connections, change the AC input fuse as follows:

Input Voltage	Fuse
120 VAC	7A, Type ABC
240 VAC	5A, Type ABC

DC Output Fuse

The DC output fuse protects the power transformer and SCRs from damage if the current limit setting is disabled or moved to its maximum setting. The fuse also blows if the battery charger output leads are shorted together.

Power On Lamp

The Power On Lamp connects across the power transformer's primary winding and indicates presence of AC power.

Battery Charger Location

Keep the following items in mind when choosing a battery charger location:

- Locate the battery charger a minimum of 1.8 m (6 ft.) from the battery and a minimum of 46 mm (18 in.) above the floor.
- Never locate the battery charger directly above battery being charged; gases from battery will corrode and damage battery charger.
- Locate the battery charger away from the battery(ies) so when reading specific gravity or filling battery cells, battery acid does not drip on the battery charger.
- Locate the battery charger in a well-ventilated area.
- Do not locate the battery charger where battery(ies) are on top of the battery charger.

Battery Charger Connection

Note: Charge only lead-acid or nickel-cadmium batteries with the battery charger.

1. Output Connections

Note: For DC connections use stranded copper wire, 600 V, 105°C (221°F) vinyl plastic insulation UL style 1015, CSA type TEW.

1.1 Move generator set master switch to OFF position.

1.2 Because of the variety of generator installations, battery cables are not provided. To make battery connections, cut red (+) 10-gauge stranded wire to desired length and strip insulation from both ends. To one end of wire attach a post-type connector. Route other end of battery cable through the knockout in the bottom of the battery charger and connect to output positive (+) terminal on charger DC terminal block. See Figure 2. Tighten terminal block lock screw to secure battery cable.

Repeat procedure with black (-) 10-gauge stranded wire; connect black wire to output negative (-) terminal on DC terminal block and secure with lock screw.

If battery charger output leads are longer than 4.6 m (15 ft.), disconnect DC terminal block jumpers and run separate battery-sensing leads to battery. Connect red 18-gauge (minimum) wire to positive (+) sensing terminal and black 18-gauge minimum wire to negative (-) sensing terminal. See Figure 2 for terminal identification.

1.3 Connect red battery charger lead(s) to battery positive (+) terminal and black charger lead(s) to battery negative (-) terminal.

1.4 Voltmeter will read zero and battery charger will not turn on if leads are reversed. See Reverse Polarity Protection for more information.

2. Input Connections

Grounding Instructions. Connect the battery charger to a grounded, metal, permanent wiring system, or connect an equipment-grounding conductor with circuit conductors to an equipment-grounding terminal or lead on battery charger. Connect battery charger to comply with all local codes and ordinances.

Note: Generator sets without an engine-driven battery charging alternator or alternator windings do not recharge the battery(ies). Connect battery charger to a power source that is energized when the generator set is running to prevent battery discharge. Failure to follow this procedure will cause the generator set battery(ies) to discharge from normal generator set prime power operation.

2.1 Battery chargers are factory-connected for 120-volt AC input. If using 120-volt AC input, connect to AC terminal block as shown in Figure 2. If using 240-volt AC input, remove the two AC terminal block jumpers and reconnect across terminals 3 and 4. Connect AC input as shown in customer input connections. See Figure 2 for AC input connections.

2.2 When changing input voltage connections, change the AC input fuse as follows:

Input Voltage	Fuse
120 VAC	7A, Type ABC
240 VAC	5A, Type ABC

2.3 Turn AC power on.

2.4 Turn ON/OFF switch ON, if equipped. Power On lamp lights, ammeter and voltmeter, show charging current and voltage.

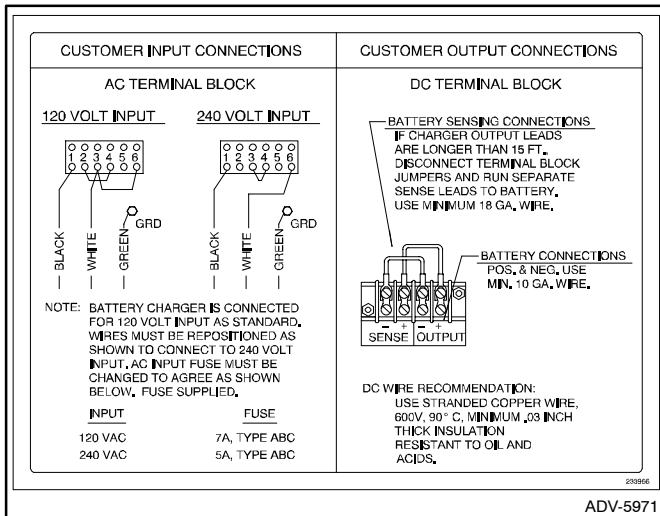

Figure 2 AC Customer Input Connections and DC Customer Output Connections

3. Battery Charger Disconnection when Replacing or Servicing Battery

Disconnection Procedure

Disconnect the battery charger from battery(ies) according to the following procedure.

- 3.1 Move generator set master switch to OFF position.
- 3.2 Place battery charger ON/OFF switch, if equipped, in OFF position.
- 3.3 Remove AC power supply from battery charger.
- 3.4 Remove battery charger connectors from battery, negative (-) lead first.

4. Battery Charger Operation

Charging Lead-Acid Batteries

Charge 6- or 12-cell lead-acid batteries according to the following procedure.

- 4.1 Check each cell's fluid level. If fluid level is low, add distilled water until fluid is at the level specified by the battery manufacturer. Sealed batteries require no maintenance. When using a dry charge battery, give the battery a conditioning charge immediately after adding the electrolyte fluid.
- 4.2 When changing a good battery check the following:
 - 4.2.1 Use a hydrometer to check specific gravity of the battery. The correct specific gravity for a fully charged battery is between 1.250 and 1.285 with an electrolyte temperature of 26.7°C (80°F). See checking Specific Gravity in this section.
 - 4.2.2 When a battery reaches 75%–80% of full charge, bubbles appear on the surface of fluid. Vigorous bubbling occurs when the battery is near full charge.

Checking Specific Gravity (Lead-Acid Batteries)

Use a battery hydrometer to check the specific gravity of the electrolyte in each battery cell. While holding the hydrometer vertically, read the number on the glass bulb at the top of the electrolyte level. The battery is fully charged if the specific gravity is 1.260 at an electrolyte temperature of 26.7°C (80°F). The difference between specific gravities of each cell should not exceed 0.01. Charge the battery if the specific gravity is below 1.215 at an electrolyte temperature of 26.7°C (80°F). The temperature of the battery electrolyte will affect the

specific gravity reading and must be considered when checking battery specific gravity. If the hydrometer does not have a temperature correction table, See Figure 3 and examples.

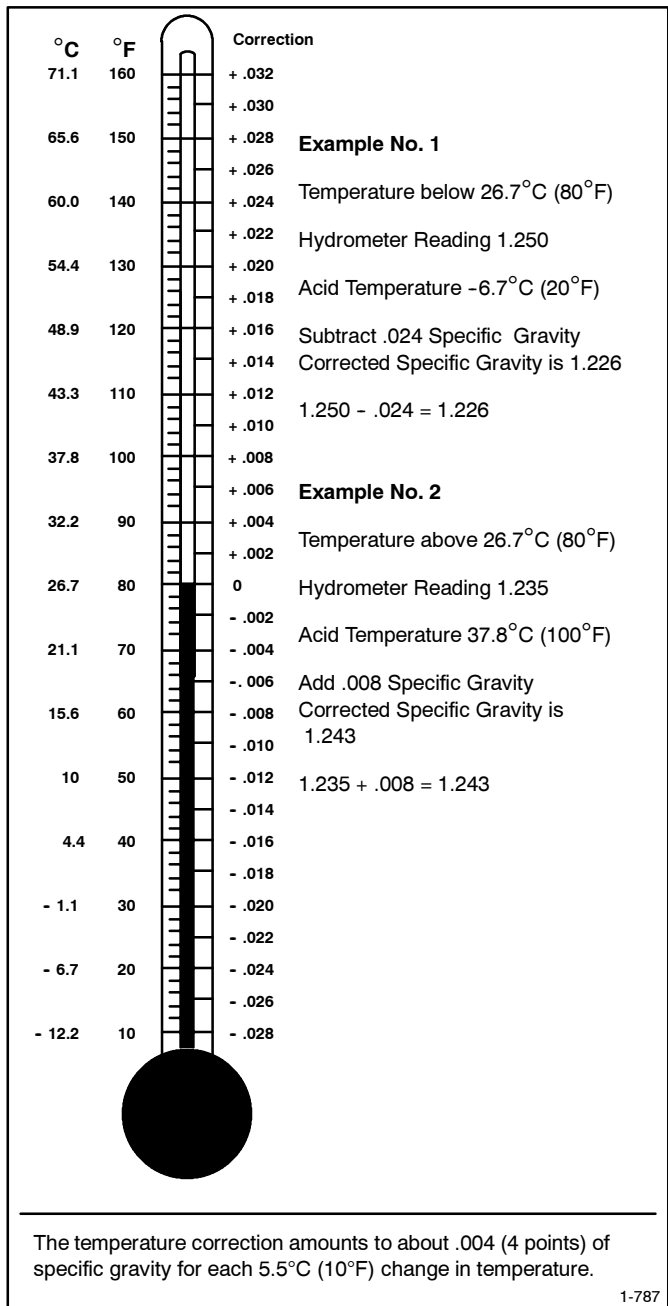

Figure 3 Specific Gravity Temperature Correction

Charging Nickel-Cadmium Batteries

Because charging recommendations vary between manufacturers of nickel-cadmium batteries, specific nickel-cadmium battery charging instructions are not provided in this manual. Contact the nickel-cadmium battery manufacturer for specific charging and maintenance instructions if not included with battery.

Battery Charger Voltage Adjustment

The battery charger's output settings are factory set and normally require no adjustment. The factory settings are shown in the Specification Section.

5. Battery Charger and Battery Maintenance

Perform battery charger and battery maintenance according to the following procedure.

5.1 Check battery terminals and battery charger connectors for clean contact surfaces. Clean battery terminals and battery charger connectors as necessary with a mild baking soda/water solution. If battery charger does not work, see Figure 4, Troubleshooting Chart.

5.2 Check battery fluid level regularly; maintain battery fluid at level specified by battery manufacturer.

Note: Process all warranty repairs through an authorized distributor/dealer.

6. SCR Module Test

The SCR module test requires a good quality multimeter with at least 20,000 ohms-per-volt sensitivity. Because multimeters vary in accuracy, use ohm readings only as a reference. Use instructions supplied with multimeter. See Figure 5 for wiring diagram of the internal circuit of the SCR modules. Disconnect the SCR module from battery charger circuit during testing.

6.1 Place multimeter on highest ohm scale. Check the anode-to-cathode circuits of the SCR by connecting meter leads across AC1 and (+) terminals. Perform test, then reverse the meter leads and perform test again. Repeat procedure across AC2 and (+) terminals. No reading or a slight meter movement with meter leads in both directions indicates a good anode-to-cathode circuit. A meter reading of zero ohms with meter leads in both directions indicates a shorted anode-to-cathode circuit. Replace the SCR module.

Note: When performing this step, carefully check the meter movement. A good anode-to-cathode circuit will cause the meter needle to move slightly.

6.2 Place multimeter on Rx1 scale. Check the gate-to-cathode circuit of the SCR by connecting meter leads across G1 and (+) terminals and then across G2 and (+) terminals.

6.2.1 Reassemble the front panel to the back panel of the annunciator box with two drill screws X-794-2.

6.2.2 Perform tests, then reverse the meter leads and test again. A good gate-to-cathode circuit results in a meter reading higher in one direction than in the other. Typical readings are 10 to 30 ohms in one direction and 60 to 130 ohms in the other.

Note: If testing with a digital multimeter, the gate-to-cathode circuit will be the same in both directions.

6.2.3 A meter reading of zero ohms with meter leads in both directions indicates a shorted gate-to-cathode circuit. Replace the SCR module.

6.2.4 No meter movement with meter leads in both directions indicates an open gate-to-cathode circuit. Replace the SCR module.

6.3 Step 3 applies only to 24-volt battery chargers:

6.3.1 Place multimeter on Rx1 scale.

6.3.2 Connect meter leads across SCR (-) terminal and AC1 terminal to check the anode-to-cathode circuit of the diode.

6.3.3 Reverse leads and test again.

6.3.4 Perform same test across SCR (-) and AC2 terminals.

6.3.5 A good anode-to-cathode circuit will result in a meter reading higher in one direction than in the other. Typical readings are from 9 to 20 ohms.

Note: The anode-to-cathode circuit will read the same in both directions if tested with a digital multimeter.

6.3.6 A meter reading of zero ohms with meter leads in both directions indicates a shorted anode-to-cathode circuit. Replace the SCR module.

6.3.7 No meter movement with meter leads in either of the two directions indicates an open anode-to-cathode circuit. Replace the SCR module.

Problem	Corrective Action
No ammeter reading	<p>Check charger connections to battery for correct polarity.</p> <p>Turn off AC supply prior to rechecking the battery charger for clean, tight connections.</p> <p>Check for AC at the charger terminal strip.</p> <p>Check AC input and DC output fuses.</p> <p>Check secondary voltage at transformer: 30 volts on a 12-volt battery, with 15 volts at center tap. 27 volts on a 24-volt battery.</p> <p>With AC supply disconnected, check DC output lead connections from transformer and SCR module to DC output terminal block.</p> <p>Check the rectifying circuit as outlined in the SCR module test.</p>

Figure 4 Troubleshooting Chart

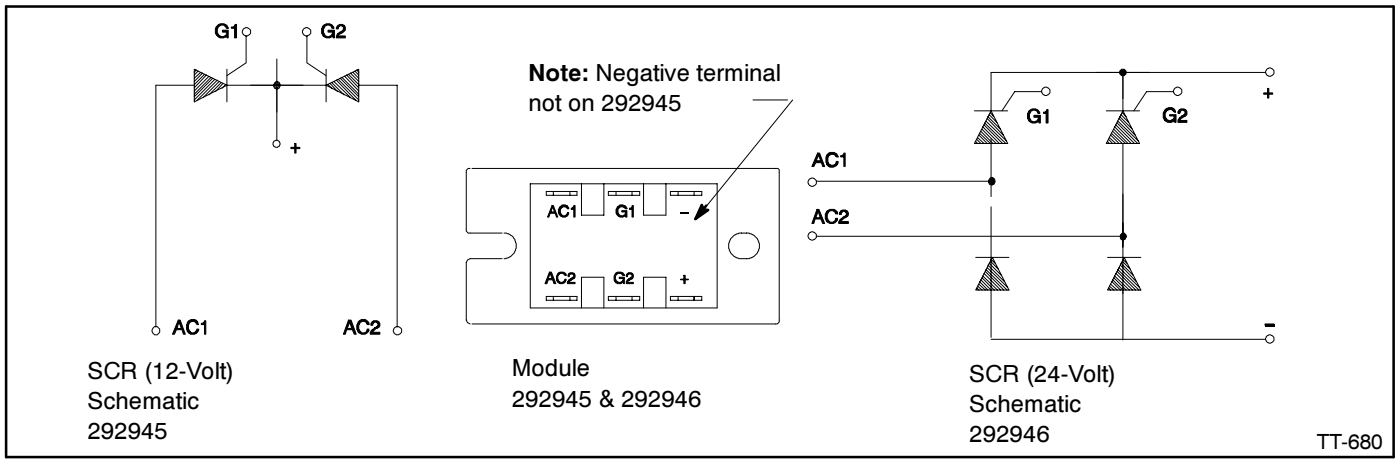

Figure 5 SCR Modules

Optional Accessories

The float/equalize battery charger with alarm option(s) provides battery charging to the engine starting battery(ies) and connects to the controller for fault detection.

Determine the type of generator set controller by the circuit board part number on the controller circuit board. The alphacharacter in the circuit board part number may be different from the one shown. See Figure 6 for controller identification and available optional accessories. See Figure 7 for wiring diagrams.

Note: All 16-light controllers have an LED panel display for optional alarms. The 6- and 7-light controllers require a remote annunciator for optional alarms.

Terminal Strip/Plug Qty.	LV	HV	BCF
TB1	X	X	X
TB1 and TB2	X	X	X
TB1, TB2, TB3, and TB4			X
TB1, TB2, TB3, TB4, and P23			X

Figure 6 Generator Set Controller Identification and Optional Accessories

Circuit Board Part Number	Terminal Strip/Plug Qty.	Wiring Diagram
A-328003	TB1	Figure 9
A-336415	TB1 and TB2	Figure 9
A-352160	TB1, TB2, TB3, and TB4	Figure 11
365486-B	TB1, TB2, TB3, TB4, and P23	Figure 12
—	Customer-supplied Connections	Figure 10

Figure 7 Wiring Diagrams

Low Battery Voltage Alarm, LV (optional)

The battery charger alarm board settings are factory set and normally require no adjustment. To make adjustments, contact an authorized distributor/dealer for service or service literature. The factory settings are shown in Figure 8.

Alarm Board Voltage	Low-Voltage Alarm		High-Voltage Alarm	
	Set	Reset	Set	Reset
12 V	12 V	12.4-12.9 V	15 V	14.1-14.6 V
24 V	24 V	24.8-25.8 V	30 V	28.2-29.2 V

Figure 8 Factory Alarm Board Settings

The low battery voltage alarm circuit monitors the battery's voltage. When the battery's voltage drops below a preset level for longer than 2 seconds, a set of normally open contacts closes to energize a customer-supplied alarm. The alarm contacts reset after the battery's voltage rises to a preset voltage above the alarm trip point. The time delay prevents nuisance alarms because of momentary dips in the battery's voltage.

Generally, the generator set controller fault indicators connect to one of the LV contacts on the alarm board terminal block. The other charger LV contact is connected to the battery ground. See Figure 9 for microprocessor controller connections, Figure 11 for controllers with A-352160 circuit board, and Figure 12 for 550 controllers.

Customer-provided fault indicators require external voltage supply equivalent to operating voltage of fault indicator if voltage supply or fault indicator is not connected to the generator set controller.

To install customer-provided external fault indicators, connect one side of fault indicator to one of the LV contacts on charger alarm board terminal block and secure with lock screw. Attach remaining lead of indicator to customer-supplied power source. Connect customer power supply to the other LV contact on alarm board terminal block. See Figure 10 for customer connections.

Note: Do not allow current draw of alarm indicator to exceed contact rating of alarm circuit (1 amp resistive load, 0.5 amp inductive load).

High Battery Voltage Alarm, HV (optional)

The high battery voltage alarm circuit monitors the battery's voltage. When the battery's voltage exceeds a preset level for longer than 2 seconds, a set of contacts closes to energize the customer-supplied alarm. The alarm contacts reset after the battery's voltage drops to a

preset voltage below the alarm trip points. The time delay prevents nuisance alarms from momentary surges on the battery line. Customer-provided fault indicators not on or connected to controller require external voltage supply equivalent to operating voltage of fault indicator.

To install customer-provided external fault indicators, connect one side of fault indicator to one of the HV contacts on charger alarm board terminal block and secure with lock screw. See Figure 10. Attach remaining lead of indicator to customer power supply. Connect customer power supply to the other HV contact on alarm board terminal block.

Note: Do not allow current draw of alarm indicator to exceed contact rating of alarm circuit (1 amp resistive load, 0.5 amp inductive load).

Battery Charger Fault Alarm, BCF (optional)

The battery charger fault alarm circuit monitors the AC input and DC output operating conditions of the battery charger. If a fault condition occurs, a set of contacts closes and energizes a customer-supplied alarm. The BCF circuit monitors whether AC voltage is present at the transformer secondary; if AC voltage is not present the contacts close. This condition could be the result of a blown AC input fuse, a shorted transformer secondary winding, or no AC power to the battery charger.

The BCF circuit also monitors whether the battery charger is in the constant-current mode for a low battery voltage alarm condition. If the battery charger is not in the constant current mode, the DC output fuse or one or both power SCRs could open.

Generally, the generator set controller fault indicators connect to one of the CM (battery charger fault) contacts of the battery charger alarm board terminal block. Connect the other CM contact to the battery ground terminal. See Figure 9 for connections.

Customer-provided fault indicators require external voltage supply equivalent to operating voltage of fault indicator if the fault indicator is not connected to the generator set controller. To install customer-provided external fault indicators, connect one side of fault indicator to one of the CM contacts on charger alarm board terminal block and secure with lock screw (see Figure 10). Attach remaining lead of indicator to customer power supply. Connect customer power supply to the other CM contact on alarm board terminal block. Do not allow amperage of alarm indicator to exceed contact rating of alarm circuit (1 amp resistive load, 0.5 amp inductive load).

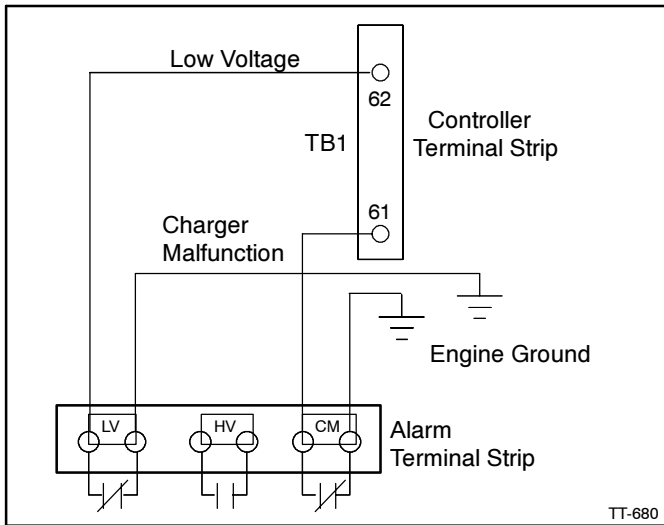

Figure 9 Microprocessor Controller Fault Indicator Connections

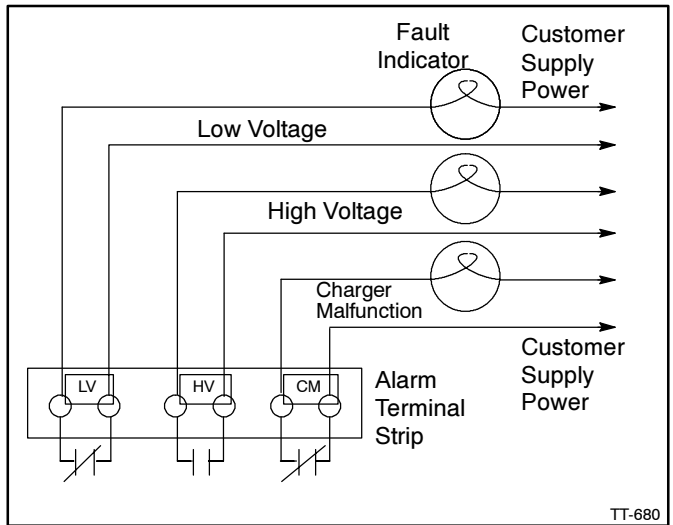

Figure 10 Customer Fault Indicator Connections

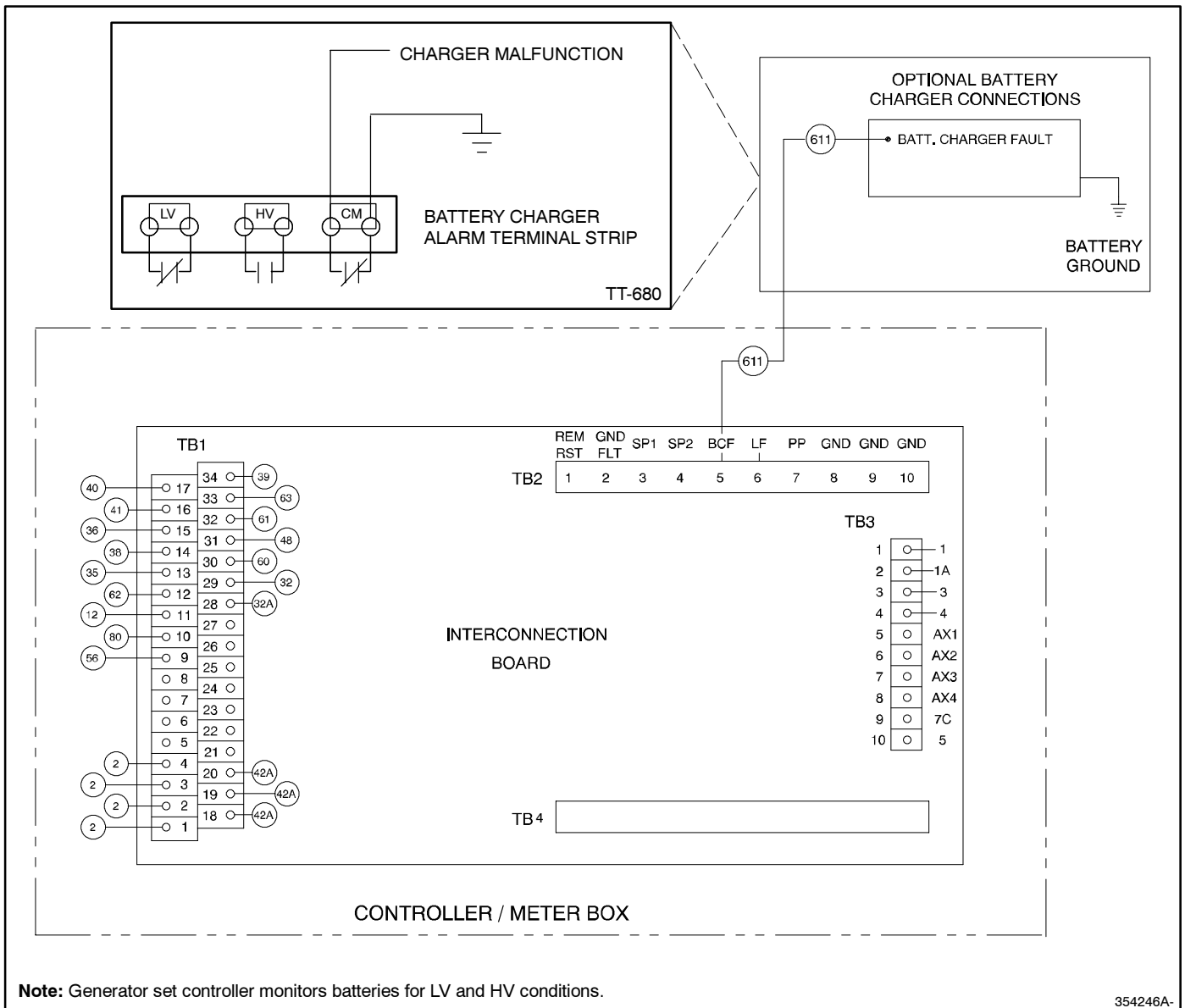
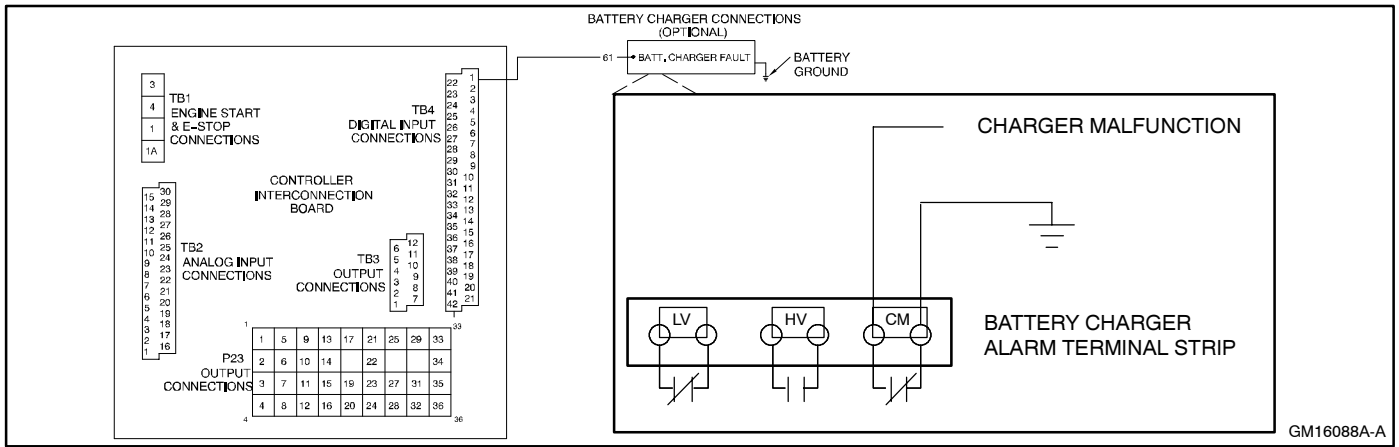

Figure 11 Controller Circuit Board A-352160 Fault Indicator Connections



GM16088A-A

Figure 12 550 Controller Circuit Board Fault Indicator Connections

Dimension Drawings and Wiring Diagrams

Use the Dimension Drawing and Wiring Diagram reference chart to determine the drawing for a given kit number.

Kit Number	Dimension Drawing	Page	Wiring Diagram	Page
PAA-326766, PAA-326767 12-volt 24-volt	A-326767	13	326781A	16
	A-326767	13	326781B	17
PAC-292862, PAC-292863, PAC-292864, PAC-292865 12-volt 24-volt	ADV-5811	15	233967A 233967B	18 19
	ADV-5811	15	233968A 233968B	20 21
PAD-292862, PAD-292863, PAD-292864, PAD-292865 12-volt 24-volt	ADV-5971	14	233967A 233967B	18 19
	ADV-5971	14	233968A 233968B	20 21
PAA-325332-SD, PAA-325333-SD, PAA-325334-SD, PAA-325335-SD 12-volt 24-volt	ADV-5811	15	233967A 233967B	18 19
	ADV-5811	15	233968A 233968B	20 21
PAB-325332-SD, PAB-325333-SD, PAB-325334-SD, PAB-325335-SD 12-volt 24-volt	ADV-5971	14	233967A 233967B	18 19
	ADV-5971	14	233968A 233968B	20 21

Figure 13 Dimension Drawings and Wiring Diagrams

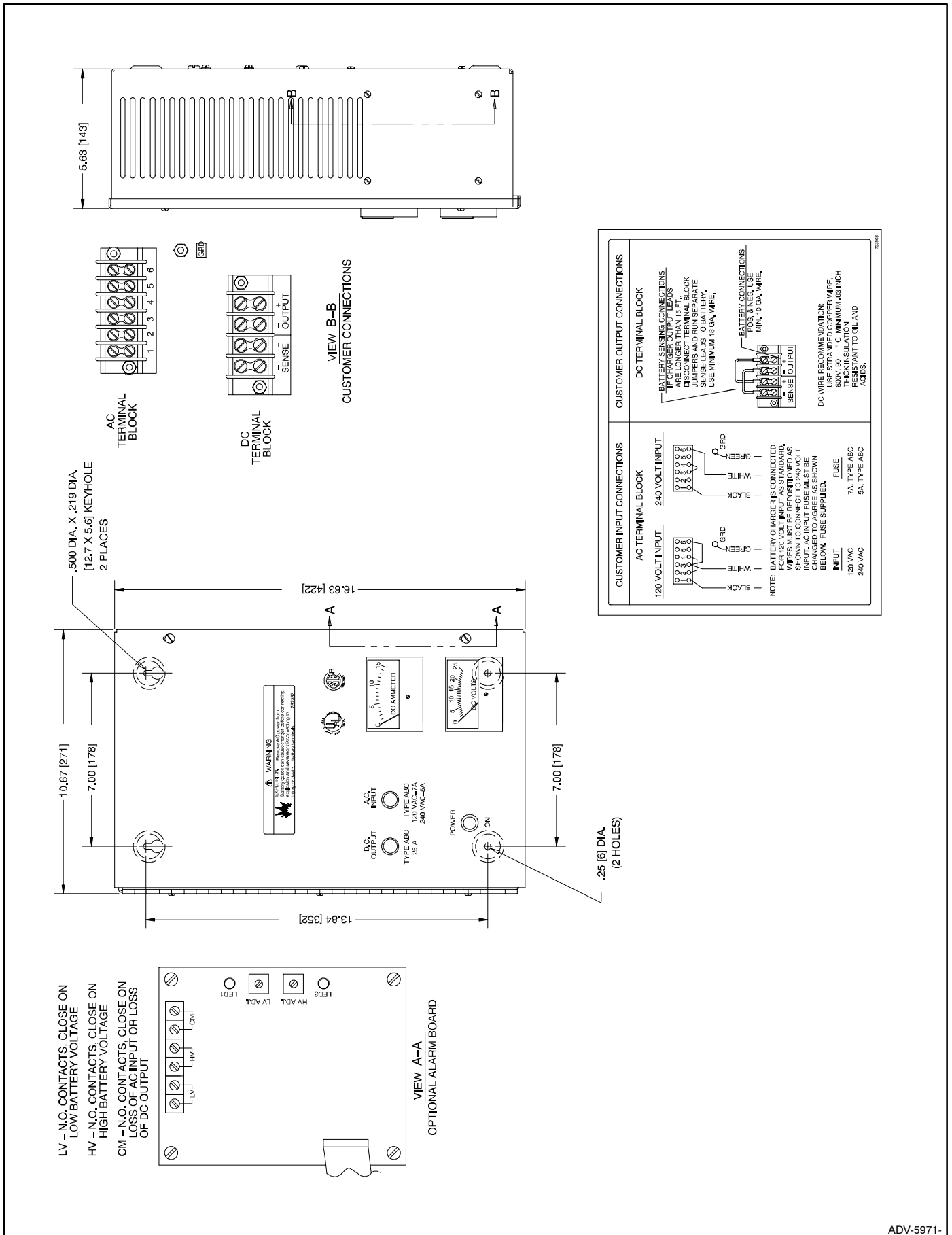

Figure 15 Battery Charger Dimension Drawing ADV-5971

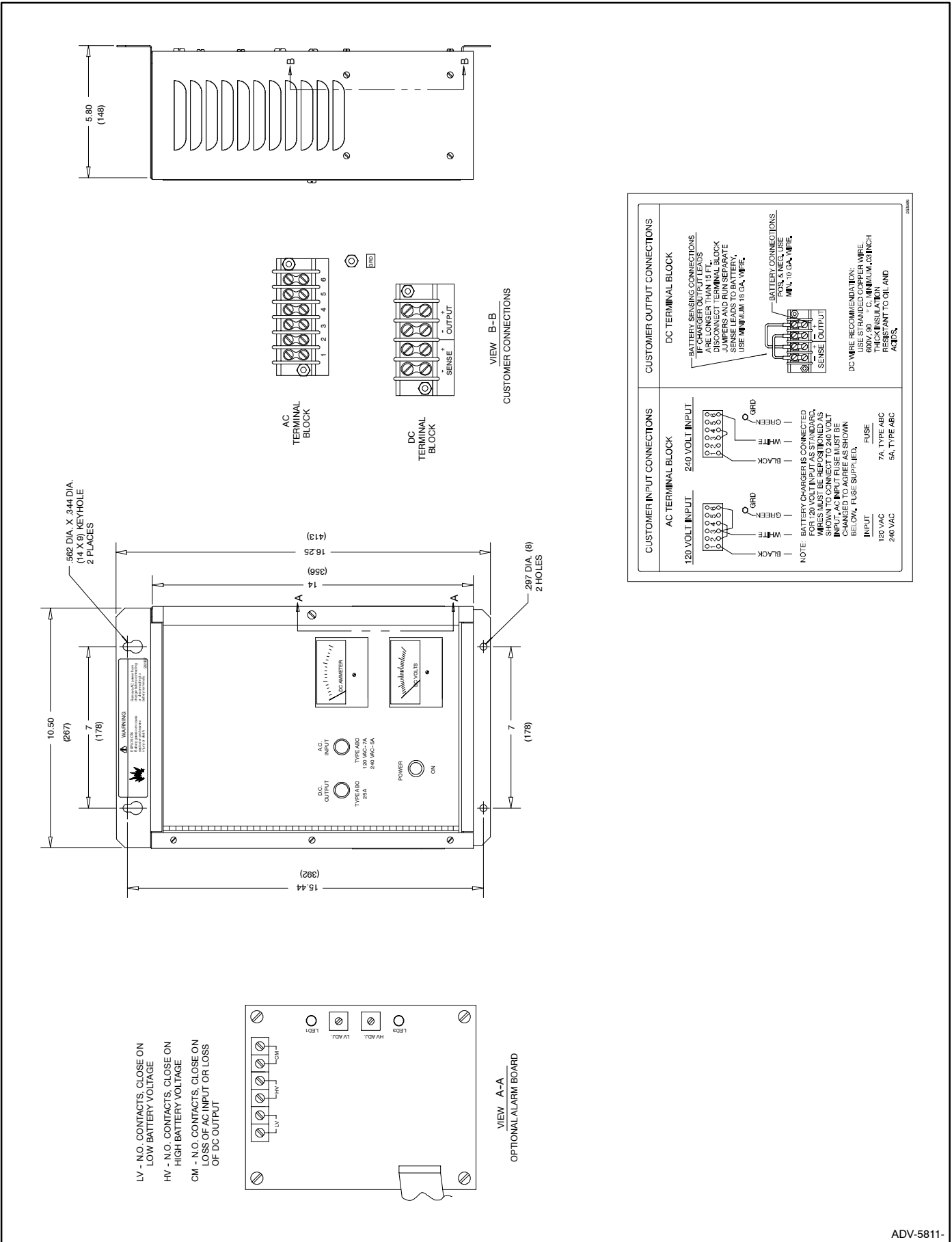
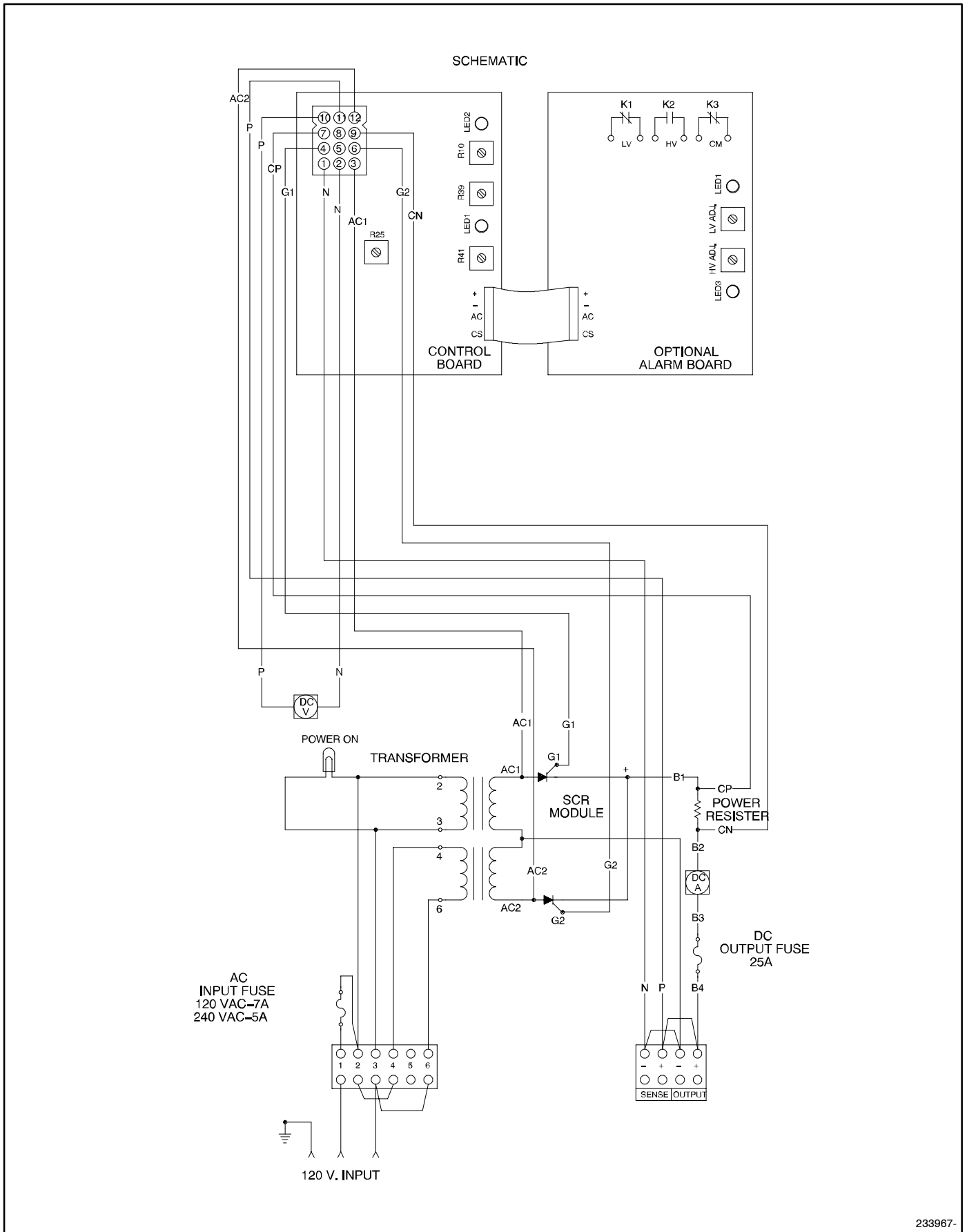

Figure 16 Battery Charger Dimension Drawing ADV-5811



233967-

Figure 19 Wiring Diagram, Schematic, 233967A

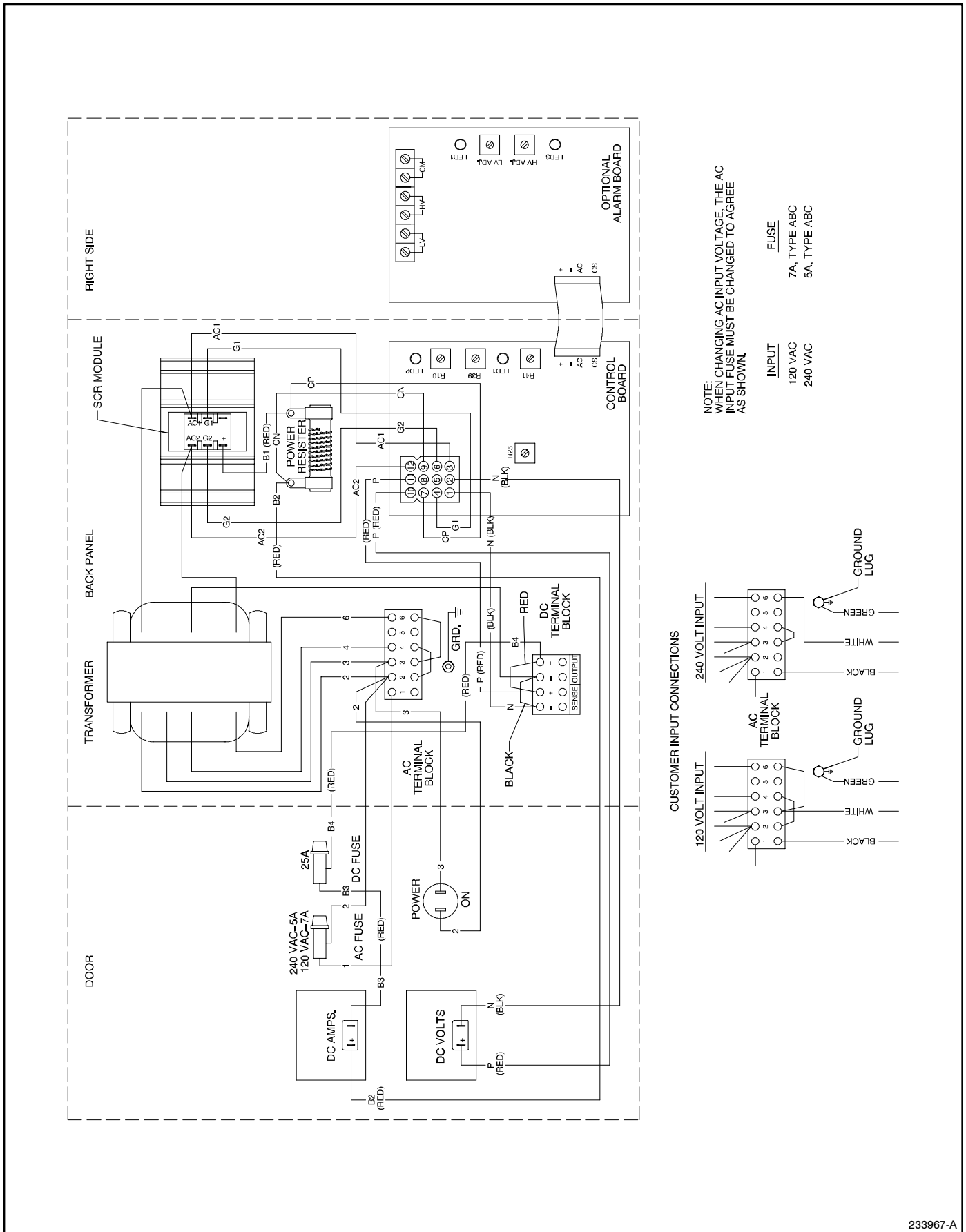
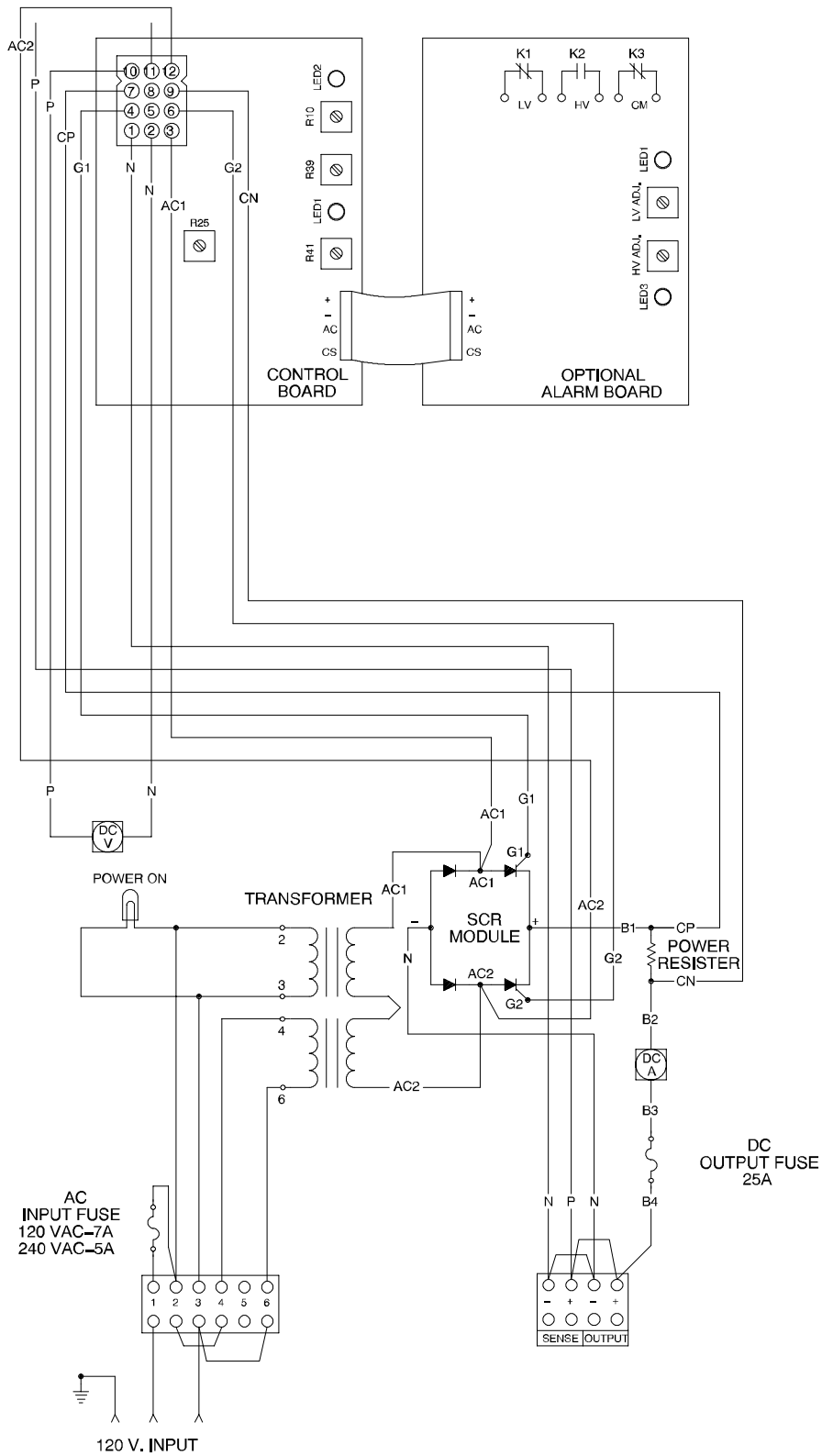

Figure 20 Wiring Diagram, Point-to-Point, 233967B

SCHMATIC



233968-A

Figure 21 Wiring Diagram, Schematic, 233968A

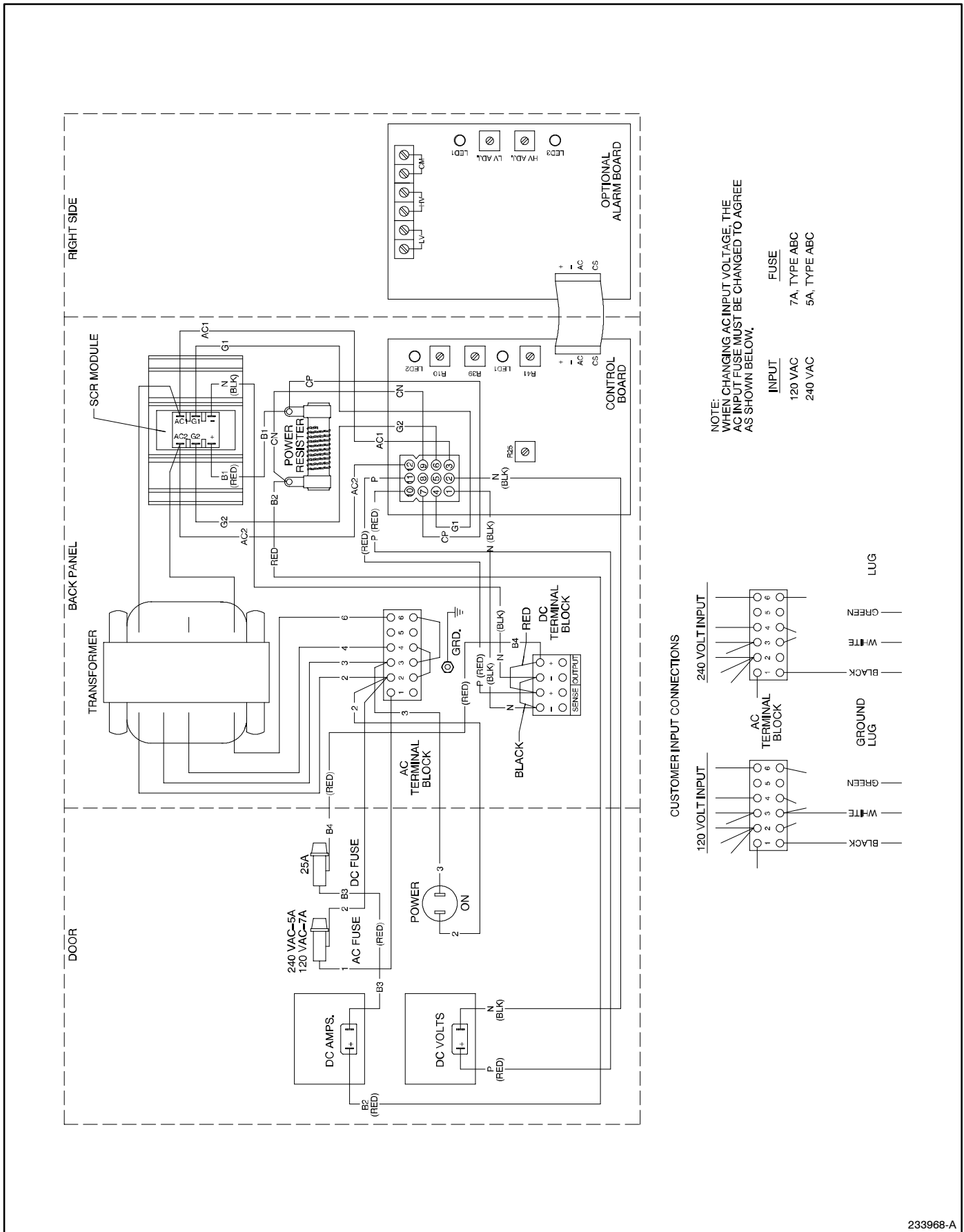

Figure 22 Wiring Diagram, Point-to-Point, 233968B

Battery Charger Parts List						
Kits: PAC-292862, PAC-292863, PAC-292864, PAC-292865, PAD-292862, PAD-292863, PAD-292864, PAD-292865			Unique Parts			
Qty.	Description	Common Parts	PAC-292862 PAD-292862	PAC-292863 PAD-292863	PAC-292864 PAD-292864	PAC-292865 PAD-292865
10	Washer, lock, #6	X-22-6				
4	Washer, lock, #8	X-22-7				
4	Washer, lock, #10	X-22-9				
4	Washer, lock, 1/4	X-22-11				
2	Washer, shakeproof, #8	X-22-18				
3	Washer, lock, #6	X-22-25				
2	Screw, RHM, 6-32 x 3/4	X-49-6				
	Screw, RHM, 6-32 x 1/4		(8) X-49-25	(5) X-49-25	(8) X-49-25	(5) X-49-25
16	Screw, RHM, 6-32 x 1/4	X-49-26				
3	Screw, pan head	X-49-36				
2	Screw, RHM, 10-32 x 1/2	X-50-1				
2	Screw, RHM, 10-24 x 3/4	X-50-3				
1	Screw, pan head, 10-32 x 1/2	X-50-72				
1	Screw, RHM, 8-32 x 5/8	X-51-9				
2	Screw, RHM, 8-32 x 3/4	X-51-11				
2	Screw, RHM, 8-32 x 1/2	X-51-15				
4	Screw, RHM, 1/4-20 x 3/4	X-51-30				
2	Nut, hex, 10-24	X-70-2				
2	Nut, hex	X-70-3				
2	Nut, hex	X-71-2				
6	Nut, hex	X-72-4				
2	Terminal	X-283-1				
2	Terminal	X-283-11				
3	Terminal	X-283-2				
2	Terminal			X-431-23		
1	Tubing, heat shrink				X-6079-2	X-6079-2
2	Tubing, heat shrink	X-6081-3				
1	Tab, indent	201620-152				
2	Retainer	226384				
1	Circuit board assembly, alarm			B-262374		
1	Circuit board assembly, alarm					B-262375
1	Box, battery charger, PAC-	262398-KCB				
1	Circuit board assembly, main		C-262377	C-262377		
1	Circuit board assembly, main				C-262378	C-262378
1	Decal, warning	292387				
1	Decal, warning, connection	292397				
1	Decal, charger, connection	233966				
1	Fuse, AC input, 5-amp	239298				
1	Fuse DC input, 25-amp	262389				
1	Transformer		262394	262394		
1	Transformer				262395	262395
1	Clip, cable	262399				
2	Holder, fuse	263156				
	Spacer, PC board		(4) 287948	(8) 287948	(4) 287948	(8) 287948
1	Lamp, power on, AC	291208				
1	Sink, heat	292938				
1	Strip, terminal	292940				
1	Ammeter, DC	292941				
1	Voltmeter, DC		292942	292942		
1	Module, SCR		292945	292945		

Battery Charger Parts List, continued

Kits: PAC-292862, PAC-292863, PAC-292864, PAC-292865, PAD-292862, PAD-292863, PAD-292864, PAD-292865			Unique Parts			
Qty.	Description	Common Parts	PAC-292862 PAD-292862	PAC-292863 PAD-292863	PAC-292864 PAD-292864	PAC-292865 PAD-292865
1	Module, SCR				292946	292946
1	Resistor, power	292947				
1	Fuse, AC input, 7-amp	292948				
1	Voltmeter, DC				292957	292957
1	Harness, wiring	292958				
1	Strip, marker	292961				
1	Strip, marker	292962				
1	Retainer	295101				
1	Block, terminal	295314				
4	Nut, captive	298810				
1	Box, battery charger, PAD-	325593-KCB				
1	Panel, silkscreen	325596				
1	Nameplate		325608	325609	325607	325610

Battery Charger Parts List

Kits: PAA-325332-SD, PAA-325333-SD, PAA-325334-SD, PAA-325335-SD, PAB-325332-SD, PAB-325333-SD, PAB-325334-SD, PAB-325335-SD						
			Unique Parts			
Qty.	Description	Common Parts	PAA-325332-SD PAB-325332-SD	PAA-325333-SD PAB-325333-SD	PAA-325334-SD PAB-325334-SD	PAA-325335-SD PAB-325335-SD
2	Washer, shakeproof, #8	X-22-18				
3	Washer, shakeproof, #6	X-22-25				
2	Screw, RHM, 6-32 x 3/4	X-49-6				
	Screw, RHM, 6-32 x 1/4		(8) X-49-25	(16) X-49-25	(8) X-49-25	(16) X-49-25
4	Screw, RHM	X-49-26				
3	Screw, pan head	X-49-39				
2	Screw, RHM, 10-32 x 1/2	X-50-1				
2	Screw, RHM, 10-24 x 3/4	X-50-3				
1	Screw, pan head, 10-32 x 1/2	X-50-68				
1	Screw, RHM, 8-32 x 5/8	X-51-9				
2	Screw, RHM, 8-32 x 3/4	X-51-11				
2	Screw, RHM, 8-32 x 1/2	X-51-15				
4	Screw, RHM, 1/4-20 x 3/4	X-51-30				
2	Terminal	X-283-1				
3	Terminal	X-283-2				
2	Terminal	X-283-11				
2	Terminal			X-431-23		
1	Tubing, heat, shrink				X-6079-2	X-6079-2
2	Tubing, heat, shrink	X-6081-3				
1	Decal, charger connection	233966				
1	Fuse, AC input, 5-amp	239298				
1	Circuit board assembly, alarm			B-262374		B-262375
1	Circuit board assembly, main		C-262377	C-262377	C-262378	C-262378
1	Fuse, DC input, 25-amp	262389				
1	Transformer		262394	262394	262395	262395
1	Decal, warning connection	262397				
1	Box, battery charger, PAA-	262398-SD				
1	Clip, cable	262399				
2	Holder, fuse	263156				
	Spacer, PC board		(4) 287948	(8) 287948	(4) 287948	(8) 287948
1	Lamp, power on, AC	291208				
1	Decal, warning	292387				
1	Sink, heat	292938				
1	Strip, terminal	292940				
1	Ammeter, DC	292941				
1	Voltmeter, DC		292942	292942	292957	292957
1	Module, SCR		292945	292945	292946	292946
1	Resistor, power	292947				
1	Fuse, AC input, 7-amp	292948				
1	Harness, wiring	292958				
1	Strip, marker	292961				
1	Strip, marker	292962				
1	Retainer	295010				
1	Block, terminal	295314				
4	Nut, captive	298810				
1	Box, battery charger, PAB-	325593-SD				
1	Panel, silkscreen	325597				
1	Nameplate		325604	325605	325603	325606

Battery Charger Parts List				
Kits: PAA-326766, PAA-326767			Unique Parts	
Qty.	Description	Common Parts	PAA-326766	PAA-326767
1	Board, assembly circuit, alarm		B-262374	B-262375
1	Board, assembly circuit, main		C-262377	C-262378
14	Washer, lock, #6	X-22-6		
4	Washer, lock, 1/4	X-22-11		
2	Washer, shakeproof, #8	X-22-18		
3	Washer, shakeproof, #6	X-22-25		
2	Screw, RHM, 6-32 x 3/4	X-49-6		
16	Screw, RHM, 6-32 x 1/4	X-49-25		
4	Screw, RHM	X-49-26		
3	Screw, pan head	X-49-39		
2	Screw, RHM, 10-32 x 1/2	X-50-1		
2	Screw, RHM, 10-24 x 3/4	X-50-3		
1	Screw, RHM, 8-32 x 5/8	X-51-9		
2	Screw, RHM, 8-32 x 3/4	X-51-11		
2	Screw, RHM, 8-32 x 1/2	X-51-15		
4	Screw, RHM, 1/4-20 x 3/4	X-51-30		
2	Nut, hex 10-32	X-70-3		
2	Nut, hex 6-32	X-71-2		
2	Screw, Phillips hex	X-6216-1		
1	Ring, lock	151511		
1	Tab, indent	201620-152		
1	Decal, connection	233966		
1	Fuse, 5-amp	239298		
2	Clip, speed	257442		
1	Fuse, 25-amp	262389		
1	Transformer		262394	262395
1	Deal, warning connection	262397		
1	Clip, cable	262399		
2	Holder, fuse	263156		
1	Switch, toggle	268015		
8	Spacer, PC board	287948		
1	Lamp	291208		
1	Decal	292387		
1	Sink, heat	292938		
1	Strip, terminal	292940		
1	Ammeter, DC	292941		
1	Voltmeter		292942	292957
1	Module, SCR		292945	292946
1	Resistor, power	292947		
1	Fuse	292948		
1	Marker, strip	292961		
1	Marker, strip	292962		
2	Retainer	295010		
1	Block, terminal	295314		
4	Nut, captive	298810		
1	Box, battery charger	325539-KCB		
1	Nameplate		325995	325996
1	Harness, wiring	326780		
1	Door, silkscreen	326784		