

INSTALLATION INSTRUCTIONS

Original Issue Date: 3/03

Model: **80/100RZG (GM 8.1 L Engines) and
80/100RZ (Ford LSG-875 Turbo Engines)**

Market: **Industrial Generator Sets (FAA)**

Subject: **LP Liquid Withdrawal Conversion Kit GM28617-KP1**

Introduction

Use the following instructions to convert an LP vapor fuel system to an LP liquid withdrawal fuel system. See Figure 1.

Installation of the LP liquid withdrawal conversion kit must comply with these installation instructions. Failure to install the fuel vaporizer following these installation instructions may result in poor generator set performance and affect the generator set warranty.

With the LP liquid withdrawal fuel system, LP fuel in liquid form is directed under pressure from the tank to a vaporizer. The vaporizer converts the fuel from a liquid to a gaseous state and then the LP vapor is drawn off to the carburetor. The system also includes a fuel valve which shuts off the fuel flow when the engine is stopped.

The electrical wiring must comply with all national and local codes.

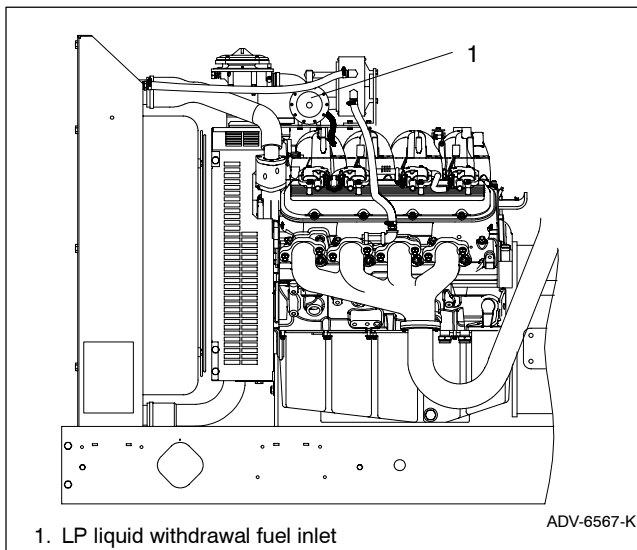

Figure 1 LP Liquid Withdrawal System

The kit procedure requires the following customer-supplied tools and/or components:

- Two #6 spade connectors, 18-22 ga. (X-285-1)
- One 1/4 in. fully insulated, push-on male connector, 18-22 ga. (X-431-29)
- One 1/4 in. fully insulated, push-on female connector, 18-22 ga. (X-431-25)
- 18 ga. wire min., as needed (two leads required; identify as N and 70 or use color code identification)
- Additional plumbing components to complete the water line system, as needed
- Additional plumbing components to complete the fuel system, as needed
- Brackets and hardware for mounting the vaporizer

Note: Hose connector X-582-1, hose connector X-582-22, pipe nipple X-209-18, pipe tee X-203-13, and street elbow X-211-1 are not used with the 80/100 kW models with Ford engines.

Read the entire installation procedure and compare the kit parts with the parts list at the end of this publication before beginning installation. Perform the steps in the order shown.

Safety Precautions

Observe the following safety precautions while installing the kit.

WARNING

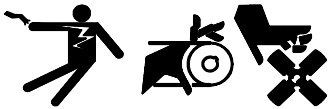

Accidental starting. Can cause severe injury or death.

Disconnect the battery cables before working on the generator set. Remove the negative (-) lead first when disconnecting the battery. Reconnect the negative (-) lead last when reconnecting the battery.

Disabling the generator set. Accidental starting can cause severe injury or death. Before working on the generator set or connected equipment, disable the generator set as follows: (1) Move the generator set master switch to the OFF position. (2) Disconnect the power to the battery charger. (3) Remove the battery cables, negative (-) lead first. Reconnect the negative (-) lead last when reconnecting the battery. Follow these precautions to prevent starting of the generator set by an automatic transfer switch, remote start/stop switch, or engine start command from a remote computer.

WARNING



Fire. Can cause severe injury or death.

Do not smoke or permit flames or sparks near fuels or the fuel system.

WARNING



Explosive fuel vapors. Can cause severe injury or death.

Use extreme care when handling, storing, and using fuels.

The fuel system. Explosive fuel vapors can cause severe injury or death. Vaporized fuels are highly explosive. Use extreme care when handling and storing fuels. Store fuels in a well-ventilated area away from spark-producing equipment and out of the reach of children. Never add fuel to the tank while the engine is running because spilled fuel may ignite on contact with hot parts or from sparks. Do not smoke or permit flames or sparks to occur near sources of spilled fuel or fuel vapors. Keep the fuel lines and connections tight and in good condition. Do not replace flexible fuel lines with rigid lines. Use flexible sections to avoid fuel line breakage caused by vibration. Do not operate the generator set in the presence of fuel leaks, fuel accumulation, or sparks. Repair fuel systems before resuming generator set operation.

Explosive fuel vapors can cause severe injury or death. Take additional precautions when using the following fuels:

Propane (LP)—Adequate ventilation is mandatory. Because propane is heavier than air, install propane gas detectors low in a room. Inspect the detectors per the manufacturer's instructions.

Natural Gas—Adequate ventilation is mandatory. Because natural gas rises, install natural gas detectors high in a room. Inspect the detectors per the manufacturer's instructions.

Gas fuel leaks. Explosive fuel vapors can cause severe injury or death. Fuel leakage can cause an explosion. Check the LP vapor gas or natural gas fuel system for leakage by using a soap and water solution with the fuel system test pressurized to 6-8 ounces per square inch (10-14 inches water column). Do not use a soap solution containing either ammonia or chlorine because both prevent bubble formation. A successful test depends on the ability of the solution to bubble.

LP liquid withdrawal fuel leaks. Explosive fuel vapors can cause severe injury or death. Fuel leakage can cause an explosion. Check the LP liquid withdrawal gas fuel system for leakage by using a soap and water solution with the fuel system test pressurized to at least 90 psi (621 kPa). Do not use a soap solution containing either ammonia or chlorine because both prevent bubble formation. A successful test depends on the ability of the solution to bubble.

Installation Procedure

1. Removing the generator set from service.

- 1.1 Place the generator set master switch in the OFF position.
- 1.2 Deenergize the battery charger, if equipped.
- 1.3 Deenergize the block heater, if equipped.
- 1.4 Disconnect the generator set engine starting battery(ies), negative (-) lead first.
- 1.5 Close all fuel supply valves.

2. Removing the existing fuel system components.

- 2.1 With the engine and radiator cool, drain the coolant into a suitable container. Dispose of all waste materials, (engine oil, fuel, coolant, etc.) in an environmentally safe manner. Contact local authority for procedures.

Note: The drain valve is located on the radiator bottom and/or on the side of engine crankcase.

- 2.2 Disconnect the fuel supply line connected to the gas valve assembly.
- 2.3 Disconnect and remove the flexible fuel line located between the gas valve assembly and the pressure regulator assembly.
- 2.4 Disconnect the leads connected to the gas valve assembly.
- 2.5 Remove the existing fuel system components shown in Figure 2 for **80/100 kW models with Ford engines**. Save the reducer bushing removed from the pressure regulator for installation later.

Remove the existing fuel system components shown in Figure 3 for **80/100 kW models with GM engines**. Save the reducer bushing removed from the pressure regulator for installation later.

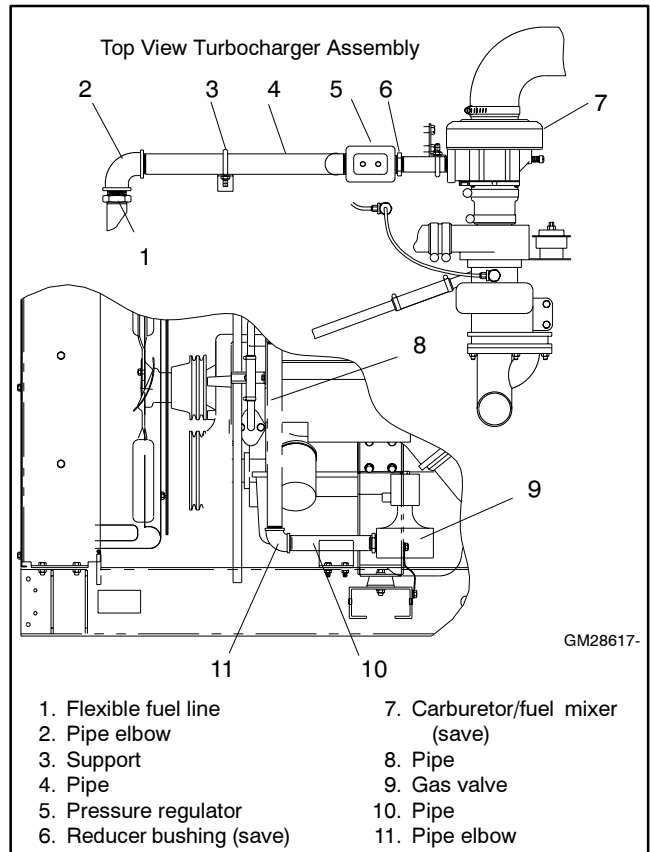

Figure 2 Existing LP Gas Fuel System (80/100 kW models with Ford engines)

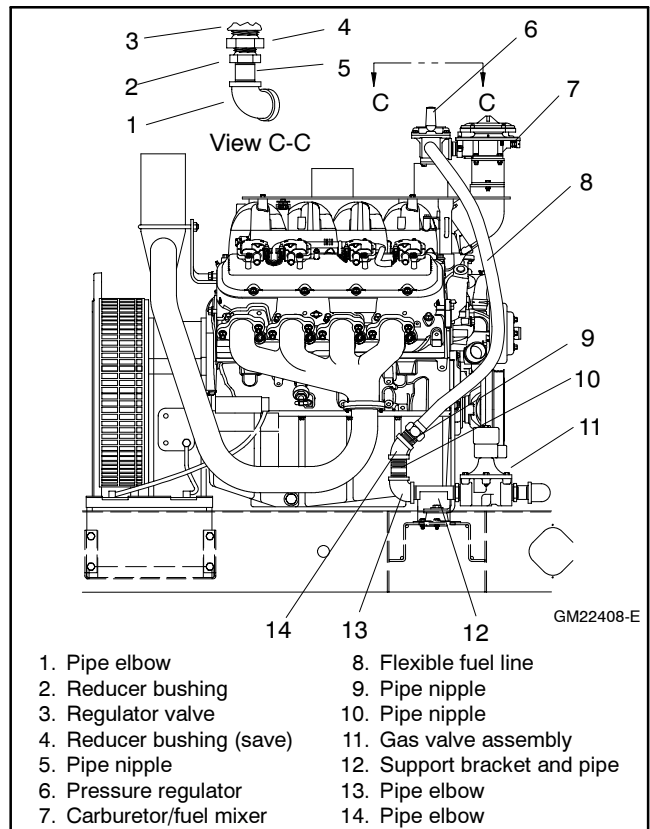

Figure 3 Existing LP Gas Fuel System (80/100 kW models with GM engines)

3. Installing the fuel system components on the LP vaporizer.

Note: Apply pipe sealant to the male threads of all components before installation.

- 3.1 Apply pipe sealant to the male threads of the reducer bushing removed from the pressure regulator and install the reducer bushing in the vaporizer outlet (326075). See Figure 4.
- 3.2 Apply pipe sealant to the male threads of the existing pipe from the carburetor/fuel mixer and install the vaporizer and reducer bushing. Position the vaporizer as shown in Figure 4.
- 3.3 Apply pipe sealant to the male threads of one of the 90° hose connectors (X-391-2) and install the hose connector in the vaporizer water inlet. Position the hose connector as shown in Figure 4.
- 3.4 Apply pipe sealant to the male threads of the second 90° hose connectors (X-391-2) and install the hose connector in the vaporizer water outlet. Position the hose connector as shown in Figure 4.
- 3.5 Apply pipe sealant to the threads of the pipe nipple (X-220-14) and install the pipe in the vaporizer fuel inlet.

- 3.6 Apply pipe sealant to the threads on the other end of the pipe nipple and install the fuel solenoid (326120). Position the fuel solenoid as shown in Figure 4.

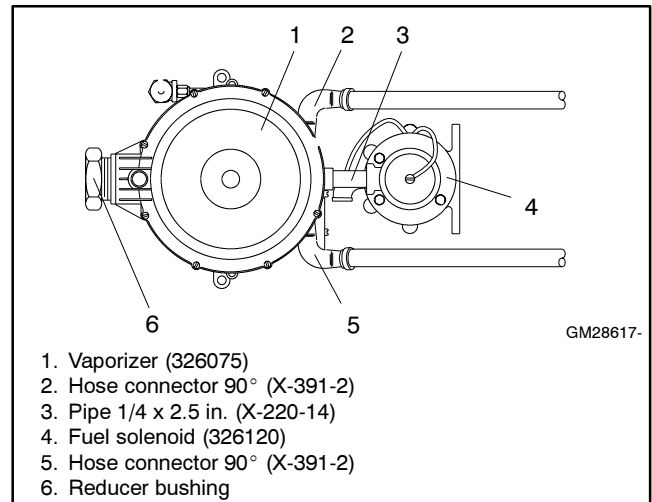

Figure 4 LP Vaporizer Installation
(top view of vaporizer assembly)

4. Connecting the engine water lines to the vaporizer on 80/100 kW models with Ford engines.

Note: If installing on 80/100 kW GM engines, skip step 4 and go to step 5.

4.1 80 kW model. Disconnect and remove the rubber hose and hose clamps between the water manifold (connection A) on the engine and the engine block (connection B).

100 kW model. Disconnect and remove the rubber hose and hose clamps between the water manifold (connection A) on the engine and the engine oil cooler (connection B).

The hose fittings will be reused. See Figure 5. The rubber hose and hose clamps will not be reused.

4.2 Slide two hose clamps (X-426-12) on rubber hose (X-577-44) and connect to the engine water manifold and connection A on the vaporizer. Position and tighten a hose clamp at each end.

4.3 Slide two hose clamps (X-426-12) on rubber hose (X-577-36) and connect to the engine block (80 kW) or engine oil cooler (100 kW) and connection B on the vaporizer. Position and tighten a hose clamp at each end.

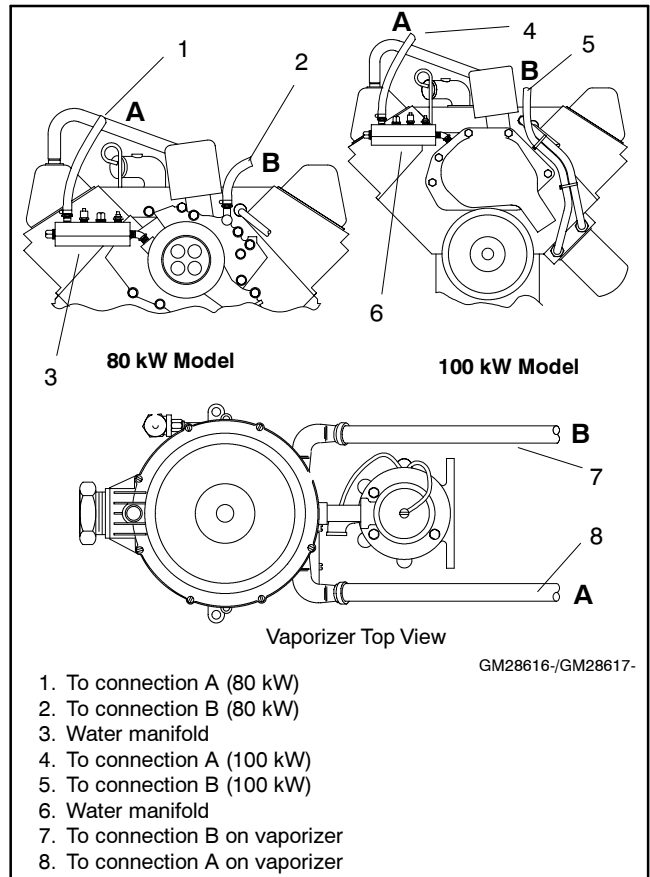

Figure 5 Vaporizer Water Line Connections (80/100 kW models with Ford engines)

5. Connecting the engine water lines to the vaporizer on 80/100 kW models with GM engines.

Note: If installing on 80/100 kW Ford engines, skip step 5 and use step 4.

- 5.1 Remove the pipe plug from the radiator at location A. See Figure 6.
- 5.2 Apply pipe sealant to threads of hose connector (X-582-22) and install in the engine at location A.
- 5.3 Remove pipe plug from engine at location B or if equipped with a block heater, loosen hose clamp and remove block heater hose and hose connector. See Figure 6 and Figure 7.
- 5.4 Apply pipe sealant to one end of pipe nipple (X-209-18) and install in the engine at location B.
- 5.5 Apply pipe sealant to the other end of the pipe nipple and install pipe tee (X-203-13) using the center opening. Position the pipe tee as shown in Figure 7.
- 5.6 Apply pipe sealant to the male threads of the street elbow (X-211-1) and install in the pipe tee. Position the female thread opening of the street elbow upward. See Figure 7.
- 5.7 Apply pipe sealant to threads of hose connector (X-582-1) and install in the street elbow for connection B.
- 5.8 Slide two hose clamps (X-426-12) on rubber hose (X-577-44) and connect between connection A on the engine radiator and connection A on the vaporizer. Position and tighten a hose clamp at each end.
- 5.9 Slide two hose clamps (X-426-12) on rubber hose (X-577-36) and connect between connection B on the engine and connection B on the vaporizer. Position and tighten a hose clamp at each end.

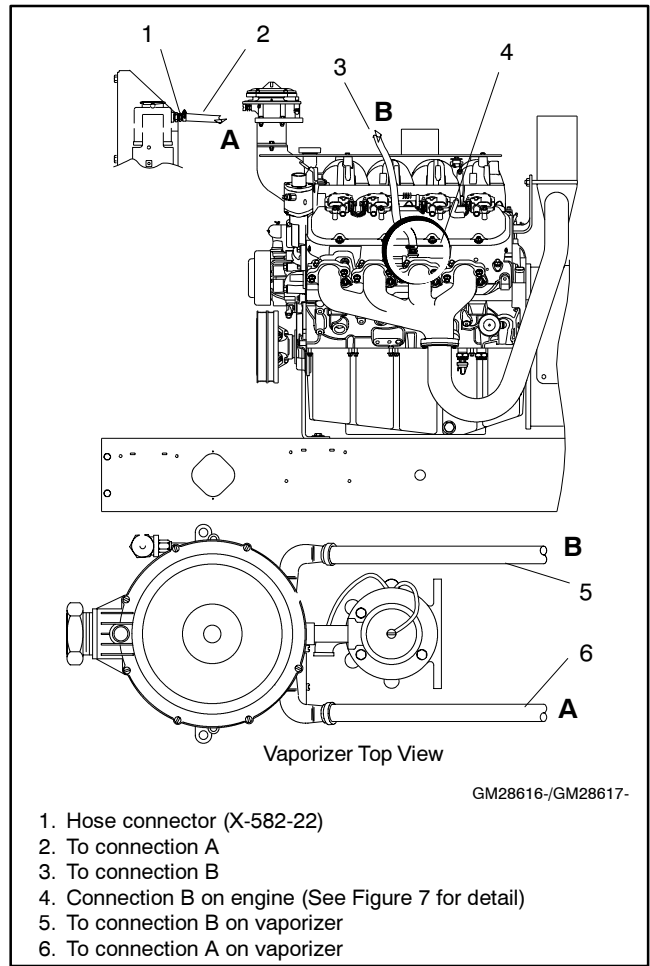

Figure 6 Vaporizer Water Line Connections (80/100 kW models with GM engines)

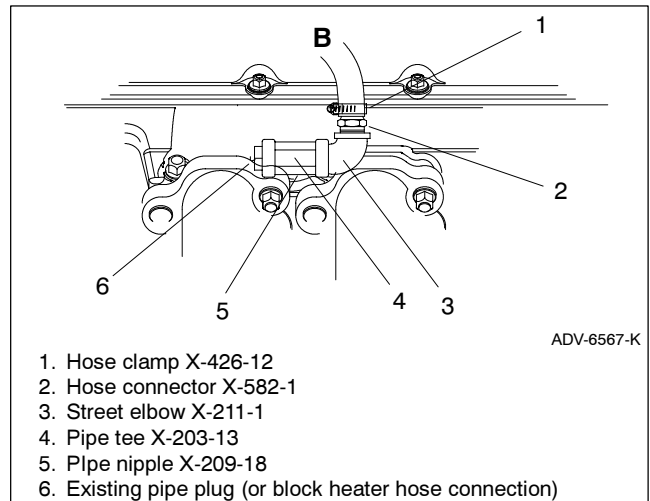

Figure 7 Engine detail for Connection B (80/100 kW models with GM engines)

6. Connecting the fuel solenoid to the wiring harness and fuel supply.

6.1 Fabricate an electrical harness connecting the vaporizer to the existing engine wiring harness using the following customer-supplied components:

- Two #6 spade connectors, 18-22 ga. (X-285-1)
- One 1/4 in. fully insulated, push-on male connector, 18-22 ga. (X-431-29)
- One 1/4 in. fully insulated, push-on female connector, 18-22 ga. (X-431-25)
- 18 ga. wire (min.), as needed (two leads required; identify as N and 70 or use color code identification)

Note: Lead N is engine ground/battery negative (-) and lead 70 is engine run/battery positive (+).

- 6.2 Connect the new harness to the existing engine wiring harness connectors previously attached to the LP gas valve.
- 6.3 Connect lead 70 to the fuel solenoid positive terminal.
- 6.4 Apply pipe sealant to the existing pipe plug or if equipped with a block heater, apply pipe sealant to the existing hose connector. Install in pipe tee opening nearest to the radiator. See Figure 7.
- 6.5 Connect lead N to the fuel solenoid negative terminal. See Figure 8.
- 6.6 Connect the (customer-supplied) fuel supply line to the fuel solenoid.
- 6.7 Turn on the fuel supply to the generator set and test the connections for leaks. Turn off the fuel supply and correct leaks, if required. Turn on the fuel supply.

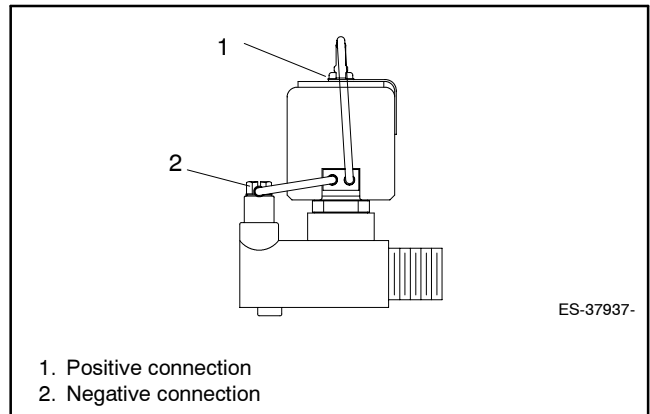

Figure 8 Fuel Solenoid Electrical Connections

LP liquid withdrawal fuel leaks. Explosive fuel vapors can cause severe injury or death. Fuel leakage can cause an explosion. Check the LP liquid withdrawal gas fuel system for leakage by using a soap and water solution with the fuel system test pressurized to at least 90 psi (621 kPa). Do not use a soap solution containing either ammonia or chlorine because both prevent bubble formation. A successful test depends on the ability of the solution to bubble.

7. Restoring the generator set to service.

- 7.1 Refill the cooling system using the procedure and coolant recommendation given in the engine operation manual and/or generator set operation manual. See the respective spec sheet for coolant capacity.
- 7.2 Check that the generator set master switch is in the OFF position.
- 7.3 Reconnect the generator set engine starting battery, negative (-) lead last.
- 7.4 Reenergize the battery charger, if equipped.
- 7.5 Reenergize the block heater, if equipped.

Parts List

LP Liquid Withdrawal Kit

Kit: GM28617-KP1		
Qty.	Description	Part Number
1	Tee, pipe	X-203-13
1	Nipple, pipe, 1/2 NPT x 4 in.	X-209-18
1	Elbow, street	X-211-1
1	Nipple, pipe, 1/4 NPT x 2.5 in.	X-220-14
2	Connector, 90 deg. 5/8 in. ID	X-391-2
4	Clamp, hose	X-426-12
1	Hose, rubber 5/8 ID x 37 in.	X-577-36
1	Hose, rubber 5/8 ID x 27 in.	X-577-44
1	Connector, hose 1/2 NPT	X-582-1
1	Connector, hose 1/4 NPT	X-582-22
1	Solenoid, fuel	326120
1	Vaporizer, LP fuel	326075