

**INSTALLATION INSTRUCTIONS**

Original Issue Date: 12/03

Model: 20-400 kW

Market: Industrial Generator Sets with 16-Light Microprocessor Controller

Subject: Ten-Relay Dry Contact Kits GM25953-KP1 and GM25953-KP1S

**Introduction**

The ten-relay dry contact kit provides normally open and normally closed contacts in a form C configuration to activate warning devices and other user-provided accessories allowing remote monitoring of the generator set. Connect up to ten controller fault outputs to the ten-relay dry-contact kit. Typically, lamps, audible alarms, or other devices signal the fault conditions. See Figure 1 for an illustration of the ten-relay dry-contact kit.

**Note:** A maximum of three inputs may be connected to a single relay driver output. Inputs include dry contacts, remote annunciator, common failure alarm, A/V alarm, and shunt trip line circuit breaker.

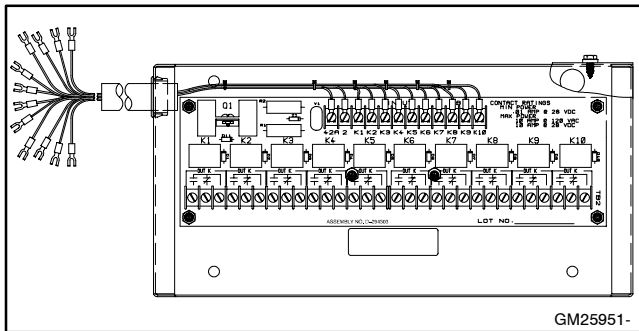

**Figure 1** Ten-Relay Dry-Contact Kit

Check the electrical requirements of the user-provided accessories prior to installation of the dry contact kit. User-provided accessories require their own electrical source and must not exceed the relay contact ratings that follow.

Do not use terminals 42A or 2 on the controller connection kit terminal strip TB8 to supply voltage to user-provided accessories. User-provided DC accessories require separate leads connected directly to the battery for the voltage supply. Attach user-supplied 12/24-volt DC accessories to the battery positive (+) connection at the starter solenoid and to the battery negative (-) connection at the engine ground. The 120 VAC accessories require a user-supplied voltage source.

**Relay Contact Rating**

Maximum Switching . . . . . 10 amps @ 120 volts AC  
 10 amps @ 28 volts DC

Minimum Switching . . . 10 milliamps @ 120 volts AC  
 10 milliamps @ 28 volts DC

Read the entire installation procedure and compare the kit parts with the parts list in this publication before beginning installation. Perform the steps in the order shown.

Observe applicable local and national electrical codes when installing the wiring system.

## Safety Precautions

Observe the following safety precautions when installing the kit.

### ⚠ WARNING

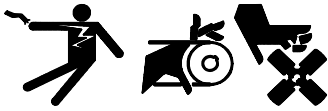

#### Accidental starting. Can cause severe injury or death.

Disconnect the battery cables before working on the generator set. Remove the negative (-) lead first when disconnecting the battery. Reconnect the negative (-) lead last when reconnecting the battery.

**Disabling the generator set. Accidental starting can cause severe injury or death.** Before working on the generator set or connected equipment, disable the generator set as follows: (1) Move the generator set master switch to the OFF position. (2) Disconnect the power to the battery charger. (3) Remove the battery cables, negative (-) lead first. Reconnect the negative (-) lead last when reconnecting the battery. Follow these precautions to prevent starting of the generator set by an automatic transfer switch, remote start/stop switch, or engine start command from a remote computer.

## Installation Procedure

### 1. Remove the generator set from service.

- 1.1 Place the generator set master switch in the OFF/RESET position.
- 1.2 Disconnect the power to the battery charger, if equipped.
- 1.3 Disconnect the generator set engine starting battery(ies), negative (-) lead first.

### 2. Mount the ten-relay dry contact assembly.

- 2.1 Remove the controller cover, if the generator set is not equipped with a controller connection kit.
- 2.2 Remove the dry contact assembly (GM25951) cover by removing four screws.
- 2.3 Mount the dry-contact box in one of the areas listed below. See Figure 2 or Figure 3 for suggested mounting locations.

- Inside the junction box.
- On top of the junction box. Limited by the size of the controller and the size of the junction box.
- On top of the generator skid. Limited by the clearance and housing options.
- In an area as near to the generator set controller as practical.

- 2.4 Drill four 7.1 mm (0.281 in.) diameter holes in the junction box as shown in Figure 2 or Figure 3.
- 2.5 Remove burrs from the drilled holes and clean up all metal chips in the junction box.
- 2.6 Attach the contact assembly (GM25951) using four vibromounts (229353), eight whiz nuts (X-6210-2), and lock washers (X-22-12) or user-supplied mounting hardware if the dry contact kit is not mounted on the generator set.

When attaching the contact assembly to the generator set junction box or skid, install the ground strap (223033) as shown in Figure 4.

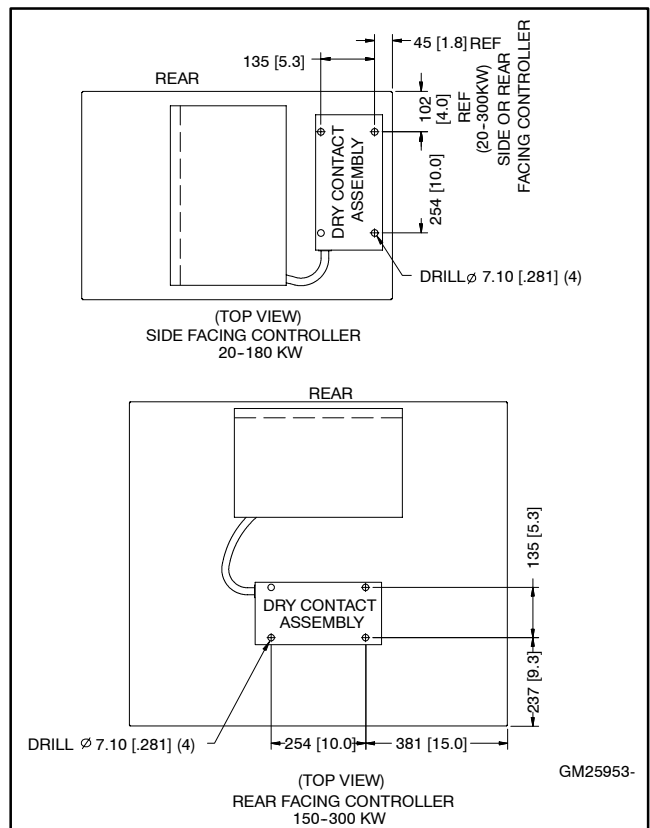

**Figure 2** Junction Box Drilling Information (20-300 kW)

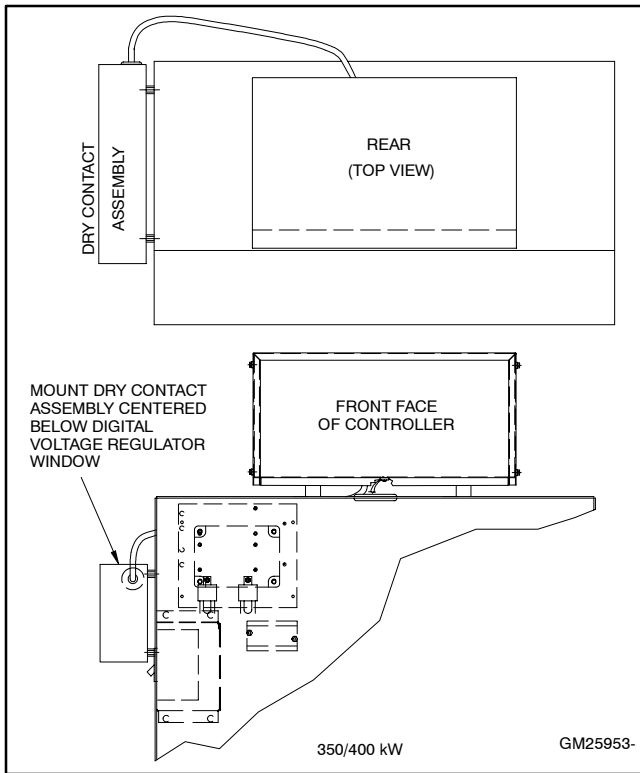

**Figure 3** Junction Box Drilling Information (350/400 kW)

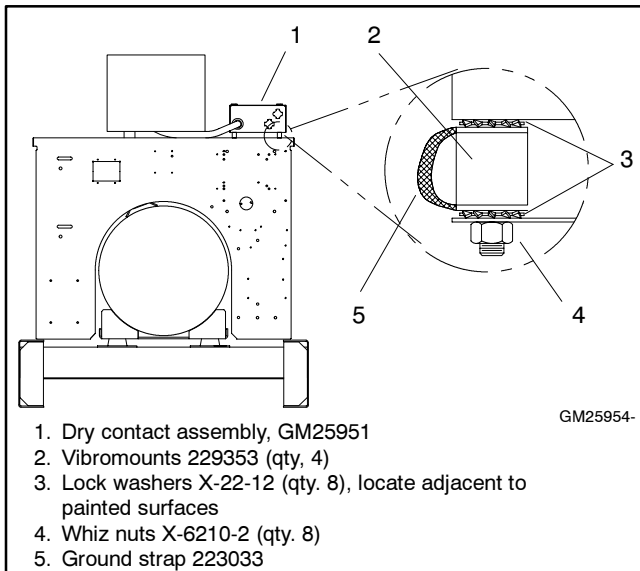

**Figure 4** Ground Strap Mounting

**3. Connect the dry contact kit to the controller connection kit or controller terminal strip.**

**Note:** Use a controller connection kit for easier connection and disconnection of generator set accessories.

Use the appropriate accessory wiring diagram found in the Wiring Diagram Manual supplied with the generator set to select the fault connection.

When a generator fault condition occurs, the contact kit relay energizes. Select either normally open or normally closed contacts from the relay depending upon application requirements. The relay contact closure corresponds to the controller output being activated.

Connect the contact assembly to the controller or controller connection kit terminal strip using the wiring harness provided. Terminals 2 (ground) and 42A (battery voltage) provide an electrical source to operate the K1-K10 relays.

**4. Connect the dry contact kit relays to the user-supplied device(s).**

Select the normally open (NO) and/or normally closed (NC) form C dry contact, depending upon the application. Use a two-wire harness for either NO or NC connections. Use a three-wire harness for both NO and NC connections.

4.1 The user must supply stranded wire long enough to connect the user-supplied device to the dry contact relay terminals and power supply. Use color-coded wire for easy identification. Make leads long enough to allow for walls, ductwork, and other obstructions. Use separate conduit for the dry contact kit wiring.

4.2 **12/24-Volt DC Devices.** Attach the user-supplied 12/24-volt DC accessories to the starting battery positive (+) connection at the starter solenoid and to the battery negative (-) connection at the engine ground. Otherwise, use a separate 12/24-volt DC supply. Do not use terminals 42A and 2 on the controller connection kit terminal strip to supply the voltage to the relay contacts. Supply separate leads directly to the battery for the supply voltage. The circuit must include fuse or circuit breaker protection.

4.3 **120-Volt AC Devices.** Connect the user-supplied accessories to a separate 120-volt AC power supply. The circuit must include fuse or circuit breaker protection.

4.4 Connect the user-supplied device per the installations and/or schematic supplied with the device to a power source and to the dry contact relay terminals. Cut the user-supplied leads to the desired length, strip lead ends, crimp on spade terminals (not supplied), and connect the leads to the relay contact screw terminals. Keep the dry contact wiring away from the generator set output leads.

4.5 Repeat step 4 for the remaining dry contact relays.

4.6 Reinstall the controller cover, if previously removed.

4.7 Replace the dry contact assembly cover and install the four screws (X-6216-1).

**5. Place the generator set into service.**

5.1 Place the generator set master switch in the OFF/RESET position.

5.2 Reconnect the generator set engine starting battery(ies), negative (-) lead last.

5.3 Reconnect the power to the battery charger, if equipped.

5.4 Move the generator set master switch to AUTO for startup by remote transfer switch or remote start/stop switch.

## Parts List

### Ten-Relay Dry-Contact Kits

Kits: GM25953-KP1 and GM25953-KP1S		
Qty.	Description	Part Number
1	Assembly, contact (includes *)	GM25951
4	* Screw	X-6216-1
1	* Bushing	X-301-29
1	* Box, dry-contact	GM25949
1	* Cover, dry-contact	GM25950
1	* Harness, wiring	273935
1	* Board assembly, circuit	D-294303
8	Nut, 1/4-20 whiz	X-6210-2
8	Washer, 1/4 lock	X-22-12
4	Vibromount	229353
1	Strap, ground	223033

## Test the Dry Contact Relays

Verify that the dry contact relays function by using the following procedure when troubleshooting.

### Test Procedure

1. Deenergize the power supply to the user-supplied device.
2. Remove the user-supplied device and power supply wiring from the dry contact relay terminals.
3. Test the relay operation by connecting an ohmmeter across the NO and C terminals on the relay terminal strip.
4. Use a jumper wire to ground the selected fault terminal on the controller connection terminal strip. The relay contacts should close and the ohmmeter should display a low resistance reading (continuity).
5. Install the user-supplied device and power supply wiring on the dry contact relay terminals.
6. Energize the power supply to user-supplied device.