

INSTALLATION INSTRUCTIONS

Original Issue Date: 2/04

Model: 20-2000 kW

Market: Industrial Generator Sets with the 550 Controller

Subject: Ten-Relay Dry Contact Kits: GM25953-KP2/-KP2S,
GM25953-KP3/-KP3S, and GM28618-KP11/-KP11S

Introduction

kW	Ten-Relay Dry Contact Kits
20-300	GM25953-KP2, GM25953-KP2S
350/400	GM25953-KP3, GM25953-KP3S
450-2000	GM28618-KP11, GM28618-KP11S

The ten-relay dry contact kit provides normally open and normally closed contacts in a form C configuration to activate warning devices and other user-provided accessories allowing remote monitoring of the generator set. Connect any controller fault output to the ten-relay dry contact kit. Typically, lamps, audible alarms, or other devices signal the fault conditions. See Figure 1 for an illustration of the ten-relay dry contact kit.

Note: A maximum of three inputs may be connected to a single relay driver output. Inputs include dry contacts, remote annunciator, common failure alarm, audiovisual alarm, and shunt trip line circuit breaker.

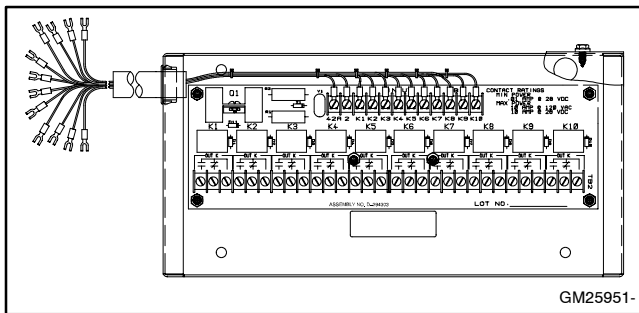

Figure 1 Ten-Relay Dry Contact Kit
(20-400 kW Model kit shown)

Check the electrical requirements of the user-provided accessories prior to installation of the dry contact kit. Customer-provided accessories require their own electrical source and must not exceed the relay contact ratings that follow.

Do not use terminals 42A or 2 on the controller connection kit terminal strip TB8 to supply voltage to user-provided accessories. User-provided DC accessories require separate leads connected directly to the battery for the voltage supply. Attach user-supplied 12/24-volt DC accessories to the battery positive (+) connection at the starter solenoid and to the battery negative (-) connection at the engine ground. The 120 VAC accessories require a user-supplied voltage source.

Relay Contact Rating

Maximum Switching 10 amps @ 120 volts AC
10 amps @ 28 volts DC

Minimum Switching . . . 10 milliamps @ 120 volts AC
10 milliamps @ 28 volts DC

Read the entire installation procedure and compare the kit parts with the parts list in this publication before beginning installation. Perform the steps in the order shown.

Observe applicable local and national electrical codes when installing the wiring system.

Safety Precautions

Observe the following safety precautions while installing the kit.

⚠ WARNING

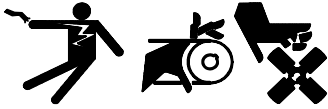

Accidental starting. Can cause severe injury or death.

Disconnect the battery cables before working on the generator set. Remove the negative (-) lead first when disconnecting the battery. Reconnect the negative (-) lead last when reconnecting the battery.

Disabling the generator set. Accidental starting can cause severe injury or death. Before working on the generator set or connected equipment, disable the generator set as follows: (1) Move the generator set master switch to the OFF position. (2) Disconnect the power to the battery charger. (3) Remove the battery cables, negative (-) lead first. Reconnect the negative (-) lead last when reconnecting the battery. Follow these precautions to prevent starting of the generator set by an automatic transfer switch, remote start/stop switch, or engine start command from a remote computer.

Installation Procedure

1. Remove the generator set from service.

- 1.1 Place the generator set master switch in the OFF position.
- 1.2 Disconnect the power to the battery charger, if equipped.
- 1.3 Disconnect the generator set engine starting battery(ies), negative (-) lead first.

2. Mount and connect the controller connection assembly.

2.1 GM25953-KP2/-KP2S kit (20-300 kW)

- 2.1.1 Remove the junction box rear panel and hardware. See Figure 2.
- 2.1.2 Attach the controller connection assembly (GM13984) to the junction box using six screws (X-51-3), spacers (X-712-9), and nuts (X-6210-4). Place the spacers between the controller connection assembly and the junction box bracket. See Figure 2 for the mounting location.
- 2.1.3 Plug the wiring connection harness (GM17033) into the controller connection assembly's P25 connector.
- 2.1.4 Proceed to step 3.

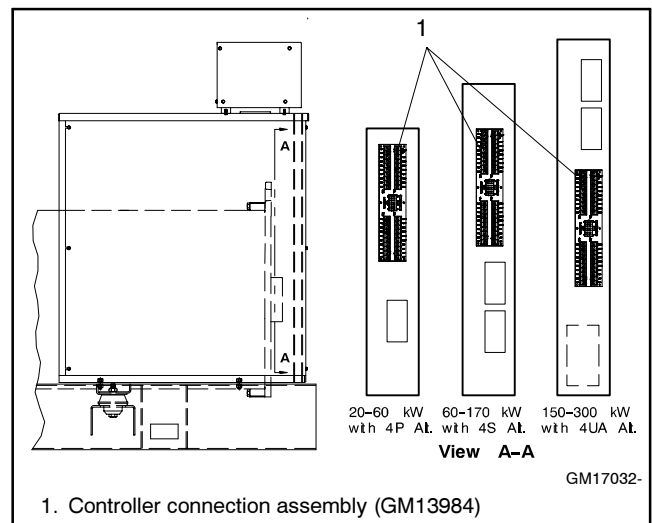

Figure 2 Controller Connection Assembly Mounting Locations in Junction Box (20-300 kW)

2.2 GM25953-KP3/-KP3S kit (350/400 kW)

- 2.2.1 Remove the junction box rear panel and hardware.
- 2.2.2 Remove the four screws attaching the controller to the junction box. See Figure 3.
- 2.2.3 Mark the drill hole locations where the terminal block bracket (347292) mounts to the junction box top panel using the dimensions given in Figure 3.
- 2.2.4 Move the controller away from the rear of the junction box in order to provide enough clearance to drill three 9 mm (0.344 in.) diameter holes in the top of the junction box.
- 2.2.5 Remove burrs from the drilled holes and clean up all metal chips in the junction box.
- 2.2.6 Attach three vibromounts (229353) to the terminal block bracket (347292) using three lock washers (X-22-12) and nuts (X-6210-2). Attach one end of green ground lead (LK-1206-1515) between terminal block bracket and nut. See Figure 3.
- 2.2.7 Place terminal block bracket assembly from previous step on the underside of the junction box top panel and mount using three lock washers (X-22-12) and nuts (X-6210-2).
- 2.2.8 Reposition the controller over the junction box holes and install the four screws removed in step 2.2.2. Attach the other end of green ground lead (LK-1206-1515) between the junction box and screw.
- 2.2.9 Attach the controller connection assembly (GM13984) to the terminal block bracket

using six screws (X-51-3), spacers (X-712-9), and nuts (X-70-12). Place the spacers between the controller connection assembly and the mounting bracket.

- 2.2.10 Plug the wiring connection harness (GM17029) into the controller connection assembly's P25 connector.

2.2.11 Proceed to step 3.

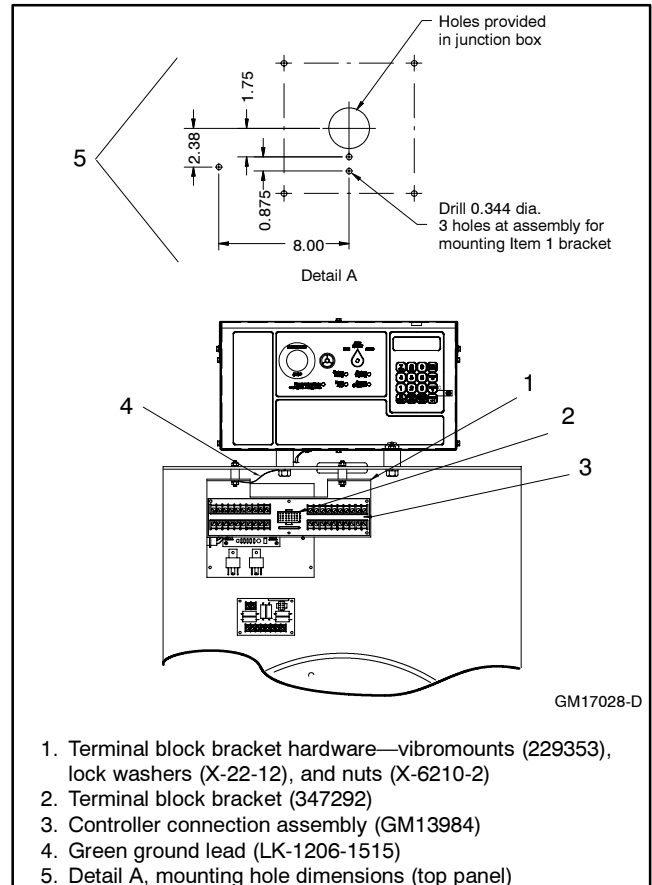

Figure 3 Terminal Block Bracket and Controller Connection Assembly Mounting (350/400 kW)

2.3 GM28618-KP11/-KP11S kits only (450-2000 kW).

- 2.3.1 Remove the junction box upper rear panel and hardware.
- 2.3.2 Remove the inner panel access door screws and swing open the access door.
- 2.3.3 Attach the controller connection assembly (GM28632-1) to the junction box bracket studs using six spacers (X-712-9) and nuts (X-70-12). Place the spacers between the controller connection assembly and the mounting bracket. See Figure 4 for the mounting location.
- 2.3.4 Plug the wiring connection harness (GM16755) into the controller connection assembly's P25 connector.
- 2.3.5 Proceed to step 3.

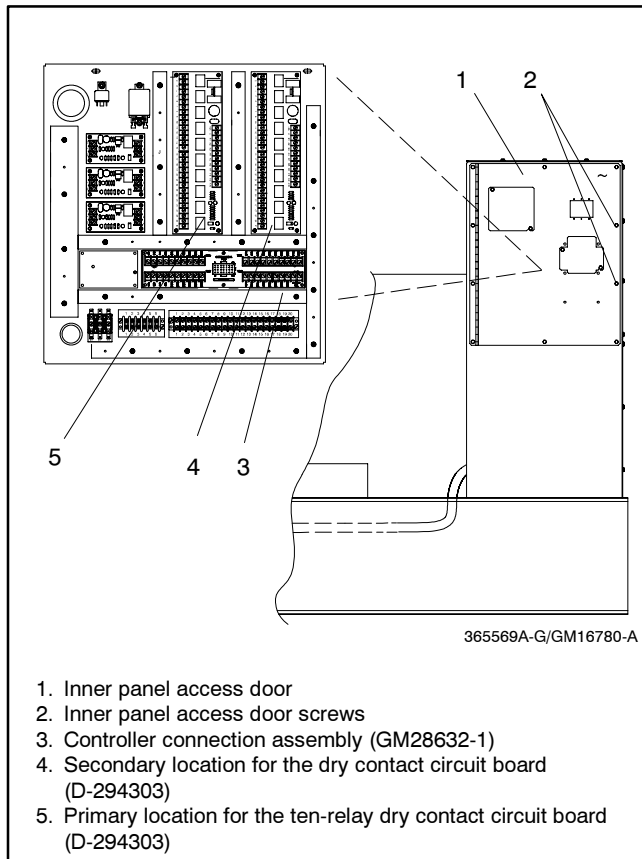

Figure 4 Junction Box Terminal Block Bracket Mounting (450-2000 kW)

3. Attach the wiring connection harness to the interconnection circuit board.

- 3.1 Remove the controller cover and hardware.
- 3.2 Route the other end of the wiring connection harness (GM17029, GM17033, or GM16755) through the junction box port to the controller interconnection circuit board.
- 3.3 Plug the wiring harness connector into the interconnection circuit board's P23 connector. Connect lead ES3 to TB-1 terminal 3 and connect lead ES4 to TB-1 terminal 4. See Figure 5. If access to the interconnection circuit board is difficult, remove the two rear controller panel top screws and loosen the bottom screws to swing the rear controller panel down.
- 3.4 Swing the rear controller panel up and replace the screws, if previously removed. Replace the controller cover and hardware. Tighten all controller screws.

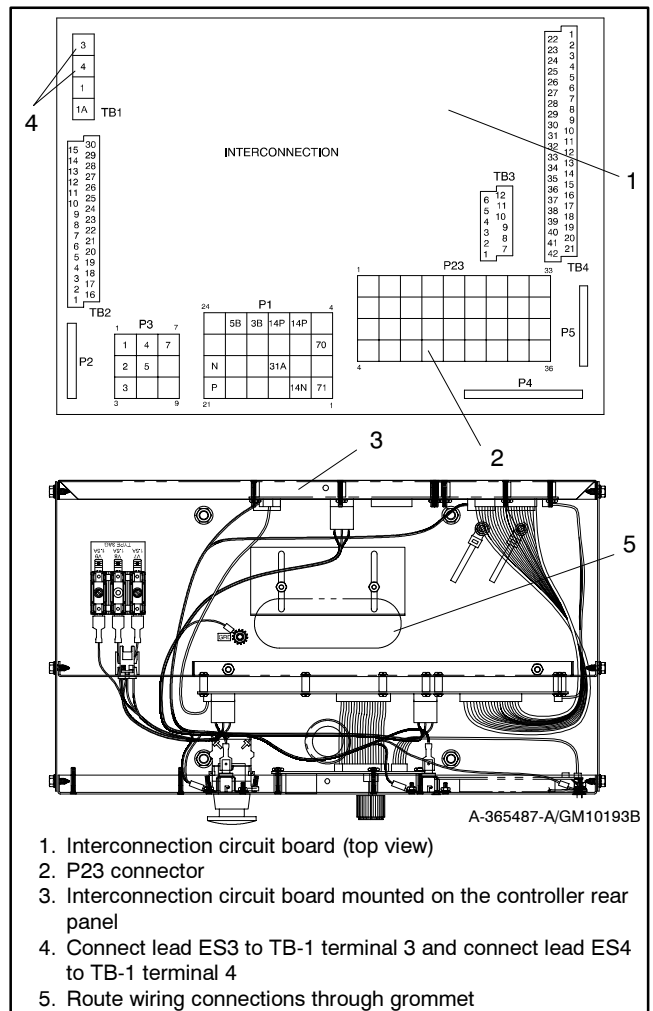

Figure 5 Controller Circuit Board Connections

4. Mount the ten-relay dry contact assembly.

4.1 GM25953-KP2/-KP2S kits (20-300 kW)

4.1.1 Drill four 7.1 mm (0.281 in.) diameter holes in the junction box as shown in Figure 6. The ten-relay dry contact kit mounts behind the controller.

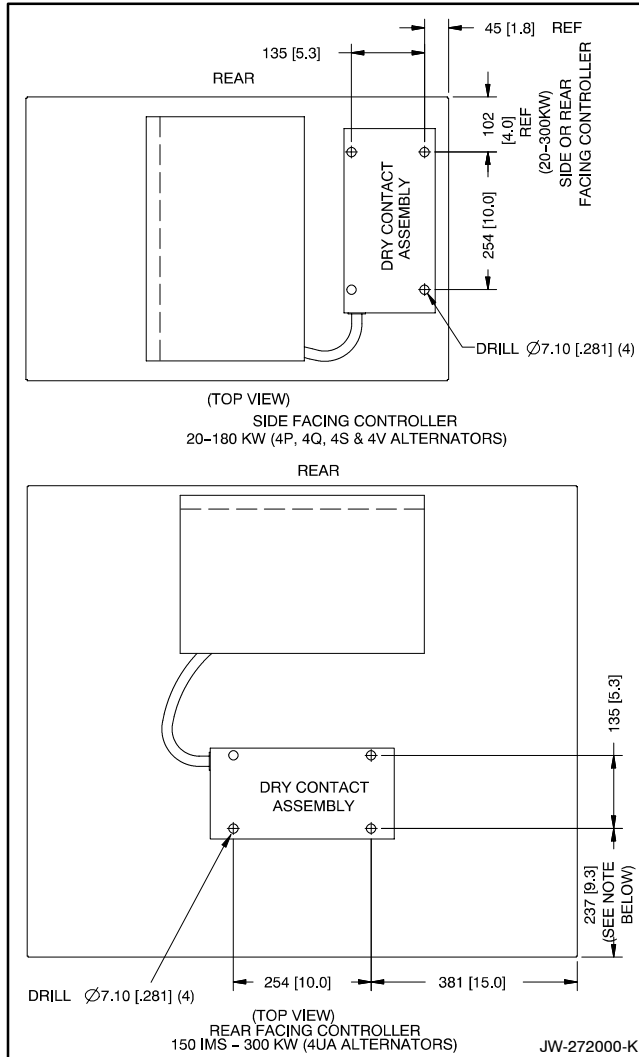

Figure 6 Junction Box Drilling Information (20-300 kW)

4.1.2 Remove burrs from the drilled holes and clean up all metal chips in the junction box.

4.1.3 Remove the cover from the ten-relay dry contact assembly (GM25951) by removing four screws.

4.1.4 Mount the ten-relay dry contact assembly (GM25951) to the junction box using four vibromounts (229353), eight lock washers (X-22-12), and eight whiz nuts (X-6210-2). See Figure 6 for the mounting position.

When attaching the dry contact assembly to the generator set junction box or skid, install the ground strap (223033) as shown in Figure 7.

4.1.5 Proceed to step 5.

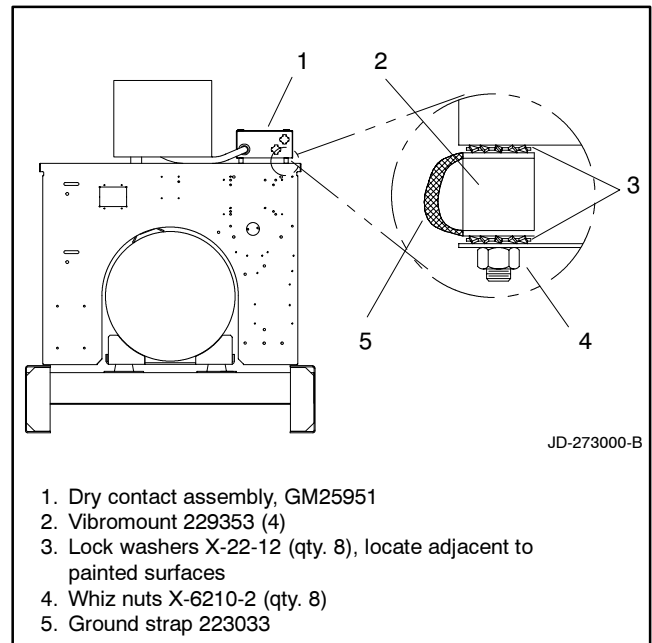

Figure 7 Ground Strap Mounting

4.2 GM25953-KP3/-KP3S kits (350/400 kW)

- 4.2.1 Drill four 7.1 mm (0.281 in.) diameter holes in the junction box as shown in Figure 8.
- 4.2.2 Remove burrs from the drilled holes and clean up all metal chips in the junction box.
- 4.2.3 Remove the cover from the ten-relay dry contact assembly (GM25951) by removing four screws.
- 4.2.4 Mount the ten-relay dry contact assembly (GM25951) to the junction box using four vibromounts (229353), eight lock washers (X-22-12), and eight whiz nuts (X-6210-2). Install the ground strap (223033) as shown in Figure 8.
- 4.2.5 Proceed to step 5.

4.3 GM28618-KP11/-KP11S kits (450-2000 kW)

- 4.3.1 Mount the ten-relay dry contact circuit board (D-294303) on the junction box bracket studs using six spacers (X-712-9) and nuts (X-70-12). Choose the primary location when available. Place the spacers between the ten-relay dry contact circuit board and the mounting bracket. See Figure 4 for the mounting location.
- 4.3.2 Connect the 12-lead dry contact relay wiring harness (GM16755) to the ten-relay dry contact kit relay input terminals. See Figure 9 for connection information.
- 4.3.3 Proceed to step 5.

5. Connect the ten-relay dry contact kit to the controller connection kit.

Use the appropriate accessory wiring diagram found in the Wiring Diagram Manual supplied with the generator set to select the fault connection.

When a generator fault condition occurs, the contact kit relay energizes. Select either normally open or normally closed contacts from the relay depending upon application requirements. The

relay contact closure corresponds to the controller light being activated.

Connect the 12-lead dry contact relay wiring harness (273935) 20-400 kW or (GM16755) 450-2000 kW from the controller connection assembly to the ten-relay dry contact assembly relay input terminals. See Figure 9. Terminals 2 (ground) and 42A (battery voltage) provide an electrical source to operate the K1-K10 relays.

The user can select up to ten fault terminals for connecting the K1-K10 signal leads. See Figure 10 and Figure 11 for terminal connections.

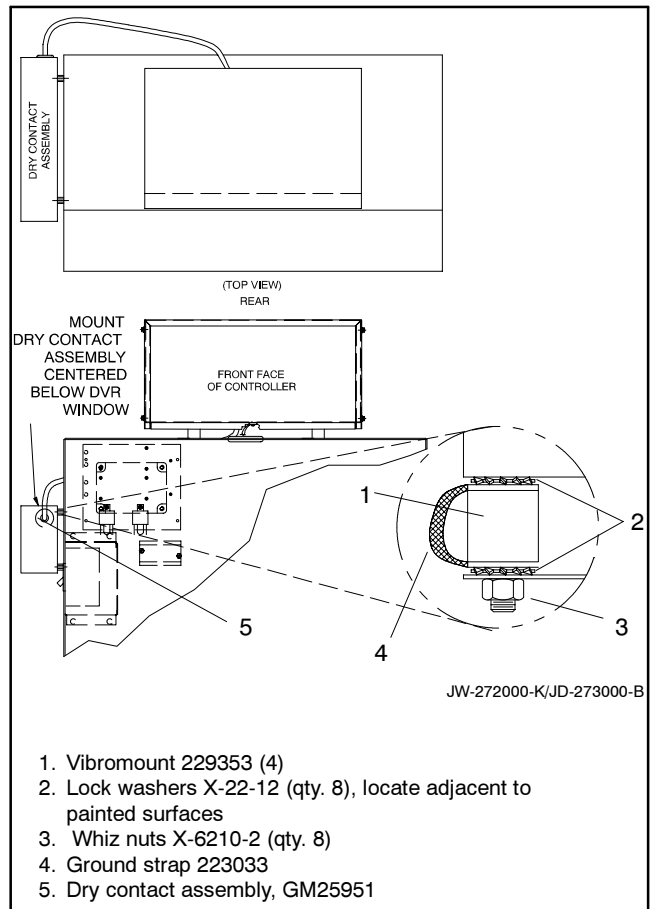

Figure 8 Junction Box Drilling Information (350/400 kW)

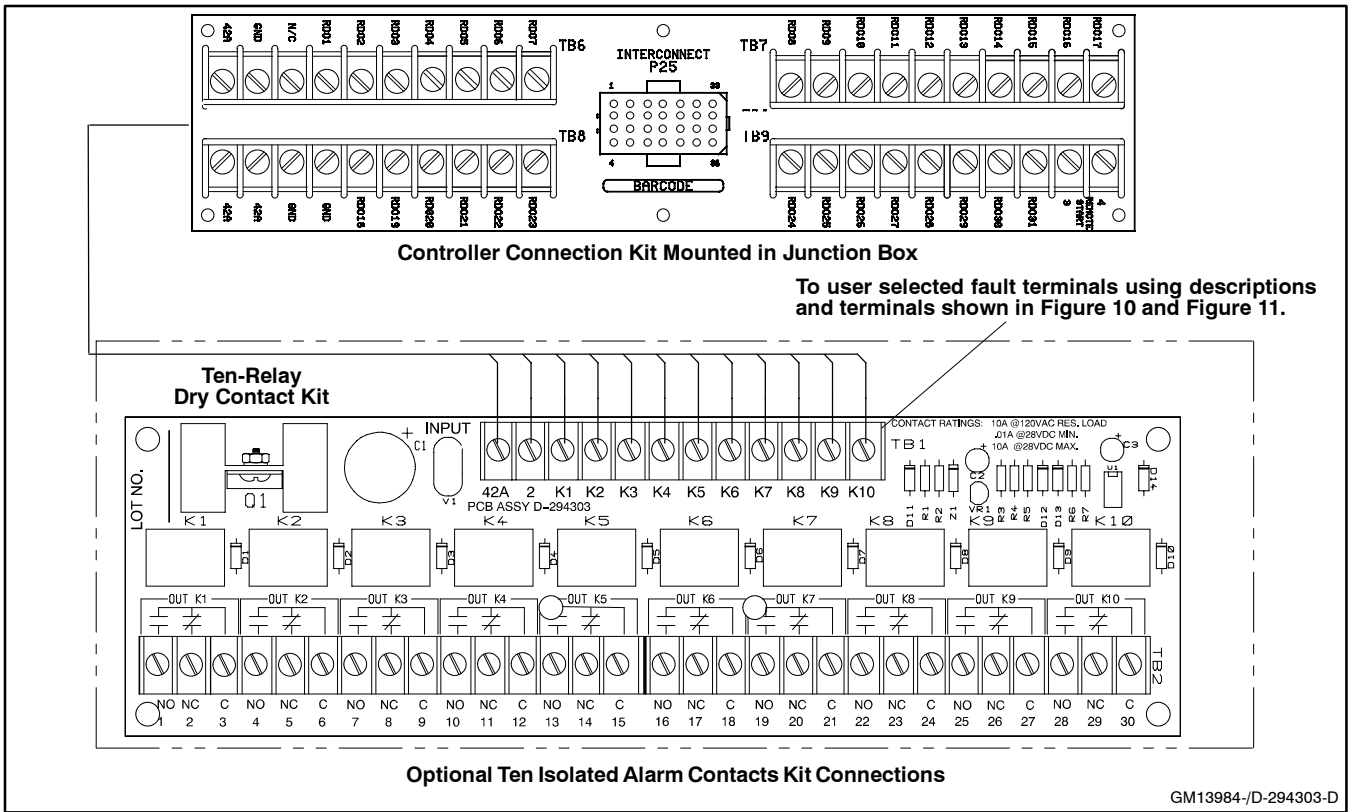

Figure 9 Ten-Relay Dry Contact Relay Kit Connections

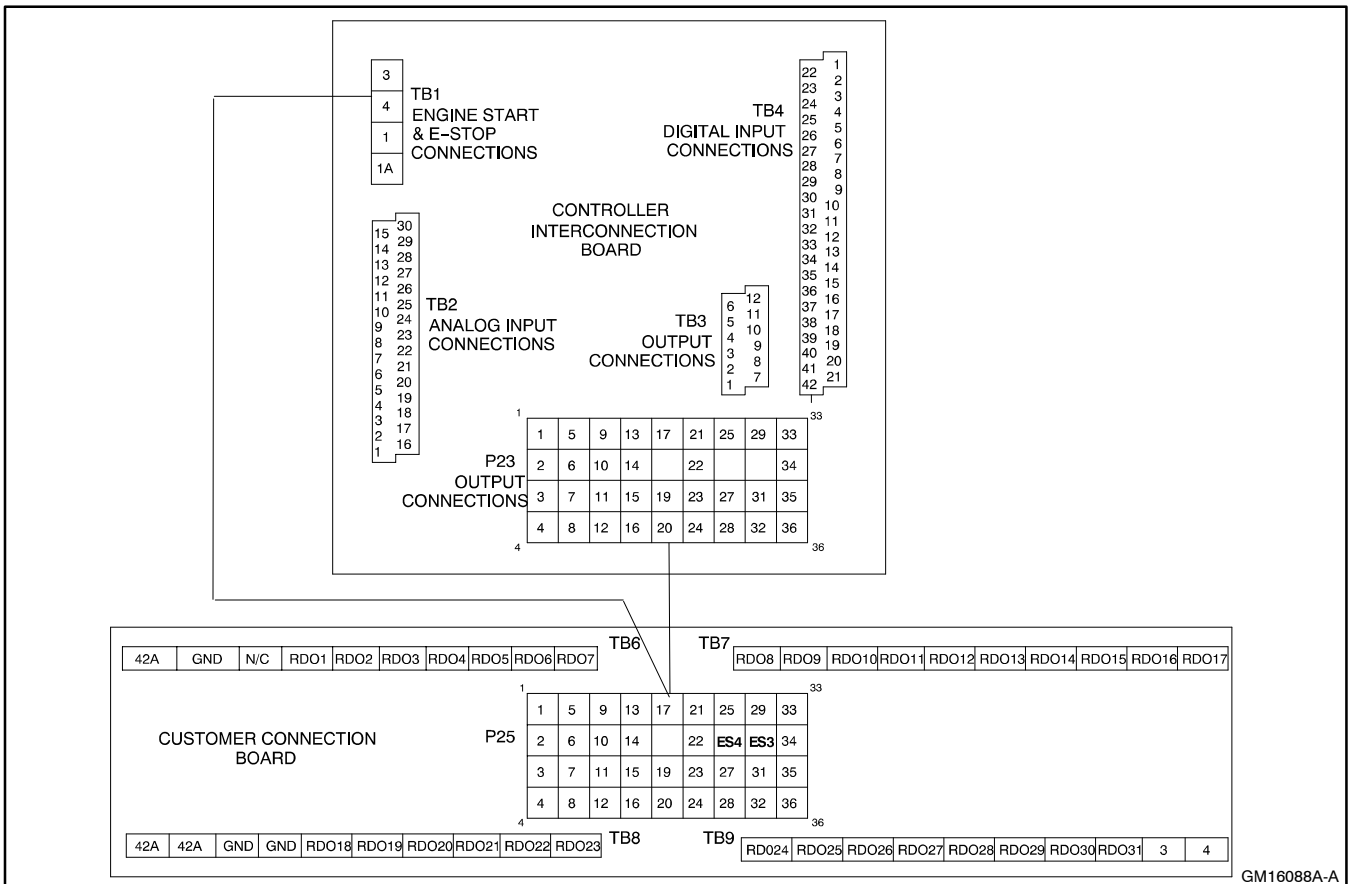

Figure 10 Controller Connection Assembly

TB6 Terminal Strip—RDOs 1-7		TB9 Terminal Strip—RDOs 24-31	
Term.	Description	Term.	Description
42A	Battery (+)	RDO24	Speed sensor fault
GND	Battery (-)	RDO25	Loss of AC sensing
N/C		RDO26	ECM loss of communication
RDO1	Overspeed (lead 39)	RDO27	Undervoltage
RDO2	Overcrank (lead 12)	RDO28	Overfrequency
RDO3	High coolant temperature shutdown (lead 36)	RDO29	Underfrequency
RDO4	Low oil pressure shutdown (lead 38)	RDO30	Load shed kW overload
RDO5	Low coolant temperature (lead 35)	RDO31	Load shed underfrequency
RDO6	High coolant temperature warning (lead 40)	3	Remote start
RDO7	Low oil pressure warning (lead 41)	4	Remote start
TB7 Terminal Strip—RDOs 8-17		Note: Lead numbers shown in parentheses are the factory default wire designations.	
Term.	Description	Note: RDO-1 through RDO-31 are user definable with the following factory defaults: emergency stop, high coolant temperature, low oil pressure, overcrank, and overspeed	
RDO8	Low fuel (lead 63)	*NFPA-110 common alarm faults include:	
RDO9	Master switch not in auto (lead 80)	Air damper indicator (RDO-23)	
RDO10	NFPA 110 common alarm (lead 32)*	Battery charger fault (RDO-11)	
RDO11	Battery charger fault (lead 61)	EPS supplying load (RDO-22)	
RDO12	Low battery voltage (lead 62)	High battery voltage (RDO-13)	
RDO13	High battery voltage	High coolant temperature warning (RDO-06)	
RDO14	Emergency stop (lead 48)	High coolant temperature shutdown (RDO-03)	
RDO15	Generator running (lead 70R)	Low battery voltage (RDO-012)	
RDO16	Time delay engine cooldown (TDEC) (lead 70C)	Low coolant level (RDO-19)	
RDO17	System ready (lead 60)	Low coolant temperature warning (RDO-05)	
TB8 Terminal Strip—RDOs 18-23		Low fuel (level or pressure) (RDO-08)	
Term.	Description	Low oil pressure warning (RDO-07)	
42A	Battery (+)	Low oil pressure shutdown (RDO-04)	
42A	Battery (+)	Master switch not in auto (RDO-09)	
2	Battery (-)	Overcrank (RDO-02)	
2	Battery (-)	Overspeed (RDO-01)	
RDO18	Defined common fault (lead 32A)		
RDO19	Low coolant level		
RDO20	Overvoltage (lead 26)		
RDO21	Idle mode		
RDO22	EPS supplying load		
RDO23	Air damper indicator (lead 56)		

Figure 11 Controller Connection Assembly Terminal Strip Identification with Relay Driver Outputs (RDOs)

6. Connect the ten-relay dry contact to the user-supplied device.

Select the normally open (NO) and/or normally closed (NC) form C dry contact, depending upon the application. Use a two-wire harness for either NO or NC connections. Use a three-wire harness for both NO and NC connections.

- 6.1 The user must supply stranded wire long enough to connect user-supplied device to the dry contact relay terminals and power supply. Use color-coded wire for easy identification. Make leads long enough to allow for walls, ductwork, and other obstructions. Use separate conduit for the dry contact kit wiring.
- 6.2 **12/24-Volt DC Devices.** Attach the user-supplied 12/24-volt DC accessories to the starting battery positive (+) connection at the starter solenoid and to the battery negative (-) connection at the

engine ground. Otherwise, use a separate 12/24-volt DC supply. Do not use terminals 42A and 2 on the controller connection kit terminal strip to supply the voltage to the relay contacts. Supply separate leads directly to the battery for the supply voltage. The circuit must include fuse or circuit breaker protection.

GM28618-KP11/-KP11S kits only (450-2000 kW). Install the 10-lead dry contact wiring harness (GM10180) to electrically connect the relay common (C) terminals together when using a DC power supply. See Figure 12. Remove the 10-lead dry contact wiring harness (GM10180) when applying an AC power supply.

- 6.3 **120-Volt AC Devices.** Connect the user-supplied accessories to a separate 120-volt AC power supply. The circuit must include fuse or circuit breaker protection.

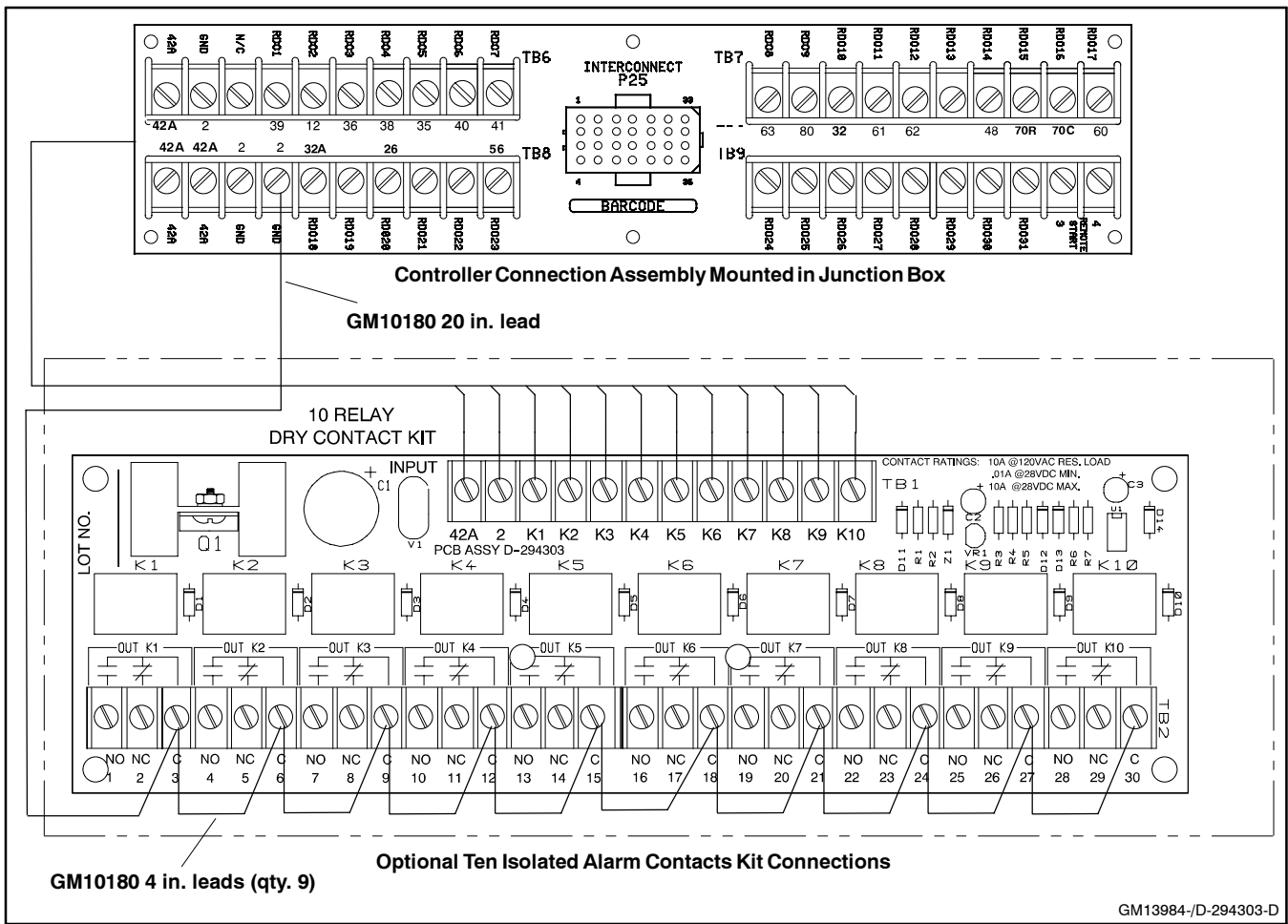

Figure 12 Wiring Harness GM10180 Connections for DC Power Supply

- 6.4 Connect the user-supplied device per the installations and/or schematic supplied with the device to a power source and to the ten-relay dry contact terminals. Cut the user-supplied leads to the desired length, strip lead ends, crimp on spade terminals (not supplied), and connect the leads to the relay contact screw terminals. Keep the ten-relay dry contact wiring away from the generator set output leads.
- 6.5 Repeat step 6 for the remaining dry contact relays.
- 6.6 **GM25953-KP2/-KP2S & GM25953-KP3/-KP3S kits only (20-400 kW).** Replace the cover of the ten-relay dry contact assembly (GM25951) and install the four screws (X-6216-1).
- 6.7 **GM28618-KP11 and GM28618-KP11S kits only (450-2000 kW).** Swing the access door closed and install the screws.
- 6.8 Replace the junction box panel and hardware.
7. **Restore the generator set to service.**
 - 7.1 Check that the generator set master switch is in the OFF position.
 - 7.2 Reconnect the generator set engine starting battery, negative (-) lead last.
 - 7.3 Reconnect power to the battery charger, if equipped.
 - 7.4 Move the generator set master switch to AUTO for startup by remote transfer switch or remote start/stop switch.

Parts List

Ten-Relay Dry Contact Kits

Kit: GM25953-KP2/-KP2S (20-300 kW)		
Qty.	Description	Part Number
1	Dry contact assembly, ten-relay (includes:)	GM25951
1	Circuit board, ten-relay dry contact	D-294303
1	Tie, cable	X-468-5
4	Screw, Phillips	X-6216-1
1	Plug, button	X-301-29
1	Bushing, nylon	X-634-14
1	Cover, dry contact	GM25950
1	Box, dry contact	GM25949
1	Harness, wiring (12 lead)	273935
8	Washer, lock	X-22-12
6	Screw, round head mach., 8-32 x 1 in.	X-51-3
6	Spacer, 0.25 in OD x 0.5 in.	X-712-9
8	Nut, whiz, 1/4-20	X-6210-2
6	Nut, whiz, 8-32	X-6210-4
1	Connection assembly, controller	GM13984
1	Harness, controller connection wiring (36 pin)	GM17033
1	Strap, ground	223033
4	Vibromount	229353

Kit: GM25953-KP3/-KP3S (350/400 kW)		
Qty.	Description	Part Number
1	Dry contact assembly, ten-relay (includes:)	GM25951
1	Circuit board, ten-relay dry contact	D-294303
1	Tie, cable	X-468-5
4	Screw, Phillips	X-6216-1
1	Plug, button	X-301-29
1	Bushing, nylon	X-634-14
1	Cover, dry contact	GM25950
1	Box, dry contact	GM25949
1	Harness, wiring (12 lead)	273935
14	Washer, lock	X-22-12
6	Screw, round head mach., 8-32 x 1 in.	X-51-3
6	Spacer, 0.25 in OD x 0.5 in.	X-712-9
14	Nut, whiz, 1/4-20	X-6210-2
6	Nut, 8-32	X-70-12
1	Connection assembly, controller	GM13984
1	Harness, controller connection wiring (36 pin)	GM17029
1	Strap, ground	223033
7	Vibromount	229353
1	Bracket, terminal block	347292
1	Strap, ground	LK-1206-1515

Kit: GM28618-KP11/-KP11S (450-2000 kW)		
Qty.	Description	Part Number
1	Circuit board, ten-relay dry contact	D-294303
1	Harness, 10-lead wiring	GM10180
6	Spacer, 0.25 in OD x 0.5 in.	X-712-9
6	Nut, 8-32	X-70-12
1	Harness, 12-lead wiring	GM16755
1	Connection board (includes:)	GM28632-1
6	Spacer, 0.25 in OD x 0.5 in.	X-712-9
6	Nut, 8-32	X-70-12

Test the Dry Contact Relays

Verify that the dry contact relays function by using the following procedure when troubleshooting.

Test Procedure

1. Deenergize the power supply to the user-supplied device.
2. Remove the user-supplied device and power supply wiring from the dry contact relay terminals.
3. Test the relay operation by connecting an ohmmeter across the NO and C terminals on the relay terminal strip.
4. Use a jumper wire to ground the selected fault terminal on the controller connection terminal strip. The relay contacts should close and the ohmmeter should display a low resistance reading (continuity).
5. Install the user-supplied device and power supply wiring on the dry contact relay terminals.
6. Energize the power supply to user-supplied device.

Notes

