

INSTALLATION INSTRUCTIONS

Original Issue Date: 1/04

Model: 20-400 kW

Market: Industrial Generator Sets with 16-Light Microprocessor Controller

Subject: Remote Annunciator Kits GM25955-KP1 and GM25955-KP1S

Introduction

The remote annunciator monitors the condition of the generator set from a location remote from the generator set. If a generator alarm condition occurs, the remote annunciator alerts the operator through visual and audible signals. The remote annunciator kit includes a 14-relay dry contact assembly to isolate the annunciator from the controller and to protect the controller from voltage surges and stray voltage.

If a generator alarm condition occurs, the appropriate relay contacts close to activate the horn and corresponding lamp on the remote annunciator. The following paragraphs describe specific features of the remote annunciator.

Features

Horn

Alarm Horn. The alarm horn sounds when a fault or prealarm condition exists, except emergency stop, battery charger fault, or low battery volts. Silence the

alarm horn with the generator set master switch in the AUTO position. See step 8, Resetting the generator set controller and remote annunciator.

Lamps

Auxiliary Fault. The lamp flashes or remains on to indicate that a fault occurred.

Flashing Lamp Condition:

- The auxiliary lamp flashes immediately when the controller senses no AC output while the generator set is running, except during the first 10 seconds after startup. When AC output is sensed, the lamp stops flashing and turns off. No manual reset is required.
- The auxiliary lamp flashes when the battery power is reconnected or low and then regains full power while the generator set master switch is in the RUN or AUTO position. A temporary low battery condition may result from a weak battery or from an undersized battery for the application. Place the generator set master switch in the OFF/RESET position to clear this condition.

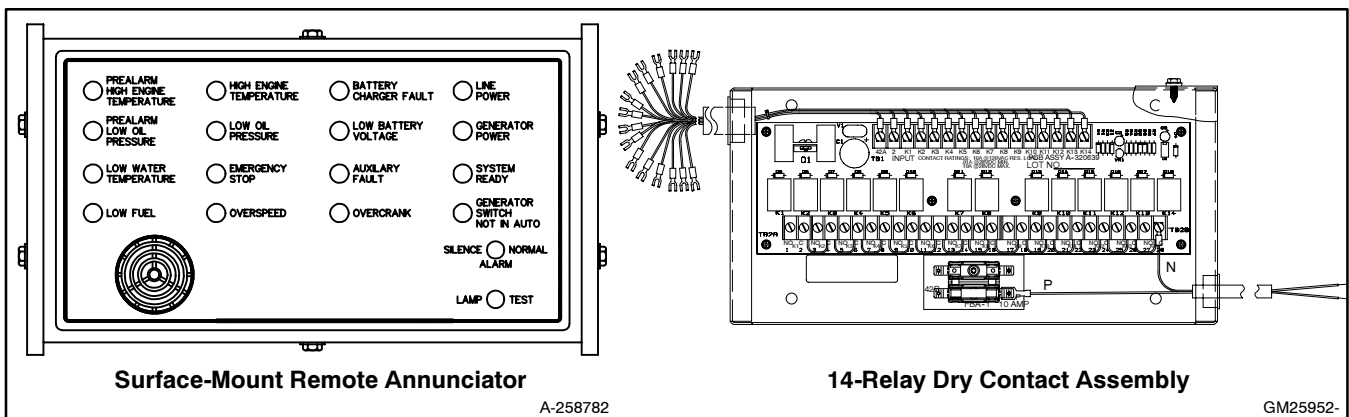

Figure 1 Remote Annunciator Kit Components

Continuous On Lamp Condition:

- The auxiliary lamp illuminates when the optional emergency stop switch is reset while the generator set master switch is in the AUTO or RUN position. Place the generator set master switch in the OFF/RESET position to clear this condition.
- The auxiliary lamp illuminates and the engine shuts down 5 seconds after high oil temperature (P1-13), low coolant level (P1-14), or auxiliary delay shutdown (P1-15) faults occur, if the generator set is so equipped. These conditions are inhibited during the first 30 seconds after a crank disconnect.
- The auxiliary lamp illuminates and the engine shuts down immediately when an overvoltage condition occurs, if the generator set is equipped with the voltage shutdown kit.
- The auxiliary lamp illuminates and the engine shuts down immediately when activated by a customer-supplied sensing device connected to the auxiliary immediate shutdown ports (P1-17 and P1-18).

Battery Charger Fault, if battery charger equipped. The lamp illuminates when the generator set battery charger malfunctions.

Emergency Stop. The lamp illuminates when the generator set stops by a local or optional emergency stop switch, if the generator set is equipped with an emergency stop switch.

Generator Power. The lamp illuminates when the generator set supplies the power.

Generator Switch Not In Auto. The lamp illuminates when the generator set master switch is not in the AUTO position.

High Engine Temperature. The lamp illuminates when the high engine coolant temperature shuts down the generator set.

Line Power. The lamp illuminates when a power supply other than the generator set supplies the power.

Low Battery Voltage, if battery charger equipped. Lamp illuminates when the battery or charging voltage drops below a preset level on the charger. The lamp also illuminates when an undervoltage condition occurs from a battery or charger malfunction while the generator set is running.

Low Fuel. The lamp illuminates when the fuel tank level approaches empty. The annunciator requires a fuel tank low-fuel sensor for the lamp to function.

Low Oil Pressure. The lamp illuminates when the generator set shuts down because of low engine oil pressure.

Low Water Temperature. The lamp illuminates when the optional engine block heater malfunctions and/or the block temperature is too low (below 60°F, [16°C]) for ten-second startup. The annunciator requires the optional prealarm sender kit for the lamp to function.

Overcrank. The lamp illuminates and the cranking stops when the generator set does not start within the defined cranking period.

Overspeed. The lamp illuminates when the generator set shuts down because of an overspeed condition.

Prealarm High Engine Temperature. The lamp illuminates when the engine coolant temperature approaches the shutdown range. The annunciator requires the optional prealarm sender kit for the lamp to function.

Prealarm Low Oil Pressure. The lamp illuminates when the engine oil pressure approaches the shutdown range. The annunciator requires the optional prealarm sender kit for the lamp to function.

System Ready. The lamp illuminates when the generator set master switch is in the AUTO position and the system has no fault conditions.

Mounting

Flush- or Surface-Mounting Capability. This instruction includes installation information for both flush- and surface-mount models.

Switches

Alarm Silence. The switch disconnects the alarm during servicing. Place the generator set master switch in the AUTO position to reset. See step 8, Resetting the generator set controller and remote annunciator.

Lamp Test. The switch tests the remote annunciator indicator lamps.

Safety Precautions

Observe the following safety precautions while installing the kit.

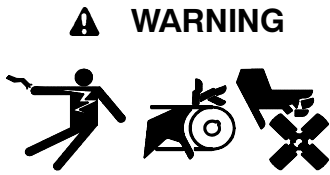

**Accidental starting.
Can cause severe injury or death.**

Disconnect the battery cables before working on the generator set. Remove the negative (-) lead first when disconnecting the battery. Reconnect the negative (-) lead last when reconnecting the battery.

Disabling the generator set. Accidental starting can cause severe injury or death. Before working on the generator set or connected equipment, disable the generator set as follows: (1) Move the generator set master switch to the OFF position. (2) Disconnect the power to the battery charger. (3) Remove the battery cables, negative (-) lead first. Reconnect the negative (-) lead last when reconnecting the battery. Follow these precautions to prevent starting of the generator set by an automatic transfer switch, remote start/stop switch, or engine start command from a remote computer.

Read the entire installation procedure and compare the kit parts with the parts list in this publication before beginning installation. Perform the steps in the order shown.

Note: Observe applicable local and national electrical codes when installing the wiring system.

Installation Procedure

1. **Remove the generator set from service.**
 - 1.1 Place the generator set master switch in the OFF/RESET position.
 - 1.2 Disconnect the power to the battery charger, if equipped.
 - 1.3 Disconnect the generator set engine starting battery(ies), negative (-) lead first.
2. **Mount the 14-relay dry contact assembly.**
 - 2.1 Mounting location. Select a mounting location for the 14-relay dry contact assembly (GM25952). Consider the supplied wiring harness length when choosing a mounting location. If the most suitable

location requires a longer harness, fabricate a new harness using supplied harness as a guide.

Note: Supplied wiring harness (293982) allows a maximum distance of 1.5 m (5 ft.) between the 14-relay dry contact assembly and the controller connection terminal strip.

Mount dry contact assembly in one of the areas listed below. Use dry contact assembly box as a template and drill necessary mounting holes. See Figure 2 or Figure 3 for suggested mounting locations.

- The junction box top; the controller size and the size of junction box limit the mounting location.
- The generator set skid top; the clearance and housing options limit the mounting location.
- An area as near to the generator set controller as practical.

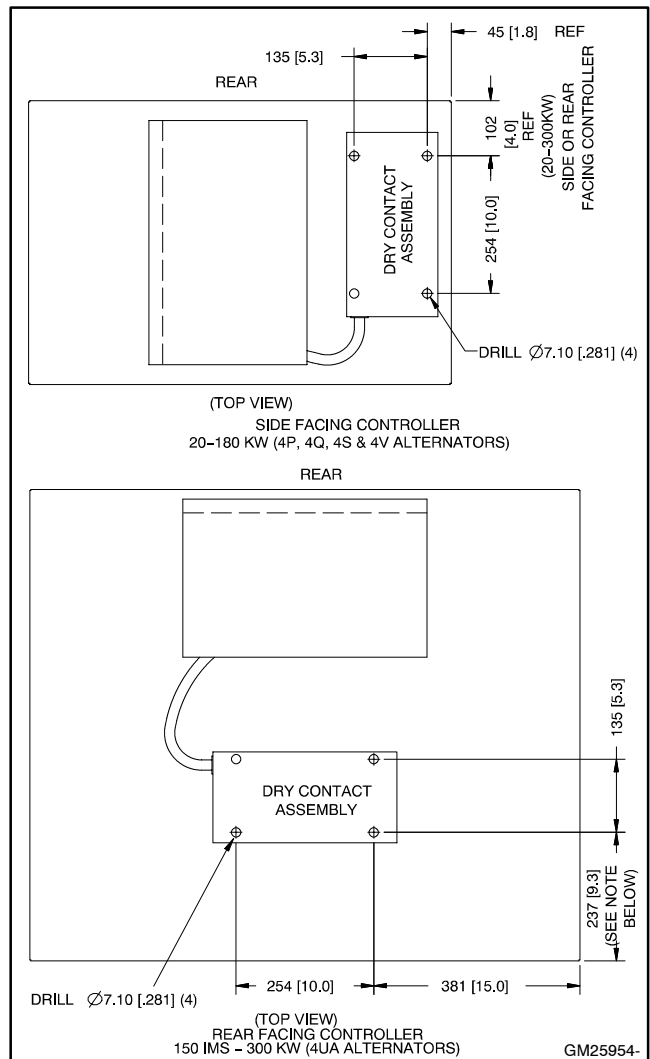

Figure 2 Junction Box Drilling Information (20-300 kW)

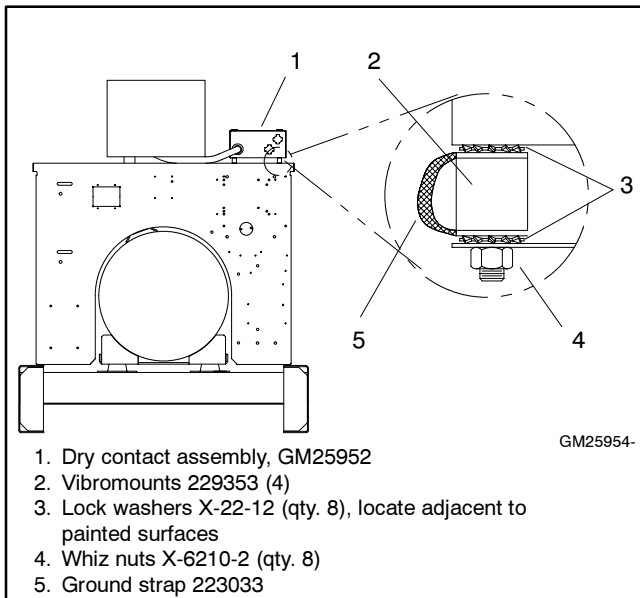

Figure 3 Ground Strap Mounting

2.2 20-300 kW

2.2.1 Drill four 7.1 mm (0.281 in.) diameter holes in the junction box as shown in Figure 2. The 14-relay dry contact kit mounts behind the controller.

2.2.2 Remove burrs from the drilled holes and clean up all metal chips in the junction box.

2.2.3 Remove the cover from the 14-relay dry contact assembly (GM25952) by removing four screws.

2.2.4 Mount the 14-relay dry contact assembly (GM25952) to the junction box using four vibromounts (229353), eight lock washers (X-22-12), and eight whiz nuts (X-6210-2). See Figure 2 for the mounting position.

When attaching the dry contact assembly to the generator set junction box or skid, install the ground strap (223033) as shown in Figure 3.

2.2.5 Proceed to step 3.

2.3 350/400 kW

2.3.1 Drill four 7.1 mm (0.281 in.) diameter holes in the junction box as shown in Figure 4. Mount the 14-relay dry contact assembly in the primary location when no ten-relay dry contact assembly is installed. If a ten-relay dry contact assembly is or will be installed, mount the 14-relay dry contact assembly in the secondary location.

2.3.2 Remove burrs from the drilled holes and clean up all metal chips in the junction box.

2.3.3 Remove the cover from the 14-relay dry contact assembly (GM25952) by removing four screws.

2.3.4 Mount the 14-relay dry contact assembly (GM25952) to the junction box using four vibromounts (229353), eight lock washers (X-22-12), and and eight whiz nuts (X-6210-2).

When attaching the dry contact assembly to the generator set junction box or skid, install the ground strap (223033) as shown in Figure 4.

2.3.5 Proceed to step 3.

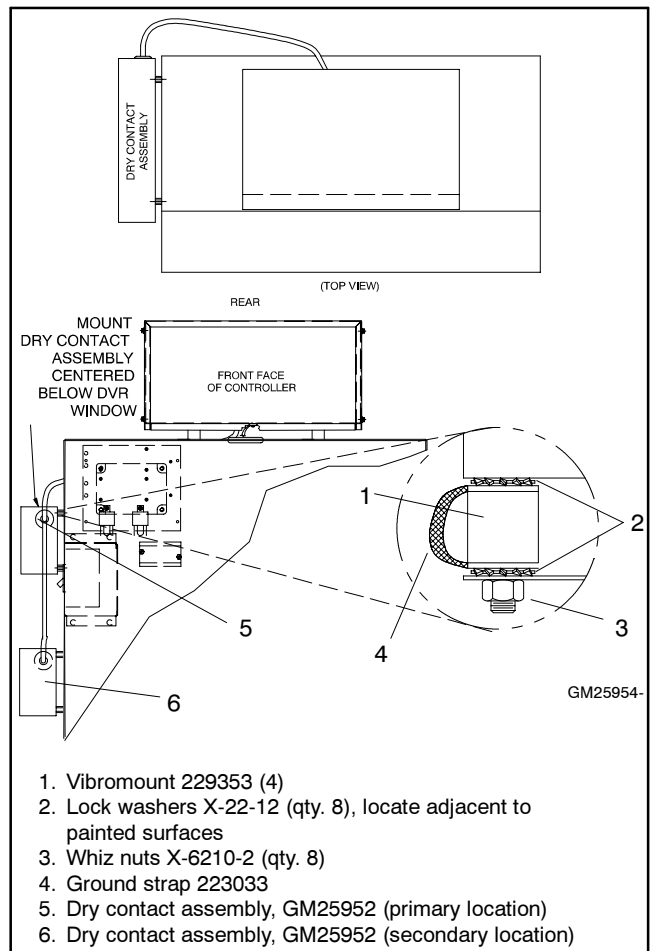

Figure 4 Junction Box Drilling Information (350/400 kW)

3. Connect the 14-relay dry contact kit to the controller connection kit or controller terminal strip.

- 3.1 Connect the 14-relay dry contact wiring harness (293982) to the controller connection assembly in the junction box. See Figure 5.
- 3.2 Connect lead P of the wiring harness (256495) from the 14-relay dry contact assembly to the battery positive (+) terminal at the starter solenoid. Lead N of the wiring harness connects to the battery's negative (-) terminal at the engine ground. Cut leads to length, strip ends, and crimp on ring terminals (X-283-4, 1/4 in. diameter), (X-283-5, 5/16 in. diameter), or (X-283-32, 1/2 in. diameter) as required.

Do not use terminals 42A and 2 on the 14-relay dry contact assembly terminal strip to supply voltage to the relay contacts. The user must attach separate leads directly to the battery for the voltage supply.

If additional load, lights, or alarms are connected to the 14-relay dry contact assembly, resize leads P and N based on the total current requirements.

4. Select a mounting location for the remote annunciator panel.

- 4.1 Select a visible location for mounting the remote annunciator panel up to 305 m (1000 ft.) from the controller. Install the remote annunciator panel, either surface- or flush-mounted, in a location easily observable by operating personnel at their work stations. See Figure 6 for remote annunciator dimensions and mounting hole dimensions.

4.2 Surface-mount remote annunciator initial installation.

- 4.2.1 Prepare the mounting site by drilling pilot holes for anchors, if used.

Note: Mount the remote annunciator kit to a standard 10 cm (4 in.) square electrical box installed in the wall.

- 4.2.2 Create an opening in the wall for the electrical wiring from the 14-relay dry contact assembly, P and N battery connections, and transfer switch.

- 4.2.3 Disassemble the remote annunciator assembly. Remove six drill screws to disassemble the side panels and separate the front and back remote annunciator panels. Retain the side panels (287798) and the drill screws (X-794-2) for reassembly.

- 4.2.4 Mount the remote annunciator back panel to the wall or to the electrical box in the wall. See Figure 6 for the mounting hole dimensions. Protect the remote annunciator from dust and debris when drilling the holes.

Note: Use mounting hardware suitable for the wall composition and thickness.

- 4.2.5 Proceed to step 5, Wire the remote annunciator.

4.3 Flush-mount remote annunciator initial installation.

- 4.3.1 Prepare the mounting site by creating an opening in the wall for flush mounting the remote annunciator.

Note: Mount the remote annunciator inside a standard 30 x 20 x 10 cm (12 x 8 x 4 in.) pull box installed in the wall.

- 4.3.2 Disassemble the remote annunciator assembly. Remove six drill screws to disassemble the side panels and separate the front and back remote annunciator panels. Retain the drill screws (X-794-2) for reassembly. Discard the side panels.

- 4.3.3 Proceed to step 5, Wire the remote annunciator.

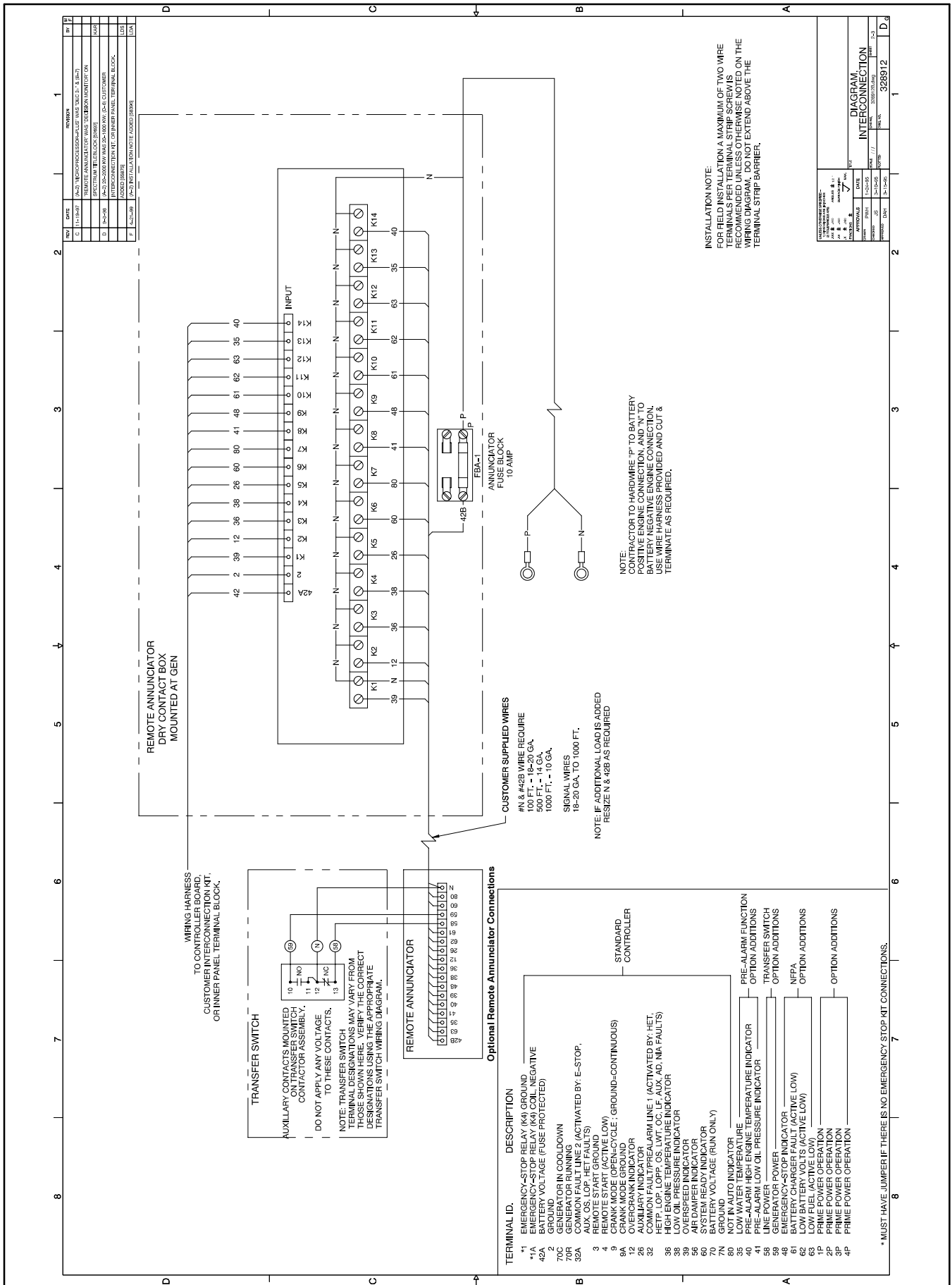

Figure 5 14-Relay Dry Contact Assembly Connections

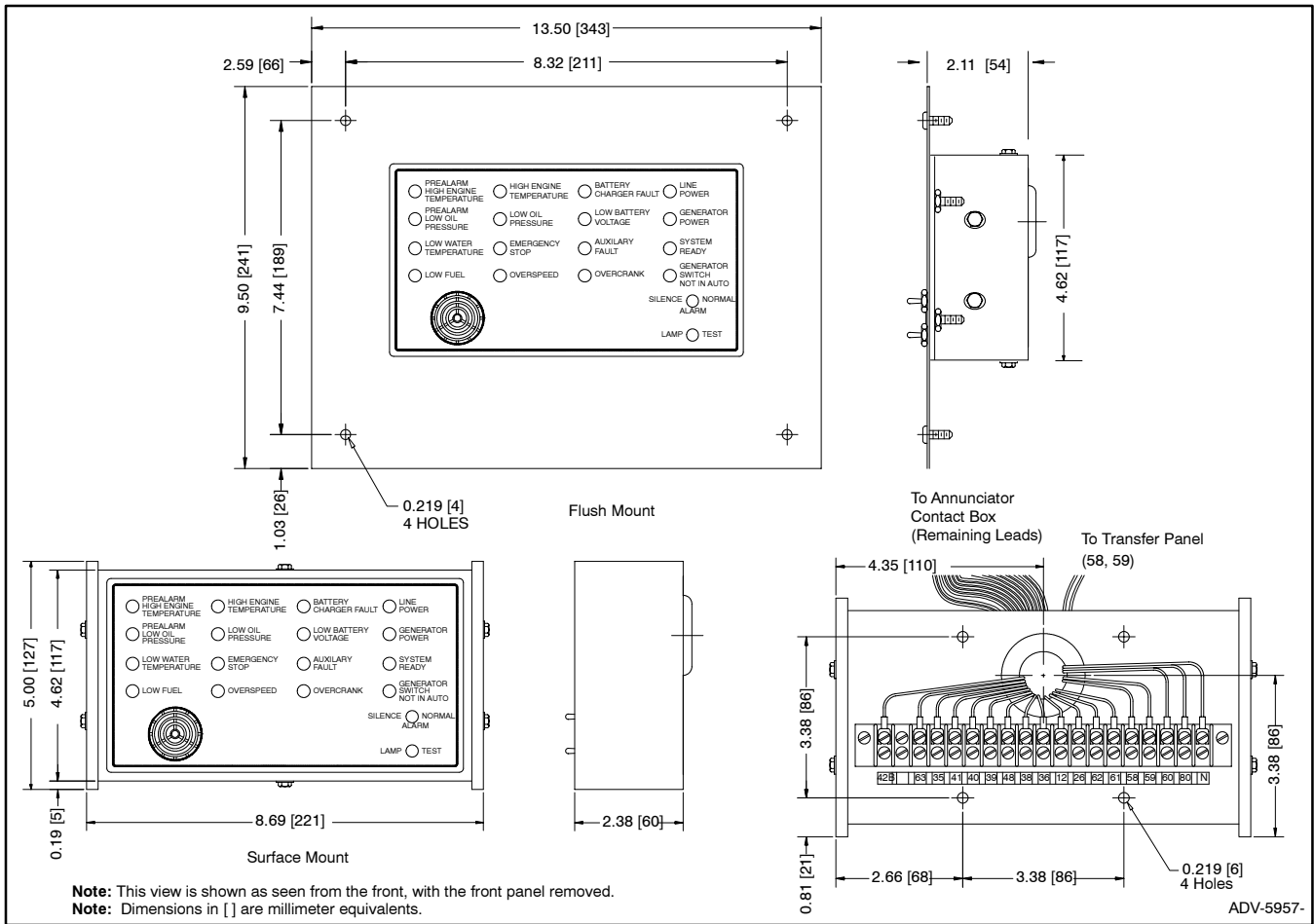

Figure 6 Component Dimensions

5. Wire the remote annunciator.

5.1 The installer must supply all leads between the 14-relay dry contact assembly (GM25952) and the remote annunciator (A-258782). Isolate the leads from all other voltages. Observe the following guidelines during installation:

- Use separate conduit for the remote annunciator leads.
- Use grounded metallic conduit for leads or use shielded cable in nonmetallic conduit.
- Use the 14-relay dry contact kit located at the generator set for all signal leads and a separate power source for the remote annunciator.

To determine the voltage supply wire gauge for leads N and 42B, measure the cable distance between the 14-relay dry contact assembly and the remote annunciator. For example, if the cable distance between the remote annunciator and the 14-relay dry-contact assembly is 122 m (400 ft), then the total wire length for each conductor is 122 m (400 ft). According to the chart in Figure 7, this example requires 14-gauge wire for leads N and 42B only.

Use stranded or solid 18- or 20-gauge wire for signal leads (39, 12, 36, etc.) at lengths up to 305 m (1000 ft.). Never mount the remote annunciator more than 305 m (1000 ft.) from the 14-relay dry contact assembly.

- 5.2 Attach wiring of the correct length and gauge to the 14-relay dry contact assembly. See Figure 7.
- 5.3 Route the wiring from the 14-relay dry contact assembly through the opening in the annunciator back panel.

Leads	Length, m (ft.)		Wire Gauge
N, 42B	0 -21	(0 -100)	18-20
	31 -152	(100 -500)	14
	152 -305	(500 -1000)	10
39, 12, 36, etc.	0 -305	(0 -1000)	18-20

Figure 7 Wire Specifications Between Remote Annunciator and Dry Contact Assembly

5.4 Attach the leads to the terminal strip. Be sure to connect the 14-relay dry contact assembly leads to the corresponding terminals in the remote annunciator. See Figure 9.

5.5 Connect transfer switch terminals 10, 12, and 13 to the remote annunciator terminals 59, N, and 58, respectively, if the electrical system has a transfer switch.

5.6 Replace the 14-relay dry contact assembly cover and install the four cover screws (X-6216-1).

6. Complete the remote annunciator final installation.

6.1 Proceed to either Step 6.2, Surface-mount remote annunciator final installation or Step 6.3, Flush-mount remote annunciator final installation.

6.2 Surface-mount remote annunciator final installation.

6.2.1 Reassemble the front panel to the remote annunciator assembly back panel with two drill screws (X-794-2).

6.2.2 Reattach the side panels with four drill screws (X-794-2).

6.2.3 Proceed to step 7.

6.3 Flush-mount remote annunciator final installation.

6.3.1 Reassemble the front panel to the back panel using two drill screws (X-794-2). See Figure 8.

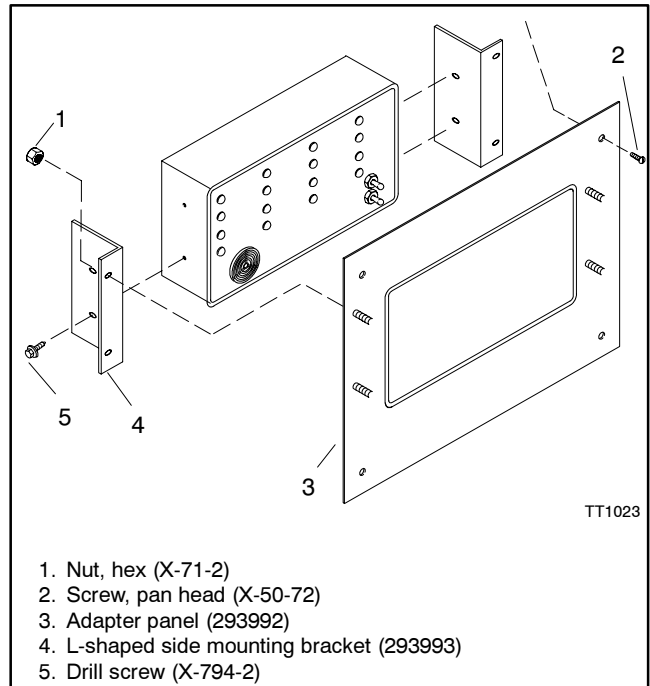

Figure 8 Flush-Mount Remote Annunciator Installation

Description	Controller Connection Kit Terminal	14-Relay Dry Contact Kit Terminal (Relay Signal)	14-Relay Dry Contact Kit Terminal (Relay Contacts)	Remote Annunciator Terminal (factory wire designations)
Battery (+)	42A	42A Input	—	—
Ground/Battery (-)	2	2 Input	—	—
Battery (+)	—	P (from battery)	42B	42B
Ground/Battery (-)	—	N (from battery)	K1, C terminal	N
Overspeed	39	K1 Input	K1, NO terminal	39
Overcrank	12	K2 Input	K2, NO terminal	12
High Engine Temperature Shutdown	36	K3 Input	K3, NO terminal	36
Low Oil Pressure Shutdown	38	K4 Input	K4, NO terminal	38
Overvoltage (Aux.)	26	K5 Input	K5, NO terminal	26
System Ready	60	K6 Input	K6, NO terminal	60
Master Switch Not in Auto	80	K7 Input	K7, NO terminal	80
Low Oil Pressure Warning	41	K8 Input	K8, NO terminal	41
Emergency Stop	48	K9 Input	K9, NO terminal	48
Battery Charger Fault	61	K10 Input	K10, NO terminal	61
Low Battery Voltage (Aux.)	62	K11 Input	K11, NO terminal	62
Low Fuel (Level or Pressure)	63	K12 Input	K12, NO terminal	63
Low Water Temperature	35	K13 Input	K13, NO terminal	35
High Engine Temperature Warning	40	K14 Input	K14, NO terminal	40

Figure 9 Remote Annunciator Kit Wiring Connections

- 6.3.2 Attach the L-shaped side mounting brackets (293993) to the back panel using four drill screws (X-794-2). Do not tighten the screws.
- 6.3.3 Attach the front adapter panel (293992-BLK) studs to the L-shaped side mounting brackets using four 6-32 hex nuts (X-71-2). Do not tighten the nuts.
- 6.3.4 Center the remote annunciator in the adapter panel opening and tighten the hardware.
- 6.3.5 Mount the kit inside the pull box using four screws (X-50-72). Use mounting hardware suitable for the wall composition and thickness for installations without a pull box.
- 6.3.6 Proceed to step 7.

7. Restore the generator set to service.

- 7.1 Check that the generator set master switch is in the OFF position.
- 7.2 Reconnect the generator set engine starting battery, negative (-) lead last.
- 7.3 Reconnect power to the battery charger, if equipped.
- 7.4 Move the generator set master switch to the AUTO position for startup by a remote transfer switch or remote start/stop switch. Move the remote annunciator alarm horn switch to the NORMAL position. If the horn sounds or a lamp illuminates, see step 8 for the resetting instructions.

8. Resetting the generator set controller and remote annunciator.

Use the following procedure to reset the controller and the remote annunciator after a fault alarm.

- 8.1 Move the alarm silence switch on the controller to the SILENCE position to silence the controller alarm horn. The respective remote controller lamp remains lit.
- 8.2 Move the alarm silence switch on the remote annunciator to the SILENCE position to silence the remote annunciator alarm horn. The respective remote annunciator lamp remains lit.
- 8.3 Disconnect the generator set from the system load with the line circuit breaker or the automatic transfer switch.
- 8.4 Correct the cause of the fault alarm (refer to the generator set service manual).
- 8.5 Move the generator set master switch to the OFF/RESET position and then to the RUN position for startup. The remote annunciator alarm horn and the controller alarm horn sound because the unit is not in the AUTO position. The remote annunciator Generator Switch Not in Auto lamp lights.
- 8.6 Verify that the cause of the alarm has been corrected.
- 8.7 Reconnect the generator set to the system load via the line circuit breaker or automatic transfer switch.
- 8.8 Move the generator set master switch to the AUTO position for startup by the remote transfer switch or the remote start/stop switch.
- 8.9 Move the remote annunciator alarm silence switch to the NORMAL position.
- 8.10 Move the controller alarm silence switch to the NORMAL position.

Parts List

Remote Annunciator Kits

Kits: GM25955-KP1/-KP1S		
Qty.	Description	Part Number
1	Strap, ground	223033
4	Vibromounts	229353
2	Bracket, mounting	293993
1	Panel, front annunciator	293992-BLK
1	Panel assembly, annunciator includes:	A-258782
2	Panel, side	287798
6	Screw, drill	X-794-2
1	Contact assembly, 14-relay includes:	GM25952
1	Circuit board, 14-relay dry contact	A-320639
2	Tie, cable	X-468-5
4	Screw, Phillips®	X-6216-1
1	Bushing, 7/8 in. dia. nylon	X-634-11
1	Bushing, 1-3/16 in. dia. nylon	X-634-14
1	Cover, dry contact	GM25950
1	Box, dry contact	GM25949
1	Harness, wiring (2 lead)	256495
1	Harness, wiring (16 lead)	293982
1	Fuse, 10 amp	223316
1	Fuse holder	343694
8	Washer, lock	X-22-12
1	Terminal, 1/2 in. dia. ring	X-283-32
1	Terminal, 1/4 in. dia. ring	X-283-4
1	Terminal, 5/16 in. dia. ring	X-283-5
4	Screw, slotted pan head	X-50-72
8	Nut, 1/4-20 whiz	X-6210-2
4	Nut, 6-32	X-71-2

Test the Dry Contact Relay

Verify that the dry contact relay functions by using the following procedure when troubleshooting.

Test Procedure

1. Deenergize the power supply to the user-supplied device.
2. Remove the user-supplied device and power supply wiring from the dry contact relay terminals.
3. Test the relay operation by connecting an ohmmeter across the NO and C terminals on the relay terminal strip.
4. Use a jumper wire to ground the selected fault terminal on the controller connection terminal strip. The relay contacts should close and the ohmmeter should display a low resistance reading (continuity).
5. Install the user-supplied device and power supply wiring on the dry contact relay terminals.
6. Energize the power supply to the user-supplied device.