

INSTALLATION INSTRUCTIONS

Original Issue Date: 4/04
 Model: **20-2800 kW Generator Sets with 550 Controller or 16-Light Microprocessor Controller**
 Market: **Industrial**
 Subject: **Remote Serial Annunciator (RSA 1000) Kits GM34474-KA1/-KA1S, GM34474-KP1/-KP1S, and GM34474-KP2/-KP2S and Communication Module Kit GM32644-KP1**

Introduction

The remote serial annunciator (Figure 1) monitors the condition of the generator set from a location remote from the generator set. If a generator alarm condition occurs, the remote annunciator alerts the operator through visual and audible signals. The RSA 1000 is offered in three kit configurations. See Figure 2.

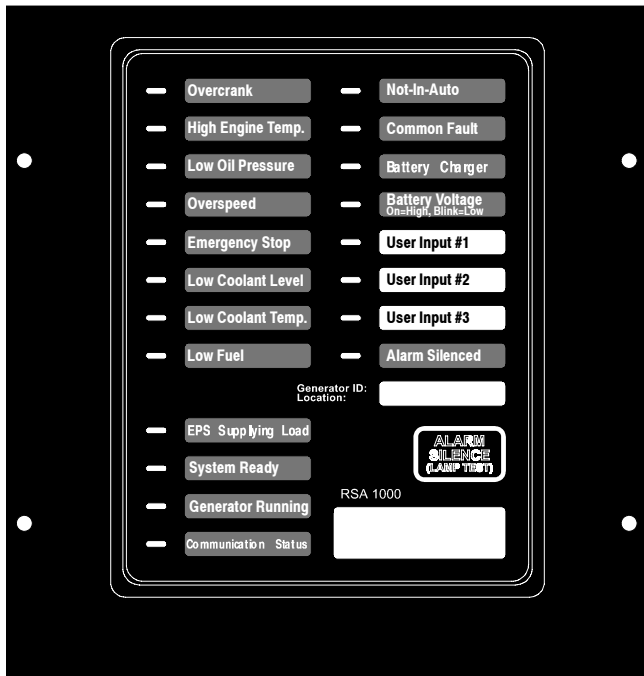

Figure 1 Remote Serial Annunciator (RSA 1000)

RSA 1000 Kits		
GM34474-KP1	GM34474-KP1	GM34474-KP2
GM34474-KP1S	GM34474-KP1S	GM34474-KP2S
Installed	Shipped Loose	Shipped Loose
16-Light	550 or 16-Light	16-Light
Includes: RSA 1000 Communication module factory-installed when ordered with a 16-light controller	Includes: RSA 1000 Order communication module GM32644-KP1/-KP1S when selecting a 16-light controller	Includes: RSA 1000 Communication module (shipped loose)

Figure 2 RSA 1000 Kit Components

The remote serial annunciator kit includes components for flush and surface mounting. One RSA (master) can support up to a maximum of three additional RSAs (slaves). The RSA will function as master or slave by changing the DIP switch position on the RSA board.

If a generator set fault occurs, the RSA 1000 horn activates and the corresponding LED illuminates. The following paragraphs describe specific features of the RSA 1000.

If the RSA 1000 is used in a network, order Modbus®/ Ethernet converter GM41143-KP2 and refer to TT-1405, Converters, Connections, and Controller Setup for Network Communication, for system installation.

Network Applications. If the RSA 1000 is connected to a network, it requires DIP switch SW1-5 be set to the ON position (Ethernet selection) and firmware version 2.0 or higher. This firmware provides the low speed communication necessary for the Modbus®/Ethernet converter. The RSA circuit board has a decal indicating the firmware version number. See Figure 3.

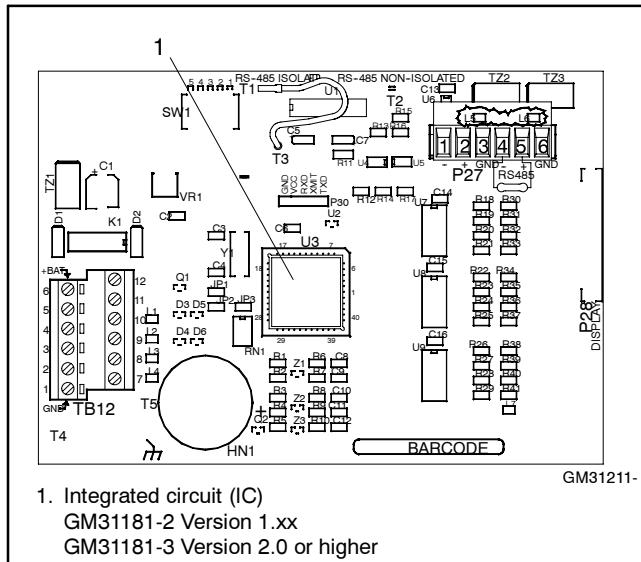

Figure 3 RSA Circuit Board

If the circuit board does not have firmware version 2.0 or higher and network communication is needed, order **RSA Circuit Board Service Kit GM46316** to upgrade the RSA 1000. See Service Disassembly at the end of this document before replacing the circuit board.

The RSA 1000 is compatible with the following controllers:

- 550 controller software code version 2.10 and higher.
- 16-Light controller software code version 1.13 and higher.

The RSA requires connection to the controller Modbus® RS-485 port. If the RS-485 port is needed for switchgear monitoring or a wireless monitor, the RSA cannot be connected to the controller. If the RS-485 port is unavailable, please select an alternate annunciator kit. See Figure 4 for kit numbers.

16-Light Controller	
20-400 kW	GM25955-KP1, -KP1S
450-2000 kW	GM27526-KP1, -KP1S
550 Controller	
20-300 kW	GM27558-KP1, -KP1S
350/400 kW	GM27558-KP2, -KP2S
450-2800 kW	GM27558-KP3, -KP3S

Figure 4 Remote Annunciators

If connecting the RSA 1000 to a generator set with a 16-light controller, the communication module board must be used. See Figure 5 for the location of communication module board. The communication module is included with RSA 1000 kits GM34474-KP2/-KP2S. The communication module is also available as a separate kit GM32644-KP1/-KP1S.

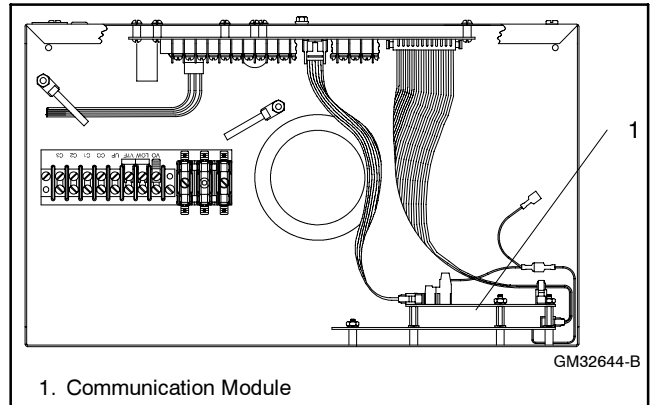

Figure 5 16-Light Controller with Installed Communication Module (Controller Top View)

Features

Horn

Alarm Horn. The alarm horn sounds giving a maximum 65 dB at 1 m (3.3 ft.) audible alarm when a warning or shutdown fault condition exists except on high/low battery voltage or EPS supplying load. Horn sounds when user inputs 1-3 are activated with a 550 controller. Horn sounds when user inputs 1-2 are activated with a 16-light controller.

Note: The alarm horn sound level may vary depending upon the mounting configuration.

Switches

Alarm Silence. Press the Alarm Silence/Lamp Test switch to quiet the alarm during servicing. The horn will reactivate upon additional faults.

Lamp Test. Press the Alarm Silence/Lamp Test switch to test the RSA indicator LEDs and horn.

LEDs

There are up to 25 LED indicating lights for status, warning, and/or shutdown. Some items have two LEDs:

- Communication status (green functional, red fault).
- High engine temperature (yellow warning and red shutdown).
- Low oil pressure (yellow warning and red shutdown).
- System ready (green functional, red fault).

Alarm Silenced. Red LED is steady on when alarm horn is deactivated by the Alarm Silence/Lamp Test switch.

Battery Charger Fault. Yellow LED flashes slow when battery charger malfunctions. Requires battery charger with alarm contact.

Battery Voltage. 16-light controller requires battery charger with alarm contacts. See Figure 38 and Figure 39 relating to battery charger for additional information.

- Yellow LED flashes (blinks) slow when battery or charging voltage drops below preset level.
- Yellow LED is steady on if battery voltage exceeds preset level.

Common Fault. Red LED flashes slow when a single or multiple common fault occurs. Common faults are selectable on the 550 controller using the respective controller menu choices. The 16-light controller offers two choices for common faults using terminal 32 or 32A.

Terminal 32 provides the following nine common faults:

- Auxiliary Warning
- High Engine Temperature Shutdown
- High Engine Temperature Warning
- Low Water Temperature Warning
- Low Fuel Warning
- Low Oil Pressure Shutdown
- Low Oil Pressure Warning
- Overcrank Shutdown
- Overspeed Shutdown

Terminal 32A provides the following five common faults:

- Auxiliary Warning
- Emergency Stop
- High Engine Temperature Shutdown
- Low Oil Pressure Shutdown
- Overspeed Shutdown

Communication Status. The RSA is shipped from the factory preset as a master device. The generator set controller is a slave device. Additional RSA devices on the same network must be reset in the field as slave devices.

- Green LED is steady on when communications is okay.
- Red LED flashes slow when no device is found on master and slave.
- Red LED flashes fast on master and slow on slave if communication is lost with generator set controller after communication was initially established.
- Red LED on the slave flashes slow when communication is lost between master and slave. The master does not change.

Emergency Power System (EPS) Supplying Load. Yellow LED is steady on when the generator set is supplying more than 5% of standby output current (550 controller) or when transfer switch is in the emergency position (16-light controller).

Emergency Stop. Red LED flashes slow and engine stops when emergency stop is made. May require an (optional) local emergency stop switch on some 16-light controllers.

Generator Running. Green LED is steady on when generator set is in operation. See System Ready note.

(Generator Switch) Not-In-Auto. Red LED flashes fast when generator set master switch is in the RUN or OFF/RESET position.

High Engine Temperature.

- Red LED flashes slow when engine has shut down because of high engine coolant temperature.
- Yellow LED flashes slow when engine coolant temperature approaches shutdown range. Requires warning sender on some generator set models.

Low Coolant Level. Red LED flashes slow when engine coolant level is below acceptable range on radiator-mounted generator sets only.

Low Coolant Temperature. Yellow LED flashes slow when optional engine block heater malfunctions and/or engine coolant temperature is too low. Requires prealarm sender on some generator set models.

Low Fuel. Yellow LED flashes slow when level in diesel fuel tank approaches empty or low pressure occurs with gas fuels. Requires customer-supplied level or pressure switch on some generator set models.

Low Oil Pressure.

- Red LED flashes slow when set shuts down because of insufficient oil pressure.
- Yellow LED flashes slow when engine oil pressure approaches shutdown range. Requires warning sender on some generator set models.

Overcrank. Red LED flashes slow and cranking stops when engine does not start in either continuous cranking or cyclic cranking modes.

Overspeed. Red LED flashes slow when engine shuts down because of an overspeed condition.

System Ready.

- Green LED is steady on when generator set master switch is in AUTO position and the system senses no faults.
- Red LED flashes slow when a system fault occurs.

Note: A System Ready red LED and/or a Generator Running LED off, without an associated LED shutdown indication on the RSA, may represent a generator set fault initiated by the engine ECM fault detection.

User Digital Inputs #1, #2, and #3. Monitors three digital inputs (status, warnings, and/or shutdowns). A separate red LED flashes slow for each input when a fault occurs or the status changes.

Note: User-defined digital inputs #1 and #2 are selected at the RSA master only and annunciated to the RSA slave(s). No user-defined digital input selection is available at the RSA slave(s).

16-Light Controller. User-defined digital input #1 and #2 are selected via the RSA master DIP switches for local or remote. User-defined digital inputs #1 and #2 tied directly to the RSA master are considered local. User-defined digital inputs #1 and #2 connected to the controller communication module board are considered remote. User-defined digital input #3 is reserved for high battery voltage and requires battery charger with alarms.

550 Controller. User-defined digital inputs #1 and #2 are selected via the RSA master DIP switches for local or remote. Input #3 is remote use only. When local, user-defined digital inputs #1 and #2 are tied directly to the RSA master. When remote, they are tied to controller digital inputs (D7, D8, and D10).

Figure 6 (16-light controller) and Figure 7 (550 controller) show the status of the system ready LED, generator running LED, communication status LED, common fault LED, common fault output, and horn for each fault or status condition.

Mounting

Flush- or Surface-Mounting Capability. This instruction includes installation information for both flush- and surface-mount models.

Fault and Status Condition	Fault LED	System Monitoring LEDs and Functions					
		System Ready LED	Generator Running LED	Communication Status LED	Common Fault LED	Common Fault Output	Horn
Overcrank Shutdown	Red	Red SF	Off	Green	Red SF	On	On
High Engine Temperature Warning *	Yellow	Red SF	Green	Green	Red SF	On	On
High Engine Temperature Shutdown	Red	Red SF	Off	Green	Red SF	On	On
Low Oil Pressure Warning *	Yellow	Red SF	Green	Green	Red SF	On	On
Low Oil Pressure Shutdown	Red	Red SF	Off	Green	Red SF	On	On
Overspeed Shutdown	Red	Red SF	Off	Green	Red SF	On	On
Emergency Stop *	Red	Red SF	Off	Green	Off	On	On
Low Coolant Level *	Red	Red SF	Off	Green	Red SF	On	On
Low Coolant Temperature *	Yellow	Red SF	Off	Green	Red SF	On	On
Low Fuel—Level or Pressure *	Yellow	Red SF	Off	Green	Red SF	On	On
EPS Supplying Load (RSA)	Yellow	Green	Green or Off	Green	Off	Off	Off
System Ready	Green	Green	Green or Off	Green	Off	Off	Off
System Not Ready	Red	Red SF	Green or Off	Green	Off	On	On
No Device at Powerup	Red	Off	Off	Red SF	Off	On	On
Loss of Controller Communication (Master RSA)	Red	Off	Off	Red FF	Off	On	On
Loss of Controller Communication (Slave RSA)	Red	Off	Off	Red SF	Off	On	On
Not-In-Auto	Red	Red SF	Green or Off	Green	Red SF	On	On
Battery Charger Fault *	Yellow	Green	Green or Off	Green	Off	On	On
High Battery Voltage (HBV) (see User Input #3)	—	—	—	—	—	—	—
Low Battery Voltage *	Yellow	Green	Green or Off	Green	Off	Off	Off
User Input #1 (RSA)	Red	Green	Green or Off	Green	Off	On	On
User Input #2 (RSA)	Red	Green	Green or Off	Green	Off	On	On
User Input #3 (reserved for HBV) *	Yellow	Green	Green or Off	Green	Off	Off	Off
User Input #1 (16-Light Controller Communication Module)	Red	Green	Green or Off	Green	Off	On	On
User Input #2 (16-Light Controller Communication Module)	Red	Green	Green or Off	Green	Off	On	On
Common Fault	Red	Green	Green or Off	Green	Red SF	On	On

SF = Slow Flash, FF = Fast Flash
 * May require optional kit or user-provided device to enable function and LED indication.

Figure 6 System Monitoring LEDs and Functions (16-Light Controller)

Fault and Status Condition	Fault LED	System Monitoring LEDs and Functions					
		System Ready LED	Generator Running LED	Communication Status LED	Common Fault LED	Common Fault Output	Horn
Overcrank Shutdown	Red	Red SF	Off	Green	Off	On	On
High Engine Temperature Warning	Yellow	Red SF	Green	Green	Off	On	On
High Engine Temperature Shutdown	Red	Red SF	Off	Green	Off	On	On
Low Oil Pressure Warning	Yellow	Red SF	Green	Green	Off	On	On
Low Oil Pressure Shutdown	Red	Red SF	Off	Green	Off	On	On
Overspeed Shutdown	Red	Red SF	Off	Green	Off	On	On
Emergency Stop	Red	Red SF	Off	Green	Off	On	On
Low Coolant Level	Red	Red SF	Off	Green	Off	On	On
Low Coolant Temperature	Yellow	Red SF	Off	Green	Off	On	On
Low Fuel—Level or Pressure *	Yellow	Red SF	Green	Green	Off	On	On
EPS Supplying Load (550 Controller)	Yellow	Green	Green	Green	Off	Off	Off
EPS Supplying Load (RSA)	Yellow	Green	Green or Off	Green	Off	Off	Off
System Ready	Green	Green	Green or Off	Green	Off	Off	Off
System Not Ready	Red	Red SF	Green or Off	Green	Off	On	On
No Device at Powerup	Red	Off	Off	Red SF	Off	On	On
Loss of Controller Communication (Master RSA)	Red	Off	Off	Red FF	Off	On	On
Loss of Controller Communication (Slave RSA)	Red	Off	Off	Red SF	Off	On	On
Not-In-Auto	Red	Red SF	Green or Off	Green	Off	On	On
Battery Charger Fault *	Yellow	Red SF	Green or Off	Green	Off	On	On
High Battery Voltage	Yellow	Green	Green or Off	Green	Off	Off	Off
Low Battery Voltage	Yellow	Green	Green or Off	Green	Off	Off	Off
User Input #1 (RSA)	Red	Green	Green or Off	Green	Off	On	On
User Input #2 (RSA)	Red	Green	Green or Off	Green	Off	On	On
User Input #1 (550 Controller)	Red	Red SF	Green or Off	Green	Off	On	On
User Input #2 (550 Controller)	Red	Red SF	Green or Off	Green	Off	On	On
User Input #3 (550 Controller)	Red	Red SF	Green or Off	Green	Off	On	On
Common Fault	Red	Green	Green or Off	Green	Red SF	On	On

SF = Slow Flash, FF = Fast Flash
* May require optional kit or user-provided device to enable function and LED indication.

Figure 7 System Monitoring LEDs and Functions (550 Controller)

Safety Precautions

Observe the following safety precautions while installing the kit.

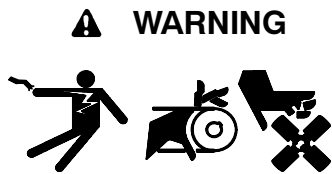

Accidental starting. Can cause severe injury or death.

Disconnect the battery cables before working on the generator set. Remove the negative (-) lead first when disconnecting the battery. Reconnect the negative (-) lead last when reconnecting the battery.

Disabling the generator set. Accidental starting can cause severe injury or death. Before working on the generator set or connected equipment, disable the generator set as follows: (1) Move the generator set master switch to the OFF position. (2) Disconnect the power to the battery charger. (3) Remove the battery cables, negative (-) lead first. Reconnect the negative (-) lead last when reconnecting the battery. Follow these precautions to prevent starting of the generator set by an automatic transfer switch, remote start/stop switch, or engine start command from a remote computer.

Read the entire installation procedure and compare kit parts with parts list in this publication before beginning installation. Perform the steps in the order shown.

Note: Observe applicable local and national electrical codes when installing the wiring system.

NOTICE

Electrostatic discharge damage. Electrostatic discharge (ESD) damages electronic circuit boards. Prevent electrostatic discharge damage by wearing an approved grounding wrist strap when handling electronic circuit boards or integrated circuits. An approved grounding wrist strap provides a high resistance (about 1 megohm), *not a direct short*, to ground.

Installation Procedure

1. Remove the generator set from service.

- 1.1 Place the generator set master switch in the OFF/RESET position.
- 1.2 Disconnect the power to the battery charger, if equipped.
- 1.3 Disconnect the generator set engine starting battery(ies), negative (-) lead first.
- 1.4 Remove the controller cover and hardware.

2. Mount and wire the communication module board in the 16-light controller.

Note: Requires 16-light controller logic board GM28725. Perform step 2 with GM34474-KP1/-KP1S kit when ordered *shipped loose*, GM34474-KP2/-KP2S kit, and GM32644-KP1 kit only. If GM34474-KP1/-KP1S kit was ordered *installed*, skip step 2 and go to step 3.

Note: Perform step 2 with GM34474-KP2/-KP2S and GM32644-KP1 kits only. When installing GM34474-KP1/-KP1S kits, skip step 2 and go to step 3.

- 2.1 Connect new 24-position ribbon cable GM32632 to the indicator panel circuit board. See Figure 8. The new ribbon cable has three connectors—one at each end and an inline connector. Attach the end connector (nearest to inline connector) to the indicator panel circuit board. The connectors are polarized and attach in one position only. All ribbon connectors shown in Figure 8 are included in the communication module kit.

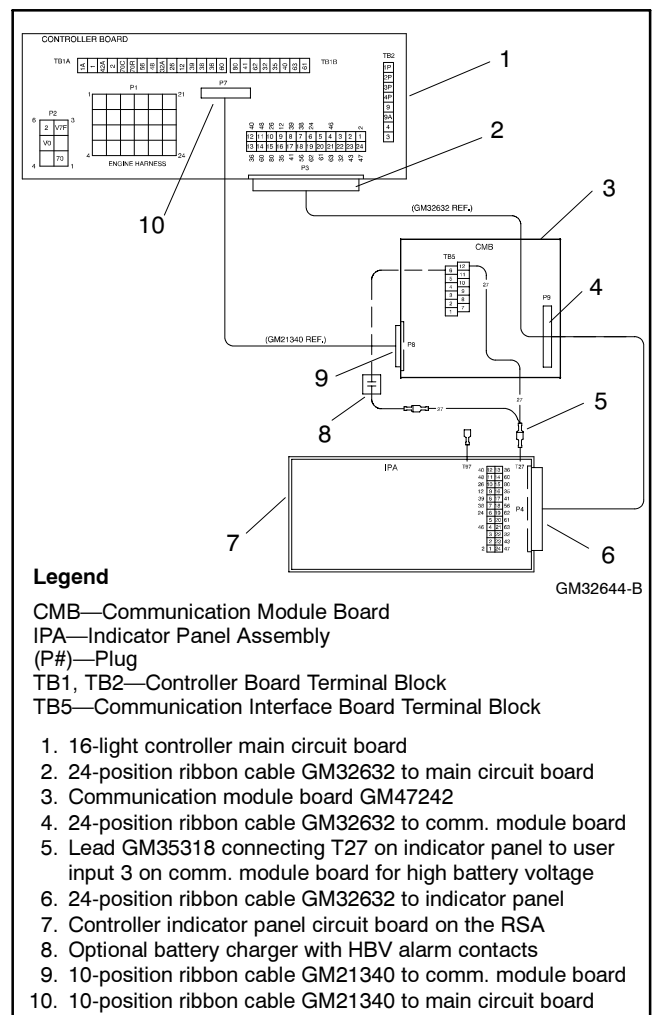

Figure 8 Communication Module Electrical Connections, 16-Light Controller

- 2.2 Remove the existing three nuts attaching the indicator panel circuit board. Leave the existing washers in place. The nuts will be reused.
- 2.3 Attach the three spacers to the indicator panel circuit board studs. See Figure 9.
- 2.4 Remove the existing 24-position ribbon cable 336428 between the indicator panel circuit board and the main circuit board. See Figure 9. This ribbon cable will not be reused.

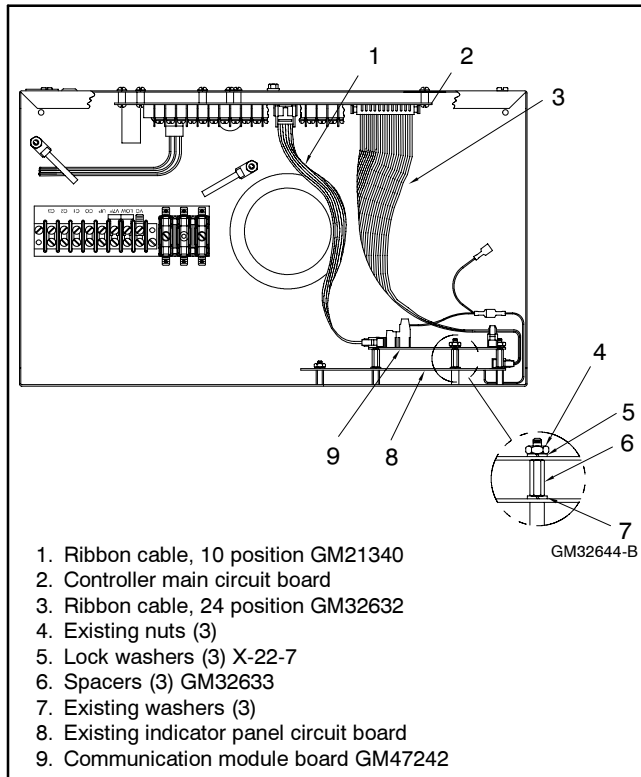

Figure 9 Mounting Communication Module in 16-Light Controller

- 2.5 Position communication module board GM47242 on the spacers.
- 2.6 Install three lock washers X-22-7 and the existing three nuts on the spacers to secure the communication module board. Do not overtighten the nuts.
- 2.7 Attach the 24-position ribbon cable GM32632 inline connector to the communication module board. Attach the remaining end connector to the main circuit board. The connectors are polarized and attach in one position only.

- 2.8 Attach the 10-position ribbon cable GM21340 to the communication module board and the main circuit board.
- 2.9 **High Battery Voltage.** Locate T27 lead on the indicator panel assembly and connect the communication board HBV harness GM35318. Use the terminal connector on GM35318 with the two leads together. Verify that the stripped end of the harness is securely connected to communication module board terminal TB5-12. See Figure 8 for an illustration of the wiring connection. See Figure 10 and Figure 11 for the communication module board terminal strip location and terminal designations.

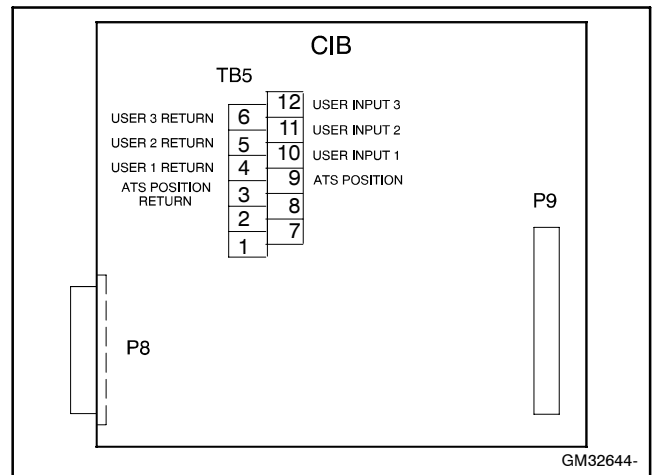

Figure 10 Communication Module

Connector Designation	Circuit Board Designation
1	Not used
2	Not used
3	ATS Position Input Return
4	User 1 Input Return
5	User 2 Input Return
6	User 3 Input Return
7	Not used
8	Not used
9	ATS Position Input
10	User 1 Input
11	User 2 Input
12	User 3 Input

Figure 11 Communication Module TB5 Terminal Strip Connections

2.10 Connect wiring from the user-supplied battery charger high battery voltage contacts to the remaining terminal on harness GM35318 and TB5-6 for RSA annunciation of *(high) Battery Voltage*. See Figure 12 for wire sizes.

Length, m (ft.)	Wire Gauge
0-137 (0-450)	22
137-213 (450-700)	20
213-343 (700-1125)	18
343-549 (1125-1800)	16
549-853 (1800-2800)	14

Figure 12 Wire Specifications for Communication Module Connections

2.11 **EPS Supplying Load.** Connect wiring from the user-supplied transfer switch (ATS) emergency position auxiliary contacts to terminals TB5-3 and TB5-9 for RSA annunciation of *EPS Supplying Load*. See Figure 12 for wire sizes.

2.12 **User Input 1 and User Input 2.** Make additional user-selected connections to the communication module board TB5 terminal block. See Figure 12 for wire sizes. The user-selected connections are defined in Figure 11 and include:

- User Input 1 (remote).
- User Input 2 (remote).

Note: User input 3 is reserved for high battery voltage as outlined in step 2.9.

Document the user-selected inputs for future reference. If user-selected inputs 1-2 (remote) are used, the user may add the identification on the RSA front panel strip. This procedure is further explained in step 4.11 of this instruction.

3. Select a mounting location for the RSA (GM34474-KP1/-KP1S and GM34474-KP2/-KP2S kits only).

Note: Use step 3 for mounting the RSA master and the RSA slaves as needed. The recommended maximum total is three RSA slaves. The RSA wiring information is covered in step 4.

3.1 Select a visible location for mounting the RSA up to 853 m (2800 ft.) from the controller. Install the RSA, either surface- or flush-mounted, in a location easily observable by operating personnel at their work stations. See Figure 13 for RSA overall dimensions.

Note: Locate all RSAs within 853 m (2800 ft.) of the controller.

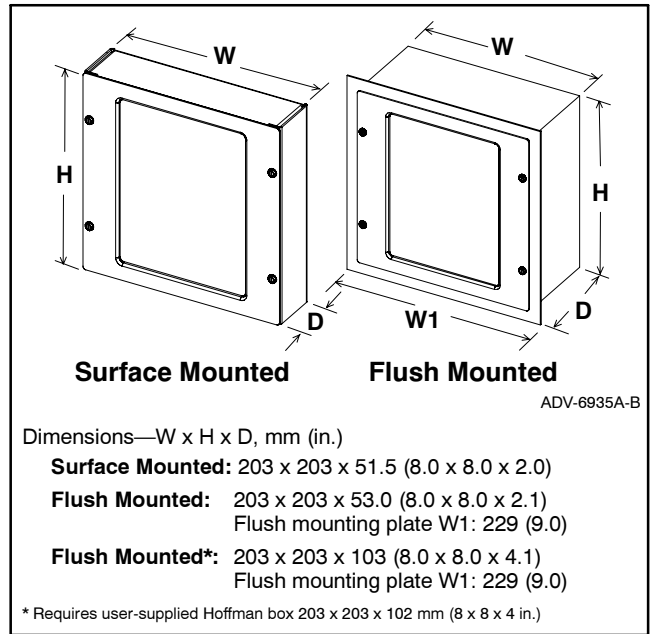

Figure 13 RSA Box Dimensions

3.2 Remove four screws X-67-154 from the RSA front panel assembly GM34433-1 or GM34433-2. Detach the RSA front panel from the box by removing whiz nut X-6210-1, flat washer X-25-36, and ground wire LK-1212-1414 at the front panel cover; see Figure 14.

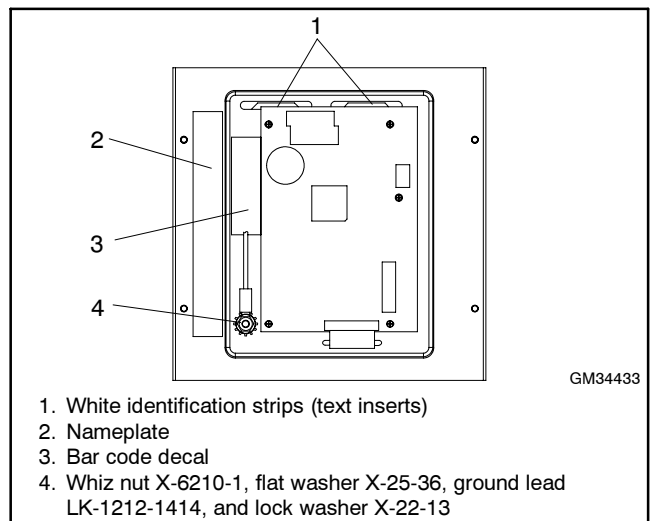

Figure 14 RSA Front Panel Assembly Ground Connection (Back View)

See Figure 15 for RSA supplied box mounting hole information.

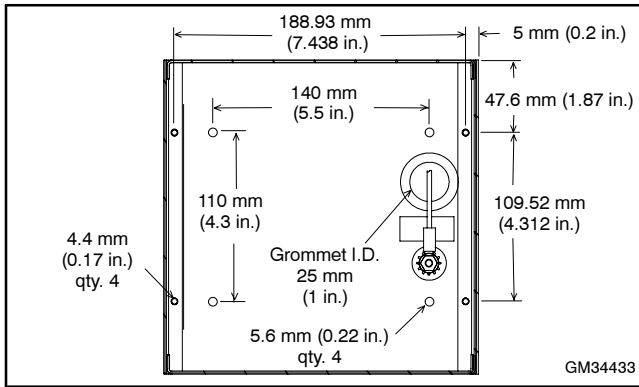

Figure 15 RSA Mounting Hole Dimensions in Supplied Box GM31884

The installation instructions describe three RSA mounting scenarios:

- Surface-mount with supplied box (step 3.3).
- Flush-mount using supplied box (step 3.4).
- Flush-mount using a user-supplied Hoffman box (step 3.5).

3.3 Surface-mount RSA initial installation.

3.3.1 Prepare the mounting site by drilling pilot holes for anchors, if used.

Note: Mount the RSA box to a standard 10 cm (4 in.) square electrical box installed in the wall.

3.3.2 Create an opening in the wall for the electrical wiring from the master RSA to the controller communications and power supply. The wall opening must allow for the wiring of the RSA slave, if used. Protect the RSA front panel assembly from dust and debris when drilling the holes.

3.3.3 Remove bushing X-634-15 from box GM31884 if a user-supplied conduit connector is required. Install the user-supplied connector.

3.3.4 Temporarily mount the RSA box to the wall or to the electrical box in the wall and check for proper hole alignment. Adjust as needed. Remove RSA box.

Note: Use mounting hardware suitable for the wall composition and thickness.

3.3.5 Repeat step 3 for the RSA slaves, as needed.

3.3.6 Proceed to step 4, Wire the RSA.

3.4 Flush-mount RSA initial installation with supplied box GM31884.

3.4.1 Prepare mounting site by creating an opening in wall for flush mounting RSA box.

3.4.2 Remove bushing X-634-15 from box GM31884 if a user-supplied conduit connector is required. Install the user-supplied connector.

Size the flexible conduit for the electrical wiring from master RSA to the controller communications and power supply. The flexible conduit size must allow for the wiring of a RSA slave, if used.

3.4.3 Attach the RSA box to the wall with user-supplied hardware. Protect the RSA front panel assembly from dust and debris when drilling the mounting holes.

3.4.4 Repeat step 3 for the RSA slaves, as needed.

3.4.5 Proceed to step 4, Wire the RSA.

3.5 Flush-mount RSA initial installation with a user-supplied Hoffman box.

- 3.5.1 Prepare the mounting site by creating an opening in the wall for flush mounting the RSA using a user-supplied 203 x 203 x 102 mm (8 x 8 x 4 in.) Hoffman box (part no. A-SG8X8X4) or equivalent.
- 3.5.2 Use wall mounting plate GM33031 as a template and drill four 4.4 mm (0.17 in.) diameter holes in the Hoffman box front edge for mounting the RSA front panel assembly if not already done. See Figure 16.

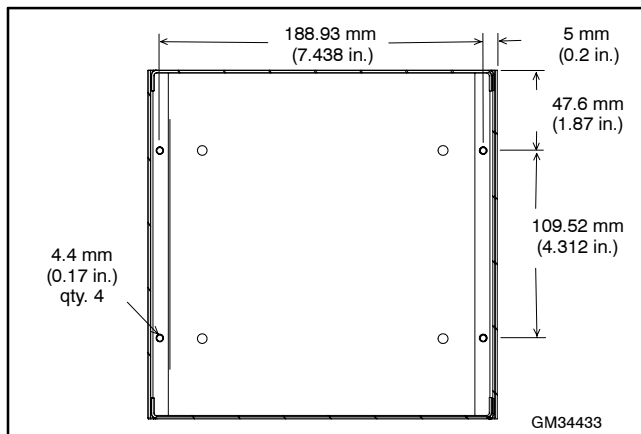

Figure 16 Drilling Mounting Holes in Hoffman Box for RSA Front Panel Assembly

- 3.5.3 Remove the ground wire and hardware from box GM31884 and install the ground wire and hardware in the Hoffman box. See Figure 15 for recommended location. Substitute user-supplied ground wire and hardware as needed. Temporarily install the RSA front panel assembly to be sure the ground wire location does not interfere with attaching the RSA front panel assembly.
- 3.5.4 Select a location on the box and install a user-supplied conduit connector or bushing. Temporarily install the RSA front panel assembly to be sure the hole location with bushing or conduit connector does not interfere with attaching the RSA front panel assembly.

Size the flexible conduit for the electrical wiring from the master RSA to the controller communications and power supply. The flexible conduit size must allow for the wiring of the RSA slave, if used.

- 3.5.5 Attach the RSA box to the wall with user-supplied hardware. Protect the RSA front panel assembly from dust and debris when drilling the mounting holes.
- 3.5.6 Repeat step 3 for the RSA slaves, as needed.
- 3.5.7 Proceed to step 4, Wiring the RSA.

4. Wire the RSA (GM34474-KP1/-KP1S and GM34474-KP2/-KP2S kits only).

The installer must supply all leads. Observe the following guidelines during installation:

- Ground the RSA box to the building electrical system.
- Isolate the RSA leads from all other voltages.
- Use separate conduit.
- Use grounded metallic conduit for leads or use shielded cable in nonmetallic conduit.
- Use color-coded wire for easy identification.
- Make leads long enough to allow for walls, ductwork, and obstructions.

Use solid or stranded 14-22 gauge wire. To determine the wire gauge, measure the cable distance between the controller and master RSA. For example, if the cable distance between the controller and the master RSA is 122 m (400 ft.), then the total wire length for each conductor is 122 m (400 ft.). According to the chart in Figure 17, this example requires 22-gauge wire.

Length, m (ft.)	Wire Gauge
0-137 (0-450)	22
137-213 (450-700)	20
213-343 (700-1125)	18
343-549 (1125-1800)	16
549-853 (1800-2800)	14

Figure 17 Wire Specifications between RSA and Generator Set Controller

Throughout step 4, refer to the following illustrations. See Figure 18 for RSA circuit board terminal strips. See Figure 19 for RSA circuit board terminal connections and DIP switch selections. See Figure 37 for the RSA wiring diagram and Figure 38 and Figure 39 for the RSA interconnection diagram.

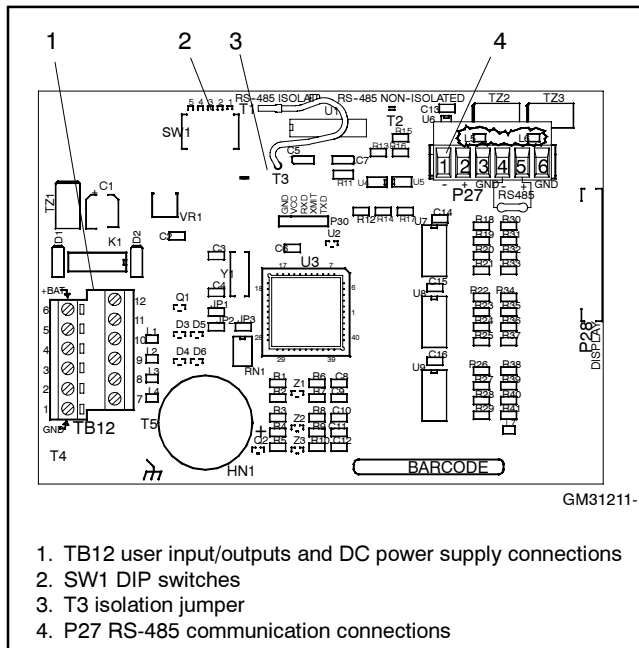

Figure 18 RSA Circuit Board

The RSA has the following wiring and selections:

- Ground wire (see step 4.3).
- DC power supply (see step 4.4).
- P27 RS-485 communication between controller and RSA master (see step 4.5).
- P27 RS-485 communication between RSA master and RSA slaves (see step 4.6).
- TB12 user input/output selections (see step 4.7).
- SW1 DIP switch positions (see step 4.9).
- T3 isolated or non-isolated RS-485 (see step 4.10).

4.1 Deenergize the RSA(s) 12-/24-volt DC power source, if not already done.

4.2 **Flush-mount RSA only.** When using a flush-mount RSA box with a bushing, it is recommended to run all wiring to the RSA box and then mount it to the wall or to the electrical box in the wall. Check that box is square to the wall; adjust as needed. After the RSA box is mounted, make the individual electrical connections to the RSA circuit board as described in the following steps.

Position the wall mounting plate GM33031 against RSA front panel assembly GM34433-1 or GM34433-2 prior to attaching the wiring.

TB12 Input/Output Connections	
TB12-1	User Input 2 return
TB12-2	User Input 1 return
TB12-3	Local ATS emergency on input return
TB12-4	Local common fault input return
TB12-5	Battery/DC power supply negative input
TB12-6	Battery/DC power supply positive input
TB12-7	User input 2
TB12-8	User input 1
TB12-9	Local ATS emergency on input
TB12-10	Local common fault input
TB12-11	Annunciator common fault relay normally open output
TB12-12	Annunciator common fault relay common output
SW1 DIP Switches (On = Closed and Off = Open)	
SW1-1	Local ATS (On is local)
SW1-2	User input 1 (On is local)
SW1-3	User input 2 (On is local)
SW1-4	Master/Slave (On is master)
SW1-5	Off for controller/On for Ethernet converter
T3 Isolation Jumper Connections	
T3 to T1	Isolated RS-485 (default setting)
T3 to T2	Non-isolated RS-485
P27 RS-485 Connections (Master)	
P27-1	(-) Black (from controller)
P27-2	(+) White (from controller)
P27-3	Shield (from controller)
P27-4	(-) Black (to slave or terminating resistor)
P27-5	(+) White (to slave or terminating resistor)
P27-6	Shield (to slave or open)
P27 RS-485 Connections (Slave)	
P27-1	(-) Black (from master or previous slave)
P27-2	(+) White (from master or previous slave)
P27-3	Shield (from master or previous slave)
P27-4	(-) Black (to next slave or terminating resistor)
P27-5	(+) White (to next slave or terminating resistor)
P27-6	Shield (to next slave or open)

Figure 19 RSA Circuit Board Terminal Connections and DIP Switch Selections

- 4.3 Attach the mounting box ground wire to the RSA front panel assembly stud by installing lock washer X-22-13, ground wire, flat washer X-25-38, and whiz nut X-6210-1. See Figure 20.

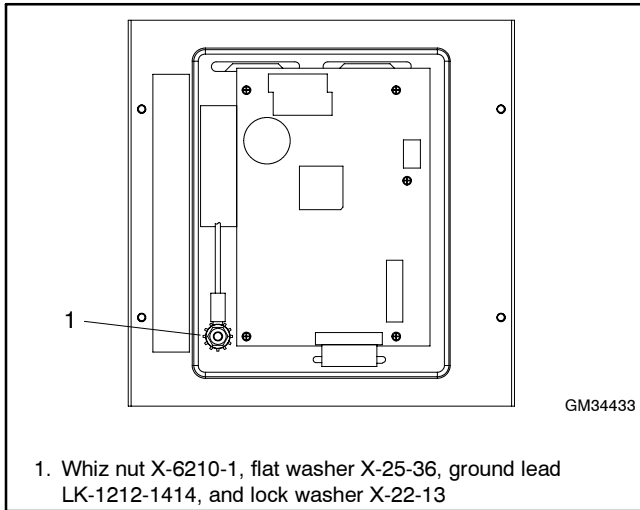

Figure 20 RSA Front Panel Assembly Ground Connection (Back View of Front Panel)

- 4.4 Each RSA requires a 12-/24-volt, 200 mA DC power source. The RSA voltage should match the generator set starting system. This power source can be from the generator set battery or an AC adapter. When RSA slaves are connected, the installer must determine whether generator set battery power, individual AC adapters, or a single AC adapter sized for all RSAs is most practical.

When the power source is the starting battery(ies), attach to the battery positive (+) connection at the starter solenoid and the battery negative (-) connection at the engine ground. Do not use terminals 42A and 2 on the controller connection kit terminal strip.

After determining the type of power supply, select and connect the wiring to each RSA. The circuit must include fuse or circuit breaker protection and

an independent circuit disconnect. Keep the power source deenergized at this time. Connect DC positive lead to TB12-6 and DC negative lead to TB12-5.

- 4.5 Select and connect the RS-485 wiring from the controller to the RSA master using Belden #9841 or equivalent. If there is only one RSA, it is the master. If several RSAs are installed, choose either the RSA closest to the generator set or determine which RSA is more practical for use as a master and use a daisy chain wiring configuration for the remaining RSAs. The RSA connected to the controller MUST be assigned as the RSA master.

Connect RS-485 wiring to the included 6-position Euroblock plug 294619 and attach to the RSA circuit board. The Euroblock connector is polarized and attaches in one position only. See Figure 21 for a typical RS-485 connection.

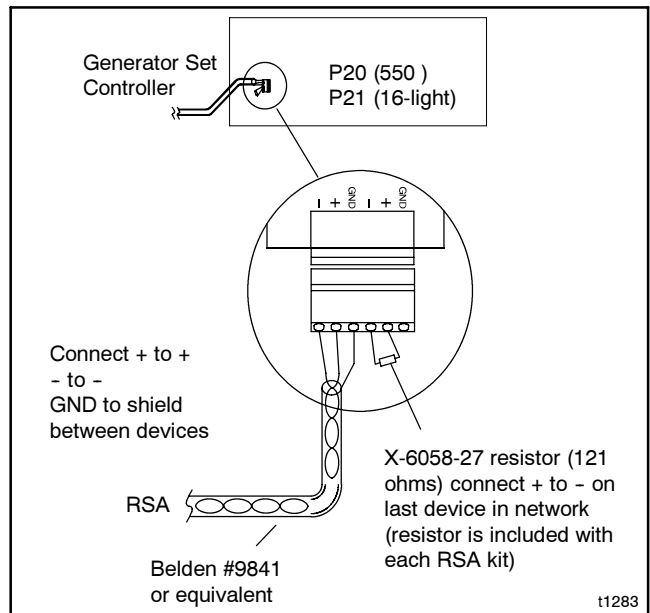

Figure 21 RS-485 Connector Details

16-Light Controller. Figure 22 shows the 16-light controller with P21 location and Figure 23 shows the RS-485 connections.

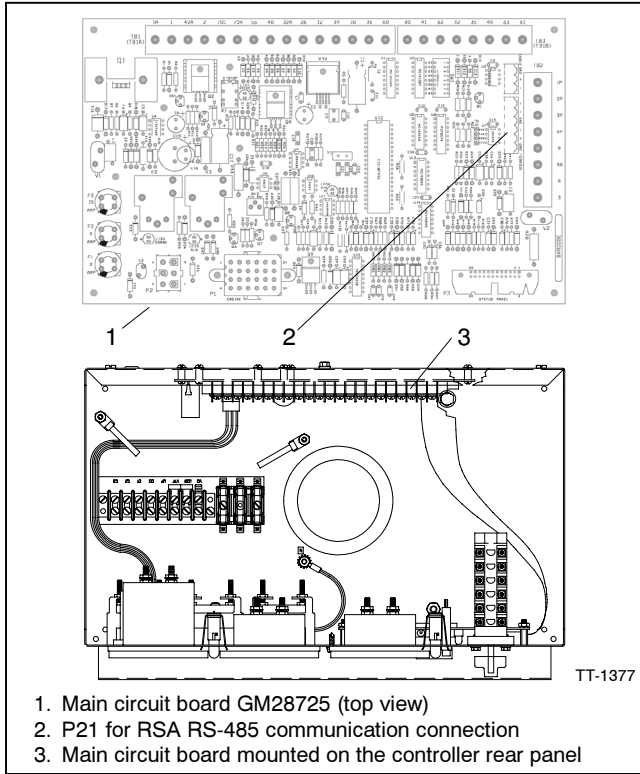

Figure 22 16-Light Controller RS-485 Connections

Circuit Board Designation	Connector Designation	Wire Designation
-	1	Black
+	2	White
GND	3	Shield

Figure 23 16-Light Controller P21 RS-485 Connections

550 Controller. Figure 24 shows the 550 controller with P20 location and Figure 25 shows the RS-485 connections.

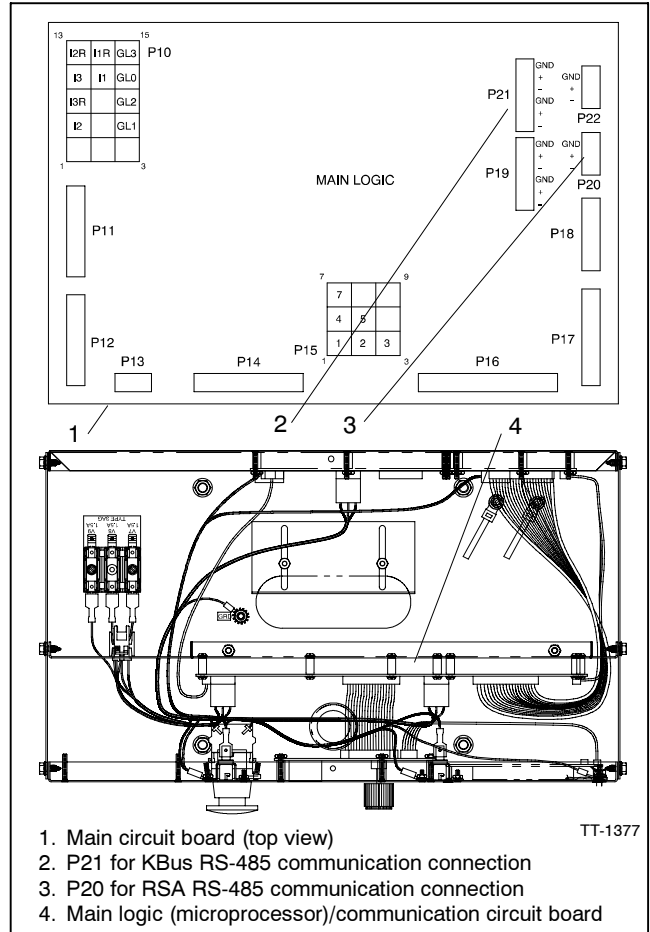

Figure 24 550 Controller RS-485 Connections

Circuit Board Designation	Connector Designation	Wire Designation
GND	1	Shield
+	2	White
-	3	Black

Figure 25 550 Controller P20 RS-485 Connections

RSA Master. Figure 26 shows the master/slave RS-485 connections and Figure 27 shows the RSA with P27 location.

Master/Slave Terminals	Circuit Board Designation	Connector Designation	Wire Designation
Master	-	1	Black
	+	2	White
	GND	3	Shield
Slave	-	4	Black
	+	5	White
	GND	6	Shield

Figure 26 P27 Connection on RSA via RS-485

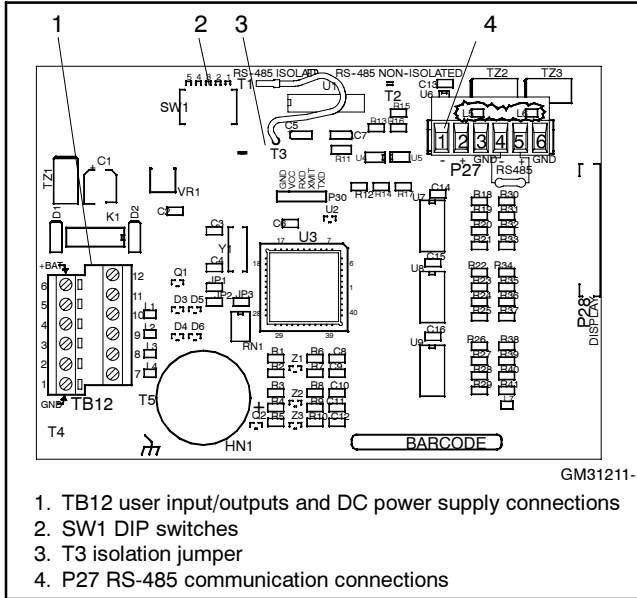

Figure 27 RSA Circuit Board

4.6 Select and connect the RS-485 wiring from the RSA master to the RSA slave(s) in a daisy chain wiring configuration using Belden #9841 or equivalent. Figure 26 shows the master/slave RS-485 connections and Figure 27 shows the RSA with P27 location. See Figure 37 for additional information regarding master/slave RSAs.

Connect the RS-485 wiring to the included 6-position Euroblock plug 294619 and plug into the RSA circuit board. The Euroblock connector is polarized and attaches in one position only.

Each RSA is shipped with a terminating 121 ohm resistor connected to P27 terminals 4 and 5. Determine the need of the resistor based on the following three applications.

RSA Master only. Verify that the terminating 121 ohm resistor is connected to P27 terminals 4 and 5 on the RSA master.

RSA Master with up to three RSA Slaves. Verify that the terminating 121 ohm resistor is connected to P27 terminals 4 and 5 on the last RSA slave in the daisy chain connection. Remove the 121-ohm resistor connected to P27 terminals 4 and 5 on the RSA master and all RSA slaves except the last RSA slave.

RSA Master with more than three RSA Slaves. Connect the terminating 121 ohm resistor in series with a 0.1 MFD, 50-volt capacitor, part no. GM28875-1 (not supplied) to P27 terminals 4 and 5 on the last RSA slave in the daisy chain connection. Remove the 121 ohm resistor connected to P27 terminals 4 and 5 on the RSA master and all RSA slaves except last RSA slave.

4.7 Make any additional *local* user-selected connections to the RSA TB12 terminal block. User-defined inputs can be used for any status, warning, or shutdown including open circuit breaker, air damper, etc. The user-selection connections are defined in Figure 28 and include:

- User Input 1 (local).
- User Input 2 (local).
- ATS emergency input (local). Connect wiring from the user-supplied transfer switch (ATS) emergency position auxiliary contacts 10-11. See Figure 29.
- Local common fault input.
- Annunciator common fault relay output.

Note: User-defined digital inputs #1 and #2 are selected at the RSA master only and annunciated to the RSA slave(s). No user-defined digital input selection is available at the RSA slave(s).

RSA Function	Optional Connections		
	RSA (Local)	550 (Remote)	16-Light (Remote)
User input 1	TB12-8 user-selectable	TB4-7 (D7) user-selectable using Menu 9	TB5-10 on communication module, user-selectable
	TB12-2 (ground)	TB4-28 (ground)	TB5-4 (ground)
User input 2	TB12-7 user-selectable	TB4-8 (D8) user-selectable using Menu 9	TB5-11 on communication module, user-selectable
	TB12-1 (ground)	TB4-29 (ground)	TB5-5 (ground)
User input 3	Remote only	TB4-10 (D10) user-selectable using Menu 9	Reserved for high battery voltage on communication module
		TB4-31 (ground)	
Local ATS emergency on input	ATS auxiliary contact 10 to TB12-9	via RSA/550 communication link	ATS auxiliary contact 10 to TB5-9 on communication module
	ATS auxiliary contact 11 to TB12-3 (ground)	via RSA/550 communication link	ATS auxiliary contact 11 to TB5-3 on communication module
Local common fault input	TB12-10	TB8-RDO18	TB1-32 or TB1-32A
	TB12-4 (ground)	TB8-GND (ground)	TB1-2 (ground)
Annunciator common fault relay output	TB12-11 (N.O. contact)	Audiovisual alarm kit or user-supplied device	Audiovisual alarm kit or user-supplied device
	TB12-12 (common contact)	Audiovisual alarm kit or user-supplied device	Audiovisual alarm kit or user-supplied device

Figure 28 RSA Local TB12 Input/Output Connections

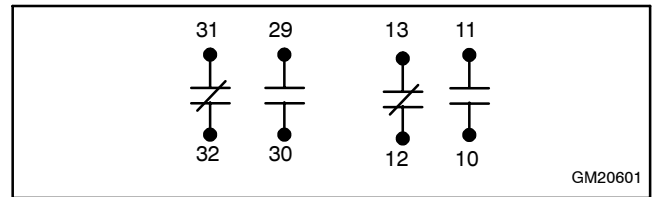

Figure 29 Auxiliary Contacts 10-13 and 29-32 (shown with contactor contacts in normal position)

4.8 **550 Controller only.** The RSA user inputs 1-3, when in the remote connection, are tied to the 550 controller digital inputs. See Figure 30.

RSA User Inputs (Remote)	Tied to 550 Controller Digital Inputs
1	D7
2	D8
3	D10

Figure 30 RSA Remote User Inputs with 550 Controller

If required, the user-input selection tied to digital inputs D7, D8, and/or D10 can be changed using the 550 Controller Menu 9, Input Setup. Refer to the 550 controller operation manual, TP-6200 or MP-6200, for instructions.

Document the user-selected inputs for future reference. If user-selected inputs 1-3 (remote) are used, the user may add the identification on the RSA front panel strip. This procedure is further explained in step 4.11 of this instruction.

4.9 Set the SW1 DIP switches on the RSA master and subsequent RSA slave (if used). See Figure 31. The RSA connected to the controller **MUST** be assigned as the RSA master. See Figure 32 for a summary of the EPS Supplying Load (ATS) annunciation sources depending upon DIP switch position.

SW1 DIP Switches (On = Closed and Off = Open)	
SW1-1	Local ATS (On is local)
SW1-2	User input 1 (On is local)
SW1-3	User input 2 (On is local)
SW1-4	Master/Slave (On is master)
SW1-5	Off for controller/On for Ethernet converter

Figure 31 RSA DIP Switch Selections

RSA SW1 Position	16-Light Controller	550 Controller
Local (hard wired)	RSA connection to the ATS	
Remote (RS-485)	Communication module board connection to ATS	550 controller connection to ATS

Figure 32 EPS Supplying Load (ATS) Annunciation Sources

When SW1-1 is OFF, the generator set controller activates the EPS Supplying Load LED. When SW1-1 is ON (local), transfer switch activates LED.

Note: When SW1-4 is in the slave position, DIP switches SW1-1, SW1-2, and SW1-3 are not functional as the RSA master annunciates the RSA slaves.

Select SW1-5 DIP switch Off for high speed mode for direct connection to the 550 controller. Select On for lower speed for network connection with the Modbus®/Ethernet converter. The lower speed allows network functionality reducing loss of communication faults.

- 4.10 In most situations, the T3 isolation jumper should be connected to T3 and T1 (isolated position) on the RSA master and slave. This configuration provides the generator set controller with the best protection against damage from stray voltage without using additional devices.

If the generator set controller has an **isolation kit installed**, the RSA master should have the T3 isolation jumper connected to T3 and T2 (non-isolated position). The RSA slaves, if installed, should have the T3 isolation jumper connected to T3 and T1 (isolated position).

- 4.11 Document any local and remote user-selected inputs for future reference. If user-selected inputs 1-3 (local or remote) are used, the user may add the identification on the RSA front panel.

Remove the white identification strip and print with black non-permanent marker. See Figure 33. The user can also fill in the Generator ID Location information if needed. Allow the marker ink to dry before replacing the white identification strip.

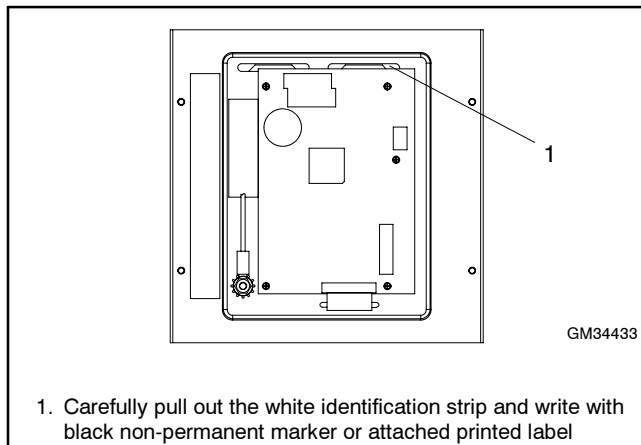

Figure 33 RSA Front Panel Assembly Identification Strips

Another method to add the information to the identification strip would be to use a PC and print the information on an adhesive label. The print font on the RSA front panel is Myriad bold 10 point. Attach the printed label(s) to the white identification strip and then insert it in the RSA front panel.

- 4.12 Replace the controller cover and hardware on the 550 controller only.

5. Complete the RSA final installation (GM34474-KP1/-KP1S and GM34474-KP2/-KP2S kits only).

Proceed to either Step 5.1, Surface-mount RSA final installation, or Step 5.2, Flush-mount RSA final installation.

5.1 Surface-mount RSA final installation.

Note: Wall mounting plate GM33031 is not used with the surface-mounted RSA.

- 5.1.1 Mount the RSA box to the wall or to the electrical box in the wall if not already done. Check that the box is square to the wall; adjust as needed.

- 5.1.2 Position the RSA front panel assembly to the surface-mount box and install the four self-tapping screws (X-67-154). Do not tighten the screws.

- 5.1.3 Center the remote annunciator in the box and square with the wall. Tighten the screws.

- 5.1.4 Proceed to step 6.

5.2 Flush-mount RSA final installation.

- 5.2.1 Place the wall mounting plate GM33031 *behind* the RSA front panel assembly flange if not already done. See Figure 34.

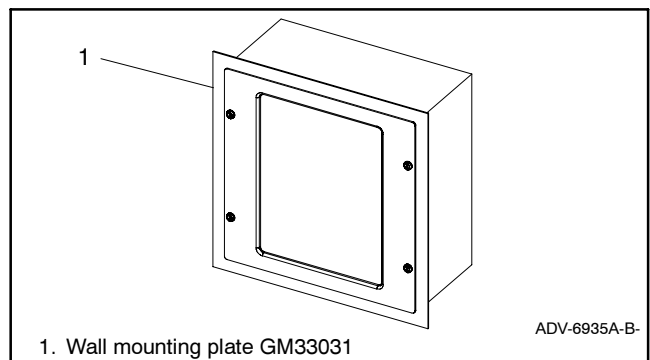

Figure 34 RSA Wall Mounting Plate

Note: The wall mounting plate can be installed behind the RSA front panel assembly flange even if RSA front panel assembly is already wired.

- 5.2.2 Align the holes of the wall mounting plate with the RSA front panel assembly to the surface-mount box and install the four self-tapping screws (X-67-154). Do not tighten the screws.
- 5.2.3 Center the remote annunciator in the box and position wall mounting plate square with the wall. Tighten the screws.
- 5.2.4 Proceed to step 6.

6. Configure the 16-light controller to the remote serial annunciator.

The RSA requires a controller with a MODBUS® address #1 and a baud rate of 19200.

Note: After setting DIP switches to the generator set application, be sure to *power down* and then *power up* the controller. Either disconnect the battery and then reconnect the battery of the generator set, use the prime power switch (if equipped), or remove and then replace the F2 controller fuse. The controller will NOT acknowledge the DIP switch change until after generator set controller is *powered up*.

- 6.1 Set the controller MODBUS® address to #1 by placing DIP switches 6, 7, and 8 to the open position. See Figure 35.

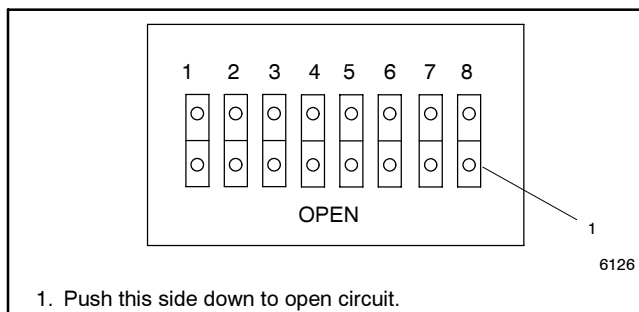

Figure 35 16-Light Controller DIP Switches

- 6.2 The 16-light controller baud rate is fixed at 19200. No change is required.
- 6.3 Replace the controller cover and hardware.
- 7. Restore the generator set to service.**
- 7.1 Check that the generator set master switch is in the OFF position.

- 7.2 Reconnect the generator set engine starting battery, negative (-) lead last.
- 7.3 Reconnect power to the battery charger, if equipped.
- 7.4 Energize the RSAs.
- 7.5 Move the generator set master switch to the AUTO position for startup by a remote transfer switch or remote start/stop switch.

- 7.6 Reset alarm horns as needed.

8. Configure the 550 controller to the remote serial annunciator.

The RSA requires a controller with a MODBUS® address #1 and a baud rate of 19200.

Note: Refer to the 550 controller operation manual, TP-6200 or MP-6200, as needed.

- 8.1 Replace the controller cover and hardware.
- 8.2 Press the Reset Menu key on the controller keypad.
- 8.3 Go to Menu 14, Programming Mode, and press the down arrow key to Programming Mode.

If Programming Mode—Local is shown, go to step 8.8.

If Programming Mode—Local is NOT shown, press the right arrow key to select Local. Press YES and the Enter key.

- 8.4 Enter the access code. The factory default access code is the number 0. Press the Enter key.
- 8.5 Press the Reset Menu key on the controller keypad.
- 8.6 Go to Menu 6, Time and Date, and set the correct time and date.
- 8.7 Press the Reset Menu key on the controller keypad.
- 8.8 Go to Menu 13, Communications, and press the right arrow key to Protocol—Modbus.
- 8.9 Set the controller MODBUS® address to #1 by pressing the down arrow key to Address. Enter number 1 and the Enter key.

8.10 Press the down arrow key to Baud Rate.

If 19200 is shown, go to step 8.12.

If 19200 is NOT shown, press the right arrow key to select 19200. Press YES and the Enter key.

8.11 Press the Reset Menu key on the controller keypad.

8.12 Go to Menu 14, Programming Mode, and press the down arrow key to Programming Mode—Local.

8.13 Press the right arrow key to Programming Mode-Off. Press YES and the Enter key,

8.14 Enter the access code. The factory default access code is the number 0. Press the Enter key.

Service Disassembly

Should it be necessary to separate the RSA annunciator panel from the RSA circuit board for servicing and/or replacement, **first unlock the P28 connector** on the RSA circuit board *before* removing the ribbon connector to avoid circuit board damage. See Figure 36. Carefully slide the locking device (white plastic) outward approximately 1.5 mm (1/16 in.).

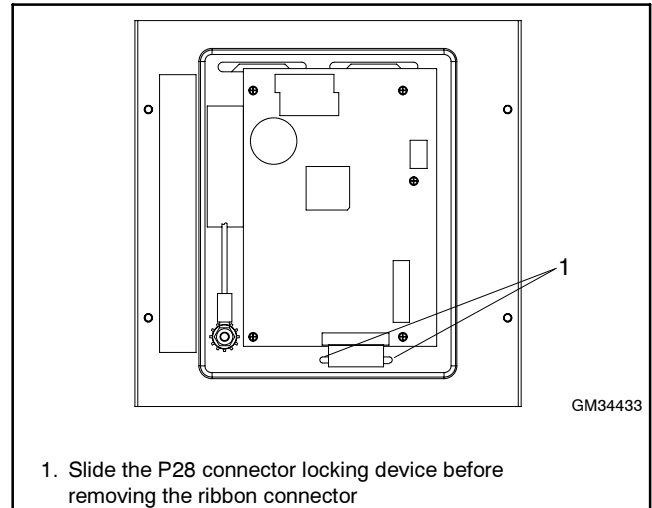

Figure 36 RSA Annunciator Panel and RSA Circuit Board (Back View of Front Panel)

Parts List

Remote Serial Annunciator Kits and Communication Module Kit

Qty.	Description	Remote Serial Annunciator Kits		Communication Module Kit
		GM34474-KP1/-KP1S	GM34474-KP2/-KP2S	GM32644-KP1
1	Plate, wall mounting	GM33031	GM33031	
1	Ribbon cable, 10-position		GM21340	GM21340
1	Communication module board		GM47242	GM47242
1	Ribbon cable, 24-position		GM32632	GM32632
3	Spacer, 8-32 x 5/8 male-female		GM32633	GM32633
3	Washer, #8 lock		X-22-7	X-22-7
1	Harness, communication HBV wiring		GM35318	GM35318
1	Annunciator assembly, remote serial, includes:	GM34433-1 (kit GM34474-KP1) GM34433-2 (kit GM34474-KP1S)	GM34433-1 (kit GM34474-KP2) GM34433-2 (kit GM34474-KP2S)	
1	Decal, ground	344295	344295	
1	Decal, bar code	GM13213	GM13213	
1	Circuit board, RSA	GM31211	GM31211	
1	Resistor, 121 ohm	X-6058-27	X-6058-27	
1	Euroblock plug, 6-position	294619	294619	
1	Box	GM31884	GM31884	
1	Cover	GM34434-1 (kit GM34474-KP1)	GM34434-1 (kit GM34474-KP2)	
1	Cover	GM34434-2 (kit GM34474-KP1S)	GM34434-2 (kit GM34474-KP2S)	
1	Nameplate	GM34618	GM34618	
1	Lead	LK-1212-1414	LK-1212-1414	
2	Washer, #10 lock	X-22-13	X-22-13	
1	Bushing, 1.0 in. x 1.375 in.	X-634-15	X-634-15	
4	Screw, self-tapping	X-67-154	X-67-154	
1	Nut, 10-32 hex	X-70-3	X-70-3	
1	Washer, #10 flat	X-25-36	X-25-36	
1	Identification strips (white)	GM34477	GM34477	

