

INSTALLATION INSTRUCTIONS

Original Issue Date: 5/04

Model: 6.5-32 kW

Market: Marine, Mobile, and Residential/Commercial

Subject: Remote Digital Gauge Kit GM32337-KP1

Introduction

The digital gauge allows for remote starting/stopping and monitoring of certain generator set functions. These generator sets have a 12-pin customer-interface connector for connection to the remote digital gauge. See Figure 1 for the remote digital gauge controls.

Operation of the remote digital gauge's start/stop function requires that the jumper is enabled on the Advanced Digital Control (ADC) (generator sets shipped from the factory already have the jumper enabled). Refer to the wiring diagram in the generator set operation manual if the jumper was disconnected from terminals 1 and 2 on the P7 connector (continuous power mode).

ADC application version 1.14 or higher is required for the remote digital gauge. Refer to TT-1285, Program Loader Instructions, for instructions to load the latest version of the controller application code, if necessary.

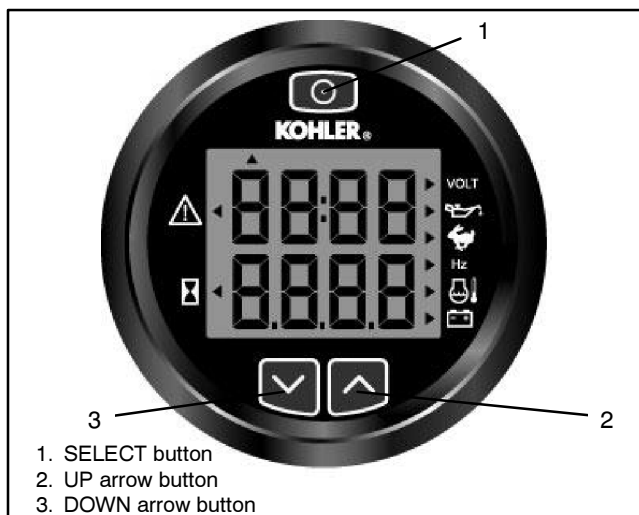
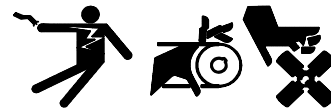

Figure 1 Remote Digital Gauge

Safety Precautions

⚠ WARNING



Accidental starting.
Can cause severe injury or death.

Disconnect the battery cables before working on the generator set. Remove the negative (-) lead first when disconnecting the battery. Reconnect the negative (-) lead last when reconnecting the battery.

Disabling the generator set. Accidental starting can cause severe injury or death. Before working on the generator set or connected equipment, disable the generator set as follows: (1) Move the generator set master switch to the OFF position. (2) Disconnect the power to the battery charger. (3) Remove the battery cables, negative (-) lead first. Reconnect the negative (-) lead last when reconnecting the battery. Follow these precautions to prevent starting of the generator set by an automatic transfer switch, remote start/stop switch, or engine start command from a remote computer.

⚠ WARNING

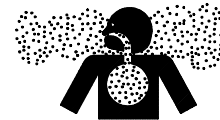

Carbon monoxide.
Can cause severe nausea, fainting, or death.



The exhaust system must be leakproof and routinely inspected.

Carbon monoxide symptoms. Carbon monoxide can cause severe nausea, fainting, or death. Carbon monoxide is a poisonous gas present in exhaust gases. Carbon monoxide poisoning symptoms include but are not limited to the following:

- Light-headedness, dizziness
- Physical fatigue, weakness in joints and muscles
- Sleepiness, mental fatigue, inability to concentrate or speak clearly, blurred vision
- Stomachache, vomiting, nausea

If experiencing any of these symptoms and carbon monoxide poisoning is possible, seek fresh air immediately and remain active. Do not sit, lie down, or fall asleep. Alert others to the possibility of carbon monoxide poisoning. Seek medical attention if the condition of affected persons does not improve within minutes of breathing fresh air.

Operating the generator set. Carbon monoxide can cause severe nausea, fainting, or death. Carbon monoxide is an odorless, colorless, tasteless, nonirritating gas that can cause death if inhaled for even a short time. Use the following precautions when installing and operating the generator set. Do not install the exhaust outlet where exhaust can be drawn in through portholes, vents, or air conditioners. If the generator set exhaust discharge outlet is near the waterline, water could enter the exhaust discharge outlet and close or restrict the flow of exhaust. Never operate the generator set without a functioning carbon monoxide detector. Be especially careful if operating the generator set when moored or anchored under calm conditions because gases may accumulate. If operating the generator set dockside, moor the craft so that the exhaust discharges on the lee side (the side sheltered from the wind). Always be aware of others, making sure your exhaust is directed away from other boats and buildings. Avoid overloading the craft.

 WARNING

<p>Explosion. Gasoline vapors can cause explosion and severe injury or death.</p> <p>Before starting the generator set, operate the blower 4 minutes and check the engine compartment for gasoline vapors.</p>

Ignition-protected equipment. Explosive fuel vapors can cause severe injury or death. Gasoline vapors can cause an explosion. USCG Regulation 33CFR183 requires that all electrical devices (ship-to-shore transfer switch, remote start panel, etc.) must be ignition protected when used in a gasoline and gaseous-fueled environment. The electrical devices listed above are not ignition protected and are not certified to operate in a gasoline and gaseous-fueled environment such as an engine room or near fuel tanks. Acceptable locations are

the wheelhouse and other living areas sheltered from rain and water splash.

Installation Procedure

1. **Remove the generator set from service.**
 - 1.1 Place the generator set master switch in the OFF position.
 - 1.2 Disconnect the generator set engine starting battery, negative (-) lead first.
2. **Install the remote digital gauge.**
 - 2.1 Select a dry location to mount the remote digital gauge. Consider the length of the wiring harness and the gauge's mounting depth and size when selecting a location. See Figure 3 for the mounting dimensions.

Note: Order a remote extension harness kit. See Figure 2 for kit selection. Do not use more than 3 remote harness kits and do not exceed 22.86 m (75 ft.) in harness length.

Remote Extension Harness Kit Number	Length m (ft.)
GM32333-KP1	4.6 (15)
GM32333-KP2	7.6 (25)

Figure 2 Remote Extension Harness Kits (For Gauge to Generator Set)

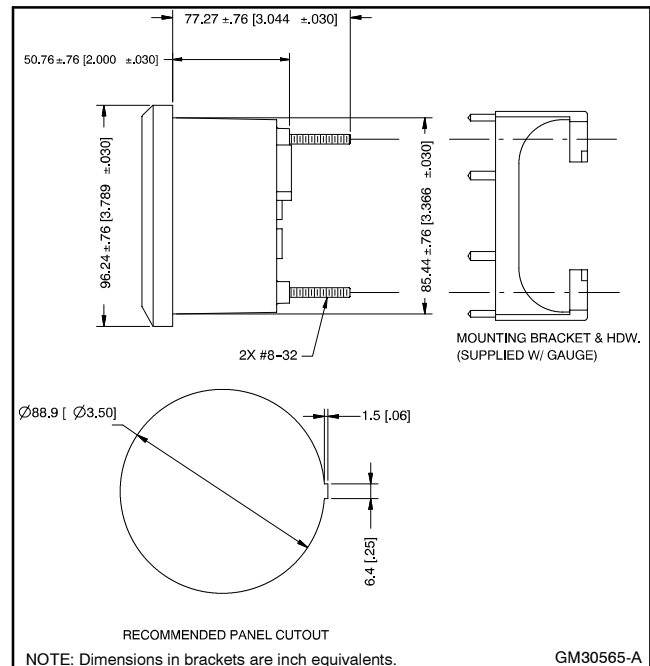

Figure 3 Mounting Dimensions

- 2.2 Connect the remote extension harness (6-pin connector) to the digital gauge (6-pin connector). Connect the 12-pin connector end of a remote extension harness to the generator set's customer-interface 12-pin connector. See Figure 4 and Figure 5.

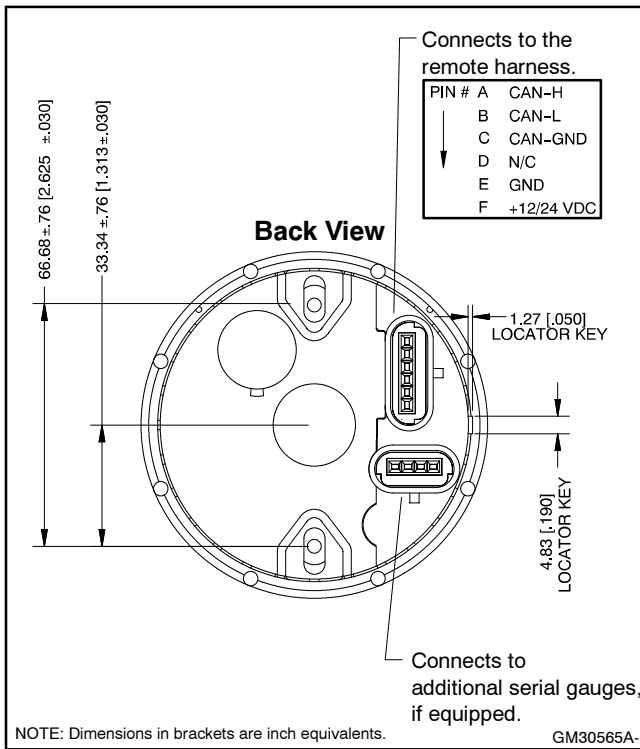

Figure 4 Remote Digital Gauge Connections

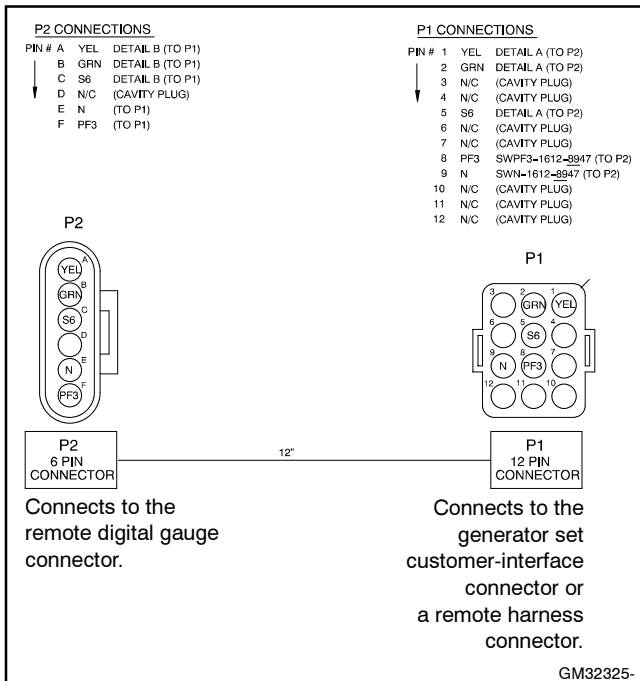

Figure 5 Remote Extension Harness GM32325

- 2.3 Use rubber grommets and cable ties as necessary to protect and secure the wiring from sharp objects, exhaust system, water, and any moving parts.

- 2.4 For gasoline-powered generator sets, select a location as near as practical to the generator remote digital gauge for mounting the warning decal. The decal should be visible when starting the generator set from the remote digital gauge. Before applying the decal, ensure that the surface is clean and dry. See Figure 6.

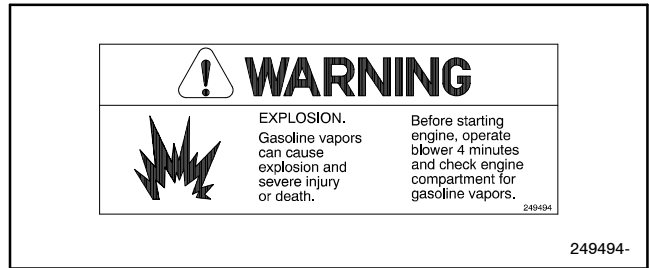

Figure 6 Warning Decal

3. Restore the generator set to service.

- 3.1 Check that the generator set master switch is in the OFF position.
- 3.2 Reconnect the generator set engine starting battery, negative (-) lead last.

4. Set the ADC parameter for J1939 communications.

- 4.1 Consult TT-1364 for parameter settings information.

Parts List

Remote Digital Gauge

Kit: GM32337-KP1		
Qty.	Description	Part Number
1	Gauge	GM30565
1	Harness	GM32325
1	Decal, warning	249494

To Select the Units of Measure:

- (1) Push and hold the SELECT button.
- (2) Apply power to the gauge.
- (3) The gauge displays: **Adc 2100**
- (4) The gauge displays: **UnIT SET**
- (5) Press and hold *both* the UP and DOWN buttons until the gauge beeps and the display changes.
- (6) Use the UP or DOWN buttons to select either **Int** or **USA** units.
- (7) Press and hold *both* the UP and DOWN buttons until the gauge beeps and the display changes.
- (8) Press the DOWN button.
- (9) The gauge displays: **ESC 08 ?**
- (10) Press and hold *both* the UP and DOWN buttons until the gauge switches to the monitor mode.

To Silence an Audible Alarm:

Faults are indicated by blinking text and an audible alarm. To silence an audible alarm, press and hold the UP and DOWN arrow buttons simultaneously until the gauge emits a long beep and then release.

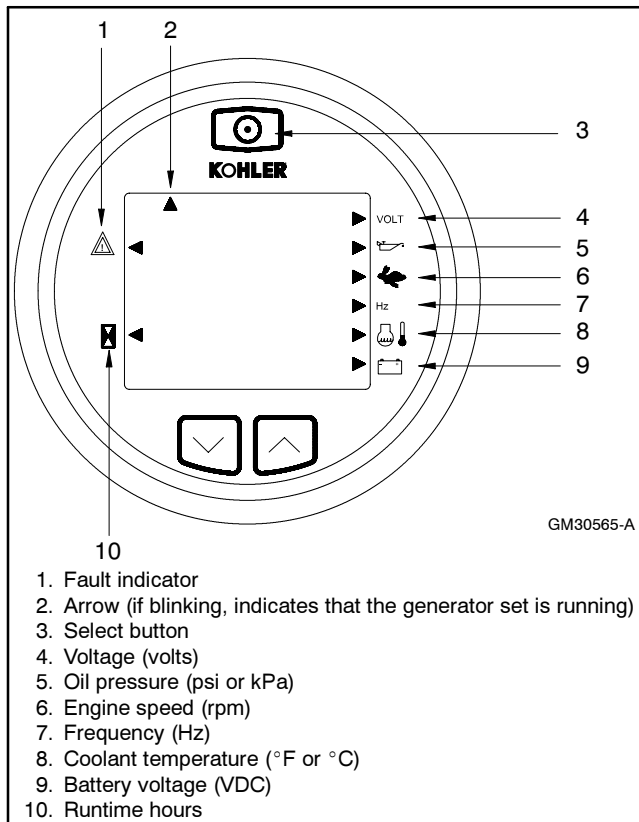

Figure 7 Remote Digital Gauge

Digital Gauge Modes:

Note: Use the SELECT button to scroll through the modes.

Monitor Mode

Use the UP or DOWN arrow to scroll through the data. The corresponding illuminated arrow indicates which data is being monitored. See Figure 7. Any faults are displayed in blinking text. The following generator set data operation is displayed in this mode:

- Voltage (AC volts)
- Oil pressure (psi or kPa). Requires installation of the optional oil pressure sender on the engine.
- Engine speed (rpm)
- Frequency (Hz)
- Coolant temperature (°F or °C)
- Battery voltage (VDC)

Note: The maximum battery voltage that the ADC will display on the remote digital gauge is 31.5 volts. If the voltage is higher than 31.5, it will display 31.5 volts.

- Runtime hours

Start/Stop Command Mode

Use the UP or DOWN arrow for a remote start/stop.

Note: The ADC master switch must be in the AUTO position for the remote start/stop. If the ADC master switch is in the RUN position, a remote stop command is not supported. The arrow, located at the top of the display, blinks to indicate that the generator set is running (see Figure 7, item 2).

Backlighting Mode

Use the UP or DOWN arrow to select a lighting level:

- 0 = no backlight
- 3 = brightest backlight.

Note: Defaults to the last selection.

Note: While in this mode, faults appear on the display, however no audible alarm is heard.

The maximum power draw of the ADC remote gauge when used with the ADC 2100 is 50 mA at 12 VDC (or 25 mA at 24 VDC) with the brightest backlight.