

---

**SERVICE BULLETIN**

---

Original Issue Date: 2/00

Model: **ATS with R340 (relay) or S340 or S340+ (solid-state) Controls**

Market: **Industrial**

Subject: **Rewiring 3-phase Switches for 1-Phase Operation**

**Introduction**

This service bulletin shows how to rewire a 3-phase transfer switch for 1-phase operation.

**Note:** The procedure in this bulletin does not affect the nominal voltage of the switch, which must match 1-phase nominal voltage.

Read the entire service bulletin before servicing. Perform steps in the order shown.

**Safety Precautions**

Observe the following safety precautions while servicing the unit.

---

**⚠ WARNING**



**Accidental starting.  
Can cause severe injury or death.**

Disconnect the battery cables before working on the generator set. Remove the negative (-) lead first when disconnecting the battery. Reconnect the negative (-) lead last when reconnecting the battery.

---

**Disabling the generator set. Accidental starting can cause severe injury or death.** Before working on the generator set or connected equipment, disable the generator set as follows: (1) Move the generator set master switch to the OFF position. (2) Disconnect the power to the battery charger. (3) Remove the battery cables, negative (-) lead first. Reconnect the negative (-) lead last when reconnecting the battery. Follow these precautions to prevent starting of the generator set by an automatic transfer switch, remote start/stop switch, or engine start command from a remote computer.

Routing	Service Manager	Sales Manager	Parts Manager	Technician No. 1	Technician No. 2	Technician No. 3	Return This to
Initial Here							

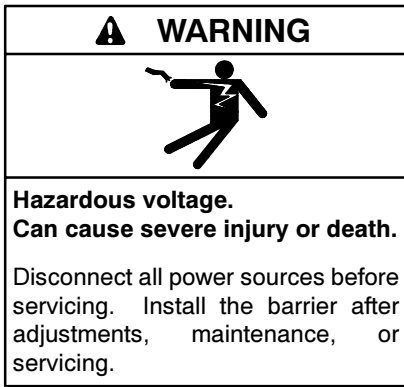

(600 volts and under)

**Servicing the transfer switch. Hazardous voltage can cause severe injury or death.** Deenergize all power sources before servicing. Open the main circuit breakers of all transfer switch power sources and disable all generator sets as follows: (1) Move all generator set master controller switches to the OFF position. (2) Disconnect power to all battery chargers. (3) Disconnect all battery cables, negative (-) leads first. Reconnect negative (-) leads last when reconnecting the battery cables after servicing. Follow these precautions to prevent the starting of generator sets by an automatic transfer switch, remote start/stop switch, or engine start command from a remote computer. Before servicing any components inside the enclosure: (1) Remove rings, wristwatch, and jewelry. (2) Stand on a dry, approved electrically insulated mat. (3) Test circuits with a voltmeter to verify that they are deenergized.

**Servicing the transfer switch controls and accessories within the enclosure. Hazardous voltage can cause severe injury or death.** Disconnect the transfer switch controls at the inline connector to deenergize the circuit boards and logic circuitry but allow the transfer switch to continue to supply power to the load. Disconnect all power sources to accessories that are mounted within the enclosure but are not wired through the controls and deenergized by inline connector separation. Test circuits with a voltmeter to verify that they are deenergized before servicing.

## Service Procedure

1. Prevent the emergency power source generator set from starting.
  - a. Place the generator set master switch in the OFF position.
  - b. Disconnect power to the generator set battery charger, if installed.
  - c. Remove the generator set engine start battery cables, negative (-) lead first.
2. Disconnect *both* the normal and emergency power sources by opening circuit breakers or switches leading to the transfer switch.
3. Open the transfer switch enclosure door.
4. Disconnect the power switching device and the controller at the inline disconnect plug P1. See Figure 1.
5. Check circuits with a voltmeter to verify that the power is off before servicing components inside the enclosure.
6. Locate the transformer assembly on the inner panel. See Figure 1.

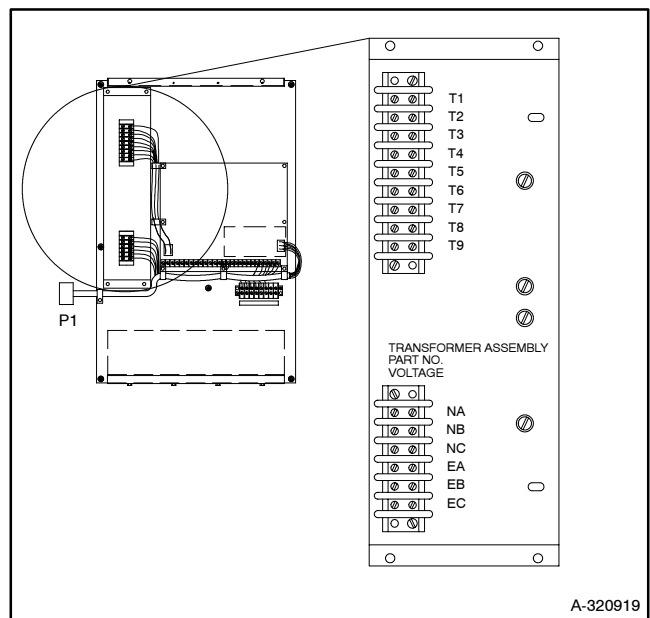

**Figure 1** Typical Transformer Assembly and Location on the Inner Panel

7. If the switch has standard 1-phase emergency source sensing, complete the following steps. If not, proceed to step 8. See Figure 2.

- a. Remove the blue leads from terminals T4 and T5 and tape off the exposed conductors. Leave

the white leads from the controller wiring harness to the terminal in place.

- b. Install a jumper between terminals T2 and T4 and a jumper between terminals T3 and T5.
- c. Proceed to step 9.

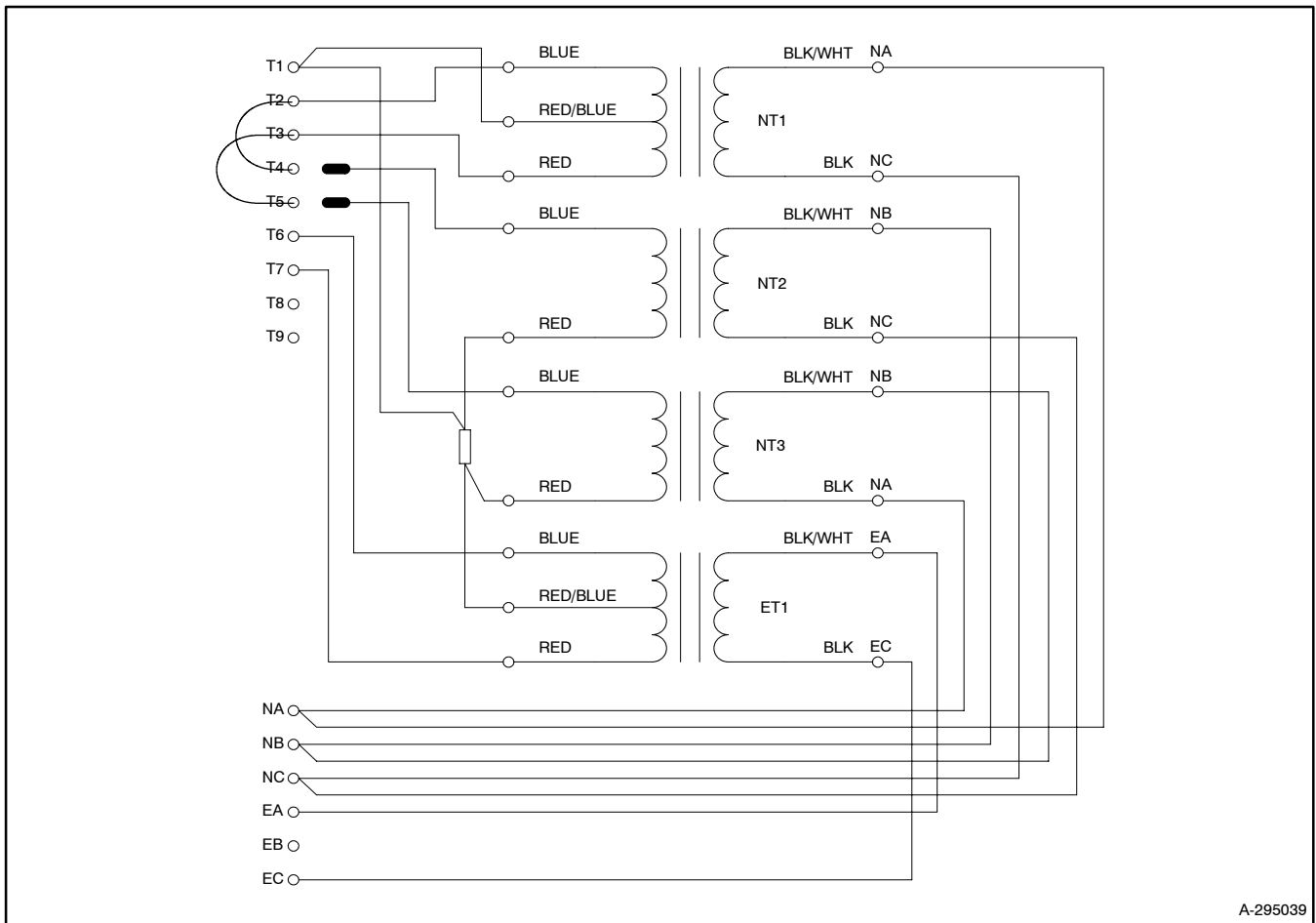

**Figure 2** Rewiring a 3-Phase Normal Source, 1-Phase Emergency Source Transformer Assembly for 1-Phase Operation

8. If the switch has 3-phase emergency source sensing such as when accessory KA-5-F or KA-5-G is installed, complete the following steps. See Figure 3.

- a. Remove the blue leads from terminals T4 and T5 and tape off the exposed conductors. Leave the white leads from the controller wiring harness to the terminal in place.

b. Remove the blue leads from terminals T8 and T9 and tape off the exposed conductors. Leave the white leads from the controller wiring harness to the terminals in place.

- c. Install a jumper between terminals T2 and T4 and a jumper between terminals T3 and T5.
- d. Install a jumper between terminals T6 and T8 and a jumper between terminals T7 and T9.

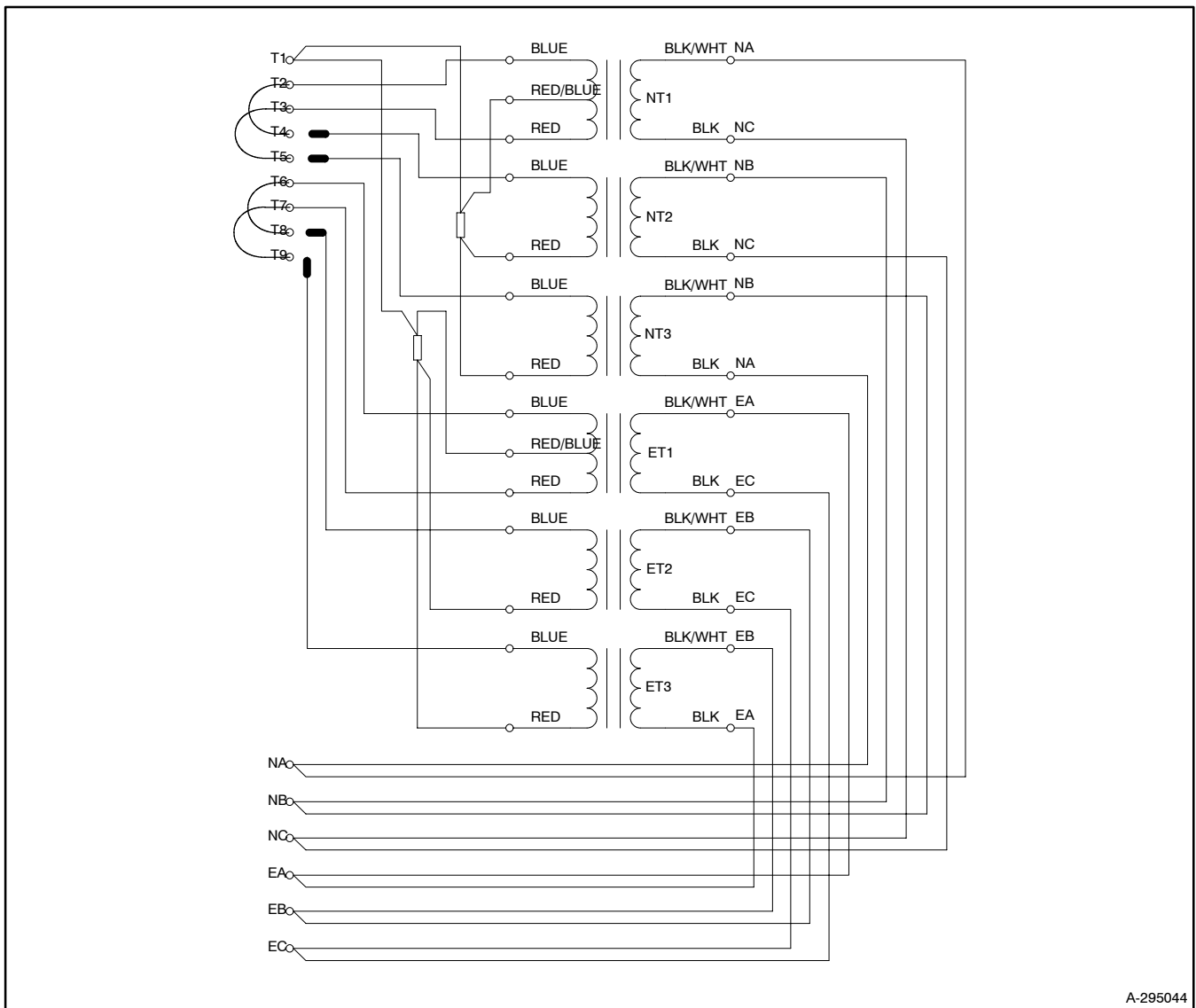

**Figure 3** Rewiring a 3-phase Normal Source, 3-Phase Emergency Source Transformer Assembly for 1-Phase Operation

9. Connect load conductors to the A and C lugs on the power switching device. Do not connect to the B lug.
10. Reconnect the power switching device and the controller at the inline disconnect plug P1. See Figure 1.
11. Reconnect power supplies to the transfer switch.

**Note:** If the normal power source is applied to a transfer switch equipped with time delay engine cooldown (TDEC) after the electrical controls have lost power, the engine start contacts remain closed and the ATS's TDEC begins timing, signalling the generator set to run until TDEC ends.

12. Allow the emergency power source generator set to start.
  - a. Reconnect the generator engine start battery cables, negative (-) leads last.
  - b. Reconnect power to the generator set battery charger, if installed.
  - c. Place the generator set master switch in the AUTO (automatic) position. The generator may start and run for a while.