

SERVICE BULLETIN

Original Issue Date: **9/01**

Model: **30-125 kW (GM-Powered Generator Sets)**

Market: **Industrial**

Subject: **Fuel Mixture Adjustment after Fuel Mixer (Carburetor) Replacement**

Introduction

This procedure details fuel mixture adjustment following fuel mixer (carburetor) replacement.

Use the following procedure to field adjust the fuel mixture on generator sets that are not California Air Resources Board (CARB) or United States Environmental Protection Agency (EPA) certified. Correct fuel metering valve adjustment provides both reliable cold starting and overall generator set performance.

The adjustment procedure requires:

- Digital voltmeter (DVM).
- Engine oxygen sensor (part number A-345052).
- Load bank capable of rated kW for the fuel being used. See step 3.5 comment.

Read the entire installation procedure before adjusting the fuel mixture. Perform the steps in the order shown.

Safety Precautions

Observe the following safety precautions while installing the kit.

⚠ WARNING

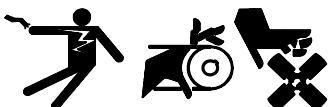

Accidental starting. Can cause severe injury or death.

Disconnect the battery cables before working on the generator set. Remove the negative (-) lead first when disconnecting the battery. Reconnect the negative (-) lead last when reconnecting the battery.

Disabling the generator set. Accidental starting can cause severe injury or death. Before working on the generator set or connected equipment, disable the generator set as follows: (1) Move the generator set master switch to the OFF position. (2) Disconnect the power to the battery charger. (3) Remove the battery cables, negative (-) lead first. Reconnect the negative (-) lead last when reconnecting the battery. Follow these precautions to prevent starting of the generator set by an automatic transfer switch, remote start/stop switch, or engine start command from a remote computer.

⚠ WARNING



Hot engine and exhaust system. Can cause severe injury or death.

Do not work on the generator set until it cools.

Servicing the exhaust system. Hot parts can cause severe injury or death. Do not touch hot engine parts. The engine and exhaust system components become extremely hot during operation.

⚠ WARNING

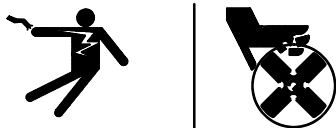

Hazardous voltage. Moving rotor. Can cause severe injury or death.

Operate the generator set only when all guards and electrical enclosures are in place.

Servicing the generator set when it is operating. Exposed moving parts can cause severe injury or death. Keep hands, feet, hair, clothing, and test leads away from the belts and pulleys when the generator set is running. Replace guards, screens, and covers before operating the generator set.

Routing	Service Manager	Sales Manager	Parts Manager	Technician No. 1	Technician No. 2	Technician No. 3	Return This to
Initial Here							

Installation Procedure

1. Remove the generator set from service.

- 1.1 Place the generator set master switch in the OFF position.
- 1.2 Disconnect power to the battery charger, if equipped.
- 1.3 Disconnect the generator set engine starting battery, negative (-) lead first.

2. Install the oxygen sensor.

- 2.1 Remove the oxygen sensor pipe plug from the exhaust pipe. See Figure 1-1 for location.
- 2.2 Install the oxygen sensor in the exhaust tube where the plug was removed.
- 2.3 Connect one of the DVM leads to the oxygen sensor lead. Connect the other DVM lead to ground and measure the oxygen sensor output voltage (potential to ground).

3. Start and warm up the generator set.

- 3.1 Check that the generator set master switch is in the OFF position.

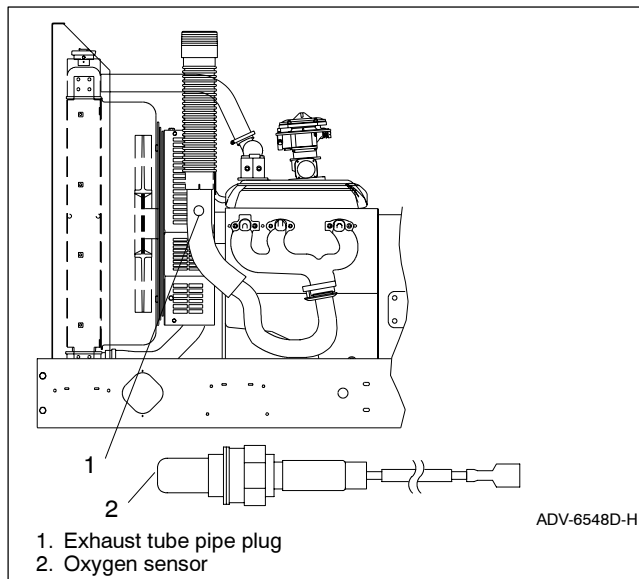

Figure 1-1 Oxygen Sensor Mounting Location, Typical (30 kW model shown)

- 3.2 Reconnect the generator set engine starting battery, negative (-) lead last.
- 3.3 Place the controller master switch in the RUN position to start generator set. The time required will depend on the size of the generator set.
- 3.4 Allow the generator set to run until the generator set reaches normal operating temperature.
- 3.5 With the generator set at normal operating temperature, apply 90%–100% of rated load. If a load bank is not available, apply a load at least comparable to what is generally connected to the generator set.

4. Adjust the fuel mixture valve.

- 4.1 Adjust the fuel metering valve (Figure 1-2) as required to obtain a 0.8–0.9 VDC oxygen sensor output. The oxygen sensor output reads high when the mixture is richer and close to zero volts when the mixture is leaner.

The fuel mixer adjustment is molded into the fuel mixer inlet on air valve-type models or is a separate fitting upstream of the fuel mixer on venturi-type models.

- 4.2 Remove the load and allow the generator set to run unloaded to cool for at least 5–10 minutes.

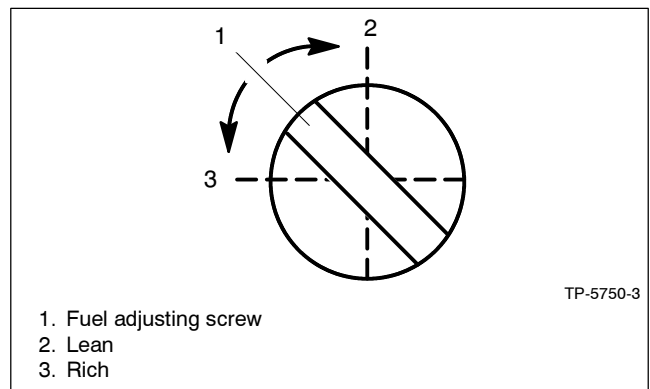

Figure 1-2 Fuel Mixer (Carburetor) Fuel Mixture Adjustment, Typical

5. Stop the generator set.

- 5.1 Place the generator set master switch in the OFF position.
- 5.2 Disconnect the generator set engine starting battery(ies), negative (-) lead first.

6. Remove the oxygen sensor.

- 6.1 Allow the generator set exhaust system to cool.
- 6.2 Disconnect the DVM leads from the oxygen sensor.
- 6.3 Remove the oxygen sensor from the exhaust tube.

- 6.4 Apply a small amount of antiseize compound to the pipe plug and reinstall the pipe plug into the exhaust tube.

7. Restore the generator set to service.

- 7.1 Check that the generator set master switch is in the OFF position.
- 7.2 Reconnect the generator set engine starting battery, negative (-) lead last.
- 7.3 Reconnect the power to the battery charger, if equipped.