

**SERVICE BULLETIN**

Original Issue Date: 10/03

Model: 30-125 kW (GM 3.0-8.1 L Engines)

Market: Industrial Generator Sets

Subject: Natural Gas to LP Gas Vapor Conversion

**Introduction**

This bulletin provides instructions for converting the General Motors 3.0-8.1 L engine-powered generator sets from natural gas to LP gas vapor. Figure 1 lists specification numbers for generator sets and engine models.

Model	Engine	Spec No.
30 kW	4.3 L	GM22383-GA1, 7, 10
		GM39370-GA1, 7, 10
	3.0 L	GM22316-GA1
35 kW	4.3 L	GM22383-GA2, 8, 11
		GM39370-GA2, 8, 11 *
45 kW	4.3 L	GM22383-GA3, 9, 12
		GM39370-GA3, 9, 12 *
50 kW	5.7 L	GM13686-GA1, 3, 5, 7
	5.0 L	GM21302-GA1, 5, 7
60 kW	5.7 L	GM21302-GA2, 6, 8
		GM39374-GA2, 6, 8 *
80 kW	8.1 L	GM22407-GA1,2,3,4
		GM34436-GA1,2,3,4
100 kW	8.1 L	GM22407-GA5,6,7,8
		GM34436-GA5,6,7,8
125 kW	8.1 L	GM20568-GA1, 2
		GM25339-GA1, 2,3,4
		GM34464-GA1, 2,3,4

\* L-series throttle body models

**Figure 1 Specification Numbers**

Figure 2 shows the natural gas configuration for the 50/60 kW models; the 30-45 kW and 80-125 kW models are similar.

When converting the 80-125 kW models, order the respective kit shown in Figure 3 that contains the LP fuel mixer and fuel regulator.

**30-60 kW Models (3.0/4.3/5.0/5.7 L GM Engines).** Use the following procedure except for Step 2. The 30-60 kW generator sets do not require fuel mixer or regulator replacement. Refer to the respective spec sheet for generator set ratings based on fuel selection.

**Note:** 30 kW models with the 3.0 L GM engine require service harness adapter part number **GM39651** for setting the engine ignition timing.

**80-125 kW Models (8.1 L GM Engine).** Use the following procedure, except Step 7. Refer to the respective specification sheet for generator set ratings based on fuel selection.



**Figure 2 Fuel System Configuration (typical)**

Models	Kit Number
80 kW	GM17010-KP2
100 kW	GM17010-KP3
125 kW	GM17010-KP4

**Figure 3 Fuel System Kit Numbers**

Routing	Service Manager	Sales Manager	Parts Manager	Technician No. 1	Technician No. 2	Technician No. 3	Return This to
Initial Here							

# Safety Precautions

Observe the following safety precautions while installing the kit.

---

**⚠ WARNING**



**Accidental starting.**  
**Can cause severe injury or death.**

Disconnect the battery cables before working on the generator set. Remove the negative (-) lead first when disconnecting the battery. Reconnect the negative (-) lead last when reconnecting the battery.

---

**Disabling the generator set. Accidental starting can cause severe injury or death.** Before working on the generator set or connected equipment, disable the generator set as follows: (1) Move the generator set master switch to the OFF position. (2) Disconnect the power to the battery charger. (3) Remove the battery cables, negative (-) lead first. Reconnect the negative (-) lead last when reconnecting the battery. Follow these precautions to prevent starting of the generator set by an automatic transfer switch, remote start/stop switch, or engine start command from a remote computer.

<b>⚠ WARNING</b>

<b>Fire.</b> <b>Can cause severe injury or death.</b> Do not smoke or permit flames or sparks near fuels or the fuel system.

---

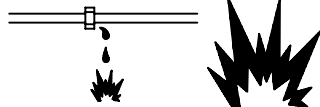
**⚠ WARNING**



**Explosive fuel vapors.**  
**Can cause severe injury or death.**

Use extreme care when handling, storing, and using fuels.

---

**The fuel system. Explosive fuel vapors can cause severe injury or death.** Vaporized fuels are highly explosive. Use extreme care when handling and storing fuels. Store fuels in a well-ventilated area away from spark-producing equipment and out of the reach of children. Never add fuel to the tank while the engine is running because spilled fuel may ignite on contact with hot parts or from sparks. Do not smoke or permit flames or sparks to occur near sources of spilled fuel or fuel vapors. Keep the fuel lines and connections tight and in good condition. Do not replace flexible fuel lines with rigid lines. Use flexible sections to avoid fuel line breakage caused by vibration. Do not operate the generator set in the presence of fuel leaks, fuel accumulation, or sparks. Repair fuel systems before resuming generator set operation.

**Explosive fuel vapors can cause severe injury or death.** Take additional precautions when using the following fuels:

**Propane (LP)**—Adequate ventilation is mandatory. Because propane is heavier than air, install propane gas detectors low in a room. Inspect the detectors per the manufacturer's instructions.

**Natural Gas**—Adequate ventilation is mandatory. Because natural gas rises, install natural gas detectors high in a room. Inspect the detectors per the manufacturer's instructions.

**Gas fuel leaks. Explosive fuel vapors can cause severe injury or death.** Fuel leakage can cause an explosion. Check the LP vapor gas or natural gas fuel system for leakage by using a soap and water solution with the fuel system test pressurized to 6-8 ounces per square inch (10-14 inches water column). Do not use a soap solution containing either ammonia or chlorine because both prevent bubble formation. A successful test depends on the ability of the solution to bubble.

# Fuel Conversion Procedure

## 1. Remove the generator set from service.

- 1.1 Place the generator set master switch in the OFF position.
- 1.2 Disconnect the power to the battery charger, if equipped.
- 1.3 Disconnect the generator set engine starting battery(ies), negative (-) lead first.
- 1.4 Close all fuel supply valves.

## 2. Replace the fuel mixer and regulator for LP gas vapor (80-125 kW models only).

- 2.1 Remove the components from the engine as shown in Figure 2.
  - 2.1.1 Remove the four screws attaching the fuel mixer to the throttle. The 80 kW has the screw heads accessible from the bottom and the 100/125 kW have the screw heads accessible from the top. Retain the gasket between the fuel mixer and throttle.
  - 2.1.2 Disconnect the fuel line at the union connector.
  - 2.1.3 Remove the supporting clamp between the fuel regulator and mixer.
- 2.2 Disconnect the piping from the fuel mixer inlet and fuel regulator inlet and outlet.
- 2.3 Apply pipe thread compound to all male threads and assemble the fuel system assembly with the new fuel mixer, reducer bushing, and fuel regulator supplied in the kit.
- 2.4 Place the fuel mixer on the throttle with the existing gasket and install the four screws. See Figure 4.
- 2.5 Reconnect the fuel line at the union connector.

## 3. Set up the fuel regulator for LP gas (30 kW model with 3.0 L engine only).

- 3.1 Rotate the fuel regulator to a downward pointing position as shown in Figure 4.

- 3.2 Remove the cover plug and adjustment screw from the fuel regulator. See Figure 5.
- 3.3 Remove the spring. The spring will not be reused.
- 3.4 Replace the adjustment screw to the approximate midpoint of the adjustment range.
- 3.5 Replace the cover plug.

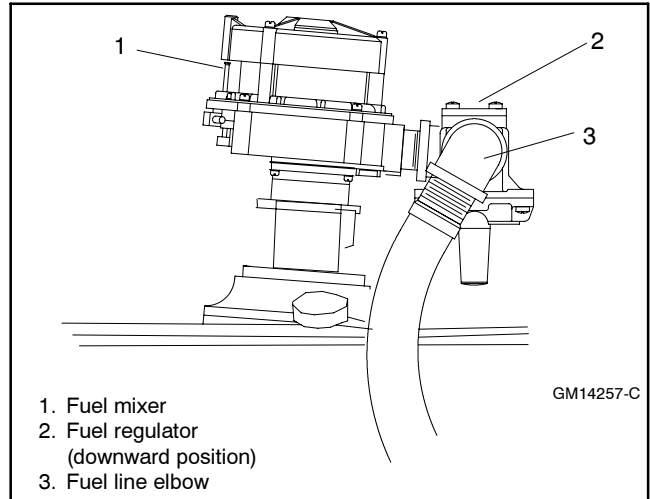

Figure 4 Fuel Mixer, Typical

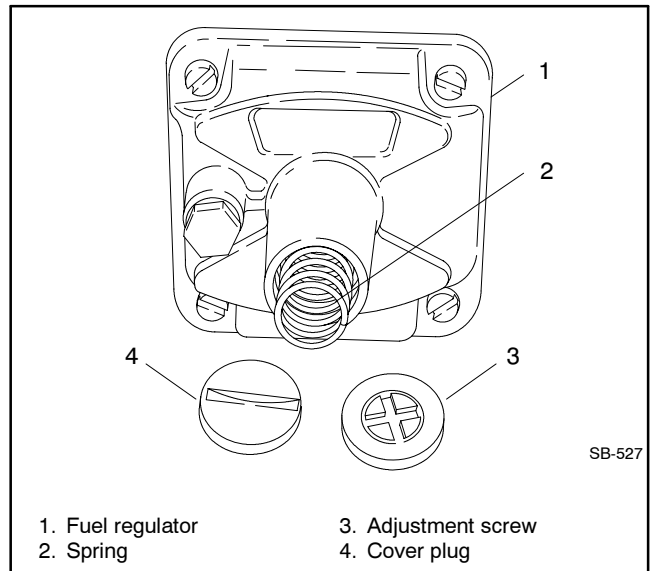

Figure 5 Fuel Regulator, Typical

#### 4. Change the fuel configuration jumper wire at junction box terminal strip

Follow the procedure for the respective model. See Figure 8 for a summary of all fuel configurations requiring the TB12 terminal strip. The fuel and frequency jumper connections on TB12 is also available in the respective Wiring Diagram Manual.

##### 4.1 30-60 kW models.

4.1.1 Remove the right side panel of the junction box and locate the fuel configuration terminal strip TB12.

4.1.2 **30 kW model with 3.0 L engine only.** Attach a user-supplied 18 ga. jumper wire between terminals 1 and 3 (LP gas vapor fuel). See Figure 6 for frequency jumper wire requirements.

**Note:** No jumper wire is used with natural gas fuel.

**30 kW model with 4.3 L engine and 35-60 kW models.** Move the jumper wire from terminals 1 and 5 (natural gas fuel) to terminals 1 and 3 (LP gas vapor fuel). See Figure 7 for frequency jumper wire requirements.

4.1.3 Attach the junction box right side panel.

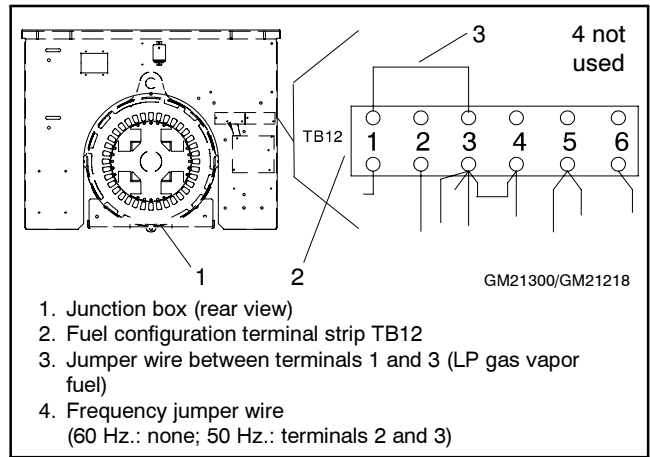

**Figure 6** Fuel Configuration Jumper Wire (LP Fuel, 60 Hz, 30 kW [3.0 L] Model)

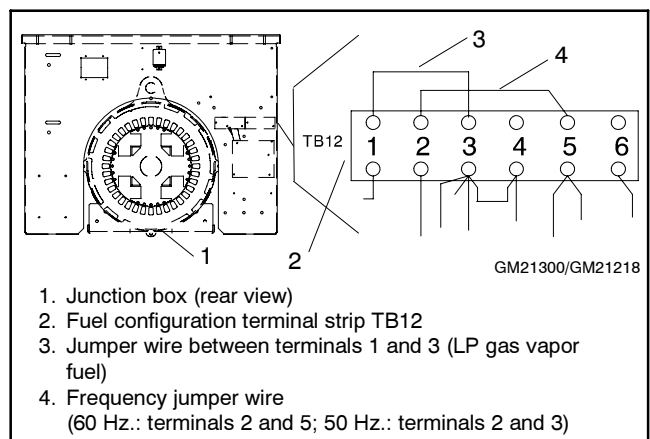

**Figure 7** Fuel Configuration Jumper Wire (LP Fuel, 60 Hz, 30 kW [4.3 L] and 35-60 kW Models)

Model	Engine	Straight Gas Fuel				NG/LP Dual Fuel		LP Liquid Withdrawal	
		LP, 60 Hz	LP, 50 Hz	NG, 60 Hz	NG, 50 Hz	60 Hz	50 Hz	60 Hz	50 Hz
30 kW	3.0 L	1-3	1-3, 2-3	none	2-3	none	2-3	1-3	1-3, 2-3
	4.3 L	1-3, 2-5	1-3, 2-3	1-5, 2-5	1-5, 2-3	1-5, 2-5	1-5, 2-3	1-3, 2-5	1-3, 2-3
35 kW									
45 kW									
50 kW									
60 kW	5.7 L	1-5	1-5, 2-5	none	2-5	none	2-5	1-5	1-5, 2-5
80 kW									
100 kW	8.1 L	1-5	1-5, 2-5	none	2-5	none	2-5	1-5	1-5, 2-5
125 kW									

**Figure 8** Fuel and Frequency Jumper Connections on TB12

## 4.2 80-125 kW models.

4.2.1 Remove the right side panel of the junction box and locate the fuel configuration terminal strip TB12. See Figure 9.

4.2.2 Attach a user supplied 18-ga. jumper wire between terminals 1 and 5 (LP gas vapor fuel). See Figure 9 for frequency jumper wire requirements.

**Note:** No jumper wire is used with natural gas fuel.

4.2.3 Attach the junction box right side panel.

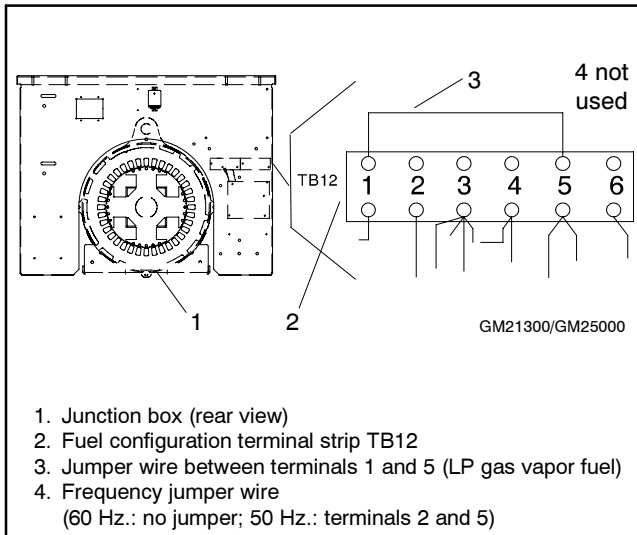

**Figure 9** Fuel Configuration Jumper Wire  
 (LP Fuel, 60 Hz, 80-125 kW Models)

## 5. Change the solenoid shutoff valve wiring (80/100 kW models only).

5.1 Locate the solenoid shutoff valve at the fuel inlet connection at the lower right side of the generator set.

5.2 Disconnect wires 72 and 73 from the solenoid shutoff valve (FV1). Tape to insulate the terminals. See Figure 10, Natural Gas view.

5.3 Connect wires 74 and 75 to the solenoid shutoff valve (FV1). See Figure 10, LP Gas view.

## 6. Restore the generator set to service.

6.1 Check that the generator set master switch is in the OFF position.

6.2 Reconnect the generator set engine starting battery, negative (-) lead last.

6.3 Reconnect power to the battery charger, if equipped.

6.4 Open the LP gas supply valve.

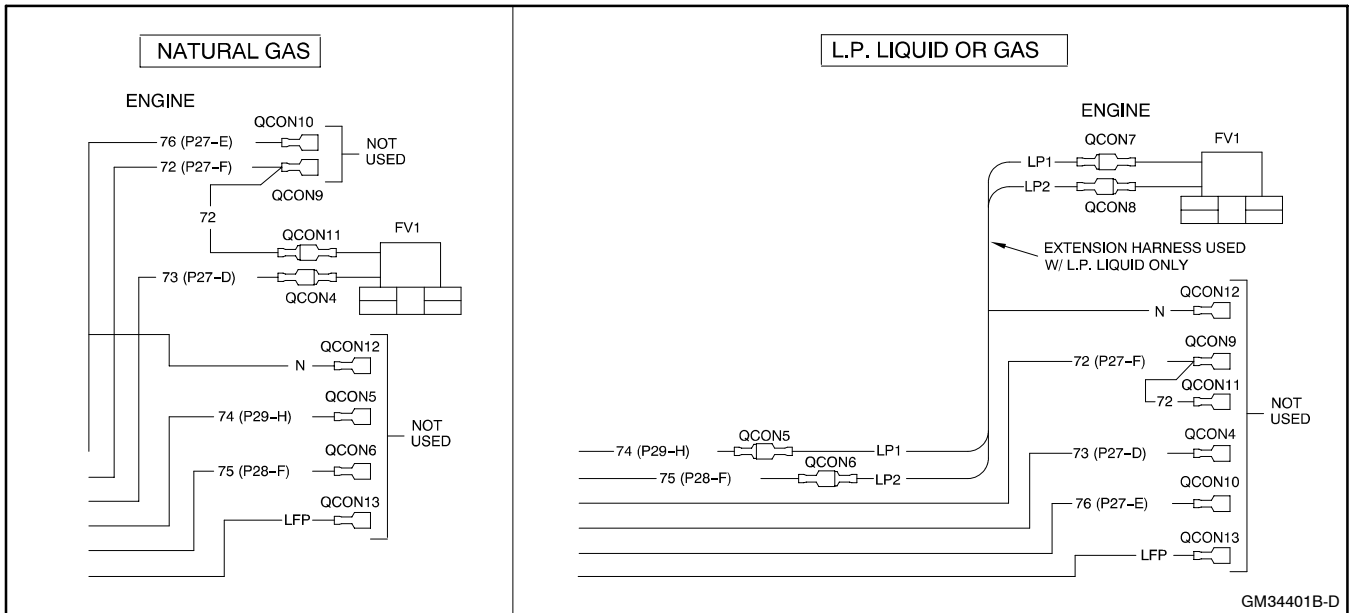

**Figure 10** Solenoid Shutoff Valve Wiring

**7. Change the engine ignition timing (30-60 kW models only).**

**Note:** The engine ignition timing for the 80-125 kW models is set by the ECM and is not adjustable.

**7.1 30 kW model with the 3.0 L GM engine only.**  
Remove the 4-pin harness connector from the base of the distributor. Plug in GM39651 service harness adapter to the distributor. Attach the lead from pin B to the battery positive (+) terminal.

The service harness adapter connects pins C and D together and connects battery positive (+) to pin B.

- 7.2 Loosen the distributor hold-down clamp screw.
- 7.3 Remove dirt and grease from the crankshaft pulley groove and engine timing plate mark using a clean rag. Highlight the timing marks with chalk.
- 7.4 Connect an ignition timing light to the engine. Follow the ignition timing light manufacturer's instructions.

Typically the ignition timing light connects to the starting battery for power and the inductive pickup goes on the no. 1 spark plug wire. The no. 1 spark plug is in the front left side of the engine. See Figure 11.

- 7.5 Set the ignition timing light adjustment to the value shown in Figure 12.
- 7.6 Place the generator set master switch in the RUN position to start the generator set.
- 7.7 Point the ignition timing light at the engine timing plate mark and slowly turn the distributor clockwise or counterclockwise until the crankshaft pulley groove aligns with the engine timing plate mark.
- 7.8 Place the generator set master switch in the OFF position to stop the generator set.

7.9 Tighten the distributor hold-down clamp to 25 Nm (18 ft. lb.) being careful not to alter the distributor position.

**7.10 30 kW model with the 3.0 L GM engine only.**  
Remove the lead from pin B lead at the battery positive (+) terminal. Unplug GM39651 service harness adapter from the distributor. Reconnect the 4-pin harness connector to the base of the distributor.

7.11 Disconnect the ignition timing light from the engine.

**8. Adjust the fuel mixture using Service Bulletin 634.**

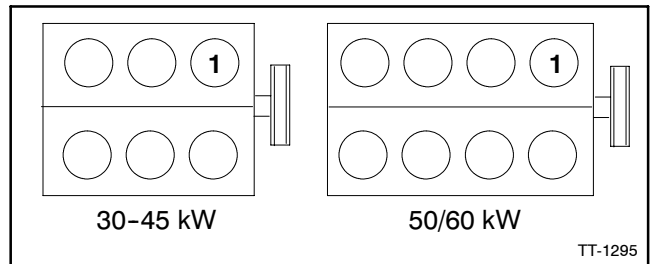

**Figure 11** Engine No. 1 Cylinder/Spark Plug

Model	Engine	NG Timing °BTDC	LP Gas Timing °BTDC	Dual Fuel Timing °BTDC	Spark Plug Gap, mm (in.)
30 kW	4.3 L	32	28	32	0.89 (0.035)
	3.0 L	0	0	0	
35 kW	4.3 L	32	28	32	
45 kW	4.3 L	32	28	32	
50 kW	5.7 L	36	28	32	
	5.0 L	36	28	32	
60 kW	5.7 L	36	28	32	
80 kW	8.1 L	ECM	ECM	ECM	
100 kW	8.1 L	ECM	ECM	ECM	
125 kW	8.1 L	ECM	ECM	ECM	

**Figure 12** Engine Ignition Timing