

SERVICE BULLETIN

Original Issue Date: **10/03**

Model: **30-125 kW (GM 3.0-8.1 L Engines)**

Market: **Industrial**

Subject: **Fuel Mixture Adjustment using Oxygen Sensor Service Kit GM29385**

Introduction

This bulletin details fuel mixture adjustment for General Motors 3.0-8.1 L engine-powered generator sets. Figure 1 lists specification numbers for generator sets and engine models.

Figure 2 provides the differences in engine components and the optimum air/fuel mixture measured with an oxygen sensor in volts.

Model	Engine	Spec No.
30 kW	4.3 L	GM22383-GA1, 7, 10
		GM39370-GA1, 7, 10
	3.0 L	GM22316-GA1
35 kW	4.3 L	GM22383-GA2, 8, 11
		GM39370-GA2, 8, 11 *
45 kW	4.3 L	GM22383-GA3, 9, 12
		GM39370-GA3, 9, 12 *
50 kW	5.7 L	GM13686-GA1, 3, 5, 7
		GM21302-GA1, 5, 7
	5.0 L	GM39374-GA1, 5, 7 *
60 kW	5.7 L	GM21302-GA2, 6, 8
		GM39374-GA2, 6, 8 *
80 kW	8.1 L	GM22407-GA1, 2, 3, 4
		GM34436-GA1, 2, 3, 4
100 kW	8.1 L	GM22407-GA5, 6, 7, 8
		GM34436-GA5, 6, 7, 8
125 kW	8.1 L	GM20568-GA1, 2
		GM25339-GA1, 2, 3, 4
		GM34464-GA1, 2, 3, 4

* L-series throttle body models

Figure 1 Specification Numbers

kW	GM Engine	Fuel Mixer Type	Electronic Control Unit (ECU) Type	Air/Fuel Mixture Measured in Volts
30	3.0	Nolff	E-Controls	2.50-2.65
30-45	4.3	Woodward	PSI	2.35-2.45
50/60	5.0, 5.7	Woodward	PSI	2.60-2.80
80/100	8.1	Nolff	E-Controls	2.50-2.65
125	8.1 Turbo (Single Fuel)	Nolff	E-Controls	2.50-2.65
125	8.1 Turbo (Dual Fuel)	Nolff	E-Controls	2.40-2.65

Figure 2 Engine Components and Optimum Air/Fuel Mixture Values

Use the following procedure to field adjust fuel mixture on generator sets that are not California Air Resources Board (CARB) or United States Environmental Protection Agency (EPA) certified. Correct fuel metering valve adjustment provides both reliable cold starting and overall generator set performance.

The adjustment procedure requires:

- Digital voltmeter (DVM).
- Engine oxygen sensor service kit GM29385 that contains:
 - UEGO Oxygen Sensor part no. GM28980
 - UEGO Sensor Interface Harness part no. GM28981
 - UEGO Air/Fuel Control Module part no. GM28982
- Load bank capable of rated kW for the fuel being used. See step 4.5 comment.
- Manometer with range of 0-15 inches of water.
- **For 125 kW with Dual Fuel Model only**, E-Controls Interface Kit GM42033 and Engine Control Module (ECM) Service Manual TP-6215.

Read the entire installation procedure before adjusting the fuel mixture. Perform the steps in the order shown.

Routing	Service Manager	Sales Manager	Parts Manager	Technician No. 1	Technician No. 2	Technician No. 3	Return This to
Initial Here							

Safety Precautions

Observe the following safety precautions while installing the kit.

WARNING

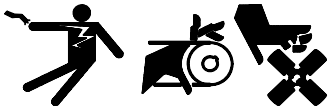

Accidental starting.
Can cause severe injury or death.

Disconnect the battery cables before working on the generator set. Remove the negative (-) lead first when disconnecting the battery. Reconnect the negative (-) lead last when reconnecting the battery.

Disabling the generator set. Accidental starting can cause severe injury or death. Before working on the generator set or connected equipment, disable the generator set as follows: (1) Move the generator set master switch to the OFF position. (2) Disconnect the power to the battery charger. (3) Remove the battery cables, negative (-) lead first. Reconnect the negative (-) lead last when reconnecting the battery. Follow these precautions to prevent starting of the generator set by an automatic transfer switch, remote start/stop switch, or engine start command from a remote computer.

WARNING



Hot engine and exhaust system.
Can cause severe injury or death.

Do not work on the generator set until it cools.

Servicing the exhaust system. Hot parts can cause severe injury or death. Do not touch hot engine parts. The engine and exhaust system components become extremely hot during operation.

WARNING

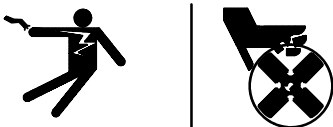

Hazardous voltage. Moving rotor.
Can cause severe injury or death.

Operate the generator set only when all guards and electrical enclosures are in place.

Servicing the generator set when it is operating. Exposed moving parts can cause severe injury or death. Keep hands, feet, hair, clothing, and test leads away from the belts and pulleys when the generator set is running. Replace guards, screens, and covers before operating the generator set.

Installation Procedure

- 1. Remove the generator set from service.**
 - 1.1 Place the generator set master switch in the OFF position.
 - 1.2 Disconnect power to the battery charger, if equipped.
 - 1.3 Disconnect the generator set engine starting battery, negative (-) lead first.
- 2. Install the oxygen sensor and interface harness.**
 - 2.1 Remove the oxygen sensor pipe plug from the exhaust pipe. See Figure 3 for location.

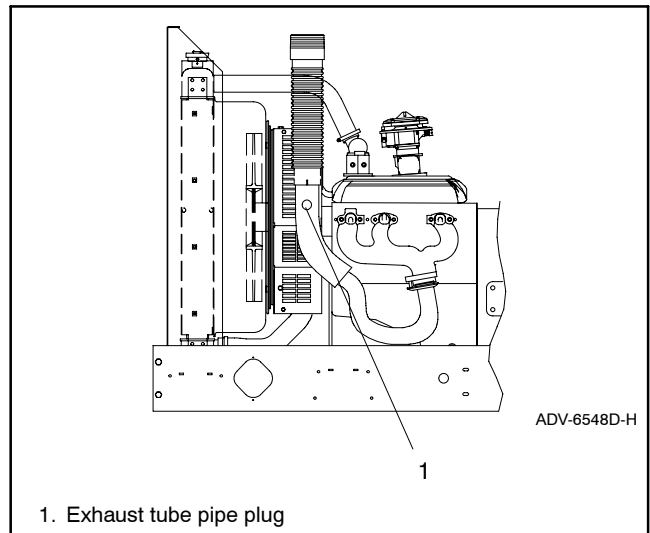

Figure 3 Oxygen Sensor Mounting Location, Typical (30 kW model shown)

- 2.2 Install the oxygen sensor in the exhaust tube where the plug was removed.
- 2.3 Connect the oxygen sensor (GM28980) to the interface harness (GM28981). See Figure 4.
- 2.4 Connect the air/fuel control module (GM28982) to the interface harness.
- 2.5 Connect the digital voltmeter (DVM) to the interface harness. Connect one of the digital voltmeter (DVM) leads to the yellow output lead. Connect the other DVM lead to the black/yellow output lead.

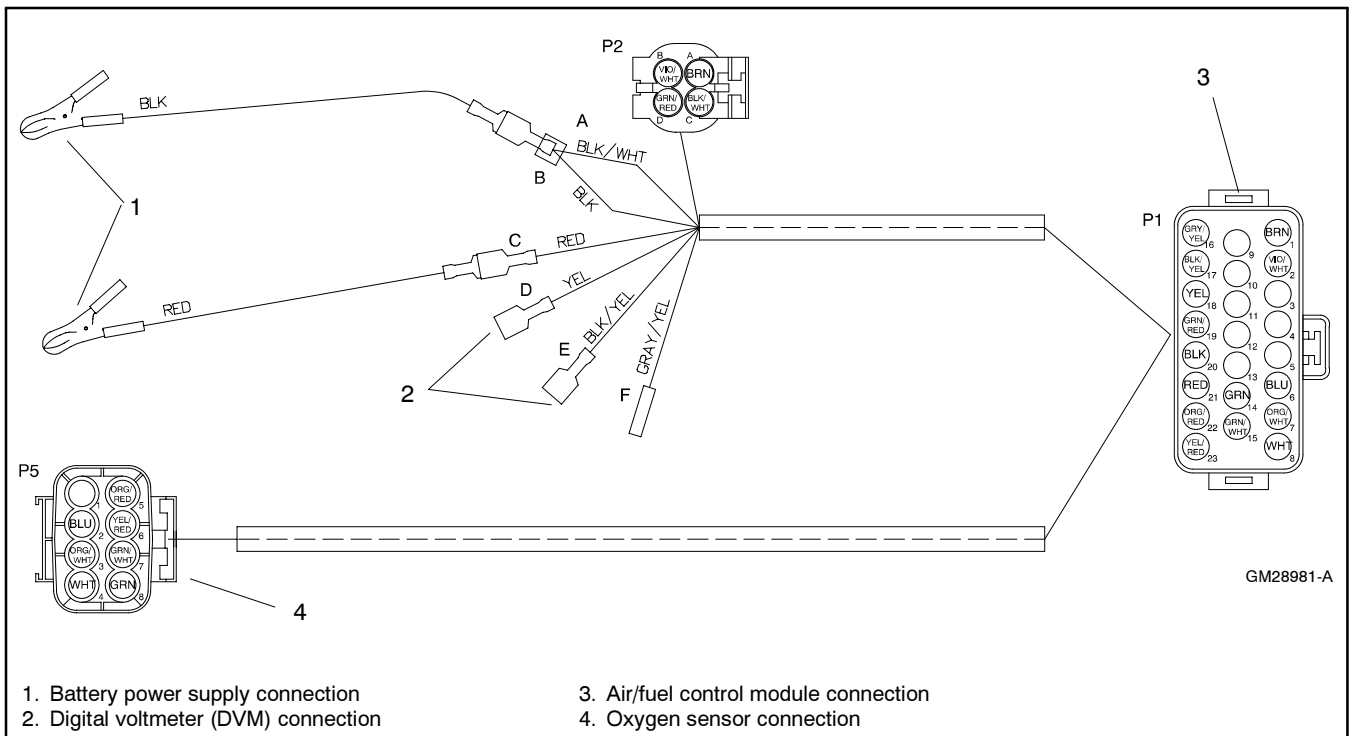

Figure 4 Sensor Interface Harness GM28981 Electrical Connections

2.6 Connect the interface harness red (+) and black (-) battery clips to a 12-volt battery

3. Install the manometer.

3.1 Remove the 1/8 NPT pipe plug from the solenoid fuel valve located at the generator set fuel inlet connection. See Figure 5.

3.2 Connect the manometer to the solenoid fuel valve port.

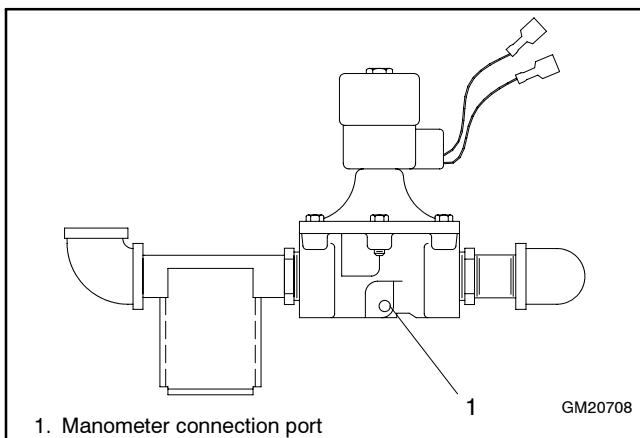

Figure 5 Solenoid Fuel Valve Manometer Port

4. Start and warm up the generator set.

4.1 Check that the generator set master switch is in the OFF position.

4.2 Reconnect the generator set engine starting battery, negative (-) lead last.

4.3 Place the generator set master switch in the RUN position to start generator set.

4.4 Allow the generator set to run until the generator set reaches normal operating temperature. The time required to reach normal operating temperature depends primarily on the ambient temperature and the size of the engine.

4.5 With the generator set at normal operating temperature, apply 90%-100% of rated load. If a load bank is not available, apply a load at least comparable to what is generally connected to the generator set.

4.6 Verify that the fuel pressure is within 7-11 inches of water at full load. Adjust the primary fuel regulator as necessary to achieve the fuel pressure of 7-11 inches of water as measured at the inlet side of the generator set fuel solenoid valve.

4.7 Remove the load and allow the generator set to run unloaded to cool for at least 5-10 minutes.

4.8 Place the generator set master switch in the OFF position to stop generator set.

5. Adjust the fuel mixture.

Choose the procedure based on the type of fuel mixer on the generator set.

- 5.1 **30-60 kW generator sets.** Venturi style fuel mixer used with an integrated throttle body governor on 4.3 L, 5.0 L, and 5.7 L GM engines. Also similar to the IMPCO model 100 used on the 30 kW with 3.0 L GM engine. See Figure 6.

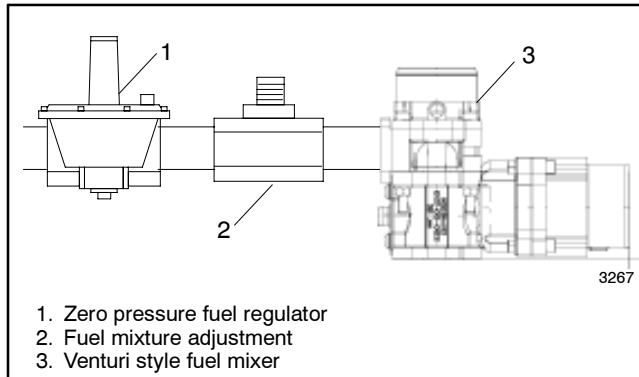

Figure 6 30-60 kW with Venturi Style Fuel Mixer

- 5.1.1 Place the generator set master switch in the RUN position to start generator set.
- 5.1.2 Allow the generator set to run until the generator set reaches normal operating temperature.
- 5.1.3 Apply 90%-100% of full rated load.
- 5.1.4 Adjust the fuel mixture adjustment (see Figure 6 and Figure 7) to obtain a full-load oxygen sensor voltage reading in the range specified in Figure 2.
- 5.1.5 Disconnect the load.

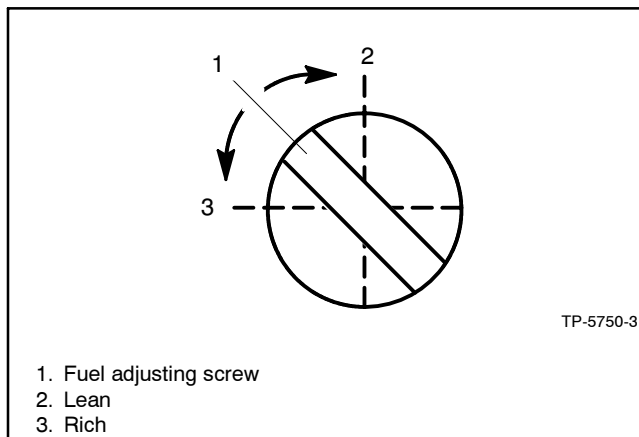

Figure 7 Fuel Mixture Adjustment, Typical

- 5.1.6 Adjust the zero pressure regulator (see Figure 6 and Figure 8) to obtain a no-load oxygen sensor voltage reading in the range specified in Figure 2.

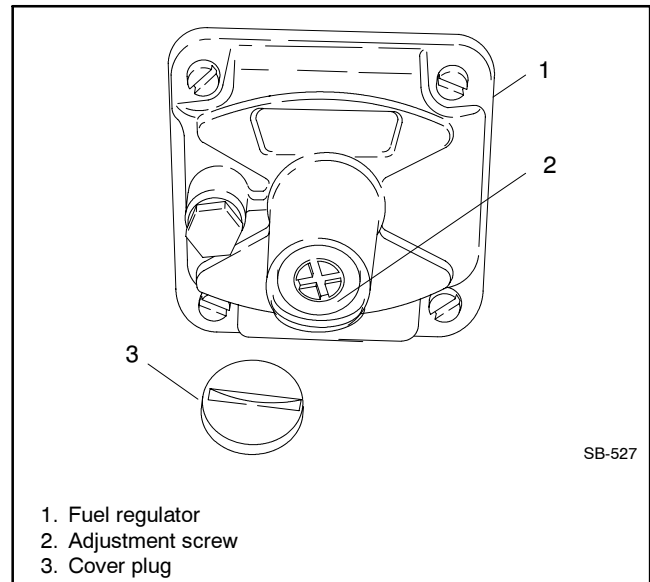

Figure 8 Fuel Regulator, Typical

- 5.1.7 Repeat steps 5.1.3 thru 5.1.6 until the oxygen sensor voltage reading is in the specified range for both no-load and full-load conditions.
- 5.1.8 Remove the load and allow the generator set to run unloaded to cool for at least 5-10 minutes.
- 5.1.9 Place the generator set master switch in the OFF position to stop generator set.

- 5.2 **30-80 kW generator sets.** Nolf NCA-225M and NCA-125M style fuel mixers used on early versions of 30-60 kW 4.3 L and 5.7 L GM engines, 30-60 kW LP liquid withdrawal systems, and 80 kW 8.1 L GM engines. See Figure 9.

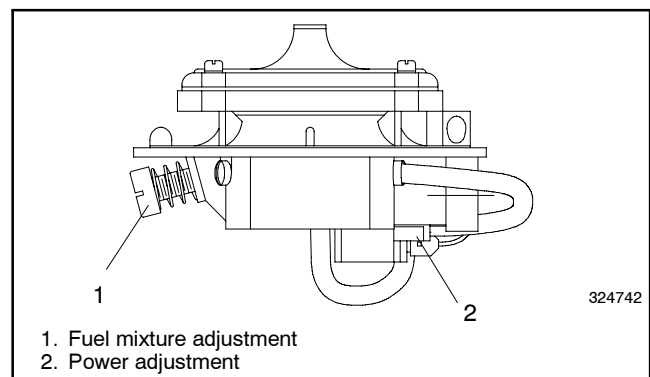

Figure 9 30-80 kW with Nolf NCA-225M and NCA-125M Style Fuel Mixers

- 5.2.1 Adjust the fuel regulator adjustment screw to the approximate midpoint of its adjustment range. See Figure 8.
 - 5.2.2 Place the generator set master switch in the RUN position to start generator set.
- Note:** If the generator set fails to start, turn the fuel regulator adjustment screw slightly in or out while the engine cranks.
- 5.2.3 Allow the generator set to run until the generator set reaches normal operating temperature.
 - 5.2.4 Apply 90%–100% of full rated load.
 - 5.2.5 Adjust the fuel mixture adjustment (Figure 9) to obtain a full-load oxygen sensor voltage reading in the range specified in Figure 2.

If the oxygen sensor voltage reading is too low with the fuel mixture adjustment in the richest position (turned in clockwise), turn the fuel regulator adjustment screw clockwise to richen the fuel mixture. Readjust the fuel mixture adjustment as needed to obtain an oxygen sensor voltage reading within specifications.

If the oxygen sensor voltage reading is too high with the fuel mixture adjustment in the leanest position (turned out counterclockwise), turn the fuel regulator adjustment screw counterclockwise to lean the fuel mixture. Readjust the fuel mixture adjustment as needed to obtain an oxygen sensor voltage reading within specifications.

- 5.2.6 Disconnect the load.
- 5.2.7 Adjust the fuel mixture adjustment to obtain a no-load oxygen sensor voltage reading within the specifications shown in Figure 2.

If the oxygen sensor specification cannot be met at no-load, turn the idle mixture screw in to the richest possible setting.
- 5.2.8 Repeat steps 5.2.4 through 5.2.7 to verify the settings.
- 5.2.9 Place the generator set master switch in the OFF position to stop generator set.

- 5.3 **100 and 125 kW (with single fuel) generator sets.** Nolff N16-475-5A and N16-475-9A style fuel mixers used on 100 kW 8.1 L GM and 125 kW 8.1 L GM turbocharged engines. See Figure 10. This fuel mixer style does not have a fuel mixture adjustment.

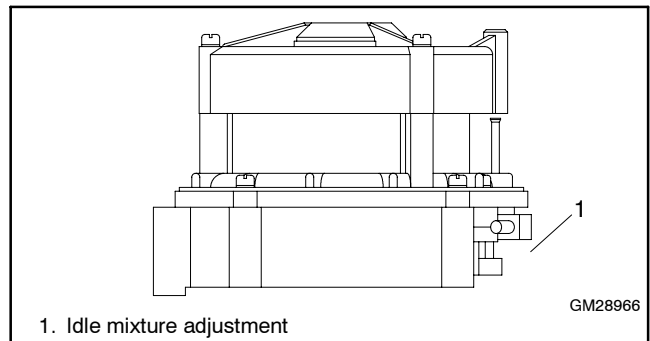

Figure 10 100/125 kW with Nolff 475 Style Fuel Mixer

- 5.3.1 Adjust the fuel regulator adjustment screw to the approximate midpoint of its adjustment range. See Figure 8.
- 5.3.2 Place the generator set master switch in the RUN position to start the generator set.
- 5.3.3 Allow the generator set to run until the generator set reaches normal operating temperature.
- 5.3.4 Apply 90%–100% of full rated load.
- 5.3.5 Adjust the fuel regulator adjustment screw to obtain a full-load oxygen sensor voltage reading in the range specified in Figure 2.
- 5.3.6 Disconnect the load.
- 5.3.7 Adjust the idle mixture adjustment (Figure 10) to obtain a no-load oxygen sensor voltage reading within specifications.

If the oxygen sensor specification cannot be met at no-load, turn the idle mixture screw out to the richest possible setting (2–2.5 turns).
- 5.3.8 Repeat steps 5.3.4 through 5.3.7 to verify the settings.
- 5.3.9 Place the generator set master switch in the OFF position to stop generator set.

5.4 **125 kW (with dual fuel) generator set.** Dual fuel units have a closed loop fuel control system that will automatically make adjustments in order to maintain a fuel/air mixture reading of approximately 2.4 volts using UEGO oxygen sensor.

5.4.1 Connect a PC laptop with monitoring software. Reference TP-6215 for instructions on how to use the software.

5.4.2 Adjust the fuel regulator adjustment screw to the approximate midpoint of its adjustment range. See Figure 8.

5.4.3 Place the generator set master switch in the RUN position to start the generator set.

5.4.4 Allow the generator set to run until the generator set reaches normal operating temperature.

5.4.5 Apply 90%–100% of full rated load.

5.4.6 Use the PC laptop and go to the Faults page and locate the Primary Trim Valve (FTV) parameter shown in the middle of the page to the right. Adjust the fuel regulator adjustment screw until the FTV indicates between 30% and 60%.

5.4.7 Disconnect the load.

5.4.8 Adjust the idle mixture adjustment (Figure 10) to obtain a no-load oxygen sensor voltage reading within specifications. See Figure 2.

If the oxygen sensor specification cannot be met at no-load, turn the idle mixture screw out to the richest possible setting (2–2.5 turns).

5.4.9 Repeat steps 5.4.5 through 5.4.8 to verify the settings.

5.4.10 Place the generator set master switch in the OFF position to stop generator set.

6. Stop the generator set.

6.1 Place the generator set master switch in the OFF position, if not already done..

6.2 Disconnect the generator set engine starting battery(ies), negative (-) lead first.

7. Remove the oxygen sensor and interface harness.

7.1 Allow the generator set exhaust system to cool.

7.2 Disconnect the battery clips from the battery.

7.3 Disconnect the interface harness from the digital voltmeter (DVM).

7.4 Disconnect the interface harness from the oxygen sensor.

7.5 Remove the oxygen sensor from the exhaust tube.

7.6 Apply a small amount of antiseize compound to the pipe plug and reinstall the pipe plug into the exhaust tube.

7.7 Remove the manometer hose fitting from the solenoid fuel valve.

7.8 Apply a small amount of antiseize compound to the pipe plug and reinstall the pipe plug into the solenoid fuel valve.

8. Restore the generator set to service.

8.1 Check that the generator set master switch is in the OFF position.

8.2 Reconnect the generator set engine starting battery, negative (-) lead last.

8.3 Reconnect the power to the battery charger, if equipped.