

SERVICE BULLETIN

Original Issue Date: **12/03**
 Model: **125 kW with General Motors Turbocharged 8.1 L Engine with Woodward or E-Controls Governor**
 Market: **Industrial**
 Subject: **Single Fuel Operation with Dual Fuel System**

Introduction

It is not uncommon for end users to select generator sets with dual fuel options and ultimately connect only one fuel. Special consideration must be taken with the 125 kW GM turbo engine because of the fuel pressure switches.

The following items are needed to convert the unit to a single fuel:

- Wiring diagram specific for the generator set spec no.
- Pipe plug for unused fuel line inlet
- Electrical tape

Low Fuel Pressure Switch (LFP1). The low fuel pressure switch no. 1 (LFP1) triggers the low pressure warning light. LFP1 is part of the optional prealarm kit and is located near the natural gas inlet which is on the lower right side toward the generator set front side. Leads 63 and N connect to LFP1. If the prealarm kit is not ordered, lead 63 terminal is taped to the harness.

Low Fuel Pressure Switch (LFP2). The low fuel pressure switch no. 2 (LFP2) signals the fuel valve control to switch from natural gas (NG) to liquid petroleum gas (LPG). The switch is located near the natural gas inlet. A black lead from pin E on the 6-pin connector and a brown lead from pin D on the 8-pin connector connect to LFP2 on a Woodward governor configuration. Leads LFP and N connect to LFP2 on an E-Controls governor configuration.

Low Fuel Pressure Switch (LFP3 with Woodward governor) or (LFPS with E-Controls governor). The low fuel pressure switch no. 3 (LFP3/LFPS) connects to the fault shutdown protecting the unit from lean backfire

damage. The switch is located near the LP inlet, which is on the lower left side near the front side on an LP vapor withdrawal system or on the upper left side if it is an LP liquid withdrawal system. Leads N and 30 (550 controller) or leads 70R and 30 (microprocessor controller) connect to LFP3/LFPS.

Safety Precautions

⚠ WARNING



**Accidental starting.
 Can cause severe injury or death.**

Disconnect the battery cables before working on the generator set. Remove the negative (-) lead first when disconnecting the battery. Reconnect the negative (-) lead last when reconnecting the battery.

Disabling the generator set. Accidental starting can cause severe injury or death. Before working on the generator set or connected equipment, disable the generator set as follows: (1) Move the generator set master switch to the OFF position. (2) Disconnect the power to the battery charger. (3) Remove the battery cables, negative (-) lead first. Reconnect the negative (-) lead last when reconnecting the battery. Follow these precautions to prevent starting of the generator set by an automatic transfer switch, remote start/stop switch, or engine start command from a remote computer.

Routing	Service Manager	Sales Manager	Parts Manager	Technician No. 1	Technician No. 2	Technician No. 3	Return This to
Initial Here							

⚠ WARNING

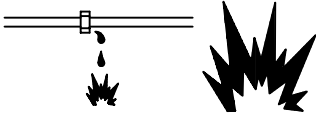

**Explosive fuel vapors.
Can cause severe injury or death.**

Use extreme care when handling,
storing, and using fuels.

Gas fuel leaks. Explosive fuel vapors can cause severe injury or death. Fuel leakage can cause an explosion. Check the LP vapor gas or natural gas fuel system for leakage by using a soap and water solution with the fuel system test pressurized to 6–8 ounces per square inch (10–14 inches water column). Do not use a soap solution containing either ammonia or chlorine because both prevent bubble formation. A successful test depends on the ability of the solution to bubble.

LPG Fuel without Natural Gas Fuel Connection

Without fuel pressure on the natural gas side, LFP2 will automatically switch to LPG. Apply pipe sealant suitable for gas fuel to male threads and install a pipe plug in the natural gas inlet.

Natural Gas Fuel without LPG Fuel Connection

1. Remove the generator set from service.

- 1.1 Place the generator set master switch in the OFF position.
- 1.2 Disconnect the power to the battery charger, if equipped.
- 1.3 Disconnect the generator set engine starting battery(ies), negative (-) lead first.
- 1.4 Close all fuel supply valves.

2. Perform the single gas fuel conversion (Woodward governor).

If the unit has an E-Controls governor, go to step 3.

The following arrangement has LFP2 functioning as LFP3. The original LFP3 is no longer connected. The function of LFP1 (if installed) is unchanged. See Figure 1 for the 550 controller connections and Figure 2 for the microprocessor connections.

- 2.1 Disconnect the brown (BRN) and black (BLK) leads from LFP2.
- 2.2 Tape to insulate the brown (BRN) and black (BLK) leads.
- 2.3 Disconnect leads N and 30 (550 controller) or 70R and 30 (microprocessor controller) from LFP3 located on the left side of the generator set.
- 2.4 Reroute and connect leads N and 30 (550 controller) or 70R and 30 (microprocessor controller) to LFP2 located on the right side of the generator set. Leads should have adequate length for this arrangement.
- 2.5 Apply pipe sealant suitable for gas fuel to male threads and install a pipe plug in the LPG inlet.

3. Perform the single gas fuel conversion (E-Controls governor).

If the unit has a Woodward governor, go to step 2.

The following arrangement has LFP2 functioning as LFPS. The original LFPS is no longer connected. The function of LFP1 (if installed) is unchanged. See Figure 3 for the 550 controller connections and Figure 4 for the microprocessor connections.

- 3.1 Disconnect lead LFP and N (jumper) from LFP2 located on the right side of the engine. Remove both ends of N (jumper).
- 3.2 Tape to insulate lead LFP.
- 3.3 Remove leads N and 30 (550 controller) or leads 70R and 30 (microprocessor controller) from LFPS located on the left side of the engine.
- 3.4 Reroute and connect leads N and 30 (550 controller) or leads 70R and 30 (microprocessor controller) to LFP2 on the right side of the generator set. Leads should have adequate length for this arrangement.
- 3.5 Apply pipe sealant suitable for gas fuel to male threads and install a pipe plug in the LPG inlet.

4. Restore the generator set to service.

- 4.1 Check that the generator set master switch is in the OFF position.
- 4.2 Reconnect the generator set engine starting battery, negative (-) lead last.
- 4.3 Reconnect power to the battery charger, if equipped.
- 4.4 Open the LP gas supply valve.

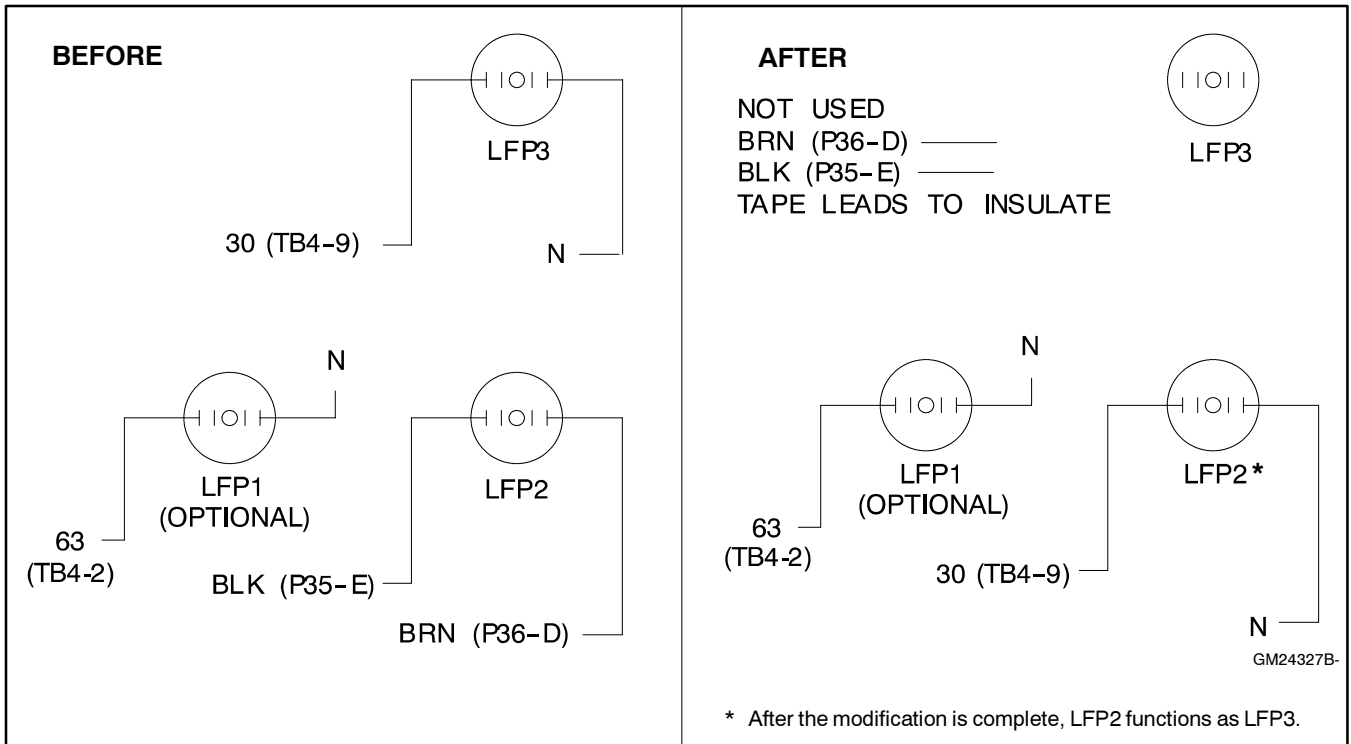

Figure 1 Fuel System Connections with 550 Controller and Woodward Governor

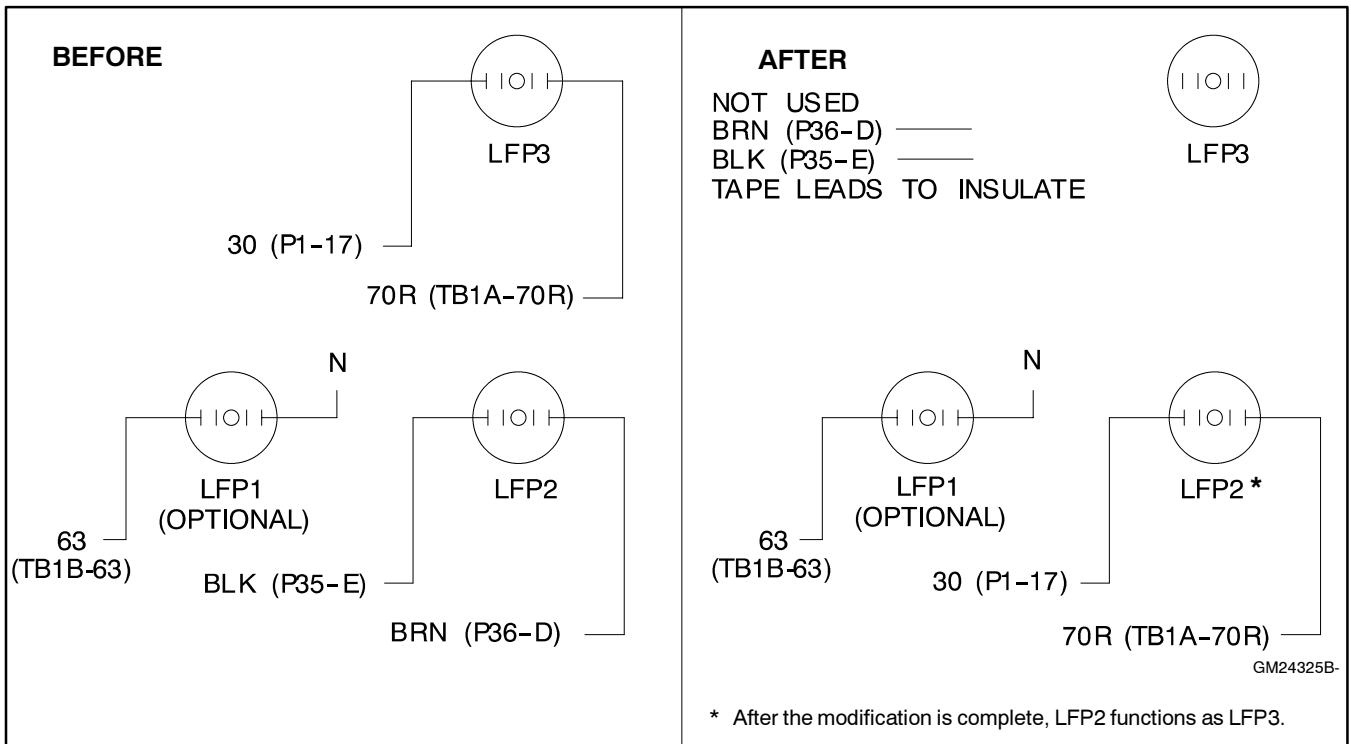

Figure 2 Fuel System Connections with Microprocessor Controller and Woodward Governor

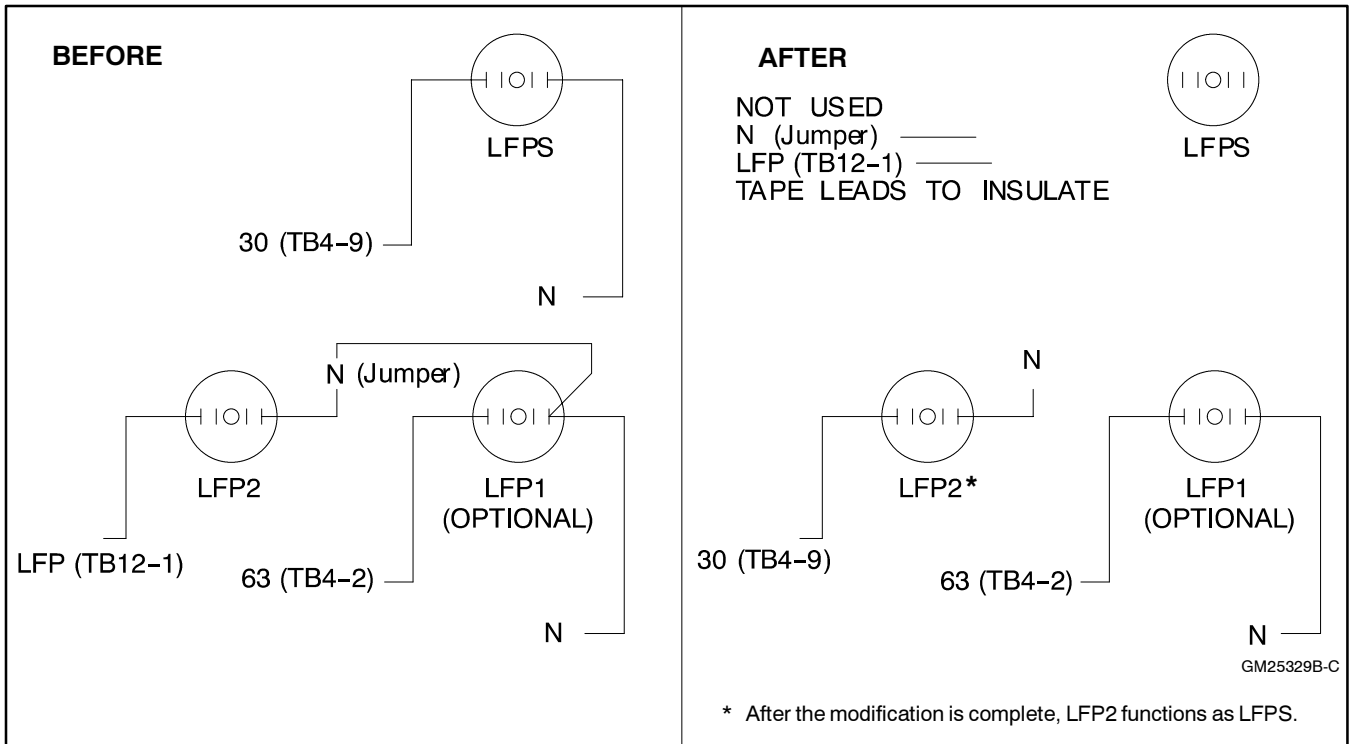

Figure 3 Fuel System Connections with 550 Controller and E-Controls Governor

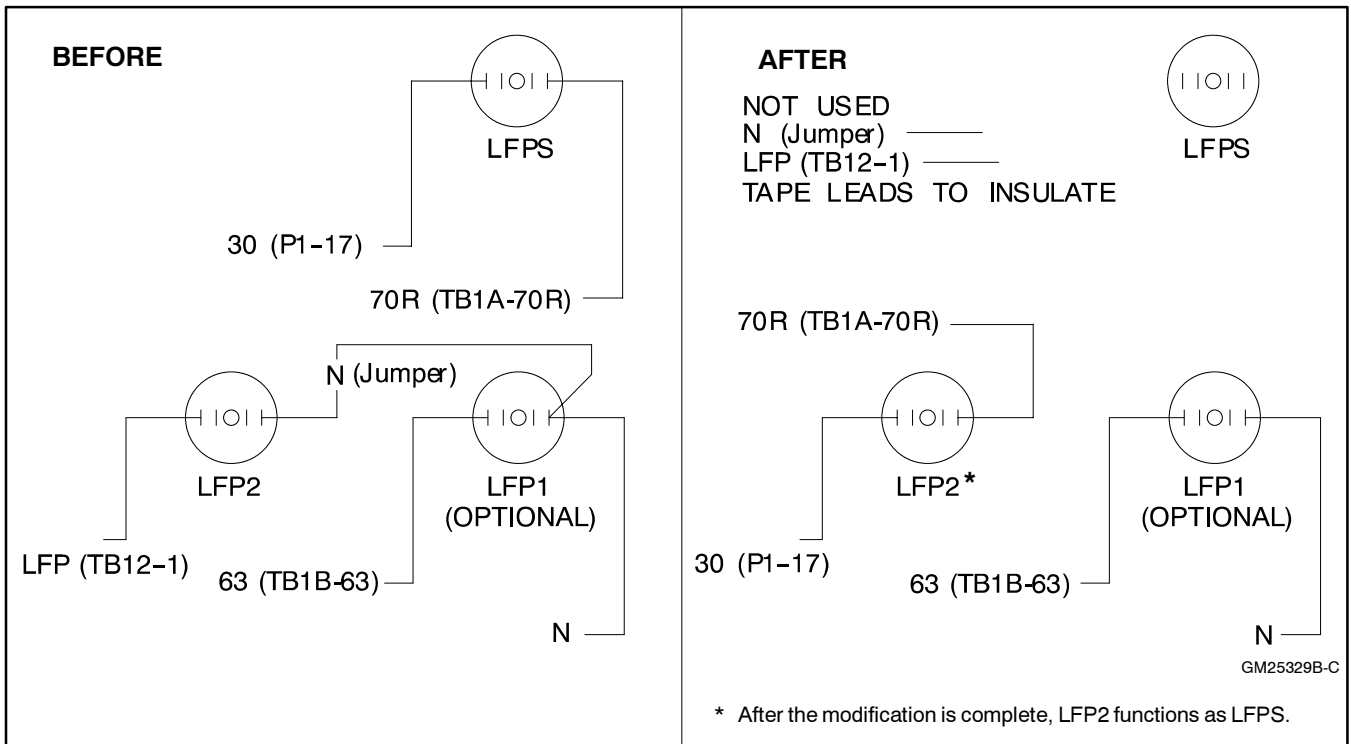

Figure 4 Fuel System Connections with Microprocessor Controller and E-Controls Governor