

**SERVICE BULLETIN**

Original Issue Date: 2/04

Model: 20-2000 kW (with 550 Controllers and Non-ECM Engines)

Market: Industrial

Subject: Coolant Temperature Sensor Service Kits GM31990 and GM31991

**Introduction**

Replacing the coolant temperature sensor on a generator set with a 550 controller and a non-ECM engine requires controller application software version 2.21 or higher.

The new sensor offers greater reliability with a different sensing range requiring the software upgrade. See Figure 1 for the coolant temperature sensor illustration and Figure 2 for coolant temperature sensor identification.

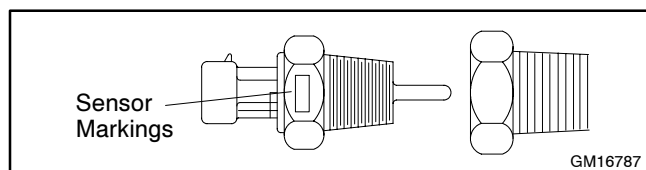

**Figure 1** Coolant Temperature Sensor and Reducer Bushing (if equipped), Typical

**Note:** Failure to upgrade to the new software, after changing the coolant temperature sensor, will cause the controller to sense a lower than actual coolant temperature. These lower temperature readings may prevent a fault shutdown during an actual high coolant temperature condition.

**Note:** If controller application software version 2.21 or higher is loaded for any reason and the coolant temperature sensor is NOT replaced, the user must change the temperature sensor selection in

Menu 20—Factory Setup. Failure to change the temperature sensor selection will cause the controller to sense a higher than actual coolant temperature and may cause nuisance high coolant temperature shutdown faults.

**Items Needed for Software Upgrade**

The following items are needed to complete the software upgrade. In order to expedite the upgrade process, it is recommended to use the KOHLERnet to request the program loader and application program software and download them on your PC *before* installing the kit. Use your SecurID® to access the KOHLERnet and click on the TechTools button URL to request the files to download.

**Note:** Technicians without access to the KOHLERnet must contact their local authorized distributor for obtaining software.

- Generator Set Operation Manual and Engine Operation Manual
- Monitor II Software Operation/Installation Manual
- Personal Computer (see Program Loader for requirements)
- Null modem RS-232 cable with a 9-pin male plug on the controller end
- Program Loader Software (see KOHLERnet)
- Application Code Software (see KOHLERnet)

SecurID® is a registered trademark of RSA Security Inc.

Sensor Service Kit Part Number	Sensor P/N (shown in Menu 20)	Sensor Thread	Sensor Version	Sensor Manufacturer and Markings on Hex	Sensor Voltage Range
—	GM16787	1/2-14 NPT	Old	Kavilco 3.2-4.4 HIGH	0.5-4.5
—	GM17362	1/2-14 NPT*	Old	Kavilco 3.2-4.4 HIGH	0.5-4.5
GM31990	GM31045-1	1/2-14 NPT	New	Airpax 5024-0443	0.2-1.5
GM31991	GM31045-2	M18-1.50	New	Airpax 5024-0468	0.2-1.5

Replace GM16787 with GM31045-1. Replace GM17362 with GM31045-2 and discard metric reducer bushing.  
 \* Long sensor tip, 41.2 mm (1.62 in.). Required with metric reducing bushing.

**Figure 2** Coolant Temperature Sensors Identification

Routing	Service Manager	Sales Manager	Parts Manager	Technician No. 1	Technician No. 2	Technician No. 3	Return This to
Initial Here							

## Safety Precautions

Observe the following safety precaution when installing the mount kit.

### **⚠ WARNING**

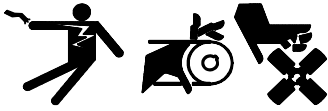

#### **Accidental starting. Can cause severe injury or death.**

Disconnect the battery cables before working on the generator set. Remove the negative (-) lead first when disconnecting the battery. Reconnect the negative (-) lead last when reconnecting the battery.

**Disabling the generator set. Accidental starting can cause severe injury or death.** Before working on the generator set or connected equipment, disable the generator set as follows: (1) Move the generator set master switch to the OFF position. (2) Disconnect the power to the battery charger. (3) Remove the battery cables, negative (-) lead first. Reconnect the negative (-) lead last when reconnecting the battery. Follow these precautions to prevent starting of the generator set by an automatic transfer switch, remote start/stop switch, or engine start command from a remote computer.

### **⚠ WARNING**



#### **Hot coolant and steam. Can cause severe injury or death.**

Before removing the pressure cap, stop the generator set and allow it to cool. Then loosen the pressure cap to relieve pressure.

### **⚠ WARNING**



#### **Hot engine and exhaust system. Can cause severe injury or death.**

Do not work on the generator set until it cools.

**Checking the coolant level. Hot coolant can cause severe injury or death.** Allow the engine to cool. Release pressure from the cooling system before removing the pressure cap. To release pressure, cover the pressure cap with a thick cloth and then slowly turn the cap counterclockwise to the first stop. Remove the cap after pressure has been completely released and the engine has cooled. Check the coolant level at the tank if the generator set has a coolant recovery tank.

## Installation Procedure

### 1. Remove the generator set from service.

- 1.1 Place the generator set master switch in the OFF/RESET position.
- 1.2 Disconnect the power to the battery charger, if equipped.
- 1.3 Disconnect the power to the block heater, if equipped.
- 1.4 Disconnect the generator set engine starting battery(ies), negative (-) lead first.

### 2. Locate and remove the coolant temperature sensor.

The coolant temperature sensor is typically at the front of the engine block near the water pump and/or intake manifold. The coolant temperature sensor has a 3-lead connector with red-black-white leads and identified as lead 5. See Figure 3 for coolant temperature sensor location.

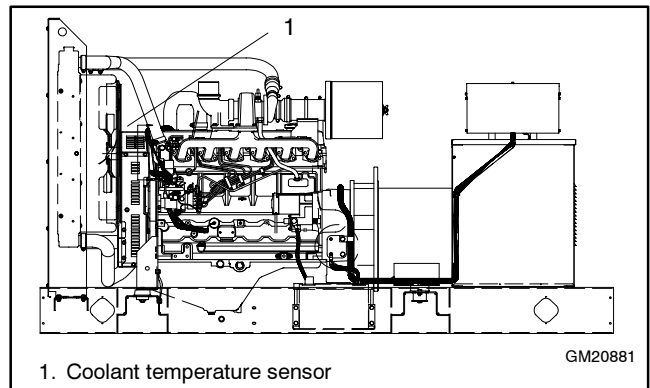

**Figure 3** Coolant Temperature Sensor Location

- 2.1 Allow the generator set to cool if the unit was recently operating.
- 2.2 Drain the coolant into a suitable container. Open the drain petcocks located at the bottom of the engine block and/or radiator. Drain the coolant to just below the coolant temperature sensor location.

2.3 Remove the electrical connector from the coolant temperature sensor.

2.4 Remove the coolant temperature sensor. Remove and discard the metric reducer bushing, if equipped.

### 3. Install the coolant temperature sensor and add coolant.

3.1 Clean the threaded hole in the engine block.

3.2 Install the new coolant temperature sensor in the engine block. The new sensor has Loctite® Vibra-Seal® 516 thread sealant already applied.

3.3 Attach the electrical connector to the coolant temperature sensor.

### 4. Fill the radiator with coolant.

4.1 Close all the drain petcocks located at the bottom of the engine block and/or radiator.

4.2 Refill the cooling system using the procedure and coolant recommendation given in the engine operation manual and/or generator set operation manual. See the respective spec sheet for coolant capacity.

Reuse the existing drained coolant if deemed acceptable. Otherwise, mix clean distilled water and coolant according to the engine manufacturer's recommendation in the engine operation manual.

Dispose of all waste materials (engine oil, fuel, coolant, etc.) in an environmentally safe manner. Contact local authority for procedures.

4.3 Use the procedure in the engine operation manual for deairating air in the cooling system. If deairation requires starting the generator set go to step 5.

### 5. Place the generator set into service.

5.1 Place the generator set master switch in the OFF/RESET position.

5.2 Reconnect the generator set engine starting battery(ies), negative (-) lead last.

5.3 Reconnect the power to the battery charger, if equipped.

5.4 Complete the deairation procedure before energizing the block heater.

5.5 Reconnect the power to the block heater, if equipped.

### 6. Install the application software (as needed).

6.1 Determine the application code version. Use the procedure found in the generator set operation manual for Menu 20—Factory Setup information.

6.2 If the application code version is 2.21 or higher, the software update is already done. The sensor installation is complete. Go to step 7.

If the application code version is less than application code version 2.21, continue with the software update.

6.3 Program loader and 550 controller application software files can be downloaded from the KOHLERnet. Use your SecurID to access the KOHLERnet and click on the TechTools button to request and download the files. Use the program loader instructions for completing the application code upgrade.

### 7. Determine the appropriate temperature sensor selection.

Change the temperature sensor selection using the controller keypad.

7.1 Go to Menu 20—Factory Setup. The menu can remain locked when changing the sensor selection. See Figure 4.

7.2 Scroll down to the TEMP SENSOR display.

7.3 Select the temperature sensor part number that matches the installed temperature sensor using the Right Arrow Key. See Figure 2 for additional identification information. When the correct display is shown, press YES and ENTER.

**Note:** For coolant temperature sensors GM31045-1 or GM31045-2, choose the GM31045X display.

7.4 Installation is complete. Place the controller master switch in the OFF/RESET position.

7.5 Disconnect the generator set engine starting battery(ies), negative (-) lead first.

**Note:** The generator set controller must have the power supply disconnected and then reconnected before the microprocessor will accept the change.

7.6 Reconnect the generator set engine starting battery(ies), negative (-) lead last.

7.7 At the next scheduled generator set exercise period or at this time, start the generator set by placing the generator set master switch in the RUN position.

Verify that the engine water temperature reading is valid and no water temperature warning/shutdown faults occur. Refer to the generator set operation manual and engine operation manual for operation information and temperature values.

When testing is complete, stop the generator set by placing the controller master switch in the OFF/RESET position.

## Parts Lists

Kit: GM31990		
Qty.	Description	Part No.
1	Sensor, coolant temperature	GM31045-1

Kit: GM31991		
Qty.	Description	Part No.
1	Sensor, coolant temperature	GM31045-2

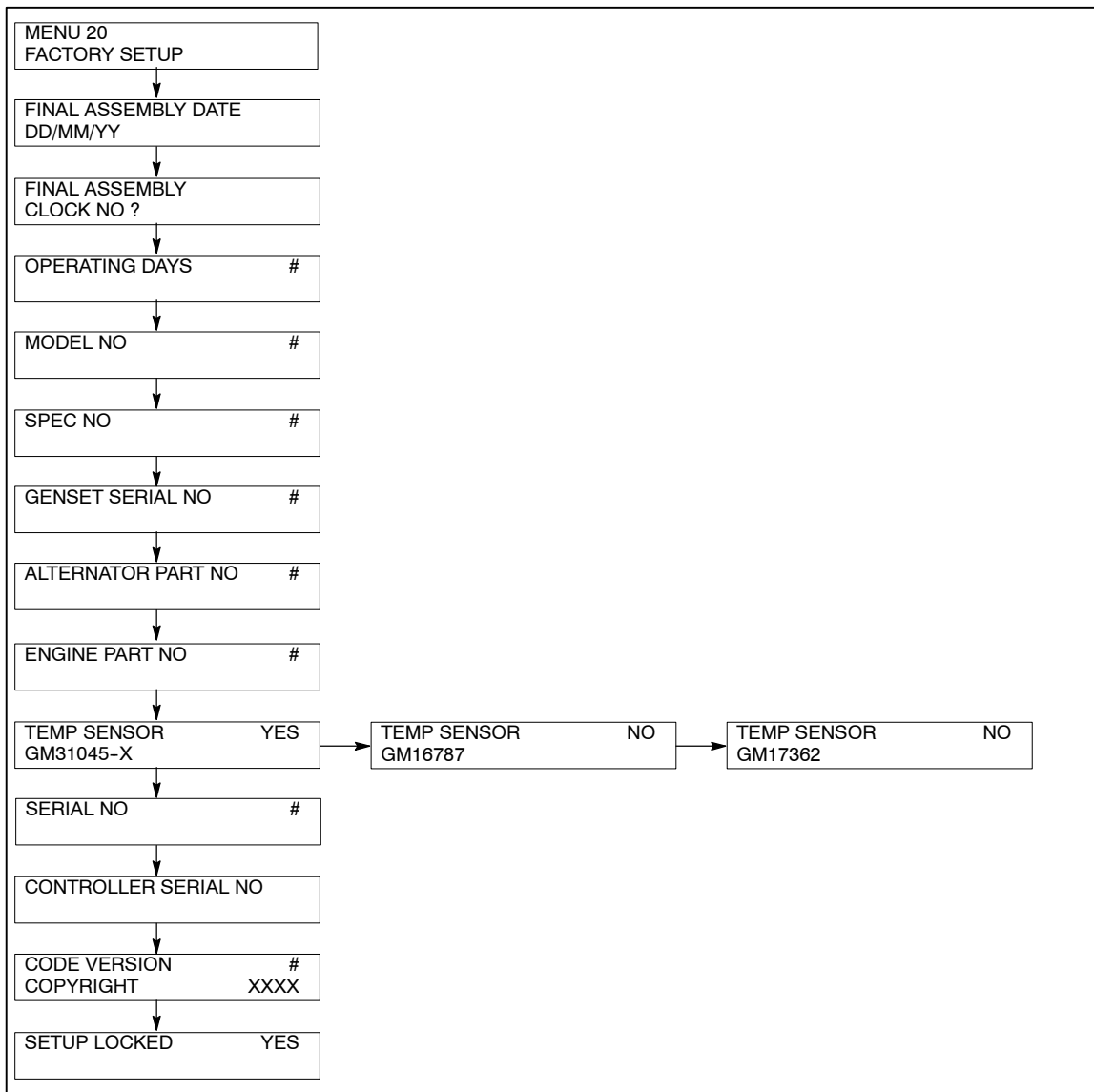

Figure 4 Menu 20—Factory Setup