

Service



Industrial Generator Sets

Models:

20-2800 kW

Controllers:

Basic

Microprocessor-Plus

Digital

Digital 550

Includes:

Gas Fuel Systems

Governor Adjustments



Table of Contents

Product Identification Information	2
Safety Precautions and Instructions	7
Introduction	13
Service Assistance	14
Section 1 Specifications	15
1.1 Introduction	15
1.2 Controller Identification	15
1.2.1 Basic	15
1.2.2 Microprocessor-Plus, 16-Light	15
1.2.3 Digital	15
1.2.4 Digital 550	15
1.3 Electrical Values	16
1.4 Pressure Senders	16
1.5 Temperature Senders	16
1.6 Temperature Switches	17
1.7 Pressure Switches	18
1.8 550 Controller Voltage Regulator	18
1.8.1 Features	18
1.8.2 Specifications	18
1.8.3 Calibrations	19
Section 2 Basic Troubleshooting	21
2.1 General Information	21
2.2 Relay Controller	26
2.3 Relay Controller Flowchart	27
Section 3 Microprocessor-Plus, 16-Light Troubleshooting	31
3.1 General Information	31
3.2 Circuit Board GM28725 Terminal/Connector Identification	39
3.3 Fault Shutdowns	41
3.4 Relay Descriptions	42
3.5 Troubleshooting	43
3.5.1 Fuses	44
3.5.2 Controller Flowcharts	45
3.6 FASTCHECK Diagnostic Tool Features and Operation	50
3.6.1 Features	50
3.6.2 Application	50
3.6.3 FASTCHECK Diagnostic Tool Use	51
3.6.4 Overcrank	51
3.6.5 Controller Speed Sensor Circuitry	52
3.6.6 Generator Set Condition Indicator Terminal (TB1 Terminal Strip)	52
Section 4 Digital Controller	55
4.1 General Repair Information	55
4.2 Controller Circuit Board Service Kits GM37440 and GM37441	56
4.2.1 Introduction	56
4.2.2 Items Required	56
4.2.3 Procedure	57
4.2.4 User-Defined Settings	61
4.3 Noise and Wiring Practices	63

Table of Contents, continued

Section 5 Digital 550 Controller	65
5.1 General Repair Information	65
5.2 Controller Service Replacement Kits	66
5.2.1 Introduction	66
5.2.2 Installation Requirements	67
5.2.3 Software Compatibility	67
5.2.4 Procedure	67
5.2.5 Display Items for Reference	74
5.2.6 User-Defined Settings (550 Controller Prior to Version 2.10)	75
5.2.7 User-Defined Settings (550 Controller Version 2.10 or Higher)	77
5.3 Coolant Temperature Sensor Service Kits	81
5.3.1 Introduction	81
5.3.2 Items Needed for Software Upgrade	81
5.3.3 Procedure	81
5.4 Controller Circuit Board Failures	84
5.5 Noise and Wiring Practices	85
Section 6 Component Testing and Adjustment	87
6.1 Controller Circuit Board Handling	87
6.1.1 Circuit Board Handling	87
6.1.2 Circuit Board Removal	87
6.1.3 Circuit Board Replacement	88
6.2 Other Service Parts	88
6.2.1 Removal	88
6.2.2 Installation	88
6.3 General Information	88
6.4 Leads/Wires/Wiring Harnesses	88
6.5 Battery Equalizer, 135-275 kW DDC-Powered Gas Models	89
6.5.1 Theory of Operation	89
6.5.2 Battery Equalizer Circuit Breaker	90
6.5.3 Battery Equalizer Troubleshooting	90
6.6 Controller Selector Switch	91
6.7 Crank Relay	92
6.8 Current Transformers	92
6.8.1 Function and Application	92
6.8.2 Testing	93
6.9 Engine Pressure and Temperature Sensors	93
6.9.1 General	93
6.9.2 Sensor Types	93
6.9.3 Switch Testing	93
6.9.4 Sender Testing	94
6.9.5 Oil Pressure Sender Testing	94
6.9.6 Water Temperature Sender Testing	94
6.10 Digital Interface (Circuit) Boards B-354647/C-354647	94
6.11 Low Fuel Pressure (Vacuum) Switches	96
6.12 Low Water Level	97
6.12.1 2-Wire Sender	97
6.12.2 3-Wire Sender	98
6.13 Over/Underfrequency Relay with 16-Light Controller	99
6.13.1 Function and Connection	99
6.13.2 Overfrequency Adjustment	99
6.13.3 Underfrequency Adjustment	99

Table of Contents, continued

6.14	Overvoltage Feature with 16-Light Controller	99
6.14.1	Function and Application	99
6.14.2	Testing and Adjustment	100
6.15	Reactive Droop Compensator	101
6.15.1	Function and Application	101
6.15.2	Reactive Droop Compensator Adjustment Procedure	101
6.15.3	Reactive Droop Compensator Alternate Adjustment Procedure	102
6.15.4	Testing	102
6.16	Remote Serial Annunciator	102
6.16.1	DIP Switches	103
6.16.2	Terminating Resistor	103
6.16.3	16-Light Controller Configuration	104
6.16.4	550 Controller Configuration	104
6.16.5	Service Disassembly	104
6.17	Communication Module Kit and Gauge Driver Circuit Board	105
6.17.1	Communication Modules (Circuit Board) Versions	106
6.17.2	Circuit Board Views	106
6.18	Speed Sensor	107
6.18.1	Speed Sensor Test with Generator Set Running	107
6.18.2	Speed Sensor Test with Separate 12 VDC Source	107
6.19	Time Delay Relay	108
6.19.1	Sequence of Operation, Engine Cranking and Running	108
6.19.2	Sequence of Operation, Engine Shutdown	108
Section 7 Gas Fuel Systems		111
7.1	Fuel System Concepts	111
7.1.1	Gas Fuel System Concept	111
7.1.2	LP Liquid Withdrawal Fuel System Concept	111
7.2	LP Gas/Natural Gas Conversion	111
7.2.1	Straight Gas Fuel System	111
7.2.2	Gas Fuel Conversion Procedure	112
7.3	Fuel System Changeover Kits	113
7.3.1	Automatic Changeover Theory of Operation	113
7.3.2	Manual Changeover Theory of Operation	113
7.4	Carburetor/Gas Mixer Adjustment	114
7.4.1	Gasoline Carburetor Adjustment Procedure	114
7.4.2	Gas Mixer Adjustment Procedure (Typical)	114
7.5	Fuel System Maintenance	114
7.5.1	Gasoline Models (20 kW, Ford LRG-425 Powered only)	114
7.5.2	Gaseous Models	114
7.6	Fuel System Troubleshooting	115
7.7	Engine Ignition Timing Specifications	115
7.8	Natural Gas to LP Gas Vapor Conversion	118
7.9	Fuel Mixture Adjustment with Oxygen Sensor A-345052	121
7.10	Natural Gas to LP Gas Vapor Conversion	123
7.11	Fuel Mixture Adjustment (Oxygen Sensor Service Kit GM29385)	128
Section 8 Governor Adjustments		133
8.1	Governor Identification	133
8.1.1	Gas Models	133
8.1.2	Diesel Models	134
8.2	Electronic Governor	135
8.2.1	A-246045	135
8.2.2	GM17644-4 (Non-Load Sharing) and GM17644-5 (Load Sharing)	136

Table of Contents, continued

8.3	Mechanical Governor	137
8.3.1	Stanadyne DB2/DB4	137
8.3.2	Bosch P	138
8.4	Magnetic Pickup Adjustment	138
8.5	Digital Isochronous Governor Programming Kit GM39344	139
8.5.1	Introduction	139
8.5.2	Kit Components	139
8.5.3	Features and Specifications	140
8.5.4	Keypad Functions	140
8.5.5	LED Display Functions (Load Share Model only)	142
8.5.6	PST Software	142
8.5.7	PC System Requirements	142
8.5.8	PST User Interface Overview	143
8.5.9	PST Menu Items	143
8.5.10	Parameter Setup	143
8.5.11	Status View	143
8.5.12	Tuning View	144
8.5.13	Chart Recorder	144
8.5.14	Installation Procedure	144
8.5.15	Troubleshooting	145
8.6	Parameter Definitions	146
8.7	Parameter Defaults Reference	150
8.8	Parameter Default Settings	151
8.9	Calibration Instructions	152
8.9.1	Basic Adjustments	152
8.9.2	Calibration Techniques	152
8.10	Diagnostics and Troubleshooting	154
8.10.1	Introduction	154
8.10.2	Display Codes (Load Share Model)	154
8.10.3	LED Indications (Non-Load Share Model)	154
8.10.4	Troubleshooting Chart	154
Appendix A Abbreviations		157
Appendix B Common Hardware Application Guidelines		159
Appendix C General Torque Specifications		160
Appendix D Common Hardware Identification		161
Appendix E Common Hardware List		162

Safety Precautions and Instructions

IMPORTANT SAFETY INSTRUCTIONS. Electromechanical equipment, including generator sets, transfer switches, switchgear, and accessories, can cause bodily harm and pose life-threatening danger when improperly installed, operated, or maintained. To prevent accidents be aware of potential dangers and act safely. Read and follow all safety precautions and instructions. **SAVE THESE INSTRUCTIONS.**

This manual has several types of safety precautions and instructions: Danger, Warning, Caution, and Notice.

DANGER

Danger indicates the presence of a hazard that **will cause severe personal injury, death, or substantial property damage.**

WARNING

Warning indicates the presence of a hazard that **can cause severe personal injury, death, or substantial property damage.**

CAUTION

Caution indicates the presence of a hazard that **will or can cause minor personal injury or property damage.**

NOTICE

Notice communicates installation, operation, or maintenance information that is safety related but not hazard related.

Safety decals affixed to the equipment in prominent places alert the operator or service technician to potential hazards and explain how to act safely. The decals are shown throughout this publication to improve operator recognition. Replace missing or damaged decals.

Accidental Starting

WARNING



**Accidental starting.
Can cause severe injury or death.**

Disconnect the battery cables before working on the generator set. Remove the negative (-) lead first when disconnecting the battery. Reconnect the negative (-) lead last when reconnecting the battery.

Disabling the generator set. Accidental starting can cause severe injury or death. Before working on the generator set or connected equipment, disable the generator set as follows: (1) Move the generator set master switch to the OFF position. (2) Disconnect the power to the battery charger. (3) Remove the battery cables, negative (-) lead first. Reconnect the negative (-) lead last when reconnecting the battery. Follow these precautions to prevent starting of the generator set by an automatic transfer switch, remote start/stop switch, or engine start command from a remote computer.

Battery

WARNING



**Sulfuric acid in batteries.
Can cause severe injury or death.**

Wear protective goggles and clothing. Battery acid may cause blindness and burn skin.

WARNING



**Explosion.
Can cause severe injury or death.
Relays in the battery charger
cause arcs or sparks.**

Locate the battery in a well-ventilated area. Isolate the battery charger from explosive fumes.

Battery electrolyte is a diluted sulfuric acid. Battery acid can cause severe injury or death. Battery acid can cause blindness and burn skin. Always wear splashproof safety goggles, rubber gloves, and boots when servicing the battery. Do not open a sealed battery or mutilate the battery case. If battery acid splashes in the eyes or on the skin, immediately flush the affected area for 15 minutes with large quantities of clean water. Seek immediate medical aid in the case of eye contact. Never add acid to a battery after placing the battery in service, as this may result in hazardous spattering of battery acid.

Battery acid cleanup. Battery acid can cause severe injury or death. Battery acid is electrically conductive and corrosive. Add 500 g (1 lb.) of bicarbonate of soda (baking soda) to a container with 4 L (1 gal.) of water and mix the neutralizing solution. Pour the neutralizing solution on the spilled battery acid and continue to add the neutralizing solution to the spilled battery acid until all evidence of a chemical reaction (foaming) has ceased. Flush the resulting liquid with water and dry the area.

Battery gases. Explosion can cause severe injury or death. Battery gases can cause an explosion. Do not smoke or permit flames or sparks to occur near a battery at any time, particularly when it is charging. Do not dispose of a battery in a fire. To prevent burns and sparks that could cause an explosion, avoid touching the battery terminals with tools or other metal objects. Remove all jewelry before servicing the equipment. Discharge static electricity from your body before touching batteries by first touching a grounded

metal surface away from the battery. To avoid sparks, do not disturb the battery charger connections while the battery is charging. Always turn the battery charger off before disconnecting the battery connections. Ventilate the compartments containing batteries to prevent accumulation of explosive gases.

Battery short circuits. Explosion can cause severe injury or death. Short circuits can cause bodily injury and/or equipment damage. Disconnect the battery before generator set installation or maintenance. Remove all jewelry before servicing the equipment. Use tools with insulated handles. Remove the negative (-) lead first when disconnecting the battery. Reconnect the negative (-) lead last when reconnecting the battery. Never connect the negative (-) battery cable to the positive (+) connection terminal of the starter solenoid. Do not test the battery condition by shorting the terminals together.

Engine Backfire/Flash Fire

⚠ WARNING

Fire. Can cause severe injury or death.
Do not smoke or permit flames or sparks near fuels or the fuel system.

Servicing the fuel system. A flash fire can cause severe injury or death. Do not smoke or permit flames or sparks near the carburetor, fuel line, fuel filter, fuel pump, or other potential sources of spilled fuels or fuel vapors. Catch fuels in an approved container when removing the fuel line or carburetor.

Servicing the air cleaner. A sudden backfire can cause severe injury or death. Do not operate the generator set with the air cleaner removed.

Combustible materials. A fire can cause severe injury or death. Generator set engine fuels and fuel vapors are flammable and explosive. Handle these materials carefully to minimize the risk of fire or explosion.

Equip the compartment or nearby area with a fully charged fire extinguisher. Select a fire extinguisher rated ABC or BC for electrical fires or as recommended by the local fire code or an authorized agency. Train all personnel on fire extinguisher operation and fire prevention procedures.

Exhaust System

⚠ WARNING

Carbon monoxide. Can cause severe nausea, fainting, or death.
The exhaust system must be leakproof and routinely inspected.

Generator set operation. Carbon monoxide can cause severe nausea, fainting, or death. Carbon monoxide is an odorless, colorless, tasteless, nonirritating gas that can cause death if inhaled for even a short time. Avoid breathing exhaust fumes when working on or near the generator set. Never operate the generator set inside a building unless the exhaust gas is piped safely outside. Never operate the generator set where exhaust gas could accumulate and seep back inside a potentially occupied building.

Carbon monoxide symptoms. Carbon monoxide can cause severe nausea, fainting, or death. Carbon monoxide is a poisonous gas present in exhaust gases. Carbon monoxide poisoning symptoms include but are not limited to the following:

- Light-headedness, dizziness
 - Physical fatigue, weakness in joints and muscles
 - Sleepiness, mental fatigue, inability to concentrate or speak clearly, blurred vision
 - Stomachache, vomiting, nausea
- If experiencing any of these symptoms and carbon monoxide poisoning is possible, seek fresh air immediately and remain active. Do not sit, lie down, or fall asleep. Alert others to the possibility of carbon monoxide poisoning. Seek medical attention if the condition of affected persons does not improve within minutes of breathing fresh air.

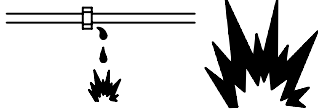
Fuel System

⚠ WARNING

Explosive fuel vapors. Can cause severe injury or death.

Use extreme care when handling, storing, and using fuels.

The fuel system. Explosive fuel vapors can cause severe injury or death. Vaporized fuels are highly explosive. Use extreme care when handling and storing fuels. Store fuels in a well-ventilated area away from spark-producing equipment and out of the reach of children. Never add fuel to the tank while the engine is running because spilled fuel may ignite on contact with hot parts or from sparks. Do not smoke or permit flames or sparks to occur near sources of spilled fuel or fuel vapors. Keep the fuel lines and connections tight and in good condition. Do not replace flexible fuel lines with rigid lines. Use flexible sections to avoid fuel line breakage caused by vibration. Do not operate the generator set in the presence of fuel leaks, fuel accumulation, or sparks. Repair fuel systems before resuming generator set operation.

Explosive fuel vapors can cause severe injury or death. Take additional precautions when using the following fuels:

Gasoline—Store gasoline only in approved red containers clearly marked GASOLINE.

Propane (LP)—Adequate ventilation is mandatory. Because propane is heavier than air, install propane gas detectors low in a room. Inspect the detectors per the manufacturer's instructions.

Natural Gas—Adequate ventilation is mandatory. Because natural gas rises, install natural gas detectors high in a room. Inspect the detectors per the manufacturer's instructions.

Fuel tanks. Explosive fuel vapors can cause severe injury or death. Gasoline and other volatile fuels stored in day tanks or subbase fuel tanks can cause an explosion. Store only diesel fuel in tanks.

Draining the fuel system. Explosive fuel vapors can cause severe injury or death. Spilled fuel can cause an explosion. Use a container to catch fuel when draining the fuel system. Wipe up spilled fuel after draining the system.

Gas fuel leaks. Explosive fuel vapors can cause severe injury or death. Fuel leakage can cause an explosion. Check the LP vapor gas or natural gas fuel system for leakage by using a soap and water solution with the fuel system test pressurized to 6–8 ounces per square inch (10–14 inches water column). Do not use a soap solution containing either ammonia or chlorine because both prevent bubble formation. A successful test depends on the ability of the solution to bubble.

LP liquid withdrawal fuel leaks. Explosive fuel vapors can cause severe injury or death. Fuel leakage can cause an explosion. Check the LP liquid withdrawal gas fuel system for leakage by using a soap and water solution with the fuel system test pressurized to at least 90 psi (621 kPa). Do not use a soap solution containing either ammonia or chlorine because both prevent bubble formation. A successful test depends on the ability of the solution to bubble.

Hazardous Noise

CAUTION



**Hazardous noise.
Can cause hearing loss.**

Never operate the generator set without a muffler or with a faulty exhaust system.

Engine noise. Hazardous noise can cause hearing loss. Generator sets not equipped with sound enclosures can produce noise levels greater than 105 dBA. Prolonged exposure to noise levels greater than 85 dBA can cause permanent hearing loss. Wear hearing protection when near an operating generator set.

Hazardous Voltage/ Electrical Shock

DANGER



**Hazardous voltage.
Will cause severe injury or death.**

Disconnect all power sources before opening the enclosure.

WARNING



**Hazardous voltage. Moving rotor.
Can cause severe injury or death.**

Operate the generator set only when all guards and electrical enclosures are in place.

WARNING



**Hazardous voltage.
Backfeed to the utility system can cause property damage, severe injury, or death.**

If the generator set is used for standby power, install an automatic transfer switch to prevent inadvertent interconnection of standby and normal sources of supply.

CAUTION



**Welding the generator set.
Can cause severe electrical equipment damage.**

Never weld components of the generator set without first disconnecting the battery, controller wiring harness, and engine electronic control module (ECM).

Grounding electrical equipment. Hazardous voltage can cause severe injury or death. Electrocutation is possible whenever electricity is present. Open the main circuit breakers of all power sources before servicing the equipment. Configure the installation to electrically ground the generator set, transfer switch, and related equipment and electrical circuits to comply with applicable codes and standards. Never contact electrical leads or appliances when standing in water or on wet ground because these conditions increase the risk of electrocution.

High voltage test. Hazardous voltage can cause severe injury or death. Follow the instructions of the test equipment manufacturer when performing high-voltage tests on the rotor or stator. An improper test procedure can damage equipment or lead to generator set failure.

Testing the photo transistor circuit board. Hazardous voltage can cause severe injury or death. When the end cover is removed, do not expose the photo transistor circuit board mounted on the generator set end bracket to any external light source, as exposure to light causes high voltage. Keep foreign sources of light away from the photo transistor circuit board during testing. Place black electrical tape over the LED on the circuit board before starting the generator set.

Installing the photo transistor circuit board. Hazardous voltage can cause severe injury or death. Ensure that the foil side of the photo transistor circuit board, the end of the shaft, and the threaded holes are clean and free of metal particles and chips. Metal debris may short-circuit the photo transistor circuit board and cause hazardous voltage in the generator set. Do not reconnect the generator set to the load until the AC voltmeter shows the correct output.

Welding on the generator set. Can cause severe electrical equipment damage. Before welding on the generator set perform the following steps: (1) Remove the battery cables, negative (-) lead first. (2) Disconnect all engine electronic control module (ECM) connectors. (3) Disconnect all generator set controller and voltage regulator circuit board connectors. (4) Disconnect the engine battery-charging alternator connections. (5) Attach the weld ground connection close to the weld location.

Installing the battery charger. Hazardous voltage can cause severe injury or death. An ungrounded battery charger may cause electrical shock. Connect the battery charger enclosure to the ground of a permanent wiring system. As an alternative, install an equipment grounding conductor with circuit conductors and connect it to the equipment grounding terminal or the lead on the battery charger. Install the battery charger as prescribed in the equipment manual. Install the battery charger in compliance with local codes and ordinances.

Connecting the battery and the battery charger. Hazardous voltage can cause severe injury or death. Reconnect the battery correctly, positive to positive and negative to negative, to avoid electrical shock and damage to the battery charger and battery(ies). Have a qualified electrician install the battery(ies).

Short circuits. Hazardous voltage/current can cause severe injury or death. Short circuits can cause bodily injury and/or equipment damage. Do not contact electrical connections with tools or jewelry while making adjustments or repairs. Remove all jewelry before servicing the equipment.

Engine block heater. Hazardous voltage can cause severe injury or death. The engine block heater can cause electrical shock. Remove the engine block heater plug from the electrical outlet before working on the block heater electrical connections.

Electrical backfeed to the utility. Hazardous backfeed voltage can cause severe injury or death. Install a transfer switch in standby power installations to prevent the connection of standby and other sources of power. Electrical backfeed into a utility electrical system can cause severe injury or death to utility personnel working on power lines.

Testing live electrical circuits. Hazardous voltage or current can cause severe injury or death. Have trained and qualified personnel take diagnostic measurements of live circuits. Use adequately rated test equipment with electrically insulated probes and follow the instructions of the test equipment manufacturer when performing voltage tests. Observe the following precautions when performing voltage tests: (1) Remove all jewelry. (2) Stand on a dry, approved electrically insulated mat. (3) Do not touch the enclosure or components inside the enclosure. (4) Be prepared for the system to operate automatically. *(600 volts and under)*

Heavy Equipment

⚠ WARNING

<p>Unbalanced weight. Improper lifting can cause severe injury or death and equipment damage.</p> <p>Do not use lifting eyes. Lift the generator set using lifting bars inserted through the lifting holes on the skid.</p>

Hot Parts

⚠ WARNING

<p>Hot coolant and steam. Can cause severe injury or death.</p> <p>Before removing the pressure cap, stop the generator set and allow it to cool. Then loosen the pressure cap to relieve pressure.</p>



⚠ WARNING

<p>Hot engine and exhaust system. Can cause severe injury or death.</p> <p>Do not work on the generator set until it cools.</p>



Servicing the alternator. Hot parts can cause severe injury or death. Avoid touching the alternator field or exciter armature. When shorted, the alternator field and exciter armature become hot enough to cause severe burns.

Checking the coolant level. Hot coolant can cause severe injury or death. Allow the engine to cool. Release pressure from the cooling system before removing the pressure cap. To release pressure, cover the pressure cap with a thick cloth and then slowly turn the cap counterclockwise to the first stop. Remove the cap after pressure has been completely released and the engine has cooled. Check the coolant level at the tank if the generator set has a coolant recovery tank.

Servicing the exhaust system. Hot parts can cause severe injury or death. Do not touch hot engine parts. The engine and exhaust system components become extremely hot during operation.

Moving Parts

⚠ WARNING	
	
Hazardous voltage. Moving rotor. Can cause severe injury or death.	
Operate the generator set only when all guards and electrical enclosures are in place.	

⚠ WARNING	
	
Rotating parts. Can cause severe injury or death.	
Operate the generator set only when all guards, screens, and covers are in place.	

⚠ WARNING	
	
Airborne particles. Can cause severe injury or blindness.	
Wear protective goggles and clothing when using power tools, hand tools, or compressed air.	

Tightening the hardware. Flying projectiles can cause severe injury or death. Loose hardware can cause the hardware or pulley to release from the generator set engine and can cause personal injury. Retorque all crankshaft and rotor hardware after servicing. Do not loosen the crankshaft hardware or rotor throbolt when making adjustments or servicing the generator set. Rotate the crankshaft manually in a clockwise direction only. Turning the crankshaft bolt or rotor throbolt counterclockwise can loosen the hardware.

Servicing the generator set when it is operating. Exposed moving parts can cause severe injury or death. Keep hands, feet, hair, clothing, and test leads away from the belts and pulleys when the generator set is running. Replace guards, screens, and covers before operating the generator set.

Notice

NOTICE	
This generator set has been rewired from its nameplate voltage to	
	
<small>246242</small>	

NOTICE

Voltage reconnection. Affix a notice to the generator set after reconnecting the set to a voltage different from the voltage on the nameplate. Order voltage reconnection decal 246242 from an authorized service distributor/dealer.

NOTICE

Hardware damage. The engine and generator set may use both American Standard and metric hardware. Use the correct size tools to prevent rounding of the bolt heads and nuts.

NOTICE

When replacing hardware, do not substitute with inferior grade hardware. Screws and nuts are available in different hardness ratings. To indicate hardness, American Standard hardware uses a series of markings, and metric hardware uses a numeric system. Check the markings on the bolt heads and nuts for identification.

NOTICE

Canadian installations only. For standby service connect the output of the generator set to a suitably rated transfer switch in accordance with Canadian Electrical Code, Part 1.

NOTICE

Electrostatic discharge damage. Electrostatic discharge (ESD) damages electronic circuit boards. Prevent electrostatic discharge damage by wearing an approved grounding wrist strap when handling electronic circuit boards or integrated circuits. An approved grounding wrist strap provides a high resistance (about 1 megohm), *not a direct short*, to ground.

Notes

This manual provides troubleshooting and repair instructions for the generator set models and controllers listed on the front cover.

Wiring diagram manuals are available separately.

Refer to the generator set controller operation manual for operating instructions. Refer to the engine operation manual for generator set engine scheduled maintenance information. Refer to the engine service manual for generator set engine repair and overhaul information.

Information in this publication represents data available at the time of print. The manufacturer of DDC/MTU Power Generation products reserves the right to change this publication and the products represented without notice and without any obligation or liability whatsoever.

Read this manual and carefully follow all procedures and safety precautions to ensure proper equipment operation and to avoid bodily injury. Read and follow the Safety Precautions and Instructions section at the beginning of this manual. Keep this manual with the equipment for future reference.

The equipment service requirements are very important to safe and efficient operation. Inspect the parts often and perform required service at the prescribed intervals. Maintenance work must be performed by appropriately skilled and suitably trained maintenance personnel familiar with generator set operation and service.

Service Assistance

For professional advice on generator power requirements and conscientious service, please contact your nearest DDC/MTU Power Generation distributor.

- Consult the Yellow Pages under the heading Generators—Electric.
- Visit the DDC/MTU Power Generation website at ddcmtupowergeneration.com.
- Look at the labels and stickers on your DDC/MTU Power Generation product or review the appropriate literature or documents included with the product.

1.1 Introduction

This service manual provides controller and accessory troubleshooting and repair information for the following controllers:

- Basic
- Microprocessor-Plus
- Digital
- Digital 550

The following illustrations identify each of the controllers. The controller specification sheets provide features and specifications for each controller.

1.2 Controller Identification

1.2.1 Basic

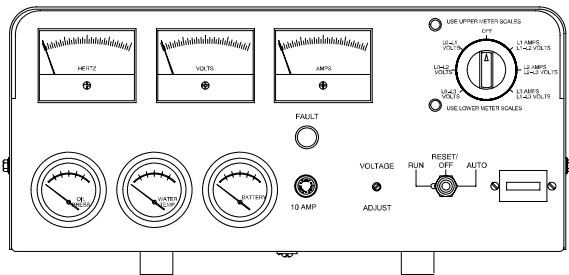

- Single-light annunciation and basic controls with NFPA capability.
- Relay logic, AC meters, and engine gauge features.
- 12-volt engine electrical system capability only.
- Remote or automatic start options.

1.2.2 Microprocessor-Plus, 16-Light

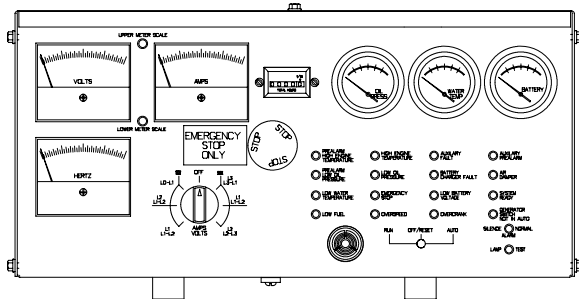

- Audiovisual annunciation with NFPA 110 Level 1 capability.
- Microprocessor logic, AC meters, and engine gauge features.
- 12- or 24-volt engine electrical system capability.
- Remote start, prime power, and remote annunciation options.

1.2.3 Digital

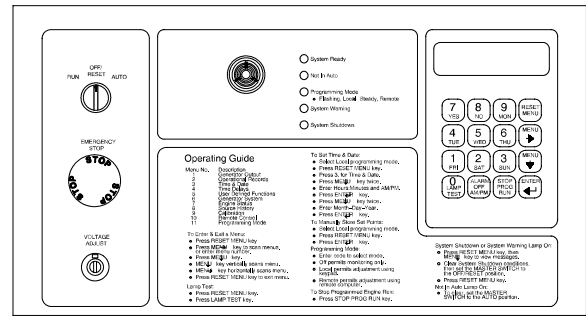

- Audiovisual annunciation with NFPA 110 Level 1 capability.
- Programmable microprocessor logic and digital display features.
- 12- or 24-volt engine electrical system capability.
- Remote start, prime power, remote annunciation, and remote communication options.

1.2.4 Digital 550

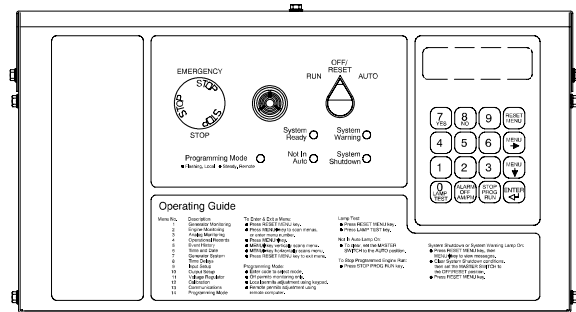

- Audiovisual annunciation with NFPA 110 Level 1 capability.
- Programmable microprocessor logic and digital display features.
- 12- or 24-volt engine electrical system capability.
- Remote start, remote annunciation, and remote communication options.

1.3 Electrical Values

Component Specification	Model, kW	Value
Controller and battery electrical system	20-180	12 volts DC
	50-400	24 volts DC (24-volt available on selected 50-180 kW models)
Speed sensor air gap	20-300	0.36-0.71 mm (0.014-0.028 in.)
Speed sensor voltage	20-300	2 (black) & 16 (white) 3-6 volts DC 2 (black) & 24 (red) 8-10 volts DC

1.4 Pressure Senders

Sensor P/N	Value A	Value B	Value C	Value D
365624	241 ± 16 ohms at 0 psi	152 ± 13 ohms at 50 psi	33.5 ohms at 200 psi	
264390	240 +17 -15 ohms at 0 psi	153 +12 -15 ohms at 25 psi	33.5 ohms at 100 psi	
328071	240 +17 -15 ohms at 0 psi	153 +12 -15 ohms at 25 psi	33.5 ohms at 100 psi	
344538	120 +9 -8 ohms at 0 psi	76.5 +6 -7.5 ohms at 25 psi	16.8 ohms at 100 psi	
226918	240 +17 -15 ohms at 0 psi	153 +12 -15 ohms at 25 psi	33.5 ohms at 100 psi	
267408	9 ± 4 ohms at 0 psi	48 ± 4 ohms at 15 psi	84 ± 4 ohms at 30 psi	120 ± 5 ohms at 45 psi
267967	9 ± 4 ohms at 0 psi	48 ± 4 ohms at 15 psi	84 ± 4 ohms at 30 psi	120 ± 5 ohms at 45 psi
249344	240 +17 -13 ohms at 0 psi	103 ± 11 ohms at 50 psi	33 +16 -12 ohms at 100 psi	
344305	10 ± 5 ohms at 0 psi	60 ± 5 ohms at 20 psi	115 ± 10 ohms at 80 psi	
343473	240 +2.5 -10.5 ohms at 0 psi	33.5 +10.5 -7.5 ohms at 100 psi		
343474	240 +2.5 -10.5 ohms at 0 psi	33.5 +10.5 -7.5 ohms at 150 psi		
364388	240 +2.5 -10.5 ohms at 0 psi	33.5 +10.5 -7.5 ohms at 100 psi		
GM29290	240 +17 -15 ohms at 0 psi	153 +12 -15 ohms at 25 psi	33.5 ohms at 100 psi	

1.5 Temperature Senders

Sensor P/N	Value A	Value B	Value C
226717	123.8 +7.2/-7.8 ohms at 195°F	35.6 +3.4/-3.6 ohms at 280°F	
249287	382 ± 40 ohms at 100°F	62 ± 6 ohms at 200°F	35 ohms at 240°F
249293	382 ± 40 ohms at 100°F	62 ± 6 ohms at 200°F	35 ohms at 240°F
249348	134 ± 10 ohms at 60°C	51.5 ± 4 ohms at 90°C	38 ± 3 ohms at 100°C
255240	180 ± 22 ohms at 130°F	71 ± 8 ohms at 180°F	
268298	180 ± 22 ohms at 130°F	71 ± 8 ohms at 180°F	
274988	123.8 ± 12.3 ohms at 195°F	35 ± 3.5 ohms at 280°F	
344539	100 ± 10 ohms at 130°F	40 ± 6 ohms at 180°F	
GM10166	123.8 +7.2/-7.8 ohms at 195°F	35.6 +3.4/-3.6 ohms at 280°F	
GM11402	180 ± 22 ohms at 130°F	71 ± 8 ohms at 180°F	
GM38523	123.8 +7.2/-7.8 ohms at 195°F	35.6 +3.4/-3.6 ohms at 280°F	

1.6 Temperature Switches

Sensor P/N	Epoxy Color	Value A	Value B
290090	Brass	Normally open-to close on temp. fall of 16°C ± 3°C (60°F ± 5°F)	Normally open-to close on temp. rise of 27°C ± 3°C (80°F ± 5°F)
255264	Brass	Normally open-to close on temp. fall of 16°C ± 3°C (60°F ± 5°F)	Normally open-to close on temp. rise of 27°C ± 3°C (80°F ± 5°F)
361956	Brass	Normally open-to close on temp. fall of 16°C ± 3°C (60°F ± 5°F)	Normally open-to close on temp. rise of 27°C ± 3°C (80°F ± 5°F)
241308	Black	Normally open-to close on temp. rise of 107°C ± 4°C (225°F ± 7°F)	
240976	Red	Normally open-to close on temp. rise of 96°C ± 4°C (205°F ± 7°F)	
240977	White	Normally open-to close on temp. rise of 80°C ± 4°C (190°F ± 7°F)	
241481	Olive	Normally open-to close on temp. rise of 103°C ± 4°C (218°F ± 7°F)	
253322		Normally open-to close on temp. rise of 107°C ± 4°C (225°F ± 7°F)	
255241	Green	Normally open-to close on temp. rise of 103°C ± 4°C (218°F ± 7°F)	
255242	Red	Normally open-to close on temp. rise of 96°C ± 4°C (205°F ± 7°F)	
326105	Black	Normally open-to close on temp. rise of 107°C ± 4°C (225°F ± 7°F)	
343160	Red w/blue dot	Normally open-to close on temp. rise of 99°C ± 4°C (210°F ± 7°F)	
326733	Red w/blue dot	Normally open-to close on temp. rise of 99°C ± 4°C (210°F ± 7°F)	
336849	Pink	Normally open-to close on temp. rise of 106°C ± 1.8°C (222°F ± 3°F)	
336848	Blue	Normally open-to close on temp. rise of 102°C ± 1.8°C (215°F ± 3°F)	
336923	Black w/white dot	Normally open-to close on temp. rise of 111°C ± 4°C (232°F ± 7°F)	
359614		Normally open-to close on temp. rise of 110°C ± 3°C (230°F ± 5°F)	
364456		Normally open-to close on temp. rise of 121°C ± 4°C (250°F ± 7°F)	
GM10061	Brass	Normally open-to close on temp. fall of 16°C ± 3°C (60°F ± 5°F)	Normally open-to close on temp. rise of 27°C ± 3°C (80°F ± 5°F)
GM19466	Brass	Normally open-to close on temp. fall of 16°C ± 3°C (60°F ± 5°F)	Normally open-to close on temp. rise of 27°C ± 3°C (80°F ± 5°F)
GM19475		Normally open-to close on temp. rise of 103°C ± 4°C (218°F ± 7°F)	
GM22525		Normally open-to close on temp. rise of 110°C ± 3°C (230°F ± 7°F)	
GM24223	Brass	Normally open-to close on temp. fall of 16°C ± 3°C (60°F ± 5°F)	Normally open-to close on temp. rise of 27°C ± 3°C (80°F ± 5°F)
GM24231		Normally open-to close on temp. rise of 103°C ± 4°C (218°F ± 7°F)	
GM24579	Red w/white dot	Normally open-to close on temp. rise of 98°C ± 2°C (208°F ± 4°F)	
GM24649	Black w/white dot	Normally open-to close on temp. rise of 111°C ± 4°C (232°F ± 7°F)	
GM24728	Brass	Normally open-to close on temp. fall of 16°C ± 3°C (60°F ± 5°F)	Normally open-to close on temp. rise of 27°C ± 3°C (80°F ± 5°F)
GM29288		Normally open-to close on temp. rise of 103°C ± 4°C (218°F ± 7°F)	
GM29293		Normally open-to close on temp. rise of 96°C ± 4°C (205°F ± 7°F)	

1.7 Pressure Switches

Sensor P/N	Value
271425	20 ± 2 psi
255912	34 ± 3 psi
255913	38 ± 3 psi
253323	15 ± 3 psi
289282	25 ± 2 psi
328308	8 ± 2.5 psi
328309	15 ± 2 psi
354564	4 ± 1.5 psi
361178	70 ± 2 psi
326856	40 ± 4 psi
364343	200 kPa ± 21 (29 ± 3 psi)
364344	234 kPa ± 21 (34 ± 3 psi)
364345	262 kPa ± 21 (38 ± 3 psi)
364346	551 kPa ± 48 (80 ± 7 psi)
364353	641 kPa ± 48 (93 ± 7 psi)
GM10574	40 ± 5 psi
GM10575	55 ± 5 psi
GM29292	20 ± 2 psi
GM30263	1 ± 0.3 psi

1.8 550 Controller Voltage Regulator

1.8.1 Features

- A digital display and keypad provide access to data. A 2-line vacuum fluorescent display provides complete and concise information.
- The controller provides an interface between the generator set and switchgear for paralleling applications incorporating multiple generator set and/or utility feeds.
- The controller can communicate with a personal computer directly or on a network.
- Using optional menu-driven, Windows®-based PC software, an operator can monitor engine and alternator parameters and also provide control capability.
- The controller supports Modbus® RTU (Remote Terminal Unit), an industry standard open communication protocol.

Modbus® is a registered trademark of Schneider Electric.
Windows® is a registered trademark of Microsoft Corporation.

1.8.2 Specifications

Specification/Feature	Voltage Regulator Type
	Integral with 550 Controller
Generator Set Capability	20–2800 kW Models
Type	Microprocessor based
Status and Shutdown Indicators	LEDs and Digital Display
Operating Temperature	-40°C to 70°C (-40°F to 158°F)
Storage Temperature	-40°C to 85°C (-40°F to 158°F)
Humidity	5-95% Non-Condensing
Circuit Protection	Solid-State, Redundant Software and Fuses
Sensing, Nominal	100–240 Volts (L-N), 50-60 Hz
Sensing Mode	RMS, Single- or 3-Phase
Input Requirements	8–36 VDC
Continuous Output	100 mA at 12 VDC
Maximum Output	100 mA at 12 VDC
Transition Frequency	50–70 Hz
Exciter Field Resistance	NA
No-Load to Full-Load Voltage Regulation	±0.25%
Thermal Drift	<0.5% (-40°C to 70°C range) [-40°F to 158°F]
Response Time	Less Than 5µS
Voltage Adjustment (of system voltage)	±10%
Voltage Adjustment	Controller Keypad
Remote Voltage Adjustment	Digital Input Standard/Analog 0–5 VDC Input Optional
Paralleling Capability	Reactive Droop Standard
VAR/PF Control Input	Standard

DVR® is a registered trademark of Marathon Electric Mfg. Corp.
NA Data not available at time of print.

1.8.3 Calibrations

Calibration	Digital Display	Range Setting	Default Selection
Voltage Adjustment	Volt Adj.	±10% of System Voltage	System Voltage
Amplifier Gain	Regulator Gain Adj.	1-10000	100%
Underfrequency Unload or Frequency Setpoint	Frequency Setpoint	30 to 70 Hz	1 Hz Below System Frequency (ECM) 2 Hz Below System Frequency (non-ECM)
Underfrequency Unload Slope	Slope	0-10% of Rated Voltage (volts per cycle)	15 Volts per Cycle at 480 Volts (3.1%)
Reactive Droop	Voltage Droop	0-10% of System Voltage	4% of System Voltage
VAR Control	kVAR Adj.	0 to Rated kVAR Generating 0 to 35% of Rated kVAR Absorbing	0 kVAR
PF Adjust Control	PF Adj.	0.7 to 1.0 Leading, 0.6 To 1.0 Lagging	0.8 Lagging
VAR/PF Gain Adjustment	VAR/PF Gain Adj.	1-10000	100%

Notes

Section 2 Basic Troubleshooting

This section contains Basic relay controller troubleshooting, diagnostic, and repair information. See the respective generator set operation manual for controller operation.

2.1 General Information

The following text covers the relay controller sequence of operation during generator start, run, stop, and fault shutdown modes. Use this information as a starting point for controller fault identification. See Figure 2-1 to identify internal components of the relay controller. Use the LEDs on the controller circuit board to assist in the troubleshooting process. An illuminated LED indicates the respective relay is receiving power; the LED does not indicate whether that relay is energized. See Figure 2-2 and Figure 2-3.

A change in the circuit board affects the function of some relays. Circuit board F-254717 has five relays with an external K10 relay for engine run components. The controller circuit board relays provide the following functions:

- K1 fault shutdown relay
- K2 engine run relay
- K3 crank disconnect/flashing control relay
- K4 crank disconnect relay
- K5 fault lamp latch relay
- K10 auxiliary run relay (external)

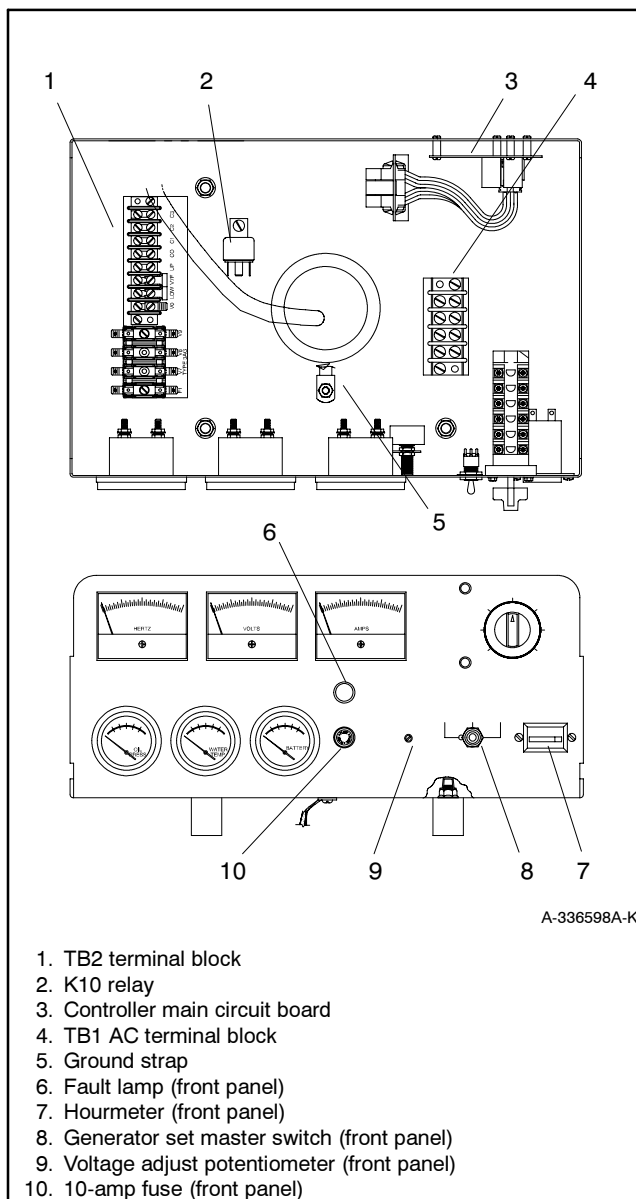

Figure 2-1 Controller Internal Components

Function	Relay	Relay Contact Normal Position	Relay Contact Action	Energizes/Action:
<p>Starting: Place the generator set master switch in the RUN position or AUTO position with contacts 3 and 4 closed. The generator set master switch closes contacts between N and 47.</p> <p>Note: Fault shutdowns are inhibited during startup until K3 energizes.</p>				K2 relay and LED2 lights
	K2	Open	Close	K10 relay, engine components (fuel system, governor, ignition, etc.), K4 relay, and LED4 lights
	K10	Open	Close	Hourmeter
	K4	Open	Close	K20 relay
	K20	Open	Close	Starter solenoid (SS) relay and starter motor (SM)
<p>Running: Alternator winding V0-V7 (P1-12 and P1-15) produces AC output.</p> <p>Note: K3 relay must obtain AC output within 30 seconds or overcrank fault occurs.</p>				K3 relay and LED3 lights
	K3	Closed	Open	Deenergizes K4 relay and LED4 deenergizes
	K4	Open	Open	Deenergizes starter solenoid (SS) and starter motor (SM)
<p>Stopping: Place the generator set master switch to the OFF position to open circuit between N and 47.</p>				Deenergizes K2 relay and LED2 deenergizes
	K2	Open	Open	Deenergizes engine components; generator set shuts down
<p>Fault shutdowns: Low oil pressure (LOP), high coolant temperature (HCT). Contacts close 5-8 seconds after reaching shutdown level.</p> <p>Note: The fault shutdown latches (K5) to keep the fault lamp lit. Move the generator set master switch to OFF/RESET.</p>				K1 relay, LED1 lights, and fault lamp
	K1	Closed	Open	Deenergizes engine components; generator set shuts down
<p>Fault shutdown: Overspeed (OS). Contacts close when engine speed reaches shutdown level.</p> <p>Note: The fault shutdown latches (K5) to keep fault lamp lit. Move the generator set master switch to OFF/RESET.</p>				K1 relay, LED1 lights, and fault lamp
	K1	Closed	Open	Deenergizes engine components; generator set shuts down
<p>Fault shutdown: Overcrank (OC). Contacts close on overcrank (locked rotor) if the speed sensor signal is absent longer than 30 seconds.</p> <p>Note: The fault shutdown latches to keep the fault lamp lit. Move the generator set master switch to OFF/RESET.</p>				K1 relay, LED1 lights, and fault lamp
	K1	Closed	Open	Deenergizes engine components; generator set shuts down

Figure 2-2 Relay Controller Sequence of Operation

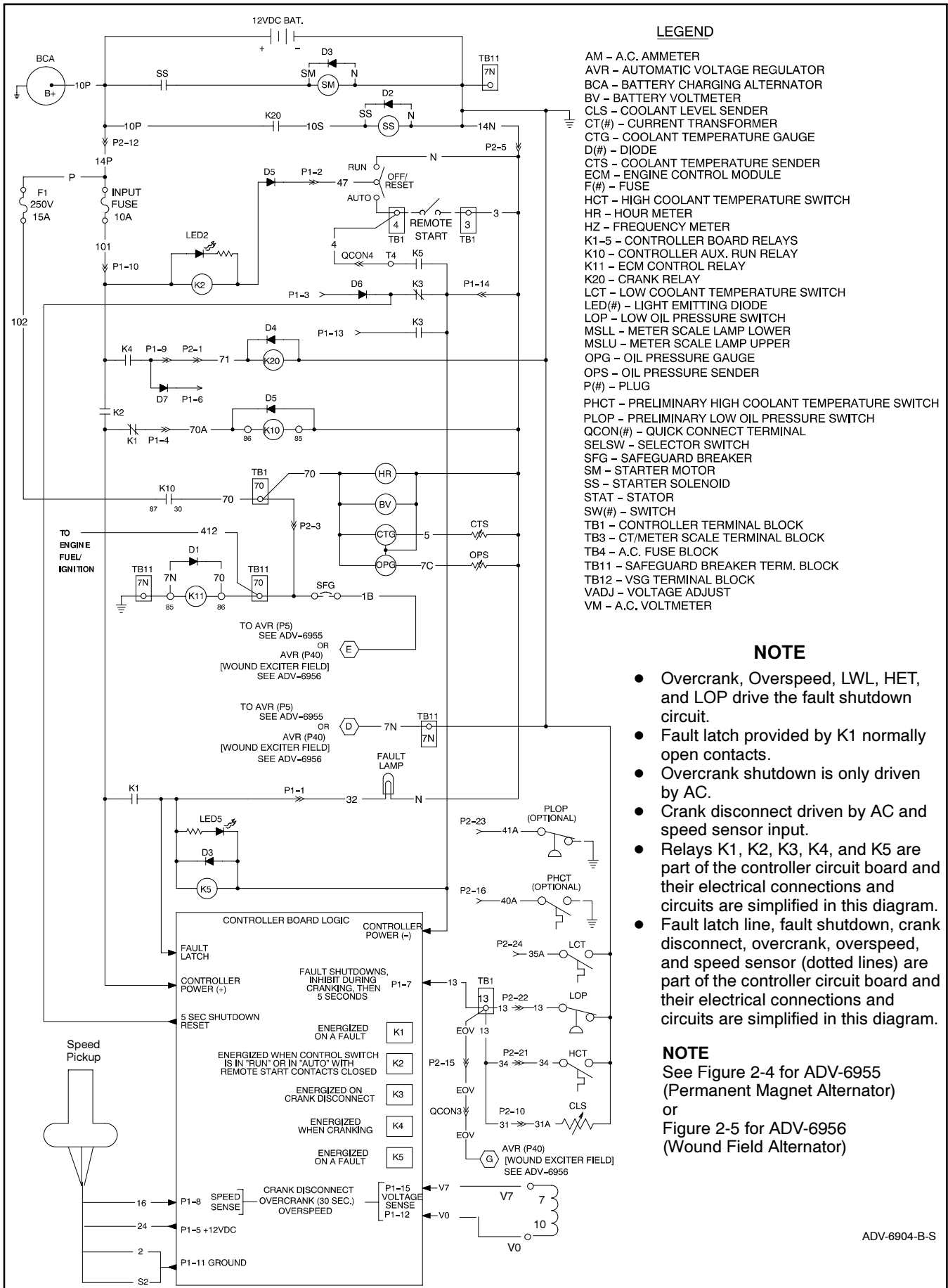

Figure 2-3 Relay Controller Sequence of Operation, Typical

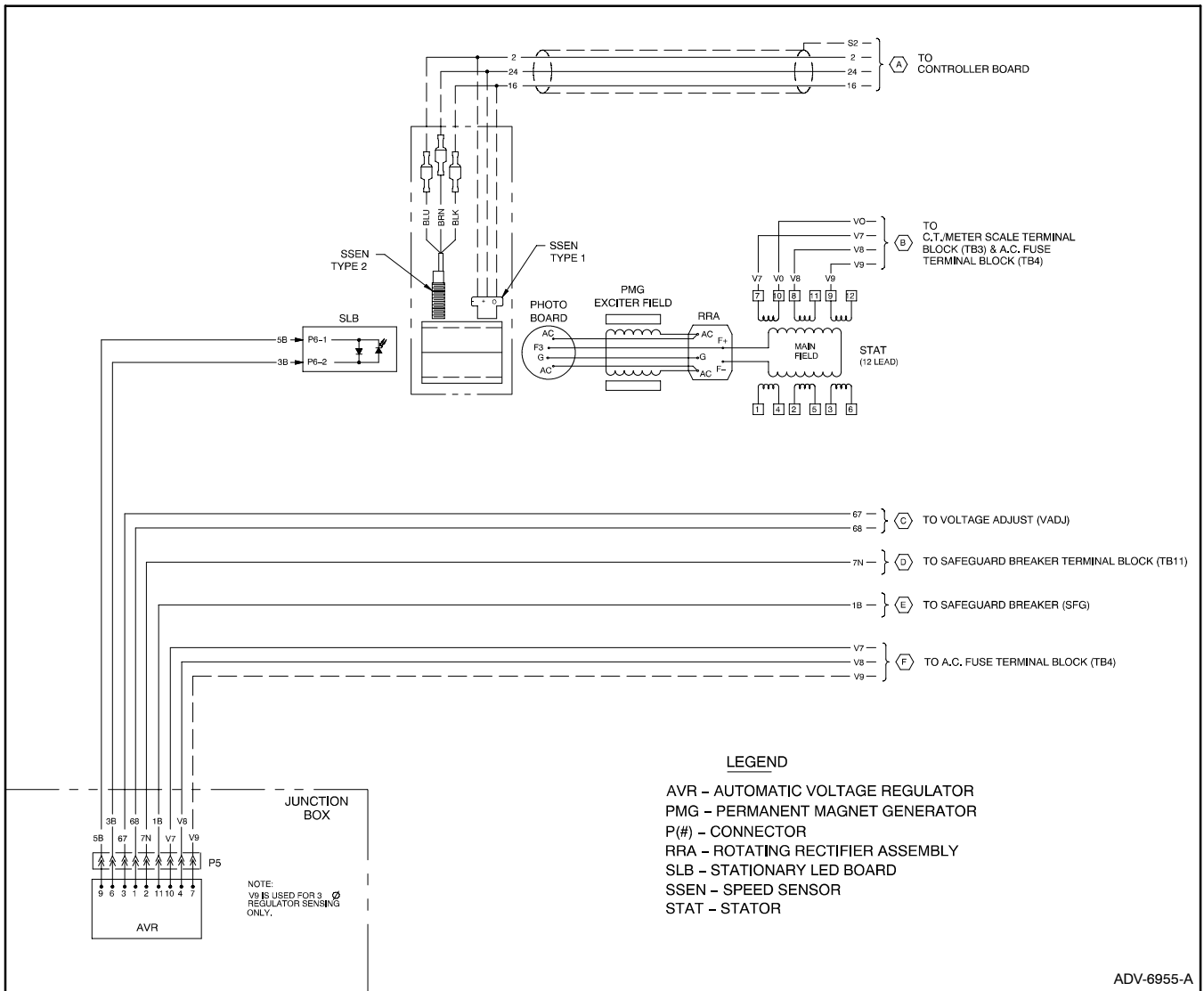

Figure 2-4 Logic Schematic, Permanent Magnet Alternator, ADV-6955-A, Typical

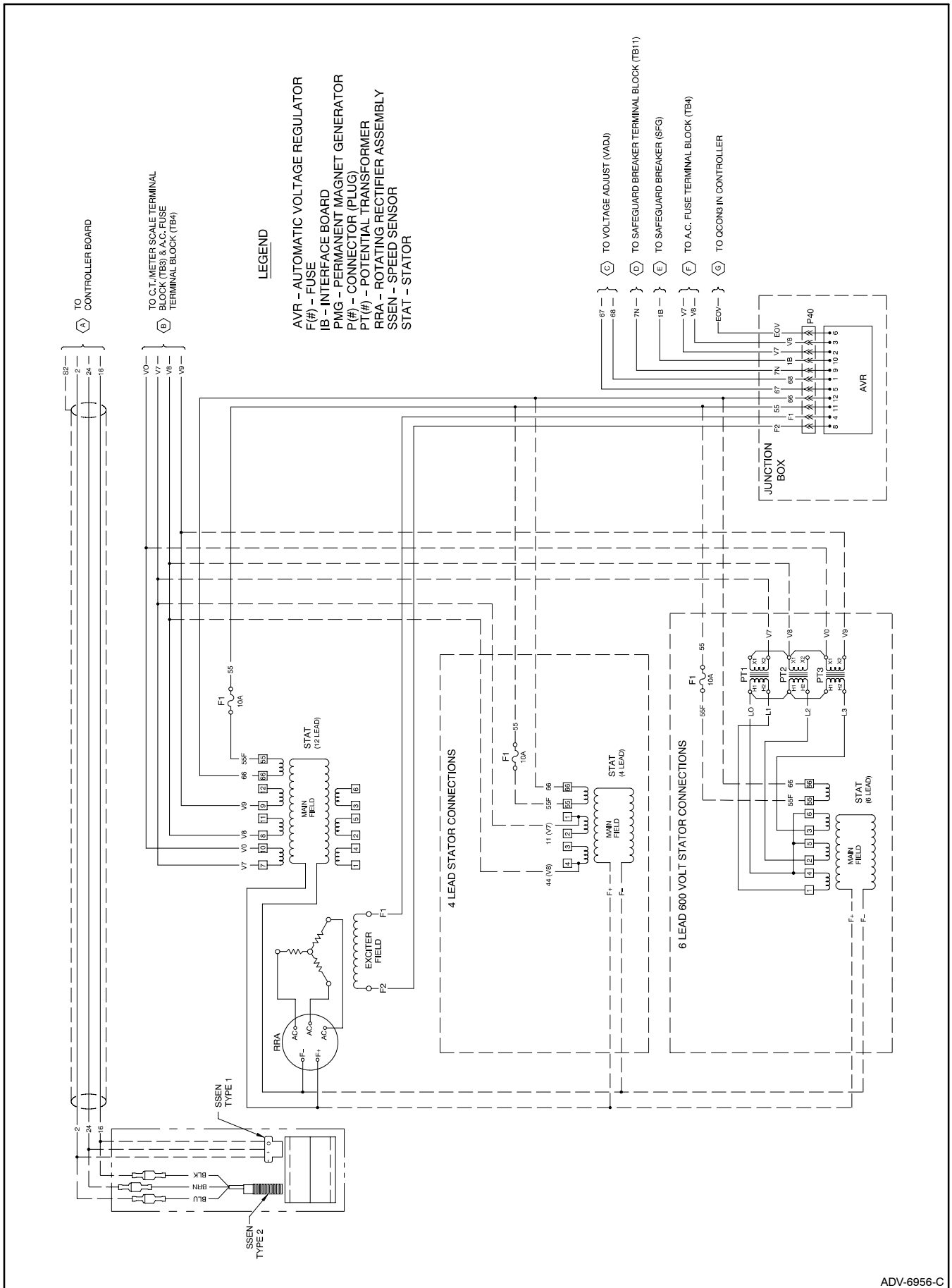
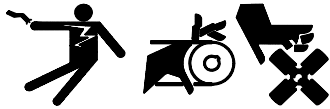

Figure 2-5 Logic Schematic, Wound Field Alternator, ADV-6956-C, Typical

2.2 Relay Controller

Use the following charts as a reference in troubleshooting individual problems. Before beginning any troubleshooting procedure, read all safety precautions at the beginning of this manual and those included in the text. Do not neglect these precautions.

WARNING



Accidental starting. Can cause severe injury or death.

Disconnect the battery cables before working on the generator set. Remove the negative (-) lead first when disconnecting the battery. Reconnect the negative (-) lead last when reconnecting the battery.

Disabling the generator set. Accidental starting can cause severe injury or death. Before working on the generator set or connected equipment, disable the generator set as follows: (1) Move the generator set master switch to the OFF position. (2) Disconnect the power to the battery charger. (3) Remove the battery cables, negative (-) lead first. Reconnect the negative (-) lead last when reconnecting the battery. Follow these precautions to prevent starting of the generator set by an automatic transfer switch, remote start/stop switch, or engine start command from a remote computer.

WARNING

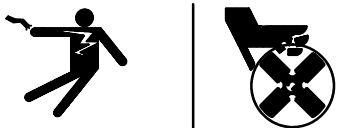

Hazardous voltage. Moving rotor. Can cause severe injury or death.

Operate the generator set only when all guards and electrical enclosures are in place.

Grounding electrical equipment. Hazardous voltage can cause severe injury or death. Electrocutation is possible whenever electricity is present. Open the main circuit breakers of all power sources before servicing the equipment. Configure the installation to electrically ground the generator set, transfer switch, and related equipment and electrical circuits to comply with applicable codes and standards. Never contact electrical leads or appliances when standing in water or on wet ground because these conditions increase the risk of electrocution.

See Figure 2-6 and use the flowchart in Section 2.3 to assist in troubleshooting the main circuit board and the generator set. If the prescribed remedy does not correct the problem, replace the circuit board. The controller circuit board includes light emitting diodes (LEDs) indicating relay coil power and aids in circuit board and generator set fault detection. When the K1, K2, K3, K4, or K5 relays receive power, the corresponding LED lights. The LED does not indicate whether the relay coil is energized. Determine if relay coil is energized by analyzing the generator set faults and performing a continuity test on the relay coil.

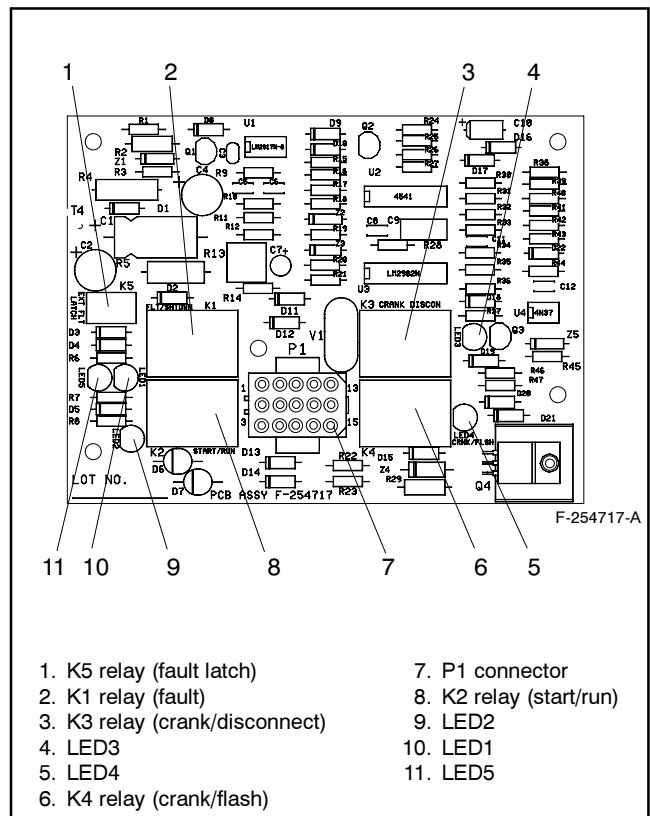
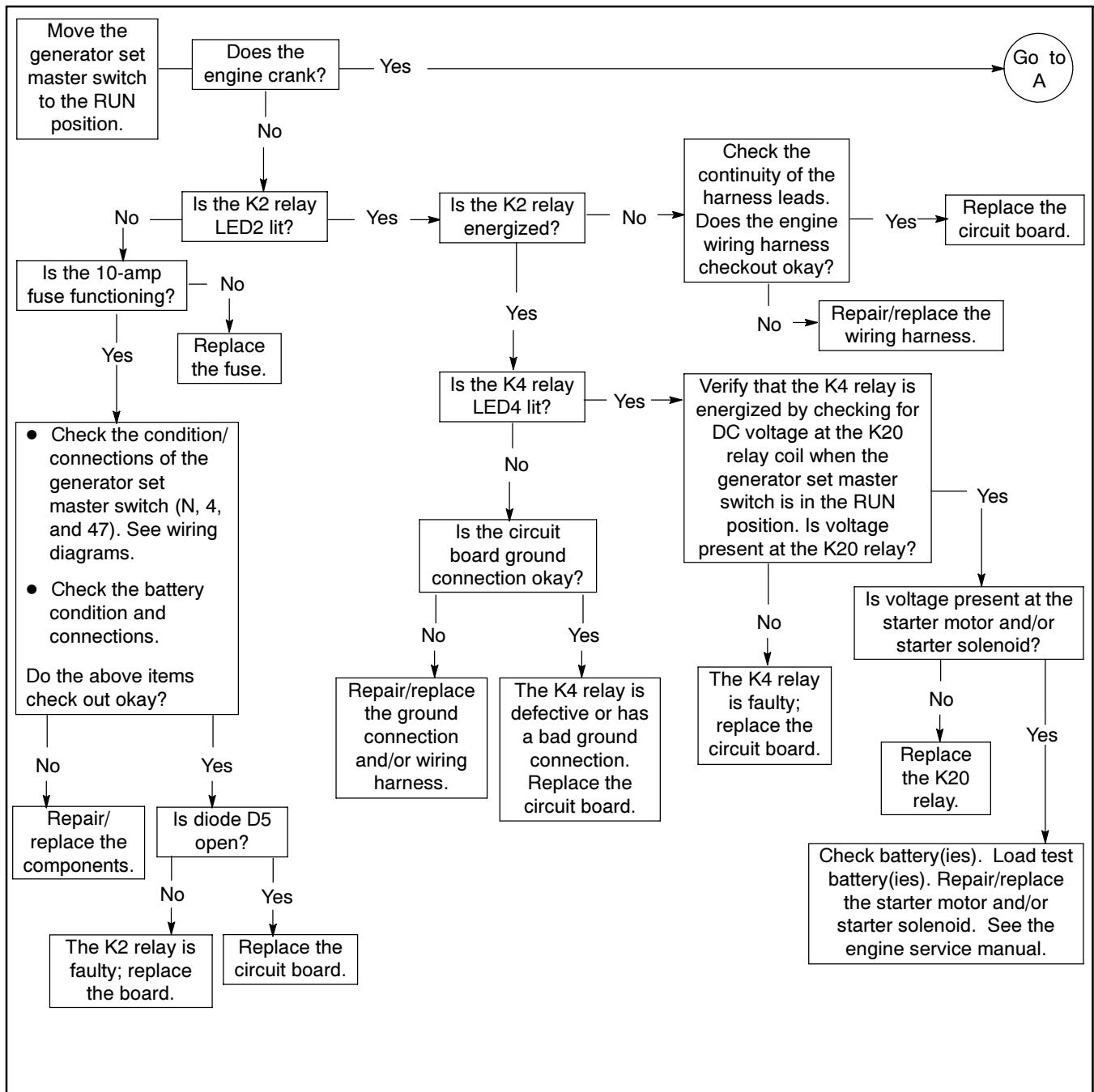
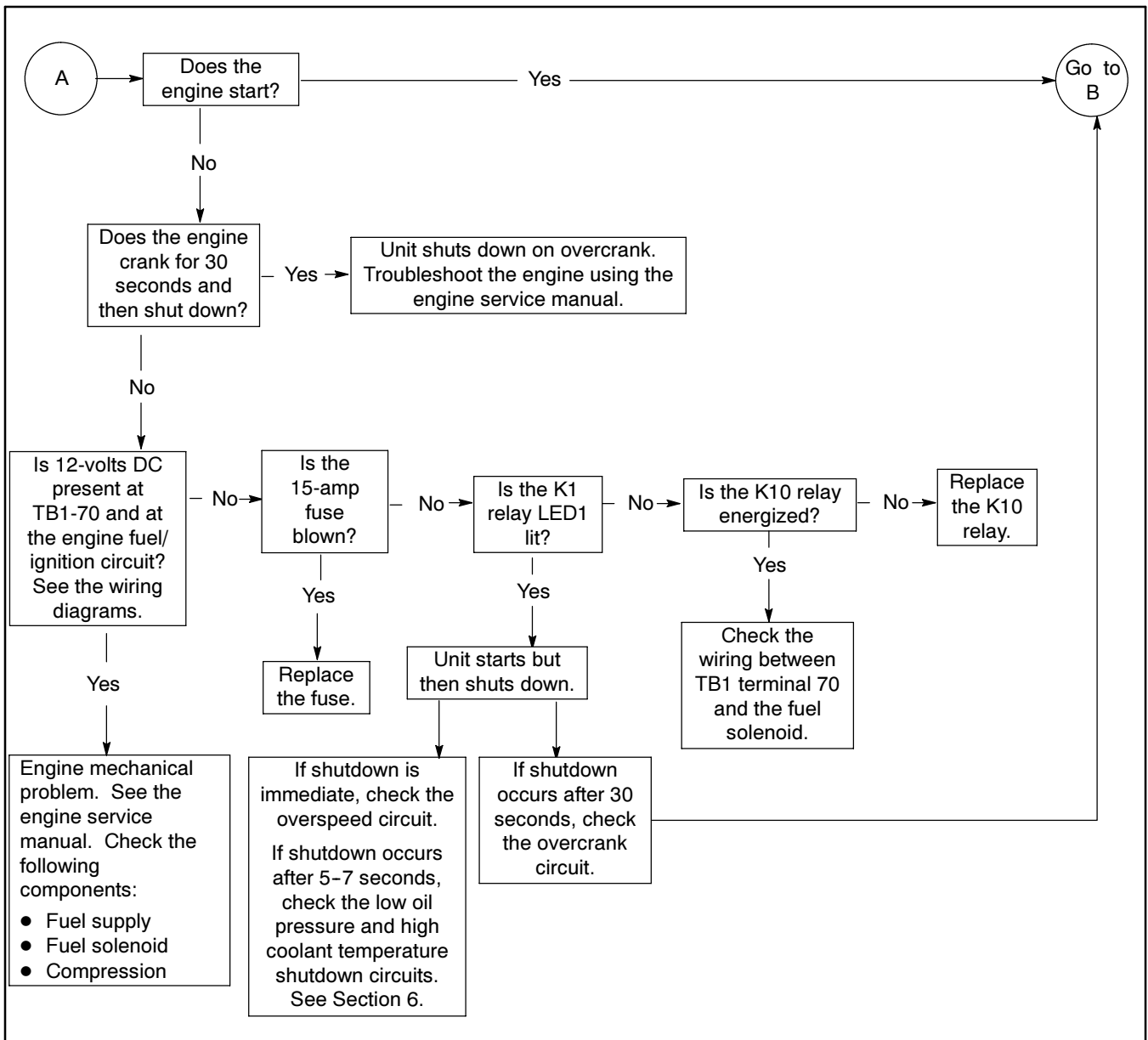
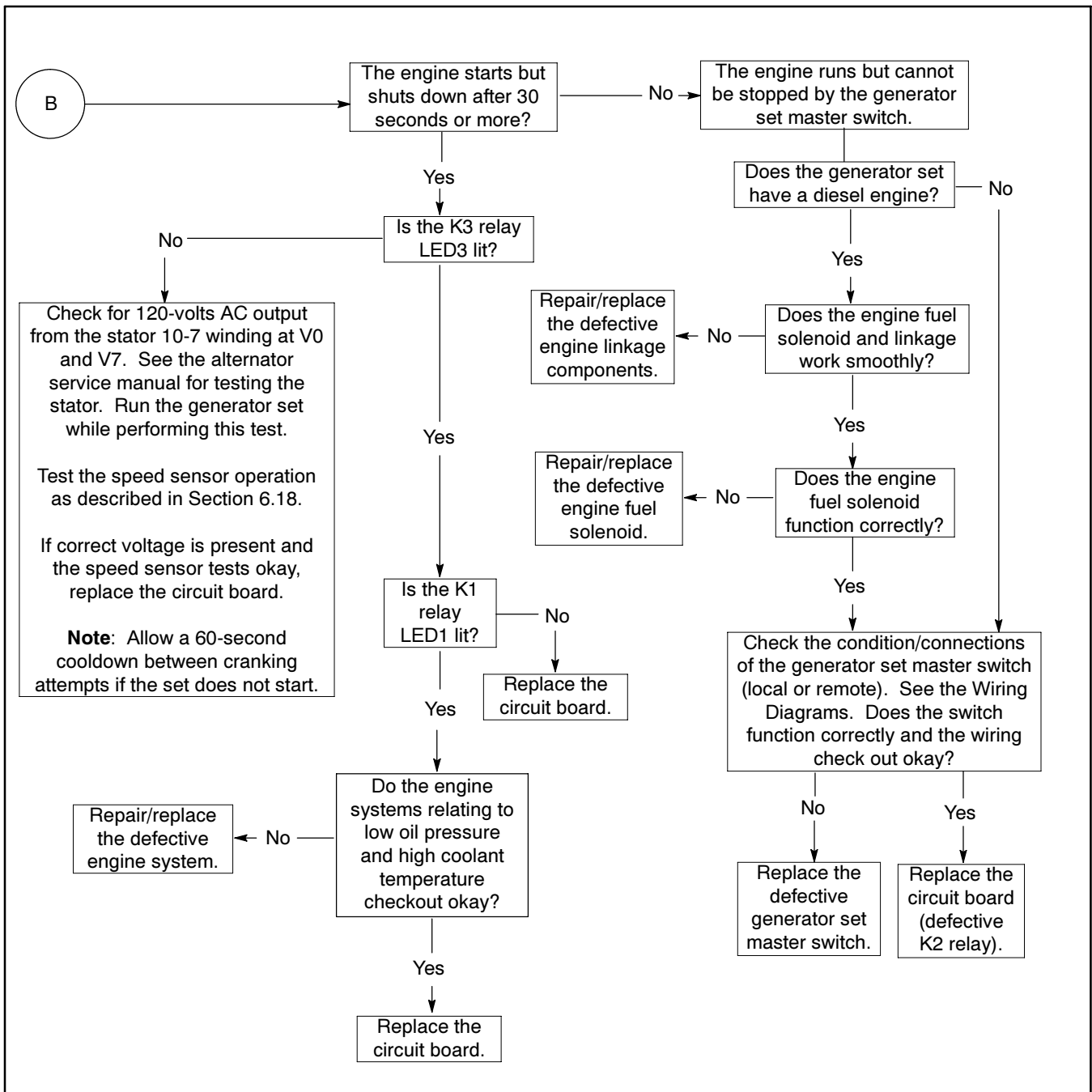

Figure 2-6 Controller Circuit Board F-254717

2.3 Relay Controller Flowchart







Notes

Section 3 Microprocessor-Plus, 16-Light Troubleshooting

3.1 General Information

Use the following illustrations and text to troubleshoot the controller. Figure 3-1 through Figure 3-6 show the locations of controller components and connections.

Troubleshooting procedures provided in this section and on the wiring diagrams may use active low and active high terminology. A battery ground connection energizes an *active low* circuit. A battery positive (+) connection energizes an *active high* circuit.

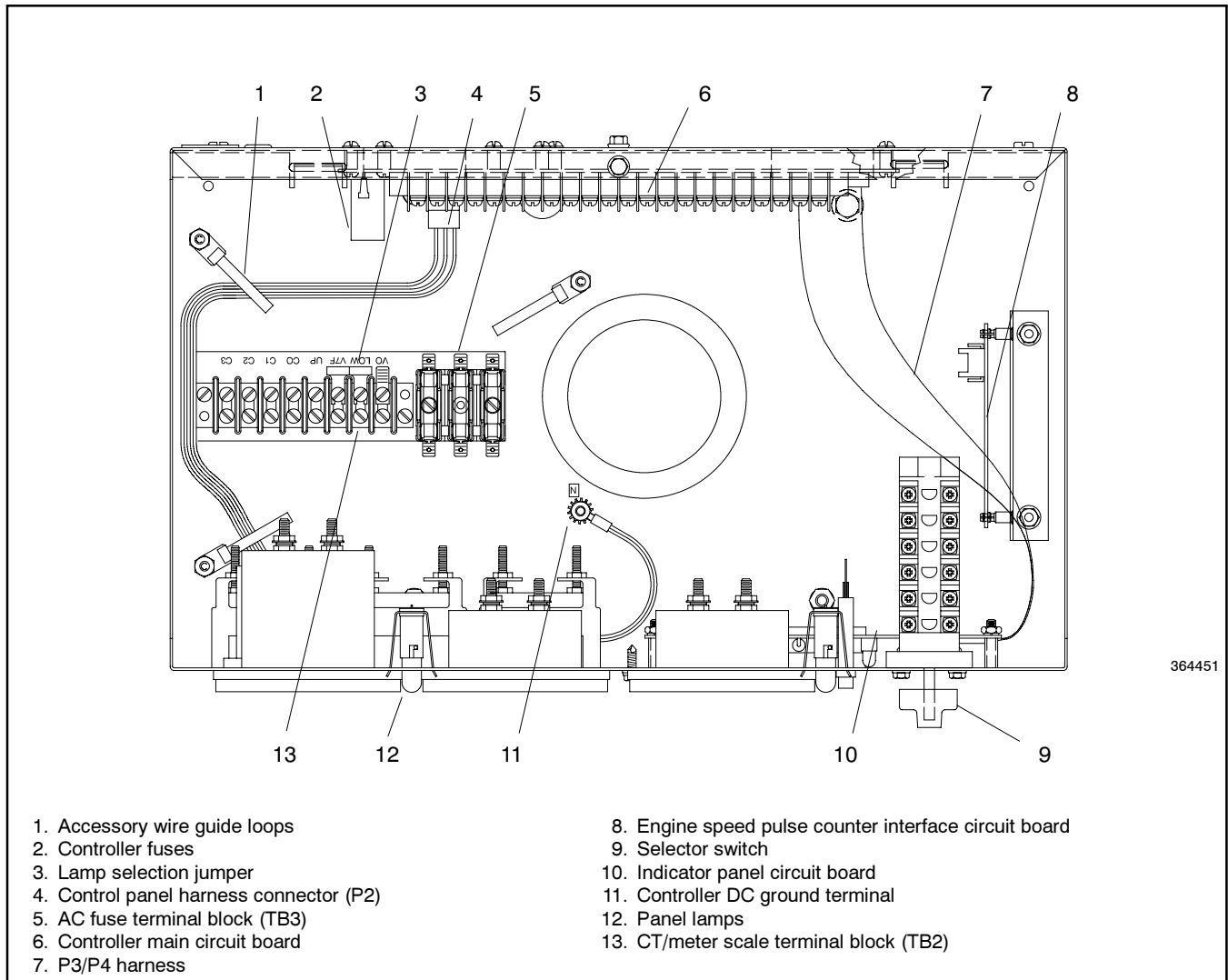

Figure 3-1 16-Light Controller Components

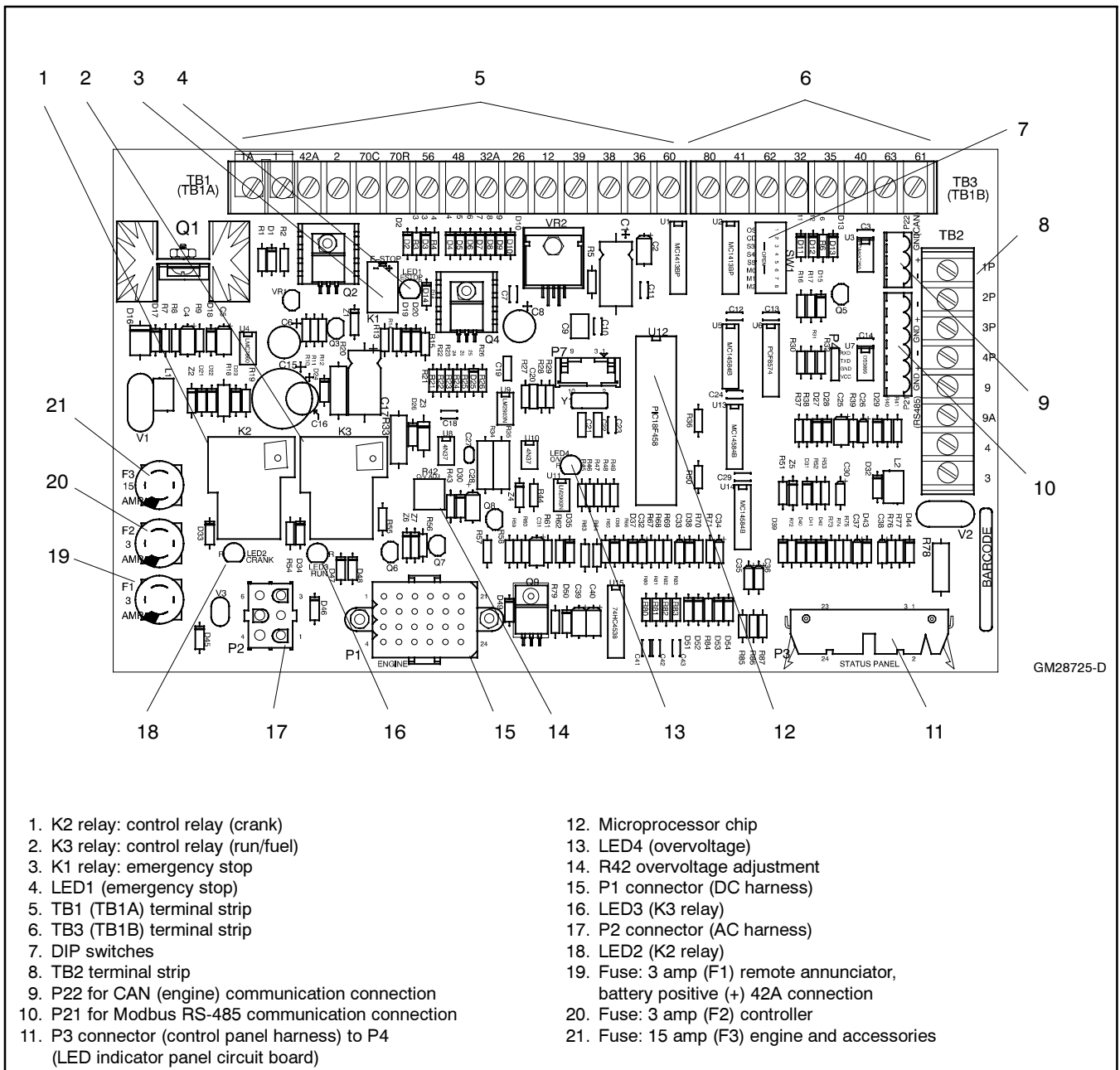

Figure 3-2 16-Light Controller Circuit Board GM28725 Components, Typical

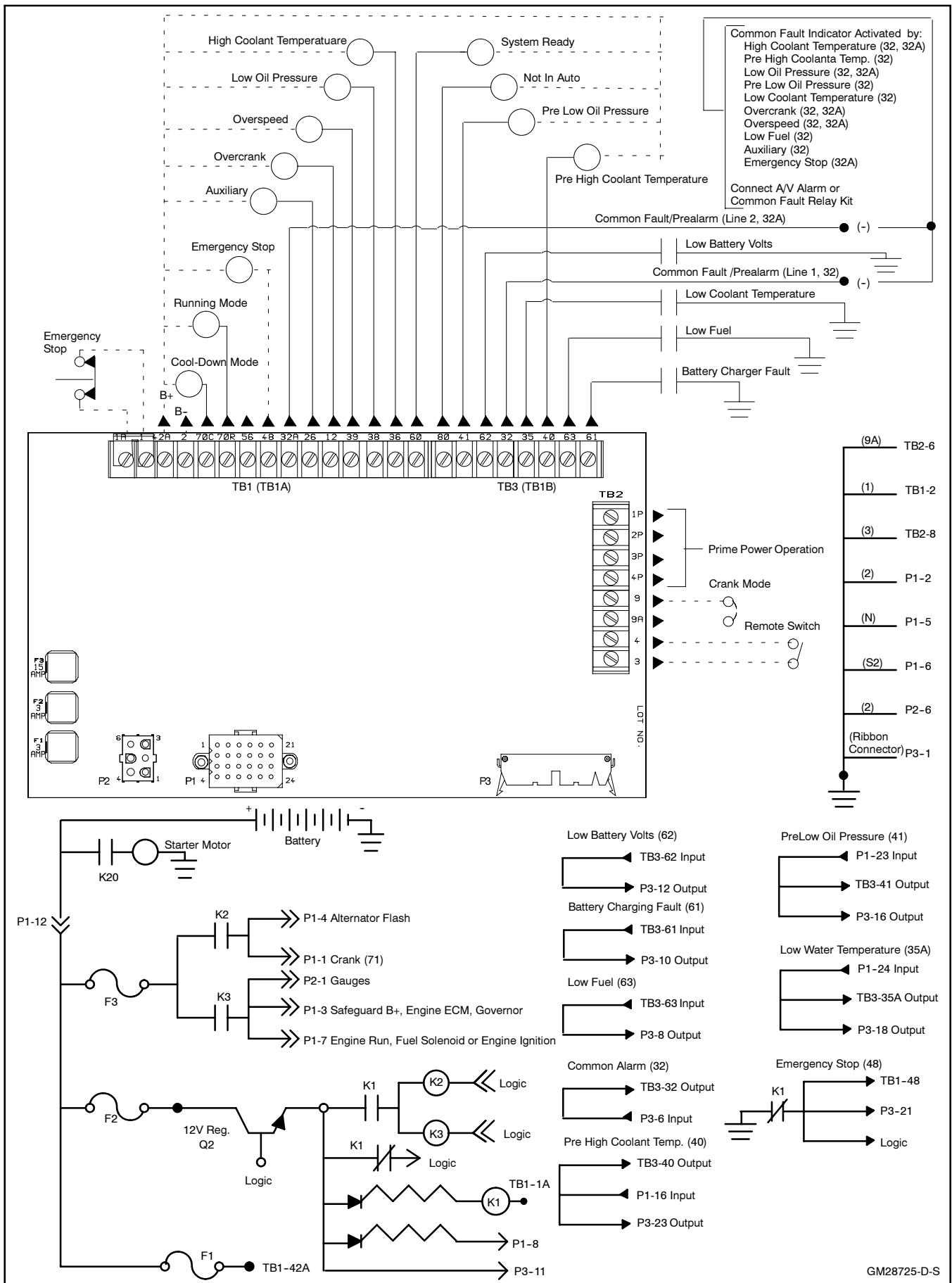

Figure 3-3 16-Light Controller Circuit Board GM28725 Connections TB1 (TB1A), TB3 (TB1B), and TB2

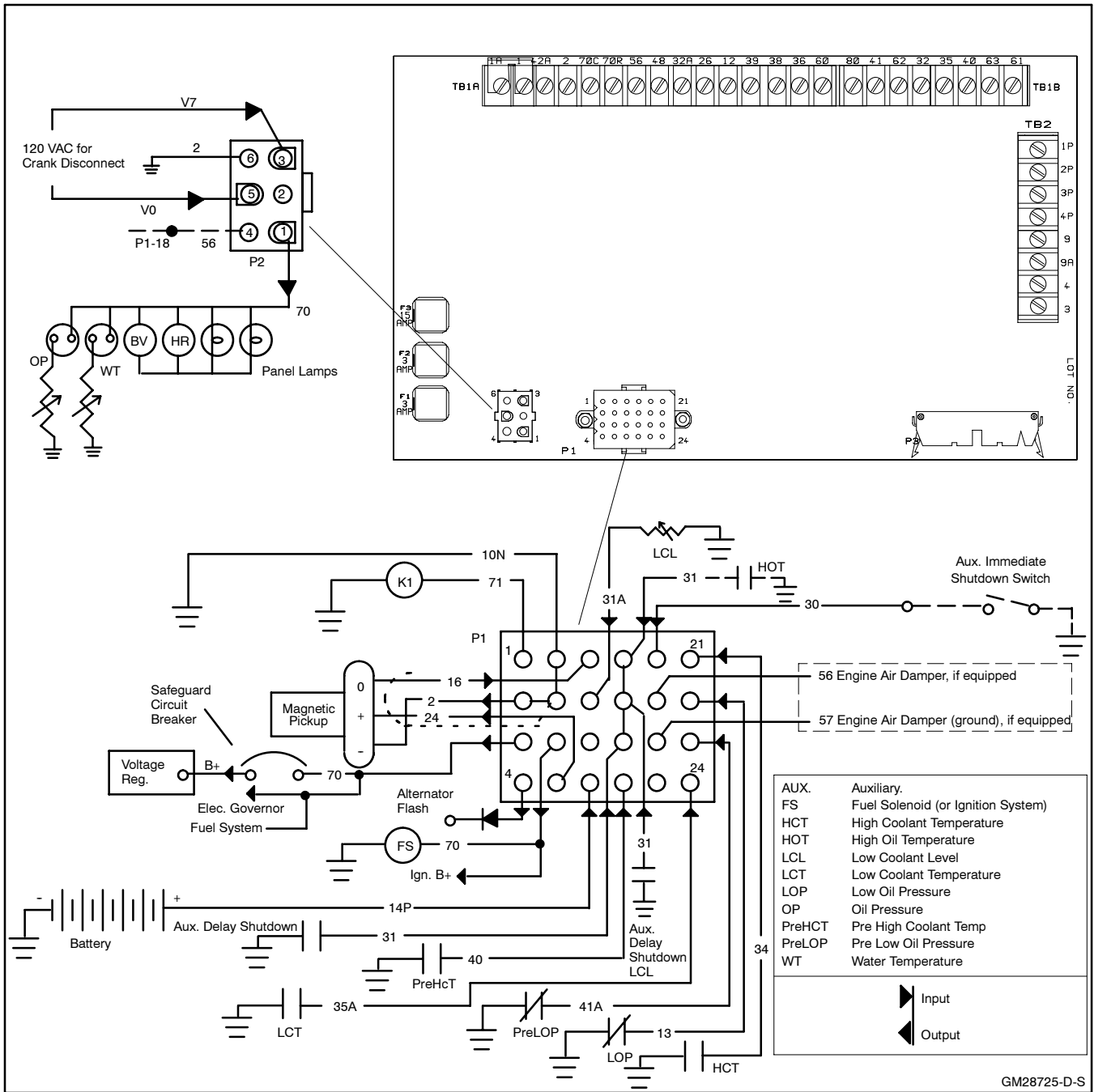

Figure 3-4 16-Light Controller Circuit Board GM28725 Connections P1 and P2

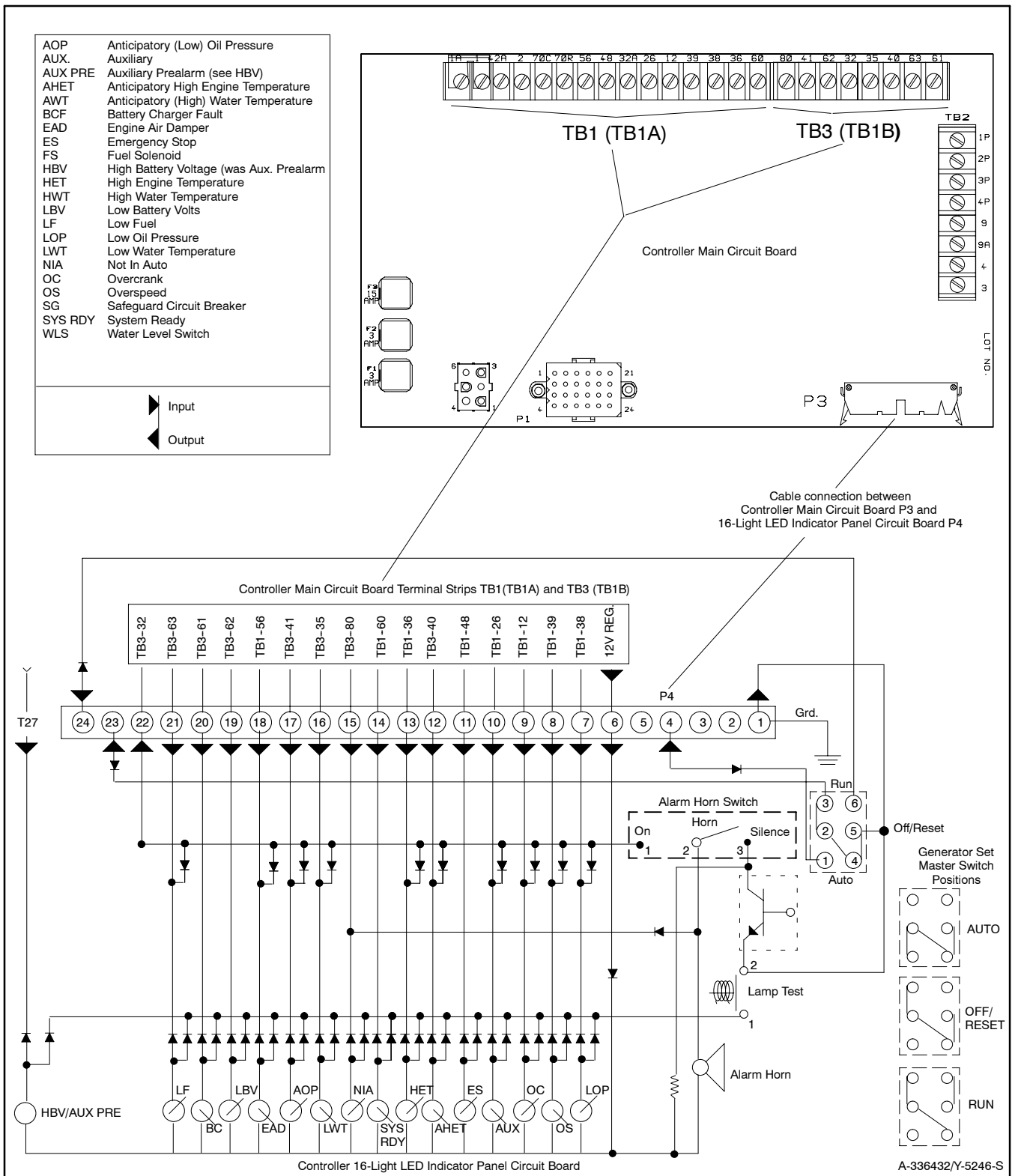

Figure 3-5 Controller to 16-Light LED Indicator Panel Circuit Board -336432 Connections P3

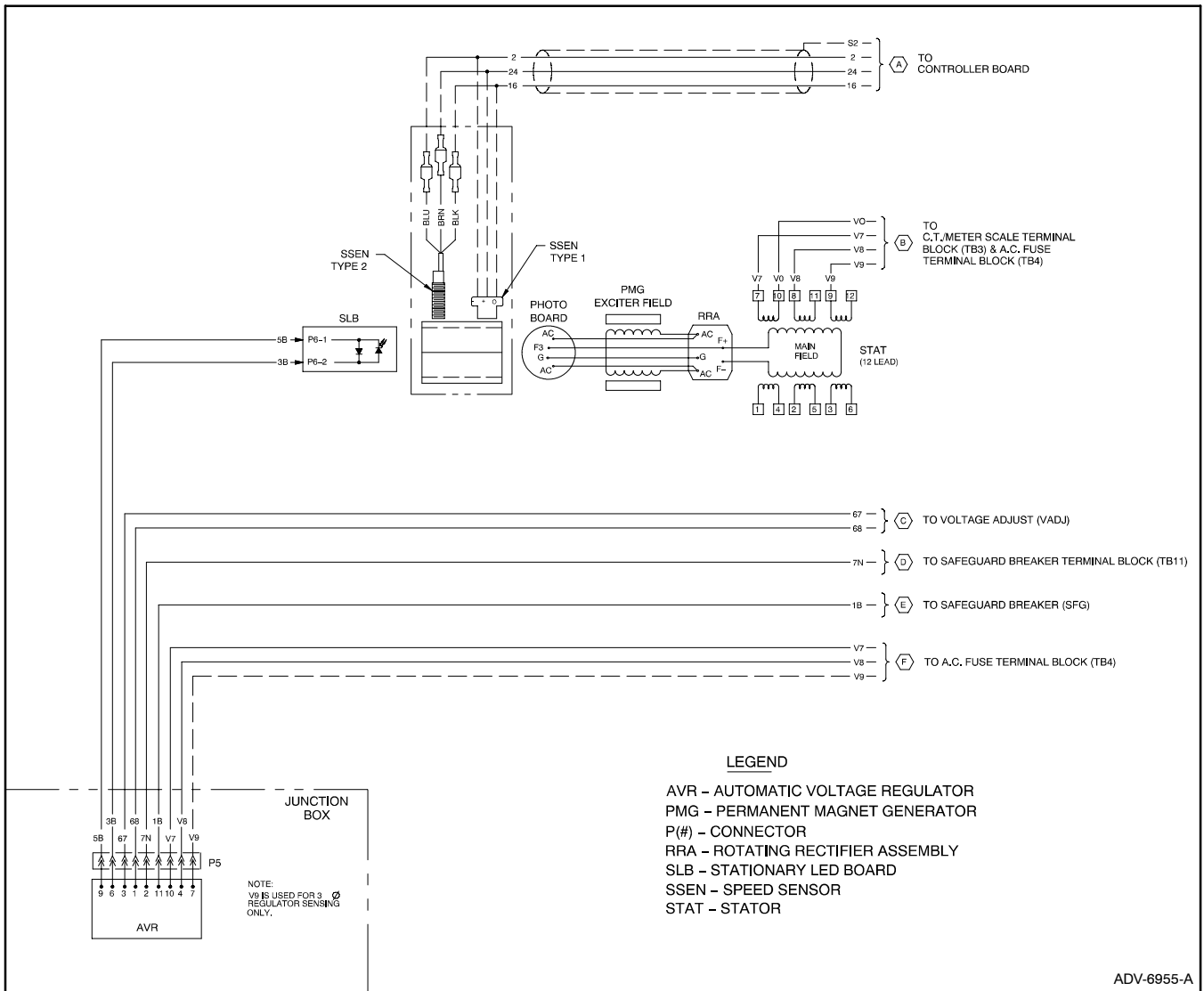

Figure 3-7 Logic Schematic, Permanent Magnet Alternator, ADV-6955-A, Typical

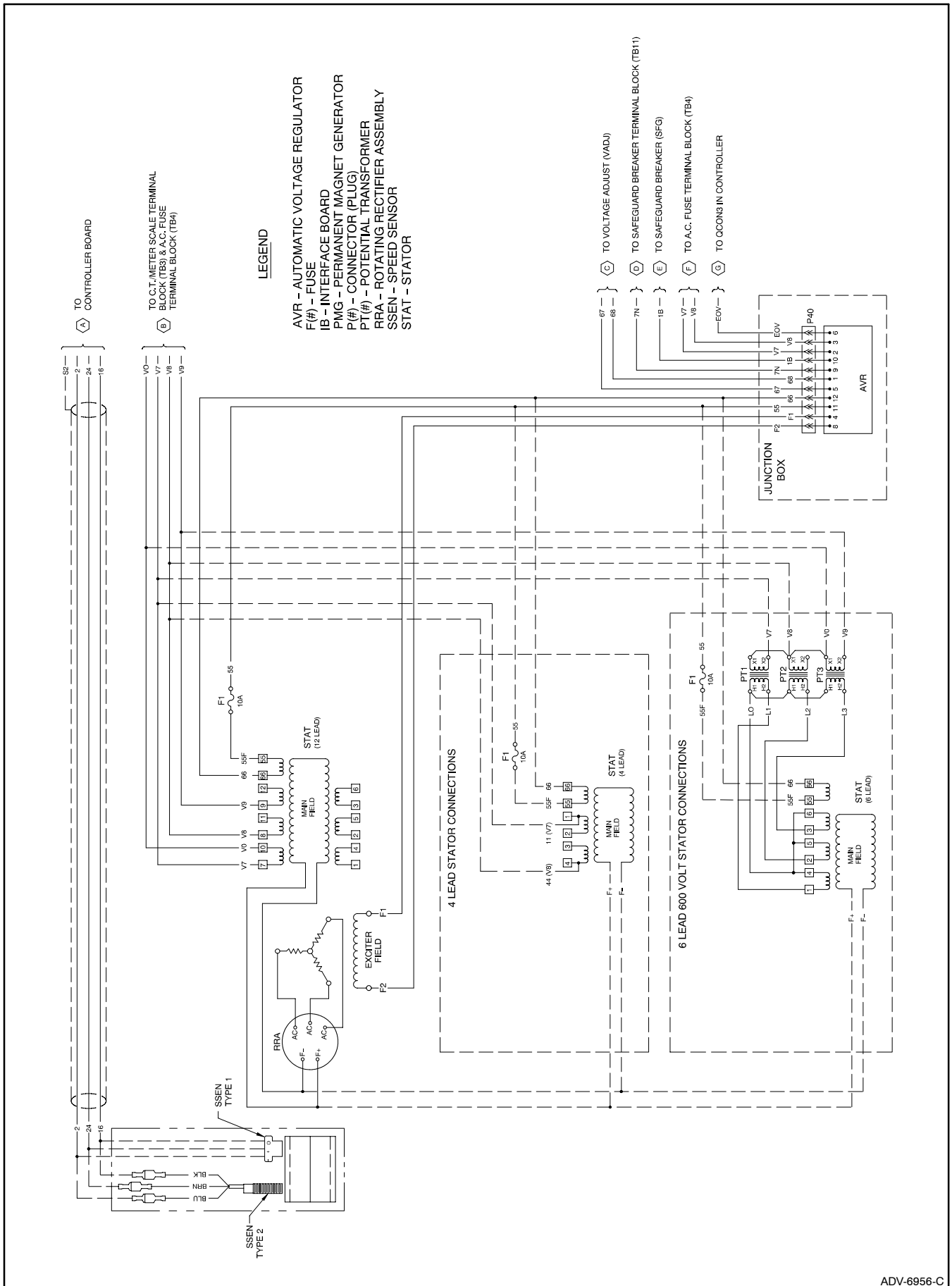

Figure 3-8 Logic Schematic, Wound Field Alternator, ADV-6956-C, Typical

3.2 Circuit Board GM28725 Terminal/Connector Identification

Controller Main Circuit Board Terminal Strip TB1 (TB1A)		
Terminal	Wire	Description
1	1A	Emergency stop relay (K1) coil negative
2	1	Emergency stop relay (K1) ground
3	42A	Battery voltage (fuse #1 protected)
4	2	Ground
5	70C	Generator set in cooldown mode signal
6	70R	Generator set in running mode signal
7	56	Engine air damper indicator (if equipped)
8	48	Emergency stop indicator
9	32A	Common fault line 2
10	26	Auxiliary indicator
11	12	Overcrank indicator
12	39	Overspeed indicator
13	38	Low oil pressure indicator
14	36	High engine temperature indicator
Controller Main Circuit Board Terminal Strip TB3 (TB1B)		
Terminal	Wire	Description
15	60	System ready indicator
16	80	Not in auto indicator
17	41	Prealarm low oil pressure indicator
18	62	Low battery volts (active low*)
19	32	Common fault/prealarm line 1
20	35A	Low water temperature
21	40	Prealarm high coolant temperature indicator
22	63	Low fuel (active low*)
23	61	Battery charger fault (active low*)

* Check active low circuits for function by grounding designated terminals.

Controller Main Circuit Board P1 Connector Pins		
Pin	Wire	Description
1	71	Output to K2 relay (crank relay) (fuse #3 protected)
2	2	Ground for speed sensor
3	70	Output to safeguard breaker terminal and K5 relay (if equipped with electronic governor) (fuse #3 protected)
4	—	Alternator flash
5	10N	Starter motor ground (-)
6	S2	Speed sensor shield ground
7	70	Output to fuel solenoid (FS) on diesel models or ignition system (I.S.) on gas/gasoline models (fuse #3 protected)
8	24	Battery positive to speed sensor (fuse #2 protected)
9	16	Input from speed sensor
10	31A	Input from low coolant level (LCL), positive temperature coefficient (PTC) sensor
11	—	Not used
12	14P	Input from battery positive
13	31	Input from auxiliary delay shutdown, high oil temperature (HOT), if used
14	31	Input from auxiliary delay shutdown, low coolant level (LCL), if used
15	31	Input from auxiliary delay shutdown, if used
16	40	Input from pre-high coolant temperature (preHCT) switch
17	30	Input from auxiliary immediate shutdown, if used
18	56	Input from engine air damper switch, if equipped
19	57	Input from K6 air damper relay (ground), if equipped
20	—	Not used
21	34	Input from high coolant temperature (HCT) switch
22	13	Input from low oil pressure (LOP) switch
23	41	Input from pre low oil pressure (preLOP) switch
24	35A	Input from low coolant temperature (LCT) switch

Controller Main Circuit Board Terminal Strip TB2		
Terminal	Wire	Description
1	1P	Prime power operation (requires optional kit)
2	2P	Prime power operation (requires optional kit)
3	3P	Prime power operation (ground) (requires optional kit)
4	4P	Prime power operation (requires optional kit)
5	9	Crank mode (open-cyclic ground-continuous)
6	9A	Crank mode (ground)
7	4	Remote start (active low*)
8	3	Remote start (ground)

* Check active low circuits for function by grounding designated terminals.

Controller Main Circuit Board P2 Connector Pins		
Pin	Wire	Description
1	70	Output to engine gauges (fuse #3 protected)
2	30A	Overvoltage auxiliary
3	V7F	Input from AC crank disconnect & instrumentation
4	—	Not used
5	V0	Input from AC crank disconnect & instrumentation
6	2	Engine ground

Controller Main Circuit Board P3 Connector Pins		
Pin	Wire	Description
1	2	Ground (-), front indicator panel
2	47	Input from generator set master switch, run position
3	—	Not used
4	43	Input from generator set master switch, off/reset position
5	—	Not used
6	32	Input from common fault/prealarm line 1
7	46	Input from generator set master switch, auto position
8	63	Output to low fuel (LF) indicator, TB3-7 (TB1B-7)
9	—	Not used
10	61	Output to battery charger fault (BCF) indicator, TB3-8 (TB1B-8)
11	24	+12 VDC to front indicator panel
12	62	Output to low battery volts (LBV) indicator, TB3-3 (TB1B-3)
13	38	Output to low oil pressure (LOP) indicator, TB1-13 (TB1A-13)
14	56	Output to engine air damper (EAD) indicator, if equipped
15	39	Output to overspeed (OS) indicator, TB1-12 (TB1A-12)
16	41	Output to pre-low oil pressure (preLOP) indicator, TB3-2 (TB1B-2)
17	12	Output to overcrank (OC) indicator, TB1-11 (TB1A-11)
18	35A	Output to low coolant temperature (LCT) indicator
19	26	Output to auxiliary (AUX) indicator, TB1-10 (TB1A-10)
20	80	Output to not in auto (NIA) indicator, TB3-1 (TB1B-1)
21	48	Output to emergency stop (ES) indicator
22	60	Output to system ready (RS) indicator, TB1-15 (TB1A-15)
23	40	Output to pre-high coolant temperature (preHCT) indicator
24	36	Output to high coolant temperature (HCT) indicator, TB1-14 (TB1A-14)

16-Light LED Indicator Panel Circuit Board A-336432 P4 Connector Pins		
Pin	Wire	Description
1	2	Ground (-), front indicator panel
2	—	Not used
3	—	Not used
4	46	Output from generator set master switch, auto position
5	—	Not used
6	24	+12 VDC to front indicator panel
7	38	Input to low oil pressure (LOP) indicator †
8	39	Input to overspeed (OS) indicator †
9	12	Input to overcrank (OC) indicator †
10	26	Input to auxiliary (AUX) indicator
11	48	Input to emergency stop (ES) indicator
12	40	Input to pre-high coolant temperature (preHCT) indicator †
13	36	Input to high coolant temperature (HCT) indicator †
14	60	Input to system ready (SR) indicator
15	80	Input to not In auto (NIA) indicator
16	35A	Input to low coolant temperature (LCT) indicator †
17	41	Input to pre-low oil pressure (preLOP) indicator †
18	56	Input to engine air damper (EAD) indicator, if equipped
19	62	Input to low battery volts (LBV) indicator
20	61	Input to battery charger fault (BCF) indicator
21	63	Input to low fuel (LF) indicator †
22	32	Input to common fault/prealarm line 1 †
23	43	Output from generator set master switch, off/reset position
24	47	Output from generator set master switch, run position,
† Common fault/prealarm line 1 triggered by high engine temperature, high engine temperature prealarm, low oil pressure, low oil pressure prealarm, low water temperature, overcrank, overspeed, low fuel, and auxiliary faults.		

16-Light LED Indicator Panel Circuit Board A-336432		
Terminal	Wire	Description
T27	—	Input to auxiliary prealarm or high battery volts indicator (if equipped)

3.3 Fault Shutdowns

If the generator set will not start or stops running because of a fault shutdown (fault lamp lit), see Figure 3-9 to identify fault conditions. Figure 3-9 contains the logic schematic showing input/output

circuits for reference in troubleshooting. Consult the engine service manual for detailed information on correcting engine related faults. To reset the unit after a fault shutdown, see the generator set operation manual.

Indicator	Generator Set Mode	Fault Condition/Causes
High Engine Temperature Lamp Lights	While running	* Engine coolant temperature is above shutdown range. See Section 1, Specifications.
		Lead 34 grounded.
Low Oil Pressure Lamp Lights	While running	* Engine oil pressure is below shutdown range. See Section 1, Specifications
		Lead 13 grounded.
Overspeed Lamp Lights	While running	* Governed frequency is in excess of 70 Hz on 60 Hz models or 60 Hz on 50 Hz models. Some 50 Hz models have shutdown at 70 Hz.
Overcrank Lamp Lights	While cranking	Continuous cranking is more than 30 seconds and no starting.
		Cyclic cranking is more than 75 seconds and no starting. (15-second cycles alternating between crank and rest)
	While cranking or running	Speed sensor signal (locked rotor) is absent longer than 15 seconds.
		Engine fails to turn over within 15 seconds after signaled to start.
Overcrank Lamp Flashes	While running	Speed sensor signal (locked rotor) is absent longer than 1 second.
Auxiliary Lamp Flashes	While running	No AC output is present.
	While running or in auto position	Battery power was reconnected or was low and then came back up again while generator set master switch was in the RUN or AUTO position. Improper master switch signal to controller main circuit board.
Auxiliary Lamp Lights	While shutdown	Optional emergency stop switch is reset while the generator set master switch is in the RUN or AUTO position.
	While running	High oil temperature (P1-13), low coolant level (P1-14), or auxiliary delay shutdown (P1-15) faults occur, if sensor equipped.
		Overvoltage shuts down the unit when the voltage is at least 15% greater than nominal voltage for period longer than two seconds. Actual overvoltage shutdown is dependant upon R42 setting on main circuit board. Factory setting is 15% above nominal voltage.
		* Activated by customer-supplied sensing device connected to auxiliary immediate shutdown ports (P1-17 and P1-18).
		Activated by engine ECM fault detection.
Emergency Stop (if equipped)	While running or in auto position	* Emergency stop switch is activated (local or remote).
		* Emergency stop switch(es) are disconnected from controller terminals TB1-1 or 1A.
Multiple Lamps Light (where illumination may only appear dim)	While running or in auto or off/reset position	Main circuit board F1 (3 amp) fuse blown. F1 fuse supplies battery voltage to a remote annunciator and/or dry contact kit.
		Defective remote annunciator and/or dry contact kit.
		Defective indicator panel circuit board.
* Immediate shutdown (ISD)		

Figure 3-9 Fault Shutdown Troubleshooting Chart

3.4 Relay Descriptions

See Figure 3-10 for controller and generator set relay descriptions and functions. Use this information to troubleshoot the generator set in conjunction with the controller flow charts in Section 3.5.2. Use Section 3.5 and the appropriate wiring diagram for additional information.

Note: Some generator set models may show relays K6, K11, and K20 with different designations. See the respective generator set wiring diagram manual.

Relay	Description/Function	Location	Illustration	Energizes/Action:
K1	Emergency stop relay energizes continuously except during emergency stop conditions	Main circuit board	Figure 3-11	LED1 lights.
K2	Crank relay energizes during crank mode	Main circuit board	Figure 3-11	Energizes K20 relay LED2 lights.
K3	Run relay energizes during crank and run modes	Main circuit board	Figure 3-11	Energizes ignition, fuel solenoid, fuel pump, choke, instrumentation, voltage regulator, etc. LED3 lights.
K6	Engine ECM control relay energizes during crank and run modes	Junction box	Figure 3-12	ECM/Governor control circuit.
K11	Diagnostic box control relay energizes when control box switches are energized (ECM engines)	Junction box	Figure 3-12	Diagnostic box circuit.
K20	Starter solenoid energizes during crank mode	Engine	Figure 3-13	Starter motor.

Figure 3-10 Relay Descriptions and Functions

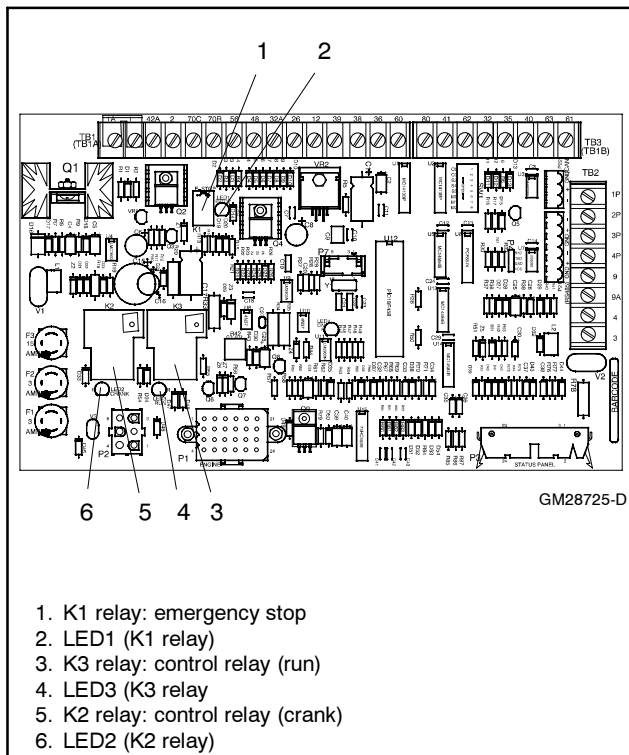

Figure 3-11 Main Circuit Board GM28725 Relays

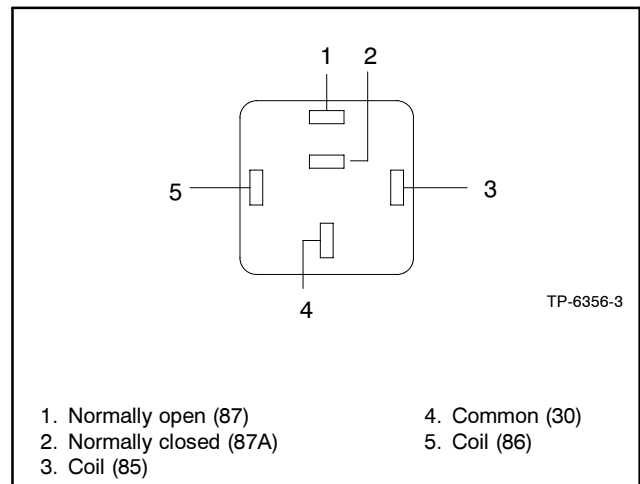

Figure 3-12 K6/K11 Relay

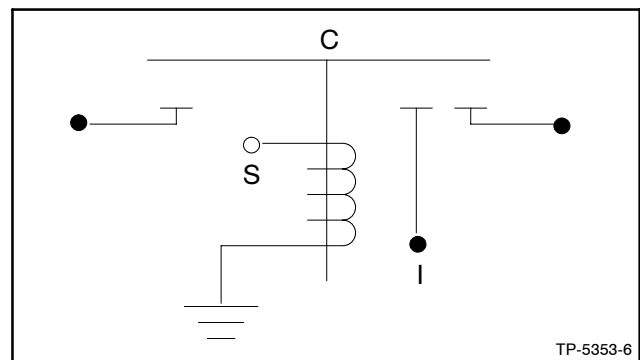

Figure 3-13 Starter Solenoid K20 Relay

3.5 Troubleshooting

Figure 3-14 lists some common problems relating to the 16-light controller. Use the following charts as a quick reference in troubleshooting individual problems. Refer to Figure 3-14 to assist in locating the cause of blown fuses. The successive charts list generator set faults by specific groups including possible causes and corrective action. Before beginning any troubleshooting procedure, read all safety precautions at the beginning of this manual and those included in the text. Do not neglect these precautions.

Note: If starting unit by remote switch, verify remote switch function before troubleshooting controller. Test remote switch operation using Figure 3-14 information. If the generator does not start, proceed with the controller troubleshooting procedure outlined in the following pages.

Problem	Possible Cause	Corrective Action	Reference
All lamps remain on	Ground fault from accessories connected to TB1 terminal strip	Disconnect and test each connection.	See wiring diagram manual
System ready lamp does not light	Defective generator set master switch	If engine/generator set checks out okay, replace generator set master switch (lamp circuit board). Check switch contacts with an ohmmeter. If switch is defective, replace generator set master switch (lamp circuit board).	
Aux. lamp goes on with generator set master switch in RUN or AUTO position	Defective generator set master switch	Check switch contacts with an ohmmeter. If switch is defective, replace generator set master switch (lamp circuit board).	
Unit will not crank when 3-4 contacts are closed (remote starting) and generator set master switch in AUTO position	Defective generator set master switch	Connect jumper wire between terminals 3-4. If unit cranks replace generator set master switch (lamp circuit board).	See wiring diagram manual
	Defective generator set master switch and/or defective ground to lamp circuit board	Connect jumper wire between terminal 4 and ground. If unit cranks and if lamp circuit board ground connection checks out okay, replace generator set master switch (lamp circuit board).	
Alarm horn will not silence using alarm horn silence switch	Improper operation sequence	Place generator set master switch in the AUTO position <i>before</i> placing the alarm horn silence switch in the SILENCE position.	See generator set operation manual

Figure 3-14 16-Light Controller Troubleshooting

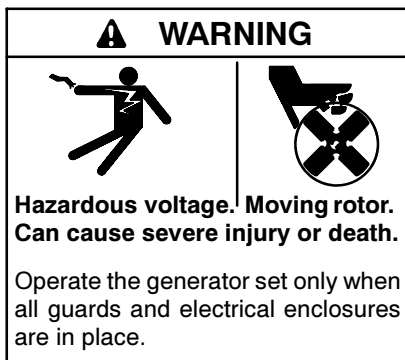

Grounding electrical equipment. Hazardous voltage can cause severe injury or death. Electrocution is possible whenever electricity is present. Open the main circuit breakers of all power sources before servicing the equipment. Configure the installation to electrically ground the generator set, transfer switch, and related equipment and electrical circuits to comply with applicable codes and standards. Never contact electrical leads or appliances when standing in water or on wet ground because these conditions increase the risk of electrocution.

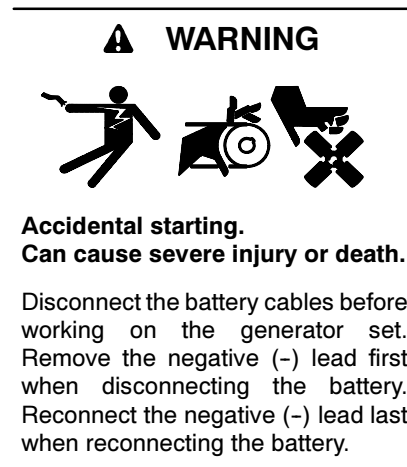

Accidental starting. Can cause severe injury or death. Disconnect the battery cables before working on the generator set. Remove the negative (-) lead first when disconnecting the battery. Reconnect the negative (-) lead last when reconnecting the battery.

Disabling the generator set. Accidental starting can cause severe injury or death. Before working on the generator set or connected equipment, disable the generator set as follows: (1) Move the generator set master switch to the OFF position. (2) Disconnect the power to the battery charger. (3) Remove the battery cables, negative (-) lead first. Reconnect the negative (-) lead last when reconnecting the battery. Follow these precautions to prevent starting of the generator set by an automatic transfer switch, remote start/stop switch, or engine start command from a remote computer.

3.5.1 Fuses

To quickly check the condition of the components mentioned in the following flowcharts, use an ohmmeter to measure resistance between designated terminal and ground. See Figure 3-15 and Figure 3-16. With ohmmeter on R x 1 scale, a reading of less than 1 ohm (continuity) indicates a potentially defective component. Isolate the defective component and repair or replace.

Component	Connect between ground and terminal:
Engine Gauges	Connector P2, pin 1
Crank (K2 Relay) Circuit	Connector P1, pin 1
Fuel/ignition Circuit	Connector P1, pin 7

Figure 3-15 P1 and P2 Connections

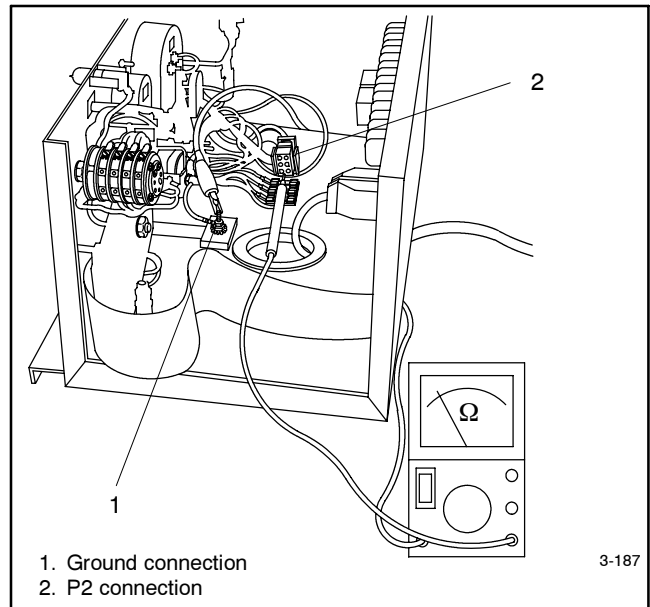

Figure 3-16 Checking P1 and P2 Connections

Figure 3-17 lists the possible causes of blown controller fuses F1, F2, and F3. Replace blown fuses and resume operation. If the fuse blows again, use the chart to identify the faulty component(s).

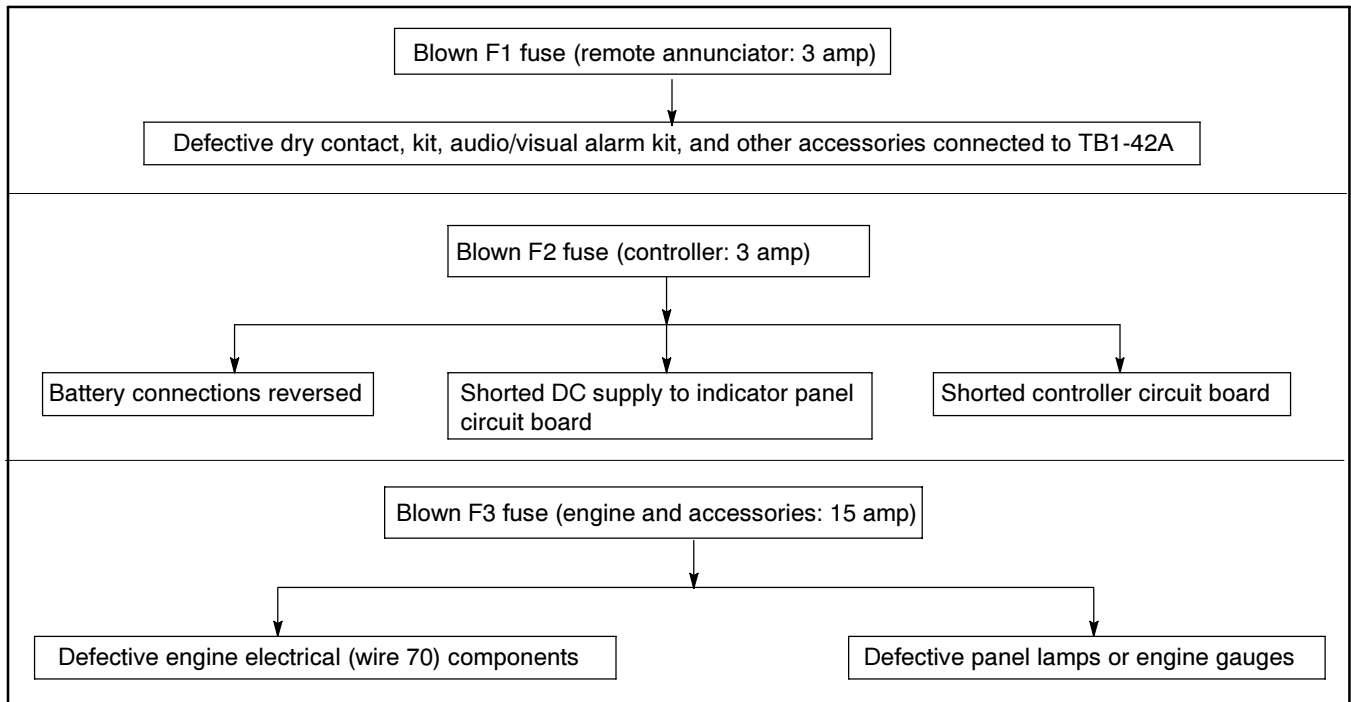
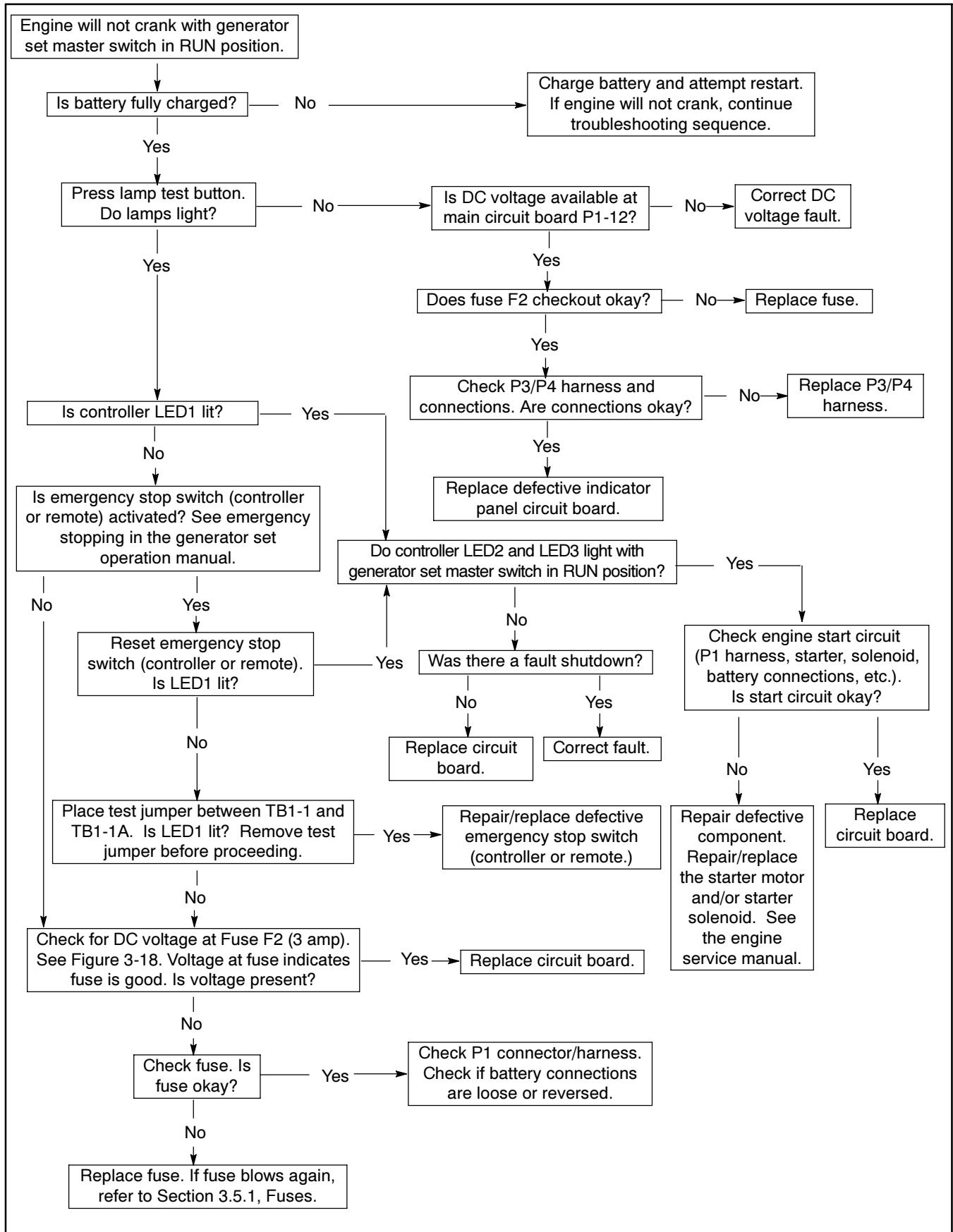

Figure 3-17 Checking Fuses F1, F2, and F3

3.5.2 Controller Flowcharts

Engine Will Not Crank



Engine Cranks, But Will Not Start

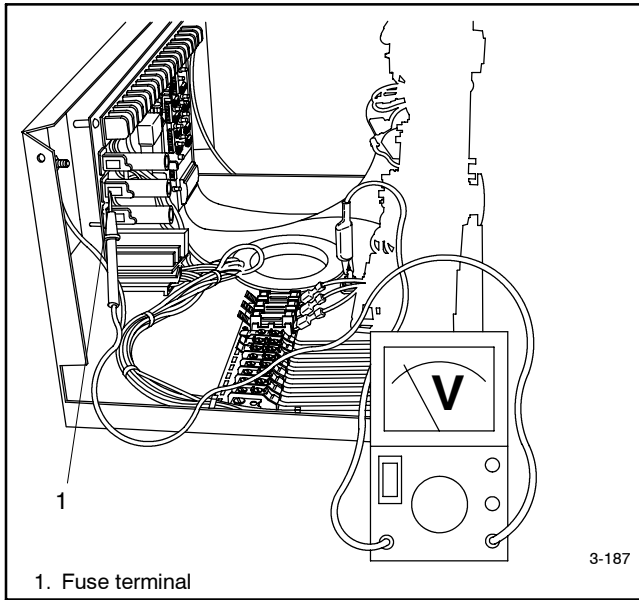
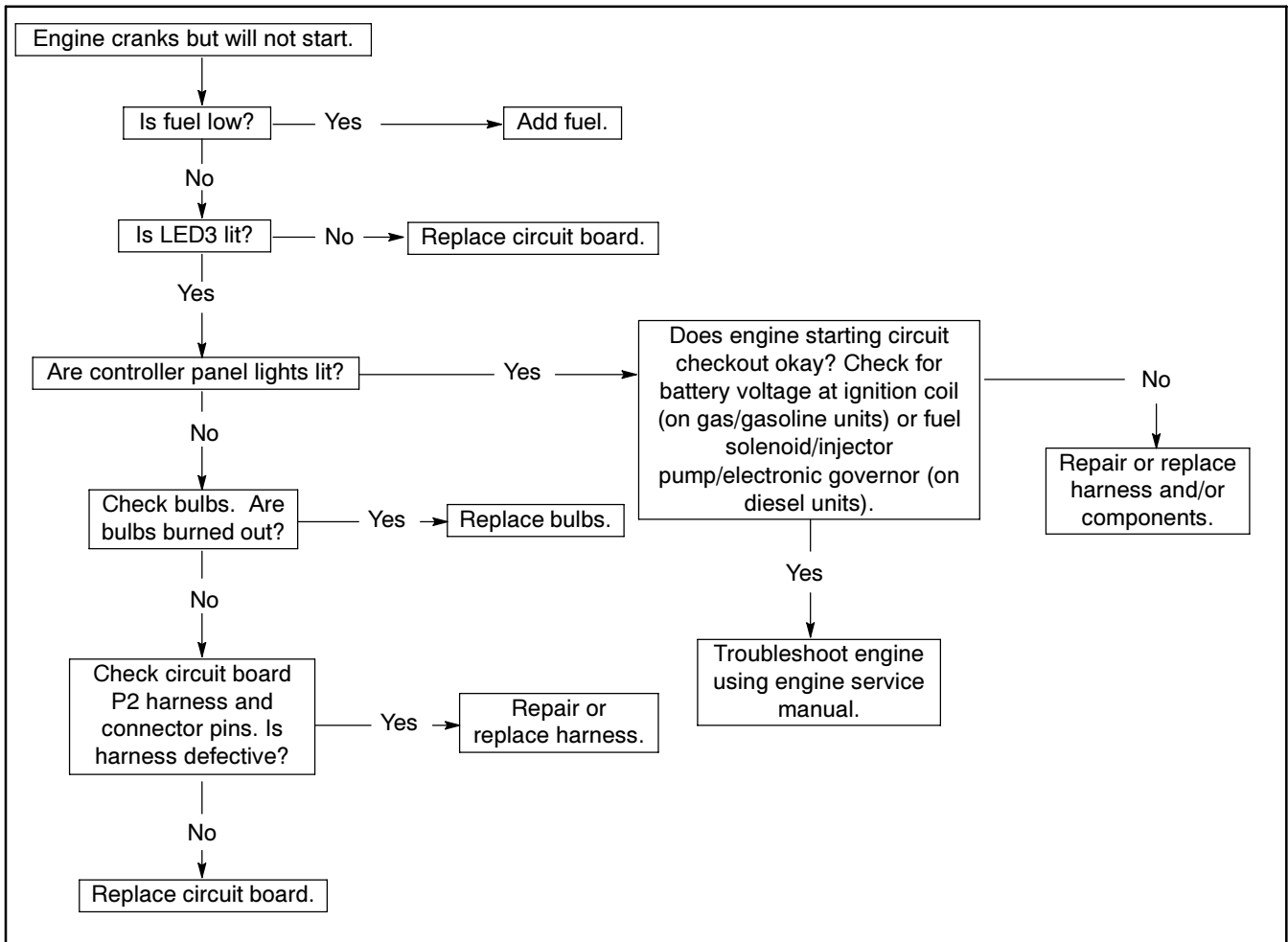
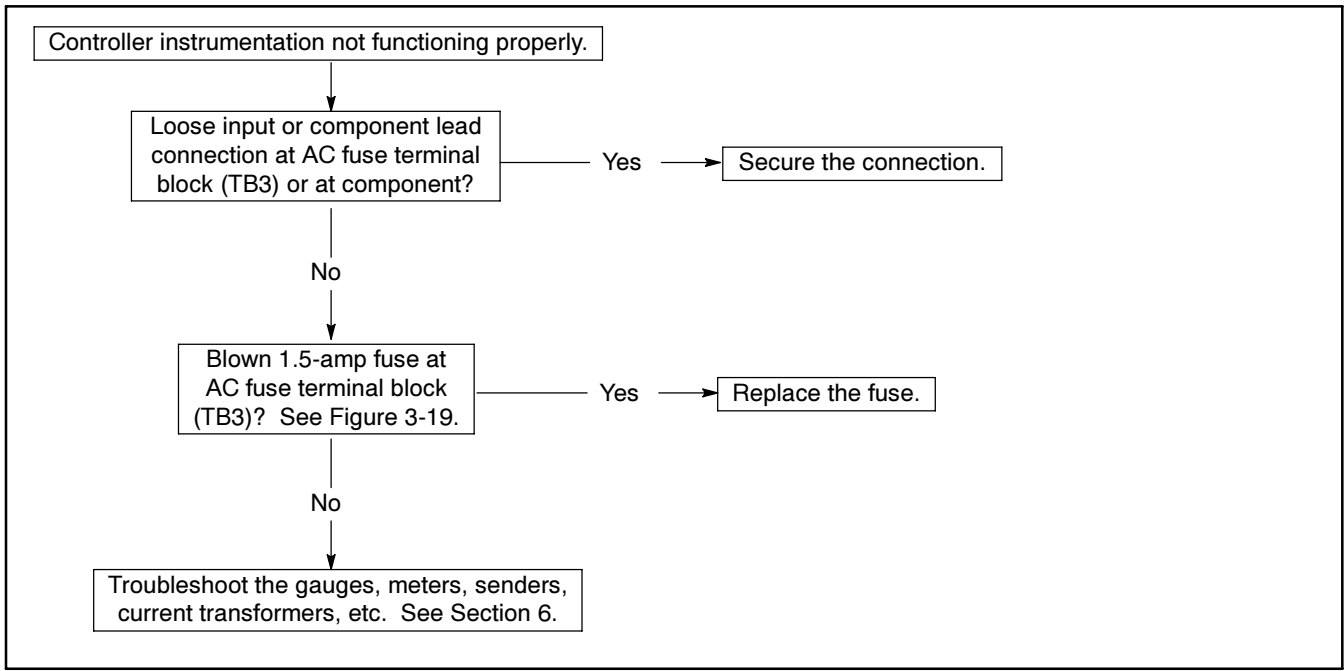

Figure 3-18 Checking Condition of Fuse F2



Controller Instrumentation



Indicator Panel Circuit Board

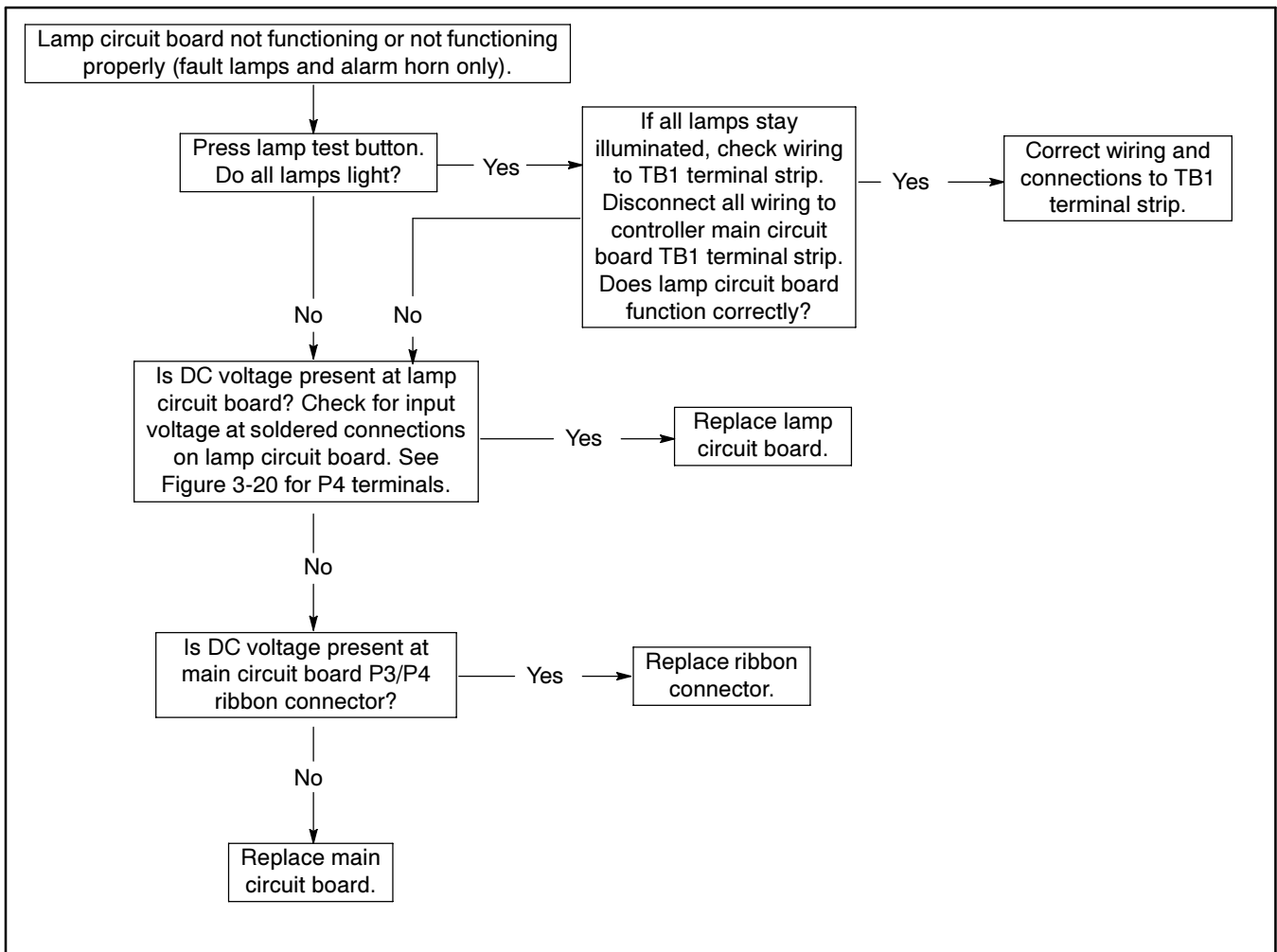

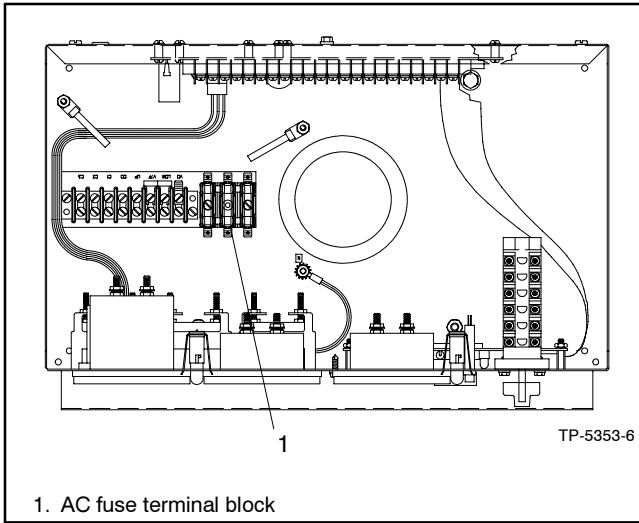

Figure 3-19 AC Fuse Terminal Block

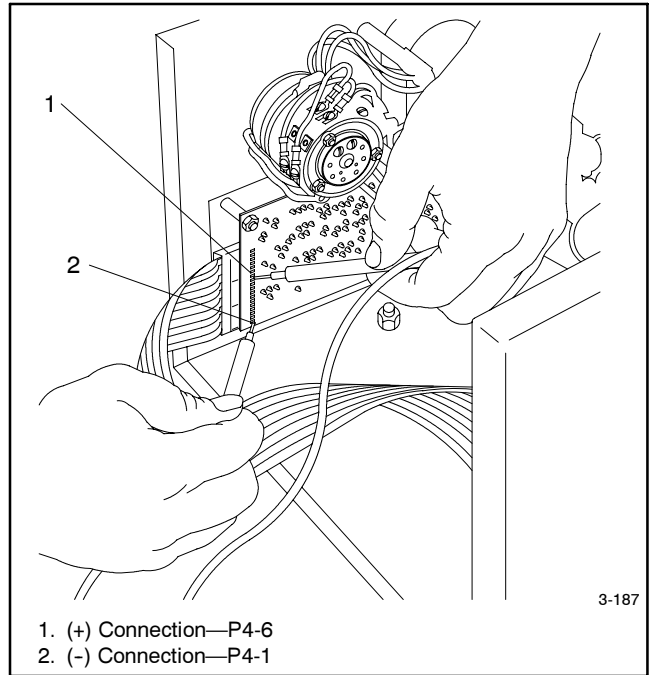
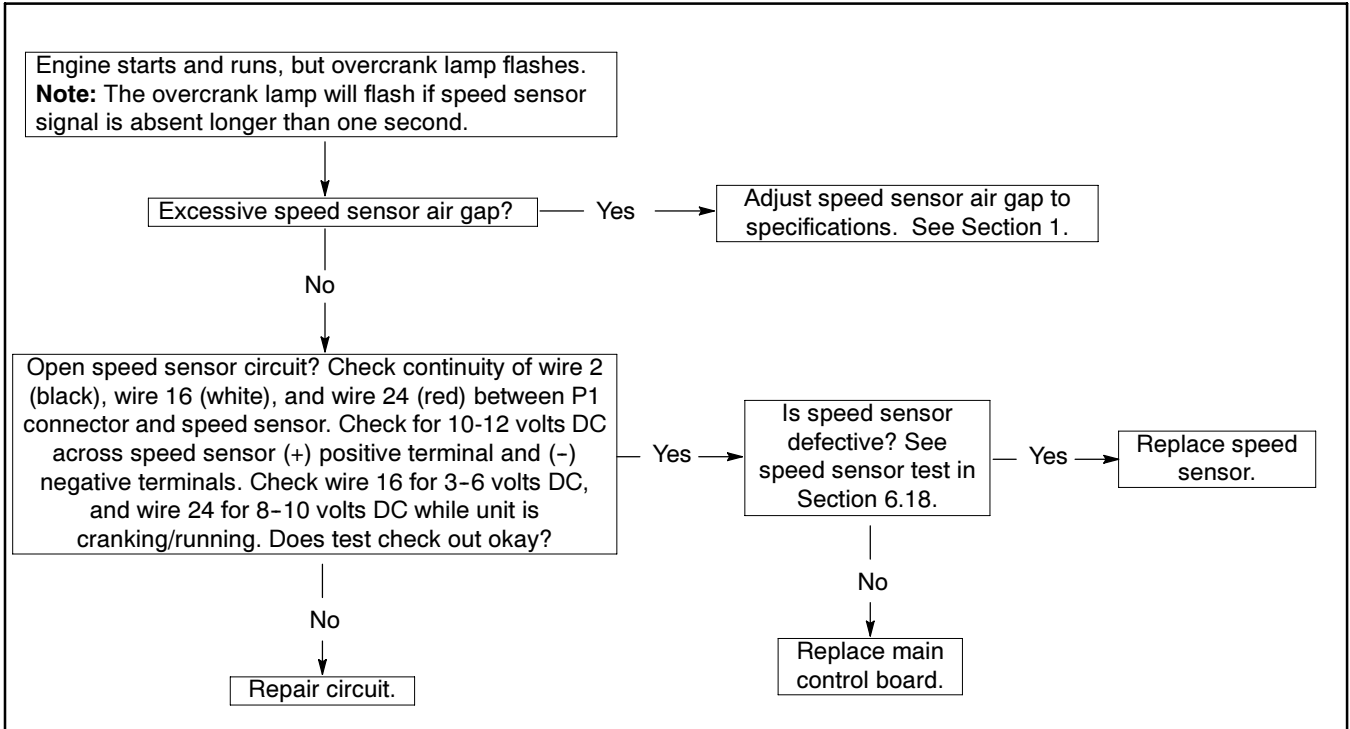

Figure 3-20 Checking Input Voltage to Lamp Circuit Board

Overcrank Lamp



Generator Set Master Switch on Indicator Panel Circuit Board

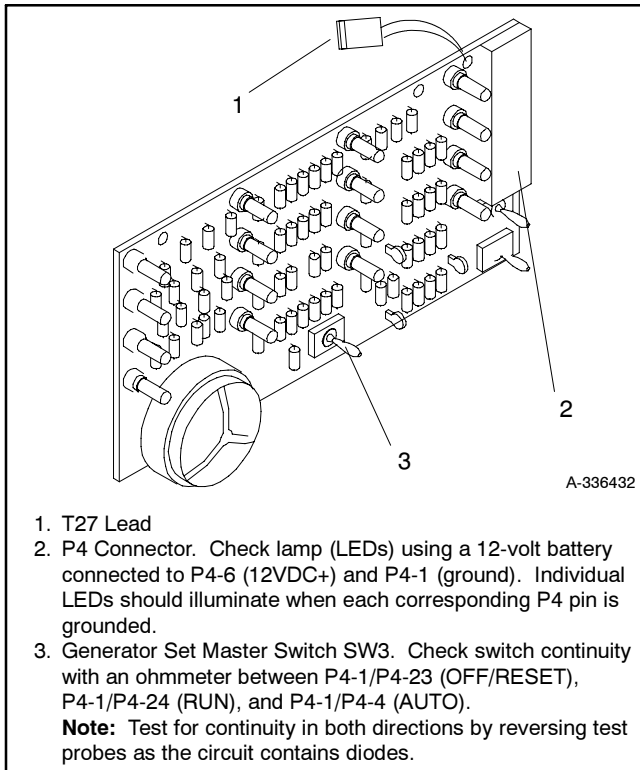
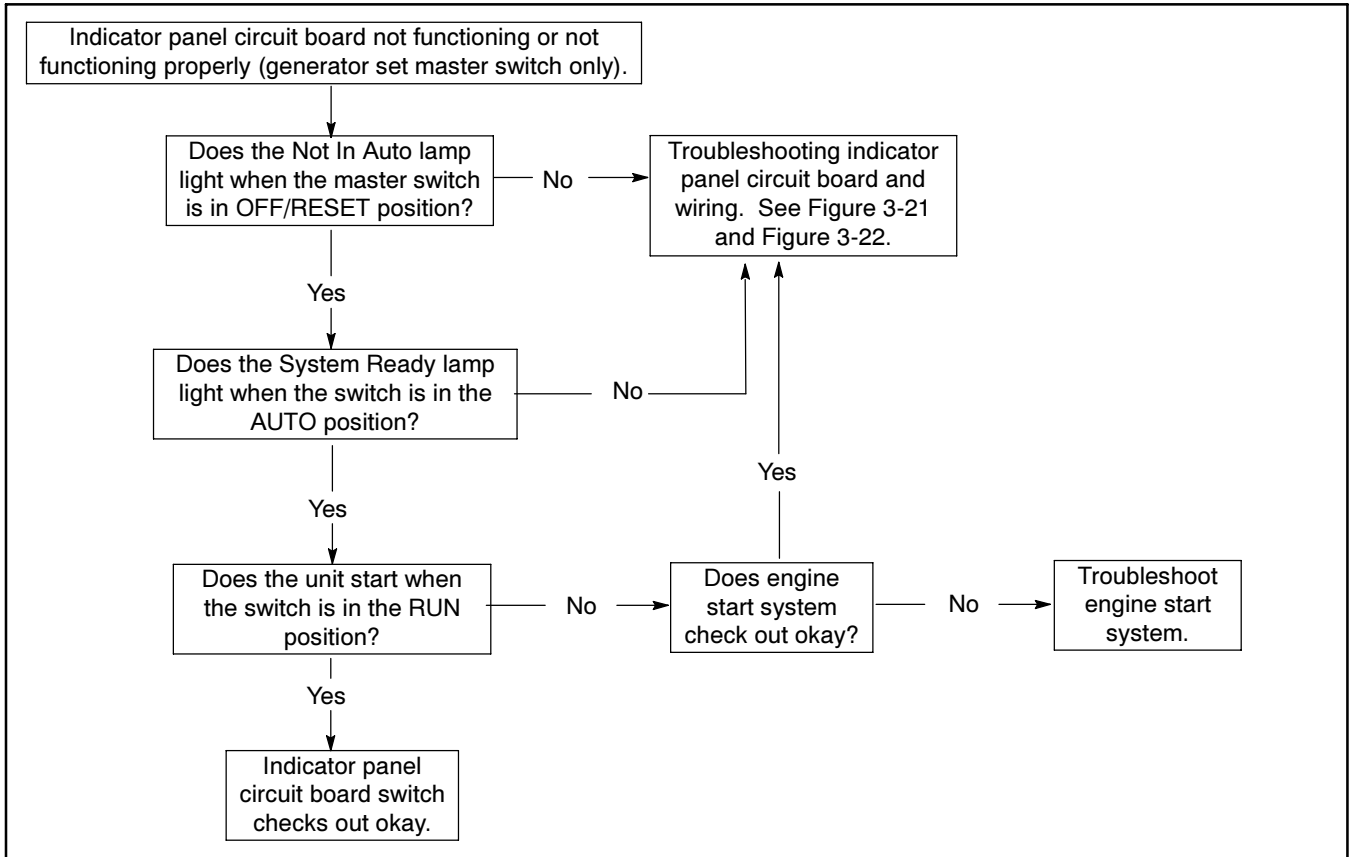

Figure 3-21 Indicator Panel Circuit Board

P4-	Wire	Description
1	2	Ground
2	—	—
3	—	—
4	46	Auto
5	—	—
6	24	12 VDC
7	38	Low Oil Pressure *
8	39	Overspeed *
9	12	Overcrank *
10	26	Auxiliary *
11	48	Emergency Stop *
12	40	Anticipatory High Engine Temperature *
13	36	High Engine Temperature *
14	60	System Ready *
15	80	Not in Auto *
16	35A	Low Water Temperature *
17	41	Anticipatory Low Oil Pressure *
18	56	Air Damper *
19	62	Low Battery Voltage *
20	61	Battery Charger Fault *
21	63	Low Fuel *
22	32	Common Fault
23	43	Off/Reset
24	47	Run
T27	—	High Battery Voltage

* Ground P4 pin to test

Figure 3-22 Indicator Panel Circuit Board P4 Connections

3.6 FASTCHECK® Diagnostic Tool Features and Operation

The FASTCHECK® diagnostic tool serves as an engine simulator for testing and troubleshooting the 16-light controller.

3.6.1 Features

The following paragraphs detail the FASTCHECK®. See Figure 3-23 for an illustration. The following engine switches simulate engine conditions:

- **OFF**—locked engine (starter energized but not turning)
- **CRANK**—engine cranking, but not started
- **RUN**—engine running

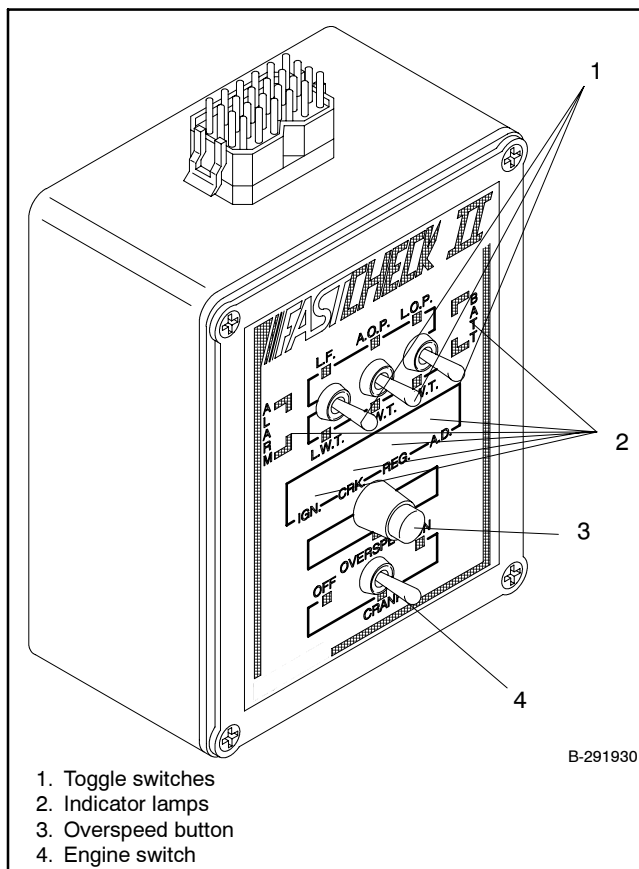

Figure 3-23 FASTCHECK® Diagnostic Tool

Indicator Lamps:

IGN—(ignition) lamp:

- Indicates battery voltage supply to ignition (gas/gasoline) or fuel solenoid (diesel), fuel valves, water valve (city-water cooled sets)
- Lights during cranking and running

CRK—(crank) lamp:

- Indicates battery voltage switched to starter (engine not necessarily turning)
- Lights only during on-crank cycles

REG—(regulator) lamp:

- Indicates battery voltage supply to generator set's AC voltage regulator
- Lights only during cranking and running

BATT—(battery) lamp:

- Indicates test battery(ies) or DC power supply availability to circuit with correct polarity

Note: LOP, HWT, and OVERSPEED simulate malfunctions causing engine to shut down. LOP and HWT circuits start timing after engine runs for 30 seconds. Engine shutdown should occur 5 seconds after pushing the LOP or HWT fault switches. The OVERSPEED shut down is immediate.

Switches:

LOP—low oil pressure

HWT—high water (engine) temperature

OVERSPEED—simulates a 70 Hz overspeed condition

LF—low fuel (not used for testing)

LWT—low engine water temperature

AOP—anticipatory (low) oil pressure

AWT—anticipatory (high) water temperature

3.6.2 Application

Use the FASTCHECK® to test the controller on the generator set when troubleshooting startup problems, or to test and troubleshoot the controller when removed from the generator set.

To operate the FASTCHECK® obtain the following equipment:

- FASTCHECK® simulator (B-291930) and harness (255915).
- Variable low-voltage DC power supply; 0-30 volt, 3 amp minimum current, 0.5% maximum output voltage ripple at 30 volts DC. A 12- or 24-volt battery (depending on system voltage) can also operate the FASTCHECK®.

Note: All 200 kW and above models use a 24-volt battery engine electrical systems. The 20-180 kW models use 12-volt or 24-volt engine electrical systems. Check generator set nameplate for engine electrical system voltage.

3.6.3 FASTCHECK Diagnostic Tool Use

1. Unplug the DC engine harness from the DC harness connector (P1). See Figure 3-24.

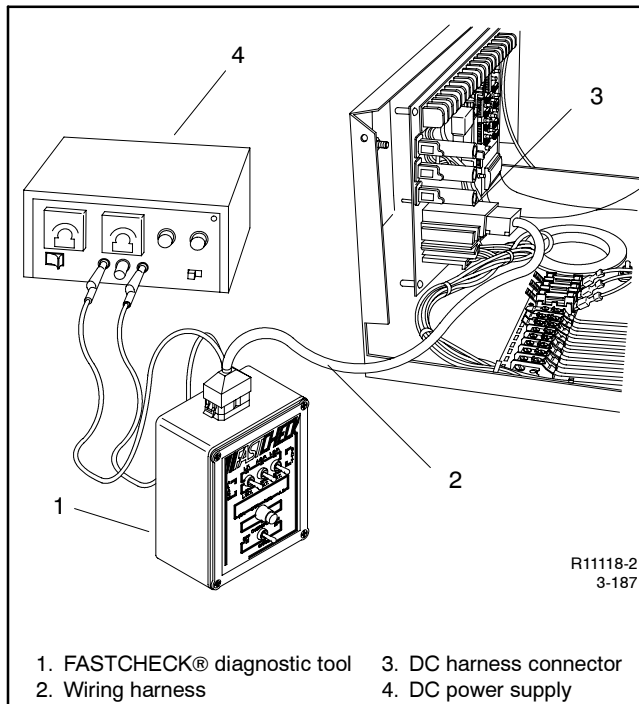

Figure 3-24 FASTCHECK® Connections

2. Connect the FASTCHECK® harness to the DC harness connector (P1) and to the top of the FASTCHECK®.
3. Move the generator set master switch to the OFF/RESET position.
4. Move the FASTCHECK® engine switch to the OFF position.
5. Clip the red (+) and black (-) harness leads to a battery(ies) or DC power supply that corresponds to the generator set engine electrical system (12 or 24 volt). Adjust the output voltage to 1-2 volts above the battery voltage when using a DC power supply. Use generator set battery(ies) if accessible and fully charged.

Note: Incorrect battery polarity may cause controller circuit board damage when connecting the FASTCHECK®.

Note: Because of the absence of AC output, the auxiliary lamp flashes during controller testing. The NOT IN AUTO lamp illuminates whenever the generator set master switch is not in the AUTO position.

6. Move the generator set master switch to the RUN position. Move the FASTCHECK® engine switch to CRANK. The FASTCHECK® IGN., CRK., and REG. lamps should light. The generator set controller causes the engine to crank until the FASTCHECK® switch is moved to RUN (or OVERCRANK shutdown appears on generator set controller).
7. Move the FASTCHECK® engine switch to RUN. The CRK. lamp should go out and the REG. and IGN. lamps should stay on.
8. Simulate engine malfunctions by pressing the FASTCHECK® fault switches. The corresponding fault lamp on the controller should light during each simulated engine malfunction.

Leave the FASTCHECK® engine switch in the RUN position for at least 30 seconds before pushing the toggle switches. Toggle the generator set master switch to OFF/RESET and the FASTCHECK® engine switch to OFF, then back to RUN after simulated fault shutdowns.

9. Use the following sections to test overcrank circuitry, speed sensor circuitry, and generator set condition indicators.

3.6.4 Overcrank

The following procedure tests the overcrank function on the generator set controller and the ability to:

- Detect a locked engine.
- Stop a startup attempt if the starter locks or will not engage.

If the OVERCRANK shutdown fails to function, check the speed sensor and related circuitry. See Section 3.6.5, Controller Speed Sensor Circuitry, and Section 6.18, Speed Sensor Test.

1. Move the FASTCHECK® engine switch to the OFF position.
2. Move the generator set master switch to the OFF position and then move the switch to the RUN position.
3. The IGN., CRK., and REG. lamps on the FASTCHECK® should light for approximately 5 seconds and then go out. Then 5 seconds later the IGN., CRK., and REG. lamps should relight for 5 seconds before going out again (15 seconds total elapsed time). The controller OVERCRANK lamp lights.
4. Check for operating voltage between terminals TB1-42A (+) and TB1-12 (-).

3.6.5 Controller Speed Sensor Circuitry

To check the controller's ability to respond to signals from the speed sensor, perform the following test:

1. Move the generator set master switch to the OFF/RESET position.
2. Move the FASTCHECK® engine switch to the OFF position.
3. Move the generator set master switch to the RUN position. Verify that the IGN., CRK., and REG. lamps light.
4. Within 5 seconds, move the FASTCHECK® engine switch to the RUN position.
5. If the CRK. lamp goes out on the FASTCHECK®, the controller speed sensor circuitry functions correctly.

3.6.6 Generator Set Condition Indicator Terminal (TB1 Terminal Strip)

Connect the remote accessories (audiovisual alarm, remote annunciator, dry contact kits, etc.) to the controller's TB1 terminal strip to signal the condition of the generator set. Some generator sets may not have the optional sending devices necessary to operate all the generator set condition indicators.

If the remote accessories will not operate, test for output voltage at the TB1 terminal strip. To test the operation of each indicator, move the generator set master switch and FASTCHECK® toggle switch to the position prescribed.

The test point voltage is slightly lower than the voltage supplied to the controller (12 or 24 volts). If the correct voltage is not detected at the test point, remote accessories (audiovisual alarm, remote annunciator, dry contact kits, etc.) will not function. Figure 3-25 and Figure 3-26 show test point connections.

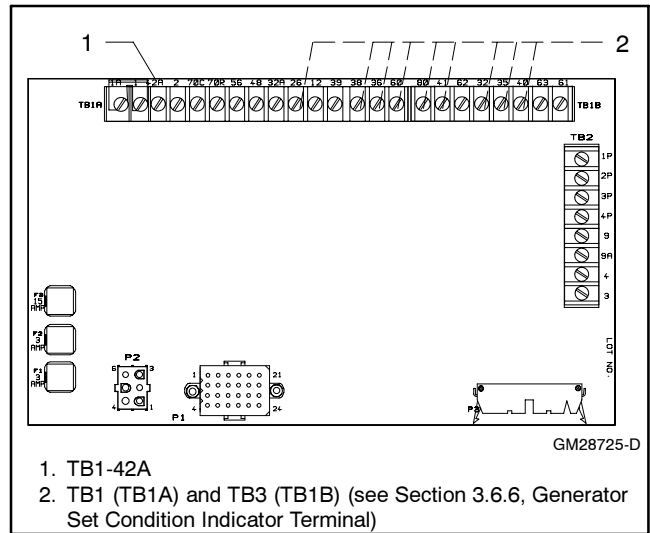

Figure 3-25 Indicator Lamp Test Connections on the Main Circuit Board

When checking the controller test point voltage, place the negative (-) lead of the voltmeter on the terminal designated in the chart and the voltmeter positive (+) lead on TB1-42A.

Because of the absence of AC output, the auxiliary lamp flashes during controller testing. The NOT IN AUTO lamp illuminates whenever the generator set master switch is not in the AUTO position.

1. Leave the FASTCHECK® engine switch in the RUN position for at least 30 seconds before pushing the toggle switches.
2. Move the generator set master switch to the OFF/RESET position.
3. Move the FASTCHECK® engine switch to the OFF position.
4. Move the generator set master switch to the RUN position. Verify that the IGN., CRK., and REG. lamps light. Within 5 seconds, move the FASTCHECK® engine switch to the RUN position.

Indicator	Switch Position/Remarks	Check for Voltage Between:
Anticipatory (High Engine) Water Temperature (AWT)	Place the generator set master switch in the RUN position. Place the engine switch in the RUN position. Press and hold the toggle switch to AWT.	TB1-42A (+) and TB3-40 (-)
Anticipatory (Low Engine) Oil Pressure (AOP)	Place the generator set master switch in the RUN position. Place the engine switch in the RUN position. Press and hold the toggle switch to AOP.	TB1-42A (+) and TB3-41 (-)
Auxiliary Fault	Place the generator set master switch in the RUN position. Place the engine switch in the RUN position and wait 10 seconds. A flashing AUX lamp indicates proper operation of all auxiliary functions.	TB1-42A (+) and TB1-26 (-)
Battery Charger Fault, if battery charger equipped and connected	Place the generator set master switch in the OFF/RESET position. Place the engine switch in the RUN position. Ground the controller terminal TB1-61 to test. If the Battery Charger lamp lights the circuit functions correctly.	Not Applicable
Common Fault/Auxiliary Prealarm	Place the generator set master switch in the RUN position. Place the engine switch in the RUN position. Press and hold the toggle switch to the LWT, HWT, or LOP position.	TB1-42 (+) and TB3-32 (-)
Emergency Stop (local/remote), if equipped	Place the generator set master switch in the RUN position. Place the engine switch in the RUN position. Remove the switch lead connected to controller terminal TB1-1 or 1A.	Not Applicable
Generator Switch Not in Auto	Place the generator set master switch in the RUN or OFF/RESET position. Place the engine switch in any position.	TB1-42A (+) and TB3-80 (-)
High Battery Volts (if battery charger equipped and connected)	Generator set master switch in OFF/RESET; engine switch in RUN position Ground controller terminal TB1-27 to test. If the High Battery Volts lamp lights the circuit functions correctly.	Not Applicable
High (Engine) Water Temperature (HWT)	Place the generator set master switch in the RUN position. Place the engine switch in the RUN position. Press and hold the toggle switch to HWT for at least 5 seconds.	TB1-42A (+) and TB1-36 (-)
Low Battery Volts, if battery charger equipped and connected	Place the generator set master switch in the OFF/RESET position. Place the engine switch in the RUN position. Ground controller terminal TB1-62 to test. If Low Battery Volts lamp lights the circuit functions correctly.	Not Applicable
Low Fuel	Place the generator set master switch in the OFF/RESET position. Place the engine switch in the RUN position. Ground controller terminal TB1-63 to test. If the Low Fuel lamp lights the circuit functions correctly.	Not Applicable
Low Oil Pressure (LOP)	Place the generator set master switch in the RUN position. Place the engine switch in the RUN position. Press and hold the toggle switch to LOP for at least 5 seconds.	TB1-42A (+) and TB1-38 (-)
Low Water Temperature (LWT)	Place the generator set master switch in the RUN position. Place the engine switch in the RUN position. Press and hold the toggle switch to LWT.	TB1-42A (+) and TB3-35A (-)
Overspeed	See Controller Speed Sensor Circuitry test in Section 3.6.5.	Not Applicable
Overcrank	See Overcrank test in Section 3.6.4.	Not Applicable
System Ready	Place the generator set master switch in the AUTO position. Place the engine switch in the OFF position.	TB1-42A (+) and TB3-60 (-)

Figure 3-26 Generator Set Condition Terminals TB1 (TB1A) and TB3 (TB1B)

Notes

Section 4 Digital Controller

4.1 General Repair Information

This section contains Digital controller repair information. Service replacement of the Digital controller is limited to the items shown in Figure 4-1. Refer to the respective controller parts catalog for service part numbers. No other replacement service parts are available.

Before replacing the controller, remove all external accessories and other electrical connections to verify that these items are not the cause of the controller problems. Verify that the accessories and connections are functioning correctly before reconnecting them to the new controller.

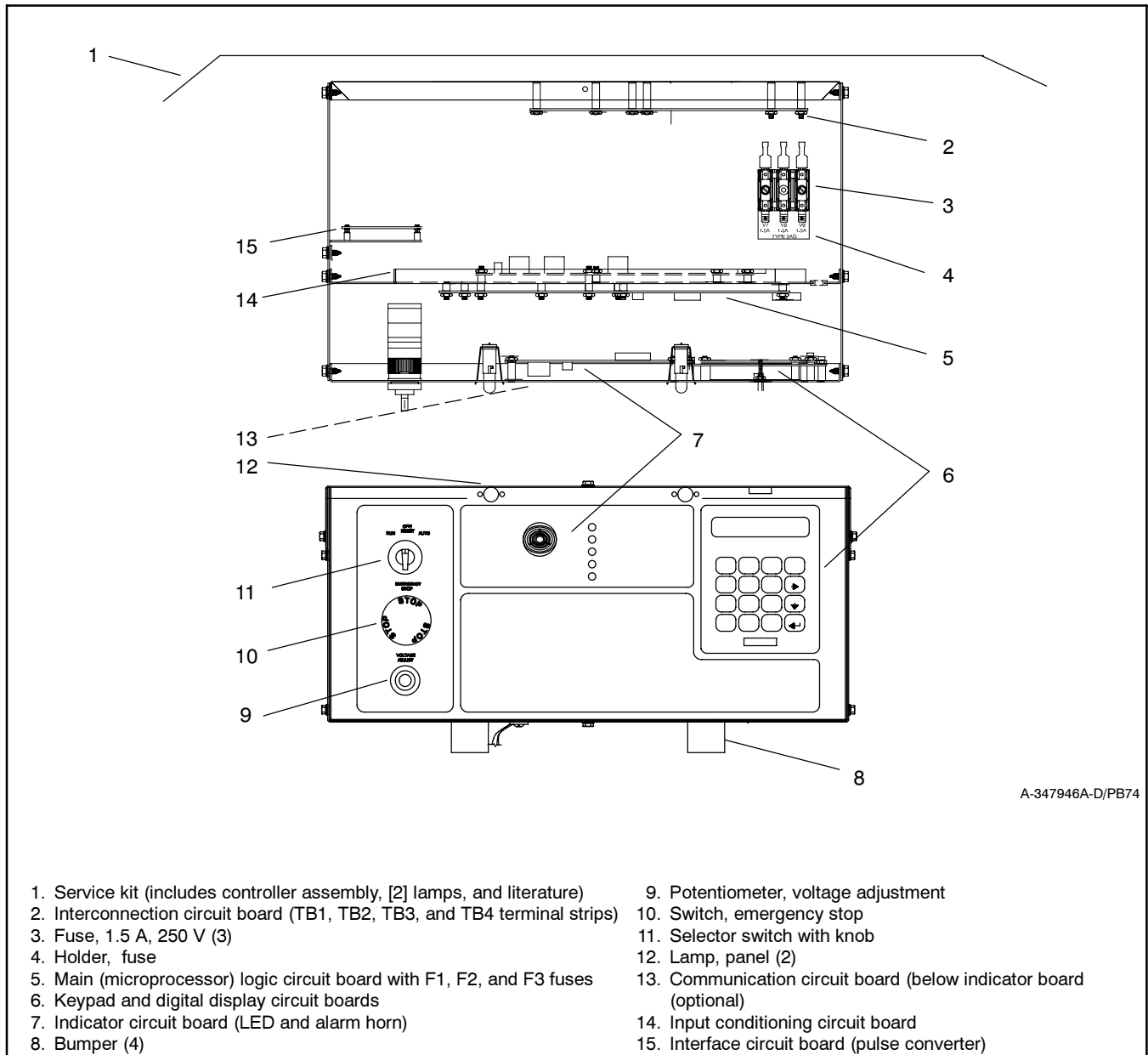

Figure 4-1 Digital Controller Service Replacement Parts

4.2 Controller Circuit Board Service Kits GM37440 and GM37441

Adapted from Installation Instruction TT-1391 8/04.

4.2.1 Introduction

The Digital controller circuit board service kits replace the circuit boards shown in Figure 4-2. See Figure 4-3 for identification of the controller and Figure 4-4 for location and descriptions of the controller circuit boards.

Service Kit Part Number	Circuit Board Part Number	Circuit Board Description
GM37440	A-352166	Input conditioning
GM37441	A-352160	Interconnection

Figure 4-2 Circuit Board Service Kits

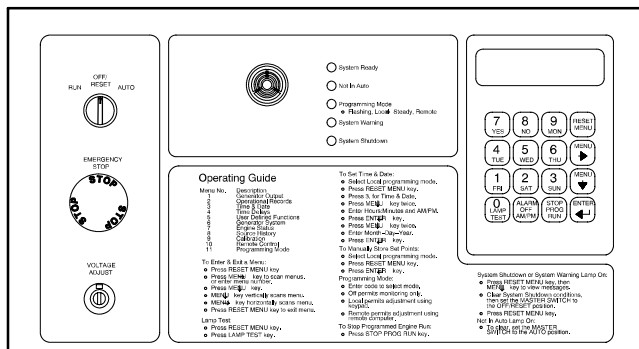

Figure 4-3 Digital Controller Front View

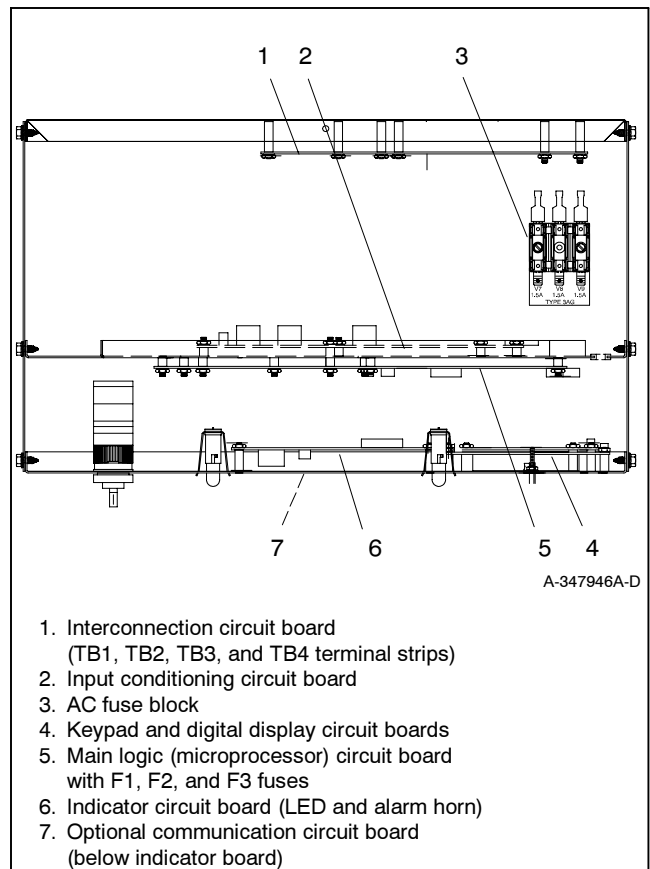

Figure 4-4 Controller Circuit Boards and Fuses, Controller Top View

4.2.2 Items Required

The following equipment is required to calibrate the generator set after a new circuit board is installed.

- Resistive load bank rated for the generator set standby rating
- RMS voltmeter and ammeter (some load banks may include metering)
- MP-5829, Controller Operation Manual
- An approved grounding wrist strap (see Safety Precaution notice)

Read the entire installation procedure perform steps in order shown.

Always observe applicable local and national electrical codes.

4.2.3 Procedure

1. Acquire the display data from Menu 6, Generator System.

When possible, make note of the data from the existing controller for entry with the new circuit board(s).

If the existing controller is not functional, the installer must determine and document this information for entry later in this procedure.

See Section 4.2.4, User-Defined Settings, for the controller default settings.

- a. Press the Reset Menu key on controller keypad.
 - b. Go to Menu 6, Generator System and press the down arrow key to System Voltage. See Figure 4-5. Record all data from each display.
2. Remove the generator set from service.
 - a. Place the generator set master switch in the OFF position.
 - b. Disconnect the power to the battery charger, if equipped.
 - c. Disconnect the generator set engine starting battery(ies), negative (-) lead first.
 3. Open the controller.
 - a. Remove the controller cover and hardware.
 - b. Partially disassemble the controller box. Remove the two controller panel top screws and center bottom screw and then loosen the bottom screw on each side to swing the controller panel down.

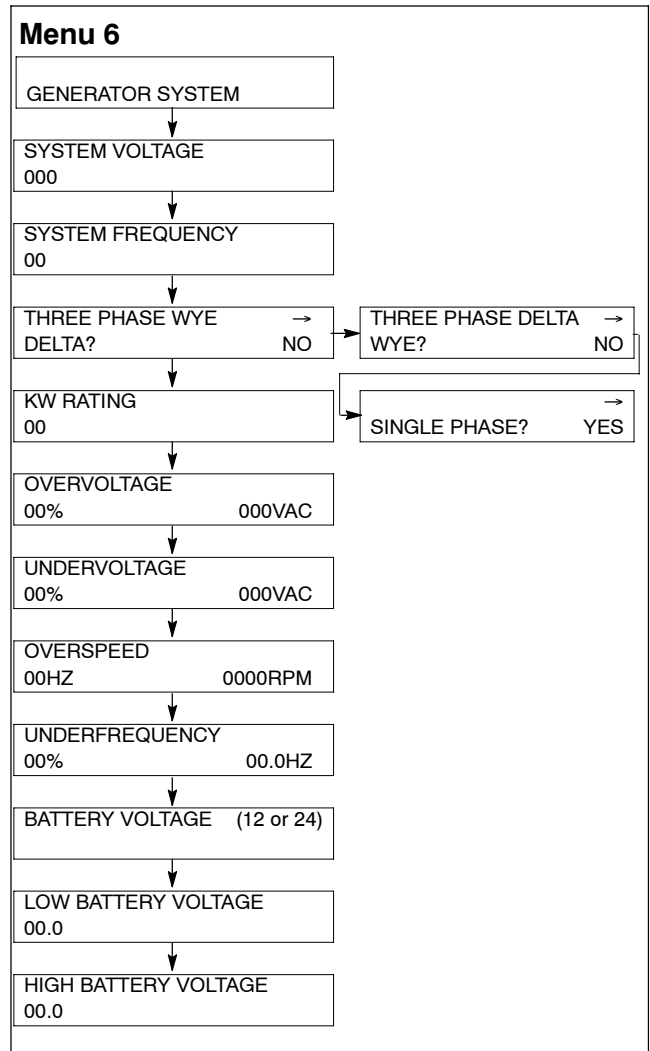

Figure 4-5 Menu 6, Generator System

4. Remove the controller circuit board external electrical connections.

Remove items mentioned in step a. input conditioning circuit board A-351166 and/or b. interconnection circuit board A-352160 as needed.

Note: Clearly mark all disconnected leads from the Digital controller with tape to simplify reconnection.

- a. Input conditioning circuit board A-352166. See Figure 4-6.
 - P11 interconnection circuit board 14-pin connector
 - P13 main logic circuit board 24-pin connector
 - P18 input conditioning circuit board 26-pin connector

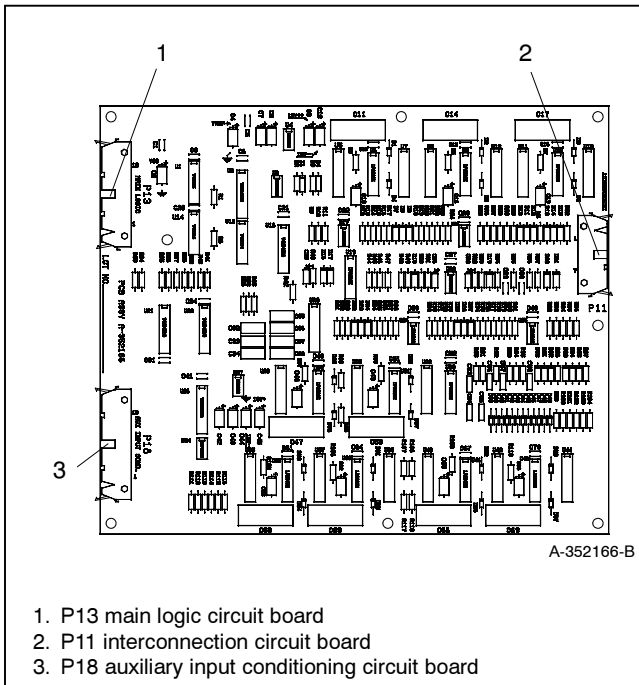

Figure 4-6 Input Conditioning Circuit Board A-352166

- b. Interconnection circuit board A-352160. See Figure 4-7.

- P5 status panel circuit board 30-pin connector
- P12 input conditioning circuit board 14-pin connector
- TB1 terminal strip connections
- TB2 terminal strip connections
- TB3 terminal strip connections
- TB4 terminal strip connections

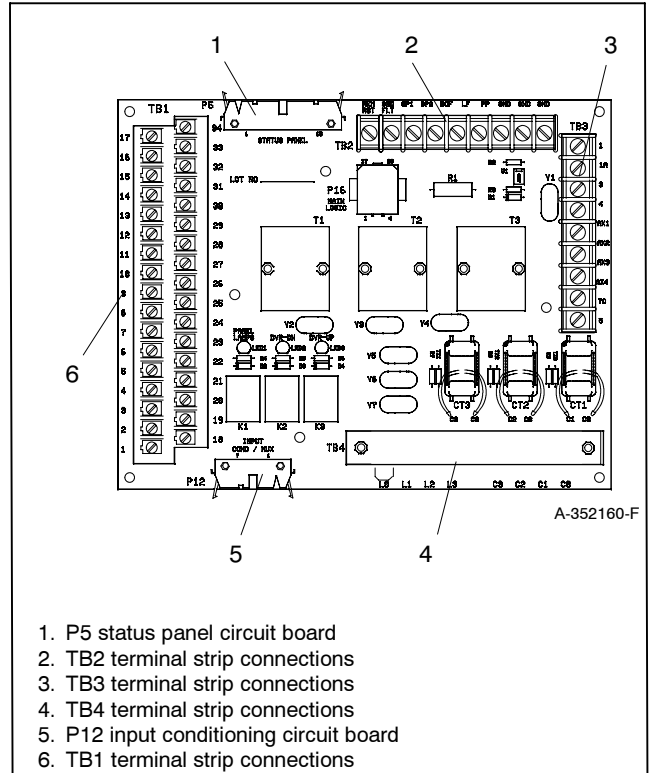

Figure 4-7 Interconnection Circuit Board A-352160

5. Remove/replace the circuit board(s) from the controller.
 - a. Observe proper circuit board grounding practices. See NOTICE in safety precautions section.
 - b. Remove the mounting hardware.
 - c. Remove the defective circuit board(s).
 - d. Install the new circuit board(s) in the same position as that of the old circuit board(s).
 - e. Secure the new circuit board(s) using the existing hardware.

6. Attach the controller circuit board(s) external electrical connections.

Reconnect the items mentioned in step a. input conditioning circuit board A-351166 and/or b. interconnection circuit board A-352160 as needed.

- a. Input conditioning circuit board A-352166. See Figure 4-6.
 - P11 interconnection circuit board 14-pin connector
 - P13 main logic circuit board 24-pin connector
 - P18 input conditioning circuit board 26-pin connector
- b. Interconnection circuit board A-352160. See Figure 4-7.
 - P5 status panel circuit board 30-pin connector
 - P12 input conditioning circuit board 14-pin connector
 - TB1 terminal strip connections
 - TB2 terminal strip connections
 - TB3 terminal strip connections
 - TB4 terminal strip connections

7. Assemble the controller.

- a. Swing the front controller panel up and replace and tighten the screws, as necessary.
- b. Replace the controller cover and hardware. Tighten all controller screws.

8. Restore power to the generator set.

- a. Check that the generator set master switch is in the OFF position.
- b. Reconnect the generator set engine starting battery, negative (-) lead last.
- c. Reconnect power to the battery charger, if equipped.

9. Set the programming mode.

Note: Refer to the controller operation manual MP-5829 as needed.

- a. Press the Reset Menu key on controller keypad.
- b. Go to Menu 11, Programming Mode, and press the down arrow key to Programming Mode.

If Programming Mode—Local is shown, go to step 10.

If Programming Mode—Local is NOT shown, press the right arrow key to select Local. Press YES and the Enter key.

- c. Enter the access code. The factory default access code is the number 0. Press the Enter key.

10. Verify the generator set system values.

Note: Refer to the controller operation manual MP-5829 as needed.

- a. Press the Reset Menu key on controller keypad.
- b. Go to Menu 6, Generator System, and press the down arrow key to System Voltage.
- c. Use the numeric and/or YES/NO keys and then press the Enter key to add the data each corresponding display shown in Figure 4-5. Press the down arrow key to access the next display. Use the right arrow key for the three-phase/single-phase entry.

Note: During step 1, the user should have recorded the values for Menu 6. The user must define these values for purposes of calibrating the controller.

11. Calibrate.

Note: Refer to the controller operation manual MP-5829 as needed for generator set starting and stopping procedures.

- a. Verify that the controller master switch is in the OFF position.
- b. Press the Reset Menu key on controller keypad.
- c. Go to Menu 9, Calibration and press the down arrow key to Auto-Zero? See Figure 4-8.

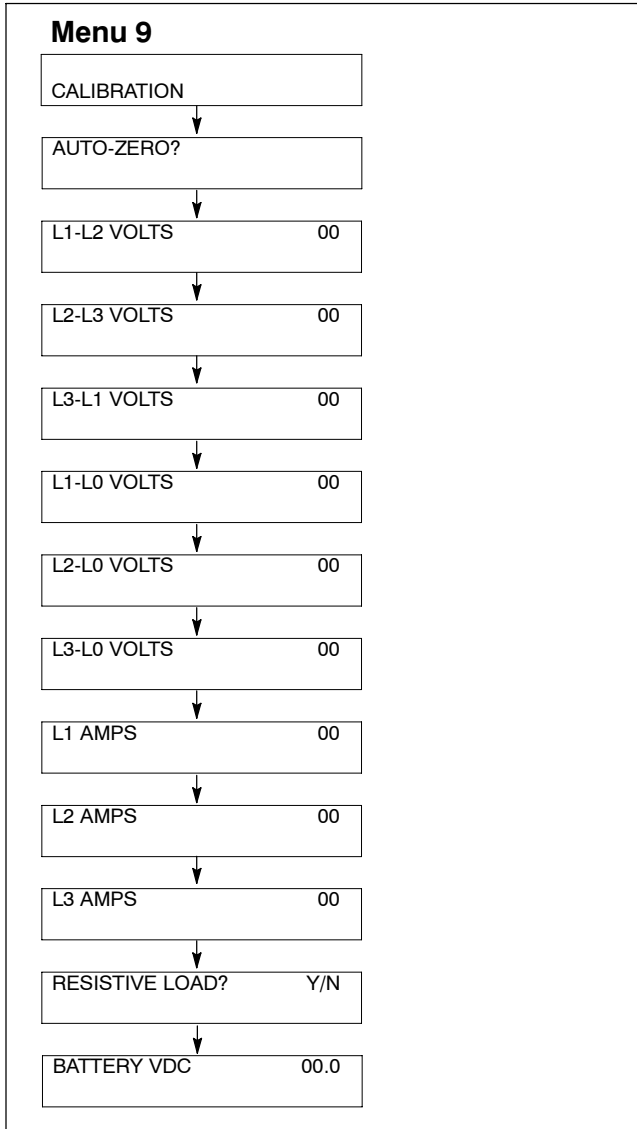

Figure 4-8 Menu 9, Calibration

- d. Press YES and the Enter key.
- e. Connect a resistive load bank to the generator set output leads. The load bank must be rated for the generator set standby nameplate rating.

If the resistive load bank does not have metering, connect an RMS voltmeter and ammeter to each corresponding generator set output lead connection under calibration.

- f. Place the controller master switch to the RUN position to start the generator set. Allow the generator set to run for 5-10 minutes to reach operating temperature.
- g. Record the L1-L2 voltage from the resistive load bank or connect an RMS voltmeter to L1-L2 output leads if the resistive load bank is not meter equipped.
- h. Press the down arrow key to L1-L2 Volts. Use the numeric keys to enter the user measured value. Press the Enter key.
- i. Record the voltage on the resistive load bank or connect an RMS voltmeter to each of the remaining voltage connections shown in Figure 4-8. Use the numeric keys to enter the user measured value of each of the corresponding voltage displays. Press the Enter key. Press the down arrow key to access the next display.
- j. Record the amps from the resistive load bank or connect an RMS ammeter to each of the amperage connections shown in Figure 4-8. Use the numeric keys to enter the user measured value of each of the corresponding amp displays. Press the Enter key. Press the down arrow key to access the next display.
- k. Press the down arrow key to access the Resistive Load? display.
- l. Press Yes and the Enter key.

Note: Enter only a Yes response and apply only a purely resistive load. Failure to comply with this request will cause incorrect kW load and power factor values.

- m. Press the down arrow key to access the Battery VDC display.
 - n. Use the numeric keys to enter the measured engine electrical system voltage. Press the Enter key.
 - o. Press the Reset Menu key.
 - p. Press the Enter key. The display indicates *Store Set Points*. Wait until display changes to *Enter Menu 1-14*.
 - q. Place the controller master switch to the OFF position to stop the generator set.
12. Enter the Menu 3, Time and Date, settings.
- a. Press the Reset Menu key on the controller keypad.
 - b. Go to Menu 3, Time and Date. Use the information from the controller operation manual as necessary to set the time and date.
13. Restore the generator set to service.
- a. Perform the Menu 10, Remote Control entries.
- Press the Reset Menu key on controller keypad.
 - Go to Menu 10, Remote Control.
 - With the information previously recorded from step 1, complete the communication entries as necessary for the application. Use the information from the controller operation manual as necessary.
- b. Perform the Menu 11, Programming Mode entries.
- Press the Reset Menu key on controller keypad.
 - Go to Menu 11, Programming Mode.
 - Change the entries for the application as necessary.
- c. The generator set system is now ready to function.
- d. Move the generator set master switch to AUTO for startup by remote transfer switch or remote start/stop switch.

4.2.4 User-Defined Settings

Use the table below to record user-defined settings during the generator set controller setup and calibration. The controller default settings and ranges provide

guidelines. The table contains all faults with ranges and time delays including items that do not have adjustments.

Status or Fault	Refer to Menu	Digital Display	Relay Driver Output (RDO)	Range Setting	Default Selection	Inhibit Time Delay* (sec.)	Time Delay (sec.)	User-Defined Settings
Access Code (Password)	11				0 (zero)			
Cyclic Cranking	4			1-6 crank cycles 1-60 sec. crank 1-60 sec. pause	3 15 sec. 15 sec.			
Coolant Temperature Signal Loss	5	No Temp Gauge Signal	User Defined			30		
Customer Auxiliary 1-4 Shutdown or Warning	4, 5	Auxiliary 1-4	User Defined		30 sec. inhibit, 5 sec. delay	0-60	0-60	Not adjustable
Emergency Power System Supplying Load	5	EPS Supplying Load	RDO—8		5% of line current			
High Battery Voltage	5, 6	High Battery Voltage	RDO—10	14.5-16.5 (12V) 29-33 (24V)	16 (12V) 32 (24V)		10	
High Coolant Temperature Shutdown	5	High Coolant Temperature	Std.			30	5	Not adjustable
High Coolant Temperature Warning	5	High Coolant Temperature Warning	Std.			30		Not adjustable

* Inhibited time delay is the time delay period after crank disconnect.

Status or Fault	Refer to Menu	Digital Display	Relay Driver Output (RDO)	Range Setting	Default Selection	Inhibit Time Delay* (sec.)	Time Delay (sec.)	User-Defined Settings
High Oil Temperature Shutdown	5	High Oil Temperature	User Defined			30	5	Not adjustable
kW Overload (Load Shed)								
Load Shed	5	Load Shed KW Overload	User Defined		100% of kW Rating		5	
		Load Shed Underfrequency	User Defined		59, (60 Hz) 49, (50 Hz)		5	
Low AC Output	5	Low AC Output	User Defined			10		
Low Battery Voltage	5, 6	Low Battery Voltage	Std.	10-12.5 (12V) 20-25 (24V)	12 (12V) 24 (24V)		10	
Low Coolant Level Shutdown	5	Low Coolant Level	RDO—7			30	5	Not adjustable
Low Oil Pressure Shutdown	5	Low Oil Pressure	Std.			30	5	Not adjustable
Low Oil Pressure Warning	5	Low Oil Pressure Warning	Std.			30		Not adjustable
Overcrank Shutdown	5	Overcrank	Std.					
Overcurrent	5	Overcurrent	User Defined		110%		10	
Overfrequency Shutdown	5, 6	Overfrequency	User Defined	102%-140%	140% Std. 103% FAA		10	
Overspeed Shutdown	5, 6	Overspeed	Std.	65-70 (60 Hz) 55-70 (50 Hz)	70 (60 Hz) 70 (50 Hz)		0.25	
Oil Pressure Signal Loss	5	No Oil Gauge Signal	User Defined			30		Not adjustable
Overvoltage Shutdown	5, 6	Overvoltage	RDO—6	105%-135%	115% 2-sec time delay		2-10	
Password (Access Code)					0 (zero)			
Starting Aid Function	4, 5		User Defined	0-10 sec.				
Time Delay Engine Cooldown (TDEC)	4		RDO—4	00:00-10:00 min:sec	5:00			
Time Delay Engine Start (TDES)	4		User Defined	00:00-5:00 min:sec	00:01			
Underfrequency Shutdown	5, 6	Underfrequency	User Defined	80%-95%	90%		10	
Undervoltage Shutdown	5, 6	Undervoltage	User Defined	70%-95%	85% 10-sec time delay		5-30	
Weak Battery	5	Weak Battery	User Defined		60%		2	

* Inhibited time delay is the time delay period after crank disconnect.

4.3 Noise and Wiring Practices

Adapted from Service Bulletin SB-640 4/04.

Electrical noise is an unwanted electrical signal that can cause errors in measurement, loss of control, malfunctions in microprocessor-based control systems, errors in data transfer between systems over communication links, or reductions in system performance.

Good system design and wiring practices can minimize noise levels and the effects of noise.

Noise, because of its random nature, is typically characterized by frequency distribution. Many noise sources are broad-spectrum, that is, they produce many frequencies distributed over a wide range. Broad-spectrum noise is particularly troublesome because it cannot be removed easily by filtering and because it can affect a variety of systems in unpredictable ways. One common source of broad-spectrum noise is a switch, which can produce voltage and current changes when an electrical circuit is connected and disconnected.

Coupling is the transfer of signals between separate circuits. Signals from one circuit become noise in another. The amount of coupling is cumulative and is a function of the proximity of the circuits, their orientation, exposed area, and length of run. Minimize coupling by the following:

- Isolating circuits from each other by using separate raceways or conduit.
- Separating circuits from each other by locating them as far apart as possible.
- Enclosing circuits with a grounded metallic shield such as an enclosure, metallic conduit, or cable shield.
- Running conductors perpendicular, rather than parallel, to each other.
- Running wires loosely and randomly rather than bundling them tightly together.
- Twisting a circuit's wires together in pairs.

In an industrial environment, there are typically five types of circuits with different noise emission and rejection capabilities. The five types of circuits are as follows:

- **High-Power Distribution.** Circuits to high-power loads such as large electric motors and heaters can emit transient high levels of broad-spectrum noise. Loads on high-power distribution circuits are nearly immune to noise.
- **General Purpose Power Distribution.** Circuits to medium-power loads such as lighting, offices, light-duty equipment, and small motors such as fans and pumps can emit transient, medium levels of broad-spectrum noise. Some electronic equipment, such as computers, emits constant levels of broad-spectrum noise in addition to transient broad-spectrum noise. Loads on general-purpose circuits, except for sensitive electronic equipment, are nearly immune to noise.
- **Control.** Control circuits include DC circuits and 120 VAC maximum AC circuits that operate at a low power level (less than 1 W). Typical circuits include circuits to switches, actuators, and dry-contact relays, including the generator engine-start circuit. Control circuits emit transient low levels of broad-spectrum noise and are fairly immune to noise.
- **Analog.** Analog circuits are low-voltage DC circuits that convey measurement information as relatively small changes in current or voltage. Typical circuits include those connected to the controller's analog inputs. Analog circuits create the lowest noise levels and are the most sensitive to noise.
- **Communication and Signaling.** Communication and signaling circuits are low-voltage circuits that convey information. Typical circuits include RS-232 and RS-485 serial communication lines, telephone lines, and computer network lines. These circuits create noise with frequencies related to the communication signaling rate. These circuits have some level of built-in noise immunity. Typical systems will detect or correct errors caused by noise below certain levels, but with a corresponding reduction in the data transfer rate.

When planning an installation, separate all of these types of circuits as much as possible to minimize the hazards of insulation failure, accidental miswiring, and noise coupling. For best results, install control circuits, analog circuits, and communication and signaling circuits separately. Combining circuit types is unavoidable in the controller's enclosure and some other areas.

Note: It is very important to isolate high- and medium-power circuits in raceways or conduit separate from the other types of circuits.

Notes

Section 5 Digital 550 Controller

5.1 General Repair Information

This section contains 550 controller repair information. Service replacement of the 550 controller is limited to the items shown in Figure 5-1. Refer to the respective controller parts catalog for service part numbers. No other replacement service parts are available.

Before replacing the controller, remove all external accessories and other electrical connections to verify that these items are not the cause of the controller

problems. Verify that the accessories and connections are functioning correctly before reconnecting them to the new controller.

Go to Menu 20, Factory Setup and verify that the application software (code version) is correct for the generator set model and alternator voltage. Use the respective controller operation manual for details regarding Menu 20, Factory Setup.

550 Controller *prior to version 2.10*, use MP-6083.

550 Controller *version 2.10 or higher*, use MP-6200.

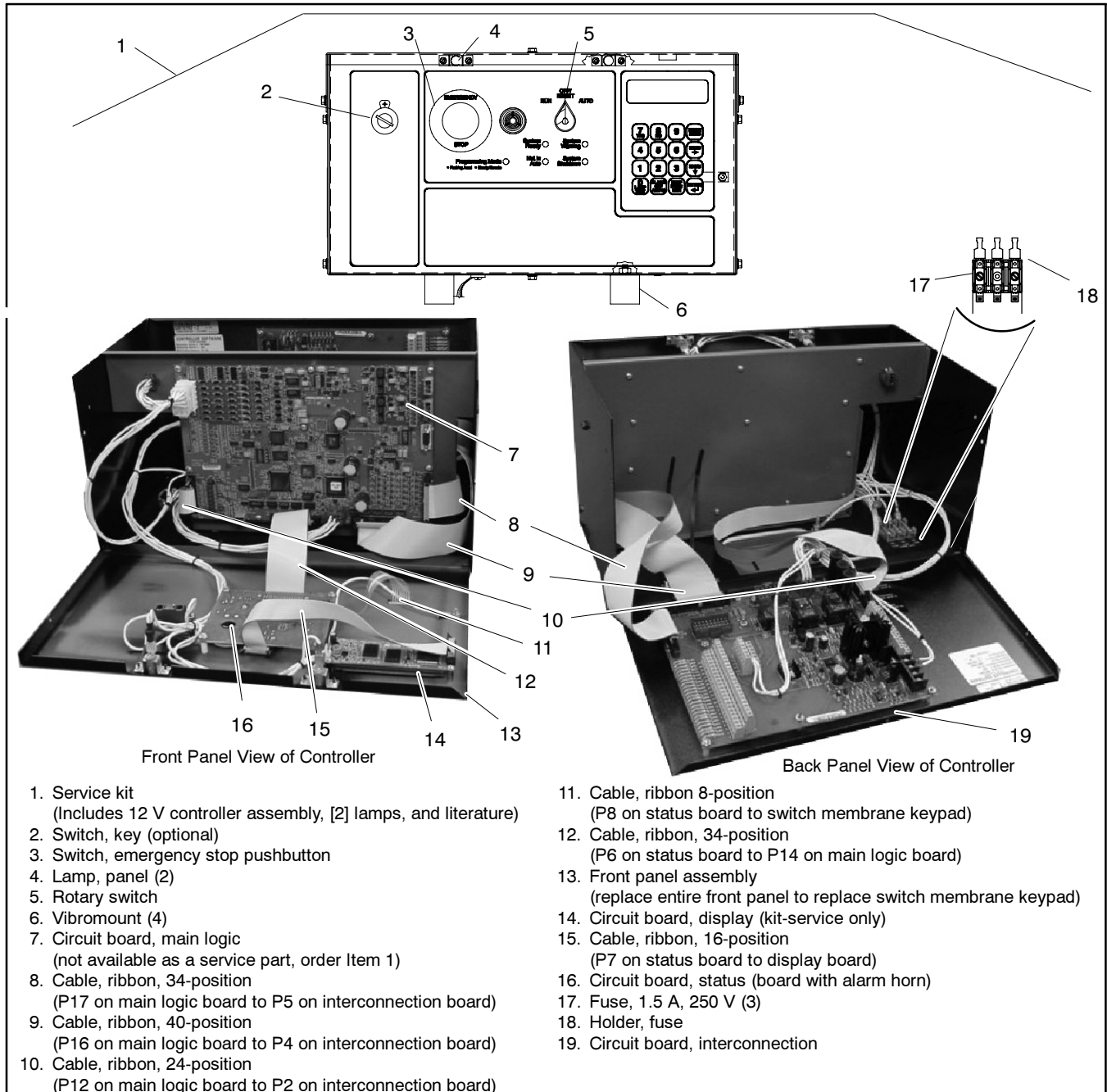

Figure 5-1 550 Controller Service Replacement Parts

5.2 Controller Service Replacement Kits

(GM20722-1, GM20722-1S, GM20722-2, and GM20722-2S)

Adapted from Installation Instruction TT-1310.

5.2.1 Introduction

The 550 controller service replacement kit is available to replace a non-functional 550 controller. Use the following procedure to install the replacement controller. See Figure 5-2 for typical controller identification. For features and operation of the 550 controller, see the operation manual in the literature kit.

Note: Do not use this controller replacement installation instruction for upgrading software.

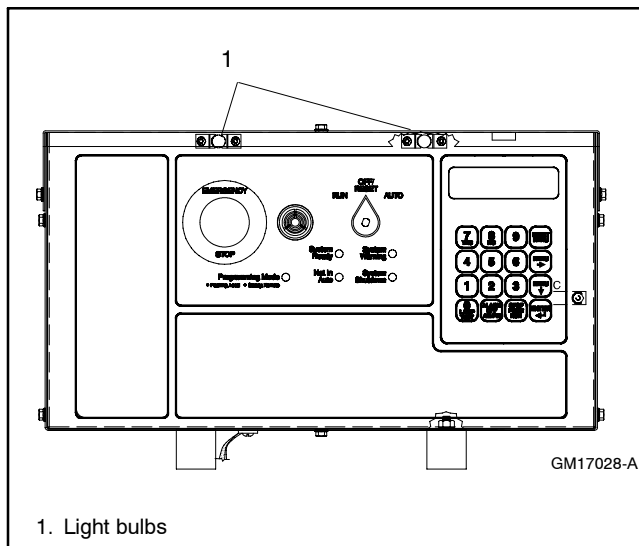

Figure 5-2 550 Controller Front Panel

When replacing the 550 controller, the personality profile must be installed in order for the 550 controller to function. Controller service replacement kits **do not** include the personality profile file installed on the generator set controller at the factory. The service technician *must* install the personality profile on the 550 controller service replacement kit.

- **Application program** contains the software that controls system operation. The application file is preprogrammed on the 550 controller service replacement kit at the factory.

Note: The application program is not backwards compatible. Do not attempt to load an application program that is an older version than the application program version already installed.

- **Personality profile** is specific to the engine and alternator and is preprogrammed on the generator set controller at the factory.

A backup disk of the personality profile and application program is supplied with the literature packet shipped with the generator set. Typically, the distributor stores this disk for possible future use such as controller replacement or other circumstances requiring a backup.

Note: If the personality profile disk is NOT available, request a replacement from the manufacturer using the generator set serial number or order number.

- **User parameters** unique to an installation include timer values, setpoints, generator set data such as kW and voltage, and input/output selections. These parameters are typically set up for or by the installer at the time of installation. Created user parameters are typically documented and stored on the personality profile disk, a separate backup disk, or written in the User-Defined Settings appendix in the 550 controller operation manual. A copy of the User-Defined Settings form is included in Section 5.2.6.

Note: If the user parameters are included on the personality disk, the disk label should indicate Site Program—Yes.

Read the entire installation procedure and perform the steps in the order shown. Always observe applicable local and national electrical codes.

Note: The following service kit procedure changes only the controller. If the generator set requires voltage reconnection and/or frequency adjustment, see the 550 controller operation manual.

550 Controller *prior to version 2.10*, use MP-6083.

550 Controller *version 2.10 or higher*, use MP-6200.

5.2.2 Installation Requirements

The following items are necessary PC requirements for installing the controller service replacement kits.

- **Controller Application Program Software Version 2.10 or higher** from KOHLER*net* using the TechTools button to download on your PC hard drive or disk.
- **Program Loader Software Version 2.2.2 or higher** from KOHLER*net* using the TechTools button to download on your PC hard drive or disk if not already installed on your PC.
- **Monitor II Software PA-361725 or PA-365196, Version 4.0.0 or higher.** Add the user parameters from a backup disk and/or enter alphanumeric data. See the Monitor II software operation/installation manual for additional items.
- **Null Modem RS-232 Cable** with a 9-pin male plug on the controller end, part no. GM16657, or kits PA-294992 or PA-294992-SD.

5.2.3 Software Compatibility

Monitor II software version 4.0.0 requires Application Program version 2.10 to support the new controller features. Monitor II software version 4.0.0 also supports Application Programs prior to version 2.10. Monitor II software prior to 4.0.0 will not function with Application Program version 2.10 or higher. See Figure 5-3.

Software Description	New Software Versions	Old Software Versions
Application Program	2.10 or higher	1.34
Monitor II	4.0.0 or higher	2.2.5
Program Loader	2.2.2 or higher	2.2.2

Figure 5-3 Software Compatibility

5.2.4 Procedure

1. Acquire the User Parameters
 - a. Choose one of the following methods to retrieve the user parameters:
 - Backup disk. If a backup disk was previously made, obtain the parameters from this disk. If a disk was not previously made, create a backup if possible using the Monitor II software, version 4.0.0 or higher. The existing controller must function in order to create the file.

- Paper form. Parameters should have been recorded on the User-Defined Settings form located in the appendix of the 550 controller operation manual or other similar form.

- Controller menu. Manually review the controller menu displays if possible and enter the parameter information in the 550 controller operation manual appendix, User-Defined Settings, form.

- b. Save the user parameter data for step a.

2. Acquire display data from the old controller for entry in the new controller.

Certain data cannot be stored on electronic media for archival purposes and must be entered using a PC or the controller keypad.

When possible, make note of the following data from the old controller for entry in the new controller. If the old controller is not functional, the installer must determine and document this information for entry later in this procedure. See Section 5.2.6 for the Controller User-Defined Settings form.

- a. From Menu 4, Operational Records
 - Total Run Time Hours
 - Total Run Time Loaded Hours
 - Total Run Time Unloaded Hours
- b. From Menu 7, Generator System
 - Metric Units, yes or no
- c. From Menu 12, Calibration
 - Scale Aux. Analog Inputs. Repeat for each input 01-07
 - Analog 01, scale value 1
 - Analog 01, scale value 2

d. From Menu 13, Communication

- Protocol KBUS
 - KBUS online, yes or no
 - Connection type
 - Local single, yes or no
 - Local LAN, yes or no
 - Local LAN conv, yes or no
 - Remote single, yes or no
 - Remote LAN, yes or no
 - Remote LAN conv, yes or no
 - Primary port
 - RS-232, yes or no
 - RS-485 ISO1, yes or no
 - Address (LAN connections)
 - System ID (remote connections)
 - BAUD rate
 - 1200
 - 2400
 - 9600
- Protocol Modbus
 - Modbus online, yes or no
 - Connection type
 - Single, yes or no
 - Convertor, yes or no
 - Primary port
 - RS-485
 - RS-232
 - Address
 - BAUD rate
 - 9600
 - 19200

e. From Menu 20, Factory Setup

- Final assembly date
- Final assembly clock number
- Model number
- Spec number
- Serial number

3. Acquire display data from the old controller for reference purposes.

When possible, write down the old controller display data in Section 5.2.6 and Section 5.2.7, User-Defined Settings. This data is not required for the new controller but may be needed for future reference. If the old controller is not functional, the information is no longer retrievable.

4. Remove the generator set from service.

- a. Place the generator set master switch in the OFF position.

- b. Disconnect the power to the battery charger, if equipped.

- c. Disconnect the generator set engine starting battery(ies), negative (-) lead first.

5. Disconnect the existing 550 controller electrical connections.

- a. Remove the controller cover. If access to the interconnection circuit board on the rear panel and/or the main logic/communication circuit board on the front panel is difficult to access, partially disassemble the controller box. Remove the two controller panel top screws and center bottom screw and then loosen the bottom screw on each side to swing the controller panel down. See Figure 5-4.

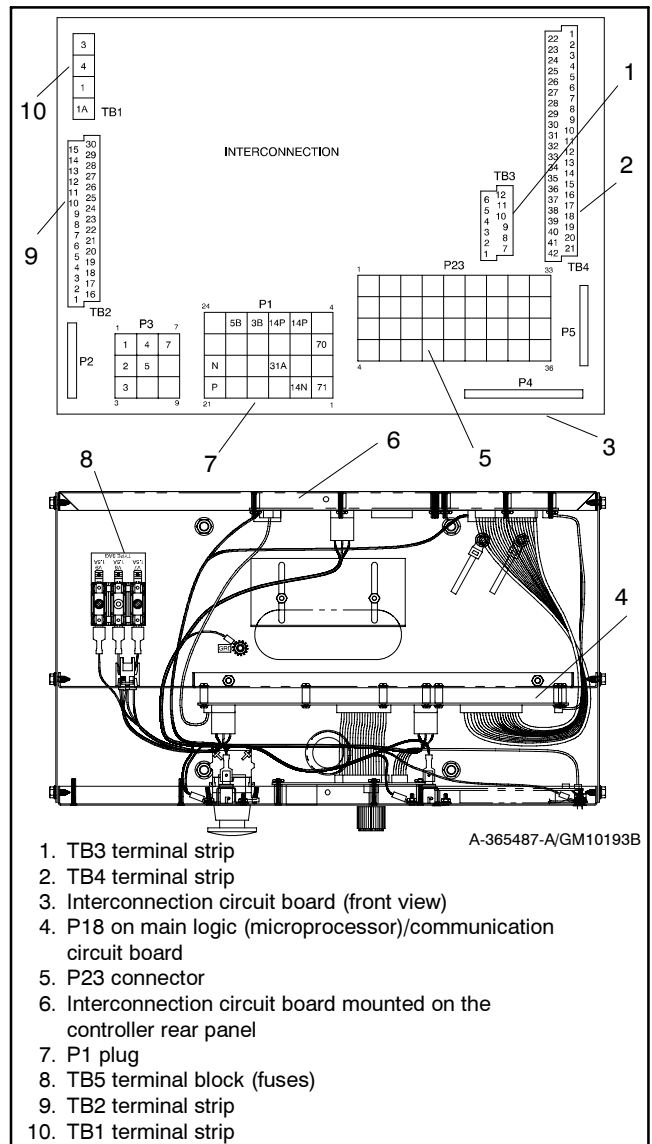

Figure 5-4 Disconnecting Controller Circuit Board External Wiring Connections

Note: Clearly mark all disconnected leads from the 550 controller with tape to simplify reconnection.

b. Disconnect the 550 controller harness leads. Listed below are some common leads and plugs that require removal or disconnection. Items below in **bold** are shown in Figure 5-4. These connections are typical and may not apply to all applications. See the corresponding wiring diagram found in the wiring diagrams manual.

- AC fuse terminal block **TB5** leads V7, V8, and V9
- All external connections to terminal strips **TB1, TB2, TB3, and TB4**
- CT/meter scale terminal block lead V0
- P24 connector to CT burden resistor board
- Plug **P1** on the burden resistor board and the Marathon excitation interface board
- Plug **P23** to the controller connection strip in the junction box
- Plug P22 to the engine wiring harness
- Plug **P18** remote communication connection (RS-232)
- Prime power kit
- Any other external leads to the controller

6. Remove the existing 550 controller.

- a. Remove the junction box panel(s) to gain access to the controller vibromount screws.
- b. Remove the four controller vibromount screws from underneath the junction box top panel.
- c. Lift off the existing 550 controller.

7. Install the replacement 550 controller.

- a. Place the replacement 550 controller on the junction box top panel holes.
- b. Align the 550 controller vibromounts with the mounting holes and install four screws.
- c. Change the controller's front display lamps, if required. See Figure 5-2 for location. See Figure 5-5 for lamp identification. The factory ships the 550 controller with 12-volt lamps.

Replace bulbs in controller with lamps provided in the replacement kit if the generator set has a 24-volt engine electrical system. Determine the engine electrical system voltage using the generator set nameplate information.

Lamp Part No.	Voltage	Bulb Part Number
255126	12	1892
283420	24	313

Figure 5-5 Lamp Identification

8. Connect the replacement 550 controller.

a. Remove the controller cover. If access to the interconnection circuit board on the rear panel and/or the communication circuit board on the front panel is difficult, partially disassemble the controller box. Remove the two controller panel top screws and center bottom screw and then loosen the bottom screw on each side to swing controller panel down. See Figure 5-4.

b. Reconnect the controller wiring that was previously removed. See the corresponding wiring diagram found in the wiring diagrams manual. Listed below are some common leads and plugs that may require reconnection. These connections are typical and may not apply to all situations.

- AC fuse terminal block **TB5** leads V7, V8, and V9
- All external connections to terminal strips **TB1, TB2, TB3, and TB4**
- CT/meter scale terminal block lead V0
- P24 connector to the CT burden resistor board
- Plug **P1** on the burden resistor board and the Marathon excitation interface board
- Plug **P23** to the controller connection strip in the junction box
- Plug P22 to the engine wiring harness
- Prime power kit
- Any other external leads to the controller

c. Swing the rear controller panel up and replace and tighten the screws, as necessary.

d. Replace the junction box panel(s) and screws.

9. Restore power to the generator set.
 - a. Check that the generator set master switch is in the OFF position.
 - b. Reconnect the generator set engine starting battery, negative (-) lead last.
 - c. Reconnect power to the battery charger, if equipped.

10. Install the program/data files.

- a. Connect the PC serial port to the controller RS-232 port using a null modem RS-232 cable with a 9-pin male plug on the controller end. See TT-1285 for details.
- b. Install the Program Loader program into the PC using the procedure outlined in TT-1285.
- c. Insert the personality profile backup disk and load the data. See TT-1285 for details.

11. Establish the controller identity in Menu 20.

The controller displays the following error message: GENSET S/N WARNING.

This procedure includes instructions on how to unlock and lock the factory setup after entering Menu 20. Use the down arrow key to go to the setup lock menu for determining the setup status.

Note: After completing the factory setup, always return the controller to the setup lock position to prevent inadvertent program changes.

- a. Press the RESET MENU key on the controller keypad.
- b. Use the controller keypad to go to Menu 14, Programming Mode, and select programming mode—local. Use the information from the 550 controller operation manual as necessary.

Note: The factory default access code is the number 0.

- c. Press the RESET MENU key on the controller keypad.
- d. Use the controller keypad to go to Menu 20, Factory Setup. See Figure 5-6 or Figure 5-7 for displays.

- e. Arrow down to the SETUP LOCK display.

If the SETUP LOCK display indicates YES, go to step f.

If the SETUP LOCK display indicates NO, go to step g.

- Press the ENTER key. Changes to Menu 20, Factory Setup, are now possible.

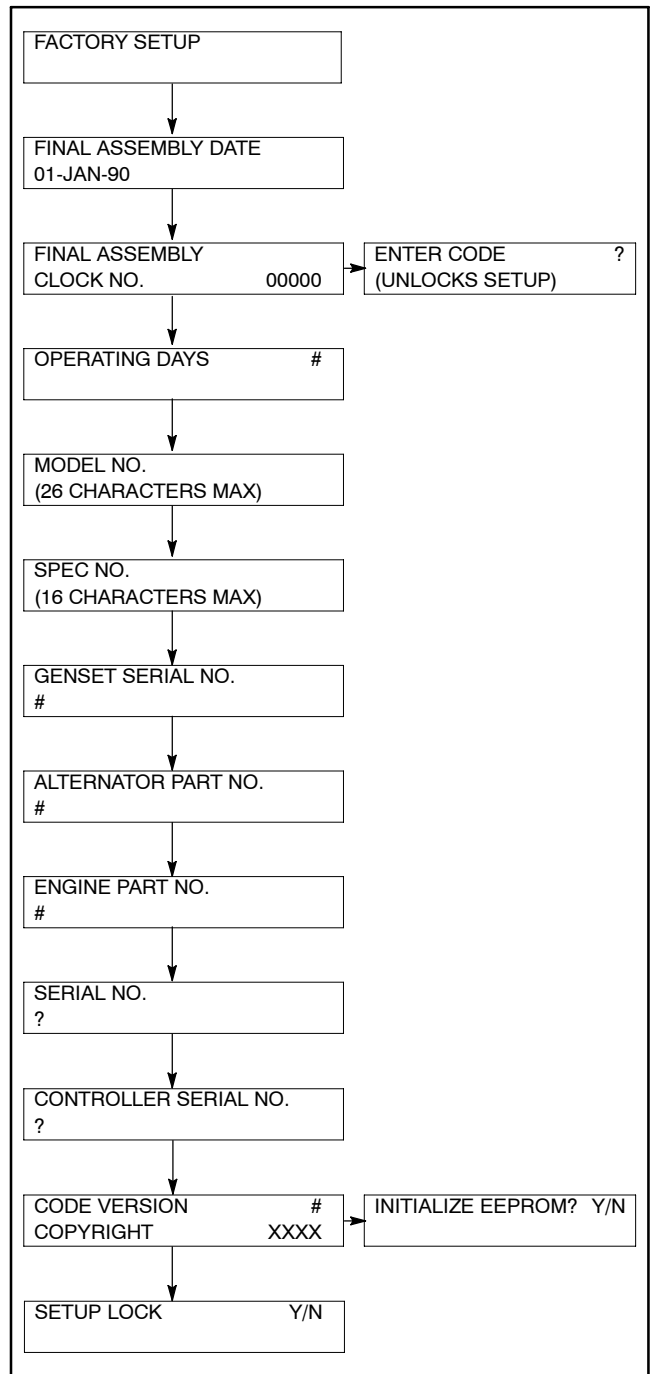

Figure 5-6 Menu 20, Factory Setup (prior to version 2.10)

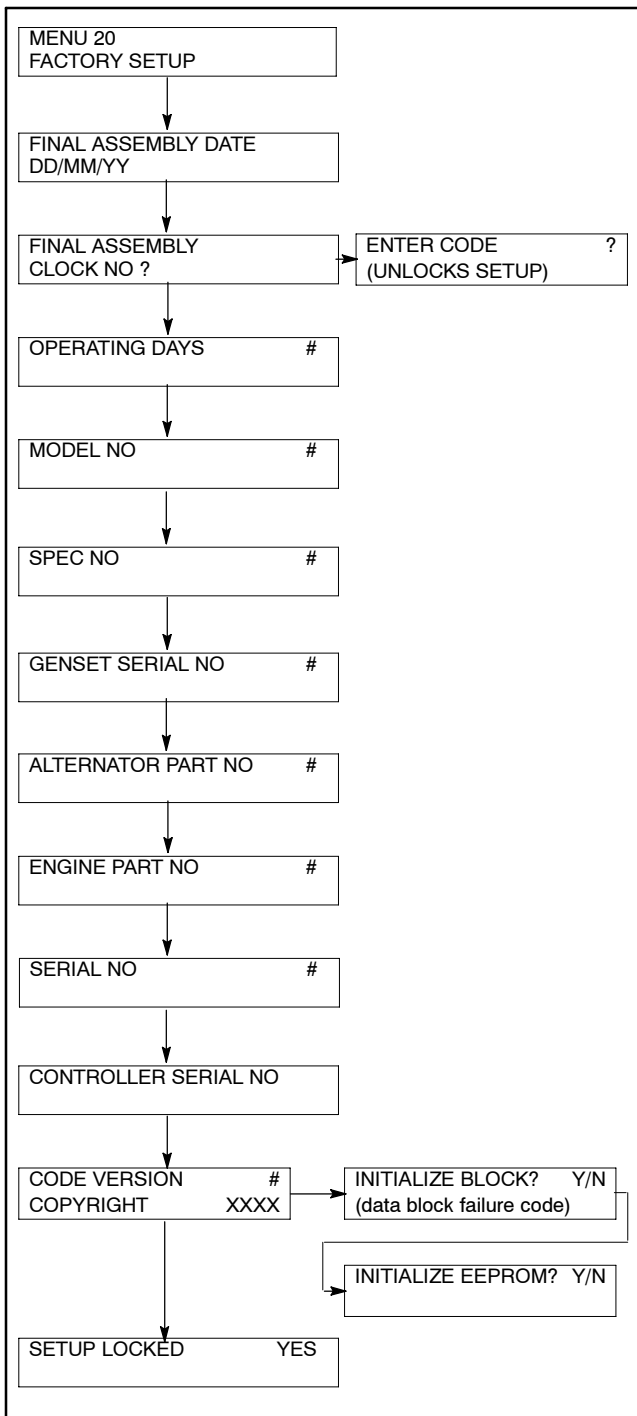

Figure 5-7 Menu 20, Factory Setup
(version 2.10 or higher)

f. Unlock the setup.

- Arrow down to the FINAL ASSEMBLY, CLOCK NO. display. Record the clock number on the controller display.
- Arrow right to ENTER CODE display.
- Use the controller keypad to enter the clock number previously recorded.

g. Initialize the EEPROM.

- Arrow down to the CODE VERSION display.
- Arrow right to INITIALIZE EEPROM display.
- Press the YES key to initialize the EEPROM.
- Press the ENTER key.

h. Wait for completion of the system reset.

i. Go to Menu 20, Factory Setup. See Figure 5-6 or Figure 5-7 for displays.

j. Change the final assembly date.

- Arrow down to the FINAL ASSEMBLY DATE display.
- Enter the final assembly date using the data recorded from the old controller, reference step 2.e. If data from the old controller is not available, keep the default setting.
- Press the ENTER key if making a new entry.

k. Change the final assembly clock number.

- Arrow down to the FINAL ASSEMBLY CLOCK NO. display.
- Enter the final assembly clock number using the data recorded from the old controller. If data from the old controller is not available, keep the default setting.
- Press the ENTER key if making a new entry.

l. Change the serial number. The 550 controller service replacement kit will show the GENSET SERIAL NO. as 123456. After the personality profile is loaded, the GENSET SERIAL NO. shows the correct serial number for the respective generator set. Use the GENSET SERIAL NO. to update the SERIAL NO. display as follows:

- Arrow down to the SERIAL NO. display.
- Enter the serial number of the generator set using data recorded from the old controller or as shown on the generator set nameplate. If the serial number is six digits, enter a *leading zero* for a seven-digit serial number.
- Press the ENTER key. The GENSET S/N WARNING display no longer appears when the GENSET SERIAL NO. and SERIAL NO. match.

12. Perform the Menu 13, Communications entries.
 - a. Press the RESET MENU key on controller keypad.
 - b. Use the controller keypad to go to Menu 13, Communications.
 - c. Complete the communication entries as necessary for remote programming. Use the information from the 550 controller operation manual as necessary.
13. Perform the Menu 14, Programming mode entries.
 - a. Press the RESET MENU key on controller keypad.
 - b. Use the controller keypad to go to Menu 14, Programming Mode, and select programming mode—remote. Use the information from the Monitor II software, version 4.0.0 or higher.
14. Perform the Menu 20, Factory Setup entries using the Generator Info window. Use the information from the Monitor II software, version 4.0.0 or higher.
 - a. Change the model number.
 - Go to the MODEL NO. display.
 - Enter the model number using the data recorded from the old controller or as shown on the generator set nameplate.
 - b. Change the spec (specification) number.
 - Go to the SPEC NO. display.
 - Enter the spec number using the data recorded from the old controller or as shown on the generator set nameplate.
15. Perform the Menu 14, Programming mode entries.
 - a. Press the RESET MENU key on the controller keypad.
 - b. Use the controller keypad to go to Menu 14, Programming Mode, and select programming mode—local. Use the information from the 550 controller operation manual as necessary.
16. Perform the Menu 4, Operational Records.
 - a. Press the RESET MENU key on controller keypad.
 - b. Use the controller keypad to go to Menu 4, Operational Records.
 - c. Complete the operational records entries as necessary. Use the information from the 550 controller operation manual as necessary.
17. Lock the Menu 20, Factory Setup entries.
 - a. Press the SETUP MENU key on the controller keypad.
 - b. Use the controller keypad to go to Menu 20, Factory Setup.
 - c. Arrow down to the SETUP LOCK display.
 - d. Press the YES key to lock the setup and prevent alterations to Menu 20, Factory Setup.
18. Enter the Menu 6, Time and Date, settings.
 - a. Press the RESET MENU key on the controller keypad.
 - b. Use the controller keypad to go to Menu 6, Time and Date. Use the information from the 550 controller operation manual as necessary to set the time and date.
19. Perform the Menu 7, Generator System, entries for English or metric displays.
 - a. Press the RESET MENU key on the controller keypad.
 - b. Use the controller keypad to go to Menu 7, Generator System. Use the information from the 550 controller operation manual as necessary to change metric unit, yes or no.
20. Perform the Menu 12, Calibration, entries.
 - a. See the 550 controller operation manual for disconnecting the ribbon connector. Disconnect ribbon connector P2 prior to zeroing out (resetting) the auxiliary analog inputs.
 - b. Press the RESET MENU key on the controller keypad.

- c. Use the controller keypad to go to Menu 12, Calibration. Use the information from the 550 controller operation manual as necessary to scale AC analog inputs.
 - d. With the information previously recorded from step 2, scale the auxiliary analog inputs. Use the information from the 550 controller operation manual as necessary.
21. Perform the Menu 14, Programming Mode entries.
- a. Press the RESET MENU key on the controller keypad.
 - b. Use the controller keypad to go to Menu 14, Programming Mode.
 - Select programming mode—remote when adding user parameter from a backup disk or PC.
 - Select programming mode—local for keypad entries. Use the information from the 550 controller operation manual as necessary.
22. Add the user parameters.
- a. Choose one of the following methods to load the user parameters.
 - Backup disk. Use a PC to load the data from the user parameter backup disk. Enable Menu 14, Programming Mode—Remote. See the information from the Monitor II software manual.
 - Paper form. Use a PC to enter the user parameter data from the filled-out 550 controller operation manual appendix, User-Defined Settings form, or other similar form. Enable Menu 14, Programming Mode—Remote. See the information supplied with the Monitor II software manual.
 - Controller menu. Use the controller keypad to manually enter the user parameter data from the filled-out 550 controller operation manual appendix, User-Defined Settings form. Enable Menu 14, Programming Mode—Local. Use the information from the 550 controller operation manual as necessary.
 - b. Create a new user parameter data backup disk if any changes are made. See the Monitor II software manual.
 - c. Disconnect the PC null modem RS-232 cable.
 - d. Install the P18 (RS-232) remote communication connection, as necessary.
 - e. Swing the front controller panel up and replace and tighten the screws, as necessary.
 - f. Replace the controller cover and hardware. Tighten all controller screws.
23. Restore the generator set to service.
- a. Perform the Menu 13, Communication, entries.
 - Press the RESET MENU key on controller keypad.
 - Use the controller keypad to go to Menu 13, Communications.
 - With the information previously recorded from step d., complete the communication entries as necessary for the application. Use the information from the 550 controller operation manual as necessary.
 - b. Perform the Menu 14, Programming Mode entries.
 - Press the RESET MENU key on controller keypad.
 - Use the controller keypad to go to Menu 14, Programming Mode.
 - Change the entries for the application as necessary.
 - c. The generator set system is now ready to function.
 - d. Move the generator set master switch to AUTO for startup by remote transfer switch or remote start/stop switch.

5.2.5 Display Items for Reference

Menu 4 Operational Records	Menu 5 Event History	Menu 20 Factory Setup	
<ul style="list-style-type: none"> ● Factory Test Date ● Total Run Time ● Total Run Time Loaded Hours ● Total Run Time Unloaded Hours ● Total Run Time kW Hours ● No. of Starts ● Engine Start Countdown <ul style="list-style-type: none"> ○ Run Time ● Records-Maintenance <ul style="list-style-type: none"> ○ Reset Records ● Run Time Since Maintenance Total Hours ● Run Time Since Maintenance Loaded Hours ● Run Time Since Maintenance Unloaded Hours ● Run Time Since Maintenance kW Hours ● Operating Days Last Maintenance ● No. of Starts Last Maintenance ● Last Start Date ● Length of Run (Un)loaded Hours 	<ul style="list-style-type: none"> ● (Message Text) ● (Scroll through up to 100 stored events) 	<ul style="list-style-type: none"> ● Final Assembly Date ● Final Assembly Clock No. ● Operating Days 	

5.2.6 User-Defined Settings (550 Controller Prior to Version 2.10)

Use the table below to record user-defined settings during the generator set controller setup and calibration. The controller default settings and ranges provide guidelines. The table contains all faults with ranges and time delays including items that do not have adjustments.

Note: The engine ECM may limit the crank cycle even if the controller is set to a longer time period.

Status or Fault	Refer to Menu	Digital Display	Relay Driver Output (RDO)	Range Setting	Default Selection	Inhibit Time Delay* (sec.)	Time Delay (sec.)	User-Defined Settings
AC Sensing Loss	10	AC Sensing Loss	RDO-25					Not adjustable
Access Code (password)	14				0 (zero)			
Analog Aux. Inputs 1-7	9	User-Defined A1-A7		Default values with Warning Enabled: HI warning 90%, LO warning 10%, HI shutdown 100%, LO shutdown 1%	30 sec. inhibit, 5 sec. delay	0-60	0-60	
Analog Aux. Input 1	9	Coolant Temperature		Default values with Warning Enabled: HI/LO warning and HI/LO shutdown are all engine dependant	30 sec. inhibit, 0 sec. delay	0-60	0-60	
Analog Aux. Input 2	9	Oil Pressure		Default values with Warning Enabled: HI/LO warning and HI/LO shutdown are all engine dependant (255 psi max.)	30 sec. inhibit, 0 sec. delay warning, 5 sec. delay shutdown	0-60	0-60	
Cyclic Cranking	8			1-6 crank cycles 10-60 sec. crank on 1-60 sec. pause	3 cycles 15 sec. 15 sec.			
Defined Common Faults	10	User-Defined	RDO-18	Default shutdowns include: Emergency stop High coolant temp Low oil pressure Overcrank Overspeed	30 sec. inhibit, 5 sec. delay	0-60	0-60	
Digital Aux. Inputs 1-21	9	User-Defined D1-D21			30 sec. inhibit, 5 sec. delay	0-60	0-60	
EPS (Emergency Power System) Supplying Load	10	EPS Supplying Load	RDO-15		5% of rated line current			
High Battery Voltage	10	High Battery Voltage	RDO-13	14.5-16.5 (12V) 29-33 (24V)	16 (12V) 32 (24V)		10	
High Coolant Temperature Shutdown	10	Hi Cool Temp Shutdown	RDO-03			30	5	Not adjustable
High Coolant Temperature Warning	10	Hi Cool Temp Warning	RDO-06			30		Not adjustable
High Oil Temperature Shutdown	10	Hi Oil Temp Shutdown	RDO-17			30	5	Not adjustable

* Inhibited time delay is the time delay period after crank disconnect.

Status or Fault	Refer to Menu	Digital Display	Relay Driver Output (RDO)	Range Setting	Default Selection	Inhibit Time Delay* (sec.)	Time Delay (sec.)	User-Defined Settings
Idle (speed) Mode Function Digital Aux. input D21	9, 10	Idle Speed Active	RDO-21	Fixed inhibit time	0 sec. inhibit, 60 sec. delay		0-600	
Load Shed kW Overload	10	Load Shed KW Over	RDO-30	80%-120%	100% of kW rating		5	
Load Shed Underfrequency	10	Load Shed Under Frequency	RDO-31		59, (60 Hz) 49, (50 Hz)		5	
Low Battery Voltage	10	Low Battery Voltage	RDO-12	10-12.5 (12V) 20-25 (24V)	12 (12V) 24 (24V)		10	
Low Coolant Level	10	Low Coolant Level	RDO-14			30	5	Not adjustable
(Low) Oil Pressure Shutdown	10	Oil Pressure Shutdown	RDO-04			30	5	Not adjustable
(Low) Oil Pressure Warning	10	Oil Pressure Warning	RDO-07			30		Not adjustable
No Coolant Temperature Signal	10	No Cool Temp Signal				30		Not adjustable
No Oil Pressure Signal	10	No Oil Pressure Signal				30		Not adjustable
Overcrank Shutdown	8	Over Crank	RDO-02	0-6 cycles	3 cycles			
Overcurrent	10	Over Current			110%		10	
Overfrequency Shutdown	7, 10	Over Frequency	RDO-28	102%-140%	140% std. 103% FAA		10	
Overspeed Shutdown	7, 10	Over Speed	RDO-01	65-70 (60 Hz) 55-70 (50 Hz)	70 (60 Hz) 60 (50 Hz)		0.25	
Overvoltage Shutdown	7, 8, 10	Over Voltage	RDO-20	105%-135%	115% 2-sec. time delay		2-10	
Password (access code)	14				0 (zero)			See Access Code entry
Time Delay Engine Cooldown (TDEC)	8, 10		RDO-23	00:00-10:00 min:sec	5:00			
Time Delay Engine Start (TES)	8, 10			00:00-5:00 min:sec	00:01			
Time Delay Starting Aid	8, 10			0-10 sec.				
Underfrequency Shutdown	7, 10	Under Frequency	RDO-29	80%-95%	90%		10	
Undervoltage Shutdown	7, 8, 10	Under Voltage	RDO-27	70%-95%	85% 10-sec. time delay		5-30	
Weak Battery	10	Weak Battery	RDO-26		60% of nominal		2	

* Inhibited time delay is the time delay period after crank disconnect.

5.2.7 User-Defined Settings (550 Controller Version 2.10 or Higher)

Use the table below to record user-defined settings during the generator set controller setup and calibration. The controller default settings and ranges provide guidelines. The table contains all faults with ranges and time delays including items that do not have adjustments.

Note: Inhibit time delay is the time delay period after crank disconnect.

Note: The engine ECM may limit the crank cycle even if the controller is set to a longer time period.

Status Event or Fault	Refer to Menu	Digital Display	Relay Driver Output (RDO)	Range Setting	Default Selection	Inhibit Time Delay (sec.)	Time Delay (sec.)	User-Defined Settings
Access Code (password)	14			User selectable	0 (zero)			
AC Sensing Loss	10	AC Sensing Loss	RDO-25*					Not adjustable
Air Damper Indicator (if used) Digital Aux. Input D20 **	9, 10	Air Damper Indicator	RDO-23* (lead 56)	Fixed	0 sec. inhibit, 0 sec. delay			Not adjustable
Air/Fuel Mixture (AFM) Remote Start ‡	10	AFM Remote Start	RDO-25‡					Not adjustable
Air/Fuel Mixture (AFM) Shutdown ‡	10	AFM Shutdown		Fixed				Not adjustable
Alternator Protection	10	Alternator Protection						Not adjustable
Analog Aux. Inputs A01-A07	9	User-Defined A01-A07		Default Values with Warning Enabled: HI warning 90% LO warning 10% HI shutdown 100% LO shutdown 1%	30 sec. inhibit, 5 sec. delay	0-60	0-60	
Analog Aux. Input A01 (non-ECM only)	9	A01 Coolant Temp		Default Values with Warning Enabled: HI/LO warning and HI/LO shutdown are all engine dependent	30 sec. inhibit, 0 sec. delay warning, 5 sec. delay shutdown			
Analog Aux. Input A02 (non-ECM only)	9	A02 Oil Pressure		Default Values with Warning Enabled: HI/LO warning and HI/LO shutdown are all engine dependent (255 psi max.)	30 sec. inhibit, 0 sec. delay warning, 5 sec. delay shutdown			
Analog Aux. Input A03‡	9	A03 Intake Air Temperature		Default Values with Warning Enabled: HI/LO warning are engine dependent	30 sec. inhibit, 0 sec. delay warning			
Analog Aux. Input A04‡	9	A04 Oil Temperature		Default Values with Warning Enabled: HI/LO warning are engine dependent	30 sec. inhibit, 0 sec. delay warning			
Analog Aux. Input A07§	9	A07 Voltage Adjust		±10% of system voltage over the range of 0.5-4.5 VDC	2.5 VDC			
Battery Charger Fault, Digital Aux. Input D01 **	9, 10	Battery Charger Fault	RDO-11 (lead 61)	Fixed	0 sec. inhibit, 0 sec. delay			Not adjustable
Battle Switch (see Fault Shutdown Override Switch)	9	Battle Switch		Fixed				Not adjustable
Breaker Trip	10	Breaker Trip	RDO-30§					Not adjustable
* All models, except Waukesha-powered models					‡ Waukesha-powered models			
‡ Non-paralleling applications					§ Paralleling applications			
** NFPA applications								

Status Event or Fault	Refer to Menu	Digital Display	Relay Driver Output (RDO)	Range Setting	Default Selection	Inhibit Time Delay (sec.)	Time Delay (sec.)	User-Defined Settings
Common Paralleling Relay Output	10	Common PR Output	RDO-31§					Not adjustable
Critical Overvoltage Shutdown	10	Critical Overvoltage		Fixed	275 volts (L1-L2)			Not adjustable
Cyclic Cranking	8			1-6 crank cycles 1-30 sec. crank on 1-60 sec. pause	3 15 sec. 15 sec.			
Defined Common Faults (each input value is set separately)	10	Defined Common Fault	RDO-18 (lead 32A)	Default shutdowns include: Emergency stop High coolant temp Low oil pressure Overcrank Overspeed	30 sec. inhibit, 5 sec. delay	0-60	0-60	
Detonation Shutdown ‡	9, 10	Deton Shutdown		Fixed				Not adjustable
Detonation Warning ‡	9, 10	Deton Warning		Fixed				Not adjustable
Digital Aux. Input D01-D21	9, 10	User-Defined D01-D21			30 sec. inhibit, 5 sec. delay	0-60	0-60	
Digital Aux. Input D05§	9, 10	D05 Breaker Closed						Not adjustable
Digital Aux. Input D06§	9, 10	D06 Enable Synch						Not adjustable
Digital Aux. Input D11‡	9, 10	D11 AFM Shutdown			30 sec. inhibit, 5 sec. delay	0-60	0-60	
Digital Aux. Input D12‡	9, 10	D12 Deton Warning			30 sec. inhibit, 5 sec. delay	0-60	0-60	
Digital Aux. Input D13 Detonation Sensing Module (DSM) ‡	9, 10	D13 Deton Shutdown			30 sec. inhibit, 5 sec. delay	0-60	0-60	
Digital Aux. Input D13 Knock Detection Module (KDM) ‡	9, 10	D13 Knock Shutdown			30 sec. inhibit, 5 sec. delay	0-60	0-60	
EEPROM Write Failure	10	EEPROM Write Failure						Not adjustable
Emergency Stop Shutdown	10	Emergency Stop	RDO-14 (lead 48)					Not adjustable
Engine Cooldown (see Time Delay)								Not adjustable
Engine Start (see Time Delay)								Not adjustable
EPS (Emergency Power System) Supplying Load	10	EPS Supplying Load	RDO-22	Fixed	1% of rated line current			Not adjustable
Fault Shutdown Override Switch	9, 10	Battle Switch						Not adjustable
Field Overvoltage Digital Aux. Input D04 (M4, M5, or M7 alternator only)	9, 10	Field Overvoltage		Fixed	1 sec. inhibit, 15 sec. delay			Not adjustable
* All models, except Waukesha-powered models ‡ Non-paralleling applications ** NFPA applications					‡ Waukesha-powered models § Paralleling applications			

Status Event or Fault	Refer to Menu	Digital Display	Relay Driver Output (RDO)	Range Setting	Default Selection	Inhibit Time Delay (sec.)	Time Delay (sec.)	User-Defined Settings
Fuel Valve Relay ‡	10	Fuel Valve Relay	RDO-23‡					Not adjustable
Generator Running	10		RDO-15 (lead 70R)					Not adjustable
Ground Fault Detected	10	Ground Fault						Not adjustable
High Battery Voltage	10	High Battery Voltage	RDO-13	14.5-16.5 V (12 V) 29-33 V (24 V)	16 V (12 V) 32 V (24 V)		10	
High Coolant Temperature Shutdown	10	Hi Cool Temp Shutdown	RDO-03 (lead 36)			30	5	Not adjustable
High Coolant Temperature Warning	10	Hi Cool Temp Warning	RDO-06 (lead 40)			30		Not adjustable
High Oil Temperature Shutdown	10	Hi Oil Temp Shutdown				30	5	Not adjustable
Idle (speed) Mode Function Digital Aux. Input D21	9, 10	Idle Mode Active	RDO-21	Fixed inhibit time	0 sec. inhibit, 60 sec. delay		0-600	
Internal Fault Shutdown	10	Internal Fault						Not adjustable
Knock Shutdown	10	Knock Shutdown		Fixed				Not adjustable
Load Shed kW Overload	10	Load Shed KW Over	RDO-30†	80%-120%	100% of kW rating with 5 sec. delay		2-10	
Load Shed Underfrequency	10	Load Shed Under Frequency	RDO-31†		59 Hz with (60 Hz) 49 Hz with (50 Hz)		5	
Locked Rotor Shutdown	10	Locked Rotor						Not adjustable
Loss of ECM Communication	10	Loss of ECM Comm	RDO-26*				4	Not adjustable
Low Battery Voltage	10	Low Battery Voltage	RDO-12 (lead 62)	10-12.5 V (12 V) 20-25 V (24 V)	12 V (12 V) 24 V (24 V)		10	
Low Coolant Level	10	Low Coolant Level	RDO-19			30	5	Not adjustable
Low Coolant Level, Digital Aux. Input D14 (with LCL switch) **	9, 10	Low Coolant Level						Not adjustable
Low Coolant Temperature	10	Low Coolant Temp	RDO-05 (lead 35)		0 sec. inhibit, 0 sec. delay			Not adjustable
Low Coolant Temperature, Digital Aux. Input D03 **	9, 10	Low Coolant Temp						Not adjustable
Low Fuel, Digital Aux. Input D02	9, 10	Low Fuel	RDO-08 (lead 63)		0 sec. inhibit, 0 sec. delay			Not adjustable
Low Fuel (Level or Pressure) Warning, Digital Aux. Input D02 **	9, 10	Low Fuel Warning						Not adjustable
Low Fuel Pressure Shutdown, Digital Aux. Input D09 (125 kW, GM engine, and ‡)	9, 10	Low Fuel Shutdown		Fixed				Not adjustable
* All models, except Waukesha-powered models † Non-paralleling applications ** NFPA applications					‡ Waukesha-powered models § Paralleling applications			

Status Event or Fault	Refer to Menu	Digital Display	Relay Driver Output (RDO)	Range Setting	Default Selection	Inhibit Time Delay (sec.)	Time Delay (sec.)	User-Defined Settings
(Low) Oil Pressure Shutdown	10	Oil Pressure Shutdown	RDO-04 (lead 38)			30	5	Not adjustable
(Low) Oil Pressure Warning	10	Oil Pressure Warning	RDO-07 (lead 41)			30		Not adjustable
Master Not In Auto (generator switch)	10	Not In Auto	RDO-09 (lead 80)					Not adjustable
Master Switch Error	10	Master Switch Error						Not adjustable
Master Switch Open	10	Master Switch Open						Not adjustable
NFPA 110 Fault	10	NFPA 110 Fault	RDO-10 (lead 32)					Not adjustable
No Coolant Temp. Signal	10	No Cool Temp Signal				30	4	Not adjustable
No Oil Pressure Signal	10	No Oil Pressure Signal				30	4	Not adjustable
Overcrank Shutdown	8, 10	Over Crank	RDO-02 (lead 12)	0-6 Cycles	3 Cycles			
Overcurrent	10	Over Current			110%		10	
Overfrequency Shutdown	7, 10	Over Frequency	RDO-28	102% - 140%	140% Std. 103% FAA		10	
Overspeed Shutdown	7, 10	Over Speed	RDO-01 (lead 39)	65-70 Hz (60 Hz) 55-70 Hz (50 Hz)	70 (60 Hz) 70 (50 Hz)		0.25	
Overvoltage Shutdown	7, 8, 10	Over Voltage	RDO-20 (lead 26)	105% - 135% of nominal	115% 2-sec. time delay† 135% 10-sec. time delay§		2-10	
Password (see Access Code)								
Pre Lube Relay	10	Pre Lube Relay	RDO-26‡				4	Not adjustable
Speed Sensor Fault	10	Speed Sensor Fault	RDO-24					Not adjustable
Starting Aid (see Time Delay Starting Aid)								Not adjustable
Synchronized	10	In Synch	RDO-29§					Not adjustable
System Ready	10		RDO-17 (lead 60)					Not adjustable
Time Delay Engine Cooldown (TDEC)	8, 10		RDO-16 (lead 70C)	00:00-10:00 min:sec	5:00			
Time Delay Engine Start (TDES)	8, 10			00:00-5:00 min:sec	00:01			
Time Delay Starting Aid	8, 10			0-10 sec.				
Underfrequency	7, 10	Under Frequency	RDO-29‡	80% - 95%	90%† 80%§		10	
Undervoltage Shutdown	7, 8, 10	Under Voltage	RDO-27	70% - 95%	85% 10-sec. time delay† 70% 30-sec. time delay§		5-30	
Weak Battery	10	Weak Battery			60% of nominal		2	
* All models, except Waukesha-powered models					‡ Waukesha-powered models			
† Non-paralleling applications					§ Paralleling applications			
** NFPA applications								

5.3 Coolant Temperature Sensor Service Kits

GM31990 and GM31991 (20–2000 kW with 550 Controllers and Non-ECM Engines)

Adapted from Service Bulletin SB-643.

5.3.1 Introduction

Replacing the coolant temperature sensor on a generator set with a 550 controller and a non-ECM engine requires controller application software version 2.21 or higher.

The new sensor offers greater reliability with a different sensing range requiring the software upgrade. See Figure 5-8 for the coolant temperature sensor illustration and Figure 5-9 for coolant temperature sensor identification.

Note: Failure to upgrade to the new software, after changing the coolant temperature sensor, will cause the controller to sense a lower than actual coolant temperature. These lower temperature readings may prevent a fault shutdown during an actual high coolant temperature condition.

Note: If controller application software version 2.21 or higher is loaded for any reason and the coolant temperature sensor is NOT replaced, the user must change the temperature sensor selection in Menu 20, Factory Setup. Failure to change the temperature sensor selection will cause the controller to sense a higher than actual coolant temperature and may cause nuisance high coolant temperature shutdown faults.

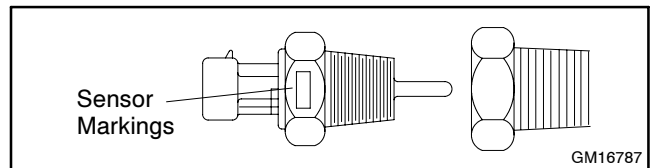

Figure 5-8 Coolant Temperature Sensor and Reducer Bushing (if equipped), Typical

Sensor Service Kit Part Number	Sensor P/N (shown in Menu 20)	Sensor Thread	Sensor Version	Sensor Manufacturer and Markings on Hex	Sensor Voltage Range
—	GM16787*	1/2-14 NPT	Old	Kavilco 3.2-4.4 HIGH	0.5-4.5
—	GM17362†	1/2-14 NPT‡	Old	Kavilco 3.2-4.4 HIGH	0.5-4.5
GM31990	GM31045-1	1/2-14 NPT	New	Airpax 5024-0443	0.2-1.5
GM31991	GM31045-2	M18-1.50	New	Airpax 5024-0468	0.2-1.5

* Replace GM16787 with GM31045-1.
† Replace GM17362 with GM31045-2 and discard metric reducer bushing.
‡ Long sensor tip, 41.2 mm (1.62 in.). Required with metric reducing bushing.

Figure 5-9 Coolant Temperature Sensors Identification

5.3.2 Items Needed for Software Upgrade

The following items are needed to complete the software upgrade. In order to expedite the upgrade process, it is recommended to use the KOHLERnet to request the program loader and application program software and download them on your PC *before* installing the kit. Use your SecurID® to access the KOHLERnet and click on the TechTools button URL to request the files to download.

Note: Technicians without access to the KOHLERnet must contact their local authorized distributor for obtaining software.

- Generator Set Operation Manual and Engine Operation Manual
- Monitor II Software Operation/Installation Manual
- Personal Computer (see Program Loader for requirements)

SecurID® is a registered trademark of RSA Security Inc.

- Null modem RS-232 cable with a 9-pin male plug on the controller end
- Program Loader Software (see KOHLERnet)
- Application Code Software (see KOHLERnet)

5.3.3 Procedure

1. Remove the generator set from service.
 - a. Place the generator set master switch in the OFF/RESET position.
 - b. Disconnect the power to the battery charger, if equipped.
 - c. Disconnect the power to the block heater, if equipped.
 - d. Disconnect the generator set engine starting battery(ies), negative (-) lead first.

2. Locate and remove the coolant temperature sensor.

The coolant temperature sensor is typically at the front of the engine block near the water pump and/or intake manifold. The coolant temperature sensor has a 3-lead connector with red-black-white leads and identified as lead 5. See Figure 5-10 for coolant temperature sensor location.

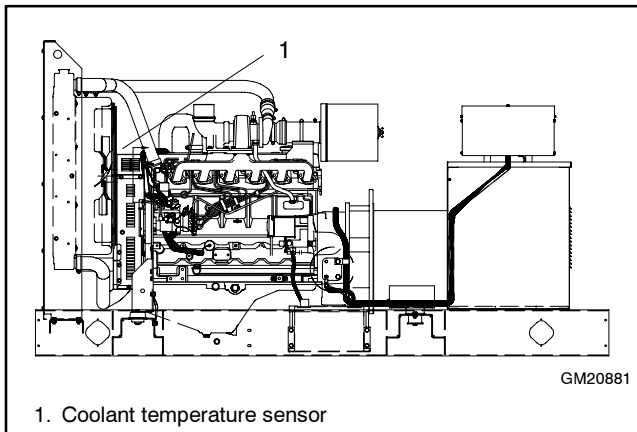

Figure 5-10 Coolant Temperature Sensor Location

- a. Allow the generator set to cool if the unit was recently operating.
 - b. Drain the coolant into a suitable container. Open the drain petcocks located at the bottom of the engine block and/or radiator. Drain the coolant to just below the coolant temperature sensor location.
 - c. Remove the electrical connector from the coolant temperature sensor.
 - d. Remove the coolant temperature sensor. Remove and discard the metric reducer bushing, if equipped.
3. Install the coolant temperature sensor and add coolant.
 - a. Clean the threaded hole in the engine block.
 - b. Install the new coolant temperature sensor in the engine block. The new sensor has Loctite® Vibra-Seal® 516 thread sealant already applied.
 - c. Attach the electrical connector to the coolant temperature sensor.
 4. Fill the radiator with coolant.
 - a. Close all the drain petcocks located at the bottom of the engine block and/or radiator.

- b. Refill the cooling system using the procedure and coolant recommendation given in the engine operation manual and/or generator set operation manual. See the respective spec sheet for coolant capacity.

Reuse the existing drained coolant if deemed acceptable. Otherwise, mix clean distilled water and coolant according to the engine manufacturer's recommendation in the engine operation manual.

Dispose of all waste materials (engine oil, fuel, coolant, etc.) in an environmentally safe manner. Contact local authority for procedures.

- c. Use the procedure in the engine operation manual for deairating air in the cooling system. If deairation requires starting the generator set go to step 5.
5. Place the generator set into service.
 - a. Place the generator set master switch in the OFF/RESET position.
 - b. Reconnect the generator set engine starting battery(ies), negative (-) lead last.
 - c. Reconnect the power to the battery charger, if equipped.
 - d. Complete the deairation procedure before energizing the block heater.
 - e. Reconnect the power to the block heater, if equipped.
 6. Install the application software (as needed).
 - a. Determine the application code version. Use the procedure found in the generator set operation manual for Menu 20, Factory Setup information.
 - b. If the application code version is 2.21 or higher, the software update is already done. The sensor installation is complete. Go to step 7.

If the application code version is less than application code version 2.21, continue with the software update.
 - c. Program loader and 550 controller application software files can be downloaded from the KOHLERnet. Use your SecurID to access the KOHLERnet and click on the TechTools button to request and download the files. Use the

Loctite® and Vibra-Seal® are a registered trademarks of Loctite Corporation.

program loader instructions for completing the application code upgrade.

7. Determine the appropriate temperature sensor selection.

Change the temperature sensor selection using the controller keypad.

- a. Go to Menu 20, Factory Setup. The menu can remain locked when changing the sensor selection. See Figure 5-11.
- b. Scroll down to the TEMP SENSOR display.

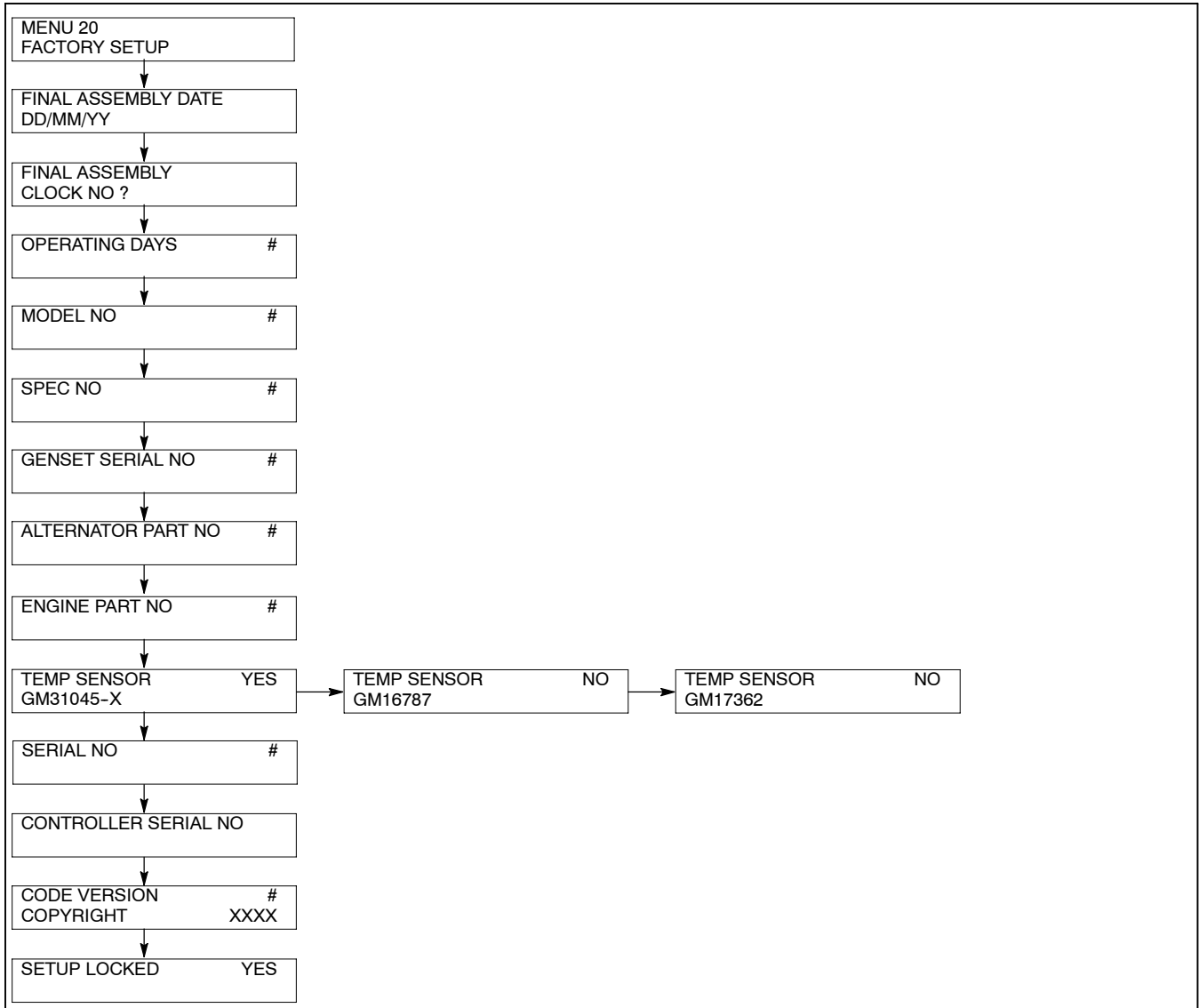

Figure 5-11 Menu 20, Factory Setup

- c. Select temperature sensor part number that matches installed temperature sensor using the right arrow key. See Figure 5-9 for additional identification information. When correct display is shown, press YES and ENTER.

Note: For coolant temperature sensors GM31045-1 or GM31045-2, choose the GM31045X display.

- d. Installation is complete. Place the controller master switch in the OFF/RESET position.
- e. Temporarily disconnect power to the controller by removing the F2 fuse located on the interconnection circuit board for 10 seconds and then replace the fuse.

Note: The generator set controller must have the power supply disconnected and then reconnected before the microprocessor will accept the change.

- f. At the next scheduled generator set exercise period or at this time, start the generator set by placing the generator set master switch in the RUN position.

Verify that the engine water temperature reading is valid and no water temperature warning/shutdown faults occur. Refer to the generator set operation manual and engine operation manual for operation information and temperature values.

When testing is complete, stop the generator set by placing the controller master switch in the OFF/RESET position.

5.4 Controller Circuit Board Failures (Units Using RS-232 Communications)

Adapted from Service Bulletin SB-640.

The generator set manufacturer has received reports of 550 controller failures using the RS-232 communication port in some types of installations. The incidents reported occurred where the generator set is installed outdoors and the RS-232 connects to a remote communication device. The controller failure may be linked to areas experiencing frequent lightning strikes.

If controller circuit board replacement is needed, verify if the unit has some type of external communication using the RS-232 port. If RS-232 communication is used, verify physical damage to circuit board components, particularly integrated circuits U28, U55, and U58. See Figure 5-12.

If circuit board damage to the integrated circuit is present, the failure was likely caused by some type of electrical voltage surge such as a lightning strike.

The generator set manufacturer has developed an RS-232 Isolation Kit (part number GM32967-KP) to help reduce the likelihood of voltage surge damage. The kit contains optical isolator GM32968 and a 152 mm (6 in.) connection cable GM32969. Install the isolation kit if the RS-232 port is used in conjunction with a remote communication device.

Technicians encountering installations using RS-232 communications should consider using RS-232 isolation kit. This kit when installed will reduce the likelihood of controller circuit board failure caused by voltage surges.

Follow the recommendations in Section 5.5, Noise and Wiring Practices.

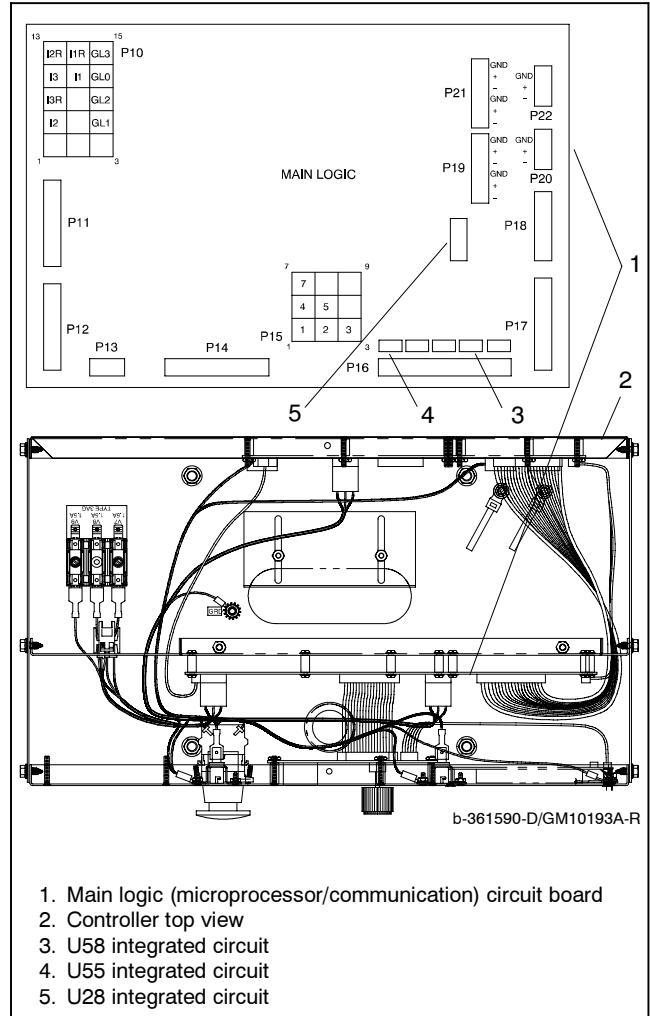

Figure 5-12 Main Circuit Board

5.5 Noise and Wiring Practices

Adapted from Service Bulletin SB-640.

Electrical noise is an unwanted electrical signal that can cause errors in measurement, loss of control, malfunctions in microprocessor-based control systems, errors in data transfer between systems over communication links, or reductions in system performance.

Good system design and wiring practices can minimize noise levels and the effects of noise.

Noise, because of its random nature, is typically characterized by frequency distribution. Many noise sources are broad-spectrum, that is, they produce many frequencies distributed over a wide range. Broad-spectrum noise is particularly troublesome because it cannot be removed easily by filtering and because it can affect a variety of systems in unpredictable ways. One common source of broad-spectrum noise is a switch, which can produce voltage and current changes when an electrical circuit is connected and disconnected.

Coupling is the transfer of signals between separate circuits. Signals from one circuit become noise in another. The amount of coupling is cumulative and is a function of the proximity of the circuits, their orientation, exposed area, and length of run. Minimize coupling by the following:

- Isolating circuits from each other by using separate raceways or conduit for AC and DC circuits
- Separating circuits from each other by locating them as far apart as possible
- Enclosing circuits with a grounded metallic shield such as an enclosure, metallic conduit, or cable shield
- Running conductors perpendicular, rather than parallel, to each other
- Running wires loosely and randomly rather than bundling them tightly together
- Twisting a circuit's wires together in pairs

In an industrial environment, there are typically five types of circuits with different noise emission and rejection capabilities. The five types of circuits are as follows:

- **High-Power Distribution.** Circuits to high-power loads such as large electric motors and heaters can emit transient high levels of broad-spectrum noise. Loads on high-power distribution circuits are nearly immune to noise.

- **General Purpose Power Distribution.** Circuits to medium-power loads such as lighting, offices, light-duty equipment, and small motors such as fans and pumps can emit transient, medium levels of broad-spectrum noise. Some electronic equipment, such as computers, emits constant levels of broad-spectrum noise in addition to transient broad-spectrum noise. Loads on general-purpose circuits, except for sensitive electronic equipment, are nearly immune to noise.

- **Control.** Control circuits include DC circuits and 120 VAC maximum AC circuits that operate at a low power level (less than 1 W). Typical circuits include circuits to switches, actuators, and dry-contact relays, including the generator engine-start circuit. Control circuits emit transient low levels of broad-spectrum noise and are fairly immune to noise.

- **Analog.** Analog circuits are low-voltage DC circuits that convey measurement information as relatively small changes in current or voltage. Typical circuits include those connected to the controller's analog inputs. Analog circuits create the lowest noise levels and are the most sensitive to noise.

- **Communication and Signaling.** Communication and signaling circuits are low-voltage circuits that convey information. Typical circuits include RS-232 and RS-485 serial communication lines, telephone lines, and computer network lines. These circuits create noise with frequencies related to the communication signaling rate. These circuits have some level of built-in noise immunity. Typical systems will detect or correct errors caused by noise below certain levels, but with a corresponding reduction in the data transfer rate.

When planning an installation, separate all of these types of circuits as much as possible to minimize the hazards of insulation failure, accidental miswiring, and noise coupling. For best results, install control circuits, analog circuits, and communication and signaling circuits separately. Combining circuit types is unavoidable in the controller's enclosure and some other areas.

Note: It is very important to isolate high- and medium-power circuits in raceways or conduit separate from the other types of circuits.

Notes

Section 6 Component Testing and Adjustment

This section provides testing and troubleshooting information on select controller and generator set accessories.

The components and tests in this section apply to all controllers unless otherwise stated.

⚠ WARNING

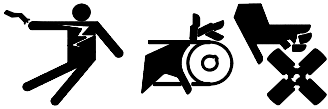

Accidental starting. Can cause severe injury or death.

Disconnect the battery cables before working on the generator set. Remove the negative (-) lead first when disconnecting the battery. Reconnect the negative (-) lead last when reconnecting the battery.

Disabling the generator set. Accidental starting can cause severe injury or death. Before working on the generator set or connected equipment, disable the generator set as follows: (1) Move the generator set master switch to the OFF position. (2) Disconnect the power to the battery charger. (3) Remove the battery cables, negative (-) lead first. Reconnect the negative (-) lead last when reconnecting the battery. Follow these precautions to prevent starting of the generator set by an automatic transfer switch, remote start/stop switch, or engine start command from a remote computer.

NOTICE

Electrostatic discharge damage. Electrostatic discharge (ESD) damages electronic circuit boards. Prevent electrostatic discharge damage by wearing an approved grounding wrist strap when handling electronic circuit boards or integrated circuits. An approved grounding wrist strap provides a high resistance (about 1 megohm), *not a direct short*, to ground.

6.1 Controller Circuit Board Handling

Electronic printed circuit boards (PCBs) are sensitive to a variety of elements and can be damaged during removal, installation, transportation, or storage. Observe the following when working with circuit boards.

6.1.1 Circuit Board Handling

- Store circuit boards in the antistatic, cushioned packaging provided by the factory in a clean environment away from moisture, vibration, static electricity, corrosive chemicals, solvents, or fumes until installation.
- Wear an approved grounding, antistatic wrist strap when handling circuit boards or components.
- Carefully hold the circuit board only by its edges, not by any of its components.
- Don't bend or drop the circuit board or any of its components.
- Don't strike the circuit board or any of its components with a hard object.
- Clean dusty or dirty circuit boards only with a vacuum cleaner, dry brush, and/or aerosol spray cans specifically for electronic equipment and components. Aerosol spray cans are typically found with computer supplies.
- Never attempt component-level circuit repairs as this may void third party certification.
- Never remove or install a circuit board with the power connected.
- Label wiring when disconnecting it for reconnection later.

6.1.2 Circuit Board Removal

1. Remove all external connections from the circuit board.
 - Loosen screws on terminal strips and remove the individual leads. Label as needed.
 - Remove push-on terminals by firmly pulling on the terminal. Use a long-nose pliers as necessary.
 - Remove wiring harnesses with plug connectors by pressing the locking tab(s) and pulling on the plug straight out to remove the wiring harness plug from the circuit board socket.

2. Remove the mounting screws typically located at the corners of the circuit board.
3. Locate the PCB push-on standoffs found at various locations on the circuit board. Standoffs are typically made of white nylon but may be other colors or made of metal.

Carefully pry the circuit board away from each standoff. Start at a location near the circuit board edge and work in succession either clockwise (CW), counterclockwise (CCW), or across the circuit board. **DO NOT USE EXCESSIVE FORCE** as circuit boards will break when sufficiently bent.

6.1.3 Circuit Board Replacement

1. Position the circuit board over the push-on standoffs on the controller mounting plate.
2. Gently push the circuit board onto the standoffs. Start at a location near the circuit board edge and work in succession either CW, CCW, or across the circuit board. **DO NOT USE EXCESSIVE FORCE** as circuit boards will break when sufficiently bent.
3. Replace the external connections on the circuit board.

6.2 Other Service Parts

The removal and installation of service parts other than circuit boards is covered by the following generic procedure. Service parts include plug-in relays, switches, lamps, meters, gauges, brackets, and other hardware.

6.2.1 Removal

1. Disconnect wiring from the part(s), noting the locations from which wiring was removed for later reconnection. Tape and label the wires as needed.
2. Note the position of the part(s) and loosen or remove hardware that holds the part(s) in place. If the removal is complex or will span several days, make sketches or use a video recorder or digital camera to help capture the detail.

Note the location, type, and condition of the hardware removed and compare it with the parts list. Replace damaged or missing hardware.

3. Carefully remove the part(s) from the unit. Gently rock plug-in parts, such as relays, from side to side while pulling straight out to remove them without bending the circuit boards.

6.2.2 Installation

1. Position the part(s) in place in the same manner that the old part was installed. Support the back of circuit boards when installing plug-in parts, such as relays and wiring harness plugs, to avoid bending the circuit board.
2. Tighten or reinstall hardware that holds the part(s) in place to the general torque specifications in Appendix C, General Torque Specifications, unless otherwise noted.

If the torque specifications do not cover the application or do not seem appropriate let common sense prevail. Avoid overtorquing hardware in sheet metal and non-metallic composites.

3. Reconnect wiring to the same location from which it was removed, torquing terminals to the specifications given in Section 1, Specifications.

6.3 General Information

Use the respective parts catalog to determine the appropriate replacement part. Sometimes service kits replace a given part where additional components in the kit are necessary to provide the functional component equivalent. The parts catalog illustrations may serve as a guide for replacement but be aware that multiple models are generally illustrated in a single view and details may not represent the specific application.

6.4 Leads/Wires/Wiring Harnesses

Repair/replace wiring when there is any doubt about its condition. Tape minor control circuit wire insulation cuts or abrasions less than 1 mm (0.04 in.) across by wrapping the section tightly with three layers of electrical tape.

Repair moderately damaged leads, where conductors are cut or insulation is damaged over sections shorter than about 100 mm (4 in.) or less than about 25% of the length of the wire by cutting out the damaged section and splicing in wire of the same type.

Replace extensively damaged or deteriorated leads completely. If the leads are part of a wiring harness, replace entire wiring harness. Fabricate replacement leads using the same type of wire as the old leads. Add terminals and lead markers at each end of the new lead.

6.5 Battery Equalizer, 135-275 kW DDC-Powered Gas Models

The 135-275 kW Detroit Diesel Series 50/60 gas models use a battery equalizer module for balanced battery charging. See Figure 6-1. The 24-volt engine (cranking) electrical system provides a 12-volt DC supply at 20 amps max to the ignition coils, fuel valves, and DDEC engine electronic control system.

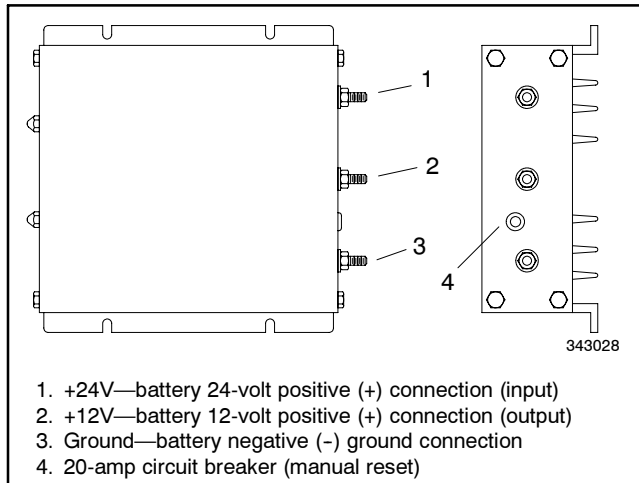

Figure 6-1 Battery Equalizer

The 135-275 kW Detroit Diesel Series 50/60 gas models use a three-battery system. See Figure 6-2. The three-battery system provides a separate 12-volt battery electrical system that is unaffected by the 24-volt cranking system voltage drop. See Figure 6-3 the for battery equalizer specifications.

Refer to the appropriate wiring diagram manual for battery equalizer electrical connections.

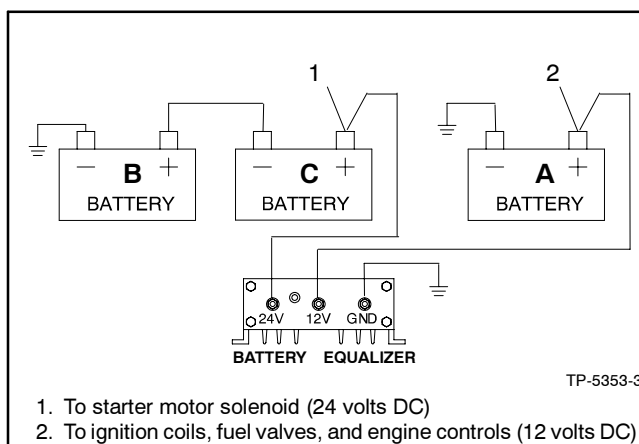

Figure 6-2 Three-Battery System

Input voltage (24 volts nominal)	20-35 volts
Input current 24 volt, max.	12 amps
Output voltage	(input voltage/2) \pm 2%
Output current (12 volts)	0-20 amps
Standby current	17 mA nominal at 28.4 volts
Operating temperature	-40°C to 71°C (-40°F to 160°F)
Storage temperature	-54°C to 85°C (-65°F to 185°F)

Figure 6-3 Battery Equalizer Specifications

6.5.1 Theory of Operation

The application requires a 12-volt battery source in a 24-volt engine electrical system. Connection to the 12-volt battery A for the 12-volt source causes a battery charging imbalance where the 12-volt batteries B/C are overcharged. The solution to this charging imbalance requires using a battery equalizer.

The battery equalizer connects at the +24 volt, +12 volt, and ground connections. The battery equalizer provides a simulated series connection for battery charging and other 24-volt engine electrical requirements and a simulated parallel connection for the 12-volt engine electrical requirements where all batteries maintain a voltage balance to within 0.10 volts under light load and 0.50 volts under full rated load.

When the voltage of one battery is higher than or equal to the other battery voltages, the battery equalizer remains in the standby mode. When a 12-volt load is present and the battery A voltage decreases to just below the voltage of the batteries B/C, the battery equalizer provides battery current to the lower voltage battery from the higher voltage batteries to satisfy load and maintain an equal voltage and charge in each battery.

6.5.2 Battery Equalizer Circuit Breaker

The battery equalizer has a manual reset circuit breaker, see Figure 6-1. The circuit breaker trips to protect the battery equalizer in the follows ways:

Note: To prevent reverse polarity damage to the battery equalizer, remove the ground (GND) connection first and attach the ground (GND) connection last when disconnecting the battery equalizer.

- When the battery is connected to +12 volt and GND battery equalizer terminals incorrectly.
- When the battery equalizer's GND terminal is connected to the chassis and the battery negative (-) *terminal* is disconnected, a short between +24 volt and chassis creates a reverse polarity on the +12 volt and GND circuit.
- When the battery equalizer's GND terminal is connected to the chassis and the battery negative (-) *cable* is disconnected, a short between +24 volt and chassis creates a reverse polarity on the +12 volt and GND circuit.

6.5.3 Battery Equalizer Troubleshooting

The battery equalizer test requires all batteries to have a full charge and pass a battery load test prior to performing the battery equalizer test. If battery conditions are not known or are questionable, test the batteries with a battery load tester. Use the instructions provided with the battery load tester.

Battery equalizer test equipment required:

- 12-volt test light with alligator clips on both ends.
- Voltmeter with 0.01 volt resolution

Note: To prevent reverse polarity damage to the battery equalizer, remove the ground (GND) connection first and attach the ground (GND) connection last when disconnecting the battery equalizer.

1. Remove the ground (GND) connections from the battery equalizer. Do not allow these connections to contact any of the other battery equalizer connections.
2. Verify that there is a differential of 12 volts between the +12 volt and +24 volt battery equalizer terminals by connecting a 12-volt light between the terminals. The test light will illuminate when connected to a functional battery equalizer. Remove the test light.
3. Connect the test light between the +12 volt and GND battery equalizer terminals. The test light will illuminate when connect to a functional battery equalizer.
4. With the test light connected, measure and record the voltage between the +12 volt and +24 volt battery equalizer terminals.
5. With the test light connected, measure and record the voltage between the +12 volt and GND battery equalizer terminals.
6. Remove the test light.
7. Compare the values recorded in steps 4 and 5. The difference between the values should be -0.5 and +0.13 volts with a functional battery equalizer.

6.6 Controller Selector Switch (Basic and 16-Light Controllers)

The illustrations in Figure 6-4 and Figure 6-5 represent the electrical connections made to the controller selector switch. Use this information to troubleshoot the selector switch when the wiring and/or the selector switch contacts are in question.

See Figure 6-6 for typical controller selector switch external connections. See the respective wiring diagram for actual connections.

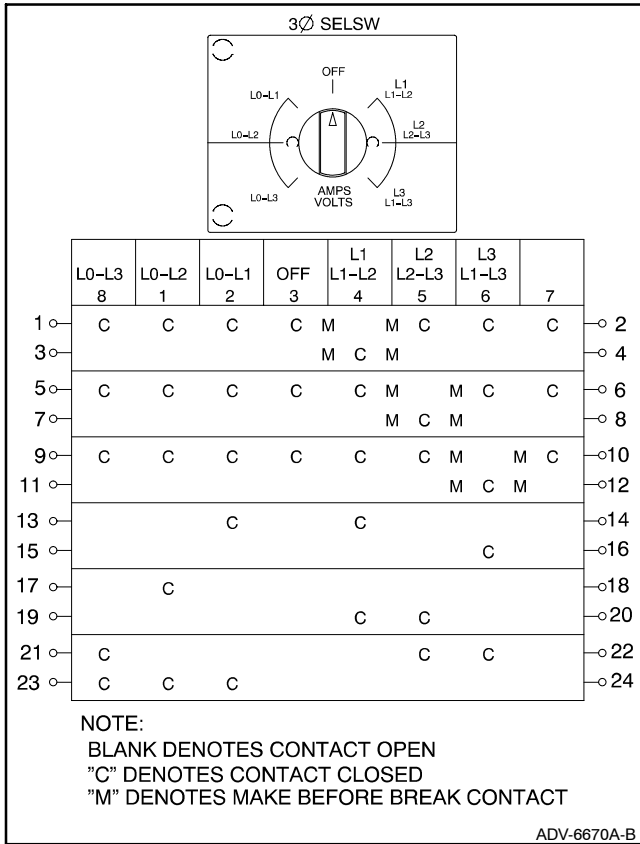

Figure 6-4 Controller Selector Switch, 3-Phase

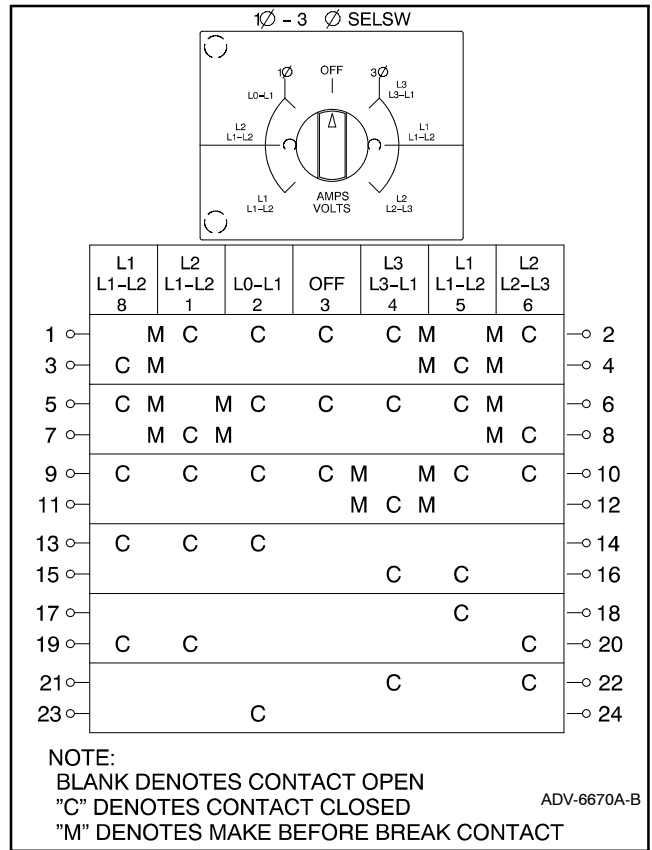

Figure 6-5 Controller Selector Switch, Single-Phase/3-Phase

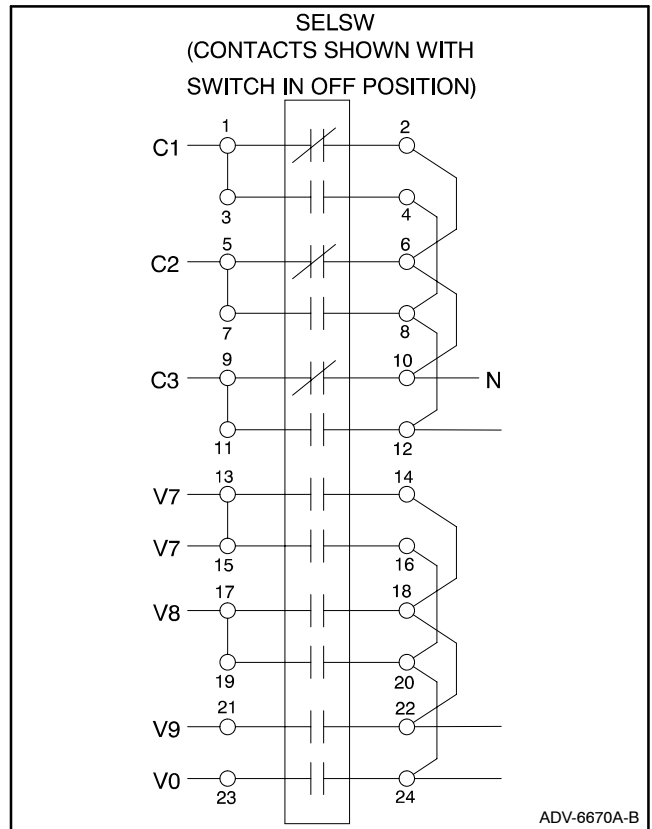

Figure 6-6 Controller Selector Switch External Connections, Typical

6.7 Crank Relay

The test procedure for the following crank relay applies to other applications of the same type relay. See Figure 6-7.

The relay is a single-pole, double-throw relay. Contacts 85 and 86 are the relay coil. See Figure 6-8 for specifications by relay part number. If replacement is necessary, do not substitute part numbers.

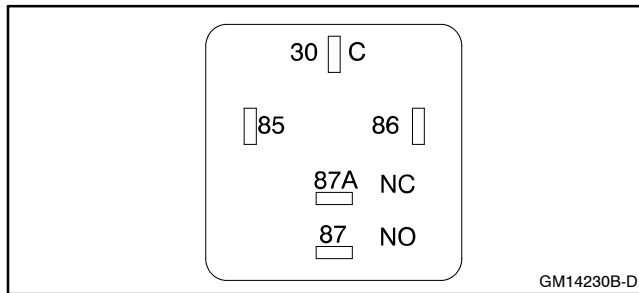

Figure 6-7 Crank Relay Contacts

Relay Part Number	Coil Voltage VDC	Coil Resistance, ohms	NO/NC Contacts Rating, Amp
259391	12	85 ±5	30/20
272684	24	305 ±15	20/16
GM28787	12	90 ±10	40/20
GM37390	12	90 ±10	40/30

Figure 6-8 Relay Specifications

6.8 Current Transformers

6.8.1 Function and Application

The current transformers provide several generator set functions including signal/drive for:

- Controller AC voltmeter/ammeter
- Safeguard circuit breaker
- Reactive droop compensator

The generator set models do not have current transformers when they do not include the above items. The meters and safeguard circuit breaker share the same current transformer while the reactive droop compensator uses a separate current transformer.

See Figure 6-9. The generator set junction box contains the stator leads and the current transformers.

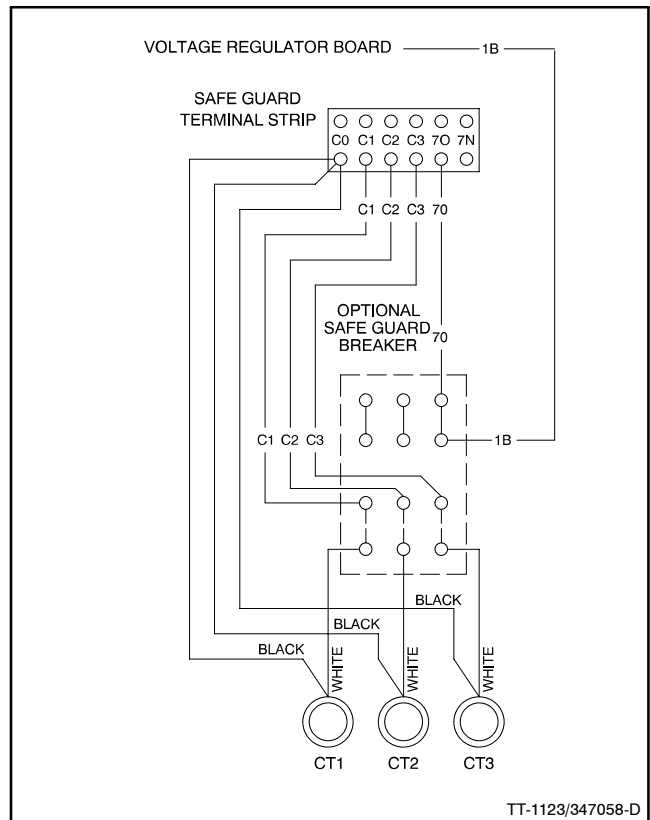

Figure 6-9 Current Transformers

When replacing the current transformer or stator assembly, install the current transformer according to the generator reconnection decal on the generator set, or see the wiring diagrams manual. Observe the correct current transformer position when installing the stator leads. The current transformer dot or HI mark position and the stator lead direction are essential for correct component function. The dot or HI mark should face toward the stator.

Two styles of current transformers are used. Round (doughnut) styles have black/white leads with no mounting provisions. The square styles have two #8-32 studs/nuts for connecting the leads and four notches in the base for mounting.

A current transformer contains a coil of wire that induces a secondary voltage/current from the primary or stator lead passing through the center. The number of coil turns inside the current transformer determines the ratio. Replacement current transformers must have the same ratio as the original.

6.8.2 Testing

Use an ohmmeter to check the current transformer. Perform this test with the current transformer disconnected from the generator set. A resistance reading of infinity or 0 ohms suggests an open or shorted current transformer that needs replacement. Consider any other resistance reading acceptable.

6.9 Engine Pressure and Temperature Sensors

6.9.1 General

Use this section to test engine sensors (switches or senders) installed by the generator set manufacturer on the engine. Refer to the respective engine service manual for testing sensors installed by the engine manufacturer.

Use the following tests to determine if the sensor is functional. All sensors should have part numbers stamped on the metal housing. In cases where the number is illegible or missing, refer to the respective generator set parts catalog for the corresponding part number. The user must determine the sensor part number in order to determine the sensor specifications which are found in Section 1, Specifications.

The sensors can be installed on the generator set provided the leads are disconnected and a temperature or pressure gauge is available to determine the engine values. Otherwise, remove the sensor after draining the respective engine fluid (oil or coolant) and test using a separate pressure or temperature source.

The resistance of the oil pressure and water temperature sender output signals varies as the respective pressure and temperature change. Use the resistance change for verification of sender function. Disconnect all leads from the sender before checking resistance. If the sender functions and the gauge does not function, check the engine wiring harness, leads, and connectors before replacing the gauge.

Some generator sets may have senders/switches incorporated with the engine ECM (electronic control module). Identify engine ECM senders/switches by lead designations listed in the following testing information. Refer to the wiring diagrams manual for additional lead identification information. Use the engine service manual for troubleshooting ECM senders/switches.

6.9.2 Sensor Types

The sensors referenced in this section typically provide the following controller inputs:

- High engine temperature shutdown switch
- High engine temperature warning (prealarm) switch
- Low oil pressure shutdown switch
- Low oil pressure warning (prealarm) switch
- Low water temperature warning switch
- Oil pressure gauge sender (see Section 6.9.5)
- Water temperature gauge sender (see Section 6.9.6)

6.9.3 Switch Testing

Before testing switch, disconnect the switch lead(s).

Pressure Switch

Some pressure switches make contact on falling pressure and some on rising pressure; refer to the respective drawing for contact style. Connect an ohmmeter to the switch terminals. Switches with one terminal require connection to ground on the switch metal body. Apply the pressure value shown in Section 1.7, Pressure Switches, and observe the ohmmeter before and after values to determine if the switch contacts open and close per specifications.

Temperature Switch

High water temperature switches make contact on rising temperature. Low water temperature switches make contact on falling temperature. Refer to the respective drawing for contact style. Connect an ohmmeter to the switch terminals. Switches with one terminal require connection to ground on the switch metal body. Apply the temperature value shown in Section 1.6, Temperature Switches, and observe the ohmmeter before and after values to determine if the switch contacts open and close per specifications.

6.9.4 Sender Testing

Before testing sender, disconnect the sender lead(s).

Pressure Sender

Pressure senders change resistance values as pressure changes. Connect an ohmmeter to the sender terminals. Senders with one terminal require connection to ground on the switch metal body. Apply pressure values shown in Section 1.4, Pressure Senders, and observe the ohmmeter values to determine if the sender changes resistance per specifications.

Temperature Sender

Temperature senders change resistance values as temperature changes. Connect an ohmmeter to the sender terminals. Senders with one terminal require connection to ground on the switch metal body. Apply temperature values shown in Section 1.5, Temperature Senders, and observe the ohmmeter values to determine if the sender changes resistance per specifications.

6.9.5 Oil Pressure Sender Testing

Disconnect the oil pressure sender lead 7C. See Figure 6-10. Check the sender resistance with an ohmmeter. Compare the resistance values when the generator set is shut down and when it is running at operating temperature to the values shown in Section 1, Specifications.

Use a mechanical oil pressure gauge to further verify correct readings.

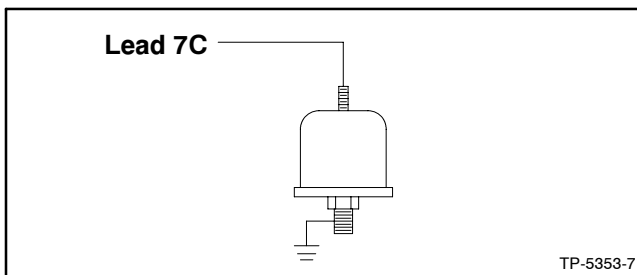

Figure 6-10 Oil Pressure Sender, Typical

6.9.6 Water Temperature Sender Testing

The water temperature sender has three configurations: (1) a single function, single-terminal type, (2) a single function, two-terminal type, and (3) a dual function, two-terminal type with temperature gauge sender and low coolant temperature switch. See Figure 6-11.

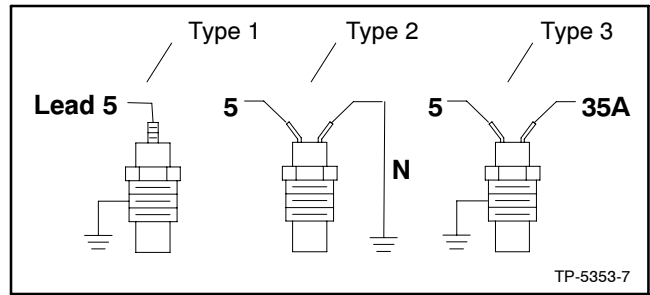

Figure 6-11 Water Temperature Sender, Typical

Sender type 3 has lead 5 connected to water temperature sender terminal with a 6-32 screw and lead 35A connected to the low water coolant temperature switch terminal with an 8-32 screw.

Disconnect the water temperature sender lead 5 (and lead N with type 2 configurations). Check the sender resistances with an ohmmeter. Compare the resistance values when the generator set is shut down and when it is running at operating temperature to the values listed in Section 1, Specifications.

6.10 Digital Interface (Circuit) Boards B-354647/C-354647 (16-Light Controller)

The generator sets using DDC Series 60/2000/4000 engines and DDEC engine controls use a digital interface (circuit) board (DIB) to convert a 12 to 2 engine speed pulse to work with the 16-light controller. In addition, other selected engine switches communicate with the 16-light controller. This allows the generator set controller to obtain engine information from the DDEC rather than from additional sensors/switches on the engine. The DIB is shown in Figure 6-12 (B-354647) and Figure 6-13 (C-354647). The C-354647 circuit board does not use the 4-position DIP switch.

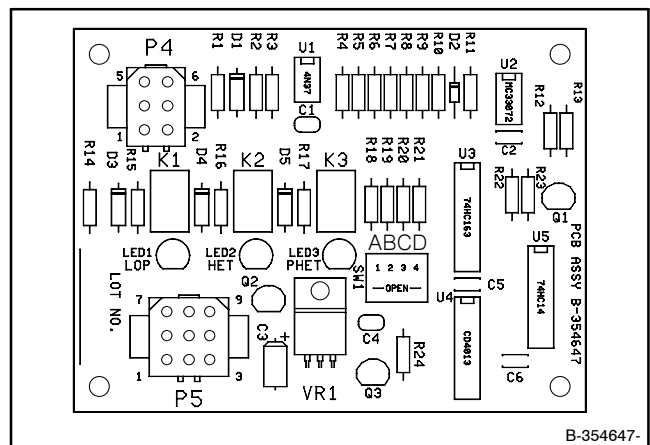

Figure 6-12 Digital Interface (Circuit) Board (DIB) B-354647

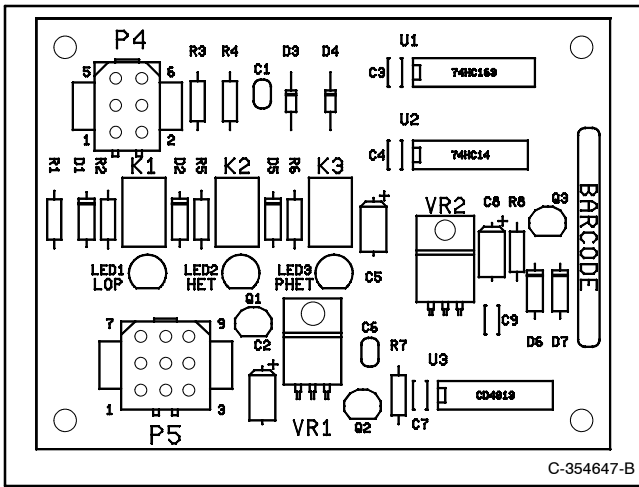

Figure 6-13 Digital Interface (Circuit) Board (DIB)
C-354647

The DIB connects between the DDEC and the 16-light controller main circuit board. See Figure 6-14. Check the DIB and its connections for damage and correct seating when troubleshooting its operation rather than

the following additional switches or sensors that are not present on the generator set controls equipped with a DIB.

- Low oil pressure switch
- High engine (coolant) temperature switch
- High engine (coolant) temperature warning switch
- Engine speed sensor

Three relays K1 (LOP), K2 (HET), K3 (PHET), and other circuitry on the interface circuit board isolate the digital warning/fault outputs of the DDEC and convert them to a signal level used by the generator set controller. LED1 (LOP), LED2 (HET), and LED3 (PHET) light and the corresponding relay coil energizes when the corresponding input to the generator set controller signals an engine problem.

The K1 (LOP) relay coil energizes and its contact closes from the low oil pressure (LOP) switch output to ground when the DDEC sends a ground signal to the circuit board on the LOP input. K1 is not used on Series 60 engines.

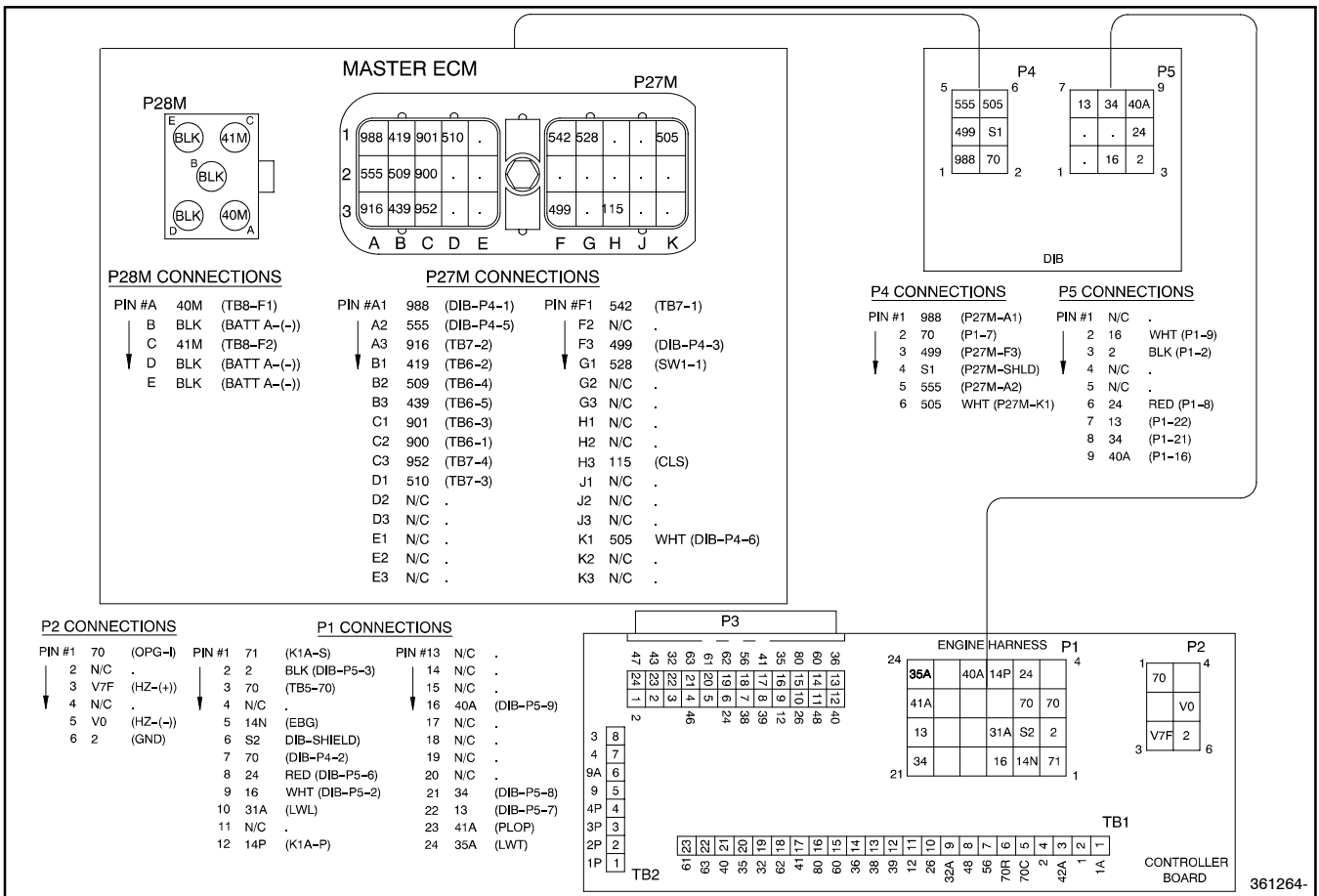

Figure 6-14 DDEC Interface Circuit Board Connections

The K2 (HET) relay coil energizes and its contact closes from the high engine (coolant) temperature (HET) switch output to ground when the DDEC sends a ground signal to the circuit board on the HET input.

The K3 (PHET) relay coil energizes and its contact closes from the high engine (coolant) temperature warning switch output to ground when the DDEC sends a +24 VDC battery signal to the circuit board on the pre-high engine (coolant) temperature (PHET) input.

The DDEC provides a 12 pulse/revolution engine speed signal. The interface circuit board converts this signal to a 2 pulse/revolution engine speed signal that is used by the generator set controller.

Interface Circuit Board (C-354647 only). The DIP switch SW1 on the interface circuit board must have the settings shown in Figure 6-15.

ID	Setting
A	Open
B	Closed
C	Open
D	Closed

Figure 6-15 DIP Switch SW1

If the engine rpm reading is incorrect or when there are problems with disconnect or overspeed functions, check the SW1 switch setting.

P27 DDEC ECM	
Pin	Description
A1	Output to DIB P4-1, low oil pressure (LOP) signal input, wire 988 (not used on Series 60 engines)
A2	Output to DIB P4-5, pre-high engine temperature (PHET) signal input, wire 555
F3	Output to DIB P4-3, high engine temperature (HET) signal input, wire 499
K1	Output to DIB P4-6, speed sensor input (12 pulses per revolution), wire 505

P4 DDEC Interface Circuit Board (DIB)	
Pin	Description
1	Input from DDEC P27-A1, LOP, wire 988
2	Input from generator set controller P1-7, engine run (battery +), wire 70
3	Input from DDEC P27-F3, HET, wire 499
4	Shield, engine speed sensor, wire S1
5	Input from DDEC P27-A2, PHET, wire 555
6	Input from DDEC P27-K1, engine speed, wire 505

P5 DDEC Interface Circuit Board (DIB)	
Pin	Description
1	Not used
2	Output to generator set controller P1-9, speed sensor input (2 pulses per revolution), wire 16
3	Ground from generator set controller P1-2, speed sensor ground, wire 2
4	Not used
5	Not used
6	Battery positive from generator set controller P1-8, speed sensor battery positive, wire 24
7	Output to generator set controller P1-22, low oil pressure switch input, wire 13
8	Output to generator set controller P1-21, high engine (coolant) temperature switch input, wire 34
9	Output to generator set controller P1-16, high engine (coolant) temperature warning switch input, wire 40A

P1 Generator Set Controller Main Circuit Board	
Pin	Description
2	Ground to DIB P5-3, speed sensor ground, wire 2
7	Output to DIB P4-2, engine run (battery +), wire 70
8	Output to DIB P5-6, speed sensor battery positive, wire 24
9	Input from DIB P5-2, engine speed sensor input, wire 16
16	Input from DIB P5-9, high engine (coolant) temperature switch input, wire 40A
21	Input from DIB P5-8, high engine (coolant) temperature switch input, wire 34
22	Input from DIB P5-7, low oil pressure switch input, wire 13

6.11 Low Fuel Pressure (Vacuum) Switches

The low fuel pressure (vacuum) switch (see Figure 6-16) is used on selected gas models to:

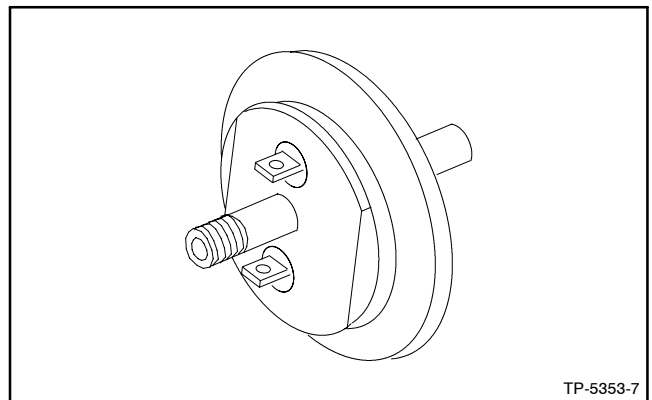

Figure 6-16 Low Fuel Pressure (Vacuum) Switch

- Signal a low fuel warning (lead 63)
- Trigger the secondary fuel source on dual fuel gas systems with automatic changeover options.
- Signal a low fuel shutdown as an immediate auxiliary shutdown on the 125 kW with turbocharged 8.1 L GM engine.

Use an ohmmeter and check for continuity across the two terminals. The circuit opens when a vacuum source indicated in Figure 6-17 is applied. These switches incorporate a diaphragm type sensing device. When testing, apply the vacuum for several minutes to help determine if the switch has a leaking diaphragm (internal leak) or a leaking canister (external leak). Replace the switch if any leakage is found or if the switch fails the continuity test.

Part Number	Switch Description	Vacuum, kPa (psi)
287387	Fuel Pressure Switch (Automatic Changeover Option)	0.87-1.0 (0.13-0.14)
345207	Low Fuel Pressure Warning (Low Fuel)	1.1-1.2 (0.16-0.18)

Figure 6-17 Low Fuel Pressure (Vacuum) Switch

6.12 Low Water Level

6.12.1 2-Wire Sender

Function

The 2-wire low water level (LWL) sender is a resistance/temperature device. Lead 31A from the controller provides a 12 VDC supply to the sender. The controller provides 12 VDC on both 12-volt and 24-volt engine electrical systems. The 12 volt supply heats the center electrode on the sender. The sender temperature remains low when immersed in coolant while the resistance to ground is high. The resistance to ground decreases when the sender is out of contact with coolant and the center electrode temperature rises.

Low sender resistance raises the current draw which lowers the voltage to approximately 7 VDC on lead 31A. A comparator circuit on the controller circuit board senses the voltage drop and sends a signal to the controller logic for an auxiliary fault shutdown after completing the time delay.

Testing

Use the following test procedure for the 2-wire low water level sender while the generator set operates. Lead 31A must remain connected to the sender during the test.

Servicing the exhaust system. Hot parts can cause severe injury or death. Do not touch hot engine parts. The engine and exhaust system components become extremely hot during operation.

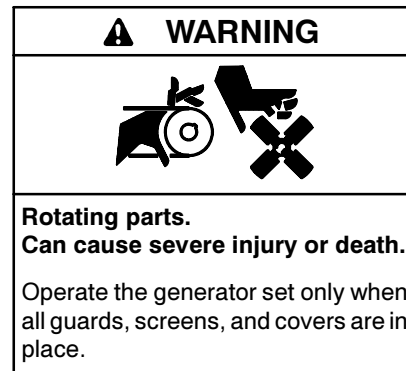

Servicing the generator set when it is operating. Exposed moving parts can cause severe injury or death. Keep hands, feet, hair, clothing, and test leads away from the belts and pulleys when the generator set is running. Replace guards, screens, and covers before operating the generator set.

LWL fault shutdown does not function during the first 30 seconds after startup. See Figure 6-18 for connections.

1. Measure the DC voltage between lead 31A (+) and ground (-) with the sender submerged in coolant. The voltmeter indicates approximately 12.5 VDC with a functioning sender.
2. Measure the DC voltage between lead 31A (+) and ground (-) with the sender removed from the coolant for at least 5-15 seconds. The voltmeter indicates a voltage drop to approximately 7 VDC with a functioning sender.

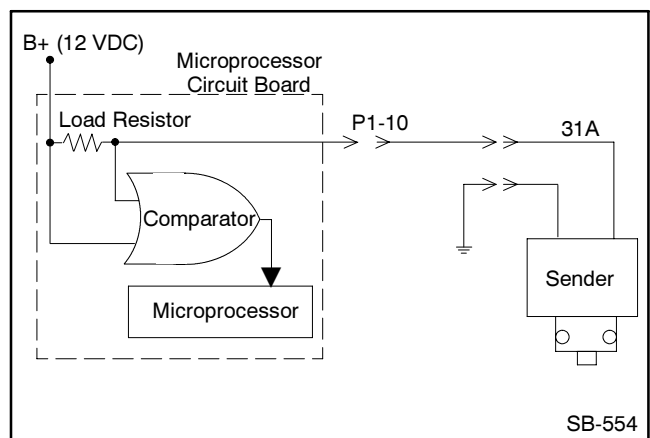

Figure 6-18 2-Wire Low Water Sender

Consider the sender defective:

- If the DC voltage between lead 31A (+) and ground (-) is 7 VDC or less with the sender submerged in coolant and the voltage rises to 12 VDC after disconnecting lead 31A from the sender.
- If the DC voltage between lead 31A (+) and ground (-) remains constant with the sender submerged in coolant and then removed for at least 5-15 seconds.

Consider the main circuit board defective:

- If the DC voltage between lead 31A (+) and ground (-) remains at 7 VDC with and without connection to the sender.

6.12.2 3-Wire Sender

Function

The 3-wire low water level (LWL) sender is a resistance device. Lead 70 supplies 12 or 24 VDC (+) engine electrical supply voltage and lead N is a ground connection. The sender has the operating voltage stamped on the sender hex surface. Lead 31 is the output to the controller logic. The sender detects the absence of coolant at the probe tip and signals the condition of a short circuit to ground.

Lead 31 (blue) signals an open circuit to ground when the sender probe tip senses coolant present and signals a short circuit to ground when the sender probe tip senses no coolant present.

Testing

Use the following test procedure for the 3-wire low water level sender while the generator set operates. All leads must remain connected to the sender during the test.

Servicing the exhaust system. Hot parts can cause severe injury or death. Do not touch hot engine parts. The engine and exhaust system components become extremely hot during operation.

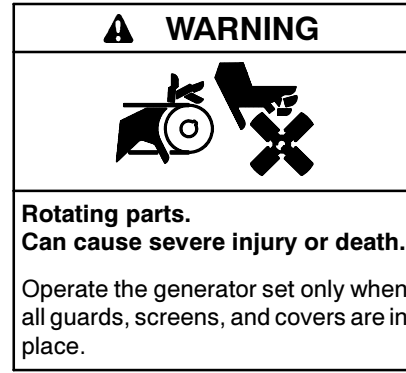

Servicing the generator set when it is operating. Exposed moving parts can cause severe injury or death. Keep hands, feet, hair, clothing, and test leads away from the belts and pulleys when the generator set is running. Replace guards, screens, and covers before operating the generator set.

LWL fault shutdown does not function during the first 30 seconds after startup. See Figure 6-19 for connections.

1. Measure the resistance between lead 31 and ground with the sender submerged in coolant. The ohmmeter indicates a high resistance reading with a functioning sender.
2. Measure the resistance between lead 31 and ground with the sender removed from the coolant for at least 5-15 seconds. The ohmmeter indicates a low resistance reading with a functioning sender.

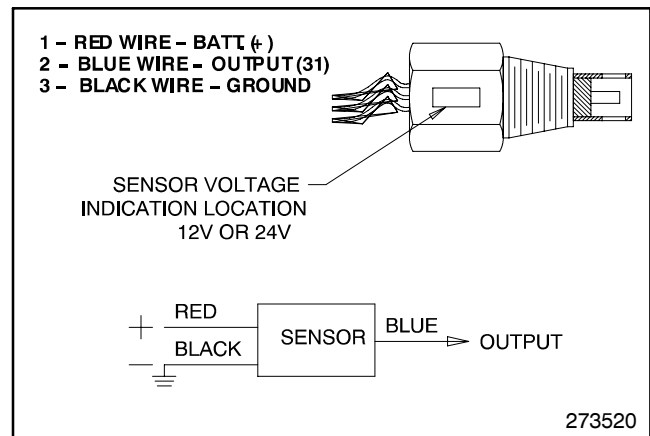

Figure 6-19 3-Wire Low Water Sender

Consider the sender defective:

- If the ohmmeter reading between lead 31 (blue) and ground remains constant with the sender submerged in coolant and then removed for at least 5-15 seconds.
- If the ohmmeter reading between lead 31 and ground indicates low resistance with the sender submerged in coolant.

6.13 Over/Underfrequency Relay with 16-Light Controller

6.13.1 Function and Connection

The over/underfrequency relay kit provides frequency protection when required. This kit mounts inside the controller with sensing connections to the CT terminal block and output to auxiliary shutdown at P1-15. Use the following procedure to set the shutdown points. See Figure 6-20.

Note: This over/underfrequency relay kit is not compatible with generator sets using electronic engine controls without a frequency adjustment provision.

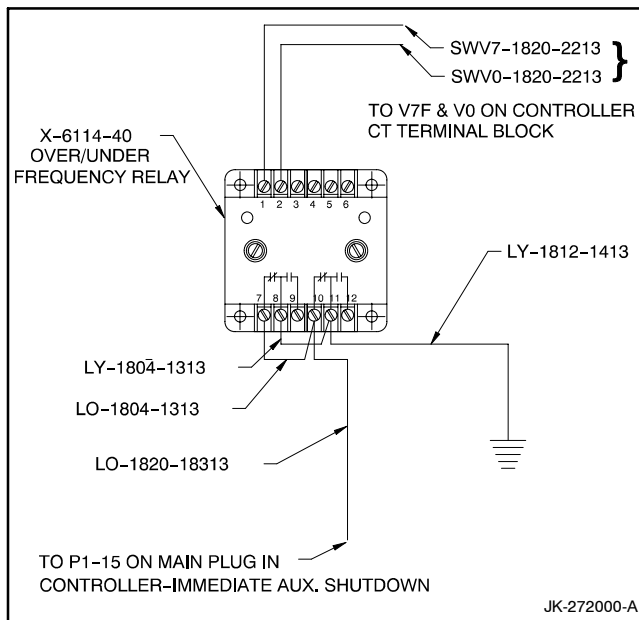

Figure 6-20 Over/Underfrequency Relay

6.13.2 Overfrequency Adjustment

1. Turn the overfrequency adjustment potentiometer fully clockwise (CW).
2. Place the generator set master switch to the RUN position to start the generator set.
3. Adjust governor. See engine operation manual, engine service manual, or the appropriate governor section of this manual for governor adjustment procedure. See Figure 6-21.

Specification Type	Overfrequency Hz	Underfrequency Hz
Standard	63	57
FAA	61.5	58.5

Figure 6-21 Over/Underfrequency Relay Specs

4. Slowly turn overfrequency potentiometer counterclockwise (CCW) until the LED starts flashing. After approximately 10 seconds, the generator set will shut down on auxiliary fault.
5. Place the generator set master switch to the OFF/RESET position to reset the controller.
6. Place the generator set master switch to the RUN position to start the generator set.
7. Readjust the governor to the desired frequency as required.
8. Place the generator set master switch to the OFF/RESET position to stop the generator set.

6.13.3 Underfrequency Adjustment

1. Turn underfrequency adjustment potentiometer fully clockwise (CW).
2. Place the generator set master switch to the RUN position to start the generator set.
3. Adjust governor. See engine operation, engine service manual, or the appropriate governor section of this manual for governor adjustment procedure. See Figure 6-21.
4. Slowly turn underfrequency potentiometer counterclockwise (CCW) until LED starts flashing. After approximately 10 seconds, the generator set will shut down on auxiliary fault.
5. Place the generator set master switch to the OFF/RESET position to reset the controller.
6. Place the generator set master switch to the RUN position to start the generator set.
7. Readjust the governor to the desired frequency as required.
8. Place the generator set master switch to the OFF/RESET position to stop the generator set.

6.14 Overvoltage Feature with 16-Light Controller

6.14.1 Function and Application

The GM28725 main circuit board on 16-light controllers integrates an overvoltage protection feature. The overvoltage feature provides overvoltage protection when output voltage is 15% above nominal voltage for more than one second. The factory-setting of 15% above nominal voltage is field-adjustable.

6.14.2 Testing and Adjustment

If the function of the overvoltage feature is questionable or requires adjustment from the factory setting, perform the following adjustment. See Figure 6-22.

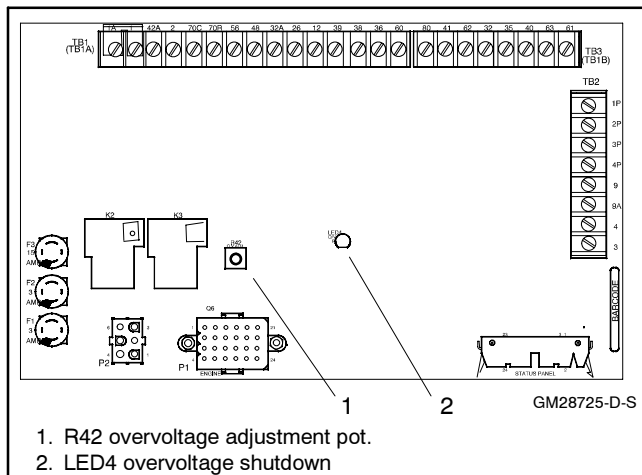
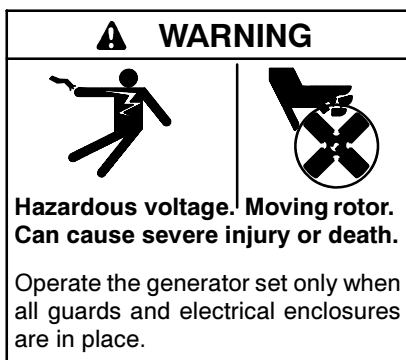

Figure 6-22 Overtolerance Adjustment Potentiometer R42



Disconnecting the electrical load. Hazardous voltage can cause severe injury or death. Disconnect the generator set from the load by opening the line circuit breaker or by disconnecting the generator set output leads from the transfer switch and heavily taping the ends of the leads. High voltage transferred to the load during testing may cause personal injury and equipment damage. Do not use the safeguard circuit breaker in place of the line circuit breaker. The safeguard circuit breaker does not disconnect the generator set from the load.

1. Disconnect the generator set from the load by opening the line circuit breaker (if equipped) or disconnecting and heavily taping the output leads (if not already done).
2. Determine the overvoltage shutdown value based on the user requirement. The factory setting is 15% above nominal line-to-neutral voltage with a maximum value of about 200 volts.
3. Remove the controller cover.

4. Place the generator set master switch in the RUN position to start the generator set.
5. Observe the controller AC voltmeter during this step because the voltage reading just prior to shutdown is the present overvoltage shutdown point.

Turn the voltage adjustment potentiometer on the controller front panel slowly CW until the generator set shuts down. See Figure 6-23. The circuit board LED4 lights and the controller auxiliary shutdown lamp lights.

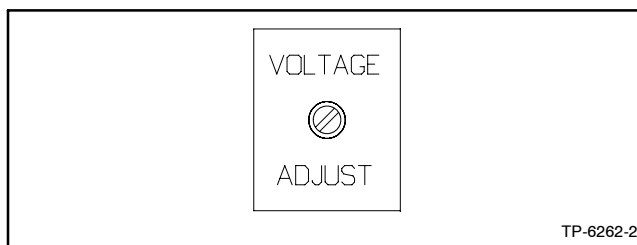

Figure 6-23 Controller Voltage Adjustment Potentiometer

6. If the present overvoltage shutdown point is correct for the application go to step 12.

If the present overvoltage shutdown point requires adjustment go to the next step.

7. Turn the controller circuit board R42 adjustment potentiometer fully CW.
8. Place the generator set master switch to the OFF/RESET position to reset the controller
9. Place the generator set master switch to the RUN position to start generator set.
10. Observe the controller AC voltmeter while turning the controller voltage adjustment potentiometer to the desired overvoltage shutdown point as determined in step 2.
11. Turn the controller circuit board R42 adjustment potentiometer slowly CCW until the generator set shuts down.
12. Turn the controller voltage adjustment potentiometer slightly CCW.

Note: Leaving the controller circuit board R42 adjustment potentiometer in the fully CW position effectively disables the overvoltage shutdown feature.

13. Place the generator set master switch to the OFF/RESET position.
14. Place the generator set master switch to the RUN position to start generator set.
15. Turn the voltage adjustment potentiometer as necessary for the controller AC voltmeter to match the voltage and phase as indicated by the selector switch.
16. Place the generator set master switch to the OFF/RESET position to stop the generator set.
17. Disconnect the battery, negative lead first.
18. Reconnect the generator set to the load by closing the line circuit breaker (if equipped) or reconnecting and heavily taping the output leads. See the wiring diagram manual for correct voltage configuration.
19. Reconnect the battery, negative lead last.

6.15 Reactive Droop Compensator

6.15.1 Function and Application

The reactive droop compensator kit distributes the generator set load evenly between two generator sets in parallel. If the kit is not factory installed, use the installation instructions supplied with the kit for field installation. Use the following procedure for reactive droop compensator adjustment.

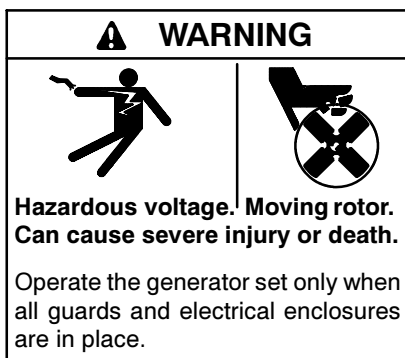

Short circuits. Hazardous voltage/current can cause severe injury or death. Short circuits can cause bodily injury and/or equipment damage. Do not contact electrical connections with tools or jewelry while making adjustments or repairs. Remove all jewelry before servicing the equipment.

6.15.2 Reactive Droop Compensator Adjustment Procedure

Parallel the two generator sets using the following procedure. Read and understand the entire procedure before beginning.

1. Remove any load connected to the generator set. Start each generator set by placing the generator set master switch in the RUN position.
2. Set the reactive droop compensator rheostat on generator set no. 1 to the minimum CCW setting. Record the rpm or frequency and voltage at 1/4 load steps to full load on unit no. 1.
3. Repeat step 2 for generator set no. 2.
4. Compare the readings and make final adjustments so that the voltage is within 1 volt at each load step and the speed is within three rpm or the frequency is within 0.1 Hz for each unit. Adjust the voltage using the controller or remote voltage adjustment potentiometer. Adjust the speed at the electronic governor or at the remote adjusting potentiometer.
5. Check the droop compensation on each unit as follows:
 - a. With unit no. 1 operating at the desired speed and voltage, apply an inductive load 1/2 to full load. Do not use a resistive load for this test.
 - b. Observe the voltmeter on unit no. 1 with the reactive droop compensator rheostat set at minimum. As the rheostat is turned CW, the voltmeter should show a decrease in voltage. If observing a larger voltage, stop the generator sets and reverse the direction of the generator set load line through the current transformer or reverse the transformer leads on unit no. 1.
 - c. Restart the generator sets and recheck the droop on unit no. 1.
 - d. Set the reactive droop compensator rheostat to a value at approximately 4% below rated voltage at full load. As an example, the voltage droops (decreases) 19.2 volts on a 480-volt system at full load or 9.6 volts at 1/2 load. Use the following formula for loads other than full load:

$$\text{Rated Voltage} \times 0.04 \times \text{Actual Load (expressed as a \% of full load)} = \text{Voltage Droop}$$

Note: With full load 0.8 power factor, a droop of 3%–5% should be adequate for paralleling.
6. Repeat step 5 for generator set no. 2. Adjust unit no. 2 where the voltage droop is equal and at the same point as on unit no. 1. The two units share reactive currents proportionately after correctly performing this procedure.

- If reactive load is not available, go to Section 6.15.3, Reactive Droop Compensator Alternate Adjustment Procedure. If reactive load is available, go to Section 6.15.4, Testing.

6.15.3 Reactive Droop Compensator Alternate Adjustment Procedure

Initially calibrate each generator set using the following procedure.

- Turn the reactive droop compensator rheostat on generator set no. 1 to the minimum setting.
- Remove the controller cover. Move the voltage sensing lead from V7 to V9 at the AC fuse terminal block.
- Remove any load connected to the generator set.
- Start the generator set by placing the generator master switch in the RUN position.
- Use the controller or remote voltage adjusting potentiometer on each generator set to fine adjust voltage as necessary.
- Apply resistive load (1.0 power factor) until reaching rated current.
- Adjust the reactive droop compensator rheostat to achieve a 4% droop (decrease) in voltage.
- Remove the resistive load.
- Stop the generator set by placing the generator master switch in the OFF position.
- Return the voltage sensing lead from V9 to V7 at the AC fuse terminal block.
- Replace the controller cover.
- Repeat steps 1-11 for generator set no. 2.

6.15.4 Testing

Use the following procedure to check that the generator sets share the reactive load proportionately.

- Parallel the units at 1/2 to full load. Verify that each unit carries equal kW load or a load proportional to its capacity using the wattmeter readings. If load unbalance exists, adjust and recheck the electronic governor throttle control to correctly balance loading. Engine speed determines load sharing ability.

- With the load balanced, check the ammeters for equal current or proportional according to capacity. If the currents are incorrect, adjust the reactive droop compensator rheostat reducing the current of the unit with the highest reading. Reduce the current to an equal division or proportionately.
- Stop each generator set by placing the generator master switch in the OFF position.

Note: Step 1 balances the load using the electronic governor and step 2 balances the current using the reactive droop compensator. Consider these settings optimum for parallel operation.

Note: Voltage must droop (decrease) on lagging power factor loads (inductive loads). A small change in voltage is acceptable on unity power factor loads (resistive loads).

6.16 Remote Serial Annunciator

The following information summarizes the setup items when troubleshooting the remote serial annunciator (RSA). Refer to the RSA installation instructions for operation and function. See Figure 6-24 for RSA front panel illustration. See Section 6.17, Communication Module Kit and Gauge Driver Circuit Board.

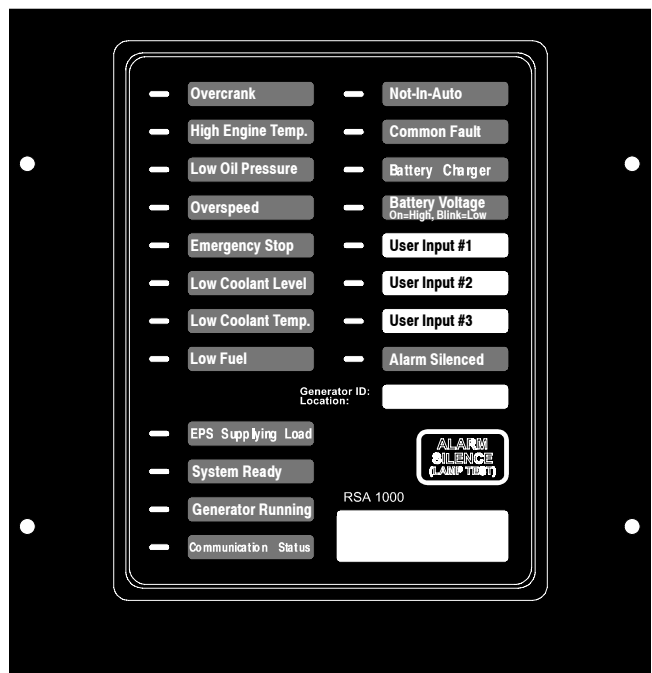

Figure 6-24 Remote Serial Annunciator (RSA)

6.16.3 16-Light Controller Configuration

The RSA requires a controller with a MODBUS® address #1 and a baud rate of 19200. The 16-light controller baud rate is fixed at 19200.

Set controller MODBUS® address to #1 by placing DIP switches 6, 7, and 8 to open position. See Figure 6-28.

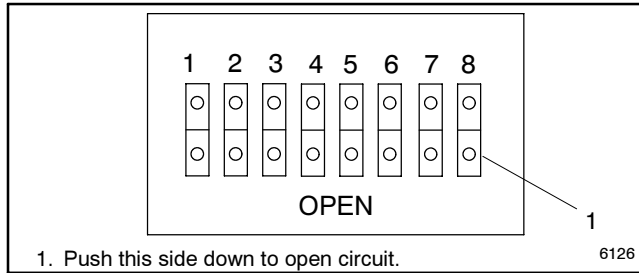

Figure 6-28 16-Light Controller DIP Switches

Note: After setting DIP switches to the generator set application, be sure to *power down* and then *power up* the controller. Either disconnect the battery and then reconnect the battery of the generator set, use the prime power switch (if equipped), or remove and then replace the F2 controller fuse. The controller will NOT acknowledge the DIP switch change until after generator set controller is *powered up*.

6.16.4 550 Controller Configuration

The RSA requires a controller with a MODBUS® address #1 and a baud rate of 19200.

Note: Refer to installation instructions furnished with RSA.

6.16.5 Service Disassembly

Should it be necessary to separate the RSA annunciator panel from the RSA circuit board for servicing and/or replacement, first unlock the P28 connector on the RSA circuit board *before* removing the ribbon connector to avoid circuit board damage. See Figure 6-29. Carefully slide the locking device (white plastic) outward approximately 1.5 mm (1/16 in.).

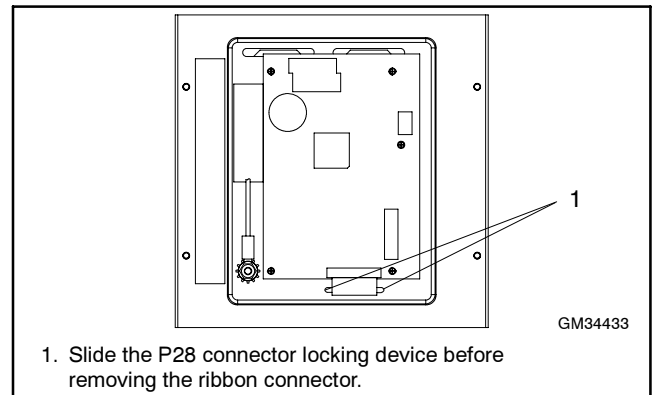

Figure 6-29 RSA Annunciator Panel and RSA Circuit Board (back view of front panel)

6.17 Communication Module Kit and Gauge Driver Circuit Board

When a remote serial annunciator (RSA) is connected to a Microprocessor-Plus controller, a communication module circuit board is required. See Figure 6-30 for location and connection.

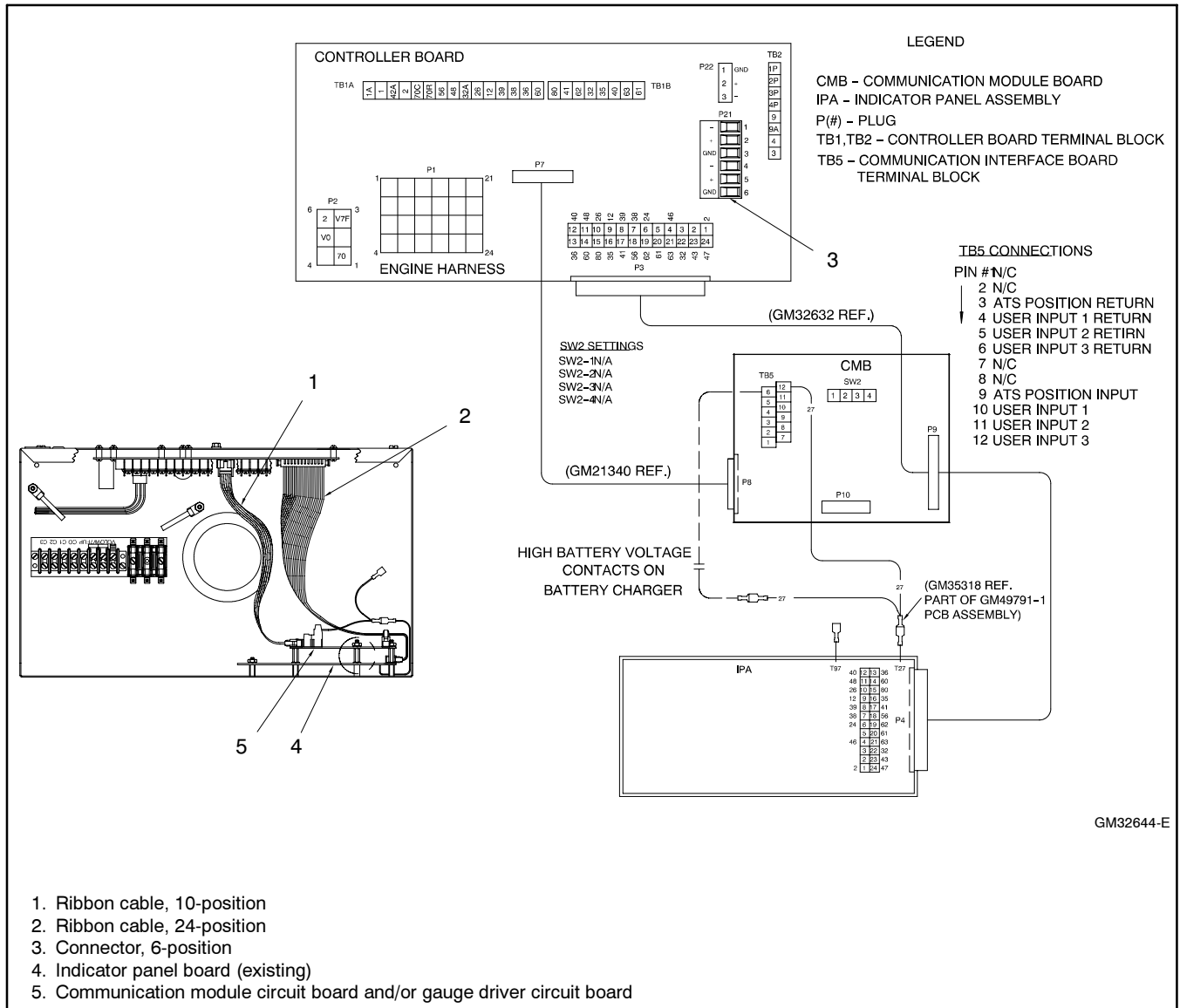

Figure 6-30 Communication Module Circuit Board Location and Connection

6.17.1 Communication Modules (Circuit Board) Versions

GM47242 Circuit Board. This is the communication module for all models and is superseded by GM49791-1. See Figure 6-31.

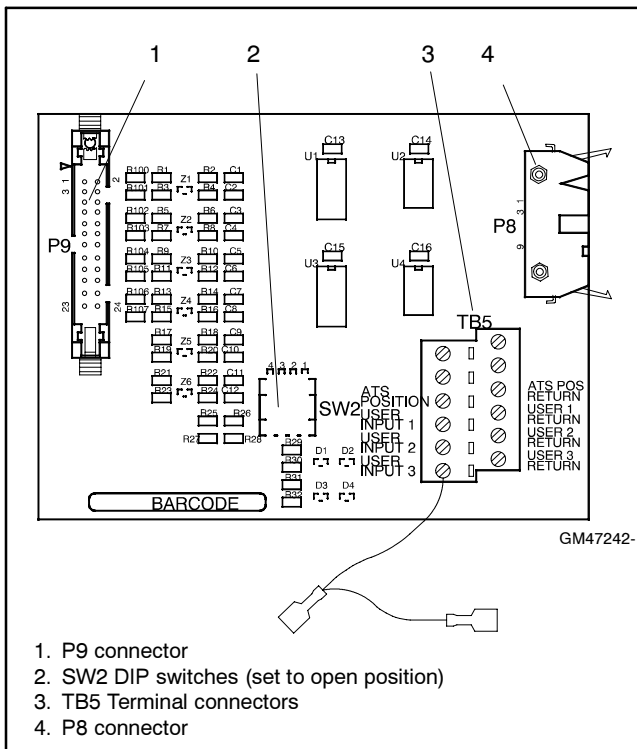

Figure 6-31 Communication Circuit Board GM47242

GM49791-1 Circuit Board. This is the communication module for all models and includes the gauge driver provision needed for some models. Requires application software version 1.23 or higher. See Figure 6-32.

6.17.2 Circuit Board Views

Figure 6-31 and Figure 6-32 show the differences between the communication circuit boards. The SW2 DIP switches should be set to the open position unless the instructions supplied with the kit indicate another configuration.

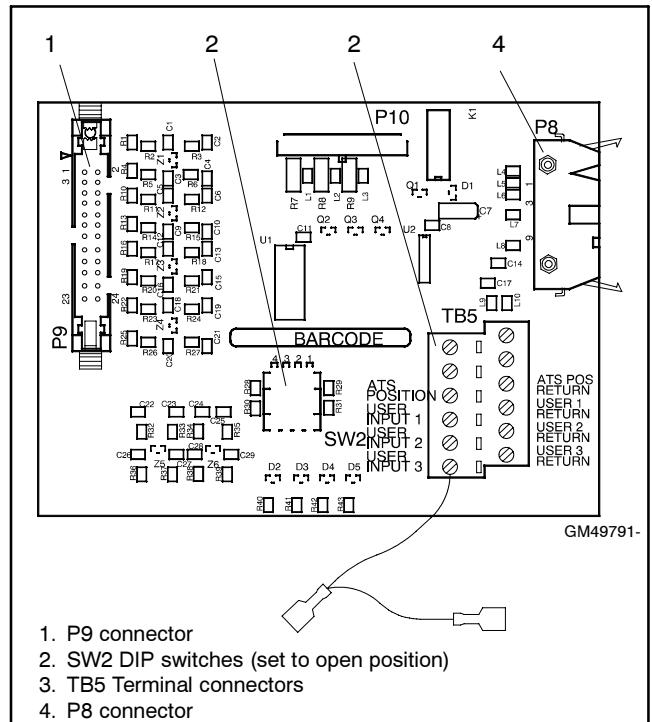

Figure 6-32 Communication Circuit Board GM49791-1

6.18 Speed Sensor

The speed sensor is found on permanent magnet (PM) and wound field (WF) alternators. The speed sensor is located on the alternator end bracket. Several styles are used, but they are all functionally the same.

Follow the procedure outlined below to determine if the speed sensor (overspeed fault) is emitting a signal.

6.18.1 Speed Sensor Test with Generator Set Running

1. With the generator set master switch in the OFF/RESET position, connect a DC voltmeter between the positive (+) lead (wire 24) at the speed sensor and the ground (wire 2). The voltmeter should read approximately 8–12 volts DC.
2. Place the generator set master switch in the RUN position to start the generator set.
3. With the generator set running, connect a DC voltmeter negative probe to the 0 terminal (wire 16—white) on the speed sensor. Place the voltmeter positive probe on the positive (+) terminal (wire 24—red). The voltmeter should indicate approximately 7–12 volts DC.

During the test, the controller leads must remain connected to the speed sensor terminals. Slide leads from speed sensor terminals only enough to expose connection for test leads. Do not disconnect the leads.

4. Place the generator set master switch in the OFF/RESET position to stop the generator set.
5. If the speed sensor is emitting a signal, check the continuity of the speed sensor leads (wires 2, 16, and 24) between the controller P1 connector and the lead terminals at the speed sensor.

If the speed sensor is not emitting a signal, go to Section 6.18.2, Speed Sensor Test with Separate 12 VDC Source.

6.18.2 Speed Sensor Test with Separate 12 VDC Source

Test the speed sensor using the following procedure. It is NOT necessary to remove the speed sensor from the end bracket.

1. Place the generator set master switch in the OFF/RESET position.
2. Disconnect the speed sensor leads.
3. Connect speed sensor, DC voltmeter, and DC voltage source as shown in Figure 6-33.

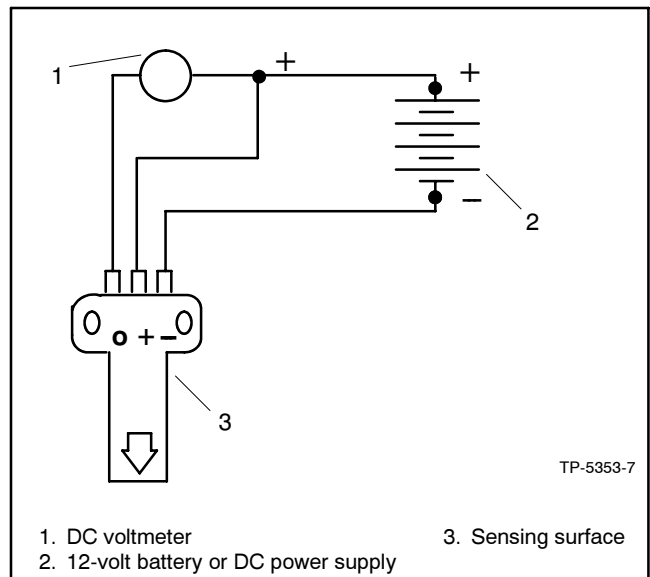

Figure 6-33 Speed Sensor Test

4. Touch sensing surface with a flat piece of iron or steel at least 4.1 cm (1/4 cu. in.) in size.
5. The DC voltmeter test reading should equal the source voltage, approximately 12 VDC.
6. Remove the iron or steel piece from the sensing surface and observe a voltmeter reading of 0 VDC.
7. If the speed sensor passes steps 5 and 6, the speed sensor is functional. Replace the speed sensor if it fails the test.
8. Connect the speed sensor leads and adjust the air gap. See Figure 6-34.

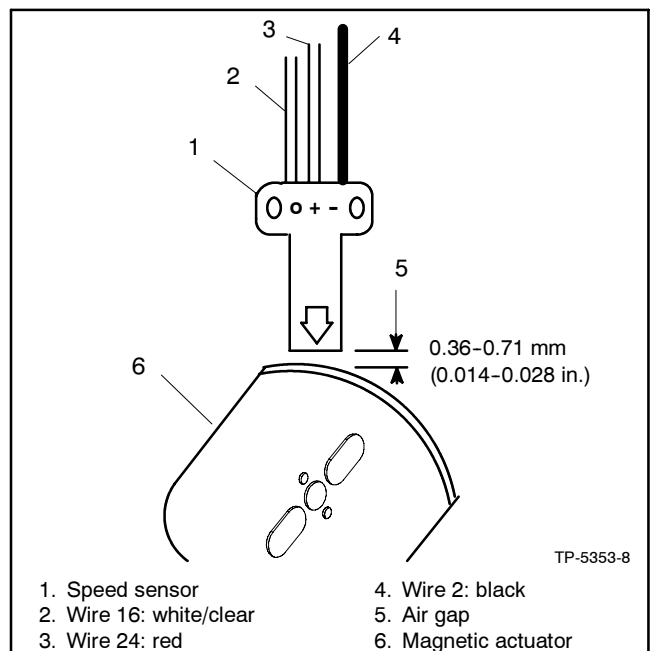

Figure 6-34 Speed Sensor Air Gap

6.19 Time Delay Relay (135-275 kW DDC-Powered Gas Models)

The 135-275 kW Detroit Diesel Series 50/60 gas models have a time delay to OFF relay (TDR) and a 3-pole relay (TDR1) providing battery power to ignition coils (P29) and throttle/ECM circuit (P30) during engine cranking and running. Battery power is maintained to P29 and P30 connectors for 10-15 seconds after the generator set stop switch activates. This additional time allows the engine to burn residual fuel from the system after the fuel valve closes preventing engine backfire. See Figure 6-35.

6.19.1 Sequence of Operation, Engine Cranking and Running

- The generator set run (start) circuit is activated by local or remote starting mode.
- Wire 71 energizes the TDR relay.
- TDR normally open contacts 9-6 close to energize TDR1 relay and TDR2 relay (wire 70T).
- TDR normally open contacts 7-4 close to enable function of the anticipatory hot coolant temperature switch (40A).
- TDR1 relay normally open contacts close. Contacts 7-4 close to energize P29-B (wire 440), contacts 8-5 close to energize P30-B (wire 121), and contacts 9-6 close to energize P30-D (wire 122).
- TDR2 relay normally open contacts 30-87 close to energize P27-B3 (wire 439) and to bypass toggle switch SW1-2 on engine light/diagnostic box and provide power to ECM.
- TDR2 relay normally closed contacts 30-87A open to toggle switch SW1-1 (wire 400) on engine light/diagnostic box.

6.19.2 Sequence of Operation, Engine Shutdown

- Generator set stop circuit is activated by local or remote stopping mode.
- Power to time delay to OFF relay (TDR) is removed and TDR times out 10-15 seconds and TDR deenergizes.
- TDR normally open contact 9-6 open to deenergize TDR1 relay and TDR2 relay (wire 70T).
- TDR normally open contacts 7-4 open to disable function of the anticipatory hot coolant temperature switch (40A).
- TDR1 relay normally open contacts open. Contacts 7-4 open to deenergize P29-B (wire 440), contacts 8-5 open to deenergize P30-B (wire 121), and contacts 9-6 open to deenergize P30-D (wire 122).
- TDR2 relay normally open contacts 30-87 open to deenergize P27-B3 (wire 439) and to enable toggle switch SW1-2 on engine light/diagnostic box and to disconnect power to ECM. This contact provides power to the ECM when operating the engine light/diagnostic box.
- TDR2 relay normally closed contacts 30-87A close to toggle switch SW1-1 (wire 400) on engine light/diagnostic box.

Notes

Section 7 Gas Fuel Systems

This section describes various gas fuel systems and contains troubleshooting information. Fuel system information provided in this section relates to fuel configurations not addressed in the engine operation manual and/or engine service manual.

7.1 Fuel System Concepts

7.1.1 Gas Fuel System Concept

The gas fuel system utilizes a fuel valve with solenoid to control the fuel flow to the fuel regulator. The generator-mounted regulator reduces fuel pressure as fuel passes to the gas mixer. See Figure 7-1. The gas mixer controls the ratio of fuel to air under varying load and speed conditions. Because the gas mixer receives fuel in a gaseous state, it does not have to perform fuel vaporization. When switching from natural gas to LP gas or LP gas to natural gas, **VERIFY THAT ENGINE SPEED MEETS SPECIFICATIONS.** The governor should compensate for different types of fuel and maintain rated engine speed. See Section 7.4, Carburetor/Gas Mixer Adjustment, for fuel adjustment when changing fuel type. If engine speed is incorrect, refer to the governor information to make adjustments.

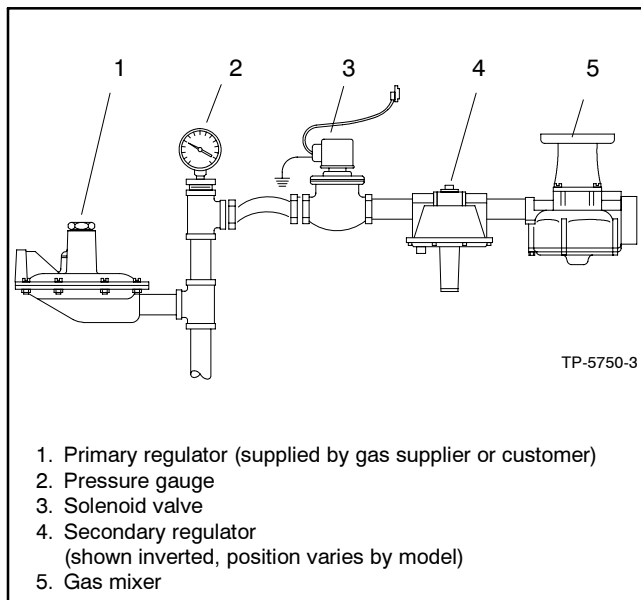

Figure 7-1 Fuel Regulator and Valve, Typical

7.1.2 LP Liquid Withdrawal Fuel System Concept

With the LP liquid withdrawal fuel system, the tank directs liquid LP fuel under high pressure to a vaporizer. The vaporizer converts the liquid fuel to a gaseous state before sending it to the gas mixer. The system also includes a fuel valve which shuts off the fuel flow when the engine stops. See Figure 7-2.

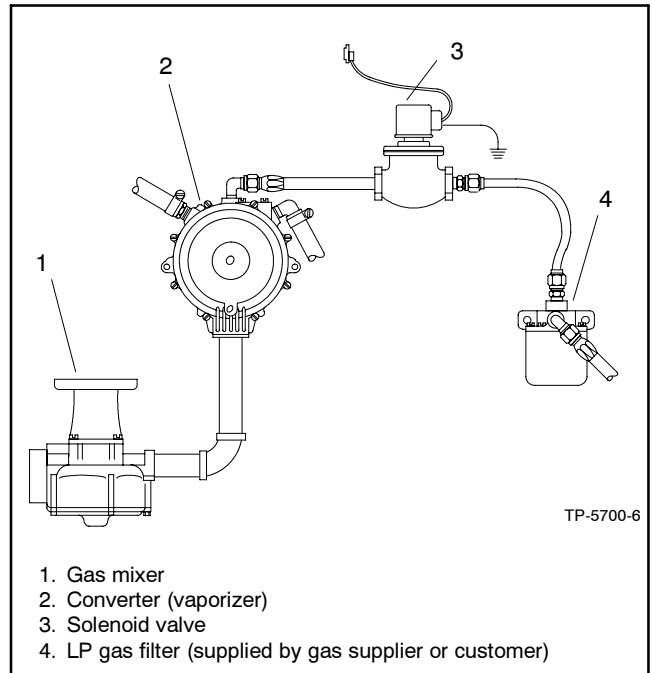

Figure 7-2 LP Liquid Withdrawal System, Typical

7.2 LP Gas/Natural Gas Conversion

7.2.1 Straight Gas Fuel System

Most models operate on either LP gas or natural gas fuel by performing the fuel conversion procedure. Some models require a different fuel kit when changing gas fuels.

Fuel conversion may decrease generator set output and affect exhaust emissions. Refer to the generator set spec sheet for ratings.

By performing the fuel conversion, some models can operate on either natural gas or LP gas fuel. The conversion may require addition/removal of the fuel regulator spring and retainer. See Figure 7-3 for specific information regarding conversion options. See Section 7.7, Engine Ignition Timing, for engine timing information.

Generator Set Model, kW	Engine	Spring Position		Additional Adjustments and Comments
		Natural Gas	LP Gas	
20	Ford LRG-425	In	Out	See Section 7.7
30-125	GM 3.0 L, 4.3 L, 5.0 L, 5.7 L, 8.1 L, 8.1 L Turbo	In	Out	Adjust fuel mixture and timing. See Sections 7.8, 7.9, 7.10, and 7.11
135-180	Detroit Diesel Series 50	—	—	Natural gas only
200-275	Detroit Diesel Series 60	—	—	Natural gas only
400-800	Waukesha	—	—	Natural gas only

* Some models require new fuel kits for fuel conversion.

Figure 7-3 Fuel Conversion Data

7.2.2 Gas Fuel Conversion Procedure

- Place the generator set master switch to the OFF/RESET position.

- Natural Gas to LP Fuel.** Use the following steps to remove the internal spring from the fuel regulator:

Note: Not all fuel regulators require spring and retainer removal for fuel conversion. A hang tag on the fuel regulator identifies the conversion procedure.

- Remove the fuel regulator cover plug. See Figure 7-4.
- Remove the adjustment screw and spring from the fuel regulator. Save the adjustment screw and spring for possible conversion back to natural gas.
- Reinstall the cover plug.
- Go to step 4.

- LP Fuel to Natural Gas.** Use the following steps to remove the internal spring from the fuel regulator:

Note: Not all fuel regulators require spring and retainer installation for fuel conversion. A hang tag on the fuel regulator identifies the conversion procedure.

- Use the following steps to convert the generator set to natural gas:

- Remove the fuel regulator cover plug. See Figure 7-4.
 - Insert the spring and adjustment screw.
 - Go to step 4.
- Connect a manometer to check the fuel supply pressure on the gas mixer side of the regulator downstream of any fuel system equipment accessories. The recommended fuel supply pressures are shown on the generator set spec sheet.
 - Connect a load bank rated for the full standby nameplate rating of the generator set.
 - Turn off the load bank.
 - Place the generator set master switch to the RUN position to start the generator set.
 - Allow the generator set to reach operating temperature.
 - Gradually apply load using the load bank until the unit is running at full load. The generator set should be running at full load when making adjustments to provide optimum performance.
 - Adjust the fuel supply pressure with the generator set running at full load. Rotate the adjustment screw on the fuel regulator until the pressure indicated by the manometer matches the specified pressure. Use the lower pressure value if the generator set still provides good response and full power. Lower-than-specified pressures may result in poor response to load changes or lack of power.

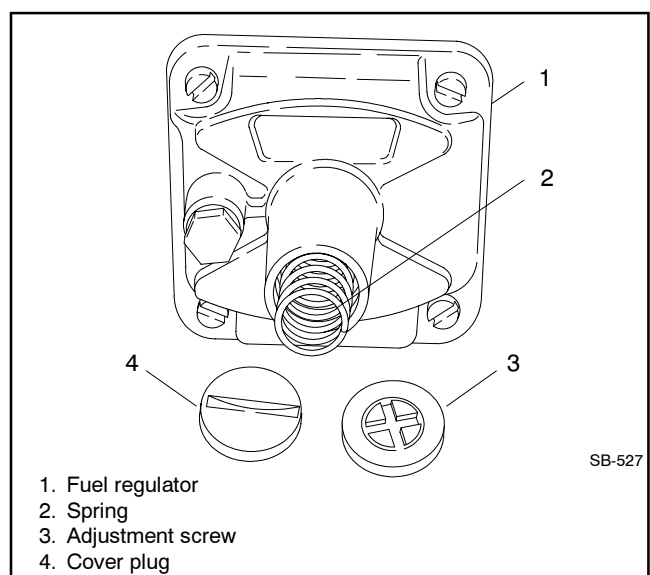

Figure 7-4 Fuel Regulator, Typical

11. Place the generator set master switch in the OFF/RESET position to stop the generator set.
12. Reinstall the cover plug on the fuel regulator.
13. Disconnect the load bank from the generator set.
14. Disconnect the manometer from the fuel system.

7.3 Fuel System Changeover Kits

Some models offer fuel system changeover kits providing dual fuel options.

7.3.1 Automatic Changeover Theory of Operation

Automatic changeover fuel system kit provides automatic changeover from natural gas to LP gas vapor or from LP gas vapor to natural gas. The primary and secondary fuels each have a secondary fuel regulator and a fuel valve. See Figure 7-5.

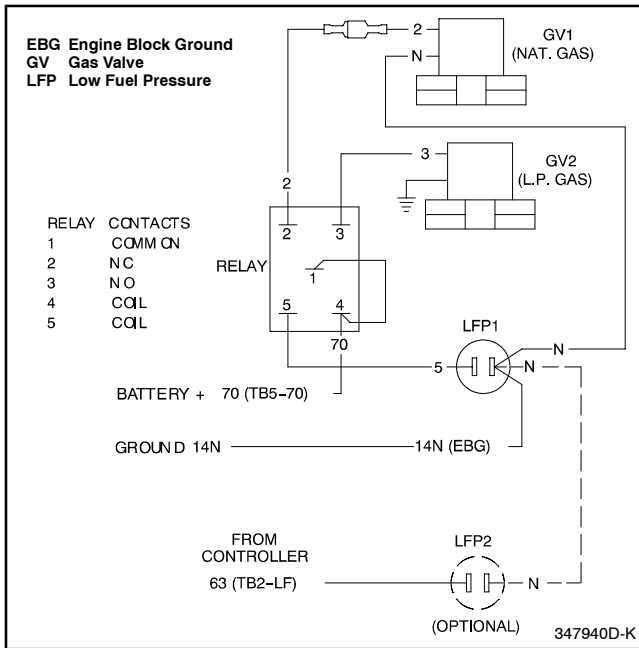

Figure 7-5 Automatic Changeover Wiring Diagram, Typical

Typically the primary fuel is natural gas; the backup fuel is LP gas vapor. The primary valve opens during generator set starting and running and the secondary fuel valve remains closed. The primary fuel line has a pressure switch in series with a control relay connected to the start/run circuit (wire 70).

When the primary fuel pressure drops below 0.87–1.0 kPa (0.13–0.14 psi), the control relay opens the secondary fuel valve and the primary fuel valve closes.

When the primary fuel pressure rises above 0.87–1.0 kPa (0.13–0.14 psi), the control relay opens the primary fuel valve and closes the secondary fuel valve.

See Section 6.11, Low Fuel Pressure (Vacuum) Switches, for testing the switch.

7.3.2 Manual Changeover Theory of Operation

(20 kW, Ford LRG-425 Powered only)

Manual changeover fuel system provides manual changeover from gasoline to natural gas or LP gas vapor, or natural gas or LP gas vapor to gasoline.

Typically the combination system utilizes gas as the primary, preferred fuel and gasoline in emergencies. Should the gas fuel be unavailable (LP gas vapor tank empty or a natural gas utility disruption), the gasoline fuel becomes the primary fuel.

A toggle switch on the generator set controls the fuel choice and energizes either a fuel solenoid and electric fuel pump for gasoline or a fuel valve for the gas fuel. Pull out the control cable for gasoline fuel and push in the control cable for gas fuel.

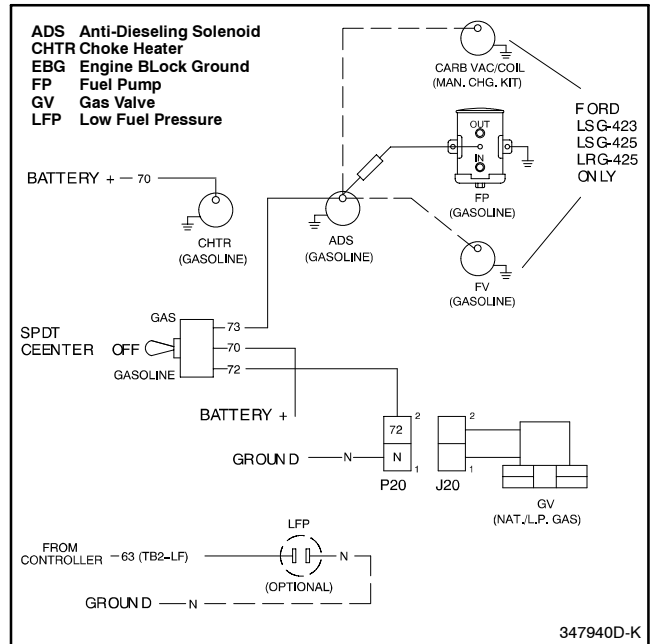

Figure 7-6 Manual Changeover Wiring Diagram, Typical

7.4 Carburetor/Gas Mixer Adjustment

Before adjusting the carburetor, verify that the engine compression and ignition system meet specifications. Do not adjust the carburetor to compensate for other engine disorders. If the engine speed is incorrect, adjust the governor to achieve 1800 rpm (at 60 Hz) or 1500 rpm (at 50 Hz). Adjust the mixer if governor adjustment alone does not result in the desired engine speed.

Adjusting the carburetor affects the engine air/fuel mixture. Routine carburetor adjustment is not necessary. However, if the carburetor is removed or tampered with, the mixer may require adjustment to achieve optimum engine performance. Some engines have sealed mixers that are not adjustable.

7.4.1 Gasoline Carburetor Adjustment Procedure

Refer to the engine operation manual and/or engine service manual for gasoline carburetor adjustment information. Otherwise, use the following procedure to adjust gasoline carburetor fuel system.

1. With generator set stopped, turn the main fuel and idle mixture (if used) adjusting needles in (clockwise) until they bottom lightly. Do not force.
2. **Preliminary Setting:** Turn main fuel adjusting needle out (counterclockwise) 1 1/2-2 1/2 turns. Turn the idle mixture adjusting needle (if used) out (counterclockwise) 1/2-1 turn. See Figure 7-7.

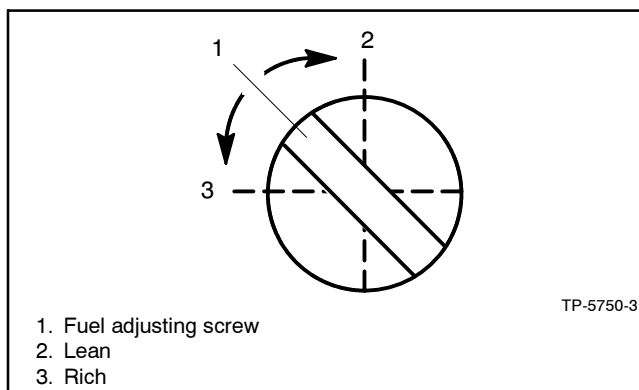

Figure 7-7 Fuel Mixture Adjustment, Typical

3. Place the generator set master switch to the RUN position to start generator set. Run at approximately half load. The engine must be warm before making final settings.
4. Apply 3/4 to full load to generator set.

5. **Final Setting:** Rotate the main fuel adjusting needle until the engine runs smoothly at the leanest setting and then turn the main fuel adjusting needle out (counterclockwise) an additional 1/4 turn.
6. Place the generator set master switch to the OFF/RESET position to stop the generator set.

7.4.2 Gas Mixer Adjustment Procedure (Typical)

Use the following procedure to adjust the gas mixer.

1. Place the generator set in the RUN position to start the generator set. Run it at approximately half load.
2. Adjust the engine fuel mixture screw (Figure 7-7) until the engine runs smoothly.
3. Apply varying loads and readjust the mixer as necessary to achieve smooth engine performance at all load levels.
4. Place the generator set master switch to the OFF/RESET position to stop the generator set.

7.5 Fuel System Maintenance

7.5.1 Gasoline Models (20 kW, Ford LRG-425 Powered only)

Clean or replace the fuel filter at the specified interval. Service the filters more frequently if the engine runs roughly, as a clogged fuel filter can cause rough engine operation. Some models use a disposable inline fuel filter, which must be replaced. Other models have a fuel pump with an integral fuel filter that requires cleaning at the specified interval.

7.5.2 Gaseous Models

Routine service items include draining water/sediment from piping at petcock or pipe end cap, checking for fuel leakage at pipe connections, checking flexible sections for cracking or chafing, and keeping components clean including fuel regulator vent holes.

A grease or wax residue tends to accumulate in the piping and fuel regulators over time. If fuel system problems persist, disassemble the fuel system components and check for residue buildup. Remove any residue with a brush and mild detergent.

Additional service for LP liquid withdrawal systems include servicing the gas supplier or customer-supplied LP gas filter.

Some models use an optional gas strainer with a reusable filter element which requires cleaning at the specified interval. See Figure 7-8 and use the following procedure to clean the gas strainer.

1. Close the fuel supply valve, if not already closed.
2. Use a wrench and remove the pipe plug.
3. Remove the filter and clean in solvent and air dry. Inspect the screen for damage and replace if damage is noted.
4. Reinstall the filter element and pipe plug.

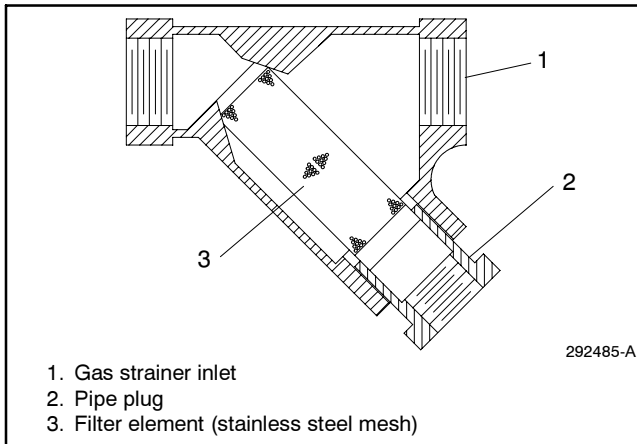

Figure 7-8 Gas Strainer Filter Element

7.6 Fuel System Troubleshooting

There are several items which affect engine performance. The following lists components that require inspection, adjustment, and/or possible replacement. Use this list as a guideline for troubleshooting.

Most problems with gas fuels involve either fuel pressure or fuel regulator function. Basic troubleshooting consists of verifying fuel pressures and checking each fuel system component.

Check the following items:

- Check primary fuel regulator outlet pressure (gas models). This is the line pressure.
- Check fuel shutoff inlet pressure (gas models).

- Check secondary fuel regulator inlet pressure (gas models).
- Check fuel inlet pressure at the gas mixer.
- Check for dirt buildup on the LP liquid withdrawal vaporizer fins. Check for generator set air flow blockage preventing heat absorption by the vaporizer (LP liquid withdrawal models).
- Perform fuel system maintenance if necessary. See Section 7.5, Fuel System Maintenance.

7.7 Engine Ignition Timing Specifications (10-100 kW Ford-Powered Models)

Adapted from Service Bulletin SB-575.

This section summarizes engine ignition timing specifications for most Ford-powered generator sets including discontinued generator set models and fuel system options.

Engine ignition timing information for all fuels and fuel combinations is generally not listed in the engine operation and service manuals.

Figure 7-9 provides the engine and/or generator set manufacturer's ignition timing recommendations for optimum engine performance at sea level.

Before adjusting the engine ignition timing on distributor ignition systems, be sure the fuel meets the engine manufacturer's specifications indicated in the engine operation manual. If engine knocking or detonation occurs, reduce engine ignition timing at 1-2 degree increments until the engine knocking stops and the engine operates smoothly.

Most distributorless ignition systems are factory-set and not adjustable. See Figure 7-9 for distributorless ignition timing specifications and Figure 7-10 to confirm the factory lead connection configurations.

Generator Set Model, kW	Ford Engine Model	Ignition Timing at Before Top Dead Center (BTDC) by Fuel Type					
		Natural Gas	LP Gas	Natural Gas/LP Gas Combination	Gasoline/Natural Gas Combination	Gasoline/LP Gas Combination	Gasoline
Breaker Point Ignition							
10	VSG-411	11°	11°	11°	—	—	—
20	LSG-423	30°	25°	25°	30°	25°	30°
30	LSG-423 Turbocharged	N/A	20°	20°	—	—	—
30	CSG-649	32°	30°	30°	32°	30°	32°
33						28°	
35							
45	LSG-875	36°	36°	36°	36°	36°	36°
50							
60							
70	LSG-875 Turbocharged	34°	34°	34°	34°	34°	34°
80							
100							
Electronic Breakerless Ignition							
17	LSG-423	30°	30°	30°	—	—	—
18			25°	25°	30°	30°	30°
20						25°	30°
30	LSG-423 Turbocharged	N/A	20°	20°	—	—	—
30	CSG-649	28°	20°	20°	28°	20°	28°
33						28°	
35							
45	LSG-875	36°	36°	36°	36°	36°	36°
40							
50							
60	LSG-875 Turbocharged	34°	34°	34°	—	—	—
70							
80							
100	LSG-875 Turbocharged	34°	22°	22°	—	—	—
80							
100							
Electronic Distributorless Ignition							
10	VSG-411	Distributorless ignition systems are factory-set and not adjustable.					
10	VSG-413						
12							
17	VSG-413, 3600 rpm						
18	LRG-423	34°	26°	26°	—	—	—
18	LRG-425	29°	24°	24°	—	—	—
20	LRG-423	34°	26°	26°	20°	20°	20°
20	LRG-425	29°	24°	24°	11°	11°	11°
22	VSG-413, 3600 rpm	Distributorless ignition systems are factory-set and not adjustable.					
<p>— Fuel system not available</p> <p>N/A Data not available</p> <p>Note: All values apply to 60 Hz models using 1800 rpm engines unless noted as 3600 rpm. Contact the Service Department for 50 Hz engine ignition timing specifications.</p> <p>Note: The LP gas data above applies to LP gas vapor and LP liquid withdrawal fuel systems.</p>							

Figure 7-9 Engine Ignition Timing Specifications

Generator Set Model, kW	Ford Engine Model	Factory Lead Connection Configuration by Fuel Type					
		Natural Gas	LP Gas	Nat. Gas/ LP Gas Combination	Gasoline/ Natural Gas Combination	Gasoline/ LP Gas Combination	Gasoline
18 kW (See Figure 7-11)	LRG-423	70—Red/Green 7N—Black 7N—Yellow/Black from pins #6 & #7	70—Red/Green 7N—Black 7N—Yellow/Black from pin #6	70—Red/Green 7N—Black 7N—Yellow/Black from pin #6	—	—	—
18 kW (See Figure 7-12)	LRG-425	70—Red/Green 70—Yellow/Black 7N—Black 7N—Brown/White	70—Red/Green 7N—Black 7N—Brown/White	70—Red/Green 7N—Black 7N—Brown/White	—	—	—
20 kW (See Figure 7-13)	LRG-423	70—Red/Green 7N—Black 7N—Yellow/Black from pins #6 & #7	70—Red/Green 7N—Black 7N—Yellow/Black from pin #6	70—Red/Green 7N—Black 7N—Yellow/Black from pin #6	70—Red/Green 7N—Black Maintain Yellow/ Black wire loop	70—Red/Green 7N—Black Maintain Yellow/ Black wire loop	70—Red/Green 7N—Black Maintain Yellow/ Black wire loop
20 kW (See Figure 7-14)	LRG-425	70—Red/Green 70—Yellow/Black 7N—Black 7N—Brown/White	70—Red/Green 7N—Black 7N—Brown/White	70—Red/Green 7N—Black 7N—Brown/White	70—Red/Green 7N—Black	70—Red/Green 7N—Black	70—Red/Green 7N—Black

— Fuel system not available

Note: All colored leads are part of the ignition module harness. Tape to insulate the exposed end of all unused leads.

Note: Lead 70 is 12 volts DC positive (+) and energized during engine run. Lead 7N is the ground connection.

Note: LRG-425 engines only
Brown/White lead connects to lead 7N for gas fuels only.
Yellow/Black advances timing 5° when connected to lead 70.
Yellow/Black retards timing 3° when connected to lead 7N.

Note: The LP gas data above applies to LP gas vapor and LP liquid withdrawal fuel systems.

Figure 7-10 Factory Lead Connection Configurations

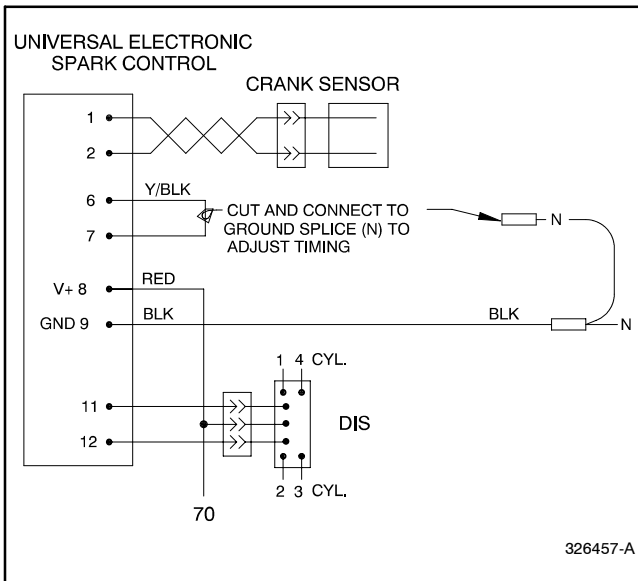

Figure 7-11 18 kW with LRG-423 Engine

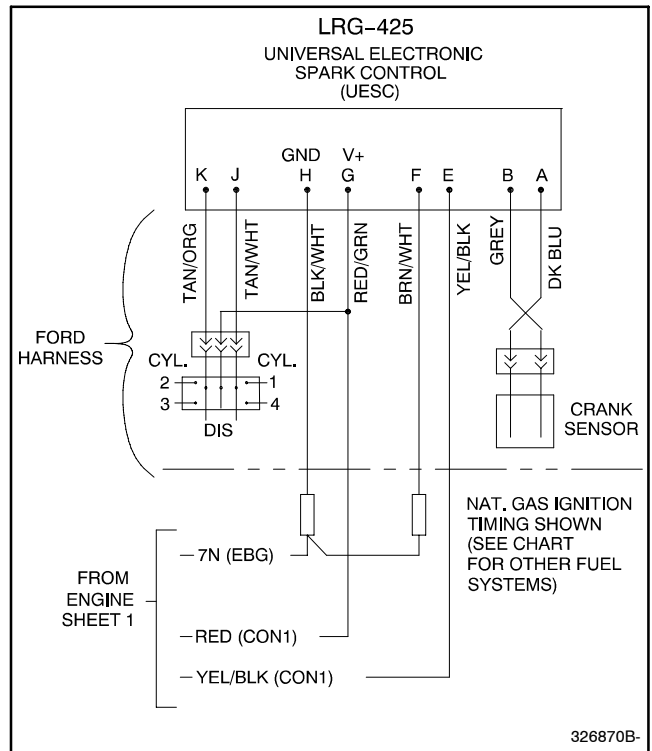

Figure 7-12 18 kW with LRG-425 Engine

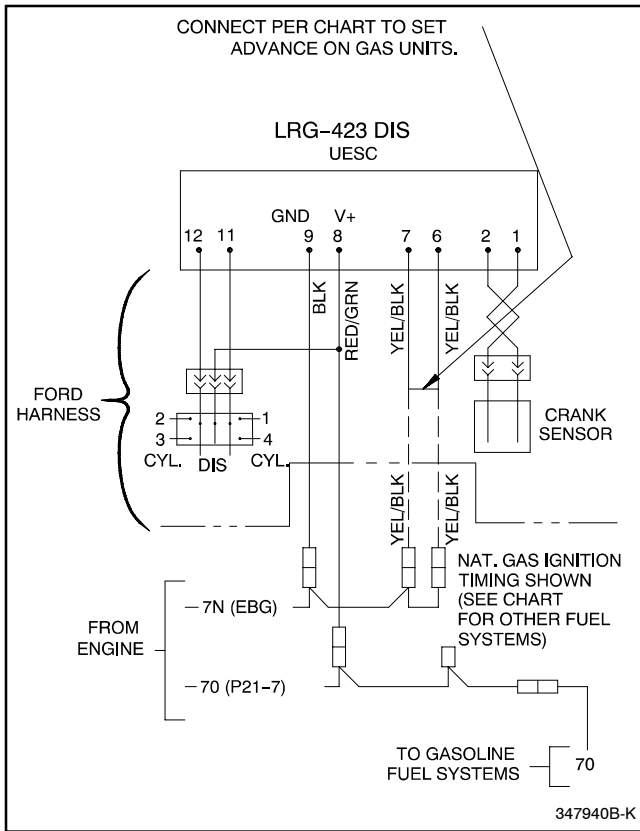

Figure 7-13 20 kW with LRG-423 Engine

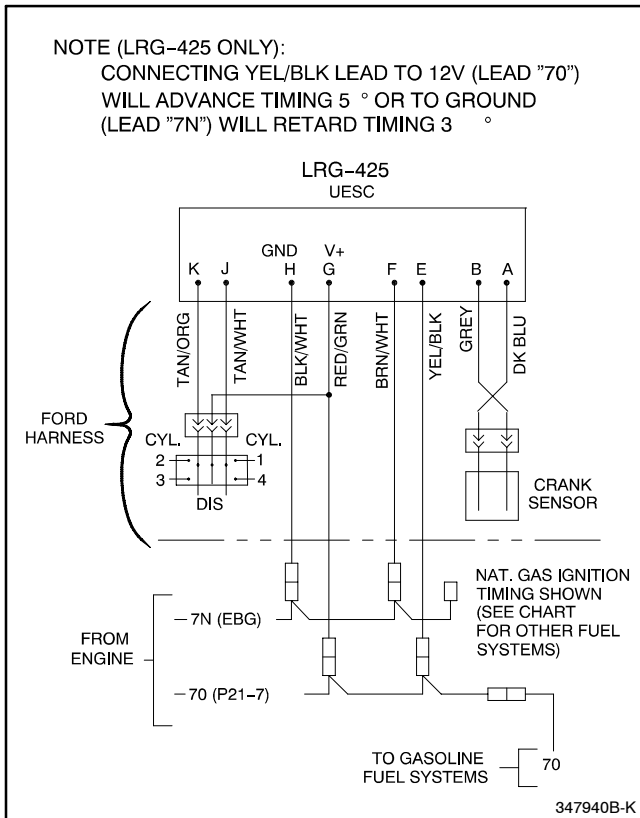

Figure 7-14 20 kW with LRG-425 Engine

7.8 Natural Gas to LP Gas Vapor Conversion

(30-100 kW GM-Powered Models with Barber-Colman Governor)

Adapted from Service Bulletin SB-612.

This section provides instructions for converting the General Motors engine-powered generator sets from natural gas to LP gas vapor on models with Barber-Colman governors. Figure 7-15 lists specification numbers for generator sets with Barber-Colman governors.

Model, kW	Spec No.
30	GM13685-GA1, 4, 7, 10
35	GM13685-GA2, 5, 8, 11
45	GM13685-GA3, 6, 9, 12
50	GM13686-GA1, 3, 5, 7
60	GM13686-GA2, 4, 6, 8
80	GM13934-GA1, 2, 3, 4
100	GM13934-GA5, 6, 7, 8

Figure 7-15 Specification Numbers

Figure 7-16 and Figure 7-17 show the 50/60 kW models; the 30-45 kW and 80/100 kW models are similar.

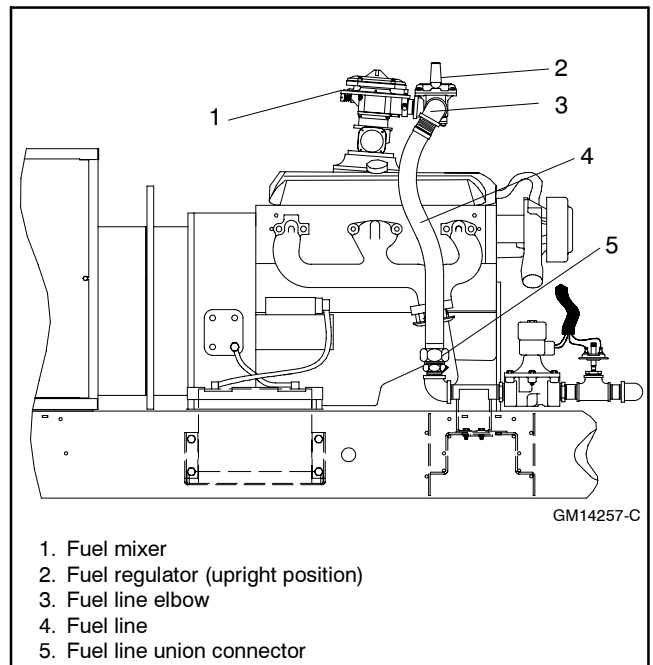

Figure 7-16 Natural Gas Fuel System Configuration

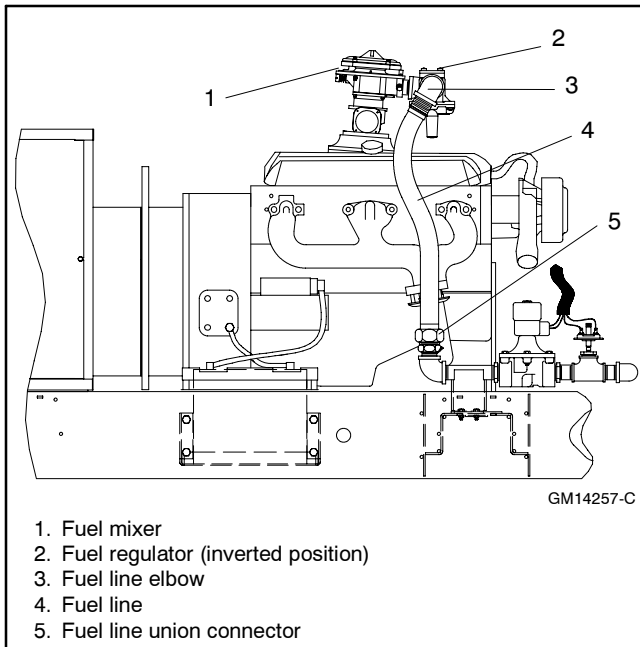

Figure 7-17 LP Gas Vapor Fuel System Configuration

Save the original gas mixer diaphragm (50–100 kW), fuel regulator spring, and adjustment screw for possible future conversion back to natural gas.

Note: When converting the 50–100 kW models, order kit GM17010-KP1, which contains the LP gas mixer diaphragm.

30–45 kW Models (4.3 L GM Engine). Use the following procedure except for step 2, Convert the gas mixer for LP gas vapor. The 30–45 kW generator set (General Motors 4.3 L engine) does not require a fuel diaphragm conversion; therefore, no kit is necessary. Refer to the respective spec sheet for generator set ratings based on fuel selection.

50/60 kW Models (5.7 L GM Engine). Use the following procedure. Refer to the respective spec sheet for generator set ratings based on fuel selection.

80/100 kW Models (8.1 L GM Engine). Use the following procedure except for step 5, Change the engine ignition timing. The 80/100 kW generator set (General Motors 8.1 L engine) does not require an engine ignition timing adjustment. Refer to the respective specification sheet for generator set ratings based on fuel selection and derate the specification sheet LP fuel ratings by 2%.

Note: No ratings derate is necessary for the 80/100 kW models with LP fuel when ignition module part no. GM19765 is installed. Order the ignition module for LP fuel through the Aftermarket Parts Dept.

1. Remove the generator set from service.

- a. Place the generator set master switch in the OFF position.
 - b. Disconnect the power to the battery charger, if equipped.
 - c. Disconnect the generator set engine starting battery(ies), negative (-) lead first.
 - d. Close all fuel supply valves.
2. Convert the gas mixer for LP gas vapor (50–100 kW models only).
 - a. Remove the five gas mixer cover plate screws. See Figure 7-18. Be aware that there is a spring under the gas mixer diaphragm, that may cause the cover plate and mixer diaphragm to pop up when the screws are loosened and removed.

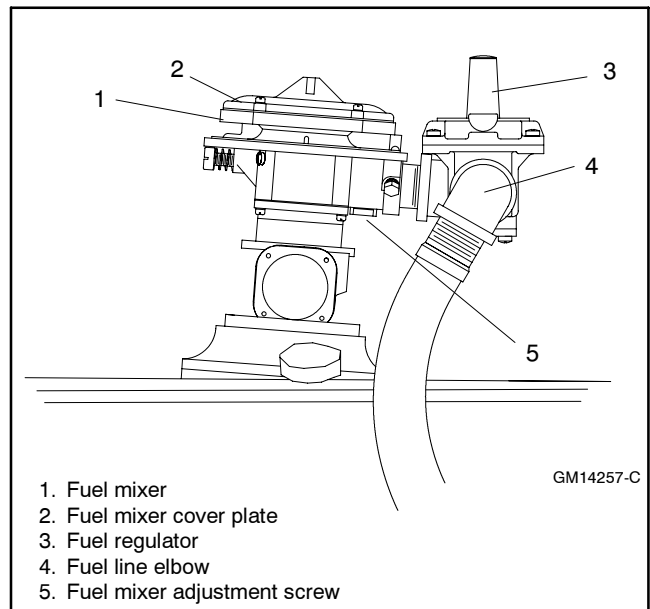

Figure 7-18 Fuel Mixer

- b. Remove the gas mixer cover plate and natural gas fuel diaphragm. See Figure 7-19. Save the natural gas fuel diaphragm for possible future conversion back to natural gas.

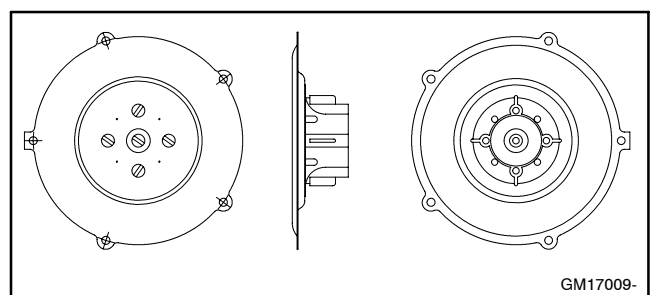

Figure 7-19 Fuel Diaphragm

- c. Clean the gas mixer, cover plate, and spring with a clean rag.
 - d. Center the spring in the mixer opening and install the LP fuel diaphragm (GM17009) from kit GM17010-KP1.
 - e. Replace the gas mixer cover plate and screws.
3. Convert the fuel regulator for LP gas vapor.
- a. Remove the fuel regulator cover plug. See Figure 7-20.
 - b. Remove the fuel regulator adjustment screw and spring. Save the fuel regulator adjustment screw and spring for possible future conversion back to natural gas.

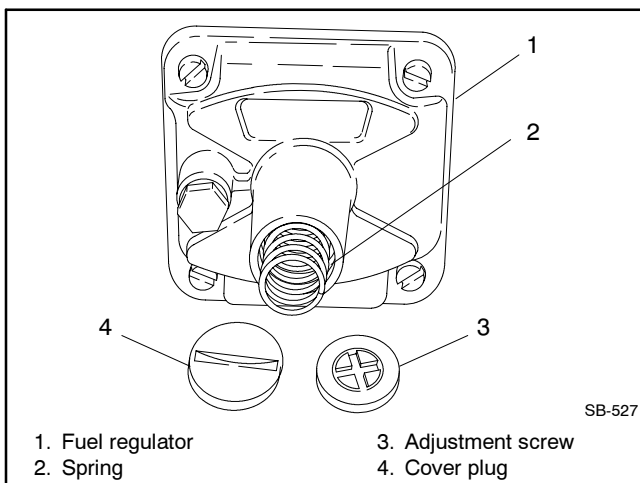

Figure 7-20 Fuel Regulator Components

- c. Replace the fuel regulator cover plug.
- d. Disconnect the fuel line at the union connector. See Figure 7-16.
- e. Change the fuel regulator position.
 - See Figure 7-21 for natural gas fuel regulator configuration. The fuel regulator is pointing upward for use with natural gas.
 - Disconnect the fuel line with elbow from the fuel regulator and fuel supply connection. Remove the pipe plug from the opposite side of the fuel regulator.
 - Rotate the fuel regulator 180° clockwise (CW) so that the fuel regulator is pointing downward for use with LP gas as shown in Figure 7-21.

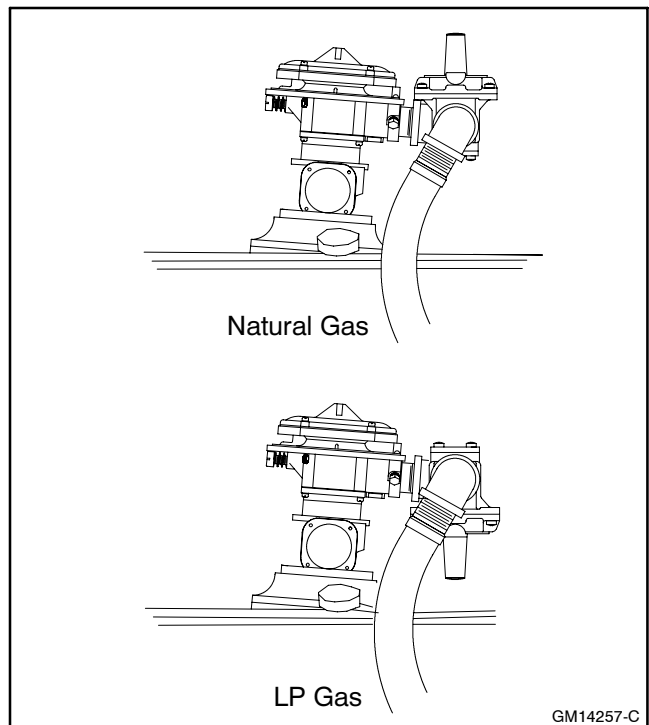

Figure 7-21 Fuel Regulator Position for Natural Gas to LP Gas Vapor Conversion

- Apply pipe sealant to the elbow threads and locate the fuel line with elbow to the opposite side of the fuel regulator as shown in Figure 7-21. Apply pipe sealant to the threads on the other end of the fuel line and attach to the fuel supply connection.
 - Apply pipe sealant to the pipe plug threads and install in the remaining opening in the fuel regulator.
- f. Reconnect the fuel line at the union connector.
4. Restore the generator set to service.
- a. Check that the generator set master switch is in the OFF position.
 - b. Reconnect the generator set engine starting battery, negative (-) lead last.
 - c. Reconnect power to the battery charger, if equipped.
 - d. Open the LP gas supply valve.
5. Change the engine ignition timing (30-60 kW models only).
- a. Loosen the distributor hold-down clamp screw.

- b. Remove dirt and grease from the crankshaft pulley groove and engine timing plate mark using a clean rag. Highlight the timing marks with chalk.
- c. Connect an ignition timing light to the engine. Follow the ignition timing light manufacturer's instructions.

Typically the ignition timing light connects to the starting battery for power and the inductive pickup goes on the no. 1 spark plug wire. The no. 1 spark plug is in the front left side of the engine. See Figure 7-22.

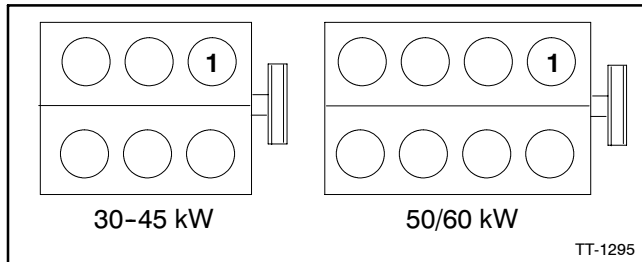

Figure 7-22 Engine No. 1 Cylinder/Spark Plug

- d. Set the ignition timing light adjustment to 28° BTDC (before top dead center) for LP gas vapor.
- e. Place the generator set master switch in the RUN position to start the generator set.
- f. Point the ignition timing light at the engine timing plate mark and slowly turn the distributor CW or counterclockwise (CCW) until the crankshaft pulley groove aligns with the engine timing plate mark.
- g. Place the generator set master switch in the OFF position to stop the generator set.
- h. Tighten the distributor hold-down clamp to 25 Nm (18 ft. lb.) being careful not to alter the distributor position.
- i. Disconnect the ignition timing light from the engine.

6. Adjust the gas mixer.

- a. Place the generator set master switch in the RUN position to start the generator set. Run the generator set at approximately half load.
- b. See Figure 7-18 for location of the fuel mixture adjustment screw and adjust the fuel mixture

screw (Figure 7-23) until the engine runs smoothly.

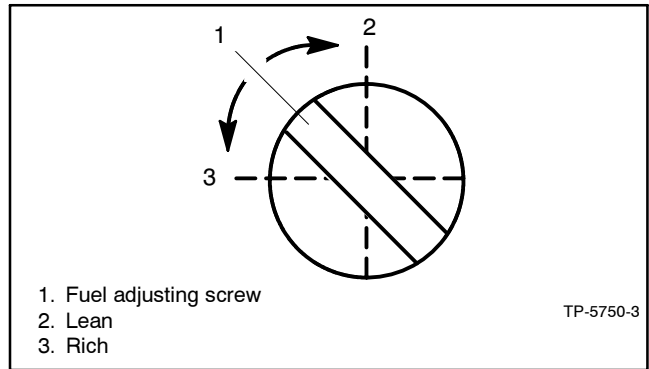

Figure 7-23 Fuel Mixture Adjustment, Typical

- c. Apply varying loads and readjust the mixer as necessary to achieve smooth engine performance at all load levels.
- d. Place the generator set master switch in the OFF position to stop the generator set.

7.9 Fuel Mixture Adjustment with Oxygen Sensor A-345052 (30-100 kW GM-Powered Models with Barber-Colman Governor)

Adapted from Service Bulletin SB-615.

This section details fuel mixture adjustment for General Motors engine-powered generator sets with Barber-Colman governors. Figure 7-24 lists specification numbers for generator sets with Barber-Colman governors.

Model, kW	Spec No.
30	GM13685-GA1, 4, 7, 10
35	GM13685-GA2, 5, 8, 11
45	GM13685-GA3, 6, 9, 12
50	GM13686-GA1, 3, 5, 7
60	GM13686-GA2, 4, 6, 8
80	GM13934-GA1, 2, 3, 4
100	GM13934-GA5, 6, 7, 8

Figure 7-24 Specification Numbers

Use the following procedure to field adjust the fuel mixture on generator sets that are not California Air Resources Board (CARB) or United States Environmental Protection Agency (EPA) certified. Correct fuel metering valve adjustment provides both reliable cold starting and overall generator set performance.

The adjustment procedure requires:

- Digital voltmeter (DVM).
- Engine oxygen sensor (part number A-345052).
- Load bank capable of rated kW for the fuel being used. See step 3.e. comment.

Read the entire installation procedure before adjusting the fuel mixture. Perform the steps in the order shown.

1. Remove the generator set from service.
 - a. Place the generator set master switch in the OFF position.
 - b. Disconnect power to the battery charger, if equipped.
 - c. Disconnect the generator set engine starting battery, negative (-) lead first.
2. Install the oxygen sensor.
 - a. Remove the oxygen sensor pipe plug from the exhaust pipe. See Figure 7-25 for location.

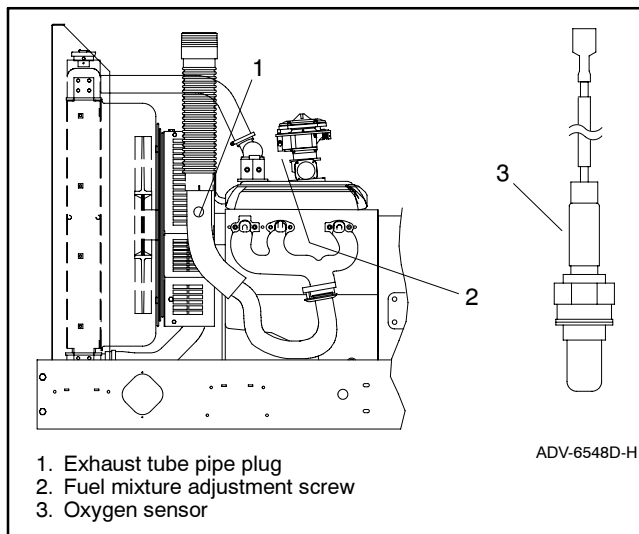

Figure 7-25 Oxygen Sensor Mounting Location, Typical (30 kW model shown)

- b. Install the oxygen sensor in the exhaust tube where the plug was removed.
 - c. Connect one of the DVM leads to the oxygen sensor lead. Connect the other DVM lead to ground and measure the oxygen sensor output voltage (potential to ground).
3. Start and warm up the generator set.
 - a. Check that the generator set master switch is in the OFF position.

- b. Reconnect the generator set engine starting battery, negative (-) lead last.
 - c. Place the controller master switch in the RUN position to start generator set. The time required will depend on the size of the generator set.
 - d. Allow the generator set to run until the generator set reaches normal operating temperature.
 - e. With the generator set at normal operating temperature, apply 90%–100% of rated load. If a load bank is not available, apply a load at least comparable to what is generally connected to the generator set.
4. Adjust the fuel mixture valve.
 - a. Adjust the fuel metering valve (Figure 7-26) as required to obtain a 0.8–0.9 VDC oxygen sensor output. The oxygen sensor output reads high when the mixture is richer and close to zero volts when the mixture is leaner.

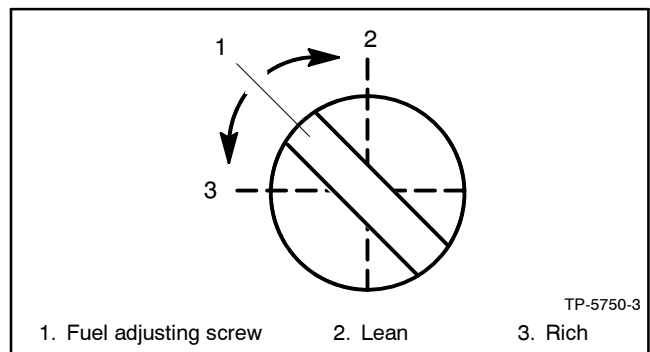

Figure 7-26 Fuel Mixer Adjustment, Typical

The gas mixer adjustment is molded into the gas mixer inlet on air valve-type models or is a separate fitting upstream of the gas mixer on venturi-type models.

- b. Remove the load and allow the generator set to run unloaded to cool for at least 5–10 minutes.
5. Stop the generator set.
 - a. Place the generator set master switch in the OFF position.
 - b. Disconnect the generator set engine starting battery(ies), negative (-) lead first.
 6. Remove the oxygen sensor.
 - a. Allow the generator set exhaust system to cool.

- b. Disconnect the DVM leads from the oxygen sensor.
- c. Remove oxygen sensor from the exhaust tube.
- d. Apply a small amount of antiseize compound to the pipe plug and reinstall the pipe plug into the exhaust tube.

7. Restore the generator set to service.

- a. Check that the generator set master switch is in the OFF position.
- b. Reconnect the generator set engine starting battery, negative (-) lead last.
- c. Reconnect the power to the battery charger, if equipped.

7.10 Natural Gas to LP Gas Vapor Conversion

(30-125 kW GM-Powered Models with Woodward and E-Controls Governor)

Adapted from Service Bulletin SB-633.

This section provides instructions for converting General Motors engine-powered generator sets from natural gas to LP gas vapor. Figure 7-27 lists specification numbers for generator sets including engine models.

Model, kW	Engine	Spec No.
30	4.3 L	GM22383-GA1, 7, 10
	3.0 L	GM22316-GA1
35	4.3 L	GM22383-GA2, 8, 11
45	4.3 L	GM22383-GA3, 9, 12
50	5.7 L	GM13686-GA1, 3, 5, 7
	5.0 L	GM21302-GA1, 5, 7
60	5.7 L	GM21302-GA2, 6, 8
80	8.1 L	GM22407-GA1, 2, 3, 4
100	8.1 L	GM22407-GA5, 6, 7, 8
125	8.1 L	GM20568-GA1, 2
		GM25339-GA1, 2, 3, 4

Figure 7-27 Specification Numbers

Figure 7-28 shows the natural gas configuration for the 50/60 kW models; the 30-45 kW and 80-125 kW models are similar.

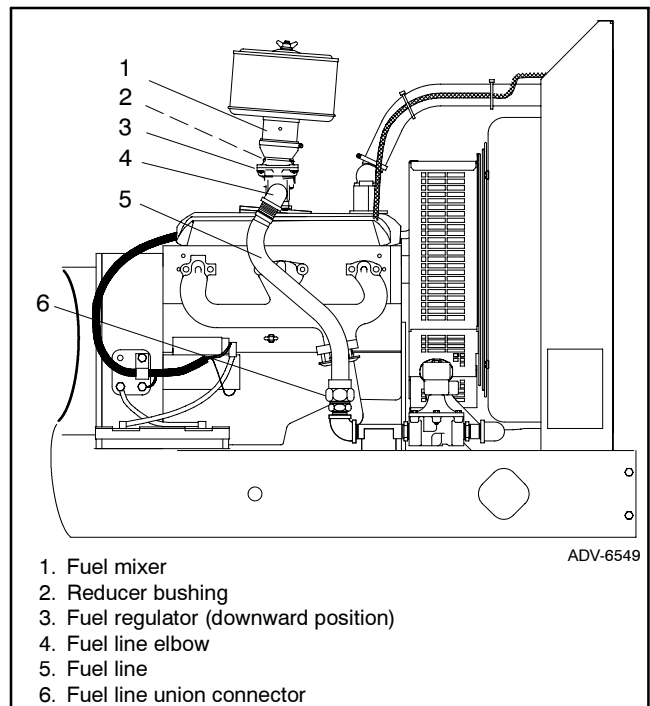

Figure 7-28 Fuel System Configuration, Typical

When converting the 80-125 kW models, order the respective kit shown in Figure 7-29 that contains the LP gas mixer and fuel regulator.

Model, kW	Kit Number
80	GM17010-KP2
100	GM17010-KP3
125	GM17010-KP4

Figure 7-29 Fuel System Kit Numbers

30-60 kW Models (3.0 L, 4.3 L, 5.0 L, and 5.7 L GM Engines). Use the following procedure except for Step 2. The 30-60 kW generator sets do not require gas mixer or regulator replacement. Refer to respective spec sheet for generator set ratings based on fuel selection.

Note: 30 kW models with the 3.0 L GM engine require service harness adapter part number GM39651 for setting the engine ignition timing.

80-125 kW Models (8.1 L GM Engine). Use the following procedure, except Step 5. Refer to the respective specification sheet for generator set ratings based on fuel selection.

1. Remove the generator set from service.
 - a. Place the generator set master switch in the OFF position.
 - b. Disconnect the power to the battery charger, if equipped.

- c. Disconnect the generator set engine starting battery(ies), negative (-) lead first.
 - d. Close all fuel supply valves.
2. Replace the gas mixer and regulator for LP gas vapor (80–125 kW models only).
- a. Remove the components from the engine as shown in Figure 7-28.
 - Remove the four screws attaching the gas mixer to the throttle. The 80 kW has the screw heads accessible from the bottom and the 100/125 kW have the screw heads accessible from the top. Retain the gasket between the gas mixer and throttle.
 - Disconnect the fuel line at the union connector.
 - Remove the supporting clamp between the fuel regulator and mixer.
 - b. Disconnect the piping from the gas mixer inlet and fuel regulator inlet and outlet.
 - c. Apply pipe thread compound to all male threads and assemble the fuel system assembly with the new gas mixer, reducer bushing, and fuel regulator supplied in the kit.
 - d. Place the gas mixer on the throttle with the existing gasket and install the four screws. See Figure 7-30.
 - e. Reconnect the fuel line at the union connector.

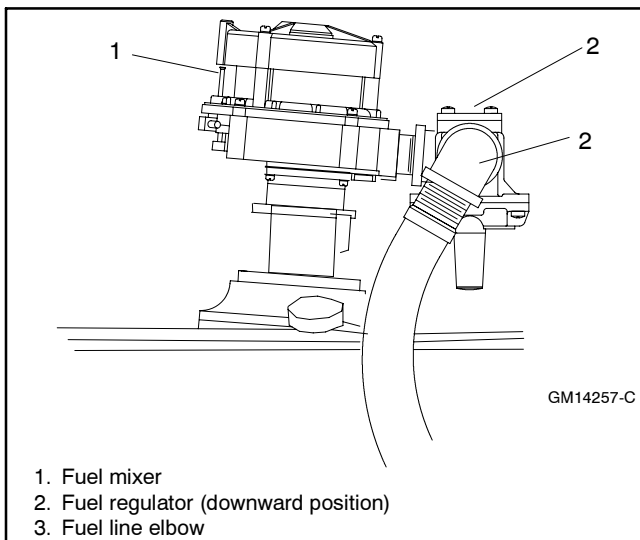

Figure 7-30 Fuel Mixer, Typical

3. Set up the fuel regulator for LP gas (30 kW model with 3.0 L engine only).

- a. Rotate the fuel regulator to a downward pointing position as shown in Figure 7-30.
- b. Remove the cover plug and adjustment screw from the fuel regulator. See Figure 7-31.

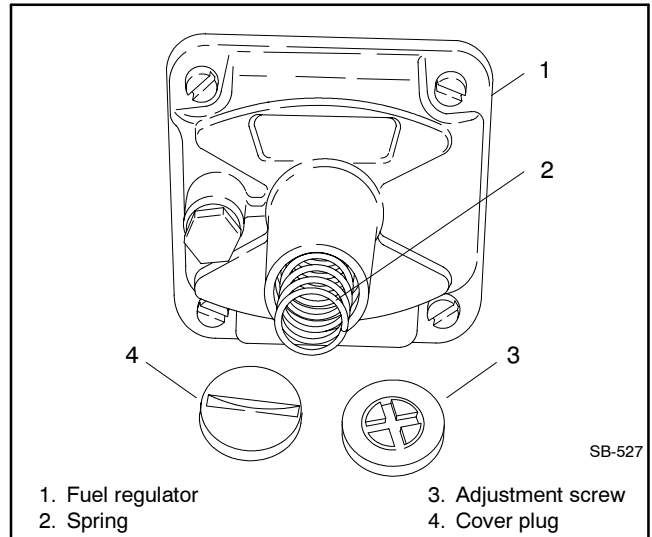

Figure 7-31 Fuel Regulator, Typical

- c. Remove the spring. The spring will not be reused.
 - d. Replace the adjustment screw to the approximate midpoint of the adjustment range.
 - e. Replace the cover plug.
4. Change the fuel configuration jumper wire at junction box terminal strip

Follow the procedure for the respective model. See Figure 7-34 for a summary of all fuel configurations requiring the TB12 terminal strip. The fuel and frequency jumper connections on TB12 is also available in the respective Wiring Diagram Manual.

a. **30–60 kW models.**

- Remove the right side panel of the junction box and locate the fuel configuration terminal strip TB12.
- **30 kW model with 3.0 L engine only.** Attach a user-supplied 18 ga. jumper wire between terminals 1 and 3 (LP gas vapor fuel). See Figure 7-32 for frequency jumper wire requirements.

Note: No jumper wire is used with natural gas fuel.

30 kW model with 4.3 L engine and 35-60 kW models. Move the jumper wire from terminals 1 and 5 (natural gas fuel) to terminals 1 and 3 (LP gas vapor fuel). See Figure 7-33 for frequency jumper wire requirements.

- Attach the junction box right side panel.

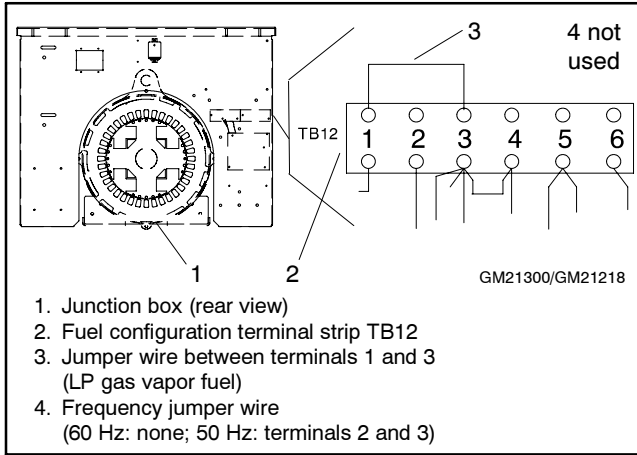

Figure 7-32 Fuel Configuration Jumper Wire (LP Fuel, 60 Hz, 30 kW [3.0 L] Model)

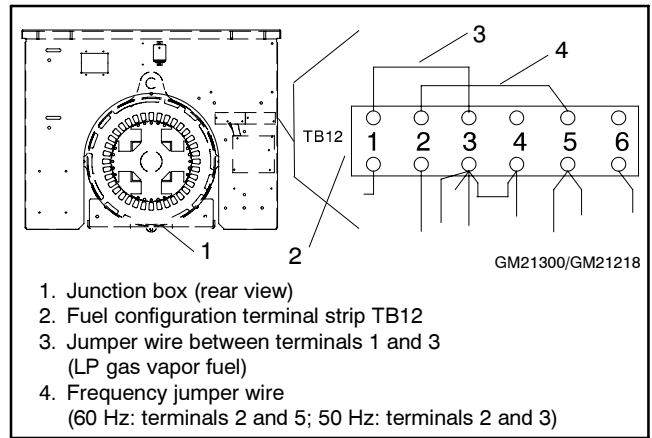

Figure 7-33 Fuel Configuration Jumper Wire (LP Fuel, 60 Hz, 30 kW [4.3 L] and 35-60 kW Models)

Model, kW	Engine	Straight Gas Fuel				NG/LP Dual Fuel		LP Liquid Withdrawal	
		LP, 60 Hz	LP, 50 Hz	NG, 60 Hz	NG, 50 Hz	60 Hz	50 Hz	60 Hz	50 Hz
30	3.0 L	1-3	1-3, 2-3	none	2-3	none	2-3	1-3	1-3, 2-3
	4.3 L	1-3, 2-5	1-3, 2-3	1-5, 2-5	1-5, 2-3	1-5, 2-5	1-5, 2-3	1-3, 2-5	1-3, 2-3
35	4.3 L								
45	5.0 L								
50	5.7 L								
60	5.7 L	1-5	1-5, 2-5	none	2-5	none	2-5	1-5	1-5, 2-5
80	8.1 L								
100	8.1 L								
125									

Figure 7-34 Fuel and Frequency Jumper Connections on TB12

b. **80-125 kW models.**

- Remove the right side panel of the junction box and locate the fuel configuration terminal strip TB12. See Figure 7-35.
- Attach a user supplied 18-ga. jumper wire between terminals 1 and 5 (LP gas vapor fuel). See Figure 7-35 for frequency jumper wire requirements.

Note: No jumper wire is used with natural gas fuel.

- Attach the junction box right side panel.

5. Change the solenoid shutoff valve wiring (80/100 kW models only).

- Locate the solenoid shutoff valve at the fuel inlet connection at the lower right side of the generator set.
- Disconnect wires 72 and 73 from the solenoid shutoff valve (FV1). Tape to insulate the terminals. See Figure 7-36, Natural Gas view.

- Connect wires 74 and 75 to the solenoid shutoff valve (FV1). See Figure 7-36, LP Gas view.

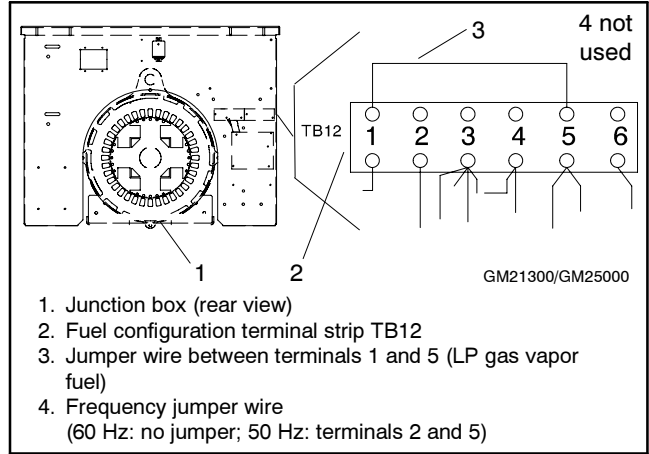

Figure 7-35 Fuel Configuration Jumper Wire (LP Fuel, 60 Hz, 80-125 kW Models)

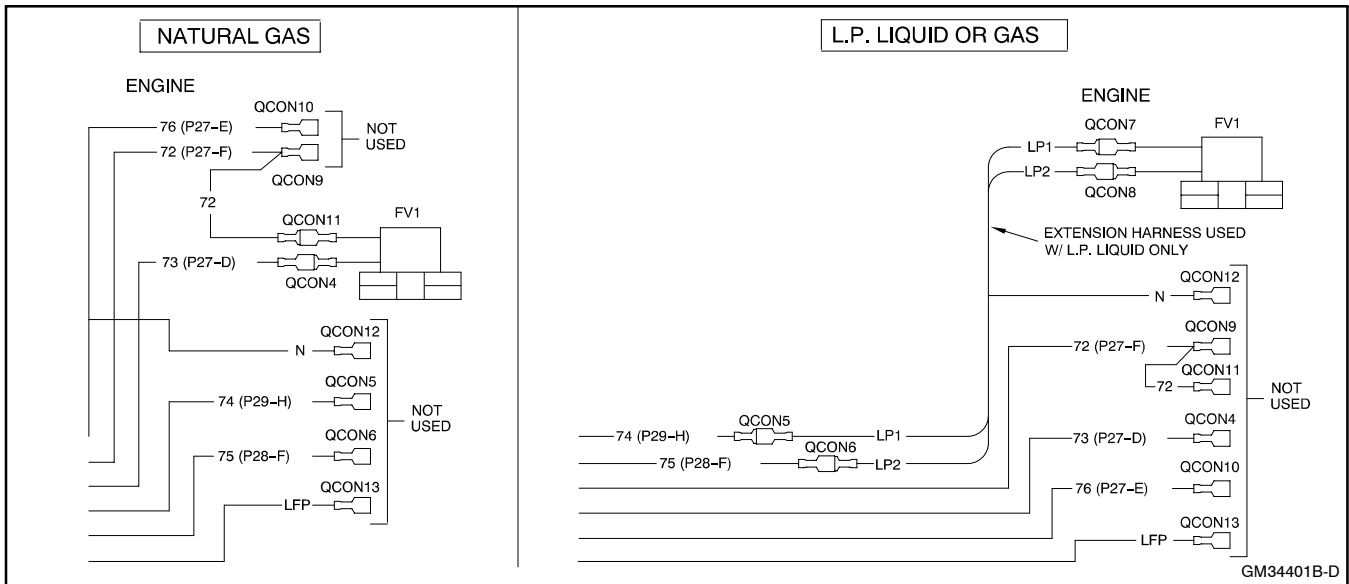

Figure 7-36 Solenoid Shutoff Valve Wiring

6. Restore the generator set to service.
 - a. Check that the generator set master switch is in the OFF position.
 - b. Reconnect the generator set engine starting battery, negative (-) lead last.
 - c. Reconnect power to the battery charger, if equipped.
 - d. Open the LP gas supply valve.
7. Change the engine ignition timing (30–60 kW models only).

Note: The engine ignition timing for the 80–125 kW models is set by the ECM and is not adjustable.

- a. **30 kW model with the 3.0 L GM engine only.** Remove the 4-pin harness connector from the base of the distributor. Plug in GM39651 service harness adapter to the distributor. Attach the lead from pin B to the battery positive (+) terminal.

The service harness adapter connects pins C and D together and connects battery positive (+) to pin B.

- b. Loosen the distributor hold-down clamp screw.
- c. Remove dirt and grease from the crankshaft pulley groove and engine timing plate mark using a clean rag. Highlight the timing marks with chalk.
- d. Connect an ignition timing light to the engine. Follow the ignition timing light manufacturer's instructions.

Typically the ignition timing light connects to the starting battery for power and the inductive pickup goes on the no. 1 spark plug wire. The no. 1 spark plug is in the front left side of the engine. See Figure 7-37.

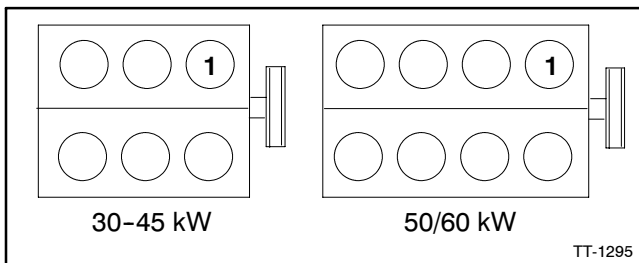

Figure 7-37 Engine No. 1 Cylinder/Spark Plug

- e. Set the ignition timing light adjustment to the value shown in Figure 7-38.

Model, kW	Engine	NG Timing °BTDC	LP Gas Timing °BTDC	Dual Fuel Timing °BTDC	Spark Plug Gap, mm (in.)
30	4.3 L	32	28	32	0.89 (0.035)
	3.0 L	0	0	0	
35	4.3 L	32	28	32	
45	4.3 L	32	28	32	
50	5.7 L	36	28	32	
	5.0 L	36	28	32	
60	5.7 L	36	28	32	
80	8.1 L	ECM	ECM	ECM	
100	8.1 L	ECM	ECM	ECM	
125	8.1 L	ECM	ECM	ECM	

Figure 7-38 Engine Ignition Timing

- f. Place the generator set master switch in the RUN position to start the generator set.
- g. Point the ignition timing light at the engine timing plate mark and slowly turn the distributor CW or CCW until the crankshaft pulley groove aligns with the engine timing plate mark.
- h. Place the generator set master switch in the OFF position to stop the generator set.
- i. Tighten the distributor hold-down clamp to 25 Nm (18 ft. lb.) being careful not to alter the distributor position.
- j. **30 kW model with the 3.0 L GM engine only.** Remove the lead from pin B lead at the battery positive (+) terminal. Unplug GM39651 service harness adapter from the distributor. Reconnect the 4-pin harness connector to the base of the distributor.
- k. Disconnect the ignition timing light from the engine.

8. Adjust the fuel mixture using Section 7.11.

7.11 Fuel Mixture Adjustment (Oxygen Sensor Service Kit GM29385)

(30-125 kW GM-Powered Models with
Woodward and E-Controls Governor)

Adapted from Service Bulletin SB-634.

This section details fuel mixture adjustment for General Motors engine-powered generator sets. Figure 7-39 lists specification numbers for generator sets including engine models.

Model, kW	Engine	Spec No.
30	4.3 L	GM22383-GA1, 7, 10, 13, 14
	3.0 L	GM22316-GA1, 4
35	4.3 L	GM22383-GA2, 8, 11, 15, 16
45	4.3 L	GM22383-GA3, 9, 12, 17, 18
50	5.7 L	GM13686-GA1, 3, 5, 7
	5.0 L	GM21302-GA1, 5, 7
60	5.7 L	GM21302-GA2, 6, 8
80	8.1 L	GM22407-GA1,2,3,4
100	8.1 L	GM22407-GA5,6,7,8
125	8.1 L	GM20568-GA1, 2
		GM25339-GA1,2,3,4

Figure 7-39 Specification Numbers

Figure 7-40 provides the differences in engine components and the optimum air/fuel mixture measured with an oxygen sensor in volts.

Model, kW	GM Engine	Fuel Mixer Type	Electronic Control Unit (ECU) Type	Air/Fuel Mixture Measured in Volts
30	3.0	Nolff	E-Controls	2.50-2.65
30-45	4.3	Woodward	PSI	2.35-2.45
50/60	5.0, 5.7	Woodward	PSI	2.60-2.80
80/100	8.1	Nolff	E-Controls	2.50-2.65
125	8.1 Turbo	Nolff	E-Controls	2.50-2.65

Figure 7-40 Engine Components and Optimum Air/Fuel Mixture Values

1. Place the generator set master switch in the OFF position.
2. Disconnect power to the battery charger, if equipped.
3. Disconnect the generator set engine starting battery, negative (-) lead first.

Use the following procedure to field adjust fuel mixture on generator sets that are not California Air Resources Board (CARB) or United States Environmental Protection Agency (EPA) certified. Correct fuel metering valve adjustment provides both reliable cold starting and overall generator set performance.

The adjustment procedure requires:

- Digital voltmeter (DVM).
- Engine oxygen sensor service kit GM29385 that contains:

UEGO Oxygen Sensor part no. GM28980

UEGO Sensor Interface Harness part no. GM28981

UEGO Air/Fuel Control Module part no. GM28982

- Load bank capable of rated kW for the fuel being used. See step e. comment.
- Manometer with range of 0-15 inches of water.

Read the entire installation procedure before adjusting the fuel mixture. Perform the steps in the order shown.

1. Remove the generator set from service.
2. Place the generator set master switch in the OFF position.
3. Disconnect power to the battery charger, if equipped.
4. Disconnect the generator set engine starting battery, negative (-) lead first.
5. Install the oxygen sensor and interface harness.
 - a. Remove the oxygen sensor pipe plug from the exhaust pipe. See Figure 7-41 for location.

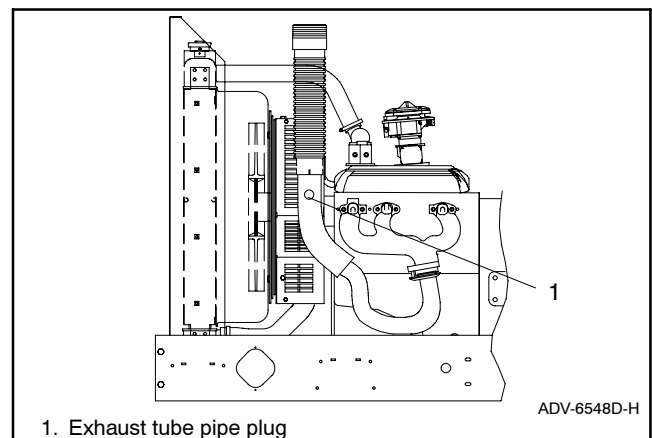

Figure 7-41 Oxygen Sensor Mounting Location, Typical (30 kW model shown)

- b. Install the oxygen sensor in the exhaust tube where the plug was removed.

- c. Connect the oxygen sensor (GM28980) to the interface harness (GM28981). See Figure 7-42.

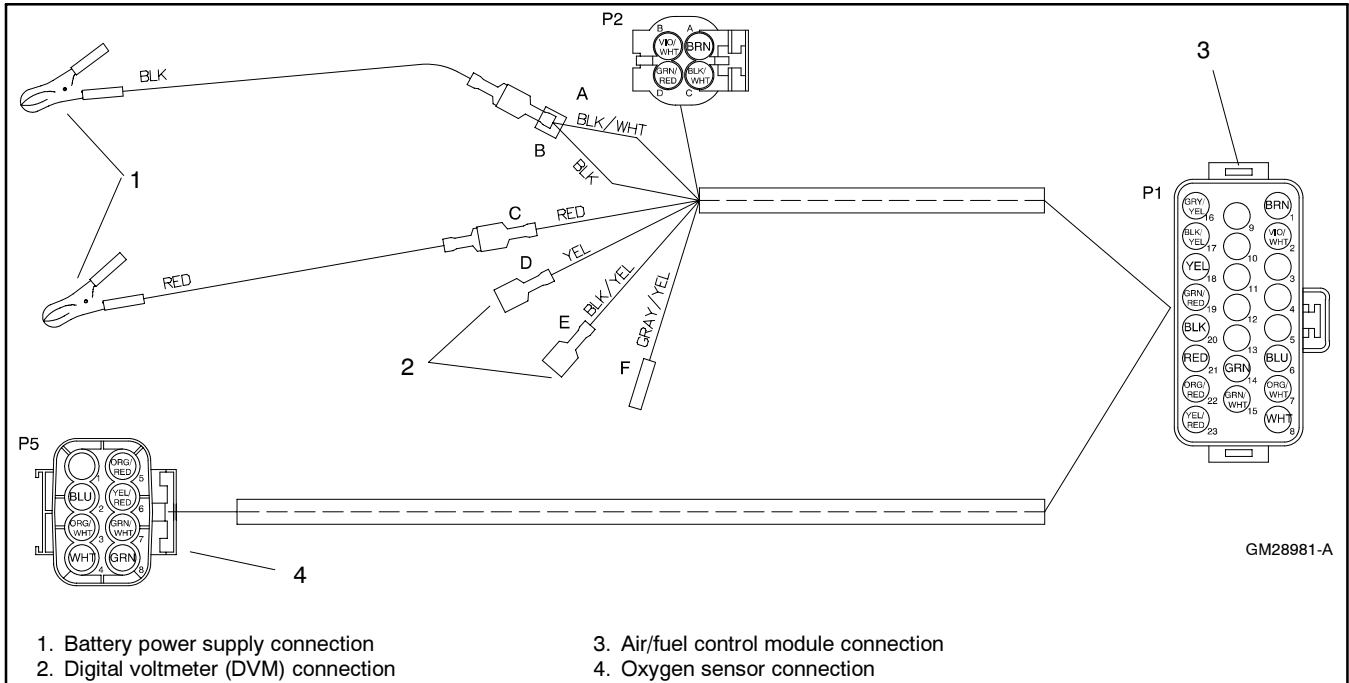

Figure 7-42 Sensor Interface Harness GM28981 Electrical Connections

- d. Connect the air/fuel control module (GM28982) to the interface harness.
- e. Connect the digital voltmeter (DVM) to the interface harness. Connect one of the digital voltmeter (DVM) leads to the yellow output lead. Connect the other DVM lead to the black/yellow output lead.
- f. Connect the interface harness red (+) and black (-) battery clips to a 12-volt battery

6. Install the manometer.

- a. Remove the 1/8 NPT pipe plug from the solenoid fuel valve located at the generator set fuel inlet connection. See Figure 7-43.
 - b. Connect the manometer to the solenoid fuel valve port.
7. Start and warm up the generator set.
- a. Check that the generator set master switch is in the OFF position.
 - b. Reconnect the generator set engine starting battery, negative (-) lead last.

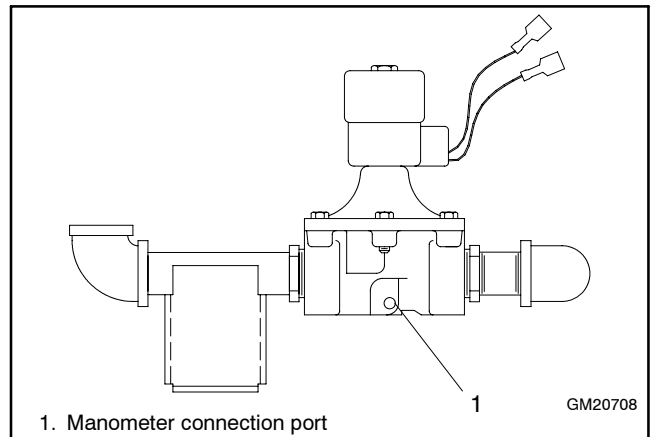

Figure 7-43 Solenoid Fuel Valve Manometer Port

- c. Place the controller master switch in the RUN position to start generator set.
- d. Allow the generator set to run until the generator set reaches normal operating temperature. The time required to reach normal operating temperature depends primarily on the ambient temperature and the size of the engine.

- e. With the generator set at normal operating temperature, apply 90%–100% of rated load. If a load bank is not available, apply a load at least comparable to what is generally connected to the generator set.
 - f. Verify that the fuel pressure is within 7–11 inches of water at full load. Adjust the primary fuel regulator as necessary to achieve the fuel pressure of 7–11 inches of water as measured at the inlet side of the generator set fuel solenoid valve.
 - g. Remove the load and allow the generator set to run unloaded to cool for at least 5–10 minutes.
 - h. Place the controller master switch in the OFF position to stop generator set.
8. Adjust the fuel mixture.

Choose the procedure based on the type of gas mixer on the generator set.

- a. **30–60 kW generator sets.** Venturi style gas mixer used with an integrated throttle body governor on 4.3 L, 5.0 L, and 5.7 L GM engines. Also similar to the IMPCO model 100 used on the 30 kW with 3.0 L GM engine. See Figure 7-44.

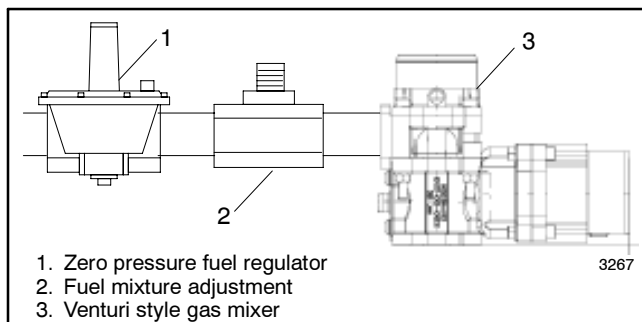

Figure 7-44 30–60 kW with Venturi Style Fuel Mixer

- Place the controller master switch in the RUN position to start generator set.
- Allow generator set to run until the generator set reaches normal operating temperature.
- Apply 90%–100% of full rated load.
- Adjust the fuel mixture adjustment (see Figure 7-44 and Figure 7-45) to obtain a full load oxygen sensor voltage reading in the range specified in Figure 7-40.
- Disconnect the load.

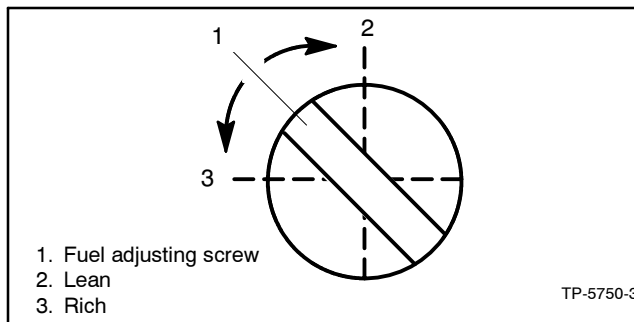

Figure 7-45 Fuel Mixture Adjustment, Typical

- Adjust the zero pressure regulator (see Figure 7-44 and Figure 7-45) to obtain a no load oxygen sensor voltage reading in the range specified in Figure 7-40.
 - Repeat the steps from applying load through adjusting the zero pressure regulator until the oxygen sensor voltage reading is in the specified range for both no-load and full-load conditions.
 - Remove load and allow generator set to run unloaded to cool for at least 5–10 minutes.
 - Place the controller master switch in the OFF position to stop generator set.
- b. **30–80 kW generator sets.** Nolf NCA-225M and NCA-125M style gas mixers used on early versions of 30–60 kW 4.3 L and 5.7 L GM engines, 30–60 kW LP liquid withdrawal systems, and 80 kW 8.1 L GM engines. See Figure 7-46.

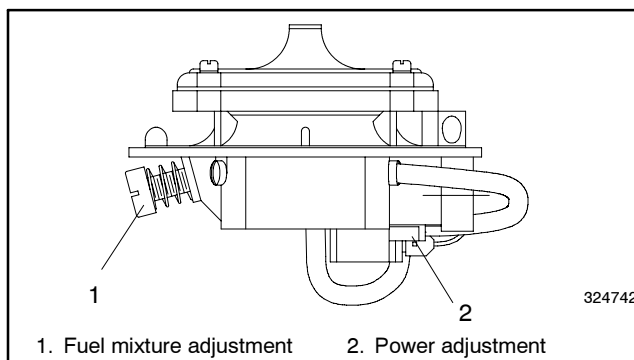

Figure 7-46 30–80 kW with Nolf NCA-225M and NCA-125M Style Fuel Mixers

- Adjust the fuel regulator adjustment screw to the approximate midpoint of its adjustment range. See Figure 7-45.
- Place the controller master switch in the RUN position to start generator set.

Note: If the generator set fails to start, turn the fuel regulator adjustment screw slightly in or out while the engine cranks.

- Allow the generator set to run until the generator set reaches normal operating temperature.
- Apply 90%–100% of full rated load.
- Adjust the fuel mixture adjustment (Figure 7-46) to obtain a full load oxygen sensor voltage reading in the range specified in Figure 7-40.

If the oxygen sensor voltage reading is too low with the fuel mixture adjustment in the richest position (turned in CW), turn the fuel regulator adjustment screw CW to richen the fuel mixture. Readjust the fuel mixture adjustment as needed to obtain an oxygen sensor voltage reading within specifications.

If the oxygen sensor voltage reading is too high with the fuel mixture adjustment in the leanest position (turned out CCW), turn the fuel regulator adjustment screw CCW to lean the fuel mixture. Readjust the fuel mixture adjustment as needed to obtain an oxygen sensor voltage reading within specifications.

- Disconnect the load.
- Adjust the fuel mixture adjustment to obtain a no load oxygen sensor voltage reading within the specifications shown in Figure 7-40.

If the oxygen sensor specification cannot be met at no load, turn the idle mixture screw in to the richest possible setting.

- Repeat steps from applying full rated load through adjusting the fuel mixture to obtain a no load oxygen sensor voltage reading with specifications to verify the settings.
- Place the controller master switch in the OFF position to stop generator set.

- c. **100/125 kW (with single fuel) generator sets.** Nolff N16-475-5A and N16-475-9A style gas mixers used on 100 kW 8.1 L GM and 125 kW 8.1 L GM turbocharged engines. See Figure 7-47. This gas mixer style does not have a fuel mixture adjustment.

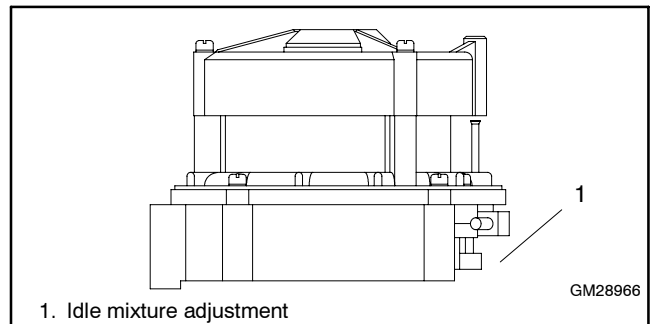

Figure 7-47 100/125 kW with Nolff 475 Style Fuel Mixer

- Adjust the fuel regulator adjustment screw to the approximate midpoint of its adjustment range. See Figure 7-45.
- Place the controller master switch in the RUN position to start the generator set.
- Allow the generator set to run until the generator set reaches normal operating temperature.
- Apply 90%–100% of full rated load.
- Adjust the fuel regulator adjustment screw to obtain a full load oxygen sensor voltage reading in the range specified in Figure 7-40.
- Disconnect the load.
- Adjust the idle mixture adjustment (Figure 7-47) to obtain a no load oxygen sensor voltage reading within specifications.

If the oxygen sensor specification cannot be met at no load, turn the idle mixture screw out to the richest possible setting (2–2.5 turns).

- Repeat the steps from applying full rated load to adjusting the idle mixture to obtain a no load oxygen sensor voltage reading within specifications to verify the settings.
- Place the controller master switch in the OFF position to stop generator set.

9. **125 kW (with dual fuel) generator set.** Dual fuel units have a closed loop fuel control system that will automatically make adjustments in order to maintain a fuel/air mixture reading of approximately 2.4 volts using UEGO oxygen sensor.

- a. Connect a PC laptop with monitoring software. Reference TP-6215 for instructions on how to use the software.
- b. Adjust the fuel regulator adjustment screw to the approximate midpoint of its adjustment range. See Figure 7-48.

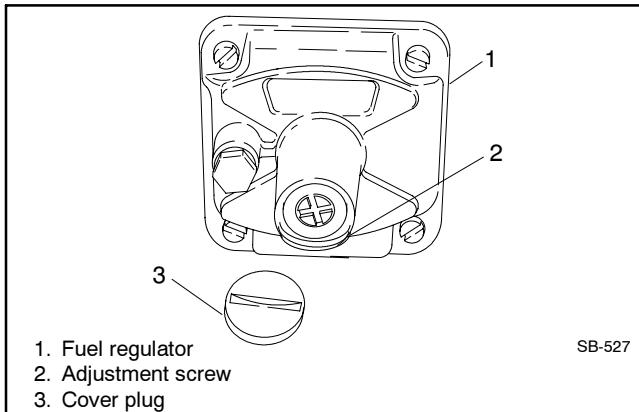

Figure 7-48 Fuel Regulator, Typical

- c. Place the generator set master switch in the RUN position to start the generator set.
- d. Allow the generator set to run until the generator set reaches normal operating temperature.
- e. Apply 90%-100% of full rated load.
- f. Use the PC laptop and go to the Faults page and locate the Primary Trim Valve (FTV) parameter shown in the middle of the page to the right. Adjust the fuel regulator adjustment screw until the FTV indicates between 30% and 60%.
- g. Disconnect the load.
- h. Adjust the idle mixture adjustment (Figure 7-47) to obtain a no-load oxygen sensor voltage reading within specifications. See Figure 7-40.

If the oxygen sensor specification cannot be met at no-load, turn the idle mixture screw out to the richest possible setting (2-2.5 turns).

- i. Repeat steps e. through h. to verify the settings.
- j. Place the generator set master switch in the OFF position to stop generator set.

10. Stop the generator set.

- a. Place the generator set master switch in the OFF position.
- b. Disconnect the generator set engine starting battery(ies), negative (-) lead first.

11. Remove the oxygen sensor and interface harness.

- a. Allow the generator set exhaust system to cool.
- b. Disconnect the battery clips from the battery.
- c. Disconnect the interface harness from the digital voltmeter (DVM).
- d. Disconnect the interface harness from the oxygen sensor.
- e. Remove the oxygen sensor from the exhaust tube.
- f. Apply a small amount of antiseize compound to the pipe plug and reinstall the pipe plug into the exhaust tube.
- g. Remove the manometer hose fitting from the solenoid fuel valve.
- h. Apply a small amount of antiseize compound to the pipe plug and reinstall the pipe plug into the solenoid fuel valve.

12. Restore the generator set to service.

- a. Check that the generator set master switch is in the OFF position.
- b. Reconnect the generator set engine starting battery, negative (-) lead last.
- c. Reconnect the power to the battery charger, if equipped.

Section 8 Governor Adjustments

8.1 Governor Identification

This section contains governor identification by model and engine including optional governors when available. See Figure 8-1. The reference column provides the source for governor adjustment. This section provides governor adjustment information when it is not available in the engine service literature. Refer to the respective wiring diagram for electrical connections. Refer to the respective parts catalog for engine literature part numbers.

8.1.1 Gas Models

When making governor adjustments, also refer to Section 7, Gas Fuel Systems, for information regarding fuel mixture adjustment, engine timing, and spark plug gap.

Model, kW	Engine	Governor Type	Part Number	Reference
20	Ford LRG-425	Electronic	A-246045	Section 8.2
30	GM 3.0 L	Electronic, ECU		Not Adjustable*
30	GM 4.3 L	Electronic		Not Adjustable*
35	GM 4.3 L	Electronic		Not Adjustable*
45	GM 4.3 L	Electronic		Not Adjustable*
50	GM 5.0 L	Electronic		Not Adjustable*
50	GM 5.7 L	Electronic		Not Adjustable*
60	GM 5.7 L	Electronic		Not Adjustable*
80	GM 8.1 L	Electronic, ECU		Not Adjustable*
100	GM 8.1 L	Electronic, ECU		Not Adjustable*
125	GM 8.1 L Turbo	Electronic, ECU		Not Adjustable*
135-275	DDC Series 50/60	Electronic, DDEC		Engine S/M
400-800	Waukesha	Electronic		Engine S/M

* See Section 7, Gas Fuel Systems, for fuel mixture adjustment, engine timing, and spark plug gap.

Figure 8-1 Governor Identification

8.1.2 Diesel Models

Model, kW	Engine	Governor Type	Part Number	Reference
20-40	John Deere 3029	Mechanical, Stanadyne DB2		Engine S/M, See Section 8.3
20-40	John Deere 3029	Electronic, Non-Load Sharing	GM17644-4	See Section 8.2.2
20-40	John Deere 3029	Electronic, Load Sharing	GM17644-5	See Section 8.2.2
50-80	John Deere 4045	Mechanical, Stanadyne DB4		Engine S/M, See Section 8.3
50-80	John Deere 4045	Electronic, Non-Load Sharing	GM17644-4	See Section 8.2.2
50-80	John Deere 4045	Electronic, Load Sharing	GM17644-5	See Section 8.2.2
80-135	John Deere 4045	Electronic, JDEC/Stanadyne DE10		Engine S/M
100-150	John Deere 6068	Mechanical, Stanadyne DB4		Engine S/M, See Section 8.3
100-150	John Deere 6068	Electronic, Non-Load Sharing	GM17644-4	See Section 8.2.2
100-150	John Deere 6068	Electronic, Load Sharing	GM17644-5	See Section 8.2.2
150/180	John Deere 6068	Electronic, JDEC/Bosch VP44		Engine S/M
180-230	John Deere 6081	Mechanical, Robert Bosch P3000		Engine S/M, See Section 8.3.2
180-230	John Deere 6081	Electronic, Non-Load Sharing	GM17644-4	See Section 8.2.2
180-230	John Deere 6081	Electronic, Load Sharing	GM17644-5	See Section 8.2.2
200	DDC Series 40E	Electronic, HEUI		Engine S/M
200	Kohler Branded D200	Electronic, GAC ESD 5500		Engine S/M
230/250	Kohler Branded D250	Electronic, GAC ESD 5500		Engine S/M
230-300	DDC Series 60	Electronic, DDEC		Engine S/M
275/300	Kohler Branded D300	Electronic, EDC III		Engine S/M
350	Kohler Branded D350	Electronic, EDC III		Engine S/M
350/400	DDC Series 60	Electronic, DDEC		Engine S/M
400	Kohler Branded D400	Electronic, EDC III		Engine S/M
450	Kohler Branded D450	Electronic, EMS II		Engine S/M
450/500	DDC Series 2000	Electronic, DDEC		Engine S/M
500	Kohler Branded D500	Electronic, GAC ESD 5500		Engine S/M
500	Kohler Branded D500	Electronic, EMS II		Engine S/M
600	Kohler Branded D600	Electronic, Woodward PROACT II		Engine S/M
600-1000	DDC Series 2000	Electronic, DDEC		Engine S/M
650-1000	DDC/MTU Series 2000	Electronic, MDEC		Engine S/M
750	Kohler Branded D750	Electronic, Woodward PROACT II		Engine S/M
800	Kohler Branded D800	Electronic, Woodward PROACT II		Engine S/M
900/1000	Kohler Branded D1000	Electronic, Woodward PROACT II		Engine S/M
1250	Kohler Branded D1250	Electronic, Woodward PROACT II		Engine S/M
1250-2000	DDC Series 4000	Electronic, DDEC		Engine S/M
1350-2800	DDC/MTU Series 4000	Electronic, MDEC		Engine S/M
1600	Kohler Branded D1600	Electronic, Woodward PROACT II		Engine S/M
1820	Kohler Branded D1820	Electronic, Woodward PROACT II		Engine S/M
2000	Kohler Branded D2000	Electronic, Woodward PROACT II		Engine S/M

8.2 Electronic Governor

8.2.1 A-246045

Some generator sets are equipped with Barber-Colman Dyna 2500 electronic governors. This is an electronic device requiring no mechanical drive or hydraulic connection. The system consists of a magnetic pickup, an electronic control unit, and an actuator. The magnetic pickup monitors engine speed and transmits this information to the electronic control unit. See Figure 8-2. The electronic control unit interprets the signal from the magnetic pickup to control current input to the throttle actuator. The throttle actuator adjusts the throttle position on the engine. See Figure 8-3. Adjust the actuator shaft linkage for smooth, nonbinding operation and to hold the carburetor throttle lever in the closed position when the power is off. The magnetic pickup air gap is 0.36–0.71 mm (0.014–0.028 in.).

See Section 8.4 for the magnetic pickup adjustment.

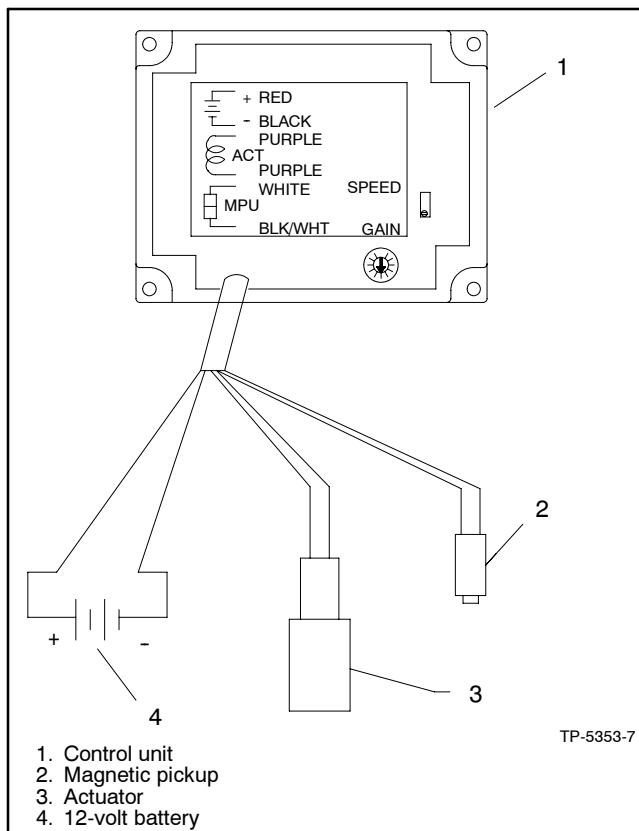

Figure 8-2 Governor Control Unit

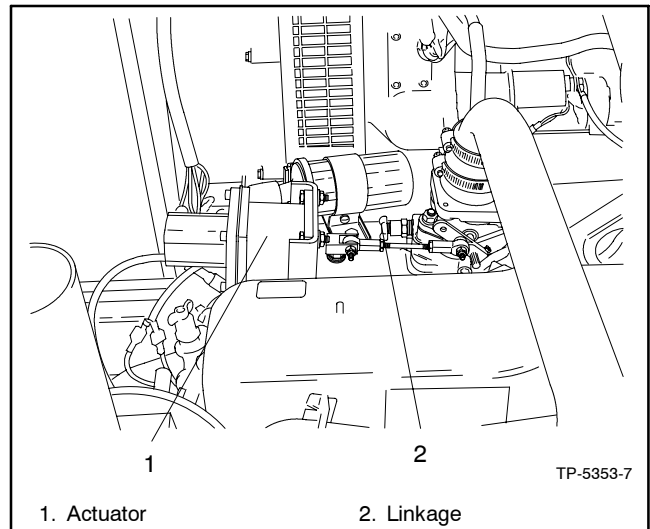

Figure 8-3 Throttle Actuator, Typical

Preliminary Adjustments

1. Place generator set master switch to the OFF position. The generator set must not be running.
2. Set the gain adjustment three divisions from zero.

Final Adjustments

1. Place generator set master switch to RUN to start generator set.
2. Adjust the control unit speed potentiometer until the engine is operating at the desired rpm (50 or 60 Hz on the frequency meter).
3. If governing is unstable, turn gain potentiometer slightly counterclockwise (CCW).
Note: Gain potentiometer has internal stops at 0% and 100%.
4. With the engine running at no load, finalize gain adjustment. Turn the gain adjustment clockwise (CW) until the output shaft and linkage is stable. Upset the linkage by hand. If the linkage oscillates 3–5 times then stops, the setting is correct.
5. Place the generator set master switch to the OFF position to stop the generator set.

8.2.2 GM17644-4 (Non-Load Sharing) and GM17644-5 (Load Sharing)

This section covers the non-load sharing governor (Figure 8-4) and the load sharing governor (Figure 8-5).

See Section 8.4 for the magnetic pickup adjustment.

Actuator Installation (John Deere)

Use the following procedure to install the actuator.

1. Install the new cover seal into the groove of the integrated actuator cover assembly.
2. Position the integrated actuator cover assembly into the top of the pump while holding the metering valve drive coupling parallel to the pump body. Slightly lift the front portion of the integrated actuator cover.
3. Carefully slide the integrated actuator cover toward the rear of the pump body until the mounting holes between the integrated actuator cover and pump body align.
4. Use two long cover screws and one short cover screw to assemble the integrated actuator cover to the pump body. Tighten the screws to 4–5 Nm (35–45 in. lb.).
5. Install a new O-ring on the return line connector assembly. Apply a light coating of all-purpose grease to the O-ring and install the connector. Tighten to 5–6 Nm (43–55 in. lb.).
6. Install the fuel return line to the return line connector.

Preliminary Adjustments

Refer to Section 8.5, Digital Isochronous Governor Programming Kit GM39344.

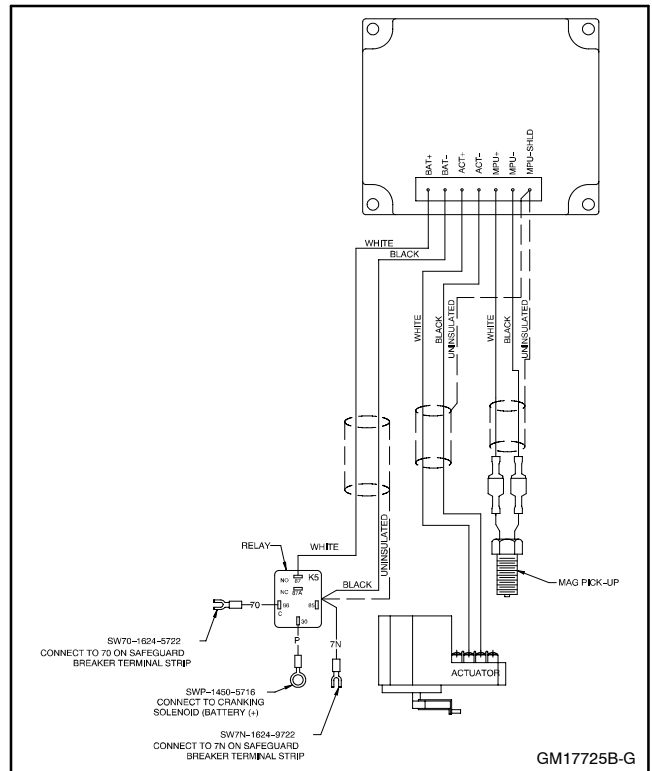

Figure 8-4 Governor Non-Load Sharing

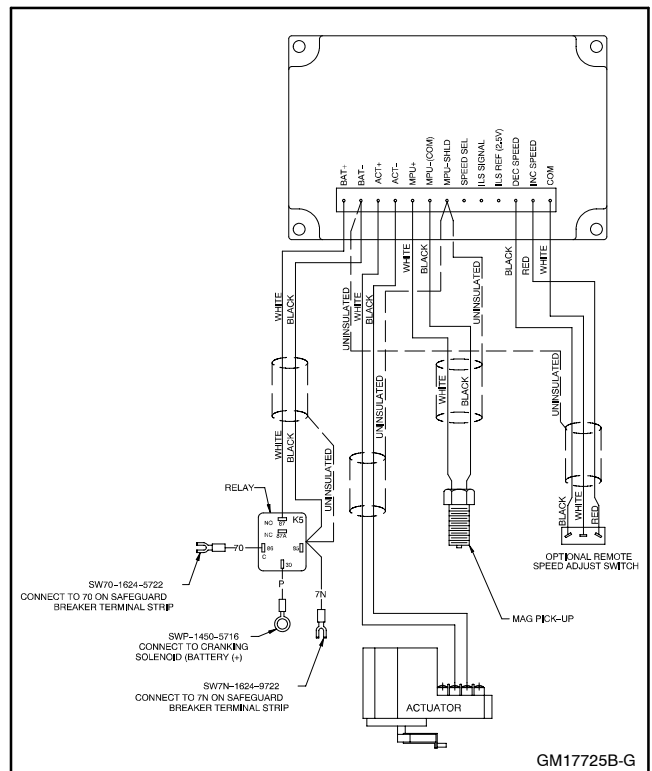

Figure 8-5 Governor Load Sharing

Final Adjustments

Warm engines are normally more stable than cold engines. If the governor is adjusted on a warm engine, decrease the overall gain, derivative gain, and integral gain by 5% to ensure a stable engine when started cold.

1. Move the generator set master switch to the RUN position.
2. Adjust the frequency with the INC/DEC buttons on governor controller to bring the frequency to 67 Hz for 60 Hz models and 56 Hz for 50 Hz models.

If the desired frequency cannot be attained, go to step 3.

If the desired frequency is attained, go to step 7.

3. Slowly back out the high idle screw while holding the engine speed lever in the high idle position until you obtain the desired frequency.
4. Tighten high idle locknut to 4-5 Nm (35-45 in. lb.).
5. Turn in the low idle screw to lock lever in place and tighten low idle locknut to 4-5 Nm (35-45 in. lb.).
6. Readjust the frequency with the INC/DEC buttons on governor controller to bring the frequency to 67 Hz for 60 Hz models and 56 Hz for 50 Hz models.
7. With no load applied, increase the overall gain until the engine begins to hunt.

If the engine does not begin to hunt, momentarily disrupt the governor power supply. Then decrease the overall gain until stable.

For optimum performance, the engine should oscillate 3-5 diminishing cycles after being disrupted.

Troubleshooting

If the governor system fails to operate and the actuator is suspected to be the problem, perform the following tests.

Measure the actuator coil resistance. The values shown in Figure 8-6 are for readings at ambient temperature.

Actuator	Resistance, ohms
12 VDC	2.05 ±0.25
24 VDC	7.20 ±0.50

Figure 8-6 Actuator Coil Resistance Values

Measure the coil isolation. The coil to case resistance should be >3 megohms.

Remove the actuator from the generator set. Manually move the actuator through its range of motion. No binding or sticking should occur.

Before testing the actuator, place a diode (Motorola P/N MUR810 or equivalent) across the actuator terminals. Energize the actuator to full fuel position. The actuator should operate smoothly throughout its entire stroke without any interruptions in motion.

If the actuator passes these tests, the problem is likely in the governor controller and/or fuel system.

8.3 Mechanical Governor

8.3.1 Stanadyne DB2/DB4

Note: Before checking and adjusting engine speed, make sure engine has reached its normal operating temperature.

All speeds indicated apply to a hot engine under load. The maximum permissible speed variation is 50 rpm for fast idle speed.

1. Disconnect speed control from fuel injection pump lever.
2. Move the generator set master switch to the RUN position to start the generator set.
3. Verify that injector pump lever is held in fast idle position against fast idle adjusting screw. See Figure 8-7.

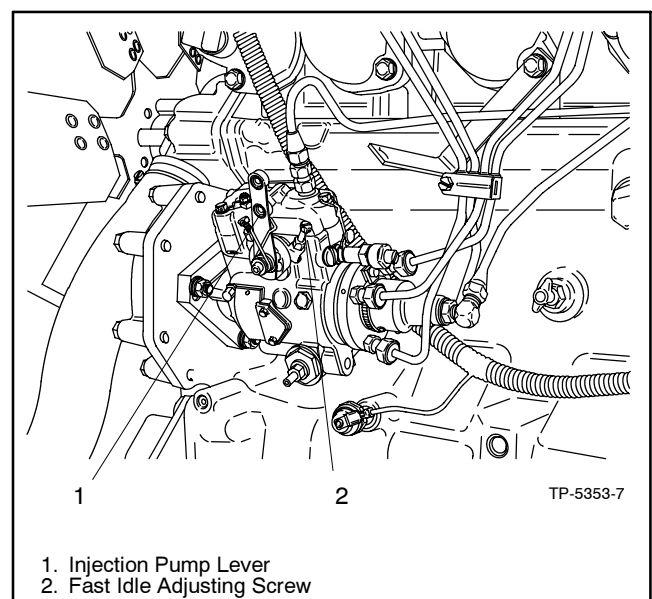

Figure 8-7 Governor Adjustments, Typical

- Using a tachometer, check engine speed. Adjust engine speed to obtain a full load engine speed of 1800 rpm (60 Hz) or 1500 rpm (50 Hz).

To increase engine speed, rotate fast idle adjusting screw CCW; rotate fast idle adjusting screw CW to decrease engine speed.

- Reconnect speed control to fuel injection pump lever.
- Move the generator set master switch to the OFF/RESET position to stop the generator set.

8.3.2 Bosch P

Note: Before checking and adjusting engine speed, make sure engine has reached its normal operating temperature.

All speeds indicated apply to an engine hot under load. The maximum permissible speed variation is 50 rpm for fast idle speed.

- Move the generator set master switch to the RUN position to start the generator set.
- Verify that injector pump lever is held in fast idle position. See Figure 8-8.
- Check fast idle engine speed. Engine speed should be 1800 rpm (60 Hz) or 1500 rpm (50 Hz) at full load.

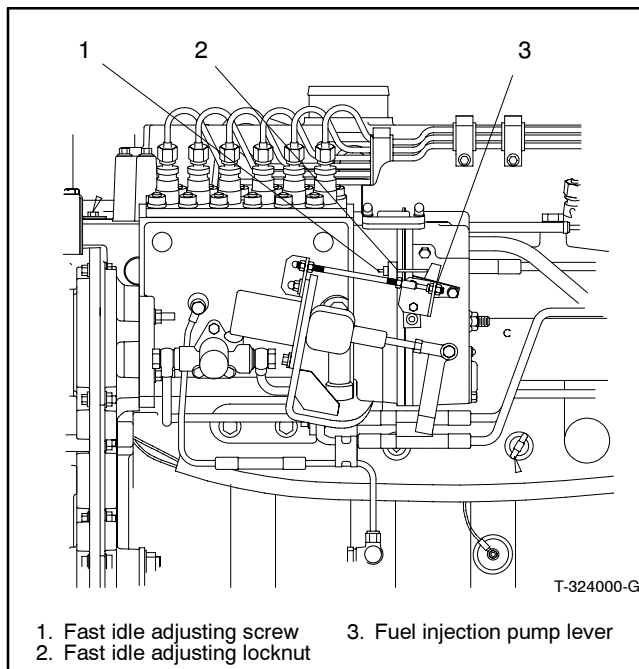

Figure 8-8 Governor Adjustments, Typical

- If fast idle speed is incorrect (but not more than 50 rpm above or below the minimum/maximum specified settings), loosen fast idle adjusting locknut.

Note: If the fast idle is 50 rpm above or below the minimum/maximum settings, have an authorized service dealer/distributor remove and adjust the pump on a test stand.

If engine speed is too low, loosen fast idle adjusting screw until speed is correct. If engine speed is too high, turn fast idle adjusting screw in until correct speed is obtained. Tighten locknut securely.

- Move the generator set master switch in the OFF/RESET position to stop the generator set.

8.4 Magnetic Pickup Adjustment

The magnetic pickup adjustment applies to all models so equipped. Use the following procedure.

- Place the generator set master switch to the OFF/RESET position.
- The flywheel must not be rotating. Loosen the jam nut.
- Turn in the magnetic pickup until the pole face of the magnetic pickup bottoms on the ring gear tooth.
- Back out the magnetic pickup 1/4 to 1/2 turn providing a 0.35–0.71 mm (0.014–0.028 in.) air gap.
- Tighten the jam nut without moving the magnetic pickup.

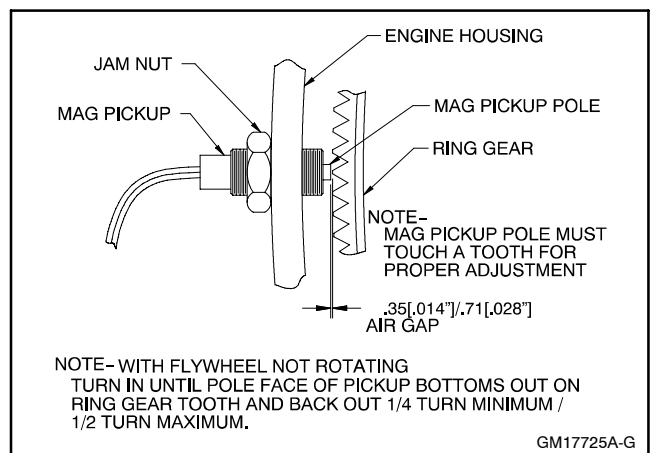

Figure 8-9 Magnetic Pickup Adjustment

8.5 Digital Isochronous Governor Programming Kit GM39344

Adapted from Instruction TT-1399.

8.5.1 Introduction

The digital isochronous governor programming kit includes the programming CD-ROM and cable for connecting the governor controller to the user's PC. This instruction is used in conjunction with the digital isochronous governor kits.

The programming kit or Parameter Setup Tool (PST) tells the governor controller how to operate the generator set governing system for that application.

The digital isochronous governor kits replace discontinued generator set governors. See Figure 8-10. Replacement governors are shipped unprogrammed. After installation and wiring, the governor kit requires downloading the PST and changing the default settings.

Service Kit	Governor Assembly	Replaces:
GM36253	GM17644-4	A-249922
GM36254	GM17644-4	A-246045
GM38323	GM17644-4	324515, 324704, 326814, 336236, 336396
GM39342*	GM17644-5	227264, 255932, 324547, 336397, 347840, 347841
GM39343	GM17644-6	GM22742
* Load share governor		

Figure 8-10 Service Kits and Discontinued Governors

The PST overwrites any original programs in the governor controller's nonvolatile memory. Make a backup copy of the files onto a disk and store the disk in a safe place.

The CD-ROM file contents can also be requested through KOHLERnet. Use your SecurID to access the KOHLERnet, click on the TechTools button, and follow the instructions to request files.

Read the entire procedure before beginning. Install the software onto a PC. Carefully follow these instructions and any additional instructions that appear on screen during the download procedure. The instructions provided assume you know how to operate a PC.

Loading incorrect or incomplete files may cause permanent damage to the governor controller's logic circuit board. Verify that the CD-ROM file contains settings for your specific generator set and engine. Do not attempt to modify the data files.

8.5.2 Kit Components

- COMM port cable (9-pin RS-232 DB9F serial port connector to a RJ11M plug)
- CD-ROM including:
 - Parameter Setup Tool Software
 - Parameter Text Files
 - Governor Parameter Detail Form
 - Governor Parameter Summary Form
 - TT-1399 Governor Programming Instructions

8.5.3 Features and Specifications

The microprocessor-based, digital isochronous governor allows adjustment of set speed and gain. Other adjustments include acceleration, deceleration, ramp rates, idle speed set, and hold time. The COMM port provides simple programming when connected to the user's PC. See Figure 8-11 for specifications and Figure 8-12 for governor controller illustrations.

Specifications	Value
Maximum Controlled Output Current	7 Amps
Maximum Current Surge	14 Amps for 10 seconds
Input Signal from Magnetic Pickup	2.0 VAC RMS min. during cranking
Ambient Operating Temperature	-40°C to +85°C (-40°F to +185°F)
Environmental Protection	Oil, water, dust resistant via conformal coating and die cast enclosure
Electrical Connections	Euro-style terminal strip

Figure 8-11 Specifications

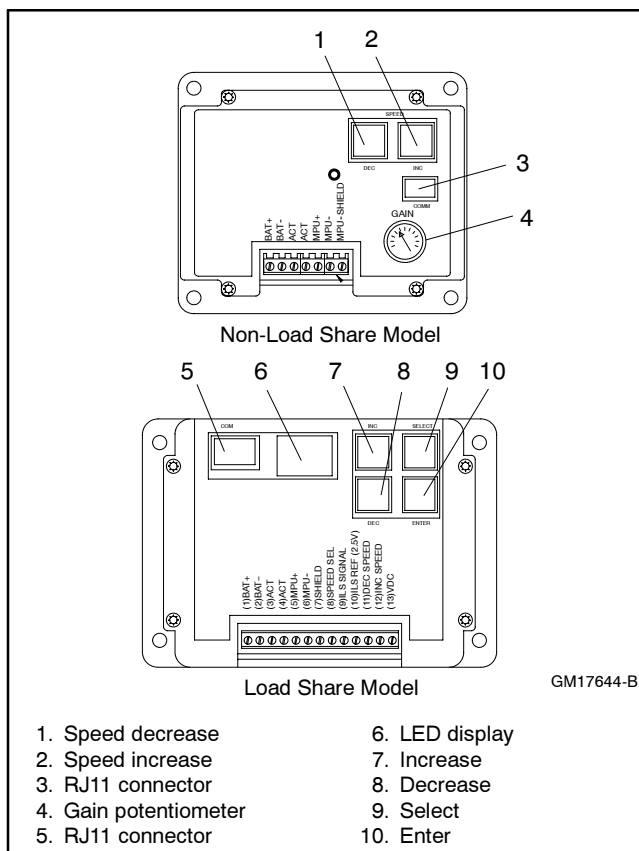

Figure 8-12 Governor Controller Functions

Other features include:

- 0.25% frequency control.
- Reverse battery protection.
- 9–30 VDC input.
- Smoke control on startup.
- Serial communication port.
- Droop operation with 0%–10% set speed with 0.10% resolution (load share model).
- Parallel input (load share model).
- Speed adjustment and voltage measurement ranges (load share model).

8.5.4 Keypad Functions

The governor controller keypad provides functions as described below. Refer to Figure 8-12 illustrations.

The Set Speed A and Gain (OVG @ Set Speed A) values can be changed using the governor controller keypad and potentiometer adjustment on non-load share models.

All values can be changed using the governor controller keypad on load share models.

Non-Load Share Model

These models provide speed adjustment for increase/decrease speed and a gain potentiometer. No other functions are available on the governor controller.

Load Share Model

The user interface operates in two modes—Parameter Select Mode and Parameter Edit Mode.

The Parameter Select Mode provides the user selection of viewing and editing parameters. This mode is active when the 2-digit value display is flashing (blinks). The value is the parameter identification (ID) number. The governor controller label lists each user-adjustable parameter and the corresponding ID number.

The Parameter Edit Mode provides the user with the selected parameter's value and allows the changing of a value. This mode is active when the 2-digit value display is steady on. The value displayed is the selected parameter's current value. The decimal point display has several meanings:

- Decimal point flashing indicates the value can be edited.

- Decimal point not flashing indicates the value cannot be edited. The selected parameter is locked and values are viewable only. This situation occurs when the password protection is active and the unlocking code has not been entered.
- The right digit's decimal point is ON—the lower two digits of a parameter's 4-digit value are displayed.
- The left decimal point is ON—the greater two digits of a parameter's value are displayed. The upper two digits of a parameter are always view only and cannot be modified directly. The upper two digits will change when the lower digits transition from 99 upward or 00 downward.

The keypad consists of four pushbuttons—Enter, Select, INC, and DEC. See Figure 8-13 for a summary of functions by mode selection.

Parameter Select Mode	
LED Display	The ID number of a parameter listed on the label is flashing.
INC key	Increase the parameter ID number by 1.
DEC key	Decrease the parameter ID number by 1.
Select key	Activate the Parameter Edit Mode on the parameter number flashing.
Enter	Display the version number of the governor's programming.
INC and DEC simultaneously	Turn on all LED segments as a test.
Parameter Edit Mode	
LED Display	The value of the selected parameter is displayed. A flashing decimal point indicates the value can be changed.
INC key	Increase the selected parameter's value.
DEC key	Decrease the selected parameter's value.
Select key	Return to Parameter Select Mode and ignore the changes made to the parameter value.
Enter	Save the parameter's new value and return to the Parameter Select Mode.
INC and DEC simultaneously	Use to display the upper digits of values greater than 99.

Figure 8-13 Keypad Function Summary

Enter key. Use the Enter key to exit the Parameter Edit Mode and return to the Parameter Select Mode while the new value gets saved to nonvolatile memory. In the Parameter Select Mode, pressing the Enter key displays the version number of the governor's programming.

Select key. Use the Select key to enter the Parameter Edit Mode from the Parameter Select Mode after a particular parameter has been selected for editing.

Also use the Select key to escape the Parameter Edit Mode and return to the Parameter Select Mode without saving a change in the parameter's value. The parameter value reverts back to the value present when the Parameter Edit Mode was entered.

INC (Increase) key. Use the INC key to increase the displayed parameter ID or value depending upon mode selection.

In the Parameter Select Mode, each press of the INC key causes the display of the next higher parameter ID. After the maximum parameter ID is reached, the display loops back to the first display.

In the Parameter Edit Mode, each press of the INC key increases the current value. Holding the INC key down automatically causes the values to rise at an increasing rate until the INC key is released or the parameter's maximum value is reached.

DEC (Decrease) key. Use the DEC key to decrease the displayed parameter ID or value depending upon mode selection.

In the Parameter Select Mode, each press of the DEC key causes the display of the next lower parameter ID. After the minimum parameter ID is reached, the display loops back to the last display.

In the Parameter Edit Mode, each press of the DEC key decreases the current value. Holding the DEC key down automatically causes the values to fall at an increasing rate until the DEC key is released or the parameter's minimum value is reached.

INC and DEC keys together. In the Parameter Select Mode, pressing and holding the two keys at the same time causes the LED segments to go ON. This serves as a test for the LED segments. Release the keys to resume displaying the parameter ID number.

In the Parameter Edit Mode, pressing and holding the two keys at the same time permits viewing the upper two digits of a 4-digit number. The left digit's decimal point is turned on indicating that the thousands and hundreds digits are displayed.

Note: Not all parameters have four digit values, in which case the upper digits will display 0.0 (zero decimal point zero).

Release the keys and the tens and ones digits are again displayed. The right digit's decimal point is flashing when editing is allowed or steady on indicating that editing is not allowed.

8.5.5 LED Display Functions (Load Share Model only)

The governor controller LED display provides two 7-segment LEDs with digit's corresponding decimal point to display values and indicate mode of operation. Refer to Figure 8-12 illustration for the load share model.

When the LED display value flashes, the Parameter Select Mode is active.

When the LED display value is steady on, the selected parameter's value is displayed and the user interface is in the Parameter Edit Mode. The decimal points also indicate which half of a 4-digit value is displayed and whether editing is allowed.

The right digit's decimal point indicates that the lower 2 digits of a value (tens and ones) are displayed. When the right decimal point flashes, the values can be changed using the INC and DEC keys. When the right digit is steady on, no editing is allowed or is password protected.

The left digit's decimal point indicates that the upper 2 digits of a value (the thousands and hundreds) are displayed. The greater 2 digits are always view only so the right decimal point does not flash.

When values exceed four digits, the LED display uses the hexadecimal numbering system to represent the value of the thousands position. See Figure 8-14 and the following examples.

Note: For generator set applications, the values will not exceed 9999. This text is for informational purposes only in the event that a value is inadvertently entered above 9999.

Decimal Value	Hexadecimal Equivalent
10	A
11	B
12	C
13	D
14	E
15	F

Figure 8-14 Decimal to Hexadecimal Conversion Chart

Example A

The desired set value is 10069 Hz. The upper two digits should display A.0 and the lower two digits should display 69.

Pentium® is a registered trademark of Intel Corporation.
 IBM® is a registered trademark of International Business Machines Corporation.
 Microsoft®, Windows®, and Windows NT® are registered trademarks of Microsoft Corporation.

Example B

The desired set value is 10972 Hz. The upper two digits should display A.9 and the lower two digits should display 72.

8.5.6 PST Software

The PST software enables the user to adjust parameter settings and monitor governor operation when a user-supplied PC is connected to the governor controller via the COMM port.

Features

- Automatic configuration to each generator set when communication is established.
- Read/write access to all of a generator set's programmable parameters and features.
- Display of each parameter's default, minimum, and maximum values.
- Diagnostics utilizing automatic refresh of the generator set's status.
- Saving and reloading generator set setup information to and from a file for reuse.
- Single button read for acquiring current parameter values.
- Single button write to program a generator set with previously saved setup values.
- Engine speed monitoring via a chart recorder to aid in governor tuning.
- Saving chart recorder data to a Microsoft® Excel compatible file.
- Help information on each of the governor's parameters.
- Help information on using the PST.

8.5.7 PC System Requirements

- 100% IBM® PC compatible with a 133 MHz or higher Pentium® compatible CPU.
- Microsoft Windows® 98SE (second edition), Windows NT® Workstation Version 4.0, Windows® 2000, or Windows XP® operating system.
- Display resolution with SVGA (800 x 600) or higher.
- CD-ROM drive and minimum of 4 MB hard drive space for installation.
- One 9-pin RS-232 DB9M serial port.
- PCs using USB ports will require a serial adapter.
- Stable power supply. A laptop system with a fully charged battery or desktop system running with a battery backup system is recommended.

8.5.8 PST User Interface Overview

The PST for generator set applications has two main display modes—Table View and Chart View. Table view is the PST default setting.

Table View

In the table view, the user can perform the following items:

- View the current values for all user-programmable parameters in the Parameter Setup panel's table.
- Edit a parameter's value by double clicking on a cell in the *Value* column of the table.
- Left click Read All to refresh the values in the table shown on the Parameter Setup panel.
- Left click Write All to transmit setup values to the governor controller.
- Left click View Status to display read only parameters in the View Status panel.
- Left click View Chart to set the display mode to Chart View.

Chart View

In the chart view, the user can perform the following items:

- View the current values for all user-programmable parameters in the Parameter Setup panel's table.
- Edit a parameter value related to governor tuning. These same parameters are also on the main parameter setup table.
- Left click Data File to open a file for saving chart recorder data.
- Left click Data Reset to start data collection to the open file at the beginning.
- Left click Pause Chart to stop the chart recorder, which also stops writing data to the file. Left click Continue to start the chart recorder function.
- Adjust the horizontal and vertical settings for the chart recorder.
- Left click View Table to set the display mode back to Table View.

8.5.9 PST Menu Items

Use the following menus as needed:

File Menu

- Open a previously saved setup data file.
- Save the setup data to a file.
- Exit the program.

View Menu

- Select the Parameter Table view (Table View).
- Select the Chart Recorder view (Chart View).

Port Menu

- Select the PC's serial port connected to the governor controller.

Help Menu

- Help on the PST for generator sets.
- Help on the governor controller that is currently in communication with the PC.
- Information about the PST for generator set application.

8.5.10 Parameter Setup

The Parameter Setup panel displays a table where each row shows the name of a user-programmable parameter, the current value, and the parameter's (default, minimum, and maximum) values.

To modify a parameter's current value, select the value by double clicking the left mouse button on a cell in the table. The selected cell will be highlighted and the value can be modified. After entering the new value, press the PC Enter key to change the governor controller value.

To get help on a particular parameter, left click the parameter's value, then press <Control> F on the PC.

To see the current values for all of the generator set's parameters, left click Read All.

Left click Write All to transmit all parameter values to the governor controller automatically. The Write All button is very useful when reusing saved setup data to configure a new system the same as a previously created one. Load an existing set of previously saved parameter values into the Parameter Setup table using Open a Setup Data File from the File menu and then left click Write All.

8.5.11 Status View

The Status View panel is displayed only after left clicking View Status. The Status View panel is part of the Table View display mode.

The Status View panel displays a table where each row shows the Name of a read only parameter and its current Value when Auto Read is ON.

Left click Start Monitoring to have the PST program automatically refresh the values. Left click Stop Monitoring to disable automatic refresh.

8.5.12 Tuning View

The Tuning View panel is displayed only after left clicking View Chart. The Tuning View panel is part of the Chart View display mode.

To modify a tuning parameter's current value, select the value by double clicking the left mouse button on a cell in the table. The selected cell will be highlighted and the value can be modified. After entering the new value, press the PC Enter key to change the governor controller value.

8.5.13 Chart Recorder

The Chart Recorder is part of the Chart View display mode. Each time Chart View is entered, the last Data File is reset, the vertical scale defaults to a preset value, and the horizontal scale defaults to 20 seconds.

The vertical and horizontal scale options control the chart recorder's display characteristics. Use the horizontal scale to provide a chart recorder display at 60, 30, 20, 10, or 5 second intervals. Larger values compress the display while smaller numbers expand the display.

The Data File button opens a dialog box to name the file and path where chart recorder data is saved.

Use the Data Reset button to start data collection over using the current data file. The progress bar to the right of this button indicates the capacity of the data file. Each data file can hold approximately 10 minutes of data and the data is sampled 100 times per second. The progress bar displays the message The Data File is Full when it can no longer accept chart recorder data.

The Pause Chart button stops the chart recorder and data file updates. Left click this button, which is now named Continue, to activate the chart recorder.

Use the View Table button to return to the Table View display mode. Be sure to open a new Data File before returning to Table View if the data already collected needs saving. The active Data File is automatically reset each time the Chart View display mode becomes active.

8.5.14 Installation Procedure

1. Determine the governor assembly part number and engine model number. Before beginning the programming procedure, the user must determine the governor assembly part number and engine model number. The selection of the correct Parameter Text File later in this procedure depends on knowing these numbers.

- a. The governor assembly part number is stamped on the replacement governor included in the service kit. Knowing the service kit number and using Figure 8-10 will also provide the governor assembly part number.
 - b. The engine model number may be shown on the engine nameplate attached to the generator set engine block. Other sources for finding the engine model number include the respective generator set spec sheet and documentation included with the generator set sales invoice and/or warranty registration.
2. Connect the governor controller to the user-supplied PC.
 - a. Place the generator set master switch in the OFF/ RESET position.
 - b. Connect the supplied cable included in the kit from the user-supplied PC 9-pin RS-232 serial port to the governor controller RJ11 connector (phone jack). See Figure 8-12.
 3. Open the CD-ROM files.

The instructions provided assume you know how to operate a PC.

- a. Login to the user-supplied PC.
- b. Load the CD-ROM in the PC.
- c. Open the Readme.doc file and follow the instructions described. Use the *pst.help* file as needed.
- d. Copy the PST, Setup, and Parameter Text files to your PC hard drive.
- e. Run the Setup file on your PC hard drive by clicking *File-Open-Setup Data* and clicking *Run*.
- f. Copy the *PST_CONFIG.mdb* (MS Accessdatabase) file and paste it in the same folder as the PST file. The default folder is *ProgramFiles\Kohler\PST*.

- g. Energize the governor controller by moving the white lead/70A from the normally open K5 contact to the normally closed K5 contact. See Figure 8-15. Connecting to the normally closed contact will energize the governor controller without starting/running the generator set.

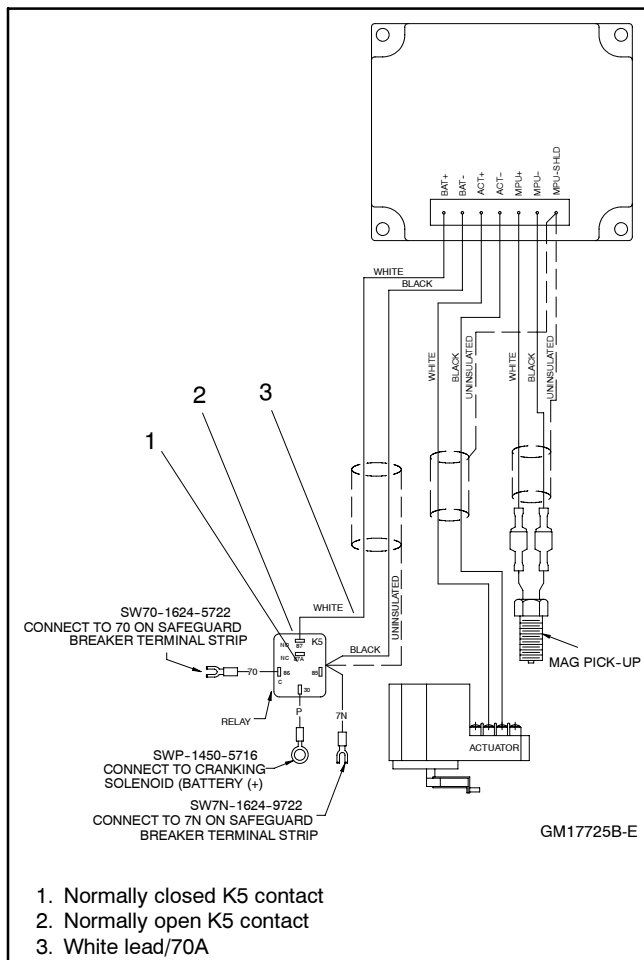

Figure 8-15 Energizing the Governor Controller (non-load share model shown)

- h. The supplied CD-ROM contains a Governor Parameter Summary for each generator set/engine combination. Print a copy of this summary as it provides the data necessary for programming the parameters for each specific generator set. See Section 8.6, Parameter Definitions, for detailed explanations of each parameter and Section 8.7, Parameter Defaults Reference.

- If Governor Parameter Summary includes your generator set/engine combination, go to step 4.

- If the Governor Parameter Summary DOES NOT include your generator set/engine combination, go to Section 8.9, Calibration Instructions.

Note: It is recommended to connect a load bank to the generator set in an effort to provide varying loads.

4. Program the governor controller and save the files.

- a. Use the part number data determined in step 1 and select the Parameter Text file by clicking *File-Open-“.Txt”*

The Read All values on the PC screen are the values shown on the printed Parameter Summary form.

- b. Click *Write All*. The selected parameter text file is then sent to the governor controller.
- c. Save and store this parameter text file on your PC hard drive, floppy disk, and/or CD-ROM for future reference.

5. Disconnect the governor controller from the user-supplied PC.

- a. Check that the generator set master switch is in the OFF position.
- b. Move the white lead/70A from the normally closed K5 contact back to the normally open K5 contact. See Figure 8-15.
- c. Disconnect the supplied cable included in the kit from the user-supplied PC 9-pin RS-232 serial port and the governor controller RJ11 connector (phone jack).
- d. Store the cable and CD-ROM together for later use as needed.

8.5.15 Troubleshooting

See Section 8.10, Diagnostics and Troubleshooting, for help in diagnosing generator set/engine problems relating to the governor controller.

8.6 Parameter Definitions

(Digital Isochronous Governor Programming Kit GM39344)

Use this section for definitions of each of the calibration values. Section 8.7, Parameter Defaults Reference, lists the default settings.

When changing values using the keypad, the PST display on the user's PC will not automatically update. To refresh the PST display, the user must select a different parameter with the PC mouse and then go back to the desired value. The PST provides *Read All* button which will refresh all of the parameter values.

1. **Number of flywheel teeth.** Enter the value from the Governor Parameter Summary. This display is not required. Displayed speeds can be changed between Hz and rpm.
2. **Set Speed A.** Enter the value from the Governor Parameter Summary.
3. **Set Speed B (load share model only).** Use the default value.
4. **Idle Speed.** Enter the value from the Governor Parameter Summary.
5. **Proportional.** Enter the value from the Governor Parameter Summary.

A speed change creates a speed error (the difference between the target speed and the actual speed.) The Proportional gain controls the size of the governor output response to a step change in the speed error. See Figure 8-16.

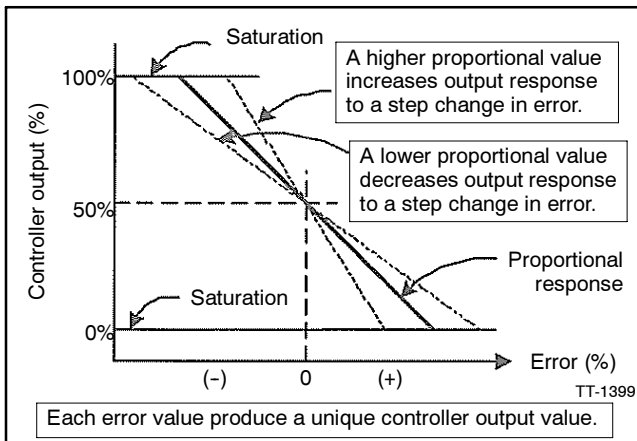

Figure 8-16 Proportional Value

6. **Integral.** Enter the value from the Governor Parameter Summary.

The Integral value acts to drive the speed error to zero. In a Proportional only control with constant load, there will be a constant speed error that inversely relates to the Proportional gain of the system.

The Integral value is key to isochronous speed control. This value eliminates the difference between the programmed set speed and the actual speed. The Integral gain changes the time it takes to drive the error to zero. The Integral value eliminates the speed offsets due to Proportional gain and should not be set to zero. See Figure 8-17.

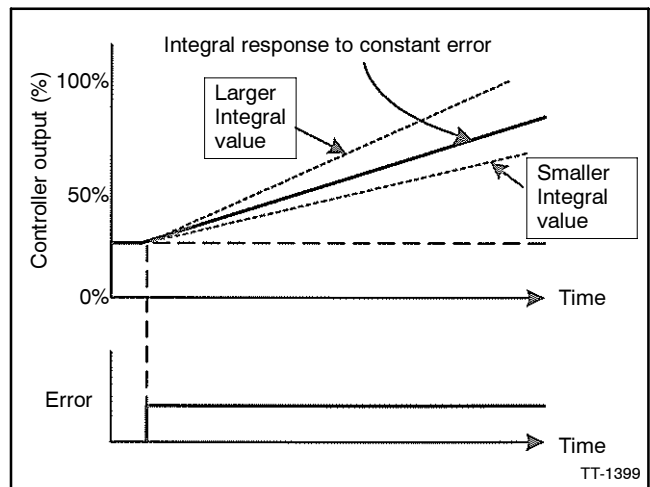

Figure 8-17 Integral Value

7. **Derivative.** Enter the value from the Governor Parameter Summary. See Figure 8-18.

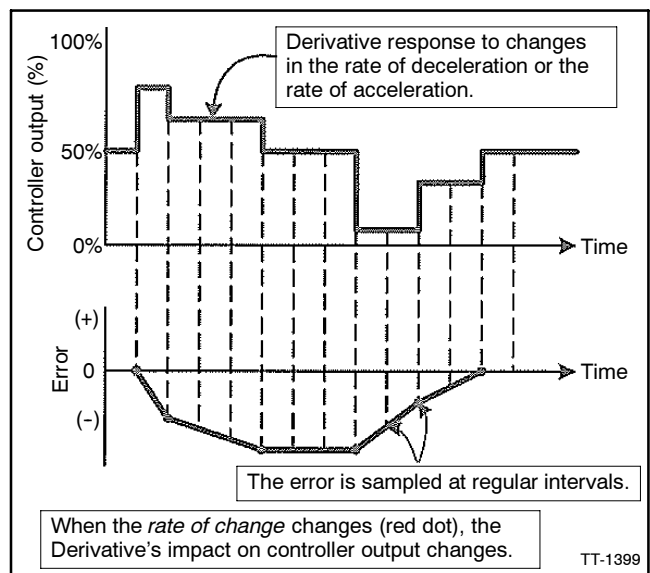

Figure 8-18 Derivative Value

The Derivative responds to the rate of change in the speed error. This parameter is primarily used to dampen very rapid oscillations resulting from large speed changes. The Derivative responds to engine acceleration or deceleration. When the engine speed approaches the target speed at a fast rate, the Derivative acts to minimize or eliminate overshoot. A zero value is allowed but systems typically require some Derivative gain to improve overall engine speed control.

- 8. Overall Gain (OVG) @ Set Speed A.** Set the default setting from the Governor Parameter Summary.

This gain value acts as a multiplier on the three Proportional, Integral, and Derivative (PID) values of Speed A.

- 9. Overall Gain (OVG) @ Set Speed B (load share model only).** Use the default value.

This gain value acts as a multiplier on the three PID values of Speed B.

- 10. Overall Gain (OVG) @ Idle.** Enter the value from the Governor Parameter Summary.

This gain value acts as a multiplier on the three PID values when the Idle Speed is the active target speed. The Idle Speed set point is active only during startup when the Idle Hold Timer is running.

- 11. Gain Factor.** Enter the value from the Governor Parameter Summary.

The Gain Factor permits more range of adjustment from the PID values. When any of the PID reaches their adjustment limit, the Gain Factor can be modified for more range of the PID and OVG values.

- 12. Speed Filter.** Enter the value from the Governor Parameter Summary.

This value indicates the number of speed signal pulses to use when calculating an average engine speed and is used to dampen out speed measurement variations that can make PID tuning difficult.

Too much filtering slows down the governor's response to speed change and too little filtering can make the governor overly sensitive and tuning difficult. As a general rule, less filtering is needed when the number of engine cylinders increases because there is less time for the engine speed to slow down before the next engine cylinder firing.

Note: Use 24 for three- or four-cylinder engines and 16 for six- or eight-cylinder engines.

- 13. Idle Hold Time.** Use the default value.

The Idle Hold Time specifies how long after starting the engine stays at Idle Speed before finishing the ramp to the target speed. The time value has a resolution of one-tenth of a second.

During the startup sequence, the governor increases the engine speed from the engine's crank speed to the active target speed at the Startup Rate specified. When the Idle Hold Time is nonzero, the initial target speed will be the Idle Speed. After the Idle Hold Time times out, the governor uses the Startup Rate to ramp the engine to the selected Set Speed (A or B). The startup sequence is complete after the engine speed reaches the specified set speed.

- 14. Accel Rate.** Use the default value.

This value specifies how fast the governor should increase the engine's speed when a new higher speed is made active.

- 15. Decel Rate.** Use the default value.

This value specifies how fast the governor should decrease the engine's speed when a new higher speed is made active.

- 16. Startup Rate.** Enter the value from the Governor Parameter Summary.

This value achieves a smooth controlled engine start. On diesel engines, this value minimizes exhaust smoke at startup. When used in conjunction with the Idle Speed and Idle Hold Time, a brief warmup cycle can be programmed.

The Startup Rate specifies how fast the governor should increase the engine speed when the engine is started. The governor increases the engine speed from the engine's crank speed to the active target speed at the rate specified. The governor brings the engine to the Idle Speed for the Idle Hold Time, then continues increasing the engine speed at this same ramp rate until the engine reaches the selected target speed (Set Speed A or B).

Note: In cases where the target speed is less than the Idle Speed and the Idle Hold Time is nonzero, the startup ramp sequence ends when Idle Speed is reached. Decel Rate is then used to ramp engine speed down to target speed from Idle Speed.

The ramp up pauses at the Startup Speed until the governor senses an magnetic pickup (MPU) signal greater than the Startup Speed. This prevents the startup ramp from reaching completion before the engine has started.

The governor treats MPU frequencies below the Startup Speed as an indication that the engine is cranking but has not yet started. The governor treats MPU frequencies above the Startup Speed as an indication that the engine has started and the governor increases the engine speed until the selected set speed is reached.

Note: In cases where target speed is less than Startup Speed, the startup ramp sequence ends when the target speed is reached.

During the startup sequence, the governor increases the engine speed from the engine's crank speed to the active target speed at the Startup Rate specified. When the Idle Hold Time is nonzero, the initial target speed is the Idle Speed. After the Idle Hold Time times out, the governor uses the Startup Rate to ramp the engine to the selected set speed (Set Speed A or B). The startup sequence is complete after the engine speed reaches the selected set speed.

17. **Startup Limit (load share model only).** Use the default value.

The Startup Limit parameter limits the fuel supplied to the engine during startup. This value is useful in reducing smoke when starting diesel engines.

Note: The engine may not start if the value is set too low.

18. **Torque Limit (load share model only).** Use the default value.

The Torque Limit parameter limits the fuel supplied to the engine during heavy generator set loads or generator set overloads.

Note: The engine may not be able to carry its rated load if the value is set too low.

19. **Integral Low Limit.** Use the default value.

The Integral Low Limit value reduces underspeed duration after a long or sustained overspeed condition was present. The low limit helps reduce the duration and amount of engine underspeed by maintaining a minimum actuator position.

Note: Setting an improper value can prevent the governor from reaching target speed.

20. **Integral High Limit.** Enter the value from the Governor Parameter Summary.

The Integral High Limit value reduces overspeed duration after a long or sustained underspeed condition was present. The high limit helps reduce the duration and amount of engine overspeed by maintaining a maximum actuator position.

Note: Setting an improper value can prevent the governor from reaching target speed.

21. **Percent (%) Droop (load share model only).** Use the default value.

The percent droop value selects droop mode operation and specifies the percentage of droop required. When the percent droop parameter is set to zero (default setting), droop is not active.

Note: This value can only be changed during the Droop Calibration Procedure detailed in Appendix 8.9.

22. **No Load Calibration (load share model only).** Use the default value.

The No Load Calibration value is determined during the Droop Calibration Procedure and should not be set manually.

Note: This value can only be changed during the Droop Calibration Procedure.

23. **Full Load Calibration (load share model only).** Use the default value.

The Full Load Calibration value is determined during the Droop Calibration Procedure and should not be set manually.

Note: This value can only be changed during the Droop Calibration Procedure.

24. **Password.** Use the default value.

The password feature provides protection against inadvertent parameter changes that can occur when keys are pressed and a parameter modification is not intended. The password parameter has three possible settings: Disabled, Locked, and Unlocked.

Disabled. This setting turns off any password protection. Use this setting if password protect is not desired. This is the default setting from the factory. Enter a value of 99 to set the password protection parameter to the Disabled mode.

Load share model only. When password protect parameter is selected, the governor controller LED display shows *Pd* for 2 seconds, indicating the password-disabled mode; then the value *00*. is displayed. The user can then edit the value.

Locked. This setting means that password protection is active and only parameter viewing is allowed (parameter editing is disabled). Enter a value of 22 to set password protection to the Locked mode.

Load share model only. For 2 seconds after selection of the password protection parameter, the LED display shows *PE* for this mode and the rightmost decimal point will be steady ON (not flashing), then the value *00*. is displayed. The user can edit the value.

Unlocked. This setting means that password protection is active but parameter editing is allowed.

Load share model only. Entering a value of 30 in the Locked mode will unlock parameter editing. The user is free to edit parameters. If there is no governor controller keypad activity for 5 minutes, the governor controller returns to the Locked mode. If not already in the Unlocked mode, the user must get into the Unlocked mode in order to enter 99 to disable password protection.

25. **Overspeed limit.** Use the default value.

This value determines the engine speed that triggers the governor output minimum fuel. The parameter's value is in terms of a percentage over the highest set speed.

Note: The governor controller must be turned off to clear the overspeed detection before the engine can be restarted.

26. **Set Speed A Min.** Enter the value from the Governor Parameter Summary.

Use Set Speed A minimum to set the lowest value allowed for adjustments of Set Speed A.

27. **Set Speed A Max.** Enter the value from the Governor Parameter Summary.

Use Set Speed A maximum to set the highest value allowed for adjustments of Set Speed A.

28. **Set Speed B Min. (load share model only).** Enter the value from the Governor Parameter Summary.

Use Set Speed B minimum to set the lowest value allowed for adjustments of Set Speed A.

29. **Set Speed B Max. (load share model only).** Enter the value from the Governor Parameter Summary.

Use Set Speed B maximum to set the highest value allowed for adjustments of Set Speed A.

30. **Idle Speed Min.** Enter the value from the Governor Parameter Summary.

The Idle Speed minimum value is the lowest value allowed for adjustments of Idle Speed.

31. **Idle Speed Max.** Enter the value from the Governor Parameter Summary.

The Idle Speed maximum value is the lowest value allowed for adjustments of Idle Speed.

32. **Duty Cycle Limit.** Enter the value from the Governor Parameter Summary.

The duty cycle maximum value sets the absolute maximum amount of drive signal to the actuator and serves as a mechanism for fuel limiting. Fuel limiting is achieved by setting the maximum duty-cycle or ontime allowed during one cycle of the pulse width modulation (PWM) signal controlling the actuator drive circuit.

33. **Startup Speed.** Use the default value.

The Startup Speed value allows the governor to determine whether the engine is cranking or running whenever an engine speed signal is present.

The Startup Speed value should be at least 10% higher than the fastest engine cranking speed but lower than the engine's Idle Speed.

If the Startup Speed is too low (less than crank speed) the governor's target speed is ramped to the active Set Speed (Idle, Set Speed A or B) before the engine has started. When the engine does not start, it may overspeed or output excessive smoke because the startup ramp, having already completed, no longer controls the rate of engine speed increase.

If the Startup Speed is too high (above the active set speed) then the Startup Speed becomes the target speed that the governor must reach before the governor considers the startup sequence complete. Typically, the startup sequence ends when the engine speed reaches the active set speed. The active set speed is the Idle Speed if the Idle Hold Time parameter is a nonzero value or the selected set speed (either Set Speed A or B).

34. **Startup Duty Cycle.** Enter the value from the Governor Parameter Summary.

The Startup Duty Cycle value is used to preload the PID values with a PWM duty cycle value that provides an actuator output signal sufficient to allow enough fuel to idle the engine.

If the Startup Duty Cycle value is too low, the engine crank time may be longer than desired because the governor's actuator output starts from a value much smaller than needed to begin opening the fuel valve.

If the Startup Duty Cycle value is too high, the engine may overspeed because the actuator opens more that needed to start the engine.

8.7 Parameter Defaults Reference (Digital Isochronous Governor Programming Kit GM39344)

No.	Parameter Name	Load Share Only	Minimum	Maximum
1	No. of flywheel teeth		0	572
2	Set Speed A (Hz)		Set Speed A Min.	Set Speed A Max.
3	Set Speed B (Hz)	Yes	Set Speed B Min.	Set Speed B Max.
4a	Idle Speed (Hz)		Idle Speed Min.	Idle Speed Max.
4b	Idle Speed (Hz)	Yes	Idle Speed Min.	Idle Speed Max.
5	Proportional		1	99
6	Integral		0	99
7	Derivative		0	99
8	OVG @ Set Speed A (gain potentiometer)	Yes	1	99
9	OVG @ Set Speed B	Yes	1	99
10	OVG @ Idle		1	99
11	Gain Factor		1	99
12	Speed Filter		1	24
13	Idle Hold Time (sec.)		0	9999
14	Accel Rate (Hz/sec.)		1	11000
15	Decel Rate (Hz/sec.)		1	11000
16	Startup Rate (Hz/sec.)		1	11000
17	Startup Limit	Yes	0	1000
18	Torque Limit	Yes	0	1000
19	Integral Low Limit		0	Integral High Limit
20	Integral High Limit		Integral Low Limit	99
21	% Droop	Yes	0	100
22	No Load Calibration	Yes	0	1000
23	Full Load Calibration	Yes	0	1000
24	Password		0	99
25	Overspeed limit (Hz)		0	6000
26	Set Speed A Min. (Hz)		10	Set Speed A
27	Set Speed A Max. (Hz)		Set Speed A	11000
28	Set Speed B Min. (Hz)	Yes	10	Set Speed A
29	Set Speed B Max. (Hz)	Yes	Set Speed B	11000
30	Idle Speed Min. (Hz)		10	Idle Speed
31	Idle Speed Max. (Hz)		Idle Speed	11000
32	Duty Cycle Limit		10	95
33	Startup Speed (Hz)		10	11000
34	Startup Duty Cycle		5	95

8.8 Parameter Default Settings

No.	Parameter Name	Load Share Only	Default Settings		
			GM17644-4	GM17644-5	GM17644-6
1	No. of flywheel teeth		0	0	0
2	Set Speed A (Hz)		1000	1000	25
3	Set Speed B (Hz)	Yes	-	1000	-
4a	Idle Speed (Hz)		500	-	20
4b	Idle Speed (Hz)	Yes	-	500	-
5	Proportional		1	1	1
6	Integral		0	0	0
7	Derivative		0	0	0
8	OVG @ Set Speed A (gain potentiometer)	Yes	-	20	-
9	OVG @ Set Speed B	Yes	-	20	-
10	OVG @ Idle		20	20	20
11	Gain Factor		1	1	1
12	Speed Filter		16	16	4
13	Idle Hold Time (sec.)		0	0	0
14	Accel Rate (Hz/sec.)		1000	1000	3000
15	Decel Rate (Hz/sec.)		1000	1000	3000
16	Startup Rate (Hz/sec.)		1000	1000	3000
17	Startup Limit	Yes	-	1000	-
18	Torque Limit	Yes	-	1000	-
19	Integral Low Limit		0	0	0
20	Integral High Limit		99	99	99
21	% Droop	Yes	-	0	-
22	No Load Calibration	Yes	-	0	-
23	Full Load Calibration	Yes	-	1000	-
24	Password		0	0	0
25	Overspeed limit (Hz)		6000	6000	450
26	Set Speed A Min. (Hz)		1000	1000	25
27	Set Speed A Max. (Hz)		5000	5000	300
28	Set Speed B Min. (Hz)	Yes	-	1000	-
29	Set Speed B Max. (Hz)	Yes	-	5000	-
30	Idle Speed Min. (Hz)		500	500	20
31	Idle Speed Max. (Hz)		5000	5000	300
32	Duty Cycle Limit		10	10	10
33	Startup Speed (Hz)		1000	1000	25
34	Startup Duty Cycle		5	5	5

8.9 Calibration Instructions

(Digital Isochronous Governor Programming Kit GM39344)

8.9.1 Basic Adjustments

The governor controller is programmed at the factory with default setting parameter settings. These settings allow the controller to operate but usually require some further adjustments to obtain the best system performance. In order to bring the engine up to a single speed for the first time, the user needs to adjust the parameters shown in Figure 8-19. Use the Calibration Instructions only when the Governor Parameter Summary does **not** include a specific generator set/engine combination.

The parameters listed in Figure 8-19 are the primary items to get the governor controller tuned and the engine running smoothly. It is recommended that the default settings in Figure 8-19 be initially used and then adjusted to satisfy the generator set/engine application. Leave all other parameters at their default settings until the primary parameter settings are determined.

Parameter No.	Parameter Name	Default Value
2	Set Speed A	1000
5	Proportional	25
6	Integral	50
7	Derivative	25
8	OVG @ Set Speed A	20
11	Gain Factor *	20
12	Speed Filter †	18

* Modify the Gain Factor only when the PID or OVG values reach their min./max. parameters.
 † The Speed Filter value should be set to 24 for 3- or 4-cylinder engines. Use a value of 16 for 6- or 8-cylinder engines.

Figure 8-19 Primary Parameter Setup

8.9.2 Calibration Techniques

After the engine is running, use the following procedure to determine optimum values for the Proportional, Integral, and Derivative (PID) values and the Overall Gain Parameters (OVG). The goal is to find PID values that allow the governor controller to govern the engine optimally at all loads while only requiring gain adjustment. Use the following steps:

1. Calibration Procedure.

The governor controller default programming provides the values shown in Figure 8-19. It is recommended to connect a load bank to the generator set in an effort to provide varying loads.

Note: Steps 1.f. through 1.j. require varying the generator set load to cause engine speed changes. Start with small load variations and continue with greater load changes to provide a better overall performance test.

With Integral, a speed error may persist after a load-on load-off transition. During steps 1.c. through 1.i., temporarily increase the Integral to get the engine speed back to the set speed, and then reset the Integral to a lower value again while working to find good Proportional and Derivative values.

Repeat steps 1.f. through 1.k. as needed to find Proportional, Integral, and Derivative values that work well with a variety of overall gain values and different load transients. See Figure 8-20.

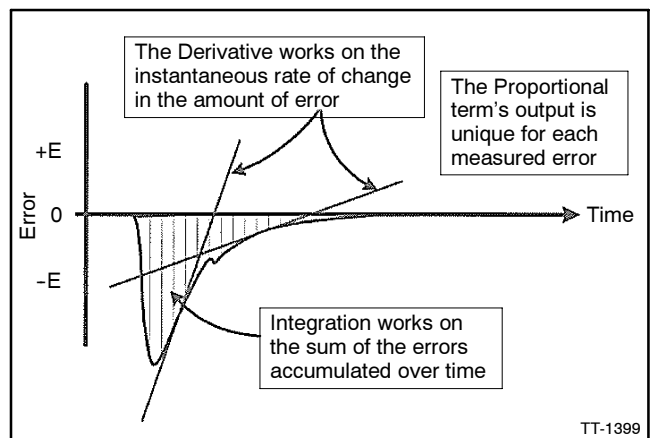

Figure 8-20 Relationships of DIP

- Open the line circuit breaker to disconnect the load from the generator set.
- Place the generator set master switch in the RUN position to start the generator set.
- Set the Set Speed A to 1800 rpm for 60 Hz models and 1500 rpm for 50 Hz models.
- Set the Integral and Derivative values to 0.
- Set the Overall Gain low (less than 20).
- Increase the Proportional value until the engine shows continuous oscillations greater than 2 Hz.
- Reduce the Proportional value by 25%–50%.
- Close line circuit breakers to connect load to the generator set.

- i. Make small Derivative value changes to dampen out *ringing* in response to load transients.
 - j. Increase the Integral to eliminate any steady-state error in the engine's speed and help decrease error recovery time.
 - k. Increase the Overall Gain to improve response time while keeping the ratios of the PID values relative to each other constant.
2. Droop Calibration Procedure (load share model only).

If droop calibration is required, go to step 2.a.

If droop calibration is not required, go to step 3.

Use this calibration procedure when droop is required.

After droop calibration, the difference between the No Load Cal and the Full Load Cal parameter values should be greater than 100 for best operation of droop. The droop function may still work for smaller differences but with less accuracy.

- a. Open the line circuit breaker to disconnect the load from the generator set.
- b. Place the generator set master switch in the RUN position to start the generator set.
- c. Set the Set Speed A to 1800 rpm for 60 Hz models and 1500 rpm for 50 Hz models if not already completed.
- d. Enter a value of 41 in the Password parameter allowing editing of the droop related parameters.
- e. Select the % Droop parameter and adjust the value to:

$\text{Selected Set Speed} / [(1000 - \text{Value of \% Droop}) / 1000]$
- f. Allow the engine to stabilize at the No Load droop speed and then press the governor controller's Enter key to set the percent droop. No Load Calibration is now complete.
- g. Select the Full Load Calibration procedure. The engine speed will return to the selected set speed.

- h. Apply full load to the engine and allow the speed to stabilize.
- i. Wait 5 seconds and then press the governor controller's Enter key to record the calibration value. Full Load Calibration is now complete.
- j. Remove the load from the generator set. The engine speed will increase to the no load droop speed. Droop calibration is now complete.
- k. Place the generator set master switch in the OFF position to stop the generator set.

3. Update the governor controller and save the files.
- a. Select WRITE ALL. The updated program is then sent to the governor controller.
 - b. Save and store this modified PST file on your PC hard drive, floppy disk, and/or CD-ROM for future reference.
 - c. In an effort to help us build a more complete data base, we request you share your calibration values by filling out the Governor Parameter Detail form. E-mail or fax the completed form to us and after our review, we will include the data in the Governor Parameter Summary.

E-mail: generatorfieldservice@Kohler.com

Fax number: 920-803-4977.

4. Disconnect the governor controller from the user-supplied PC.
- a. Check that the generator set master switch is in the OFF position.
 - b. Move the white lead/70A from the normally closed K5 contact back to the normally open K5 contact. See Figure 8-15.
 - c. Disconnect the supplied cable included in the kit from the user-supplied PC 9-pin RS-232 serial port and the governor controller RJ11 connector (phone jack).
 - d. Store the cable and CD-ROM together for later use as needed.

8.10 Diagnostics and Troubleshooting

(Digital Isochronous Governor Programming Kit GM39344)

8.10.1 Introduction

Use the troubleshooting chart to help diagnose generator set/engine problems relating to the governor controller.

8.10.2 Display Codes (Load Share Model)

Code	Fault
E0	Controller memory failure. Replace governor controller.
E1	Loss of remote speed potentiometer signal.
E2	Overspeed detected. Governor controller must be turned off and reset to allow an engine restart.
E3	Actuator drive overcurrent detected. Check wiring. Check actuator loading and linkage.

8.10.3 LED Indications (Non-Load Share Model)

LED State	Fault
Off	Governor controller is either not currently powered or is being reverse powered. (Check polarity of supplied power.) If correctly powered, governor controller is malfunctioning.
Blinking Slow (1/2 Hz)	Governor controller is powered, but not sensing a speed signal. OK if engine is not running. If the engine is running, this indicates a fault with the speed signal.
Blinking Fast (1 1/2 Hz)	Governor controller is powered and an engine speed signal is being detected. If the engine is not running, this indicates electrical noise on the speed signal wires.
ON and Not Blinking	Governor controller is powered and is malfunctioning. Replace governor controller.

8.10.4 Troubleshooting Chart

Symptom	Possible Cause	Remedy
LED display does not light up when the governor controller is powered	BAT+ and BAT- leads are reversed.	Check and correct wiring.
	Battery voltage is too low. Governor controller supply voltage should be 9-30 VDC.	Charge or replace the battery.
	Governor controller is defective.	Replace governor controller.
Unable to modify parameters	The parameter's value is the maximum value allowed.	Enter acceptable value.
	The parameter's value is the minimum value allowed.	Enter acceptable value.
	A display code is active (load share model).	Refer to Section 8.10.2, Display Codes.
	Password protection is enabled (load share model).	Enter Password.
	PST not communicating with the controller (non-load share model).	Check cable connection.
	Keypad is defective.	Replace governor controller.
Engine does not start	Actuator leads not connected or shorted.	Check and correct actuator wiring.
	No fuel source.	Check fuel supply, fuel line, and shutoff valves.
	Battery voltage is low.	Charge or replace the battery.
	Set speed is lower than crank speed.	Increase the set speed value.
	Startup rate setting is too low. The target speed ramps up too slow.	Increase the startup rate value.
	Startup limit is too low, limiting the actuator drive signal too much.	Increase the startup limit value.
	No magnetic pickup (MPU) speed signal present. Magnetic pickup should be 2.0 VRMS minimum.	Adjust the MPU gap. Try reversing the MPU leads; otherwise, replace the MPU.
	If a speed signal is present, measure the actuator output duty cycle.	If not greater than 5%, restore all parameter values to factory default settings and crank the engine again.
	Final target speed must be greater than crank speed before the governor will attempt to drive the actuator open (non-load share model).	Increase the final target speed value and/or decrease the crank speed value.
Engine overspeeds at startup	The proportional value is too low.	Increase the proportional value.
	The appropriate overall gain (OVG) value is too low.	Increase the appropriate OVG value.
	The startup limit is incorrect (load share model).	Adjust the startup limit value.
	The startup ramp rate is too high.	Decrease the startup ramp rate value.

Symptom	Possible Cause	Remedy
Engine does not reach set speed	Improper Proportional, Integral, and Derivative (PID) tuning values.	Check and adjust the PID values.
	Integral value is too low or zero.	Increase the integral value.
	Derivative value is too low or zero (load share model).	Increase the derivative value.
	PID values are too low. A tuning that is too soft can prevent the governor from delivering the needed actuator drive signal to reach the set speed.	Check and adjust the PID values.
	PID values are too high. Tuning is too hot or oversensitive to small speed errors causing the governor to make large, rapid changes in actuator drive signal, creating an average signal that is inadequate.	Decrease PID tuning values.
	The integral low limit setting is too high.	Return the integral low limit value to the default setting of zero.
	The integral high limit setting is too low.	Return the integral high limit value to the default setting of 99.
Engine takes too long to reach the set speed	Improper PID tuning values.	Check and adjust the PID values.
	Integral setting is too low.	Increase the integral value.
	Startup rate setting is too low.	Increase the startup rate value.
	Accel rate setting is too low.	Increase the Accel rate value.
	Speed filter setting is too high.	Decrease the speed filter value.
Engine does not track speed setting changes	Is the LED decimal point flashing (load share model)?	If yes, enter password.
	Is the LED flashing fast (3 Hz) (non-load share model)?	If no, check speed sensing circuit.
	Is the selected set speed parameter being modified?	If yes, speed setting display is unavailable during changes.
	A PID value or an OVG value is too high.	Decrease the PID values or OVG value.
	A PID value is too low or zero.	Increase the PID value.
	Accel rate is set too low.	Increase the Accel rate value.
	Decel rate is set too low.	Increase the Decel rate value.
Excessive smoke at startup	Improper PID tuning values.	Check and adjust the PID values.
	The startup rate is too high.	Use a lower startup rate value.
	The startup limit is too high.	Use a lower startup limit value.
	No/low MPU speed signal present. MPU should be 2.0 VRMS minimum.	Adjust the MPU gap. Try reversing the MPU leads; otherwise, replace the MPU.
Slow response to load changes	Gain value set too low.	Decrease the gain value.
	Improper PID tuning values.	Check and adjust the PID values.
	Speed filter setting is too high.	Decrease the speed filter value.
Engine instability with no load	Improper PID tuning values.	Check and adjust the PID values.
	Speed filter setting is too low.	Increase the speed filter value.
	Fuel flow is restricted.	Check actuator linkage.
	Battery voltage is too low.	Charge or replace the battery.
Engine instability with load	Improper PID tuning values.	Check and adjust the PID values.
	Fuel flow is restricted.	Check actuator linkage.
	Battery voltage is too low.	Charge or replace the battery.
Engine unable to carry rated load	PID values may be too high, causing the governor to overreact and make large, rapid changes in PWM duty cycle output to the actuator.	Check and decrease the PID values.
	Improper PID tuning values.	Check and adjust the PID values.
	Torque limit is set too low (load share model).	Increase the torque limit.
	Fuel flow is restricted.	Check actuator linkage.
Load share does not work (load share model)	No/low ILS input signal present. ILS should be 2.375-2.625 VDC.	Check ILS wiring; otherwise, replace the ILS.
	ILS signal wiring having electrical interference problems.	Use shielded wiring.
Droop does not work (load share model)	The no load and full load values are not calibrated.	Perform the droop calibration procedure.
	Difference between no load and full load calibration values is too small. Should be >100 for best performance.	Adjust the no load and/or full load calibration values.
	Actuator linkage range too small.	Modify or adjust actuator linkage to increase range of actuator loading.

Notes

Appendix A Abbreviations

The following list contains abbreviations that may appear in this publication.

A, amp	ampere	cfm	cubic feet per minute	est.	estimated
ABDC	after bottom dead center	CG	center of gravity	E-Stop	emergency stop
AC	alternating current	CID	cubic inch displacement	etc.	et cetera (and so forth)
A/D	analog to digital	CL	centerline	exh.	exhaust
ADC	advanced digital control; analog to digital converter	cm	centimeter	ext.	external
adj.	adjust, adjustment	CMOS	complementary metal oxide substrate (semiconductor)	F	Fahrenheit, female
ADV	advertising dimensional drawing	cogen.	cogeneration	fglass.	fiberglass
Ah	amp-hour	com	communications (port)	FHM	flat head machine (screw)
AHWT	anticipatory high water temperature	coml	commercial	fl. oz.	fluid ounce
AISI	American Iron and Steel Institute	Coml/Rec	Commercial/Recreational	flex.	flexible
ALOP	anticipatory low oil pressure	conn.	connection	freq.	frequency
alt.	alternator	cont.	continued	FS	full scale
Al	aluminum	CPVC	chlorinated polyvinyl chloride	ft.	foot, feet
ANSI	American National Standards Institute (formerly American Standards Association, ASA)	crit.	critical	ft. lb.	foot pounds (torque)
AO	anticipatory only	CRT	cathode ray tube	ft./min.	feet per minute
APDC	Air Pollution Control District	CSA	Canadian Standards Association	ftp	file transfer protocol
API	American Petroleum Institute	CT	current transformer	g	gram
approx.	approximate, approximately	Cu	copper	ga.	gauge (meters, wire size)
AQMD	Air Quality Management District	cUL	Canadian Underwriter's Laboratories	gal.	gallon
AR	as required, as requested	CUL	Canadian Underwriter's Laboratories	gen.	generator
AS	as supplied, as stated, as suggested	cu. in.	cubic inch	genset	generator set
ASE	American Society of Engineers	cw.	clockwise	GFI	ground fault interrupter
ASME	American Society of Mechanical Engineers	CWC	city water-cooled	GND, ⊕	ground
assy.	assembly	cyl.	cylinder	gov.	governor
ASTM	American Society for Testing Materials	D/A	digital to analog	gph	gallons per hour
ATDC	after top dead center	DAC	digital to analog converter	gpm	gallons per minute
ATS	automatic transfer switch	dB	decibel	gr.	grade, gross
auto.	automatic	dB(A)	decibel (A weighted)	GRD	equipment ground
aux.	auxiliary	DC	direct current	gr. wt.	gross weight
avg.	average	DCR	direct current resistance	H x W x D	height by width by depth
AVR	automatic voltage regulator	deg., °	degree	HC	hex cap
AWG	American Wire Gauge	dept.	department	HCHT	high cylinder head temperature
AWM	appliance wiring material	DFMEA	Design Failure Mode and Effects Analysis	HD	heavy duty
bat.	battery	dia.	diameter	HET	high exhaust temp., high engine temp.
BBDC	before bottom dead center	DI/EO	dual inlet/end outlet	hex	hexagon
BC	battery charger, battery charging	DIN	Deutsches Institut fur Normung e. V. (also Deutsche Industrie Normenausschuss)	Hg	mercury (element)
BCA	battery charging alternator	DIP	dual inline package	HH	hex head
BCI	Battery Council International	DPDT	double-pole, double-throw	HHC	hex head cap
BDC	before dead center	DS	disconnect switch	HP	horsepower
BHP	brake horsepower	DVR	digital voltage regulator	hr.	hour
blk.	black (paint color), block (engine)	E, emer.	emergency (power source)	HS	heat shrink
blk. htr.	block heater	ECM	electronic control module, engine control module	hsg.	housing
BMEP	brake mean effective pressure	EDI	electronic data interchange	HVAC	heating, ventilation, and air conditioning
bps	bits per second	EFR	emergency frequency relay	HWT	high water temperature
br.	brass	e.g.	for example (<i>exempli gratia</i>)	Hz	hertz (cycles per second)
BTDC	before top dead center	EG	electronic governor	IC	integrated circuit
Btu	British thermal unit	EGSA	Electrical Generating Systems Association	ID	inside diameter, identification
Btu/min.	British thermal units per minute	EIA	Electronic Industries Association	IEC	International Electrotechnical Commission
C	Celsius, centigrade	EI/EO	end inlet/end outlet	IEEE	Institute of Electrical and Electronics Engineers
cal.	calorie	EMI	electromagnetic interference	IMS	improved motor starting
CAN	controller area network	emiss.	emission	in.	inch
CARB	California Air Resources Board	eng.	engine	in. H ₂ O	inches of water
CB	circuit breaker	EPA	Environmental Protection Agency	in. Hg	inches of mercury
cc	cubic centimeter	ES	engineering special, engineered special	in. lb.	inch pounds
CCA	cold cranking amps	ESD	electrostatic discharge	Inc.	incorporated
ccw.	counterclockwise			ind.	industrial
CEC	Canadian Electrical Code			int.	internal
cert.	certificate, certification, certified			int./ext.	internal/external
cfh	cubic feet per hour			I/O	input/output
				IP	iron pipe
				ISO	International Organization for Standardization
				J	joule
				JIS	Japanese Industry Standard

k	kilo (1000)	MTBO	mean time between overhauls	rms	root mean square
K	kelvin	mtg.	mounting	rnd.	round
kA	kiloampere	MTU	Motoren-und Turbinen-Union	ROM	read only memory
KB	kilobyte (2 ¹⁰ bytes)	MW	megawatt	rot.	rotate, rotating
KBus	Kohler communication protocol	mW	milliwatt	rpm	revolutions per minute
kg	kilogram	μF	microfarad	RS	right side
kg/cm ²	kilograms per square centimeter	N, norm.	normal (power source)	RTU	remote terminal unit
kgm	kilogram-meter	NA	not available, not applicable	RTV	room temperature vulcanization
kg/m ³	kilograms per cubic meter	nat. gas	natural gas	RW	read/write
kHz	kilohertz	NBS	National Bureau of Standards	SAE	Society of Automotive Engineers
kJ	kilojoule	NC	normally closed	scfm	standard cubic feet per minute
km	kilometer	NEC	National Electrical Code	SCR	silicon controlled rectifier
kOhm, kΩ	kilo-ohm	NEMA	National Electrical Manufacturers Association	s, sec.	second
kPa	kilopascal	NFPA	National Fire Protection Association	SI	<i>Systeme international d'unites</i> , International System of Units
kph	kilometers per hour	Nm	newton meter	SI/EO	side in/end out
kV	kilovolt	NO	normally open	sil.	silencer
kVA	kilovolt ampere	no., nos.	number, numbers	SN	serial number
kVAR	kilovolt ampere reactive	NPS	National Pipe, Straight	SNMP	simple network management protocol
kW	kilowatt	NPSC	National Pipe, Straight-coupling	SPDT	single-pole, double-throw
kWh	kilowatt-hour	NPT	National Standard taper pipe thread per general use	SPST	single-pole, single-throw
kWm	kilowatt mechanical	NPTF	National Pipe, Taper-Fine	spec	specification
kWth	kilowatt-thermal	NR	not required, normal relay	specs	specification(s)
L	liter	ns	nanosecond	sq.	square
LAN	local area network	OC	overcrank	sq. cm	square centimeter
L x W x H	length by width by height	OD	outside diameter	sq. in.	square inch
lb.	pound, pounds	OEM	original equipment manufacturer	SS	stainless steel
lbm/ft ³	pounds mass per cubic feet	OF	overfrequency	std.	standard
LCB	line circuit breaker	opt.	option, optional	stl.	steel
LCD	liquid crystal display	OS	oversize, overspeed	tach.	tachometer
ld. shd.	load shed	OSHA	Occupational Safety and Health Administration	TD	time delay
LED	light emitting diode	OV	overvoltage	TDC	top dead center
Lph	liters per hour	oz.	ounce	TDEC	time delay engine cooldown
Lpm	liters per minute	p., pp.	page, pages	TDEN	time delay emergency to normal
LOP	low oil pressure	PC	personal computer	TDES	time delay engine start
LP	liquefied petroleum	PCB	printed circuit board	TDNE	time delay normal to emergency
LPG	liquefied petroleum gas	pF	picofarad	TDOE	time delay off to emergency
LS	left side	PF	power factor	TDON	time delay off to normal
L _{wa}	sound power level, A weighted	ph., ∅	phase	temp.	temperature
LWL	low water level	PHC	Phillips® head Crimptite® (screw)	term.	terminal
LWT	low water temperature	PHH	Phillips® hex head (screw)	THD	total harmonic distortion
m	meter, milli (1/1000)	PHM	pan head machine (screw)	TIF	telephone influence factor
M	mega (10 ⁶ when used with SI units), male	PLC	programmable logic control	TIR	total indicator reading
m ³	cubic meter	PMG	permanent magnet generator	tol.	tolerance
m ³ /hr.	cubic meters per hour	pot	potentiometer, potential	turbo.	turbocharger
m ³ /min.	cubic meters per minute	ppm	parts per million	typ.	typical (same in multiple locations)
mA	milliampere	PROM	programmable read-only memory	UF	underfrequency
man.	manual	psi	pounds per square inch	UHF	ultrahigh frequency
max.	maximum	psig	pounds per square inch gauge	UL	Underwriter's Laboratories, Inc.
MB	megabyte (2 ²⁰ bytes)	pt.	pint	UNC	unified coarse thread (was NC)
MCCB	molded-case circuit breaker	PTC	positive temperature coefficient	UNF	unified fine thread (was NF)
MCM	one thousand circular mils	PTO	power takeoff	univ.	universal
meggar	megohmmeter	PVC	polyvinyl chloride	US	undersize, underspeed
MHz	megahertz	qt.	quart, quarts	UV	ultraviolet, undervoltage
mi.	mile	qty.	quantity	V	volt
mil	one one-thousandth of an inch	R	replacement (emergency) power source	VAC	volts alternating current
min.	minimum, minute	rad.	radiator, radius	VAR	voltampere reactive
misc.	miscellaneous	RAM	random access memory	VDC	volts direct current
MJ	megajoule	RDO	relay driver output	VFD	vacuum fluorescent display
mJ	millijoule	ref.	reference	VGA	video graphics adapter
mm	millimeter	rem.	remote	VHF	very high frequency
mOhm, mΩ	milliohm	Res/Coml	Residential/Commercial	W	watt
MOhm, MΩ	megohm	RFI	radio frequency interference	WCR	withstand and closing rating
MOV	metal oxide varistor	RH	round head	w/	with
MPa	megapascal	RHM	round head machine (screw)	w/o	without
mpg	miles per gallon	rly.	relay	wt.	weight
mph	miles per hour			xfrm	transformer
MS	military standard				
ms	millisecond				
m/sec.	meters per second				
MTBF	mean time between failure				

Appendix B Common Hardware Application Guidelines

Use the information below and on the following pages to identify proper fastening techniques when no specific reference for reassembly is made.

Bolt/Screw Length: When bolt/screw length is not given, use Figure 1 as a guide. As a general rule, a minimum length of one thread beyond the nut and a maximum length of 1/2 the bolt/screw diameter beyond the nut is the preferred method.

Washers and Nuts: Use split lock washers as a bolt locking device where specified. Use SAE flat washers with whiz nuts, spirallock nuts, or standard nuts and preloading (torque) of the bolt in all other applications.

See Appendix C, General Torque Specifications, and other torque specifications in the service literature.

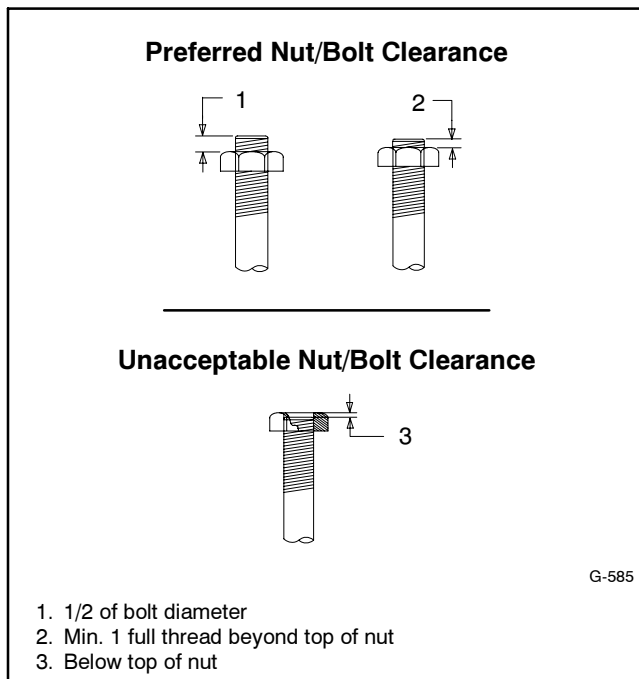

Figure 1 Acceptable Bolt Lengths

Steps for common hardware application:

1. Determine entry hole type: round or slotted.
2. Determine exit hole type: fixed female thread (weld nut), round, or slotted.

For round and slotted exit holes, determine if hardware is greater than 1/2 inch in diameter, or 1/2 inch in diameter or less. Hardware that is *greater than 1/2 inch* in diameter takes a standard nut and SAE washer. Hardware *1/2 inch or less* in diameter can take a properly torqued whiz nut or spirallock nut. See Figure 2.

3. Follow these SAE washer rules after determining exit hole type:
 - a. Always use a washer between hardware and a slot.
 - b. Always use a washer under a nut (see 2 above for exception).
 - c. Use a washer under a bolt when the female thread is fixed (weld nut).
4. Refer to Figure 2, which depicts the preceding hardware configuration possibilities.

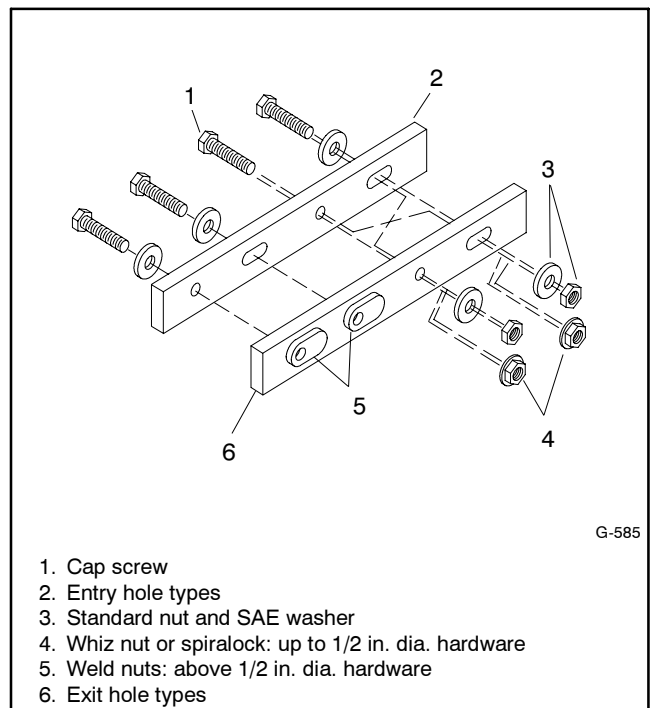

Figure 2 Acceptable Hardware Combinations

Appendix C General Torque Specifications















American Standard Fasteners Torque Specifications					
Size	Torque Measurement	Assembled into Cast Iron or Steel			Assembled into Aluminum Grade 2 or 5
		Grade 2	Grade 5	Grade 8	
8-32	Nm (in. lb.)	1.8 (16)	2.3 (20)	—	See Note 3
10-24	Nm (in. lb.)	2.9 (26)	3.6 (32)	—	
10-32	Nm (in. lb.)	2.9 (26)	3.6 (32)	—	
1/4-20	Nm (in. lb.)	6.8 (60)	10.8 (96)	14.9 (132)	
1/4-28	Nm (in. lb.)	8.1 (72)	12.2 (108)	16.3 (144)	
5/16-18	Nm (in. lb.)	13.6 (120)	21.7 (192)	29.8 (264)	
5/16-24	Nm (in. lb.)	14.9 (132)	23.1 (204)	32.5 (288)	
3/8-16	Nm (ft. lb.)	24.0 (18)	38.0 (28)	53.0 (39)	
3/8-24	Nm (ft. lb.)	27.0 (20)	42.0 (31)	60.0 (44)	
7/16-14	Nm (ft. lb.)	39.0 (29)	60.0 (44)	85.0 (63)	
7/16-20	Nm (ft. lb.)	43.0 (32)	68.0 (50)	95.0 (70)	
1/2-13	Nm (ft. lb.)	60.0 (44)	92.0 (68)	130.0 (96)	
1/2-20	Nm (ft. lb.)	66.0 (49)	103.0 (76)	146.0 (108)	
9/16-12	Nm (ft. lb.)	81.0 (60)	133.0 (98)	187.0 (138)	
9/16-18	Nm (ft. lb.)	91.0 (67)	148.0 (109)	209.0 (154)	
5/8-11	Nm (ft. lb.)	113.0 (83)	183.0 (135)	259.0 (191)	
5/8-18	Nm (ft. lb.)	128.0 (94)	208.0 (153)	293.0 (216)	
3/4-10	Nm (ft. lb.)	199.0 (147)	325.0 (240)	458.0 (338)	
3/4-16	Nm (ft. lb.)	222.0 (164)	363.0 (268)	513.0 (378)	
1-8	Nm (ft. lb.)	259.0 (191)	721.0 (532)	1109.0 (818)	
1-12	Nm (ft. lb.)	283.0 (209)	789.0 (582)	1214.0 (895)	











Metric Fasteners Torque Specifications, Measured in Nm (ft. lb.)				
Size (mm)	Assembled into Cast Iron or Steel			Assembled into Aluminum Grade 5.8 or 8.8
	Grade 5.8	Grade 8.8	Grade 10.9	
M6 x 1.00	6.2 (4.6)	9.5 (7)	13.6 (10)	See Note 3
M8 x 1.25	15.0 (11)	23.0 (17)	33.0 (24)	
M8 x 1.00	16.0 (11)	24.0 (18)	34.0 (25)	
M10 x 1.50	30.0 (22)	45.0 (34)	65.0 (48)	
M10 x 1.25	31.0 (23)	47.0 (35)	68.0 (50)	
M12 x 1.75	53.0 (39)	80.0 (59)	115.0 (85)	
M12 x 1.50	56.0 (41)	85.0 (63)	122.0 (90)	
M14 x 2.00	83.0 (61)	126.0 (93)	180.0 (133)	
M14 x 1.50	87.0 (64)	133.0 (98)	190.0 (140)	
M16 x 2.00	127.0 (94)	194.0 (143)	278.0 (205)	
M16 x 1.50	132.0 (97)	201.0 (148)	287.0 (212)	
M18 x 2.50	179.0 (132)	273.0 (201)	390.0 (288)	
M18 x 1.50	189.0 (140)	289.0 (213)	413.0 (305)	





Notes:

1. The torque values above are general guidelines. Always use the torque values specified in the service manuals and/or assembly drawings when they differ from the above torque values.
2. The torque values above are based on new plated threads. Increase torque values by 15% if non-plated threads are used.
3. Hardware threaded into aluminum must have either two diameters of thread engagement or a 30% or more reduction in the torque to prevent stripped threads.
4. Torque values are calculated as equivalent stress loading on American hardware with an approximate preload of 90% of the yield strength and a friction coefficient of 0.125.

Appendix D Common Hardware Identification

Screw/Bolts/Studs	
Head Styles	
Hex Head or Machine Head	
Hex Head or Machine Head with Washer	
Flat Head (FHM)	
Round Head (RHM)	
Pan Head	
Hex Socket Head Cap or Allen™ Head Cap	
Hex Socket Head or Allen™ Head Shoulder Bolt	
Sheet Metal Screw	
Stud	
Drive Styles	
Hex	
Hex and Slotted	
Phillips®	
Slotted	
Hex Socket	

Nuts	
Nut Styles	
Hex Head	
Lock or Elastic	
Square	
Cap or Acorn	
Wing	
Washers	
Washer Styles	
Plain	
Split Lock or Spring	
Spring or Wave	
External Tooth Lock	
Internal Tooth Lock	
Internal-External Tooth Lock	

Hardness Grades	
American Standard	
Grade 2	
Grade 5	
Grade 8	
Grade 8/9 (Hex Socket Head)	
Metric	
Number stamped on hardware; 5.8 shown	

Allen™ head screw is a trademark of Holo-Krome Co.

Phillips® screw is a registered trademark of Phillips Screw Company.

Sample Dimensions

American Standard (Screws, Bolts, Studs, and Nuts)

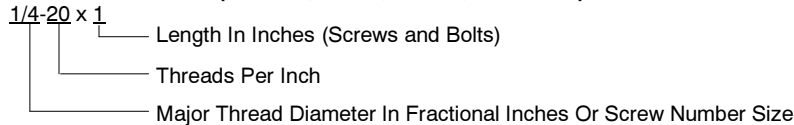

Metric (Screws, Bolts, Studs, and Nuts)

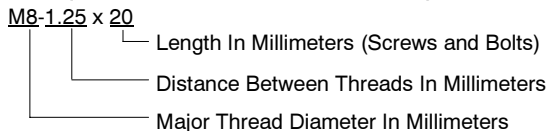

Plain Washers

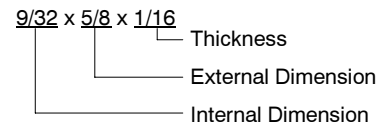

Lock Washers



Appendix E Common Hardware List

The Common Hardware List lists part numbers and dimensions for common hardware items.

American Standard

Part No.	Dimensions	Part No.	Dimensions	Part No.	Dimensions	Type
Hex Head Bolts (Grade 5)						
X-465-17	1/4-20 x .38	X-6238-14	3/8-24 x .75	X-6009-1	1-8	Standard
X-465-6	1/4-20 x .50	X-6238-16	3/8-24 x 1.25	X-6210-3	6-32	Whiz
X-465-2	1/4-20 x .62	X-6238-21	3/8-24 x 4.00	X-6210-4	8-32	Whiz
X-465-16	1/4-20 x .75	X-6238-22	3/8-24 x 4.50	X-6210-5	10-24	Whiz
X-465-18	1/4-20 x .88			X-6210-1	10-32	Whiz
X-465-7	1/4-20 x 1.00	X-6024-5	7/16-14 x .75			
X-465-8	1/4-20 x 1.25	X-6024-2	7/16-14 x 1.00	X-6210-2	1/4-20	Spiralock
X-465-9	1/4-20 x 1.50	X-6024-8	7/16-14 x 1.25	X-6210-6	1/4-28	Spiralock
X-465-10	1/4-20 x 1.75	X-6024-3	7/16-14 x 1.50	X-6210-7	5/16-18	Spiralock
X-465-11	1/4-20 x 2.00	X-6024-4	7/16-14 x 2.00	X-6210-8	5/16-24	Spiralock
X-465-12	1/4-20 x 2.25	X-6024-11	7/16-14 x 2.75	X-6210-9	3/8-16	Spiralock
X-465-14	1/4-20 x 2.75	X-6024-12	7/16-14 x 6.50	X-6210-10	3/8-24	Spiralock
X-465-21	1/4-20 x 5.00	X-129-15	1/2-13 x .75	X-6210-11	7/16-14	Spiralock
X-465-25	1/4-28 x .38	X-129-17	1/2-13 x 1.00	X-6210-12	1/2-13	Spiralock
X-465-20	1/4-28 x 1.00	X-129-18	1/2-13 x 1.25	X-6210-15	7/16-20	Spiralock
		X-129-19	1/2-13 x 1.50	X-6210-14	1/2-20	Spiralock
X-125-33	5/16-18 x .50	X-129-20	1/2-13 x 1.75			
X-125-23	5/16-18 x .62	X-129-21	1/2-13 x 2.00	X-85-3	5/8-11	Standard
X-125-3	5/16-18 x .75	X-129-22	1/2-13 x 2.25	X-88-12	3/4-10	Standard
X-125-31	5/16-18 x .88	X-129-23	1/2-13 x 2.50	X-89-2	1/2-20	Standard
X-125-5	5/16-18 x 1.00	X-129-24	1/2-13 x 2.75			
X-125-24	5/16-18 x 1.25	X-129-25	1/2-13 x 3.00			
X-125-34	5/16-18 x 1.50	X-129-27	1/2-13 x 3.50			
X-125-25	5/16-18 x 1.75	X-129-29	1/2-13 x 4.00			
X-125-26	5/16-18 x 2.00	X-129-30	1/2-13 x 4.50			
230578	5/16-18 x 2.25	X-463-9	1/2-13 x 5.50			
X-125-29	5/16-18 x 2.50	X-129-44	1/2-13 x 6.00			
X-125-27	5/16-18 x 2.75					
X-125-28	5/16-18 x 3.00	X-129-51	1/2-20 x .75			
X-125-22	5/16-18 x 4.50	X-129-45	1/2-20 x 1.25			
X-125-32	5/16-18 x 5.00	X-129-52	1/2-20 x 1.50			
X-125-35	5/16-18 x 5.50					
X-125-36	5/16-18 x 6.00	X-6021-3	5/8-11 x 1.00			
X-125-40	5/16-18 x 6.50	X-6021-4	5/8-11 x 1.25			
		X-6021-2	5/8-11 x 1.50			
X-125-43	5/16-24 x 1.75	X-6021-1	5/8-11 x 1.75			
X-125-44	5/16-24 x 2.50	273049	5/8-11 x 2.00			
X-125-30	5/16-24 x .75	X-6021-5	5/8-11 x 2.25			
X-125-39	5/16-24 x 2.00	X-6021-6	5/8-11 x 2.50			
X-125-38	5/16-24 x 2.75	X-6021-7	5/8-11 x 2.75			
		X-6021-12	5/8-11 x 3.75			
X-6238-2	3/8-16 x .62	X-6021-11	5/8-11 x 4.50			
X-6238-10	3/8-16 x .75	X-6021-10	5/8-11 x 6.00			
X-6238-3	3/8-16 x .88					
X-6238-11	3/8-16 x 1.00	X-6021-9	5/8-18 x 2.50			
X-6238-4	3/8-16 x 1.25					
X-6238-5	3/8-16 x 1.50	X-6239-1	3/4-10 x 1.00			
X-6238-1	3/8-16 x 1.75	X-6239-8	3/4-10 x 1.25			
X-6238-6	3/8-16 x 2.00	X-6239-2	3/4-10 x 1.50			
X-6238-17	3/8-16 x 2.25	X-6239-3	3/4-10 x 2.00			
X-6238-7	3/8-16 x 2.50	X-6239-4	3/4-10 x 2.50			
X-6238-8	3/8-16 x 2.75	X-6239-5	3/4-10 x 3.00			
X-6238-9	3/8-16 x 3.00	X-6239-6	3/4-10 x 3.50			
X-6238-19	3/8-16 x 3.25					
X-6238-12	3/8-16 x 3.50	X-792-1	1-8 x 2.25			
X-6238-20	3/8-16 x 3.75	X-792-5	1-8 x 3.00			
X-6238-13	3/8-16 x 4.50	X-792-8	1-8 x 5.00			
X-6238-18	3/8-16 x 5.50					
X-6238-25	3/8-16 x 6.50					

Washers				Bolt/ Screw
Part No.	ID	OD	Thick.	
X-25-46	.125	.250	.022	#4
X-25-9	.156	.375	.049	#6
X-25-48	.188	.438	.049	#8
X-25-36	.219	.500	.049	#10
X-25-40	.281	.625	.065	1/4
X-25-85	.344	.687	.065	5/16
X-25-37	.406	.812	.065	3/8
X-25-34	.469	.922	.065	7/16
X-25-26	.531	1.062	.095	1/2
X-25-15	.656	1.312	.095	5/8
X-25-29	.812	1.469	.134	3/4
X-25-127	1.062	2.000	.134	1

Metric

Hex head bolts are hardness grade 8.8 unless noted.

Part No.	Dimensions	Part No.	Dimensions	Part No.	Dimensions
Hex Head Bolts (Partial Thread)					
M931-05055-60	M5-0.80 x 55				
M931-06040-60	M6-1.00 x 40				
M931-06055-60	M6-1.00 x 55				
M931-06060-60	M6-1.00 x 60				
M931-06060-SS	M6-1.00 x 60				
M931-06070-60	M6-1.00 x 70				
M931-06070-SS	M6-1.00 x 70				
M931-06075-60	M6-1.00 x 75				
M931-06090-60	M6-1.00 x 90				
M931-06145-60	M6-1.00 x 145				
M931-06150-60	M6-1.00 x 150				
Hex Head Bolts (Full Thread)					
M931-08035-60	M8-1.25 x 35				
M931-08040-60	M8-1.25 x 40				
M931-08045-60	M8-1.25 x 45				
M931-08050-60	M8-1.25 x 50				
M931-08055-60	M8-1.25 x 55				
M931-08055-82	M8-1.25 x 55*				
M931-08060-60	M8-1.25 x 60				
M931-08070-60	M8-1.25 x 70				
M931-08070-82	M8-1.25 x 70*				
M931-08075-60	M8-1.25 x 75				
M931-08080-60	M8-1.25 x 80				
M931-08090-60	M8-1.25 x 90				
M931-08095-60	M8-1.25 x 95				
M931-08100-60	M8-1.25 x 100				
M931-08110-60	M8-1.25 x 110				
M931-08120-60	M8-1.25 x 120				
M931-08130-60	M8-1.25 x 130				
M931-08140-60	M8-1.25 x 140				
M931-08150-60	M8-1.25 x 150				
M931-08200-60	M8-1.25 x 200				
M931-10040-82	M10-1.25 x 40*				
M931-10040-60	M10-1.50 x 40				
M931-10045-60	M10-1.50 x 45				
M931-10050-60	M10-1.50 x 50				
M931-10050-82	M10-1.25 x 50*				
M931-10055-60	M10-1.50 x 55				
M931-10060-60	M10-1.50 x 60				
M931-10065-60	M10-1.50 x 65				
M931-10070-60	M10-1.50 x 70				
M931-10080-60	M10-1.50 x 80				
M931-10080-82	M10-1.25 x 80*				
M931-10090-60	M10-1.50 x 90				
M931-10090-82	M10-1.50 x 90*				
M931-10100-60	M10-1.50 x 100				
M931-10110-60	M10-1.50 x 110				
M931-10120-60	M10-1.50 x 120				
M931-10130-60	M10-1.50 x 130				
M931-10140-60	M10-1.50 x 140				
M931-10180-60	M10-1.50 x 180				
M931-10235-60	M10-1.50 x 235				
M931-10260-60	M10-1.50 x 260				
M960-10330-60	M10-1.25 x 330				
M931-12045-60	M12-1.75 x 45				
M960-12050-60	M12-1.25 x 50				
M960-12050-82	M12-1.25 x 50*				
M931-12050-60	M12-1.75 x 50				
M931-12050-82	M12-1.75 x 50*				
M931-12055-60	M12-1.75 x 55				
M931-12060-60	M12-1.75 x 60				
M931-12060-82	M12-1.75 x 60*				
M931-12065-60	M12-1.75 x 65				
M931-12075-60	M12-1.75 x 75				
M931-12080-60	M12-1.75 x 80				
M931-12090-60	M12-1.75 x 90				
M931-12100-60	M12-1.75 x 100				
M931-12110-60	M12-1.75 x 110				
Hex Head Bolts (Partial Thread), continued					
M960-16090-60	M16-1.50 x 90				
M931-16090-60	M16-2.00 x 90				
M931-16100-60	M16-2.00 x 100				
M931-16100-82	M16-2.00 x 100*				
M931-16120-60	M16-2.00 x 120				
M931-16150-60	M16-2.00 x 150				
M931-20065-60	M20-2.50 x 65				
M931-20090-60	M20-2.50 x 90				
M931-20100-60	M20-2.50 x 100				
M931-20120-60	M20-2.50 x 120				
M931-20140-60	M20-2.50 x 140				
M931-20160-60	M20-2.50 x 160				
M931-22090-60	M22-2.50 x 90				
M931-22120-60	M22-2.50 x 120				
M931-22160-60	M22-2.50 x 160				
M931-24090-60	M24-3.00 x 90				
M931-24120-60	M24-3.00 x 120				
M931-24160-60	M24-3.00 x 160				
M931-24200-60	M24-3.00 x 200				
Hex Head Bolts (Full Thread)					
M933-04006-60	M4-0.70 x 6				
M933-05030-60	M5-0.80 x 30				
M933-05035-60	M5-0.80 x 35				
M933-05050-60	M5-0.80 x 50				
M933-06010-60	M6-1.00 x 10				
M933-06012-60	M6-1.00 x 12				
M933-06014-60	M6-1.00 x 14				
M933-06016-60	M6-1.00 x 16				
M933-06020-60	M6-1.00 x 20				
M933-06025-60	M6-1.00 x 25				
M933-06030-60	M6-1.00 x 30				
M933-06040-60	M6-1.00 x 40				
M933-06050-60	M6-1.00 x 50				
M933-07025-60	M7-1.00 x 25				
M933-08010-60	M8-1.25 x 10				
M933-08012-60	M8-1.25 x 12				
M933-08016-60	M8-1.25 x 16				
M933-08020-60	M8-1.25 x 20				
M933-08025-60	M8-1.25 x 25				
M933-08030-60	M8-1.25 x 30				
M933-08030-82	M8-1.25 x 30*				
M933-10012-60	M10-1.50 x 12				
M961-10020-60	M10-1.25 x 20				
M933-10020-60	M10-1.50 x 20				
M933-10025-60	M10-1.50 x 25				
M961-10025-60	M10-1.25 x 25				
M933-10025-82	M10-1.50 x 25*				
M961-10030-60	M10-1.25 x 30				
M933-10030-60	M10-1.50 x 30				
M933-10030-82	M10-1.50 x 30*				
M961-10035-60	M10-1.25 x 35				
M933-10035-60	M10-1.50 x 35				
M933-10035-82	M10-1.50 x 35*				
M961-10040-60	M10-1.25 x 40				
M933-12016-60	M12-1.75 x 16				
M933-12020-60	M12-1.75 x 20				
M961-12020-60F	M12-1.50 x 20				
M933-12025-60	M12-1.75 x 25				
M933-12025-82	M12-1.75 x 25*				
M961-12030-60	M12-1.25 x 30				
M933-12030-82	M12-1.75 x 30*				
M961-12030-82F	M12-1.50 x 30*				
M933-12030-60	M12-1.75 x 30				
M933-12035-60	M12-1.75 x 35				
M961-12040-82	M12-1.25 x 40*				
M933-12040-60	M12-1.75 x 40				
M933-12040-82	M12-1.75 x 40*				
M961-14025-60	M14-1.50 x 25				
M933-14025-60	M14-2.00 x 25				
M961-14050-82	M14-1.50 x 50*				
M961-16025-60	M16-1.50 x 25				
M933-16025-60	M16-2.00 x 25				
M961-16030-82	M16-1.50 x 30*				
M933-16030-82	M16-2.00 x 30*				
M933-16035-60	M16-2.00 x 35				
M961-16040-60	M16-1.50 x 40				
M933-16040-60	M16-2.00 x 40				
M961-16045-82	M16-1.50 x 45*				
M933-16045-82	M16-2.00 x 45*				
M933-16050-60	M16-2.00 x 50				
M933-16050-82	M16-2.00 x 50*				
M933-16060-60	M16-2.00 x 60				
M933-16070-60	M16-2.00 x 70				
M933-18035-60	M18-2.50 x 35				
M933-18050-60	M18-2.50 x 50				
M933-18060-60	M18-2.50 x 60				
M933-20050-60	M20-2.50 x 50				
M933-20055-60	M20-2.50 x 55				
M933-24060-60	M24-3.00 x 60				
M933-24065-60	M24-3.00 x 65				
M933-24070-60	M24-3.00 x 70				
Pan Head Machine Screws					
M7985A-03010-20	M3-0.50 x 10				
M7985A-03012-20	M3-0.50 x 12				
M7985A-04010-20	M4-0.70 x 10				
M7985A-04016-20	M4-0.70 x 16				
M7985A-04020-20	M4-0.70 x 20				
M7985A-04050-20	M4-0.70 x 50				
M7985A-04100-20	M4-0.70 x 100				
M7985A-05010-20	M5-0.80 x 10				
M7985A-05012-20	M5-0.80 x 12				
M7985A-05016-20	M5-0.80 x 16				
M7985A-05020-20	M5-0.80 x 20				
M7985A-05025-20	M5-0.80 x 25				
M7985A-05030-20	M5-0.80 x 30				
M7985A-05080-20	M5-0.80 x 80				
M7985A-05100-20	M5-0.80 x 100				
M7985A-06100-20	M6-1.00 x 100				
Flat Head Machine Screws					
M965A-04012-SS	M4-0.70 x 12				
M965A-05012-SS	M5-0.80 x 12				
M965A-05016-20	M5-0.80 x 16				
M965A-06012-20	M6-1.00 x 12				

* This metric hex bolt's hardness is grade 10.9.

Metric, continued

Part No.	Dimensions	Type
Hex Nuts		
M934-03-50	M3-0.50	Standard
M934-04-50	M4-0.70	Standard
M934-04-B	M4-0.70	Brass
M934-05-50	M5-0.80	Standard
M934-06-60	M6-1.00	Standard
M934-06-64	M6-1.00	Std. (green)
M6923-06-80	M6-1.00	Spirallock
M982-06-80	M6-1.00	Elastic Stop
M934-08-60	M8-1.25	Standard
M6923-08-80	M8-1.25	Spirallock
M982-08-80	M8-1.25	Elastic Stop
M934-10-60	M10-1.50	Standard
M934-10-60F	M10-1.25	Standard
M6923-10-80	M10-1.50	Spirallock
M6923-10-62	M10-1.50	Spirallock†
M982-10-80	M10-1.50	Elastic Stop
M934-12-60	M12-1.75	Standard
M934-12-60F	M12-1.25	Standard
M6923-12-80	M12-1.75	Spirallock
M982-12-80	M12-1.75	Elastic Stop
M982-14-60	M14-2.00	Elastic Stop
M6923-16-80	M16-2.00	Spirallock
M982-16-80	M16-2.00	Elastic Stop
M934-18-80	M18-2.5	Standard
M982-18-60	M18-2.50	Elastic Stop
M934-20-80	M20-2.50	Standard
M982-20-80	M20-2.50	Elastic Stop
M934-22-60	M22-2.50	Standard
M934-24-80	M24-3.00	Standard
M982-24-60	M24-3.00	Elastic Stop
M934-30-80	M30-3.50	Standard

Washers

Part No.	ID	OD	Thick.	Bolt/ Screw
M125A-03-80	3.2	7.0	0.5	M3
M125A-04-80	4.3	9.0	0.8	M4
M125A-05-80	5.3	10.0	1.0	M5
M125A-06-80	6.4	12.0	1.6	M6
M125A-08-80	8.4	16.0	1.6	M8
M125A-10-80	10.5	20.0	2.0	M10
M125A-12-80	13.0	24.0	2.5	M12
M125A-14-80	15.0	28.0	2.5	M14
M125A-16-80	17.0	30.0	3.0	M16
M125A-18-80	19.0	34.0	3.0	M18
M125A-20-80	21.0	37.0	3.0	M20
M125A-24-80	25.0	44.0	4.0	M24

† This metric hex nut's hardness is grade 8.



DDC/MTU Power Generation
605 North 8th Street, Suite 501
Sheboygan, Wisconsin 53081 USA
Phone 920-451-0846, Fax 920-451-0843
ddcmtupowergeneration.com