

# **KOHLER** engines

## **twin cylinder engine** **SERVICE MANUAL**

Models K482, K532,  
K582, K662

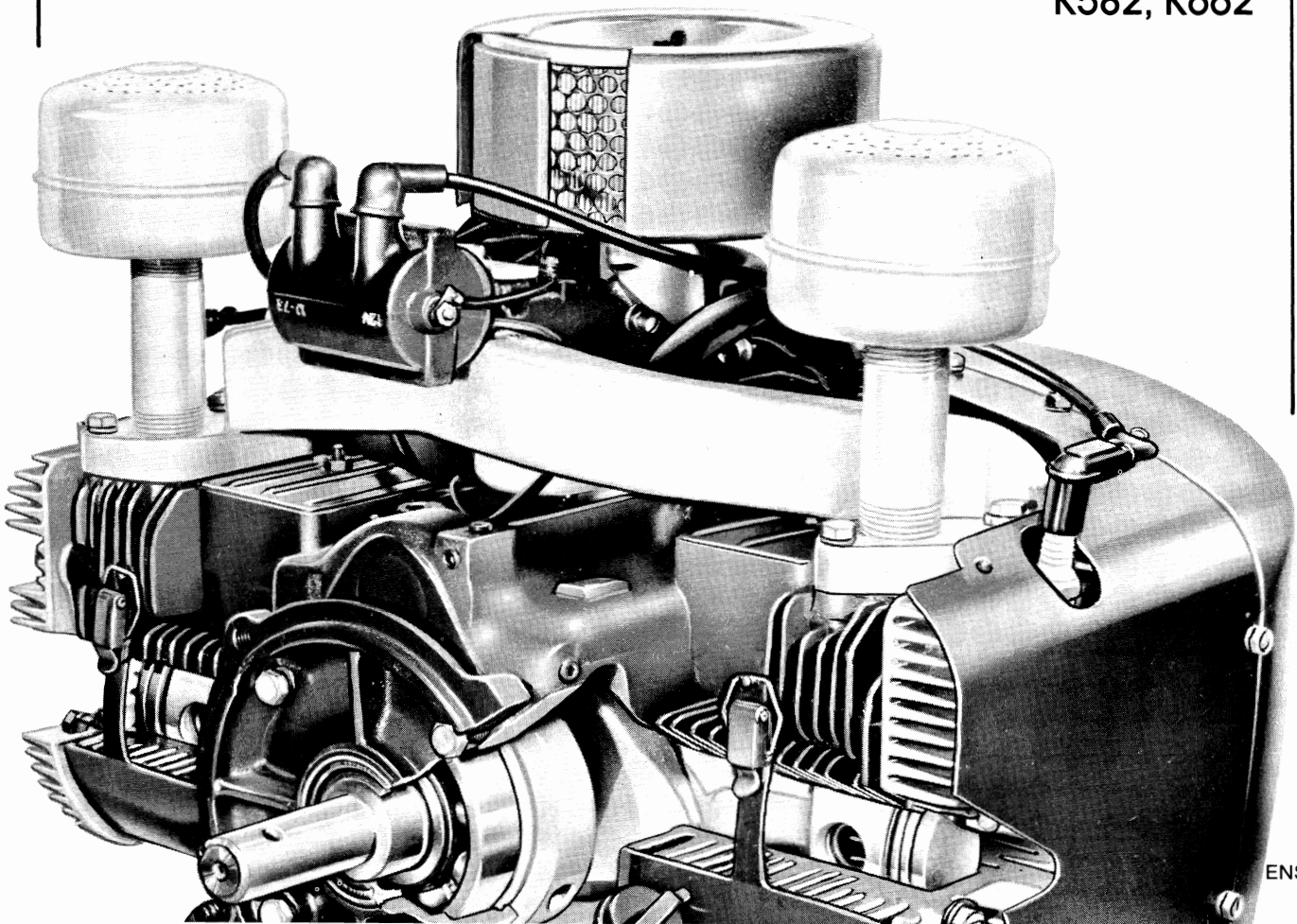

The Models K532 and K582 are identical to the Model K482 except for bore and horsepower differences, the information pertaining to the Model K482 in this Manual also applies to the Models K532 and K582.

# CONTENTS

| Description                       | Page | Description                             | Page |
|-----------------------------------|------|---|------|
| OPERATING INSTRUCTIONS .....      | 1.1  | ENGINE - GENERAL SERVICES .....         | 8.1  |
| Pre-Start .....                   | 1.1  | Cooling System .....                    | 8.1  |
| Starting Procedure .....          | 1.2  | Cylinder Head Service .....             | 8.1  |
| Stopping Procedure .....          | 1.2  | Valve - Tappet Clearance .....          | 8.1  |
| Service Schedule .....            | 1.3  | Crankcase Breather Systems .....        | 8.2  |
| Trouble Shooting .....            | 1.4  | Engine Storage Instructions .....       | 8.2  |
| LUBRICATION .....                 | 2.1  | Crankcase Vacuum Test .....             | 8.3  |
| Oil Level .....                   | 2.1  | Compression Test .....                  | 8.4  |
| Oil Type .....                    | 2.1  | INSPECTION - DISASSEMBLY .....          | 9.1  |
| Run-in Oil .....                  | 2.1  | Work Area .....                         | 9.1  |
| Oil Change .....                  | 2.1  | Inspection .....                        | 9.1  |
| Oil Filters .....                 | 2.2  | Disassembly Procedure .....             | 9.1  |
| Oil Pressure - Oil Pumps .....    | 2.4  | ENGINE RECONDITIONING .....             | 10.1 |
| AIR INTAKE .....                  | 3.1  | Cylinder Block .....                    | 10.1 |
| Dry Type Air Cleaner .....        | 3.1  | Crankshaft - Closure Plate (K482) ..... | 10.2 |
| Multi-Phase Air Cleaner .....     | 3.2  | Piston - Rings .....                    | 10.3 |
| Oil Bath Air Cleaner .....        | 3.3  | Piston - Rod Assemblies .....           | 10.4 |
| FUEL SYSTEM .....                 | 4.1  | Connecting Rods .....                   | 10.5 |
| Gasoline Carburetors .....        | 4.1  | Valves - Valve Mechanism .....          | 10.5 |
| Automatic Chokes .....            | 4.8  | Cylinder Heads .....                    | 10.6 |
| Fuel Pumps .....                  | 4.9  | Ring Gear .....                         | 10.6 |
| Fuel Filters .....                | 4.10 | REASSEMBLY .....                        | 11.1 |
| GOVERNOR .....                    | 5.1  | Procedure .....                         | 11.1 |
| K482 Governors .....              | 5.1  | Run-in Instructions .....               | 11.8 |
| K662 Governors .....              | 5.3  | SPECIAL FUEL SYSTEMS .....              | 12.1 |
| IGNITION SYSTEMS .....            | 6.1  | Gas Systems .....                       | 12.1 |
| Operational Test .....            | 6.1  | Operating Instructions - Gas .....      | 12.2 |
| Spark Plug .....                  | 6.1  | Gas Adapters .....                      | 12.3 |
| Breaker Points .....              | 6.1  | Gas Carburetors .....                   | 12.4 |
| Ignition Coil .....               | 6.2  | Gas Regulators .....                    | 12.9 |
| Condenser .....                   | 6.2  | MODIFICATIONS, ACCESSORIES .....        | 13.1 |
| Magnetos (K662) .....             | 6.3  | Clutch, Wet Type .....                  | 13.1 |
| Ignition Timing (K482) .....      | 6.8  | Clutch - Gear Reduction Unit .....      | 13.2 |
| ELECTRICAL SYSTEMS .....          | 7.1  | Air-Vac Cooling .....                   | 13.3 |
| Battery .....                     | 7.1  | Tool Listing .....                      | 13.4 |
| Voltage Regulator .....           | 7.2  | SPECIFICATIONS K482, K532, K662 .....   | 14.1 |
| Generator .....                   | 7.4  | Specifications and Tolerances .....     | 14.1 |
| Starting Motors & Drives .....    | 7.5  | Torque Values and Sequences .....       | 14.3 |
| Flywheel-Alternator Systems ..... | 7.9  |   |      |

## General Safety Warnings

- ⚠ **WARNING: ACCIDENTAL STARTS** - Before servicing the engine or equipment, always remove the spark plug lead to prevent the engine from starting accidentally. Ground the lead to prevent sparks that could cause fires.
  - ⚠ **WARNING: EXPLOSIVE FUEL** - Gasoline is extremely flammable, and its vapors can explode if ignited. Store gasoline only in approved containers, in unoccupied buildings, away from sparks or flames. Do not add gasoline while the engine is hot or running, or start the engine near spilled gasoline. Never use gasoline as a cleaning agent.
  - ⚠ **WARNING: HOT, MOVING PARTS** - The engine and exhaust system get extremely hot from operation. Do not operate the equipment with covers, shrouds, or guards removed. Keep hands, feet, clothing, and hair away from all moving parts. Do not allow the equipment to run unattended.
  - ⚠ **WARNING: LETHAL EXHAUST GASES** - Engine exhaust gases contain poisonous carbon monoxide. Avoid inhaling fumes, and never run the engine in a closed building or confined area.
  - ⚠ **WARNING: DANGEROUS ACID, EXPLOSIVE GASES** - Batteries contain sulphuric acid. Avoid contact with skin, eyes, and clothing. Batteries produce explosive hydrogen gas while being charged. Ventilate the area when charging the battery. Keep cigarettes, sparks, open flame, and other sources of ignition away from battery at all times. Keep batteries and acid out of the reach of children. Remove all jewelry when working on battery.
- CAUTION: Do not tamper with the governor setting to increase the maximum engine speed. Overspeed is hazardous and will void the warranty.

# OPERATING INSTRUCTIONS

## PRE-START INSTRUCTIONS

### LUBRICATING OIL

CHECK OIL LEVEL

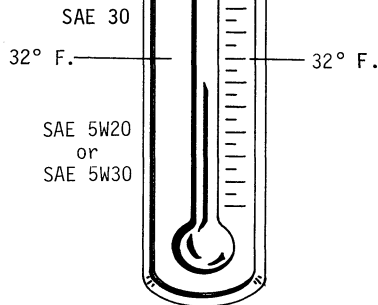
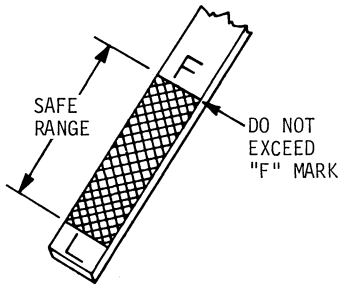

Use SAE service class SC, SD, SE or SF oil.

MAKE SURE LUBE OIL IS ADDED TO DRIVEN EQUIPMENT WHEN REQUIRED

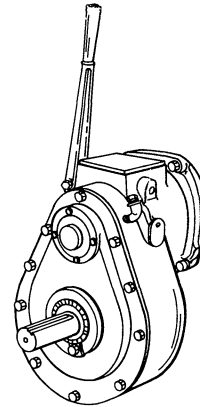

### AIR CLEANER

DRY TYPE AIR CLEANERS  
USE ONLY GENUINE  
KOHLER ELEMENT

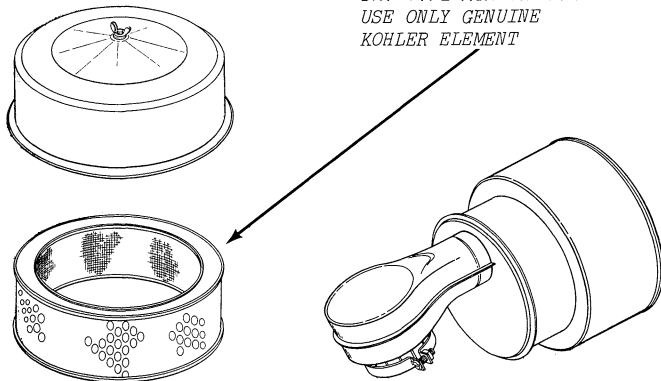

### COOLING

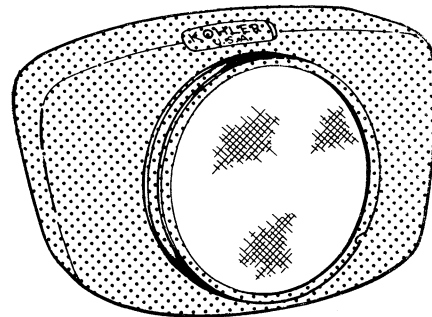

MAKE SURE AIR INTAKE SCREEN IS CLEAN AND UNOBSTRUCTED AT ALL TIMES

### BATTERY

CHECK POLARITY

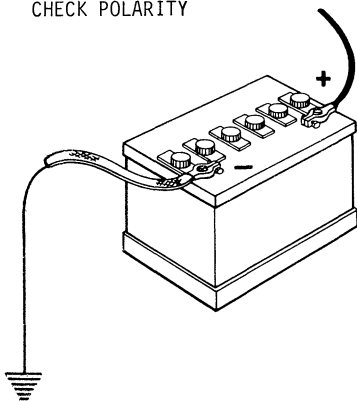

NEGATIVE (-) GROUND SYSTEM USED

### FUEL

FILL FUEL TANK WITH FRESH, REGULAR GRADE NO-LEAD OR LEADED GASOLINE. DO NOT MIX OIL WITH GASOLINE.

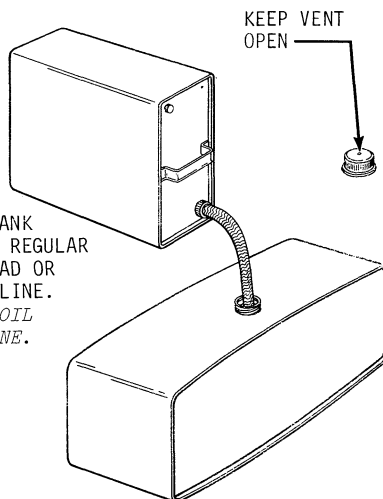

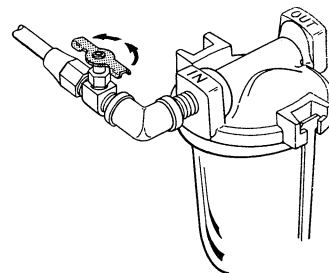

### FUEL ON

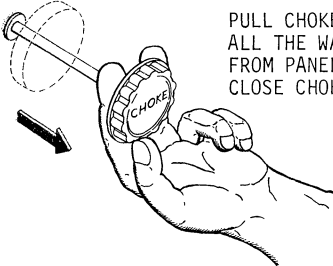
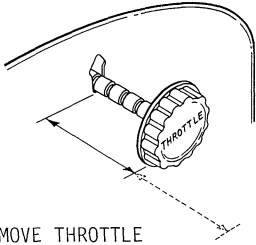
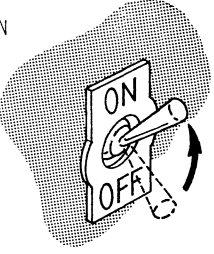
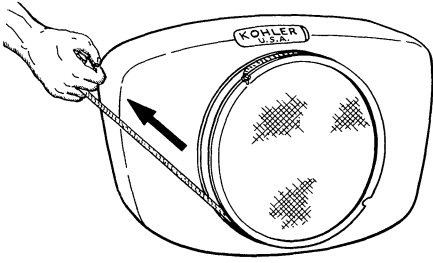
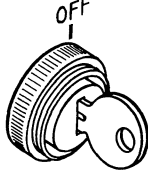

TURN FUEL VALVE TO ON POSITION (COUNTERCLOCKWISE) OBSERVE CONDITION OF FUEL & FILTER, SERVICE IF NEEDED.

## STARTING PROCEDURE

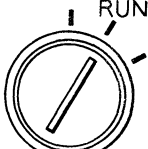
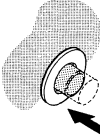
| CHOKE  | THROTTLE  | IGNITION   |
|--|---|--|
|  <p style="text-align: center;">PULL CHOKE KNOB ALL THE WAY AWAY FROM PANEL* (TO CLOSE CHOKE PLATE)</p> <p><small>*LESS CHOKING MAY BE REQUIRED IN MODERATE TEMPERATURES.</small></p> |  <p style="text-align: center;">MOVE THROTTLE HALFWAY OPEN</p>   | <p style="text-align: center;">MOVE TOGGLE SWITCH TO "ON" POSITION</p>  |
| CRANK ENGINE (HAND)  | CRANK ENGINE (ELECTRIC START)   |  |
|  <p style="text-align: center;">PULL STARTING ROPE IN DIRECTION SHOWN - USE QUICK, STEADY MOTION</p>  | <div style="display: flex; justify-content: space-around; align-items: center;"> <div style="text-align: center;">  <p>OFF</p> </div> <div style="text-align: center;">  <p>START</p> </div> <div style="text-align: center;">  <p>RUN</p> </div> </div> <p style="text-align: center;">KEYSTART - MOVE KEY TO START POSITION,* RELEASE WHEN ENGINE STARTS (SWITCH AUTOMATICALLY RETURNS TO RUN)</p> <div style="display: flex; justify-content: space-around; align-items: center;"> <div style="text-align: center;">  <p>PUSH BUTTON - DEPRESS AND HOLD BUTTON,* RELEASE WHEN ENGINE STARTS</p> </div> <div style="border: 1px dashed black; padding: 5px;"> <p style="text-align: center;">GRADUALLY PUSH CHOKE KNOB BACK IN AS ENGINE WARMS UP (TO OPEN CHOKE PLATE)</p> <p><small>*Limit cranking time (continuous) to 10 seconds, then allow a 60 second cooldown period to protect starter.</small></p> </div> </div> |  |

## STOPPING PROCEDURE

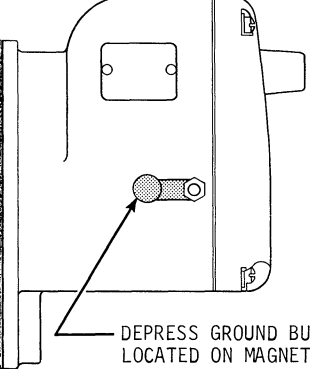
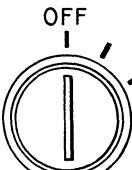
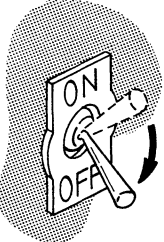
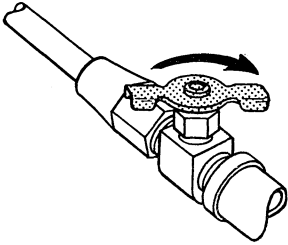
| STOP BUTTON  | STOP SWITCH  | STOP FUEL   |
|--|--|---|
|  <p style="text-align: center;">DEPRESS GROUND BUTTON LOCATED ON MAGNETO - HOLD UNTIL ENGINE COMES TO COMPLETE HALT</p> | <p style="text-align: center;">RETURN SWITCH TO "OFF" POSITION</p> <div style="display: flex; justify-content: space-around; align-items: center;"> <div style="text-align: center;">  <p>OFF</p> </div> <div style="text-align: center;">  </div> </div> |  <p style="text-align: center;">TURN FUEL VALVE OFF AFTER ENGINE IS SHUTDOWN (CLOCKWISE)</p> |

# SERVICE SCHEDULE

| SERVICE AT INTERVALS INDICATED                | DAILY<br>(PRE-START) | EVERY<br>25 HOURS | EVERY<br>50 HOURS | EVERY<br>100 HOURS | EVERY<br>500 HOURS |
|---|----------------------|-------------------|-------------------|--------------------|--------------------|
| CLEAN AIR INTAKE SCREEN -----                 | -X                   |                   |                   |                    |                    |
| CHECK OIL LEVEL -----                         | -X                   |                   |                   |                    |                    |
| REPLENISH FUEL SUPPLY -----                   | -X                   |                   |                   |                    |                    |
| SERVICE DRY TYPE AIR CLEANER -----            |                      |                   | -X                |                    |                    |
| SERVICE DRY TYPE AIR CLEANER PRECLEANER ----- |                      | -X                |                   |                    |                    |
| SERVICE MULTI-PHASE AIR CLEANER -----         |                      | -X                |                   |                    |                    |
| SERVICE OIL BATH AIR CLEANER -----            |                      | -X                |                   |                    |                    |
| CLEAN EXTERNAL SURFACES OF UNIT -----         |                      |                   | -X                |                    |                    |
| CHANGE LUBE OIL -----                         |                      |                   | -X                |                    |                    |
| CHANGE LUBE OIL FILTER -----                  |                      |                   |                   | -X                 |                    |
| SERVICE FUEL FILTER -----                     |                      |                   | -X                |                    |                    |
| SERVICE SPARK PLUGS -----                     |                      |                   |                   | -X                 |                    |
| CHANGE OIL IN WET TYPE CLUTCH -----           |                      |                   |                   | -X                 |                    |
| SERVICE CRANKCASE BREATHER -----              |                      |                   |                   |                    | -X                 |
| CHECK AND SERVICE BREAKER POINTS -----        |                      |                   |                   |                    | -X                 |
| CHECK IGNITION TIMING -----                   |                      |                   |                   |                    | -X                 |
| CHECK VALVE - TAPPET CLEARANCE -----          |                      |                   |                   |                    | -X                 |
| CHECK CRANKCASE VACUUM -----                  |                      |                   |                   |                    | -X                 |
| CHECK COMPRESSION -----                       |                      |                   |                   |                    | -X                 |
| CHECK SPECIFIC GRAVITY - BATTERY -----        |                      |                   |                   |                    | -X                 |
| SERVICE DC GENERATOR -----                    |                      |                   |                   |                    | -X                 |
| SERVICE STARTING MOTOR AND DRIVE -----        |                      |                   |                   |                    | -X                 |
| SERVICE CYLINDER HEADS -----                  |                      |                   |                   |                    | -X*                |

\*If leaded gasoline is used, service cylinder head every 250 hours.

NOTE: Intervals stated are for good, clean operating conditions only -- service items more frequently (even daily or more often) if extremely dusty or dirty conditions prevail. See appropriate service section for service details.

# TROUBLE SHOOTING

| CONDITION                                 | POSSIBLE CAUSE   |
|---|--|
| A. <u>Hard Starting or Loss of Power</u>  | <ol style="list-style-type: none"> <li>1. Faulty Ignition.               <ol style="list-style-type: none"> <li>a. Loose or grounded high tension or breaker point leads.</li> <li>b. Improper breaker point gap and timing.</li> <li>c. Defective breaker points.</li> <li>d. Faulty spark plug or improper gap.</li> <li>e. Faulty condenser or coil.</li> </ol> </li> <li>2. Faulty Fuel System.               <ol style="list-style-type: none"> <li>a. Gasoline not getting to carburetor.                   <ol style="list-style-type: none"> <li>1. Dirt or gum in fuel line.</li> <li>2. Fuel pump faulty.</li> </ol> </li> <li>b. Dirt in carburetor.</li> <li>c. Carburetor improperly adjusted.</li> </ol> </li> </ol> |
| B. <u>Overheating</u>                     | <ol style="list-style-type: none"> <li>1. Insufficient available cool air.</li> <li>2. Dirty air intake screen, shroud or cooling fins.</li> <li>3. Improper fuel.</li> <li>4. Fuel mixture too lean.</li> <li>5. Improper ignition timing.</li> <li>6. Engine overloaded.</li> <li>7. Tight tappet clearance.</li> </ol>  |
| C. <u>Backfiring</u>                      | <ol style="list-style-type: none"> <li>1. Fuel mixture too lean.</li> <li>2. Improper timing.</li> <li>3. Valve "sticking".</li> </ol>   |
| D. <u>Occasional "Skip" at High Speed</u> | <ol style="list-style-type: none"> <li>1. Spark plug gap too wide.</li> <li>2. Improper carburetor setting or lack of fuel.</li> <li>3. Wrong type spark plug. Use recommended spark plug.</li> <li>4. Improper timing.</li> </ol>   |
| E. <u>Operating Erratically</u>           | <ol style="list-style-type: none"> <li>1. Clogged fuel line.</li> <li>2. Water in fuel.</li> <li>3. Faulty choke control.</li> <li>4. Improper fuel mixture.</li> <li>5. Loose ignition connections.</li> <li>6. Air leaks in manifold or carburetor connections.</li> <li>7. Vent in gas cap plugged.</li> <li>8. Fuel pump faulty.</li> </ol>  |
| F. <u>Engine Will Not Idle</u>            | <ol style="list-style-type: none"> <li>1. Improper carburetor idling adjustment.</li> <li>2. Carburetor clogged.</li> <li>3. Spark plug gap set too close.</li> <li>4. Leaking carburetor or manifold gaskets.</li> </ol>  |

# LUBRICATION

The 2 cylinder engines have positive pressure gear type oil pumps which supply oil through inter-galleys to main bearing, camshaft bearing, connecting rod and other wear areas. On K662 models, transfer sleeves are used to direct oil to the anti-friction type main bearings. On some early K482 engines, oil is picked up through a floating oil screen--a fixed oil screen is used on most K482 and all K532, K662 models.

## OIL LEVEL

The lubricating oil level must be maintained in the "safe" operating range at all times. Oil level must be between the L (low) and F (full) marks on the dipstick. Always clean area around dipstick so that dirt does not fall into engine when dipstick is removed. Check daily and add oil as necessary to maintain proper level--DO NOT OVERFILL--oil level must not exceed the F mark.

There are several different types of dipsticks in use. On the shorter type, which consists of a combined dipstick-oil fill plug, turn plug all the way out of crankcase, remove and wipe oil off dipstick then reinsert--shoulder plug on top of hole (do not turn plug in) before removing for reading. With the extended oil fill tube and bayonette type dipstick, push or twist cap until dipstick is all the way down on tube, then remove and take reading. Check gasket (or O ring) inside cap occasionally to make sure it is clean and in good condition.

**CAUTION:** New engines are usually shipped from factory with dry sump--check to make sure proper amount of oil is in the engine or added before engine is started for the first time. (Also add oil as needed to driven equipment such as wet type clutch.)

## OIL TYPE

Use high-quality detergent oil of API (American Petroleum Institute) Service Class SF. Select viscosity based on the air temperature at the time of operation as shown below:

### RECOMMENDED SAE VISCOSITY GRADES

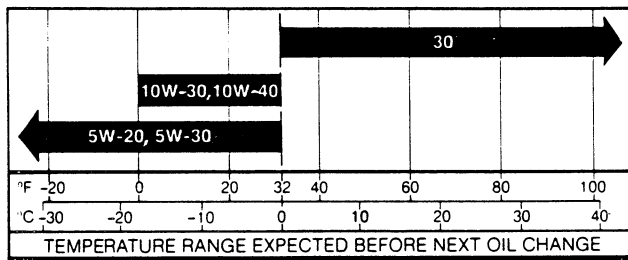

A logo or symbol on oil containers identifies the API service class and SAE viscosity grade.

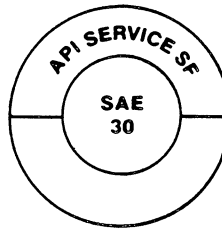

The top portion of the symbol shows service class, such as API SERVICE SF in the example. The symbol may show additional categories, such as SE, SF/CC, CD. The center portion shows the viscosity grade, such as SAE 30 in the example.

Straight 30-weight oil is preferred. If multiviscosity is used, be aware of the resulting increase in oil consumption and combustion deposits when used in temperatures above 32°F (0°C).

**CAUTION:** Using other than Service Class SF oil or extending oil-change intervals longer than recommended could cause engine damage which is not covered by the engine warranty.

## RUN-IN OIL

A special "break-in" oil is used in the factory during the test and run-in period. After factory "run-in", the special oil is drained and the engine is fogged with a special preservative oil. Further use of "break-in" oil is not required nor recommended for new Kohler Engines. Engines should be run-in on the detergent type oil listed in the foregoing chart. Engines should be placed under load from the very first as this promotes final seating of the rings. Change oil after the initial five hours of operation.

On overhauled engines or those rebuilt with new short blocks or mini blocks, use 30W SB or SC oil during summer and 10W SB or SC oil during winter for the first five hours of operation to promote seating of the piston rings. If these oils are unavailable, any 30W oil may be used. After this initial run-in period, change to the oils listed above.

## OIL CHANGE

On a new or rebuilt engine, change oil after the first 5 hours of operation and then every 50 operating hours thereafter. Change oil more frequently under dirty, dusty conditions.

Drain oil when engine is warm - it flows more freely, carrying away more impurities. After draining oil reinstall drain plug. Remove dipstick and add the proper viscosity of oil for the temperature in which your engine will be operating. Fill to the "F" mark on the dipstick as opposed to adding a given quantity of oil. Check level on dipstick before adding more oil. Oil capacity is 3.0 quarts. Add an additional 1/2 quart when oil filter is changed on the K482, K532 and K582 models. Add an additional 1 quart on K662 models when oil filter element or cartridge is replaced.

## OIL FILTER

K482 and K532 engines use full flow type oil filters while by-pass type filters are available as an option on K662 models. Failure to change oil and oil filter elements at the recommended intervals can lead to serious damage to the engine. This is especially true when using detergent oils which have the ability to hold a specific amount of unfilterable impurities in suspension; however, when a saturation point is reached, the oil may suddenly break down to form a gelatin-like substance which seriously impairs and can even stop flow of lube oil. An oil filter does a very effective job; however, it must be replaced each 100 hours of operation (every other oil change) under normal conditions or more often if the engine is subject to extremely dirty conditions.

Two basic types of oil filters are in use on the 2 cylinder engines. The replaceable cartridge (full flow) type is fitted to an adapter which is mounted directly on the crankcase. The other type (bypass) is usually mounted at a point remote from the crankcase and uses external oil inlet and outlet lines.

When replacing the cartridge type unit or the element in the remote type filter--use only genuine Kohler replacement parts from the Kohler blue and white parts cartons. The gaskets, where necessary, are included in each parts carton. Be sure to follow instructions pertaining to the type of filter used.

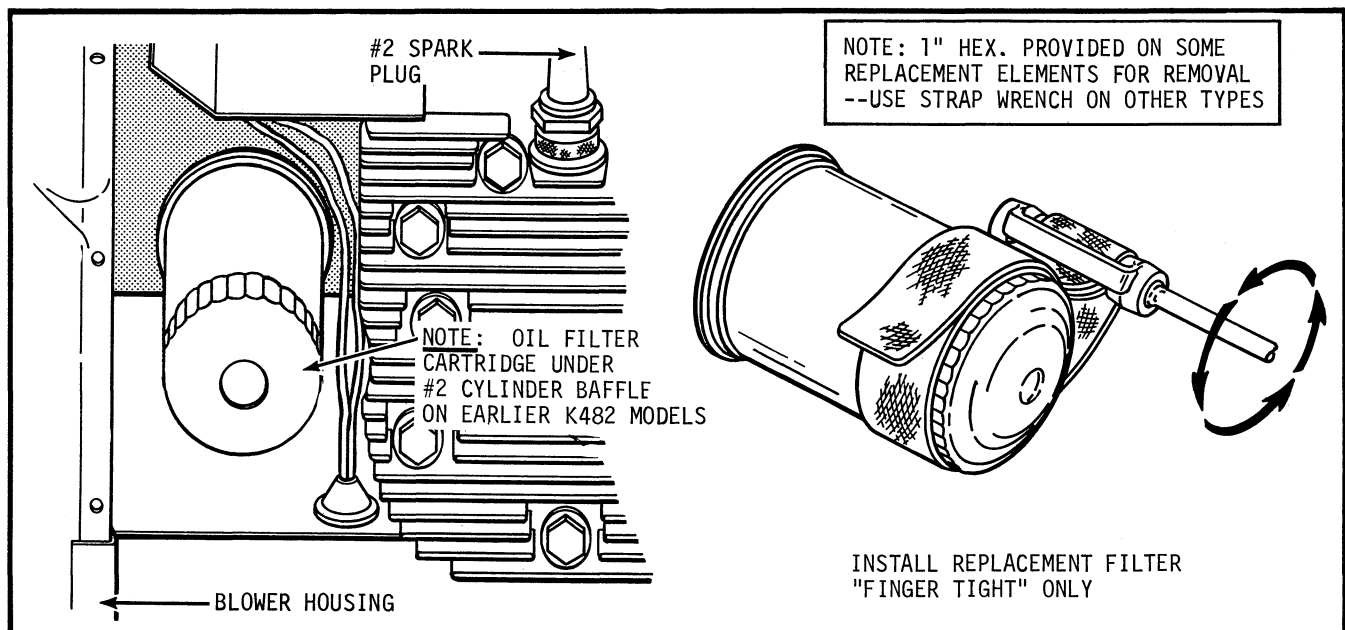

FIGURE 2-1 -- K482 CARTRIDGE TYPE OIL FILTER -- LOCATION

Cartridge Type Oil Filter: On some K482 models, it will be necessary to remove the air baffle on #2 cylinder to gain access to the cartridge--on latest K482 and all K532 models, the cartridge protrudes thru the baffle making removal of the air baffle unnecessary. Earlier models can be converted for direct access with Kit #277577--after this kit is installed, the cartridge element can be replaced without removing the air baffle. On K662 models, the cartridge, when used, is located in a readily accessible point at the rear of the #1 cylinder--baffles do not have to be removed on the K662.

A special strap wrench can be obtained to facilitate easy removal and installation of the cartridge type filters. See "Special Tool" section for further details. Use following procedure for replacing cartridge.

1. Place pan or rags below cartridge to catch oil that may drip from the cartridge as it is loosened and removed.
2. Place strap wrench around cartridge--turn in counterclockwise direction to remove. Discard old cartridge and gasket.
3. Thoroughly clean filter adapter and wipe up any oil that may have spilled on crankcase.
4. Grease gasket then turn new cartridge (with new gasket in place) into adapter--hand tighten only.
5. Reinstall #2 air baffle on K482 models where removal was necessary.

After the proper amount of lubricating oil is added to engine (additional pint required when filter replaced) and after the engine is restarted and again placed in operation, check area around cartridge for evidence of oil leakage--correct if necessary by turning cartridge tighter into adapter (clockwise direction).

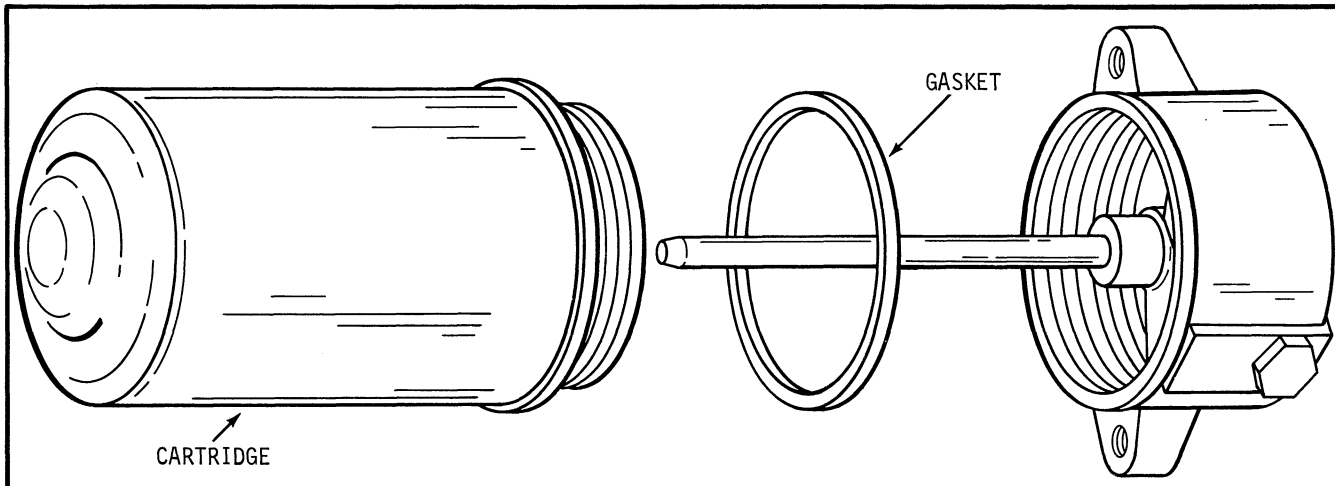

FIGURE 2-2 -- K662 CARTRIDGE TYPE OIL FILTER

Remote Mount Oil Filters: The remote mount filter can be serviced as the lube oil is drained from the engine. No special tools are required for this type of filter. The following procedure is used for replacing element:

1. Drain oil through plug provided on filter body.
2. Remove screw securing cover to the filter body, then remove cover.
3. Grasp clip on top of filter element and pull element out of filter body--slip pan or rag under element as it is removed to prevent oil from dripping on engine. Discard old element.
4. Thoroughly clean inside of cover and body--make sure all trace of dirty oil is removed. Replace cover gaskets if needed. Close drain plug after cleaning.
5. Slip new element (make sure proper replacement element is used) then position and secure cover with retaining screw. Remember to add one quart of oil for filter capacity.

After oil is added and engine restarted, observe area around filter and flexible oil lines for evidence of oil leakage. Correct oil leaks as necessary. Replace any flexible lines that are worn, cracked or frayed to prevent sudden loss of oil and possible engine damage.

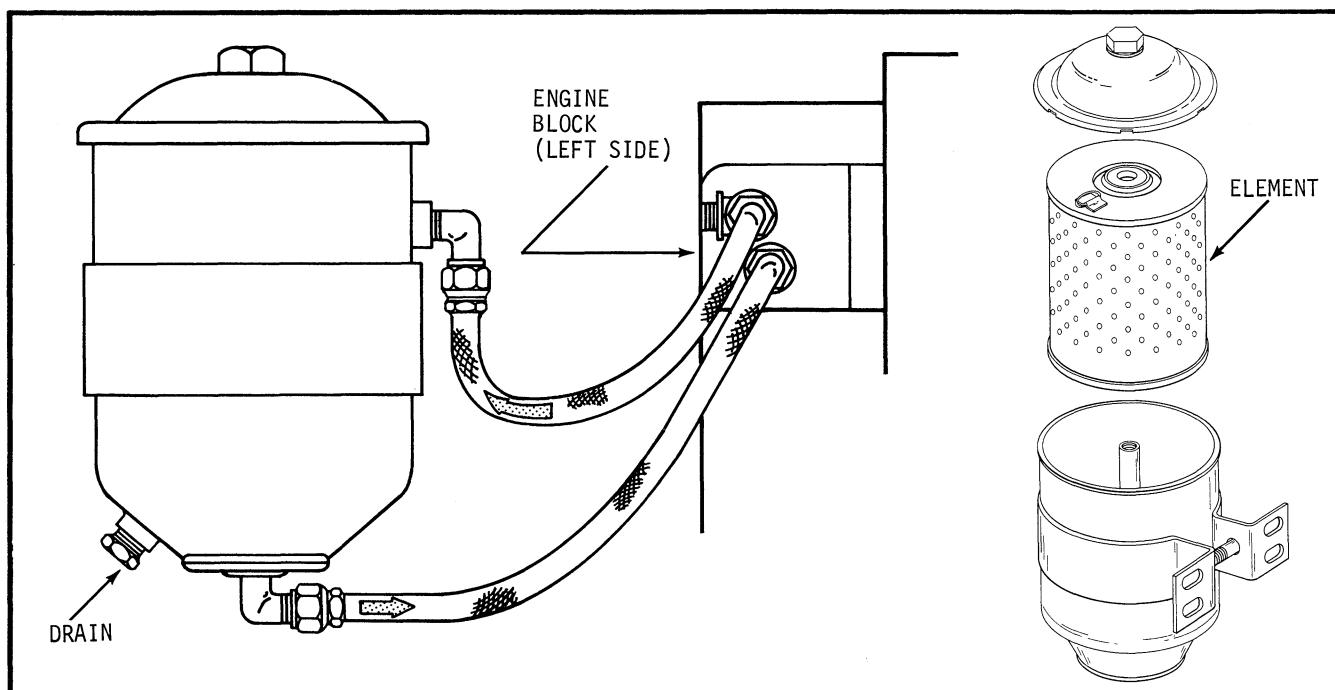

FIGURE 2-3 -- K662 REMOTE MOUNT OIL FILTER

## OIL PRESSURE — OIL PUMPS

If an engine is operating at normal temperatures (with proper weight of oil) and at speed specified, oil pressure should be within the range as shown in the accompanying Oil Pressure Chart.

| <u>APPLICATION</u>     | <u>SPEED (RPM)</u> | <u>OIL PRESSURE RANGE</u> |
|------------------------|--------------------|---------------------------|
| INDUSTRIAL: K482, K532 | IDLE               | 40-50 PSI                 |
| INDUSTRIAL: K662       | 1200 RPM           | 25 PSI (Minimum)          |
| ELECTRIC PLANT         | 1500               | 30-50 PSI                 |
| ELECTRIC PLANT         | 1800               | 30-50 PSI                 |
| INDUSTRIAL             | 2200               | 35-55 PSI                 |
| INDUSTRIAL             | 3200               | 45-65 PSI                 |

Oil pressure is the same for all two cylinder models. Pressure higher than specified will not cause damage; however, it could indicate operation with too thick oil. If oil pressure drops suddenly, this could indicate that oil pump is faulty or that check valve is clogged with dirt or other foreign particles. Other causes of low oil pressure are badly worn bearings and/or transfer sleeves. If oil pump is faulty, do not attempt to disassemble and repair the pump--they are permanently sealed during manufacture. Replace faulty pump with new unit. An external oil pressure adjustment is provided on the K5 K482 and K532 but not on K662 models.

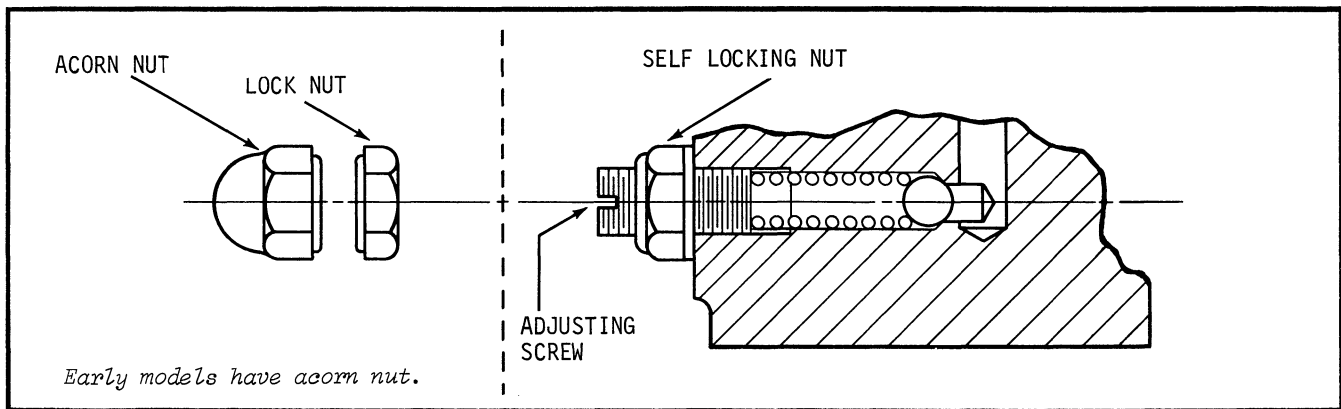

FIGURE 2-4 -- OIL PRESSURE ADJUSTMENT -- K482, K532

ADJUSTMENT K482, K532: The adjusting screw is located just forward of the #1 cylinder. If adjustment becomes necessary, remove acorn nut, loosen jam nut then turn screw in or out until proper pressure is obtained. Turn the setscrew clockwise to increase pressure or in counterclockwise direction to decrease pressure. Adjust only with engine running at normal operating temperature and with proper weight of oil in crankcase. Tighten jam nut to lock adjusting screw at the new setting then reinstall protective acorn nut.

# AIR INTAKE

The importance of maintaining an air cleaner in proper condition cannot be overemphasized! Dirt induced through improperly installed, improperly serviced or inadequate elements, wears out more engines than does long hours of operation. Even a small amount of dirt will wear out a set of piston rings in just a few hours. Furthermore, operating with a clogged element causes the fuel mixture to be richer which can lead to formation of harmful sludge deposits in the engine. Always cover carburetor or air intake horn when air cleaner is removed for servicing. Do not neglect servicing air cleaner at recommended intervals and use only genuine Kohler parts for replacement. Keep other air intake components such as adapters, hoses, clamps, etc. secure and in good condition to prevent entrance of unfiltered air.

Under normal operating conditions, disassemble and service air cleaner components every 50 hours of operation. Do this more frequently (even daily) if extremely dusty or dirty conditions prevail. Do not attempt to clean dry type elements in any liquid or with compressed air as this will damage paper filter material. Wipe dirt or dust accumulation from cover including base plate where used. Replace when dirty with genuine Kohler filter element.

When replacing element use only genuine Kohler part. Carefully handle new element--do not use if gasket surfaces are bent or twisted. Not only must the right filter be used but it must be properly installed to prevent unfiltered air from entering the engine. Check the following when installing new or serviced element.

1. Back plate (K482, K532) air horns and adapters must be securely tightened to carburetor. Replace bent or cracked back plate when used. Gaskets between back plate or air horn and carburetor must be in good condition.
2. Gasket surfaces of element must be flat against cover (and back plate when used) to seal effectively.
3. Copper washer (if used) must be positioned between cover and wing nut to seal and prevent unfiltered air from entering through center hole in cover. If wing nut is used that does not require copper washer, make sure lower flange area of wing nut properly seals around hole in cover. Wing nuts must be finger tightened 1/2 to 1 full turn after nut contacts cover. Do not overtighten.

## Precleaner

Some models are equipped with a precleaner. Precleaners extend the useful life of the paper air cleaner element by removing coarse particles.

Precleaners should be washed and oiled every 25 operating hours, or more often under extremely dirty, dusty conditions, as follows:

1. Remove precleaner from air cleaner element and wash in warm water with detergent.
2. Rinse thoroughly until all traces of detergent are eliminated and squeeze away excess water. Air dry. (Do not wring precleaner.)
3. Soak in fresh clean engine oil and squeeze out excess oil.
4. Reinstall precleaner over air cleaner element.

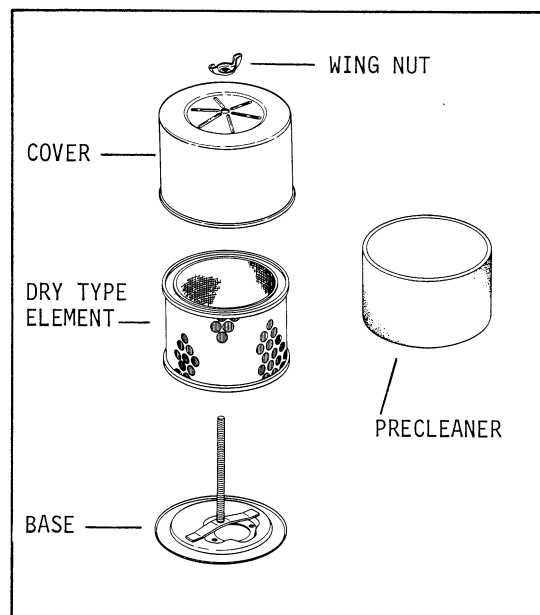

FIGURE 3-1 -- TYPICAL DRY TYPE AIR CLEANER

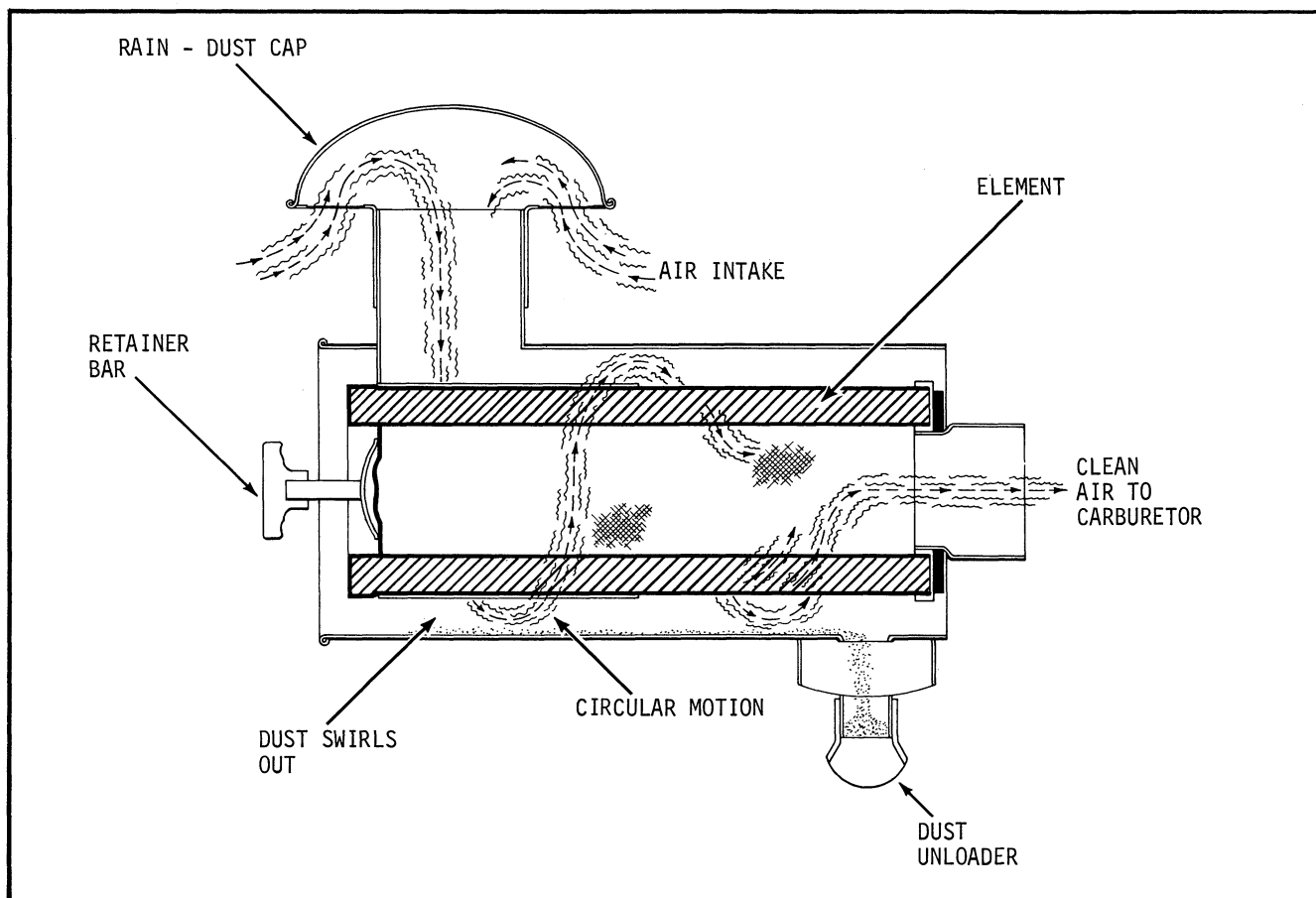

FIGURE 3-2 -- MULTI-PHASE DRY TYPE AIR CLEANER -- CUTAWAY VIEW

### MULTI-PHASE (DRY TYPE) AIR CLEANER

The multi-phase (or tri-phase) air cleaner is a dry type filter for heavy duty applications requiring extra protection against dirt and dust. On this type, after air is drawn in through the rain cap, it spins in circular motion around the outside of the dry type element. This circular motion causes the heavier particles to be centrifuged or thrown outward to the outer shell of the cleaner. The heavy particles then fall to the bottom of the shell and are eventually expelled through the automatic dust unloader. The normal vacuum within the air cleaner holds the lips of the unloader closed until the weight of the accumulated particles builds up sufficiently to overcome that of the vacuum and the lips open briefly to "dump" the accumulation. Air cleaned by centrifugal action is then drawn through the dry type element and into the carburetor. The dry type element on the multi-phase air cleaner is serviceable--it can be cleaned in water and soap (see following instructions) up to 10 times before replacement is required.

Service multi-phase cleaner at the intervals stated in the following steps--perform services more often under severe conditions or if power loss is noted.

1. Check condition of screen on rain cap daily--keep screen clean and free of debris at all times.
2. After every 25 hours of operation, disconnect retainer bar and remove element. Clean out inside of filter body. Compressed air can be used to clean out this element if air pressure is less than 100 PSI.
  - (A) Insert air nozzle inside element and blow dust out.
  - (B) Hold nozzle at least 6 inches away from element to clean dust from outside surface.
  - (C) If compressed air is not available, gently tap element against palm of hand--do not tap against hard surface.

3. After every 50 hours of operation remove retaining bar and remove element for thorough cleaning. Since element must be allowed to drip dry after washing, keep extra element on hand to prevent down time during the drying period. Wash element as follows:
  - (A) Swish element briskly in warm water containing a non-sudsing detergent. DO NOT WASH IN ANY OTHER SOLUTION OR WITH HOT WATER.
  - (B) Direct gentle stream of clean water into inside of element to reverse flush element. Rinse thoroughly.
  - (C) Shake out excess water then place element on end in clean area--allow element to air dry. CAUTION: DO NOT use compressed air to speed up drying process as this will rupture filter material.
  - (D) After element is dry, insert flashlight inside element. An even fine pattern of light as observed through the filter material indicates element is clean and ready for re-use. If a large spot of light is observed, element is ruptured and must be replaced.

Before installing serviced element, wipe out inside of filter body. Inspect gasket end of element --replace element if gasket is damaged or missing. Element should be replaced after 10 washings or after one year of use. Also replace automatic dust unloader after one year of use.

### OIL BATH TYPE AIR CLEANERS

Oil bath air cleaners are often used where above normal concentration of dust, lint, chaff, etc. is present. Normally, the oil bath cleaner should be serviced after every 25 hours of operation; however, if extremely dusty or dirty conditions exist, service cleaner more frequently--even every 8 hours or twice daily if conditions warrant this.

There are several different types of oil bath air cleaners in use. On most, outside air is drawn in through a screen or rain cap and is then pulled across a pool of oil which absorbs the heavier particles. The partially cleaned air is then drawn through an oil laden filter element for final filtering and then into the carburetor. On some, a series of elements with varying degrees of filtration qualities are used for final filtering.

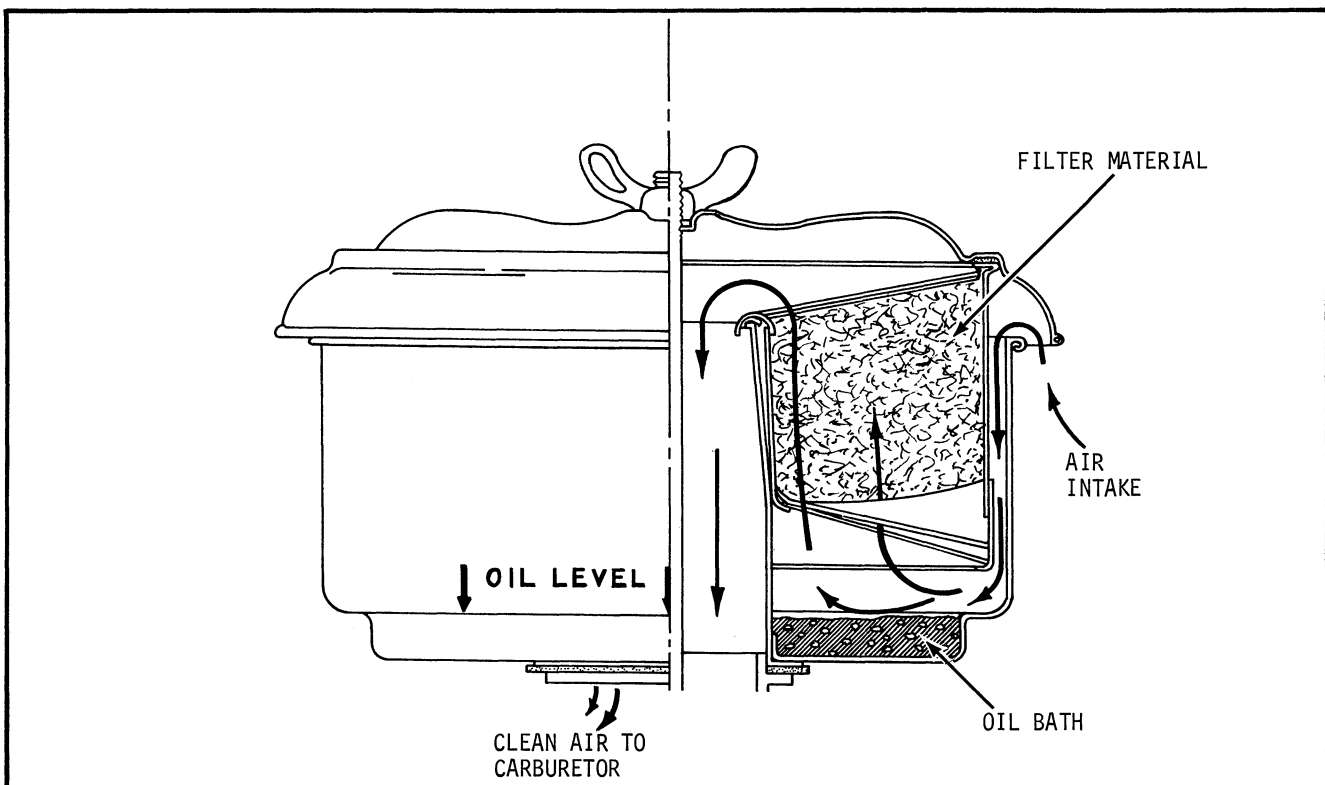

FIGURE 3-3 -- TYPICAL OIL BATH AIR CLEANER (NORMAL CAPACITY TYPE)

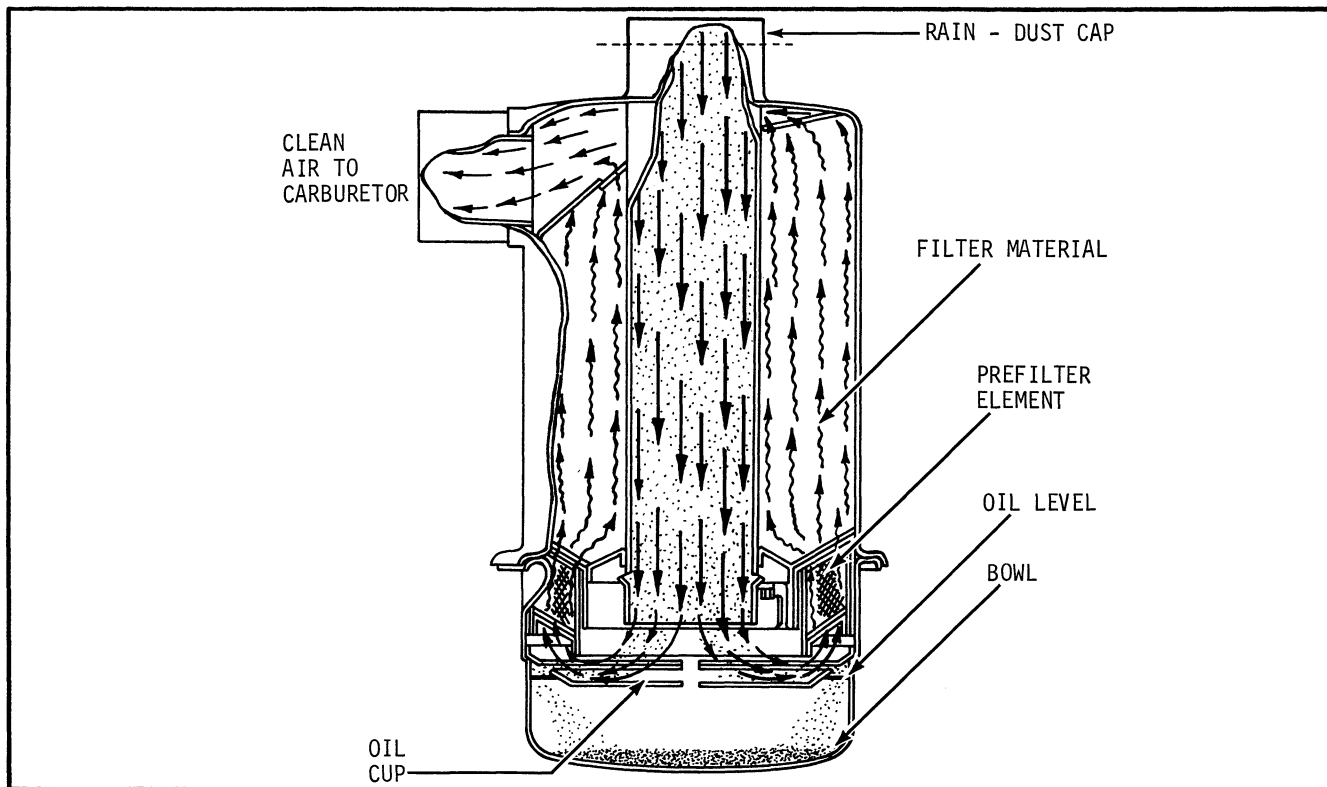

FIGURE 3-4 -- TYPICAL LARGE CAPACITY OIL BATH AIR CLEANER

To service normal capacity type oil bath air cleaners, remove wing nut and remove air cleaner components as a unit. Use the following procedure for cleaning.

1. Remove cover, lift element out of bowl, drain dirty oil from bowl.
2. Thoroughly wash cover and bowl in clean solvent. Swish element in solvent, allow element to drip dry. DO NOT dry with air hose as this can ruin filtering material in this type of cleaner. Lightly re-oil element after cleaning with same type of oil as used in engine.
3. Inspect air horn, filter bowl and cover gaskets. Replace gaskets if badly grooved or cracked.
4. Install gasket then place cleaned filter bowl on air horn. Add oil (same grade and weight as engine oil) to OIL LEVEL mark stamped on filter bowl.
5. Reinstall element in bowl, position cover, place copper washer (when used) then secure with wing nut--firmly tighten with fingers only.
6. Check to make sure cleaner is properly installed so that no unfiltered air can enter carburetor.

Servicing of the large capacity type oil bath is essentially the same as that stated for the normal capacity type cleaners. The main difference is that the bowl is removed from the bottom of the unit. To remove, unfasten clamps or, if clamps are not used, twist bowl until it is free of the locking tabs. Service large capacity units as follows:

1. After removing bowl, empty old oil and clean out sediment.
2. Thoroughly clean disc and bowl. If prefilter element is used, press element upward, then twist to left until locking tabs line up with vertical slots then pull downward to remove. Swish prefilter in clean solvent. Allow to drip dry.
3. After installing serviced prefilter (when used), add clean oil of same type used in engine to level indicated in bowl. Place disc in bowl and reinstall bowl cleaner body.

# FUEL SYSTEM

## CARBURETOR (GASOLINE)

Downdraft and sidedraft carburetors are used on the two cylinder engines. Carburetors are adjusted in the factory, and under normal conditions, require no further adjustment unless one of the following conditions is noted: Before readjusting carburetor, check condition of air cleaner--an "over-rich" mixture is often caused by a poorly serviced, clogged air cleaner element. Also check for leaking intake manifold or poor ignition which could also cause some of the conditions.

| <u>CONDITION</u>   | <u>POSSIBLE CAUSE/PROBABLE REMEDY</u>   |
|--|---|
| A. Black, sooty exhaust smoke, engine sluggish.                  | A. Mixture too rich - readjust main fuel needle.  |
| B. Engine misses and backfires at high speed.                    | B. Mixture too lean - readjust main fuel needle.  |
| C. Engine starts, sputters and dies under cold weather starting. | C. Mixture too lean - turn main fuel adjustment 1/4 turn counterclockwise.                          |
| D. Engine runs rough or stalls at idle speed.                    | D. Idle speed too low or improper idle adjustment - readjust speed then idle fuel needle if needed. |

Two types of sidedraft carburetors are used. One type has external adjustments for Main Fuel and Idle Fuel. The other is a fixed main jet type which has an external adjustment for the Idle Fuel needle only. On fixed jet carburetors, main fuel adjustment is possible only by changing to a discharge jet of different size. If an engine with fixed jet carburetor is to be operated at high altitudes (above 6000 feet) the standard jet should be replaced by a special 6000' jet. Another special jet is available for operating at 12,000 feet above sea level. See parts manual for correct part numbers.

Carburetor Adjustment: Maximum power and efficiency are possible only with proper carburetion. Improper carburetor adjustment can lead to overheating, fouled spark plug, excessive valve wear and other problems. Do not neglect carburetor if any of the above problems persist. The following adjustment procedure is for sidedraft and downdraft gasoline carburetors--see Special Fuel System Section for procedure on other types of carburetors.

STEP 1 - Stop engine and carefully turn Main Fuel and Idle Fuel Needle adjusting screws all the way in (clockwise direction) until they bottom gently--DO NOT FORCE SCREWS as this will damage the needle valves.

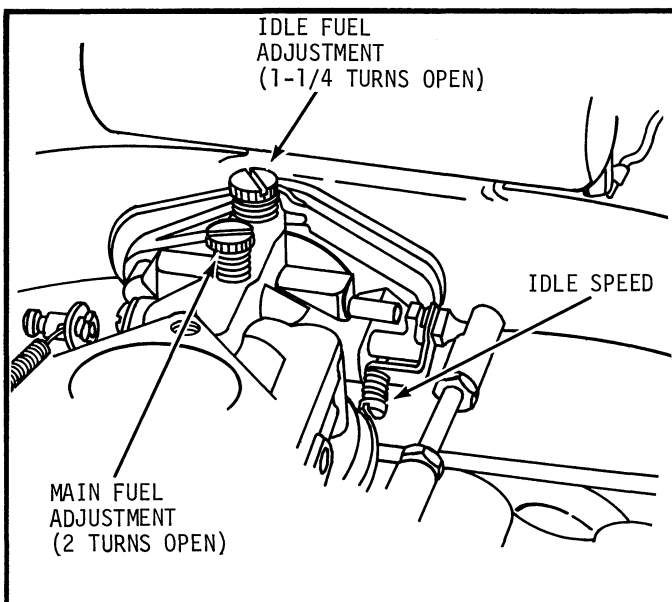

FIGURE 4-1 -- ADJUSTMENTS, TYPICAL SIDEDRAFT CARBURETOR (K482, K532)

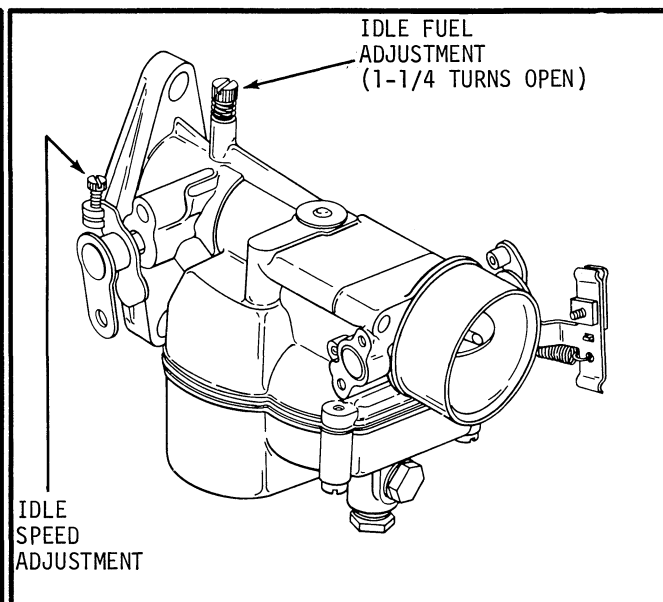

FIGURE 4-2 -- ADJUSTMENTS, FIXED MAIN JET CARBURETOR

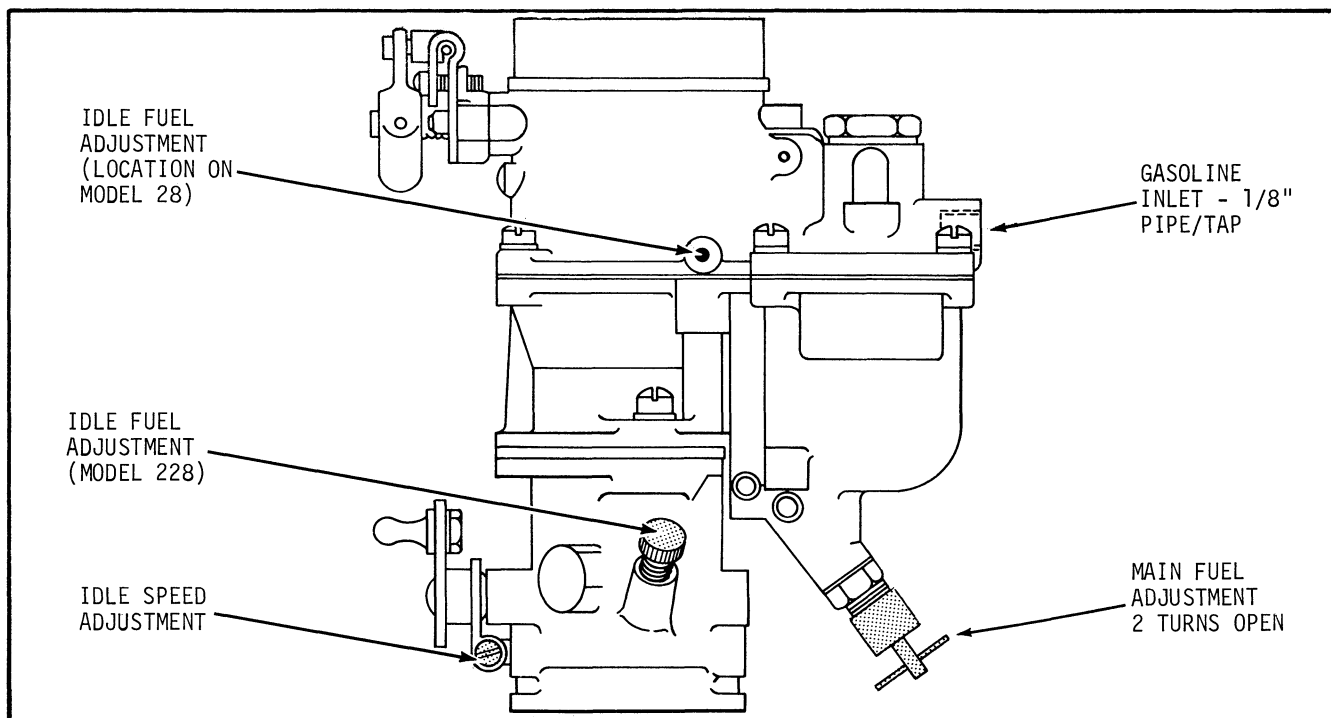

FIGURE 4-3 -- ADJUSTMENTS, DOWNDRAFT CARBURETOR MODELS 28 AND 228, K662 ENGINES

- STEP 2 - For preliminary adjustment, turn Main Fuel needle 3 turns in a counterclockwise direction, turn Idle Fuel needle 1-1/4 turns in a counterclockwise direction.
- STEP 3 - Start engine and operate at normal speed until normal operating temperatures are reached.
- STEP 4 - Main Fuel Adjustment - With engine operating at full throttle and full load, turn Main Fuel Needle in (clockwise) until engine slows down (lean), note position of screw, then turn needle out (counterclockwise) until engine regains speed and then again slows down (overrich). Turn needle back in until it is positioned halfway between lean and overrich settings. If adjusted properly, the engine should accelerate smoothly and operate with steady governor action.
- STEP 5 - Idle Fuel Adjustment - Operate engine at idle speed of about 1000 RPM (adjust Idle Speed screw until this speed is attained - check with tachometer). Turn Idle Fuel Needle in (clockwise) until engine slows down and idles rough then turn screw out until engine speeds up and idles smoothly at the desired idle speed.
- STEP 6 - Final Adjustment - Since main fuel and idle fuel adjustment have some effect on each other, recheck engine and make final adjustments as necessary to achieve smoothest operation.
- NOTE: If the preceding steps do not remedy problems attributed to carburetor, carburetor reconditioning may be necessary.

Carburetor Reconditioning: Hard starting, loss of power and rough idle are some of the problems that can be attributed to improper adjustment or dirt, gum or varnish deposits within the carburetor. If a problem still exists after carburetor is readjusted, the carburetor should be disassembled and thoroughly cleaned. This should also be done as a regular pre-season service after engine has been stored for a considerable length of time.

All parts should be cleaned in solvent. Gum is easily removed with alcohol or acetone solvent. Be sure carbon deposits are removed from bore especially in area where throttle plate seats in casting. Blow out all passages with compressed air. DO NOT use wire brush or drill to clean out jets. Replace all worn and damaged parts. Always use new gaskets. Carburetor repair kits are available for most carburetors--kits include bowl nut gaskets (when required) bowl ring gasket, float pin, bowl baffle gasket, and fuel inlet needle and seat.

### Disassembly - Side Draft Carburetor (A-277061)

1. After removing carburetor from engine, remove bowl nut and separate bowl from carburetor body. Remove and discard bowl ring and bowl baffle gaskets.
2. Remove float pin and float. Check for dents, leaks and excessive wear on float in needle valve contact area. Check pin brackets for wear. Replace float as necessary.
3. Remove and discard fuel inlet needle, needle seat and gasket. Any wear on needle or seat can cause improper fuel level--always use new parts.
4. Remove idle and main fuel adjusting needles and springs. Inspect needle points--replace needle if chipped or grooved.
5. DO NOT REMOVE choke and throttle plates and shafts. If these parts are worn or damaged, replace carburetor.
6. Thoroughly clean carburetor per instructions in reconditioning paragraph.

### Reassembly - Side Draft Carburetor (A-277061)

1. Install new fuel inlet needle seat, gasket and fuel inlet needle.
2. Install float and float pin. Invert casting so that float lip rests lightly against fuel inlet needle. There should be  $1/64$ " (plus or minus  $1/32$ ") clearance between machined surface of casting and free end of float (side opposite needle seat). Adjust clearance by carefully bending float lip with needle nose pliers.
3. Install new baffle gasket, bowl ring gasket then install bowl and secure with bowl nut (with bowl nut gasket in place and centered properly).
4. Install idle fuel and main fuel needles and springs. Turn needles in until they bottom gently then back out 2 turns on main fuel needle and 1-1/4 turns on idle fuel needle for preliminary adjustment. DO NOT use force on needles.

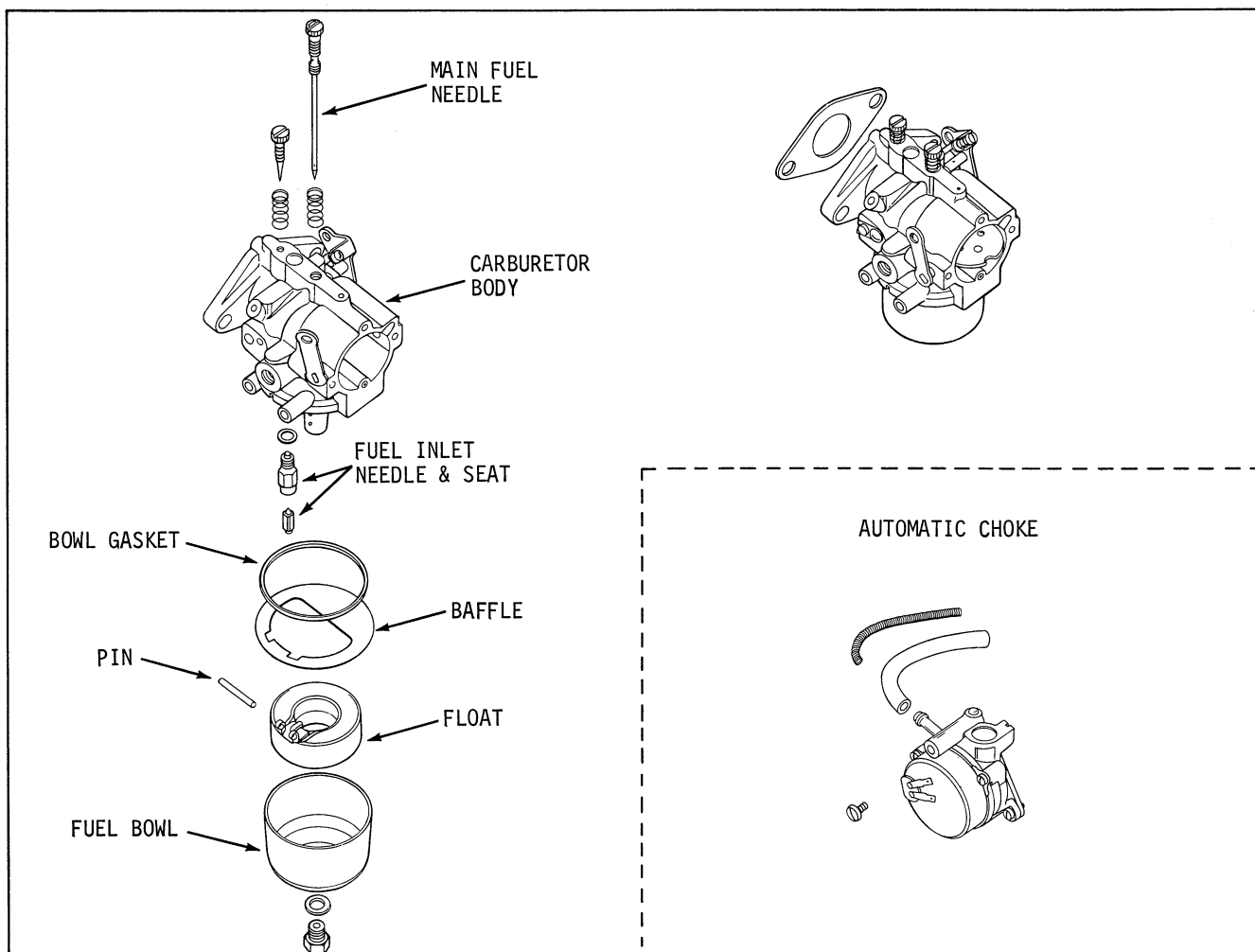

FIGURE 4-4 -- DISASSEMBLED VIEW -- SIDEDRAFT CARBURETOR

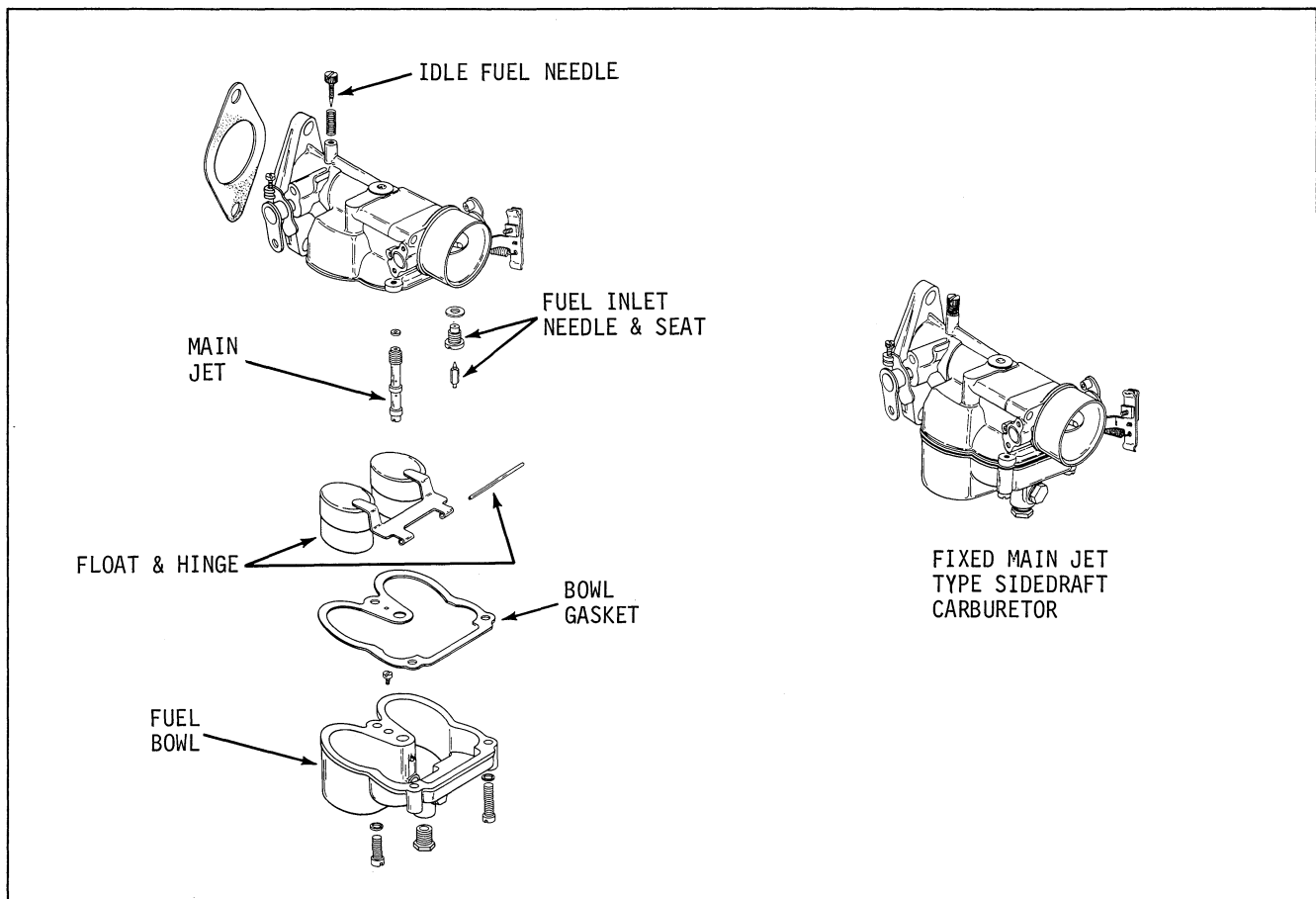

FIGURE 4-5 -- DISASSEMBLED VIEW -- TYPICAL FIXED MAIN JET CARBURETOR

Disassembly - Fixed Main Jet Type Side Draft Carburetor

1. After removing carburetor from engine, remove capscrews on bowl and remove bowl assembly. Remove and discard bowl gasket.
2. Remove float pin and float. Replace float if dented, leaking or if worn excessively in area where fuel inlet needle seats against bowl bracket.
3. Carefully remove discharge tube and rubber (or fibre) seal.
4. Remove idle fuel needle and spring. Replace needle if nicked or grooved.
5. Do not remove throttle or choke plate and shaft assemblies. Replace carburetor if these parts worn or damaged.
6. Clean carburetor as directed in reconditioning paragraph.

Reassembly - Fixed Jet Type Side Draft Carburetor

1. Position seal and install main discharge tube.
2. Install gasket and fuel inlet needle seat and fuel inlet needle.
3. Invert carburetor body and install float and float pin. Hold in inverted position and measure distance between machined surface (no gasket) and top of floats. This should be  $31/32''$  (plus or minus  $1/32''$ ) at highest point. If float position off more than  $1/16''$ , replace float. To adjust, use long nose pliers and bend bracket close to float body--each float must be set individually.
4. Install new bowl gasket then install bowl. Secure bowl with three capscrews--install shorter screw at throttle plate end of carburetor.
5. Install idle fuel needle and spring. Turn needle all the way in until it bottoms gently. Then back out 1-1/4 turns for initial adjustment. **DO NOT FORCE IDLE ADJUSTMENT SCREW** as this will damage needle point.

Disassembly - Fixed Jet Type Side Draft Carburetor (B-272041)

1. Remove carburetor from engine. Remove bowl assembly from body.
2. Remove float pin, float and needle. Check float for dents, leaks and wear on float lip or in float pin holes.
3. Remove discharge tube being careful not to lose rubber or fibre seal. Remove idle adjusting needle and spring. Do not remove choke and throttle valves and shafts.

Reassembly - Carburetor (B-272041)

1. Replace discharge tube. Be sure seal is in place.
2. Place bowl gasket in position.
3. Install needle float and float pin. Set float level with carburetor body inverted and float resting lightly against needle in its seat. There should be 1-1/4" between machined surface of casting (no gasket) and top of float. Float should be level from one side to the other. Adjust by bending float lever close to body with needle-nose pliers.
4. Assemble fuel bowl to body.
5. Install idle mixture screw. Back out 1-1/4 turns after seating.

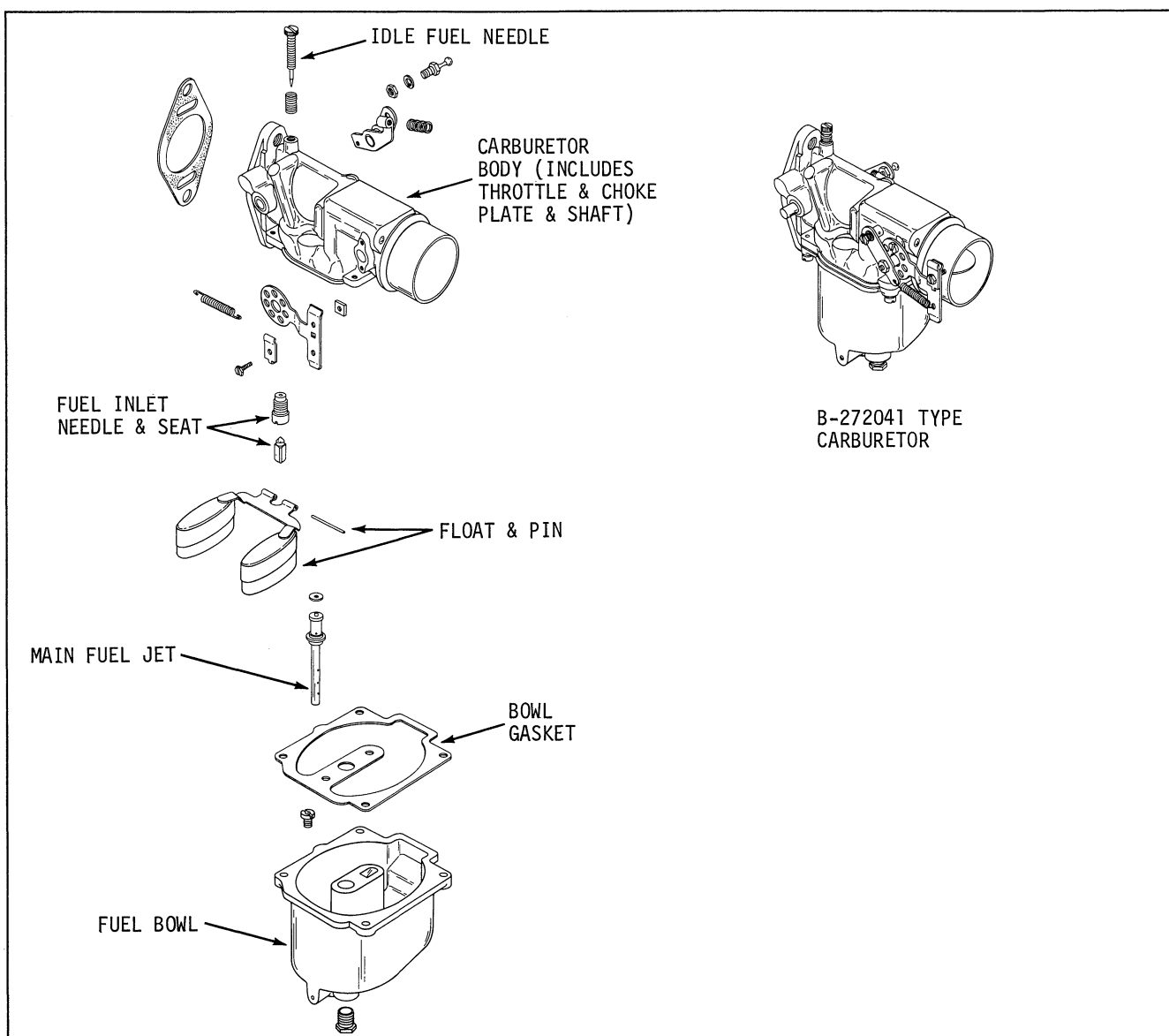

FIGURE 4-6 -- DISASSEMBLED VIEW -- B-272041 TYPE FIXED JET CARBURETOR

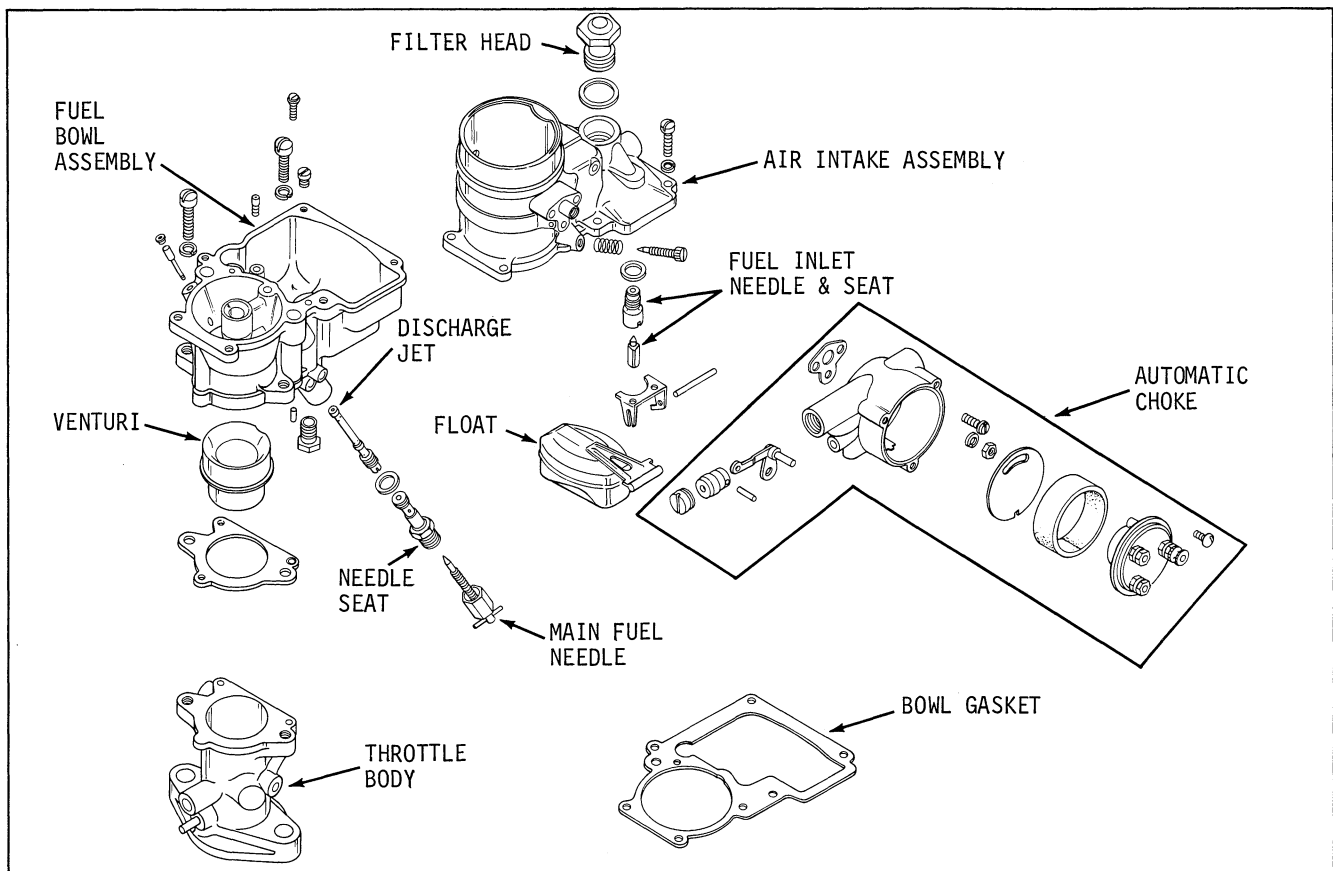

FIGURE 4-7 -- DOWNDRAFT CARBURETOR -- K662 (ZENITH TYPE)

#### Disassembly - Down Draft Carburetor

Several different types of down draft carburetors are in use on K662 engines. The most common are the Zenith Model 28 (Kohler 270374) and Model 228 (Kohler 270864) carburetors. The main difference between these two models is that the idle fuel adjusting screw is on the air intake (choke) segment of the Model 28, while this same adjusting screw is located in the throttle segment of the Model 228. The 228 uses a two hole idle system which calls for the lower position of the idle needle. The same general reconditioning procedure can be followed for both carburetor models. Use service repair kit when reconditioning. After carburetor is disconnected and removed from engine, disassemble as follows:

1. Remove capscrews holding air intake assembly to fuel bowl assembly. Lift air intake assembly off--use care to avoid bending float as assembly is removed. Remove and discard gasket.
2. Remove capscrews and separate fuel bowl assembly from throttle assembly.

Service each assembly separately per the following instructions:

#### Air Intake Assembly:

1. Remove float pin and float. Inspect float--discard if dented, cracked or leaking.
2. Remove and discard fuel valve, seat and gasket. (Always replace these parts.)
3. Remove and inspect idle fuel needle--replace if nicked or if ridges are present.
4. Remove and clean filter head.
5. Do not remove choke plate or shaft--if worn or damaged, replace air intake assembly.
6. If automatic choke is used, partially disassemble this unit to allow cleaning along with air intake assembly. (see Choke instructions for procedure.)
7. Thoroughly clean assembly then reverse procedure and reassemble--use new gaskets, fuel valve, etc. Fuel float level should be adjusted just prior to reassembly of carburetor sub-assemblies.

Fuel Bowl Assembly:

1. Remove main jet adjusting needle and main fuel needle seat. Inspect these parts and replace if nicked, grooved or otherwise damaged.
2. Wash assembly in clean solvent, blow out ports, venturi, etc. with compressed air.
3. Reinstall main fuel needle seat and needle--turn needle all the way in with fingers then back off about 1-1/2 turns for preliminary adjustment.

Throttle Assembly:

1. Remove and inspect venturi for damage. Clean venturi.
2. Remove gasket (throttle body to bowl) make sure all trace of gasket material is removed from face of throttle body.
3. Do not remove throttle plate or shaft--if these parts are worn, replace with new throttle body.

After cleaning and renewing parts where required, reassemble as follows:

1. After installing new gasket, place large venturi in throttle body.
2. Position bowl assembly on throttle body and secure with capscrews.
3. Just before final assembly, set float level: Turn intake assembly upside down so that float rests lightly against fuel valve. Measure distance between machined surface of assembly and top of float--this should be 1-1/2". If adjustment is necessary, use needle-nose pliers and bend float lever up close to float body.
4. Insert gasket on fuel bowl assembly then carefully guide air intake assembly into position on fuel bowl--be careful not to hook float when installing as this may alter float setting.
5. Securely tighten air intake with capscrews to complete assembly. Adjust carburetor per previous instructions.

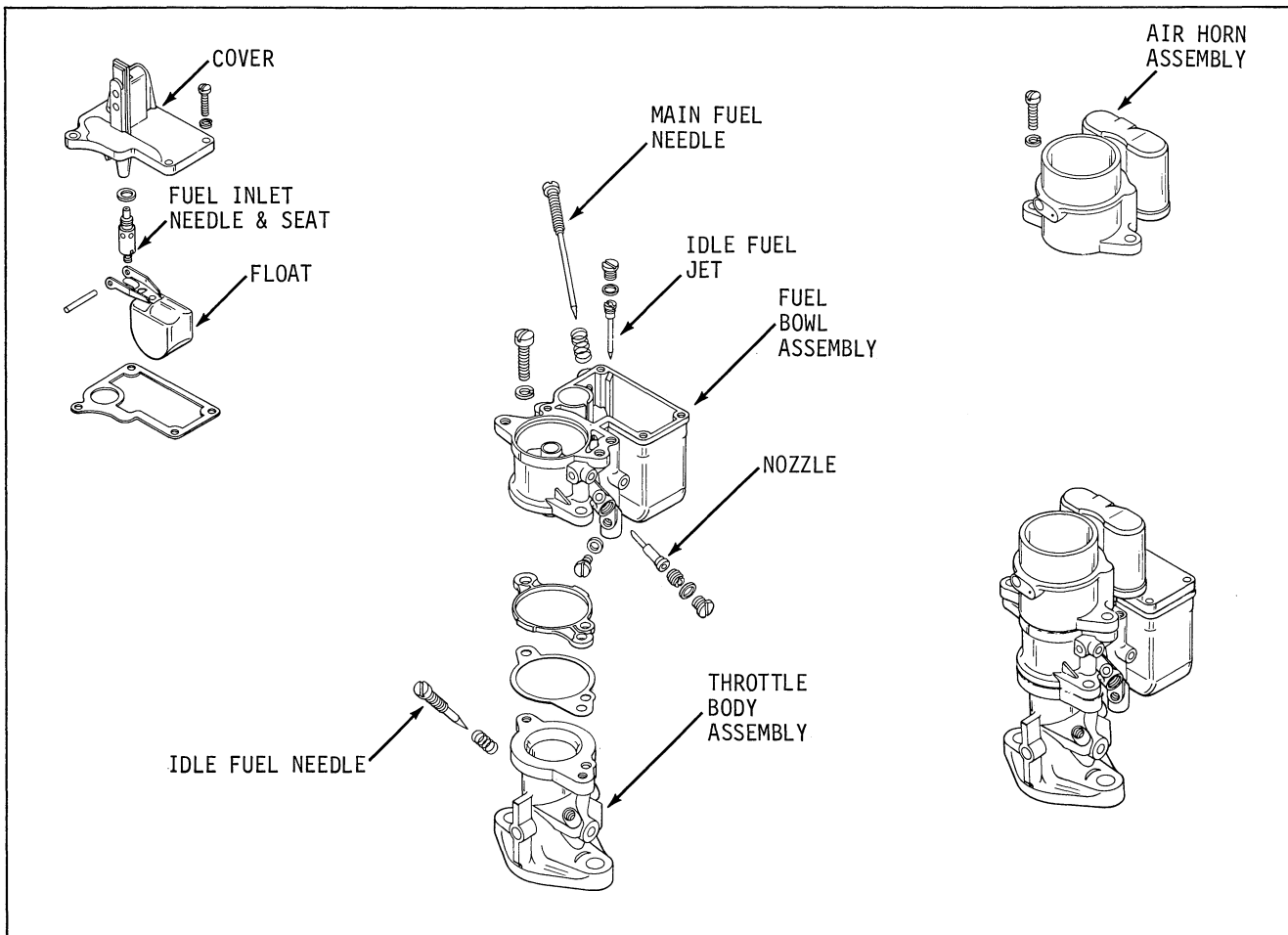

FIGURE 4-8 -- DOWNDRAFT CARBURETOR -- K662

## AUTOMATIC CHOKES

Two different electric - thermostatic type automatic chokes are used on the K662 models. One type is an integral part of a special down draft carburetor while the other type is mounted on the exhaust manifold and connected through external linkage to the choke plate in carburetor.

Both types operate on the same basic principles. The electrical lead to the choke is connected so that current flows to the thermostatic element only when the ignition is turned on. Tension of the thermostatic spring is set to allow full choke at starting. Current through a heating element furnishes heat to control tension of the thermostatic spring which causes the choke plate to be gradually returned to the open position as the engine warms up.

The automatic chokes are adjusted in the factory, however, slight readjustment may be necessary initially to accommodate different starting conditions. Adjust chokes as follows:

Carburetor Unit: Choke unit is set for average conditions. To readjust to local starting conditions, loosen screws on outside of cover plate then shift cover in clockwise direction (arrow) for richer setting or in counterclockwise direction for leaner setting. Tighten cover screws after final adjustment.

Exhaust Manifold Mounted Unit: Remove air cleaner from carburetor to observe position of choke plate. Choke adjustment must be made on cold engine. If starting in extreme cold, choke should be in full closed position before engine is started. A lesser degree of choking is needed in milder temperatures. If adjustment is needed, proceed as follows:

1. Move choke arm until hole in brass shaft lines up with slot in bearings.
2. Insert #43 drill (.089) and push all the way down to engine manifold to engage in notch in base of choke unit (See Figure 4-9B).
3. Loosen clamp bolt on choke lever, push arm upward to move choke plate toward closed position. After desired position is attained, tighten clamp bolt then remove drill.
4. After replacing air cleaner, check for evidence of binding in linkage--correct if necessary. Be sure chokes are fully open when engine is at normal operating temperature.

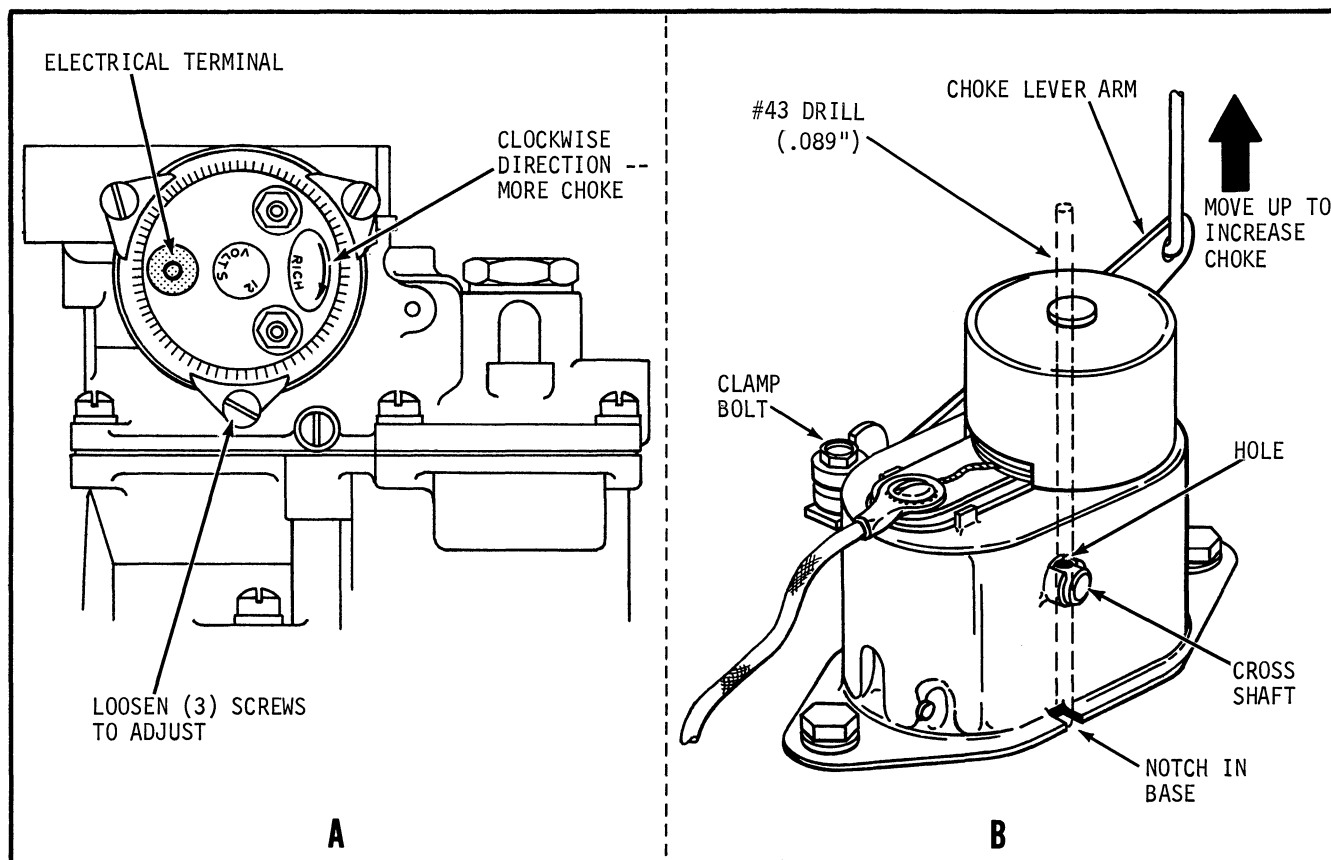

FIGURE 4-9 -- AUTOMATIC CHOKES (A) CARBURETOR UNIT -- (B) MANIFOLD UNIT

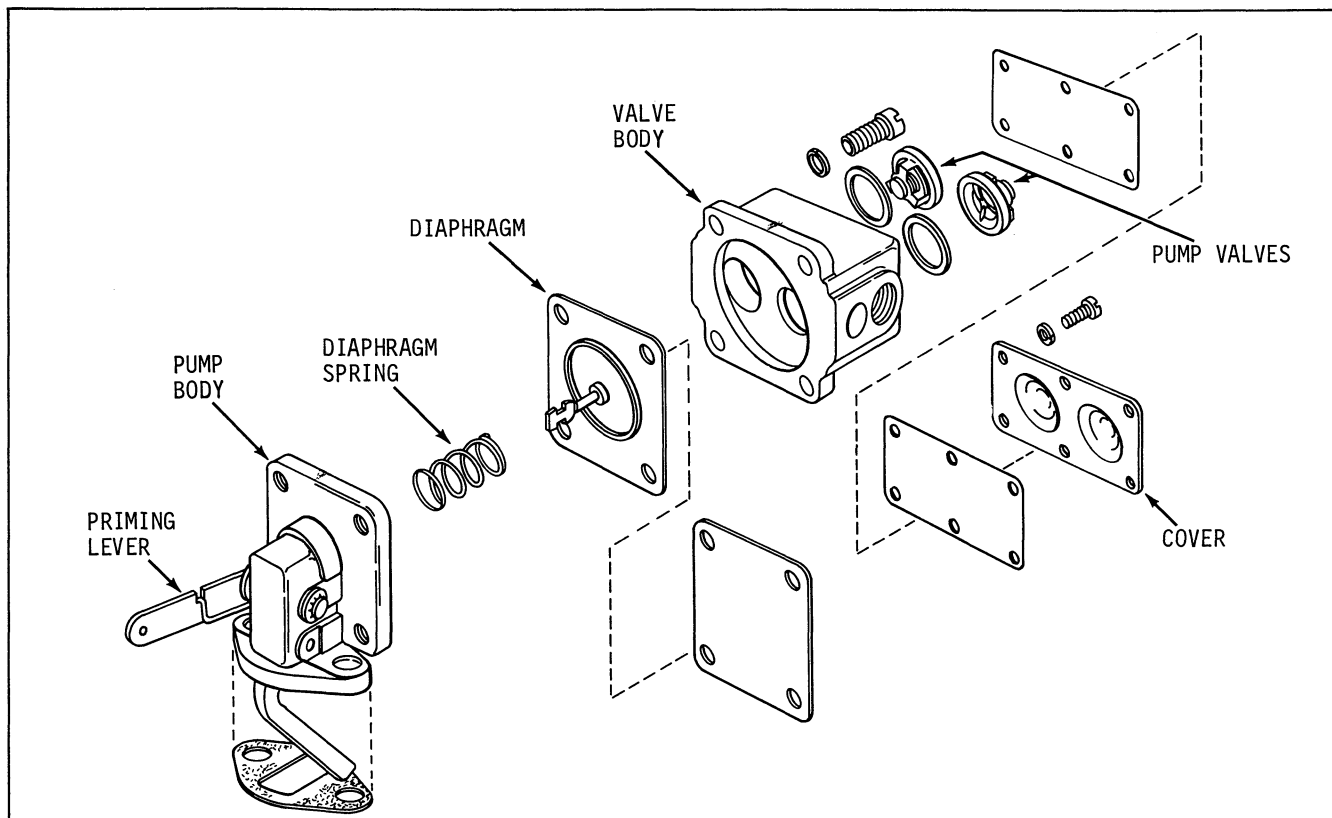

FIGURE 4-10 -- DISASSEMBLED VIEW, FUEL PUMP (K662)

## FUEL PUMPS

All Kohler Two Cylinder Engines have a mounting pad and provision on top of crankcase for a mechanically operated fuel pump. Mechanical fuel pumps are furnished by Kohler--certain applications use pulse pumps which are furnished by the equipment manufacturer. The mechanical pump operates off a cam on the camshaft. The fuel pump lever rides on the cam and transmits this mechanical action to a diaphragm within the pump body. Most mechanical pumps have an external lever for priming. Repair kits are available for reconditioning fuel pumps.

### Reconditioning Procedure

1. Remove fuel lines and mounting screws holding pump to engine.
2. With a file, make an indicating mark across a point at the union of fuel pump body and cover. This is a positive marking to assure proper reassembly. Remove assembly screws and remove cover.
3. Turn cover over and remove valve plate screw and washer. Remove valve retainer, valves, valve springs and valve gasket, noting their position. Discard valve springs, valves and valve retainer gasket.
4. Clean fuel head thoroughly with solvent and a fine wire brush.
5. Holding pump cover with diaphragm surface up, place new valve gasket into the cavity. Now assemble the valve spring and valves into the cavity and reassemble valve retainer and lock in position by inserting and tightening fuel pump valve retainer screw.
6. Place pump cover assembly in a clean place and rebuild the lower diaphragm section.
7. Holding mounting bracket, press down on the diaphragm to compress spring under it, then turn bracket 90° to unhook diaphragm so it can be removed.
8. Clean mounting bracket with a solvent and a fine wire brush.
9. Replace the diaphragm operating spring, stand new spring in casting, position diaphragm and press down on diaphragm to compress spring and turn it 90° to reconnect diaphragm.
10. Hold mounting bracket, then place the pump cover on it (make sure that indicating marks are in line) and insert the screws. **DO NOT TIGHTEN**. With the hand on the mounting bracket only, push the pump lever to the limit of its travel and hold in this position while tightening the four screws. This is important to prevent stretching the diaphragm.
11. Mount the fuel pump on engine, using the new mounting gaskets. Reconnect the fuel lines.

## **FUEL FILTERS**

A sediment bowl filter may be used to trap solid impurities in the fuel. Before servicing, turn fuel off at valve located on top of filter assembly, then loosen retaining bail at bottom of fuel bowl, remove and clean bowl. If filter element is used, swish element in clean solvent. After reinstalling and opening fuel valve, use primer (if so equipped) on fuel pump to pump fuel back into bowl.

# GOVERNOR

The 2 cylinder engines are equipped with centrifugal flyweight type mechanical governors which are externally mounted at the rear of the gear cover and driven off the camshaft gear. The governors are self-contained units except models prior to Serial No. 9224060 which were lubricated through an external oil line which connects the engine lubrication system to the governor.

Governors are adjusted in the factory and further adjustment should not be needed unless linkage becomes loose or disconnected. Always make sure linkage between governor and carburetor moves freely. If governor is out of adjustment, engine speed will surge or hunt with changing load or speed will drop considerably when a normal load is applied. Governors also function to establish safe operating speed limits--these must not be exceeded.

Although mechanical type governors are used on all two cylinder models, the K662 governors are different in design and therefore the adjustment procedure varies slightly. Governors are set at either a constant speed setting or at a variable speed setting as determined by the engine application. Make sure the proper procedure is followed for the particular engine involved.

## K482, K532 GOVERNORS

On the K482 and K532, the breaker points are mounted on the governor and are activated by the breaker rod which rides on a cam on the governor drive shaft. For this reason, it is necessary to time this governor to the engine. This is initially done during assembly of the engine and it will not have to be done again unless governor has been removed from the engine.

Installation and Timing: Use the following procedure to install and retune the governor to the engine:

1. Uncover ignition timing sight hole on blower housing and also remove sight hole plug located at top of gear cover.
2. Turn engine over until Top Dead Center (DC) mark on flywheel is centered in ignition timing sight hole.
3. One of the teeth on the governor gear has a special timing bevel or deep chamfer--turn gear so that this tooth is in the approximate 12 o'clock position or where it can be observed in the gear cover sight hole after governor is installed (See Figure 5-1).

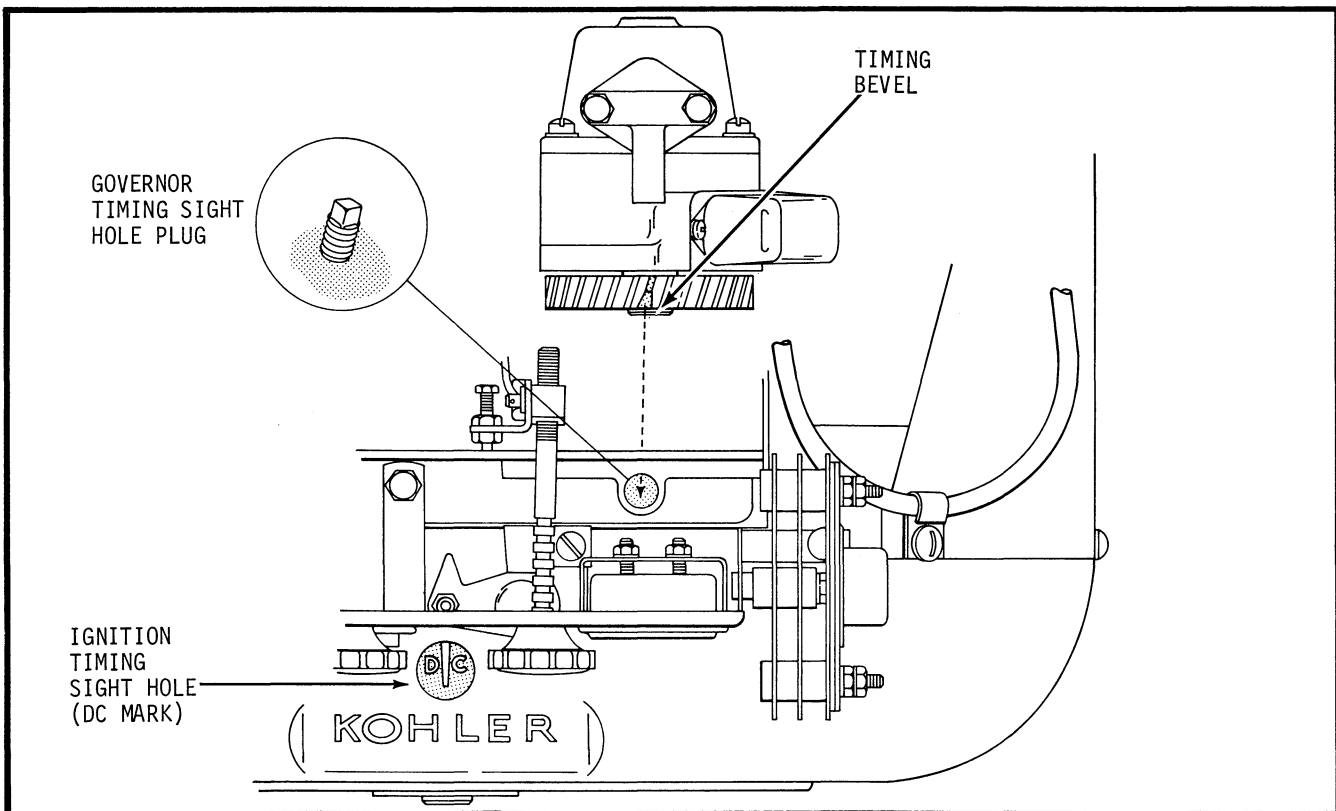

FIGURE 5-1 -- TIMING K482, K532 GOVERNOR TO ENGINE

4. Install gasket and governor then secure to gear cover with two capscrews. Before closing gear cover sight hole with plug, check to make sure beveled tooth on cam can be observed in hole.
5. Ignition timing must be readjusted after governor is installed. On the K482 and K532, this is done by loosening the capscrews and rotating governor--see Ignition Timing instructions (Section 6) for exact details.

**Speed Adjustment:** On most engines with the variable speed type governor (See Figure 5-2, View A), maximum speed is set at 3600 RPM no load. On some applications, a lower maximum speed is specified --make sure that the allowable speed for the particular application is not exceeded. Use the following procedure to readjust speed limit on engines with the variable speed governor:

1. Start engine and operate at full throttle (no load).
2. Check engine speed with hand tachometer--if within 50 RPM of specified limit, readjustment is not absolutely necessary.
3. Loosen locking nuts on speed stop setscrew--turn screw out or in as necessary to attain specified top speed. Retighten locking nuts to secure stop at new setting.

With the Constant Speed type governor (Figure 5-2 -- View B), the throttle shaft is fixed at a definite length to establish a specific operating speed such as 1800 RPM for 60 cycle electric plants. Any variation in speed causes frequency changes in output of the generator--for this reason, only slight readjustment of speed is possible with constant speed governors. To increase speed, loosen the inside speed adjusting locking nut and tighten the outside nut to draw the eye of the bolt closer to the bracket --to decrease speed, loosen the outside nut and tighten the inside nut. After speed is correct, tighten the nut that was loosened to lock the eye bolt at the new setting.

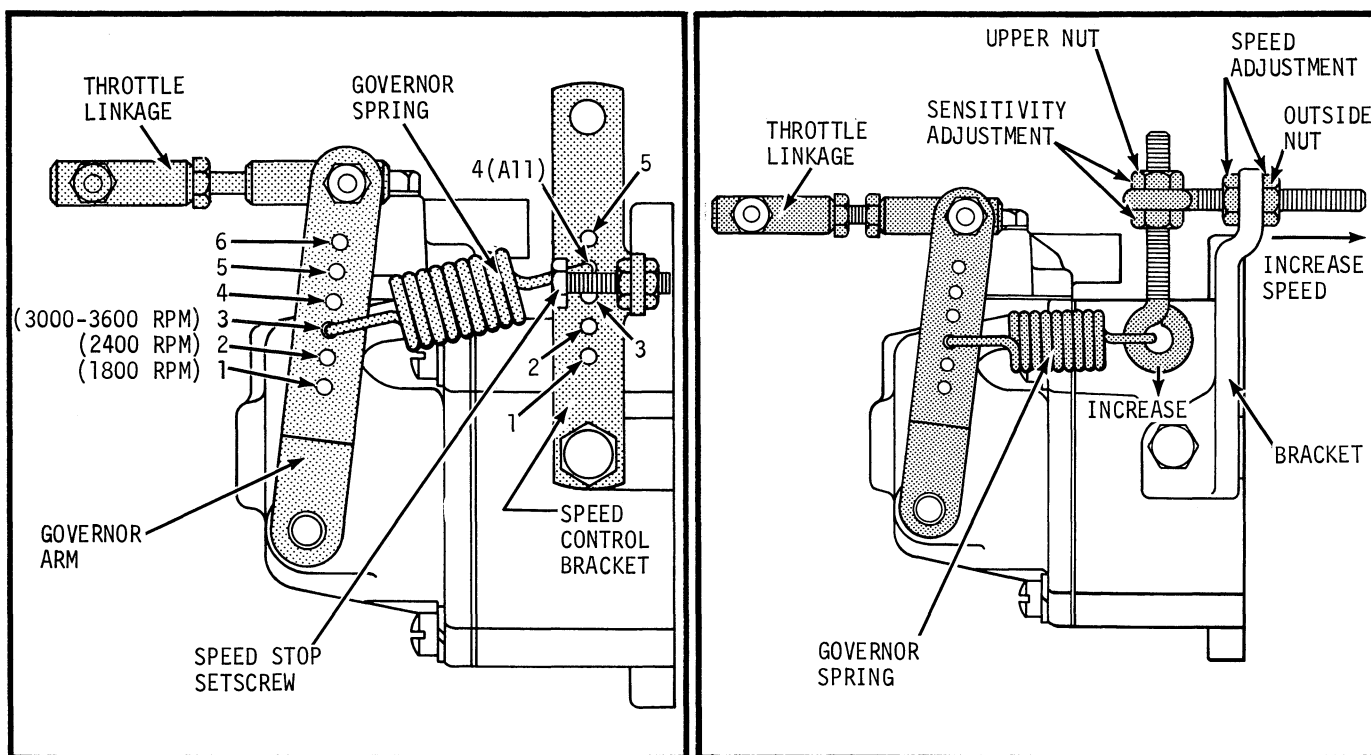

FIGURE 5-2 (A) -- K482, K532 VARIABLE SPEED GOVERNOR      FIGURE 5-2 (B) -- K482, K532 CONSTANT SPEED GOVERNOR

**Governor Sensitivity Adjustment:** If the governor is too sensitive, speed surging will occur with change in load. If a big drop in speed occurs when normal load is applied, the governor should be set for greater sensitivity.

On engines with Variable Speed governors, sensitivity can be adjusted by repositioning the governor spring in different holes in the governor arm. Normal hole settings for different operating speeds are shown in View A of Figure 5-2. To make governor control more sensitive, move spring hook into holes higher up on the governor arm. To make governor control less sensitive, move spring hook in holes spaced further apart. Move spring one hole at a time and recheck sensitivity and speed after each move.

With Constant Speed governors, sensitivity is changed by repositioning the sensitivity adjusting eye bolt as shown in Figure 5-2--View B. To make governor control more sensitive, loosen the upper nut and tighten the lower nut to force the eye bolt downward. To make control less sensitive, draw the eye bolt upward by loosening the lower nut and tighten the upper nut. Recheck speed after making sensitivity adjustment. Retighten nut that was loosened to lock eye bolt at the new setting.

## K662 GOVERNORS

Since the breaker points are not mounted or driven off the K662 governor, this governor does not have to be timed to the engine during installation. No routine lubrication service is required of the K662 governor as it too is lubricated off the engine system. K662 governors are adjusted in the factory and further adjustment should not be necessary unless linkage becomes loose or is disconnected. If poor control is noted, always check linkage between carburetor and governor for evidence of binding or sticking--linkage must move freely at all times.

**SPEED ADJUSTMENT:** On most K662 industrial engines which use variable speed type governors, maximum no load speed is set at 3000 RPM. On engines using the constant speed governors such as electric plant application, the maximum load speed is 1800 RPM. Check speed with hand tachometer--if adjustment is necessary, loosen the locknut on the speed adjusting setscrew (see illustrations below) and turn screw in or out until speed is correct. Retighten locknut after adjustment.

**SENSITIVITY ADJUSTMENT:** If governor control is too sensitive, speed surging or "hunting" will occur with changing load. An excessive drop in speed when load is applied indicates that the governor should be set for greater sensitivity. Recheck speed after making sensitivity adjustment as changing this will affect speed.

On variable speed type governors (see Figure 5-3 -- View A), increase sensitivity by loosening the upper nut and tightening the lower nut thus moving the head of the eye bolt downward. To make control less sensitive, loosen the bottom nut and tighten the upper nut to draw the head of the eye bolt upward. When sensitivity is correct, retighten the nut that was loosened to lock the eye bolt at the new setting.

On constant speed type governors (see Figure 5-3 -- View B), increase sensitivity by loosening the lower nut and tightening the upper nut thus drawing the head of the eye bolt in closer to the pivot point. To make governor control less sensitive, loosen the upper nut and tighten the lower nut to move the head downward or away from the pivot point. After sensitivity is correct, tighten the nut that was loosened to lock the eye bolt at the new setting.

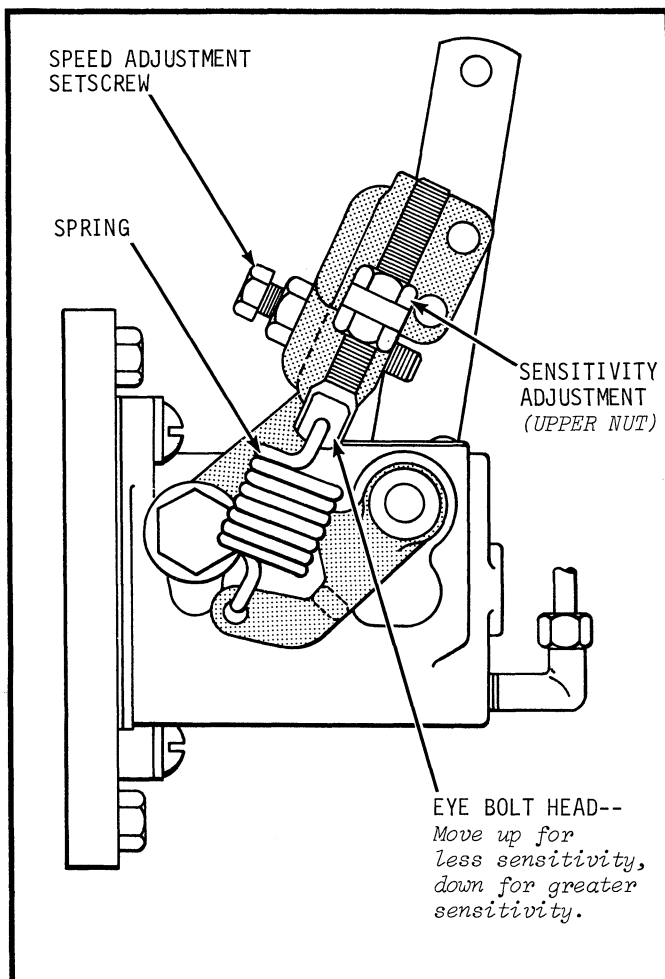

FIGURE 5-3 (A) -- K662 VARIABLE SPEED GOVERNOR

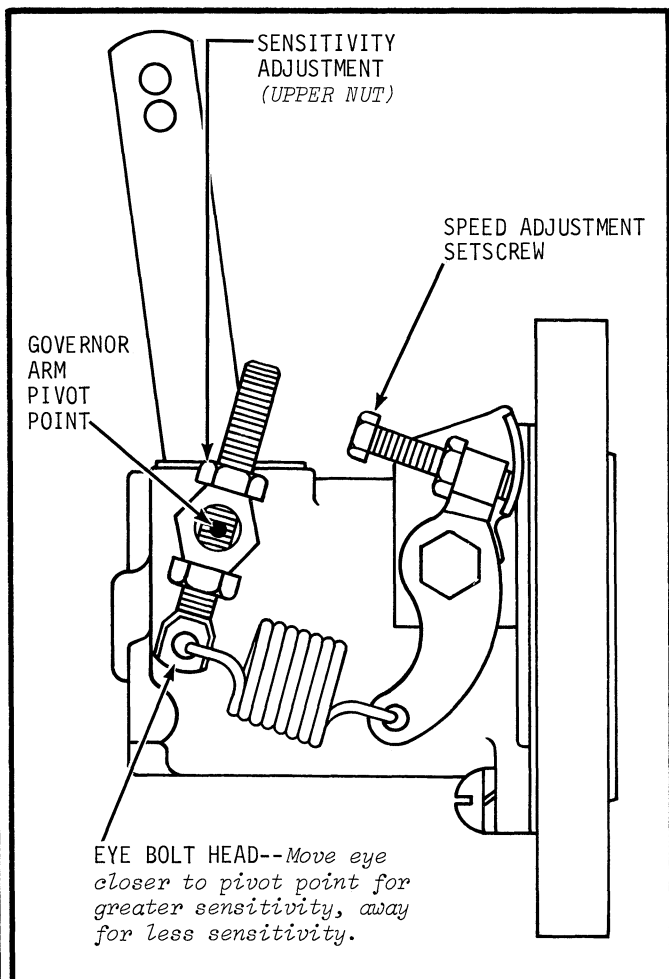

FIGURE 5-3 (B) -- K662 CONSTANT SPEED GOVERNOR

Governor Compensator - K662: On certain K662 electric welder applications, a compensator is used in combination with the governor to provide better regulation under the rapidly changing load conditions common to this type of equipment. Briefly, this device places a slight tension on the throttle rod to stabilize governor control with sudden change in load. The compensator spring is adjusted with engine running at high speed (3000 RPM). To adjust, turn hex nuts in proper direction until there is just enough tension on the spring so that it floats without any end play. Lock nuts after readjustment is made.

# IGNITION SYSTEMS

While the source of energy for the ignition system may be either magneto or battery (generator or alternator), most other components are common in function in all systems even though they may not be alike in appearance or location.

When checking out an ignition system, start with the components that require most frequent service or adjustment. Hard starting, roughness, low power and erratic operation are often attributed to faulty ignition. All components must be in top condition and the ignition spark must be properly timed to maintain good performance.

## SPARK PLUG

Engine misfire or generally poor operation is often caused by spark plugs in poor condition or with improper gap setting. Always clean area around spark plugs before removing to prevent dirt from falling into engine. The first thing to do after removing a spark plug is to carefully note its condition as this is often an indicator of the ignition trouble. Plugs fail for various reasons. Often the porcelain insulator cracks or becomes coated with oil, carbon or other deposits. This can cause the high voltage ignition impulse to pass from the center electrode to ground without jumping the spark gap. As an engine operates, the electrodes are gradually burned or worn away. In time, the gap becomes so wide that the available ignition voltage cannot jump the gap and the engine misses.

Spark Plug Service: Every 100 hours remove plug, check condition and reset gap. Good operating conditions are indicated if plug has light coating of gray or tan deposit. A dead white, blistered coating could indicate overheating. A black (carbon) coating may indicate an "overrich" fuel mixture caused by clogged air cleaner or improper carburetor adjustment. Do not sandblast, wire brush, scrape or otherwise service plug in poor condition--best results are obtained with new plug.

### SPARK PLUG DETAILS

| MODEL     | IGNITION TYPE | PART NO.   | GAP            |
|-----------|---------------|------------|----------------|
| K482-K582 | Battery       | 235040-S   | .035 in. .89mm |
|           |               | *235041-S  | .025 in. .64mm |
| K662      | Magneto       | 270321-S   | .025 in. .64mm |
|           |               | *41 132 06 |                |

\*Standard resistor plug.

## BREAKER POINTS

Engine operation is greatly affected by breaker point condition and adjustment of the gap. If points are burned or badly oxidized, little or no current will pass and as a result the engine may not operate at all, or if it does run it is likely to miss particularly at full throttle. Adjusting breaker point gap affects the time that the contacts are opened and closed. If the points are adjusted to a wider gap, they will open earlier and close later in terms of cam movement. A definite time is required for the magnetic field within the ignition coil to build up to sufficient value. If the contact points are closed for too short a time, a weak spark will be produced by the coil. If points are set too wide, they will open before the primary current reaches the maximum value and on the other hand if set too close, they will open after the primary current has passed its maximum value.

Always replace badly burned or pitted breaker points. A certain amount of build up or metal transfer occurs under normal operating conditions; however, if this occurs too frequently and becomes excessive, the condenser may be at fault--see Condenser Service for details. Slightly pitted points can be dressed down with a point file, although this should be done only as a temporary field fix since points may tend to arc more readily after filing. Replace points at first opportunity after filing. If the points are oxidized, rub a piece of coarse cloth between the surfaces. Dirty or oily points can be cleaned with cloth but make sure no particles of lint are left between surfaces. On engines equipped with the Alternator system, the breaker points are externally mounted on the governor and operated off a cam on the governor driveshaft. On engines with the external unit magnetos, the breaker points are located inside the magneto. Refer to Magneto or Alternator headings (depending on type used on the engine) in this section for specific details on breaker points or contacts.

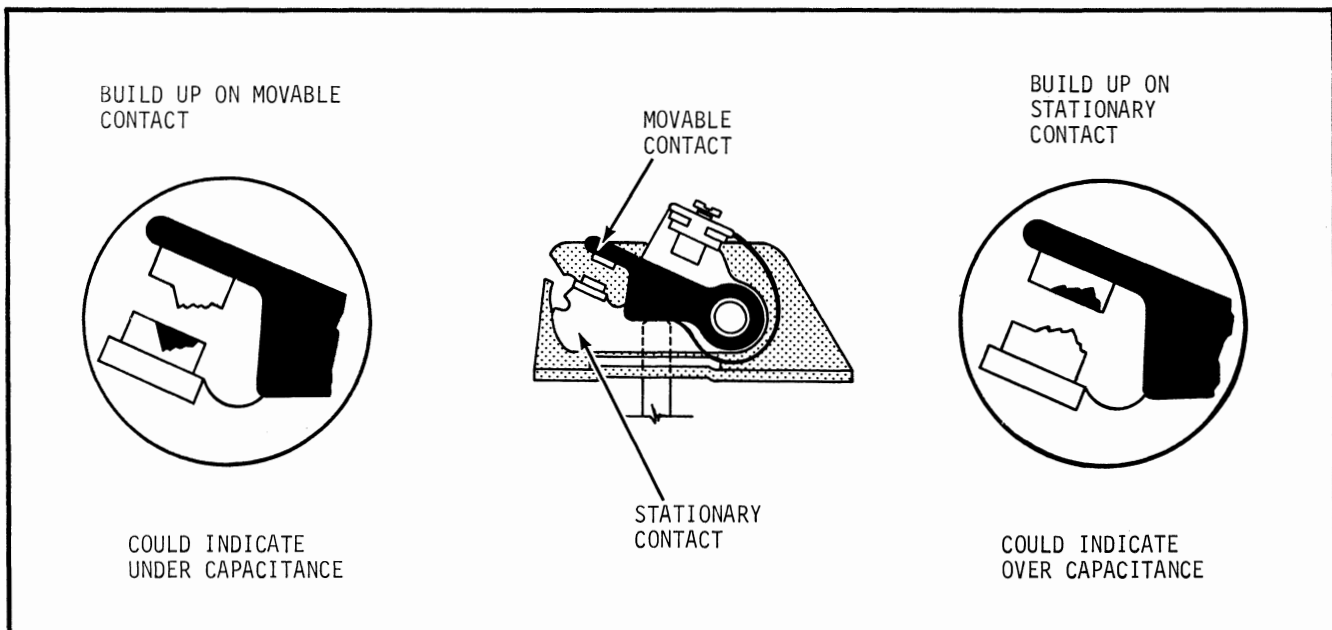

FIGURE 6-1 -- METAL TRANSFER--BREAKER POINTS

## IGNITION COIL

Ignition coils as used on the 30 amp alternator ignition systems do not require servicing on a regular basis, however, the coil should be kept in clean condition and the terminals and connections must be tight to provide good electrical contact. The rubber nipple on the high tension terminal must be in good condition to prevent leakage of current across exposed surfaces.

If the terminals are marked, make sure the coil is hooked up properly. On negative ground systems (as used on all Kohler Engines), the positive (+) coil primary terminal must be connected to the positive battery terminal. The negative (-) coil terminal is then connected to the distributor or directly to the breaker points. Reverse polarity can require up to 8,000 more volts to fire the plugs. If terminals are not marked, hook up either way.

Special test instruments are required to accurately test ignition coils. When using such equipment, carefully follow instructions stated by the tester manufacturer.

A coil can be checked for opens with a simple test lamp. To test for an open primary winding, connect the two test points to the primary terminals--the lamp will not light if the circuit is grounded.

To check the secondary circuit, connect one test point to the high tension terminal and the other point to either of the primary terminals. In this case, the lamp will not light but tiny sparks should be noted as the test points are rubbed across the terminals. If the secondary is opened, no sparks will occur. If the tests show that the primary or secondary is open, replace coil or test further with the coil tester.

## CONDENSER

If the condenser shorts out, the coil will be unable to produce output voltage. On the other hand, if it opens or decreases in capacitance, the output voltage will be greatly reduced and the ignition points will burn excessively. If badly burned breaker points occur too frequently, the condition of the condenser should be suspected. If condenser has too small capacitance, metal will transfer from the stationary contact to the movable contact. If capacitance is too large, the metal will build up on the stationary contact.

The condenser can be tested with an ohmmeter or a commercial condenser tester. To check with the ohmmeter, remove the condenser then connect leads between the condenser lead and a good ground on the engine. At first, a low resistance should be indicated; however, this should very quickly rise to a high value. If low resistance is indicated continuously, the condenser is definitely faulty and must be replaced. When using a commercial condenser tester, follow instructions given by the tester manufacturer.

## MAGNETO (K662)

Magnetos on the K662 are external, self contained units which are flange mounted on the gear housing and driven off the cam gear. Two basic types of magnetos are used. The standard magneto (Wico Model XH-2D) is referred to as a simultaneous firing magneto. A special radio shielded simultaneous firing magneto is also used. This type fires both spark plugs at the same instant. Ignition occurs only in the cylinder in which the piston is at the ignition point--the spark in the other cylinder is ineffective since this occurs on the exhaust stroke.

The other magneto is classified as a distributor type magneto. This has a built in distributor rotor which switches or directs the ignition voltage to the proper spark plug at the appropriate time. Two different distributor magnetos are used. One is the Wico Model XHG-2 and the other is the Fairbanks-Morse Model FM-XE1-2B44. The Fairbanks-Morse is a radio shielded magneto which is used mainly on electric plant applications where any high frequency emission must be suppressed or contained. Since the service and timing procedure varies for each magneto, each is covered separately in this manual. Special tools and test equipment are required to properly recondition magnetos. This work should therefore be done only at a qualified magneto repair station.

Most magnetos use impulse couplings which function to intensify the ignition spark at low speeds to facilitate starting. The impulse coupling functions as a mechanical reservoir to store energy. Basically the impulse coupling consists of a shell and a hub connected together by a strong spring. One half of the coupling (the shell) is fitted to a drive member on the engine drive shaft, while the other half (the hub) is keyed to the magneto rotor shaft. In operation at slow speeds, a pawl on the magneto half of the coupling engages a stop pin mounted on the magneto frame which acts to prevent further movement of the rotor while the engine half of the coupling continues to rotate. The relative change in position winds the connecting spring. When ignition spark is required, the pawl is released and the drive spring permitted to snap the magneto rotor forward at high speed through its firing position. As the speed of the engine picks up, the centrifugal force acting on the pawls withdraws them in a position where they no longer engage the coupling stop pin and the impulse coupling then acts as a solid drive member.

Standard Magneto (Wico XH-2D): After every 500 hours of operation, remove end cap and lubricate cam wick with Rycon grease then check condition of breaker contacts. If dirty, clean with solvent such as lacquer thinner and a coarse cloth. If a slight amount of metal transfer or pitting is noted, dress contacts with either a small tungsten file or a fine stone. Contact point gap must be readjusted after replacement or performance of any service on contacts. Use following procedure to adjust:

1. Turn engine over by hand until points are wide open (at highest point on cam).
2. Loosen the two clamp screws until contact plate can be moved.
3. Insert blade of screwdriver in adjusting slot and move plate until .015" maximum clearance is measured (feeler gauge) between contacts. After proper gap is attained, securely tighten clamp screws to lock plate at this setting.

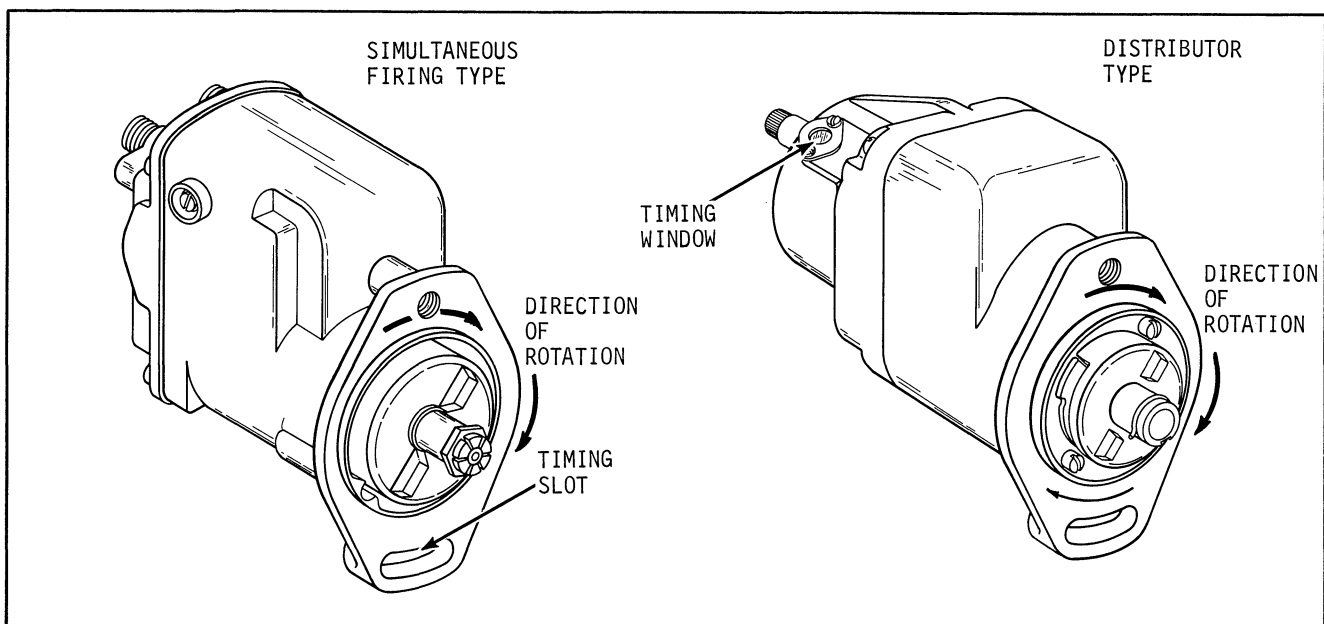

FIGURE 6-2 -- MAGNETO TYPES -- K662 ENGINE

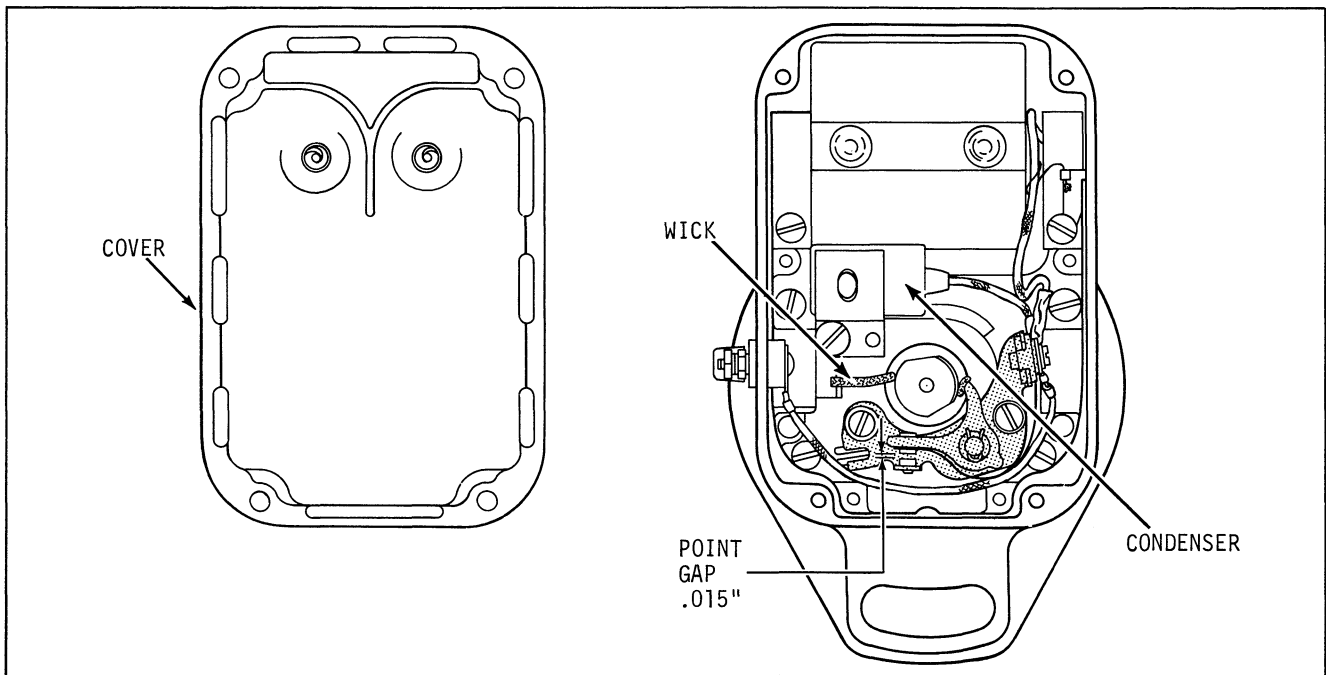

FIGURE 6-3 -- ADJUSTMENT, SERVICE POINTS ON STANDARD MAGNETO

If contact points are badly worn or pitted, they must be replaced. Do not replace only one contact--replace both the fixed contact and contact on breaker arm. Replace as follows:

1. Remove breaker spring contact screw then breaker arm lock and washer.
2. Lift breaker arm off pivot--discard arm.
3. Remove the two breaker plate contact screws then remove and discard the fixed contact plate.
4. Position and secure new contact plate and breaker arm then adjust breaker point gap per instructions stated in the foregoing.
5. Replace old cam wick with new wick--lubricate with Rycon grease.

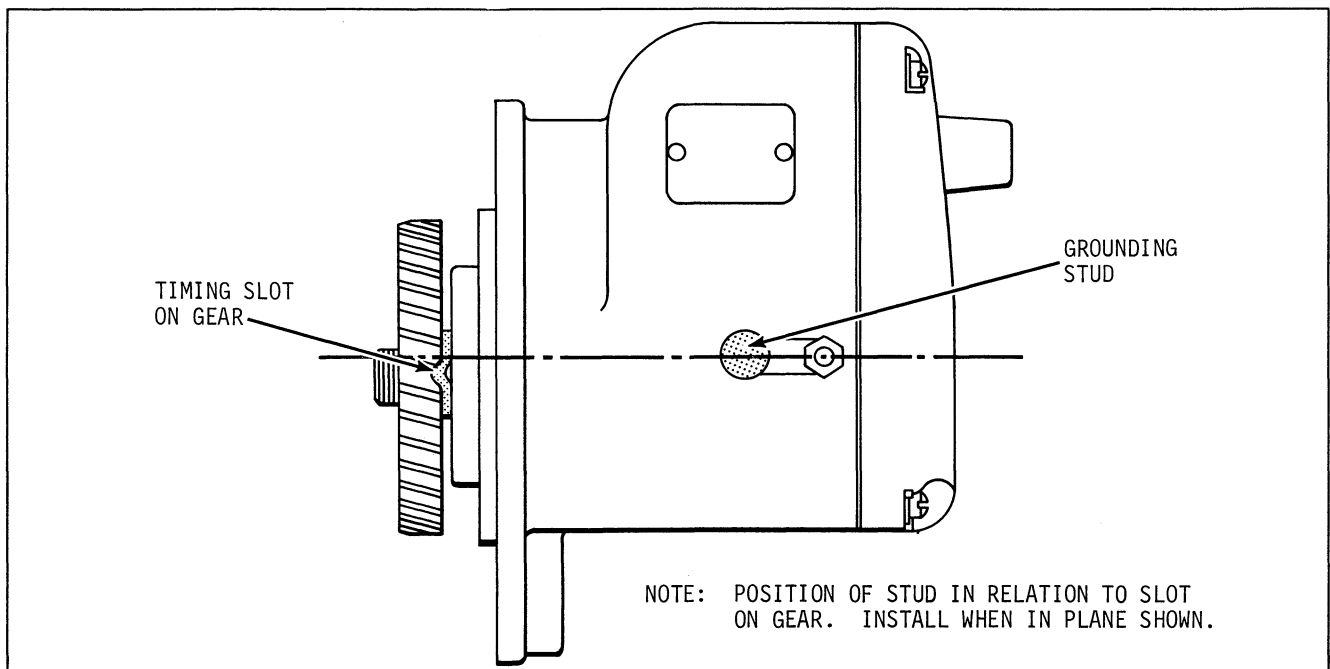

FIGURE 6-4 -- TIMING MARKS -- STANDARD MAGNETO

Magnetos are timed to the engine in the factory and retiming should not be necessary unless magneto has been removed for reconditioning. Use the following procedure for initial timing of the standard type magneto to the engine.

1. Uncover timing sight hole on blower housing of engine. Turn engine over by hand until DC mark on flywheel is centered in sight hole.
2. Turn magneto gear in clockwise direction (when facing gear end) until impulse coupling trips--loud click will be heard. After coupling trips, back up slightly (turn in counterclockwise direction) on gear until it drags lightly and remains in stationary position. Refer to Figure 6-4 for relative position of slot in gear to grounding stud when timing position is reached.
3. Place new gasket on flange then while holding gear in timing position attained in Step 2, carefully guide magneto gear into engagement with cam gear.
4. After securing magneto to housing, test by turning flywheel in clockwise direction until impulse coupling trips (loud click)--DC mark on flywheel should be just past center mark in sight hole.

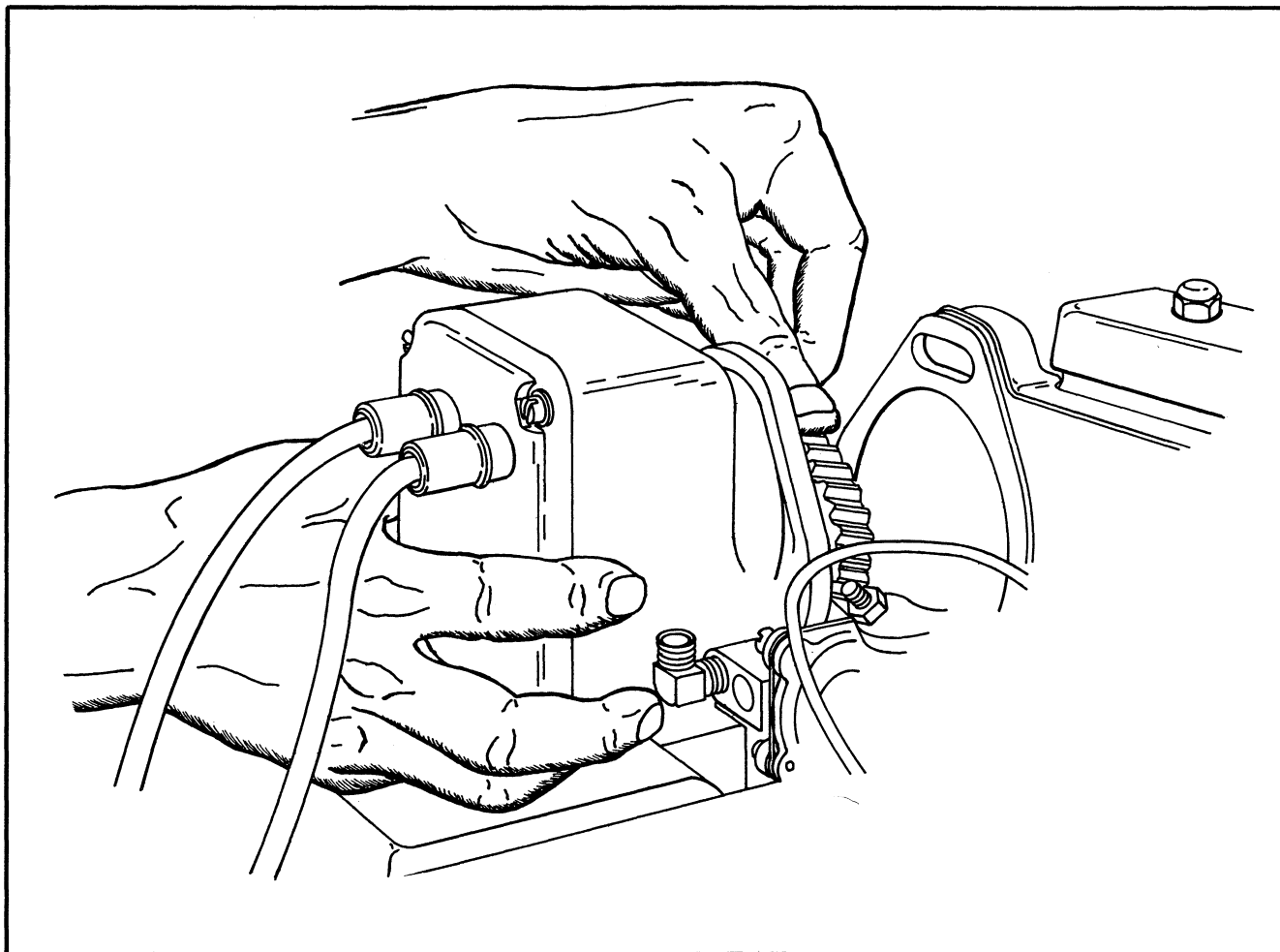

FIGURE 6-5 -- INSTALLING AND TIMING MAGNETO TO ENGINE

Use timing light to time ignition after installation. Under no circumstances should battery be hooked up to a magneto as this will severely damage coil windings. With timing light properly hooked up (refer to timing light instructions), time ignition as follows:

1. Start engine and run at 1200 RPM or above while timing.
2. Aim timing light into sight hole. SP mark should be centered in the hole just as the light flashes. To adjust, loosen the two capscrews on the flange then shift position of magneto until SP mark is properly aligned in sight hole. Tighten capscrews after adjusting.

DISTRIBUTOR MAGNETO (WICO XHG-2) After every 500 hours of operation, remove distributor (end cap. Lubricate cam wick with Rycon grease, then check condition of breaker contacts. If dirty, clean with lacquer thinner and coarse cloth. If slight amount of pitting and metal transfer is noted, dress contacts with either a small tungsten file or a fine stone. Contact point gap must be readjusted whenever contacts are replaced or serviced. Use following procedure to adjust gap:

1. Turn engine over by hand until contact points are wide open (at highest point on cam).
2. Loosen two clamp screws slightly so that contact plate can be moved.
3. Insert blade of screwdriver in adjusting slot and move contact plate until .015" maximum clearance is measured (feeler gauge) between contacts. Securely tighten clamp screws after adjustment.

Replace contact points if badly worn or pitted. Replace as a set--do not replace only one contact. Replace as follows:

1. Remove distributor gear screw and gear.
2. To remove breaker arm, remove spring clamp screw, arm lock and washer then slip arm off pivot. Discard old breaker arm.
3. Breaker plate is removed after spacer washer and two clamp screws are removed. Discard old breaker plate.
4. Reverse procedure to install new breaker plate and arm (which include new contacts) then adjust contact point gap per previous instructions. Remove and discard old cam wick and replace with new wick, lubricating with Rycon grease.

Magnetos are timed to the engine in the factory and retiming should not be necessary unless the magneto has been removed for reconditioning or some other reason. Magnetos should be reconditioned only at qualified magneto repair stations since special tools and test instruments are required. If magneto has been removed, it must be retimed to engine as follows:

1. Remove #1 spark plug (cylinder closest to flywheel), turn engine over by hand until compression is on #1 cylinder and "M" mark on flywheel is centered in timing sight hole.
2. Turn magneto gear counter-clockwise until white mark appears in sight window on distributor or end cap. When mark appears, gear should hold in this position.

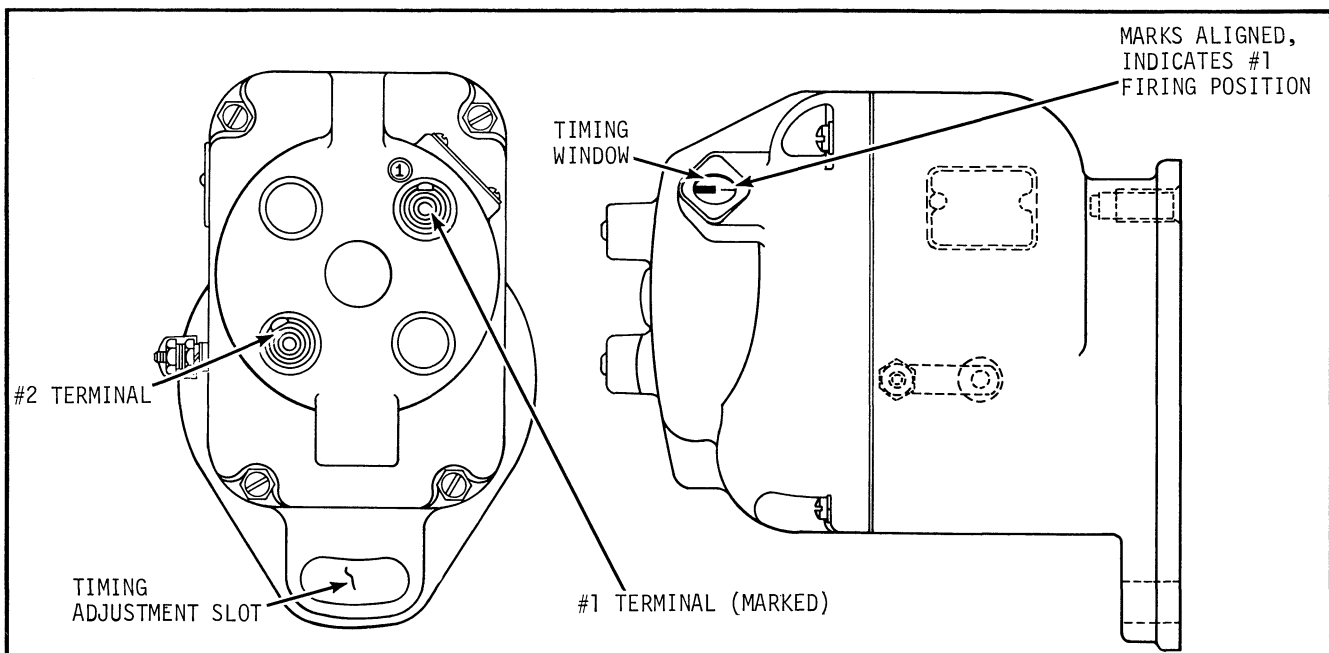

FIGURE 6-6 -- DISTRIBUTOR TYPE MAGNETO WITH TIMING WINDOW

3. Carefully guide magneto gear into engagement with cam gear--make sure mark remains centered and magneto gear remains stationary when installing. Secure magneto to gear housing with two capscrews.
4. To check for proper timing, rotate engine by hand until a loud click is heard--at this instant the DC mark on flywheel should be just past the center of the timing sight hole on engine.

For precision timing of the ignition system use timing light. Carefully follow light manufacturer's instructions. Never connect battery to magneto as this will damage windings. Time magneto ignition as follows:

1. Start engine and run at 1200 RPM.
2. Aim timing light into sight hole on engine. SP mark should be centered in sight hole just as light flashes. To adjust, loosen two capscrews on magneto mounting flange and shift position of magneto until SP mark is centered--on LPG fueled engines it is permissible to increase advance slightly--on these engines the SP mark can be set slightly to the left of center (facing front of engine) when the light flashes. When proper timing is attained, secure magneto flange capscrews.

#### SHIELDED MAGNETO (FAIRBANKS-MORSE FM-XE1-2B44)

The shielded type of magneto can be identified by the large metal end cap and screw type terminals. These magnetos are prelubricated during assembly and normally require no further lubrication. After each 500 hours of operation, the end cap should be removed and the condition of the contact points and carbon brush should be checked. If the points are dirty, clean with lacquer thinner and coarse cloth. If slightly pitted, dress with small tungsten file or a fine stone. Badly pitted contact points must be replaced. Regap contacts after service or replacement.

The carbon brush in the end cap should be under slight pressure and should move freely in its holder. Replace brush if unevenly or excessively worn. Use the following procedure to replace breaker contacts:

1. To remove breaker arm, remove breaker arm terminal screw (which releases coil, condenser and ground leads and breaker arm spring) then remove snap ring on fulcrum pin and lift breaker arm off pin. Discard old breaker arm.
2. To remove contact support bracket, remove two locking screws (including lock and plate washers) then remove bracket from bearing support.
3. Reverse procedure to replace contact support and breaker arm. Gap must be adjusted after replacement.

To adjust contact point gap use the following procedure:

1. Loosen the two locking screws on contact support.
2. Insert screwdriver blade in horizontal slot on support then shift support (pivot blade between two small bosses) until proper clearance of .015" (maximum opening) is measured between contacts. Lock support in place with two capscrews then recheck clearance after support has been secured.

Magnetos are timed to the engine in the factory and retiming should not be necessary unless magneto has been removed for reconditioning. Use the following procedure for initial timing of the standard type magneto to the engine.

1. Uncover timing sight hole on blower housing of engine. Turn engine over by hand until DC mark on flywheel is centered in sight hole.
2. Turn magneto gear in clockwise direction (when facing gear end) until impulse coupling trips--loud click will be heard. After coupling trips, back up slightly (turn in counterclockwise direction) on gear until it drags lightly and remains in stationary position.
3. Place new gasket on flange then while holding gear in timing position attained in Step 2, carefully guide magneto gear into engagement with cam gear.
4. After securing magneto to housing, test by turning flywheel in clockwise direction until impulse coupling trips (loud click)--DC mark on flywheel should be just past center mark in sight hole.

## IGNITION TIMING-K482, K532 ENGINES

On K482 and K532 engines, the breaker point assembly is mounted on the governor. The breaker rod rides on a cam on the governor drive shaft. The governor is therefore timed to the engine and must be retimed if it has been removed for any reason (see Governor Instructions in Section 5). The governor also incorporates an automatic spark advance-retard mechanism. Retard is  $8^{\circ}$  BTDC while the advance point is  $27^{\circ}$  BTDC. The advance spark point is marked "SP" on the flywheel of the engine.

Use the following procedure to adjust breaker point gap:

1. Remove breaker point cover.
2. Turn engine over until breaker points are full open--measure gap with feeler gauge. Maximum opening should be .020". Adjust by loosening gap adjusting screw then insert screwdriver blade in adjusting notch to shift movable plate until .020" maximum opening is attained. Retighten gap adjusting screw and replace breaker point cover after initial adjustment.
3. Follow up with the final or precision adjustment using a timing light. Final adjustment is made by shifting position of governor--refer to procedure below.

Several different types of timing lights are available--follow the manufacturer's instructions for the particular type of timing light used. The following procedure can be used with most timing lights. Rotating the governor advances or retards the timing depending on which way the unit is turned.

1. If boot type lead is used, remove boot at #1 cylinder (nearest flywheel) then wrap one end of a short piece of fine wire around spark plug terminal. Reconnect boot to terminal so that free end of the wire can protrude under the boot. (Step 1 applies to timing lights having alligator clips.)
2. Connect one of the timing light leads to the wire protruding from under the boot.
3. Connect second timing light lead to hot (ungrounded) side of battery--see timing light instructions for proper battery size, wire connections, etc.
4. Connect third timing light lead to common ground.
5. Before starting, rotate engine until "SP" mark is observed in timing sight hole--chalk mark the line for easy reading.
6. Start engine and operate at 1200 RPM or above. Aim timing light into sight hole--light should flash just as "SP" mark is centered in sight hole. If light flashes before mark is centered, timing is overadvanced. If light flashes after mark is centered, timing is retarded.
7. To adjust, loosen (do not remove) governor flange mounting capscrews and shift or rotate until timing mark is exactly centered as light flashes. Retighten flange mounting screws after exact timing is achieved.

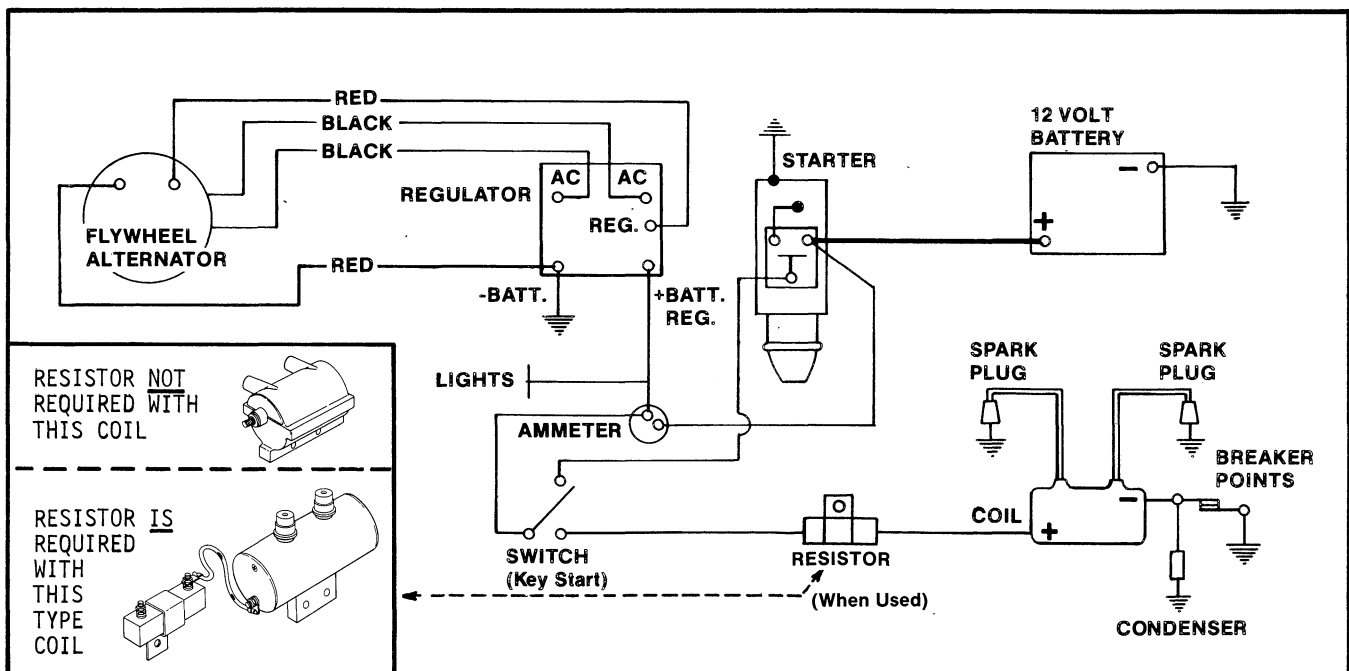

FIGURE 6-7 -- K482 - 30 AMP ALTERNATOR SYSTEM, WIRING DIAGRAM

# ELECTRICAL SYSTEMS

Two basic types of battery electrical systems are used on the 2 cylinder engine. The major components of the conventional system includes a D. C. generator, a starting motor and a voltage-current regulator. The other system, the Flywheel Alternator system includes a permanent magnet ring, the alternator stator and a rectifier-regulator. A 12 volt storage battery is used with both types of systems. An electrical system usually consists of a charging circuit and a cranking circuit. The major components of each circuit are listed in the following chart under the basic type of electrical systems.

## CONVENTIONAL SYSTEM

### CHARGING CIRCUIT

1. Battery - 12 volt
2. Voltage-Current Regulator
3. D. C. Generator

### CRANKING CIRCUIT

1. Starting Motor (Bendix Type)

## FLYWHEEL-ALTERNATOR

### CHARGING CIRCUIT

1. Battery - 12 volt
2. Rectifier-Regulator
3. Alternator

### CRANKING CIRCUIT

1. Starting Motor (Bendix Type)

## BATTERY

Storage batteries used with Kohler Engines are usually of the lead-acid type. Most are 12 volt batteries--6 volt batteries are used on some applications. Lead is used in the construction of the cell-plates and sulfuric acid serves as the electrolyte. "Wet" batteries are filled with electrolyte and are stored ready to use if satisfactory charge has been maintained. With "dry charged" batteries, the plates are charged but an electrolyte of specific grade must be added just before using. Both types function in the same general way.

The typical 12 volt battery has a hard rubber case with six individual compartments or cells. Each cell contains a specific number of sets of negative and positive plates. Generally, the greater the number of plates per cell, the higher the ampere-hour rating of the battery. All plates of like charge are interconnected so that the accumulative charges are present at the positive and negative terminals of the battery. All Kohler Engines use negative ground systems. With this system, the negative (-) terminal of the battery is connected in common ground to the engine while the positive (+) terminal is the "live" terminal. When disconnecting battery always remove ground (-) terminal first.

Voltage Test: With a battery in good condition, each cell contributes approximately 1.95 to 2.08 volts. If less than 0.05 volt difference is noted between the highest and lowest cells, the battery may be recharged. If the difference is more than .05 volts, this could indicate a cracked plate or other damage which could call for replacement of the battery.

Specific Gravity Test: As a battery discharges and the energy is not replenished, sulfuric acid is chemically withdrawn from the electrolyte and lead sulfate deposits continue to build up on the plates. This results in a diminishing specific gravity of the electrolyte. If the specific gravity drops below 1.240, the battery must be recharged. In fully charged condition, the specific gravity will be in the 1.260 - 1.280 range. Some batteries are designed specifically for use in tropical zones--these have a lower specific gravity than other batteries. Hydrometer readings must be correct for variation in temperature of electrolyte. Add .004 to the reading for every 10° above 80° F. and subtract .004 for every 10° below 80° F.

As a battery is recharged, a reverse chemical reaction takes place which causes the lead sulfate deposits to be changed back to lead, lead dioxide and sulfuric acid. In effect, this reverses the discharge reaction and restores materials to active condition. If sulfate deposits become too great or if the level of the electrolyte is not maintained above the level of the plates, the battery may be permanently damaged.

Safety Precaution: Adequate ventilation must be provided when batteries are being recharged. Also sparks, open flames and smoking should be avoided since hydrogen gas is produced which, if ignited, can cause an internal explosion that can shatter the battery. This gas is produced in quantity only while the battery receives high rate of charge but can linger for several hours in a poorly ventilated area.

Service: To maintain battery in top condition, perform the following services at frequent intervals:

1. Regularly check level of electrolyte--add water as necessary to maintain level above plates--do not overfill as this can cause poor performance or early failure due to loss of electrolyte.
2. Keep terminals and top of battery clean. Wash with baking soda and rinse with clear water. Do not allow soda solution to enter cells.
3. Check other electrical components if battery repeatedly becomes discharged.

## VOLTAGE REGULATOR

The current-voltage regulator is automatic in its control of current and voltage to battery. A grounding strap is used to connect case of voltage regulator in common ground with engine. If this becomes loose and makes poor electrical connection, poor regulation can result. Make sure regulator is properly grounded at all times. Many cases of regulator trouble can be eliminated by a simple cleaning of the contact points plus possible readjustment. The flat point always develops a slight cavity and is the point that requires most attention. It is not necessary to have a perfectly flat surface on this point, but cleaning the surface down to pure metal with a fine cut riffer file will insure long periods of service. The file should not be allowed to become greasy and should not be used on other metals. After filing, wipe points with lintless cloth, saturated in carbon tetrachloride to insure clean surfaces. The flat point is in the armature. Clean by loosening the upper contact support and moving it to one side. CAUTION: NEVER USE EMERY CLOTH OR SANDPAPER TO CLEAN CONTACT POINTS.

Run engine for at least 20 minutes before making voltage adjustments as this will allow temperature of regulator to stabilize. Use same battery and generator that will be used on engine for correct settings.

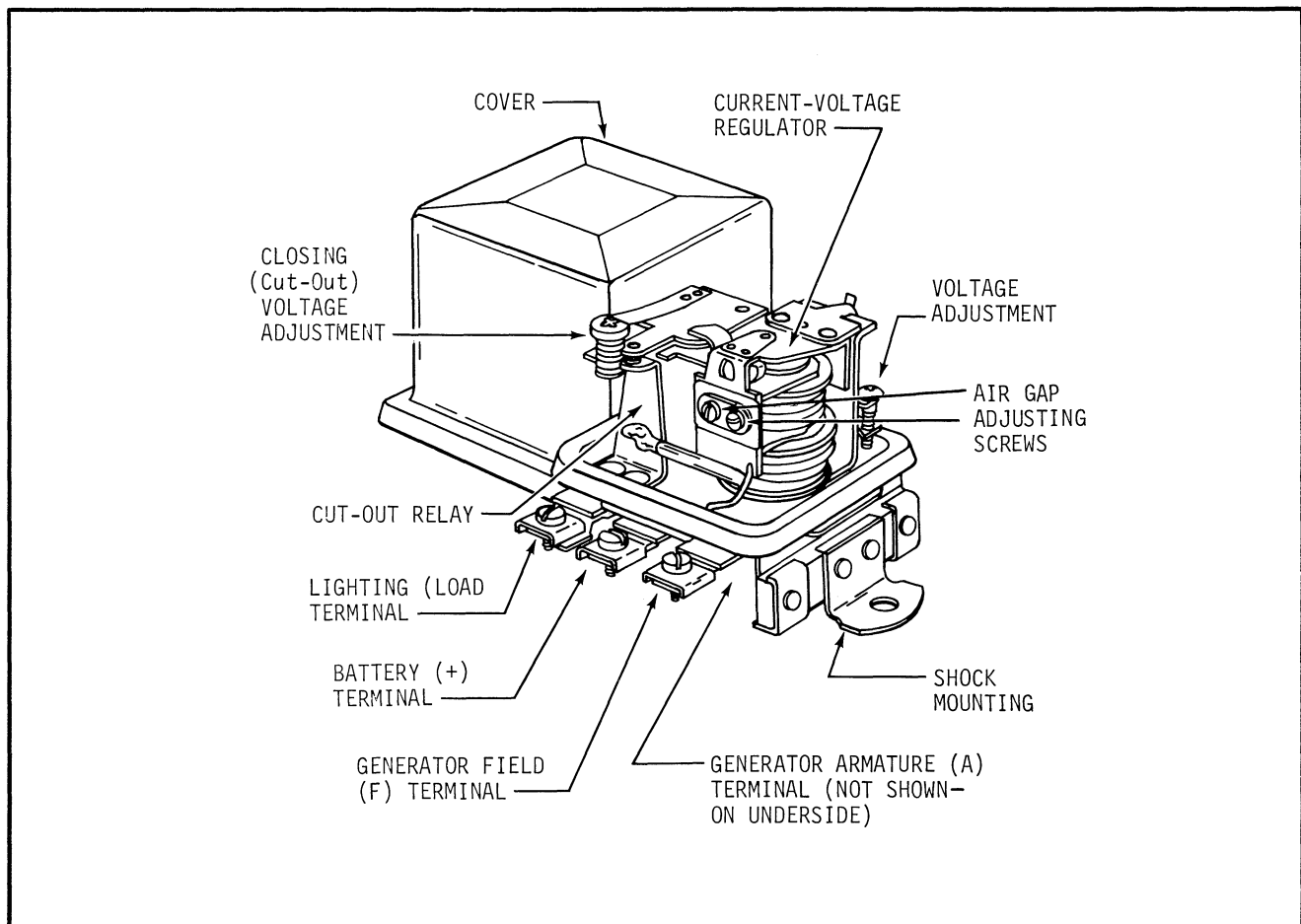

FIGURE 7-1 -- TYPICAL TWO UNIT TYPE VOLTAGE REGULATOR

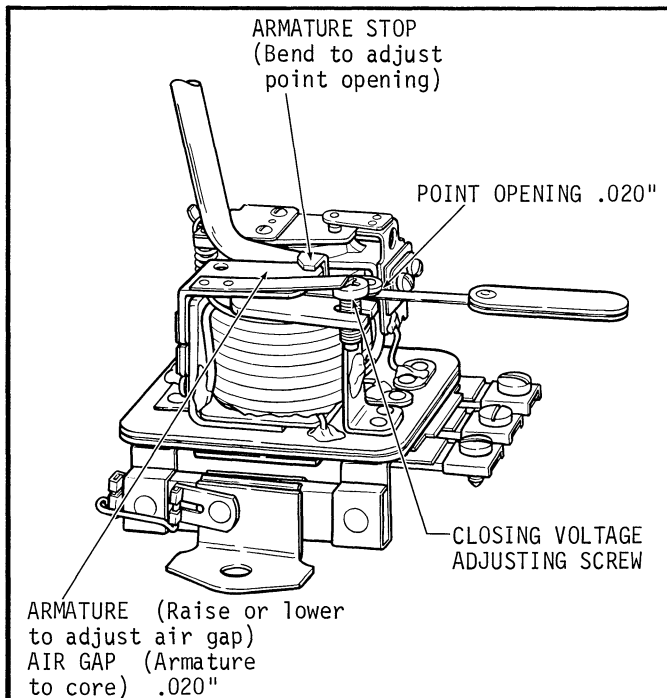

FIGURE 7-2 -- CUTOUT RELAY ADJUSTMENTS

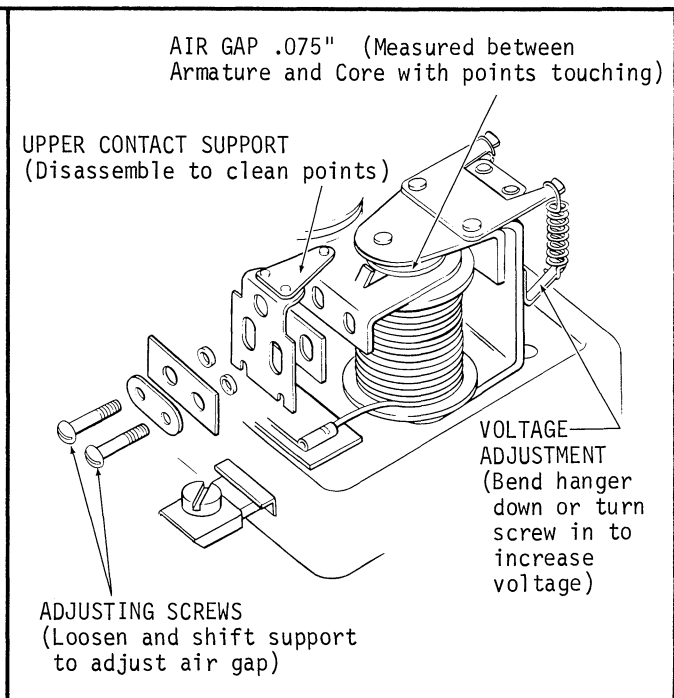

FIGURE 7-3 -- CURRENT-VOLTAGE ADJUSTMENTS

Cutout Relay Unit: This requires three checks and adjustments: air gap, point opening and closing voltage. The air gap and point opening adjustments must be made with the battery disconnected!

1. Air Gap: Place fingers on the armature directly above the core and press armature down until the points just close, then measure the air gap between the armature and the center of the core. Gap should be .020". Adjust by raising or lowering armature at its hinge mounting. Retighten screws after adjustment.
2. Point Opening: Adjust point opening by bending the armature stop. Opening should be .020".
3. Closing Voltage: Adjust closing voltage by turning screw clockwise to increase spring tension and voltage, counterclockwise to decrease spring tension and closing voltage. Be sure that closing voltage adjustment is at least 0.5 volt less than the current voltage regulator unit setting. This should be 12.8 volts.

Current-Voltage Regulator Unit: This requires two inspections and adjustments: The armature air gap and the voltage setting. Disconnect battery before making these adjustments.

1. Armature Air Gap: To check air gap, push the armature down until contact points are still just touching, then measure air gap. This should be .075". Adjust by loosening contact mounting screws and raising or lowering the contact bracket as required. Be sure points are lined up and screws are retightened after adjustment and before resetting voltage setting.
2. Voltage Setting: Adjust the voltage setting by turning adjusting screw--clockwise to increase the voltage setting and counterclockwise to decrease the voltage setting. After each adjustment, replace cover and allow ample running time to again stabilize voltage and temperature before rechecking the voltage setting.

**CAUTION:** If adjusting screw is turned down (clockwise) beyond normal range required for adjustment, the spring support may fail to return when pressure is relieved. If this happens, turn screw counterclockwise until enough clearance develops between the screw head and spring support. Then bend spring support upward carefully with a small pliers until contact is made with the screw head. The final setting should always be approached by increasing spring tension. In other words, if setting is too high, unit should be adjusted below the required value then raised to the exact setting by increasing spring tension. Be sure screw is exerting force on hanger.

## GENERATOR

Most of the generators used on the K662 are of the 3 brush, shunt wound type DC generators for 12 volt electrical systems. Some earlier generators have hinged oiler caps and require lubrication at regular intervals, although most have sealed bearings which do not require regular servicing. On all generators, the brushes and commutator must be checked at specific intervals. Service generators at the intervals stated in the following service steps.

### Brushes

After each 500 hours of operation, remove thru bolts and take off end frame to observe condition of brushes, springs and holders. Replace brushes if unevenly worn or if worn to less than 1/2 their original length (new--about 1" long). Replace springs if corroded or if blued or discolored from excessive heat. Brush arms and brushes must move freely without tendency to bind or cock in holders.

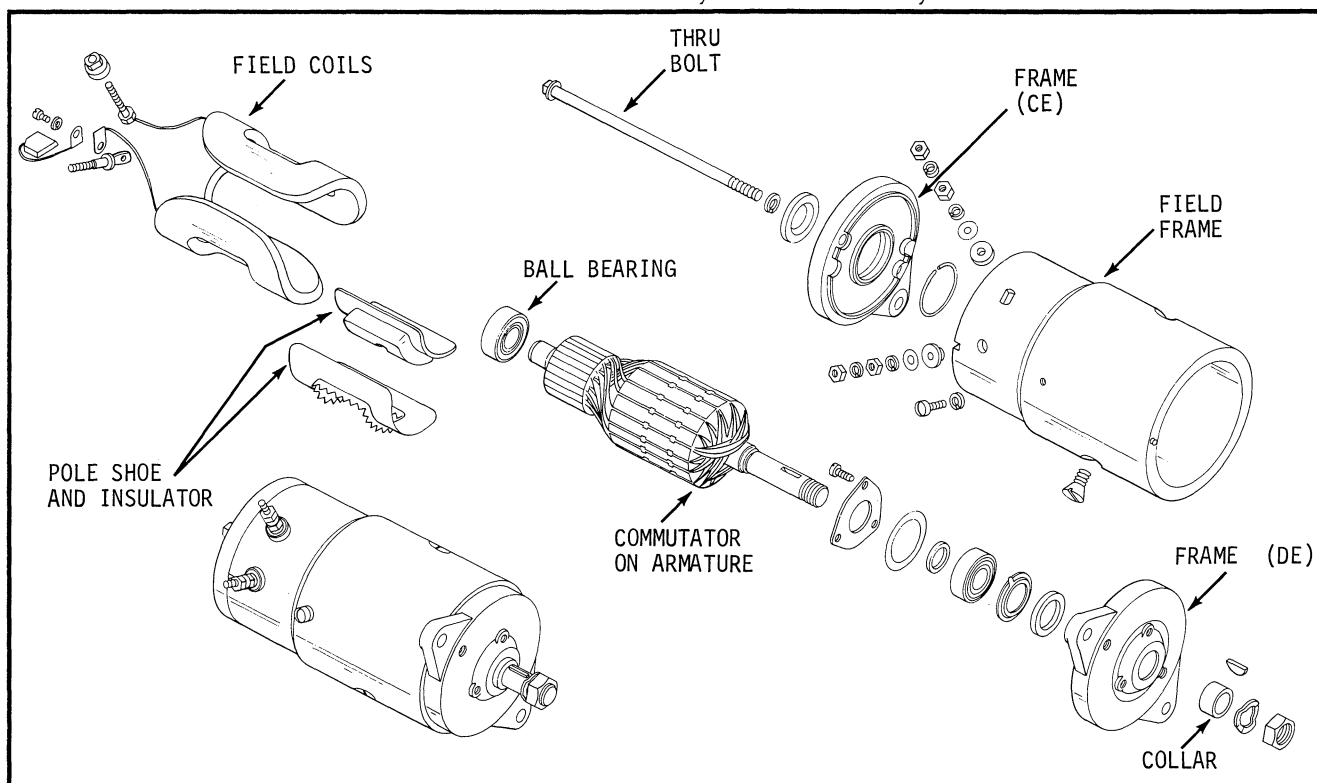

FIGURE 7-4 -- TYPICAL DC GENERATOR (K662) DISASSEMBLED VIEW

### Commutator

Observe condition of the commutator at the same time the brushes are serviced (500 hours). If dirty, clean with No. 00 Sandpaper. Make sure dust is removed after cleaning. If surface is grooved, rough or out of round, remove armature and place in lathe so that commutator can be turned down. Remove only enough material to make commutator smooth and round. After resurfacing, undercut the mica insulation 1/32" deep. Finish with No. 00 Sandpaper after undercutting and blow out all dust.

### Lubrication

On generator having the hinged cap oilers, add several drops of SAE 20 weight oil to both caps (at commutator and drive end frames) after each 200 hours of operation or every fourth oil change period. CAUTION: Do not add too much oil as this may cause overheating of the bearing. Add only a few drops at each service period.

### Belt Tension

Occasionally check condition of belt and also check belt tension. Belt should be adjusted so that it deflects about 1/2" when depressed with finger at midpoint on upper span. Too little tension results in belt slippage and rapid wear of the belt. Excessive tension also causes rapid wear and can damage generator bearings. Loosen generator mounting bracket and move generator until proper tension is attained.

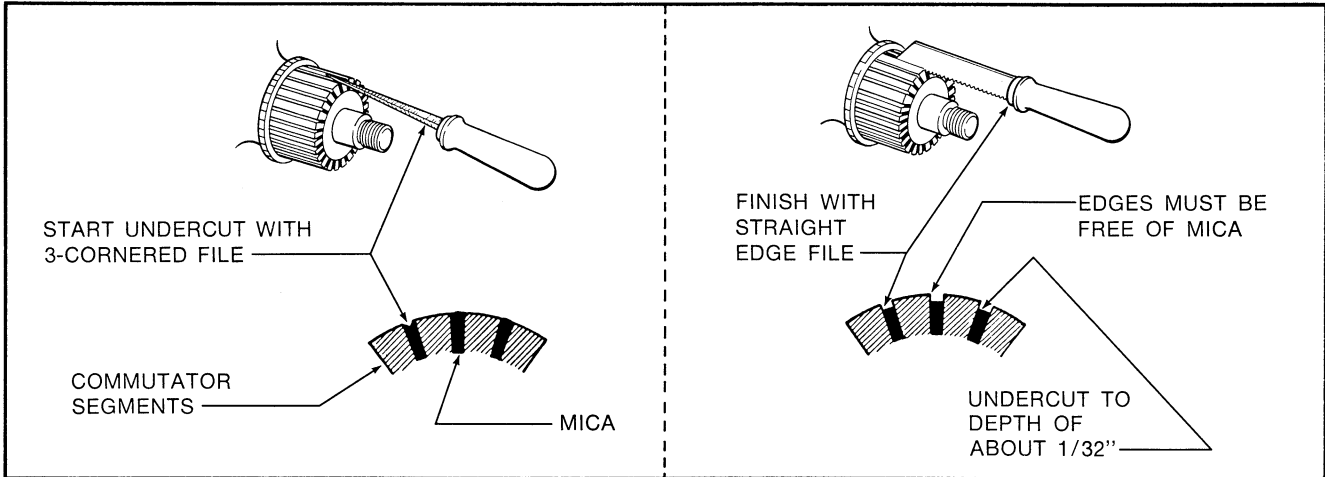

FIGURE 7-5 -- UNDERCUTTING MICA ON COMMUTATOR

### STARTING MOTORS & DRIVES

Starting motors on these engines use either Bendix or Solenoid Shift type drives to engage and disengage. Two different types of Bendix drives are used. One type (K482) locks in positive engagement and features an overrunning clutch device to protect the motor from overspeed. On this type, the centrifugal action of the overrunning clutch deactivates the locking pin and allows the Bendix drive pinion to retract in conventional manner. Operating principles of the motors and drives are discussed further in the following.

Operation: Current from the battery is directed through field windings (coils) and also thru the armature windings. This sets up a magnetic field around both windings which "buck" each other causing the armature to rotate. With the solenoid shift type drive, the drive pinion is shifted into engagement with the ring first then main contacts within the solenoid close to start the armature turning. With Bendix drive, the drive pinion moves laterally on a splined sleeve into engagement as the armature starts to rotate. When the pinion butts against a stop located at end of the armature shaft (K662 Bendix starters), it locks in positive engagement with the shaft to crank the engine. On K482 Bendix type starters, a spring loaded pin drops into a slot in the armature shaft to lock the pinion to shaft for cranking. The shaft and pinion remain in positive engagement until the engine "fires" and attains sufficient speed for the flywheel to begin overriding that of the armature. The K482 Bendix type and K662 solenoid shifted starters include overrunning clutches which permit the pinion to be momentarily spun faster than armature to protect the motor from overspeed. On the K482, the spinning or centrifugal action forces the locking pin out of the shaft and allows the pinion to retract. On K662 type starters, the overrunning action throws the pinion out of engagement. A small anti-drift spring holds the pinion in retracted position until the armature coasts to a stop after the starting circuit is opened.

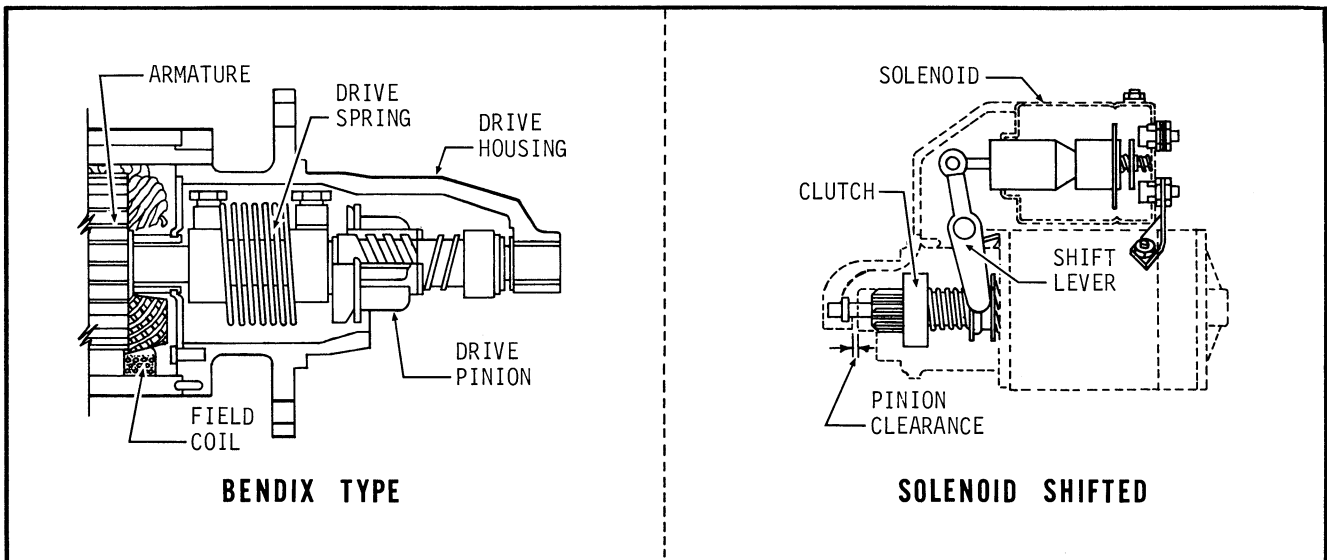

FIGURE 7-6 -- TYPICAL STARTING DRIVE TYPES

Precautions: In the event of a "false start" (engine gets up sufficient speed to disengage starter but fails to continue running), the engine must be completely stopped before another starting attempt is made--if the flywheel is still rotating, the drive pinion and ring gear will clash and almost certainly be damaged.

Also limit cranking (continuous) to a period of 10 seconds to prevent overheating of the starter. If cranked for 10 seconds, starter should not be operated again for 60 seconds to allow time for sufficient cooling.

Service: Most starters are pre-lubricated during assembly and do not require further lubrication until disassembled for overhaul or other reasons. Some earlier model starters on the K662 have hinged oiler cups--these should be lubricated every 300 hours with 8 - 10 drops of medium grade engine oil.

The condition of brushes and commutator should be checked occasionally. Replace brushes that are unevenly worn or if excessively worn. Brushes must slide freely in holders. Replace springs if discolored (blue) from overheating. If commutator is dirty, clean with coarse cloth. If extremely dirty, polish with #00 sandpaper or commutator stone--do not use emery cloth. If commutator is grooved or mica insulation is high, the armature should be removed for reconditioning.

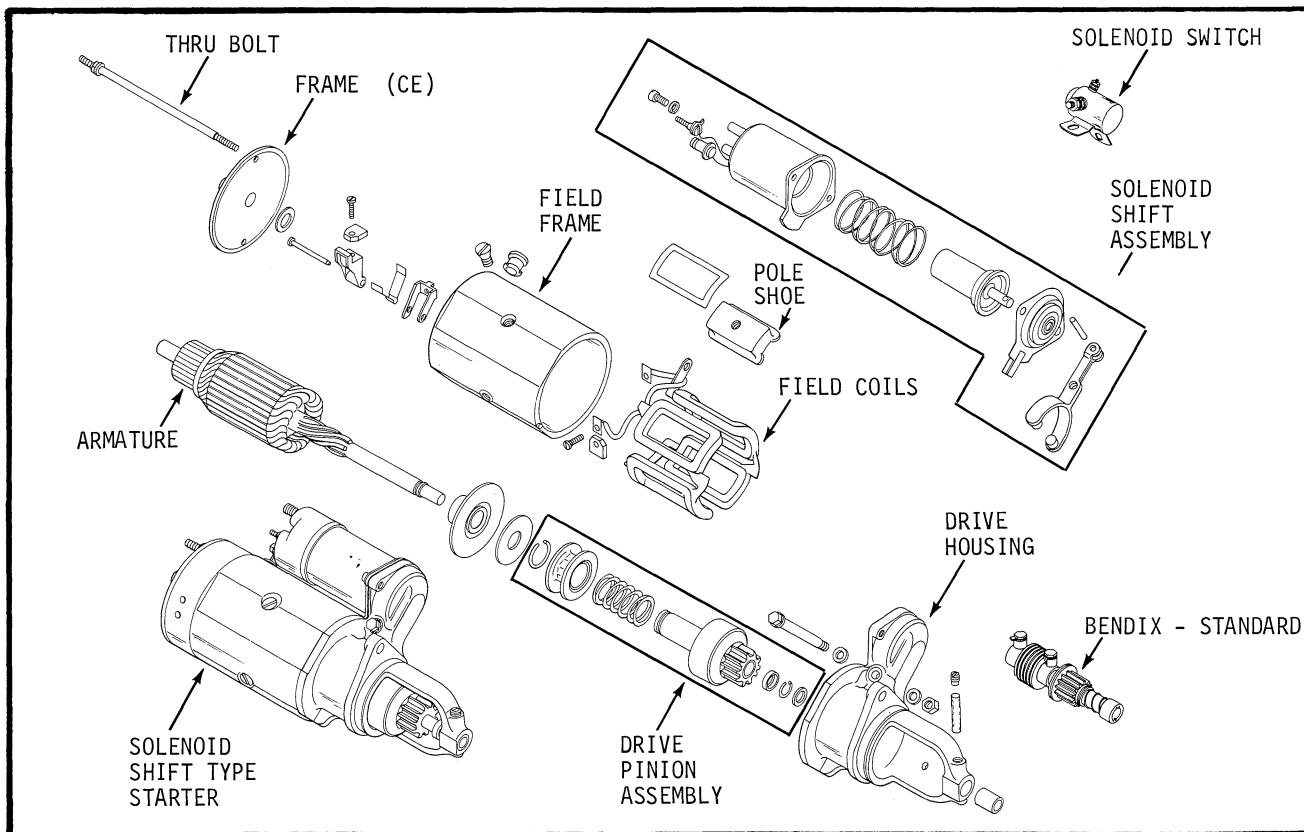

FIGURE 7-7 -- K662 STARTING MOTORS - EXPLODED VIEW

Trouble Analysis: If starter fails to energize, first check wiring, starting switch or solenoid and condition of battery. Clean or replace badly corroded or dirty contacts--replace wires if frayed or cracked. Bypass start switch or solenoid with jumper wire--if starter cranks normally, replace defective switch or solenoid. If starter turns too slowly and battery is in good condition, check for dirty brushes or commutator and service if needed.

If starter turns too slowly after brushes and commutator are checked, remove starter from engine and check armature for binding. Armature should turn freely--if not, the cause could be too little end play or improperly lubricated or badly worn sleeve bearings.

If starter spins without engaging (applies to Bendix type only), the cause may be a dirty or improperly lubricated Bendix assembly. Do not dip drive in cleaning solution as this could damage clutch. Brush solution on spline, wipe dry then apply dry spray type lubricant. Replace Bendix assembly if pinion or splined sleeve is damaged. If the K482 type Bendix is moved into the extended or engaged position while being cleaned, it will lock in this position--do not try to force it back into the retracted position. K482 starter can be installed on engine with pinion in engaged or disengaged position.

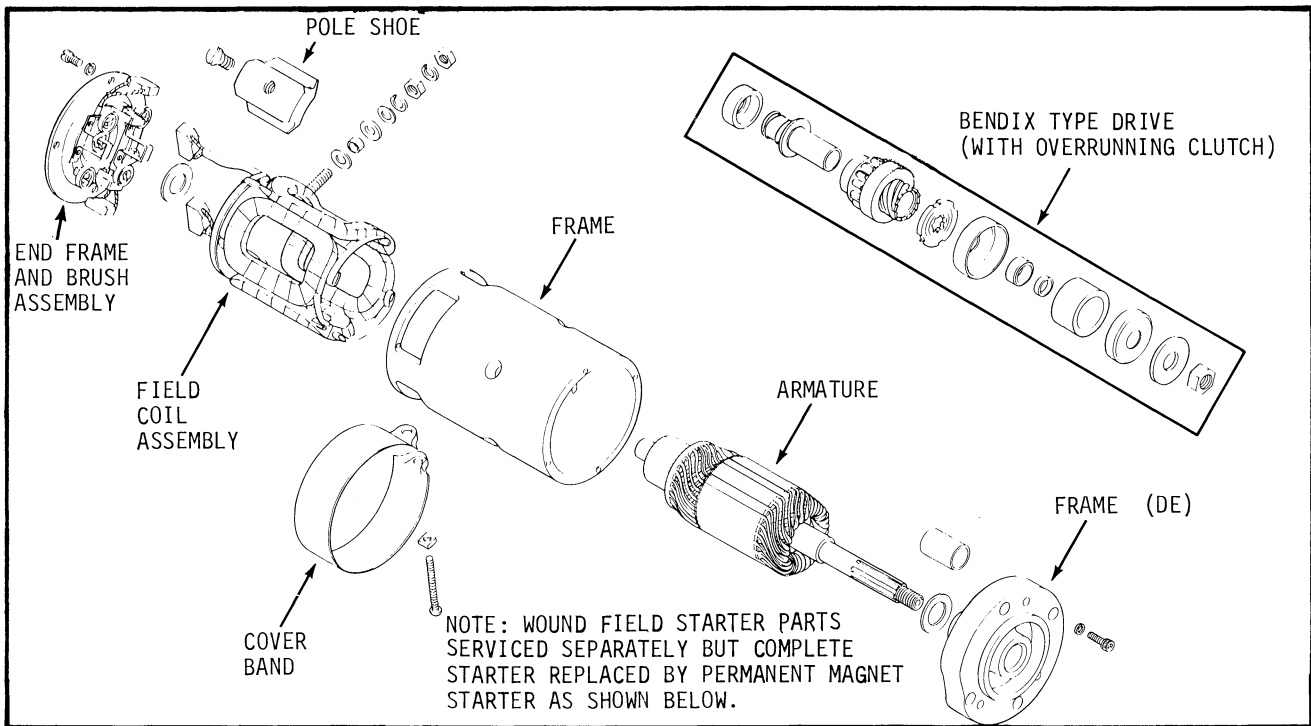

FIG. 7-8A -- WOUND FIELD, OVERRUNNING CLUTCH STARTER (K482)

Alignment: On K482 engines, alignment of starter pinion to ring gear is established by the machined surface of starter mounting flange on the oil pan and thru special (Allen head) mounting bolts. To prevent misalignment and gear damage, make sure the same bolts are used and that they are securely tightened at all times.

On K662 engines, the starter is supported by brackets at front and rear. The brackets, when properly installed and tightened, provide alignment of the drive pinion to ring gear. Make sure these are secure at all times to prevent gear damage.

Drive pinion to ring gear backlash must be from .015 to .030" on K482 and .015 to .035" on K662 models. To measure this, move drive pinion into engagement then check clearance between the pinion tooth that is solidly engaged between two teeth of ring gear. Excessive backlash indicates gear wear--replace drive pinion and/or ring gear in this event.

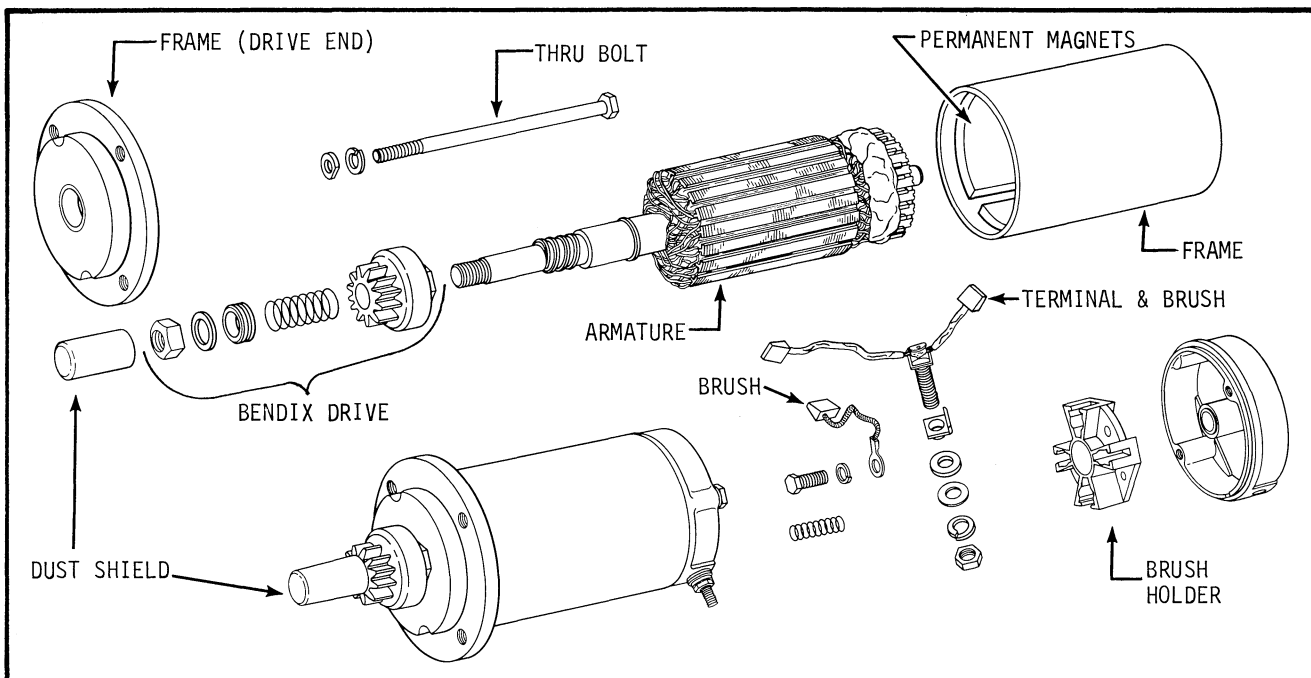

FIGURE 7-8B -- PERMANENT MAGNET, BENDIX DRIVE STARTER (K482, K532)

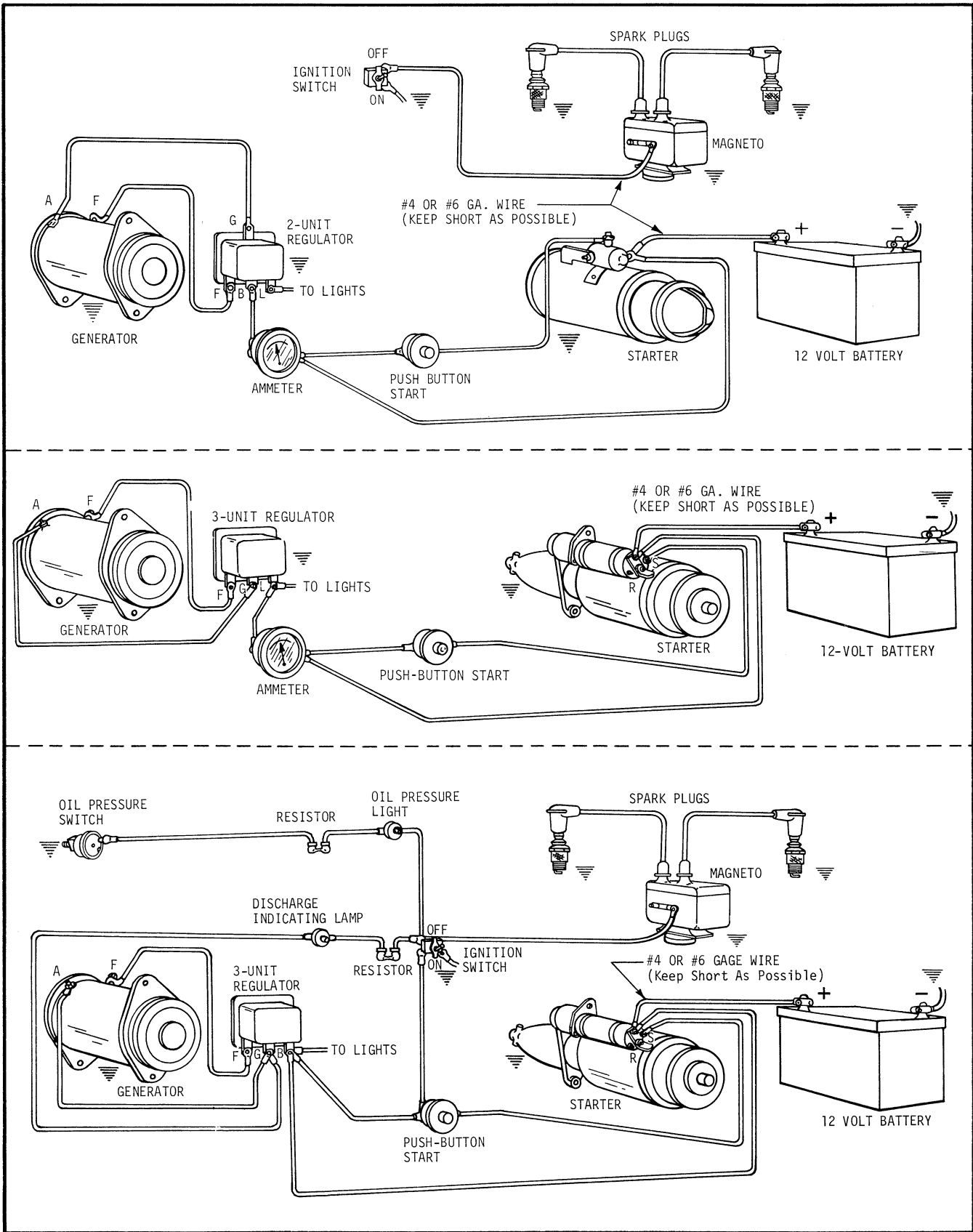

FIGURE 7-9 -- WIRING DIAGRAMS -- K662 ELECTRICAL SYSTEMS

# ALTERNATOR (CHARGING) SYSTEMS

The alternator system provides electrical energy to charge the battery and for lighting of accessory circuits. Your engine may have either a 15 amp or a 30 amp system--the type can be determined by the rectifier-regulator as shown above. In addition to the solid state rectifier-regulator, which is mounted externally on the engine or on the equipment powered by the engine, the system also includes an alternator-stator and permanent magnet ring inside the flywheel. With the exception of the magnet ring which revolves around the stator, these systems have no moving parts and are therefore virtually service free--the only required service is an occasional check to make sure that all electrical connections are tight and that wires are not frayed or cracked. Refer to the wiring diagrams on the following pages for connections. While the function of the two systems is basically the same, regulation differs which results in differing precautions for the systems--check the precautions pertaining to the system used on your engine to avoid damaging charging system components.

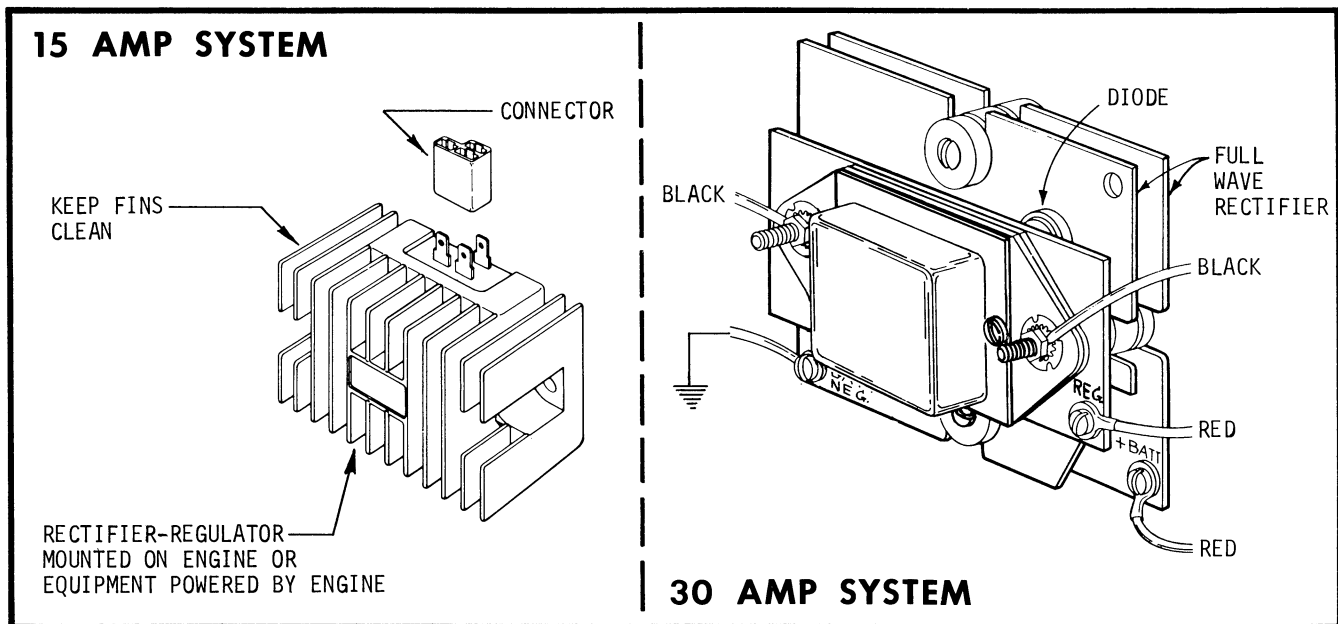

FIGURE 7-10 -- RECTIFIER-REGULATOR IDENTIFIES CHARGING SYSTEM

## PRECAUTIONS-15 AMP SYSTEM

1. Battery polarity must be correct. Negative ground systems are used with Kohler Engines.
2. Prevent alternator leads (AC) from touching or shorting. This could permanently damage the stator.
3. Disconnect leads at rectifier-regulator before electric welding is done on equipment in common ground with engine.
4. Do not operate for any length of time without a battery in the system.

## PRECAUTIONS-30 AMP SYSTEM

1. Battery polarity must be correct--negative (-) battery terminal is connected to ground.
2. Rectifier-Regulator must be in common ground with engine and battery.
3. Make sure that no fuses, resistors or wires smaller than #10 AWG are in connection from battery to rectifier.
4. Disconnect wire at terminal marked "BATT. NEG." if arc welding is done on equipment in common ground with engine.
5. Disconnect battery to regulator lead when battery is being recharged.
6. DO NOT operate engine with battery disconnected from Alternator System.
7. Make sure AC leads are prevented from being grounded at all times.

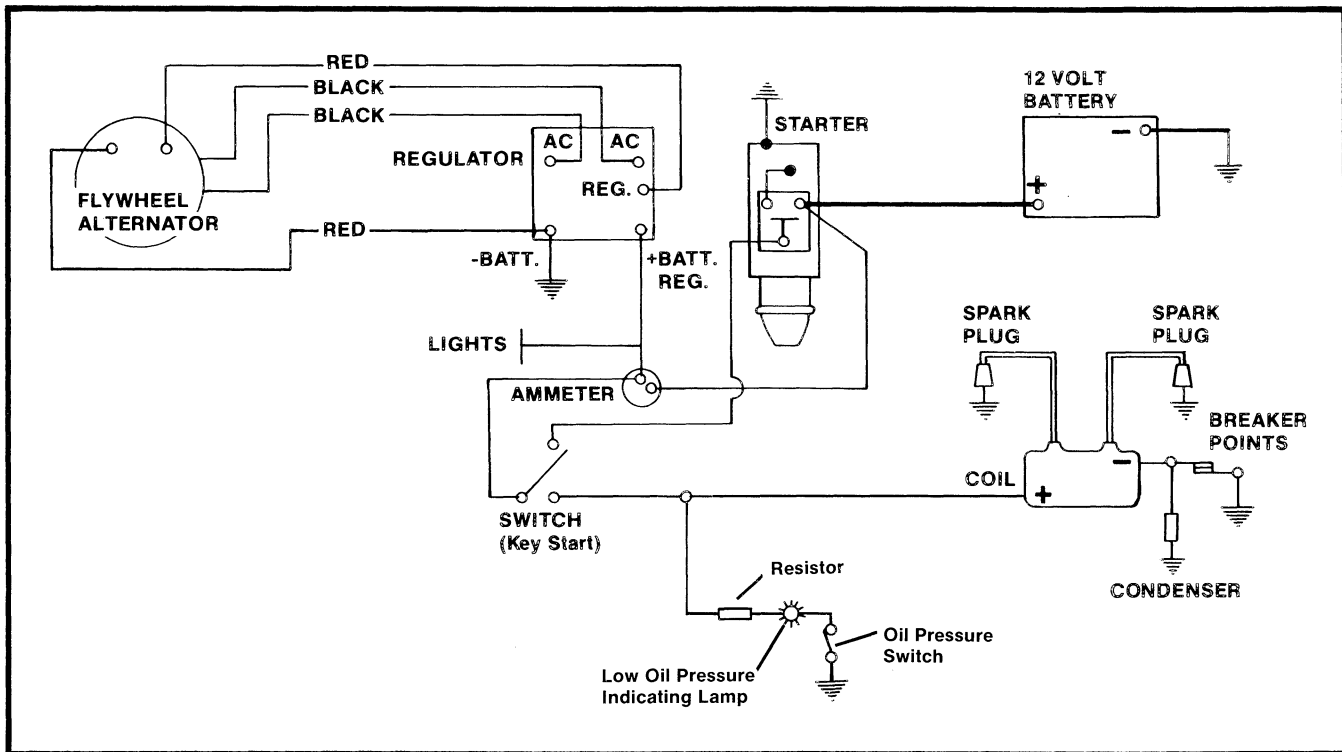

FIGURE 7-11 -- WIRING DIAGRAM -- 30 AMP ALTERNATOR SYSTEM WITH OIL PRESSURE INDICATOR AND SWITCH

### TROUBLE ANALYSIS - 30 AMP ALTERNATOR SYSTEM

| CONDITION                                   | POSSIBLE FAULT   | TEST AND CORRECTIVE ACTION  |
|---|--|---|
| NO OUTPUT                                   | A. Faulty windings in stator<br><br>B. Defective diode(s) in rectifier | A. Remove four input leads from Rectifier - Regulator. Check resistance on RX1 scale of Ohmmeter. Replace stator if readings not at test values. Test with engine stopped<br>Test 1 - Connect Ohmmeter leads to 2 red leads - about 2.0 ohms resistance should be noted.<br>Test 2 - Connect Ohmmeter leads to 2 black leads - about 0.1 ohms should be noted.<br><br>B. With engine stopped, connect leads of flashlight type continuity tester between BAT-NEG and one of the AC terminals then reverse these leads--lamp should turn ON one way and OFF the other. Repeat procedure on the other AC terminal. If lamp indication is the same both ways, diode is faulty. |
| NO CHARGE<br>(When load applied to battery) | A. Faulty regulator winding  | A. Remove red lead from "REG." terminal on Rectifier - Regulator. Start engine and operate at full speed. With regulator winding disconnected, alternator should charge at full output. Replace stator if full output of at least 30 amps is not attained.  |
| FULL CHARGE - NO REGULATION                 | A. Faulty regulator winding<br><br>B. Defective regulator              | A. Remove 2 red leads from Rectifier - Regulator -- connect these two leads together then start engine and operate at full speed. A maximum 4 amp charge should be noted if stator is OK.<br><br>B. If stator checks out, trouble is in regulator portion of Rectifier - Regulator. Replace unit.   |

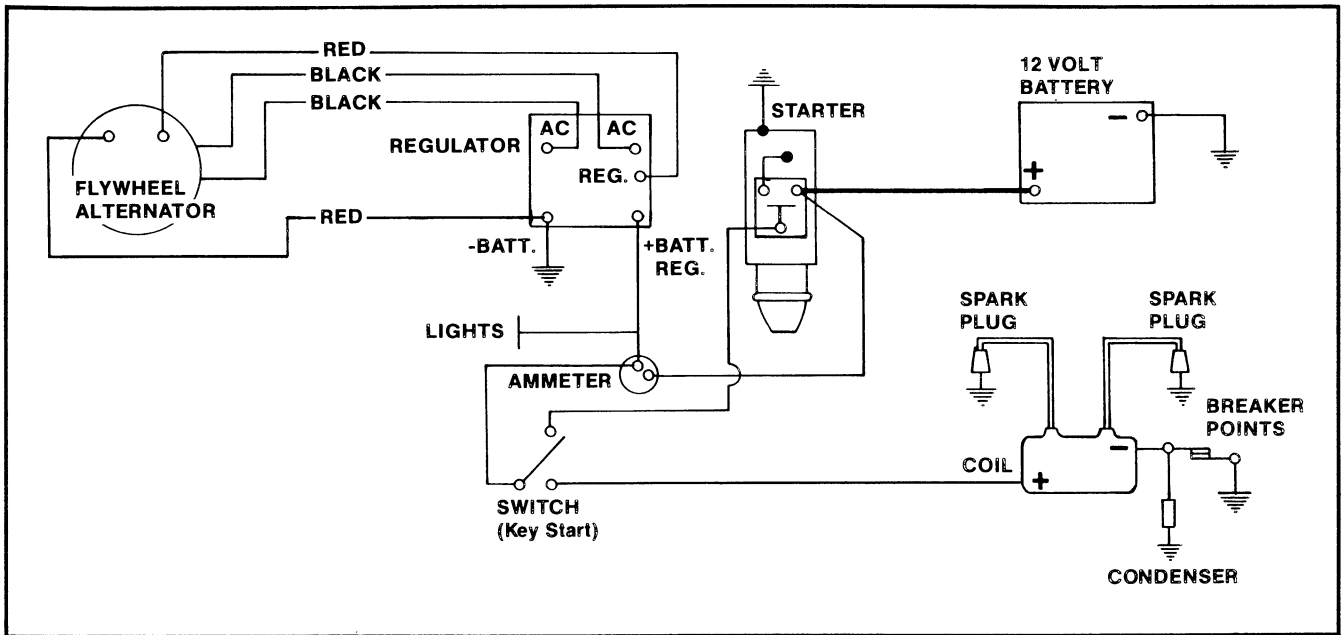

FIGURE 7-12 -- TYPICAL 30 AMP ALTERNATOR SYSTEM, WIRING DIAGRAM

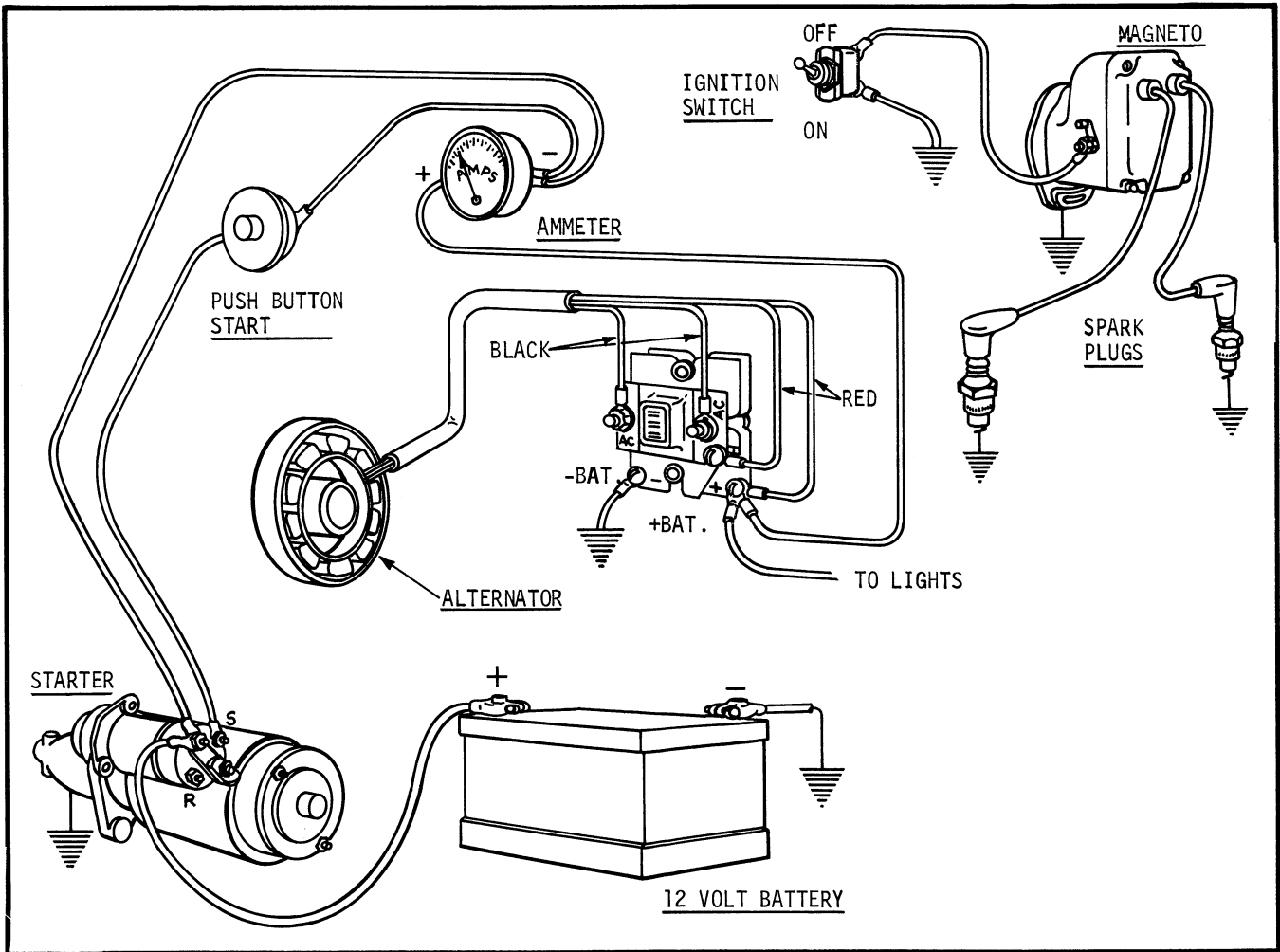

FIGURE 7-13 -- K662 30 AMP BATTERY CHARGING, MAGNETO IGNITION SYSTEM

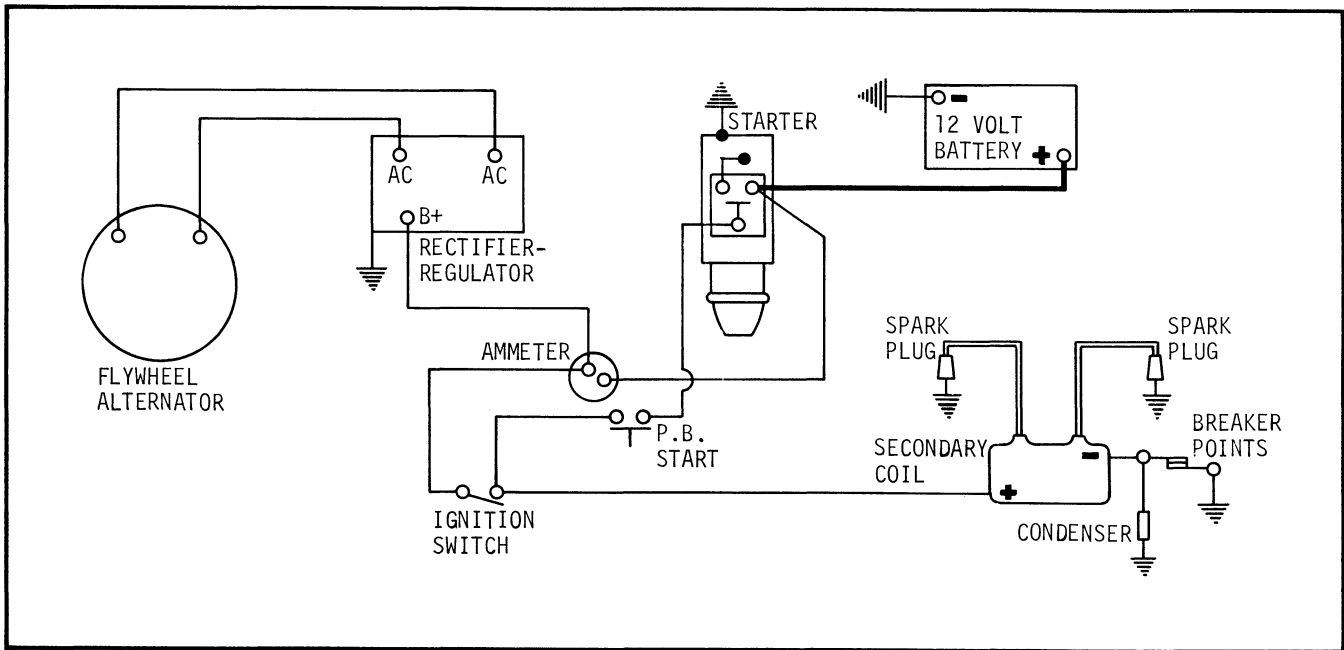

FIGURE 7-14 -- TYPICAL 15 AMP SYSTEM, WIRING DIAGRAM

### TROUBLE SHOOTING - 15 AMP SYSTEM

TEST WITH ENGINE RUNNING AT 3600 RPM - NO LOAD

| CONDITION: NO CHARGE TO BATTERY   | POSSIBLE FAULT/REMEDY  |
|---|--|
| <p>TEST A -- With B+ cable connected, check B+ (at terminal on rectifier-regulator) to ground with DC Voltmeter. If 13.8 volts or higher, place minimum load of 5* amps on battery to reduce voltage:</p> <p>A-1 -- If charge rate increases.</p> <p>A-2 -- If charge rate does not increase.</p> | <p>A-1 -- Indicates alternator system OK, battery was fully charged.</p> <p>A-2 -- Check for defective stator or rectifier-regulator (TEST B).</p>   |
| <p>TEST B -- Unplug leads at rectifier-regulator, connect VOM (multimeter) across AC leads, check AC voltage:</p> <p>B-1 -- If less than 28 volts.</p> <p>B-2 -- If more than 28 volts.</p>   | <p>B-1 -- Defective stator, replace with new assembly.</p> <p>B-2 -- Defective rectifier-regulator, replace with new unit.</p>   |
| CONDITION: BATTERY CONTINUOUSLY CHARGES AT HIGH RATE  | POSSIBLE FAULT/REMEDY  |
| <p>TEST C -- Check B+ to ground with DC Voltmeter:</p> <p>C-1 -- If over 14.7 volts.</p> <p>C-2 -- If under 14.7 volts.</p>   | <p>C-1 -- Rectifier-regulator not functioning properly. Replace with new unit.</p> <p>C-2 -- Alternator system OK. Battery unable to hold charge. Check specific gravity of battery. Replace if necessary.</p> |

\*Turn lights on if 60 watts or more or simulate load by placing a 2.5 ohm 100 watt resistor across battery terminals.

# ENGINE - GENERAL SERVICES

## COOLING

On engines with the standard forced air cooling system, rotation of the blades or fins on the fly-wheel causes cooling air to be drawn in through the rotating air screen where it is forced through the blower housing and baffles past the cooling fins on cylinder block and heads where it is finally ejected as heated air toward the rear of the engine. In all applications, recirculation of the heated air must be avoided--make sure air heated by the engine cannot be drawn back into the air intake.

The rotating air screen and cooling fins must be kept clean and unobstructed at all times. DO NOT operate engine with blower housing, baffles or any other cooling shrouds removed as this will result in improper circulation past the cooling fins and overheating.

Other external surfaces of an engine should also be kept free of oil and dirt accumulation. This should be done not only for safety and appearance but because poor cooling efficiency results from dirty external surfaces on engine and components.

## CYLINDER HEAD SERVICE

After each 500 hours of operation, the cylinder heads should be taken off the engine and serviced. Remove carbon deposits from combustion chamber in head. Scrape and remove carbon with a sharp piece of wood--wood or similar material is suggested to avoid scratching aluminum surfaces of head. Always use new cylinder head gaskets, make sure head bolts are tightened in the proper sequence and to the torque value stated in the Specification Section. Before reinstalling the serviced heads, check and adjust valve-tappet clearance per the following instructions.

## VALVE — TAPPET CLEARANCE

After each 500 hours, check clearance between the valve stems and tappets. The engine must be stopped and cooled to normal ambient temperatures to accurately gauge and adjust valve clearances. Use the following procedure to adjust:

1. Turn engine over until piston in #1 cylinder (closest to flywheel) is at Top Dead Center on compression--in this position, both valves will be closed and cam will have no effect on tappet.
2. Measure clearance between valve stem and tappet with a feeler gauge. To adjust, turn adjusting screw on tappet in or out until proper clearance is attained.

| <u>CLEARANCE SPEC.</u>          | <u>K482, K532</u> | <u>K662</u>  |
|---------------------------------|-------------------|--------------|
| Intake valve -- cold clearance  | .008 - .010"      | .006 - .008" |
| Exhaust valve -- cold clearance | .017 - .020"      | .015 - .017" |
3. After adjusting valve-tappet clearance on #1 cylinder, turn engine over until #2 cylinder is at TDC on compression and repeat adjustment on this cylinder.
4. After valves are in proper adjustment, position new head gaskets and reinstall cylinder heads. Make sure head bolts are tightened in the proper sequence and to the torque value specified on page 14.3.

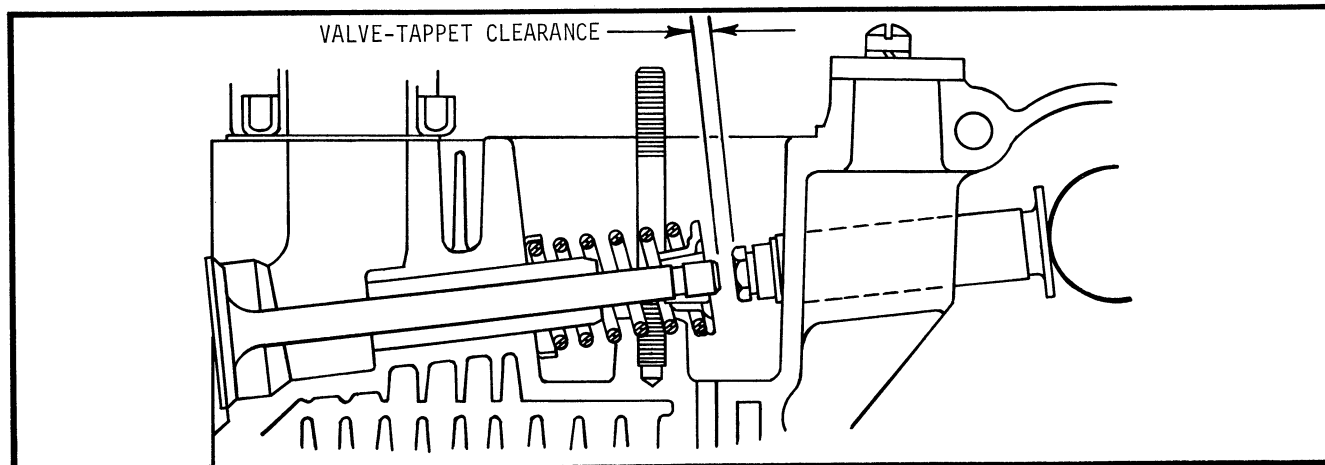

FIGURE 8-1 -- VALVE-TAPPET CLEARANCE (INTAKE VALVE SHOWN)

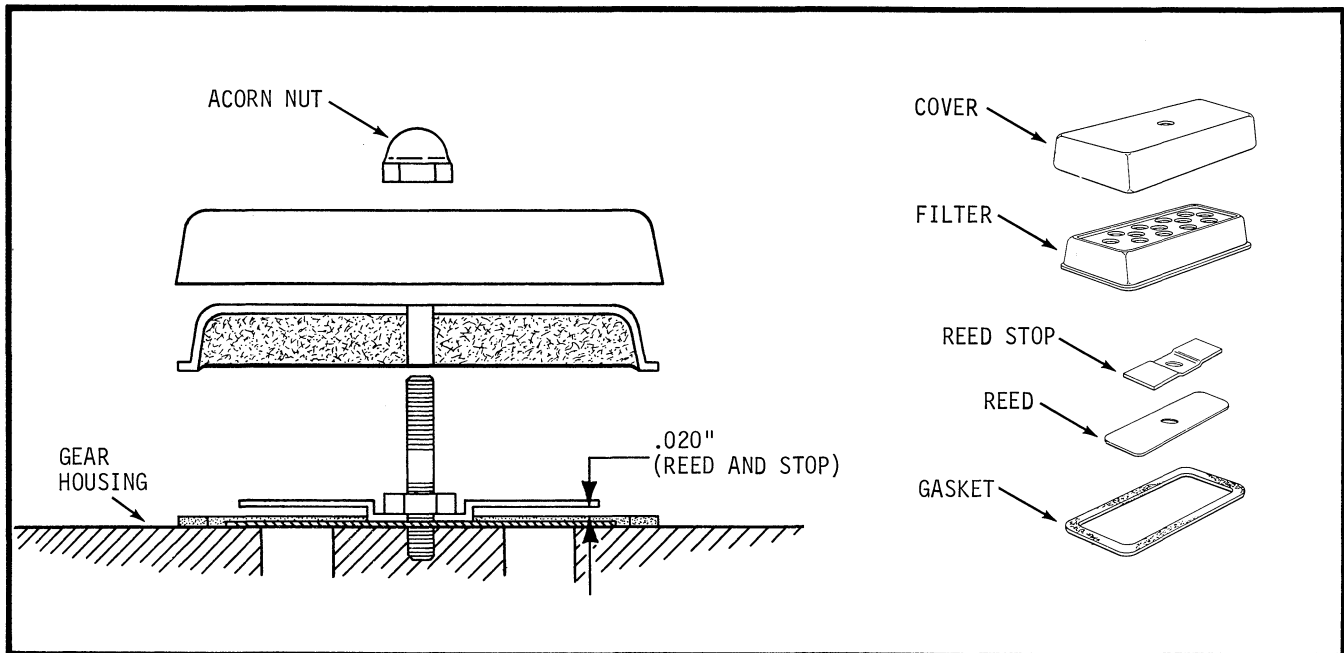

FIGURE 8-2 -- REED TYPE CRANKCASE BREATHER -- K662

### CRANKCASE BREATHER SYSTEMS

The breather functions as a one-way valve to allow pressure to be expelled from the crankcase and also to block or prevent air from being drawn back into the crankcase. A proper functioning breather system thus helps maintain a slight vacuum within the crankcase.

K482 and K532 models use a closed or positive type breather system. A nonserviceable breather valve is pressed into the breather housing which is assembled to the governor. If the valve is faulty, replace breather-housing as a unit. A tube connects the breather to air inlet side of the carburetor. The flow of air to the carburetor thus creates a vacuum on the tube which pulls air (and fumes) from the crankcase to maintain vacuum.

Most K662 engines use the reed type breather arrangement as shown in Figure 8-2. The breather is located at the top of the gear housing on these engines. The components must be properly installed to function properly. The tabs on the reed stop must be adjusted so that they are .020" above the flat surface of the reed (when the engine is not running). The reed allows air to exit from the crankcase but blocks return of air. The filter element should be serviced occasionally so that crankcase ventilation is not blocked. A closed system is also employed on the K662. The components of this system are the same as the standard system except for a special housing. A tube connects the housing to the air inlet side of the carburetor to maintain positive draw on breather whenever the engine is in operation.

### **ENGINE STORAGE INSTRUCTIONS**

If engine is to be out of service for a considerable length of time, the following steps are recommended:

1. Drain oil from crankcase while engine is still hot and flush with clean, light oil. Refill crankcase.
2. Drain fuel tank and carburetor.
3. Remove, clean and replace sediment bowl.
4. Clean exterior of engine.
5. Spread a light film of oil over any exposed surfaces of engine subject to corrosion.
6. Pour tablespoon of oil into spark plug holes, crank engine slowly by hand and replace spark plugs. Store in dry place.

## CRANKCASE VACUUM TEST

The results of a crankcase vacuum test can be very useful in determining the general condition of an engine. A negative pressure of specific value (or vacuum) should be present within the crankcase when an engine is running at normal operating speed and temperature. Crankcase vacuum reading should be taken with the engine operating at 3200 RPM (or 3600 RPM on models operated at this speed). Vacuum can be checked with a "U" tube water manometer or with a vacuum gauge which can be inserted tightly in the oil fill hole. An engine in good condition will have a crankcase vacuum reading no lower than the values stated in the accompanying chart.

| <u>TYPE BREATHER</u> | <u>K482, K532</u>    | <u>K662</u>          |
|----------------------|----------------------|----------------------|
| Reed Type Breather   | -----                | 16" H <sub>2</sub> O |
| Closed Breather      | 12" H <sub>2</sub> O | 12" H <sub>2</sub> O |

**NOTE:** Values shown in inches of water (H<sub>2</sub>O) column as read on water manometer with engine operating at 3200 or 3600 RPM.

If vacuum is lower than the minimum values stated, this could be attributed to several different factors. The condition easiest to remedy should be checked first.

- A. Clogged Crankcase Breather: Can cause low vacuum or positive pressures to build up. An improperly assembled and adjusted reed valve can also cause this. Disassemble breather, thoroughly clean then recheck crankcase pressure after serviced breather is reinstalled.
- B. Worn or Damaged Oil Seals: Oil leakage is usually evident around worn or damaged oil seals. Replace oil seals and recheck vacuum.
- C. Blowby, Leaky Valves: Can be the cause of positive crankcase pressures. These conditions can be confirmed by taking compression readings on engine.

Construction Details - "U" Tube Manometer: To construct water manometer, proceed as follows:

- (A) Procure length of clear plastic tubing. Bend tube to form "U" and mount on board as shown in accompanying illustration. Make gradual, rather than sharp bend in tube.
- (B) Measure inside, straight section of tube and mark in increments from 0 to 24 inches.
- (C) Procure cork having outside diameter which will be a snug fit in the oil fill hole. Drill hole in center of cork to receive one end of tube.
- (D) Pour water (colored for easier reading) into tube until level reaches the approximate halfway mark on scale.

When using manometer, place cork end into oil fill hole (other end open to atmosphere) and measure difference between columns. If water column is higher in tube connected to engine, vacuum or negative pressure is indicated. If the higher column is on the atmospheric side of manometer, positive pressure is present.

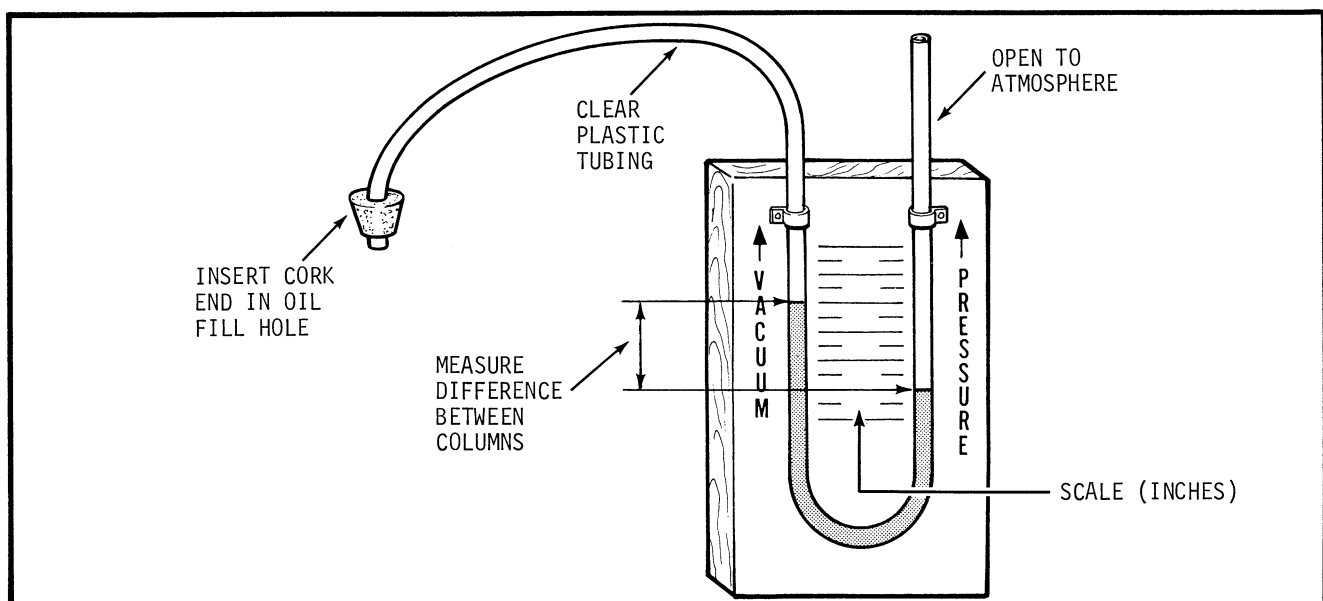

FIGURE 8-3 -- CONSTRUCTION DETAILS -- "U" TUBE WATER MANOMETER

## COMPRESSION TEST

The results of a compression check can be useful in determining if an engine is in good operating condition or if reconditioning is necessary. To check compression, remove spark plugs, insert compression gauge in spark plug hole, set the throttle and choke to the wide open position, insure that air intake and exhaust systems are not restricted, and motor the engine using the starting motor. Take several readings on both cylinders. A difference in pressure reading between cylinders in excess of 15% or readings below 90 PSI can indicate the following:

| POSSIBLE CAUSE                           | REMEDY  |
|--|---|
| A. Cylinder head gasket blown.           | A. Remove head, check for flatness, replace gasket, reinstall head, recheck compression. Locate cause of initial failure and rectify. |
| B. Cylinder head warped or loose.        | B. Remove head, check for flatness, (see cylinder head service). Locate cause of initial failure and rectify.                         |
| C. Piston rings worn - blowby occurring. | C. Recondition engine.  |
| D. Valves leaking.                       | D. Recondition valves and seats.  |
| E. Excessive combustion deposits.        | E. Remove head and clean combustion deposits from combustion chamber.   |

# INSPECTION-DISASSEMBLY

## WORK AREA

Before starting disassembly of an engine, make sure work area is in clean, neat condition and that adequate tools are on hand. Certain special tools are required to satisfactorily install oil seals, "O" rings, etc. (Refer to Special Tool Section.) Good lighting is also essential for proper inspection and reconditioning. Observe all rules of safety when working on an engine. Make sure cleaning solvents and other flammable liquids are properly identified and stored in covered containers safely away from danger of combustion from open flames, sparks, etc. The best protection against accidents in all situations is provided mainly through the use of good common sense.

## INSPECTION

When disassembling an engine, carefully inspect and note the physical appearance of each of the components. Often the appearance of parts will indicate operation under other than ideal conditions. In observing these indicators, you may be able to suggest improved service and operating techniques which will result in prolonged engine service life. Some of the things to look for are:

1. Excessive sludge and varnish formation.
2. Scoring of the cylinder walls.
3. Severe piston damage.
4. Evidence of external oil leakage.

These are just a few of the more common indicators. Numerous others exist and are obvious to the experienced mechanic. Often the cause will become apparent in view of the particular condition of the part. Always look for these signs when disassembling an engine prior to reconditioning.

Excessive Sludge: This is a natural by-product of combustion and a small accumulation is normal. Excessive sludge formation could indicate several things. The most common cause is perhaps too infrequent oil and oil filter changes. It can also indicate operation with improper ignition timing or overrich carburetor adjustment or a poorly serviced clogged air cleaner which restricts air intake and also results in an overrich mixture.

Scoring of the Cylinder Wall: Unburnt fuel not only adds to sludge formation but can, in severe cases, cause scuffing and scoring of the cylinder walls. As raw fuel seeps down the cylinder walls, it washes the necessary lubricating oils off the piston and cylinder walls so that the piston rings make metal to metal contact with the walls. Scoring of the cylinder walls can also be caused by localized hot spots resulting from blocked cooling fins or from inadequate or contaminated lubrication.

Severe Piston Damage: Major damage to pistons and rings can take various forms. The top of the piston ring may be burned through or the top groove may be excessively worn and the ring broken or stuck in the groove. This can be attributed to abnormal combustion. If ignition timing is overadvanced, ignition will occur while the piston still has a long distance to travel on its compression stroke. As a result, the combined heat of compression plus the heat of pre-ignited fuel raises temperatures to values comparable to that of an acetylene torch. This, of course, acts mainly on the top land and top ring of the piston and results in early failure.

Evidence of External Oil Leakage: If excessive oil leakage is evident, this may indicate improperly serviced breather systems. Normally, an engine operates internally at pressures under atmospheric or, in other words, with a negative crankcase pressure. If positive pressures build up within the crankcase from a clogged breather or from piston blowby, oil will be forced out of an engine at oil seals, gaskets or any other available spot.

## DISSASSEMBLY PROCEDURE

The following is intended as a guide to disassembly of standard engine models. The procedure will have to be varied to facilitate removal of special equipment or accessory items such as gas fuel system components, clutches, reduction gears, etc.

Prior to disassembly, remove drain plugs and allow ample time for complete drainage of fuel and lubricating oil. It is good practice to do this outside or at a location away from the work bench to keep this area in clean condition. If engine is dirty externally, it should be steam cleaned or thoroughly cleaned in some other manner before being moved to the work bench. Keep the work area in cleanest possible condition at all times.

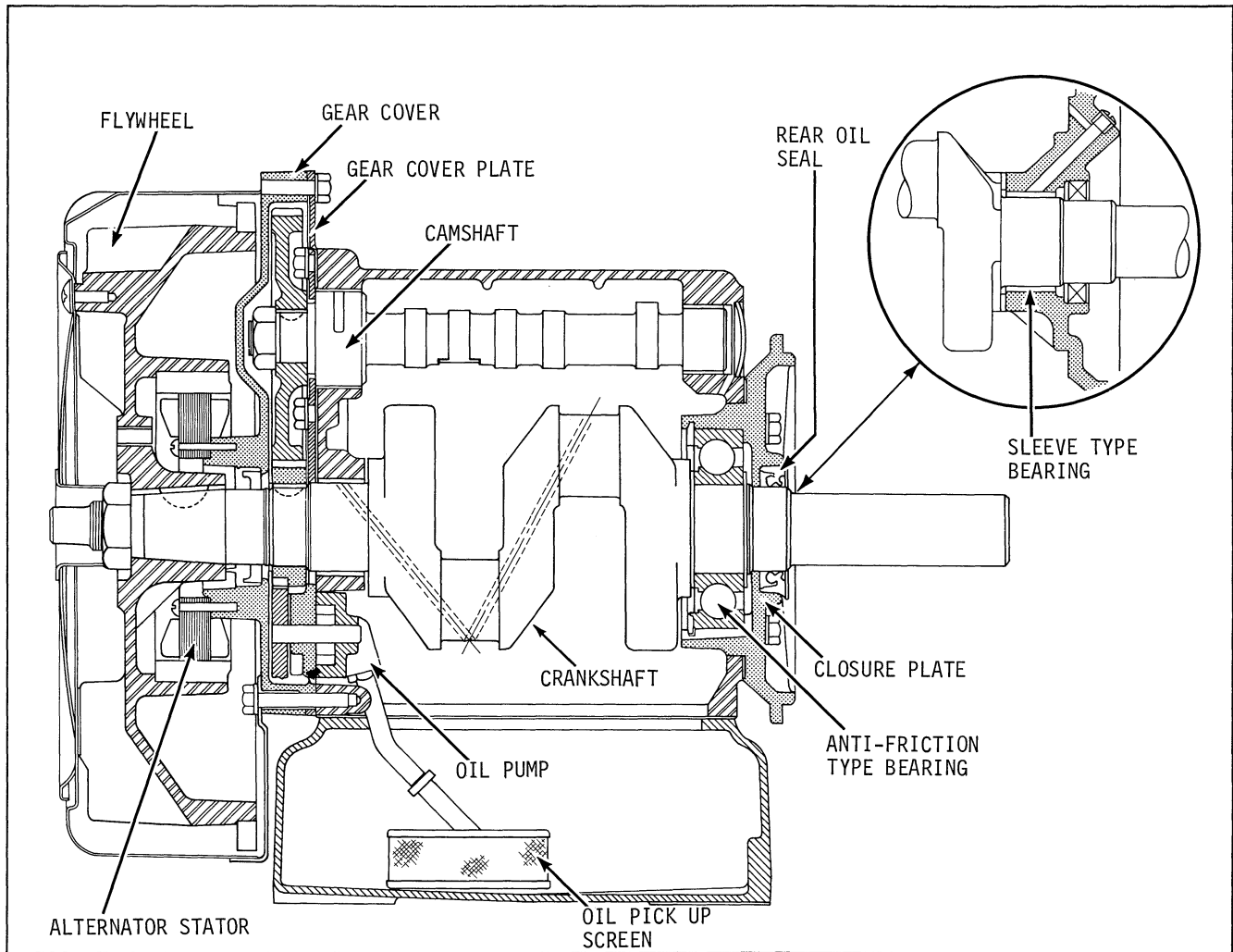

FIGURE 9-1 -- CROSS SECTIONAL VIEW, TYPICAL K482

To prevent unintentional starting, disconnect battery and/or spark plug leads before doing any work on engine or equipment driven by engine. The following sequence is suggested for complete disassembly of the engine:

1. Air Cleaner: Remove air cleaner, adapters, backing plates, etc. from carburetor.
2. Carburetor: Disconnect fuel lines, breather tube, choke and throttle linkage at carburetor then remove carburetor from intake manifold.
3. Air Cooling Shroud: Remove rotating air screen, cylinder baffles and blower housing. (If this has not already been done for cleaning external surfaces of engine.)
4. Instrument Panel: Disconnect line to oil pressure gauge, affix numbers (for ease in reconnecting later) to and disconnect all electrical leads then remove instrument panel from gear housing. Other electrical components such as ignition coil, condenser, rectifier-regulator can also be removed at this time.
5. External Units: Remove units such as magneto, distributor and governor at this time.
6. Manifolds: Disconnect intake and exhaust manifolds and remove from block.
7. Fuel System Components: Remove fuel filter on its bracket and disconnect and remove fuel pump then complete disassembly of any remaining externally mounted equipment.

8. Flywheel: The flywheel is keyed to and positioned on a taper on the crankshaft. The flywheel retaining nut may be secured with either a roll pin or setscrew. Loosen setscrew with Allen head wrench or drive roll pin out with small punch before attempting to remove retaining nut. On some K482 engines, it will be necessary to partially disassemble Bendix before the flywheel can be removed. Use the following procedure to remove flywheel:
  - (A) K482 (early models only): Bendix assembly is pinned to the starter shaft--drive pin out, remove nut at end of starter shaft then slip Bendix Assembly off shaft.
  - (B) After loosening setscrew or removing roll pin, block and prevent flywheel from turning (insert board between cooling fins on flywheel) then remove retaining nut.
  - (C) Use puller to remove flywheel from shaft--Do not "bump" to remove as this may weaken or break end of crankshaft. Remove key from keyway on crankshaft.
  
9. Alternator-Stator: On engines so equipped, the alternator-stator can be removed after flywheel is pulled. Remove capscrews securing stator to gear cover and slip stator off.

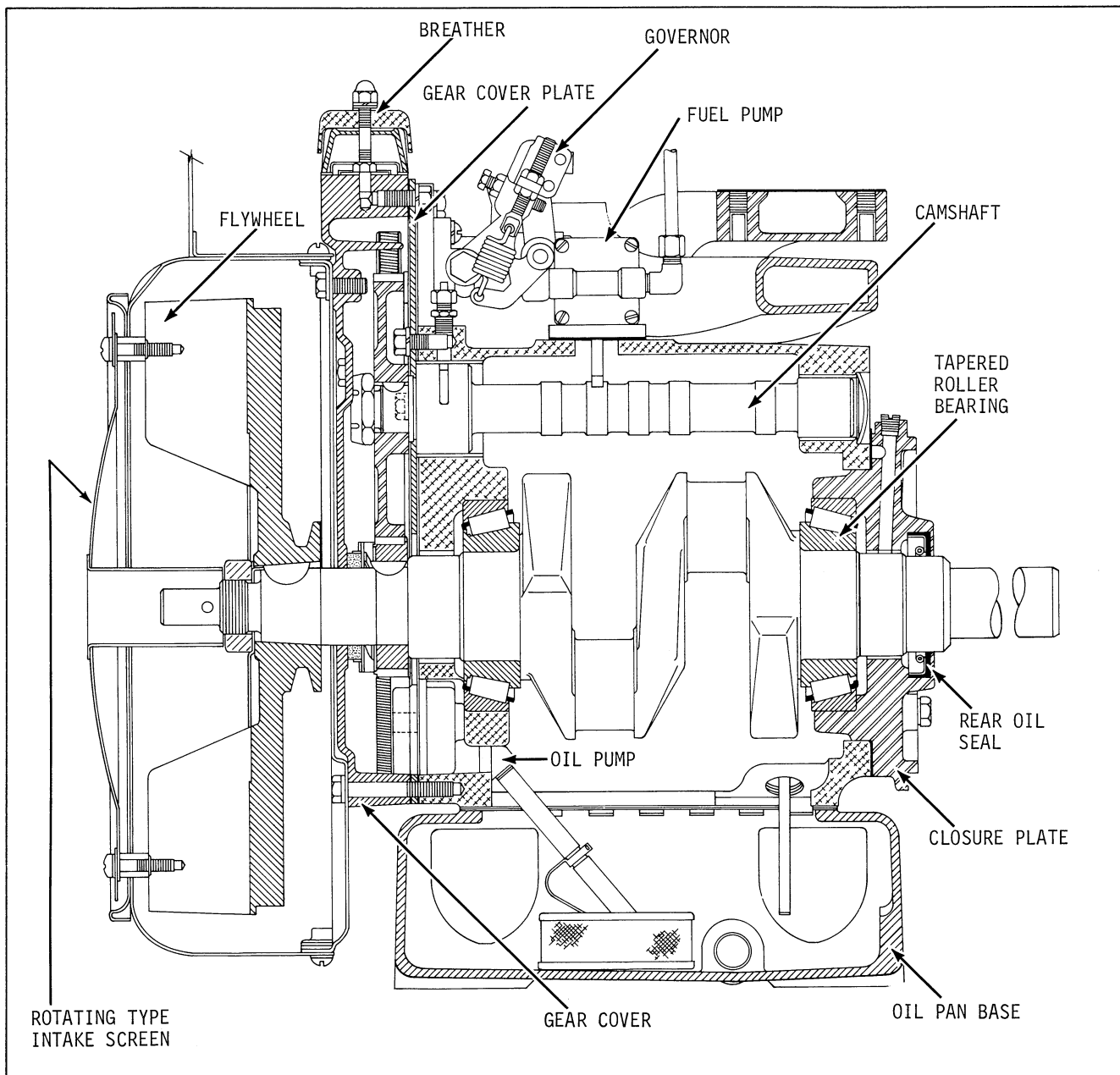

FIGURE 9-2 -- CROSS SECTIONAL VIEW, TYPICAL K662

10. Cylinder Heads: Remove spark plugs, then cylinder heads and gaskets.
11. Valve Mechanism: Remove valve covers then, using a spring compressor, remove taper locks, rotators (if used), or spring retainers and springs. Carefully slip valves out of guides. Tappets are removed most easily after camshaft and oil pan have been removed.
12. Gear Cover: Remove capscrews to block and gear cover, remove shroud mounting plate (or blower housing support) first then gear cover. On the K662, remove breather components from gear cover. Front oil seal will be removed along with gear cover on the K482 and K532--slide seal off crankshaft first on K662.
13. Camshaft Gear: Wedge piece of wood between cam gear and crank gear then remove camshaft retaining nut and washer. Cam gear is keyed to crankshaft--use gear puller to remove. Remove key from keyway after cam gear is pulled.
14. Cover Plate: Remove capscrews securing cover plate to block and remove cover plate.
15. Camshaft: Rotate camshaft so that tappets are pushed away and will not interfere as shaft is removed. Pull camshaft out through front end of block--carefully guide and support shaft until completely removed. If unsupported, it could fall when clear of bushings and damage bushings and journals. After camshaft is removed, tappets can fall inside crankcase when engine is tilted to remove oil pan. To prevent damage to tappets or other parts, temporarily run a wire from adjusting nut on one tappet to the other--do this to tappets on both cylinders. Also tag tappets so that they can be reinstalled (if reusable) in same cylinder during reassembly.
16. Oil Pan: Tilt engine on its side to gain access to thru bolts securing pan to crankcase. Remove thru bolts then, being careful not to damage oil screen, remove oil pan. Tappets can now be removed working thru inside of crankcase.
17. Oil Pump: After pan is removed, disconnect oil screen tube at body of oil pump. Screen must be removed from pump as it would interfere with pump removal. Remove capscrews securing pump to crankcase and pull pump out through front of engine.
18. Connecting Rods-Pistons: Working through bottom of crankcase, disconnect connecting rod capscrews and remove rod caps. Tag these components #1 and #2 cylinder--do not mix. Carefully guide rod-piston assembly out through head side of cylinder bore. Temporarily reinstall rod cap on piston-rod assembly.
19. Crankshaft Gear: Remove both snap rings (K482, K532) then use gear puller to remove crank gear (crank gear is light press fit on crankshaft--it may be possible to pry crank gear off using two screwdrivers with large blades). Remove key from crankshaft.
20. Crankshaft-Closure Plate: Remove capscrews securing closure plate to crankcase then carefully guide crankshaft-closure plate assembly out through the rear end of the crankcase --avoid damaging front bushing (K482, K532) or bearing on K662. Carefully note number and thickness of closure plate to crankcase gaskets--these are used to control crankshaft end play. Upon reassembly, use new gaskets of same size and in same sequence as they were originally. Engine is now disassembled and ready for complete inspection and reconditioning.

# ENGINE RECONDITIONING

All parts should be thoroughly cleaned--dirty parts cannot be accurately gauged or properly inspected for wear or damage. There are many commercial cleaners available that quickly remove grease, oil and grime accumulation from engine parts. If such a cleaner is used, make sure that all trace of the cleaner is removed before the engine is reassembled and placed in operation. Even small amounts of these cleaners quickly break down the lubricating properties of engine oils.

## CYLINDER BLOCK

### 1. Inspection

- A. Gasket surfaces - Check all surfaces to make sure that they are free of gasket fragments. Surfaces must also be free of deep scratches or nicks.
- B. Bearings, Races, Transfer Sleeves - On K482, K532 models, carefully inspect sleeve type bearing that is press fitted in block. On two sleeve bearing models, also inspect sleeve bearing in closure plate at this same time. On K662 models, check oil transfer sleeves and outer bearing races. If visual inspection of these parts reveals no evidence of scoring, grooving or scuffing, check further to see if wear is within limits. Do not remove parts unless replacement is necessary. If crankshaft has to be reground, undersize bearings (K482, K532) and transfer sleeves (K662) will have to be used regardless of condition of old parts. Running clearance of transfer sleeves on K662 is .000-.0025".
- C. Bushings (Camshaft) - Check bushings for signs of scuffing, scoring and excessive wear. See Clearance Section for wear limits. Precision type bushings, which do not require line reaming, are available if replacement is necessary.
- D. Cylinder Bore - If badly scored, excessively worn or tapered or out of round more than .005, reboring is necessary. Use an inside micrometer to determine amount of wear (See Fits and Clearance Section). If cylinder bore is not damaged and is within tolerances, only light deglazing may be necessary.

### 2. Reconditioning - Cylinder Block

- A. Reboring Procedure - See Clearance Section for original cylinder bore size. Use an inside micrometer to measure wear then select nearest suitable oversize of either .010, .020 or .030". Reboring to one of these oversizes will allow usage of the available oversize piston and ring assemblies. While most commercial cylinder hones can be used with either portable drills or drill presses, the use of a low speed drill press is preferred as

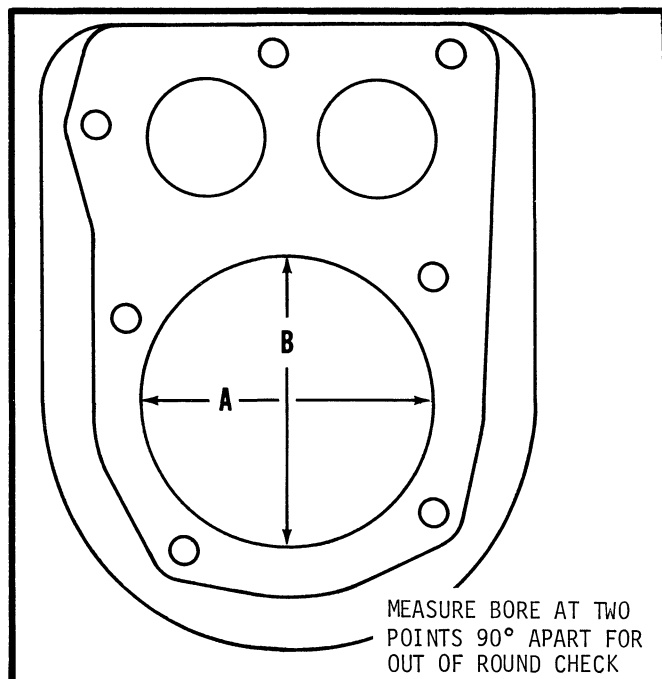

FIGURE 10-1 -- OUT OF ROUND MEASUREMENT

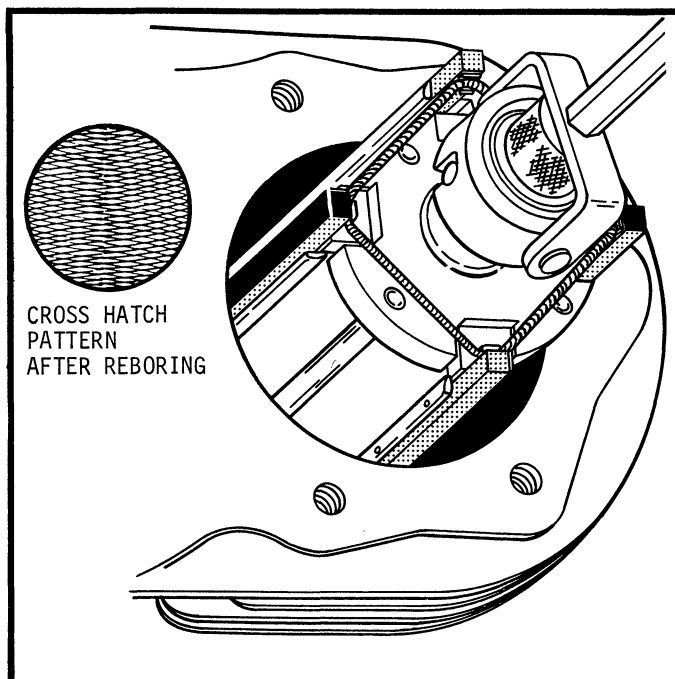

FIGURE 10-2 -- REBORING CYLINDER WITH HONE

it facilitates more accurate alignment of the bore in relation to the crankshaft crossbore. Reboring is best accomplished at drill speed of about 600 RPM. After installing coarse stones in hone, proceed as follows:

- STEP 1** - Lower hone into bore and after centering, adjust so that stones are in contact with walls. Diesel fuel oil or kerosene can be applied to the stones as a cutting-cooling agent.
- STEP 2** - With the lower edge of each stone positioned even with the lowest edge of the bore, start drill and honing process. Move hone up and down while reboring to prevent formation of cutting ridges. Check size frequently.
- STEP 3** - When bore is within .0025" of desired size, remove coarse stones and replace with burnishing stones. Continue with burnishing stones until within .0005" of desired size then use finish stones and polish to final size.
- STEP 4** - After reboring, carefully clean cylinder wall with soap and water, then after drying thoroughly, apply light coat of SAE #10 oil to prevent rust.

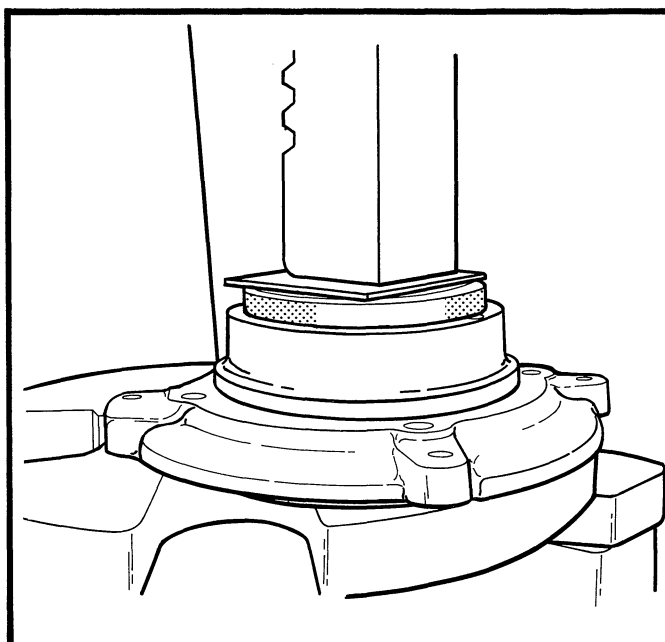

FIGURE 10-3 -- PRESSING BEARING INTO CLOSURE PLATE

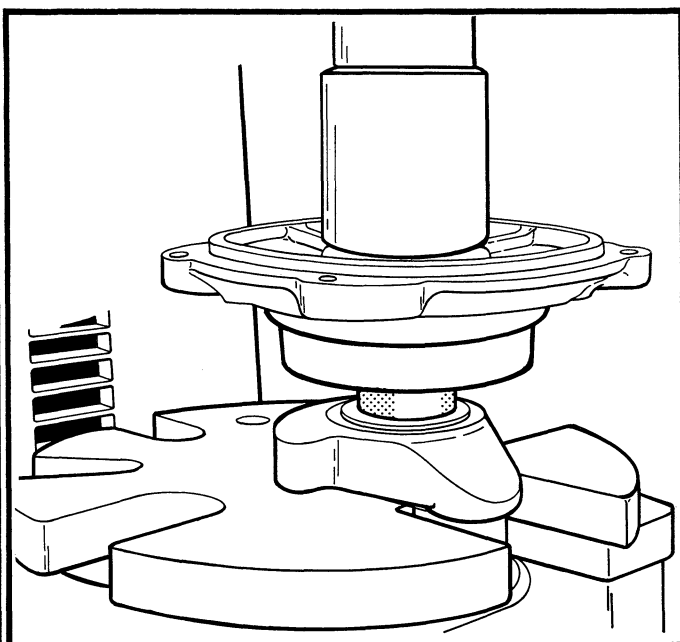

FIGURE 10-4 -- PRESSING CLOSURE PLATE ON CRANKSHAFT

## CRANKSHAFT-CLOSURE PLATE (K482, K532)

Some engines use a ball bearing which is locked in place in the closure plate and on crankshaft. On these engines, it is not necessary to separate the crankshaft from the closure plate if the bearing turns easily and noiselessly on the shaft. Replacement of the bearing is not usually necessary. To recondition or replace bearing, remove inner retaining ring then press crankshaft out of closure plate. The bearing will remain on the shaft and can be pressed off after two remaining snap rings are removed, if this is necessary. To clean ball bearings, swish in cleaning solvent, allow to drip dry (do not spin dry with air hose), then re-oil with light weight engine oil.

### CRANKSHAFT

1. Keyways-Gears - If keyways for flywheel are badly worn or chipped, replacement of the crankshaft may be necessary.
2. Crankpins - Inspect crankpins for score marks or metallic pickup. Slight score marks can be cleaned with crocus cloth soaked in oil. If wear limits, as stated in Clearance Section are exceeded, it will be necessary to either replace crankshaft or regrind the crankpin undersize. On K662 models, .002" undersize bearings are available for crankpins worn .002" undersize. The appropriate undersize connecting rod (big end) on K482 and K532 or undersize bearing on K662 must then be used to achieve proper running clearance.

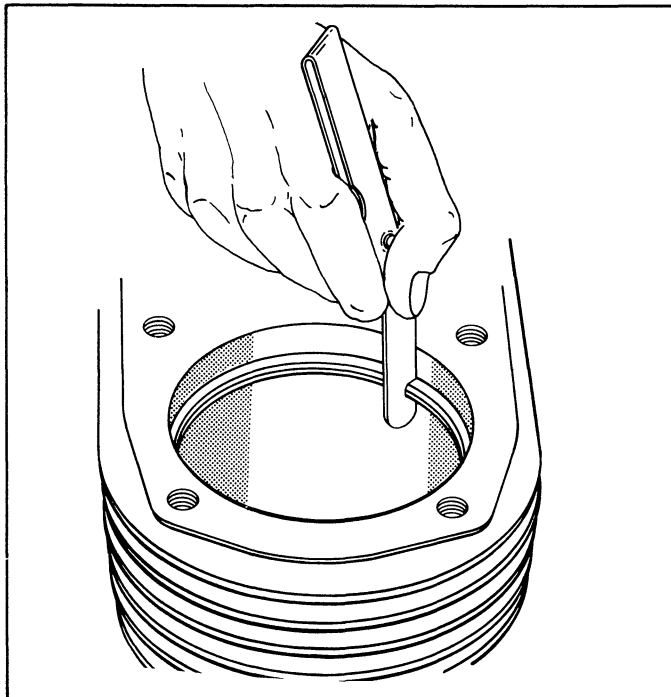

FIGURE 10-5 -- MEASURING RING END GAP IN CYLINDER

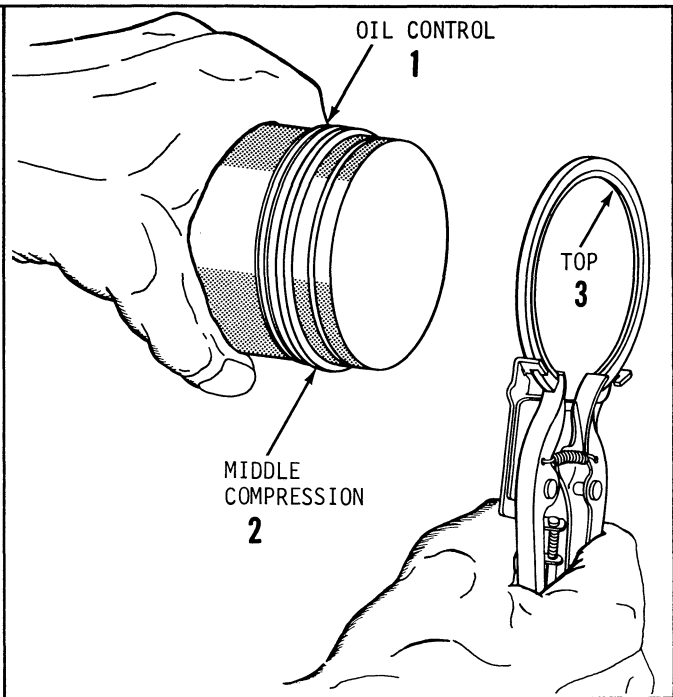

FIGURE 10-6 -- RING INSTALLATION SEQUENCE

**PISTON RINGS**

Replacement Ring Sets: Service type ring replacement sets are available in the standard size plus .010", .020" and .030" oversize sets. Service type sets are used when cylinder is worn but within wear and out of round limits (wear limit .005" oversize, out of round limit .004"). Service sets usually include expanders or other arrangement to provide uniform pressure on ring and better conformity to cylinder wall regardless of wear. Cylinder bore must be deglazed before service ring sets are used. Chrome plated rings, when used, should be installed in the top groove.

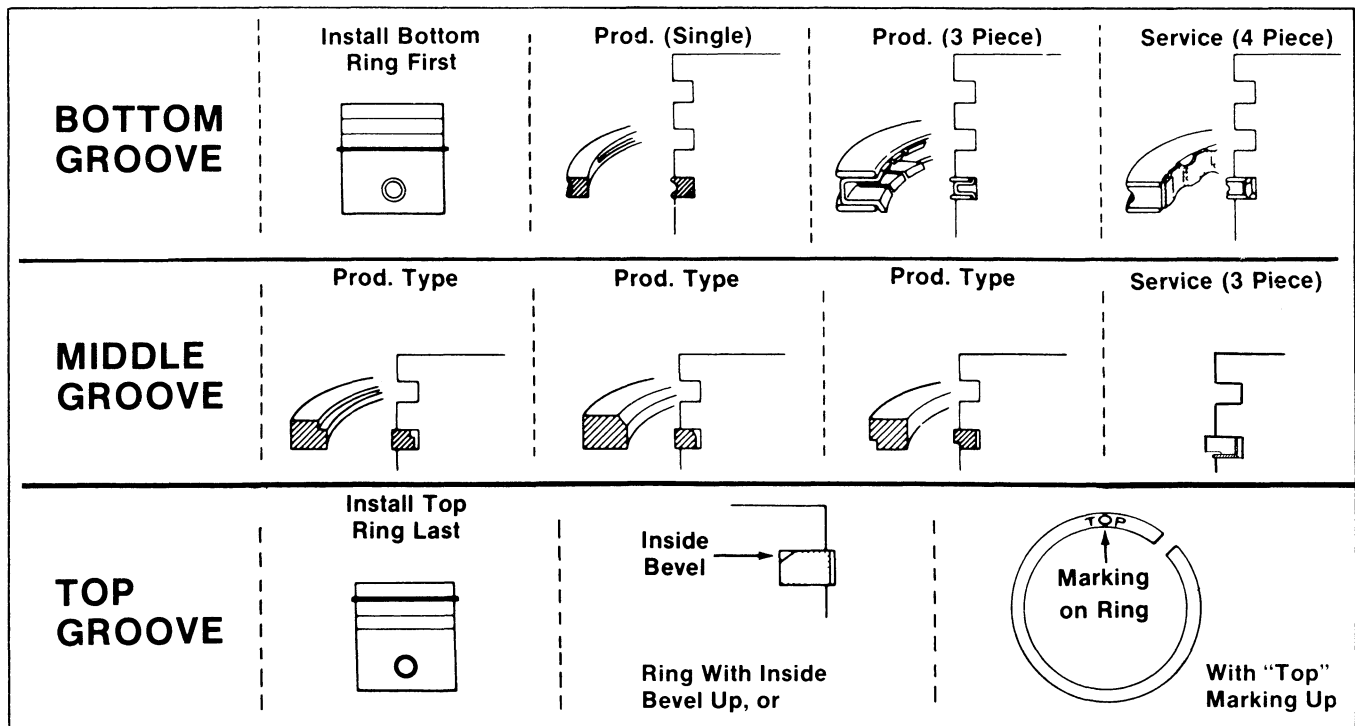

FIGURE 10-7 -- PRODUCTION AND SERVICE TYPE RINGS - INSTALLATION

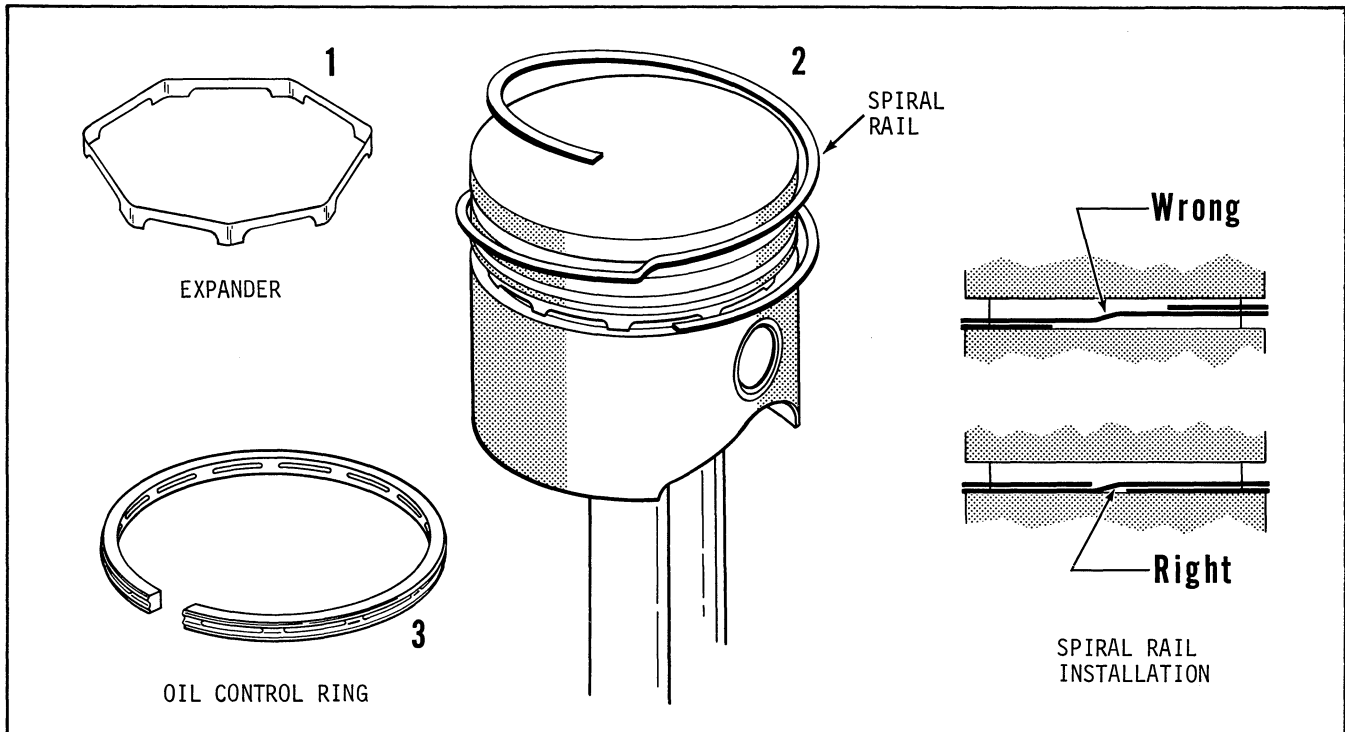

FIGURE 10-8 -- INSTALLATION OF K662 OIL CONTROL RING WITH SPIRAL RAIL

### PISTON — PISTON RINGS

1. If the cylinder block does not need reboring and if the old piston is within wear limits and free of score or scuff marks, it may be reused. Do not reuse old rings, however. Oversize pistons and ring sets are available in .010, .020 and .030" sizes for use with rebored cylinders. .003 oversize pistons are available and are used with the standard size service ring set.
2. Remove old rings with ring expander and clean up grooves.
3. Before installing new rings on piston, place each ring in turn in its running area in cylinder bore and check end clearance.
4. Rings must be installed according to markings on rings. Generally compression rings must be installed with groove or bevel up when this is on inside diameter of ring. The chrome plated ring, when used, must be installed in the top groove. When the bevel is on outside of ring, install in down position or toward the piston skirt. Refer to Figure 10-7 for typical ring types and installation in grooves. Ring installation instructions are also included with new ring sets either printed on the carton or on a printed sheet included in container. Follow instructions carefully. Use ring expander to install rings and check side clearance of each ring after installation. Be careful not to overexpand rings when installing on piston.

### PISTON — ROD ASSEMBLIES

Normally very little wear takes place in the piston boss-piston area. If the original piston and connecting rod can be reused after reconditioning, the pin will usually not have to be replaced.

If the piston boss or connecting rod small end is worn beyond limits, use a new piston-rod assembly rather than rework the old piston boss and connecting rod. A new piston pin should be used when a new connecting rod is used with the original piston.

After checking pin, rod and piston boss to make sure proper clearances are available, assemble piston to rod with pin (light interference to loose fit) and lock pin with new retainers--make sure retainers are fully engaged in grooves.



Seating surfaces should be held as close as possible to 1/32" width. Seats worn to more than 1/16" width must be reconditioned with 45° and 15° cutters to obtain proper width. Reground or new valves must be lapped in to provide proper fit.

Use a hand valve grinder with suction cup for final lapping. Lightly coat valve face with "fine" grade of grinding compound then rotate valve on seat with grinder. Continue grinding until smooth surface is obtained on seat and on valve face.

Valve Clearance: Valve clearance must be checked after resurfacing and lapping in. Install valves in guides, rotate camshaft to position where cam has no effect on tappet (TDC on compression stroke) --hold valve firmly on seat and check clearance between valve stem and tappet (See Clearance Section). If clearance is insufficient, adjustment will be necessary. Loosen the adjusting screw, turn in or out until proper clearance is attained. See Engine-General Service Section for valve clearance and adjustment procedure.

## **CYLINDER HEADS**

Blocked cooling fins often cause localized "hot spots" which can result in "blown" cylinder head gaskets. If gasket fails in area surrounding one of the retaining capscrews, high temperature combustion gases can burn away portions of aluminum alloy head. If no evidence of this is found, head should be checked for flatness. A slightly warped head can be resurfaced by simply rubbing it on a piece of sandpaper positioned on a flat surface. Carefully clean carbon deposits from cylinder head if it is to be reused--use piece of wood or similar soft material to scrape deposits. Be careful not to nick or scratch aluminum, especially in gasket seat area.

## **RING GEAR (ELECTRIC START ONLY)**

Do not replace ring gears in the field. Kohler will no longer provide ring gears as a serviceable part. If a ring gear is damaged, the entire flywheel will have to be replaced. Refer to page 11.5, Step 10 for flywheel replacement procedure.

# REASSEMBLY

The following sequence is suggested for reassembling engine after components have been reconditioned and all sub-assembly work, such as reinstalling bearings, guides, bushings, etc., has been completed. The procedure may be varied slightly to accommodate special equipment used on certain engines. Also the procedure varies in certain areas because of design differences between the various models--these differences are called out where the sequence is affected.

- STEP 1 - Tappets:** Lightly coat outside of tappets with oil, then insert in tappet bore. All four tappets are identical and are therefore interchangeable between intake and exhaust and between the cylinder banks if new tappets are used. If old tappets are used, install in same position as removed (noted in Disassembly Section).
- STEP 2 - Camshaft:** Check to make sure oil hole in camshaft sleeve bearing lines up with crankcase porting, lubricate camshaft and bearings, then carefully guide camshaft through bearings (front end first) and into position in block. Install welch plug at rear end of camshaft if this has been removed.
- STEP 3 - Gear Cover Plate:** Position new gasket, then install gear cover plate and secure to block at four points (three points on model K662 engines) around the camshaft opening. This plate and gasket controls end play of camshaft which should be in the .003" to .024" range on all models. If end play is greater than this, plate is probably worn excessively in camshaft contact area and must therefore be replaced. Before installing, grease plate around camshaft contact area to prevent seizure during initial start up.
- STEP 4 - Crankshaft-Closure Plate:** While some K482, K532 models use sleeve bearings at both ends of the crankshaft, other models have a sleeve bearing at the front and a ball bearing at the rear or closure plate end. On the models with the ball bearing, the closure plate must be assembled to the crankshaft as per instructions in the Reconditioning Section before the crankshaft is installed in the block. On this type, the ball bearing is locked in position and this controls crankshaft end play. If the retaining rings, grooves and bearing are in good shape, the end play should be within limits. K662 engines use tapered roller bearings and have oil transfer sleeves. Crankshaft end play is controlled by thickness of the gaskets used between the closure plate and block. The procedure for adjusting and checking crankshaft end play differs between the K482 or K532 with sleeve bearings and the model K662. The following assembly and end play checking procedure assumes that the sleeve bearings, oil transfer sleeves, bearing races and bearings have been pressed into the block or on the crankshaft per instructions in the Reconditioning Section.

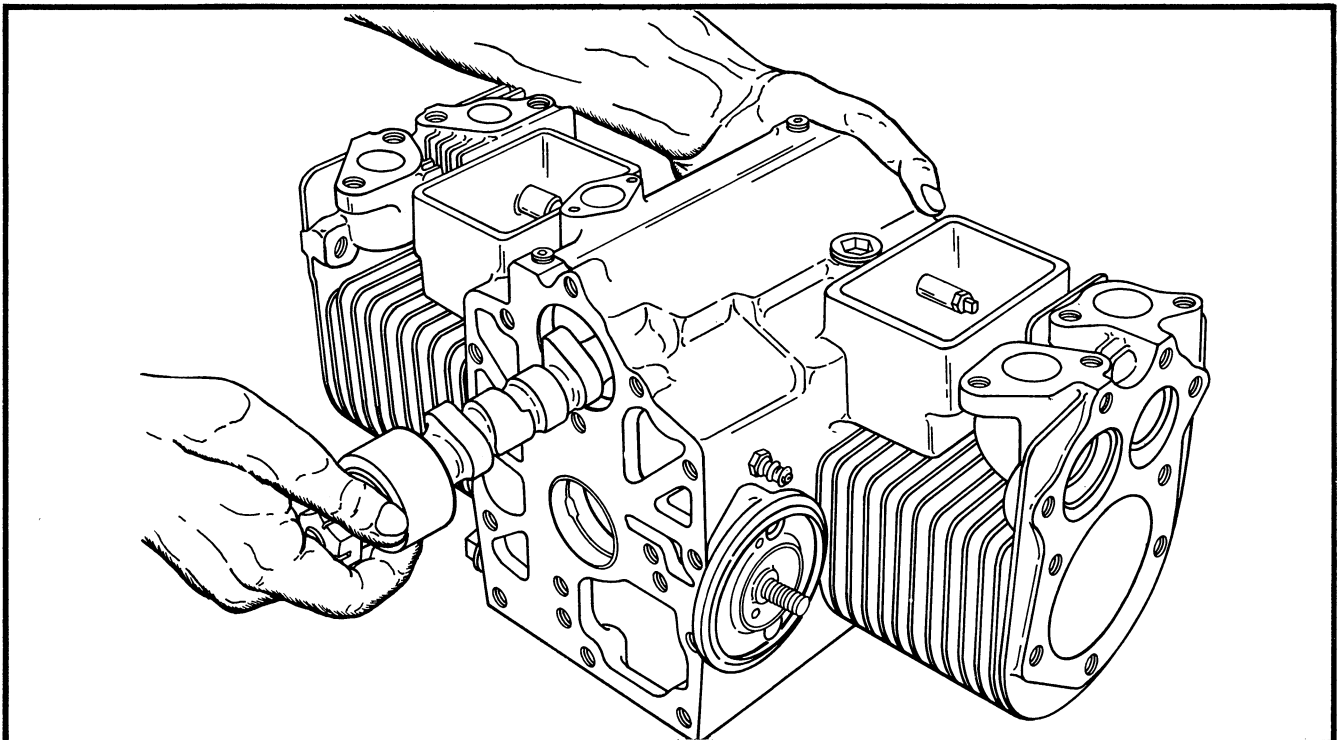

FIGURE 11-1 -- INSTALLING CAMSHAFT (K482 SHOWN)

## Crankshaft Installation and End Play Adjustment

### K482--Two Sleeve Bearing Type--End Play .004" to .010"

1. Start with one white gasket (next to block) then add one blue gasket (.005"). (Or use same gasket combination and sequence as noted during disassembly procedure.)
2. Install closure plate and secure with four capscrews and lock washers. Tighten capscrews to specified torque value. Bump end of shaft with soft head hammer to make sure it is all the way down.
3. Mount dial indicator as shown in Figure 11-2, set dial at zero then place screw driver blade between counterweight and block. Pry crankshaft toward closure plate end and observe reading on dial indicator. If end play is not in the .004" - .010" range, proceed with Step 4.
4. Remove closure plate then add or subtract gaskets to achieve proper end play (use .005", .010" and .020" gaskets as required). Replace closure plate, torque capscrews, and repeat end play check. Install rear oil seal after end play is corrected.

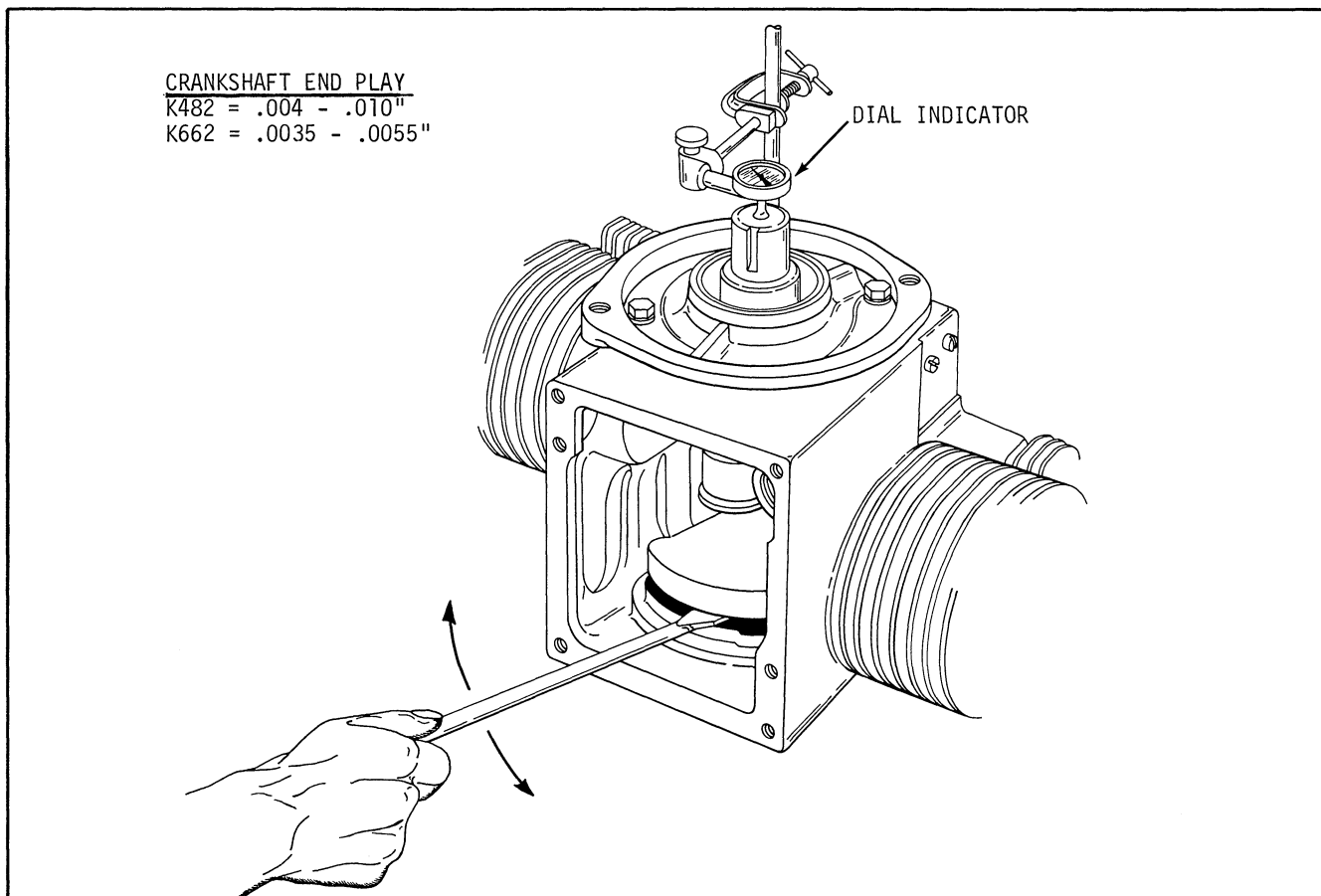

FIGURE 11-2 -- CHECK CRANKSHAFT END PLAY

### K662--End Play .0035" to .0055"

1. Start with two white (.007") gaskets then place steel shim .020". Place three white (.007") gaskets on top of shim. NOTE: Do not use shim if gasket thickness on either side is less than .014" or if gasket stack totals less than .048"--substitute .020" size paper gasket if shim cannot be used.
2. Install closure plate and secure with capscrews and lock washers. Tighten capscrews to specified torque value. Bump end of crankshaft to make sure bearings are fully seated.
3. Mount dial indicator as shown in Figure 11-2. Set dial at zero then place screw driver blade between counterweight and block. Pry crankshaft toward closure plate end and observe reading on dial indicator. If end play is not within the .0035" to .0055" range, proceed with Step 4.
4. Remove closure plate then add or subtract gaskets as necessary to achieve proper end play (.005", .007", .010" and .020" gaskets are available). Replace closure plate, torque capscrews, and repeat end play check. Install rear oil seal in closure plate after end play is corrected.

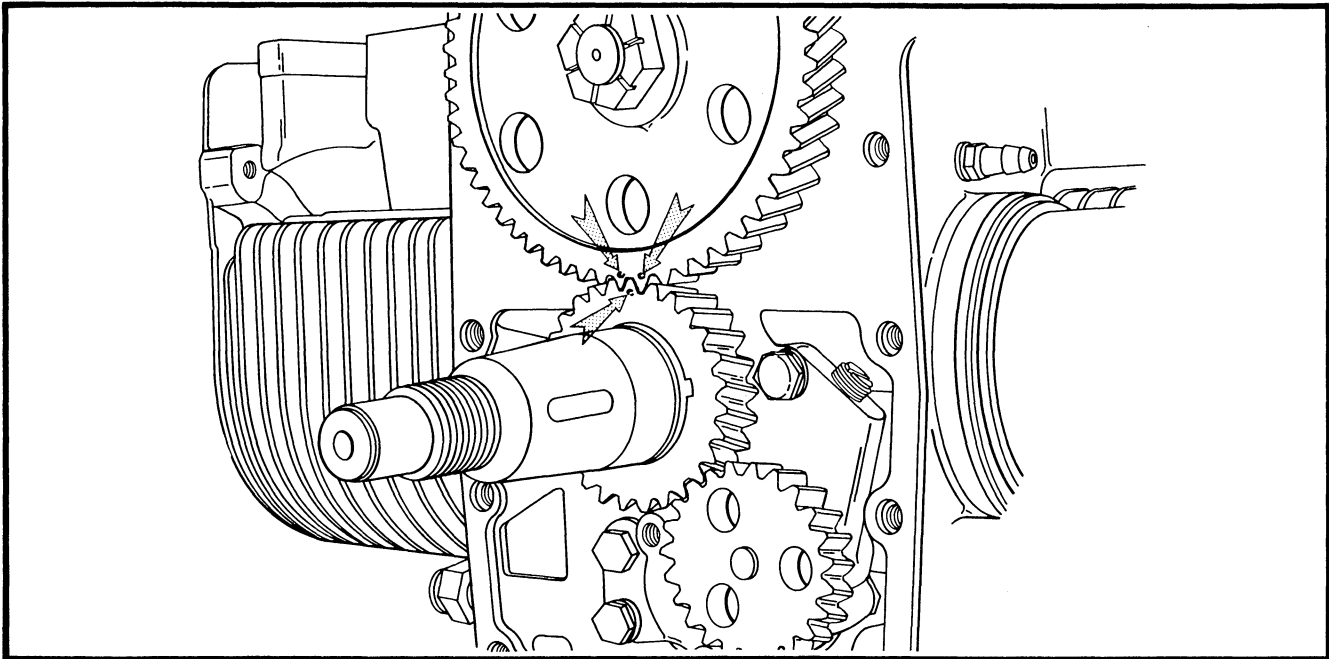

FIGURE 11-3 -- TIMING MARKS ON CRANK AND CAM GEARS (K482, K532)

**STEP 5 - Timing Gear Installation:**

- A. **Crank Gear:** Insert woodruff key in keyway, block opposite end of crankshaft and press or drive gear into position on shaft. Use a brass drift for driving. On K482 and K532 models, install snap ring in groove to lock gear on shaft.
- B. **Oil Pump Gear:** Position oil pump with gear teeth in mesh with crank gear then secure pump body to block.
- C. **Cam Gear:** Turn crank gear until tooth with punch mark is in 12 o'clock position as shown in Figure 11-3. Install woodruff key on camshaft, rotate camshaft so that the two timing marks punched on adjacent teeth of cam gear will straddle single mark on crank gear. After marks are aligned, install cam gear and secure with retaining nut--tighten nut to 480 in. lbs. torque value. When tightening nut, insert screw driver blade thru holes in cam gear and wedge against one of the capscrews to prevent gear from turning.

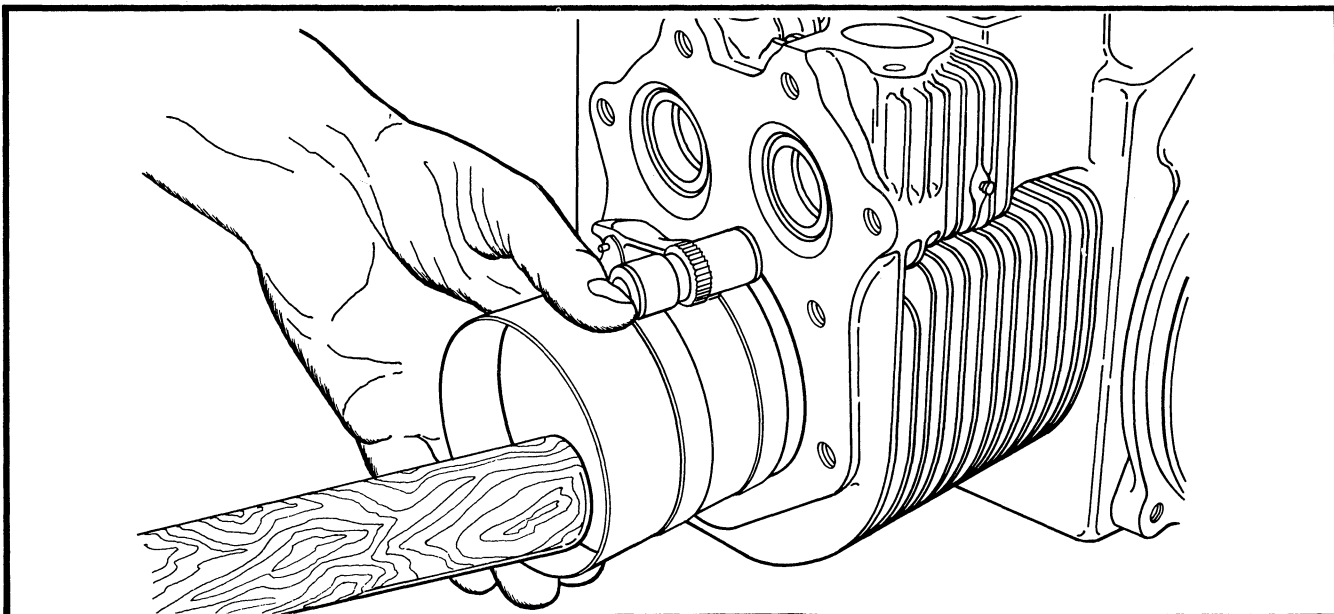

FIGURE 11-4 -- INSTALLING PISTON ASSEMBLY USING RING COMPRESSOR

**STEP 6 - Piston, Connecting Rod Assemblies:**

- A. Place flywheel loosely on crankshaft and tip engine using flywheel as supporting base.
- B. Separate rod caps from assemblies but be careful not to mix caps.
- C. Lightly oil bearings, crank pins, piston rings, then rotate rings so that gaps are not in line. Use ring compressor to install piston assemblies into cylinder bore. Make sure raised markings on connecting rods and caps face the front (flywheel) end. Also, if arrow is stamped on top of K482 piston, arrow must face direction of crankshaft rotation (clockwise when facing flywheel). Arrow stamping on early models only. Gently push piston into bore with hammer handle--do not pound into position.
- D. Position rod caps then secure to connecting rods with capscrews and locking washers. To avoid the possibility that screws may be tight but cap is still loose on crank pin, tighten screws to torque values specified on page 14.3.

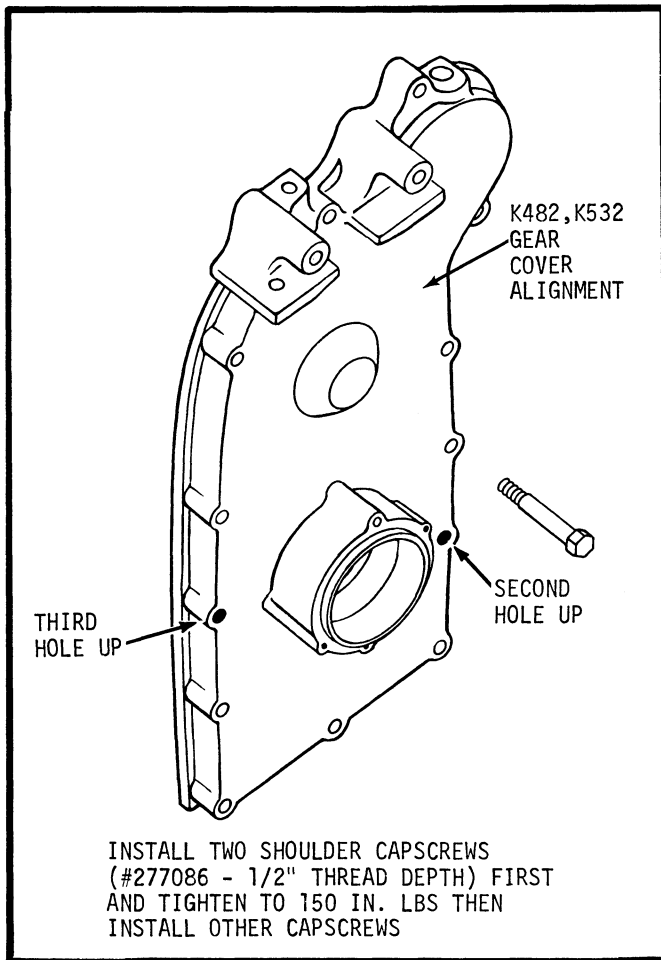

FIGURE 11-5 -- GEAR COVER ALIGNMENT CAPSCREWS - K482, K532

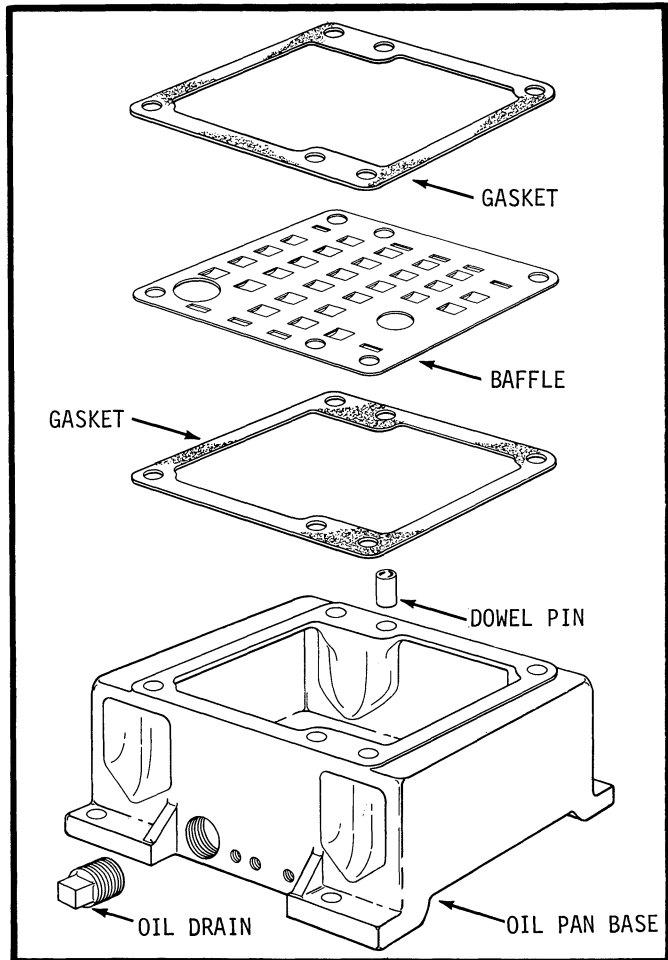

FIGURE 11-6 -- K662 OIL PAN BASE WITH BAFFLE

**STEP 7 - Oil Screen and Oil Pan Base:** Connect oil screen or strainer to oil pump body. Thread oil tube into body then assemble clip and strainer to tube. After installing strainer, position new oil pan gasket, place dowel, then secure oil pan to block with oil pan capscrews. If pan baffle is used, position gasket on each side of baffle.

**STEP 8 - Gear Cover:**

K482: Grease seal to make it slide easier then install new oil seal in cover, position new cover gasket then carefully guide cover over shaft. Gently work cover when installing to prevent damage to the seal. Before inserting capscrews, position the blower housing support then secure cover and support to block with the capscrews. When installing gear cover on K482, K532, make sure that the two shoulder screws are installed in locations shown above to align cover. Misalignment will cause stator damage.

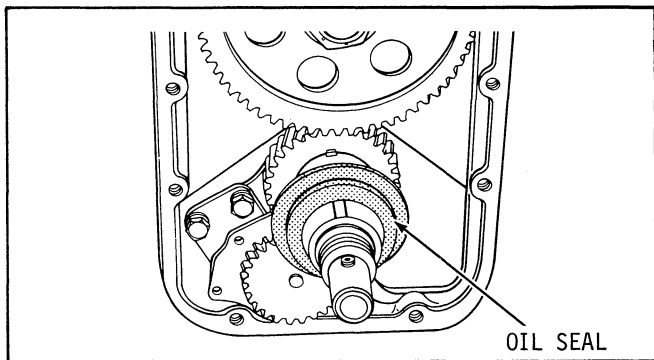

FIGURE 11-7 -- K662 FRONT OIL SEAL INSTALLATION

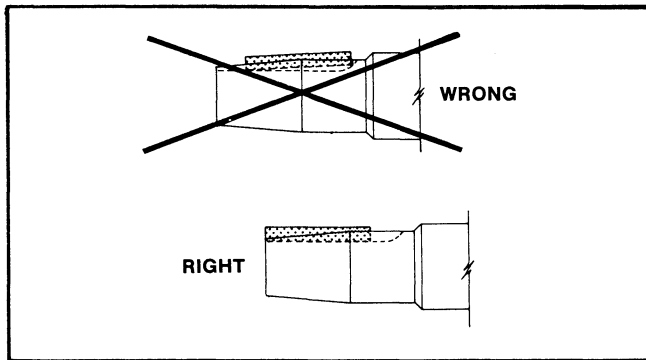

FIGURE 11-8 -- RIGHT AND WRONG WAY TO INSTALL FLYWHEEL KEY

K662: Slide oil seal unit into position with seal slot aligned with crank gear key. Place new gasket on gear cover then position cover. Install blower housing support plate, (plus starter or generator brackets when used) then secure cover etc. to block with cover capscrews and lock washers.

**STEP 9 - Alternator Stator or Magneto Coil:** On engines with alternator system or with flywheel magneto ignition, secure stator ring or ignition coil assembly to gear cover. Affix leads so that they will be accessible after flywheel is installed.

**STEP 10 - Flywheel**

**WARNING:** *Improper procedures for installation of flywheels can lead to cracked flywheels and broken crankshafts. This not only results in extensive damage to an engine but presents a serious threat to the safety of persons close to the engine.*

*DO NOT apply grease, oil, or any lubricant to the taper of the crankshaft or hub of the flywheel, as this will cause excessive stress and possible cracking of the flywheel while tightening.*

*DO NOT allow the key to be pushed inward on the keyway while installing the flywheel. If the key rides up on the rounded surface at the end of the keyway as shown in Figure 8-16, it will act as a wedge and crack the flywheel hub.*

*DO NOT reuse a flywheel if it has been dropped or damaged in any way.*

*DO NOT use a steel bar or any other object (between the flywheel fins) to hold the flywheel when the flywheel nut is being torqued, as this practice could break or crack flywheel fins.*

1. Make sure the flywheel hub and taper of the crankshaft are clean, dry and completely free of any lubricant, before installing flywheel.
2. Position key properly in keyway as shown in Figure 11-8 and carefully guide key slot in flywheel hub over the key (if generator belt pulley is used, install belt before placing flywheel on shaft).
3. Install lock nut or retaining nut and locking tab. Hold flywheel with a strap wrench, and tighten nut to its proper torque value (115 ft. lbs. for K482, K532 and K582 models and 130 ft. lbs. for K662).
4. Bend lock tabs (if used) over flywheel nut. Drive roll pin back into crankshaft (see Figure 11-9) or install crank pin and lock in position with set screw.

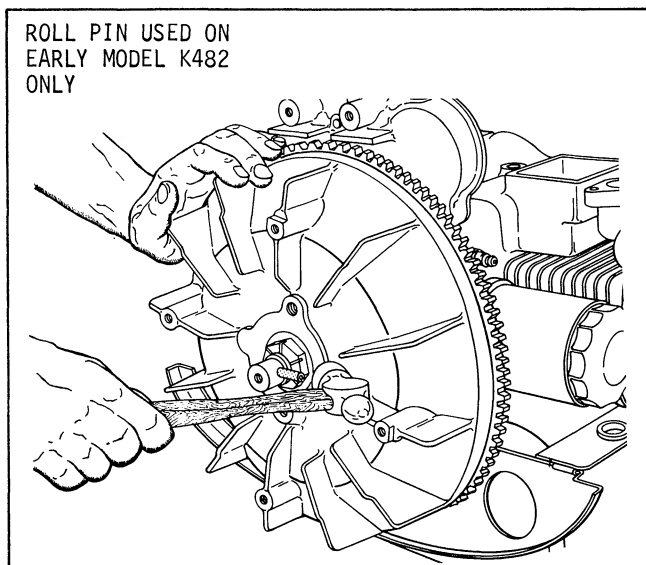

FIGURE 11-9 -- INSTALL ROLL PIN ON K482 MODELS

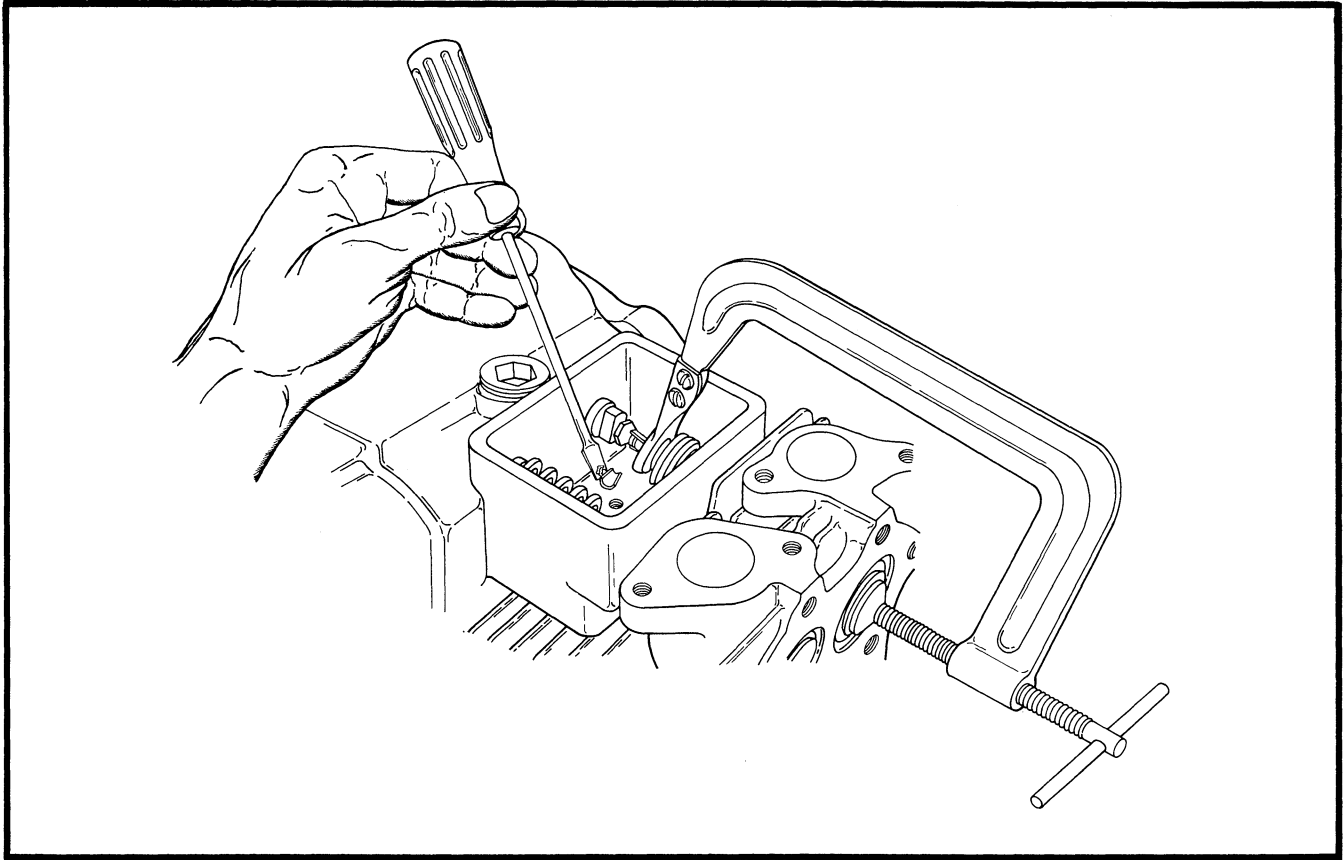

FIGURE 11-10 -- INSTALLING VALVES WITH RING COMPRESSOR

**STEP 11 - Valve Mechanism:** Start with cylinder #1 and proceed as follows:

- A. Position valves, springs, spring seats, retainers or rotators when used. Compress springs with spring compressor and install taper locks.
- B. Turn engine until #1 piston is at TDC on compression stroke (both valves closed) then adjust valve to tappet clearance on both intake and exhaust valves. Intake valve clearance is .008" - .010" on all models. Exhaust valve clearance is set at .017" - .020" on K482 and K532 and .015" - .017" on K662. These are cold clearances.
- C. After replacing gasket (stud if previously removed) and cover for valve chamber, repeat foregoing procedure for #2 cylinder. Use plain brass washer and nut to secure cover.

**STEP 12 - Cylinder Heads:** Use new gaskets, position heads and secure with capscrews--make sure washers are used. Tighten capscrew in the sequence and to the torque values as stated in the Specification Section of this manual. Install new spark plugs and tighten to 324 in. lbs. (27 ft. lbs.) torque value.

**STEP 13 - Intake & Exhaust Manifolds:** Place heavy flat washer or spacer on manifold where capscrews are used to secure manifold and side baffles. Place intake and exhaust manifolds and secure with capscrew specifically for manifold.

**STEP 14 - Crankcase Breather (Reed Type K662):** Place new gasket on breather pad located on top of gear housing. Position reed and reed stop plate (raised edges up or away from reed). Clearance between raised edges of stop and reed must be .020". Carefully bend tabs to obtain proper clearance. Turn holding nut all the way down on stud to breather reed and stop plate firmly. Place breather body and cover over stud and secure with acorn nut. On engines with closed breather systems, breather components are connected to other systems such as carburetor.

**STEP 15 - Engine System Components:** At this point in reassembly, components such as governor, fuel pump, carburetor, air cleaner, oil filter, magnetos, etc. can be reinstalled on the engine with new gaskets or elements where applicable--refer to the appropriate Service Section in this manual for installation and adjustment instructions on this equipment.

**STEP 16 - Blower Housing, Baffles & Shrouds:**

- A. Install lower baffles (support) on K662 models. (Support baffle has been installed with gear cover on K482 and K532 models.)
- B. Install blower housing. Note: On K662 engines with wire mesh screen, install screen on flywheel before placing housing in position. On engines with rotating air screen, install blower housing then screen assembly. Use spacers between flywheel and screen assembly to provide clearance between screen and housing.
- C. Install lower shrouds on both models and starter shield on K482 and K532 models.

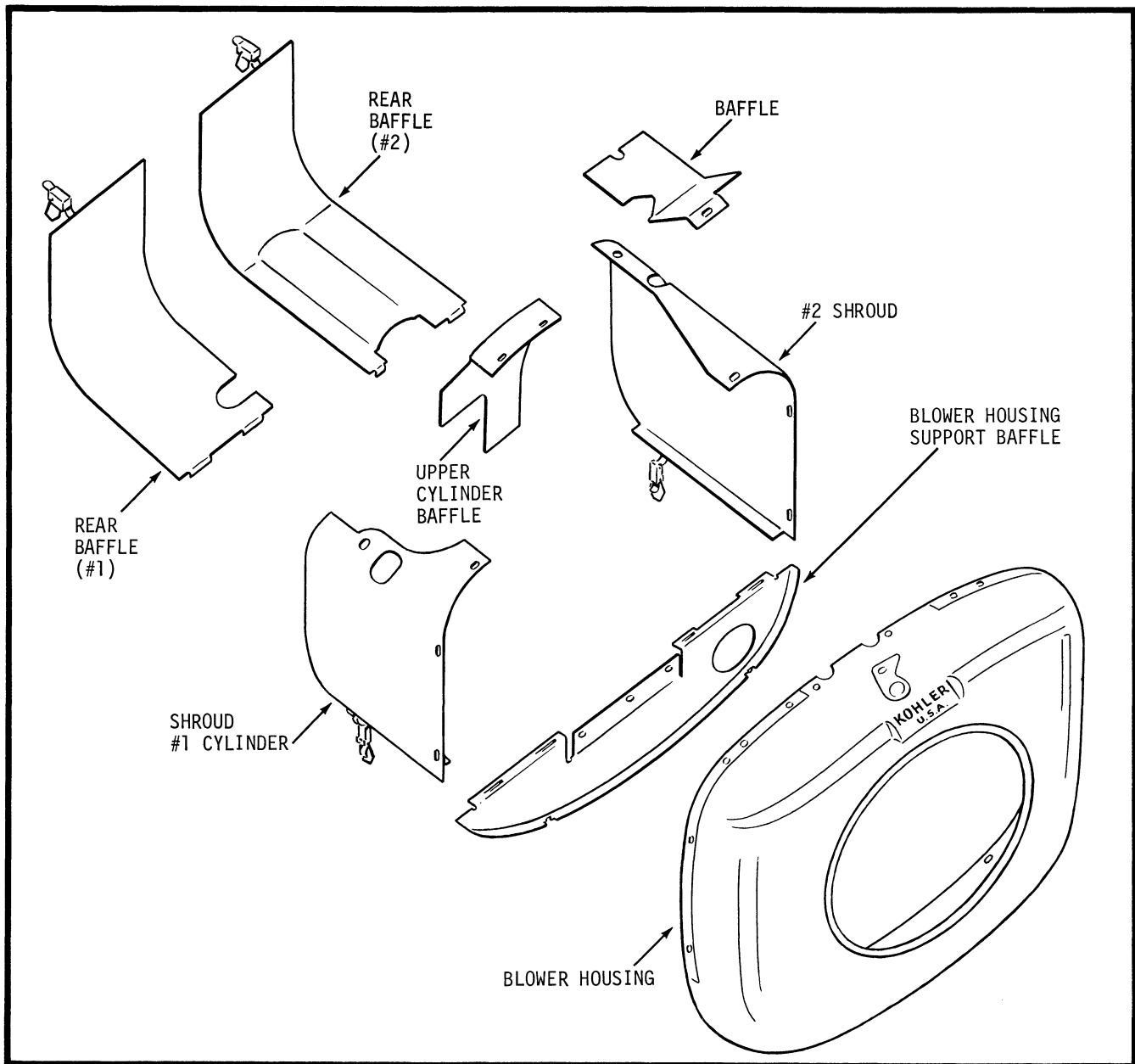

FIGURE 11-11 -- K482, K532, TYPICAL BLOWER HOUSING -- BAFFLES AND SHROUD

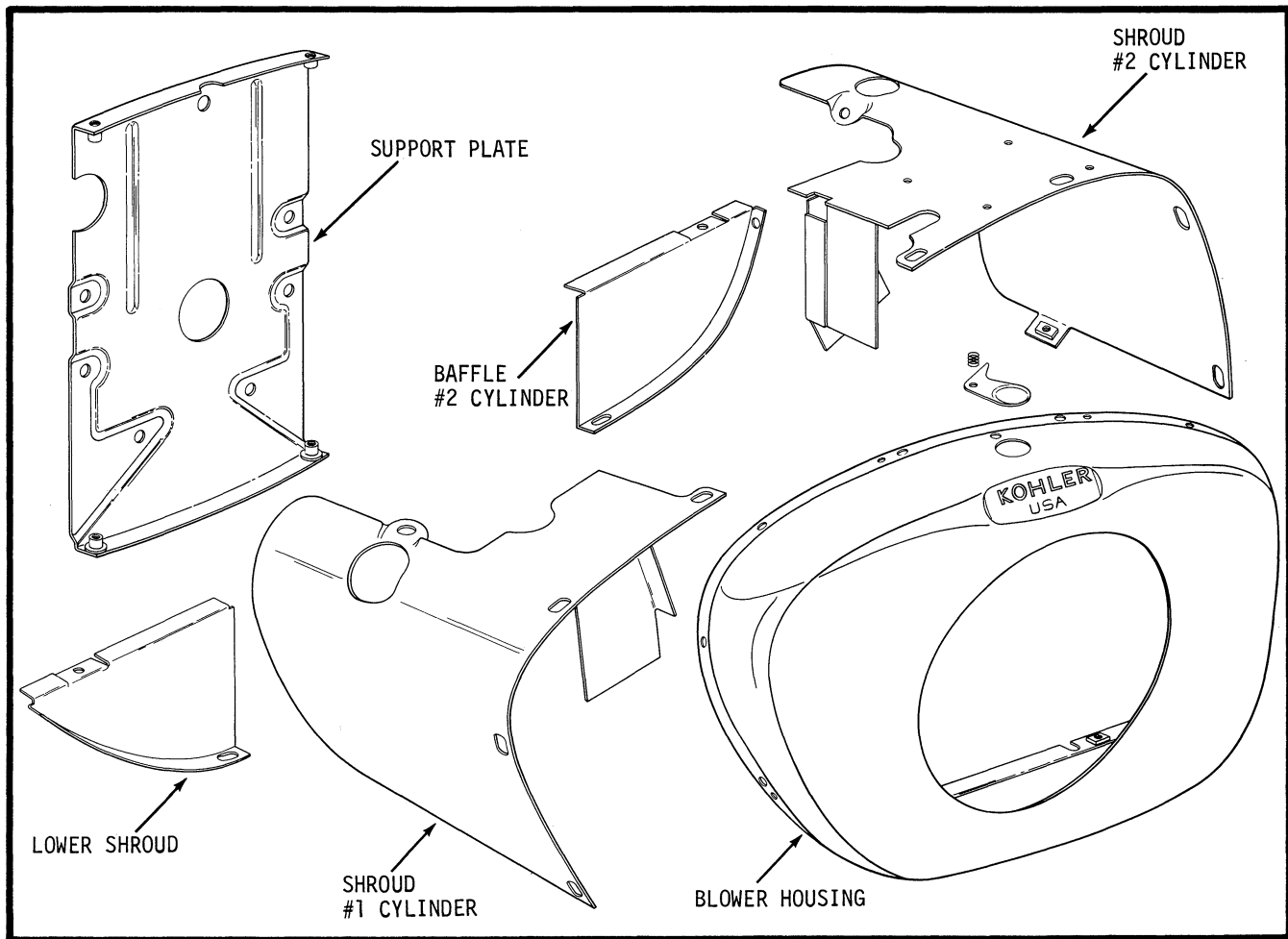

FIGURE 11-12 -- K662, BLOWER HOUSING -- BAFFLES AND SHROUD

- D. Install upper cylinder baffle (K482, K532) then install cylinder head shrouds to complete installation of cooling baffles and shrouds. Note: On earlier K482 models make sure new oil filter is in place before #2 shroud is installed.

**STEP 17 - Instrument, Control Panel:** On engines so equipped, attach panel to bearing housing. On K662 models, remove acorn nut on breather, attach upper bracket supports to stud then replace acorn nut. Refer to wiring diagrams (see Section 6 and 7) for proper connections of electrical equipment. Connect throttle, choke, ammeter and oil pressure gauges.

## RUN-IN INSTRUCTIONS

Refer to appropriate Service Section for adjustment procedures for carburetor, governor, etc. After initial adjustment, fill engine to proper oil level mark with non-detergent type oil and run in under load for a period of about 5 hours. Make final adjustments as needed during this period. After the initial 5 hour run in, stop engine, drain the oil and refill with detergent type API Service SC oil of proper weight.

# SPECIAL FUEL SYSTEMS

## PRECAUTIONS

When properly installed and maintained, a gas fuel system can be just as safe as any other fuel system. While gas and gasoline are both highly volatile and flammable, gas presents an additional danger in that it is heavier than air and tends to settle in low areas where even the slightest spark could ignite the gas. Because of this, extra precautions must be taken to insure safety when using gas as an engine fuel. The following precautions are offered not to discourage the use of gas but rather as reminders to exercise care in the handling of gas fuel. While adherence to federal, state and local laws governing gas systems lessens the potential dangers, good common sense is the final safeguard in installing, handling or repairing engines with gas fuel systems.

- Installation and subsequent repair of gas fuel systems must be done only by qualified gas system technicians.
- Gas must never be used for pressure testing of new or rebuilt gas equipment--compressed air will do the job safely.
- Never bleed gas out of any part of a gas system to check flow of gas or when adjusting, for example, gas regulators. Compressed air should be used for these purposes.
- An engine with a gas fuel system must never be installed or operated in a poorly ventilated area where leakage of gas could endanger the safety of building occupants or persons in the vicinity.

## GAS SYSTEMS

Natural gas and liquefied petroleum gas (LPG) systems are used on the two cylinder engines. These systems require special equipment including gas carburetors (or gasoline carburetors with gas adapters) and primary and secondary regulators. In some applications, a 2-stage regulator is used--this provides both primary and secondary regulation.

Natural gas, as supplied from main transmission lines, is normally received at pressures not greater than 50 pounds per square inch (psi). With LPG (butane or propane or a mixture of the two gases) the pressure may go as high as 180-200 psi depending on the mixture and the prevailing temperatures. To be used by the engine, the pressure must be reduced to about 4 to 6 ounces per square inch.

The fuel supplier should insure that gas pressure is sufficient to operate the primary regulator. If pressure drops too low, the regulator may not function at all. While propane tends to maintain some vaporizing pressure even at temperatures down to -20° F., butane returns to liquid state and offers little or no vapor pressure when the temperature drops to freezing or 32° F. For this reason, fuel suppliers usually supply LPG of higher butane content in hot weather but will alter this to a higher percentage of propane during cold weather. If this ratio is not changed, starting and operating difficulties may be encountered in cold weather.

Two different types of LPG systems are used. One system, the vapor withdrawal system, utilizes vapor that normally forms in the space above the liquid fuel in the tank. To allow for expansion of the gas from liquid to vapor, the maximum liquid level is usually held at about 80 or 90 per cent of the total capacity of the tank. With this system, the temperature of the air surrounding the tank must be high enough to sustain adequate vaporization of the fuel.

The other LPG system is the liquid withdrawal system. On this type, liquid fuel is drawn out of the tank and introduced into a vaporizer which is mounted so that air heated by the engine is used to change the liquid fuel into vapor. The usual regulatory equipment must also be used with this system.

Since the gas carburetor receives fuel in vapor state, it does not have to provide further vaporization as does a gasoline carburetor. The gas carburetor therefore serves only to control the ratio of gas to air under varying load and speed conditions. There are two basic types of gas carburetors used on Kohler two cylinder engines. One type utilizes the venturi and nozzle system while the other type uses a diaphragm which is activated by pressure differential.

In a venturi type carburetor, the gas nozzle is located at the point of greatest pressure drop inside the venturi. This creates a suction within that nozzle that varies with changing rate of air flow and causes a greater volume of gas to be metered at heavier loads and a lower volume at lighter engine load.

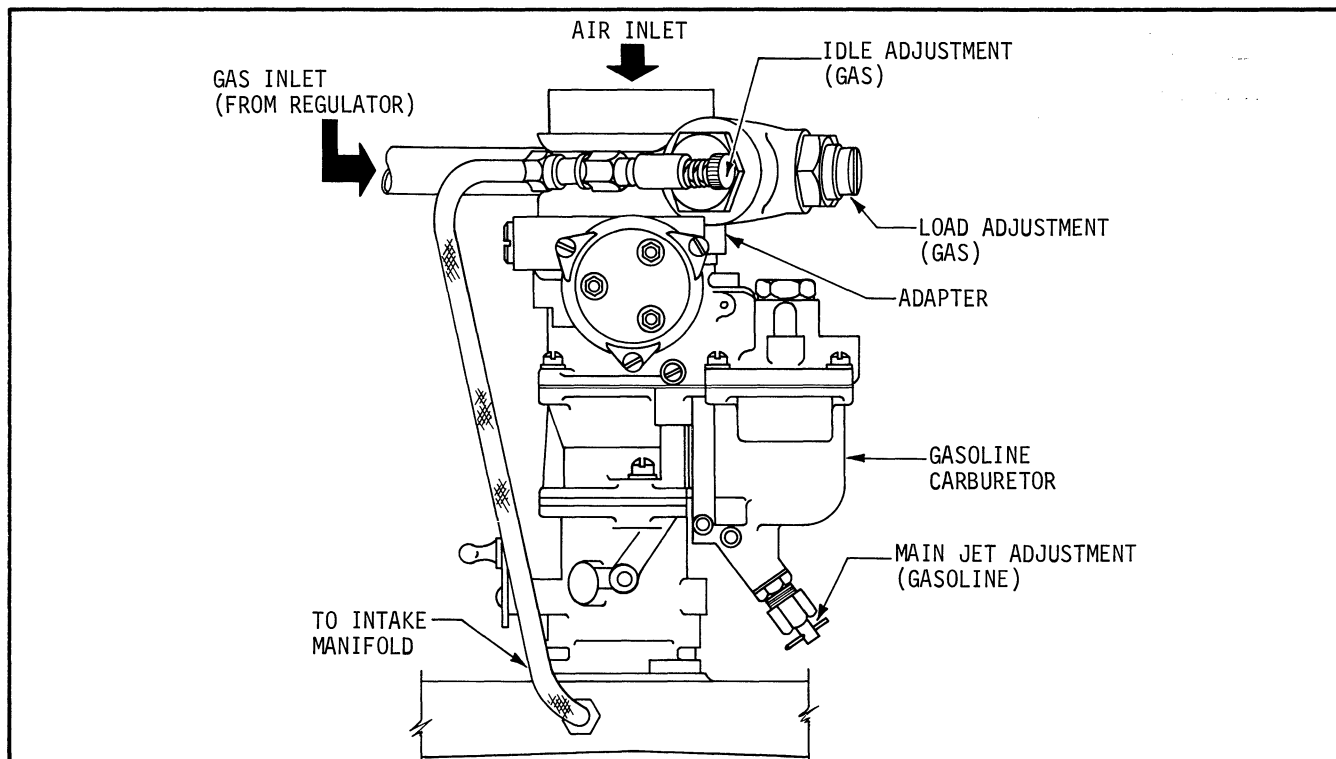

FIGURE 12-1 -- COMBINATION GAS-GASOLINE SYSTEM, K662

At idle speed, the velocity of air through a carburetor may not be high enough to draw sufficient fuel to sustain operation. For this reason, some carburetors have an idle line which carries a certain amount of fuel from the secondary regulator to the air intake side of the carburetor where it is introduced at the lower idle speeds. When fuel demand drops to a certain point, the regulator diverts fuel from the main fuel system into the idle fuel system. On carburetors with this setup, the idle mixture adjustment is made at the regulator rather than at the carburetor.

The throttle valve within the carburetor regulates the rate of air flow through the carburetor. When an engine is at top speed, this valve is wide open and offers little restriction to air flow. Closing the throttle causes a decrease in air flow and lowers engine speed and power. As the valve closes, pressure builds up behind the valve which reduces pressure through the venturi and past the fuel nozzle. The ratio of air to fuel is thus kept fairly constant at varying speeds.

The diaphragm type uses a diaphragm activated air-gas valve to proportion the flow of air and gas. A metering valve is linked to the diaphragm, therefore the greater the air flow, the greater the valve opening and a corresponding increase in intake of gas. Since the valve was opened only by a vacuum created by passage of air, it closes completely when the engine is stopped.

On engines with the gasoline carburetor, an adapter is installed between the carburetor and air cleaner. The adapter consists of a gas jet and venturi. Accurate metering of the gas is accomplished by load and starting or idle adjustment screws in the body of the adapter.

On some other systems, a balance line is used to avoid the problem of overrich fuel mixture which can be caused by restricted air flow due to a clogged air cleaner. The balance line is connected to the atmospheric side of the secondary regulator and to the carburetor air horn. This balance insures a constant ratio of fuel to air under varying degree of air cleaner restriction.

### OPERATING INSTRUCTIONS — GAS FUELED ENGINES

Because of the nature of the gaseous fuels, a slightly different procedure should be followed when starting and making initial adjustment on gas fueled engines. Adjustments vary according to the type of equipment used. For example, the idle fuel adjustment is made at the secondary regulator on some systems while on other types, this is done on the carburetor. The different types of carburetors and regulator equipment are described in the remainder of this section. Adjustment instructions are stated for each type along with a brief description of the operating principles plus necessary service and reconditioning information.

## GAS ADAPTERS (COMBINATION GAS — GASOLINE)

Engines having standard gasoline carburetors are modified to also use gaseous fuels thru the addition of a gas adapter plus the necessary gas pressure regulatory equipment. The gas adapter is installed on the air intake side of the carburetor. The adapter consists of a venturi and gas jet arrangement with an external main fuel (load) adjustment and usually an idle fuel adjustment. See Figure 12-2 (K482) and Figure 12-1 (K662) for initial settings. The combination system must also include fuel shut-off valves in both gas and gasoline lines to facilitate switching from one fuel to the other.

Gas Operation: Before switching from gasoline to gas, disconnect the automatic choke lead wire on engines equipped with electric choke. Tape end of lead wire to prevent grounding then proceed as follows:

1. Close gasoline shut-off valve (usually located on fuel filter). Open gas valve in gas fuel line.
2. Depress gas primer (if so equipped) then start engine. Use Step 3 if final adjustments are needed.
3. Allow engine to warm up to normal operating temperatures. Move throttle control to normal operating speed and place engine under load. Loosen locknut then move load adjustment in until engine starts to slow down from lean mixture then back out on adjustment past the point where engine speed picks up then slows down again from overrich mixture--lock adjustment at point halfway between overrich and lean settings. If engine runs unsteady at no load, idle speeds, move idle adjustment screw in or out to attain smoothest idle.

Gasoline Operation: Reconnect electric choke lead (when used) then shut off gas valve and open gasoline valve. If engine is so equipped, prime gasoline system with priming lever on fuel pump. See Gasoline Carburetor in Section 4 if adjustment is needed.

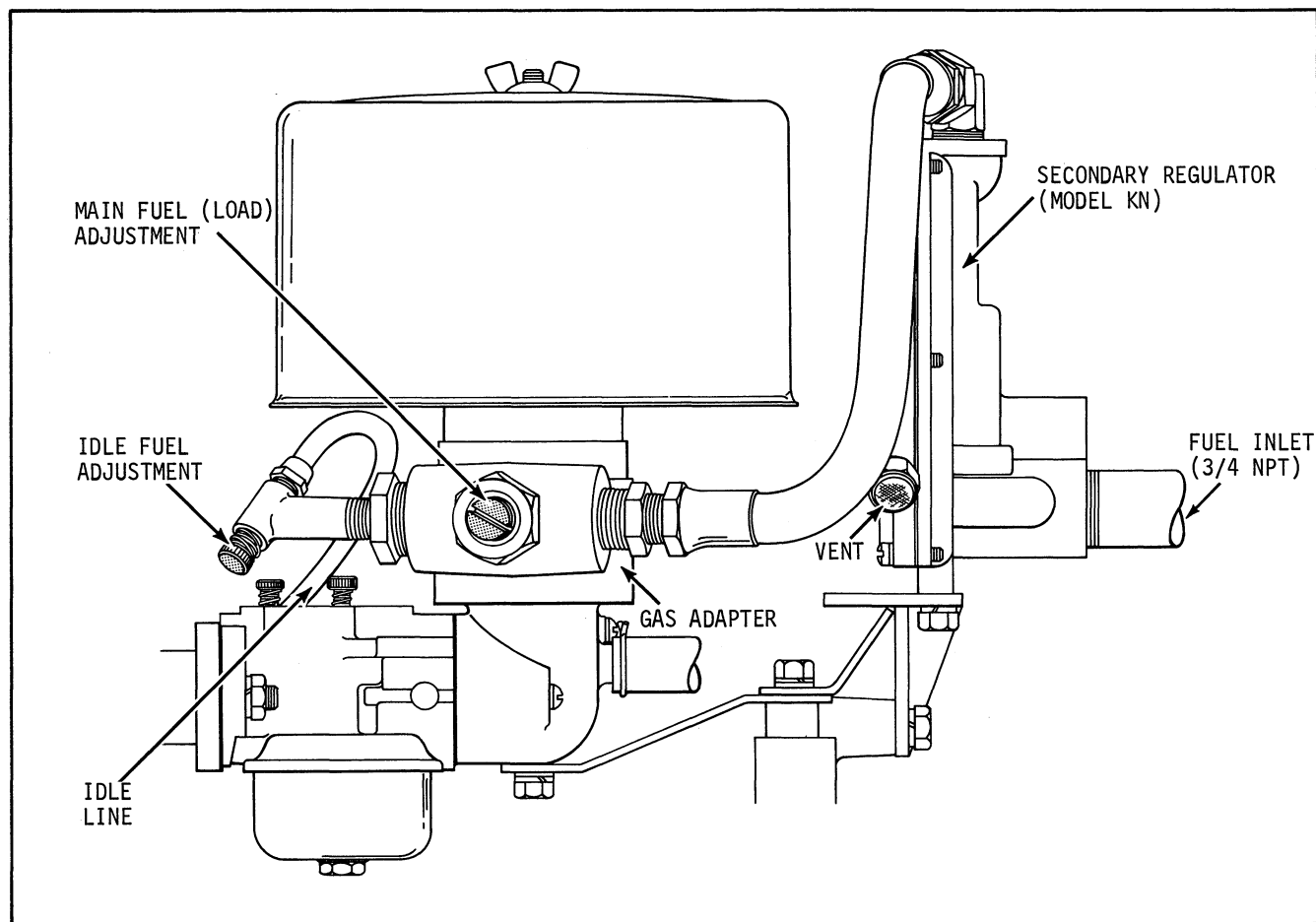

FIGURE 12-2 -- COMBINATION GAS-GASOLINE SYSTEM, K482

## GAS CARBURETORS

### KOHLER #A-271105 (KG1) GAS CARBURETOR

The model KG1 is a venturi and nozzle type straight gas carburetor suitable for use with Natural gas and LPG. This carburetor is usually used with the Model B secondary regulator (Kohler #A-265082) and with idle and balance line connections.

Operation: The carburetor features a separate gas system for enriching the fuel mixture during starting. When the choke plate is closed, gas flows thru the special starting orifices. The starting mixture can be varied to facilitate easy starting in changing weather conditions by means of the starting adjustment screw. Since the main fuel system is blocked and the engine operates on the "rich" starting mixture when the choke plate is closed, the choke must be returned to the full open position soon after the engine starts. The choke plate is strictly a two position device with no intermediate positions--it is either in full open or full closed positions.

When the choke is opened and the throttle plate is advanced beyond the idle speed range, gas enters the carburetor thru the gas nozzle in volume proportionate to the velocity of air through the venturi. The velocity is, in turn, controlled by position of the throttle plate. The balance line compensates for restrictions, such as clogged air cleaner, to keep the fuel-air ratio constant. When the throttle is returned to the idle position, the velocity of air may not be sufficient to induce enough gas to sustain operation. The KG1 carburetor has a separate idle fuel system which allows continued operation at slow idle speeds.

Adjustment: Carburetor (and regulator where applicable) adjustments are made in the factory and readjustment should not be necessary until carburetor is reconditioned or disassembled for some other reason. The initial adjustments on carburetor (and B regulator) are:

1. Starting adjustment -- 1-1/4 turns open (from full closed position).
2. Load adjustment -- 4 turns open.
3. Idle adjustment -- 1-1/2 turns open. Make this adjustment on B regulator.

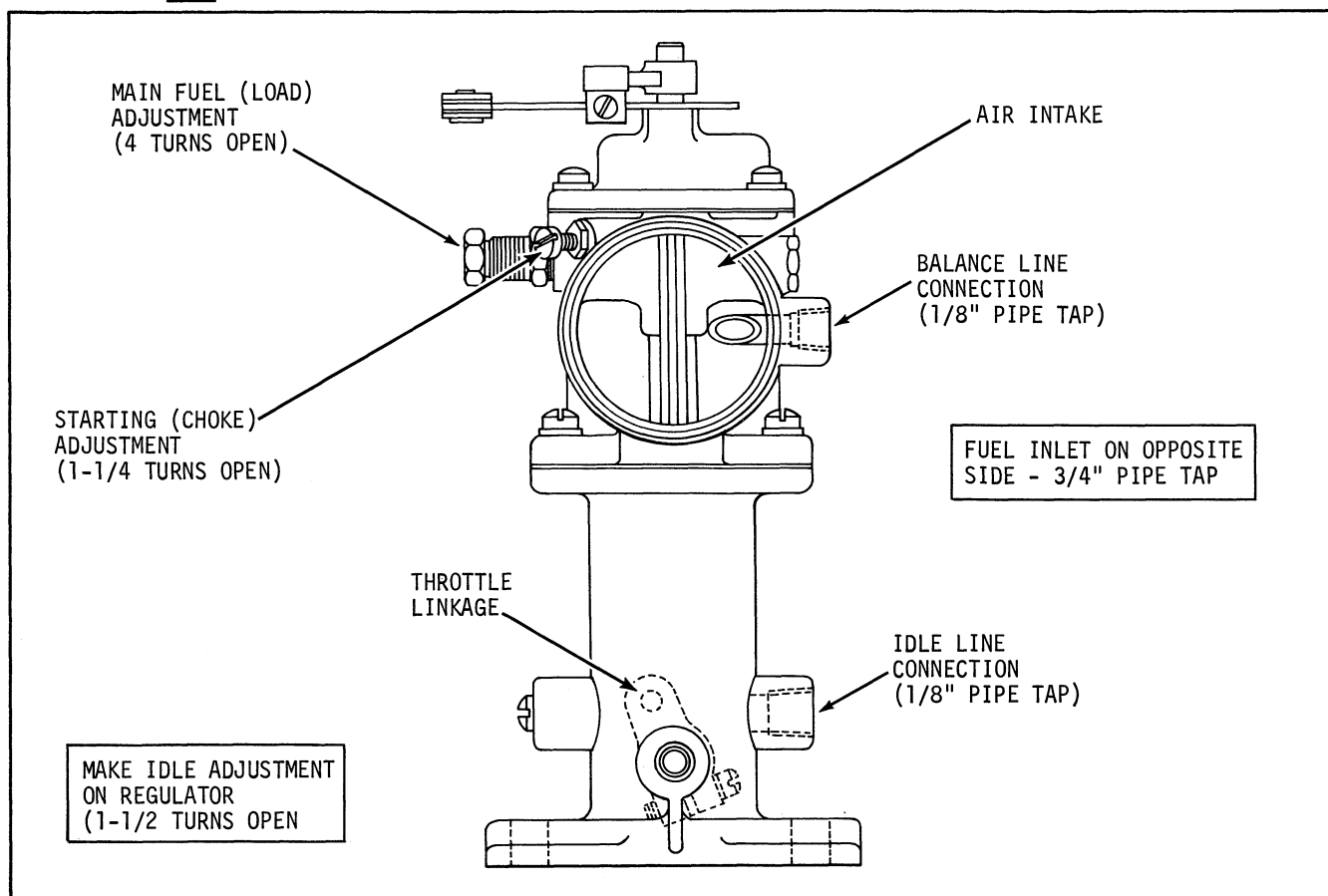

FIGURE 12-3 -- KG1 GAS CARBURETOR - ADJUSTMENTS

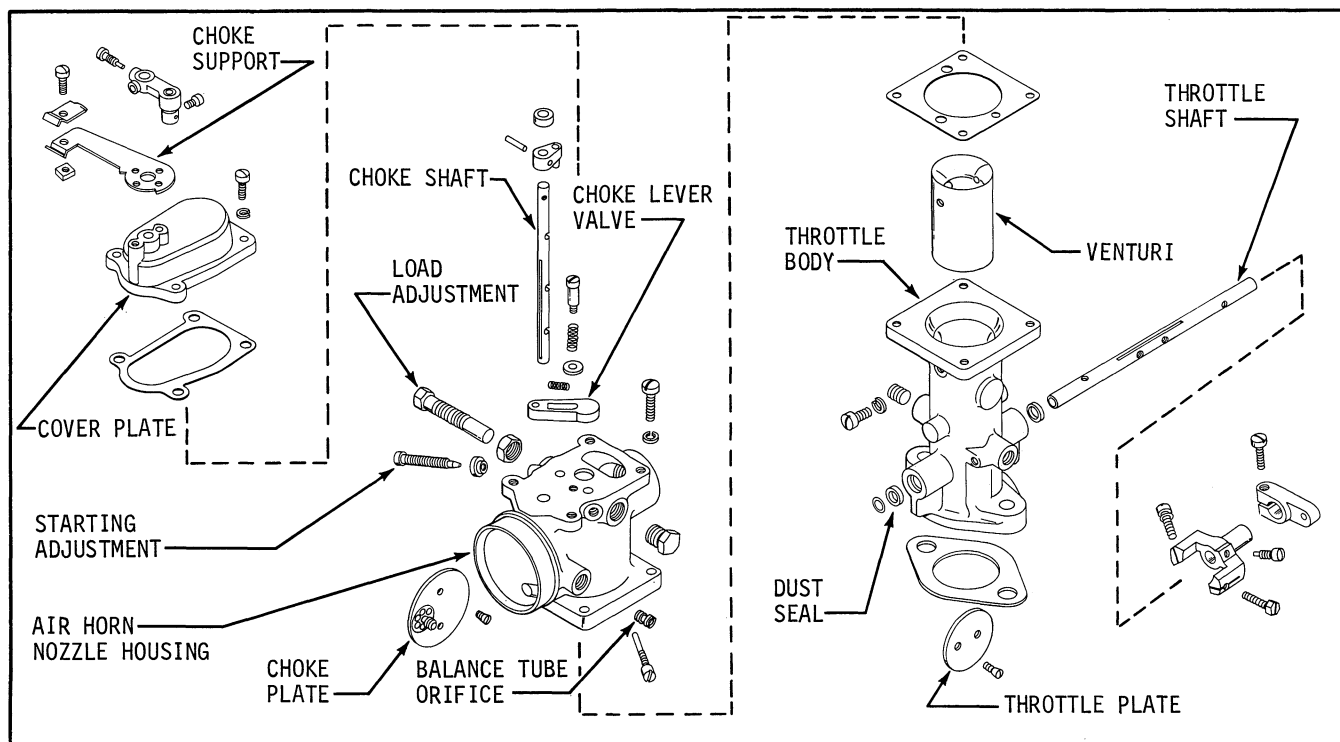

FIGURE 12-4 -- KGI GAS CARBURETOR - DISASSEMBLED VIEW

Final adjustments are made as follows:

1. Close choke and start engine. Hold choke in closed position and adjust starting mixture. Loosen locknut then move setscrew until engine speed picks up from richer mixture--continue turning toward richer setting until speed drops slightly from overrich setting. Lock setscrew in this position then move choke to open position.
2. Allow engine to warm up then return throttle to idle speed. Check RPM with tachometer and adjust to proper idle speed. Move idle adjustment in or out until smoothest idle is attained.
3. Open throttle and place normal load on engine. Loosen locknut then turn load adjustment in (lean) until engine speed starts to drop then turn adjustment out until speed increases again then drops due to overrich setting--move adjustment halfway between lean and rich settings for best mixture for normal load conditions. Tighten nut on load adjustment after final setting is attained.

Reconditioning Procedure: The KGI does not require servicing on a regular basis, however, if the carburetor cannot be adjusted to give satisfactory performance it should be completely disassembled and reconditioned. All necessary replacement gaskets, seals, etc., are included in the Kohler Repair Kit for this carburetor--refer to the Parts Manual (K662) for the correct part number. Recondition carburetor as follows: (Wash parts in solvent, blow out all passages.)

1. Disconnect balance, idle and fuel inlet lines, also throttle and choke linkage at carburetor.
2. Remove carburetor from engine for bench disassembly.
3. Separate throttle body from air horn-nozzle housing (remove four capscrews). Recondition these units separately.
4. Remove two brass screws on throttle plate, slip plate out of slot in shaft. Loosen setscrew, remove collar then pull shaft out of body. Inspect shaft and bushings--replace if worn or damaged. Always use new dust seals. Remove screw holding venturi to body (screw also used for identification tag) then remove venturi and inspect. Make sure hole in venturi lines up with pin hole in throttle body when reinstalling. After thoroughly cleaning, reassemble throttle body components.
5. Remove cover plate, choke plate, choke lever, choke shaft, load and starting adjustment screws then thoroughly clean air horn and nozzle housing. Make sure all passages are blown out with air hose. Use new dust seal on choke shaft, replace damaged parts and all gaskets. Reassemble parts.
6. Reassemble throttle body to air horn-nozzle housing (new gasket between) then reinstall carburetor with new gasket on manifold. After reconnecting lines, make initial adjustments on carburetor.

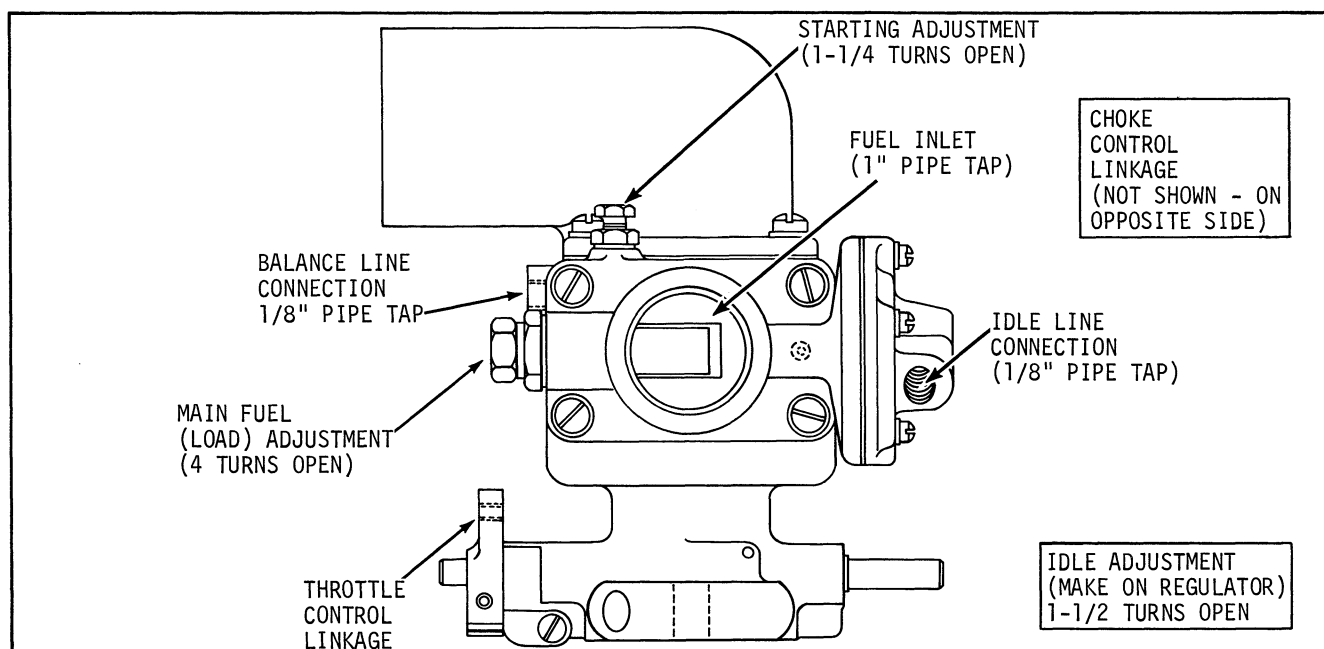

FIGURE 12-5 -- XG GAS CARBURETOR - ADJUSTMENTS

KOHLER #A-271329 (MODEL XG) GAS CARBURETOR

The Model XG carburetor is also of the venturi-nozzle type straight gas carburetor suitable for Natural and LP gas. The XG features an "Economizer" unit which automatically provides a rich power mixture when the engine is under heavy load and a leaner economy mixture for part load and part throttle operation. A diaphragm in the economizer is actuated by manifold vacuum which is applied to the unit through the combined idle-economizer line. The idle line, which extends to the secondary regulator, provides sufficient gas for operation at low idle speeds when the velocity of air through the venturi is too low to draw enough fuel to sustain operation. When the economizer feature is used, the idle line is usually extended by means of a Tee to connect on the intake manifold side of the throttle plate (lower flange on carburetor). With this arrangement, the idle adjustment is made on the regulator.

The XG carburetor also features a separate starting system which blocks off the main system to provide a rich mixture for starting. The starting mixture system operates only when the choke is fully closed. The choke is in either full open or full closed position with no intermediate positions. When the choke is closed, the small volume of air needed is drawn thru a small hole in the choke plate.

Operation: The XG carburetor functions much the same as the previously described model KG1 carburetor. Refer to operation section on that carburetor for explanation of operating principles.

Adjustments: Refer to Figure 12-5 for initial settings on carburetor. After initial adjustment is made, start engine and make final adjustments as follows:

1. After engine starts, hold choke in closed position while making final starting mixture adjustment. Move starting adjustment to obtain maximum speed then continue adjusting richer until speed drops slightly--retighten locknut at this setting then return choke to full open position.
2. Allow engine to warm up then move throttle control to idle position. Adjust idle speed stop if needed to attain proper idle speed (check with hand tachometer) then move idle adjustment screw (on regulator) until smoothest idle is attained.
3. Open throttle and place engine under normal load. Turn load adjustment in until speed drops (lean setting) then turn adjustment back out until speed again increases then drops from an overrich setting--move adjustment halfway between lean and rich settings for best mixture under normal load conditions.

Reconditioning: No regular service is required on the XG carburetor. If reconditioning becomes necessary, completely disassemble carburetor and replace all gaskets, dust seals and worn or damaged parts. The diaphragm in the economizer should also be replaced during reconditioning. Thoroughly wash all parts in solvent and blow out all passages with compressed air. After reassembling and reinstalling carburetor, check all connections and gasket joints for evidence of leakage.

KOHLER #A-271923 (MODEL PC2-10) GAS CARBURETOR

The model PC2-10 can be classified a diaphragm type carburetor although it also uses a venturi. The diaphragm arrangement provides final regulation of the fuel which is received from the primary regulator (or vaporizer-regulator) at a pressure of about 8 psi. This pressure setting must not exceed 12 psi. The PC2 serves two functions--as a carburetor and as the secondary regulator.

Operation: Fuel is supplied to the carburetor at above atmospheric pressure--as long as inlet pressure does not exceed 20 psi, the regulator segment will block off fuel and prevent leakage into the engine when it is not operating. Briefly, when the engine is in operation, flow of air thru the carburetor causes pressure differences which act upon diaphragms which, in turn, activate a fuel lever to admit fuel according to engine demand. When the engine is at low idle speeds, the fuel is directed into the engine thru separate idle discharge jets which permit operation even when flow of air through the venturi would be too low to draw sufficient fuel to sustain operation. The carburetor also features a back suction type of "economizer" which meters an economy mixture of fuel during part throttle and part load operation. At full throttle and full load operation, the position of the throttle plate is such that maximum fuel is metered to the engine. The maximum amount of fuel allowed is determined by setting of the main fuel (load) adjustment.

Adjustment: For preliminary adjustment of carburetor refer to Figure 12-6. Turn screws in lightly against seats--before opening--do not force closed. Final adjustments are made as follows:

Idle: Start engine, move throttle to idle position, adjust idle speed to proper range. Move idle fuel adjusting screw in and out until smoothest idle is attained.

Load: Allow engine to warm up, then open throttle and place under normal load. Move main fuel adjustment in until engine starts to slow down from lean mixture then turn adjustment in the opposite direction until engine speed increases then starts to slow down again from overrich mixture. Move adjustment halfway between lean and overrich settings for best mixture under normal load.

Reconditioning: The PC2 does not require service at regular intervals. If carburetor troubles occur that cannot be remedied by readjustment, the carburetor should be completely disassembled and reconditioned. Replace all diaphragms, gaskets, O-rings and dust seals when reconditioning. Use the Kohler Repair Kit (see parts manual) for this carburetor when reconditioning. The following special tools are required for satisfactory overhaul: Main Jet Wrench (#C161-193), Fuel Valve Lever Gauge (#C161-194), Aligning Studs (#C166-52 set).

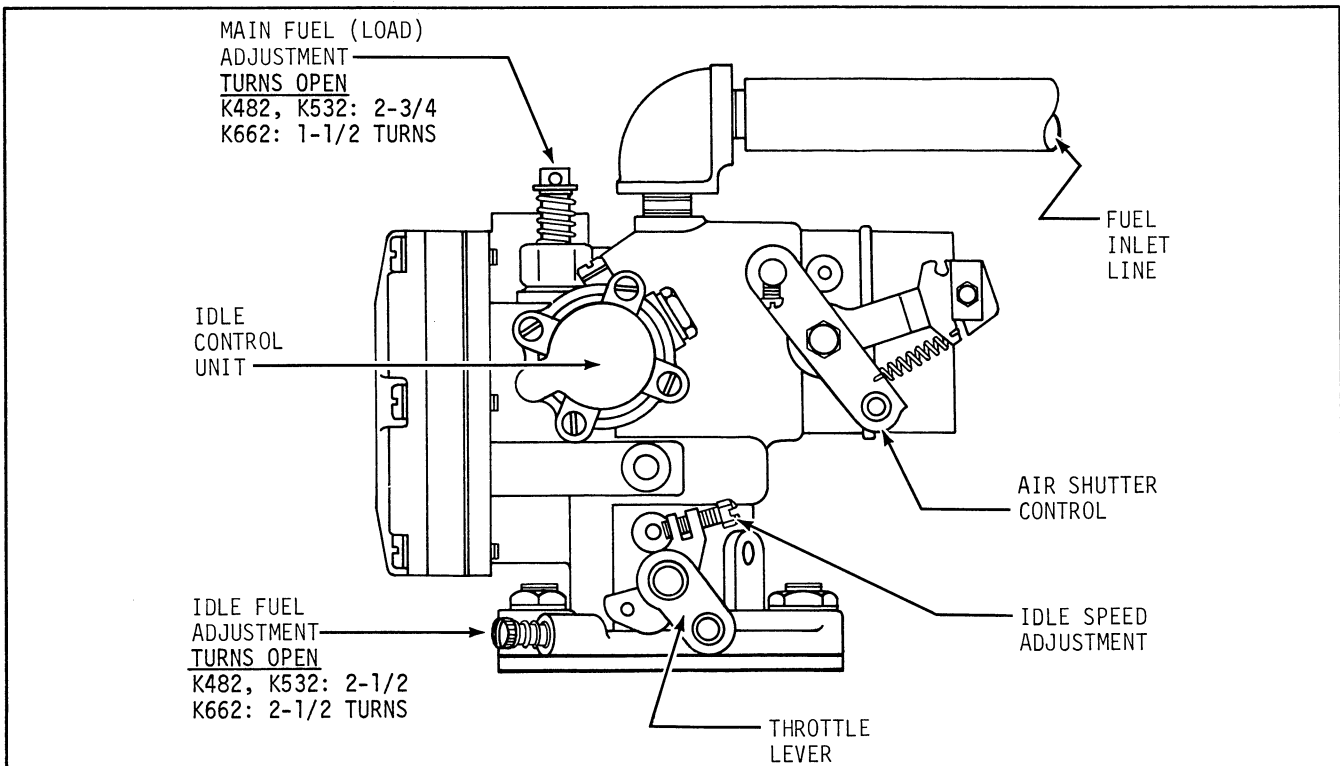

FIGURE 12-6 -- PC2-10 GAS CARBURETOR

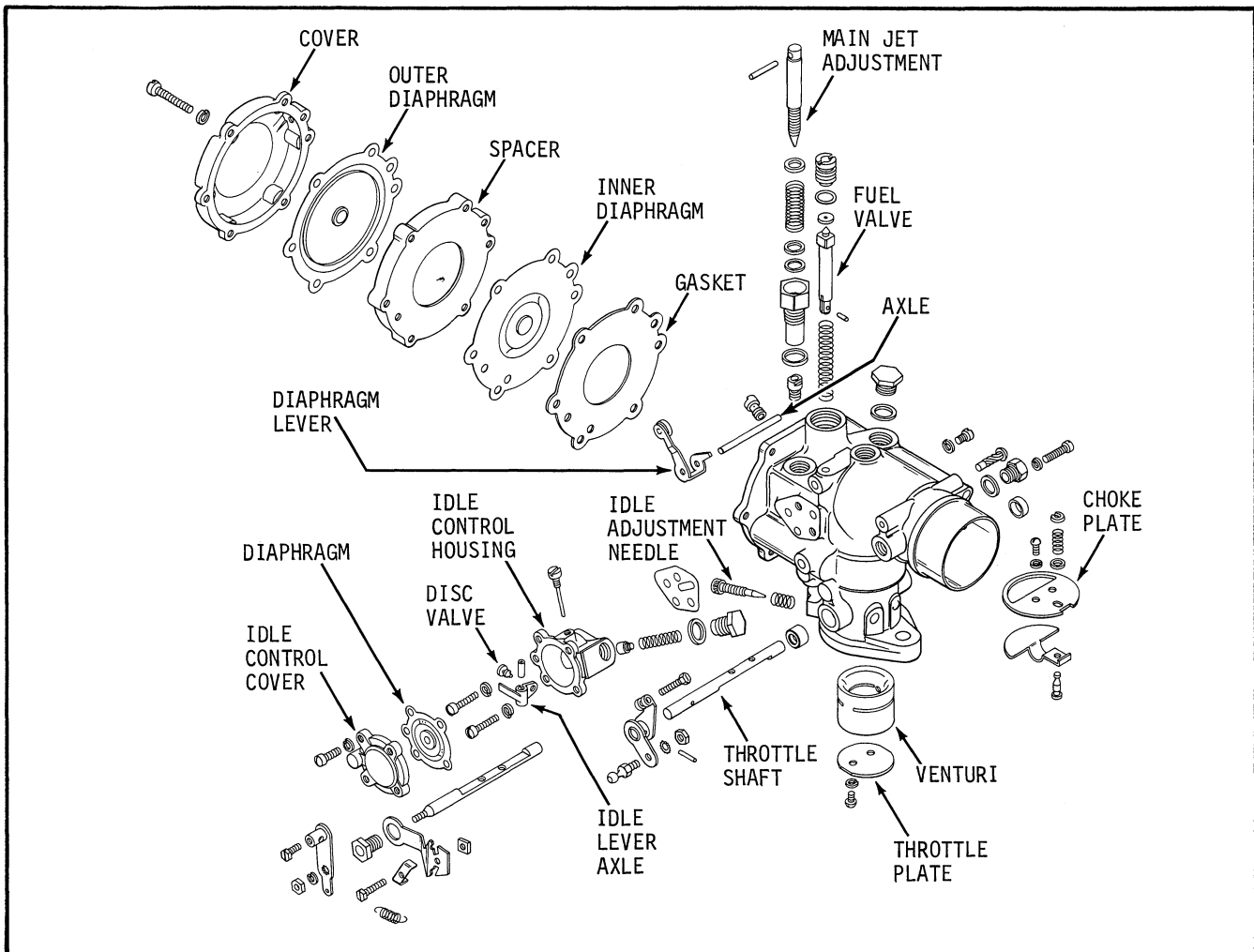

FIGURE 12-7 -- MODEL PC2-10 GAS CARBURETOR, EXPLODED VIEW

The following sequence is suggested for reconditioning PC2 carburetor after it has been disconnected and removed from engine:

#### Disassembly

1. Throttle: Turn throttle stop screw to left until plate is fully closed. Remove screws and throttle plate. Remove economizer valve plug and valve then throttle shaft and seal retainers and seals.
2. Venturi: Remove venturi retaining screw then slip venturi out of carburetor throat.
3. Choke: Remove choke plate screws, choke plate and choke shaft.
4. Idle Diaphragm: Remove idle adjusting needle and spring. Remove four cover screws on idle control unit, remove cover, diaphragm, control channel plug, fibre washer and spring. Remove idle lever axle, lever and rubber disc valve. Remove the two housing screws then remove idle diaphragm housing and gasket.
5. Regulator Diaphragm: Remove four cover screws then remove regulator diaphragm as a unit. Separate components, discard used diaphragms.
6. Main Fuel Valve: Remove fuel valve axle retainer, axle and valve lever. Loosen inlet orifice setscrew (8-32 Allen) then remove orifice. Remove inlet valve stem and spring. Remove main fuel adjusting needle. Use 5/8" socket wrench to remove main jet body. Use C161-193 tool to remove main jet.

#### Reconditioning

Discard all diaphragms, gaskets, O-rings and throttle shaft seals. Thoroughly clean all parts in carburetor cleaner, blow out all passages. Make sure all gasket material is removed from surfaces. Inspect parts for wear or damage--especially needles and seats--replace defective parts.

## Reassembly

Reassembly is for the most part, the reverse of disassembly. The following special instructions should be noted:

Main Fuel Valve: Place new O-ring on inlet orifice and turn orifice part way into casting. After installing fuel valve lever in slot in valve stem, install axle and retainer. For K662, place gauge (#C161-194) on machined surface of casting and against nylon roller. Turn inlet orifice in or out (with screwdriver 1/2" blade) until fuel lever is positioned in 3rd notch (above casting face) on gauge. If this gauge is not available, set at .090" above machined surface of casting for K662, or at .060" for K482, K532 models. Secure orifice with 8-32 Allen setscrew.

Regulator Diaphragm Assembly: Install three aligning studs (from tool #C166-52) in casting. Note location of ports and install components so openings correspond--install in following order:

1. Gasket.
2. Inner diaphragm (spacer cup out).
3. Diaphragm spacer (recessed side out).
4. Outer diaphragm (diaphragm plate in).
5. Diaphragm cover. Install three cover screws then remove aligning studs and replace with remaining cover screws.

Idle Diaphragm: Use new valve disc. After reinstalling housing and lever, position diaphragm (cup side next to lever) and cover then secure with cover screws and lock washers.

After carburetor is completely reassembled, make preliminary adjustments as shown in Figure 12-6. Carefully check carburetor and connections for leaks after reinstalling on engine.

## **GAS REGULATORS**

Model F1 (F) and KN secondary regulators are used. While they differ in appearance, they are single diaphragm type regulators which function to control the amount of fuel entering an engine under varying speed and load conditions. Vacuum created within the engine is communicated to one side of the diaphragm while the other side is subject to atmospheric pressure. Movement of the diaphragm caused by this difference in pressure is transmitted through linkage to the fuel valve which opens to admit fuel to the carburetor. The higher the pressure differential, the greater the volume of fuel.

The secondary regulator receives fuel from the primary regulator at a pressure of 4 to 7 ounces per square inch (7-12" water column) and reduces this to about 3 ounces when the engine is at idle. When the engine is stopped, the fuel valve in the secondary regulator should close to prevent fuel from entering the carburetor. A manual or electrically operated fuel shut-off valve is often used in the system to provide a more positive means of turning off the fuel.

## **TROUBLE ANALYSIS**

| <u>CONDITION</u>                  | <u>POSSIBLE FAULT</u>  |
|-----------------------------------|--|
| ENGINE FAILS TO START             | <ol style="list-style-type: none"><li>1. Main diaphragm broken or linkage binding--no fuel.</li><li>2. Fuel valve stuck open--too much fuel.</li></ol>   |
| ENGINE IDLES POORLY               | <ol style="list-style-type: none"><li>1. Idle line connections leaking or plugged.</li><li>2. Diaphragm stiff or ruptured.</li><li>3. Balance line plugged.</li></ol>  |
| ENGINE OPERATES POORLY UNDER LOAD | <ol style="list-style-type: none"><li>1. Excessive pressure--regulator discharges in surges.</li><li>2. Balance line improper size or restricted.</li><li>3. Dirt in regulator causing sticking or sluggish operation of fuel valve.</li></ol> |

## KOHLER #A-240492 (MODEL F1) SECONDARY REGULATOR

When balance and idle lines are used, the lines should be 3/16" size copper tubing. To check inlet pressure, remove plug on fuel inlet, insert manometer or ounce pressure gauge. Adjust inlet pressure to 4-7 ounces (7-12" water column)--inlet pressure is adjusted on primary regulator. If trouble persists after readjustment and above points are checked, recondition the secondary regulator as follows:

Disassembly: Remove assembly screws, separate cover from regulator body. Remove diaphragm then remove retainer block screw and lever retainer, diaphragm lever and spring. Inspect brass orifice for nicks or damage--do not remove unless replacement is needed.

Reconditioning: Thoroughly wash all metal parts in cleaning solution, blow out all passages. Replace all worn, damaged parts. Inspect diaphragm and gaskets bonded to both sides of diaphragm--replace as unit if diaphragm or gasket damage is evident. Check brass orifice--replace if nicked. Replace rubber seat if crushed or if foreign material imbedded in rubber. Before reassembling regulator, make sure all parts are clean and free of dirt, lint, etc.

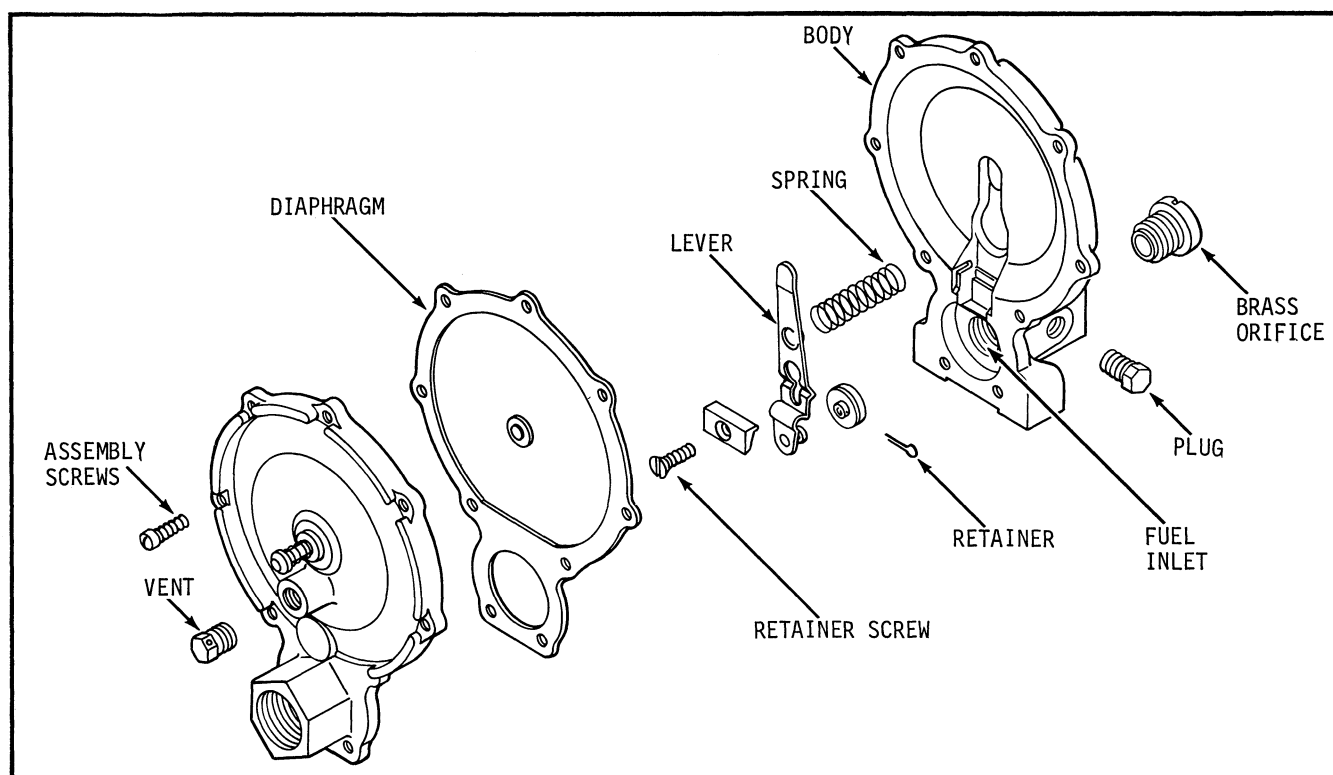

FIGURE 12-8 -- MODEL F1 REGULATOR - DISASSEMBLED VIEW

Reassembly: After reinstalling orifice, seat and idle adjustment, insert diaphragm lever and spring then carefully secure with retaining screw--tighten screw only enough to hold lever in place--overtightening will bind lever. Position diaphragm and engage it to lever. Position cover then secure with assembly screws--tighten evenly.

## KOHLER #A-230695 (MODEL KN) SECONDARY REGULATOR

The model KN secondary regulator is very similar to the model F1 which is discussed in the foregoing. The KN does not, however, have provision for an idle line nor does it have an idle adjustment needle. The model KN is used most frequently with the gas adapter in the combination gas-gasoline systems. The adapter in this case has the idle adjustment. The KN is a very sensitive regulator and offers excellent starting without need for choking or priming if properly installed.

The orifice size and maximum inlet pressure are stamped on the cover of the KN--do not permit inlet pressure to exceed maximum (usually 6 oz.). If an electric solenoid is used, it should be mounted close to the model KN. The orifice size of the solenoid must be at least as large as orifice in regulator.

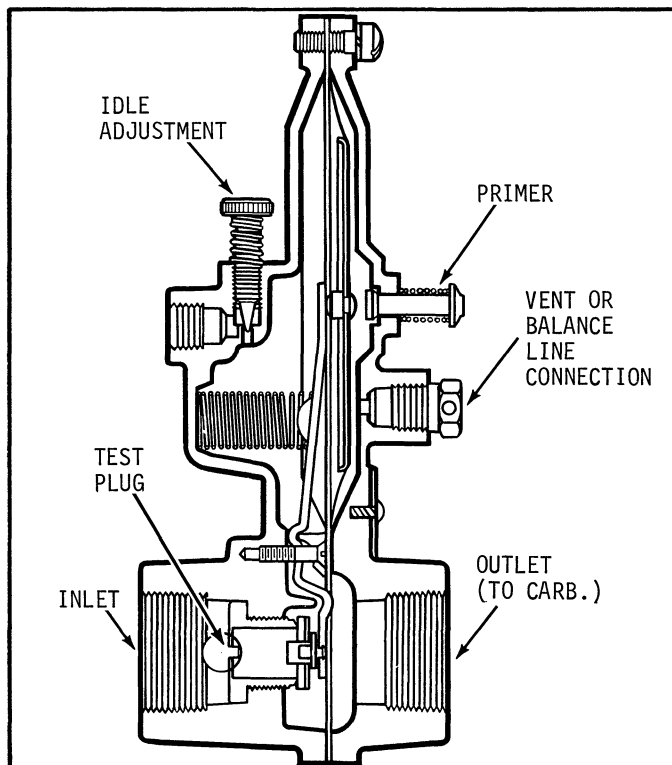

FIGURE 12-9 -- MODEL FT REGULATOR - CROSS SECTIONAL VIEW

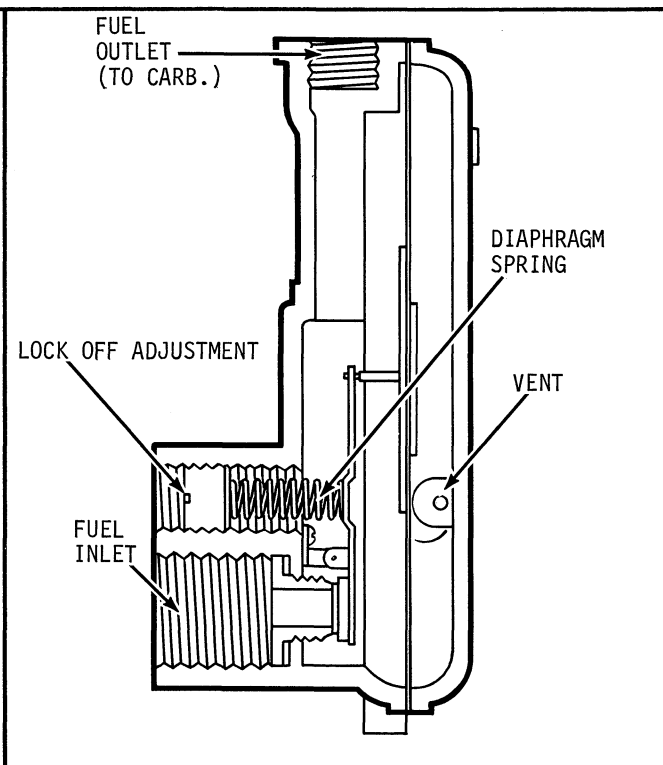

FIGURE 12-10 -- MODEL KN REGULATOR - CROSS SECTIONAL VIEW

Adjustment (Lock Off): The lock off adjustment is provided only to shut off fuel when engine is not operating--it is not for adjusting fuel mixture or engine speed. Readjustment should be necessary only after regulator has been completely disassembled or if fuel is not being shut off properly after engine stops. Use following procedure to adjust:

With engine stopped, slowly turn lock off screw out (counterclockwise direction) until fuel starts to flow through the regulator then turn screw in (clockwise) until the flow stops--note position of screw when flow stops then turn in one more turn for final setting.

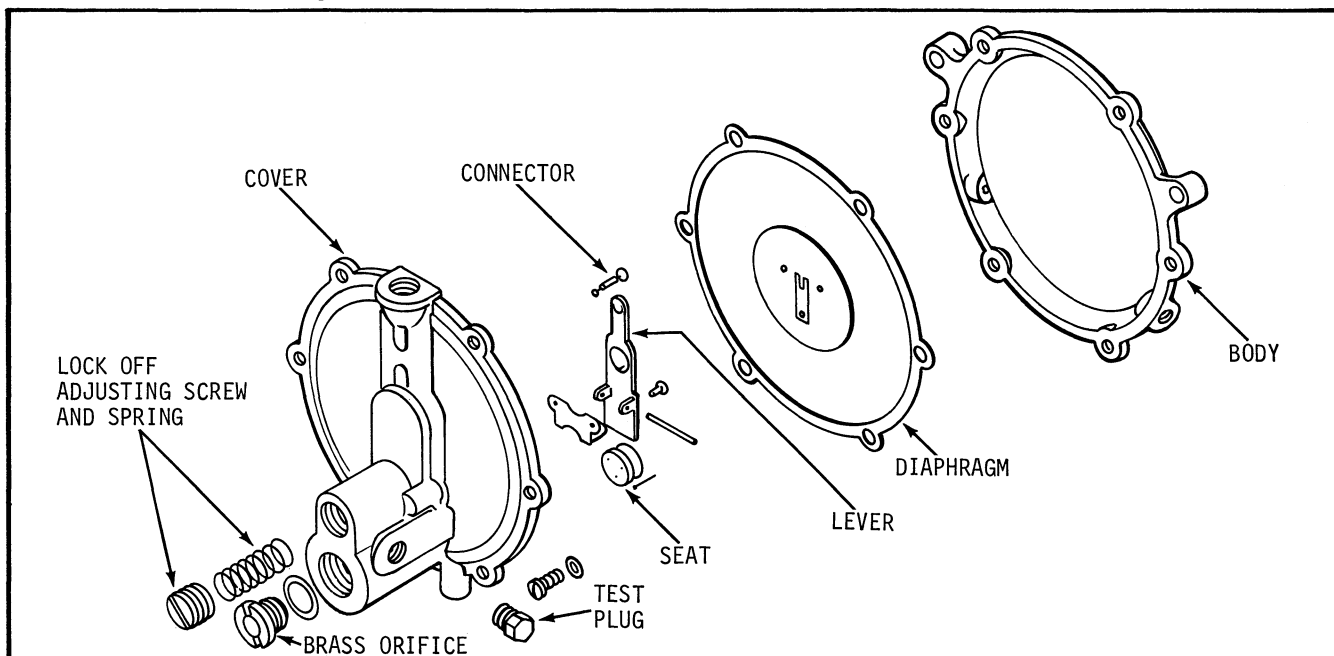

FIGURE 12-11 -- MODEL KN REGULATOR - DISASSEMBLED VIEW

Reconditioning: The reconditioning procedure stated previously for the model F1 regulator can also be followed for the model KN. Certain changes in procedure will have to be made to allow for minor design differences that will become obvious as the unit is disassembled. After reconditioning is complete and unit is reinstalled in system, adjust lock off per previous instructions.

KOHLER #A-271310 (MODEL RCB) TWO-STAGE REGULATOR

The model RCB two-stage regulator provides primary and secondary regulation for LPG vapor withdrawal systems provided a vaporizer unit is installed on fuel tank side of the system. The RCB also features an electrically operated fuel solenoid to provide positive shut off whenever engine is not in operation. The RCB is often used with the model XG carburetor and an optional vacuum gauge to provide automatic starting without the need for priming.

Operation: Fuel entering regulator passes through a screen then flows to the electric solenoid valve. When actuated, the valve disc is lifted off its seat which allows fuel to flow through the high pressure valve which is in turn controlled by a diaphragm to reduce pressure to about 4-5 psi. From here fuel flows into the low pressure chamber where it is drawn off as demanded by engine.

A balance line or tube usually connects atmospheric side of the low pressure diaphragm to the air horn side of carburetor. Depression caused by an increasingly dirty or restricted air cleaner is thus communicated back to the regulator to maintain constant air-fuel ratio. Without this line, the mixture would become proportionately richer as the air restriction increased. Balance line must have minimum I. D. of 1/4" to be effective.

A separate idle line is not required with this unit, although the idle adjustment is made at the regulator. Idle fuel flows to the carburetor through the main fuel line.

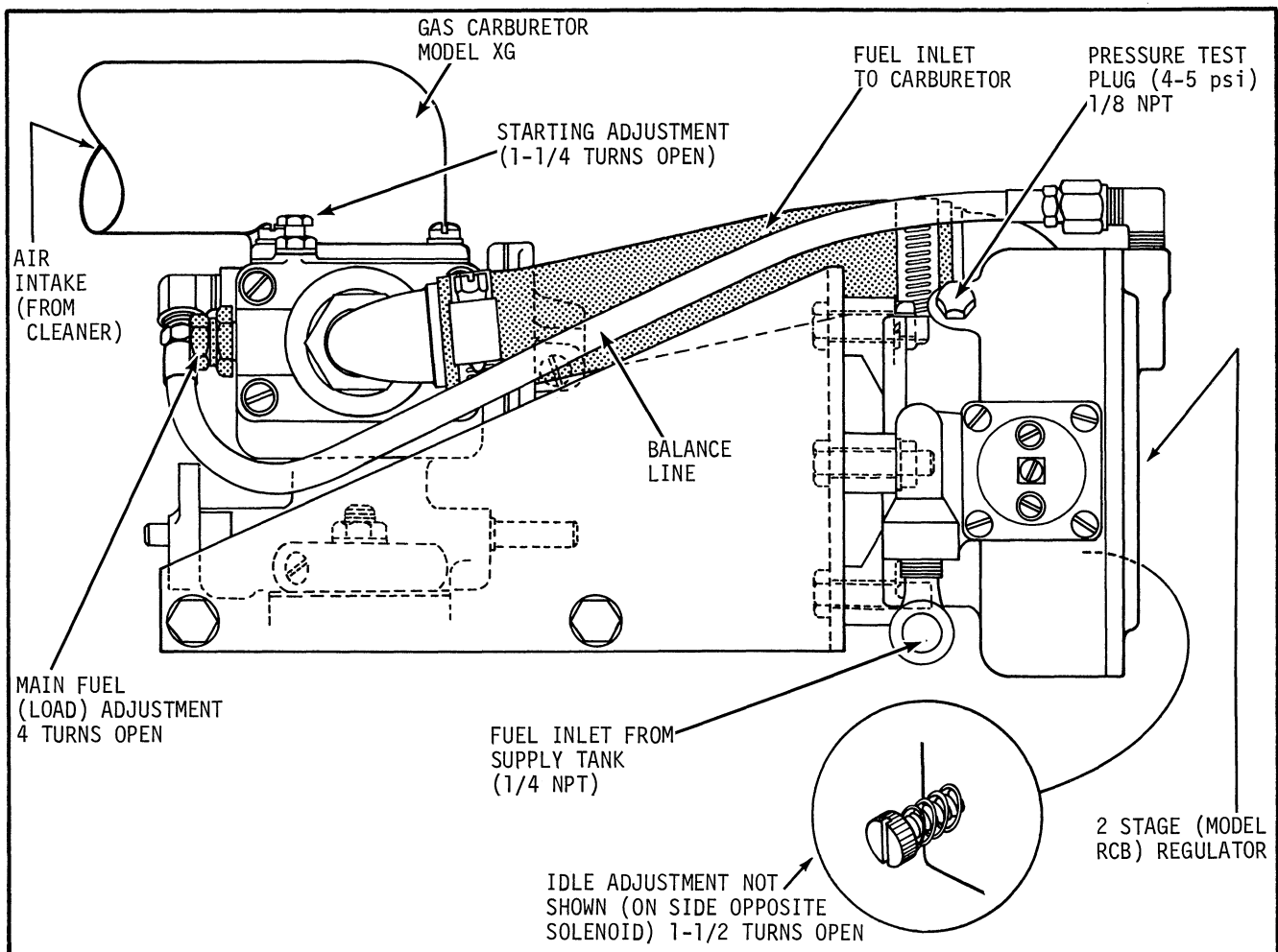

FIGURE 12-12 -- MODEL RCB TWO-STAGE REGULATOR WITH SG CARBURETOR

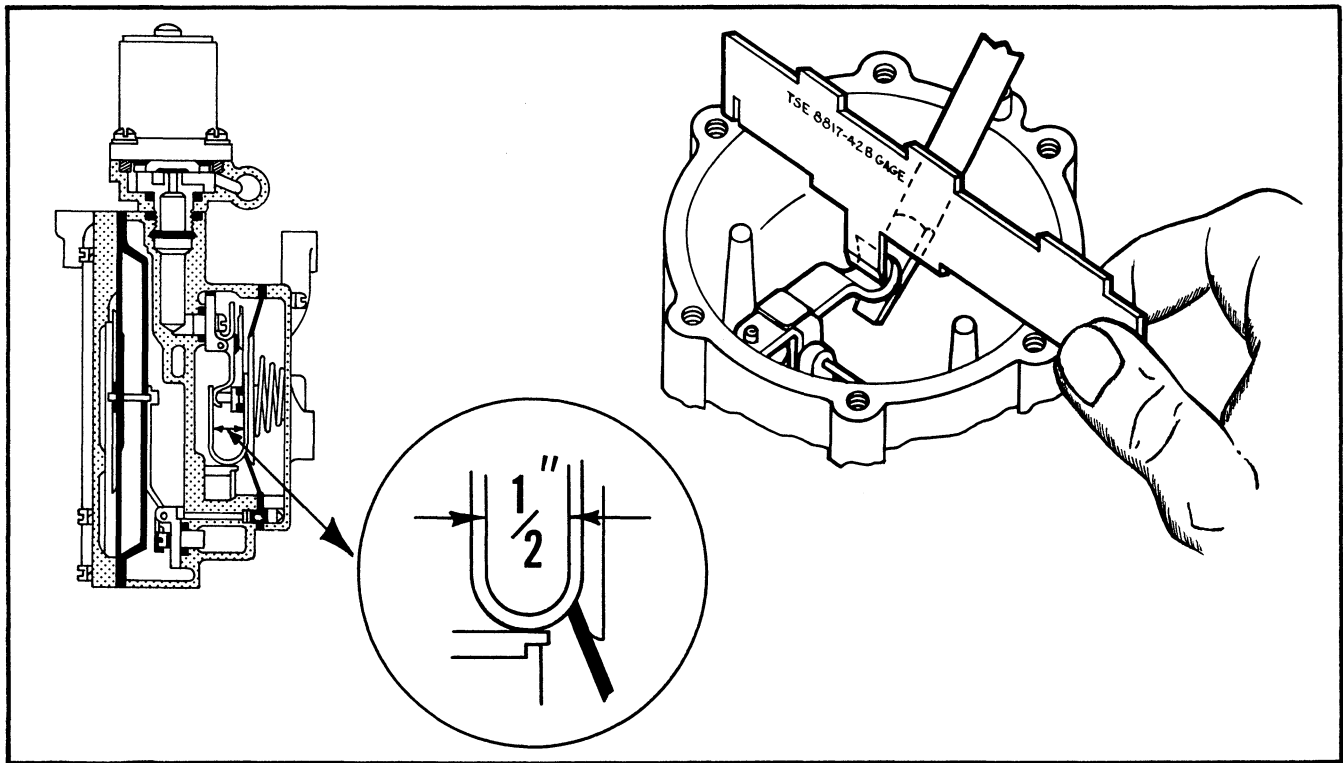

FIGURE 12-13 -- MODEL RCB REGULATOR - CROSS SECTIONAL VIEW

**Trouble Shooting:** If engine fails to start after ascertaining that fuel reaches solenoid inlet, first check that solenoid is operating; an audible click will be heard when solenoid is energized. In the event that still no fuel flows from outlet of regulator, the difficulty may be traced to a sticky valve disc in solenoid assembly.

If engine does not idle with adjusting screw in any position, the trouble, most likely, can be traced to the low pressure valve, as dirt or foreign matter may have become lodged on the seat. This can be remedied by washing the valve and seat in a solvent.

**Service Instructions:** It is preferable to have the LP-gas regulating unit serviced by dealer with parts and facilities for testing. However, if this is not possible, proceed as follows:

1. Completely disassemble the model RCB unit. Thoroughly wash all parts and blow out all passageways with compressed air.
2. It is suggested that a repair kit be used in reassembling the regulator.
3. The use of short pins (2" long), inserted in threaded screw holes of casting, will materially aid in the installation of gaskets and diaphragms.
4. When replacing the high pressure valve assembly, make certain that machined seat in casting is perfectly clean and free of nicks. Wipe out any foreign matter which could affect proper seating of valve body and O-ring. Apply a small amount of oil to O-ring to aid in the initial sealing.
5. Carefully note the dimension shown on insert Figure 12-13. This should be 1/2" as indicated, from the high-pressure side of the body casting to the inside of the groove in valve lever when the valve is held firmly shut. This may be measured with Ensign Gauge TSE 8817-42B.
6. Completely assemble the high-pressure section before proceeding further.
7. A post or boss is machined and marked with an arrow for the purpose of setting the low-pressure valve lever. The valve lever should be centered on the arrow before tightening the screws holding the valve block. Top of lever should be flush with the top of the post. Bend the valve lever, if necessary, to the correct height.
8. The push pin in lever must be centered through hole in partition plate. Re-align low pressure lever if necessary by shifting valve assembly and retightening screws.
9. The push pin must be positively fastened to diaphragm plate with spring washer and cotter pin.

# MODIFICATIONS

## CLUTCH

Most clutches on these engines are of the "wet" disc type. On this type, an oil "splash" type lubrication system is used. The proper oil level must be maintained to provide efficient lubrication. The oil should be changed after each 100 hours of operation. When refilling, use 1 pint of non-detergent oil of proper weight (SAE viscosity) for the prevailing temperatures (see accompanying chart).

### TEMPERATURE

Above 50° F.  
0° to 50° F.  
Below 0° F.

### SAE VISCOSITY

SAE 30  
SAE 20  
SAE 10

Adjustment: Slight readjustment may be needed after a few hours on a new clutch to accommodate normal run-in wear. A firm pressure should be required to engage clutch (40-45 pounds pull at lever handle). If clutch slips and overheats or if clutch handle jumps out after engagement, readjust as follows: Remove nameplate, release clutch then, using large screwdriver, turn collar clockwise one notch at a time until firm pressure is required to engage clutch. Adjustment ring is spring loaded and does not, therefore, have to be loosened before adjustment is made. Do not attempt to pry or force spring lock away from the ring.

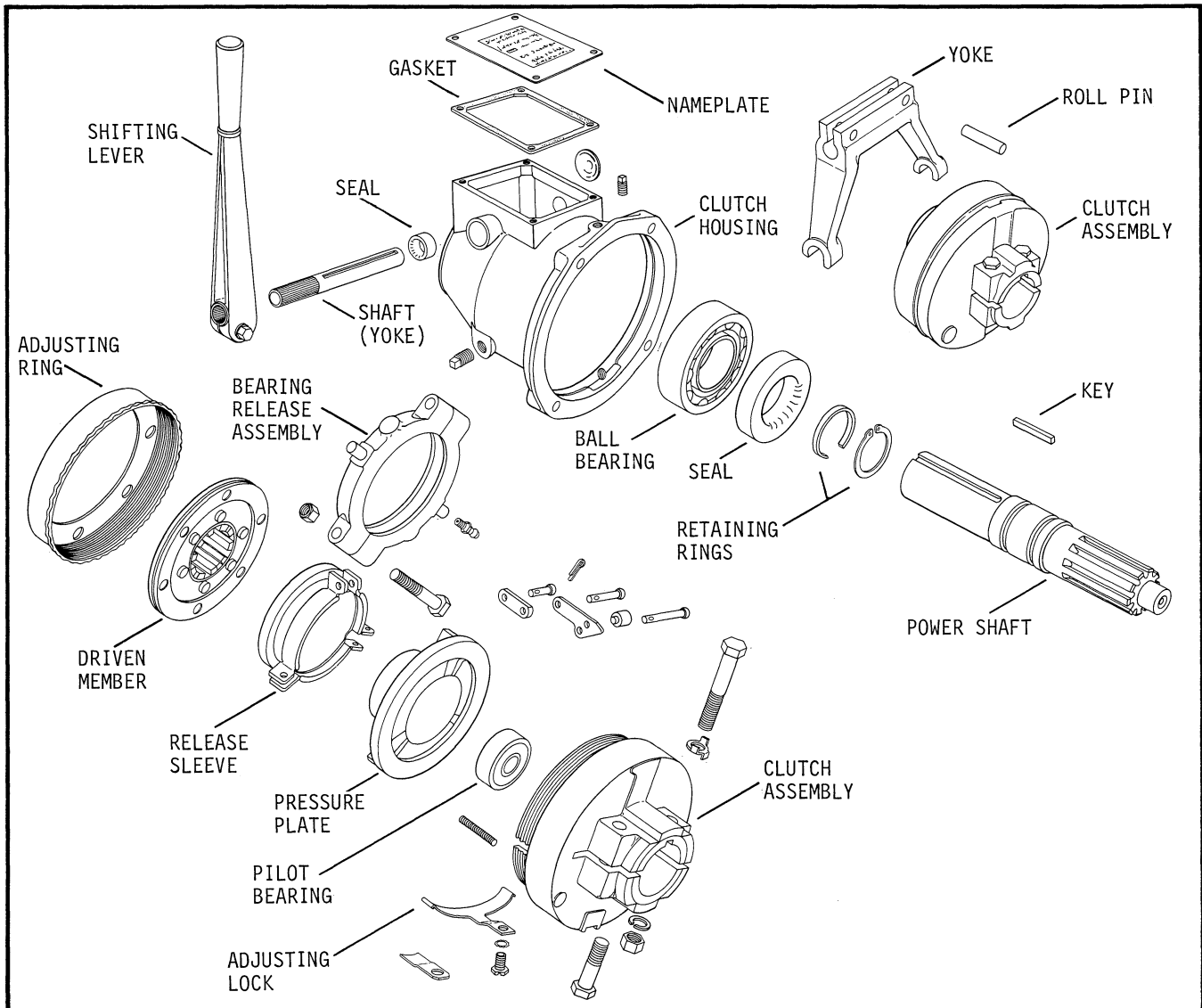

FIGURE 13-1 -- WET TYPE CLUTCH - DISASSEMBLED VIEW

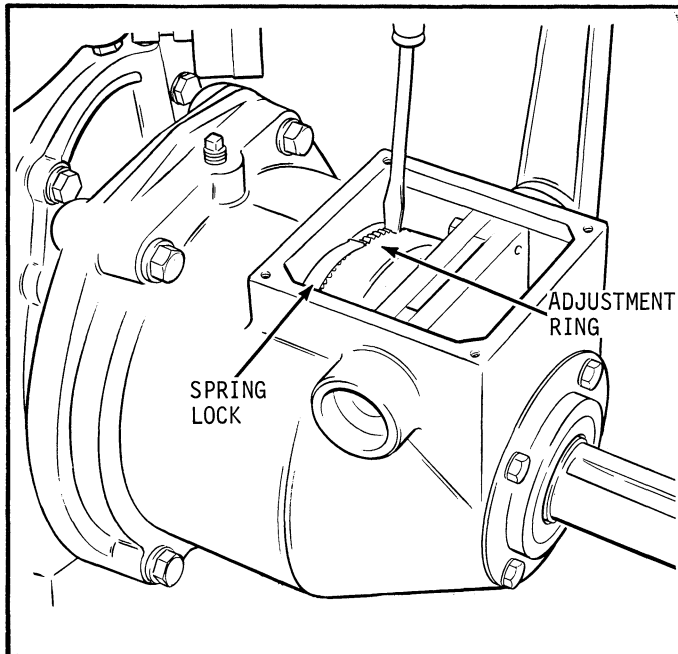

FIGURE 13-2 -- ADJUSTING CLUTCH

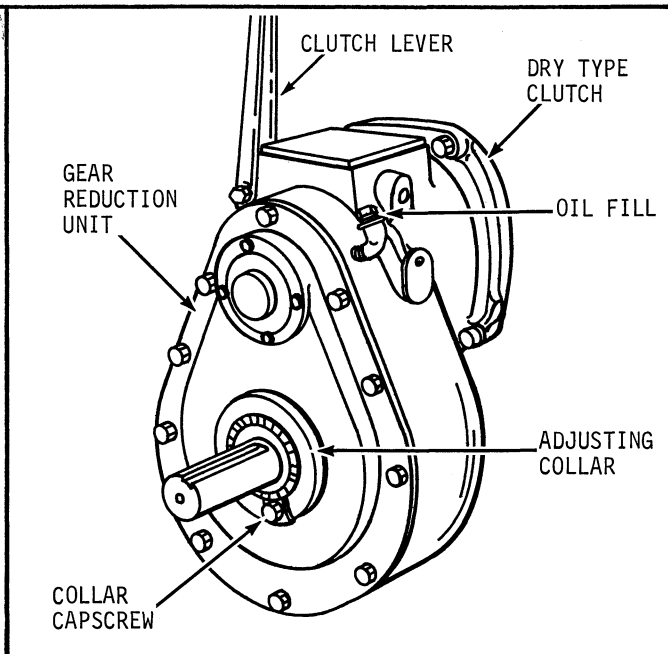

FIGURE 13-3 -- CLUTCH - GEAR REDUCTION UNIT

After adjustment is made, engage clutch and check to make sure rollers go over center to lock the unit in engaged position and prevent releasing under load. If trouble persists after readjustment, clutch reconditioning is indicated.

Reconditioning: Drain oil and remove nameplate and proceed as follows:

1. Remove capscrews (2) from clutch yoke and remove spacers.
2. Remove cross shaft.
3. Remove housing bolts (4) and slide housing off.
4. Loosen bolts securing clutch unit to crankshaft then remove locking screw.
5. Pull unit off.

To replace clutch plate, simply turn adjustment collar off and remove plate. Reverse procedure for reassembly. Adjust and lubricate per previous instructions.

### CLUTCH — GEAR REDUCTION UNIT

The combined clutch-gear reduction unit utilizes a dry type clutch which is linked through chain-sprocket drive to a gear reduction unit which runs in oil. Service the separate units as follows at 50 hour intervals:

Clutch: Open lubrication cover plate (marked) on side of clutch housing and lightly lubricate the clutch bearing collar. If clutch slippage or overheating is noted, readjust clutch as follows: Remove nameplate, release clutch then (using large screwdriver) turn collar clockwise one notch at a time until firm pressure is required to engage clutch (40-45 pounds force at lever handle). Do not pry or force spring lock nor loosen adjustment ring when readjusting. Make sure rollers go over center to lock in position when clutch is engaged.

Gear Reduction: After each 50 hours, drain old oil from unit and refill with 3 pints of oil--use same grade of oil as used in engine.

End play of the power take-off shaft is adjustable--end play must be maintained in the .0015 to .003" range. To check, mount dial indicator at shaft and move shaft in and out. To adjust, loosen capscrew on adjustable collar and shift position of collar. When proper end play is attained, secure collar with capscrews.

## AIR-VAC COOLING

With optional air-vac cooling, air circulation is opposite to that of the standard system. On Air-Vac equipped engines, a blower unit and support are attached to a special flywheel which does not have fins. Rotation of the blower causes cooling air to be drawn in from the sides and rear of the engine, past the cooling fins and into the special scroll work located at front of engine. From here, the heated air is ejected usually toward either side of the engine--the scroll can also be mounted to outlet in up or down positions depending on the application. The only service required with this system is to make sure that cooling fins, blower and outlet screen are maintained in clean condition at all times to prevent overheating due to restricted air circulation.

Special cold weather equipment is also available with Air-Vac systems. This system is comprised of a thermostatically operated air shutter unit and often includes a carburetor de-icer or heating unit. When the engine is cold, the shutters are held in partially closed position to restrict air circulation thereby allowing more rapid warm up of the engine. A bellows type thermostat, which is mounted on a bracket on the cylinder head, gradually expands with increasing temperature. This action is transmitted through ball joint linkage to gradually open the shutters with increasing operating temperatures. When engine is thoroughly warmed up, the shutters will be wide open (unless operating in severe cold), and offer zero restriction to air flow.

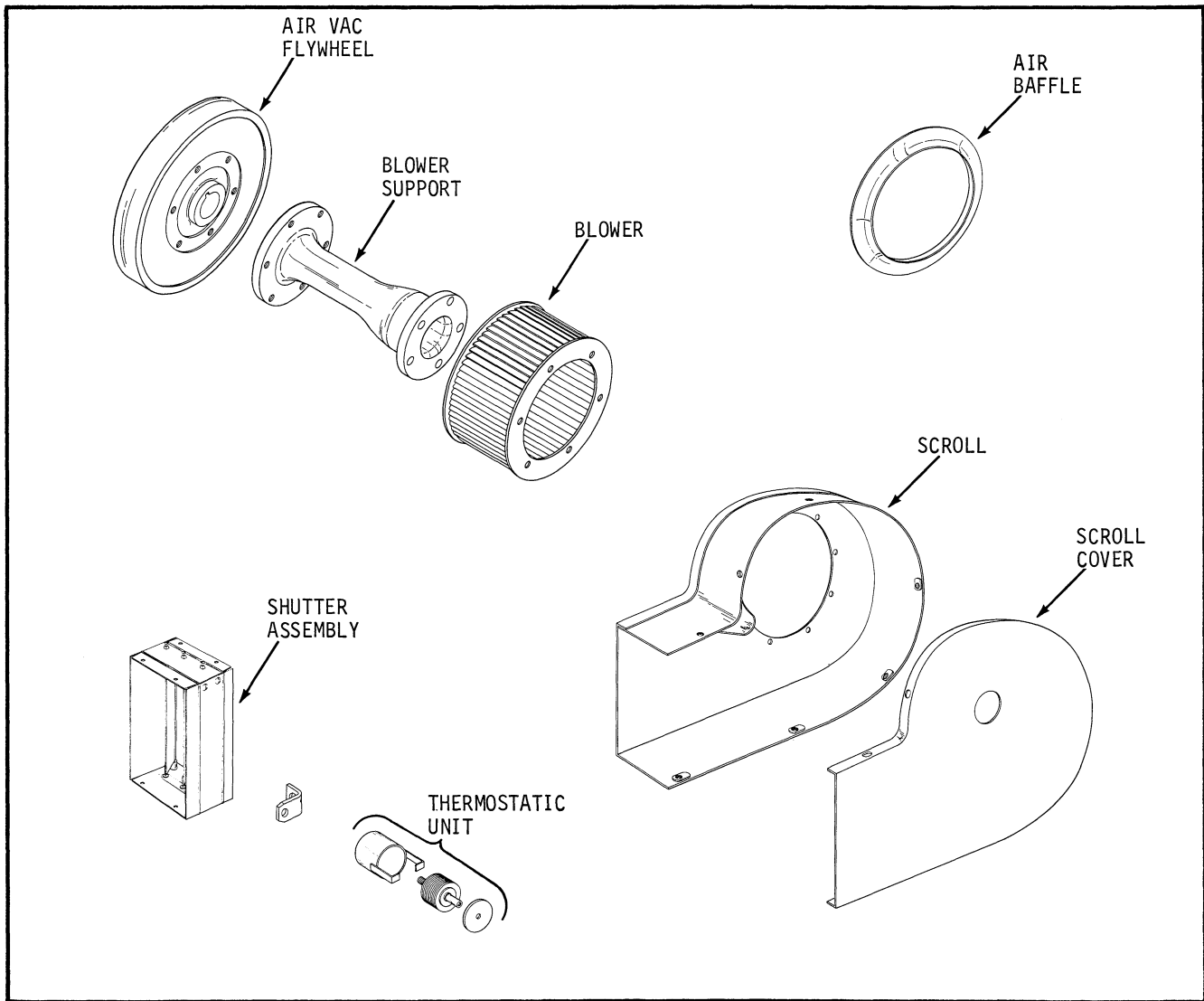

FIGURE 13-4 -- AIR VAC COOLING COMPONENTS - DISASSEMBLED

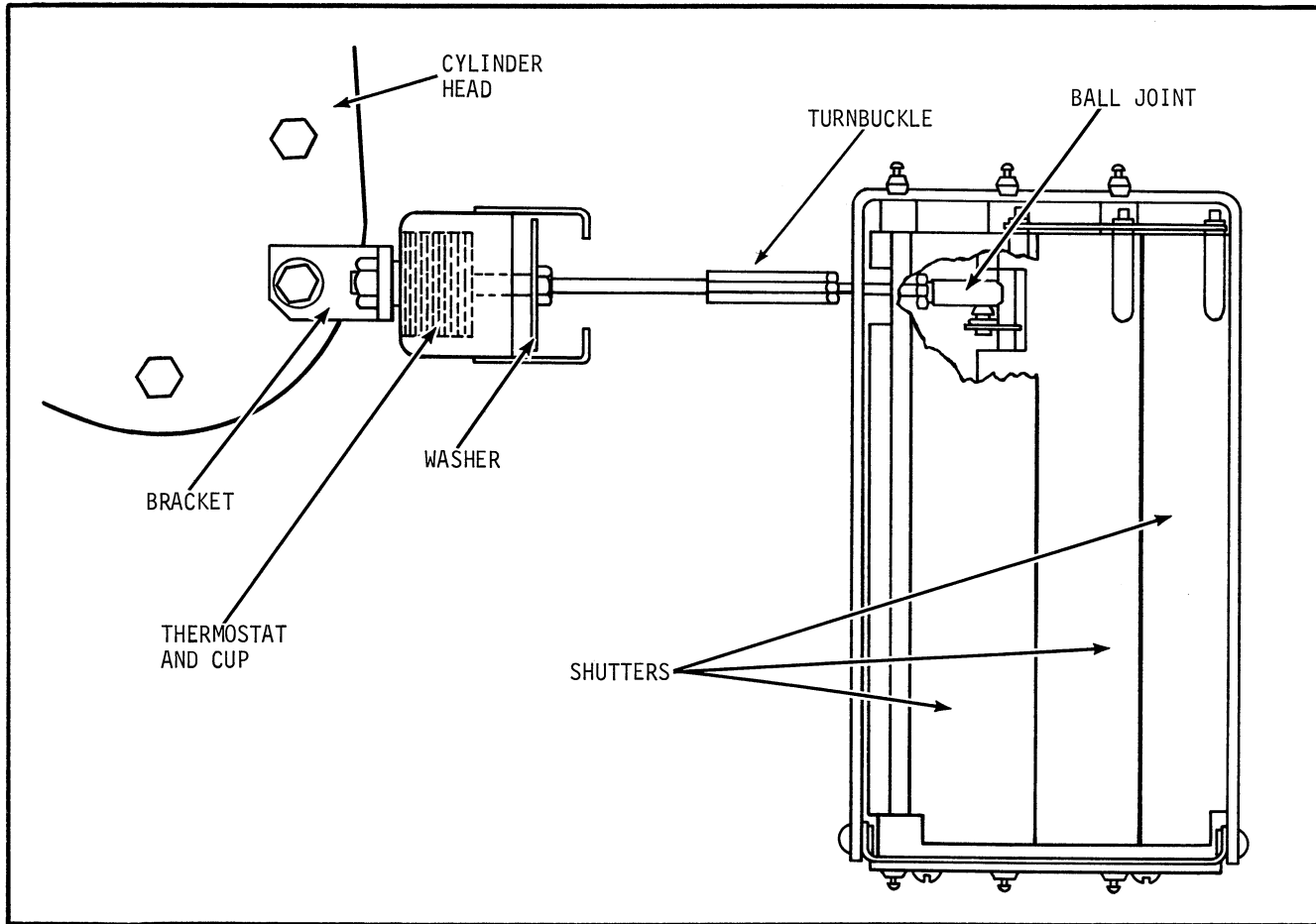

FIGURE 13-5 -- THERMOSTATICALLY OPERATED AIR SHUTTER UNIT

The carburetor de-icer unit is connected to the scroll with a flexible hose positioned so that heated air is forced up into the heat baffles surrounding the carburetor. When the shutters are closed, more warm air is forced into the de-icer--as the shutters open wider, a decreasing amount of air is directed to the unit.

Thermostatic shutter units are adjusted in the factory, however, slight readjustment may have to be made to suit local weather conditions. A turnbuckle is provided in the linkage for adjustment of shutters. To adjust, loosen locknut then move turnbuckle to reposition angle of shutters. Adjustment is made on cold engine.

### TOOL LISTING

Common Tools: Following is a list of tools commonly used in servicing Kohler Engines:

| DESCRIPTION        | SIZE             | DESCRIPTION  | SIZE                | DESCRIPTION                                |
|--------------------|------------------|--------------|---------------------|--|
| Combination Wrench | 3/8"             | Feeler Gauge | 25 Blade            | Ft. Lb. Torque Wrench                      |
| Combination Wrench | 7/16"            | Drift Punch  | 5/16"               | In. Lb. Torque Wrench                      |
| Combination Wrench | 1/2"             | Ratchet      | 3/8" Drive          | Ring Compressor                            |
| Combination Wrench | 9/16"            | 3" Extension | 3/8" Drive          | Ring Expander                              |
| Combination Wrench | 5/8"             | 3/8" Socket  | 7/16" Hex. Standard | Valve Spring Compressor                    |
| Screw Driver       | 5/16" x 6"       | 3/8" Socket  | 1/2" Hex. Standard  | Needle Nose Pliers                         |
| Screw Driver       | 3/8" x 10"       | 3/8" Socket  | 1/2" Deep           | Timing Light                               |
| Screw Driver       | #1 Phillips x 3" | 3/8" Socket  | 9/16" Deep          | Tachometer                                 |
| Pliers             | 6"               | 3/8" Socket  | 13/16" Deep         | Strap-Wrench,                              |
| Ball Peen Hammer   | 12 oz.           |              |                     | Oil Filter Removal<br>(Snap-On Tool A-91B) |

**SPECIFICATIONS AND TOLERANCES**  
ALL DIMENSIONS IN INCHES

| HORSEPOWER (Maximum RPM)<br>Engine Model |  |                                    | 18                            | 20            | 23            | 24                         |               |
|--|--|------------------------------------|-------------------------------|---------------|---------------|----------------------------|---------------|
|  |  |                                    | K482                          | K532          | K582          | K662                       |               |
| <b>GENERAL</b>                           | <b>Bore x Stroke</b>                     |                                    | 3.251 x 2.875                 | 3.375 x 3.000 | 3.500 x 3.000 | 3.625 x 3.250              |               |
|  | <b>Displacement Cu. In.</b>              |                                    | 47.70                         | 53.70         | 57.73         | 67.20                      |               |
|  | <b>Max. Operating RPM</b>                |                                    | 3600                          | 3600          | 3600          | 3200                       |               |
| <b>CAMSHAFT</b>                          | <b>Sleeve I.D. Installed</b>             | <b>Rear</b>                        | 1.251/1.252                   | 1.251/1.252   | 1.251/1.252   | 1.251/1.252                |               |
|  |  | <b>Front</b>                       | 1.876/1.877                   | 1.876/1.877   | 1.876/1.877   | 1.876/1.877                |               |
|  | <b>End Play</b>                          |                                    | .003/.024                     | .003/.024     | .003/.024     | .017/.038                  |               |
| <b>CARBURETOR</b>                        | <b>Preliminary Turns Out</b>             | <b>Main</b>                        | 3                             | 3             | 3             | 3                          |               |
|  |  | <b>Idle</b>                        | 1-1/4                         | 1-1/4         | 1-1/4         | 1-1/4                      |               |
| <b>CONNECTION ROD</b>                    | <b>Running Clearance</b>                 | <b>Rod To Crank-Pin (New)</b>      | .001/.002                     | .001/.002     | .001/.002     | .0003-.0023                |               |
|  |  | <b>Rod To Crank-Pin Wear Limit</b> | .0025                         | .0025         | .0025         | .0025                      |               |
|  |  | <b>Rod To Piston Pin (New)</b>     | .0003/.0008                   | .0003/.0008   | .0003/.0008   | .0001/.0006                |               |
|  | <b>Small End I.D. (New)</b>              |                                    | .8596/.9599                   | .8757/.8760   | .8757/.8760   | .8754/.8756                |               |
| <b>CRANKSHAFT</b>                        | <b>MAINS</b>                             | <b>PTO &amp; Flywheel End O.D.</b> | <b>New</b>                    | 1.7716/1.7721 | 1.7716/1.7721 | 1.7716/1.7721 <sup>2</sup> | 2.2510/2.2515 |
|  |  |                                    | <b>Maximum Wear Limit</b>     | 1.7711        | 1.7711        | 1.7711                     | —             |
|  |  | <b>Max. Out of Round (Sleeve)</b>  |                               | .0005         | .0005         | .0005                      | —             |
|  |  | <b>Max. Taper (Sleeve)</b>         |                               | .001          | .001          | .001                       | —             |
|  |  | <b>Running Clearance (Sleeve)</b>  | <b>Maximum New</b>            | .004          | .004          | .004                       | —             |
|  |  |                                    | <b>Wear Limit<sup>1</sup></b> | .005          | .005          | .005                       | —             |
|  | <b>New Sleeve Bearing I.D. Installed</b> |                                    | 1.7515/1.7535                 | 1.7515/1.7535 | 1.7515/1.7535 | —                          |               |
|  | <b>CRANKPIN</b>                          | <b>New</b>                         |                               | 1.6250/1.6245 | 1.6250/1.6245 | 1.6250/1.6245              | 1.8750/1.8745 |
|  |  | <b>Max. Wear Limit</b>             |                               | 1.6240        | 1.6240        | 1.6240                     | 1.8740        |
|  |  | <b>Max. Out of Round</b>           |                               | .0005         | .0005         | .0005                      | .0005         |
|  |  | <b>Max. Taper</b>                  |                               | .001          | .001          | .001                       | .001          |
| <b>End Play</b>                          |  | .004/.010                          | .004/.010                     | .004/.010     | .0035/.0055   |                            |               |
| <b>CYLINDER BORE</b>                     | <b>Inside Diameter</b>                   | <b>New</b>                         | 3.2515/3.2510                 | 3.3755/3.3745 | 3.5005/3.4995 | 3.6255/3.6245              |               |
|  |  | <b>Maximum Wear Limit</b>          | 3.254                         | 3.378         | 3.503         | 3.628                      |               |
|  | <b>Max. Out of Round</b>                 |                                    | .005                          | .005          | .005          | .005                       |               |
|  | <b>Max. Taper</b>                        |                                    | .002                          | .002          | .002          | .002                       |               |

<sup>1</sup>Maximum limits combination of I.D. and O.D. measurements.

<sup>2</sup>Sleeve bearing 1.7495/1.7500.

| HORSEPOWER (Maximum RPM)<br>Engine Model         |  | 18                        | 20            | 23          | 24            |               |
|--|--|---------------------------|---------------|-------------|---------------|---------------|
|  |  | K482                      | K532          | K582        | K662          |               |
| <b>CYLINDER HEAD</b>                             | <b>Max. Out of Flatness</b>                              | .003                      | .003          | .003        | .003          |               |
| <b>IGNITION</b>                                  | <b>Spark Plug Type &amp; Gap</b>                         | <b>Type<sup>1</sup></b>   | RH-10         | RH-10       | RH-10         | RCJ-8         |
|  |  | <b>Battery</b>            | .025          | .025        | .025          | .025          |
|  |  | <b>Magneto</b>            | —             | —           | —             | .025          |
|  |  | <b>Gaseous Fuels</b>      | .018          | .018        | .018          | .018          |
|  | <b>Nominal Point Gap</b>                                 | .020                      | .020          | .020        | .020          |               |
| <b>PISTON</b>                                    | <b>Service Replacement Sizes</b>                         | ◀ .003—.010—.020—.030 ▶   |               |             |               |               |
|  | <b>Thrust Face O.D.<sup>2</sup></b>                      | <b>New</b>                | 3.2432/3.2413 | 3.368/3.365 | 3.4941/3.4925 | 3.6240/3.6235 |
|  |  | <b>Maximum Wear Limit</b> | 3.238         | 3.363       | 3.491         | 3.691         |
|  | <b>Thrust Face To Bore Clearance (New)<sup>2,3</sup></b> |                           | .007/.010     | .007/.010   | .007/.010     | .0005/.002    |
|  | <b>Ring End Gap</b>                                      | <b>New Bore</b>           | .010/.020     | .010/.020   | .010/.020     | .010/.020     |
|  |  | <b>Used Bore (Max.)</b>   | .030          | .030        | .030          | .030          |
| <b>Max. Ring Side Clearance</b>                  |  | .006                      | .006          | .006        | .006          |               |
| <b>PISTON PIN</b>                                | <b>Outside Diameter</b>                                  | .8591/.8593               | .8752/.8754   | .8752/.8754 | .8749/.8751   |               |
| <b>VALVES</b>                                    | <b>Guide Reamer Size</b>                                 |                           | .3125         | .3125       | .3125         | .34375        |
|  | <b>Tappet Clearance (Cold)</b>                           | <b>Intake</b>             | .008/.010     | .008/.010   | .008/.010     | .006/.008     |
|  |  | <b>Exhaust</b>            | .017/.020     | .017/.020   | .017/.020     | .015/.017     |
|  | <b>Minimum Lift (Zero Lash)</b>                          | <b>Intake</b>             | .318          | .318        | .318          | .318          |
|  |  | <b>Exhaust</b>            | .318          | .318        | .318          | .318          |
|  | <b>Minimum Valve Stem O.D.</b>                           | <b>Intake</b>             | .3103         | .3103       | .3103         | .3418         |
|  |  | <b>Exhaust</b>            | .3074         | .3074       | .3074         | .3403         |
|  | <b>Nominal Angle Valve Seat</b>                          |                           | 45°           | 45°         | 45°           | 45°           |
| <b>Guide I.D. Maximum Wear Limit<sup>3</sup></b> | <b>Intake</b>  | .006                      | .006          | .006        | .006          |               |
|  | <b>Exhaust</b>   | .008                      | .008          | .008        | .008          |               |

<sup>1</sup>Champion spark plugs or equivalent.

<sup>2</sup>Measure just below oil ring groove and at right angles to piston pin

<sup>3</sup>Maximum limits combination of I.D. and O.D. measurements.

# TORQUE VALUES & SEQUENCES FOR FASTENERS

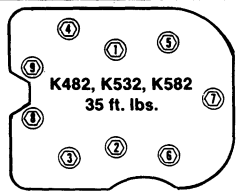
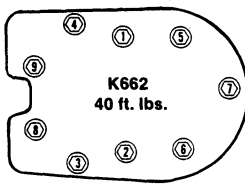
| HORSEPOWER (Max. RPM)<br>Engine Model  | 18<br>K482   | 20<br>K532      | 23<br>K582 | 24<br>K662   |
|--|--|-----------------|------------|--|
| Connecting Rods <sup>1 2</sup>         | 5/16—200 in. lbs.<br>3/8—300 in. lbs.  |                 |            | 35 ft. lbs.  |
| Spark Plugs                            | 18-22 ft. lbs.   |                 |            | 18-22 ft. lbs.   |
| CYLINDER HEAD <sup>1</sup>             | <br>K482, K532, K582<br>35 ft. lbs. |                 |            | <br>K662<br>40 ft. lbs. |
| FLYWHEEL NUT                           | 115 ft. lbs.   |                 |            | 130 ft. lbs.   |
| GRASS SCREEN                           | Metal  | 70-138 in. lbs. |            |  |
|  | Plastic  | —               |            |  |
| OIL PAN                                | Aluminum   | 30 ft. lbs.     |            |  |
|  | Cast Iron  | 35 ft. lbs.     |            |  |
| MANIFOLD SCREW/NUT                     | 210 in. lbs.   |                 |            | 300 in. lbs.   |
| CAMSHAFT NUT                           | 40 ft. lbs.  |                 |            | 25 ft. lbs.  |
| NON METALLIC FUEL PUMP MOUNTING SCREWS | 40-45 in. lbs.   |                 |            | —  |
| CLOSURE PLATE                          | 30 ft. lbs.  |                 |            | 50 ft. lbs.  |

USE STANDARD TORQUE SETTINGS WHEN SPECIFIC VALUES ARE NOT SPECIFIED.

Cast Iron or Steel

| Size    | Grade 2     | Grade 5*    | Grade 8     |
|---------|-------------|-------------|-------------|
|         |             |             |             |
| 8-32    | 20 in. lb.  | 25 in. lb.  |             |
| 10-24   | 32 in. lb.  | 40 in. lb.  |             |
| 10-32   | 32 in. lb.  | 40 in. lb.  |             |
| 1/4-20  | 70 in. lb.  | 115 in. lb. | 165 in. lb. |
| 1/4-28  | 85 in. lb.  | 140 in. lb. | 200 in. lb. |
| 5/16-18 | 150 in. lb. | 250 in. lb. | 350 in. lb. |
| 5/16-24 | 165 in. lb. | 270 in. lb. | 30 ft. lb.  |
| 3/8-16  | 260 in. lb. | 35 ft. lb.  | 50 ft. lb.  |
| 3/8-24  | 300 in. lb. | 40 ft. lb.  | 60 ft. lb.  |
| 7/16-14 | 35 ft. lb.  | 55 ft. lb.  | 80 ft. lb.  |
| 7/16-20 | 45 ft. lb.  | 75 ft. lb.  | 105 ft. lb. |
| 1/2-13  | 50 ft. lb.  | 80 ft. lb.  | 115 ft. lb. |
| 1/2-20  | 70 ft. lb.  | 105 ft. lb. | 165 ft. lb. |
| 9/16-12 | 75 ft. lb.  | 125 ft. lb. | 175 ft. lb. |
| 9/16-18 | 100 ft. lb. | 165 ft. lb. | 230 ft. lb. |
| 5/8-11  | 110 ft. lb. | 180 ft. lb. | 260 ft. lb. |
| 5/8-18  | 140 ft. lb. | 230 ft. lb. | 330 ft. lb. |
| 3/4-10  | 150 ft. lb. | 245 ft. lb. | 350 ft. lb. |
| 3/4-16  | 200 ft. lb. | 325 ft. lb. | 470 ft. lb. |

Aluminum

|         |             |             |             |
|---------|-------------|-------------|-------------|
| 8-32    | 20 in. lb.  | 20 in. lb.  | 20 in. lb.  |
| 10-24   | 32 in. lb.  | 32 in. lb.  | 32 in. lb.  |
| 1/4-20  | 70 in. lb.  | 70 in. lb.  | 70 in. lb.  |
| 5/16-18 | 150 in. lb. | 150 in. lb. | 150 in. lb. |

\*Also Self Tapping Screws

## Conversions

in. lbs. x .083 - ft. lbs.  
ft. lbs. x 12 - in. lbs.  
ft. lbs. x .1383 - kgm  
ft. lbs. x 1.3558 - N m

## OIL DRAIN PLUGS (Oil at Assembly)

| Size    | Tightening Torque |                |
|---------|-------------------|----------------|
|         | Cast Iron Pans    | Aluminum Pans  |
| 1/4"    | 150 in. lb.       | 100 in. lb.    |
| 3/8"    | 180 in. lb.       | 120 in. lb.    |
| 1/2"    | 20 ft. lbs.       | 13 ft. lbs.    |
| 3/4"    | 25 ft. lbs.       | 16 ft. lbs.    |
| X-708-1 | 20-25 ft. lbs.    | 20-25 ft. lbs. |

## K482, K532, K582

### Oil Pump Drive Gear Backlash

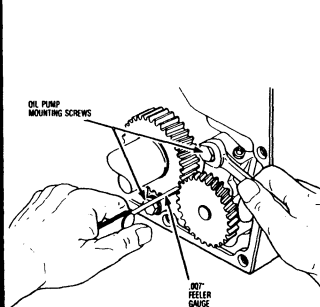

#### Feeler Gauge Method

Check backlash at three points on the gear (120° apart) to determine if backlash, through the gear circumference, falls within the specified range (.005"-.010").

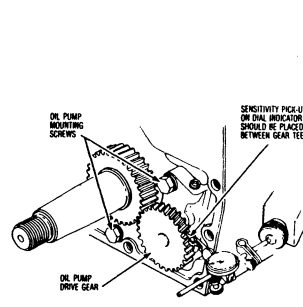

#### Dial Indicator Method

Check backlash at three points on the gear (120° apart) to determine if backlash, through the gear circumference, falls within the specified range (.005"-.010").

### Gear Cover

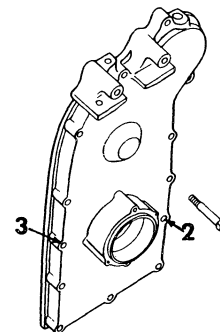

Install two shoulder capscrews (1/2" thread depth) in second and third holes as indicated. Tighten to 150 in. lbs. — then install other capscrews and torque to 150 in. lbs.

① Lubricate with engine oil

② Overtorque 20%, loosen below torque value & retorque to final torque value











# **KOHLER** **engines**

ENGINE DIVISION, KOHLER CO., KOHLER, WISCONSIN 53044