

KOHLER engines

twin cylinder engine SERVICE MANUAL

Models KT17 & KT19 **SERIES II** &
Models KT17, KT19, KT21

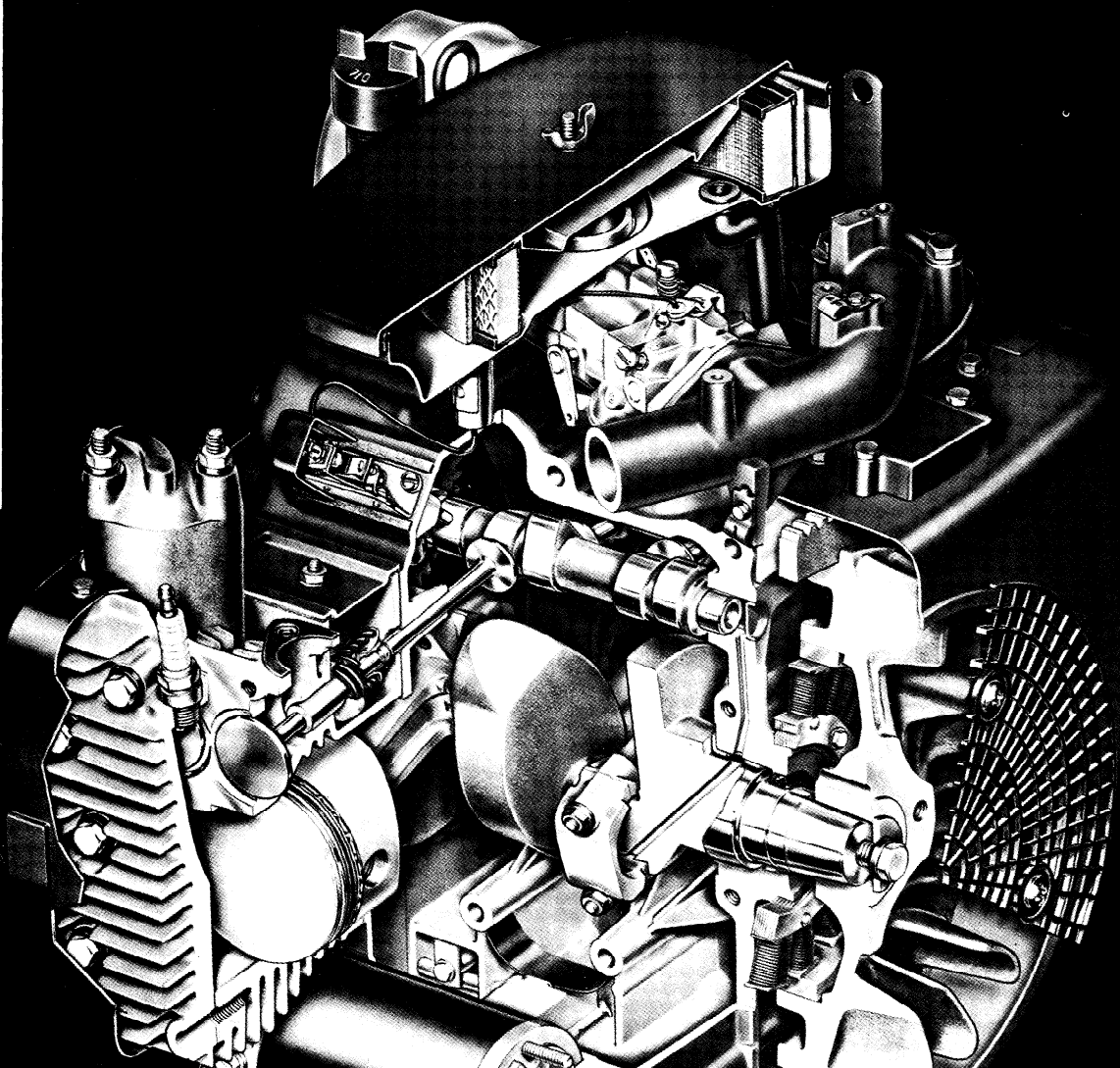

Section 1 - GENERAL INFORMATION	3-10
Section 2 - TROUBLESHOOTING	11-13
Section 3 - AIR INTAKE SYSTEM	15-18
Section 4 - FUEL SYSTEM AND GOVERNOR	19-26
Section 5 - LUBRICATION SYSTEM	27-28
Section 6 - ELECTRICAL SYSTEMS & COMPONENTS ..	29-40
Section 7 - DISASSEMBLY	41-52
Section 8 - ASSEMBLY	53-69
SUBJECT INDEX	71-74

INTRODUCTION

Long-life strength and on-the-job durability are designed and built into these Kohler engines. Parts subject to most wear and tear — like cylinders, crankshafts and camshafts — are made from precision-formulated cast iron . . . and because the cast iron cylinders can be rebored, these engines can last even longer.

These Kohler engines are easy to service. All routine service parts — points, condenser, spark plugs, air cleaner, carburetor — are easily and quickly accessible.

This manual provides the technician with information and instructions for servicing and repairing the KT17 & KT19 Series II, and KT17-KT19-KT21 engines. It is recommended the technician study the procedures and illustrations in this manual and use them as references when performing repairs.

KT engines use one of two types of Pressurized Lubrication Systems.

KT **SERIES II** engines have a *Full Pressure* lubrication system. The Specification Numbers for KT Series II models are:

KT17 Series II — Specifications 24300 And Higher

KT19 Series II — Specifications 49200 And Higher

Other KT17-KT19-KT21 engines use a *Pressurized Spray* lubrication system. The Specification Numbers for those models are:

KT17 — Specifications 24299 And Lower

KT19 — Specifications 49199 And Lower

KT21 — All Specifications

Refer to Section 5 — Lubrication System for additional information.

The **SERIES II** logo appears throughout this manual to identify information and service procedures unique to the Series II models.

SECTION 1 — GENERAL INFORMATION

ENGINE IDENTIFICATION NUMBERS

When ordering parts, or in any communication involving an engine, always include the Model, Specification, and Serial numbers of the engine.

The Model and Specification numbers appear on the engine identification decal, and directly below it is the decal with the Serial number. Both decals are located on the top of the engine shrouding.

The significance of each of these numbers is shown below.

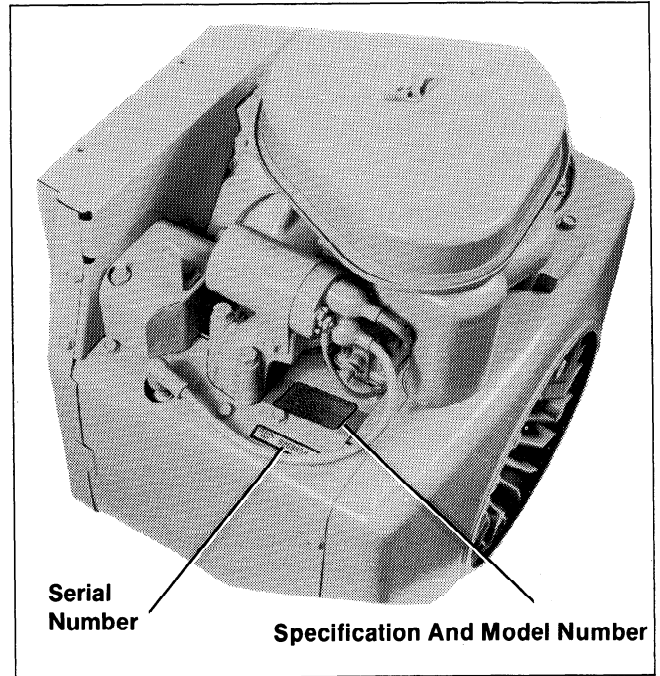
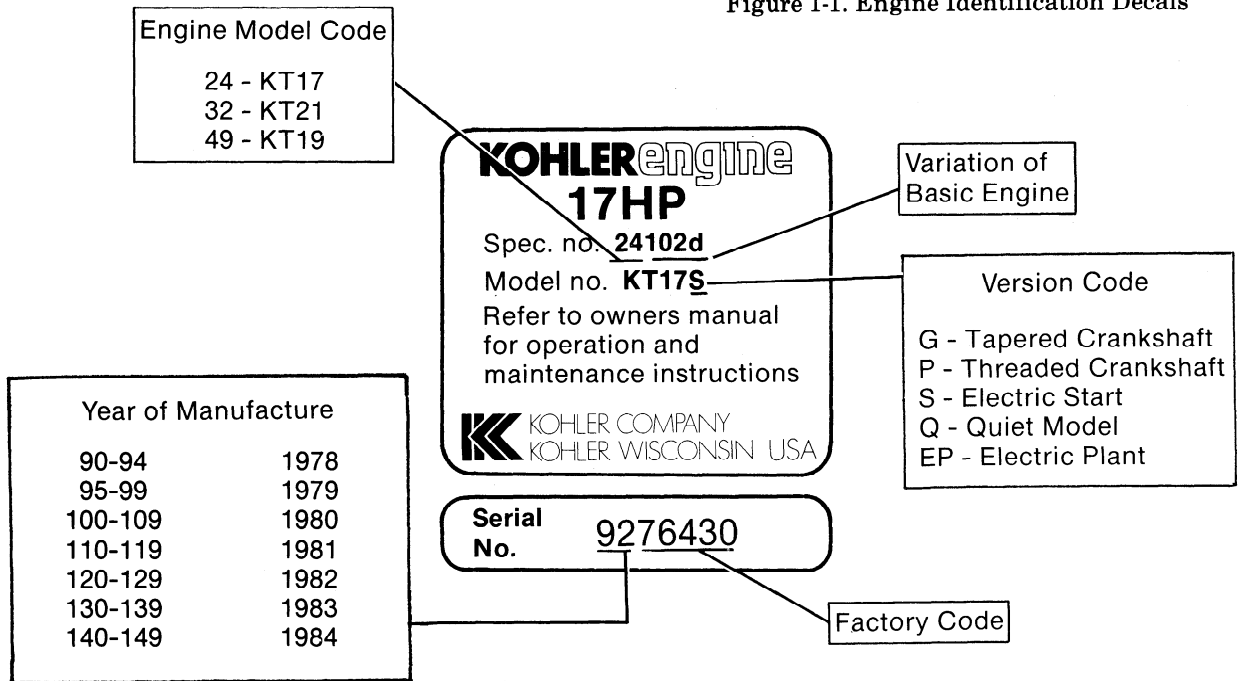

Figure 1-1. Engine Identification Decals



**SECTION 1
GENERAL INFORMATION**

FOR YOUR SAFETY



This symbol points out important safety **WARNINGS** and **CAUTIONS** which should be followed at all times. Follow **WARNINGS** to ensure the safety of yourself and others. Follow **CAUTIONS** to prevent damage to the engine or equipment.

General Safety Warnings

Before working on engine or equipment, disconnect battery cables from battery. Always disconnect the negative (ground) cable first. When connecting battery cables, always connect the negative (ground) cable last.

Never inhale exhaust fumes—all engine exhaust contains poisonous carbon monoxide. Never run the engine in a closed building or a confined area without adequate ventilation.

Never operate engine or equipment with shrouds, covers or safety guards removed. Hands, feet, clothing, or hair can get caught in moving parts resulting in personal injury.

Never touch the engine cylinder block, exhaust system, or cylinder head while the engine is running—or immediately after it is turned off. These parts can get hot and could burn you.

Never touch electrical wires or components while engine is running—they may be sources of electrical shock, which could severely injure or kill you.

Make sure cleaning solvents and other flammable liquids are properly identified and stored in covered containers safely away from the danger of combustion from open flames, sparks, etc.

OIL RECOMMENDATIONS

The importance of checking and changing crankcase oil cannot be overemphasized. Insufficient, or dirty oil causes premature engine wear and failure.

Oil Type

Use high quality detergent oil of API (American Petroleum Institute) service class SF or SG. Select the viscosity based on the air temperature at the time of operation as shown below:

Recommended SAE Viscosity Grades

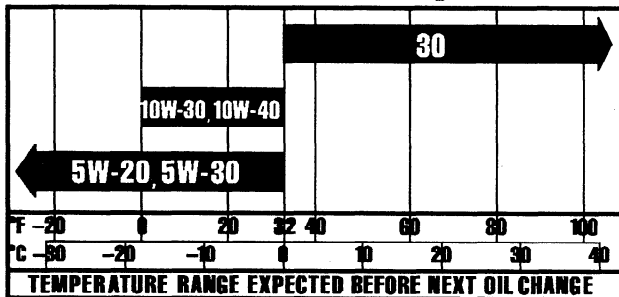

Straight 30-weight oil is recommended. Do not use multi-viscosity oils above 32°F (0°C) as considerable increases in oil consumption and combustion deposits will result.

NOTE: Using other than service class SF or SG oil or extending oil change intervals longer than recommended can cause engine damage which is not covered by the engine warranty.

A logo or symbol on oil containers identifies the API service class and SAE viscosity grade.



Oil Change

On a new engine, change oil after the first 5 hours of operation and then every 25 operating hours thereafter.

Drain oil while the engine is still warm from operation – it flows freely and carries away more impurities. Better drainage will result if the engine is tilted slightly toward the oil drain. After draining, reinstall drain plug.

Fill with proper viscosity oil to the “F” mark on dipstick. Always check level on dipstick before adding more oil. Engine must be level for accurate reading. Overfilling can cause engine to overheat.

On overhauled engines or those rebuilt with a new shortblock, use straight 30 weight service class SF or SG for the first 5 hours of operation. Change the oil after this initial run-in period. Refill with oil as specified in oil type.

Checking Oil

Before checking oil level, clean areas around dipstick and oil fill to prevent dirt from falling into engine.

Always check oil with engine stopped and on a level surface.

Check oil before each use when the engine is cool and the oil has drained back into the sump. Add oil, if low, to bring level up to, but not over the "F" mark on the dipstick.

NOTE: Do not operate engine with oil level below the "L" mark or over the "F" mark on the dipstick.

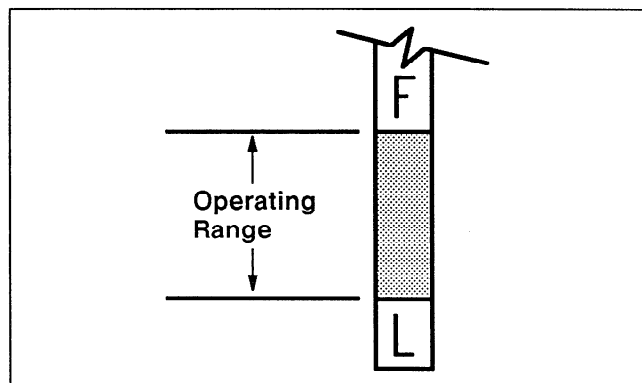

FUEL RECOMMENDATIONS

WARNING: Explosive Fuel!



Gasoline is extremely flammable and its vapors can explode if ignited. Store gasoline only in approved containers, in well-ventilated, unoccupied buildings, away from sparks or flames. Do not fill the fuel tank while the engine is hot or running, since spilled fuel could ignite if it comes in contact with hot parts or sparks from ignition. Do not start the engine near spilled fuel. Never use gasoline as a cleaning agent.

General Recommendations

Purchase gasoline in small quantities and store in clean, approved containers. A container with a capacity of 2 gallons or less with a pouring spout is recommended. Such a container is easier to handle and helps eliminate spoilage during refueling.

Do not use gasoline left over from the previous season, to minimize gum deposits in your fuel system and to insure easy starting.

Do not add oil to the gasoline.

Do not overfill the fuel tank. Leave room for the fuel to expand.

On gravity feed systems, turn the fuel valve off when the engine is not in use. Keep the vent hole in the tank filler cap open. If vent hole is plugged, pressure may build up in tank causing flooding or dangerous spraying of gasoline when cap is removed. A vacuum may also be created which could disrupt fuel flow to the carburetor during engine operation.

Fuel Type

For best results, use only clean, fresh, unleaded gasoline with a pump sticker octane rating of 87 or higher. In countries using the Research method, it should be 90 octane minimum.

Unleaded gasoline is recommended, as it leaves less combustion chamber deposits. Leaded gasoline may be used in areas where unleaded is not available and exhaust emissions are not regulated. Be aware however, that the cylinder head will require more frequent service.

Gasoline/Alcohol blends

Gasohol (up to 10% ethyl alcohol, 90% unleaded gasoline by volume) is approved as a fuel for Kohler engines. Other gasoline/alcohol blends are not approved.

Gasoline/Ether blends

Methyl Tertiary Butyl Ether (MTBE) and unleaded gasoline blends (up to a maximum of 15% MTBE by volume) are approved as a fuel for Kohler engines. Other gasoline/ether blends are not approved.

SERVICE SCHEDULE

NOTE: Intervals stated are for good, clean operating conditions. Service more frequently (even daily) if extremely dusty or dirty conditions prevail.

Service	Frequency
Change Lube Oil	25 hrs.
Service Precleaner	25 hrs.
Check Air Cleaner	50 hrs.
Clean Cooling Fins and External Surfaces	50 hrs.
Check Spark Plugs	100 hrs.
Check Compression	500 hrs.
Service Breaker Points	500 hrs.
Check Ignition Timing	500 hrs.
Check Valve & Tappet Clearance	500 hrs.
Service Cylinder Head	500 hrs.
Service Starting Motor Drive	500 hrs.

*250 hours when leaded gasoline is used.

The above service procedures should also be performed as part of any seasonal tune-up.

SECTION 1 GENERAL INFORMATION

AIR CLEANER SERVICE

KT engines have tear drop, square, or round air cleaners with dry type filter elements. Elements should be checked every 50 operating hours and replaced when dirty. Check and replace more often under extremely dirty, dusty conditions.

Replace with a genuine Kohler element. Carefully handle element - do not use if sealing surfaces are damaged.

Some models are equipped with Precleaners, which should be washed and oiled every 25 hours—see Section 3 for details, and for proper disassembly and reassembly procedures of air cleaners.

COOLING SYSTEM SERVICE

Air is drawn into the cooling shrouds by fins on the flywheel. The air intake screen and cooling fins on the cylinder heads and barrels must be kept clean and unobstructed at all times.

CAUTION: Do not operate engine with blower housing or cooling shrouds removed. They direct air flow past cooling fins and removal results in improper air circulation, overheating and engine damage.

External surfaces (see Figure 1-2), must be kept clean, free of oil and dirt accumulation. Dirty external surfaces result in poor cooling efficiency.

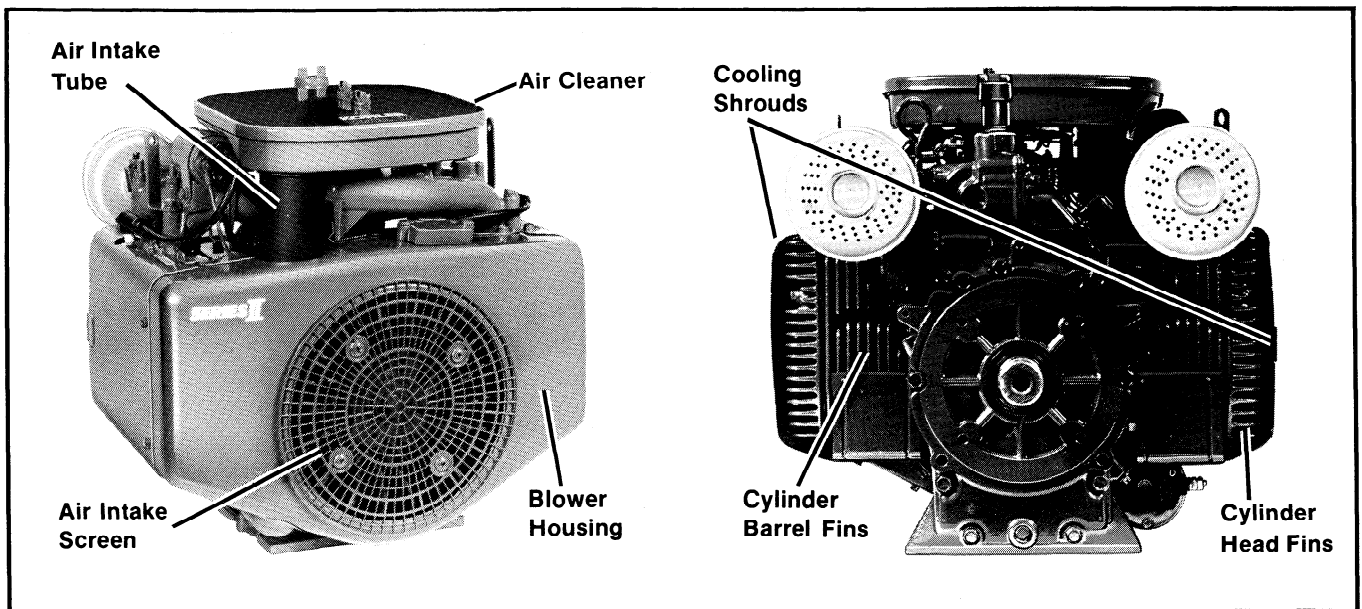

Figure 1-2. Keep These Areas Clean

SPECIFICATIONS AND TOLERANCES

GENERAL SPECIFICATIONS

	KT17	KT19	KT21
Bore (Nominal)	3.125" (79.375 mm)	3.125" (79.375 mm)	3.312" (84.125 mm)
Stroke	2.750" (69.8 mm)	3.063" (77.8 mm)	3.063" (77.8 mm)
Displacement	42.18 cu. in. (691.4 cc)	47 cu. in. (770.4 cc)	52.76 cu. in. (864.7 cc)
Horsepower at 3600 RPM	17 (12.7 kW)	19 (14.2 kW)	21 (15.7 kW)
Weight	118 lb. (53.5 kg)	121 lb. (54.9 kg)	124 lb. (56.2 kg)
Oil Capacity	3 pts. (1.42 L)	3 pts. (1.42 L)	3 pts. (1.42 L)
Spark Plug Gap025" (0.635 mm)	.025" (0.635 mm)	.025" (0.635 mm)
Spark Plug Size	14 mm	14 mm	14 mm
Spark Plug Reach460 (11.7 mm)	.460" (11.7 mm)	.460" (11.7 mm)
Spark Plug Type	Champion RBL15Y or Equivalent		
Breaker Point Gap017/.023" (.432/.580 mm)	.017/.023" (.432/.580 mm)	.017/.023" (.432/.580 mm)

TORQUE SETTINGS - Special

	KT17	KT19	KT21
Spark Plugs (ft. lbs.)	10-15 (14-20 N m) (1.4-2.1 kgm)	10-15 (14-20 N m) (1.4-2.1 kgm)	10-15 (14-20 N m) (1.4-2.1 kgm)
Flywheel Retaining Screw (ft. lbs.)	40 (54 N m) (5.5 kgm)	40 (54 N m) (5.5 kgm)	40 (54 N m) (5.5 kgm)
Manifold Screws (in. lbs.)	150 (17 N m) (1.7 kgm)	150 (17 N m) (1.7 kgm)	150 (17 N m) (5.5 kgm)
Closure Plate Screws (in. lbs.)	150 (17 N m) (1.7 kgm)	150 (17 N m) (1.7 kgm)	150 (17 N m) (1.7 kgm)
 (See Closure Plate Diagram Page 62 for Correct Tightening Sequence)		
Cylinder Head Screws* (ft. lbs.)	15-20 (20-27 N m) (2.8-3.7 kgm)	15-20 (20-27 N m) (2.8-3.7 kgm)	15-20 (20-27 N m) (2.8-3.7 kgm)
 (See Cylinder Head Diagram Page 63 for Correct Tightening Sequence)		
Cylinder Barrel Stud Nuts (in. lbs.)	360 (40.5 N m) (4 kgm)	360 (40.5 N m) (4 kgm)	360 (40.5 N m) (4 kgm)
 (See Barrel Diagram Page 62 for Correct Tightening Sequence)		
Connecting Rod Screws* (in. lbs.)	200 (23 N m) (2.3 kgm)	200 (23 N m) (2.3 kgm)	200 (23 N m) (2.3 kgm)
Connecting Rod Nuts* (Posi-Lock Rods) New Rod (in. lbs.)	140 (15.8 Nm) (1.6 kgm)	140 (15.8 Nm) (1.6 kgm)	_____
Used Rod (in. lbs.)	100 (11.3 Nm) (1.2 kgm)	100 (11.3 Nm) (1.2 kgm)	_____
Crankcase Stud Nuts (in. lbs.)	260 (29 N m) (3 kgm)	260 (29 N m) (3 kgm)	260 (29 N m) (3 kgm)
Crankcase Cap Screws	(See Crankcase Diagram Page 60 for Torque and Sequence)		
Crankcase Slot Head Screw (in. lbs.)	35 (4 N m) (0.4 kgm)	35 (4 N m) (0.4 kgm)	35 (4 N m) (0.4 kgm)

*Lubricate with oil at assembly.

TOLERANCES, FITTED PARTS

Crankcase End Play (Ball Bearing)002/.023" (.051/.580 mm)	.002/.023" (.051/.580 mm)	.002/.023" (.051/.580 mm)
Crankshaft End Play (Sleeve Bearing)002/.014" (.051/.355 mm)	.002/.014" (.051/.355 mm)	.002/.014" (.051/.355 mm)
Crankshaft Running Clearance (Sleeve Bearing)0013/.0033" (.034/.083 mm)	.0013/.0033" (.034/.083 mm)	.0013/.0033" (.034/.083 mm)
Camshaft End Play003/.013" (.077/.330 mm)	.003/.013" (.077/.330 mm)	.003/.013" (.077/.330 mm)
Camshaft Bearing0010/.0025" (.025/.063 mm)	.0010/.0025" (.025/.063 mm)	.0010/.0025" (.025/.063 mm)
Connecting Rod to Piston Pin Running0006/.0011" (.016/.027 mm)	.0006/.0011" (.016/.027 mm)	.0003/.0008" (.008/.020 mm)
Connecting Rod to Side Play on Crankpin005/.016" (.13/.41 mm)	.005/.016" (.13/.41 mm)	.005/.016" (.13/.41 mm)
Connecting Rod to Crankpin Running0012/.0024" (.030/.060 mm)	.0012/.0024" (.030/.060 mm)	.0012/.0024" (.030/.060 mm)
Piston Thrust Face to Bore Running (@ Gage Dia.)006/.008" (.15/.20 mm)	.0065/.0085" (.165/.216 mm)	.0065/.0085" (.165/.216 mm)
Rings - Side Clearance	Top .002/.004" (.051/.10 mm)	.002/.004" (.051/.10 mm)	.002/.004" (.051/.10 mm)
	Int .001/.003" (.025/.077 mm)	.001/.003" (.025/.077 mm)	.0015/.004" (.038/.01 mm)
	Oil .001/.003" (.025/.077 mm)	.001/.003" (.025/.077 mm)	.001/.003" (.025/.077 mm)
Rings - End Gap010/.020" (.254/.508 mm)	.010/.020" (.254/.508 mm)	.010/.020" (.254/.508 mm)
Wrist Pin to Piston Boss - Max.0003" (.008 mm)	.0003" (.008 mm)	.0003" (.008 mm)
Wrist Pin to Rod0006/.0011" (.016/.027 mm)	.0006/.0011" (.016/.027 mm)	.0003/.0008" (.008/.020 mm)
Intake Valve to Tappet - Cold003/.006" (.076/.150 mm)	.003/.006" (.076/.150 mm)	.003/.006" (.076/.150 mm)
Exhaust Valve to Tappet - Cold011/.014" (.279/.355 mm)	.011/.014" (.279/.355 mm)	.011/.014" (.279/.355 mm)
Valve Lift - Zero Lash280" (7.11 mm)	.280" (7.11 mm)	.280" (7.11 mm)
Intake Valve Stem to Guide - Max.0045" (.114 mm)	.0045" (.114 mm)	.0045" (.114 mm)
Exhaust Valve Stem to Guide - Max.0065" (.165 mm)	.0065" (.165 mm)	.0065" (.165 mm)

SECTION 1 GENERAL INFORMATION

TOLERANCES, FITTED PARTS (Cont'd)

	KT17	KT19	KT21
Tappet Clearance in Guide - Max.0005/.0024" (.013/.060 mm)	.0005/.0024" (.013/.060 mm)	.0005/.0024" (.013/.060 mm)
Valve Guide Interference Fit in Cylinder005/.002" (.013/.051 mm)	.005/.002" (.013/.051 mm)	.005/.002" (.013/.051 mm)
Valve Guide Ream Diameter.....	.312/.313" (7.925/7.950 mm)	.312/.313" (7.925/7.950 mm)	.312/.313" (7.925/7.950 mm)
Pump Shaft to Crankcase Running0010/.0025" (.025/.063 mm)	.0010/.0025" (.025/.063 mm)	.0010/.0025" (.025/.063 mm)
Pump Drive Gear End Play010/.029" (.254/.736 mm)	.010/.029" (.254/.736 mm)	.010/.029" (.254/.736 mm)

WEAR TOLERANCES

Cylinder Bore - New Diameter	3.125" (79.375 mm)	3.125" (79.375 mm)	3.312" (84.125 mm)
Cylinder Bore - Max. Wear Diameter	3.128" (79.45 mm)	3.128" (79.45 mm)	3.315" (84.201 mm)
Cylinder Bore - Max. Taper0015" (.038 mm)	.0015" (.038 mm)	.0015" (.038 mm)
Cylinder Bore - Max. Out of Round002" (.05 mm)	.002" (.05 mm)	.002" (.05 mm)
Crankshaft Crankpin New Diameter	1.3733 (34.882/34.895 mm) 1.3738"	1.3733/ (34.882/34.895 mm) 1.3738"	1.4993/ (38.082/38.095 mm) 1.4998"
Series II	1.3733/ (34.882/34.895 mm) 1.3738"	1.4993/ (38.082/38.095 mm) 1.4998"	_____
Crankshaft Crankpin - Max. Out of Round0005" (.013 mm)	.0005" (.013 mm)	.0005" (.013 mm)
Crankshaft Crankpin - Max. Taper001" (.025 mm)	.001" (.025 mm)	.001" (.025 mm)
Crankshaft Main Bearing New Diameter	1.7412/ (44.226/44.252 mm) 1.7422"	1.7412/ 44.226/44.252 mm) 1.7422"	1.7412/ (44.226/44.252 mm) 1.7422"
Crankshaft Main Bearing - Min. Diameter	1.7407" (44.22 mm)	1.7407" (44.22 mm)	1.7407" (44.22 mm)
Connecting Rod Crankpin Bore - New Diameter	1.3750/ (34.925/34.943 mm) 1.3757"	1.3750/ (34.925/34.943 mm) 1.3757"	1.5010/ (38.125/38.143 mm) 1.5017"
Series II	1.3750/ (34.925/34.943 mm) 1.3757"	1.5010/ (38.125/38.143 mm) 1.5017"	_____
Connecting Rod Crankpin Bore - Max. Diameter	1.3765 (34.963 mm) 1.3765 (34.963 mm)	1.3765 (34.963 mm) 1.5025 (38.164 mm)	1.5025 (38.164 mm) _____
Series II	1.3765 (34.963 mm)	1.5025 (38.164 mm)	_____
Connecting Rod Wristpin Bore - New Diameter62565" (15.891 mm)	.7511" (19.078 mm)	.85975" (21.837 mm)
Piston Thrust Face - Max. Wear Dia.*	3.1165" (79.159 mm)	3.1165" (79.159 mm)	3.303" (83.896 mm)

*Measured just below oil ring at right angles to pin.

TORQUE SETTINGS - General

Tightening Torque Into Cast Iron or Steel



Size	Grade 2	Grade 5	Grade 8
8-32	20 in. lb.	25 in. lb.	
10-24	32 in. lb.	40 in. lb.	
10-32	32 in. lb.	40 in. lb.	
1/4-20	70 in. lb.	115 in. lb.	165 in. lb.
1/4-28	85 in. lb.	140 in. lb.	200 in. lb.
5/16-18	150 in. lb.	250 in. lb.	350 in. lb.
5/16-24	165 in. lb.	270 in. lb.	30 ft. lb.
3/8-16	260 in. lb.	35 ft. lb.	50 ft. lb.
3/8-24	300 in. lb.	40 ft. lb.	60 ft. lb.
7/16-14	35 ft. lb.	55 ft. lb.	80 ft. lb.
7/16-20	45 ft. lb.	75 ft. lb.	105 ft. lb.
1/2-13	50 ft. lb.	80 ft. lb.	115 ft. lb.
1/2-20	70 ft. lb.	105 ft. lb.	165 ft. lb.
9/16-12	75 ft. lb.	125 ft. lb.	175 ft. lb.
9/16-18	100 ft. lb.	165 ft. lb.	230 ft. lb.
5/8-11	110 ft. lb.	180 ft. lb.	260 ft. lb.
5/8-18	140 ft. lb.	230 ft. lb.	330 ft. lb.
3/4-10	150 ft. lb.	245 ft. lb.	350 ft. lb.
3/4-16	200 ft. lb.	325 ft. lb.	470 ft. lb.

Tightening Torque Into Aluminum

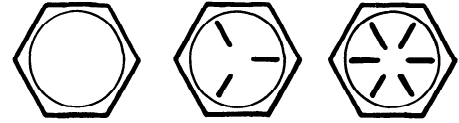

Size	Grade 2	Grade 5	Grade 8
8-32	20 in. lb.	20 in. lb.	20 in. lb.
10-24	32 in. lb.	32 in. lb.	32 in. lb.
1/4-20	70 in. lb.	70 in. lb.	70 in. lb.
5/16-18	150 in. lb.	150 in. lb.	150 in. lb.

Conversions

in. lbs. x .083 - ft. lbs.
 ft. lbs. x 12 - in. lbs.
 ft. lbs. x .1383 - kgm
 ft. lbs. x 1.3558 - N m

SPECIAL TOOLS

Service and repair procedures will be made easier by using proper tools. Use only the correct size tool to fit each size of fastener.

Some procedures detailed in this manual recommend use of tools which can be made by the service man. (Figures 1-5 and 1-6)

Some procedures require the use of special Kohler designed tools (Figures 1-3 and 1-4) which are available from your Kohler distributor.

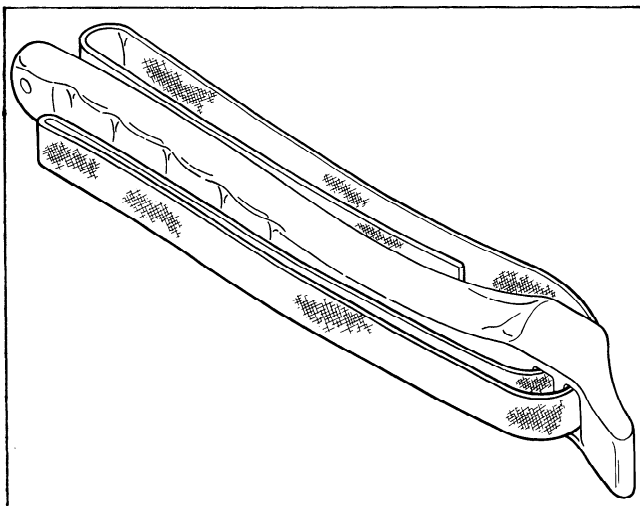

Figure 1-3. Flywheel Strap Wrench (52 455 03)
 Replacement Strap (52 445 04)

WARNING: Suitable eye protection through the use of safety glasses, goggles, or face hood should be worn for any procedure involving the use of compressed air, punches, hammers, chisels, drills, or grinding tools.

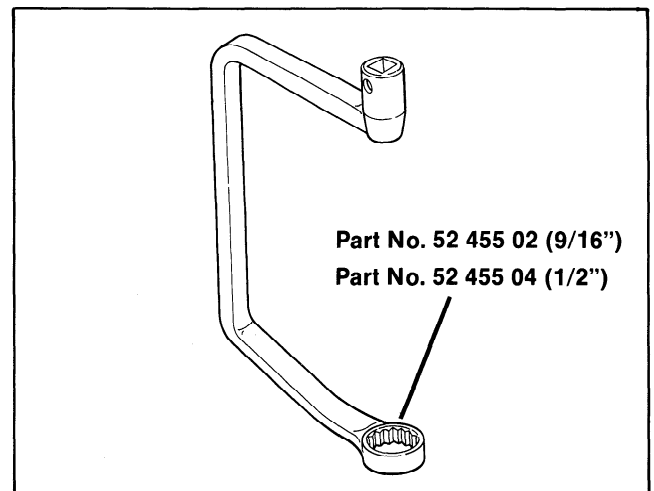

Figure 1-4. Barrel Wrench

SECTION 1 GENERAL INFORMATION

How to make a "U" Tube Manometer

(Used to measure Crankcase Vacuum. See Section 2 - Troubleshooting.)

1. Cut a piece of 1/2" plywood so it measures 10" x 30" as in Figure 1-5.
2. Fasten a six foot length of 1/2" O.D. clear plastic tubing to the plywood board as shown in Figure 1-5. Make a gradual rather than a sharp bend in the tube.
3. Inside the "U" formed by the tubing, measure off at least a 24" segment on the plywood board between the straight sides of the "U". Divide the segment into one inch increments and mark these increments on the board. Start with the middle increment as zero and number in both directions.
4. Drill a 1/2" hole in the center of a rubber stopper the size to be a snug fit in the engine oil fill hole. Insert long end of tube thru stopper hole.
5. Add a shut-off valve or clamp in front of the stopper to prevent engine from drawing water into crankcase under cranking conditions.
6. Pour colored water into the tube until the level reaches the halfway (0) mark of the scale marked on the plywood board.

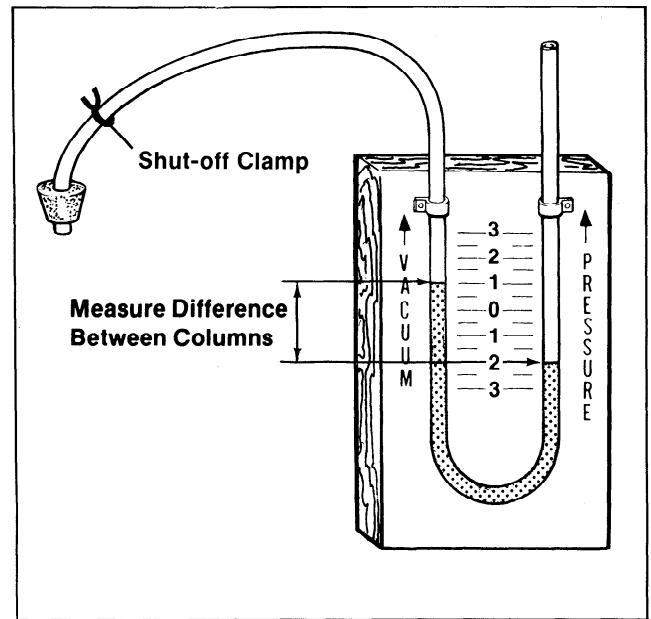

Figure 1-5. "U" Tube Manometer

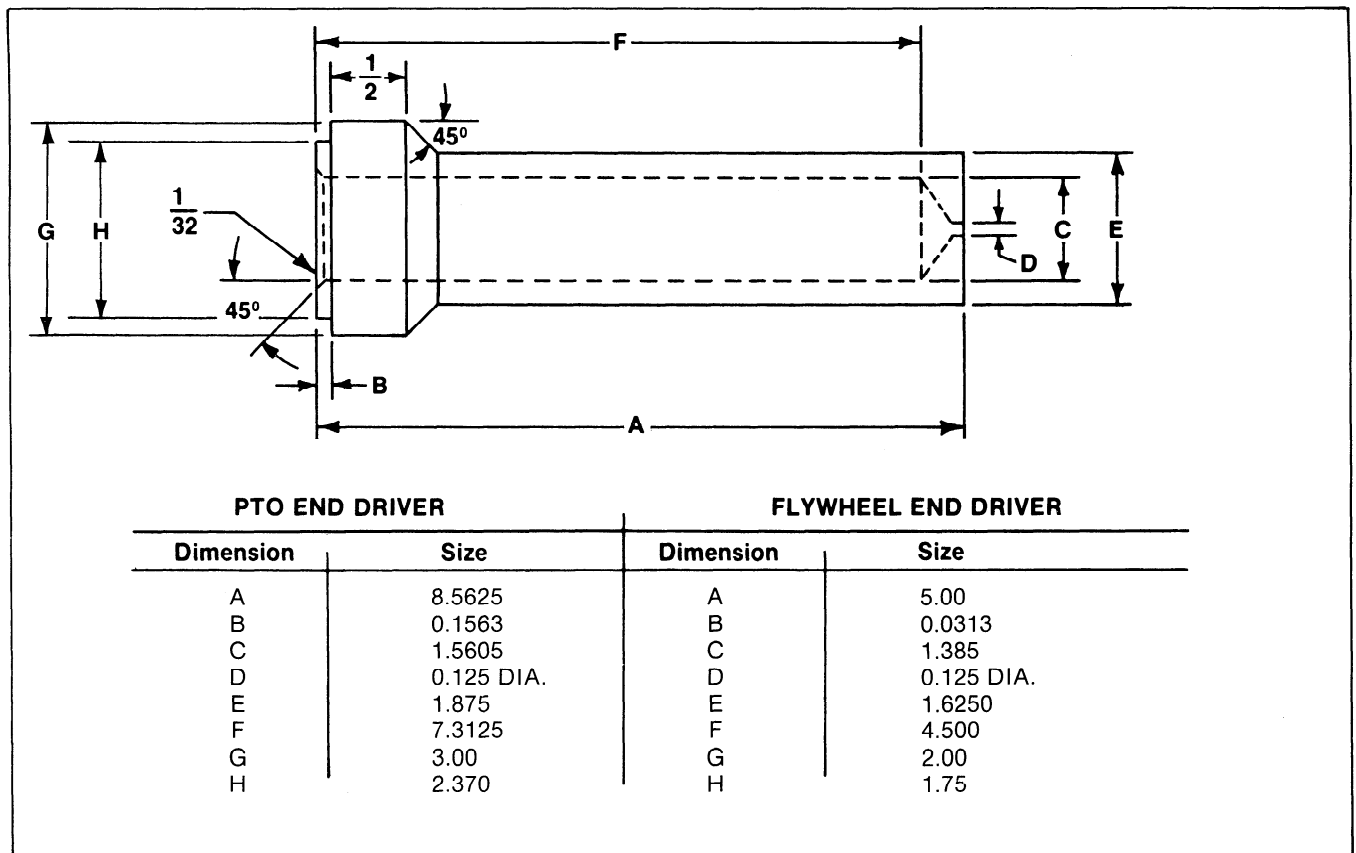

Figure 1-6. Seal Driver (P.T.O.)—Seal Driver (Flywheel)

SECTION 2 — TROUBLESHOOTING

When troubles occur, don't overlook simple causes which might seem too obvious to be considered. A starting problem could, for example, be attributed

simply to an empty fuel tank. The chart below lists some common causes of engine troubles - use this as a guide to locate causing factors.

Engine Starts But Fails To Keep Running

- Restricted fuel tank vent.
- Carburetor not properly adjusted.
- Broken choke cable.
- Dirt or water in fuel system.
- Breaker points not properly adjusted.
- Loose wires or connections.
- Defective head gasket.
- Faulty condenser.
- Faulty fuel shutdown control.

Engine Runs But Misses

- Breaker points not properly adjusted.
- Defective spark plugs.
- Loose wires or connections.
- High tension leads loose at coil.
- Carburetor float leaking or not properly adjusted.
- Dirt or water in fuel system.
- Wrong valve clearance.
- Faulty coil.
- Air intake or shrouding plugged.

Engine Misses Under Load

- Defective spark plugs.
- Carburetor not properly adjusted.
- Incorrect spark plugs.
- Breaker points not properly adjusted.
- Ignition out of time.
- Dirt or water in fuel system.

Engine Will Not Idle

- Idle speed too slow.
- Idle mixture needle not properly adjusted.
- Dirt or water in fuel system.
- Restricted fuel tank filler cap.
- Defective spark plugs.
- Wrong valve clearance.
- Low engine compression.

Engine Overheats

- Air intake or shrouding plugged.
- Carburetor not properly adjusted.
- Too much oil in crankcase.
- Crankcase low on oil.
- Excessive engine load.

Engine Knocks

- Engine out of time.
- Excessive engine load.
- Crankcase low on oil

Engine Uses Excessive Amount of Oil

- Clogged breather assembly.
- Breather not assembled properly.
- Worn or broken piston rings.
- Worn cylinder bores.

- Wrong size piston rings.
- Worn valve stems and/or valve guides.
- Incorrect oil viscosity.

Engine Will Not Crank

- Hydrostatic drive not in neutral.
- Battery discharged or defective.
- PTO drive engaged.
- Defective safety switch.
- Defective starter.
- Defective solenoid.
- Loose electrical connections.
- Defective key switch.

Engine Cranks But Will Not Start

- Empty fuel tank.
- Restricted fuel tank vent.
- Fuel shut-off valve closed.
- Clogged or restricted fuel line.
- Breaker points worn or pitted.
- Defective spark plugs.
- Battery not fully charged.
- Loose electrical connections.
- High tension leads loose at coil.
- Faulty condenser.
- Defective ignition coil.
- Dirt in fuel system.
- Faulty fuel shutdown control.

SECTION 2 TROUBLESHOOTING

Engine Starts Hard

Defective spark plugs.
Breaker points worn or pitted.
Loose wires or connections.
Restricted fuel tank vent.
Clogged or restricted fuel line.
Broken choke or throttle cable.
Dirt or water in fuel system.
Carburetor not properly adjusted.
Wrong valve clearance.
Head gasket leaking.
Low compression.

Engine Loses Power

Crankcase low on oil.
Air intake or shrouding plugged.
Excessive engine load.
Restricted air filter.
Dirt or water in fuel system.
Carburetor not properly adjusted.
Defective spark plugs.
High tension leads loose at coil.
Too much oil in crankcase.
Low engine compression.
Worn cylinder bore.

EXTERNAL ENGINE INSPECTION

Before cleaning or disassembling an engine, check the external condition—it may give clues to what may be found inside the engine once it is disassembled.

- Check for buildup of dirt and debris on the engine block and other external surfaces. Pay close attention to the air intake screen and cooling fins—a plugged screen or fins can cause overheating.
- Check for obvious fuel and oil leaks and damaged components.
If excessive oil leakage is evident, this may indicate an improperly serviced breather system. Normally, an engine operates with a slight vacuum in the crankcase. If pressures build up in the crankcase from a clogged breather or piston blow by, oil will be forced out at oil seals, gaskets, or any other available spot.
- Check the air cleaner cover and baseplate for damage or indications of improper fit and seal. Also check the seal on the air cleaner cover wing nut—a missing or damaged seal could allow dirt to enter the engine.
- Check the air cleaner element. Look for holes, tears, cracked or damaged sealing surfaces, or other damage that could allow dirt to enter engine. Also note if the element is plugged or restricted, which would indicate that it has been underserviced.
- Check the carburetor throat for dirt. Dirt in the throat is further indication that the air cleaner is not functioning properly.

- Check the oil level. Note if the oil is at the recommended level or if low or overfilled.
- Check the condition of the oil. Drain the oil into a container—the oil should flow freely. Check for metal chips and other foreign particles.

NOTE: It is good practice to drain oil at a location away from the work bench. Be sure to allow ample time for complete drainage.

Sludge is a natural by-product of combustion, and a small accumulation is normal. Excessive sludge formation could indicate several things: the oil has not been changed often enough, operating with improper ignition timing, or an overrich carburetor adjustment, to name a few.

Cleaning Engine

After checking the external condition of the engine, it should be thoroughly cleaned prior to disassembly. Also, clean all parts as the engine is disassembled. Only clean parts can be accurately gauged and inspected for wear or damage.

There are many commercially available cleaners that quickly remove grease, oil, and grime accumulation from engine parts. If such a cleaner is used, *follow the manufacturer's instructions carefully*. Make sure that all traces of the cleaner are removed before the engine is reassembled and placed in operation. Even small amounts of these cleaners quickly break down the lubricating properties of engine oils.

BASIC ENGINE TESTS

Crankcase Vacuum

A partial vacuum should be present in the crankcase when engine is operating at normal temperatures.

Crankcase vacuum check is best accomplished with the “U” tube manometer.

Vacuum gauges, mercury and water manometers are available commercially. However, a simple “U” tube manometer can easily be constructed. See “Section 1 Special Tools” for instructions.

An engine in good condition will have crankcase vacuum of 15 inches (minimum) water column as read on “U” tube water manometer, or 1.10 inches (minimum) Hg as on mercury vacuum gauge.

Crankcase Vacuum Test

To test crankcase vacuum with a manometer:

1. Insert stopper in oil fill hole, leave other end of tube open to atmosphere. Make sure shut-off clamp is closed.
2. Start engine and run at high speed—3200 to 3600 rpm.

3. Release the clamp and note the water level in the tube. The level in the engine side should be 15-20” above the level in the open side. If there is no vacuum or a positive pressure, check for the following conditions:

NOTE: Clamp must be closed before stopping engine.

- a. **Crankcase breather clogged or inoperative.** Disassemble breather, clean parts thoroughly, reassemble, and recheck pressure.
- b. **Seals and/or gaskets leaking.** Check for proper sealing of crankcase.
- c. **Blowby or leaky valves.** Confirm by testing compression.
- d. **Exhaust restriction.** Check for defective muffler.

Compression Test

To check compression, remove spark plugs, insert compression gauge in each spark plug hole, set the throttle and choke to the wide open position, insure that air intake and exhaust systems are not re-

stricted, and motor engine using the starting motor. Take several readings on both cylinders. A difference in pressure reading between cylinders in excess of 15%, or readings below 90 PSI can indicate the following:

LOW COMPRESSION

Possible Cause	Remedy
A. Cylinder head gasket blown.	A. Remove head, check for flatness, replace gasket, reinstall head, recheck compression. Locate and correct the cause of initial failure.
B. Cylinder head warped or loose.	B. Remove head, check for flatness (see cylinder head service). Locate and correct the cause of initial failure.
C. Piston rings worn - blowby occurring.	C. Recondition engine.
D. Valves leaking.	D. Recondition valves and seats.
E. Excessive combustion deposits.	E. Remove head and clean combustion deposits from combustion chamber.

SECTION 3 — AIR INTAKE SYSTEM

3

AIR CLEANER ASSEMBLY

Three types of air cleaner assemblies are used on KT models: tear drop, square, and round.

Some air cleaners may be equipped with a specially designed “anti-icing” system. The anti-icing system uses heat from the exhaust manifold to prevent ice buildup in the carburetor and intake manifold during cold weather operation.

The following guidelines apply to all air cleaner assemblies:

1. Air cleaner base must be flat on gasket of air intake elbow. Replace base if bent or cracked.
2. Gasket surfaces of element must be flat against base and cover to seal effectively.
3. Cover seal must be in place to reduce noise and vibration of cover. Excess vibration can cause stud hole in cover to enlarge, permitting dirt to enter carburetor.
4. Wing nut must be finger tightened 1/2 to 1 full turn after nut contacts cover—do not over-tighten.

Refer to the instructions for the specific type of air cleaner being serviced.

Tear Drop (Figure 3-1)

Disassembly

1. Remove the wing nut, cover, air cleaner cover seal, and element.
2. Remove the breather hose and air intake tube from air cleaner base.
3. Remove the screws securing base to intake elbow. Lift base from intake elbow.

Assembly

1. Install air cleaner base and new base gasket on elbow and secure with four 10-32 x 9/16” hex washer head screws. Secure base to manifold with hex nut on manifold stud.
2. Pull end of breather tube through 9/16” hole in base making sure lips on end of tube seal securely around hole in base.

NOTE: Early KT17 models have the breather tube attached to intake elbow.

3. Slide air intake tube through hole in base so that the end of tube extends into the blower housing. The angled end of tube should face to the right (long side-left, short side-right) when inserted into blower housing (as seen from flywheel end). Make sure lips on end of tube seal securely around hole in base.
4. Place element on base.
5. Attach air cleaner cover seal to cover. Place cover on base and secure with wing nut finger tightened 1/2 to 1 full turn after nut contacts cover—do not over-tighten. (Seal on cover must be in place and cover tightened to prevent vibration.)

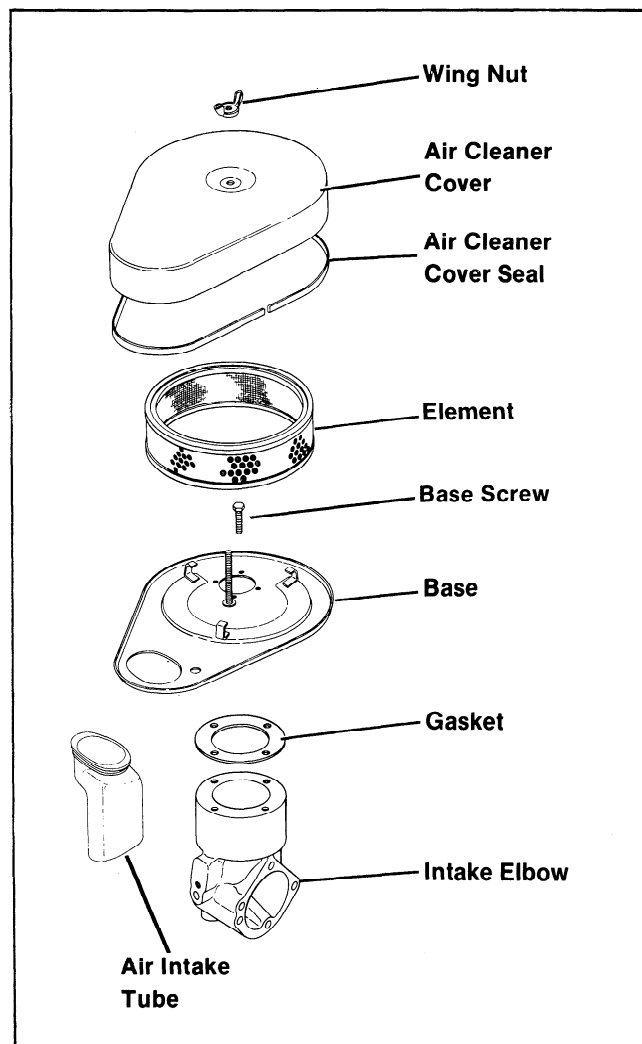

Figure 3-1. Tear Drop Air Cleaner Assembly

SECTION 3 AIR INTAKE SYSTEM

Fabricated Breather Hose

KT17 engines with the teardrop shape air cleaner built prior to 1980 had a three-piece fabricated breather hose (Figure 3-2) installed as original equipment. Some engines show interference between the governor spring and this fabricated hose resulting in the end of the hose being dislodged from the air cleaner base plate.

When servicing a KT17 engine with a teardrop air cleaner, note the breather hose, and if it is fabricated, check the center portion around the hose clamps for any indication (rubbing, abrasion, or wear) of interference with the governor spring. If interference is found, replace the fabricated hose with a new one-piece molded hose (Figure 3-3).

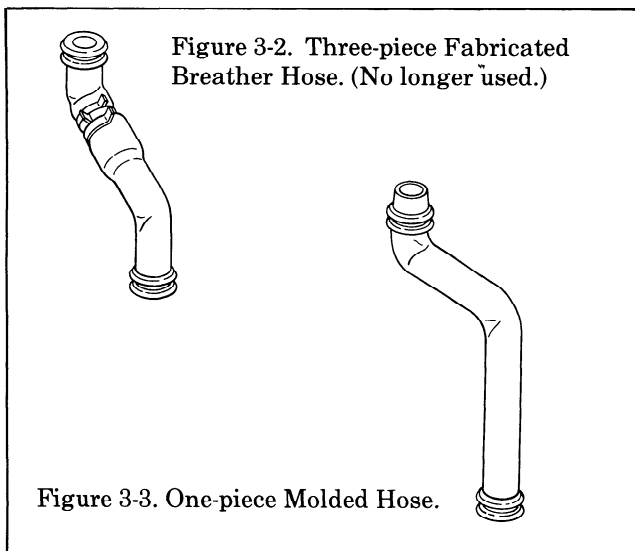

Square (Figure 3-4)

Disassembly

1. Remove wing nuts, air cleaner cover, element cover seals, element cover, and element (with precleaner).
2. Remove the breather hose, air intake tube, and air cleaner cover seal from air cleaner base.
3. Remove the screw securing air cleaner base to intake manifold. Lift base from intake elbow.

Assembly

1. Install air cleaner base and new base gasket on elbow and secure to intake manifold with hex head screw.
2. Pull end of breather tube through 9/16" hole in base making sure lips on end of tube seal securely around hole in base.

3. Slide air intake tube through hole in base so that end of tube extends into the blower housing. The angled end of tube should face to the right (long side-left, short side-right) when inserted into the blower housing (as seen from the flywheel end). Make sure lips on end of tube seal securely around hole in base.
4. Place element on base.
- 4a. Elements with precleaners have a cover which fits on top of the element. Place seals on studs extending through top of cover.
5. Install air cleaner cover seal on base. Place cover on base and secure with two wing nuts—finger tightened 1/2 to 1 full turn after nuts contact cover—do not overtighten. (Seal on base must be in place and cover tightened to prevent vibration.)

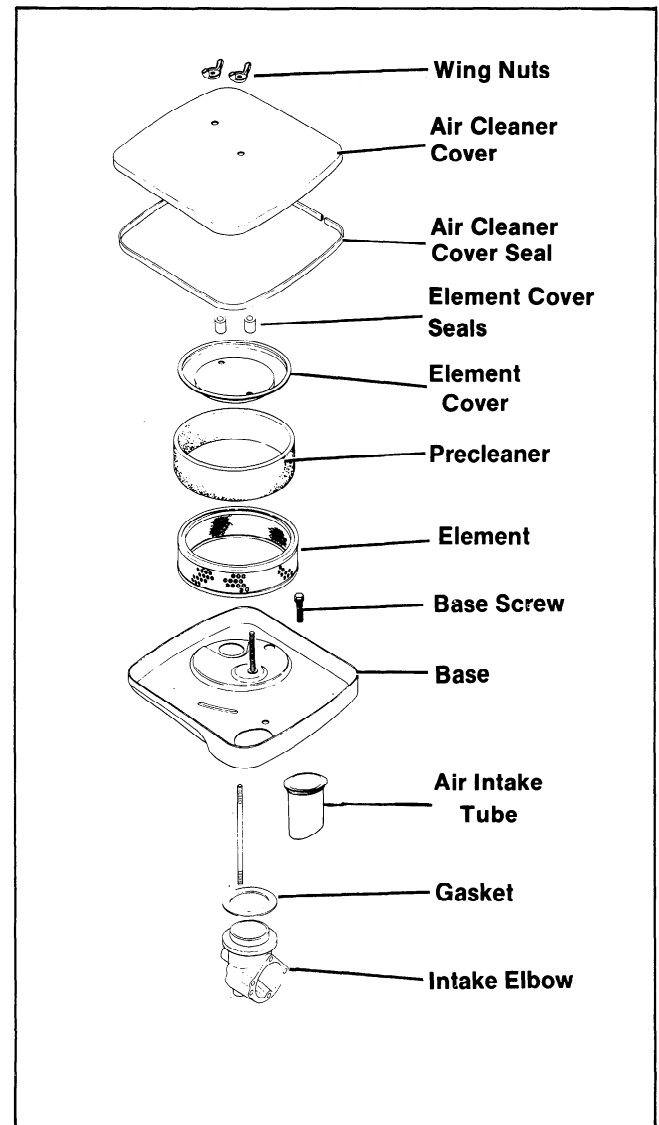

Round (Figure 3-5)

Disassembly

1. Remove wing nut, air cleaner cover, element cover seal, element cover, and element (with precleaner).
2. Remove the breather hose from air cleaner base.
3. Remove the screws securing base to intake elbow. Lift base from intake elbow.

Assembly

1. Install air cleaner base and new base gasket on elbow and secure with four hex washer head screws.
2. Pull end of breather tube through 9/16" hole in base making sure lips on end of tube seal securely around hole in base.
3. Install precleaner over element and place on base.
4. Place element cover on element and the seal on the stud extending through top of element cover.
5. Secure air cleaner cover with wing nut—finger tightened 1/2 to 1 full turn after nut contacts cover—do not overtighten.

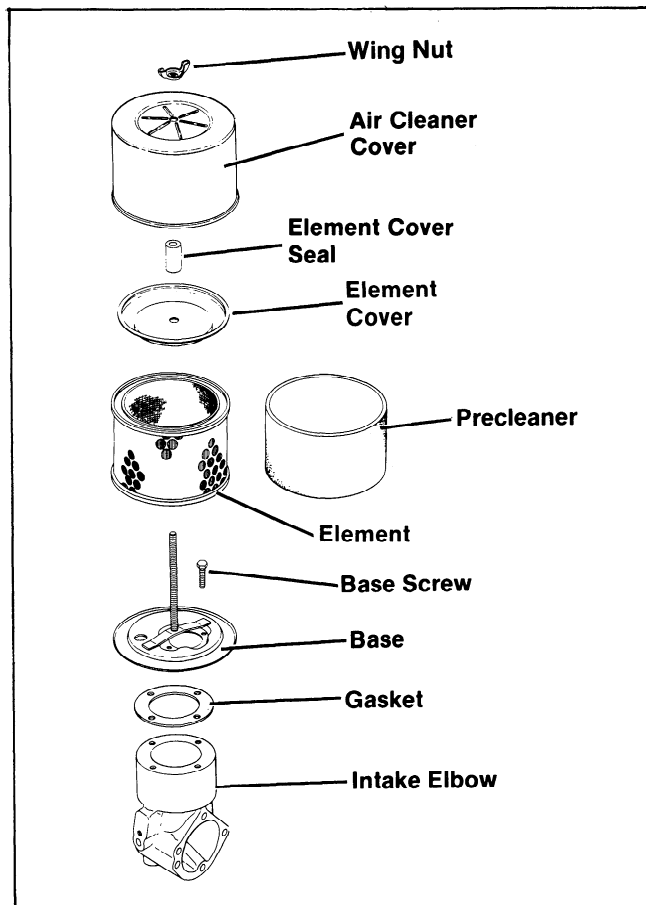
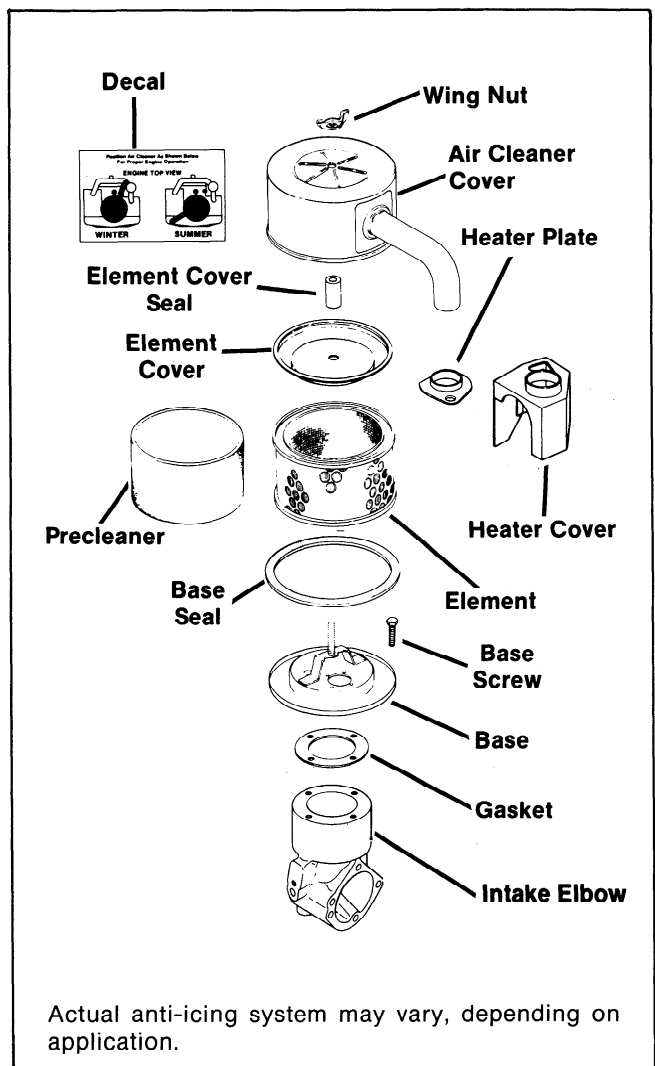

Figure 3-5. Round Air Cleaner Assembly

Anti-Icing System (Figure 3-6)



Actual anti-icing system may vary, depending on application.

Figure 3-6. Anti-Icing System

Disassembly

1. Remove wing nut, air cleaner cover, element cover seal, element cover, element (with pre-cleaner), and air cleaner base seal.
2. Remove the breather hose from air cleaner base.
3. Remove the screws securing air cleaner base to intake elbow. Lift base from intake elbow.
4. Remove the air inlet heater cover, air inlet heater, or heater plate, if so equipped.

Assembly

1. If so equipped, install inlet heater cover, or heater plate over the exhaust outlet on the #2 side of crankcase.
2. Install new base gasket and air cleaner base to intake elbow and secure with four hex washer head screws.

SECTION 3 AIR INTAKE SYSTEM

- Pull end of breather tube through 9/16" hole in base. Make sure lips on end of tube seal securely around hole in base.
- Place air cleaner base seal on base. Install precleaner over element and place on base.
- Place element cover on element. Slip the element cover seal over the stud extending through top of element cover.
- Install air cleaner cover with air inlet duct positioned for the correct season. Refer to the decal affixed to the cover (see Figure 3-7).

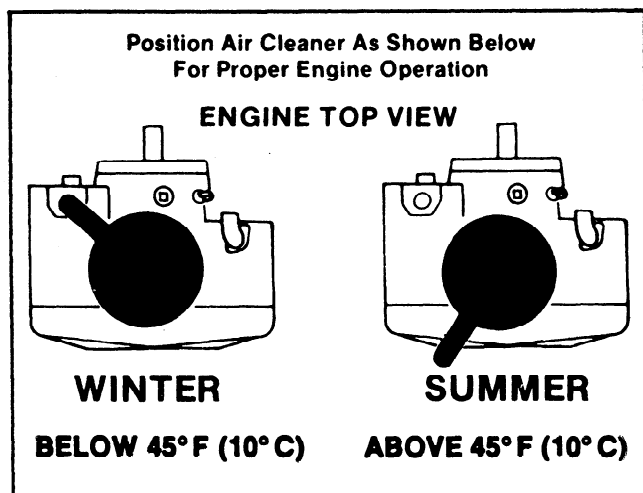

Figure 3-7. Typical Anti-Icing Air Cleaner Cover Positions

For "winter" position—make sure air inlet duct fits completely over heater cover or heater plate. See Figure 3-8. To prevent unfiltered air from

entering engine, make sure air cleaner cover is sealed around entire perimeter of base.

- Install wing nut and finger tighten 1/2 to 1 full turn after nut contacts cover. Do not overtighten.

CAUTION: To prevent vapor-lock and to ensure proper engine operation, do not operate engine during "summer" seasons with air cleaner cover in "winter" position.



Precleaner

Some models are equipped with a precleaner. Precleaners extend the useful life of the paper element by trapping and retaining dust.

Precleaners should be washed and oiled every 25 operating hours, or more often under extremely dirty, dusty conditions, as follows:

- Remove precleaner from air cleaner element and wash precleaner in water with detergent.
- Rinse thoroughly until all traces of detergent are eliminated.
- Squeeze away excess water and air dry. (Do not wring precleaner.)
- Soak in fresh, clean engine oil and squeeze out excess oil.
- Reinstall precleaner over air cleaner element.

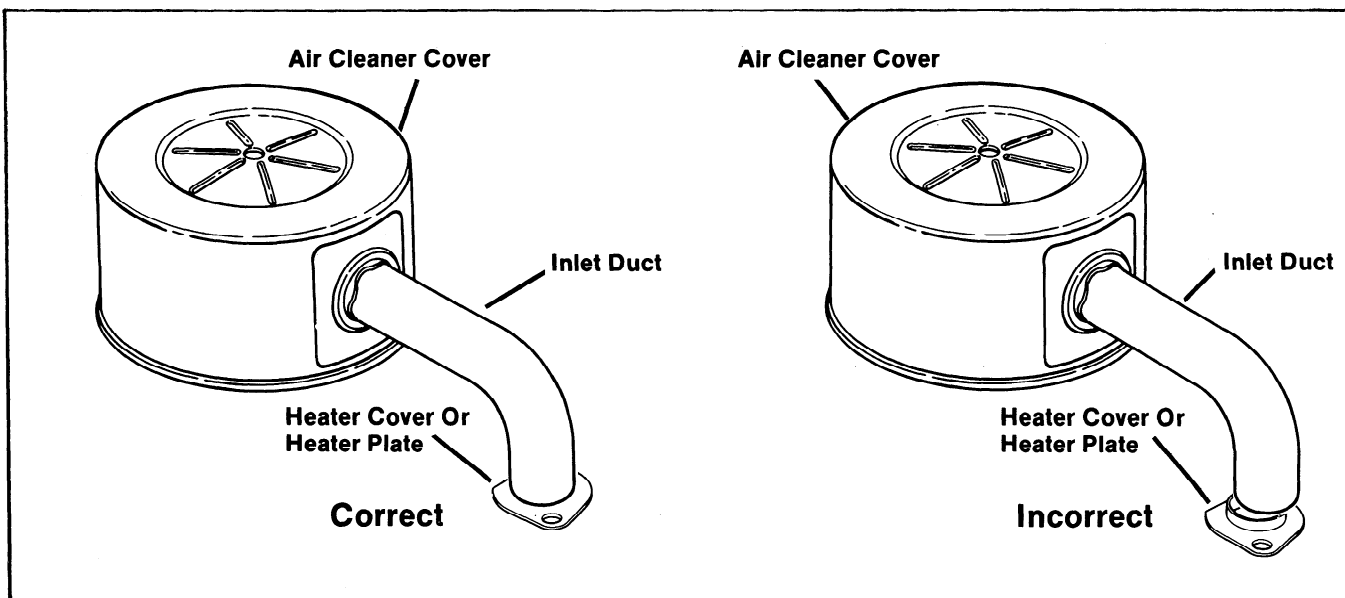

Figure 3-8. Installing Anti-Icing Air Inlet Duct

SECTION 4 - FUEL SYSTEM & GOVERNOR

CARBURETOR

These engines are equipped with a side draft, adjustable jet carburetor that was properly set at the factory and should not have to be reset. If black exhaust smoke is noted, check the air cleaner first -an apparent "overrich" mixture can actually be

due to a clogged air cleaner element. If element is replaced and black smoke continues, or if other conditions listed in the following table exist, adjust the carburetor immediately. An incorrect setting can lead to fouled spark plugs, overheating, excessive valve wear or other problems.

Condition	Possible Cause/Probable Remedy
<ol style="list-style-type: none"> 1. Black, sooty exhaust smoke, engine sluggish. 2. Engine misses and backfires at high speed. 3. Engine starts, sputters and dies under cold weather starting. 4. Engine runs rough or stalls at idle speed. 	<ol style="list-style-type: none"> 1. Mixture too rich - readjust main fuel screw. 2. Mixture too lean - readjust main fuel screw. 3. Mixture too lean - turn main fuel adjustment 1/4 turn counterclockwise. 4. Idle speed too low or improper idle adjustment — readjust speed then idle fuel screw if needed.

4

To Adjust Carburetor:

Carburetor adjustments should be made only after engine has warmed up.

1. Stop engine, turn main fuel and idle fuel adjusting screws clockwise, until they bottom **lightly**.

CAUTION: Adjusting screw ends taper to critical needle valves which will be damaged if screws are turned in forcefully.



2. **Preliminary Settings—Main Fuel** - (Models KT17 and KT19) - turn main fuel adjusting screw counterclockwise 2-1/2 turns from bottom. (Model KT21) - turn main fuel adjusting screw counterclockwise 3 turns from bottom. **Idle Fuel** - (For all KT models) - turn idle fuel adjusting screw counterclockwise 1 to 1-1/4 turns from bottom.

3. **Final Setting—Main Fuel** - Start and run engine at half-throttle for 5-10 minutes to warm up. Turn main fuel adjusting screw clockwise from the preliminary setting until speed decreases and note position of the screw. Now turn the screw counterclockwise - the engine speed may first increase, then it will decrease as it is turned. Note the position of the screw when engine speed starts to decrease. Set the screw midway between the two points noted.

4. **Final Setting—Idle Fuel** - Allow engine speed to fall to idle or put throttle in Idle position. Make adjustment using the same procedure as Final Setting - Main Fuel in Step 3.
5. **Idle Speed Setting**—Run engine at half-throttle for 5-10 minutes to warm up. Allow engine speed to fall to idle, or put throttle in Idle position. Set engine speed to 1200 RPM (\pm 75 RPM) by turning the idle speed screw clockwise or counterclockwise.

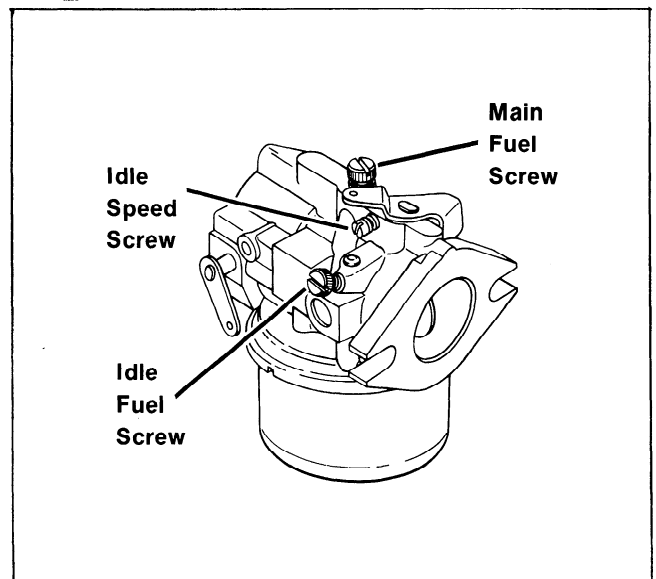

Figure 4-1. Carburetor Adjustments

SECTION 4 FUEL SYSTEM AND GOVERNOR

CARBURETOR RECONDITIONING

Difficulties with fuel systems usually originate from improper carburetor settings, or from dirt, gum or varnish in carburetor components. The necessity of cleaning will depend upon use and operating conditions. To clean thoroughly, it will be necessary to disassemble carburetor.

Cleaning Carburetor

All parts should be carefully cleaned using a carburetor cleaner (such as acetone). *Follow cleaner manufacturer's warnings and instructions on its proper and safe use.*

CAUTION: Carburetor should not be submersed in cleaner or solvent, it may damage fiber and rubber seals.



Be sure all deposits are removed from bore, especially where throttle plate seats in casting. Blow out all passages with compressed air. Replace all worn and damaged parts. Always use new gaskets.

Carburetor repair kits are available from your Kohler parts supplier. Kits include a bowl retaining screw gasket, bowl ring gasket, float pin, bowl baffle gasket, and fuel inlet needle and seat.

Disassembly of Carburetor

(see Figure 4-2 for location of parts)

WARNING: *Disconnect and ground spark plug leads to eliminate electrical spark. When disconnecting fuel lines be sure to wipe up any spilled fuel and make sure no sources of heat, flame or sparks are near, as these can cause gasoline fumes to explode.*



1. Shut off fuel source.
2. Disconnect breather hose from carburetor intake elbow or from air cleaner base. (See Figure 8-39).
3. Remove air cleaner assembly.
4. Disconnect fuel line, governor linkage and choke linkage from carburetor.
5. Disconnect carburetor (with elbow attached) from manifold by removing two nuts. Separate carburetor from elbow by removing three screws.
6. Remove bowl retaining screw and bowl. (*Bowl may still contain gasoline—handle carefully.*)
7. Remove float pin, float, fuel inlet needle and seat. Check float for dents and leaks, also check for wear on float tabs or float hinge.
8. Remove baffle gasket and bowl gasket.
9. Remove idle fuel adjusting screw, main fuel adjusting screw and springs.
10. If the throttle and choke shafts are worn, a repair kit is available. Refer to the Parts Manual for the part number of this kit.

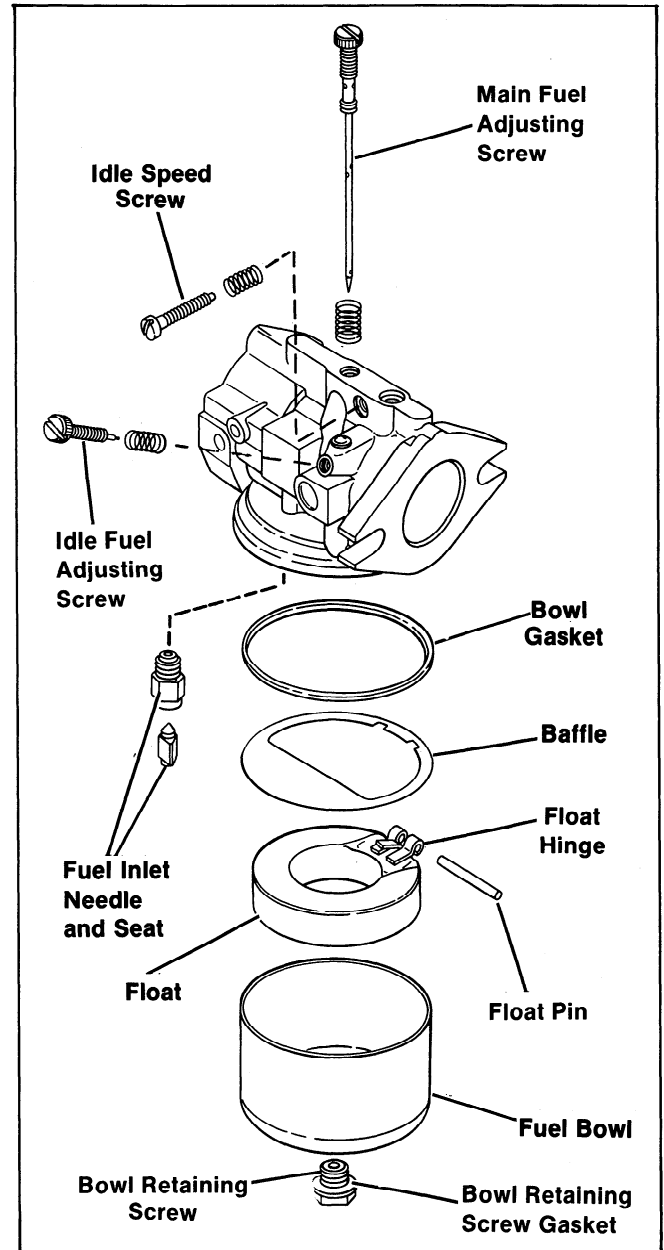

Figure 4-2. Side Draft Carburetor - Exploded View

Assembly of Carburetor

1. With carburetor casting inverted, install fuel inlet seat. Torque seat to 35 in. lbs.
Install inlet needle, float, and float pin.
- NOTE:** Floats in current production carburetors have two tabs on the float hinge. Bend tab

“A” to set float level (Step 2). Bend tab “B” to set float drop (Step 3). See Figure 4-3.

For floats with tab “A” only, set float level (Step 2) - omit Step 3.

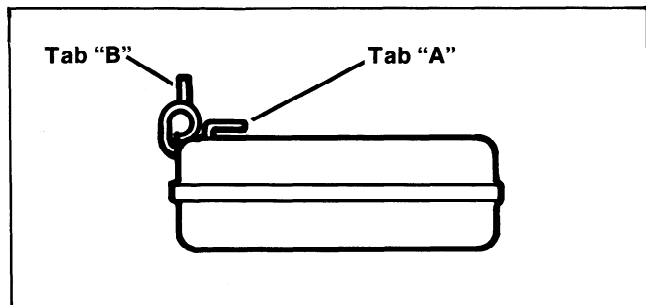

Figure 4-3. Float Tab Details

2. **Set float level.** Invert carburetor—with float resting lightly against inlet needle in its seat, there should be $11/64$ " ($\pm 1/32$ ") clearance between machined surface of casting and free end of float (side opposite needle seat). Adjust by bending float tab “A” with a small screwdriver. See Figure 4-4.

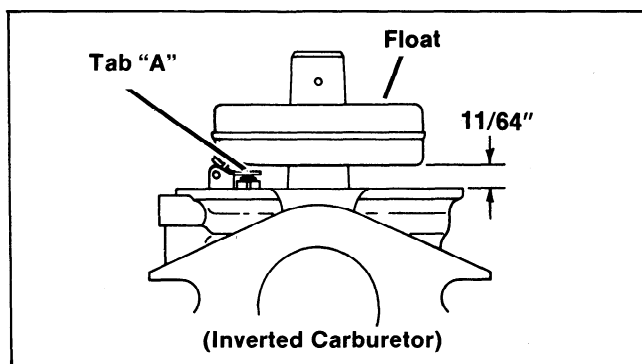

Figure 4-4. Setting Float Level

3. **Set float drop.** With carburetor in normal operating position, float drop should be limited to $1-1/32$ " between machined surface of casting and free end of float. Adjust by bending float tab “B.” See Figure 4-5.

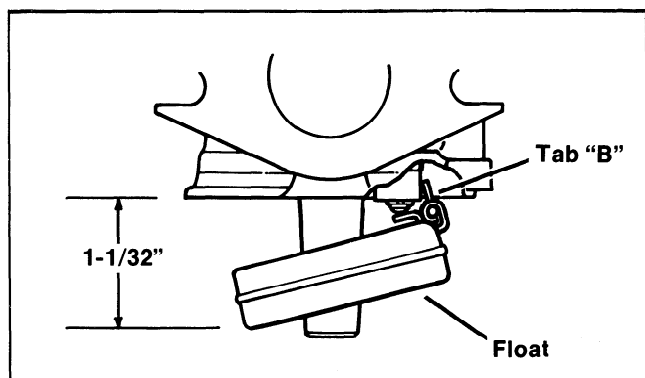

Figure 4-5. Setting Float Drop

4. **Check float clearance.** Invert carburetor—check clearance between float and float pin towers with a $.010$ " feeler gauge. If feeler cannot be inserted or if there is interference between the float and towers, file the towers to achieve proper clearance. See Figure 4-6.

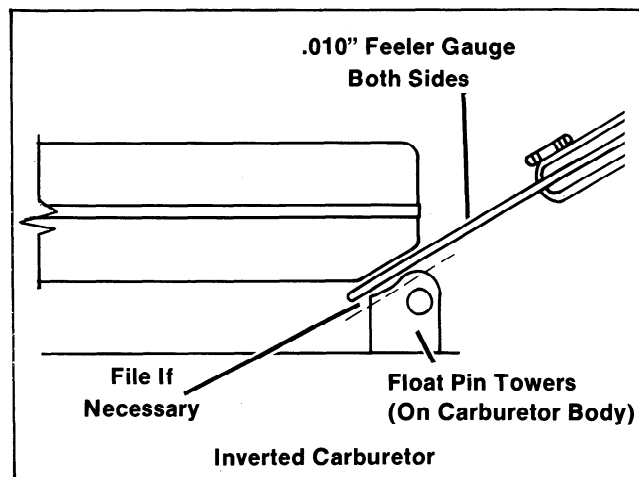

Figure 4-6. Checking Float Clearance

5. Install new bowl gasket and baffle gasket. Position baffle gasket so that the inner edge of gasket is against float pin towers.
6. Install fuel bowl—make sure it is centered on baffle gasket to form a good seal. Install bowl retaining screw and gasket. Torque screw to 50 in. lbs.
7. Install main fuel and idle fuel adjusting screws and springs. Turn in until needle bottoms **lightly**. Install idle speed adjusting screw and spring.
8. Connect carburetor to inlet elbow with three screws. Connect carburetor with inlet elbow to manifold with two nuts.
9. Connect fuel line, governor linkage and choke linkage to carburetor. (See Figure 4-7.)
10. Assemble air cleaner. (See Section 3.)
11. Connect breather hose to inlet elbow (early KT17 models only) or air cleaner base.
12. Turn fuel source back on.
13. Adjust carburetor as instructed under “To Adjust Carburetor.”

SECTION 4 FUEL SYSTEM AND GOVERNOR

GOVERNOR SYSTEM

WARNING: *Never tamper with governor settings to increase the maximum speed of the engine. Overspeeding can cause equipment parts to exceed design limitations, resulting in component failures. Parts breaking under excess stress can become lethal missiles if thrown off by the equipment. Broken parts flying through the air can injure or kill.*

These engines are equipped with a centrifugal flyweight mechanical governor. The governor gear/flyweight mechanism is mounted within the crankcase and driven off a gear on the camshaft.

Governor Operation

Centrifugal force causes the flyweights to move outward as speed increases and inward as speed decreases. As the flyweights move outward, they force the rod portion of the assembly to push outward. The rod, in turn, contacts a tab on the governor cross shaft causing it to rotate with changing speed. One end of the cross shaft protrudes through the side of the crankcase. Through external linkage, the action of the cross shaft is transmitted to the throttle (or butterfly) valve in the carburetor.

When the engine is at rest and the throttle is in the "Fast" position, the tension of the governor spring holds the throttle valve open. When the engine is operating (governor gear is turning), the force applied by the governor gear against the cross shaft tends to close the throttle valve. The governor spring tension and the force applied by the governor gear are in "equilibrium" during operation and hold the engine speed constant.

When a normal load is applied and engine (and governor) speed decrease, the tension of the governor spring rotates the governor arm to open the throttle valve wider. This admits more fuel and restores engine speed. (With the governor properly adjusted, this action takes place so rapidly, a reduction in speed is hardly noticed.) As speed reaches the governed setting, the tension of the governor spring and the force applied by the governor gear will again be in equilibrium, maintaining speed at a relatively constant level. For identification of the governor components mentioned above, see Figure 4-7.

Governed speed may be at a fixed point as on constant speed applications, or variable as determined by a throttle control.

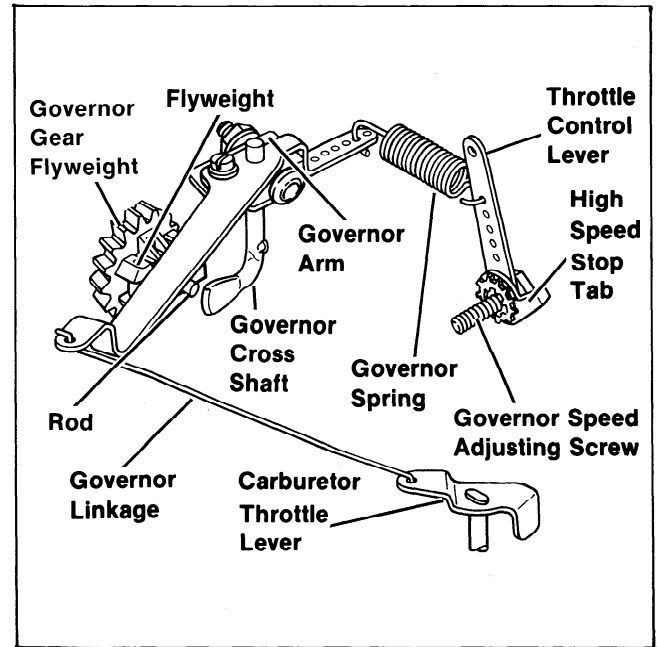

Figure 4-7. Governor Components

Adjustments

Governors are adjusted at the factory and further adjustment should not be necessary. Governor adjustment may be indicated if engine speed surges with changing load, or if speed drops considerably when **normal** load is applied.

Speed Adjustment - Maximum allowable speed for these engines is 3600 RPM, no load. Check operating speed with a hand tachometer. Do not exceed this speed. If adjustment is necessary loosen the governor speed adjusting screw and pivot the high speed stop tab until desired speed setting is reached, then tighten the screw.

Sensitivity Adjustment - Governor sensitivity can be adjusted by repositioning the governor spring in the holes on the governor arm. If set too sensitive, speed surging will occur with change of load. If a big drop in speed occurs when normal load is applied, the governor should be set for greater sensitivity.

Normally, the governor spring is placed in the fifth hole from pivot of the governor arm and in the sixth hole from pivot on the throttle control lever. To make governor control more sensitive, increase governor spring tension by moving the spring end closer to the center of the governor arm. To allow broader governor control but less sensitivity, decrease spring tension by moving the spring toward the end of the arm.

SERIES II

OPTIONAL THROTTLE AND CHOKE CONTROL

Some Series II Engines are equipped with throttle and choke controls mounted to the intake manifold.

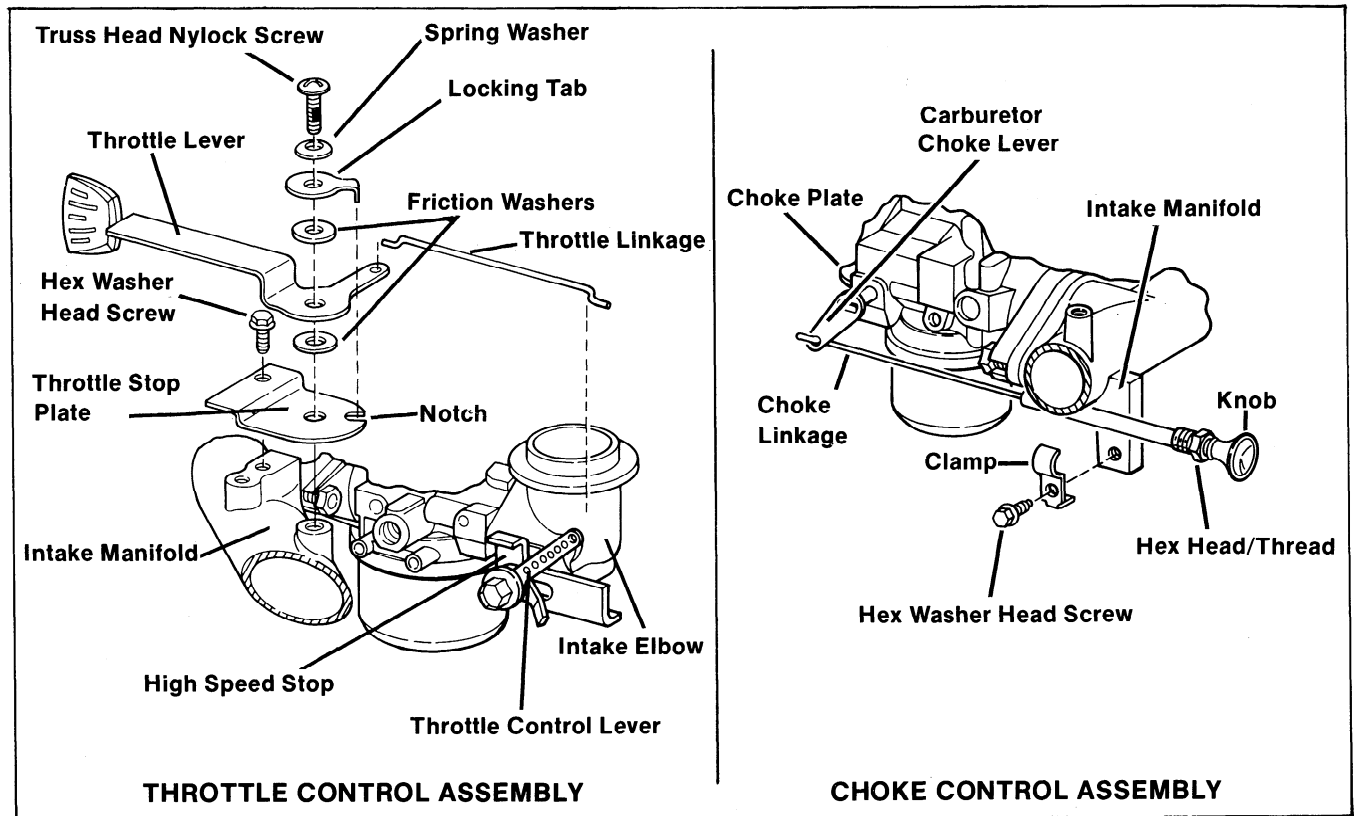

Figure 4-8. Engine Throttle And Choke Controls

Disassembly

1. Remove the 1/4-20x5/8" truss head nylock screw securing throttle control components to intake manifold. Remove the spring washer, locking tab, friction washers and throttle lever. Disconnect throttle linkage.
2. Remove the 10-24x3/8" hex washer head screw and throttle stop plate from intake manifold.
3. Remove the 10-24x3/8" hex washer head screw and clamp securing choke control assembly to intake manifold. Disconnect choke linkage from choke lever on carburetor.

Assembly

1. Install throttle stop plate to intake manifold. Secure with a 10-24x3/8" hex washer head screw.
2. Connect throttle linkage to throttle lever and throttle control lever (on carburetor intake elbow).

3. Install friction washers and throttle lever, locking tab, spring washer, and 1/4-20x5/8" truss head nylock screw. Make sure locking tab is positioned in the notch in throttle stop plate. See Figure 4-8.
Tighten the nylock screw enough to hold throttle lever in position while the engine is running. Do not overtighten the screw—the throttle lever should still operate smoothly.
4. Connect choke linkage to choke lever on carburetor. Loosely install choke control assembly to intake manifold with clamp and 10-24x3/8" hex washer head screw.

Adjustment: With choke knob against hex head/thread, move choke control assembly towards carburetor until choke plate is in the wide open position—tighten screw securely. See Figure 4-8.

SECTION 4 FUEL SYSTEM AND GOVERNOR

FUEL PUMP

These engines have a mounting pad and provision on the crankcase for a mechanically operated fuel pump. On applications with gravity feed systems, the pad is covered and the fuel pump is not used.

Fuel Pump Operation

The mechanical pump operates off a cam on the camshaft. The fuel pump lever rides on the cam transmitting a pumping action to a diaphragm within the pump body as illustrated in Figure 4-9.

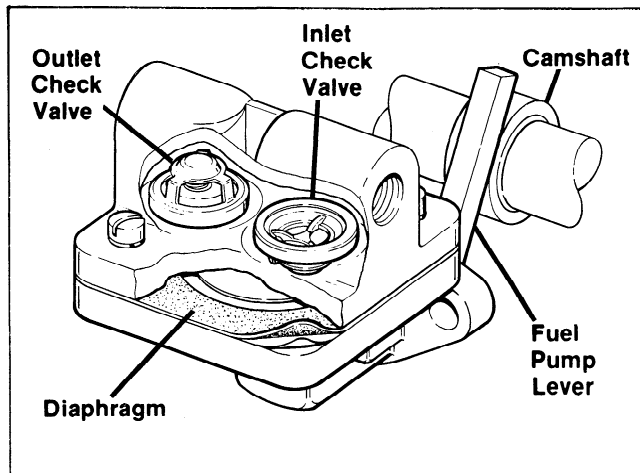

Figure 4-9. Fuel Pump Function

Fuel Pump Check

WARNING: Before performing this check be sure to wipe up any spilled fuel and make sure no sources of heat, flame or sparks are near, as these can cause gasoline fumes to explode. Disconnect and ground spark plug leads to eliminate electrical spark.

1. Remove the fuel line at the carburetor and crank the engine. If no fuel comes out of fuel line check the fuel flow into pump (Step 2).
2. Remove the fuel line at the inlet side of the fuel pump and hold the line lower than the gas tank. If fuel flows freely from the fuel line the pump is faulty and should be replaced. Fuel pumps are not serviceable—replacement kits are available from your Kohler parts supplier.

See Fuel Pump installation instructions in Section 8.

OPTIONAL AUTOMATIC CHOKE AND SHUTDOWN CONTROL

Some KT17 engines on generator applications may be equipped with an optional Thermo-Electric Automatic Choke, and with a Fuel Shutdown Control.

Automatic Choke Function

The choke is an integral part of the carburetor. The choke will close automatically from ambient air. Upon starting, the engine vacuum will partially open the choke. The bi-metal spring in the choke is electrically connected to the ignition coil and the current flowing through the bi-metal spring will heat to a point that the choke will open fully.

Automatic Choke Adjustment

The choke unit (Figure 4-10) is set at the factory for average conditions. To readjust for local conditions, loosen the cover retaining screws and shift the cover in clockwise direction for richer setting or counterclockwise direction for leaner setting. Tighten the cover retainer screws.

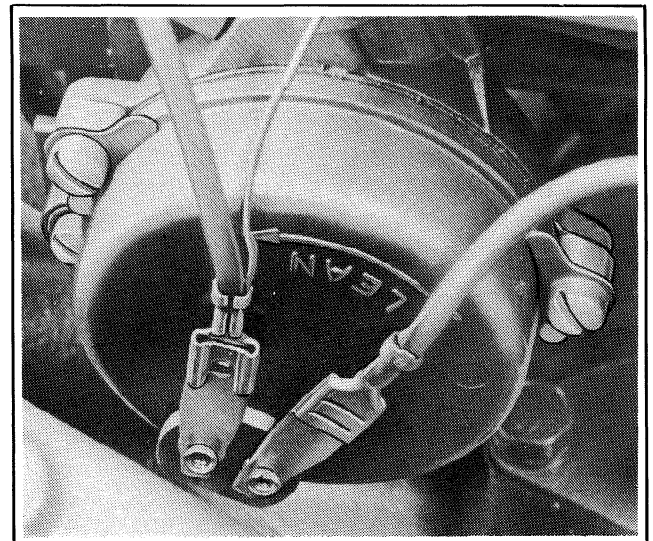

Figure 4-10. Automatic Choke.

Automatic Choke Service Guide

Problem	Causes	Solutions
Choke Won't Close When Cranking	Faulty lead to choke.	<ol style="list-style-type: none"> 1. Check for secure lead connections 2. Make continuity check on lead. Replace if no continuity.
	Faulty lead to ground.	<ol style="list-style-type: none"> 1. Check for secure lead connections. 2. Make continuity check on lead. Replace if no continuity.
	Poor adjustment.	<ol style="list-style-type: none"> 1. Adjust choke. 2. Repair with kit or replace choke.
Choke Will Not Fully Open	<ol style="list-style-type: none"> 1. Poor adjustment. 2. Faulty choke. 	<ol style="list-style-type: none"> 1. Adjust choke. 2. Repair with kit or replace choke.

4

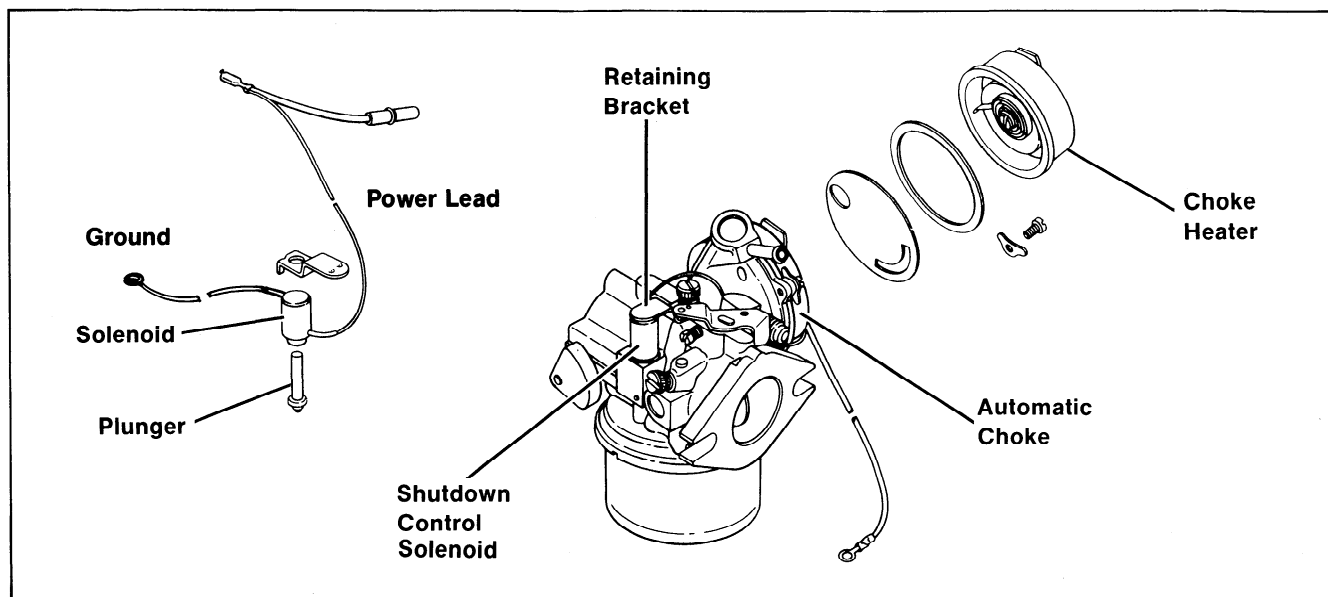

Figure 4-11. Engine Shutdown Control And Automatic Choke

Automatic Choke Inspection

1. Disconnect the high tension leads from spark plugs so the engine will not start.
2. Remove the air cleaner cover, element and base.
3. Push the start switch on the controller to the start position and hold for five seconds. The choke should fully close and release when the start switch is released.
4. If the choke does not function properly (Step 3) see Service Guide.

Automatic Choke Service

Choke Unit Replacement (see Figures 4-10 And 4-11).

1. Position the choke unit on the two mounting screws so that it is slightly loose.
2. Rotate the choke unit clockwise on the carburetor (viewed from the choke side) with a slight pressure until the choke valve is positioned 4 to 6 degrees towards the closed position.
3. While holding the choke unit in the above position, tighten the two mounting screws
4. This adjustment must be accomplished at an ambient temperature of 70-75° F.

SECTION 4

FUEL SYSTEM AND GOVERNOR

Shutdown Control Function

The engine shutdown control device is a solenoid and plunger mounted on the carburetor which prevents the engine from “running on” after the ignition is turned off. See Figure 4-11. When the switch is in the start position, battery current thru the solenoid holds the plunger and continues to hold it while the engine is running. When the switch is moved to the stop position the solenoid de-energizes and drops the plunger into a porting in the carburetor to stop all flow of fuel.

The engine shutdown control has two lead wires on it — a ground lead from the top of the shutdown solenoid and a power lead from the bottom of the solenoid. The power lead is wired into the (+) side of the ignition coil.

Shutdown Control Inspection

1. Make sure the solenoid has a secure electrical connection and good contact with the retaining bracket (ground).
2. Check for stuck plunger. Replace if damaged.
3. Check for defective solenoid with an ohmmeter or multimeter. Solenoid resistance is approximately 20 ohms.

Shutdown Control Test

Refer to Figure 4-11 for identification of parts.

1. Remove shutdown control (solenoid and plunger) from carburetor body by loosening the main fuel adjusting screw so the bracket holding the control can be shifted. Do not disconnect the lead wires.
2. Pull the shutdown control out of the carburetor.
3. Hold the plunger approximately 1/4” away from the solenoid. Turn the ignition switch to “ON” and release the plunger.

If the plunger is drawn into the solenoid, the shutdown control is functioning properly.

If the plunger is not drawn into the solenoid, the solenoid is faulty and must be replaced.

As a temporary fix, until a replacement solenoid can be obtained, the plunger can be removed from the shutdown control and the solenoid reinstalled minus the plunger.*

After replacing solenoid, reset main fuel adjusting screw according to procedures under “To Adjust Carburetor”.

*The removal of the plunger will not affect normal carburetor function; however, to prevent unfiltered air from entering the carburetor, the defective solenoid must be reinstalled over shutdown control vent hole, after the plunger has been removed.

SECTION 5 — LUBRICATION SYSTEM

These engines use a Pressurized Lubrication System. A rotor-type oil pump pushes oil through galleries machined into the crankcase. Openings in the galleries permit oil to lubricate critical engine components. The center oil pickup ensures proper lubrication at operating angles up to 30°.

Two types of Pressurized Lubrication Systems are used on these engines, depending on the engine Specification Number.

PRESSURIZED SPRAY LUBRICATION SYSTEM

Model KT17—Specifications 24299 And Lower

Model KT19—Specifications 49199 And Lower

Model KT21—All Specifications

In the Pressurized Spray Lubrication System, the oil pump delivers oil to the main crankshaft and camshaft bearings at approximately 5 PSI. Lubrication for the connecting rod journals is provided by oil sprayed from two small holes drilled in the camshaft. See Figure 5-1.

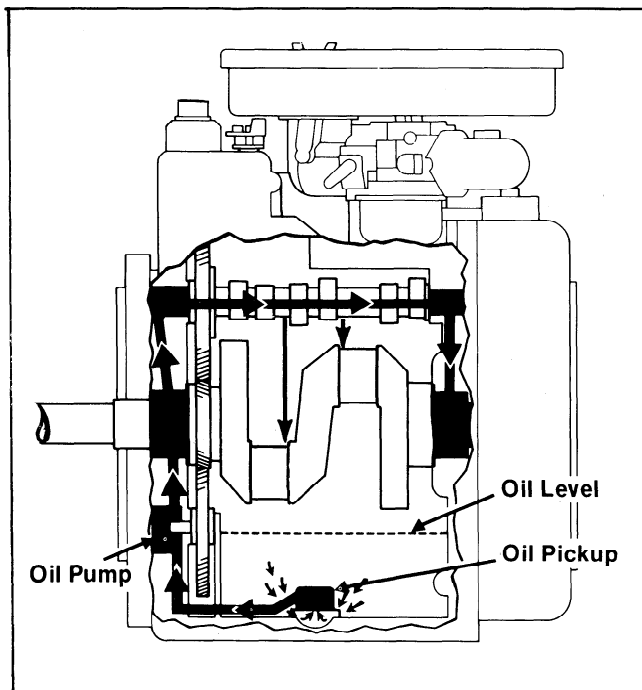

Figure 5-1. Pressurized Spray Lubrication System

SERIES II

FULL-PRESSURE LUBRICATION SYSTEM

Model KT17 Series II—Specifications 24300 And Higher

Model KT19 Series II—Specifications 49200 And Higher

KT17 Series II and KT19 Series II engines have a Full-Pressure Lubrication System that delivers oil to the crankshaft, camshaft, and connecting rod journal bearings at approximately 25-50 PSI (see Figure 5-2). A pressure relief valve, located in the engine crankcase behind the closure plate, limits the maximum oil pressure in the system (See Figure 5-3). A 1/16" NPTF pipe plug in the #1 crankcase side (PTO end) is removable to permit installation of an oil pressure gauge (See Figure 5-4).

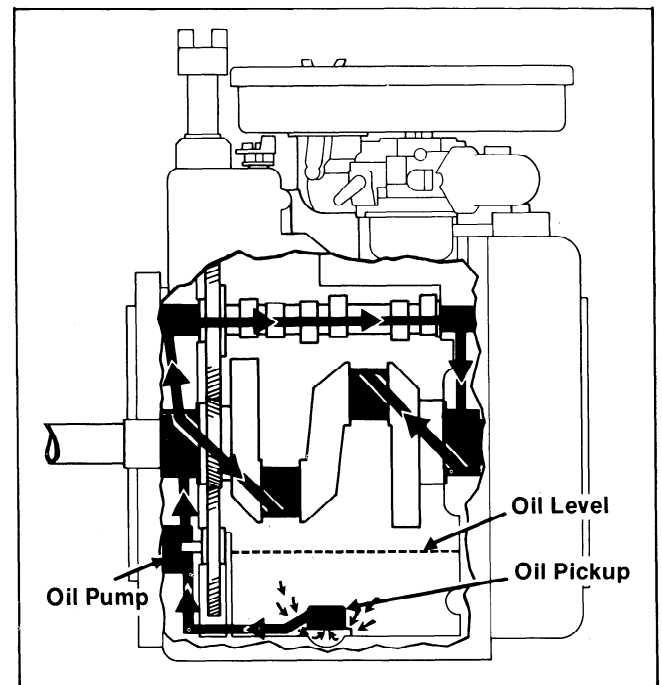

Figure 5-2. Full Pressure Lubrication System

OIL PUMP

The oil pump is driven off the crankshaft and is located behind the closure plate on the PTO side of

SECTION 5 LUBRICATION SYSTEM

the engine. The pump is secured by a square cover and four screws. The component parts contained in the pump assembly are shown in Figure 5-5.

LUBRICATION SYSTEM SERVICE

The oil pump cover and rotors, and pressure relief valve ball and spring can be serviced without splitting the crankcase. To service these parts, the closure plate must be removed.

To service the rest of the pump components, the crankcase must be split. See Sections 7 and 8 for disassembly and assembly of crankcase and oil pump.

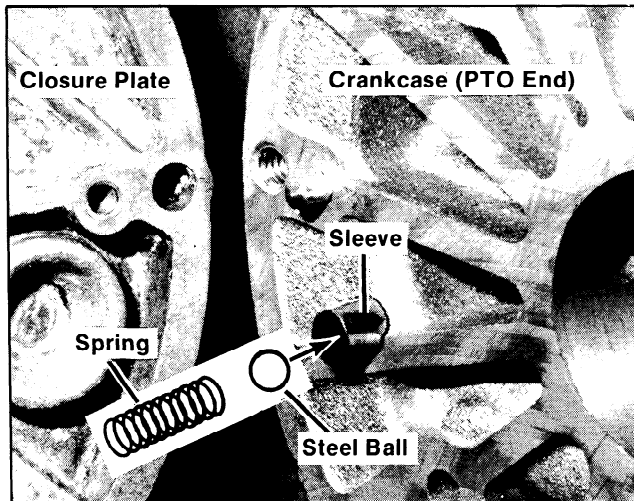

Figure 5-3. Oil Pressure Relief Valve

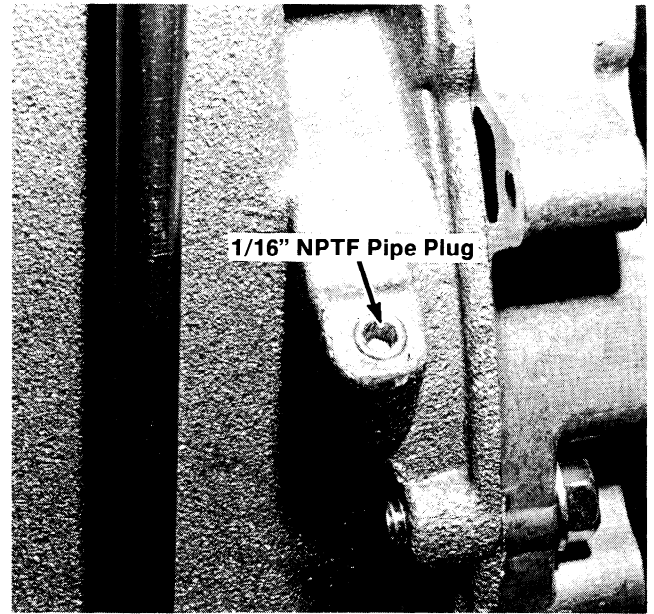

Figure 5-4. Oil Pressure Pickup Point

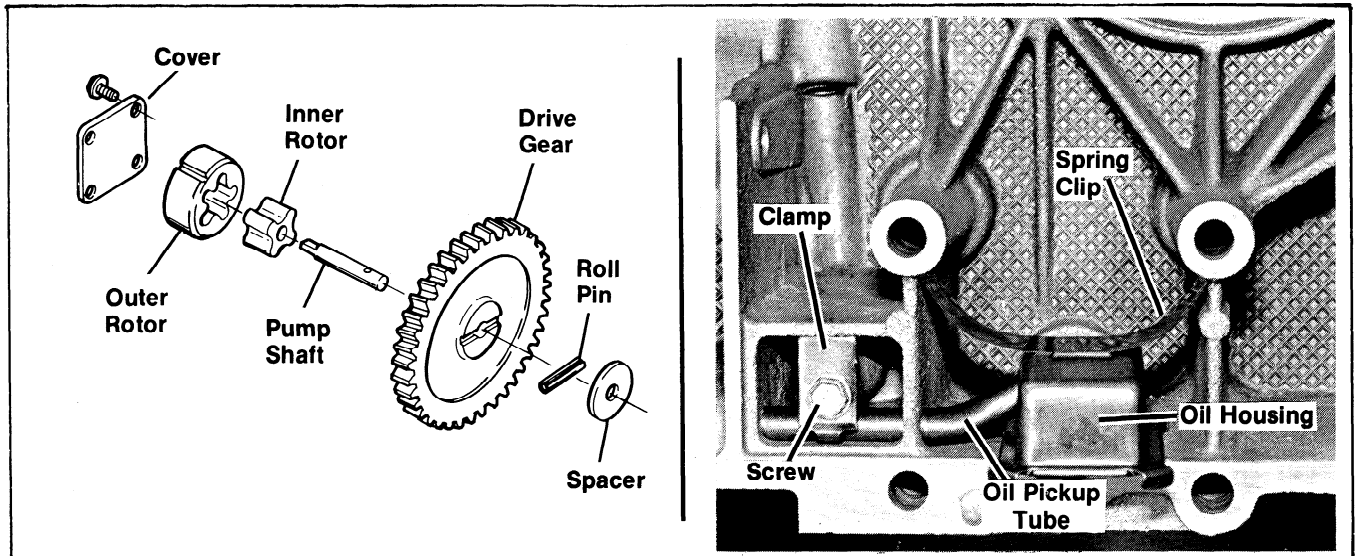

Figure 5-5. Oil Pump Assembly and Center Oil Pickup

SECTION 6 - ELECTRICAL SYSTEMS & COMPONENTS

BATTERY IGNITION SYSTEM

These engines use a battery ignition system, which uses the electrical charge stored in the battery to induce a high voltage in the ignition coil. This high voltage is impressed across the spark plugs where it jumps the gaps producing the spark that ignites the air-fuel mixture in the cylinders.

The basic components of the battery ignition system are the battery, ignition coil, condenser, breaker points and spark plugs as shown in Figure 6-1.

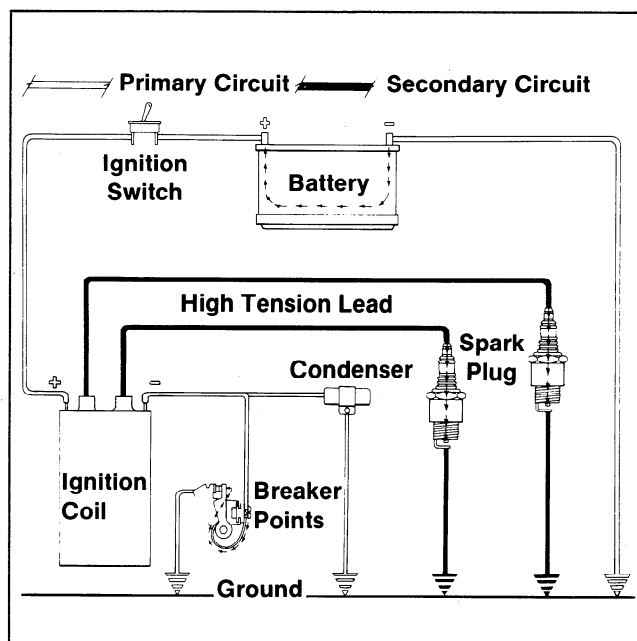

Figure 6-1. Schematic of a Typical Battery Ignition System

Ignition System Service

Several factors contribute to the overall performance of an ignition system — all components must be in good condition and the spark must be properly timed. Hard starting, low power and erratic operation can often be attributed to faulty ignition. The following operational test will determine if the ignition system actually is faulty.

Operational Test

WARNING: Performing this test near explosive gases could result in bodily injury from explosion. Wipe up spilled gasoline and cover containers of flammable liquids.

Attach an in-line tester between each spark plug lead and spark plug. Crank engine rapidly. If a sharp spark jumps the tester gap, the trouble apparently is not in the ignition coil, condenser, or breaker points. A weak spark indicates ignition trouble.

When checking out an ignition system, the components most commonly requiring service or adjustment should be checked first.

Ignition System Analyzers

To determine the condition of components of the ignition system, an ignition tester should be used. A wide variety of testers are available from various manufacturers such as Graham, Merc-O-Tronic or Stevens. These units have provisions for testing all functions of the ignition system. Always refer to the analyzer manufacturer instruction manual for proper procedures.

SPARK PLUGS

Engine misfire or generally poor operation is often caused by spark plugs in poor condition or with improper gap setting. Clean area around spark plugs before removing to prevent dirt or debris from falling into engine. Every 100 hours remove plugs, check condition and regap to .025". Bend outside (or grounded) electrode only, never the center electrode.

Abrasive cleaning machines should never be used. Best results are obtained with new plugs. Always replace in pairs to prevent misfiring. Use Champion spark plugs RBL15Y or equivalent. Torque to 10-15 ft. lbs. (1.4-2.8 Kgm).

Examine plugs as soon as they have been removed - the deposits on the tip are an indication of the general condition of rings, valves, carburetor, and ignition system. Normal and worn plugs are shown in the accompanying illustrations.

SECTION 6
ELECTRICAL SYSTEMS AND COMPONENTS



Normal: A plug taken from an engine operating under good conditions will have light tan or gray colored deposits. If the center electrode is not rounded off, a plug in this condition could be re-gapped and reused.

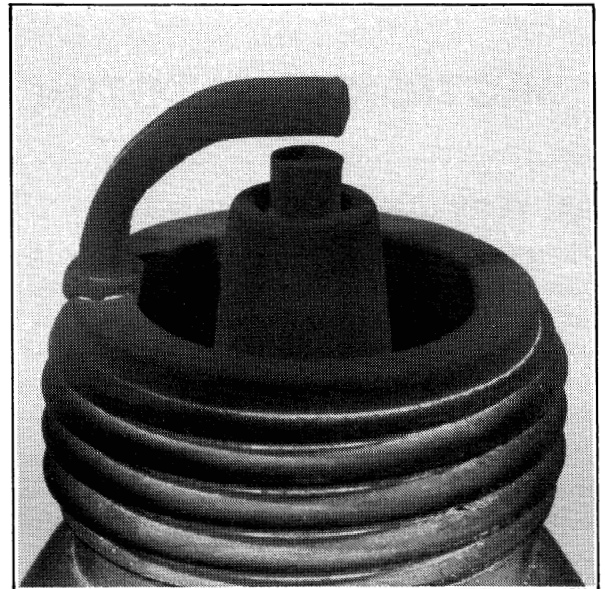

Carbon: Soft, sooty black deposits indicate incomplete combustion which could be attributed to rich carburetion, weak ignition, retarded timing or poor compression.



Worn: On a plug which has been in service too long, the center electrode will be rounded off and the gap will be eroded .010" or more than the correct setting. Replace worn plugs as they will require excessive voltage to fire properly. Always replace plugs in pairs.

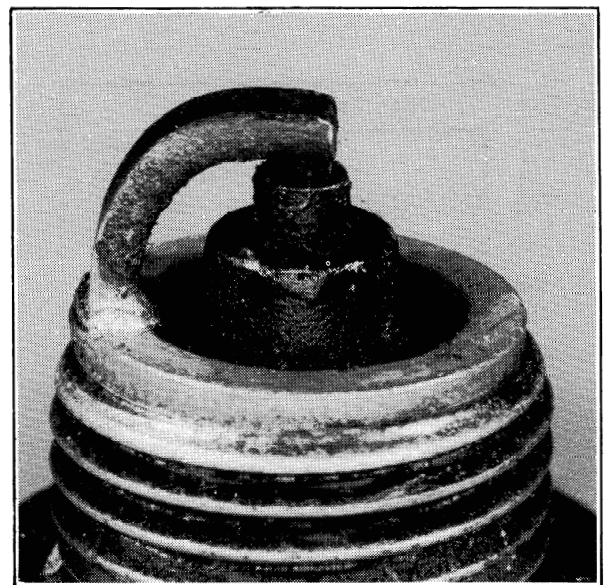

Wet: A wet plug could be caused by drowning with raw fuel or oil in the combustion chamber. The raw fuel problem may be caused by operating with too much choke. Oil in the combustion chamber area is usually caused by worn rings or valve guides.

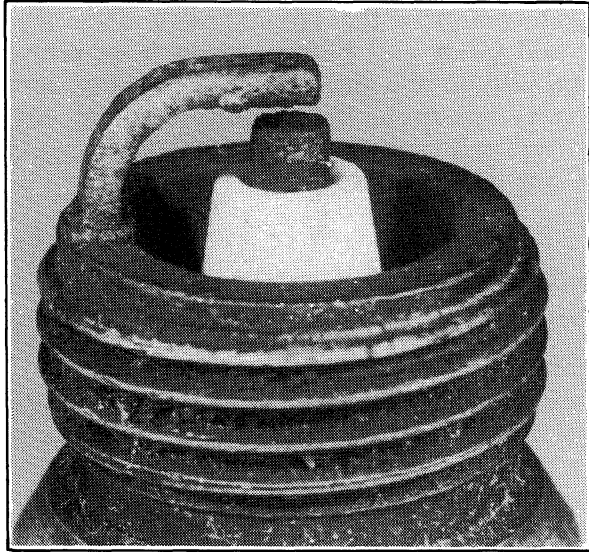

White Chalky Deposits: Overheating will be indicated by chalk white colored deposits, not burned black as might be expected. This condition is also usually accompanied by excessive gap erosion. Overadvanced timing, lean carburetion, clogged air intake and blocked cooling fins are some of the causes of overheating.

If abnormal conditions are indicated, also check the number on the plug - it may be of the wrong heat range for the engine. If the center electrode is eroded round, don't try to square it with a file for reuse.

CONDENSER

If the condenser shorts out, the coil will be unable to produce output voltage. On the other hand, if it opens or decreases in capacitance, the ignition points will burn excessively. If badly burned breaker points occur too frequently, the condenser should be checked.

If capacitance of condenser is too low, metal will transfer from the stationary contact to the movable contact. If capacitance is too high, metal will build up on stationary contact. See Figure 6-2.

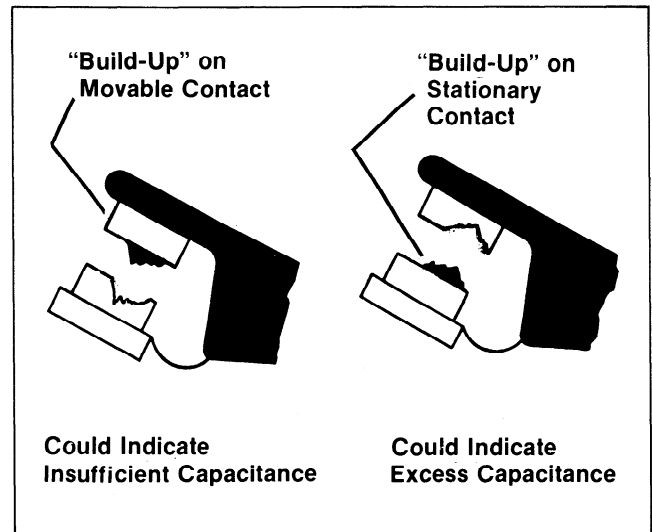

Figure 6-2. Metal Transfer On Points

BREAKER POINTS

Engine operation is greatly affected by breaker point condition and adjustment. If points are burned or badly oxidized, little or no current will pass. As a result, the engine may not operate at all or if it does run, it is likely to misfire particularly at full throttle.

Breaker point gap affects the time that the contacts are opened and closed. If too wide, the ignition spark will be advanced and the engine may knock or kick back during starting. If too close, the ignition spark will be retarded and the engine will lose power and overheat.

When installing or servicing breaker points, extra care should be taken to keep contacts clean. To remove foreign materials or oil from new points, or to clean existing points after servicing or readjusting, insert a piece of heavy paper or light cardboard between the closed points and draw it between the points. To prevent lint or fibers from remaining on the points, open the breaker points to withdraw the paper.

Condenser Check

The condenser can also be tested with an ohmmeter as follows: Discharge the condenser by grounding the condenser lead, then set ohmmeter on the Rx10,000 scale and connect the meter leads between condenser lead and condenser case. On a good condenser the indicator on the meter should bounce up into the scale and then fall back to infinity. On a faulty condenser the needle will either not fall back to infinity (indicating a short) or will not move at all when the test is performed (indicating an open circuit). This test is not fool proof as the condenser could be intermittent and actually appear good when it is faulty. When using a commercial condenser tester, follow the instructions provided by the manufacturer.

SECTION 6 ELECTRICAL SYSTEMS AND COMPONENTS

IGNITION COIL

NOTE: Erratic operation, short breaker point life, hard starting, lack of spark, or no start, are symptoms of coil problems which may develop. Engines may run well for a time before any of the symptoms are noticed.

However, possible ignition related causes produce similar symptoms, as do interlock systems incorporated on the equipment the engine powers, which also could lead to erratic operation and should not be overlooked.

Should any of these symptoms be encountered, first check the following ignition related problems:

NO SPARK
<ol style="list-style-type: none">1. Ignition switch off or faulty.2. Leads disconnected or broken.3. Spark plug bad.4. Breaker points stuck or oxidized.5. Condenser faulty.

POOR IGNITION
<ol style="list-style-type: none">1. Spark plug gap excessive.2. Spark plug wet or fouled.3. Wrong spark plug.4. Breaker points dirty.5. Ignition timing wrong.6. Weak condenser.

Ignition Coil Function

The ignition coil functions to transform or step up the low voltage primary current to the high voltage current necessary to bridge the gap between the center and side electrodes on the spark plug.

There are two primary terminals provided on the ignition coil and they must be connected correctly for the coil to function properly. The positive (+) terminal must be connected to the positive side of the battery through the ignition switch. The breaker points and condenser are connected to the negative (-) terminal.

Ignition Coil Check - Terminals

Loose primary terminal nuts also can lead to erratic operation and should be checked. Check

coils by removing the terminal nut and star washer, and point and battery leads from primary terminals on the coil. Check continuity across primary terminals. If continuity is found, coil is not faulty. If continuity is not found coil is faulty and should be replaced.

Ignition Coil Check - Ohmmeter

NOTE: Ignition parts should be checked with the engine stopped.

Check the continuity of the primary winding by connecting an ohmmeter between the (+) and (-) terminals of the coil. The reading on the meter when set on the Rx1 scale should be 4 - 5 ohms at room temperature. Make sure the ohmmeter is zeroed properly before measuring primary continuity. (See Figure 6-3).

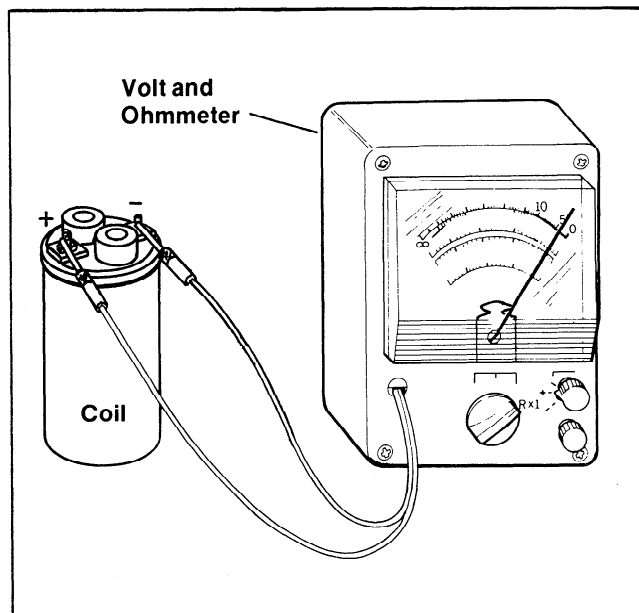

Figure 6-3. Continuity Check of Coil Primary

To check the secondary resistance, set ohmmeter on Rx 100 scale, zero the meter, and connect one test lead to each high tension terminal. The reading here should be between 9,500 and 11,500 Ohms on a good coil. If not within these limits, the secondary is faulty and the coil should be replaced. Note that a coil could pass these tests and still be breaking down under operating conditions. (See Figure 6-4.)

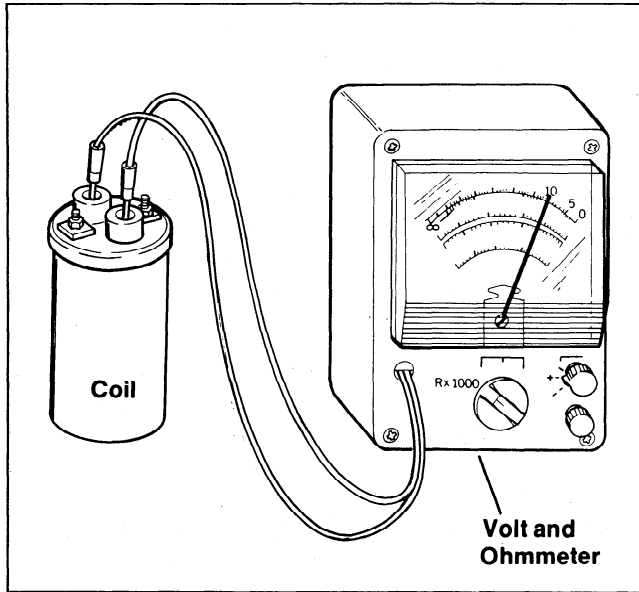

Figure 6-4. Resistance Check of Coil Secondary

High Tension Leads — Removal and Installation

The ignition coil used on KT series engines has threaded terminals in the high tension towers for attaching the high tension lead wires. Proper removal and installation of the high tension leads is necessary to prevent damage to the leads and to insure good contact between the terminal and the carbon core of the lead wire.

CAUTION: Failure to follow repair procedures may result in poor or erratic engine performance. The improper removal and installation of spark plug leads will simulate operating conditions normally associated with defective coils, breaker points, condenser, or poor wiring. Before replacing any of these items, check the lead connections at the coil.



Removal

Before attempting to remove a high tension lead from the coil, disconnect the boot end from the spark plug, free the lead wire from any clamps or retaining clips and rotate lead free of any brackets, manifolds, sheet metal, etc. Break seal between boot and coil tower by rolling boot back. Grasp the lead wire close to the tower and turn the lead wire counterclockwise while pulling lightly in an outward direction. Continue turning the lead until it comes free of the coil terminal. After the wire is free, remove the boot from the lead.

Installation

If the original lead wire is being reused, cut the end of the lead wire off about 3/8" to expose fresh sections of the carbon core. Slide boot onto the lead wire approximately 2 inches. Insert high tension lead into coil tower and turn in a clockwise direction while applying an inward pressure. Continue turning and inserting the lead until it is snug. Slide boot on wire toward coil tower and fix boot to the coil tower.

BATTERY

WARNING: Batteries contain sulphuric acid—avoid contact with skin, eyes or clothing. Batteries produce explosive hydrogen gas while being charged. Ventilate area when charging battery. Keep smoking materials such as cigarettes, open flame and sparks away from battery at all times.



Keep batteries and acid out of the reach of children at all times. To prevent accidental shorting and resulting sparks, remove all jewelry when working on battery.

Disconnect battery cables or unplug rectifier-regulator before charging.

When removing battery from equipment always disconnect the negative (-) (ground) cable first. When replacing battery connect the negative (-) (ground) cable last.

Battery Check

If battery charge is not sufficient to turn starter motor over, recharge the battery. DO NOT attempt to "jump start" the engine with another battery—batteries larger than those recommended can cause starter motor burn-out.

Test battery voltage by connecting a DC voltmeter across the battery terminals. Crank the engine—if battery voltage falls below 9 volts while cranking, the battery is run-down or defective. (See Figure 6-5.)

Battery Maintenance

A build-up of corrosive acid across the top of the battery can cause the battery to self-discharge. Even a light coating of this grayish-white substance can complete a circuit to drain and exhaust the energy in the battery — especially bad when moisture is present.

SECTION 6 ELECTRICAL SYSTEMS AND COMPONENTS

To maintain a battery in top condition:

1. Regularly check level of electrolyte — add water as necessary to maintain level above plates — do not overfill as this can cause poor performance or early failure due to loss of electrolyte.
2. Keep terminals and top of battery clean. Wash with baking soda and rinse with clear water. Do not allow soda solution to enter cells as this will destroy the electrolyte.

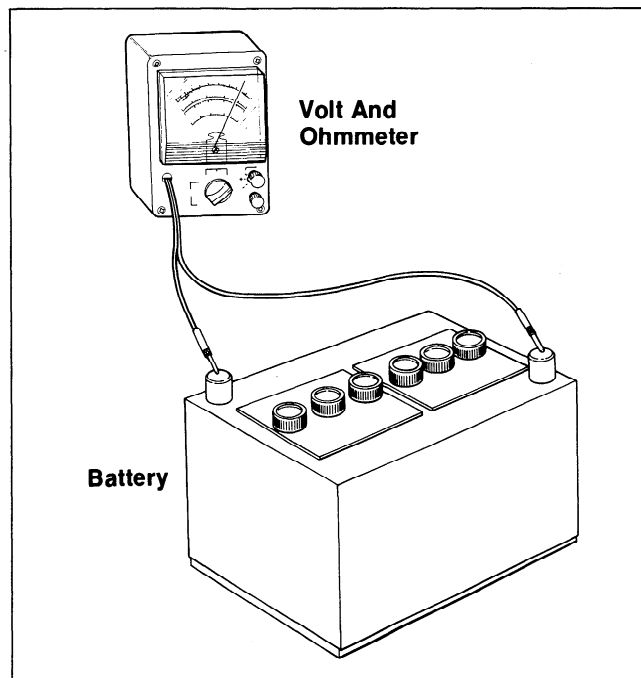

Figure 6-5. Checking Battery Charge

IGNITION TIMING

These engines are equipped with a timing sight hole in the #1 side of the blower housing. Two timing marks are stamped on the flywheel — the T mark indicates Top Dead Center (TDC) while the S mark indicates the Spark or Spark Run point which is 23° before top dead center.

Various methods can be used for timing — the timing light method is the more precise way of achieving exact timing.

Method 1 - Static Timing

Make sure ignition switch is off. Completely disconnect spark plug leads from plugs to prevent unintentional starting.

1. Remove breaker point cover, then connect an ohmmeter or continuity tester from breaker point terminal to ground.
2. Rotate the engine by hand in direction of normal rotation (clockwise when viewed from flywheel

end.) Watch continuity tester or ohmmeter, if light on tester goes out or infinity ohms is measured on ohmmeter, points are just beginning to break.

When the points are just breaking, the “S” mark on the flywheel should be directly opposite the roll pin in the #1 cylinder barrel, (as seen through timing sight hole) if the engine is properly timed. If “S” is above or below roll pin the timing is off and the point gap will have to be adjusted in or out until “S” mark is directly opposite the roll pin.

If an ohmmeter or continuity tester is not available, measure gap with feeler gauge — gap should be .020” fully open. If necessary loosen point gap adjustment screw and readjust gap to .020” fully open. However, maximum gap setting can vary a few thousandths (.017” - .023”) to achieve smoothest running. Securely tighten adjusting screw after timing (see Figure 6-6).

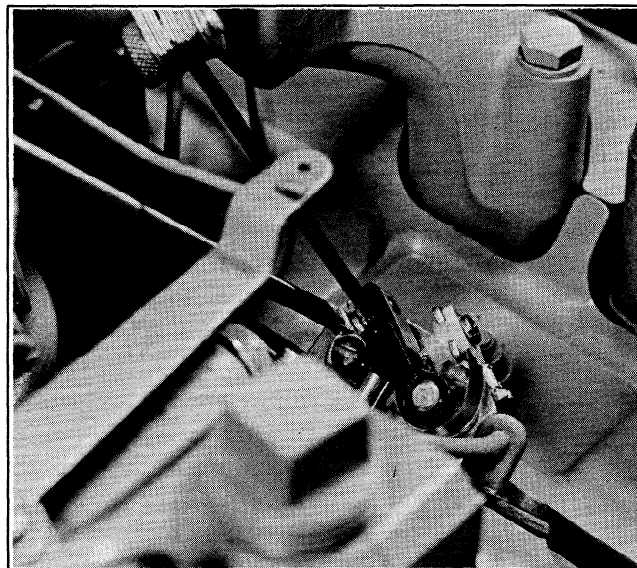

Figure 6-6. Point Gap Adjustment

Method 2 - Timing Light

Several different types of timing lights are available—follow manufacturer’s instructions for type used.

1. Remove high tension lead at spark plug—wrap one end of a short piece of fine wire around spark plug terminal. Reconnect lead to terminal—free end of wire must protrude from under boot.

NOTE: For timing lights with alligator clips—some lights have sharp prongs on spark lead—simply push prong thru boot until it contacts metal connector.

3 Amp System Service Guide

NOTE: Always zero ohmmeters on each scale before testing, or inaccurate readings will result.

Problem	Test	Conclusion
BATTERY NOT CHARGING	1 -With engine running at 3000 rpm, disconnect battery charging lead from battery, measure DC voltage from charging lead to ground.	If voltage is over 28 the stator is OK.
	2 -With charging lead disconnected from battery measure resistance of lead to ground. Now reverse the ohmmeter leads and take the resistance reading again - In one direction resistance should read infinity ohms (open circuit). With ohmmeter leads reversed some resistance should be measured (about mid-scale with meter set at R x 1).	If both resistance readings are low the the diode is shorted. If both resistance readings are high, the diode or stator is open.
	3 -Cut the sleeving on the battery charge lead to expose the diode connections. Check resistance on the stator side of diode to ground (reading should be 1 ohm).	If the reading is 0 ohms, the winding is shorted . . . if infinity ohms, the stator winding is open or the lead wire is broken.
NO LIGHTING	1 -Disconnect lighting lead from wiring harness. Measure open circuit voltage with AC voltmeter from lighting lead to ground with engine running at 3000 rpm.	If 15 volts or more stator is OK - if less than 15 volts wiring may be shorted.
	2 -Check resistance of lighting winding lead to ground.	If 0.5 ohms, stator is OK; if 0 ohms, stator is shorted; if infinity ohms, the stator is open or the lead broken.

6

**15 Amp System
(see Figure 6-9)**

The 15 amp alternator system consists of three major components: a ceramic magnet ring which is permanently affixed to an inner rim of the flywheel, the alternator stator mounted on the crankcase and a rectifier-regulator unit which is mounted on the #1 side of the blower housing. Use the 15 Amp System Service Guide when servicing the system.

 **CAUTION:**

1. Make sure battery polarity is correct. Negative ground systems are used.
2. Prevent alternator leads (AC) from touching or shorting. This could permanently damage the stator.
3. Disconnect leads at rectifier-regulator before electric welding is done on equipment in common ground with the engine.

SECTION 6 ELECTRICAL SYSTEMS AND COMPONENTS

15 Amp System Service Guide

NOTE: Always zero ohmmeters on each scale before testing or inaccurate readings will result.

Problem	Test	Conclusion
BATTERY NOT CHARGING	1-Insert ammeter in rectifier-regulator B+ lead as shown in Figure 6-9. With engine running at 3600 RPM no-load and with B+ lead connected, measure voltage from B+ (at terminal on rectifier-regulator) to ground with DC voltmeter.	If the charge rate increases, the alternator is OK and battery was fully charged.
	If 13.8 volts or higher, place minimum load of 5 amps ¹ on battery to reduce voltage.	If charge rate does not increase, check for faulty stator or rectifier-regulator (Test 2).
	2-Disconnect both AC leads from rectifier-regulator. With engine running at 3600 RPM no-load, measure AC voltage across leads with AC voltmeter.	If voltage is less than 28 volts, the stator is faulty.
BATTERY CONTINUOUSLY CHARGING AT HIGH RATE	With AC leads connected to rectifier-regulator and engine running at 3600 RPM no-load, measure voltage from B+ (at terminal on rectifier-regulator) to ground with a DC voltmeter.	If voltage is more than 28 volts, the rectifier-regulator is faulty ² .
		If less than 14.7 volts, the alternator is OK, but battery is unable to hold charge. Check condition of battery. If more than 14.7 volts, the rectifier-regulator is faulty ² .

NOTES:

¹Turn lights if 60 watts or more, or simulate load by placing a 2.5-ohm, 100-watt resistor across battery terminals.

²Faulty ignition switch or poor connections also can cause increased resistance, disrupting rectifier-regulator operation.

STARTING MOTOR

The starting motor is of permanent magnet design. The magnets are of ceramic construction and can be damaged quite easily if the starter motor is dropped or struck sharply.

Starter Motor Operation

When the starting circuit is closed and the armature starts to rotate, the drive pinion moves laterally on a splined shaft into mesh with the flywheel ring gear. When the pinion butts against a stop

washer at the end of the armature shaft, the pinion rotates along with the armature to crank the engine. The armature and pinion remain in positive engagement until the engine starts and the flywheel begins overriding the armature. At this instant, the great momentum of the flywheel throws the pinion out of mesh and back into the retracted or disengaged position. After the starting circuit is opened and as the armature coasts to a stop, a small anti-drift spring holds the pinion in the retracted position (see Figure 6-10).

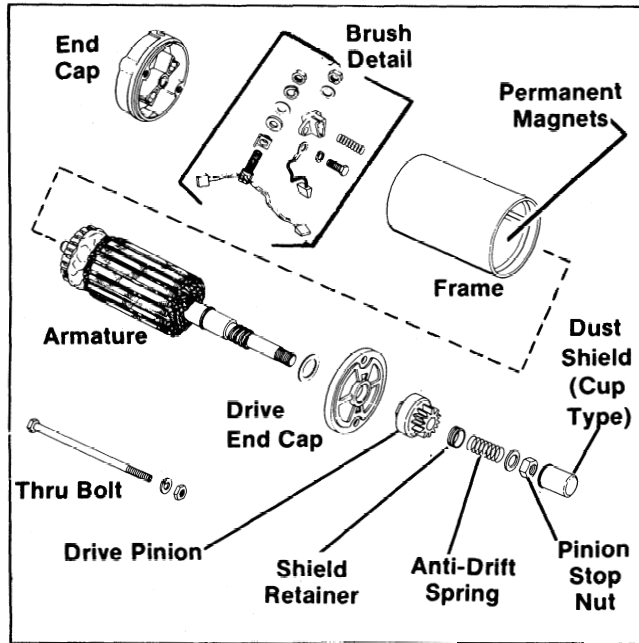

Figure 6-10. Components of Permanent Magnet Starter

CAUTION: In the event of a “false start”, that is if the engine develops sufficient speed to disengage the starter, but fails to



CAUTION: (Cont.) continue running, the engine must be allowed to come to a complete stop before a restart attempt is made. If the starter motor is activated while the flywheel is still rotating, the starter pinion and flywheel ring gear may clash and be damaged.



If starter motor will not turn the engine over, shut off starter motor immediately and make no further attempt to start engine until the condition is corrected.

DO NOT crank engine continuously for more than 10 seconds at a time.

A 60 second cool-down period must be allowed between cranking attempts if the engine does not start. Failure to follow these guidelines may result in burn-out of the starter motor.

Starter Motor Service

Following are problems that can occur during normal usage — possible faults — and suggested corrections. If the corrections do not solve the problem, replace the starter motor.

Problem	Possible Fault	Correction
STARTER FAILS TO ENERGIZE	Wiring	1. Clean corroded connections — tighten loose connections. 2. Replace wires in poor condition — frayed or broken insulation.
	Starter Switch or Solenoid	Bypass the switch or solenoid with a jumper wire — if starter cranks normally, replace either defective part.
	Battery	Check specific gravity of battery — if low, recharge — or replace, if necessary.
STARTER ENERGIZES BUT TURNS SLOWLY	Battery	Check specific gravity of battery — if low, recharge — or replace, if necessary.
	Brushes	Check for excessively dirty, or worn brushes and commutator. To clean, use a coarse cloth (not emery paper). Replace brushes if excessively or unevenly worn. (See Brush Replacement procedures.)

SECTION 6 ELECTRICAL SYSTEMS AND COMPONENTS

BRUSH REPLACEMENT AND COMMUTATOR SERVICE

The starter must be completely disassembled to service brushes and commutator. Refer to Figure 6-10 and proceed as follows:

1. Remove drive pinion unit (see "Drive Assembly" for correct procedure).
2. Remove thru bolts.
3. Separate end cap from armature.

NOTE: Brush springs will probably fall out when brushes pull free of commutator.

4. Clean commutator with a coarse, lint-free cloth — if badly worn or grooved, turn down on lathe.
5. Replace brushes as follows: The positive brushes are part of the terminal stud assembly. To replace, remove nuts, and pull stud out thru inside of end cap. Insert new stud terminal-brush unit after transferring insulation bushing from old unit. To replace insulated (negative) brushes, simply remove capscrew and lock washer. Always use new brushes and springs. Assemble brushes with chamfered side away from springs. Keep brush leads away from contact with metal of end cap.
6. To keep brushes in position so that they will fit over the commutator as the end cap is reinstalled, use a brush holder tool as shown in Figure 6-11. It can easily be cut out of thin sheet metal.
7. Line-up bench marks on both end caps with those on the motor frame, insert thru bolts and tighten.

DRIVE ASSEMBLY

If drive pinion is badly worn, has chipped or broken teeth, it must be replaced. Replacement drive kits are available from your Kohler parts supplier.

It is not necessary to disassemble the starting motor to remove or reinstall the pinion or the retaining nut. Refer to Figure 6-10 and proceed as follows:

1. Hold the drive pinion in a vise with soft jaws

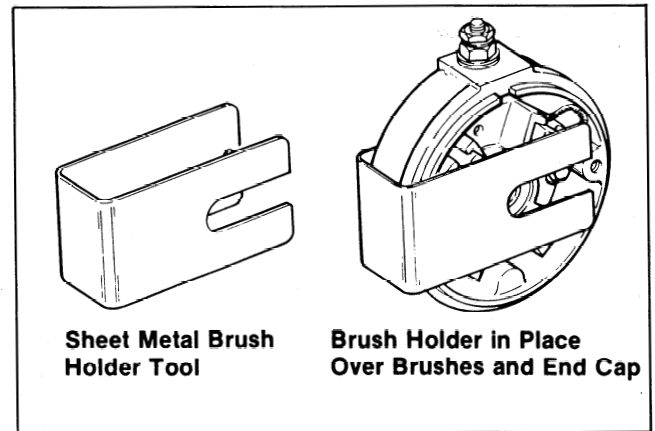

Figure 6-11. Brush Holder Tool

while turning the nut on or off. The armature will turn with the nut only until the pinion stops against internal spacers.

CAUTION: Do not overtighten vise as this could distort the shape of the pinion.



2. Remove the drive pinion stop nut and the drive parts in the order shown.
3. Clean the drive shaft splines with a good commercial solvent, dry thoroughly and apply a small amount of Kohler electric starter drive lubricant - available from your Kohler parts supplier.
4. Apply a small amount of Loctite #271 to the drive pinion stop nut threads and assemble drive parts in reverse order of disassembly. Torque pinion stop nut to 160 in. lbs.

(Some field reports have indicated drive assembly problems were nothing more than gummed assembly components. When cleaning, make certain step 3 is followed.)

RING GEAR

WARNING: Do not attempt to replace the flywheel ring gear. Kohler no longer provides the ring gear as a serviceable part. Replace the flywheel if the ring gear is damaged.



2. Connect one timing light lead to the wire that has just been wrapped around spark plug terminal.
3. Connect second timing light lead to hot (ungrounded) side of battery - see timing light instructions for battery size, wiring, etc.
4. Connect third timing light lead to ground.
5. Start engine, run at 1200-1800 RPM, aim timing light into sight hole—light should flash just as “S” mark is opposite the roll pin in the cylinder barrel (see Figure 6-7).

NOTE: If a double image is seen in the timing sight hole, time the engine so that the roll pin is exactly between the two images.

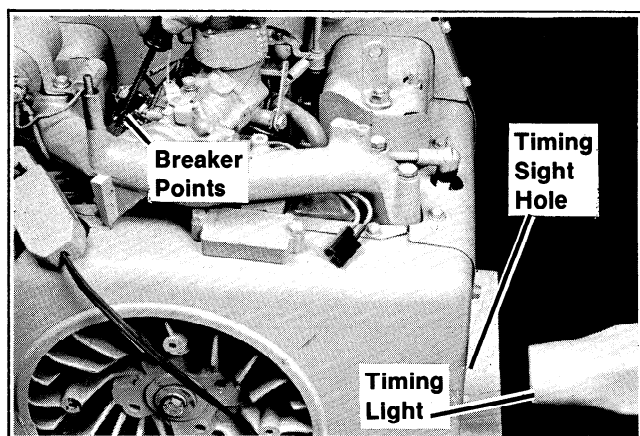

Figure 6-7. Timing Light Method

6. If timing is off — remove breaker point cover. *(Breaker point cover screws must be screwed back into mounting pad after cover is removed. The screws keep engine oil from squirting out of the crankcase through the breaker point cover screw holes, while engine is being timed.)* Loosen gap adjusting screw, shift breaker plate until “S” mark is exactly centered, retighten adjusting screw. Check timing before replacing breaker point cover.

Breaker Point Gap Method

After setting timing with a timing light, check the breaker point gap with a feeler gauge—it should be .017” to .023”. If the gap is not within this range, camshaft to crankshaft timing is incorrect, or push rod or cam lobe is worn.

Valve Overlap Method

If the cam to crankshaft timing is correct, the intake and exhaust valve will be level with each other (equal valve lift) at top dead center on valve overlap. If the cam to crankshaft timing is off by one tooth, there will be approximately .030” difference in the valve lift from intake and exhaust at top dead center on the valve overlap.

ALTERNATOR CHARGING SYSTEMS

3 amp and 15 amp alternator charging systems are used on these engines. The 15 amp system has a rectifier-regulator mounted on the number one side of the blower housing. The 3 amp system does not use a rectifier-regulator. In addition to the rectifier-regulator, other components of the two systems differ; therefore, there can be no interchanging of parts between them. No adjustments are possible on these alternator systems and field service is not recommended. All faulty parts should be replaced.

3 amp System Service (See Figure 6-8).

The 3 amp alternator system consists of three major components: a permanent magnet ring with five or six magnets on the inside rim of the flywheel, an alternator stator assembly which is affixed to the crankcase and a diode which is located in the charging output lead from the stator. The accompanying service guide can be used to pinpoint any source of trouble.

⚠ CAUTION:

1. Battery polarity must be correct. Negative ground systems are used.
2. Disconnect wiring harness plug before electric welding is done on equipment powered by the engine and in common ground with engine.

SECTION 6 ELECTRICAL SYSTEMS AND COMPONENTS

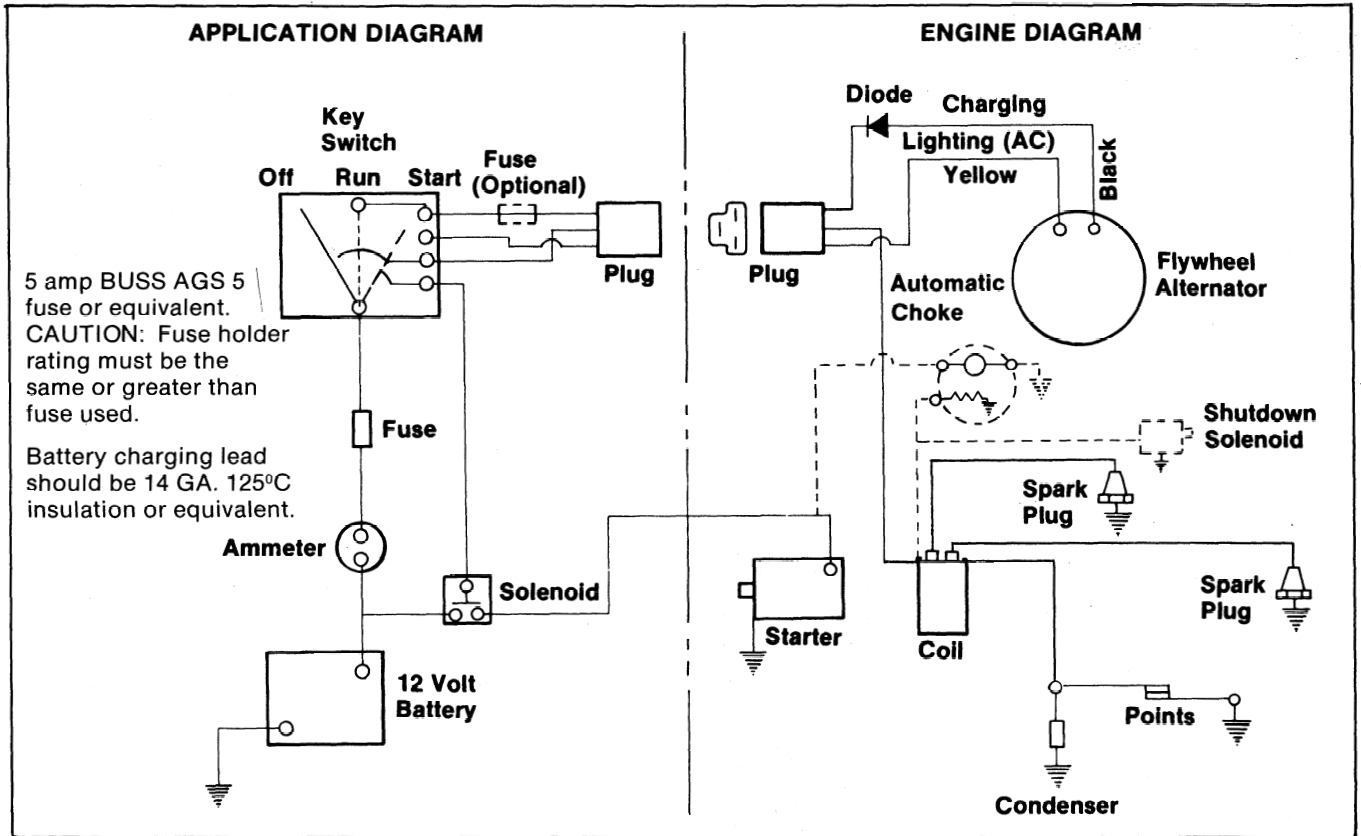

Figure 6-8. 3 Amp System Wiring Diagram

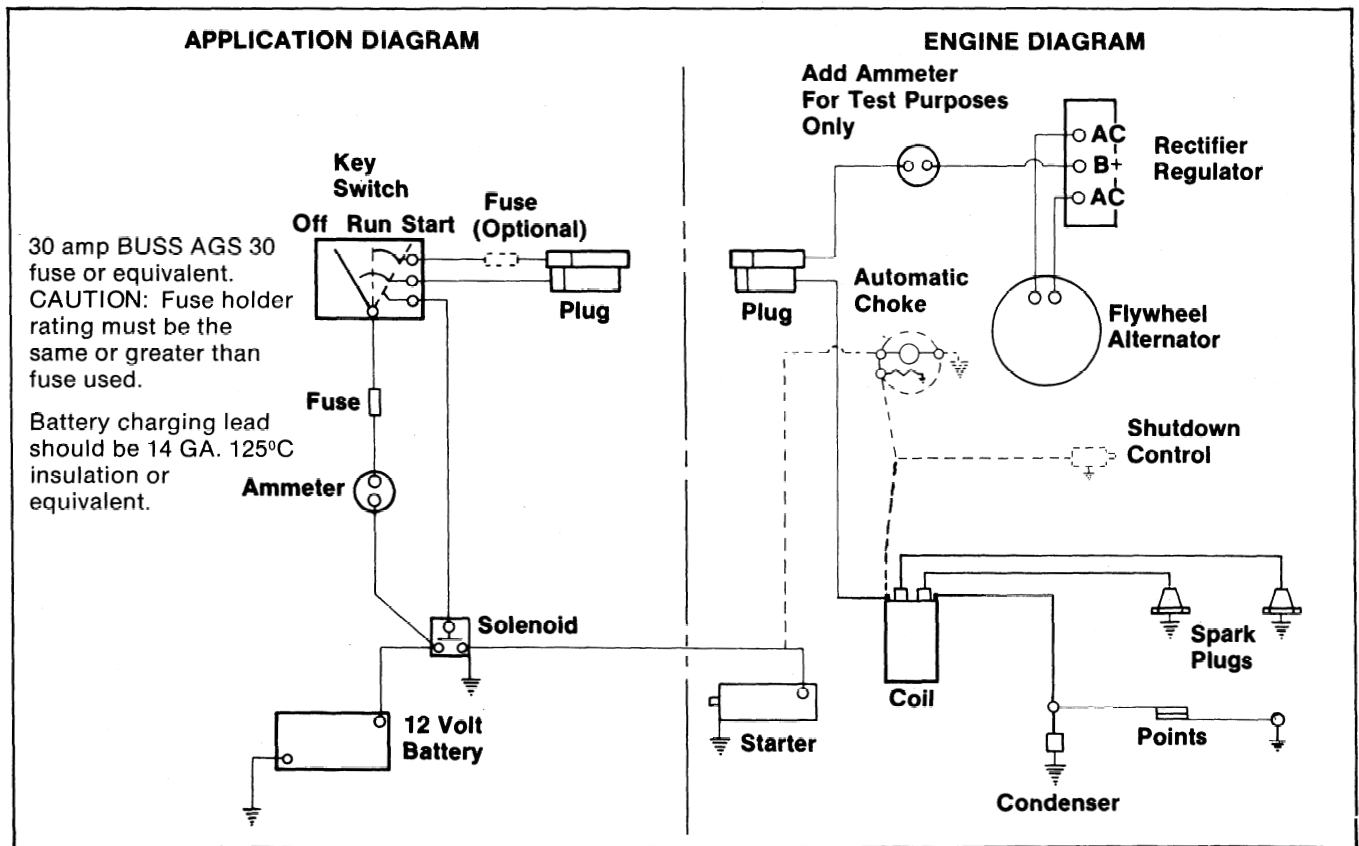

Figure 6-9. 15 Amp System Wiring Diagram

SECTION 7 — DISASSEMBLY

WARNING: *Before working on engine, remove the spark plugs to prevent unintentional starting or compression kickback when rotating engine by hand. To prevent dirt and residue from falling into combustion chamber, clean area around plugs before removing.*



The following sequence is suggested for complete disassembly of an engine. The procedure may have to be varied slightly to accommodate special equipment.

All parts should be thoroughly cleaned — dirty parts cannot be accurately gauged or inspected properly for wear or damage. There are many commercially available cleaners that quickly remove grease, oil and grime accumulation from engine parts. If such a cleaner is used, *follow the manufacturers instructions carefully*, and make sure that all trace of the cleaner is removed before the engine is reassembled and placed in operation. Even small amounts of these cleaners quickly break down the lubricating properties of engine oils.

EXTERNAL COMPONENTS

Follow the steps below when removing external components. Refer to the appropriate sections in this manual when servicing these parts.

1. Remove air cleaner assembly.
2. Disconnect low tension wiring from coil and breaker point assembly, and high tension leads from spark plugs. Disconnect other wiring harnesses as necessary.
3. Remove the governor arm from governor clamp then disconnect the governor linkage.
4. Disconnect the fuel line from carburetor.
5. Disconnect the breather hose from the intake elbow (early KT17 models only).
6. Remove the intake manifold with carburetor and intake elbow intact.

If necessary, the carburetor and intake elbow can be removed from the intake manifold at this time.

NOTE: Some Series II engines may be equipped with a throttle and choke control mounted

on the intake manifold. Disconnect these controls before removing carburetor. See Section 4, Figure 4-8.

7. Remove exhaust manifolds.
8. If so equipped, remove the grass deflector attached to the blower housing.
9. If so equipped, remove the grass screen from flywheel.
10. Remove the blower housing and other baffles and shrouds.

If necessary, remove the rectifier-regulator from blower housing.

Flywheel

11. Use a Kohler strap wrench, part 52 455 03, to hold the flywheel when removing the flywheel retaining screw and washer.

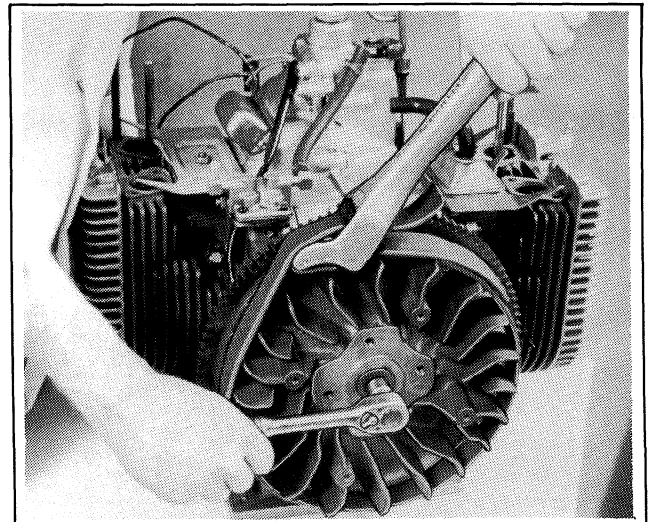

Figure 7-1. Using Strap Wrench

WARNING: *Improper procedures for removal of the flywheel can lead to a cracked flywheel and broken crankshaft. This not only results in extensive engine damage, but presents a serious threat to the safety of persons close by, since broken fragments may possibly be thrown from the engine.*



When removing the flywheel:

DO NOT use a flywheel puller that

SECTION 7 DISASSEMBLY

WARNING: *grips the outside diameter of the flywheel, as damage to the flywheel could result.*
(Cont.)



DO NOT use any type of bar between the flywheel fins when loosening the flywheel nut. This can crack the fins which may fly off when the engine is running.

CAUTION: Whenever the flywheel retaining screw is removed on KT series engines, the flywheel washer should be replaced. This is a new service procedure and must be performed to ensure joint integrity.



12. Use a flywheel puller to remove the flywheel from the crankshaft (see Figure 7-2).

Flywheel-Inspection

Inspect the flywheel for cracks, and the flywheel keyway for damage. Replace flywheel if cracked. Replace the flywheel, the crankshaft, and the key if flywheel key is sheared or the keyway damaged.

Inspect ring gear for cracks or damage. Kohler no longer provides ring gears as a serviceable part. Replace flywheel if the ring gear is damaged.

13. Remove the alternator stator. (Stator is exposed when flywheel is removed.)

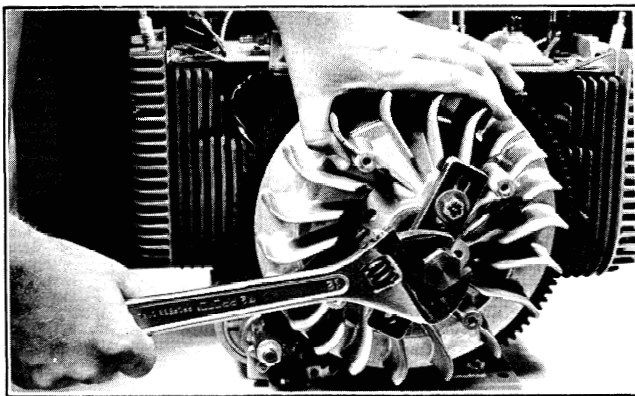

Figure 7-2. Flywheel Removal

Identify Engine Sides

14. To ensure proper reassembly, it is necessary to identify one side of the engine from the other. The #1 side of the crankcase is the side with the cylinder barrel closest to the flywheel.

With a marking pen, paint, or chalk, mark the crankcase halves and cylinder heads #1 side and #2 side (see Figure 7-3).

CAUTION: Do not use a metal stamp to mark crankcase as damage to crankcase may result.

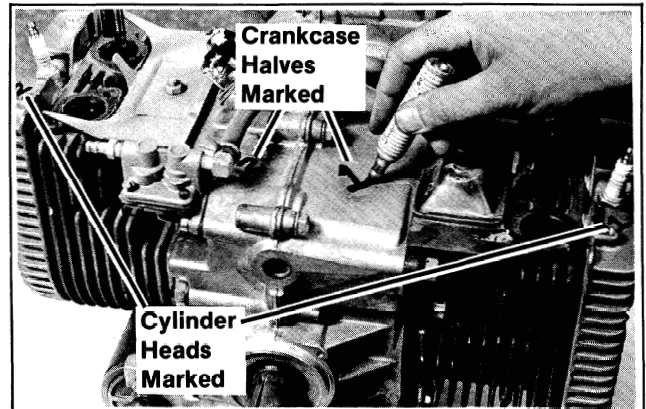

Figure 7-3. Marking The Case Halves For Identification

15. Remove the starter motor.

NOTE: On earlier models the starter end cap will come loose when the starter is disconnected from the engine, this could cause the brush springs to fall out of the starter. To prevent this, always hold the end cap firmly against the starter frame when removing the starter motor.

16. Remove the breather assembly from the #1 valve chamber and the valve cover from the #2 valve chamber.
17. Disconnect the breaker points and remove the breaker push rod.
18. Remove the fuel pump.

CYLINDER HEADS, BARRELS, VALVES AND PISTONS

1. Remove the cylinder head screws and cylinder heads.
2. Remove the cylinder barrels and barrel gaskets. The cylinder barrels are identified as either #1 or #2 by a mark already stamped into the gasket seating surface of each valve chamber (see Figure 7-4).

When removing and reinstalling cylinder barrels make sure each barrel is assembled to the correct crankcase side. (The #1 side of the crankcase is the side with the cylinder barrel closest to the flywheel.)

To simplify service requirements, and as a standardization procedure, a service replacement cylinder barrel with both hardened valve seat inserts assembled is now available. It can be assembled to either crankcase side.

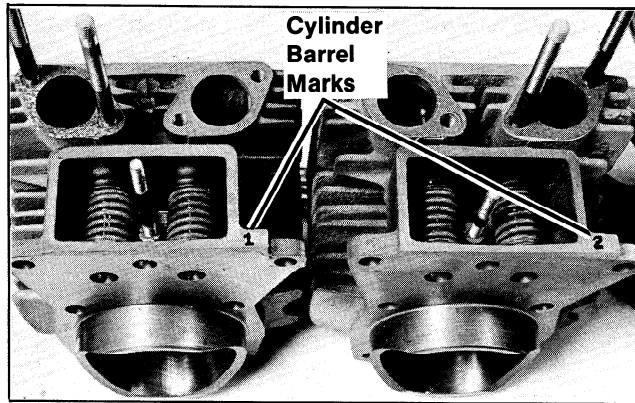

Figure 7-4. Cylinder Barrel Identification

- Using a valve spring compressor, compress the valve springs until the valve keepers can be removed, then release the compressor and remove the valves, retainers and springs. Some engines also contain intake valve seals, these should also be removed from the intake valve guides.

NOTE: Mark valve assemblies with marking pen or paint as coming from either the #1 or #2 side. Reused valves must be placed back in the correct cylinders.

- Remove piston pin retainers with a pliers. Using a drift punch, tap piston pin through piston and rod, disconnecting piston from rod. Mark pistons and rods with paint or marker pen as either #1 or #2.

NOTE: When removing piston pin, support piston to prevent bending the connecting rod.

Cylinder Heads - Inspection And Service

Blocked cooling fins often cause localized “hot spots” which can result in “blown” cylinder head gaskets. If gasket fails in area surrounding one of the retaining capscrews, high temperature gases can burn away portions of the aluminum alloy head. A cylinder head in this condition must be replaced.

If the cylinder heads appear in good condition, use a block of wood to scrape away carbon deposits. Be careful not to nick or scratch the aluminum, especially in gasket seating area (see Figure 7-5).

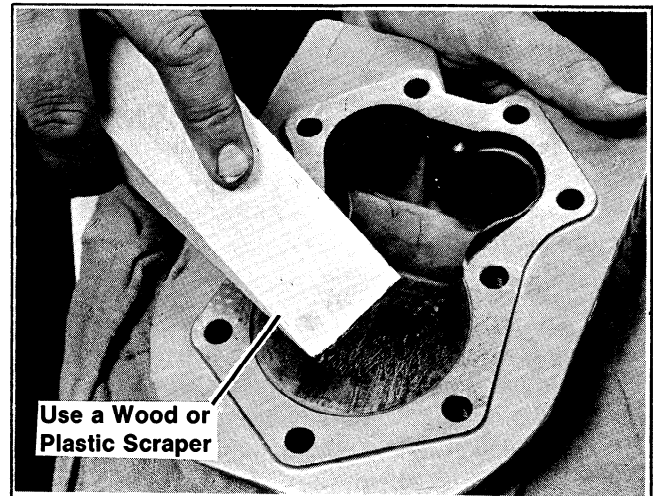

Figure 7-5. Cleaning Cylinder Heads

Cylinder heads should also be checked for flatness. Use a feeler gauge and a surface plate or piece of plate glass to make this check. Cylinder head flatness should not vary more than .003”, if it does, replace the cylinder head (see Figure 7-6).

NOTE: Measure cylinder head flatness between each cap screw hole.

In cases where the head is warped or burned away it will also be necessary to replace the head screws. The high temperatures that warped or burned the head could have made the screws ductile which will cause them to stretch when tightened.

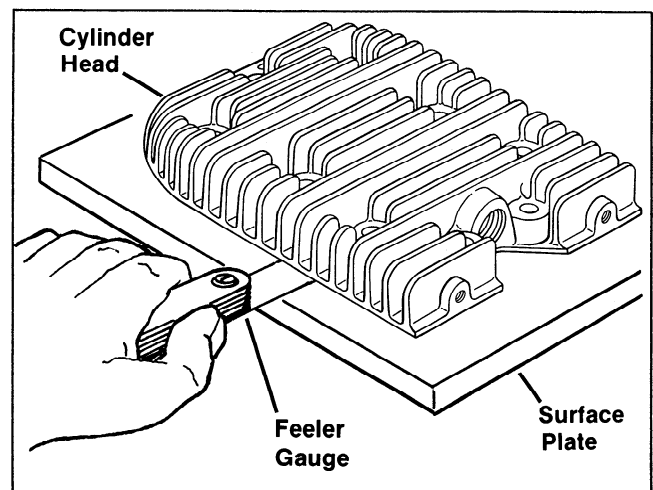

Figure 7-6. Checking Cylinder Head Flatness

Cylinder Barrels - Inspection And Overhaul

Check all gasket surfaces to make sure they are free of gasket fragments. Gasket surfaces must also be free of deep scratches or nicks.

Scoring of the Cylinder Walls: Unburned fuel; in severe cases, can cause scuffing and scoring of

SECTION 7 DISASSEMBLY

the cylinder walls. As raw fuel seeps down the cylinder walls, it washes the necessary lubricating oils off the piston and cylinder walls so that the piston rings make metal to metal contact with the walls. Scoring of the cylinder walls can also be caused by localized hot spots resulting from blocked cooling fins or from inadequate or contaminated lubrication.

If the cylinder bore is badly scored, excessively worn, tapered, or out of round more than .002" resizing is necessary. Use an inside micrometer to determine amount of wear (see "Specifications And Tolerances," Section 1), then select the nearest suitable oversize of either .003", .010", .020" or .030". Resizing to one of these oversizes will allow usage of the available oversize piston and ring assemblies. Initially resize using a boring bar, then use the following procedures for honing the cylinder.

Honing

While most commercially available cylinder hones can be used with either portable drills or drill presses, the use of a low speed drill press is preferred as it facilitates more accurate alignment of the bore in relation to the crankshaft crossbore. Honing is best accomplished at a drill speed of about 250 RPM and 60 strokes per minute. After installing coarse stones in hone, proceed as follows:

1. Lower hone into bore and after centering, adjust so that stones are in contact with walls. Use of a commercial cutting-cooling agent is recommended.
2. With the lower edge of each stone positioned even with the lowest edge of the bore, start drill and honing process. Move hone up and down while resizing to prevent formation of cutting ridges. Check size frequently.

NOTE: Measure the piston diameter and resize the bore to the piston to obtain the specified running clearances. Keep in mind the temperatures caused by honing may cause inaccurate measurements. Make sure the barrel is cool when measuring.

3. When bore is within .0025" of desired size, remove coarse stones and replace with burnishing stones. Continue with burnishing stones until within .0005" of desired size then use finish stones (220-280) and polish to final size. A cross-hatch should be observed if honing is done

correctly. The cross-hatch should intersect at approximately 23-33° off the horizontal. Too flat an angle could cause the rings to skip and wear excessively, too high an angle will result in high oil consumption (see Figure 7-7).

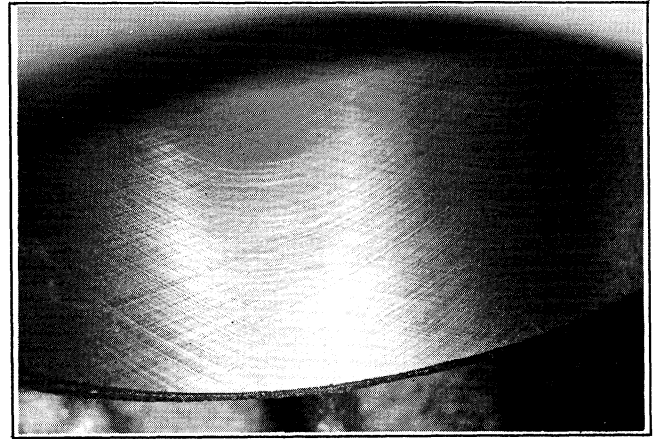

Figure 7-7. Cylinder Bore Cross-Hatch After Honing

4. After resizing, check the bore for roundness, taper, and size. Use an inside micrometer, telescoping gauge, or bore gauge to take measurements. The measurements should be taken at three locations in the cylinder—at the top, middle, and bottom. Two measurements should be taken (perpendicular to each other) at each of the three locations.
5. Carefully clean cylinder wall with soap and hot water, then after drying thoroughly, apply light coat of SAE 10 oil to prevent rust.

Valves - Inspection and Service

Carefully inspect valve mechanism parts. Check valves and valve seat area or inserts for evidence of deep pitting, cracks or distortion. Check clearance of valve stems in guides. See Figure 7-8 for valve details and specifications.

Hard starting, or loss of power accompanied by high fuel consumption may be symptoms of faulty valves. These symptoms could also be attributed to worn rings, however, remove and check valves first. After removal, clean valve head, face and stem with power wire brush then carefully inspect for defects such as warped valve head, excessive corrosion or worn stem ends. Replace valves found to be in bad condition. A normal valve and a valve in bad condition are shown in the accompanying illustrations, followed by explanations of other common valve conditions.

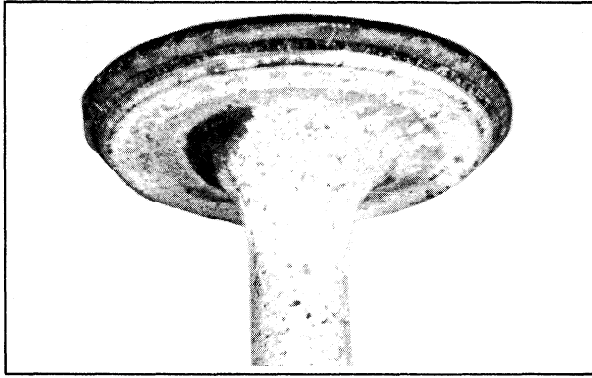

Normal: Even after long hours of operation a valve can be reconditioned and reused if the face and margin are in good shape. If a valve is worn to where the margin is less than 1/32" do not reuse it. The valve shown was in operation for almost 1000 hours under controlled test conditions.



Leakage: A poor grind on face or seat of valve will allow leakage resulting in a burned valve on one side only.



Stem Corrosion: Moisture in fuel or from condensation are the most common causes of valve stem corrosion. Condensation occurs from improper preservation during storage and when engine is repeatedly stopped before it has a chance to reach normal operating temperatures. Replace corroded valves.

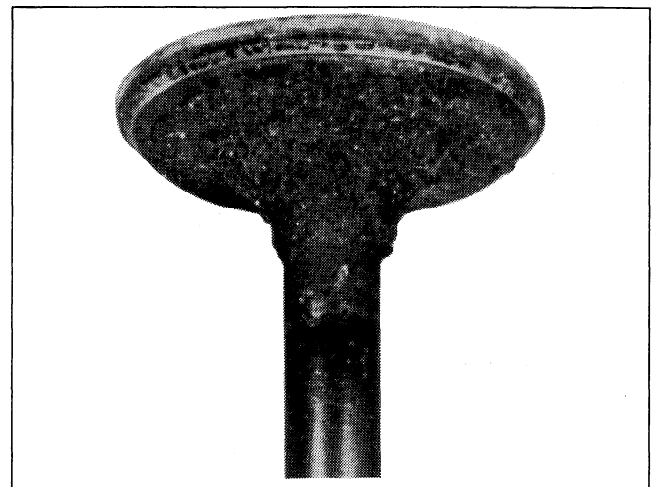

Coking: Coking is normal on intake valves and is not harmful. If the seat is good, the valve could be reused after cleaning.



Bad Condition: The valve depicted here should be replaced. Note the warped head; margin damaged and too narrow. These conditions could be attributed to excessive hours or a combination of poor operating conditions.



Gum: Gum deposits usually result from using stale gasoline. This condition is often noted in applications where fuel is not drained out of tank during the off season. Gum is a prevalent cause of valve sticking. The cure is to ream the valve guides and clean or replace the valves, depending on their condition.

SECTION 7 DISASSEMBLY



Overheating: An exhaust valve subject to overheating will have a dark discoloration in the area above the valve guide. Worn guides and faulty valve springs may cause this condition. Also check for clogged air intake, blocked fins, and lean fuel mixture when this condition is noted.

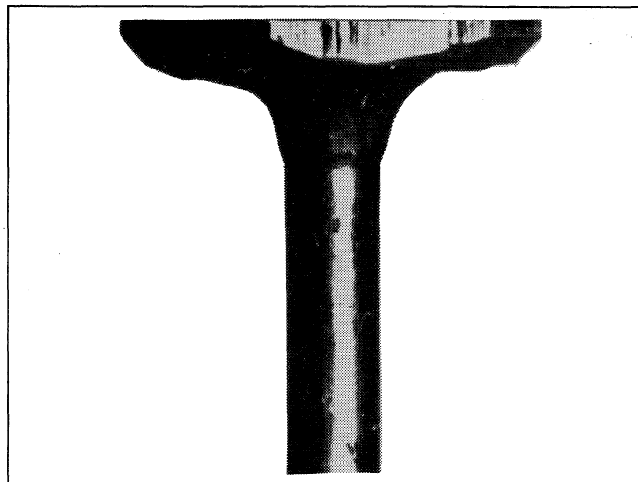

Carbon Cut: Excessive buildup of deposits in the combustion chamber may result in valve damage because deposits can become hard enough to cut the valve. Cleaning of the cylinder head at proper intervals could prevent such damage.

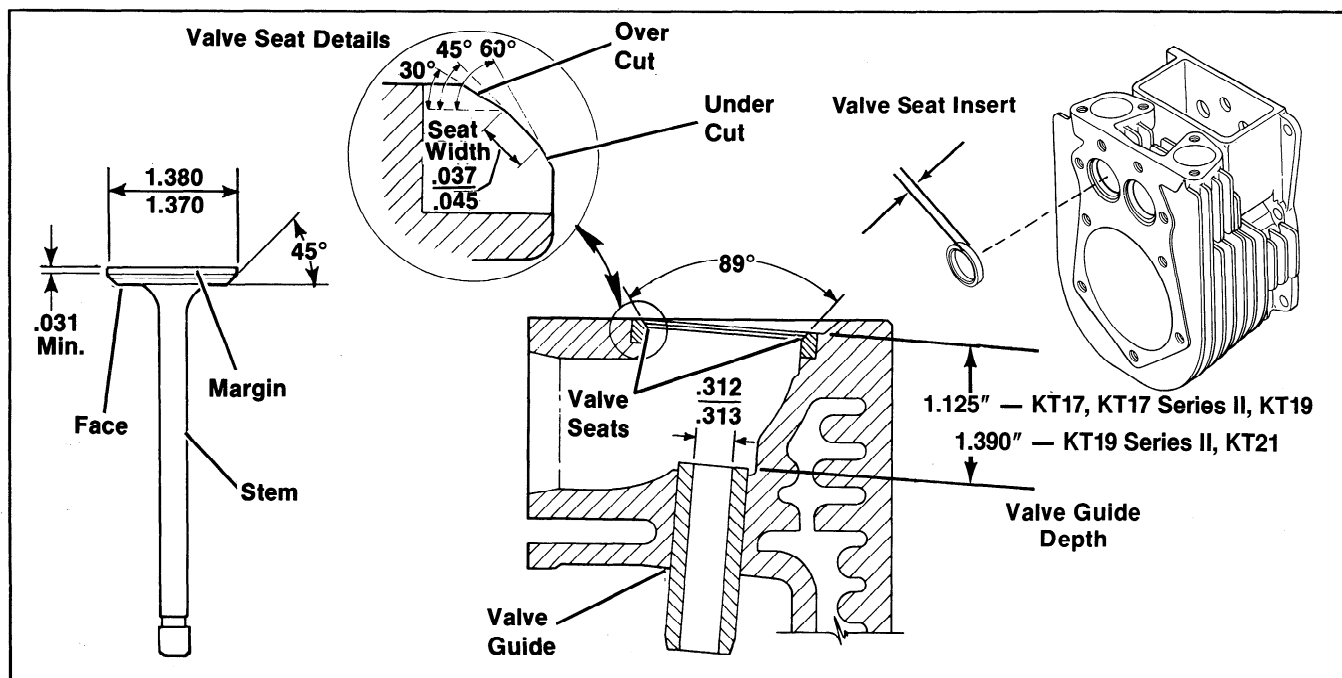

Figure 7-8. Valve Details

Valve Guides

Guides must be replaced if worn sufficiently to allow valve stem guide clearance to exceed limits stated in Section 1 "Specifications, Wear Tolerances, Torques and Special Tools."

To remove, press guide down into valve chamber and carefully break protruding end until guide is completely removed. Be careful not to damage the cylinder barrel when removing the old guide.

Clean the valve guide bores thoroughly. Press

replacement guides into cylinder barrel to depth specified, then ream to proper I.D. (see Figure 7-8).

Valve Seat Inserts

Intake valve seats are machined into the cylinder barrel on most KT models, however, certain applications may call for hard alloy intake valve seat inserts. The exhaust valve seats on these models are always replaceable alloy inserts. If the seats become badly pitted, cracked or distorted the inserts must be replaced.

When replacing valve seat inserts, measure the width of the insert before removal to be sure you order the correct size insert for your cylinder barrel. (See Figure 7-8.)

Two different width inserts have been used due to a change of cylinder barrels and the inserts are not interchangeable:

Width .199 (.200/.198)

Width .220 (.221/.219)

The inserts are a tight press fit in the cylinder barrel. A commercial valve seat removal tool is recommended for this job. Since insert removal causes loss of metal in the insert bore area, use only Kohler service replacement inserts which are slightly larger to provide proper retention in the cylinder barrel. Make sure new inserts are properly started and pressed into bore to prevent cocking of the insert.

Seating surfaces should be held between .037" and .045" width. Seats with more than .045" must be reconditioned with a 45° cutter and overcutting or undercutting with 30° and 60° cutters, to obtain the proper seat width, is recommended. See Figure 7-8 for valve seat details.

Reground or new valves must be lapped in to provide proper fit. Use a hand valve grinder with suction cup for final lapping. Lightly coat valve face with "fine" grade of grinding compound then rotate valve on seat with grinder. Continue grinding until smooth surface is obtained on seat and on valve face (see Figure 7-9). Remove all traces of grinding compound.

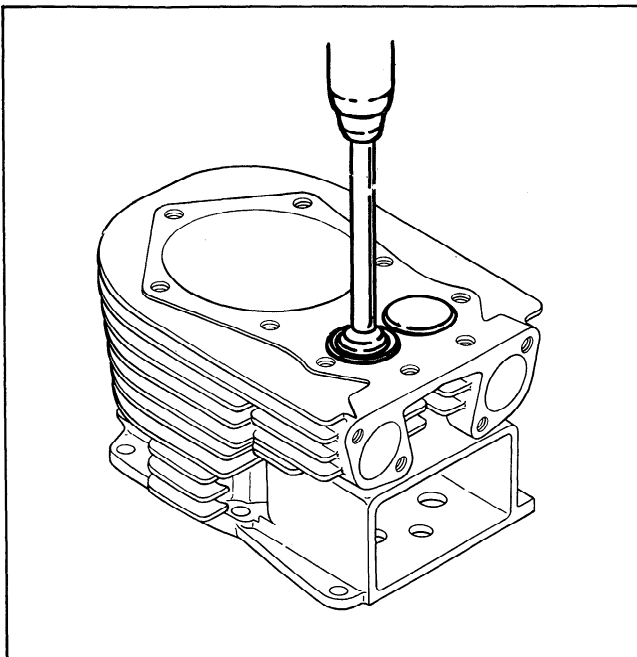

Figure 7-9. Lapping Valves

Valve Stem Seals

Some engines use valve stem seals on the intake valves. Always use new seals when valves are removed from cylinder. Seals should also be replaced if damaged or deteriorated in any way. Never reuse old seals.

NOTE: Some early production KT17 models do not use valve stem seals.

Valve Springs

There are two different valve springs used on these models: a short spring (free length 1.542") and a longer spring (free length 1.6876"). The short spring is used with valve rotators, while the long spring is used without rotators. Both of the springs are progressively wound, that is, coils are closer together on one end than the other. Install springs with close coils toward cylinder head.

A valve spring will seldom wear out, but if it does, it will usually break. Broken springs must be replaced.

Pistons And Rings - Inspection

Scuffing and scoring of pistons and cylinder walls occurs when internal temperatures approach the welding point of the piston. Temperatures high enough to do this are created either by friction which is usually attributed to improper lubrication and/or overheating of the engine.

Normally, very little wear takes place in the piston boss-piston pin area. If the original piston and connecting rod can be reused after new rings are installed, the original pin can also be reused but new piston pin retainers are required. Piston pins are included as part of the piston assemblies—if the pin boss in piston, or the pin are worn or damaged, a new piston assembly is required.

Ring failure is usually indicated by excessive oil consumption and blue exhaust smoke. When rings fail, oil is allowed to enter the combustion chamber where it is burned along with the fuel. High oil consumption can also occur when gap is incorrect, rings cannot properly conform to the cylinder walls under this condition. Oil control is also lost when ring gaps are not staggered during installation.

When cylinder temperatures get too high, lacquer and varnish collect on pistons causing rings to stick which results in rapid wear. A worn ring takes on a shiny or bright appearance. Scratches on rings and pistons are caused by abrasive material such as carbon, dirt, or pieces of hard metal.

SECTION 7 DISASSEMBLY

Detonation damage occurs when a portion of the fuel charge ignites spontaneously from heat and pressure shortly **after** ignition. This creates two flame fronts which meet and explode to create extreme hammering pressures on a specific area of the piston. Detonation generally occurs from using fuels with too low an octane rating.

Preignition or ignition of the fuel charge **before** the timed spark can cause damage similar to

detonation. Preignition damage is often more severe than detonation damage—often, a hole is quickly burned right thru the piston dome by preignition. Preignition is caused by a hot spot in the combustion chamber from sources such as: glowing carbon deposits, blocked fins, improperly seated valves or wrong spark plugs.

See Figure 7-10 for some common sources of piston and ring damage.

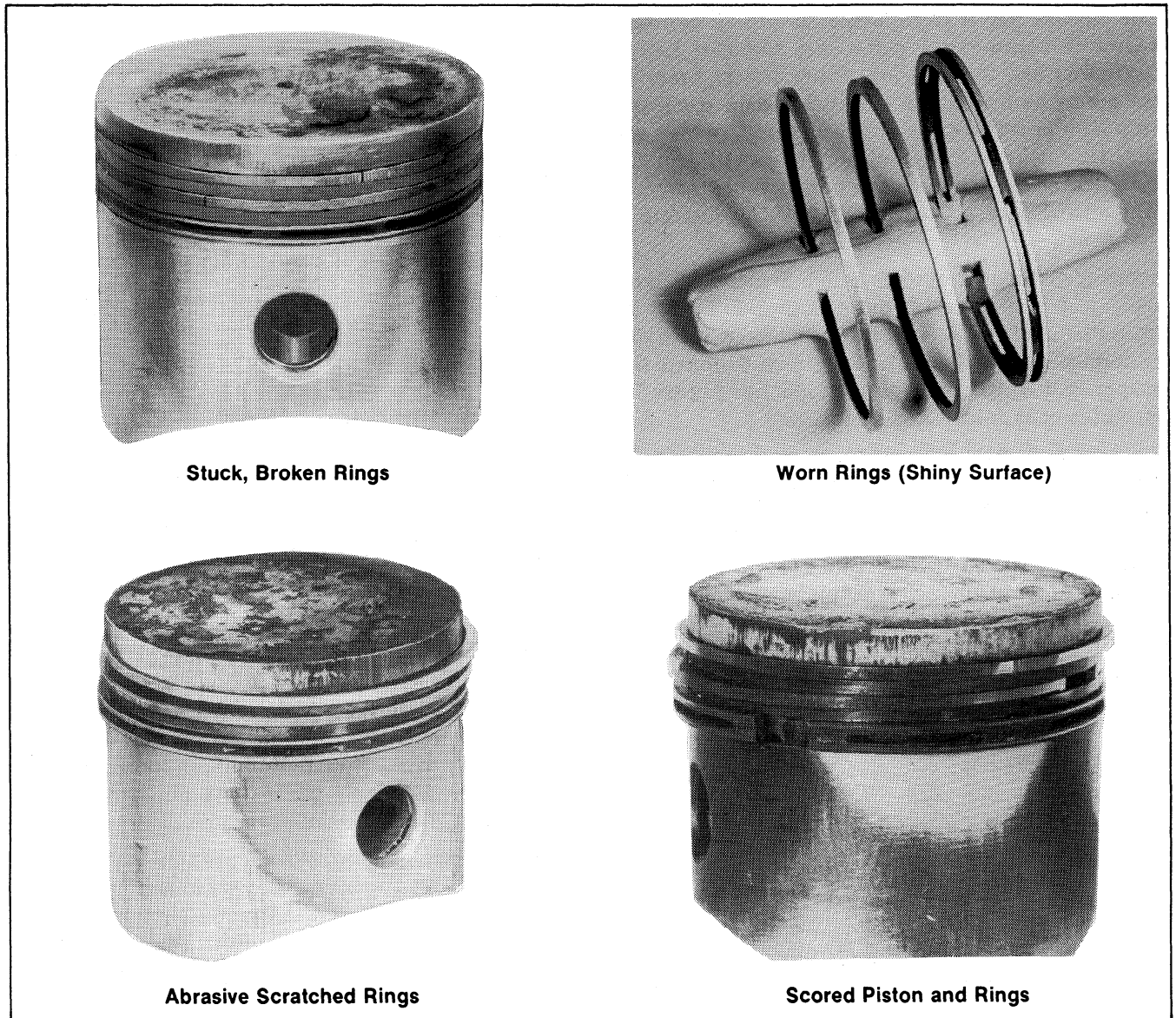

Figure 7-10. Common Sources Of Piston And Ring Damage

Pistons And Rings - Service

Service ring replacement sets and piston assemblies are available in the standard size, and in .010", .020" and .030" oversize sets. The service oversize piston assemblies are used only when the

cylinder has been rebored to the corresponding oversize.

NOTE: If engine is .003 oversize and piston is to be replaced, use .003 piston and STD service rings.

SECTION 7 DISASSEMBLY

The cylinder bore must be deglazed before service ring sets are used.

Some important points to remember when servicing piston rings:

1. If the cylinder block does not need reboring and if the old piston is within wear limits and free of score or scuff marks, it may be reused.
2. Remove old rings and clean up grooves. **Never** reuse old rings.
3. Before installing new rings on piston, place top two rings each in turn in its running area in cylinder bore and check end gap (see Figure 7-11). This gap should be .010"-.030" in a used

cylinder bore and .010"-.020" in a new cylinder bore.

In service ring sets, oil ring may have up to .060" ring end gap. Be sure to stagger ring and rails on installation to piston.

4. Rings must be installed correctly. Ring installation instructions are usually included with new ring sets. Follow instructions carefully. Use ring expander to install rings and check side clearance of each ring after installation (see Figure 7-12). For side clearances see "Specifications And Tolerances" Section 1.

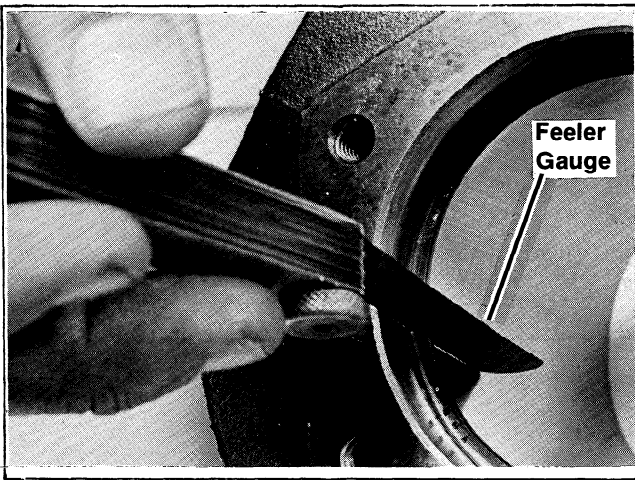

Figure 7-11. Checking Ring End Gap In Bore

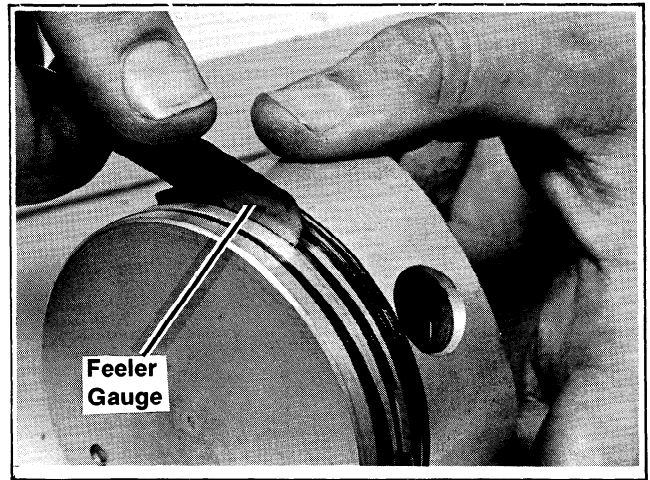

Figure 7-12. Checking Piston - Ring Side Clearance

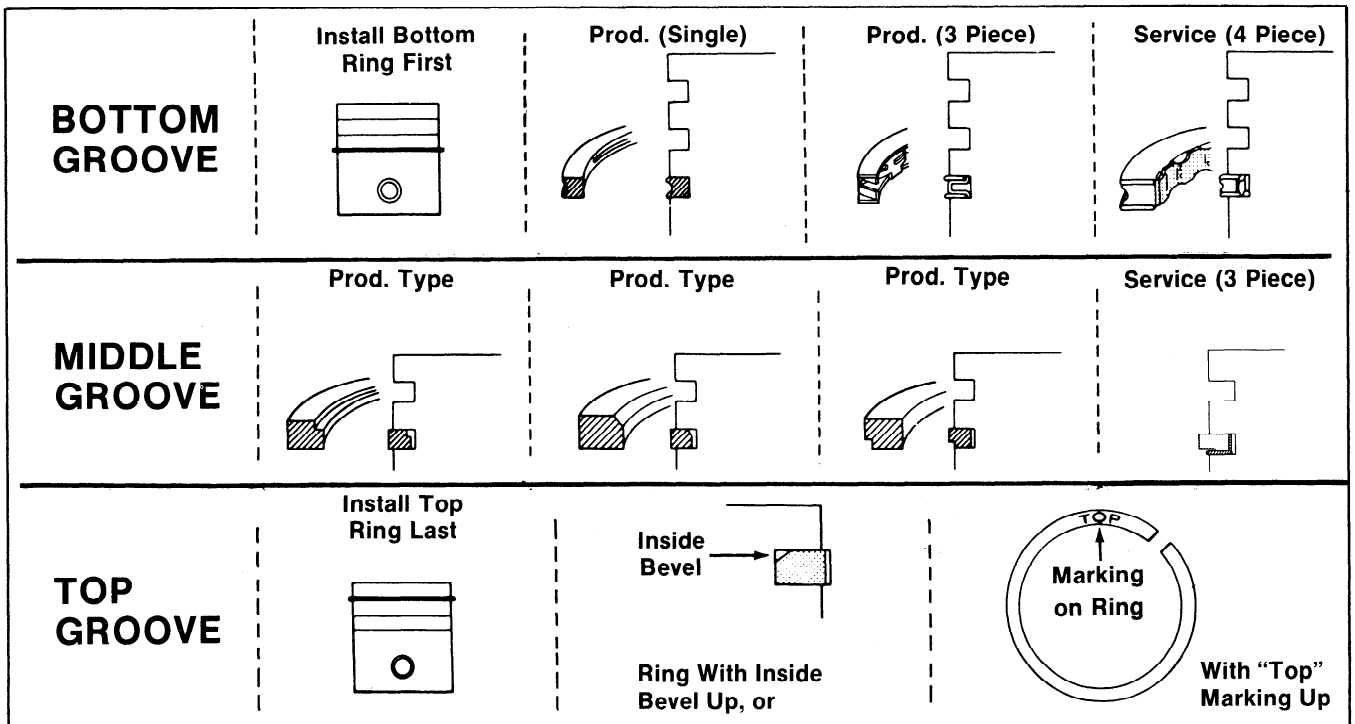

Figure 7-13. Production Type And Service Type Piston Rings

7

SECTION 7 DISASSEMBLY

CLOSURE PLATE AND CRANKCASE

1. Loosen the closure plate screws, then slide the closure plate off the crankshaft.

SERIES II

Oil Pressure Relief Valve

2. Remove the oil pressure relief valve ball and spring (and steel sleeve, if necessary) from crankcase. See Figure 7-14.
3. Measure the free length of the spring—length should be 0.940" (± 0.010). Replace spring if free length is not within tolerance.

NOTE: A replacement ball and spring, and steel sleeve are available in kit form. Refer to the Parts Manual for the part number of this kit.

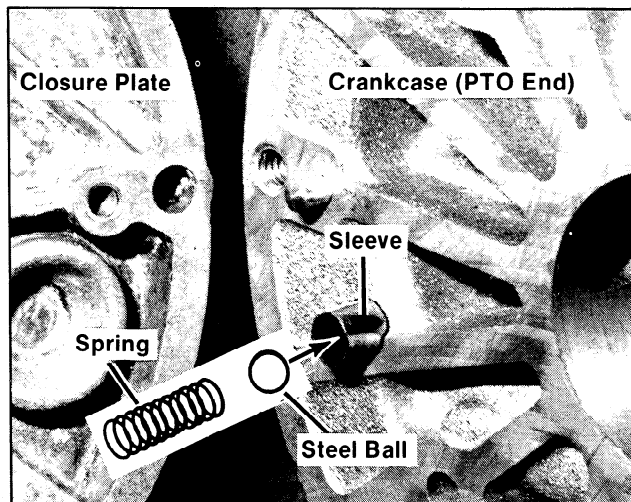

Figure 7-14. Oil Pressure Relief Valve

SERIES II

Camshaft Bore Plug

4. Scribe a line across the camshaft bore plug (flywheel end of engine) and the #1 crankcase half. This is used to align the plug on reassembly.

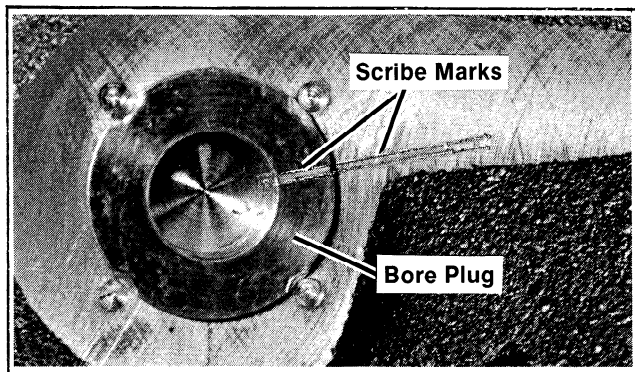

Figure 7-15. Machined Camshaft Bore Plug
(Series II Engines Only)

5. Loosen and remove the crankcase nuts and screws.
6. Put tape or governor spring around the tappet stems on the #2 side of the case to prevent the tappets from falling into the case when the halves are split.
7. Lay crankcase down so that #2 side is up. Locate the crankcase splitting notches in the seam formed by the two halves. With the tip of a large flat blade screwdriver, pry the two case halves apart as shown in Figure 7-16.

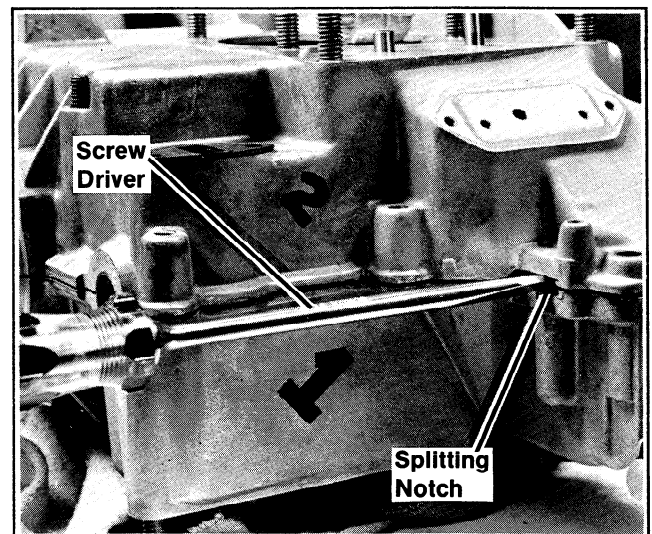

Figure 7-16. Splitting the Crankcase

CAMSHAFT, TAPPETS, CRANKSHAFT AND CONNECTING RODS

1. Remove the camshaft, pulling it from the #1 side of the crankcase.
2. Lift tappets from crankcase.
3. If tappets are to be reused they must be marked, at this time, according to crankcase side, and as either intake or exhaust. If new tappets are used marking will not be necessary as all four tappets are the same.
4. Lift the crankshaft out of the crankcase. Slide the oil seal from flywheel end of shaft, then remove bearings (either sleeve or ball) and spacer from crankshaft.
5. Loosen connecting rod bolts and remove connecting rods from crankshaft.

Posi-Lock Connecting Rods

The rod caps on Posi-Lock connecting rods have a light press fit when assembled. If difficulty in disassembling a Posi-Lock rod from the crankshaft is experienced, use the following procedure.

1. Loosen and unthread the connecting rod nuts until the ends of the studs are slightly below the top of the nuts. See Figure 7-17.
2. Using a plastic tipped hammer, lightly tap the nuts until the rod and rod cap are separated.

Remove the nuts and disassemble connecting rod from crankshaft.

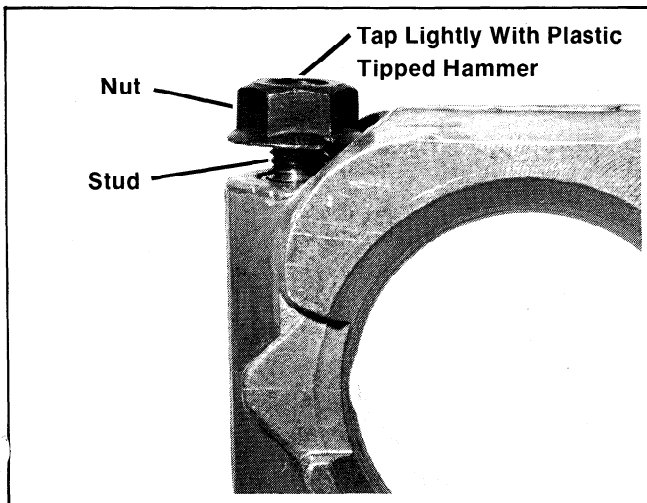

Figure 7-17. Removing Posi-Lock Connecting Rods

**Camshaft And Crankshaft -
Inspection And Service**

Inspect the gear teeth on both the crankshaft and camshaft. If the teeth are badly worn, chipped or some are missing, replacement of the damaged components will be necessary.

Also inspect the crankshaft bearings. Do not replace bearings unless they show signs of damage. If crankshaft turns easily and noiselessly and there is no evidence of scoring or grooving on the races or bearing surfaces, the bearings can be reused.

Check crankshaft keyways. If worn or chipped, replacement of the crankshaft may be necessary. Also inspect the crankpin for score marks or metallic pickup. Slight score marks can be cleaned with crocus cloth soaked in oil. If wear limits, as stated in Section 1 - "Specifications" and "Tolerances" are exceeded by more than .002" it will be necessary to either replace the crankshaft or regrind the crankpin to .010" undersize. If regrind, a .010" undersize connecting rod (big end) must then be used to achieve proper running clearance.

**Connecting Rods -
Inspection And Service**

Check bearing area (big end) for excessive wear, score marks, running and side clearances (see Section 1 - "Specifications" and "Tolerances"). Replace rod and cap if scored or excessively worn. Connecting rods with bearing diameter area .010" undersize are available for use with reground crankpin.

GOVERNOR GEAR AND CROSS SHAFT

1. Unscrew and remove governor stop pin and washer from crankcase.
2. Loosen the governor arm nut and slide the governor arm off the governor cross shaft.
3. Remove the retaining ring and washer from the end of the cross shaft and pull the shaft out of the case.
4. Slide the governor gear off stub shaft and out of crankcase.

Cross Shaft—Generator Applications

Engines on generator applications are equipped with a governor cross shaft that rotates inside of caged needle bearings (see Figure 7-18).

1. Remove the screws, lockwashers, and "L" bracket. Pull the cross shaft out of bearings.
2. The upper and lower bushings and needle bearings are pressed into the crankcase. If replacement is necessary—replace all 4 components at the same time.

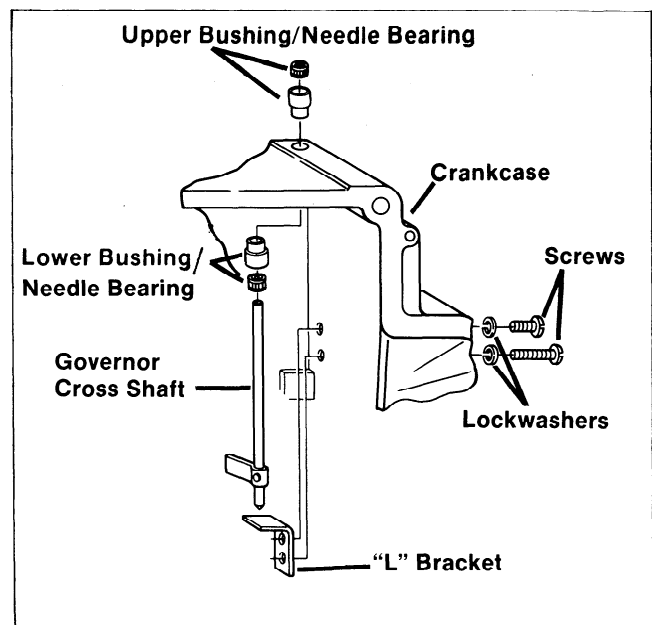

Figure 7-18. Removing Governor Cross Shaft—Generator Applications

SECTION 7 DISASSEMBLY

Governor Gear - Inspection

Inspect the governor gear teeth. Look for any evidence of worn, chipped or cracked teeth. If one or more of these problems is noted, replace the governor gear.

OIL PUMP

1. Unscrew the four small capscrews that hold the pump cover to the #1 side of the crankcase, then remove the cover and the inner and outer pump rotors. See Figures 7-19 and 5-5.
2. Pump gear and shaft should be removed only if service is necessary.

Using a small diameter drift punch, drive the roll pin in the oil pump gear hub through the hub and into the crankcase as in Figure 7-20. Discard the roll pin. Now remove the pump shaft, gear and spacer.

Oil Pump - Inspection And Service

Check oil pump gear for any cracked, chipped or badly worn teeth. Replace gear if any of these problems exist.

Oil pump rotors and shaft are virtually trouble free and will require very little service.

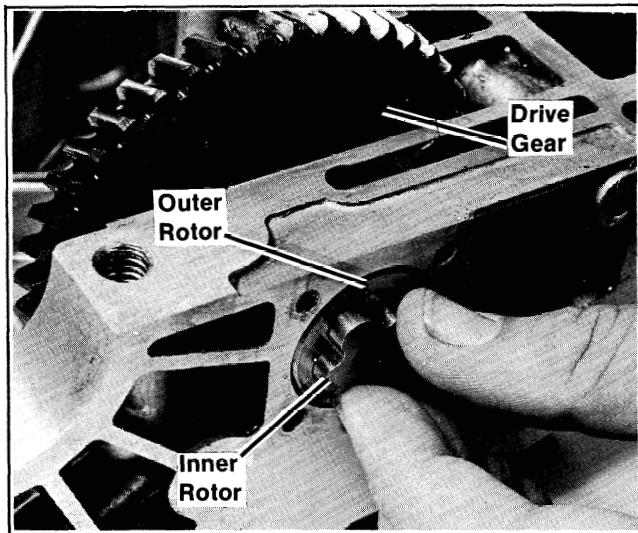

Figure 7-19. Removing Oil Pump Rotors (Early design crankcase shown).

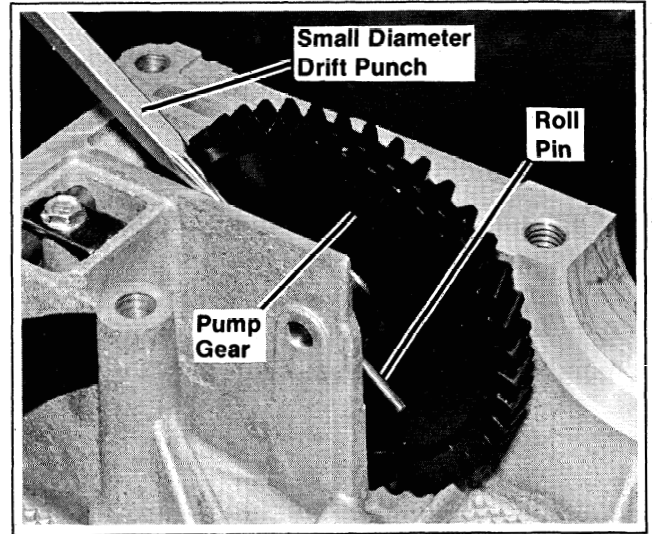

Figure 7-20. Removing the Oil Pump Gear

Center Oil Pickup

1. Remove spring clip using a long nosed pliers. Remove oil housing from end of oil pickup tube.
2. Remove the screw, clamp, and oil pickup tube from crankcase.

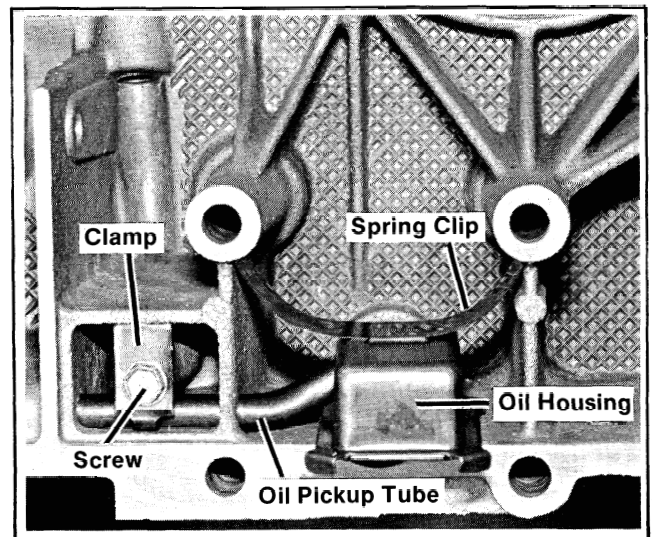

Figure 7-21. Center Oil Pickup

SECTION 8 — ASSEMBLY

The following sequence is suggested for reassembling engine after components have been reconditioned and all sub-assembly work such as reinstalling locating pins, plugs, bushings, etc., has been completed. The procedure may have to be varied slightly to accommodate special equipment.

CAUTION: Make sure all specified torque values and tightening sequences are followed when assembling engine.



GOVERNOR GEAR AND CROSS SHAFT

1. Slide the governor gear onto the governor stub shaft located inside the crankcase as shown in Figure 8-1.

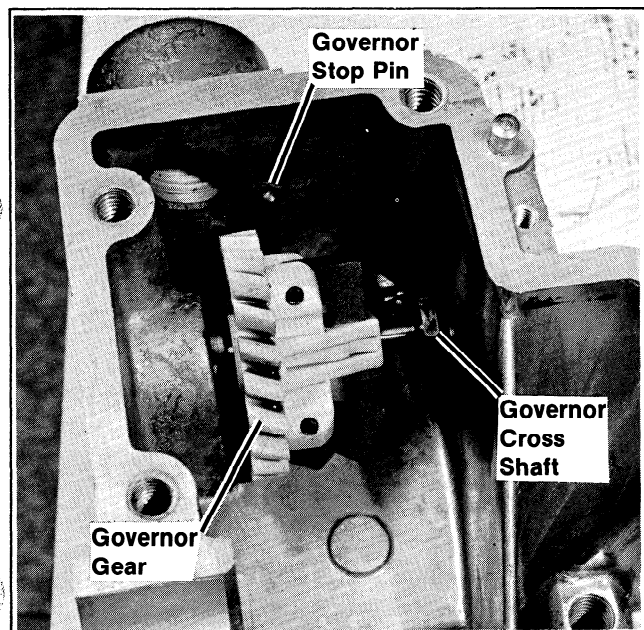

Figure 8-1. Governor Gear And Cross Shaft - Installed

2. Install governor stop pin and washer into crankcase. Torque pin to 70 in. lbs.
3. Slide one plain washer (.266 I.D., .375 O.D., .030W) onto governor cross shaft, then insert shaft through hole in crankcase. Slide another plain washer (same as above) over end of shaft. Secure shaft with retaining ring (.214/.206 I.D., .027/.023 W).

NOTE: For later production engines using the 1-piece governor arm/clamp, slide one additional plain washer over end of shaft.

Cross Shaft—Generator Applications

1. Insert cross shaft through needle bearings.
2. Install “L” bracket under cross shaft; secure bracket with screws and lockwashers.

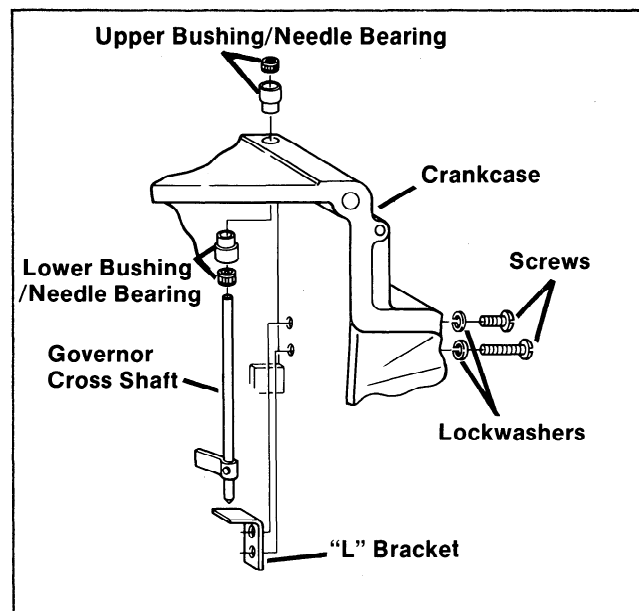

Figure 8-2. Installing Governor Cross Shaft—Generator Applications

CENTER OIL PICKUP

1. Install the oil pickup tube into crankcase—make sure tube is angled upward. Secure tube with clamp and screw.
2. Install oil housing and spring clip. (Install short side of spring clip into crankcase first.)

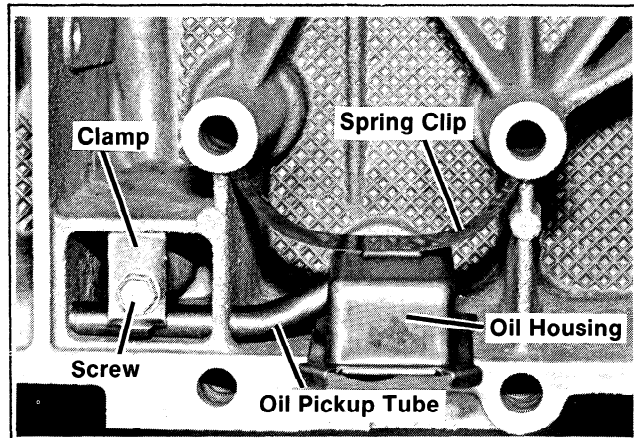

Figure 8-3. Installing Center Oil Pickup

SECTION 8 ASSEMBLY

OIL PUMP

1. Slide oil pump drive gear shaft through support rib from the inside of the crankcase. Put drive gear and spacer into position in crankcase (slotted end of gear hub facing support rib and spacer between rib and gear).
2. Push pump drive gear shaft through center hole in spacer and gear hub and into pump cavity.
3. Rotate pump shaft and gear hub until hole in shaft lines up with slot in gear hub. Lubricate a new roll pin with grease and drive the pin flush to the hub as shown in Figure 8-4.
4. Measure pump drive gear end play with a feeler gauge, if the end play is greater than .029", service spacers are available to bring end play to specified tolerance. Minimum drive gear end play is .010".
5. Lubricate the pump cavity with oil, then insert inner and outer rotors into cavity. (See Figures 5-5 and 7-19.) Assemble the pump cover to the crankcase with four self-tapping, slotted hex washer screws (#10-32 x 3/8").

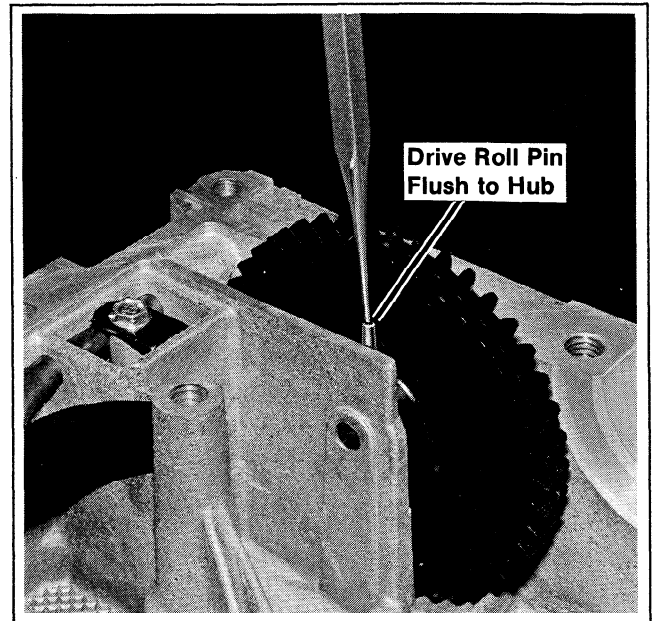

Figure 8-4. Securing Oil Pump Gear To Shaft

CONNECTING RODS

Lubricate the connecting rod journals and rod bolts, then install the rods on the crankshaft in the following manners:

KT17 - Cast Rod. Two raised markings (bosses) between rod bolt holes on top must face toward flywheel.

KT19 - Forged Rod. Machined edge of bolt hole must face up toward camshaft.

KT21 - Forged Rod. Machined edge of bolt hole must face up toward camshaft.

On earlier model KT17 -

Position rods on crankshaft so that when crankcase is in its upright position, oil hole in rod caps will be facing up.

Overtorque the rod bolts to 240 in. lbs., loosen, then retorque to 200 in. lbs.

Posi-Lock Connecting Rods

Posi-Lock connecting rods are used on all Series II engines, and may be used for service replacement of connecting rods on other KT17 engines. The

Posi-Lock design ensures positive alignment of connecting rod and cap for uniform bearing loading and eliminates bore distortion and cap shift.

NOTE: Posi-Lock connecting rods are not available for service replacement on pre-Series II KT19 engines (specifications before 49200).

1. Make sure match marks are aligned when rod is installed to crankshaft.

2. KT19 connecting rods have an angled design with respect to the shank and the rod cap. Install KT19 rods to crankshaft with the shank angled down and away from the camshaft. See Figure 8-5.

3. When installing a new Posi-Lock rod—torque nuts to 140 in. lb.

When installing a used Posi-Lock rod—torque nuts to 100 in. lb.

CAUTION: Do not overtorque, loosen, and retorque Posi-Lock connecting rods. Torque nuts on Posi-Lock rods directly to the specified values.



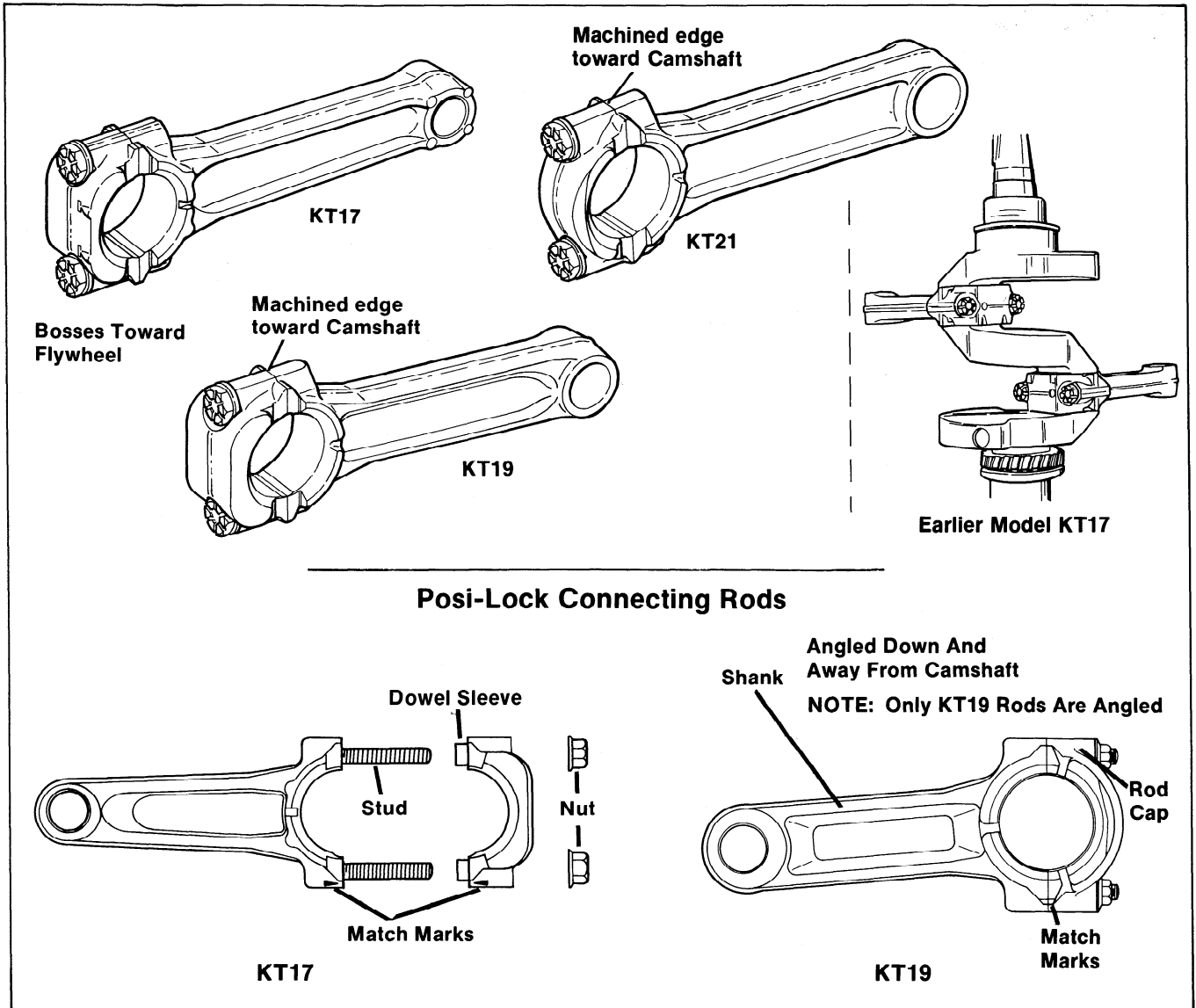

Figure 8-5. Note Differences In Connecting Rod Design

CRANKSHAFT AND COMPONENTS

1. Slide thrust washer onto P.T.O. end of shaft (chamfer toward crankshaft). Lubricate bearing journals on crankshaft and assemble bearings (sleeve or ball) on either end (see Figure 8-6). NOTE: Engines with ball bearings do not use a thrust washer.

Some early production KT17 sleeve bearing models have a notched spacer between the lip of the bearing and the crankcase on the flywheel end of the crankshaft. The bearing tab should fit into this notch.

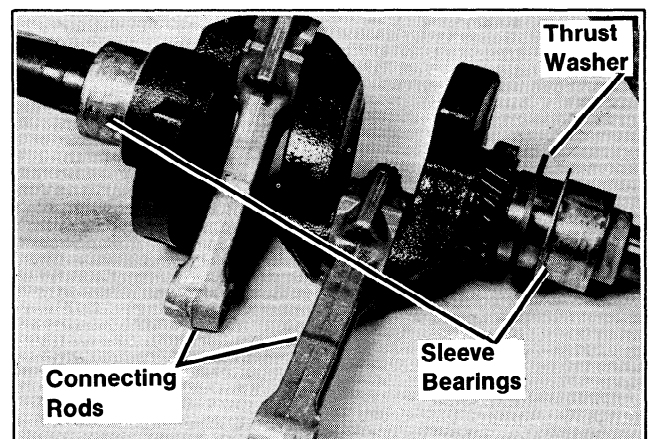

Figure 8-6. Crankshaft Components Assembled (Sleeve Bearings Shown)

SECTION 8 ASSEMBLY

SERIES II

Roller Thrust Bearing

Some Series II engines use a roller thrust bearing and flat thrust washers on the flywheel end of the crankshaft.

- A. Slide 0.1575" shaft locating washer, roller thrust bearing, and 0.039" thrust washer on flywheel end of crankshaft. Lubricate bearing journal, and install sleeve bearing (without flange) to flywheel end.
- B. Slide thrust washer on PTO end of crankshaft. Lubricate bearing journal, and install sleeve bearing (with flange) to PTO end.

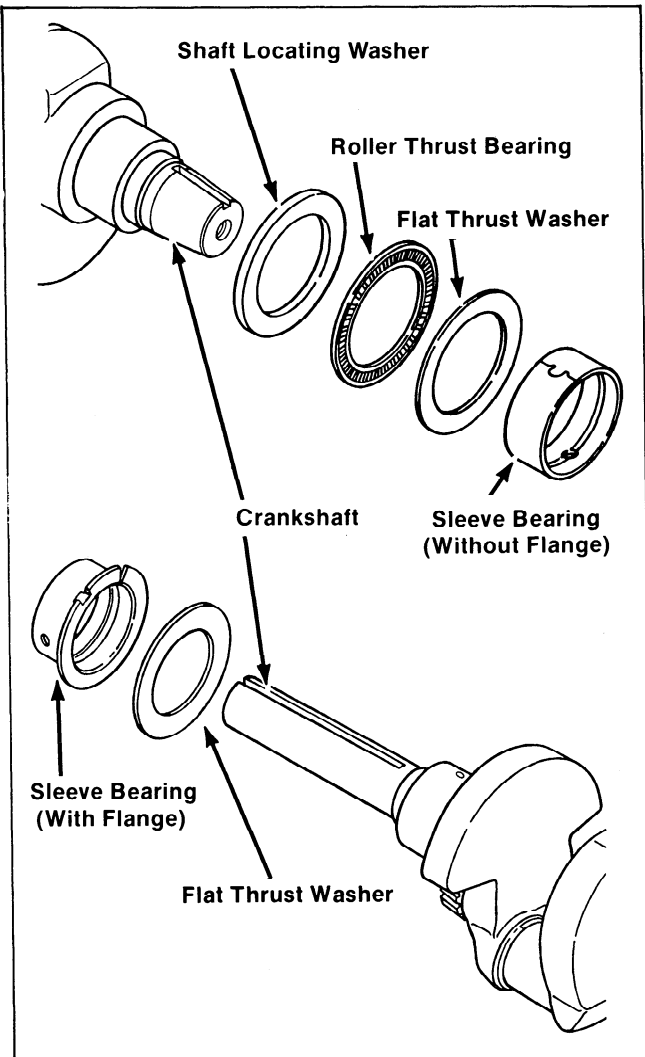

Figure 8-7. Assembly Of Roller Thrust Bearing

2. Position crankshaft over side #1 of crankcase (P.T.O. toward oil pump side) then lower crankshaft into case. Position locating tabs on sleeve

bearings to notches in the crankcase. If bearings are correctly installed, one of the oil holes in the sleeve bearing will line up with the oil hole or channel in the crankcase (see Figure 8-8).

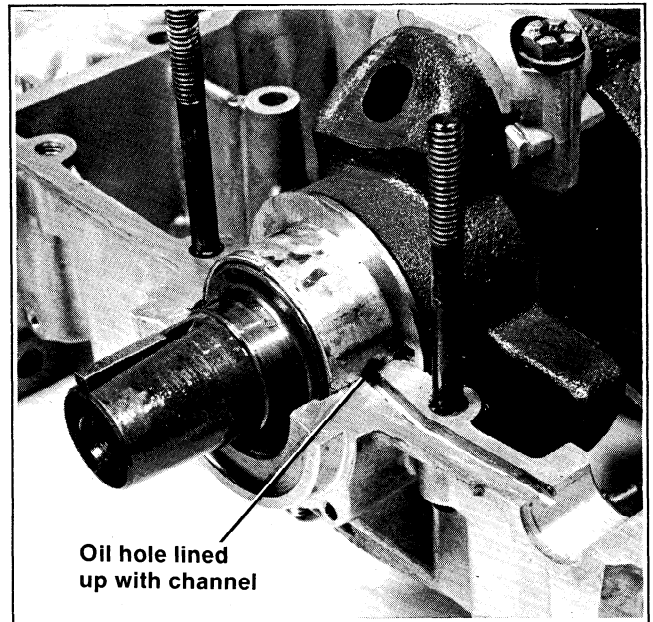

Figure 8-8. Position Of The Bearing To The Crankcase

3. Check crankshaft end play with a feeler gauge (see Section 1 - "Specifications" and "Tolerances"), then add correct thrust washer to bring clearance within specification (see Figure 8-9). Three sizes of thrust washers are available: .123/.126, .130/.133 and .138/.141. Refer to the parts manual for part numbers of these washers.

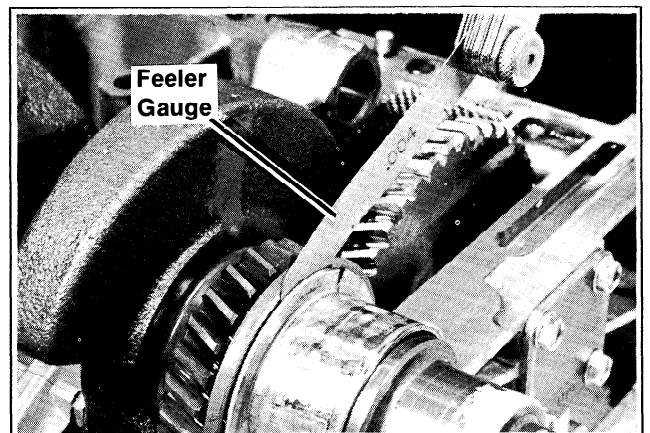

Figure 8-9. Checking Crankshaft End Play

TAPPETS AND CAMSHAFT

1. Lubricate the tappet stems and insert the tappets into both crankcase halves. To keep the tappets in #2 side from falling into the case when the case halves are assembled, secure tappet stems with tape or governor spring as shown in Figure 8-10.

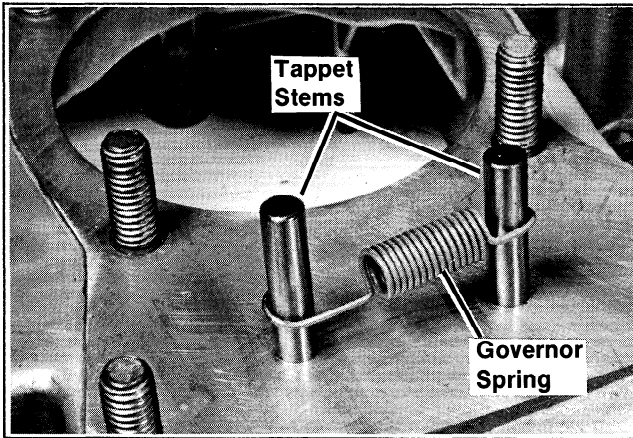

Figure 8-10. Use Governor Spring to Hold Tappets (#2 Side)

2. Assemble camshaft into #1 side of case, making sure timing marks on cam gear align with timing marks on crankshaft (see Figure 8-11).

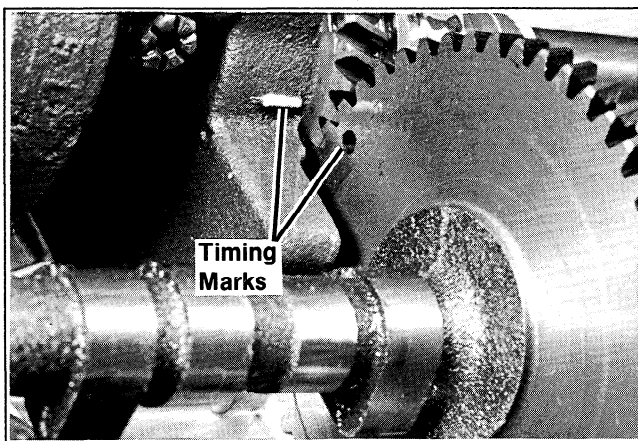

Figure 8-11. Match Timing Marks On Cam And Crank

3. Check camshaft end play (see Section 1 - "Specifications" and "Tolerances") with feeler gauge (see Figure 8-12). If camshaft exceeds clearances, service shims are available to bring camshaft end play into specification.

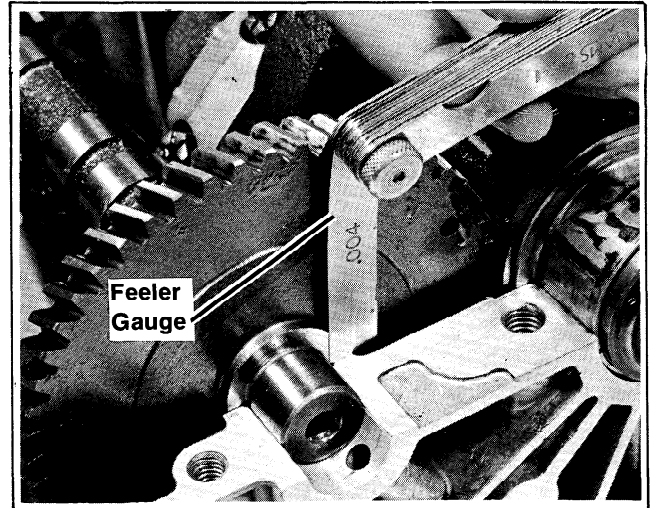

Figure 8-12. Checking Camshaft End Play

SECTION 8 ASSEMBLY

CRANKCASE SEALING

1. Prepare the sealing surfaces of the crankcase halves as directed by the sealant manufacturer. **DO NOT SCRAPE** the sealing surface when cleaning, as this will damage the sealing surface and inhibit sealing. Peel off or use lacquer thinner or gasket remover to remove old sealant.
2. Apply a 1/16" (1.5mm) DIA. sealant bead to the #2 crankcase half as shown in Figure 8-13 and 8-14. Follow sealant manufacturer's instructions regarding "setting." Recommended Sealants are listed in the table below.

CAUTION: Keep crankcase sealant out of oil passages and holes. Sealant left in oil passages will prohibit adequate lubrication, resulting in engine failure.

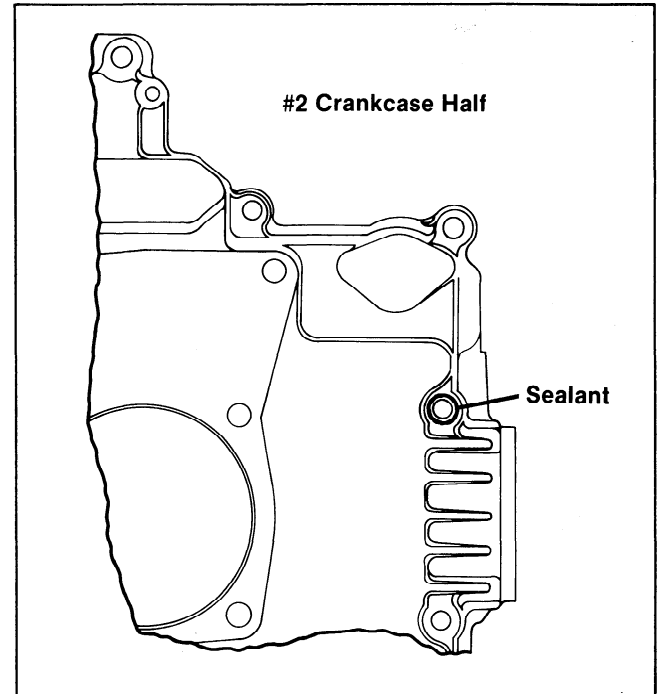

Figure 8-13. Applying Crankcase Sealant—
Crankcase Exterior

RECOMMENDED SEALANTS

These commercially available sealants are recommended for use on crankcase assemblies of KT17, KT19 and KT21 engines.

VENDOR	PRODUCT	VENDOR NO. & DESCRIPTION	AVAILABILITY
Dow Corning	Silicone Rubber Sealant	732 Aluminum, Black, Bronze, Clear, White	Automotive, Hardware, and Discount stores
GE	RTV Silicone Rubber	RTV102 - White RTV109 - Gray RTV103 - Black RTV154 - Gray RTV106 - Red RTV156 - Red RTV108 - Clear	GE Silicone Products Distributors
GE	Silicone Instant Gasket	Red	Automotive, Hardware, and Discount stores
GE	Silicone Hi Temp Instant Gasket	Red	Automotive, Hardware, and Discount stores
Loctite	Superflex Silicone Adhesive Sealant	593 - Black 594 - White 595 - Clear	Loctite Distributors
Permatex	Silicone Form-A-Gasket	6 Blue 3 oz. Bubble pack tube 6B Blue 3 oz. Boxed tube 6C Blue 11 oz. Cartridge 6M Blue 12 oz. Tube 66B Clear 3 oz. Tube 66C Clear 11 oz. Tube	Automotive, Hardware, and Discount stores

All of the above sealants have a one to two year storage life.

Using an outdated sealant can result in seal leakage.

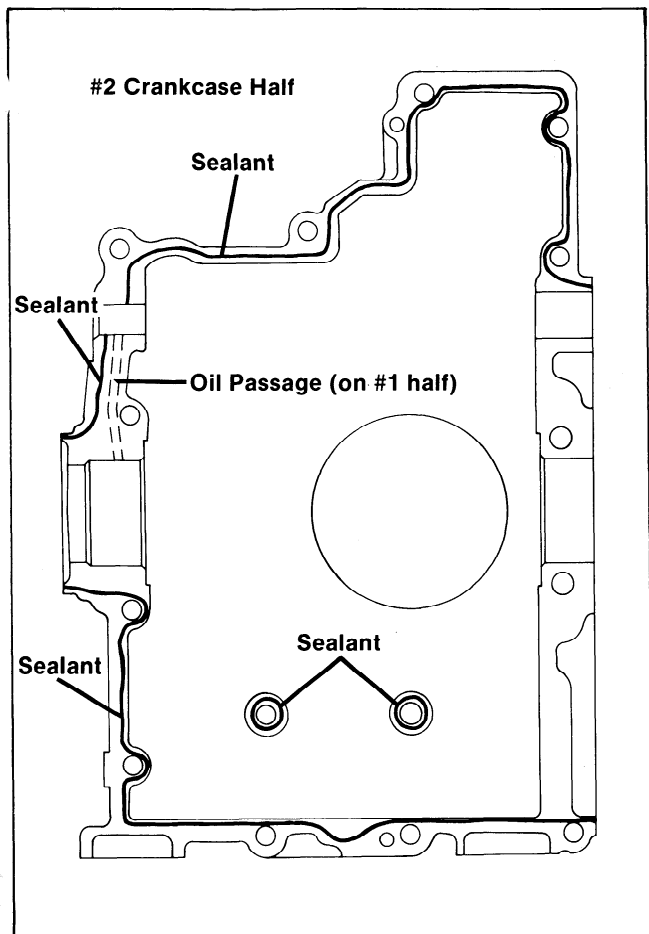

Figure 8-14. Applying Crankcase Sealant

SERIES II

Machined Camshaft Bore Plug With O-ring

Series II engines use a machined plug with an O-ring to seal the camshaft bore. Install this plug *before* placing the crankcase halves together. See steps #3-5 below.

Other KT17, KT19 and KT21 engines use a stamped cup plug that is installed *after* the crankcase halves are fastened together. When servicing engines using this type of plug—apply crankcase sealant, place the crankcase halves together, and install crankcase fasteners as instructed in steps 6 and 7. Install camshaft bore cup plug as instructed on page 60.

3. Inspect the plug and O-ring. Replace plug if bent, cracked, or damaged. Replace O-ring if stretched, cut, or hard and inflexible.
4. Lubricate the O-ring with engine oil or liquid soap. Insert the plug into the camshaft bore in the #1 crankcase half. When reinstalling a used plug, make sure the marks scribed on the plug and crankcase during disassembly are aligned. See Figure 8-15.

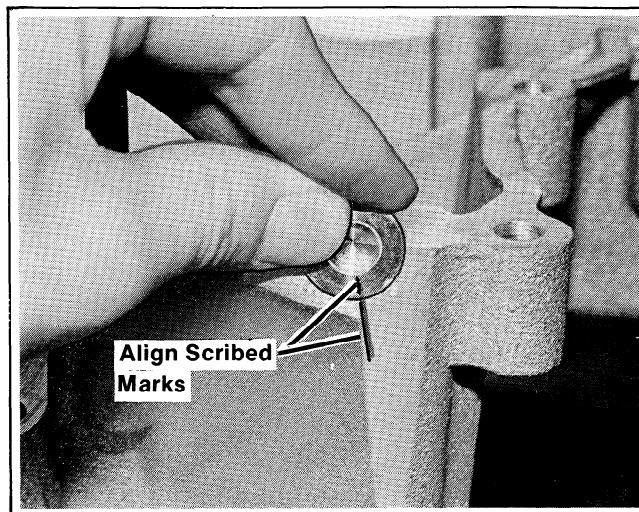

Figure 8-15. Installing Machined Camshaft Bore Plug Into #1 Half

5. Place the #2 crankcase half on the #1 half.

Place thumb pressure on the plug as the halves are brought together (see Figure 8-16). Maintain pressure on the plug as the crankcase fasteners are installed and tightened. This will ensure that the plug shoulder is bottomed tightly against the crankcase.

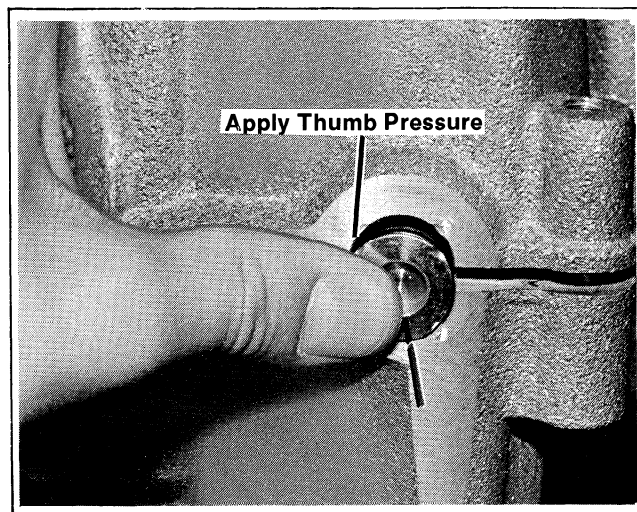

Figure 8-16. Installing #2 Crankcase Half

6. Install the fasteners and torque numbers 1 thru 6 in the sequence shown in Figure 8-17 to a preliminary value of approximately 100 in. lbs. (11 Nm-1.0 Kgm). Torque the remaining bolts to 100 in. lbs. (11 Nm, 1.0 Kgm) in the most expedient sequence.

Engines with serial number 9755084 or earlier have an extra crankcase bolt (#16 Figure 8-18). Torque to 35 in. lbs. (4 Nm, 0.4 Kgm).

SECTION 8 ASSEMBLY

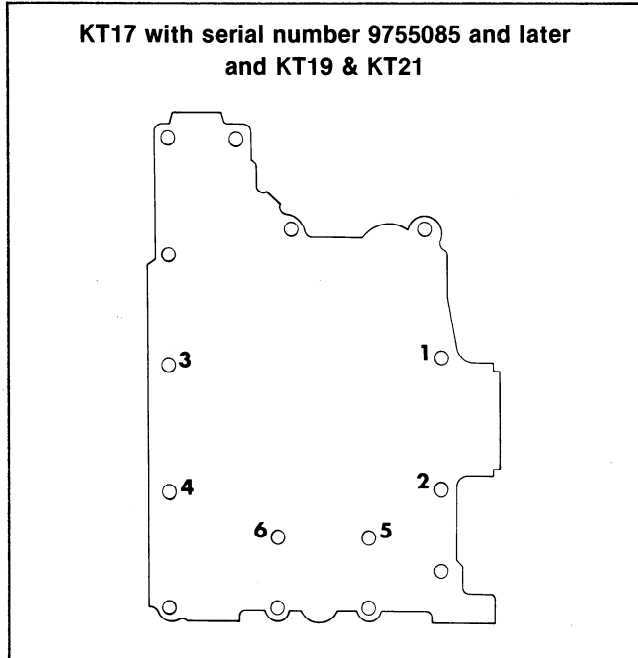

Figure 8-17. Crankcase Torque Sequence.

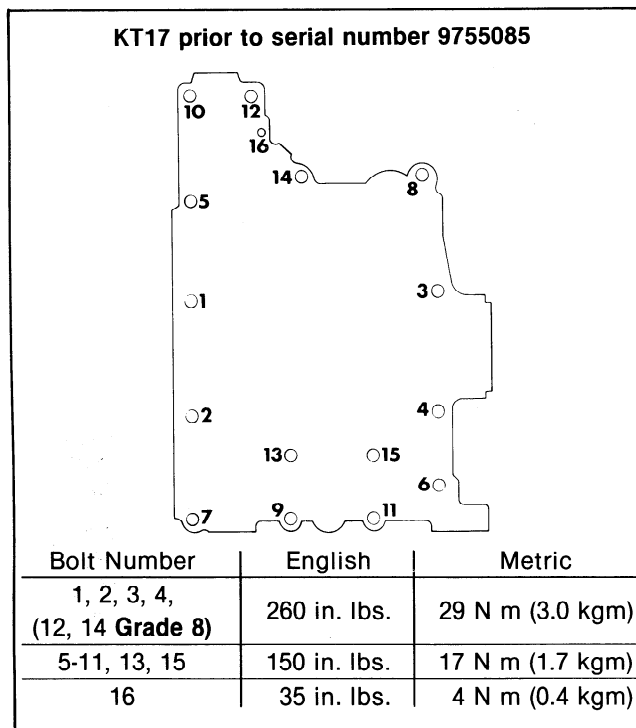

Figure 8-18. Crankcase Torque Sequence.

7. **Engines with serial number of 9755085 or later**, torque fasteners 1, 2, 3 and 4 to 260 in. lbs. (29 Nm or 3.0 Kgm), and fasteners 5 and 6 to 200 in. lbs. (23 Nm or 3.3 Kgm) in the sequence shown in Figure 8-17. Torque the remaining fasteners to 200 in. lbs. (23 Nm or 3.3 Kgm) in the most expedient sequence.

Engines with serial number 9755084 or earlier, torque the crankcase bolts according to the sequence and values shown in Figure 8-18.

8. Locate a center punch in the previous stake marks around the machined camshaft bore plug. Restake the plug securely in place. See Figure 8-19.

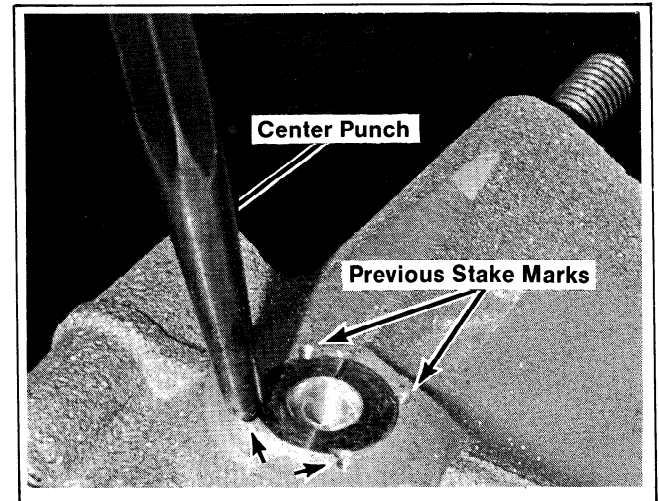

Figure 8-19. Restaking Camshaft Bore Plug.

Camshaft Bore Cup Plug

1. Squeeze a 1/16" bead of crankcase sealer around outside edge of camshaft cup plug.
2. Drive plug into camshaft bore (flywheel end) until it is flush with surface of crankcase. See Figure 8-20.

NOTE: Cupped end of plug must face out.

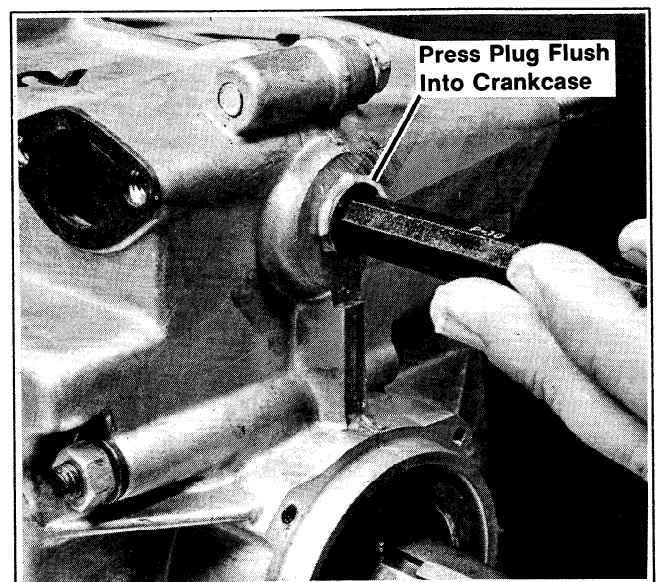

Figure 8-20. Installing Camshaft Bore Cup Plug

Front Oil Seal

1. Apply a 1/16" (1.5mm) diameter sealant bead around the outside edge of the front oil seal. Lubricate inside diameter of oil seal lip and slide the seal onto flywheel end of crankshaft (open end of seal toward case).
2. Use a driver to insert oil seal to a depth of .0313" (see Section 1 - "Special Tools"). Clean all lubricant off crankshaft after installing oil seal.
3. Wipe off all crankcase sealing compound that may have been forced out around the oil seal, camshaft bore plug, and mating edges of crankcase.
4. Remove governor spring or tape securing tappets.

STATOR

1. Position the stator on the crankcase (flywheel end) so that the clip holding the leads together on the stator frame is approximately between the eight and ten o'clock positions.
2. Secure the stator to the case using four #10-24 x 3/4" hex washer head screws. See Figure 8-21.

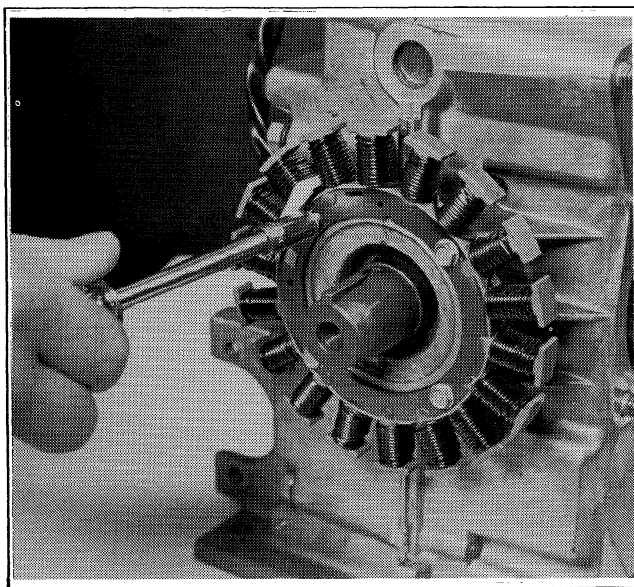

Figure 8-21. Installing Stator.

PISTONS, CYLINDER BARRELS AND CLOSURE PLATE

1. Position barrel gaskets on crankcase barrel studs.
2. Using a piston ring compressor push pistons into cylinder barrels (from cylinder head end) until piston pin bore is completely exposed on the crankcase end of the barrel-but make sure oil ring is not exposed.

IMPORTANT: Make sure locating mark on top of both pistons is toward PTO (exhaust port) side of barrel as shown in Figure 8-22.

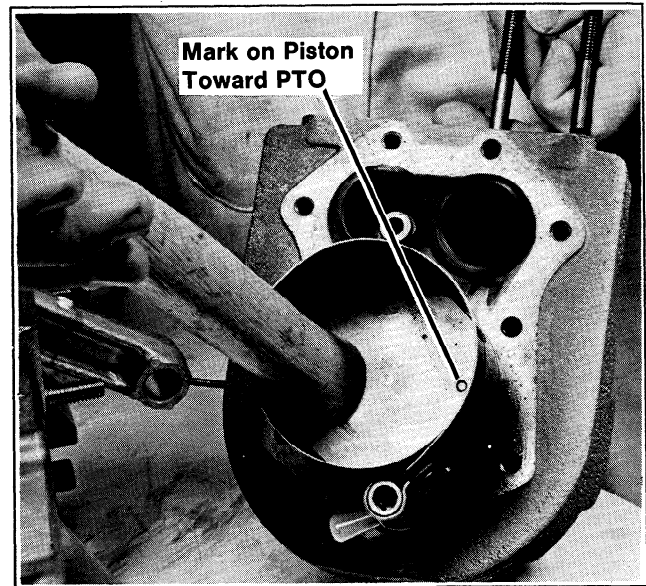

Figure 8-22. Installing Pistons In Cylinder Barrels

3. Install piston pin retainer in one side of the piston pin bore.
4. Assemble piston to connecting rod by sliding piston pin into pin bore and through connecting rod journal as in Figure 8-23. Secure piston pin with retainer.

NOTE: Barrel must be supported at all times so connecting rod does not contact edges of opening in crankcase.

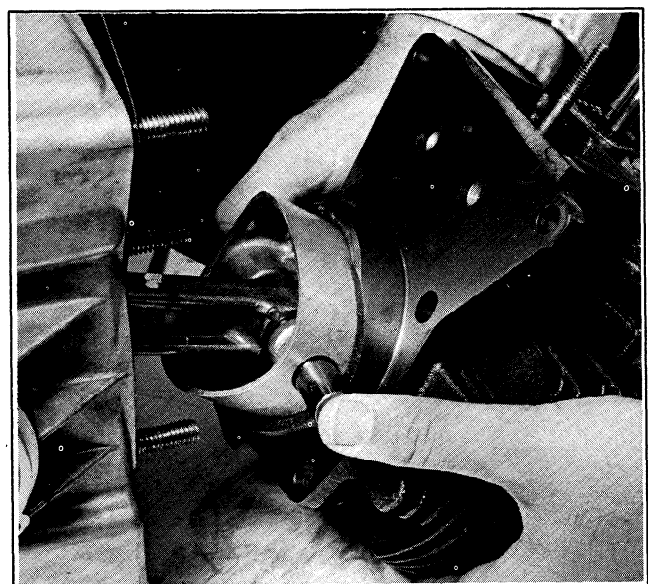

Figure 8-23. Assembling Piston to Connecting Rod

SECTION 8 ASSEMBLY

- Slide cylinder barrels onto crankcase studs and secure barrel to crankcase with six 3/8" lock washers and six 3/8-16 hex nuts. Torque number 1 and number 2 nuts to 100 in. lbs., then tighten the remainder of the nuts using the sequence shown in Figure 8-24. When this is complete, torque all the nuts to 360 in. lbs. following the recommended sequence.

NOTE: A special "Horizontal Twin" barrel wrench is available from your Kohler parts supplier. Refer to Section 1 - "Special Tools".

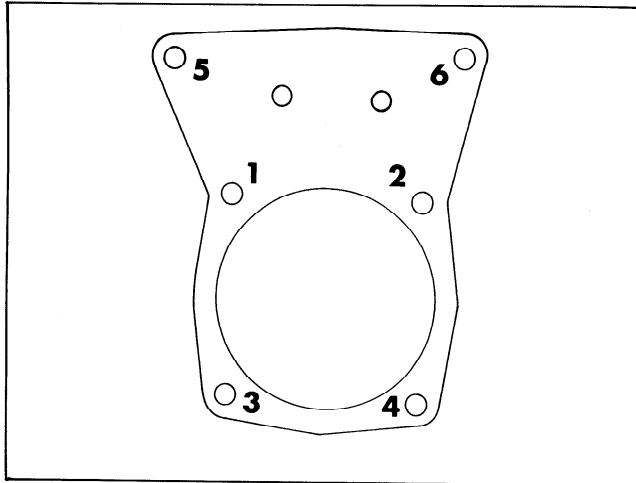

Figure 8-24. Barrel Nut Tightening Sequence

SERIES II

Oil Pressure Relief Valve

- Install the steel sleeve, and steel ball and spring into the machined hole in the PTO side of crankcase.

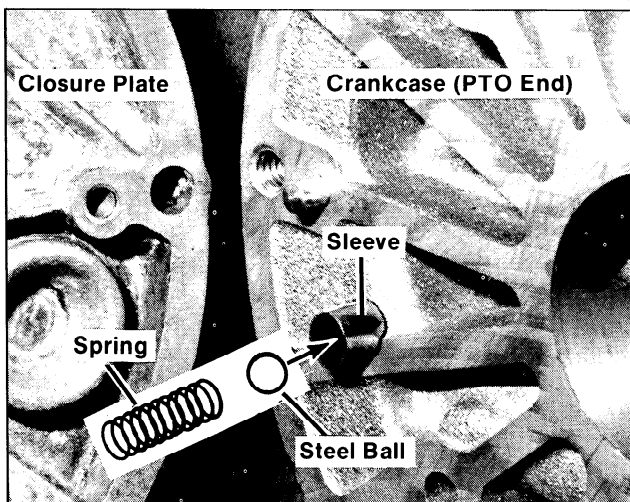

Figure 8-25. Installing Oil Pressure Relief Valve

- Position closure plate gasket on crankcase. Secure plate to case, with nine 5/16-18 x 1" hex washer screws turned in finger tight. Tighten the screws to 150 in. lbs. following the recommended tightening sequence shown in Figure 8-26.

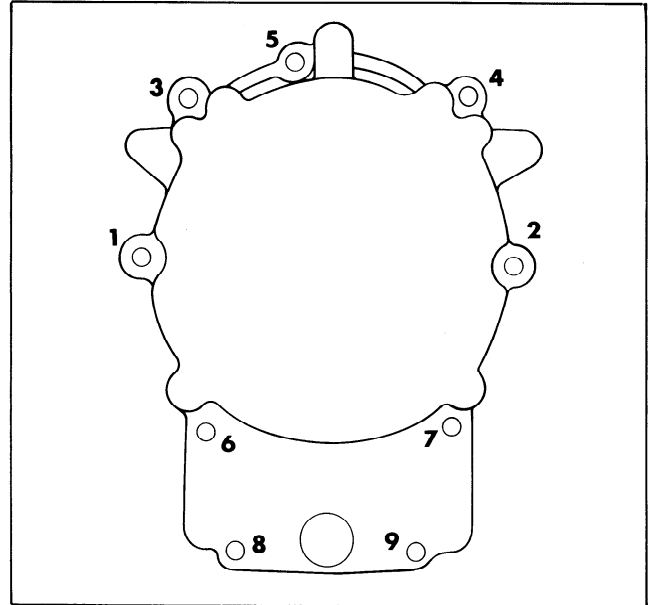

Figure 8-26. Closure Plate Screw Tightening Sequence

Rear Oil Seal

- Apply a 1/16" diameter sealant bead around outside edge of closure plate oil seal. Lubricate inside edges of oil seal and slide seal over crankshaft and into seal bore in closure plate. Drive seal into closure plate to a depth of 5/32" (on generator applications, flush with surface of closure plate). See Section 1 - "Special Tools" for seal driver dimensions.

VALVE COMPONENTS AND CYLINDER HEADS

- Lubricate valve stems and insert into valve guides. Intake valves toward flywheel side of engine, exhaust valves toward P.T.O. end. Valves will be marked "IN" for intake and "EX" for exhaust.
- Rotate camshaft to position where cam has no effect on tappets—hold valve firmly on seat and check clearance between valve stem and tappet. Intake valve clearance (cold) should be between .003" and .006", and exhaust valve clearance (cold) is between .011" and .014" (see Figure 8-27). If clearance is insufficient, grind end of valve stem until correct clearance is attained. Make sure stem is ground perfectly flat.

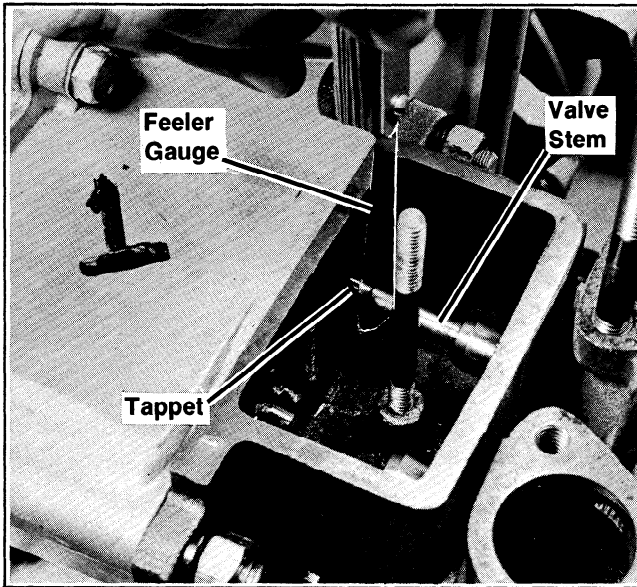

Figure 8-27. Checking Valve Clearance

3. Install valve stem seals over the intake valve stems and onto the valve guides. Make sure lip on seal is completely over machined area of valve guide.

NOTE: Early production models do not use valve stem seals.

4. Assemble the upper spring retainers, springs (close coils toward cylinder head) and lower spring retainers or rotators to valve stems.
5. Compress valve springs with a valve spring compressor and install valve keepers. Release compressor when keepers are in place.
6. Lubricate the 5/16-18x1-1/2" cylinder head screws with engine oil (nine screws for each

head). Install the screws and 5/16" washers in heads. Position new head gaskets on screws and assemble cylinder heads to barrels.

Torque screws to 15-20 ft. lbs. in the sequence shown in the following diagram.

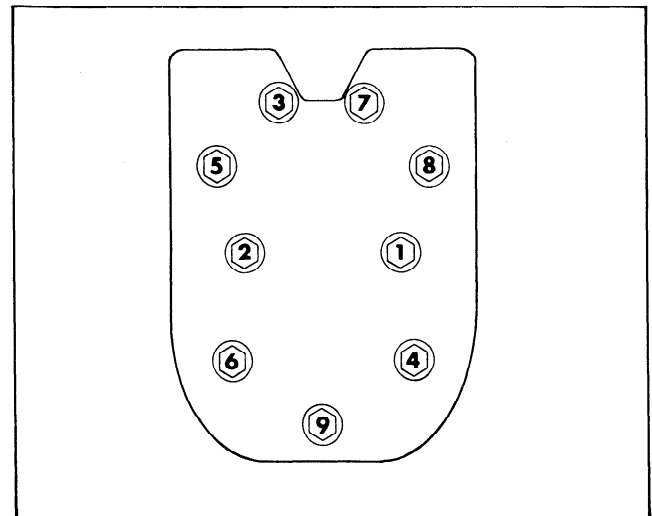

Figure 8-28. Cylinder Head Screw Tightening Sequence

BREATHER AND VALVE COVER

1. Assemble breather components on stud in valve chamber of the #1 cylinder barrel. Use the illustrations in Figure 8-29 to assemble breather components in the proper order.
2. Assemble valve cover and gasket on stud in #2 valve chamber and secure with one 1/4-20 nut.

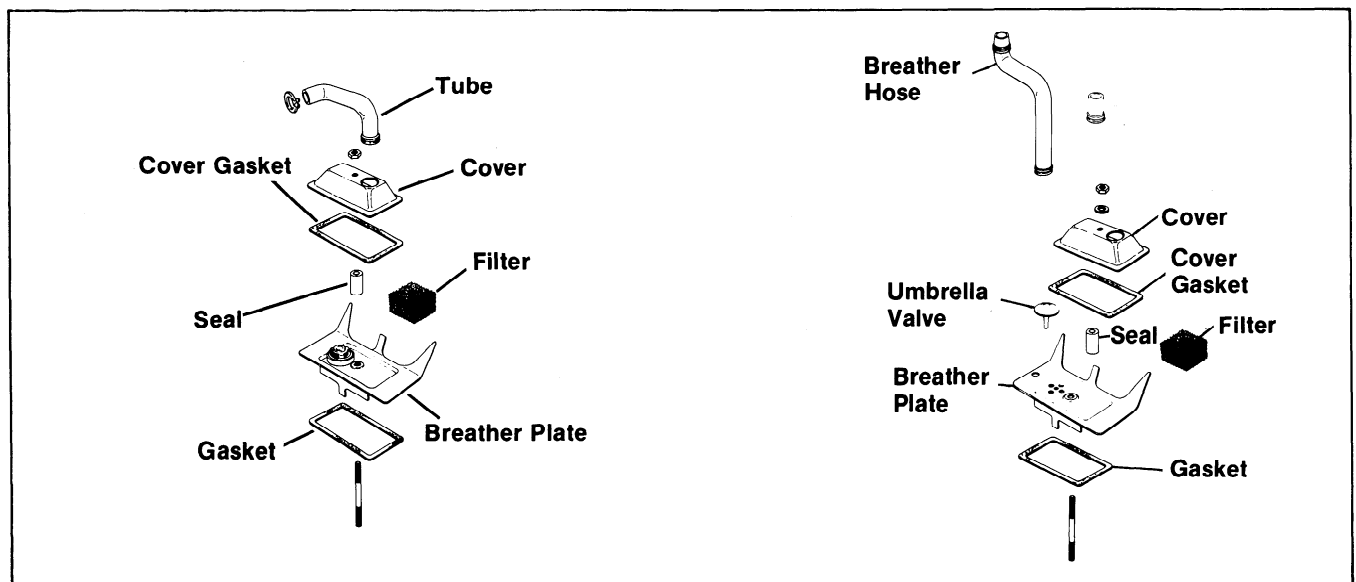

Figure 8-29. Exploded View Of Breather Components (Early Design On Left)

SECTION 8 ASSEMBLY

FUEL PUMP

CAUTION: Never install fuel pump on crankcase before the case halves are assembled, as fuel pump lever could be incorrectly positioned below the cam. *Correct lever position is above the cam.* Fuel pump damage and subsequent severe engine damage could result if lever is positioned below the camshaft. (See Figure 8-30.)

NOTE: Replacement fuel pumps are available in kit form from your Kohler parts supplier. They are of a non-metallic design which effectively insulates and prevents fuel from vaporizing inside the pump, and are interchangeable with the metal pumps. The kit includes the pump, new mounting gasket and two flat washers.

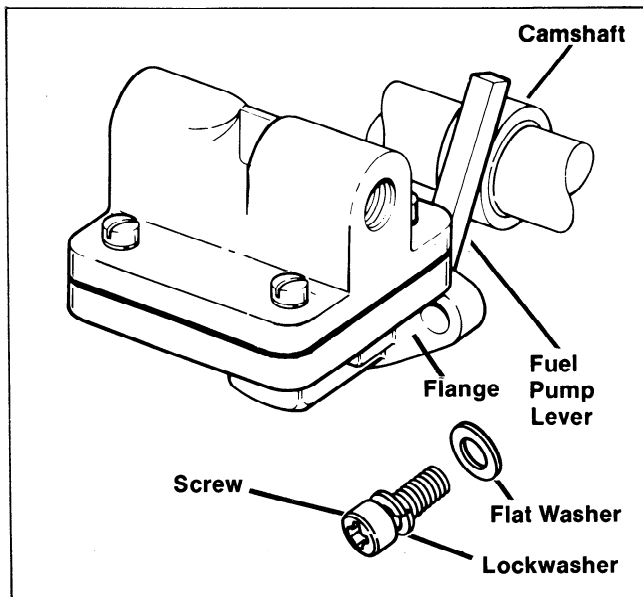

Figure 8-30. Installing Fuel Pump

Installing Non-Metallic Pumps

1. Apply a small amount of a gasoline resistant thread sealant to fuel fitting threads. Turn fittings into pump *6 full turns* and continue in same direction until required position is attained.
2. Install pump to engine using *only* the gasket provided in the kit. If a thick insulating gasket was used with the metal pump, discard it. It could cause distortion of the flange while tightening the mounting capscrews.
3. Install the flat washers from the kit next to the flange to prevent the lockwasher from damaging the flange. (The lockwashers and mounting screws from the old pump can be reused with the new pump.)

4. Install the two 1/4-20 x 3/4" fillister head screws, and lockwashers into fuel pump flange. Position pump gasket on screws, then secure pump to fuel pump mounting pad, which is just to the right of the #2 cylinder barrel, toward the flywheel end of the engine. Torque screws to 40-45 in. lbs. - do not overtighten.
5. Attach fuel hose to outlet side of fuel pump with hose clamp.

STARTER MOTOR

1. Attach starter motor to the mounting flange on the #2 side of crankcase just below the cylinder barrel.
2. Secure starter with two grade #2, 1/4-20 hex nuts and 1/4" lock washers.

FLYWHEEL

WARNING: *Improper procedures for installation of the flywheel can lead to a cracked flywheel and broken crankshaft. This results in extensive engine damage, and presents a serious threat to personal safety, since broken fragments may possibly be thrown from a running engine.*



When installing the flywheel:

DO NOT apply grease or oil or any lubricant to the taper of the crankshaft or hub of the flywheel, as this will cause excessive stress to be developed in the flywheel hub, and possible cracking of the flywheel while tightening.

DO NOT allow the key to be pushed inward on the keyway while installing the flywheel. If the key rides up on the rounded surface at the end of the keyway as shown in Figure 8-31, it will act as a wedge and crack the flywheel hub.

DO NOT reuse a flywheel if it has been dropped or damaged in any way.

DO NOT use a steel bar or any other object between the flywheel fins to hold the flywheel when the flywheel nut is being torqued, as this could break or crack flywheel fins, which may fly off when the engine is running.

WARNING: *DO NOT use impact wrenches to install the flywheel retaining nut as this may over-torque the nut and crack the flywheel hub.*



To install engine flywheel follow these steps:

1. Make sure the flywheel hub and taper of the crankshaft are clean, dry and completely free of any lubricant, before installing flywheel.
2. Position key properly in keyway as shown in Figure 8-31 and carefully guide key slot in flywheel hub over the key, to avoid pushing the key inward.

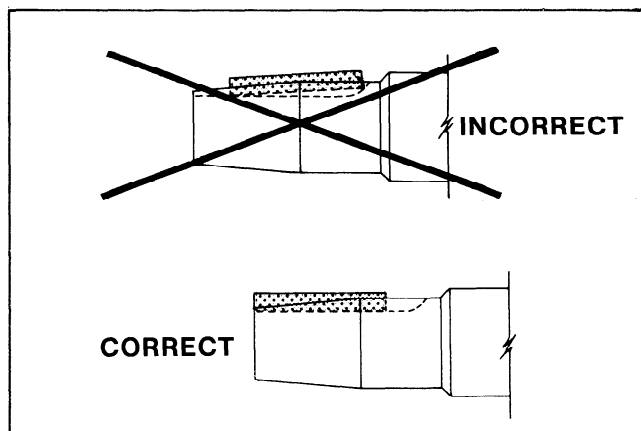

Figure 8-31. Correct And Incorrect Way To Install Flywheel Key

3. Install new washer before adding flywheel retaining screw. Refer to KT17, 19, 21 parts manual for appropriate part number of washer.
4. Use a torque wrench to tighten the flywheel retaining screw to 40 ft. lbs. (see Figure 8-32). Hold flywheel with a Kohler strap wrench (part no. 52 455 03) while torquing nut. (See Section 1 "Special Tools".)

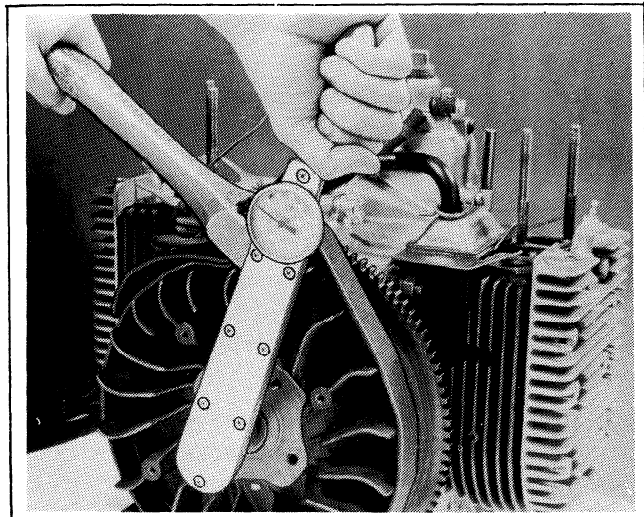

Figure 8-32. Torquing Flywheel Retaining Screw

5. Attach the air intake/grass screen to the flywheel with four 1/4-20 x 3/4" pan head screws and torque as follows:

Metal Air Intake/Grass Screen—70-138 in. lbs.

Nylon Air Intake/Grass Screen—20-30 in. lbs.

NOTE: Overlapping air intake/grass screen must be installed after blower housing is installed. Refer to "Baffles and Shrouds."

BAFFLES AND SHROUDS

1. Attach both cylinder head baffles to engine. Top cylinder baffle and #2 cylinder head baffle are fastened together and must be installed at the same time (see Figure 8-33).

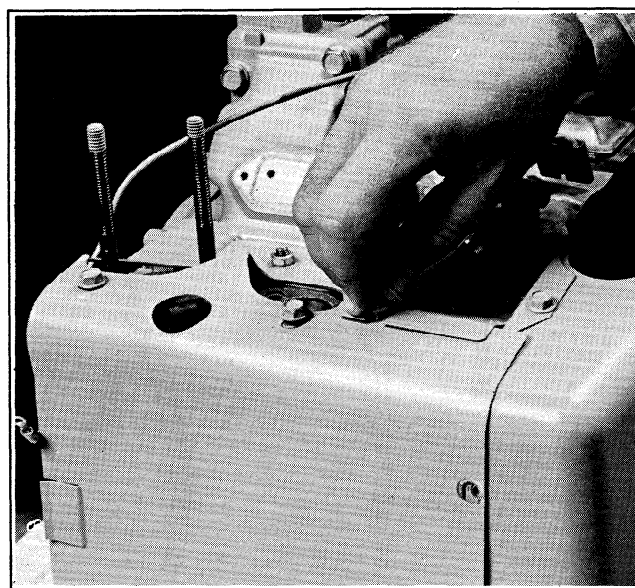

Figure 8-33. Attaching Cylinder Head Baffles

NOTE: Leave sheet metal capscrews slightly loose until all pieces are in place to permit shifting of pieces to obtain proper alignment—then tighten screws.

2. Put upper housing support behind flywheel, then attach blower housing to housing support and #1 and #2 cylinder head baffles. All baffling is attached using 1/4-20 x 7/16" hex washer head screws.
3. Install overlapping air intake/grass screen to flywheel, if so equipped. Refer to step 5 under "Flywheel".

SECTION 8 ASSEMBLY

SERIES II

Optional Ignition Switch And Starter Solenoid

Some Series II engines are equipped with an ignition key switch (instrument panel) and starter solenoid.

Mount the instrument panel to the upper left hand corner of the blower housing (when viewed from flywheel end); mount the starter solenoid to the lower left hand corner. Use the existing 1/4-20 x 7/16" hex washer head screws. Refer to Figure 8-34.

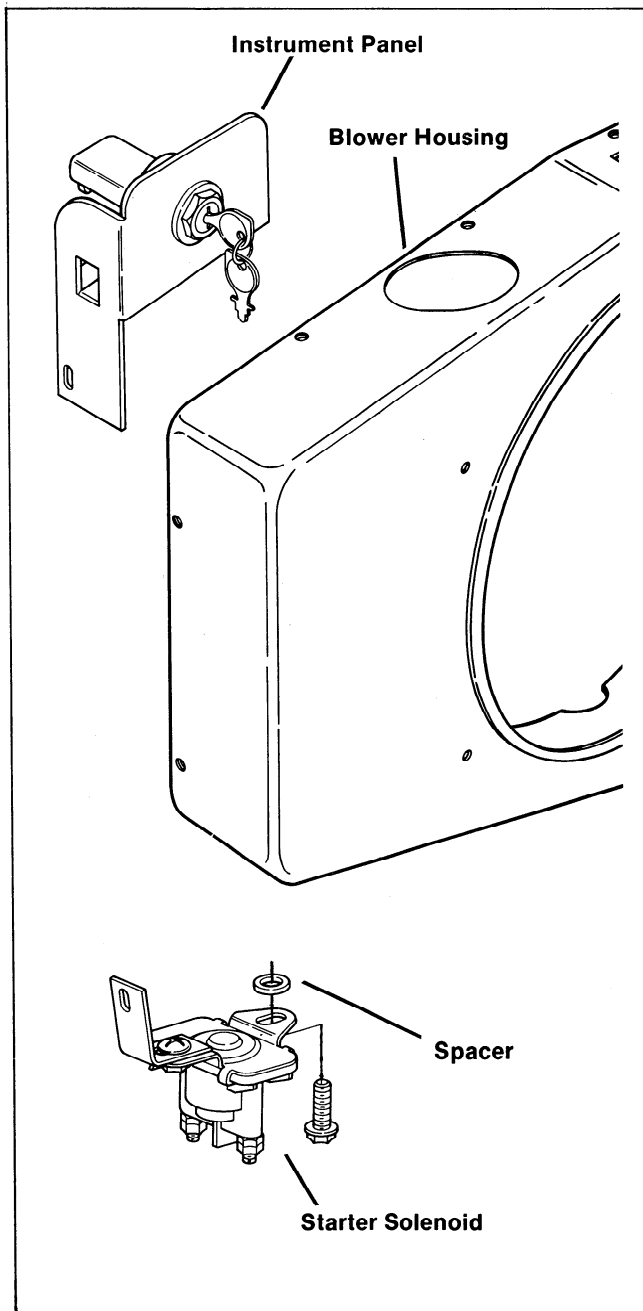

Figure 8-34. Mounting Ignition Switch And Starter Solenoid

GRASS DEFLECTOR

Some KT17 and KT19 engines are equipped with a grass deflector attached to the blower housing. When servicing engines so equipped, care must be taken when attaching deflector to housing. Refer to Figure 8-35.

CAUTION: Before installing deflector, check position of air intake/grass screen on flywheel. Screen must be centered on flywheel to prevent it from rubbing on deflector and damaging one or both of these parts.



1. Fasten lower leg of deflector to blower housing.

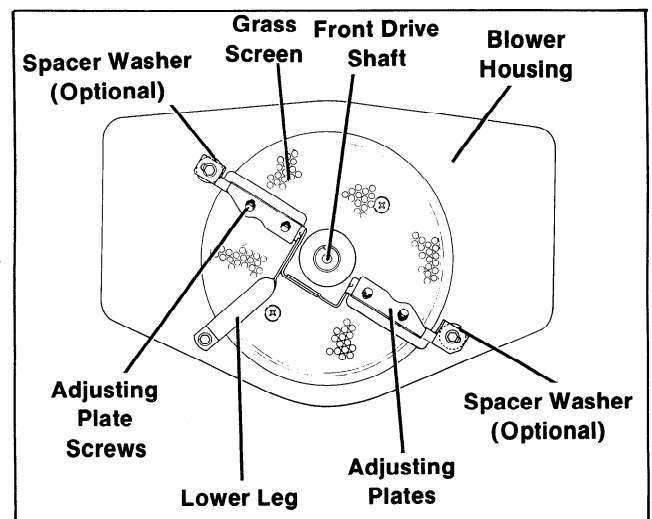

Figure 8-35. Attaching Grass Deflector

2. Center deflector over screen. If engine is equipped with a front drive shaft, center deflector around shaft.
3. Fasten the two remaining legs of deflector to blower housing.
4. Adjust the plates on the deflector for proper clearance using a feeler gauge.

Adjustment

1. Loosen adjusting plate screws, set plates .050" from screen. Tighten screws.
2. Manually turn engine through one complete revolution to check clearance. If plates contact screen, adjust clearance accordingly—clearance must be above .015."
3. If proper clearance cannot be set, it may be necessary to add a spacer between blower housing and two upper deflector legs.
4. When proper clearance is established, torque the four adjusting plate screws to 24-28 in. lbs.

RECTIFIER-REGULATOR

Attach rectifier-regulator to the top #1 side of the blower housing with two 1/4-20 x 1 hex head screws. The terminals on the rectifier-regulator must face toward the P.T.O. end of the engine.

BREAKER POINTS

1. Push breaker push rod through center bore on the breaker point mounting pad.

NOTE: When installing a "steel tipped" breaker push rod, make sure the end with the steel tip is inserted into the crankcase (toward camshaft).

2. Attach breaker point assembly to crankcase with two #10-24 x 3/8 fillister head screws.
3. Adjust breaker points to an initial setting of .020" fully open (see Figure 8-36). For final timing procedure after engine assembly is complete, see "Ignition Timing" in Section 6.

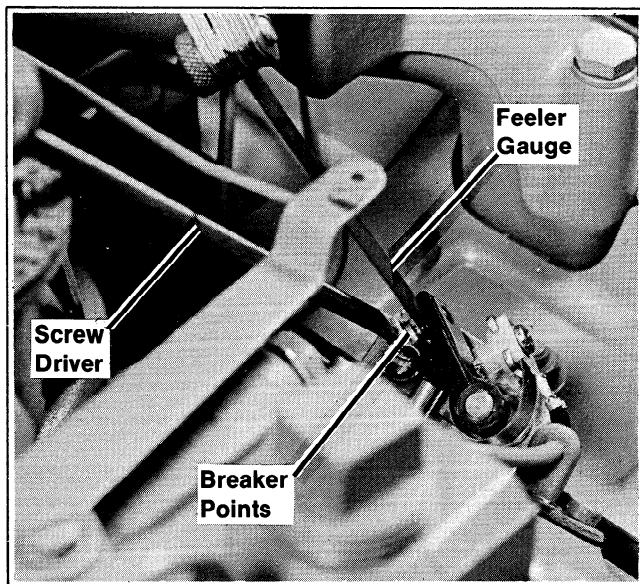

Figure 8-36. Adjusting Breaker Points

4. Connect plug to rectifier-regulator before installing intake manifold.

CARBURETOR, INTAKE MANIFOLD AND EXHAUST MANIFOLD

1. Attach air intake elbow to carburetor with one #10 plain washer and 10-32 x 2-1/4" screw in top of elbow, and two #10 internal teeth washers and 10-32 x 1-1/2" pan head screws in side of elbow. Use a new gasket between elbow and carburetor.

NOTE: Make certain none of the holes in the carburetor body are covered by the gasket.

2. Position carburetor gasket on mounting studs on the intake manifold. Fasten carburetor to manifold using 5/16" lock washers and 5/16-18 hex nuts. Torque nuts to 150 in. lbs. (see Figure 8-37.)

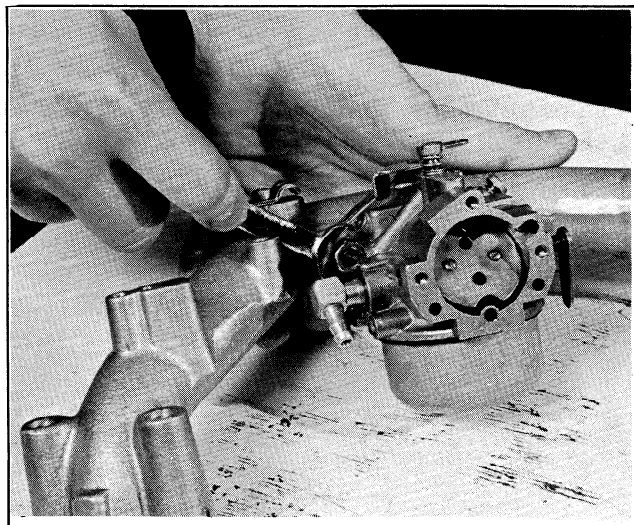

Figure 8-37. Mounting Carburetor On Intake Manifold

3. Attach manifold to cylinder barrels with four 5/16" lock washers and 5/16-18 x 2-3/4" hex head screws. Use new gaskets between intake manifold and cylinder barrels. Torque screws to 150 in. lbs.
4. Install one gasket over each pair of exhaust manifold studs, then the exhaust manifold. Secure with 5/16" lock washers and 5/16-18 hex nuts and torque to 150 in. lbs.

NOTE: Manifold gaskets can only be put on one way, they are not symmetrical.

GOVERNOR ARM, GOVERNOR LINKAGE, BREATHER HOSE AND FUEL LINE

1. Attach high speed stop tab and governor speed control lever to carburetor elbow as shown in Figure 8-38.

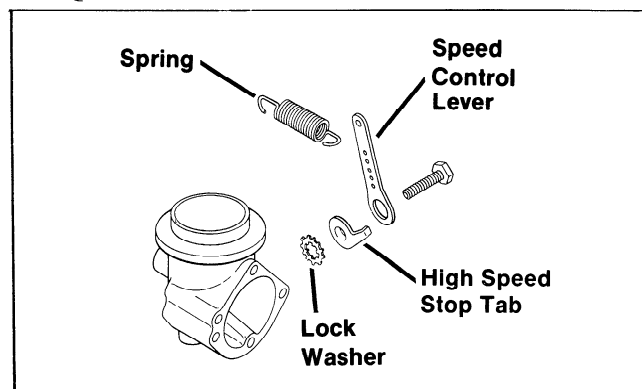

Figure 8-38. Assembling Governor Speed Control Lever

SECTION 8 ASSEMBLY

2. On some early production KT17 models, — attach breather hose to carburetor elbow with hose clamp as shown in Figure 8-39.

On later KT17, KT19, and KT21 models, the breather hose is inserted into a hole in the air cleaner base. Refer to Section 3 - Air Intake System.

3. Clamp fuel line from fuel pump outlet side to carburetor (see Figure 8-39).

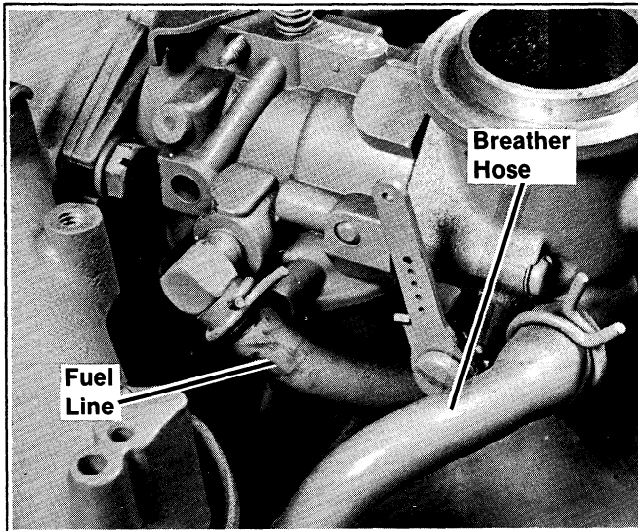

Figure 8-39. Fuel And Breather Hose Connections

4. Connect carburetor throttle lever to governor arm with governor linkage.
5. Install governor arm to governor cross shaft. See Figure 8-40 for the type of arm used. Do not fully tighten nut until governor arm is adjusted (step 6).
6. With a pliers turn governor cross shaft clockwise as far as it will go. Pull governor arm back away from carburetor as far as it will go, then tighten governor clamp nut (see Figure 8-41).
7. Attach governor spring between governor lever and governor speed control. For proper spring position see "Governor Adjustments" Section 4.
8. Install a spark plug into each cylinder head. Make sure spark gap is set to .025" (.65 mm). Torque plugs to 10-15 ft. lbs.
9. Attach breaker point lead wire to points and all electrical connections.

NOTE: Use the appropriate wiring diagram in Section 6 when making all electrical connections.

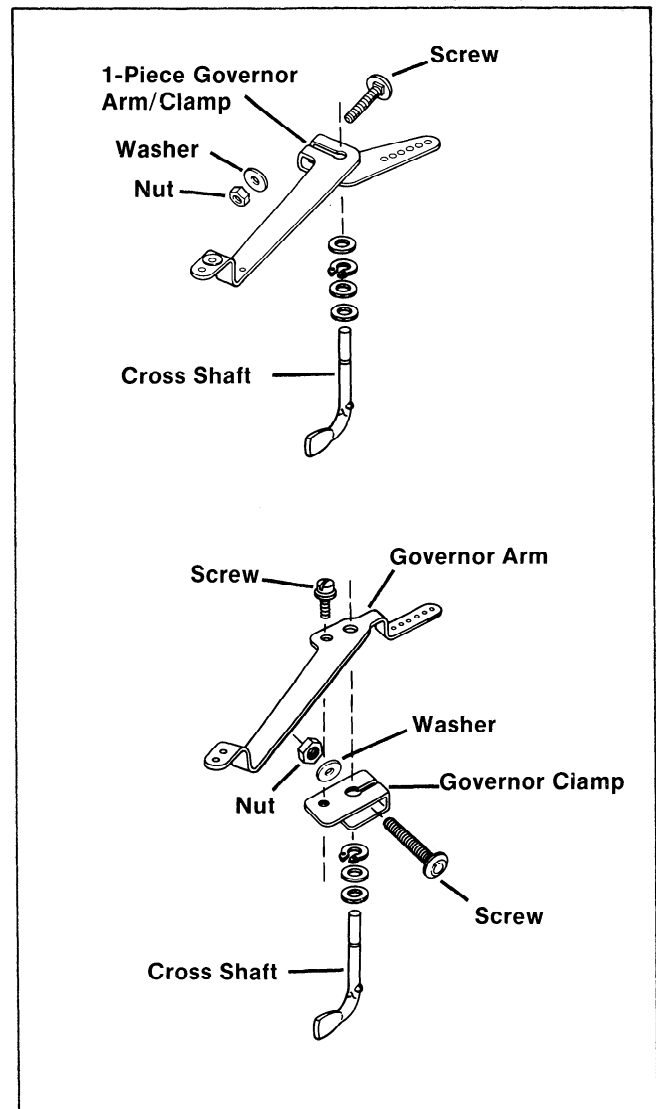

Figure 8-40. Installing Governor Arm

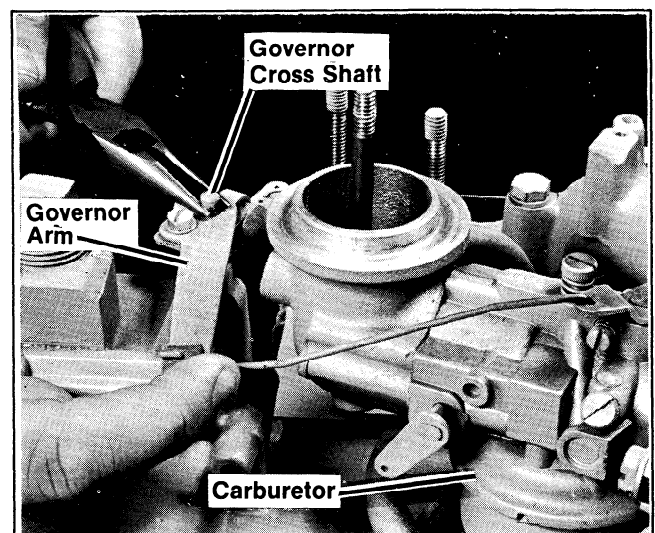

Figure 8-41. Governor Arm Adjustment

IGNITION COIL AND CONDENSER

1. Set ignition coil on intake manifold so that high tension terminals are one over the other and face toward the flywheel end of engine. When looking at the coil from the flywheel end, the minus (-) terminal should be on the right.
2. Set coil strap over coil, then secure lower end of strap to intake manifold with a 1/4-20 x 7/16" hex washer head screw.
3. On early models, set condenser over hole in other end of strap (condenser faces flywheel end) then secure condenser and strap to manifold with a 1/4-20 x 7/16" hex washer head screw.
4. On later models, place condenser (with condenser leads facing breaker) over crankcase boss, located above breaker (see Figure 8-42). Secure condenser to crankcase with 1/4-20 x 7/16" self-tapping screw.
5. Secure condenser "hook" lead to breaker.
6. Fasten condenser "eyelet" lead to negative (-) ignition coil terminal with head nut.
7. Install the two #10-24 x 3/8" fillister head breaker point cover screws into the breaker mounting pad.

NOTE: The breaker point cover screws must be installed at this time to prevent engine oil from

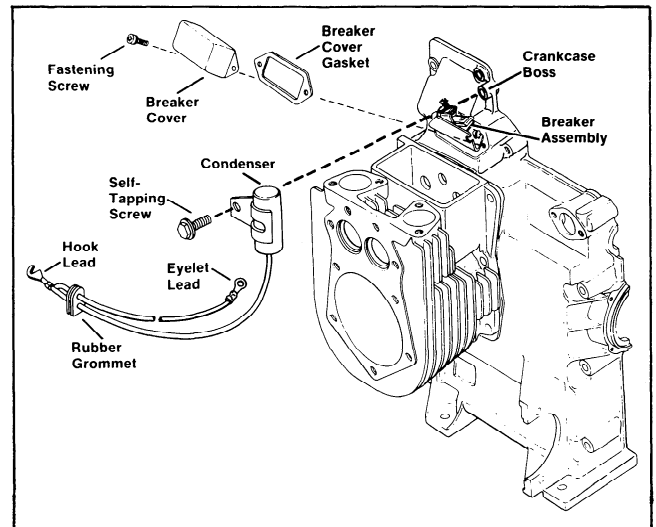

Figure 8-42. Condenser Assembly

squirting out of the crankcase while the ignition timing is adjusted. Install the breaker point cover gasket and cover after engine assembly and ignition timing is completed.

AIR CLEANER ASSEMBLY

Install air cleaner assembly to carburetor. Refer to Section 3—Air Intake System; follow the instructions pertaining to the type of air cleaner used on the engine being serviced.

The engine is now completely assembled. Before placing the engine into service, be sure to do the following:

- Fill the crankcase with the correct weight and grade of oil before starting. Refer to "Oil Recommendations" in Section 1.
- Adjust the carburetor main fuel, idle fuel, and idle speed adjusting screws as necessary. Refer to "To Adjust Carburetor" in Section 4.
- Make sure the maximum engine speed does not exceed 3600 RPM. Adjust the high speed stop tab as necessary. Refer to "Governor System—Speed Adjustment" in Section 4.
- Adjust ignition timing. Refer to "Ignition Timing" in Section 6.

Install breaker point cover gasket and cover after adjusting timing.

SUBJECT INDEX

SUBJECT	SECTION	PAGE
Air Cleaner Assembly	3	15
Anti-Icing	3	17
Round	3	17
Square	3	16
Tear Drop	3	15
Air Cleaner Service — General	1	6
Alternator Charging Systems	6	35
3 Amp System Service	6	35
3 Amp System Service Guide	6	37
15 Amp System	6	37
15 Amp System Service Guide	6	38
Assembly and Installation Section	8	53
Automatic Choke Function	4	24
Adjustment	4	24
Inspection	4	25
Service	4	25
Service Guide	4	25
Baffles and Shrouds — Assembly	8	65
Basic Engine Tests	2	12
Compression	2	13
Crankcase Vacuum	2	12
Battery Check	6	33
Battery Maintenance	6	33
Breaker Points — General Information	6	31
Breaker Points — Installation	8	67
Breather and Valve Cover — Assembly	8	63
Breather Hose and Fuel Line — Assembly	8	67
Camshaft Bore Plug (Machined) — Installation	8	59
Camshaft Bore Plug (Machined) — Removal	7	50
Camshaft Bore Cup Plug — Installation	8	60
Camshaft & Crankshaft — Inspection & Service	7	51
Camshaft, Tappets, Crankshaft and Connecting Rods — Removal	7	50
Posi-Lock Connecting Rods — Removal	7	51
Carburetor	4	19
Carburetor Adjustments	4	19
Carburetor Assembly	4	20
Carburetor Disassembly	4	20
Carburetor Mounting	8	67
Carburetor Reconditioning	4	20
Choke Control — Engine Mounted	4	23
Cleaning Engine	2	12
Closure Plate & Crankcase — Removal	7	50
Compression Test	2	13
Condenser	6	31
Condenser Check	6	31
Condenser Installation	8	69

SUBJECT INDEX

SUBJECT	SECTION	PAGE
Connecting Rods — Assembly	8	54
Connecting Rods — Inspection and Service	7	51
Cooling System Service	1	6
Crankcase Sealing	8	58
Recommended Sealants	8	58
Crankcase Vacuum Test	2	13
Crankshaft and Components — Assembly	8	55
Cylinder Barrels — Disassembly	7	42
Inspection and Overhaul	7	43
Cylinder Head — Disassembly	7	42
Inspection and Service	7	43
Disassembly Section	7	41
Electrical Systems Section	6	29
External Components — Removal	7	41
External Engine Inspection	2	12
Flywheel Installation	8	64
Flywheel Removal	7	41
Front Oil Seal — Installation	8	61
Fuel Pump	4	24
Fuel Pump Installation	8	64
Fuel Pump Operation	4	24
Fuel Pump Check	4	24
Fuel Recommendations	1	5
General Information Section	1	3
Governor System	4	22
Governor Adjustments	4	22
Governor Operation	4	22
Governor Arm and Linkage Assembly	8	67
Governor Gear and Cross Shaft Assembly	8	53
Governor Gear and Cross Shaft Removal	7	51
Governor Cross Shaft Assembly — Generator Applications	8	53
Governor Cross Shaft Removal — Generator Applications	7	51
Governor Gear Inspection	7	52
Grass Deflector Installation	8	66
Identification Number Significance	1	3
Identify Engine Sides	7	42
Ignition Coil	6	32
Ignition Coil Check — Ohmmeter	6	32
Ignition Coil Check — Terminals	7	32
Ignition Coil Function	6	32
Ignition Coil High Tension Leads — Removal and Installation	6	33
Ignition Coil and Condenser Installation	8	69
Ignition Switch And Starter Solenoid — Installation	8	66
Ignition System Analyzers	6	29
Ignition System — Battery	6	29
Ignition System Operational Test	6	29
Ignition System Service	6	29

SUBJECT INDEX

SUBJECT	SECTION	PAGE
Ignition Timing	6	34
Breaker Point Gap Method	6	35
Static Timing Method	6	34
Timing Light Method	6	34
Valve Overlap Method	6	35
Lubrication System Section	5	27
Full-Pressure Lubrication System	5	27
Pressurized Spray Lubrication System	5	27
Service	5	28
Manifold — Intake and Exhaust — Installation	8	67
Oil Change	1	4
Oil Check	1	5
Oil Pump	5	27
Oil Pickup — Assembly	8	53
Oil Pickup — Removal	7	52
Oil Pressure Relief Valve — Installation	8	62
Oil Pressure Relief Valve — Removal	7	50
Oil Pump Assembly	8	54
Oil Pump Inspection and Service	7	52
Oil Pump Removal	7	52
Oil Type	1	4
Pistons — Removal	7	42
Pistons and Rings — Inspection	7	47
Pistons and Rings — Service	7	48
Pistons, Cylinder Barrels and Closure Plate — Assembly	8	61
Posi-Lock Connecting Rods — Installation	8	54
Posi-Lock Connecting Rods — Removal	7	51
Precleaner — for Air Cleaner Elements — Service	3	18
Rear Oil Seal — Installation	8	62
Rectifier Regulator — Installation	8	67
Ring Gear	6	40
Roller Thrust Bearing — Installation	8	56
Safety — General Statements	1	4
Service Schedule	1	5
Shutdown Control Function	4	26
Inspection	4	26
Test	4	26
Special Tools	1	9
Specifications & Tolerances	1	6
Spark Plugs	6	29
Starter Motor	6	28
Brush Replacement	6	40
Commutator Service	6	40
Drive Assembly	6	40
Installation	8	64
Operation	6	38
Removal	7	42
Service	6	39

SUBJECT INDEX

SUBJECT	SECTION	PAGE
Stator — Installation	8	61
Stator — Removal	7 Step 13	42
Tappets and Camshaft — Assembly	8	57
Throttle Control — Engine Mounted	4	23
Torque Settings	1	9
Troubleshooting	2	11
Valves — Inspection and Service	7	44
Valves — Removal	7	43
Valve Guides	7	46
Valve Seat Inserts	7	46
Valve Springs	7	47
Valve Stem Seals	7	47
Valve Components and Cylinder Heads — Assembly	8	62

KOHLER engines

ENGINE DIVISION, KOHLER CO., KOHLER, WISCONSIN 53044

FOR SALES AND SERVICE INFORMATION
IN U.S. AND CANADA, CALL
1-800-544-2444

FORM NO.	TP-2043-A
ISSUED	3/84
REVISED	11/91
MAILED	

LITHO IN U.S.A.