

twin cylinder engine

SERVICE MANUAL

MAGNUM

MODELS M18 & M20



KOHLER
engines

CONTENTS

SECTION 1. Safety and General Information	1
SECTION 2. Special Tools	2
SECTION 3. Periodic Maintenance	3
SECTION 4. Troubleshooting	4
SECTION 5. Air Cleaner	5
SECTION 6A. Fuel Systems and Governors – Kohler Carburetors 6B. Fuel Systems – Walbro Carburetors	6
SECTION 7. Lubrication System	7
SECTION 8. Electrical System and Components	8
SECTION 9. Disassembly	9
SECTION 10. Inspection and Reconditioning	10
SECTION 11. Reassembly	11

SECTION 1

SAFETY AND GENERAL INFORMATION

SAFETY INFORMATION

For Your Safety!

These precautions should be followed at all times. Failure to follow these precautions could result in injury to yourself and others.

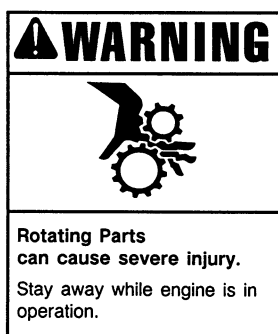
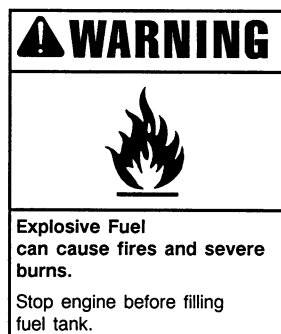

Explosive Fuel!

Gasoline is extremely flammable and its vapors can explode if ignited. Store gasoline only in approved containers, in well-ventilated, unoccupied buildings, away from sparks or flames. Do not fill the fuel tank while the engine is hot or running, since spilled fuel could ignite if it comes in contact with hot parts or sparks from ignition. Do not start the engine near spilled fuel. Never use gasoline as a cleaning agent.

Rotating Parts!

Keep hands, feet, hair, and clothing away from all moving parts to prevent injury. Never operate the engine with covers, shrouds, or guards removed.

Hot Parts!

Engine components can get extremely hot from operation. To prevent severe burns, do not touch these areas while the engine is running—or immediately after it is turned off. Never operate the engine with heat shields or guards removed.

SECTION 1

SAFETY AND GENERAL INFORMATION



Accidental Starts!

Before servicing the engine or equipment, always disconnect the spark plug lead to prevent the engine from starting accidentally. Ground the lead to prevent sparks that could cause fires. Make sure the equipment is in neutral.



CAUTION: High Voltage!

Never touch electrical wires or components while the engine is running. They can be sources of electrical shock.



WARNING: Overspeed Is Hazardous!

Do not tamper with the governor setting. Overspeed is hazardous and could cause personal injury.



WARNING: Flammable Solvents!

Carburetor cleaners and solvents are extremely flammable. Keep sparks, flames, and other sources of ignition away from the area. Follow the cleaner manufacturer's warnings and instructions on its proper and safe use. Never use gasoline as a cleaning agent.

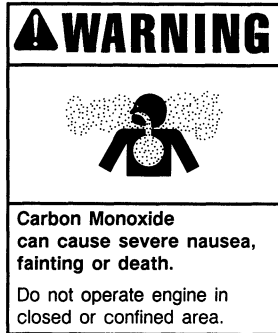

Lethal Exhaust Gases!

Engine exhaust gases contain poisonous carbon monoxide. Carbon monoxide is odorless, colorless, and can cause death if inhaled. Avoid inhaling exhaust fumes, and never run the engine in a closed building or confined area.



WARNING: Spring Under Tension!

Retractable starters contain a powerful, flat wire recoil spring that is under tension. Do not remove the center screw from the starter until the spring tension is released. Removing the center screw before releasing spring tension, or improper starter disassembly, can cause the sudden and potentially dangerous release of the spring.

Always wear safety goggles when servicing retractable starters—full face protection is recommended.

To ensure personal safety and proper starter disassembly and reassembly, follow the procedures in this section carefully.

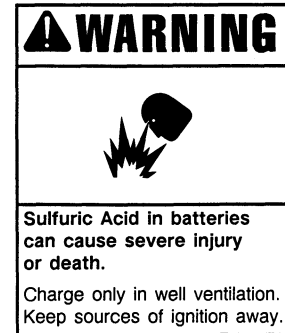

Dangerous Acid, Explosive Gases!

Batteries contain sulfuric acid. To prevent acid burns, avoid contact with skin, eyes, and clothing. Batteries produce explosive hydrogen gas while being charged. To prevent a fire or explosion, charge batteries only in well ventilated areas. Keep sparks, open flames, and other sources of ignition away from the battery at all times. Keep batteries out of the reach of children. Remove all jewelry when servicing batteries.

Before disconnecting the negative (-) ground cable, make sure all switches are OFF. If ON, a spark will occur at the ground cable terminal which could cause an explosion if hydrogen gas or gasoline vapors are present.

ENGINE IDENTIFICATION NUMBERS

When ordering parts, or in any communication involving an engine, always give the model, specification, and serial numbers of the engine.

The engine identification numbers appear on a decal (or decals) affixed to the engine shrouding. Refer to Figure 1-1. The significance of these numbers is shown below:

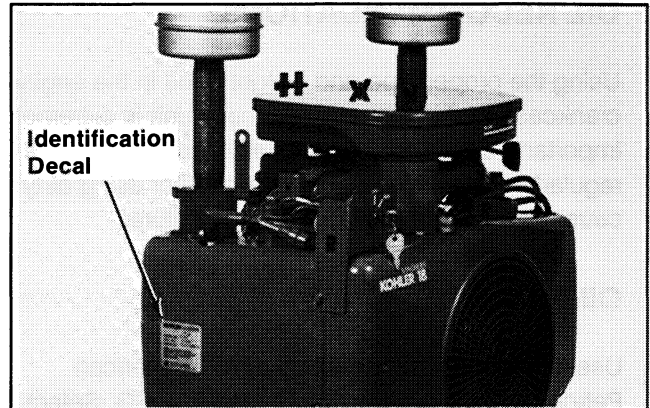

Figure 1-1. Location of Engine Identification Decal.

A. MODEL NO.

	M	18	S	
Magnum Engine	┌───┐			Version Code S-Electric Start G-Tapered Crankshaft (Generator Application)
Horsepower	└───┘			

P-Threaded Crankshaft (Pump Application)
EP-Generator
Q-Quiet Model

B. SPEC. NO.

	24501	
Engine Model Code	┌───┐	Variation Of Basic Engine
Code* Model	└───┘	
245 M18		
495 M20		

C. SERIAL NO.

	1523128516	
Year Manufactured	┌───┐	Factory Code
	└───┘	
15 1985		
16 1986		
17 1987		
18 1988		
19 1989		
20 1990		
21 1991		
22 1992		
23 1993		
24 1994		
25 1995		

KOHLERengine

MODEL NO. M18S ← **A**

SPEC. NO. 24501 ← **B**

SERIAL NO. 1523128516 ← **C**

REFER TO OWNER'S MANUAL FOR OPERATION/MAINTENANCE INSTRUCTIONS AND SAFETY PRECAUTIONS.

K KOHLER COMPANY
KOHLER WISCONSIN USA

*NOTE: Engine model codes with a 3rd digit of 5 or greater denote MAGNUM engines.

Figure 1-2. Engine Identification Decals.

SECTION 1 SAFETY AND GENERAL INFORMATION

OIL RECOMMENDATIONS

Using the proper type and weight of oil in the engine crankcase and in the gear reduction unit is extremely important, as is checking oil daily and changing oil regularly. Failure to use the correct oil or using dirty oil causes premature engine wear and failure.

Oil Type

Use high-quality detergent oil of API (American Petroleum Institute) Service Class SF or SG. Select the viscosity based on the air temperature at the time of operation as shown in the table.

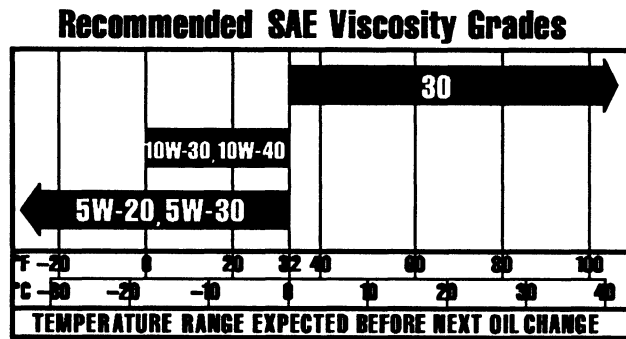

Straight 30-weight oil is preferred. SAE 10W-30 and 10W-40 are not recommended above 32°F (0°C). Using these oils substantially increases oil consumption and combustion chamber deposits.

NOTE: Using other than Service Class SF or SG oil or extending oil change intervals longer than recommended could cause engine damage which is not covered by the engine warranty.

A logo or symbol on oil containers identifies the API service class and SAE viscosity grade.

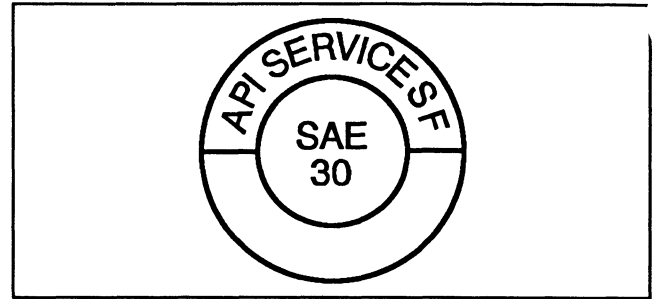

Check Oil Level

Check oil level **BEFORE EACH USE**.

NOTE: Do not operate the engine with the oil level below "L" mark or over "F" mark on dipstick.

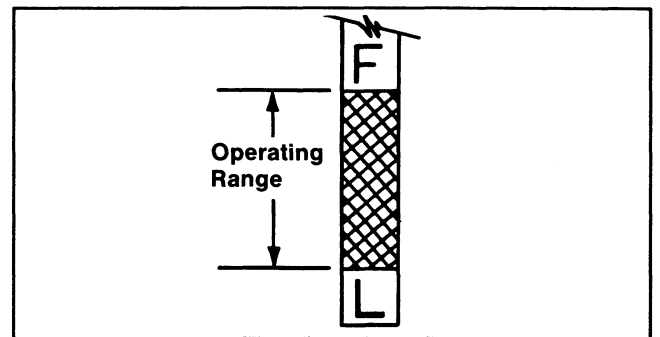

Change Oil

For a new engine, change oil after the first 5 hours of operation. Thereafter, change the oil as specified in the following "Oil Change Intervals" table.

For an overhauled engine or those rebuilt with a new short block, use straight 30-weight Service Class SF or SG oil for the first 5 hours of operation. Change the oil after this initial run-in period. Refill with Service Class SF or SG oil as specified in the table.

OIL CHANGE INTERVALS

Temperature	Oil Type	Engine Type	Interval
ABOVE 32°F (0°C)	SAE 30	With Filter	50 Hours*
		Without Filter	25 Hours
BELOW 32°F (0°C)	Multiviscosity	With Filter	50 Hours
		Without Filter	25 Hours

*25 hours for continuous and/or heavy duty operation.

SECTION 1

SAFETY AND GENERAL INFORMATION

1

Oil Filter

Some engines are equipped with an oil filter. Replace the oil filter every other oil change, in accordance with the "Oil Change Intervals" table. Always use a genuine Kohler replacement oil filter.

Refer to the "Periodic Maintenance" Section for detailed oil checking and changing procedures.

FUEL RECOMMENDATIONS



WARNING: Explosive Fuels!

Gasoline is extremely flammable, and its vapors can explode if ignited. Store gasoline only in approved containers, in well-ventilated, unoccupied buildings, away from sparks or flames. Do not fill fuel tank while the engine is hot or running since spilled fuel could ignite if it comes in contact with hot parts or sparks from ignition. Do not start engine near spilled fuel; wipe up spills immediately. Never use gasoline as a cleaning agent.

General Recommendations

Purchase gasoline in small quantities and store in clean, approved containers. A container with a capacity of 2 gallons or less with a pouring spout is recommended. Such a container is easier to handle and helps eliminate spillage during refueling.

Do not overfill the fuel tank. Leave room for the fuel to expand.

Do not use gasoline left over from the previous season, to minimize gum deposits in your fuel system and to insure easy starting.

Do not add oil to the gasoline.

Fuel Type

For best results, use only clean, fresh, unleaded gasoline with a pump sticker octane rating of 87 or higher. In countries using the Research method, it should be 90 octane minimum.

Unleaded gasoline is recommended, as it leaves less combustion chamber deposits. Leaded gasoline may be used in areas where unleaded is not available and exhaust emissions are not regulated. Be aware however, that the cylinder head will require more frequent service.

Gasoline/Alcohol blends

Gasohol (up to 10% ethyl alcohol, 90% unleaded gasoline by volume) is approved as a fuel for Kohler engines. Other gasoline/alcohol blends are not approved.

Gasoline/Ether blends

Methyl Tertiary Butyl Ether (MTBE) and unleaded gasoline blends (up to maximum of 15% MTBE by volume) are approved as a fuel for Kohler engines. Other gasoline/ether blends are not approved.

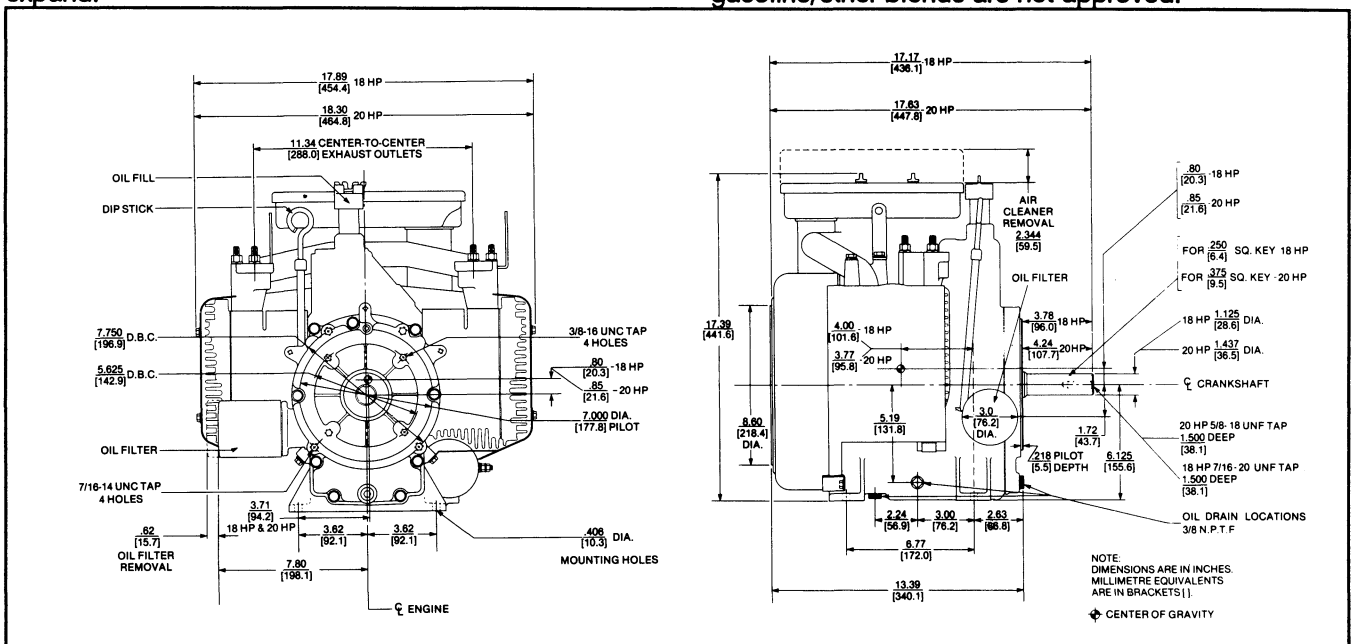

Figure 1-3. Overall Dimensions--Model M18 and M20.

SECTION 1

SAFETY AND GENERAL INFORMATION

SPECIFICATIONS, TOLERANCES, AND SPECIAL TORQUE VALUES²

DESCRIPTION	Model	Model
General Specifications	M18	M20
Horsepower (@ 3,600 RPM)	18	20
Displacement (cu. in.)	42.18	46.98
Bore	3.12	3.12
Stroke	2.75	3.06
Compression Ratio	6.0:1	6.6:1
Approx. Weight (lb.)	130	130
Approx. Oil Capacity* (U.S. Quarts)	1.5	1.5
<p>* For best results, fill to "F" mark on dipstick as opposed to adding a given quantity of oil. Always check level on dipstick before adding more oil. On engines equipped with oil filter, an additional 1/2 U.S. pint of oil is required when oil filter is replaced.</p>		
Angle of Operation – Maximum		
(At Full Oil Level; Intermittent Operation)		
Carb. Side Up	#1Cyl. Up 35°	#1 Cyl. Up 35°
Carb. Side Down	#1 Cyl. Down 35°	#1 Cyl. Down 35°
Flywheel End Up	30°	30°
Flywheel End Down	30°	30°
Camshaft		
End Play003/.013	.003/.013
Camshaft to Camshaft Bearing		
Running Clearance0010/.0025	.0010/.0025
Carburetor		
Preliminary Main Fuel		
Screw Setting (Turns)	2-1/2	2-1/2
Preliminary Idle Fuel		
Screw Setting (Turns)	1	1
Float Level	11/64 (+ or - 1/32)	11/64 (+ or - 1/32)
Float Drop	1-1/32	1-1/32
Fuel Inlet Seat Torque (in. lb.)	35	35
Bowl Retaining Screw Torque (in. lb.)	50	50
Float to Float Pin Tower Clearance010	.010

SECTION 1

SAFETY AND GENERAL INFORMATION

1

	Model M18	Model M20
Connecting Rod (Posi-Lock)		
New Service Rod Nut Torque (in. lb.) ^{4,6}	140	140
Used Rod Nut Torque (in. lb.) ^{4,6}	100	100
Rod to Crankpin Running Clearance – New0012/.0024	.0012/.0024
Rod to Crankpin Max. Wear Limit0029	.0029
Rod to Piston Pin Running Clearance – New0006/.0011	.0006/.0011
Rod to Side Play on Crankpin005/.016	.005/.016
Crankcase/Cylinder Barrel		
Intake and Exhaust Manifold Fastener		
Torque (in. lb.)	150	150
Closure Plate Fastener Torque (in. lb.) ⁷	150	150
Closure Plate Oil Gallery Pipe Plug		
Torque (in. lb.)	65/80	65/80
Cylinder Barrel Nut Torque (in. lb.) ⁷	200	200
Crankcase Nut Torque (in. lb.) ⁷	260	260
5/16" Crankcase Screw Torque (in. lb.) ⁷	200	200
3/8" Crankcase Screw Torque (in. lb.) ⁷	260	260
Crankshaft		
Crankshaft End Play002/.014	.002/.014
Main Bearing Surface Max. Wear Limit	1.7407	1.7407
Sleeve Bearing Max. Out of Round0005	.0005
Sleeve Bearing Max. Taper001	.001
New Sleeve Bearing Max. Running Clearance0049	.0049
Sleeve Bearing Running Clearance Max. Wear Limit0059	.0059
New Sleeve Bearing I.D. (installed)	1.7439/1.7461	1.7439/1.7461
Crankpin O.D. – New	1.3733/1.3738	1.4993/1.4998
Crankpin O.D. Max. Wear Limit	1.3728	1.4988
Crankpin O.D. Max. Out of Round0005	.0005
Crankpin O.D. Max. Taper001	.001

SECTION 1

SAFETY AND GENERAL INFORMATION

	Model M18	Model M20
Cylinder Bore		
I.D. – New	3.1245/3.1255	3.1245/3.1255
I.D. Max. Wear Limit	3.128	3.128
I.D. Max. Out of Round002	.002
I.D. Max. Taper0015	.0015
Cylinder Head		
Cap Screw Torque (ft. lb.) ⁴	15/20	15/20
Max. Out of Flatness003	.003
Fan/Flywheel		
Fan Fastener Torque (in. lb.)	115	115
Flywheel Fastener Torque (ft. lb.) ⁴	40	40
Fuel Pump		
Mounting Screw Torque (in. lb.)	40/45	40/45
Ignition		
Ignition Module to Magnet Air Gap008/.012	.008/.012
Spark Plug Type (Champion® or Equiv.)	RV17YC	RV17YC
Spark Plug Gap	0.035	0.035
Spark Plug Torque (ft. lb.)	10/15	10/15
Oil Fill/Oil Filter¹⁰		
#52 173 01 Oil Fill Cap Torque (in. lb.)	30/45	30/45
Engine Mtd. Filter Adapter Fastener Torque (in. lb.)	125	125
Remote Oil Filter Cover Fastener Torque (in. lb.)	125	125
Remote Oil Line Fitting Nut Torque (in. lb.)	65/80	65/80
Remote Oil Line Reducing Connector Torque (in. lb.)	65/80	65/80
Remote Oil Line Flare Nut Torque (in. lb.)	100/120	100/120
Remote Oil Filter Adapter Fitting Torque (in. lb.)	90/130	90/130
Oil Filter Installation Torque (in. lb.)	50/80	50/80
Oil Filter Bypass Cover Fastener Torque (in. lb.)	125	125
Oil Pump		
Pump Shaft to Crankcase Running Clearance0010/.0026	.0010/.0026
Pump Drive Gear End Play010/.029	.010/.029

SECTION 1

SAFETY AND GENERAL INFORMATION

	Model M18	Model M20
Piston and Piston Rings		
(Style "D" Pistons)		
Thrust Face O.D. @ D1 – New ⁹	3.1203/3.1210	3.1208/3.1215
Thrust Face O.D. @ D1 – Max. Wear Limit ⁹	3.1181	3.1186
Thrust Face to Bore Clearance @ D1 – New ⁹0035/.0052	.0030/.0047
Piston Ring End Gap – New ⁸010/.023	.010/.023
Piston Ring End Gap – Used (Max.) ⁸032	.032
Piston Ring Side Clearance – Max.006	.006
Piston Pin O.D. – New6247/.6249	.7499/.7501
Valves and Tappets		
Intake Valve to Tappet Clearance – Cold003/.006	.003/.006
Exhaust Valve to Tappet Clearance – Cold		
(Serial No. 1816500646 and earlier)016/.019	.016/.019
(Serial No. 1816500656 and later)011/.014	.011/.014
Intake Valve Minimum Lift – Zero Lash274	.274
Exhaust Valve Minimum Lift – Zero Lash274	.274
Intake Valve Minimum Stem O.D.3103	.3103
Exhaust Valve Minimum Stem O.D.3088	.3088
Nominal Valve Seat Angle		
(Serial No. 1816500646 and earlier)	45°	45°
(Serial No. 1816500656 and later)	30°	30°
Valve Guide Reamer Size3125	.3125
Intake Valve Guide I.D. Max. Wear Limit005	.005
Exhaust Valve Guide I.D. Max. Wear Limit007	.007

SECTION 1 SAFETY AND GENERAL INFORMATION

NOTES:

1. Use standard torque values when specific values are not given. Standard values have a tolerance of (+ or -) 20%.
2. All dimensions are in inches unless otherwise specified.
3. Also applies to self-tapping screws.
4. Lubricate with oil at assembly.
5. 3/8-16 thread with hex. head nut and fiber gasket.
6. Torque in increments to the value specified. Do not overtorque--do not loosen and retorquer hex. nuts on Posi-Lock connecting rods.
7. Refer to the "Reassembly" Section for instructions and tightening sequence.

8. Top and center compression rings.

9. Measurements @ D1 on Style D pistons are made perpendicular to piston pin in the position shown.

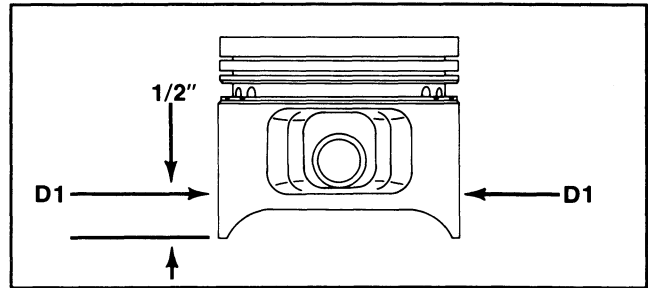

10. Refer to the "Lubrication System" Section for additional information.

STANDARD TORQUE VALUES¹

Bolts, Screws, Nuts and Fasteners Assembled Into Cast Iron or Steel			
Size	Grade 2	Grade 5 ³	Grade 8
#8-32	20 in. lb.	25 in. lb.	--
#10-24	32 in. lb.	40 in. lb.	--
#10-32	32 in. lb.	40 in. lb.	--
1/4-20	70 in. lb.	115 in. lb.	165 in. lb.
1/4-28	85 in. lb.	140 in. lb.	200 in. lb.
5/16-18	150 in. lb.	250 in. lb.	350 in. lb.
5/16-24	165 in. lb.	270 in. lb.	30 ft. lb.
3/8-16	260 in. lb.	35 ft. lb.	50 ft. lb.
3/8-24	300 in. lb.	40 ft. lb.	60 ft. lb.
7/16-14	35 ft. lb.	55 ft. lb.	80 ft. lb.
7/16-20	45 ft. lb.	75 ft. lb.	105 ft. lb.
1/2-13	50 ft. lb.	80 ft. lb.	115 ft. lb.
1/2-20	70 ft. lb.	105 ft. lb.	165 ft. lb.
9/16-12	75 ft. lb.	125 ft. lb.	175 ft. lb.
9/16-18	100 ft. lb.	165 ft. lb.	230 ft. lb.
5/8-11	110 ft. lb.	180 ft. lb.	260 ft. lb.
5/8-18	140 ft. lb.	230 ft. lb.	330 ft. lb.
3/4-10	150 ft. lb.	245 ft. lb.	350 ft. lb.
3/4-16	200 ft. lb.	325 ft. lb.	470 ft. lb.

Bolts, Screws, Nuts and Fasteners Assembled Into Aluminum			
Size	Grade 2	Grade 5	Grade 8
#8-32	20 in. lb.	20 in. lb.	20 in. lb.
#10-24	32 in. lb.	32 in. lb.	32 in. lb.
1/4-20	70 in. lb.	70 in. lb.	70 in. lb.
5/16-18	150 in. lb.	150 in. lb.	150 in. lb.

Oil Drain Plugs⁴

Size	Into Cast Iron Pans	Into Aluminum Pans
1/4"	150 in. lb.	100 in. lb.
3/8"	180 in. lb.	120 in. lb.
1/2"	20 ft. lb.	13 ft. lb.
3/4"	25 ft. lb.	16 ft. lb.
X-708-1 ⁵	20/25 ft. lb.	20/25 ft. lb.

Conversions	
ft. lb. = in. lb. x 0.083	
in. lb. = ft. lb. x 12	
kgm = ft. lb. x 0.1383	
N•m = ft. lb. x 1.3558	

SECTION 2 SPECIAL TOOLS

SPECIAL SERVICE TOOL KIT NO. 3211

These quality tools are designed to help you perform specific disassembly, repair, and reassembly procedures. By using tools designed for the job, you can service engines easier, faster, and safer! In addition, you'll increase your service capabilities and customer satisfaction by decreasing engine down time.

The Special Service Tool Kit No. 3211 can be ordered complete as shown (Refer to Figure 2-1), or the tools can be ordered individually. Contact your Kohler Distributor for price and availability.

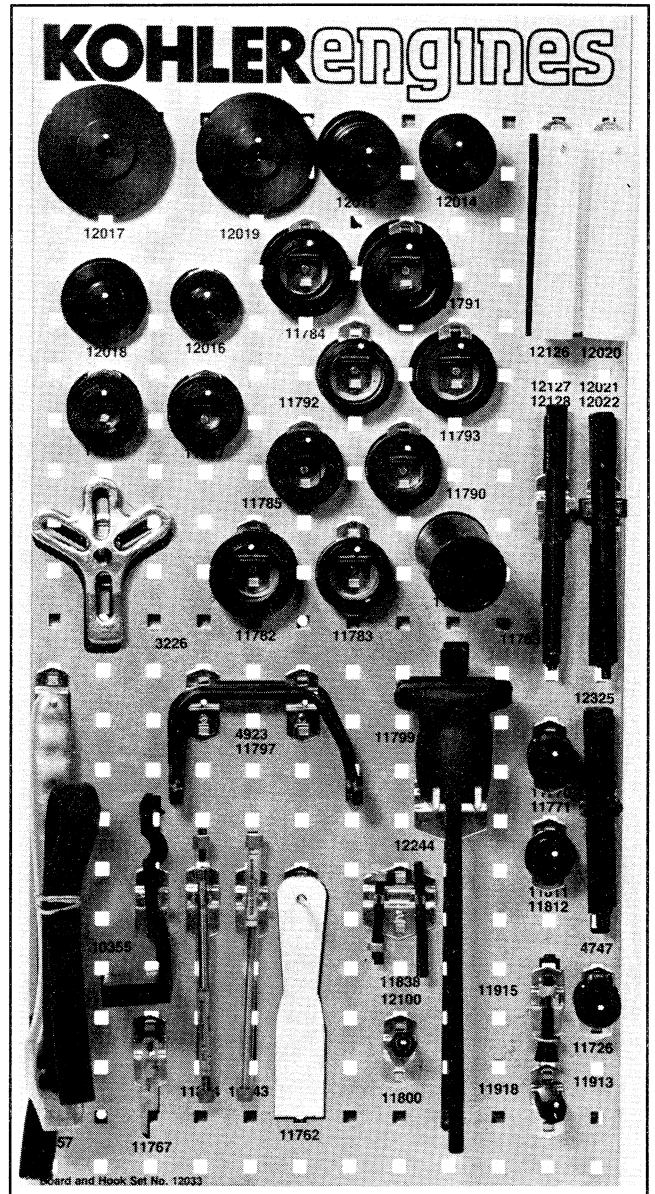
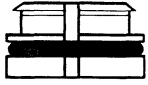
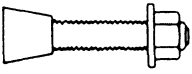
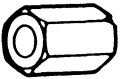

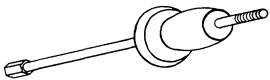
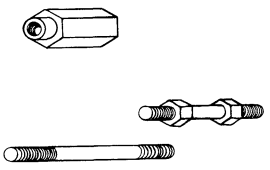
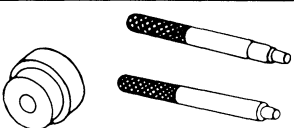

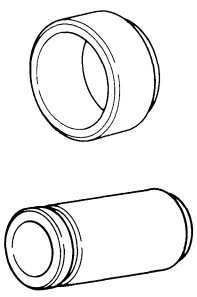



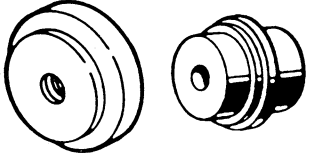
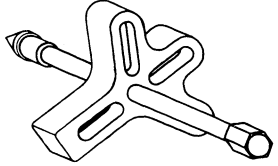
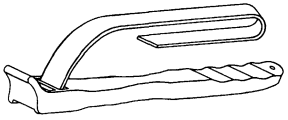

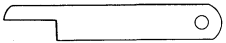



Figure 2-1. Special Service Tool Kit--No. 3211.

SECTION 2 SPECIAL TOOLS

VALVE SERVICE TOOLS		
TOOL NO. & NAME	APPLICATION	ILLUSTRATION
VALVE SEAT PULLERS 11726 11913	Removal of valve seats, use 11918 adapter, 3222 slide hammer & 11915 forcing screw	
FORCING SCREW 11915	Used with valve seat pullers 11726 & 11913	
ADAPTER 11918	Used to connect valve seat pullers to slide hammer	
VALVE SEAT INSTALLER 11811 11812	Used to install intake and exhaust seats. Use with 4747 handle.	
3222 SLIDE HAMMER 11799 Weight 12244 Slide Bolt	Provides pulling force for valve seat and guide removal. Use 4747 handle.	
3268 VALVE GUIDE REMOVAL KIT 11838 Stud 3 1/2" 12100 Stud 2 1/2" 11800 Adapter 0917 Nut 12008 Nut	Used to pull valve guides with 3222 slide hammer.	
3224 VALVE GUIDE INSTALLER KIT 12325 Driver 11763 Driver 11770 Gauge 11771 Gauge	Used to install valve guides to proper depth. Use 11763 driver with 11770 & 11771 depth gauges.	
REAMERS (Valve Guide) 11843 5/16" 11844 1/4"	To ream valve guides.	
SEAL AND BEARING INSTALLERS		
3223 SEAL INSTALLER KIT 11782 Seal Installer 11783 Seal Installer 11784 Seal Installer 11785 Seal Installer 11786 Seal Installer 11787 Seal Installer 11790 Seal Installer 11791 Seal Installer 11792 Seal Installer 11793 Seal Installer 11795 Handle	Used to install seals without damage and to proper depth. Use 11795 handle with installers.	

SECTION 2 SPECIAL TOOLS

2

SEAL AND BEARING INSTALLERS		
TOOL NO. & NAME	APPLICATION	ILLUSTRATION
3242 SEAL PROTECTOR SLEEVE KIT 12020 .75" 12021 1.00 12022 1.25 12126 1.12 12127 1.50 12128 1.44	Used on crankshaft when installing seals to prevent damage.	
3241 BEARING INSTALLING KIT 12014 Ins. (Crank Bushing) 12015 Ins. (Cam Bushing) 12016, 12017, 12018 & 12109 Brg. Installers	Used to install & remove engine bearings and bushings.	
OTHER APPLICATIONS		
3226 FLYWHEEL PULLER KIT 12485 Puller w/forcing screw 5108 Bolt - 1/4" w/washer (3) 12505 Bolt - 10-24 w/washer (2) 12504 Bolt - 3/8" w/washer (2) 12506 Storage Bag	Used to remove flywheels and bearing plates from engine.	
FLYWHEEL STRAP WRENCH 10357	Used to hold flywheel for nut removal.	
OFFSET WRENCH 11797 Wrench 1/2" 4923 Wrench 9/16"	Used to remove & install cylinder barrel retaining nuts.	
FEELER GAUGE 11767	Used to set oil pump drive gear backlash on twin cylinder engine.	
TIMING GAUGE 10355 Timing Gauge	Used to hold balance gears in timed position when assembling engine.	
SCRAPER 11762	Used to scrape machined surfaces without damage.	
HANDLE 4747 Handle	Used with bearing installers, slide hammer, and valve seat installers.	
TOOL BOARD AND HOOK SET 12033	Used to store and identify tools.	SEE FRONT PAGE

**SECTION 2
SPECIAL TOOLS**

**TOOL USAGE CHART
KIT NO. 3211**

VALVE TOOLS		
PART NO. & NAME	M18	M20
11726 Valve Seat Puller	●	●
11915 Forcing Screw	●	●
11918 Adapter	●	●
11811 Valve Seat Installer	●	●
3222 Slide Hammer	●	●
3268 Valve Guide Removal Kit	●	●
11763 Valve Guide Driver (depth)	●	●
11770 Valve Guide Depth Gauge	●	
11771 Valve Guide Depth Gauge		●
11843 Valve Guide Reamer 5/16"	●	●
BEARING AND SEAL INSTALLERS		
11782 Installer - Seal (PTO)	●	●
11783 Installer - Seal (Flywheel)	●	●
11795 Handle - Installer Seal	●	●
12020 Seal Sleeve	USE AS REQUIRED	
12021 Seal Sleeve	USE AS REQUIRED	
12022 Seal Sleeve	USE AS REQUIRED	
12126 Seal Sleeve	USE AS REQUIRED	
12127 Seal Sleeve	USE AS REQUIRED	
12128 Seal Sleeve	USE AS REQUIRED	
MISCELLANEOUS TOOLS		
10357 Flywheel Strap Wrench 1/2"	●	●
11797 Offset Wrench 1/2"	●	●
11762 Scraper	●	●
4747 Drive Handle	●	●
3226 Flywheel Puller Kit	●	●

ENGINE ANALYSIS KIT NO. KO-1000

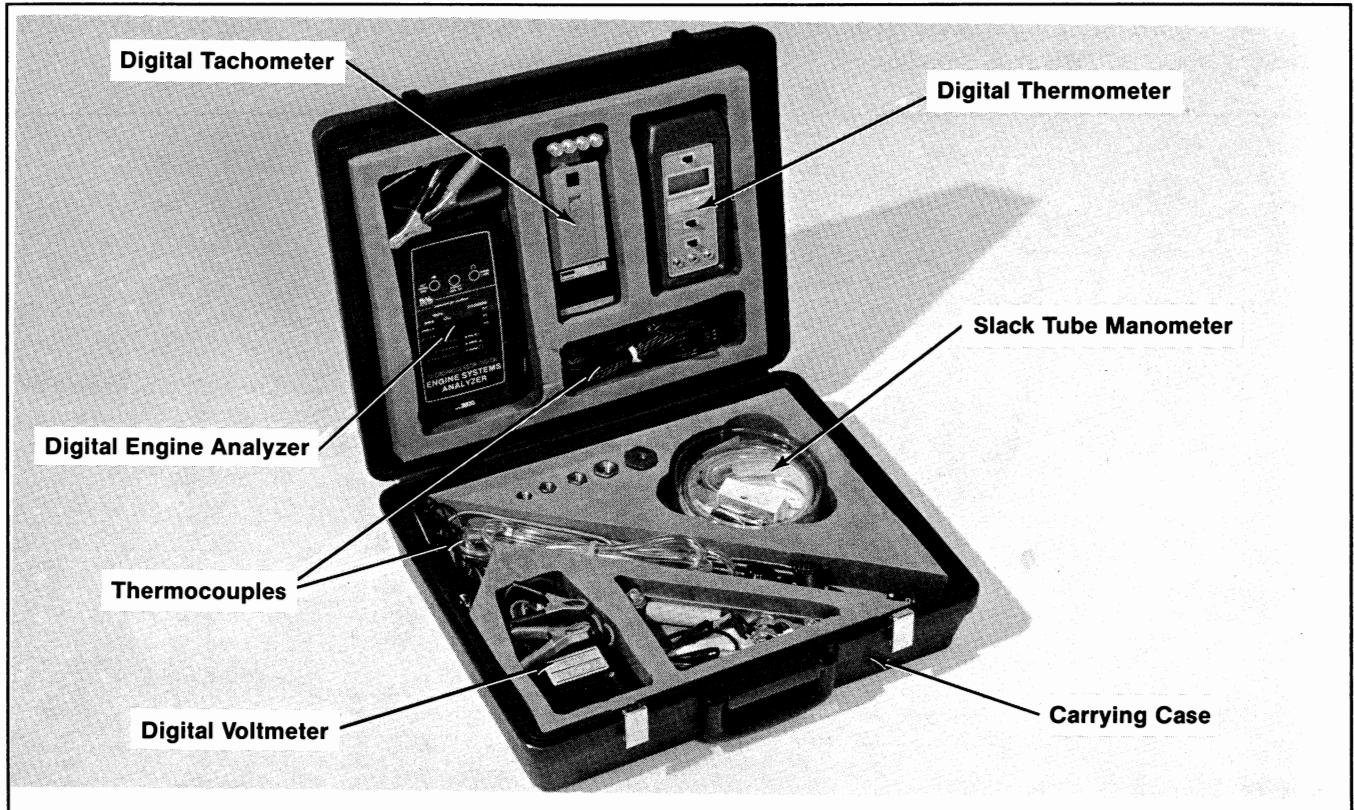

Figure 2-2. Engine Analysis Kit No. - KO-1000

The Kohler Engine Analysis Kit contains a selection of instruments which will enable you to measure critical items that relate to engine performance. You will find many uses for these instruments--from basic crankcase vacuum checks to sophisticated application tests.

The kit includes the following:

Qty.	Description	Part No.
1	Digital Voltmeter	KO-1001
1	Digital Tachometer	KO-1002
1	Digital Thermometer	KO-1004
1	Digital Engine Analyzer	KO-1003
1	Slack Tube Manometer	KO-1005
1	8 ft. Lead With Plug	KO-1006
3	14 mm Spark Plug	
	Thermocouple	KO-1007
2	Head Bolt Thermocouple	KO-1008
1	Oil Sump Thermocouple	KO-1009
1	1/4" x 1/8" Bushing	KO-1010-B
1	3/8" x 1/8" Bushing	KO-1010-A
1	1/2" x 1/8" Bushing	KO-1010-C
1	3/4" x 1/8" Bushing	KO-1010-D
1	Tube With Fittings	KO-1011-B
1	Carrying Case	KO-1013
3	Plain Thermocouple	KO-1015

The voltmeter, tachometer, thermometer, and engine analyzer feature state of the art electronic circuitry and digital readouts. Guidelines for using the instruments and testing are included.

Using the instruments in the kit you will be able to:

- Measure temperatures of -
 - spark plug base gasket/cylinder head bolt.
 - oil sump.
 - air into flywheel and carburetor.
- Measure engine speed (RPM).
- Measure crankcase vacuum and exhaust system back pressure.
- Measure voltage.
- Measure charging system current.
- Measure electric starter current (amp) draw.

The Engine Analysis Kit can be ordered complete as shown, or the instruments can be ordered individually. Contact your Kohler Distributor for price and availability.

SECTION 2 SPECIAL TOOLS

IGNITION SYSTEM TESTER

Magnum engines use a state of the art electronic ignition module. A simple tester can be used to determine if the ignition module is functioning properly.

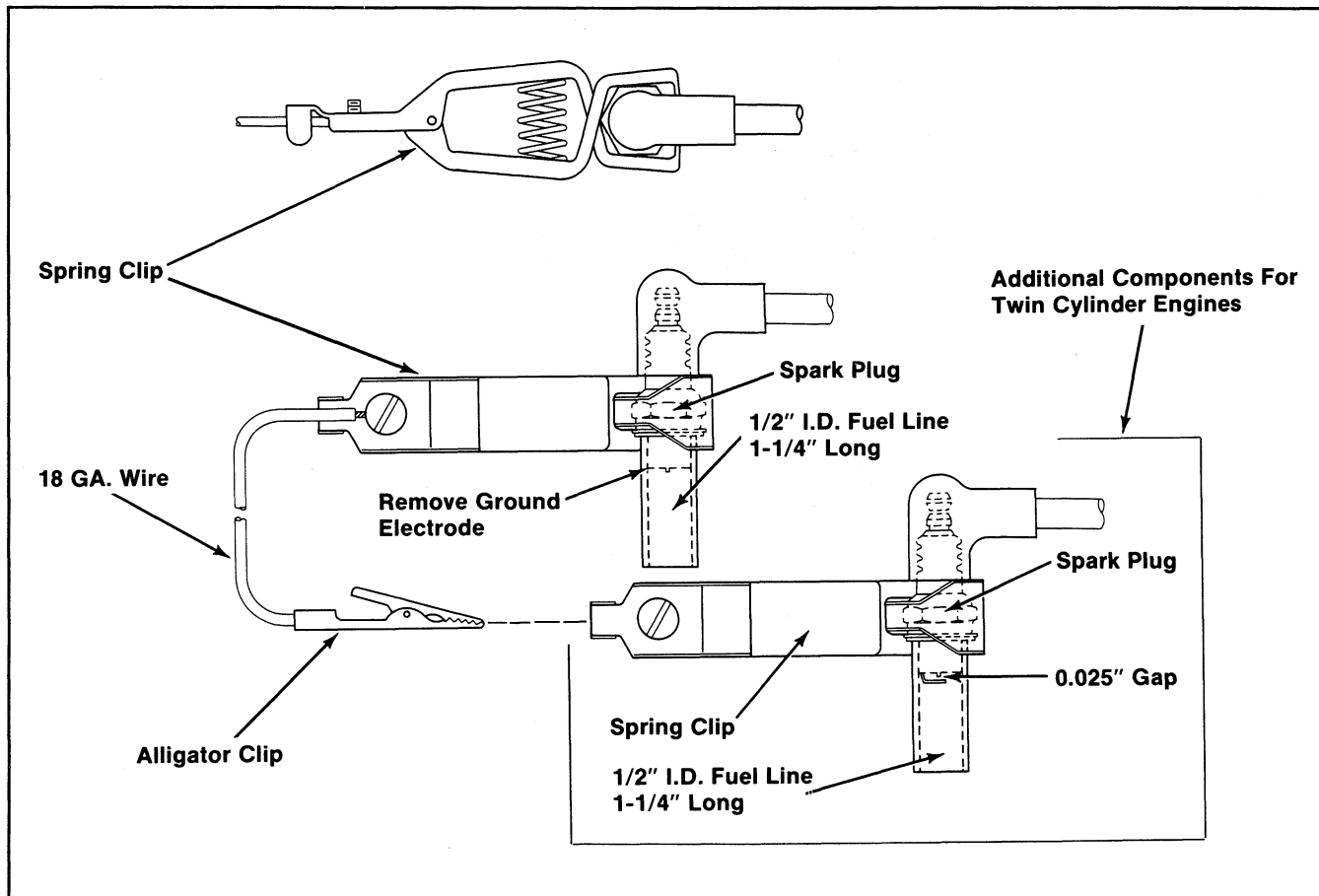

Figure 2-3. Electronic Ignition System Tester.

For Twin Cylinder Engines (Models M18 and M20)

1. Obtain a new RJ-8 or RCJ-8 spark plug.
2. Remove the ground electrode from the spark plug. This gives a spark gap of 0.13". This large gap simulates the spark required under actual engine conditions.
3. Make a lead assembly using a large spring clip, an alligator clip, and 18 gauge wire as shown.
4. Cut a 1-1/4" length of 1/2" I.D. fuel line and slide it onto the threads of the test plug. The fuel line will shade the firing tip to make the spark more visible.
5. Obtain another new RJ-8 or RCJ-8 spark plug. Set the gap to 0.035".
6. Obtain another large spring clip. Attach the spring clip to the new spark plug. Connect the alligator clip from the single cylinder tester to the screw terminal end of the spring clip.
7. Install a 1-1/4" length of 1/2" I.D. fuel line onto the threads of the new spark plug.

Using The Tester

Follow the instructions given in the "Electrical System and Components" Section.

RTV SILICONE SEALANT

RTV silicone sealant is used as a gasket between the crankcase, closure plate and cylinder barrels.

An easy-to-use **silicone sealant dispenser tube, Part No. 52 597 02**, is available. This dispenser tube contains 2.8 fl. oz. of RTV-108.

To order, contact your source of supply.

WATER MANOMETER

The Kohler Part No. 25 800 50 U-Tube water manometer is a useful tool to check crankcase vacuum (or

pressure) and to check for exhaust back pressure. It can also be used to adjust primary regulators used with gaseous fuel systems. Complete instructions are provided in the kit.

CYLINDER LEAKDOWN TESTER

The Kohler Part No. 47 800 02 Cylinder Leakdown Tester is a valuable alternate to a compression test. By pressurizing the combustion chamber from an external air source, this tool can determine if valves or rings are leaking. Instruction for using this tester are found on page 4.4 of this manual.

SECTION 2
SPECIAL TOOLS

SECTION 3 PERIODIC MAINTENANCE

REQUIRED MAINTENANCE

These required maintenance procedures should be performed at the frequency stated in the table:

Required Maintenance	Frequency
Check Oil Level	Daily
Clean Grass Screen	Daily*
Check/Replace Fuel Filter	As Required
Change Oil and Filter	As Specified in "Oil Change Intervals" Table
Clean Foam Precleaner	25 Hours*
Clean Cooling Fins and External Surfaces	50 Hours*
Clean Paper Air Cleaner Element	100 Hours*
Check Spark Plugs	100 Hours
Check Valve-To-Tappet Clearance	500 Hours
Clean Cylinder Heads and Combustion Chambers	500 Hours**
Service Starter Motor Drive	Annually or 500 Hours

*Perform these maintenance procedures more frequently when engine is operated under extremely dusty and dirty conditions.

**250 Hours when leaded gasoline is used.



WARNING: Accidental Starts!

Before servicing the engine or equipment, always remove the spark plug leads to prevent the engine from starting accidentally. Ground the leads to prevent sparks that could cause fires.

CHECK OIL LEVEL

The importance of checking and maintaining the proper oil level in crankcase cannot be overemphasized. Check oil BEFORE EACH USE as follows:

1. Make sure the engine is stopped, level, and is cool so the oil has had time to drain into the sump.
2. Clean the area around dipstick before removing to keep dirt, grass clippings, etc., out of the engine.
3. Remove dipstick and wipe oil off. Reinsert dipstick and push it all the way down into tube. Remove dipstick and check the level.

The oil level should be up to, but not over, the "F" mark on the dipstick. Refer to Figure 3-1.

SECTION 3 PERIODIC MAINTENANCE

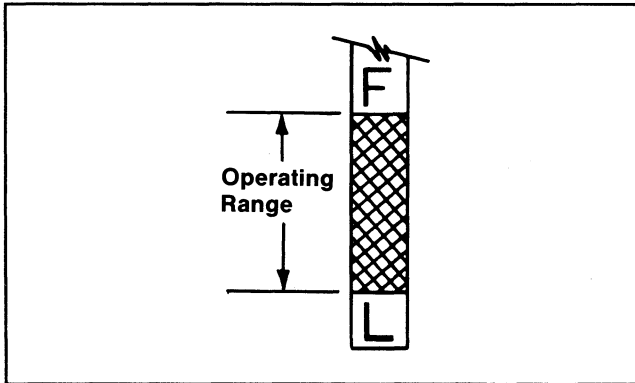

Figure 3-1. Oil Level Range.

4. Add the proper type of oil if the level is low. Always check the level with dipstick before adding more oil.

NOTE: Never operate the engine with the oil level below "L" mark or over "F" mark on dipstick.

Oil Sentry™

Some engines are equipped with optional Oil Sentry™ oil pressure monitor. Oil Sentry™ will either stop the engine or activate a "low oil" warning light, if the oil pressure gets low. Actual Oil Sentry™ use will vary depending on the engine application.

NOTE: Oil Sentry™ is not a substitute for checking oil level BEFORE EACH USE. Make sure the oil level is maintained up to the "F" mark on dipstick.

CHANGE OIL

For a new engine, change oil after the first 5 hours of operation. Thereafter, change oil as specified in the "Oil Change Intervals" table.

For an overhauled engine or those rebuilt with a new short block, use straight 30-weight Service Class SF or SG oil for the first 5 hours of operation. Change the oil after this initial run-in period. Thereafter, change the oil as specified in the "Oil Change Intervals" table.

Drain oil while the engine is still warm from operation. The oil will flow more freely and carry away more impurities. Change oil as follows:

1. Remove the oil drain plug and dipstick. Refer to Figure 3-2. Tilt the engine slightly towards the drain hole to obtain better drainage.

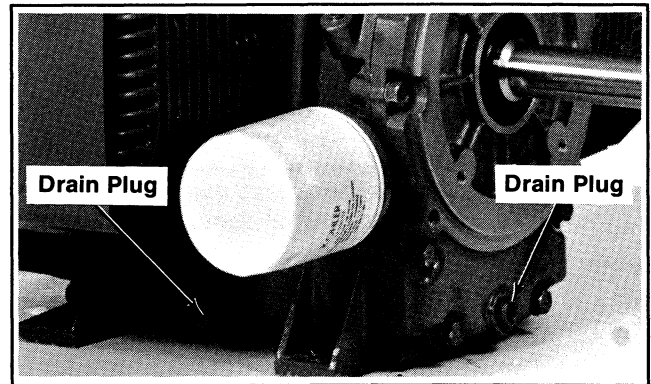

Figure 3-2. Oil Drain Plug Location.

OIL CHANGE INTERVALS

Temperature	Oil Type	Engine Type	Interval
ABOVE 32°F (0°C)	SAE 30	With Filter	50 Hours*
		Without Filter	25 Hours
BELOW 32°F (0°C)	Multiviscosity	With Filter	50 Hours
		Without Filter	25 Hours

*25 hours for continuous and/or heavy duty operation.

2. Reinstall the drain plug. Make sure it is tightened securely.
3. Fill with new oil of the proper type to the "F" mark on the dipstick. Always check the level on dipstick before adding more oil. Make sure the engine is level when filling and checking oil.

CHANGE OIL FILTER

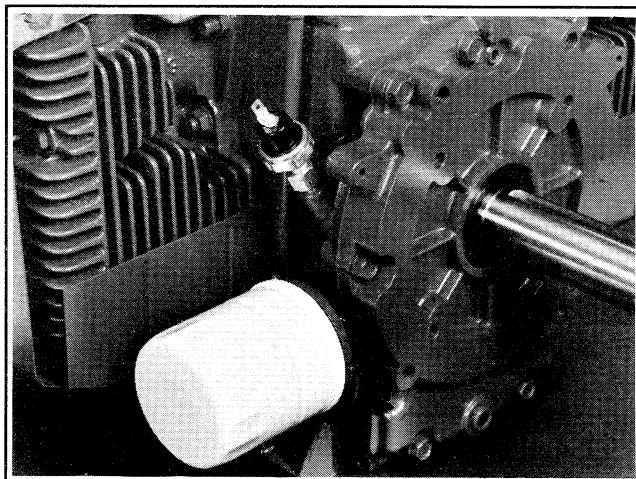

Figure 3-3. Oil Filter.

Change the oil filter every other oil change, in accordance with the "Oil Change Intervals" table. Always use a genuine Kohler oil filter and change as follows:

1. Drain crankcase oil, then remove old filter.
2. Before installing replacement filter, apply a thin coating of oil on surface of the rubber seal.
3. Turn filter clockwise until rubber seal contacts the filter adapter, then tighten the filter an additional turn.
4. Add an additional 1/2 pint of oil for the filter capacity.
5. Start the engine and check for and correct any oil leaks.

SERVICE AIR CLEANER

Magnum engines are equipped with a high-density paper air cleaner element. Some specifications are also equipped with an oiled foam precleaner which surrounds the paper element. Refer to Figure 3-4.

Also refer to the "Air Cleaner" Section for disassembly and reassembly procedures for all styles of air cleaners used on these engines.

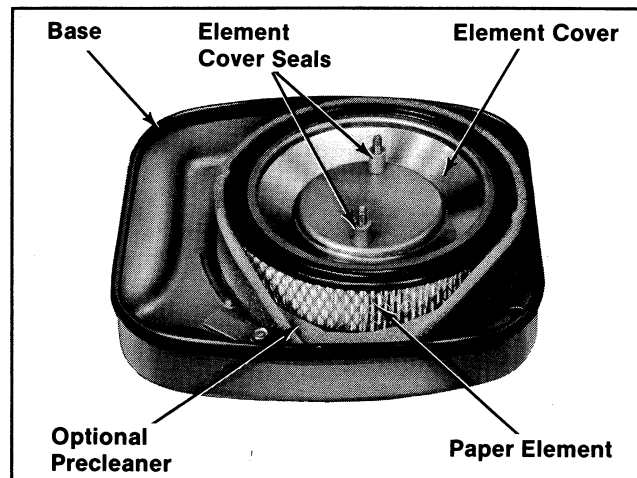

Figure 3-4. Air Cleaner Components.

Precleaner

If so equipped, wash and reoil the precleaner every 25 operating hours (more often under extremely dusty, dirty conditions).

1. Remove precleaner from paper element. Wash the precleaner in warm water with detergent.
2. Rinse precleaner thoroughly until all traces of detergent are eliminated. Squeeze out excess water (do not wring). Allow precleaner to air dry.
3. Saturate precleaner in clean, fresh engine oil. Squeeze out excess oil.
4. Reinstall precleaner over paper element.

Paper Element

Every 100 operating hours (more often under extremely dusty or dirty conditions) check the paper element. Replace the element as follows:

1. Remove the precleaner (if so equipped), element cover seals, element cover, and paper element.
2. Replace a dirty, bent or damaged element with a new genuine Kohler element. Handle new elements carefully; do not use if surfaces are bent or damaged.

SECTION 3 PERIODIC MAINTENANCE

NOTE: Do not wash the paper element or use **pressurized air** as this will damage element.

3. Install the precleaner (cleaned and oiled) over paper element.
4. Reinstall the paper element, element cover, and element cover seals.
5. Install air cleaner cover and wing nuts. Tighten wing nuts 1/2 to 1 full turn after nuts contact cover--do not overtighten.

Inspect Air Cleaner Components

Whenever the air cleaner cover is removed, or the element or precleaner serviced, check the following components:

- Air Cleaner Base – Make sure it seals tightly against intake elbow, and is not bent or damaged.
- Element Cover and Element Cover Seals – Make sure element cover is not bent or damaged. Make sure element cover seals are in place to ensure element is sealed tightly between element cover and air cleaner base.
- Breather Tube – Make sure it is sealed tightly in air cleaner base and breather cover.

NOTE: Damaged, worn, or loose air cleaner components could allow unfiltered air into the engine causing premature wear and failure. Replace all damaged or worn components.

CLEAN AIR INTAKE/COOLING AREAS

To ensure proper cooling, make sure the grass screen, cooling fins, and other external surfaces of engine are kept clean at all times. Refer to Figure 3-5.

Every 50 operating hours (more often under extremely dusty, dirty conditions), remove the blower housing and other cooling shrouds. Clean the cooling fins and external surfaces as necessary. Make sure the cooling shrouds are reinstalled.

Refer to the “Disassembly” and “Reassembly” Sections for cooling shroud removal and installation procedures.

NOTE: Operating the engine with a blocked grass screen, dirty or plugged cooling fins, and/or cooling shrouds removed will cause engine damage due to overheating.

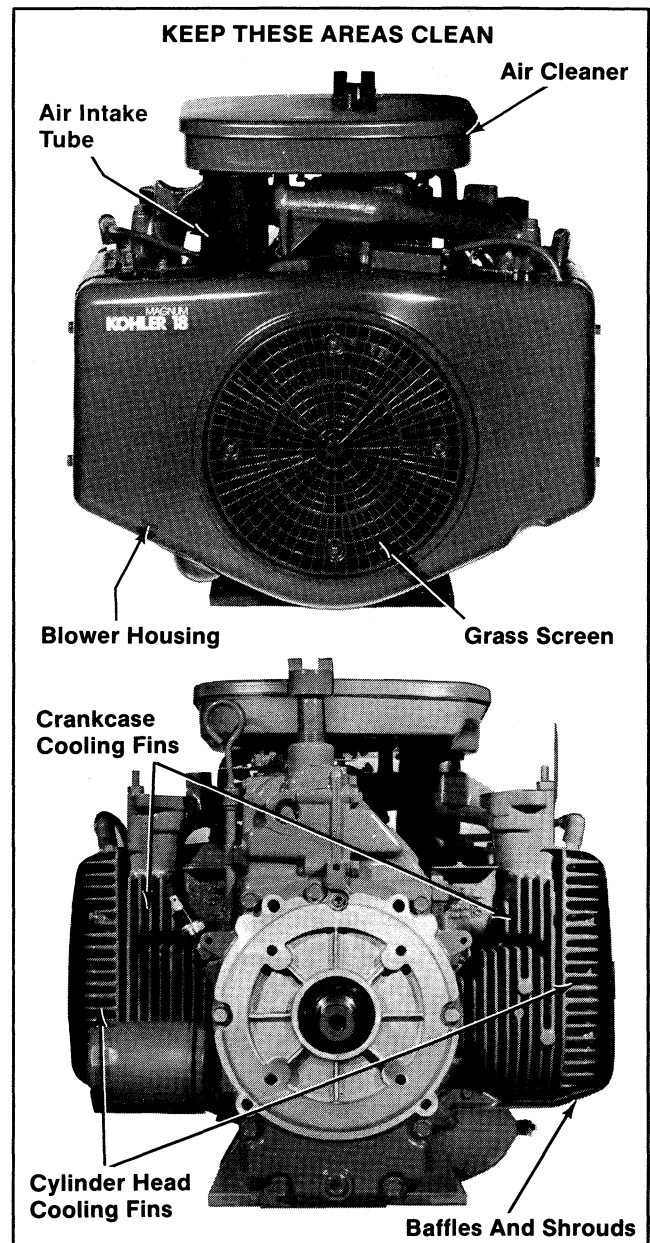

Figure 3-5. Air Intake and Cooling Areas.

CHECK SPARK PLUGS

Every 100 operating hours, remove the spark plugs, check condition and reset gaps, or replace with new plugs as necessary. Refer to Figure 3-6.

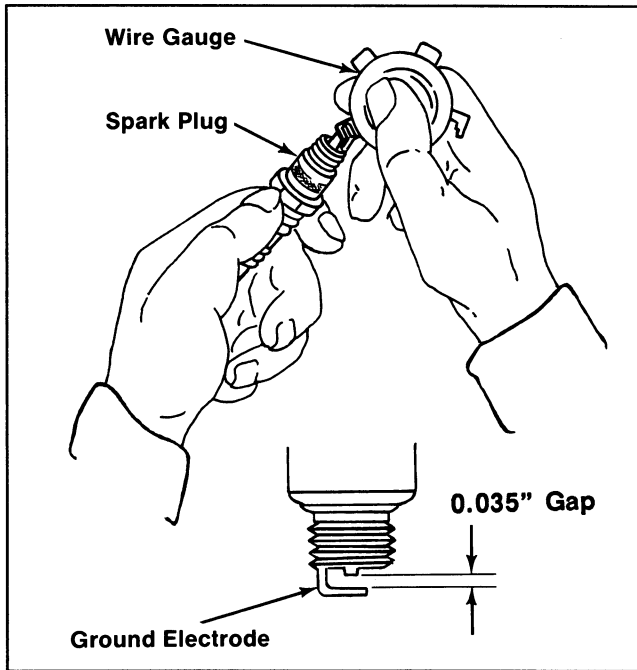

Figure 3-6. Servicing Spark Plugs.

1. Before removing spark plugs, clean the area around the base of plugs to keep dirt and debris out of engine.
2. Remove the plugs and check conditions. Replace the plugs if worn or if reuse is questionable.

Use Champion® Type RV17YC or equivalent spark plugs.

NOTE: Do not clean the spark plugs in a machine using abrasive grit. Some grit could remain in spark plugs and enter the engine causing extensive wear and damage.

3. Check gaps using a wire feeler gauge. Adjust gaps to **0.035"** by carefully bending the ground electrode.
4. Reinstall spark plugs into cylinder heads. Torque plugs to **10/15 ft. lb.**

IGNITION SYSTEM SERVICE

Magnum engines are equipped with a dependable electronic magneto ignition system. Other than periodically checking/replacing the spark plugs, no maintenance, timing, or adjustments are necessary or possible with this system.

CHECK FUEL FILTER

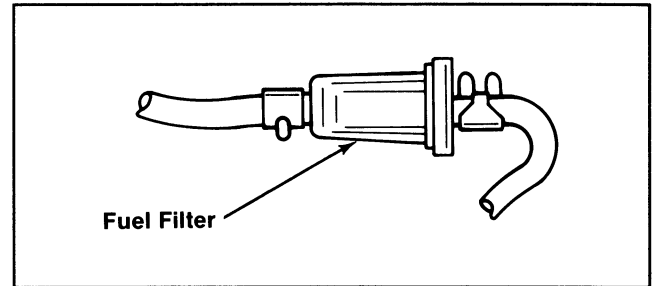

Figure 3-7. In-line Fuel Filter.

Some engines are equipped with an in-line fuel filter. Visually inspect the filter periodically. Replace when dirty with a genuine Kohler filter.

SERVICE STARTER MOTOR DRIVE

Every 500 operating hours, or annually (whichever occurs first), clean and lubricate the drive splines of the Bendix-drive electric starter motor. Refer to Figure 3-8.

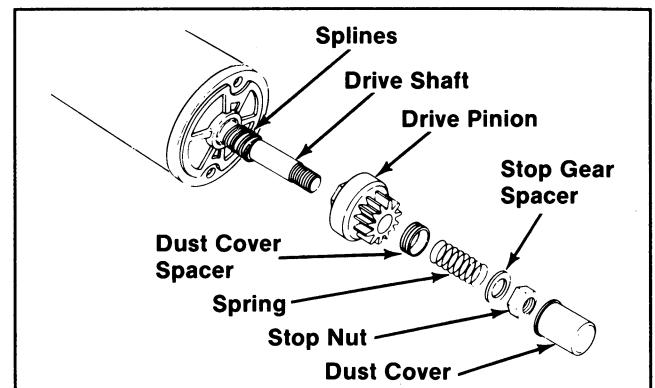

Figure 3-8. Starter Drive Components.

1. Remove starter from crankcase. (Refer to the "Disassembly" Section.)
2. Remove dust cover, stop nut, stop gear spacer, spring, dust cover spacer, and drive pinion.

SECTION 3 PERIODIC MAINTENANCE

3. Clean the drive shaft splines with solvent. Dry splines thoroughly.
4. Apply a small amount of Kohler electric starter drive lubricant (Part No. 52 357 01) to splines.

NOTE: Kohler starter drive lubricant (Part No. 52 357 01) must be used on all Kohler electric starter drives. The use of other lubricants can cause the drive to stick or bind.

5. Apply a small amount of Loctite® No. 271 to stop nut threads. Assemble drive parts in reverse order of removal. Torque stop nut to **160 in. lb.**
6. Reinstall starter to crankcase.

CLEAN CYLINDER HEADS AND COMBUSTION CHAMBERS

Every 500 operating hours (250 hours when leaded gasoline is used), remove cylinder heads and clean combustion chambers. Refer to Figure 3-9.

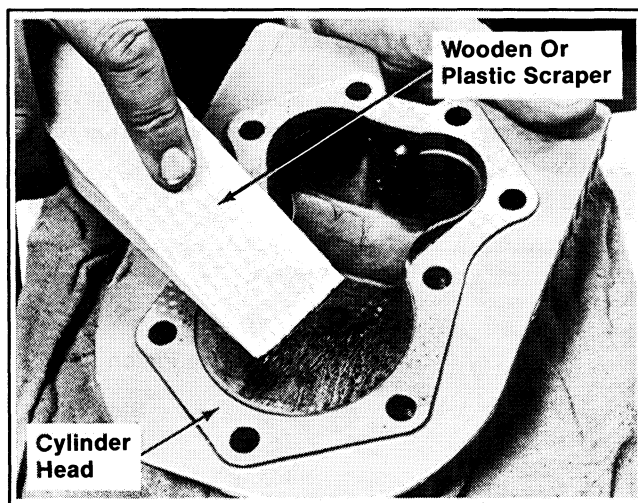

Figure 3-9. Cleaning Cylinder Heads and Combustion Chambers.

1. Remove cylinder head baffles and cylinder heads.

2. Clean away combustion deposits using a wooden or plastic scraper.
3. Reinstall cylinder heads using new gaskets. Torque cylinder head fasteners in increments to **15/20 ft. lb.** in the sequence specified in Figure 3-10.

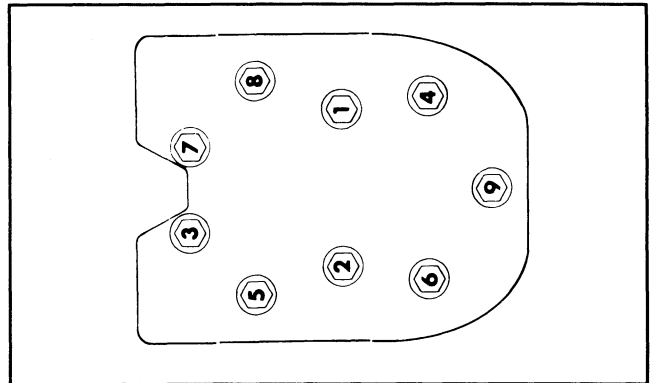

Figure 3-10. Cylinder Head Fastener Tightening Sequence.

CHECK VALVE-TO-TAPPET CLEARANCE

Every 500 operating hours, remove breather/valve covers and check valve-to-tappet clearance with a flat feeler gauge. Refer to Figure 3-11. The engine must be cold when checking this clearance.

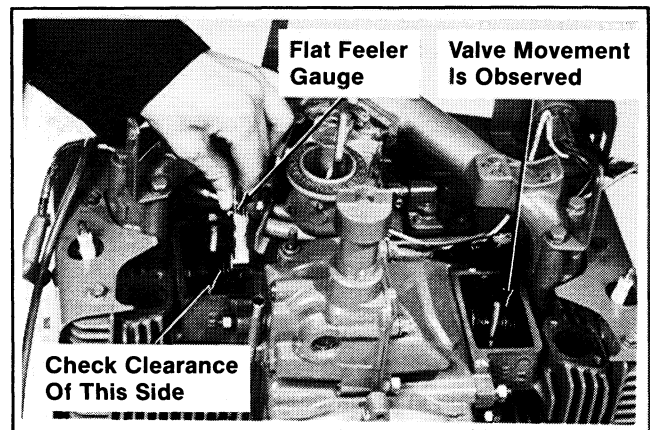

Figure 3-11. Measuring Valve-To-Tappet Clearance.

Remove Air Cleaner, Valve Covers, Breather, And Spark Plugs

1. Disassemble air cleaner. Disconnect breather tube from air cleaner base. Remove base from air intake elbow and intake manifold.
2. Remove the valve cover and breather assembly from the #1 cylinder barrel. Remove the valve cover from the #2 cylinder barrel.
3. Remove the spark plugs.

Measure Valve-to-Tappet Clearance

IMPORTANT:

The piston must be at top dead center (TDC) of the compression stroke to measure valve-to-tappet clearance. By rotating the flywheel and observing the valves and tappets for movement, it can be determined if a cylinder is at TDC.

If, for example, the flywheel is rotated and movement is noticed in the #2 side valve box--the opposite cylinder (#1 side) will be at TDC and valve-to-tappet clearance can be measured.

Rotating the flywheel one complete revolution (360°) will then cause movement in the #1 side valve box--the #2 side cylinder will be at TDC, enabling measurement of valve-to-tappet clearance for that side.

Clearance Specifications--

Intake Valve

(Closest to Flywheel) .003"/.006"

Exhaust Valve (Serial No. 1816500646 and earlier)
(Closest to PTO) .016"/.019"

Exhaust Valve (Serial No. 1816500656 and later)
(Closest to PTO) .011"/.014"

1. Rotate the flywheel and look into the valve boxes. The valves and tappets will move in only one of the boxes. Measure the valve-to-tappet clearance for the cylinder in which **no movement** was observed--use a flat feeler gauge. Refer to Figure 3-11.

2. Rotate the flywheel 360° and measure the valve-to-tappet clearance for the remaining cylinder.
3. *If clearance is too small*, remove the valves and grind the valve stems until the correct clearance is obtained. Make sure valve stems are ground perfectly flat and smooth.

If clearance is too large, replace the valves and recheck clearance.

NOTE: Large clearance can also be reduced by grinding the valves and/or valve seats. Refer to the "Inspection And Repair/Reconditioning" Section for valve specifications.

Reinstall Spark Plugs, Breather, Valve Covers, and Air Cleaner

1. Reinstall spark plugs and torque to **10/15 ft. lb.**
2. Reinstall valve cover to #2 cylinder barrel. Reinstall breather assembly and valve cover to #1 cylinder barrel. Make sure breather is assembled correctly using new gaskets.
3. Reinstall air cleaner base to intake manifold and air intake elbow using new gasket.
4. Insert end of breather tube through hole in air cleaner base.

NOTE: Make sure breather tube seals tightly in breather cover and in air cleaner base to prevent unfiltered air from entering engine.

5. Reassemble remaining air cleaner components and tighten wing nut(s) 1/2 to 1 full turn after nut contacts cover. Do not overtighten.
6. Reconnect spark plug leads.

SECTION 3

PERIODIC MAINTENANCE

STORAGE

If the engine will be out of service for approximately two months or more, use the following storage procedure:

1. Clean the exterior surfaces of the engine.
2. Change the oil and filter while the engine is still warm from operation. See "Change Oil and Oil Filter."
3. The fuel system must be completely emptied, or the gasoline must be treated with a stabilizer to prevent deterioration. If you choose to use a stabilizer, follow the manufacturers recommendations, and add the correct amount for the capacity of the fuel system. Fill the fuel tank with clean, fresh gasoline. Run the engine for 2-3 minutes to get stabilized fuel into the carburetor.
4. Remove the spark plugs. Add one tablespoon of engine oil into each spark plug hole. Install plugs, but do not connect the plug leads. Crank the engine two or three revolutions.
5. Store the engine in a clean, dry place.

To empty the system, drain the fuel tank and carburetor, or run the engine until the tank and system are empty.

SECTION 4

TROUBLESHOOTING

TROUBLESHOOTING GUIDE

When troubles occur, be sure to check the simple causes which, at first, may seem too obvious to be considered. For example, a starting problem could be caused by an empty fuel tank.

Some common causes of engine troubles are listed below--use this as a guide to locate causing factors.

Engine Cranks But Will Not Start

1. Empty fuel tank.
2. Fuel shutoff valve closed.
3. Clogged fuel line.
4. Spark plug leads disconnected.
5. Key switch or kill switch in "off" position.
6. Faulty spark plugs.
7. Faulty ignition module.
8. Dirt or water in the fuel system.

Engine Starts But Does Not Keep Running

1. Restricted fuel tank vent.
2. Dirt or water in fuel system.
3. Faulty choke or throttle controls/cables.
4. Loose wires or connections which short kill terminal of ignition module to ground.
5. Carburetor improperly adjusted.
6. Faulty cylinder head gaskets.
7. Faulty fuel pump.

Engine Starts Hard

1. Hydrostatic transmission is not in neutral/PTO drive is engaged.
2. Loose wires or connections.
3. Dirt or water in fuel system.
4. Clogged or restricted fuel lines.
5. Faulty choke or throttle controls/cables.
6. Faulty spark plugs.
7. Carburetor improperly adjusted.
8. Incorrect valve-to-tappet clearance.
9. Low compression.

Engine Will Not Crank

1. Hydrostatic transmission is not in neutral/PTO drive is engaged.
2. Battery is discharged.
3. Safety interlock switch is "engaged".
4. Loose or faulty wires or connections.
5. Faulty key switch or ignition switch.
6. Faulty electric starter/starter solenoid.
7. Seized internal engine components.

Engine Runs But Misses

1. Dirt or water in fuel system.
2. Spark plug leads loose.
3. Loose wires or connections which intermittently short kill terminal of ignition module to ground.
4. Carburetor improperly adjusted.
5. Engine overheating.
6. Incorrect valve-to-tappet clearance.
7. Faulty ignition module

Engine Will Not Idle

1. Idle speed adjusting screw improperly set.
2. Dirt or water in fuel system.
3. Idle fuel adjusting screw improperly set.
4. Restricted fuel tank vent.
5. Faulty spark plugs.
6. Incorrect valve-to-tappet clearance.
7. Low compression.
8. Stale fuel and/or gum in carburetor.

Engine Overheats

1. Grass screen, cooling fins, or shrouding clogged.
2. Excessive engine load.
3. Low crankcase oil level.
4. High crankcase oil level.
5. Carburetor improperly adjusted.

SECTION 4 TROUBLESHOOTING

Engine Knocks

1. Low crankcase oil level.
2. Excessive engine load.
3. Old/improper fuel.
4. Internal wear or damage.

Engine Loses Power

1. Low crankcase oil level.
2. High crankcase oil level.
3. Restricted air cleaner element.
4. Dirt or water in fuel system.
5. Excessive engine load.
6. Engine overheating.
7. Faulty spark plugs.
8. Carburetor improperly adjusted.
9. Low compression.

Engine Uses Excessive Amount Of Oil

1. Incorrect oil viscosity/type.
2. Clogged or improperly assembled breather system.
3. Worn or broken piston rings.
4. Worn cylinder bores.
5. Worn valve stems and/or valve guides.
6. Crankcase being overfilled.

EXTERNAL ENGINE INSPECTION

Before cleaning or disassembling the engine, check its external appearance and condition. This inspection can give clues to what might be found inside the engine (and the cause) once it is disassembled.

- Check for buildup of dirt and debris on the crankcase, cooling fins, grass screen, and other external surfaces. Dirt or debris in these areas are causes of overheating.
- Check for obvious fuel and oil leaks, and damaged components. Excessive oil leakage can indicate a clogged or improperly assembled breather, worn or damaged seals and gaskets, or loose or improperly torqued fasteners.
- Check the air cleaner cover, element cover, and air cleaner base for damage or indications of improper fit and seal. Also check the seals on the air cleaner cover wing nuts. Missing or damaged seals could allow dirt to enter the engine.

- Check the air cleaner element. Look for holes, tears, cracked or damaged sealing surfaces, or other damage that could allow dirt to enter the engine. Also note if the element is clogged or restricted. These could indicate that the air cleaner has been under serviced.
- Check the carburetor throat for dirt. Dirt in the throat is further indication that the air cleaner is not functioning properly.
- Check the oil level. Note if the oil level is within the operating range on the dipstick, or if it's low or overfilled.
- Check the condition of the oil. Drain the oil into a container—it should flow freely. Check for metal chips and other foreign particles.

NOTE: It is good practice to drain oil at a location away from the workbench. Be sure to allow ample time for complete drainage.

Sludge is a natural by-product of combustion; a small accumulation is normal. Excessive sludge formation could indicate that the oil has not been changed as recommended, an incorrect type or weight of oil was used, over rich carburetor settings, and weak ignition, to name a few.

CLEANING THE ENGINE

After inspecting the external condition of the engine, clean it thoroughly before disassembling. Also clean individual components as the engine is disassembled. Only clean parts can be accurately inspected and gauged for wear or damage.

There are many commercially available cleaners that quickly remove grease, oil, and grime from engine parts. When such a cleaner is used, *follow the manufacturer's instructions carefully*. Make sure all traces of the cleaner are removed before the engine is reassembled and placed into operation. Even small amounts of these cleaners quickly break down the lubricating properties of engine oil.

BASIC ENGINE TESTS

Crankcase Vacuum Test

A partial vacuum should be present in the crankcase when the engine is operating at normal temperatures. Pressure in the crankcase (usually caused by a clogged or improperly assembled breather) can cause oil to be forced out at oil seals, gaskets, or other available spots.

Crankcase vacuum is best measured with a water manometer. Kohler Part No. 25 800 50 is recommended. Complete instructions are provided in kit.

Test the crankcase vacuum with the manometer as follows:

1. Insert the stopper/hose into the oil fill hole. Leave the other vent of manometer open to atmosphere. Make sure the shut-off clamp is closed.
2. Start the engine and run at high speed (3200 to 3600 RPM).
3. Open the clamp and note the water level in the tube. The level in the engine side should be 13 to 20 in. above the level in the open side. If there is no vacuum (level in engine side is the same as open side) or a positive pressure (level in open side is higher than engine side) check for the conditions below.
4. Close the shut-off clamp **before** stopping the engine.



NO CRANKCASE VACUUM/PRESSURE IN CRANKCASE

Possible Cause	Solution
1. Crankcase breather clogged or inoperative.	1. Disassemble breather, clean parts thoroughly, reassemble, and recheck pressure.
2. Seals and/or gaskets leaking. Loose or improperly torqued fasteners.	2. Replace all worn or damaged seals and gaskets. Make sure fasteners are tightened securely. Use appropriate torque values and sequences when necessary.
3. Piston blowby or leaky valves. (Confirm with compression or cylinder leakdown test.)	3. Recondition piston, rings, cylinder bores, valves, and valve guides.
4. Restricted exhaust.	4. Replace restricted muffler/exhaust system.

SECTION 4 TROUBLESHOOTING

Compression Test

To test compression:

1. Remove the spark plugs. Install compression tester in each spark plug hole.
2. Set the throttle and choke controls to the wide open position. Make sure air cleaner and exhaust system are not restricted.

3. Crank the engine using the starter motor. Take several readings for both cylinders.

If the difference in pressure between cylinders is 15% or greater, or pressure is less than 90 psig, check for the conditions below:

LOW COMPRESSION

Possible Cause	Solution
1. Blown cylinder head gaskets.	1. Remove cylinder heads, inspect heads for flatness (replace heads if necessary), replace gaskets, re-install heads, and recheck compression. Locate and correct the cause of initial failure.
2. Warped or loose cylinder heads.	2. Remove cylinder heads, check for flatness (replace heads if necessary). Make sure cylinder head fasteners are torqued in the proper sequence to the proper value.
3. Excessive combustion chamber deposits.	3. Remove cylinder heads and clean deposits from combustion chamber.
4. Worn piston rings – blowby occurring.	4. Recondition piston rings and cylinder bores.
5. Worn valves.	5. Recondition valves and valve seals.

Cylinder Leakdown Test

A cylinder leakdown test can be a valuable alternative to a compression test. By pressurizing the combustion chamber from an external air source you can determine if the valves or rings are leaking, and how badly:

The Kohler Part No. 47 800 02 is a relatively simple, inexpensive leakdown tester for small engines. The tester includes a quick disconnect for attaching the adapter hose and a holding tool.

Leakdown Test Instructions

1. Run engine for 3–5 minutes to warm it up.
2. Remove spark plug(s) and air filter from engine.
3. Rotate crankshaft until piston (of cylinder being tested) is at top dead center of compression stroke. You will need to hold the engine in this position while testing. The holding tool supplied with the tester can be used if the PTO end of the crankshaft is accessible. Slide the holding tool onto the crankshaft and adjust the set screw to fit in the key slot. Install a 3/8" breaker bar into the

square hole of the holding tool, so it is perpendicular to both the holding tool and crankshaft PTO. If the flywheel end is more accessible, you can use a breaker bar and socket on the flywheel nut/screw to hold it in position. You may need an assistant to hold the breaker bar during testing. If the engine is mounted in a piece of equipment, you may be able to hold it by clamping or wedging a driven component. Just be certain that the engine cannot rotate off of T.D.C. in either direction

4. Install the adapter into the spark plug hole, but do not attach it to the tester at this time.
5. Connect an adequate air source to the tester.
6. Turn the regulator knob in the increase (clockwise) direction until the gauge needle is in the yellow "set" area at the low end of the gauge.
7. Connect tester quick-disconnect to the adapter. Note the gauge reading and listen for escaping air at the carburetor intake, exhaust outlet, and crankcase breather.
8. Check your test results against the table below:

LEAKDOWN TEST RESULTS

Air escaping from crankcase breather	Defective rings or worn cylinder walls.
Air escaping from exhaust system	Defective exhaust valve.
Air escaping from carburetor	Defective intake valve.
Gauge reading in "low" (green) zone	Piston rings and cylinder in good condition.
Gauge reading in "moderate" (yellow) zone	Engine is still usable, but there is some wear present. Customer should start planning for overhaul or replacement.
Gauge reading in "high" (red) zone	Rings and/or cylinder have considerable wear. Engine should be reconditioned or replaced.



SECTION 4 TROUBLESHOOTING

SECTION 5 AIR CLEANER

Magnum engines are equipped with a high-density paper air cleaner element. Some specifications are also equipped with an oiled foam precleaner which surrounds the paper element. Refer to Figure 5-1.

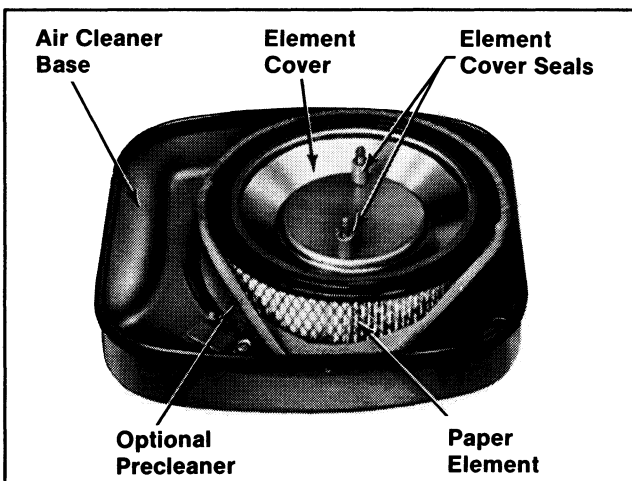

Figure 5-1. Air Cleaner Components.

Three types of air cleaner assemblies are used on Model M18 and M20 engines; square, dome, or anti-icing. Refer to the instructions for the specific type of air cleaner being serviced.

SQUARE

(Refer To Figure 5-2)

Disassembly

1. Remove the wing nuts and air cleaner cover.
2. Remove the element cover seals, element cover, paper element and precleaner.
3. Remove the breather hose, base screw, air cleaner base, air intake tube, and gasket.

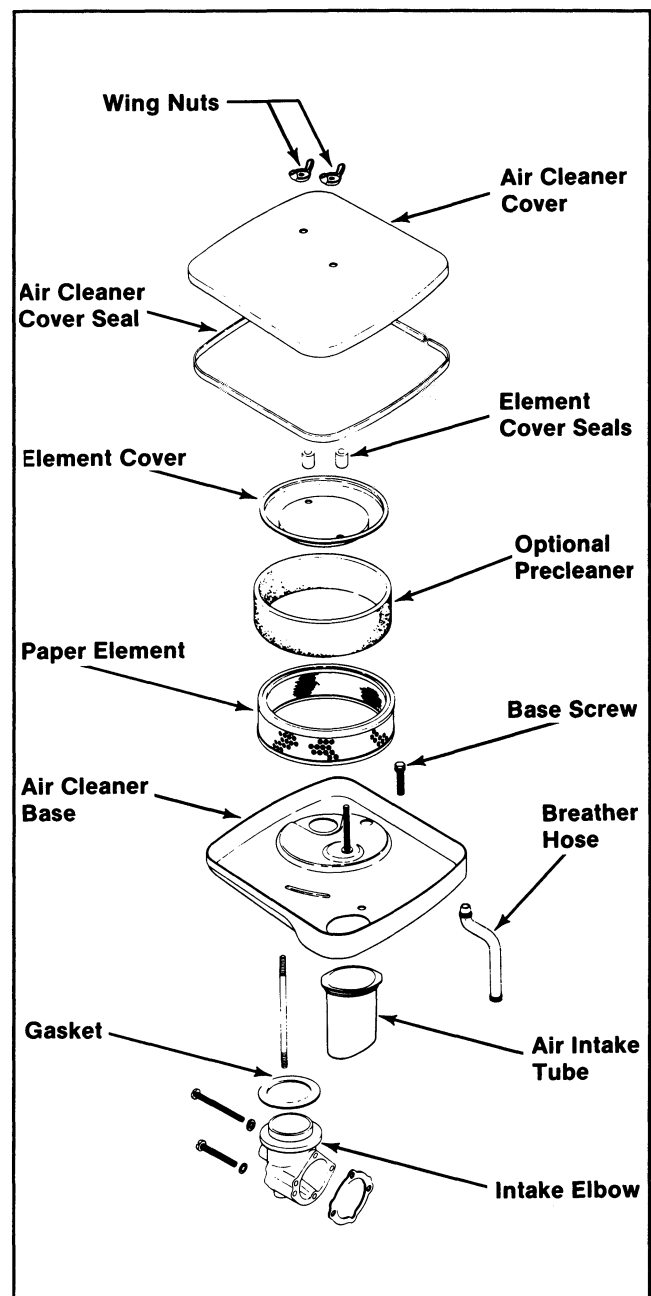

Figure 5-2. Square Air Cleaner Assembly.

SECTION 5 AIR CLEANER

Reassembly

1. Install the gasket, air cleaner base, air intake tube, breather hose, and base screw.

NOTE: Make sure breather hose seals tightly in air cleaner base and breather cover to prevent unfiltered air from entering engine. The air cleaner cover seal must be installed to base to prevent vibration. Excess vibration can cause stud holes in cover to enlarge which will allow dirt to enter the engine.

2. Install the paper element, precleaner (cleaned and oiled), element cover, and element cover seals.
3. Install the air cleaner cover and wing nuts. Tighten wing nuts 1/2 to 1 full turn after nuts contact cover. Do not overtighten.

DOME

(Refer To Figure 5-3)

Disassembly

1. Remove the wing nut and air cleaner cover.
2. Remove the element cover seal, element cover, paper element, and precleaner.
3. Remove the base screws, air cleaner base, breather hose, and gasket.

Reassembly

1. Install the gasket, air cleaner base, breather hose, and base screws.

NOTE: Make sure breather hose seals tightly in air cleaner base and breather cover to prevent unfiltered air from entering engine.

2. Install the paper element, precleaner (cleaned and oiled), element cover, and element cover seal.
3. Install the air cleaner cover and wing nut. Tighten wing nut 1/2 to 1 full turn after nut contacts cover. Do not overtighten.

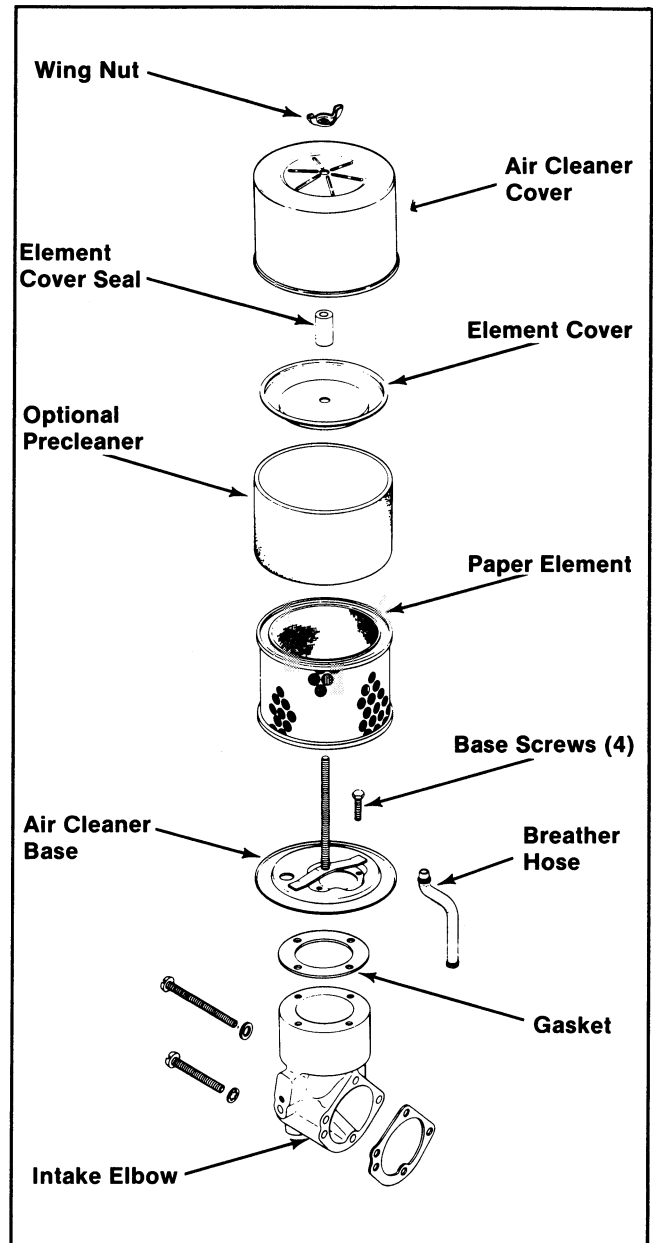

Figure 5-3. Dome Air Cleaner Assembly.

ANTI-ICING

(Refer To Figure 5-4)

The anti-icing air cleaner assembly uses heat from the exhaust manifold to prevent ice buildup in the carburetor and intake manifold during cold weather operation.

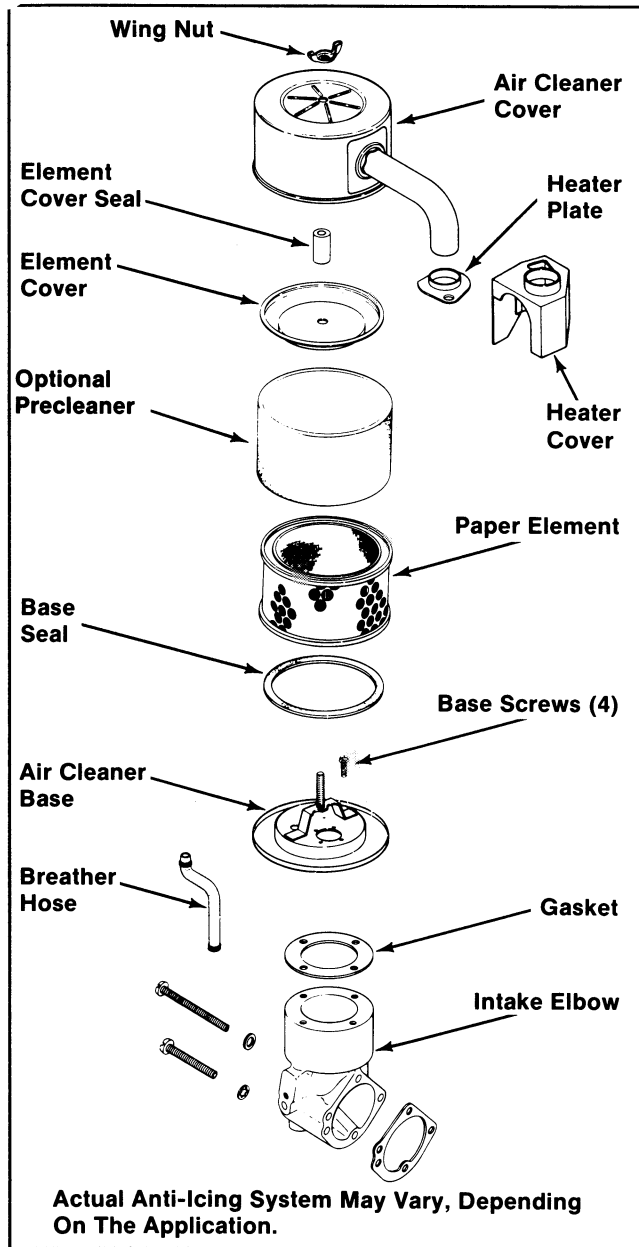

Figure 5-4. Anti-Icing Air Cleaner Assembly.

Disassembly

1. Remove the wing nut and air cleaner cover.
2. Remove the element cover seal, element cover, paper element, precleaner, and air cleaner base seal.
3. Remove the base screws, air cleaner base, breather hose, and gasket.

Reassembly

1. Install the gasket, air cleaner base, breather hose, and base screws.

NOTE: Make sure breather hose seals tightly in the air cleaner base and breather cover to prevent unfiltered air from entering engine.

2. Install the air cleaner base seal, paper element, precleaner (cleaned and oiled), element cover, and element cover seal.
3. Install the air cleaner cover with the inlet duct positioned for the season of operation. Refer to the decal on the air cleaner cover (Figure 5-5).

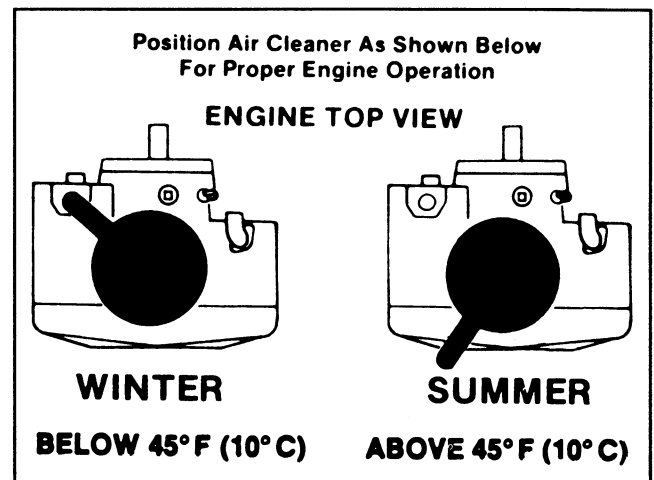

Figure 5-5. Typical Decal - Anti-Icing Air Cleaner Cover Positions.

For "Winter" Position - Make sure the inlet duct fits completely over heater plate or heater cover. Refer to Figure 5-6. Make sure the air cleaner cover is sealed tightly around the entire perimeter of air cleaner base.

NOTE: Proper sealing around base is necessary to prevent unfiltered air from entering the engine.

To prevent vapor lock and to ensure proper engine operation, do not operate the engine during "summer" season with the air cleaner cover in the "winter" position. Always refer to the decal on the air cleaner cover for proper position.

SECTION 5 AIR CLEANER

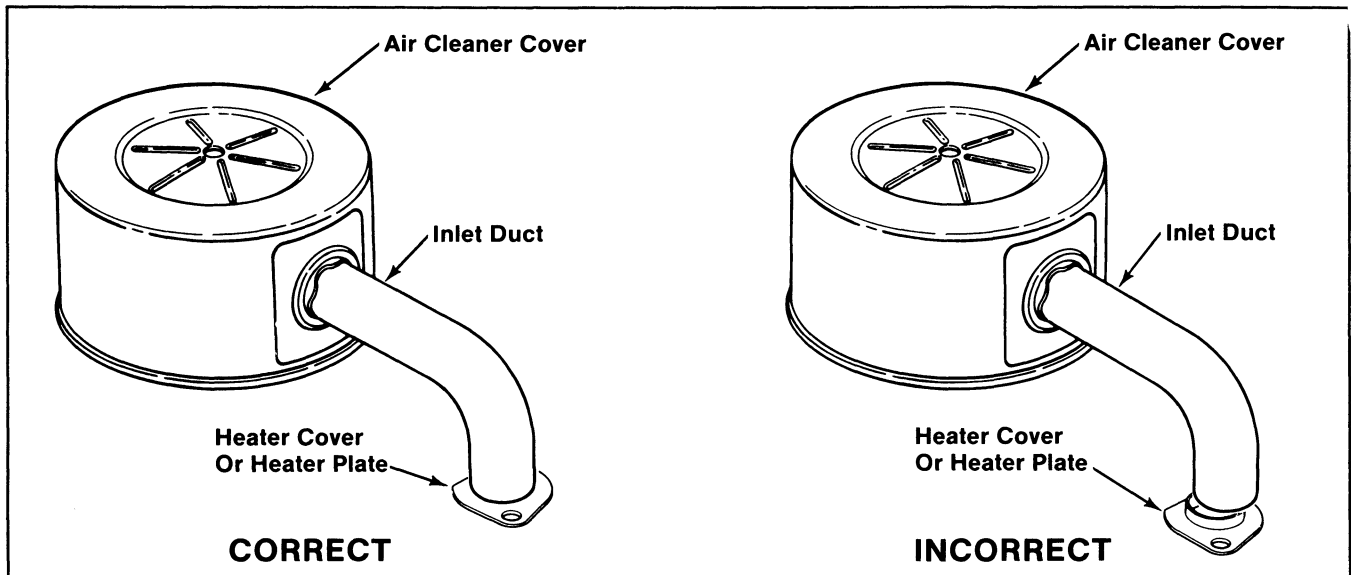

Figure 5-6. Installing Anti-Icing Air Cleaner Cover.

5. Install the wing nut. Tighten wing nut 1/2 to 1 full turn after nut contacts cover. Do not overtighten.

SERVICE

Precleaner

If so equipped, wash and reoil the precleaner every 25 operating hours (more often under extremely dusty or dirty conditions).

1. Remove the precleaner from paper element. Wash precleaner in warm water with detergent.
2. Rinse the precleaner thoroughly until all traces of detergent are eliminated. Squeeze out excess water (do not wring). Allow precleaner to air dry.
3. Saturate the precleaner in clean, fresh engine oil. Squeeze out excess oil.
4. Reinstall the precleaner over paper element.

Paper Element

Every 100 operating hours (more often under extremely dusty or dirty conditions) check the paper element. Replace the element as follows:

1. Remove the precleaner (if so equipped), element cover seal(s), element cover, and paper element.
2. Gently tap the flat side of the paper element to dislodge dirt. Do not wash the paper element or use pressurized air as this will damage the element. Replace a dirty, bent or damaged element with a new genuine Kohler element. Handle new elements carefully; do not use if surfaces are bent or damaged.

3. Reinstall the precleaner (cleaned and oiled) over the paper element.
4. Reinstall the paper element, element cover, and element cover seal(s). Make sure element is sealed tightly against the element cover and air cleaner base.
5. Install the air cleaner cover and wing nuts. Tighten wing nuts 1/2 to 1 full turn after nuts contact cover. Do not overtighten.

Inspect Air Cleaner Components

Whenever the air cleaner cover is removed, or servicing the element or precleaner, check the following components:

- **Air Cleaner Base** – Make sure it seals tightly against intake elbow, and is not bent or damaged.
- **Element Cover and Element Cover Seals** – Make sure element cover is not bent or damaged. Make sure element cover seals are in place to ensure element is sealed tightly between element cover and air cleaner base.
- **Breather Tube** – Make sure it is sealed tightly in air cleaner base and breather cover.

NOTE: Damaged, worn, or loose air cleaner components could allow unfiltered air into the engine causing premature wear and failure. Replace all damaged or worn components.

SECTION 6A

FUEL SYSTEMS AND GOVERNORS

FUEL SYSTEM

The typical fuel system and related components include the fuel tank with vented cap, in-line fuel filter, fuel pump, carburetor, and interconnecting fuel line. Refer to Figure 6A-1. Kohler-built carburetors are discussed in this section plus Dual Fuel System. Walbro carburetors are covered in Section 6B.

Operation

The fuel from the tank is moved through the in-line filter, and fuel lines by the fuel pump. Fuel then enters the carburetor float bowl and is moved into the carburetor body where it is mixed with air. This fuel-air mixture is then burned in the engine combustion chambers.

Troubleshooting

Use the following procedure to check if fuel is reaching the combustion chamber.



WARNING: Explosive Fuel!

Gasoline is extremely flammable and its vapors can explode if ignited. Before troubleshooting the fuel system, make sure there are no sources of heat, flames, or sparks nearby as these can ignite gasoline vapors. Disconnect and ground the spark plug leads to eliminate the possibility of sparks from the ignition system.

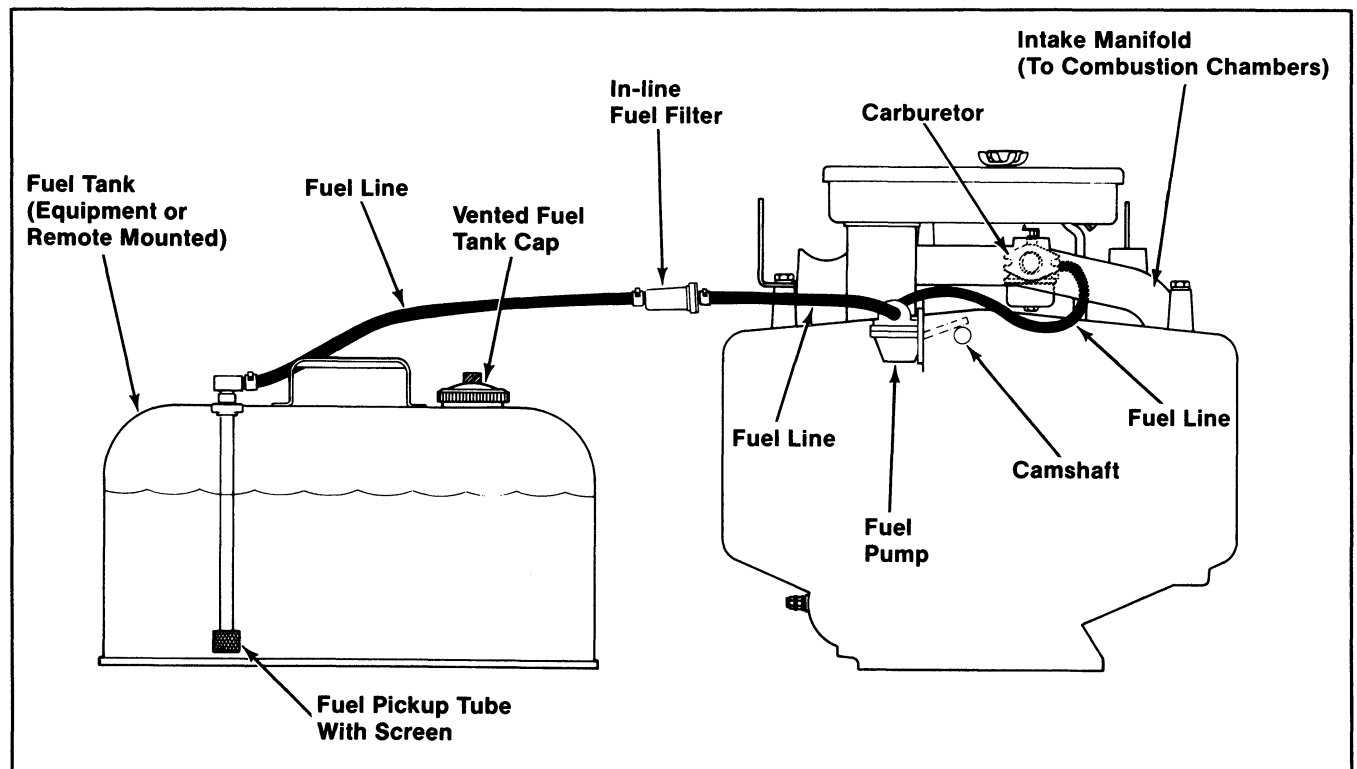

Figure 6A-1. Typical Fuel System.

SECTION 6A

FUEL SYSTEMS AND GOVERNORS

Test	Conclusion
<p>1. Check for the following:</p> <p>A. Make sure the fuel tank contains fuel.</p> <p>B. Make sure the vent in fuel tank cap is open.</p> <p>C. Make sure the fuel shut-off valve is open.</p>	
<p>2. Check for fuel in the combustion chamber.</p> <p>A. Disconnect the spark plug leads.</p> <p>B. Close the choke on carburetor.</p> <p>C. Crank the engine several times.</p> <p>D. Remove the spark plugs and check for fuel at tips.</p>	<p>2. If there is fuel at tips of spark plugs, fuel is reaching the combustion chambers.</p> <p>If there is no fuel at tips of spark plugs, check for fuel flow from the fuel tank. (Test 3).</p>
<p>3. Check for fuel flow from the fuel tank to fuel pump.</p> <p>A. Remove the fuel line from inlet fitting of fuel pump.</p> <p>B. Hold the line below the bottom of tank. Open the shut-off valve (if so equipped) and observe flow.</p>	<p>3. If fuel does flow from line, check for faulty fuel pump. (Test 4).</p> <p>If fuel does not flow from line, check for clogged fuel tank vent, shut-off valve, screen, and fuel lines.</p>
<p>4. Check operation of fuel pump.</p> <p>A. Remove the fuel line from inlet fitting of carburetor.</p> <p>B. Crank the engine several times and observe flow.</p>	<p>4. If fuel does not flow from line, check for clogged fuel line. If line is unobstructed, fuel pump is faulty and must be replaced.</p> <p>If fuel does flow from fuel line, the carburetor is probably faulty. Refer to the "Carburetor" portion of this section.</p>

FUEL FILTER

Some engines are equipped with an in-line fuel filter. Visually inspect the filter periodically. Replace when dirty with a genuine Kohler filter. Refer to Figure 6A-2.

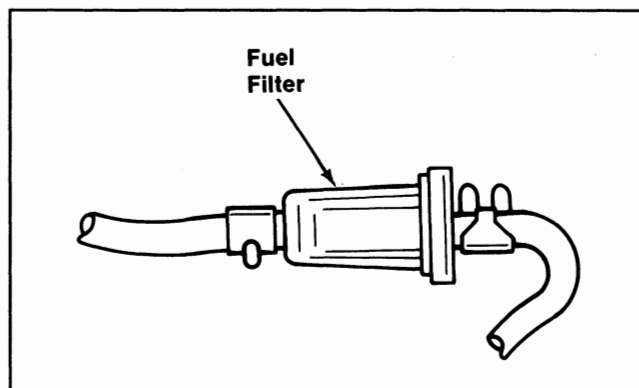

Figure 6A-2. In-Line Fuel Filter.

FUEL PUMP

Most Magnum engines are equipped with a mechanically operated fuel pump. On applications using a gravity feed fuel system, the fuel pump is not used and the pump mounting pad on the crankcase is covered.

The fuel pump body is constructed of a nylon material. The nylon body insulates the fuel from the hot engine crankcase and prevents fuel from vaporizing inside the pump.

Operation

The mechanical fuel pump is operated by a lever which rides on the engine camshaft. The lever transmits a pumping action to the diaphragm inside the pump body. This pumping action draws fuel in through the inlet check valve on the downward stroke of diaphragm. On the upward stroke of the diaphragm, the fuel is forced out through the outlet check valve. Refer to Figure 6A-3.

SECTION 6A

FUEL SYSTEMS AND GOVERNORS

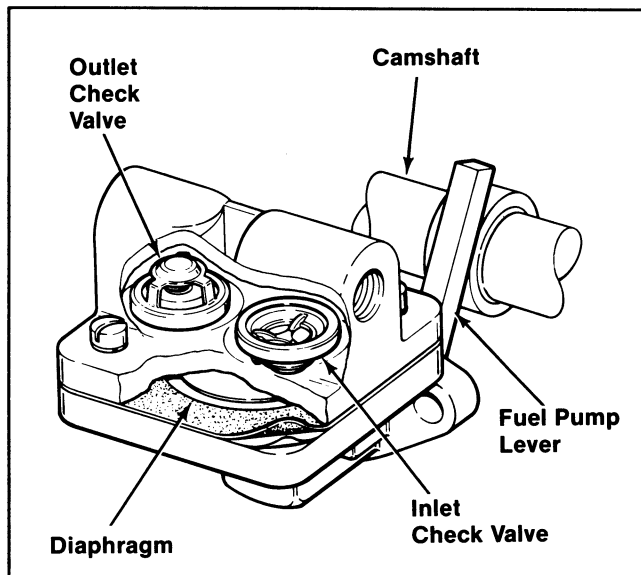

Figure 6A-3. Mechanical Fuel Pump.

Removal

1. Disconnect the fuel lines from the inlet and outlet fittings of pump.
2. Remove the truss head nylock screws, fuel pump, and gasket.
3. If necessary, remove the fittings from pump body.

Repair

Nylon-bodied fuel pumps are not serviceable and must be replaced when faulty. Replacement pumps are available in kits which include the pump and mounting gasket.

Installation

(Refer to Figure 6A-4.)

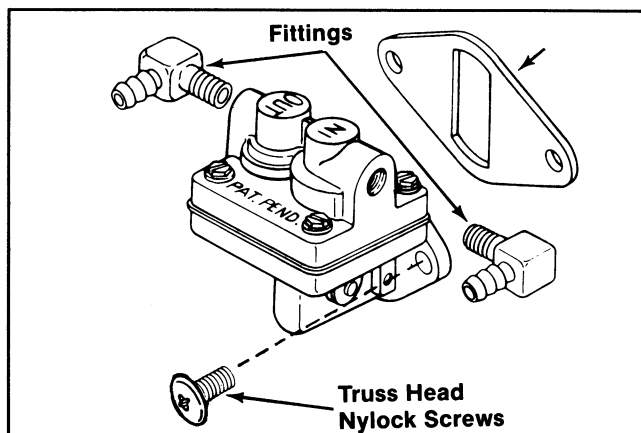

Figure 6A-4. Installing Fuel Pump.

1. **Fittings** – Apply a small amount of Permatex® Aviation Perm-A-Gasket (or equivalent) gasoline resistant thread sealant to fittings. Turn fittings into pump **6 full turns**; continue turning fittings in same direction until desired position is reached.
2. Install new gasket, fuel pump, and truss head nylock screws.

NOTE: Make sure the fuel pump lever is positioned above the camshaft. Damage to the fuel pump, and subsequent severe engine damage could result if the lever is positioned below the camshaft.

Torque screws to **40/45 in. lb.**

3. Connect fuel lines to inlet and outlet fittings.

CARBURETOR

This subsection covers the adjustment, disassembly, cleaning, inspection, repair, and reassembly of Kohler-built, side draft, adjustable jet carburetors.



WARNING: Explosive Fuel!

Gasoline may be present in the carburetor and fuel system. Gasoline is extremely flammable and its vapors can explode if ignited. Keep sparks, open flame and other sources of ignition away from engine. Wipe up spilled fuel immediately.

Adjustment

The carburetor is designed to deliver the correct fuel/air mixture to the engine under all operating conditions. Carburetors are set at the factory and normally do not need adjustment. If the engine exhibits conditions like those found in the table on page 6A.4, it may be necessary to adjust the carburetor.

Turning the adjusting needles **in** (clockwise) decreases the supply of fuel to the carburetor. This gives a **leaner** fuel/air mixture. Turning the adjusting needles **out** (counterclockwise) increases the supply of fuel to the carburetor. This gives a **richer** fuel/air mixture. Refer to Figures 6A-5 and 6A-6.

NOTE: Incorrect settings can cause a fouled spark plug, overheating, excessive valve wear, and other problems. To ensure correct settings, make sure the following adjustment procedures are used.

Make carburetor adjustments after the engine has warmed.

SECTION 6A FUEL SYSTEMS AND GOVERNORS

Condition	Possible Cause/Probable Solution
1. Black sooty exhaust smoke*, engine sluggish.	1. Main fuel mixture too rich. Turn main fuel adjusting needle in (clockwise).
2. Engine misses and backfires at high speed.	2. Main fuel mixture too lean. Turn main fuel adjusting needle out (counterclockwise).
3. Engine starts and then stops under cold weather conditions.	3. Main fuel mixture too lean. Turn main fuel adjusting needle out (counterclockwise).
4. Engine runs roughly or stalls at idle speed.	4. Idle speed too low or improper idle fuel mixture. Turn idle speed adjusting screw, then idle fuel adjusting needle.

* If black exhaust smoke is noted, check the air cleaner first. An apparent "over rich" mixture can actually be caused by a clogged air cleaner element. If after element is replaced, black smoke or other problems continue, adjust the carburetor immediately.

1. Stop the engine. Turn the main fuel and idle fuel adjusting needles **In** (clockwise) until they bottom *lightly*.

NOTE: The ends of the main fuel and idle fuel adjusting needles are tapered to critical dimensions. Damage to needles and seats will result if the needles are forced.

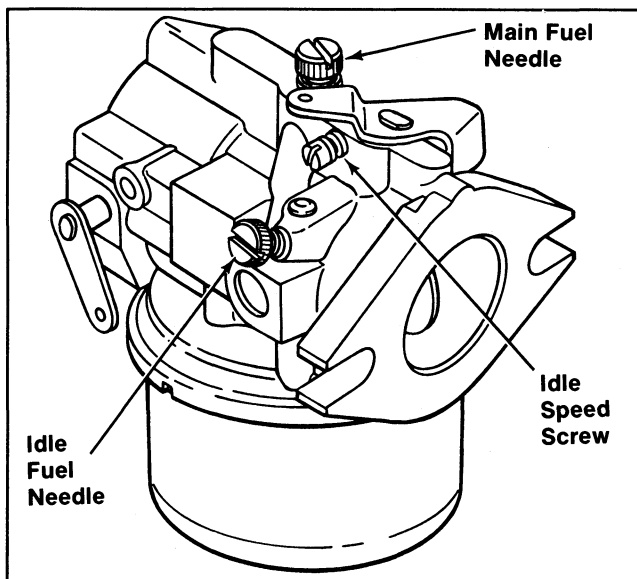

Figure 6A-5. Kohler-Built Adjustable Jet Carburetor.

2. **Preliminary Settings:** Turn the main fuel and idle fuel adjusting needles **out** (counterclockwise) from lightly bottomed as follows:

Main Fuel Needle	2-1/2 Turns
Idle Fuel Needle	1 Turn

3. Start the engine and run at half-throttle for 5-10 minutes to warm up. Engine must be warm before making final settings (Steps 4-6).
4. **Final Setting - Main Fuel:** Place throttle in wide open position; and if possible, place engine under load. Turn main fuel adjusting needle **out** (counterclockwise) from preliminary setting until the engine speed decreases (rich). Note the position of the needle.

Now turn the adjusting needle **In** (clockwise). The engine speed may increase, then it will decrease as the needle is turned in (lean). Note the position of the needle.

Set the adjusting needle **midway** between the rich and lean settings noted. Refer to Figure 6A-6.

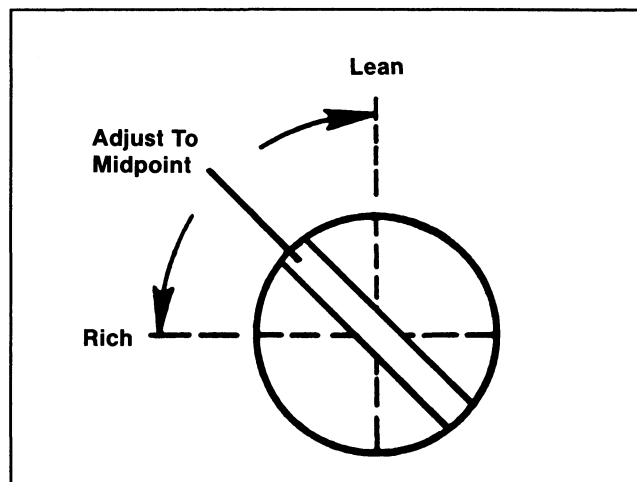

Figure 6A-6. Carburetor Adjustment.

SECTION 6A FUEL SYSTEMS AND GOVERNORS

5. **Final Setting - Idle Fuel:** Place throttle into idle or slow position. Set idle fuel adjusting needle using the same procedure as in Step 4.

NOTE: To ensure best results when setting idle fuel mixture, the idle speed must not exceed 1500 RPM. Typical idle speed is 1200* RPM. See Step 6.

6. **Idle Speed Setting:** Place throttle into idle or slow position. Set idle speed to 1200* RPM (+ or - 75 RPM) by turning the idle speed adjusting screw in or out.

*NOTE: The actual idle speed depends on the application. Refer to the equipment manufacturer's instructions for specific idle speed settings.

Disassembly

(Refer to Figure 6A-7.)

1. Remove the bowl retaining screw, retaining screw gasket, and fuel bowl.
2. Remove the float pin, float, fuel inlet needle, baffle gasket, and bowl gasket.
3. Remove the fuel inlet seat and inlet seat gasket. Remove the idle fuel and main fuel adjusting needles and springs. Remove the idle speed adjusting screw and spring.
4. Further disassembly to remove the throttle and choke shafts is recommended only if these parts are to be replaced. Refer to "Throttle And Choke Shaft Replacement."

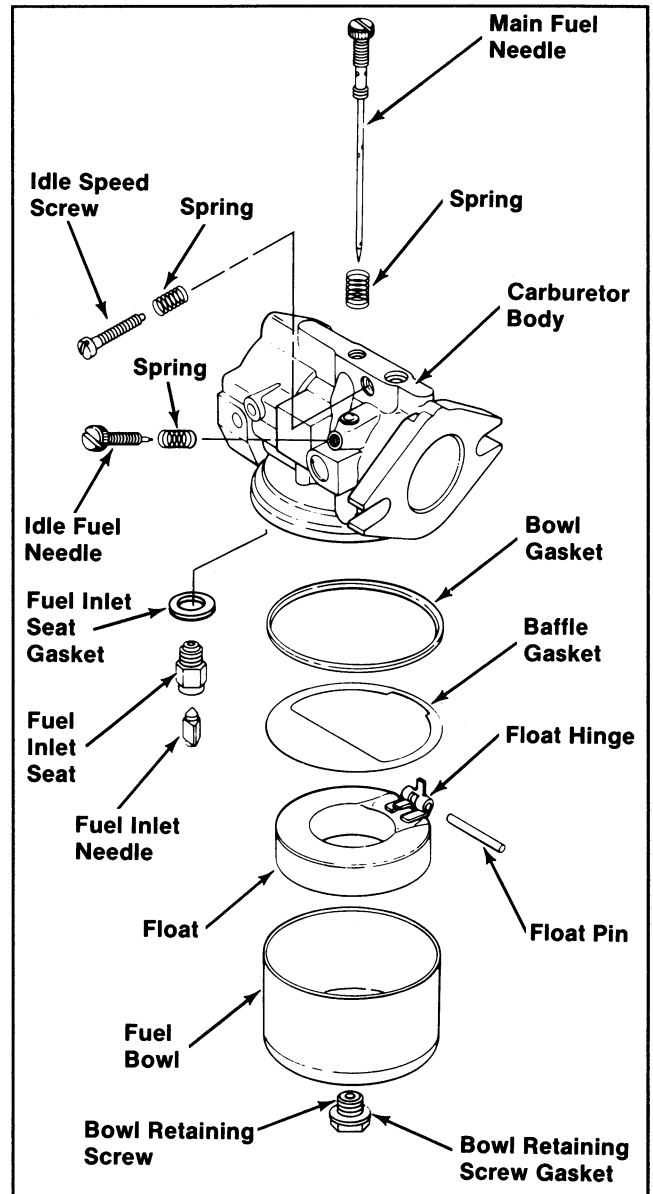

Figure 6A-7. Kohler-Built Adjustable Jet Carburetor - Exploded View.

Cleaning



WARNING: Flammable Solvents!

Carburetor cleaners and solvents are extremely flammable. Keep sparks, flames, and other sources of ignition away from area. Follow the cleaner manufacturer's warnings and instructions on its proper and safe use. Never use gasoline as a cleaning agent.

SECTION 6A

FUEL SYSTEMS AND GOVERNORS

All parts should be carefully cleaned using a carburetor cleaner (such as acetone). Be sure all gum deposits are removed from the following areas:

- **Carburetor body and bore;** especially the areas where throttle plate, choke plate and shafts are seated.
- **Float and float hinge.**
- **Fuel bowl.**
- **Idle fuel and "off-idle" ports in carburetor bore, ports in main fuel adjusting needle, and main fuel seat.** (Note: these areas can be cleaned using piece of fine wire in addition to cleaners. Be careful not to enlarge the ports, or break the cleaning wire within ports.)

Blow out all passages with compressed air.

NOTE: Do not submerge carburetor in cleaner or solvent when fiber and rubber seals are installed. The cleaner may damage these seals.

Inspection

Carefully inspect all components and replace those that are worn or damaged.

- Inspect the carburetor body for cracks, holes, and other wear or damage.
- Inspect the float for dents or holes. Check the float hinge for wear, and missing or damaged float tabs.
- Inspect the inlet needle and seat for wear or grooves.
- Inspect the tips of the main fuel and idle fuel adjusting needles for wear or grooves.
- Inspect the throttle and choke shaft and plate assemblies for wear or excessive play.

CARBURETOR REPAIRS

Always use new gaskets when repairing and reinstalling a carburetor. The following covers the kits available for reconditioning the Kohler-built 1" venturi size gasoline fuel carburetors used on the M18 & M20 engines. Three repair kits, one Choke and one Throttle Shaft Replacement Kits are now available. (Refer to Figure 6A-7 for components described in the following.)

Carburetor Repair Kits No. 25 757 01 and No. 25 757 02 Contains:

These kits include all gaskets and fuel inlet components generally used in reconditioning a Kohler-built 1" carburetor. Kit No. 25 757 01 is for basic carburetors while 25 757 02 is used for carburetors with float dampening springs.

Qty.	Description
1	Gasket, bowl retaining screw
1	Gasket, bowl ring
1	Gasket, baffle
1	Gasket, fuel inlet seat
1	Needle and Seat, fuel inlet
1	Pin, float hinge

Float Repair Kit No. 25 757 03 Contains:

Use this kit to replace damaged or leaking floats on all Kohler-built 1" carburetors.

Qty.	Description
1	Float Assembly
1	Gasket, baffle

Choke Shaft Replacement Kit No. 25 757 21

This kit is used to replace worn or damaged choke shaft assemblies. Each kit contains installation instructions and the following components.

Qty.	Description
1	Gasket, bowl retaining screw
1	Gasket, bowl ring
1	Gasket, baffle
1	Spring, choke shaft
1	Ball, choke shaft
1	Screw, slotted head machine
1	Shaft, choke
2	Bushings, choke shaft
1	Sealer, Loctite® No. 609
3	Screw, slotted bind head

SECTION 6A FUEL SYSTEMS AND GOVERNORS

Throttle Shaft Replacement Kits 25 757 14, 25 757 15, 25 757 16 and 25 757 17

To determine which kit to use, measure the throttle shaft being replaced and select the shaft with corresponding dimensions shown in the chart below. Each kit contains installation instructions and the following.

Qty.	Description
1	Gasket, bowl retaining screw
1	Gasket, bowl ring
1	Gasket, baffle
1	Screw, slotted head machine
1	Shaft, throttle
1	Bushing, throttle shaft
1	Sealer, Loctite® No. 609
3	Screw, slotted bind head
1	Spacer X-400-80

CHART THROTTLE SHAFT REPLACEMENT KIT SELECTION

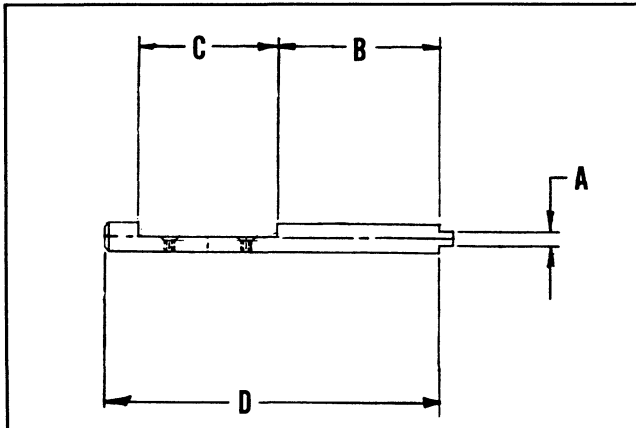

1" Throttle Shaft Kit Numbers	Dimensions			
	A	B	C	D
25 757 14	.104"	.619"	1.227"	2.164"
25 757 15	.104"	1.416"	1.289"	3.00"
25 757 16	.104"	1.447"	1.227"	3.00"
25 757 17	.122"	1.073"	1.227"	2.66"

To Replace Throttle and Choke Shafts--



WARNING: Prevent Eye Injury!

Suitable eye protection (safety glasses, goggles, or face hood) should be worn for any procedure involving the use of compressed air, punches, hammers, chisels, drills, or grinding tools.

Disassemble Carburetor

Refer to "Disassembly" Steps 1-3.

Remove Choke Plate and Choke Shaft; Transfer Choke Lever

1. To ensure correct reassembly, mark choke plate and carburetor body with a marking pen. Also take note of choke plate position in bore, and choke lever position.
2. *Carefully and slowly* remove the screws securing choke plate to choke shaft. Remove and save the choke plate as it will be reused.
3. File off any burrs which may have been left on choke shaft when screws were removed. Place carburetor on workbench with choke side down. Remove choke shaft; the detent ball and spring will drop out.
4. Note the position of the choke lever with respect to the cutout portion of choke shaft.
5. Carefully grind or file away the riveted portion of shaft. Remove and save choke lever; discard old choke shaft.
6. Install choke lever to new choke shaft from kit. Make sure lever is installed correctly as noted in Step 5. Apply Loctite® to threads of (1) #3-48 x 7/32" brass screw; secure lever to shaft.

SECTION 6A FUEL SYSTEMS AND GOVERNORS

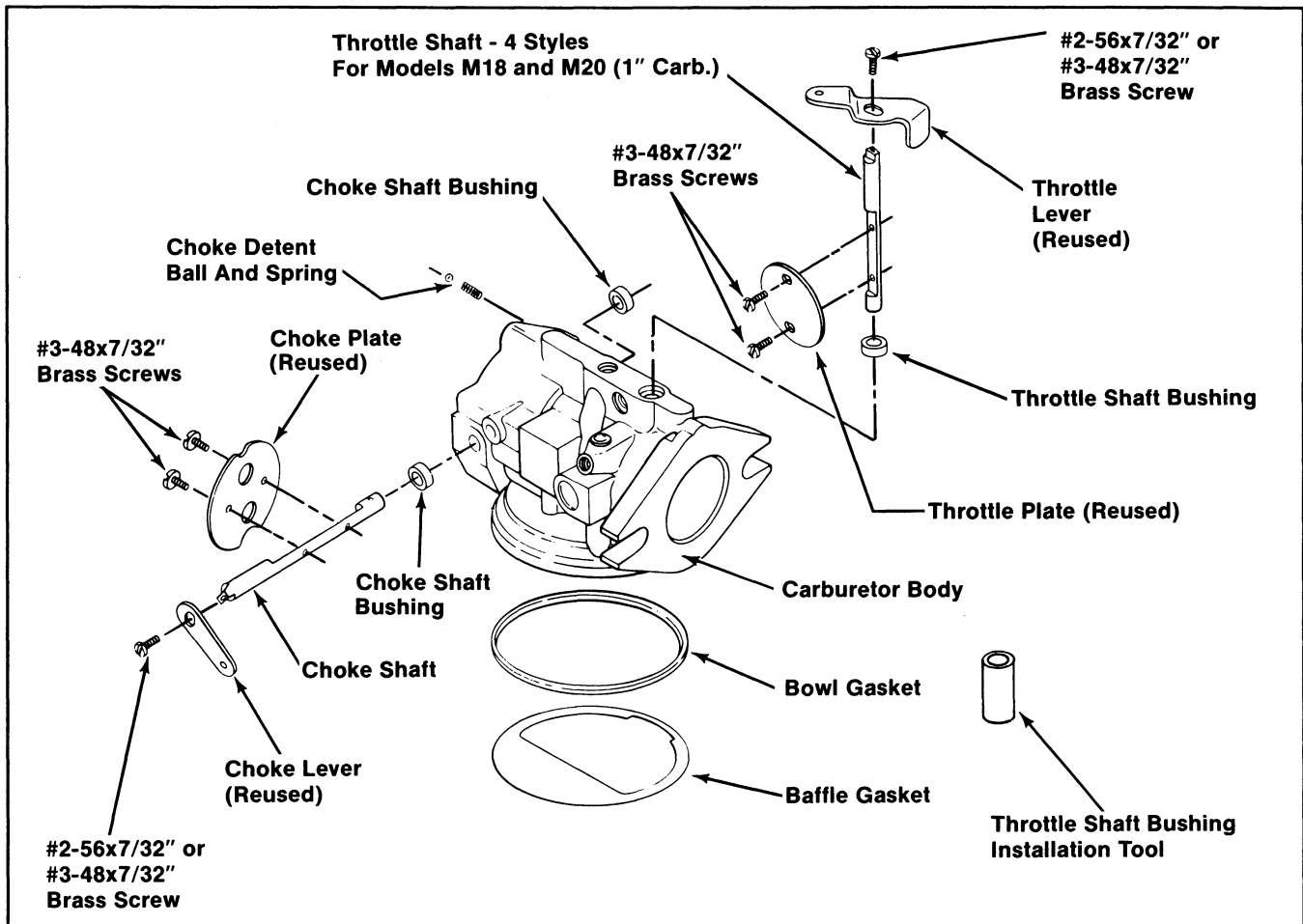

Figure 6A-8. Throttle and Choke Shaft Replacement Kits.

Remove Throttle Plate and Throttle Shaft; Transfer Throttle Lever

1. To ensure correct reassembly, mark throttle plate and carburetor body with a marking pen. Also take note of throttle plate position in bore, and throttle lever position.
2. *Carefully and slowly* remove the screws securing the throttle plate to throttle shaft. Remove and save the throttle plate as it will be reused.
3. File off any burrs which may have been left on throttle shaft when screws were removed.
4. Remove the throttle shaft from carburetor body. Remove and discard the foam rubber dust seal from throttle shaft.

5. Remove/transfer throttle lever as follows:

- a. Note the position of the throttle lever with respect to the cutout portion of throttle shaft.
- b. Carefully grind or file away the riveted portion of shaft; remove throttle lever.
- c. Carefully compare the old shaft to the new shafts from kit. Select the appropriate new shaft and discard the old shaft.
- d. Install throttle lever to throttle shaft. Make sure lever is installed correctly as noted in Step a.
- e. Apply Loctite® to threads of (1) #2-56 x 7/32" brass screw (use #3-48 x 7/32" screw with 2-49/64" shaft); secure lever to shaft.

Drill Choke Shaft Bores Using a Drill Press

1. Mount the carburetor body in a drill press vise. Keep vise slightly loose.
2. Install a 1/4" dia. drill in drill press chuck. Lower drill (not rotating) through both choke shaft bores; then tighten vise. This ensures the carburetor body and drill are perpendicular and in correct alignment. Refer to Figure 6A-9.

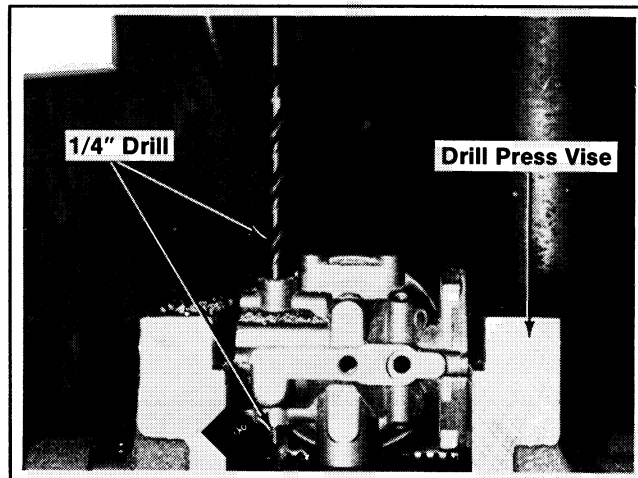

Figure 6A-9. Aligning/Drilling Carburetor Body.

3. Install a 19/64" dia. drill a chuck. Set drill press speed to a low speed suitable for aluminum. Feed drill slowly to obtain a good finish to holes.
4. Ream the choke shaft bores to a final size of 5/16". For best results use a piloted 5/16" reamer.
5. Blow out all metal chips using compressed air. Thoroughly clean the carburetor body in a carburetor cleaner.

Install Choke Shaft Bearings

1. Install screws into the tapped holes that enter the choke shaft bores until the screws bottom *lightly*. Refer to Figure 6A-10.

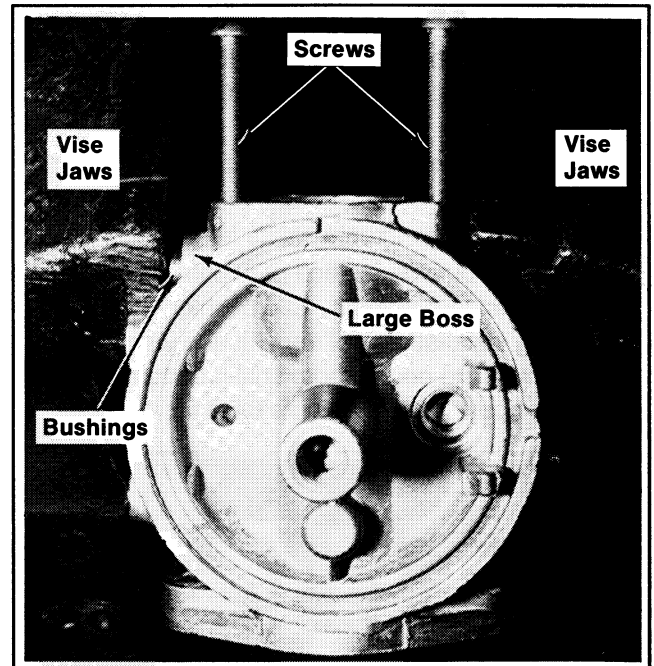

Figure 6A-10. Installing Choke Shaft Bushings.

2. Coat the outside surface of choke shaft bushings with Loctite® from kit. Carefully press bushings into carburetor body using a smooth-jawed vise. Stop pressing when bushings bottom against screws.
3. Allow Loctite® to "set" for 5-10 minutes then remove screws.
4. Install new choke shaft in bushings. Rotate shaft and check for binding.

NOTE: If binding occurs, locate and correct the cause before proceeding. Use choke shaft to align bushings if necessary.

5. Remove choke shaft and allow Loctite® to "set" for an additional 30 minutes before proceeding.
6. Wipe away all excess Loctite® from bushings and choke shaft.

SECTION 6A

FUEL SYSTEMS AND GOVERNORS

Install Throttle Shaft Bushing

1. Make sure the dust seal counterbore in carburetor body is thoroughly clean and free of chips and burrs.
2. Install a throttle shaft (without throttle lever) into carburetor body to use as a pilot. (Use one of the remaining new throttle shafts from kit.)
3. Coat the outside surface of throttle shaft bushing with Loctite® from kit. Slip bushing over shaft. Using installation tool from kit and vise, press bushing into counterbore until it bottoms in carburetor body. Refer to Figure 6A-11.

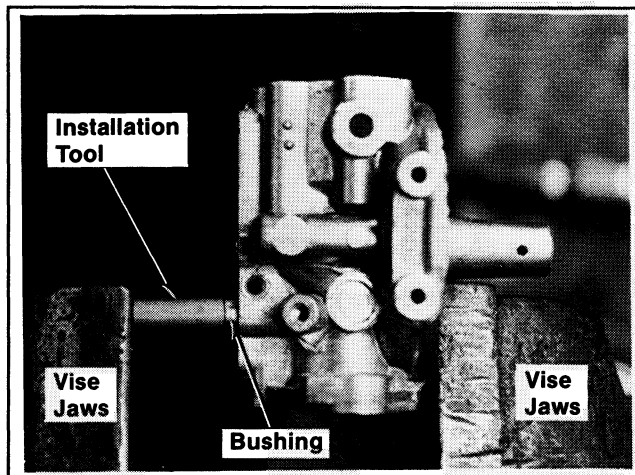

Figure 6A-11. Installing Throttle Shaft Bushings.

4. Allow Loctite® to “set” for 5–10 minutes then remove throttle shaft.
5. Install new throttle shaft with lever into carburetor body. Rotate shaft and check for binding.
NOTE: If binding occurs, locate cause and correct before proceeding. Use throttle shaft to align bushing if necessary.
6. Remove shaft and allow Loctite® to “set” for an additional 30 minutes before proceeding.
7. Wipe away all excess Loctite® from bushing and throttle shaft.

Install Detent Spring and Ball, Choke Shaft, and Choke Plate

1. Install new detent spring and ball into carburetor body in the side opposite choke lever.
2. Compress detent ball and spring and insert choke shaft through bushings. Make sure the choke lever is on the correct side of carburetor body. Refer to Figure 6A-12.

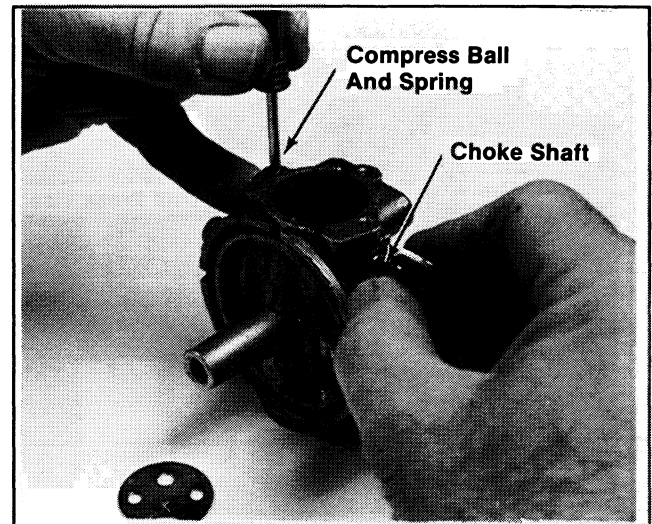

Figure 6A-12. Installing Choke Shaft.

3. Install choke plate to choke shaft. Make sure marks are aligned and plate is positioned properly in bore. Apply Loctite® to threads of (2) #3–48 x 7/32” screws. Install screws so they are slightly loose.
4. Operate choke lever. Check for binding between choke plate and carburetor bore. Loosen screws and adjust plate as necessary; then tighten screws securely.

Install Throttle Shaft And Throttle Plate

1. Install throttle shaft into carburetor with cutout portion of shaft facing out.
2. Install throttle plate to throttle shaft. Make sure marks are aligned and plate is positioned properly in bore. Apply Loctite® to threads of (2) #3–48 x 7/32” screws. Install screws so they are slightly loose.
3. Apply finger pressure to throttle shaft to keep it firmly seated against pivot in carburetor body. Rotate the throttle shaft until throttle plate fully closes the bore around its entire perimeter; then tighten screws.

SECTION 6A

FUEL SYSTEMS AND GOVERNORS

- Operate the throttle lever and check for binding between the throttle plate and carburetor bore. Loosen screws and adjust plate as necessary; then tighten screws securely.

Reassemble Carburetor

Refer to the following "Reassembly" portion of this section.

Reassembly

- Install the fuel inlet seat gasket and fuel inlet seat into carburetor body. Torque seat to **35/45 in. lb.**
- Install the fuel inlet needle into inlet seat. Install float and slide float pin through float hinge and float hinge towers on carburetor body.
- Set float level:** Invert carburetor so the float tab rests on the fuel inlet needle. There should be **11/64"** (+ or - 1/32") clearance between the machined surface of body and the free end of float. Bend the float tab with a small screwdriver to adjust. Refer to Figure 6A-13.

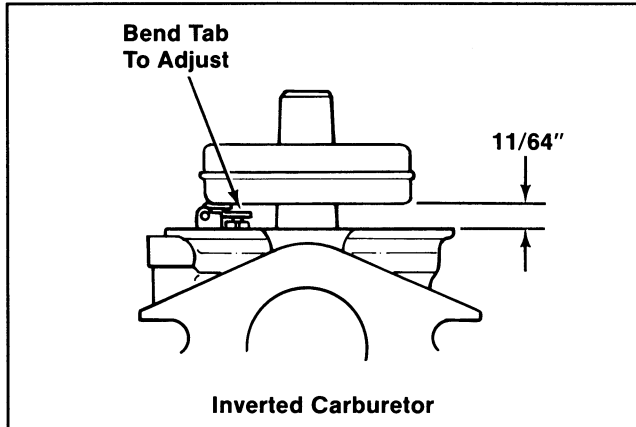

Figure 6A-13. Setting Float Level.

- Set float drop:** Turn the carburetor over to its normal operating position and allow float to drop to its lowest level. The float drop should be limited to **1-1/32"** between the machined surface of body and the bottom of the free end of float. Bend the float tab with a small screwdriver to adjust. Refer to Figure 6A-14.

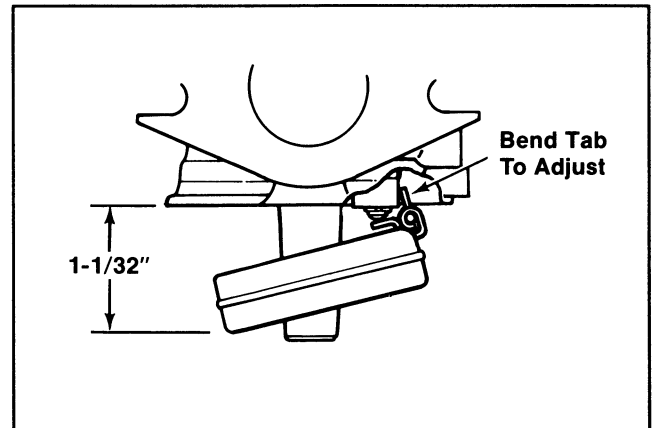

Figure 6A-14. Setting Float Drop.

- Check float to float hinge tower clearance:** Invert the carburetor so the float tab rests on the fuel inlet needle. Insert a **.010"** feeler gauge between float and float hinge towers. If the feeler gauge cannot be inserted, or there is interference between the float and towers, file the towers to obtain the proper clearance. Refer to Figure 6A-15.

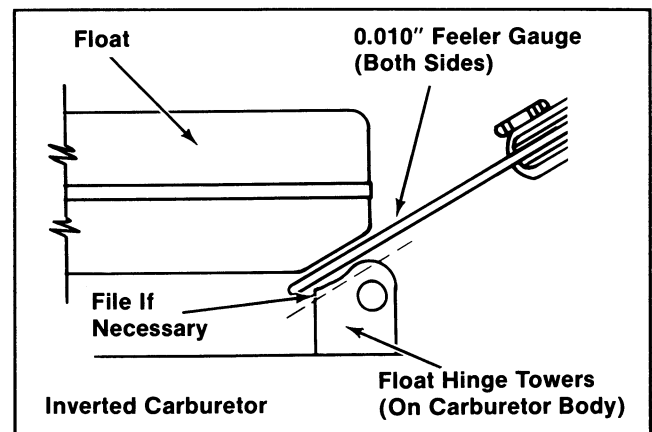

Figure 6A-15. Checking Float Clearance.

- Install the bowl gasket and baffle gasket. Position baffle gasket so the inner edge is against the float hinge towers.
- Install the fuel bowl so it is centered on the baffle gasket. Make sure the baffle gasket and bowl are positioned properly to ensure a good seal.
- Install the bowl retaining screw gasket and bowl retaining screw. Torque screw to **50/60 in. lb.**

SECTION 6A

FUEL SYSTEMS AND GOVERNORS

9. Install the idle speed adjusting screw and spring. Install the idle fuel and main fuel adjusting needles and springs. Turn the adjusting needles clockwise until they bottom *lightly*.

NOTE: The ends of adjusting needles are tapered to critical dimensions. Damage to needles and seats will result if needles are forced.

10. Reinstall the carburetor to the engine using a new gasket.
11. Adjust the carburetor as outlined under the "Adjustment" portion of this section.

GOVERNOR

Magnum engines are equipped with a centrifugal flyweight mechanical governor. It is designed to hold the engine speed constant under changing load conditions. The governor gear/flyweight mechanism is mounted within the crankcase and is driven off the gear on the camshaft. Refer to Figure 6A-16.

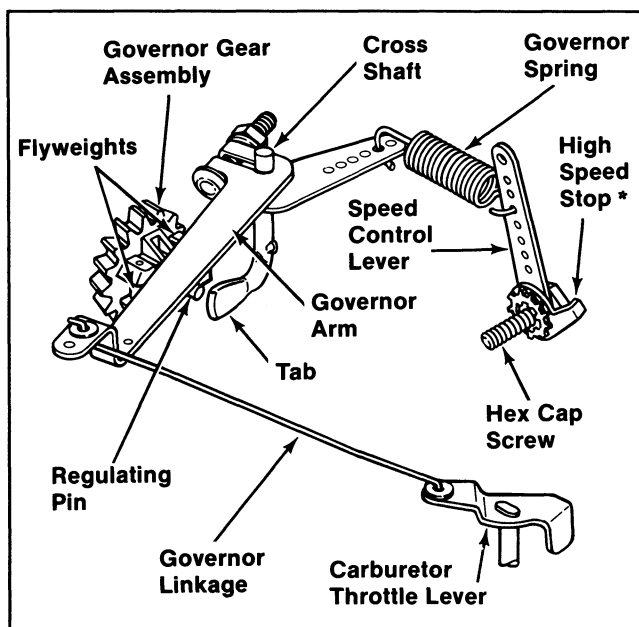

Figure 6A-16. Centrifugal Flyweight Mechanical Governor.

*NOTE: Earlier models only – later use bracket as shown in Figure 6A-19.

Operation

Centrifugal force acting on the rotating governor gear assembly causes the flyweights to move outward as speed increases and inward as speed decreases. As the flyweights move outward they force the regulating pin of the assembly to move outward. The regulating pin contacts the tab on the cross shaft, causing the shaft to rotate with changing speed. One end of the cross shaft protrudes through the top of the crankcase. Through external linkage attached to the cross shaft, the rotating action is transmitted to the throttle plate of carburetor.

When the engine is at rest and the throttle is in the "fast" position, the tension of the governor spring holds the throttle valve open. When the engine is operating (governor gear assembly is rotating), the force applied by the regulating pin against the cross shaft tends to close the throttle valve. The governor spring tension and the force applied by the regulating pin are in "equilibrium" during operation, holding the engine speed constant.

When a load is applied and the engine speed (and governor speed) decreases, the governor spring tension moves the governor arm to open the throttle plate wider. This admits more fuel and restores engine speed. (This action takes place very rapidly, so a reduction in speed is hardly noticed.) As the speed reaches the governed setting, the governor spring tension and the force applied by the regulating pin will again be in equilibrium. This maintains engine speed at a relatively constant level.

Governed speed may be at a fixed point as on constant speed applications, or variable as determined by a throttle control lever.

Adjustment



WARNING: Overspeed Is Hazardous!

The maximum allowable speed for these engines is 3600 RPM, no load. Never tamper with the governor settings to increase the maximum speed. Severe personal injury and damage to the engine or equipment can result if operated at speeds above maximum.

SECTION 6A

FUEL SYSTEMS AND GOVERNORS

INITIAL ADJUSTMENT

Make this initial adjustment whenever the governor arm is loosened or removed from cross shaft. Make sure the throttle linkage is connected to governor arm and throttle lever on carburetor to ensure proper setting. Refer to Figure 6A-17.

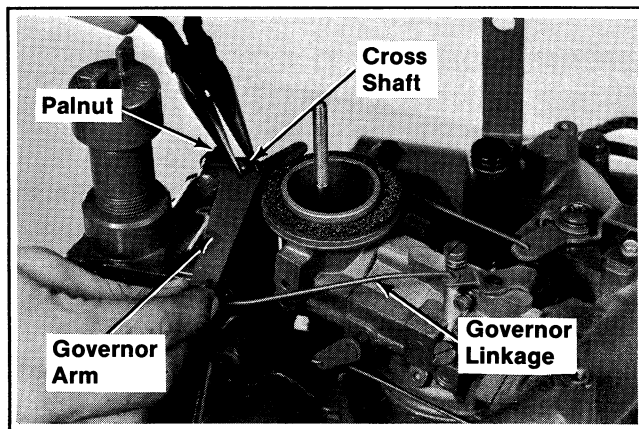

Figure 6A-17. Initial Governor Adjustment.

1. Pull the governor arm away from the carburetor as far as it will go.
2. Grasp the end of cross shaft with pliers and turn clockwise as far as it will go.
3. Tighten the palnut on governor arm to 15 in. lb. torque.

HIGH SPEED ADJUSTMENT

The maximum allowable speed is 3600 RPM, no load. The actual high speed setting depends on the application. Refer to the equipment manufacturer's instructions for specific high speed settings. Check the operating speed with a tachometer; do not exceed the maximum. To adjust high speed stop:

For Remote Throttle Control (Early Tab Version)

NOTE: High Speed Stop Tab as shown in Figure 6A-18 used only on earlier models. Later models all use high speed stop bracket as shown in Figure 6A-19. If engine involved has bracket type, adjust high speed following instructions for Engine Mounted Throttle Control.

1. Loosen the hex. cap screw securing high speed stop tab to intake elbow. Refer to Figure 6A-18.

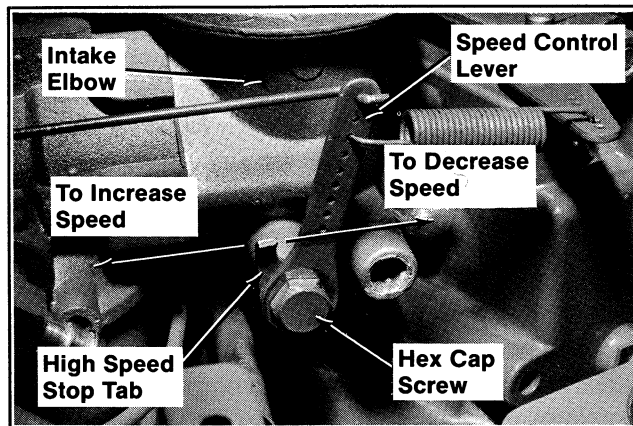

Figure 6A-18. High Speed Adjustment - Remote Throttle Control (Early Tab Version).

2. Pivot the high speed stop tab until the desired speed is reached.
3. Tighten the hex. cap screw tightly.

For Engine Mounted Throttle Control (and Later Remote with Stop Bracket)

1. Loosen the hex. cap screw securing the high speed stop bracket to intake elbow. Refer to Figure 6A-19.

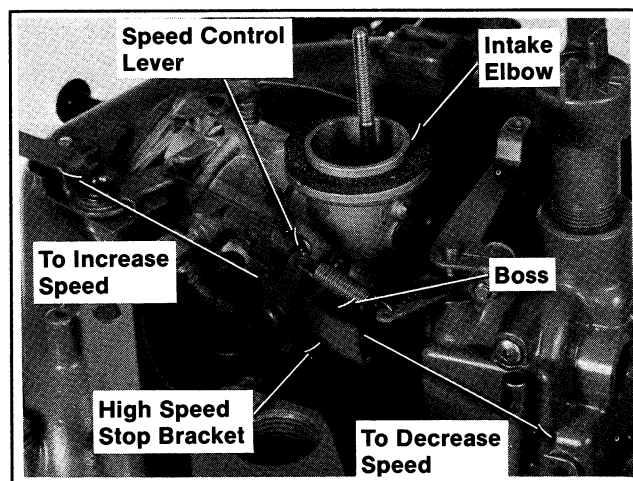

Figure 6A-19. High Speed Adjustment - Engine Mounted Throttle Control (and Later Remote Mounted).

2. Slide bracket until the desired speed is reached.
3. Make sure the bracket is resting against boss on intake elbow and tighten hex. cap screw securely. Recheck the speed with the tachometer; readjust if necessary.

SECTION 6A

FUEL SYSTEMS AND GOVERNORS

SENSITIVITY ADJUSTMENT

Governor sensitivity is adjusted by repositioning the governor spring in the holes in governor arm. If set too sensitive, speed surging will occur with a change in load. If a big drop in speed occurs when normal load is applied, the governor should be set for greater sensitivity.

The standard spring position is in the **fifth** hole from cross shaft in **governor arm**, and in the **sixth** hole from hex. cap screw in **speed control lever**. The positions can vary, depending on the engine application. Therefore, make a note of (or mark) the spring positions before removing it from the governor arm and speed control lever. Refer to Figure 6A-20.

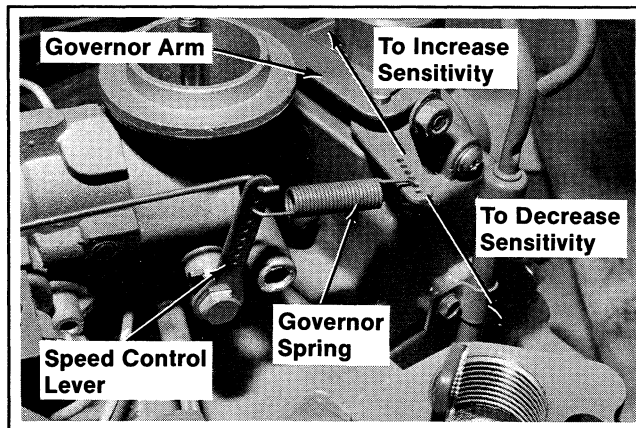

Figure 6A-20. Governor Sensitivity Adjustment.

To increase sensitivity, increase the governor spring tension by moving the spring in governor arm towards the cross shaft.

To decrease sensitivity, and allow broader control, decrease spring tension by moving the spring in governor arm away from the cross shaft.

ENGINE MOUNTED THROTTLE AND CHOKE CONTROLS

Some M18 and M20 engines are equipped with throttle and choke controls mounted to the intake manifold. Refer to Figure 6A-21.

DISASSEMBLY

1. Remove the intake manifold/carburetor from engine.
2. Remove the truss head nylock screw, spring washer, locking tab, friction washers, and throttle control lever. Disconnect throttle linkage from speed control lever on intake elbow.
3. Remove the self-tapping screw and throttle stop plate from intake manifold.
4. Remove the hex. cap screw, speed control lever, high speed stop tab, and high speed stop bracket from intake elbow.

SECTION 6A FUEL SYSTEMS AND GOVERNORS

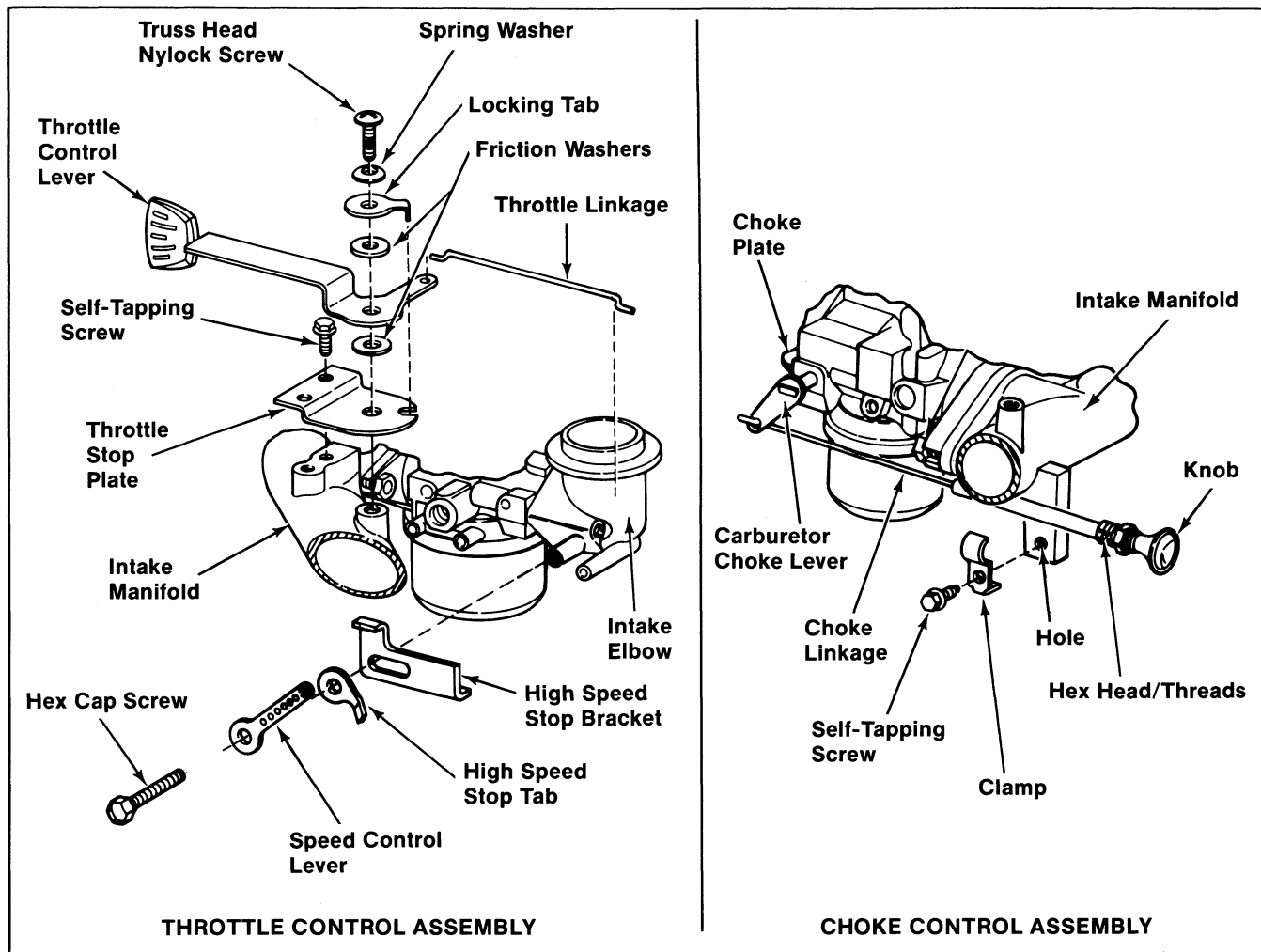

Figure 6A-21. Engine Mounted Throttle and Choke Controls.

5. Remove the self-tapping screw and clamp securing choke control assembly to intake manifold. Disconnect choke linkage from choke lever on carburetor.

Reassembly

1. Install the high speed stop bracket, high speed stop tab, speed control lever, and hex. cap screw to intake elbow.
Make sure the high speed stop tab does not interfere with the movement of the speed control lever. The high speed stop tab is used as a pivot only.
2. Install the throttle stop plate and self-tapping screw to intake manifold.
3. Connect the throttle linkage to throttle control lever and speed control lever.

4. Install the friction washers, throttle control lever, locking tab, spring washer, and truss head nylock screw. Make sure locking tab is positioned in the hole in throttle stop plate.

Tighten the nylock screw enough to hold throttle lever in position while the engine is running. Do not overtighten the screw--the lever must operate smoothly.

5. Connect the choke linkage to choke lever on carburetor. Loosely install choke control assembly to intake manifold with clamp and self-tapping screw.
6. Adjust Choke Control--Make sure the choke knob is held against the hex. head/threads. Move the assembly towards carburetor until the choke plate is wide open. Tighten the self-tapping screw securely.

SECTION 6A FUEL SYSTEMS AND GOVERNORS

OPTIONAL AUTOMATIC CHOKE AND SHUTDOWN CONTROL

Some Magnum twins on may be equipped with an optional Thermo-Electric Automatic Choke, and with a Fuel Shutdown Control.

Automatic Choke Function

The choke is an integral part of the carburetor. The choke will close automatically from ambient air. Upon starting, the engine vacuum will partially open the choke. The bi-metal spring in the choke is electrically connected to the rectifier-regulator and the current flowing through the bi-metal spring will heat to a point that the choke will open fully.

Automatic Choke Adjustment

The choke unit (Figure 6A-22) is set at the factory for average conditions. To readjust for local conditions, loosen the cover retaining screws and shift the cover

in clockwise direction for richer setting or counter-clockwise direction for leaner setting. Tighten the cover retainer screws.

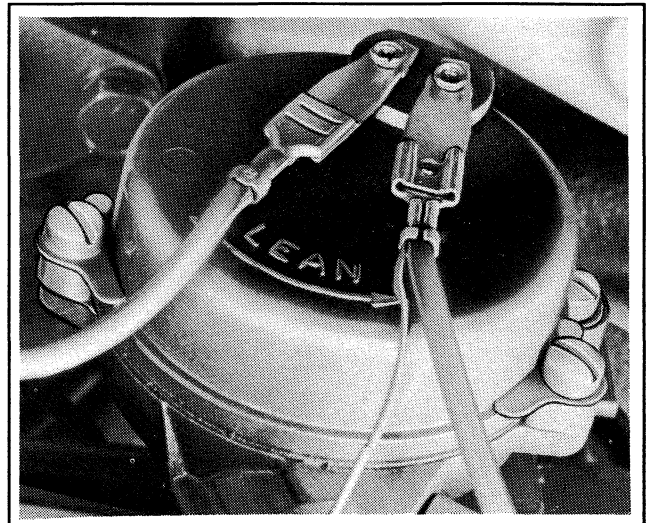

Figure 6A-22. Automatic Choke.

Automatic Choke Service Guide

Problem	Causes	Solutions
Choke Won't Close When Cranking	Faulty lead to choke.	1. Check for secure lead connections. 2. Make continually check on lead. Replace if no continuity.
	Faulty lead to ground.	1. Check for secure lead connections. 2. Make continuity check on lead. Replace if no continuity.
	1. Poor adjustment. 2. Choke shaft binds - varnish.	1. Adjust choke. 2. Repair with kit or replace choke. 3. Wash with carburetor cleaner.
Choke Will Not Fully Open	1. Poor adjustment. 2. Faulty choke.	1. Adjust choke. 2. Repair with kit or replace choke.

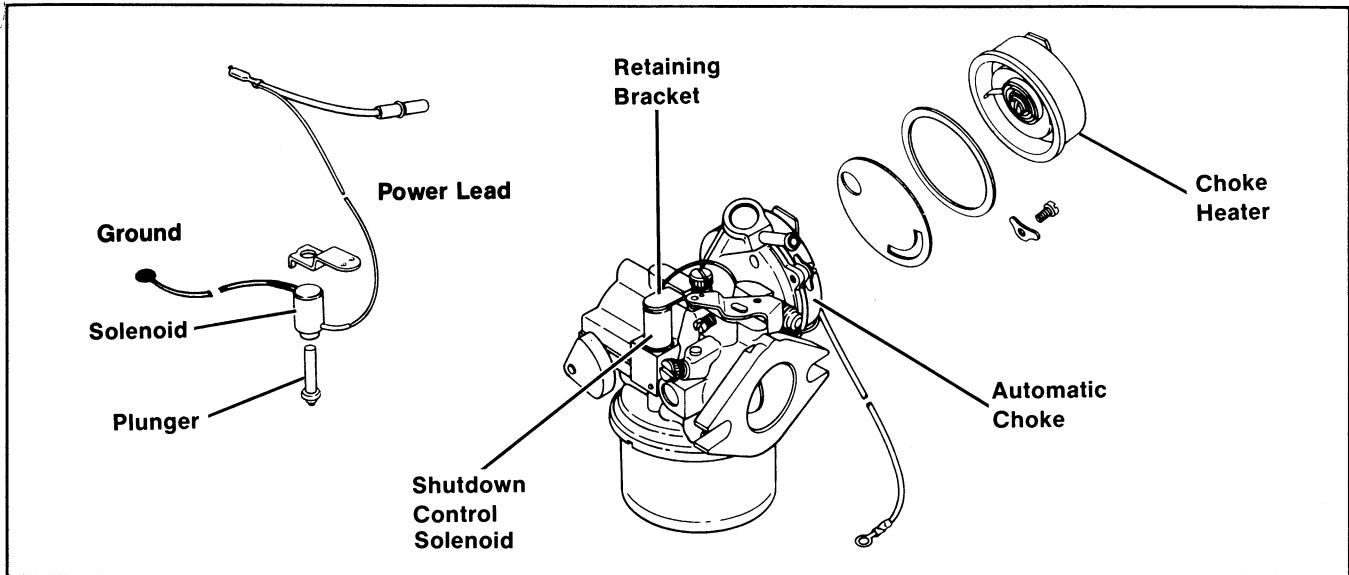

Figure 6A-23. Engine Shutdown Control and Automatic Choke.

Automatic Choke Inspection

1. Disconnect the high tension leads from spark plugs so the engine will not start.
2. Remove the air cleaner cover, element and base.
3. Turn the start switch to the start position and hold for five seconds. The choke should fully close and release when the start switch is released.
4. If the choke does not function properly (Step 3) see Service Guide on previous page.

Automatic Choke Service

Choke Unit Replacement (see Figure 6A-23)

1. Position the choke unit on the two mounting screws so that it is slightly loose.
2. Rotate the choke unit clockwise on the carburetor (viewed from the choke side) with a slight pressure until the choke valve is positioned 4 to 6 degrees towards the closed position.
3. While holding the choke unit in the above position, tighten the two mounting screws.
4. This adjustment must be accomplished at an ambient temperature of 70–75°F.

Shutdown Control Function

The engine shutdown control device is a solenoid and plunger mounted on the carburetor which prevents the engine from “running on” after the ignition is turned off. See Figure 6A-23. When the switch is in the start position, battery current thru the solenoid holds the

plunger and continues to hold it while the engine is running. When the switch is moved to the stop position the solenoid de-energizes and drops the plunger into a porting in the carburetor to stop all flow of fuel.

The engine shutdown control has two lead wires on it—a ground lead from the top of the shutdown solenoid and a power lead from the bottom of the solenoid. The power lead is wired into the (+) side of the rectifier-regulator.

Shutdown Control Inspection

1. Make sure the solenoid has a secure electrical connection and good contact with the retaining bracket (ground).
2. Check for stuck plunger. Replace if damaged.
3. Check for defective solenoid with an ohmmeter or multimeter. Solenoid resistance is approximately 20 ohms.

Shutdown Control Test

Refer to Figure 6A-23 for identification of parts.

1. Remove shutdown control (solenoid and plunger) from carburetor body by loosening the screw so the retaining bracket holding the control can be shifted. Do not disconnect the lead wires.
2. Pull the shutdown control out of the carburetor.
3. Hold the plunger approximately 1/4” away from the solenoid. Turn the ignition switch to “ON” and release the plunger.

SECTION 6A FUEL SYSTEMS AND GOVERNORS

If the plunger is drawn into the solenoid, the shutdown control is functioning properly.

If the plunger is not drawn into the solenoid, the solenoid is faulty and must be replaced.

As a temporary fix, until a replacement solenoid can be obtained, the plunger can be removed from the shutdown control and the solenoid reinstalled minus the plunger.*

After replacing solenoid, refer to Section 6A for carburetor adjustment.

*The removal of the plunger will not affect normal carburetor function; however, to prevent unfiltered air from entering the carburetor, the defective solenoid must be reinstalled over shutdown control vent hole, after the plunger has been removed.

ENGINES EQUIPPED FOR DUAL FUEL

Hard starting and low power on units equipped for dual fuel (gasoline/LPG) have been traced to two causes:

1. Improper size venturi
2. Improper adjustments to regulator and adapter.

The following changes and/or adjustments must be made to the unit to assure proper performance.

NOTE: When switching from gasoline to LPG make sure that gasoline supply has been tuned off and that all gasoline is vacated from the float bowl and fuel lines by running the engine out of gasoline.

1. Check venturi size of adapter.
 - a. If adapter is equipped with no. 26 size venturi, move on to adjustment procedure.
 - b. If the adapter is equipped with a no. 20 size venturi, (see Figure 6A-24) remove no. 20 venturi and replace with no. 26 size venturi.

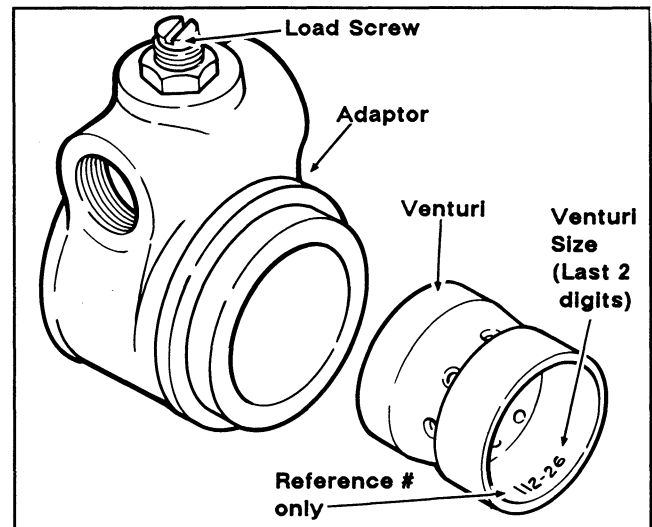

Figure 6A-24. Venturi Identification.

2. Check and make adjustments to regulator and adapter.
 - a. Before starting engine, set the mixture load screw at the adapter 1-1/2 turns out from closed.
 - b. If engine is equipped with Century brand regulator/vaporizer, no idle adjustment is necessary. Move to Step C. If equipped with Beam model 50 or 50E secondary regulator, proceed as follows:

Start engine, with engine running, manually hold throttle against idle stop screw. Confirm that engine is running at or below 1500 RPM with tachometer.

Turn the idle mixture screw located on secondary regulator **IN** toward the rich side until RPM drops. (This should be confirmed with a tachometer.) Then turn screw **OUT** toward the lean side until engine RPM recovers and again, begins to fall off. At this point, again turn the screw **IN** just until the engine reaches top RPM and stop.

NOTE: Setting the idle mixture screw halfway between the two ranges will cause a rich mixture setting.

SECTION 6A FUEL SYSTEMS AND GOVERNORS

- c. Increase engine RPM to the high speed setting of 3600. Apply a load and adjust the high speed mixture screw at the adapter (see Figure 6A-24), as follows:

Turn high speed mixture screw **OUT** toward the rich side until engine RPM drops (this should be confirmed with tachometer). Then turn screw **IN** toward lead side until engine RPM recovers and begins to fall off. At this point, again turn the screw **OUT** just until engine reaches top RPM and stop.

If this procedure is used correctly, the unit will now be adjusted to **LEAN BEST POWER**.

- d. When using a dual fuel adapter with a gasoline carburetor, the gasoline carburetor mixture setting will need to be adjusted from that of the factory.

LPG CARBURETOR

Some M18 & M20 Engines are equipped with Kohler-built Liquid Propane Gas (LPG) carburetors as shown in Figure 6A-25. On applications using this carburetor, the equipment manufacturer furnishes the regulators, fuel tank and other LPG system components.

Use the part number stamped on the body of the carburetor for ordering the correct replacement components for the carburetor involved as listed in the M18 & M20 parts manual.

The Venturi, fuel inlet fitting, adjusting needles, screws and springs can be replaced on these carburetors however the throttle shaft/lever assembly is non-serviceable. If the shaft or bore become worn or damaged, the carburetor will have to be replaced.

If starting or performance problems occur, check the air cleaner first and service LPG system components following instructions provided by the equipment manufacturer. If carburetor readjustment is indicated, stop the engine and reset the needle adjusting screws to the initial settings shown in Figure 6A-25 then restart the engine, allow it to warm up and make final adjustments on regulators and/or carburetor to achieve best performance.

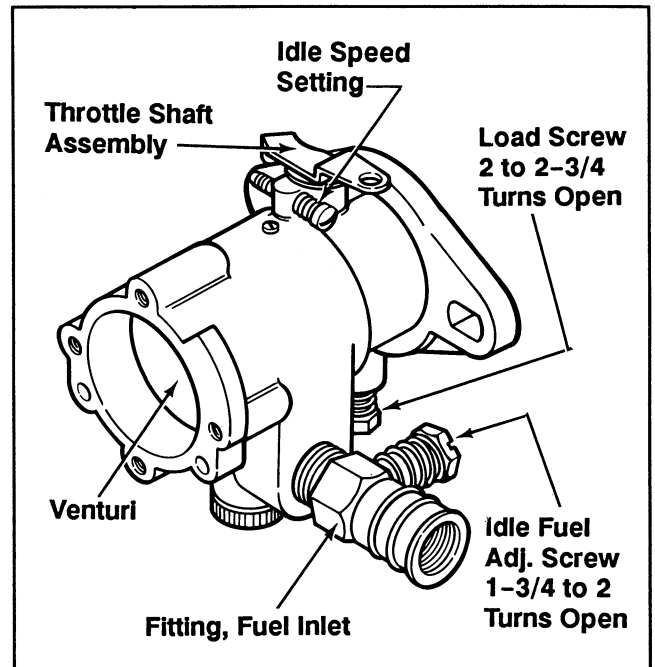

Figure 6A-25. Kohler LPG Carburetor.

**SECTION 6A
FUEL SYSTEMS AND GOVERNORS**

SECTION 6B FUEL SYSTEMS

CARBURETOR SERVICE (WALBRO-BUILT)

Two types of Walbro carburetors are used on the Magnum M18 & M20 engines. One is the fixed main jet type while the other features an adjustable main or high speed needle. These are built to Kohler Co. specifications by Walbro Corp.

This section covers the adjustment, disassembly, cleaning, inspection, repair and reassembly of both types of these Walbro-built side draft carburetors with differences called out wherever pertinent. Most components are identical.

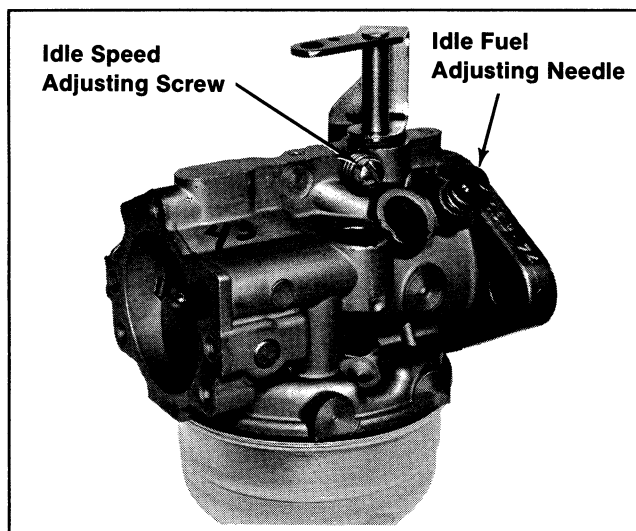

Figure 6B-1. Walbro Carburetor.



WARNING: Accidental Starts!

Before servicing the carburetor, engine, or equipment, always remove the spark plug leads to prevent the engine from starting accidentally. Ground the leads to prevent sparks that could cause fires.



WARNING: Explosive Fuel!

Gasoline may be present in the carburetor and fuel system. Gasoline is extremely flammable and its vapors can explode if ignited. Keep sparks, open flame, and other sources of ignition away from the area to prevent the possibility of fires or explosions.



WARNING: Prevent Eye Injury!

Suitable eye protection (safety glasses, goggles, or face shield) should be worn for any procedure involving the use of compressed air, punches, hammers, chisels, drills, or grinding tools.

SECTION 6B FUEL SYSTEMS

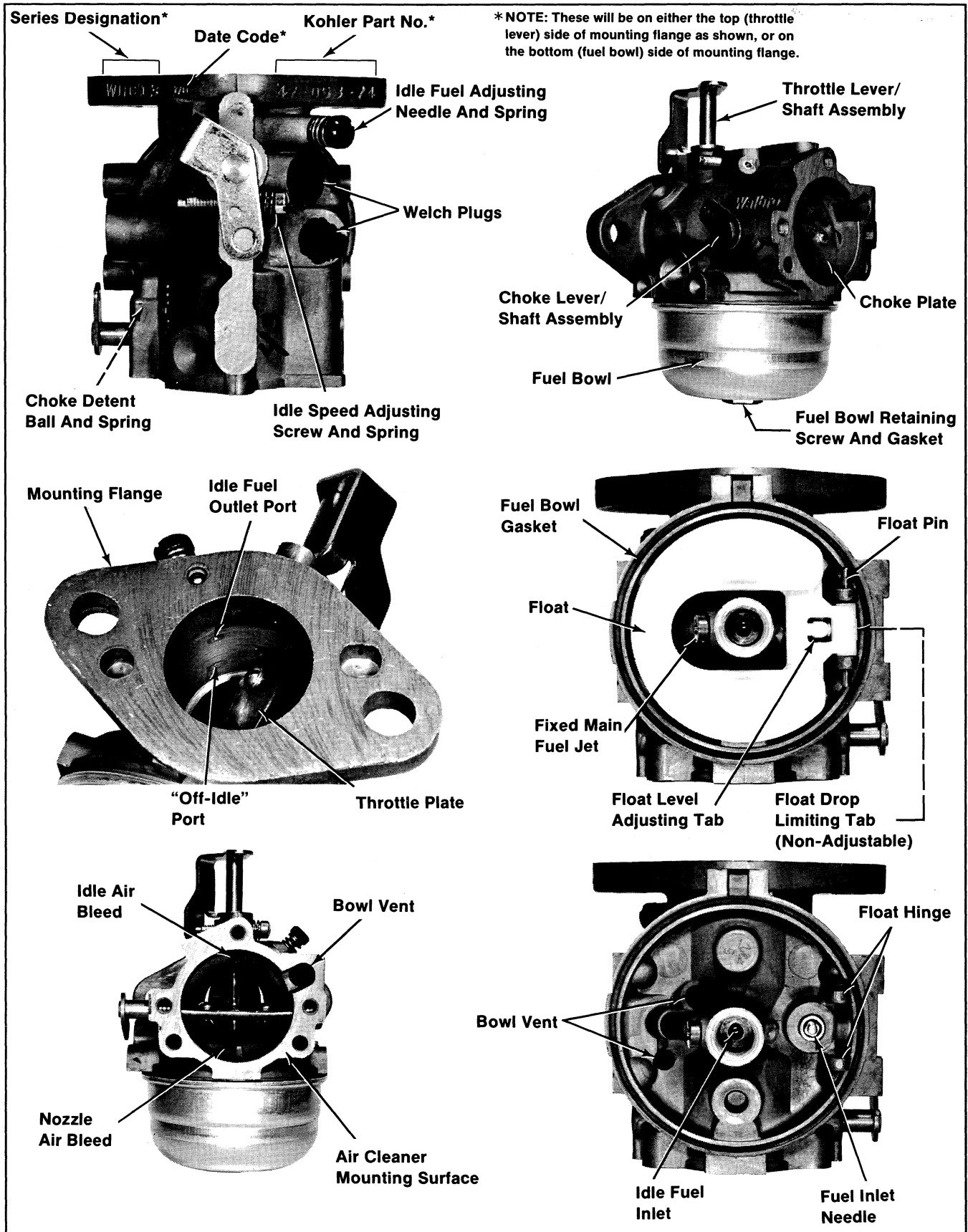

Figure 6B-2. Major Components and Service Locations - Typical Walbro Carburetor.

Troubleshooting

If engine troubles are experienced that appear to be fuel system related, check the following areas before adjusting or disassembling the carburetor.

- Make sure the fuel tank is filled with clean, fresh gasoline.
- Make sure the fuel tank cap vent is not blocked and that it is operating properly.
- Make sure fuel is reaching the carburetor. This includes checking the fuel shut-off valve, fuel tank filter screen, in-line fuel filter, fuel lines, and fuel pump for restrictions or faulty components.

- Make sure the carburetor is securely fastened to the engine using gaskets in good condition.
- Make sure the air cleaner element is clean and all air cleaner components are fastened securely.
- Make sure the ignition system, governor system, exhaust system, and throttle and choke controls are operating properly.

If, after checking the items listed above, starting problems or other conditions similar to those listed in the following table exist, it may be necessary to adjust or service the carburetor.

Condition	Possible Cause/Probable Remedy
1. Engine starts hard, or runs roughly or stalls at idle speed.	1. Idle fuel mixture or idle speed are improperly adjusted. Adjust the idle speed screw, then adjust idle fuel needle.
2. Engine runs rich. (Indicated by black, sooty exhaust smoke, misfiring, loss of speed and power, governor hunting, or excessive throttle opening.)	2a. Choke partially closed during operation. Check the choke lever and linkage to ensure choke is opening after warm-up. b. Idle and/or main fuel mixture improperly adjusted. Adjust idle and/or main fuel needle. c. Float level set too high. With fuel bowl removed and carburetor inverted, set exposed surface of float parallel with the bowl gasket surface of carburetor body. d. Dirt under fuel inlet needle. Remove needle. Clean needle and seat and blow with compressed air. e. Bowl vent or air bleeds plugged. Remove fuel bowl, idle fuel adjusting needle, and welch plugs. Clean vent, ports, and air bleeds. Blow out all passages with compressed air. f. Fuel bowl gasket leaks. Remove fuel bowl and replace gasket. g. Leaky, cracked, or damaged float. Submerge float to check for leaks.
3. Engine runs lean. (Indicated by misfiring, loss of speed and power, governor hunting, or excessive throttle opening.)	3a. Idle and/or main fuel mixture improperly adjusted. Adjust idle and/or main fuel needle. b. Float level set too low. With fuel bowl removed and carburetor inverted, set exposed surface of float parallel with the bowl gasket surface of carburetor body. c. Idle holes plugged; dirt in fuel delivery channels. Remove fuel bowl, idle fuel adjusting needle, main fuel jet, and welch plugs. Clean all passages and blow out with compressed air.
4. Fuel leaks from carburetor.	4a. Float level set too high. See Remedy 2c. b. Dirt under fuel inlet needle. See Remedy 2d. c. Bowl vent plugged. Remove fuel bowl and clean bowl vent. Blow out with compressed air. d. Float is cracked or damaged. Replace float. e. Bowl retaining screw gasket damaged. Replace gasket. f. Bowl retaining screw is not tightened. Torque screw to specifications.

SECTION 6B FUEL SYSTEMS

ADJUSTING WALBRO CARBURETORS

In general, turning the adjusting needles **in** (clockwise) decreases the supply of fuel to the carburetor. This gives a *leaner* fuel-to-air mixture. Turning the adjusting needles **out** (counterclockwise) increases the supply of fuel to the carburetor.

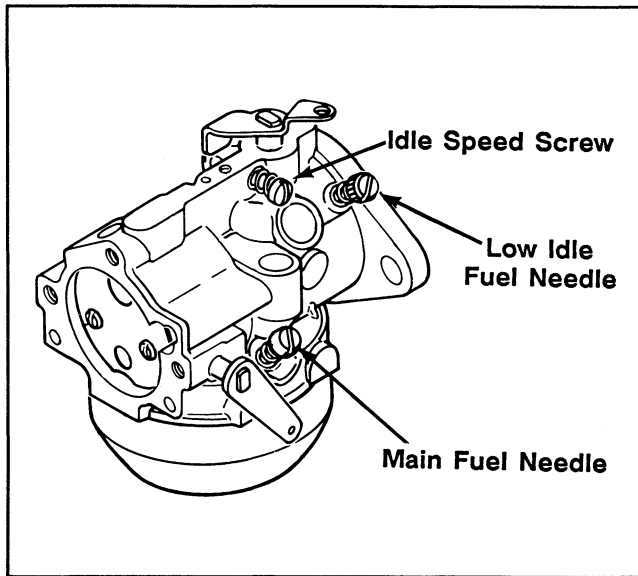

Figure 6B-3. Walbro Adjustable Main Jet Carburetor.

NOTE: The tip of the low idle fuel and main fuel adjusting needles are tapered to critical dimensions. Damage to the needles and the seats in carburetor body will result if the needles are forced.

1. With the engine stopped, turn the adjusting needle(s) **In** (clockwise) until it bottoms *lightly*.
2. **Preliminary Settings:** Turn the adjusting needle(s) **out** (counterclockwise) from lightly bottomed as follows or to the rich side of adjustment.

WALBRO FIXED JET	LOW IDLE
M18	1-1/4 TURNS
M20	1-1/4 TURNS

WALBRO ADJ	LOW IDLE	MAIN FUEL
M18	1-1/4 TURNS	1-1/4 TURNS
M20	1-1/4 TURNS	1 TURN

3. Start the engine and run at half throttle for five to ten minutes to warm up. **The engine must be warm before making final settings.**

4. **Main Fuel Needle Setting:** *This adjustment is possible only on adjustable main jet carburetors. If the carburetor is a fixed main jet type, disregard this.*

Place the throttle into the "fast" position.

Turn the adjusting needle **in** (clockwise). The engine speed may increase, then it will decrease as the needle is turned in (lean). Note the position of the needle. Back the needle out approximately 1/4 turn. See Figure 6B-4A for best main fuel performance.

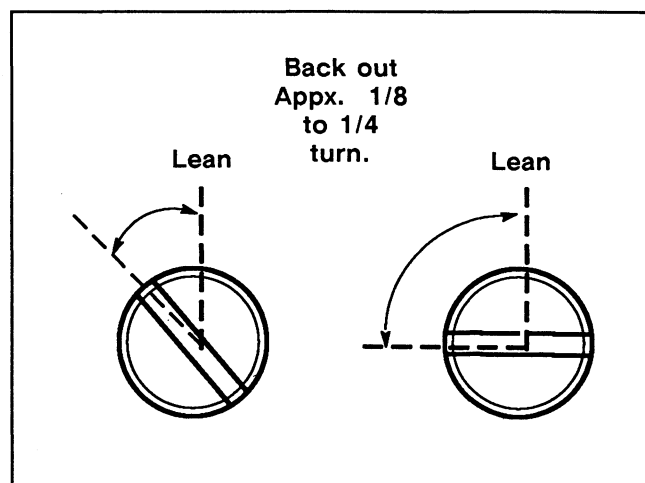

Figure 6B-4A. Optimum Main Fuel Setting.

5. **Low Idle Speed Setting:** Place the throttle control into the "idle" or "slow" position. Set the low idle speed to **1200 RPM*** (+ or - 75 RPM) by turning the low idle speed adjusting screw **in** or **out**. Check the speed using a tachometer.

***NOTE:** The actual low idle speed depends on the application. Refer to the equipment manufacturer's instructions for specific low idle speed settings. To ensure best results when setting the low idle fuel needle, the low idle speed must not exceed 1500 RPM.

6. **Low Idle Fuel Needle Setting:** Place the throttle into the "idle" or "slow" position. Turn the adjusting needle **in** (clockwise). The engine speed may increase, then it will decrease as the needle is turned in (lean). Note the position of the needle. Back the needle out approximately 1/8 to 1/4 turn. See Figure 6B-4B for best low idle fuel performance.

SECTION 6B FUEL SYSTEMS

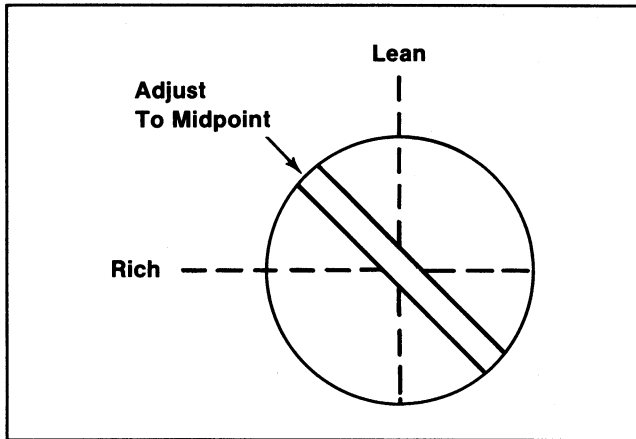

Figure 6B-4B. Optimum Low Idle Fuel Setting.

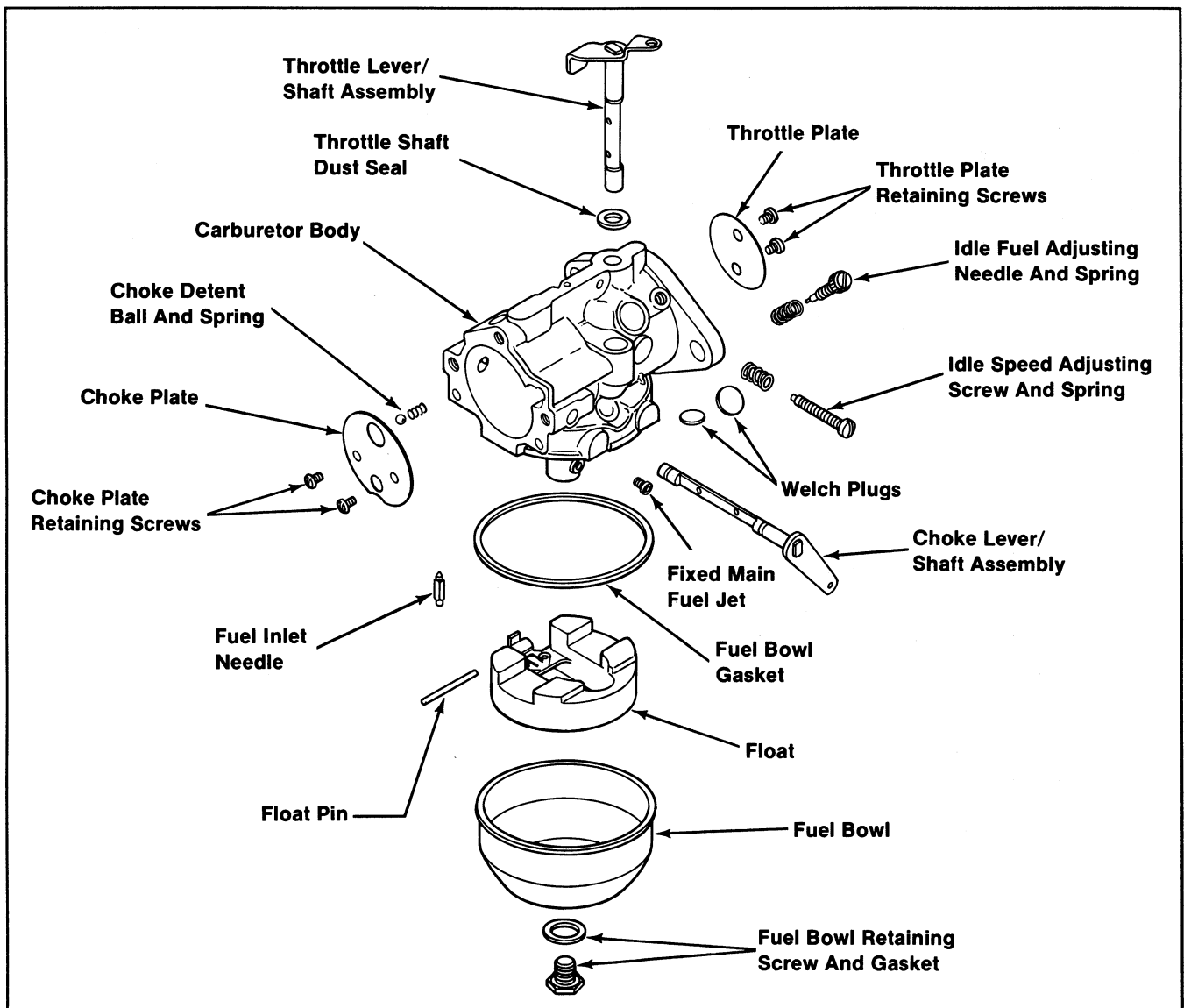

Figure 6B-5. Walbro-Built Carburetor - Exploded View.

SECTION 6B FUEL SYSTEMS

Disassembly

Refer to Figures 6B-2 and 6B-5.

1. Remove the bowl retaining screw, retaining screw gasket, and fuel bowl.
2. Remove the bowl gasket, float pin, float, and fuel inlet needle.

NOTE: To prevent damage to the carburetor, do not attempt to remove the fuel inlet seat as it is not serviceable. Replace the carburetor if the fuel inlet seat is damaged.

3. Remove the idle fuel adjusting needle and spring. Remove the idle speed adjusting screw and spring.
4. Remove the main fuel jet.
5. In order to clean the "off-idle" ports and the bowl vent channel thoroughly, the welch plugs covering these areas must be removed. Use tool No. KO1018 and the following procedure to remove the welch plugs. Refer to Figure 6B-6.

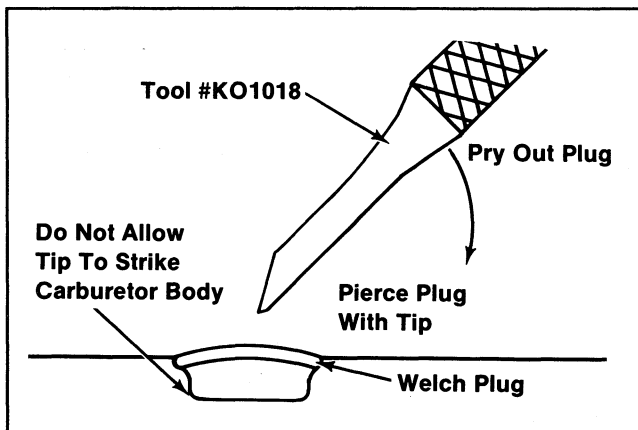

Figure 6B-6. Removing Welch Plugs.

- a. Pierce the welch plug with the tip of the tool.

NOTE: To prevent damage to the carburetor, do not allow the tool to strike the carburetor body.

- b. Pry out the welch plug using the tool.

Throttle and Choke Shaft Removal

Further disassembly to remove the throttle shaft and choke shaft is recommended only if these parts are to be cleaned or replaced.

Throttle Shaft Removal

1. Because the edges of throttle plate are beveled, mark the throttle plate and carburetor body with a marking pen to ensure correct reassembly (refer to Figure 6B-7). Also take note of the throttle plate position in bore, and the position of the throttle lever.

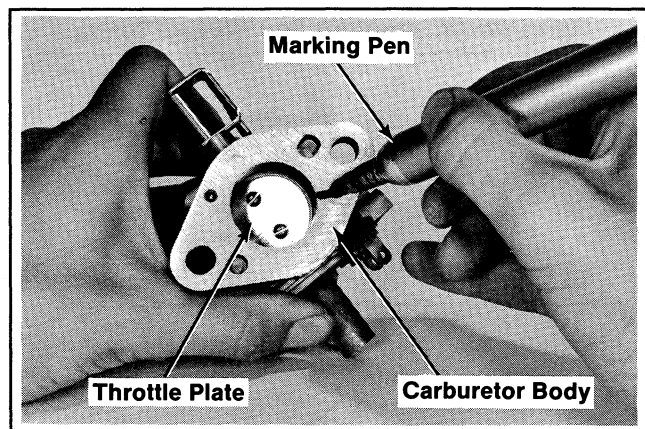

Figure 6B-7. Marking Throttle Plate and Carburetor Body.

2. Carefully and slowly remove the screws securing the throttle plate to throttle shaft. Remove the throttle plate.
3. File off any burrs which may have been left on the throttle shaft when the screws were removed. Do this **before** removing the throttle shaft from carburetor body.
4. Remove the throttle lever/shaft assembly with foam dust seal from carburetor body.

Choke Shaft Removal

1. Because the edges of choke plate are beveled, mark the choke plate and carburetor body with a marking pen to ensure correct reassembly (refer to Figure 6B-8). Also take note of the choke plate position in bore, and the position of the choke lever.

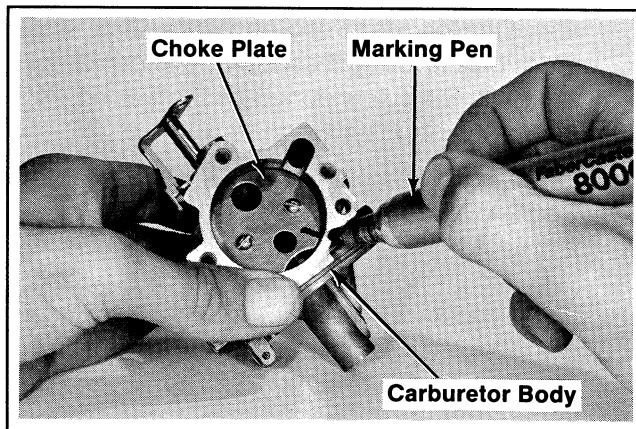

Figure 6B-8. Marking Choke Plate and Carburetor Body.

2. Carefully and slowly remove the screws securing the choke plate to choke shaft. Remove the choke plate.
3. File off any burrs which may have been left on the choke shaft when the screws were removed. Do this **before** removing the choke shaft from carburetor body.
4. Rotate the choke shaft until the cutout portion of shaft is facing the air cleaner mounting surface (refer to Figure 6B-9). Place the carburetor body on workbench with choke side down. Remove the choke lever/shaft assembly from carburetor body; the detent ball and spring will drop out.

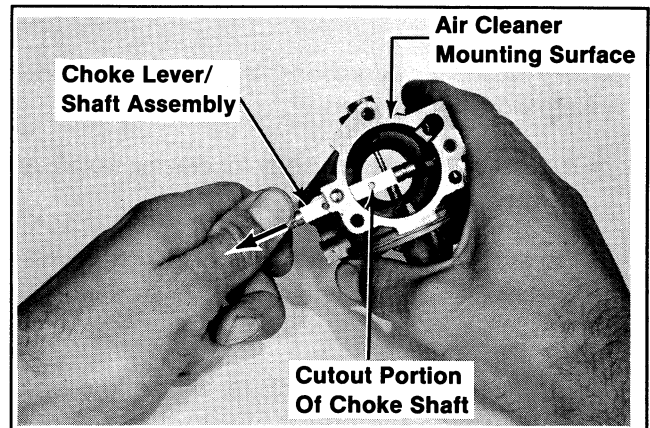

Figure 6B-9. Removing Choke Lever/Shaft.

Cleaning



WARNING: Flammable Solvents!

Carburetor cleaners and solvents are extremely flammable. Keep sparks, flames, and other sources of ignition away from the area. Follow the cleaner manufacturer's warnings and instructions on its proper and safe use. Never use gasoline as a cleaning agent.

All parts should be carefully cleaned using a carburetor cleaner (such as acetone). Be sure all gum deposits are removed from the following areas:

- **Carburetor body and bore;** especially the areas where the throttle plate, choke plate, and shafts are seated.
- **Idle fuel and "off-idle" ports in carburetor bore, main jet, bowl vent, and fuel inlet seat.**

NOTE: These areas can be cleaned using a piece of fine wire in addition to cleaners. Be careful not to enlarge the ports, or break the cleaning wire within ports. Blow out all passages with compressed air.

- **Float and float hinge.**
- **Fuel Bowl.**
- **Throttle plate, choke plate, throttle shaft, and choke shaft.**

NOTE: Do not submerge the carburetor in cleaner or solvents when fiber, rubber, or foam seals or gaskets, or the fuel inlet needle are installed. The cleaner may damage these parts.

SECTION 6B FUEL SYSTEMS

Inspection

Carefully inspect all components and replace those that are worn or damaged.

- Inspect the carburetor body for cracks, holes, and other wear or damage.
- Inspect the float for cracks or holes. Check the float hinge for wear, and missing or damaged float tabs.
- Inspect the fuel inlet needle for wear or grooves.
- Inspect the tip of the idle fuel adjusting needle for wear or grooves.
- Inspect the throttle and choke shaft and plate assemblies for wear or excessive play.

Repair

Always use new gaskets when servicing and reinstalling carburetors. Repair kits are available which include new gaskets and other components. These kits are described below.

Components such as the throttle and choke shaft assemblies, throttle plate, choke plate, idle fuel needle, main jet, and others, are available separately.

Refer to the appropriate Parts Manual to ensure the correct carburetor repair kits and replacement parts are ordered.

Carburetor Repair Kit No. 25 757 11 (For WHG-Series 1") Contains:

Qty.	Description
3	Gasket, carburetor (3 different styles)
4	Gasket, air cleaner (4 different styles)
1	Gasket, fuel bowl
1	Gasket, bowl retaining screw
1	Plug, 3/8" dia. welch
1	Plug, 5/16" dia. welch
1	Needle, fuel inlet
1	Valve, fuel inlet assembly

Float Assembly Kit No. 25 757 09 (For WHG-Series Carbs.) Contains:

Qty.	Description
1	Float Assembly
1	Float Pin

Reassembly

Throttle Shaft Installation

1. Install the foam dust seal on throttle shaft. Insert the throttle lever/shaft assembly into carburetor body with the cutout portion of shaft facing the carburetor mounting flange.
2. Install the throttle plate to throttle shaft. Make sure the plate is positioned properly in bore as marked and noted during disassembly (the numbers stamped on plate should face the carburetor mounting flange). Apply Loctite® #609 to threads of 2 plate retaining screws. Install screws so they are slightly loose.
3. Apply finger pressure to the throttle lever/shaft to keep it firmly seated against pivot in carburetor body. Rotate the throttle shaft until the throttle plate fully closes the bore around its entire perimeter; then tighten screws. Refer to Figure 6B-10.

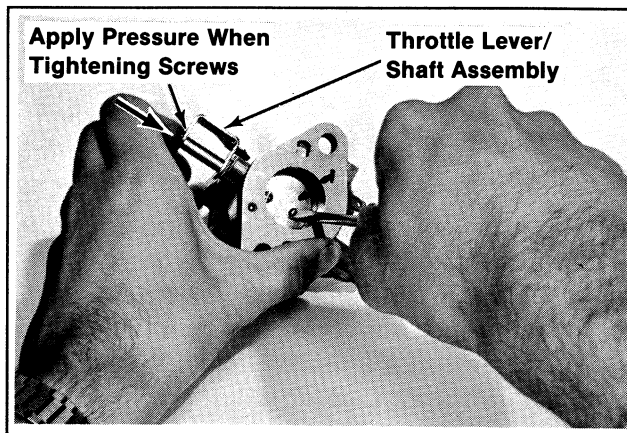

Figure 6B-10. Installing Throttle Lever/Shaft.

4. Operate the throttle lever; check for binding between the throttle plate and carburetor bore. Loosen screws and adjust throttle plate as necessary; then torque screws to 8/12 in. lb.

Choke Shaft Installation

1. Install the detent spring and ball into the carburetor body.

NOTE: If the detent ball does not drop through the tapped air cleaner base screw hole by its own weight, do not force it. Forcing the ball could permanently lodge it in the hole.

Install the ball through the choke shaft bore instead.

2. Compress the detent ball and spring. Insert the choke lever/shaft assembly into carburetor body with the cutout portion of shaft facing the air cleaner mounting surface (refer to Figure 6B-11). Make sure the choke lever is on the correct side of carburetor body.

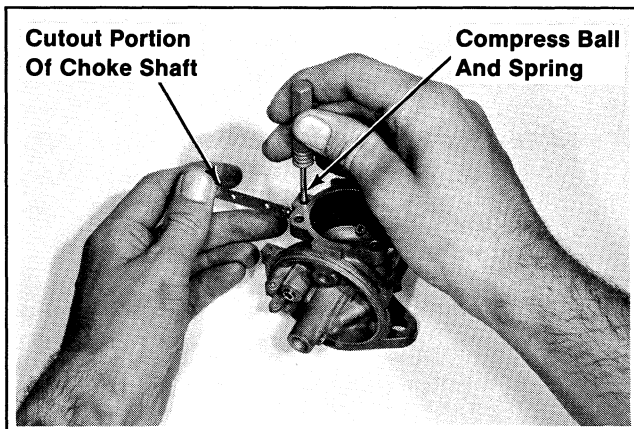

Figure 6B-11. Installing Choke Lever/Shaft.

3. Install the choke plate to choke shaft. Make sure the plate is positioned properly in bore as marked and noted during disassembly. (The numbers stamped on plate should face the air cleaner mounting surface and be upright.) Apply Loctite® #609 to threads of 2 plate retaining screws. Install the screws so they are slightly loose.
4. Operate the choke lever; check for binding between the choke plate and carburetor bore. Adjust plate as necessary; then torque screws to **8/12 in. lb.**

Carburetor Reassembly

1. If the welch plugs have been removed for cleaning, new welch plugs must be installed. Use tool No. KO1017 and the following procedure to install the welch plugs.

- a. Position the carburetor body securely with the welch plug cavities to the top.
- b. Place a new welch plug into the cavity with the raised portion up. Use the end of the tool that is about the same size as plug and **flatten** the plug. Do not force the plug below the top surface. Refer to Figure 6B-12.

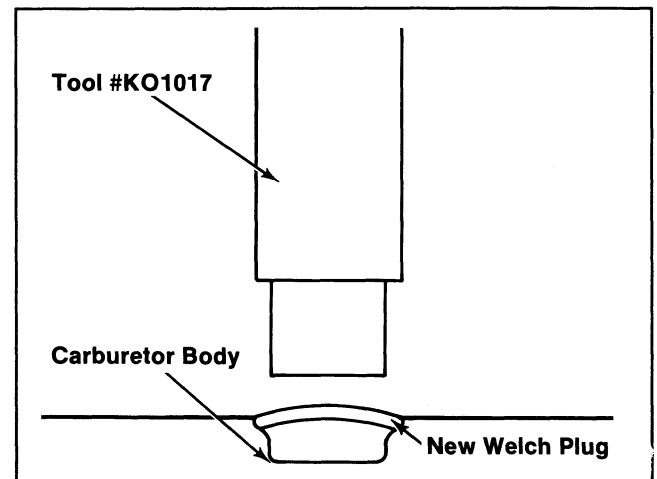

Figure 6B-12. Installing Welch Plugs.

- c. After welch plugs are installed, seal the exposed surface with Glyptal™ (or an equivalent sealant). Allow the sealant to dry.

NOTE: If a commercial sealant is not available, fingernail polish can be used.

2. Install the main fuel jet and torque to **12/16 in. lb.**
3. Install fuel inlet needle/clip assembly, attach clip to the adjusting tab on float as shown in Figure 6B-13, slowly lower float into position in seat.
4. **Set Float Level:** Invert the carburetor so the float tab rests on the fuel inlet needle. The exposed surface of float should be **parallel** with the bowl gasket surface of the carburetor body (exposed, free end of float .690"/.720" from bowl gasket surface). Refer to Figure 6B-14.

SECTION 6B FUEL SYSTEMS

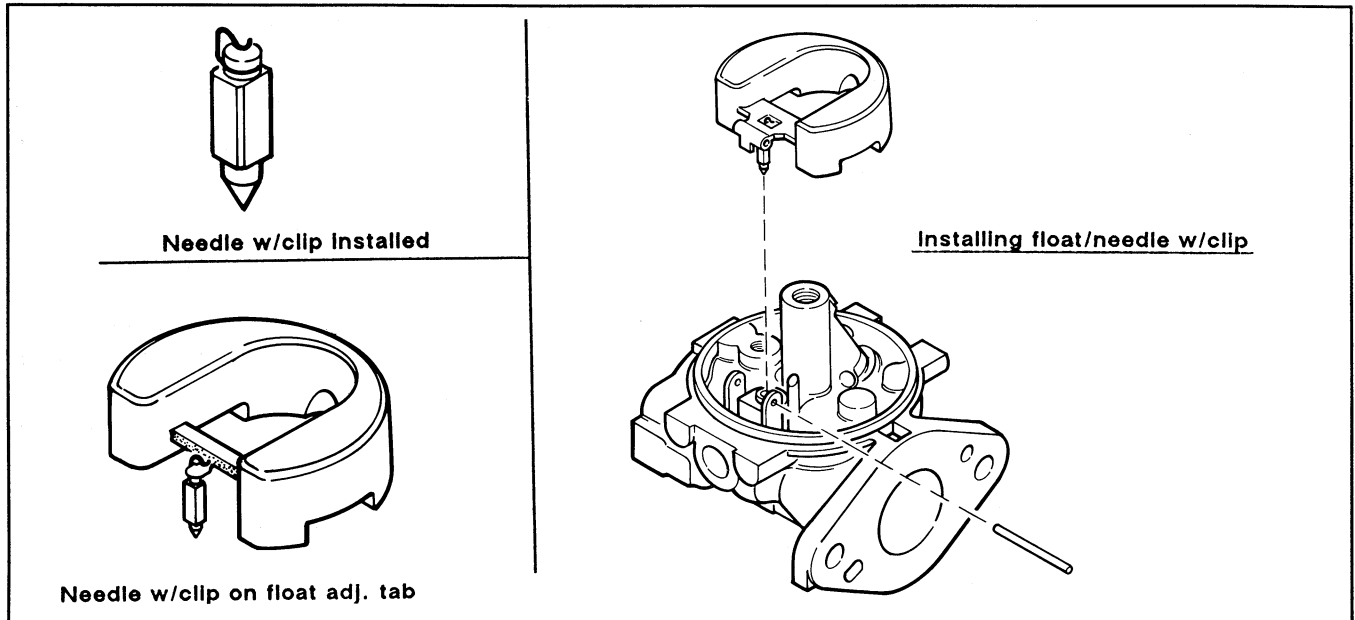

Figure 6B-13. Fuel Needle Clip.

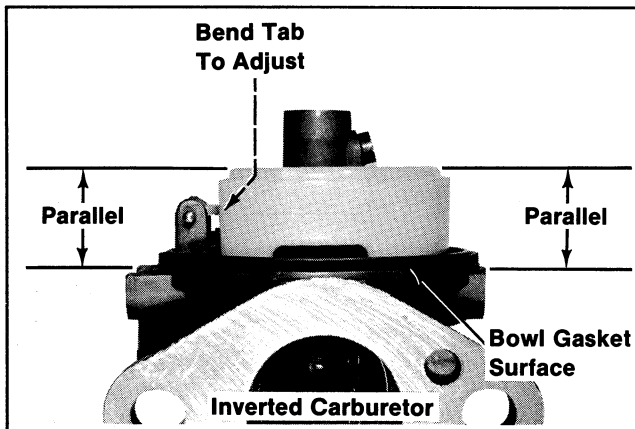

Figure 6B-14. Setting Float Level.

Bend the float tab with a small screwdriver to adjust.

5. Install a new bowl gasket and the fuel bowl. Make sure the bowl gasket and bowl are centered and positioned properly to ensure a good seal.
6. Install a new bowl retaining screw gasket and the bowl retaining screw. Torque screw to **45/55 in. lb.**
7. Install the idle speed adjusting screw and spring.

8. Install the idle fuel adjusting needle and spring. Turn the adjusting needle **in** (clockwise) until it bottoms **lightly**.

NOTE: The tip of the idle fuel adjusting needle is tapered to critical dimensions. Damage to the needle and the seat in carburetor body will result if the needle is forced.

9. Turn the idle fuel needle **out** (counterclockwise) from lightly bottomed according to the instructions in the "Adjustment" portion of this Section.

High Altitude Operation (Fixed Main Carburetors)

When operating the engine at high altitudes, the main fuel mixture tends to get over rich. An over rich mixture can cause conditions such as black, sooty exhaust smoke, misfiring, loss of speed and power, poor fuel economy, and poor or slow governor response.

To compensate for this, a special high altitude main fuel jet is available for each carburetor. The high altitude main fuel jet is sold in a kit which includes the jet and necessary gaskets.

The following table lists the kits and the altitudes above which the kits should be used.

Engine Model	Kit No.	Altitude
M18	52 755 74	6000 ft.
M20	52 755 68	6000 ft.

High Altitude Jet Installation

1. Remove the fuel bowl retaining screw, retaining screw gasket, fuel bowl, and bowl gasket.

NOTE: If necessary, remove the air cleaner and carburetor from engine to make fuel bowl removal easier.

2. Remove the float pin, float, and fuel inlet needle.
3. Remove the existing main fuel jet.
4. Install the new high altitude main fuel jet and torque to **12/16 in. lb.**
5. Reinstall the fuel inlet needle, float, and float pin.
6. Install the new bowl gasket from kit and the fuel bowl. Make sure the bowl gasket and bowl are centered and positioned properly to ensure a good seal.
7. Install the new bowl retaining screw gasket from kit and the bowl retaining screw. Torque screw to **45/55 in. lb.**
8. Reinstall the carburetor and air cleaner to engine as necessary using the new gaskets from kit.

M20 Linkage and Dampening Spring Installation

M20 engines built between Serial No. 1619504216 and 1631600816 inclusive were built with a dampening spring connected to the governor arm and the bushing in carburetor throttle lever. The dampening spring can be eliminated by installing a new governor linkage and new bushings as shown in Figure 6B-15. These parts are available in Kit No. 52 755 64.

To reinstall the existing dampening spring, bushings, and governor linkage, use the following procedure:

1. Install the bushings and governor linkage as shown in Figure 6B-15.
2. Install the dampening spring to governor arm and bushing on carburetor throttle lever as shown in Figure 6B-16. Make sure the end of spring with larger hook is installed around the bushing in carburetor throttle lever.

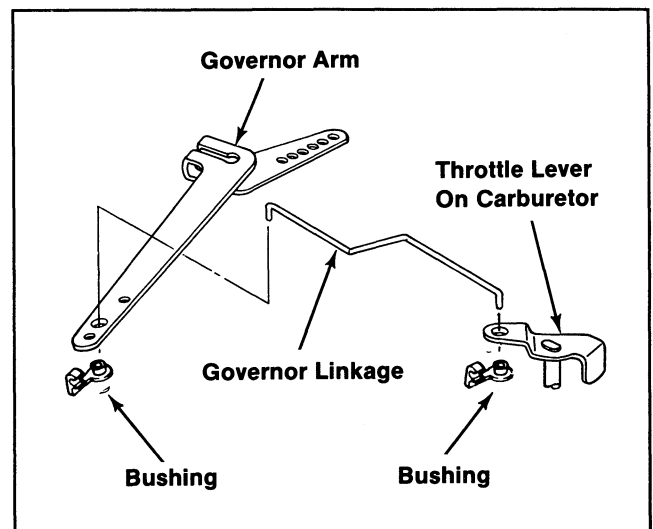

Figure 6B-15. Installing Bushings And Governor Linkage -- M20 Engines.

SECTION 6B FUEL SYSTEMS

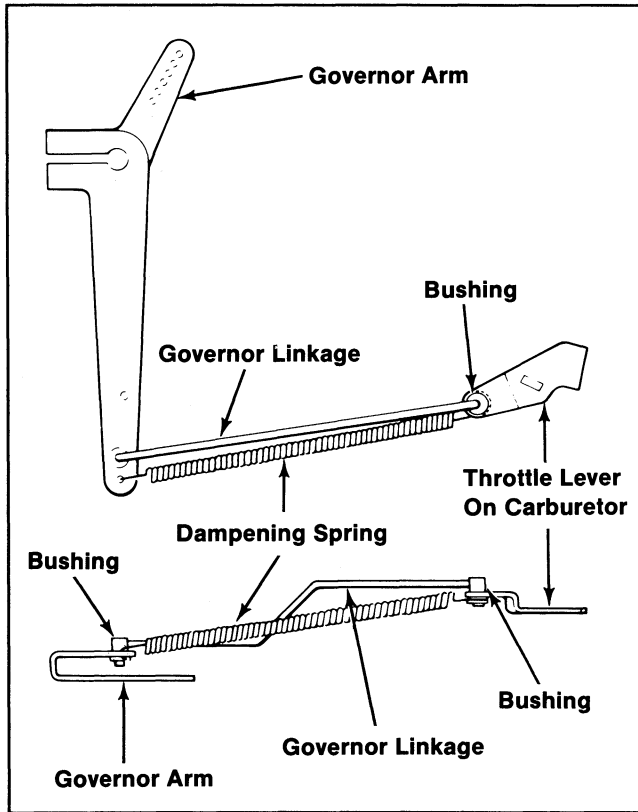

Figure 6B-16. Installing Dampening Spring --
M20 Engines.

SECTION 7 LUBRICATION SYSTEM

OPERATION

Magnum M18 and M20 engines use a full-pressure lubrication system that delivers oil to the crankshaft, camshaft, and connecting rod journal surfaces. Under normal engine operating conditions, the oil pressure can be as high as 50 psi. A high-efficiency Gerotor™

oil pump maintains high oil flow and oil pressure, even at low speeds and high operating temperatures. A pressure relief valve, located in the engine crankcase behind the closure plate, limits the maximum oil pressure in the system. No adjustments to relief valve are possible. Refer to Figure 7-1.

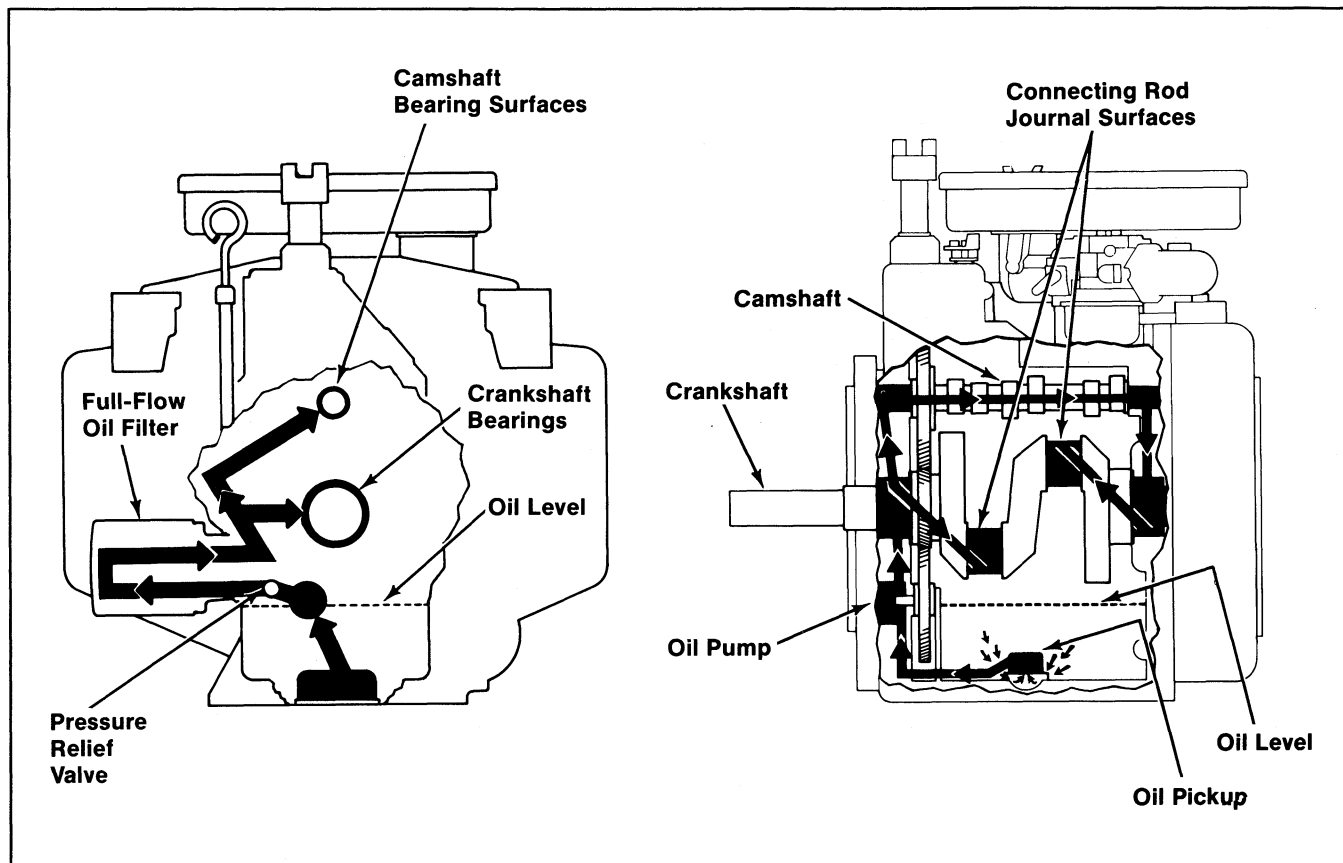

Figure 7-1. Full-Pressure Lubrication System.

LUBRICATION SYSTEM SERVICE

The oil pump cover and rotors, and pressure-relief valve can be serviced without splitting the crankcase. Remove the rear closure plate to service those parts.

The crankcase must be split to service the pump shaft, drive gear, oil pickup, etc.

Refer to Figures 7-2, 7-3, and 7-4. Also refer to the "Disassembly" and "Reassembly" Sections for oil pump component removal and installation procedures.

SECTION 7 LUBRICATION SYSTEM

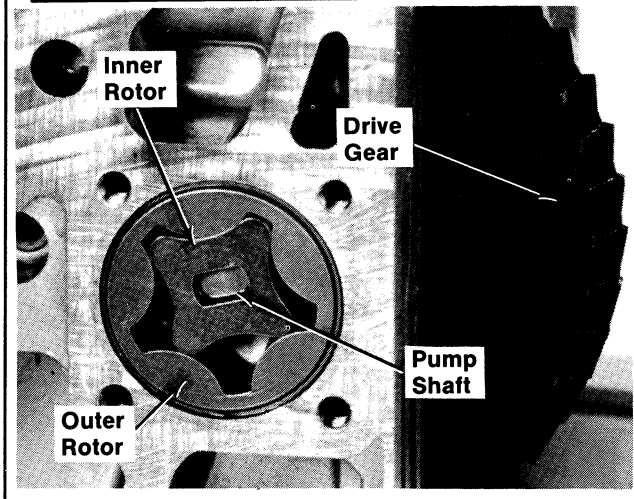
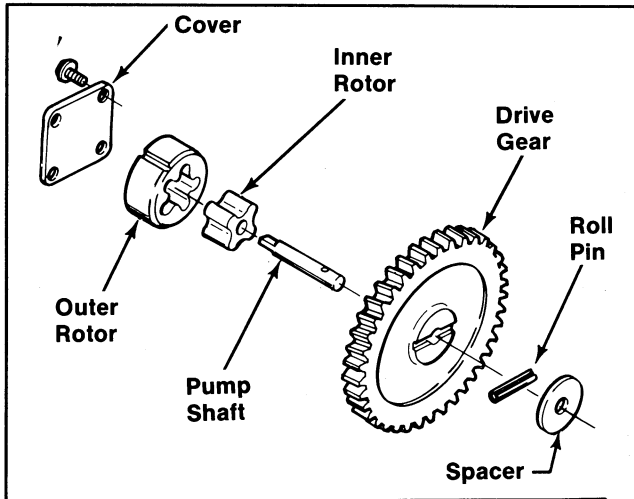

Figure 7-2. Oil Pump Assembly.

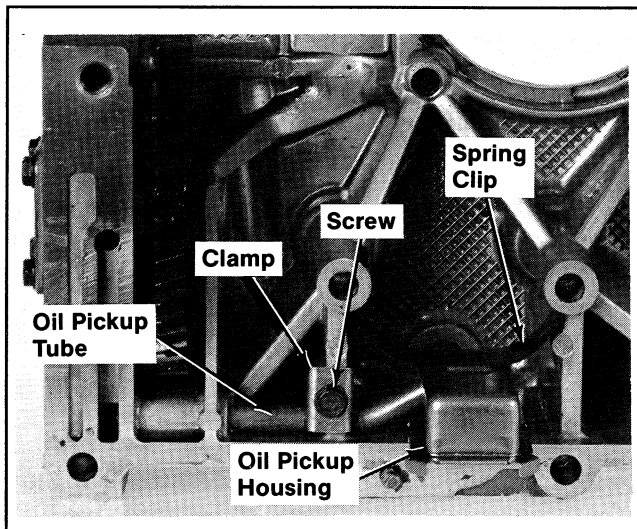

Figure 7-3. Oil Pickup.

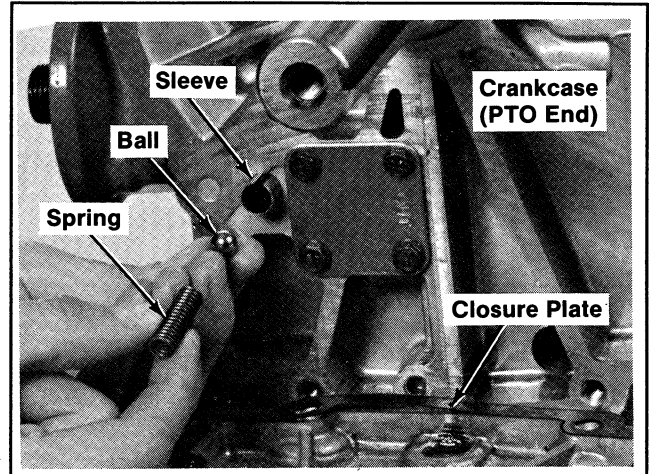

Figure 7-4. Oil Pressure Relief Valve.

OIL FILTER

All basic engines are equipped with a full-flow oil filter. The filter helps remove sludge and other combustion by-products from the oil, extends the oil change interval, and helps cool the oil.

Oil filters are optional for special spec engines and are available in engine-mounted or remote-mounted types. A cover plate seals the crankcase on those engines not equipped with an oil filter.

Refer to Figures 7-5, 7-6, 7-7, and 7-8. Also refer to the "Periodic Maintenance" Section for oil and oil filter change instructions.

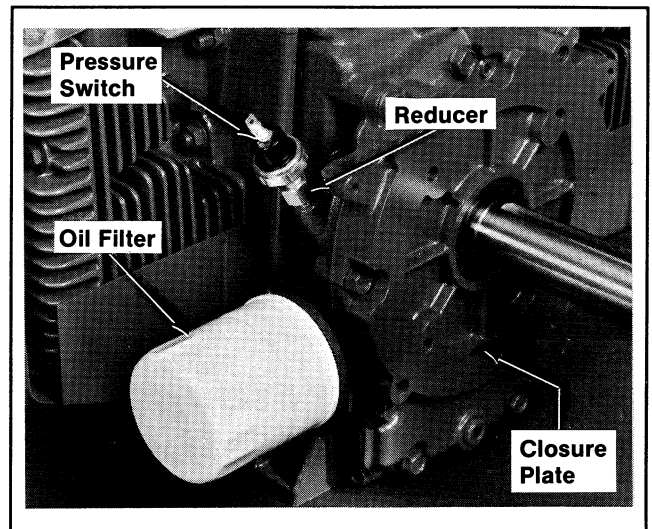

Figure 7-5. Engine Mounted Oil Filter and Oil Sentry™ Pressure Switch.

SECTION 7 LUBRICATION SYSTEM

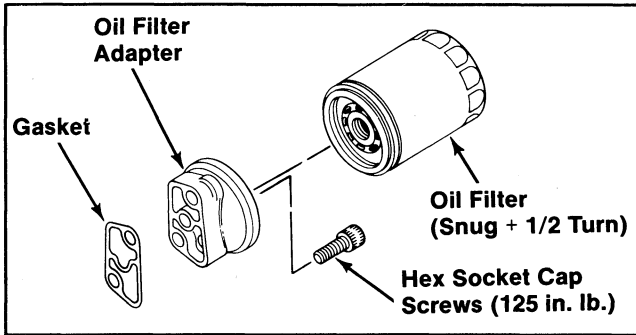

Figure 7-6. Installation Torques--
Engine Mounted Oil Filter.

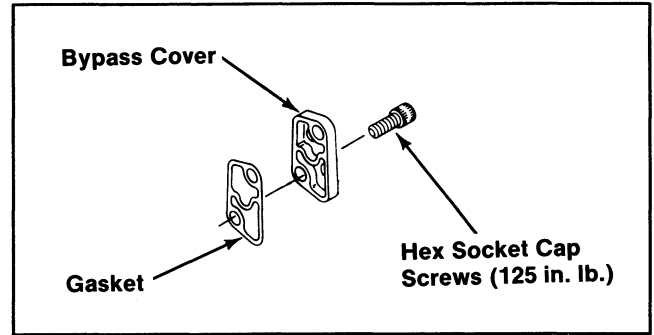

Figure 7-7. Installation Torque--Filter Bypass Cover
(Engines Without Oil Filter).

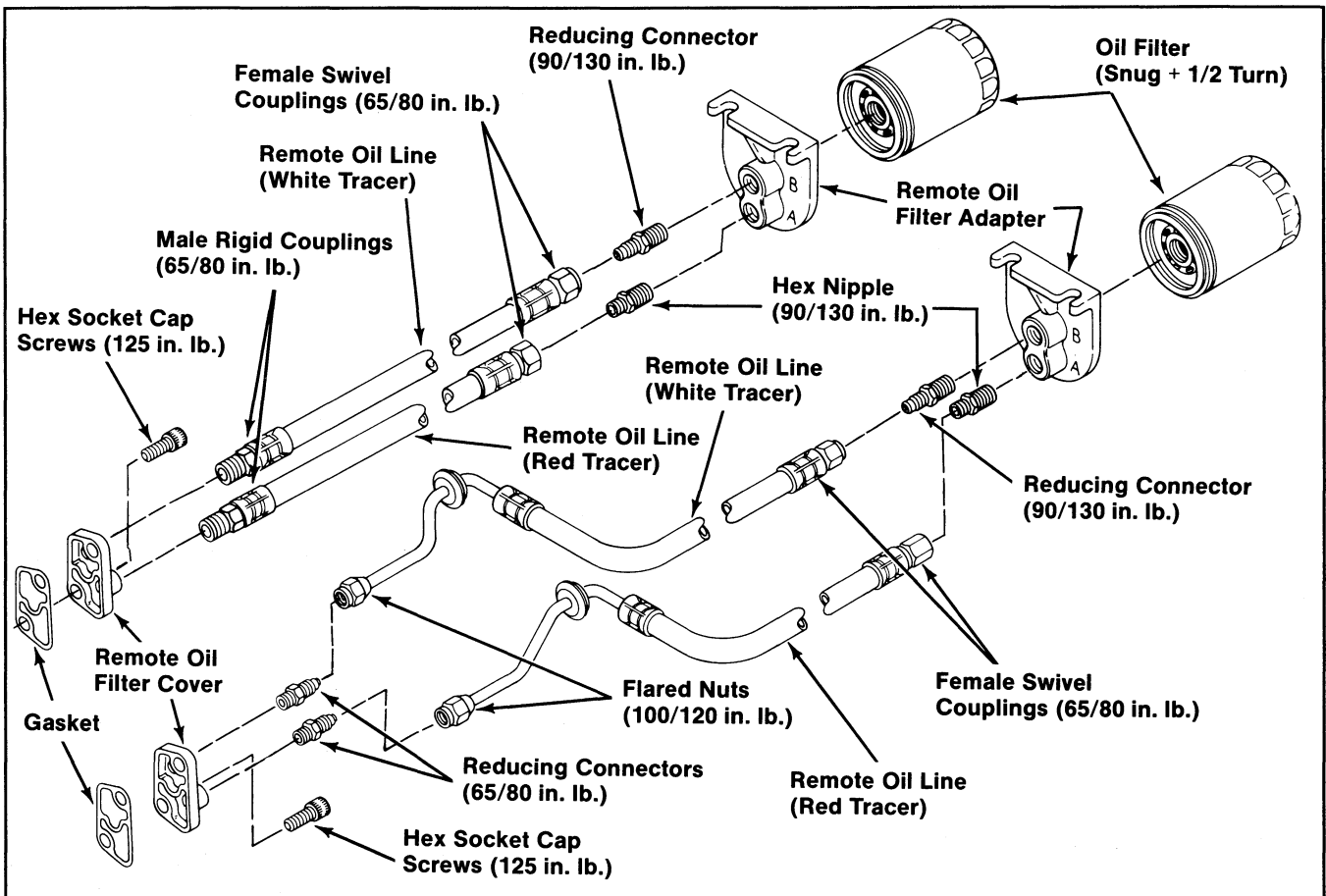

Figure 7-8. Installation Torques--Remote Mounted Oil Filters.

CRANKSHAFT SPLINED INSERT LUBE INTERVAL RECOMMENDATION

While it was previously thought that spline lubricant would remain effective for as long as the pump mounting remained intact, we now recommend that splines be re-lubricated **every 500 hours** of operation.

Misalignment and lack of lubricant remain as the two major causes of premature wear and/or costly tooth damage to splined inserts. Without any recommended interval, spline service was being neglected, resulting in damage.

SECTION 7 LUBRICATION SYSTEM

Every 500 hours of operation, separate the pump from the engine. Clean the splined areas and lightly grease the male portion of pump spline. Use either Dow Corning G-N Metal Assembly Paste or #77 Assembly Paste.

As you remount the pump to the engine, be certain the mating surfaces are clean and free of any foreign material, and that the pump is correctly aligned.

If you have a splined insert that has been damaged, the following kits are available for spline replacement.

Description	Kohler Part No.
9 tooth insert	82 755 02
11 tooth insert	48 755 23
13 tooth insert	48 755 21

OIL SENTRY™ OIL PRESSURE MONITOR



Some engines are equipped with the optional Oil Sentry™ oil pressure monitor. Oil Sentry™ will either stop the engine or activate a "low oil" warning light, if the oil pressure gets low. Actual Oil Sentry™ use will depend on the engine application.

Operation

Oil Sentry™ uses a pressure switch in one of the main crankcase oil galleries to detect low oil pressure. At oil pressures below approximately 3-1/2 psi, the pressure switch closes. At oil pressures above approximately 3-1/2 psi the pressure switch opens.

On stationary or unattended applications (pumps, generators, etc.), the pressure switch can be used to ground the ignition module to stop the engine.

On vehicular applications (garden tractors, mowers, etc.), the pressure switch can be used to activate a "low oil" warning light.

NOTE: Oil Sentry™ is not a substitute for checking oil level BEFORE EACH USE. Make sure the oil level is maintained up to the "F" mark on dipstick.

Installation

The pressure switch is installed in the oil gallery located near the dipstick tube and closure plate on the #1 side of crankcase (refer to Figure 7-5). On engines not equipped with Oil Sentry™, the oil gallery is sealed with a 1/16" N.P.T.F. pipe plug.

1. Remove the 1/16" N.P.T.F. pipe plug (or old switch and reducer) from crankcase.
2. Apply Loctite® No. 592 Teflon sealant (or equivalent) to threads of switch. Install reducer to switch and tighten securely.
3. Apply Loctite® No. 592 Teflon sealant (or equivalent) to threads of reducer. Install reducer/switch assembly into crankcase. Tighten the reducer securely into the crankcase.

Testing

The pressure switch is a normally closed type, calibrated to open (break contact) with increasing pressure, and close (make contact) with decreasing pressure within the range of 2.0/5.0 psi.

Compressed air, a pressure regulator, a pressure gauge, and a continuity tester are required to test the switch.

1. Connect the continuity tester across the blade terminal and metal case of switch. With 0-psi pressure applied to switch, the tester should indicate continuity (switch closed).
2. Gradually increase the pressure to the switch. The tester should indicate a change to no continuity (switch open) as the pressure increases through the range of 2.0/5.0-psi. The switch should remain open as pressure is increased to 90-psi maximum.
3. Gradually decrease the pressure to the switch. The tester should indicate a change to continuity (switch closed) as the pressure decreases through the range of 2.0/5.0-psi, approaching 0-psi.

SECTION 8

ELECTRICAL SYSTEM AND COMPONENTS

MAGNUM ELECTRONIC MAGNETO IGNITION SYSTEM

This engine is equipped with a state-of-the-art electronic magneto ignition system. The system consists of the following components (refer to Figure 8-1):

- A magnet assembly, which is PERMANENTLY affixed to the flywheel.
- An electronic magneto ignition module, which is mounted to the #1 side cylinder barrel.
- A kill switch (or key switch) which stops the engine by grounding the ignition module.

Operation

As the flywheel rotates and the magnet assembly moves past the ignition module, a low voltage is induced in the primary windings of the module. When the primary voltage is precisely at its peak, the module induces a high voltage in its secondary windings.

This high voltage creates a spark at the tip of the spark plugs, igniting the fuel-air mixture in the combustion chambers. The timing of the spark is automatically controlled by the module. Therefore, no ignition timing adjustments are necessary or possible with this system.

NOTE: Do not connect 12 volts to the ignition system or to any wire connected to the ignition module.

The ignition system operates independently of the battery, starting, charging, and other auxiliary electrical systems. Connecting 12 volts to the ignition module can cause the module to burn out. This type of damage is not covered by the engine warranty.

A break-before-make type key switch is required to prevent damage to the ignition module.

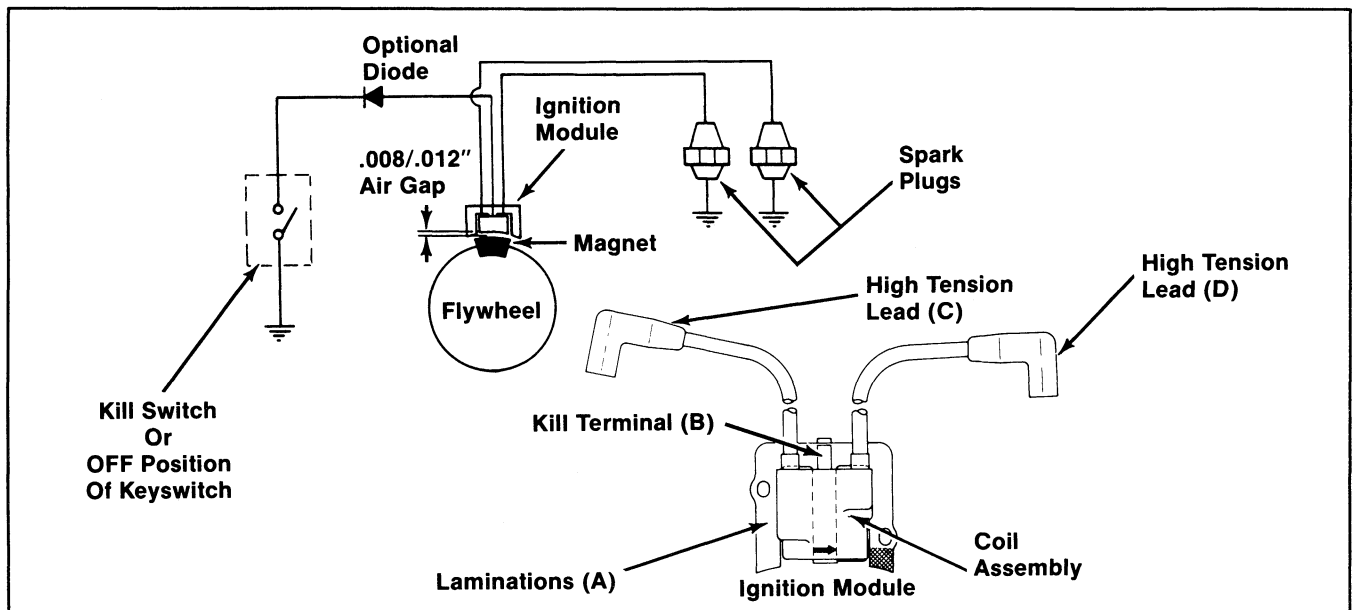

Figure 8-1. Magnum Electronic Magneto Ignition System.

SECTION 8 ELECTRICAL SYSTEM AND COMPONENTS

Ignition System Troubleshooting Guide

The following guide will help locate and correct ignition system-related starting problems. This procedure uses a simple tester which can be easily made by the serviceman. Refer to the "Special Tools" Section for ignition system tester construction details.

NOTE: Use a low-voltage ohmmeter when ohmmeter is required. **Always zero ohmmeter on each scale before testing to ensure accurate readings.**

Problem	Test	Conclusion				
ENGINE WILL NOT START	1. Make sure spark plug leads are connected to spark plugs.					
	2. Check condition of spark plugs. Make sure gaps are set to .035".	If plugs are in good condition, check/adjust gaps and reinstall.				
	3. Check ignition module using test plugs (refer to the "Special Tools" section and Figure 8-2). a. Remove the high-tension leads from the engine spark plugs, and connect them to the test plugs. NOTE: To maintain engine speeds normally obtained during cranking, do not remove the engine spark plugs. b. Make sure the engine ignition switch (kill switch) and/or key switch are in the "run" position. c. Crank the engine and observe the test plugs. Visible and audible sparks should be produced.	If visible and audible sparks ARE produced, the ignition module is OK. If visible and audible sparks ARE NOT produced: a. Make sure engine ignition switch and/or key switch are in the "run" position. b. Check wires and terminals of ignition module and other components for accidental grounding and/or damaged insulation. c. If wires and terminals are OK, the ignition module is probably faulty and should be replaced. Test module further using an ohmmeter (Test 4).				
	4. Measure the secondary resistance of module using an ohmmeter. Refer to Figures 8-1 and 8-4. NOTE: Module must have been "fixed" to perform Test 4.	If resistance is within range, module secondary is OK. If resistance is low or 0 ohms, module secondary is shorted. Replace module. If resistance is high or infinity ohms, module secondary is open. Replace module.				
	<table border="0"> <tr> <td style="text-align: center;">Secondary Leads/Terminals</td> <td style="text-align: center;">Secondary Resistance</td> </tr> <tr> <td style="text-align: center;">C - D</td> <td style="text-align: center;">22,000/42,000 ohms</td> </tr> </table>	Secondary Leads/Terminals	Secondary Resistance	C - D	22,000/42,000 ohms	
Secondary Leads/Terminals	Secondary Resistance					
C - D	22,000/42,000 ohms					

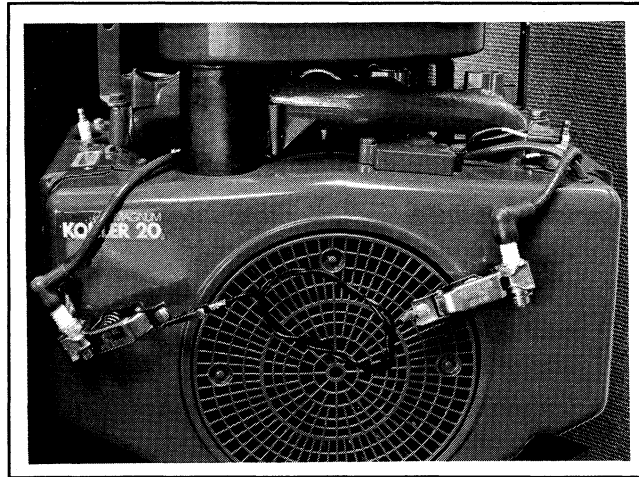

Figure 8-2. Ignition System Tester.

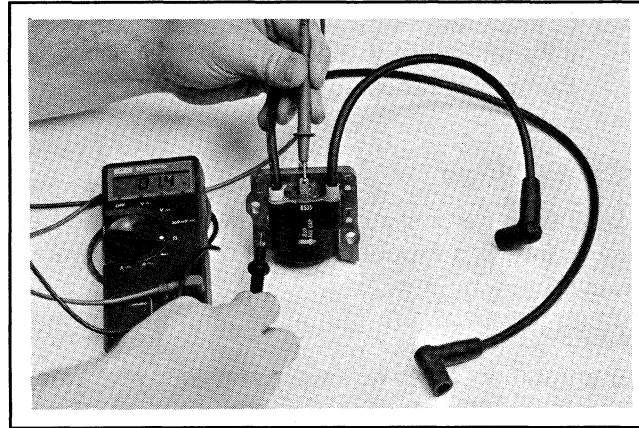

Figure 8-3. Testing Module Primary.

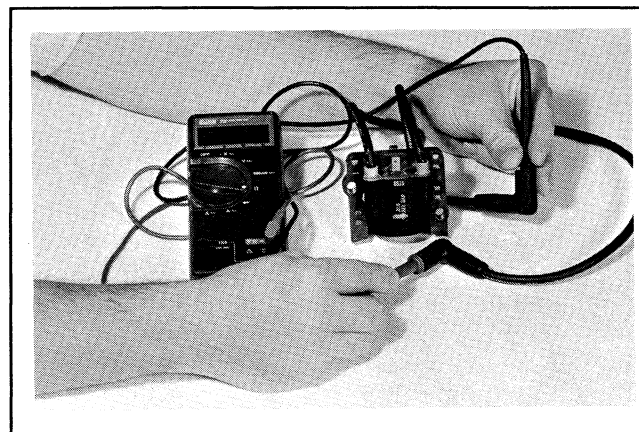

Figure 8-4. Testing Module Secondary.

Ignition Module

REMOVAL

1. Remove the blower housing.
2. Remove the kill lead from kill terminal of module. Refer to Figure 8-5.

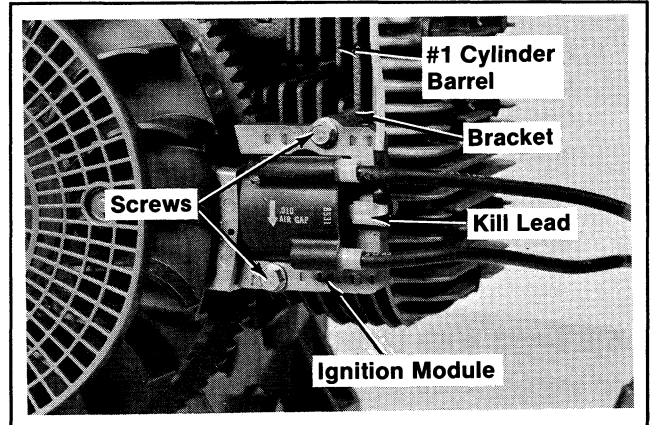

Figure 8-5. Removing Ignition Module.

3. Remove the hex. flange screws and module from bracket on #1 cylinder barrel.

INSTALLATION

1. Install the module and hex. flange screws to bracket. Move the module as far from flywheel/magnet as possible—tighten the hex. flange screws slightly.
2. Insert a .014" flat feeler gauge (or shim stock) between the magnet and module. Refer to Figure 8-5.

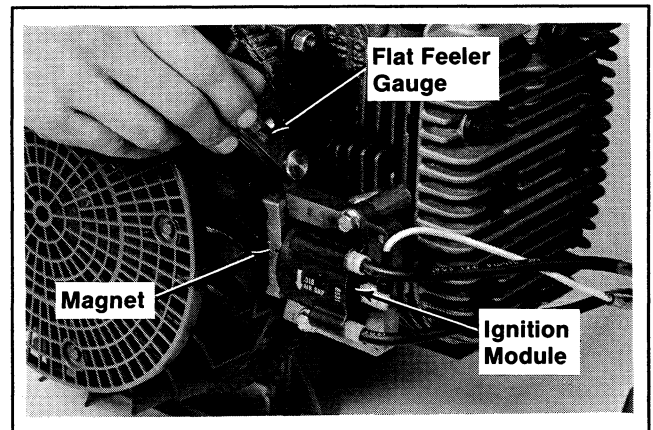

Figure 8-6. Setting Magnet-to-Module Air Gap.

SECTION 8 ELECTRICAL SYSTEM AND COMPONENTS

3. Loosen the hex. flange screw so the magnet pulls module against feeler gauge. Tighten the hex. flange screw securely.
4. Remove the feeler gauge or shim stock. Due to the pull of the magnet, the bracket and hardware will flex slightly. The magnet-to-module air gap should be within the range of .008/.012".
5. Rotate the flywheel back and forth; check to make sure the magnet does not strike the module. Check gap with feeler gauge and readjust if necessary.
6. Install the kill lead to kill terminal of module. Reinstall the blower housing.

Kill Lead With Optional Diode

An optional in-line diode was installed in the kill lead of some early Magnum engines, to protect the module from burning out, if voltage was applied to the kill lead. Refer to Figure 8-7. The diode was later added to the internal circuitry of the module, so they would all have the same protection.

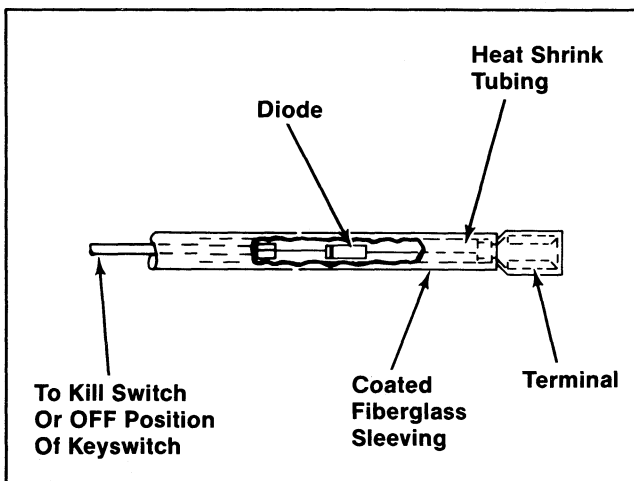

Figure 8-7. Kill Lead With In-Line Diode.

The diode is rated such that diode failure is highly unlikely. If the diode should fail, however, two failure modes are possible. If the diode fails in the shorted mode and voltage is applied to the kill lead, the module will burn out. If the diode fails in the open mode, the engine will continue to run when the kill switch is placed in the "off" position. If either of these symptoms is experienced, the diode should be tested.

DIODE TEST

Use an ohmmeter (or continuity tester) to test the diode. Set the meter on Rx1 scale and zero.

1. Disconnect the kill lead terminals from the kill switch and ignition module.
2. Connect the meter/tester leads to the kill lead terminals. Then reverse the leads.

In one direction the resistance should be infinity ohms (no continuity). With the leads reversed, some resistance (continuity) should be measured.

3. If the resistance is infinity ohms in both directions (no continuity), the kill lead or diode is open and the wiring harness must be replaced. Refer to the appropriate Parts Manual for the correct part number.

If the resistance is 0 ohms in both directions, and the module is burned out; replace the module only.

Spark Plugs

Engine misfire or starting problems are often caused by spark plugs in poor condition or with improper gap setting.

SERVICE

Every 100 operating hours remove the spark plugs, check condition, and reset gaps or replace with new plugs as necessary. Refer to Figure 8-8.

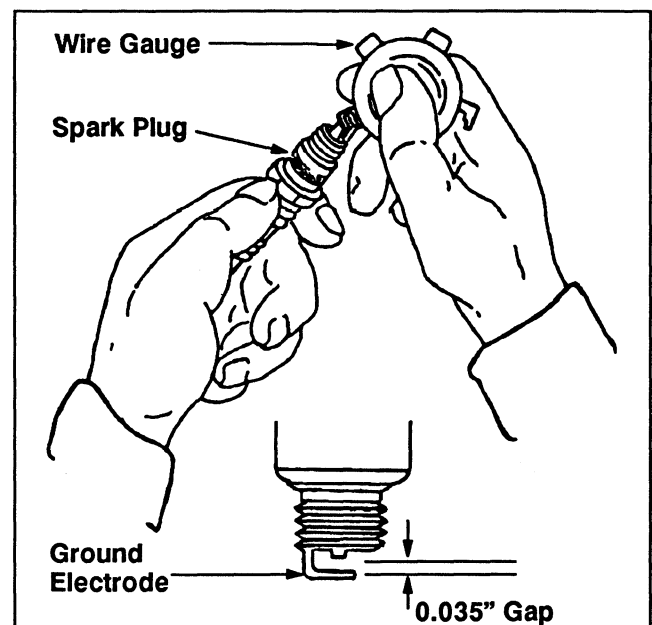

Figure 8-8. Servicing Spark Plug.

SECTION 8

ELECTRICAL SYSTEM AND COMPONENTS

1. Before removing the spark plugs, clean the area around the base of plugs to keep dirt and debris out of the engine.
2. Remove the plugs and check condition. Replace the plugs if worn or if reuse is questionable.

Use Champion® type RV17YC (or equivalent) spark plugs.

NOTE: Do not clean the spark plugs in a machine using abrasive grit. Some grit could remain in spark plugs and enter the engine causing extensive wear and damage.

3. Check the gaps using a wire feeler gauge. Adjust gaps to **0.035" (0.89 mm)** by carefully bending the ground electrode.
4. Reinstall the spark plugs into cylinder heads. Torque plugs to **10/15 ft. lb (14/20 N•m)**.

INSPECTION

Inspect the spark plugs as soon as they are removed from the cylinder heads. The deposits on the tips are an indication of the general condition of piston rings, valves, and carburetor.

Normal and faulty spark plugs are shown in the following photos.

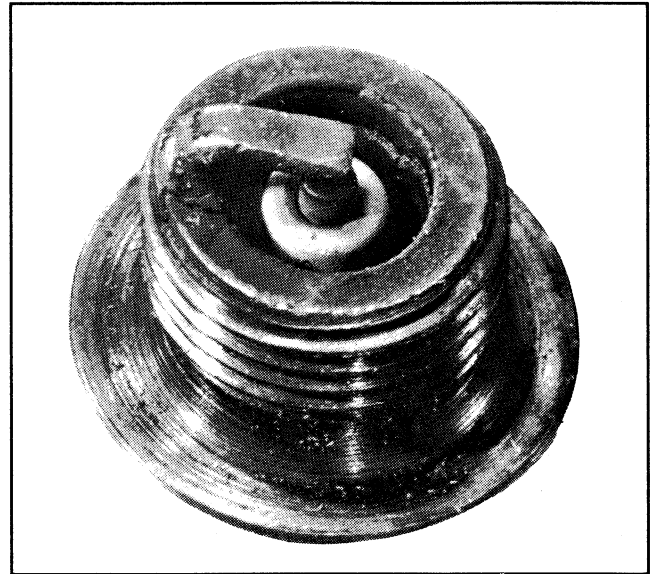

Normal: A plug taken from an engine operating under normal conditions will have light tan or gray colored deposits. If the center electrode is not worn, a plug in this condition could be regapped and reused.



Carbon Fouled: Soft, sooty, black deposits indicate incomplete combustion. Incomplete combustion is usually caused by over rich carburetion, weak ignition, or poor compression.

SECTION 8 ELECTRICAL SYSTEM AND COMPONENTS

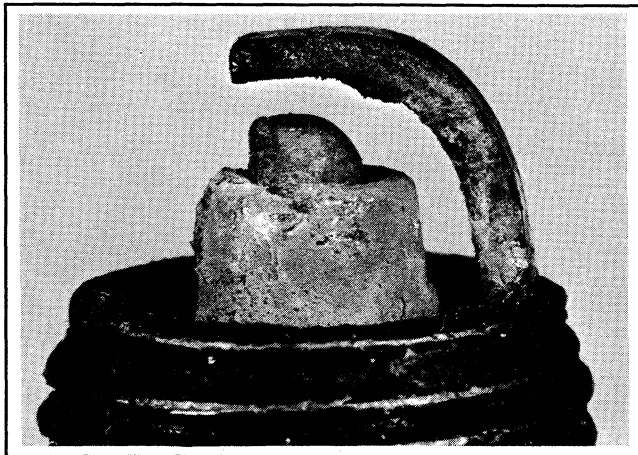

Worn: On a worn plug, the center electrode will be rounded and the gap will be eroded .010" or more than the correct gap. Replace a worn spark plug immediately.



Wet Fouled:* A wet plug is caused by excess fuel, or oil in the combustion chamber. Excess fuel could be caused by operating the engine with too much choke. Oil in the combustion chamber is usually caused by worn piston rings or valve guides.

*NOTE: For repeated spark plug fouling, order and install Carburetor Baffle Kit 82 755 24.



Chalky White Deposits: Chalky white colored deposits indicate overheating. This condition is usually accompanied by excessive gap erosion. A clogged grass screen, clogged cooling fins, and lean carburetion are some causes of overheating.

ELECTRICAL SYSTEMS WIRING DIAGRAMS AND BATTERY CHARGING SYSTEMS

The following battery charging systems are available on Magnum twin cylinder engines.

- 15 Amp Regulated Battery Charging System
- 25 Amp Regulated Battery Charging System

Refer to the following wiring diagrams and troubleshooting guides to test and service these battery charging systems.

NOTE: To prevent damage to the electrical system and components:

1. Make sure battery polarity is correct. A negative (-) ground system is used.
2. Disconnect the rectifier-regulator leads and/or wiring harness plug before electric welding is done on the equipment powered by the engine. Also disconnect other electrical accessories in common ground with the engine.
3. Prevent the stator (AC) leads from touching or shorting while engine is running. This could permanently damage the stator.

SECTION 8 ELECTRICAL SYSTEM AND COMPONENTS

Electric Start Engines 15 amp Regulated Charging System

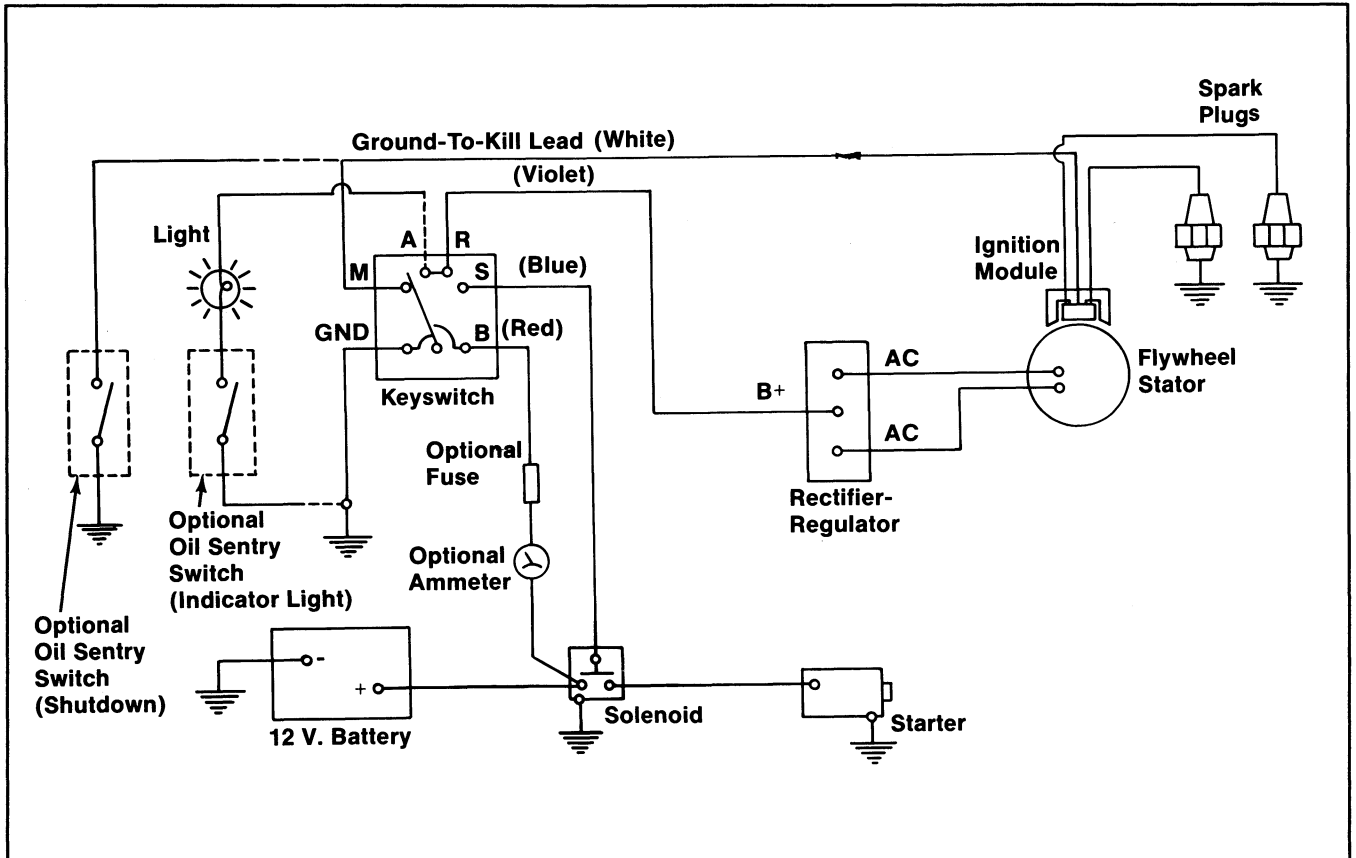

Figure 8-9. Wiring Diagram - Electric Start Engines/15 amp Regulated Battery Charging System.

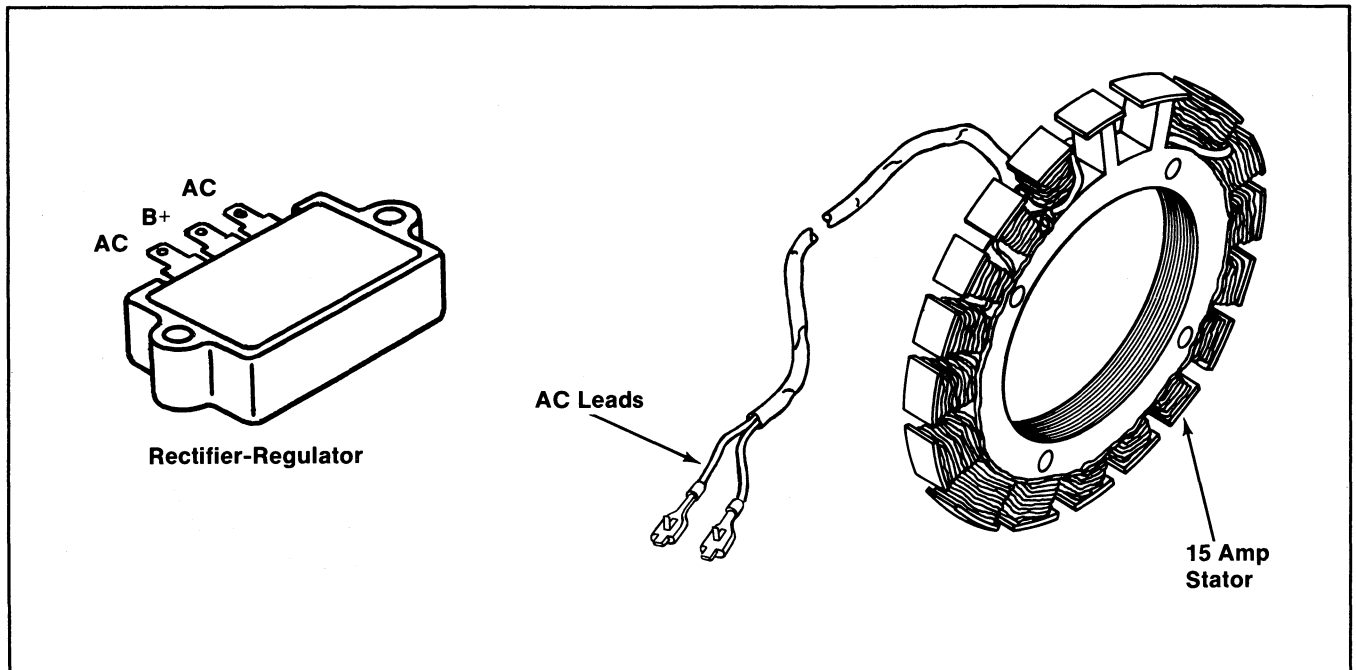

Figure 8-10. 15 amp Stator and Rectifier-Regulator.

SECTION 8 ELECTRICAL SYSTEM AND COMPONENTS

Electric Start Engines 25 amp Regulated Charging System

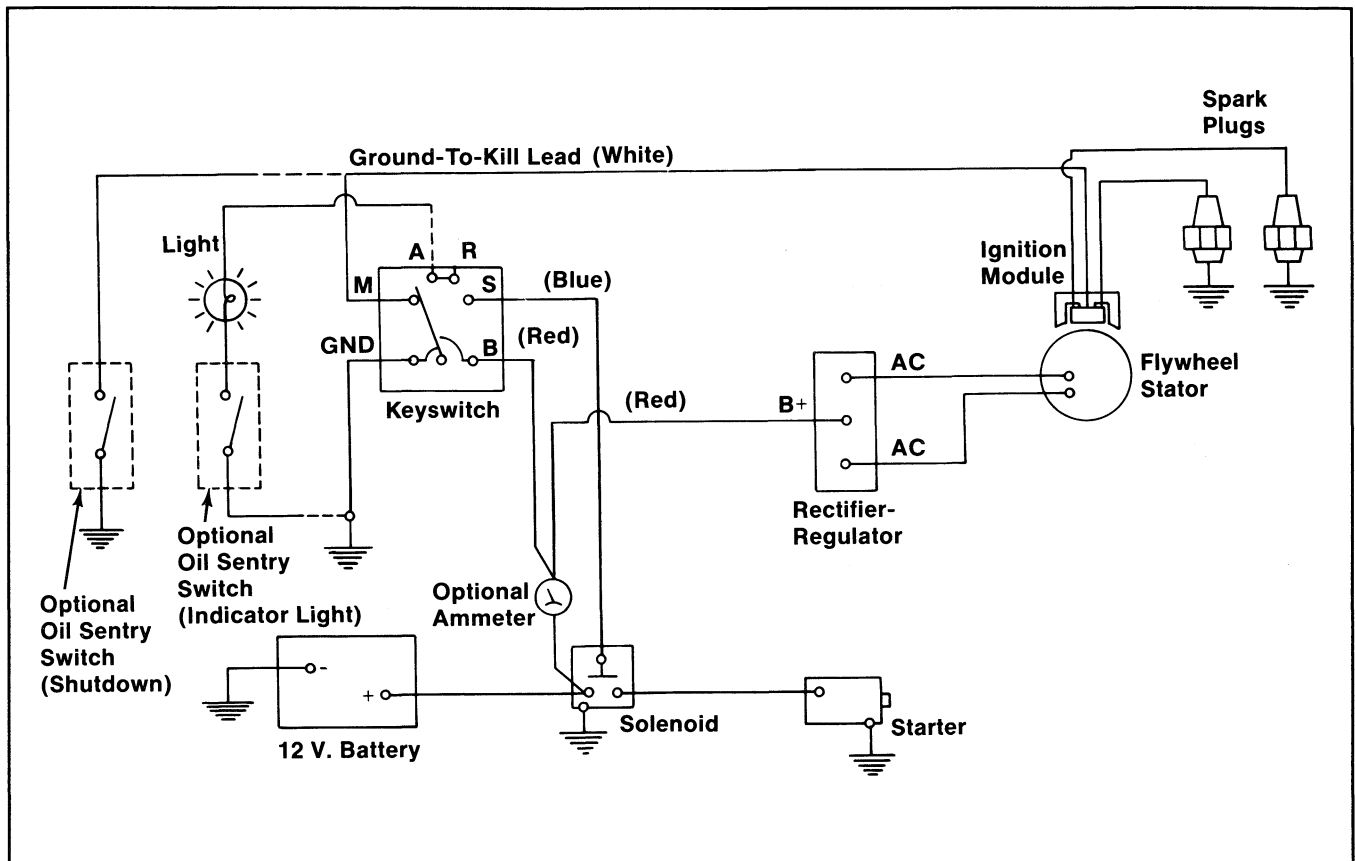

Figure 8-11. Wiring Diagram - Electric Start Engines/25 amp Regulated Battery Charging System.

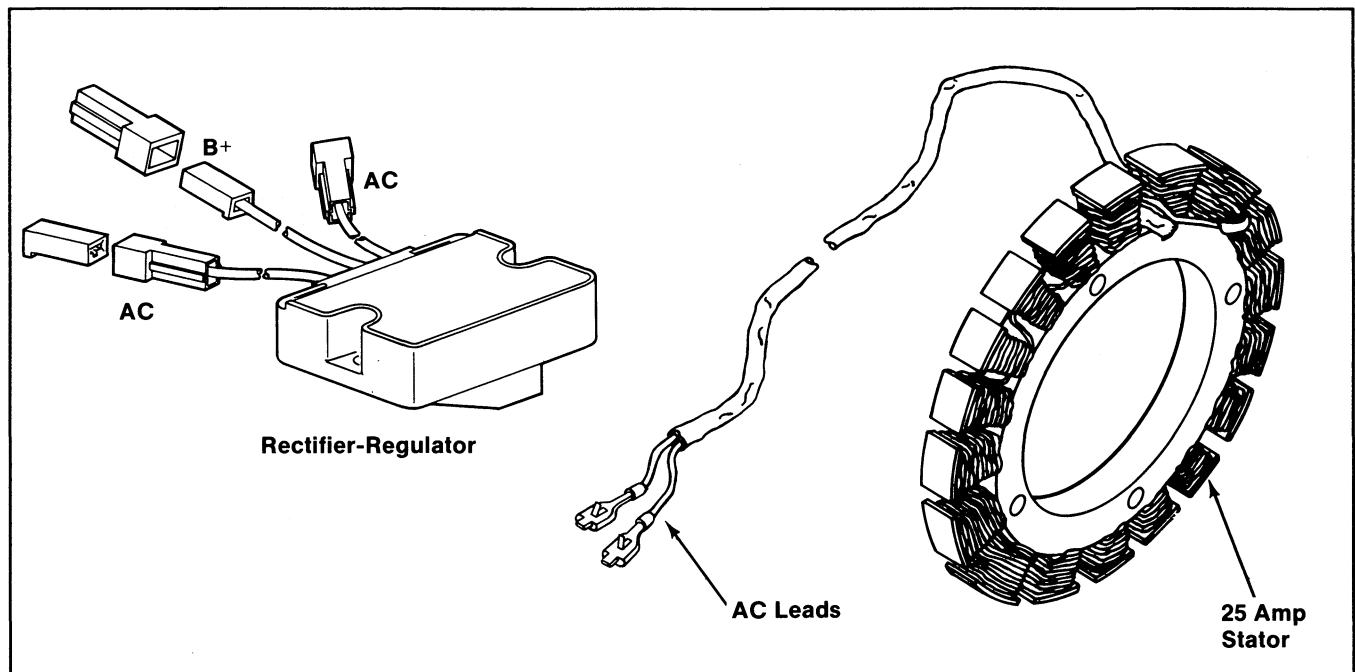

Figure 8-12. 25 amp Stator and Rectifier-Regulator.

SECTION 8

ELECTRICAL SYSTEM AND COMPONENTS

Troubleshooting Guide

15/25 amp Battery Charging Systems

NOTE: Zero ohmmeters on each scale to ensure accurate readings. Voltage tests should be made with engine running at 3600 RPM – no load. Battery must be fully charged.

Problem	Test	Conclusion
NO CHARGE TO BATTERY	<p>1. Trace B+ lead from rectifier-regulator to key switch, or other accessible connection. Disconnect it from switch or connection. Connect an ammeter from loose end of B+ lead to positive terminal of battery. Connect DC voltmeter from loose end of B+ lead to negative terminal of battery. With engine running at 3600 RPM, read voltage on voltmeter.</p> <p>If voltage is 13.8 volts or more, place a minimum load of 5 amps* on battery to reduce voltage. Observe ammeter.</p> <p>*NOTE: Turn on lights, if 60 watts or more. Or place a 2.5 ohm, 100 watt resistor across battery terminals.</p>	<p>1. If voltage is 13.8-14.7 and charge rate increases when load is applied, the charging system is OK and battery was fully charged.</p> <p>If voltage is less than 13.8 or charge rate does not increase when load is applied, test stator (Tests 2 and 3).</p>
	<p>2. Remove connector from rectifier-regulator. With engine running at 3600 RPM, measure AC voltage across stator leads using an AC voltmeter.</p>	<p>2. If voltage is 28 volts or more, stator is OK. Rectifier-regulator is faulty. Replace the rectifier-regulator.</p> <p>If voltage is less than 28 volts, stator is probably faulty and should be replaced. Test stator further using an ohmmeter (Test 3).</p>
	<p>3a. With engine stopped, measure the resistance across stator leads using an ohmmeter.</p>	<p>3a. If resistance is .064/0.2 ohms, the stator is OK.</p> <p>If resistance is infinity ohms, stator is open. Replace stator.</p>
	<p>3b. With engine stopped, measure the resistance from each stator lead to ground using an ohmmeter.</p>	<p>3b. If resistance is infinity ohms (no continuity), the stator is OK (not shorted to ground).</p> <p>If resistance (or continuity) is measured, the stator leads are shorted to ground. Replace stator.</p>
BATTERY CONTINUOUSLY CHARGES AT HIGH RATE	<p>1. Perform same test as Step 1 above.</p>	<p>1. If voltage is 14.7 volts or less the charging system is OK. The battery is unable to hold charge. Service battery or replace as necessary.</p> <p>If voltage is more than 14.7 volts, the rectifier-regulator is faulty. Replace rectifier-regulator.</p>

SECTION 8 ELECTRICAL SYSTEM AND COMPONENTS

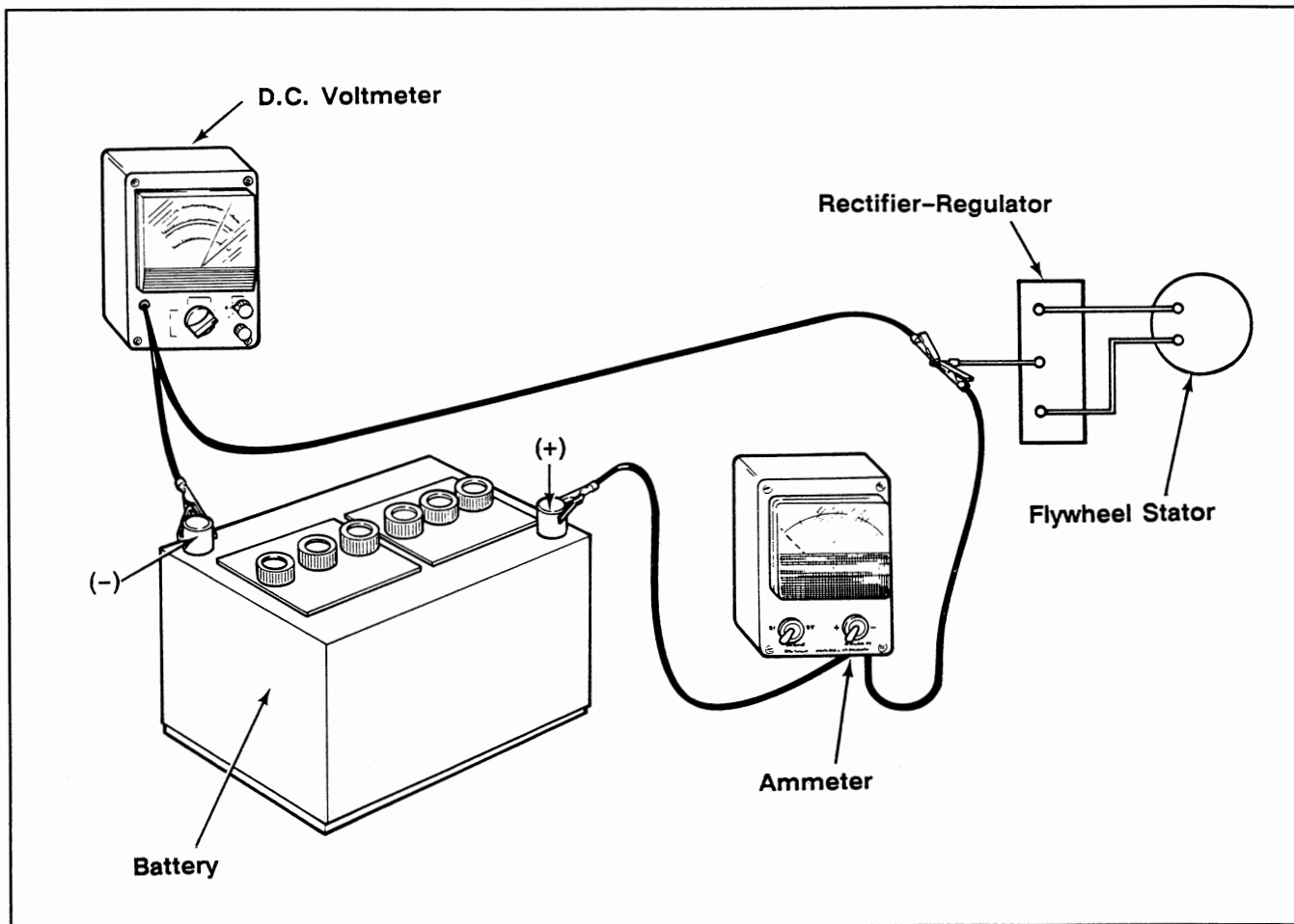

Figure 8-13. Connections for Testing 15 and 25 Systems.

BATTERY

Batteries are supplied by the equipment manufacturer. A 12-volt battery with a rating of 250 (minimum) cold cranking amps is normally used. Refer to the equipment manufacturer's instructions for specific information.

Battery Test

If the battery charge is not sufficient to crank the engine, recharge the battery.

NOTE: Do not attempt to "jump start" the engine with another battery. Starting the engine with batteries larger than those recommended can burn out the starter motor.

Test the battery voltage by connecting DC voltmeter across the battery terminals--crank the engine. If the battery drops below 9 volts while cranking, the battery is discharged or faulty. Refer to Figure 8-14.

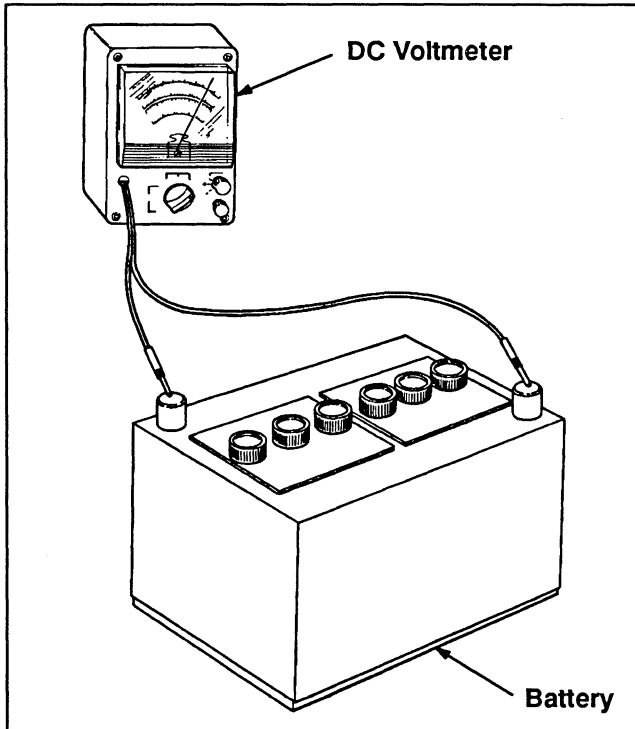

Figure 8-14. Checking Battery Voltage.

Battery Charging



WARNING: Dangerous Acid, Explosive Gases!

Batteries contain sulfuric acid. To prevent acid burns, avoid contact with skin, eyes, and clothing.

Batteries produce explosive hydrogen gas while being charged. Charge the battery in well-ventilated areas. Keep cigarettes, sparks, open flame, and other sources of ignition away from battery at all times.

To prevent accidental shorting and the resulting sparks, remove all jewelry when servicing the battery.

When disconnecting battery cables, always disconnect the negative (-) (ground) cable first. When connecting battery cables, always connect the negative cable last.

Before disconnecting the negative (-) ground cable, make sure all switches are OFF. If ON, a spark will occur at the ground cable terminal which could cause an explosion if hydrogen gas or gasoline vapors are present.

Keep batteries and acid out of the reach of children.

Battery Maintenance

Regular maintenance will ensure the battery will accept and hold a charge.

1. Regularly check the level of electrolyte. Add **distilled** water as necessary to maintain the recommended level.

NOTE: Do not overfill the battery. Poor performance or early failure due to loss of electrolyte will result.

2. Keep the cables, terminals, and external surfaces of battery clean. A build-up of corrosive acid or grime on the external surfaces can self-discharge the battery. Self-discharging happens rapidly when moisture is present.

Wash the cables, terminals, and external surfaces with a baking soda and water solution. Rinse thoroughly with clear water.

SECTION 8 ELECTRICAL SYSTEM AND COMPONENTS

NOTE: Do not allow the baking soda solution to enter the cells as this will destroy the electrolyte.

KEY SWITCH

The key switch used on Magnum engines equipped with instrument panels is shown in Figure 8-15. It is a three position (OFF, RUN, START), break-before-make type switch.

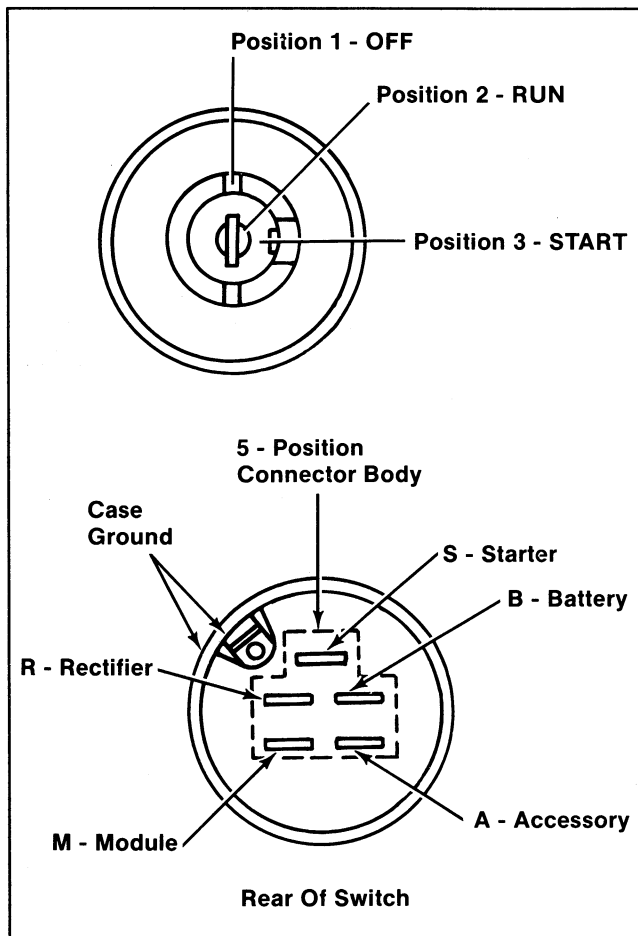

Figure 8-15. Key Switch.

Testing

Test the switch for continuity using an ohmmeter or continuity test light. For each switch position, continuity should be present across the terminals listed in the table below:

Switch Position	Continuity Across Terminals
1 - OFF	G + M + A
2 - RUN	B + A + R
3 - START	B + S

SOLENOID

A solenoid is used on applications. The solenoid is an electrically-actuated normally open switch designed for heavy current loads. Refer to Figure 8-16.

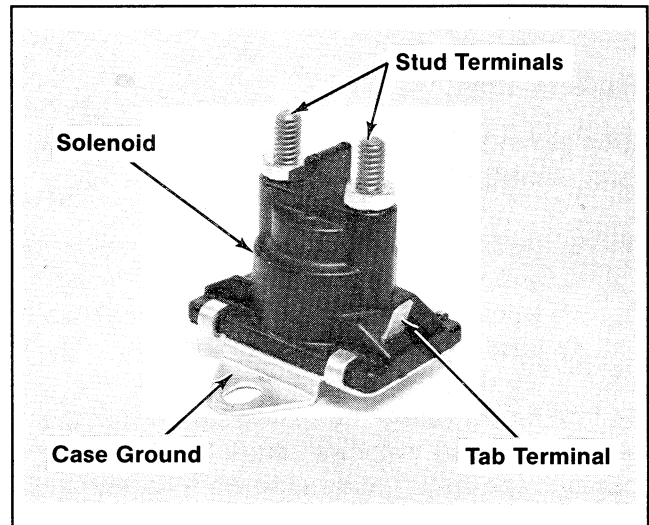

Figure 8-16. Starter Solenoid.

The solenoid is used to switch the heavy current required by the starter using the key switch (designed for low current loads).

Testing

1. Connect an ohmmeter or continuity tester across the stud terminals of solenoid.
2. Apply 12 volts DC across the tab terminal and case ground of solenoid and observe ohmmeter or tester.

NOTE: Apply positive (+) of voltage supply to tab terminal; negative (-) to case ground.

3. The ohmmeter or tester should indicate continuity as long as voltage is applied. If there is no continuity, the solenoid is probably faulty and should be replaced.

Check the solenoid further using an ohmmeter (Step 4).

SECTION 8 ELECTRICAL SYSTEM AND COMPONENTS

4. Measure the resistance of the coil in the solenoid using an ohmmeter. Connect one meter lead to the case ground and one lead to the tab terminal.

If the resistance is 5.2/6.3 ohms, the coil is OK.

If the resistance is low or 0 ohms, the coil is shorted. Replace solenoid.

If the resistance is infinity ohms, the coil is open. Replace solenoid.

ELECTRIC STARTER

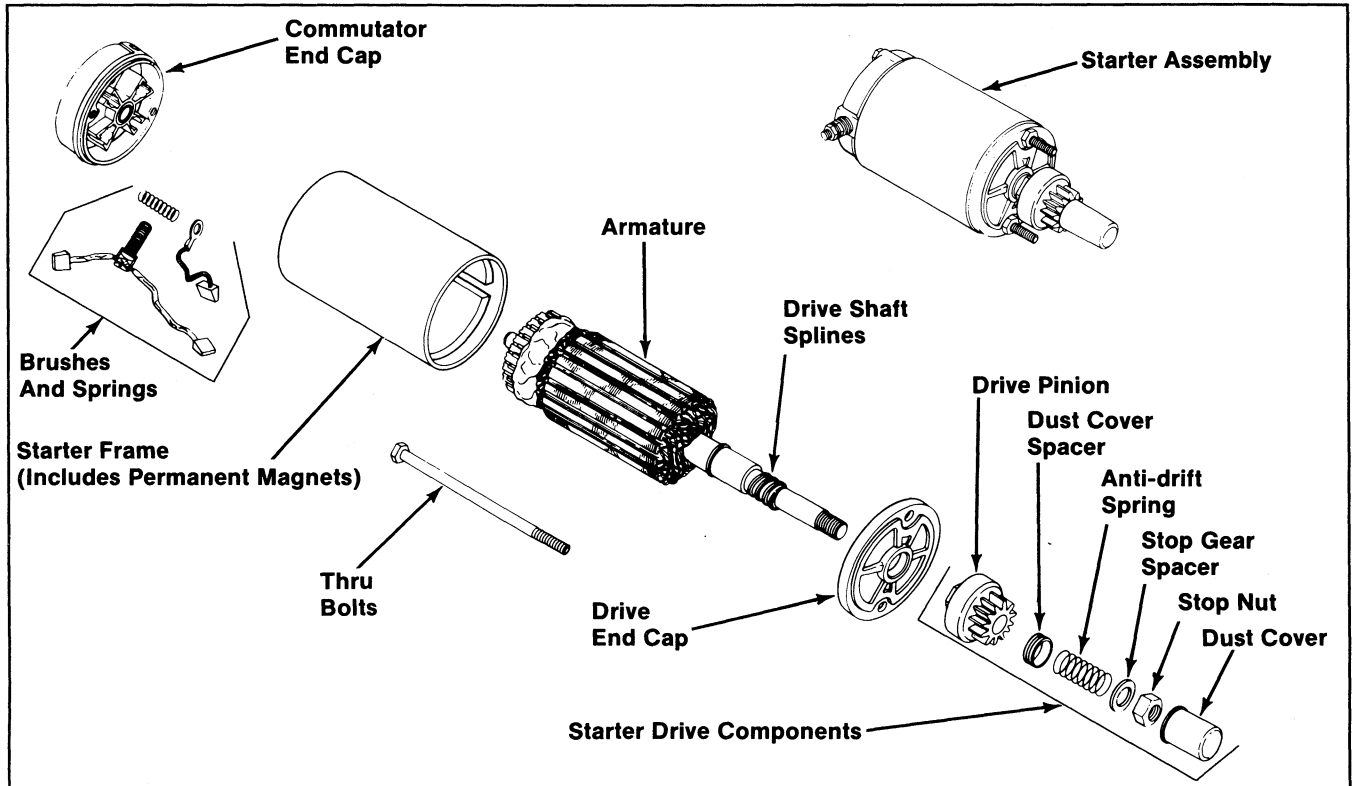

Figure 8-17. Bendix Drive Electric Starter.

BENDIX DRIVE ELECTRIC STARTER

The M18 & M20 engines will use either a Bendix drive starter as shown in Figure 8-17 or a solenoid shift type starter described on pages 8.16 through 8.21.

Operation – (Bendix Drive Type Starter)

When power is applied to the starter, the armature rotates. As the armature rotates, the drive pinion moves out on the splined drive shaft into mesh with the flywheel ring gear. When the pinion reaches the end of the drive shaft, it rotates the flywheel cranking the engine.

When the engine starts, the flywheel rotates faster than the armature and drive pinion. This moves the drive pinion out of mesh with the ring gear and into the retracted position. When power is removed from the starter, the armature stops rotating and the pinion is held in the retracted position by the anti-drift spring.

NOTE: Do not crank the engine continuously for more than 10 seconds at a time. If the engine does not start, allow a 60 second cool-down period between starting attempts. Failure to follow these guidelines can burn out the starter motor.

SECTION 8 ELECTRICAL SYSTEM AND COMPONENTS

NOTE: If the engine develops sufficient speed to disengage the starter but does not keep running (a "false start"), the engine rotation must be allowed to come to a complete stop before attempting to restart the engine. If the starter is engaged while the flywheel is rotating, the starter pinion and flywheel ring gear may clash. This can damage the starter.

NOTE: If the starter does not crank the engine, shut-off the starter immediately. Do not make fur-

ther attempts to start the engine until the condition is corrected. Do not jump start using another battery. Using batteries larger than those recommended can burn out the starter motor.

NOTE: Do not drop the starter or strike the starter frame. Doing so can damage the ceramic permanent magnets.

Troubleshooting Guide

Problem	Possible Fault	Correction
STARTER FAILS TO ENERGIZE	Wiring	1. Clean corroded connections and tighten loose connections. 2. Replace wires in poor condition and with frayed or broken insulation.
	Starter Switch or Solenoid	Bypass the switch or solenoid with a jumper wire—if starter cranks normally, replace the faulty parts.
	Battery	Check specific gravity of battery. If low, recharge or replace battery as necessary.
STARTER ENERGIZES BUT TURNS SLOWLY	Battery	Check specific gravity of battery. If low, recharge or replace battery as necessary.
	Brushes	Check for excessively dirty or worn brushes and commutator. Clean using a coarse cloth (not emery paper). Replace brushes if excessively or unevenly worn.
	Transmission or Engine	Make sure the clutch or transmission is disengaged or placed in neutral. This is especially important on equipment with hydrostatic drive. The transmission must be exactly in neutral to prevent resistance which could keep the engine from starting. Check for seized engine components such as the bearings, connecting rod, and piston.

Starter Drive Service

Every 500 operating hours or annually (whichever comes first), clean and lubricate the drive splines of the starter. If the drive pinion is badly worn, or has chipped or broken teeth, it must be replaced.

It is not necessary to disassemble the starter to service the drive components. Refer to Figure 8-17 and service drive as follows:

1. Hold the drive pinion in a vise with soft jaws when removing and installing the stop nut. The armature will rotate with the nut only until the drive pinion stops against internal spacers.

NOTE: Do not overtighten the vise as this can distort the drive pinion.

2. Remove the dust cover, stop nut, stop gear spacer, anti-drift spring, dust cover spacer, and drive pinion.
3. Clean the drive shaft splines with solvent. Dry the splines thoroughly.

4. Apply a small amount of Kohler electric starter drive lubricant (Part No. 52 357 01) to splines.

NOTE: Kohler starter drive lubricant (Part No. 52 357 01) must be used on all Kohler electric starter drives. The use of other lubricants can cause the drive to stick or bind.

5. Apply a small amount of Loctite® No. 271 to stop nut threads.
6. Reinstall the drive pinion, dust cover spacer, anti-drift spring, stop gear spacer, and stop nut. Torque stop nut to **160 in. lb.** Install the dust cover.

Disassembly

1. Remove the dust cover, stop nut, stop gear spacer, anti-drift spring, dust cover spacer, and drive pinion. Refer to "Starter Drive Service."
2. Remove the thru bolts.
3. Remove the drive end cap and thrust washer.

4. Remove the commutator end cap with brushes and springs.
5. Remove the armature from inside the starter frame.

Brush Replacement (Refer to Figure 8-18.)

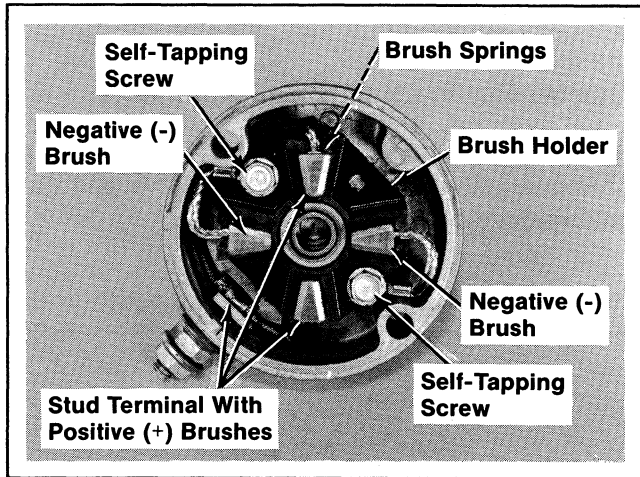

Figure 8-18. Commutator End Cap With Brushes.

1. Remove the brush springs from the pockets in brush holder.
2. Remove the self-tapping screws, negative (-) brushes, and plastic brush holder.
3. Remove the hex. nut, split lock washer, plain washer, and fiber washer from the stud terminal.

Remove the stud terminal with positive (+) brushes and plastic insulating bushing from end cap.

4. Reinstall the insulating brushing to new stud terminal with positive (+) brushes. Install the bushing and stud terminal into end cap. Secure with the fiber washer, plain washer, split lock washer, and hex. nut.
5. Install the brush holder and new negative (-) brushes. Secure with the self-tapping screws.
6. Install the brush springs and brushes into the pockets in brush holder. Make sure the chamfered sides of brushes are away from the springs.

NOTE: Use a brush holder tool to keep the brushes in the pockets. A brush holder tool can easily be made from thin sheet metal. Refer to Figure 8-19.

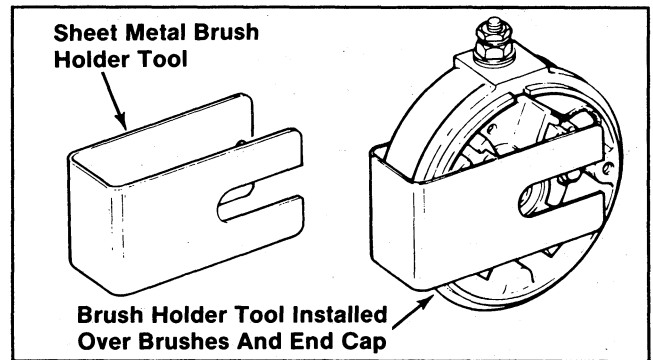

Figure 8-19. Brush Holder Tool.

Commutator Service

Clean the commutator with a coarse, lint free cloth. Do not use emery cloth. If the commutator is badly worn or grooved, turn down on a lathe, or replace the armature.

Reassembly

1. Insert the armature into the starter frame. Make sure the magnets are closer to the drive shaft end of armature. The magnets will hold the armature inside the frame.
2. Install the thrust washer and drive end cap. Make sure the match marks on end cap and frame are aligned. Refer to Figure 8-20.

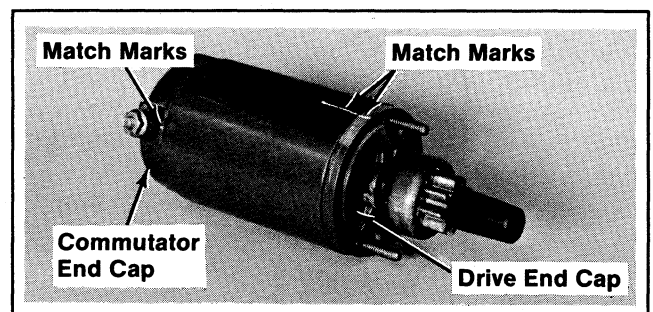

Figure 8-20. Starter Assembly Match Marks.

3. Install the brush holder tool to keep the brushes in the pockets of commutator end cap. Refer to Figure 8-19.
4. Install the commutator end cap to armature and starter frame. Firmly hold the drive end cap and commutator end cap to the starter frame. Remove the brush holder tool.
5. Make sure the match marks on end cap and frame are aligned. Refer to Figure 8-20. Install the thru bolts and tighten securely.

SECTION 8 ELECTRICAL SYSTEM AND COMPONENTS

6. Install the drive pinion, dust cover spacer, anti-drift spring, stop gear spacer, stop nut, and dust cover. Refer to "Starter Drive Service."

SOLENOID SHIFT ELECTRIC STARTER

This subsection covers the Nippondenso solenoid shift electric starter. Much of the information in the preceding subsection relates to this starter, therefore it is not repeated here. Please use the exploded view (Figure 8-21) for reference during the disassembly and assembly procedure.

Operation

When power is applied to the starter, the electric solenoid moves the drive pinion out onto the drive shaft

and into mesh with the flywheel ring gear. When the pinion reaches the end of the drive shaft it rotates the flywheel and cranks the engine.

When the engine starts and the start switch is released the starter solenoid is deactivated, the drive lever moves back, and the drive pinion moves out of mesh with the ring gear into the retracted position.

Starter Removal and Reinstallation

Refer to the engine disassembly and reassembly sections later in this manual for starter removal and installation procedures.

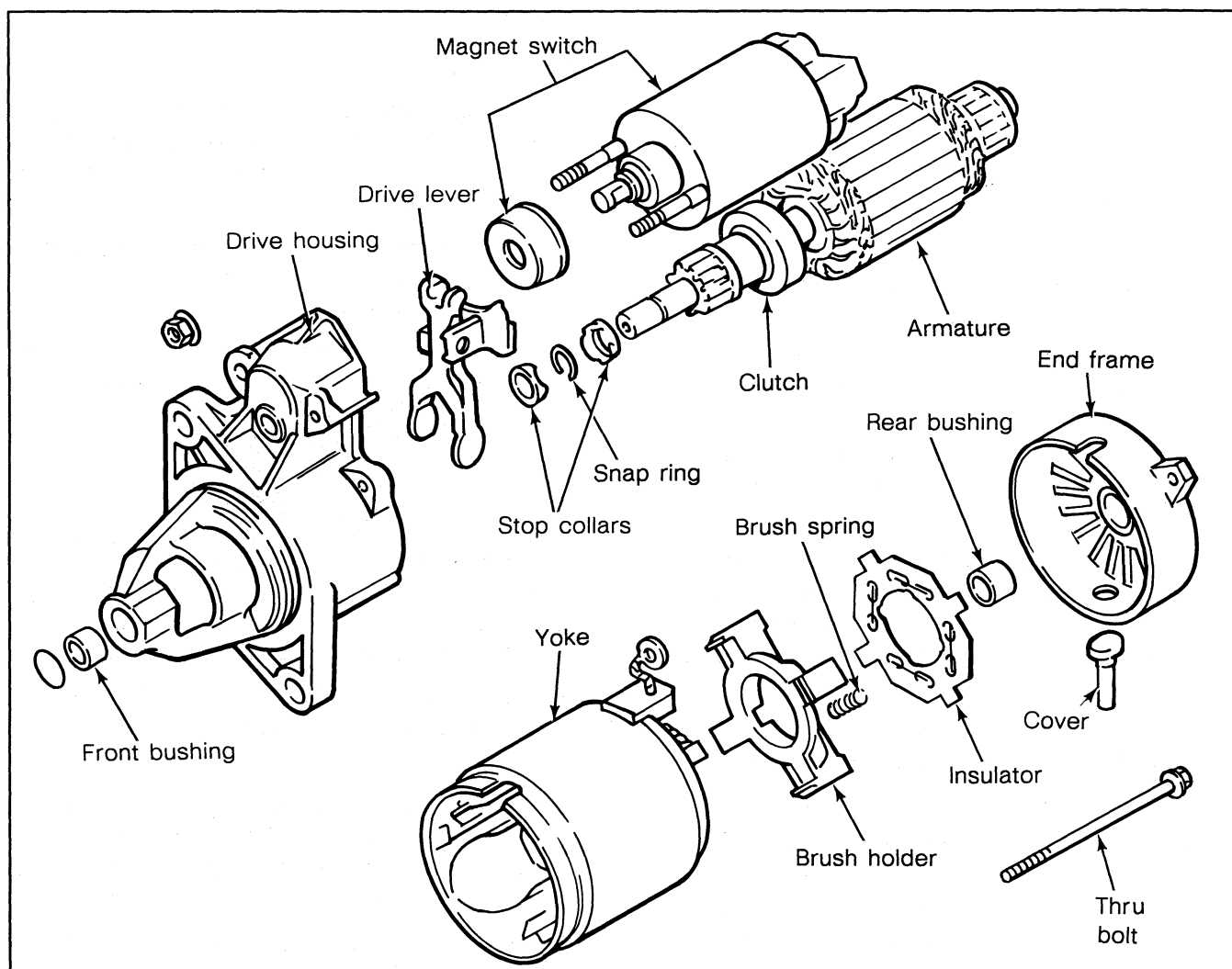

Figure 8-21. Exploded View of Nippondenso Solenoid Shift Starter.

SECTION 8

ELECTRICAL SYSTEM AND COMPONENTS

Starter Disassembly

1. Disconnect the wire from the solenoid.
2. Remove the hex. nuts securing the solenoid, and remove the solenoid from the starter assembly.
3. Remove the two thru bolts.
4. Remove the commutator end cap.
5. Remove the insulator and brush springs from the brush spring holder.

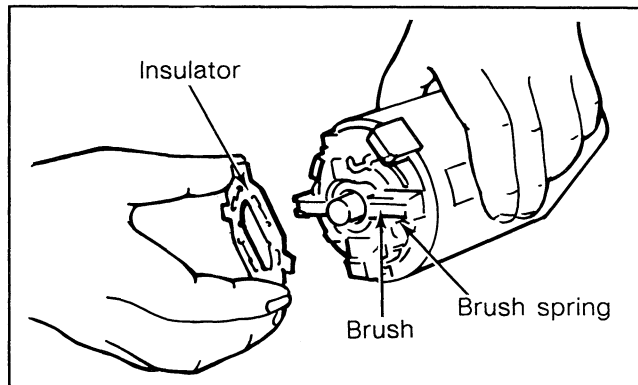

Figure 8-22. Removing the Insulator.

6. Remove the armature from the frame.
7. Remove the drive lever and armature from the drive end cap.

NOTE: When removing the lever and armature be careful not to lose the thrust washer and be sure to reinstall it later.

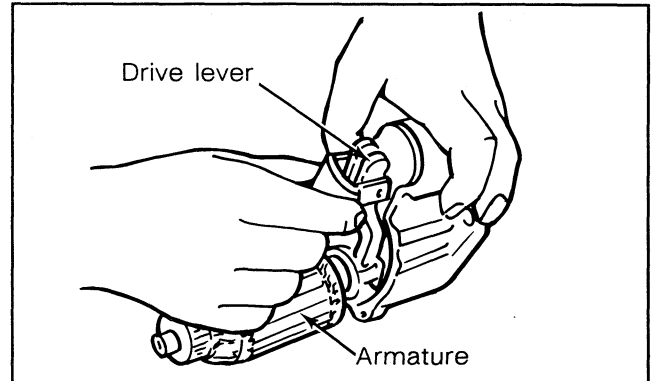

Figure 8-23. Removing the Armature and Drive Lever.

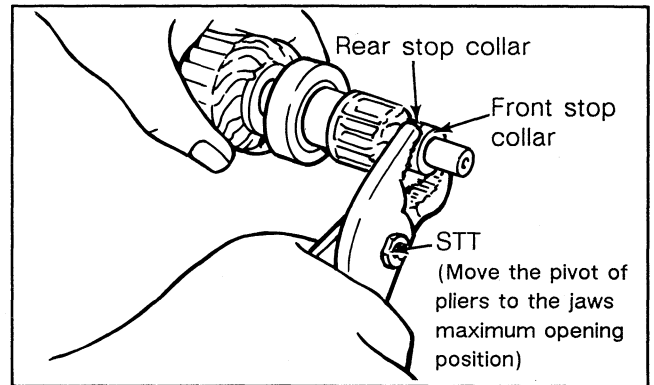

Figure 8-24. Removing the Stop Collar (1).

8. The stop collar consists of two similar pieces held in place by being snapped over a retainer. The retainer is held in place by a groove in the armature shaft. To remove the stop collar, the two pieces must be pried off the retainer.

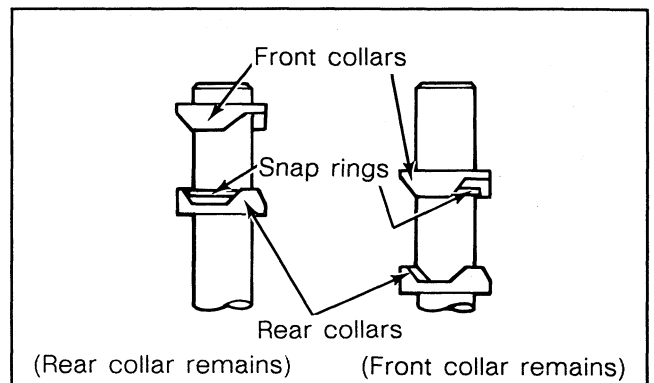

Figure 8-25. Removing the Stop Collar (2).

Using the SST (tool for removing the GA stop collar), remove the stop collar as shown in Figure 8-24; insert the blade of the SST into the groove between the two adjacent stop collars, and then remove the stop collar while widening the groove.

SECTION 8 ELECTRICAL SYSTEM AND COMPONENTS

NOTE: Since the rear stop collar may engage with the snap ring if the shaft's end is hit too hard, be sure to hit it with the proper force.

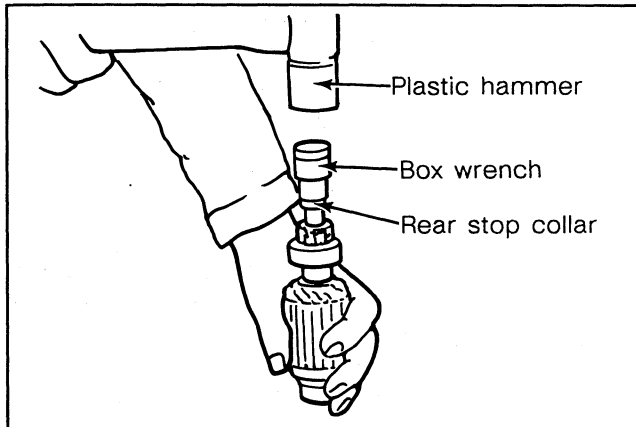

Figure 8-26. Removing the Rear Stop Collar.

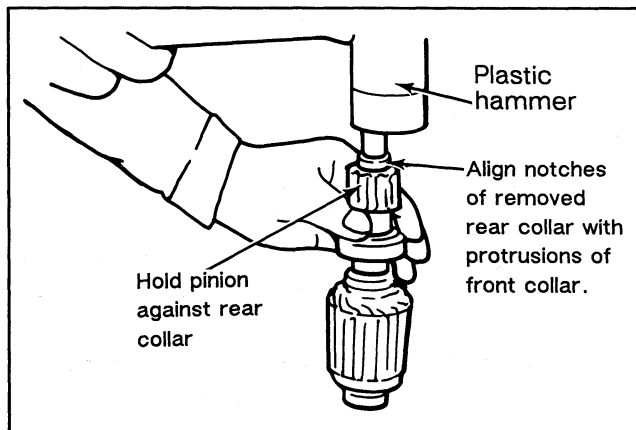

Figure 8-27. Removing the Front Stop Collar.

9. After the stop collars are removed, the retainer can be removed from the armature shaft. Do not reuse the retainer.

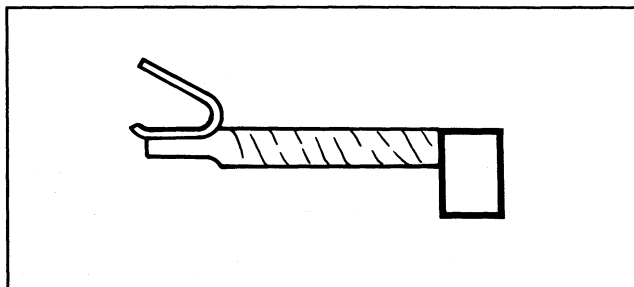

Figure 8-28. Replacement Brush.

BRUSH REPLACEMENT

The brushes in the starter are part of the starter frame, brush kit Part No. 52 221 01 contains four replacement brushes and springs. If replacement is necessary, all four brushes should be replaced.

1. Remove brushes from brush holder, and remove brush holder from frame.

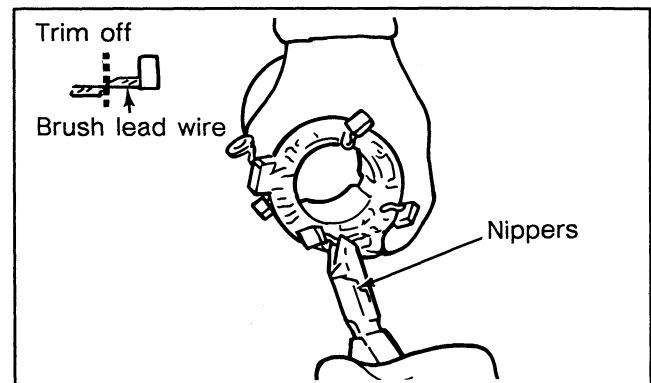

Figure 8-29. Cutting Brush Lead Wires from the Frame Posts.

2. Cut the brush lead wire at the edge of the post with a pair of nippers.

3. File off burrs on the post.

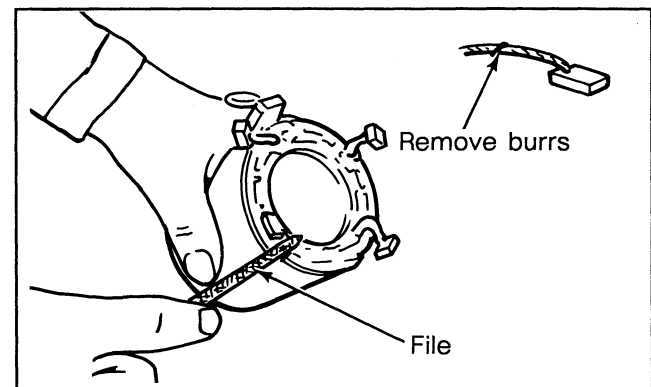

Figure 8-30. Filing Off Burrs on Posts.

4. Place the plate of the spare brush on the welded portion of the brush lead wire, and then crimp them together with a pair of pliers. Be sure to align the edge of the lead wire.

SECTION 8 ELECTRICAL SYSTEM AND COMPONENTS

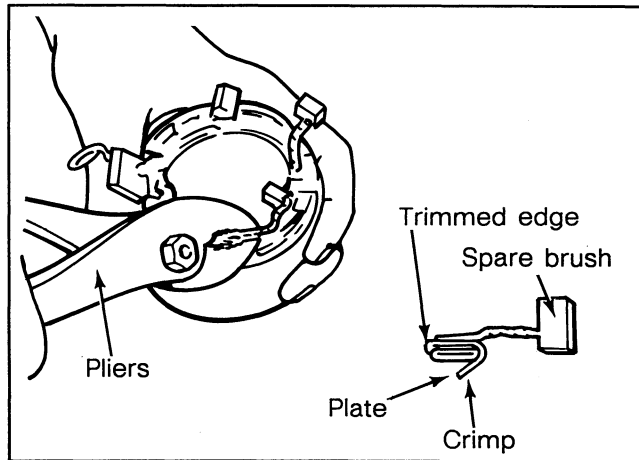

Figure 8-31. Connecting Replacement Brushes.

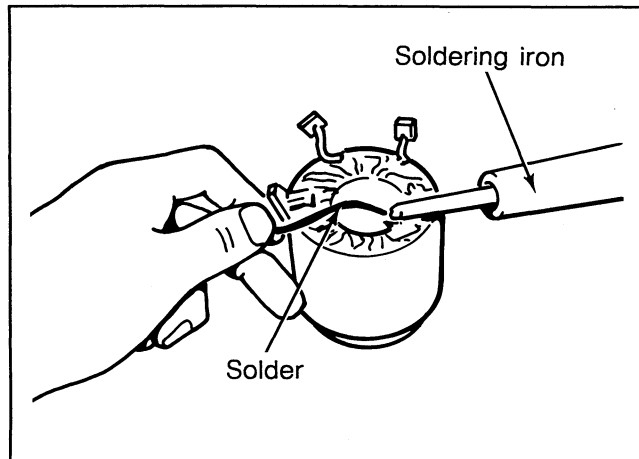

Figure 8-32. Soldering Brush Clips to Posts.

5. Solder the crimped portion to the post.
6. Replace the brush holder in the frame and place the brushes in the brush holder. Reinstall the springs.

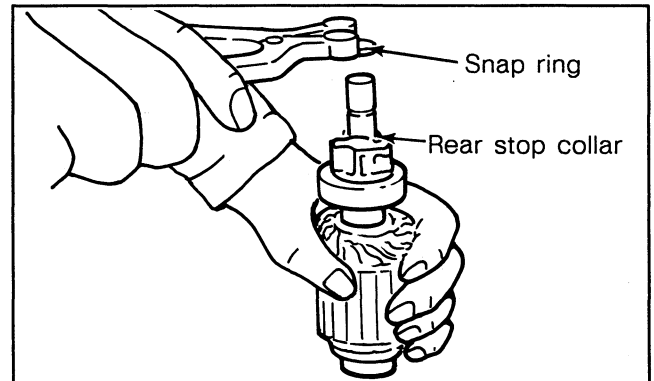

Figure 8-33. Installing Snap Ring.

Starter Service

Clean drive lever and armature shaft then apply Kohler electric starter drive lubricant or equivalent to lever and shaft.

Starter Reassembly

1. Insert the rear stop collar on the armature shaft.
Always use new snap ring.

SECTION 8 ELECTRICAL SYSTEM AND COMPONENTS

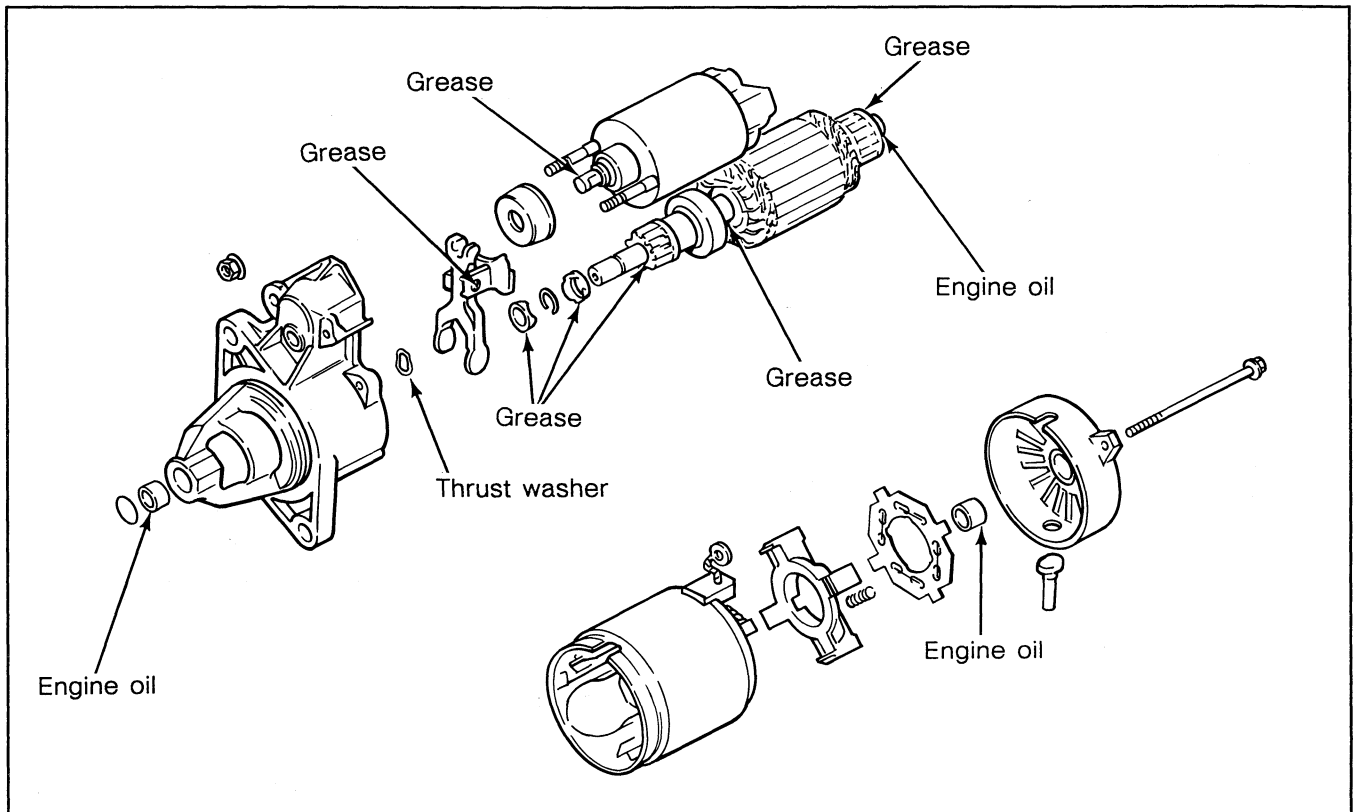

Figure 8-34. Lubrication Points.

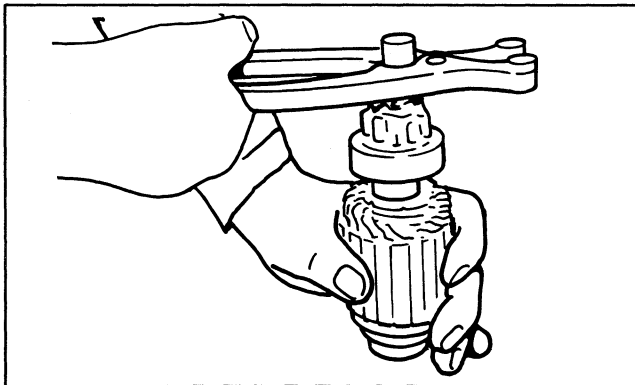

Figure 8-35. Tightening the Snap Ring.

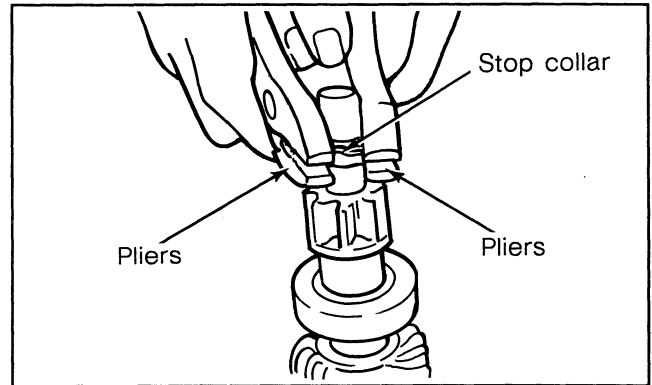

Figure 8-36. Installing the Stop Collar.

- Place the retainer in the groove on the armature shaft.

NOTE: Always use a new retainer. Tighten the retainer in the groove to secure.

- Fit the front stop collar over the shaft and bring the front and the rear stop collars together over the retainer. Using two pairs of pliers apply even force to the two collars until they snap over the retainer and nest into one another.

SECTION 8 ELECTRICAL SYSTEM AND COMPONENTS

- Note that the cross section of the brush spring is oval, not circular; therefore, inserting this spring with its longer axis facing upwards makes installation easier.

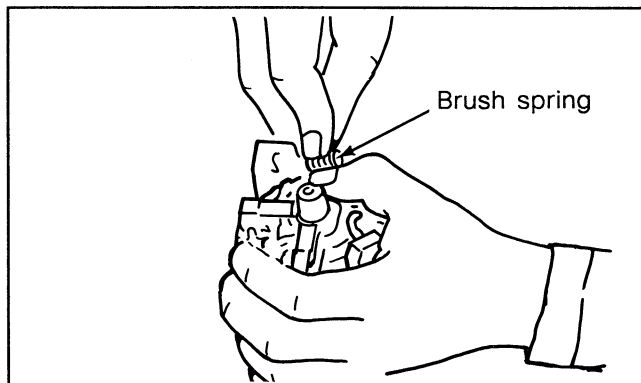

Figure 8-37. Installing the Brush Springs.

- Reassemble the remaining components of the starter in reverse order of disassembly.

**SECTION 8
ELECTRICAL SYSTEM AND COMPONENTS**

SECTION 9 DISASSEMBLY



WARNING: Accidental Starts!

Before servicing the engine or equipment, always remove the spark plug leads to prevent the engine from starting accidentally. Ground the leads to prevent sparks that could cause fires.

The following sequence is suggested for complete engine disassembly. This procedure may have to be varied slightly to accommodate options or special equipment.

Clean all parts thoroughly as the engine is disassembled. Only clean parts can be accurately inspected and gauged for wear or damage. There are many commercially available cleaners that quickly remove grease, oil, and grime from engine parts. When such a cleaner is used, follow the manufacturer's instructions carefully. Make sure all traces of the cleaner are removed before the engine is reassembled and placed in operation—even small amounts of these cleaners quickly break down the lubricating properties of engine oil.

TYPICAL DISASSEMBLY SEQUENCE

1. Disconnect spark plug leads.
2. Drain oil and remove oil filter.
3. Remove mufflers and exhaust elbows.
4. Remove air cleaner.
5. Remove intake manifold and carburetor.
6. Disconnect wiring; remove rectifier-regulator, key switch, and solenoid.
7. Remove top baffle, cylinder head baffles, and blower housing.
8. Remove breather and valve cover.
9. Remove fuel pump.
10. Remove ignition module and bracket.
11. Remove grass screen, flywheel, and fan.
12. Remove electric starter.
13. Remove stator.

14. Identify engine sides.
15. Remove spark plugs and cylinder heads.
16. Remove cylinder barrels.
17. Remove valves.
18. Remove pistons from connecting rods.
19. Remove piston rings.
20. Remove closure plate, oil pressure relief valve, and rear oil seal.
21. Remove oil filter adapter.
22. Split the crankcase.
23. Remove camshaft and tappets.
24. Remove crankshaft, front oil seal, and bearings.
25. Remove connecting rods.
26. Remove governor gear and cross shaft.
27. Remove oil pickup and oil pump.

DISCONNECT SPARK PLUG LEADS DRAIN OIL AND REMOVE OIL FILTER

1. Remove the oil fill cap, dipstick, and oil drain plug. Drain the oil from crankcase. Refer to Figure 9-1.
2. Remove and discard the oil filter.

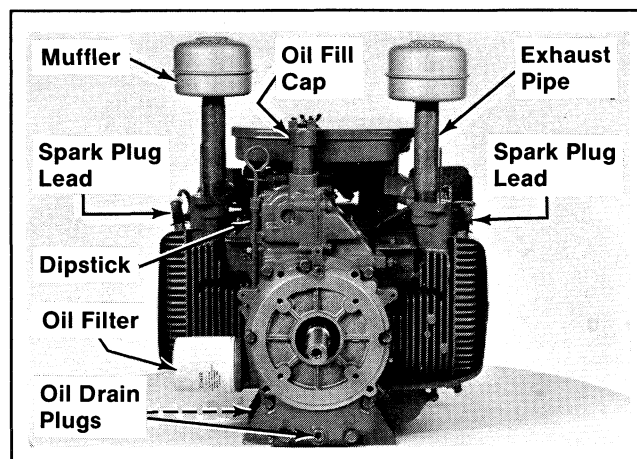

Figure 9-1. Removing Spark Plug Leads, Oil Drain, Oil Filter, and Mufflers.

SECTION 9 DISASSEMBLY

REMOVE MUFFLERS AND EXHAUST ELBOWS

1. Remove the mufflers and exhaust pipes. Refer to Figure 9-1.
2. Remove the hex. socket screws, exhaust elbows, and gaskets. Refer to Figure 9-2.

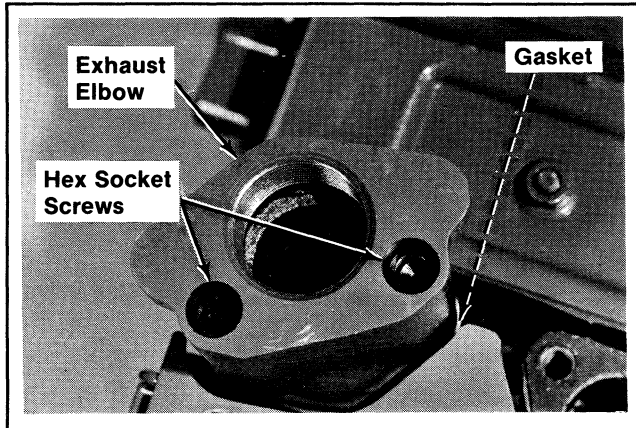

Figure 9-2. Removing Exhaust Elbows.

REMOVE AIR CLEANER

NOTE: The instructions given here are for the basic spec engine with the square style air cleaner. If the engine is equipped with an optional style air cleaner, refer to the "Air Cleaner" Section for removal procedures.

1. Remove the wing nuts and air cleaner cover. Refer to Figure 9-3.

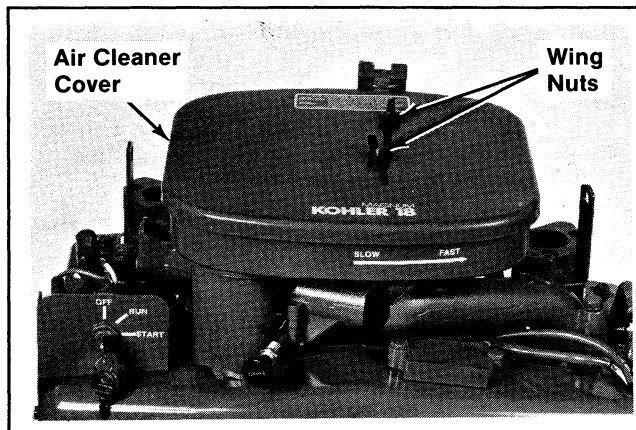

Figure 9-3. Removing Air Cleaner Cover.

2. Remove the element cover seals, element cover, and paper element (with precleaner, if so equipped). Refer to Figure 9-4.

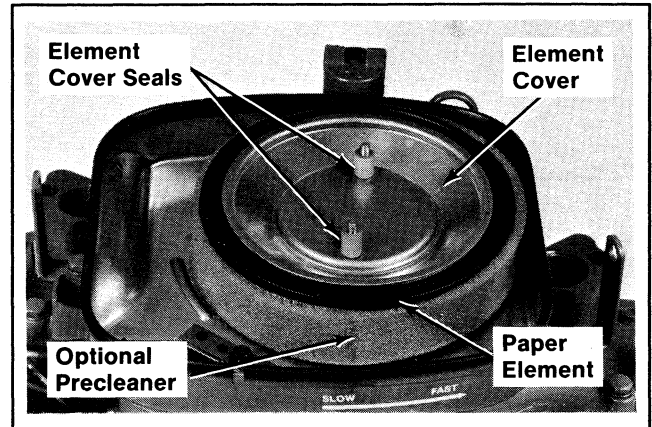

Figure 9-4. Removing Air Cleaner Element.

3. Remove the breather hose, self-tapping screw, air cleaner base, air intake tube, and gasket. Refer to Figure 9-5.

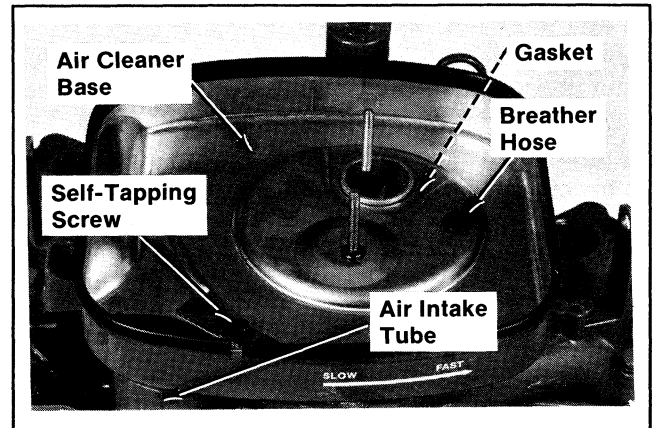

Figure 9-5. Removing Air Cleaner Base.

REMOVE INTAKE MANIFOLD AND CARBURETOR



WARNING: Explosive Fuel!

Gasoline may be present in the intake manifold, carburetor, and fuel system. Gasoline is extremely flammable, and its vapors can explode if ignited. Keep cigarettes, sparks, open flames, and other sources of ignition away from the engine. Wipe up spilled fuel immediately.

SECTION 9 DISASSEMBLY

1. Note the position of governor spring in governor arm and speed control lever. Loosen the hex. nut and remove governor arm and plain washer from cross shaft. Refer to Figure 9-6.

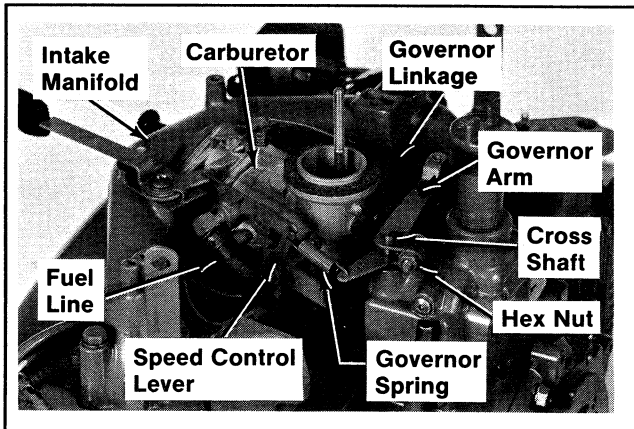

Figure 9-6. Removing Governor Arm, Carburetor, and Intake Manifold.

NOTE: Loosening the hex. nut or removing governor arm will disrupt governor arm to cross shaft adjustment. Readjustment will be required upon reassembly.

2. Remove the governor spring from governor arm and speed control lever. Remove the governor linkage from governor arm and carburetor throttle lever.
3. Loosen the hose clamp and remove fuel line from fuel pump outlet.
4. Remove the hex. cap screws, split lock washers, lifting straps, intake manifold with carburetor, and intake manifold gaskets. Refer to Figure 9-7.

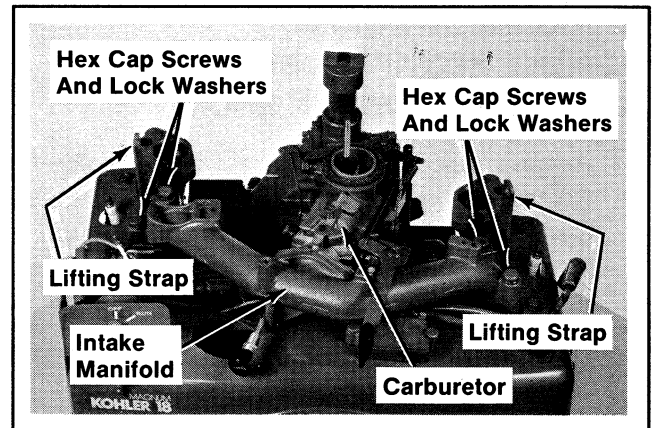

Figure 9-7. Removing Intake Manifold and Carburetor.

5. Remove the engine-mounted throttle and choke controls, if so equipped.
6. Remove the hex. nuts, carburetor with intake elbow, and gasket from intake manifold. Refer to Figure 9-8.

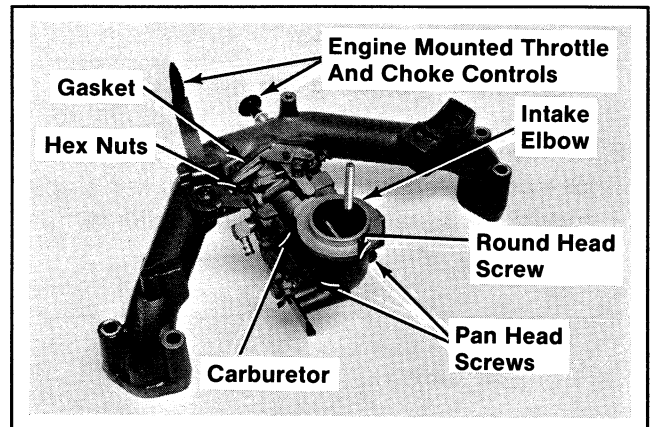

Figure 9-8. Removing Carburetor From Intake Manifold.

7. Remove the pan head screws, int. tooth lock washers, round head screw, plain washer, intake elbow, and gasket from carburetor.

SECTION 9 DISASSEMBLY

DISCONNECT WIRING; REMOVE RECTIFIER-REGULATOR, KEY SWITCH, AND SOLENOID

1. Remove the connector from rectifier-regulator. Remove the lead from center position of connector. Remove the hex. cap screws and rectifier-regulator. Refer to Figure 9-9.

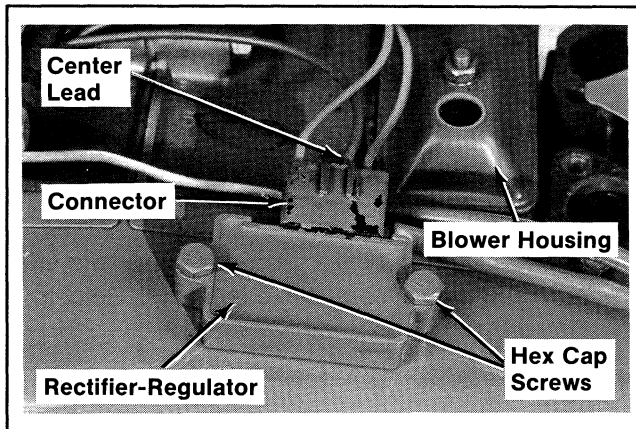

Figure 9-9. Removing Rectifier-Regulator.

2. Remove the connector from key switch. Remove kill lead from connector. Remove the self-tapping screws and panel with key switch. Refer to Figure 9-10.

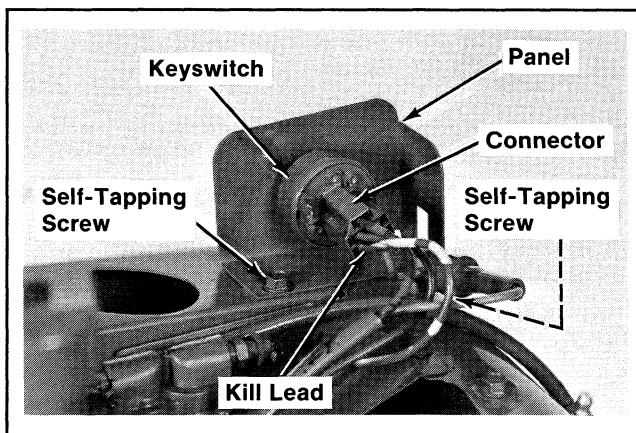

Figure 9-10. Removing Key Switch.

3. Disconnect the leads from starter solenoid. Remove the wire tie, self-tapping screws, solenoid with bracket, and spacer. Refer to Figure 9-11.

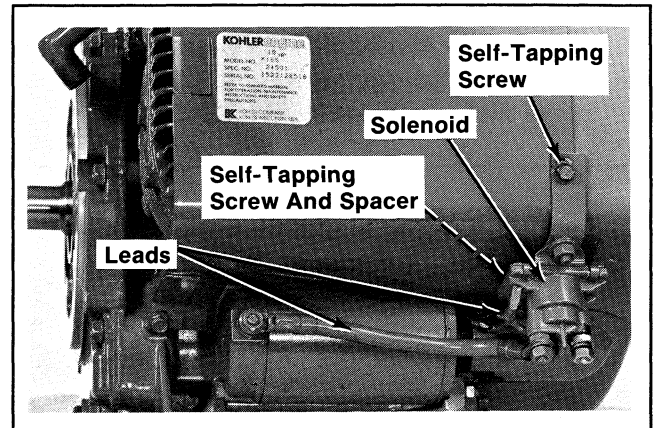

Figure 9-11. Removing Starter Solenoid.

REMOVE TOP BAFFLE, CYLINDER HEAD BAFFLES, AND BLOWER HOUSING

1. Remove the self-tapping screws and top baffle.
2. Remove the self-tapping screws and #1 side cylinder head baffle.
3. Remove the self-tapping screws and #2 side cylinder head baffle.
4. Remove the self-tapping screws and blower housing.

REMOVE BREATHER AND VALVE COVER

On #1 Side

1. Remove the hex. nut, copper washer, breather cover, and gasket. Refer to Figure 9-12.

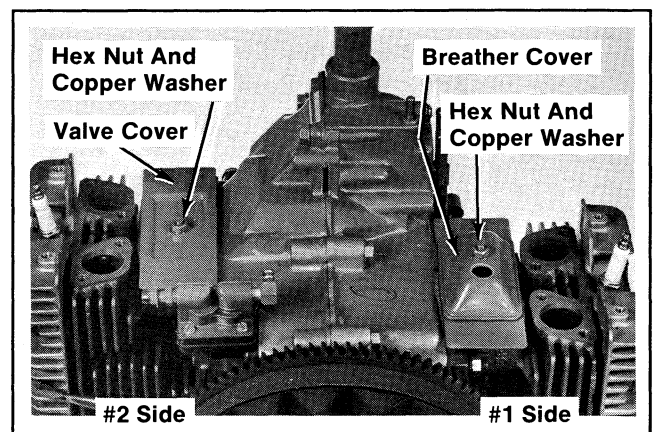

Figure 9-12. Removing Breather and Valve Cover.

2. Remove the filter, seal, breather plate, and gasket. Refer to Figure 9-13.

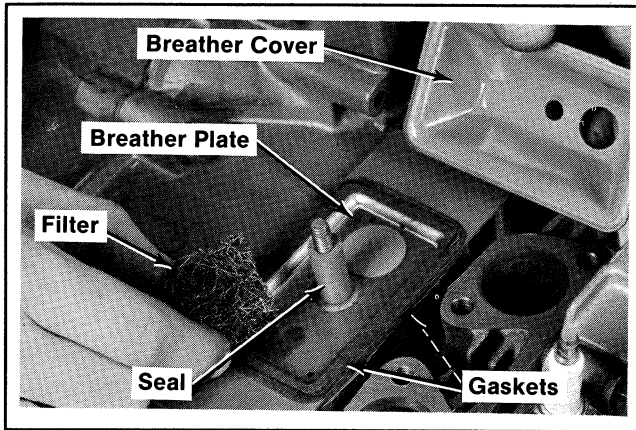

Figure 9-13. Removing Breather Components.

On #2 Side

1. Remove the hex. nut, copper washer, valve cover, and gasket. Refer to Figure 9-12.

REMOVE FUEL PUMP



WARNING: Explosive Fuel!

Gasoline may be present in the fuel pump. Gasoline is extremely flammable, and its vapors can explode if ignited. Keep cigarettes, sparks, open flames, and other sources of ignition away from engine. Wipe up spilled fuel immediately.

1. Remove the truss head screws, fuel pump, and gasket. Refer to Figure 9-14.

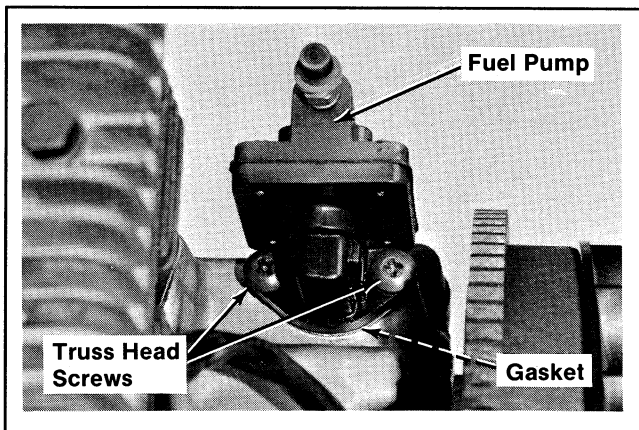

Figure 9-14. Removing Fuel Pump.

REMOVE IGNITION MODULE AND BRACKET

1. Remove the hex. flange screws and ignition module. Refer to Figure 9-15.

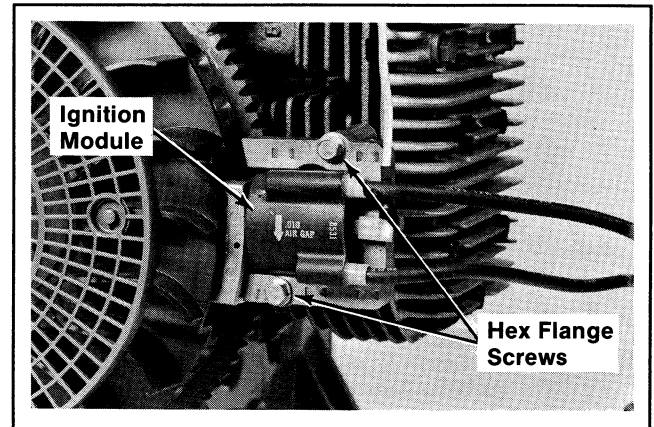

Figure 9-15. Removing Ignition Module.

2. Remove the hex. flange screws and bracket from #1 cylinder barrel. Refer to Figure 9-16.

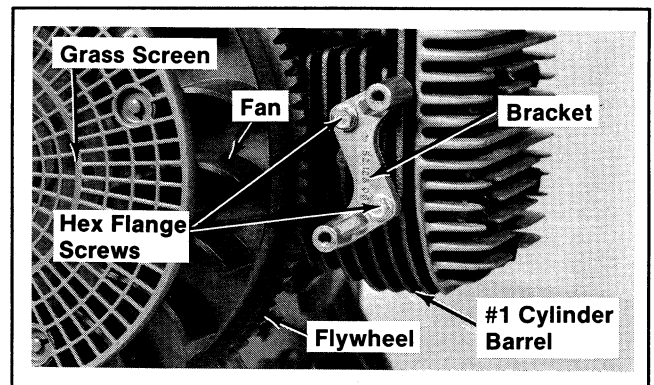

Figure 9-16. Removing Ignition Module Bracket.

REMOVE GRASS SCREEN, FLYWHEEL, AND FAN

NOTE: Always use the flywheel strap wrench to hold the flywheel when loosening or tightening flywheel and fan retaining fasteners. Do not use any type of bar or wedge between fins of cooling fan, as the fins could become cracked or damaged.

Always use a puller to remove flywheel from crankshaft. Do not strike the crankshaft or flywheel, as these parts could become cracked or damaged.

Refer to Section 2, "Special Tools" for recommended tools.

SECTION 9 DISASSEMBLY

1. Remove the grass screen from fan. Refer to Figure 9-16.
2. Hold the flywheel with the strap wrench and loosen the hex. cap screw. Remove hex. cap screw, split lock washer, and plain washer. Refer to Figure 9-17.

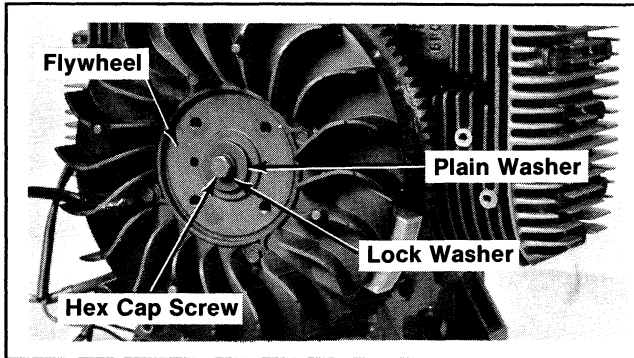

Figure 9-17. Removing Flywheel Fastener.

3. Remove the flywheel from crankshaft using a puller. Refer to Figure 9-18.

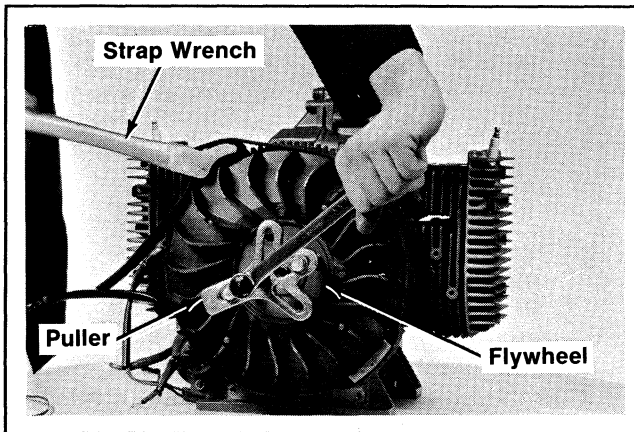

Figure 9-18. Removing Flywheel Using A Puller.

4. Remove the hex. flange screws, spacers, and fan. Refer to Figure 9-19.

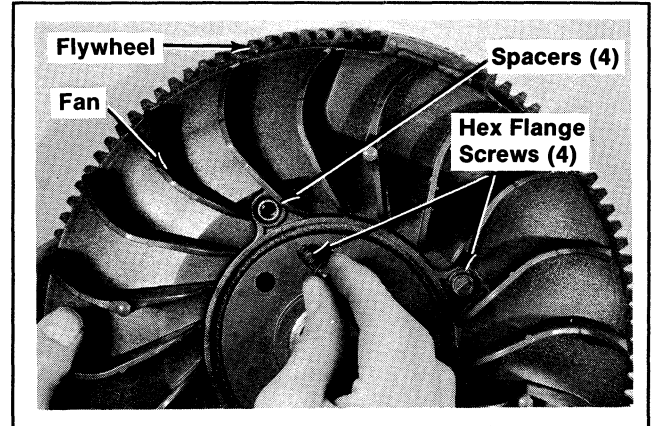

Figure 9-19. Removing Fan From Flywheel.



WARNING: Ignition Magnet Is Not Removable or Serviceable!

Do not attempt to remove the ignition magnet from flywheel. Loosening or removing the magnet mounting screws could cause the magnet to come loose and be thrown from the engine causing severe injury. Replace the flywheel if magnet is damaged.

REMOVE ELECTRIC STARTER

1. Remove the hex. nuts, split lock washers, wiring harness clamp, wiring harness, and electric starter. Refer to Figure 9-20.

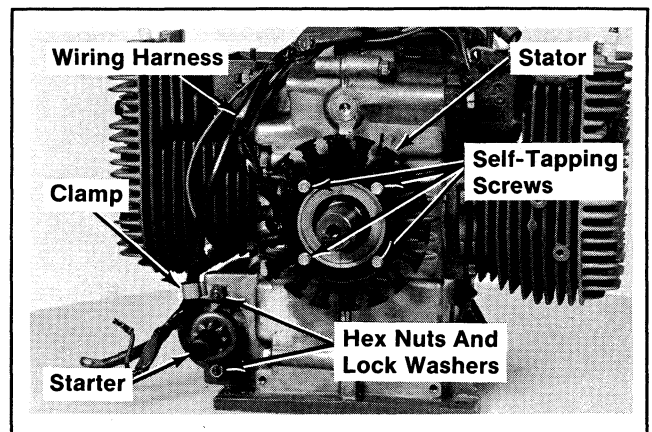

Figure 9-20. Removing Electric Starter and Stator.

REMOVE STATOR

1. Remove the self-tapping screws and stator. Refer to Figure 9-20.

IDENTIFY ENGINE SIDES

To ensure proper reassembly, it is necessary to identify the engine sides and various other engine components. Refer to Figure 9-21. The #1 side of engine has the cylinder barrel closest to the flywheel end of crankshaft. The #2 side of engine has the cylinder barrel closest to the PTO end of crankshaft.

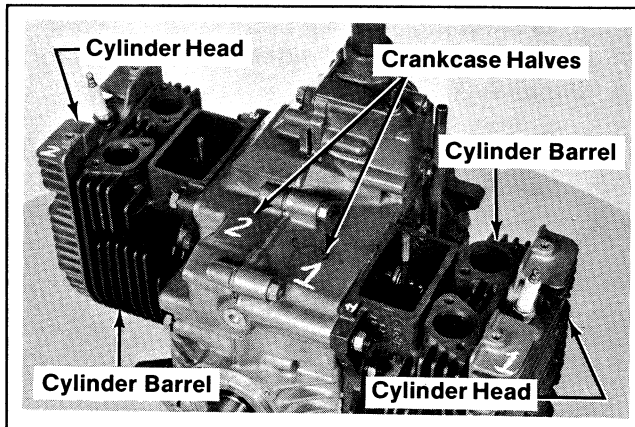

Figure 9-21. Identifying Engine Sides.

NOTE: To prevent damage to the engine crankcase and other components, do not mark using a metal stamp.

1. With a marking pen, paint, or chalk, mark the crankcase halves and cylinder heads as #1 side and #2 side.
2. The cylinder barrels are already identified as #1 or #2 by a mark stamped near the valve cover/breather gasket surface.
3. Identify other engine components, such as the valves, pistons, connecting rods and rod caps, and valve tappets, prior to removal or disassembly.

REMOVE SPARK PLUGS AND CYLINDER HEADS

1. Remove the spark plugs from cylinder heads.
2. Remove the hex. cap screws, plain washers, cylinder heads, and gaskets. Refer to Figure 9-22.

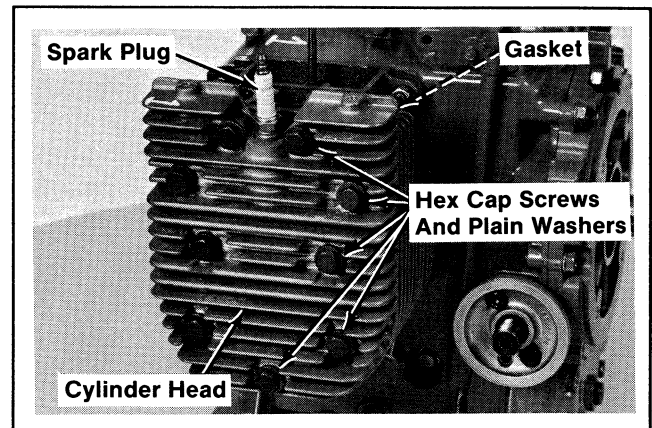

Figure 9-22. Removing Spark Plugs and Cylinder Heads.

REMOVE CYLINDER BARRELS

1. Remove the hex. nuts and plain washers using the barrel wrench. Refer to Figure 9-23.

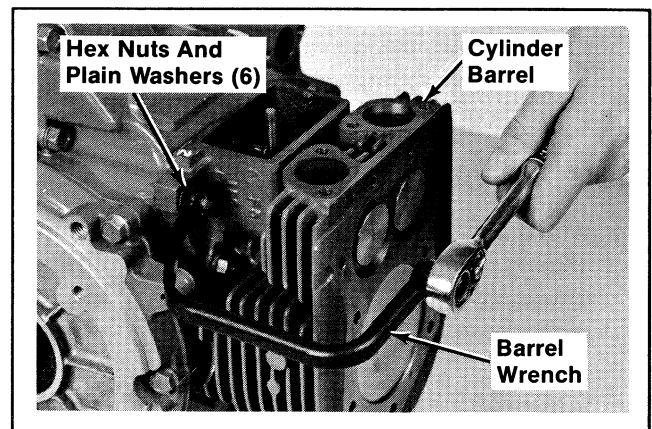

Figure 9-23. Removing Cylinder Barrel Fasteners.

2. Using a soft-faced hammer, carefully tap the cylinder barrels between the intake and exhaust ports to break the seal between cylinder barrels and crankcase.
3. Support the weight of barrels with hands, and carefully pull the barrels from the studs and pistons. Refer to Figure 9-24.

NOTE: To prevent damage to pistons or connecting rods when removing barrels, make sure the cylinder barrels and connecting rods are supported at all times. Do not allow the pistons or connecting rods to drop against edges of crankcase.

SECTION 9 DISASSEMBLY

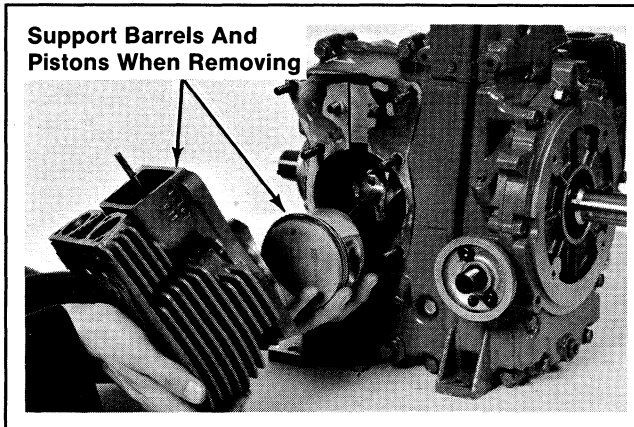

Figure 9-24. Removing Cylinder Barrels.

4. Thoroughly remove the sealant from the mating surfaces of crankcase and cylinder barrels.

NOTE: The use of a gasket-removing solvent is recommended. Do not scrape the surfaces with a metal putty knife or similar tool. Scratching the mating surfaces will cause leaks.

REMOVE VALVES

1. With a marking pen or paint, mark the valves as coming from the #1 or #2 cylinder barrel. Exhaust valves are already identified with an "EX" stamp on the valves.
2. Compress the valve springs with a valve spring compressor and remove keepers. Refer to Figure 9-25.

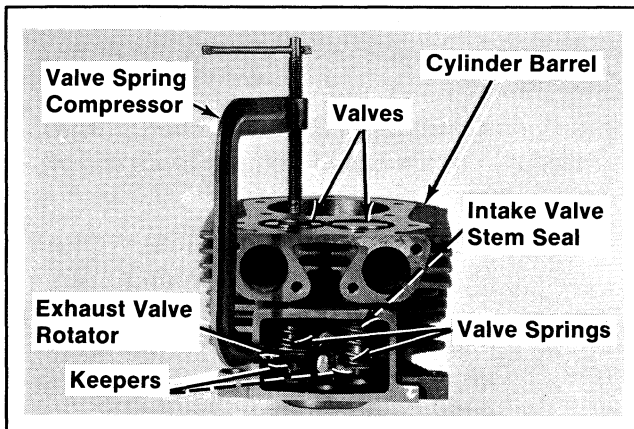

Figure 9-25. Removing Valves.

3. Remove the valve spring compressor; then remove valves, lower intake valve spring retainers, exhaust valve rotators, and valve springs.
4. Remove the intake valve seals from valve guides.

REMOVE PISTONS FROM CONNECTING RODS

1. With a marking pen or paint, mark the pistons and connecting rods as #1 side and #2 side. Refer to Figure 9-26.

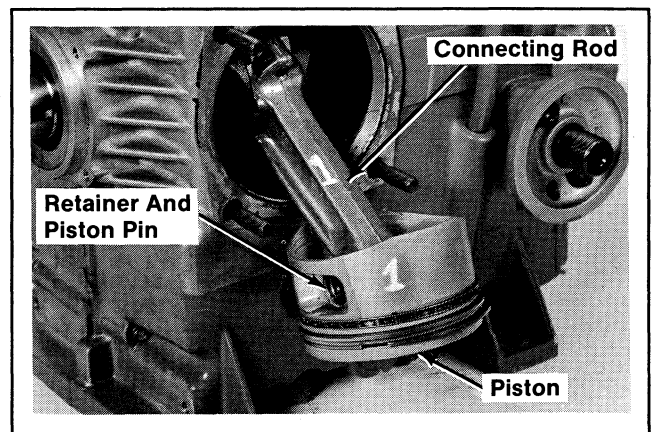

Figure 9-26. Removing Pistons.

2. Remove the piston pin retainers, piston pins, and pistons.

REMOVE PISTON RINGS

1. Remove the top and center compression rings using a ring expander tool. Refer to Figure 9-27.

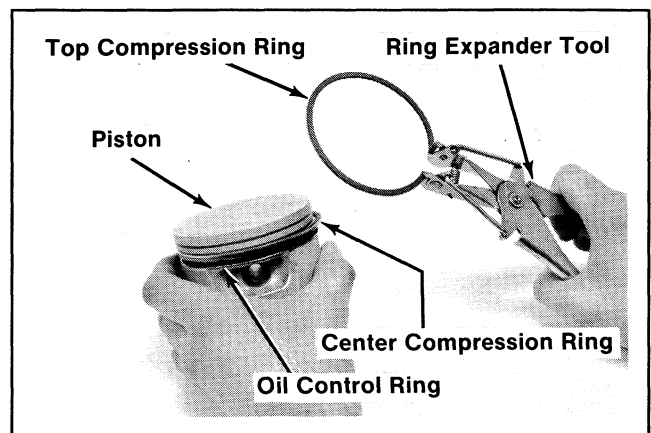

Figure 9-27. Removing Piston Rings.

2. Remove the oil control ring rails; then remove rails spacer.

REMOVE CLOSURE PLATE, OIL PRESSURE RELIEF VALVE, AND REAR OIL SEAL

1. Remove the hex. flange screws, closure plate, and gasket. Refer to Figure 9-28.

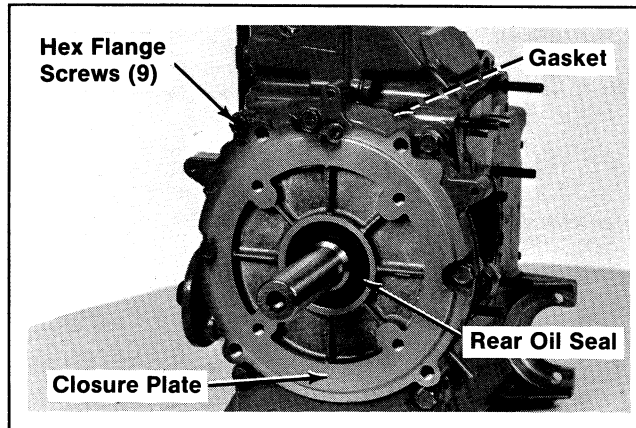

Figure 9-28. Removing Closure Plate.

2. Remove the oil pressure relief valve spring, steel ball, and sleeve. Refer to Figure 9-29.

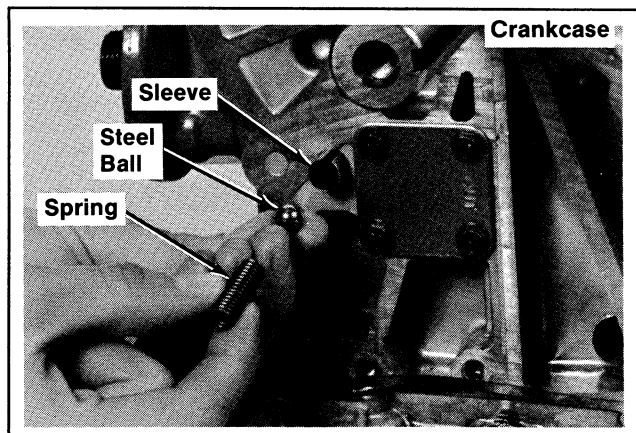

Figure 9-29. Removing Oil Pressure Relief Valve.

3. Remove the rear oil seal from closure plate.

REMOVE OIL FILTER ADAPTER

1. Remove the hex. socket head screws, oil filter adapter, and gasket. Refer to Figure 9-30.

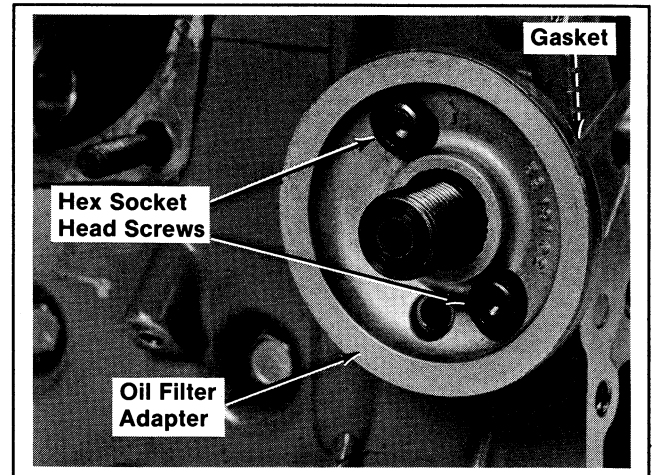

Figure 9-30. Removing Oil Filter Adapter.

SPLIT THE CRANKCASE

1. Scribe a line across the camshaft bore plug and the #1 crankcase side. This line is used to align the plug on reassembly. Refer to Figure 9-31.

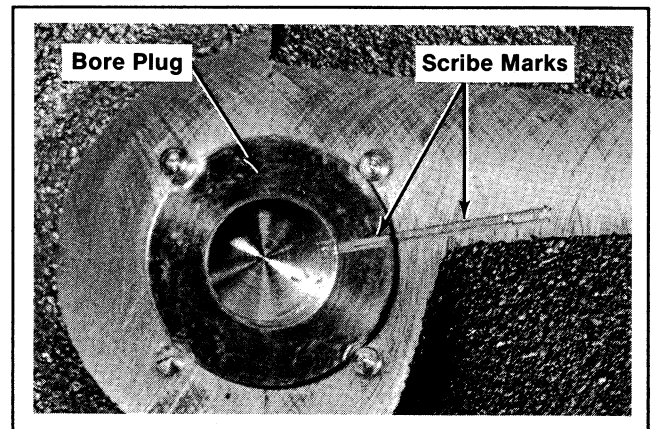

Figure 9-31. Camshaft Bore Plug.

2. Put tape or governor spring around the tappet stems in the #2 crankcase side. This prevents the tappets from falling into the #1 side when the crankcase is split.
3. Remove the hex. nuts, plain washers, and hex. flange screws securing the crankcase halves together.
4. Lay the crankcase down so the #2 side is up. Locate the splitting notches in the seam of the crankcase. Pry the halves apart using the blade of a large screwdriver. Refer to Figure 9-32.

SECTION 9 DISASSEMBLY

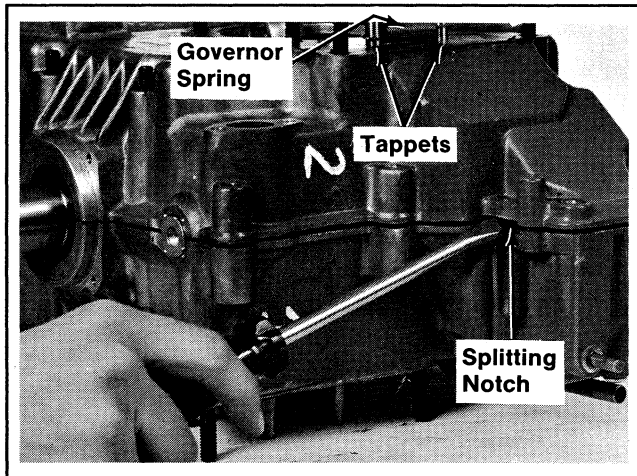

Figure 9-32. Splitting The Crankcase.

NOTE: Insert the screwdriver only in the splitting notches. Do not pry on the gasket surfaces of crankcase as this can cause leaks.

REMOVE CAMSHAFT AND TAPPETS

1. Remove the camshaft and camshaft bore plug from the #1 crankcase side. Refer to Figure 9-33.

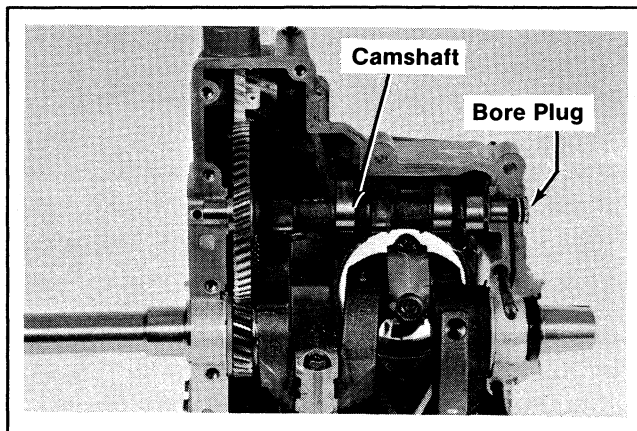

Figure 9-33. Removing The Camshaft and Camshaft Bore Plug.

2. With a marking pen or paint, mark the tappets according to crankcase side and as either intake or exhaust. Remove tappets from both crankcase sides. Refer to Figure 9-34.

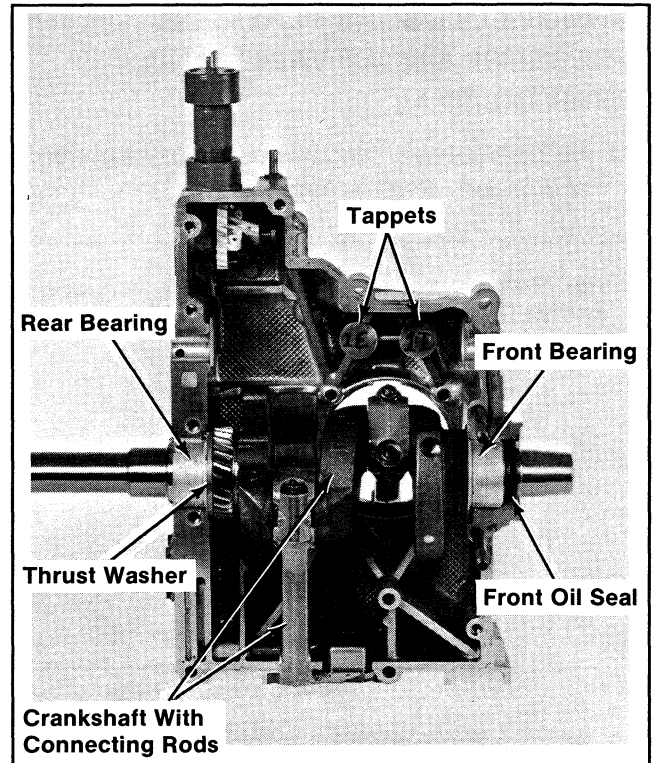

Figure 9-34. Removing Tappets, Crankshaft, Front Oil Seal, and Bearings.

NOTE: The intake valve tappet is closest to the flywheel side of crankcase. The exhaust valve tappet is closest to the PTO side of crankcase.

REMOVE CRANKSHAFT, FRONT OIL SEAL, AND BEARINGS

1. Remove the crankshaft with connecting rods, bearings, and front oil seal from the #1 crankcase side. Refer to Figure 9-34.
2. Remove the front oil seal from the flywheel end of crankshaft. Remove bearings and thrust washer from crankshaft.

REMOVE CONNECTING RODS

1. With a marking pen or paint, mark the connecting rods and rod caps as #1 side and #2 side. On M18 mark which side is top.
2. Remove the hex. nuts, connecting rod caps, and connecting rods from crankshaft. Refer to Figure 9-35.

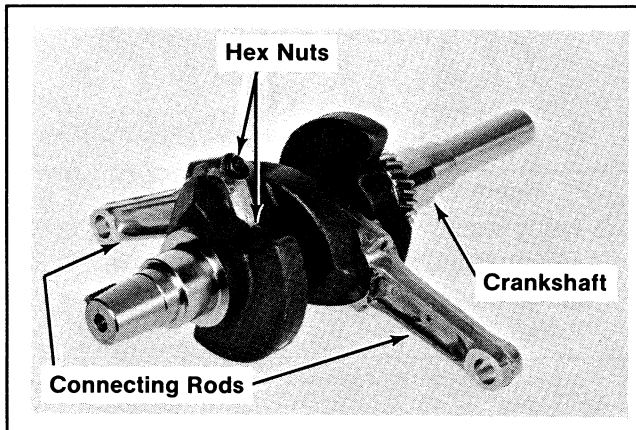

Figure 9-35. Removing Connecting Rods.

REMOVE GOVERNOR GEAR AND CROSS SHAFT

1. Remove the governor stop pin and copper washer. Refer to Figure 9-36.

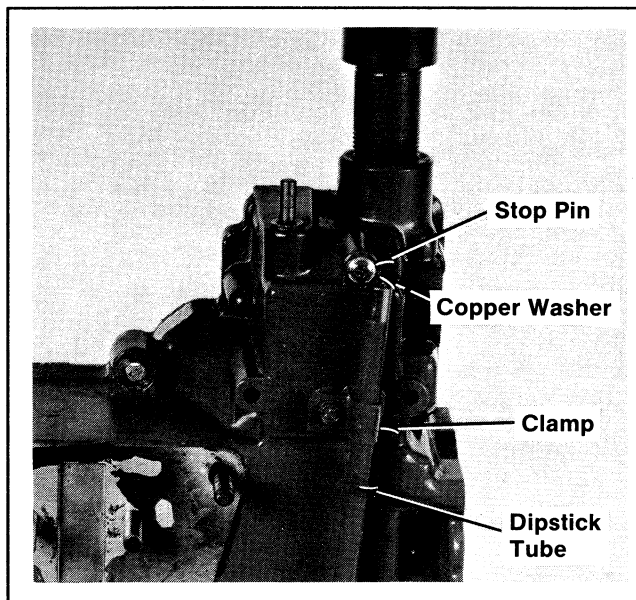

Figure 9-36. Removing Governor Stop Pin.

NOTE: Loosen the clamp securing dipstick tube to crankcase. Move the dipstick tube out of the way to ease removal of stop pin.

2. Remove the governor gear and thrust washer from stub shaft. Refer to Figure 9-37.
3. Remove the retaining ring, plain washers, and cross shaft.

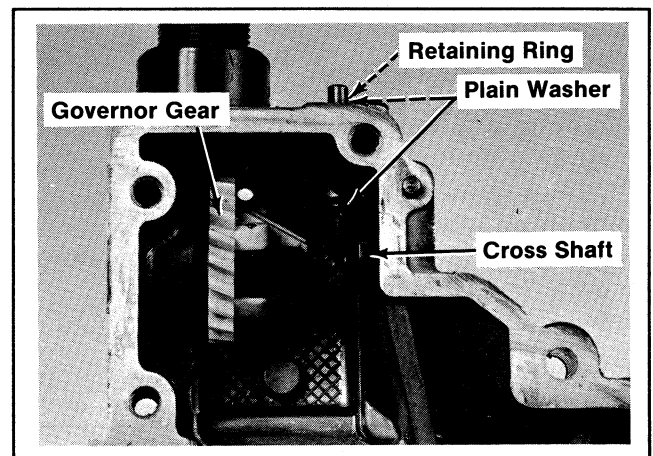

Figure 9-37. Removing Governor Gear.

REMOVE OIL PICKUP AND OIL PUMP

Oil Pickup

1. Remove the spring clip using a long-nosed pliers. Remove the oil pickup housing. Refer to Figure 9-38.

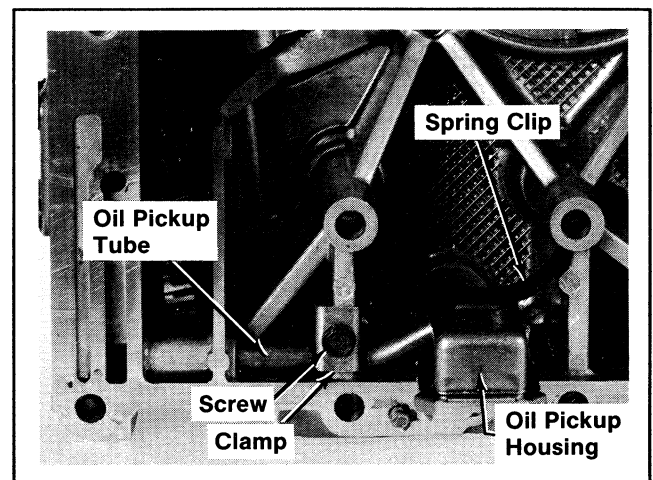

Figure 9-38. Removing Oil Pickup Components.

2. Remove the self-tapping screw, clamp, and oil pickup tube.

SECTION 9 DISASSEMBLY

Oil Pump

NOTE: The oil pump rotors, shaft, and drive gear are virtually trouble-free and normally require little service. These parts should be removed only if service or replacement is necessary.

1. Remove the self-tapping screws, cover, and pump rotors. Refer to Figures 9-39 and 9-40.

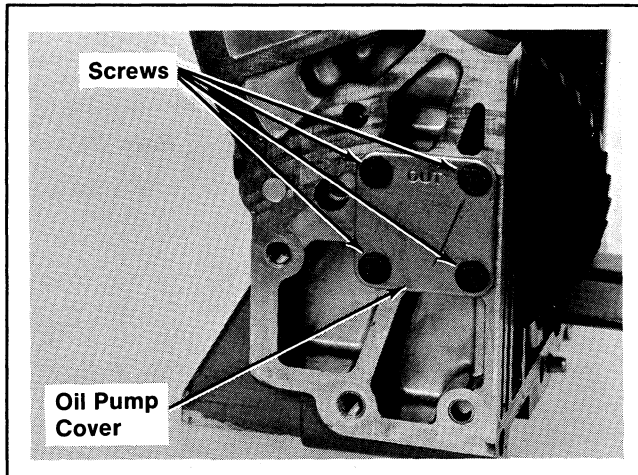

Figure 9-39. Removing Oil Pump Cover.

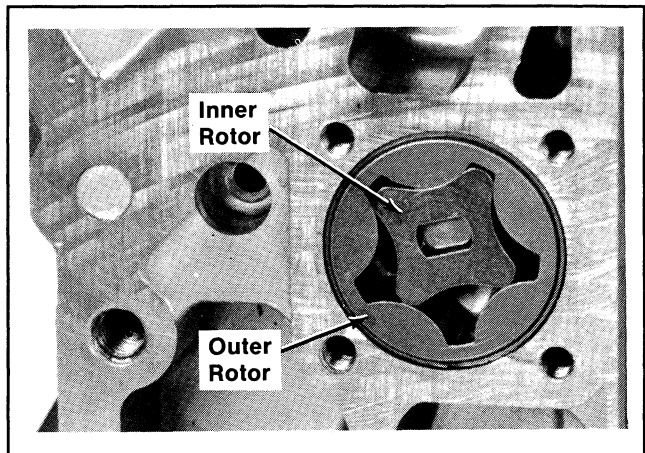

Figure 9-40. Removing Oil Pump Rotors.

2. Using a small-diameter drift punch, drive the roll pin out of the pump drive gear and shaft. Remove shaft, drive gear, and shim spacer. Refer to Figure 9-41.

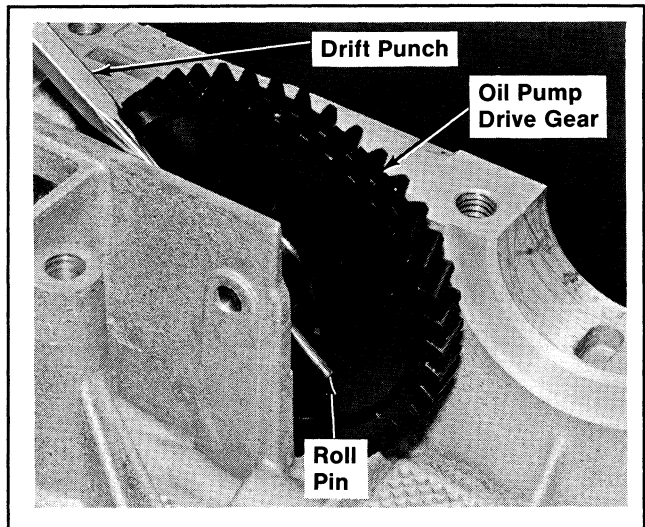

Figure 9-41. Removing Oil Pump Drive Gear.

SECTION 10

INSPECTION AND RECONDITIONING

Clean all parts thoroughly. Only clean parts can be accurately inspected and gauged for wear or damage. There are many commercially available cleaners that quickly remove grease, oil and grime accumulation from engine parts. When such a cleaner is used, *follow the manufacturers instructions and safety precautions carefully*. Use gasket remover or paint remover to remove RTV from crankcase and closure plate. Do not scrape the surfaces when cleaning as this will damage the surfaces. This could result in leaks.

Make sure that all of the cleaner is removed before the engine is reassembled and placed in operation. Even small amounts of these cleaners quickly break down the lubricating properties of engine oil.

Refer to A Guide to Engine Rebuilding (TP-2150) for additional information. Measurement Guide (TP-2159-A) and Engine Inspection Data Record (TP-2435) are also available; use these to record inspection results.

FLYWHEEL

Inspection

Inspect the flywheel for cracks, and the flywheel keyway for damage. Replace flywheel if cracked. Replace the flywheel, the crankshaft, and the key if flywheel key is sheared or the keyway damaged.

Inspect ring gear for cracks or damage. Kohler no longer provides ring gears as a serviceable part. Replace flywheel if the ring gear is damaged.

CYLINDER HEADS

Inspection

Blocked cooling fins often cause localized "hot spots" which can result in "blown" cylinder head gaskets. If gasket fails in area surrounding one of the retaining

capscrews, high temperature gases can burn away portions of the aluminum alloy head. A cylinder head in this condition must be replaced. It will also be necessary to replace the head screws. The high temperatures that caused the "blown" gasket could have made the screws ductile which will cause them to stretch when tightened.

If the cylinder heads appear in good condition, use a block of wood or plastic scraper to scrape away carbon deposits. Be careful not to nick or scratch the aluminum, especially in gasket seating area.

Cylinder heads should also be checked for flatness. Use a feeler gauge and a surface plate or piece of plate glass to make this check. Cylinder head flatness should not vary more than $.003$ "; if it does, replace the cylinder head (see Figure 10-1).

NOTE: Measure cylinder head flatness between each cap screw hole.

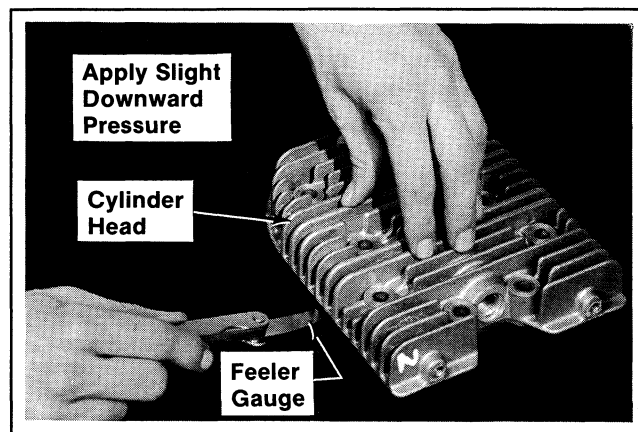

Figure 10-1. Checking Cylinder Head Flatness.

SECTION 10

INSPECTION AND RECONDITIONING

CYLINDER BARRELS

Inspection and Reconditioning

Check all gasket surfaces to make sure they are free of gasket fragments. Gasket surfaces must also be free of deep scratches or nicks.

Scoring of the Cylinder Wall: Unburned fuel, in severe cases, can cause scuffing and scoring of the cylinder wall. As raw fuel seeps down the cylinder wall, it washes the necessary lubricating oils off the piston and cylinder wall so that the piston rings make metal to metal contact with the wall. Scoring of the cylinder wall can also be caused by localized hot spots resulting from blocked cooling fins or from inadequate or contaminated lubrication.

If the cylinder bore is badly scored, excessively worn, tapered, or out of round, resizing is necessary. Use an inside micrometer to determine amount of wear (refer to "Specifications, Tolerances, and Special Torque Values", Section 1), then select the nearest suitable oversize of either .003", .010", .020" or .030". Resizing to one of these oversizes will allow usage of the available oversize piston and ring assemblies. Initially, resize using a boring bar, then use the following procedures for honing the cylinder:

Honing

While most commercially available cylinder hones can be used with either portable drills or drill presses, the use of a low speed drill press is preferred as it facilitates more accurate alignment of the bore in relation to the crankshaft crossbore. Honing is best accomplished at a drill speed of about 250 RPM and 60 strokes per minute. After installing coarse stones in hone, proceed as follows:

1. Lower hone into bore and after centering, adjust so that the stones are in contact with the cylinder wall. Use of a commercial cutting-cooling agent is recommended.
2. With the lower edge of each stone positioned even with the lowest edge of the bore, start drill and honing process. Move hone up and down while resizing to prevent formation of cutting ridges. Check size frequently.

NOTE: Keep in mind the temperatures caused by honing may cause inaccurate measurements. Make sure the barrel is cool when measuring.

3. When bore is within .0025" of desired size, remove coarse stones and replace with burnishing stones. Continue with burnishing stones until within .0005" of desired size and then use finish stones (220–280 grit) and polish to final size. A crosshatch should be observed if honing is done correctly. The crosshatch should intersect at approximately 23–33° off the horizontal. Too flat of an angle could cause the rings to skip and wear excessively, too steep of an angle will result in high oil consumption (refer to Figure 10–2).

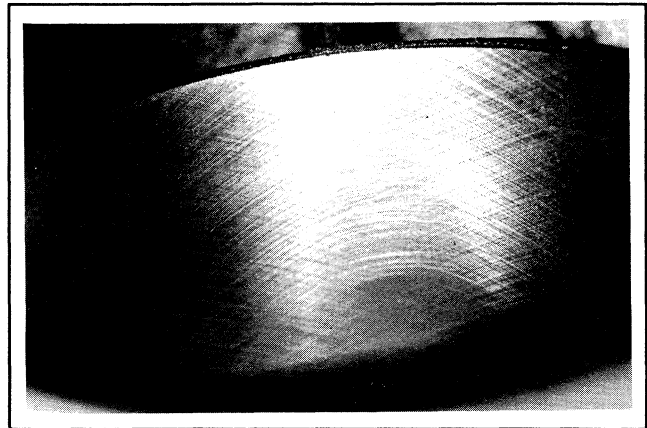

Figure 10–2. Cylinder Bore Crosshatch After Honing.

4. After resizing, check the bore for roundness, taper, and size. Use an inside micrometer, telescoping gauge, or bore gauge to take measurements (Refer to Figure 10–3). The measurements should be taken at three locations in the cylinder—at the top, middle, and bottom. Two measurements should be taken (perpendicular to each other) at each of the three locations.

NOTE: Your final bore size should be exactly .003, .010, .020, or .030 over standard size. Service replacement pistons are manufactured to precise tolerances to match those sizes.

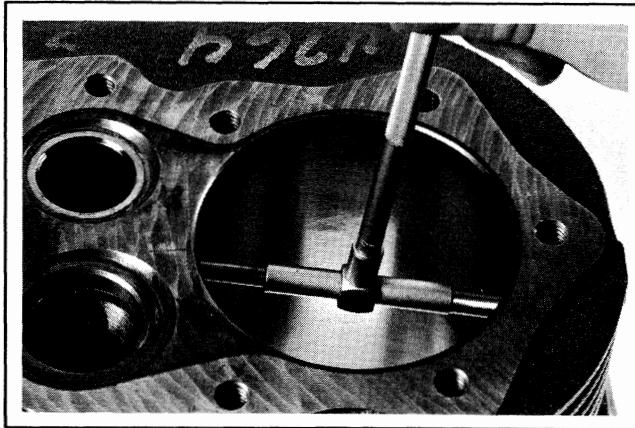

Figure 10-3. Measuring Cylinder Bore.

Clean Cylinder Bore After Honing

Proper cleaning of the cylinder walls following boring and/or honing is very critical to a successful overhaul. Machining grit left in the cylinder bore can destroy an engine in less than one hour of operation after a rebuild.

The final cleaning operation should always be a thorough scrubbing with a brush and hot, soapy water. Use a strong detergent that is capable of breaking down the machining oil while maintaining a good level of suds. If the suds break down during cleaning, discard the dirty water and start again with more hot water and detergent. Following the scrubbing, rinse the cylinder with very hot, clear water, dry it completely, and apply a light coating of engine oil to prevent rusting.

Measuring Piston-to-Bore Clearance

Before installing the piston into the cylinder bore, it is necessary that the clearance be accurately checked. This step is often overlooked, and if the clearances are not within specifications, generally engine failure will result.

NOTE: Do not use a feeler gauge to measure piston-to-bore clearance—it will yield inaccurate measurements—Use a micrometer.

The following procedures should be used to accurately measure the piston-to-bore clearance:

1. Use a micrometer and measure the diameter of the piston, 1/2" above bottom of piston skirt, perpendicular to the piston pin (see Figure 10-4).

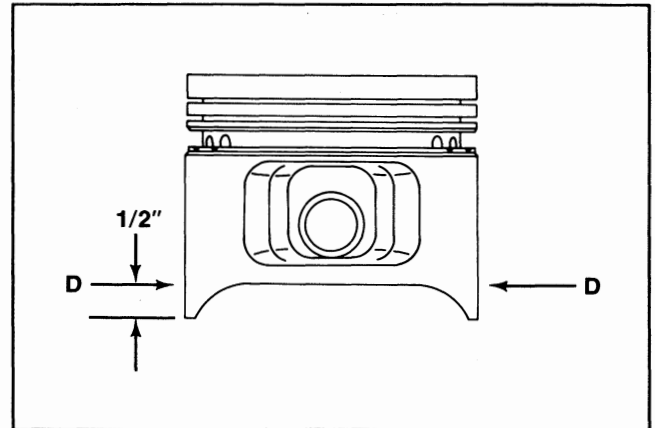

Figure 10-4. Measuring Piston Diameter (Style "D" Piston)

2. Use an inside micrometer, telescoping gauge, or bore gauge and measure the cylinder bore. Take the measurement approximately 2-1/2" below the top of the bore and perpendicular to the piston pin.
3. Piston-to-bore clearance is the difference between the bore and the piston diameter (step 2 minus step 1).

VALVES

Inspection and Service

Carefully inspect valve mechanism parts. Inspect valve springs and related hardware for excessive wear or distortion. Valve spring free height should be approximately 1.68" (1-11/16"). Check valves and valve seat area or inserts for evidence of deep pitting, cracks, or distortion. Check clearance of valve stems in guides. See Figure 10-5 for valve details and specifications for 45° angle or 10-5A for the new 30° exhaust valve. See page 10.4.

Hard starting, or loss of power accompanied by high fuel consumption may be symptoms of faulty valves. Although these symptoms could also be attributed to worn rings, remove and check valves first. After removal, clean valve head, face, and stem with power wire brush and then carefully inspect for defects such as warped valve head, excessive corrosion, or worn stem end. Replace valves found to be in bad condition. A normal valve and valves in bad condition are shown in the accompanying illustrations.

SECTION 10 INSPECTION AND RECONDITIONING

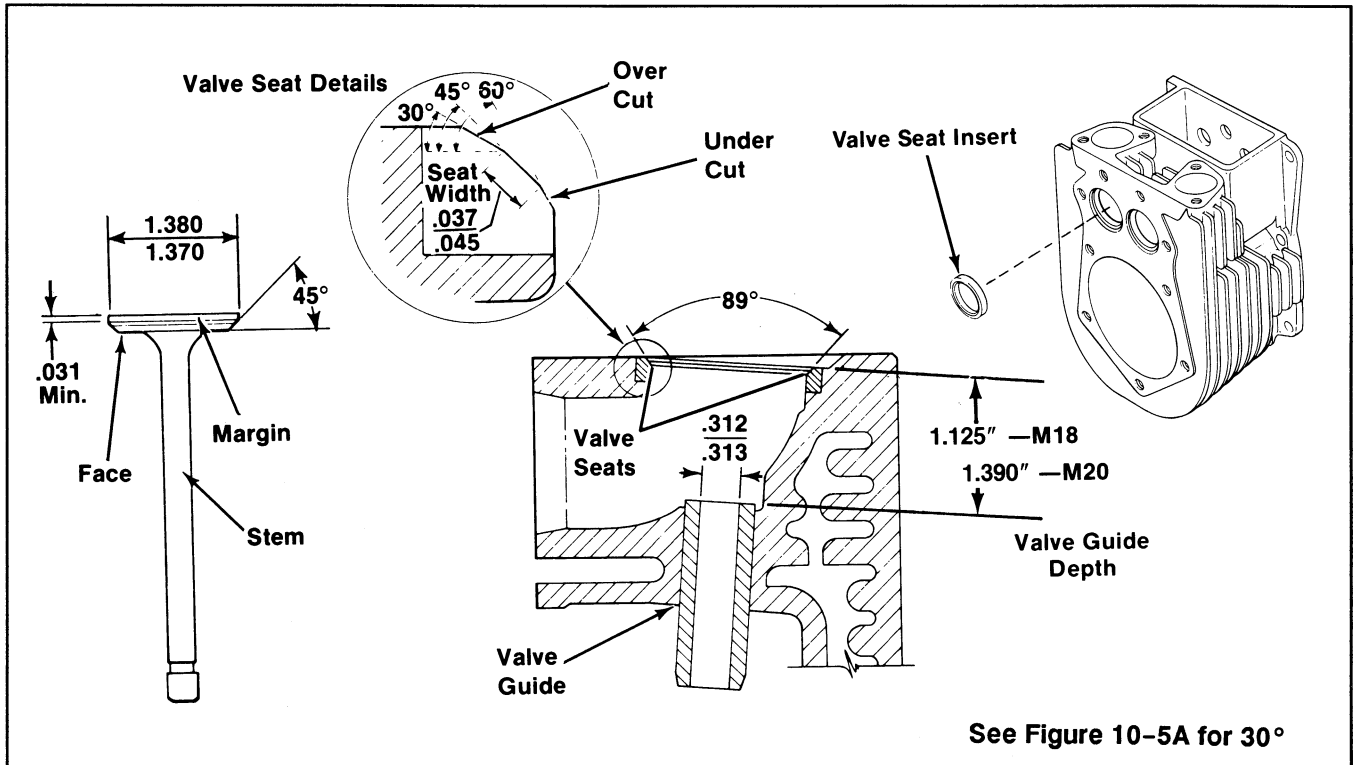

Figure 10-5. Valve Details (45° Angle).

30° CHANGEOVER (See Figure 10-5A)

Beginning with Serial No. 1917809296, a new camshaft and 30° exhaust valve and seat went into production for all Magnum twin cylinder engines and Short Blocks. Cylinder barrels are now serviced as #1 and #2 side. (The same barrel does not work for both sides as it had previously.)

The new camshaft is marked with a circle (3/8" diameter) of orange dye for easy part identification. The new camshaft is available as a kit Part No. 82 755 13.

This kit includes a camshaft and four tappets. The tappets included in the kit require a setting of .003"/.006" intake, .013"/.016" exhaust.

When replacing the camshaft on engines prior to Serial No. 1917809296, also order and install valve kit 82 755 11 (for M18) or 82 755 12 (for M20). The valve kit includes a 30° exhaust valve and valve seat. Remove the old seat, install new seat and grind the seat to the 30° angle. The new 30° exhaust valve has a clearance specification of .013"/.016".

SECTION 10 INSPECTION AND RECONDITIONING

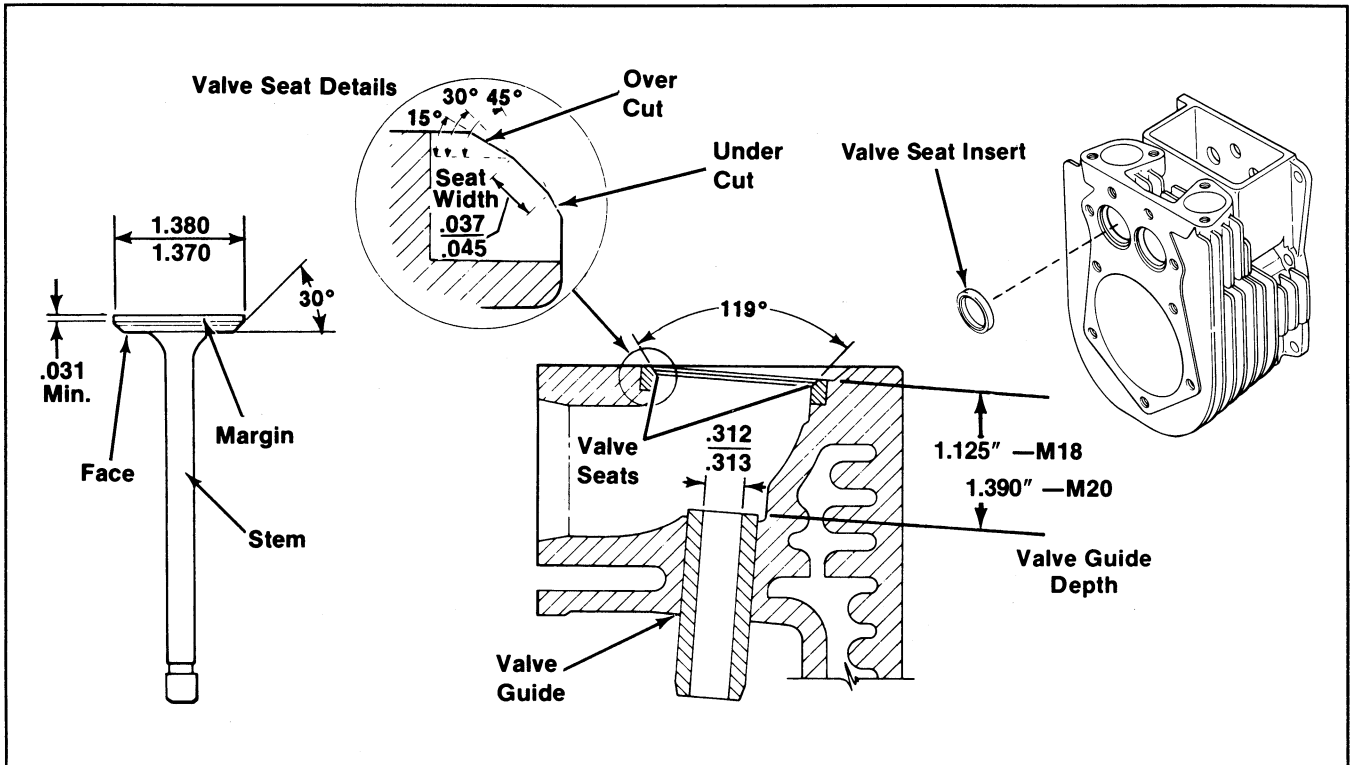
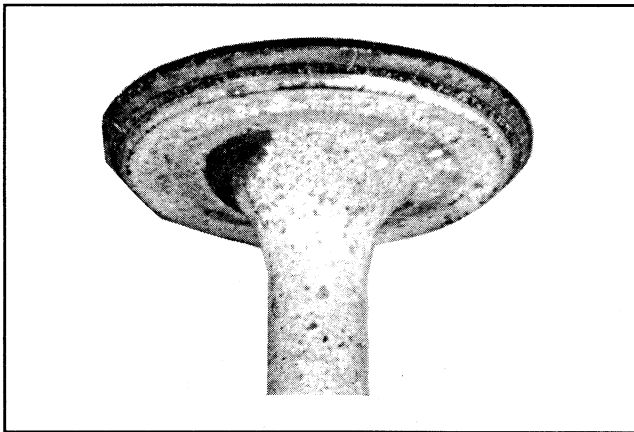
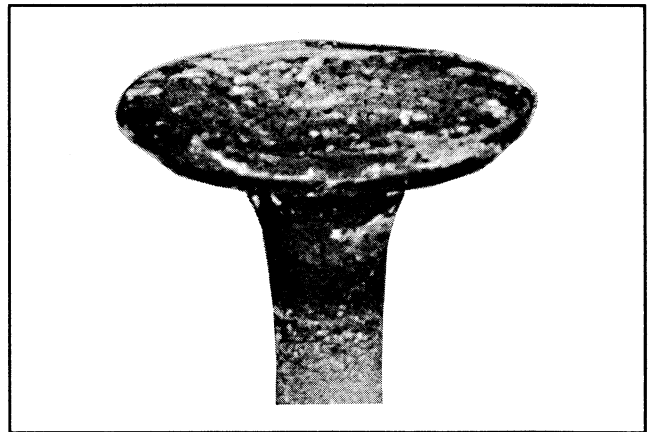

Figure 10-5A. Exhaust Valve Details (30° Angle).



Normal: Even after long hours of operation a valve can be reconditioned and reused if the face and margin are in good shape. If a valve is worn to where the margin is less than 1/32" do not reuse it. The valve shown was in operation for almost 1000 hours under controlled test conditions.



Bad Condition: The valve depicted here should be replaced. Note the warped head; margin damaged and too narrow. These conditions could be attributed to excessive hours or a combination of poor operating conditions.

SECTION 10 INSPECTION AND RECONDITIONING



Leakage: A poor grind on face or seat of valve will allow leakage resulting in a burned valve on one side only.

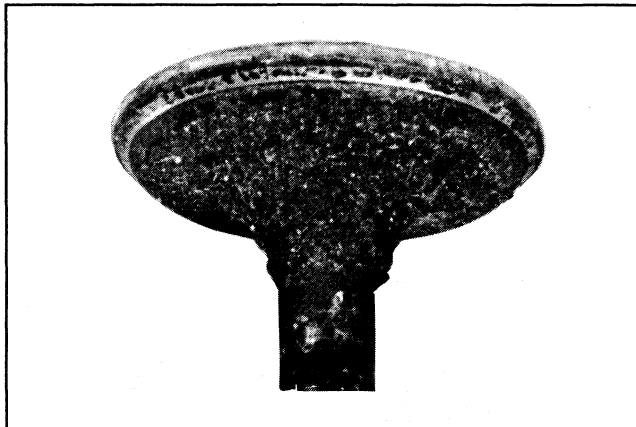

Coking: Coking is normal on intake valves and is not harmful. If the seat is good, the valve could be reused after cleaning.

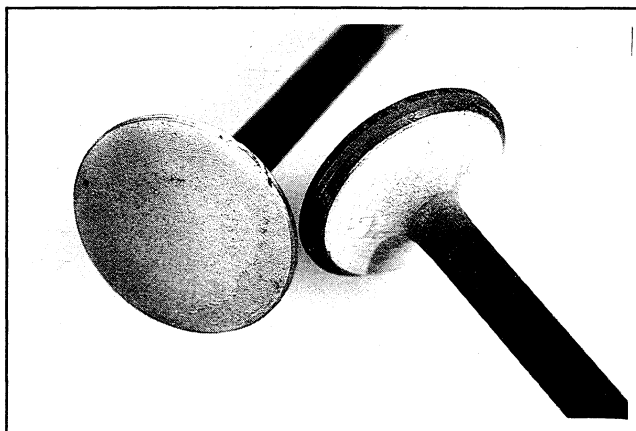

Excessive Combustion Temperatures: The white deposits seen here indicate very high combustion temperatures, usually due to a lean fuel mixture.



Gum: Gum deposits usually result from using stale gasoline. This condition is often noted in applications where fuel is not drained out of tank during the off season. Gum is a prevalent cause of valve sticking. The cure is to ream the valve guides and clean or replace the valves, depending on their condition.

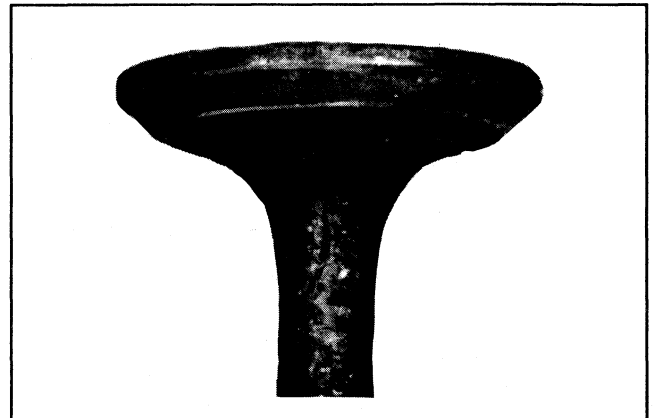

Stem Corrosion: Moisture in fuel or from condensation are the most common causes of valve stem corrosion. Condensation occurs from improper preservation during storage and when engine is repeatedly stopped before it has a chance to reach normal operating temperatures. Replace corroded valves.

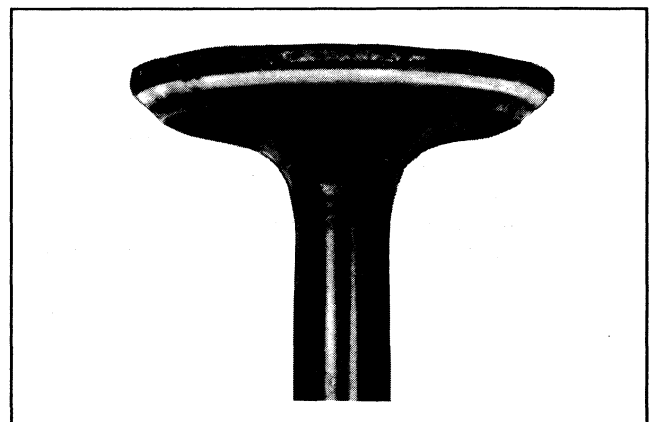

Overheating: An exhaust valve subject to overheating will have a dark discoloration in the area above the valve guide. Worn guides and faulty valve springs may cause this condition. Also check for clogged air intake, blocked fins, and lean fuel mixture when this condition is noted.

Valve Guides

If a valve guide is worn beyond specifications, it will not guide the valve in a straight line. This may result in burnt valve faces or seats, loss of compression, and excessive oil consumption.

To check valve guide to valve stem clearance, thoroughly clean the valve guide and, using a split-ball gauge, measure the inside diameter. Then, using an outside micrometer, measure the diameter of the valve stem at several points on the stem where it moves in the valve guide. Use the largest stem diameter to calculate the clearance. If the clearance exceeds **.005"** on intake or **.007"** on exhaust valve, determine whether the valve stem or the guide is responsible for the excessive clearance.

If the valve stem diameter is within specifications, then replace the valve guide.

Remove Valve Guide

The valve guides are a tight press fit in the cylinder barrel. A valve guide removal tool is recommended to remove the guides (refer to Section 2, "Special Tools"). To remove valve guide, refer to Figure 10-6 and proceed as follows:

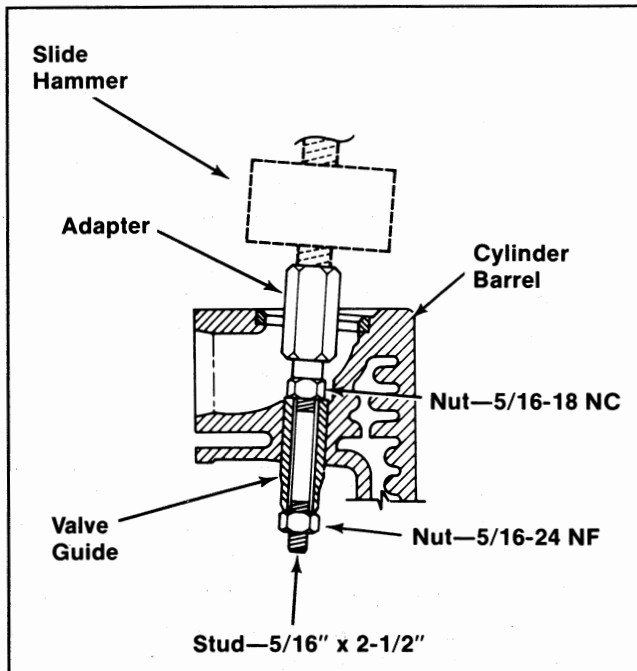

Figure 10-6. Pulling Valve Guide.

1. Install 5/16-18 NC nut on coarse threaded end of 2-1/2" long stud.
2. Insert other end of stud through valve guide bore and install 5/16-24 NF nut. Tighten both nuts securely.

NOTE: Valve guide must be held firmly by the stud assembly so that all slide hammer force will act on the guide.

3. Assemble the valve guide removal adapter to the stud and then the slide hammer to the adapter.
4. Use the slide hammer to pull the guide out.

Install Valve Guide

To install valve guide, proceed as follows:

1. Make sure valve guide bore is clean and free of nicks or burns.
2. Using valve guide driver (Refer to Section 2, "Special Tools"), align and then press guide in until valve guide driver bottoms on depth gauge. See Figure 10-7.

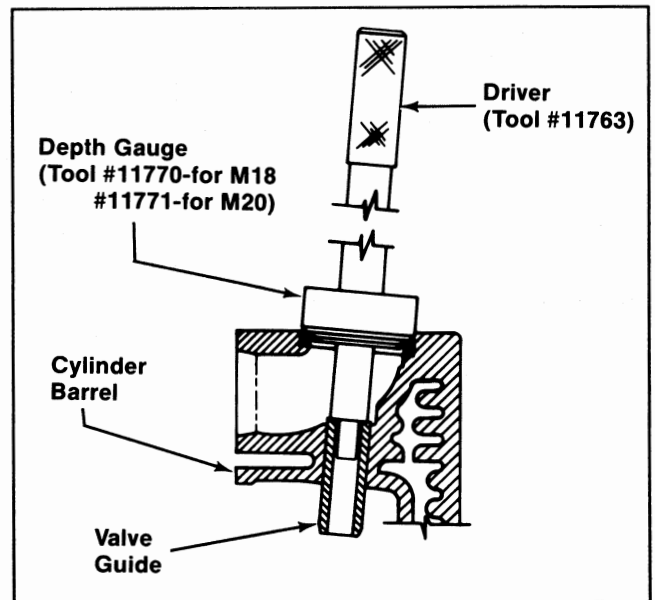

Figure 10-7. Installing Valve Guide.

3. Valve guides are often slightly compressed during insertion. Use a piloted reamer (Refer to Section 2, "Special Tools") and then a finishing reamer to resize the guide bore to **.3125"**. Refer to Figure 10-8.

SECTION 10 INSPECTION AND RECONDITIONING

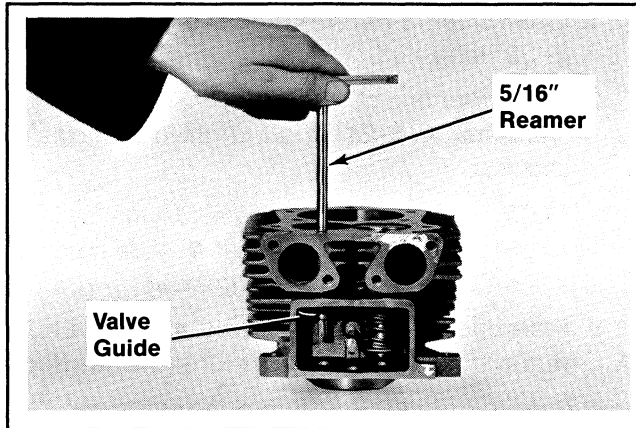

Figure 10-8. Reaming Valve Guide.

Valve Seat Inserts

Intake valve seats are usually machined into the cylinder barrel, however, certain applications may specify hard alloy inserts. The exhaust valve seats are replaceable alloy inserts. If the seats become badly pitted, cracked, or distorted, the inserts must be replaced.

The inserts are a tight press fit in the cylinder barrel. A valve seat removal tool is recommended for this job (Refer to Section 2, "Special Tools"). Since insert removal causes loss of metal in the insert bore area, use only Kohler service replacement inserts, which are slightly larger to provide retention in the cylinder barrel. Make sure new inserts are properly started and pressed into bore to prevent cocking of the insert.

Remove Valve Seat Insert

To remove a valve seat insert, refer to Figure 10-9 and proceed as follows:

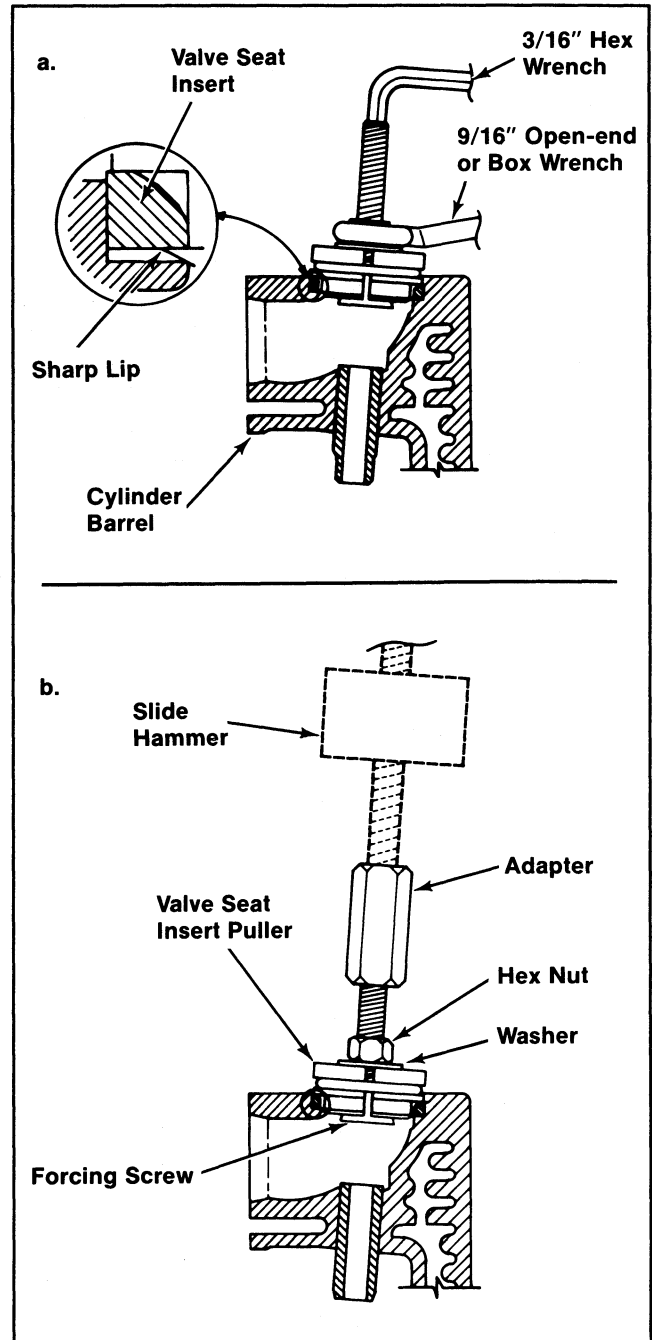

Figure 10-9. Pulling Valve Seat Insert.

1. Install valve seat puller on forcing screw and lightly secure with washer and nut.
2. Center the puller assembly on valve seat insert.
3. Hold forcing screw with a hex. wrench to prevent turning and slowly tighten nut. (See Figure 10-9a.)
4. Continue to tighten nut until puller is tight against valve seat insert.

5. Assemble adapter to valve seat puller forcing screw and slide hammer to adapter. (See Figure 10-9b.)
6. Use slide hammer to remove valve seat insert.

Install Valve Seat Insert

To install valve seat insert, proceed as follows:

1. Make sure valve seat insert bore is clean and free of nicks or burrs.
2. Align valve seat insert in counterbore and using valve seat installer and driver (Refer to Section 2, "Special Tools"), press seat in until bottomed.
3. Use a standard valve seat cutter (see Figure 10-10) and cut seat to dimensions shown in Figure 10-5.

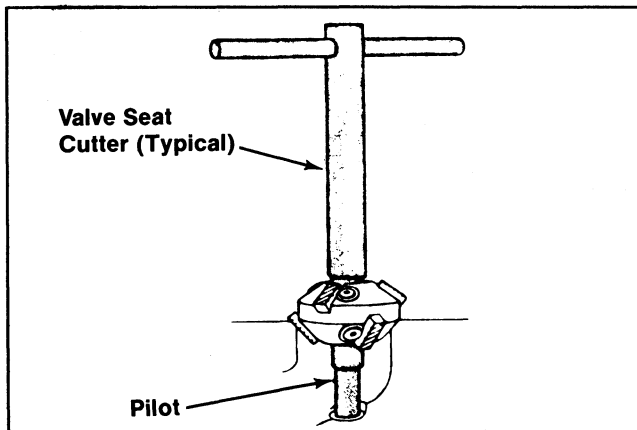

Figure 10-10. Standard Valve Seat Cutter.

Reground or new valves must be lapped in, to provide fit. Use a hand valve grinder with suction cup for final lapping. Lightly coat valve face with "fine" grade of grinding compound, then rotate valve on seat with grinder. Continue grinding until smooth surface is obtained on seat and on valve face. Thoroughly clean cylinder barrel in soap and hot water to remove all traces of grinding compound. After drying cylinder barrel, apply a light coating of SAE 10 oil to prevent rusting.

Valve Stem Seals

These engines use valve stem seals on the intake valves. Always use new seals when valves are removed from cylinder. Seals should also be replaced if deteriorated or damaged in any way. Never reuse old seals.

PISTONS AND RINGS

Identification

All Magnum M18 and M20 engines use the new, style D pistons and matching piston rings. Style D pistons are identified by the installation direction identifier "Fly", which is stamped into the top of the piston, and by the rectangular recessed area around the piston pin. See Figure 10-11. Also, the piston pin bosses are thicker than other styles of similar pistons.

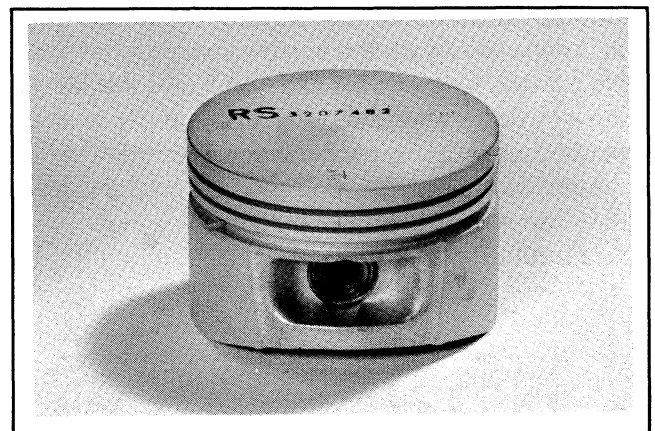

Figure 10-11. Style D Piston.

NOTE: The Posi-Lock connecting rods used with the style D pistons are narrower at piston pin end to accommodate the increased piston pin boss thickness. See "Posi-Lock Connecting Rods" elsewhere in this section.

SECTION 10

INSPECTION AND RECONDITIONING

Inspection

Scuffing and scoring of pistons and cylinder walls occurs when internal temperatures approach the welding point of the piston. Temperatures high enough to do this are created by friction, which is usually attributed to improper lubrication, and/or overheating of the engine.

Normally, very little wear takes place in the piston boss–piston pin area. If the original piston and connecting rod can be reused after new rings are installed, the original pin can also be reused but new piston pin retainers are required. The piston pin is included as part of the piston assembly—if the pin boss in piston, or the pin are worn or damaged, a new piston assembly is required.

Ring failure is usually indicated by excessive oil consumption and blue exhaust smoke. When rings fail, oil is allowed to enter the combustion chamber where it is burned along with the fuel. High oil consumption can also occur when the piston ring end gap is incorrect because the ring cannot properly conform to the cylinder wall under this condition. Oil control is also lost when ring gaps are not staggered during installation.

When cylinder temperatures get too high, lacquer and varnish collect on pistons causing rings to stick which results in rapid wear. A worn ring usually takes on a shiny or bright appearance. Scratches on rings and pistons are caused by abrasive material such as carbon, dirt, or pieces of hard metal.

Detonation damage occurs when a portion of the fuel charge ignites spontaneously from heat and pressure shortly after ignition. This creates two flame fronts which meet and explode to create extreme hammering pressures on a specific area of the piston. Detonation generally occurs from using low octane fuels.

Preignition or ignition of the fuel charge before the timed spark can cause damage similar to detonation. Preignition damage is often more severe than detonation damage. Preignition is caused by a hot spot in the combustion chamber from sources such as: glowing carbon deposits, blocked fins, improperly seated valves, or wrong spark plugs.

See Figure 10–12 for some common types of piston and ring damage.

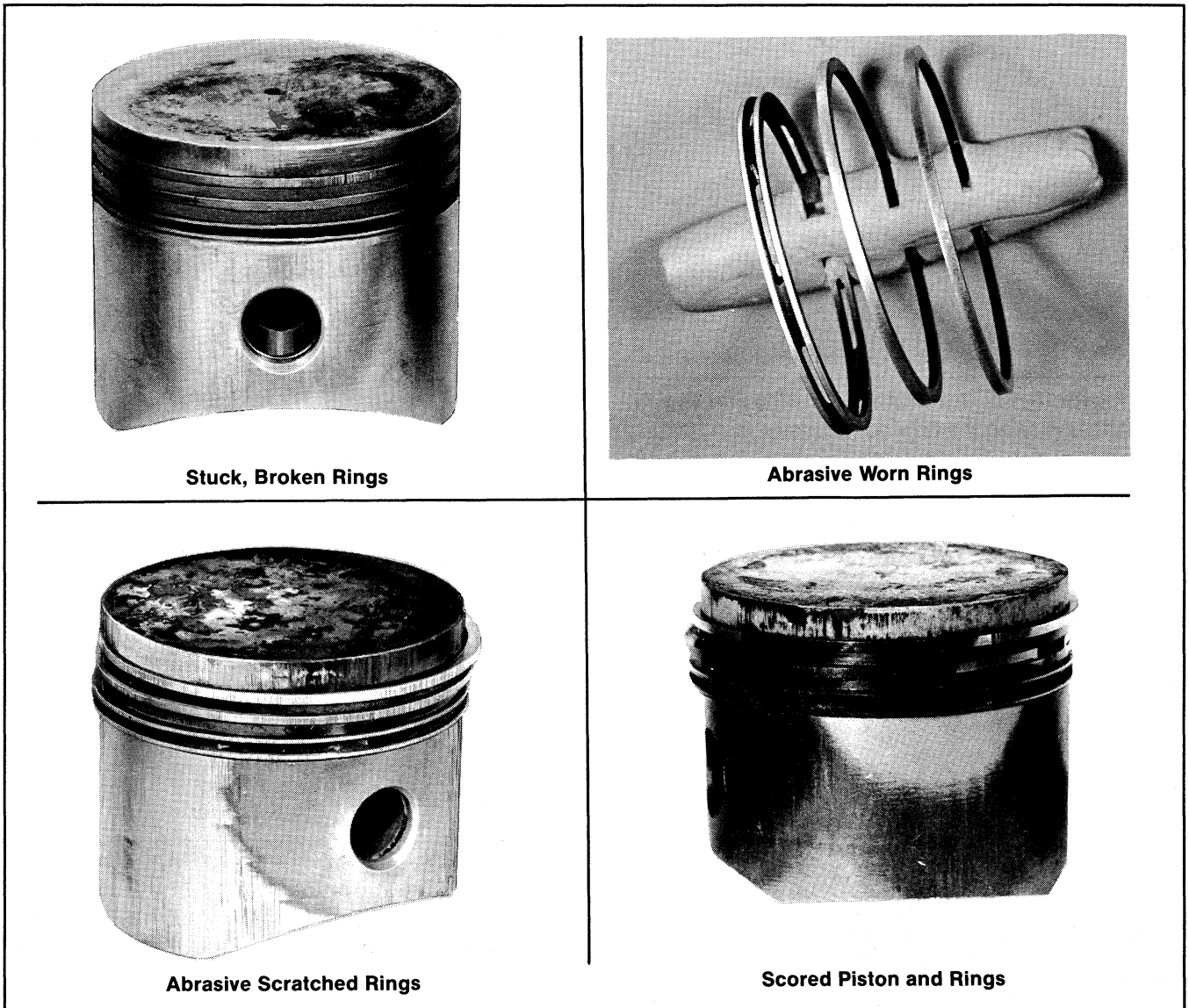

Figure 10-12. Common Types of Piston and Ring Damage.

Service

Magnum M18 and M20 service replacement pistons are available in STD bore size, and in .003", .010", .020", and .030" oversizes. Replacement pistons include new piston ring sets and new piston pins.

Service replacement piston ring sets are also available separately for STD/.003" (same ring set for both sizes), .010", .020", and .030" oversized pistons. Always use new piston rings when installing pistons. Never reuse old rings.

The cylinder bore must be deglazed before service ring sets are used.

Some important points to remember when servicing piston rings:

1. If the cylinder block does not need reboring and if the old piston is within wear limits and free of score or scuff marks, the old piston may be reused.
2. Remove old rings and clean up grooves. Never reuse old rings.
3. Before installing new rings on piston, place top two rings, each in turn, in its running area in cylinder bore and check end gap (see Figure 10-13). This gap should be .010"/.032" in a used cylinder bore and .010"/.023" in a new cylinder bore.

SECTION 10 INSPECTION AND RECONDITIONING

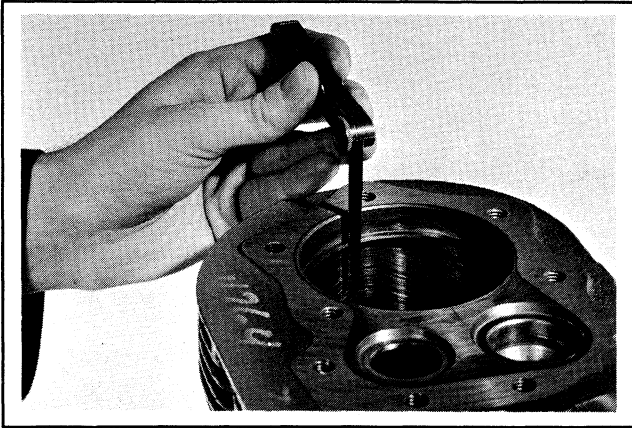

Figure 10-13. Measuring Piston Ring End Cap.

- After installing the new compression (top and middle) rings on piston, check piston-to-ring side clearance. Maximum recommended side clearance is .006". If side clearance is greater than .006", a new piston must be used. Refer to Figure 10-14.

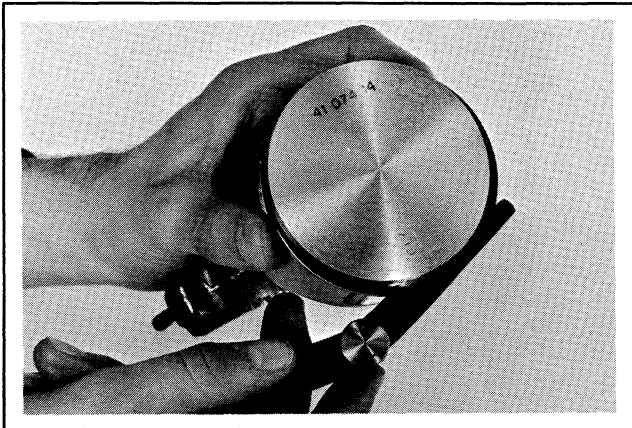

Figure 10-14. Measuring Piston Ring Side Clearance.

Install Piston Rings

To install piston rings, proceed as follows:

NOTE: Rings must be installed correctly. Ring installation instructions are usually included with new ring sets. Follow instructions carefully. Use a piston ring expander to install rings. Install the bottom (oil control) ring first and the top compression ring last. Refer to Figure 10-15.

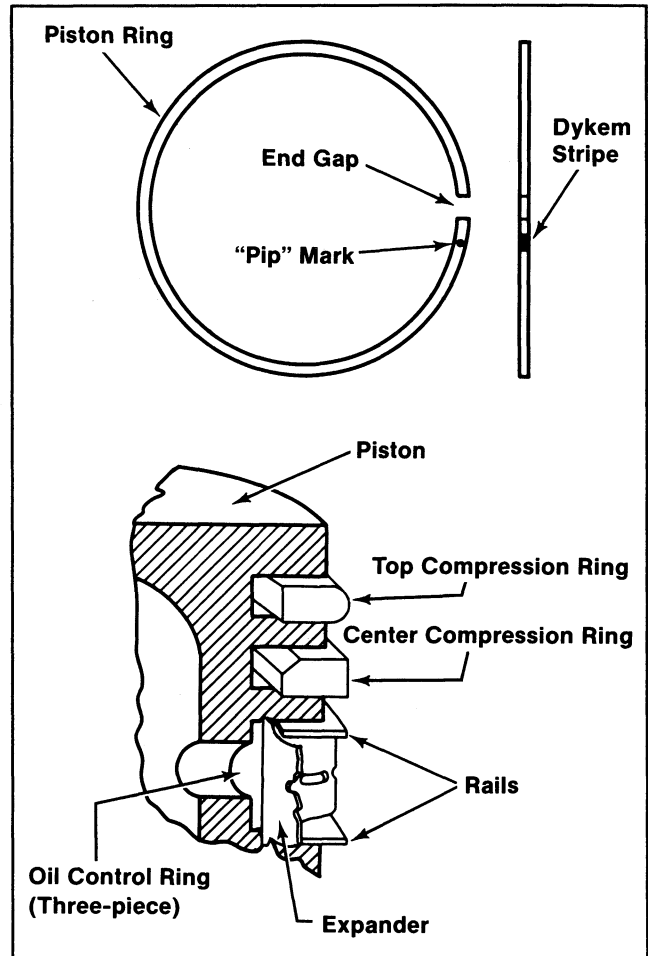

Figure 10-15. Piston Ring Installation.

- Oil Control Ring (Bottom Groove):** Install the expander and then the rails. Make sure the ends of expander are not overlapped.
- Compression Ring (Center Groove):** Install the beveled ring using a piston ring installation tool. Make sure the "pip" mark is up and the PINK dykem stripe is to the left of end gap.
- Compression Ring (Top Groove):** Install the top ring using a piston ring installation tool. Make sure the "pip" mark is up and the BLUE dykem stripe is to the left of end gap.

POSI-LOCK CONNECTING RODS

Posi-Lock Connecting Rods are used in all Magnum M18 and M20 engines. Because of the increase in piston pin boss thickness of the new, style D pistons used, the connecting rods on these engines have a narrower piston pin end than on older style Posi-Lock connecting rods. Therefore, the Posi-Lock connecting rods for the new pistons are not interchangeable with the Posi-Lock connecting rods for the standard pistons used on KT17 and KT19, and KT17* and KT19 Series II engines. Refer to Figure 10-16.

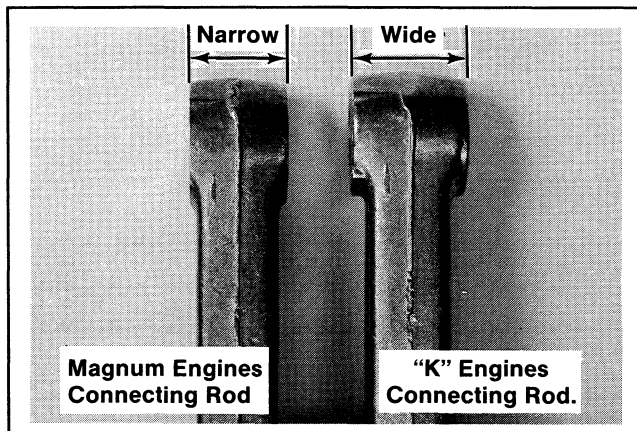

Figure 10-16. Posi-Lock Connecting Rods.

*NOTE: KT17 Series II engines built after Serial No. 15089862 are equipped with the new style D pistons, piston rings, and connecting rods.

Inspection and Service

Check bearing area (big end) for excessive wear, score marks, running and side clearances (Refer to Section 1, "Specifications, Tolerances, and Special Torque Values"). Replace rod and cap if scored or excessively worn.

Service replacement connecting rods are available in STD crankpin size and .010" undersize. The .010" undersized rod can be identified by the drilled hole located in the lower end of the rod shank (refer to Figure 10-17). Always refer to the appropriate parts information to ensure that correct replacements are used.

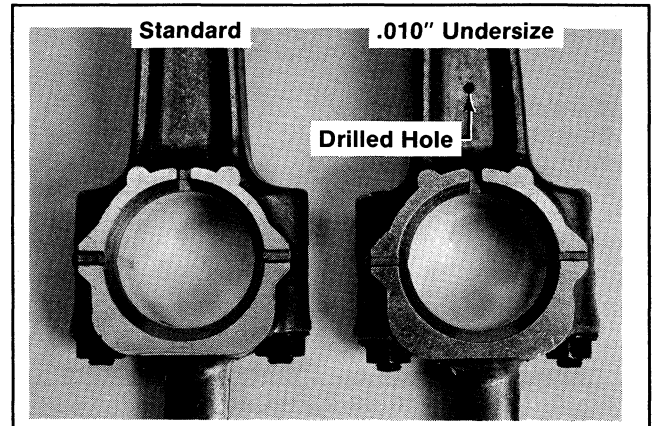

Figure 10-17. Standard and .010" Undersize Service Connecting Rods.

CAMSHAFT AND CRANKSHAFT

Inspection and Service

Inspect the gear teeth on both the crankshaft and camshaft. If the teeth are badly worn, chipped, or some are missing, replacement of the damaged components will be necessary.

Also, inspect the crankshaft bearings for scoring, grooving, etc. Do not replace bearings unless they show signs of damage or are out of running clearance specifications. If crankshaft turns easily and noiselessly, and there is no evidence of scoring, grooving, etc., on the races or bearing surfaces, the bearings can be reused.

Check crankshaft keyways. If worn or chipped, replacement of the crankshaft will be necessary. Also inspect the crankpin for score marks or metallic pick-up. Slight score marks can be cleaned with crocus cloth soaked in oil. If wear limits, as stated in "Specifications and Tolerances" are exceeded, it will be necessary to either replace the crankshaft or regrind the crankpin to .010" undersize. If reground, a .010" undersize connecting rod (big end) must then be used to achieve proper running clearance. Measure the crankpin for size, taper, and out-of-round.

NOTE: If the crankpin is reground, visually check to insure that the fillet blends smoothly with the crankpin surface. Refer to Figure 10-18.

SECTION 10 INSPECTION AND RECONDITIONING

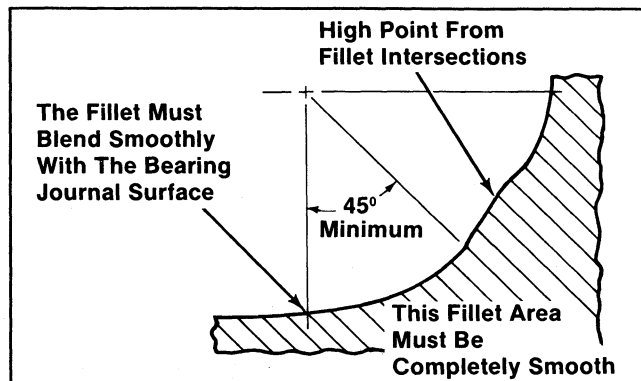

Figure 10-18. Crankpin Fillets.

CAMSHAFT/VALVE TO TAPPET CLEARANCE CHANGE

All M18 and M20 engines and short blocks, Serial No. 1816500656 and later, are being built with a new camshaft and tappets. In addition to the new parts, new valve to tappet cold clearances apply.

To service the camshaft (and tappets) in engines with Serial No. 1816500646 and earlier, camshaft kit 82 755 09 is available.

Serial No.	New Parts	Replace	Service With
1816500656 and later	52 012 08 Camshaft 52 019 02 Tappet (4)	52 012 07 Camshaft 52 019 03 Tappet (4)	52 012 08 Camshaft 52 019 02 Tappet (4)
1816500646 and earlier	-----	-----	82 755 09 Camshaft Kit ¹

¹Camshaft kit 82 755 09 contains the 52 012 08 camshaft and 52 019 02 tappets (4).

Engines Equipped With:	Valve to Tappet Cold Clearance	
	Intake	Exhaust
52 012 08 Camshaft 52 019 02 Tappets	.003/.006 in.	.011/.014 in.
52 012 07 Camshaft 52 019 03 Tappets	.003/.006 in.	.016/.019 in.

When installing the camshaft from the 82 755 09 kit, make sure the new tappets are also installed. The new camshaft cannot be used with the original 52 019 03 tappets. Set the valve to tappet clearance as specified above.

NOTE: The engine must be *cold* when setting valve to tappet clearance.

OIL PUMP

Inspection and Service

Check oil pump gear for any cracked, chipped, or badly worn teeth. Replace gear if any of these problems exist. See Figure 10-19 for oil pump gear removal.

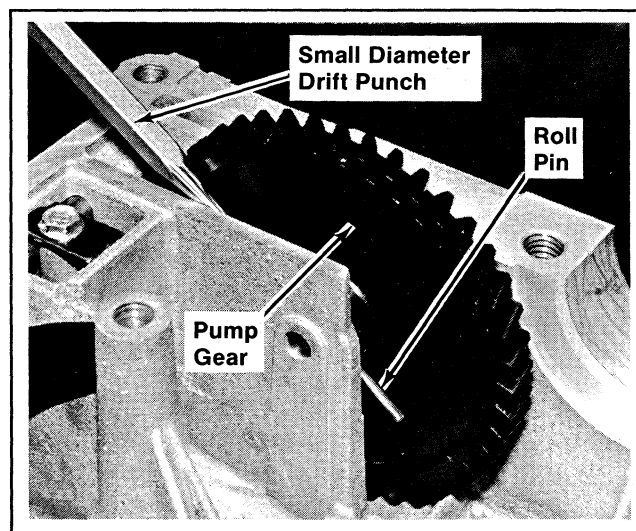

Figure 10-19. Removing the Oil Pump Gear.

SECTION 10 INSPECTION AND RECONDITIONING

Check oil pump relief valve ball, seat and spring (refer to Figure 10-20). Ball and seat should be free of nicks or burrs. Check spring for wear or distortion. Spring free length should be approximately .992". Replace spring if distorted or worn.

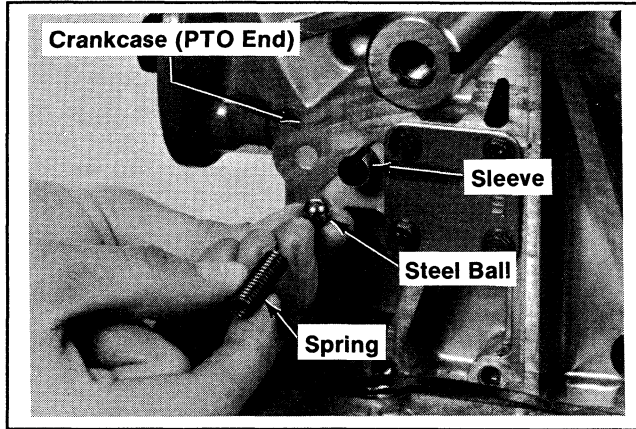

Figure 10-20. Oil Pressure Relief Valve.

NOTE: An oil relief valve repair kit is available which contains a new spring, check ball and sleeve. Refer to your parts manual for correct kit part number.

GOVERNOR GEAR

Inspection

Inspect the governor gear teeth. Look for any evidence of worn, chipped, or cracked teeth. If one or more of these problems is noted, replace the governor gear.

**SECTION 10
INSPECTION AND RECONDITIONING**

SECTION 11 REASSEMBLY

The following sequence is suggested for complete engine reassembly. This procedure assumes that all components are new or have been reconditioned, and all component subassembly work has been completed. This procedure may have to be varied slightly to accommodate options or special equipment. Make sure old RTV sealant has been removed from components using this before reassembling.

NOTE: Make sure the engine is assembled using all specified torque values, tightening sequences, and clearances. Failure to observe specifications could cause severe engine wear or damage.

NOTE: Always use new gaskets.

NOTE: Make sure all components have been cleaned **BEFORE** reassembly.

TYPICAL REASSEMBLY SEQUENCE

1. Install oil pump and oil pickup.
2. Install cross shaft and governor gear.
3. Install connecting rods.
4. Install bearings and crankshaft.
5. Install tappets and camshaft.
6. Install camshaft bore plug and seal crankcase.
7. Install front oil seal.
8. Install oil filter adapter.
9. Install oil pressure relief valve, closure plate, and rear oil seal.
10. Install piston rings.
11. Install pistons in cylinder barrels.
12. Install cylinder barrels.
13. Measure valve-to-tappet clearance.
14. Install valves.
15. Install cylinder heads and spark plugs.
16. Install stator.
17. Install electric starter.
18. Install fan, flywheel, and grass screen.
19. Install bracket and ignition module.
20. Install fuel pump.
21. Install valve cover and breather.
22. Install blower housing, cylinder head baffles, and top baffle.
23. Install solenoid, key switch, rectifier-regulator, and connect wiring.
24. Install carburetor and intake manifold.
25. Install air cleaner.
26. Install exhaust elbows and mufflers.
27. Install oil filter.

INSTALL OIL PUMP AND OIL PICKUP

Oil Pump

1. Install the shim spacer (next to support rib), oil pump drive gear (slotted end of gear hub towards spacer and rib), and oil pump drive shaft (through support rib and into pump cavity). Refer to Figures 11-1 and 11-2.

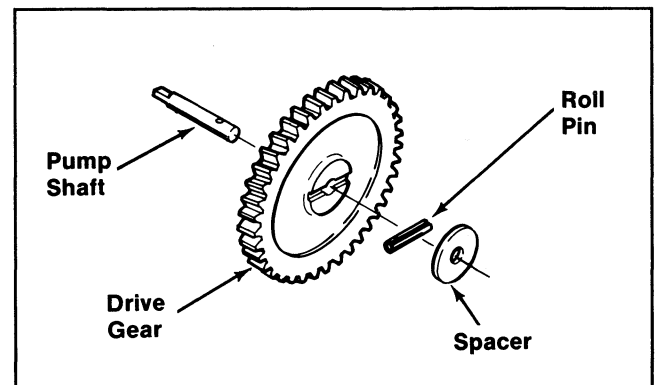

Figure 11-1. Installing Oil Pump Drive Gear.

2. Rotate the drive shaft and drive gear until hole in shaft is aligned with slot in gear hub.
3. Lubricate a new roll pin with grease. Drive the roll pin until it is flush with gear hub. Refer to Figure 11-2.

SECTION 11 REASSEMBLY

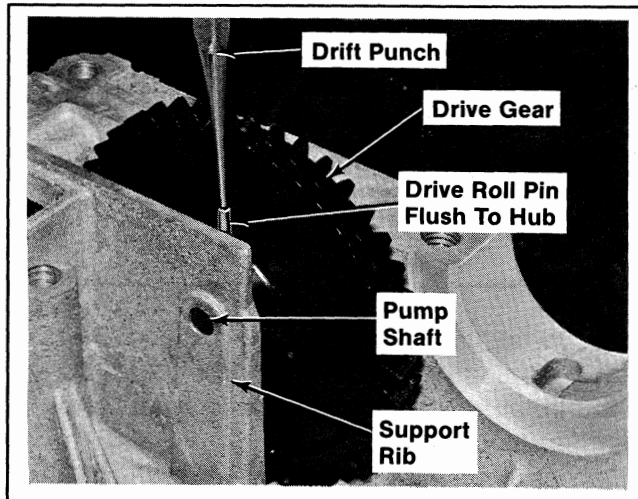

Figure 11-2. Securing Oil Pump Drive Gear to Shaft.

4. Measure pump drive gear end play with a flat feeler gauge. Refer to Figure 11-3. Recommend end play is $.010/.029$ ". Add one (1) additional shim spacer, if necessary, to bring end play within range.

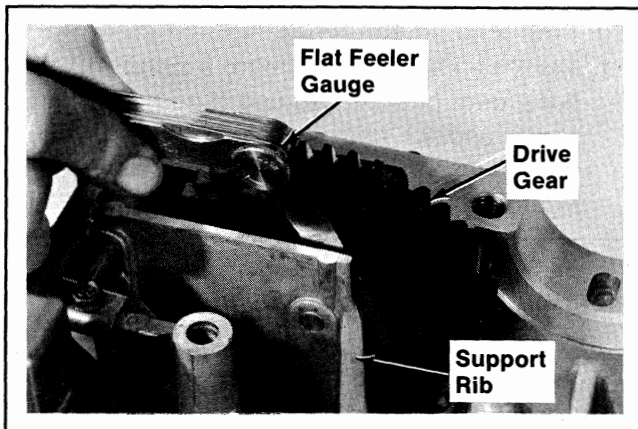

Figure 11-3. Measuring Oil Pump Drive Gear End Play.

5. Lubricate the oil pump cavity with engine oil. Install inner and outer rotors. Refer to Figure 11-4.

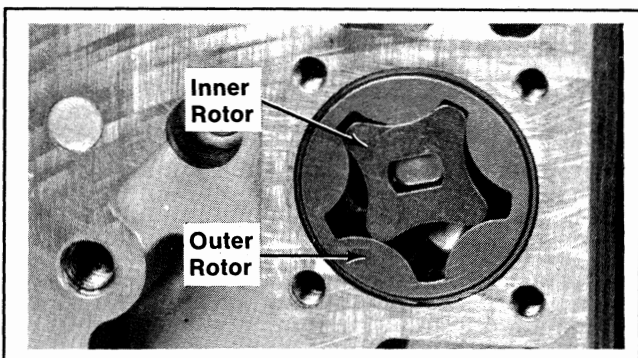

Figure 11-4. Installing Oil Pump Rotors.

6. Install the cover (side marked "OUT" away from crankcase) and self-tapping screws. Refer to Figure 11-5.

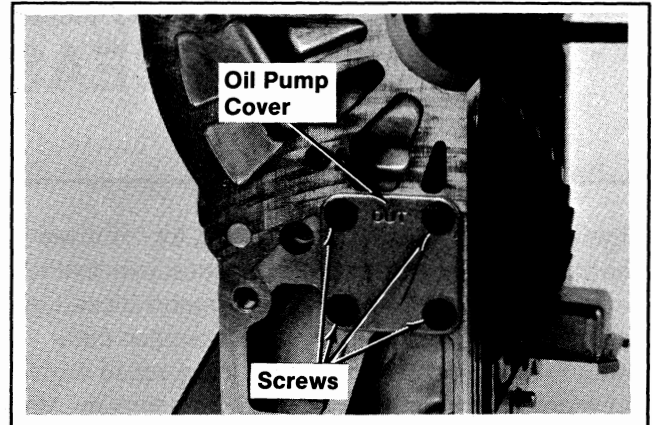

Figure 11-5. Installing Oil Pump Cover.

Oil Pickup

1. Install the oil pickup tube. Make sure tube is angled upward. Install clamp and self-tapping screw. Refer to Figure 11-6.

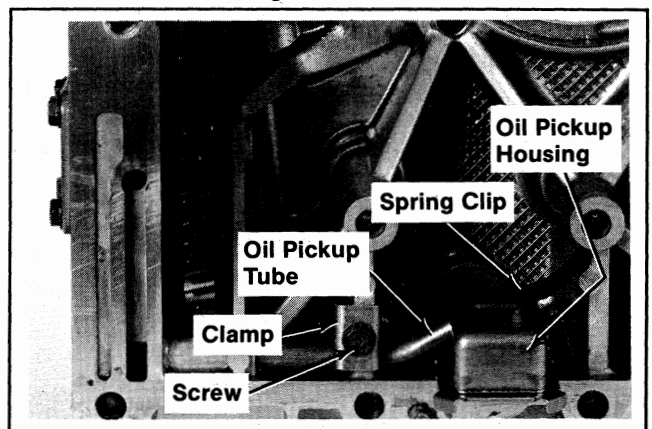

Figure 11-6. Installing Oil Pickup Components.

2. Install the oil pickup housing and spring clip (install narrow side of clip into crankcase first).

INSTALL CROSS SHAFT AND GOVERNOR SHAFT

1. Install the plain washer, cross shaft, plain washer, and retaining ring. Refer to Figure 11-7.

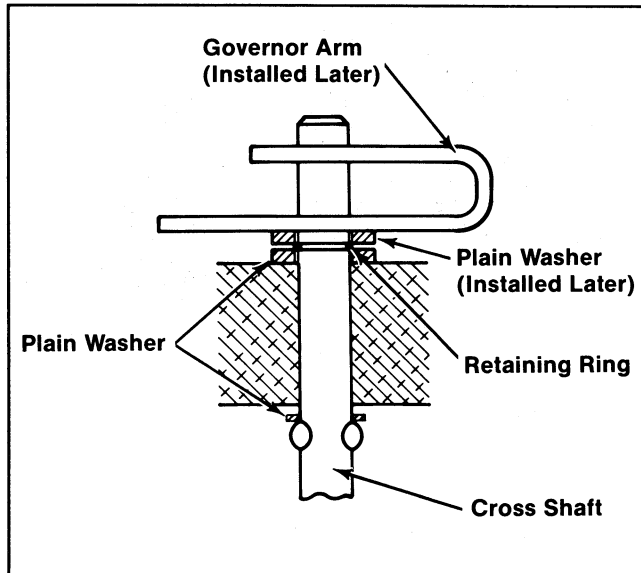

Figure 11-7. Installing Governor Cross Shaft.

2. Install the thrust washer and governor gear to stub shaft. Refer to Figure 11-8.

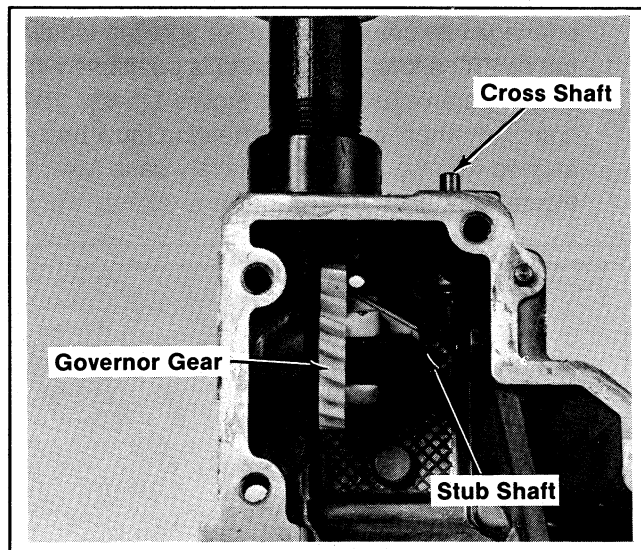

Figure 11-8. Installing Governor Gear.

3. Install the copper washer and governor stop pin. Refer to Figure 11-9.

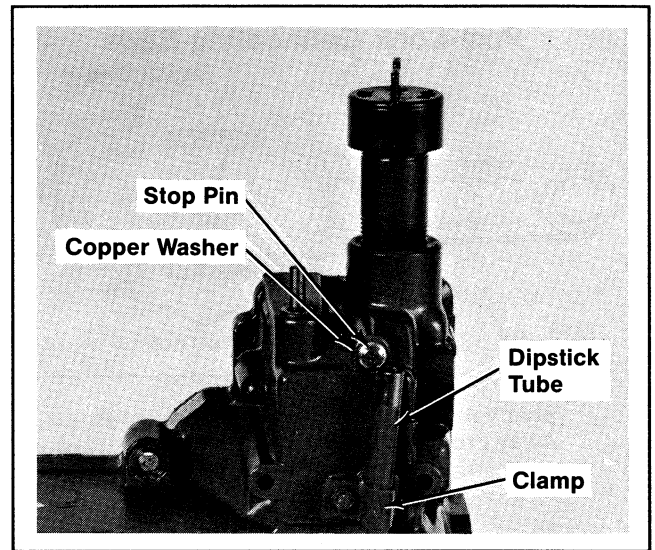

Figure 11-9. Installing Governor Stop Pin.

NOTE: If not loosened during disassembly, loosen the clamp securing the dipstick tube to crankcase. Move the dipstick tube out of the way to ease installation of stop pin. Tighten the clamp securely after installing stop pin.

INSTALL CONNECTING RODS

1. Lubricate the connecting rod journals and studs with engine oil and install connecting rods to crankshaft.
 - **When Reinstalling Used Rods:** Install the #1 connecting rod to crankshaft journal closest to flywheel end of crankshaft. Install #2 connecting rod to the journal closest to PTO end of crankshaft.
 - **On Model M20:** Install the connecting rods with the shanks angled down and away from the camshaft (top of crankcase). Refer to Figure 11-10.

SECTION 11 REASSEMBLY

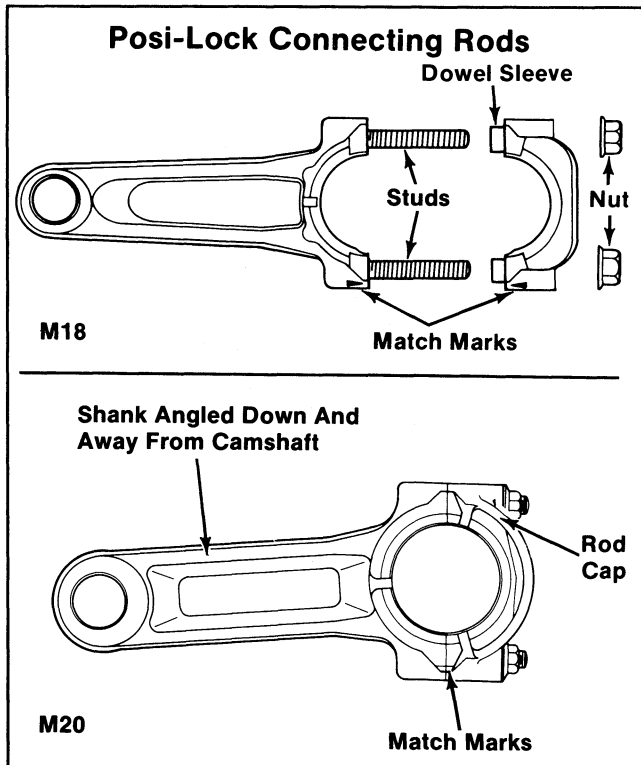

Figure 11-10. Installing Posi-Lock Connecting Rods.

2. Install the connecting rod caps. Make sure the match marks are aligned and the proper cap is reinstalled to each connecting rod.
3. Install the hex. nuts and torque as follows:

	Torque
New Service Rod	140 in. lb.
Used/Reinstalled Rod	100 in. lb.

NOTE: To prevent damage to the connecting rods and engine, do not overtorque—loosen—and retorquer the hex. nuts on Posi-Lock connecting rods. Torque the nuts, in increments, directly to the specified values.

INSTALL BEARINGS AND CRANKSHAFT

1. Lubricate the crankshaft bearing journals with engine oil. Install the .130" thrust washer to PTO end of crankshaft. Refer to Figure 11-11.

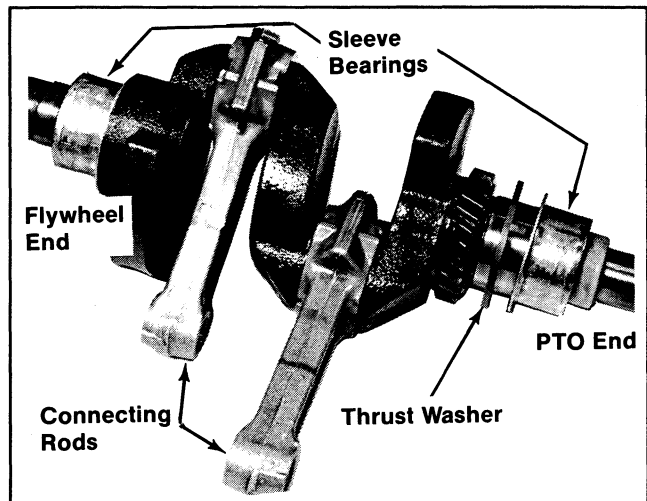

Figure 11-11. Installing Thrust Washer and Bearings to Crankshaft.

2. Install the bearings to PTO and flywheel end of crankshaft.
3. Install the crankshaft with connecting rods and bearings into crankcase. Make sure the locating tab of PTO end sleeve bearing is positioned in notch in crankcase (refer to Figure 11-12). The oil hole in flywheel end sleeve bearing must be aligned with the oil gallery in crankcase (refer to Figure 11-13).

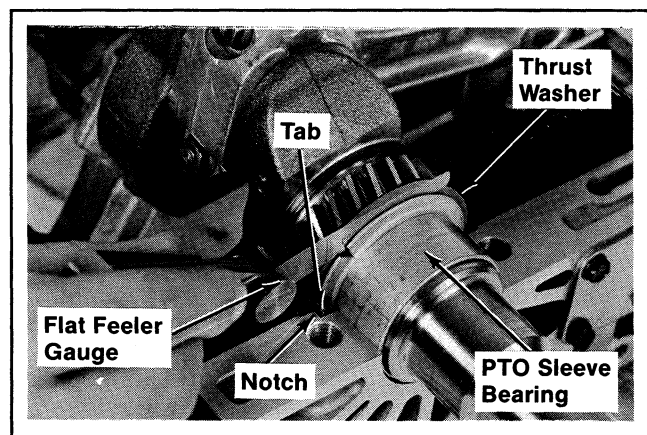

Figure 11-12. Position of PTO Bearing/Measuring Crankshaft End Play.

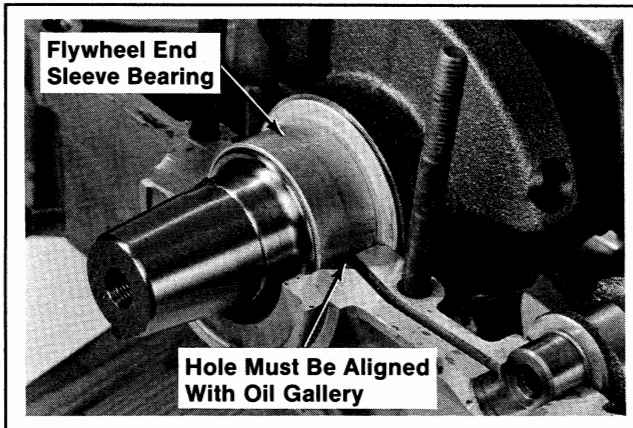

Figure 11-13. Position of Flywheel Bearing.

NOTE: Improper positioning of bearings could result in engine failure due to lack of lubrication.

4. Measure the crankshaft end play with a flat feeler gauge. The recommended crankshaft end play is **.002/.014"**.

Exchange thrust washer, if necessary, to bring end play within range. Three sizes of thrust washers are available: **.121"**, **.130"** (STD), and **.139"**.

Roller Thrust Bearings

Some engines for high thrust applications use a roller thrust bearing and flat thrust washers on the flywheel end of the crankshaft. Refer to Figure 11-14.

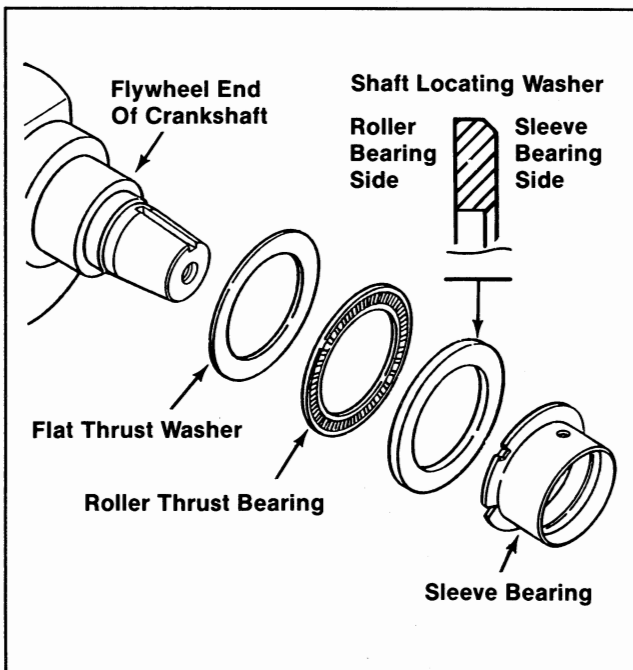

Figure 11-14. Installing Roller Thrust Bearings.

Install the **.039"** thrust washer, roller thrust bearing, **.156"** shaft locating washer, and flanged sleeve bearing to flywheel end of crankshaft.

INSTALL TAPPETS AND CAMSHAFT

1. Lubricate the stems of tappets with engine oil. Install the tappets into crankcase sides. Make sure that used tappets are reinstalled into the proper sides and positions (intake or exhaust) as marked during disassembly.

NOTE: The intake valve tappet is closest to the flywheel side of crankcase. The exhaust tappet is closest to the PTO side of crankcase.

2. Put tape or governor spring around the tappet stems in the #2 crankcase side. This prevents the tappets from falling into the #1 side when reassembling crankcase. Refer to Figure 11-15.

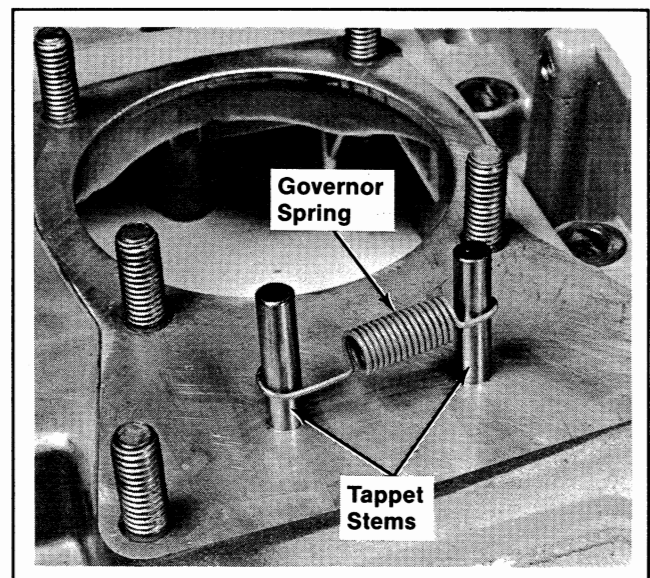

Figure 11-15. Holding Tappets (#2 Side) Using Governor Spring.

3. Place the camshaft into the #1 side of crankcase. Make sure the timing mark on crankshaft aligns with the timing mark on cam gear. Refer to Figure 11-16.

SECTION 11 REASSEMBLY

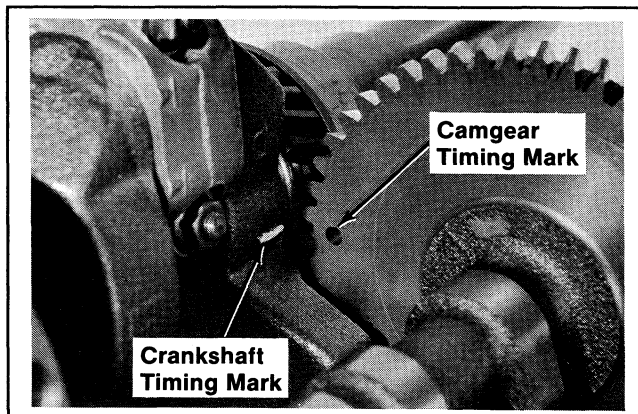

Figure 11-16. Aligning Crankshaft and Cam Gear Timing Marks.

4. Measure the camshaft end play with a flat feeler gauge. The recommended camshaft end play is .003/.013". Refer to Figure 11-17.

Add shim spacers, if necessary, to bring end play within range.

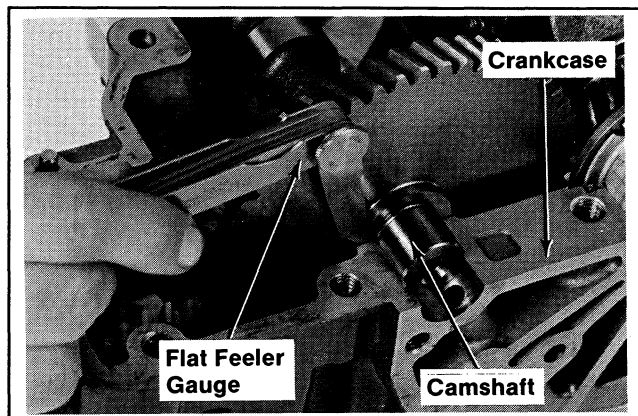

Figure 11-17. Measuring Camshaft End Play.

INSTALL CAMSHAFT BORE PLUG AND SEAL CRANKCASE

1. Prepare the sealing surfaces of the crankcase sides and mating surfaces of crankcase and cylinder barrels as directed by the sealant manufacturer.

NOTE: Do not scrape the surfaces when cleaning as this will damage the surfaces causing leaks. The use of a gasket removing solvent is recommended.

2. Apply a 1/16" bead of sealant to the #2 crankcase side as shown in Figure 11-18. Follow the sealant manufacturer's recommendations regarding "setting." Recommended sealants are listed below.

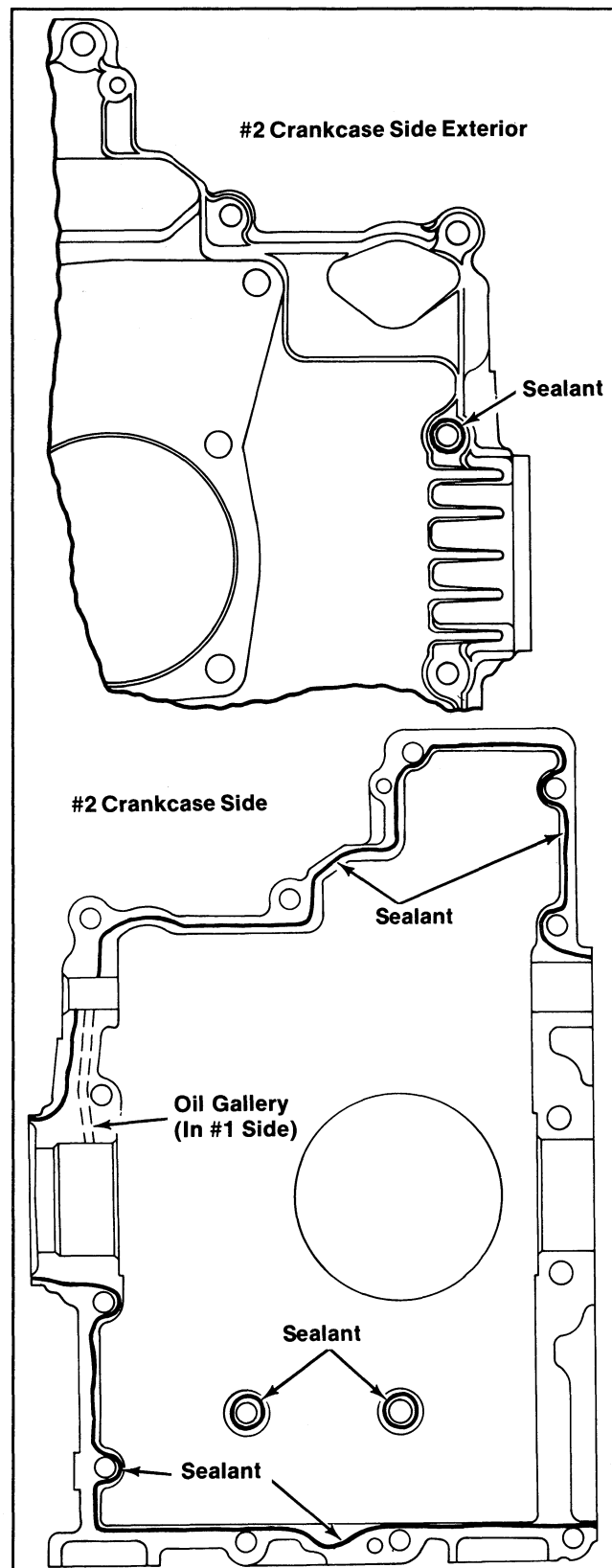

Figure 11-18. Crankcase Sealant Pattern.

Recommended Sealants

These commercially available sealants are recommended for use on MAGNUM M18 and M20 engines.

VENDOR	PRODUCT	VENDOR NO. & DESCRIPTION		AVAILABILITY
Dow Corning	Silicone Rubber Sealant	732 Aluminum, Black, Bronze, Clear, White		Automotive, Hardware, and Discount Stores
GE	RTV Silicone Rubber	RTV102-White RTV103-Black RTV106-Red RTV108-Clear	RTV109-Gray RTV154-Gray RTV156-Red Silmate-Black	GE Silicone Products Distributors
GE	Silicone Instant Gasket	Red		Automotive, Hardware, and Discount Stores
GE	Silicone Hi Temp Instant Gasket	Red		Automotive, Hardware, and Discount Stores
Loctite®	Superflex Silicone Adhesive Sealant	593 - Black 594 - White 595 - Clear		Loctite® Distributors
Permatex	Silicone Form-A-Gasket	6 Blue 6B Blue 6C Blue 6M Blue 66B Clear 66C Clear	3 oz. Bubble pack tube 3 oz. Boxed tube 11 oz. Cartridge 12 oz. Tube 3 oz. Tube 11 oz. Tube	Automotive Hardware, and Discount Stores

NOTE: Using an outdated sealant can result in seal leakage. All of the above sealants have a one to two year storage life.

- Lubricate the O-Ring of camshaft bore plug with engine oil. Insert the plug into the camshaft bore in flywheel end of #1 crankcase side.

When reinstalling a used plug, make sure the marks scribed on the crankcase and plug during disassembly are aligned. Refer to Figure 11-19.

- Place the #2 crankcase side on the #1 side. Apply thumb pressure on the plug as the sides are brought together. Maintain pressure on the plug as the crankcase fasteners are installed and tightened. This ensures the plug shoulder is bottomed tightly against the crankcase. Refer to Figure 11-20.

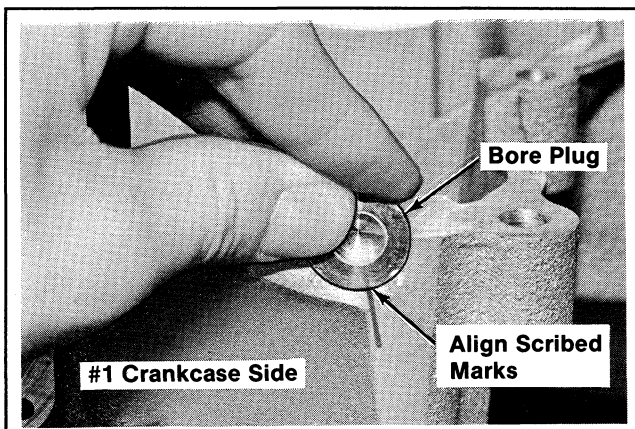

Figure 11-19. Installing Camshaft Bore Plug.

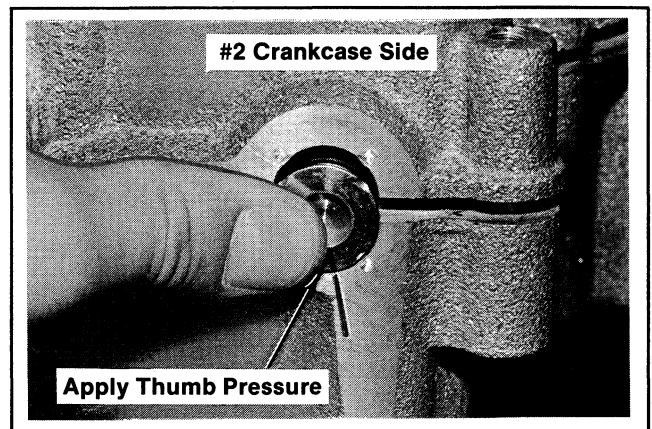

Figure 11-20. Installing #2 Crankcase Side.

SECTION 11 REASSEMBLY

5. Install the hex. flange screws, plain washers, and hex. nuts.
6. Torque fasteners #1 through #6 in the sequence shown to a preliminary value of **100 in. lb.** Torque the remaining fasteners to **100 in. lb.** in the most expedient sequence. Refer to Figure 11-21.

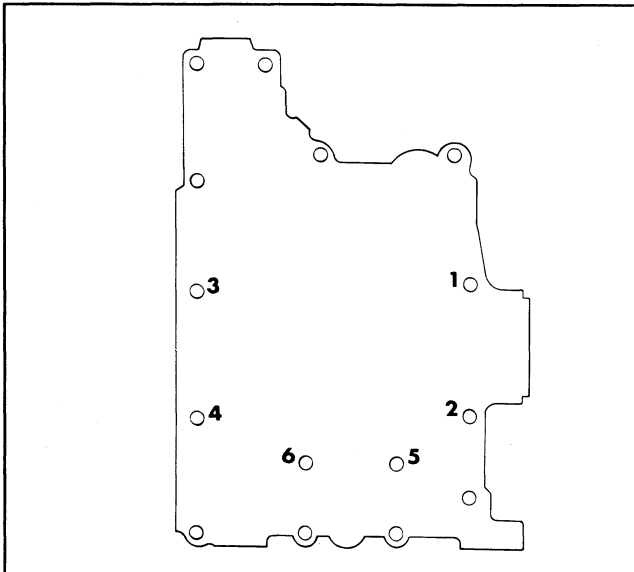

Figure 11-21. Crankcase Fastener Torque Sequence.

7. Torque fasteners #1 through #4 to **260 in. lb.** Torque fasteners #5 and #6 to **200 in. lb.** Torque the remaining fasteners to **200 in. lb.** in the most expedient sequence. Refer to Figure 11-21.
8. Locate a center punch in the previous stake marks surrounding the camshaft bore plug. Restake the plug securely in place. Refer to Figure 11-22.

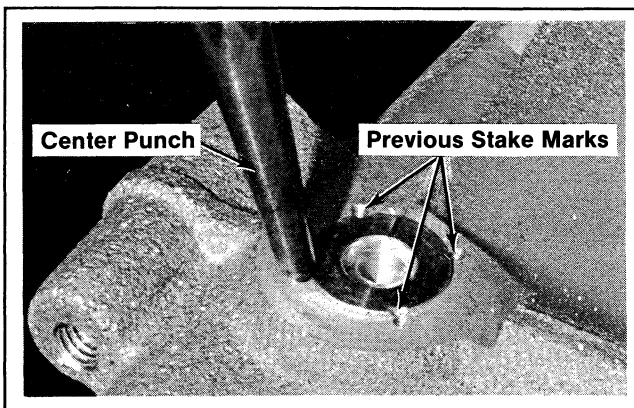

Figure 11-22. Restaking Camshaft Bore Plug.

9. Remove the tape or governor spring from tappets in #2 crankcase side.

INSTALL FRONT OIL SEAL

1. Slide the appropriate seal sleeve (refer to Section 2, "Special Tools") over flywheel end of crankshaft. Generously lubricate lips of front oil seal with light grease. Slide oil seal over sleeve. Refer to Figure 11-23.

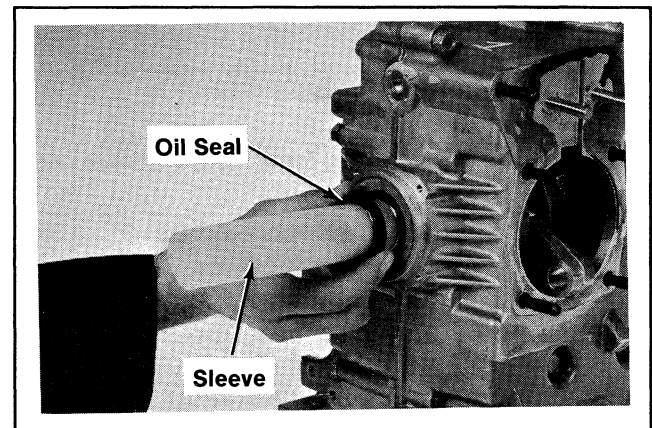

Figure 11-23. Installing Oil Seal Using Sleeve.

2. Using the #11795 handle and appropriate seal driver, install the front oil seal to a depth of $\frac{1}{32}$ " ($+\frac{3}{64}$ "; $-\frac{1}{64}$ "). Refer to Figure 11-24.

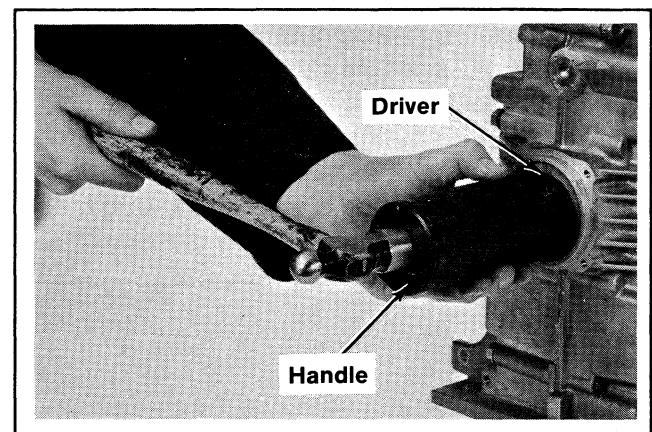

Figure 11-24. Installing Oil Seal Using Driver.

INSTALL OIL FILTER ADAPTER

1. Install the gasket, oil filter adapter, and hex. socket head screws. Make sure the arrow on filter adapter is pointing to top of crankcase. Refer to Figure 11-25.

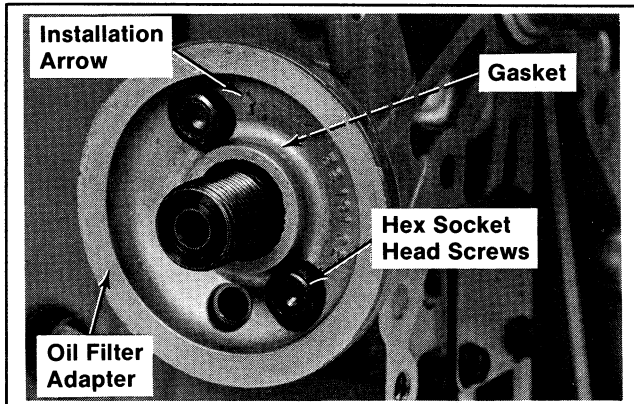

Figure 11-25. Installing Oil Filter Adapter.

- Torque the hex. socket head screws to 75/90 in. lb.

NOTE: Refer to the "Lubrication System" section for installation torques of remote oil filter and oil filter bypass components.

INSTALL OIL PRESSURE RELIEF VALVE, CLOSURE PLATE, AND REAR OIL SEAL

NOTE: Later production models use silicone sealant as a gasket between the closure plate and crankcase. In order to eliminate the fiber gasket and use sealant, an additional .020" of material was added to the closure plate. Therefore, closure plates designed for use with gaskets cannot be installed using sealant; closure plates designed for use with sealant cannot be installed using a gasket.

Follow these general guidelines when reinstalling or replacing closure plates:

- When reinstalling a closure plate originally installed using a gasket, use a new gasket.
 - When reinstalling a closure plate originally installed using sealant or installing a service replacement closure plate kit, apply a new bead of sealant to the closure plate as shown in Figure 11-27.
- Install the oil pressure relief valve sleeve, steel ball, and spring. Refer to Figure 11-26.
 - Make sure the mating surfaces of the crankcase and closure plate are cleaned and prepared as directed by the sealant manufacturer. Refer to "INSTALL CAMSHAFT BORE PLUG AND SEAL

CRANKCASE" earlier in this section for more information on sealants.

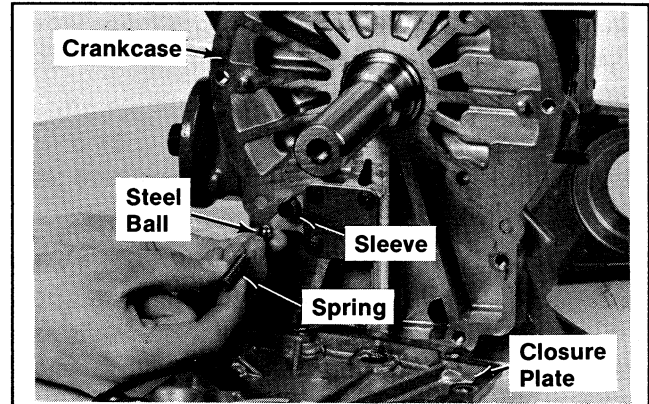

Figure 11-26. Installing Oil Pressure Relief Valve.

- Apply a 1/16" bead of sealant to the closure plate as shown in Figure 11-27. Follow the sealant manufacturer's recommendations regarding setting.

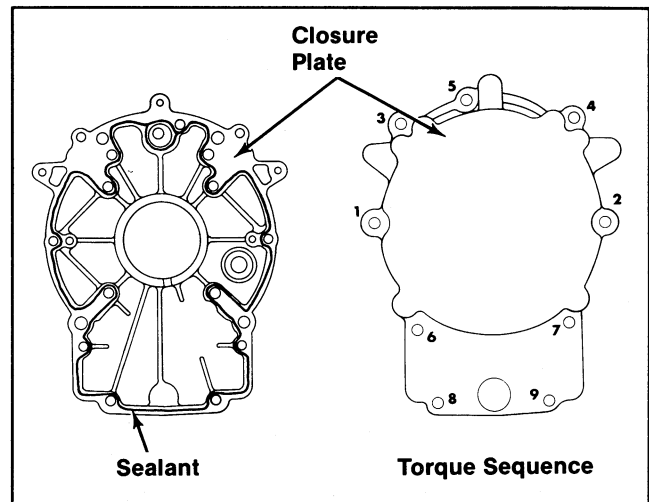

Figure 11-27. Closure Plate Sealant Pattern/Closure Plate Fastener Torque Sequence.

- Install the closure plate and hex. flange screws. Torque screws to 150 in. lb. in the sequence shown in Figure 11-27.
- Slide the appropriate seal sleeve over PTO end of crankshaft. Generously lubricate the lips of rear oil seal with light grease. Slide the oil seal over sleeve. Refer to Figure 11-23.
- Using the #11795 handle and appropriate seal driver, install the rear oil seal to a depth of 5/32" (+ 3/64"; -1/64"). Refer to Figure 11-24.

SECTION 11 REASSEMBLY

CLOSURE PLATE ALIGNMENT

Engines with Serial No. 1830500016 and higher have two alignment pins pressed into the crankcase (see Figure 11-26) to provide proper alignment of the closure plate.

On direct connected applications having splined crankshafts, the correct alignment is essential to prevent rapid spline wear due to excessive run-out.

When rebuilding splined crankshaft engines that were built before the permanent alignment pins were added, use the available alignment pin tools when installing new or serviced closure plates. Hobart Welders use Part No. 52 455 05 pins while all other splined shaft specifications use 52 380 06 pins. The closure plate kits which are available for these earlier engines include the pins and instructions for using.

Follow preceding instructions for reinstalling the closure plate, however, before tightening the plate and before installing the oil seal, insert the four alignment pins into four equal distant locations between the crankshaft seal surface and the closure plate outer circumference. If any pins become tight, shift the closure plate to allow all pins to position equally against crankshaft sealing surface. After aligning tighten closure plate screws as specified in Step 4. Remove the pins after tightening the closure plate to allow installing the oil seal.

INSTALL PISTON RINGS

NOTE: For detailed piston inspection procedures and piston ring installation procedures, refer to the "Inspection and Reconditioning" Section.

INSTALL PISTONS IN CYLINDER BARRELS

NOTE: Proper orientation of the pistons within cylinder barrels is extremely important. Improper orientation may cause extensive wear or damage.

1. Stagger the piston rings in grooves until the end gaps are 120° apart.
2. Lubricate the pistons and rings with engine oil. Install piston ring compressor around pistons. Refer to Figure 11-28.

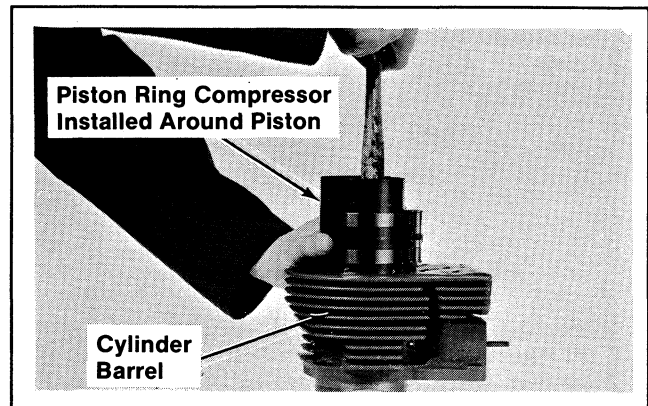

Figure 11-28. Installing Pistons.

3. Orient the "Fly" mark on pistons so it points towards flywheel (intake port) side of cylinder barrels. Refer to Figure 11-29.

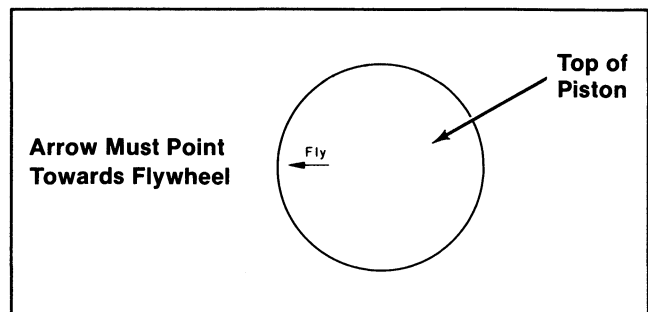

Figure 11-29. Piston Installation Direction Identifier.

Gently push the pistons into cylinder bores from cylinder head side—do not pound on piston. Refer to Figure 11-28.

Make sure that used pistons are reinstalled into the proper cylinder barrels as marked during disassembly.

4. Continue pushing the piston into bore until the piston pin bore is completely exposed on the crankcase side of cylinder barrel. Make sure the oil control ring is not exposed.

INSTALL CYLINDER BARRELS

1. Make sure the mating surfaces of crankcase and cylinder barrels are cleaned and prepared as directed by the sealant manufacturer. Refer to "INSTALL CAMSHAFT BORE PLUG AND SEAL CRANKCASE."
2. Apply a 1/16" bead of sealant to the crankcase as shown in Figure 11-30. Follow the sealant manufacturer's recommendations regarding setting.

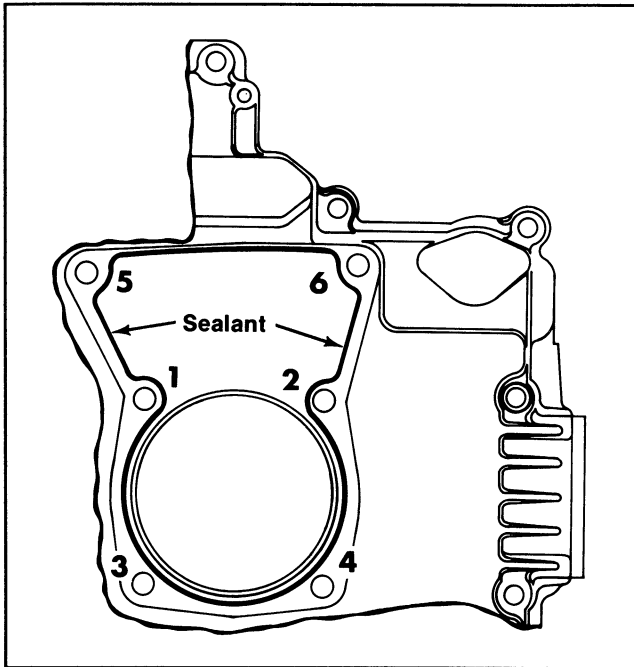

Figure 11-30. Cylinder Barrel Sealant Pattern/Cylinder Barrel Fastener Torque Sequence.

3. Install one (1) new piston pin retainer in one side of each piston pin bore.
4. Install the pistons (inside cylinder barrels), piston pins, and new piston pin retainers to connecting rods. Refer to Figure 11-31.

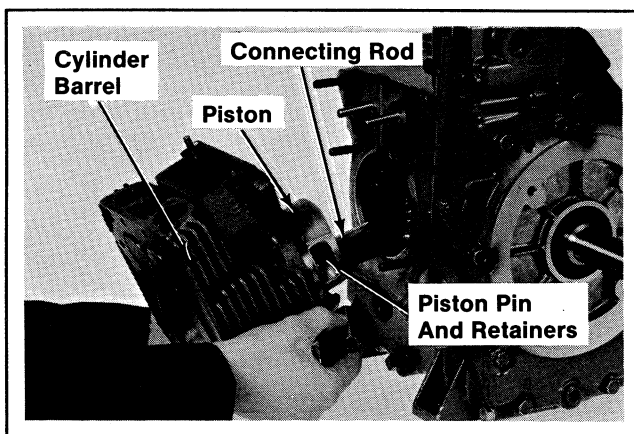

Figure 11-31. Installing Pistons/Cylinder Barrels to Connecting Rod.

NOTE: To prevent damage to the connecting rods when reinstalling the cylinder barrels, make sure the barrels and connecting rods are supported at all times. Do not allow the connecting rods to drop against the edges of crankcase.

5. Slide the cylinder barrels over pistons and crankcase studs.
6. Install the plain washers and hex. nuts. Torque hex. nuts #1 and #2 to **100 in. lb.** Torque the remaining hex. nuts to **100 in. lb.** in the most expedient sequence. Refer to Figure 11-30.
7. Torque all hex. nuts to **200 in. lb.** in the sequence shown.

MEASURE VALVE-TO-TAPPET CLEARANCE

IMPORTANT:

The piston must be at top dead center (TDC) of the compression stroke to measure valve-to-tappet clearance. By rotating the crankshaft and observing the tappets for movement, it can be determined if a cylinder is at TDC.

If, for example, the crankshaft is rotated and movement is observed in the #2 side valve box--the opposite cylinder (#1 side) will be at TDC and valve-to-tappet clearance can be measured.

Rotating the flywheel one complete revolution (360°) will then cause movement in the #1 side valve box. The #2 side cylinder will be at TDC, enabling measurement of valve to tappet clearance for that side.

The valve faces and seats must be lapped-in before checking/adjusting valve-to-tappet clearance.

1. Rotate the crankshaft and look into the valve boxes. The tappets will move in only one of the boxes.
2. Install valves into valve guides for the cylinder in which **no movement** was observed. Hold valves firmly against seat and measure valve-to-tappet clearance with a flat feeler gauge. Refer to Figure 11-32.

SECTION 11 REASSEMBLY

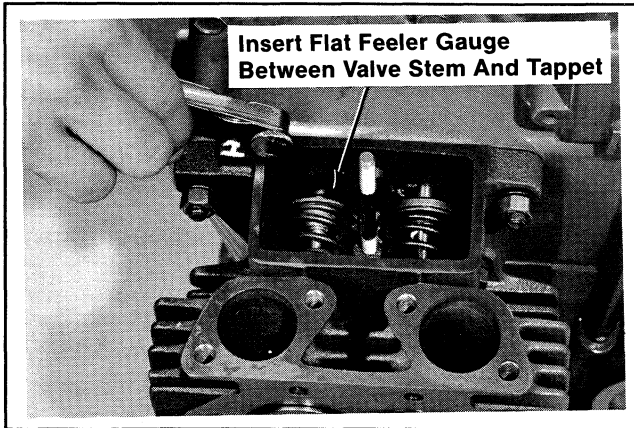

Figure 11-32. Measuring Valve-to-Tappet Clearance.

Clearance Specifications -

Intake Valve
(Closest to Flywheel) .003"/.006"

Exhaust Valve (Seat Angle)
(Closest to PTO) 45° .016"/.019"
30°* .011"/.014"

*Serial No. 1816500646 and later.

3. Rotate the crankshaft 360° and measure the valve-to-tappet clearance for the remaining cylinder.
4. If the clearance is insufficient, grind the valve stems until the correct clearance is obtained. Make sure the valve stems are ground perfectly flat and smooth.

If the clearance is excessive, replace the valves and recheck clearance.

INSTALL VALVES

1. Install the intake valve seals to valve guides.
2. Install the valve springs (close coils towards cylinder head surface), exhaust valve rotators, lower intake valve spring retainers, and valves.
3. Compress the springs using a valve spring compressor and install keepers. Refer to Figure 11-33.

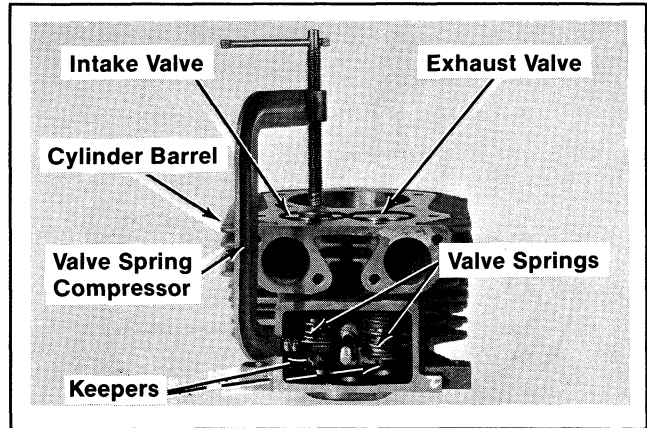

Figure 11-33. Installing Valves. Side #2 Shown.

INSTALL CYLINDER HEADS AND SPARK PLUGS

1. Install gaskets, cylinder heads, plain washers, and hex. cap screws (lubricate threads with oil). Torque hex. cap screws in increments in the sequence shown in Figure 11-34 to 15/20 ft. lb.

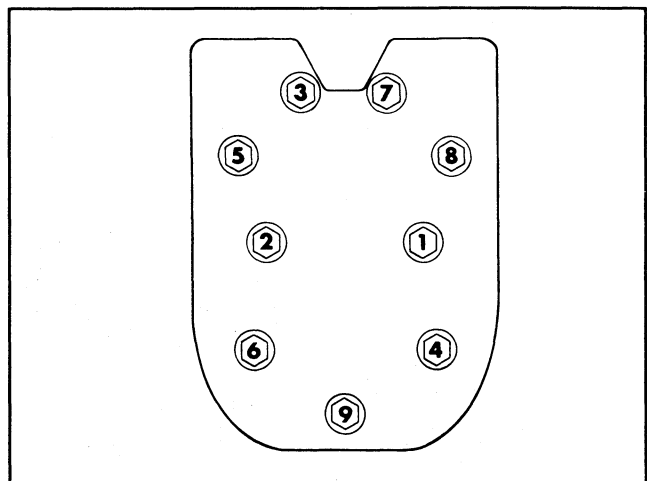

Figure 11-34. Cylinder Head Fastener Torque Sequence.

2. Install the spark plugs (0.035" gap); torque to 10/15 ft. lb.

INSTALL STATOR

1. Install the stator and self-tapping screws. Refer to Figure 11-35.

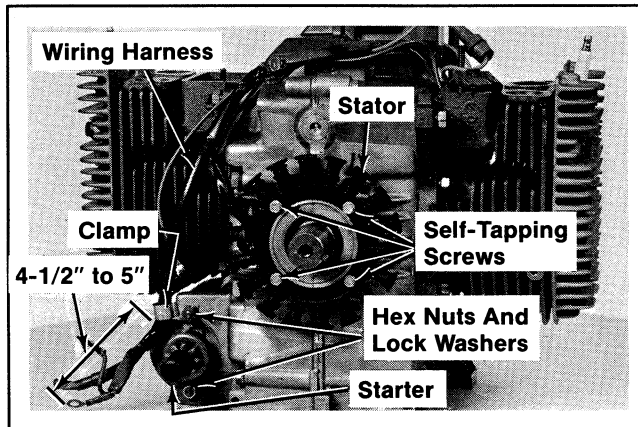

Figure 11-35. Installing Stator and Electric Starter.

INSTALL ELECTRIC STARTER

1. Install the starter, wiring harness clamp, split lock washers, and hex. nuts. Refer to Figure 11-35.
2. Install the wiring harness in clamp so that the end of lead which connects to solenoid is approximately 4-1/2" to 5" from the clamp. Bend clamp securely around wiring harness.

INSTALL FAN, FLYWHEEL, AND GRASS SCREEN

⚠ WARNING: Damaging Crankshaft and Flywheel Could Cause Personal Injury! *Using improper procedures to install the flywheel can crack or damage the crankshaft and/or flywheel. This not only causes extensive engine damage, but also is a serious threat to the safety of person nearby, since broken fragments could be thrown from the engine. Always observe and use the following precautions and procedures when installing the flywheel.*

NOTE: A. Before installing the flywheel, make sure the crankshaft taper and flywheel hub are clean, dry, and completely free of lubricants. The presence of lubricants can cause the flywheel to be over stressed and damaged when the cap screw is torqued to specification.

B. Make sure the flywheel key is installed only in the flat area of keyway, not in the rounded

area. The flywheel can become cracked or damaged if the key is installed in the rounded area of keyway.

C. Always use a flywheel strap wrench to hold flywheel when tightening the flywheel fastener. Do not use any type of bar or wedge between the cooling fins or flywheel ring gear, as these parts could become cracked or damaged.

1. Install the spacers, fan, and hex. flange screws. Refer to Figure 11-36.

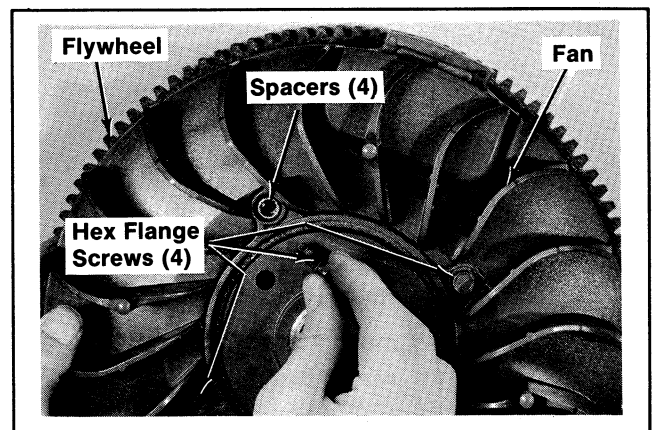

Figure 11-36. Installing Fan To Flywheel.

2. Place the flywheel on crankshaft and install plain washer, split lock washer, and hex. cap screw (lubricate threads with oil). Refer to Figure 11-37.

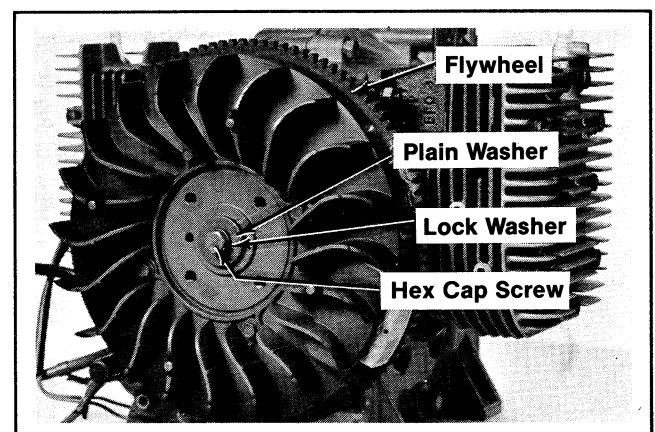

Figure 11-37. Installing Flywheel Fastener.

3. Hold the flywheel with the strap wrench and torque the hex. cap screw to **40 ft. lb.**
4. Install the grass screen to fan.

SECTION 11 REASSEMBLY

INSTALL BRACKET AND IGNITION MODULE

1. Install the bracket and hex. flange screws to #1 cylinder barrel. Make sure the arrow on bracket is pointing to top of crankcase. Refer to Figure 11-38.

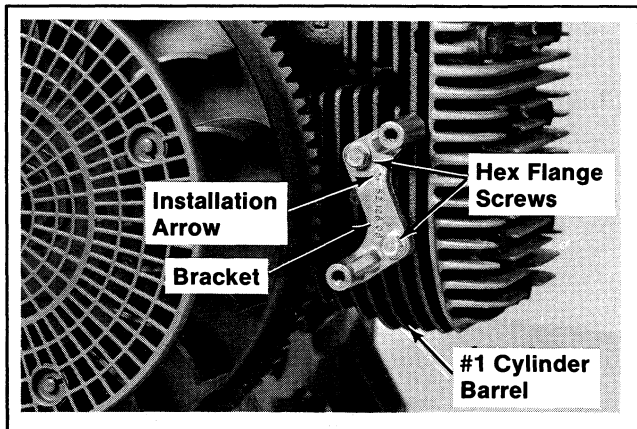

Figure 11-38. Installing Ignition Module Bracket.

2. Rotate flywheel magnet away from module position.
3. Install the module and hex. flange screws to bracket. Move module as far from flywheel as possible--tighten hex. cap screws slightly.
4. Insert a .014" flat feeler gauge or shim stock between magnet and module. Loosen the hex. flange screws so magnet pulls the module against feeler gauge (refer to Figure 11-39). Tighten the hex flange screws securely. Remove the feeler gauge or shim stock. Due to the pull of the magnet, the magnet-to-module air gap should be within the final range of .008"/.012".

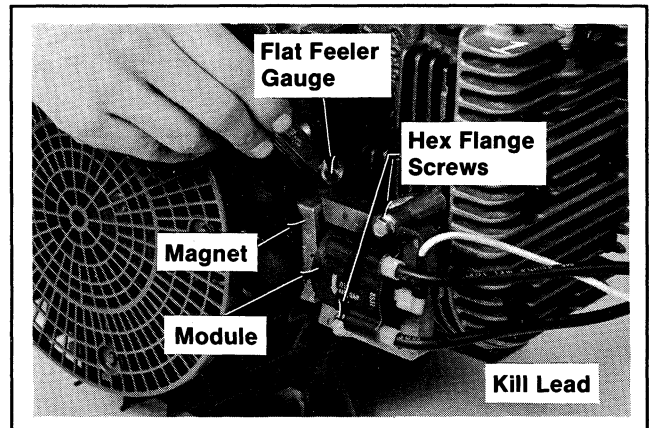

Figure 11-39. Installing Ignition Module.

4. Rotate the flywheel back and forth; check to make sure the magnet does not strike the module. Readjust gap, if necessary.
5. Install the kill lead to kill terminal on module.

INSTALL FUEL PUMP

1. Install the gasket, fuel pump, and truss head screws. Refer to Figure 11-40.

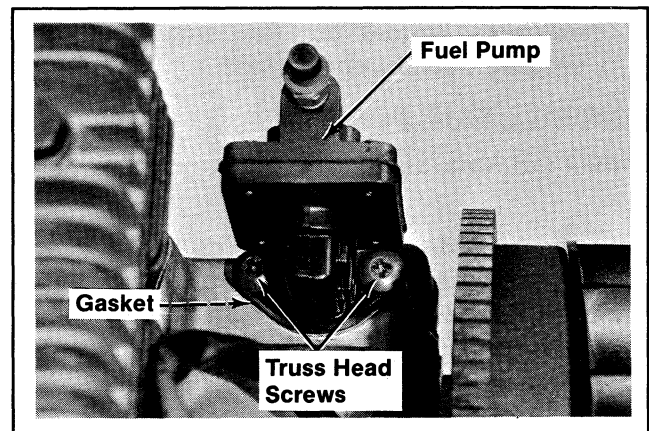

Figure 11-40. Installing Fuel Pump.

NOTE: Make sure the fuel pump lever is positioned above the camshaft. Damage to the fuel pump and subsequent severe engine damage could result if the lever is positioned below the camshaft.

2. Torque screws to 40/45 in. lb.

INSTALL VALVE COVER AND BREATHER

On #1 Side:

1. Install the gasket, breather plate, seal, and filter. Refer to Figure 11-41.

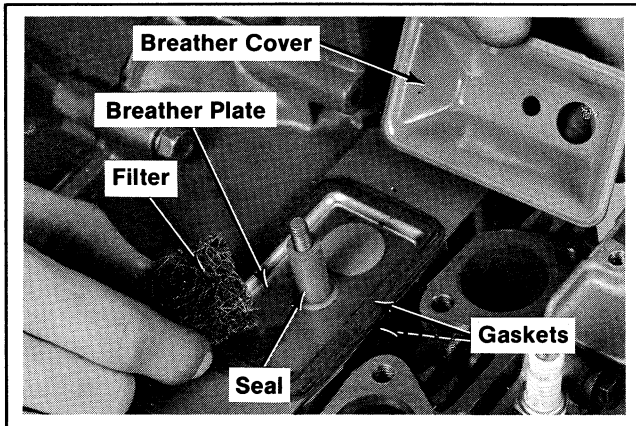

Figure 11-41. Installing Breather Components.

2. Install the gasket, breather cover, copper washer, and hex. nut. Refer to Figure 11-42.

NOTE: Hole in cover should be directly over mesh filter.

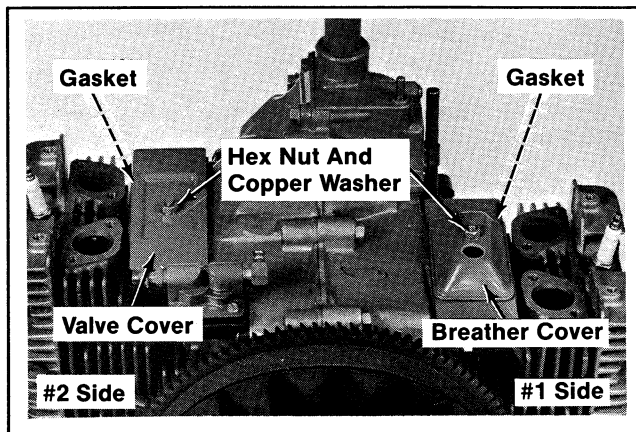

Figure 11-42. Installing Breather And Valve Cover.

On #2 Side:

1. Install the gasket, valve cover, copper washer, and hex. nut. Refer to Figure 11-42.

INSTALL BLOWER HOUSING, CYLINDER HEAD Baffles, AND TOP Baffle

1. Route the stator leads and wiring harness to top of crankcase; between crankcase and fuel pump.
2. Install the high tension leads and kill lead into grommet. Install the grommet in slot in blower housing.
3. Install the blower housing and self-tapping screws.
4. Install the #1 side cylinder head baffle and self-tapping screws.
5. Install the #2 side cylinder head baffle and self-tapping screws.
6. Install the top baffle and self-tapping screws.

INSTALL SOLENOID, KEY SWITCH, RECTIFIER-REGULATOR, AND CONNECT WIRING

1. Install the spacer, solenoid with bracket, and self-tapping screws. Connect the leads to starter solenoid. Secure wiring harness to solenoid with a new wire tie. Refer to Figure 11-43.

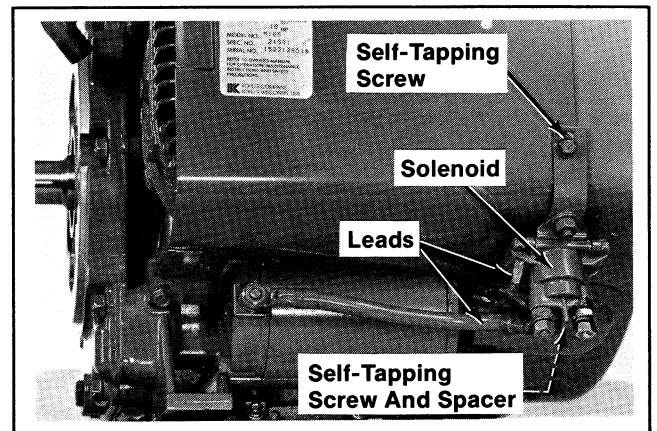

Figure 11-43. Installing Starter Solenoid.

2. Install the panel with key switch and self-tapping screws. Install the kill lead to connector. Install the connector to back of key switch. Refer to Figure 11-44.

SECTION 11 REASSEMBLY

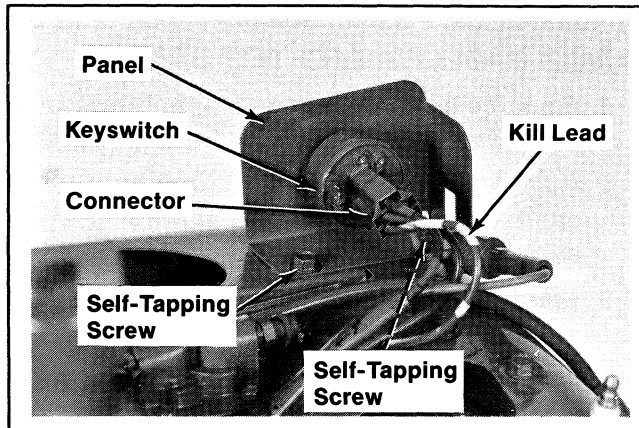

Figure 11-44. Installing Key Switch.

3. Install the rectifier-regulator and hex. cap screws. Install the lead to center position of connector. Install the connector to rectifier-regulator. Refer to Figure 11-45.

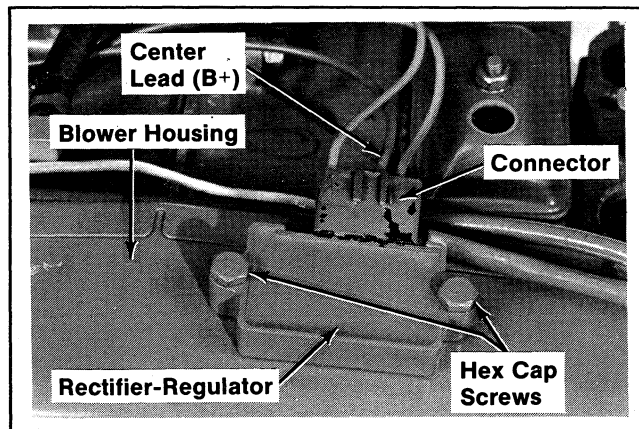

Figure 11-45. Install Rectifier-Regulator.

INSTALL CARBURETOR AND INTAKE MANIFOLD

1. Install the gasket, intake elbow, plain washer, round head screw, internal tooth lock washers, and pan head screws to carburetor. Refer to Figure 11-46.

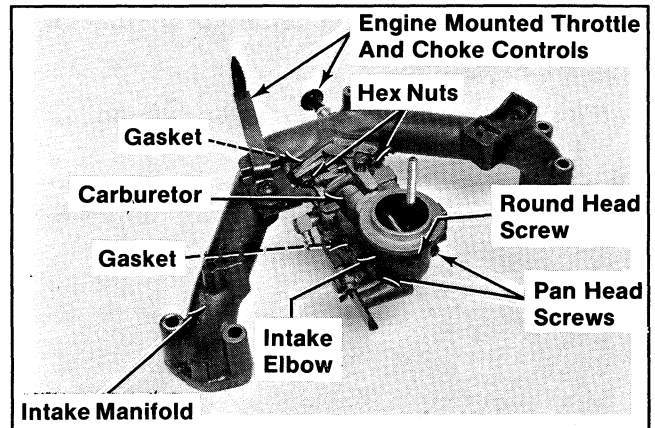

Figure 11-46. Installing Carburetor to Intake Manifold.

2. Install the gasket, carburetor with intake elbow, and hex. nuts to intake manifold. Torque hex. nuts to 150 in. lb.
3. Install the engine mounted throttle and choke controls, if so equipped.
4. Install the gaskets, intake manifold with carburetor, lifting straps, split lock washers, and hex. cap screws. Torque screws to 150 in. lb. Refer to Figure 11-47.

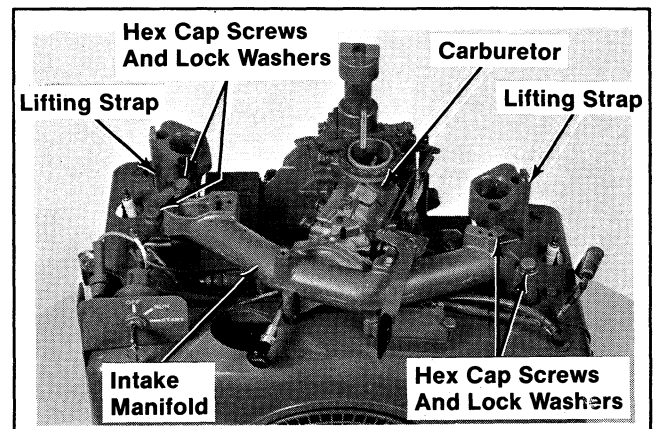

Figure 11-47. Installing Intake Manifold and Carburetor.

5. Install the fuel line and hose clamp to fuel pump outlet. Refer to Figure 11-48.

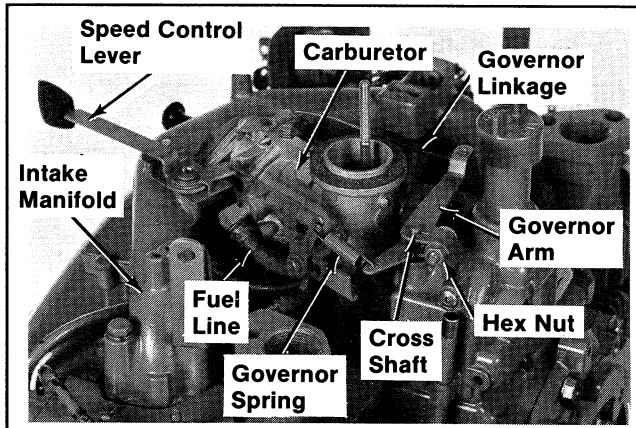

Figure 11-48. Installing Intake Manifold, Carburetor, and Governor Arm.

6. Install the governor linkage to governor arm and carburetor throttle lever. Install the plain washer and governor arm to cross shaft (refer to Figure 11-7). Do not tighten hex. nut on governor arm until arm is adjusted (Step 7).
7. Governor Adjustment (refer to Figure 11-49):
 - a. Grasp the cross shaft with pliers and turn shaft clockwise as far as it will go.
 - b. Pull the governor arm away from carburetor as far as it will go. Tighten the hex. nut securely.

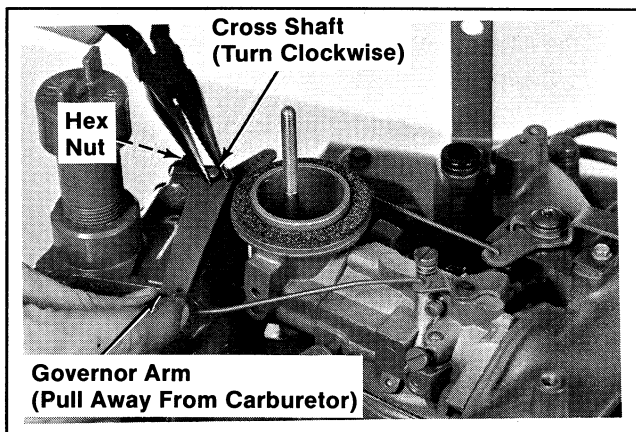

Figure 11-49. Adjusting Governor Arm/Cross Shaft.

8. Install governor spring to governor arm and speed control lever. Make sure spring is installed in correct positions for proper operation.

INSTALL AIR CLEANER

NOTE: The instructions given here are for the basic spec engine with the square style air cleaner. If the engine is equipped with an optional style air cleaner, refer to the "Air Cleaner" Section for installation procedures.

1. Install the gasket, air cleaner, base, air intake tube, breather hose, and self-tapping screw. Refer to Figure 11-50.

NOTE: Make sure breather hose seals tightly in air cleaner base and breather cover to prevent unfiltered air from entering engine.

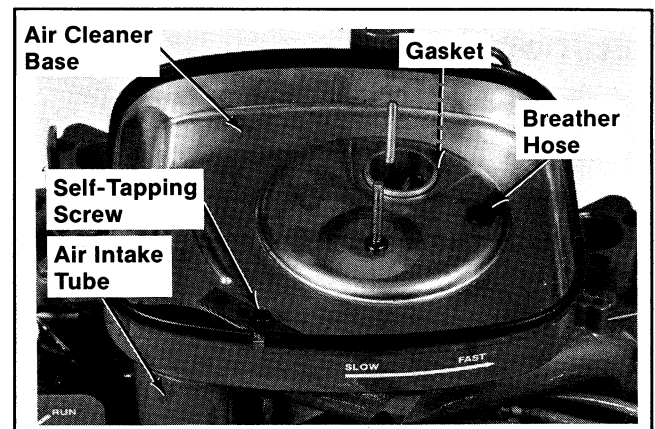

Figure 11-50. Installing Air Cleaner Base.

2. Install the paper element, precleaner (if so equipped), element cover, and element cover seals. Refer to Figure 11-51.

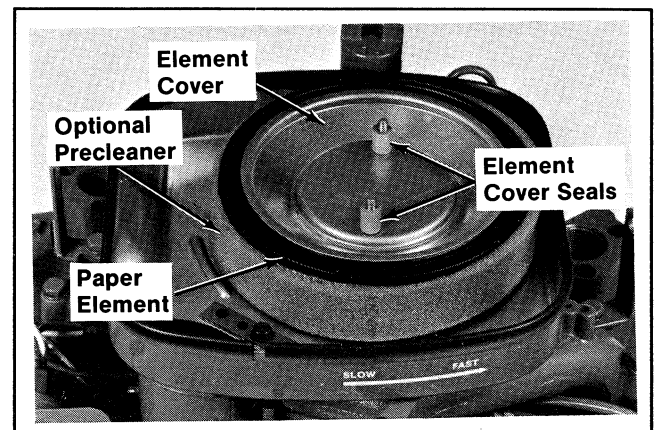

Figure 11-51. Installing Air Cleaner Element.

3. Install the air cleaner cover and wing nuts. Tighten the wing nuts 1/2 to 1 full turn after nuts contact cover. Do not overtighten. Refer to Figure 11-52.

SECTION 11 REASSEMBLY

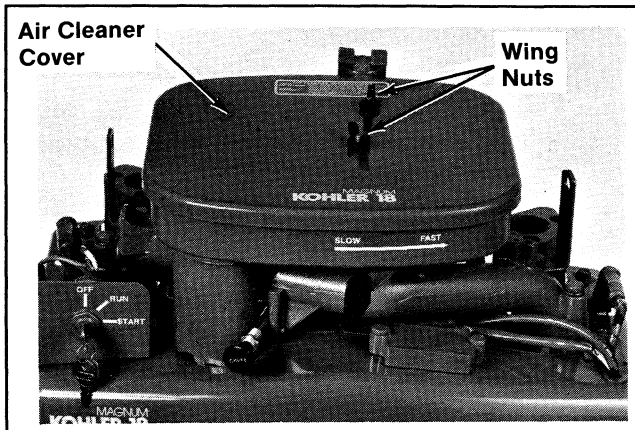

Figure 11-52. Installing Air Cleaner Cover.

INSTALL EXHAUST ELBOWS AND MUFFLERS

1. Install the gaskets, exhaust elbows, and hex socket screws. Torque screws to 150 in. lb. Refer to Figure 11-53.

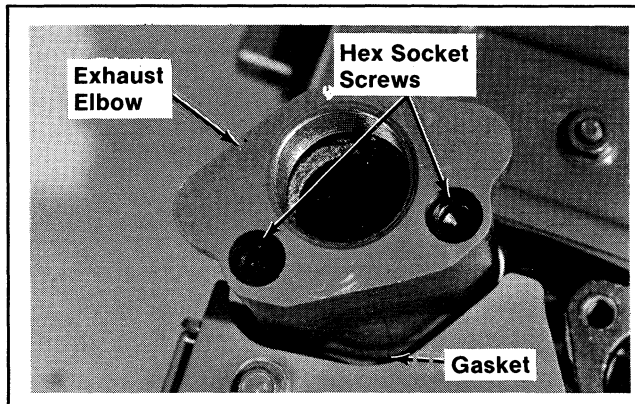

Figure 11-53. Installing Exhaust Elbows.

2. Install the exhaust pipes and mufflers. Refer to Figure 11-54.

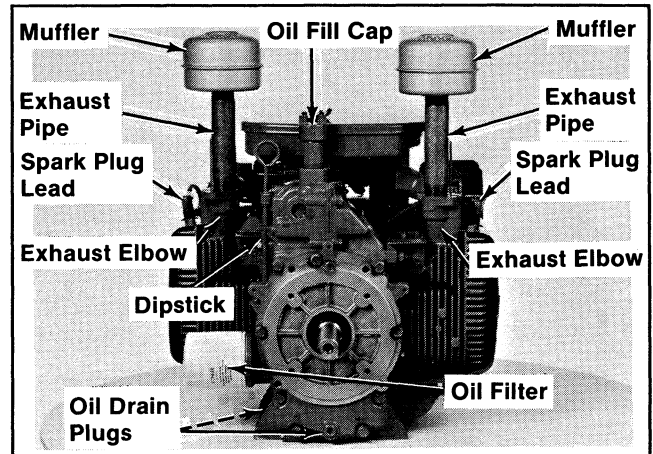

Figure 11-54. Installing Mufflers, Oil Filter, Oil Drain, and Spark Plug Leads.

INSTALL OIL FILTER

NOTE: The instructions given here are for the basic spec engine with the engine mounted oil filter. If the engine is equipped with an optional remote oil filter system, refer to Section 7 in this manual for installation details.

1. Apply a thin coating of oil on the surface of the rubber seal.
2. Turn the filter clockwise until rubber seal contacts the filter adapter, then tighten filter an additional 1/2 turn.
3. Add an additional 1/2 pint of oil for the filter capacity.

PREPARE THE ENGINE FOR OPERATION

The engine is now completely reassembled. Before operating the engine, be sure to do the following:

- Make sure all hardware is tightened securely and oil drain plugs are installed.
- Fill the crankcase with the correct amount, weight, and type of oil. Refer to the oil recommendations and procedures in the "Safety and General Information" and "Periodic Maintenance" Sections.
- Adjust the carburetor main fuel needle, idle fuel needle, or idle speed adjusting screw as necessary. Refer to the "Fuel System and Governor" section.
- Make sure the maximum engine speed does not exceed 3600 RPM. Adjust the high speed stop as necessary. Refer to the "Fuel System and Governor" Section.

TESTING THE ENGINE

It is recommended that the engine be operated on a test stand or bench prior to installation in the piece of equipment.

1. Set the engine up on a test stand. Install an oil pressure gauge in the location normally used for Oil Sentry™. Refer to "Lubrication System" Section, Figure 6-4. Start the engine and check to be certain that oil pressure (20 psi or more) is present. Run the engine for 5-10 minutes between idle and midrange. Adjust the carburetor mixture settings as necessary.
2. Make sure the maximum engine speed does not exceed 3750 RPM (no load). Adjust the throttle and choke controls and the high speed stop as necessary. Refer to the "Fuel System and Governor" Section.

THE NEW SHAPE OF KOHLER POWER

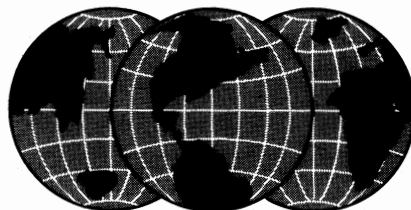

KOHLERengines

ENGINE DIVISION, KOHLER CO., KOHLER, WISCONSIN 53044

FOR SALES AND SERVICE INFORMATION
IN U.S. AND CANADA, CALL
1-800-544-2444

FORM NO.:	TP-2204-B
ISSUED:	3/86
REVISED:	5/93
MAILED:	6/93

LITHO IN U.S.A.