

KOHLER[®]engines

**Single Cylinder Engine
SERVICE MANUAL
K91, K141, K161, K181,
K241, K301, K321, K341**



K-SERIES

CONTENTS

SECTION 1. General Information	1
SECTION 2. Special Tools	2
SECTION 3. Periodic Maintenance	3
SECTION 4. Troubleshooting	4
SECTION 5. Air Cleaner And Air Intake System	5
SECTION 6. Fuel System And Governor	6
SECTION 7. Retractable Starters	7
SECTION 8. Electrical Systems And Components	8
SECTION 9. Automatic Compression Release	9
SECTION 10. Disassembly	10
SECTION 11. Inspection and Repair	11
SECTION 12. Reassembly	12

SECTION 1

GENERAL INFORMATION

SAFETY INFORMATION

For Your Safety!

These safety precautions should be followed at all times. Failure to follow these safety precautions could result in serious injury to yourself and others.

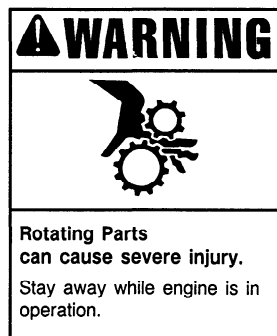
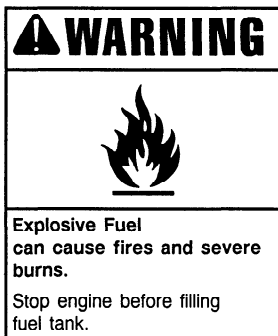

WARNING: Explosive Fuel!

Gasoline is extremely flammable and its vapors can explode if ignited. Store gasoline only in approved containers, in well-ventilated, unoccupied buildings, away from sparks or flames. Do not fill the fuel tank while the engine is hot or running, since spilled fuel could ignite if it comes in contact with hot parts or sparks from ignition. Do not start the engine near spilled fuel. Never use gasoline as a cleaning agent.

WARNING: Rotating Parts!

Keep hands, feet, hair, and clothing away from all moving parts to prevent injury. Never operate the engine with covers, shrouds, or guards removed.

WARNING: Hot Parts!

Engine components can get extremely hot from operation. To prevent severe burns, do not touch these areas while the engine is running—or immediately after it is turned off. Never operate the engine with heat shields or guards removed.



WARNING: Accidental Starts!
Before servicing the engine or equipment, always disconnect the spark plug lead to prevent the engine from starting accidentally. Ground the lead to prevent sparks that could cause fires. Make sure the equipment is in neutral.

CAUTION: Electrical Shock!

Never touch electrical wires or components while the engine is running. They can be sources of electrical shock.

WARNING: Overspeed Is Hazardous!

Do not tamper with the governor setting. Overspeed is hazardous and could cause personal injury.

WARNING: Flammable Solvents!

Carburetor cleaners and solvents are extremely flammable. Keep sparks, flames, and other sources of ignition away from the area. Follow the cleaner manufacturer's warnings and instructions on its proper and safe use. Never use gasoline as a cleaning agent.

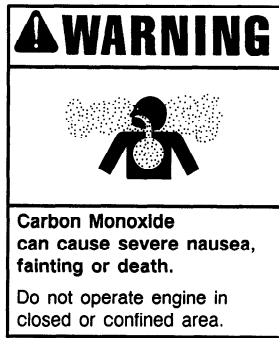

WARNING: Lethal Exhaust Gases!
Engine exhaust gases contain poisonous carbon monoxide. Carbon monoxide is odorless, colorless, and can cause death if inhaled. Avoid inhaling exhaust fumes, and never run the engine in a closed building or confined area.

WARNING: Spring Under Tension!

Retractable starters contain a powerful, flat wire recoil spring that is under tension. Do not remove the center screw from the starter until the spring tension is released. Removing the center screw before releasing spring tension, or improper starter disassembly, can cause the sudden and potentially dangerous release of the spring.

Always wear safety goggles when servicing retractable starters—full face protection is recommended.

To ensure personal safety and proper starter disassembly and reassembly, follow the procedures in this section carefully.

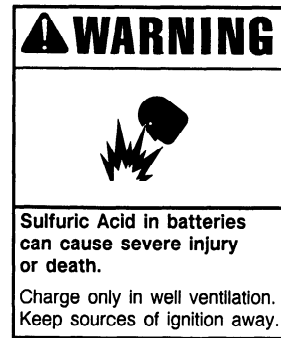

WARNING: Dangerous Acid, Explosive Gases!
Batteries contain sulfuric acid. To prevent acid burns, avoid contact with skin, eyes, and clothing. Batteries produce explosive hydrogen gas while being charged. To prevent a fire or explosion, charge batteries only in well-ventilated areas. Keep sparks, open flames, and other sources of ignition away from the battery at all times. Keep batteries out of the reach of children. Remove all jewelry when servicing batteries.

Before disconnecting the negative (-) ground cable, make sure all switches are OFF. If ON, a spark will occur at the ground cable terminal which could cause an explosion if hydrogen gas or gasoline vapors are present.

ENGINE IDENTIFICATION NUMBERS

When ordering parts, or in any communications involving an engine, always give the model, specification and serial number of the engine.

The engine identification numbers appear on a decal (or decals) affixed to the engine blower housing. Refer to Figure 1-1. The significance of these numbers is shown below:

1

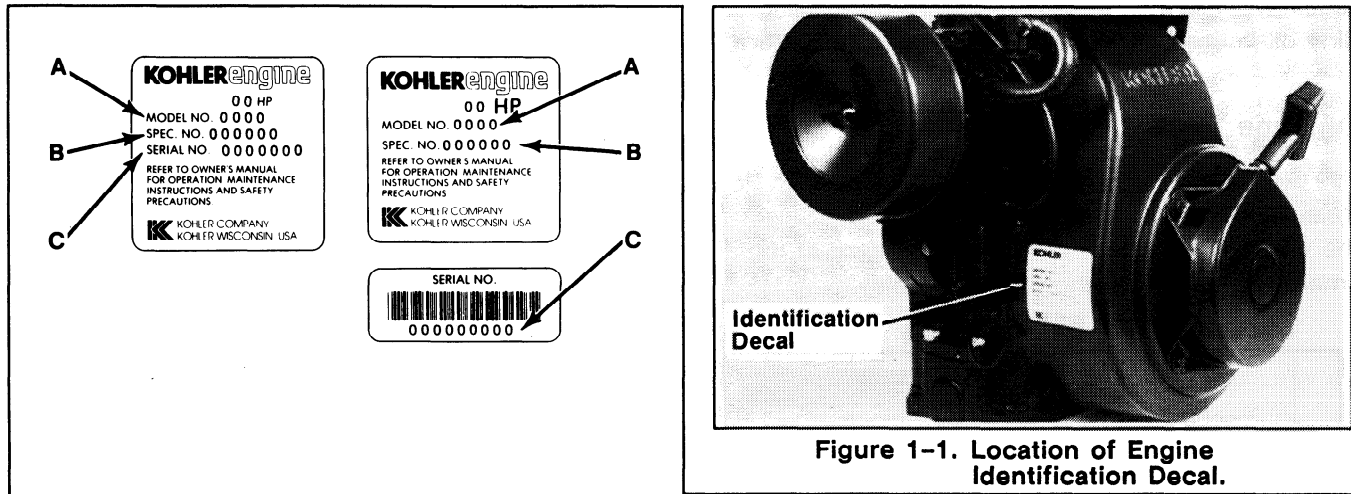
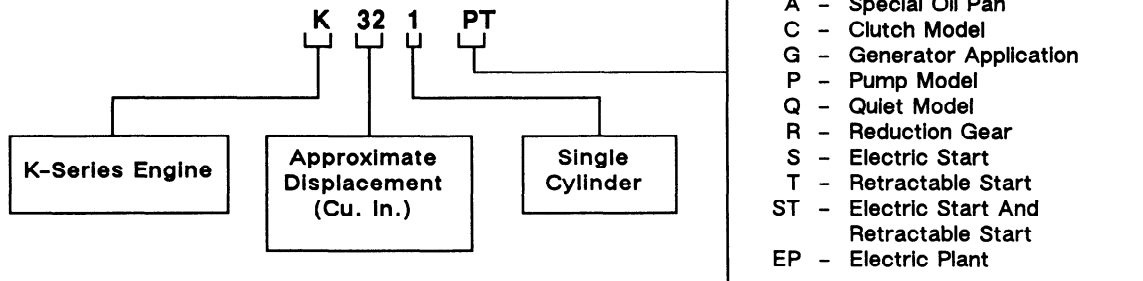
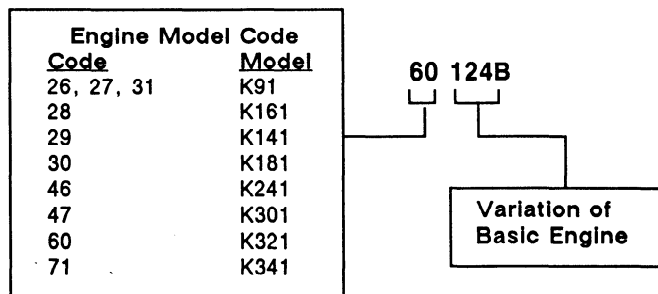

Figure 1-1. Location of Engine Identification Decal.

A. MODEL NO.



B. SPEC NO.



C. SERIAL NO.

E - 1 7 2 4 5 2 □ A Letter	9 0 7 6 4 3 0 □ First Two Digits / If Seven Digit Number	1 0 0 2 6 6 9 2 □ First Three Digits / If Eight Digit Number	1 5 0 1 8 9 7 5 9 1 □ First Two Digits / If Ten Digit Number
A 1965	10-19 1969	100-109 1980	15 1985
B 1966	20-29 1970	110-119 1981	16 1986
C 1967	30-39 1971	120-129 1982	17 1987
D 1968	40-49 1972	130-139 1983	18 1988
E 1969	50-59 1973	140-149 1984	19 1989
	60-69 1974	150-159 1985	20 1990
	70-72 1975		21 1991
	73-79 1976		22 1992
	80-89 1977		23 1993
	90-94 1978		24 1994
	95-99 1979		25 1995

Remaining digits are a factory code.

Figure 1-2. Engine Identification Decals.

OIL RECOMMENDATIONS

Using the proper type and weight of oil in the engine crankcase and in the gear reduction unit is extremely important, as is checking oil daily and changing oil regularly. Failure to use the correct oil or using dirty oil causes premature engine wear and failure.

Oil Type

Use high-quality detergent oil of API (American Petroleum Institute) Service Class SF or SG. Select the viscosity based on the air temperature at the time of operation as shown in the table.

Recommended SAE Viscosity Grades

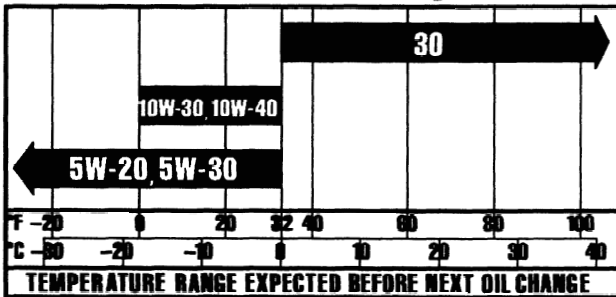

Straight 30-weight oil is preferred. SAE 10W-30 and 10W-40 are not recommended above 32°F (0°C). Using these oils substantially increases oil consumption and combustion chamber deposits.

NOTE: Using other than Service Class SF or SG oil or extending oil change intervals longer than recommended could cause engine damage which is not covered by the engine warranty.

A logo or symbol on oil containers identifies the API service class and SAE viscosity grade.



Check Oil Level

Check oil level BEFORE EACH USE.

Check gear reduction unit oil level by removing the drain plug on the lower part of the cover. Oil level should be up to the bottom of the plug hole. If oil level is low, remove the vented plug at the top of the cover, add oil until it reaches the bottom of the drain plug hole, and replace drain plug and vented plug.

NOTE: Do not operate the engine with the oil level below the "L" mark or over the "F" mark on the dipstick.

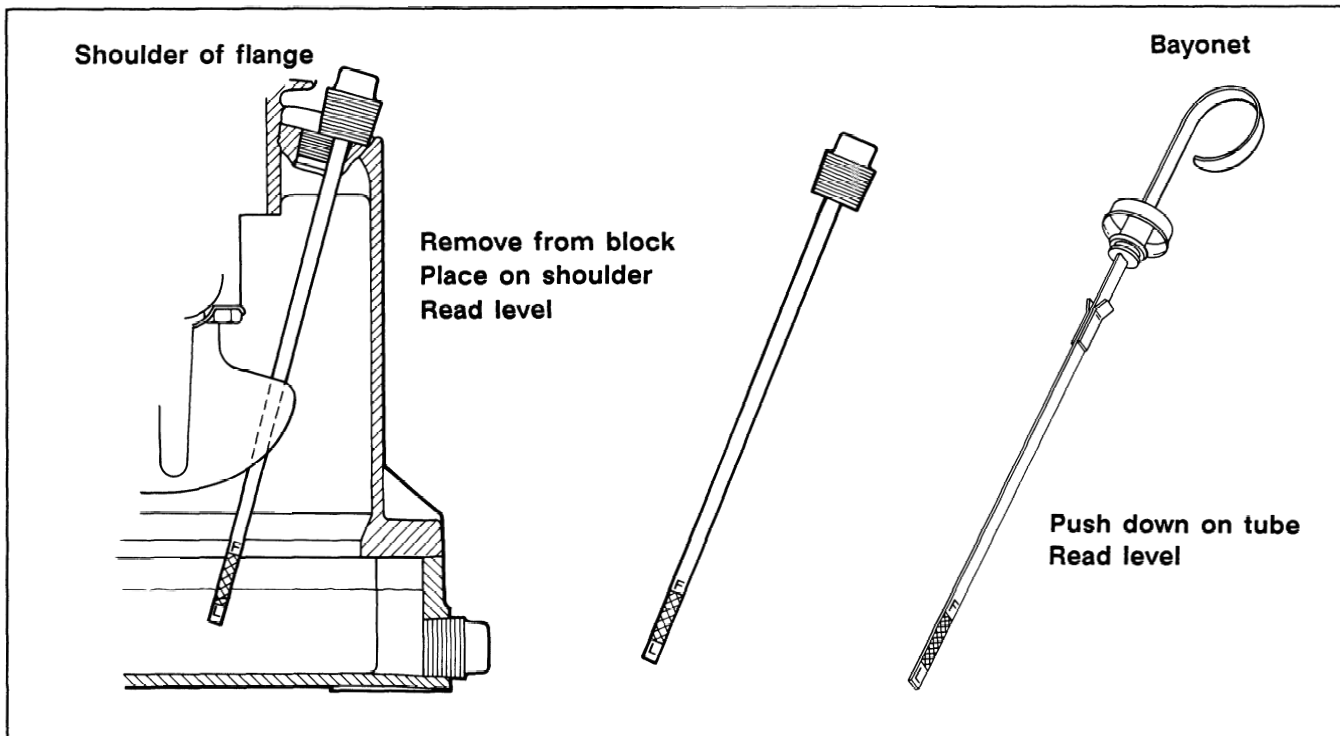

Figure 1-3. Dipsticks And Oil Fill Tubes.

Change Oil

For a new engine, change oil after the first 5 hours of operation. Change oil every 25 hours of operation thereafter.

For an overhauled engine or one rebuilt with a new shortblock or miniblock, use straight 30-weight Service Class SF or SG oil for the first 5 hours of operation. Change the oil after this initial run-in period. Refill with Service Class SF or SG oil as specified in the table. Change oil every 25 operating hours thereafter.

FUEL RECOMMENDATIONS



WARNING: Explosive Fuel!

Gasoline may be present in the carburetor and fuel system. Gasoline is extremely flammable and it can explode if ignited. Keep sparks, open flames, and other sources of ignition away from the engine. Disconnect and ground the spark plug lead to prevent the possibility of sparks from the ignition system.

General Recommendations

Purchase gasoline in small quantities and store in clean, approved containers. A container with a capacity of 2 gallons or less with a pouring spout is recommended. Such a container is easier to handle and helps eliminate spoilage during refueling.

Do not use gasoline left over from the previous season, to minimize gum deposits in your fuel system and to insure easy starting.

Do not add oil to the gasoline.

Do not overfill the fuel tank. Leave room for the fuel to expand.

Fuel Type

For best results, use only clean, fresh, unleaded gasoline with a pump sticker octane rating of 87 or higher. In countries using the Research method, it should be 90 octane minimum.

Unleaded gasoline is recommended, as it leaves less combustion chamber deposits. Leaded gasoline may be used in areas where unleaded is not available and exhaust emissions are not regulated. Be aware however, that the cylinder head will require more frequent service.

Gasoline/Alcohol blends

Gasohol (up to 10% ethyl alcohol, 90% unleaded gasoline by volume) is approved as a fuel for Kohler engines. Other gasoline/alcohol blends are not approved.

Gasoline/Ether blends

Methyl Tertiary Butyl Ether (MTBE) and unleaded gasoline blends (up to a maximum of 15% MTBE by volume) are approved as a fuel for Kohler engines. Other gasoline/ether blends are not approved.

OIL REFILL QUANTITIES (U.S. STANDARD QUARTS)

K91	K141, K161, K181	K241, K301, K321, K341	K241A, K301A, K321A, K341A
1/2 Quart	1 Quart	2 Quarts	1 Quart*

(After refilling, always check oil level -- DO NOT OVERFILL)

* A-type oil pan capacity varies from 1 to 1-3/4 quarts. On these add 1 quart of oil, check level, then add oil as necessary to bring up to full level.

Figure 1-4.

HORSEPOWER (Maximum RPM) Engine Model		4	7	8	10	12	14	16	
		K91	K161	K181	K241	K301	K321	K341	
GENERAL	Bore x Stroke	2.375x2.000	2.938x2.500	2.938x2.750	3.251x2.875	3.375x3.250	3.500x3.250	3.750x3.250	
	Displacement Cu. In.	8.86	16.94	18.64	23.85	29.07	31.27	35.90	
	Max. Operating RPM	4000	3600	3600	3600	3600	3600	3600	
BALANCE GEAR	Shaft O.D.	—	—	—	.4998/.5001	.4998/.5001	.4998/.5001	.4998/.5001	
	End Play	—	—	—	.002/.010	.002/.010	.002/.010	.002/.010	
CAMSHAFT	Sleeve I.D. Installed	—	—	—	—	—	—	—	
	End Play	.005/.020	.005/.010	.005/.010	.005/.010	.005/.010	.005/.010	.005/.010	
CONNECTING ROD	Running Clearance	Rod to Crank Pin (New)	.001/.0025	.001/.002	.001/.002	.001/.002	.001/.002	.001/.002	
		Rod to Crank Pin Wear Limit	.003	.0025	.0025	.0025	.0025	.0025	
		Rod to Piston Pin (New)	.0007/.0008	.0006/.0011	.0006/.0011	.0003/.0008	.0003/.0008	.0003/.0008	.0003/.0008
	Small End I.D. (New)	.5630/.5633	.6255/.6258	.6255/.6258	.8596/.8599	.8757/.8760	.8757/.8760	.8757/.8760	
CRANKSHAFT	PTO & Flywheel End O.D.	New	.9841/.9844	1.1811/1.1814	1.1811/1.1814	1.5745/1.5749	1.5745/1.5749	1.5745/1.5749	
		Maximum Wear Limit	.9841	1.1811	1.1811	1.5745	1.5745	1.5745	1.5745
	Max. Out of Round (Sleeve)	—	—	—	—	—	—	—	
		Max. Taper (Sleeve)	—	—	—	—	—	—	—
	Running Clearance (Sleeve)	Maximum New	—	—	—	—	—	—	
		Wear Limit ①	—	—	—	—	—	—	
	New Sleeve Bearing I.D. Installed	New	.9360/.9355	1.1860/1.1855	1.1860/1.1855	1.5000/1.4995	1.5000/1.4995	1.5000/1.4995	1.5000/1.4995
		Max. Wear Limit	.9350	1.1850	1.1850	1.4990	1.4990	1.4990	1.4990
		Max. Out of Round	.0005	.0005	.0005	.0005	.0005	.0005	.0005
		Max. Taper	.001	.001	.001	.001	.001	.001	.001
End Play	.004/.023	.002/.023	.002/.023	.003/.020	.003/.020	.003/.020	.003/.020		
CYLINDER BORE	Inside Diameter	New	2.3755/2.3745	2.9380/2.9370	2.9380/2.9370	3.2515/3.2505	3.3755/3.3745	3.5005/3.4995	3.7505/3.7495
		Maximum Wear Limit	2.378	2.941	2.941	3.254	3.378	3.503	3.753
	Max. Out of Round	.003	.003	.003	.003	.003	.003	.003	
	Max. Taper	.003	.003	.003	.002	.002	.002	.002	
CYLINDER HD.	Max. Out of Flatness	.003	.003	.003	.003	.003	.003	.003	
IGNITION	Spark Plug Type & Gap	Type②	RCJ-8	RCJ-8	RCJ-8	RH-10	RH-10	RH-10	
		Battery	.025	.025	.025	.035	.035	.035	.035
		Magneto	.025	.025	.025	.025	.025	.025	.025
		Gaseous Fuels	.018	.018	.018	.018	.018	.018	.018
	Nominal Point Gap	.020	.020	.020	.020	.020	.020	.020	
PISTON	Service Replacement Sizes		.003 — .010 — .020 — .030						
	Thrust Face O.D. ⑦	New	2.371/2.369	2.9297/2.9281	2.9297/2.9281	3.2432/3.2413	3.368/3.365	3.4941/3.4925	3.7425/3.7410⑧
		Maximum Wear Limit	2.366	2.925	2.925	3.238	3.368	3.491	3.738⑧
	Thrust Face To Bore Clearance (New)⑨		.0035/.006	.007/.010	.007/.010	.007/.010	.007/.010	.007/.010	.007/.010⑩
	Ring End Gap	New Bore	.007/.017	.007/.017	.007/.017	.010/.020	.010/.020	.010/.020	.010/.020
		Used Bore (Max.)	.027	.027	.027	.030	.030	.030	.030
	Max. Ring Side Clearance		.006	.006	.006	.006	.006	.006	.006
PISTON	Service Replacement Sizes		.003 — .010 — .020 — .030						
	Thrust Face O.D. ⑩	New	—	—	2.9329/2.9336	—	3.3700/3.3693	3.4945/3.4938	3.7465/3.7455
		Maximum Wear Limit	—	—	2.931	—	3.367	3.492	3.744
	Thrust Face To Bore Clearance (New)⑪		—	—	.0034/.0051	—	.0045/.0062	.0050/.0067	.0030/.0050
	Ring End Gap	New Bore⑫	—	—	.010/.023	—	.010/.020	.010/.020	.010/.020
		Used Bore⑬ (Max.)	—	—	.032	—	.030	.030	.030
	Max. Ring Side Clearance		—	—	.006	—	.006	.006	.006
PISTON PIN	Outside Diameter	.5623/.5625	.6247/.6249	.6247/.6249	.8591/.8593	.8752/.8754	.8752/.8754	.8752/.8754	
	Guide Reamer Size	.250	.3125	.3125	.3125	.3125	.3125	.3125	
VALVES	Tappet Clearance (Cold)	Intake	.005/.009	.006/.008	.006/.008	.008/.010	.008/.010	.008/.010⑭	
		Exhaust	.011/.015	.017/.019	.017/.019	.017/.019	.017/.019	.017/.019	
	Minimum Lift (Zero Lash)	Intake	.2035	.2718	.2718	.318	.318	.318	
		Exhaust	.1768	.2482	.2482	.318	.318	.318	
	Minimum Valve Stem O.D.	Intake	.2478	.3103	.3103	.3103	.3103	.3103	
		Exhaust	.2458	.3088	.3088	.3074	.3074	.3074	
	Nominal Angle Valve Seat		45°	45°	45°	45°	45°	45°	
	Guide I.D. Maximum Wear Limit⑮	Intake	.005	.005	.005	.006	.006	.006	
Exhaust		.007	.007	.007	.008	.008	.008		

① Maximum limits combination of I.D. and O.D. measurements
 ② Ball bearing 1.3779/1.3784, Maximum Wear 1.3779
 ③ Ball bearing 1.7716/1.7721, Maximum Wear 1.7716

④ Pre Series II 1.3733/1.3738, Maximum Wear 1.3728
 ⑤ Ball bearing .002/.023
 ⑥ Champion spark plugs or equivalent
 ⑦ Measure just below oil ring groove and at right angles to piston pin

⑧ 1800 RPM generator sets .005/.007
 ⑨ Measure 1/2" above the bottom of the piston skirt.
 ⑩ Top and center compression rings.

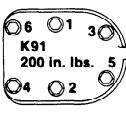
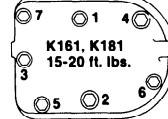
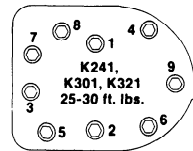
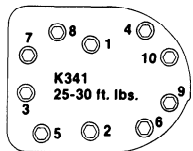

* Includes K141

Figure 1-5. Engine Specifications And Tolerances.

HORSEPOWER (Max. RPM) Engine Model		4	7	8	10	12	14	16
		K91	K161	K181	K241	K301	K321	K341
CONNECTING RODS ^①	Posi-lock ^②	—	—	New 140 in. lbs. Used 100 in. lbs.	New 260 in. lbs. Used 200 in. lbs.			
	Capscrew ^③	140 in. lbs.	200 in. lbs.		285 in. lbs.			
SPARK PLUGS		18-22 ft. lbs.	18-22 ft. lbs.		18-22 ft. lbs.			
CYLINDER HEAD ^④		 K91 200 in. lbs. 5	 K161, K181 15-20 ft. lbs.	 K241, K301, K321 25-30 ft. lbs.	 K341 25-30 ft. lbs.			
FLYWHEEL RETAINING	NUT	40-50 ft. lbs.	85-90 ft. lbs. ^⑤		50-60 ft. lbs.			
	SCREW	250 in. lbs.	—		22-27 ft. lbs.			
GOVERNOR BUSHING		70-90 in. lbs.	130-150 in. lbs.		100-120 in. lbs.			
GRASS SCREEN	Metal	—	70-140 in. lbs.		70-140 in. lbs.			
	Plastic	—	—		20-30 in. lbs.			
OIL PAN	Aluminum	—	—		—			
	Cast Iron	250 in. lbs.	Grade 5-250 in. lbs. Grade 8-350 in. lbs.		35 ft. lbs.			
	Sheet Metal ^④	—	—		200 in. lbs.			
MANIFOLD SCREW/NUT		—	—		—			
CAMSHAFT NUT		—	—		—			
NON METALLIC FUEL PUMP MOUNTING SCREWS		—	37-45 in. lbs.		37-45 in. lbs.			

USE STANDARD TORQUE SETTINGS WHEN SPECIFIC VALUES ARE NOT SPECIFIED.

Cast Iron or Steel

Size	Grade 2	Grade 5*	Grade 8
			
8-32	20 in. lb.	25 in. lb.	
10-24	32 in. lb.	40 in. lb.	
10-32	32 in. lb.	40 in. lb.	
1/4-20	70 in. lb.	115 in. lb.	165 in. lb.
1/4-28	85 in. lb.	140 in. lb.	200 in. lb.
5/16-18	150 in. lb.	250 in. lb.	350 in. lb.
5/16-24	165 in. lb.	270 in. lb.	30 ft. lb.
3/8-16	260 in. lb.	35 ft. lb.	50 ft. lb.
3/8-24	300 in. lb.	40 ft. lb.	60 ft. lb.
7/16-14	35 ft. lb.	55 ft. lb.	80 ft. lb.
7/16-20	45 ft. lb.	75 ft. lb.	105 ft. lb.
1/2-13	50 ft. lb.	80 ft. lb.	115 ft. lb.
1/2-20	70 ft. lb.	105 ft. lb.	165 ft. lb.
9/16-12	75 ft. lb.	125 ft. lb.	175 ft. lb.
9/16-18	100 ft. lb.	165 ft. lb.	230 ft. lb.
5/8-11	110 ft. lb.	180 ft. lb.	260 ft. lb.
5/8-18	140 ft. lb.	230 ft. lb.	330 ft. lb.
3/4-10	150 ft. lb.	245 ft. lb.	350 ft. lb.
3/4-16	200 ft. lb.	325 ft. lb.	470 ft. lb.

Aluminum

8-32	20 in. lb.	20 in. lb.	20 in. lb.
10-24	32 in. lb.	32 in. lb.	32 in. lb.
1/4-20	70 in. lb.	70 in. lb.	70 in. lb.
5/16-18	150 in. lb.	150 in. lb.	150 in. lb.

*Also Self Tapping Screws

Conversions

in. lbs. x .083 = ft. lbs.
ft. lbs. x 12 = in. lbs.
ft. lbs. x .1383 = kgm
ft. lbs. x 1.3558 = N m

**OIL DRAIN PLUGS
(Oil at Assembly)**

Size	Tightening Torque	
	Cast Iron Pans	Aluminum Pans
1/4"	150 in. lb.	100 in. lb.
3/8"	180 in. lb.	120 in. lb.
1/2"	20 ft. lbs.	13 ft. lbs.
3/4"	25 ft. lbs.	16 ft. lbs.
X-708-1 ^⑤	20-25 ft. lbs.	20-25 ft. lbs.

① Lubricate with engine oil

② DO NOT overtorque — loosen — and retorque the hex nuts on Posi-Lock connecting rods.

NEW — Component directly from stock.

USED — Component that was in a running engine.

③ Overtorque 20%, loosen below torque value and retorque to final torque value

④ Torque twice with minimum of one minute interval

⑤ 3/8-16 thread with hex head nut and fibre gasket

⑥ Prior to Ser. #23209832 45-55 ft. lbs.

* Includes K141

Figure 1-6. Torque Values & Sequences For Fasteners.

SECTION 2

SPECIAL TOOLS



SPECIAL SERVICE TOOL KIT NO. 3211-A



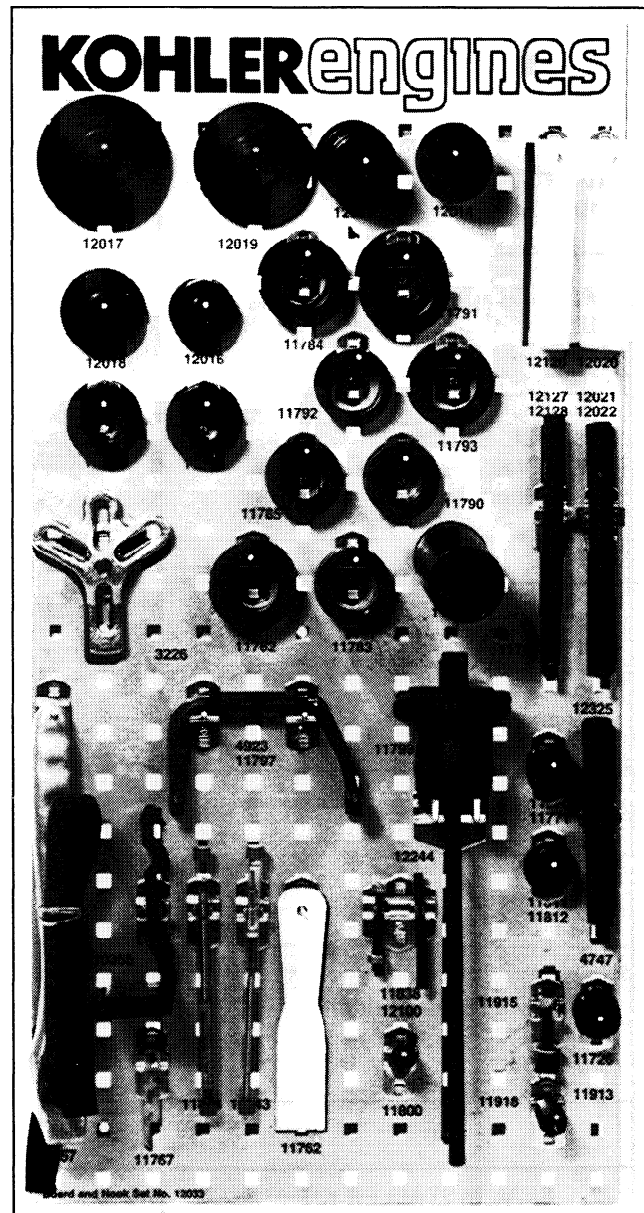

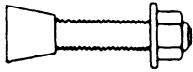

These quality tools are designed to help you perform specific disassembly, repair and reassembly procedures. By using tools designed for the job, you can service engines easier, faster and safer! In addition, you'll increase your service capabilities and customer satisfaction by decreasing engine down time.

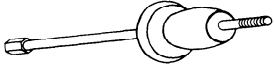
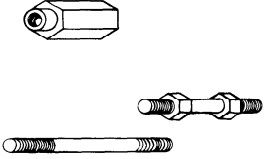
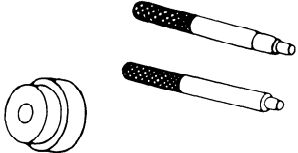
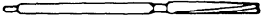
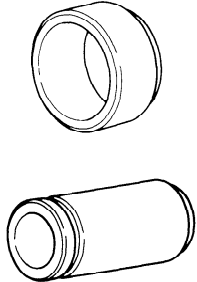
The Special Service Tool Kit No. 3211-A can be ordered complete as shown in Figure 2-1 or the tools can be ordered individually. Contact your Kohler Engine Distributor for price and availability.

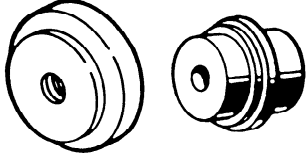
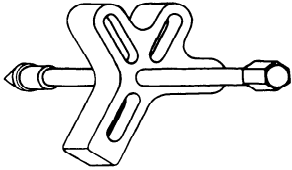
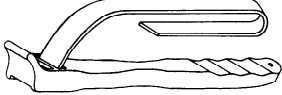

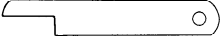
VALVE SERVICE TOOLS

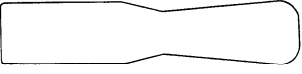
TOOL NO. & NAME	APPLICATION	ILLUSTRATION
VALVE SEAT PULLERS 11726 11913	Removal of valve seats, Use 11918 adapter, 3222 slide hammer & 11915 forcing screw	
FORCING SCREW 11915	Used with valve seat pullers 11726 & 11913	
ADAPTER 11918	Used to connect valve seat pullers to slide hammer	
VALVE SEAT INSTALLER 11811 11812	Used to install intake and exhaust seats. Use with 4747 handle	
3222 SLIDE HAMMER 11799 Weight 12244 Slide Bolt	Provides pulling force for valve seat and guide removal. Use 4747 handle.	
3268 VALVE GUIDE REMOVAL KIT 11838 Stud 3 1/2" 12100 Stud 2 1/2" 11800 Adapter 0917 Nut 12008 Nut	Used to pull valve guides with 3222 slide hammer	
3224 VALVE GUIDE INSTALLER KIT 12325 Driver 11763 Driver 11770 Gage 11771 Gage	Used to install valve guides to proper depth. Use 11763 driver with 11770 & 11771 depth gages	
REAMERS (Valve Guide) 11843 5/16" 11844 1/4"	To ream valve guides	
SEAL AND BEARING INSTALLERS		
3223 SEAL INSTALLER KIT 11782 Seal Installer 11783 Seal Installer 11784 Seal Installer 11785 Seal Installer 11786 Seal Installer 11787 Seal Installer 11790 Seal Installer 11791 Seal Installer 11792 Seal Installer 11793 Seal Installer 11795 Handle	Used to install seals without damage and to proper depth. Use 11795 handle with installers	

SEAL AND BEARING INSTALLERS		
TOOL NO. & NAME	APPLICATION	ILLUSTRATION
3242 SEAL PROTECTOR SLEEVE KIT 12020 .75" 12021 1.00 12022 1.25 12126 1.12 12127 1.50 12128 1.44	Used on crankshaft when installing seals to prevent damage	
3241 BEARING INSTALLING KIT 12014 Ins. (Crank Bushing) 12015 Ins. (Cam Bushing) 12016, 12017, 12018 & 12109 Brg. Installers	Used to install & remove engine bearings and bushings	
OTHER APPLICATIONS		
3226 FLYWHEEL PULLER KIT 12485 Puller w/forcing screw 5108 Bolt - 1/4" w/washer (3) 12505 Bolt - 10-24 w/washer (2) 12504 Bolt - 3/8" w/washer (2) 12506 Storage Bag	Used to remove flywheels and bearing plates from engine	
FLYWHEEL STRAP WRENCH 10357	Used to hold flywheel for nut removal	
OFFSET WRENCH 11797 Wrench 1/2" 4923 Wrench 9/16"	Used to remove & install cylinder barrel retaining nuts	
FEELER GAGE 11767	Used to set oil pump drive gear backlash on twin cylinder engine	
TIMING GAGE 10355 Timing Gage	Used to hold balance gears in timed position when assembling engine	
SCRAPER 11762	Used to scrape machined surfaces without damage	
HANDLE 4747 Handle	Used with bearing installers, slide hammer, and valve seat installers	
TOOL BOARD AND HOOK SET 12033	Used to store and identify tools	SEE FRONT PAGE

KIT NO. 3211-A		TOOL USAGE CHART												
PART NO & NAME		MODEL ("K" SERIES)												
		K-91	K-161	K-181	K-241	K-301	K-321	K-341	KT-17	KT-19	K-532	K-582		
VALVE TOOLS														
11726	Valve Seat Puller		●	●	●	●	●	●	●	●	●	●	●	●
11913	Valve Seat Puller		●	●	●	●	●							
11915	Forcing Screw		●	●	●	●	●	●	●	●	●	●	●	●
11918	Adapter		●	●	●	●	●	●	●	●	●	●	●	●
11811	Valve Seat Installer		●	●	●	●	●	●	●	●	●	●	●	●
11812	Valve Seat Installer	●												
3222	Slide Hammer		●	●	●	●	●	●	●	●	●	●	●	●
3268	Valve Guide Removal Kit		●	●	●	●	●	●	●	●	●	●	●	●
12325	Valve Guide Driver		●	●	●	●	●	●				●	●	●
11763	Valve Guide Driver (depth)									●	●			
11770	Valve Guide Depth Gage									●	①			
11771	Valve Guide Depth Gage										●			
11843	Valve Guide Reamer 5/16"		●	●	●	●	●	●	●	●	●	●	●	●
11844	Valve Guide Reamer 1/4"	●												

¹KT19 engines prior to Series II (Spec No. 49199 and lower).

BEARING AND SEAL INSTALLERS

12014	Installer — Crank Bushing												●	●
12015	Installer — Cam Bushing												●	●
12016	Installer — Bearing	●												
12017	Installer — Bearing (PTO)												●	●
12018	Installer — Bearing		●	●										
12019	Installer — Bearing				●	●	●	●						
11782	Installer — Seal (PTO)									●	●			
11783	Installer — Seal (Flywheel)									●	●			
11784	Installer — Seal (PTO)				●	●	●	●						
11785	Installer — Seal (PTO)		●	●										
11786	Installer — Seal (Flywheel)	●												
11787	Installer — Seal (PTO)	●												
11790	Installer — Seal (Flywheel)		●	●										
11791	Installer — Seal (PTO)												●	●
11792	Installer — Seal (Flywheel)				●	●	●	●						
11793	Installer — Seal (Flywheel)												●	●
11795	Handle — Installer Seal	●	●	●	●	●	●	●	●	●	●	●	●	●
12020	Seal Sleeve													
12021	Seal Sleeve													
12022	Seal Sleeve													
12126	Seal Sleeve													
12127	Seal Sleeve													
12128	Seal Sleeve													

MISCELLANEOUS TOOLS

10357	Flywheel Strap Wrench 1/2"	●	●	●	●	●	●	●	●	●	●	●	●	●
11797	Offset Wrench 1/2"									●	●			
4923	Offset Wrench 9/16"									●	●			
11767	Feeler Gauge-Crank(Oil Pump)												●	●
10355	Timing Tool (Balance Gear)				●	●	●	●						
11762	Scraper	●	●	●	●	●	●	●	●	●	●	●	●	●
4747	Drive Handle	●	●	●	●	●	●	●	●	●	●	●	●	●
3226	Flywheel Puller Kit	●	●	●	●	●	●	●	●	●	●	●	●	●

NOTE: K141 requires same tools as K161.

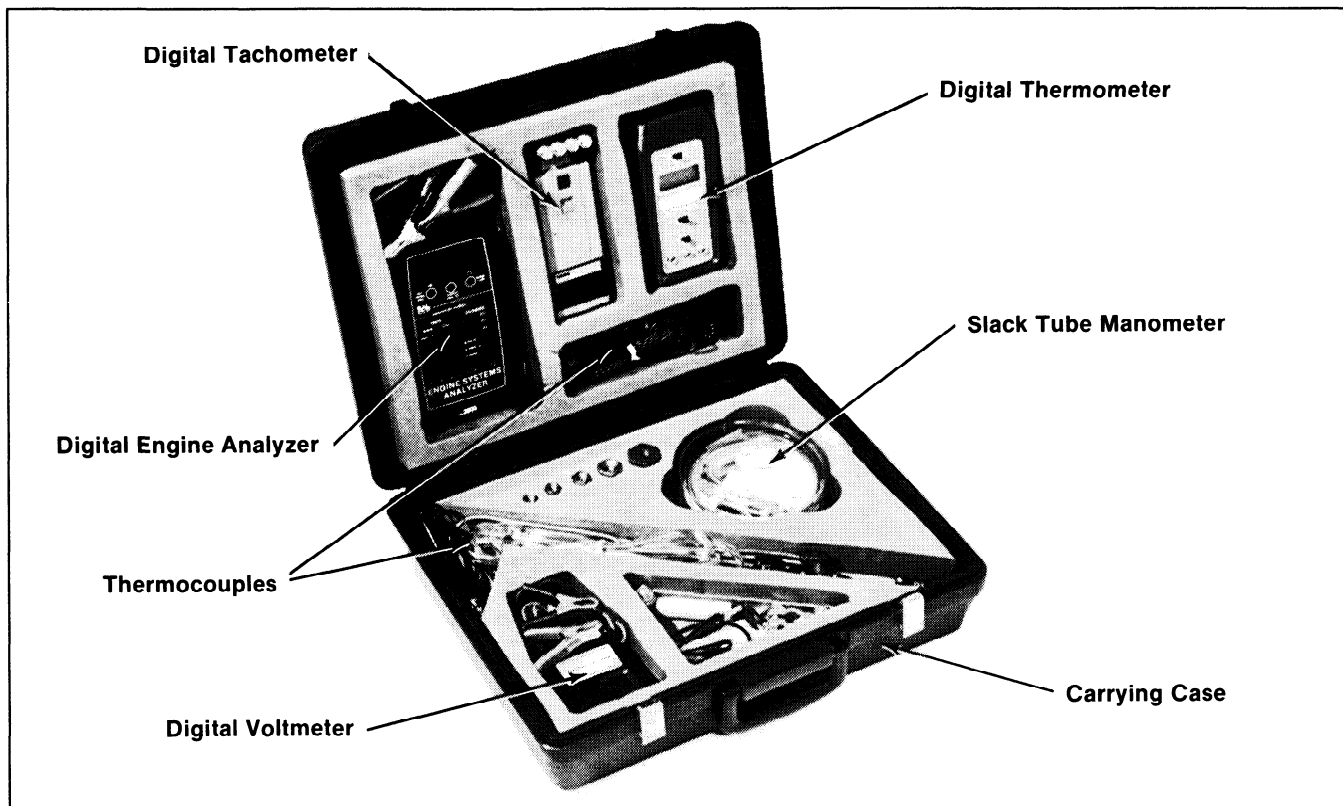

Figure 2-2. Engine Analysis Kit

The Kohler Engine Analysis Kit contains a selection of instruments which will enable you to measure critical items that relate to engine performance. You will find many uses for these instruments — from basic crankcase vacuum checks to sophisticated application tests.

The kit includes the following:

Qty.	Description
1	Digital Voltmeter
1	Digital Tachometer
1	Digital Thermometer
1	Digital Engine Analyzer
1	Slack Tube Manometer
1	8 Ft. Lead With Plug
3	14 mm Spark Plug
	Thermocouple
2	Head Bolt Thermocouple
1	Oil Sump Thermocouple
1	1/4" x 1/8" Bushing
1	3/8" x 1/8" Bushing
1	1/2" x 1/8" Bushing
1	3/4" x 1/8" Bushing
1	Tube With Fittings
1	Carrying Case
3	Plain Thermocouple

The voltmeter, tachometer, thermometer and engine analyzer feature state of the art electronic circuitry and digital readouts. Guidelines for using the instruments and for testing are included. Using the instruments in the kit you will be able to:

- Measure temperatures of —
 - spark plug base gasket/cylinder head bolt.
 - oil sump.
 - air into flywheel and carburetor.
- Measure engine speed (RPM).
- Measure crankcase vacuum and exhaust system back pressure.
- Measure voltage.
- Measure charging system current.
- Measure electric starter current (Amp) draw.

The Engine Analyzer Kit can be ordered complete as shown, or the instruments can be ordered individually. Contact your Kohler Distributor for price and availability.

SECTION 3

PERIODIC MAINTENANCE

REQUIRED MAINTENANCE

These required maintenance procedures should be performed at the frequency stated in the table:

Required Maintenance	Frequency
Check Oil Level	Daily
Clean Grass Screen	Daily*
Clean/Replace Fuel Filter	As Required
Clean Foam Precleaner	25 Hours*
Change Oil	25 Hours
Check Optional Reduction Gear Unit	50 Hours
Clean Cooling Fins and External Surfaces	50 Hours*
Clean Paper Air Cleaner Element	100 Hours*
Check Spark Plug	100 Hours
Check Valve-To-Tappet Clearance	500 Hours
Clean Cylinder Head and Combustion Chamber*	500 Hours**
Service Starter Motor Drive	Annually or 500 Hours

* Perform these maintenance procedures more frequently when engine is operated under extremely dusty and dirty conditions.

** 250 Hours when leaded gasoline is used.



WARNING: Accidental Starts!

Before servicing the engine or equipment, always remove the spark plug to prevent the engine from starting accidentally. Ground the lead to prevent sparks that could cause fires.

CHECK OIL LEVEL

The importance of checking and maintaining the proper oil level in crankcase cannot be overemphasized. Check oil BEFORE EACH USE as follows:

1. Make sure the engine is stopped, level, and is cool so the oil has had time to drain into the sump.
2. Clean the area around oil fill cap/dipstick before removing to keep dirt, grass clippings, etc., out of the engine.
3. Remove oil fill cap/dipstick; wipe oil off. Reinsert dipstick and push it all the way down into tube. Remove dipstick and check the level.
4. On engines with threaded type plug dipstick, shoulder plug on top of hole to observe level.

The oil level should be up to, but not over, the "F" mark on the dipstick. Refer to Figure 3-1.

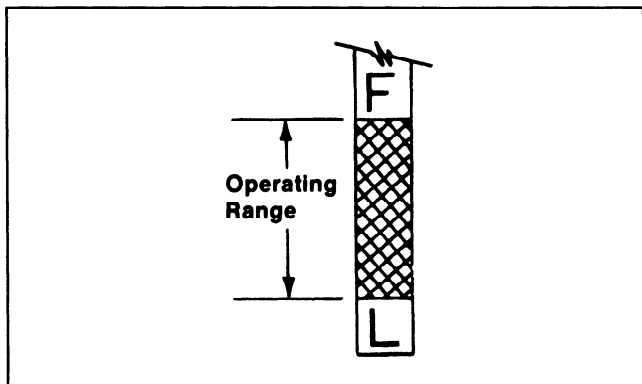

Figure 3-1. Oil Level Range.

5. Add the proper type of oil if the level is low. Always check the level with dipstick before adding more oil.

CAUTION: Never operate the engine with the oil level below "L" mark or over "F" mark on dipstick.

CHANGE OIL

For a new engine, change oil after the first 5 hours of operation. Change oil every 25 operating hours thereafter. For an overhauled engine or those rebuilt with a new shortblock or miniblock, use straight 30-weight Service Class SF or SG oil for the first 5 hours of operation. Change the oil after this initial run-in period. Change oil every 25 hours thereafter. Drain oil while the engine is still warm from operation. The oil will flow freely and carry away more impurities. Change oil as follows:

1. Remove the oil drain plug and dipstick. Tilt the engine slightly towards the drain hole to obtain better drainage.
2. Reinstall the drain plug. Make sure it is tightened securely.
3. Fill with new oil of the proper type to the "F" mark on the dipstick. Always check the level on dipstick before adding more oil. Make sure the engine is level when filling and checking oil.

SERVICE AIR CLEANER

K-Series engines are equipped with a high-density paper air cleaner element. Some specifications are also equipped with an oiled foam precleaner which surrounds the paper element. Refer to Figure 3-2.

Precleaner

If so equipped, wash and reoil the precleaner every 25 operating hours (more often under extremely dusty, dirty conditions).

1. Remove precleaner from paper element. Wash the precleaner in warm water with detergent.
2. Rinse precleaner thoroughly until all traces of detergent are eliminated. Squeeze out excess water (do not wring). Allow precleaner to air dry.
3. Saturate precleaner in clean, fresh engine oil. Squeeze out excess oil.
4. Reinstall precleaner over paper element.

Paper Element

Every **100 hours** of operation (more often under extremely dusty or dirty conditions), check the paper element. Replace the element as necessary.

1. Remove the precleaner (if so equipped), element cover, and paper element.
2. Replace a dirty, bent, or damaged element with a genuine Kohler element. Handle new elements carefully; do not use if the sealing surfaces are bent or damaged.

NOTE: Do not wash the paper element or use compressed air as this will damage element.

3. Reinstall the paper element.
4. Install the precleaner (cleaned and oiled) over the paper element.
5. Install the air cleaner cover and wing nut. Tighten wing nut. Make sure element is sealed tightly against air cleaner base.

Inspect Air Cleaner Components

Whenever the air cleaner cover is removed, or servicing the element or precleaner, check the following components:

Air Cleaner Base – Make sure it is secured tightly to carburetor and is not bent or damaged.

Element Cover and Element Cover Nut – On K181 New Look engines only, make sure element cover is not bent or damaged. Check that element cover nut is secured tightly to seal element between air cleaner base and element cover. Tighten nut to 50 in. lb. torque.

Breather Tube – Make sure it is sealed tightly in air cleaner base and breather cover.

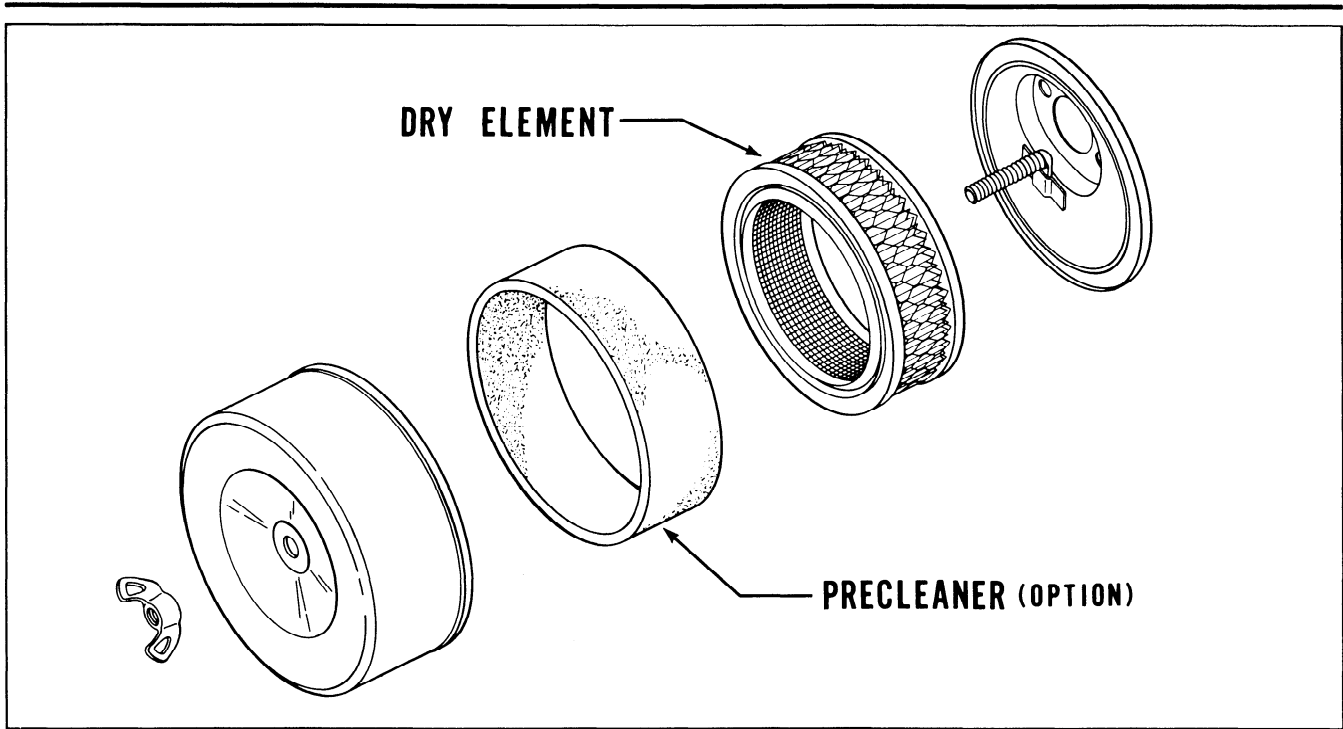

Figure 3-2. Air Cleaner Components.

NOTE: Damaged, worn, or loose air cleaner components could allow unfiltered air into the engine causing premature wear and failure. Replace all damaged or worn components.

CLEAN AIR INTAKE/COOLING AREAS

To ensure proper cooling, make sure the grass screen, cooling fins, and other external surfaces of engine are kept clean at all times. Every 50 operating hours (more often under extremely dusty, dirty conditions), remove the blower housing and other cooling shrouds. Clean the cooling fins and external surfaces as necessary. Make sure the cooling shrouds are reinstalled. Refer to the "Disassembly" and "Reassembly" sections for cooling shroud removal and installation procedures.

NOTE: Operating the engine with a blocked grass screen, dirty or plugged cooling fins, and/or cooling shrouds removed will cause engine damage due to overheating.

CHECK SPARK PLUG

Every 100 operating hours, remove the spark plug, check its condition, and reset gap or replace with new plug as necessary. Refer to Figure 3-3.

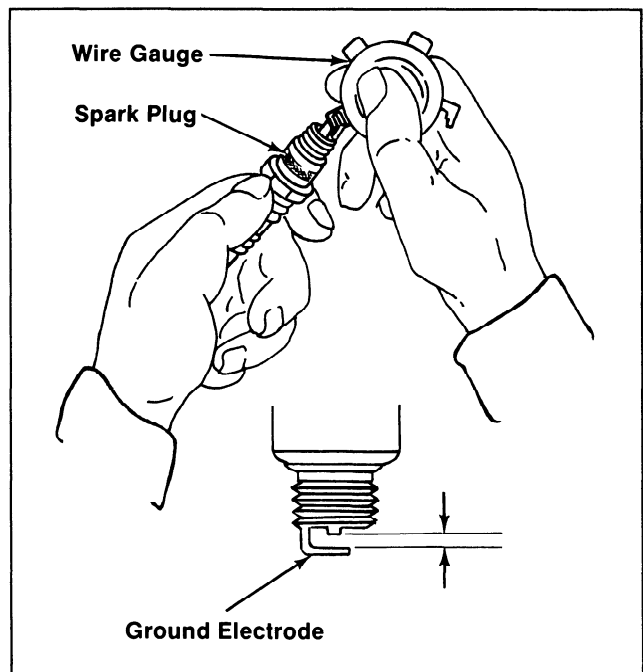

Figure 3-3. Servicing Spark Plug.

1. Before removing spark plug, clean the area around the base of plug to keep dirt and debris out of engine.
2. Remove the plug and check its condition. Replace the plug if worn or if reuse is questionable.

NOTE: Do not clean the spark plug in a machine using abrasive grit. Some grit could remain in spark plug and enter the engine causing extensive wear and damage.

3. Check gap using a wire feeler gauge. Adjust gap by carefully bending the ground electrode.
4. Reinstall spark plug into cylinder head. Torque plug to **18/22 ft. lb.**

SERVICE OPTIONAL REDUCTION GEAR UNIT

On engines equipped with a reduction gear unit, check the oil level in unit every 50 operating hours. Refer to Figure 3-4.

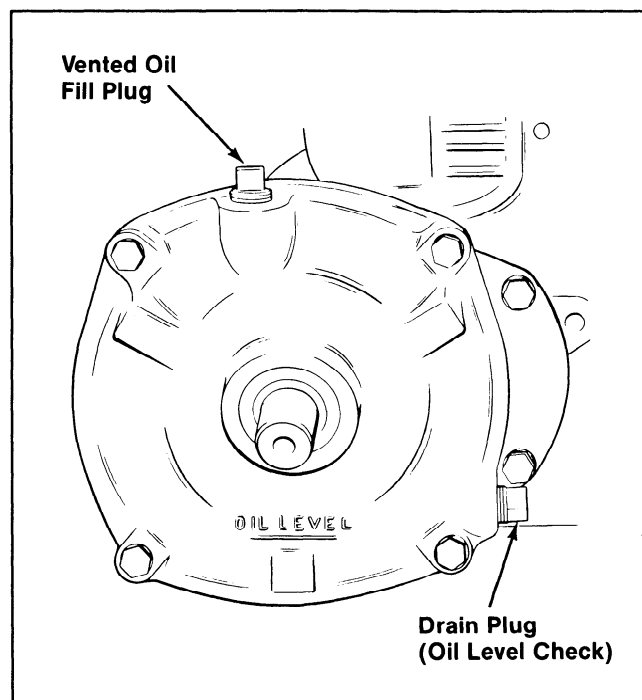

Figure 3-4. Reduction Gear Unit.

1. Remove the plug on the lower part of gear unit cover. With engine level, the oil should be up to the bottom of the plug hole.
2. To add oil, remove the vented fill plug at the top of the unit. Use the same type of oil as used in the engine crankcase.
3. Reinstall and tighten the plugs securely.

CHECK FUEL FILTER

Some engines are equipped with an in-line fuel filter. Visually inspect the filter periodically. Replace when dirty with a genuine Kohler filter. Refer to Figure 3-5.

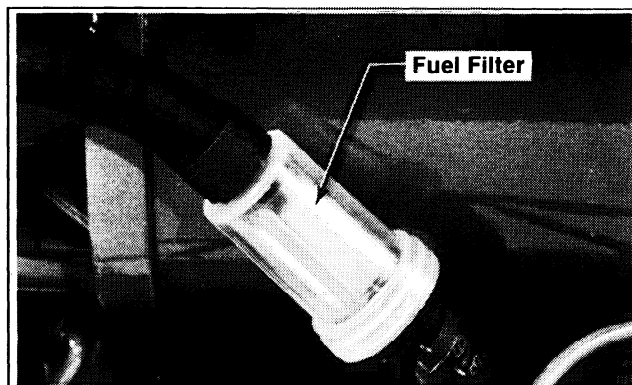

Figure 3-5. In-line Fuel Filter.

SERVICE STARTER MOTOR DRIVE

Every 500 operating hours or annually (whichever occurs first), clean and lubricate the drive splines of the Bendix-drive electric starter motor.

1. Remove starter from crankcase. (Refer to appropriate "Disassembly" section.)
2. Remove dust cover, stop nut, stop gear spacer, spring, dust cover spacer, and drive pinion.
3. Clean the drive shaft splines with solvent. Dry solvent thoroughly.
4. Apply a small amount of Kohler electric starter drive lubricant (Part No. 52 357 01) to splines.

NOTE: Kohler starter drive lubricant (Part No. 52 357 01) must be used on all Kohler electric starter drives. The use of other lubricants can cause the drive to stick or bind.

5. Apply a small amount of Loctite® No. 271 to stop nut threads. Assemble drive parts in reverse order of removal. Torque stop nut to 160 in. lb.
6. Reinstall starter to crankcase. (Refer to appropriate "Reassembly" section.)

CLEAN CYLINDER HEAD AND COMBUSTION CHAMBER

Every 500 operating hours (250 hours when leaded gasoline is used), remove cylinder head and clean combustion chamber. Refer to Figure 3-6.

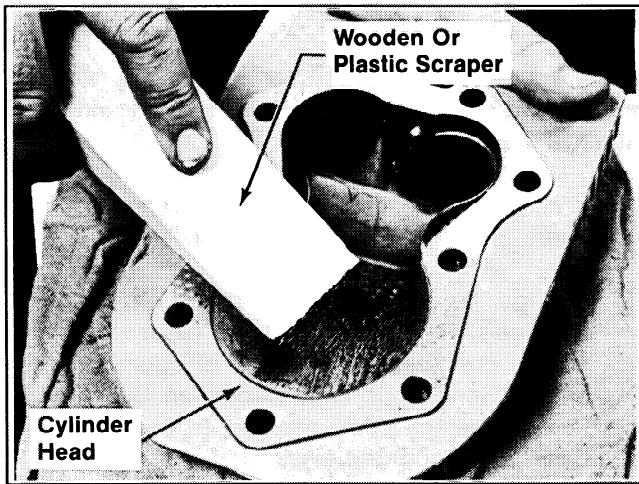

Figure 3-6. Cleaning Cylinder Head And Combustion Chamber.

1. Remove the cylinder head baffle and cylinder head.
2. Clean away combustion deposits using a wooden or plastic scraper.
3. Reinstall the cylinder head using a new gasket. Torque the cylinder head fasteners in sequence to the values specified in Figure 3-7.

CHECK VALVE-TO-TAPPET CLEARANCE

Every 500 operating hours, remove breather/valve cover and check valve-to-tappet clearance with a flat feeler gauge. Refer to Figure 3-8. The engine must be cold when checking this clearance.

1. Remove the air cleaner assembly, carburetor, and breather assembly. (Refer to appropriate "Disassembly" section.)
2. Position the crankshaft so the piston is at top of compression stroke (cam has no effect on tappets).

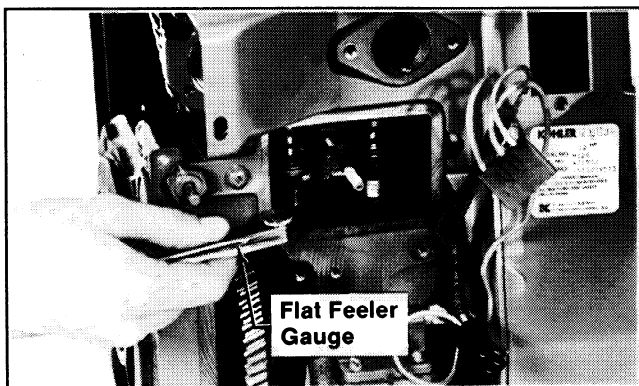
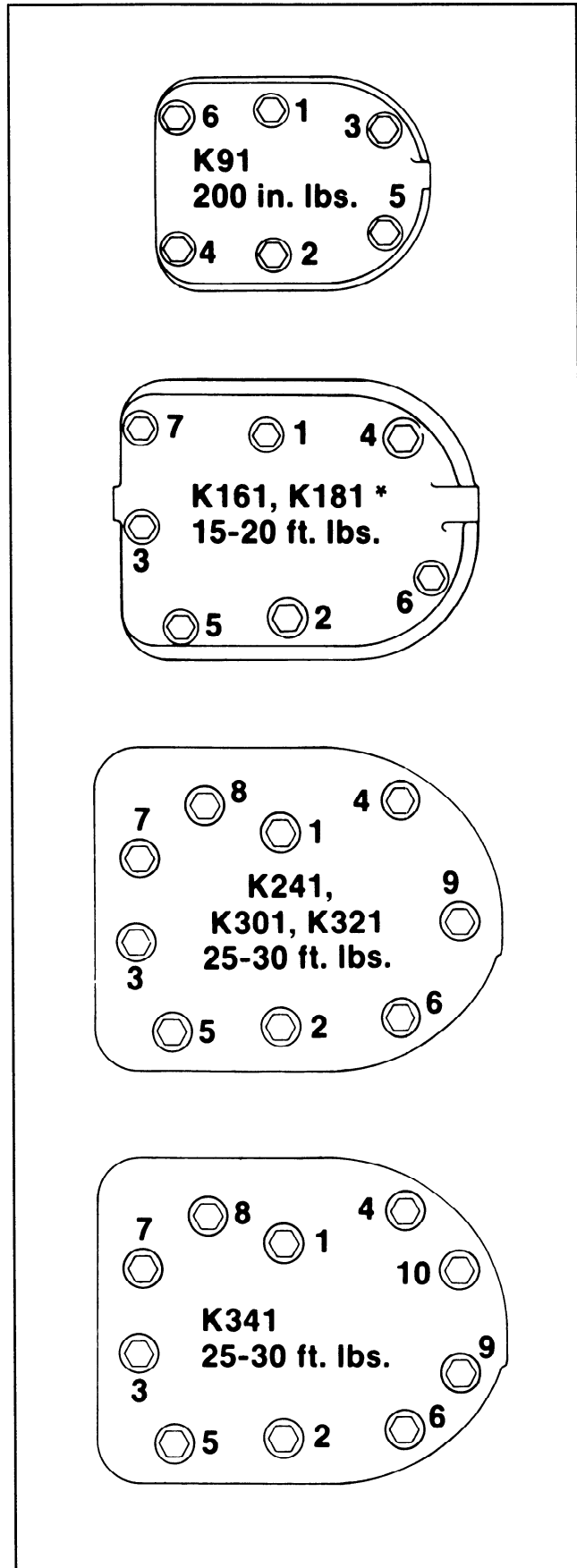

Figure 3-8. Measuring Valve-To-Tappet Clearance.



* Includes K141

Figure 3-7. Cylinder Head Fastener Tightening Sequence.

3. Measure valve-to-tappet clearance with a flat feeler gauge.

On Model K91, K141, K161, K181 – If the clearance is too small, remove the valves and grind the valve stems until the correct clearance is obtained. Make sure valve stems are ground perfectly flat and smooth.

Model	Intake Valve	Exhaust Valve
K91	.005"/.009"	.011"/.015"
K161, K181	.006"/.008"	.017"/.019"
K241, K301	.008"/.010"	.017"/.019"
K321, K341		

Figure 3-9. Valve Clearances

If clearance is too large, replace the valves and recheck clearance.

NOTE: Large clearances can also be reduced by grinding the valves and/or valve seats. Refer to the "Inspection And Repair/Reconditioning" section for valve specifications.

On Models K241, K301, K321, K341 – Adjust the clearance by turning the adjusting screw on tappets. Refer to Figure 3-9.

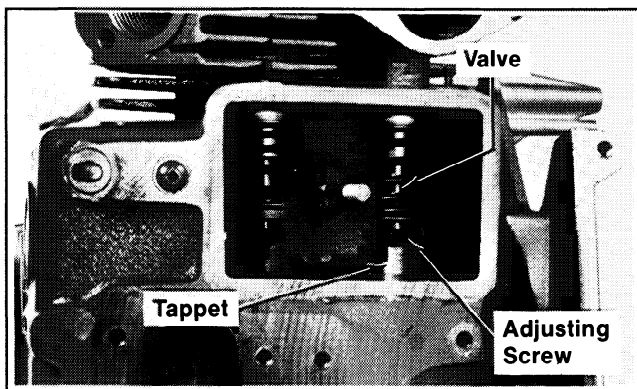

Figure 3-10. Adjusting Valve-To-Tappet Clearance – Models K241 Through K341.

STORAGE

If the engine will be out of service for approximately two months or more, use the following storage procedure.

1. Change the oil when engine is still warm from operation. Refer to "Change Oil."
2. Change the oil in reduction gear unit, if so equipped. Refill with the same oil as used in engine crankcase for season of operation. Refer to "Service Optional Reduction Gear Unit." Run engine for a few minutes to distribute clean oil throughout engine.
3. Drain the fuel tank and fuel system (or run engine until fuel tank and fuel system are empty).
4. Remove the spark plug. Add one tablespoon of engine oil into the spark plug hole. Install plug, by do not connect plug lead. Crank the engine two or three revolutions.
5. Remove the spark plug. Cover the spark plug hole with thumb and turn engine over until the piston is at the top of its stroke (pressure against thumb is greatest). Reinstall plug, but do not connect plug lead.
6. Clean the exterior surfaces of engine. Spread a light film of oil over any exposed metal surfaces of engine to prevent rust.
7. Store the engine in a clean, dry place.

SECTION 4

TROUBLESHOOTING

TROUBLESHOOTING GUIDE

When trouble occurs, be sure to check the simple causes which, at first, may seem too obvious to be considered. For example, a starting problem could be caused by an empty fuel tank.

Some common causes of engine troubles are listed below. Use this as a guide to locate trouble causing factors.

Engine Cranks But Will Not Start

1. Empty fuel tank.
2. Fuel shutoff valve closed.
3. Clogged fuel line.
4. Spark plug lead disconnected.
5. Keyswitch or kill switch in "off" position.
6. Faulty spark plug.
7. Faulty ignition.
8. Dirt or water in fuel system.

Engine Starts But Does Not Keep Running

1. Restricted fuel tank vent.
2. Dirt or water in fuel system.
3. Faulty choke or throttle controls/cables.
4. Loose wires or connections shorting ignition to ground.
5. Carburetor improperly adjusted.
6. Faulty cylinder head gasket.
7. Faulty fuel pump.

Engine Starts Hard

1. Hydrostatic transmission not in neutral/PTO drive is engaged.
2. Loose wires or connections.
3. Dirt or water in fuel system.
4. Clogged or restricted fuel lines.
5. Faulty choke or throttle controls/cables.
6. Faulty spark plug.
7. Carburetor improperly adjusted.
8. Incorrect valve-to-tappet clearance.
9. Low compression.
10. Faulty ACR mechanism.

Engine Will Not Crank

1. Hydrostatic transmission is not in neutral/PTO drive is engaged.

2. Battery is discharged.
3. Safety interlock switch is "engaged".
4. Loose or faulty wires or connections.
5. Faulty keyswitch or ignition switch.
6. Faulty electric starter/starter solenoid.
7. Retractable starter not engaging in drive cup.
8. Seized internal engine components.

Engine Runs But Misses

1. Dirt or water in fuel system.
2. Spark plug lead loose.
3. Loose wires or connections intermittently shorting ignition to ground.
4. Carburetor improperly adjusted.
5. Engine overheating.
6. Incorrect valve-to-tappet clearance.

Engine Will Not Idle

1. Idle speed adjusting screw improperly set.
2. Dirt or water in fuel system.
3. Idle fuel adjusting screw improperly set.
4. Fuel tank vent restricted.
5. Faulty spark plug.
6. Incorrect valve-to-tappet clearance.
7. Low compression.

Engine Overheats

1. Grass screen, cooling fins or shrouding clogged.
2. Excessive engine load.
3. Low crankcase oil level.
4. High crankcase oil level.
5. Carburetor improperly adjusted.

Engine Knocks

1. Low crankcase oil level.
2. Excessive engine load.

Engine Loses Power

1. Low crankcase oil level.
2. High crankcase oil level.
3. Restricted air cleaner element.
4. Dirt or water in fuel system.
5. Excessive engine load.
6. Engine overheating.
7. Faulty spark plug.
8. Carburetor improperly adjusted.

9. Low compression.

Engine Uses Excessive Amount of Oil

1. Incorrect oil viscosity or type.
2. Clogged or improperly assembled breather system.
3. Worn or broken piston rings.
4. Worn cylinder bore.
5. Worn valve stems and/or guides.

EXTERNAL ENGINE INSPECTION

- Before cleaning or disassembling the engine, check its external appearance and condition. This inspection can give clues to what might be found inside the engine (and the cause) once it is disassembled.
- Check for buildup of dirt and debris on the crankcase, cooling fins, grass screen and other external surfaces. Dirt or debris in these areas are causes of overheating.
- Check for obvious fuel and oil leaks and damaged components. Excessive oil leakage can indicate a clogged or improperly assembled breather, worn or damaged seals and gaskets or loose or improperly torqued fasteners.
- Check the air cleaner cover, element cover and air cleaner base for damage or indications of improper fit or seal.
- Check the air cleaner element. Look for holes, tears, cracked or damaged sealing surfaces or other damage that could allow dirt to enter the engine. Also note if the element is clogged or restricted. These conditions could indicate that the air cleaner has been underserviced.
- Check the carburetor throat for dirt. Dirt in the throat is further indication that the air cleaner is not functioning properly.
- Check the oil level. Note if the oil level is within the operating range on the dipstick, or if it is low or overfilled.
- Check the condition of the oil. Drain the oil into a container – it should flow freely. Check for metal chips and other foreign particles.

NOTE: It is good practice to drain oil at a location away from the workbench. Be sure to allow ample time for complete drainage.

Sludge is a natural by-product of combustion; a small accumulation is normal. Excessive sludge formation could indicate that the oil has not been changed as recommended, an incorrect type or weight of oil has been used, over-rich carburetor settings or weak ignition, to name a few.

CLEANING THE ENGINE

After inspecting the external condition of the engine, clean it thoroughly before disassembling. Also clean individual components as the engine is disassembled. Only clean parts can be accurately inspected and gauged for wear or damage.

There are many commercially available cleaners that quickly remove grease, oil and grime from engine parts. When such a cleaner is used, follow the manufacturer's instructions carefully. Make sure all traces of the cleaner are removed before the engine is reassembled and placed in operation. Even small amounts of these cleaners quickly break down the lubricating properties of engine oil.

BASIC ENGINE TESTS

Fuel System Test

To determine if fuel is getting to the carburetor, disconnect the fuel line at inlet to carburetor – if fuel does not flow out of line, check system back to tank for clogged lines, wrong (unvented) filler cap, blocked filter screen, faulty fuel pump, etc. If fuel is getting as far as the carburetor, remove the spark plug, crank engine and check for fuel inside combustion chamber. If no fuel is present here, check for faulty carburetor.

Ignition System Test

To determine if the ignition system is good, remove the spark plug and place plug with side electrode against cylinder head then crank engine at sufficient speed to produce a good spark. If a sharp, snappy spark is noted, this eliminates the ignition system components as the cause, although the ignition timing could be off.

If no spark or a weak spark is produced, check the ignition system further. If points are pitted, don't attempt to service them – replace points in bad shape. Dirty points may be cleaned. A bad condenser will cause premature failure of points. Check the breaker push rod for evidence of binding or sticking – replace as needed. Condenser can be tested on commercial tester per tester manufacturer's instructions. Check ignition coil on coil tester for continuity.

Crankcase Vacuum

A partial vacuum should exist in the crankcase when the engine is operating at normal temperatures. Pressure in the crankcase (usually caused by a clogged or improperly assembled breather) can cause oil to be forced out at oil seals, gaskets or other available spots.

Crankcase vacuum is best measured with a slack tube manometer. The manometer included in the

Kohler Engine Analysis Kit is recommended. Refer to the "Special Tools" section for more information.

Crankcase Vacuum Test

To test crankcase vacuum with the manometer:

1. Insert the stopper hose into the oil fill hole. Leave the other vent of the manometer open to the atmosphere. Make sure the shutoff clamp is closed.
2. Start the engine and run at high speed (3200 to 3600 RPM).
3. Open the clamp and note the water level in the tube. The level in the engine side should be 5 to 10 inches above the level in the open

side. If there is no vacuum (level in engine side is the same as in open side) or a positive pressure (level in open side is higher than in engine side) check for the conditions in the following table.

4. Close the shutoff clamp before shutting off the engine.

Compression Test

Because these engines are equipped with an automatic compression release mechanism (ACR), it is difficult to obtain an accurate compression reading.

To check the condition of the combustion chamber and related mechanisms, physical inspection and a crankcase vacuum test are recommended.

4

NO CRANKCASE VACUUM/PRESSURE IN CRANKCASE

Possible Cause	Solution
1. Crankcase breather clogged or inoperative.	1. Disassemble breather, clean parts thoroughly, reassemble, and recheck pressure.
2. Seals and/or gaskets leaking. Loose or improperly torqued fasteners.	2. Replace all worn or damaged seals and gaskets. Make sure fasteners are tightened securely. Use appropriate torque values and sequences when necessary.
3. Piston blowby or leaky valves. (Confirm by inspecting components.)	3. Recondition piston, rings, cylinder bore, valves, and valve guides.
4. Restricted exhaust.	4. Replace restricted muffler/exhaust system.

Figure 4-1.

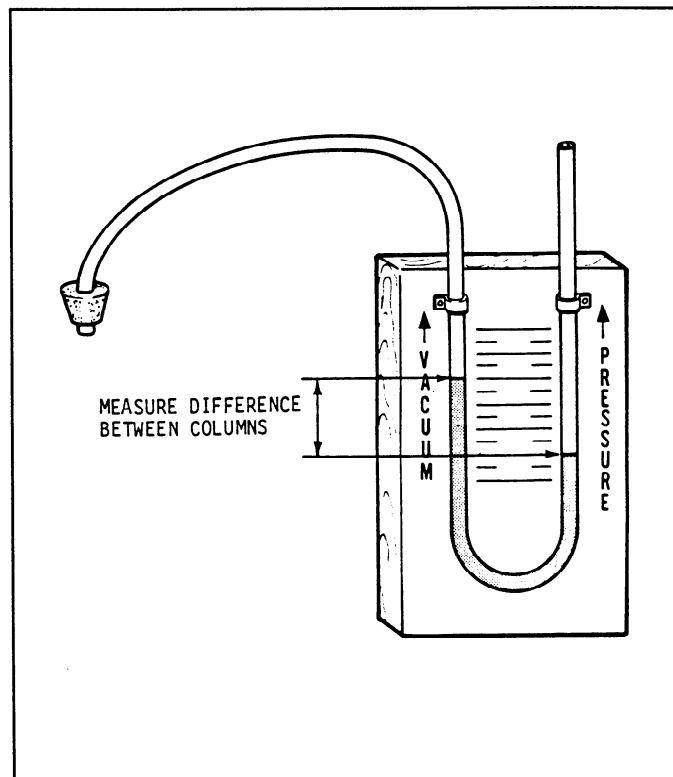

Figure 4-2. "U" Tube Manometer

SECTION 5

AIR CLEANER AND AIR INTAKE SYSTEM

K series engines are equipped with a high-density paper air cleaner element. Engines of some specifications are also equipped with an oiled foam precleaner that surrounds the paper element. Refer to Figure 5-1.

AIR CLEANER DISASSEMBLY

1. Remove the wing nut and air cleaner cover.
2. Remove the precleaner (if so equipped), paper element and seal.
3. Remove the base screws, air cleaner base, gasket and hose.

AIR CLEANER SERVICE

Precleaner

If so equipped, wash and re-oil the precleaner every 25 operating hours (more often under extremely dusty or dirty conditions).

1. Wash the precleaner in warm water and detergent.
2. Rinse the precleaner thoroughly until all traces of detergent are eliminated. Squeeze out excess water (do not wring). Allow precleaner to dry.
3. Saturate the precleaner with clean, fresh engine oil. Squeeze out excess oil.
4. Reinstall the precleaner over the paper element.

5

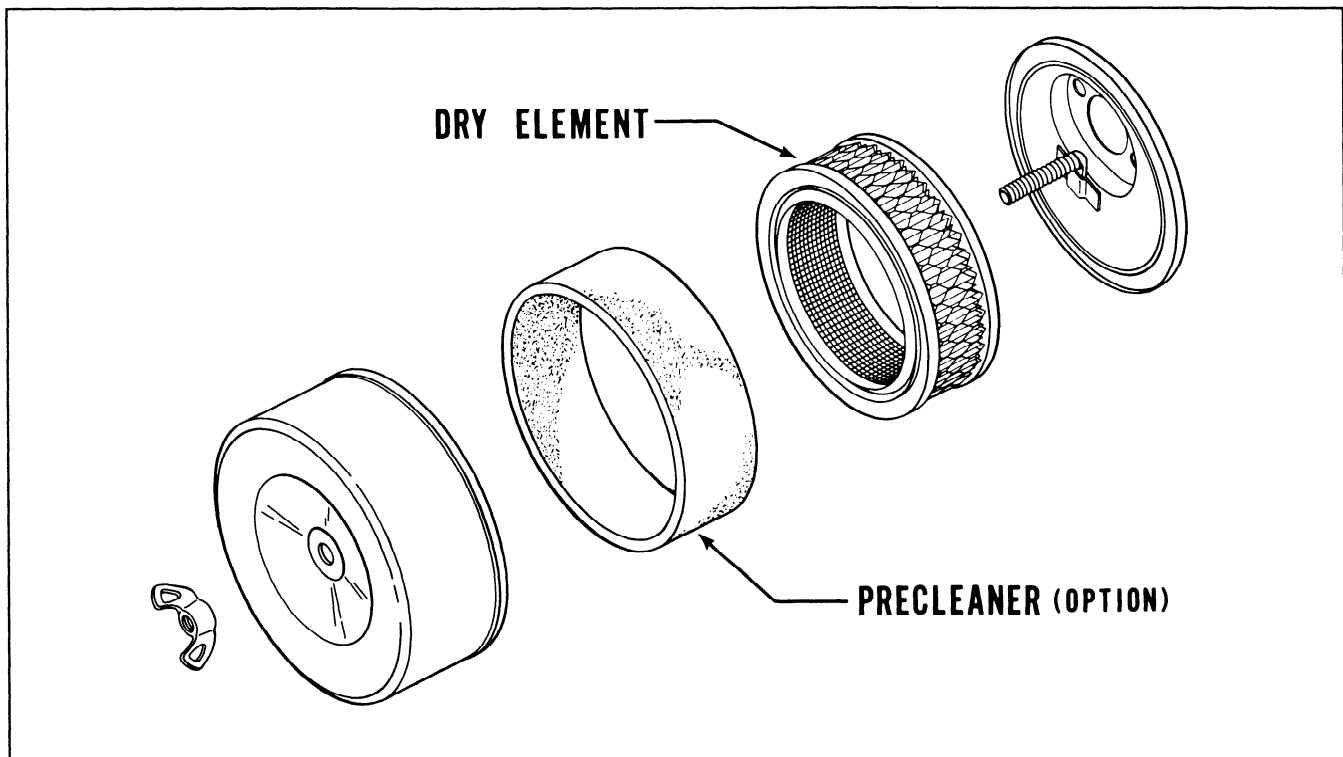

Figure 5-1. Air Cleaner Assembly – Exploded View.

Paper Element

Every 100 operating hours (more often under extremely dusty or dirty conditions) check the paper element. Replace the element as follows:

1. Remove the precleaner (if so equipped), element cover nut, element cover and paper element.
2. Replace a dirty, bent or damaged element with a new genuine Kohler element. Handle new elements carefully; do not use if surfaces are bent or damaged.

NOTE: Do not wash the paper element or use compressed air as this will damage the element.

3. Reinstall the paper element.
4. Install the precleaner (cleaned and oiled) over the paper element.
5. Install the air cleaner cover and wing nut. Tighten wing nut. Make sure element is sealed tightly against air cleaner base.

Inspect Air Cleaner Components

Whenever the air cleaner cover is removed, or when servicing the paper element or precleaner, check the following components:

1. **Air Cleaner Base** – Make sure it is secured tightly to carburetor and is not bent or damaged.
2. **Element Cover and Element Cover Nut** – On K181 New Look engines only, make sure element cover is not bent or damaged. Check that element cover nut is secured tightly to seal element between air cleaner base and element cover. Tighten nut to 50 in. lb. torque. Refer to Figure 5-2.
3. **Breather Tube** – Make sure it is sealed tightly in the air cleaner base and breather cover.

NOTE: On Model K181 New Look engines of certain specifications, the element cover may contact the breather tube, making it impossible to maintain crankcase vacuum. To prevent this problem, cut the end of the breather tube that protrudes through the air cleaner base at approximately a 45 degree angle.

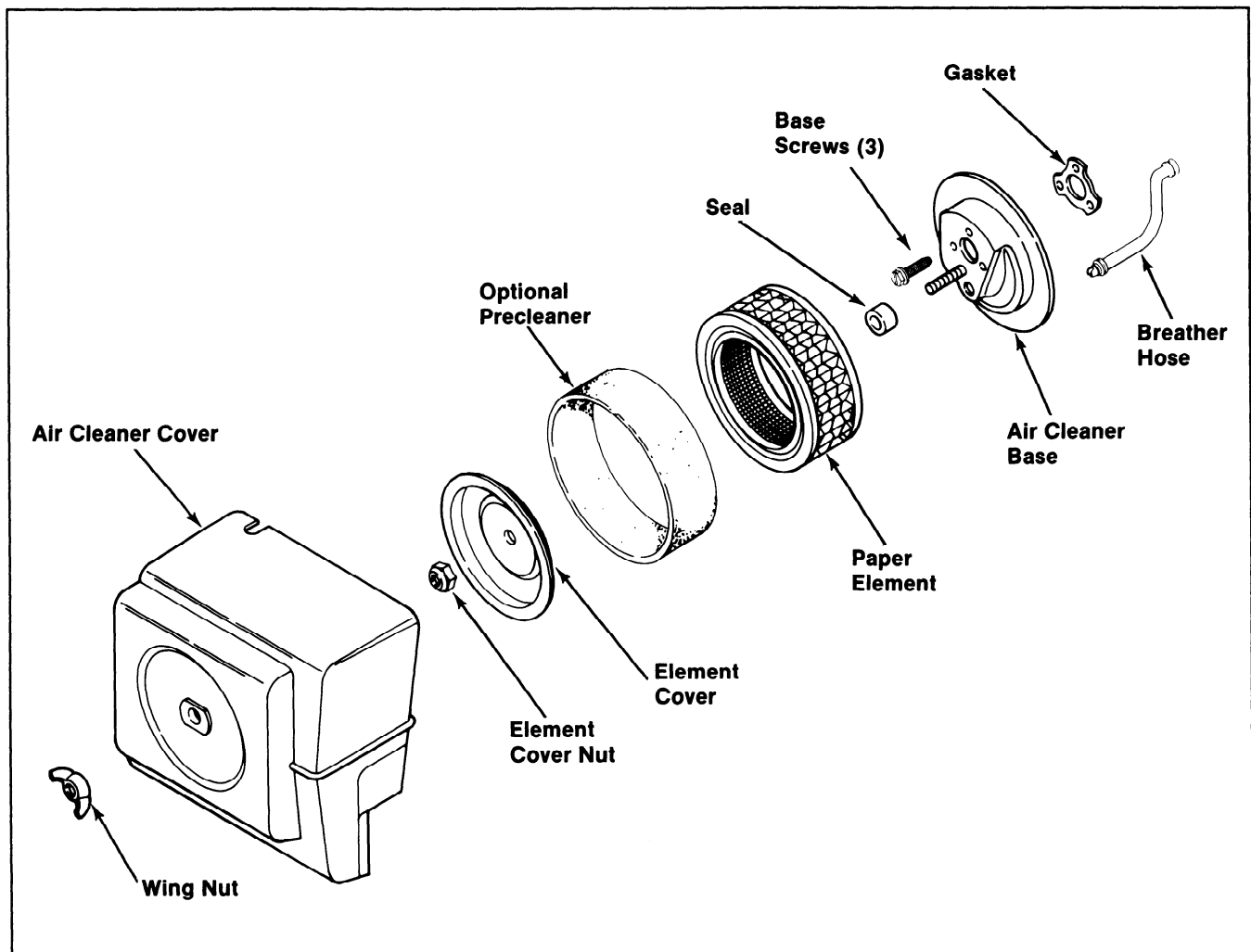

Figure 5-2. K181 New Look, Air Cleaner Assembly.

NOTE: Damaged, worn or loose air cleaner components could allow unfiltered air into the engine causing premature wear and failure. Replace all damaged or worn components.

OPTIONAL OIL BATH AIR CLEANER

If the engine has an oil bath type air cleaner, clean and service it after every 25 hours of operation or more frequently if conditions warrant. Refer to Figure 5-3.

1. Remove the cover, lift the element out of the bowl and drain the oil from the bowl.
2. Thoroughly wash bowl and cover in clean solvent. Swish the element in the solvent and allow it to dry.

NOTE: Do not use compressed air to dry the element. The filtering material could be damaged.

3. Lightly re-oil the element with engine oil.
4. Inspect base and cover gaskets. Replace if damaged.

5. Install base gasket and place filter on air horn.
6. Add engine oil to filter and fill to the OIL LEVEL mark.
7. Install filter element, cover gasket and cover. Secure with wing nut finger tight only.

COOLING AIR INTAKE SYSTEM

Effective cooling of an air cooled engine depends on an unobstructed flow of air over the cooling fins. Air is drawn into the cooling shroud by fins located on the flywheel. The blower housing, cooling shroud, air screen covering the flywheel and cooling fins on the cylinder and cylinder head must be kept clean and unobstructed at all times.

Never operate the engine with the blower housing or cooling shroud-removed. These devices direct air flow over the cooling fins.

NOTE: Some engines use a plastic grass screen and some use metal. The two are not interchangeable unless other modifications are made to the engine.

5

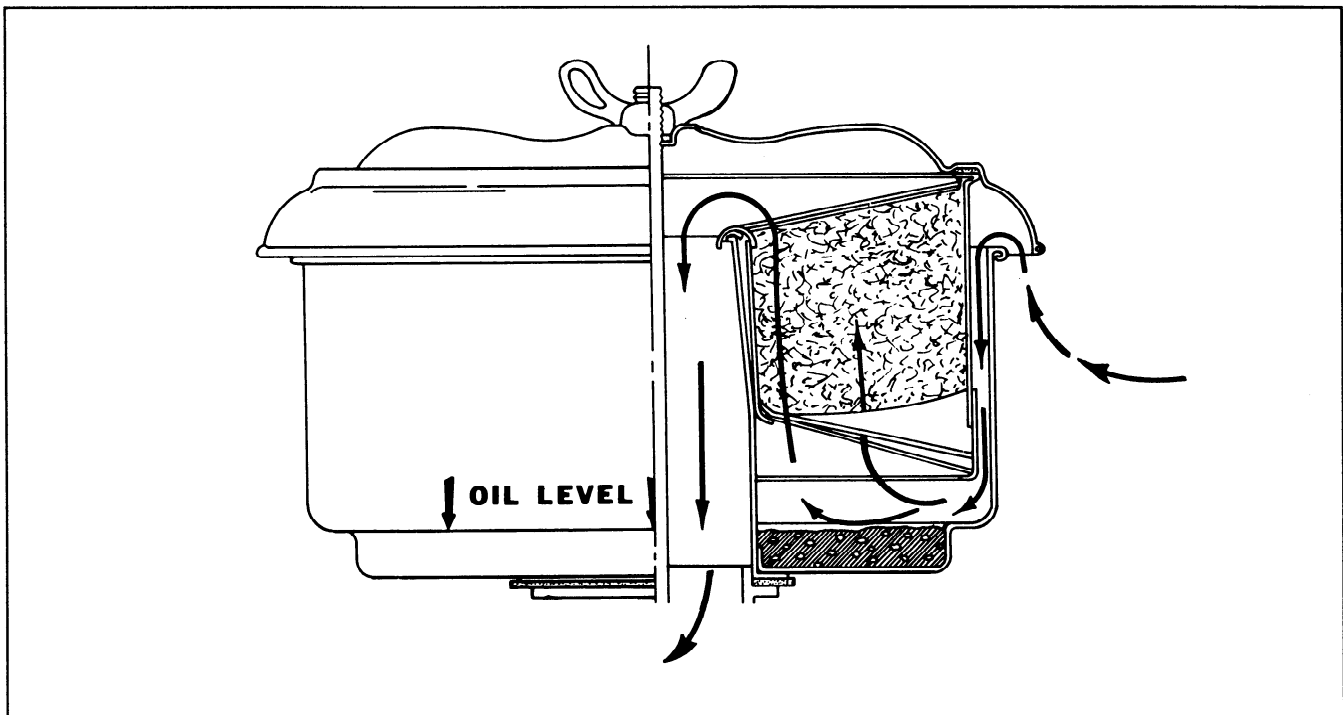

Figure 5-3. Optional Oil Bath Air Cleaner.

SECTION 6

FUEL SYSTEM AND GOVERNOR

FUEL SYSTEM – GASOLINE

The typical gasoline fuel system and related components include the fuel tank with vented cap, shutoff valve with screen, in-line fuel filter, fuel pump (some models), carburetor and interconnecting fuel line.

Operation

The fuel from the tank is moved through the screen and shutoff valve, in-line filter and fuel lines by the fuel pump (if so equipped) or gravity. Fuel enters the carburetor float bowl and is moved into the carburetor body where it is mixed with air. The fuel-air mixture is drawn into the combustion

chamber where it is compressed, then ignited by the spark plug.

Troubleshooting

Use the following procedure to check that fuel is reaching the combustion chamber.



WARNING: Explosive Fuel!

Gasoline may be present in the carburetor and fuel system. Gasoline is extremely flammable and it can explode if ignited. Keep sparks, open flames, and other sources of ignition away from the engine. Disconnect and ground the spark plug lead to prevent the possibility of sparks from the ignition system.

Test	Conclusion
<p>1. Check for the following:</p> <ul style="list-style-type: none"> A. Make sure the tank contains fuel. B. Make sure the fuel cap vent is open. C. Make sure the fuel shutoff valve is open. 	
<p>2. Check for fuel in the combustion chamber.</p> <ul style="list-style-type: none"> A. Disconnect the spark plug lead. B. Close the choke on carburetor. C. Crank the engine several times. D. Remove the spark plug and check for fuel at tip. 	<p>2. If there is fuel at tip of spark plug, fuel is reaching the combustion chamber.</p> <p>If there is no fuel at tip of spark plug, check for fuel from the fuel tank. (Test 3).</p>
<p>3. Check for fuel flow from tank to fuel pump.</p> <ul style="list-style-type: none"> A. Remove fuel line from inlet fitting at fuel pump. B. Hold line below bottom of tank. Open shutoff valve and observe flow. 	<p>3. If fuel does flow from line, check for faulty fuel pump. (Test 4).</p> <p>If fuel does not flow from line, check for clogged fuel tank vent, shutoff valve screen, and fuel lines.</p> <p>If the fuel tank cap vent does not allow air to escape from the tank, modify the vent for proper operation by cutting 1/32" to 1/16" off the bottom. Refer to Figure 6-1.</p>
<p>4. Check operation of fuel pump</p> <ul style="list-style-type: none"> A. Remove fuel line from inlet fitting at carburetor. B. Crank engine several times and observe flow. 	<p>4. If fuel does not flow from line, check for clogged fuel line. If line is unobstructed, fuel pump is faulty and must be replaced.</p> <p>If fuel does flow from fuel line, the carburetor probably is faulty. Refer to the "Carburetor" portion of this section.</p>

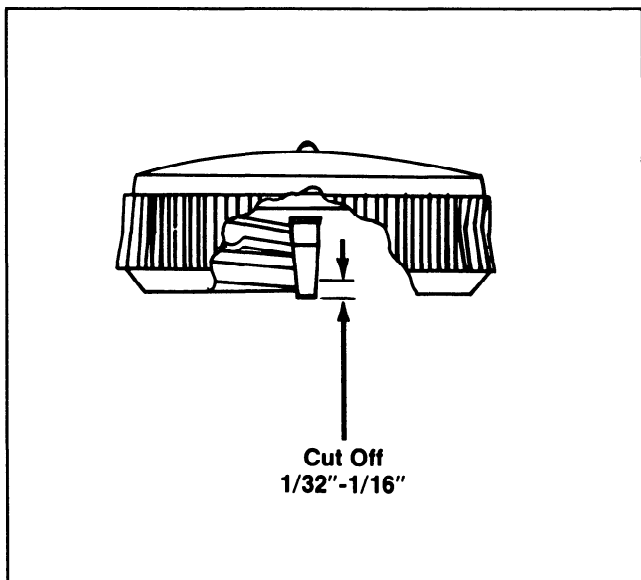

Figure 6-1. Fuel Tank Cap.
(“New Look” Only)

FUEL TANK

Engine-mounted fuel tanks on K series engines are constructed of steel. They are fitted with a vented cap. The venting properties of the cap should be checked regularly. A clogged vent can cause pressure buildup in the tank, which could result in fuel spraying from the filler when the cap is loosened. It can also cause a partial vacuum in the tank, stopping the engine.

Fuel Shutoff Valve

Some engines are equipped with a fuel shutoff valve with a wire mesh screen. On engines without a shutoff valve, a straight outlet fitting is used. The wire mesh prevents relatively large particles in the tank from reaching the carburetor. The shutoff valve permits work on the fuel system without the need for draining the tank.

FUEL FILTER

Some engines covered by this manual may be equipped with a see-through inline fuel filter. When the interior of the filter appears to be dirty, it should be replaced.

FUEL PUMP

All K series engines except the K91 have provisions for mounting a mechanically operated fuel pump. If no fuel pump is mounted on these engines, a cover is placed over the pump mounting pad on the crankcase.

Older fuel pumps have a metal body. Later models have a body made of plastic. The plastic body better insulates the fuel from the hot engine, minimizing the chance of vapor lock.

Operation

The mechanical fuel pump is operated by a lever that rides on the engine camshaft. The lever transmits a pumping action to the flexible diaphragm inside the pump body. The pumping action draws fuel in through the inlet check valve on the downward stroke of the diaphragm. On the upward stroke, the fuel is forced out through the outlet check valve. Refer to Figure 6-2.

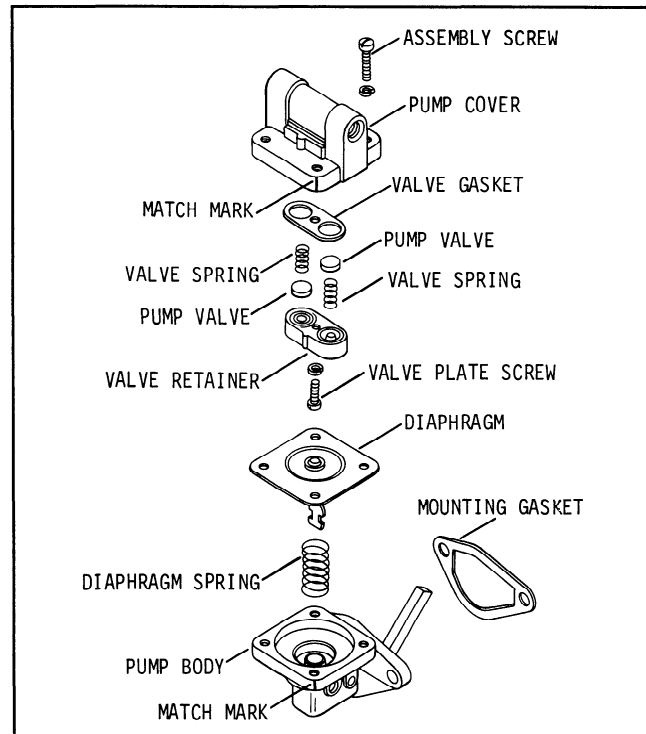

Figure 6-2. Mechanical Fuel Pump.

Removal

1. Disconnect the fuel lines from the inlet and outlet fittings of the pump.
2. Remove the fillister head sems screws, flat washers, fuel pump and gasket.
3. If required, remove the fittings from the pump body.

Repair

Plastic bodied fuel pumps are not serviceable and must be replaced when faulty. Replacement pumps are available in kits which include the pump, mounting gasket and plain washers.

Installation

1. Fittings – Apply a small amount of Permatex® Aviation Perm A Gasket (or equivalent gasoline resistant thread sealant) to fittings. Turn fittings into pump **six full turns**; continue turning fittings in the same direction until desired direction is reached.
2. Install new gasket, fuel pump, flat washers, lock washers and fillister head sems screws. Refer to Figure 6-3.

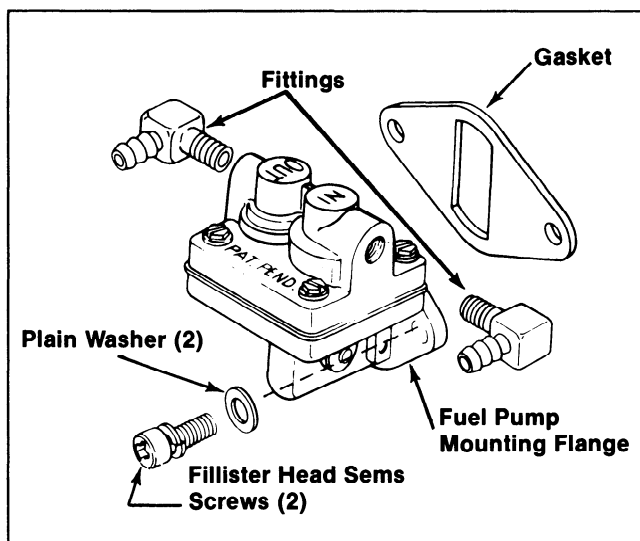

Figure 6-3. Installing Fuel Pump.

NOTE: Make sure that the fuel pump lever is positioned above the camshaft. Damage to the fuel pump and severe damage to the engine could result if the lever is positioned below the camshaft.

Make sure that the flat washers are installed next to the mounting flange to prevent damage from the lock washers.

If a metal bodied pump was replaced by a plastic bodied pump, make sure that the old thick gasket is discarded and the new thin gasket is used.

3. Torque screws to 37 - 45 in./lb.
4. Connect fuel lines to inlet and outlet fittings.

CARBURETOR - GASOLINE



WARNING: Explosive Fuel!

Gasoline may be present in the carburetor and fuel system. Gasoline is extremely flammable and it can explode if ignited. Keep sparks, open flames, and other sources of ignition away from the engine. Disconnect and ground the spark plug lead to prevent the possibility of sparks from the ignition system.

Adjustment

The carburetor is designed to deliver the correct fuel/air mixture to the engine under all operating conditions. Carburetors are set at the factory and normally do not need adjustment. If the engine exhibits conditions like those found in the table that follows, it may be necessary to adjust the carburetor.

In general, turning the adjusting needles in (clockwise) decreases the supply of fuel to the carburetor.

This gives a *leaner* fuel-to-air mixture. Turning the adjusting needles **out** (counterclockwise) increases the supply of fuel to the carburetor. This gives a *richer* fuel-to-air mixture. Setting the needles midway between the lean and rich positions will usually give the best results. Adjust the carburetor as follows:

1. With the engine stopped, turn the low idle fuel adjusting needle **in** (clockwise) until it bottoms lightly.

NOTE: The tip of the low idle fuel and high idle fuel adjusting needles are tapered to critical dimensions. Damage to the needles and the seats in carburetor body will result if the needles are forced.

2. Preliminary Settings: Turn the adjusting needles **out** (counterclockwise) from lightly bottomed according to the table shown in Figure 6-4.
3. Start the engine and run at half throttle for five to ten minutes to warm up. The engine must be warm before making final settings (Steps 4, 5, 6, and 7).
4. High Idle Fuel Needle Setting: This adjustment is required only for adjustable high idle (main) jet carburetors. If the carburetor is a fixed main jet type, go to step 5.

Place the throttle into the "fast" position. If possible, place the engine under load.

Turn the high idle fuel adjusting needle **out** (counterclockwise) from the preliminary setting until the engine speed decreases (rich). Note the position of the needle.

Now turn the adjusting needle **in** (clockwise). The engine speed may increase, then it will decrease as the needle is turned in (lean). Note the position of the needle.

Set the adjusting needle **midway** between the rich and lean settings. See Figure 6-5.

5. Low Idle Speed Setting: Place the throttle control into the "idle" or "slow" position. Set the low idle speed to 1200 rpm* (+ or - 75 rpm) by turning the low idle speed adjusting screw **in or out**. Check the speed using a tachometer.

NOTE: The actual low idle speed depends on the application. Refer to the equipment manufacturer's instructions for specific low idle speed settings. The recommended low idle speed for Basic Engines is 1200 rpm. To ensure best results when setting the low idle fuel needle, the low idle speed must not exceed 1500 rpm.

PRELIMINARY SETTINGS - K-SERIES MODELS

	KOHLER ADJUSTABLE JET		WALBRO FIXED JET	NOTE: Refer to publication TP2377B Carburetor Reference Manual for additional information.
	Low Idle	High Idle	Low Idle	
K91	1-1/2 turns	2 turns	NOT APPL.	
K141	1-1/2 turns	3 turns	NOT APPL.	
K161*	1-1/2 turns	3 turns	NOT APPL.	
K181*	1-1/4 turns	2 turns	2-1/2 turns	
K241	2-1/2 turns	2 turns	1-1/4 turns	
K301	2-1/2 turns	2 turns	1-1/4 turns	
K321	2-1/2 turns	3-1/4 turns	1-1/2 turns	
K341	2-1/2 turns	3-1/2 turns	1 turn	

* Includes "New Look" Models

Figure 6-4. Preliminary Low Idle And High Idle Fuel Needle Settings.

6. Low Idle Fuel Needle Setting: Place the throttle into the "idle" or "slow" position.

Turn the low idle fuel adjusting needle **out** (counterclockwise) from the preliminary setting until the engine speed decreases (rich). Note the position of the needle.

Now turn the adjusting needle **in** (clockwise). The engine speed may increase, then it will decrease as the needle is turned in (lean). Note the position of the needle.

Set the adjusting needle **midway** between the rich and lean settings. See Figure 6-5.

7. Recheck the low idle speed using a tachometer. Readjust the speed as necessary.

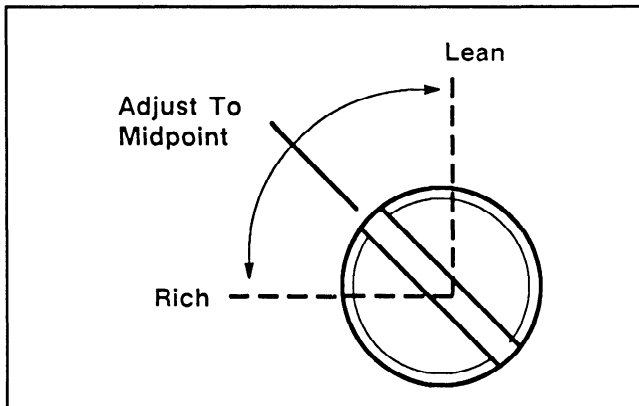

Figure 6-5. Optimum Low Idle Fuel Setting.

Disassembly

(Refer to Figure 6-7)

1. Remove the bowl retaining screw, retaining screw gasket and fuel bowl.

2. Remove the float pin, float, fuel inlet needle, baffle gasket and bowl gasket.
3. Remove the fuel inlet seat and inlet seat gasket. Remove the idle fuel and main fuel adjusting needles and springs. Remove the idle speed adjusting screw and spring.
4. Further disassembly to remove the throttle and choke shafts is recommended only if these parts are to be replaced. Refer to "Throttle and Choke Shaft Replacement" later in this section.

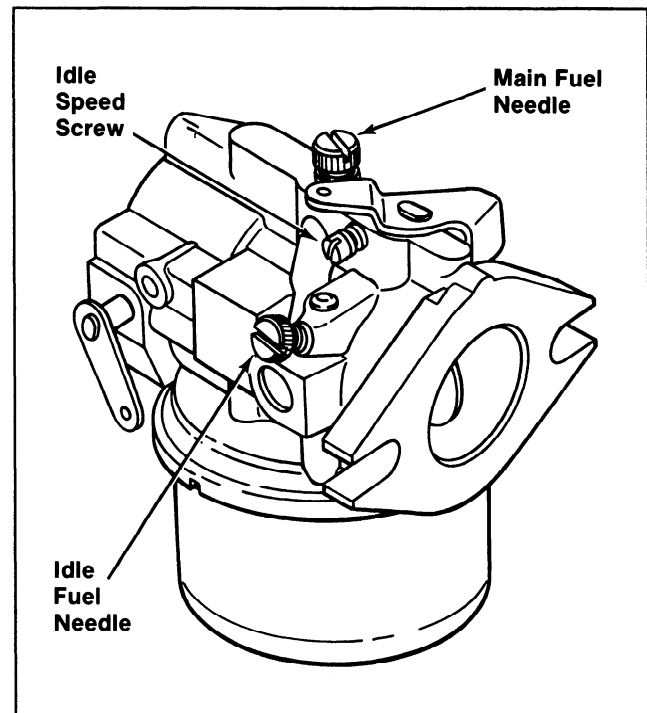

Figure 6-6. Kohler-Built Adjustable Jet Carburetor.

Cleaning

WARNING: Flammable Solvents!



Carburetor cleaners and solvents are extremely flammable. Keep sparks, flames and other sources of ignition away from the area. Follow the cleaner manufacturer's warnings and instructions on its proper and safe use. Never use gasoline as a cleaning agent.

All parts should be carefully cleaned using a carburetor cleaner (such as acetone). Be sure all gum deposits are removed from the following areas:

Carburetor body and bore; especially the areas where throttle plate, choke plate and shafts are seated.

Float and float hinge.

Fuel bowl.

Idle fuel and "off-idle" ports in carburetor bore, ports in main fuel adjusting needle and main fuel seat.

NOTE: These areas can be cleaned using a piece of fine wire in addition to cleaners. Be careful not to enlarge the ports or break the cleaning wire within the ports.

Blow out all passages with compressed air.

NOTE: Do not submerge carburetor in cleaner or solvent when fiber or rubber seals are installed. The cleaner may damage these seals.

Inspection

1. Carefully inspect all components and replace those that are worn or damaged.
2. Inspect the carburetor body for cracks, holes and other wear or damage.
3. Inspect the float for dents or holes. Check the float hinge for wear and missing or damaged float tabs.
4. Inspect the inlet needle and seat for wear or grooves.
5. Inspect the tips of the main and idle fuel adjusting needles for wear or grooves.

Inspect the throttle and choke shafts and plate assemblies for wear or excessive play.

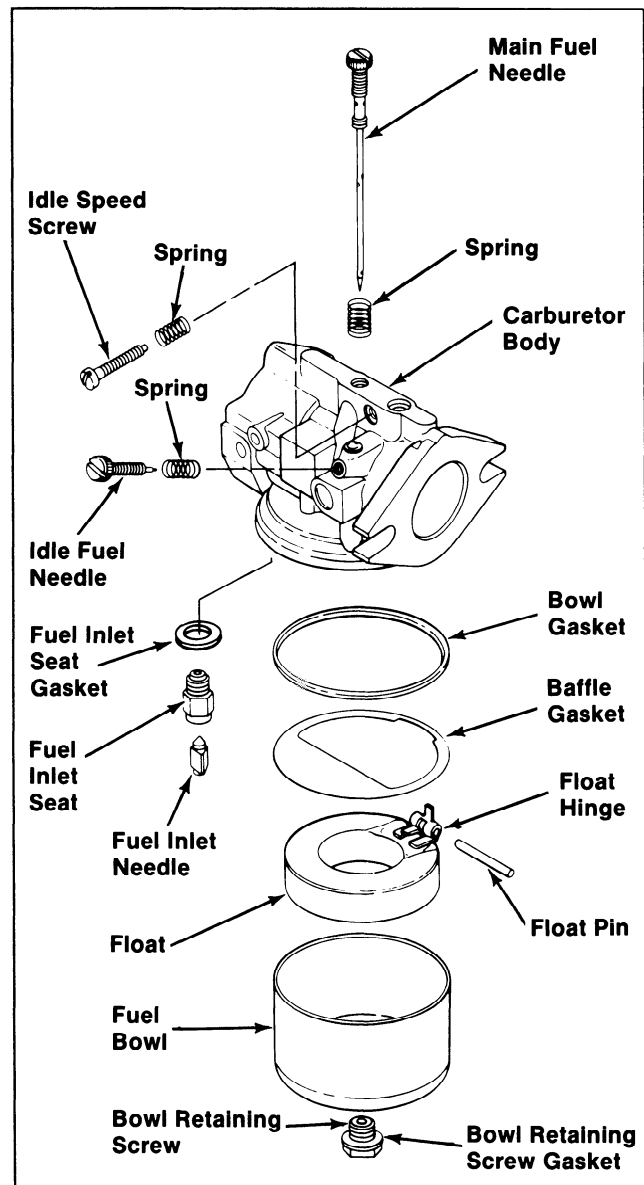

Figure 6-7. Kohler-Built Adjustable Jet Carburetor - Exploded View.

Choke Plate Modification

The choke action has been changed on production carburetors to reduce the chances of over chocking. On production carburetors now used on the K321 and K341, both relief holes in the choke plate have been enlarged to 11/32" while on the K241 and K301, one relief hole is now 11/32" and the other is 3/16". If you find that the relief holes are smaller than this, enlarge them to these dimensions.

NOTE: When redrilling the holes, take the necessary precautions to prevent chips from entering the engine.

Repair

Always use new gaskets when servicing and reinstalling carburetors. Several repair kits, which include the gaskets and other components, are

available. Always refer to the Parts Manual for the engine being serviced to ensure that the correct carburetor repair kits and replacement parts are ordered.

Throttle And Choke Shaft Replacement

To Replace Throttle And Choke Shafts

Two kits are available that allow replacement of the carburetor throttle and choke shafts of Kohler carburetors. Refer to Figure 6-8.

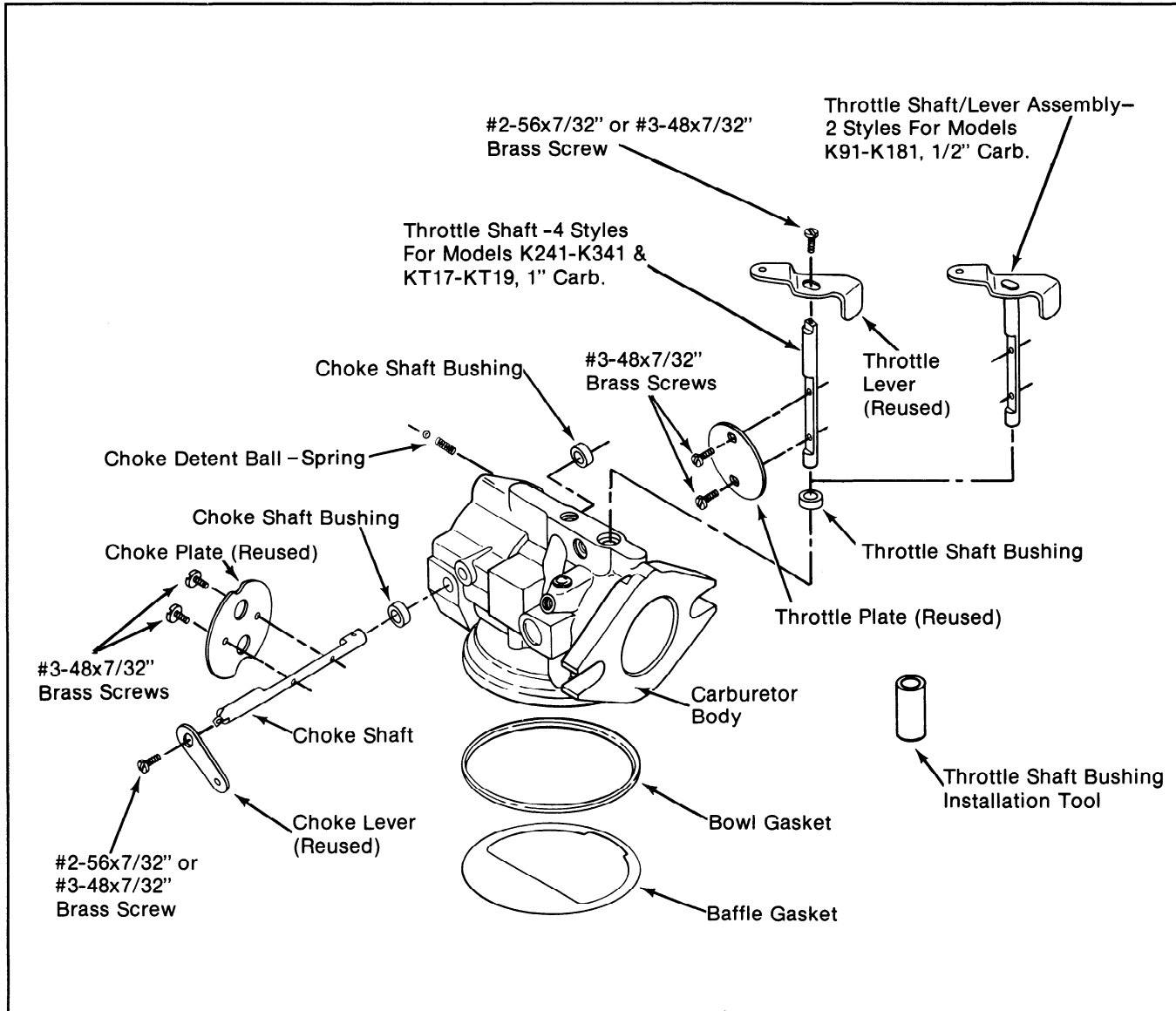

Figure 6-8. Throttle And Choke Shaft Replacement Kits.



WARNING: Prevent Eye Injury!

Suitable eye protection (safety glasses, goggles, or face hood) should be worn for any procedure involving the use of compressed air, punches, hammers, chisels, drills, or grinding tools.

Disassemble Carburetor

Refer to "Disassembly" at the beginning of this section.

Remove Choke Plate and Choke Shaft; Transfer Choke Lever

1. To ensure correct reassembly, mark choke plate and carburetor body with a marking pen. Also take note of choke plate position in bore and choke lever position.
2. Carefully and slowly remove the screws securing choke plate to choke shaft. Remove and save the choke plate as it will be reused.

3. File off any burrs which may have been left on the choke shaft when the screws were removed. Place carburetor on workbench with choke side down. Remove choke shaft; the detent ball and spring will fall out.
4. Note the position of the choke lever with respect to the cut out portion of the choke shaft.
5. Carefully grind or file away the riveted portion of the shaft. Remove and save the choke lever; discard the old choke shaft.
6. Attach the choke lever to the new choke shaft from the kit. Make sure the lever is installed correctly as noted in step 4. Secure lever to choke shaft as follows:

Models K91 – K181; Apply Loctite to threads of 1 #2–56 x 7/32" brass screw. Secure lever to shaft.

Models K241 – K341; Apply Loctite to threads of 1 #3–48 x 7/32" brass screw. Secure lever to shaft.

Remove Throttle Plate and Throttle Shaft; Transfer Throttle Lever

1. To ensure correct reassembly, mark throttle plate and carburetor body with a marking pen. Also take note of the throttle plate position in the bore and the throttle lever position.
2. *Carefully and slowly* remove the screws securing the throttle plate to throttle shaft. Remove and save the throttle plate for reuse.
3. File off any burrs that may have been left on the throttle shaft when screws were removed.

NOTE: Failure to remove burrs from the throttle shaft may cause permanent damage to carburetor body when shaft is removed.

4. Remove throttle shaft from carburetor body. Remove and discard the foam rubber dust seal from the throttle shaft.
5. Remove and transfer the throttle lever as follows:

Models K91 – K181 (1/2" Carb.);

Carefully grind or file away the riveted portion of the throttle shaft. Save the throttle shaft as it will be used to install the new throttle shaft bushing. Discard the throttle lever.

Models K241 – K341 (1" Carb.);

- a. Note the position of the throttle lever with respect to the cutout portion of the throttle shaft.
- b. Carefully grind or file away the riveted portion of the shaft. Remove the throttle lever.

- c. Compare the old shaft with the new shafts in the kit. Select the appropriate new shaft and discard the old shaft.
- d. Attach throttle lever to throttle shaft. Make sure lever is installed correctly as noted in step a.
- e. Apply Loctite to threads of 1 #2–56 x 7/32" brass screw (use #3–48 x 7/32" screw if shaft is 2–49/64" long. Secure lever to shaft.

Drill Choke Shaft Bores Using A Drill Press

1. Mount the carburetor body in a drill press vise. Keep the vise jaws slightly loose.
2. Install a drill bit of the following size in the drill press chuck. Lower the bit (not rotating) through both choke shaft bores; then tighten vise. This ensures accurate alignment of the carburetor body with the drill press chuck.

Models K91 – K181 (1/2" Carb.); Use a 7/32" diameter drill bit.

Models K241 – K341 (1" Carb.); Use a 1/4" diameter drill bit.

Refer to Figure 6–9.

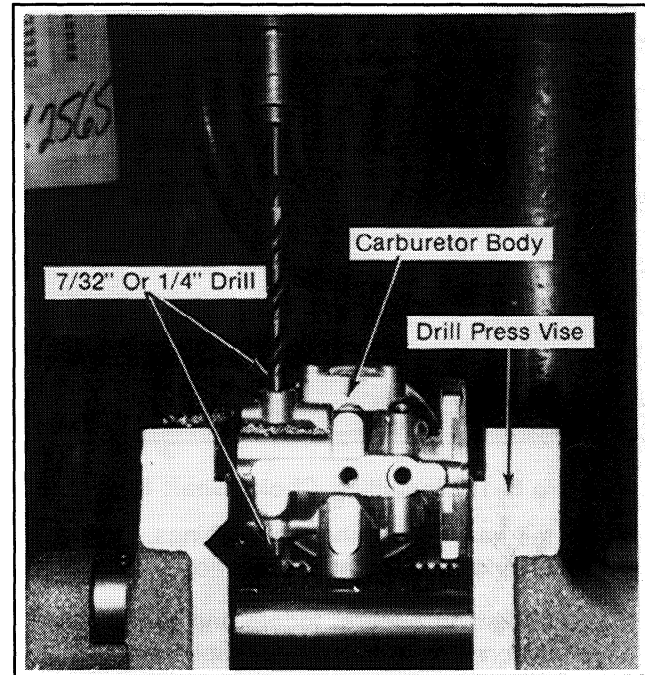

Figure 6–9. Aligning/Drilling Carburetor Body.

3. Install a 19/64" drill bit in the chuck. Set drill press to a low speed suitable for aluminum. Drill slowly to ensure a good finish.
4. Ream the choke shaft bores to a final size of 5/16". For best results use a piloted 5/16" reamer.
5. Blow out all metal chips using compressed air. Thoroughly clean the carburetor body in carburetor cleaner.

Install Choke Shaft Bushings

1. Install screws in the tapped holes that enter the choke shaft bores until the screws bottom *lightly*. Refer to Figure 6-10.
2. Coat the outside surface of the kit-supplied choke shaft bushings with Loctite from the kit. Carefully press the bushings into the carburetor body using a smooth-jawed vise. Stop pressing when bushings bottom against screws.

Models K91 – K181 (1/2" Carb.); Make sure the bushing is pressed below the surface of the large choke shaft boss until the bushing bottoms against screw.

3. Allow Loctite to "set" for 5 to 10 minutes, then remove screws.

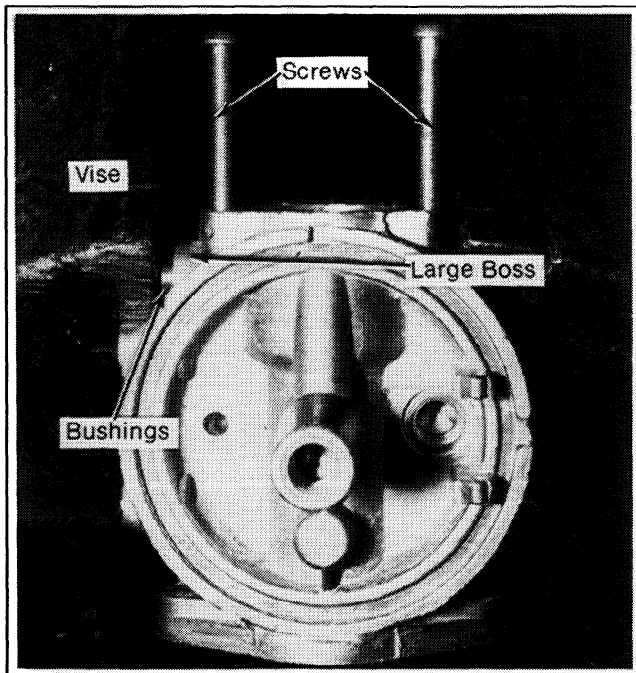

Figure 6-10. Installing Choke Shaft Bushings.

4. Install new choke shaft in bushings. Rotate shaft and check that it does not bind.

NOTE: If binding occurs, locate and correct the cause before proceeding. Use choke shaft to align bushings if necessary.

5. Remove choke shaft and allow Loctite to "set" for an additional 30 minutes before proceeding.
6. Wipe away any excess Loctite from bushings and choke shaft.

Install Throttle Shaft Bushing

1. Make sure the dust seal counterbore in the carburetor body is thoroughly clean and free of chips and burrs.

2. Install a throttle shaft (without throttle lever) in carburetor body to use as a pilot:

Models K91 – K181 (1/2" Carb.); Use the old throttle shaft removed previously.

Models K141 – K341 (1" Carb.); Use one of the remaining new throttle shafts from the kit.

3. Coat the outside surface of the throttle shaft bushing with Loctite from the kit. Slip the bushing over the shaft. Using a vise and the installation tool from the kit, press the bushing into the counterbore until it bottoms in the carburetor body. Refer to Figure 6-11.

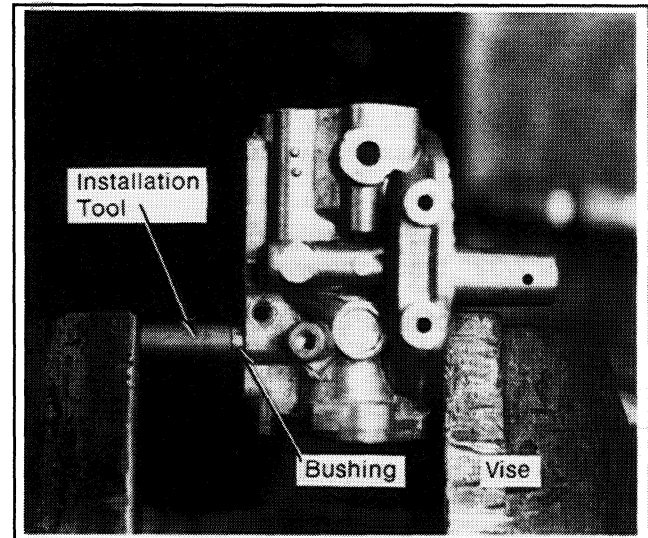

Figure 6-11. Installing Throttle Shaft Bushing.

4. Allow the Loctite to "set" for 5 to 10 minutes, then remove the throttle shaft.
5. Install the new throttle shaft and lever in carburetor body. Rotate the shaft and check that it does not bind.

NOTE: If binding occurs, locate the cause and correct before proceeding. Use throttle shaft to align bushing if necessary.

6. Remove the shaft and allow the Loctite to "set" for an additional 30 minutes before proceeding.
7. Wipe away all excess Loctite from bushing and throttle shaft.

Install Detent Spring and Ball, Choke Shaft and Choke Plate

1. Install new detent spring and ball in carburetor body in the side opposite the choke lever.
2. Compress detent ball and spring and insert choke shaft through bushings. Make sure the choke lever is on the correct side of the carburetor body. Refer to Figure 6-12.

3. Attach choke plate to choke shaft. Make sure marks are aligned and plate is positioned properly in the bore. Apply Loctite to threads of 2 #3-48 x 7/32" brass screws. Install screws so that they are slightly loose.
4. Operate the choke lever. Check that there is no binding between choke plate and carburetor bore. Loosen screws and adjust plate as necessary; then tighten screws.

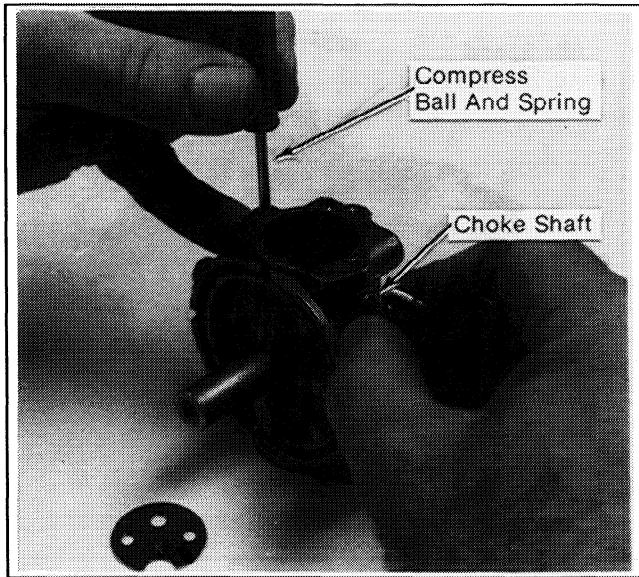

Figure 6-12. Installing Choke Shaft.

Install Throttle Shaft and Throttle Plate

1. Install throttle shaft in carburetor with cutout portion of the shaft facing out.
2. Attach throttle plate to throttle shaft. Make sure marks are aligned and plate is positioned properly in the bore. Apply Loctite to threads of 2 #3-48 x 7/32" brass screws. Install screws so that they are slightly loose.
3. Apply finger pressure to throttle shaft to keep it firmly seated against pivot in carburetor body. Rotate the throttle shaft until the throttle plate fully closes the bore around its perimeter; then tighten screws.
4. Operate the throttle lever and check that the throttle plate does not bind in the bore. Loosen screws and adjust plate if necessary; then tighten screws securely.

Reassemble Carburetor

Refer to the following "Reassembly" portion of this section.

Reassembly

1. Install the fuel inlet seat gasket and fuel inlet seat into carburetor body. Torque seat to 35/45 in. lb.
2. Install the fuel inlet needle into inlet seat. Install float and slide float pin through float hinge and float hinge towers on carburetor body.
3. **Set float level:** Invert carburetor so the float tab rests on the fuel inlet needle. There should be 11/64" (+- 1/32") clearance between the machined surface of body and the free end of float. Bend the float tab with a small screwdriver to adjust. Refer to Figure 6-13.

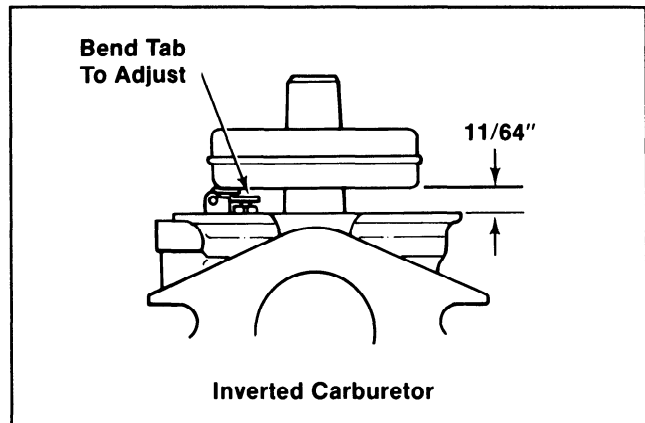

Figure 6-13. Setting Float Level.

4. **Set float drop:** Turn the carburetor over to its normal operating position and allow float to drop to its lowest level. The float drop should be limited to 1-1/32" between the machined surface of body and the bottom of the free end of float. Bend the float tab with a small screwdriver to adjust. Refer to Figure 6-14.

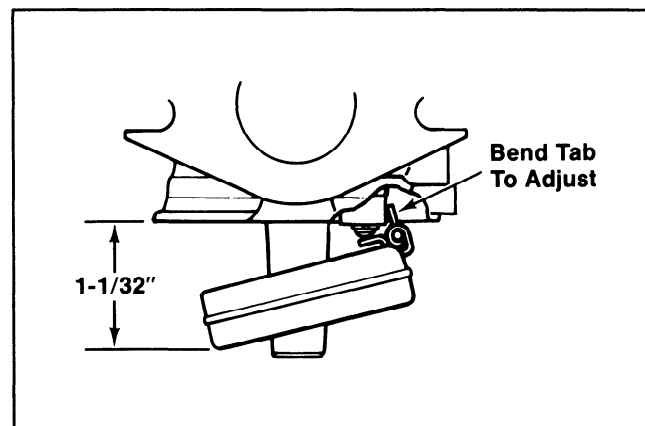

Figure 6-14. Setting Float Drop.

5. **Check float-to-float hinge tower clearance:** Invert the carburetor so the float tab rests on the fuel inlet needle. Insert a **.010"** feeler gauge between float and float hinge towers. If the feeler gauge cannot be inserted, or there is interference between the float and towers, file the towers to obtain the proper clearance. Refer to Figure 6-15.
6. Install the bowl gasket and baffle gasket. Position baffle gasket so the inner edge is against the float hinge towers.
7. Install the fuel bowl so it is centered on the baffle gasket. Make sure the baffle gasket and bowl are positioned properly to ensure a good seal.
8. Install the bowl retaining screw gasket and bowl retaining screw Torque screw to **50/60 in. lb.**

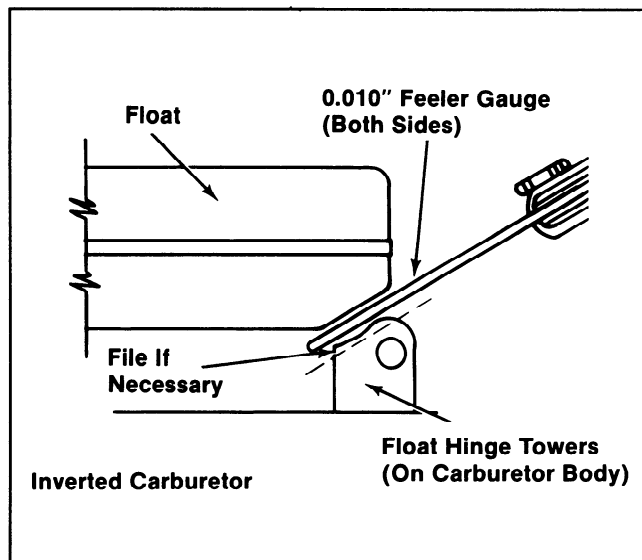

Figure 6-15. Checking Float Clearance.

9. Install the idle speed adjusting screw and spring. Install the idle fuel and main fuel adjusting needles and springs. Turn the adjusting needles clockwise until they bottom *lightly*.

NOTE: The ends of adjusting needles are tapered to critical dimensions. Damage to needles and seats will result if needles are forced.

10. Reinstall the carburetor to the engine using a new gasket.
11. Adjust the carburetor as outlined under the "Adjustment" portion of this section.

WALBRO FIXED/ADJUSTABLE CARBURETOR

This section covers the idle adjustment, disassembly, cleaning, inspection, repair, and reassembly of the Walbro-built, side draft, fixed/adjustable main jet carburetors.

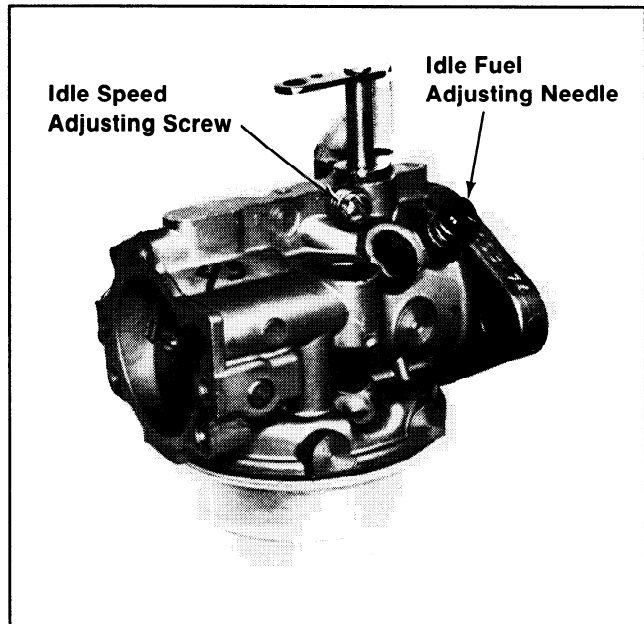

Figure 6-16. Fixed Main Jet Carburetor.



WARNING: Accidental Starts!

Before servicing the carburetor, engine, or equipment, always remove the spark plug leads to prevent the engine from starting accidentally. Ground the leads to prevent sparks that could cause fires.



WARNING: Explosive Fuel!

Gasoline may be present in the carburetor and fuel system. Gasoline is extremely flammable and its vapors can explode if ignited. Keep sparks, open flame, and other sources of ignition away from the area to prevent the possibility of fires or explosions.



WARNING: Prevent Eye Injury!

Suitable eye protection (safety glasses, goggles, or face shield) should be worn for any procedure involving the use of compressed air, punches, hammers, chisels, drills, or grinding tools.

Series Designation* Date Code* Kohler Part No.*

*NOTE: These will be on either the top (throttle lever) side of mounting flange as shown, or on the bottom (fuel bowl) side of mounting flange.

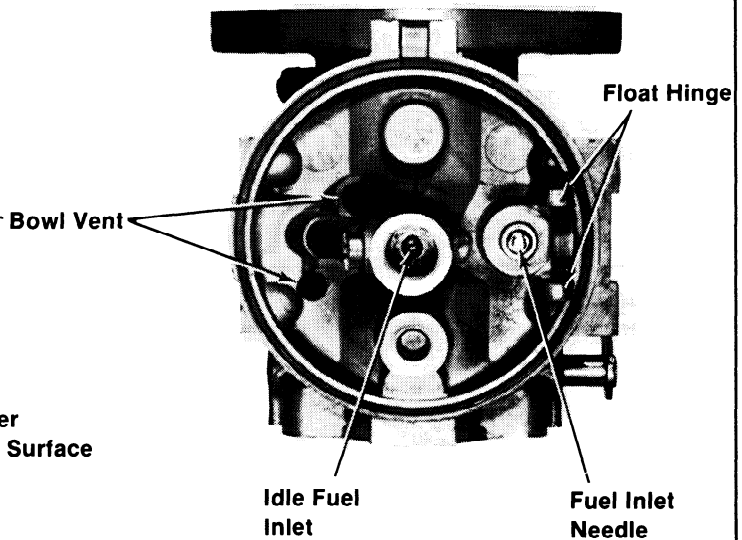
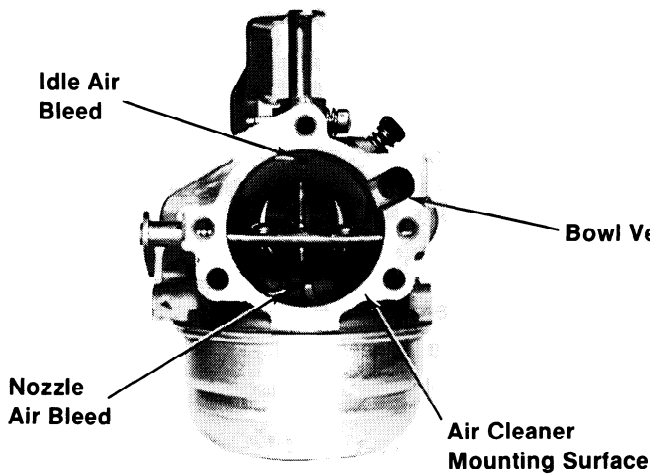
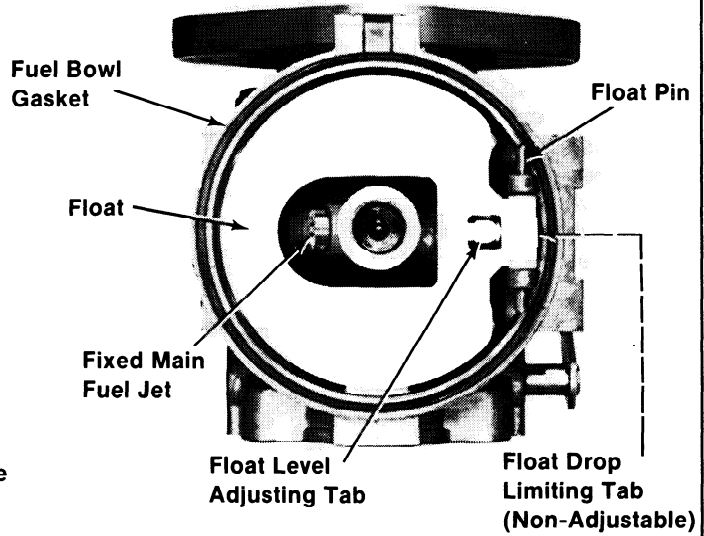
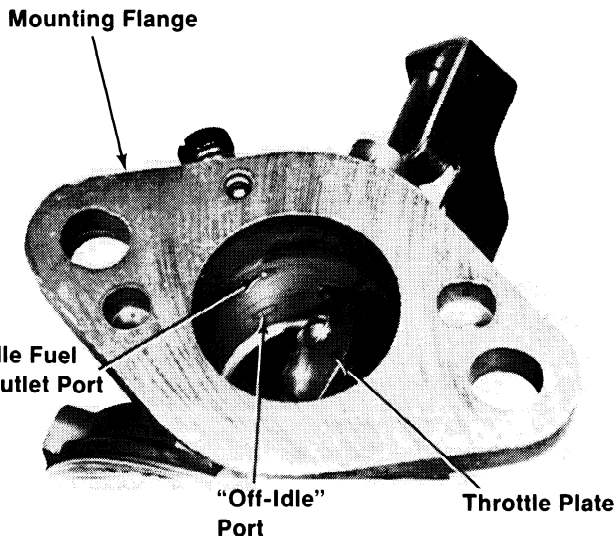
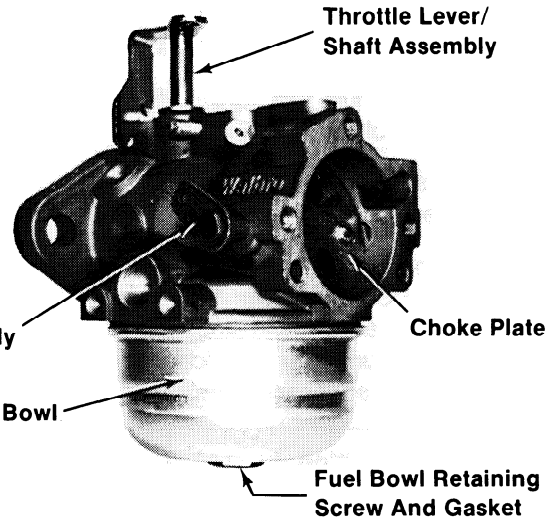
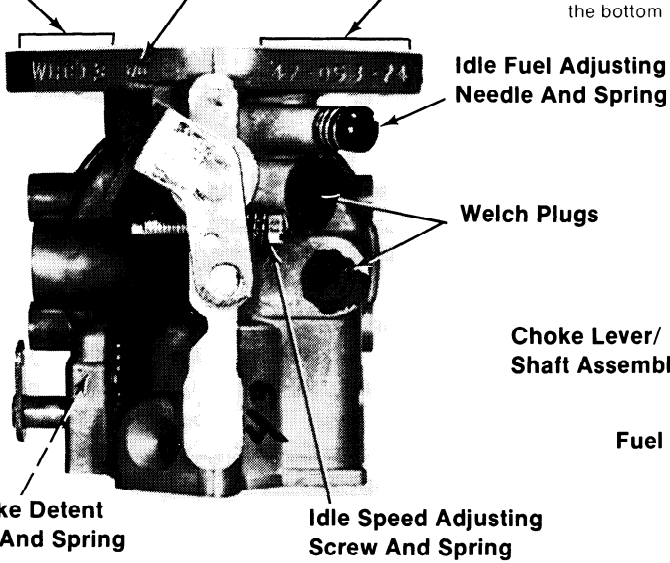

6

Figure 6-17. Major Components And Service Locations - Typical Fixed Jet Carburetor.

TROUBLESHOOTING

If engine troubles are experienced that appear to be fuel system related, check the following areas before adjusting or disassembling the carburetor.

- Make sure the fuel tank is filled with clean, fresh gasoline.
- Make sure the fuel tank cap vent is not blocked and that it is operating properly.
- Make sure fuel is reaching the carburetor. This includes checking the fuel shut-off valve, fuel tank filter screen, in-line fuel filter, fuel lines, and fuel pump for restrictions or faulty components as necessary.

- Make sure the carburetor is securely fastened to the engine using gaskets in good condition.
- Make sure the air cleaner element is clean and all air cleaner components are fastened securely.
- Make sure the ignition system, governor system, exhaust system, and throttle and choke controls are operating properly.

If, after checking the items listed above, starting problems or other conditions similar to those listed in the following table exist, it may be necessary to adjust or service the carburetor.

Condition	Possible Cause/Probable Remedy
1. Engine starts hard, or runs roughly or stalls at idle speed.	1. Idle fuel mixture or idle speed are improperly adjusted. Adjust the idle speed screw, then adjust idle fuel needle.
2. Engine runs rich. (Indicated by black, sooty exhaust smoke, misfiring, loss of speed and power, governor hunting, or excessive throttle opening.)	2a. Choke partially closed during operation. Check the choke lever and linkage to ensure choke is opening after warm-up. b. Idle fuel mixture is improperly adjusted. Adjust idle fuel needle. c. Float level set too high. With fuel bowl removed and carburetor inverted, set exposed surface of float parallel with the bowl gasket surface of carburetor body. d. Dirt under fuel inlet needle. Remove needle. Clean needle and seat and blow with compressed air. e. Bowl vent or air bleeds plugged. Remove fuel bowl, idle fuel adjusting needle, and welch plugs. Clean vent, ports, and air bleeds. Blow out all passages with compressed air. f. Fuel bowl gasket leaks. Remove fuel bowl and replace gasket. g. Leaky, cracked, or damaged float. Submerge float to check for leaks.
3. Engine runs lean. (Indicated by misfiring, loss of speed and power, governor hunting, or excessive throttle opening.)	3a. Idle fuel mixture is improperly adjusted. Adjust idle fuel needle. b. Float level set too low. With fuel bowl removed and carburetor inverted, set exposed surface of float parallel with the bowl gasket surface of carburetor body. c. Idle holes plugged; dirt in fuel delivery channels. Remove fuel bowl, idle fuel adjusting needle, main fuel jet, and welch plugs. Clean all passages and blow out with compressed air.
4. Fuel leaks from carburetor.	4a. Float level set too high. See Remedy 2c. b. Dirt under fuel inlet needle. See Remedy 2d. c. Bowl vent plugged. Remove fuel bowl and clean bowl vent. Blow out with compressed air. d. Float is cracked or damaged. Replace float. e. Bowl retaining screw gasket damaged. Replace gasket. f. Bowl retaining screw is not tightened. Torque screw to specifications.

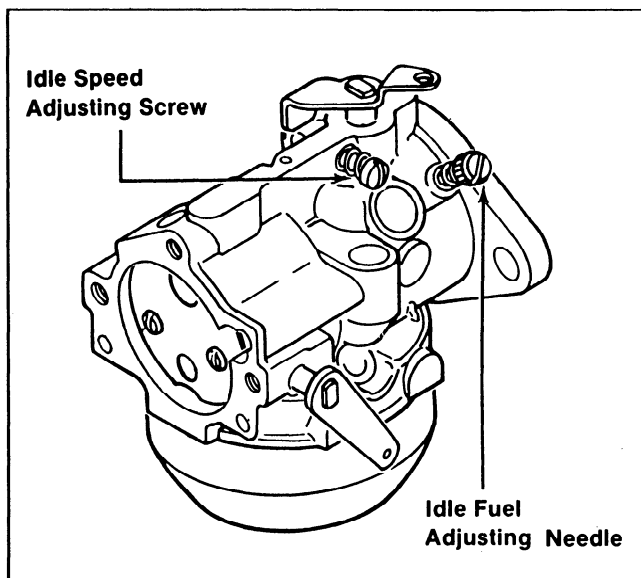

Figure 6-18. Fixed Main Jet Carburetor.

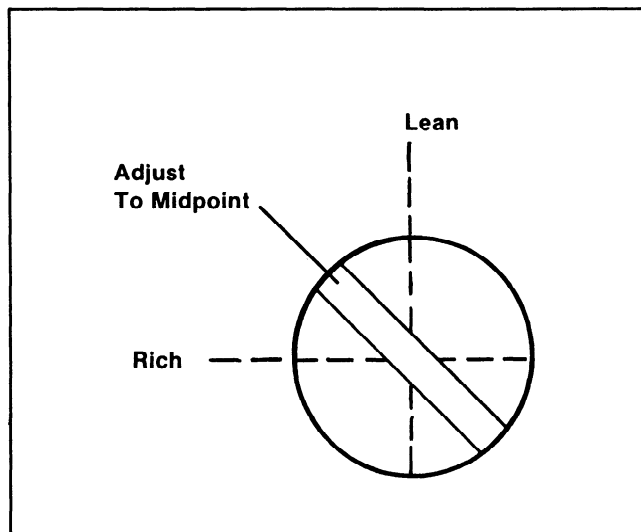

Figure 6-19. Carburetor Adjustment.

CARBURETOR ADJUSTMENT

NOTE: The tip of the low idle fuel and high idle fuel adjusting needles are tapered to critical dimensions. Damage to the needles and the seats in carburetor body will result if the needles are forced.

In general, turning the adjusting needles in (clockwise) decreases the supply of fuel to the carburetor. This gives a *leaner* fuel-to-air mixture. Turning the adjusting needles out (counterclockwise) increases the supply of fuel to the carburetor. This gives a *richer* fuel-to-air mixture. Setting the needles **midway** between the lean and rich positions will usually give the best results.

Adjust the carburetor as follows:

1. With the engine stopped, turn the low idle fuel adjusting needle in (clockwise) until it bottoms *lightly*.
2. **Preliminary Settings:** Turn the adjusting needles out (counterclockwise) from lightly bottomed according to the table shown in Figure 6-20.
3. Start the engine and run at half throttle for five to ten minutes to warm up. The engine must be warm before making final settings (Steps 4, 5, 6, and 7).
4. **High Idle Fuel Needle Setting:** *This adjustment is required only for adjustable high idle (main) jet carburetors. If the carburetor is a fixed main jet type, go to step 5.*

6

Place the throttle into the "fast" position. If possible, place the engine under load.

Turn the high idle fuel adjusting needle **out** (counterclockwise) from the preliminary setting until the engine speed decreases (rich). Note the position of the needle.

Now turn the adjusting needle **in** (clockwise). The engine speed may increase, then it will decrease as the needle is turned in (lean). Note the position of the needle.

Set the adjusting needle **midway** between the rich and lean settings. See Figure 6-21.

5. **Low Idle Speed Setting:** Place the throttle control into the "idle" or "slow" position. Set the low idle speed to **1200 rpm*** (+ or - 75 rpm) by turning the low idle speed adjusting screw **in or out**. Check the speed using a tachometer.

*NOTE: The actual low idle speed depends on the application. Refer to the equipment manufacturer's instructions for specific low idle speed settings. The recommended low idle speed for Basic Engines is 1200 rpm. To ensure best results when setting the low idle fuel needle, the low idle speed must not exceed 1500 rpm.

PRELIMINARY SETTINGS

K-SERIES MODELS

	KOHLER ADJUSTABLE JET		WALBRO FIXED JET	WALBRO ADJUSTABLE JET	
	Low Idle	High Idle	Low Idle	Low Idle	High Idle
K91	1-1/2 turns	2 turns	NOT APPL.	2 B DETERMD	2 B DETERMD
K141	1-1/2 turns	3 turns	NOT APPL.	NOT APPL.	NOT APPL.
K161*	1-1/2 turns	3 turns	NOT APPL.	2 B DETERMD	2 B DETERMD
K181*	1-1/4 turns	2 turns	2-1/2 turns	2-1/2 turns	3/4 turn
K241	2-1/2 turns	2 turns	1-1/4 turns	1-3/4 turns	1-1/8 turns
K301	2-1/2 turns	2 turns	1-1/4 turns	1-3/4 turns	1-1/8 turns
K321	2-1/2 turns	3-1/4 turns	1-1/2 turns	2 B DETERMD	2 B DETERMD
K341	2-1/2 turns	3-1/2 turns	1 turn	2 B DETERMD	2 B DETERMD
KT17	1 turn	2-1/2 turns	1-1/4 turns	1-1/4 turns	1-1/4 turns
KT19	1 turn	2-1/2 turns	1-1/4 turns	1-1/4 turns	1 turn
K582	1-1/4 turns	3 turns	NOT APPL.	2 B DETERMD	2 B DETERMD

*Includes "New Look" Models

Figure 6-20. Preliminary Low Idle And High Idle Fuel Needle Settings.

6. **Low Idle Fuel Needle Setting:** Place the throttle into the "idle" or "slow" position.

Turn the low idle fuel adjusting needle **out** (counterclockwise) from the preliminary setting until the engine speed decreases (**rich**). Note the position of the needle.

Now turn the adjusting needle **in** (clockwise). The engine speed may increase, then it will decrease as the needle is turned in (**lean**). Note the position of the needle.

Set the adjusting needle midway between the rich and lean settings. See Figure 6-21.

7. Recheck the low idle speed using a tachometer. Readjust the speed as necessary.

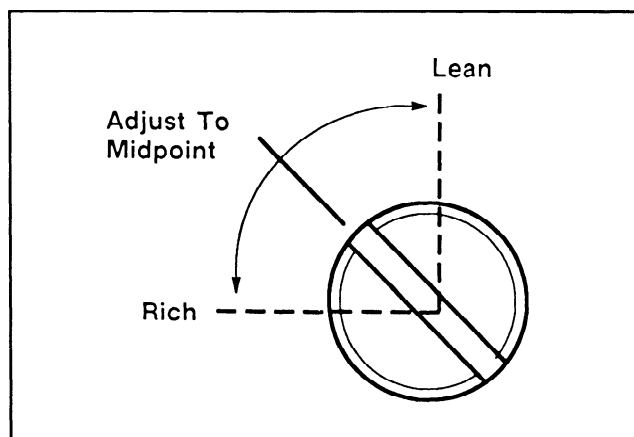

Figure 6-21. Optimum Low Idle Fuel Setting.

DISASSEMBLY

Refer To Figures 6-17 and 6-22.

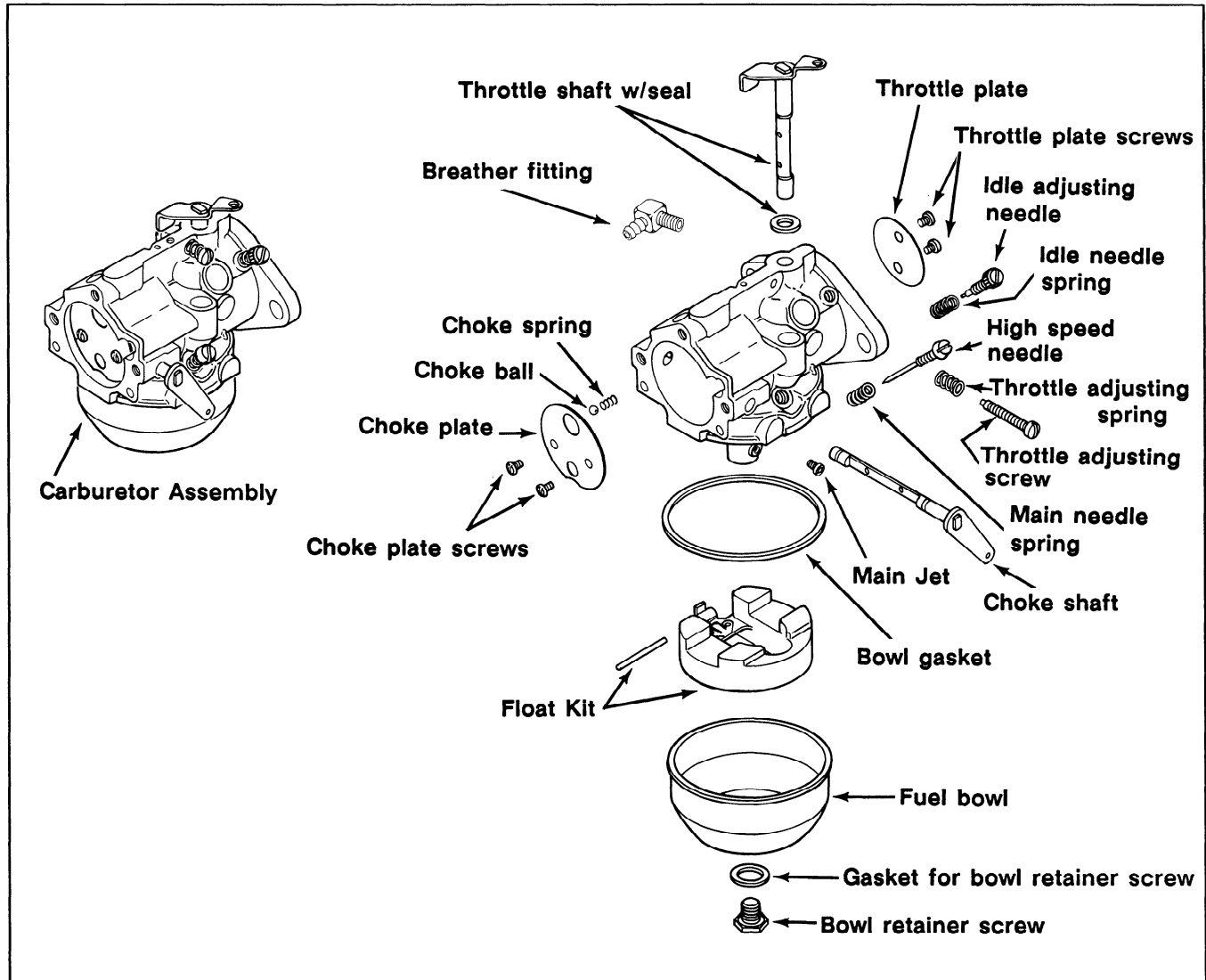

Figure 6-22. Walbro Fixed/Adjustable Jet Carburetor - Exploded View

1. Remove the bowl retaining screw, retaining screw gasket, and fuel bowl.
 2. Remove the bowl gasket, float pin, float, and fuel inlet needle.
- CAUTION:** To prevent damage to the carburetor, do not attempt to remove the fuel inlet seat as it is not serviceable. Replace the carburetor if the fuel inlet seat is damaged.
3. Remove the idle fuel adjusting needle and spring. Remove the idle speed adjusting screw and spring.
 4. Remove the main fuel jet.
 5. In order to clean the "off-idle" ports and the bowl vent channel thoroughly, the welch plugs covering these areas must be removed. Use

tool No. KO1018 and the following procedure to remove the welch plugs. Refer to Figure 6-23.

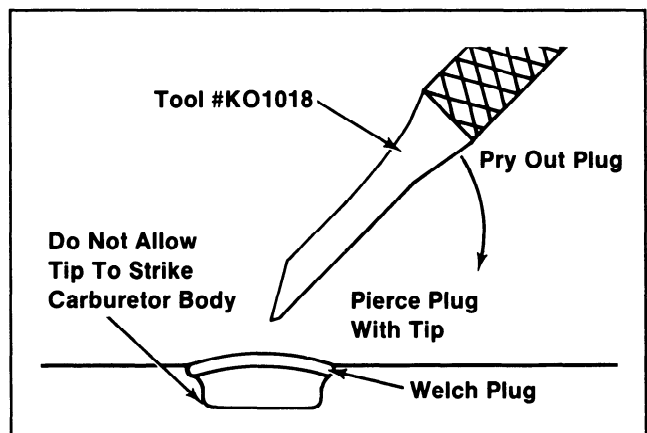

Figure 6-23. Removing Welch Plugs.

A. Pierce the welch plug with the tip of the tool.

CAUTION: To prevent damage to the carburetor, do not allow the tool to strike the carburetor body.

B. Pry out the welch plug using the tool.

Throttle And Choke Shaft Removal

Further disassembly to remove the throttle shaft and choke shaft is recommended only if these parts are to be cleaned or replaced.

Throttle Shaft Removal

1. Because the edges of throttle plate are beveled, mark the throttle plate and carburetor body with a marking pen to ensure correct reassembly (refer to Figure 6-24). Also take note of the throttle plate position in bore, and the position of the throttle lever.

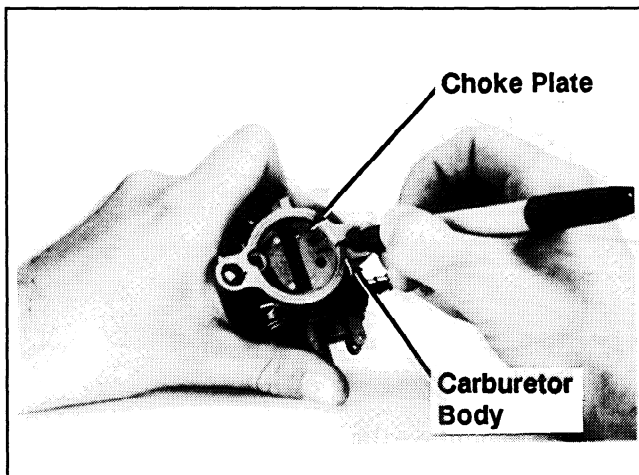

Figure 6-24. Marking Throttle Plate And Carburetor Body.

2. Carefully and slowly remove the screws securing the throttle plate to throttle shaft. Remove the throttle plate.
3. File off any burrs which may have been left on the throttle shaft when the screws were removed. Do this **before** removing the throttle shaft from carburetor body.
4. Remove the throttle lever/shaft assembly with foam dust seal from carburetor body.

Choke Shaft Removal

1. Because the edges of choke plate are beveled, mark the choke plate and carburetor body with a marking pen to ensure correct

reassembly (refer to Figure 6-25). Also take note of the choke plate position in bore, and the position of the choke lever.

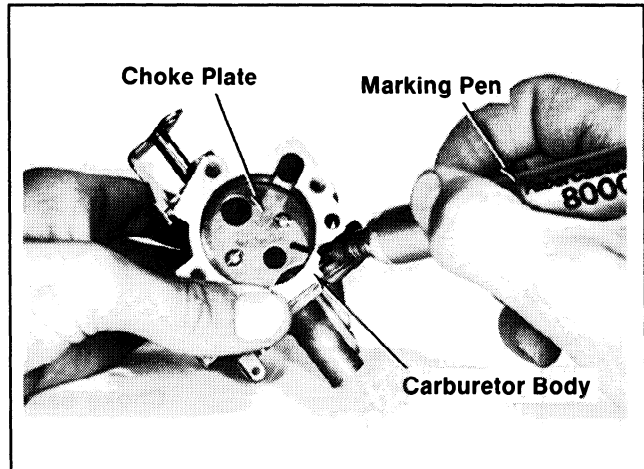

Figure 6-25. Marking Choke Plate And Carburetor Body.

2. Carefully and slowly remove the screws securing the choke plate to choke shaft. Remove the choke plate.
3. File off any burrs which may have been left on the choke shaft when the screws were removed. Do this **before** removing the choke shaft from carburetor body.
4. Rotate the choke shaft until the cutout portion of shaft is facing the air cleaner mounting surface (refer to Figure 6-26). Place the carburetor body on work bench with choke side down. Remove the choke lever/shaft assembly from carburetor body; the detent ball and spring will drop out.

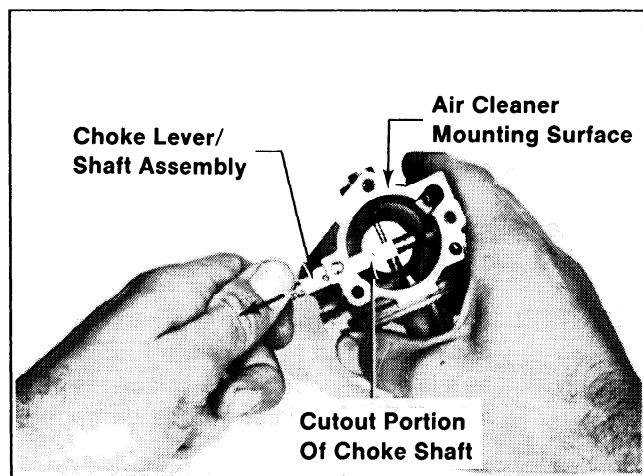

Figure 6-26. Removing Choke Lever/Shaft.

CLEANING



WARNING: Flammable Solvents!

Carburetor cleaners and solvents are extremely flammable. Keep sparks, flames and other sources of ignition away from the area. Follow the cleaner manufacturer's warnings and instructions on its proper and safe use. Never use gasoline as a cleaning agent.

All parts should be carefully cleaned using a carburetor cleaner (such as acetone). Be sure all gum deposits are removed from the following areas:

- **Carburetor body and bore;** especially the areas where the throttle plate, choke plate, and shafts are seated.
- **Idle fuel and "off-idle" ports in carburetor bore, main jet, bowl vent, and fuel inlet seat.**

NOTE: These areas can be cleaned using a piece of fine wire in addition to cleaners. Be careful not to enlarge the ports, or break the cleaning wire within ports. Blow out all passages with compressed air.

- **Float and float hinge.**
- **Fuel Bowl.**
- **Throttle plate, choke plate, throttle shaft, and choke shaft.**

CAUTION: Do not submerge the carburetor in cleaner or solvents when fiber, rubber, or foam seals or gaskets, or the fuel inlet needle are installed. The cleaner may damage these parts.

INSPECTION

Carefully inspect all components and replace those that are worn or damaged.

- Inspect the carburetor body for cracks, holes, and other wear or damage.
- Inspect the float for cracks or holes. Check the float hinge for wear, and missing or damaged float tabs.
- Inspect the fuel inlet needle for wear or grooves.
- Inspect the tip of the idle fuel adjusting needle for wear or grooves.
- Inspect the throttle and choke shaft and plate assemblies for wear or excessive play.

REPAIR

Always use new gaskets when servicing and reinstalling carburetors. Repair kits are available which include new gaskets and other components. These kits are described below.

Components such as the throttle and choke shaft assemblies, throttle plate, choke plate, idle fuel needle, main jet, and others, are available separately.

Refer to the appropriate Parts Manual to ensure the correct carburetor repair kits and replacement parts are ordered.

REASSEMBLY

Throttle Shaft Installation

1. Install the foam dust seal on throttle shaft. Insert the throttle lever/shaft assembly into carburetor body with the cutout portion of shaft facing the carburetor mounting flange.
2. Install the throttle plate to throttle shaft. Make sure the plate is positioned properly in bore as marked and noted during disassembly (the numbers stamped on plate should face the carburetor mounting flange). Apply Loctite® #609 to threads of 2 plate retaining screws. Install screws so they are slightly loose.
3. Apply finger pressure to the throttle lever/shaft to keep it firmly seated against pivot in carburetor body. Rotate the throttle shaft until the throttle plate fully closes the bore around its entire perimeter; then tighten screws. Refer to Figure 6-27.

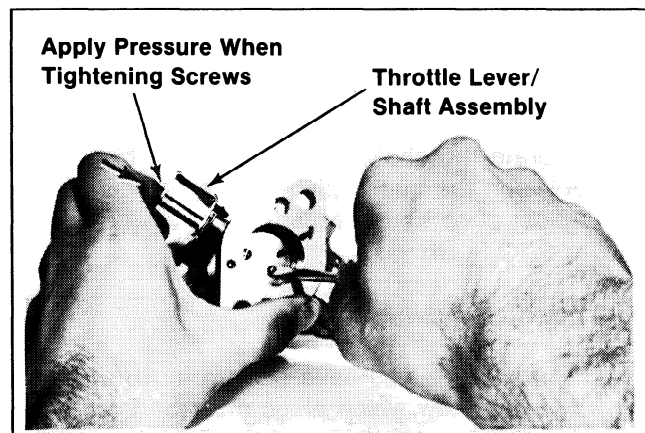

Figure 6-27. Installing Throttle Lever/Shaft.

4. Operate the throttle lever; check for binding between the throttle plate and carburetor bore. Loosen screws and adjust throttle plate as necessary; then torque screws to $\frac{8}{12}$ in. lb.

Choke Shaft Installation

1. Install the detent spring and ball into the carburetor body.

CAUTION: If the detent ball does not drop through the tapped air cleaner base screw hole by its own weight, do not force it. Forcing the ball could permanently lodge it in the hole.

Install the ball through the choke shaft bore instead.

2. Compress the detent ball and spring. Insert the choke lever/shaft assembly into carburetor body with the cutout portion of shaft facing the air cleaner mounting surface (refer to Figure 6-28). Make sure the choke lever is on the correct side of carburetor body.

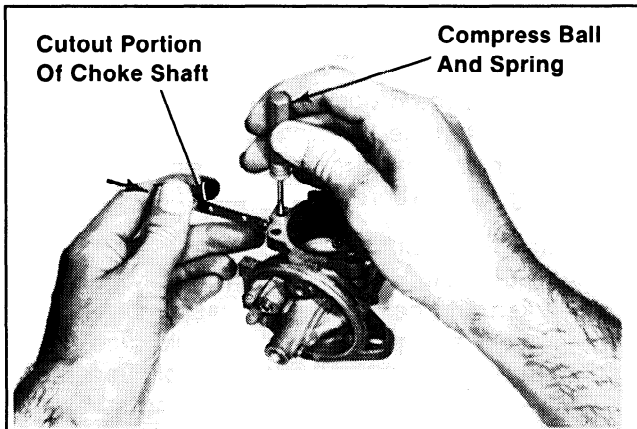

Figure 6-28. Installing Choke Lever/Shaft.

3. Install the choke plate to choke shaft. Make sure the plate is positioned properly in bore as marked and noted during disassembly. (The numbers stamped on plate should face the air cleaner mounting surface and be upright.) Apply Loctite® #609 to threads of 2 plate retaining screws. Install the screws so they are slightly loose.
4. Operate the choke lever; check for binding between the choke plate and carburetor bore. Adjust plate as necessary; then torque screws to 8/12 in. lb.

Carburetor Reassembly

1. If the welch plugs have been removed for cleaning, new welch plugs must be installed. Use tool No. KO1017 and the following procedure to install the welch plugs.
 - A. Position the carburetor body securely with the welch plug cavities to the top.
 - B. Place a new welch plug into the cavity with the raised portion up. Use the end of the tool that is about the same size as plug and **flatten** the plug. Do not force the plug below the top surface. Refer to Figure 6-29.

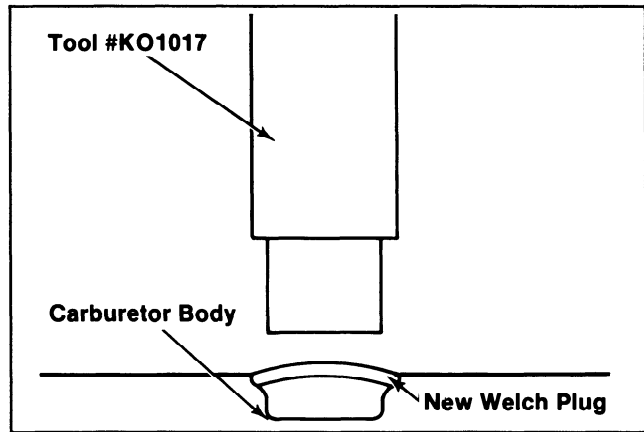

Figure 6-29. Installing Welch Plugs.

- C. After welch plugs are installed, seal the exposed surface with glyptal (or an equivalent sealant). Allow the sealant to dry.

NOTE: If a commercial sealant is not available, fingernail polish can be used.

2. Install the main fuel jet.
3. Install fuel inlet needle into inlet seat. Install float and slide float pin through float hinge and float hinge towers on carburetor body.
4. **Set Float Level:** Invert the carburetor so the float tab rests on the fuel inlet needle. The exposed surface of float should be **parallel** with the bowl gasket surface of the carburetor body (exposed, free end of float .690"/.720" from bowl gasket surface). Refer to Figure 6-30.

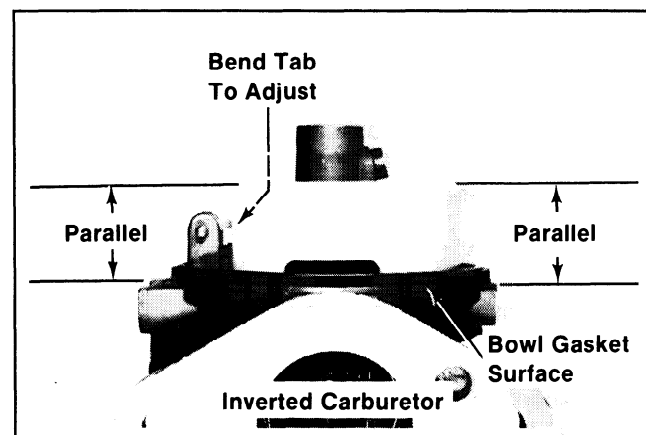

Figure 6-30. Setting Float Level.

Bend the float tab with a small screw driver to adjust.

5. Install a new bowl gasket and the fuel bowl. Make sure the bowl gasket and bowl are centered and positioned properly to ensure a good seal.
6. Install a new bowl retaining screw gasket and the bowl retaining screw. Torque screw to 45/55 in. lb.

7. Install the idle speed adjusting screw and spring.
8. Install the idle fuel adjusting needle and spring. Turn the adjusting needle **in** (clockwise) until it bottoms **lightly**.

CAUTION: The tip of the idle fuel adjusting needle is tapered to critical dimensions. Damage to the needle and the seat in carburetor body will result if the needle is forced.

9. Turn the idle fuel needle **out** (counterclockwise) from lightly bottomed according to the instructions in the "Adjustment" section of this Bulletin.

HIGH ALTITUDE OPERATION (FIXED JET)

When operating the engine at high altitudes the main fuel mixture tends to get overrich. An overrich mixture can cause conditions such as black, sooty exhaust smoke, misfiring, loss of speed and power, poor fuel economy, and poor or slow governor response.

To compensate for this, a special high altitude main fuel jet is available for each carburetor. The high altitude main fuel jet is sold in a kit which includes the jet and necessary gaskets.

High Altitude Jet Installation (Fixed Jet)

1. Remove the fuel bowl retaining screw, retaining screw gasket, fuel bowl, and bowl gasket.

NOTE: If necessary, remove the air cleaner and carburetor from engine to make fuel bowl removal easier.

2. Remove the float pin, float, and fuel inlet needle.
3. Remove the existing main fuel jet.

4. Install the new high altitude main fuel jet and torque to **12/16 in. lb.**
5. Reinstall the fuel inlet needle, float, and float pin.
6. Install the new bowl gasket from kit and the fuel bowl. Make sure the bowl gasket and bowl are centered and positioned properly to ensure a good seal.
7. Install the new bowl retaining screw gasket from kit and the bowl retaining screw. Torque screw to **45/55 in. lb.**
8. Reinstall the carburetor and air cleaner to engine as necessary using the new gaskets from kit.

IDLE ADJUSTMENT PROCEDURE FOR K341AQS ENGINES WITH ANTI-DIESELING SOLENOID

The idle speed of some vibro-mounted K341AQS engines has been increased to allow smoother operation at low idle and an anti-dieseling solenoid has been added to prevent dieseling during shutdown at the higher idle speed. If called upon to adjust the idle on any K341AQS engine with this solenoid, use the following procedure. Refer to Figure 6-31.

STEP 1 – IDLE FUEL MIXTURE ADJUSTMENT: With engine stopped, turn the idle fuel adjusting screw all the way in (clockwise) until it bottoms lightly then back out 1/2 turn.

STEP 2 – IDLE SPEED ADJUSTMENT: Start engine and check idle speed with a hand tachometer. Idle, no load, speed should be 2100 RPM. To set the idle speed, loosen the jam nut on the anti-dieseling solenoid and turn the solenoid in or out until 2100 RPM idle speed is attained – retighten jam nut to lock solenoid in position.

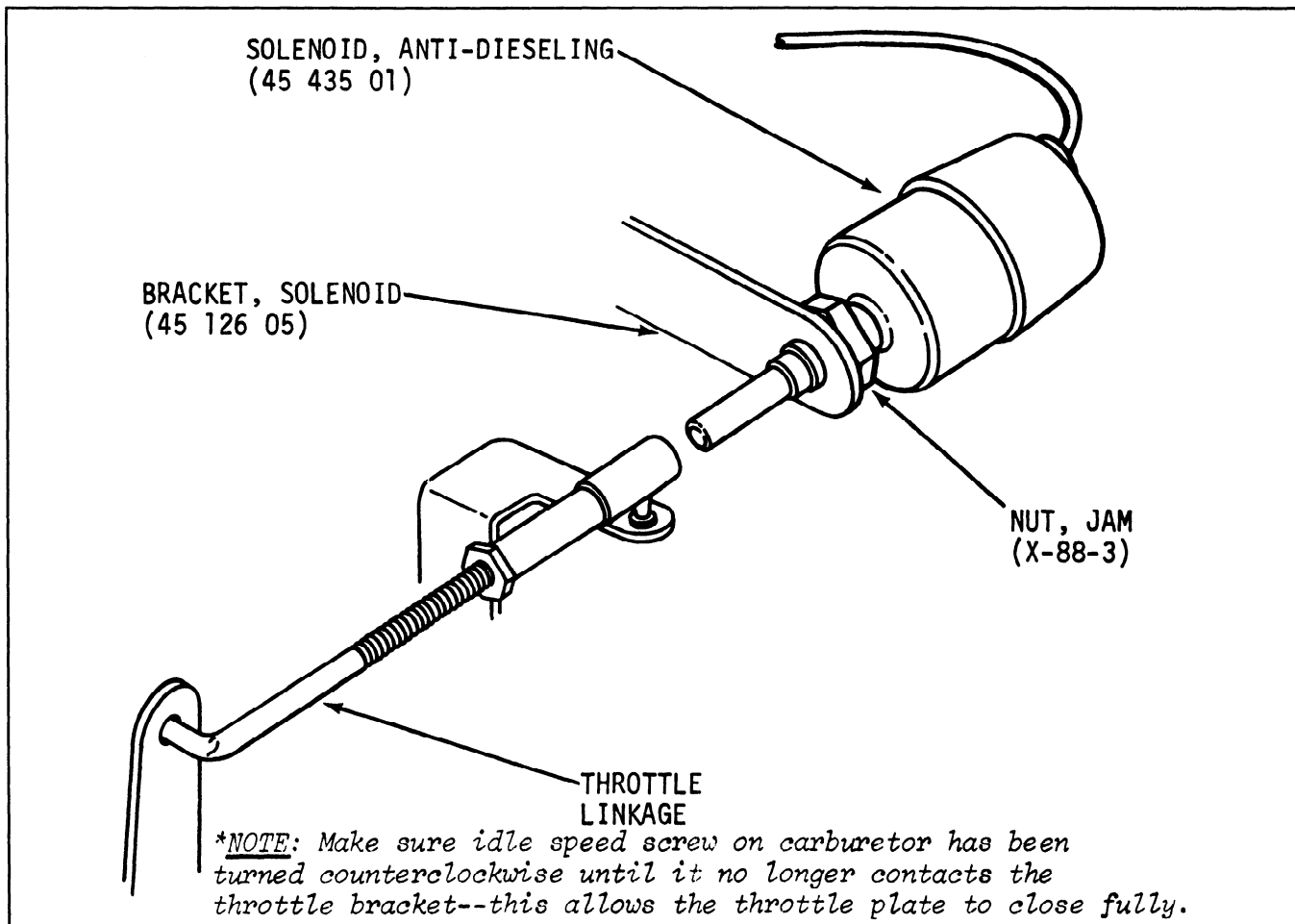

Figure 6-31. Anti-Dieseling Solenoid.

Automatic Chokes

Thermostatic Type

The automatic choke is a heat sensitive thermostatic unit. At room temperature, choke lever will be set in a vertical position. If engine should fail to start when cranked, adjust choke lever by hand to determine if choke setting is too lean or too rich. Once this has been established, adjustment can be made to remedy situation.

Adjustment

1. Loosen adjustment lock screw on choke body. This allows the position of adjustment to be changed.
2. Moving adjustment bracket downward will increase the amount of choking. Upward movement will result in less choking.
3. After adjustment is made, tighten adjustment lock screw.

Electric-Thermostatic Type

Remove air cleaner from carburetor to observe position of choke plate. Choke adjustment must be

made on cold engine. If starting in extreme cold, choke should be in full closed position before engine is started. A lesser degree of choking is needed in milder temperatures.

Adjustment

1. Move choke arm until hole in brass shaft lines up with slot in bearings.
2. Insert #43 drill (.089) and push all the way down to engine manifold to engage in notch in base of choke unit.
3. Loosen clamp bolt choke lever, push arm upward to move choke plate toward closed position. After desired position is attained, tighten clamp bolt then remove drill.
4. After replacing air cleaner, check for evidence of binding in linkage, adjust as needed. Be sure chokes are fully open when engine is at normal operating temperature.

THERMO-ELECTRIC AUTOMATIC CHOKES

Service

Before working on or near the carburetor or choke area take these PRECAUTIONS:

1. Do not operate engine without air cleaner as injury may result.
2. When checking choke operation, during crank-

ing, always remove spark plug lead to prevent engine from starting and to avoid personal injury. Refer to Figure 6-32.

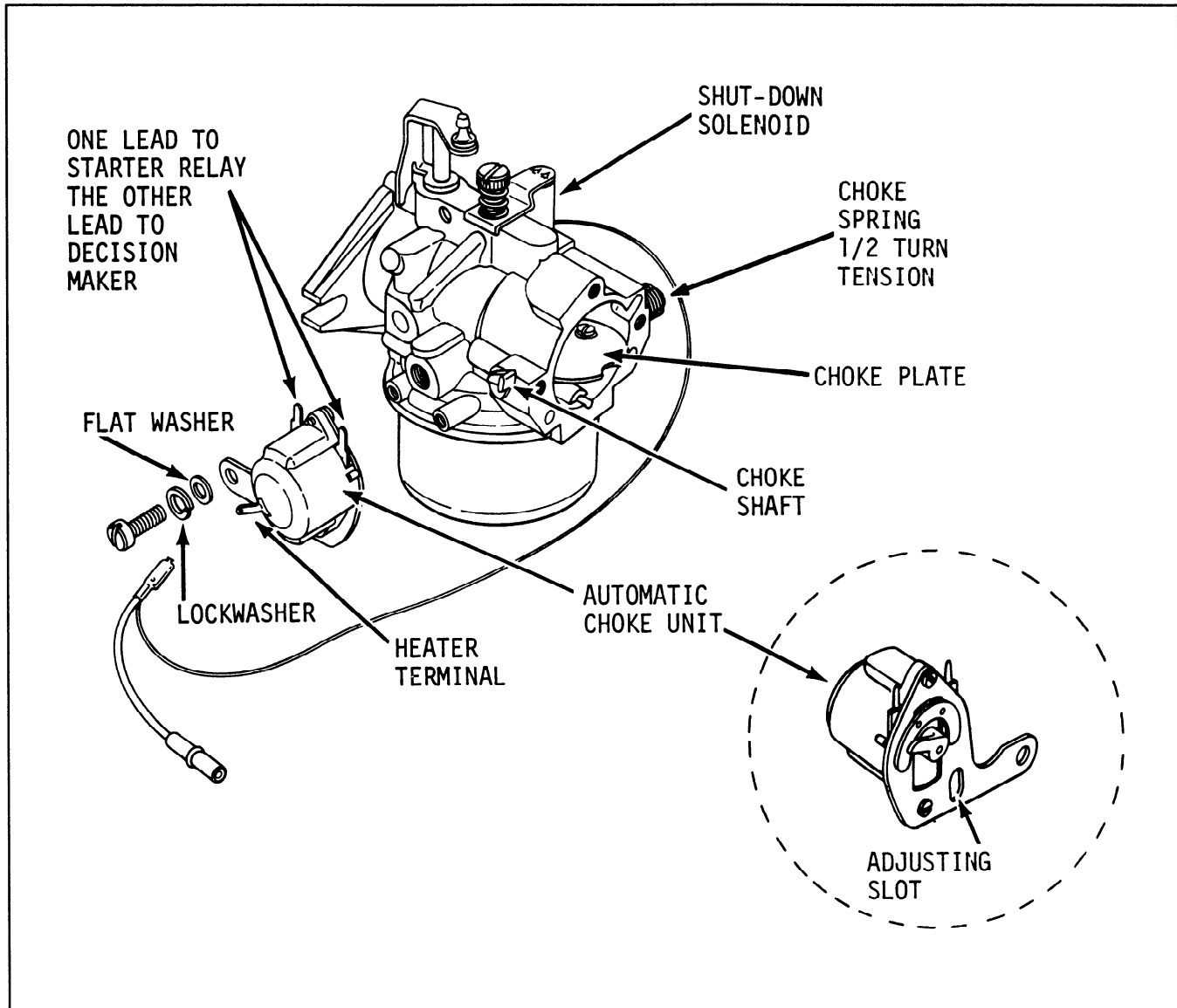

6

Figure 6-32. Thermo-Electric Automatic Choke.

Troubleshooting

Before proceeding with analysis of choke problems, check resistance of heater terminal using an

ohmmeter. Resistance should be 3 ohms or more. If resistance is less than 3 ohms, replace the choke.

PROBLEM	CAUSES	SOLUTIONS
Choke will not fully open.	<ol style="list-style-type: none"> 1. Choke spring not properly adjusted. 2. Choke shaft fails to move freely. 3. Faulty choke adjustment. 	<ol style="list-style-type: none"> 1. Remove spring retainer and with choke wide open windup spring 1/2 turn. 2. Install new shaft assembly repair kit. 3. Adjust choke.*
Choke shaft breaks or plate comes out.	<ol style="list-style-type: none"> 1. Incorrect ignition timing. 2. Too much compression. 	<ol style="list-style-type: none"> 1. Time engine as specified and install new shaft assembly repair kit. 2. Adjust ACR to specification and install new shaft assembly repair kit.
Choke won't close when cranking.	<ol style="list-style-type: none"> 1. Faulty lead wires or terminals. 2. Air cleaner gasket interference with choke shaft lever (4.5 KW only). 3. Open circuit in solenoid wiring. 4. Faulty Decision Maker or ground in Decision Maker. 5. Choke lever lacks sufficient travel or smooth movement. 	<ol style="list-style-type: none"> 1. Change lead wires or replace choke.* 2. Reposition flat of gasket to provide clearance for choke shaft lever. 3. Check continuity with ohmmeter between the two solenoid terminals on the choke unit. Replace choke if open circuit. 4. Replace lead to Decision Maker with a jumper wire to ground. If choke functions properly, replace Decision Maker. 5. Manually move the choke lever until the choke plate is fully closed. Replace the choke unit if it does not move freely.*

*Choke Replacement And Adjustment

1. Position the choke unit on the two mounting screws so that it is slightly loose.
2. Hold the choke plate in the wide open position.
3. Rotate the choke unit clockwise on the carburetor (viewed from the choke side) with a slight pressure until it can no longer be rotated.
4. While holding the choke unit in the above position, tighten the two mounting screws.

NOTE: With engine not running and before any cranking, the choke plate will be closed 5° to 10° at a temperature of about 75° F. As the tempera-

ture decreases the choke plate will close even more.

5. Check choke function by removing the spark plug lead and cranking the engine. The choke plate should close a minimum of 45° at temperatures above 75° F. The plate will close more at lower temperatures.

NOTE: During cranking, the choke will remain closed only 5 to 10 seconds, as choke closing time is controlled by the Decision Maker.

Choke Shaft Spring Adjustment

1. To adjust the choke spring, hold the plate in the wide open position. Windup the spring 1/2 turn and then place the straight end of the spring through the hole in the shaft.

GAS FUEL SYSTEM

The main components of the gas fuel system as used with Kohler K series engines are:

Liquified petroleum gas tank

Primary regulator

Secondary regulator

Gas Carburetor

In some applications, the primary and secondary regulators are combined in one two-stage unit. The gas carburetor and secondary regulator (or two stage regulator) are normally furnished with the engine. Other components are furnished by the fuel supplier.

There are some isolated instances in which the equipment manufacturer supplies the entire fuel system for operation with gas. Information on servicing these systems must be obtained from the equipment manufacturer.

Depending on the air temperature and the mixture of gasses in the tank, pressure at the outlet of the tank can be as high as 180 to 200 psi. Refer to Figure 6-33.

Secondary Regulator

The secondary regulators used on Kohler engines are compact single diaphragm types. This type regulator accurately regulates the flow of gas to the carburetor and shuts the gas off automatically when the demand for gas ceases. If the regulator fails, it must be replaced or reconditioned by an authorized gas equipment repair shop. *Do not attempt to repair a faulty regulator.*

Secondary regulators used on Kohler engines require only one adjustment. Ensign Models F or F1 regulators have an idle adjustment. This adjustment should be performed while the engine is running. Refer to Figure 6-34.

Garretson Model S, SD and KN regulators have a lockoff or fuel control adjustment. Use the following procedure to make this adjustment. Refer to Figures 6-35 and 6-36.

NOTE: The regulator should be mounted as close to vertical as possible, and adjusted in the position in which it will be mounted on the engine.

1. Connect regulator inlet to a source of clean compressed air, not over 10 psi. Do not connect to a gas supply.
2. Turn air supply on.
3. If the regulator being adjusted is a Model KN, open the lock off adjusting screw until air just starts flowing through the regulator.

4. Turn the lock off adjusting screw in slowly until air flow stops.

NOTE: A soap bubble test is a good way to check for complete shutoff. If bubbles indicate that air is still flowing, turn the screw in one more full turn.

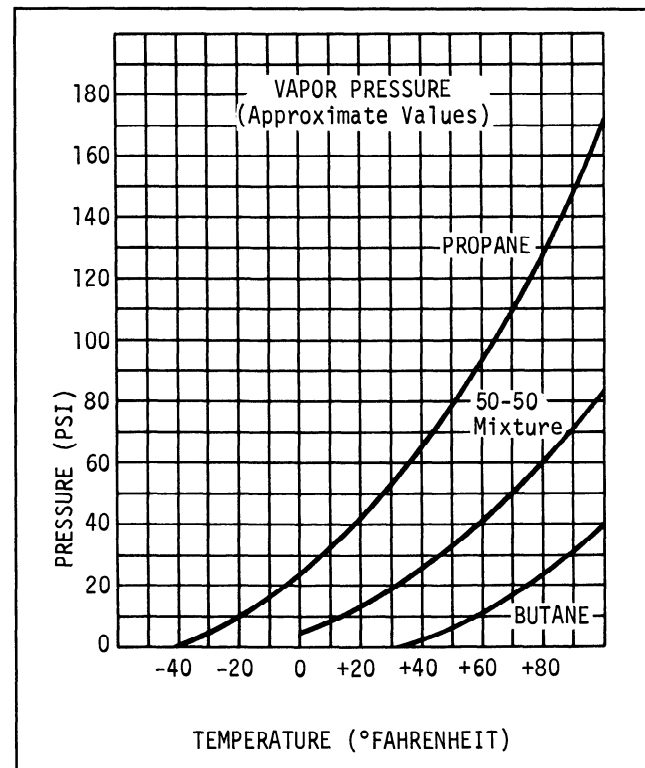

Figure 6-33. LP Gas Vapor Pressure Curve.

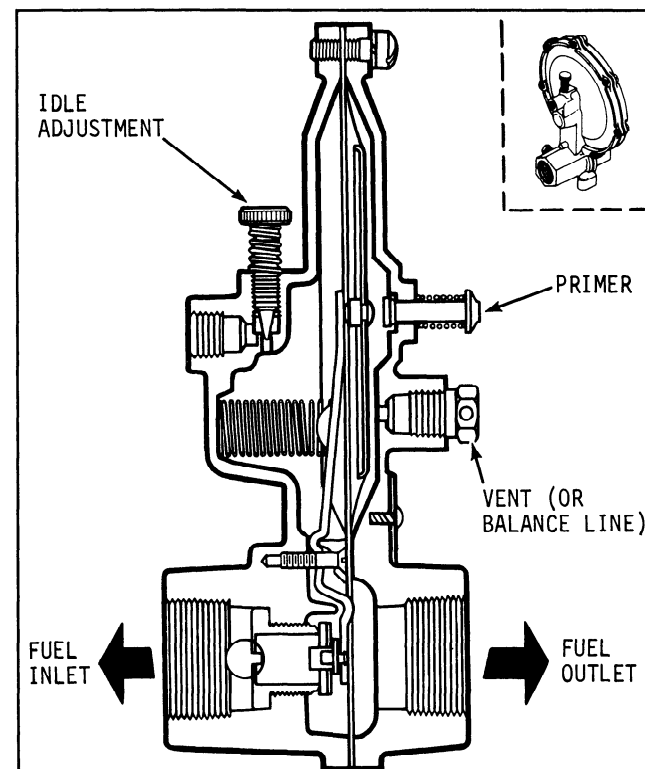

Figure 6-34. Model F and F1 Secondary Regulators.

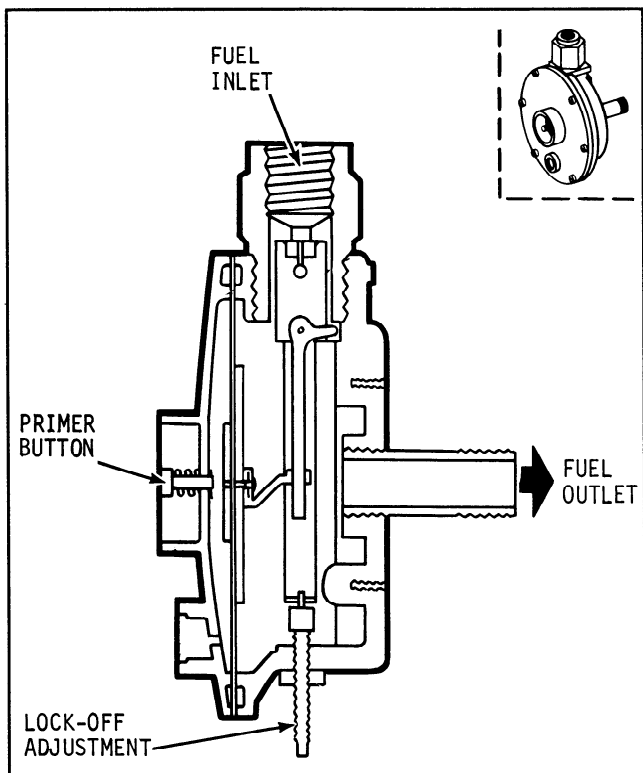

Figure 6-35. Models S and SD Secondary Regulators.

NOTE: The lock off adjusting screw may be used to adjust fuel flow while the engine is idling. Never adjust at any speed above idle.

5. If the regulator being adjusted is a Model S or SD, depress the primer button for an instant. This will allow air to flow through the regulator.

6. Check that air flow stops when the primer is released.
7. If air flow does not stop completely, loosen the adjustment screw lock nut and turn the adjustment screw in until air flow stops, then one more full turn.
8. Repeat steps 5 through 7 until air flow stops every time.
9. Tighten adjustment screw lock nut.

Primary Regulator

The primary regulator provides initial control of the fuel under pressure as it comes from the fuel supply tank. The inlet pressure for primary regulators should never exceed 250 psi. The primary regulator is adjusted for outlet pressure of approximately 6 ounces per square inch (11" W.C.). If the regulator does not function properly, replace it or have it serviced by an authorized gas equipment shop. *Never attempt to service a faulty primary regulator.*

Upon demand for fuel, pressure drops on the outlet side of the regulator diaphragm. The gas inlet valve then begins to open, allowing fuel to pass through the regulator to the secondary regulator. As the need for more fuel increases, the fuel inlet valve opens further, allowing more fuel to pass. Refer to Figure 6-37.

Pressure may be adjusted by removing the bonnet cap and turning the spring tension adjustment with a large screwdriver. Turning clockwise increases the pressure; turning counterclockwise decreases it.

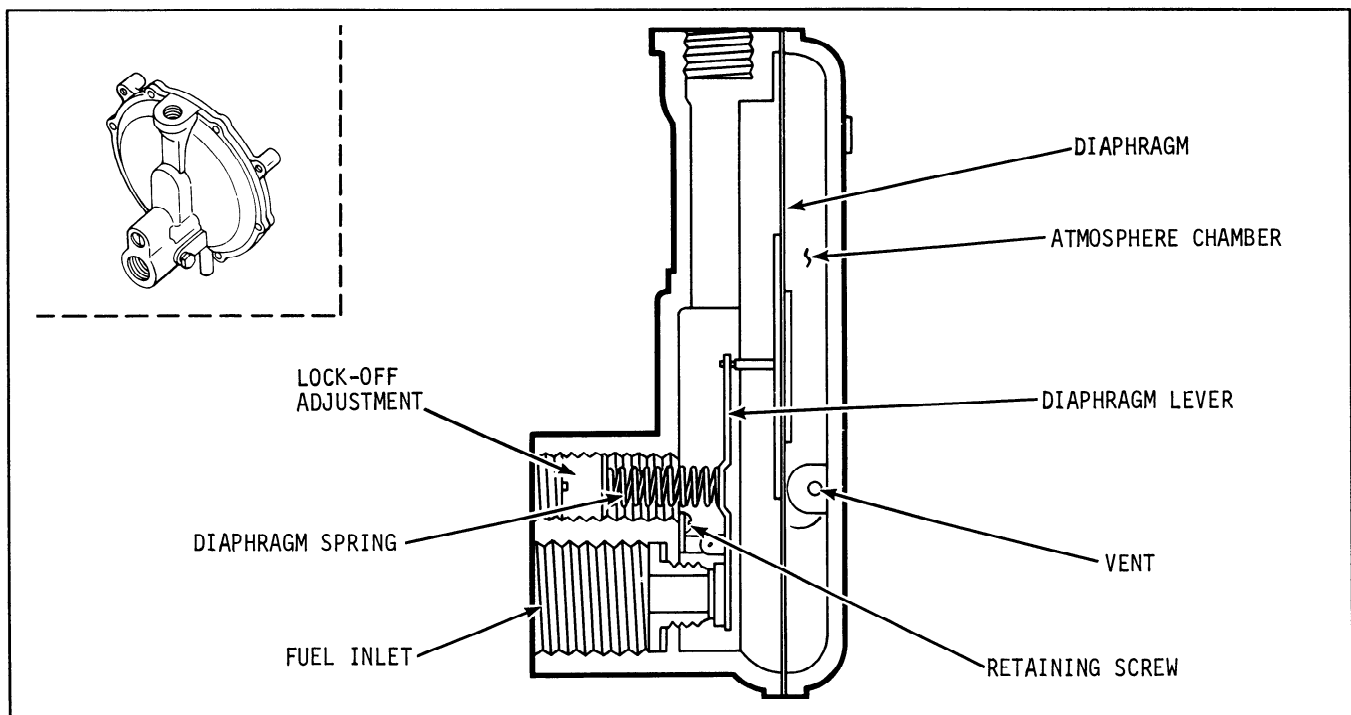

Figure 6-36. Model KN Secondary Regulator.

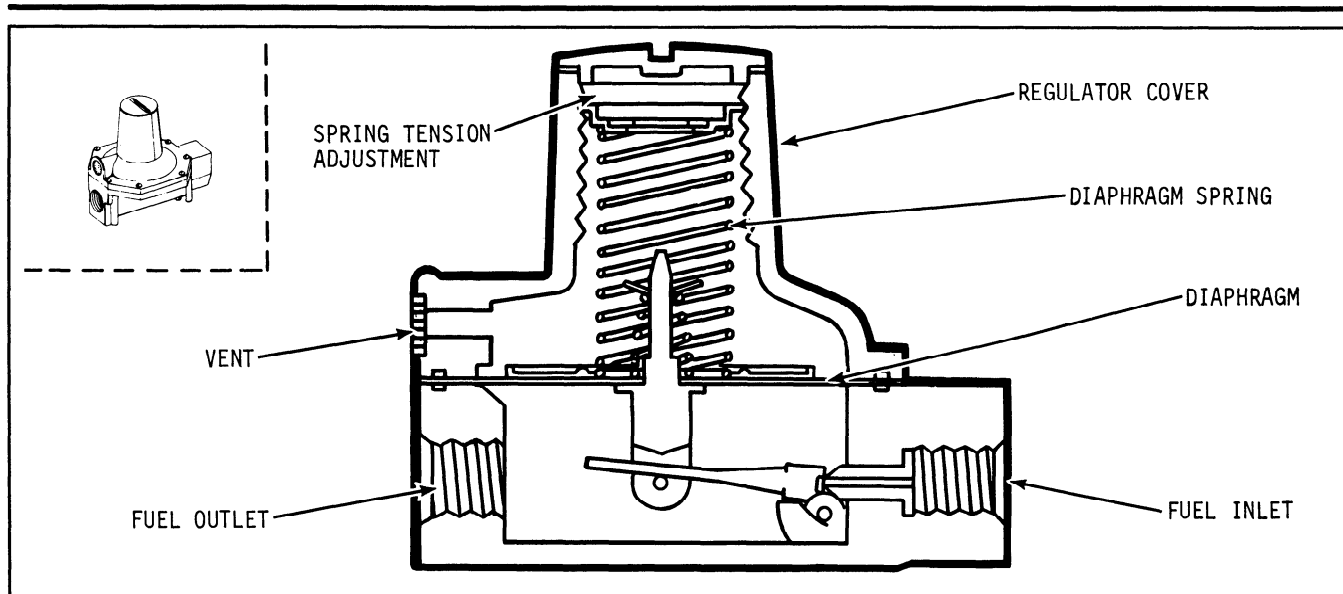

Figure 6-37. Typical Primary Regulator.

Two Stage Regulator

The two stage regulator used on Kohler engines is a double diaphragm type regulator designed for use with air-cooled engines. It combines primary and secondary regulation in one unit. The regulator fuel inlet is connected to the fuel tank. Its outlet is connected to the carburetor. If the regulator fails to operate properly, replace it or have it serviced by an authorized gas equipment shop. *Never attempt to service a faulty regulator.*

Vaporized fuel is admitted to the regulator at fuel tank pressure (up to 250 psi). Because the secondary valve is closed (engine not running), the pressure on the internal side of the primary diaphragm builds up until the pressure overcomes the spring action on the opposite side of the diaphragm. This primary diaphragm spring has suffi-

cient tension to require approximately 10 psi pressure on the internal side of the diaphragm to counteract the opening force due to the spring. When the pressure reaches this level, the valve is closed, preventing further pressure rise.

The secondary diaphragm acts against the secondary valve spring. Its action results from vacuum caused by the carburetor. As the vacuum begins acting on the diaphragm, the diaphragm is moved nearer to the center of the regulator, opening the secondary valve until equilibrium is reached. As more fuel is needed, vacuum from the carburetor increases, causing the secondary valve to open further. When fuel is flowing, pressure on the primary diaphragm is lowered slightly, permitting the spring to open the primary valve in an attempt to bring the pressure back to 10 psi. Refer to Figure 6-38.

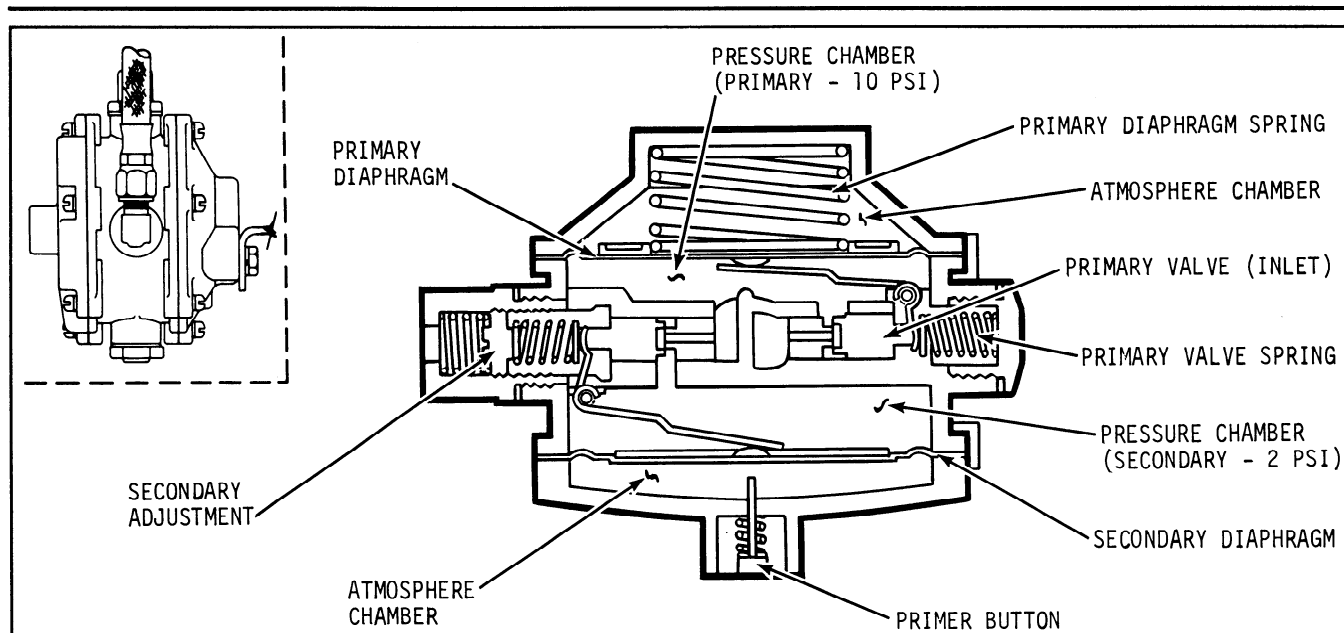

Figure 6-38. Two Stage Regulator.

Adjust the two stage regulator as follows.

1. Turn the secondary adjustment counterclockwise as far as it will go. Then turn it clockwise 3 turns.
2. Connect a source of clean compressed air of at least 25 psi to the regulator inlet and depress primer button 3 times.
3. Connect a 0 to 15 psi pressure gauge to the fuel outlet and press and hold the primer button. The pressure gauge should read approximately 2 psi and hold steady at this reading. If pressure rises slowly, the primary valve is leaking and the regulator must be replaced. If pressure remains constant, proceed.
4. Remove pressure gauge and cover outlet with a film of soap solution. If a bubble forms, the secondary valve is leaking.
5. Slowly turn the secondary adjustment to the left until the bubble expands, then to the right one complete turn to stop the leak. If leaking persists, replace the regulator.

GOVERNOR

Engine speed governors in the K series of engines (with the exception of the K91) are of the centrifugal flyweight mechanical type. The K91 utilizes a flyball. The governor gear and flyweight mechanism are contained within the crankcase. The governor gear is driven by a gear on the camshaft.

Operation

In operation, centrifugal force causes the flyweights (or flyball) to move outward with an in-

crease in speed and inward with a decrease. As the flyweights move outward, they force the regulating pin of the assembly to move outward. The regulating pin contacts the tab on the cross shaft, causing the shaft to rotate with changing speed. One end of the cross shaft protrudes through the side of the crankcase. Through external linkage attached to the cross shaft, the rotating action is transmitted to the throttle on the carburetor.

When the engine is not running, the governor spring holds the throttle in the open position. When a normal load is applied to an operating engine, the speed tends to decrease. The resulting rotation of the cross shaft acts against the governor spring, opening the throttle wider. This action admits more fuel, restoring engine speed. As speed again reaches the governed setting, the shaft rotates to close the throttle valve enough to maintain governed speed.

Governed speed may be at a fixed point as on constant speed applications or variable as determined by a throttle control setting.

Initial Adjustment - K91, K141, K161, K181

Governors are adjusted at the factory. Further adjustment should not be necessary unless the governor arm or linkage work loose or become disconnected. The need for governor adjustment may be indicated by engine speed surges or hunting with changes in load or by a considerable drop in engine speed when a normal load is applied. The internal governor mechanism is basically similar for all K series engines. The external mechanism is different on the K241 through K341 models. Be sure to follow the adjustment procedure for the model engine being serviced.

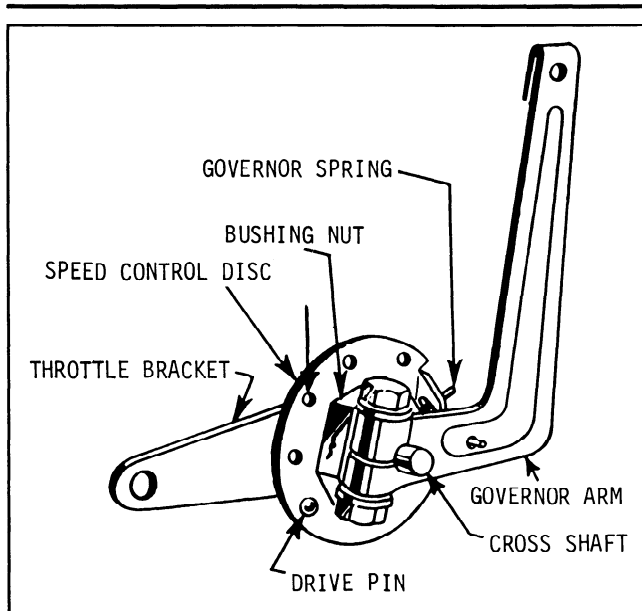

Figure 6-39. Governor Components.

Make initial adjustment as follows.

1. Loosen, but do not remove, the nut that holds the governor arm to the governor cross shaft.
2. Grasp the end of the cross shaft with pliers and turn counterclockwise as far as possible. The tab on the cross shaft will touch the rod on the governor gear assembly.
3. Pull the governor arm away from the carburetor as far as it will go, then tighten nut holding governor arm to cross shaft.

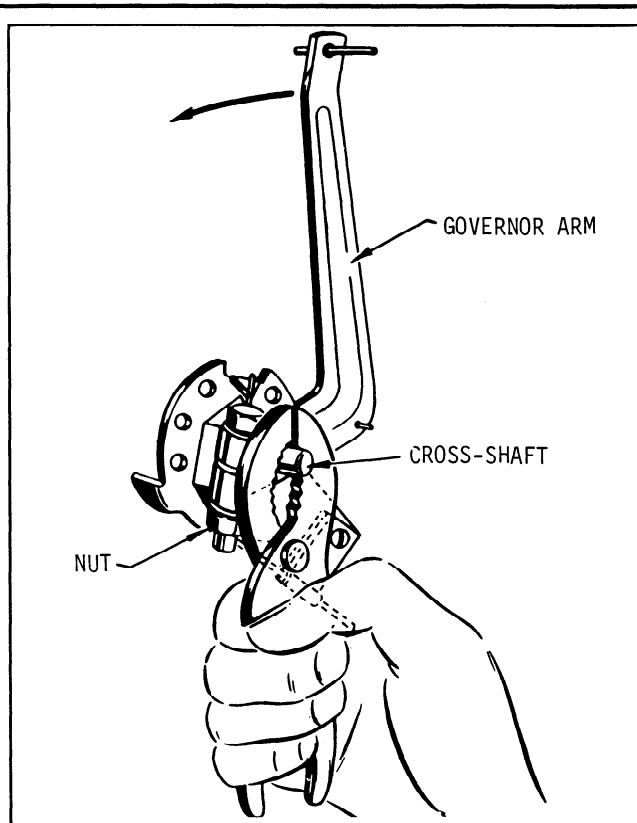

Figure 6-40. Initial Adjustment.

Throttle Wire Installation

In those applications where a throttle is to be connected to the engine, connect it as follows. Refer to Figure 6-41.

1. Bend the end of the throttle wire as shown in Figure 6-41.
2. Place throttle control in open position. Insert throttle wire in speed control disc hole nearest the throttle bracket.
3. Install throttle cable clamp and bolt it to the throttle bracket.
4. Remove drive pin from speed control disc and operate the throttle control, rotating the disc from idle to full speed.

Speed Adjustment



WARNING: Overspeed Is Hazardous!

The maximum allowable speed for Model K91 is 4000 RPM. Models K161 and K181 are restricted to 3600 RPM maximum. Never tamper with the governor setting to increase engine speed above these limits. Severe personal injury and damage to the engine or equipment can result if the engine is operated at speeds above these maximums.

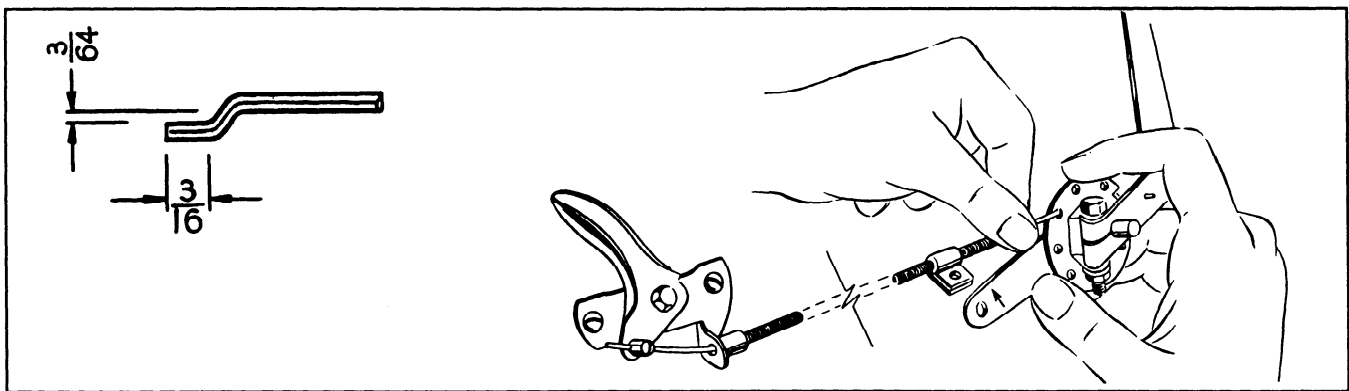

Figure 6-41. Installing Throttle.

After making an initial adjustment or connecting a throttle wire, set speed adjustment as follows. Refer to Figure 6-42.

1. Start the engine and allow a few minutes for warmup.
2. Open the throttle to full speed and check engine speed with a tachometer. Speed should be approximately 4000 RPM for Model K91 and 3600-RPM for Model K161 or K181.
3. If speed is not as required, slightly loosen the bushing nut at the speed control disc.
4. Move the throttle bracket counterclockwise to increase engine speed or clockwise to decrease speed.
5. When proper speed is set, tighten the bushing nut.

NOTE: Do not use excessive force in tightening the bushing nut. Excessive force could cause binding or stripping of threads.

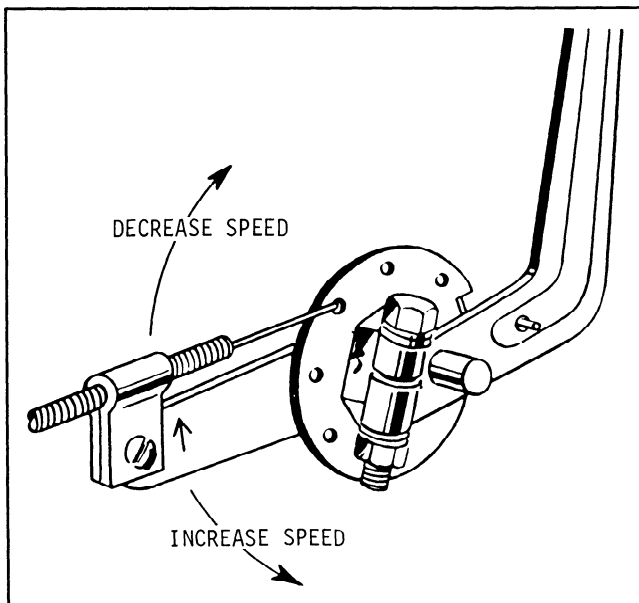

Figure 6-42. Speed Adjustment.

Governor "New Look" K181

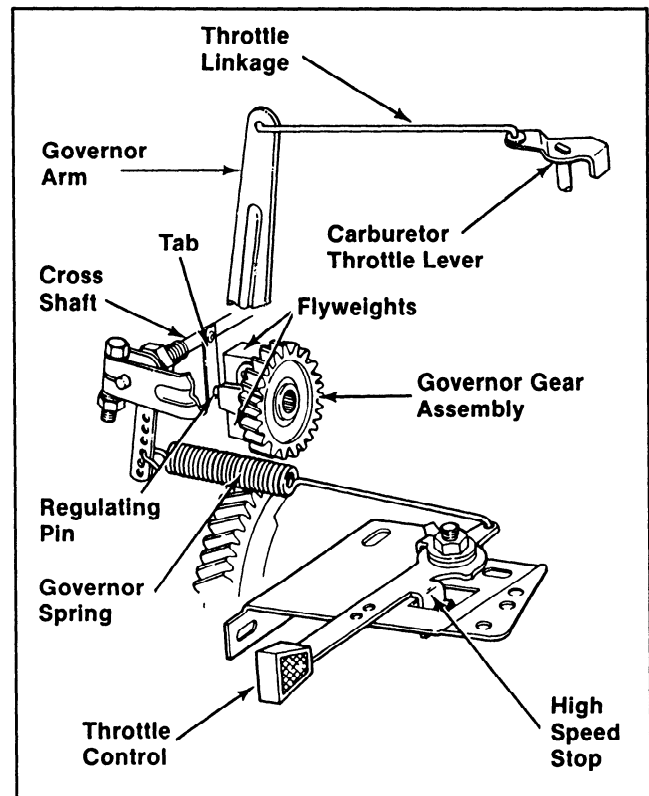

Figure 6-43. Centrifugal Flyweight Mechanical Governor.

Operation

Centrifugal force acting on the rotating governor gear assembly causes the flyweights to move outward as speed increases and inward as speed decreases. As the flyweights move outward they force the regulating pin of the assembly to move outward. The regulating pin contacts the tab on the cross shaft, causing the shaft to rotate with changing speed. One end of the cross shaft protrudes through the side of the crankcase. Through external linkage attached to the cross shaft, the rotating action is transmitted to the throttle plate of carburetor.

When the engine is at rest and the throttle is in the "fast" position, the tension of the governor

spring holds the throttle valve open. When the engine is operating (governor gear assembly is rotating), the force applied by the regulating pin against the cross shaft tends to close the throttle valve. The governor spring tension and the force applied by the regulating pin are in "equilibrium" during operation, holding the engine speed constant.

When a load is applied and the engine speed (and governor speed) decreases, the governor spring tension moves the governor arm to open the throttle plate wider. This admits more fuel and restores engine speed. (This action takes place very rapidly, so a reduction in speed is hardly noticed.) As the speed reaches the governed setting, the governor spring tension and the force applied by the regulating pin will again be in equilibrium. This maintains engine speed at a relatively constant level.

Governed speed may be at a fixed point as on constant speed applications, or variable as determined by a throttle control lever.

Adjustment



WARNING: Overspeed Is Hazardous!

The maximum allowable speed for these engines is 3600 RPM, no load. Never tamper with the governor setting to increase the maximum speed. Severe personal injury and damage to the engine or equipment can result if operated at speeds above maximum.

INITIAL ADJUSTMENT

Make this initial adjustment whenever the governor arm is loosened or removed from cross shaft. Make sure the throttle linkage is connected to governor arm and throttle lever on carburetor to ensure proper setting. Refer to Figure 6-44.

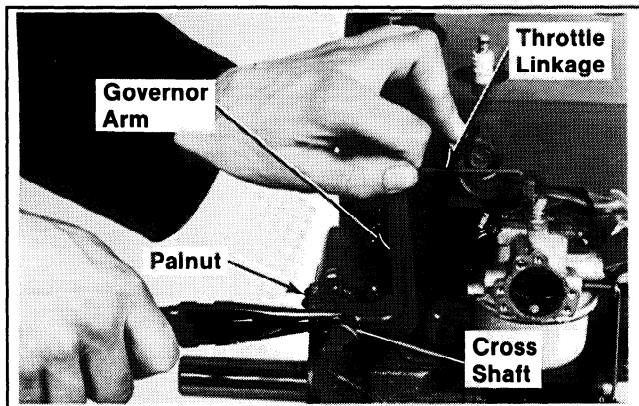

Figure 6-44. Initial Governor Adjustment.

1. Pull the governor arm away from the carburetor as far as it will go.
2. Grasp the end of cross shaft with pliers and turn counterclockwise as far as it will go.
3. Tighten the palnut on governor arm to 15 in. lb. torque.

NOTE: Make sure there is at least 1/16" clearance between governor arm and cross shaft bushing nut to prevent interference.

HIGH SPEED ADJUSTMENT

The maximum allowable speed is 3600 RPM, no load. The actual high speed setting depends on the application. Refer to the equipment manufacturer's instructions for specific high speed settings. Check the operating speed with a tachometer; do not exceed the maximum. To adjust high speed stop:

1. Loosen the lock nut on high speed adjusting screw. Refer to Figures 6-45.

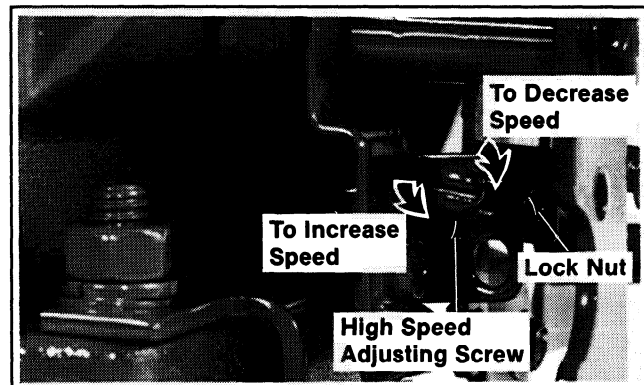

Figure 6-45. High Speed Adjusting Screw.

2. Turn the adjusting screw in or out until desired speed is reached. Tighten the lock nut.
3. Recheck the speed with the tachometer; readjust if necessary.

SENSITIVITY ADJUSTMENT

Governor sensitivity is adjusted by repositioning the governor spring in the holes in governor arm. If set too sensitive, speed surging will occur with a change in load. If a big drop in speed occurs when normal load is applied, the governor should be set for greater sensitivity.

The standard spring position is in the third hole from the cross shaft. The position can vary, depending on the engine application. Therefore, make a note of (or mark) the spring position before removing it from the governor arm. Refer to Figure 6-46.

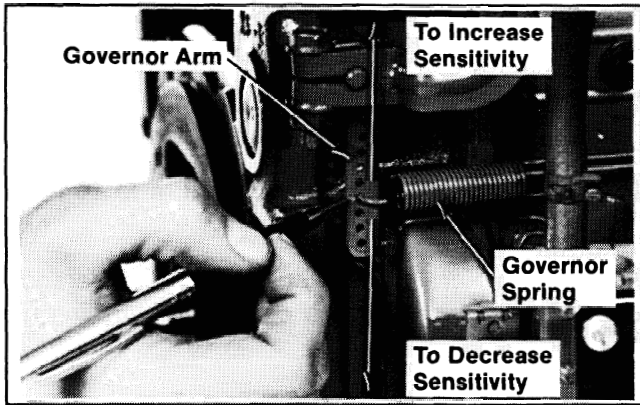

To increase sensitivity, increase the governor spring tension by moving the spring towards the cross shaft.

To decrease sensitivity, and allow broader control, decrease spring tension by moving the spring away from the cross shaft.

Figure 6-46. Governor Sensitivity Adjustment.

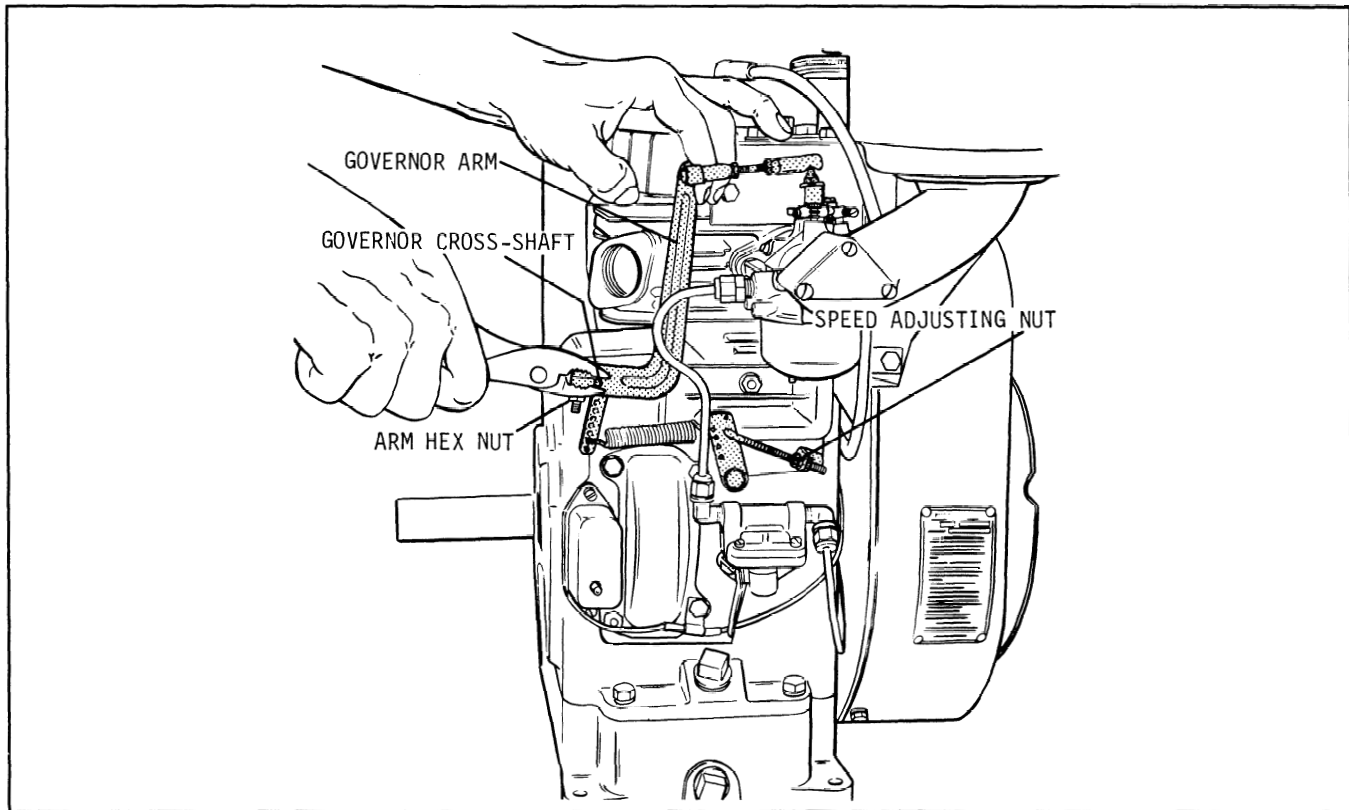

Figure 6-47. Initial Adjustment.

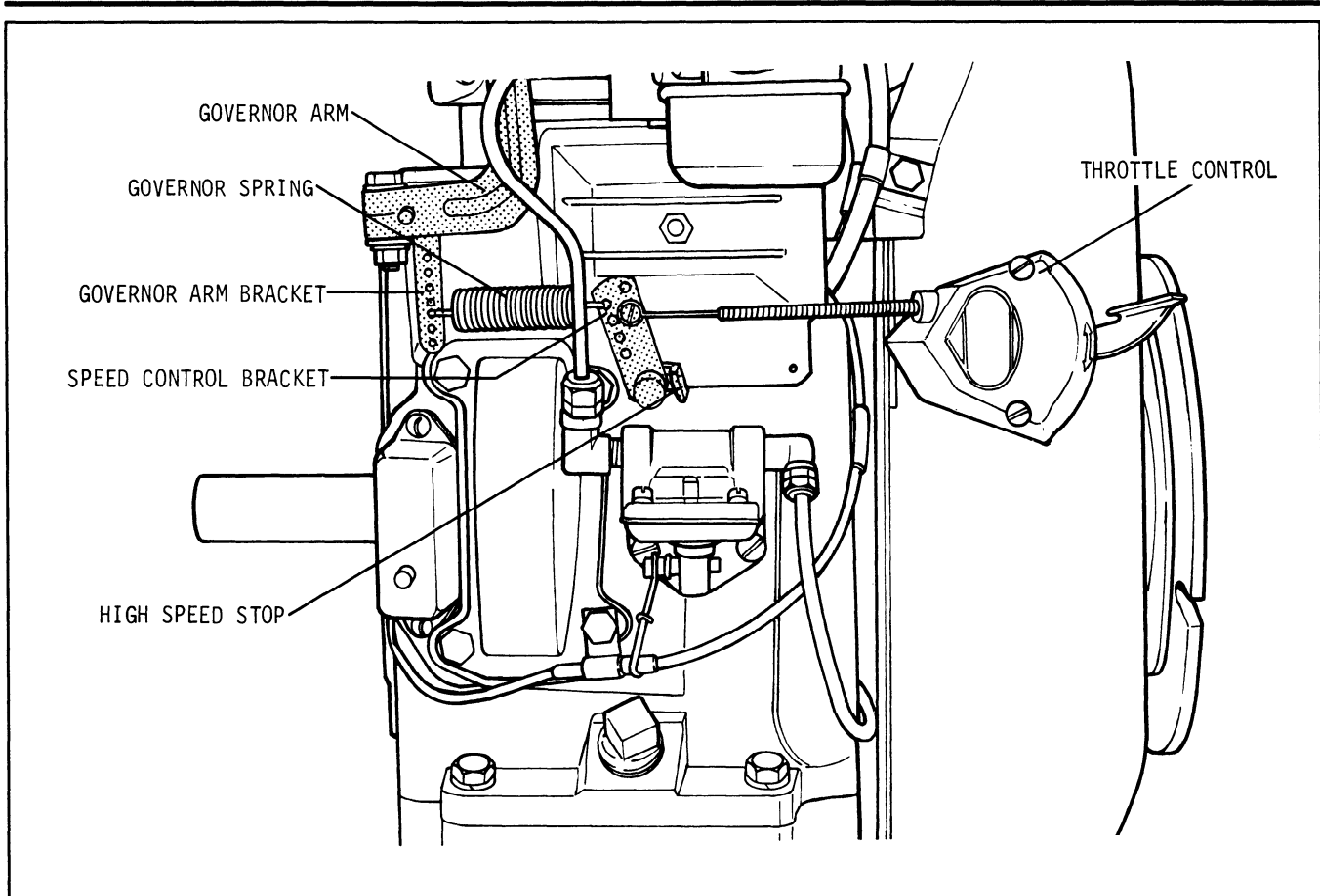

Figure 6-48. Variable Speed Governor.

Initial Adjustment – K241, K301, K321, K341

Initial adjustment for these models is essentially the same as for models K91 through K181. Refer to Figure 6-47 for parts description.

Throttle Wire Installation

Install a throttle for variable speed applications as follows. Refer to Figure 6-48.

1. Mount the throttle control or throttle cable clamp on the blower housing as shown in Figure 6-48.
2. Move the throttle control to the open position and place the end of the throttle wire through the hole in the pin on speed control bracket.
3. Use a long nose pliers or similar tool to loop the end of the throttle wire around the pin.

Speed Adjustment



WARNING: Overspeed Is Hazardous!

The maximum allowable speed for Models K241 through K341 is 3600 RPM, no load. Never tamper with the governor setting to increase the maximum speed. Severe personal injury and damage to the engine or equipment can result if operated at speeds above the established maximum.

Adjust the governed speed of these models as follows. Refer to Figure 6-48.

1. Start the engine and allow a short warmup period.
2. Open the throttle fully and check engine speed with a tachometer. Speed should be approximately 3600 RPM.
3. If speed is not correct, loosen the capscrew on the high speed stop bracket and adjust the bracket to achieve the required speed.
4. Tighten the high speed stop bracket screw.

Sensitivity Adjustment

Governor sensitivity is adjusted by repositioning the governor spring in the holes in the governor arm. If set too sensitive, speed surging will occur with any change in load. If a considerable speed drop occurs with the application of a load, sensitivity is set too low. The governor spring is placed in the third hole from the end of the governor arm when the engine leaves the factory. To increase governor control sensitivity, move the spring to a hole closer to the cross shaft. To decrease sensitivity, move it to a hole farther from the cross shaft.

Sensitivity adjustment may not cure a hunting problem in all cases. If hunting persists after sensitivity is adjusted, try one or more of the following steps.

1. Set spark plug point gap to .020" and readjust the carburetor for peak performance. (See "Carburetor Adjustment" subsection of this section.)

2. Stop the engine and check for free movement of the governor linkage from idle to full open throttle. Remove excess paint from the governor spring and make sure that there is no interference between governor components and other parts.
3. With the engine shut down the throttle will be in the wide open position. Adjust the governor linkage so that there is approximately 1/32" of space between the throttle lever and carburetor body.
4. Use a tachometer to set the idle speed to 1680 RPM with the throttle lever against the idle speed screw.

If hunting still occurs, move the governor spring to the last hole in the governor arm. If this improves governing but permits too great a speed reduction when going from no load to full load, move the spring up one position in the arm.

SECTION 7

RETRACTABLE STARTERS

Retractable starters are lubricated during manufacture and should require no further lubrication until disassembly for cord or rewind spring replacement or for other repair.

Frequently check mounting screws to make sure starter is securely tightened on blower housing of engine. If screws are loose, starter realignment may be necessary. Also make sure that the air intake screen is maintained in clean condition at all times.

MODEL K91

FAIRBANKS-MORSE STARTERS

Starters have die cast aluminum housings. A friction shoe assembly under spring tension is used and engages in the drive cup when the starter handle is pulled. The drive cup is held in place on the engine with the flywheel nut. A pin on the cup is engaged in crankshaft keyway to prevent slippage of the drive cup.

Refer to Figure 7-1.

Operation

1. Be sure starter screen is kept clean when operating engine or serious engine damage can result from lack of cooling air.
2. After engine has started, do not allow starter rope to snap back into starter housing. Continue to hold handle and allow starter rope to rewind slowly.

NOTE: Releasing handle when starter rope is extended will shorten life of starter.

3. Do not use starter in a rough manner, such as jerking or pulling starter rope all the way out. A smooth, steady pull will start engine under normal conditions.
4. Always pull starter handle straight out so that rope will not receive excessive wear from friction against guide. Proper procedure will prevent unnecessary wear.
5. If recoil starter should ever fail, starter assembly can be removed and engine cranked with a rope. The starter drive cup will serve as a pulley for emergency purposes.

7

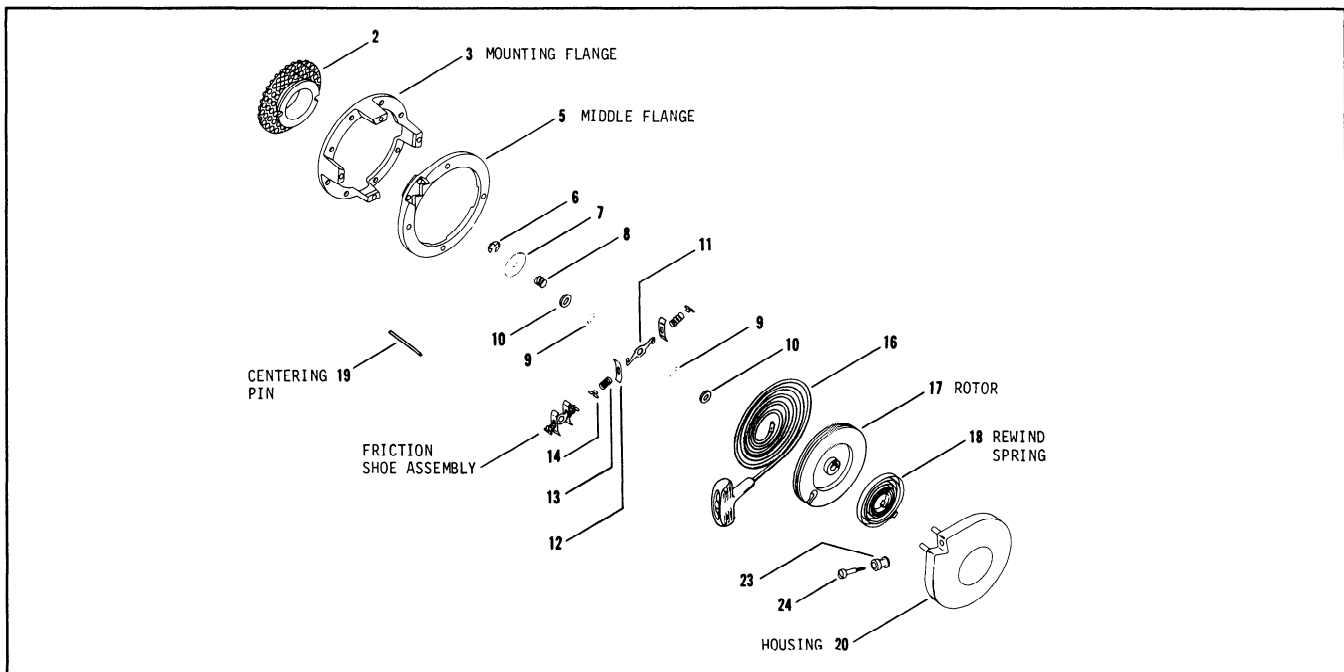

Figure 7-1. Fairbanks-Morse Starter - Exploded View.

Disassembly

If starting rope breaks or if starting spring fails, the following procedure should be followed.

NOTE: Handle rewind springs with extreme caution.

1. To remove starter from engine, remove four mounting bolts. Refer to Figure 7-2.
2. Hold washer (Key 7) in position with thumb while removing retainer ring (Key 6) with a screwdriver.
3. Remove washer (Key 7), spring (Key 8), washers (Keys 9 and 10) then remove friction shoe assembly (Keys 11, 12, 13, and 14).
4. Prevent rewind spring from escaping from cover by carefully lifting rotor about 1/2 inch and detach inside spring loop from rotor.

NOTE: If spring should escape, it can easily be replaced in cover by coiling in turns.

Starting Rope Replacement

1. When installing a new rope (Key 16) in rotor, thread through rotor hole, then wind rope onto rotor, as explained in "Reassembly." Replace handle and washer, if used, and tie a double knot in the end of the rope.

Rewind Spring Replacement

1. Start with the inside loop, remove spring carefully from cover by pulling out one loop at a time, holding back the rest of the turns. When replacing with new spring, note the position of spring loop.

2. Spring holders furnished with replacement springs simplify the assembly procedure. Place spring in proper position as shown, with the outside loop engaged around the pin. Then press the spring into cover cavity thus releasing the spring holder. A few drops of SAE 20 or 30 oil should then be applied to spring and light grease on cover shaft.

Reassembly

1. Replace washers (Keys 9 and 10), friction shoe assembly, washers (Keys 9 and 10), spring (Key 8), washer (Key 7), and retaining ring (Key 6).
2. Starter rope is now completely wound on rotor in the direction shown in Figure 7-2.
3. The starter will be damaged if not centered properly. To insure the proper centering of the starter, pull out the centering pin (Key 19) about 1/8". Place the starter on the four screws, make sure the centering pin engages the centerhole in the crankshaft and press into position. Hold the starter with one hand and place the lock washers and nuts on the screws and tighten securely.

Reinstalling Starter On Engine:

1. To align the starter, place it on the blower housing in the desired position, with the centering pin engaged in the center hole of the crankshaft. (If the centering pin is too short to reach the crankshaft, use a pair of pliers and pull the pin out to the correct length.)

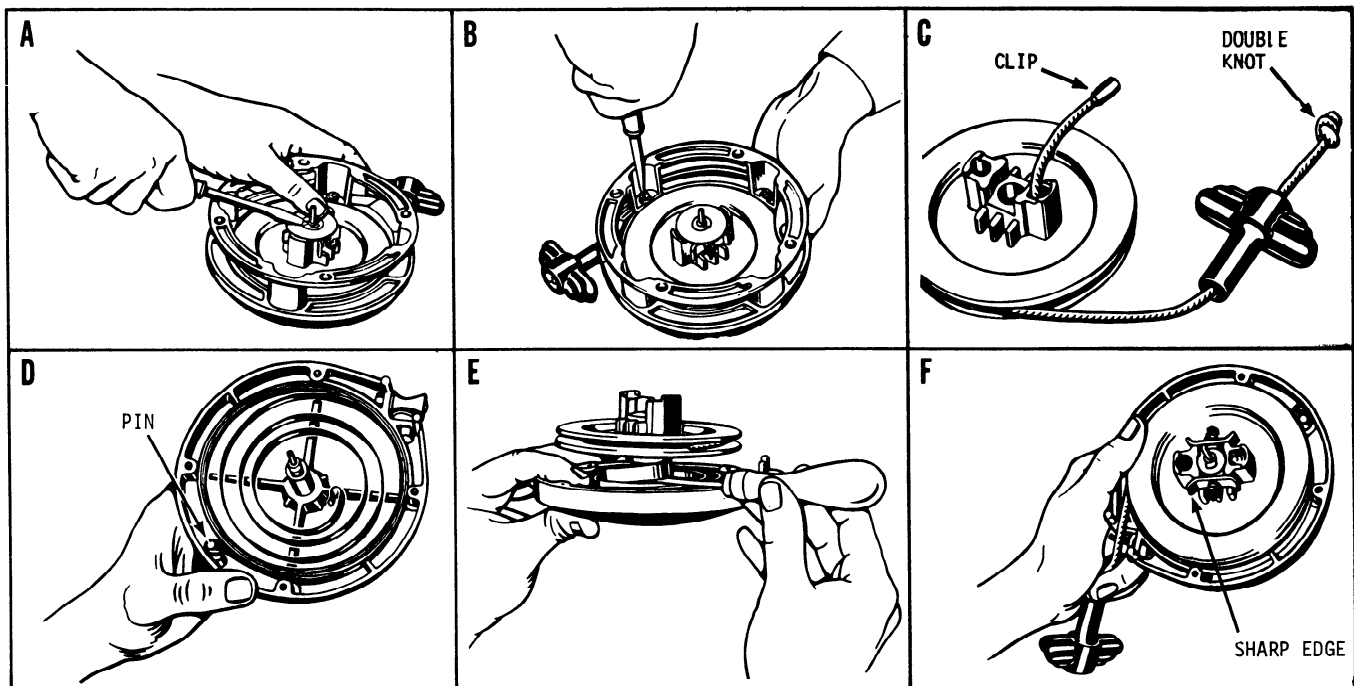

Figure 7-2. Fairbanks-Morse Starter Disassembly.

2. Press the starter into position and install the four screws with lock washers and flat washers.
3. Hold the starter assembly in this centered position and securely tighten the four screws.

STAMPED HOUSING MODELS



CAUTION: Spring Under Tension!

Retractable starters contain a powerful flat wire recoil spring that is under tension. Do not remove the center screw from the starter until the tension is released. Removing the center screw before releasing spring tension, or improper starter disassembly, can cause the sudden and potentially dangerous release of the spring.

Always wear safety goggles when servicing retractable starters – full face protection is recommended. To ensure personal safety and proper starter disassembly, the following procedures must be followed carefully.

To Remove Starter

1. Remove the five screws securing the starter assembly to blower housing.

To Install Starter

1. Install starter to blower housing using the five mounting screws. Leave screws slightly loose.
2. Pull the handle out approximately 8" to 10" until the pawls engage in the drive cup. Hold the handle in this position and tighten the screws securely.

To Replace Starter Pawls (Dogs)

Use pawl repair kit # 41 757 02. This kit includes two starter pawls, two pawl springs, two retaining rings, and installation instructions.

1. Remove starter from engine.

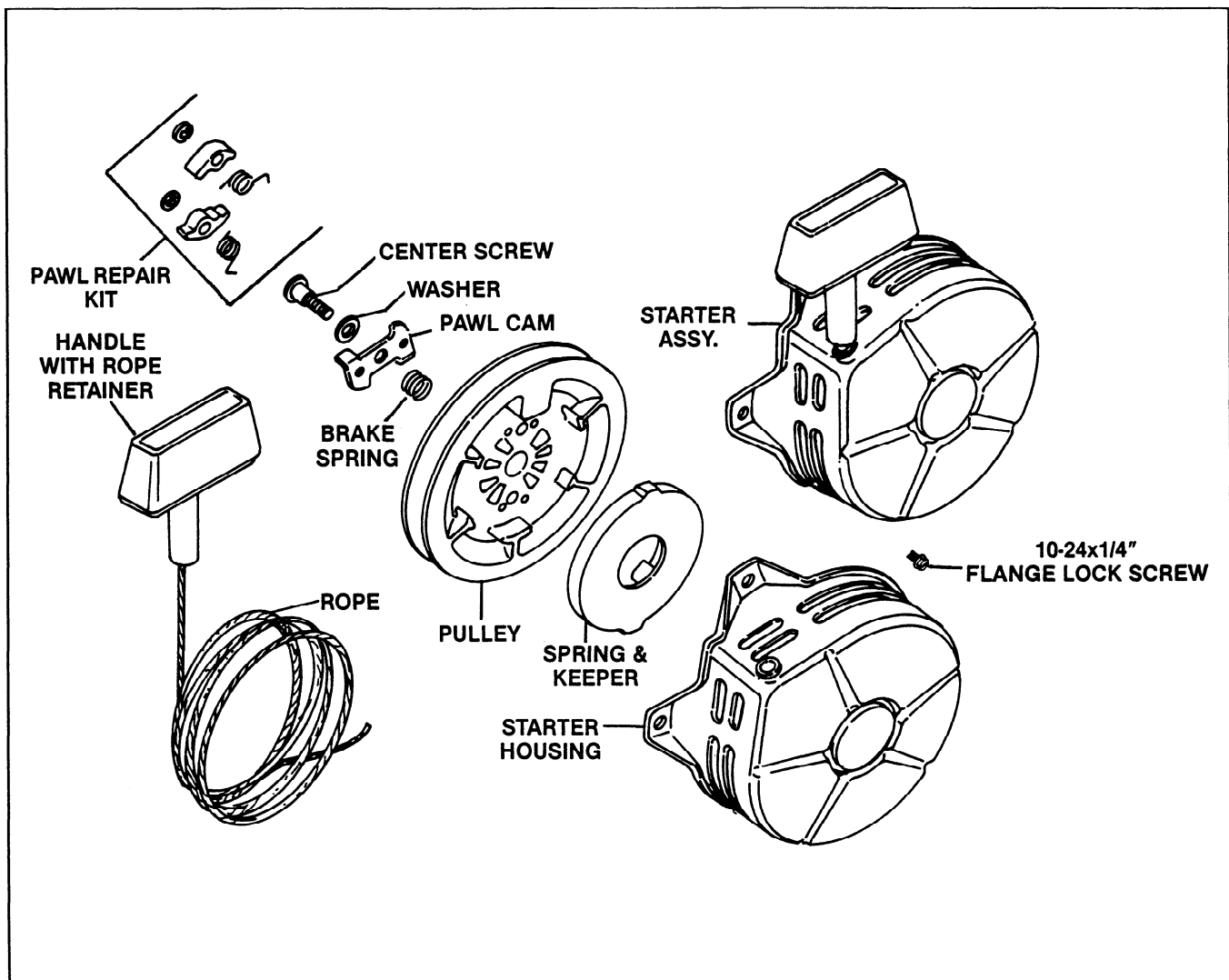

Figure 7-3. Exploded View.



CAUTION: Spring Under Tension!

Do not remove the center screw of the starter when replacing pawls. Removal of the center screw can cause the sudden and potentially dangerous release of the recoil spring. It is not necessary to remove the center screw when making this repair.

2. Carefully note position of the pawls, pawl springs, and retaining rings before disassembly. (Components must be assembled correctly for proper operation.) Refer to Figure 7-4.
3. Remove the retaining rings, pawls, and pawl springs from pawl pins on pulley.
4. Clean pins and lubricate with any commercially available bearing grease.
5. Install new pawl springs, pawls, and retaining rings. When properly installed, the pawl springs will hold the pawls against the pawl cam.

NOTE: Make sure the snap rings are securely seated in grooves of pawl pins. Failure to seat the snap ring can cause pawls to dislodge during operation.

6. Pull rope to make sure pawls operate properly.
7. Install starter to engine as instructed under "To Install Starter."

To Replace Rope

The rope can be replaced without complete starter disassembly.

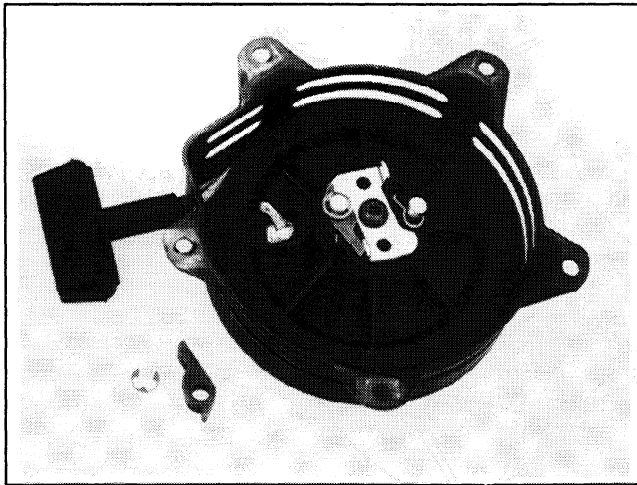

Figure 7-4. Starter Pawls.

1. Remove the starter from engine.
2. Pull the rope out approximately 12" and tie a temporary (slip) knot in it to keep it from retracting into starter. Refer to Figure 7-5.

3. Remove the rope retainer from inside handle. Untie the knot and remove the retainer and handle.
4. Hold the pulley firmly with thumb and untie the slip knot. Allow the pulley to rotate **slowly** as the spring tension is released. Refer to Figure 7-6.
5. When all spring tension on the starter pulley is released, remove old rope from pulley.
6. Tie a single knot in one end of new rope.
7. Rotate the pulley counterclockwise (when viewed from pawl side of pulley) until the spring is tight. (Approx. 6 full turns of pulley).
8. Rotate the pulley clockwise until the rope pocket is aligned with the rope guide bushing of housing.

NOTE: Do not allow pulley/spring to unwind. Enlist the aid of a helper if necessary, or use a c-clamp to hold pulley in position.

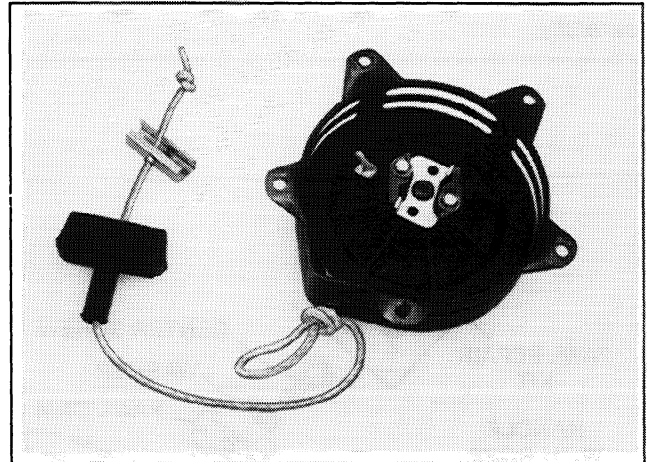

Figure 7-5. Removing Handle.

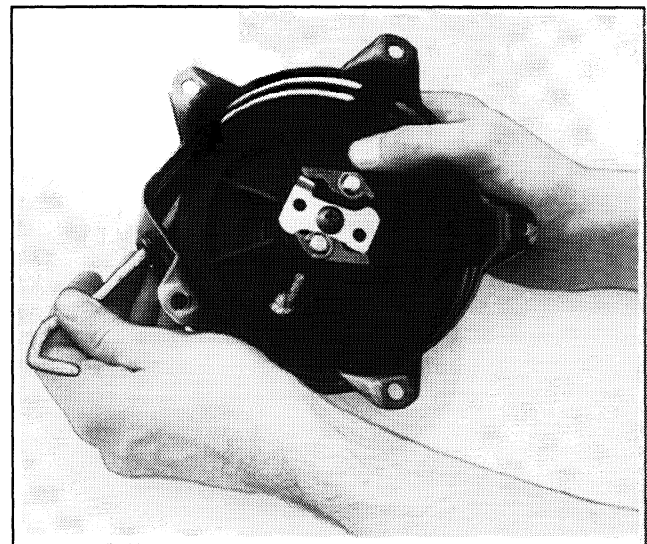

Figure 7-6. Releasing Spring Tension.

9. Insert the new rope into the rope pocket of pulley and through rope guide bushing in housing. Refer to Figure 7-7.

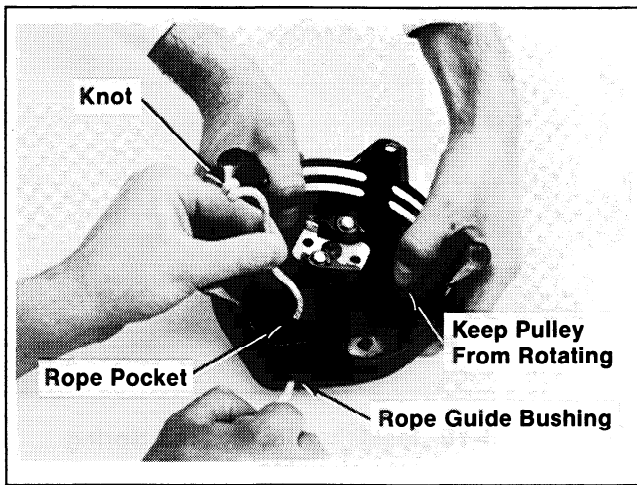

Figure 7-7. Installing Rope.

10. Tie a slip knot approximately 12" from the free end of rope. Hold pulley firmly with thumb and allow pulley to rotate **slowly** until the temporary knot reaches the rope guide bushing in housing.
11. Slip the handle and rope retainer onto rope. Tie a single knot at the end of rope and install rope retainer into handle. Refer to Figure 7-5.
12. Untie the slip knot in rope and pull the handle out until the rope is fully extended. Slowly retract the rope into the starter. If the spring has been properly tensioned, the rope will fully retract until the handle hits the housing.

Disassembly

1. Remove starter from engine.



CAUTION: Spring Under Tension!

Do not remove the center screw of the starter until the tension of recoil spring has been released. Removing the center screw before releasing spring tension, or improper starter disassembly can cause the sudden and potentially dangerous release of the recoil spring. Follow these instructions carefully to ensure personal safety and proper starter disassembly. Make sure adequate face protection is worn by all persons in the area.

2. Pull the rope out approximately 12" and tie a temporary (slip) knot in it to keep it from retracting into starter. Refer to Figure 7-5.
3. Remove the rope retainer from inside handle and untie the knot to remove retainer and handle.
4. Hold the pulley firmly with thumb and untie the slip knot. Allow pulley to rotate **slowly** as the spring tension is released. Refer to Figure 7-6.

5. When all spring tension on the starter pulley has been released, remove the rope from the pulley.
6. Remove the center screw, washer, pawl cam, and brake spring.
7. Rotate the pulley clockwise 2 full turns. This will ensure the pulley is disengaged from the spring.
8. Hold the pulley into starter housing and invert starter so the pulley is away from your face, and away from others in the area.
9. Rotate the pulley slightly from side to side and **carefully** separate the pulley from the starter housing. Refer to Figure 7-8.

If the pulley and housing do not separate easily, the spring could be engaged with the pulley, or there is still tension on the spring. Return the pulley to the housing and repeat step 7 before separating the pulley and housing.

10. Note the position of the spring and keeper assembly on the pulley. Also refer to Figure 7-9. (The spring and keeper assembly must be correctly positioned on pulley for proper operation.) Remove the spring and keeper assembly from the pulley **as a package**.

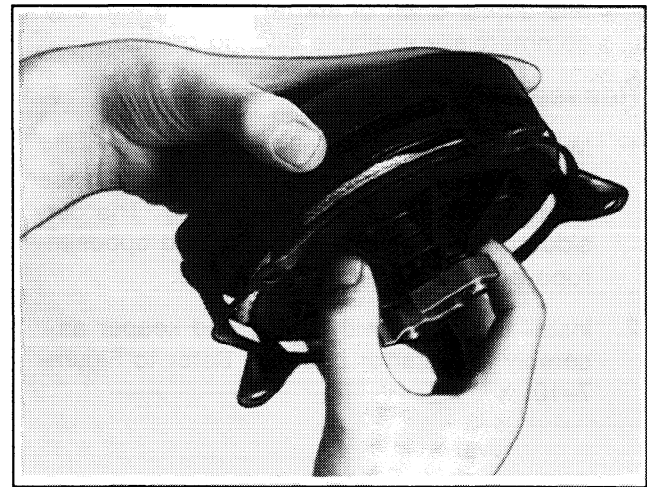

Figure 7-8. Removing Pulley From Housing.

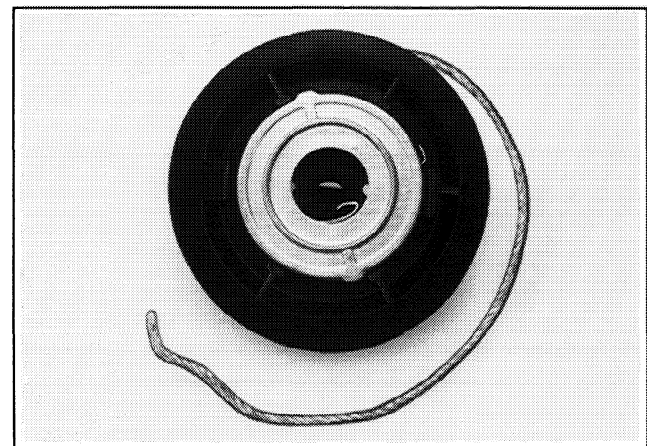

Figure 7-9. Position Of Spring And Keeper On Pulley.



CAUTION: Spring Under Tension!

Do not remove the spring from the keeper. Severe personal injury could result from sudden uncoiling of the spring.

11. Remove the rope from pulley. If necessary, remove the starter pawl components from pulley as instructed under "To Replace Starter Pawls."

Inspection and Service

1. Carefully inspect rope, starter pawls, housing, center screw, and other components for wear or damage.
2. Replace all worn or damaged components. Use only genuine Kohler replacement parts specified in the Parts Manual. All components shown in Figure 7-3 are available as service parts. Do not use nonstandard parts.
3. Do not attempt to rewind a spring that has come out of the keeper. Order and install a new spring and keeper assembly.
4. Clean away all old grease and dirt from starter components. Generously lubricate the spring and center shaft of starter housing with any commercially available bearing grease.

Reassembly

1. Make sure spring is well lubricated with grease. Position the spring and keeper assembly to pulley (side opposite pawls). The outside spring tail must be positioned opposite rope pocket. Refer to Figure 7-9.
2. Install the pulley with spring and keeper assembly into starter housing. Refer to Figure 7-10.

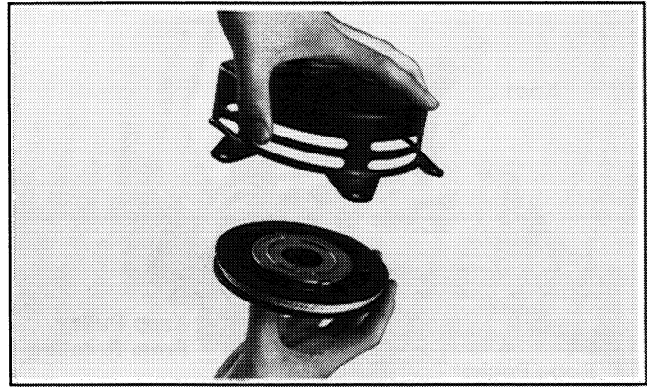

Figure 7-10. Installing Pulley And Spring Into Housing.

The pulley is in position when the center shaft is extending slightly above the face of the pulley. **Do not wind the pulley and recoil spring at this time.**

3. Lubricate the brake spring **sparingly** with grease. Install the brake spring into the recess in center shaft of starter housing. Refer to Figure 7-3. (Make sure the threads in center shaft remain clean, dry, and free of grease or oil.)
4. Apply a small amount of Loctite #271 to the threads to center screw. Install the center screw with washer and cam to the center shaft. Torque screw to **65/75 in. lb.**
5. If necessary, install the pawl springs, pawls, and retaining rings to pins on starter pulley. Refer to "To Replace Starter Pawls."
6. Tension the spring and install the rope and handle as instructed in steps 5 through 12 under "To Replace Rope."
7. Install the starter to engine.

CAST HOUSING MODELS

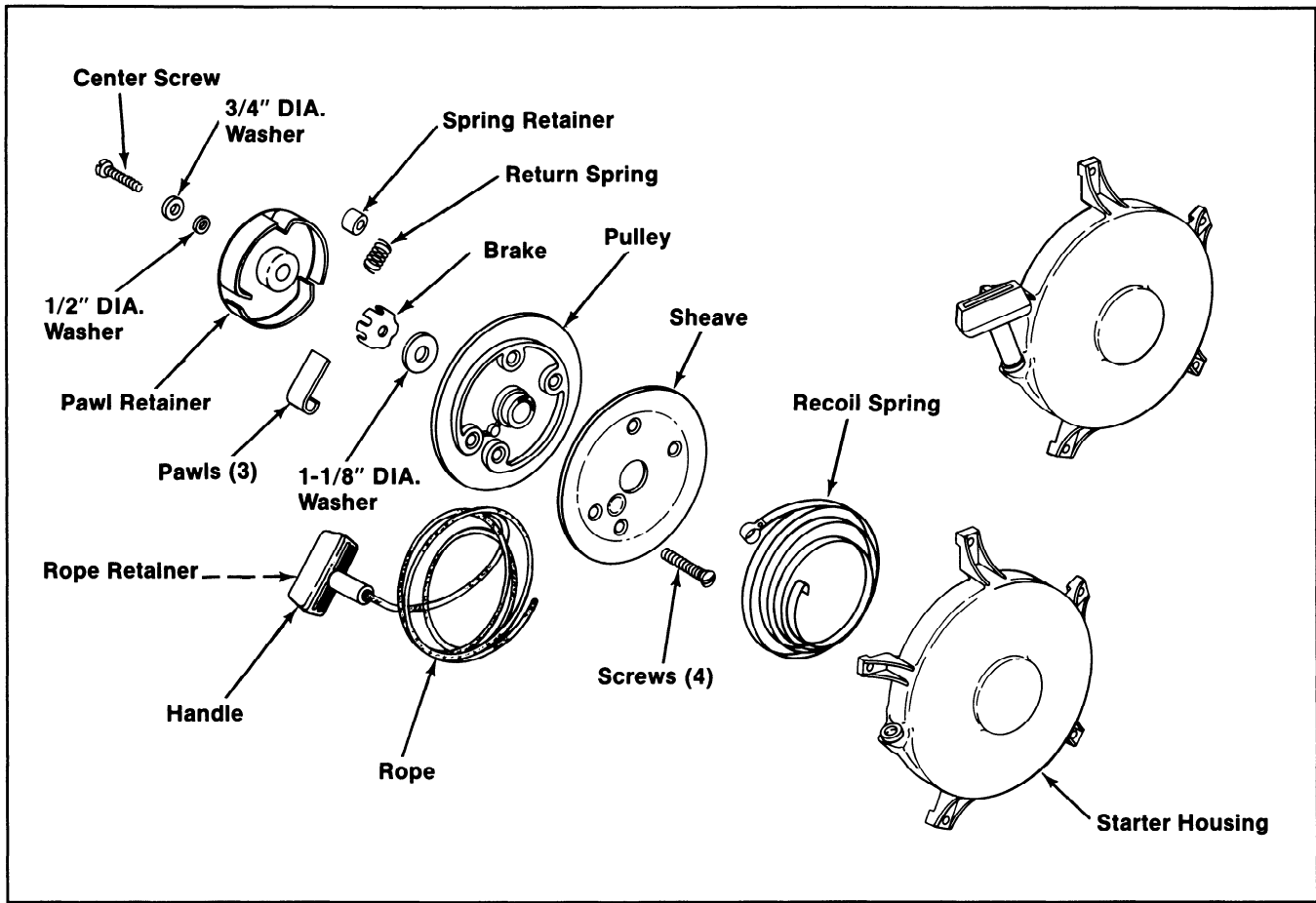

Figure 7-11. Exploded View.

1. Remove the starter from engine.



CAUTION: Spring Under Tension!

Do not remove the center screw of the starter until the tension of recoil spring has been released. Removing the center screw before releasing spring tension, or improper starter disassembly can cause the sudden and potentially dangerous release of the recoil spring. Follow these instructions carefully to ensure personal safety and proper starter disassembly. Make sure adequate face protection is worn by all persons in the area.

2. Pull the rope out approximately 12" and tie a temporary (slip) knot in it to keep it from retracting into starter. Refer to Figure 7-12.
3. Remove the rope retainer from inside handle. Untie the knot and remove the retainer and handle.

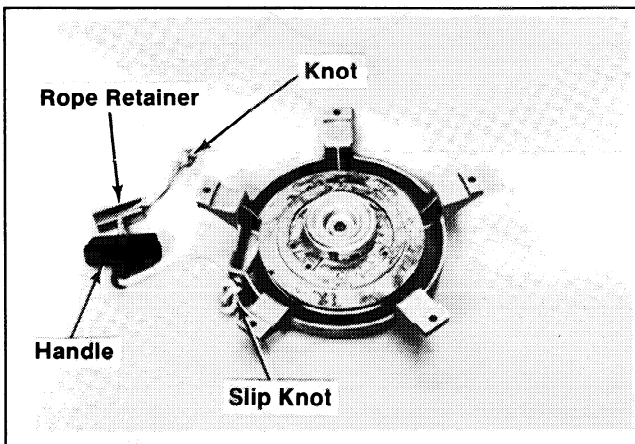

Figure 7-12. Removing Handle.

4. Rotate the pulley counterclockwise until the notch in pulley is next to the rope guide bushing.
5. Hold the pulley firmly to keep it from turning. Untie the slip knot and pull the rope through the bushing.
6. Place the rope into the notch in pulley. This will keep the rope from interfering with the starter housing leg reinforcements as the pulley is rotated (step 7).
7. Hold the housing and pulley with both hands. Release pressure on the pulley and allow it to rotate **slowly** as the spring tension is released. Be sure to keep the rope in the notch. Refer to Figure 7-13.

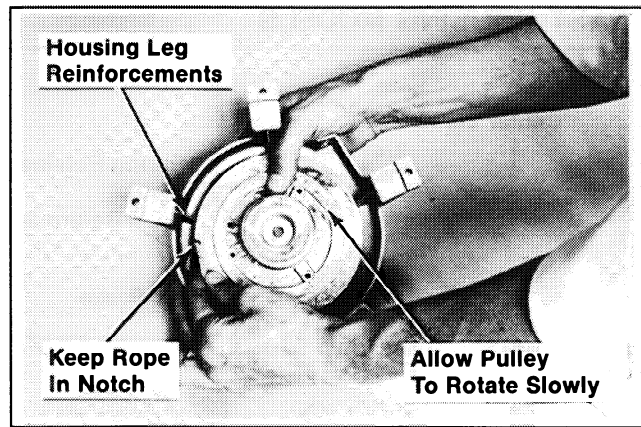

Figure 7-13. Releasing Spring Tension.

8. Make sure the spring tension is fully released. (The pulley should rotate easily in either direction.)
9. When **all** spring tension on the pulley is released, remove the center screw, 3/4" DIA. washer, and 1/2" DIA. washer.
10. **Carefully** lift the pawl retainer from pulley. Refer to Figure 7-14.

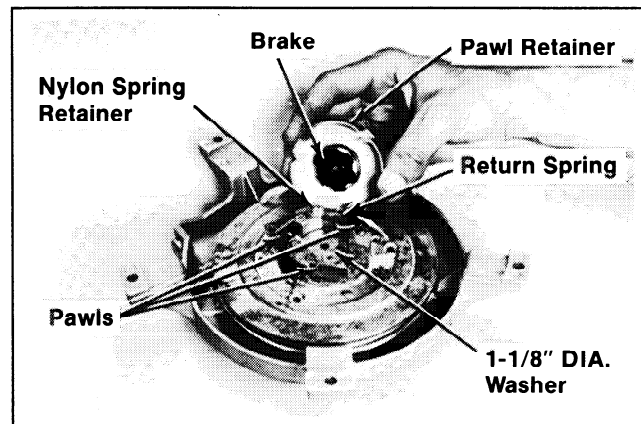

Figure 7-14. Removing Pawl Retainer, Pawls, And Related Components.

NOTE: A small return spring and nylon spring retainer (spacer) are located under the pawl retainer. These parts are fragile and can be easily lost or damaged. If necessary, use a small screwdriver to loosen the spring retainer from the post on pulley. Replace the spring if it is broken, stretched, or shows other signs of damage.

11. Remove the 1-1/8" DIA. thrust washer, brake, return spring, nylon spring retainer, and pawls.
12. Rotate the pulley clockwise 2 full turns. There should be no resistance to this rotation. This will ensure the pulley is disengaged from the recoil spring.
13. Hold the pulley into the starter housing and invert starter so the pulley is away from your face and others in the area.
14. Rotate the pulley slightly from side to side and **carefully** separate the pulley from the starter housing. Refer to Figure 7-15.

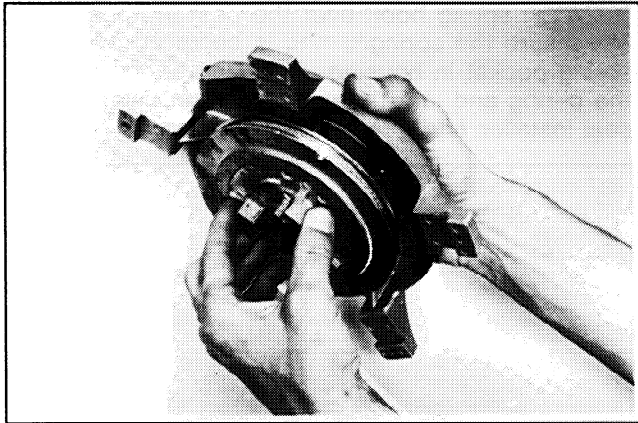

Figure 7-15. Removing Pulley From Housing.

If the pulley and housing do not separate easily, the spring could be engaged with pulley, or there is still tension on the spring. Return the pulley to the housing and repeat step 12 before separating the pulley and housing.

15. Only if it is necessary for the repair of starter, remove the spring from the starter housing as instructed under "To Replace Recoil Spring." **Do not remove the spring unless it is absolutely necessary.**

Inspection and Service

1. **Carefully** inspect the rope, starter pawls, housing, center screw, center shaft, spring and other components for wear or damage.
2. Replace all worn or damaged components. Use only genuine Kohler replacement parts specified in the Parts Manual. All components shown in Figure 7-11 are available as service parts. Do not use nonstandard parts.
3. Carefully clean all old grease and dirt from starter components. Lubricate the spring, center shaft, and certain other components as specified in these instructions with any commercially available bearing grease.

To Replace Rope

The starter must be completely disassembled to replace the rope.

1. Remove the starter from engine.
2. Disassemble starter as instructed in steps 2 through 14 under "Disassembly."
3. Remove the 4 Phillips head screws securing the pulley and sheave. Separate the pulley and sheave and remove the old rope. Refer to Figure 7-16.

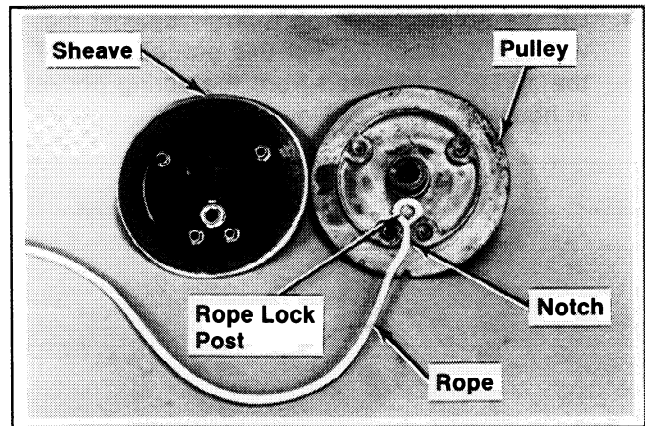

Figure 7-16. Replacing Rope.

4. Position the new rope in the notch in the pulley and around the rope lock post.

NOTE: Use only a genuine Kohler replacement rope which is designed for this starter. Using rope of the incorrect diameter and/or type will not lock properly in the pulley.

5. Install the sheave to the pulley and install the 4 Phillips head screws. Use care not to strip or cross-thread the threads in pulley.
6. Inspect the pulley to make sure the sheave is securely joined to the pulley. Pull firmly on the rope to make sure it is securely retained in the pulley.

To Replace Recoil Spring



CAUTION: Spring Under Tension!

Do not attempt to pull or pry the recoil spring from the housing. Doing so can cause the sudden and potentially dangerous release of the spring from the housing. Follow these instructions carefully to ensure personal safety and proper spring replacement. Make sure adequate face protection is worn throughout the following procedure.

1. Carefully note the position of the spring in the housing. Also refer to Figure 7-17. The new spring must be installed in the proper position – it is possible to install it backwards in the housing.
2. Place the housing on a flat wooden surface with the recoil spring and center shaft down and away from you.
3. Grasp the housing by the top so that your fingers are protected. Do not wrap your fingers around the edge of the housing.

- Lift the housing and rap it firmly against the wooden surface. Repeat this procedure until the spring is released from the spring pocket in housing. Refer to Figure 7-18.

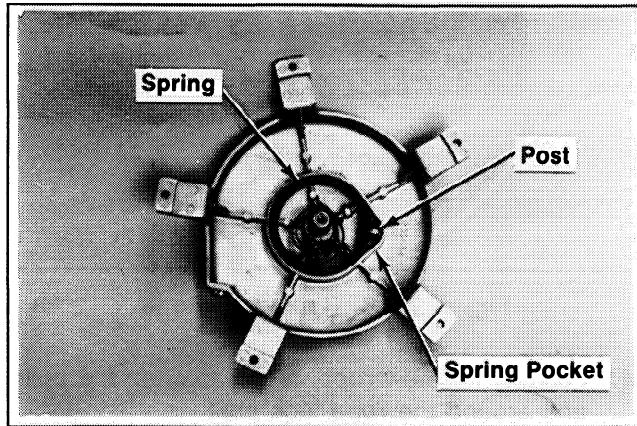

Figure 7-17. Position Of Spring In Housing.

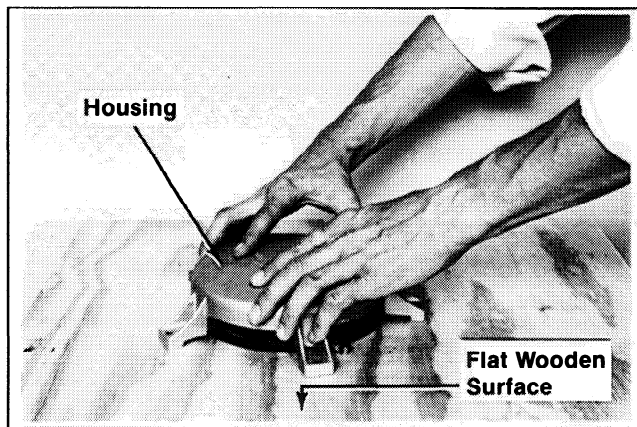

Figure 7-18. Removing Spring From Housing.

- Discard the old spring.



CAUTION: Old Spring Cannot Be Reinstalled!

Do not attempt to rewind or reinstall a spring once it has been removed from the starter housing. Severe personal injury could result from the sudden uncoiling of the spring. Always order and install a new spring which is held in a specially designed "c-ring" spring retainer.

- Thoroughly clean the starter housing removing all old grease and dirt.
- Carefully** remove the masking tape surrounding the new spring/c-ring.
- Position the spring/c-ring to the housing so the spring hook is over the post in the housing. Make sure the spring is coiled in the correct direction. Refer to Figures 7-17 and 7-19.
- Obtain Seal Installer # 11791 and Handle #11795. (Refer to "Special Tools" Section.)

Hook the spring hook over the post in housing. Make sure the spring/c-ring is centered over the spring pocket in housing. Drive the spring out of the c-ring and into the spring pocket using the seal installer and handle. Refer to Figure 7-20.

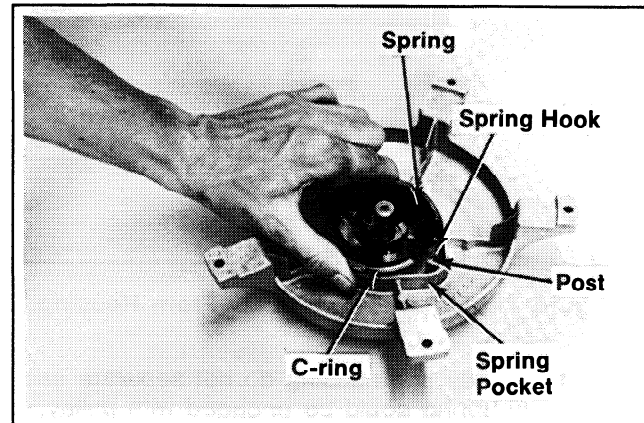

Figure 7-19. Positioning New Spring/C-Ring.

- Make sure all of the spring coils are bottomed against ribs in spring pocket. Use the seal installer and handle to bottom the coils, as necessary.
- Lubricate the spring moderately with wheel bearing grease before reassembling the starter.

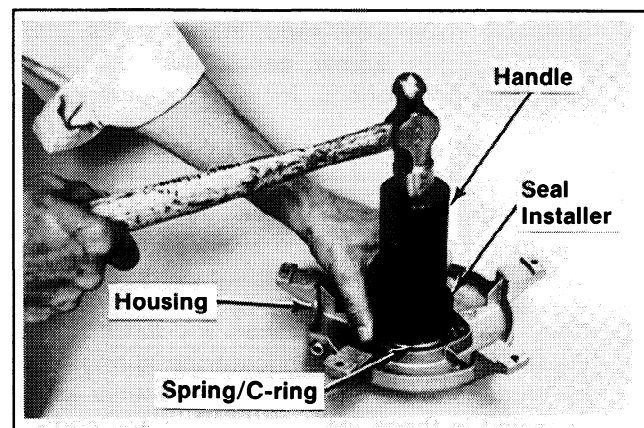

Figure 7-20. Installing Spring Using Seal Installer And Handle.

Reassembly

- Install the recoil spring into the starter housing as instructed under "To Replace Recoil Spring."
- Sparingly lubricate the center shaft of starter with wheel bearing grease.
- Make sure the rope is in good condition. If necessary, replace the rope as instructed under "To Replace Rope."

Ready the pulley and rope for assembly by unwinding all of the rope from the pulley. Place the rope in the notch in the pulley. This will keep the rope from interfering with the

starter housing leg reinforcements as the pulley is rotated later during reassembly.

4. Install the pulley onto the center shaft.

If the pulley does not fully seat, it is resting on the inner center spring coil. Rotate the pulley slightly from side to side while exerting slight downward pressure. This should move the inner spring coil out of the way and allow the pulley to drop into position.

The pulley is in position when the center shaft is flush with the face of the pulley. **Do not wind the pulley and recoil spring at this time.**

5. Install the starter pawls into the appropriate pockets in the pulley. Refer to Figure 7-21.

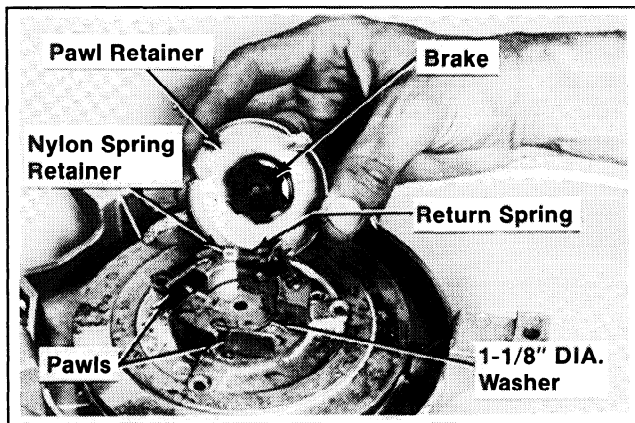

Figure 7-21. Installing Pawls, Pawl Retainer, And Related Components.

6. **Sparingly** lubricate the underside of the 1-1/8" DIA. washer with grease and install it over the center shaft. Make sure the threads in center shaft remain clean, dry, and free of grease or oil.
7. **Sparingly** lubricate the insides of the "legs" of the brake spider with grease. Install the brake to the retainer.
8. Install the small return ring to the pawl retainer. Make sure it is positioned properly.
9. Position the pawl retainer and return spring next to the small post on pulley. Install the free loop of the return spring over the post. Install the nylon spring retainer over the post.
10. Invert the pawl retainer over the pawls and center hub of pulley. Take great care not to damage or unhook the return spring. Make sure the pawls are positioned in the slots of pawl retainer.

11. As a test, rotate the pawl retainer slightly clockwise. Pressure from the return spring should be felt. In addition, the pawl retainer should return to its original position when released. If no spring pressure is felt or the retainer does not return, the spring is damaged, unhooked, or improperly assembled. Repeat steps 8, 9, and 10 to correct the problem.

12. **Sparingly** lubricate the 1/2" DIA. washer and 3/4" DIA. washer in the center of pawl retainer. Make sure the threads in center shaft remain clean, dry, and free of grease or oil.

13. Apply a small amount of Loctite #271 to the threads of center screw. Install the center screw to center shaft. Torque screw to **55/70 in. lb.**

14. Rotate the pulley counterclockwise (when viewed from the pawl side of pulley) until the spring is tight. (Approximately 4 full turns of pulley.) Make sure the fully extended rope is held in the notch in pulley to prevent interference with the housing leg reinforcements. Refer to Figure 7-22.

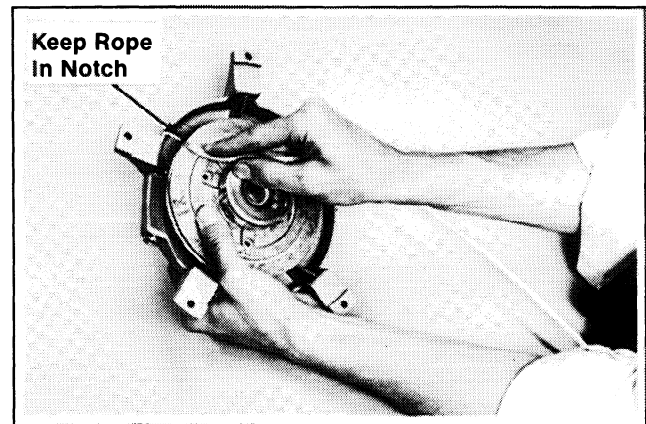

Figure 7-22. Tensioning Spring.

15. Rotate the pulley clockwise until the notch is aligned with the rope guide bushing of housing.

NOTE: Do not allow the pulley/spring to unwind. Enlist the aid of a helper, or use a c-clamp to hold pulley in position.

16. Insert the free end of rope through rope guide bushing. Tie a temporary (slip) knot approximately 12" from the free end of the rope.
17. Hold the pulley firmly with thumbs and allow the pulley to rotate **slowly** until the slip knot reaches the rope guide bushing of housing. Refer to Figure 7-23.

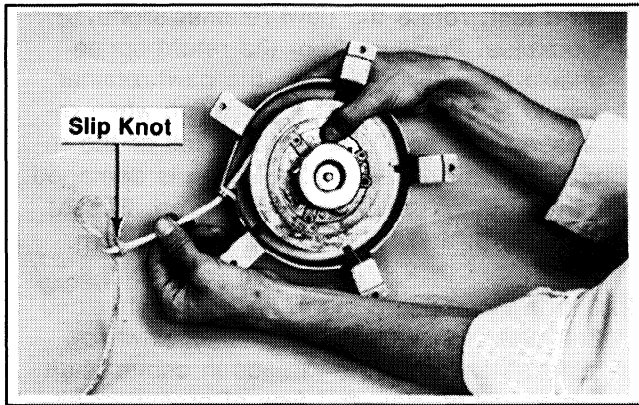

Figure 7-23. Winding Rope Onto Pulley.

18. Slip the handle and rope retainer onto rope. Tie a single knot at the end of rope and install rope retainer into handle. Refer to Figure 7-12.
19. Untie the slip knot and pull the handle out until the rope is fully extended. Slowly retract the rope into the starter. If the spring has been properly tensioned, the rope will fully retract until the handle hits the housing.

SECTION 8

ELECTRICAL SYSTEMS AND COMPONENTS

IGNITION SYSTEMS

Kohler K series engines are fitted with one of three types of ignition systems, each available in several different versions. Most parts in one system are not interchangeable with parts from another system. Care should be taken in selection of replacement parts to ensure the right parts are used. The three types of systems and their available versions are:

Magneto Ignition System

1. Magneto rotor type; ignition only
2. Magneto flywheel type (magnet ring; ignition only)
3. Magneto flywheel type with 3 Amp lighting coils
4. Magneto flywheel type with 10 Amp alternator

Battery Ignition Systems

1. Battery ignition with motor generator
2. Battery ignition with 10 Amp alternator

3. Battery ignition with 15 Amp alternator
4. Battery ignition with 30 Amp alternator

Breakerless Ignition System

1. Breakerless ignition with 10 Amp alternator
2. Breakerless ignition with 15 Amp alternator

Magneto Ignition System Operation

In all magneto ignition systems, high-strength permanent magnets provide the energy for ignition. In rotor type systems, the magnet is pressed onto the crankshaft and is rotated inside a coil-core assembly (stator) mounted on the bearing plate. In the other systems, a permanent magnet ring on the inside of the flywheel revolves around the stator. Movement of the magnets past the stator induces electric current flow in the stator coil (and in alternator and lighting coils if provided). The magnets are mounted with alternate North and South poles so that the direction of magnetic flux constantly changes, producing an alternating current (AC) in the stator coil windings. Refer to Figure 8-1.

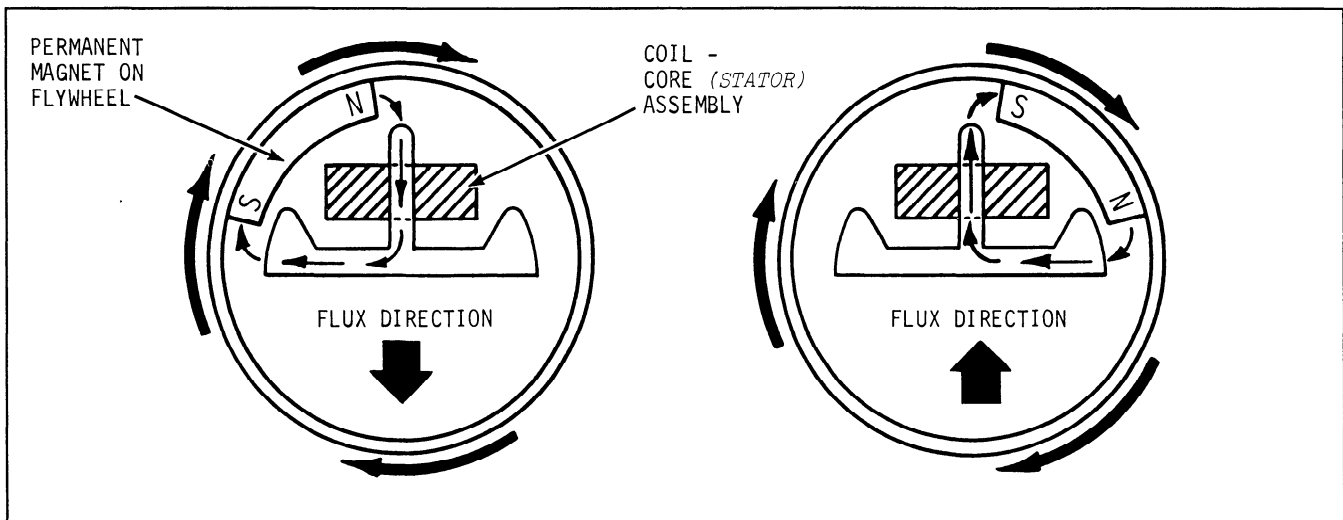

Figure 8-1. Magneto Cycle Showing Flux Reversal.

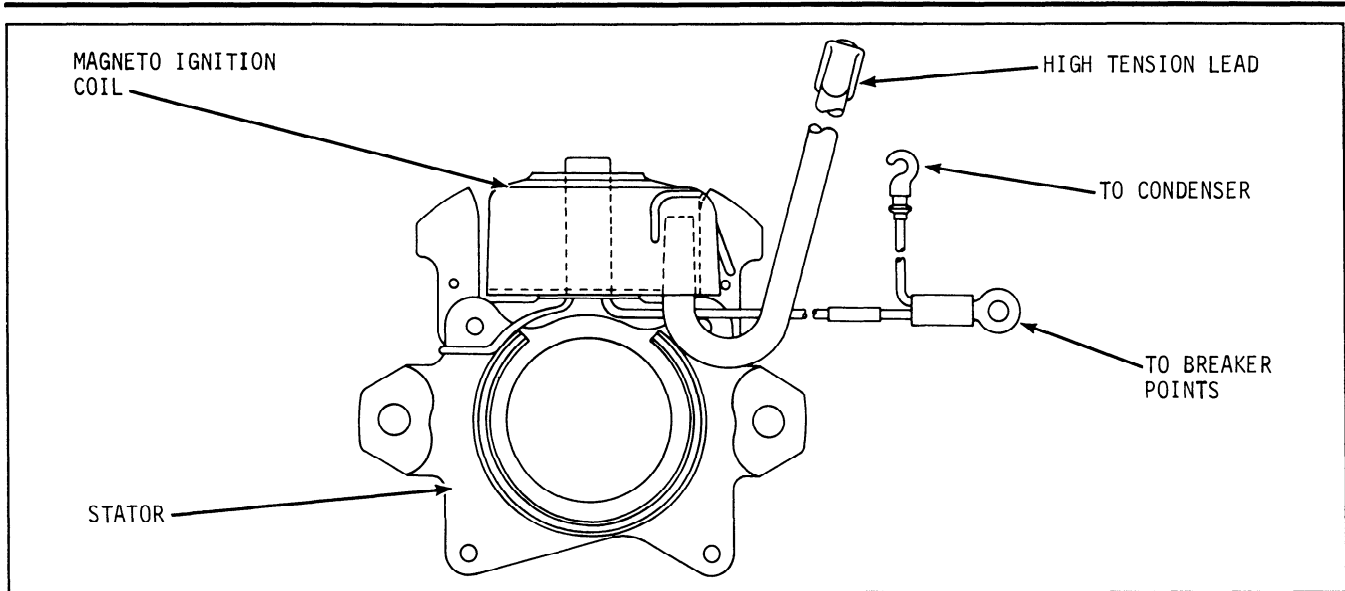

Figure 8-2. Typical Flywheel Magneto Ignition Coil And Stator.

The stator windings are connected to the magneto ignition coil. Current flow in the ignition coil reaches its highest peak at the instant the magnetic flux reverses direction. This is the point at which the system is timed to provide a spark at the spark plug.

The ignition coil has a low tension primary winding and a high tension secondary winding. The secondary winding has approximately 100 turns of wire for every 1 turn in the primary. This relationship causes the voltage induced in the secondary winding to be about 100 times higher than in the primary. If the magneto produces 250 volts in the primary winding, the secondary winding voltage will be 25,000 volts.

When ignition is required, the breaker points open to break the primary circuit. The resultant sudden collapse of the field around the primary winding causes sufficient energy to be produced in the secondary winding to bridge the spark plug gap. The collapsing field also induces energy in the primary winding, but the condenser shunts this energy to ground, preventing it from bridging the breaker point gap. Figure 8-2 shows a typical stator and coil assembly.

Magneto Ignition Timing

Engines are equipped with a timing sight hole either in the bearing plate or in the blower housing. If a snap button covers the hole, pry it out with a screwdriver or similar tool so that the timing marks may be seen. Two marks will be present on the flywheel; T for top dead center, and S or SP for the firing point (20 deg. before top dead center).

There are two ways to time a magneto ignition system, static and timing light. The timing light

method is the more accurate of the two. A storage battery is needed for use with most timing lights.

Static Timing Method – Perform static timing as follows.

1. Remove the breaker point cover.
2. Remove the spark plug lead to prevent unintentional starting of the engine.
3. Rotate the engine slowly by hand in the direction of normal operation. Rotation should be clockwise when viewed from the flywheel end.
4. The breaker points should just begin to open when the S or SP mark (T mark on Model K91) appears in the center of the timing sight hole. Continue rotating the engine until the breaker points are fully opened.
5. Measure the breaker point gap with a feeler gauge. The gap should be .020".
6. If the gap is not .020", loosen the gap adjustment screw and adjust the gap.
7. Tighten the gap adjustment screw.
8. Replace the breaker point cover.

Timing Light Timing Method – Several different types of timing lights are available. Follow the manufacturer's directions for use. Perform timing with a timing light as follows.

1. Remove the lead from the spark plug.
2. Wrap one end of a short piece of fine bare wire around the spark plug terminal and replace the lead. The free end of the wire must protrude from beneath the rubber boot on the lead.

NOTE: The preceding step is for timing lights using an alligator clip to connect to the spark plug. If the light in use has a sharp prong on the spark plug lead, simply penetrate the rubber boot with the prong and make contact with the spark plug lead metal connector.

3. Connect one timing light lead to the wire wrapped around the spark plug terminal.
4. Connect one timing light lead to the hot (ungrounded) terminal of the battery.
5. Connect the third timing light lead to engine ground.
6. Start the engine and run it at 1200 to 1800 RPM.
7. Aim the timing light at the timing sight hole. The light should flash just as the S or SP mark is centered in the sight hole or is in line with the center mark on the bearing plate or blower housing.
8. If timing is not as specified, carefully remove the breaker point cover and slightly loosen the gap adjusting screw, shift the breaker point plate until the timing mark is properly positioned, and tighten the screw.
9. Shut off the engine and replace the breaker point cover.

Battery Ignition System Operation

The battery ignition system operates in a manner similar to the magneto system. The major difference is that, in the battery system, energy is provided by a battery. The battery is maintained at full charge by an engine mounted motor-generator or alternator.

The coil in a battery ignition system is connected as follows. Refer to Figure 8-3.

The positive (+) terminal is connected to the positive terminal of the battery.

The negative (-) terminal is connected to the breaker points.

The high tension (center) terminal is connected to the spark plug.

Battery Ignition System Timing

The timing procedure for the battery ignition system is the same as for the magneto system. When using a timing light, refer to the manufacturer's instructions.

NOTE: The Model K341QS Specification 71276A engine is unique in that it is timed slightly differently than other K series engines. These engines operate at lower speed, so the timing is set at 16 degrees before top dead center to improve running smoothness. Instead of having an S or SP mark at the timing mark on the flywheel, these engines have a 1 above and a 6 below the mark. When timing these engines, the timing mark is centered as with other engines.

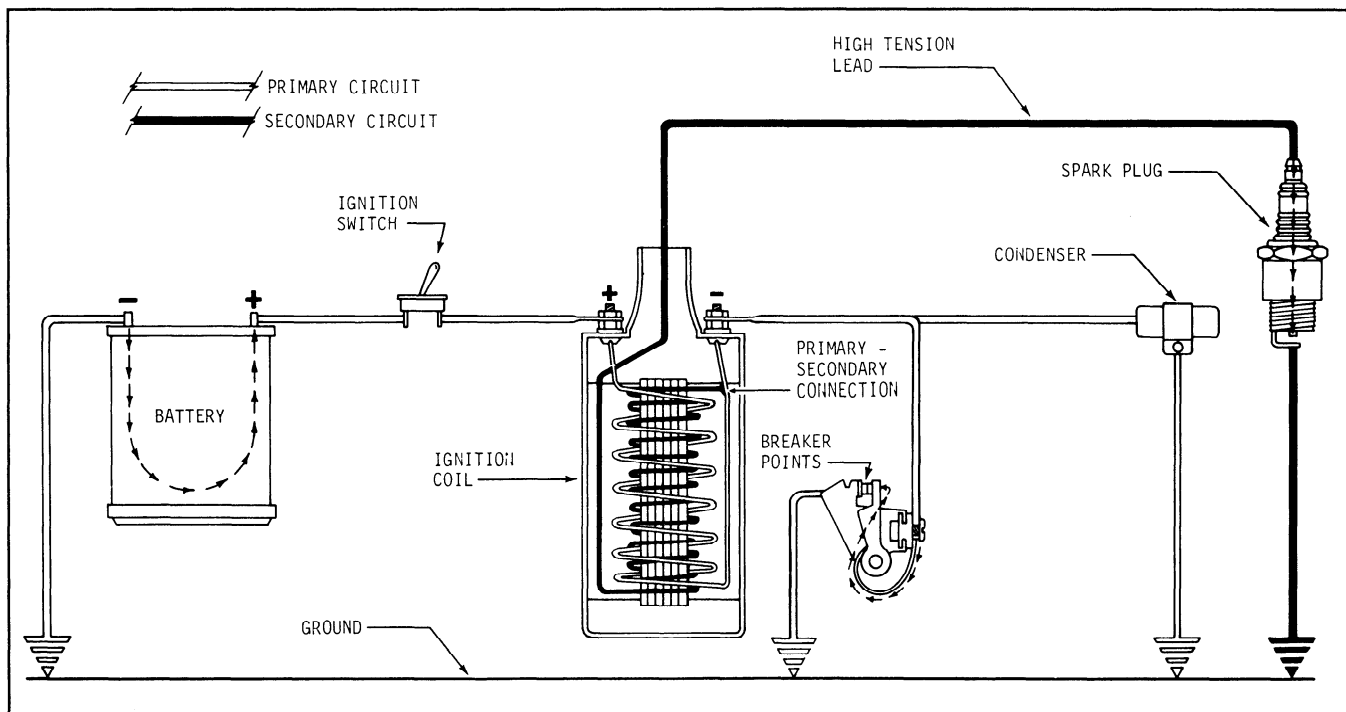

Figure 8-3. Wiring Diagram - Battery Ignition System.

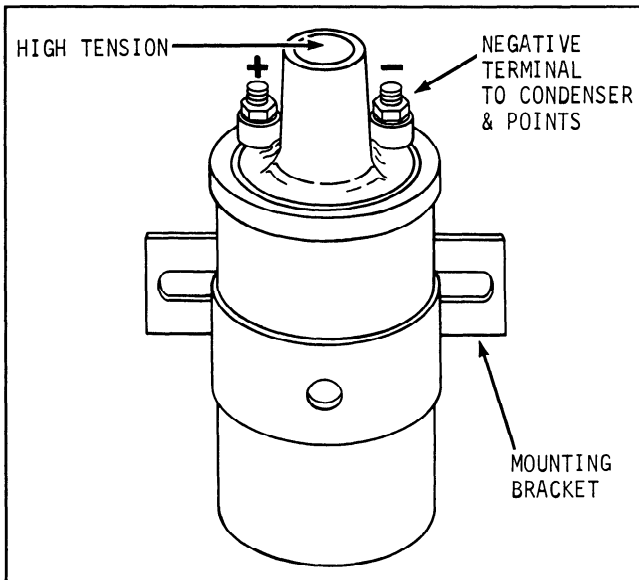

Figure 8-4. Typical Battery Ignition Coil.

Battery Ignition Service - 10 - 16 HP Single Cylinder Models

Ignition problems and poor performance on these models are often the result of using an incorrect ignition coil, spark plug, or plug gap setting. When replacing an ignition coil always use the genuine Kohler replacement. Use of the correct spark plug and gap setting is also important. The specified plug is a Champion H10/RH10, or equivalent, gapped at .035" (.9mm). Failure to follow these recommendations will result in erratic high speed ignition misfire or cutting-out under load.

Breakerless Ignition System Operation

The breakerless ignition system operates on the same general principle as the magneto system but does not use breaker points and conventional ignition condenser to time the spark. A trigger module containing solid state electronics performs the same function as the breaker points. Refer to Figure 8-5.

The breakerless system consists of four major components:

- Ignition winding on alternator stator
- Trigger module
- Ignition coil assembly
- Flywheel-mounted trigger

The ignition winding is separate from the other windings on the alternator stator. It functions like the magneto winding. The trigger module contains three diodes, a resistor, a sensing coil and magnet and an SCR, a sort of electronic switch. The ignition coil assembly includes a capacitor and a pulse transformer that serves the same purpose as the ignition coil in other systems. The flywheel has a projection that triggers ignition. Refer to Figure 8-6.

In some applications a 22 ohm, 1/2 watt resistor has been placed between the key switch and the ignition coil. This has been added to prevent current feedback through a dirty or wet switch. This feedback, if not held in check by a resistor, can damage the trigger unit.

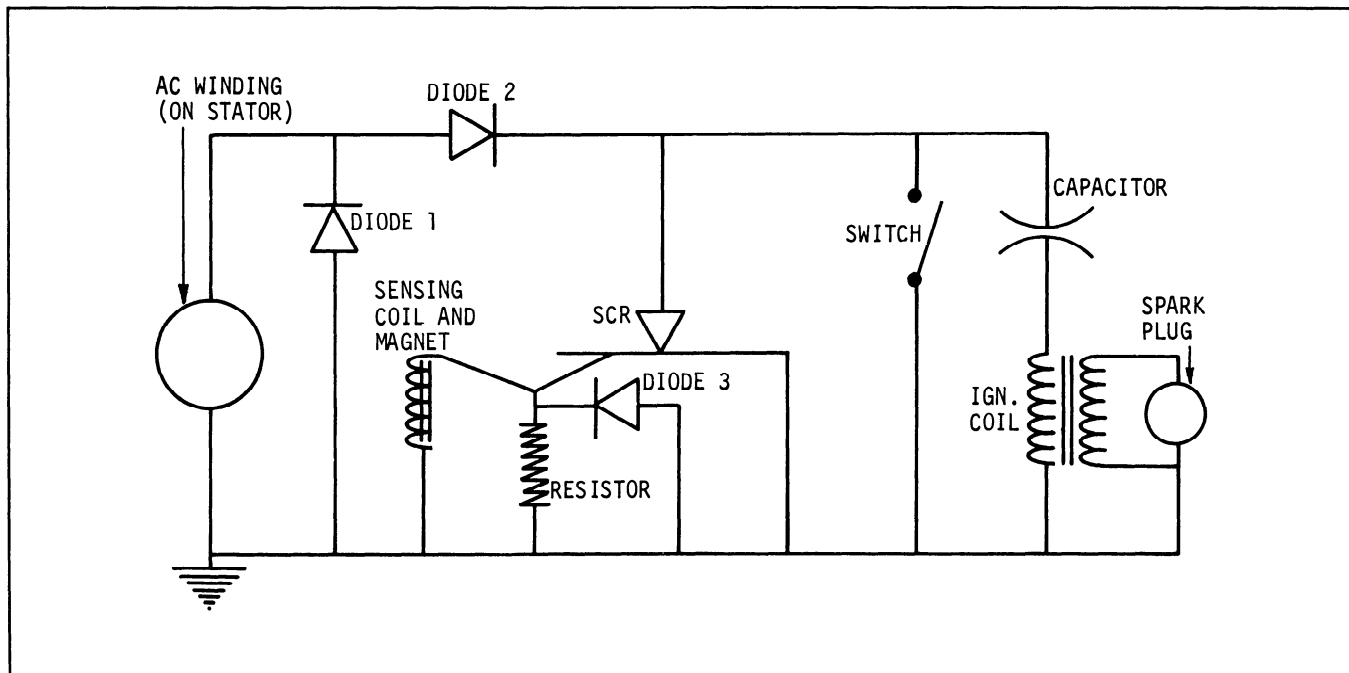

Figure 8-5. Schematic Of Typical Breakerless Ignition System.

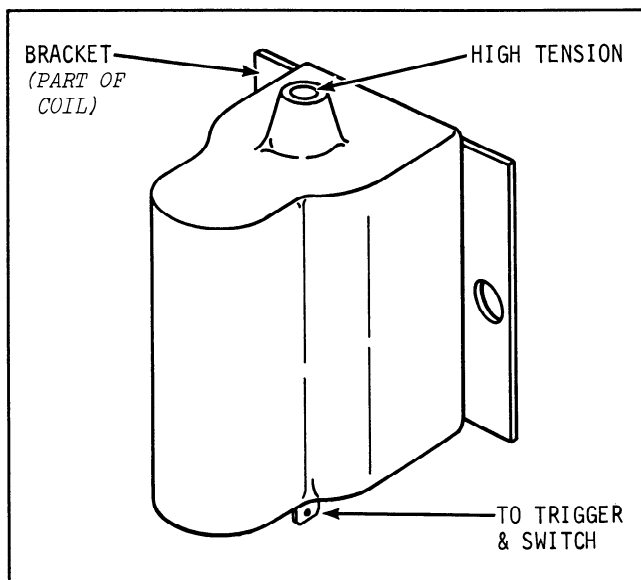

Figure 8-6. Typical Breakerless Ignition Coil.

Breakerless Ignition System Timing

Because there are no breaker points in this system, there is no requirement for timing. However, there is a requirement for positioning the trigger module for proper relationship with the flywheel projection. The gap between the projection and trigger module is normally set between .005 and .010". This setting is not critical, but selecting a .005" gap promotes better cold weather starting. Set the gap as follows.

1. Remove the spark plug lead to prevent inadvertent starting.
2. Rotate the flywheel so that the projection is aligned with the trigger module.
3. Loosen the cap screws on the trigger module bracket and insert a .005" feeler gauge in the gap.
4. Move the trigger module until it touches the feeler gauge, making sure that the flat surfaces of module and projection are parallel.
5. Tighten the cap screws and replace the spark plug lead.

The trigger module has two clip-on type terminals. Make sure that the leads are connected as shown in Figure 8-7.

TRIGGER MODULE (BREAKERLESS)

The trigger module used on breakerless ignition systems is a solid state device which includes diodes, resistor, sensing coil and magnet plus an electronic switch called an SCR. The terminal marked A must be connected to the alternator while terminal I must be connected to the ignition switch or ignition coil. Operating with these leads reversed will cause damage to the solid state de-

vices. If a faulty trigger module is suspected, disconnect and remove the trigger from the engine and perform the following tests with a flashlight tester. Reset air gap when reinstalling trigger.

Diode Test

Turn tester switch ON and connect one lead to the I terminal and the other to the A terminal then reverse these leads—light should come on with leads one way but not the other way. If light stays on or off both ways, this indicates diodes are faulty—replace trigger module.

SCR Test

Turn tester on then connect one lead to the I terminal and the other to the trigger mounting bracket.

NOTE: If light comes on, reverse the leads as the light must be off initially for this test.

Lightly tap magnet with a metal object—when this is done, tester light should come on and stay on until leads are disconnected. If light does not come on, this indicates SCR is not switching properly in which case trigger module should be replaced.

IGNITION COILS

Breakerless Type Ignition Coil

Use an ohmmeter to test breakerless type coil assembly. (A) -- Remove high tension lead from terminal on coil. Insert one ohmmeter lead in coil terminal and the other to the coil mounting bracket. A resistance of about 11,500 ohms should be indicated here. (B) -- Connect one tester lead to the coil mounting bracket and the other to the ignition switch wire. Continuity should not be indicated here. Replace ignition coil assembly if wrong results are obtained from either of these tests.

Magneto and Battery System Breaker Points

Engine operation is greatly affected by breaker point condition and adjustment of the gap. If points are burned or badly oxidized, little or no current will pass. The engine may not operate at all or may miss at high speed. Size of the breaker point gap affects the amount of time the points are open and closed. If the gap is set too wide, they will open too early and close too late. A definite period of time is required for the field to build in the ignition coil. If the points are closed for too long or too short a period, a weak spark will be produced by the coil.

Figure 8-8 shows the effects of too little and too much capacitance in the condenser. Severe metal buildup on either contact indicates that the condenser is not properly matched to the rest of the system and should be replaced.

Spark Plugs

Engine misfire and starting difficulty are often caused by the spark plug being in poor condition or being improperly gapped. The spark plug

should be removed after every 100 hours of operation for a check of its condition. At this time the gap should be reset or the spark plug replaced as necessary. Refer to Figure 8-9.

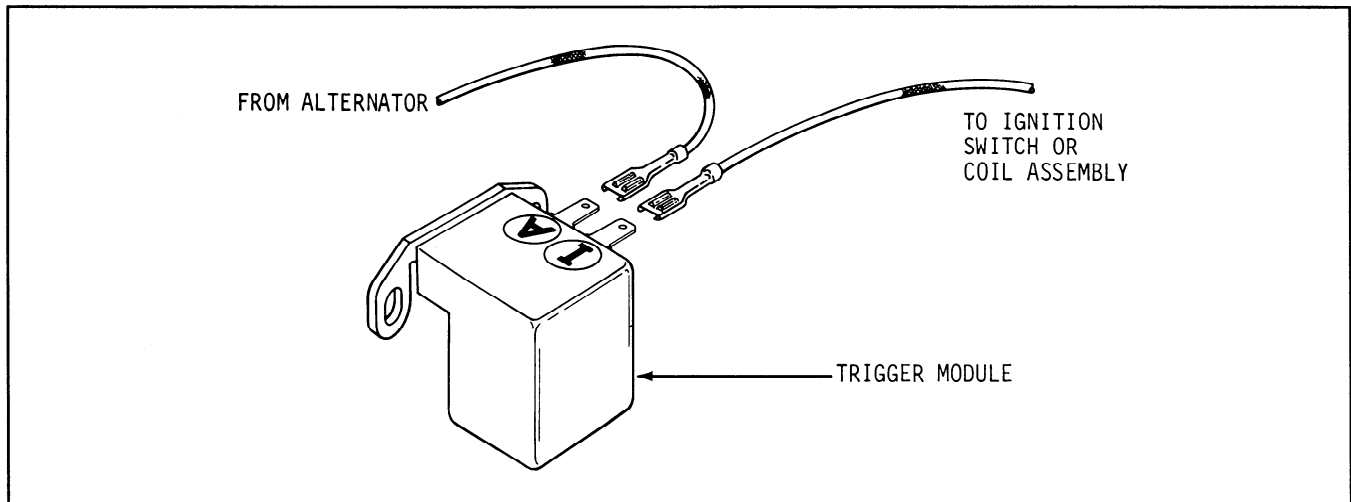

Figure 8-7. Trigger Module Lead Connections.

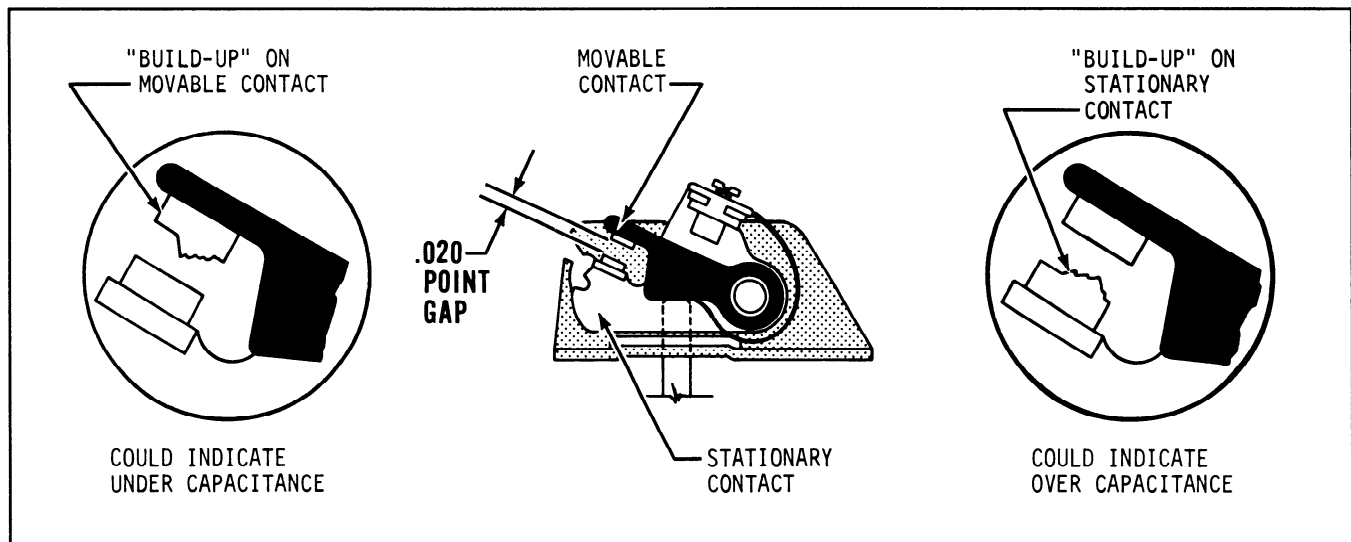

Figure 8-8. Metal Transfer On Breaker Points.

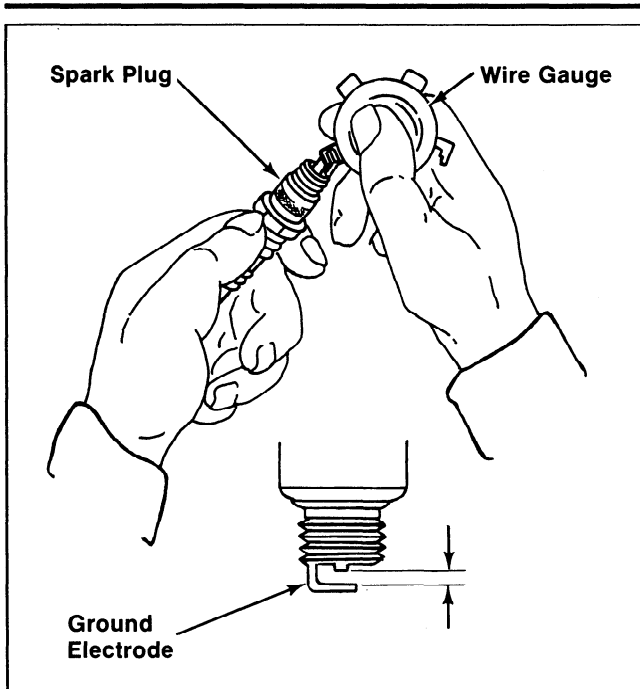

Figure 8-9. Setting Spark Plug Gap.

Service the spark plug as follows.

1. Clean the area around the base of the spark plug to keep dirt out of the engine upon removal.
2. Remove the spark plug and check its condition. Replace it if it is badly worn or if re-use is questionable. Clean it if it is re-useable.

NOTE: Do not clean the spark plug in a machine that uses abrasive grit. Some grit could remain in recesses and enter the engine, causing extensive wear and damage.

3. Check the gap with a wire type feeler gauge. Set the gap as shown in the following table by carefully bending the side electrode.
4. Install the spark plug and torque to 18 to 20 ft. lb.

Spark Plug Specifications

Inspect the spark plug as soon as it is removed from the engine. The deposits on tip are a good indicator of the general condition of piston rings, valves and carburetor. Normal and faulty spark plugs are shown in Figures 8-10 through 8-14.

Engine	Ignition Type	Plug Part No.	Gap
K91-K181	Battery	270321-S	.025"
	Magneto	41 132 06*	.025"
	Breakerless	41 132 02**	.025"
K241-K341	Battery	235040-S	.035"
	Breakerless	235041-S*	.035"
		41 132 02**	.035"
K241-K341	Magneto	235040-S	.025"
		235041-S*	.025"

* Standard resistor plug

** Short resistor plug

NOTE: On gas fueled engines, gap is .018" on all models

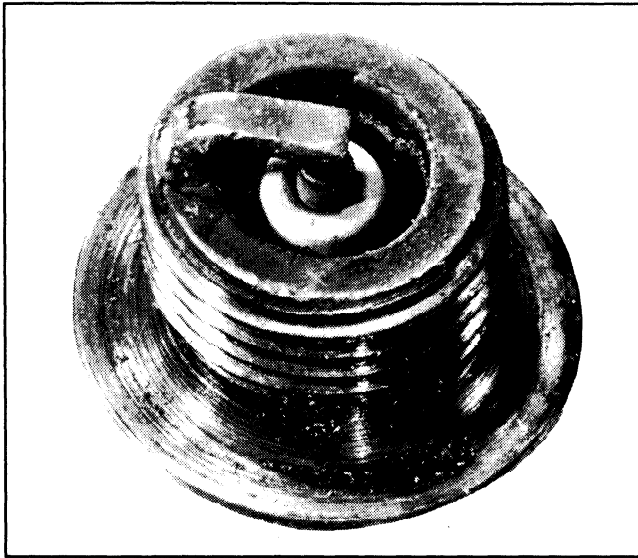

Figure 8-10. Normal.

Normal: A plug taken from an engine operating under normal conditions will have light tan or gray deposits. If the center electrode is not worn, a plug in this condition may be gapped and re-used.



Figure 8-11. Carbon Fouled.

Carbon Fouled: Soft, sooty, black deposits indicate incomplete combustion. This is usually caused by overrich carburetor settings, weak ignition or poor compression.

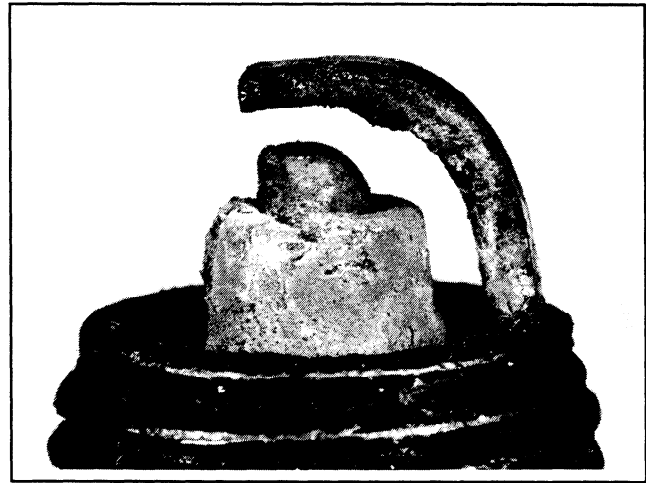

Figure 8-12. Worn.

Worn: On a worn plug, the center electrode will be rounded and the gap will be eroded .010" or more beyond the correct gap. Replace a worn spark plug.

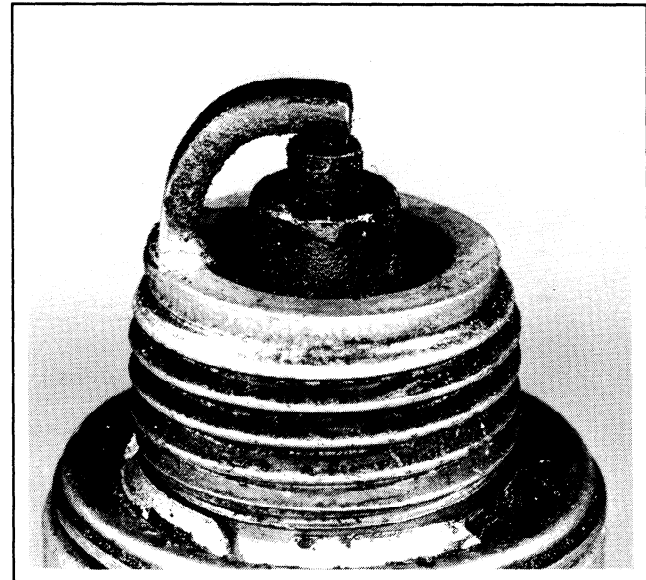

Figure 8-13. Wet Fouled.

Wet Fouled: Wetness is caused by excess fuel or oil in the combustion chamber. Excess fuel could be caused by operating the engine without fully opening the choke after warmup. Oil in the combustion chamber is usually the result of worn piston rings and/or valve guides.



Figure 8-14. Chalky White Deposits.

Chalky White Deposits: Chalky white deposits indicate overheating. This condition is usually accompanied by excessive gap erosion. A clogged grass screen, clogged cooling fins and excessively lean carburetion are some causes of overheating.

Alternator Operation

There are five different models of alternators used in the K series of engines. They are rated at 1.25, 3, 10, 15 and 30 amperes. The 1.25 amp system is intended for battery charging only. The 3 amp

device is intended for battery charging and lighting.

Refer to the wiring diagrams and troubleshooting guides in this subsection to test and service these systems. There are no adjustments in these systems. Replace if faulty.

NOTE: To prevent damage to the electrical system and components:

- a. Make sure the battery polarity is correct. A negative (-) ground system is used with K series engines.
- b. Disconnect the rectifier-regulator leads and/or wiring harness plug if electric (arc) welding is to be done on the equipment powered by the engine. Disconnect any other electrical accessories that share a common ground with the engine.
- c. Make sure the stator (AC) leads do not touch. Shorting them together could permanently damage the stator.
- d. Do not operate the engine with the battery disconnected.

NOTE: If a battery has discharged to less than 4 volts, there may not be sufficient power to activate the rectifier-regulator. If the battery fails to accept a charge from the alternator, charge it on a battery charger and reinstall.

Troubleshooting Guide

1.25 Amp Or 3 Amp Unregulated Charging System Optional 70 Watt Lighting

NOTE: Zero ohmmeters and voltmeters on each scale to ensure accurate readings. Voltage test should be made with engine running at 3000 RPM –no load. Battery must be fully charged.

Problem	Test	Conclusion
No Charge To Battery	1. With engine running at 3000 RPM, measure voltage across battery terminals using a DC voltmeter.	1. If voltage is more than 12.5 volts, charging system is OK. If voltage is 12.5 volts or less, the stator or diode are probably faulty. Test the stator and diode (Test 2, 3, and 4).
	2. Disconnect the charging lead from battery. With engine running at 3000 RPM, measure voltage from charging lead to ground using a DC voltmeter.	2a. 1.25 amp. If voltage is 11.5 volts or more stator winding is OK. 2b. 3 amp. If voltage is 28 volts or more, stator winding is OK. If voltage is less than specified test stator using an ohmmeter (Tests 3 and 4).
	3. With charging lead disconnected from battery and engine stopped, measure resistance from charging lead to ground using an ohmmeter. Note reading. Reverse the leads and measure resistance again. In one direction, the resistance should be infinity ohms (open circuit). With the leads reversed, some resistance should be measured (about midscale on Rx1 range).	3. If resistance is low in both directions, the diode is shorted. Replace the diode. If resistance is high in both directions, the diode or stator winding is open. (Use Test 4).
	4. Cut the sleeving on the charging lead to expose the diode connections. Measure the resistance from the stator side of diode to ground using an ohmmeter.	4. If resistance is 0.7/1.3 ohms, stator winding is OK. If resistance is 0 ohms, stator winding is shorted. Replace stator. If resistance is infinity ohms, stator winding or lead is open. Replace stator.
No Lights	1. Make sure lights are not burned out.	1. Replace burned out lights.
	2. Disconnect the lighting lead from the wiring harness. With engine running at 3000 RPM, measure voltage from lighting lead to ground using an AC voltmeter.	2. If voltage is 15 volts or more, stator is OK. Check for loose connections or shorts in wiring harness. If voltage is less than 15 volts, test stator using an ohmmeter (Test 3).
	3. With engine stopped, measure the resistance of stator from lighting lead to ground using an ohmmeter.	3. If resistance is approx. 0.4 ohms, stator is OK. If resistance is 0 ohms, stator is shorted. Replace stator. If resistance is infinity ohms, stator or lighting lead is open. Replace stator.

Electric Start Engines
1.25 Amp Or 3 Amp Unregulated Battery Charging System
Optional 70 Watt Lighting

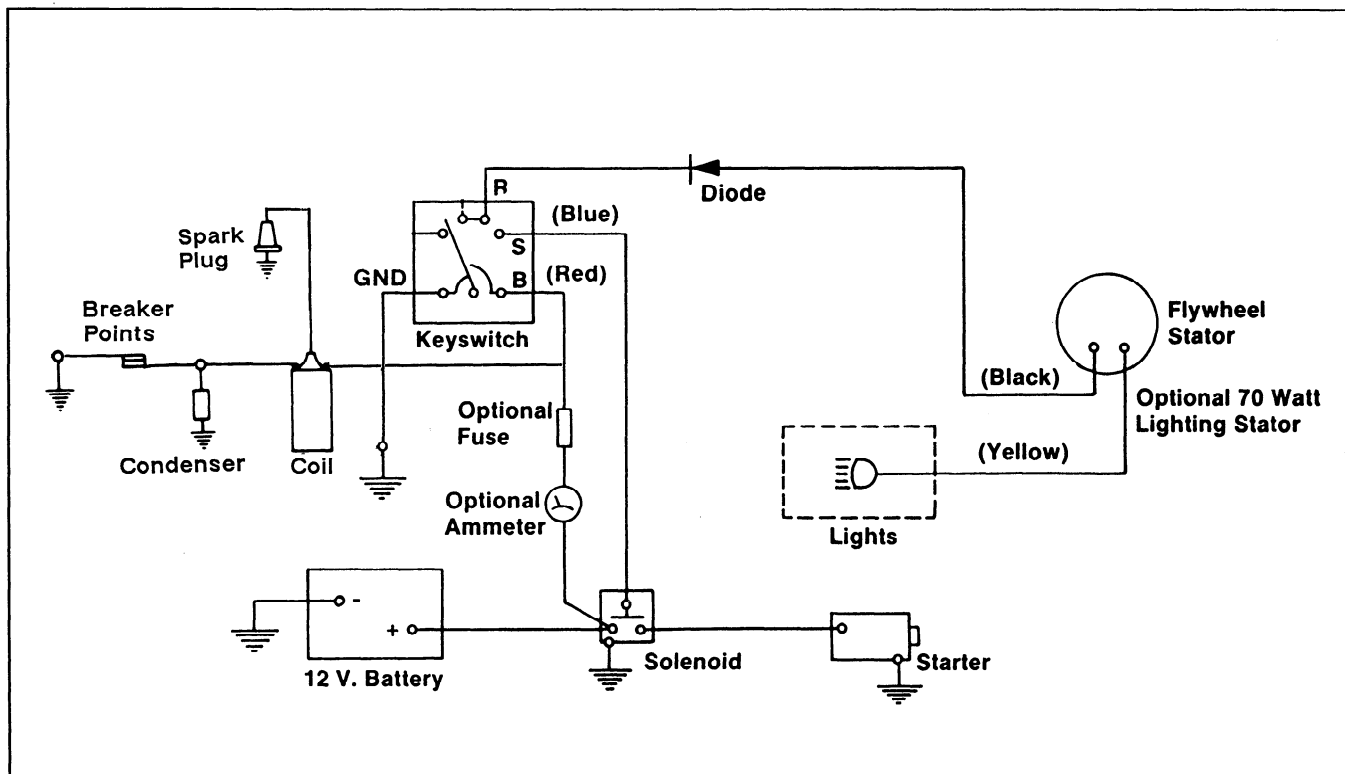

Figure 8-15. Wiring Diagram – Electric Start Engines 1.25 Amp or 3 Amp Unregulated Battery Charging System/70 Watt Lighting.

TROUBLE ANALYSIS – 10 AMP ALTERNATOR SYSTEM

TEST WITH ENGINE RUNNING AT 3600 RPM – NO LOAD

CONDITION: No Charge To Battery	Possible Fault/Remedy
<p>TEST A -- Disconnect B+ cable to positive terminal of battery. Connect DC Voltmeter between B+ cable and ground. Check DC voltage:</p> <p>A-1 -- If above 14 volts.</p> <p>A-2 -- If less than 14 volts (but above 0 volts).</p> <p>A-3 -- If 0 volts.</p>	<p>A-1 -- Alternator system OK--ammeter may be giving false reading. Repair or replace ammeter.</p> <p>A-2 -- Check for defective rectifier-regulator (TEST C).</p> <p>A-3 -- Check for defective stator or rectifier - regulator (Test C).</p>
<p>TEST B -- With B+ cable reconnected, check B+ (at terminal on rectifier-regulator) to ground with DC Voltmeter. If 13.8 volts or higher, place minimum load of 5 amps* on battery to reduce voltage.</p> <p>B-1 -- If charge rate increases.</p> <p>B-2 -- If charge rate does not increase.</p>	<p>B-1 -- Indicates alternator system OK, battery was fully charged.</p> <p>B-2 -- Check for defective stator or rectifier - regulator (TEST C).</p>
<p>TEST C -- Unplug leads at rectifier-regulator, connect VOM (multimeter) across AC leads, check AC voltage:</p> <p>C-1 -- If less than 20 volts.</p> <p>C-2 -- If more than 20 volts.</p>	<p>C-1 -- Defective stator, replace with new assembly.</p> <p>C-2 -- Defective rectifier-regulator, replace with new unit.</p>
CONDITION: Battery Continuously Charges At High Rate	Possible Fault/Remedy
<p>TEST D -- Check B+ to ground with DC Voltmeter:</p> <p>D-1 -- If over 14.7 volts.</p> <p>D-2 -- If under 14.7 volts.</p>	<p>D-1 -- Rectifier - regulator not functioning properly. Replace with new unit.</p> <p>D-2 -- Alternator system OK. Battery unable to hold charge. Check specific gravity of battery. Replace if necessary.</p>

*Turn lights on if 60 watts or more or simulate load by placing a 2.5 ohm 100 watt resistor across battery terminals.

Electric Start Engines
15 Amp Regulated Battery Charging System

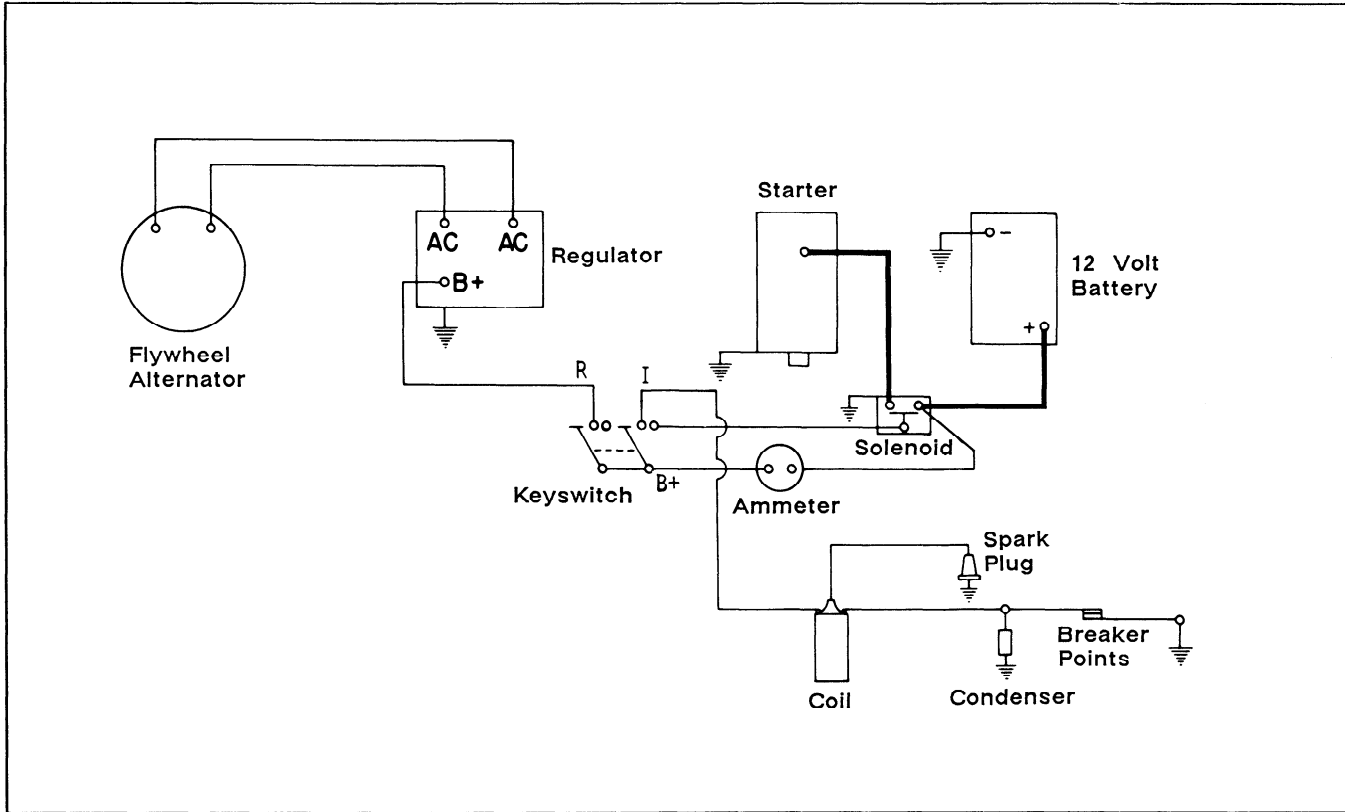

Figure 8-16. Wiring Diagram - Electric Start Engines/15 Amp Regulated Battery Charging System.

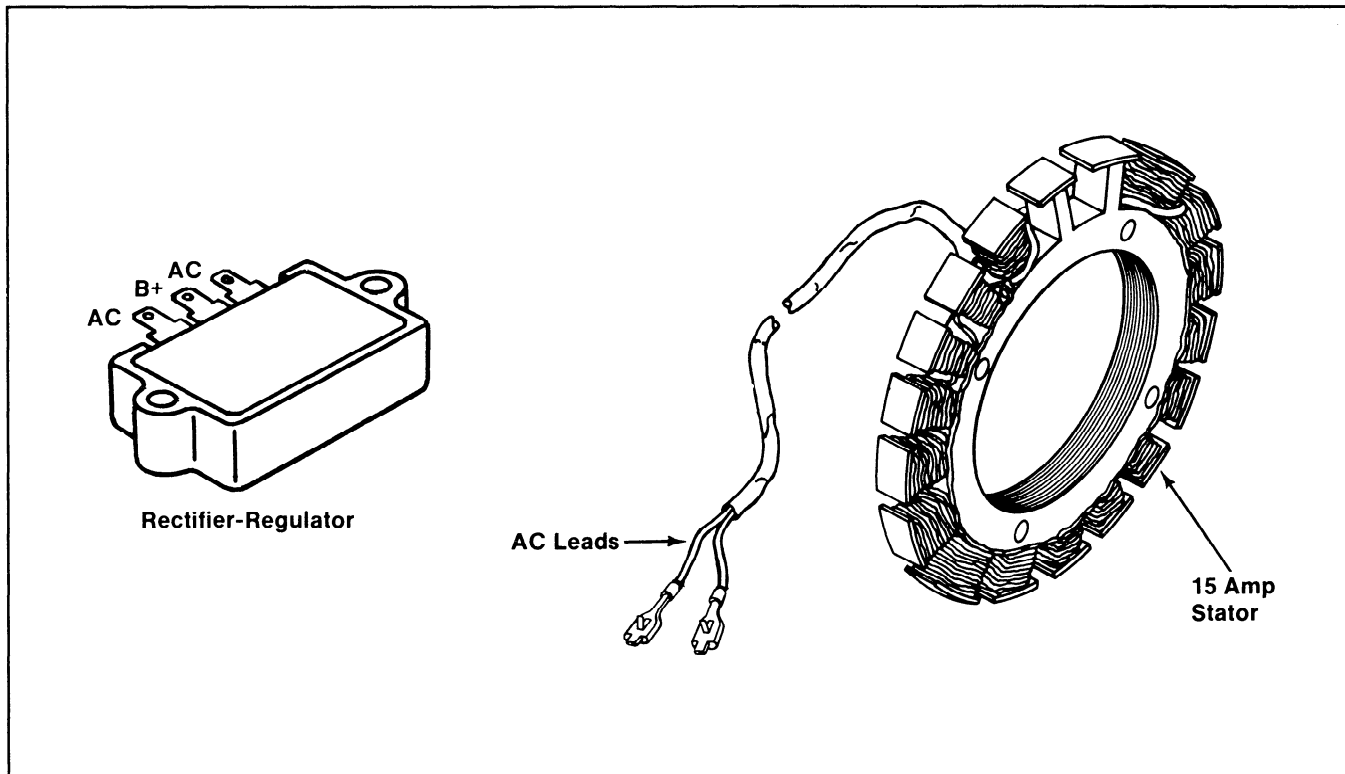

Figure 8-17. 15 Amp Stator And Rectifier-Regulator.

Troubleshooting Guide

15 Amp Battery Charging System

NOTE: Zero ohmmeters and voltmeters on each scale to ensure accurate readings. Voltage tests should be made with engine running at 3600 RPM – no load. Battery must be fully charged.

Problem	Test	Conclusion
No Charge To Battery	<p>1. Insert an ammeter in B+ lead from rectifier-regulator. With engine running at 3600 RPM and B+ lead connected, measure the voltage from B+ (at terminal on rectifier-regulator) to ground using a DC voltmeter.</p> <p>If voltage is 13.8 volts or more, place a minimum load of 5 Amps* on battery to reduce voltage. Observe ammeter.</p> <p>*NOTE: Turn on lights, if 60 watts or more. Or place a 2.5 ohm, 100 watt resistor across battery terminals.</p>	<p>1. If charge rate increases when load is applied, the charging system is OK and battery was fully charged.</p> <p>If charge rate does not increase when load is applied, test stator and rectifier-regulator (tests 2 and 3).</p>
	<p>2. Remove connector from rectifier-regulator. With engine running at 3600 RPM, measure AC voltage across stator leads using an AC voltmeter.</p>	<p>2. If voltage is 28 volts or more, stator is OK. Rectifier-regulator is faulty. Replace the rectifier-regulator.</p> <p>If voltage is less than 28 volts, stator is probably faulty and should be replaced. Test stator further using an ohmmeter (test 3).</p>
	<p>3a. With engine stopped, measure the resistance across stator leads using an ohmmeter.</p>	<p>3a. If resistance is 0.1/0.2 ohms, the stator is OK.</p> <p>If resistance is infinity ohms, stator is open. Replace stator.</p>
	<p>3b. With engine stopped, measure the resistance from each stator lead to ground using an ohmmeter.</p>	<p>3b. If resistance is infinity ohms (no continuity), the stator is OK (not shorted to ground).</p> <p>If resistance (or continuity) is measured, the stator leads are shorted to ground. Replace stator.</p>
Battery Continuously Charges At High Rate	<p>1. With engine running at 3600 RPM, measure voltage from B+ lead to ground using a DC voltmeter.</p>	<p>1. If voltage is 14.7 volts or less the charging system is OK. The battery is unable to hold charge. Service battery or replace as necessary.</p> <p>If voltage is more than 14.7 volts, the rectifier-regulator is faulty. Replace rectifier-regulator.</p>

**Electric Start Engine
25 Amp Regulated Battery Charging System**

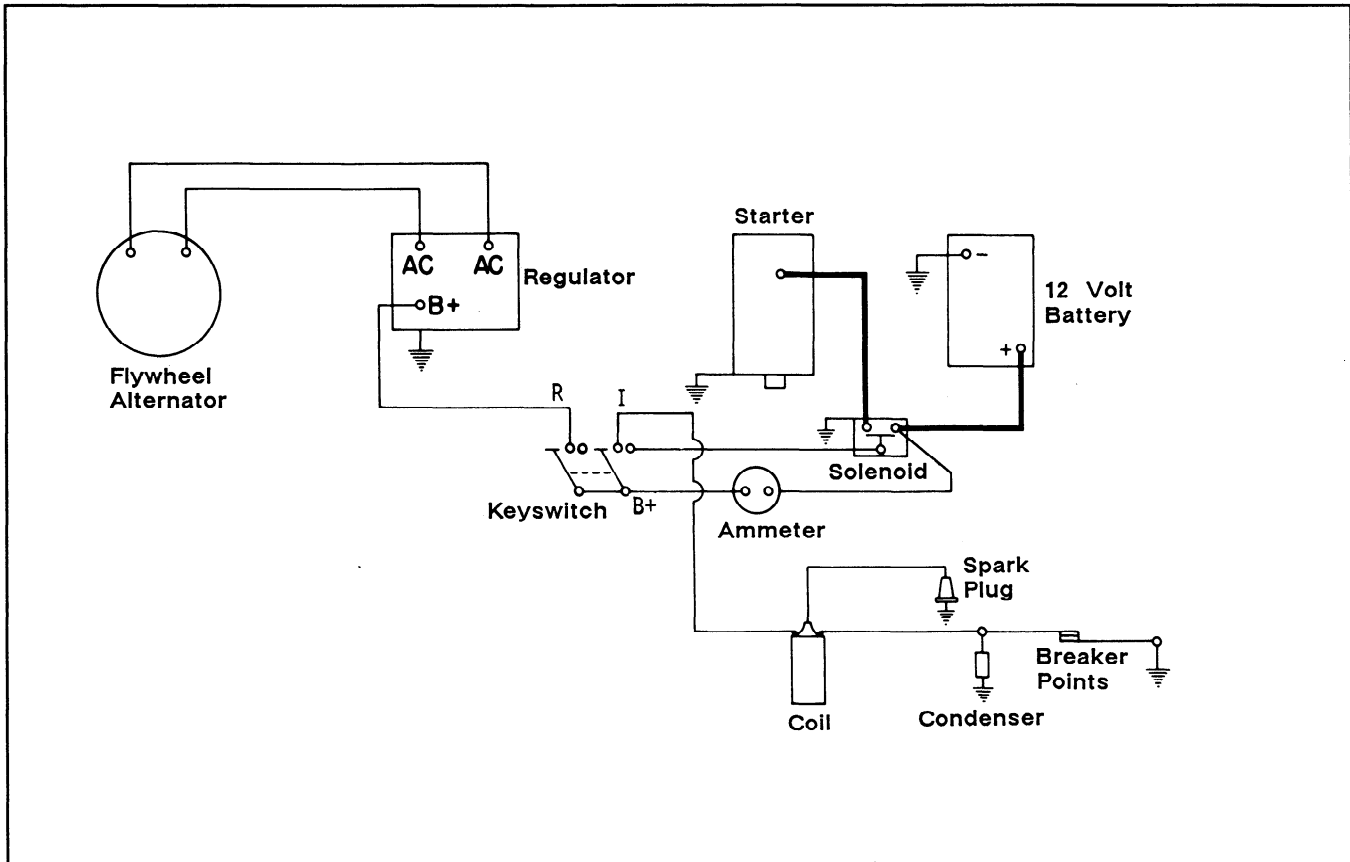

Figure 8-18. Wiring Diagram - Electric Start Engines/25 Amp Regulated Battery Charging System.

8

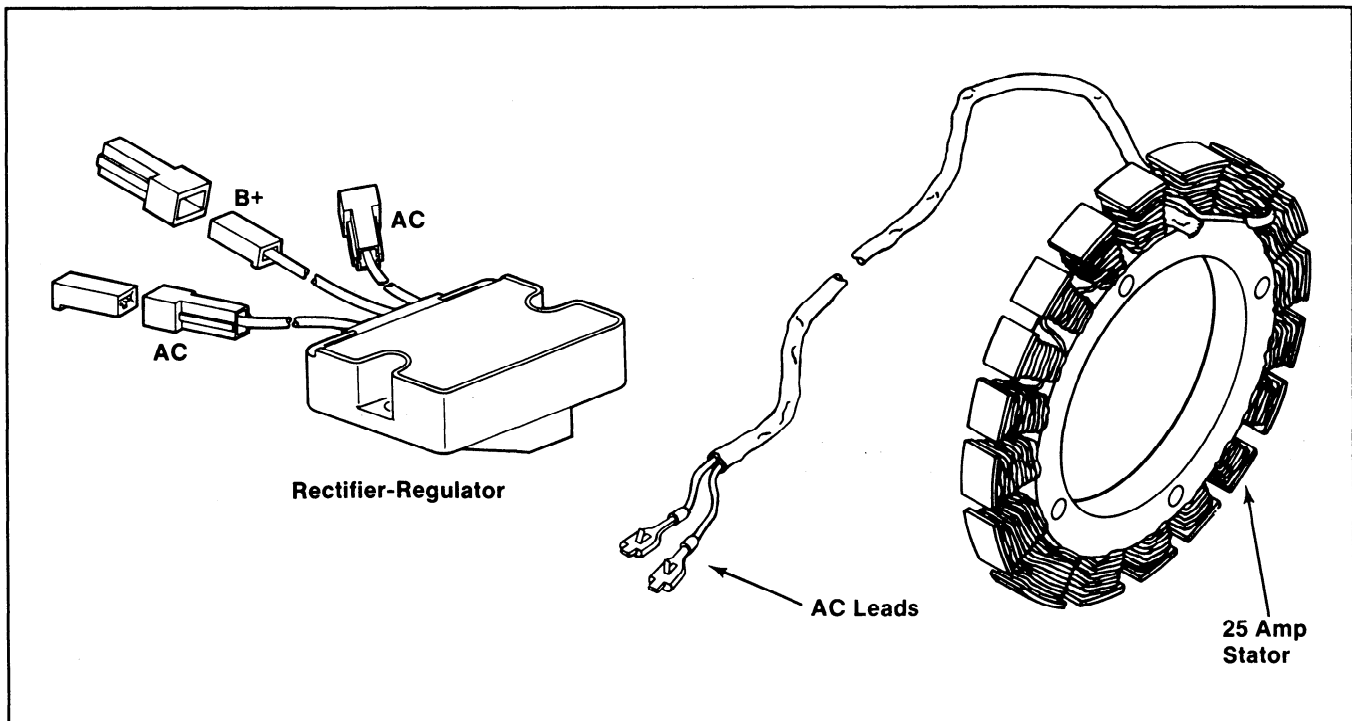

Figure 8-19. 25 Amp Stator And Rectifier-Regulator.

Troubleshooting Guide

25 Amp Battery Charging System

*NOTE: Zero ohmmeters and voltmeters on each scale to ensure accurate readings. Voltage tests should be made with engine running at 3600 RPM – no load. Battery must be fully charged.

Problem	Test	Conclusion
No Charge To Battery	<p>1. Insert an ammeter in B+ lead from rectifier-regulator. With engine running at 3600 RPM and B+ lead connected, measure the voltage from B+ (at terminal on rectifier-regulator) to ground using a DC voltmeter.</p> <p>If voltage is 13.8 volts or more, place a minimum load of 5 Amps* on battery to reduce voltage. Observe ammeter.</p> <p>*NOTE: Turn on lights, if 60 watts or more. Or place a 2.5 100 ohm, watt resistor across battery terminals.</p>	<p>1. If charge rate increases when load is applied, the charging system is OK and battery was fully charged.</p> <p>If charge rate does not increase when load is applied, test stator and rectifier-regulator (tests 2 and 3).</p>
	<p>2. Remove connector from rectifier-regulator. With engine running at 3600 RPM, measure AC voltage across stator leads using an AC voltmeter.</p>	<p>2. If voltage is 28 volts or more, stator is OK. Rectifier-regulator is faulty. Replace the rectifier-regulator.</p> <p>If voltage is less than 28 volts, stator is probably faulty and should be replaced. Test stator further using an ohmmeter (test 3).</p>
	<p>3a. With engine stopped, measure the resistance across stator leads using an ohmmeter.</p>	<p>3a. If resistance is 0.064/0.096 ohms, the stator is OK.</p> <p>If resistance is infinity ohms, stator is open. Replace stator.</p>
	<p>3b. With engine stopped, measure the resistance from each stator lead to ground using an ohmmeter.</p>	<p>3b. If resistance is infinity ohms (no continuity) the stator is OK (not shorted to ground).</p> <p>If resistance (or continuity) is measured, the stator leads are shorted to ground. Replace stator.</p>
Battery Continuously Charges At High Rate	<p>1. With engine running at 3600 RPM, measure voltage from B+ lead to ground using a DC voltmeter.</p>	<p>1. If voltage is 14.7 volts or less the charging system is OK. The battery is unable to hold charge. Service battery or replace as necessary.</p> <p>If voltage is more than 14.7 volts, the rectifier-regulator is faulty. Replace rectifier-regulator.</p>

**Electric Start Engine
30 Amp Regulated Battery Charging System**

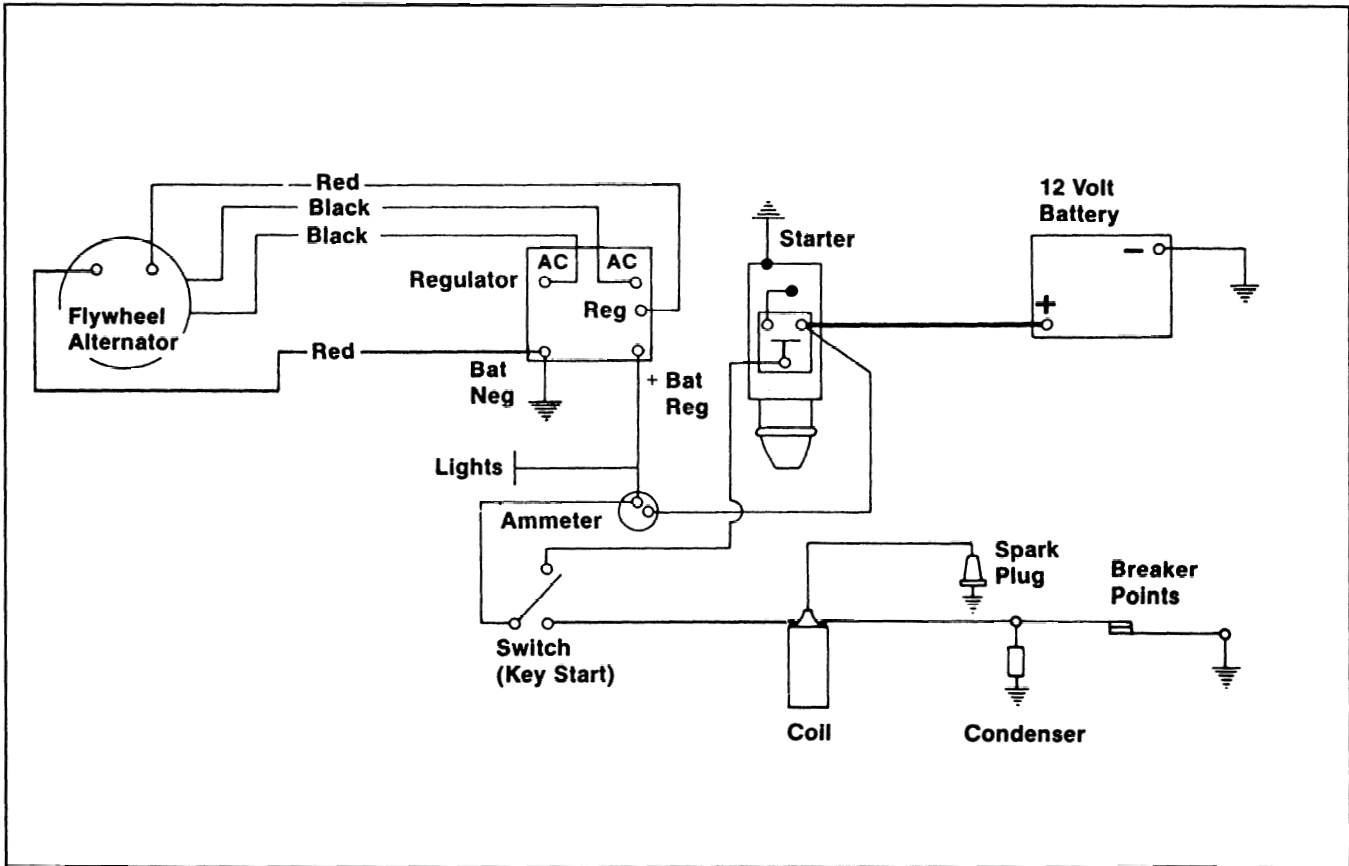

Figure 8-20. Wiring Diagram - Electric Start Engines/30 Amp Regulated Battery Charging System.

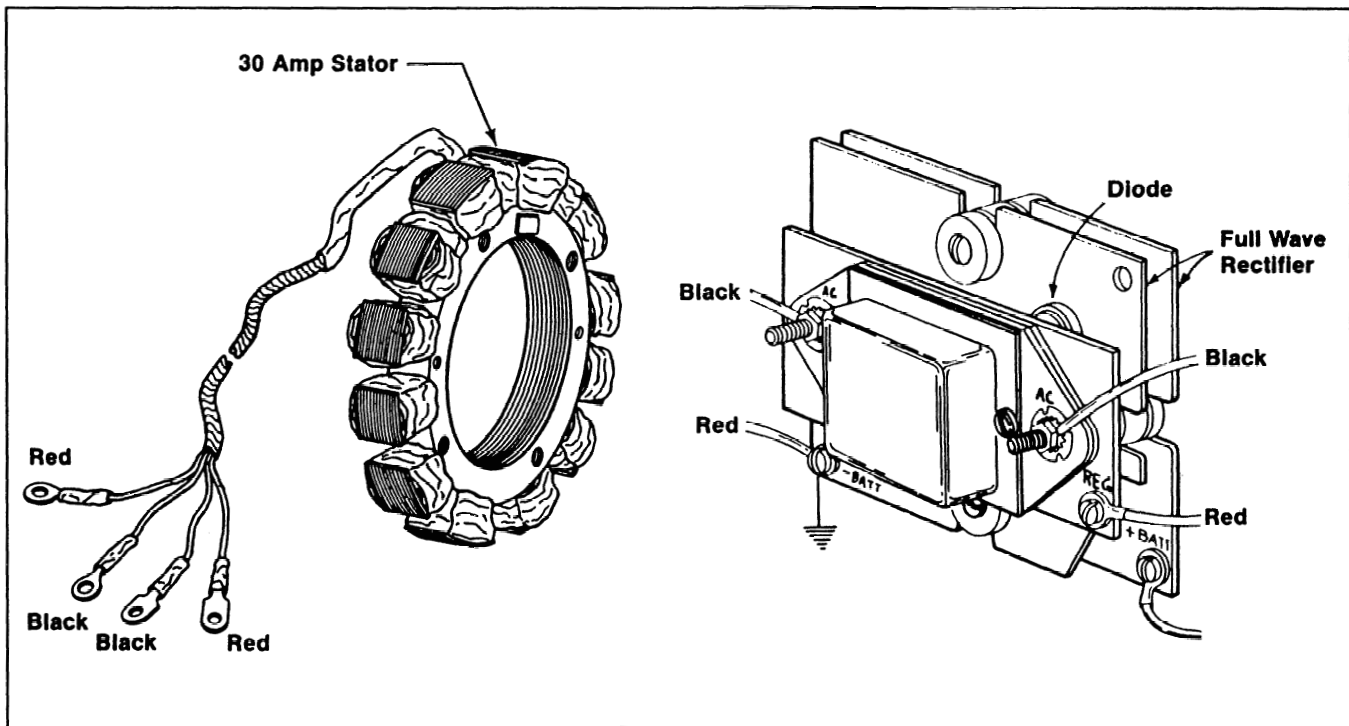

Figure 8-21. 30 Amp Stator And Rectifier-Regulator.

Troubleshooting Guide

30 Amp Regulated Battery Charging System

Output tests should be made with engine running at 3600 RPM – no load. Battery must be fully charged.

Problem	Test	Conclusion
No Charge To Battery	Remove 4 input leads from rectifier-regulator. Set ohmmeter on Rx1 scale and zero scale.	
	1a. Connect ohmmeter across red leads and check resistance.	1a. Resistance should be 2.0 ohms.
	1b. Connect ohmmeter across black leads and check resistance.	1b. Resistance should be 0.1 ohms.
	1c. Measure the resistance from each stator lead to ground. Replace stator if specified values are not found.	1c. Resistance should be infinity ohms (no continuity).
	2. Connect leads of flashlight type continuity tester from BAT NEG to one AC terminal, then reverse leads. Repeat procedure on the other AC terminal.	2. Lamp off in one direction, on when leads are reversed. Diodes in regulator are good. Replace rectifier-regulator if lamp indication is the same in both directions.
	3. Remove red lead from REG terminal (all other leads connected to appropriate terminals). If unit does not have ammeter, connect ammeter between + BAT REG terminal and battery. Start engine and operate at full speed.	3. Charging system output less 20 amps. Faulty regulator winding on stator, replace stator.
Battery Continuously Charges At High Rate	1. Remove two red leads from rectifier-regulator, connect these two leads together. Start engine and operate at full speed.	1. Charge rate is 4 amps or less. Stator is good. Replace rectifier-regulator. Charging system continues to charge at high rate. Regulator winding shorted, replace stator.

ELECTRIC STARTING SYSTEMS

There are three types of starters used in the K series of engines. The three types are:

Motor-Generator – This starter also functions as a DC generator. In the starting mode, it turns the crankshaft through a V belt arrangement. The V belt transmits turning force from a small pulley on the motor-generator to a large pulley on the crankshaft.

Wound-Field Bendix Drive Starter – In the field-wound starters, electrical current flows through coils to build up a strong magnetic field to turn the armature. When the armature starts to rotate, a drive pinion moves forward on the armature shaft and meshes with a ring gear on the flywheel. The armature and ring gear remain engaged until the engine starts to run. When the flywheel begins to turn faster than the starter, the pinion is thrown from the ring gear and returns to the disengaged position. A small anti-drift spring on the armature

shaft holds the pinion in this position as the starter slows to a stop.

Permanent Magnet Bendix Drive Starter – Operation of this type starter is the same as that of the wound-field starter. The major difference between the two is in the method of generating the magnetic field to turn the armature. This starter uses strong permanent magnets in place of field coils.

Safety Interlocks

In an effort to enhance safe operation of their equipment, many manufacturers install safety interlocks to prevent engine start before certain safety requirements are met. These interlocks are usually incorporated in the starter circuit. Unless all interlock switches are closed, the starter will not function.

Before servicing a starter that is reported to have failed, always check the safety interlock system first. This is done by bypassing the interlock switches with a temporary jumper wire.

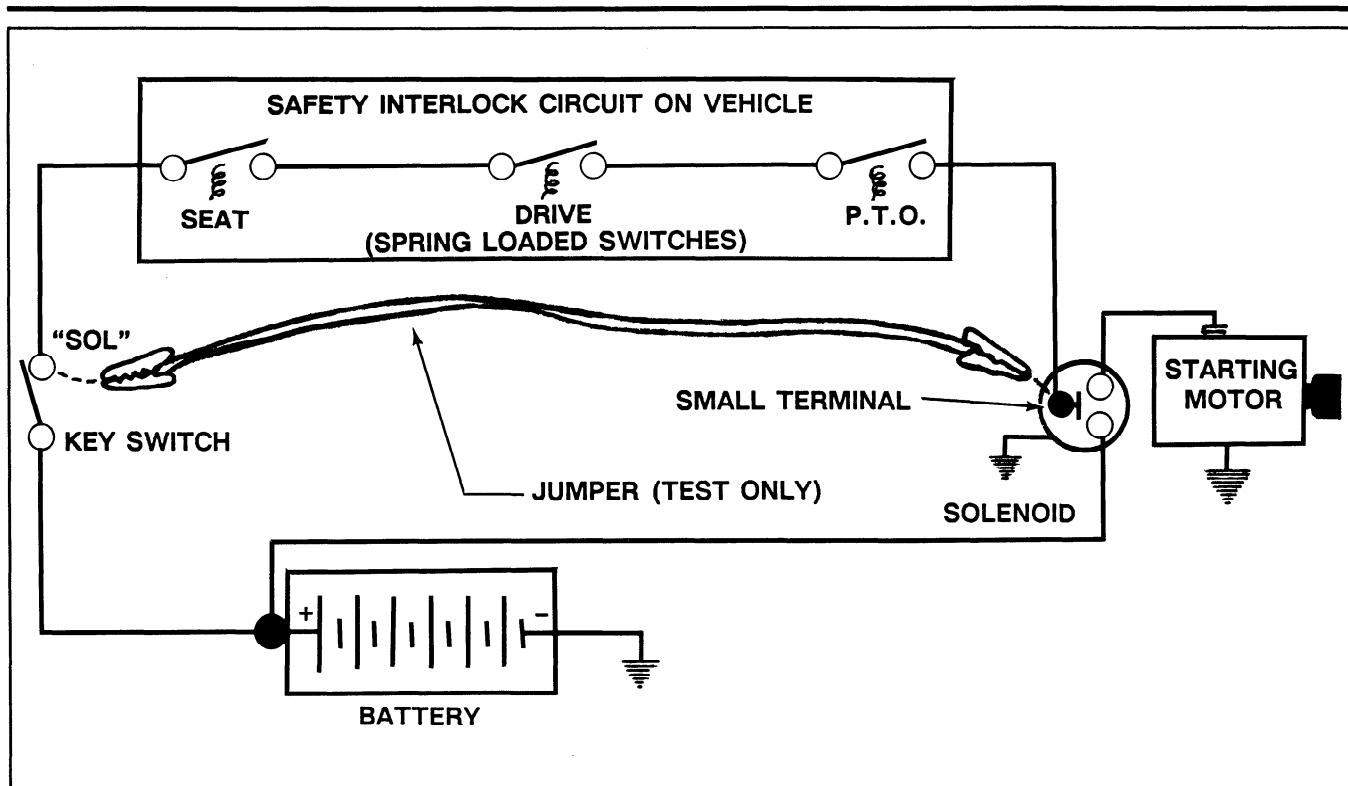

Figure 8-22. Battery Ignition Interlock Bypass.

⚠ WARNING: Never return an engine to the owner with the safety interlock system removed or bypassed.

Great bodily harm or equipment damage could result.

Interlocks connected to an engine with a battery ignition system are bypassed simply by placing a jumper wire as shown in Figure 8-22.

⚠ WARNING: Make sure all safety conditions have been observed before starting an engine with the interlocks bypassed.

The safety interlock system on manual start magneto ignition engines is placed in the ignition system. The series connected interlock switches are connected to a solid state module that is connected to the ignition system. The module serves two functions. It grounds the ignition system until all interlocks have closed and, after the engine has started, it prevents the ignition from grounding as the individual interlocks are opened in normal operation (transmission placed in Drive, PTO engaged, etc.). Refer to Figure 8-23.

Brush Replacement (Refer to Figure 8-23.)

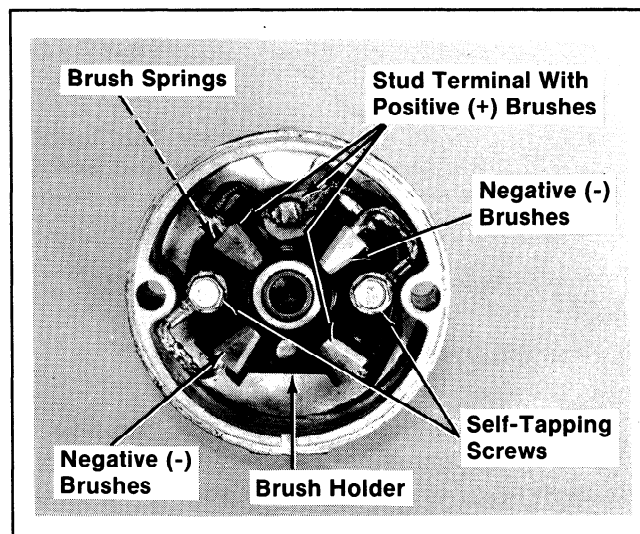

Figure 8-23. Commutator End Cap With Brushes.

1. Remove the brush springs from the pockets in brush holder.
2. Remove the self-tapping screws and negative (-) brushes.
3. Remove hex nut, split lock washer, plain washer, and fiber washer from the stud terminal.

Remove the stud terminal with positive (+) brushes, and plastic brush holder from end cap.

- Reinstall the brush holder and new stud terminal with positive (+) brushes into end cap. Secure with the fiber washer, plain washer, split lock washer, and hex nut.

CAUTION: To prevent electric arcing, make sure the stud terminal and braided brush leads do not touch the end cap.

- Install the new negative (-) brushes and secure with the self-tapping screws.
- Install the brush springs and brushes into the pockets in brush holder. Make sure the chamfered sides of brushes are away from the springs.

NOTE: Use a brush holder tool to keep the brushes in the pockets. A brush holder tool can easily be made from thin sheet metal. Refer to Figure 8-24.

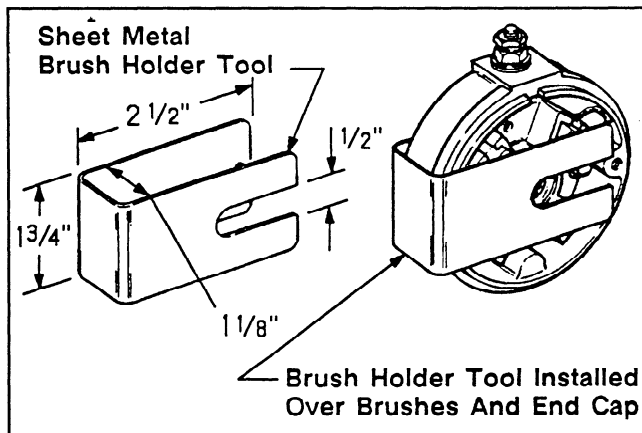

Figure 8-24. Brush Holder Tool.

Commutator Service

Clean the commutator with a coarse, lint free cloth. Do not use emery cloth. If the commutator is badly worn or grooved, turn down on a lathe, or replace the armature.

Reassembly

- Insert the armature into the starter frame. Make sure the magnets are closer to the drive shaft end of armature. The magnets will hold the armature inside the frame.
- Install the thrust washer and drive end cap. Make sure the match marks on end cap and frame are aligned. Refer to Figure 8-25.

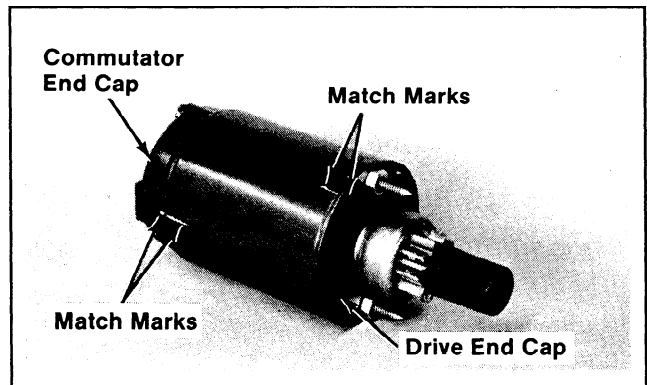

Figure 8-25. Starter Assembly Match Marks.

- Install the brush holder tool to keep the brushes in the pockets of commutator end cap. Refer to Figure 8-24.
- Install the commutator end cap to armature and starter frame. Firmly hold the drive end cap and commutator end cap to the starter frame. Remove the brush holder tool.
- Make sure the match marks on end cap and frame are aligned. Refer to Figure 8-25. Install the thru bolts.
- Install the drive pinion, dust cover spacer, anti-drifting spring, stop gear spacer, stop nut, and dust cover. Refer to "Starter Drive Service."

NOTE: If the engine being serviced is equipped with special shouldered cap screws and lock washers for mounting, make sure these same parts are used for reinstalling the starter. These special parts ensure alignment of the pinion and ring gear.

Wound-Field Bendix Drive Starter Service

NOTE: In the event of a false start (engine starts but fails to keep running) the engine must be allowed to come to a complete stop before the starter is re-engaged. If the flywheel is still rotating when the starter is engaged, the pinion and ring gear may be damaged.

NOTE: Do not crank the engine for longer than 10 seconds. A 60-second cool-down period must be allowed between starting attempts. Failure to follow this procedure could result in starter burnout.

NOTE: If the engine being serviced is a Model K161 or K181 and has special shouldered cap screws and lock washers for mounting, make sure these same parts are used for reinstalling the starter. These special parts ensure alignment of the pinion and ring gear.

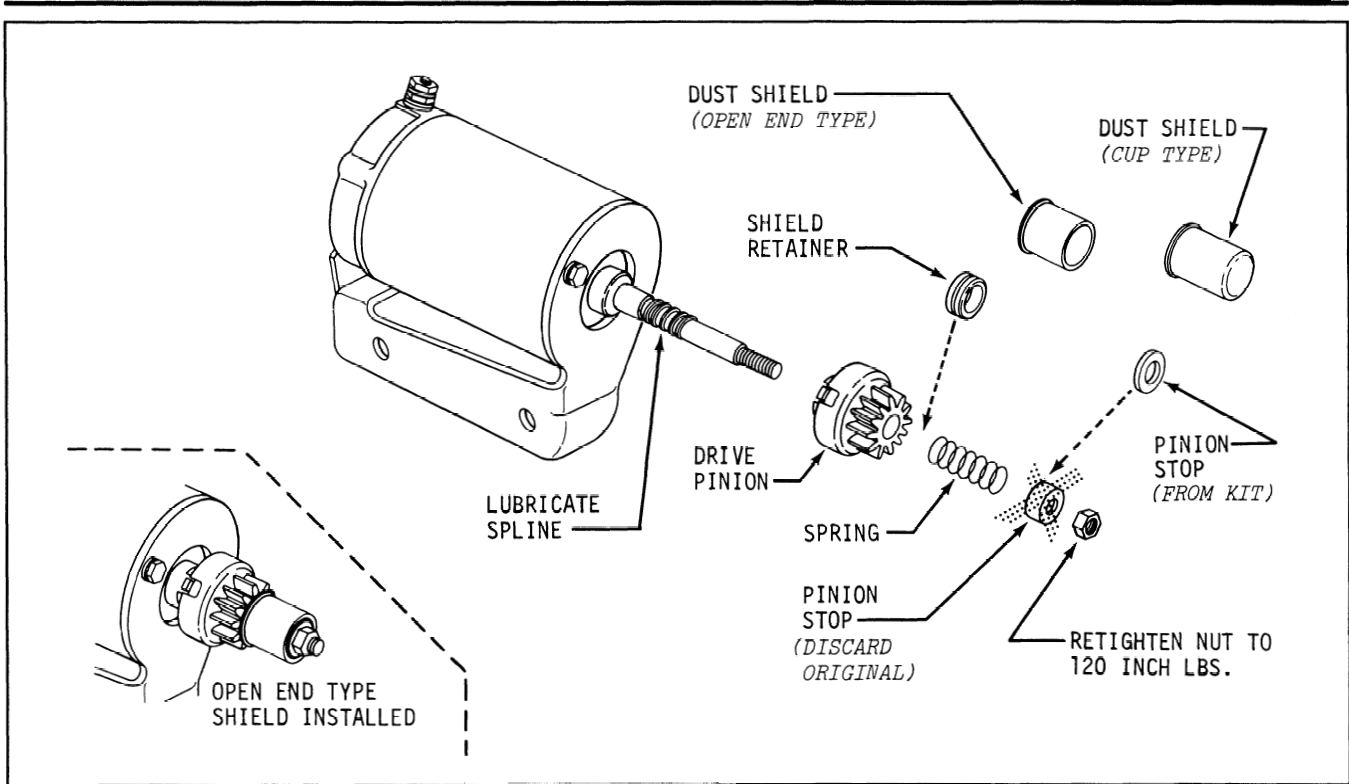

Figure 8-26. Bendix Drive Installation.

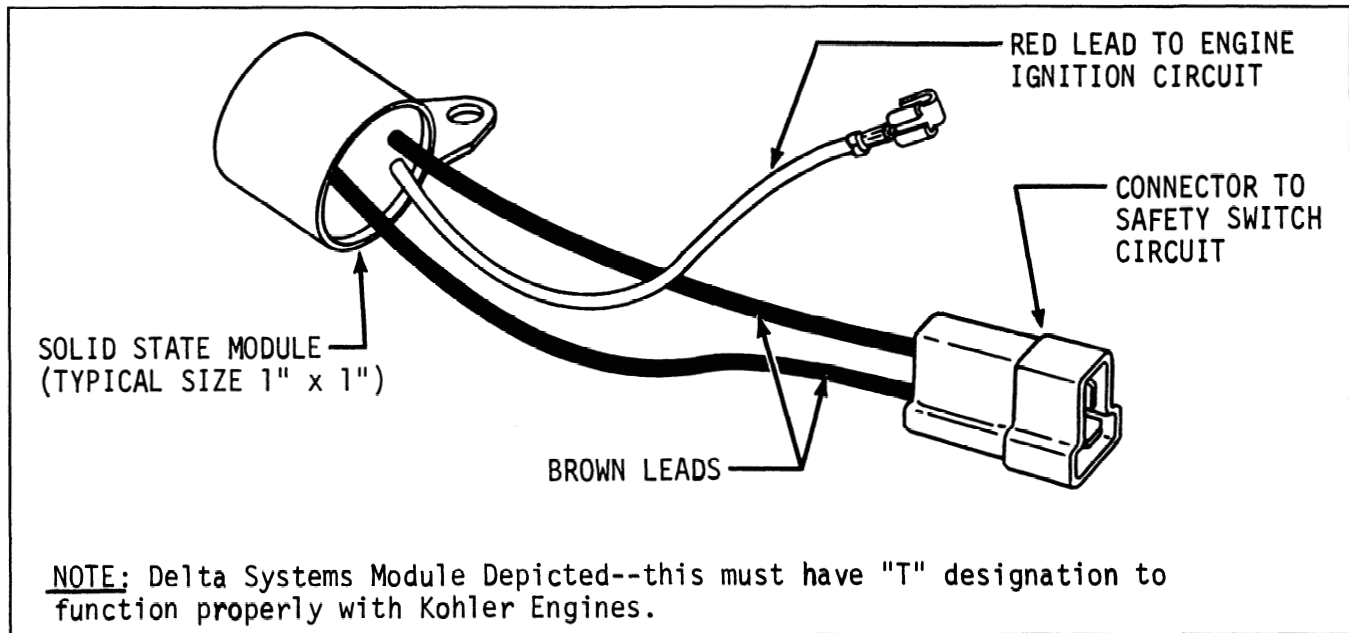

Figure 8-27. Magneto Ignition Safety Interlock System.

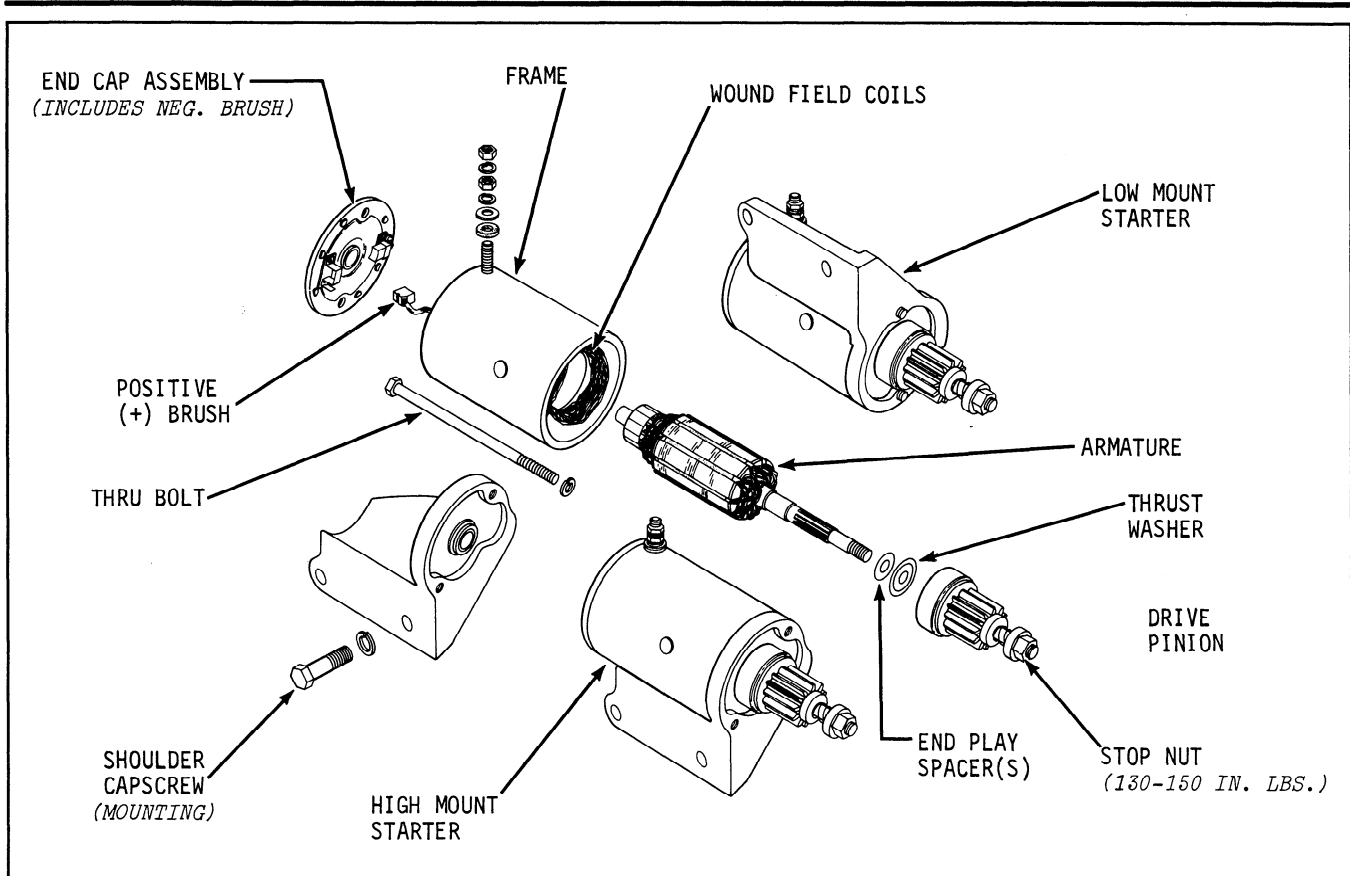

Figure 8-28. Wound-Field Starter - Exploded View.

Service the wound-field starter as follows. Refer to Figure 8-28.

1. Remove the end cap assembly by taking out the two through bolts and carefully slipping the end cap off of the armature.
2. Lift the spring holding the positive brush and remove the brush.
3. Carefully remove the armature.
4. Inspect both brushes (positive on frame; negative on end cap). If brushes are worn unevenly or are shorter than 5/16", replace them.
5. Remove the negative brush by drilling out the rivet holding it to the end cap. Install the replacement brush and rivet.
6. Remove the positive brush by peeling back insulating material on the field winding and unclipping or unsoldering. Install the replacement brush and clip or solder in place.
7. Use a coarse cloth to clean the commutator. If the commutator is grooved or extremely dirty, use a commutator stone or fine sandpaper.

NOTE: Never use emery cloth to clean a commutator.

8. Carefully insert the armature.

9. Lightly coat the end cap bushing and armature shaft with light engine oil.
10. Hold the positive brush spring back and carefully place end cap in position on armature shaft. Release spring after brushes are contacting commutator.
11. Insert two through bolts and torque to 40 to 55 in. lb.
12. Inspect pinion and splined shaft. If any damage is noted, replace the Bendix drive.
13. If the Bendix drive is in good condition, wipe everything clean and apply a very thin coat of special silicone grease (Kohler Part No. 52 357 01) to the splined portion of the armature shaft.

Permanent Magnet Bendix Drive Starter Service

NOTE: In the event of a false start (engine starts but fails to keep running) the engine must be allowed to come to a complete stop before the starter is re-engaged. If the flywheel is still rotating when the starter is engaged, the pinion and ring gear may be damaged.

NOTE: Do not crank the engine for longer than 10 seconds. A 60-second cool-down period must be allowed between starting attempts. Failure to follow this procedure could result in starter burnout.

Service the permanent magnet starter as follows. Refer to Figure 8-29.

1. Remove the stop nut and the remainder of the Bendix drive.
2. Remove both through bolts.
3. Remove the end bracket capscrew from the end cap.
4. Remove mounting bracket and frame by rotating the end bracket and slipping the mounting bracket and frame off of the drive end of the armature.
5. Separate the end cap from the armature, being careful to restrain the brushes in the end cap.
6. Inspect the commutator. If dirty, clean it with a coarse, lint-free cloth. If grooved, dress it with a commutator stone or turn it down on a lathe and undercut the mica.

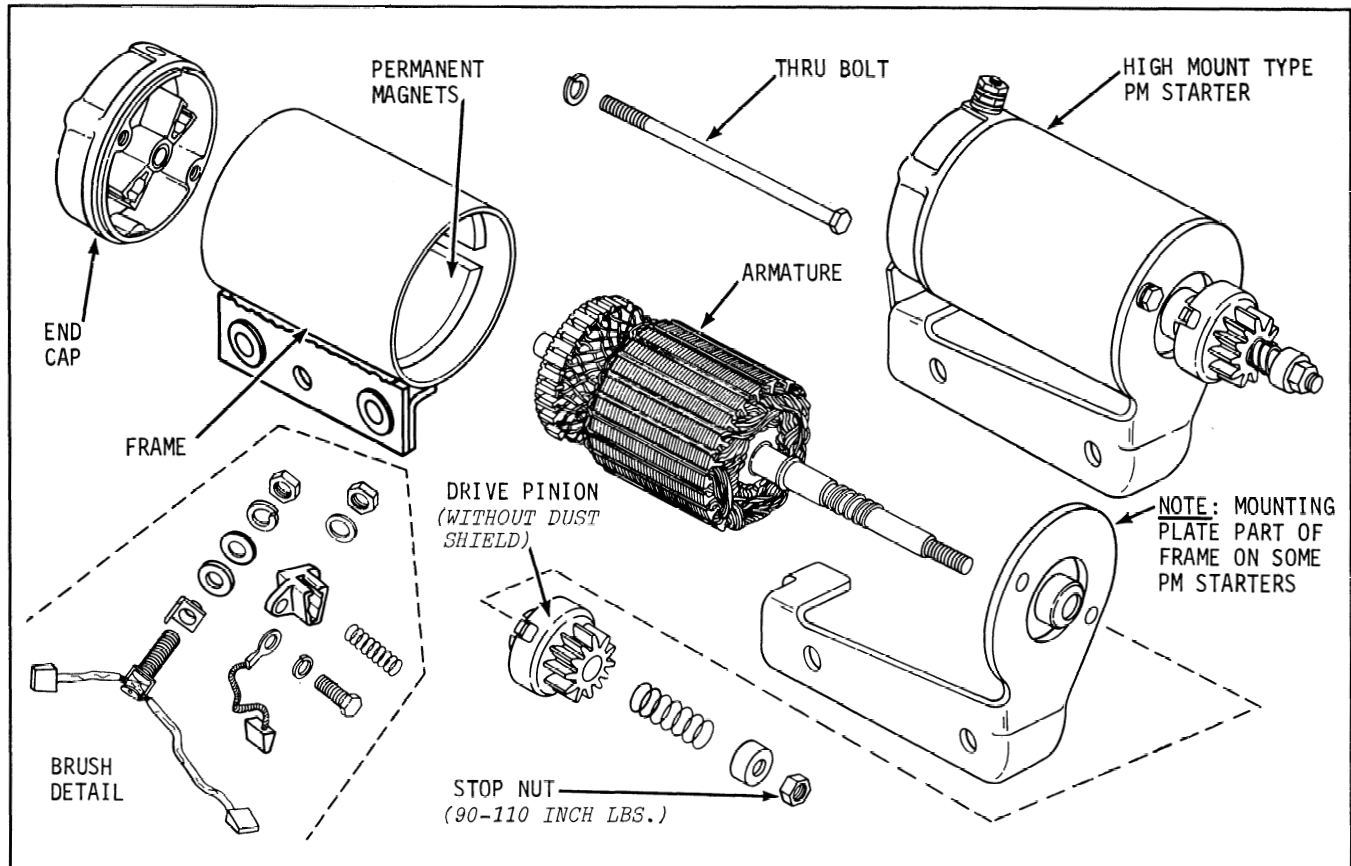

Figure 8-29. Permanent Magnet Starter - Exploded View.

Failure Analysis - Bendix Drive Starters

Starter failures from overcranking* or cranking with an abnormal parasitic load** on the engine, will display one or a number of the following signs:

1. The armature wire insulation or coating will appear discolored and may be swollen. In many cases, you may be able to detect an odor from the burnt wire coating or see it oozing from the starter housing.
2. One or a number of the armature windings may have wires or wire connections that have burnt in two. Wires may have insulation missing or be partially fused together.
3. The starter brushes will show heavy surface galling and brush material transfer. Addition-

ally, in many instances the starter brushes will be welded or stuck in the brush holders.

Some of the frequent causes of abnormal parasitic load at cranking are:

1. Improper viscosity engine crankcase oil.
2. Incorrect fluid in a direct coupled hydrostatic unit - remember, even in the idle or neutral position, a direct coupled hydrostatic pump will place a parasitic load on the engine at cranking.
3. Malfunctioning or inoperative direct coupled clutch assembly.
4. Engaged accessory or drive clutch assembly.

Starter failures from overcranking or cranking against an abnormal parasitic load are not covered

by Kohler engine Warranty. We would recommend that you identify the root of the problem and advise the engine owner of your findings.

The starter bendix drive used by Kohler is designed and manufactured to withstand forces far in excess of those required for normal operation when the recommended starter procedures are followed. Missing or damaged teeth on the bendix drive gears are not being caused by a defect in material or workmanship. Rather, our testing and analysis of returned failed starter drives has shown that bendix drive damage is being caused by engaging the starting motor while the flywheel is in motion. For this reason, warranty claims for a failed bendix drive with damaged or missing teeth will no longer be accepted.

*Overcranking – cranking the starter continuously for more than the recommended period and/or not allowing a sufficient cool down period between starting attempts.

**Parasitic Load at cranking – a load or force on the engine at cranking that opposes normal engine rotation.

Battery Service

A battery is supplied by the equipment manufacturer. The battery should be a 12 volt unit, rated at 32 amp hours minimum.

Battery Test – If the battery does not have enough charge to crank the engine, recharge it.

NOTE: Do not attempt to jump-start the engine with another battery. Starting with a battery larger than recommended can burn out the starter motor.

The battery is tested by connecting a DC voltmeter across the battery terminals and cranking the engine. If the battery voltage drops below 9 while cranking, the battery is in need of a charge or replacement.

Battery Charging –



WARNING: Dangerous Acid, Explosive Gases!

Batteries contain sulfuric acid. To prevent acid burns, avoid contact with skin, eyes and clothing.

Batteries produce explosive hydrogen gas while being charged. Charge the battery only in a well-ventilated area. Keep cigarettes, sparks, open flame and other sources of ignition away from the battery at all times.

To prevent accidental shorting and the resultant sparks, remove all jewelry before servicing the battery.

When disconnecting battery cables, always disconnect the negative (-) cable first. When connecting battery cables, always connect the negative cable last.

Before disconnecting the negative (-) cable, make sure all switches are OFF. If any switch is ON, a spark will occur at the ground terminal. This could result in an explosion if hydrogen gas or gasoline vapors are present.

Keep batteries and acid out of the reach of children.

Battery Maintenance – Regular maintenance will ensure that the battery will accept and hold a charge.



WARNING: Ignition Coil Overheat!

Always turn the ignition switch OFF or disconnect the battery cables before charging the battery. Failure to do this could result in overheating and explosion of the ignition coil.

1. Check the level of the electrolyte regularly. Add **distilled** water to maintain it at its recommended level.

NOTE: Do not overfill the battery. Poor performance or early failure will result.

2. Keep the cables, terminals and external battery surfaces clean. A buildup of corrosive acid or dirt on the surfaces can cause the battery to self-discharge. Wash the cables, terminals and external surfaces with a baking soda and water solution. Rinse thoroughly with clean water.

NOTE: Do not allow the baking soda solution to enter the battery cells. The solution will chemically destroy the electrolyte.

SECTION 9

AUTOMATIC COMPRESSION RELEASE

All K-Series single cylinder engines, except the K91, are equipped with Automatic Compression Release (ACR). The ACR mechanism lowers compression at cranking speeds to make starting easier.

OPERATION

The ACR mechanism consists of two flyweights and a spring attached to the gear on camshaft. When the engine is rotating at low cranking speeds (600 RPM or lower) the flyweights are held by the spring in the position shown in Figure 9-1.

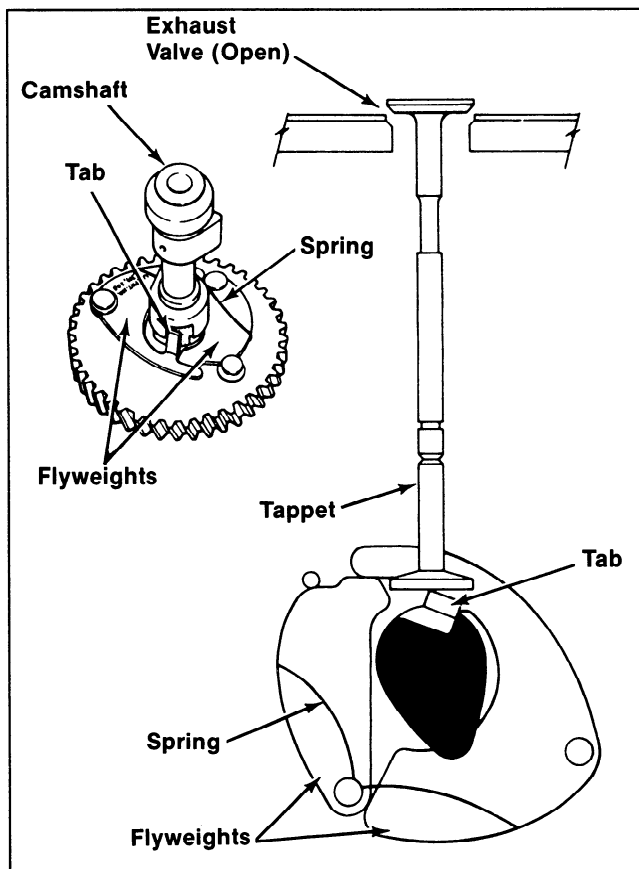

Figure 9-1. Automatic Compression Release (ACR) - Starting Position.

In this position, the tab on the larger flyweight protrudes above the exhaust cam lobe. This lifts the exhaust valve off its seat during the first part of the compression stroke. The reduced compression

results in an effective compression ratio of about 2:1 during cranking.

After the engine speed increases to about 600 RPM, centrifugal force moves the flyweights to the position shown in Figure 9-2. In this position the tab on the larger flyweight drops into the recess in the exhaust cam lobe. When in the recess, the tab has no effect on the exhaust valve and the engine operates at full compression and full power.

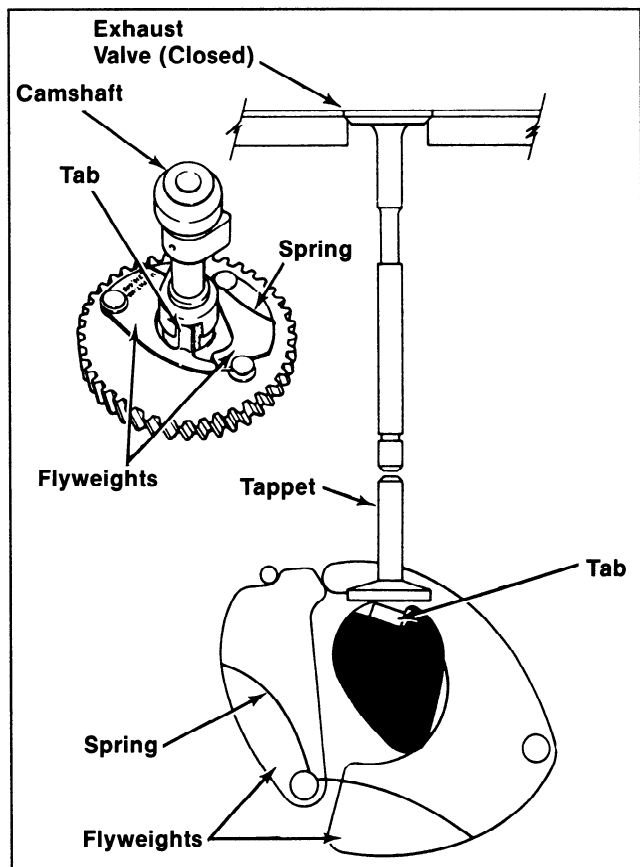

Figure 9-2. Automatic Compression Release (ACR) - Running Position.

When the engine is stopped, the spring returns the flyweights to the position shown in Figure 9-2, ready for the next start.

BENEFITS

Because of the reduced compression pressures at cranking speeds, several important benefits are obtained.

- Manual starting (rope start or retractable start) is much easier. Without ACR, manual starting at full compression would be virtually impossible.
- Electric start models can use a starter and battery size that are practical for the applications in which these engines are used.
- ACR eliminates the need for a spark retard/advance mechanism. A spark retard/advance mechanism would be required on engines without ACR to prevent "kickback" that occurs when starting. ACR eliminates this "kickback" making manual starting safer.
- The choke control setting is less critical, and in the event of flooding, excess fuel is blown out of the lifted exhaust valve and does not hamper starting.
- Engines with ACR start much faster in cold weather than those without ACR.
- Engines with ACR can be started with spark plugs that are worn or fouled. Engines without ACR probably could not be started with those same plugs.

INSPECTION AND SERVICE

The ACR mechanism is extremely rugged and virtually troublefree. If hard starting is experienced, check the exhaust valve for lift as follows:

1. Check exhaust valve to tappet clearance and adjust as necessary to specification.
2. Remove cylinder head and turn the crankshaft clockwise by hand and observe the exhaust valve carefully.

When the piston is approximately 2/3 of the way up the cylinder during the compression stroke, the exhaust valve should lift off the seat slightly.

If the exhaust valve does not lift, the ACR spring may be unhooked or broken. To service the spring, remove the oil pan and rehook spring or replace it. The camshaft does not have to be removed.

The flyweights are not serviceable. If they are stuck or worn excessively, the camshaft must be replaced.

NOTE: The tab on the flyweights is hardened and is not adjustable. Do not attempt to bend the tab – it will break and a new camshaft will be required.

COMPRESSION TESTING

Because of the ACR mechanism, it is difficult to obtain an accurate compression reading.

To check the condition of the combustion chamber, and related mechanisms, physical inspection and a crankcase vacuum test are recommended.

AUTOMATIC COMPRESSION RELEASE (ACR) CHANGES

New ACR Tabs

Engines with serial no. 9006118 and after have hardened and ground steel ACR tabs on the camshaft assemblies. These new assemblies are manufactured with improved techniques, which permanently set the ACR mechanism, making adjustments to the mechanism unnecessary and impossible.

NOTE: Do not attempt to bend these hardened steel ACR tabs. These tabs will break if bent.

Procedure For Checking And Adjusting ACR On Engines Prior To Serial No. 9006118

On engines manufactured before serial no. 9006118 the ACR can still be checked and reset using the procedure described below.

ACR is set according to the amount of valve lift on the exhaust valve. The correct amount of lift is established by the height of the lifting tab in relation to the camshaft. If improper lift is suspected, the setting can be checked and adjusted as follows:

1. Check valve tappet clearances and adjust as necessary to specification.
2. Remove cylinder head and turn the engine over by hand until you reach BDC of the intake stroke (intake valve will be closing).
3. Mount a dial indicator on the top of the exhaust valve and set at 0.
4. Slowly turn the flywheel clockwise and watch the dial indicator. When the piston is about 2/3 of the way up the cylinder, the exhaust valve should open for ACR. Exhaust valve opening as indicated on the dial indicator should be .031 – .042.

If the exhaust valve does not open to the specified amount, adjust the ACR according to STEP 5.

NOTE: Caution must be exercised in the bending of the tab as it is hardened and may crack or break if bent back and forth more than 3 or 4 times.

5. If the valve lift was above .042, hold a wooden dowel or peg on the top of the valve and tap it

down carefully to within the .031 – .042 range. If the valve lift was below .031, remove the camshaft cover on the side of the engine exposing the cam gear and bend the ACR tab carefully upward until the valve lift is within the specified range.

SECTION 10

DISASSEMBLY



WARNING: Accidental Starts!

Before servicing the engine or equipment, always remove the spark plug lead to prevent the engine from starting accidentally. Ground the lead to prevent sparks that could cause fires.

Clean all parts thoroughly as the engine is disassembled. Only clean parts can be accurately inspected and gauged for wear or damage. There are many commercially available cleaners that quickly remove grease, oil, and grime from engine parts. When such a cleaner is used, follow the manufacturer's instructions carefully. Make sure all traces of the cleaner are removed before the engine is reassembled and placed in operation—even small amounts of these cleaners quickly break down the lubricating properties of engine oil.

Check all parts for evidence of:

- Excessive sludge and varnish
- Scoring of the cylinder wall
- Piston damage
- Evidence of external oil leaks
- Evidence of overheating.

Any of the listed problems could be the result of improper engine servicing or maintenance. The owner should be made aware of the benefits of proper servicing and maintenance.

The following sequence is suggested for complete engine disassembly. This procedure may have to be varied slightly to accommodate options or special equipment.

1. Disconnect spark plug lead.
2. Drain oil from crankcase.
3. Remove air cleaner.
4. Remove muffler.
5. Remove throttle linkage and carburetor.
6. Remove external governor components and throttle control.
7. Remove fuel pump.
8. Remove retractable starter.

9. Remove electric starter.
10. Remove fuel tank.
11. Remove dipstick.
12. Remove cylinder head baffle and side air baffles.
13. Remove breather assembly.
14. Remove spark plug and cylinder head.
15. Remove blower housing.
16. Remove drive cup or rope start pulley, grass screen and flywheel.
17. Remove stator.
18. Remove valves.
19. Remove oil pan.
20. Remove connecting rod and piston.
21. Remove piston from connecting rod.
22. Remove piston rings.
23. Remove crankshaft and bearing plate.
24. Remove camshaft and tappets.
25. Remove balance gears.
26. Remove governor gear and cross shaft.
27. Remove oil seals.
28. Remove bearings.

DISCONNECT SPARK PLUG LEAD DRAIN OIL FROM CRANKCASE REMOVE AIR CLEANER

1. Disconnect the spark plug lead and position it away from the spark plug terminal.
2. Unscrew the oil drain plug(s) and drain the crankcase oil into a suitable container for disposal.
3. Remove the wing nut, air cleaner cover, precleaner (if so equipped), paper element, three base screws, base, and base gasket.

REMOVE MUFFLER

1. If the engine is equipped with a flat muffler, remove muffler and gasket by unscrewing cap screws. If equipped with a round muffler remove by turning the threaded exhaust pipe between the muffler and engine with a pipe wrench.

REMOVE THROTTLE LINKAGE AND CARBURETOR



WARNING: Explosive Fuel!

Gasoline may be present in the carburetor and fuel system. Gasoline is extremely flammable and it can explode if ignited. Keep sparks, open flames, and other sources of ignition away from the engine. Disconnect and ground the spark plug lead to prevent the possibility of sparks from the ignition system.

1. Close the fuel shut-off valve at fuel tank (if so equipped) or drain fuel from tank.
2. Loosen the hose clamp and remove fuel line from the carburetor inlet.
3. Remove two slotted hex cap sems screws, the carburetor, and gasket.
4. Remove the throttle linkage from the carburetor throttle lever.

REMOVE EXTERNAL GOVERNOR COMPONENTS AND THROTTLE CONTROL

1. Note the position of the governor spring in governor arm.
2. Loosen palnut. Remove governor arm and spacer from cross shaft.

NOTE: Loosening palnut or removing governor arm will disrupt governor arm to cross shaft adjustment. Readjustment will be required upon reassembly.

3. Remove the governor spring from the governor arm.
4. Remove the hex cap screw, plain washer, spacer, bracket and throttle lever.

REMOVE FUEL PUMP



WARNING: Explosive Fuel!

Gasoline may be present in the carburetor and fuel system. Gasoline is extremely flammable and it can explode if ignited. Keep sparks, open flames, and other sources of ignition away from the engine. Disconnect and ground the spark plug lead to prevent the possibility of sparks from the ignition system.

1. Disconnect the fuel line from the fuel pump inlet fitting.

2. Disconnect the fuel line from the fuel pump outlet fitting. Refer to Figure 10-1.

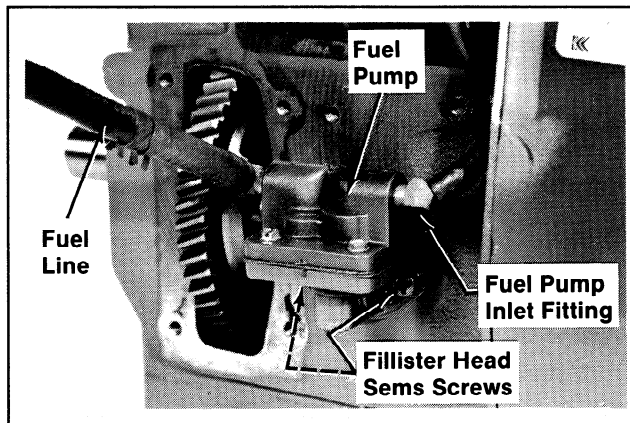

Figure 10-1. Removing Fuel Pump.

3. Remove the fillister head sems screws, plain washers, fuel pump, and gasket.

REMOVE RETRACTABLE STARTER

1. Remove screws, washers and the retractable starter assembly.

REMOVE ELECTRIC STARTER

1. Disconnect electrical connector(s) from back of keyswitch.
2. Disconnect lead from electrical starter.
3. Remove keyswitch panel.
4. Remove hex cap sems screws which mount electric starter to engine.
5. Remove electric starter.

REMOVE FUEL TANK



WARNING: Explosive Fuel!

Gasoline may be present in the carburetor and fuel system. Gasoline is extremely flammable and it can explode if ignited. Keep sparks, open flames, and other sources of ignition away from the engine. Disconnect and ground the spark plug lead to prevent the possibility of sparks from the ignition system.

1. Remove fuel line from fuel tank outlet fitting.
2. Remove tank with bracket(s).

REMOVE DIPSTICK

1. Remove the dipstick.

REMOVE CYLINDER HEAD BAFFLE AND SIDE AIR BAFFLES

1. Remove the cylinder head baffle.

2. Remove the carburetor side air baffle.
3. Remove the starter side air baffle.

REMOVE BREATHER ASSEMBLY

1. Remove palnut, breather cover, and gasket.

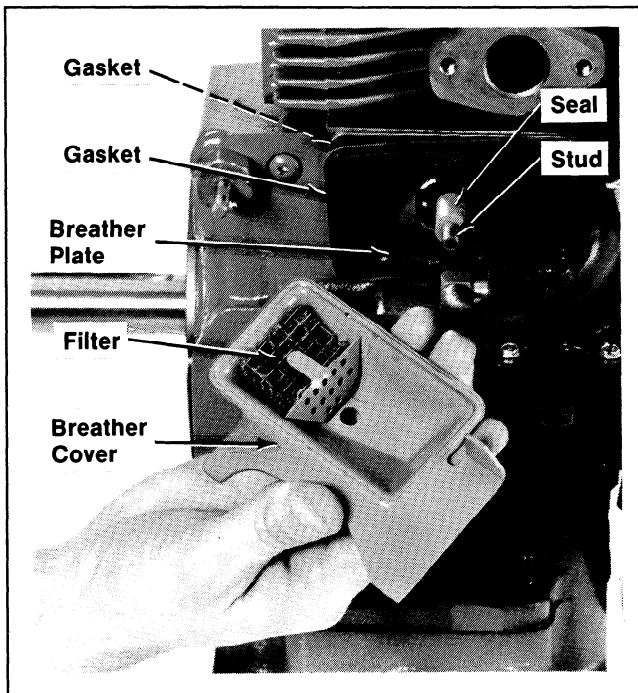

Figure 10-2. Removing Breather Components.

2. Remove the filter, seal, reed stop, reed, breather plate, gasket, and stud.

REMOVE SPARK PLUG AND CYLINDER HEAD

1. Remove the spark plug, cylinder head, and gasket.

REMOVE BLOWER HOUSING

1. Remove breaker point cover, gasket, breaker point lead, breaker assembly and push rod.

REMOVE DRIVE CUP OR ROPE START PULLEY, GRASS SCREEN AND FLYWHEEL

NOTE: Always use a flywheel strap wrench to hold the flywheel when loosening or tightening flywheel and fan retaining fasteners. Do not use any type of bar or wedge between fins of cooling fan, as the fins could become cracked or damaged. Always use a puller to remove flywheel from crankshaft. Do not strike the crankshaft or flywheel, as these parts could become cracked or damaged.

Rope Start Models

1. Remove the grass screen retainer and wire mesh grass screen from rope pulley.
2. Hold the flywheel with a strap wrench and loosen the hex cap screw. Remove the hex cap screw, plain washer, rope pulley, and spacer. Remove the nylon grass screen from the fan.

Retractable Start Models

1. Hold the flywheel with a strap wrench and loosen hex cap screw securing flywheel to crankshaft. Remove the hex cap screw, plain washer, and drive cup.
2. Remove the grass screen from the drive cup.

Electric Start Models

1. Remove the grass screen from the fan.
2. Hold the flywheel with a strap wrench and loosen hex cap screw or hex nut securing flywheel to crankshaft. Remove the hex cap screw or hex nut. Remove plain washer.

On All Models

1. Flywheel is mounted on tapered portion of crankshaft. Use of a puller is recommended for removing flywheel. Bumping end of crankshaft with hammer to loosen flywheel should be avoided as this can damage crankshaft. Refer to Figure 10-3.

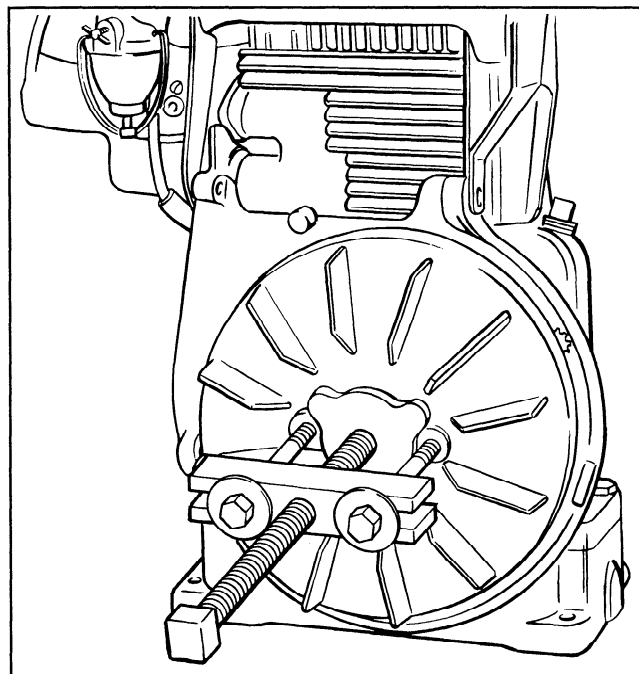

Figure 10-3. Removing Flywheel With A Puller.

NOTE: Ignition magnet is not removable or serviceable!

Do not attempt to remove ignition magnet from flywheel. Loosening or removing magnet mounting

screws could cause the magnet to come off during engine operation and be thrown from the engine causing severe injury. Replace the flywheel if magnet is damaged.

REMOVE STATOR

1. Remove the screws and stator.

REMOVE VALVES

1. Rotate the crankshaft until the piston is at top dead center of compression stroke (both valves closed and piston flush with top of bore).
2. Compress the valve springs with a valve spring compressor and remove the keepers. Refer to Figure 10-4.

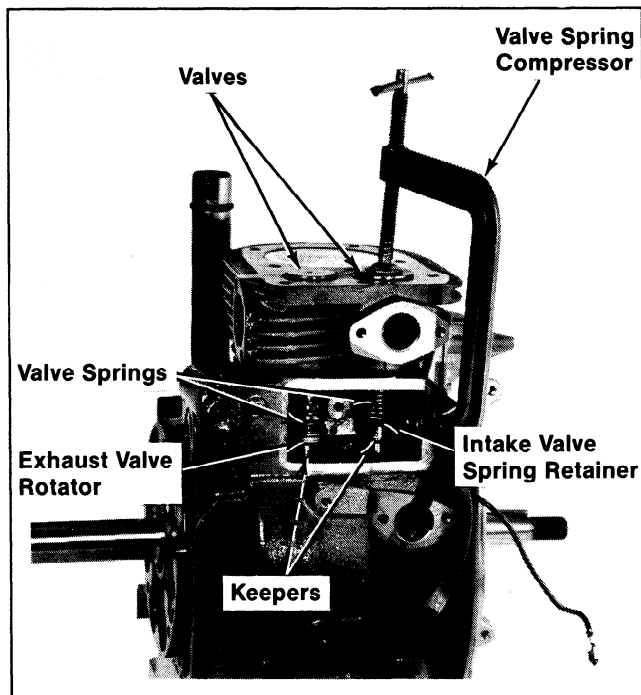

Figure 10-4. Removing Valves.

3. Remove the valve spring compressor, then remove the valves, intake valve spring lower retainer, exhaust valve rotator, valve springs, and valve spring upper retainers.

NOTE: Some models use a valve rotator on both valves.

REMOVE OIL PAN

NOTE: Make sure the piston is at top dead center in bore to prevent damage to oil dipper on connecting rod.

1. Remove the hex cap sems screws, oil pan, and gasket.

REMOVE CONNECTING ROD AND PISTON

1. Remove the connecting rod cap. Refer to Figure 10-5.

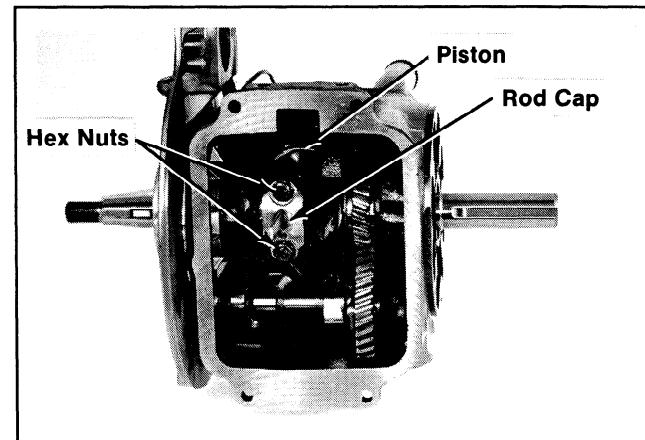

Figure 10-5. Removing Connecting Rod And Piston.

NOTE: If a carbon ridge is present at top of bore, use a ridge reamer tool to remove it before attempting to remove piston.

2. Carefully push the connecting rod and piston out top of bore.

REMOVE PISTON FROM CONNECTING ROD

1. Remove the retainer and wrist pin. Separate the piston from the connecting rod. Refer to Figure 10-6.

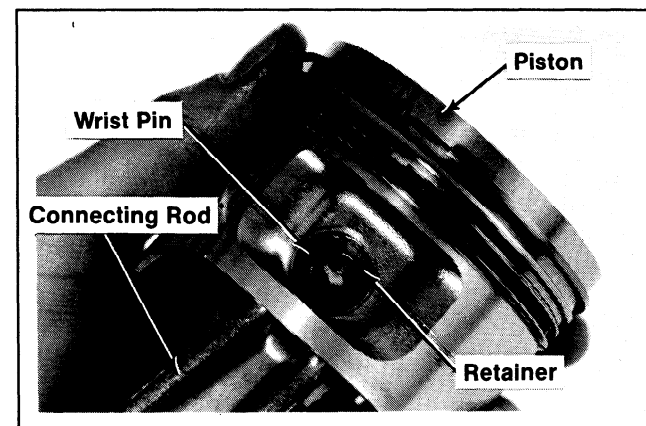

Figure 10-6. Removing Piston From Connecting Rod.

REMOVE PISTON RINGS

1. Remove the top and center compression rings and the oil control ring spacer using a ring expander tool. Refer to Figure 10-7.
2. Remove the rails and expander spring(s).

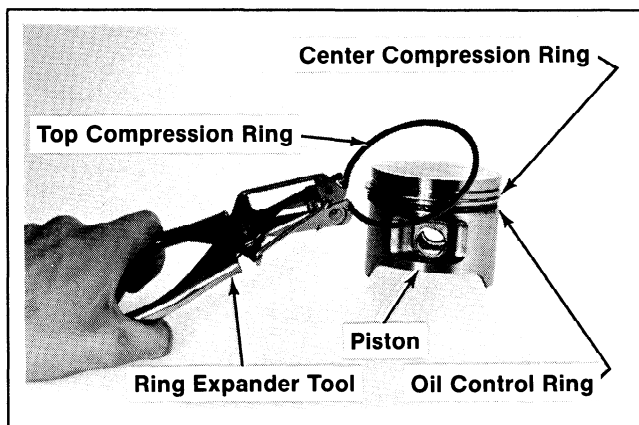

Figure 10-7. Removing Piston Rings.

REMOVE CRANKSHAFT AND BEARING PLATE

1. Remove the hex cap sems screws securing the bearing plate to crankcase.
2. Remove the bearing plate from the crankshaft using a puller. Refer to Figure 10-8.

NOTE: The front bearing may remain either in the bearing plate or on the crankshaft when the bearing plate is removed.

3. Press the crankshaft out of the crankcase from the PTO side. It may be necessary to press crankshaft out of cylinder block. Bearing plate should be removed first if this is done.

NOTE: If the repair does not require separating the bearing plate from crankshaft, the crankshaft and bearing plate can be pressed out as an assembly.

REMOVE CAMSHAFT AND TAPPETS

1. Drive the camshaft pin (and cup plug on bearing side plate) out of the crankcase from the PTO side.
2. Remove the camshaft pin, camshaft, and shim(s) on bearing plate side of camshaft. Refer to Figure 10-9.

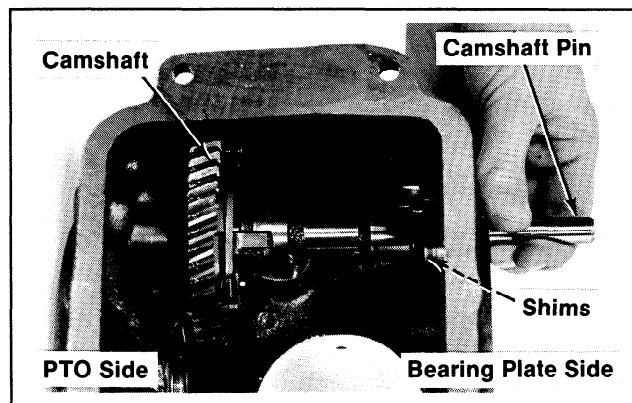

Figure 10-9. Removing Camshaft.

3. Mark the tappets as being either intake or exhaust. Remove the tappets from the crankcase. Refer to Figure 10-10.

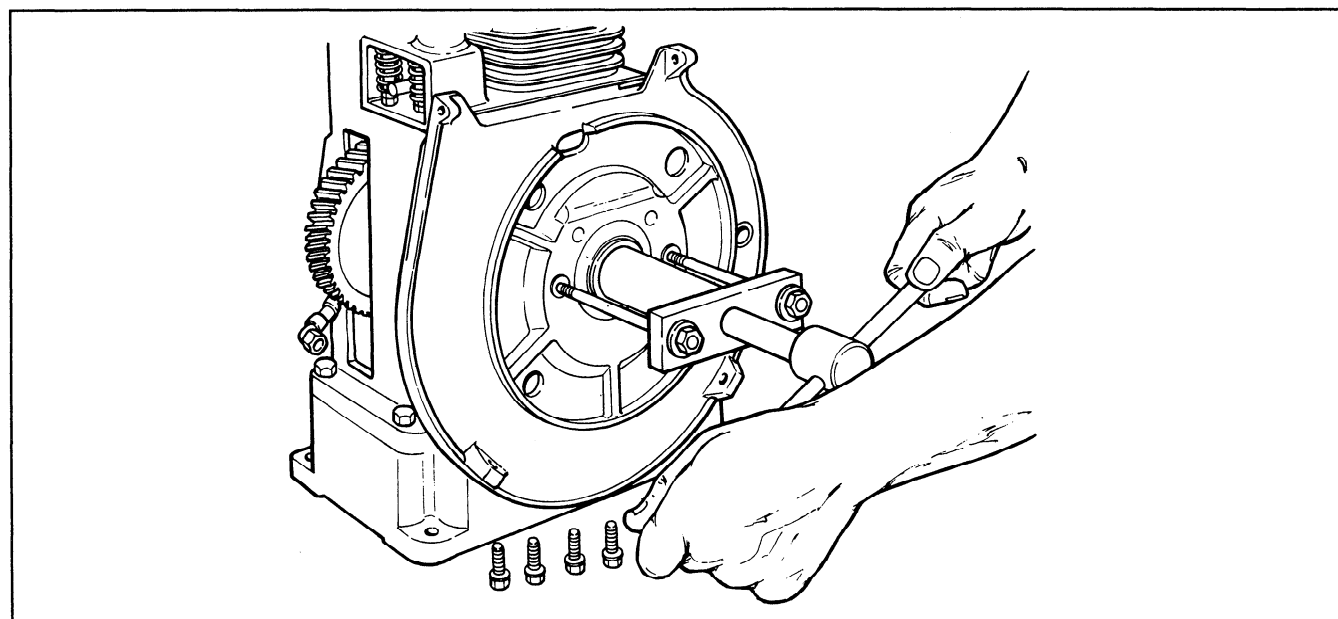

Figure 10-8. Removal Of Bearing Plate With Puller.

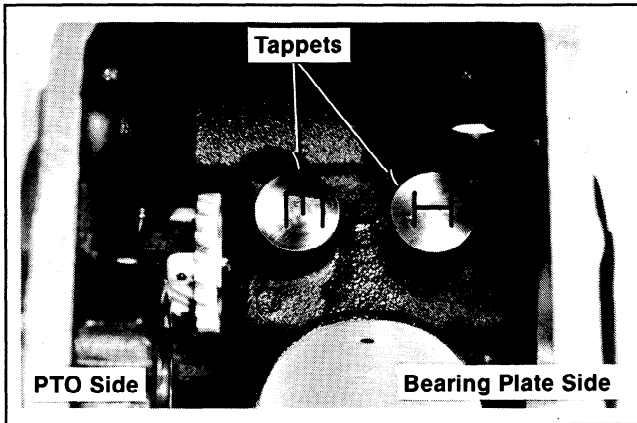

Figure 10-10. Removing Tappets.

NOTE: The intake valve tappet is closest to the bearing plate side of crankcase. The exhaust valve tappet is closest to the PTO side of crankcase.

REMOVE BALANCE GEARS

1. Remove the retaining rings, shims, balance gears with needle bearings, shims, and spacers. Refer to Figure 10-11.

NOTE: Extreme care must be taken when handling the new needle bearings or when removing balance gears containing the new bearings. The needles are no longer caged and will drop out. If this should occur, the bearing case should be greased and the needles reset. There are 27 individual needles in each bearing.

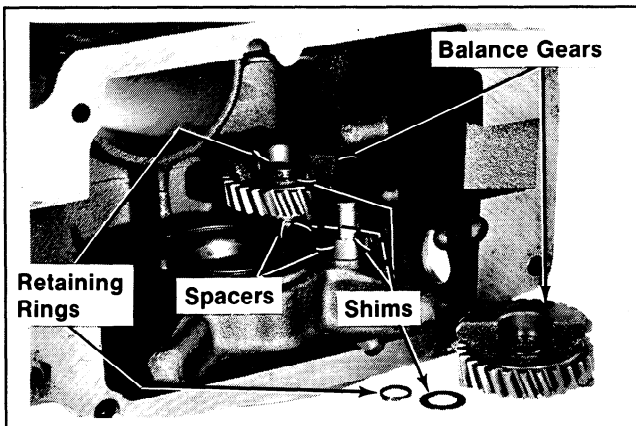

Figure 10-11. Removing Balance Gears.

REMOVE GOVERNOR GEAR AND CROSS SHAFT

1. Remove the stop pin, copper washer, governor gear, and thrust washer. Refer to Figures 10-12 and 10-13.

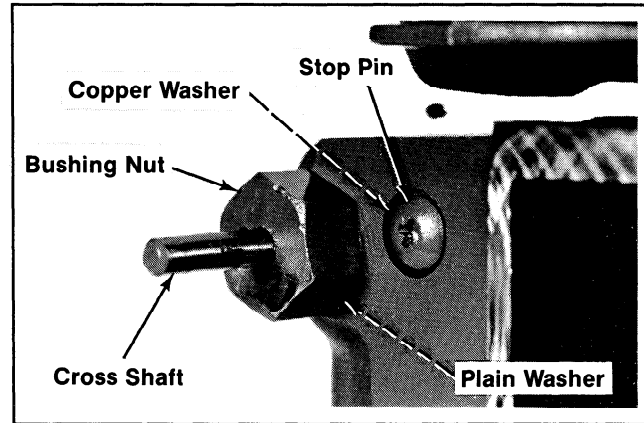

Figure 10-12. Removing Cross Shaft And Stop Pin.

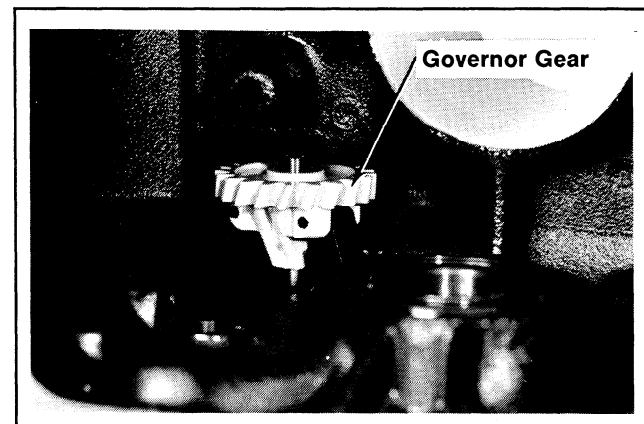

Figure 10-13. Removing Governor Gear.

2. Remove bushing nut and sleeve. Remove cross shaft from inside crankcase.

REMOVE OIL SEALS

1. Remove the oil seals from the crankcase and bearing plate.

REMOVE BEARINGS

1. Press the bearings out of the bearing plate and crankcase.

NOTE: If the bearings have remained on the crankshaft, remove bearing by using a puller.

SECTION 11

INSPECTION AND REPAIR

All parts should be thoroughly cleaned. Dirty parts cannot be accurately gauged or inspected properly for wear or damage. There are many commercially available cleaners that quickly remove grease, oil and grime accumulation from engine parts. If such a cleaner is used, follow the *manufacturer's instructions carefully*, and make sure that all of the cleaner is removed before the engine is reassembled and placed in operation. Even small amounts of these cleaners quickly break down the lubricating properties of engine oils.

Refer to TP-2150, A Guide to Engine Rebuilding, for additional information. Also available is TP-2159, Measurement Guide, which you can use to record your inspection results.

FLYWHEEL

Inspection

Inspect the flywheel for cracks, and the flywheel keyway for damage. Replace flywheel if cracked. Replace the flywheel, the crankshaft, and the key if flywheel key is sheared or the keyway is damaged.

Inspect ring gear for cracks or damage. Kohler no longer provides ring gears as a serviceable part. Replace flywheel if the ring gear is damaged.

FLYWHEEL KEY

Inspection

Shearing has been reported specifically on engines with flywheel drives and battery ignition systems. Check conditions such as overload, ignition timing and spark plug gap when flywheel key shearing occurs.

Spark plug gap on battery ignition engines must be set as specified. If improperly gapped, a maverick spark can occur, which can cause improper ignition of unburned gases and can create a force causing the flywheel key to shear.

When repairing this type of failure, replace the flywheel, crankshaft, key, flywheel washer and nut or bolt.

CYLINDER HEAD

Inspection

Blocked cooling fins often cause localized "hot spots" which can result in a "blown" cylinder head gasket. If the gasket fails, high temperature gases can burn away portions of the aluminum alloy head. A cylinder head in this condition must be replaced.

If the cylinder head appears in good condition, use a block of wood or plastic scraper to scrape away carbon deposits. Be careful not to nick or scratch the aluminum, especially in gasket seating area.

The cylinder head should also be checked for flatness. Use a feeler gauge and a surface plate or a piece of plate glass to make this check. Cylinder head flatness should not vary more than $.003$ "; if it does, replace the cylinder head. Refer to Figure 11-1.

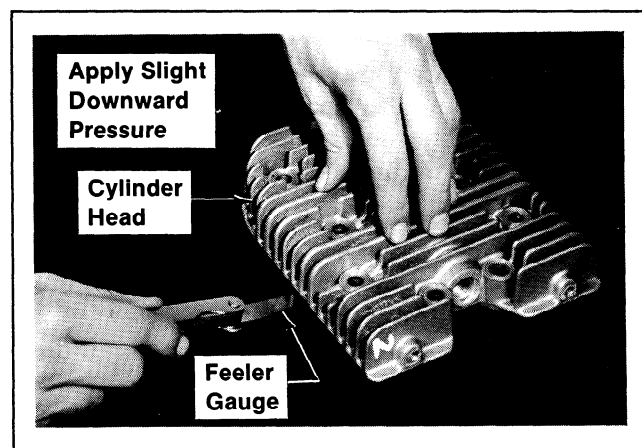

Figure 11-1. Checking Cylinder Head Flatness.

NOTE: Measure cylinder head flatness between each cap screw hole.

In cases where the head is warped or burned, it will also be necessary to replace the head screws. The high temperatures that warped or burned the head could have made the screws ductile which will cause them to stretch when tightened.

CYLINDER BLOCK

Inspection and Reconditioning

Check all gasket surfaces to make sure they are free of gasket fragments. Gasket surfaces must also be free of deep scratches or nicks.

Scoring of the Cylinder Wall: Unburned fuel, in severe cases, can cause scuffing and scoring of the cylinder wall. As raw fuel seeps down the cylinder wall, it washes the necessary lubricating oils off the piston and cylinder wall so that the piston rings make metal to metal contact with the wall. Scoring of the cylinder wall can also be caused by localized hot spots resulting from blocked cooling fins or from inadequate or contaminated lubrication.

If the cylinder bore is badly scored, excessively worn, tapered, or out of round, resizing is necessary. Use an inside micrometer to determine amount of wear (see "General Information", Section 1), then select the nearest suitable oversize of either .003", .010" .020" or .030". Resizing to one of these oversizes will allow usage of the available oversize piston and ring assemblies. Initially, resize using a boring bar, then use the following procedures for honing the cylinder:

Honing

While most commercially available cylinder hones can be used with either portable drills or drill presses, the use of a low speed drill press is preferred as it facilitates more accurate alignment of the bore in relation to the crankshaft crossbore. Honing is best accomplished at a drill speed of about 250 RPM and 60 strokes per minute. After installing coarse stones in hone, proceed as follows:

1. Lower hone into bore and after centering, adjust so that stones are in contact with the cylinder wall. Use of a commercial cutting-cooling agent is recommended.
2. With the lower edge of each stone positioned even with the lowest edge of the bore, start drill and honing process. Move hone up and down while resizing to prevent formation of cutting ridges. Check size frequently.

NOTE: Keep in mind the temperatures caused by honing may cause inaccurate measurements. Make sure the block is cool when measuring.

3. When bore is within .0025" of desired size, remove coarse stones and replace with burnishing stones. Continue with burnishing stones until within .0005" of desired size and then use

finish stones (220-280 grit) and polish to final size. A crosshatch should be observed if honing is done correctly. The crosshatch should intersect at approximately 23°-33° off the horizontal. Too flat an angle could cause the rings to skip and wear excessively, too high an angle will result in high oil consumption. Refer to Figure 11-2.

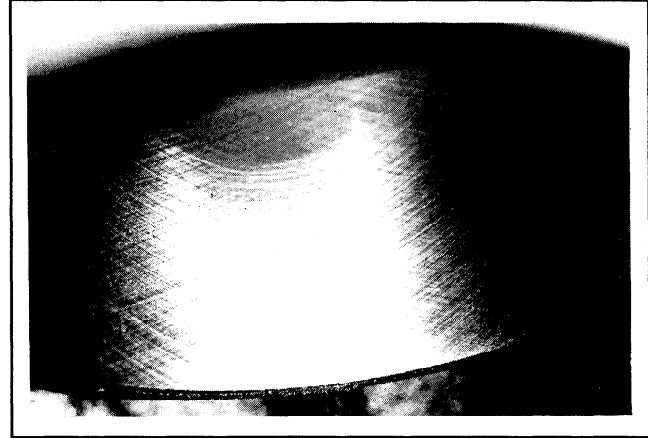

Figure 11-2. Cylinder Bore Crosshatch After Honing.

4. After resizing, check the bore for roundness, taper, and size. Use an inside micrometer, telescoping gauge, or bore gauge to take measurements. Refer to Figure 11-3. The measurements should be taken at three locations in the cylinder - at the top, middle, and bottom. Two measurements should be taken (perpendicular to each other) at each of the three locations.

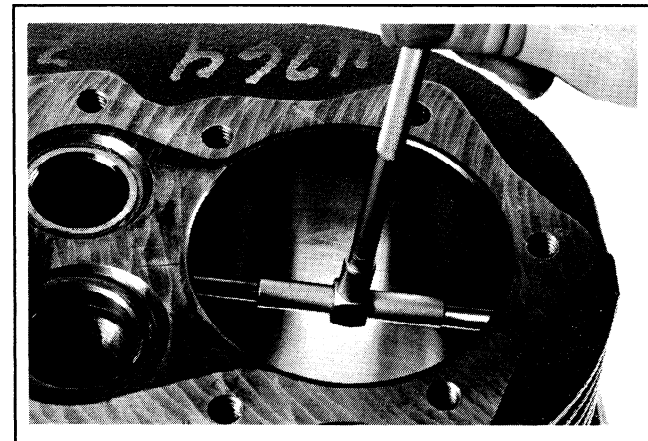

Figure 11-3. Measuring Cylinder Bore.

5. Thoroughly clean cylinder wall with soap and hot water. Use a scrub brush to remove all traces of boring/honing process. Dry thoroughly and apply a light coat of SAE 10 oil to prevent rust.

Measuring Piston-to-Bore Clearance

Before installing the piston into the cylinder bore, it is necessary that the clearance be accurately checked. This step is often overlooked, and if the clearances are not within specifications, generally engine failure will result.

NOTE: Do not use a feeler gauge to measure piston-to-bore clearance, it will yield inaccurate measurements. Use a micrometer.

The following procedures should be used to accurately measure the piston-to-bore clearance:

1. Use a micrometer and measure the diameter of the piston as shown in Figure 11-4.

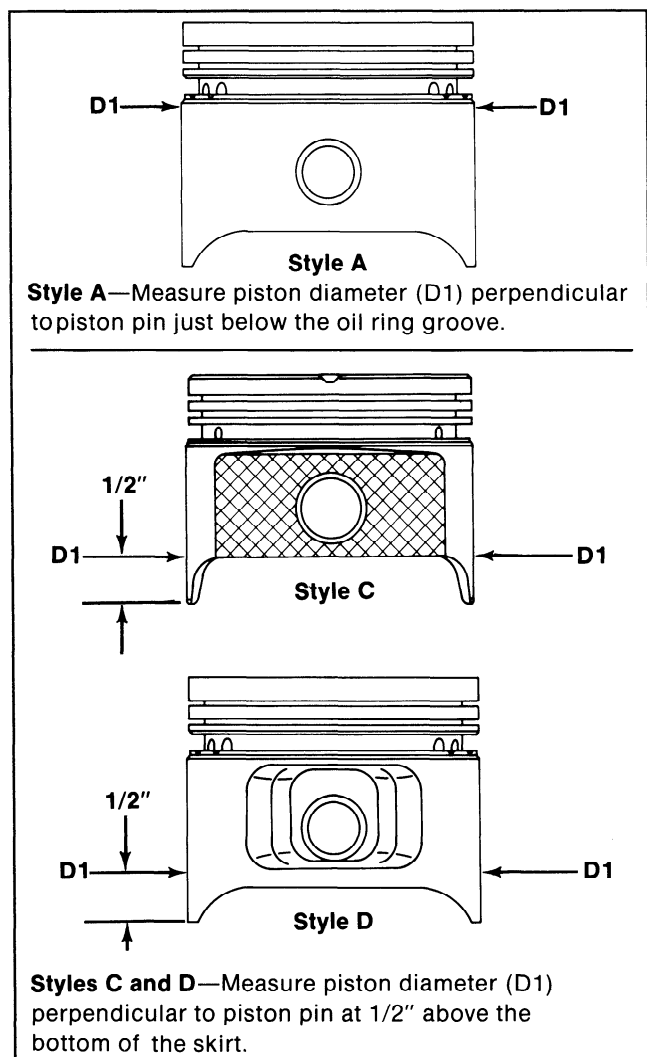

Figure 11-4. Measuring Piston Diameter.

2. Use an inside micrometer, telescoping gauge, or bore gauge and measure the cylinder bore. Take the measurement approximately 2-1/2" below the top of the bore and perpendicular to the piston pin.
3. Piston-to-bore clearance is the difference between the bore and the piston diameter (step 2 minus step 1). For style A pistons only, clearance should be: .0035"/.006" for K91, .007"/.010" for K161-K341. For piston styles C and D, clearance should be: .0034"/.0051" for K181, .0045"/.0062" for K301, .0050"/.0067" for K321, and .0030"/.0050" for K341.

VALVES

Inspection and Service

Carefully inspect valve mechanism parts. Inspect valve springs and related hardware for excessive wear or distortion. Valve spring free height should be at approximately the dimension given in the chart below. Check valves and valve seat area or inserts for evidence of deep pitting, cracks or distortion. Check clearance of valve stems in guides. See Figure 11-5 for valve details and specifications.

DIMENSION (SEE FIG. 11-5)	Model K91		Model K161, K181		Model K241, K301, K321, K341	
	Intake	Exhaust	Intake	Exhaust	Intake	Exhaust
A SEAT ANGLE	89°	89°	89°	89°	89°	89°
B SEAT WIDTH	.037/.045	.037/.045	.037/.045	.037/.045	.037/.045	.037/.045
C INSERT O.D.	-----	.972/.973	-----	1.2535/1.2545	-----	1.2535/1.2545
D GUIDE DEPTH	NONE	NONE	1.312	1.312	1.586	1.497
E GUIDE I.D.	NONE	NONE	.312/.313	.312/.313	.312/.313	.312/.313
F VALVE HEAD DIA.	.979/.989	.807/.817	1-3/8	1-1/8	1.370/1.380	1.120/1.130*
G VALVE FACE ANGLE	45°	45°	45°	45°	45°	45°
H VALVE STEM DIA.	.2480/.2485	.2460/.2465	.3105/.3110	.3090/.3095	.3105/.3110	.3084/.3091

*1.370"/1.380" on all K341 engines and any K321 with suffix "D" or later.

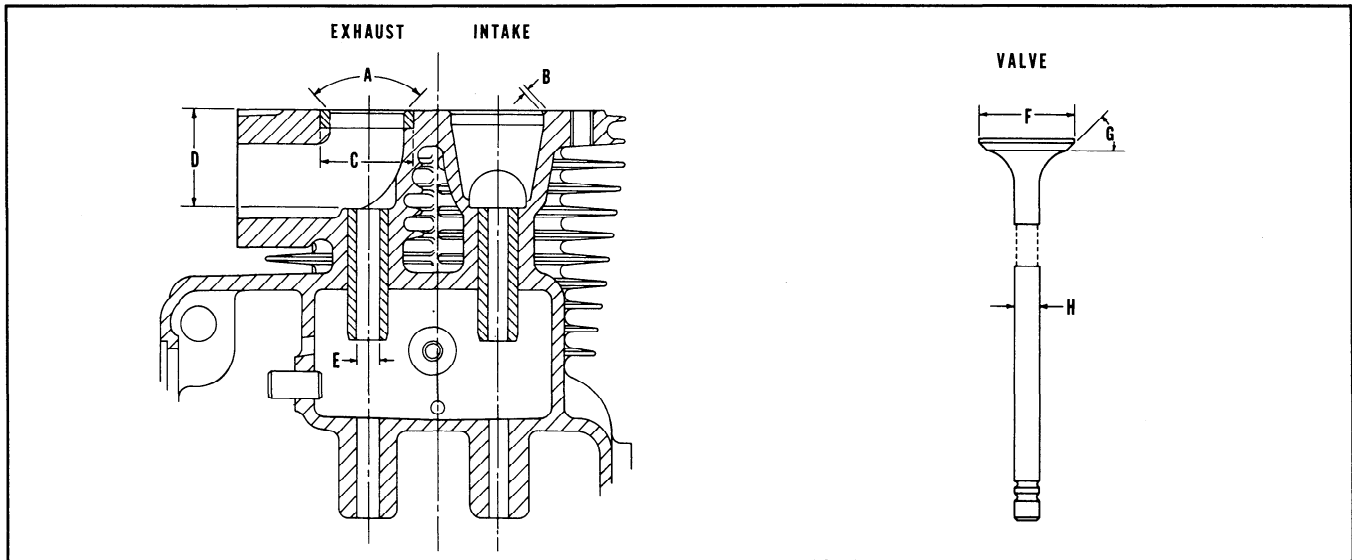
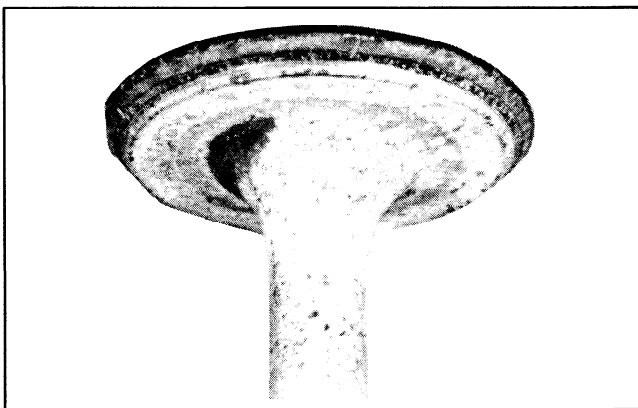

Figure 11-5. Valve Details.

Hard starting, or loss of power accompanied by high fuel consumption may be symptoms of faulty valves. Although these symptoms could also be attributed to worn rings, remove and check valves first. After removal, clean valve head, face and stem with power

wire brush and then carefully inspect for defects such as warped valve head, excessive corrosion or worn stem end. Replace valves found to be in bad condition. A normal valve and valves in bad condition are shown in the accompanying illustrations.



Normal: Even after long hours of operation a valve can be reconditioned and reused if the face and margin are in good shape. If a valve is worn to where the margin is less than 1/32", do not reuse it. The valve shown was in operation for almost 1000 hours under controlled test conditions.

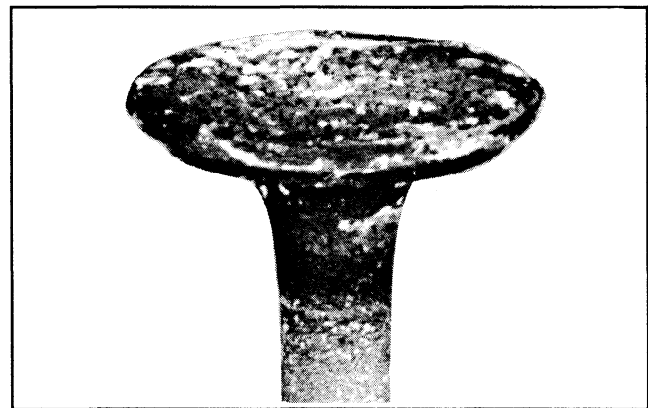

Bad Condition: The valve depicted here should be replaced. The head is warped, the margin is damaged and is too narrow. These conditions could be attributed to excessive hours or a combination of poor operating conditions.



Leakage: A poor grind on face or seat of valve will allow leakage resulting in a burned valve on one side only.

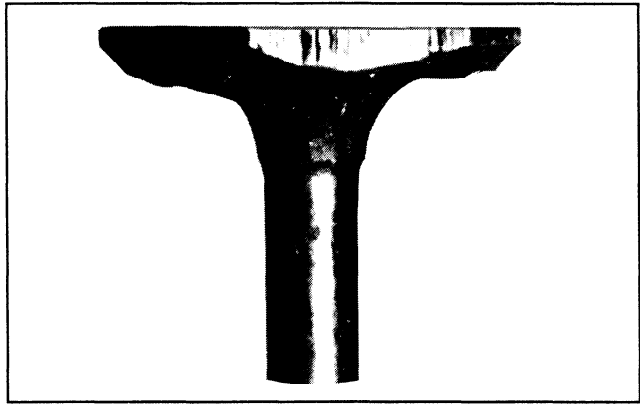

Carbon Cut: Excessive build up of deposits in the combustion chamber may result in valve damage because deposits can become hard enough to cut the valve. Cleaning of the cylinder head at proper intervals could prevent such damage.

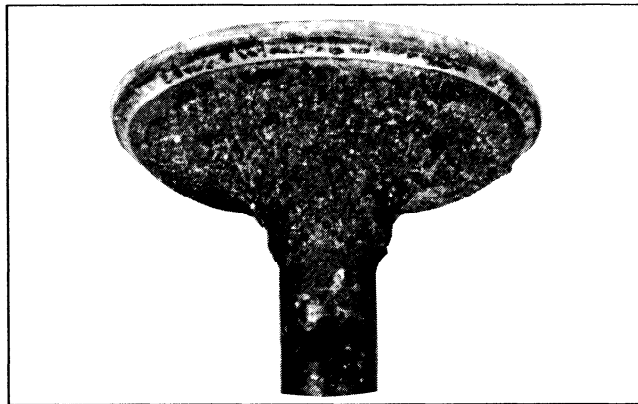

Coking: Coking is normal on intake valves and is not harmful. If the seat is good, the valve could be reused after cleaning.



Stem Corrosion: Moisture from the fuel or from condensation are the most common causes of valve stem corrosion. Condensation occurs from improper preservation during storage and when engine is repeatedly stopped before it has a chance to reach normal operating temperatures. Replace corroded valves.

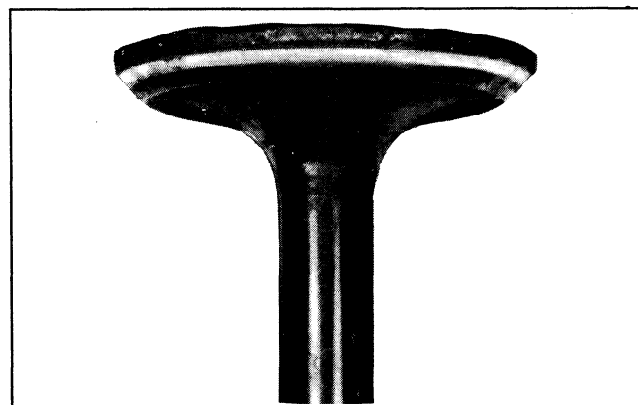

Overheating: An exhaust valve subject to overheating will have a dark discoloration in the area above the valve guide. Worn guides and faulty valve springs may cause this condition. Also check for clogged air intake, blocked fins, and lean fuel mixture when this condition is noted.



Gum: Gum deposits usually result from using stale gasoline. This condition is often noted in applications where fuel is not drained out of the tank during the off season. Gum is a prevalent cause of valve sticking. The cure is to ream the valve guides and clean or replace the valves, depending on their condition.

Valve Guides

If a valve guide is worn beyond specifications, it will not guide the valve in a straight line. This may result in a burnt valve face or seat, loss of compression, and excessive oil consumption.

To check valve guide to valve stem clearance, thoroughly clean the valve guide and, using a split-ball gauge, measure the inside diameter. Then, using an outside micrometer, measure the diameter of the valve stem at several points on the stem where it moves in the valve guide. Use the largest stem diameter to calculate the clearance. On models K91, K161 and K181, the clearance should not exceed .005" for intake and .007" for exhaust valves. On models K241, K301, K321 and K341, the clearance should not exceed .006" for intake and .008" for exhaust valves. If the clearance exceeds these specifications, determine whether the valve stem or the guide is responsible for the excessive clearance.

NOTE: The exhaust valves on these engines have a slightly tapered valve stem to help prevent sticking. Because of the taper, the valve stem must be measured in two places to determine if the valve stem is worn. If the valve stem diameter is within specifications, replace the valve guide. See Figure 11-5.

Remove Valve Guide

The valve guides are a tight press fit in the cylinder block. A valve guide removal tool is recommended to remove the guides (refer to "Special Tools" section). To remove valve guide, refer to Figure 11-6 and proceed as follows:

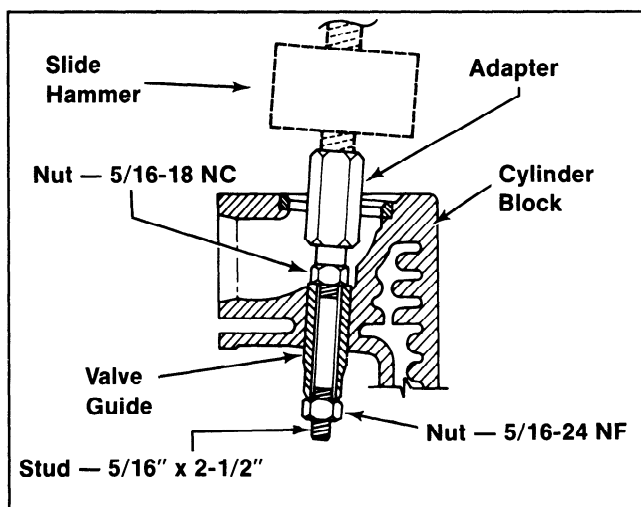

Figure 11-6. Pulling Valve Guide.

1. Install 5/16-18 NC nut on coarse threaded end of 2-1/2" long stud (K161 and K181) or 3-1/2" long stud (K241, K301, K321, and K341).

2. Insert other end of stud through valve guide bore and install 5/16-24 NF nut. Tighten both nuts securely.

NOTE: Valve guide must be held firmly by the stud assembly so that all slide hammer force will act on the guide.

3. Assemble the valve guide removal adapter to the stud and then the slide hammer to the adapter.
4. Use the slide hammer to pull the guide out.

Install Valve Guide

To install valve guide, proceed as follows:

1. Make sure valve guide bore is clean and free of nicks or burrs.
2. Using valve guide driver (refer to "Special Tools" section), align and then press guide in until valve guide driver bottoms on valve guide counterbore.
3. Valve guides are often slightly compressed during insertion. Use a piloted reamer and then a finishing reamer to resize the guide bore to .3125" for K161, K181, K241, K301, K321, and K341. Refer to Figure 11-7.

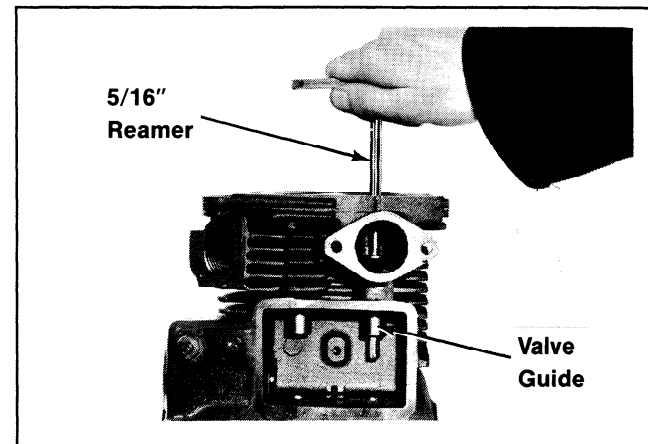

Figure 11-7. Reaming Valve Guide.

Valve Seat Inserts

The intake valve seat is usually machined into the cylinder block, however, certain applications may specify a hard alloy insert. If the seat becomes badly pitted, cracked, or distorted, the insert must be replaced.

The insert is a tight press fit in the cylinder block. A valve seat removal tool is recommended for this job (refer to "Special Tools" section). Since insert removal causes loss of metal in the insert bore area, use only Kohler service replacement inserts, which are slightly larger to provide proper retention in the cylinder block. Make sure new insert is properly started and pressed into bore to prevent cocking of the insert.

Remove Valve Seal Insert

To remove a valve seat insert, refer to Figure 11-8 and proceed as follows:

1. Install valve seat puller on forcing screw and lightly secure with washer and nut.
2. Center the puller assembly on valve seat insert.
3. Hold forcing screw with a hex wrench to prevent turning and slowly tighten nut. See Figure 11-8a.

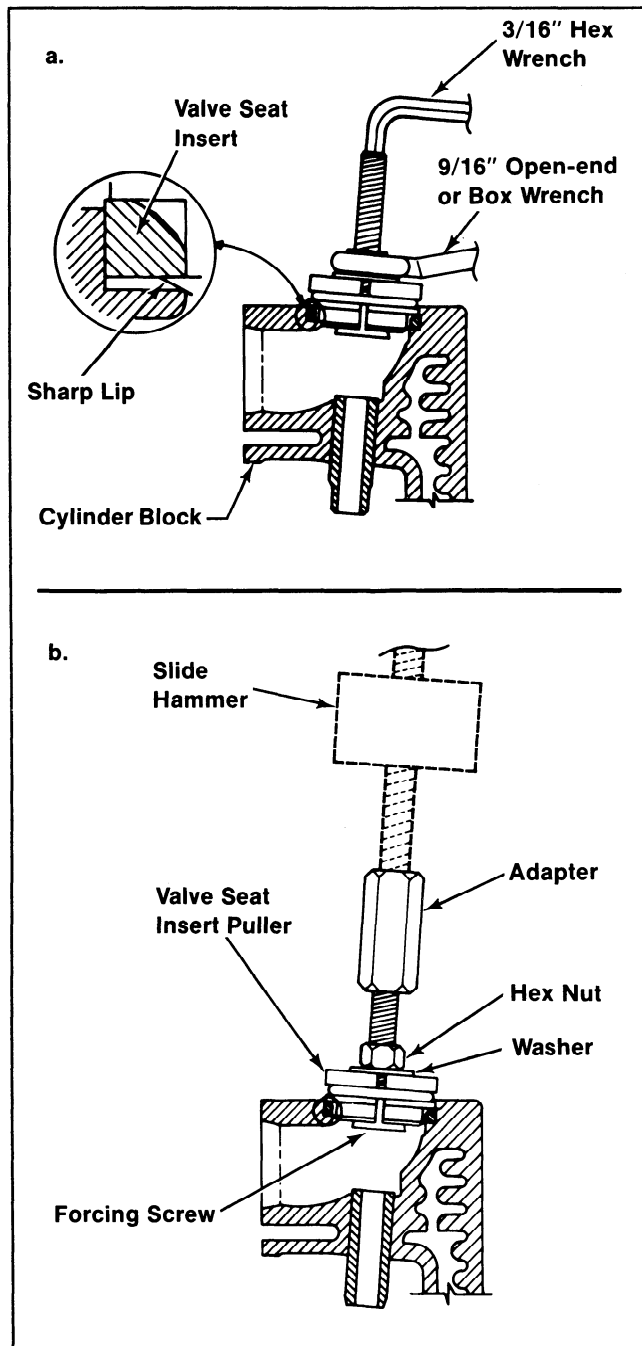

Figure 11-8. Pulling Valve Seat Insert (Typical).

NOTE: Make sure sharp lip on puller (see insert) engages in joint between bottom of valve seat insert and cylinder block counterbore, all the way around.

4. Continue to tighten nut until puller is tight against valve seat insert.
5. Assemble adapter to valve seat puller forcing screw and slide hammer to adapter. See Figure 11-8b.
6. Use slide hammer to remove valve seat insert.

Install Valve Seat Insert

To install valve seat insert, proceed as follows:

1. Make sure valve seat insert bore is clean and free of nicks or burrs.
2. Align valve seat insert in counterbore and using valve seat installer and driver (refer to "Special Tools" section), press seat in until bottomed.
3. Use a standard valve seat cutter (see Figure 11-9) and cut seat to dimensions shown in Figure 11-5.

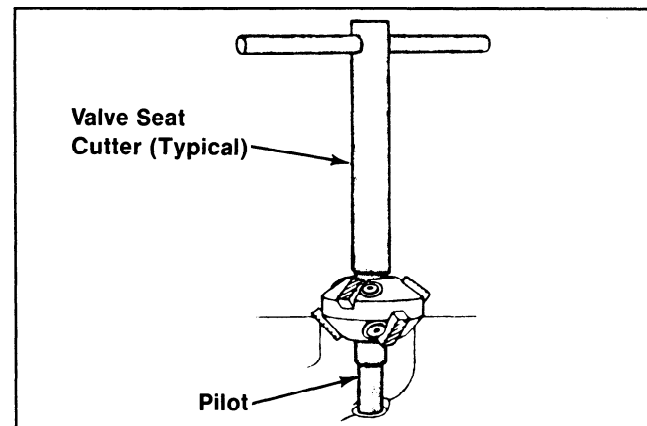

Figure 11-9. Standard Valve Seat Cutter.

Reground or new valves must be lapped in to provide proper fit. Use a hand valve grinder with suction cup for final lapping. Lightly coat valve face with "fine" grade of grinding compound, then rotate valve on seat with grinder. Continue grinding until smooth surface is obtained on seat and on valve face. Thoroughly clean cylinder block in soap and hot water to remove all traces of grinding compound. After drying cylinder block apply a light coating of SAE 10 oil to prevent rusting.

PISTON AND RINGS

Identification

Three different styles of pistons are currently being used in Kohler K-Series engines.

Style "A" pistons can be used in all K-Series engines. The style A piston can be identified by its full skirt and its lack of an installation direction identifier on its crown (a new piston can be installed facing either direction).

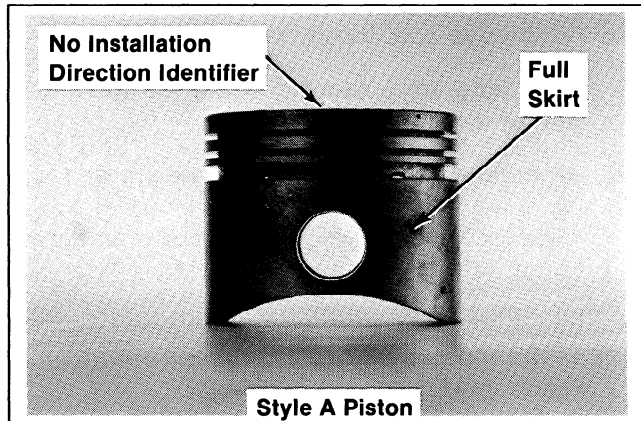

The Style "C" piston is used on the K341 engines only. It can be identified by its partial skirt and raised criss-cross design in the recessed area around the piston pin bore. In addition, it has an installation direction identifier (a notch) at its top. The style C piston is to be installed with the notch facing the flywheel.

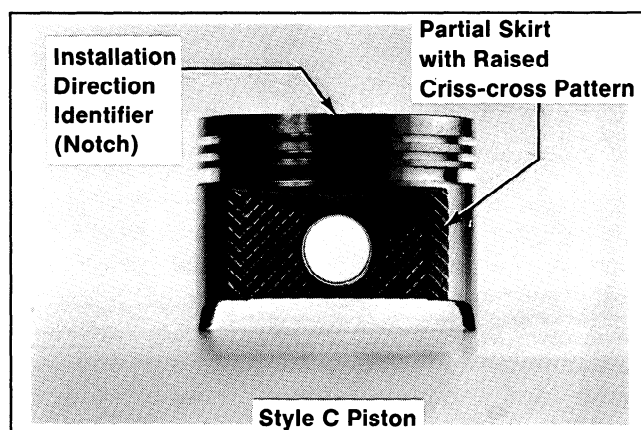

The Style "D" piston has been used on the K181, K301, and K321 engines. It can be identified by its partial skirt and rectangular recessed area around the piston pin bore. In addition, it has an installation direction identifier, Fly, which is stamped into the top of the piston. The style D piston is to be installed with the arrow of the Fly mark pointing towards the flywheel.

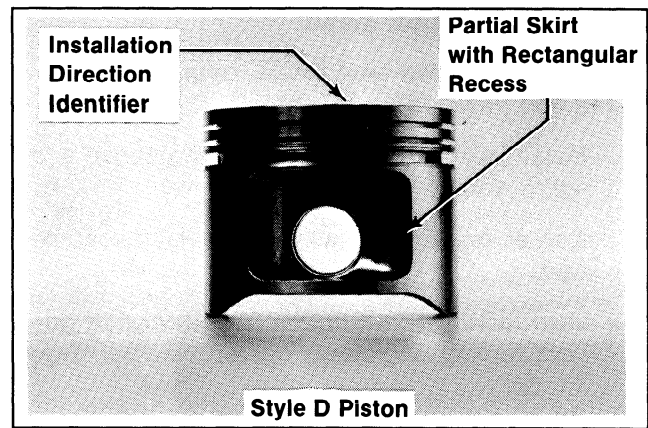

Piston Sizes – All Styles

In order to ensure a correct fit between piston and cylinder we utilize two cylinder bore sizes at the factory. Cylinder blocks are honed to the Standard (STD) size or .003: (.075mm) oversize with corresponding pistons. Blocks using the oversize are stamped on the cylinder head gasket surface with ".003". It is essential that ".003" oversize pistons are used in these blocks to prevent possible failure such as a noisy engine or eventual piston skirt cracking. These pistons are available from Kohler. Standard Service Rings should be used with both Standard and ".003" oversize pistons. Ring end gap will increase slightly when installed on ".003" oversize pistons; however, sealing is maintained due to the ring design.

Inspection

Scuffing and scoring of piston and cylinder wall occur when internal temperatures approach the melting point of the piston. Temperatures high enough to do this are created by friction, which is usually attributed to improper lubrication, and/or overheating of the engine.

Normally, very little wear takes place in the piston boss-piston pin area. If the original piston and connecting rod can be reused after new rings are installed, the original pin can also be reused but new piston pin retainers are required. The piston pin is included as part of the piston assembly – if the pin boss in piston, or the pin are worn or damaged, a new piston assembly is required.

Ring failure is usually indicated by excessive oil consumption and blue exhaust smoke. When rings fail, oil is allowed to enter the combustion chamber where it is burned along with the fuel. High oil consumption can also occur when the piston ring end gap is incorrect because the ring cannot properly conform to the cylinder wall under this condition. Oil control is also lost when ring gaps are not staggered during installation.

When cylinder temperatures get too high, lacquer and varnish collect on piston causing rings to stick which results in rapid wear. A worn ring usually

takes on a shiny or bright appearance. Scratches on rings and piston are caused by abrasive material such as carbon, dirt, or pieces of hard metal.

Detonation damage occurs when a portion of the fuel charge ignites spontaneously from heat and pressure shortly after ignition. This creates two flame fronts which meet and explode to create extreme hammering pressures on a specific area of the piston. Detonation generally occurs from using fuels with too low of an octane rating.

Pre-ignition or ignition of the fuel charge before the timed spark can cause damage similar to detonation. Pre-ignition damage is often more severe than detonation damage – often, a hole is quickly burned right through the piston dome. Pre-ignition is caused by a hot spot in the combustion chamber from sources such as: glowing carbon

deposits, blocked fins, improperly seated valves or wrong spark park plug.

See Figure 11-10 for some common types of piston and ring damage.

Service

K-Series service replacement pistons are available in STD bore size, and in .003", .010", .020", and .030" oversizes. Replacement pistons include new piston ring sets and new piston pins.

Service replacement piston ring sets are also available separately for STD/.003" (same ring set for both sizes), .010", .020" and .030" oversized pistons. Always use new piston rings when installing pistons. Never reuse old rings.

The cylinder bore must be deglazed before service ring sets are used.

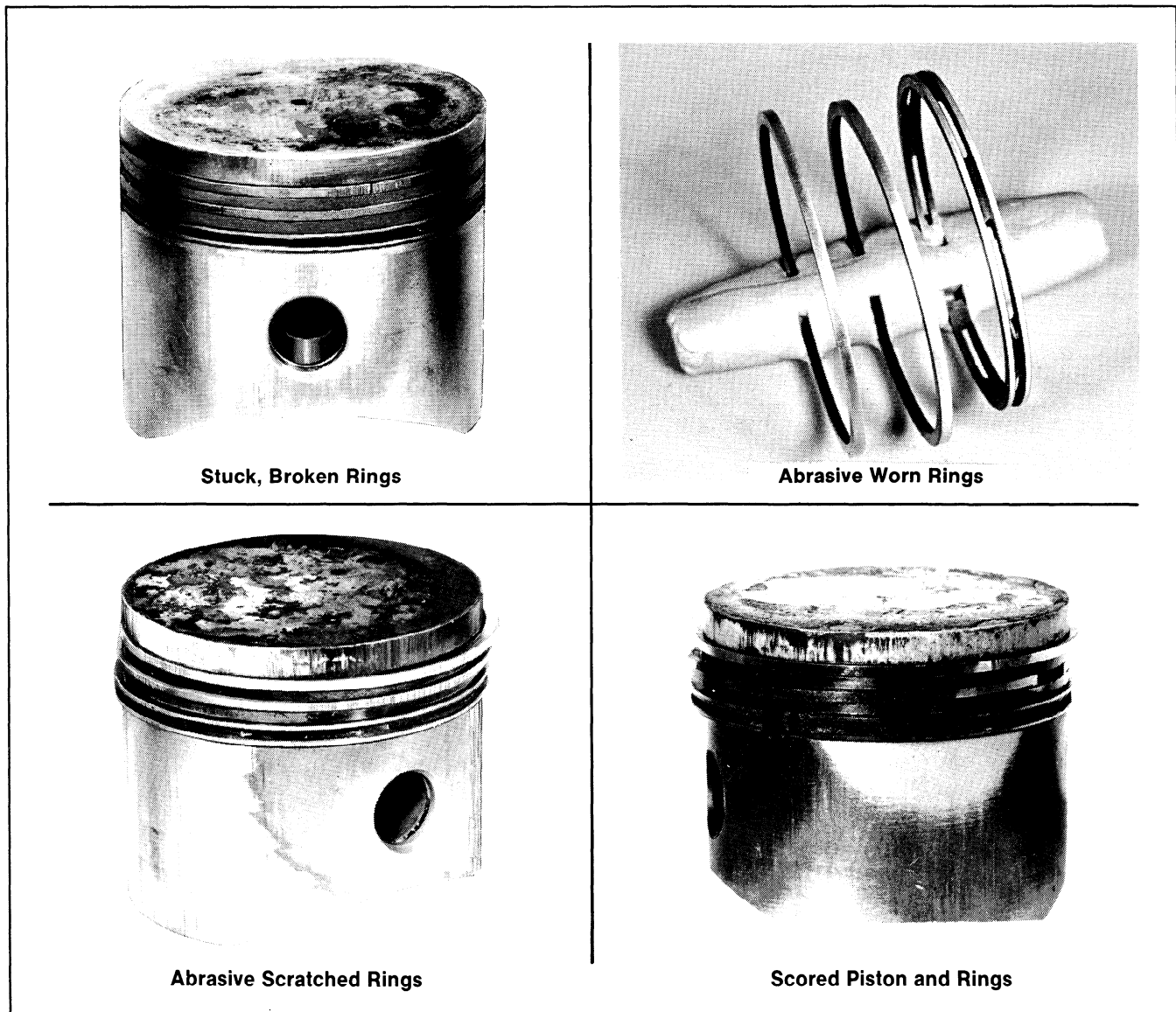

Figure 11-10. Common Types Of Piston And Ring Damage.

Some important points to remember when servicing piston rings:

1. If the cylinder block does not need reboring and if the old piston is within wear limits (refer to Section 1, "General Information") and free of score or scuff marks, the old piston may be reused.
2. Remove old rings and clean up grooves. Never reuse old rings.
3. Before installing new rings on piston, place top two rings, each in turn, into its running area in cylinder bore and check end gap (see Figure 11-11).

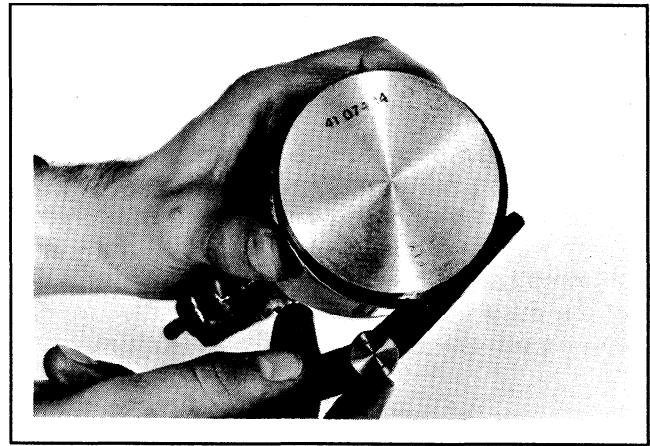
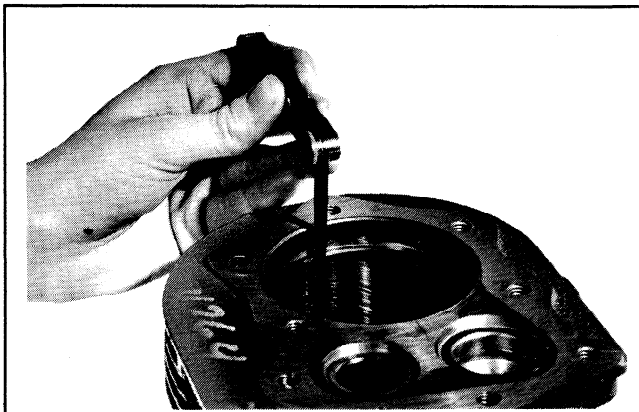

Figure 11-12. Measuring Piston Ring Side Clearance.



Model	End Gap	
	New	Used
K91, K161, K181	.007/.017*	.007/.027*
K241, K301, K321, K341	.010/.020	.010/.030

*On Model K181 using piston style C or D, New .010/.023, Used .010/.032.

Figure 11-11. Measuring Piston Ring End Gap.

4. After installing the new compression (top and middle) rings on piston, check piston-to-ring side clearance. Maximum recommended side clearance is **.006"**. If side clearance is greater than **.006"**, a new piston must be used. Refer to Figure 11-12.

Oil Ring End Gaps

Although 4 sizes of service ring sets are available (Std., $\pm .010$ ", $\pm .020$ ", $\pm .030$ "), only two sizes of oil rings are supplied (Std. and $.020$ " oversize). When using $.010$ " and $.030$ " oversize ring sets, the oil rings appear to have excessive end gap. This is not detrimental and proper sealing will be achieved due to the additional scraper rings and expander.

NOTE: Scraper and main ring end gaps should be staggered around the groove to prevent combustion blow-by.

Install Piston Rings

NOTE: Rings must be installed correctly. Ring installation instructions are usually included with new ring sets. Follow instructions carefully. Use a piston ring expander to install rings. Install the bottom (oil control) ring first and the top compression ring last.

POSI-LOCK CONNECTING RODS

Posi-Lock connecting rods are used in some K-Series engines. On model K181 engines with the style D pistons (refer to "Piston and Rings, Identification" earlier in this section), the connecting rods have a narrower piston pin end than on the earlier (style A) Posi-Lock connecting rods (refer to Figure 11-13). Therefore, the Posi-Lock connecting rods used with the style D pistons are not interchangeable with the Posi-Lock connecting rods used with style A pistons.

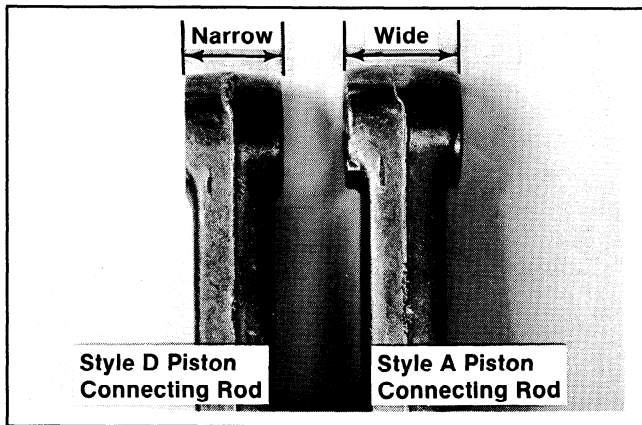

Figure 11-13. Posi-Lock Connecting Rods.

Inspection and Service

Check bearing area (big end) for excessive wear, score marks, running and side clearances (refer to Section 1, "General Information"). Replace rod and cap is scored or excessively worn.

Service replacement connecting rods are available in STD crank pin size and .010" undersize. The .010" undersize rod can be identified by the drilled hole located in the lower end of the rodshank (refer to Figure 11-14). Always refer to the appropriate parts information to ensure the correct replacements are used.

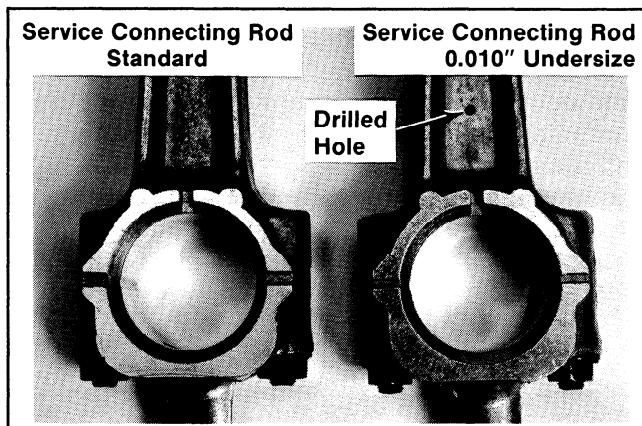

Figure 11-14. Standard And .010" Undersize Connecting Rods.

BALANCE GEARS AND STUB SHAFTS

Most K321 and K341 K-Series engines are equipped with a balance gear system. K91, K161, and K181 engines do not have balance gears. Some K241 and K301 engines are equipped with a balance gear system.

The system consists of two gears and spacer (used to control end play) mounted on stub shafts which are pressed into the crankcase. The gears and spacers are held on the shafts with snap-ring retainers. The gears are timed with and driven by the engine crankshaft.

Inspection and Repair

Use a micrometer and measure the stub shaft diameter. If the diameter is less than .4996", replace the stub shaft. Use an arbor press to push old shaft out and new shaft in. Refer to Figure 11-15. The stub shaft must protrude a specific distance above the stub shaft boss. If the stub shaft boss is about 7/16" above the main bearing boss, press the shaft in until it is .735" above the stub shaft boss. On blocks where the stub shaft boss is only about 1/16" above the main bearing boss, press shaft in until it is 1.110" above the stub shaft boss. A 3/8" spacer must be used with the shaft which protrudes 1.110".

Inspect the gears for worn or chipped teeth and for worn needle bearings. Use an arbor press and driver to replace bearings, if required.

BALANCE GEAR BEARING AND BALANCE GEAR ASSEMBLY

A new needle bearing for the Dynamic Balance System is now being used on 10-16 HP Kohler engines. The new bearing (part number 47030 01) has been in use beginning with serial number 9641311. It is not interchangeable with the old needle bearing, part number 236506.

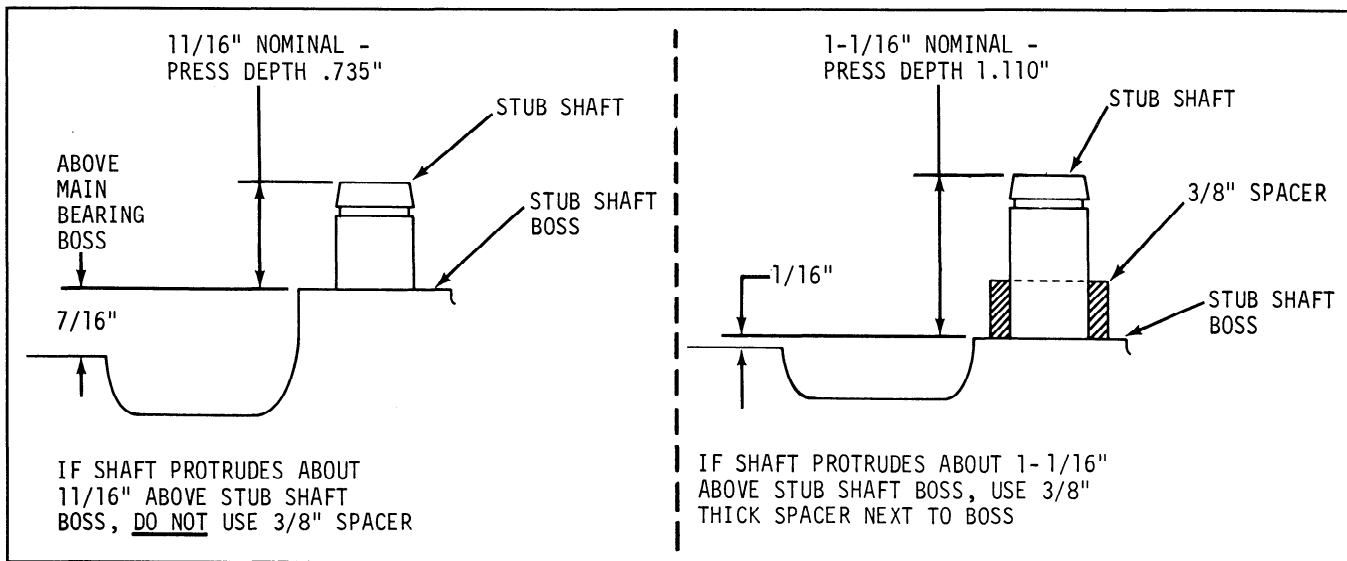

Figure 11-15. Stub Shaft Press Depth.

Complete balance gear assemblies are interchangeable – and old style gear assemblies have been superseded with a new gear assembly, part number 47 042 01.

Critical consideration is required when only the needle bearing is to be replaced. The engine serial number alone can correctly determine which needle bearing is involved on original equipment engines. However should a bearing replacement be required after a complete balance gear has been replaced on an engine with a serial number prior to 9641311, the following methods will assist in identifying the correct bearing:

Method #1 – I.D. of Balance Gear Bore

.6825 – 236506
.6821

.6865 – 47 030 01
.6869

Method #2 – O.D. of Old Bearing

.6825 – 236506
.6828

.6870 – 47 030 01
.6875

GOVERNOR GEAR

Inspection

Inspect the governor gear teeth. Look for any evidence of worn, chipped or cracked teeth. If one

or more of these problems is noted, replace the governor gear.

CAMSHAFT AND CRANKSHAFT

Inspection and Service

Inspect the gear teeth on both the crankshaft and camshaft. If the teeth are badly worn, chipped or some are missing, replacement of the damaged components will be necessary.

Also, inspect the crankshaft bearings for scoring, grooving, etc. Do not replace bearings unless they show signs of damage or are out of running clearance specifications. If crankshaft turns easily and noiselessly, and there is not evidence of scoring, grooving, etc., on the races or bearing surfaces, the bearings can be reused.

Check crankshaft keyways. If worn or chipped, replacement of the crankshaft will be necessary. Also inspect the crank pin for scoremarks or metallic pickup. Slight score marks can be cleaned with crocus cloth soaked in oil. If wear limits, as stated in Section1, "General Information", are exceeded, it will be necessary to either replace the crankshaft or regrind the crank pin to .010" under-size. If reground, a .010" undersize connecting rod (big end) must then be used to achieve proper running clearance. Measure the crank pin for size, taper and out-of-round.

NOTE: If the crank pin is reground, visually check to ensure that the fillet blends smoothly with the crank pin surface. Refer to Figure 11-16.

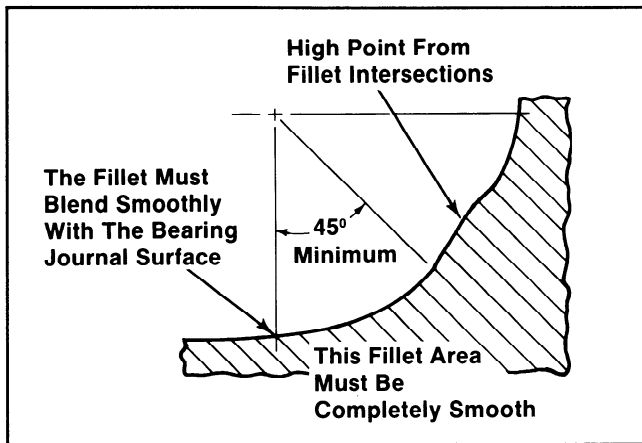

Figure 11-16. Crankpin Fillets.

When replacing a crankshaft with external threads on the flywheel end with one that has internal

threads, different mounting hardware is required. The internally threaded crankshafts are sold in kits which include the hardware. The mounting hardware can also be purchased separately.

NOTE:

1. Use a 13/32 I.D. x 1-1/4 O.D. x 1/8 TH. plain washer (Part No. 52114 01) when installing drive cups with a 1-1/4" Dia. spotface (machined, recessed area around mounting hole). These drive cups are primarily used on International Harvester applications, but may be found on other applications. Therefore, use the drive cup to identify which washer should be used.
2. Required for drive cups with 5/8" mounting hole.

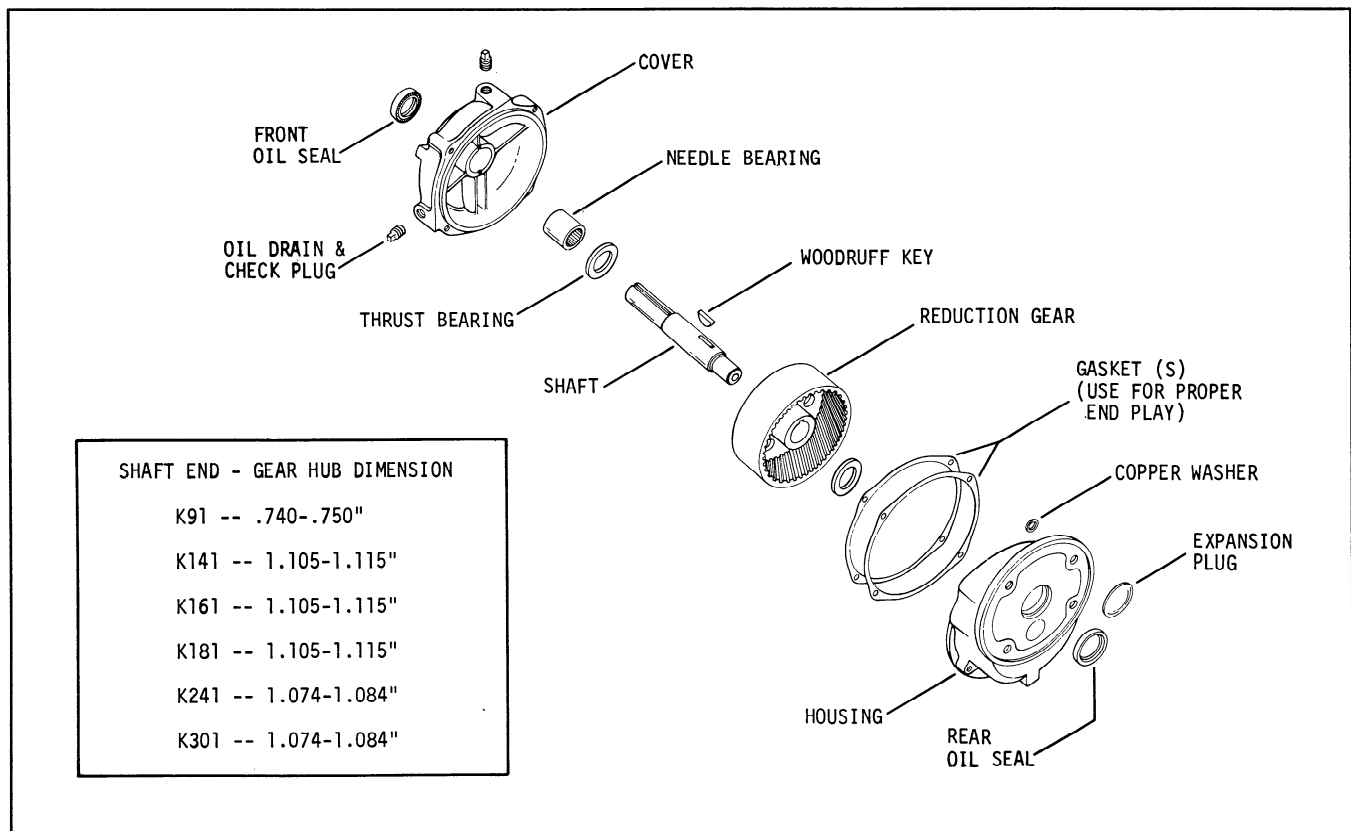

Figure 11-17. Gear Reduction Unit - Exploded View.

OPTIONAL GEAR REDUCTION UNIT

The reduction unit consists of a driven gear which is pressed on the power take off (PTO) shaft. The drive gear is an integral part of the engine crankshaft. The gear reduction on the K91 and K181 units is 6:1. The gear reduction on the K301 engine is 4:1. The PTO shaft is supported by two bearings, one in the cover and the other in the housing. Oil seals are provided at both ends of the shaft. Refer to Figure 11-17.

Removal

1. Drain lubricating oil from unit.
2. Remove four cap screws from gear housing and slide cover off along drive gear.
3. Remove four cap screws holding gear housing to engine.
4. Wash all parts and inspect shaft, bushing and gear for wear. Replace worn parts.
5. Remove old oil seals and install new seals (flat side out) in the gear housing and cover.

Installation

1. Wrap piece of tape or roll paper around crankshaft gear to protect the oil seal, slide housing over the shaft and attach to the block. Two lock washers are used on the outside of housing and copper washers inside.
2. Tape or paper should be wrapped around the shaft to prevent the keyway from damaging the cover oil seal. Install the gasket(s) and reduction gear cover and tighten cap screws.
3. Adjust shaft end clearance to .001/.006 inches by varying the total gasket thickness, adding or removing gaskets as required.
4. Remove oil fill plug and oil level plug, fill unit to the oil level hole. Use the same grade of oil as used in the engine.

SECTION 12

REASSEMBLY

The following sequence is suggested for complete engine reassembly. This procedure assumes that all components are new or have been reconditioned, and all component subassembly work has been completed. This procedure may have to be varied slightly to accommodate options or special equipment.

NOTE: Make sure the engine is assembled using all specified torque values, tightening sequences, and clearances. Failure to observe specifications could cause severe engine wear or damage.

Always use new gaskets.

1. Install rear bearing.
2. Install governor gear and cross shaft.
3. Install tappets and camshaft.
4. Install balance gears.
5. Install crankshaft.
6. Install front bearing.
7. Install fuel line and wiring harness.
8. Install bearing plate.
9. Install oil seals.
10. Install piston rings
11. Install piston to connecting rod.
12. Install piston/connecting rod.
13. Install oil pan.
14. Install valves.
15. Install stator.
16. Install flywheel, grass screen, and drive cup or rope start pulley.
17. Install blower housing.
18. Install cylinder head and spark plug.
19. Install breather assembly.
20. Install side air baffles and cylinder head baffle.
21. Install dipstick.
22. Install fuel tank.
23. Install electric starter.
24. Install retractable starter.
25. Install fuel pump.
26. Install external governor components and throttle controls.
27. Install carburetor and throttle linkage.
28. Install muffler.
29. Install air cleaner.

INSTALL REAR BEARING

1. Install the rear bearing into crankcase using the #4747 handle and appropriate bearing installer. (Refer to the "Special Tools" section). Make sure the bearing is bottomed fully, and is straight and true in bore. Refer to Figure 12-1. Install the rear main bearing by pressing it into cylinder block. If using a shielded type bearing, install with shielded side facing toward inside of block.

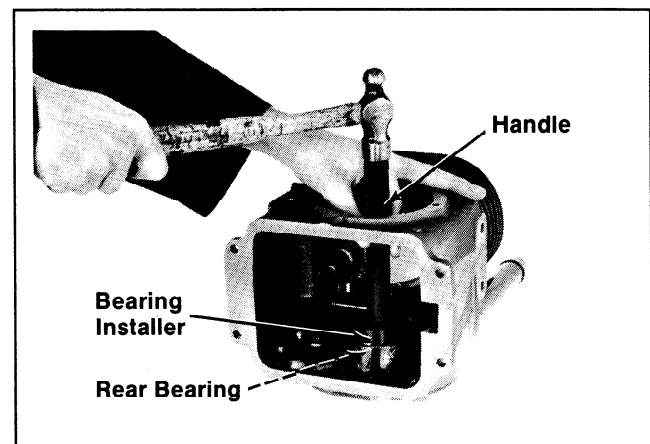

Figure 12-1. Installing Rear Bearing.

INSTALL GOVERNOR GEAR AND CROSS SHAFT

1. Slide cross shaft into place from inside of block.
2. Place speed control disc on governor bushing nut and thread bushing nut into block. On earlier models, the cross shaft has an extension riveted in place to line up with governor gear. Torque bushing nut as follows:

K91	70/90 in. lb.
K161, K181	130/150 in. lb.
K241, K301, K321, K341	100/120 in. lb.
3. Install the thrust washer, governor gear, copper washer, and stop pin. Refer to Figures 12-2 and 12-3.

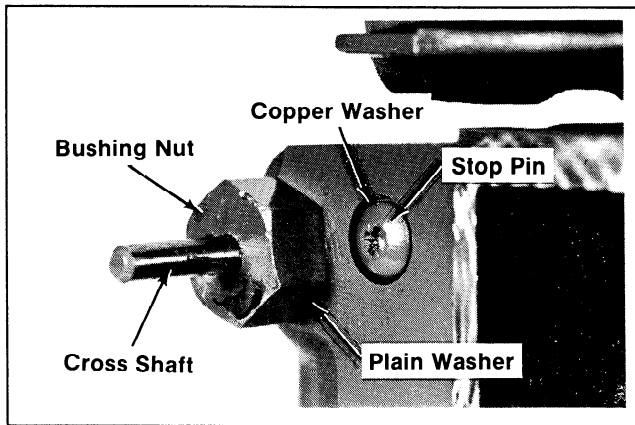

Figure 12-2. Installing Cross Shaft And Stop Pin.

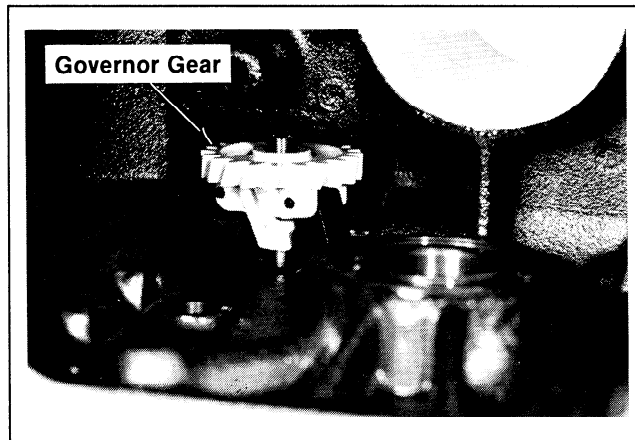

Figure 12-3. Installing Governor Gear.

4. Rotate governor gear assembly to be sure stop pin does not contact weight section of governor gear.

INSTALL TAPPETS AND CAMSHAFT

1. Install the intake valve tappet and exhaust valve tappet into crankcase. (Intake valve tappet towards bearing plate side; exhaust valve tappet towards PTO side of crankcase.) Refer to Figure 12-4.

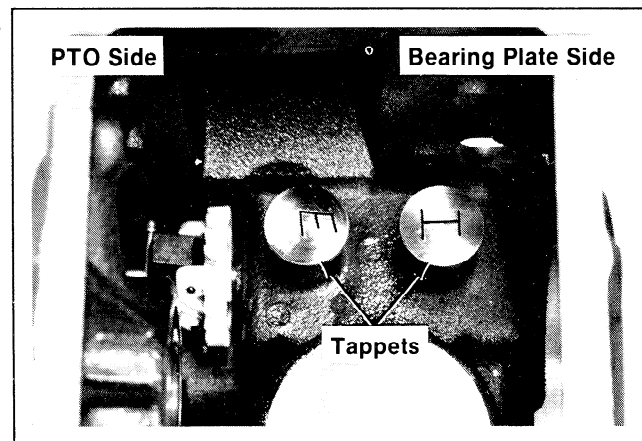

Figure 12-4. Installing Tappets.

NOTE: On K161 and K181 ACR engines, install the shorter tappet in the exhaust bore guide. Intake and exhaust tappets are interchangeable on other models.

2. Install the camshaft, one .005" shim spacer, and the camshaft pin (from bearing plate side). Do not drive the camshaft pin into its final position at this time. Refer to Figure 12-5.

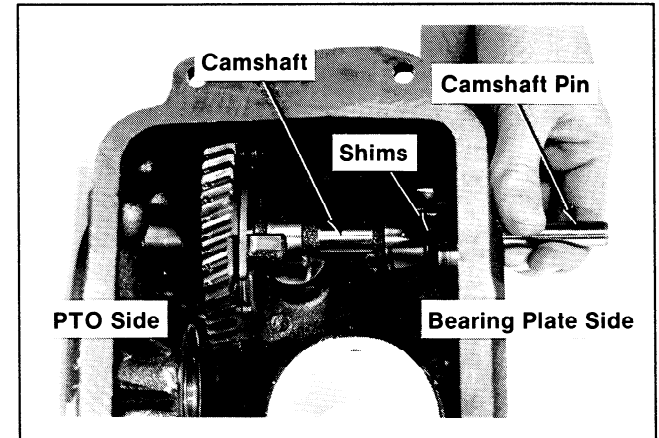

Figure 12-5. Installing Camshaft.

NOTE: On pre-ACR models with the automatic spark advance camshaft, spread actuators and insert cam. Align the timing marks on cam and gear as shown in Figure 12-6.

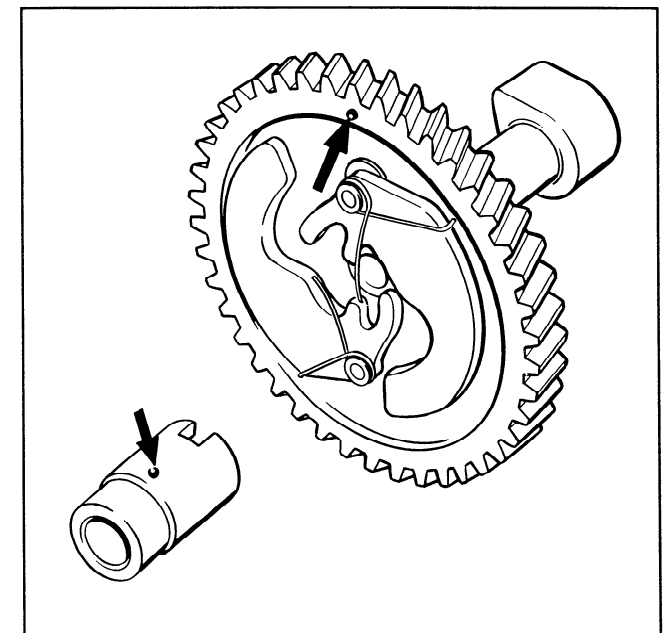

Figure 12-6. Timing Marks - Pre-ACR Camshaft.

3. Measure the camshaft end play between the spacer and crankcase boss using a flat feeler gauge. Refer to Figure 12-7. Recommended camshaft end play is .005"/.020" for model K91 and .005"/.010" - for all other K-Series models. Add or subtract .005" and/or .010"

shim spacers as necessary to obtain the proper end play.

4. K-Series engines now use a new camshaft pin, the new camshaft pins are shorter than the old pins originally used in K-Series engines.

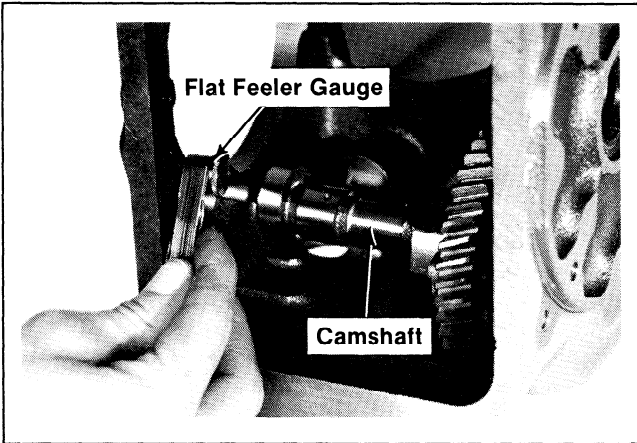

Figure 12-7. Measuring Camshaft End Play.

To install the new (shorter) camshaft pin, drive the camshaft pin from the bearing plate side of crankshaft into the PTO side of crankcase:

- a. For Models K161 and K181 – drive the camshaft pin to a depth of $.275''$ / $.285''$ from the machined bearing plate gasket surface.
- b. For Models K241, K301, K321, and K341 – drive the camshaft pin to a depth of $.300''$ / $.330''$ from the machined bearing plate gasket surface. Refer to Figure 12-8.

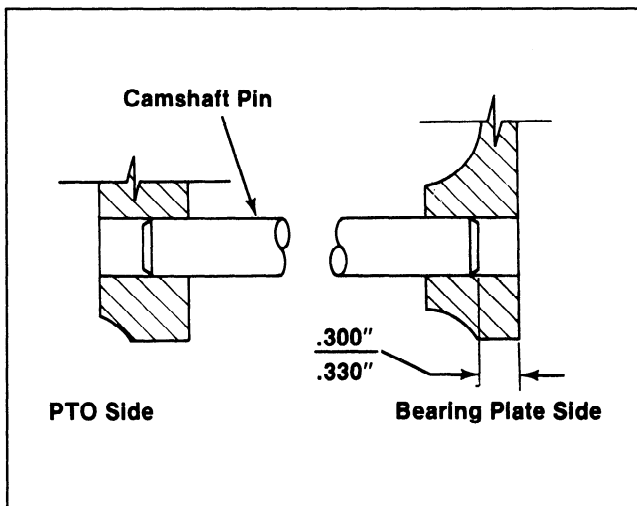

Figure 12-8. Installing Camshaft Pin.

To install the old (longer) camshaft pin, drive the camshaft pin into the crankcase until the PTO end of camshaft pin is flush with the mounting surface on PTO side of crankcase.

INSTALL BALANCE GEARS

On Engines So Equipped

NOTE: The balance gears must be timed to the crankshaft whenever the crankshaft is installed. Use a balance gear timing tool to simplify this procedure (refer to the "Special Tools" section in this manual). If the balance gears must be timed without using the tool, do not install the lower balance gear (closest to the oil pan) until **after** the crankshaft has been installed.

Refer to "INSTALL CRANKSHAFT" for specific timing procedures.

1. Install the $3/8''$ spacer, one $.010''$ shim spacer, balance gear, one $.020''$ shim spacer, and retaining ring (rounded edge towards balance gear). Refer to Figure 12-9. A new style needle bearing is now being used on the K-Series balance gear assembly.

NOTE: Extreme care must be taken when handling the new needle bearings or when removing balance gears containing the new bearings. The needles are no longer caged and will drop out. If this should occur, the bearing case should be greased and the needles reset. There are 27 individual needles in each bearing.

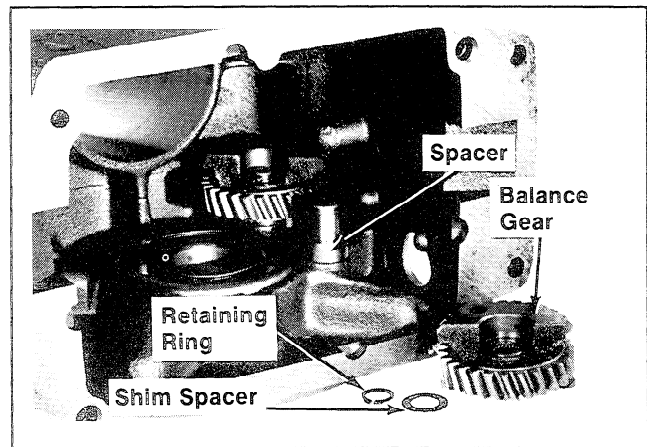

Figure 12-9. Installing Balance Gears.

2. Check end play with a flat feeler gauge. Refer to Figure 12-10. Recommended end play is $.002''$ / $.010''$. If end play is not within range, install or remove $.005''$ and $.010''$ spacers*, as necessary.

*Balance gear spacer kit, Kohler Part 47 755 01, contains enough $3/8''$, $.005''$, $.010''$, and $.020''$ spacers to obtain correct end play for both balance gears.

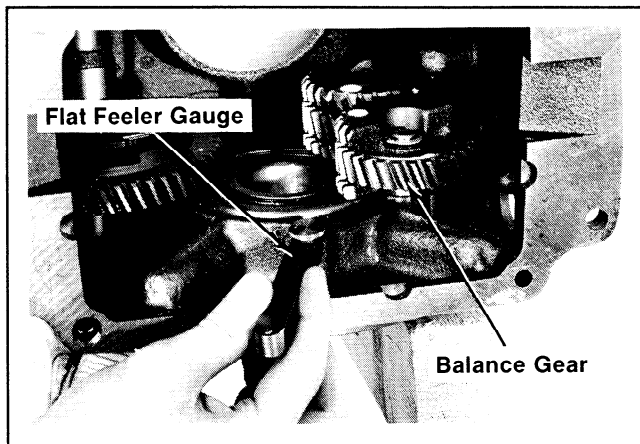

Figure 12-10. Measuring Balance Gear End Play.

INSTALL CRANKSHAFT

On Engines Without Balance Gears

1. Lubricate the crankshaft rear bearing surface. Insert the crankshaft through the rear bearing.

NOTE: If the crankshaft and bearing plate have not been separated, position the fuel line and wiring harness between the bearing plate and crankcase before pressing the crankshaft all the way in.

2. Align the primary timing mark on crankshaft with the timing mark on camshaft. Refer to Figure 12-11. Press the crankshaft into rear bearing. Make sure the camshaft and crankshaft gears mesh and that the timing marks remain aligned while pressing.

On Engines With Balance Gears

K-Series engines have two styles of balance gear assemblies. To provide improved vibration reducing characteristics, redesigned balance gear assemblies are being used in the K241, K301, K321 and K341 single cylinder engines. These new bal-

ance gear assemblies (Part No. 45 043 03) are being used in engines with a Serial No. of 1613600013 and later, and for service replacement. Figure 12-12 shows the physical differences between the old and new style gear assemblies.

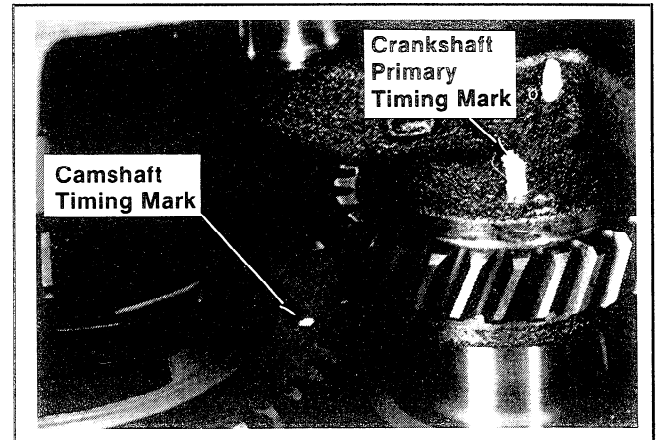

Figure 12-11. Aligning Crankshaft And Camshaft Timing Marks.

Because of the physical differences of the gear, new procedures for installing the crankshaft, and timing the balance gears, crankshaft, and camshaft are required.

The following "INSTALL CRANKSHAFT" procedures are broken down into four sections;

- 1A) OLD STYLE BALANCE GEAR ASSEMBLY - WITH A BALANCE GEAR TIMING TOOL
- 1B) OLD STYLE BALANCE GEAR ASSEMBLY - WITHOUT A BALANCE GEAR TIMING TOOL
- 2A) NEW STYLE BALANCE GEAR ASSEMBLY - WITH A BALANCE GEAR TIMING TOOL
- 2B) NEW STYLE BALANCE GEAR ASSEMBLY - WITHOUT A BALANCE GEAR TIMING TOOL METHOD

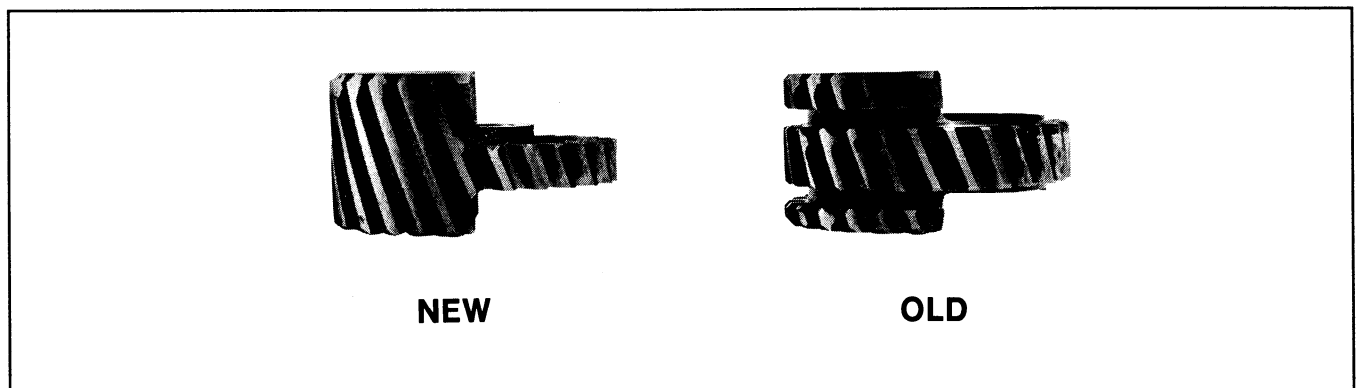

Figure 12-12. Old And New Style Balance Gear Assemblies.

1A) OLD STYLE BALANCE GEAR ASSEMBLY – WITH A BALANCE GEAR TIMING TOOL

1. Align the primary timing marks of balance gears with the teeth on timing tool. Insert tool so it meshes with gears. Hold or clamp tool against oil pan gasket surface. Refer to Figure 12-13.

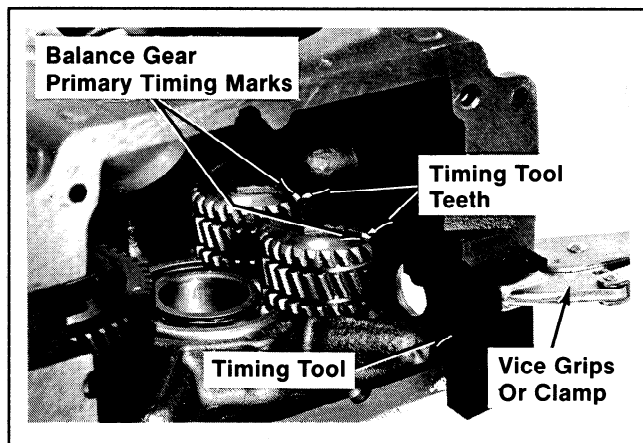

Figure 12-13. Installing Balance Gear Timing Tool.

2. Lubricate the crankshaft rear bearing surface. Insert the PTO end of crankshaft through rear bearing. "Straddle" the primary and secondary timing marks on crankshaft over the rear bearing oil drain (refer to Figure 12-14). Press the crankshaft into rear bearing until the crankgear is just above the camshaft gear but not in mesh with it.

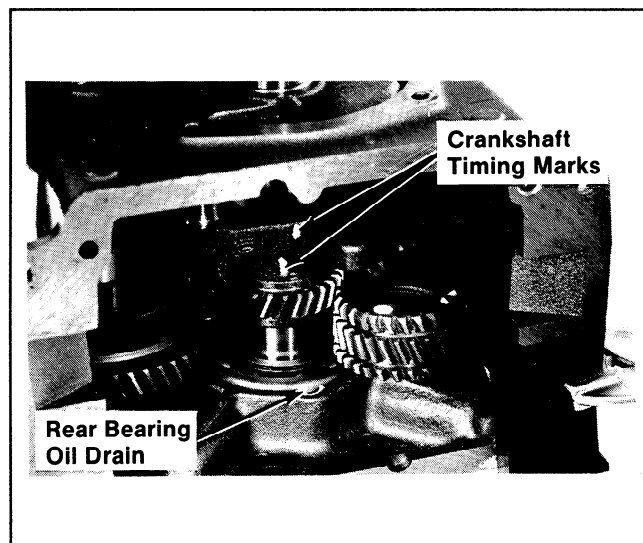

Figure 12-14. Aligning Crankshaft And Balance Gears.

NOTE: If the crankshaft and bearing plate have not been separated, position the fuel line and wiring harness between the bearing plate and crankcase before pressing the crankshaft all the way in.

3. Remove the balance gear timing tool and align the primary timing mark on the crankshaft with the timing mark on the camshaft gear. Refer to Figure 12-15. Press the crankshaft all the way into the rear bearing. Make sure the camshaft and crankshaft gears mesh and that the timing marks align while pressing.

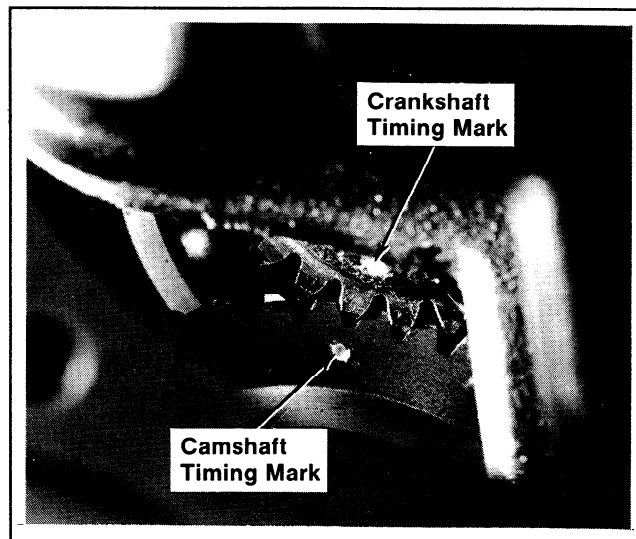

Figure 12-15. Aligning Crankshaft And Camshaft Timing Marks.

4. Check the timing of the crankshaft, camshaft, and balance gears:
 - The primary timing mark on crankshaft should align with the secondary timing mark on lower balance gear. Refer to Figure 12-16.

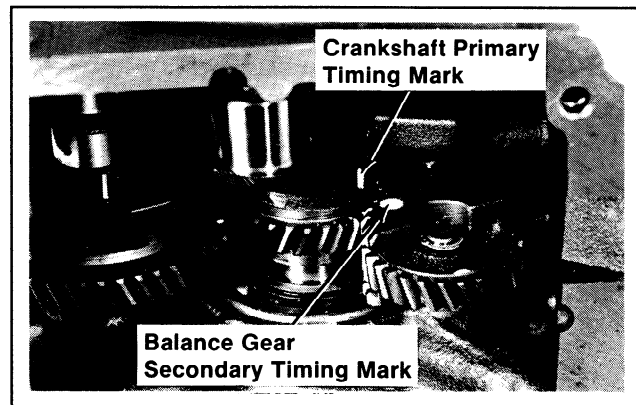

Figure 12-16. Checking Crankshaft And Balance Gear Alignment.

- The primary timing mark on crankshaft should align with the timing mark on camshaft. Refer to Figure 12-15.

If the marks do not align, the timing is incorrect and must be corrected.

1B) OLD STYLE BALANCE GEAR ASSEMBLY – WITHOUT A BALANCE GEAR TIMING TOOL

NOTE: The lower balance gear should be installed after the crankshaft has been installed.

1. Lubricate the crankshaft rear bearing surface. Insert the PTO end of crankshaft through rear bearing. Align the primary timing mark on crankshaft with the primary timing mark on upper balance gear. Refer to Figure 12-17. Press the crankshaft into rear bearing until the crankgear just starts to mesh (about 1/16") with the center ring of balance gear teeth.

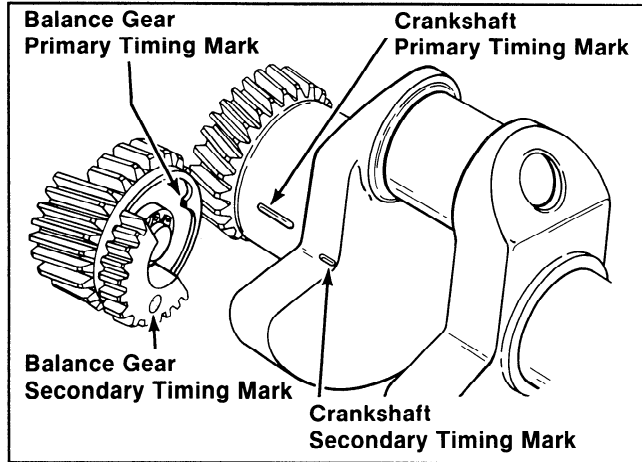

Figure 12-17. Timing Marks On Balance Gear And Crankshaft.

NOTE: If the crankshaft and bearing plate have not been separated, position the fuel line and wiring harness between the bearing plate and crankcase before pressing the crankshaft all the way in.

2. Align the primary timing mark on the crankshaft with the timing mark on the camshaft gear. Refer to Figure 12-15. Press the crankshaft all the way into the rear bearing. Make sure the camshaft and crankshaft gears mesh and that the timing marks align while pressing.
3. Position the crankshaft so it is about 15° past BDC. Install 3/8" spacer, and one .010" shim spacer. Align the secondary timing mark on the lower balance gear with the secondary timing mark on the crankshaft. Install the lower balance gear on the stub shaft. If properly timed, the primary timing mark on the crankshaft will now be aligned with the secondary timing mark on the lower balance gear. Refer to Figures 12-9 and 12-17.
4. Install one (1) .020" shim spacer and retaining ring (rounded edge towards gear). Check end

play of lower balance gear as instructed under "INSTALL BALANCE GEARS." Refer to Figures 12-9 and 12-10.

5. Check the timing of the crankshaft, camshaft, and balance gears.
 - The primary mark on crankshaft should align with the primary timing mark on upper balance gear. Refer to Figure 12-17.
 - The primary mark on crankshaft should align with the secondary timing mark on lower balance gear. Refer to Figure 12-16.
 - The primary mark on crankshaft should align with timing mark on camshaft. Refer to Figure 12-15. If the marks do not align, the timing is incorrect and must be corrected.

2A) NEW STYLE BALANCE GEAR ASSEMBLY - WITH A BALANCE GEAR TIMING TOOL

1. Count and mark the teeth on the crankshaft gear, and the lands (notches between teeth) on the camshaft gear as follows:

Crankshaft - Locate the primary timing mark on crankshaft. While looking at the PTO end of crankshaft, start with the tooth directly below timing mark and count five (5) teeth in a **counterclockwise** direction. Mark the fifth tooth. Refer to Figure 12-18.

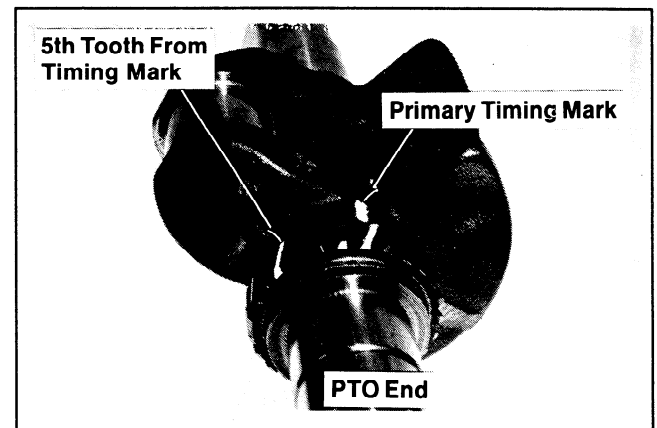

Figure 12-18. Marking Tooth On Crankshaft Gear.

Camshaft - Locate the timing mark on camshaft. Starting with the land next to the timing mark, count five (5) lands in a **counterclockwise** direction. Mark the fifth land. Refer to Figure 12-19.

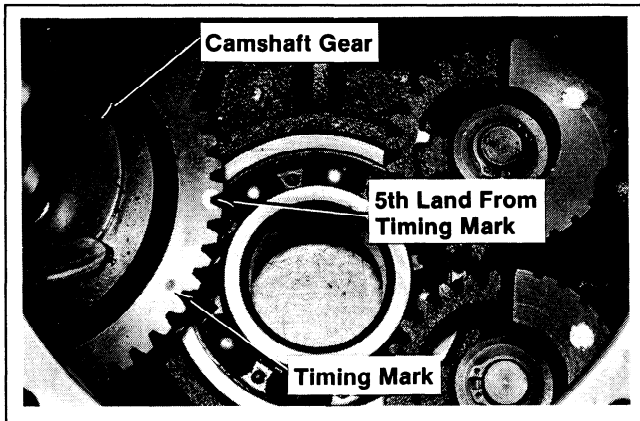

Figure 12-19. Marking Land On Camshaft Gear.

- Align the primary timing marks on balance gears with the teeth on timing tool. Insert the tool so it meshes with the gears. Hold or clamp the tool against oil pan gasket surface of crankcase. Refer to Figure 12-4.

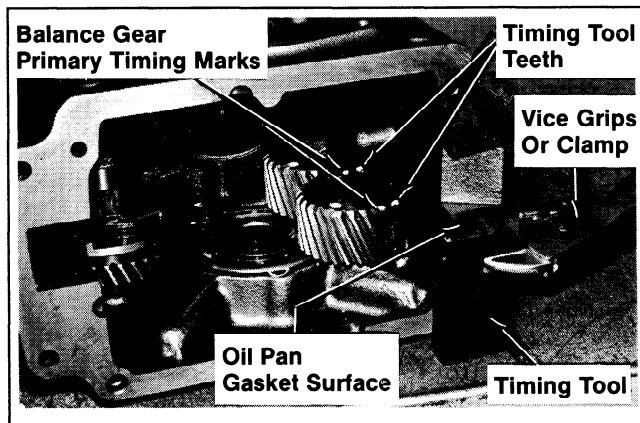

Figure 12-20. Installing Balance Gear Timing Tool.

- Lubricate the rear bearing surface of crankshaft. Insert the PTO end of crankshaft through the rear bearing. "Straddle" the primary and secondary timing marks on crankshaft over the rear bearing oil drain. Refer to Figure 12-21.

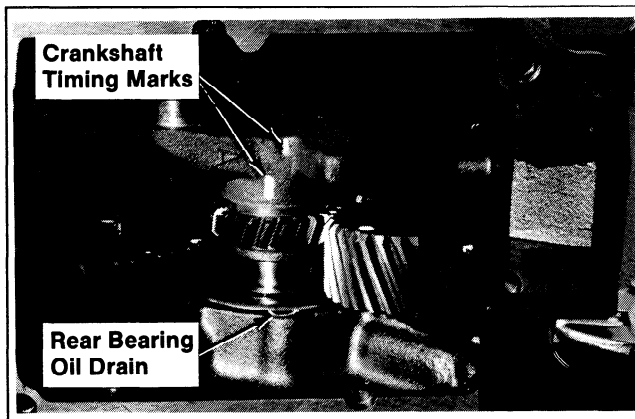

Figure 12-21. Aligning Crankshaft And Rear Bearing Oil Drain.

Press the crankshaft into the rear bearing until the crankshaft gear is just above the camshaft gear, but not in mesh with it. **Do not remove the balance gear timing tool at this time.**

- Align the fifth (5th) land marked on camshaft gear with the fifth (5th) tooth marked on crankshaft gear. Refer to Figure 12-22.

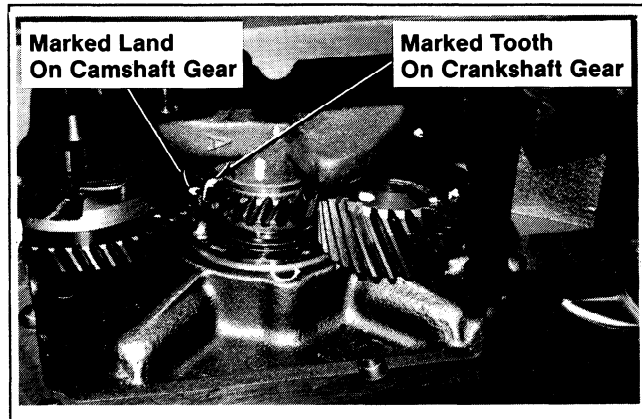

Figure 12-22. Aligning Camshaft Gear And Crankshaft Gear.

Press the crankshaft all the way into the rear bearing. Make sure the camshaft and crankshaft gears mesh and the marks align while pressing.

- Remove the balance gear timing tool. Check the timing of the crankshaft, camshaft, and balance gears:

- The primary timing mark on crankshaft should align with the secondary timing mark on lower balance gear. Refer to Figure 12-23.

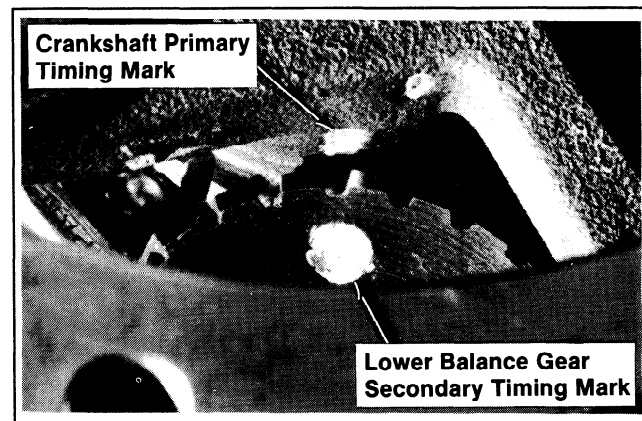

Figure 12-23. Crankshaft Gear/Lower Balance Gear Alignment.

- The primary timing mark on crankshaft should align with the timing mark on camshaft. Refer to Figure 12-24.

If the marks do not align, the timing is incorrect and must be corrected.

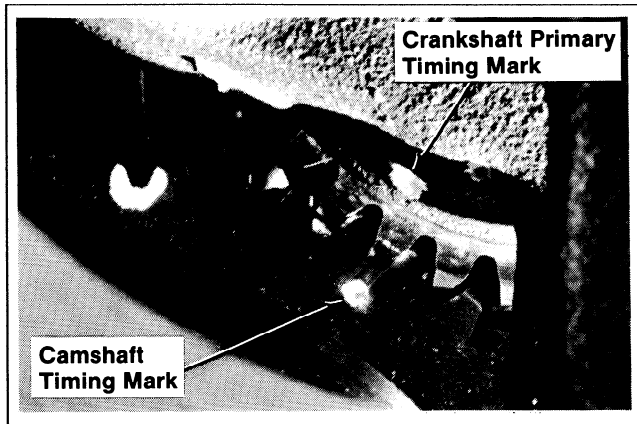

Figure 12-24. Crankshaft Gear/Camshaft Gear Alignment.

2B) NEW STYLE BALANCE GEAR ASSEMBLY- WITHOUT A BALANCE GEAR TIMING TOOL

NOTE: The lower balance gear should be installed after the crankshaft has been installed.

1. Count and mark the teeth on the crankshaft gear, and the land (notches between teeth) on the upper balance gear as follows:

Crankshaft – Locate the primary timing mark on crankshaft. While looking at the PTO end of crankshaft, start with the tooth directly below timing mark and count **twelve (12)** teeth in a **counterclockwise** direction. Mark the twelfth tooth. Refer to Figure 12-25.

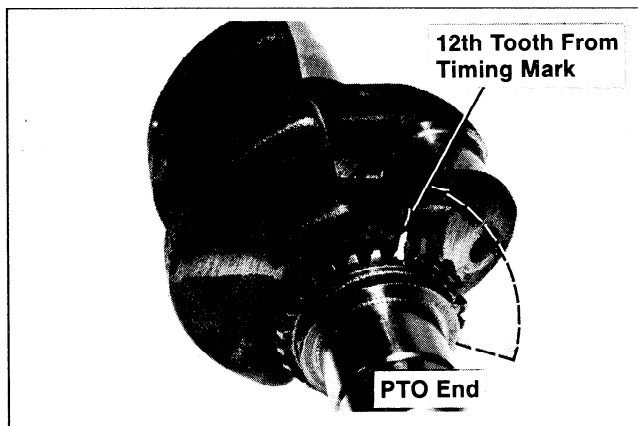

Figure 12-25. Marking Tooth On Crankshaft Gear.

Upper Balance Gear – Locate the secondary timing mark on balance gear. Starting with the land next to the timing mark, count **seven (7)** lands in a **clockwise** direction. Mark the seventh land. Refer to Figure 12-26.

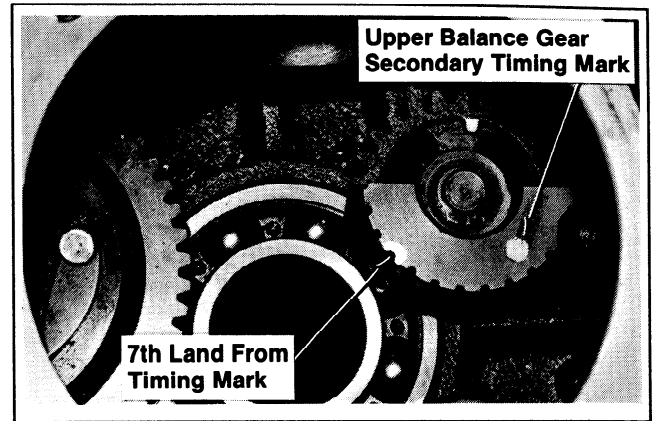

Figure 12-26. Marking Land On Upper Balance Gear.

2. Lubricate the rear bearing surface of crankshaft. Insert the PTO end of crankshaft through the rear bearing. Align the twelfth (12th) tooth marked on crankshaft gear with the seventh (7th) land marked on upper balance gear. Refer to Figure 12-27.

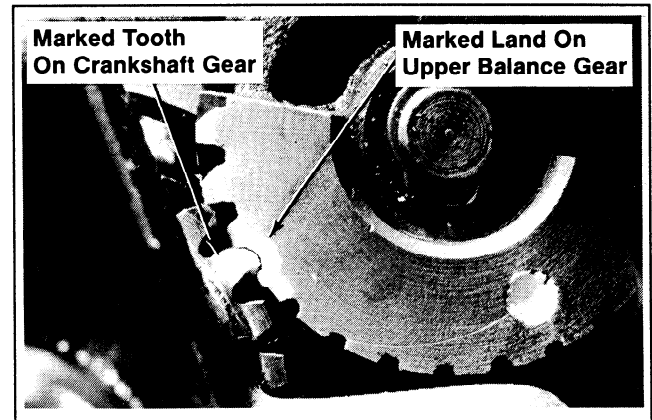

Figure 12-27. Aligning Crankshaft Gear And Upper Balance Gear.

Press the crankshaft into the rear bearing until the crankshaft gear is just above the camshaft gear, but not in mesh with it.

3. Align the timing mark on camshaft with the primary timing mark on crankshaft.

NOTE: To align the marks, rotate the camshaft only – do not rotate the crankshaft. Rotating the crankshaft could cause the crankshaft gear to come out of mesh (and out of time) with the wide band of teeth on upper balance gear.

Press the crankshaft all the way into the rear bearing. Make sure the camshaft and crankshaft gears mesh and the marks align while pressing. Refer to Figure 12-28.

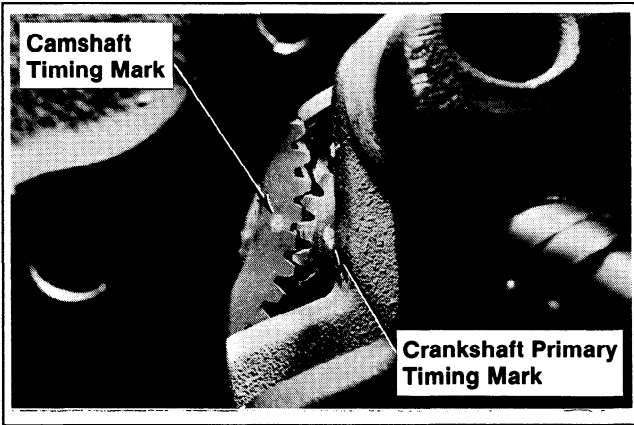

Figure 12-28. Aligning Camshaft Gear And Crankshaft Gear.

4. Install the 3/8" spacer and one (1) .010" shim spacer to the stub shaft for the lower balance gear.
5. Position the crankshaft so it is about 15° past bottom dead center (BDC). Align the secondary timing mark on lower balance gear with the secondary timing mark on crankshaft. Refer to Figure 12-29.

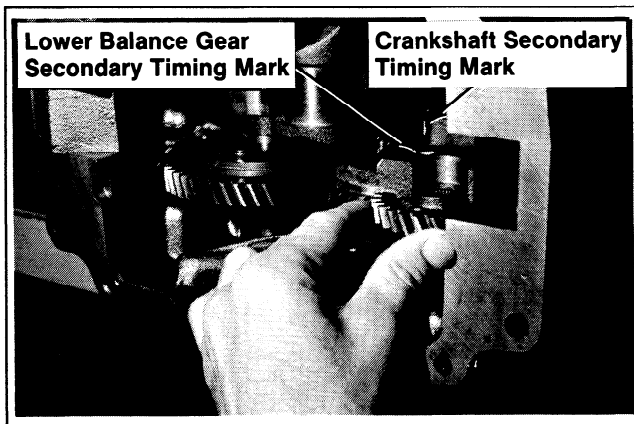

Figure 12-29. Aligning Lower Balance Gear And Crankshaft.

Install the lower balance gear to the stub shaft. If properly timed, the secondary timing mark on lower balance gear will now be aligned with the primary timing mark on crankshaft. Refer to Figure 12-30.

6. Secure the lower balance gear to stub shaft using one (1) .020" shim spacer and retaining ring (rounded edge towards gear). Check end play of lower balance gear as instructed in "INSTALL BALANCE GEARS".

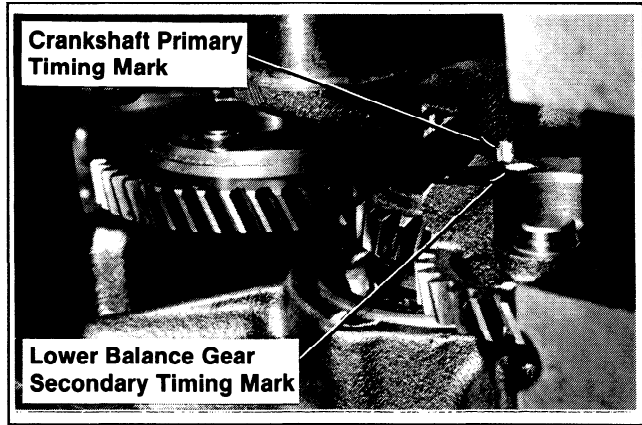

Figure 12-30. Crankshaft Gear/Lower Balance Gear Alignment.

7. Check the timing of the crankshaft, camshaft, and balance gears:
 - The primary timing mark on crankshaft should align with the secondary timing mark on lower balance gear. Refer to Figure 12-23.
 - The primary timing mark on crankshaft should align with the timing mark on camshaft. Refer to Figure 12-24.
 - The primary timing mark on crankshaft should align with the primary timing mark on upper balance gear. Refer to Figure 12-31.

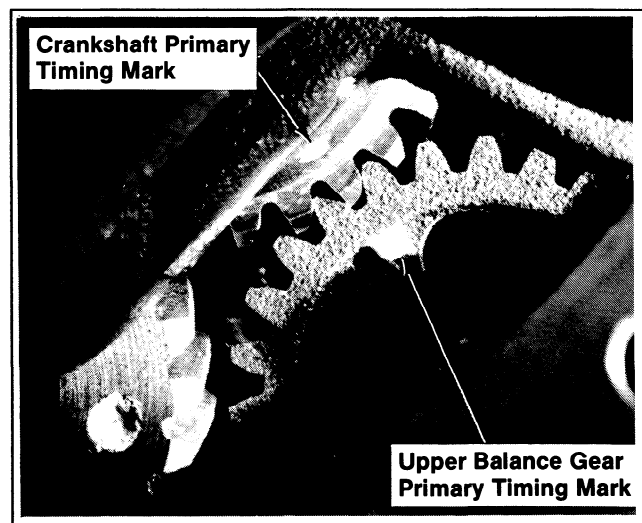

Figure 12-31. Crankshaft Gear/Upper Balance Gear Alignment.

If the marks do not align, the timing is incorrect and must be corrected.

INSTALL FRONT BEARING

1. Install the front bearing into the bearing plate using the #4747 handle and appropriate bearing installer. (Refer to the "Special Tools" section). Make sure the bearing is bottomed fully, and straight and true in the bore.

INSTALL FUEL LINE AND WIRING HARNESS

1. Position the fuel line and wiring harness (if so equipped) to crankcase.
2. Adjust the fuel line and wiring harness to their final positions just before securing the bearing plate to the crankcase.

INSTALL BEARING PLATE

1. The installation of bearing plate and gaskets can be made considerably easier with the use of two simple, easy to make alignment guides. Using 2-1/2" long bolts with the hexagon heads removed and screwdriver slots cut in the stem, screw the two headless bolts into the cylinder block diagonally from each other. Bolt thread sizes are 1/4-20 U.N.C. for K91-K181; 3/8-16 U.N.C. for K241-K361.
2. Lubricate the bearing surface of crankshaft and bearing. Install the gasket, two or three .005" shims (as required)*, and bearing plate over studs.

*NOTE: Crankshaft end play is determined by the thickness of the gasket and shims between crank-

case and bearing plate. Check the end play after the bearing plate is installed.

3. Install two hex cap sems screws and hand tighten. Remove the locating studs, and install the remaining two hex cap sems screws and hand tighten.
4. Tighten the screws evenly, drawing bearing plate to crankcase. Torque K91-K181 to 115 in. lb. Torque K241-K341 to 35 ft. lb.
5. Check crankshaft end play between the inner bearing race and shoulder of crankshaft using a flat feeler gauge. Refer to Figure 12-32. Recommended total end play is:

K91	.004"/.023"
K161, K181	.002"/.023"
K241, K301, K321, K341	.003"/.020"

If measured end play is not within limits, remove the bearing plate and, remove or install shims as necessary.

NOTE: Crankshaft end play is especially critical on gear reduction engines.

ENGINE MODEL	FRONT OIL SEAL LOCATION					
	MAGNETO ROTOR	FLYWHEEL MAGNETO	3 AMP ALTERNATOR	10 AMP ALTERNATOR	BREAKERLESS	BATTERY
K91	1/32"	1/32"	----	----	----	1/32"
K141	----	1/32" *	Full In	1/32"	----	Full In
K161	1/32"	1/32"	----	1/32"	----	1/32"
K181	1/32"	1/32" *	1/32"	1/32"	.486"	1/32"
K241	----	1/2"	1/2"	1/2"	.73"	1/2"
K241A	----	.52"	----	1/2"	.52"	.12"
K301	----	1/2"	1/2"	1/2"	.73"	1/2"
K301A	----	.52"	.52"	1/2"	.52"	.12"
K321	----	1/2"	1/2"	1/2"	.73"	1/2"
K341	----	----	----	----	----	1/2"

* With sleeve bearing-drive seal in until it bottoms against shoulder.

REAR OIL SEAL DEPTH: 1/32" for K91 through K181, 1/8" for K241 through K341. Depth measured in from crankcase face at PTO end.

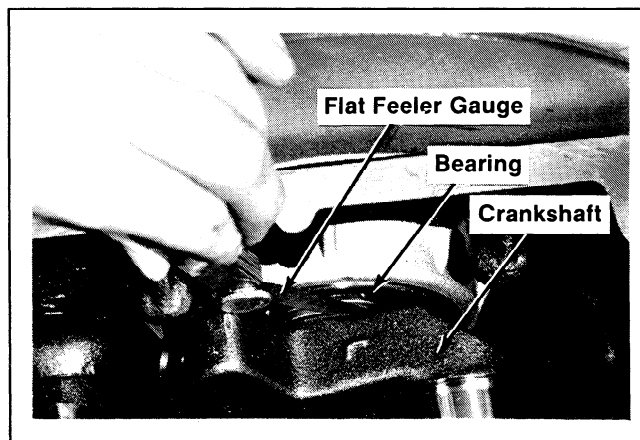

Figure 12-32. Measuring Crankshaft End Play.

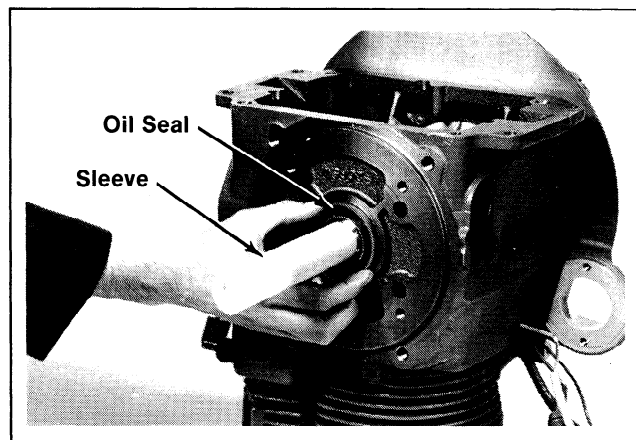

Figure 12-33. Installing Oil Seals Using Sleeves.

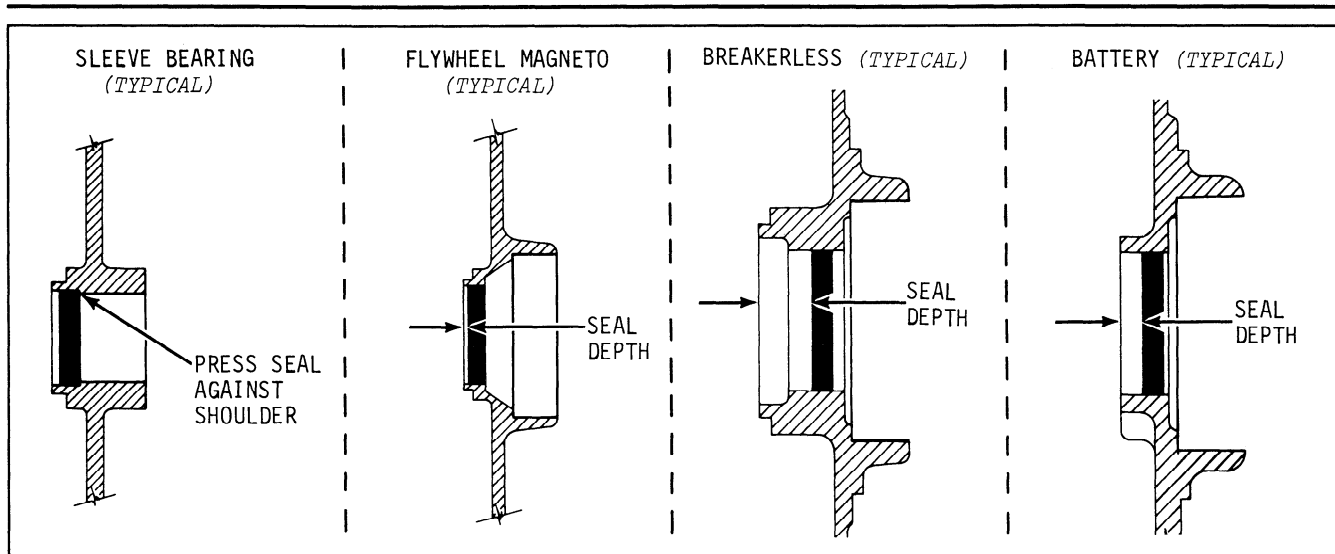

Figure 12-34. Front Oil Seal Location.

INSTALL OIL SEALS

1. Slide the appropriate seal sleeves over the crankshaft (refer to the "Special Tools" section). Generously lubricate the lips of the oil seals with light grease. Slide the oil seals over the sleeves. Refer to Figure 12-33.
2. Use the #11795 handle and appropriate seal drivers to install the front oil seals to the following depths:

Note that the front oil seal depth varies with engine model and type of bearing plate used—bearing plate configuration differs with type of ignition system used—these differences are shown in the cut-away views in Figure 12-33 to help identify the various bearing plate types. Rear oil seal installation details are shown in Figure 12-34.

INSTALL PISTON RING

NOTE: For detailed piston inspection and piston ring installation procedures, refer to the "Inspection And Repair/Reconditioning" section.

INSTALL PISTON TO CONNECTING ROD

Style "A" Piston

1. Install wrist pin and retainers.

Style "C" And "D" Pistons

NOTE: Proper orientation of the piston to the connecting rod is extremely important. Improper orientation may cause extensive wear or damage.

1. Orient piston and connecting rod so that the notch (Style "C" piston) or Fly symbol (Style "D" piston) on piston and the match mark on connecting rod are facing the same direction.
2. Install wrist pin and retainers. Refer to Figure 12-35.

INSTALL PISTON/CONNECTING ROD

NOTE: Proper orientation of the piston to the connecting rod is extremely important. Improper orientation may cause extensive wear or damage.

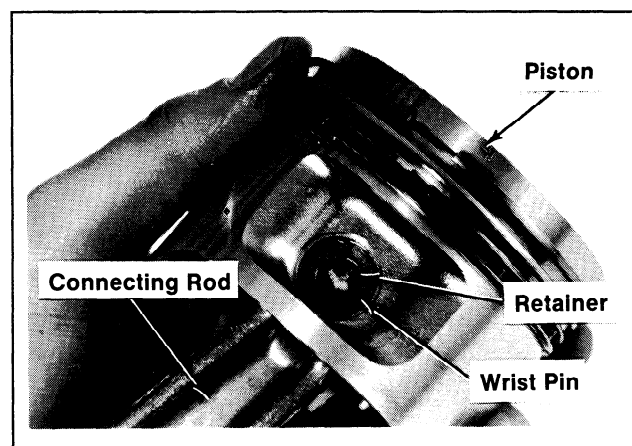

Figure 12-35. Installing Piston To Connecting Rod (Style "D" Piston Shown).

1. Stagger the piston rings in their grooves until end gaps are 120° apart.
2. Lubricate the piston and rings with engine oil. Install the piston ring compressor around piston. Refer to Figure 12-36.

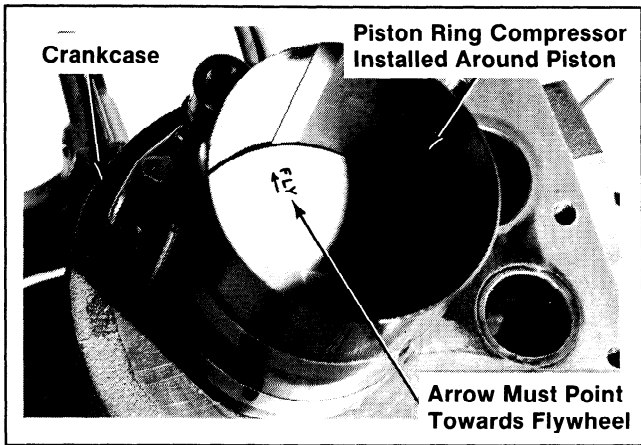

Figure 12-36. Installing Pistons.

3. Orient the notch (on Style "C" piston) or Fly symbol (Style "D" piston) and match marks on connecting rod towards the flywheel end of crankshaft. Gently push the piston/connecting rod into bore – do not pound on piston.
4. Lubricate the crankshaft and connecting rod journal surfaces with engine oil. Install the connecting rod cap – make sure the match marks are aligned and the oil hole is towards the camshaft. It is important that marks on connecting rod and cap line up and face flywheel end of engine. Refer to Figure 12-37.

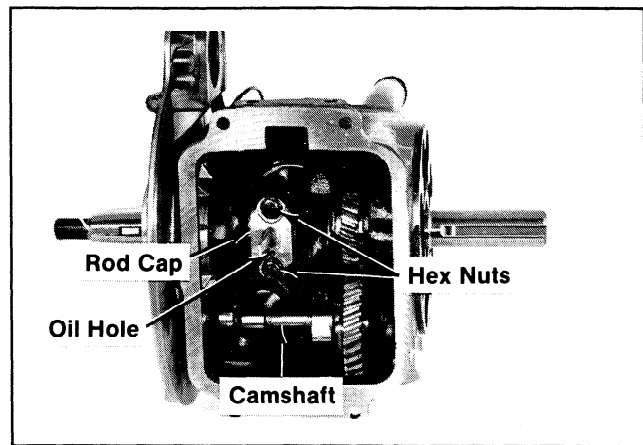

Figure 12-37. Installing Connecting Rod Cap.

5. Torque the capscrew to 20% over the nominal torque value listed below. Loosen cap screws to below the nominal value--do not leave overtorqued. Retorque bolts to the nominal torque value.

NOTE: To prevent damage to connecting rod and engine, do not overtorque—loosen—and retorque the hex nuts on Posi-Lock connecting rods. Torque nuts, in increments, directly to the specified value.

6. Rotate the crankshaft until the piston is at top dead center in bore to protect the dipper on the connecting rod. If locking tabs are used, bend tabs to lock cap screws.

Engine Model	Connecting Rod	New Service Rod	Used/Reinstalled Rod
K91	All	140 in. lb.	140 in. lb.
K161	All	200 in. lb.	200 in. lb.
K181	Posi-Lock	140 in. lb.	100 in. lb.
K181	Capscrew	200 in. lb.	200 in. lb.
K241, K301, K321, K341	Posi-Lock	260 in. lb.	200 in. lb.
K241, K301, K321, K341	Capscrew	285 in. lb.	285 in. lb.

INSTALL OIL PAN

1. Install the gasket, oil pan, and oil drain plug.

Torque screws and oil drain plug as specified in "General Information."

INSTALL VALVES

1. Rotate the crankshaft until piston is at top dead center of compression stroke.
2. Install the valves and measure the valve-to-tappet clearance using a flat feeler gauge. Refer to Figure 12-38.

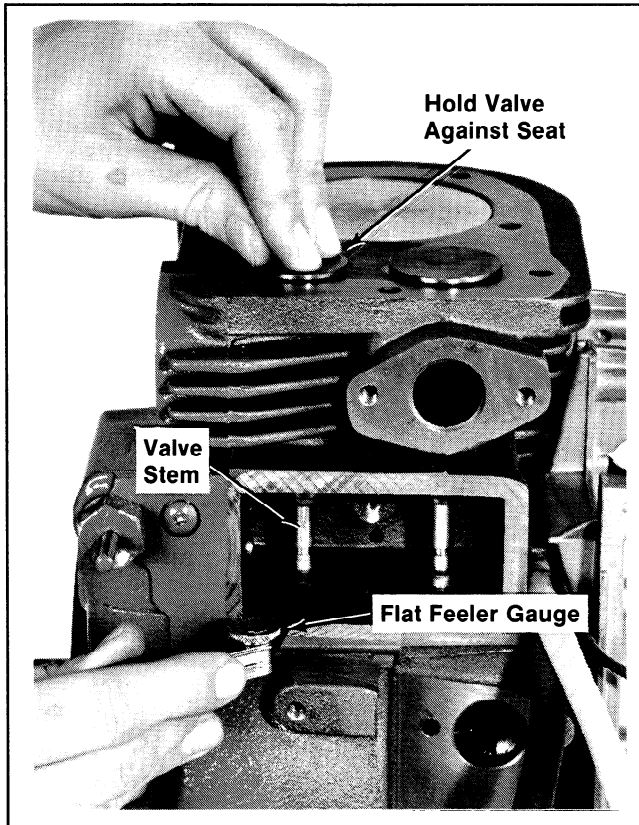

Figure 12-38. Measuring Valve-To-Tappet Clearance.

NOTE: Valve faces and seats must be lapped-in before checking/adjusting valve clearance. Refer to the "Inspection And Repair/Reconditioning" section.

Valve-to-tappet clearance:

Model	Intake Valve	Exhaust
Valve K91	.005"/.009"	.011"/.015"
K161, K181	.006"/.008"	.017"/.019"
K241, K301, K321, K341	.008"/.010"	.017"/.019"

3. Adjust valve-to-tappet clearance, as necessary.

On Models K91, K141, K161, and K181:

If clearance is too small, grind end of valve stems until correct clearance is obtained. Make sure stems are ground perfectly flat and smooth.

If clearance is too large, replace the valves and recheck clearance.

NOTE: Large clearances can also be reduced by grinding the valves and/or valve seats. Refer to the "Inspection And Repair/Reconditioning" section for valve specifications.

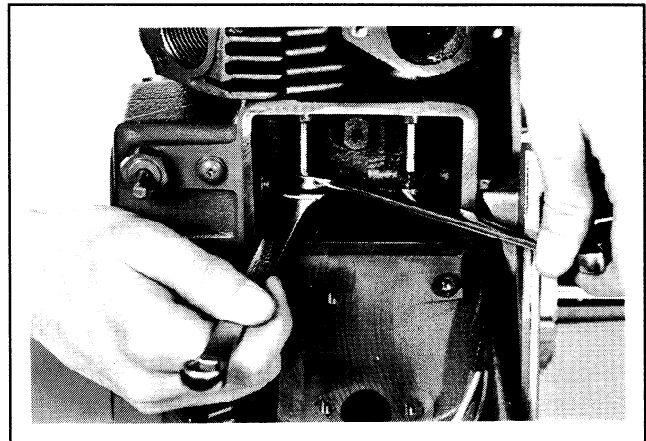

Figure 12-39. Adjusting Valve-To-Tappet Clearance.

On Models K241, K301, K321, and K341, adjust valve-to-tappet clearance by turning the adjusting screw on tappets. Refer to Figure 12-39.

4. On Models K91, K161 and K181, install the valve springs (close coils to top), intake valve spring retainer, exhaust valve rotator or retainer, and valves. Refer to Figure 12-40.

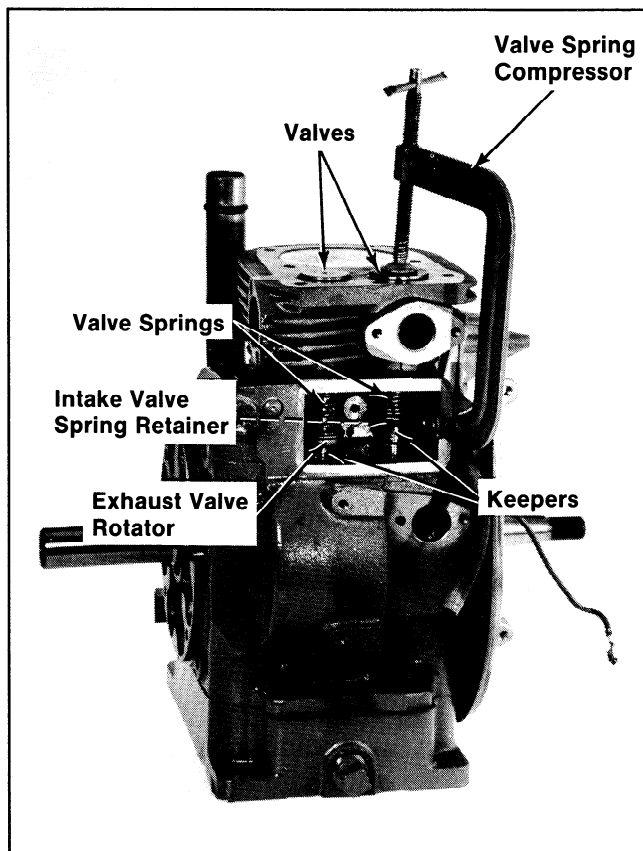

Figure 12-40. Installing Valves - K91, K161 And K181.

On Models K241, K301, K321 and K341, install the valve spring upper retainers, valve springs (close coils to top), intake valve spring lower retainer, exhaust valve rotator or retainer, and valves. Refer to Figure 12-41.

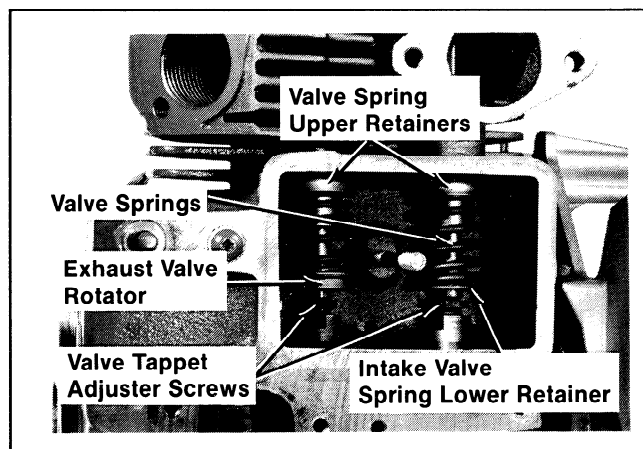

Figure 12-41. Installing Valves - K241, K301, K321 And K341.

NOTE: Some models use a valve rotator on both valves.

5. Compress springs using a valve spring compressor and install keepers. Refer to Figure 12-42.

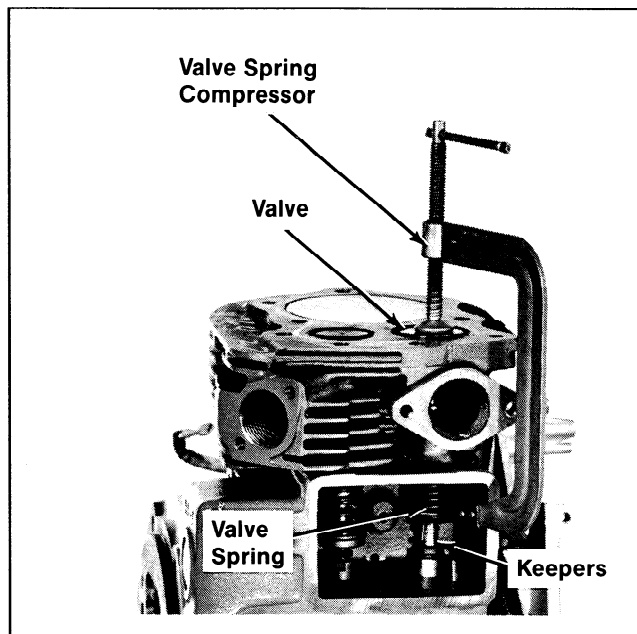

Figure 12-42. Installing Valve Keepers.

INSTALL STATOR

1. On flywheel-magneto ignition systems, the magneto coil-core assembly is secured in stationary position on the bearing plate. On the magneto-alternator systems, the coil is part of the stator assembly which is also secured to the bearing plate. Permanent magnets are affixed to the inside rim of the flywheel except in rotor type magneto systems. On these the magnet or rotor has a keyway and is press fitted on crankshaft. The magnet rotor is marked "engine-side" for proper assembly.
2. After installing magneto components, run all leads out through hole provided (in 11 o'clock position) on bearing plate.

INSTALL FLYWHEEL, GRASS SCREEN, AND DRIVE CUP OR ROPE START PULLEY



WARNING: Damaging Crankshaft and Flywheel Could Cause Personal Injury!

Using improper procedures to install the flywheel can crack or damage the crankshaft and/or flywheel. This not only causes extensive engine damage, but also is a serious threat to the safety of persons nearby, since broken fragments could be thrown from the engine. Always observe and use the following precautions and procedures when installing the flywheel:

NOTE:

- A: Before installing the flywheel, make sure the crankshaft taper and flywheel hub are clean

dry and completely free of lubricants. The presence of lubricants can cause the flywheel to be overstressed and damaged when the cap screw is torqued to specification.

- B: Make sure square flywheel key is installed only in the flat area of keyway, not in the rounded area. The flywheel can become cracked or damaged if the key is installed in the rounded area of keyway.
- C: Always use a flywheel strap wrench to hold flywheel when tightening flywheel fastener. Do not use any type of bar or wedge between the cooling fins or flywheel ring gear, as these parts could become cracked or damaged.
- D: Do not use impact wrenches to install the flywheel retaining nut as this may overstress the nut and crack the flywheel hub.
- E: Do not reuse a flywheel if it has been dropped or damaged in any way.
- F: Do make a through visual inspection of the flywheel and crankshaft before installation to make sure they are in good condition and free of cracks.

The old crankshaft design has an externally threaded end and uses a square key, plain washer, and marsden nut to align and secure the flywheel.

The new crankshaft design has an internally threaded end and uses a woodruff key, washer, and/or bushing, hex cap screw or hex nut.

1. Position key properly in keyway as shown in Figure 12-43 and carefully guide key slot in flywheel hub over the key while installing to avoid pushing the key inward.

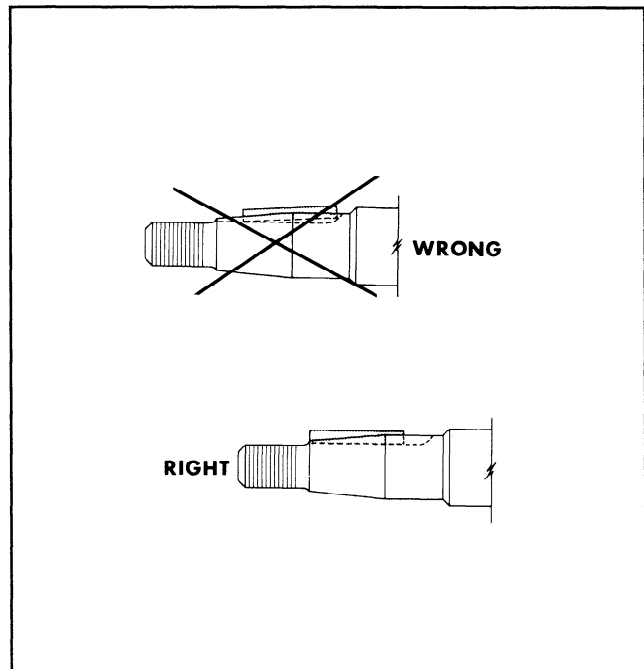

Figure 12-43. Installing A Square Flywheel Key. Models K91, K161 And K181

Rope Start Models

- A. Install rope pulley, plain washer, and hex nut (lubricate threads with oil). Hold flywheel with strap wrench and torque hex nut to **40/50 ft. lb.** for K91 and **85/90 ft. lb.** for K161 and K181. If a hex head sems screw is used, torque screw to **250 in. lb.**

Retractable Start Models

- A. Install the grass screen.
- B. Install the drive cup, plain washer, and hex nut (lubricate threads with oil). Hold the flywheel with strap wrench and torque hex nut to **40/50 ft. lb.** for K91 and **85/90 ft. lb.** for K161 and K181. If a hex head sems screw is used, torque screw to **250 in. lb.**

Electric Start Models

- A. Install the plain washer and hex nut (lubricate threads with oil). Hold the flywheel with strap wrench and torque hex nut to **40/50 ft. lb.** for K91 and **85/90 ft. lb.** for K161 and K181. If a hex head sems screw is used, torque screw to **250 in. lb.**
- B. Install the grass screen.

Models K241, K301, K321 And K341

Rope Start

- A. Install the nylon grass screen.
- B. Install the spacer, rope pulley, plain washer, and hex cap screw (lubricate threads with oil). Hold the flywheel with a strap wrench and torque hex cap screw to **35/40 ft. lb.** If a hex nut is used, torque to **50/60 ft. lb.**
- C. Install the wire mesh grass screen and grass screen retainer to rope pulley.

Retractable Start

- A. Install the grass screen.
- B. Install the drive cup, plain washer, and hex cap screw (lubricate threads with oil). Hold the flywheel with a strap wrench and torque hex cap screw to **35/40 ft. lb.** If a hex nut is used, torque to **50/60 ft. lb.**

Electric Start

- A. Install the plain washer and hex cap screw (lubricate threads with oil). Hold the flywheel with a strap wrench and torque hex cap screw to **35/40 ft. lb.** If a hex nut is used, torque to **50/60 ft. lb.**
- B. Install the grass screen.
3. For all models, torque the grass screen fasteners to **70/140 in. lb.** for a metal grass screen and **20/30 in. lb.** for a plastic grass screen.

INSTALL BLOWER HOUSING

1. Install the spark plug lead and kill lead into the slots in the baffle.
2. Install the remaining self-tapping screws and the blower housing.

NOTE: On some models, the grass screen must be installed before installing the blower housing.

3. Install push rod, breaker assembly, and breaker point lead.
4. Set breaker point gap at .020" full open.
5. Install gasket and breaker point cover.

INSTALL CYLINDER HEAD AND SPARK PLUG

1. Install the gasket and cylinder head. Always use a new gasket when head has been removed for service work.
2. Torque the hex cap screws and hex nuts (in increments) in the sequence and torques shown in Figure 12-44.

NOTE: The importance of torquing cylinder head bolts to specified values and following the recommended sequences cannot be overemphasized. Blown head gaskets and cylinder head distortion may result from improper torquing.

Following is the recommended torquing procedure:

1. Lubricate the cylinder head bolts with oil before installation.
2. Initially torque each bolt to 10 ft. lbs following the recommended torque sequence.
3. Sequentially tighten each bolt in 10 ft. lb. increments until the specified torque values are reached.

NOTE: After reaching the final torque value, run the engine for 15 minutes, stop, and allow to cool. Then, sequentially retorque the head bolts to the specified torque value.

4. Make sure the spark plug is properly gapped.
5. Install the spark plug and torque it to **18/22 ft. lb.**

INSTALL BREATHER ASSEMBLY

1. Install the stud, gasket, breather plate, reed, reed stop, seal, and filter. The accompanying illustrations show the correct order of assembly for two types of breather assemblies. Make sure reed valve is installed properly and that oil drain hole on breather plate is down. Refer to Figures 12-45 and 12-46.

NOTE: All K181 Specifications have been changed to call for 2 pieces of breather filter 231419 instead of 1. Testing has revealed the use of two filters prevents oil droplets from being expelled through the breather system. All K181 engines are now being built with two filters and when serviced, two should always be used.

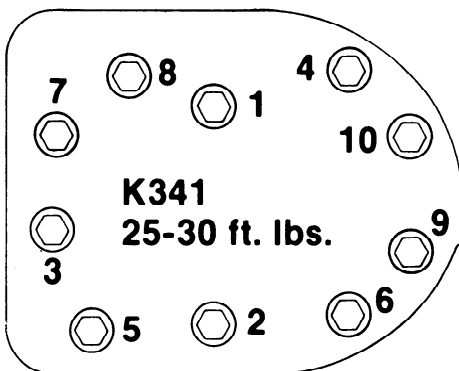
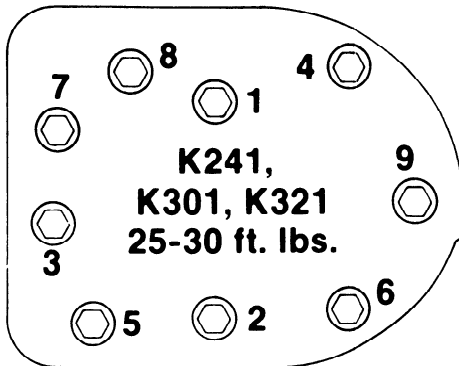
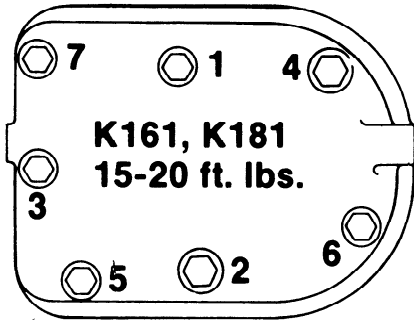
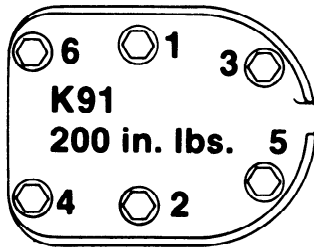

Figure 12-44. Cylinder Head Fastener Torque Sequence.

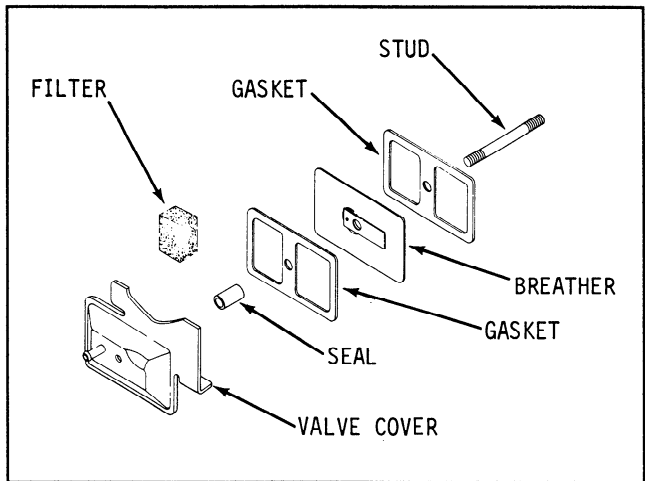

Figure 12-45. K181 Breather Assembly.

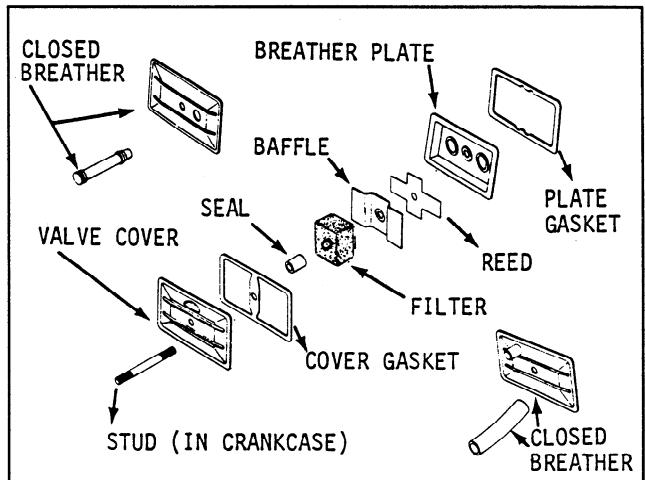

Figure 12-46. K241 Breather Assembly.

2. Install the gasket, breather cover, and palnut.

INSTALL SIDE AIR BAFFLES AND CYLINDER HEAD BAFFLE

1. Install the starter side air baffle, plain washer, and hex cap sems screws. Leave the screws loose.
2. Install the carburetor side air baffle, plain washer, and hex cap sems screws. Leave the screws loose.
3. Install the cylinder head baffle, plain washer, and hex cap sems screws. Leave the screws loose.
4. Tighten the screws securely when all pieces are in position.

NOTE: Shorter screws go into lower portion of blower housing.

INSTALL DIPSTICK

1. Install dipstick.

INSTALL FUEL TANK



WARNING: Explosive Fuel!

Gasoline may be present in the carburetor and fuel system. Gasoline is extremely flammable and it can explode if ignited. Keep sparks, open flames, and other sources of ignition away from the engine. Disconnect and ground the spark plug lead to prevent the possibility of sparks from the ignition system.

1. Install fuel tank with brackets.
2. Install fuel line on fuel tank outlet fitting.

INSTALL ELECTRIC STARTER

1. Install electric starter.
2. Install hex cap sems screws which mount electric starter to engine.
3. Install keyswitch panel.
4. Connect lead to electrical starter.
5. Connect electrical connector(s).

INSTALL RETRACTABLE STARTER

1. Install the retractable starter and hex cap screws. Leave the screws slightly loose.
2. Pull the starter handle out 8–10" until the pawls engage in the drive cup. Hold the handle in this position and tighten screws securely.

INSTALL FUEL PUMP

1. Install the gasket, fuel pump, plain washers, and fillister head screws. Refer to Figure 12-47.

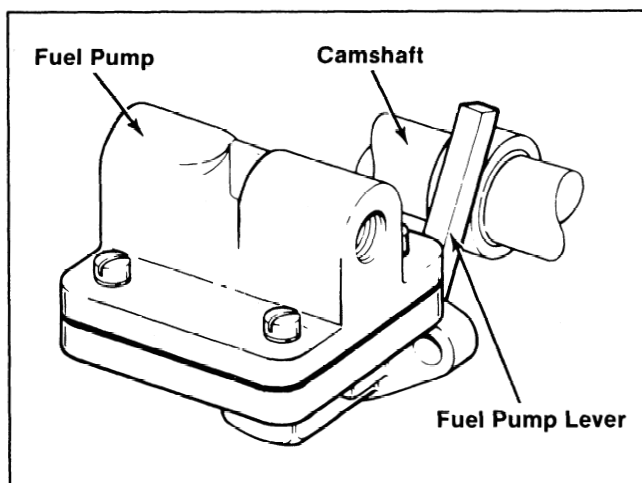

Figure 12-47. Mechanical Fuel Pump.

NOTE: Make sure the fuel pump lever is positioned above the camshaft. Damage to the fuel pump, and subsequent severe engine damage could result if the lever is positioned below the camshaft. Refer to Figure 12-48.

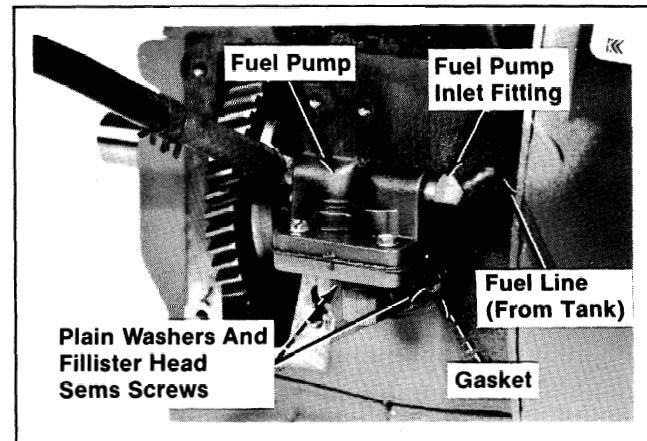

Figure 12-48. Installing Fuel Pump.

Torque the screws to $37/45$ in. lb.

2. Connect the fuel lines to fuel pump inlet and outlet fittings.

INSTALL EXTERNAL GOVERNOR COMPONENTS AND THROTTLE CONTROLS

1. Install the throttle lever, bracket, spacer, plain washer and hex cap screw.
2. Install the governor spring to the governor arm. Install the governor arm to the cross shaft. Leave the palnut slightly loose as the governor arm and cross shaft will be adjusted after the carburetor and throttle linkage are installed.

INSTALL CARBURETOR AND THROTTLE LINKAGE

1. Install the fuel line and hose clamps.
2. Install the gasket, carburetor, and slotted hex cap sems screws.
3. Install the throttle linkage into the nylon inserts in the governor arm and carburetor throttle lever.
4. Adjust the governor as instructed below.
5. Refer to "Fuel System And Governor" section for carburetor adjustment procedure.

Governor Adjustment

The governor cross shaft/governor arm must be adjusted every time the governor arm is loosened or removed from cross shaft.

1. Pull the governor arm away from the carburetor as far as it will go.
2. Grasp end of cross shaft with pliers and turn counterclockwise as far as it will go. The governor shaft can be adjusted for end clearance by moving needle bearing in block. Set bearing to allow a slight back-and-forth movement of shaft.
3. Torque the palnut on governor arm to **15 in. lb.**

NOTE: Make sure there is at least **1/16"** clearance between the governor arm and the upper-left cam gear cover fastener to prevent interference.

INSTALL MUFFLER

1. If the engine is equipped with a flat muffler, install muffler and gasket using cap screws. If equipped with a round muffler, install muffler and threaded exhaust pipe between the muffler and engine using a pipe wrench. Refer to Figure 12-49.

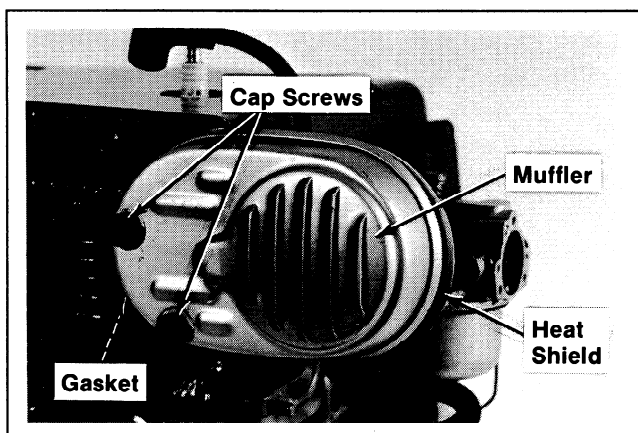

Figure 12-49. Installing Muffler.

INSTALL AIR CLEANER

1. Install the base gasket, base, and air cleaner.

PREPARE THE ENGINE FOR OPERATION

The engine is now completely reassembled. Before starting or operating the engine, be sure to do the following:

1. Make sure all hardware is tightened securely.
2. Make sure the oil drain plugs, oil sentry pressure switch, and a new oil filter are installed.
3. Fill the crankcase with the correct amount, weight, and type of oil. Refer to the oil recommendations and procedures in the "General Information" and "Periodic Maintenance" sections.
4. Fill the fuel tank with the proper type of gasoline and open fuel shut-off valve (if equipped). Refer to the fuel recommendations in the "General Information" section.
5. Adjust the carburetor main fuel needle, idle fuel needle, or idle speed adjusting screw as necessary. Refer to the "Fuel System and Governor" section.

TESTING THE ENGINE

It is recommended that the engine be operated on a test stand or bench prior to installation in the piece of equipment.

1. Set the engine up on a test stand. Run the engine for 5-10 minutes between idle and midrange. Adjust the carburetor mixture settings as necessary. Refer to "Fuel System and Governor" section.
2. Make sure the maximum engine speed does not exceed 3600 RPM (4000 RPM for model K91 only). Adjust the high speed stop as necessary. Refer to the "Fuel System and Governor" section.

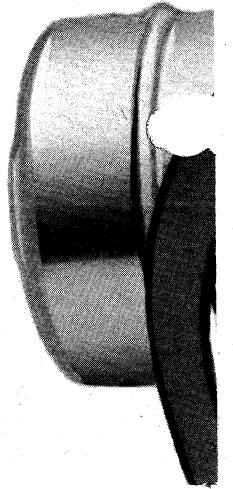

FOR SALES AND SERVICE INFORMATION
IN U.S. AND CANADA, CALL
1-800-544-2444

This publication replaces ENS-575

KOHLERengines

ENGINE DIVISION, KOHLER CO., KOHLER, WISCONSIN 53044

FORM NO.:	TP-2379
ISSUED:	4/90
REVISED:	11/92
MAILED:	

LITHO IN U.S.A.