

RV GENERATOR SERVICE MANUAL

“POWER BOOST”
MODEL: 4.5 CKM



KOHLER
GENERATORS

TABLE OF CONTENTS

SUBJECT	PAGE	SUBJECT	PAGE
Introduction	i	Idle Fuel Mixture	3-5
Service Assistance	i	Idle Speed	3-5
Safety Precautions	i	Gasoline Shut-Down Solenoid	3-5
Section 1. Specifications	1-1	Choke Adjustment	3-5
Engine	1-1	LP Gas Carburetor Adjustments	3-6
Generator	1-1	Main Fuel Adjustment	3-6
Controller	1-1	Governor Adjustments	3-6
Section 2. Operation	2-1	Speed	3-6
Prestart Checklist	2-1	Sensitivity	3-6
Controller Features	2-1	Cylinder Head Service	3-7
Remote Start Panel Features (Optional)	2-1	Section 4. General Troubleshooting	4-1
Starting	2-1	Section 5. Controller Troubleshooting	5-1
Automatic Anti-Icing	2-1	Starting	5-1
Stopping	2-1	Running	5-2
Circuit Protection	2-1	Stopping	5-2
Controller Fuses	2-2	Low Oil Pressure (LOP) Shutdown Switch	5-2
Engine Shutdown Switch	2-2	Section 6. Generator Troubleshooting	6-1
Section 3. Scheduled Maintenance	3-1	General	6-1
General	3-1	Separate Excitation	6-1
Service Schedule	3-1	Section 7. Component Testing	7-1
Lube Oil Selection	3-2	Voltage Regulator Test	7-1
Air Cleaner	3-2	Rotor	7-2
Element Service	3-2	Stator	7-2
Cover Adjustment	3-2	Brushes	7-3
Ignition System	3-2	Controller Circuit Board	7-4
Spark Plugs	3-2	Circuit Board Foil Damage	7-7
Breaker Points	3-2	Wiring Harness	7-9
Timing	3-3	Section 8. Disassembly/Reassembly	8-1
Gasoline Fuel Specifications and Service	3-3	Section 9. Wiring Diagrams	9-1
Fuel Specifications	3-3	Index	10-1
Fuel Filter Service	3-3	Specifications Chart	11-1
Cooling System	3-4	Generator	11-1
Gasoline Carburetor Adjustments	3-5	Engine	11-1
Main Fuel Mixture	3-5	Installation	11-2

INTRODUCTION

This manual covers operation, troubleshooting, and repair of 4.5 CKM-RV generator sets. Differences between models are noted throughout the manual.

Engine service and parts catalogs are available separately for particular models and specifications.

SERVICE ASSISTANCE

See the Yellow Pages under GENERATORS—Electric for your closest Kohler Generator Dealer or contact your local RV Service Center. Give MODEL, SPECIFICATION,

SERIAL, and ENGINE SERIAL numbers from generator nameplate for complete Engine Service Manual (TP-2043-A) and generator set Parts Catalog (TP-5146).

SAFETY PRECAUTIONS

A Generator Set, like any other electro-mechanical device, can pose potential dangers to life and limb if improperly maintained or imprudently operated. The best safeguards against accident are to be ever mindful of the potential dangers and to always use good common sense. In the interest of safety, some general precautions relating to operating of a Generator set follow. Keep these in mind. This manual contains several types of safety precautions which are explained below.

DANGER

Danger is used to indicate the presence of a hazard which *will* cause *severe* personal injury, death, or substantial property damage if the warning is ignored.

WARNING

Warning is used to indicate the presence of a hazard which *can* cause *severe* personal injury, death, or substantial property damage if the warning is ignored.

CAUTION

Caution is used to indicate the presence of a hazard which *will* or *can* cause *minor* personal injury or property damage if the warning is ignored.

NOTE

Note is used to notify people of installation, operation, or maintenance information which is important but not hazard-related.

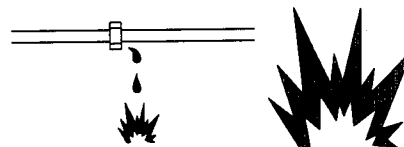

WARNING

All fuels are highly explosive in a vapor state. Use extreme care when handling, storing, and using fuels. Store fuel in a well-ventilated area away from spark producing equipment and out of the reach of children. Never add fuel to the tank while the engine is running since spilled fuel may ignite on contact with hot parts or from ignition spark. Do not smoke or permit flame or spark to occur near potential sources of spilled fuel or fuel vapors. Keep fuel lines and connections tight and in good condition—don't replace flexible fuel lines with rigid lines. Flexible sections are used to avoid breakage due to vibration. Additional precautions must be taken when using the following fuels:

Gasoline—Store gasoline only in approved red containers clearly marked GASOLINE. Do not store gasoline in any occupied building.

Propane (LP)—Adequate ventilation is mandatory. Propane is heavier than air; install gas detectors low in room. Inspect detectors often.

CAUTION

RV generator fuel system is susceptible to explosion when used in non-RV applications. Use generator sets specified for RV use in RV installations only.





CAUTION

Fuel leakage can cause an explosion. Check LP gas fuel system for leakage using a soap-water solution with fuel system test pressurized to 6-8 ounces (10-14 inches water column). Do not use test solutions that contain ammonia or chlorine, since the soap will not bubble for an accurate leakage test.



WARNING

A flash fire can cause serious burns. Do not smoke or permit flame or spark to occur near carburetor, fuel line, fuel filter, fuel pump, or other potential sources of spilled fuel or fuel vapors. When removing fuel line or carburetor, use a proper container to catch all fuel.

Spilled fuel can ignite on contact with hot engine parts. Use a container to catch fuel when draining fuel system. Wipe up all spilled fuel after draining system.



WARNING

Hazardous voltage can cause death or severe injury. Perform electrical service only as prescribed in equipment manual. Be sure that generator is properly grounded. Never touch electrical leads or appliances with wet hands, when standing in water, or on wet ground as the chance of electrocution is especially prevalent under such conditions. Wiring should be inspected at the interval recommended in the service schedule—replace leads that are frayed or in poor condition. The function of a generator set is to produce electricity and wherever electricity is present, there is the hazard of electrocution.

Hazardous “backfeed” voltage can cause death or severe injury.

The generator must not be used to “backfeed” by connecting it to building/campground electrical circuits. Install a transfer switch in RV generator installations to prevent connection of RV and other sources of power. Electrical backfeed into a utility electrical system can cause serious injury or death to utility personnel working on transmission lines.

Hazardous voltage can cause death or severe injury. Follow instructions of test equipment manufacturer when performing high voltage test. Improper test procedure can damage equipment or lead to future generator failures.

Hazardous voltage can cause death or severe injury. When testing voltage regulator, always unplug power cord from AC power source before connecting or disconnecting wires to prevent danger of electrocution. When the power cord is plugged in during voltage regulator test, the AC pins become “hot” and there is danger of electrocution.



WARNING

Hazardous voltage can cause death or severe injury. Do not contact electrical connections with adjustment tool while the generator is running. Remove wristwatch, rings, and jewelry that can cause short circuits. Do not touch electrical equipment when standing in water, on wet ground, or when your hands are wet.



WARNING

Hazardous voltage can cause death or serious injury. The heat sink of the voltage regulator contains high voltage. Do not touch voltage regulator heat sink when testing or electrical shock will occur.



CAUTION

Short circuits can cause bodily injury and/or equipment damage. Do not contact electrical connections with tools or jewelry while adjustments are made. Remove wristwatch, rings, and jewelry that can cause short circuits.



WARNING

Accidental starting can cause death or serious personal injury. Disconnect battery cables (remove negative lead first and reconnect it last) to disable generator set before working on any equipment connected to generator. The generator set can be started by remote start/stop switch unless this precaution is followed.



WARNING

Exposed moving parts can cause severe injury. Keep hands, feet, hair, and clothing away from belts and pulleys when unit is running. Replace guards, covers, and screens before operating generator set. Do not open generator compartment door when unit is running.

⚠ WARNING



Battery gases can cause an explosion.

Do not smoke or permit flame or spark to occur near a battery at any time, particularly when it is being charged. Avoid contacting terminals with tools, etc. to prevent burns and to prevent sparks that could cause an explosion. Remove wristwatch, rings, and any other jewelry before handling battery. Never connect negative (-) battery cable to position (+) connection terminal of starter solenoid. Do not test battery condition by shorting terminals together or sparks could ignite battery gases or fuel vapors. Any compartment containing batteries must be well ventilated to prevent accumulation of explosive gases. Do not mount battery in generator compartment. To avoid sparks, do not disturb battery charger connections while battery is being charged and always turn charger off before disconnecting battery connections. When disconnecting battery, remove negative lead first and reconnect it last.

⚠ WARNING



Sulfuric acid in batteries can cause permanent damage to eyes, burn skin, and eat holes in clothing.

Always wear splash-proof safety goggles when working around the battery. If battery electrolyte is splashed in the eyes or on skin, immediately flush the affected area for 15 minutes with large quantities of clean water. In the case of eye contact, seek immediate medical aid. Never add acid to a battery once the battery has been placed in service. Doing so may result in hazardous spattering of electrolyte.

⚠ CAUTION



Hot exhaust system can ignite adjacent combustible materials. Do not locate electrical wiring, fuel lines, or combustible material above the exhaust muffler. Be careful when parking your RV to prevent grass fires started by exhaust system and hot exhaust gases.

Hot generator can ignite debris in compartment. Keep the compartment and generator set clean and free of debris and combustible materials to minimize chances of fire. Do not block fuel/oil drain opening in generator mounting tray. If sub-flooring is used, cut a corresponding hole in the sub-flooring for drain opening.

⚠ CAUTION



Hazardous noise can cause loss of hearing.

Never operate generator without adequate hearing protection or muffler. Never operate generator with faulty exhaust system.

⚠ WARNING

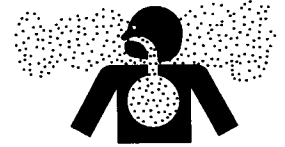

Carbon monoxide can cause death, severe nausea or fainting. Never operate the generator set inside a building unless the exhaust gas is piped safely outside. Never operate in any area where exhaust gas could accumulate and seep back inside an occupied building or coach. Be careful when parking your coach to avoid obstructing the exhaust outlet. The exhaust gases must discharge freely, otherwise carbon monoxide may deflect into the vehicle. Avoid breathing exhaust fumes when working on or near the generator set. Carbon monoxide is particularly dangerous because it is an odorless, colorless, tasteless, nonirritating gas which can cause death if inhaled for even a short period of time. The exhaust system must be leakproof and routinely inspected.

Carbon monoxide can cause death, severe nausea, or fainting. Install exhaust system tail pipe so discharged exhaust gases will not be drawn into vehicle interior through windows, doors, air conditioners, etc. Do not use flexible tail piping since this type could crack and allow lethal exhaust fumes to enter the vehicle.

⚠ CAUTION

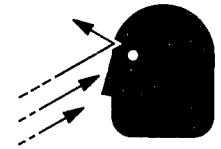

Flying projectiles can cause injury.

Retorque all crankshaft and rotor hardware after servicing. When making adjustments or servicing generator set, do not loosen crankshaft hardware or rotor thru-bolt. If rotating crankshaft manually, direction should be clockwise only. Turning crankshaft or rotor thru-bolt counterclockwise can loosen hardware and result in serious personal injury from hardware or pulley flying off engine while unit is running.

⚠ CAUTION

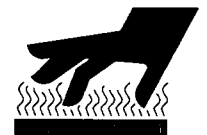

Hot parts can cause personal injury. Do not touch hot engine parts. An engine gets hot while running and exhaust system components get extremely hot.

⚠ WARNING



A sudden backfire can cause serious burns. Do not operate with air cleaner removed.

NOTE

RV generator sets do not comply with United States Coast Guard (U.S.C.G.) requirements and must not be used for marine applications. Use only generator sets specified for marine use in marine installations. U.S.C.G. Regulation 33CFR183 requires a generator set to be "ignition protected" when used in a gasoline-fueled environment.

SECTION 1. SPECIFICATIONS

Engine

The Kohler generator set is powered by a Kohler two cylinder model KT17 Series II air-cooled, four-cycle gasoline engine. Some general specifications are listed below — refer to the “Scheduled Maintenance” section for specific service details.

	Model KT17II
Bore x Stroke	3.125 in. x 2.750 in. (79.375 mm x 69.80 mm)
Displacement	42.18 cu. in. (691.4 cc)
Horsepower	9.9
RPM	1800
Lube Oil Capacity	3.0 U.S. Pints (1.4 L)
Battery Voltage	12 Volts
Battery Recommendation	290 Cold Cranking Amps/55 Amp Hr.
Battery Cranking Current (Varies indirectly with decreasing ambient temperature)	76 Amps
Battery Charging (max.)	7 Amps
Spark Plug Type	Champion RV15YC
Spark Plug Size	14 mm
Spark Plug Gap (Gasoline)	.025 in. (0.64 mm)
Spark Plug Gap (LP Gas)	.018 in. (0.45 mm)
Plug Tightening Torque	10/15 ft. lbs. (14/20 Nm)
Breaker Point Gap	.017/.023 in. (.432/.580 mm)
Timing (Degrees)	23° BTDC
Valve Clearance	
Intake	.003/.006 in. (.076/.152 mm)
Exhaust	.011/.014 in. (.279/.355 mm)
Fuel Type	Unleaded Regular Gasoline

Generator

Kohler designed and built rotating field 60 Hertz generators are direct connected to engine for permanent alignment. Generator features safeguard circuit breakers to protect generator against damage due to overload. The single-phase generator produces 4500 Watt, 120 Volt, 37.5 Amp Alternating Current or 4500 Watt, 120/240 Volt, 18.75 Amp Alternating Current.

DERATION: The kilowatts of the generator set will decrease 3.5% for each 1000 feet (305 metres) above sea level, 1% for each 10° F (5.5° C) above 60° F (16° C) and 11.1% when converted to LP gas.

Model 4.5 CKM

Rated kW, 60 Hz	4.5
Rated Voltage	120 V, 1Ø, 2W 120/240 V, 1Ø, 3W
Rated Amperes	
120 V, 60 Hz	37.5
120/240V, 60 Hz	18.75
Rotor Resistance	4.6 Ohms
Stator Resistance	
1-2, 3-4, 33-44	.25 Ohms
55-66	2.8 Ohms
B1 and B2 (without center — tapped winding)	.15 Ohms
B1 and B2 (with center — tapped winding)	.10 Ohms
B1 and B3 (with center — tapped winding)	.15 Ohms
Coupling Type	Tapered Shaft, Thru-Bolt
Thru-Bolt Torque	50 ft. lbs. (68 Nm)
Over-Bolt Torque	260 in. lbs. (29 Nm)
Excitation Method	Static Brush-Type
Rotor Field Voltage/ Current Readings at Rated Output Voltage	
No Load (63 Hz)	23.2/4.8
Full Load (60 Hz)	35.6/6.6

Controller

The Kohler relay controller has a rocker type momentary contact START/STOP switch for test operating the set at the controller. Also included is a keyed connector for starting and stopping set at a remote switch located inside the vehicle. The green GENERATOR ON lamp at the optional remote control panel will light whenever AC output is available from the generator. If the generator set has automatically stopped due to low oil pressure, 3.5 psi (24 kPa) or less, the cause must be eliminated before the set can be restarted. For a description of the controller, see “Controller Features.”

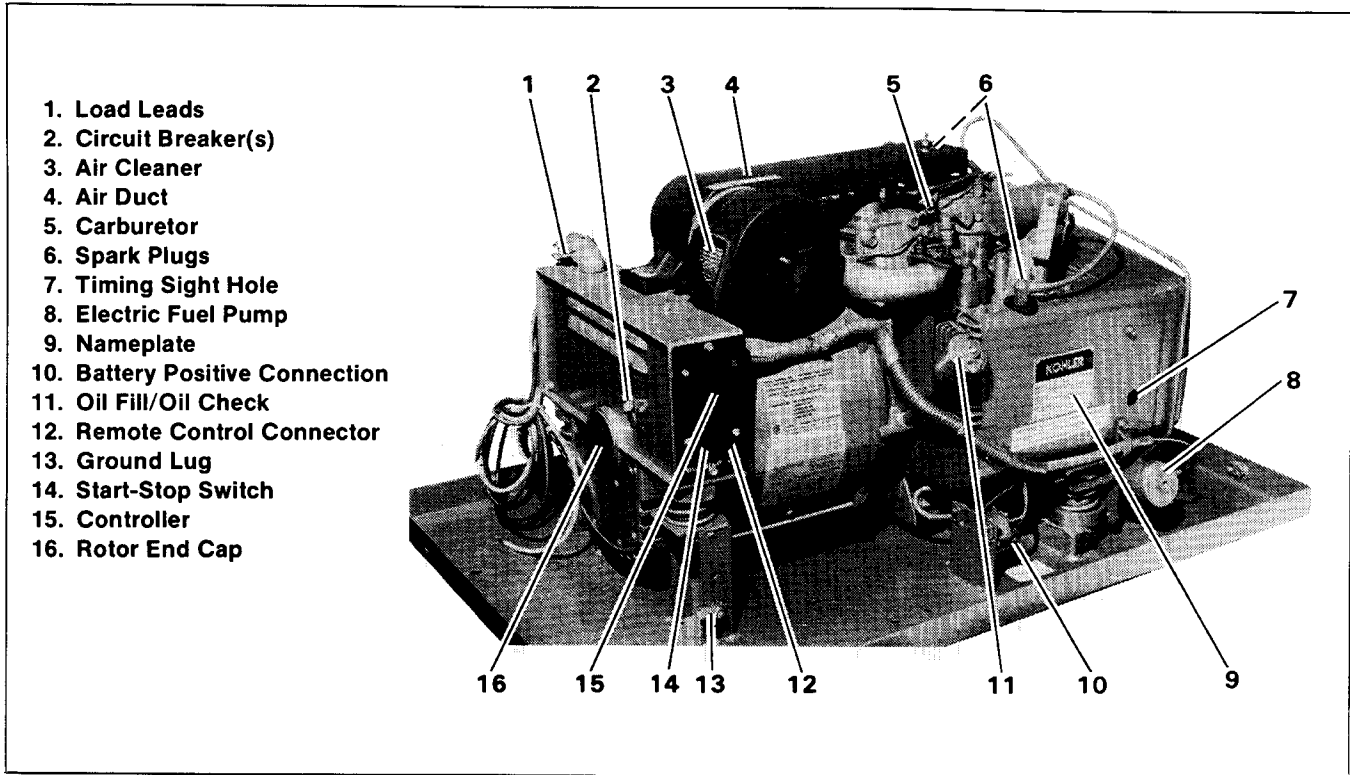

Figure 1-1. Service View — Gasoline Powered

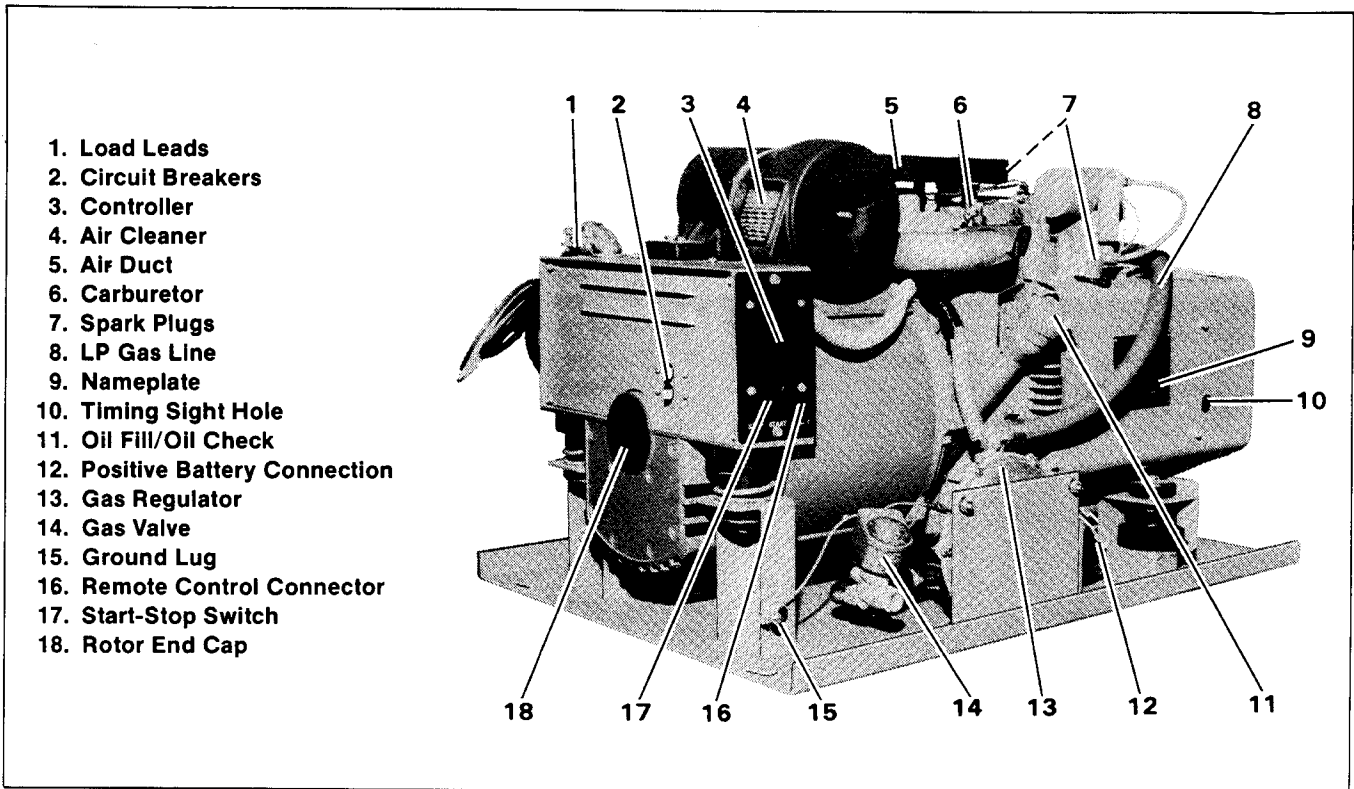

Figure 1-2. Service View — LPG Powered

SECTION 2. OPERATION

To insure continued satisfactory operation, the following items should be checked before each start-up.

Prestart Checklist

- Oil Level:** Should be at or near full mark (not over).
- Compartment:** Interior must be clean.
- Air Cleaner:** Must be clean and properly installed.
- Air Shrouding:** Must be tight and in proper position.
- Exhaust:** Tail pipe must be clear, muffler and piping tight and in good condition.
- Electrical:** All connections including battery must be tight.

Controller Features

For identification of controller components, see Figure 2-1.

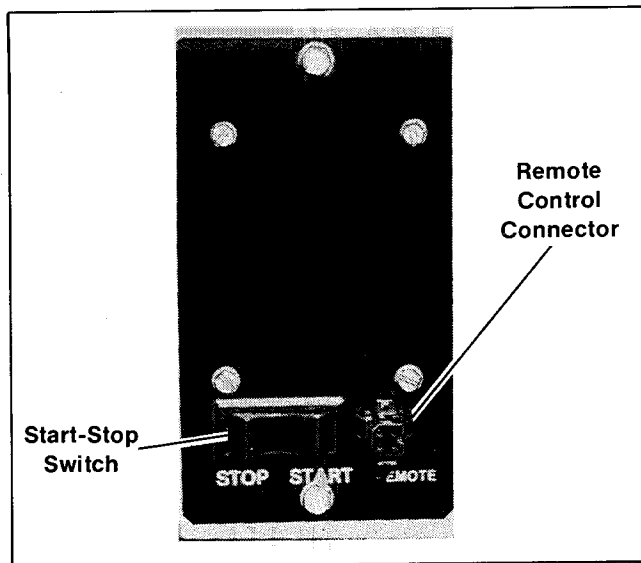

Figure 2-1. Controller

1. Start/Stop Switch — provides test operation at generator set — refer to "Starting" and "Stopping" following.
2. Remote Control Connector — allows connection of remote start/stop panel. See "Remote Start Panel Features (Optional)."

Remote Start Panel Features (Optional)

For identification of remote panel components see Figure 2-2.

1. Start/Stop Switch — provides remote operation of generator set — refer to "Starting" and "Stopping" following.

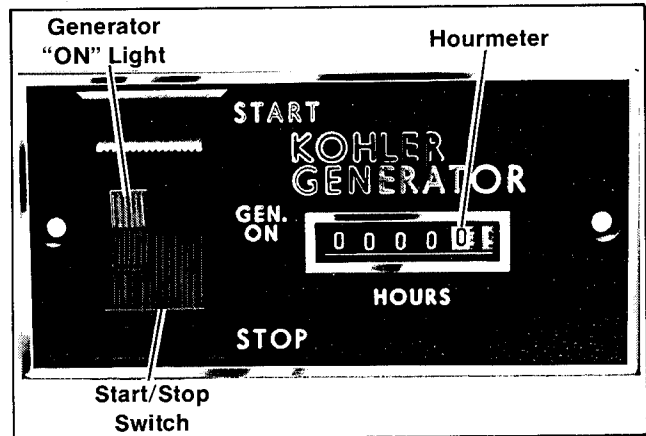

Figure 2-2. Remote Panel (Optional)

2. Generator "ON" Light — a green light on the switch indicates the generator is running and producing AC output.
3. Hourmeter — records number of hours run so routine servicing can be scheduled at recommended maintenance intervals.

Starting

Move rocker switch on controller to "Start" position and hold until engine starts, or use remote start/stop switch. Green "ON" light will illuminate when generator set is running.

Automatic Anti-Icing

The automatic anti-icing system utilizes an electric heat element to warm the carburetor whenever the generator set is running. The system is activated when the START switch is pressed; current flow to the anti-icing heat element stops when the generator is stopped. Current required to operate the automatic anti-icing system decreases from approximately 3 Amps. at start-up to 0.75 Amps. when the carburetor temperature reaches 100-110°F (38-43°C). No adjustment or manual intervention is required with this system.

Stopping

Run generator set at no load for five minutes to allow engine cool down. Move rocker switch to "Stop" position, and wait until generator set comes to a complete stop, or use remote start/stop switch.

Circuit Protection

Circuit breaker(s) located in the end bracket (Figure 2-3) protect the generator set from damage due to overload or short circuits. If the circuit breaker(s) trip, reduce load and switch the breaker(s) back to the "ON" position. With the breaker(s) in the "OFF" position, the engine will run but there will be no AC output voltage.

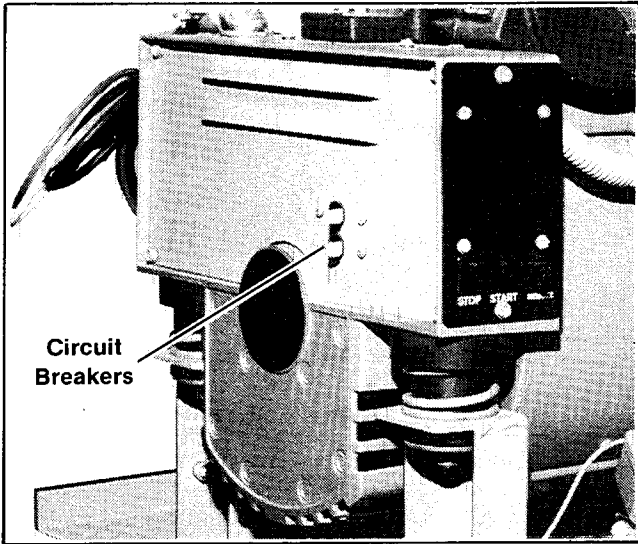
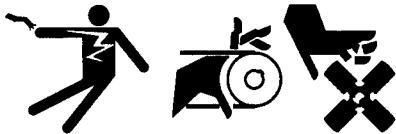

Figure 2-3. Circuit Breaker(s)

Controller Fuses

There are two fuses located inside the relay controller compartment, see Figure 2-4. The 10 Amp. fuse protects the controller against damage in the event a short develops in the engine wiring system or the wiring harness to the remote start/stop switch. The 5 Amp. fuse protects the voltage regulator circuit in the event of an overload in the circuit. If there is no AC output, check the 5 Amp. fuse; if blown, replace the fuse, then restart the generator set. If the fuse blows again, troubleshoot generator and components.

WARNING



Accidental starting can cause death or serious personal injury. Disconnect battery cables (remove negative lead first and reconnect it last) to disable generator set before working on any equipment connected to generator. The generator set can be started by remote start/stop switch unless this precaution is followed.

NOTE

If the 5 Amp. fuse is blown, the engine will crank and start but will not continue to run after the "Start" switch is released. If the 10 Amp. fuse is blown, the engine will not crank. If either fuse blows while the generator set is running, the set will stop.

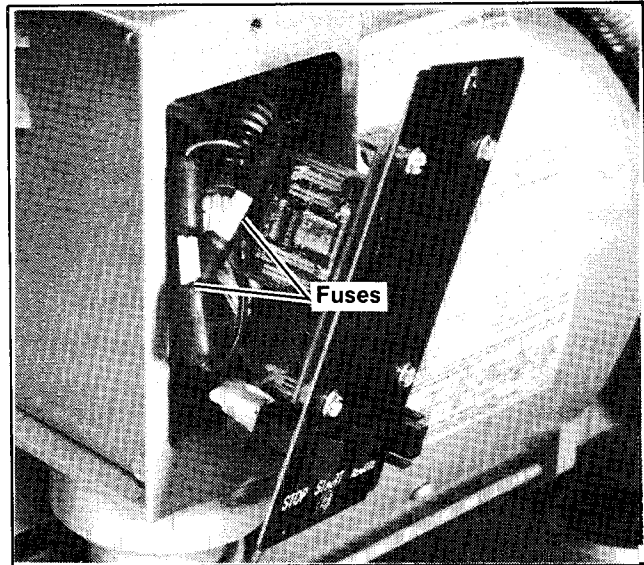

Figure 2-4. Controller Fuses

Engine Shutdown Switch

The engine is protected by a low oil pressure, 3.5 psi (24 kPa) or less, shutdown switch which automatically resets after the problem is corrected. See Figure 2-5 for location.

NOTE

This switch is not intended to act as a low oil level switch.

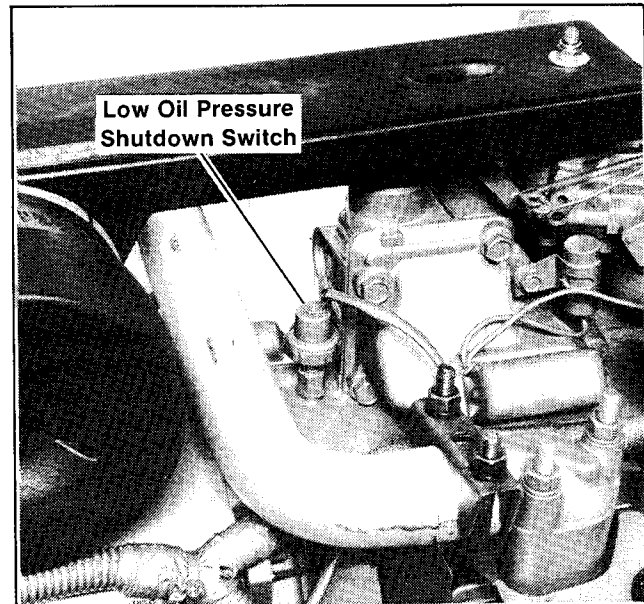

Figure 2-5. Low Oil Pressure Shutdown Switch

SECTION 3. SCHEDULED MAINTENANCE

General

Schedule routine maintenance using the "Service Schedule" following and the hourmeter located on the optional remote panel, see "Remote Start Panel Features (Optional)." If the generator set will be subject to extreme operating conditions, service unit accordingly.

WARNING

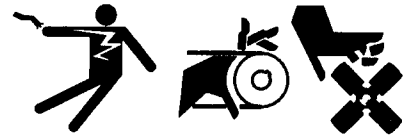

Accidental starting can cause death or serious personal injury. Disconnect battery cables (remove negative lead first and reconnect it last) to disable generator set before working on any equipment connected to generator. The generator set can be started by remote start/stop switch unless this precaution is followed.

Service Schedule

Perform Service at Intervals Indicated (X)	Before Each Start-Up	Every 50 Hrs. or 3 Months	Every 100 Hrs. or 6 Months	Every 200 Hrs. or Yearly	Every 400 Hrs.
Check oil level	X				
Check fuel supply	X				
Keep cooling air inlets and outlets clean	X				
Remove loose dirt from compartment	X				
Change lube oil (change oil initially after first five hours of operation)		X			
Check air cleaner (replace if dirty)		X			
Service fuel pump internal filter (early models only)		X			
Check electrolyte level in battery		X			
Check battery specific gravity			X		
Service or replace spark plugs			X		
Check and tighten electrical connections			X		
Check and tighten mounting bolts and vibro mounts			X		
Check generator brushes			X		
Blow dust out of generator			X		
Check compression				X	
Check and service breaker points				X	
Check ignition timing				X	
Check valve-tappet clearance				X	
Service cylinder heads					X
Replace fuel filter (external-later models only)					X

NOTE

Unleaded gasoline is recommended. If leaded gasoline is used, service cylinder heads every 200 hours.

Lube Oil Selection

Use high quality detergent oil of API (American Petroleum Institute) service class SF. Select viscosity based on the air temperature at the time of operation, see chart below.

Straight 30 weight oil is preferred. If multi-viscosity is used, be aware of the resulting increase in oil consumption and combustion deposits when used in temperatures above 32° F (0° C).

Using other than service class SF oil, or extending oil change intervals longer than recommended could cause engine damage which is not covered by the engine warranty.

RECOMMENDED SAE VISCOSITY GRADES

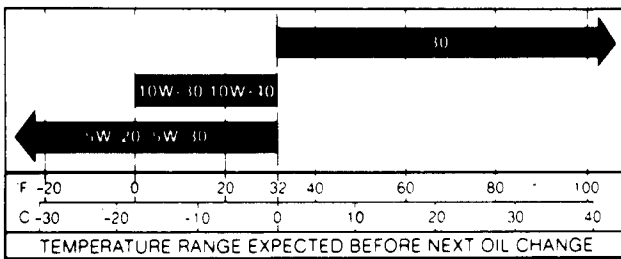

Air Cleaner

Element Service

The engine is equipped with a dry-type air cleaner. Every 50 hours remove element and service by tapping element lightly against flat surface to dislodge loose surface dirt, do not clean in any liquid or blow out with compressed air as this will ruin filter material in element. Service air cleaner after each 50 hours of operation, if dirty replace with genuine Kohler replacement element.

Cover Adjustment

To make seasonal adjustment of the air cleaner cover, loosen wing nut and turn cover. Line up arrow on air cleaner cover with arrow on air chute according to outside temperature. See Figure 3-1. Position air cleaner cover at winter setting to draw heated air from around exhaust tubing when the outside temperature falls below 45° F (24° C). Failure to turn the air cleaner to the winter position can cause carburetor icing and oil breather freeze-up.

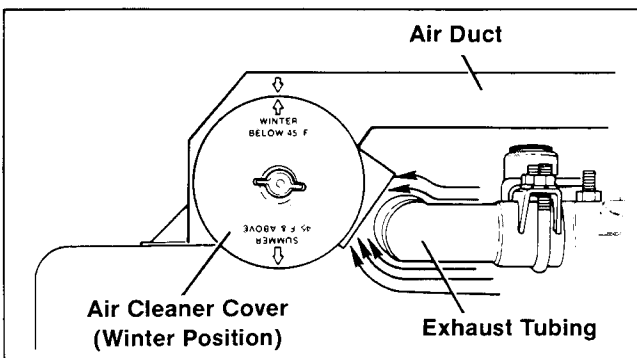

Figure 3-1. Air Cleaner Cover Adjustment

When outside temperature is 45° F (24° C), or above, move air cleaner to summer position. Failure to turn the air cleaner to summer position can result in lower than normal kW output. After adjustment, tighten wing nut firmly with fingers. Do not tighten with a tool.

Ignition System

Spark Plugs

Every 100 hours remove both spark plugs and check condition. Reset gap or replace plug if needed. Good operating conditions are indicated if plug has light coating of gray or tan deposit. A dead white, blistered coating could indicate overheating. A black (carbon) coating may indicate an "overrich" fuel mixture caused by a clogged air cleaner or improper carburetor adjustment.

NOTE

Do not sandblast, wire brush, scrape, or otherwise service plug in poor condition — best results are obtained with a new plug. Use only resistor type plugs. For gasoline models spark plug gap .025" (0.64 mm), LPG models, spark plug gap .018" (0.46 mm). Tighten plug to 10-15 ft. lbs. (13.6-20.3 Nm) when installing.

Breaker Points

WARNING

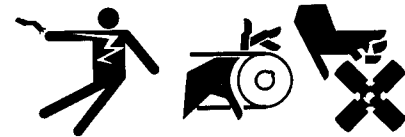

Accidental starting can cause death or serious personal injury. Disconnect battery cables (remove negative lead first and reconnect it last) to disable generator set before working on any equipment connected to generator. The generator set can be started by remote start/stop switch unless this precaution is followed.

WARNING

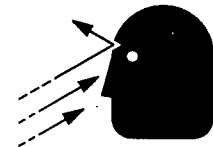

Flying projectiles can cause injury.

Retorque all crankshaft and rotor hardware after servicing. When making adjustments or servicing generator set, do not loosen crankshaft hardware or rotor thru-bolt. If rotating crankshaft manually, direction should be clockwise only. Turning crankshaft or rotor thru-bolt counter-clockwise can loosen hardware and result in serious personal injury from hardware or pulley flying off engine while unit is running.

Every 200 hours the breaker points should be inspected and serviced. If oxidized, dirty, or oily, clean with coarse cloth—do not use emery cloth or sandpaper. Replace badly pitted or burned points. The gap must be adjusted after points are serviced or replaced since this setting establishes ignition timing. Read the following procedure before beginning the adjustment.

1. Disconnect battery (negative lead first) and remove the spark plug leads to prevent unintentional starting.
2. Remove the breaker point cover. See Figure 3-2.

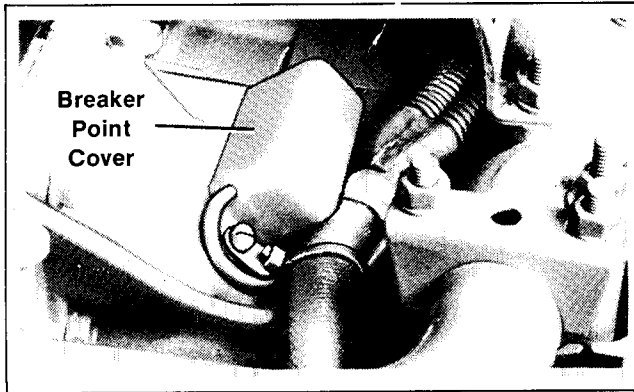

Figure 3-2. Breaker Point Cover

3. Remove the rotor end cap. See Figure 1-1 or 1-2. With 3/4" socket wrench, rotate the rotor bolt clockwise until the points reach maximum opening.
4. Measure the gap with a feeler gauge. The gap at full open should be .017/.023 inch (.432/.580 mm). If not, loosen the point gap adjustment screw with an offset screwdriver or an allen wrench. Adjust the gap to .017/.023 inch (.432/.580 mm) by inserting a screwdriver blade in the adjusting notch and shifting the movable plate. See Figure 3-3. Securely tighten the adjusting screw after setting the gap.

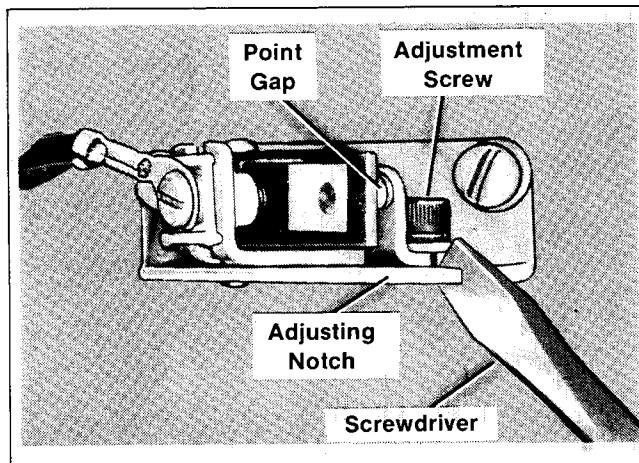

Figure 3-3. Breaker Point Gap Adjustment

5. Replace the breaker point cover.
6. Reconnect battery (negative lead last) and reconnect the spark plug leads.
7. Follow up with the final or precision adjustment using a timing light.

Timing

Your generator set is equipped with a timing sight hole on the side of the blower housing. The T mark indicates Top Dead Center while the S mark indicates the Spark or Spark Run point which is 23° BTDC (Before Top Dead

Center). Several different types of timing lights are available—follow manufacturer's instructions for type used. The following timing procedure can be used with most timing lights.

1. Rotate engine until S mark is visible—chalk S line for easy reading.
2. Start unit and operate at 1800-1920 rpm. Aim timing light into sight hole. Light should flash just as S mark is centered in sight hole. If light flashes before mark is centered, timing is overadvanced. If light flashes after mark is centered, timing is retarded.
3. If timing is off—remove breaker point cover, loosen gap adjusting screw, shift breaker plate until mark is exactly centered. Retighten adjusting screw and recheck timing before replacing breaker point cover.

NOTE

Breaker point cover screws must be screwed back into mounting pad after cover is removed. The screws keep the engine oil from spurting out of the crankcase through the breaker point cover screw holes while engine is being timed.

Gasoline Fuel Specifications and Service

Fuel Specifications

For best results, use only clean, fresh, regular grade unleaded gasoline with a pump sticker octane rating of 87 or higher in the U.S.A. In countries using the Research rating method, it should be 90 octane minimum.

Unleaded gasoline is recommended since it leaves less combustion chamber deposits. Regular grade leaded gasoline may also be used; however, be aware that the combustion chamber and cylinder head will require more frequent service. Do not use gasohol or valve and carburetor damage will occur. Gasohol containing no more than 10% ethanol can be used if unleaded gasoline is unavailable. Never use gasohol containing more than 10% ethanol or gasoline containing Methanol. Oil must not be mixed with the fuel.

Use fresh gasoline to ensure it is blended for the season and to reduce the possibility of gum deposits forming which could clog the fuel system. Do not use gasoline left over from the previous season.

Fuel Filter Service

Early model generators were equipped with fuel pumps with built in fuel filters. See Figure 3-4a. The internal filter on this type pump should be cleaned every 100 hours of operation. Remove the pump cover to remove the filter. Swish the filter in cleaning solvent to remove debris. Wipe the magnet and internal surfaces with a clean rag before reassembling.

Later model sets utilize a screw-in type fuel filter connected to the electric fuel pump. Replace the filter every 400 hours of running time or when rough operation indicates an engine tune-up may be necessary. Location of the fuel filter is shown in Figure 3-4b.

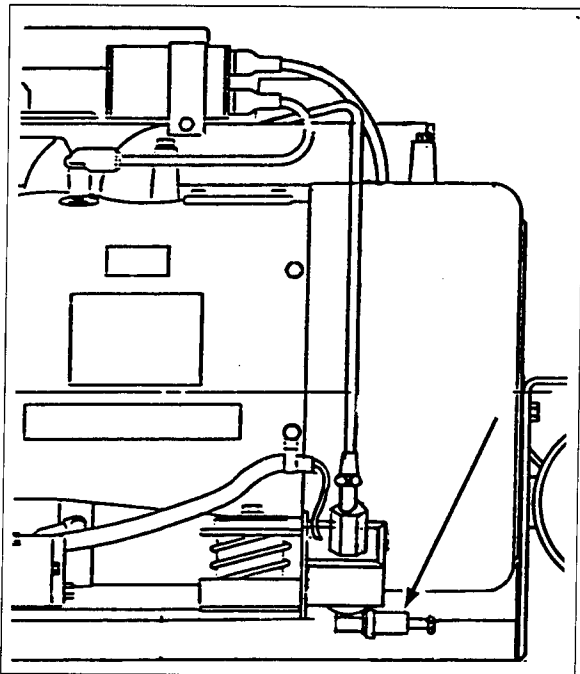

**Figure 3-4a. Fuel Pump
Cooling System**

To prevent damage of the generator set from overheating, keep the cooling air inlets to the compartment clean and unobstructed at all times.

A fan on the rotor of the generator draws cooling air into the compartment through the generator cooling slots and

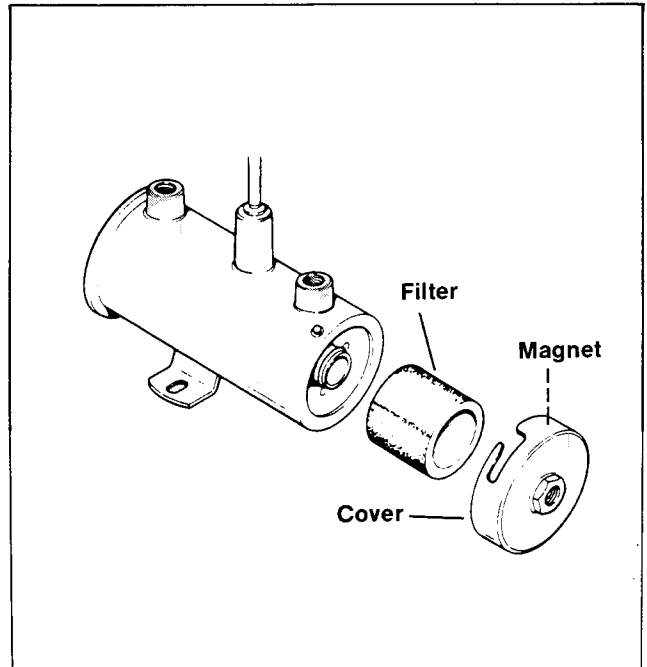

Figure 3-4b. External Fuel Filter

exits at the engine-generator adapter. The engine of the generator set features an air-vac reverse flow cooling system. Fins on the engine flywheel pull cooling air past the fins of the cylinder heads and heated air is discharged downward and out of the compartment through the discharge chute. See Figure 3-5.

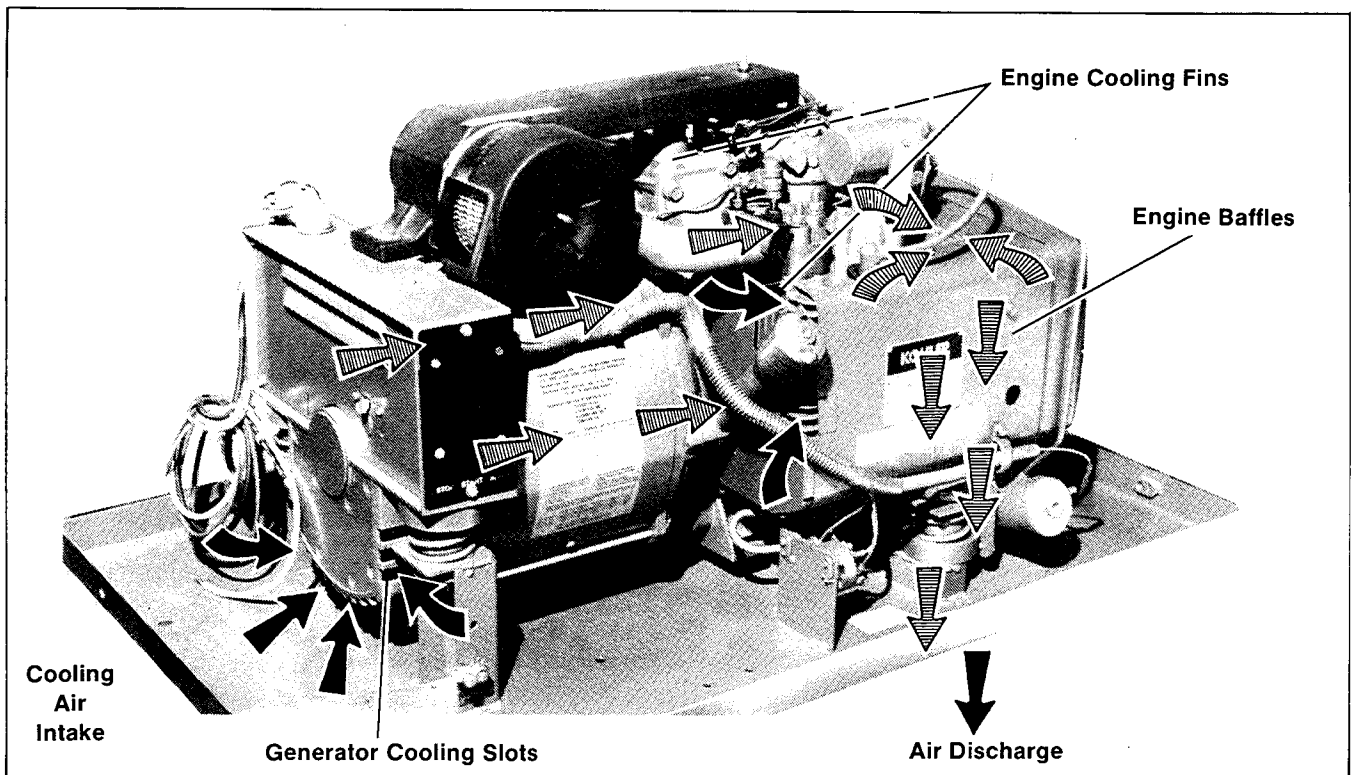

Figure 3-5. Cooling Air Circulation

Gasoline Carburetor Adjustments

Lack of power and black sooty exhaust usually indicate that the fuel mixture is too rich. An overrich mixture may be caused by a clogged air cleaner or improperly adjusted choke. Always check the air cleaner before readjusting the choke or carburetor. If the engine skips (misses) or backfires, the fuel mixture may be too lean. To locate adjustment screws refer to Figure 3-6.

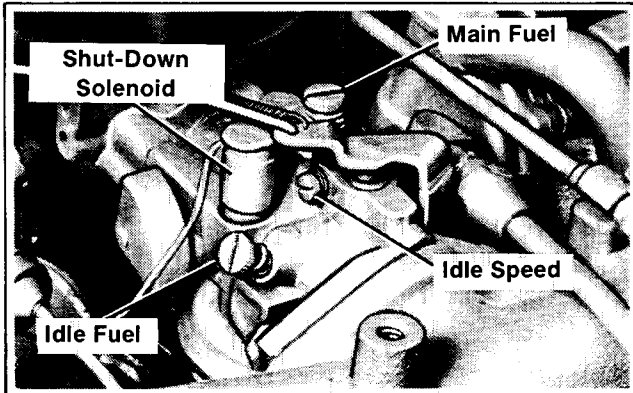

Figure 3-6. Carburetor Adjustment Screws

Main Fuel Mixture

For preliminary setting turn the MAIN FUEL screw in a clockwise direction until it bottoms lightly (do not force), then back out 2-3/4 to 3 turns. With the engine thoroughly warmed up and running at rated rpm under full load, turn MAIN FUEL screw in until the engine slows down (lean setting) then turn screw out until the engine regains speed and then starts to slow down (overrich setting). Turn the screw back in until it is positioned halfway between lean and overrich settings. When properly adjusted, the engine will operate with steady governor action.

Idle Fuel Mixture

The idle system functions only as the engine comes up through idle range. For this reason, the idle setting has only a momentary effect. To adjust, stop the engine and then turn the IDLE FUEL needle all the way in (clockwise) until it bottoms lightly (do not force) then back out 1-1/2 to 1-3/4 turns. No further adjustment is needed.

Idle Speed

To adjust the idle speed, run the generator set at no load. Push the throttle lever counterclockwise until it hits the idle speed screw. Holding the throttle lever against the screw, adjust the idle speed until it runs at 55 Hertz (1650 rpm).

Gasoline Shut-Down Solenoid

After running with a heavy load, engines tend to continue running (diesel) after the switch is moved to the stop

position. To prevent this, the carburetor on your engine is equipped with a shut-down control (Figure 3-7) which stops all flow of fuel when the switch is moved to the stop position. When the engine is running, battery current through the solenoid attracts and holds a plunger (Figure 3-7). When the switch is moved to the stop position, the solenoid de-energizes and releases the plunger in the carburetor to equalize pressure and stop all flow of fuel.

Should the solenoid fail, fuel cannot flow and the set will not run. As a temporary fix, the plunger can be removed until the solenoid is replaced. To remove, first turn the main fuel screw in until it bottoms lightly (do not force) and record the number of turns in; then turn the main fuel screw out far enough to shift the solenoid retaining bracket. Lift the solenoid and remove the plunger. Reinstall the solenoid and retaining bracket. Turn the main fuel screw in until it bottoms lightly, then back out number of turns recorded (minor adjustments may have to be made). The lead on top of the shut-down solenoid grounds to the ignition coil clamp (which bolts to intake manifold). It is important that both connections are secure.

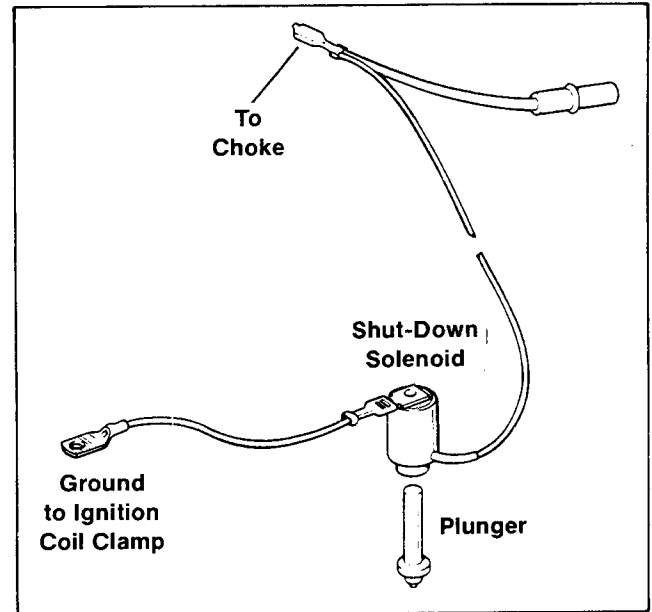

Figure 3-7. Shut-Down Solenoid

Choke Adjustment

A Kohler Thermo-electric automatic choke is used to enrich the fuel mixture during starting. The choke automatically closes as the ambient air temperature cools or as the engine temperature decreases. As the engine warms, the coils allow the choke plate to open. If readjustment is needed, loosen the screws securing the choke bracket to the carburetor and shift the position of the choke assembly (see Figure 3-8). When properly set, the choke plate will be within 5 to 10 degrees of full open at approximately 70°F (21°C).

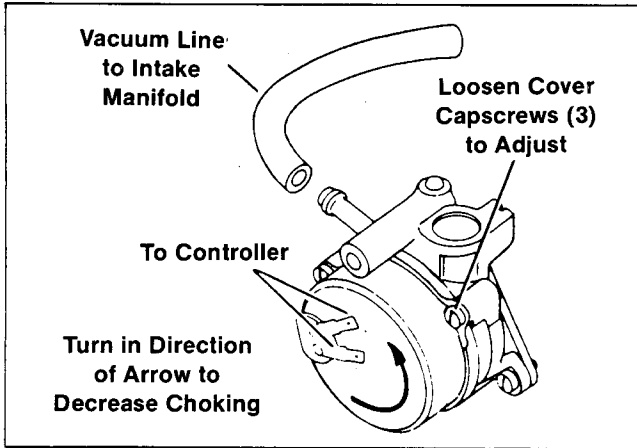

Figure 3-8. Automatic Choke Adjustment

LP Gas Carburetor Adjustments

The LP gas system consists of a shut-off fuel valve, a secondary regulator, and carburetor that adjusts the mixture of fuel and air for proper combustion. A propane LP gas is used.

Main Fuel Adjustment

Turn load block fuel adjustment screw in until it bottoms lightly. From the closed position back the screw out three complete turns. Refer to Figure 3-9.

The gas and supply pressure should not exceed six ounces. To check inlet pressure, remove plug on fuel inlet of gas regulator. Insert ounce pressure gauge or manometer. Adjust pressure to 4-6 ounces or 7-11" water column, inlet pressure is adjusted on primary regulator.

Governor Adjustments

Speed

With the Constant Speed type governor, the throttle shaft is fixed at a definite length to establish a specific full load

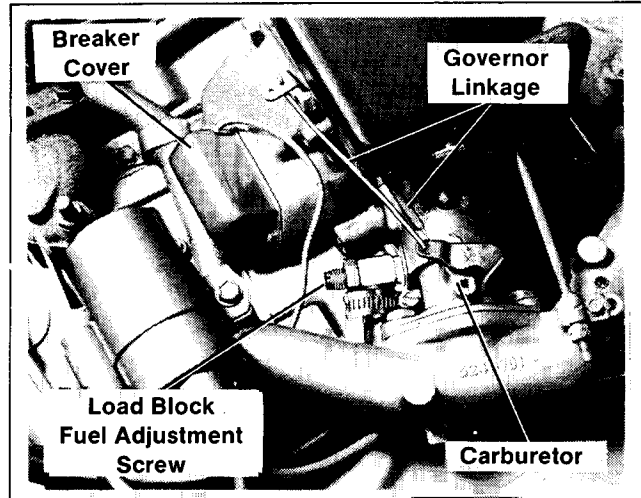

Figure 3-9. LPG Carburetor Adjustments

speed of 1800 rpm (60 Hz). Any variation in speed causes frequency changes in output of the generator. Before making any speed adjustments loosen the outside locking nut. To increase speed, tighten the inside speed adjusting nut to draw back the speed adjusting arm. To decrease speed, loosen the speed adjusting nut. After the speed is correct, secure at the new setting by tightening the outside locking nut. See Figure 3-10.

Sensitivity

If the governor is too sensitive, speed surging will occur with change in load. If a big drop in speed occurs when normal load is applied, the governor should be set for greater sensitivity. Sensitivity is changed by repositioning the governor spring in the governor arm holes (Figure 3-10). To make the governor control more sensitive, move the spring in. To make control less sensitive move the spring out. Recheck speed after making sensitivity adjustment.

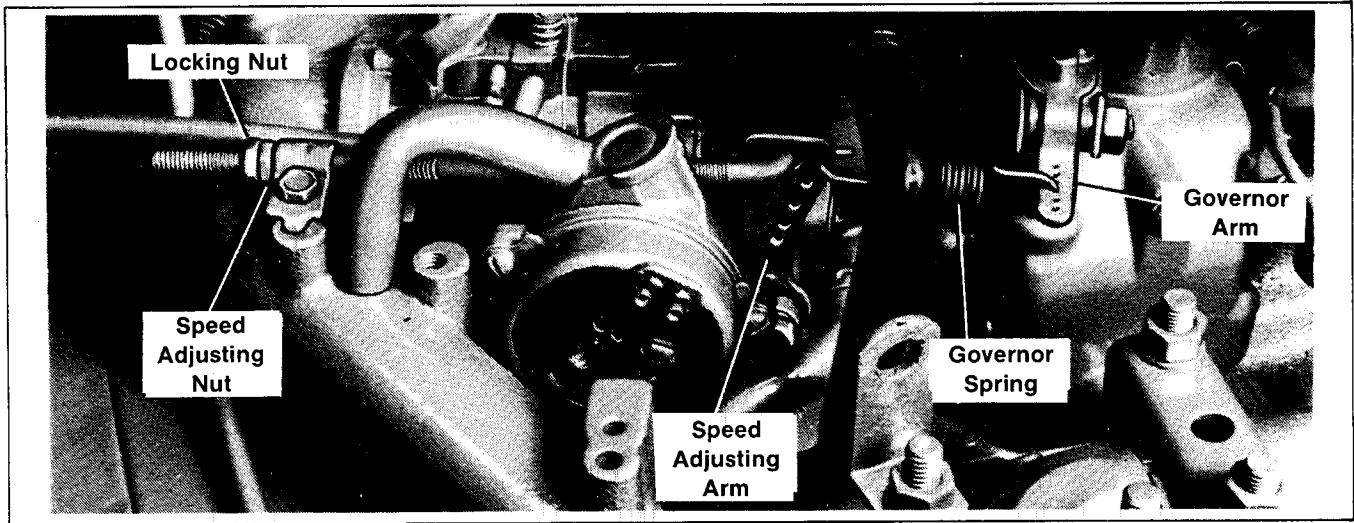

Figure 3-10. Governor Adjustments

Cylinder Head Service

After each 400 hours of operation, the cylinder heads should be taken off the engine and serviced. Remove carbon deposits from combustion chamber in head. Scrape and remove carbon with a sharp piece of wood. Wood or similar material is suggested to avoid scratching aluminum surfaces of head. Always use new cylinder head gaskets, make sure head bolts are tightened in the proper sequence and to the torque value specified. See Figure 3-11.

NOTE

If engine is operated on leaded fuel or under certain conditions, such as continued light load or relatively constant speed, carbon may build up more rapidly. If there are early indications of this, such as heavy deposits of carbon on spark plug electrodes, service the heads more frequently. 200 hours intervals are suggested under these conditions.

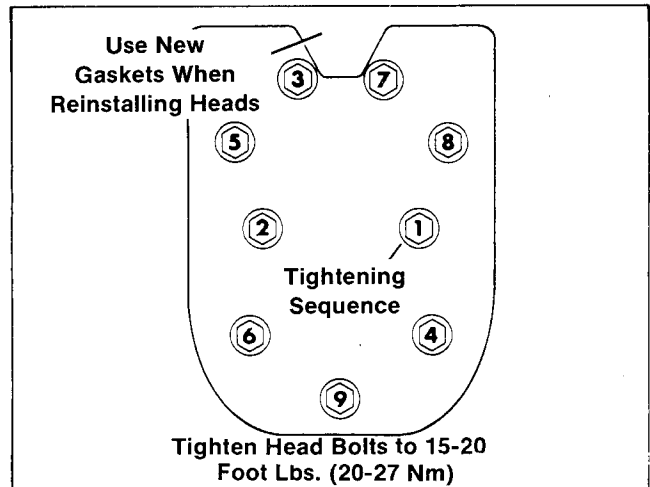

Figure 3-11. Cylinder Head Tightening Sequence and Torque Values

SECTION 4. GENERAL TROUBLESHOOTING

This section lists probable causes and corrections of generator set problems by specific groups. It is a quick reference for troubleshooting individual problems and indicates where to find more detailed information. The sources include various sections of this manual, the Operation and Installation Manual (TP-5167), and the Engine Service Manual (TP-2043-A).

Corrective action and testing in many cases requires some knowledge of electrical and electronic circuits and, therefore, it is recommended that service only be done by Authorized Service Dealers. Improper repair by unauthorized personnel can lead to additional and/or multiple failures.

Problem	Cause	Correction	Reference
Will not crank (dead)	Blown fuse	Replace fuse, if fuse blows again check circuit and components	Section 9. Wiring Diagrams Section 7. Component Testing
	Battery disconnected	Check connections	Section 9. Wiring Diagrams
	Dead battery	Charge or replace	
	Corroded or loose terminal connections	Clean or replace	
	Open wiring, terminal, pin, foil, etc. (P2 connector)	Check continuity	Section 9. Wiring Diagrams
	Defective start/stop switch (T1-T3)	Check continuity	Section 9. Wiring Diagram Section 7. Component Testing
	Defective starter solenoid	Check continuity of circuit Bypass solenoid using jumper wire. If starter cranks, replace solenoid	Section 9. Wiring Diagrams Section 7. Component Testing TP-2043-A, "Electrical Systems & Components"
Defective starter	Rebuild or replace	TP-2043-A, "Electrical Systems & Components"	
Will not start (cranks OK)	Carburetor choke misadjusted or defective (gasoline model only)	Check and/or adjust	Section 3. Scheduled Maintenance TP-2043-A, "Fuel System & Governor"
	No fuel in tank	Replenish	
	Defective or misadjusted spark plug	Regap or replace	Section 3. Scheduled Maintenance TP-2043-A, "Electrical Systems & Components"
	Defective ignition coil	Test and/or replace	TP-2043-A, "Electrical Systems & Components"
	Fuel shut-off valve not functioning (gasoline model only)	Check and/or replace	Section 3. Scheduled Maintenance TP-2043-A, "Fuel Systems & Governor"
	Defective electric fuel pump (gasoline model only)	Check fuel pressure of 4.5 psi (31 kPa)	
	Defective or grounded breaker points	Adjust or replace	Section 3. Scheduled Maintenance TP-2043-A, "Electrical Systems & Components"
	Open wiring, terminal, or pin (P2 connector)	Check continuity	Section 9. Wiring Diagrams
	Defective anti-icing heat element	Test and/or replace	Section 7. Component Testing
Defective K3 relay (anti-icing)	Test and/or replace	Section 7. Component Testing	

Problem	Cause	Correction	Reference
Will not start (cranks OK) (Continued)	K2 relay coil defective	Check continuity	Section 9. Wiring Diagrams Section 7. Component Testing TP-2043-A, "Troubleshooting"
	Engine defective (no compression, stuck valves, etc.)	Troubleshoot engine	
	Defective LP gas valve or secondary regulator	Check LP gas pressure at secondary regulator. Pressure should be 4 to 6 oz. or 7 to 11 inches water column.	
Engine starts, but does not continue to run after start switch is released	No generator output voltage	Check AC voltage Check stator continuity	Section 9. Wiring Diagrams Section 7. Component Testing
	Open wiring (P1 or P2 connector)	Check continuity	
	No engine oil pressure	Check oil pressure and pump	TP-2043-A, "Lubrication System"
	Defective low oil pressure (LOP) shutdown switch	Bypass LOP shutdown switch using jumper wire to ground. If engine continues to run after start switch is released, replace LOP shutdown switch. LOP switch contacts close at approx. 3.5 psi (24 kPa).	Section 2. Operation, "Engine Shutdown Switch" (for location of switch)
	K1 relay coil defective	Check continuity	Section 9. Wiring Diagrams Section 7. Component Testing
	K1 relay (N.O.) contacts remain open	Check continuity	Section 9. Wiring Diagrams
No generator output voltage	Line circuit breaker open or defective	Check position of circuit breaker Check AC voltage on generator side of circuit breaker.	Section 1. Specifications "Service Views" for location Section 9. Wiring Diagrams
	No battery voltage to terminal (+) and (-) of regulator during cranking	Check for DC voltage at voltage regulator (+) and (-)	Section 9. Wiring Diagrams
	Blown fuse in regulator circuit	Replace fuse, if fuse blows again, check voltage regulator and stator aux. windings	Section 9. Wiring Diagrams Section 7. Component Testing
	Open wiring, terminal, or pin in build-up circuit (P1 connector)	Check continuity	Section 9. Wiring Diagrams
	Open D1 or D2 diode	Check for open or shorted diode. (A good diode has high resistance one way and low resistance the other way, when tested with ohmmeter)	Section 9. Wiring Diagrams Section 7. Component Testing
	K1 relay (N.C.) contacts open (contacts between D2 and P3-4)	Check continuity	Section 9. Wiring Diagrams Section 7. Component Testing
	Brushes sticking in holder	Check alignment	Section 7. Component Testing
	Rotor slip rings dirty or corroded	Check and/or service	Section 7. Component Testing

Problem	Cause	Correction	Reference
No generator output voltage (Continued)	Broken, weak, or missing brush spring	Check condition	Section 7. Component Testing
	Defective voltage regulator	Excite (rotor) separately Test and/or replace	Section 6. Generator Troubleshooting Section 7. Component Testing
	Defective rotor (open, grounded, or shorted windings)	Check continuity Check voltage	Section 7. Component Testing Section 6. Generator Troubleshooting
	Defective stator (open, grounded, or shorted windings)	Check continuity Check voltage	Section 7. Component Testing Section 6. Generator Troubleshooting
High generator output voltage	Open or poor splice connection at terminals 33-3 or 44-4 on stator (regulator sensing)	Check continuity	Section 7. Component Testing
Low generator output voltage	Low engine rpm	Check speed using tachometer or frequency meter NOTE: Hz x 120 = rpm x no. of rotor poles	Section 3. Scheduled Maintenance TP-2043-A, "Fuel System & Governor"
	Defective voltage regulator	Test and/or replace	Section 7. Component Testing
Generator set shuts down by itself	No fuel in tank	Replenish	
	Fuel line restriction	Check fuel lines and tank. Check gasoline fuel pressure of 4.5 psi (31 kPa)	
	Dirty electric fuel pump filter (gasoline model only)	Clean filter	Section 3. Scheduled Maintenance
	Fuel line drawing air	Check fuel lines and tank	
	Defective electric fuel pump (gasoline model only)	Check fuel pressure of 4.5 psi (31 kPa)	
	Engine overloaded	Reduce electrical load	Specifications Chart — "Installation" TP-5167, "Wattage Requirements" & "Electrical Load"
	Engine overheated	Check air intake, carburetor adjustment, oil level, timing, etc.	TP-5167, "Troubleshooting" TP-2043-A, "Troubleshooting"
	Low engine oil pressure	Check pressure and pump components	TP-2043-A, "Lubrication System"
	Ignition coil fails when hot	Check using "cold" test NOTE: If coil checks out okay, it may still fail during operation and require replacement	TP-2043-A, "Electrical Systems & Components"
	Fuel vapor lock	Reroute fuel lines away from exhaust system	TP-5167, "Installation — Fuel System"

Problem	Cause	Correction	Reference
Generator set shut down by itself (cont.)	Loss of generator output voltage to K1 relay	Check AC voltage at rectifier Check continuity of B1 & B2 stator leads NOTE: Some models with center-tapped windings use B1 and B3. Always check leads connected to P1-1 P1-2.	Section 9. Wiring Diagrams Section 7. Component Testing
Will not carry load or runs rough	Excessive load connected to generator Engine not operating at rated rpm Governor not properly adjusted or defective Carburetor not properly adjusted or defective (gasoline model only) Carburetor not properly adjusted or defective (LP gas model only) Defective or grounded breaker points Improper timing Defective ignition coil Defective or misadjusted spark plug Carburetor choke misadjusted or defective (gasoline model only) Fuel line restriction	Reduce electrical load Check speed using tachometer or frequency meter NOTE: Hz x 120 = rpm x no. of rotor poles Check speed using tachometer or frequency meter NOTE: Hz x 120 = rpm x no. of rotor poles Check and/or adjust Check and/or adjust Adjust or replace Check timing Test and/or replace Regap or replace Check and/or adjust Check fuel lines and tank. Check gasoline fuel pressure of 4.5 psi (31 kPa)	Specifications Chart — "Installation" TP-5167, "Wattage Requirements" & "Electrical Load" Section 3. Scheduled Maintenance TP-2043-A, "Fuel Systems & Governor" Section 3. Scheduled Maintenance TP-2043-A, "Fuel System & Governor" Section 3. Scheduled Maintenance TP-2043-A, "Fuel System & Governor" Section 3. Scheduled Maintenance TP-533, "Straight LP Conversion Kit" Instruction Section 3. Scheduled Maintenance TP-2043-A, "Electrical Systems & Components" TP-2043-A, "Electrical Systems & Components" Section 3. Scheduled Maintenance TP-2043-A, "Electrical Systems & Components" Section 3. Scheduled Maintenance TP-2043-A, "Fuel System & Governor"

Problem	Cause	Correction	Reference
Will not carry load or runs rough (cont.)	Dirty electric fuel pump filter (gasoline model only)	Clean filter	Section 3. Scheduled Maintenance
	Defective electric fuel pump (gasoline model only)	Check fuel pressure 4.5 psi (31 kPa)	
	Excessive carbon build-up	Clean cylinder head	Section 3. Scheduled Maintenance TP-2043-A, "Cylinder Heads — Inspection & Service"
	Valves not seating	Check valves and valve seats	TP-2043-A, "Valves — Inspection & Service"
Unit is noisy	Exhaust system leak	Check and/or replace	
	Broken or damaged vibro mounts	Check and/or replace	Section 8. Disassembly/ Reassembly
	Worn mounting springs	Check and/or replace	Section 8. Disassembly/ Reassembly
	Loose or vibrating sheet metal	Retighten screws. If necessary, add additional screws to secure	
	No installation clearance (unit hits compartment)	Check clearances	Specifications Chart — "Installation" TP-5167, "Compartment Size"
	Exhaust or air outlet ducts hit mounting tray opening	Check clearances. Secure loose parts	
	No compartment sound insulation	Install fireproof insulation	TP-5167, "Compartment Size"
	Excessive vibration (engine/generator internal imbalance)	Check rotor, crankshaft, bearing, etc. (Disassembly of engine and/or generator may be necessary.)	TP-2043-A, "Disassembly" Section 8. Disassembly/ Reassembly

SECTION 5. CONTROLLER TROUBLESHOOTING

The following is the sequence of operation that the controller goes through when starting, running, stopping, or engine fault shutdown stopping. This section should serve as a starting point for controller troubleshooting. Refer to Figure 5-1a, 5-1b, or 5-1c for proper wiring schematic.

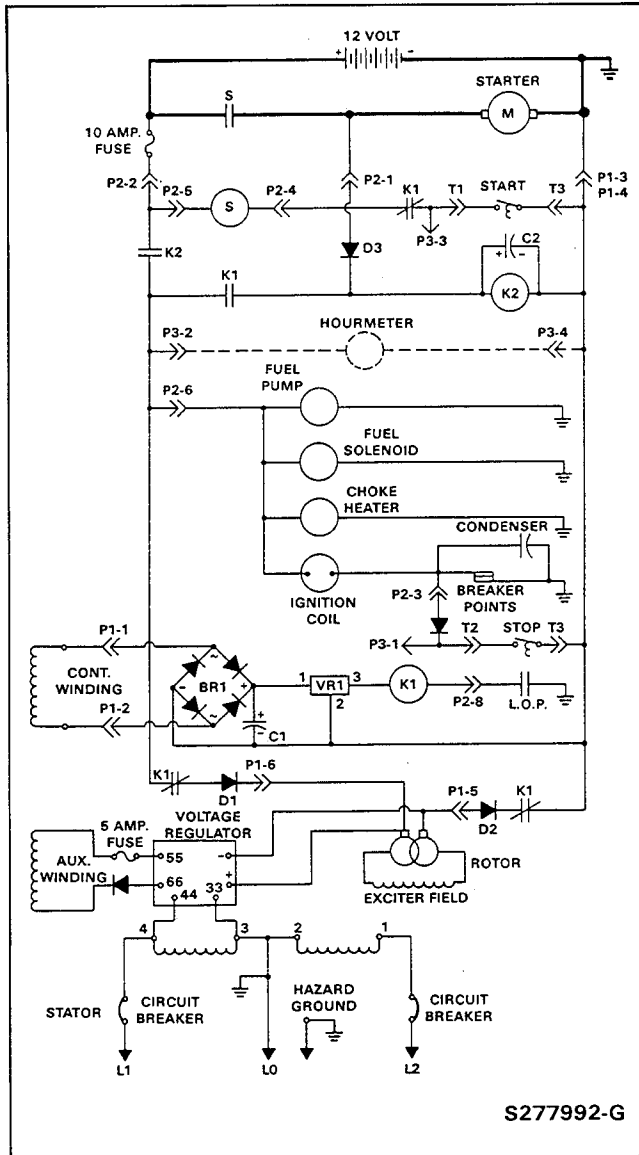

Figure 5-1a. Sequence of Operation
(Generators equipped with B-239396 or
C-239396 Circuit Board)

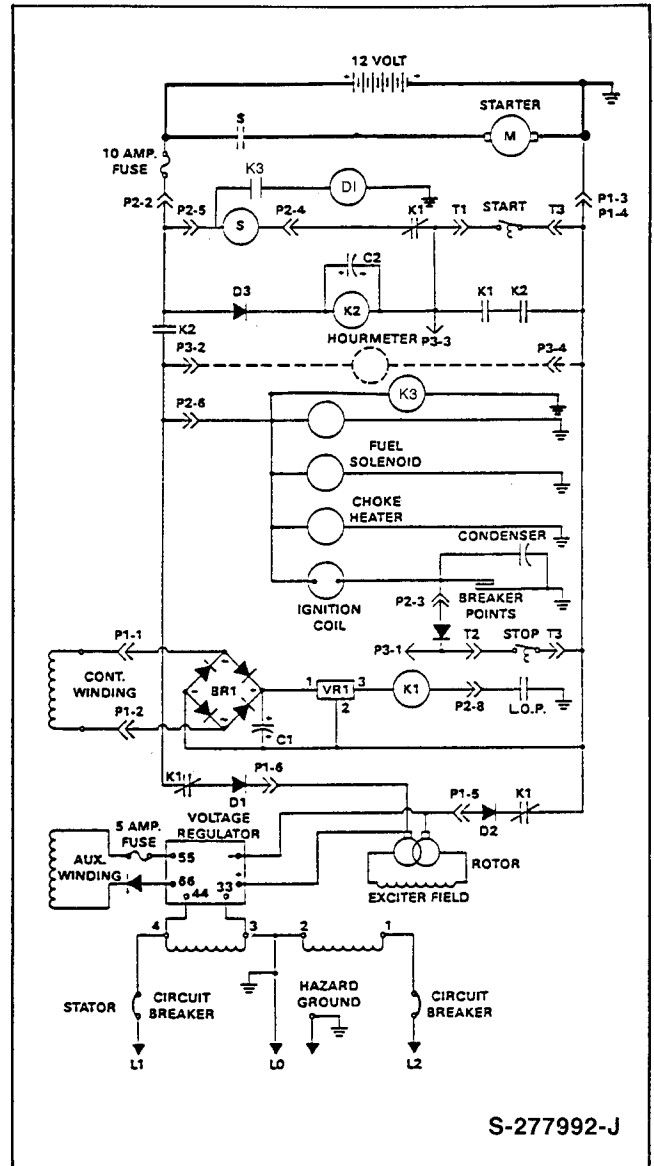

Figure 5-1b. Sequence of Operation
(Generators equipped with E-239396
Circuit Board—No SDR Relay)

Starting

- Close the start-switch between T3 and T1 (local starting) or P3-4 and P3-3 (remote starting).
- S relay energizes. Normally open S contacts close and starter is engaged.
- K2 relay is energized. Normally open K2 contacts close to energize fuel pump or gas valve; carburetor shut-down valve, choke heater, ignition coil, hourmeter, and voltage regulator terminal + (field flashing).
- K3 relay is energized (if equipped). Normally open K3 contacts close to energize anti-icing heat element.

Running

- Once the unit comes up to proper voltage and proper oil pressure, K1 relay is energized.
- Normally open K1 contacts close to maintain voltage to K2 relay and normally open K2 contacts remain closed to maintain engine running voltage.
- Once the unit is running, start-switch contacts are opened by releasing rocker switch.
- The first set of normally closed K1 contacts open to de-energize S relay. S relay contacts open to disengage starter.
- The second set of normally closed K1 contacts open to disconnect circuit to voltage regulator terminal + (field flashing) and rotor field winding.
- The third set of normally closed K1 contacts open ground circuit to voltage regulator terminal (-) and rotor field winding.

Stopping

- Close the stop-switch between T3 and T2 (local stopping) or P3-4 and P3-1 (remote stopping).
- Early Models: Ignition coil circuit to breaker points is grounded and unit shuts down.
- Later Models: SDR relay is energized. Normally-closed SDR contacts open to de-energize fuel pump/valve, fuel solenoid, choke heater, and ignition coil. Generator set shuts down.

Low Oil Pressure (LOP) Shutdown Switch

- Low oil pressure will cause (LOP) switch contacts to open and de-energize K1 relay.
- Normally open K1 contacts open to de-energize K2 relay.
- Normally open K2 contacts open to remove engine running voltage.

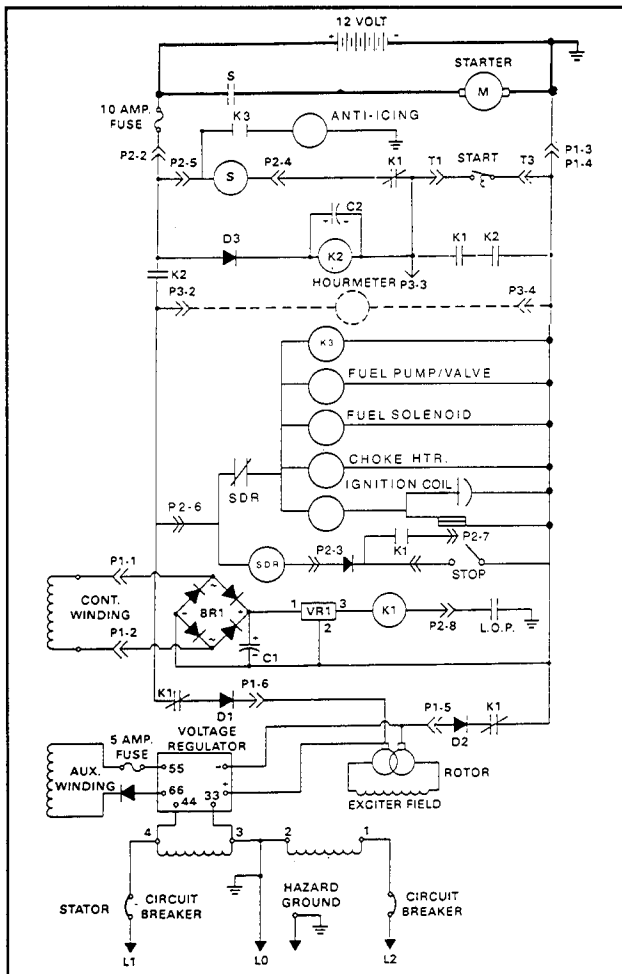

**Figure 5-1c. Sequence of Operation
(Generators equipped with E-239396
Circuit Board and SDR Relay)**

SECTION 6. GENERATOR TROUBLESHOOTING

The flow chart below is a guide to troubleshoot the generator set. Before beginning the troubleshooting procedures, read all safety precautions at the beginning of this manual. Additional safety precautions are included with the tests; do not neglect these precautions.

General

To determine the cause of no or low AC output, separately excite the generator. The generator field (rotor) may be excited (magnetized) using an outside DC power source (12 Volt automotive battery) and the following procedures. While separately exciting the generator to determine the presence of a faulty voltage regulator, it is possible to determine if a running fault exists in the rotor and/or stator. A generator component that appears good while static (stationary) may exhibit a running open or short while dynamic (moving). This fault can be caused by centrifugal forces acting on the windings while rotating or insulation breakdown as temperatures increase.

! WARNING

Battery gases can cause an explosion.

Do not smoke or permit flame or spark to occur near a battery at any time, particularly when it is being charged. Avoid contacting terminals with tools, etc. to prevent burns and to prevent sparks that could cause an explosion. Remove wristwatch, rings, and any other jewelry before handling battery. Never connect negative (-) battery cable to positive (+) connection terminal of starter solenoid. Do not test battery condition by shorting terminals together or sparks could ignite battery gases or fuel vapors. Any compartment containing batteries must be well ventilated to prevent accumulation of explosive gases. Do not mount battery in generator compartment. To avoid sparks, do not disturb battery charger connections while battery is being charged and always turn charger off before disconnecting battery connections. When disconnecting battery, remove negative lead first and reconnect it last.



! WARNING

Hazardous voltage can cause death or severe injury. Perform electrical service only as prescribed in equipment manual. Be sure that generator is properly grounded. Never touch electrical leads or appliances with wet hands, when standing in water, or on wet ground as the chance of electrocution is especially prevalent under such conditions. Wiring should be inspected at the interval recommended in the service schedule—replace leads that are frayed or in poor condition. The function of a generator set is to produce electricity and wherever electricity is present, there is the hazard of electrocution.



Separate Excitation

1. Disconnect all leads from voltage regulator. See Figure 6-1.
2. Connect an ammeter and a 12-Volt automotive battery to the positive (+) and negative (-) brush leads. Refer to Figure 6-2. Note and record the ammeter reading.

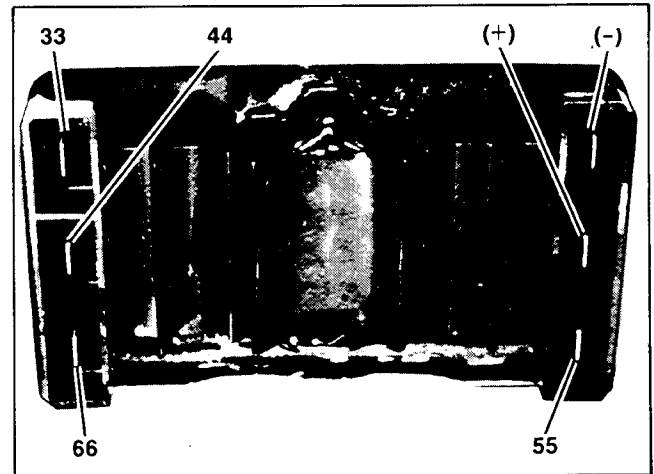
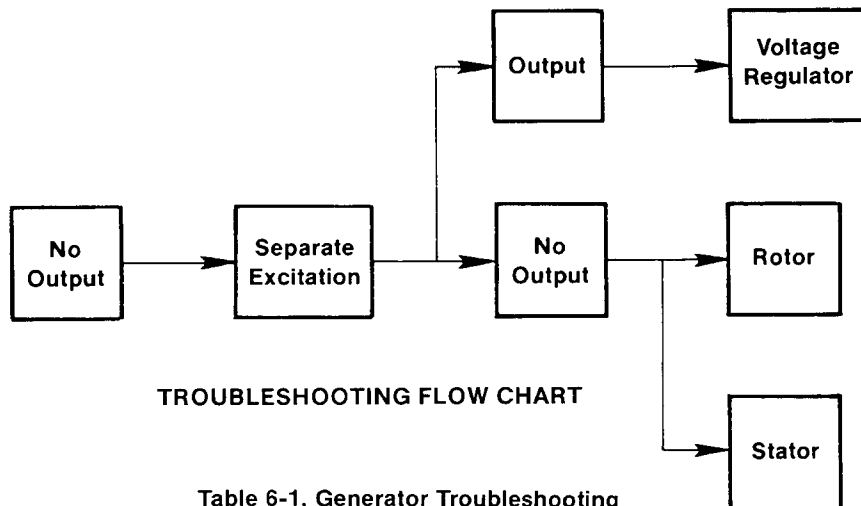

Figure 6-1. 6-Pin Voltage Regulator



TROUBLESHOOTING FLOW CHART

Table 6-1. Generator Troubleshooting

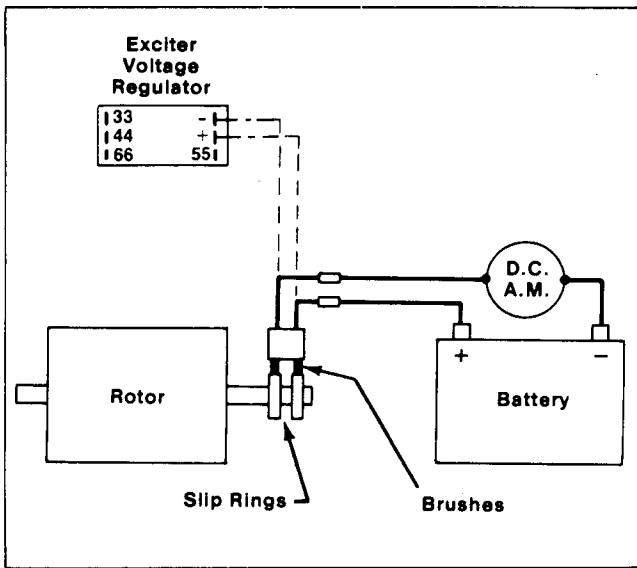

Figure 6-2. Separate Excitation Connections

- The ammeter reading should be approximate battery voltage divided by specified rotor resistance (Table 7-1).

Example:

$$\frac{12 \text{ Volts (Battery Voltage)}}{4.6 \text{ Ohms (Rotor Resistance)}} = \frac{2.6 \text{ Amps.}}{\text{(Rotor Current)}}$$

- Start engine and check that ammeter remains stable. An increasing meter reading indicates a shorted rotor. A decreasing meter reading to zero or unstable reading suggests a running open. Refer to "Component Testing." If ammeter is stable, proceed to Step 5.
- Check for AC output across stator leads (reference Figure 7-4) and compare to readings in Table 6-2. If readings vary considerably with those in Table 6-2, a faulty stator is likely. Refer to "Component Testing."

Leads	4.5 kW
1-2, 3-4, 33-44	40-75
55-66	40-75
B1-B2 (w/o center tapped winding)	6-12
B1-B2 (with center tapped winding)	4-8
B1-B3 (with center tapped winding)	6-12

Table 6-2. Stator Output Voltages with Separately Excited Rotor Using 12 Volt Battery

- If rotor and stator checks are positive, this indicates a faulty voltage regulator. Refer to "Component Testing."

SECTION 7. COMPONENT TESTING

This section is a guide in checking generator components for improper operation. Follow the safety precautions in front of this manual. Additional safety precautions are included with the tests; do not neglect these precautions.

Voltage Regulator Test

This test is designed to check regulator output. To test, the following components will be needed.

- Variable Transformer, 0-140 Volts (.5 Amp Min.)
- 1 to 1 Isolation Transformer (.6 Amp Min.)
- 120 Volt AC Plug (60 Hz)
- Double Pole, Single Throw Switch
- 120 Volt, 100 Watt Lamp
- 2 Amp Fuse and Fuse Holder
- AC Voltmeter
- Recommended #14 AWG Copper Wire (Minimum)

⚠ WARNING

Hazardous voltage can cause death or serious injury. The heat sink of the voltage regulator contains high voltage. Do not touch voltage regulator heat sink when testing or electrical shock will occur.



⚠ WARNING

Hazardous voltage can cause death or severe injury. Perform electrical service only as prescribed in equipment manual. Be sure that generator is properly grounded. Never touch electrical leads or appliances with wet hands, when standing in water, or on wet ground as the chance of electrocution is especially prevalent under such conditions. Wiring should be inspected at the interval recommended in the service schedule—replace leads that are frayed or in poor condition. The function of a generator set is to produce electricity and wherever electricity is present, there is the hazard of electrocution.



1. Connect components as shown in Figure 7-1.
2. Plug in variable transformer and AC plug.
3. Turn switch S1 on. Lamp should be on. If lamp does not go on, this indicates a faulty voltage regulator; replace.
4. Turn variable transformer on. Slowly increase variable transformer; the lamp should go out at approximately 120 Volts and remain out as voltage is increased.
5. If the lamp does not go out or stays at a dull glow, this indicates a faulty regulator and should be replaced.
6. Turn switch S1 off and unplug AC cords.

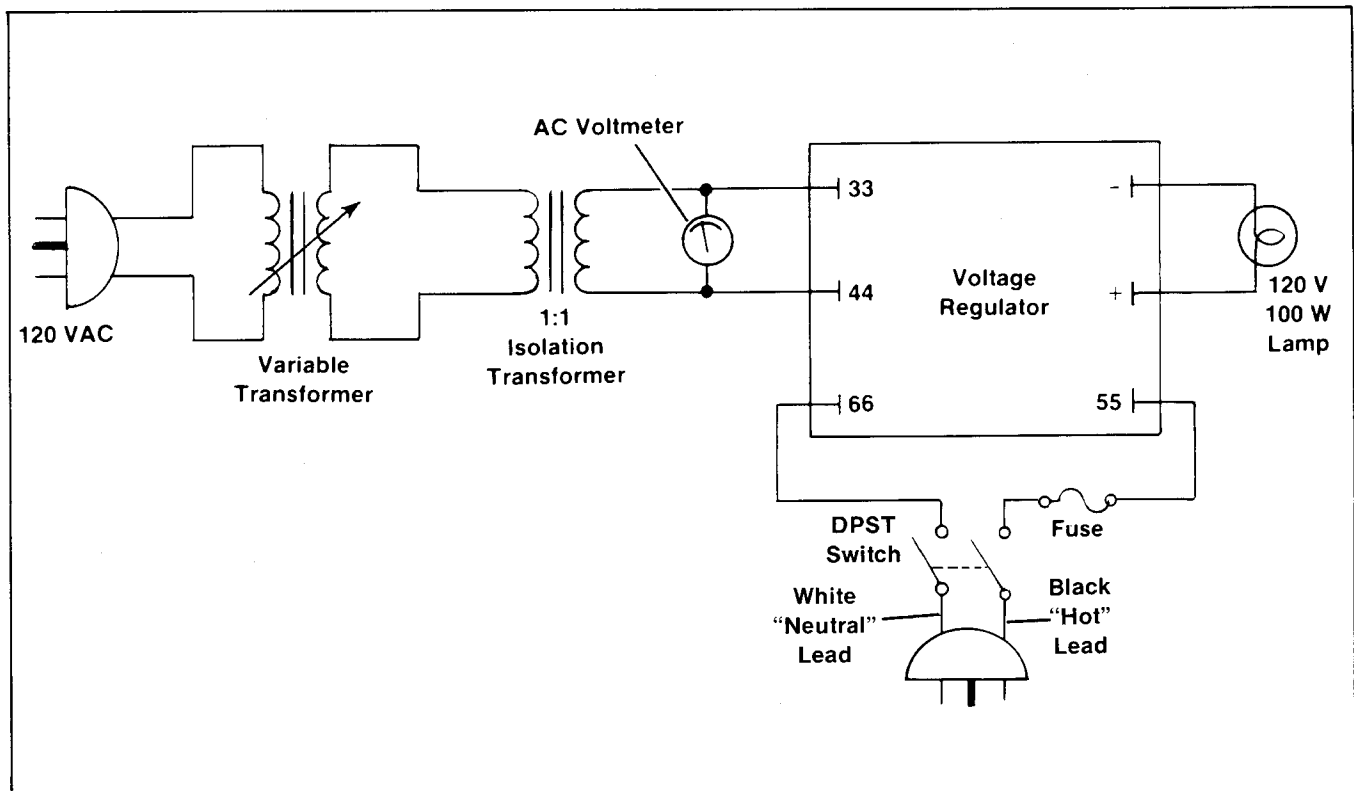

Figure 7-1. Voltage Regulator Test

Rotor

The four-pole rotor creates the magnetic field needed to raise alternating current in the stator windings. Prior to testing, inspect the rotor for visible damage to pole shoes, insulation, exposed coil windings, and slip ring surfaces. Check bearing for noise when rotated, wear, or heat discoloration.

Slip rings acquire a glossy brown finish in normal operation. Do not attempt to maintain a bright, newly-machined appearance. Ordinary cleaning with a dry, lint-free cloth is usually sufficient. Very fine sandpaper (#00) may be used to remove roughness. Use light pressure on the sandpaper. Do not use emery or carborundum paper or cloth. Clean out all carbon dust from the generator. If the rings are black or pitted, remove the rotor and remove some of the surface material by using a lathe.

Check the rotor for continuity and resistance. Measure the rotor resistance (ohms) between the two slip rings (Figure 7-2). See Table 7-1 for typical readings.

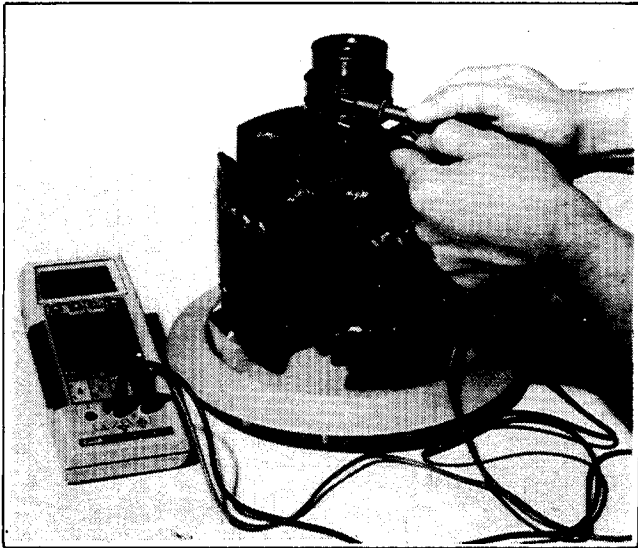

Figure 7-2. Rotor Resistance Check

Model	Resistance $\pm 10\%$
4.5 CKM	4.6 Ohms

Table 7-1. Rotor Resistance

To check for rotor shorted to ground, adjust ohmmeter to zero ohms. Touch one ohmmeter lead to either slip ring and other lead to rotor poles or shaft. Meter should register no continuity.

NOTE

Since ohmmeters do vary in their accuracy, use Table 7-1 as a reference for approximate readings. Readings must be at room temperature.

Should any fault be found with the rotor in any of the above tests, the rotor must be repaired or replaced.

Stator

The stator consists of a series of coils or wire laid in a laminated steel frame. The stator leads supply voltage to the AC load and exciter regulator.

Prior to testing, inspect stator for visible damage to lead wires, heat discoloration, exposed coil windings, exposed and varnished areas of frame laminations and housing, and make sure stator is securely riveted in housing.

Checking Stator Continuity and Resistance

1. To check stator continuity, set ohmmeter on R x 1 scale (Figure 7-3). Contact red and black meter leads; adjust meter to zero ohms. Check stator continuity, connect-

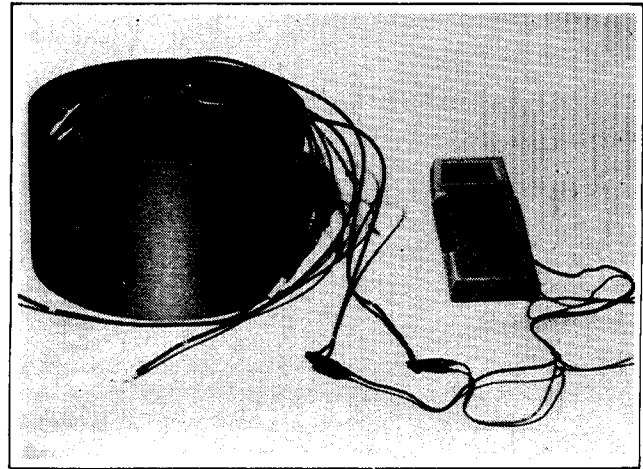

Figure 7-3. Checking Stator Continuity

ing meter leads to stator leads (Figure 7-4). Leads 1, 2, 3, and 4 are the generator output leads. Leads 33, 44, 55, and 66 are voltage regulator supply and sensing leads. Leads B1 and B2 are auxiliary voltage supply.

NOTE

Some models with center-tapped windings use B1 and B3. Reference appropriate wiring diagram.

- There must be continuity between leads 1 and 2.
- There must be continuity between leads 3, 4, 33, and 44.
- There must be continuity between leads 55 and 66.
- There must be continuity between leads B1 and B2.
- There should be no continuity between lead 1 and leads 3, 4, 33, and 44.
- There should be no continuity between lead 1 and leads 55, 66, B1, and B2.
- There should be no continuity between lead 4 and leads 55, 66, B1, and B2.
- There should be no continuity between lead 55 and leads B1 and B2.
- There should be no continuity between any stator lead and ground on the stator housing or frame laminations.

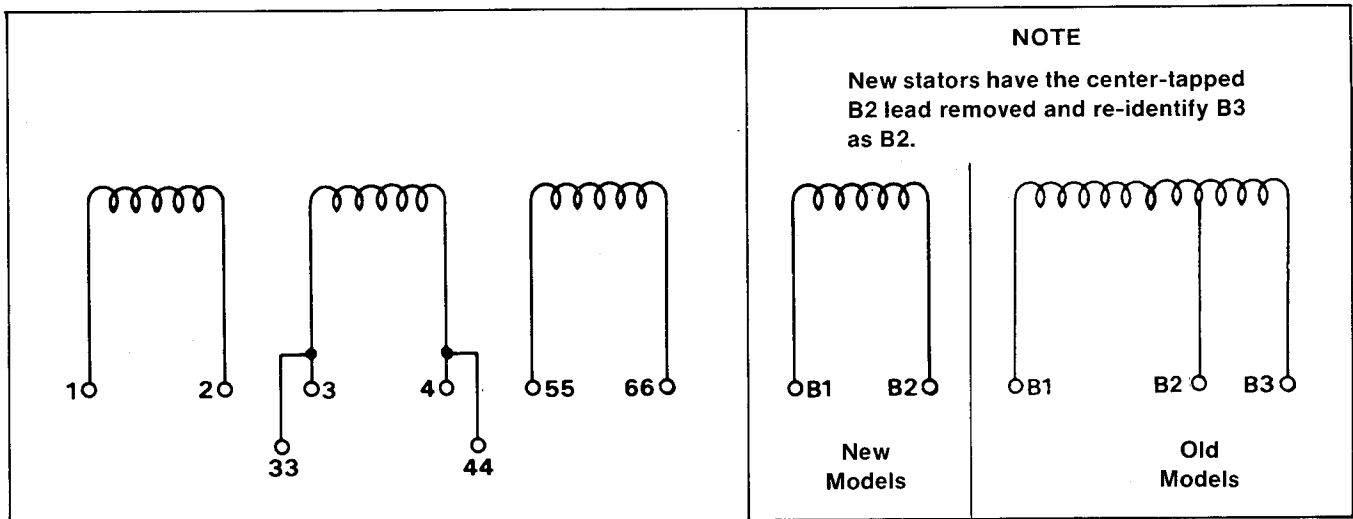

Figure 7-4. Generator Stator Leads

- Contact red and black meter leads and readjust ohmmeter to zero ohms. Check cold resistance of stator windings, connecting meter leads to stator leads 1 and 2, leads 3 and 4, leads 33 and 44, leads 55 and 66, and leads B1 and B2. See Table 7-2 for typical stator resistance readings.

NOTE

Since ohmmeters do vary in their accuracy, use Table 7-2 as a reference for approximate readings. Readings must be at room temperature.

NOTE

Most ohmmeters will not give accurate readings when measuring less than 1 ohm. Therefore, in all likelihood, the stator can be considered good if the reading shows low resistance or continuity and there is no evidence of it being shorted (heat discoloration).

NOTE

When taking an ohmmeter reading using lead 55, make connection prior to in-line fuse. When taking an ohmmeter reading using lead 66, make connection prior to in-line diode.

Leads	Readings $\pm 10\%$ (in Ohms) 4.5 CKM
1 and 2	.25
3 and 4	.25
33 and 44	.25
55 and 66	2.8
B1 and B2 (without center-tapped winding)	.15
B1 and B2 (with center-tapped winding)	.10
B1 and B3 (with center-tapped winding)	.15

Table 7-2. Stator Winding Cold Resistance Readings

NOTE

New and old style stators are not directly interchangeable. Newer style stators have the center-tapped B2 lead removed and B3 re-identified as B2.

Should any of the stator readings vary considerably during the above checks, the stator must be repaired or replaced.

Brushes

The brushes transfer current from the voltage regulator to slip rings. The brushes carry a very low current (approximately 2 Amps) and should last the life of the generator set. Abrasive dust on the slip rings could, however, shorten the life of the brushes. Excessive arcing at the brushes could damage the voltage regulator. Arcing could be caused by weak springs, damaged slip rings, sticking brushes, loose holder, or poor brush contact.

The brushes must be free to move within the holder and be held in proper contact by the springs. When properly positioned, spring pressure on the brush surface will cause the brush to wear evenly. Brushes must ride 100% on rings or arcing will occur, resulting in burned rings or failure of the voltage regulator. Figure 7-5 shows the correct positioning of the brushes.

Replace brushes if worn excessively or unevenly. Replace the springs if damaged or discolored.

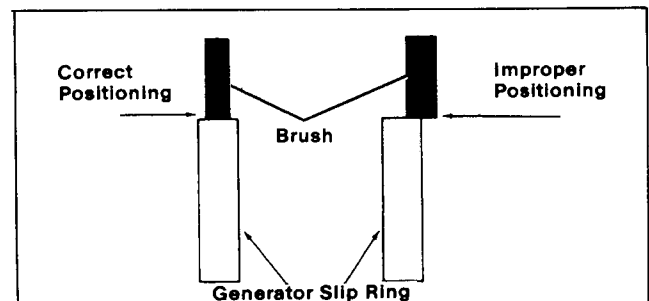

Figure 7-5. Brush Positioning

Controller Circuit Board

It is possible to check some controller circuit board components without removing the component from the board. These checks should be made prior to installing a new board and attempting start-up. Most of the tests are referenced in Section 4, General Troubleshooting. Use a

high quality multimeter and follow the manufacturer's instructions. To obtain accurate readings, all connectors must be removed from the circuit board and remove conformal coating (transparent insulation) from leads of components before testing. Use the following chart and see Figure 7-6a, 7-6b, or 7-6c.

NOTE

If controller circuit board 239396 has failed due to foil damage, see Appendix A, "Circuit Board Foil Damage" prior to replacing circuit board and attempting start-up.

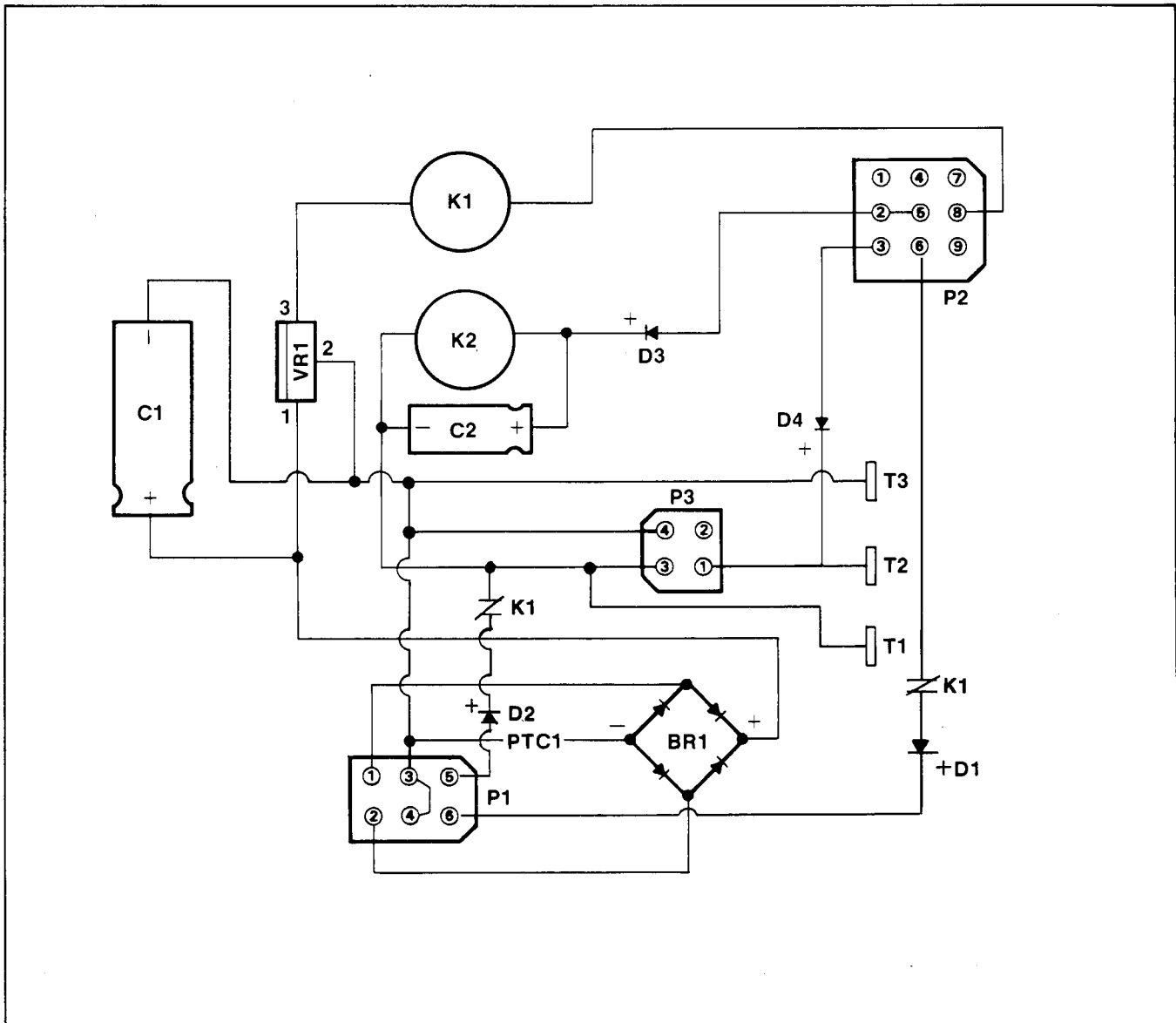

Figure 7-6a. Controller Circuit Board E-239396 Testing

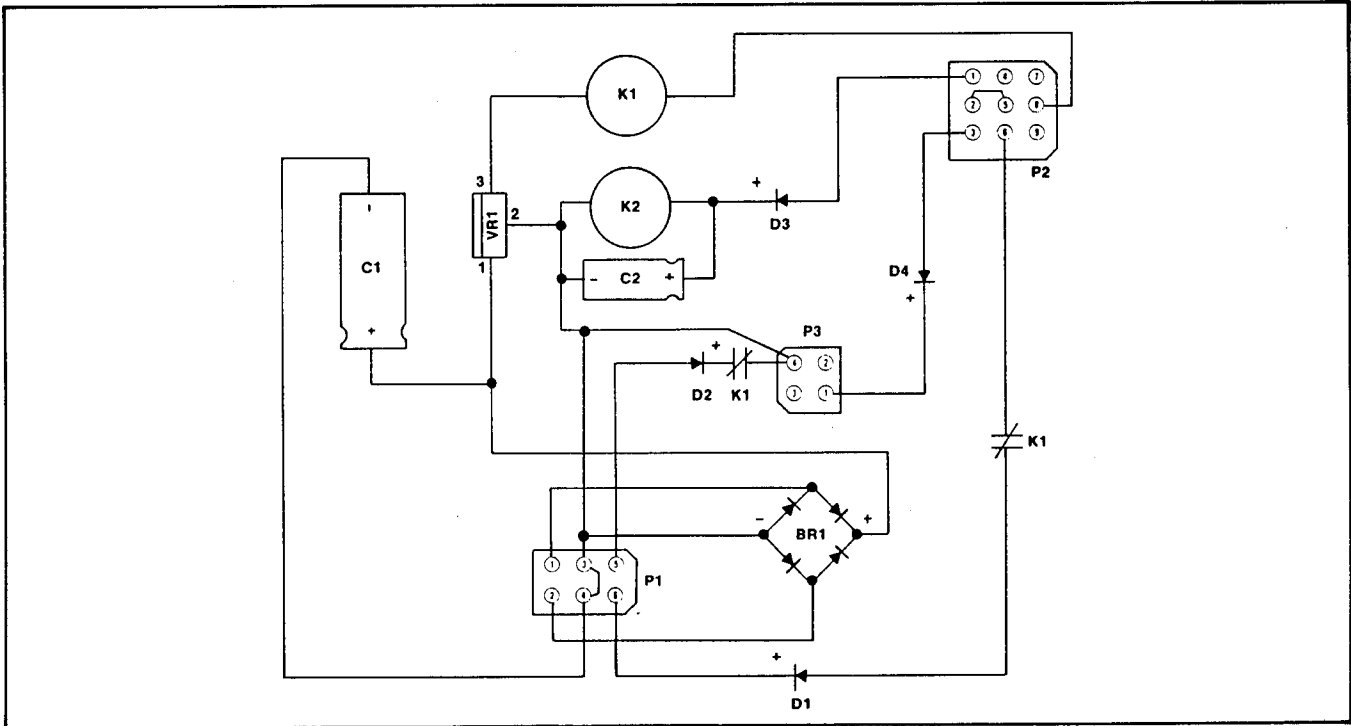

Figure 7-6b. Controller Circuit Board C-239396 Testing

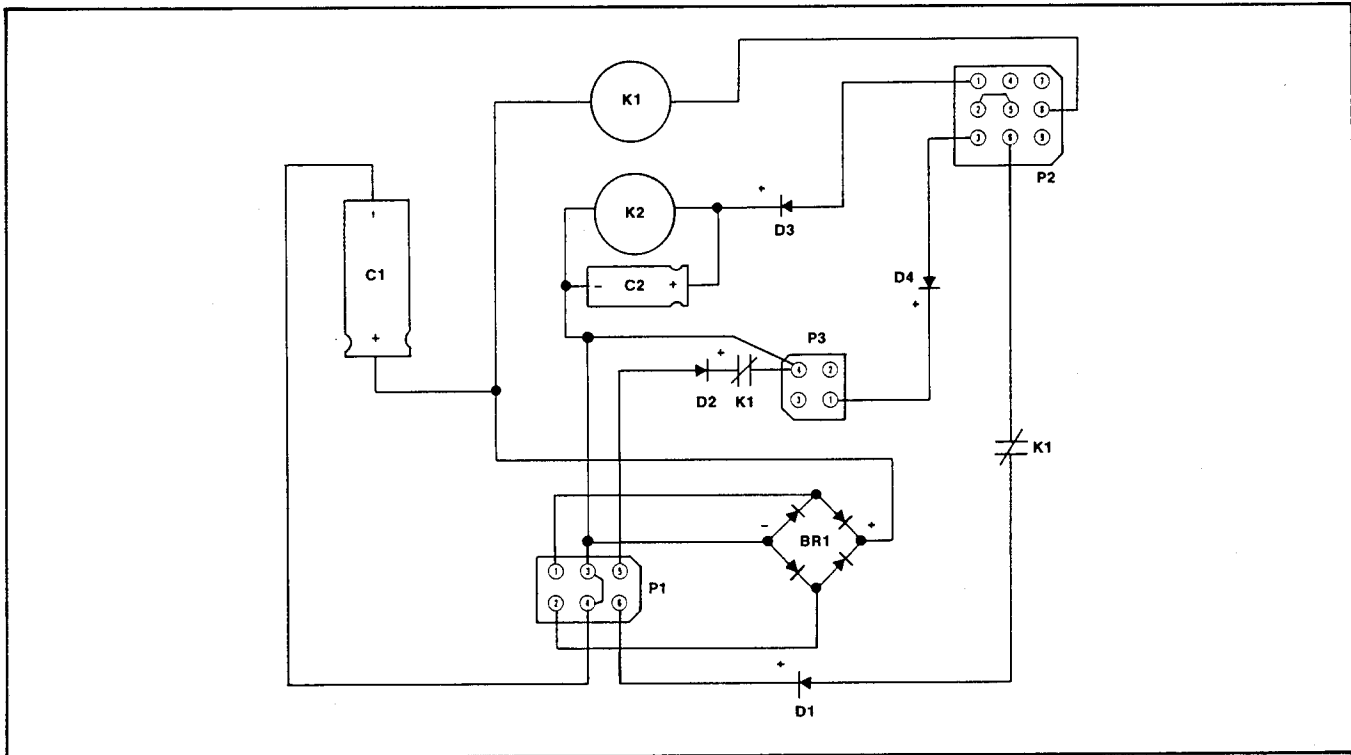

Figure 7-6c. Controller Circuit Board B-239396 Testing

Components	Ohmmeter Connections	Results	Remarks
K1 relay coil	If circuit board C-239396 or E-239396, use VR1 terminal 3 (output lead) and P2-8. If circuit board B-239396, use C1 (+) lead and P2-8.	If good — approx. 200 ohms. Low resistance — shorted. High resistance — open.	Ohmmeter on R x 100 scale.
K2 relay coil, C2, and D3	If circuit board B-239396 or C-239396, use P2-1 and P3-4. If circuit board E-239396, use P2-2 and P3-3. Take reading and reverse leads.	If good — high resistance one direction and low resistance the other direction. All other readings indicate one or more components are bad.	Ohmmeter on R x 1000 scale. Test components individually. Test D3 and test K2 relay coil and C2.
D3	If circuit board B-239396 or C-239396, use P2-1 and C2 (+) lead. If E-239396 circuit board, use P2-2 and C2 (+) lead. Take reading and reverse leads.	If good — high resistance one direction and low resistance the other direction. Low resistance both ways — shorted. High resistance both ways — open.	Ohmmeter on R x 1000 scale.
K2 relay coil and C2	If circuit board B-239396 or C-239396, use C2 (+) lead and P3-4. If E-239396 circuit board, use C2 (+) lead and P3-3.	If good — approx. 400 ohms. This indicates relay coil is good, but C2 could be open. Low resistance — K2 coil and/or C2 are shorted. High resistance — K2 coil and C2 are open.	Ohmmeter on R x 10000 scale. If C2 is open, unit will start, but may not continue to run after start button is released. If K2 is open and C2 is good, C2 will charge and discharge when ohmmeter leads are connected and then reversed.
D1 and K1 (N.C.) contacts	P2-6 and P1-6. Take reading and reverse leads.	If good — high resistance one direction and low resistance the other direction. Low resistance both ways — D1 is shorted. High resistance both ways — K1 (N.C.) contacts and/or D1 are open.	Ohmmeter on R x 1000 scale. Test components individually. Test D1 and test K1 (N.C.) contacts.
D1	P1-6 and D1 (-) lead. Take reading and reverse leads.	If good — high resistance one direction and low resistance the other direction. Low resistance — shorted. High resistance — open.	Ohmmeter on R x 1000 scale.
K1 (N.C.) contacts	D1 (-) lead P2-6	If good — zero ohms. Any resistance other than zero ohms, contacts are bad.	Ohmmeter on R x 1 scale.
D2 and K1 (N.C.) contacts	If circuit board B-239396 or C-239396, use P1-5 and P3-4. If E-239396 circuit board, use P1-5 and P3-3.	If good — high resistance one direction and low resistance the other direction. Low resistance both ways — D2 is shorted. High resistance both ways — K1 (N.C.) contacts and/or D2 are open.	Ohmmeter on R x 1000 scale. Test components individually. Test D2 and test K1 (N.C.) contacts.
D2	P1-5 and D2 (+) lead	If good, high resistance one direction and low resistance the other direction. Low resistance both ways — shorted. High resistance both ways — open.	Ohmmeter on R x 1000 scale.
K1 (N.C.) contacts	If circuit board B-239396 or C-239396, use D2 (+) lead and P3-4. If E-239396 circuit board, use D2 (+) lead and P3-3.	If good — zero ohms. Any resistance other than zero ohms, contacts are bad.	Ohmmeter on R x 1 scale.

Components	Ohmmeter Connections	Results	Remarks
D4	P2-3 and P3-1	If good — high resistance one direction and low resistance the other direction. Low resistance both ways — shorted. High resistance both ways — open.	Ohmmeter on R x 1000 scale.
C1	C1 (+) and P1-3. Take reading and reverse leads.	If good — capacitor will charge and discharge. No deflection in meter reading indicates C1 is bad.	Ohmmeter on R x 1000 scale. If BR1 or VR1 is shorted, C1 cannot be checked.
BR1	P1-1 and C1 (+) lead; C1 (+) lead and P1-2; P1-2 and P1-3; P1-3 and P1-1. Take reading and reverse leads for each pair of terminals.	If good — high resistance one direction and low resistance the other direction. Low resistance both ways — shorted. High resistance both ways — open.	Ohmmeter on R x 1000 scale. Readings will show increasing resistance in one direction due to C1 discharging. This discharging is normal. If C1 or VR1 is shorted, BR1 cannot be checked.
PTC1 (E-239396 circuit board)	BR1 (-) at PTC1 and P1-3.	If good — approximately 7.0 ohms.	Ohmmeter on R x 1000 scale. Allow PTC1 to cool before checking resistance.

Circuit Board Foil Damage

If controller circuit board — 239396 has failed due to foil damage, determine and correct the cause prior to replacing circuit board and attempting start-up. Controller circuit board — 239396 is susceptible to foil damage if subjected to the following conditions. Recent circuit board revisions should provide adequate circuit board protection against most of these possible conditions. See Figure 7-7 for circuit board foil damage locations.

1. Stator auxiliary winding shorted to ground.
2. Stator auxiliary winding B1/B2 shorted to ground.
3. Shorted starter solenoid terminals.
4. Defective starter solenoid (internal short).
5. Shorted rotor and/or brushes.

To detect conditions leading to circuit board foil damage, follow the test guidelines described in the following paragraphs. Refer to the appropriate section of this service manual for additional information on disassembly/reassembly and troubleshooting procedures. Observe all safety precautions while performing these tests.

Equipment Needed:

- Megohmmeter
- Ohmmeter

CAUTION

Short circuits can cause bodily injury and/or equipment damage. Do not contact electrical connections with tools or jewelry while adjustments are made. Remove wristwatch, rings, and jewelry that can cause short circuits.



WARNING

Hazardous voltage can cause death or severe injury. Perform electrical service only as prescribed in equipment manual. Be sure that generator is properly grounded. Never touch electrical leads or appliances with wet hands, when standing in water, or on wet ground as the chance of electrocution is especially prevalent under such conditions. Wiring should be inspected at the interval recommended in the service schedule—replace leads that are frayed or in poor condition. The function of a generator set is to produce electricity and wherever electricity is present, there is the hazard of electrocution.

Hazardous voltage can cause death or severe injury. Follow instructions of test equipment manufacturer when performing high voltage test. Improper test procedure can damage equipment or lead to future generator failures.



1. Stator auxiliary winding shorted to ground

Foil damage between P1-6 and D1 (+) (anode) and/or D1 (-) (cathode) and K1 N.C. contact caused by auxiliary winding 55-66 shorted to ground. Reference 1 on Figure 7-7. Possible problem on A-, B-, and C- circuit boards. E- circuit boards make use of higher current carrying diodes. This problem may also occur if the 8 Amp. fuse in lead 55 is changed to one of a higher rating. Test stator windings with an ohmmeter using "Stator" section. If this test proves inconclusive, it will require testing with a megohmmeter using the following procedure.

With megohmmeter on 500 Volt scale, connect red (+) meter probe to stator lead 55 or 66. Connect black (-) meter probe to stator shell (ground). Be sure meter leads make good contact with test surface. Following the instructions of the megohmmeter manufacturer, perform megohmmeter test. A reading of approximately 500K ohms (1/2 megohm) and higher indicates a good stator auxiliary winding. A reading of less than 500K ohms (approx.) indicates deterioration of auxiliary winding insulation and possible current flow to ground. Repair or replacement of the stator is necessary.

2. Stator auxiliary winding B1/B2 shorted to ground

Foil damage between BR1 (AC) and P1-2 caused by auxiliary winding B1/B2 shorted to ground. Reference 2 on Figure 7-7. Possible problem on A-, B-, and C- circuit boards. E- circuit boards are equipped with PTC1 to reduce the likelihood of circuit board damage. Test stator windings with an ohmmeter using "Stator" section. If this test proves inconclusive, it will require testing with a megohmmeter using the following procedure.

With megohmmeter on 500 Volt scale, connect meter red (+) probe to stator lead B1 or B2. Connect meter black (-) probe to stator shell (ground). Be sure meter probes make good contact with test surface. Following the instructions of the meter manufacturer, perform megohmmeter tests. A reading of approximately 500K ohms (1/2 megohm) and higher indicates a good B1/B2 winding. A reading less than 500K ohms (approx.) indicates deterioration of B1/B2 winding insulation and possible current flow to ground. Repair or replacement of the stator is necessary.

3. Shorted starter solenoid terminals

Foil damage between K1 N.C. contact and P2-4 caused by battery positive (+) lead shorting to ground through P2-4 when start switch is activated. Reference 3 on Figure 7-7. This can occur due to improper starter solenoid connections, battery positive (+) lead contacting starter solenoid coil negative (-) terminal (P2-4) because of terminal bending, or by a short during "jumpstarting."

Verify that starter leads are connected to correct terminals and are not in electrical contact with each other.

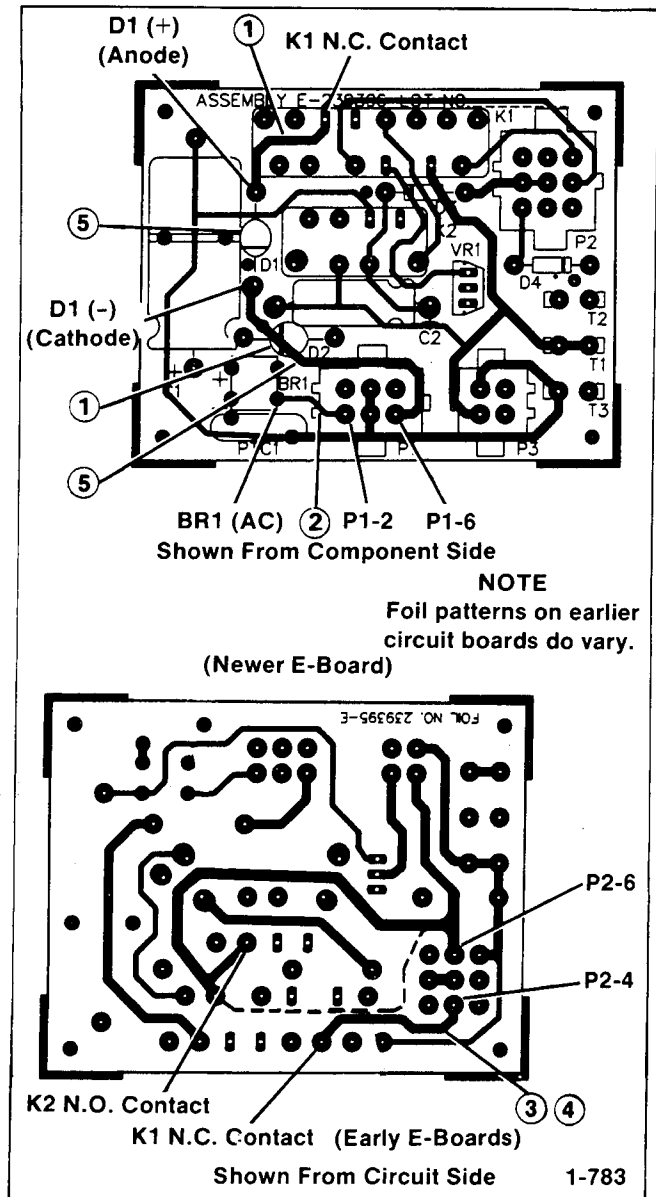

Figure 7-7. Circuit Board Foil Damage Locations

4. Defective starter solenoid (internal short)

Foil damage between K1 N.C. contact and P2-4 caused by starter solenoid component failing. Reference 4 on Figure 7-7.

With ohmmeter on R x 1 scale, connect meter leads to solenoid coil. With all leads disconnected, connect ohmmeter to terminals where leads 71 and battery (+) were connected. Starter solenoid resistance should be 3 Ohms. If solenoid resistance is less than that given (continuity), starter solenoid may be shorted. No resistance reading at all indicates an open solenoid coil.

5. Shorted/defective rotor, voltage regulator, and/or brushes

D1 and/or D2 diodes damaged caused by shorted rotor or brush retaining tool not removed after disassembly. Reference 5 on Figure 7-7. Possible problem on A-, B-, and C- circuit boards. E- circuit boards have higher current carrying diodes. To test these components, see "Rotor" and/or "Brushes" sections.

WIRING HARNESS

With the generator set battery connected, the wiring harness and some engine/generator components can be checked. Place the controller or remote start/stop switch in the corresponding position and check for 12 Volts DC at each component using a DC voltmeter. This will verify that the switches function and 12 Volts DC is present at each component. To further check components, disconnect battery and remove wiring harness plugs from controller circuit board. Check continuity of components using an

ohmmeter to isolate defective components. Use the following chart and see Figures 7-8 and 7-9.

CAUTION

When making ohmmeter checks, generator set battery must be disconnected or ohmmeter damage will result.



CAUTION

Short circuits can cause bodily injury and/or equipment damage. Do not contact electrical connections with tools or jewelry while adjustments are made. Remove wristwatch, rings, and jewelry that can cause short circuits.

Components	Voltmeter Connections	Results	Remarks
Hourmeter and wiring	Red test clip to (+) terminal. Black test clip to (-) terminal. Place controller or remote switch to Start position. None (See "Remarks")	If good—12 Volt DC reading indicates wiring harness is okay. If good—hourmeter will operate.	Voltmeter setting 12 Volts DC or greater. To determine if hourmeter is good, proceed to next step. Disconnect hourmeter leads and apply 12 Volts DC to hourmeter. CAUTION: Hourmeter is polarity sensitive.
B1 and B2 aux. stator winding NOTE: Some models with center-tapped windings use B1 and B3. Reference appropriate wiring diagram.	B1 and B2 connector (if equipped) in controller. NOTE: If unit is not equipped with connector, cut at insulink and add fully insulated push-on terminals on 120 Volt models. If unit is 120/240 Volt model, connect to battery charging rectifier terminals. Place controller or remote switch to Start position.	If good— B1 and B2 (without center-tap winding), 12-16V AC reading. B1 and B2 (with center-tap winding), 8-12V AC reading. B1 and B3 (with center-tap winding), 12-16V AC reading.	Voltmeter setting 20 Volts AC or greater. Voltmeter setting 15 Volts AC or greater. Voltmeter setting 20 Volts AC or greater. Unit must be running at proper speed for voltage test to be conclusive.
Ignition coil, choke, carburetor shutdown solenoid, and fuel pump (or gas valve), anti-icing heat element (if equipped)	Red test clip to each component positive (+) terminal. Black test clip to engine block (ground). Place controller or remote switch to Start position.	If good—12 Volt DC reading indicates wiring harness is okay.	Voltmeter setting 12 Volts DC or greater. See fuel pump/gas valve and anti-icing heat element sections following for additional test procedures. Consult Engine Service Manual TP-2043-A for all other component testing procedures.
Fuel pump/gas valve	None (see "Remarks")	If good—fuel pump will operate or gas valve will open.	Disconnect battery positive lead and apply 12 Volts DC.

Component(s)	Voltmeter Connections	Results	Remarks
Low oil pressure (LOP) shutdown switch	Red test clip to battery positive (+) terminal. Black test clip to switch terminal. Place controller or remote switch to Start position.	If good—12 Volt DC reading.	 WARNING See "Safety Precautions." Voltmeter setting 12 Volts DC or greater. Disconnect harness lead to switch. NOTE: The engine must provide at least 3.5 psi (24 kPa) while cranking for this test to be conclusive. To determine if the low oil pressure shutdown switch is the cause for the generator set to shut down after the start switch is released, proceed to the next step. Bypass LOP switch using a jumper wire between switch lead and ground. Consult Engine Service Manual TP-2043-A regarding oil pressure test.
	None (see "Remarks"). Place controller or remote switch to Start position.	If generator set continues to run after start switch is released, replace shutdown switch. Replace shutdown switch only after proper engine oil pressure is verified.	

Component(s)	Ohmmeter Connections	Results	Remarks
Controller switch or remote switch	1 and 3. Place rocker switch in Start position. 1 and 2. Place rocker switch in Stop position.	If good—zero ohms. Any resistance other than zero ohms, replace switch.	Ohmmeter on R x 1000 scale.
Remote switch light	4 and 6	If good—continuity. No continuity—replace switch.	Ohmmeter on R x 1 scale.
Hourmeter	(-) and (+) terminals.	If good—continuity. No continuity—replace hourmeter.	Ohmmeter on R x 1 scale.
P3 wiring harness to remote switch.	P3-4 and P3-3. Place rocker switch to Start position. P3-4 and P3-1. Place rocker switch in Stop position.	If good—zero ohms. Any other reading indicates P3 wiring or switch is defective.	Ohmmeter on R x 1000 scale. To determine if remote switch is defective, disconnect leads and test separately.
P3 Wiring harness to remote switch light and hourmeter	P3-2 and P3-4	If good—continuity. Zero ohms—shorted component and/or wiring harness. High resistance—open component and/or wiring harness.	Ohmmeter on R x 100 scale. To determine which component is defective, disconnect leads and test separately.
Anti-icing heat element (if equipped)	Heat element terminal and ground	If good—zero ohms (continuity).	Ohmmeter on R x 1000 scale.
K3 and SDR Relays (if equipped)	Relay terminals 85 and 86.	If good—zero ohms (continuity).	Ohmmeter on R x 1000 scale.

Component(s)	Ohmmeter Connections	Results	Remarks
P1 wiring harness, brushes, rotor, and stator	P1-3 and ground	If good — zero ohms. Any other reading indicates a poor ground connection.	Ohmmeter on R x 1 scale.
	P1-1 and P1-2 (B1 and B2 stator leads). NOTE: Some models with center-tapped windings use B1 and B3. Reference appropriate wiring diagram.	If good — B1 and B2 (without center-tap winding) .15 ohms. B1 and B2 (with center-tap winding) .10 ohms. B1 and B3 (with center-tap winding) .15 ohms. Low Resistance — B1/B2 or B1/B3 stator winding shorted. High Resistance — B1/B2 or B1/B3 stator winding open.	Ohmmeter on R x 1 scale. (See Section 7. Stator)
	P1-5 and P1-6 (disconnect brush leads at voltage regulator (+) and (-) terminal).	If good — 4-6 ohms. Low resistance — rotor and/or brushes shorted. High resistance — rotor and/or brushes open.	Ohmmeter on R x 1 scale. (See Section 7 — Rotor and Brushes)
P2 Wiring Harness to Engine Components			
10 Amp fuse and wiring	P2-2 and starter solenoid "battery" side.	If good — zero ohms. No continuity — open circuit and/or blown fuse.	Ohmmeter on R x 100 scale.
Ignition coil (primary coil) and wiring	P2-3 and P2-6 (disconnect breaker points lead from coil (-) terminal).	If good — 4-5 ohms. Low resistance — shorted ignition coil and/or wiring. High resistance — open ignition and/or wiring.	Ohmmeter on R x 1 scale. See See TP-2043-A, "Ignition Coil Check" for additional procedures.
S relay coil (starter solenoid) and wiring	P2-4 and P2-5	If good — 3-5 ohms. Low resistance — shorted S relay coil and/or wiring. High resistance — open S relay coil and/or wiring.	Ohmmeter on R x 1 scale.
Low oil pressure shutdown switch and wiring	P2-8 and engine block (ground).	If good — open circuit. Any resistance — shorted switch and/or grounded wiring.	Ohmmeter on R x 100 scale.
	P2-8 and switch lead	If good — zero ohms. High resistance — open wiring.	Ohmmeter on R x 1 scale. Test with lead disconnected from switch.
Fuel pump or gas valve	Fuel pump — fuel pump "hot" lead and fuel pump body (ground). Gas valve — gas valve "hot" lead and gas valve ground lead.	If good — low resistance High resistance — open.	Ohmmeter on R x 1 scale.

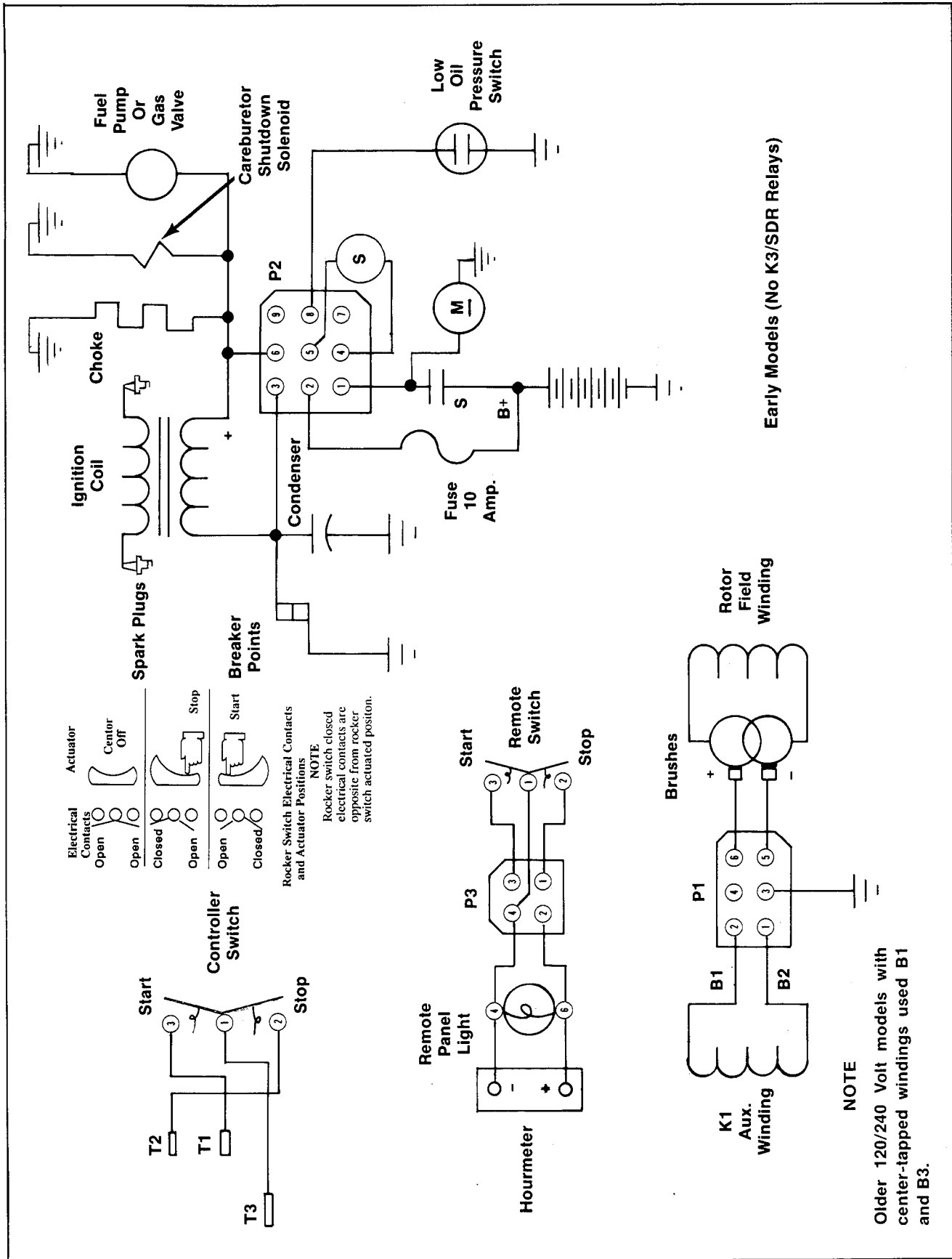

Figure 7-8. Wiring Harness Connections

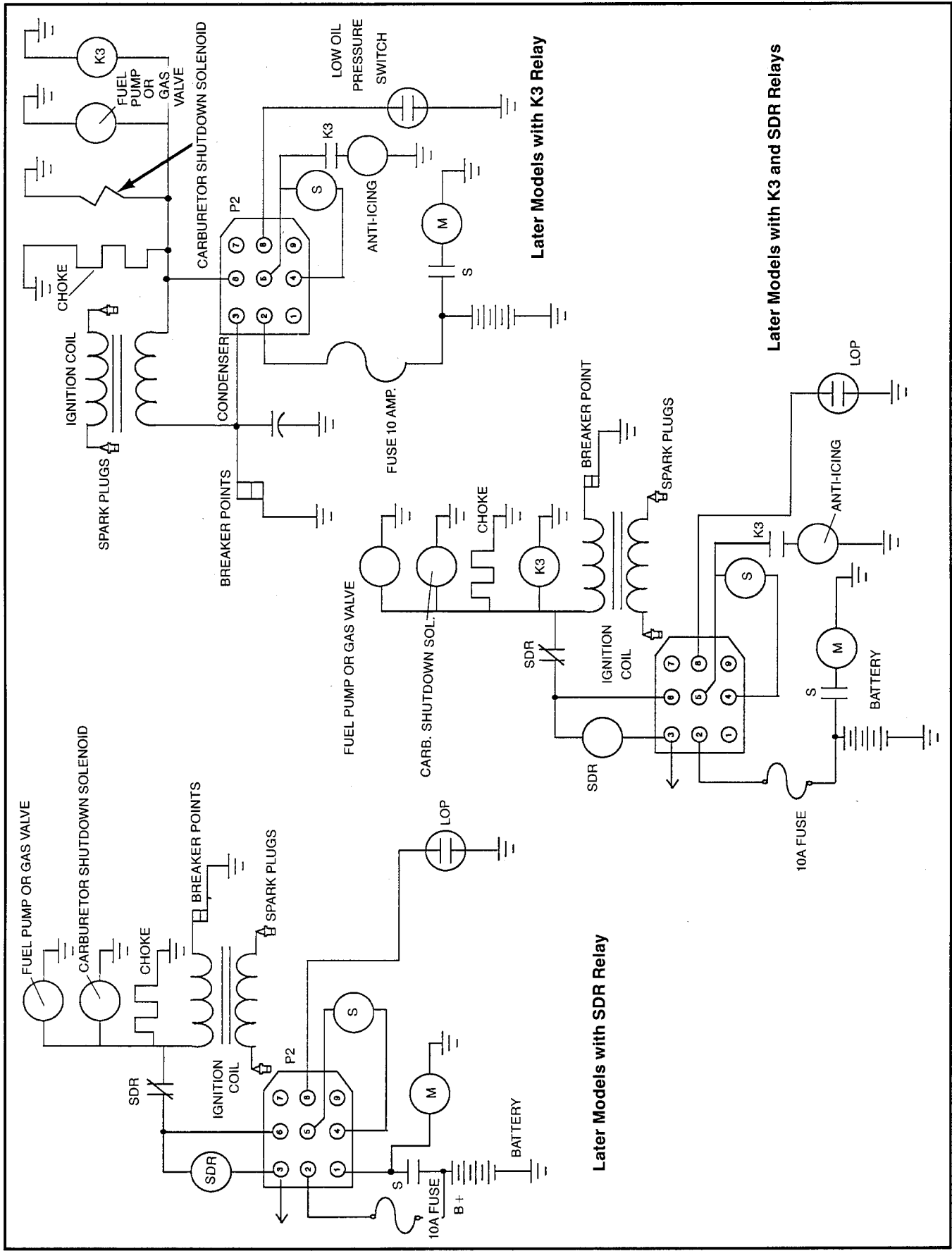

Figure 7-9. Wiring Harness Connections — Cont'd.

SECTION 8. DISASSEMBLY/REASSEMBLY

Prior to disassembly, the generator set must be removed from the coach. Disconnect battery, fuel lines, load leads, exhaust system, and air intake system. Follow all safety precautions before proceeding.

Disassembly

1. Remove air cleaner assembly by removing two screws and internal-external tooth lock washers at end bracket, lock nut and washer at carburetor elbow, and breather hose at air cleaner.
2. Remove four screws to release end bracket panel, see Figure 8-1. With the end bracket panel removed, the voltage regulator is now accessible. To remove controller panel, remove two screws and unplug P1, P2, and P3, see Figure 8-2. Remove circuit breaker leads (Figure 8-3) and remove end bracket panel.

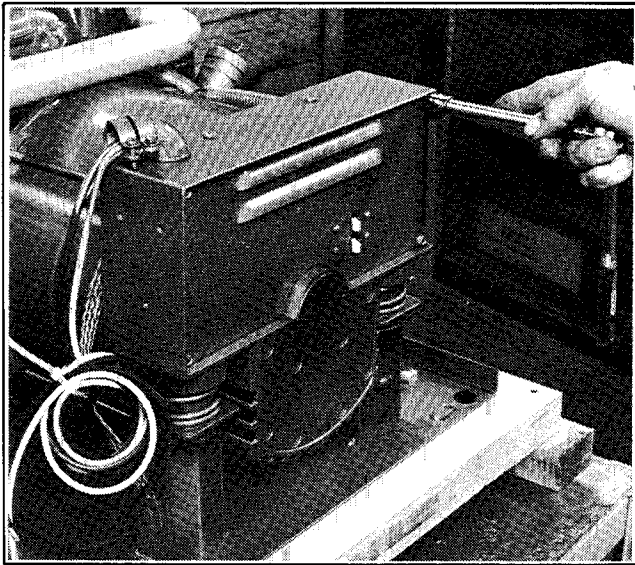

Figure 8-1. Removing End Bracket Panel

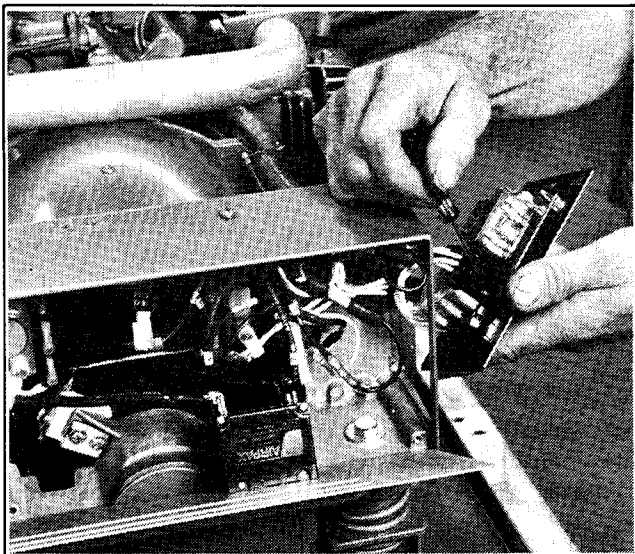

Figure 8-2. Removing Controller Harness Plugs

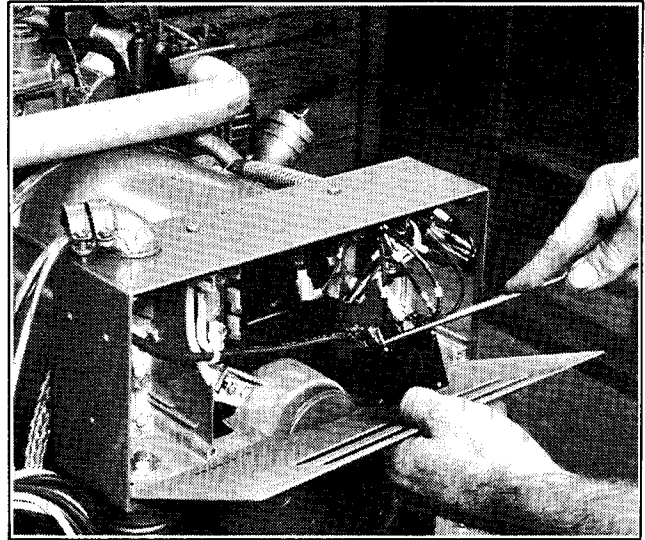

Figure 8-3. Removing Circuit Breaker Leads

3. Lift the brushes by the leads and lock in this position by inserting a retainer wire. See Figure 8-4.

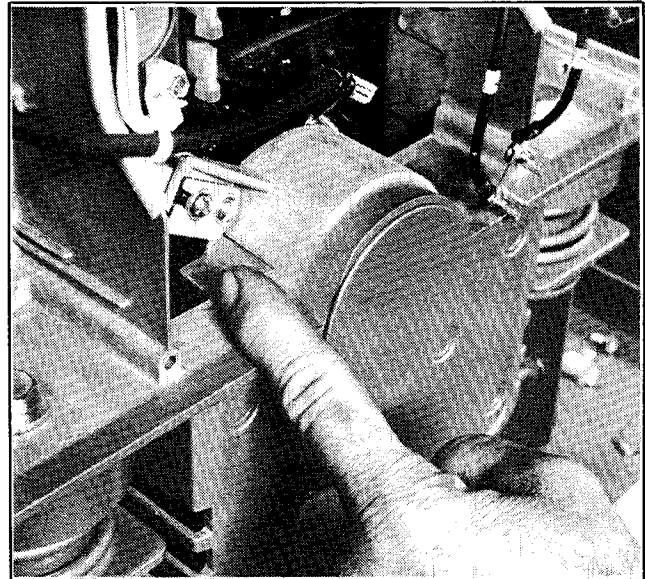

Figure 8-4. Inserting Brush Retainer

4. Cut cable tie(s) securing plastic conduit to over-bolt. Disconnect leads 33, 44, 55, and 66 from voltage regulator. Unscrew cable tie at upper right-hand corner of voltage regulator and cut cable tie to release leads. Disconnect B1/B2 connector (if equipped) or cut leads B1 and B2 at insulinks and add fully insulated push-on terminals to 120 Volt models. If unit is a 120/240 Volt model, disconnect B1/B2 connector (if equipped), or disconnect leads from P1 connector at battery charging rectifier and disconnect stator leads B1 and B2. If unit is a 120/240 Volt model, disconnect battery charging lead from circuit breaker to starter solenoid at in-line connector.

NOTE

Some models with center-tapped windings use B1 and B3.

Remove stator leads and P1-3 lead from end bracket ground (neutral) screw, see Figure 8-5.

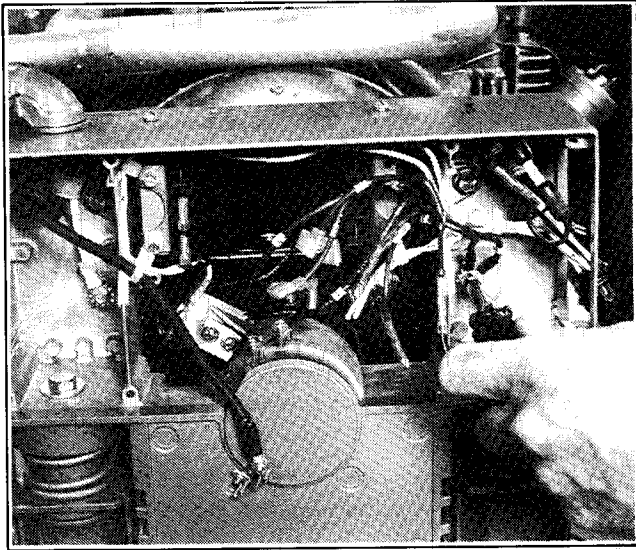

Figure 8-5. Removing Ground (Neutral) Screw

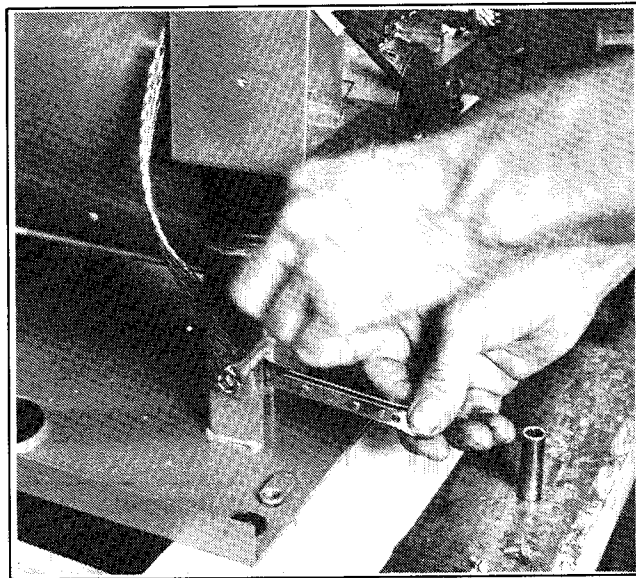

Figure 8-6. Removing Ground Strap

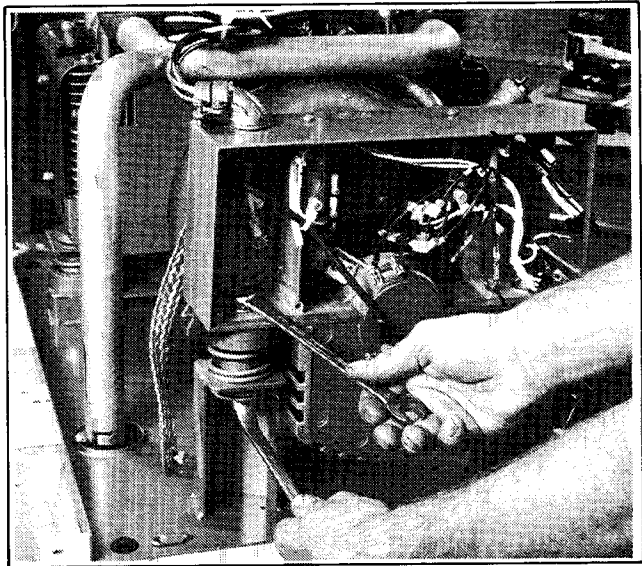

Figure 8-7. Removing Vibro-Mount Hardware

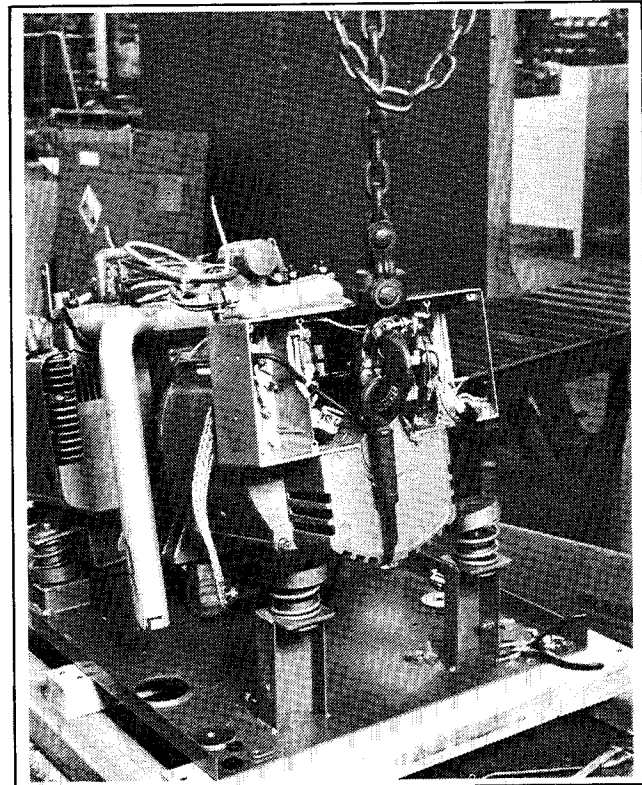

Figure 8-8. Hoisting Generator End

5. Remove ground strap at vibro-mount, see Figure 8-6. Remove vibro - mount nuts, lock washers, flat washers, and bolts from end bracket, see Figure 8-7.
6. Slide engine wiring harness (plastic conduit) from end bracket grommet.
7. Place hoist hook into end bracket air vents and raise generator end, see Figure 8-8. Place a wood block

under generator adapter and lower generator until adapter is supported by block.

8. Disassemble vibro-mount rubber caps and springs to remove four over-bolts from end bracket, see Figure 8-9.
9. Use a plastic hammer to remove end bracket from stator. See Figure 8-10.

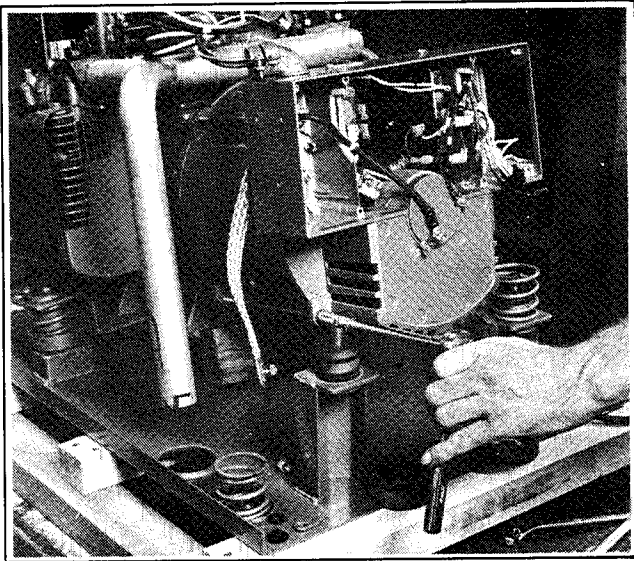

Figure 8-9. Removing Overbolts

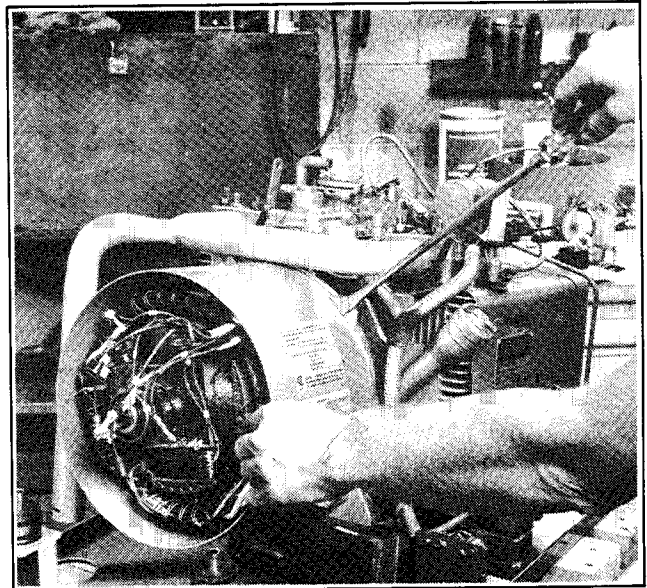

Figure 8-11. Prying Stator from Adapter

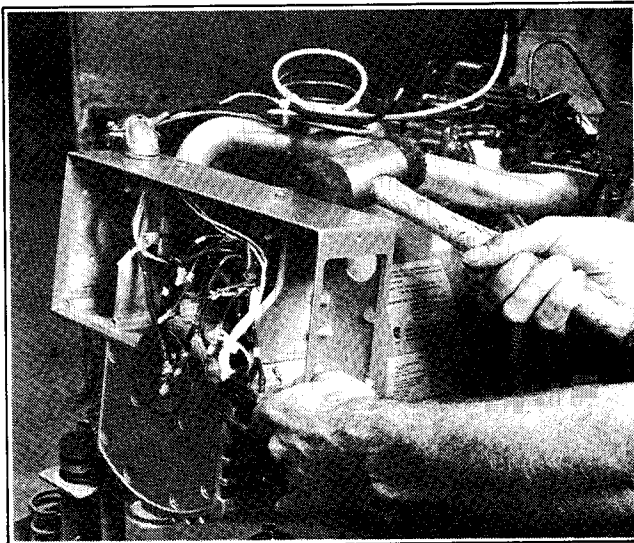

Figure 8-10. Removing End Bracket with Plastic Mallet

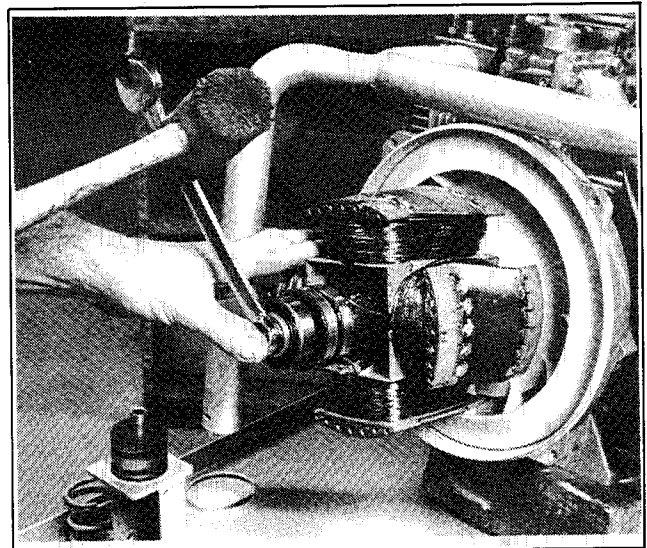

Figure 8-12. Loosening Thru-Bolt

10. Use a pry bar or large screwdriver to loosen stator from generator adapter, see Figure 8-11. Be careful not to damage rotor while removing stator. Note position of stator leads before removing stator.
11. Loosen thru-bolt 2-3 turns leaving a 1/8 inch (3 mm) gap between bolt and rotor (Figure 8-12) and then strike thru-bolt head with a lead hammer using a medium force blow to loosen rotor, see Figure 8-13.
12. Remove thru-bolt and slide rotor from tapered shaft.

CAUTION

Do not attempt to remove rotor by blocking engine cooling fan and turning rotor with any kind of wrench. Damage to fan blades and rotor may result.

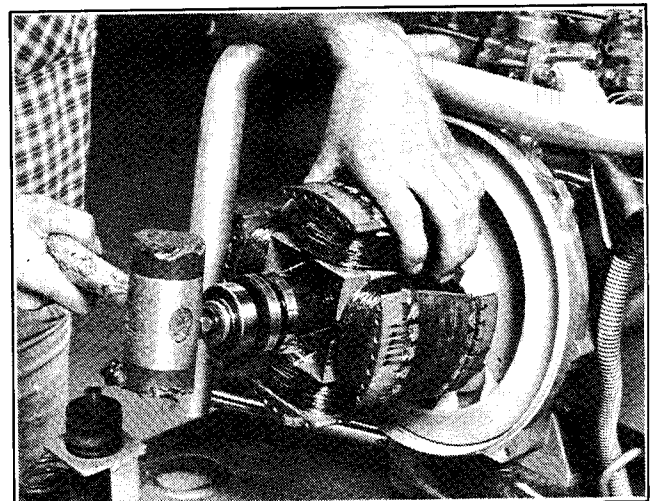

Figure 8-13. Striking Thru-Bolt

Reassembly

1. Coat tapered shaft with anti-seize compound, see Figure 8-14.

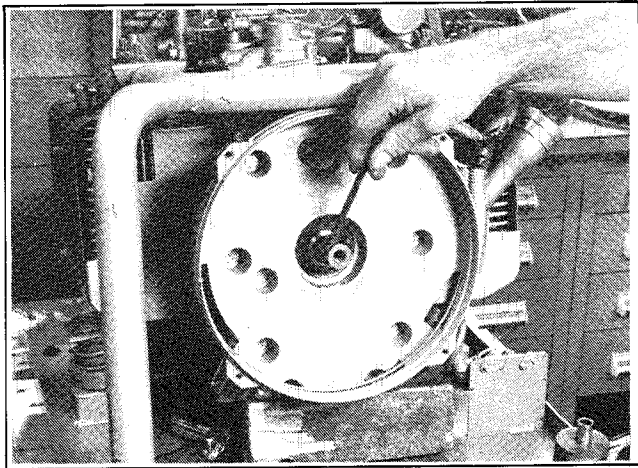

Figure 8-14. Applying Anti-Seize Compound

2. Slide rotor onto tapered shaft and hand-tighten thru-bolt. Attach a strap wrench to rotor and torque thru-bolt to 50 ft. lbs. (68 Nm), see Figure 8-15.

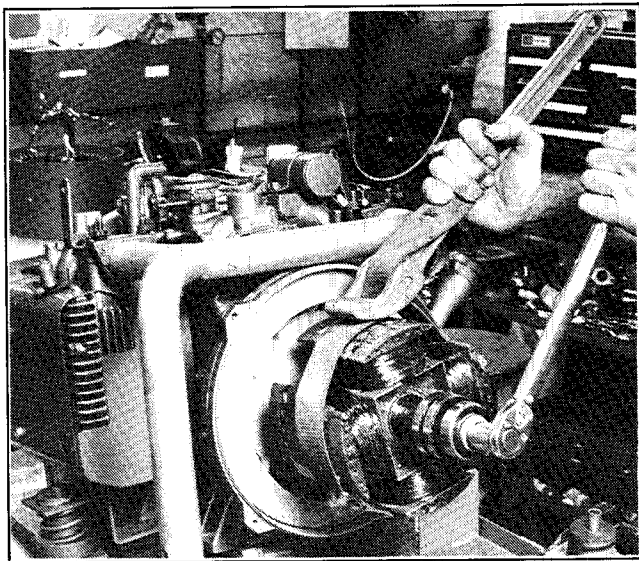

Figure 8-15. Torquing Rotor Thru-Bolt

3. Place stator over rotor and onto adapter lip. Be careful not to damage rotor. Position of stator should be with stator shell seam to the bottom and leads at the 2 o'clock position, see Figure 8-16.

NOTE

If a new stator (without center-tapped B1/B2 winding) is installed on a 120 Volt model, the circuit board B-239396 must be replaced with a C-239396.

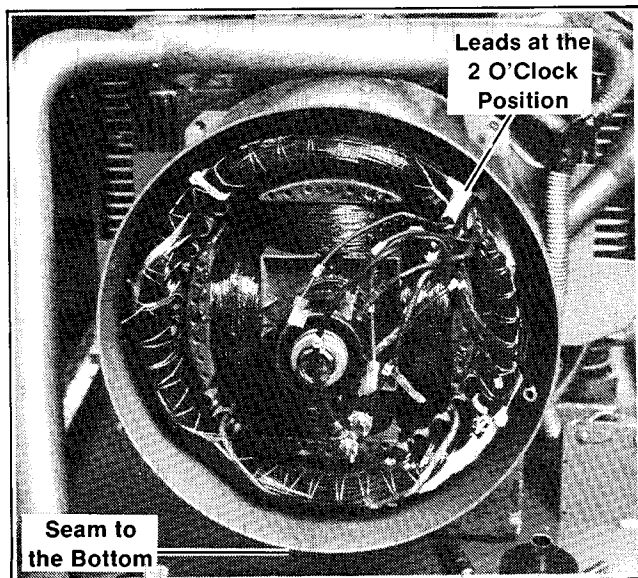

Figure 8-16. Installing Stator

4. Slide stator leads through opening in end bracket and use a plastic hammer to install end bracket to stator. Align end bracket top edge parallel with exhaust manifold. Replace four over-bolts securing end bracket and stator to generator adapter, see Figure 8-17. Torque over-bolts to 260 in. lbs. (7.9 Nm). Replace vibro-mount rubber caps and springs.

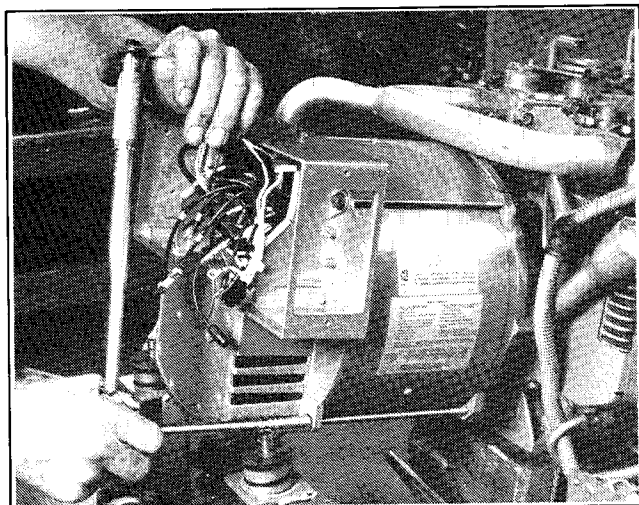

Figure 8-17. Torquing Over-Bolts

5. Place hoist hook into end bracket air vents and raise generator enough to remove wood block. Lower generator onto vibro-mounts and remove hoist.
6. Slide engine wiring harness (plastic conduit) through end bracket grommet.
7. Replace bolts, flat washers, lock washers, and nuts to vibro-mounts and end bracket. Reconnect ground strap to vibro-mount. Place internal-external tooth lock washer between vibro-mount and strap.

8. See "Section 9. Wiring Diagrams" for proper wiring of generator set. Remount stator leads and P1-3 lead using end bracket ground (neutral) screw. If unit is a 120/240 Volt model, reconnect in-line connector of battery charging lead from circuit breaker to starter solenoid. If unit is a 120 Volt model, reconnect B1/B2 connector (if equipped) or add fully insulated push-on terminals to leads and connect B1 to P1-2 and B2 to P1-1. If unit is a 120/240 Volt model, reconnect B1/B2 connector (if equipped); otherwise, connect B1 to P1-2 and B2 to P1-1 at battery charging rectifier.

NOTE

Some models with center-tapped windings used B1 and B3.

NOTE

If circuit board C-239396 is used with an old stator (with center-tapped B1/B2 winding), connect to B1 and B3 on 120 Volt and 120/240 Volt models.

Reconnect leads 33, 44, 55, and 66 to voltage regulator. Secure voltage regulator and P1 leads using a screw-type-mounting cable tie. Connect cable tie to voltage regulator mounting using a self-tapping screw. Use cable tie(s) to secure plastic conduit to overbolt.

CAUTION

All leads must be secured away from rotor to prevent damage when generator set is running.

9. Remove retainer wire from brush holder, see Figure 8-18. Make sure brushes are centered on the slip

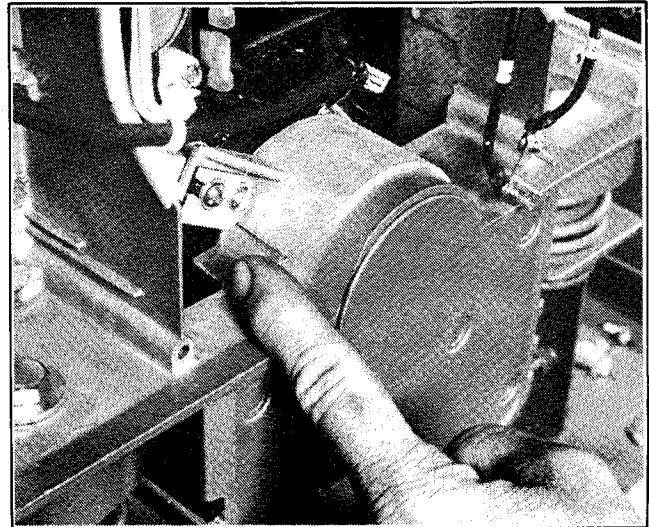
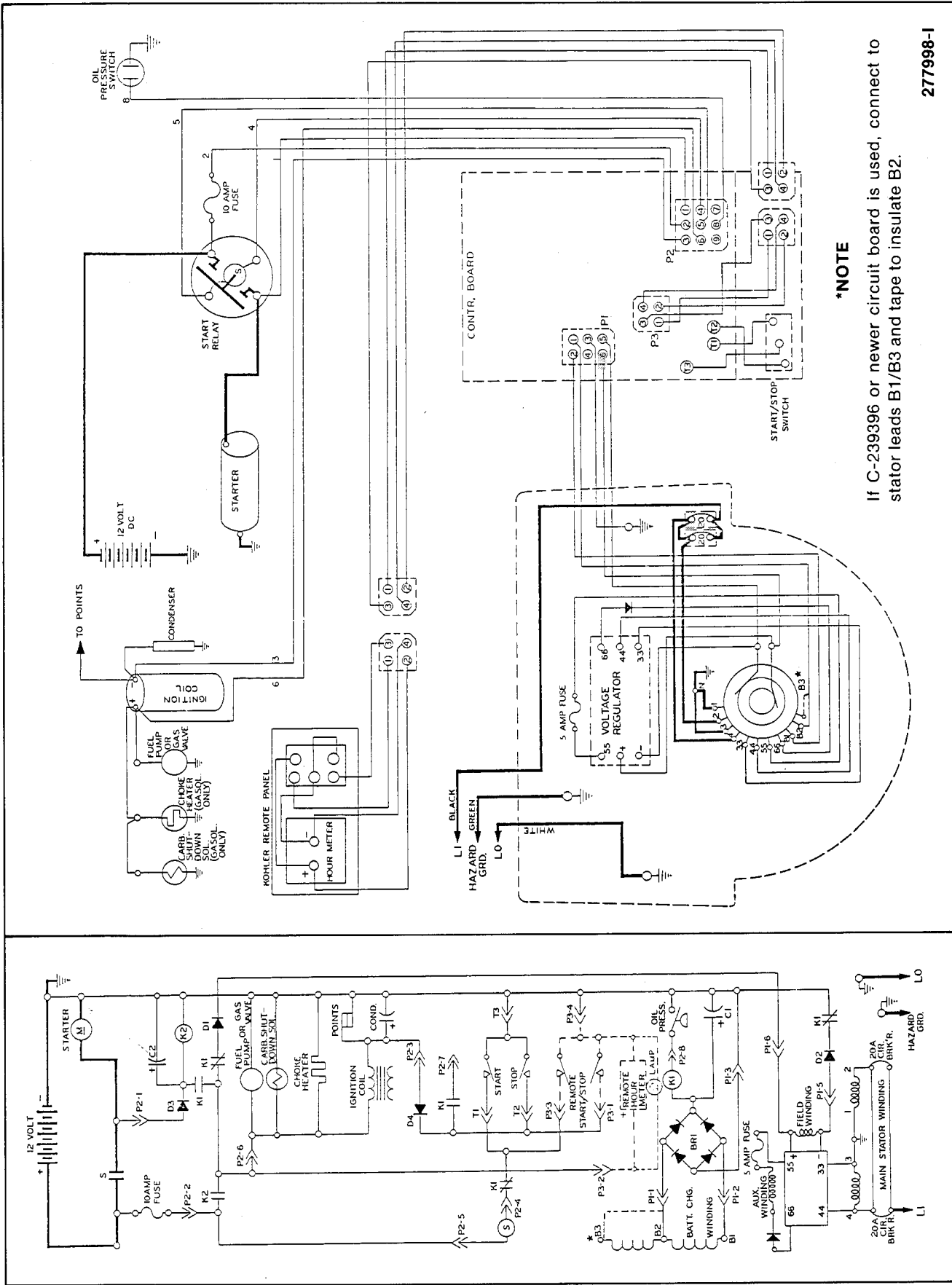

Figure 8-18. Removing Brush Retainer

rings. Improper positioning will cause brushes to wear.

10. Reconnect P1, P2 and P3 to controller circuit board. Mount controller panel to end bracket using two screws.
11. See "Section 9. Wiring Diagrams" for reconnection of circuit breaker leads. Mount panel to end bracket using four screws.
12. Install air cleaner assembly. Attach two screws and internal-external tooth lock washers to end bracket, install washer and lock nut to carburetor elbow stud, and attach breather hose.

SECTION 9. WIRING DIAGRAMS



277998-1

Wiring Diagram, 120 Volt with early B1/B2/B3 Stator (C-239396 Circuit Board)

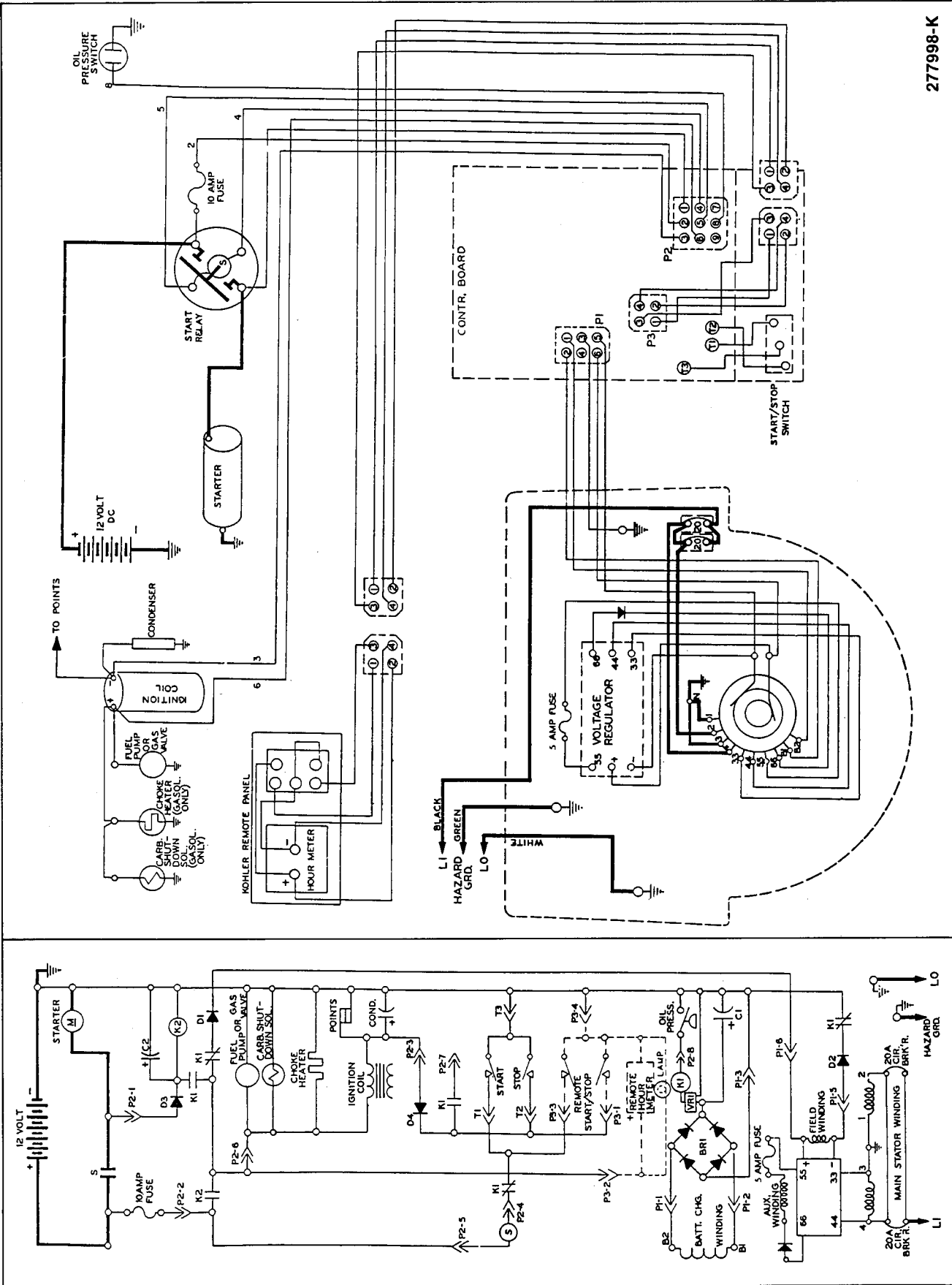

Wiring Diagram, 120 Volt with C-239396 Circuit Board (B1/B2 Stator)

277998-K

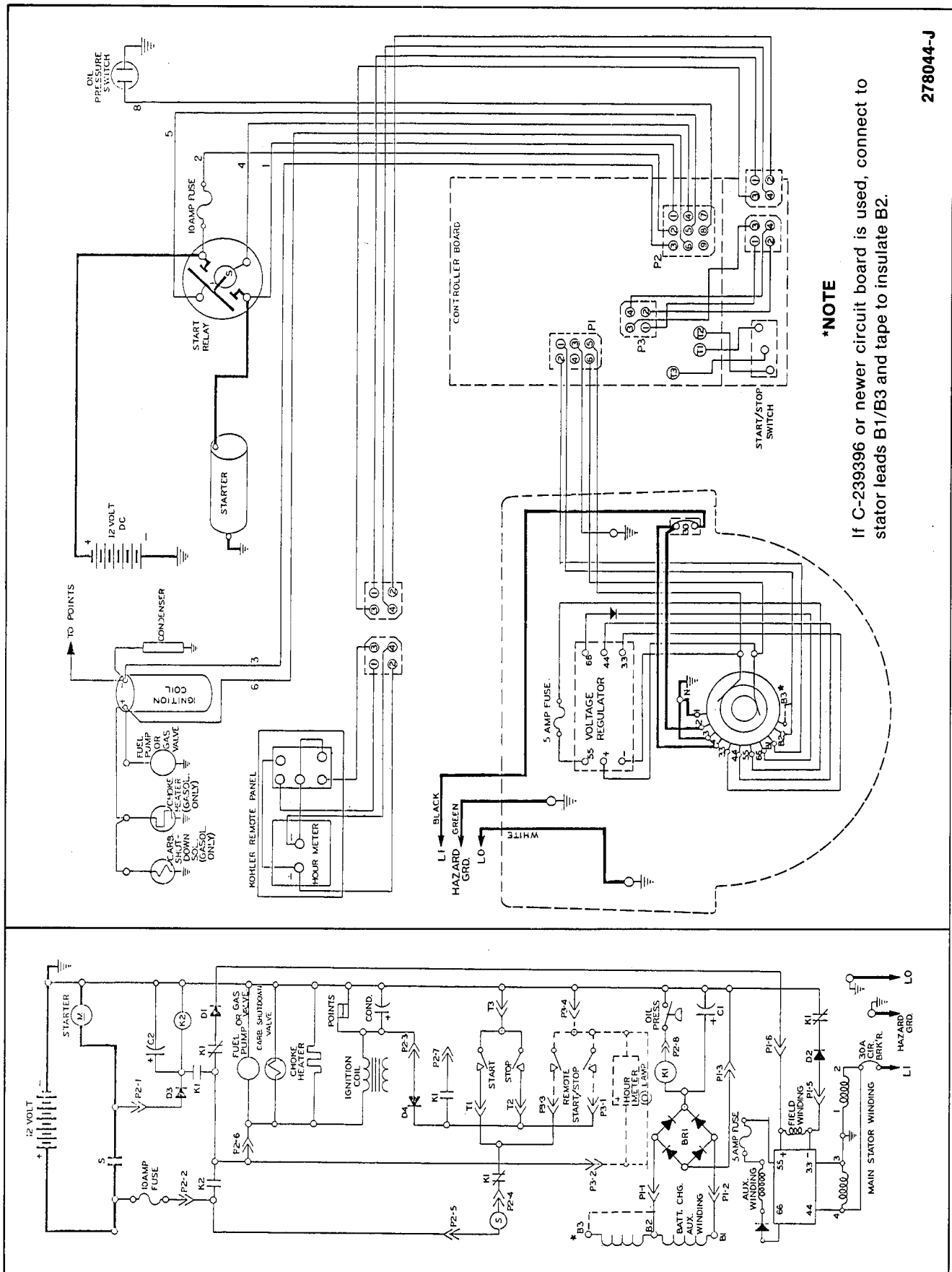

Wiring Diagram, 120 Volt (Winnebago) with early B1/B2/B3 Stator (C-239396 Circuit Board)

278044-J

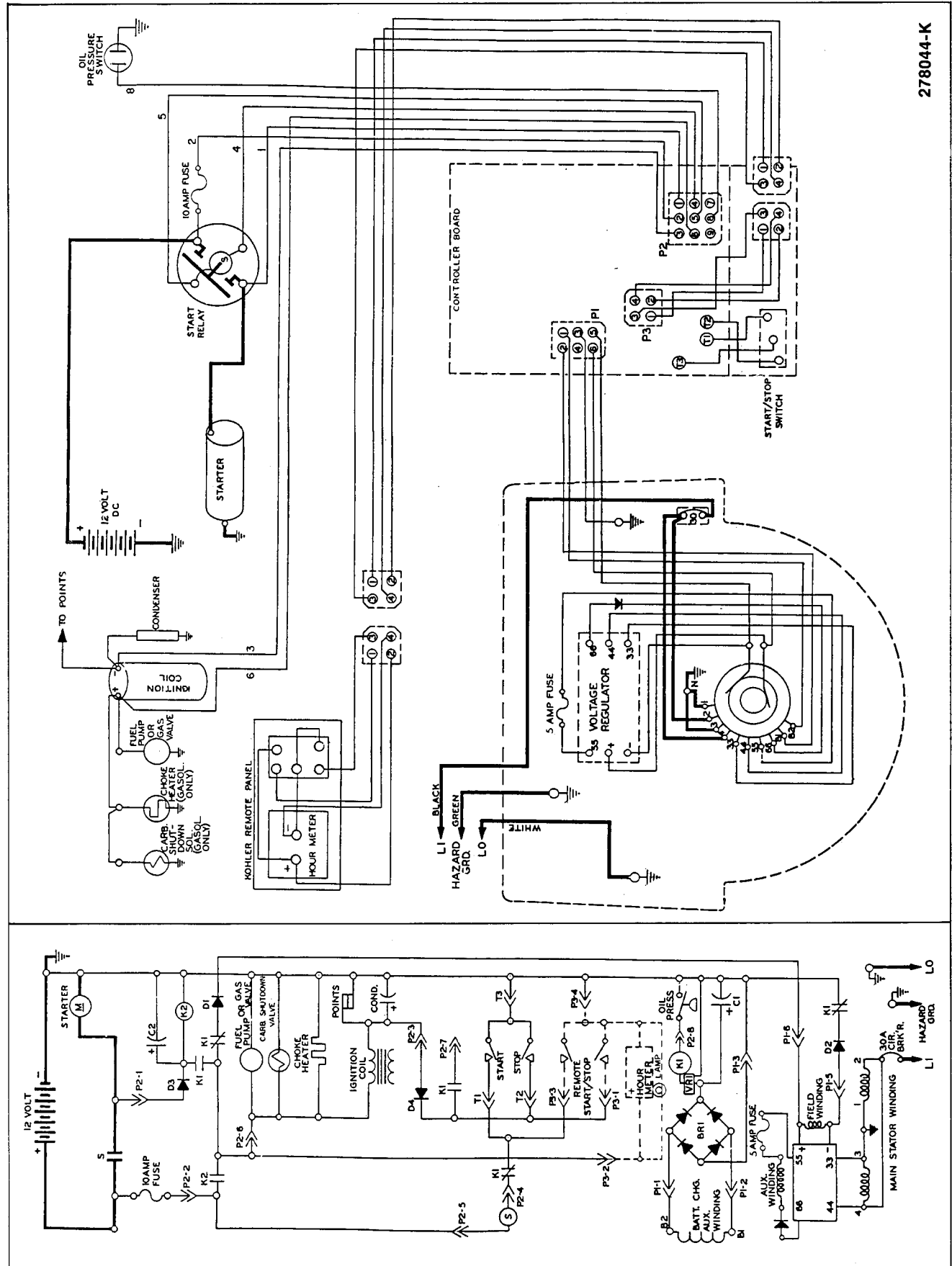

Wiring Diagram, 120 Volt (Winnebago) with C-239396 Circuit Board

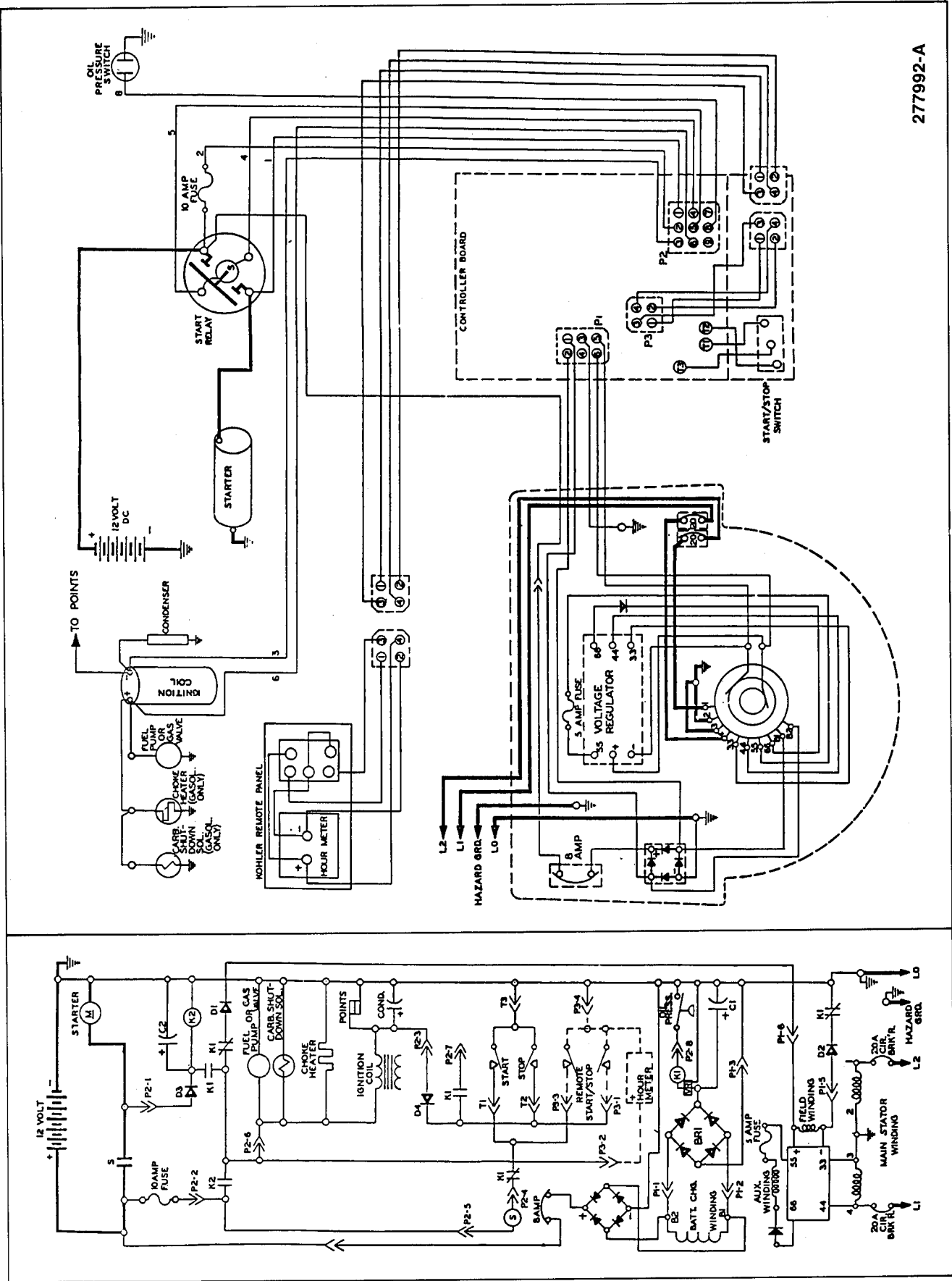

277992-A

Wiring Diagram, 120/240 Volt with C-239396 Circuit Board (B1/B2 Stator)

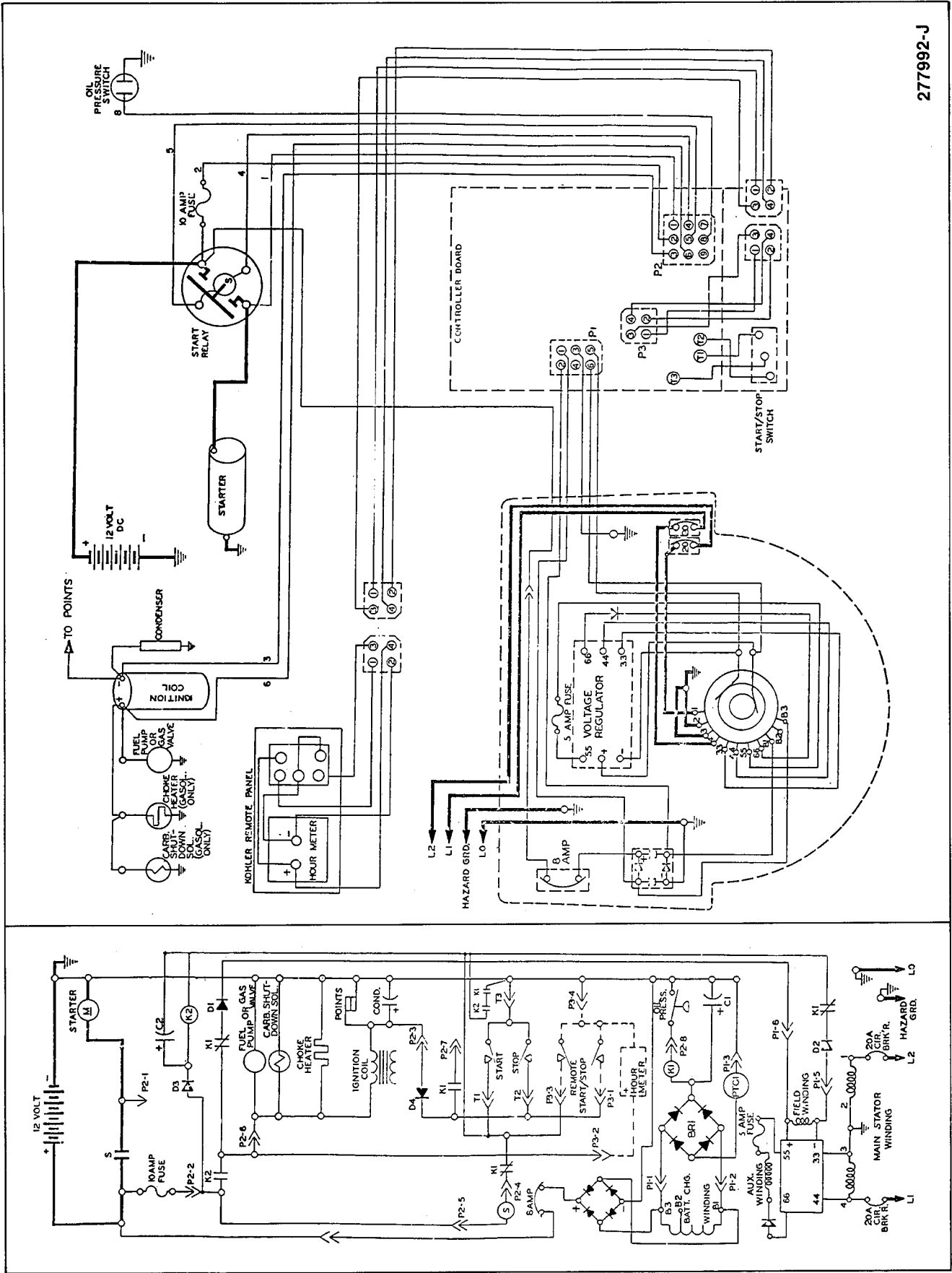

277992-J

Wiring Diagram, 120/240 Volt with B1/B2/B3 Stator (C-239396 Circuit Board)

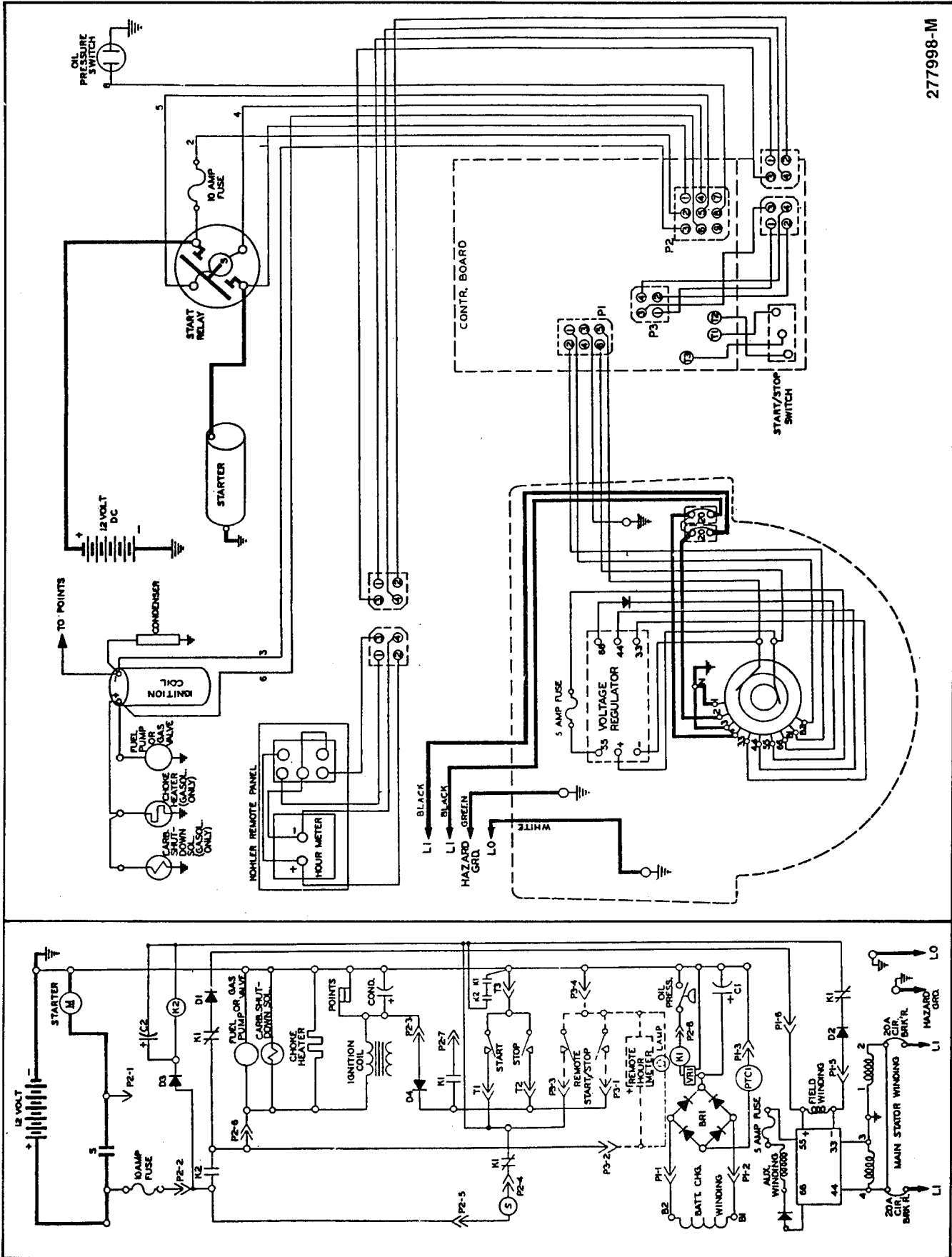

277998-M

Wiring Diagram, 120 Volt with E-239396 Circuit Board

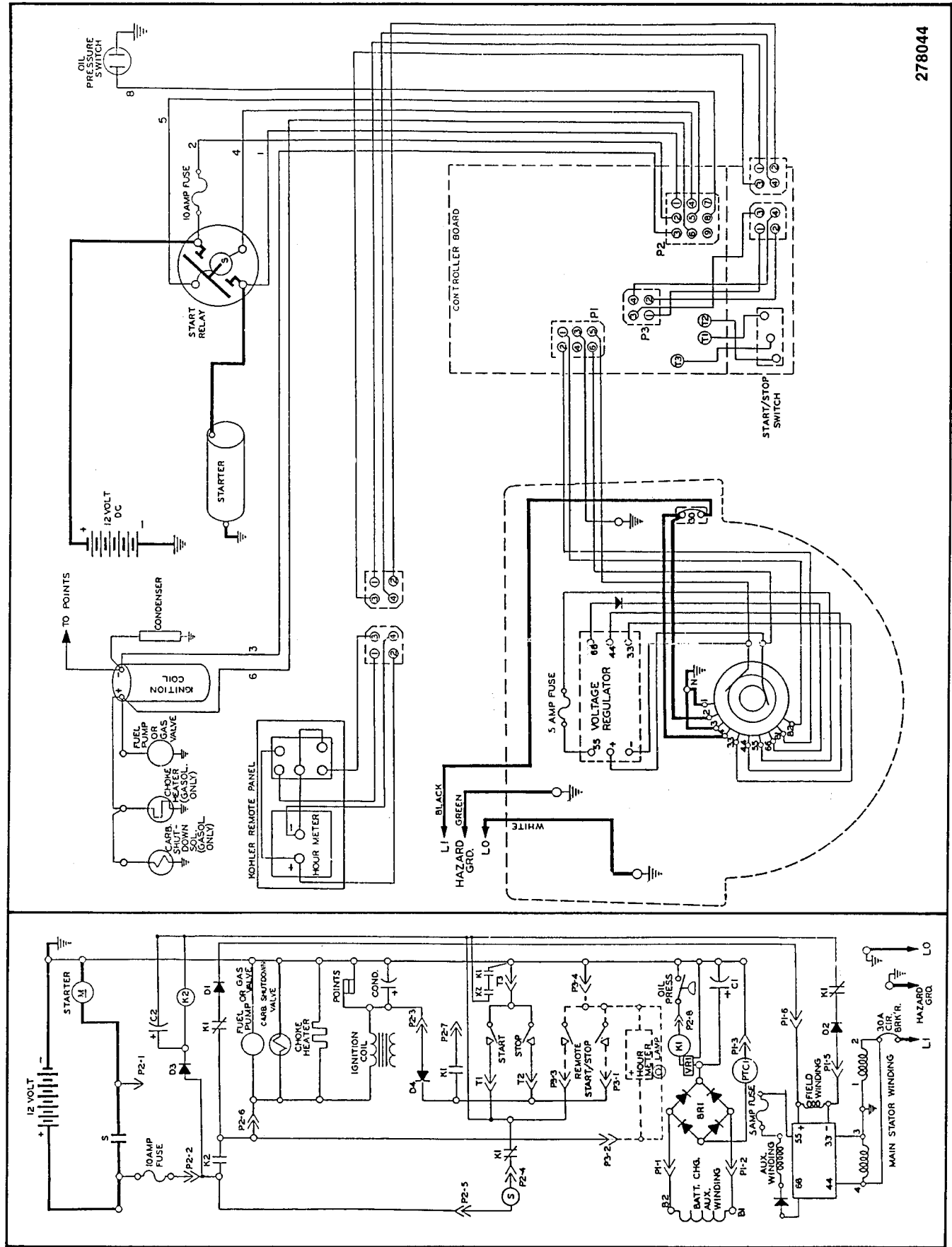

278044

Wiring Diagram, 120 Volt (Winnebago) with E-239396 Circuit Board

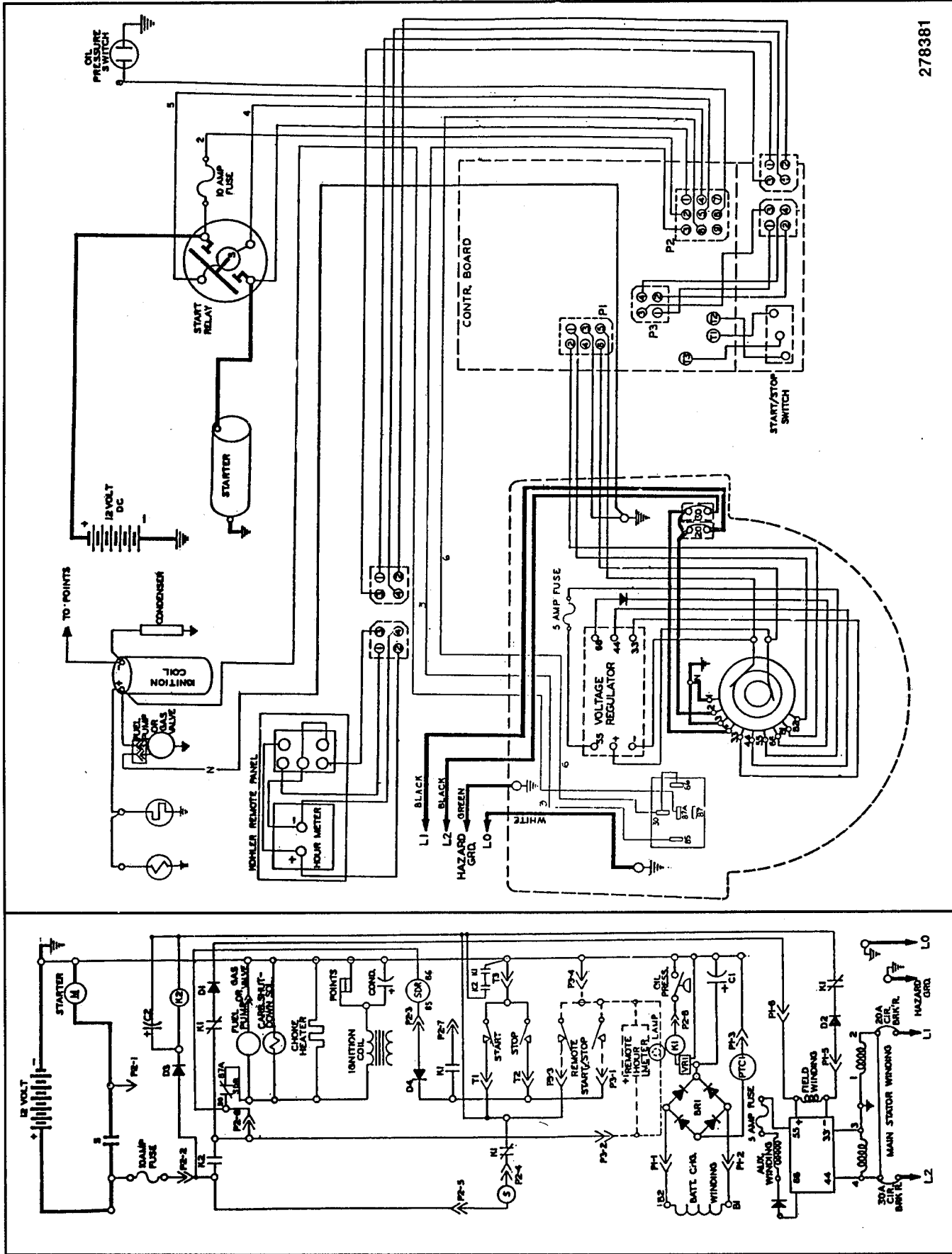

278381

120 Volt with E-239396 Circuit Board (20/30 Amp. Circuit Breakers)

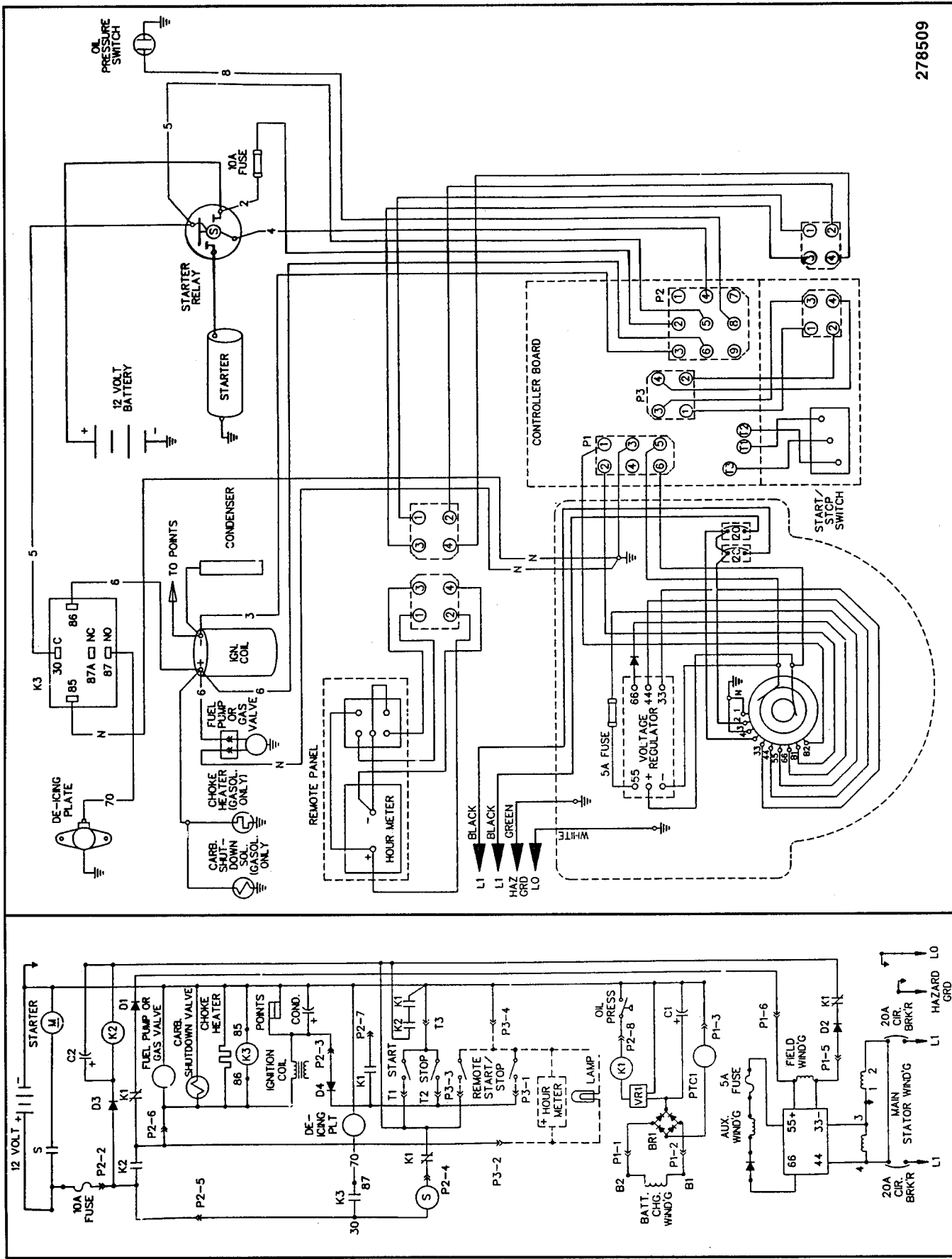

278509

120 Volt with E-239396 Circuit Board and K3 Relay (Anti-Icing)

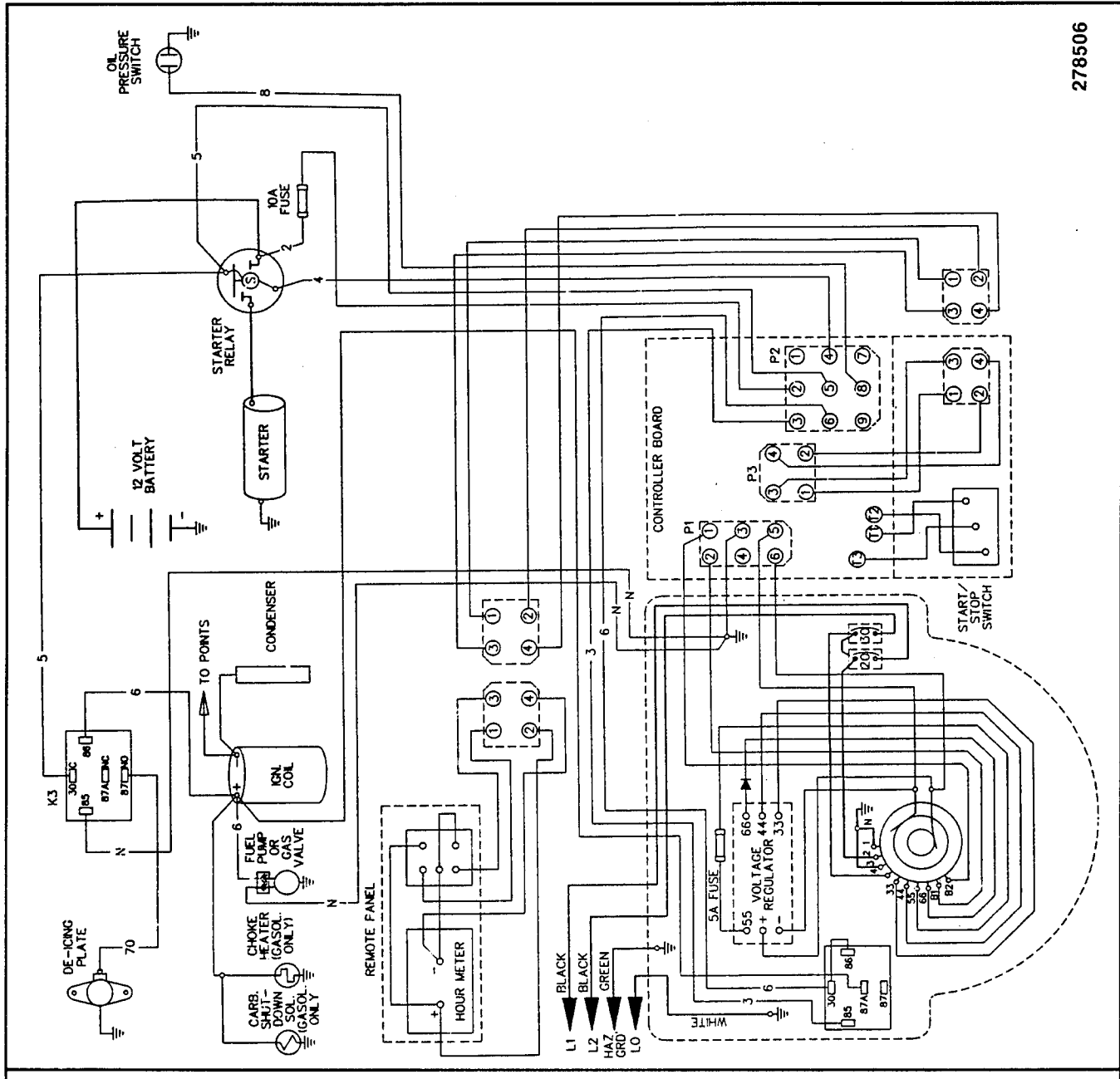
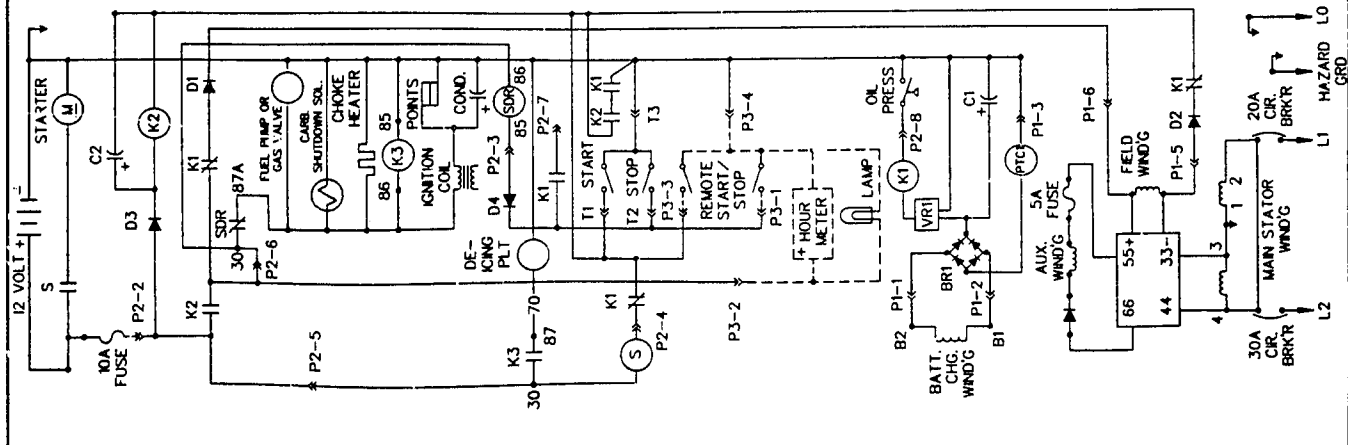

278506

120 Volt (Holiday Rambler) with E-239396 Circuit Board and K3 Relay (Anti-Icing)

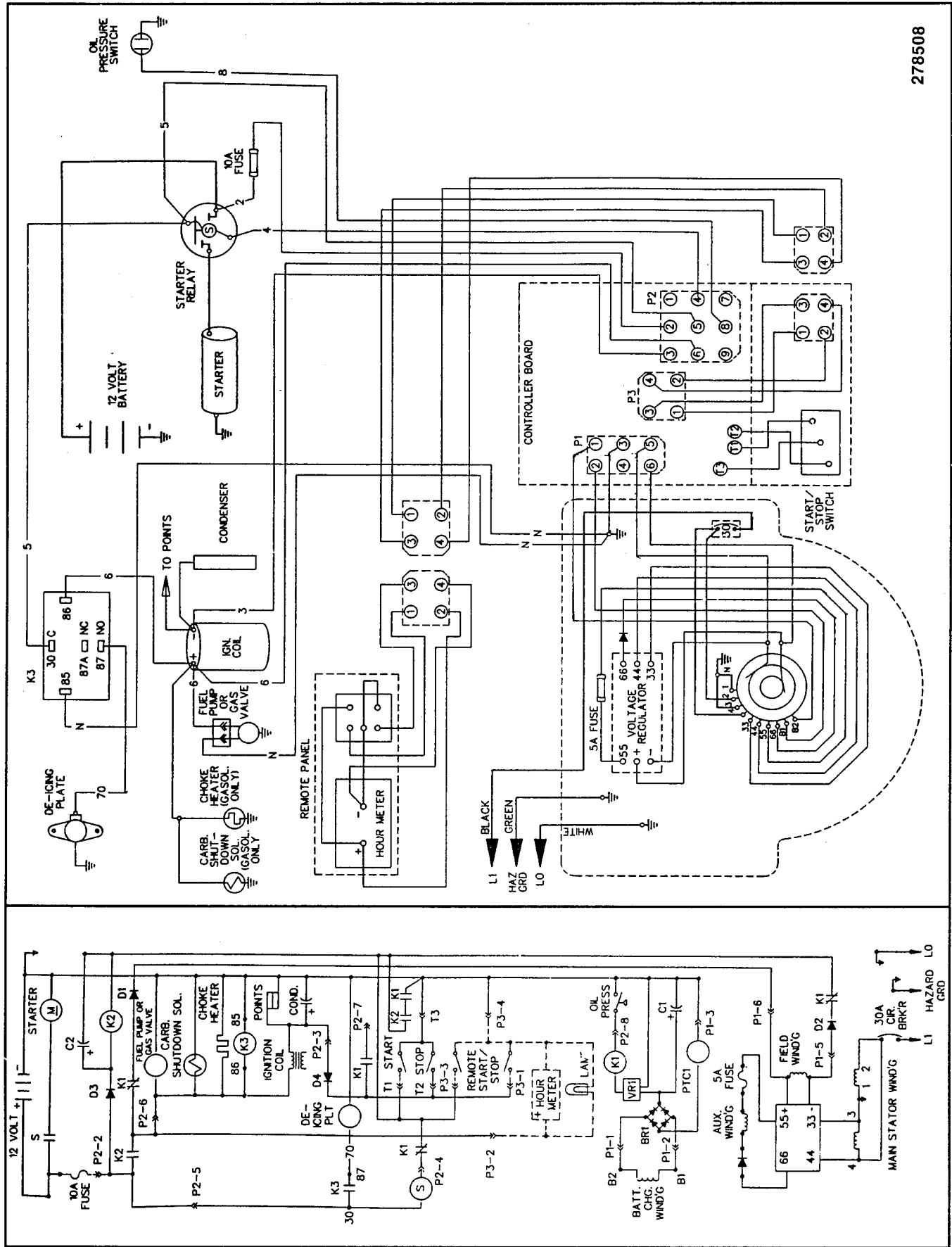

278508

120 Volt (Winnebago) with E-239396 Circuit Board and K3 Relay (Anti-icing)

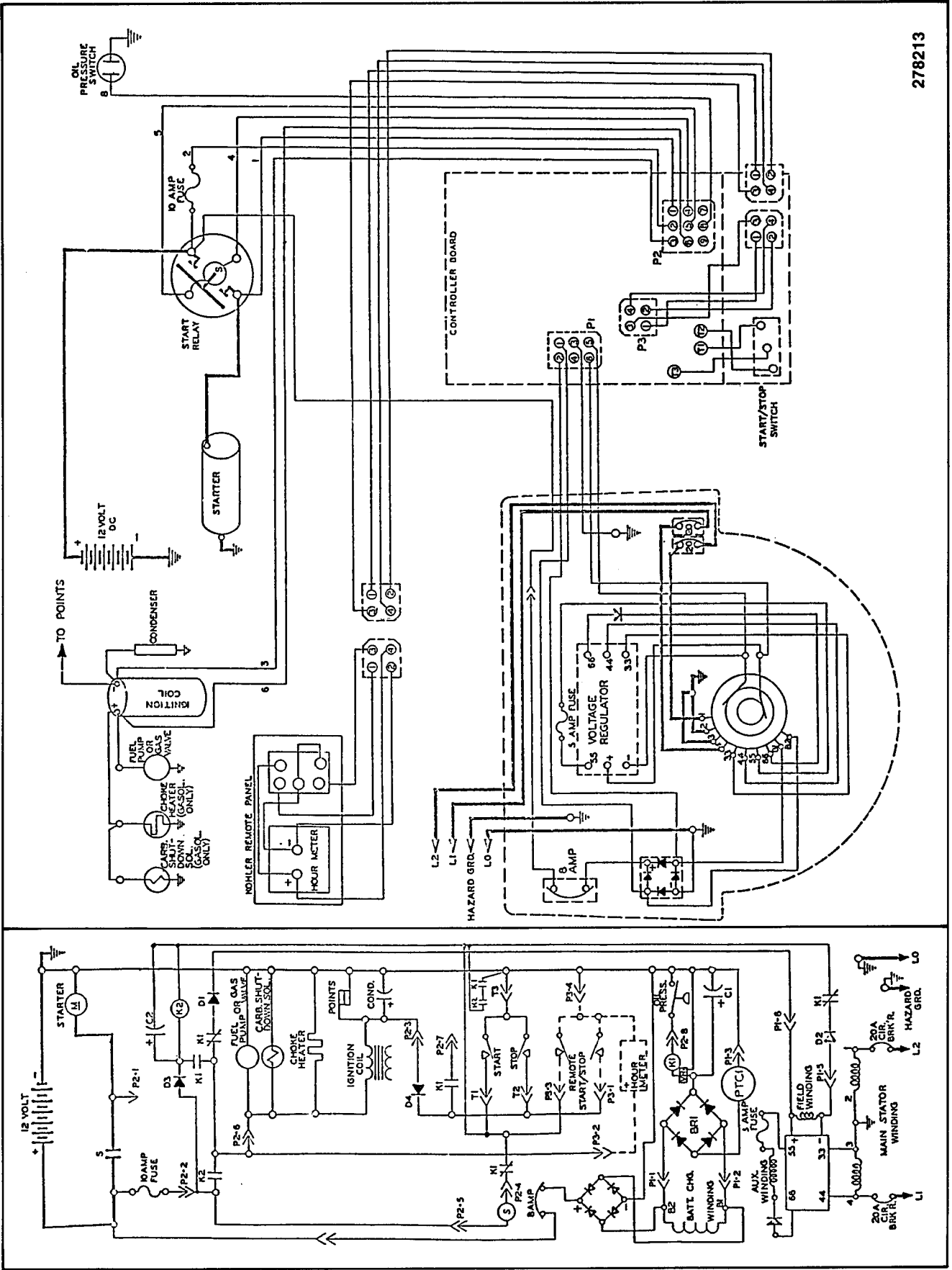

278213

Wiring Diagram, 120/240 Volt with E-239396 Circuit Board (No K3 Relay)

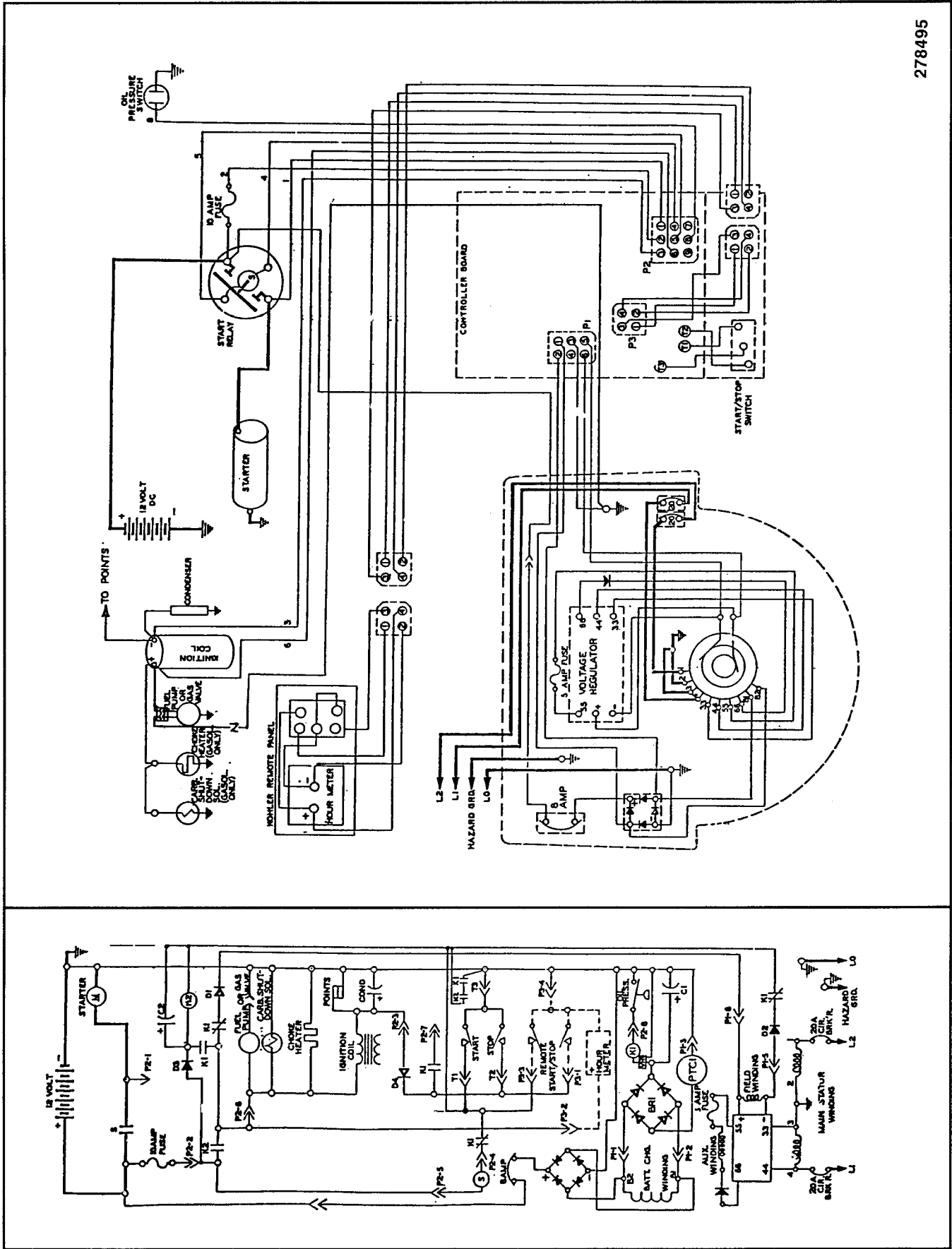

278495

120/240 Volt with E-239396 Circuit Board and Fuel Pump/Valve Connector (No K3 Relay)

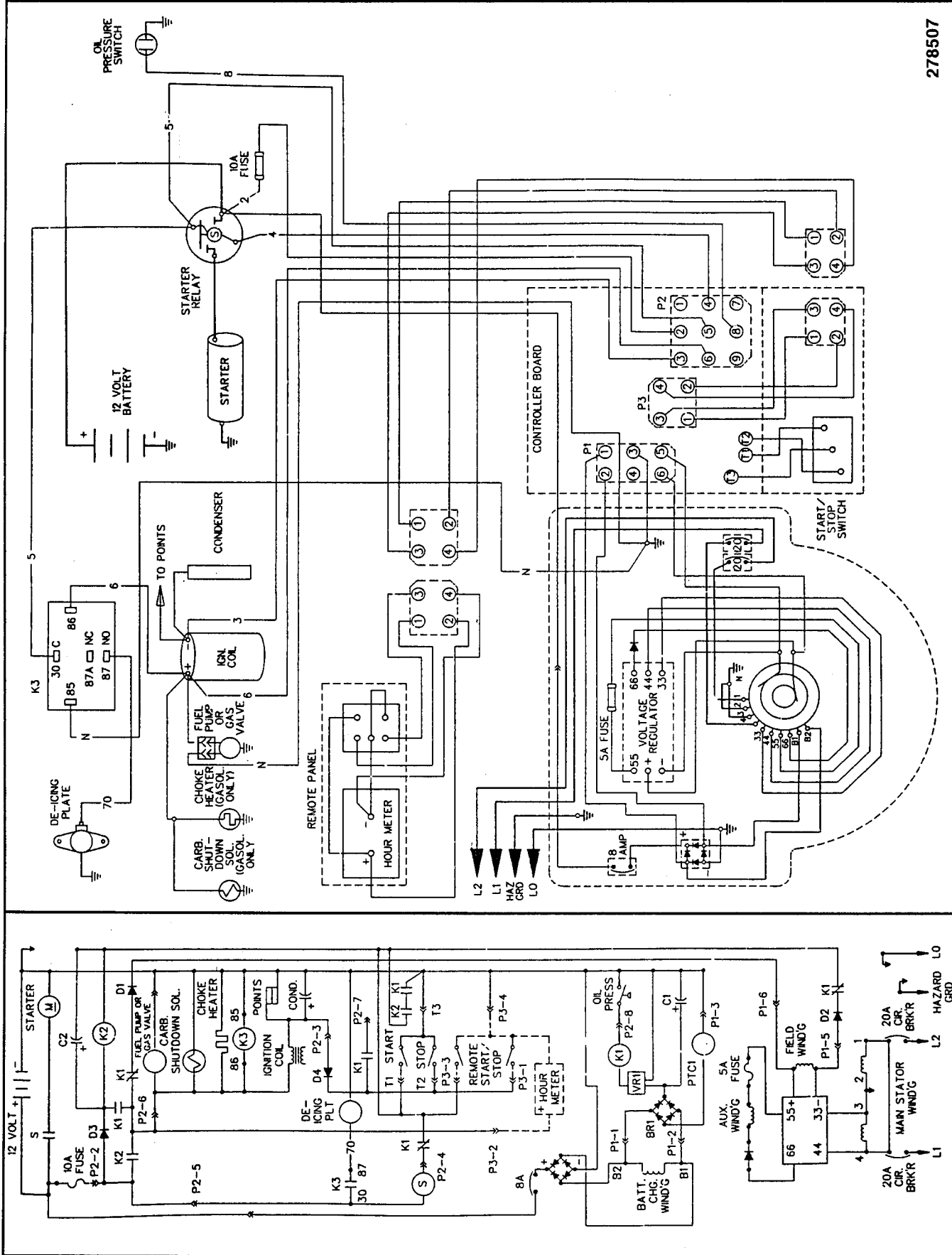

278507

120/240 Volt with E-239396 Circuit Board and K3 Relay (Anti-Icing)

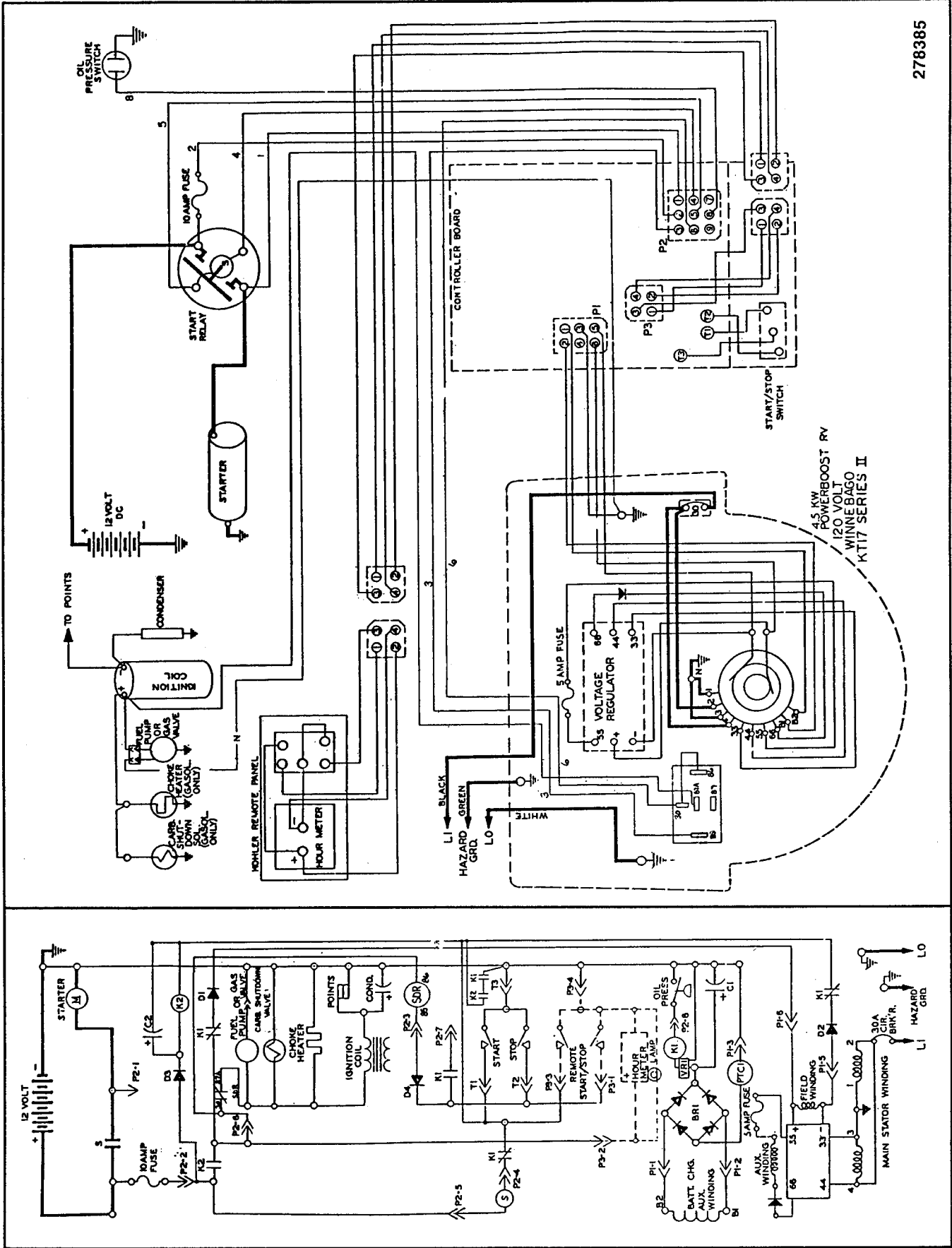

278385

120 Volt (Winnebago) with E-239396 Circuit Board and SDR Relay

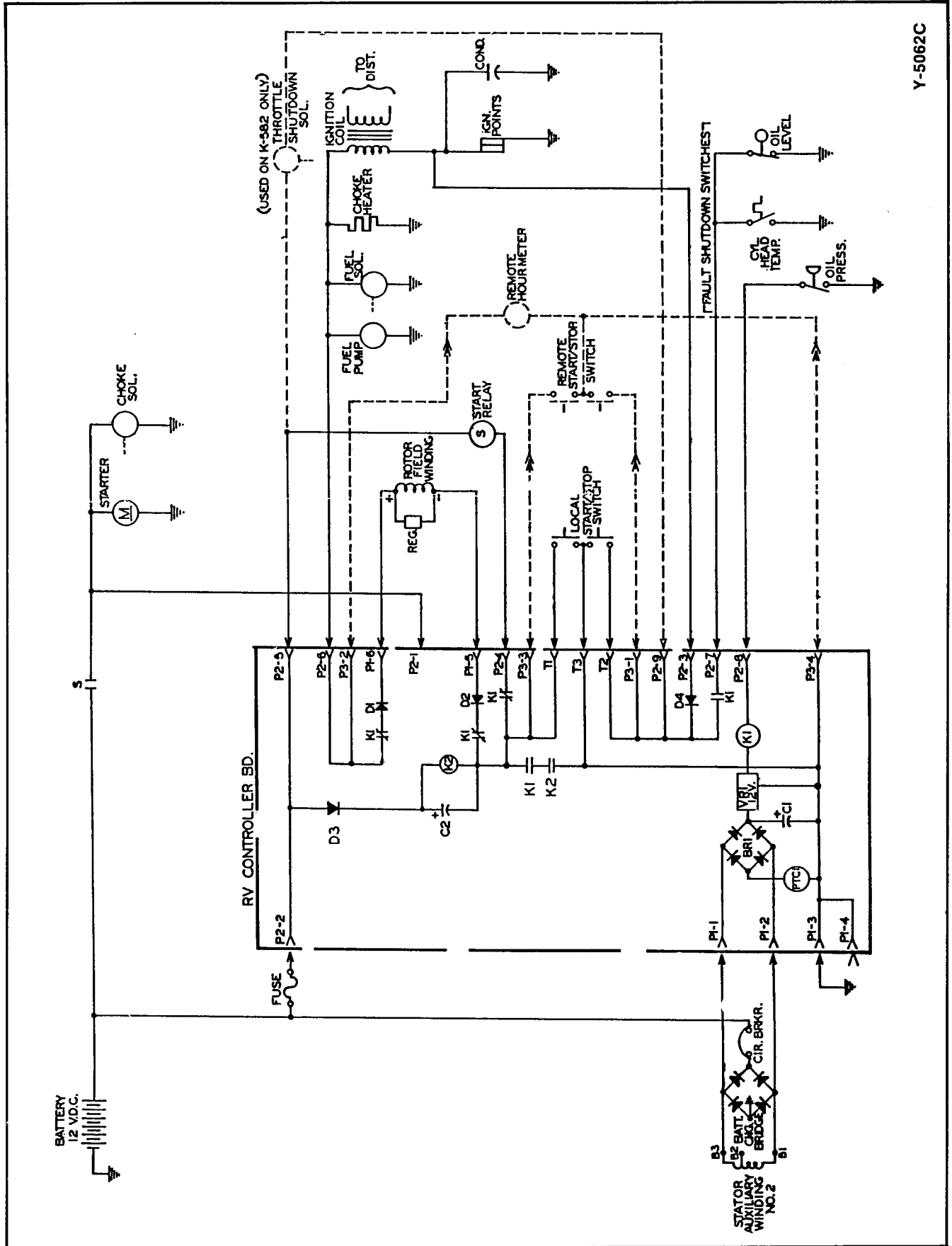

Y-5062C

Controller and Wiring Harness (with E-239396 Circuit Board)

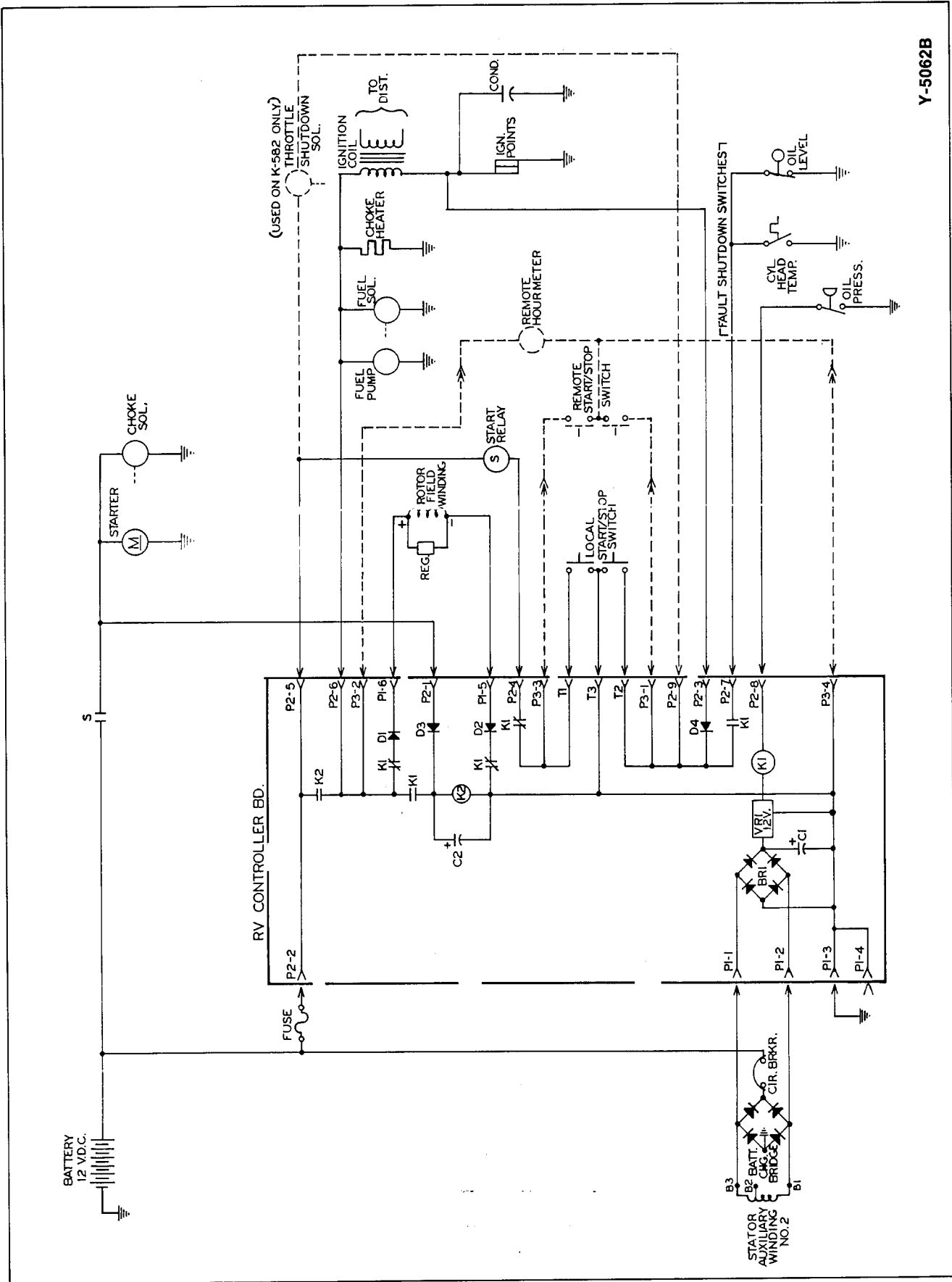

Y-5062B

Controller and Wiring Harness (with C-239396 Circuit Board)

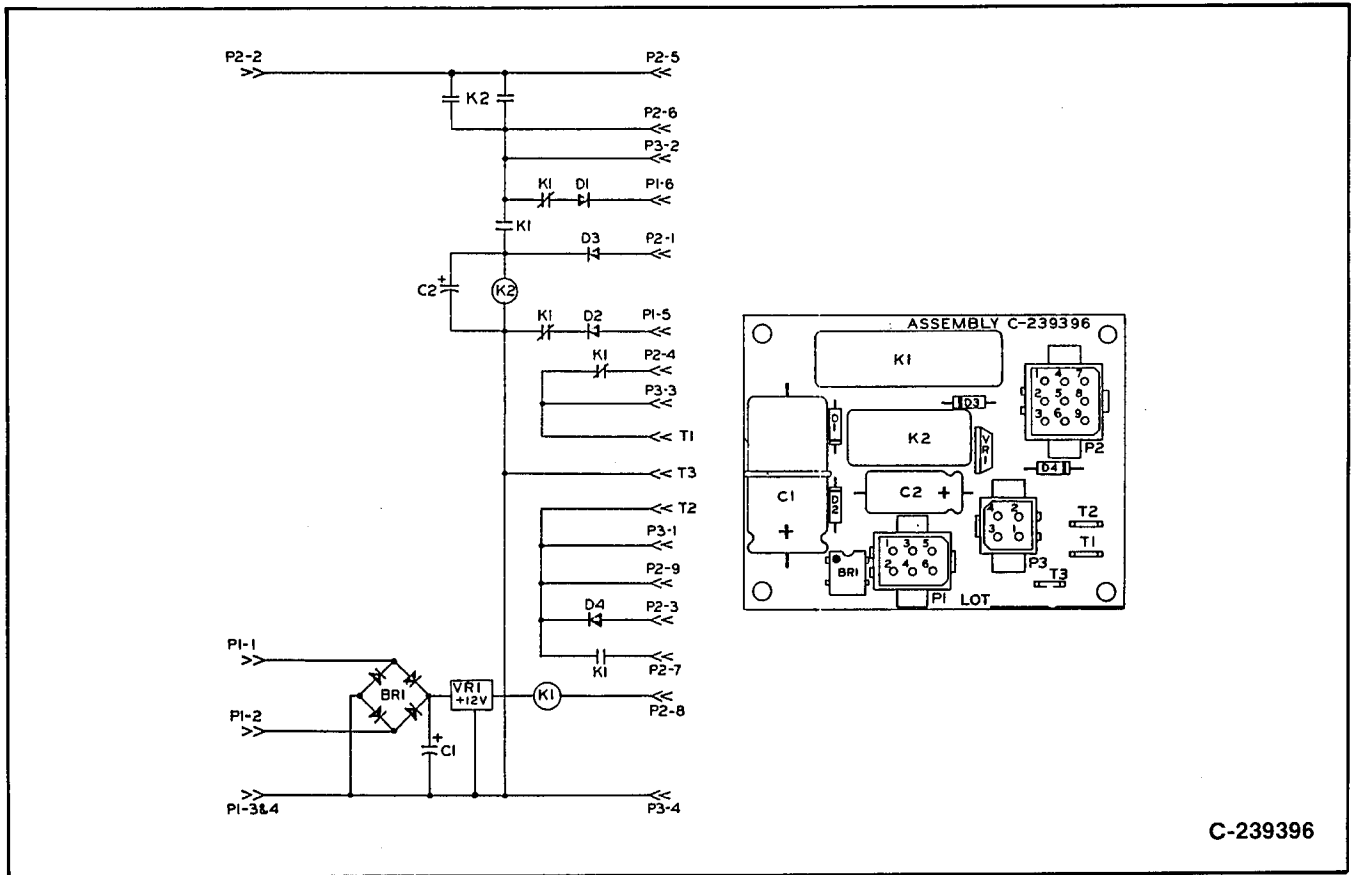

Controller Circuit Board (C-239396)

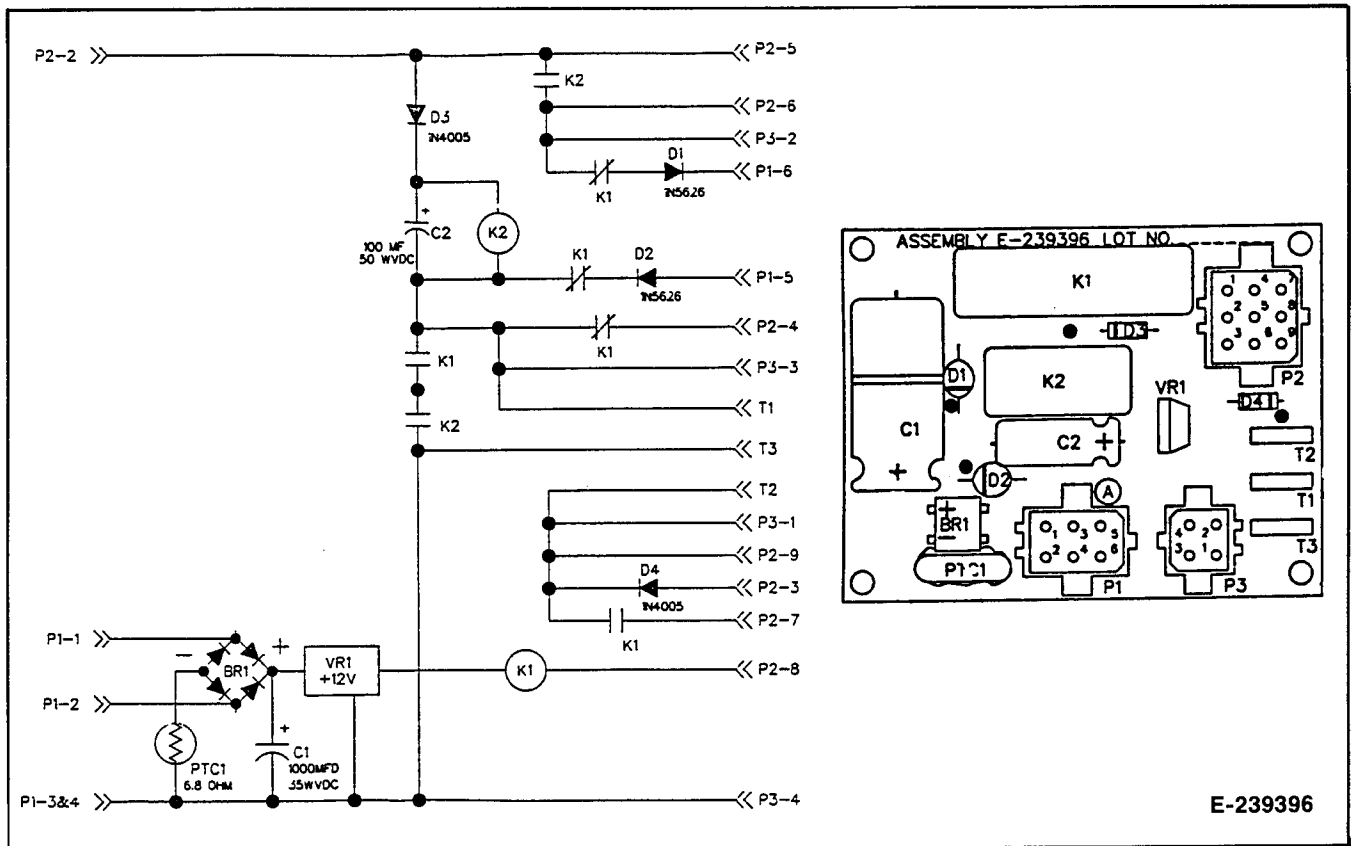

Controller Circuit Board (E-239396)

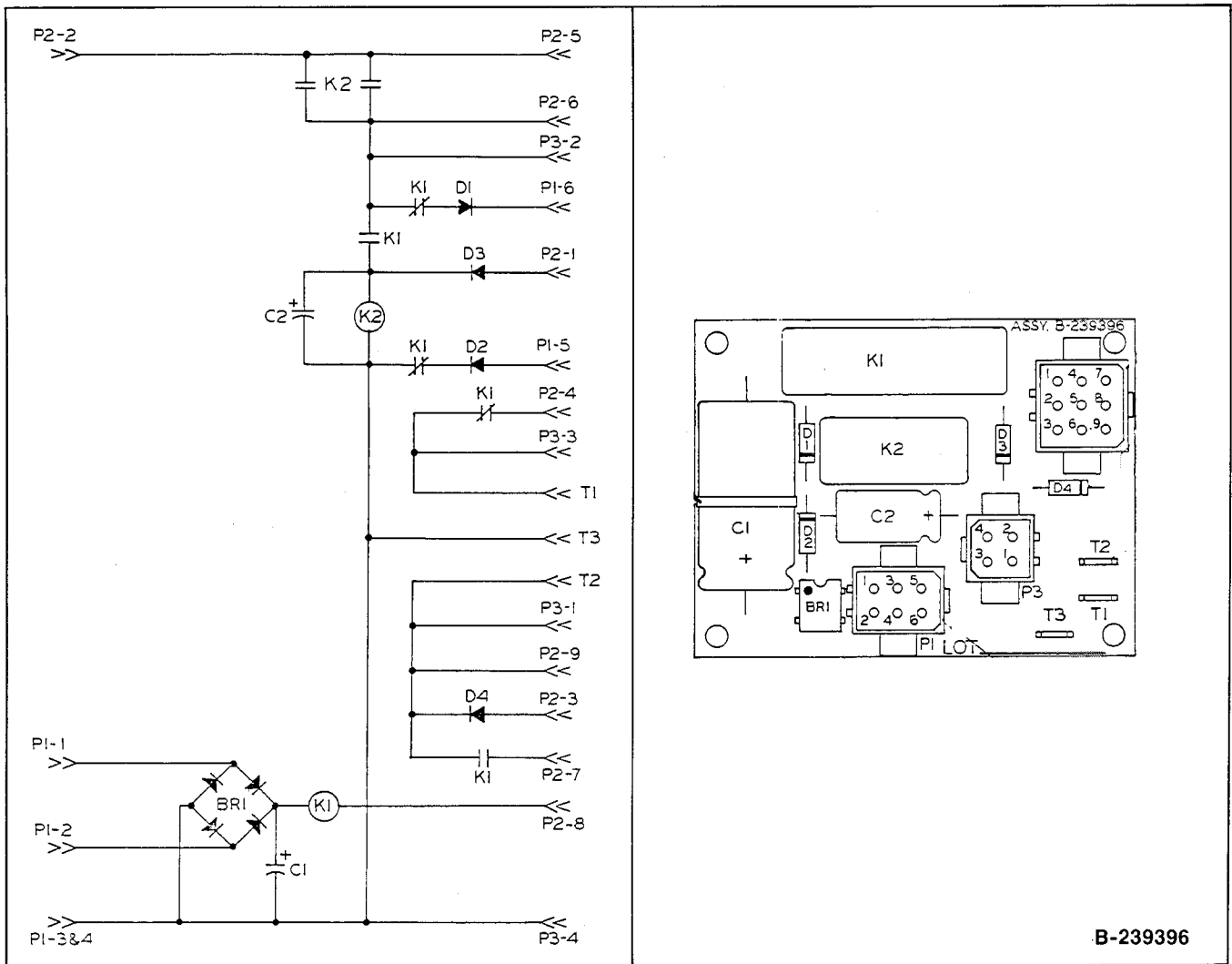

Controller Circuit Board (B-239396)

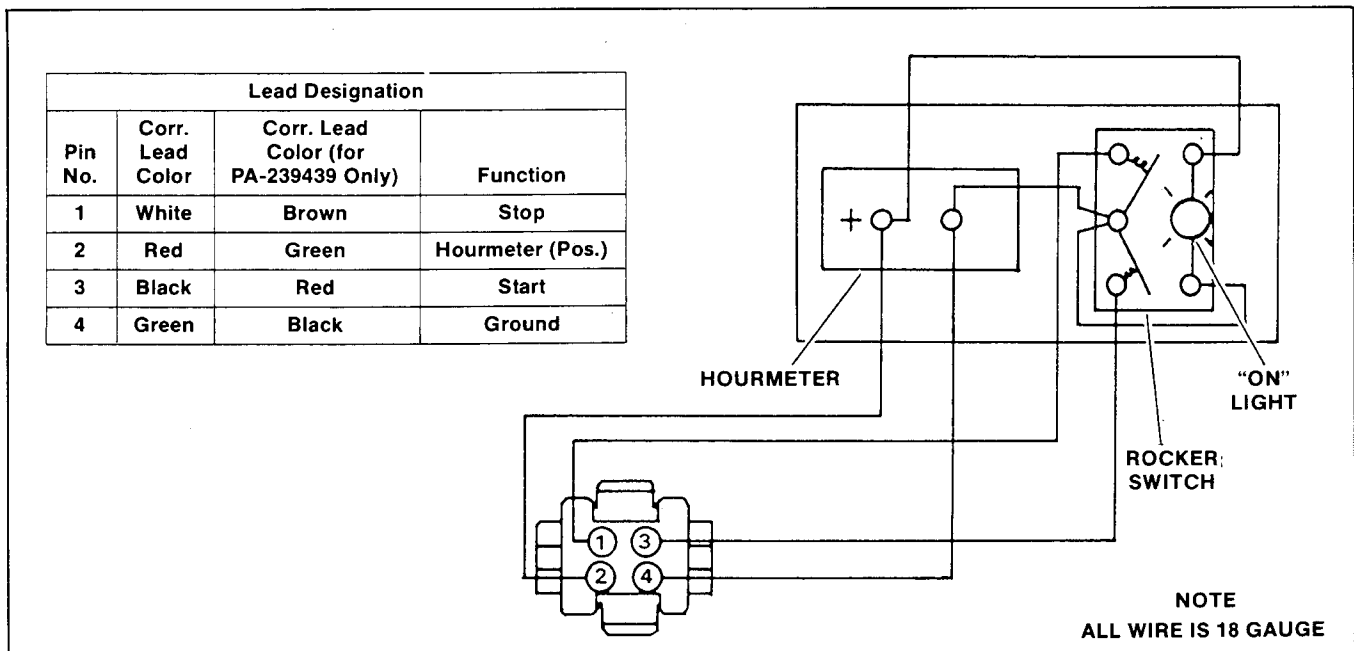

Remote Control Panel Wiring

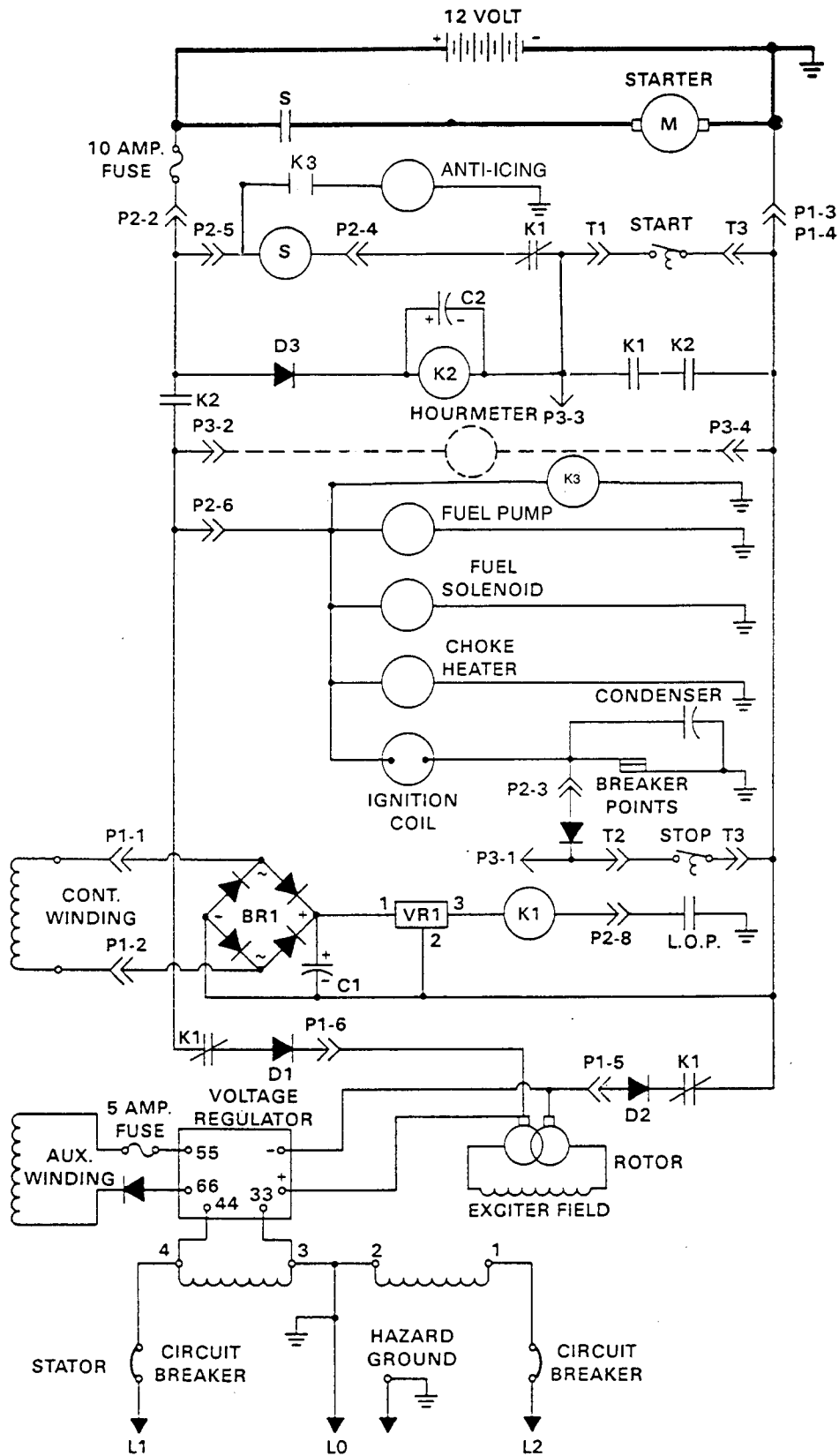

S277992-J

Wiring Diagram—4.5 CKM 120/240 Volt, 1-Phase, 3 Wire (Basic Circuit without SDR Relay)

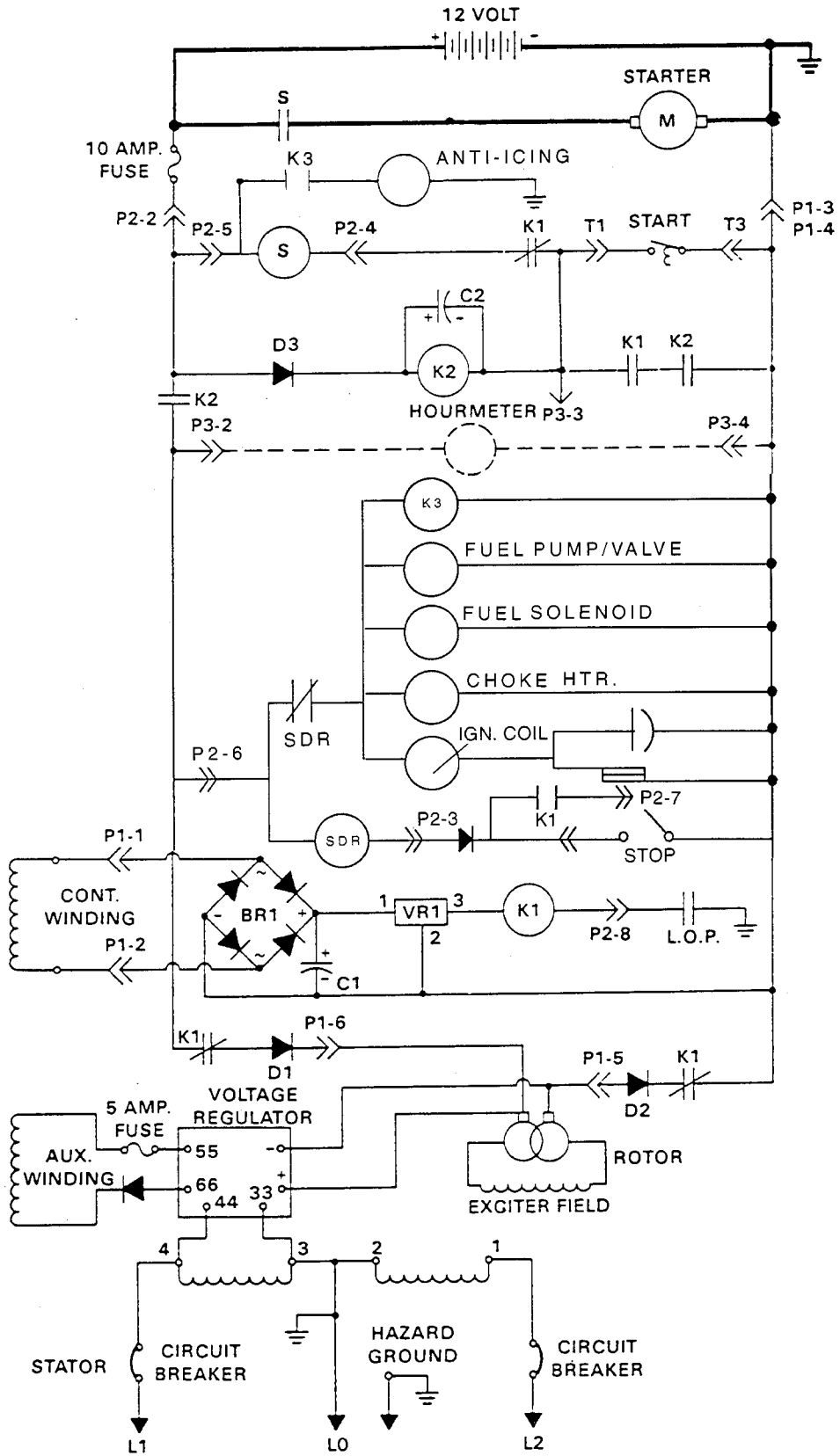

S277992-J

Wiring Diagram—4.5 CKM 120/240 Volt, 1-Phase, 3 Wire (Basic Circuit with SDR Relay)

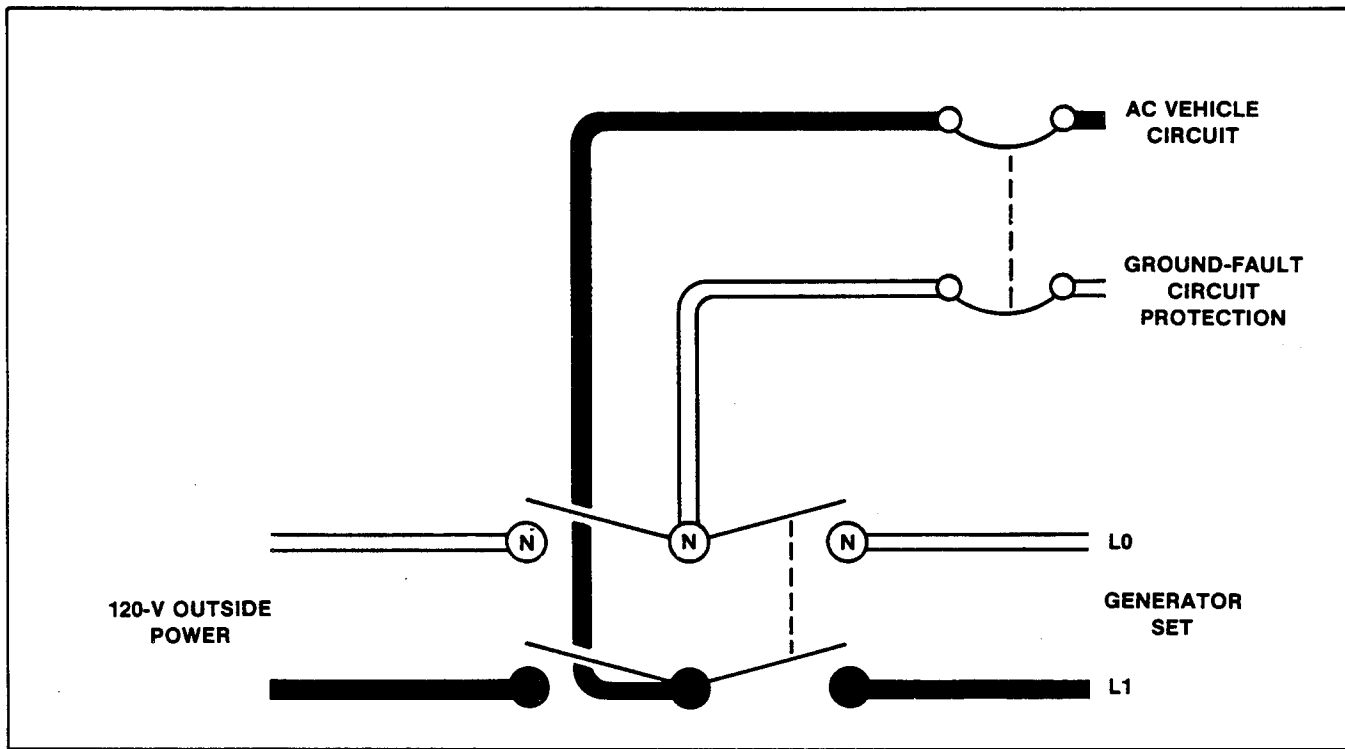

Transfer Switch Connection, 2-Wire AC Circuit

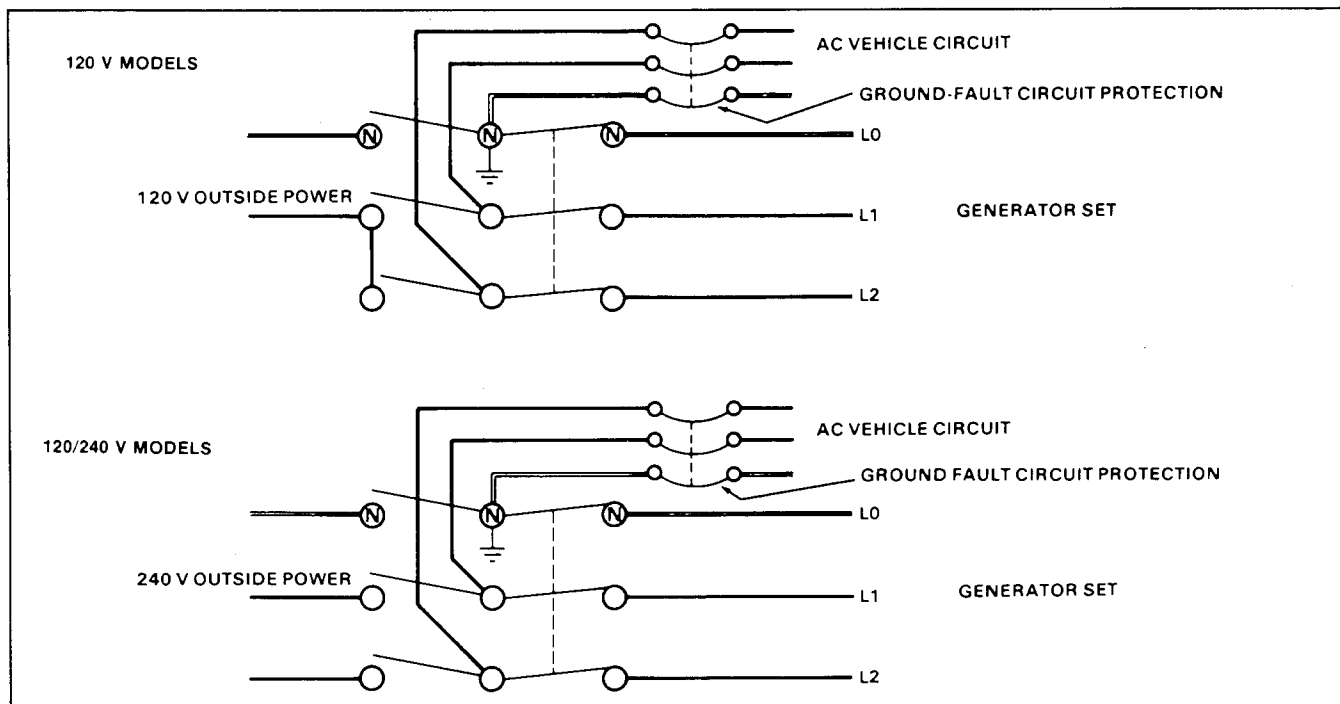

Transfer Switch Connection, 3-Wire AC Circuit

INDEX

	Page		Page
Air Cleaner		Lube Oil Selection	3-2
Cover Adjustment	3-2	Ohmmeter Checks	7-2, 7-3, 7-4, 7-10
Element Service	3-2	Operation (See Starting)	
Ammeter Checks	6-2	Parts Catalog Procurement	i
Breaker Points (See Ignition System)		P.C. Board (See Controller Circuit Bd.)	
Brush Troubleshooting	7-3, 7-9	Prestart Checklist	2-1
Carburetor (See Gasoline or LP Gas Carb.)		Printed Circuit Board (See Controller Cir. Bd.)	
Choke Adjustment	3-5	Reassembly	8-4
Circuit Board (See Controller Cir. Bd.)		Remote Panel Starting	2-1
Circuit Protection (Breakers)	2-1	Resistance	
Component		Rotor	1-1, 7-2
Testing	7-1	Stator	1-1, 7-3
Troubleshooting	7-1	Rotor	
Controller Circuit Board		Disassembly/Reassembly	8-3, 8-4
Test	7-1	Resistance	1-1, 7-2
Troubleshooting	7-4	Test	6-1, 7-2, 7-11
Controller		Troubleshooting	6-1, 7-2
Features	2-1	Safety Precautions	i
Fuses	2-2, 7-11	Scheduled Maintenance	3-1
Specifications	1-1	Separate Excitation	6-1
Troubleshooting	5-1	Service	
Cooling System	3-4	Assistance	i
Cylinder Head Service	3-7	Schedule	3-1
Deration (See Kilowatt Deration)		Shutdown Switches (See Low Oil Pres. Shut. Sw.)	
Disassembly	8-1	Six-Pin Voltage Reg. (See Voltage Reg.)	
Engine		Spark Plugs (See Ignition System)	
Engine Oil (See Lube Oil Selection)		Specification Chart	11-1
Service Manual Procurement	i	Specifications	
Shutdown Switches (Low Oil Pres. Shut. Sw.)		Controller	1-1
Specifications	1-1	Engine	1-1, 11-1
Troubleshooting	4-1	Generator	1-1, 11-1
Fuses (See Controller Fuses)		Installation	11-2
Gasoline Carburetor Adjustments		Starting	2-1
Idle Fuel Mixture	3-5	Stator	
Idle Speed	3-5	Disassembly/Reassembly	8-3, 8-4
Main Fuel Mixture	3-5	Resistance	1-1, 7-3
Gasoline Fuel Specifications and Service		Test	6-1, 7-2, 7-11
Fuel Filter Service	3-3	Troubleshooting	6-1, 7-2
Fuel Specifications	3-3	Stopping	2-1
Gasoline Shut-Down Solenoid	3-5	Testing	
General Troubleshooting	4-1	Component	7-1
Generator		Controller Circuit Board	7-4
Specifications	1-1	Rotor	6-1, 7-2, 7-11
Troubleshooting	4-2, 6-1	Stator	6-1, 7-2, 7-11
Governor Adjustments		Voltage Regulator	6-1, 7-1
Sensitivity	3-6	Wiring Harness	7-9
Speed	3-6	Timing (See Ignition System)	
Ignition System		Torque Values	1-1, 3-6, 8-4, 11-1
Breaker Points	3-2	Troubleshooting	
Spark Plugs	3-2	Brushes	7-3, 7-9
Timing	3-3	Component	7-1
Kilowatt Derating	1-1	Controller	5-1
Low Oil Pressure (LOP) Shutdown Switch	2-2, 7-10	Controller Circuit Board	7-4
LP Gas Carburetor Adjustments		Engine	4-1
Main Fuel Adjustment	3-6	General	4-1

	Page		Page
Generator	4-2, 6-1	Troubleshooting	6-1, 7-1
Rotor	6-1, 7-2, 7-9	Voltmeter Checks	6-2, 7-1, 7-7
Stator	6-1, 7-2, 7-9	Warnings (See Safety Precautions)	
Voltage Regulator	6-1, 7-1	Wiring Diagrams	9-1
Wiring Harness	7-7	Wiring Harness	
Voltage Regulator		Test	7-7
Disassembly/Reassembly	8-1, 8-5	Troubleshooting	7-7
Test	6-1, 7-1		

SPECIFICATIONS CHART

Generator

Rated kW, 60 Hz	4.5
Rated Voltage	120 V, 1Ø, 2 W; 120/240 V, 1Ø, 3 W
Rated Amperes	
120 Volt, 2 W	37.5
120/240 Volt, 3 W	18.75
Shaft rpm, 60 Hz	1800
Rotor Resistance (in ohms)	4.6
Stator Resistance (in ohms)	
1-2, 3-4, 33-4425
55-66	2.8
Coupling Type	Tapered Shaft, Thru-Bolt
Thru-Bolt Torque	50 ft. lbs. (68 Nm)
Overbolt Torque	260 in. lbs. (29 Nm)
Excitation Method	Static Brush-Type
Rotor Field Readings at Rated Voltage	Voltage/Current
No Load (63 Hz)	23.2/4.3
Full Load (60 Hz)	35.6/6.6
Stator Output Voltage with Separately Excited Rotor Using 12 Volt Battery	
1-2, 3-4, 33-44	40-75
55-66	40-75
B1-B2 (without center-tapped winding)	6-12
B1-B2 (with center-tapped winding)	4-8
B1-B3 (with center-tapped winding)	6-12

Engine

Manufacturer	Kohler
Model	KT17 Series II, Air-Cooled, Four-Cycle
No. of Cylinders	2
Bore x Stroke	
In.	3.125 x 2.750
(mm)	79.375 x 69.80
Displacement	42.18 cu. in. (691.4 cc)
Horsepower	9.9
RPM	1800
Lube Oil Capacity	3.0 U.S. pints (1.4 L)
Battery Voltage	12 Volts
Battery Recommendation	290 Cold Cranking Amps/55 Amp Hr.
Battery Cranking Current (Varies indirectly with decreasing ambient temperature)	76 Amps
Battery Charging (max.)	7 Amps
Spark Plug Type	Champion RV15YC
Spark Plug Size	14 mm
Spark Plug Gap (Gasoline)025 in. (0.64 mm)
Spark Plug Gap (LP Gas)018 in. (0.45 mm)
Plug Tightening Torque	10-15 ft. lbs. (13.6-20.3 Nm)
Breaker Point Gap017-.023 in. (.432-.580 mm)
Timing (Degrees)	23° BTDC
Valve Clearance	
Intake003-.006 in. (.076-.152 mm)
Exhaust011-.014 in. (.279-.355 mm)
Carburetor Main Adj.	
(Preliminary Turns Out)	2-3/4 to 3
Fuel Type	Unleaded Regular Gasoline

Installation

Motor Requirements	1/4 HP	1/3 HP	1/2 HP	3/4 HP	1 HP	2 HP	3 HP
Starting (In-Rush)	750	1000	1500	2000	3300	4000	5000
Running Watts	350	400	600	750	1100	2000	3000

Motor Requirements

Electrical Appliance	Rating (Watts)	Electrical Appliance	Rating (Watts)
Blanket	50-250	Heater, Water	1500
Blender	600	Pan, Frying	1200
Broiler	1350	Percolator, Coffee	650
Dryer, Hair	500-1200	Radio	50-100
Fan, Air Circulating	25-100	Television	300-750
Fan, Furnace	270	Toaster	750-1200
Heater, Space	750-1500		

Appliance Ratings

Model	Wattage Capacity	Will Operate Air Conditioner(s) of Size Indicated
4.5 kW	4500	One 13,500 Btu or Two 11,000 Btu

Air Conditioner Ratings

Fuel Inlet Connection Size — Gasoline		5/16 in. I.D. (7.9 mm)			
Load	25%	50%	75%	100%	
Gasoline gph (Lph)	.40 (1.5)	.50 (1.9)	.60 (2.3)	.80 (3.0)	
LP gph (Lph)	.52 (2.0)	.65 (2.5)	.84 (3.2)	.99 (3.7)	

Fuel Consumption and Fuel Inlet Size

Weight (approx.)	235 lbs. (106.6 kg)
Length — Overall	28-5/16 in. (71.9 cm)
Width — Overall	20-3/4 in. (51.8 cm)
Height — Overall	18-1/8 in. (44.6 cm)

Dimensions and Weight

Air Requirements — Total	417 CFM (11.8 CMM)
--------------------------	--------------------

Air Requirements

Min. Free Air Opening in Compartment Door	100 sq. in. (645 sq. cm)
--	--------------------------

Compartment Door Opening

Distance Between Generator Set and Battery	At 0°F (-18°C)	Cable Size (AWG) at 32°F (0°C)	At 75°F (24°C)
40 Feet (12.2 m)	00	0	1
30 Feet (9.1 m)	0	1	2
25 Feet (7.6 m)	1	2	4
20 Feet (6.1 m)	2	2	6
15 Feet (4.6 m)	2	4	6
10 Feet (3.0 m)	4	6	8
5 Feet (1.5 m)	6	6	8
2.5 Feet (0.8 m)	8	8	8

Battery Cable Size

Front	1-1/2 in. (38.1 mm)
Side	1-1/2 in. (38.1 mm)
Top	1-1/2 in. (38.1 mm)
Rear	1 in. (25.4 mm)

Compartment Minimum Clearance Requirements

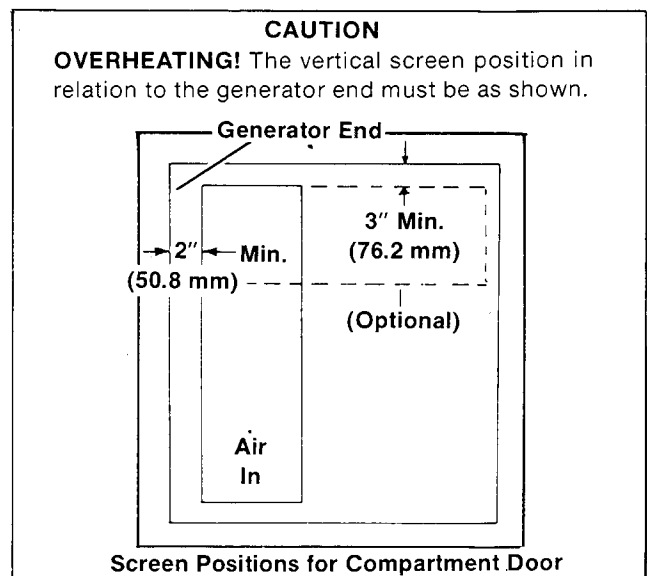

TP-5206 6/90
PRINTED IN U.S.A.

KOHLER GENERATORS

KOHLER CO. KOHLER, WISCONSIN 53044