

RV GENERATOR SETS

SERVICE MANUAL

MODEL: 2.5CMZ



KOHLER[®]
POWER SYSTEMS

TP-5403 10/91

Table of Contents

SUBJECT	PAGE	SUBJECT	PAGE
Safety Precautions and Warning		Battery Service (If Equipped)	3-8
Decals	i	Governor Adjustments	3-8
SECTION 1.		Fuse Replacement	3-8
SPECIFICATIONS	1-1	Wattage Requirements	3-9
Introduction	1-1	Storage Procedures	3-10
General Specification	1-1	SECTION 4.	
Generator	1-1	TROUBLESHOOTING	4-1
Engine	1-2	Engine	4-1
Service View	1-3	Generator	4-6
SECTION 2. OPERATING	2-1	Circuit Breaker	4-7
Prestart Checklist	2-1	Electrical Connections	4-7
To Start	2-1	Capacitor	4-7
To Stop	2-2	Stator	4-8
SECTION 3. SCHEDULED		Field Flashing	4-8
MAINTENANCE	3-1	Rotor & Rotor Circuit Board . . .	4-9
Service Schedule	3-1	Fuel Pump Control Circuit Board	4-9
Lubrication System	3-2	Remote Start/Stop Switch	4-10
Oil Check	3-2	SECTION 5. DISASSEMBLY/	
Oil Change	3-3	REASSEMBLY	5-1
Low Oil Shutdown	3-3	Disassembly	5-1
Oil Selection	3-4	Reassembly	5-4
Air Cleaner	3-4	SECTION 6. WIRING	
Spark Plugs	3-5	DIAGRAMS	6-1
Fuel System	3-6	SECTION 7. APPENDIX A	7-1
Fuel Specifications	3-6	SECTION 8. SPECIFICATION	
Gasoline	3-6	CHART	8-1
LP Gas	3-6	Generator	8-1
Fuel Filter Service	3-6	Engine	8-1
Carburetor Adjustments	3-7	Installation	8-2
Gasoline Carburetor Adj. . . .	3-7		
LP Gas Carburetor Adj.	3-7		

Safety Precautions and Warning Decals

A Generator Set, like any other electro-mechanical device can pose potential dangers to life and limb if improperly maintained or imprudently operated. The best safeguards against accidents are to be ever mindful of the potential dangers and to always use good common sense. In the interest of safety, some general precautions relating to operating of a Generator set follow. Keep these in mind. This manual contains several types of safety precautions which are explained below.

DANGER

Danger is used to indicate the presence of a hazard which *will* cause *severe* personal injury, death, or substantial property damage if the warning is ignored.

WARNING

Warning is used to indicate the presence of a hazard which *can* cause *severe* personal injury, death, or substantial property damage if the warning is ignored.

CAUTION

Caution is used to indicate the presence of a hazard which *will* or *can* cause *minor* personal injury or property damage if the warning is ignored.

NOTE

Note is used to notify people of installation, operation, or maintenance information which is important but not hazard-related.

CAUTION



Hot exhaust system can ignite adjacent combustible materials. Do not locate electrical wiring, fuel lines, or combustible material above the exhaust muffler. Be careful when parking your RV to prevent grass fires started by exhaust system and hot exhaust gases.

Hot generator can ignite debris in compartment. Keep the compartment and generator set clean and free of debris and combustible materials to minimize chances of fire. Do not block fuel/oil drain opening in generator mounting tray. If sub-flooring is used, cut a corresponding hole in the sub-flooring for drain opening.

WARNING



A flash fire can cause serious burns. Do not smoke or permit flame or spark to occur near carburetor, fuel line, fuel filter, fuel pump, or other potential sources of spilled fuel or fuel vapors. When removing fuel line or carburetor, use a proper container to catch all fuel.

Spilled fuel can ignite on contact with hot engine parts. Use a container to catch fuel when draining fuel system. Wipe up all spilled fuel after draining system.

NOTE

Fuel leakage could cause an explosion. After all LP-Gas connections have been completed, the entire system must be test pressurized to 6–8 ounces (10–14 inches water column).

⚠ WARNING



Battery gases can cause an explosion.

Do not smoke or permit flame or spark to occur near a battery at any time, particularly when it is being charged. Avoid contacting terminals with tools, etc. to prevent burns and to prevent sparks that could cause an explosion. Remove wristwatch, rings, and any other jewelry before handling battery. Never connect negative (–) battery cable to positive (+) connection terminal of starter solenoid. Do not test battery condition by shorting terminals together or sparks could ignite battery gases or fuel vapors. Any compartment containing batteries must be well ventilated to prevent accumulation of explosive gases. Do not mount battery in generator compartment. To avoid sparks, do not disturb battery charger connections while battery is being charged and always turn charger off before disconnecting battery connections. When disconnecting battery, remove negative lead first and reconnect it last.

⚠ WARNING

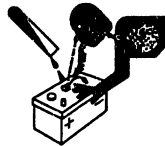

Sulfuric acid in batteries can cause permanent damage to eyes, burn skin, and eat holes in clothing.

Always wear splash-proof safety goggles when working around the battery. If battery electrolyte is splashed in the eyes or on skin, immediately flush the affected area for 15 minutes with large quantities of clean water. In the case of eye contact, seek immediate medical aid. Never add acid to a battery once the battery has been placed in service. Doing so may result in hazardous spattering of electrolyte.

⚠ WARNING

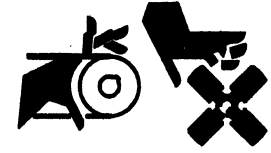

Exposed moving parts can cause severe injury.

Keep hands, feet, hair, and clothing away from belts and pulleys when unit is running. Replace guards, covers, and screens before operating generator set. Do not open generator compartment door when unit is running.

⚠ WARNING



Accidental starting can cause death or serious personal injury.

Disconnect battery cables (remove negative lead first and reconnect it last) to disable generator set before working on any equipment connected to generator. The generator set can be started by remote start/stop switch unless this precaution is followed.

⚠ CAUTION



Hazardous noise can cause loss of hearing.

Never operate generator without adequate hearing protection or muffler. Never operate generator with faulty exhaust system.

⚠ CAUTION



RV generator fuel system is susceptible to explosion when used in non-RV applications.

Use generator sets specified for RV use in RV installations only.

⚠ CAUTION



Hot parts can cause personal injury. Do not touch hot engine parts. An engine gets hot while running and exhaust system components get extremely hot.

⚠ WARNING

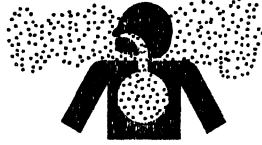

Carbon monoxide can cause death, severe nausea or fainting. Never operate the generator set inside a building unless the exhaust gas is piped safely outside. Never operate in any area where exhaust gas could accumulate and seep back inside an occupied building or coach. Be careful when parking your coach to avoid obstructing the exhaust outlet. The exhaust gases must discharge freely, otherwise carbon monoxide may deflect into the vehicle. Avoid breathing exhaust fumes when working on or near the generator set. Carbon monoxide is particularly dangerous because it is an odorless, colorless, tasteless, nonirritating gas which can cause death if inhaled for even a short period of time. The exhaust system must be leakproof and routinely inspected.

Carbon monoxide can cause death, severe nausea or fainting. When mounting the remote switch with choke cable, make sure the panel is air tight to prevent exhaust fumes from entering the coach.

Carbon monoxide can cause death, severe nausea or fainting. Install exhaust system tail pipe so discharged exhaust gases will not be drawn into vehicle interior through windows, doors, air conditioners, etc. Do not use flexible tail piping since this type could crack and allow lethal exhaust fumes to enter the vehicle.

⚠ WARNING



Hazardous voltage can cause death or severe injury.

Perform electrical service only as prescribed in equipment manual. Be sure that generator is properly grounded. Never touch electrical leads or appliances with wet hands, when standing in water, or on wet ground as the chance of electrocution is especially prevalent under such conditions. Wiring should be inspected at the interval recommended in the service schedule — replace leads that are frayed or in poor condition. The function of a generator set is to produce electricity and that wherever electricity is present, there is the hazard of electrocution.

Hazardous "backfeed" voltage can cause death or severe injury.

The generator must not be used to "backfeed" by connecting it to building/campground electrical circuits. Install a transfer switch in RV generator installations to prevent connection of RV and other sources of power. Electrical backfeed into a utility electrical system can cause serious injury or death to utility personnel working on transmission lines.

⚠ CAUTION

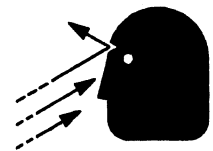

Flying projectiles can cause injury.

Retorque all crankshaft and rotor hardware after servicing. When making adjustments or servicing generator set, do not loosen crankshaft hardware or rotor thru-bolt. If rotating crankshaft manually, direction should be clockwise only. Turning crankshaft bolt or rotor thru-bolt counterclockwise can loosen hardware and result in serious personal injury from hardware or pulley flying off engine while unit is running.

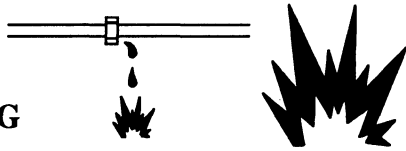
 **WARNING**

All fuels are highly explosive in a vapor state. Use extreme care when handling, storing, and using fuels

Store fuel in a well-ventilated area away from spark producing equipment and out of the reach of children. Never add fuel to the tank while the engine is running since spilled fuel may ignite on contact with hot parts or from ignition spark. Do not smoke or permit flame or spark to occur near potential sources of spilled fuel or fuel vapors. Keep fuel lines and connections tight and in good condition—don't replace flexible fuel lines with rigid lines. Flexible sections are used to avoid breakage due to vibration. Additional precautions must be taken when using the following fuels:

Gasoline – Store gasoline only in approved red containers clearly marked GASOLINE. Do not store gasoline in any occupied building.

Propane (LP) – Adequate ventilation is mandatory. Propane is heavier than air; install gas detectors low in room. Inspect detectors often.

Natural Gas – Adequate ventilation is mandatory. Natural gas rises; install gas detectors high in room. Inspect detectors often.

NOTE

RV generator sets do not comply with United States Coast Guard (U.S.C.G.) requirements and must not be used for marine applications. Use only generator sets specified for marine use in marine installations. U.S.C.G. Regulation 33CFR183 requires a generator set to be "ignition protected" when used in a gasoline-fueled environment.

 **CAUTION**

Short circuits can cause bodily injury and/or equipment damage. Do not contact electrical connections with tools or jewelry while adjustments are made. Remove wristwatch, rings, and jewelry that can cause short circuits.

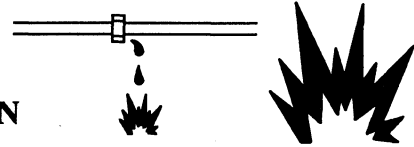
 **CAUTION**

Fuel leakage can cause an explosion. Check LP gas fuel system for leakage using a soap-water solution with fuel system test pressurized to 6–8 ounces per square inch (10–14 inches water column). Do not use test solutions that contain ammonia or chlorine, since the soap will not bubble for an accurate leakage test.

 **WARNING**

A sudden backfire can cause serious burns. Do not operate with air cleaner removed.

 **WARNING**



Hazardous voltage can cause death or serious injury. Do not touch electrical connections when flashing the generator. When flashing the generator set, 120 Volts AC will be present at the alligator clips when push button is pressed.

Hazardous voltage can cause death or serious injury. Use caution when handling the capacitor; possible electrical shock can result. Discharge capacitor by shorting terminals together.



Warning Decals

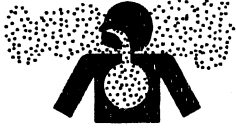

Warning decals are affixed to the generator set in prominent places to advise the operator or service technician of potentially hazardous situations. These decals are reproduced here to improve operator recognition and thereby increase decal effectiveness. For a further explanation of decal warn-

ing statements, reference preceding safety precautions. Before operating or servicing the generator set, be sure you understand the message of these decals. Replace decals if damaged or missing.

 WARNING	
	<p>Hazardous voltage Backfeed to utility system can cause electrocution or property damage.</p> <p>Do not connect to any building electrical system without connecting through an approved device and after building main switch is open. See operator's manual.</p> <p style="text-align: right;">239771</p>

 WARNING	
	<p>carbon monoxide. Can cause severe nausea, fainting, or death.</p> <p>Completely seal off compartment to maintain vapor tightness to living space. See operator's manual for complete installation instructions.</p> <p style="text-align: right;">239796</p>

 CAUTION	
	<p>Hot engine and exhaust system. Can cause severe burns.</p> <p>Do not work on generator set until unit is allowed to cool.</p> <p style="text-align: right;">249809</p>

 WARNING	
	<p>Fire or accident hazard. Can cause severe injury or death.</p> <p>Install unit only in accordance with manufacturer's detailed installation instructions.</p> <p style="text-align: right;">239773</p>

Section 1. Specifications

Introduction

Your recreation vehicle is equipped with a dependable Kohler Alternating Current RV Generator Set. Service requirements of the Generator Set are minimal but it is important that the required services be performed at the prescribed intervals. Please take a few moments to read through this manual then carefully follow all service recommendations to keep your set in top condition. In

the space provided, record the MODEL, SPECIFICATION, SERIAL and ENGINE SPEC. numbers as found on the nameplate attached to the frame of the generator. This information will enable your Kohler Generator Service Dealer to supply the correct part or data for your particular version. Keep this manual in your RV for future reference.

General Specifications

2.5CMZ-RV (60Hz)

Dimensions – L x W x H —in. (mm) 15.75 x 14.00 x 19.74
(400 x 356 x 501)

Weight (dry) – lbs. (kg) 93.75 (42.19)
With Muffler 99.75 (44.89)

Air Requirements

Combustion & Cooling 40 sq. in. inlet duct

Fuel Consumption **2.5kW – Gasoline – gph (Lph)**

Load	25%	50%	75%	100%
2.5 kW Gasoline	0.28 (1.1)	0.38 (1.4)	0.48 (1.8)	0.56 (2.1)
2.5 kW LP	0.29 (1.0)	0.34 (1.3)	0.41 (1.6)	0.51 (1.9)

Generator

2.5CMZ

Rated kW	2.5
Frequency – Hz	60
Rated Voltage	120
Rated Amps.	20.8
Overbolt Torque – in. lbs. (Nm)	70 (7.9)
Rotor Resistance (ohms)	3.2
Stator Resistance (ohms)**	
Leads:	
1–2, 3–4	0.5
55–66	1.5
Insulation (Rotor and Stator)	Class 155, Epoxy Varnish, Vacuum Impregnated
Fungus Resistance	Meets Mil-E-04970A Standard
Winding Material	Copper
Circuit Protection – Generator	25Amp.
Watts	2500

** Most ohmmeters will not give accurate readings when measuring less than 1 ohm. The stator can be considered good if a low resistance reading (continuity) is obtained and there is no evidence of shorted windings (discoloration). Do not confuse a low resistance reading with a reading indicating a shorted winding.

DERATION: The kilowatts of the generator set will decrease 3–1/2% for each 1000 feet (305 meters) above sea level and 1% for each 10°F (5.5°C) above 60°F (16°C).

Engine

Some general engine specifications are listed below. Refer to the appropriate service section and the engine service manual for specific service details.

Manufacturer	Tecumseh
Model	TVM 140
	Vertical Shaft
Cycle	4
Number Cylinders	1
Displacement – cu.in. (cc)	13.53 (221.75)
Rated Horsepower	6.0
RPM @ 60 Hz	3600
Bore – in. (mm)	2.6 (66.7)
Stroke – in. (mm)	2.5 (63.5)
Valve Material	
Intake	Alloy steel
Exhaust	Austenitic steel
Cylinder Head Material	Aluminum
Cylinder Block Material	Aluminum
Crankshaft Material	Iron alloy
Bearings	Anti-friction, Aluminum alloy
Governor	Oil bathed, Mechanical
Lubrication System	Positive displacement pump
Oil Capacity – qts. (L)	1.25 (1.08)
Fuel Type	Unleaded Regular Gasoline
Fuel System	
Choke	Manual
Fuel Pump	Electric – with fuel shut-off
Battery Voltage	12
Battery Recommendation	12 Volt, 55 Amp. Hr.
Spark Plug Type	Champion® RJ-8 or RJ-17LM
Spark Plug Gap – in. (mm)	0.030 (0.76)
Ignition System	Electronic
Starter Motor	12 Volt
Cooling System	Forced air

FRONT VIEW

- 1. Air Cleaner
- 2. Carburetor
- 3. Nameplate
- 4. Electrical Box
- 5. Circuit Protector
- 6. Oil Fill / Oil Check
- 7. Fuel Pump
- 8. Oil Drain
- 9. Start/Stop Panel Connection

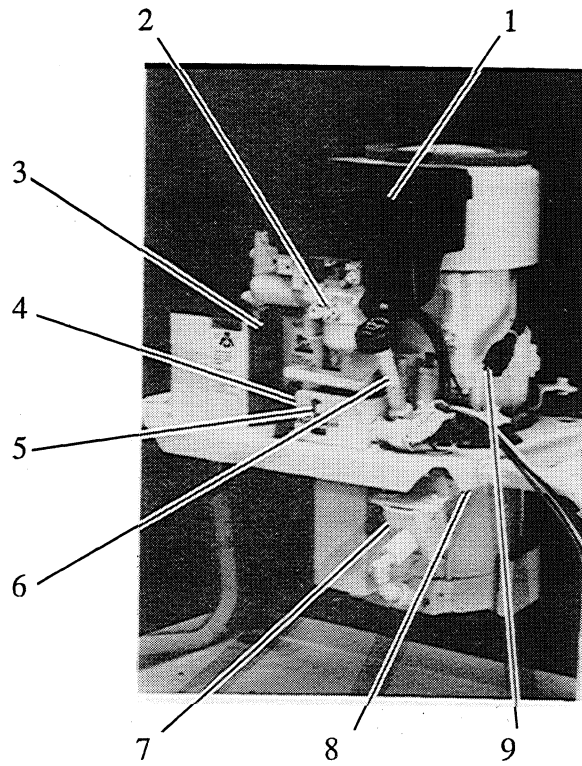

BACK VIEW

- 10. Air Intake
- 11. Starter
- 12. Battery Negative Connection
- 13. Splash Guard
- 14. Battery Positive Connection
- 15. Starter Solenoid
- 16. Spark Plug

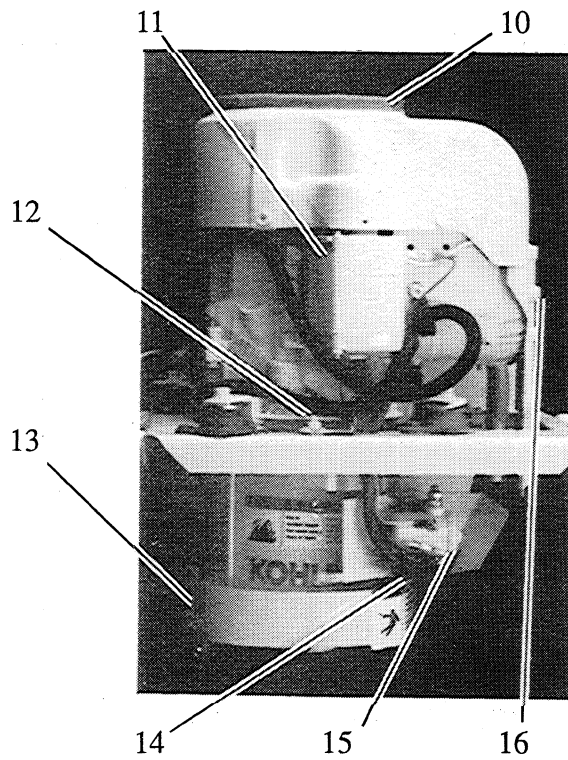

1-911

Figure 1-1 Service View

Section 2. Operating Instructions

To insure continued satisfactory operation, the following items should be checked before each start-up.

Prestart checklist

OIL LEVEL: Should be at or near Full mark (not over).

AIR INLETS: Must be clear and unobstructed.

COMPARTMENT: Interior must be clean.

AIR CLEANER: Must be clean and properly installed.

AIR SHROUDING: Must be tight and in proper position.

EXHAUST: Tail pipe must be clear, muffler and piping tight and in good condition.

ELECTRICAL: All connections (including battery) must be tight.

To Start

Pull the choke knob out to the closed position, see Figure 2-1. Place rocker switch to "START" position and hold until the engine is running but not more than ten seconds. When the switch is in the "START" position the "ON" light will go on indicating battery voltage availability to the electrical fuel pump. When the switch is released from the "START" position it will automatically return to the "RUN" position. If the generator set is running, the "ON" light will remain illuminated; otherwise, the light will go off indicating the engine failed to start. Normally the engine will start within five seconds. As the engine warms up, push the choke knob in.

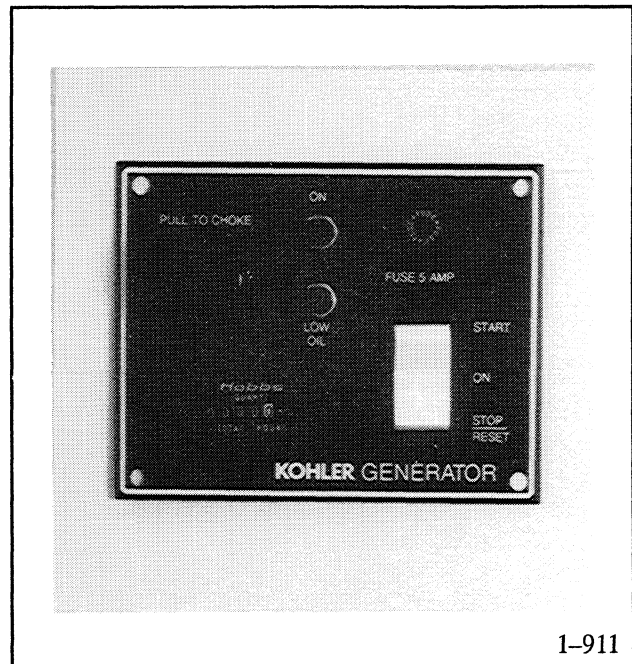

Figure 2-1. Remote Panel

NOTE

Do not crank engine continuously for more than ten seconds at a time. A 60 second cool-down period must be allowed between cranking attempts if the engine does not start. If the unit fails to start after three attempts have problem corrected by an Authorized Service Dealer. Failure to follow these guidelines may result in burn-out of the starter motor from overheating.

NOTE

Do not attempt to start the generator set while the unit is running. Teeth on the flywheel and starter will clash and could result in damage to the starter or flywheel.

NOTE

When starting LP gas units, do not use the choke when outside temperature is greater than 30°F (-1°C). When temperature is 30°F (-1°C) or below, choke for 3 seconds after starting and then open choke.

To indicate generator set output, a low wattage night light can be used as a generator "ON" light. Plug night light into any AC outlet in the motor-home and leave in the "ON" position.

To Stop

Whenever possible, allow a brief cooling period by running the set at low or no load for a few minutes prior to shut-down. To stop, place rocker switch in "OFF/RESET" position.

Section 3. Scheduled Maintenance

Service Schedule

In addition to the routine services listed in this manual, there are other important steps that should be taken to keep a generator set in top condition. Usually, tools and instruments required for these additional steps are not available to the generator set owner. For this reason, the set should be returned periodically to an authorized Service Dealer for complete servicing and tune-up every 200 hours or once a year. The benefits of such service will be im-

proved performance and continuous satisfactory operation during a long trouble free service life.

If operating under extremely dusty and dirty conditions, use dry compressed air to blow dust out of the generator at frequent intervals. Do this with the generator set operating and direct the stream of air through the cooling slots at the end of the generator.

Perform Service at Intervals Indicated (X)	Before Each Start-Up	Every 25 Hours	Every 50 Hours	Every 100 Hours	Every 200 Hours	Every 500 Hours
Check exhaust outlet		X				
Check oil level		X				
Check fuel supply		X				
Keep cooling air inlets and outlets clean		X				
Remove loose dirt from compartment		X				
Change lube oil (see Lubrication)			X			
(Change oil initially after first two hours of operation.)						
Service Air Cleaner			X			
Check generator set battery electrolyte level (if equipped)				X		
Service spark plugs					X	
Retighten electrical connections					X	
Check mounting bolts and vibro mounts					X	
Check and tighten electrical connections					X	
Blow dust out of generator					X	
"Tune-up" at Authorized Service Dealer (plug, decarbonize engine, lap valves)						X
Replace in-line fuel filter						X

Lubrication System

Oil Check

NOTE

Check the oil in the crankcase daily or before each startup to insure the level is in the safe range. DO NOT operate the set if the level is below the "ADD" mark. To bring the level from the "ADD" mark to full, add approx. 0.75 quart (0.71 liters).

Do not check oil level when the set is in operation. The Engine must be stopped.

1. Make sure unit is on a flat, level surface.
2. Wipe area around oil cap to prevent dirt or particles from entering the oil fill tube.
3. Unscrew oil cap and wipe dipstick clean. See Figure 3-1.
4. Re-insert dipstick into oil fill tube. Dipstick must be fully seated and tightened into oil fill tube when checking oil level. Remove dipstick to check oil level.
5. Add oil until level is above the "ADD" mark and below the "FULL" mark.
6. To add oil, a funnel is recommended to prevent oil spill.

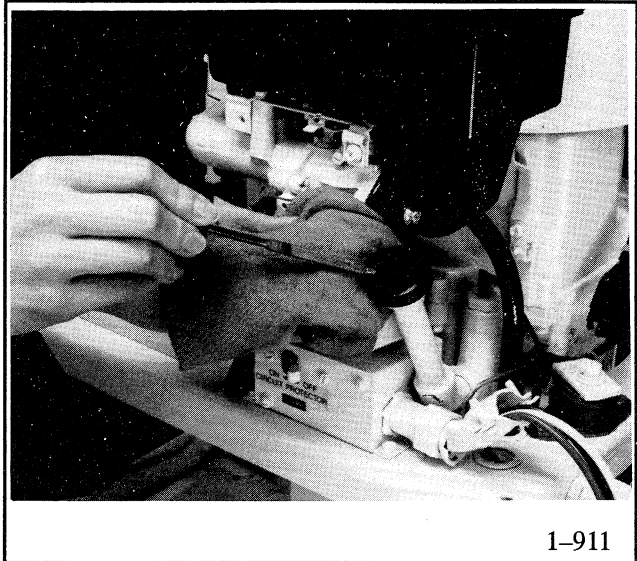

Figure 3-1. Oil Check

Oil Change

Change the oil after the first two (2) hours of operation and at 25 hour intervals thereafter. Change more frequently if operating under dirty, dusty conditions. If possible, drain oil while hot. To drain, open valve. Oil drain valve is located underneath mounting tray. Figure 3-3. Place a container underneath drain valve to catch draining oil. Close valve after oil has completely drained. Oil capacity is 1.25 quarts (1.08 liters). Refer to Oil Selection chart following for correct oil type.

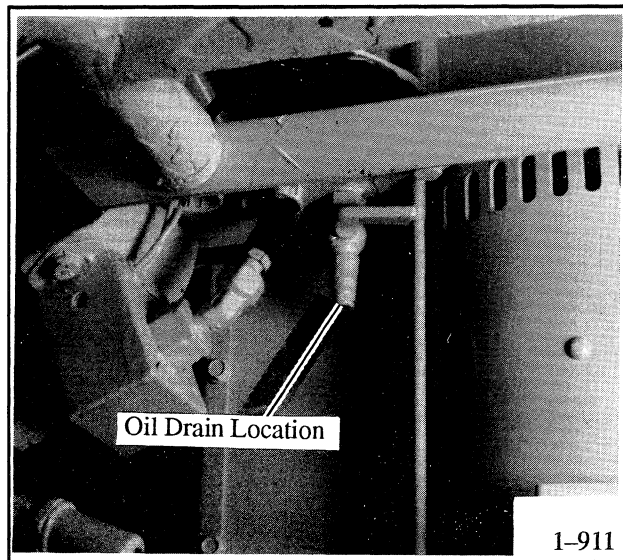

Figure 3-3. Oil Drain Location

Low Oil Shutdown Switch

The low oil shutdown feature protects the engine against internal damage if the oil level drops below "ADD" mark on dipstick. When oil level drops below safe operating level, unit will shutdown and the red light on the remote panel (labeled "Low Oil") will light. Oil level must be corrected and switch returned to "OFF/RESET" position before engine is restarted. Location of the low oil level switch is shown in Figure 3-4.

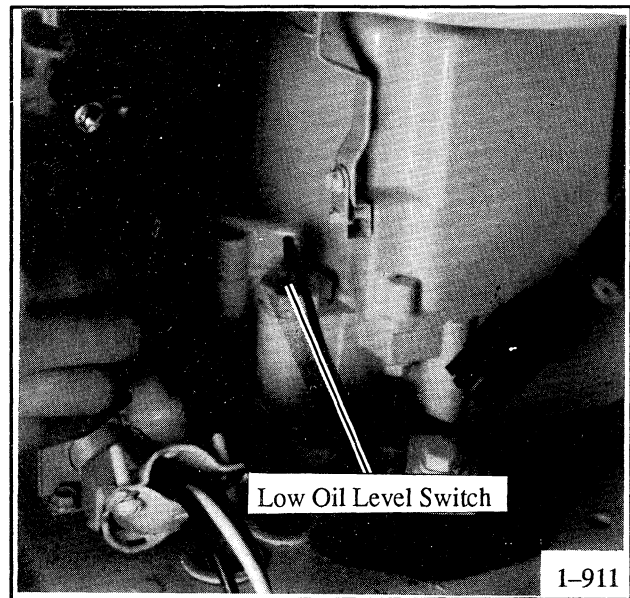

Figure 3-4. Low Oil Level Switch

Oil Selection

USE A CLEAN, HIGH QUALITY, DETERGENT OIL. Be sure original container is marked with engine service classification SC, SD, SE, or SF.

DO NOT USE SAE10W40 OIL.

Refer to the Oil Selection Chart for proper oil types; use of lighter weight oil, other than recommended, will cause increased oil consumption.

Oil Selection Chart

Air Temperature	Oil Viscosity
Above 32°F (0°C)	SAE 30 (SAE 10W30 is an acceptable substitute)
Below 32°F (0°C)	SAE 5W20 or 5W30 (SAE 10W is an acceptable substitute)

Air Cleaner

Your engine is equipped with a foam-type air filter. Every 25 hours remove the element and clean. Clean more frequently if using under extremely dirty, dusty conditions. Use the following procedure to service the air cleaner.

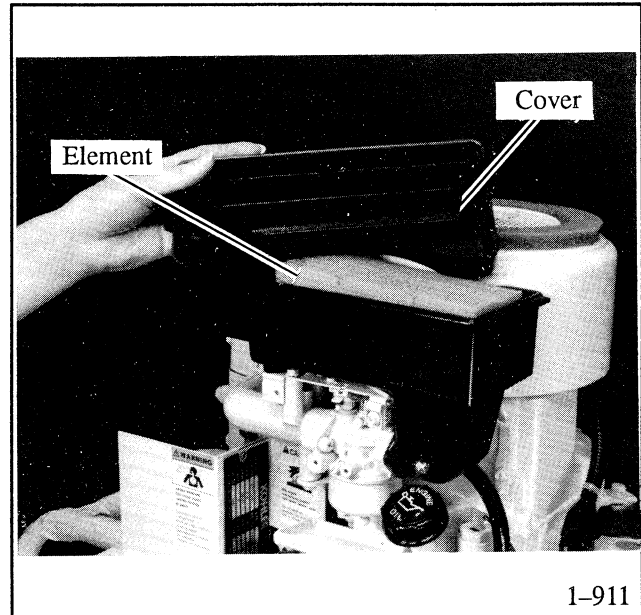

Figure 3-5. Air Cleaner Service

NOTE

If generator is equipped with optional air duct kit, remove baffle panel (secured with wing nuts) to access air cleaner.

1. Unsnap air cleaner cover. See Figure 3-5.
2. Remove filter. Wash filter in a water and DETERGENT solution.
3. Wrap in a clean cloth and squeeze dry (don't twist). Then apply liberal amounts of SAE 30W oil to filter. Work oil well into filter and then squeeze out excess oil.
4. Reinstall element, making sure it fits properly. Snap air cleaner cover back in place.

Spark Plugs

Every 100 hours remove the spark plug and check its condition. Good operating conditions are indicated when the plug has a light coating of gray or tan deposit. A dead white, blistered coat could indicate overheating. A black (carbon) coating may indicate an "overrich" fuel mixture caused by a clogged air cleaner or improper carburetor adjustment. Do not sandblast, wire brush, scrape or otherwise service a plug in poor condition – best results are obtained with a new plug.

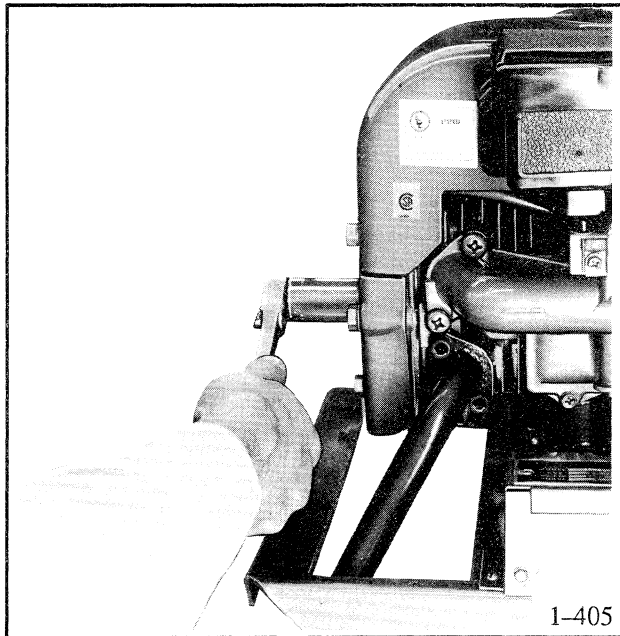

Figure 3-6. Spark Plug Removal

To service, remove plug as shown in Figure 3-6. Spark plug gap is 0.030 in. (0.76 mm). Figure 3-7. For replacement plugs use Champion RJ-8 or RJ-17LM. A Champion RJ-17LM resistor plug is required for Canadian radio frequency interference regulations.

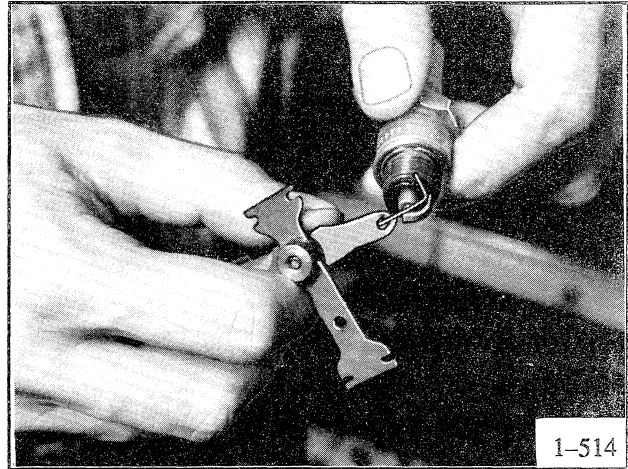

Figure 3-7. Gapping Spark Plug

Fuel System

Fuel Specifications

Gasoline

For best results, use only clean, fresh, regular grade unleaded gasoline with a pump sticker octane rating of 87 or higher in the U.S.A. In countries using the Research rating method, it should be 90 octane minimum.

Unleaded gasoline is recommended since it leaves less combustion chamber deposits. Regular grade leaded gasoline may also be used; however, be aware that the combustion chamber and cylinder head will require more frequent service.

Use fresh gasoline to ensure it is blended for the season, and to reduce the possibility of gum deposits forming which could clog the fuel system. Do not use gasoline left over from the previous season. Gasohol containing no more than 10% ethanol can be used if unleaded fuel is unavailable.

Never use gasoline containing METHANOL, gasohol containing more than 10% ethanol, gasoline additives, premium gasoline, or white gas because engine/fuel system damage could result.

Do not add oil to the gasoline.

LP Vapor Fuel

After all the LP connections have been completed, the entire system shall be pressurized to not less than 10 inches not more than 14 inches water column, and the connections tested for leakage with soapy water or bubble solution. Do not use solution that contain ammonia or chlorine, for soap will not bubble for an accurate leakage test.

Before starting the generator set, check the (secondary) gas regulator inlet pressure using an ounce pressure gauge or manometer. Pressure should be 4–6 ounces or 7–11 inches water column, adjust pressure on primary gas regulator.

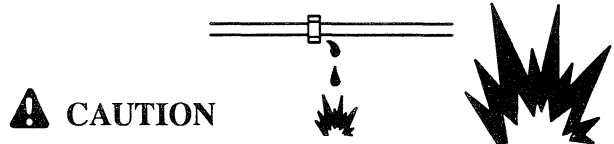

Fuel leakage can cause an explosion. Check LP gas fuel system for leakage using a soap–water solution with fuel system test pressurized to 6–8 ounces per square inch (10–14 inches water column). Do not use test solutions that contain ammonia or chlorine, since the soap will not bubble for an accurate leakage test.

Fuel Filter Service

Before servicing the fuel filter, drain the fuel from the carburetor/fuel line. This model utilizes an in-line type fuel filter connected to the fuel line, see Figure 3–8. Replace the filter every 500 hours of running time or when rough operation indicates an engine tune–up may be necessary.

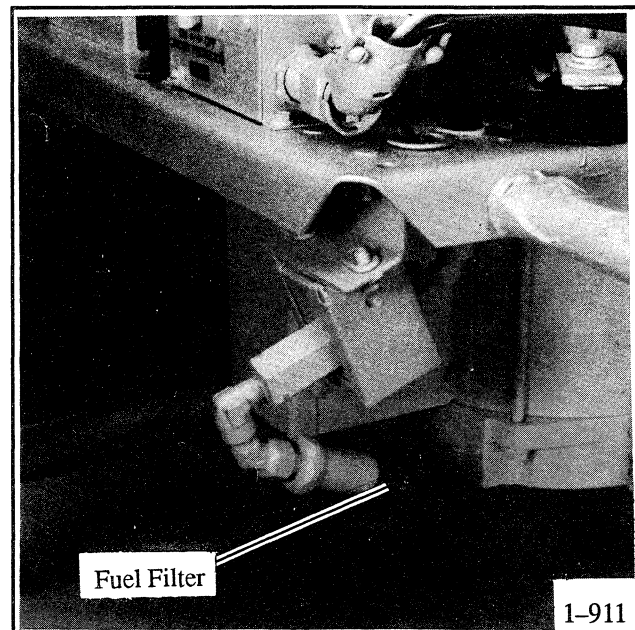

Figure 3–8. Fuel Filter Service

Carburetor Adjustments

Gasoline Carburetor Adjustments

The main fuel adjustment screw is located on the bottom of the carburetor bowl. Figure 3-9. Turn screw in until it bottoms lightly, then back out 1-1/4 turns. Minor adjustments may have to be made with the engine running at full load to achieve maximum power.

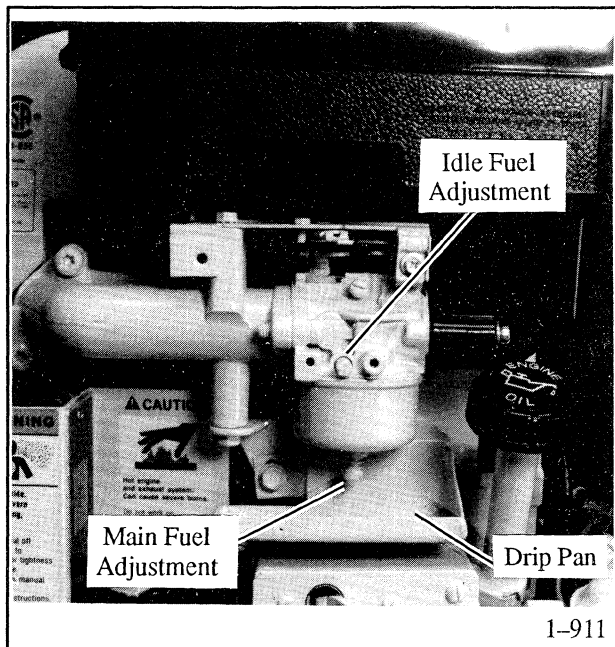

Figure 3-9. Gasoline Carburetor Adjustments

The idle fuel adjustment is located in the front, center of the carburetor. Turn the needle in until it bottoms lightly. Back out 3/4 of a turn.

LP Gas Carburetor Adjustments

The main fuel adjustment screw is located on the bottom of the carburetor bowl. Figure 3-10. Turn screw in until it bottoms lightly, then back out 1 full turn. Minor adjustments may have to be made with the engine running at full load to achieve maximum power.

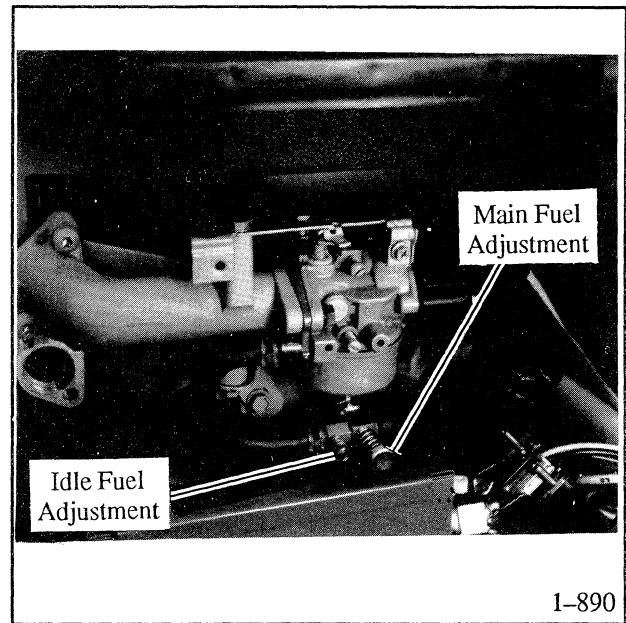

Figure 3-10. LP Gas Carburetor Adjustments

Open or close the idle fuel adjustment screw until smooth operation is obtained at no load (approximately 1-3 turns out from fully closed).

Battery Service (If Equipped)

Check the electrolyte level in the battery at frequent intervals and add distilled water as needed. To avoid unintentional starting while you are working on the set, disconnect the negative battery cable. Use a 12-Volt battery with an Amp. hour rating of at least 55. A negative ground system is used. Make sure the battery is properly connected and terminals are tight.

Governor Adjustments

The governor speed adjustment tab is located behind the carburetor (Figure 3-11). Governor speed at no load should be set at 63.5 Hz (3810 rpm). To increase speed, bend the control bracket outward (to expand the governor spring). To decrease speed, bend the control bracket inward (to compress the governor spring).

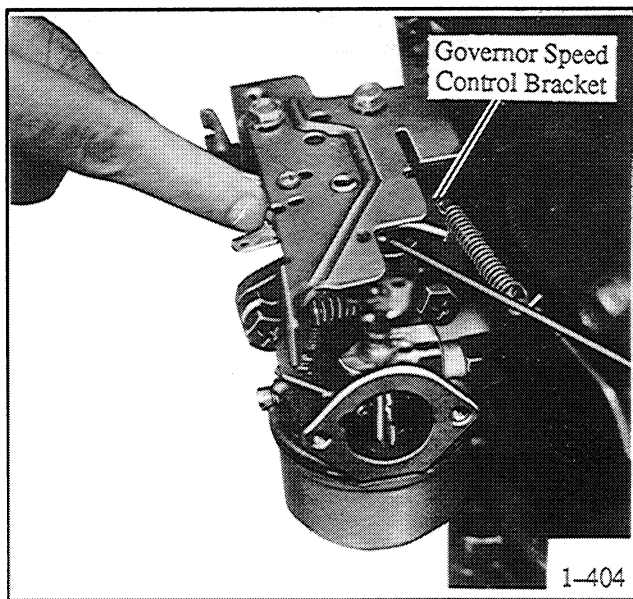

Figure 3-11. Governor Adjustment

Fuse Replacement

There is one 5 Amp. fuse on the start panel. This fuse protects the primary starting circuit and the electric fuel pump or LP fuel solenoid. Refer to Figure 3-12 for fuse location. If this fuse "blows", the fuel pump, or LP fuel solenoid will be deenergized and the set will stop when starved of fuel. Replace the fuse. If it "blows" again, contact an Authorized Kohler Generator Service Dealer for assistance in locating and correcting the cause.

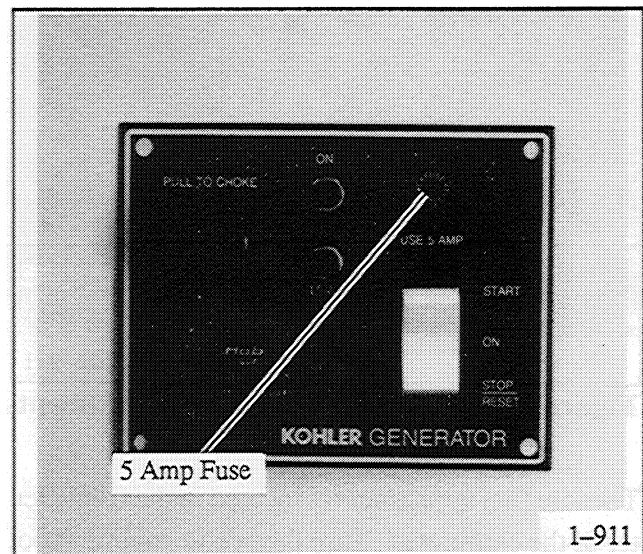

Figure 3-12. Fuse Replacement

Wattage Requirements

If the rated capacity of your generator is exceeded, the circuit protector located on the generator electrical box will trip to protect the generator against damage. This could be caused by a short in the AC circuit in your RV or simply by having too many appliances on at the same time, resulting in an overload condition. If the circuit protector trips, the set will continue running but there will be no AC output to the protected circuit. Before resetting the protector, turn off some of the appliances and lights inside the RV to bring the load down within the rated limits of the set. If this is done and the protector trips again after being reset, a short circuit is indicated. In this event, turn off the set and have an Authorized Kohler Generator Service Dealer locate and correct the cause of the short circuit.

NOTE

To reset the circuit protector in installations where the protector is barely visible, the ON position is where the handle is pointing outward.

The average wattage requirements of some common RV appliances and motor loads are listed in the following chart. Use these figures to calculate the total load on your set to avoid the inconvenience of having the circuit protector trip due to overload. The 2.5kW generator set will operate one 11,000 BTU air conditioner with 700 Watts to spare or one 13,500 BTU air conditioner with 300 Watts to spare.

Electrical Appliance	Rating (Watts)
Blanket	50–250
Blender	600
Broiler	1350
Dryer, Hair	500–1200
Fan, Air Circulating	25–100
Fan, Furnace	270
Heater, Space	750–1500
Heater, Water	1500
Pan, Frying	1200
Percolator, Coffee	650
Radio	50–100
Television	300–750
Toaster	750–1200

Storage Procedures

If your generator set is to be out of service for a considerable length of time (2 months or more), the following steps should be taken to preserve the set before placing it in storage.

- Step 1. Drain the oil from the crankcase (while hot) then flush with clean light-weight oil. Refill crankcase with regular oil. See "Oil Type" section in this manual.

- Step 2. Run generator until fuel tank is empty (if separate tank is used). Drain the fuel from the carburetor bowl to prevent gasoline from becoming "stale" and forming gum deposits. If gasohol has been used as fuel, run generator for a short time on unleaded regular grade gasoline and repeat preceding instructions in Step 2.

- Step 3. Remove the spark plug, squirt about 1 tablespoon of engine oil into the hole, crank the engine several times, then reinstall spark plug.

- Step 4. Clean exterior surfaces of the generator set, then spread a light film of oil over any unpainted metallic surfaces which could rust or corrode.

Section 4. Troubleshooting

Under normal conditions, generator service will not be required on a regular basis. If operating under extremely dusty and dirty conditions, use dry compressed air to blow dust out of the generator at frequent intervals. Do this with the generator set operating and direct the stream of air in through the cooling slots at the end of the generator.

When troubles occur, don't overlook simple causes. A starting problem could be caused, for ex-

ample, by improper fuel or an empty fuel tank. Make sure all electrical connections are secure. Remember the battery negative must have a good ground. The following charts list some common problems. If procedures in this manual do not correct the problem, take this generator set to an Authorized Kohler Service Dealer. Tell the service dealer personnel exactly what happened when the problem occurred and any adjustments made to the set.

Engine

Problem	Possible Cause	Corrective Action
Will Not Crank	<p>Low battery.</p> <p>Loose or corroded battery leads or terminals.</p> <p>Loose connections or open conductor from battery supply.</p> <p>Defective "C" cranking. (starter solenoid)</p> <p>Blown 5 Amp fuse.</p> <p>Defective start switch.</p> <p>Defective starter motor.</p>	<p>Battery voltage must be at least 10 Volts measure at battery with start selector switch in "START" position.</p> <p>Tighten or clean.</p> <p>Separate harness connector and check for 12-13 Volts DC voltage between pins 3 and 6 (on female connector).</p> <p>Separate harness connector and check for continuity between pins 1 and 3 (female connector). Check for readings of 18-20 ohms (R x 1 scale).</p> <p>Check panel mount fuse.</p> <p>See "Remote Start/Stop Switch."</p> <p>If "C" cranking contactor energizes (audible click), but starter does not turn, remove battery supply and check starter terminal and ground strap; this should indicate very low resistance (ohmmeter on R x 1 scale).</p>

Engine (Cont'd)

Problem	Possible Cause	Corrective Action
Will Not Crank (Cont'd)	<p>Out of fuel.</p> <p>Clogged fuel filter</p> <p>Engine flooded or over-choked.</p>	<p>Replenish.</p> <p>Clean.</p> <p>Readjust choke setting.</p>
Unit Cranks in "RUN" position	Start switch miswired.	Refer to wiring diagram, Section 6.
Unit Cranks but Will Not Run	<p>Start switch miswired.</p> <p>Defective start switch (does not disconnect ground from engine magneto).</p> <p>Defective fuel pump.</p> <p>No fuel.</p> <p>Faulty spark plug.</p> <p>Ignition wiring or connections.</p> <p>Defective magneto.</p> <p>Clogged air cleaner.</p> <p>Defective fuel pump control circuit board.</p>	<p>Refer to wiring diagram, Section 6.</p> <p>Separate harness connector and check for an open circuit between pins 3 and 4 (male connector) with the start selector switch in the "START" position. See "Remote Start/Stop Switch."</p> <p>Disconnect lead(s) to fuel pump and apply 12 Volts DC. If good, fuel pump will operate. See Safety Precautions section before proceeding.</p> <p>Check fuel supply. Check restrictions from fuel tank to fuel pump; fuel pump to carburetor input; and restrictions in fuel lines, fittings and fuel pump filter.</p> <p>Clean, adjust or replace.</p> <p>Repair or reconnect as necessary.</p> <p>Refer to Tecumseh service manual.</p> <p>Clean.</p> <p>See "Fuel Pump Control Circuit Board" Page 4-9.</p>

Engine (Cont'd)

Problem	Possible Cause	Corrective Action
Hard Starting	Stale or bad fuel. Air cleaner clogged. Faulty carburetor adjustments. Faulty spark plug. Weak magneto. Weak battery. Low engine compression.	Replace. Clean. Correct. Clean, adjust or replace. Refer to Tecumseh service manual. Recharge. Refer to Tecumseh service manual.
Stops Suddenly	Out of fuel. Overheated Air cleaner clogged. 5-Amp fuse blown. Faulty spark plug. Fuel pump not functioning properly. Clogged fuel filter. Low oil level. Defective fuel pump control circuit board.	Replenish. Check air flow, clogged intake screens or obstructions preventing air flow. Clean. Replace. Clean, adjust or replace. Check fuel pump wiring. Check for clogged fuel lines. Clean filter. Refer to Tecumseh service manual. See "Fuel Pump Control Circuit Board" Page 4-9.
Lacks Power	Air cleaner clogged. Improper cooling. Engine overloaded. Bad or stale fuel. Faulty spark plug.	Clean. Check air flow, clogged intake screens or obstructions preventing air flow. Reduce load. Replace fuel. Clean, adjust or replace.

Engine (Cont'd)

Problem	Possible Cause	Corrective Action
Lacks Power (Cont'd)	Carburetor adjustments wrong. Carbon build-up. Low compression. Governor adjustment wrong. Misadjusted choke. Lack of engine lubrication.	Correct. Refer to Tecumseh service manual. Refer to Tecumseh service manual. Readjust. Readjust. Refer to Tecumseh service manual.
Operate Erratically	Faulty spark plug. Faulty carburetor or governor adjustments	Clean, adjust or replace. Readjust.
Overheats	Improper cooling. Carburetor adjustment too lean. Engine ignition timing wrong. Wrong spark plug. Low oil level. Generator overloaded.	Check air flow, clogged intake screens or obstructions preventing air flow. Readjust. Refer to Tecumseh service manual. Replace. Replenish. Reduce load.
Electric Fuel Pump Continues to Run after Generator Set is Stopped	Defective fuel pump control circuit board.	See "Fuel Pump Control Circuit Board" (Remove fuse from remote panel to de-activate generator set) Page 4-9.
Generator Set Shuts Down by Itself	Out of fuel. Fuel line restriction. Clogged fuel filter.	Replenish Check fuel lines and tank. Clean fuel filter.

Engine (Cont'd)

Problem	Possible Cause	Corrective Action
Generator Set Shuts Down by Itself (Cont'd)	<p>Engine overloaded.</p> <p>Engine overheated.</p> <p>Blown 5 Amp. fuse in engine wiring circuit.</p>	<p>Reduce electrical load.</p> <p>Check air intake, cooling system, oil level, etc.</p> <p>Replace fuse. If fuse blows again, check for short or failure in engine wiring.</p>
Will Not Carry	<p>Excessive load generator.</p> <p>Governor not properly adjusted or defective (engine not operating at rated load.)</p> <p>Clogged fuel filter.</p> <p>Improper type of fuel.</p> <p>Water, dirt in fuel system.</p> <p>Clogged air filter.</p>	<p>Reduce electrical load.</p> <p>Check speed using tachometer or frequency meter. NOTE: $\text{Hz} \times 120 = \text{rpm} \times \text{no. of rotor poles.}$ (Example: $60 \times 120 = 3600 \times 2.$)</p> <p>Clean fuel filter.</p> <p>Use proper type of fuel.</p> <p>Drain, flush, and fill the system.</p> <p>Clean filter.</p>
Unit is Noisy	<p>Exhaust system leak.</p> <p>Exhaust system not securely installed.</p> <p>Broken or damaged vibro mounts.</p> <p>Loose or vibrating sheet metal.</p> <p>No installation clearance (unit hits coach.)</p> <p>No compartment sound installation.</p> <p>Excessive vibration (engine/generator imbalance.)</p>	<p>Check and replace as necessary.</p> <p>Check for loose parts.</p> <p>Check and replace as necessary.</p> <p>Retighten screws. If necessary, add additional screws to secure.</p> <p>Check clearances.</p> <p>Install approved installation.</p> <p>Check rotor, crankshaft, etc. Disassembly of engine and/or generator may be necessary.</p>

Generator

Problem	Possible Cause	Corrective Action
No Generator Output Voltage	<p>Line circuit breaker open or defective.</p> <p>Circuit breaker tripping due to overload or defective RV wiring.</p> <p>Open wiring, terminal or pin in auxiliary winding/ capacitor circuit (field flashing).</p> <p>Loss of residual magnetism in rotor.</p> <p>Defective capacitor.</p> <p>Defective rotor diode circuit board.</p> <p>Defective rotor (open, grounded, or shorted windings).</p> <p>Defective stator (open, grounded or shorted windings).</p>	<p>Check position of AC circuit breaker. Check AC voltage on generator side of circuit breaker.</p> <p>Reduce load and reset circuit breaker. If breaker trips repeatedly, check RV wiring and appliances.</p> <p>Check continuity.</p> <p>Flash the (rotor) field.</p> <p>Test and/or replace.</p> <p>Test and/or replace.</p> <p>Check continuity.</p> <p>Check continuity.</p>
High Generator Output Voltage	High engine rpm.	<p>Check speed using tachometer or frequency meter. (adjust governor). NOTE: $\text{Hz} \times 120 = \text{rpm} \times \text{no. of rotor poles}$ (Example: $60 \times 120 = 3600 \times 2.$)</p>
Low Generator Output Voltage	Low engine rpm.	<p>Check speed using tachometer or frequency meter. (adjust governor). NOTE: $\text{Hz} \times 120 = \text{rpm} \times \text{no. of rotor poles}$ (Example: $60 \times 120 = 3600 \times 2.$)</p>

Circuit Breaker

The line circuit breaker will trip to protect the generator if load exceeds maximum circuit breaker rating. Check the line circuit breaker and reset if necessary. See Figure 4-4.

The breaker switch can also be used to disconnect the load from the generator by manually turning the breaker to the "OFF" position.

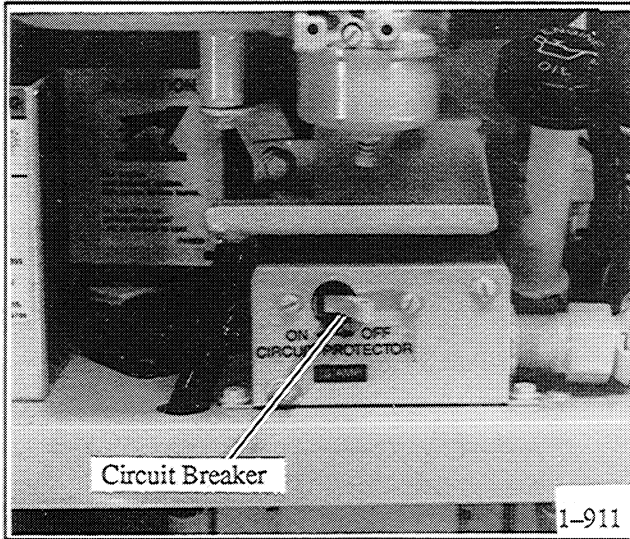

Figure 4-4. Circuit Breaker Location

Electrical Connections

Check for loose leads in the electrical box. Reconnect as necessary.

Capacitor

Disconnect exciter winding lead 55 and 66 from capacitor. With an ohmmeter on the R x 1000 scale, check the capacitor for charging and discharging readings, Figure 4-5. Place the ohmmeter leads on the capacitor terminals, a meter deflection should be indicated; reverse the leads and check again for charging and discharging readings. Continuous continuity or no meter deflection indicates a shorted or open capacitor. No continuity should be indicated between the capacitor case and terminals.

⚠ WARNING



Hazardous voltage can cause death or serious injury. Use caution when handling the capacitor; possible electrical shock can result. Discharge capacitor by shorting terminals together.

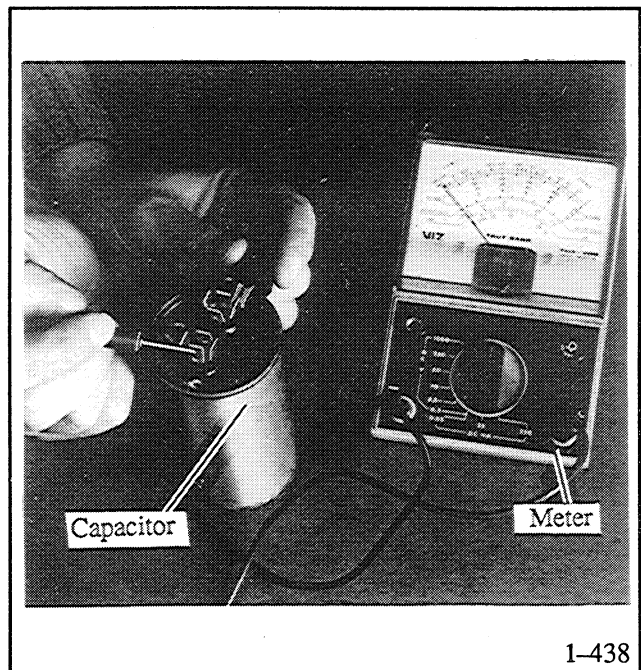

Figure 4-5. Capacitor Test

Stator

With leads 55 and 66 removed from the capacitor, check for an open, shorted, or grounded winding. Using an ohmmeter, check for readings of approximately 1.5 ohms across leads 55 and 66, Figure 4-6. There should be no continuity between windings and stator frame.

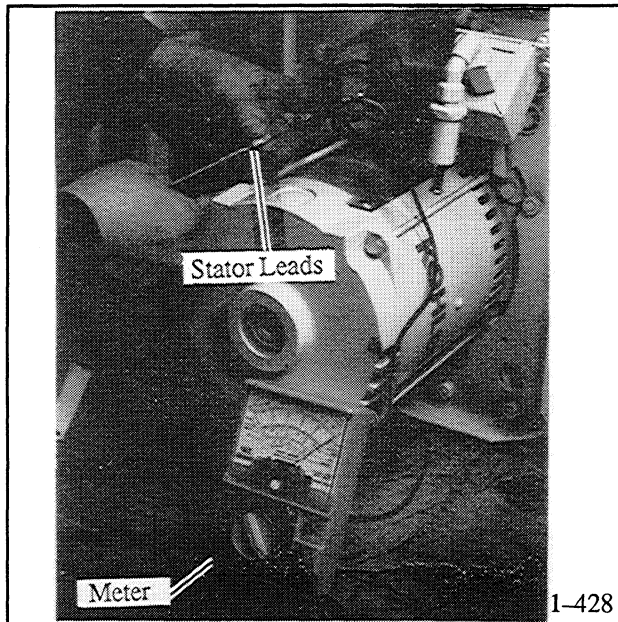

Figure 4-6. Stator Winding Test

Disconnect main stator leads 1 and 2 from their connection points. Using an ohmmeter, check for readings of less than 0.5 ohms across leads 1 and 2. There should be no continuity between windings and ground.

Field Flashing

The residual magnetism held in the rotor is sufficient to produce 2-5 Volts AC output from the stator. If the generator has been disassembled or if it

has been subjected to rough handling the rotor may have to be remagnetized ("flashed").

A flashing box can be assembled using the diagram in Figure 4-7. Components needed are a 120 Volt AC cord, push-button switch, fuse holder, 20 Amp fuse, and cord with alligator clips. Assemble in an insulated box.

⚠ WARNING



Hazardous voltage can cause death or serious injury. Do not touch electrical connections when flashing the generator. When flashing the generator set, 120 Volts AC will be present at the alligator clips when push button is pressed.

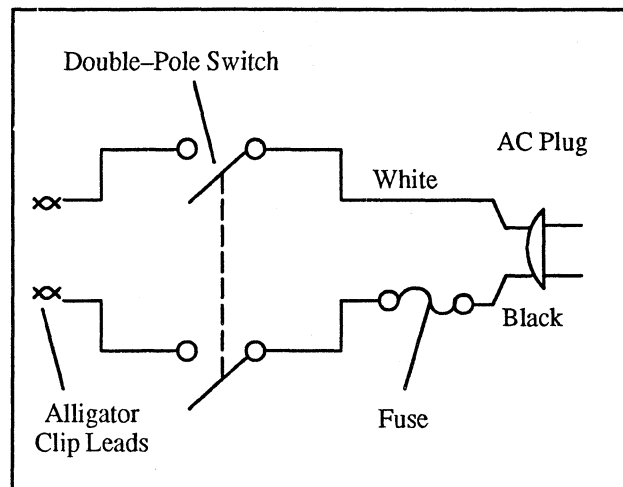
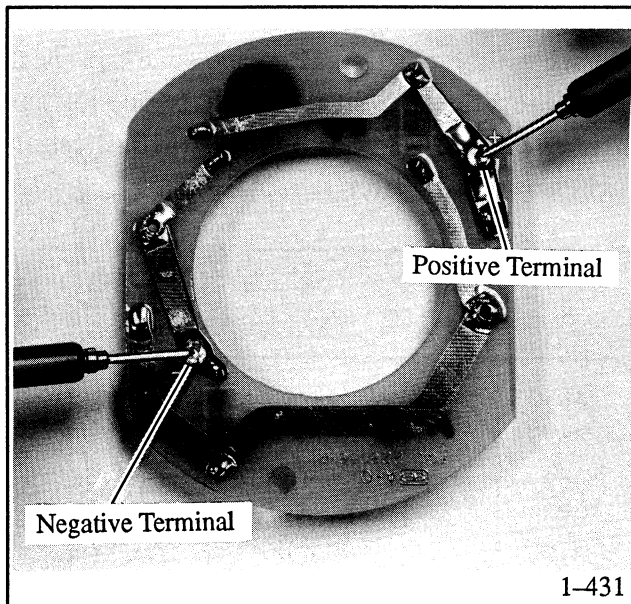

Figure 4-7. Flashing Box Assembly

Restoring magnetism to the rotor can be accomplished by momentarily (1 second) applying 120 Volts AC to the stator exciter windings (leads 55 and 66). This will induce a current flow in the rotor, restoring the needed residual magnetism.

Rotor and Rotor Circuit Board

To test the rotor, the end bracket must be removed. Refer to the disassembly procedures in Section 5, Generator Disassembly/Reassembly. Using an ohmmeter (R x 1 scale), check for 3.5 ohms between the (+) and negative (-) terminals on the rotor circuit board, Figure 4-8. Good contact is necessary to get proper readings; remove the varnish before testing. A reading of 5 ohms or more indicates an open winding in the rotor. A resistance reading of 1 ohm or less indicates a defective circuit board or shorted rotor. Rotor field leads must be unsoldered from the circuit board to determine a shorted rotor winding or a defective rotor circuit board. There would be no continuity between rotor windings and rotor shaft.



**Figure 4-8. Rotor Testing
(Rotor Circuit Board)**

To check for open or shorted diodes on the rotor circuit board, a field lead positive (+) or negative (-) must be unsoldered from the circuit board. A high resistance value in one direction and low resistance in the reverse direction indicates a good circuit board. A high resistance value in both directions indicates open diodes. Low resistance values in both directions indicated shorted diodes.

Fuel Pump Control Circuit Board

The fuel pump circuit board can be tested using the following procedures. While it can be checked when connected to the start/stop switch, it is recommended that the circuit board be disconnected from the panel. The following components are required to test the circuit board:

12-Volt Automotive Battery
5 Amp. Fuse and Fuse Holder
Momentary Push-Button SPST Switch
0-15 V.D.C. Voltmeter or 12 Volt Bulb and Socket
14 Ga. Wire and Alligator Clips
12-Volt Lamp

1. Remove four screws to access rear of remote start/stop switch.
2. Locate circuit board behind mounting panel. The circuit board has seven leads connected to it and is covered with a piece of heat shrink tubing.
3. Connect colored leads to points as shown in Figure 4-9.
4. With main switch "ON" – push Test Button.
5. "Test" indicator should be energized.
6. When Test Button is released, "Test" indicator should be deenergized.
7. While pushing Test Button, momentarily depress fault switch.
8. Fault indicator should light and test indicator should be deenergized. Release test switch.
9. Fault lamp should remain lit until circuit is interrupted by opening the main ON/OFF switch.

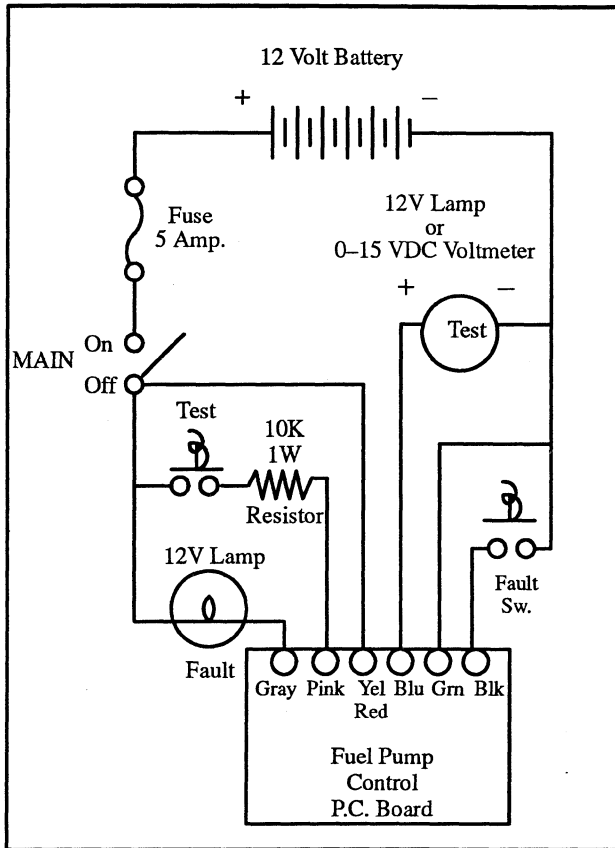

Figure 4-9. Fuel Pump Circuit Board Test

5. If any of the checks in Step 4 are negative or if the fuse blows, the circuit board is defective – replace.
6. Disconnect fuse lead from battery positive (+).
7. Reconnect new circuit board to remote panel using appropriate wiring diagram.

NOTE

It will be necessary to add a male fully insulated push-on terminal to end of new circuit board blue lead.

Remote Start/Stop Switch

The remote start/stop switch can be checked for proper function. Remove all leads connected to switch. Refer to Figure 4-10 for internal contacts at each switch position. Replace switch if checks prove negative. Switch terminals do not have marked identification. Figure 4-10 illustrates switch as viewed from terminal side.

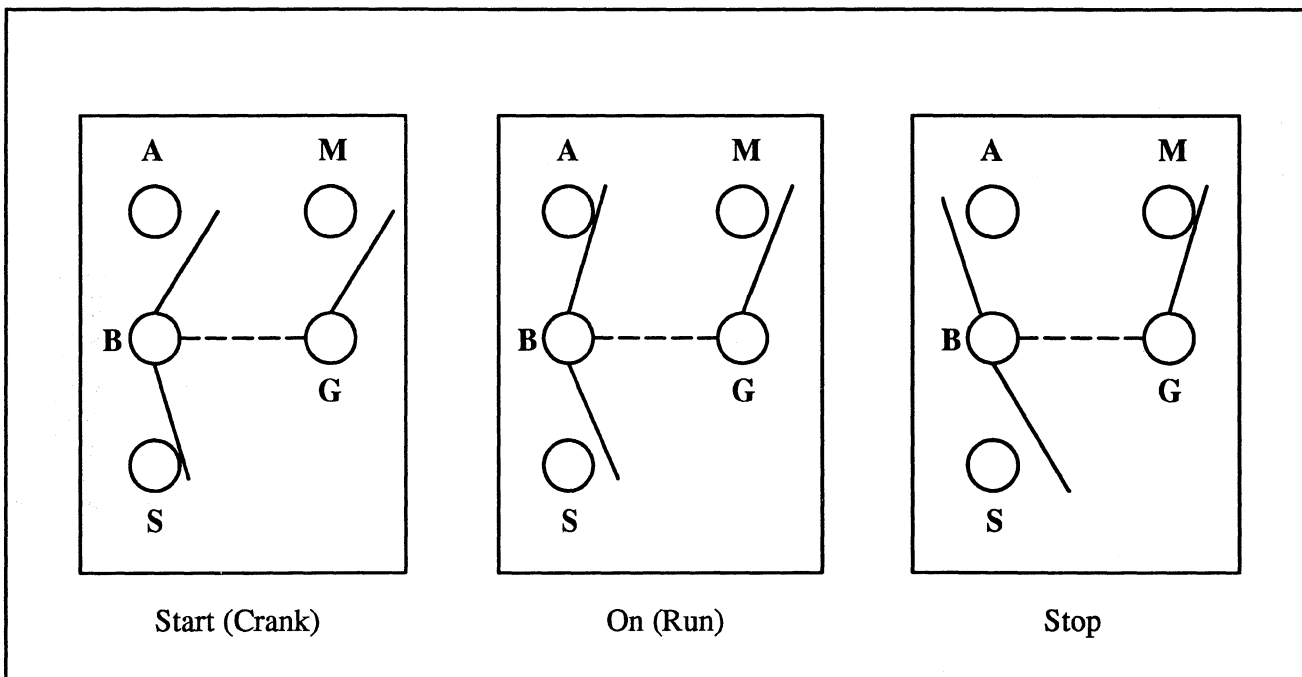

Figure 4-10. Start/Stop Panel Switch Internal Contacts (Terminal Side)

Section 5. Disassembly/Reassembly

When disassembling or reassembling your generator set follow all safety precautions listed in front of this manual.

Disassembly

1. Drain all the oil and fuel from engine.
2. Remove three screws securing splash guard to generator end bracket. (Figure 5-1).

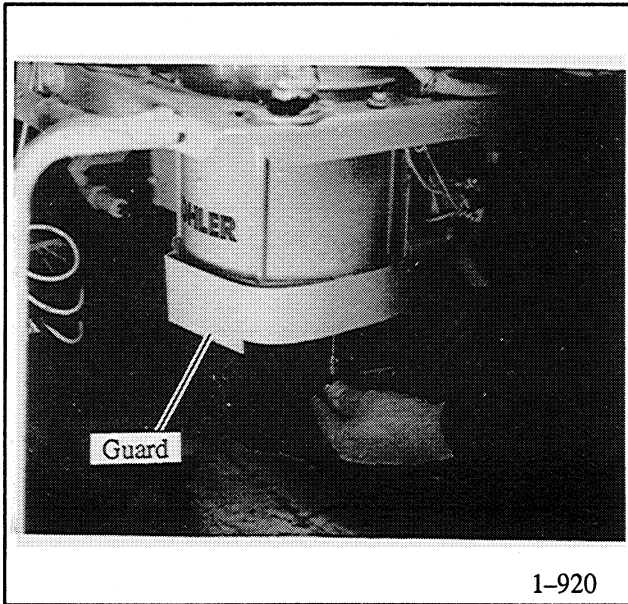

Figure 5-1. Removing Splash Guard.

3. Remove two screws securing cover to breaker box. (Figure 5-2).

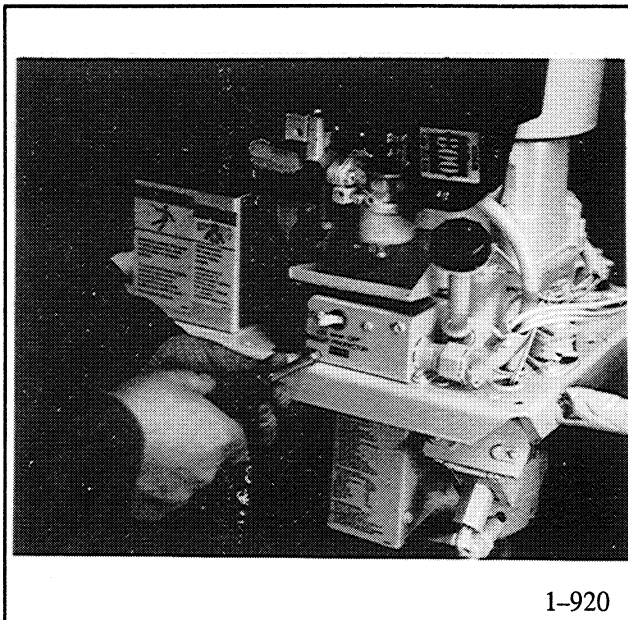

Figure 5-2. Circuit Breaker Box Cover.

4. Disconnect line and load leads. (Figure 5-3).
5. Remove four screws from cover on capacitor box. (Figure 5-4).

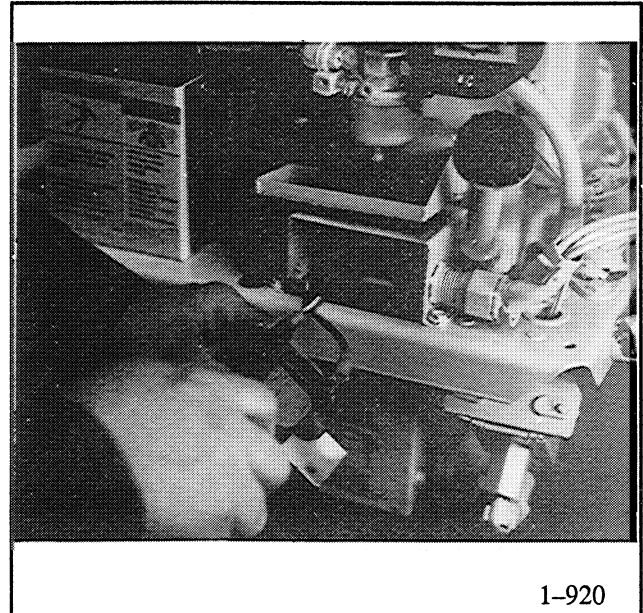

Figure 5-3. Disconnecting Line & Load Leads

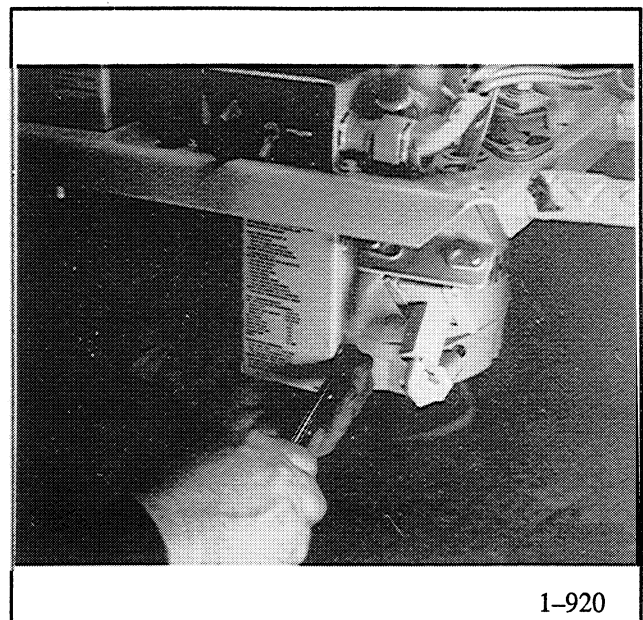

Figure 5-4. Removing Capacitor Box Cover.

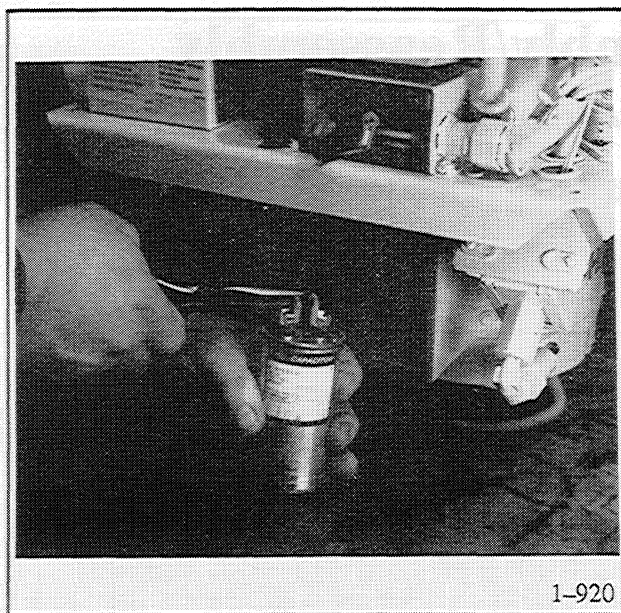

Figure 5-5. Disconnecting Stator Leads.

6. Disconnect stator leads (55 & 66) from capacitor. (Figure 5-5).

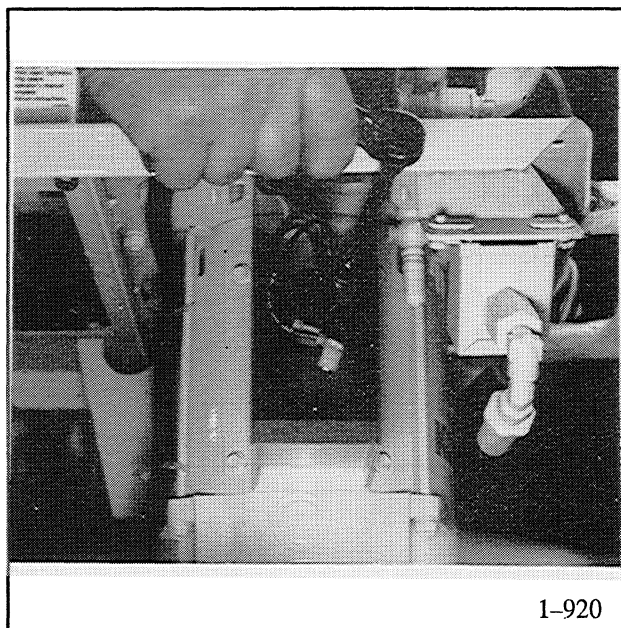

Figure 5-6. Disconnecting Ground Leads.

7. Disconnect ground leads from stator shell. (Figure 5-6).

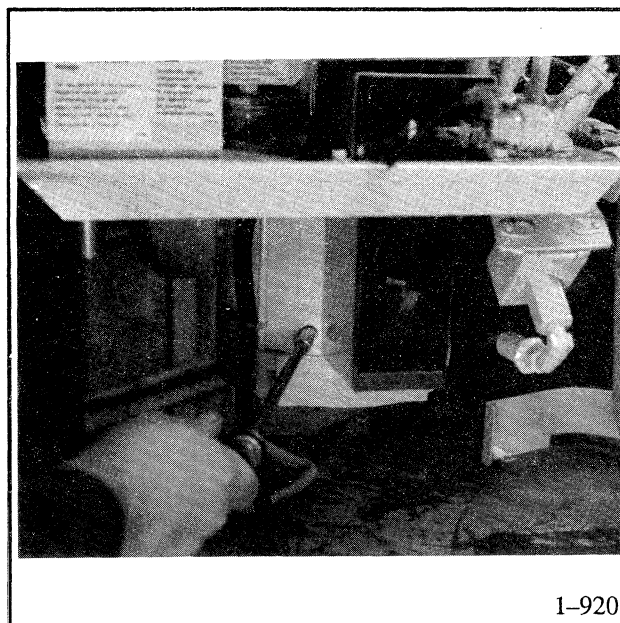

Figure 5-7. Removing Capacitor Box.

8. Remove capacitor box as shown in Figure 5-7.

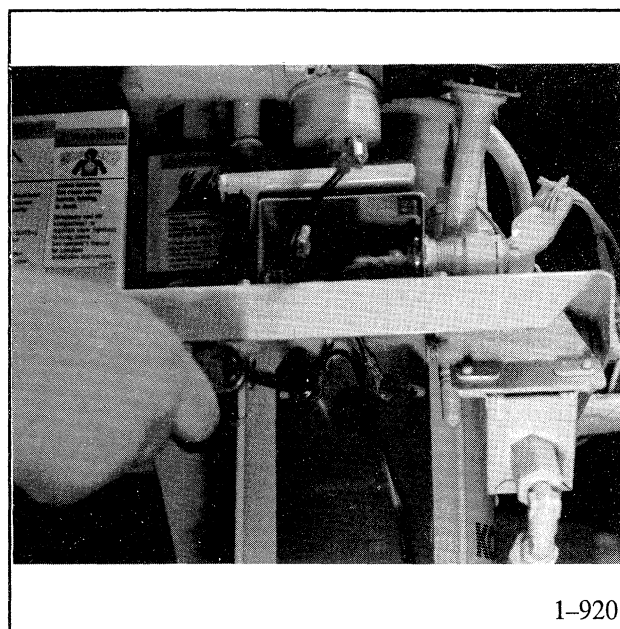

Figure 5-8. Disconnecting LO Ground Leads.

9. Disconnect LO ground leads (Neutral and Hazard ground) from stator shell as shown in Figure 5-8.

NOTE

Take extra care to support the stator during removal of the overbolts.

10. Remove overbolts. (Figure 5-9).

11. Bump end bracket loose. (Figure 5-10).

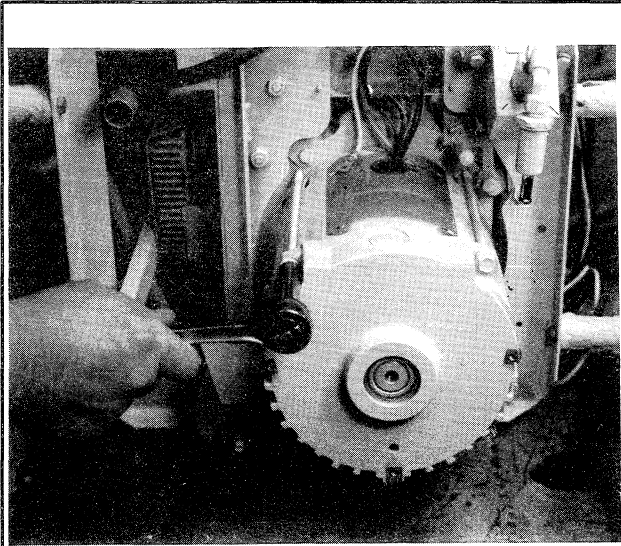

1-920

Figure 5-9. Removing Overbolts.

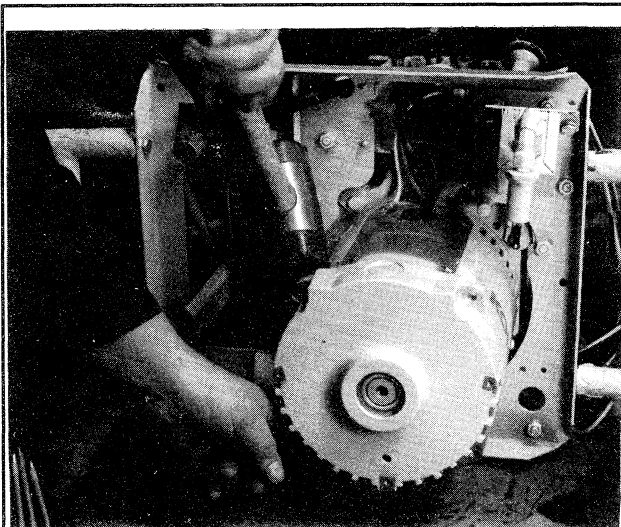

1-920

Figure 5-10. Bumping End Bracket.

NOTE

Do not attempt to pry stator from engine base using a screwdriver or other sharp object. Damage can result from the sharp edge puncturing engine crankcase.

12. Pull stator over rotor. Be careful not to damage rotor or stator while removing. See Figure 5-11.

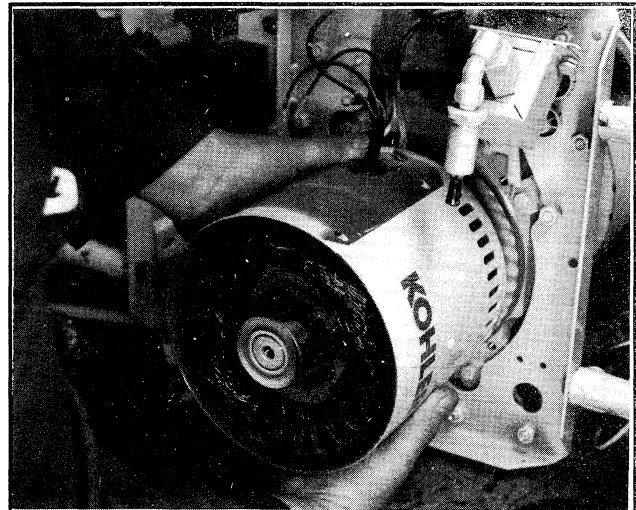

1-920

Figure 5-11. Removing Stator.

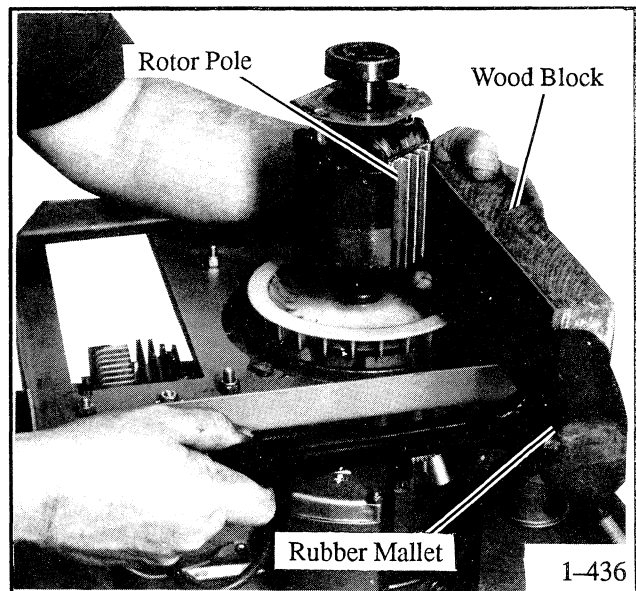

1-436

Figure 5-12. Removing Rotor.

13. The rotor is held to the engine crankshaft by right-hand threads on the crankshaft and rotor shaft. To remove rotor, place a wood block on a trailing edge of one rotor pole (not on aluminum heat sink). Figure 5-12. One or two sharp, medium-force hammer blows to the wood block's end will free the rotor, allowing it to be turned off by hand.

NOTE

ROTOR DAMAGE! Do not attempt to remove rotor by blocking engine cooling fan and turning rotor with any kind of wrench; damage to fan blades and rotor will result.

14. Remove fan.

Reassembly

1. Clean rotor shaft and crankshaft threads with compressed air. Install fan. Coat crankshaft threads with anti-seize compound. Figure 5-13. Thread rotor onto crankshaft, turning handtight. Final tighten by placing a wood block against the leading edge of one of the rotor poles and tightening with slight hammer blows.

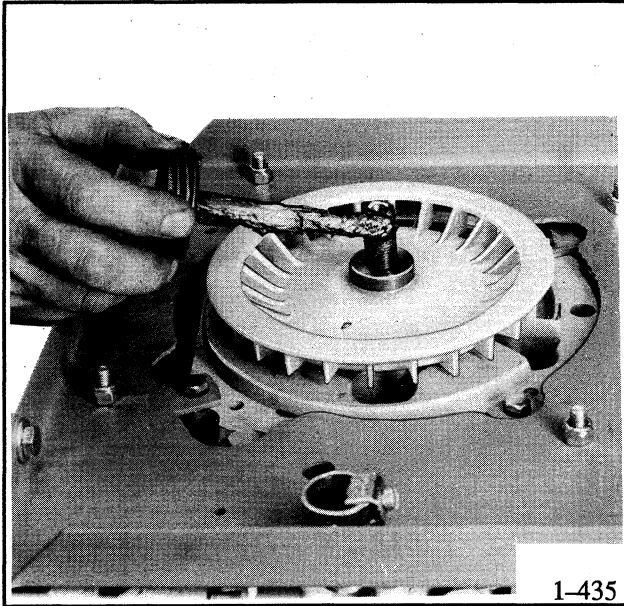

Figure 5-13. Applying Anti-Seize Compound.

2. Position the stator over the rotor so that it is aligned to where the circuit breaker box would go. See Figure 5-14.

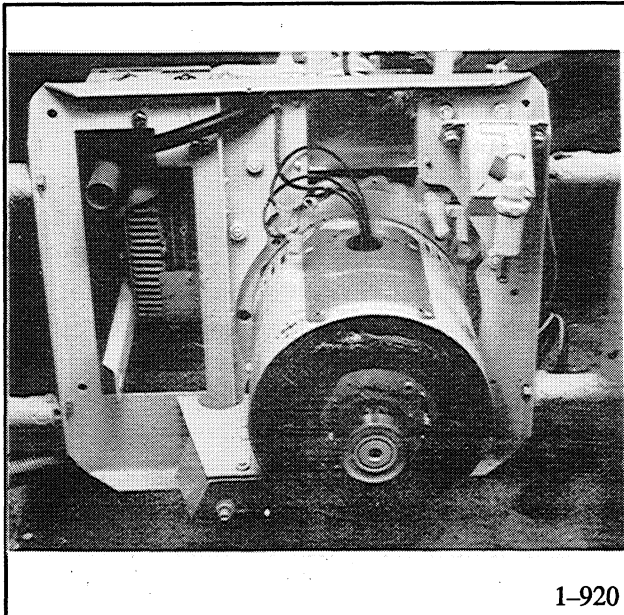

Figure 5-14. Aligning Stator.

3. Install a new tolerance ring in the end bracket. Figure 5-15.

NOTE

Use of old tolerance ring can result in bearing to spin.

4. Position the end bracket on the stator. Check to make sure stator and end bracket are aligned properly.

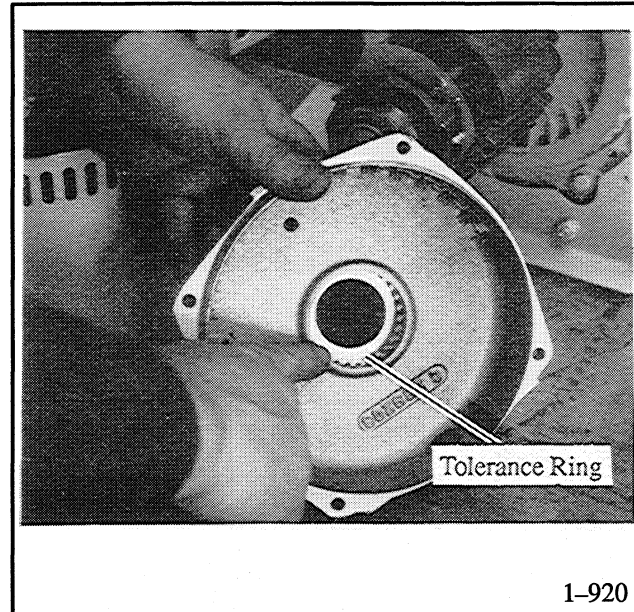

Figure 5-15. Tolerance Ring.

5. Installing end bracket. To determine which procedure should be used, check rotor bearing end for a tapped hole. Newer style rotors have a tapped hole which allows the end bracket/tolerance ring to be drawn over the rotor bearing using a screw, plate, and washers.

The following components are required when installing end bracket on rotor with tapped hole:

Qty.	Description
1	Screw, 3/8-16 x 1-1/2 in.
1	Steel Plate, 3 in. x 3 in. x 1/4 in thickness (7/16 in. dia. hole in center of plate)
2-3	Flat Washer, 1-1/4 in. (O.D.) x 13/32 in. (I.D.). Combined thickness of washers must be 7/32 in. +/- 1/32 in. Kohler Part No. X-25-38.

- a. If rotor has a tapped hole in the shaft, assemble plate and washers on screw and thread on rotor shaft. Tighten screw to draw end bracket/tolerance ring onto rotor bearing. When tightened, end bracket lip should fit snugly in stator shell. Remove mounting screw from rotor shaft.
- b. If rotor does not have a tapped hole in shaft, use a rubber mallet to install end bracket/tolerance ring onto rotor bearing. When mounted, end bracket lip should fit snugly in stator shell.

NOTE

In cases where leads are being reconnected, refer to the wiring diagram on page 6-1.

6. Install overbolts and torque to 70 in. lbs. (7.9 Nm), see Figure 5-16. Stator shell must be tight against engine and end bracket.
7. Reconnect LO ground (neutral and hazard ground) leads to stator shell.
8. Replace capacitor box making sure leads are routed through hole.

9. Reconnect ground leads.
10. Reconnect stator leads (#55 and #66) to capacitor and position capacitor into box.
11. Replace capacitor box cover.
12. Reconnect line and load leads.
13. Replace circuit breaker box cover.

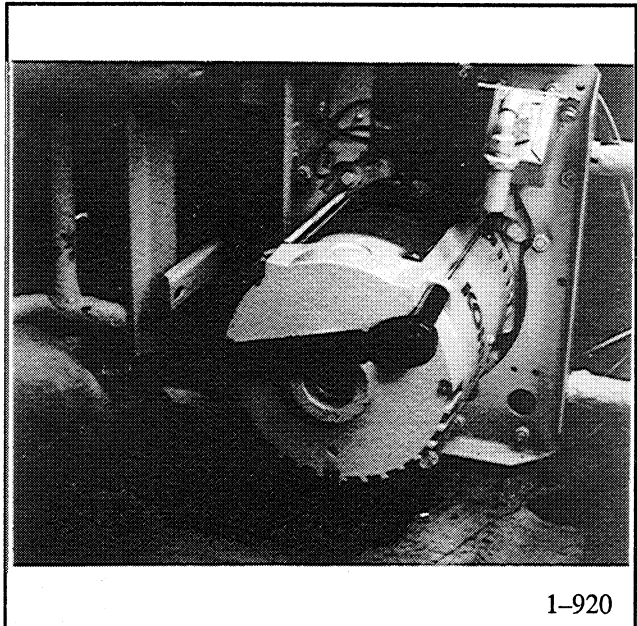

Figure 5-16. Tightening Overbolts

14. Mount splash guard to end bracket, see Figure 5-17.

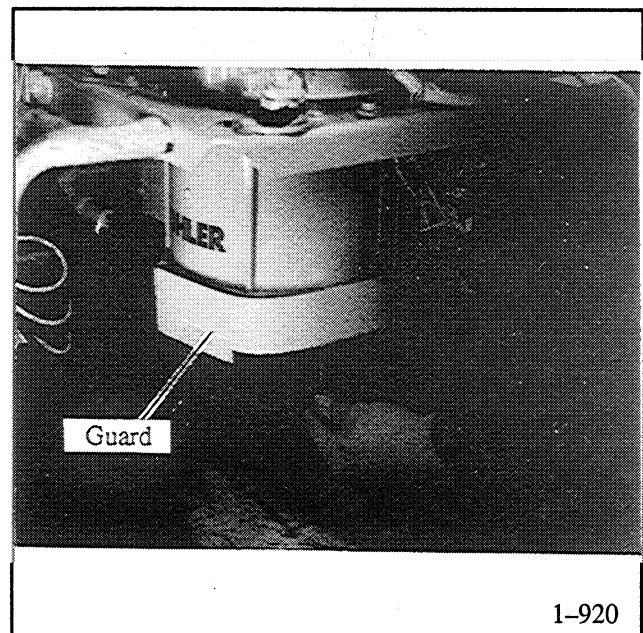

Figure 5-17. Mounting Splash Guard.

15. Prior to start-up, the crankshaft end play (drag) must be checked. Use the following procedure:

NOTE

Failure to check crankshaft end play can cause premature engine wear or engine seizure.

- a. Disconnect spark plug lead and remove spark plug. Place a torque wrench on crankshaft nut and turn clockwise. The force required to turn engine should not exceed 40 in. lbs. (4.5 Nm). See Figure 5-18. If reading is 40 in. lbs. (4.5 Nm) or less, crankshaft play is correct – go to Step 16.

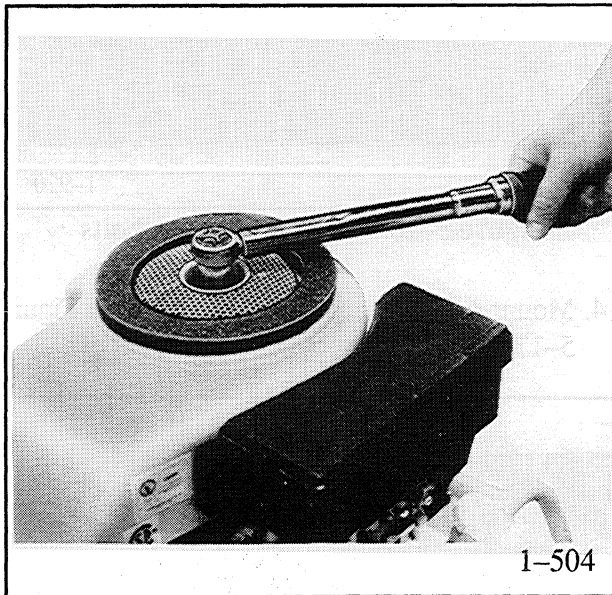
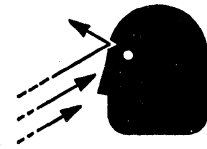

Figure 5-18. Checking Crankshaft End Play (Drag)

! CAUTION



Flying projectiles can cause injury.

Retorque all crankshaft and rotor hardware after servicing. When making adjustments or servicing generator set, do not loosen crankshaft hardware or rotor thru-bolt. If rotating crankshaft manually, direction should be clockwise only. Turning crankshaft bolt or rotor thru-bolt counterclockwise can loosen hardware and result in serious personal injury from hardware or pulley flying off engine while unit is running.

- b. Lightly strike the end bracket with a rubber mallet, see Figure 5-19. Recheck drag using torque wrench. If reading is 40 in. lbs. (4.5 Nm) or less, crankshaft end play is correct – go to Step 16.

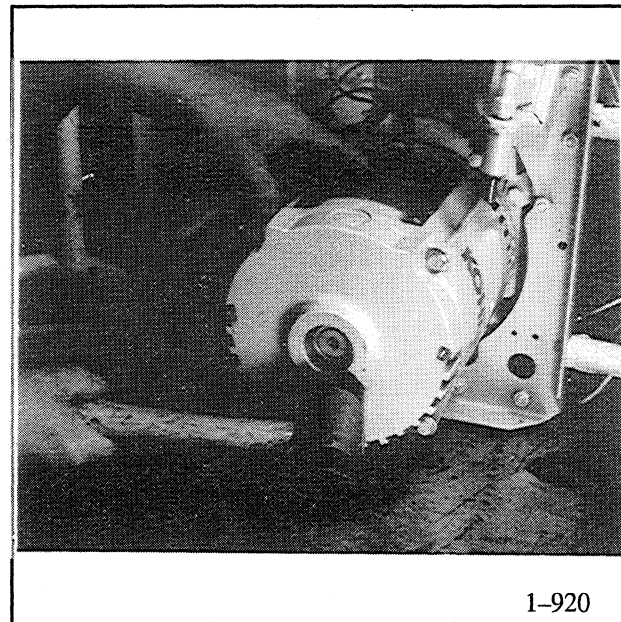

Figure 5-19. Tapping End Bracket

- c. Place a socket over the crankshaft nut (to protect the threads) and strike with a rubber mallet, see Figure 5-20.

NOTE

If required force is greater than 40 in. lbs. (4.5 Nm), generator and engine must be disassembled and components checked for galling. Problem must be corrected before starting the generator set.

16. Install spark plug and torque to 18-23 ft. lbs. (24-31 Nm). Reconnect spark plug lead.

NOTE

If rotor disassembly/reassembly took place, the rotor may require flashing, see Section 4, Loss of Rotor Residual Magnetism.

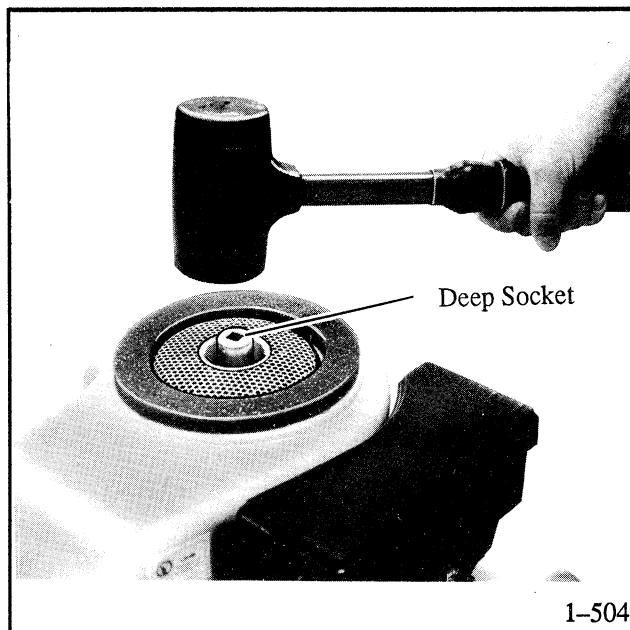
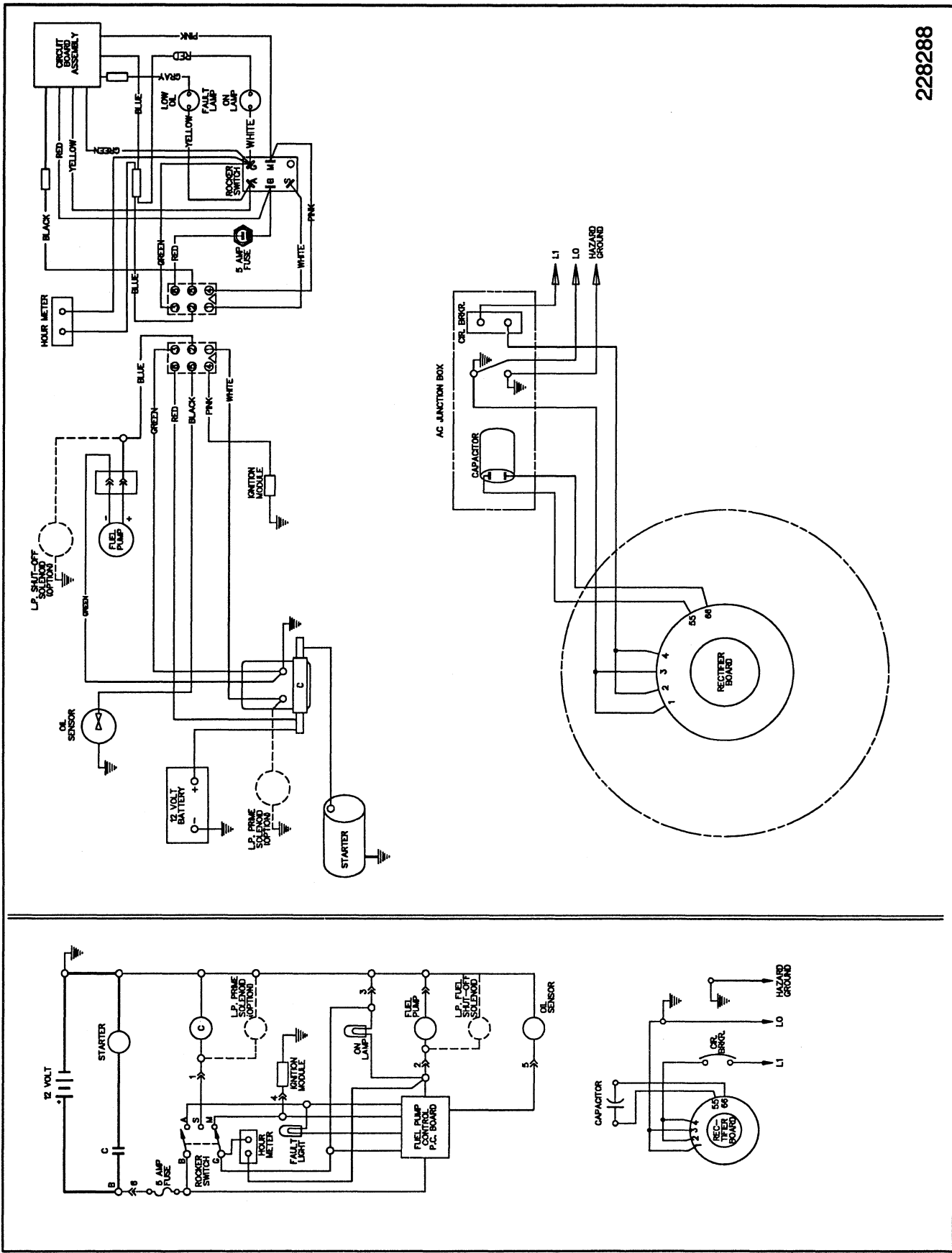
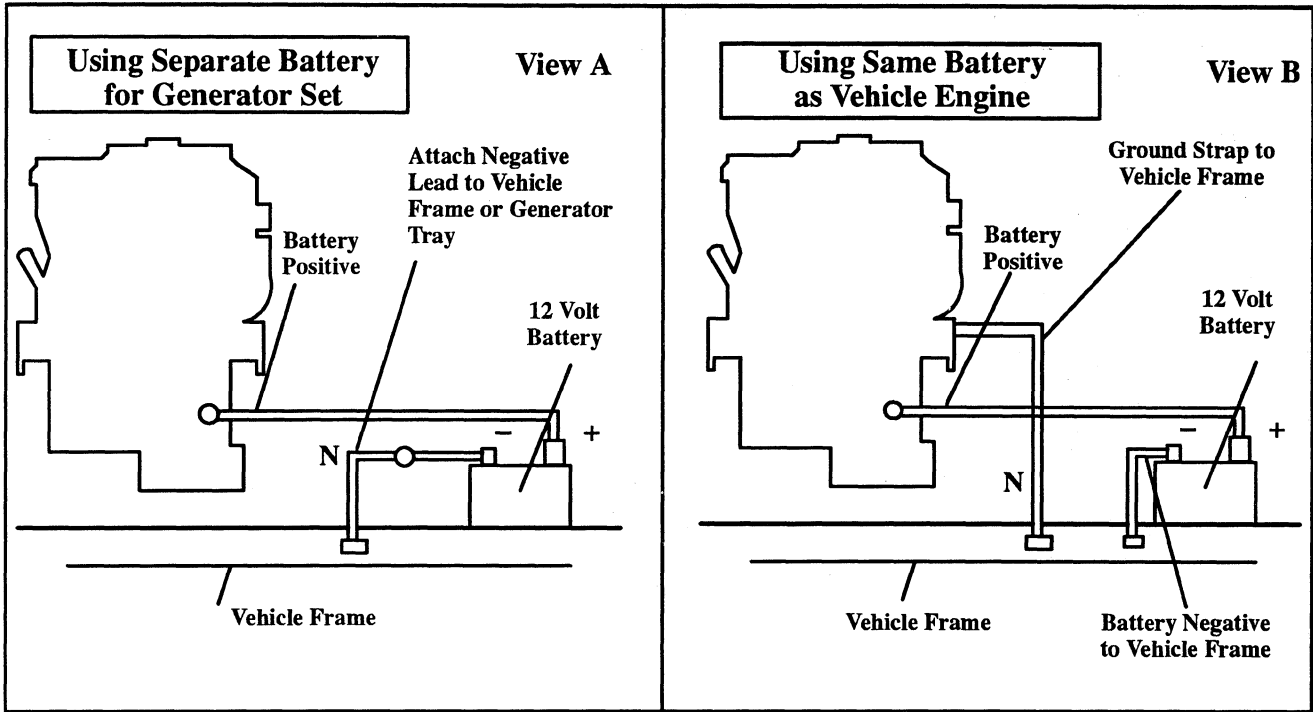

Figure 5-20. Striking Crankshaft Nut

Section 6. Wiring Diagram

228288





Battery Connection Details

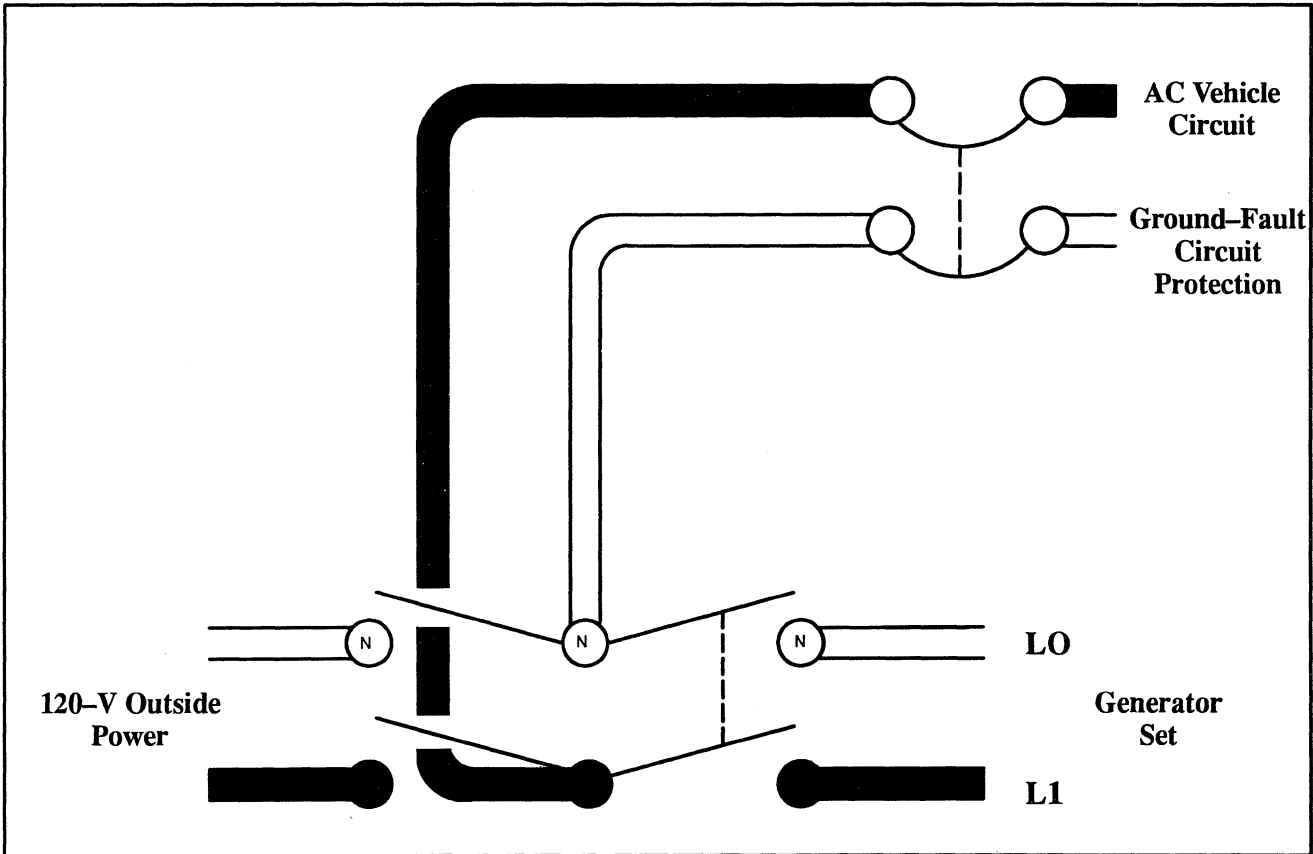

Transfer Switch Connection, 2-Wire AC Circuit

Appendix A. Start/Stop Panel Mounting

The start/stop panel is supplied with your generator set. Mount the panel inside of the motor home and as close to the generator set as possible.

Choke cable length is 72 in. (183 cm) (73 in., 185 cm including knob). The panel should be located so the choke cable will not make any sharp corners or bends within a 3 in. (76 mm) minimum radius. A 3-5/8 in. (9.2 cm) minimum recess is needed for start/stop panel installation.

To install, make a cutout for the panel as shown in Figure 7-1. Insert the start/stop panel into the cutout and mount with the four screws included. A hole must be made through the compartment wall for the choke cable. The cable must be sealed with a flexible sealant (silicone sealer) to make it air tight.

⚠ WARNING



Carbon monoxide can cause death, severe nausea or fainting. When mounting the remote switch with choke cable, make sure the panel is air tight to prevent exhaust fumes from entering the coach.

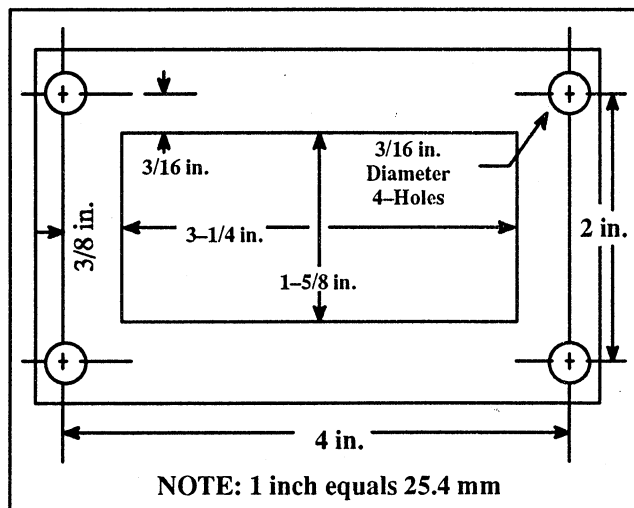

Figure 7-1. Start Panel Cutout Dimensions

To mount remote choke cable to carburetor choke lever, proceed as follows:

1. With remote panel mounted in coach, loosen screw on mounting clamp and slide cable under clamp. See Figure 7-2.

2. With knob on remote panel fully pushed in, cut cable leaving 1-1/4 in. (32 mm) beyond mounting clamp.
3. Remove cable from clamp and cut-off 1-1/4 in. (32 mm) of cable outer-casing. Be careful not to nick or bend cable rod.
4. Bend cable rod using dimensions shown in Figure 7-3. Install cable rod through hole in choke lever, slide cable under clamp and tighten screw. Cable outer-casing should be about flush with end of mounting clamp.
5. Check for full travel of choke lever using choke knob. Adjust as necessary.
6. Connect remote start/stop panel connector to generator set wiring harness connector.

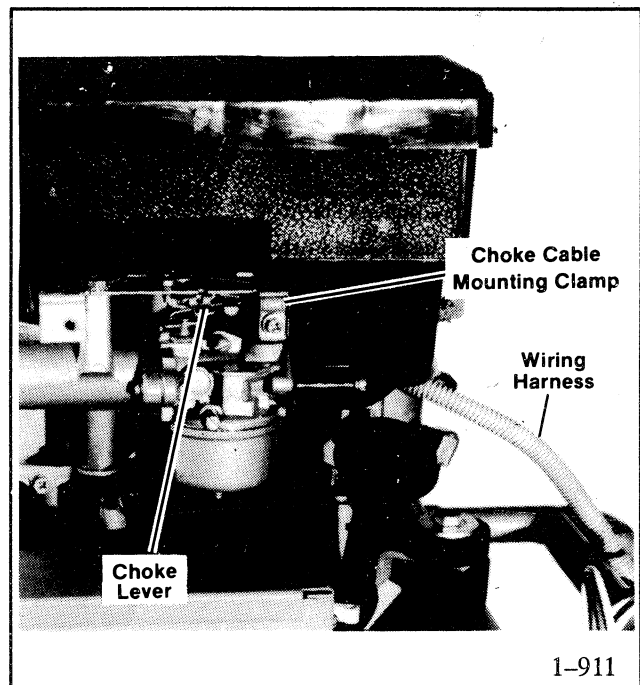

Figure 7-2. Start Panel Connections

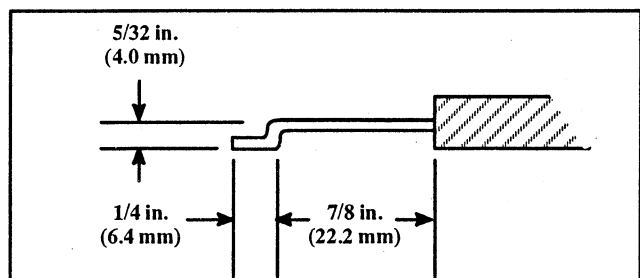

Figure 7-3. Cable Mounting Dimensions

Section 8. Specification Chart

Generator

	2.5 CMZ
Rated kW, 60 Hz	2.5
Rated Voltage	120
Rated Amperes – 120 Volt	20.8
Rotor Resistance (in ohms)	3.2
Stator Resistance (in ohms)	
1–2, 3–4	0.5
55–66	1.5
Overbolt Torque – in. lbs. (Nm)	70 (7.9)
Crankshaft End Play (Drag) Test	40 in. lbs. (4.5 Nm) max.
Generator Type	2–Pole, Rotating Field
Excitation Method	Brushless – Exciter Capacitor/Winding
Circuit Breaker (Amperes)	25

Engine

	2.5 CMZ
Manufacturer	Tecumseh
Model	TVM140, four–cycle, air cooled
No. of Cylinders	One
Bore x Stroke – in. (mm)	2–5/8 x 2–1/2 (66.7 x 63.5)
Displacement – cu. in. (cc)	13.53 (221.75)
Compression Ratio	6.69:1
Horsepower	6.0
RPM @ 60 Hz	3600
Lube Oil Capacity – qts. (L)	1.25 (1.08)
Battery Voltage	12
Battery Recommendation	55 Amp. Hr.
Spark Plug Type (Champion)	RJ–8 or RJ–17LM
Spark Plug Gap – in. (mm)	0.030 (0.76)
Plug Tightening Torque	18–23 ft. lbs. (24.31 Nm)
Ignition System	Electronic
Timing Dimensions (B.T.D.C.)	0.080 in. (2.03 mm)
Valve Clearance (Cold)	0.010 in. (0.254 mm)
Carburetor Main Adj.	
(Preliminary Turns Out)	1–1/4
Carburetor Idle Adj.	
(Preliminary Turns Out)	3/4
Electric Fuel Pump	12 Volt, 1.75 psi (12.1 kPa)
Fuel Type	Unleaded Regular Gasoline

Installation

Weight

without muffler)	93.75 lbs. (42.19 kg)
(with muffler)	99.75 lbs. (44.89 kg)
Length – overall	15.75 in. (400 mm)
Width – overall	14.00 in. (356 mm)
Height – overall	19.74 in. (501 mm)

Weight and Dimensions

Load	25%	50%	75%	100%
2.5kW – Gasoline gph (Lph)	0.28 (1.1)	0.38 (1.4)	0.48 (1.8)	0.56 (2.1)
2.5kW – LP gph (Lph)	0.29 (1.0)	0.34 (1.3)	0.41 (1.6)	0.51 (1.9)

Fuel Inlet Connection Size –

Gasoline 1/4 I.D. (6.3 mm)

Fuel Consumption and Fuel Inlet Size

Side	2 in. (50.8 mm) on spark plug side
.	1 in. (25.4 mm) on opposite side
Top	1/4 in. (6 mm) + air duct (see air requirements)
Rear	1 in. (25.4 mm)
Font	1/4 in. (6 mm)

Minimum Clearance Requirements

Distance Between Generator Set and Battery	Cable Size (AWG)		
	At 0°F (-18°C)	at 32°F (0°C)	At 75°F (24°C)
40 Feet (12.2 m)	00	0	1
30 Feet (9.1 m)	0	1	2
25 Feet (7.6 m)	1	2	4
20 Feet (6.1 m)	2	2	6
15 Feet (4.6 m)	2	4	6
10 Feet (3.0 m)	4	6	8
5 Feet (1.5 m)	6	6	8
2.5 Feet (0.8 m)	8	8	8

Battery Cable Size Chart

Motor Requirements	1/4 HP	1/3 HP	1/2 HP	3/4 HP
Starting (In-Rush)	750	1000	1500	2000
Running Watts	350	400	600	750

Motor Requirements

Electrical Appliance	Rating (Watts)	Electrical Appliance	Rating (Watts)
Blanket	50–250	Heater, Water	1500
Blender	600	Pan, Frying	1200
Broiler	1350	Percolator, Coffee	650
Dryer, Hair	500–1200	Radio	50–100
Fan, Air Circulating	25–100	Television	300–750
Fan, Furnace	270	Toaster	750–1200
Heater, Space	750–1500		

Appliance Requirements

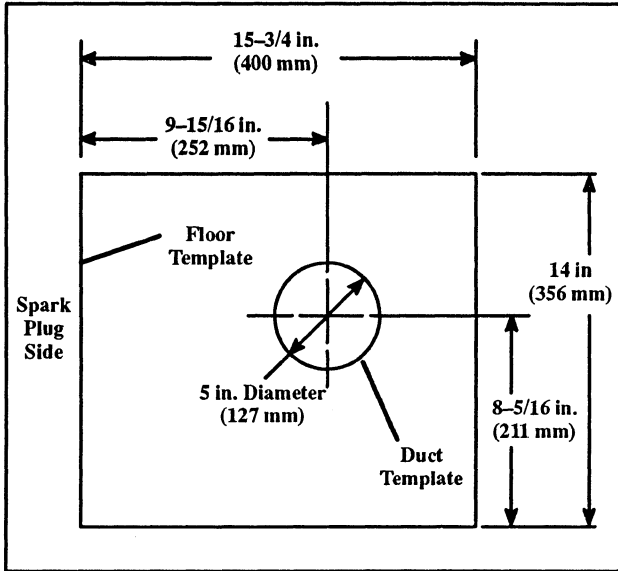

Air Duct Dimensions

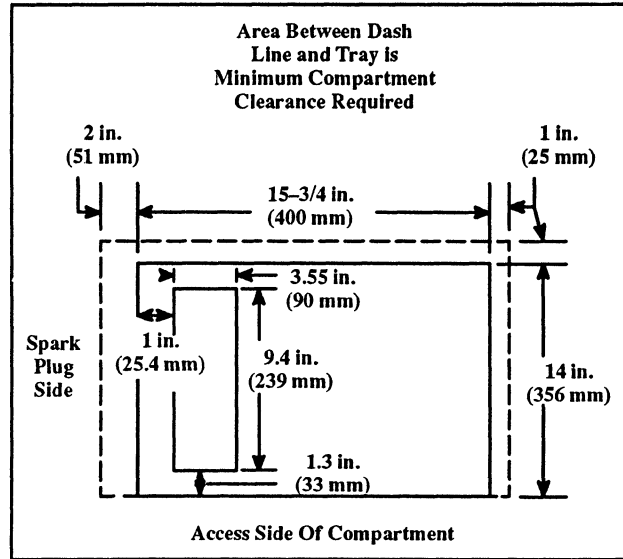

Floor Dimensions

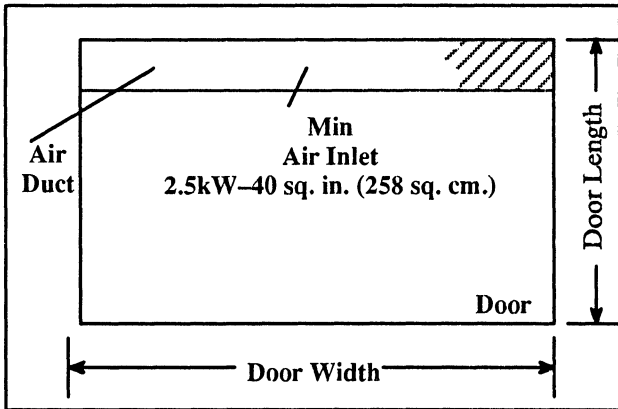

Air Requirements and Compartment Door Details

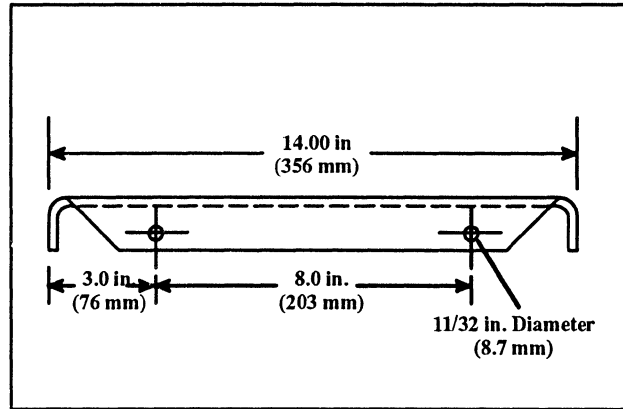

Tray Mounting Hole Dimensions

KOHLER[®]
POWER SYSTEMS

KOHLER CO. KOHLER, WISCONSIN 53044
PHONE 414-565-3381, TELEX 26888, FAX 414-565-3648
FOR SALES & SERVICE IN U.S.A. & CANADA PHONE 1-800-544-2444

TP-5403 10/91

PRINTED IN U.S.A.