

Service Manual

RV/Mobile Generator Sets



Models:

7CCO

7CCFO

10CCO

10CCFO

KOHLER[®]
POWER SYSTEMS

Table of Contents

SUBJECT	PAGE	SUBJECT	PAGE
SAFETY PRECAUTIONS and INSTRUCTIONS ..	i	Cleaning	3-20
SECTION 1. INTRODUCTION	1-1	Checking Electrolyte Level	3-20
Specifications	1-1	Checking Specific Gravity	3-21
Generator	1-1	Generator Service	3-22
Engine	1-1	General	3-22
Service Views	1-3	Wattage Requirements	3-22
SECTION 2. OPERATION	2-1	Storage Procedure	3-23
Prestart Checks	2-1	SECTION 4. GENERAL TROUBLESHOOTING	4-1
Controller	2-2	Engine	4-2
Start Procedure	2-3	Electrical System	4-11
Stop Procedure	2-3	Generator	4-13
Circuit Protection	2-4	SECTION 5. CONTROLLER	
Engine Safety Shutdown Switches	2-5	TROUBLESHOOTING	5-1
Accessories	2-6	Sequence of Operation	5-1
SECTION 3. SCHEDULED MAINTENANCE ...	3-1	SECTION 6. GENERATOR/CONTROLLER	
Service Schedule	3-2	TROUBLESHOOTING	6-1
Lubrication System	3-3	Controller Circuit Board	6-1
Oil Selection	3-3	SECTION 7. COMPONENT TESTING AND	
Oil Check	3-3	ADJUSTMENT	7-1
Oil Change	3-4	Separate Excitation	7-1
Oil Filter	3-5	PowerBoost™ III E Voltage Regulator Test	7-3
Fuel System	3-6	Rotor	7-6
Specifications	3-6	Stator (with PowerBoost™ III E Voltage Regulator)	7-7
Fuel Filter	3-6	Brushes	7-9
Fuel Filter (Supplied Loose)	3-7	Slip Ring Replacement	7-9
Fuel/Water Separator (if equipped)	3-8	Controller Circuit Board	7-10
Bleeding the Fuel System	3-9	Engine/Generator Components	7-12
Air Cleaner Service	3-10	Fuel Solenoid	7-16
Governor	3-11	Remote Start Panels (Optional)	7-17
Valve Adjustment	3-12	SECTION 8. DISASSEMBLY/REASSEMBLY ..	8-1
Cylinder Head Retightening	3-13	Disassembly	8-1
Cooling Systems	3-14	Reassembly	8-5
Filling and Checking	3-14	SECTION 9. WIRING DIAGRAMS	9-1
Flushing and Cleaning	3-14	SECTION 10. SPECIFICATIONS	10-1
Pressure Cap	3-14	Generator Models	10-1
Servicing Cooling System	3-16	Engine Models	10-3
Belt Tension	3-18	Installation	10-4
Battery Charging	3-18	Common Hardware Application Guidelines ...	10-6
Battery	3-19	General Torque Specifications	10-10

Glossary of Abbreviations

Abbreviations are used throughout this manual. Normally in the text they will appear in complete form with the abbreviation following in parentheses the first time they are used. After that they will appear in the abbreviated form. The commonly used abbreviations are shown below.

ABDC	after bottom dead center	cu. in.	cubic inch, cubic inches
AC	alternating current	cyl.	cylinder
AISI	American Iron and Steel Institute	dBA	decibels
AHWT	anticipatory high water temp.	DC	direct current
ALOP	anticipatory low oil pressure	DCR	direct current resistance
AM	amplitude modulation	deg.	degree
amp.	ampere	dept.	department
amps.	amperes	dia.	diameter
ANSI	American National Standard Institute	DIN	Deutsches Institut fur Normung e. V. (also Deutsche Industrie Normenausschuss)
API	American Petroleum Institute	e.g.	example given
approx.	approximate, approximately	EIA	Electronic Industries Association
A/R	as required, as requested	EMI	electromagnetic interference
A/S	as supplied, as stated, as suggested	EPA	Environmental Protection Agency
ASA	American Standards Association (former name of ANSI)	etc.	etcetera, (and so forth)
ASME	American Society of Mechanical Engineers	ext.	external
assy.	assembly	°F	Fahrenheit degree
ASTM	American Society for Testing Materials	fl. oz.	fluid ounce, fluid ounces
ATDC	after top dead center	FM	frequency modulation
aux.	auxiliary	ft.	foot, feet
A/V	audio-visual	ft. lbs.	foot pound, foot pounds
AWG	American Wire Gauge	fs	full scale
AWM	appliance wiring material	ga.	gauge (meters, wire size)
BBDC	before bottom dead center	gal., gals.	gallon, gallons
BDC	before dead center	gal./hr.	gallons per hour
bhp	brake horsepower	gph	gallons per hour
bmep	brake mean effective power	gpm	gallons per minute
B.&S.	Brown & Sharpe Wire Gauge	gr.	grade
BTDC	before top dead center	grd.	ground
Btu	British thermal unit	HCHT	high cylinder head temperature
°C	Celsius degree	HET	high exhaust temperature
cc	cubic centimeter	Hg	mercury (element)
CCA	cold cranking Amps.	H ₂ O	water
CEC	Canadian Electrical Code	hp	horsepower
cfh	cubic feet per hour	hr, hrs	hour
cfm	cubic feet per minute	HWT	high water temperature
CID	cubic inch displacement	Hz	hertz (cycles per second)
cm	centimeter, centimeters	ID	inside diameter
cmm	cubic meters per minute	IEEE	Institute of Electrical and Electronics Engineers
co.	company	in.	inch(es)
cont'd.	continued	inc.	incorporated
CPVC	chloropoly vinyl chloride	in. lbs.	inch pounds
CRT	cathode ray tube	int.	internal
C.S.A.	Canadian Standards Association	int.-ext.	internal-external
CT	current transformer		

ISO	International Standards Organization	NPT	National Standard taper pipe thread per general use
J	joule, joules	N/R	not required
JIS	Japanese Industry Standard	OC	overcrank
kg	kilogram, kilograms	OD	outside diameter
kg/cm ²	kilograms per square centimeter	OEM	original equipment manufacturer
kgm	kilogram meter(s)	OS	overspeed, oversize
km	kilometer, kilometers	OSHA	Occupational Safety and Health Act
kPa	kiloPascal, kiloPascals	OV	overvoltage
kph	kilometers per hour	oz.	ounce, ounces
kV	kilovolt	PF	power factor
kVA	kilovolt amperes	PMG	permanent magnet generator
kW	kilowatt, kilowatts	pot.	potentiometer
kWH	kilowatt hour	ppm	parts per million
L	liter, liters	psi	pounds per square inch
L x W x H	length x width x height	pt., pts.	pint, pints
LED, LEDs	light emitting diode	PVC	polyvinyl chloride
lb., lbs.	pound, pounds	qt., qts.	quart, quarts
L/hr.	liter per hour, liters per hour	qty.	quantity
L/min.	liter(s) per minutes,	ref.	reference
LOP	low oil pressure	RFI	radio frequency interference
LP	liquefied petroleum	r.h.m.	round head machine (screw)
LWT	low water temperature	rms	root mean square
m	meter, meters	rpm	revolutions per minute
m ³	cubic meter, cubic meters	RV	recreational vehicle
max.	maximum	SAE	Society of Automotive Engineers
MCM	one thousand circular mils.	SCR	silicon controlled rectifier
MHz	megahertz	sec.	second, seconds
mi.	mile, miles	spec, specs	specification
mil	one one-thousandth of an inch	sq.	square
min.	minimum	sq. cm	square centimeters
mJ	milli joule, milli joules	sq. in.	square inch, square inches
MJ	mega joule, mega joules	tach	tachometer
mm	millimeter, millimeters	TDC	top dead center
m ³ /min	cubic meters per minute	tech. pub.	technical publications
MPa	megaPascal	temp.	temperature
MPG	miles per gallon	TIF	telephone influence factor
mph	miles per hour	TP, TPs	technical publications
MS	military standard	turbo	turbocharger
mW	milliwatt, milliwatts	UHF	ultra high frequency
MW	megawatt, megawatts	UNC	Unified coarse thread (was NC)
N/A	not available	UNF	Unified fine thread (was NF)
NBS	National Bureau of Standards	UL	Underwriter's Laboratories, Inc.
NEC	National Electrical Code	US	undersize
NEMA	National Electrical Manufacturers Association	V	volt, volts
meggar	megohmmeter	VAC	volts alternating current
misc.	miscellaneous	VDC	volts direct current
NFPA	National Fire Protection Association	VHF	very high frequency
Nm	Newton meter, Newton meters	W	watt, watts
no., nos.	number, numbers		

Safety Precautions and Instructions

A Generator Set, like any other electro-mechanical device can pose potential dangers to life and limb if improperly maintained or imprudently operated. The best way to prevent accidents is to be aware of the potential dangers and to always use good common sense. In the interest of safety, some general precautions relating to operating of a Generator Set follow. Keep these in mind. This manual contains several types of safety precautions which are explained below.



DANGER

Danger is used to indicate the presence of a hazard which will cause severe personal injury, death, or substantial property damage if the warning is ignored.



WARNING

Warning is used to indicate the presence of a hazard which can cause severe personal injury, death, or substantial property damage if the warning is ignored.



CAUTION



Caution is used to indicate the presence of a hazard which will or can cause minor personal injury or property damage if the warning is ignored.

NOTE

Note is used to notify people of installation, operation, or maintenance information which is important but not hazard-related.

Safety decals are affixed to the generator set in prominent places to advise the operator or service technician of potentially hazardous situations. The decals are reproduced here to improve operator recognition and thereby increase decal effectiveness. For a further explanation of decal information, reference the accompanying safety precautions. Before operating or servicing the generator set, be sure you understand the message of these decals. Replace decals if missing or damaged.

EXHAUST SYSTEM

 WARNING

<p>Carbon monoxide. Can cause severe nausea, fainting, or death.</p> <p>The exhaust system must be leakproof and routinely inspected.</p>

Carbon monoxide can cause severe nausea, fainting, or death. Install exhaust system tail pipe so discharged exhaust gases will not be drawn into vehicle interior through windows, doors, air conditioners, etc. Do not use flexible tail piping since this type could crack and allow lethal exhaust fumes to enter the vehicle.

Carbon monoxide can cause severe nausea, fainting, or death. Never operate the generator set inside a building unless the exhaust gas is piped safely outside. Never operate in any area where exhaust gas could accumulate and seep back inside an occupied building or vehicle. Be careful when parking your vehicle to avoid obstructing the exhaust outlet. The exhaust gases must discharge freely, otherwise carbon monoxide may deflect into the vehicle. Avoid breathing exhaust fumes when working on or near the generator set. Carbon monoxide is particularly dangerous because it is an odorless, colorless, tasteless, nonirritating gas which can cause death if inhaled for even a short period of time.

Carbon monoxide can cause severe nausea, fainting, or death. Diesel fumes can rapidly destroy copper tubing in diesel exhaust systems. Do not use copper tubing in diesel exhaust systems. Exhaust sulphur will cause rapid deterioration and this could result in exhaust leakage.

(Diesel Models only.)

ACCIDENTAL STARTING





Accidental starting.

Can cause severe injury or death.

Disconnect battery cables before working on generator set (negative lead first and reconnect it last).

Accidental starting can cause severe injury or death. Disconnect battery cables (remove negative lead first and reconnect it last) to disable generator set before working on any equipment connected to generator. The generator set can be started by remote start/stop switch unless this precaution is followed.

MOVING PARTS

⚠ WARNING	
	
Hazardous voltage.	Moving rotor.
Can cause severe injury or death.	
Do not operate generator set without all guards and electrical enclosures in place.	

⚠ WARNING	
	
Rotating parts.	
Can cause severe injury or death.	
Do not operate generator set without all guards, screens, or covers in place.	

Exposed moving parts can cause severe injury or death. Keep hands, feet, hair, clothing, and test leads away from belts and pulleys when unit is running. Replace guards, covers, and screens before operating generator set.



Flying projectiles can cause severe injury or death. Retorque all crankshaft and rotor hardware after servicing. When making adjustments or servicing generator set, do not loosen crankshaft hardware or rotor thru-bolt. If rotating crankshaft manually, direction should be clockwise only. Turning crankshaft bolt or rotor thru-bolt counterclockwise can loosen hardware and result in serious personal injury from hardware or pulley flying off engine while unit is running.

ENGINE BACKFIRE/FLASH FIRE

⚠ WARNING	
	
Fire.	
Can cause severe injury or death.	
Do not smoke or permit flame or spark to occur near fuel or fuel system.	

A sudden backfire can cause severe injury or death.
Do not operate with air cleaner removed.

HAZARDOUS VOLTAGE/ ELECTRICAL SHOCK

⚠ WARNING	
	
Hazardous voltage.	Moving rotor.
Can cause severe injury or death.	
Do not operate generator set without all guards and electrical enclosures in place.	

⚠ WARNING	
	
Hazardous voltage.	
Backfeed to utility system can cause severe injury, death, or property damage.	
Do not connect to any building electrical system without connecting through an approved device and after building main switch is open.	

Hazardous voltage can cause severe injury or death. The heat sink of the voltage regulator contains high voltage. Do not touch voltage regulator heat sink when testing or electrical shock will occur.

(PowerBoost, PowerBoost III, and PowerBoost V Voltage Regulator Models only.)

Hazardous voltage can cause severe injury or death. Perform electrical service only as prescribed in equipment manual. Be sure that generator is properly grounded. Never touch electrical leads or appliances with wet hands, when standing in water, or on wet ground as the chance of electrocution is especially prevalent under such conditions. Wiring should be inspected at the interval recommended in the service schedule—replace leads that are frayed or in poor condition. The function of a generator set is to produce electricity and wherever electricity is present, there is the hazard of electrocution.

Hazardous “backfeed” voltage can cause severe injury or death. The generator must not be used to “backfeed” by connecting it to building/campground electrical circuits. Install a transfer switch in vehicle generator installations to prevent connection of vehicle and other sources of power. Electrical backfeed into a utility electrical system can cause serious injury or death to utility personnel working on transmission lines.

Hazardous voltage can cause severe injury or death. Short circuits can cause bodily injury and/or equipment damage. Do not contact electrical connections with tools or jewelry while adjustments are made. Remove wristwatch, rings, and jewelry that can cause short circuits.

FUEL SYSTEM

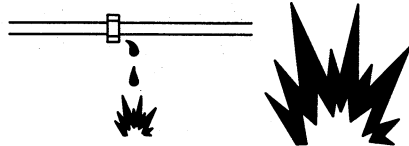

**Explosive fuel vapors.
Can cause severe injury or death.**

Use extreme care when handling, storing,
and using fuels.

Explosive fuel vapors can cause severe injury or death. All fuels are highly explosive in a vapor state. Use extreme care when handling, storing, and using fuels. Store fuel in a well-ventilated area away from spark producing equipment and out of the reach of children. Never add fuel to the tank while the engine is running since spilled fuel may ignite on contact with hot parts or from ignition spark. Do not smoke or permit flame or spark to occur near potential sources of spilled fuel or fuel vapors. Keep fuel lines and connections tight and in good condition—don't replace flexible fuel lines with rigid lines. Flexible sections are used to avoid breakage due to vibration. Should any fuel leakage, fuel accumulation, or electrical sparks be noted, **DO NOT OPERATE GENERATOR SET.** Have systems repaired before resuming generator operation.

Explosive fuel vapors can cause severe injury or death. Spilled fuel can cause an explosion. Use a container to catch fuel when draining fuel system. Wipe up all spilled fuel after draining system.

HAZARDOUS NOISE



**Hazardous noise.
Can cause loss of hearing.**

Never operate generator without a muffler or
with faulty exhaust system.

BATTERY

⚠ WARNING





**Sulfuric acid in batteries.
Can cause severe injury or death.**

Use protective goggles and clothes. Can cause permanent damage to eyes, burn skin, and eat holes in clothing.

Sulfuric acid in batteries can cause severe injury or death. Sulfuric acid in battery can cause permanent damage to eyes, burn skin, and eat holes in clothing. Always wear splash-proof safety goggles when working around the battery. If battery electrolyte is splashed in the eyes or on skin, immediately flush the affected area for 15 minutes with large quantities of clean water. In the case of eye contact, seek immediate medical aid. Never add acid to a battery once the battery has been placed in service. Doing so may result in hazardous spattering of electrolyte.

Explosion can cause severe injury or death. Battery gases can cause an explosion. Do not smoke or permit flame or spark to occur near a battery at any time, particularly when it is being charged. Avoid contacting terminals with tools, etc. to prevent burns and to prevent sparks that could cause an explosion. Remove wristwatch, rings, and any other jewelry before handling battery. Never connect negative (-) battery cable to positive (+) connection terminal of starter solenoid. Do not test battery condition by shorting terminals together or sparks could ignite battery gases or fuel vapors. Any compartment containing batteries must be well ventilated to prevent accumulation of explosive gases. To avoid sparks, do not disturb battery charger connections while battery is being charged and always turn charger off before disconnecting battery connections. When disconnecting battery, remove negative lead first and reconnect it last.

HOT PARTS

 WARNING

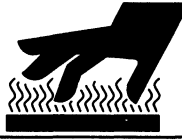
<p>Hot coolant and steam. Can cause severe injury or death.</p> <p>Before removing pressure cap stop generator, allow to cool and loosen pressure cap to relieve pressure.</p>

 WARNING

<p>Hot engine and exhaust system. Can cause severe injury or death.</p> <p>Do not work on generator set until unit is allowed to cool.</p>

Hot coolant can cause severe injury or death. Allow engine to cool and release pressure from cooling system before opening pressure cap. To release pressure, cover the pressure cap with a thick cloth then turn it slowly counterclockwise to the first stop. After pressure has been completely released and the engine has cooled, remove cap. If generator set is equipped with a coolant recovery tank, check coolant level at tank.

Hot parts can cause severe injury or death. Do not touch hot engine parts. An engine gets hot while running and exhaust system components get extremely hot.

Fire can cause severe injury or death. Hot exhaust system can ignite adjacent combustible materials. Do not locate electrical wiring, fuel lines, or combustible material above the exhaust muffler. Be careful when parking your vehicle to prevent grass fires started by exhaust system and hot exhaust gases.

Fire can cause severe injury or death. Hot generator can ignite debris in compartment. Keep the compartment and generator set clean and free of debris and combustible materials to minimize chances of fire. Do not block fuel/oil drain opening in generator mounting tray. If sub-flooring is used, cut a corresponding hole in the sub-flooring for drain opening.

NOTES

NOTICE
This generator set has been rewired from its nameplate voltage to:
<div style="border: 1px solid black; width: 100%; height: 30px;"></div>
246242

NOTICE
This is a positive terminal only. Do not attach negative lead!

NOTE

This generator set does not comply with United States Coast Guard (U.S.C.G.) requirements and must not be used for marine applications. Use only generator sets specified for marine use in marine installations. U.S.C.G. Regulation 33CFR183 requires a generator set to be "ignition protected" when used in a gasoline-fueled environment.

NOTE

Do not "tee" into fuel injected fuel systems. Use a two dip tube arrangement for fuel supply. Consult an Authorized Kohler Service Dealer for further fuel system installation information.

NOTE

Wipe up all spilled diesel fuel after bleeding system. Wash hands after any contact with fuel oil. *(Diesel models only).*

NOTE

Special attention should be given when checking for proper coolant level. After the coolant has been drained, it normally requires some time before complete refill of the engine water jacket takes place.

NOTE

HARDWARE DAMAGE! Engine and generator may make use of both American Standard and metric hardware. Be sure to use the correct size tools to prevent rounding of bolt heads and nuts.

NOTE

When replacing hardware, do not substitute with inferior grade hardware. Screws and nuts are available in different hardness ratings. American Standard hardware uses a series of markings and metric hardware uses a numeric system to indicate hardness. Check markings on bolt head and nuts for proper identification.

Section 1. Introduction

Service requirements are minimal but are very important to the safe and efficient operation of the generator set.

Please take a few moments to read this manual, then carefully follow all service recommendations to keep the generator set in top condition. See Figure 1-1 for

identification and location of components.

All information found in this publication is based on data available at time of printing. Kohler Co. reserves the right to make changes to this literature and the products represented at any time without notice and without incurring obligation.

Specifications

Generator

Model Series	Voltage Code	Voltage	Amps.	kW/kVA	PH
60 Hz Models:					
7CCO	61/67	120/240	58.4/29.2	7/7	1
7CCO	101/107	100/200	70.0/35.0	7/7	1
7CCO	11/17	100	70	7/7	1
50 Hz Models:					
7CCFO	61/67	110/220	52.8/26.4	5.8/5.8	1
7CCFO	11/17	100/200	58.0/29.0	5.8/5.8	1
7CCFO	101/107	120/240	48.4/24.2	5.8/5.8	1
7CCFO	41/47	220	26.4	5.8/5.8	1
60 Hz Models:					
10CCO	61/67	120/240	83.4/41.7	10/10	1
10CCO	101/107	100/200	100.0/50.0	10/10	1
50 Hz Models:					
10CCFO	61/67	110/220	75.6/37.8	8.3/8.3	1
10CCFO	101/107	100/200	83.0/41.5	8.3/8.3	1
10CCFO	61/67	120/240	69.2/34.6	8.3/8.3	1
10CCFO	41/47	220	37.8	8.3/8.3	1

NOTE

DERATING: All units are rated 1.0 power factor. The kilowatts of the generator set will decrease 3.5% per 1000 ft. (305 m) above 500 ft. (152 m) above sea level. Derate 1% for every 10°F (5.5°C) above 85°F (30°C).

Engine

The 7CCO/CCFO is powered by a Kubota D905BG-2 three-cylinder, four-cycle diesel engine.

The 10CCO/CCFO is powered by a Kubota V1305BG-2 four-cylinder, four-cycle diesel engine.

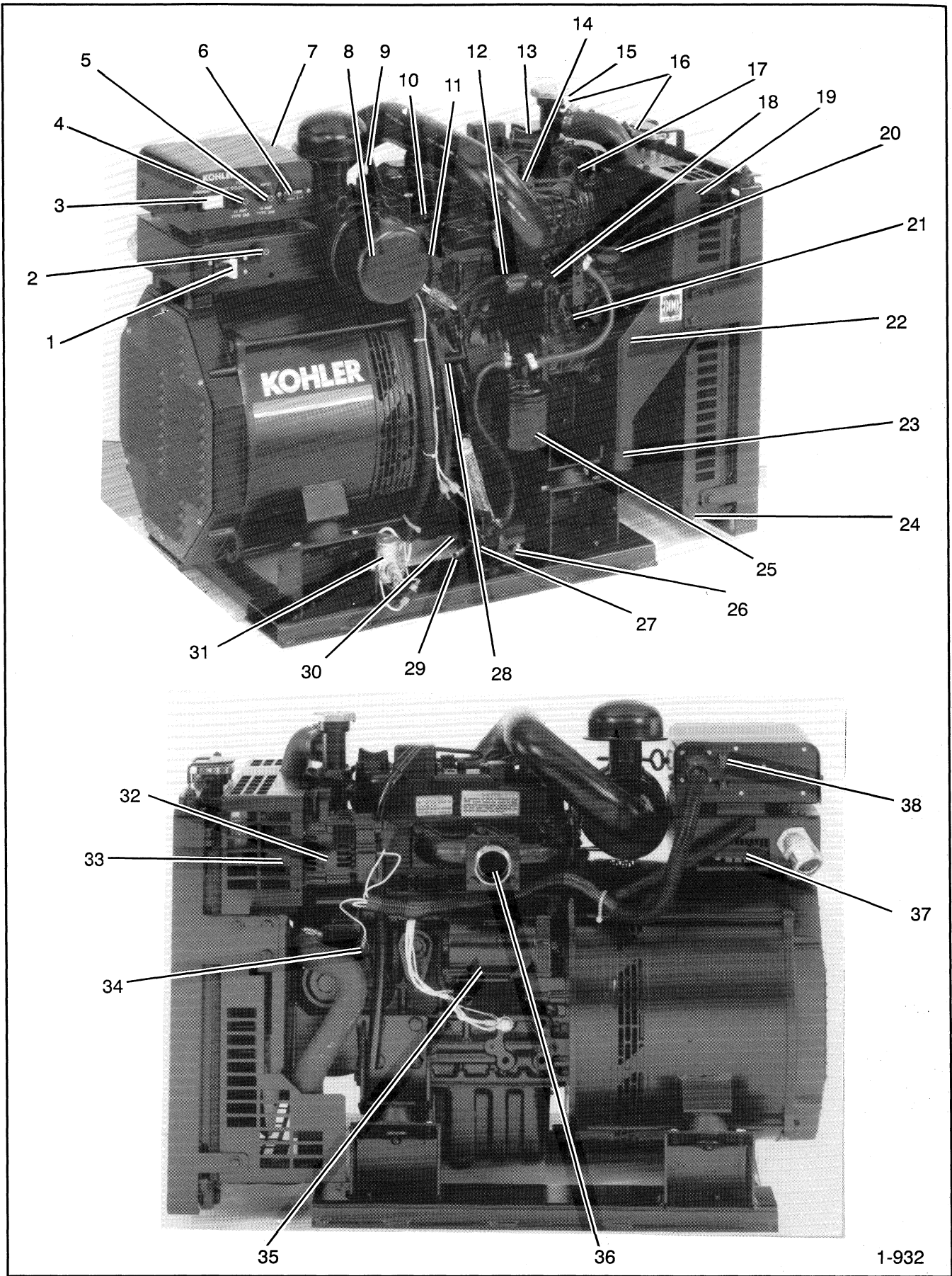

Figure 1-1. Service Views - 7CCO Shown.

SERVICE VIEWS

1. AC Circuit Breaker
2. Voltage Regulator Fuse
3. Start-Stop/Preheat Switch
4. Fuel Solenoid Fuse
5. Controller Fuse
6. Hourmeter
7. Controller
8. Air Cleaner
9. Lifting Eye
10. Fuel Return Connection Point
11. High Water Temperature Shutdown
12. Fuel Solenoid
13. Oil Fill
14. Fuel Injectors
15. Coolant Fill
16. Pressure Cap
17. Lifting Eye
18. Fuel Injection Pump
19. Inline Radiator
20. Oil Fill
21. Mechanical Governor
22. Nameplate
23. Oil Filter
24. Coolant Drain
25. Fuel Filter
26. Ground Connection
27. Fuel Pump
28. Oil Check
29. Fuel Inlet Connection Point
30. Oil Drain
31. Glow Plug Relay
32. Battery Charging Alternator
33. Belt Guard
34. Low Oil Pressure Shutdown
35. Starter
36. Exhaust Outlet
37. Voltage Regulator
38. Remote Connection

Section 2. Operation

Prestart Checks

To insure continued satisfactory operation, the following items should be checked before each startup.

OIL LEVEL: Should be at or near Full mark (not over).

AIR INLETS: Must be clear and unobstructed.

COMPARTMENT: Interior must be clean. Check the condition of fuel system, exhaust piping, hoses, and muffler. If fuel leaks, fumes, exhaust gases, or electrical sparks are noted, contact a qualified service technician before operating the generator set.

AIR CLEANER: Must be clean and properly installed to prevent unfiltered air from entering the engine.

ELECTRICAL: All connections (including battery) must be tight.

FUEL LEVELS: Make sure the fuel tank(s) are full and the fuel system primed for operation.

COOLING: If the cooling system is equipped with a coolant recovery tank, check the coolant level at the tank. Maintain the level according to markings on the tank. On units without coolant recovery tanks, remove the pressure cap to check coolant level. Coolant level should be just below the overflow tube.

BATTERY: Check the connections and level of the battery electrolyte.

OPERATING AREA: Make sure there are no obstructions that could block the flow of cooling air. Make sure the area is clean. Rags, tools, or debris must not be left on or near the generator set.

EXHAUST SYSTEM: Exhaust outlet must be clear; silencer and piping must be tight and in good condition. Exhaust gas must be vented safely outside.

Controller

Depending on the application, the Kohler relay controller may be located at the set or at a location remote from the generator. Remote harnesses for the controller are available in 7.5- and 15-foot (2.3- and 4.6-meter) lengths. If the generator set has automatically stopped due to high water temperature (230°F/110°C) or low oil pressure (7 psi/48.3 kPA or less), the cause must be corrected before the set can be restarted.

For identification of controller, see Figure 2-1 and Figure 2-2.

1. **Generator Start and Stop/Preheat Switch** serves as dual function of generator operation and generator preheat. When pressed to the “preheat” position, the preheat switch aids in cold-weather starting. Refer to “Start/Stop” and “Preheating procedures following.
2. **Fuel Solenoid Fuse** (10-amp.) protects the fuel solenoid circuitry.
3. **Controller Fuse** (10-amp.) protects controller circuitry against damage if a short develops in the engine wiring system or the wiring to the remote start/stop switch.
4. **Hourmeter** records total generator set operating hours for reference in maintenance scheduling.
5. **Remote Switch Connector** is used to operate the generator set at a location remote from the set. Controller connections are made through the plug connector at the rear of the unit.

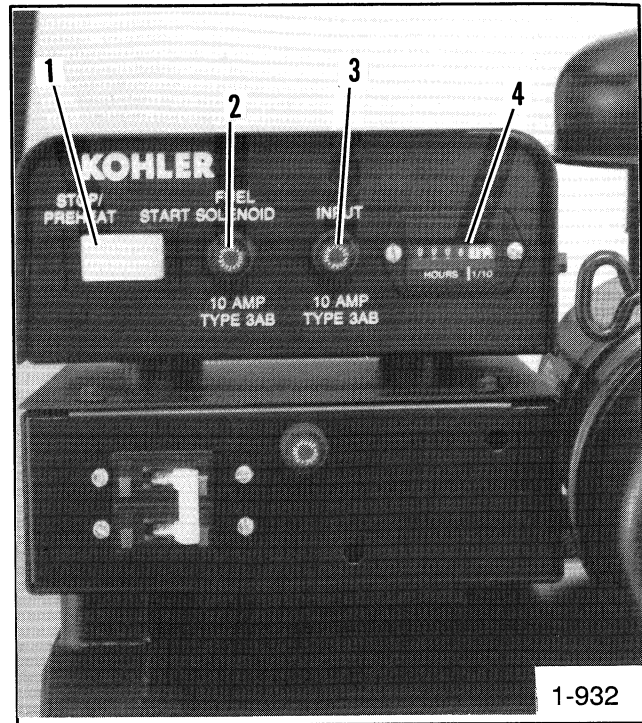

Figure 2-1. Controller Front.

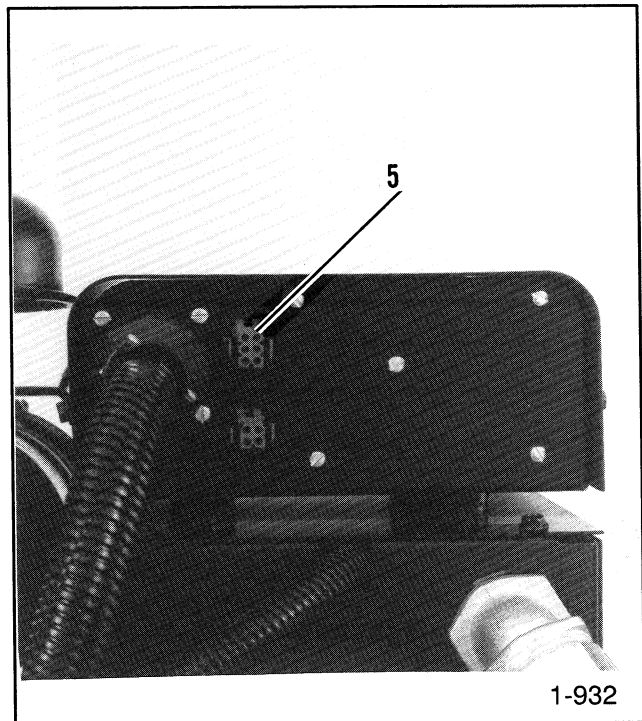
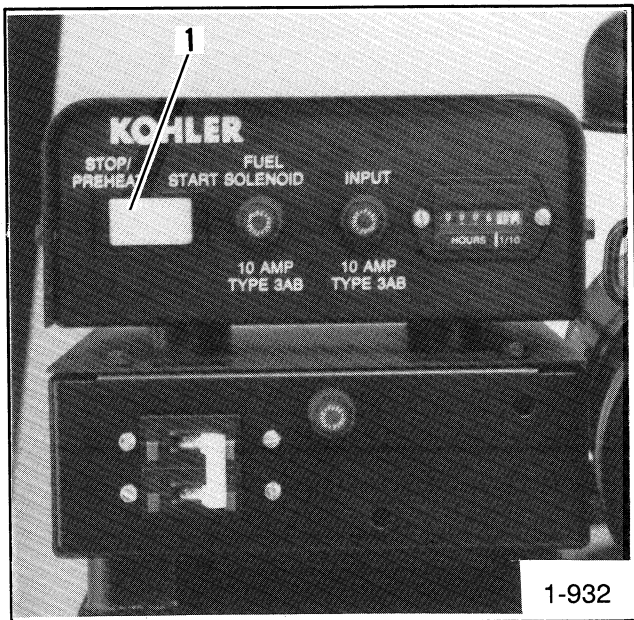

Figure 2-2. Controller Back.

Start Procedure

The generator is equipped with a preheat feature. Place the controller start switch in STOP/PREHEAT position for the amount of time shown in Figure 2-4 before attempting to start the generator set. This provides energizing of the glow plugs. Do not energize the preheat feature for more than 20 seconds or damage may occur. See Figure 2-3. Move the START-STOP switch into the START position and hold in this position until the engine is running, then release. Do not crank engine continuously for more than 10 seconds at a time. A 60-second cooldown period must be allowed between cranking attempts if the engine does not start. Failure to follow these guidelines may result in burnout of the starter motor.



1 - Preheat Switch

Figure 2-3. Preheat Switch Location.

Ambient Temperature	Preheating Time
Above 23°F (-5°C)	Approx. 5 Seconds
Below 23°F (-5°C)	Approx. 10 Seconds
Limit of Continuous Use	20 Seconds

Figure 2-4. Preheating Time.

NOTE

If the engine starts and then stops, allow the engine to come to a complete halt before making a restart attempt. If the flywheel ring gear is still rotating when the starter pinion gear is engaged, the pinion gear will clash which may damage the ring gear teeth.

Stop Procedure

Whenever possible, allow a brief cooling period by running the set at low or no load for a few minutes just prior to shutdown. To stop, move the switch into the STOP position. If the generator set shuts down automatically, identify and correct the problem before attempting to restart.

NOTE

Do not place Start-Stop/Preheat Switch in Stop/Preheat position for more than 20 seconds or damage may occur to the preheat feature.

Circuit Protection

Refer to Figure 2-6 and the following descriptions to identify controller components.

1. **Optional AC Circuit Breaker(s)** will trip when the amperage limit of the breaker is exceeded. Reset AC circuit breaker(s) by placing in "ON" position. Unit is now ready to be restarted. See Figure 2-5 for AC circuit breaker ratings.



Model	AC Circuit Breaker (2-Pole)(Amps.)
7CCO	30
10CCO	45

Figure 2-5. AC Circuit Breakers.

2. **Input (Controller) Fuse (10 Amp)** protects controller circuitry. If the generator will not crank and the battery and/or connections appear okay, the controller fuse may be "blown". If this fuse is replaced then "blows" again, find the cause of the problem. Location of the Controller fuse is shown in Figure 2-6.
3. **Voltage Regulator Fuse (10 Amp)** protects the voltage regulator circuitry. If this fuse is "blown," the generator set will shutdown. If this fuse is replaced then "blows" again, find the cause of the problem. Location of the Voltage Regulator Fuse is shown in Figure 2-6.
4. **Fuel Solenoid Fuse (10 Amp)** protects the fuel solenoid. If this fuse is "blown," the generator will shut down. If the fuse is replaced then "blows" again, find the cause of the problem. Location of the Fuel Solenoid Fuse is shown in Figure 2-6.



WARNING

Accidental starting.
Can cause severe injury or death.
 Disconnect battery cables before working on generator set (negative lead first and reconnect it last).

Accidental starting can cause severe injury or death. Disconnect battery cables (remove negative lead first and reconnect it last) to disable generator set before working on any equipment connected to generator. The generator set can be started by remote start/stop switch unless this precaution is followed.

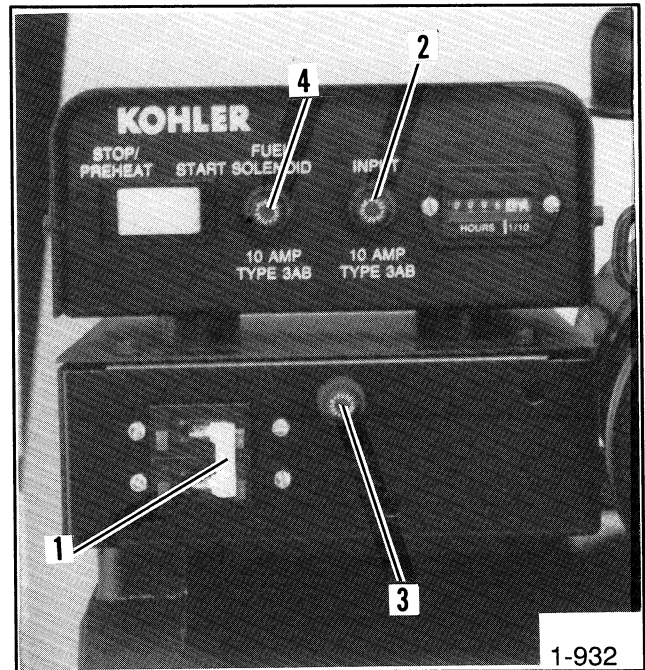

Figure 2-6. Circuit Protection.

Engine Safety Shutdown Switches

The engine is protected by two shutdown switches, which automatically reset after the problem is corrected or the unit is allowed to cool (if overheating was the problem).

Engine safety shutdown switches become functional when unit comes up to speed and AC voltage is available.

Low Oil Pressure Shutdown Switch

The low oil pressure (LOP) shutdown feature protects the engine against internal damage if the oil pressure drops below 7 psi (48.3 kPa) due to an oil pump fault or other engine malfunction. The LOP shutdown does not protect the set from damage due to operating with the oil level below the recommended "low" limit—IT IS NOT A LOW OIL LEVEL SHUTDOWN. The only protection against running out of oil is to check the oil level regularly and add oil as needed. Location of the LOP shutdown switch is shown in Figure 2-7.

NOTE

This is not a low oil *level* shutdown. Proper oil level must be maintained for low oil pressure shutdown switch to function.

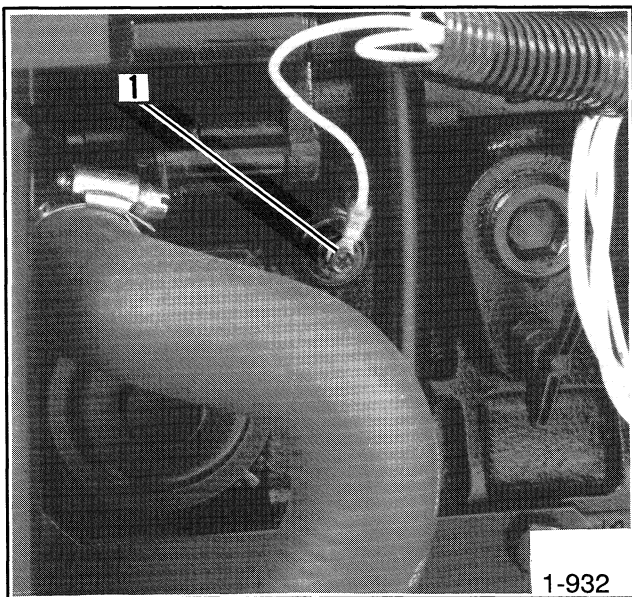

1 - LOP Switch

Figure 2-7. Low Oil Pressure Shutdown Switch.

High Water Temperature Shutdown Switch

The generator set is also equipped with a high water temperature (HWT) shutdown switch. See Figure 2-8. The unit will automatically shut down when the engine coolant temperature exceeds 230°F (110°C). Cause of the shutdown must be corrected before the generator can be restarted.

NOTE

This is not a low coolant level switch. Proper coolant level must be maintained for high water temperature shutdown switch to function.

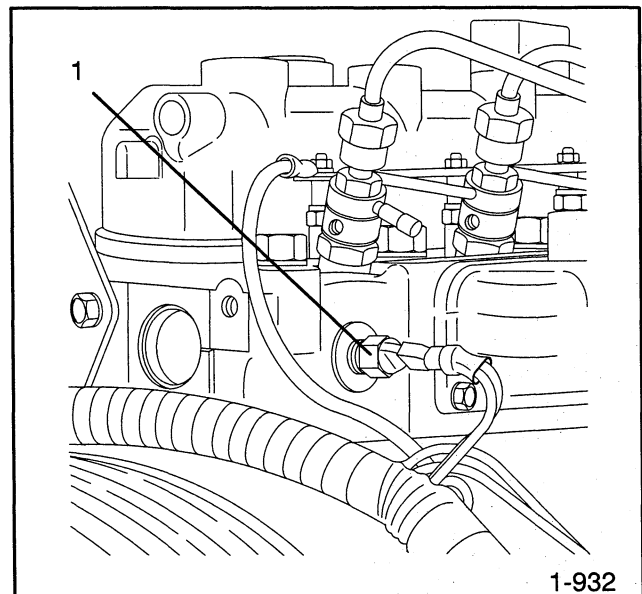

1 - HWT Switch

Figure 2-8. High Water Temp. Shutdown Switch.

Accessories

Several accessories are available to finalize the installation or to add convenience to operation and service. All the most current information can be obtained by contacting your local Kohler Dealer/Distributor. Available accessories at the time of print of this publication are as follows.

Remote Connection/Extension Harness

Provides additional wiring between all remote panels and controller connector in 15 foot (4.6 m) or 25 ft. (7.6 m) increments. One required for each Remote Meter Panel Kit.

Engine Sender Kit

Provides gauge senders for the Remote Start and Two-Meter Panel kit, and the Remote Start and Four-Meter Panel kit. The gauge sender kit is required to make the oil pressure and water temperature gauges functional.

12-Inch Remote Wiring Harness

This one-foot (0.3-m) wiring harness has a 6-pin connector on one end which is keyed to controller box connector. The other end has pigtails for connection to customer-supplied start switch, generator "ON" light, hourmeter, etc.

Exhaust Systems

This silencer is engineered and designed specifically for your Kohler RV generator set to assure optimal performance and sound attenuation. Stainless steel flexible exhaust connectors help to absorb shock and prevent damage to your genset's exhaust system. Exhaust connectors are both corrosion and heat resistant.

Remote Panels (Optional)

Remote Start Panel

Allows starting/stopping from a location remote of the generator set. Supplied with 15 foot (4.6 m) connection harness. Overall mounting dimensions are 4.06 in. (103 mm) by 2.12 in. (54 mm). Generator sets are equipped with a 6-pin connector on controller for connection of the kit. See Figure 2-9 and Figure 2-10.

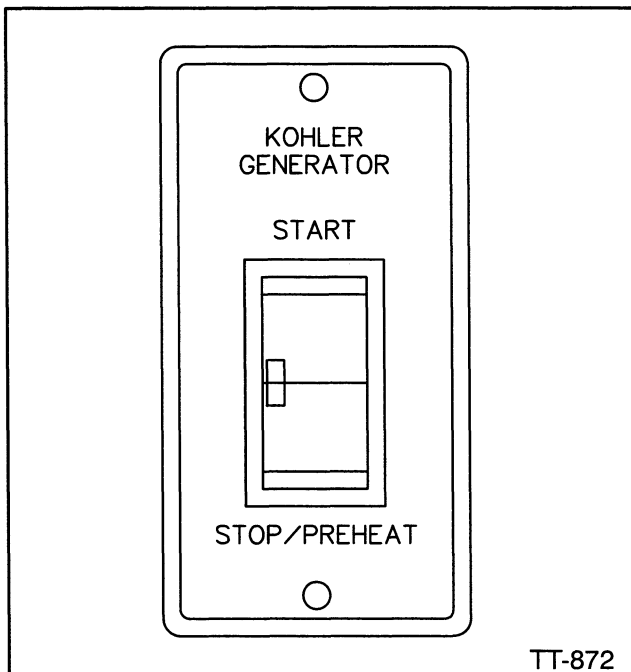

Figure 2-9. Remote Start Panel.

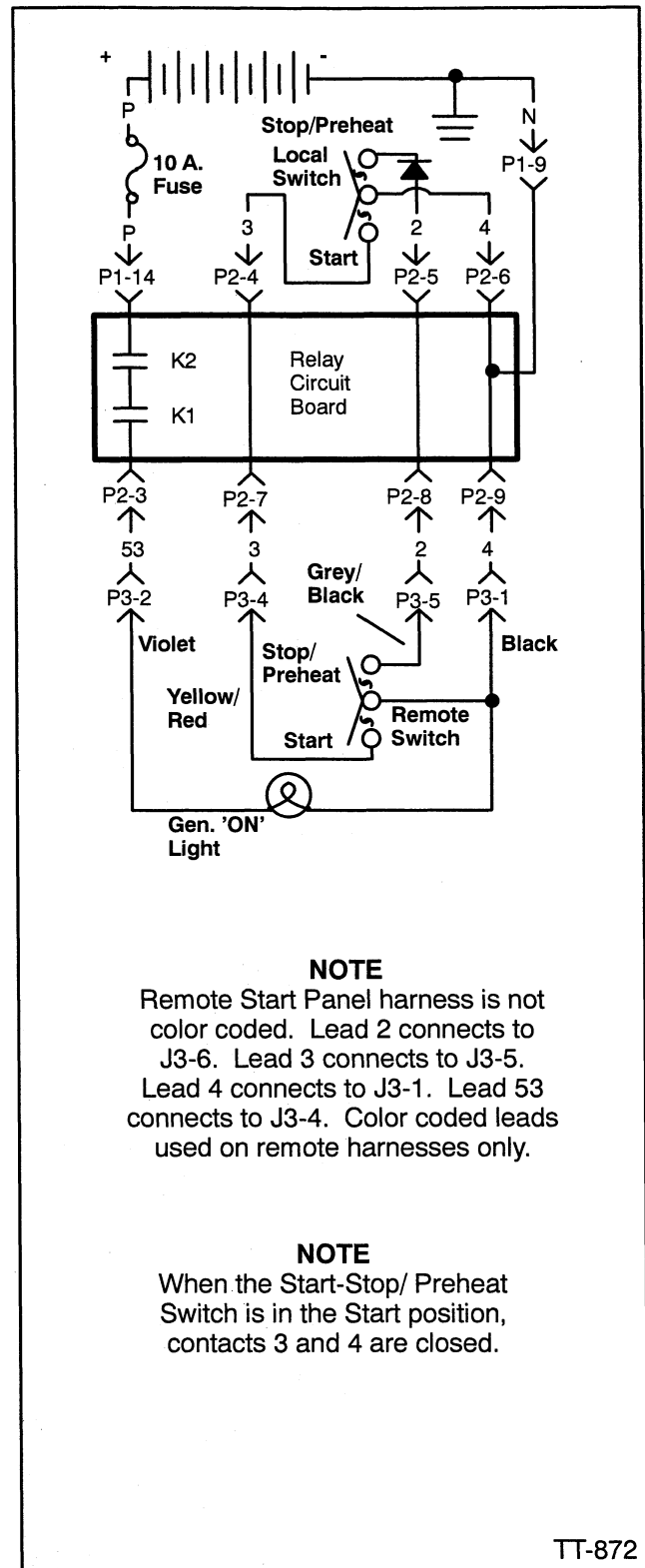

Figure 2-10. Remote Start Panel Kit.

Remote Start and Two-Meter Panel Kit

Allows starting/stopping from a location remote of the generator set. The illuminated gauges include engine oil pressure gauge and water temperature gauge. Generator sets come equipped with a 6-pin connector on controller for connection of the kit. Overall dimensions are 6 in. (152 mm) by 6 in. (152 mm) with a minimum mounting depth of 2.75 in. (70 mm). Requires Remote Connection/Extension Harness and sender kit. See Figure 2-11 and Figure 2-12 for remote start and two-meter panel kit.

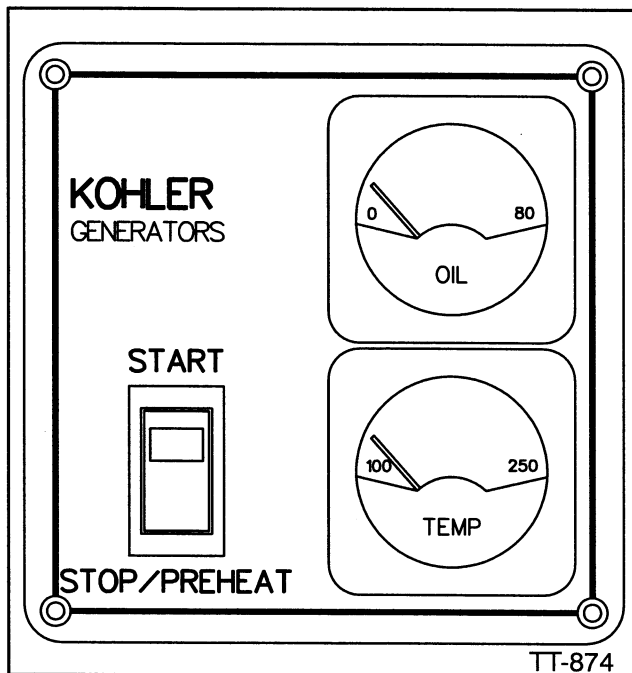

Figure 2-11. Remote Start & Two-Meter Panel Kit.

Start-Stop/Preheat Switch—Rocker-type switch with “ON” light used to start and stop generator set.

During cold weather starts (below 50°F [10°C]): Place controller start switch in STOP/PREHEAT position for 15-20 seconds before attempting to start generator set. This provides energizing of the glow plugs.

Engine Oil Pressure Gauge—Measures engine oil pressure. Normal engine operating range is 36-50 psi (248-345 kPa).

NOTE

During the engine break-in period, it is normal for the engine to produce higher oil pressure readings.

Water Temperature Gauge—Measures engine coolant temperature. Normal engine operating range is 180-205° F (82-96°C).

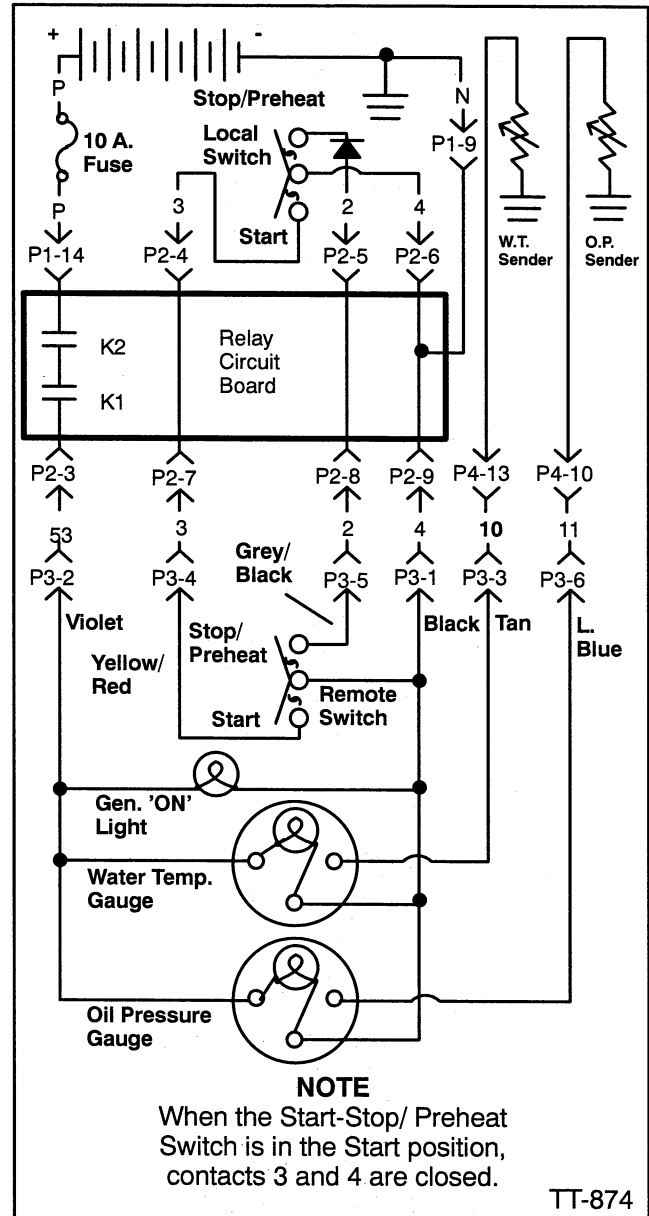

Figure 2-12. Remote Start and Two-Meter Panel Kit.

Remote Start and Four-Meter Panel Kit

Allows starting/stopping from a location remote of the generator set. The illuminated gauges include a DC voltmeter, engine oil pressure gauge, water temperature gauge, and generator running time hourmeter which records total generator set operating hours. Generator sets come equipped with a 6-pin connector on controller back panel for connection of the kit. Overall dimensions are 9 in. (229 mm) by 6 in. (152 mm) with a minimum depth of 4 in. (102 mm). Requires Remote Connection/Extension Harness and sender kit. See Figure 2-13 and Figure 2-14 for remote start and four-meter panel features.

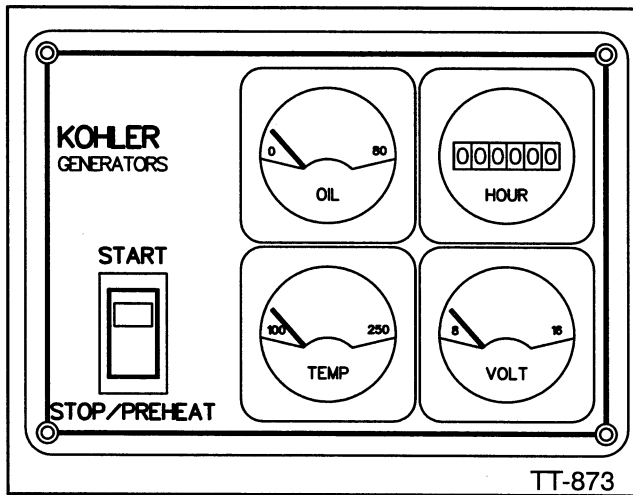

Figure 2-13. Remote Start and Four-Meter Panel Features

Start-Stop/Preheat Switch—Rocker-type switch with “ON” light used to start and stop the generator set. During cold weather starts (below 50°F [10°C]): Place controller start switch in STOP/PREHEAT position for 15-20 seconds before attempting to start generator set. This provides energizing of the glow plugs.

DC Voltmeter—Measures voltage of starting battery(ies). Normal battery operating range is 12-14 Volts.

Engine Oil Pressure Gauge—Measures engine oil pressure. Normal engine operating range is 36-50 psi (248-345 kPa).

NOTE

During the engine break-in period, it is normal for the engine to produce higher oil pressure readings.

Water Temperature Gauge—Measures engine coolant temperature. Normal engine operating range is 180-205° F (82-96° C).

Hourmeter—Records total generator set operating hours for reference in maintenance scheduling.

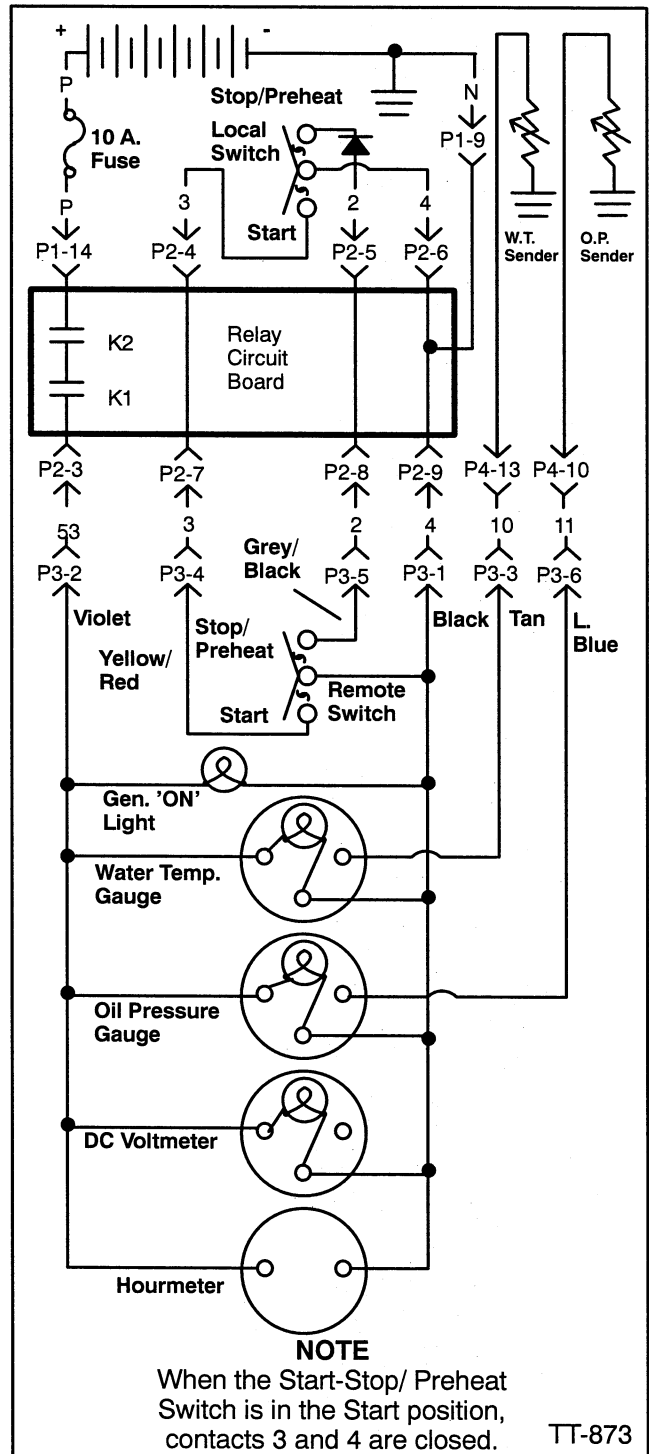

Figure 2-14. Remote Start & Four-Meter Panel Kit.

Section 3. Scheduled Maintenance

Schedule routine maintenance using the “Maintenance Schedule” following and the hourmeter located on the generator controller. If the generator will be subject to extreme operating conditions, service the unit more frequently. Instructions to perform most of the scheduled services are provided in the following pages. Items in the maintenance schedule marked with an asterisk (*) should be performed more often if the generator set is operated in dirty, dusty conditions. Items identified with asterisks (**) should only be performed by an Authorized Kohler Service Dealer. Usually, tools and instruments required for these additional steps are not available to the generator set owner. For this reason, the set should be returned periodically to an Authorized Service Dealer/Distributor for complete servicing and tune-up. The benefits of such service will be improved performance and continuous satisfactory operation during a long trouble-free service life.

NOTE

The items listed in the maintenance schedule must be performed at the designated intervals for the life of the generator. For example, an item to be serviced “Every 100 Hours or 3 Months” must also be serviced after 200 Hours or 6 Months, 300 Hours or 9 Months, etc. The generator will eventually accumulate enough hours to warrant a complete overhaul. The exact time at which extensive service will be necessary cannot be predicted. However, rough operation, lack of power, and excessive oil use indicate serious generator set problems. As part of a preventive maintenance program, service the engine (clean cylinder head, inspect valves, check compression, etc.) and generator (replace bearing, inspect wiring, remove debris, etc.) at the earliest indication that a serious problem exists.

NOTE

HARDWARE DAMAGE! Engine and generator may make use of both American Standard and metric hardware. Be sure to use the correct size tools to prevent rounding of bolt heads and nuts.

WARNING

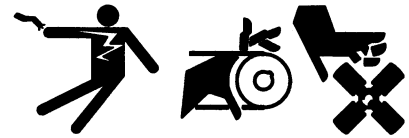

Accidental starting.

Can cause severe injury or death.

Disconnect battery cables before working on generator set (negative lead first and reconnect it last).

Accidental starting can cause severe injury or death. Disconnect battery cables (remove negative lead first and reconnect it last) to disable generator set before working on any equipment connected to generator. The generator set can be started by remote start/stop switch unless this precaution is followed.

WARNING

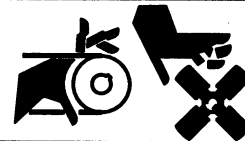

Rotating parts.

Can cause severe injury or death.

Do not operate generator set without all guards, screens, or covers in place.

Exposed moving parts can cause severe injury or death. Keep hands, feet, hair, clothing, and test leads away from belts and pulleys when unit is running. Replace guards, covers, and screens before operating generator set.

Perform Service at Intervals Indicated (X)	Before Each Start-Up	Every 50 Hours or 1 Month	Every 100 Hours or 3 Months	Every 400 Hours or 6 Months	Every 500 Hours or Yearly
<u>FUEL SYSTEM</u>					
Check the fuel level	X				
Fill fuel tank	X				
Check fuel pipes and clamps		X			
Remove sediment from fuel tank				X	
and fuel/water separator (if equipped)*		X		X	
		(Break-in Period)		(Replace Element 600 Hrs.)	
Replace the fuel filter element				X	
Check governor operation and adjust as necessary**					X
Check the nozzle injection pressure**					X
					(1000 Hrs)
<u>LUBRICATION SYSTEM</u>					
Check the oil level in crankcase	X				
Replace the oil in crankcase*		X	X		
		(Break-in Period)			
Replace the lube oil filter element*		X	X		
		(Break-in Period)			
<u>COOLING SYSTEM</u>					
Check coolant level	X				
Check water pipes and clamps			X		
Adjust the tension of water pump V-belt		X	X		
		(Break-in Period)			
Change coolant					X
Clean radiator fins, inspect hoses			X		
<u>AIR CLEANER, ETC.</u>					
Replace the air cleaner element*				X	
				(300 Hrs)	
Clean the breather pipe*			X		
<u>ELECTRICAL SYSTEM</u>					
Verify proper operation of gauges (if equipped)	X				
Check the electrolyte level in the battery	X				
Check the electrical connections		X			
Check the battery specific gravity				X	
Adjust battery charging alternator V-belt				X	
<u>CYLINDER HEAD, ETC.</u>					
Check for leakage of water and oil	X	X			
Retighten all major nuts and bolts		X			X
		(Break-in Period)			
Check mounting bolts and vibro mounts for tightness				X	
Retighten the cylinder head bolts**					X
Adjust intake exhaust valve clearance**					X
					(800 Hrs)
<u>GENERATOR</u>					
Blow dust out of generator*					X
Clean slip rings and inspect brushes**					X

* Service more frequently if operated in dusty areas

** Should be performed by an authorized Kohler Service Dealer/Distributor

Lubrication System

Your engine has a positive pressure lubrication system and a low oil pressure shutdown.

Oil Selection

The selection of engine oil is very important to a diesel engine. If an unsuitable oil is used or an oil change is neglected, it may result in damage and a shorter engine life. Oil must meet the API (American Petroleum Institute) classification of CC, CD or CE. Avoid mixing different brands of oils and lubricants; oils of different manufacturers may be incompatible and deteriorate when mixed. Recommended SAE (Society of Automotive Engineers) viscosity designation for given temperature ranges in which the generator set will be operated are listed in Figure 3-1.

Air Temperature

Below 32° F (0° C)
32° - 77° F (0° - 25° C)
Above 77° F (25° C)

Oil Viscosity

SAE10W or 10W-30
SAE 20 or 10W-30
SAE 30 or 10W-30

Figure 3-1. Engine Oil Selection.

NOTE

Failure to observe these standards may cause inadequate oil pressure and cold-starting difficulties.

Oil Check

Check crankcase oil level daily or before each start to insure that the level is in the "safe range." To check oil level, remove oil dipstick and wipe dipstick clean. Reposition dipstick in crankcase and push it all the way down into the tube. Remove dipstick and check the level. Oil level should read between MIN and MAX marks on dipstick. Do not operate set if the oil level exceeds the MAX mark or registers below the MIN mark on the dipstick.

NOTE

Do not check oil level when the set is in operation. The engine must be stopped and on a level surface when checking oil. Most accurate oil reading is obtained by shutting down the generator and waiting several minutes before checking oil.

Oil Change

BREAK-IN PERIOD OIL RECOMMENDATIONS

On a new engine, change the oil after the first 50 hours of operation and thereafter at 100-hour intervals or 3 months, whichever occurs first. Change oil more frequently under dirty, dusty conditions. Change oil while the engine is still warm.

1. Place a container below the oil drain hole and remove the oil drain plug. See Figure 3-2. Allow sufficient time for the old oil to drain completely. Replace oil drain plug. Dispose of used engine oil in an environmentally safe manner. Take used oil to a suitable collection facility in your area. **DO NOT POUR USED OIL ON THE GROUND, DOWN SEWERS, OR INTO STREAMS OR OTHER BODIES OF WATER.**

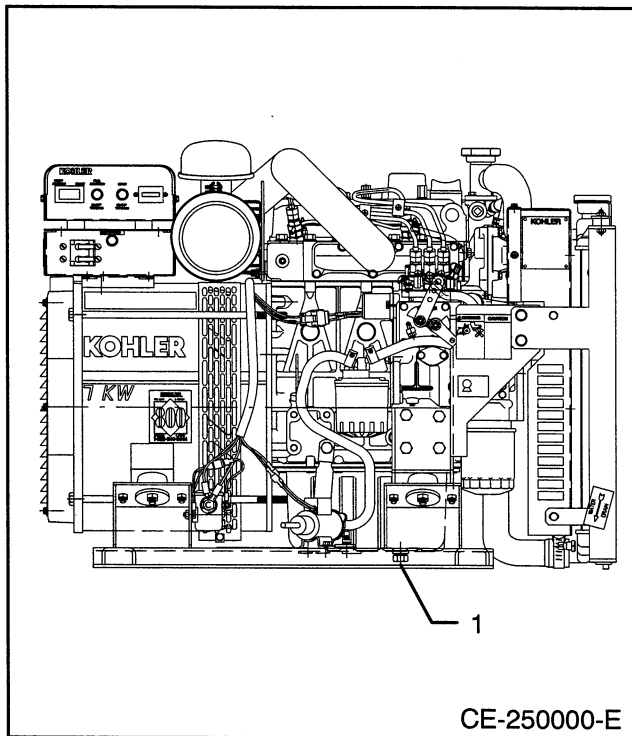

1 - Oil Drain

Figure 3-2. Oil Drain Petcock.

2. Remove either oil fill cap. One is located on the rocker arm cover and one is located near the fuel injector pump. See Figure 3-4.
3. If the engine oil filter is to be replaced, see "Oil Filter" following.

OIL CAPACITY (with Filter) qts. (L)	
7CCO	5.4 (5.1)
10CCO	6.3 (6.0)

Figure 3-3. Oil Capacity.

4. Fill crankcase with proper amount and type of oil, see Figure 3-3 and "Oil Selection."
5. Replace oil fill cap. Start the generator set and check for oil leaks.
6. Stop the generator set. Remove the dipstick and wipe clean, reinsert as far as possible, and remove to check oil level. Add oil, as necessary, to bring level up to MAX mark.

NOTE

Too high an oil level causes high oil consumption and carbonizing of the engine. Low oil level will cause engine damage.

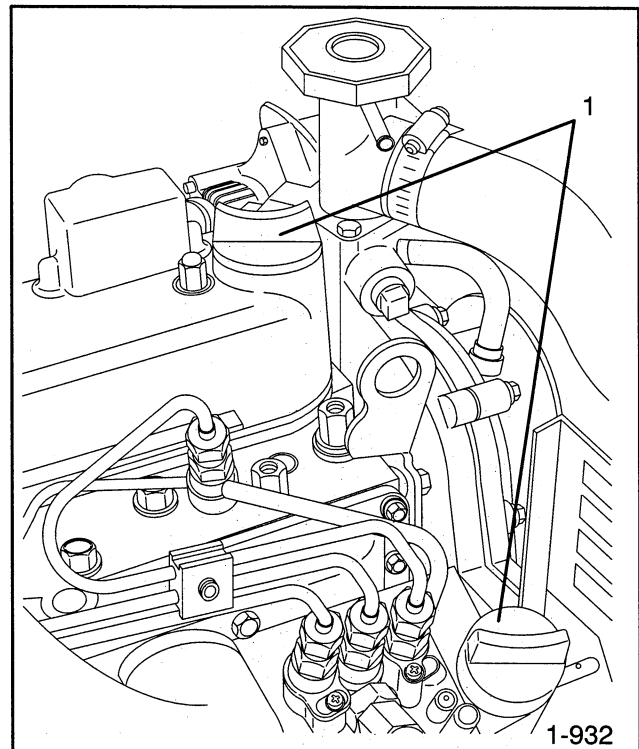

1 - Oil Fill

Figure 3-4. Oil Fill Locations.

Oil Filter

Replace the oil filter for the first time after 50 hours or 1 month of operations and then every 100 hours or 3 months. Change more frequently if operating in dirty, dusty conditions. See Figure 3-5 and refer to the following procedure.

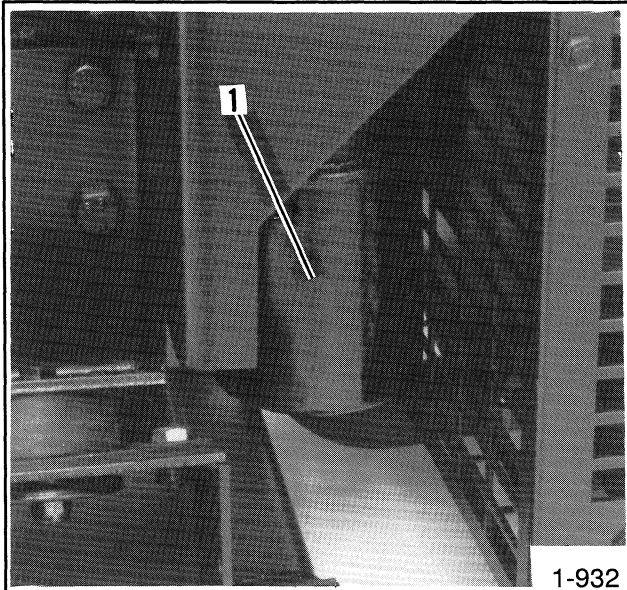

1 - Oil Filter

Figure 3-5. Oil Filter Location.

1. With oil system drained, loosen oil filter by turning with a filter wrench in a counterclockwise direction. Use rags to clean up spilled oil. Remove and discard.
2. Clean contact surface on oil filter adapter.
3. Lightly lubricate the gasket surface of the new oil filter with the fresh engine oil. Thread oil filter to adapter until gasket makes contact, hand-tighten an additional one-half turn.
4. Replace engine oil. See "Oil Change" section for proper oil capacity.
5. Start the generator set and check for oil leaks.
6. Stop the generator set. Remove dipstick and wipe clean, reinsert as far as possible, and remove to check oil level. Add oil as necessary to bring level up to MAX level.

Fuel System

Specification

Use a clean, good quality No. 2-D (DIN 51 601) diesel fuel oil. The fuel must meet the requirements of the American Society of Testing and Materials (ASTM) diesel fuel classification D975 (Federal Specification W-F-800a). Cleanliness of the fuel is especially important on diesel engines which have easily clogged, precision fuel injectors and pumps. See chart below.

United States	ASTM/D975	No. 2-D Diesel
United Kingdom	BS2869	Class A1

Other Considerations:

Sulfur Content Less than 0.5%
Sediment/Water Content Not to exceed 0.05%
Cetane Number 45 minimum
Flash point At least 125°F (52°C)

NOTE

Never store diesel fuel in galvanized containers; diesel fuel and the galvanized coating react chemically to produce flaking which quickly clogs filters or causes failure of the fuel pump or injectors. Do not run the generator set out of fuel; air will be drawn into the fuel lines and the entire system will have to be bled before the unit can be restarted.

NOTE

Avoid storing fuel over long periods of time. Take special precautions to keep all dirt, water, and other contaminants out of the fuel. Storage tanks containing diesel fuel contaminated with water may cause the growth of "microbes." The presence of microbes will form a slime which will clog fuel filters and lines.

Fuel Filter

The fuel filter serves to remove water and dirt contained in the fuel. The fuel filter element is paper and no attempt should be made to clean it. Its useful life will be determined largely by the quality and condition of the fuel used. Under normal conditions, the fuel filter element should be replaced for the first time after 50 hours or one month and then every 400 hours or six months. See Figure 3-6 for location and use the following procedure to service the fuel filter.

1. Loosen the fuel filter by turning in a counterclockwise direction. Use rags to clean up spilled fuel oil. Remove and discard.
2. Clean contact service on the fuel filter adapter.
3. Lightly lubricate the gasket surface of the new fuel filter with fresh fuel oil. Thread the fuel filter to the adapter until the gasket makes contact, hand-tighten an additional one-half turn.
4. See "Bleeding" section following.

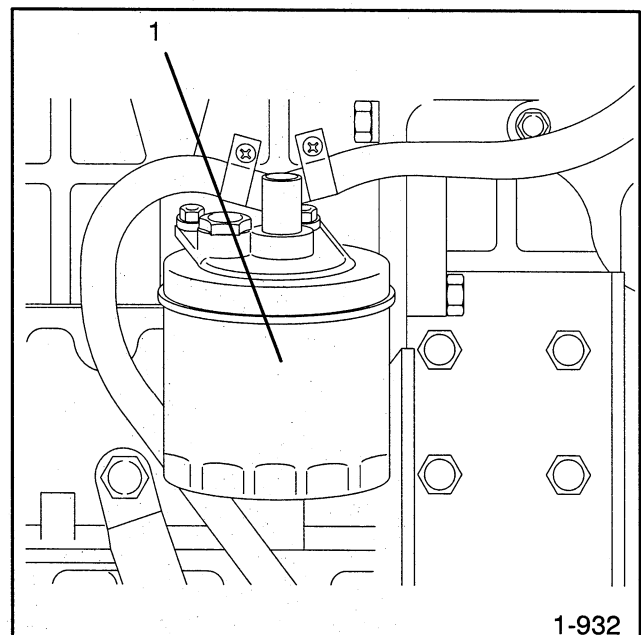

1 - Fuel Filter

Figure 3-6. Fuel Filter Location.

Fuel Filter (Supplied Loose)

The fuel filter, supplied loose with the unit, serves as a preliminary source to remove dirt and metal particles from the fuel system before they reach the electric fuel pump. If the fuel filter is clogged with debris, the generator may be difficult to start or may run rough. The service life of the fuel filter is solely dependent on the quality of the diesel fuel used and the amount of debris entering the fuel system when refueling. As part of a regular maintenance program, the fuel filter should be checked and/or replaced every six months or 100 hours of operation. The fuel filter cannot be cleaned and should be replaced if fuel starvation or poor engine performance is evident.

Fuel/Water Separator (If equipped)

The fuel/water separator is used to drain off accumulated water and trap fuel oil sediment. At the specified interval, remove water drain plug at bottom of water separator and allow water to flow into a suitable container. When complete, replace water drain plug. Drain off only the water as fuel oil will continue to flow from this point. At the specified interval, replace the water separator element. To replace element use the following procedure and see Figure 3-7.

1. Close fuel valve at nearest point to water separator inlet fitting or at fuel tank.
2. Remove water drain plug (or push-up drain valve) and allow water and fuel oil to flow into a suitable container.

NOTE

Depending upon the location of fuel valve, a considerable amount of fuel oil may drain out.

3. Remove fuel/water separator element from mounting head with bowl connected.
4. Remove the bowl from the fuel/water separator. Wipe off excess fuel oil from the bowl and O-ring. Do not discard bowl or O-ring.
5. Inspect components for wear or damage. Replace parts as necessary.
6. Lubricate the O-ring with clean diesel fuel or motor oil and replace in the bowl.
7. Replace bowl onto a new fuel/water separator element.

NOTE

Kohler service replacement fuel/water separator element #225259.

8. Lubricate fuel/water separator element top seal with clean diesel fuel or motor oil.
9. Fill bowl/element assembly with clean fuel. Replace bowl/element onto fuel/water separator mounting head. Tighten centerbolt to 65 inch pounds.

10. Replace water drain plug (if removed) and close vent.
11. Open fuel valve on water separator inlet fitting or at fuel tank.
12. After fuel oil fills water separator and air is displaced, fuel oil (free of air bubbles) will flow from the air bleed hole. Replace air bleed screw.
13. If other fuel system components were removed and/or replaced, air may have entered the fuel system. If this happens, the engine may experience starting difficulty and/or erratic operation which requires bleeding of the fuel system. See "Bleeding" section following.

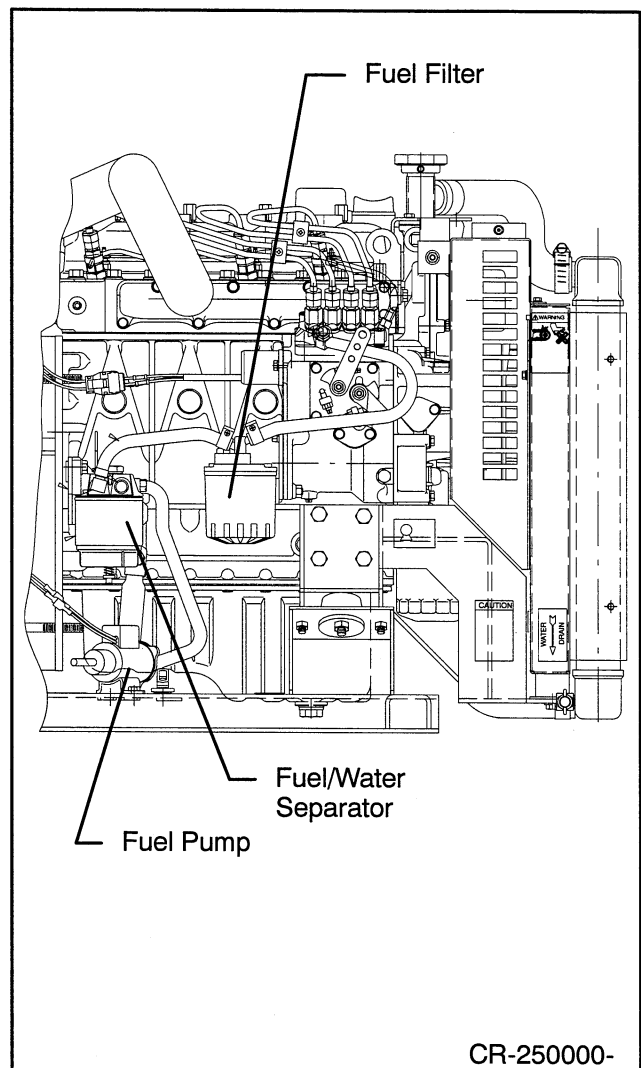

Figure 3-7. Fuel/Water Separator Location.

Bleeding the Fuel System

If the generator set engine runs out of fuel, air leaks develop in the suction side of the fuel system, or the fuel filter is replaced, it will be necessary to bleed the entire system to prevent starting failures and/or erratic operation. See Figure 3-8 and refer to the following procedure.

1. Fill the fuel tank to the fullest extent.
2. Loosen the small vent screw a few turns on the fuel filter.
3. Using the start switch on the controller, operate the fuel pump until fuel, free from air bubbles, flows from this point. Tighten vent screw.
4. Loosen the line connection (bleed point) at the fuel injection pump inlet.
5. Using the start switch on the controller, operate the fuel pump until fuel, free from air bubbles, flows from this point. Tighten line connection.

 **WARNING**

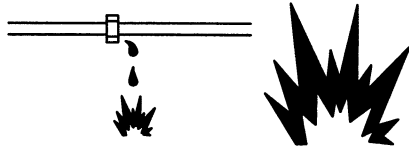

Explosive fuel vapors.
Can cause severe injury or death.

Use extreme care when handling, storing, and using fuels.

Explosive fuel vapors can cause severe injury or death. Spilled fuel can cause an explosion. Use a container to catch fuel when draining fuel system. Wipe up all spilled fuel after draining system.

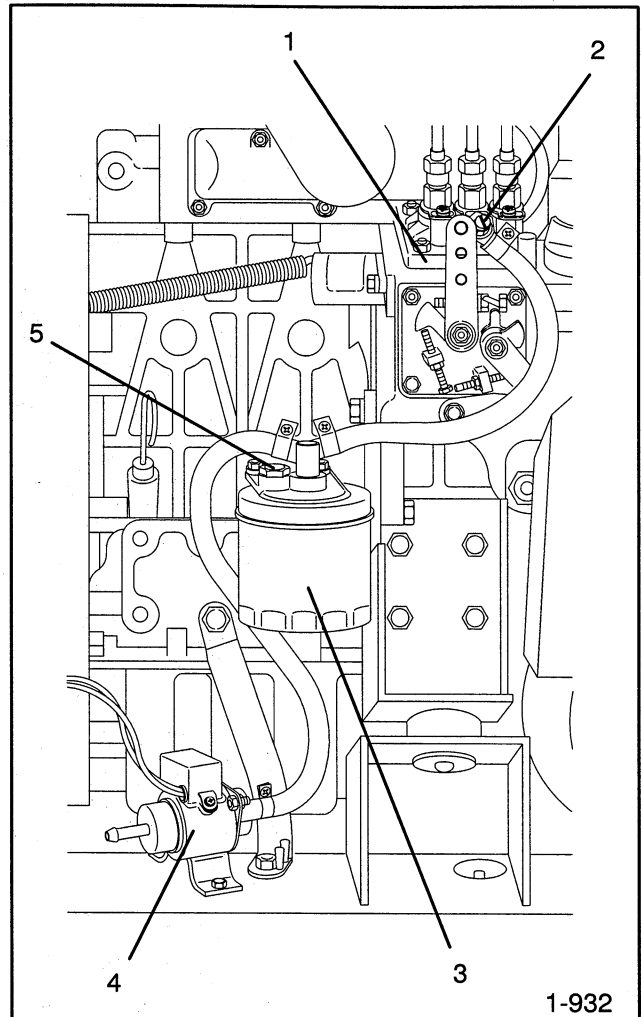

- 1 - Fuel Injection Pump
- 2 - Line Connection (Bleed Point)
- 3 - Fuel Filter
- 4 - Electric Fuel Pump
- 5 - Vent Screw

Figure 3-8. Bleeding the Fuel System.

Air Cleaner Service

The paper element should be replaced at 400-hour or 6-month intervals; change more frequently if operating under extremely dirty, dusty conditions. Operating the generator set with a dirty air cleaner element may cause engine damage and also increase fuel consumption. See Figure 3-9 and refer to the following procedure.

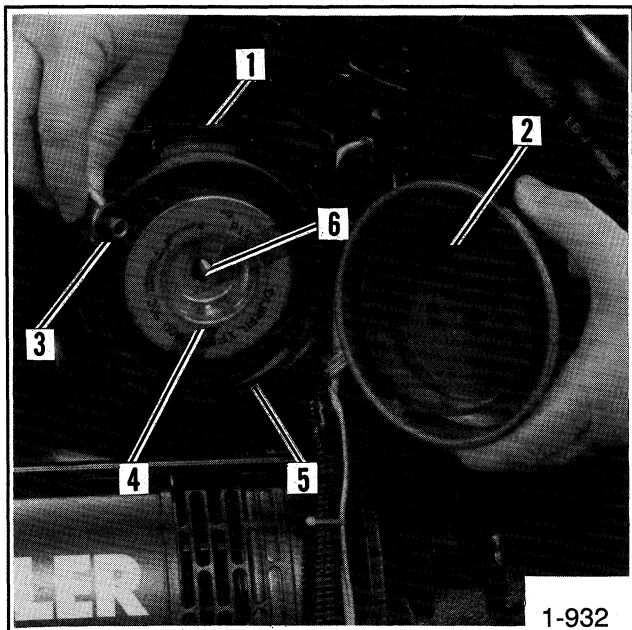

- 1 - Eye Bolt/Clamp
- 2 - Cover
- 3 - Wing Nut
- 4 - Element
- 5 - Base
- 6 - Threaded Rod

Figure 3-9. Air Cleaner Components.

1. Loosen eye bolt and clamp enough to remove the air cleaner cover.
2. Remove wing nut and slide air cleaner element from the threaded rod.
3. Clean the dry element by tapping edges on a hard surface. Replace if damaged or very dirty.

NOTE

Do not attempt to clean dry-type element in any liquid or with compressed air as this will damage paper filter material.

4. Wipe dirt or dust accumulation from cover and base. Check that all clamps are tight on inlet/outlet connections.
5. Install air cleaner element on threaded rod. Tighten wing nut making sure parts fit properly.
6. Position cover with arrow "up;" place clamp over base and cover, and tighten eye.

Governor

The centrifugal, mechanical-type governor serves to keep the engine speed constant by automatically adjusting the amount of fuel supplied to the engine according to changes in the load. No regular service is required on the unit. The governor is adjusted during run-in at the factory, and further adjustment should not be needed unless greatly varying load conditions are encountered or if poor governor control develops after extended usage.

60-Hz generator sets are designed to operate at 60-63 Hz, 1800 rpm under full load and 1890 rpm under no load.

50-Hz generator sets are designed to operate at 50-52.5 Hz, 1500 rpm under full load and 1575 rpm under no load.

To check speed, use a hand-held tachometer or frequency meter. See Figure 3-10. Loosen locking nut on the speed-adjusting screw. Turn the screw in clockwise direction to increase speed (and frequency) or in counterclockwise direction to decrease speed. Tighten the locknut to secure screw at new setting.

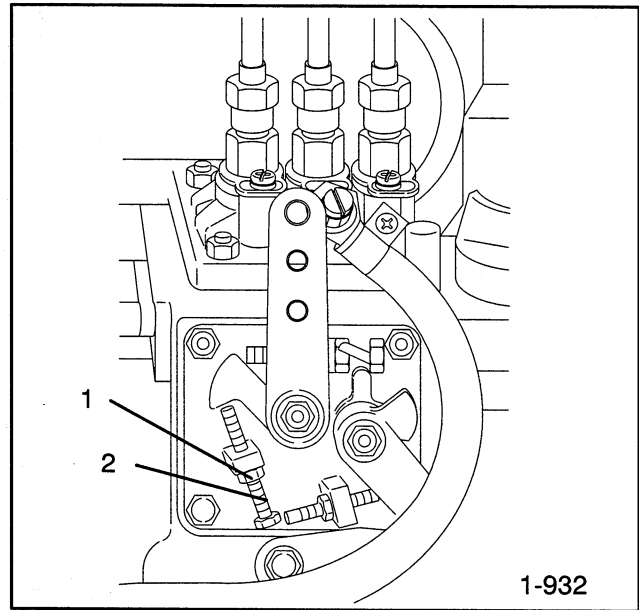

- 1 - Locking Nut
- 2 - Speed Adjusting Screw

Figure 3-10. Governor.

Valve Adjustment

With poppet-type valve mechanism, each valve is spring-held in the closed position until forced open by the action of the rocker arm in contact with the push rod which is moved by the tappet which rides on a lobe of the camshaft. Rocker arms have adjusting screws with lock nuts for adjusting the valve stem-to-rocker arm clearance. Check the intake/exhaust valve clearance every 800 hours or six months. Valve clearance on both intake and exhaust valve is 0.006-0.007 in. (0.145-0.185 mm) with the engine cold.

⚠ WARNING

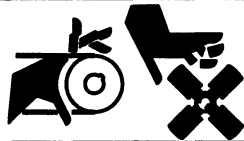

**Rotating parts.
Can cause severe injury or death.**

Do not operate generator set without all guards, screens, or covers in place.

Flying projectiles can cause severe injury or death.

Retorque all crankshaft and rotor hardware after servicing. When making adjustments or servicing generator set, do not loosen crankshaft hardware or rotor thru-bolt. If rotating crankshaft manually, direction should be clockwise only. Turning crankshaft bolt or rotor thru-bolt counterclockwise can loosen hardware and result in serious personal injury from hardware or pulley flying off engine while unit is running.

NOTE

The engine firing order is based on the number 1 piston being next to the crankshaft pulley, not the flywheel.

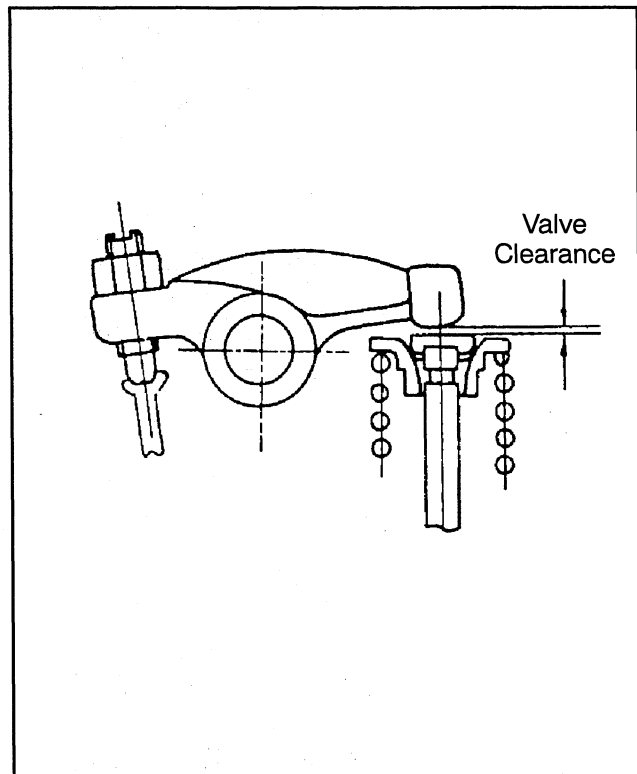

Figure 3-11. Valve Adjustment.

1. Remove the rocker arm cover screws and breather hose at the rocker arm cover connection. Carefully remove the rocker arm cover from the cylinder head. Wipe excess oil from components using a clean rag.

NOTE

Be careful not to damage gasket or mating surfaces. Gasket must be replaced if damaged.

2. Locate intake/exhaust valves of number 1 cylinder. These are the first set of valves nearest the crankshaft pulley. Remove cooling fan and place three screws in the threaded holes of the pulley. Use a bar to rotate until maximum clearance between intake/exhaust valves and rocker arms is achieved. This is the period between the closing of the intake valve and the opening of the exhaust valve. At this point the No. 1 piston is at Top Dead Center (TDC), and both intake and exhaust valves will be closed.

3. Insert feeler gauge between rocker arm and exhaust valve. If necessary, loosen locknut and move adjusting screw so that very slight drag is felt on the feeler gauge as it is withdrawn. Tighten locknut on adjusting screw. Recheck clearance. See Figure 3-11. Repeat step for intake valve.

4. Repeat procedure for each additional cylinder to be checked and/or adjusted.
5. With mating surfaces clean and gasket properly aligned, install rocker arm cover and screws. Be careful that rocker arm cover gasket is properly seated in recessed hole.

Cylinder Head Retightening

After each 500 hours of operation, the cylinder heads should be taken off the engine and serviced. Always use new cylinder head gaskets. Make sure head bolts are tightened in the proper sequence and to the torque value specified. See Figure 3-12.

1. Remove the cylinder head screws in the order of (14 or 18) to (1), and remove the cylinder head.
2. Remove the cylinder head gasket and O-ring.
3. Replace the head gasket.
4. Install the cylinder head, making sure not to damage the O-ring.
5. Tighten the cylinder head screws gradually in the order of (1) to (14 or 18) after applying engine oil.
6. Retighten the cylinder head screws after running the engine for 30 minutes.

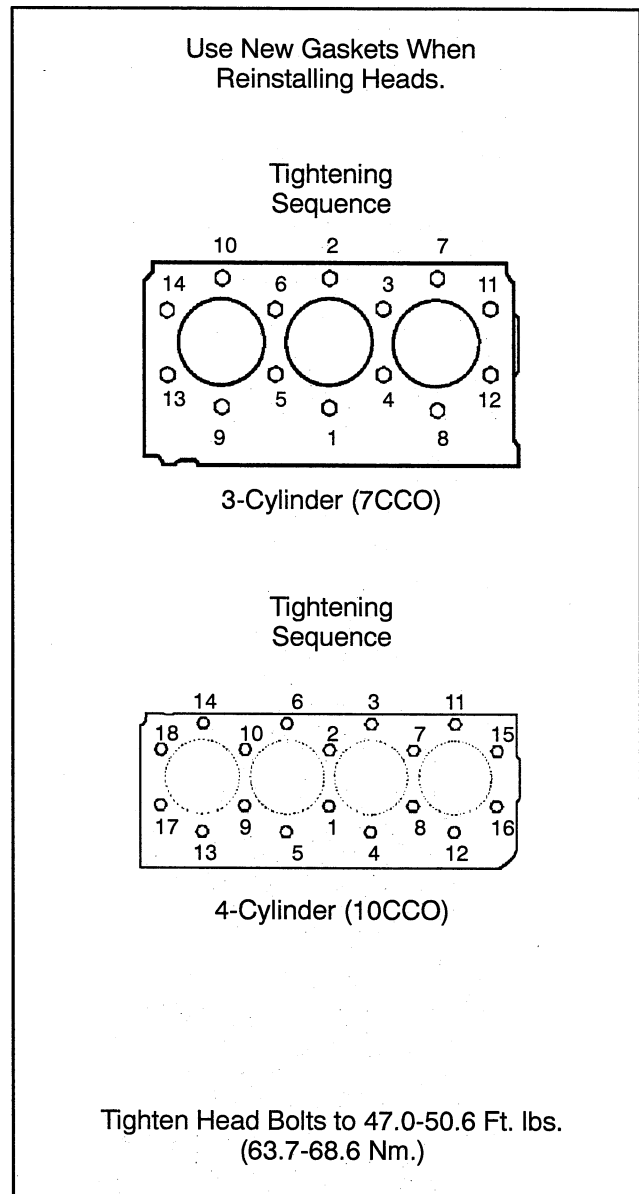



Figure 3-12. Cylinder Head Fastener, Tightening Sequence.

Cooling Systems

Filling and Checking

Before filling the cooling system, verify that all petcocks are closed and all hose clamps are tight. Remove pressure cap located on the top of the engine and fill with the recommended coolant until level is just below overflow tube opening. If a coolant recovery tank is used, fill to just below the HOT (full) mark. Maintain proper coolant level in coolant recovery tank. The COLD (add) mark indicates full when cold and the HOT (full) mark indicates full when hot. Coolant level should always be between these marks. The coolant level can be checked using the coolant recovery tank markings, but it is recommended to periodically remove the pressure cap and check coolant level.

 WARNING

Hot coolant and steam. Can cause severe injury or death.
Before removing pressure cap stop generator, allow to cool and loosen pressure cap to relieve pressure.

Hot coolant can cause severe injury or death. Allow engine to cool and release pressure from cooling system before opening pressure cap. To release pressure, cover the pressure cap with a thick cloth then turn it slowly counterclockwise to the first stop. After pressure has been completely released and the engine has cooled, remove cap. If generator set is equipped with a coolant recovery tank, check coolant level at tank.

Flushing and Cleaning

For optimum protection, the cooling system should be periodically drained, flushed, and refilled, see Service Schedule. Open petcocks located at the radiator and engine block and let the system completely drain. Removal of the pressure cap will make draining easier. Drain, clean, and flush coolant recovery tank, if used. Chemical cleaners are available for badly rusted or corroded cooling system; follow manufacturer's instructions. Flush system with clean water before filling with recommended coolant.

Pressure Cap

The coolant system incorporates a pressurized cap(s) to raise the boiling point of the coolant and make use of higher operating temperatures. If leakage or malfunction occurs, replace with same rating type of cap. The pressure cap ratings are as follows:

7CCO Pressure Cap on Radiator	20-24 psi (138-165 kPa)
7CCO Pressure Cap on Coolant Fill	13 psi (89 kPa)
10CCO Pressure Cap on Coolant Fill	13 psi (89 kPa)

To prevent the inconvenience of having the generator set shut down or become damaged due to overheating, keep the cooling air inlets to the component clean and unobstructed at all times. Inspect the exterior of the radiator for obstructions; remove all dirt and foreign material with a soft brush or cloth (to avoid damaging radiator fins). Check all hoses and connections for leaks and replace any hoses that are cracked, frayed, or feel spongy. When coolant level checks are made, check condition of the radiator cap rubber seal; replace if cracked or deteriorating. Remove dirt and other debris from the radiator cap and filler neck.

Consult the coach manufacturer for remote radiator cooling system capacity. Coolant capacity for the 7CCO-RV in-line radiator model is 2.44 qts (2.3 L). The 10CCO-RV in-line radiator model coolant capacity is 5.1 qts (5.4 L). A drain petcock is provided on the underside of the radiator and the engine block to drain the system. When draining the coolant, remove the radiator cap on the coolant fill and open the block drain located near the flywheel housing; this will allow the entire system to drain and prevent air pockets from forming and

restricting coolant passage in the block. When operating in climates subject to freezing temperatures, make sure a sufficient amount of antifreeze solution is added to prevent freeze-up of the system. The antifreeze should contain a rust inhibitor and be changed every two years. A coolant solution of 50% ethylene glycol and 50% clean, softened water is recommended to inhibit corrosion and prevent freezing to -34°F (-37°C). Do not use alcohol or methanol antifreeze or mix them with the coolant. For maximum protection, always use a solution which will remain liquid below the lowest anticipated temperature.

Check coolant level frequently and add water or antifreeze solution as needed to maintain level just below the overflow tube.

NOTE

Special attention should be given when checking for proper coolant level. After a radiator has been drained, it normally requires some time before complete refill of all air cavities take place.

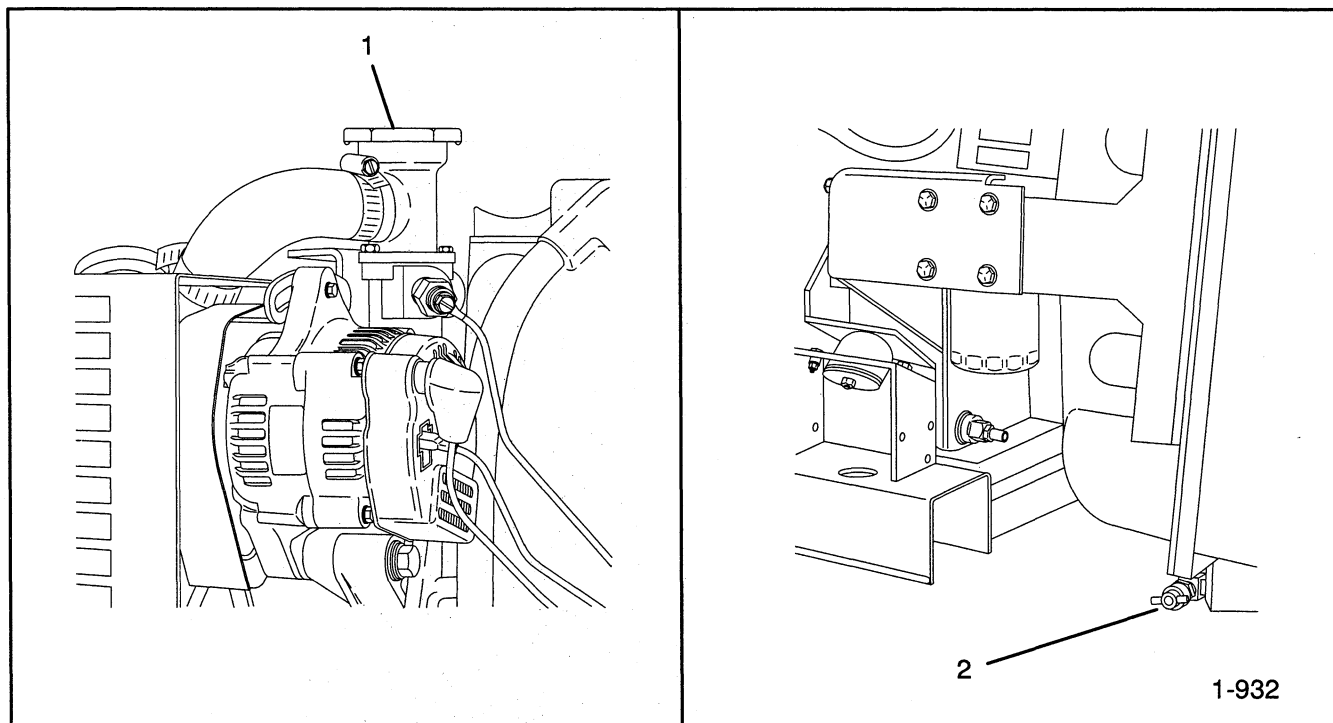

1. - Initial Coolant Fill (after initial fill, use coolant recovery tank to maintain coolant level)
2. - Coolant Drain in Radiator

Figure 3-13. Coolant Fill/Drain.

Servicing Cooling System

For servicing the 7/10CCO generator set, refer to Figure 3-14 for proper coolant system disassembly and reassembly sequence. During the reassembly procedure, follow the General Torque Specifications found in Section 10. This generator set features a suction-type fan which is mounted to the hub, which is mounted to the crankshaft pulley. The suction fan draws air into the unit from the radiator inlet and then the air is discharged downward. See Figure 3-15.

Observe the following recommendations for properly maintaining the generator set's coolant system:

- Never use dirty or sea water as coolant.
- Make sure the pressure cap is tightened after using.
- Do not fill the coolant beyond the "HOT" mark on the coolant recovery tank.

Check and maintain the coolant level at the coolant recovery tank. See Figure 3-17 for coolant capacities.

Refer to Figure 3-16 for remote radiator specifications.

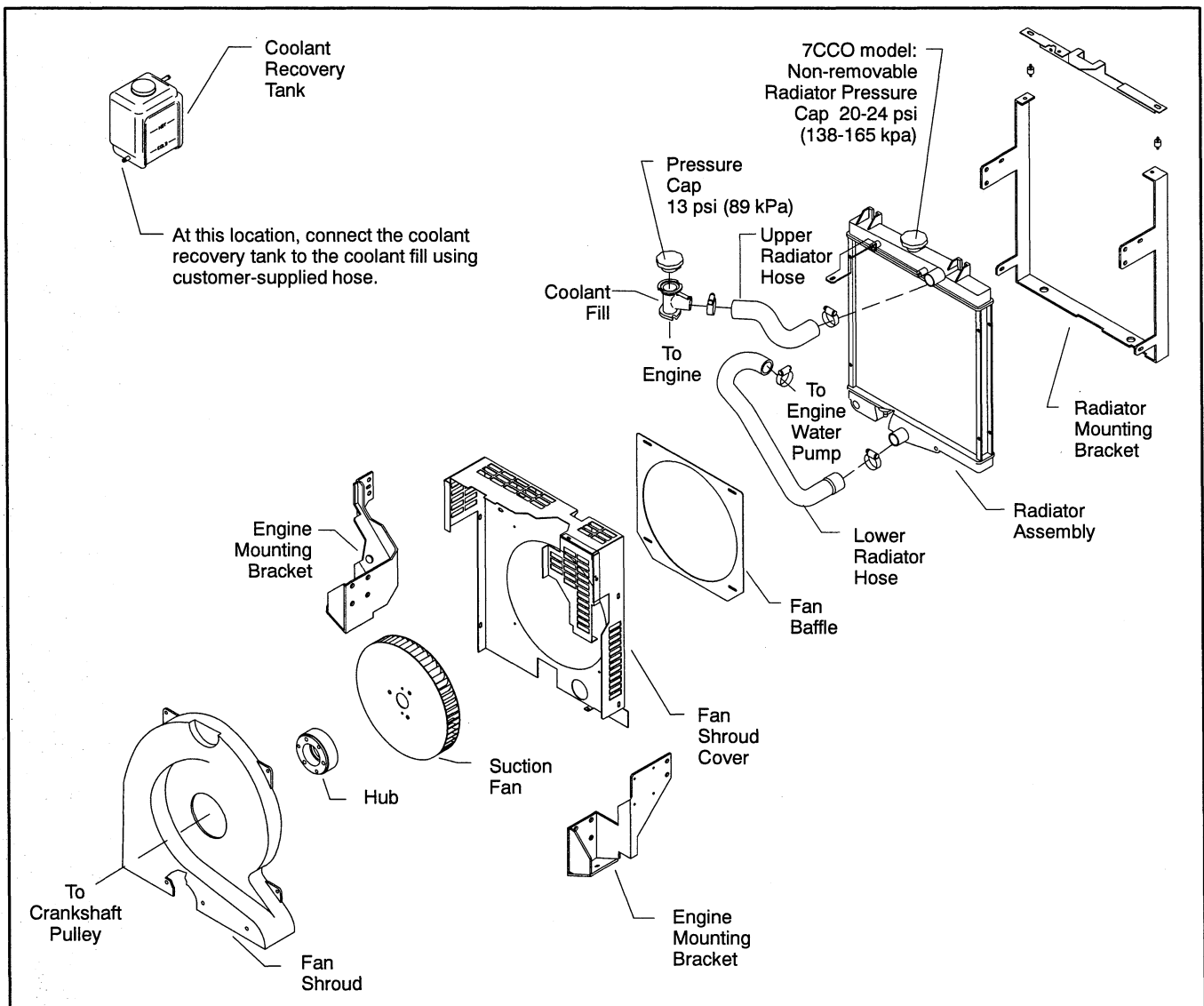

Figure 3-14. 7/10CCO Coolant System Exploded View.

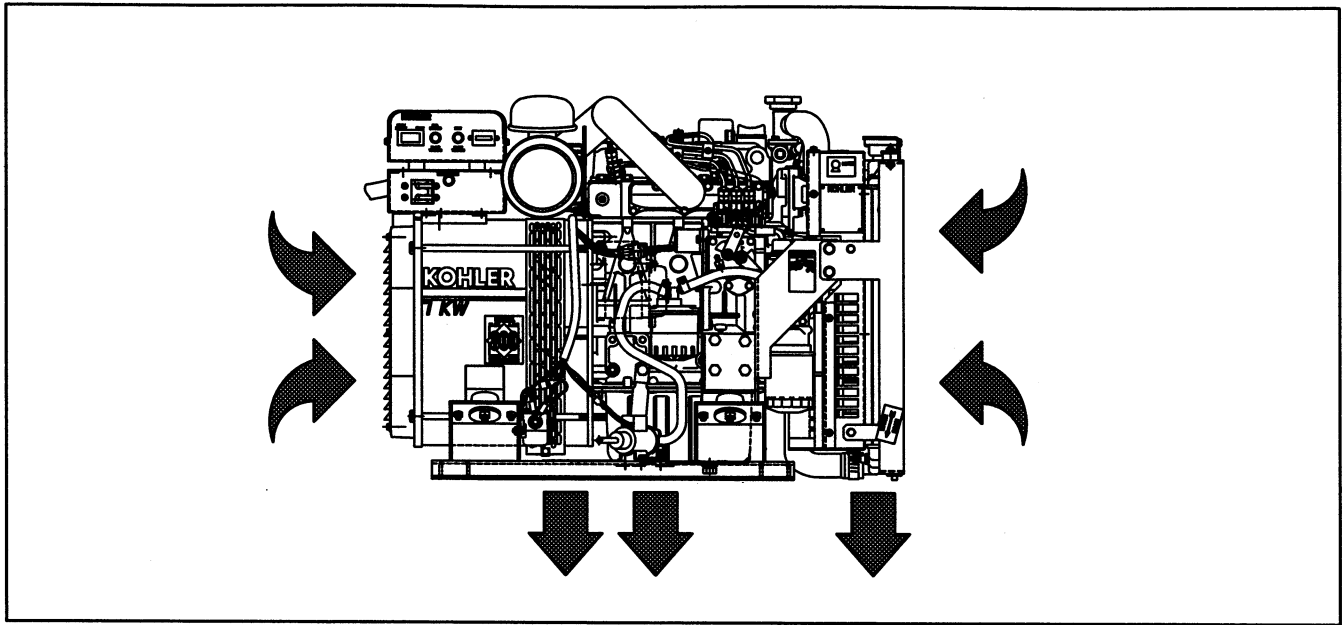

Figure 3-15. 7/10CCO Air Flow Direction Using Suction Fan.

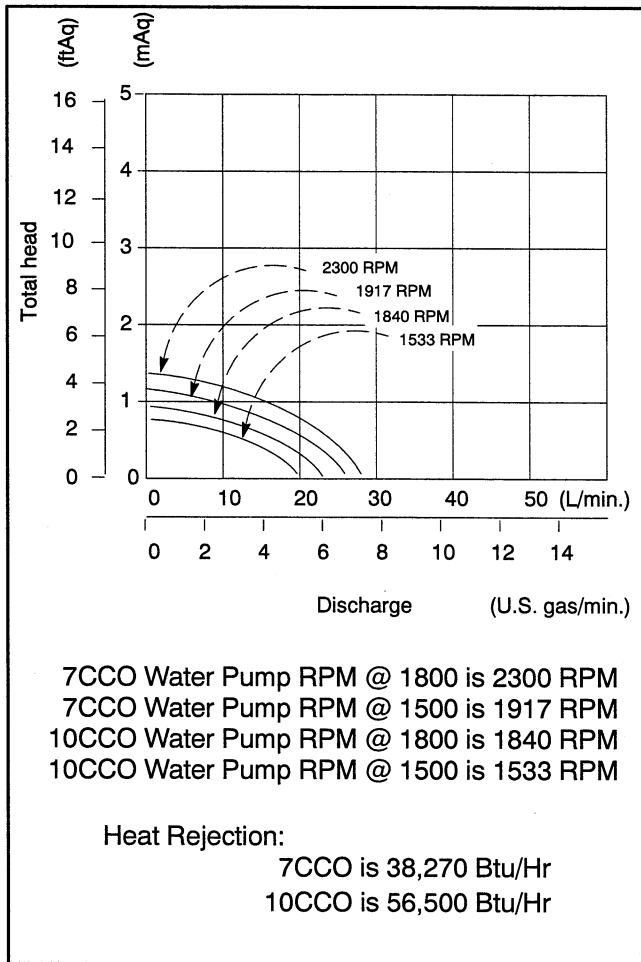

Figure 3-16. Water Pump Flow Rates and Engine Heat Rejection Values.

7CCO	Inline Radiator	2.4 qts. (2.3 L)
10CCO	Inline Radiator	5.1 qts. (5.4 L)

Figure 3-17. Coolant Capacity.

Belt Tension

The belt tension should be adjusted so that it can be depressed about 0.28 to 0.35 in (7 to 9 mm) with about 22 lbs. (10 kg) or forced, see Figure 3-18.

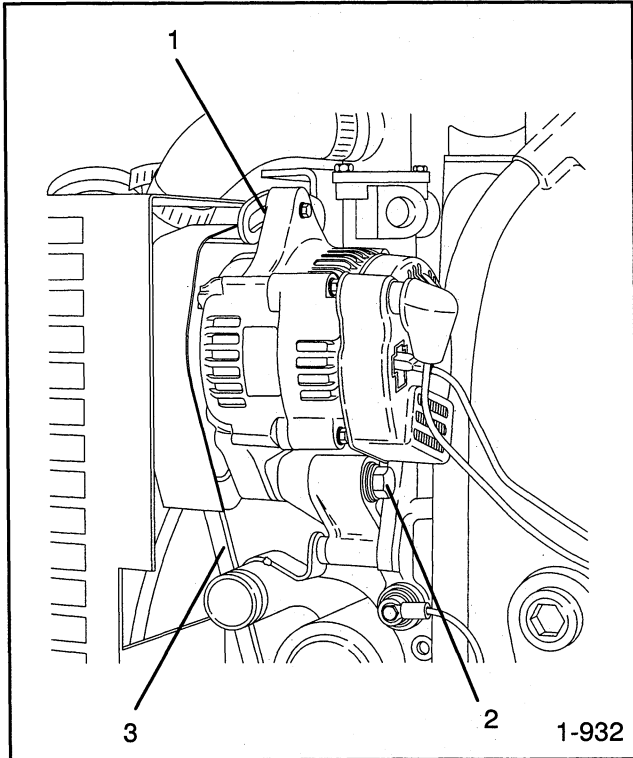

- 1. - Adjusting Screw
- 2. - Pivot Screw
- 3. - Fan Belt

Figure 3-18. Belt Tension.

1. Loosen pivot and adjusting screws.
2. While prying battery charging alternator outward, tighten adjusting screw.
3. Tighten pivot screw.
4. Recheck and adjust as necessary.

NOTE

Also, check fan belt for cracks or tears and replace if necessary.

⚠ WARNING

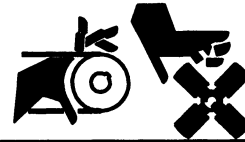

**Rotating parts.
Can cause severe injury or death.**

Do not operate generator set without all guards, screens, or covers in place.

Exposed moving parts can cause severe injury or death. Keep hands, feet, hair, clothing, and test leads away from belts and pulleys when unit is running. Replace guards, covers, and screens before operating generator set.

Battery Charging

The generator is equipped with a 20-amp. belt-driven battery charging alternator. See Figure 3-19. It is attached to the engine block by a bracket and serves to keep the battery constantly charged. Be sure to observe battery polarity when connecting the battery to the generator set. The alternator requires no maintenance other than maintaining belt tension. To adjust the alternator belt tension, see "Belt Tension."

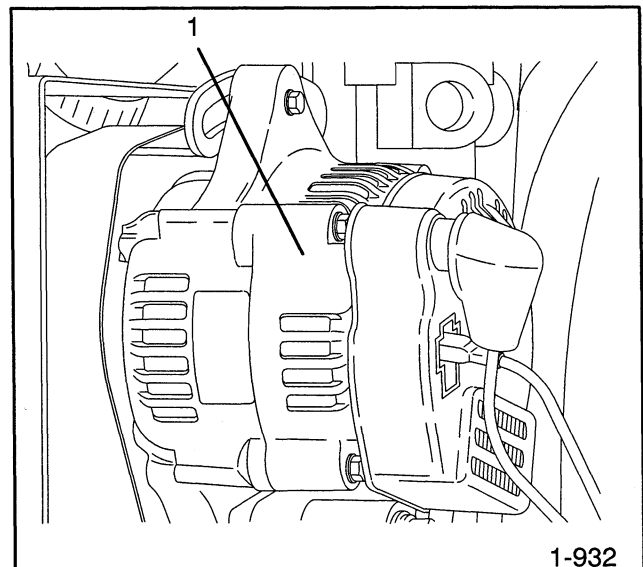

1 - Battery Charging Alternator

Figure 3-19. Battery Charging Alternator.

Battery

The recommended starting battery is one 12-volt with a minimum CCA (cold cranking amps.) of 625 at 0° F (-18° C) or 100 amp. hr. When using a maintenance free battery it is not necessary to check the specific gravity or electrolyte level. Otherwise, these procedures should be done at the intervals specified in the Service Schedule. A negative ground system is used. Battery connections are shown on the wiring diagrams. Make sure that the battery is properly connected and the terminals are tight.

NOTE

The generator set will not start if the battery connections are made in reverse.

WARNING



**Sulfuric acid in batteries.
Can cause severe injury or death.**

Use protective goggles and clothes. Can cause permanent damage to eyes, burn skin, and eat holes in clothing.

Sulfuric acid in batteries can cause severe injury or death. Sulfuric acid in battery can cause permanent damage to eyes, burn skin, and eat holes in clothing. Always wear splash-proof safety goggles when working around the battery. If battery electrolyte is splashed in the eyes or on skin, immediately flush the affected area for 15 minutes with large quantities of clean water. In the case of eye contact, seek immediate medical aid. Never add acid to a battery once the battery has been placed in service. Doing so may result in hazardous spattering of electrolyte.

Explosion can cause severe injury or death. Battery gases can cause an explosion. Do not smoke or permit flame or spark to occur near a battery at any time, particularly when it is being charged. Avoid contacting terminals with tools, etc. to prevent burns and to prevent sparks that could cause an explosion. Remove wristwatch, rings, and any other jewelry before handling battery. Never connect negative (-) battery cable to positive (+) connection terminal of starter solenoid. Do not test battery condition by shorting terminals together or sparks could ignite battery gases or fuel vapors. Any compartment containing batteries must be well ventilated to prevent accumulation of explosive gases. To avoid sparks, do not disturb battery charger connections while battery is being charged and always turn charger off before disconnecting battery connections. When disconnecting battery, remove negative lead first and reconnect it last.

Cleaning

Keep battery clean by wiping it with a damp cloth. Keep all electrical connections dry and tight. If corrosion is present, disconnect cables from battery and remove corrosion with a wire brush. Clean battery and cables with a solution of baking soda and water. Be careful that cleaning solution does not enter battery cells. When cleaning is complete, flush battery and cables with clean water and wipe with a dry cloth. After the battery cables are reconnected, coat terminals with petroleum jelly, silicon grease, or other nonconductive grease.

Checking Electrolyte Level

Check the level of electrolyte before each startup. Remove filler caps and check to see that electrolyte level is up to bottoms of filler holes, see Figure 3-20. Refill as necessary with distilled water or clean tap water. **DO NOT** add fresh electrolyte! Be sure filler caps are tight. If water is added during freezing temperatures, run generator set 20-30 minutes to allow mixing of added water and electrolyte. This will prevent damage to battery due to freezing.

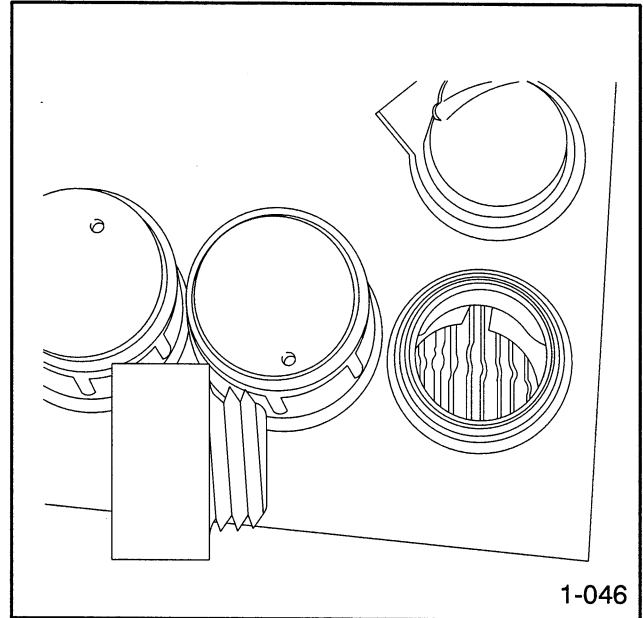
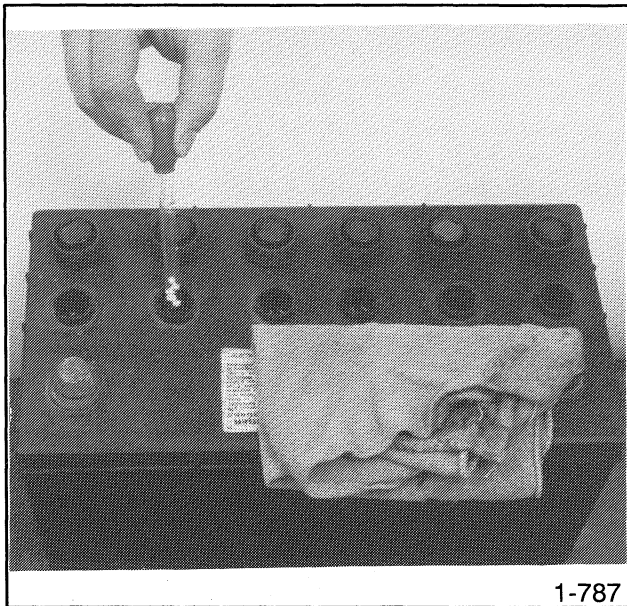

Figure 3-20. Checking Electrolyte Level.

Checking Specific Gravity

Use a battery hydrometer to check the specific gravity of the electrolyte in each battery cell. While holding the hydrometer vertical, read the number on the glass bulb at the top of the electrolyte level (or the number adjacent to the pointer), see Figure 3-21. If the hydrometer used does not have a correction table, use the one in Figure 3-22. Determine specific gravity and electrolyte temperature of battery cells. Locate temperature in Figure 3-22 and adjust gravity by amount shown. The battery is fully charged if the specific gravity is 1.260 at an electrolyte temperature of 80° F (26.7° C). The difference between specific gravities of each cell should not exceed ± 0.01 . The battery should be charged if the specific gravity is below 1.215 at an electrolyte temperature of 80° F (26.7° C).



1-787

Figure 3-21. Checking Specific Gravity.

NOTE

Some battery testers available simply have four or five beads in the tube. Draw electrolyte into the tube as done with the other type of hydrometer. Use instructions with tester.

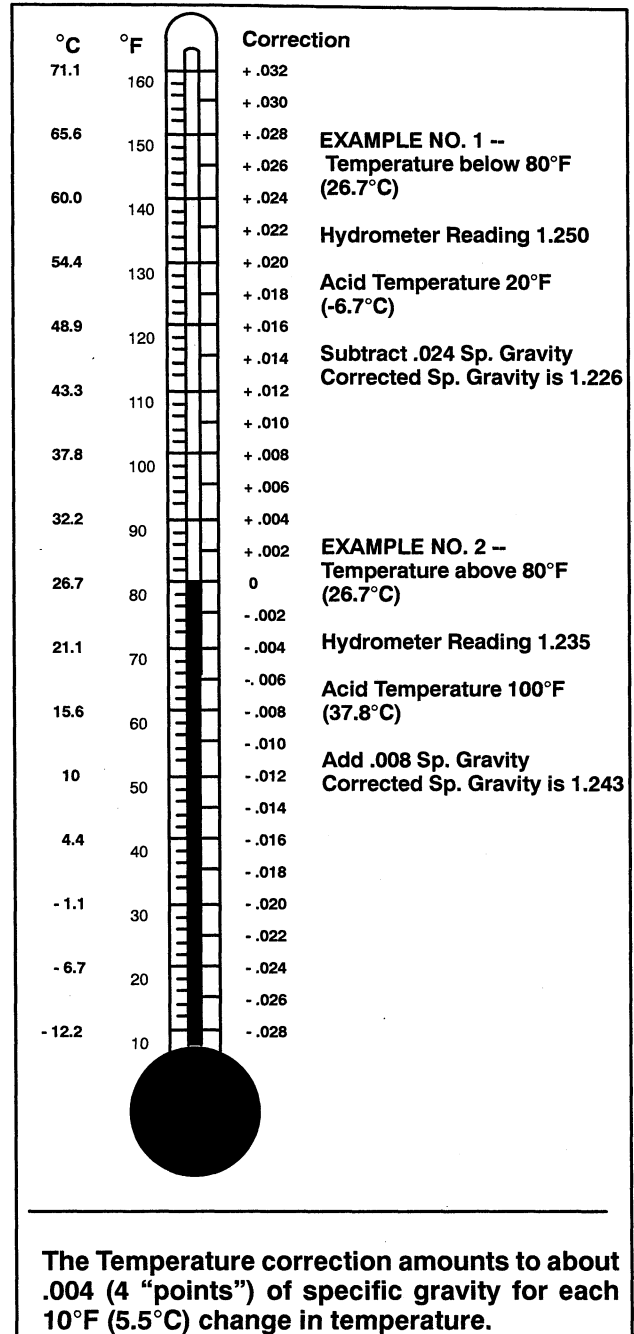

Figure 3-22. Specific Gravity Temperature Correction.

Generator Service

General

Under normal conditions generator service will not be required on a regular basis. If operating under extremely dusty and dirty conditions, use DRY compressed air to blow out the generator at frequent intervals. Do this with the generator set operating and direct the stream of air in through the cooling slots at the end of the generator. Because of the generator set design, brush service should be practically nonexistent. The brushes operate at a very low amperage and should last indefinitely. Abrasive dust on the slip rings could,

however shorten the life of the brushes. If brush replacement becomes necessary due to poor or no AC output, contact an Authorized Service Dealer to have this done.

The end bracket bearing should be replaced every 10,000 hours of operation. Service more frequently if bearing inspection indicates excessive rotor end play or bearing damage from corrosion or heat build-up. The end bracket bearing is sealed and requires no additional lubrication. All generator service must be performed by an Authorized Service Dealer.

Wattage Requirements

If the rated capacity of your generator is exceeded, the circuit breaker(s) located in the controller will trip to protect the generator against damage. This could be caused by a short in the AC circuit in your RV or simply by having too many appliances on at the same time resulting in an overload condition. If the circuit breaker(s) trip, the set may continue running but there will be no AC output to the protected circuit. Before resetting the circuit breaker(s), turn off some of the appliances and lights inside the RV to bring the load down within the rated limits of the set. If this is done and the circuit breaker(s) trips again after being reset, a short circuit is indicated. In this event, turn off the set and have a qualified electrician locate and correct the cause of the short circuit.

The average wattage requirements of some common RV appliances and motor loads are listed in the following chart. Use these figures to calculate the total load on your set to avoid the inconvenience of having the circuit breaker trip due to overload. The lighting load is easily

determined by adding the wattage rating of each bulb in the circuit. Check the nameplate rating on motors and appliances in your RV for exact wattage requirements.

Electrical Appliance	Rating (Watts)
Blanket	50-250
Blender	600
Broiler	1350
Fan, Air Circulating	25-100
Fan, Furnace	270
Heater, Space	750-1500
Heater, Water	1500
Pan, Frying	1200
Percolator, Coffee	650
Radio	50-100
Television	300-750
Toaster	750-1200

Figure 3-23. Appliance Average Wattage Ratings

Storage Procedure

If your generator set is to be out of service for a considerable length of time (2 months or more), the following steps should be taken to preserve the set before placing it in storage.

1. Drain the oil (while hot) from the crankcase then refill with regular grade oil. See Section 3, "Oil Selection" in this manual.
2. Drain the fuel from the fuel tank to prevent accumulated moisture from mixing with the fuel.
3. Check the engine coolant protection. See Section 3, "Cooling System" for additional information.
4. Disconnect battery (negative lead first) and place in storage.
5. Seal all openings in the engine with non-absorbent adhesive tape. Mask off all areas to be used for electrical contact.
6. Clean exterior surface of the generator. Spread a light film of oil over unpainted metallic surfaces which could rust or corrode.

Section 4. General Troubleshooting

Use the following tables as a quick reference in troubleshooting individual problems. Generator set faults are listed by specific groups and include likely causes and remedies. The source of more detailed information needed to correct a problem is indicated. These sources include various sections of this manual, the Operation and Installation Manual (TP-5594), and the Kubota Engine Service Manual (TP-5546).

When troubles occur, don't overlook simple causes. A starting problem could be caused, for example, by improper fuel or an empty fuel tank. Make sure all electrical connections are secure. Remember the battery negative must have a good ground.

Corrective action and testing in many cases requires knowledge of electrical and electronic circuits. It is recommended that service be done only by Authorized Service Dealers/Distributors. Improper repair by unqualified personnel can lead to additional failures.

Problem	Possible Cause	Corrective Action	Reference
ENGINE Will not crank (dead)	Controller voltage supply fuse blown	Replace fuse. If fuse failure continues, replace fuse and troubleshoot DC circuit and wiring.	Section 7. Engine/ Generator Components Section 8. Wiring Diagrams
	Battery disconnected or improperly connected	Check connections	Section 9. Wiring Diagrams Section 3. Battery
	Dead battery	Check electrolyte level and specific gravity (batteries with filler caps only). Perform load test	Section 3. Battery
	Corroded or loose battery connections	Clean or replace	Section 3. Battery
	Open wiring, terminal, pin, foil, etc.	Check continuity	Section 7. Component Testing Section 9. Wiring Diagrams
	Defective starter	Service or Replace	Engine Service Manual
	Defective starter relay	Check continuity of circuit. Bypass relay using jumper wire. If starter cranks, replace relay	Section 7. Engine/ Generator Components Section 9. Wiring Diagrams Engine Service Manual
	Defective start/stop switch	Check continuity	Section 7. Component Testing Section 9. Wiring Diagrams
	Remote start/stop switch not operating properly.	Check wiring and connection to controller. If start/stop switch on controller functions, replace/repair remote switch and/or wiring.	Section 9. Wiring Diagrams Section 7. Component Testing

Problem	Possible Cause	Corrective Action	Reference
Will not start (cranks okay)	No fuel in tank	Replenish	
	Defective fuel solenoid	Check continuity	Section 7. Fuel Solenoid
	Defective fuel feed pump	Replace fuel feed pump NOTE: Fuel pump is polarity sensitive and will fail if the lead connections are made in reverse. (Black lead is positive, White/Black lead is negative)	Engine Service Manual
	Air cleaner clogged	Clean or replace element	Section 3. Air Cleaner Service
	Engine malfunction	Troubleshoot engine	Engine Service Manual
	Air in fuel system	Bleed air	Section 3. Fuel System
	Water, dirt in fuel system	Drain, flush fuel system	
	Dirty or faulty injectors	Check injectors	Engine Service Manual
	Improper compression	Check compression	Engine Service Manual
	Improper type of fuel	Use proper type of fuel; consult fuel supplier	Section 3. Fuel System
	Improper type of crankcase lube oil	Use proper lube oil	Section 3. Lubrication System
	Improper valve clearance	Check valve clearance	Section 3. Valve adjustment/ Engine Service Manual
	Clogged fuel filter	Replace filter	Section 3. Fuel Filter Service/Engine Service Manual
Open wiring, terminal, or pin (P2 connector)	Check continuity	Section 9. Wiring Diagrams	
K4 relay defective (K2 relay must be energized).	Check relay coil continuity	Section 7. Controller Circuit Board Section 9. Wiring Diagrams	

Problem	Possible Cause	Corrective Action	Reference
Will not start (cranks okay (cont'd.))	Weak or dead battery	Recharge battery. Check electrolyte level and specific gravity (batteries with filler caps only). Perform load test, or replace battery.	Section 3. Battery

Problem	Possible Cause	Corrective Action	Reference
Engine starts, but stops after start switch is released	Incorrect generator output voltage	Check AC output voltage.	Section 9. Wiring Diagrams Section 7. Component Testing—Separate Excitation Section 9. Wiring Diagrams
	Fuse blown on voltage regulator circuit	Replace fuse	Section 9. Wiring Diagrams
	Open wiring (P1 or P2 connector)	Check continuity	Section 9. Wiring Diagrams
	K1 relay coil defective.	Check continuity	Section 7. Controller Circuit Board Section 9. Wiring Diagrams
	If LED1 is not lit, K1 relay is not receiving power from stator B1/B2 winding		Section 7. Stator Section 7. Component Testing—Engine/Generator Components
	No/low oil pressure (time delay of 5-10 seconds on E-239563 circuit board)	Check oil pressure, oil pump, and low oil pressure shutdown switch	Engine Service Manual
	Low oil pressure (LOP) or high water temperature (HWT) fault	Correct fault condition	
Defective low oil pressure (LOP) shutdown	Disconnect lead from LOP switch and isolate terminal. If engine continues to run, replace LOP switch. LOP switch contacts close at approx. 7 psi (48.3 kPa). NOTE: Verify proper engine oil pressure, before replacing LOP shutdown switch.		

Problem	Possible Cause	Corrective Action	Reference
Hard starting	Stale or bad fuel	Replace	Section 3. Service Air Cleaner Engine Service Manual Section 3. Cooling System Section 3. Fuel System Engine Service Manual Section 3. Fuel System
	Air cleaner clogged	Clean or replace element	
	Worn piston rings, valves, etc.	Check compression	
	Improper cooling (hot engine only)	Inspect cooling system	
	Air in fuel system	Bleed air	
	Water, dirt in fuel system	Drain, flush fuel system	
	Dirty or faulty injectors	Check injectors	
	Improper type of fuel	Use proper type of fuel; consult fuel supplier	

Problem	Possible Cause	Corrective Action	Reference
Generator set shuts down by itself	No fuel in tank	Replenish	Section 3. Fuel System Engine Service Manual Section 3. Wattage Requirements Section 3. Scheduled Maintenance Engine Service Manual Section 9. Wiring Diagrams Section 7. Stator Section 3. Servicing Air Cleaner
	Fuel line restriction	Inspect fuel lines and tank	
	Clogged fuel filter	Replace filter	
	Defective fuel feed pump	Check fuel feed pump NOTE: Fuel pump is polarity sensitive and will fail if the lead connections are made in reverse. (Black lead is positive, White/Black lead is negative)	
	Engine overloaded (hot engine only)	Reduce electrical load	
	Engine overheated (hot engine only)	Check air intake, governor adjustment, oil level, etc.	
	Loss of generator output voltage to K1 relay (LED1 not lit)	Check AC voltage at rectifier (BR1) Check continuity of B1/B2 stator leads	
	Air cleaner clogged	Clean or replace element	

Problem	Possible Cause	Corrective Action	Reference
Generator set shuts down by itself (cont'd.)	No/low oil pressure	Check oil pressure, oil pump, and low oil pressure shutdown switch	Engine Service Manual
	High water temperature (HWT) shutdown	Check coolant level and temperature	Section 3. Fuel System
	Air in fuel system	Bleed air	
	Defective low oil pressure (LOP) shutdown	Disconnect lead from LOP switch and isolate terminal. If engine continues to run, replace LOP switch. LOP switch contacts close at approx. 7 psi (48.3 kPa). NOTE: Verify proper engine oil pressure, before replacing LOP shutdown switch.	
	Defective high water temperature (HWT) safety shutdown switch	Disconnect lead from HWT switch and isolate terminal of lead. NOTE: Verify proper engine operating temperature before replacing HWT switch. If engine continues to run, replace HWT switch. HWT switch contacts close at approx. 230° F (110° C).	

Problem	Possible Cause	Corrective Action	Reference
Will not carry load or runs rough	Excessive load connected to generator	Reduce electrical load	Section 3. Wattage Requirements
	Improper cooling (hot engine only)	Inspect cooling system	Section 3. Cooling System
	Governor not properly adjusted or defective (Engine not operating at rated rpm)	Check speed using tachometer or frequency meter. NOTE: Hz x 120/ No. of rotor poles = rpm (Example: 60 x 120/4 = 1800)	Section 3. Governor

Problem	Possible Cause	Corrective Action	Reference
Will not carry load or runs rough (cont'd.)	Fuel line restriction	Inspect fuel lines and tank.	
	Dirty fuel filter	Replace fuel filter	Section 3. Fuel System
	Defective fuel feed pump	Check fuel feed pump NOTE: Fuel pump is polarity sensitive and will fail if the lead connections are made in reverse (Black lead is positive, White/Black lead is negative)	Engine Service Manual
	Excessive carbon build-up	Clean cylinder head	Engine Service Manual
	Valves not seating	Inspect valves and valve seats	Section 3. Valve Service Engine Service Manual
	Air cleaner clogged	Clean or replace element	Section 3. Air Cleaner Service
	Improper type of fuel	Use proper type of fuel; consult fuel supplier	Section 3. Fuel System
	Incorrect fuel injection timing	Check injection timing	Engine Service Manual
	Vent in fuel tank cap obstructed	Clean cap in solvent, blow dry	
	Water, dirt, or air in fuel system	Drain, flush, fill, and bleed air in the system	Section 3. Fuel System
	Dirty or faulty injectors	Check injectors	Engine Service Manual
	Improper cylinder top clearance	Check clearance	Engine Service Manual
	Defective piston or piston ring	Check components	Engine Service Manual
	Defective crankshaft bearing or piston pin bearing	Check components	Engine Service Manual
Improper valve clearance	Adjust proper valve clearance	Section 3. Valve Adjustment	
Improper compression	Check compression	Engine Service Manual	

Problem	Possible Cause	Corrective Action	Reference
Will not carry load or runs rough (cont'd.)	Defective injection pump	Check injection pump	Engine Service Manual
	Improper lube oil	Use proper viscosity oil	Section 3. Lubrication System

Problem	Possible Cause	Corrective Action	Reference
Lacks power	Governor not properly adjusted or defective (Engine not operating at rated RPM)	Check engine speed using frequency meter or tachometer. NOTE: Hz x 120/No. of rotor poles = rpm (Example: 60 x 120/4 = 1800)	Section 3. Governor
	Air cleaner clogged	Clean or replace element	Section 3. Air Cleaner Service
	Carbon build-up	Clean carbon from cylinder heads	Engine Service Manual
	Improper cooling	Inspect cooling system	Section 3. Cooling System
	Engine overloaded	Reduce electrical load	Section 3. Wattage Requirements
	Stale or bad fuel	Replace	
	Fuel line restriction	Check fuel lines and tank	
	Dirty fuel filter	Replace fuel filter	Section 3. Fuel System

Problem	Possible Cause	Corrective Action	Reference
Overheats	Improper cooling (Check hoses for blockage and components for function.)	Check cooling system	Section 3. Cooling System
	Air cleaner clogged	Clean or replace element	Section 3. Air Cleaner Service
	Engine malfunction	Troubleshoot engine	Engine Service Manual
	Defective fuel feed pump	Check fuel feed pump NOTE: Fuel pump is polarity sensitive and will fail if the lead connections are made in reverse (Black lead is positive, White/Black lead is negative)	Engine Service Manual

Problem	Possible Cause	Corrective Action	Reference
Operates erratically	Air cleaner clogged	Clean or replace element	Section 3. Air Cleaner Service
	Stale or bad fuel	Replace	
	Governor not properly adjusted or defective (Engine not operating at rated RPM)	Check engine speed using frequency meter or tachometer. NOTE: Hz x 120/No. of rotor poles = rpm (Example: 60 x 120/4 = 1800)	Section 3. Governor
	Fuel line restriction	Inspect fuel lines and tank.	

Problem	Possible Cause	Corrective Action	Reference
Unit is noisy	Exhaust system leak	Check and replace as necessary	Operation and Installation Manual—Exhaust Systems
	Broken or damaged vibro mounts	Check and replace as necessary	Section 8. Disassembly/ Reassembly
	Loose or vibrating sheet metal/housing	Retighten screws	
	Inadequate compartment clearances	Check clearances	Section 10. Specifications Chart—Generator Operation and Installation Manual—Compartment Size
	Exhaust piping or air inlets/outlets not securely installed	Inspect for loose parts	Operation and Installation Manual—Exhaust Systems
	No compartment sound insulation	Install fireproof insulation	Operation and Installation Manual—Compartment Size
	Excessive vibration—engine/generator	Check rotor, crankshaft, bearing, etc. (Disassembly of engine and/or generator may be required)	Section 8. Disassembly/ Reassembly Engine Service Manual

Problem	Possible Cause	Corrective Action	Reference
ELECTRICAL SYSTEM Battery will not charge	Loose or corroded connections	Clean and tighten connections	Section 3. Battery
	Sulfated or worn-out battery	Check electrolyte level and specific gravity (batteries with filler caps only)	Section 3. Battery
	Defective alternator	Test and replace, if necessary	Section 7. Component Testing
	Loose or defective alternator belt	Adjust belt tension or replace belt	Section 3. Belt Tension
	Defective alternator voltage regulator	Test and replace, if necessary	Section 7. Component Testing

Problem	Possible Cause	Corrective Action	Reference
Starter does not work properly	Loose or corroded connections	Clean and tighten loose connections	Section 3. Battery
	Low battery output	Check electrolyte level and specific gravity (batteries with filler caps only)	Section 3. Battery
	Defective starter relay	Check starter relay Replace starter relay, as necessary	Section 7. Component Testing Engine Service Manual
	Defective start/stop switch	Replace switch	Section 7. Component Testing
	Defective wiring	Check wiring	Section 8. Wiring Diagrams
	Defective starter	Replace starter	Engine Service Manual
	Battery cables undersize	Select proper size cable	Section 10. Specifications Chart—Installation Operation and Installation Manual—Electrical System

Problem	Possible Cause	Corrective Action	Reference
Starter cranks slowly	Low battery output	Check electrolyte level and specific gravity (batteries with filler caps only)	Section 3. Battery
	Too heavy viscosity lube oil	Use proper viscosity oil	Section 3. Lubrication System
	Loose or corroded wiring	Clean and tighten loose connections	Section 3. Battery
	High starter current draw	Repair/Replace starter	
	Battery cable undersize	Select proper size cable	Section 10. Specifications Chart—Installation Operation and Installation Manual—Electrical Systems

Problem	Possible Cause	Corrective Action	Reference
GENERATOR No generator output voltage	Optional AC output circuit breaker open or defective	Check position of circuit breaker Check AC voltage on generator side of circuit breakers	Section 2. Circuit Protection Section 9. Wiring Diagrams
	Optional AC circuit breaker tripping due to overload on unit	Reduce load Reset and attempt startup	Section 3. Wattage Requirement
	Transfer switch in OFF or <i>other</i> power source position	Turn handle to proper position	Section 9. Wiring Diagrams Operation and Installation Manual—Electrical Connections
	No battery voltage to terminal (+) and (-) of voltage regulator during cranking	Check for 12 VDC at voltage regulator (+) and (-)	Section 9. Wiring Diagrams
	Fuse blown in voltage regulator circuit (lead 55)	Replace fuse. If fuse blows again, check voltage regulator and stator aux. windings	Section 7. Voltage Regulator Section 9. Wiring Diagrams
	Short circuit in coach wiring causing circuit breaker to trip	Reset circuit breaker. If breaker trips again, check coach wiring.	Section 9. Wiring Diagrams Coach Wiring Diagram
	Open wiring, terminals or pin in aux. winding circuit (field flashing)	Check continuity	Section 9. Wiring Diagrams
	Defective rotor (open, grounded, or shorted windings)	Test and/or replace	Section 7. Rotor
	Defective stator (open, grounded, or shorted windings)	Test and/or replace	Section 7. Stator
	Open D5 or D8 diode	Check for open or shorted diode (a good diode has high resistance one way and low resistance the other way, when tested with ohmmeter)	Section 9. Wiring Diagrams Section 7. Circuit Board
Optional AC Circuit breaker(s) in OFF position	Reset to ON position		
No DC power to controller	Check battery connections		

Problem	Possible Cause	Corrective Action	Reference
No generator output voltage (cont'd.)	K1 relay (Normally Closed) contacts open	Check continuity	Section 9. Wiring Diagrams Section 7. Circuit Board
	Brushes sticking in holder	Check alignment	Section 7. Brushes
	Rotor slip rings dirty or corroded	Check and/or service	Section 7. Brushes
	Broken, weak, or missing brush spring	Check condition	Section 7. Brushes
	Defective voltage regulator. Misadjusted voltage regulator	Excite (rotor) separately	Section 7. Separate Excitation Section 7. Voltage Regulator Test

Problem	Possible Cause	Corrective Action	Reference
Low generator output voltage	Low engine rpm	Check engine speed using frequency meter or tachometer. NOTE: Hz x 120/No. of rotor poles = rpm. (Example: 60 x 120/4 = 1800)	Section 3. Governor Adjustments
	Set overloaded	Make sure capacity is not being exceeded	Section 3. Wattage Requirements
	Defective rotor	Test and/or replace	Section 7. Rotor
	Defective stator	Test and/or replace	Section 7. Stator
	Defective voltage regulator	Test and/or replace	Section 7. Voltage Regulator
	Improperly adjusted voltage regulator	Readjust	Section 7. Voltage Regulator

Problem	Possible Cause	Corrective Action	Reference
High generator output voltage	Defective voltage regulator Voltage regulator misadjusted Open or poor splice connection at terminals 33-3 or 44-4 on stator (regulator sensing); or poor pin connection at voltage regulator	Test and/or replace Readjust Check continuity	Section 7. Voltage Regulator Section 7. Voltage Regulator Section 7. Stator

Section 5. Controller Troubleshooting

The following test is the controller sequence of operation when starting, running, stopping, or during fault shutdown of the set. Use this section as a starting point for controller fault identification. Refer to Figure 5-1 for the accompanying wiring schematic. See Legend for symbol descriptions.

Sequence of Operation

Starting

- Energize the preheat feature (by the amount of time shown on page 2-3) by closing the start/stop switch between 2 and 4. This energizes C1 relay. Normally open C1 contacts close to energize the glow plugs. Glow plugs are de-energized by releasing the stop switch. **NOTE:** Do not energize the preheat feature for more than 20 seconds or damage may occur.
- Close the start/stop switch between 3 and 4 (local or remote starting).
- K2 relay is energized (LED2 lights) and (-) field flashing current is energized. Normally open K2 contacts close to energize K3 relay (LED3 lights), K25 (fuel solenoid) relay, fuel pump, controller hourmeter, and (+) field flashing current.
- K3 relay normally open contacts close to energize K20 relay. K20 relay normally open contacts close to energize S relay (starter solenoid). S relay normally open contacts close to engage starter motor and energize "pull-in" coil of fuel solenoid.
- K25 normally open contacts close to energize "hold" coil of fuel solenoid.

Running

- When proper output is obtained from stator B1/B2 winding, K1 relay is energized (LED1 lights). After a 5-10 second time delay, K5 relay is energized (LED5 lights). **NOTE:** Voltage to the K1 relay and K5 relay are rectified and regulated at 12 volts DC by BR1 and VR1.
- Stator winding 33-44 provides a voltage-sensing source to voltage regulator.
- One set of normally-open K1 (A) contacts close to maintain voltage to K2 relay (LED2 remains lit). Normally open K2 contacts remain closed to maintain voltage to fuel solenoid, fuel pump and controller hourmeter.
- A second set of normally open K1 (B) contacts close to energize the (optional) remote hourmeter, generator 'ON' light, battery voltmeter, oil pressure gauge, and water temperature gauge.

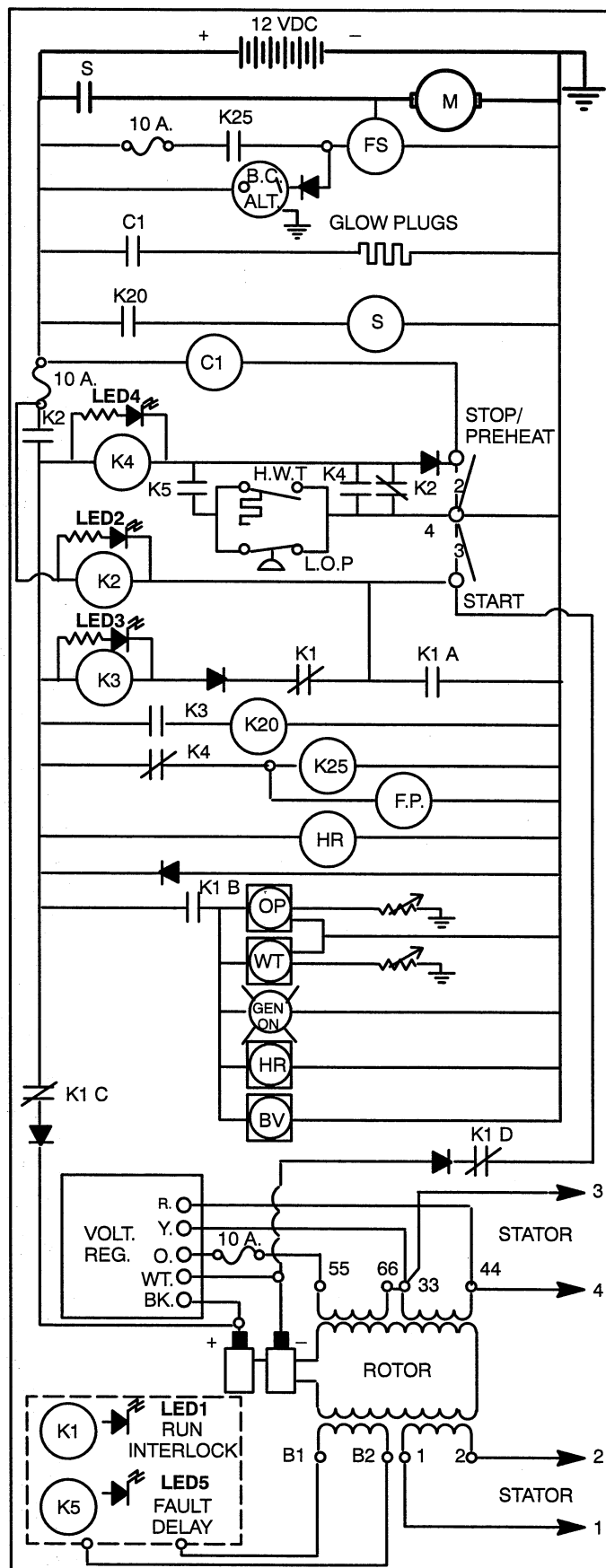

Figure 5-1. Sequence of Operation

- One set of normally closed K1 (C) contacts open to disconnect (+) field flashing current.
- A second set of normally closed K1 (D) contacts open to disconnect (-) field flashing current. Another set of contacts also opens to de-energize K3 relay (LED 3 goes out) and prevents accidental reenergizing of starter motor. K3 contacts open to de-energize K20 relay. K20 relay contacts open to de-energize S relay. S relay contacts open to de-energize starter motor and the "pull-in" coil of the fuel solenoid.
- When the unit is running, start switch contacts 3 and 4 are opened by releasing start/stop rocker switch.
- Normally-open K5 contacts close to permit engine high water temperature (HWT), and low oil pressure (LOP) switches to function. **NOTE:** LOP switch contacts open when engine develops proper oil pressure.

Stopping

- **NOTE:** Keeping in stop position too long will energize glow plugs (see page 2-3).
- Close start/stop switch between 2 and 4 (local or remote).
- K4 relay is energized (LED4 lights).
- Normally closed K4 contacts open to de-energize K25 relay and fuel pump relay. K25 normally open contacts open to de-energize fuel solenoid.
- Normally open K4 contacts close to maintain ground to K4 relay.
- As unit is shutting down, K1 relay is de-energized (LED1 goes out). Normally-open K1 (A) contacts open to de-energize K2 relay (LED2 goes out). Normally closed K2 contacts close to ground circuit to K4 relay until unit comes to a complete stop.

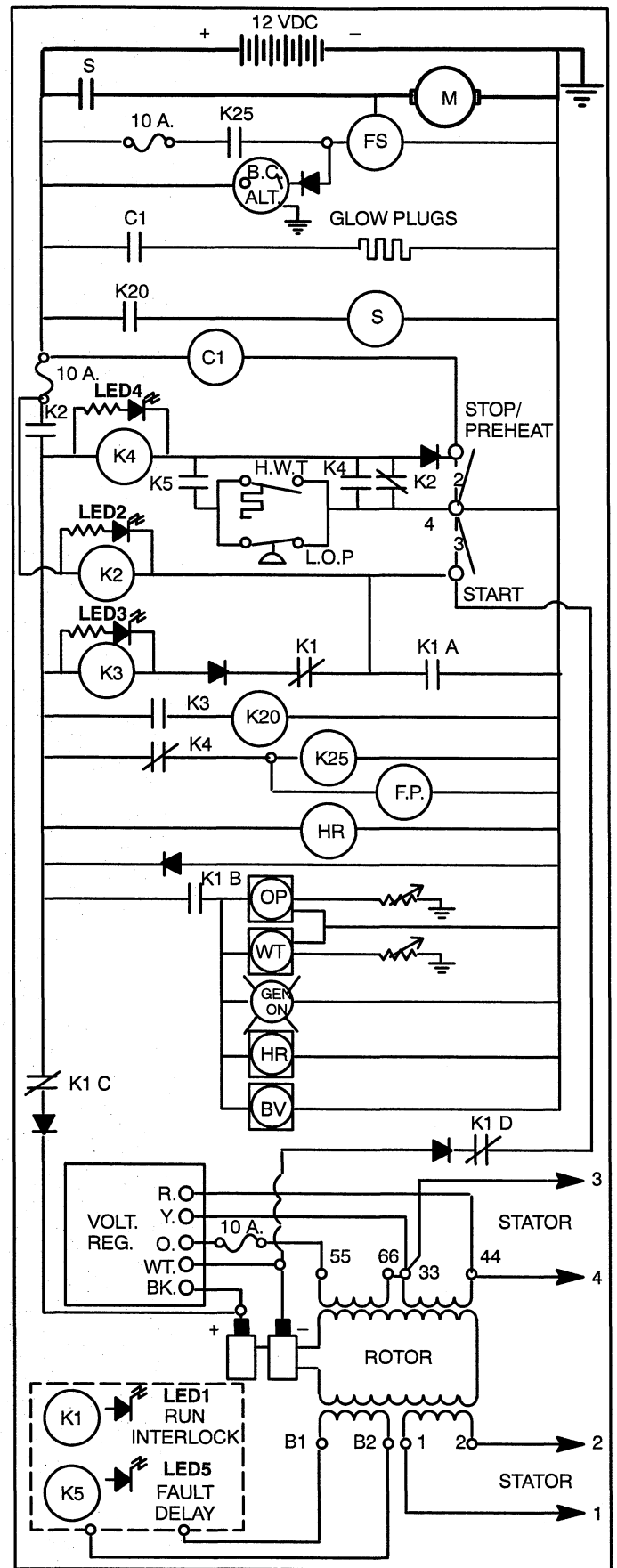

Figure 5-1. Sequence Of Operation.

Engine Safety Shutdown Switches

LEGEND

Low oil pressure (LOP) shutdown switch

- When low oil pressure is encountered, LOP shutdown switch contacts close and energize K4 relay (LED4 lights).
NOTE: During cranking low oil pressure shutdown switch is deactivated until K5 relay is energized. This is to allow engine to reach normal operating oil pressure. Normally closed LOP contacts open when unit develops adequate oil pressure.
- Normally closed K4 contacts open to de-energize K25 relay and fuel pump relay. K25 normally open contacts open to de-energize fuel solenoid.
- Normally open K4 contacts close to maintain ground to K4 relay.
- As unit is shutting down, K1 relay is de-energized (LED1 goes out). Normally open K1 (A) contacts open to de-energize K2 relay (LED2 goes out). Normally closed K2 contacts close to ground circuit to K4 relay until unit comes to a complete stop.

High water temperature (HWT) shutdown switch

- When high temperature is encountered, the shutdown switch contacts close and energize K4 relay (LED4 lights).
- Normally closed K4 contacts open to de-energize K25 relay and fuel pump relay. K25 normally open contacts open to de-energize fuel solenoid.
- Normally open K4 contacts close to maintain ground to K4 relay.
- As unit is shutting down, K1 relay is de-energized (LED1 goes out). Normally open K1 (A) contacts open to de-energize K2 relay (LED2 goes out). Normally closed K2 contacts close to ground circuit to K4 relay until unit comes to a complete stop.

A	Ampere rating (fuse or circuit breaker)
BC	Battery Charging
BR1	Bridge Rectifier (Supply Voltage)
BV	Battery Volts
C1	Glow Plug Relay
CB	Circuit Board
D	Diode
FP	Fuel Pump
FS	Fuel Solenoid
GRD	Ground
HR	Hour Meter
HWT	High Water Temperature
K1	AC Crank Disconnect Relay (circuit board)
K2	Engine Run Control Relay (circuit board)
K3	Engine Crank Control Relay (circuit board)
K4	Fault Shutdown Relay (circuit board)
K5	Fault Time Relay (circuit board)
K20	Engine Crank Relay
K25	Fuel Solenoid Control Relay
LED	Light Emitting Diode
LOP	Low Oil Pressure Switch
M	Starter Motor
OP	Oil Pressure Gauge
OPS	Oil Pressure Sender
PTC1	Positor
S	Starter Relay
VR1	Voltage Regulator
WT	Water Temperature Gauge
WTS	Water Temperature Sender

Section 6. Generator/Controller Troubleshooting

The flow chart is a guide to troubleshooting the generator set including the controller circuit board. Before beginning the troubleshooting procedures, read all safety precautions at the beginning of this manual. Additional safety precautions are included with the tests; DO NOT NEGLECT THESE PRECAUTIONS.

Where a check or test is referenced, go to that appropriate part of Section 7. Generator Testing and Adjustment for detailed instructions.

Controller Circuit Board

The controller circuit board is equipped with LEDs (light emitting diodes) to indicate the presence of relay coil power and aid in circuit board and generator fault detection. See Figure 6-1.

When K1, K2, K3, K4, or K5 relays are receiving power, the corresponding LED will light. The LED does not indicate whether the relay coil is energized. This conclusion can only be reached through deductive analysis of generator faults and by performing a continuity test on the relay coil (see Section 7. Controller Circuit Board).

Use the following flow chart as an aid in troubleshooting the generator set.

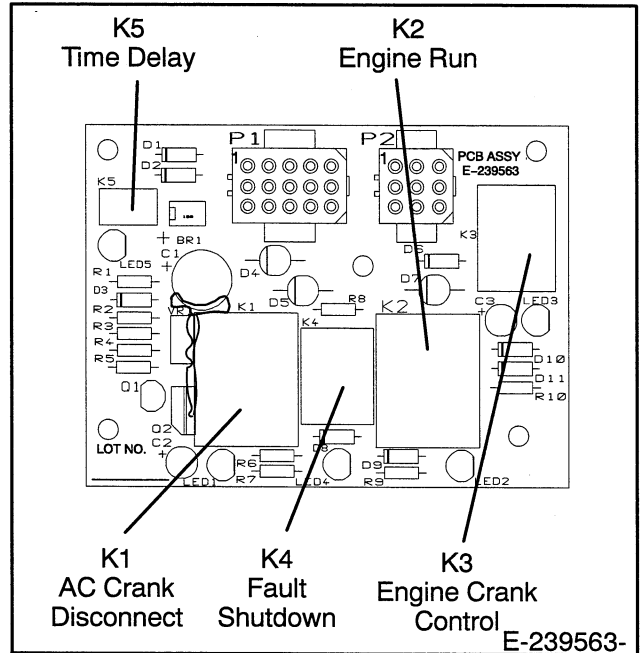
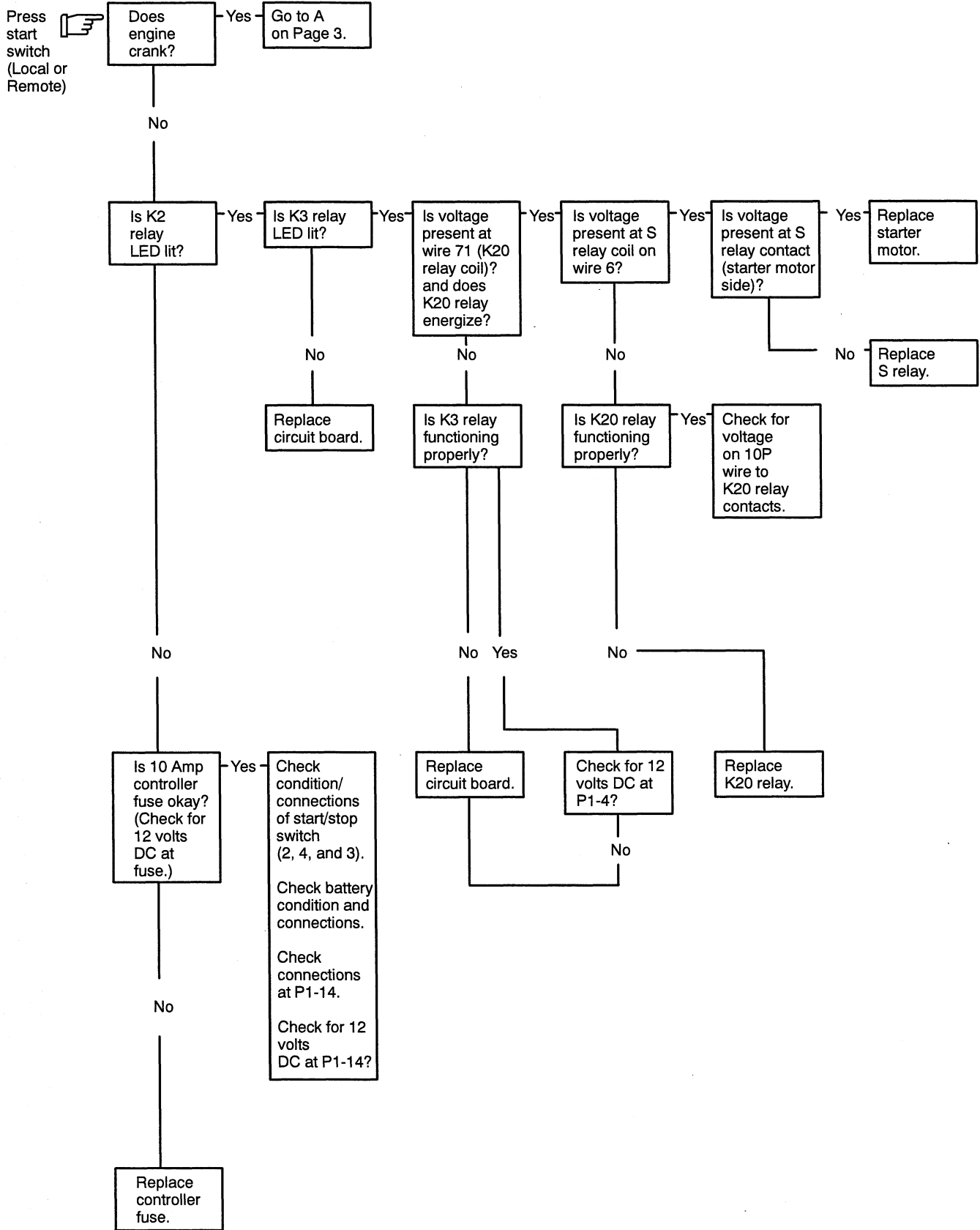
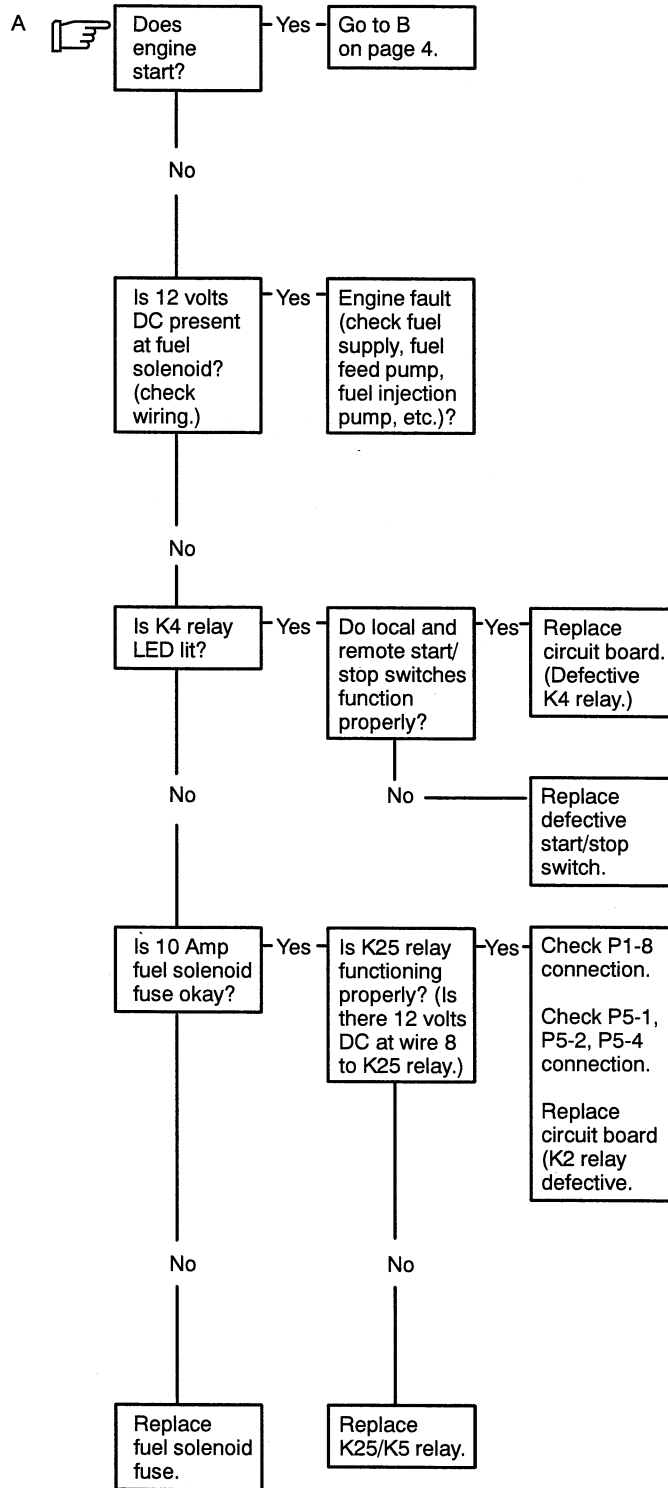

Figure 6-1. Controller Circuit Board E-239563.

GENERATOR/CONTROLLER TROUBLESHOOTING



GENERATOR/CONTROLLER TROUBLESHOOTING



GENERATOR/CONTROLLER TROUBLESHOOTING

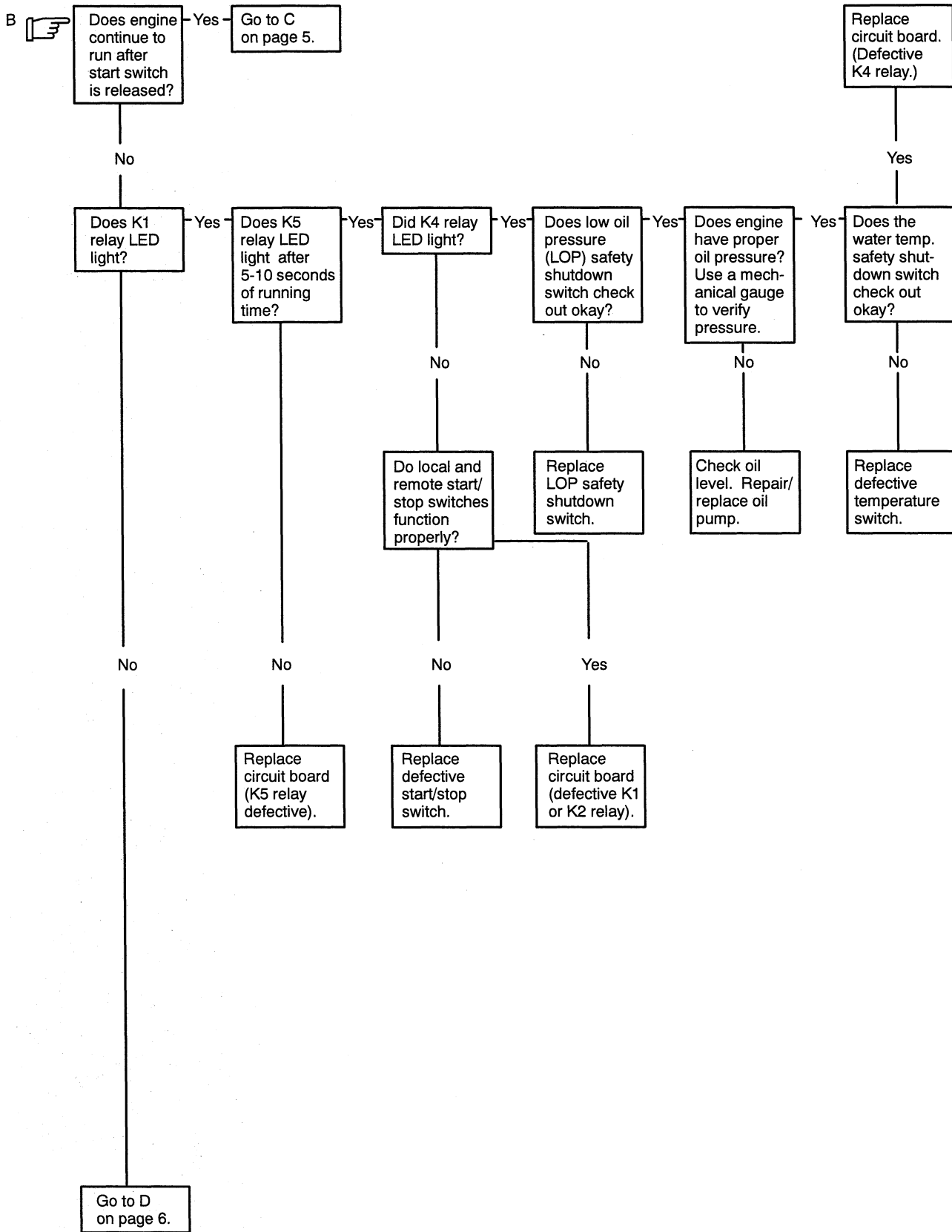

GENERATOR/CONTROLLER TROUBLESHOOTING

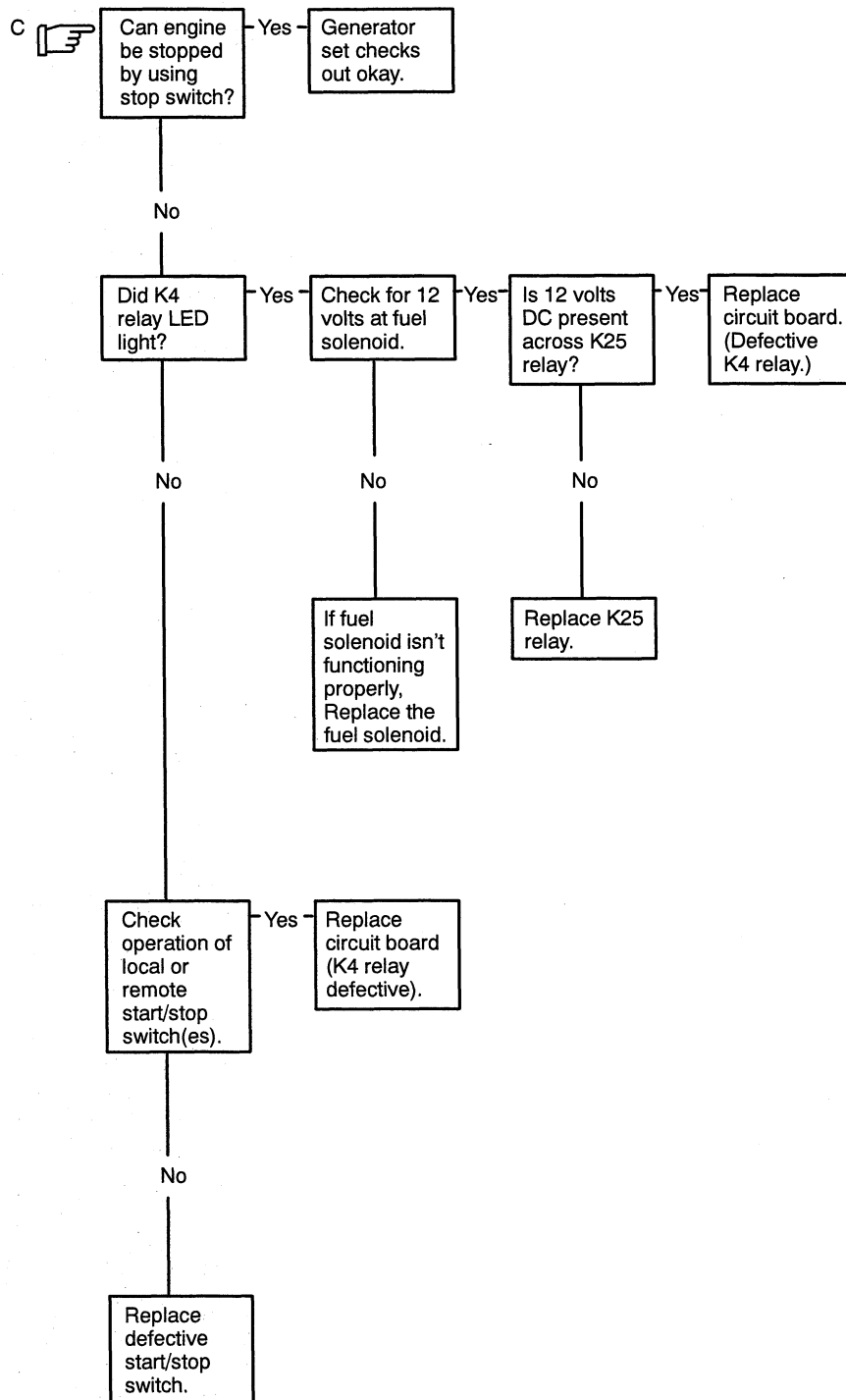

GENERATOR/CONTROLLER TROUBLESHOOTING

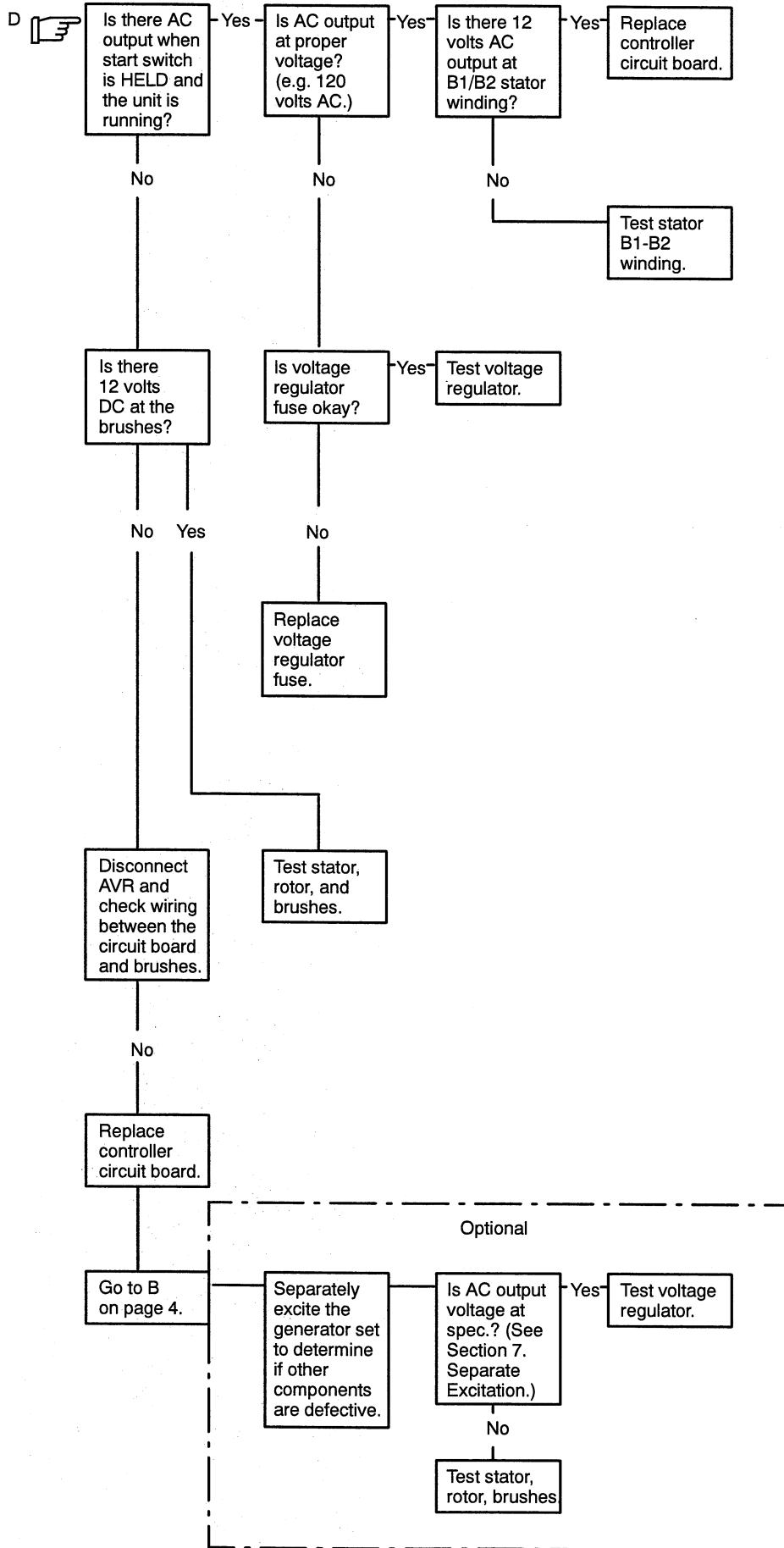



Section 7. Component Testing and Adjustment

This section is a guide for checking generator, controller, and some engine components for improper operation. Follow the safety precautions at the beginning of this manual during all test procedures. Additional safety precautions are included with the tests; OBSERVE THESE PRECAUTIONS!

Separate Excitation

To determine the cause of no AC output, separately excite the generator. The generator field (rotor) may be excited (magnetized) using an outside DC power source or 12-volt automotive battery and the following procedures. While separately exciting the generator to determine the presence of a faulty voltage regulator, it is possible to determine if a running fault exists in the rotor and/or stator. A generator component that appears good while static (stationary) may exhibit a running open or short while dynamic (moving). This fault can be caused by centrifugal forces acting on the windings while rotating or insulation breakdown as temperatures increase.

 WARNING	
	
Hazardous voltage.	Moving rotor.
Can cause severe injury or death.	
Do not operate generator set without all guards and electrical enclosures in place.	

Hazardous voltage can cause severe injury or death. Perform electrical service only as prescribed in equipment manual. Be sure that generator is properly grounded. Never touch electrical leads or appliances with wet hands, when standing in water, or on wet ground as the chance of electrocution is especially prevalent under such conditions. Wiring should be inspected at the interval recommended in the service schedule—replace leads that are frayed or in poor condition. The function of a generator set is to produce electricity and wherever electricity is present, there is the hazard of electrocution.

WARNING



Sulfuric acid in batteries.
Can cause severe injury or death.

Use protective goggles and clothes. Can cause permanent damage to eyes, burn skin, and eat holes in clothing.

Sulfuric acid in batteries can cause severe injury or death. Sulfuric acid in battery can cause permanent damage to eyes, burn skin, and eat holes in clothing. Always wear splash-proof safety goggles when working around the battery. If battery electrolyte is splashed in the eyes or on skin, immediately flush the affected area for 15 minutes with large quantities of clean water. In the case of eye contact, seek immediate medical aid. Never add acid to a battery once the battery has been placed in service. Doing so may result in hazardous spattering of electrolyte.

Explosion can cause severe injury or death. Battery gases can cause an explosion. Do not smoke or permit flame or spark to occur near a battery at any time, particularly when it is being charged. Avoid contacting terminals with tools, etc. to prevent burns and to prevent sparks that could cause an explosion. Remove wristwatch, rings, and any other jewelry before handling battery. Never connect negative (-) battery cable to positive (+) connection terminal of starter solenoid. Do not test battery condition by shorting terminals together or sparks could ignite battery gases or fuel vapors. Any compartment containing batteries must be well ventilated to prevent accumulation of explosive gases. To avoid sparks, do not disturb battery charger connections while battery is being charged and always turn charger off before disconnecting battery connections. When disconnecting battery, remove negative lead first and reconnect it last.

1. Disconnect all leads from voltage regulator. See Figure 7-1.

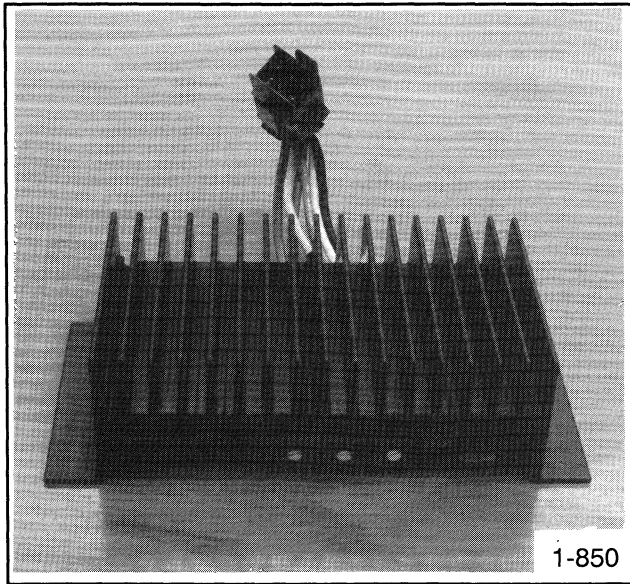

Figure 7-1. PowerBoost III Voltage Regulator.

2. Connect an ammeter and a 12-volt automotive battery to the positive (+) and negative (-) brush leads. Include a 10-amp. fuse to protect the circuit in case of a shorted rotor. Refer to Figure 7-2. Note and record the ammeter reading.

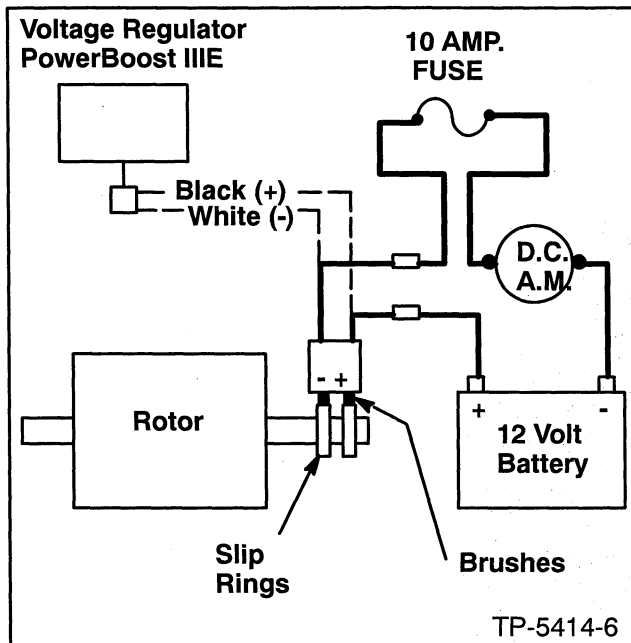

Figure 7-2. Separate Excitation Connections (PowerBoost III).

3. The approximate ammeter reading should be battery voltage divided by specified rotor resistance. For rotor resistance, see Section 10. Specifications—Generator.

Example:

$$\frac{12 \text{ Volts (Battery Voltage)}}{4.7 \text{ Ohms (Rotor Resistance)}} = 2.6 \text{ Amps. (Rotor Current)}$$

4. Start engine and check that ammeter remains stable. An increasing meter reading indicates a shorted rotor. A decreasing meter reading to zero or unstable reading suggests a running open (see Section 7. Rotor). If ammeter is stable proceed to Step 5.
5. Check for AC output across stator leads (see Section 7. Stator) and compare to readings in Section 10. Specifications—Generator. If readings vary considerably from those in Section 10. Specifications—Generator, a faulty stator is likely. Refer to Section 7. Component Testing for further information.
6. If rotor and stator test good in prior steps, the voltage regulator is probably defective. Refer to Section 7. Component Testing.

NOTE

Stator Output Voltages (with Separately Excited Rotor) found in Section 10. Specifications—Generator are based on a battery voltage of 12 Volts. Should actual battery voltage vary (11-14 Volts), resulting values will also vary.

PowerBoost IIIE Voltage Regulator Test

The voltage regulator monitors output voltage magnitude and frequency to supply current to the generator exciter field. To test the voltage regulator the following components will be needed:

- Variable Transformer, 0-140 volts (0.5-amp. Minimum)
- 120-volt AC Plug
- 120-volt, 100-watt Lamp
- AC voltmeter
- #14 AWG Copper Wire (minimum)

1. Connect components as shown in Figure 7-3.

2. Turn variable transformer setting to zero. Plug in variable transformer.

3. Turn variable transformer on. Slowly increase variable transformer voltage to 100 volts. The lamp should go on between 30 to 40 volts up to 100 volts. If the lamp does not light, turn the voltage adjustment pot. clockwise. If the light still does not go on, the voltage regulator is defective and should be replaced. This would correspond to a low- or no-voltage output condition.

4. Slowly increase voltage to 120 volts. The lamp should go out and stay out as voltage is further increased. If the lamp does not go out, turn the voltage adjustment pot. counterclockwise. If the light still does not go out, the voltage regulator is defective and should be replaced. This would correspond to a high voltage output condition.

5. Turn variable transformer to zero and unplug AC cord.

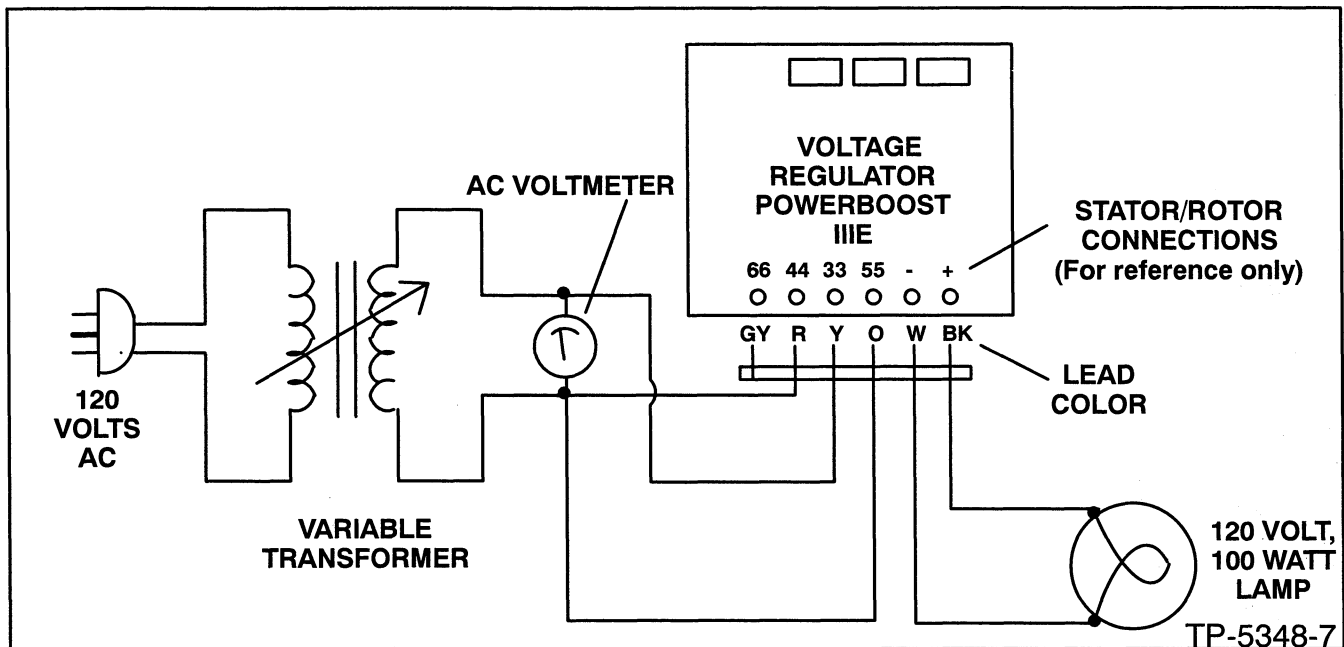

Figure 7-3. PowerBoost IIIE Voltage Regulator Test.

VOLTAGE REGULATOR ADJUSTMENT

NOTE

The voltage regulator is factory set for proper generator operation under a variety of load conditions. Under normal circumstances, no further adjustment is necessary. However, if the regulator is replaced or has been tampered with, readjust according to the following procedure. Voltage regulator components are identified in Figure 7-4 and described in the following paragraphs.

The voltage regulator is located in the junction box. Adjustments are possible without removing the regulator from the junction box. See Figure 7-5.

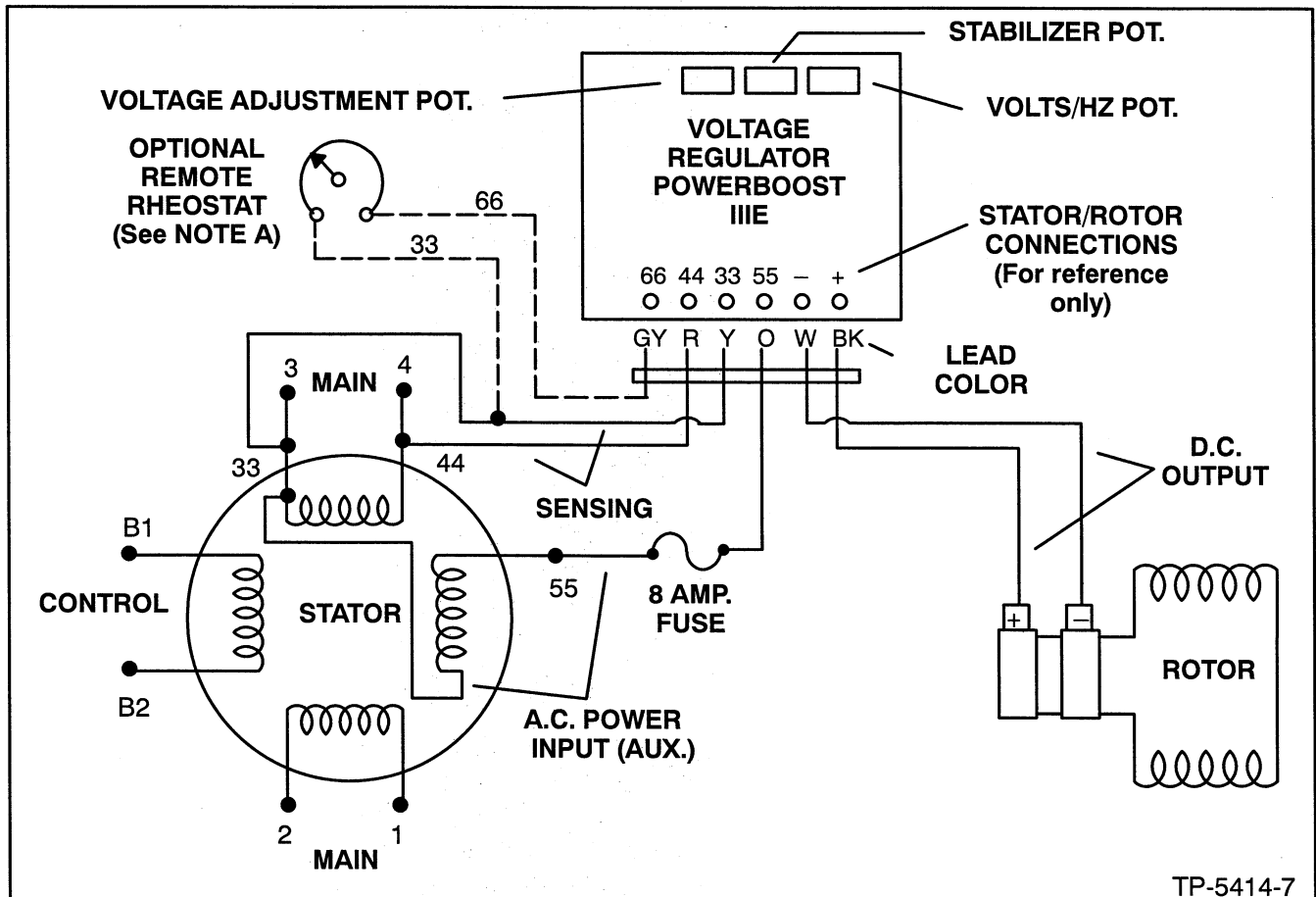
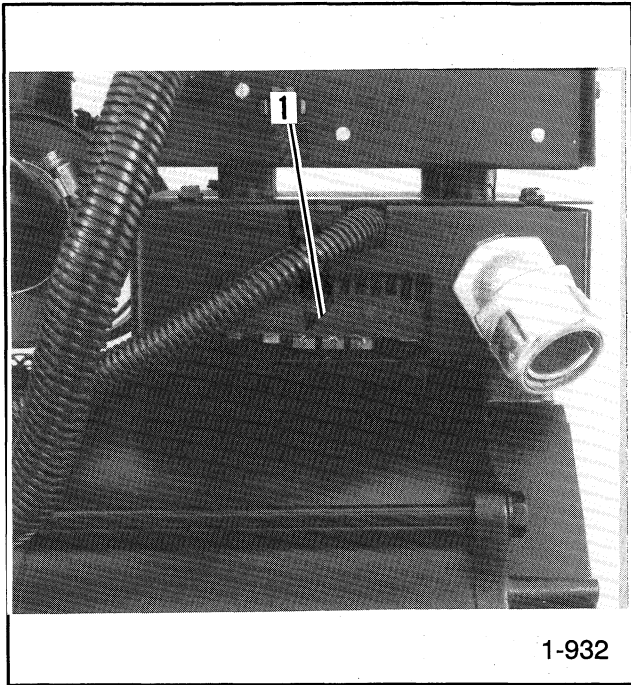

Figure 7-4. PowerBoost™ III E Voltage Regulator.



1-932

1 - Voltage Regulator

Figure 7-5. PowerBoost™ IIIE Voltage Regulator Installed.

NOTE A

A customer-provided rheostat may be connected across regulator leads/terminals 33 and 66 to adjust generator output voltage from a location remote from the set. The rheostat (10k ohms, 1/2-watt minimum) will provide a 5-volt adjustment range.

Voltage Adjustment Pot.—Adjusts generator output within range of approx. 100-130 Volts.

Stabilizer Pot.—Fine-tunes regulator circuitry to reduce light flicker.

Volts/Hz Pot.—Adjustment determines engine speed (Hz) at which generator output voltage will begin to drop. The 7/10CCO generator sets have the Volts/Hz feature disabled by turning the Volts/Hz pot. out (fully counterclockwise).

NOTE

For optimum results, full load should be applied when adjusting stability pot.

1. With generator set off, turn remote rheostat (if equipped) to midpoint. Turn **Voltage and Stability pots.** fully counterclockwise. Connect voltmeter and frequency meter to AC circuit or an electrical outlet.
2. Start generator set. Rotate **voltage adjustment pot.** clockwise to increase voltage (counterclockwise to decrease voltage) until desired output voltage is achieved.
3. Rotate **stability pot.** clockwise until minimum light flicker is obtained.
4. Readjust **voltage adjustment pot.** (if necessary).
5. Readjust engine speed to normal (1800 rpm for 60 Hz or 1500 rpm for 50 Hz).
6. Readjust **voltage adjustment pot.** (if necessary).
7. Readjust **stability pot.** (if necessary).
8. Use optional remote rheostat (if equipped) to make final voltage adjustments. **STOP GENERATOR SET.**

Rotor

The four-pole rotor creates the magnetic field needed to sustain alternating current in the stator windings. Prior to testing, inspect the rotor for visible damage to pole shoes, insulation, exposed coil windings, and slip ring surfaces. Check rotor bearing for noisy operation, excessive wear, and heat discoloration. Replace or repair these components if any of the above conditions exist.

Slip rings acquire a glossy brown finish in normal operation. Do not attempt to maintain a bright, newly machined appearance. Ordinary cleaning with a dry, lint-free cloth is usually sufficient. Very fine sandpaper (#00) may be used to remove roughness. Use light pressure on the sandpaper. Do not use emery or carborundum paper or cloth. Clean out all carbon dust from the generator. If the rings are black or pitted, remove the rotor and remove some of the surface material using a lathe.

Check the rotor for continuity and resistance. Measure the rotor resistance (ohms) between the two slip rings (Figure 7-6). See Section 10. Specifications—Generator for typical readings.

NOTE

Since ohmmeters do vary in their accuracy, use values in Section 10. Specifications—Generator as a reference for approximate readings. Readings must be at room temperature or about 70° F (21° C).

To check for rotor shorted to ground, adjust ohmmeter to zero ohms. Touch one ohmmeter lead to either slip ring and other lead to rotor poles or shaft. Meter should register no continuity.



Figure 7-6. Rotor Resistance Check

NOTE

Rotor resistance will vary directly with increase in temperature.

NOTE

When checking rotor resistance with rotor installed, brushes must not be in contact with rotor slip rings. Use brush retainer on brushes for accurate resistance readings.

The rotor must be repaired or replaced if any faults are detected in the previous tests.

Stator

The stator consists of a series of coils of wire placed in a laminated steel frame. The stator leads supply voltage to the AC load and exciter regulator.

Prior to testing, inspect the stator for heat discoloration and visible damage to housing lead wires, exposed coil windings, and exposed and varnished areas of frame laminations. Be sure the stator is securely riveted in the stator housing.

Checking Stator Continuity and Resistance

1. To check stator continuity, set ohmmeter on R x 1 scale. Contact the red and black meter leads; adjust ohmmeter to zero ohms. Check stator continuity by connecting meter leads to stator leads as shown in Figure 7-7.

NOTE

Disconnect all stator leads prior to performing stator continuity tests.

Leads 1, 2, 3, and 4 are the generator output leads. Leads 33 and 44 are the voltage regulator sensing leads. Leads 33 and 55 are the voltage regulator power supply. Leads B1 and B2 are the generator output interlock circuit for the controller. Refer to the schematic in Figure 7-8 when performing the following tests.

- There must be continuity between leads 1 and 2.
- There must be continuity between leads 3 and 4.
- There must be continuity between leads 33 and 44.
- There must be continuity between leads 33 and 55.
- There must be continuity between leads B1 and B2.
- There must be NO continuity between lead 1 and leads 3, 4, 33, 44, and 55.
- There must be NO continuity between lead 1 and leads B1 and B2.
- There must be NO continuity between lead 4 and leads B1 and B2.
- There must be NO continuity between any stator lead and ground on stator housing or frame laminations.

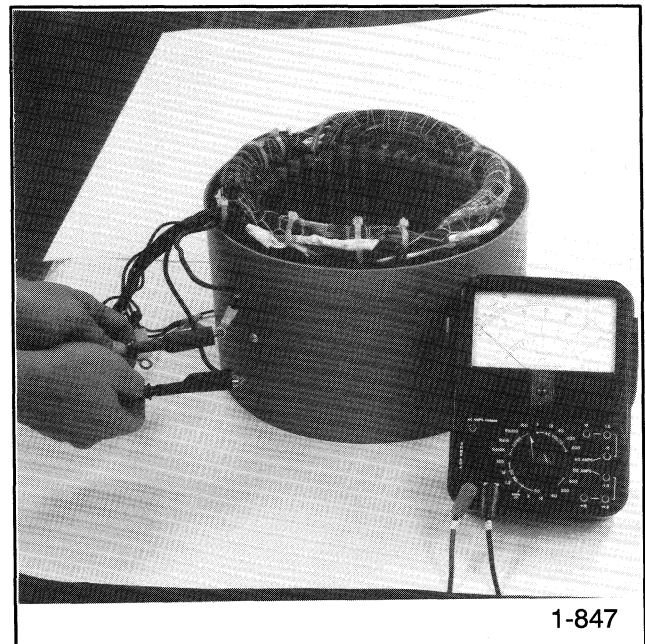

Figure 7-7. Stator Resistance Check.

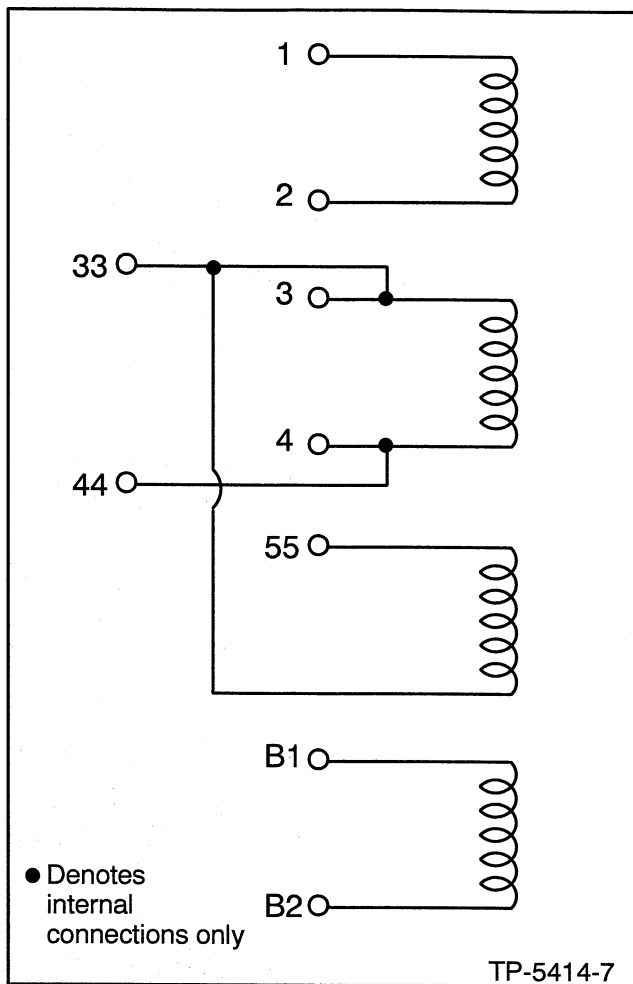

Figure 7-8. Generator Stator Leads.

2. Contact ohmmeter leads and readjust ohmmeter to zero ohms. Check cold resistance of stator windings by connecting meter leads to stator leads 1 and 2, 3 and 4, 33 and 44, 33 and 55, and B1 and B2. Stator winding resistance readings are found in Section 10. Specifications—Generator.

NOTE

Since ohmmeters do vary in their accuracy, use data from Section 10. Specifications—Generator as a reference for approximate readings. Ohmmeter readings must be taken at room temperature or about 70° F (21° C).

NOTE

Most ohmmeters will not provide accurate readings when measuring less than 1 ohm. The stator can be considered good if a low resistance reading (continuity) is obtained and there is no evidence of shorted windings (heat discoloration).

NOTE

When taking an ohmmeter reading using lead 55, make connection prior to in-line fuse.

NOTE

Stator resistance will vary directly with increased temperature.

Should any of the stator readings vary considerably during the previous checks, the stator must be repaired or replaced.

Brushes

The brushes transfer current from the voltage regulator to the slip rings. Since the brushes carry a low current, they should last the life of the generator. Abrasive dust on the slip rings could, however, shorten the life of the brushes. Excessive arcing at the brushes could damage the voltage regulator. Arcing could be caused by weak springs, damaged slip rings, sticking brushes, loose holder, or poor brush contact due to dirt.

The brushes must be free to move within the holder and be held in proper contact by the springs. When properly positioned, spring pressure on the brush surface will cause the brush to wear evenly. Brushes must ride 100% on the rings or arcing will occur and cause burned rings or failure of the voltage regulator. Figure 7-9 shows the correct positioning of the brushes. Add or remove shims as necessary to center brushes on slip rings.

Replace brushes if they show excessive or uneven wear.

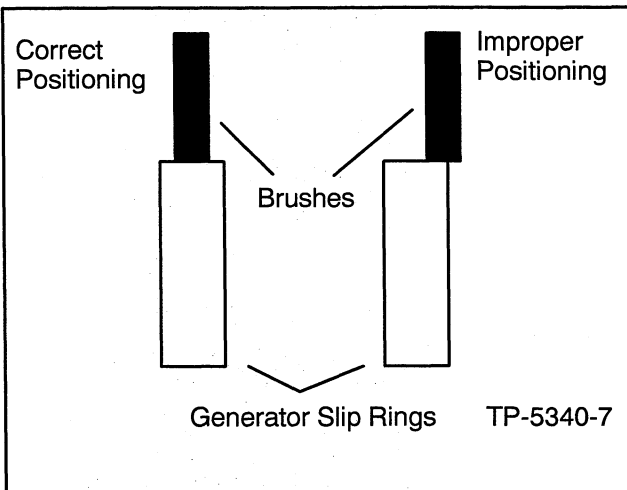
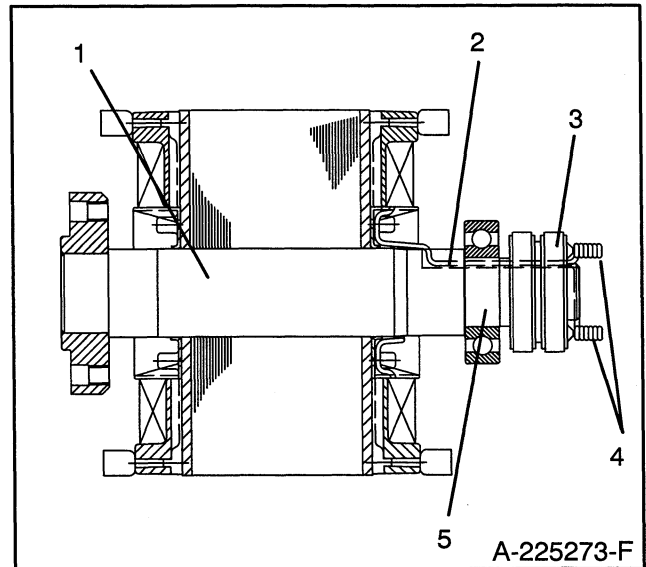

Figure 7-9. Brush Positioning.

Slip Ring Replacement

If slip ring replacement is necessary, have the rotor removed from the unit (follow the generator disassembly procedure found in Section 8). Using a soldering gun, heat the wires around the two terminal ends of the slip ring. Carefully unravel the wires to remove from each terminal. Pull off the slip ring using a gear puller and clean the rotor shaft surface.

Replace the new slip ring (Kohler part number 238134) onto the rotor shaft (with the terminal end pointing outward) using a press with a proper size fixture. Position slip ring onto the rotor shaft as far as the collar permits. Exhibit care in routing the rotor leads through the keyway (the lengthwise groove on the rotor shaft) so as not to pinch or cut through insulation. Rewrap the wires around each terminal on the slip ring and resolder. See Figure 7-10. Mount the rotor onto a lathe and turn the slip ring outer diameter to the dimension shown in Figure 7-11 with a surface finish of 64 micro-inch.



1. - Rotor Shaft
2. - Wires
3. - Slip Ring
4. - Terminals on Slip Ring
5. - Ball Bearing

Figure 7-10. Slip Ring Replacement on Rotor Assembly

Allowable size of Slip Ring after being turned down on a lathe:

Maximum Size Allowed	2.391 inches
Minimum Size Allowed	2.360 inches

Figure 7-11. Proper Slip Ring Size.

Controller Circuit Board

It is possible to check some controller circuit board components (relays) without removing the component from the board. These checks should be made prior to installing a new board and attempting startup. Most of the tests are referenced in Section 4. General Troubleshooting. Use a high quality multimeter and follow the manufacturer's instructions. To obtain

accurate readings when testing, remove all circuit board connectors and conformal coating (transparent insulation) from component terminals. Use the following chart and see the controller circuit board schematic on the following pages.

E-239563 Circuit Board

Component	Ohmmeter Connections	Remarks	Results
K1 Relay Coil	K1 coil terminals (See relay schematic)	Ohmmeter on R x 10 scale	If good—approx. 160 ohms. Low resistance (continuity)— shorted coil. High resistance—open coil.
K2 Relay Coil	K2 coil terminals (See relay schematic)	Ohmmeter on R x 10 scale	If good—approx. 160 ohms. Low resistance (continuity)— shorted coil. High resistance—open coil.
K3 Relay Coil	K3 coil terminals (See relay schematic)	Ohmmeter on R x 10 scale	If good—approx. 400 ohms. Low resistance (continuity)— shorted coil. High resistance—open coil.
K4 Relay Coil	K4 coil terminals (See relay schematic)	Ohmmeter on R x 10 scale	If good—approx. 125 ohms. Low resistance (continuity)— shorted coil. High resistance—open coil.
K5 Relay Coil	K5 coil terminals (See relay schematic)	Ohmmeter on R x 10 scale	If good—approx 510 ohms. Low resistance (continuity)— shorted coil. High resistance—open coil.

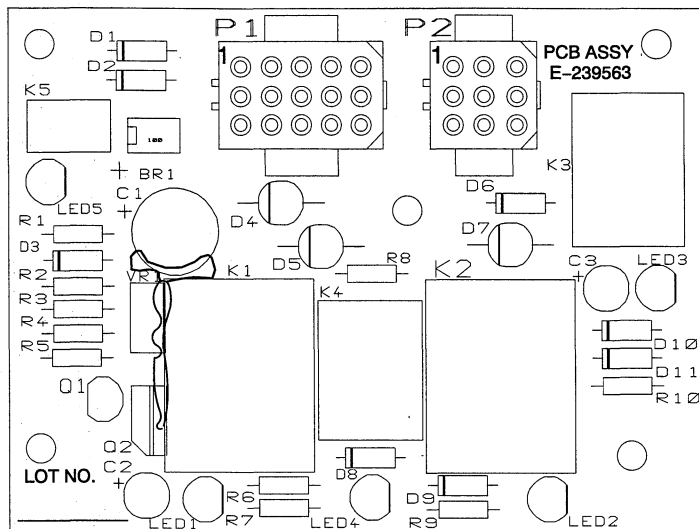

E-239563-

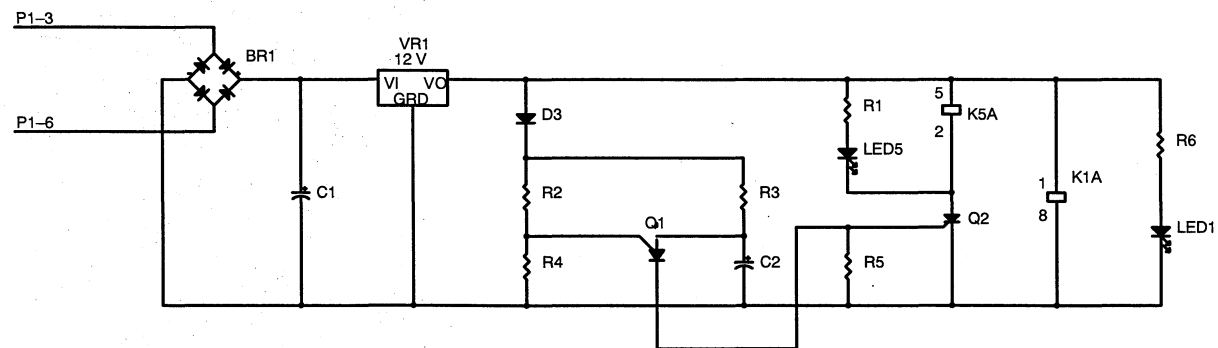
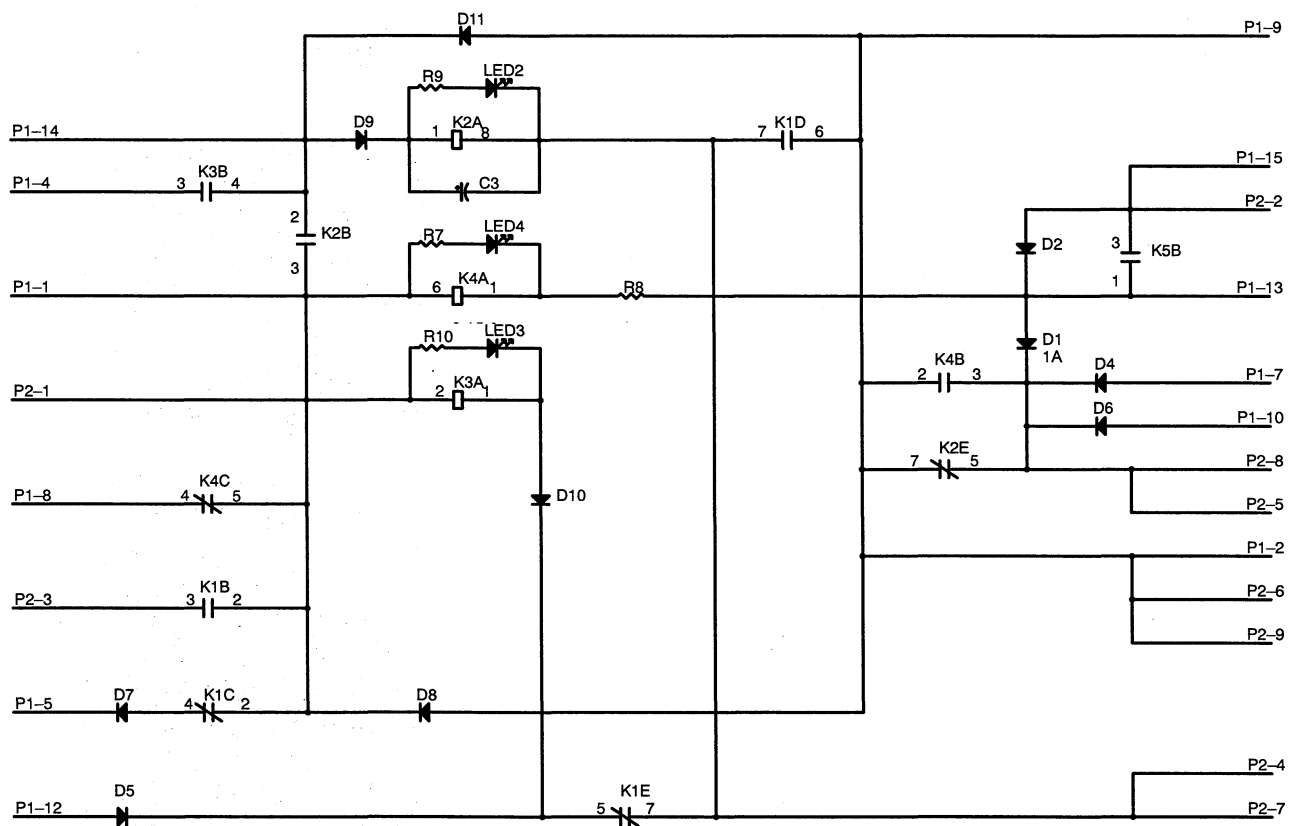

Y-5179

Figure 7-12. Controller Circuit Board Testing.

Engine/Generator Components

With the generator set battery connected, the wiring harness and some engine/generator components can be checked. Place the controller or remote start/stop switch in the prescribed position and check for 12 volts

DC at each component using a DC voltmeter. This will verify that the switches function and 12 volt DC is present at each component.

Component	Voltmeter Connections	Remarks	Results
Hourmeter and wiring	Red test clip to hourmeter (+) terminal. Black test clip to (-) terminal.	Voltmeter setting 12 volts DC reading indicates wiring harness is okay.	If good—12 Volts DC or greater. To determine if hourmeter is good, proceed to next step.
	None (see Remarks)	Disconnect hourmeter leads and apply 12 volts DC to hourmeter. NOTE: Hourmeter is polarity sensitive.	If good—hourmeter will operate.
B1 and B2 stator auxiliary winding	Disconnect B1/B2 leads. Connect AC voltmeter to leads. NOTE: Voltage can only be measured momentarily since unit will not continue to run after start switch is released. STOP generator.	Voltmeter setting 20 volts AC or greater. Start generator set and allow to reach proper speed.	Reading of 12-15 Volts indicates B1/B2 winding is good.
Fuel solenoid (three-lead)	Red test clip to #6 lead of solenoid and black test clip to engine block (ground). Place controller switch to Start position. STOP generator set	Voltmeter setting 12 volts or greater. If lead can not be disconnected, cut leads and crimp-on fully insulated push-on terminals. To determine if fuel solenoid is good, proceed to next step.	If good—12 Volts DC reading indicates wiring is okay.
	None (see Remarks)	Push out leads #6 and "P" at the 4-pin connector. Apply 12 Volts DC to #6 lead and momentarily apply 12 Volts DC to "P" lead. NOTE: Apply voltage only momentarily to "P" lead to prevent fuel solenoid damage. This coil draws 50 Amps. and is intended only to energize the solenoid.	If good—fuel solenoid plunger will energize when voltage is applied to "P" lead and remain held in after "P" lead is disconnected as long as #6 lead has voltage applied to it.

⚠ WARNING



**Sulfuric acid in batteries.
Can cause severe injury or death.**

Use protective goggles and clothes. Can cause permanent damage to eyes, burn skin, and eat holes in clothing.

Explosion can cause severe injury or death. Battery gases can cause an explosion. Do not smoke or permit flame or spark to occur near a battery at any time, particularly when it is being charged. Avoid contacting terminals with tools, etc. to prevent burns and to prevent sparks that could cause an explosion. Remove wristwatch, rings, and any other jewelry before handling battery. Never connect negative (-) battery cable to positive (+) connection terminal of starter solenoid. Do not test battery condition by shorting terminals together or sparks could ignite battery gases or fuel vapors. Any compartment containing batteries must be well ventilated to prevent accumulation of explosive gases. To avoid sparks, do not disturb battery charger connections while battery is being charged and always turn charger off before disconnecting battery connections. When disconnecting battery, remove negative lead first and reconnect it last.

To further check generator set components, disconnect the battery and remove wiring harness plugs from the controller circuit board. Use an ohmmeter to check continuity and to isolate defective components. Use the following charts and refer to the proper wiring diagram in Section 9.

NOTE

Before performing ohmmeter checks, disconnect generator set battery to prevent damage to the ohmmeter.

Component	Ohmmeter Connections	Remarks	Results
Controller switch	P2-6 and P2-4	Ohmmeter on R x 1 scale. Place rocker switch in START position.	If good, zero ohms (continuity). Any resistance other than zero or very low ohms—replace switch.
	P2-6 and P2-5	Ohmmeter on R x 1 scale. Place rocker switch in STOP position.	If good, zero ohms (continuity). Any resistance other than zero or very low ohms—replace switch.
K20 relay coil	P1-4 and P1-9	Ohmmeter on R x 1 scale	If good, 85 ohms. Low resistance—shorted K20 relay coil and/or wiring. High resistance—open K20 relay and/or wiring.
K25 relay coil	P1-8 and P1-9	Ohmmeter on R x 1 scale	If good, 85 ohms. Low resistance—shorted K25 relay coil and/or wiring. High resistance—open K25 relay and/or wiring.
Starter relay ('S' relay)	P4-4 and battery (-) cable. NOTE: J4 and P4 must be disconnected to perform this test.	Ohmmeter on R x 1 scale.	If good, approx. 0.20-0.35 ohms at 80° F (27° C).
Controller 10 Amp. fuse and wiring	Battery positive (+) cable and P1-14 NOTE: J4 and P4 must be connected to perform this test.	Ohmmeter on R x 1 scale.	If good, zero or very low ohms. No reading (infinity)—open circuit or fuse blown.
Glow plug relay (C1)	P4-8 and P4-1	Ohmmeter on R x 1 scale.	If good, approx. 16-20 ohms at 80° F (27° C).

Component	Ohmmeter Connections	Remarks	Results
B1/B2 aux. stator windings	P1-3 and P1-6 NOTE: J4 and P4 must be connected to perform this test.	Ohmmeter on R x 1 scale.	If good, see Section 10. Specifications. Low resistance—B1/B2 windings shorted. High resistance—B1/B2 windings open.
P1 ground connection	P1-9 and ground	Ohmmeter on R x 1 scale.	If good, zero ohms (continuity). Any other reading indicates a poor ground connection.
Low oil pressure (LOP) safety shutdown switch	P1-15 and engine block (ground) NOTE: J4 and P4 must be connected to perform this test.	Ohmmeter on R x 1 scale. This test is not conclusive until the temperature shutdown switches are checked.	If good, zero ohms (continuity). Then, disconnect LOP switch lead and isolate terminal. Meter reading should show an open circuit.
High water temperature (HWT) safety shutdown switch	P1-15 and engine block (ground) NOTE: LOP switch lead should be removed and isolated. NOTE: J4 and P4 must be connected to perform this test.	Ohmmeter on R x 1 scale.	If good, open circuit. Any continuity suggests that temperature switch(es) are defective. Disconnect individual leads to determine which switch is defective.

Fuel Solenoid

The fuel solenoid serves to pull the injector pump lever to the "fuel on" position when energized. The fuel solenoid is spring loaded to return the injector pump lever to the "fuel off" position when de-energized. See Figure 7-14 for fuel solenoid location.

The 7/10CCO models use a three-lead fuel solenoid. This solenoid has a lead marked "P" which energizes the "pull" coil only during cranking. During operation the lead "6" energizes the "hold" coil and the lead marked "N" is the common ground.

Current (amps.) and resistance readings are shown in Figure 7-13. Resistance readings can be taken to determine if the solenoid windings are open or shorted. These tests must be made with fuel solenoid disconnected from engine wiring harness.

Fuel Solenoid	Reading
"pull" current	31 amps.
"hold" current	0.8 amps.
Plunger "pull" resistance	0.387 ohms
Plunger "hold" resistance	14.94 ohms

Figure 7-13. Fuel Solenoid Readings.

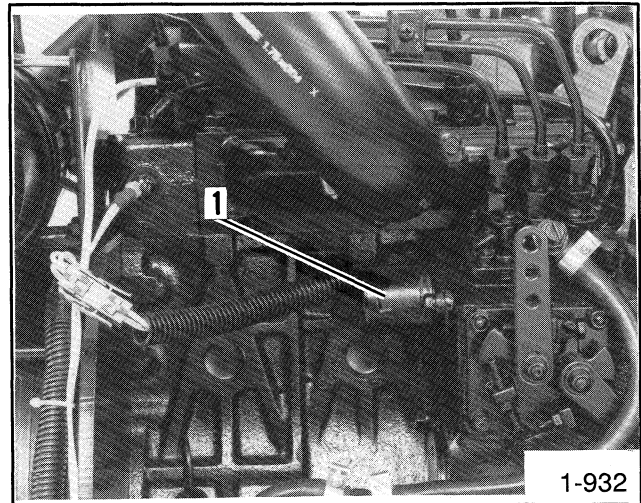

1 - Fuel Solenoid

Figure 7-14. Fuel Solenoid Location.

Remote Start Panels (Optional)

Three remote panels are offered. The first uses a start/stop switch. The second has a start/stop switch and two gauges. The third incorporates a start/stop switch and four gauges. If difficulty with remote operation occurs, the switch, gauges, and gauge senders can be tested for proper function. Prior to testing, disconnect J3/P3 connector.

To test water temperature sender, connect ohmmeter to controller socket P3-1 and P3-3. See Figure 7-15 for resistance by varying temperatures. Start generator set to change temperature. STOP generator set when test is complete.

To test oil pressure sender, connect ohmmeter to controller socket P3-1 and P3-6. See Figure 7-16 for resistances by varying pressure. Start generator set to change pressure. STOP generator set when test is complete.

Generally, senders can be presumed good if they change their resistance values as their respective pressure/temperature change. A defective sender will either be open or shorted.

VDO (2-Meter, 4-Meter Panel)	
Temperature @	
100°F (38°C)	450 ± 10%
160°F (71°C)	130 ± 10%
220°F (104°C)	47 ± 10%

Figure 7-15. Water Temperature Sender Resistance (in Ohms).

VDO (2-Meter, 4-Meter Panel)	
Pressure @	
0 PSI (0 kPa)	227-257
25 PSI (172 kPa)	138-162
50 PSI (345 kPa)	92-114
75 PSI (517 kPa)	50-80
100 PSI (690 kPa)	21-50

Figure 7-16. Oil Pressure Sender Resistance (in Ohms)

Component	Ohmmeter Connections	Remarks	Results
Remote switch	P3-1 and P3-4 (Plug side). Place remote rocker switch to START position.	If good - continuity	Ohmmeter on R x 1 scale
	P3-1 and P3-5 (Plug side). Place remote rocker switch to STOP position.	If good - continuity	Ohmmeter on R x 1 scale

Component	Voltmeter Connections	Remarks	Results
Remote switch "ON" light, gauge lights, DC voltmeter, and hourmeter (if equipped)	Red test lead to P3-2 (socket side) and black test to P3-1 (socket side). Place controller start/stop switch to start position. STOP generator set when test is completed.	If 12 Volt DC is present and component does not function after P3 plug is connected to controller - replace	Voltmeter setting 12 Volts or greater. Generator set does not need to be running, just cranking for this test. NOTE: Hourmeter is not illuminated. To further test components, connect to 12-volt battery. NOTE: Hourmeter is polarity sensitive.
Water temperature gauge	Red test lead to P3-2 (socket side) and black test lead to P3-3 (socket side). Start generator set for test. STOP unit when test is completed.	If 0.5-12 Volts DC is present and gauge does not function after P3 is connected to controller - replace gauge.	Voltmeter setting 12 Volts or greater.
Oil pressure gauge	Red test lead to P3-2 (socket side). and black test lead to P3-6 (socket side). Start generator set for test. STOP unit when test is completed.	If 0.5-12 Volts is present and gauge does not function after P3 plug is connected to controller - replace gauge.	Voltmeter setting 12 Volts or greater.

Section 8. Disassembly/Reassembly

Prior to disassembly, the generator set must be unbolted from the vehicle compartment. Disconnect all external connections—battery cables at battery (negative lead first), AC output leads in controller, remote start panel at controller connector, fuel line at fuel pump filter inlet, and exhaust connections. Observe all safety precautions listed at the beginning of this manual during the disassembly/reassembly procedure.

NOTE

Several models are covered in this manual and the procedure for disassembly/reassembly may vary due to product updates and assembly variations. Major differences are noted where appropriate.

NOTE

The voltage regulator is located in the junction box on these models. Adjustments are possible without removing the junction box or controller.

NOTE

HARDWARE DAMAGE! Engine and generator may make use of both American Standard and metric hardware. Be sure to use the correct size tools to prevent rounding of bolt heads and nuts.

Disassembly

1. Remove the six screws securing the end bracket panel to the unit using a 5/16 in. nutdriver. Remove the panel to expose the end bracket assembly. See Figure 8-1.

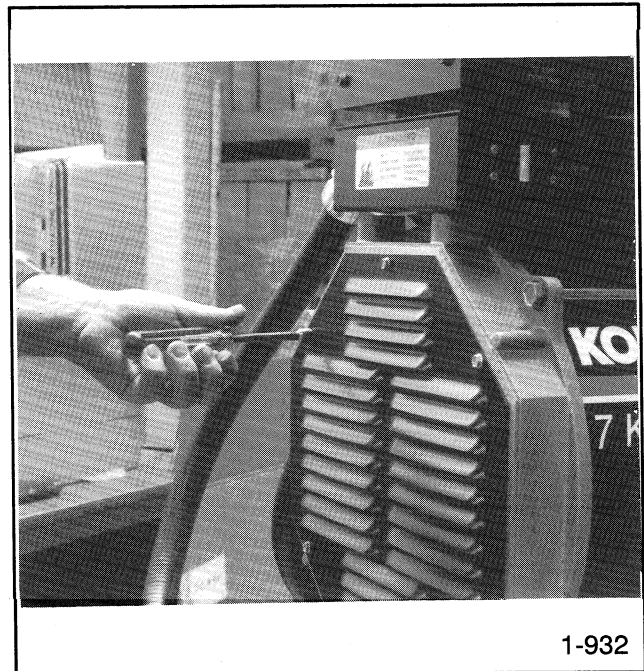

Figure 8-1. End Bracket Removal.

2. Raise brushes in holders (two sets) by pushing leads upward in the slots. Retain brushes by inserting a length of wire or a paper clip. See Figure 8-2.

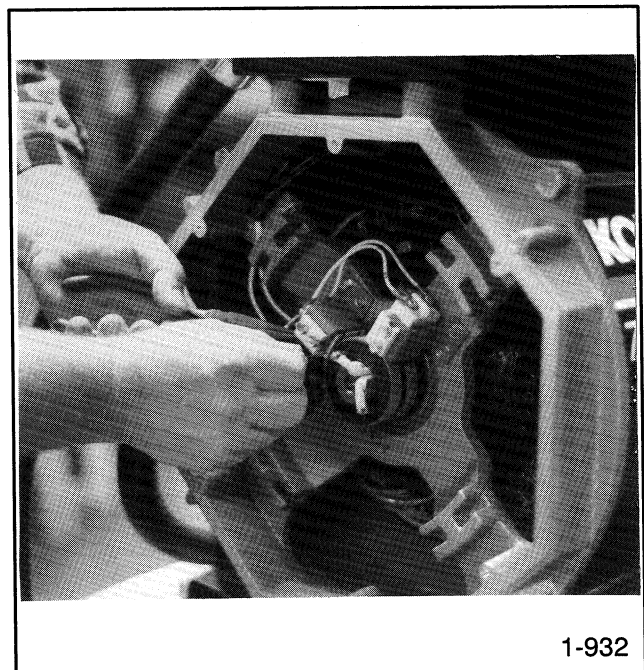
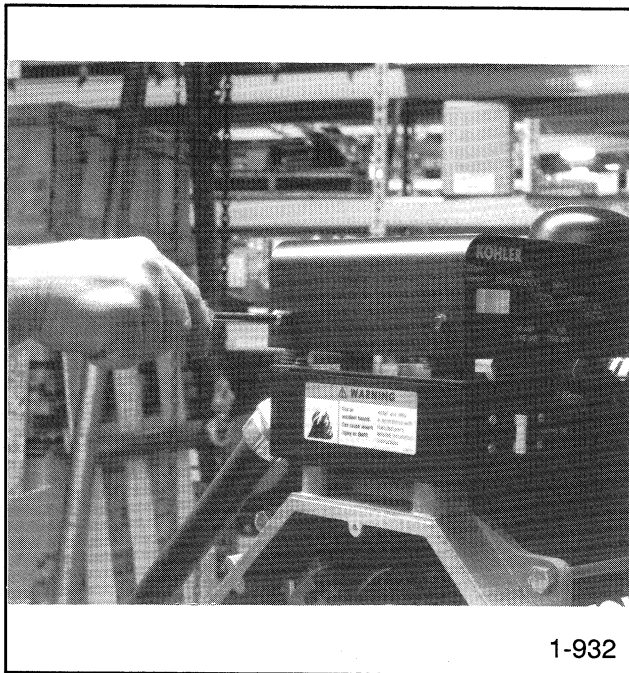

Figure 8-2. Raising Brushes.

- Remove the mounting screws securing the controller cover. Separate the cover from the controller. See Figure 8-3.



1-932

Figure 8-3. Removing the Controller Cover.

- Disconnect the 22-pin controller harness (P4) located at the back of the controller. See Figure 8-4.

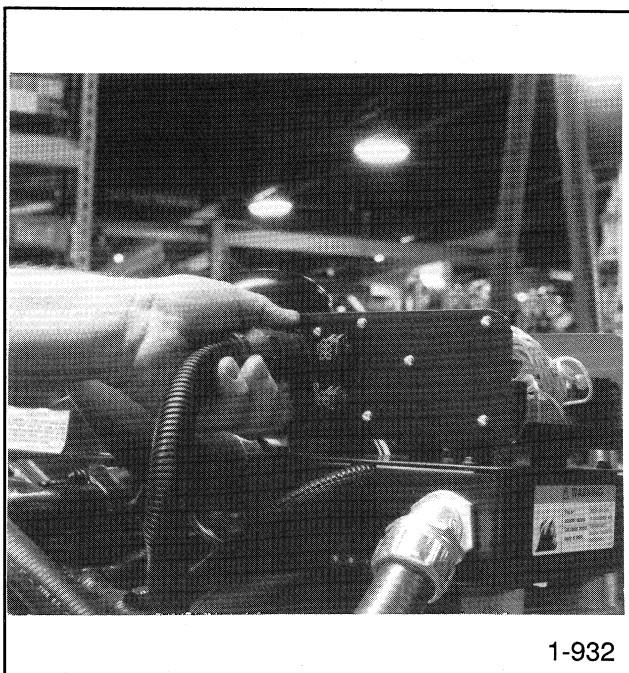

1-932

Figure 8-4. Disconnecting the 22-Pin Connector.

- Loosen the screws on the junction box cover using a 5/16 in. nutdriver or 5/16 in. wrench. See Figure 8-5.

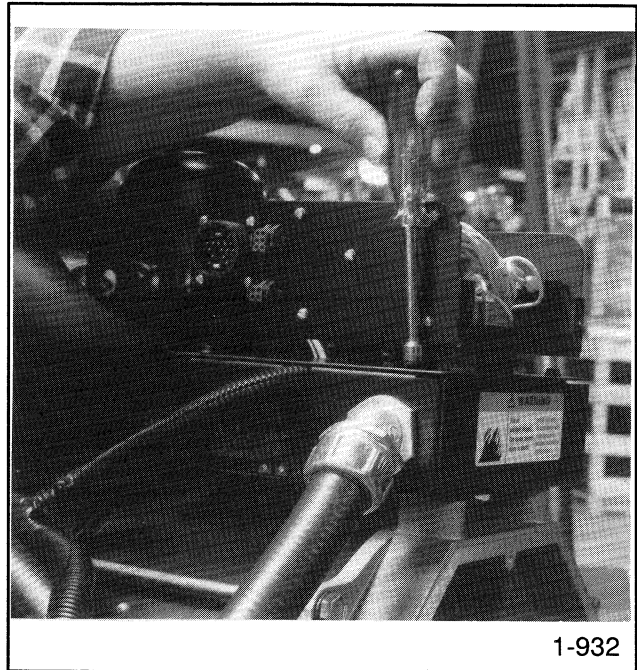

1-932

Figure 8-5. Removing the Junction Box Cover.

- Slide the junction box cover (and controller box) forward and lift to remove.
- Inside the junction box, cut the cable tie and disconnect leads 9 and 20 at the white plastic connector.
- Disconnect leads 33 and 44.
- Disconnect the 6-pin connector (P10) to the voltage regulator.
- Disconnect B1 and B2 battery charging leads.
- Disconnect lead 55 from the fuse holder.
- Remove the negative lead from the hazard ground stud using a 7/16 in. nutdriver.
- Disconnect stator leads 1 and 4 from the line side of the circuit breaker using a 5/16 in. wrench. Disconnect stator leads 2 and 3 from L0 ground stud using a 7/16 in. nutdriver.
- Remove the four junction box mounting screws using a 7/16 in. ratchet to remove the junction box from the stator mounting bracket. See Figure 8-6.

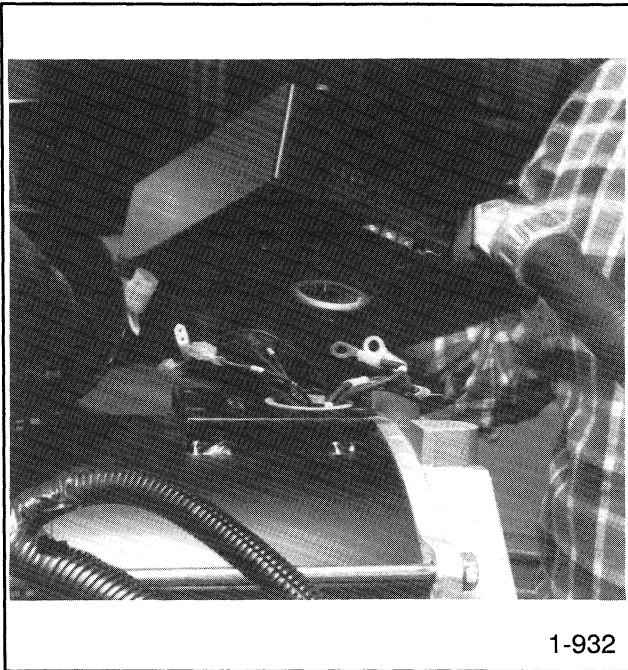

1-932

Figure 8-6. Removing the Junction Box.

15. Remove the bolts from the two generator vibromounts. See Figure 8-7.

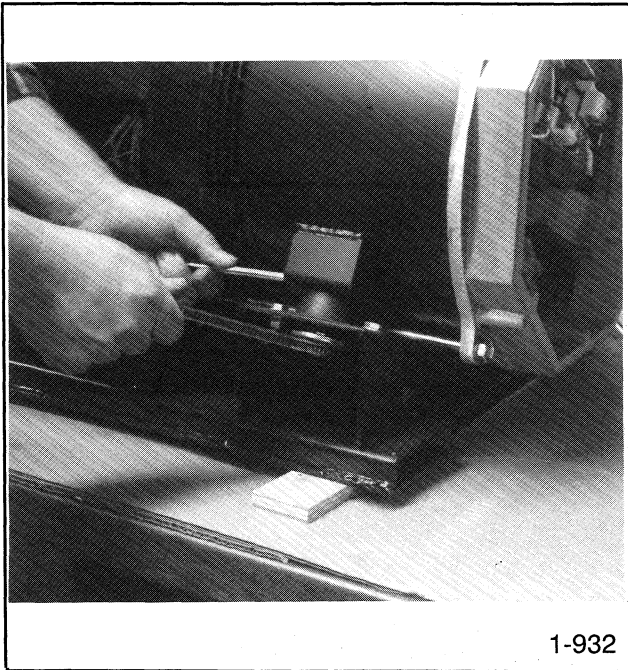

1-932

Figure 8-7. Removing the Vibromounts.

16. Place the hoist hook into the generator hoisting eye and raise generator end, see Figure 8-8. Place a wood block under flywheel housing and lower generator until housing is supported by block. See Figure 8-8.

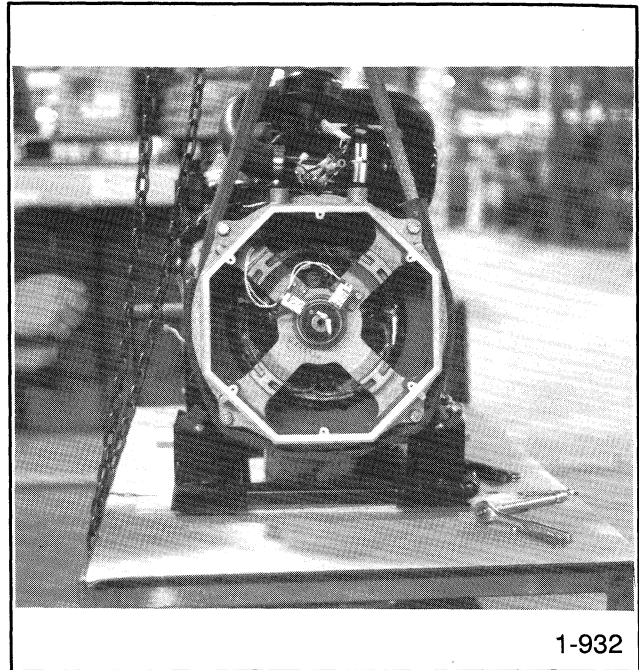

1-932

Figure 8-8. Using Hoist to Raise Generator Set.

NOTE

Hoist capacity should be rated at one-half ton or greater.

17. Remove the four over-bolts securing the end bracket using a 17-mm ratchet. See Figure 8-9.

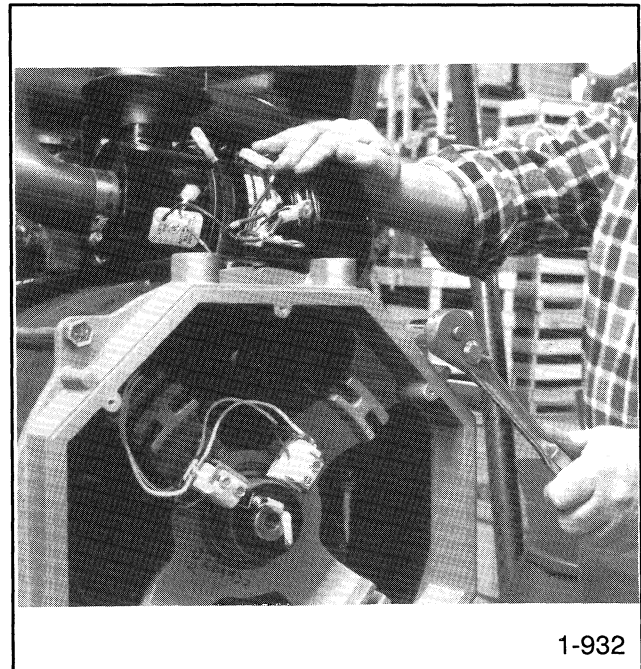

1-932

Figure 8-9. Removing the Over-Bolts.

18. Pull the brush lead harness (containing leads 9 and 20) through hole in stator.

19. Remove the end bracket by bumping with a soft rubber mallet on end bracket flanges. See Figure 8-10.

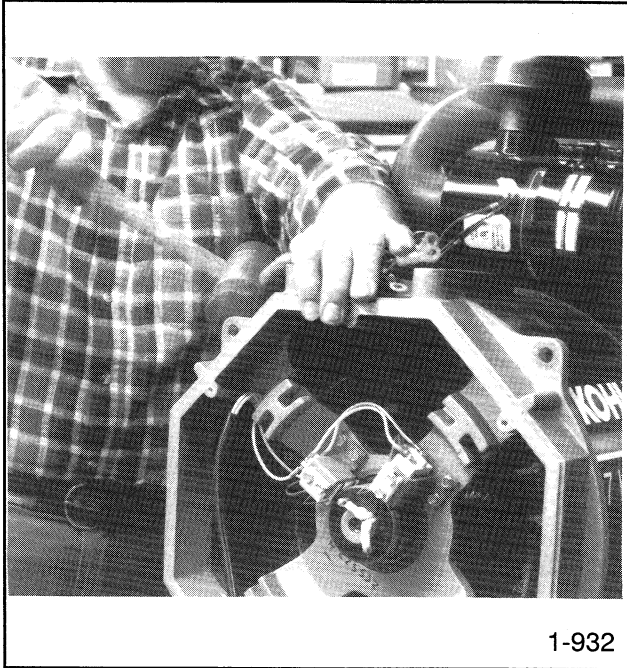

Figure 8-10. Removing the End Bracket.

20. Carefully remove the stator by pulling the stator over the rotor assembly. See Figure 8-11.

NOTE

Due to the weight of the stator, it is recommended that it be placed on a hoist during removal to prevent damage to stator, rotor, and/or drive disks.

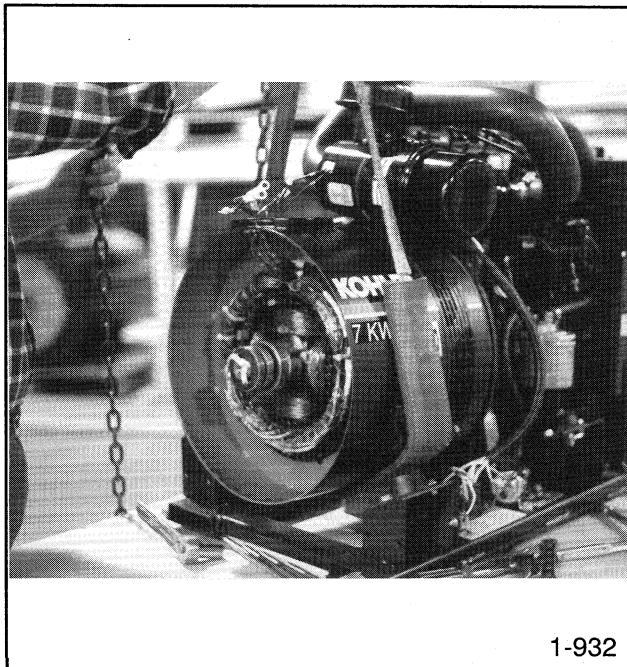

Figure 8-11. Removing the Stator.

21. Remove the generator cooling fan by removing eight screws and four spacers. See Figure 8-12.

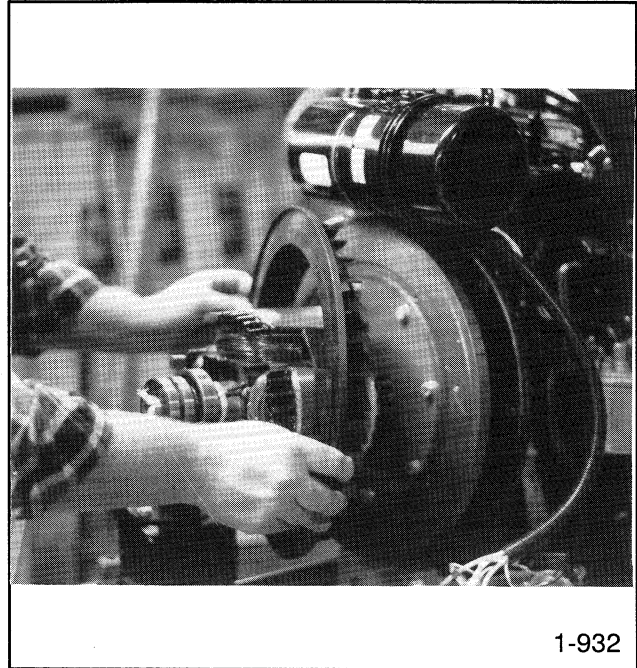

Figure 8-12. Removing the Cooling Fan.

22. Support the rotor with a strap and hoist. Remove eight bolts connecting the drive disk to the engine flywheel using a 13-mm ratchet.
23. Remove the rotor drive disk from the engine flywheel. See Figure 8-13.

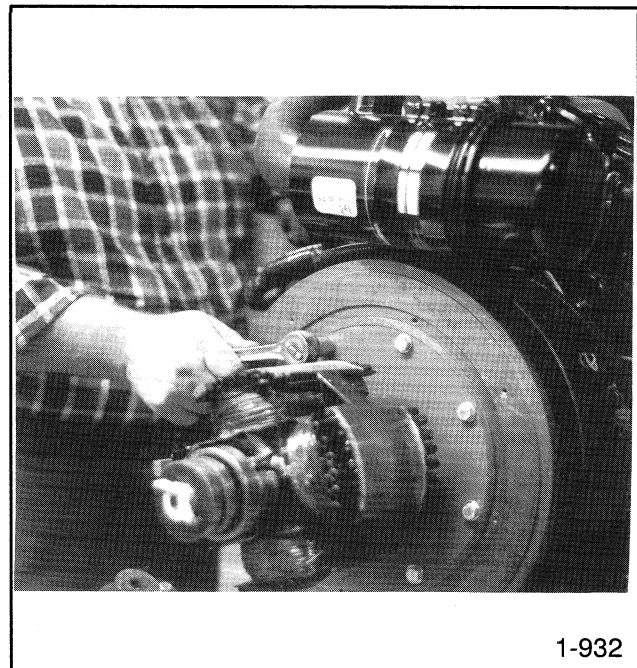
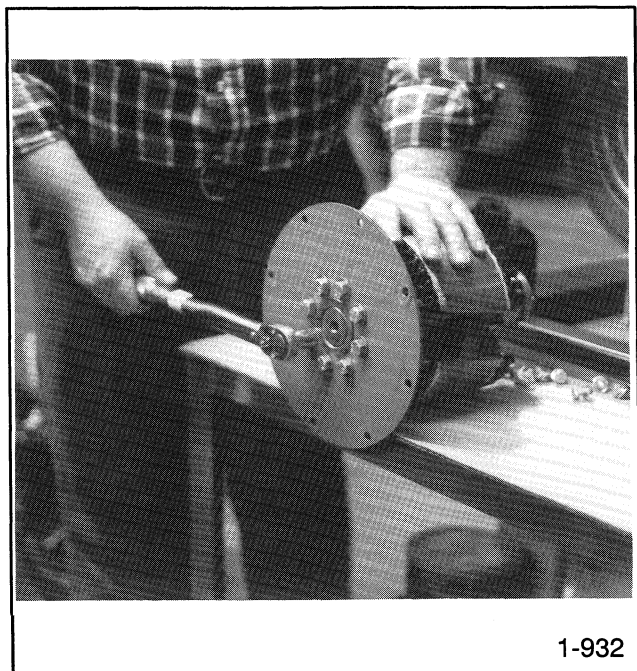

Figure 8-13. Removing the Rotor.

- Remove the drive disk from the rotor by removing eight bolts using a torque wrench with a 14-mm socket. See Figure 8-14.



1-932

Figure 8-14. Removing the Drive Disk.

Reassembly

- Secure the drive disk to the rotor using eight bolts. Torque bolts to 28 ft. lbs. (338 in. lbs.). Be sure to follow the proper tightening sequence.

NOTE

Check condition of drive disks for flatness. If disks are uneven or bent, then replace. Bent disks will cause vibration and premature wear to end bearing in end bracket.

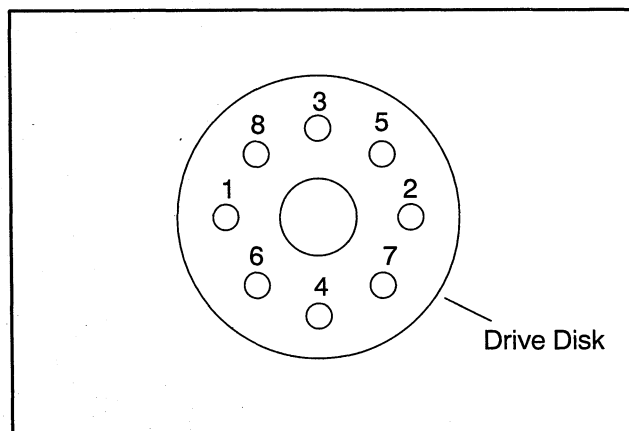





Figure 8-15. Drive Disk Tightening Sequence.





- Position the rotor with the drive disk onto the engine flywheel using eight bolts. Torque bolts to 14 ft. lbs. (168 in. lbs.). Follow the tightening sequence as shown above.
- Attach the generator cooling fan using eight screws and four spacers. Reassemble applying Loctite® #271 to screws.
- Reposition the stator over the rotor and onto the adapter lip. Be careful to avoid damaging the rotor. When the stator is properly positioned, the stator leads should be at the 12 o'clock position.
- Route the stator leads through the opening in the end bracket. Use a rubber mallet to secure the end bracket onto the stator. Replace the overbolts securing the end bracket and stator to the generator adapter. Torque the overbolts to 25 ft. lbs. (300 in. lbs.).
- Pull the brush lead harness and stator leads through the hole in the stator.
- Use a hoist to raise the alternator end of the generator set. Remove the wood block(s) from underneath the alternator. Lower the generator set.

8. Replace the bolts securing the generator vibromounts to the stator mounting brackets.
9. Run the stator leads (1, 2, 3, 4, 55, B1, B2, 33, 44, 9, 20, and N) into the junction box through the hole in the bottom of the box.
10. Position the junction box onto the stator mounting bracket and secure using four mounting screws.
11. Inside the junction box, reconnect stator leads 1 and 4 to the line side of the circuit breaker and reconnect stator leads 2 and 3 to the L0 ground stud.
12. Reconnect the negative lead to the hazard ground stud.
13. Reconnect lead 55 to the fuse holder.
14. Reconnect leads B1 and B2 battery charging leads.
15. Reconnect the 6-pin connector (P10) to the voltage regulator.
16. Reconnect leads 33 and 44.
17. Reconnect the white plastic connector containing leads 9 and 20.
18. Reposition the junction box cover onto the junction box and secure.
19. Reconnect the 22-pin controller harness (P4) to the back of the controller.
20. Replace the mounting screws securing the controller cover to the controller.
21. Remove the retaining wires from the brush holders in the end bracket. Be sure that the brushes are centered on the slip rings. Improper brush position will cause premature wear.
22. Replace the six screws securing the end bracket panel.

Section 9. Wiring Diagrams

 WARNING	
 Hazardous voltage.	 Moving rotor.
Can cause severe injury or death.	
Do not operate generator set without all guards and electrical enclosures in place.	

Hazardous voltage can cause severe injury or death. Perform electrical service only as prescribed in equipment manual. Be sure that generator is properly grounded. Never touch electrical leads or appliances with wet hands, when standing in water, or on wet ground as the chance of electrocution is especially prevalent under such conditions. Wiring should be inspected at the interval recommended in the service schedule—replace leads that are frayed or in poor condition. The function of a generator set is to produce electricity and wherever electricity is present, there is the hazard of electrocution.

 WARNING			
--	---	---	---

Accidental starting.
Can cause severe injury or death.
Disconnect battery cables before working on generator set (negative lead first and reconnect it last).

Accidental starting can cause severe injury or death. Disconnect battery cables (remove negative lead first and reconnect it last) to disable generator set before working on any equipment connected to generator. The generator set can be started by remote start/stop switch unless this precaution is followed.

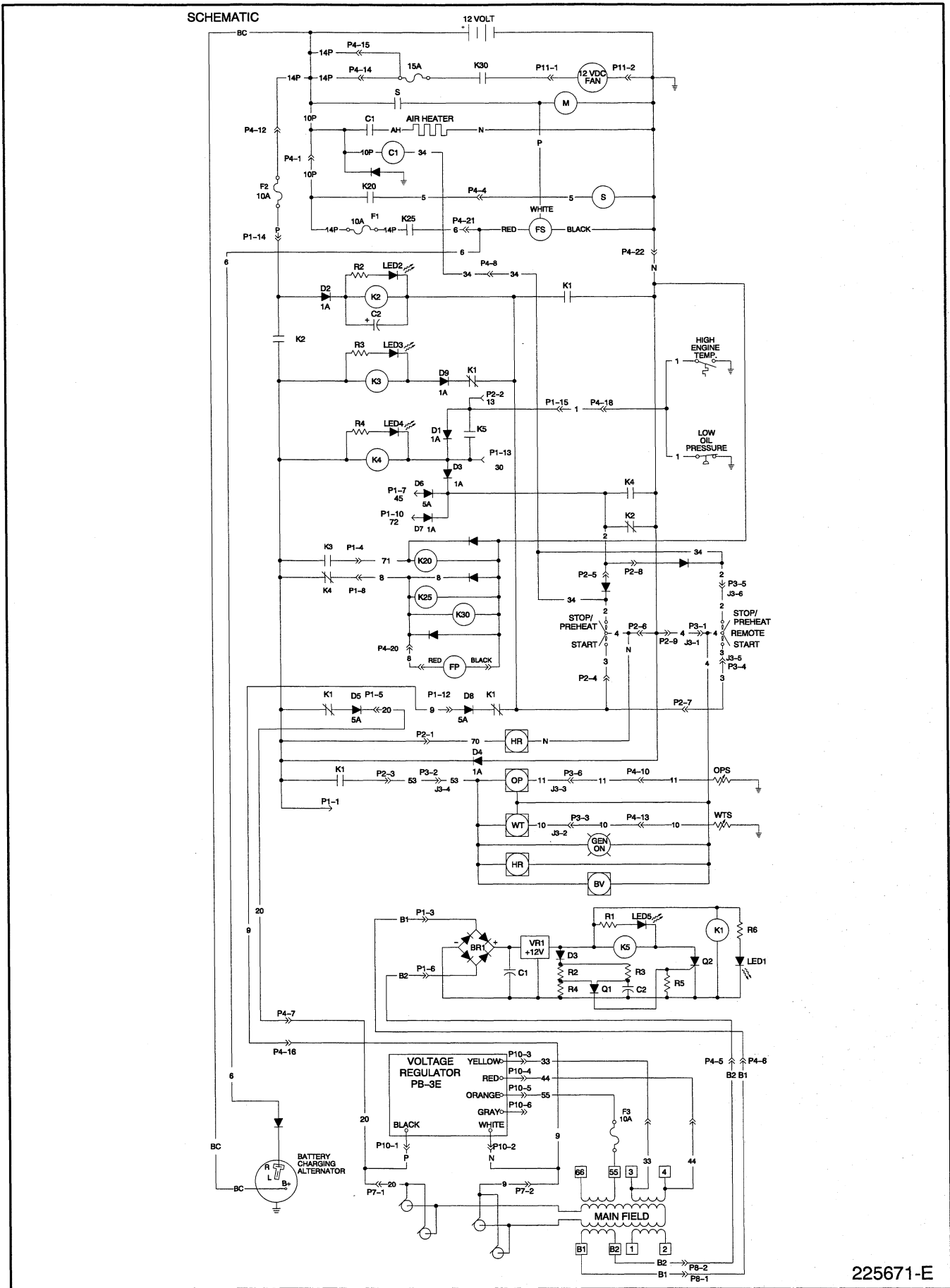

Figure 9-1. Wiring Diagram—Schematic 7/10CCO-RV Single Phase.

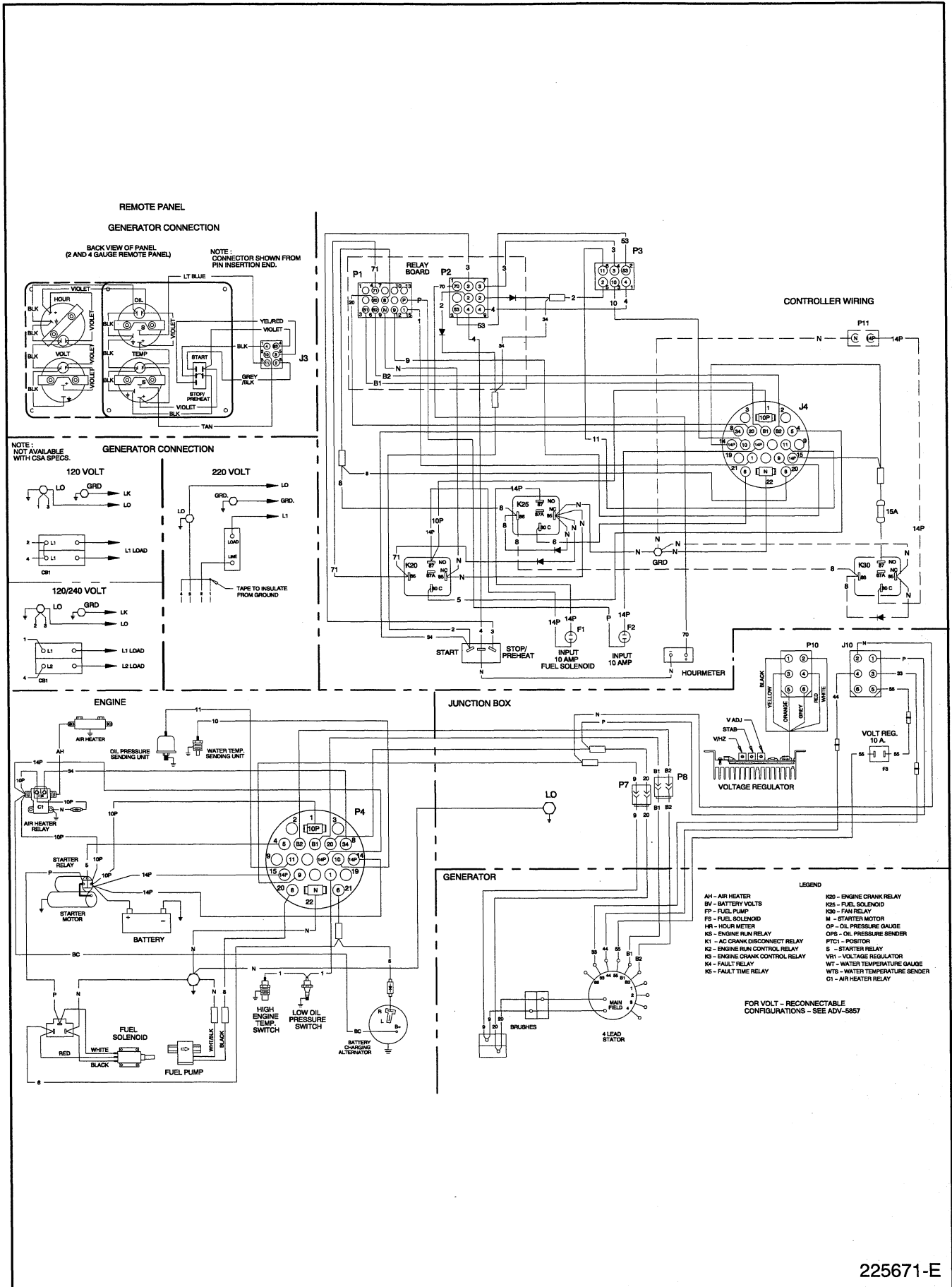
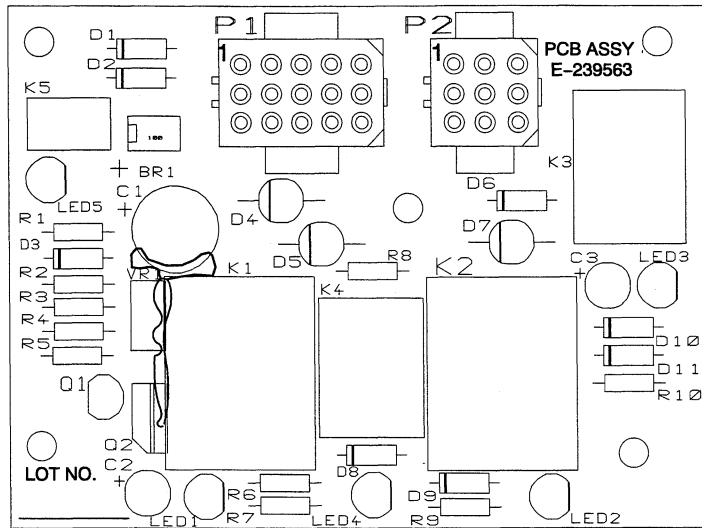
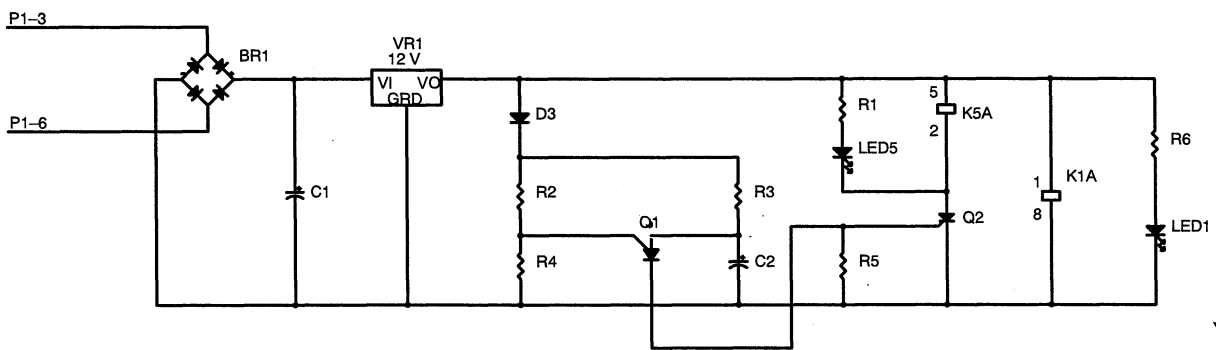
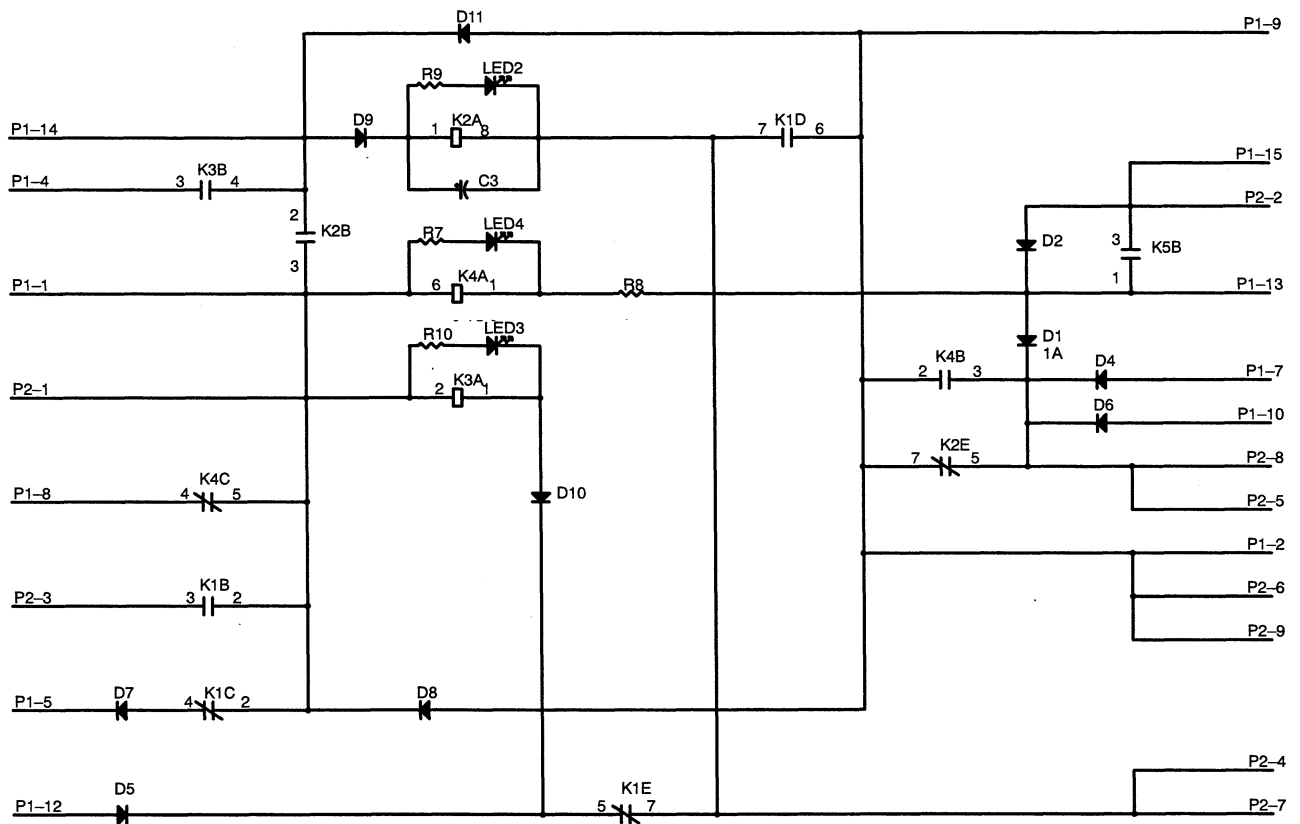

Figure 9-2. Wiring Diagram—Point-to-Point Wiring 7/10CCO-RV Single Phase.



E-239563-



Y-5179

Figure 9-3. Controller Circuit Board E-239563.

Four-Lead Reconnectable (Single-Phase) Generator Sets Where Generator Output Can Be Reconnected For 120 volt or 120/240 volt, 60 Hz; or 110 volt or 110/220 volt, 50 Hz

To illustrate the proper reconnection of 4-lead generator sets, the following information is provided. In all cases, the National Electrical Code (NEC) should be followed.

NOTE: When a generator set is reconnected to a voltage different than nameplate voltage, notice should be placed on the unit indicating this change. A decal (part no. 246242) is available for this purpose from Authorized Kohler Dealers.

120-volt (or 110-volt) Configurations—(Views A and B) FOR NON-CSA Certified Units.

The load-side terminals of the circuit breaker are not to be connected together when a factory two-pole circuit breaker is used. See View A. If the installation requires a 120-volt, 2-wire system, a single-pole circuit breaker must be used. See View B. When connecting stator phase leads together, the output lead (L1) must be sized accordingly. It is recommended that a jumper lead be used on the *line* side of the circuit breaker. This allows for balancing of the load of the generator set.

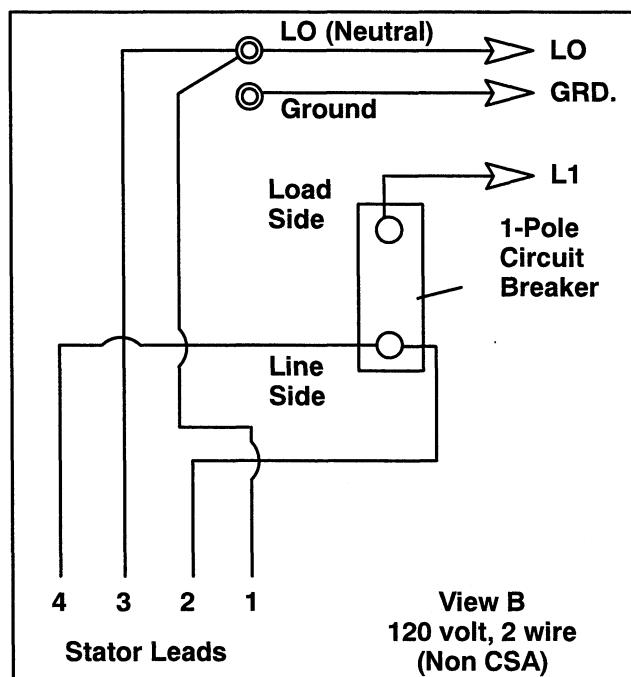
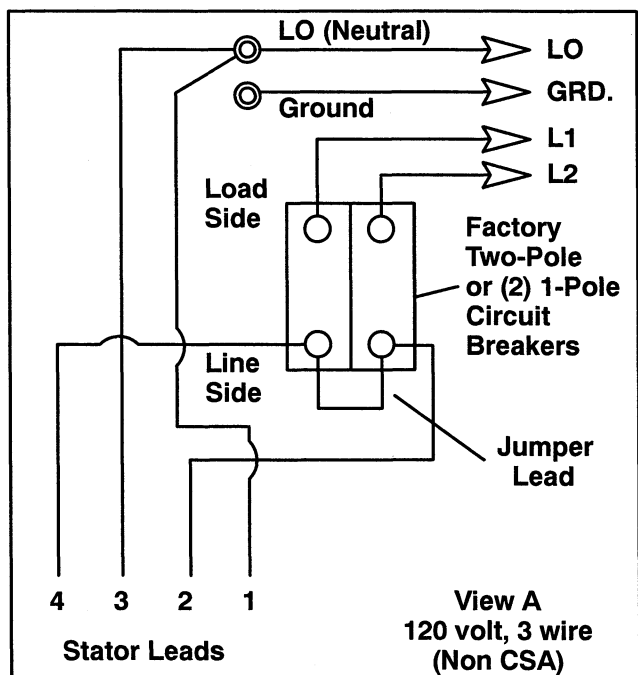

	60 Hz	50 Hz
L0-L1	120 volt	110 volt
L0-L2	120 volt	110 volt

120/240-Volt (or 110/220-Volt) Configurations—(View C)

Jumper lead not used. If unit was originally wired for straight 120 volt (or 110 volt), 3 wire, be sure jumper lead is removed (see Figure 1 for location). Circuit breaker **MUST** be a circuit breaker manufacturer two-pole circuit breaker. Two single-pole circuit breakers do not conform to NEC requirements when supplying a 240-volt (or 220-volt) load. This is true even if they are mechanically attached together. Leads L1 and L2 are different phases and must never be connected together.

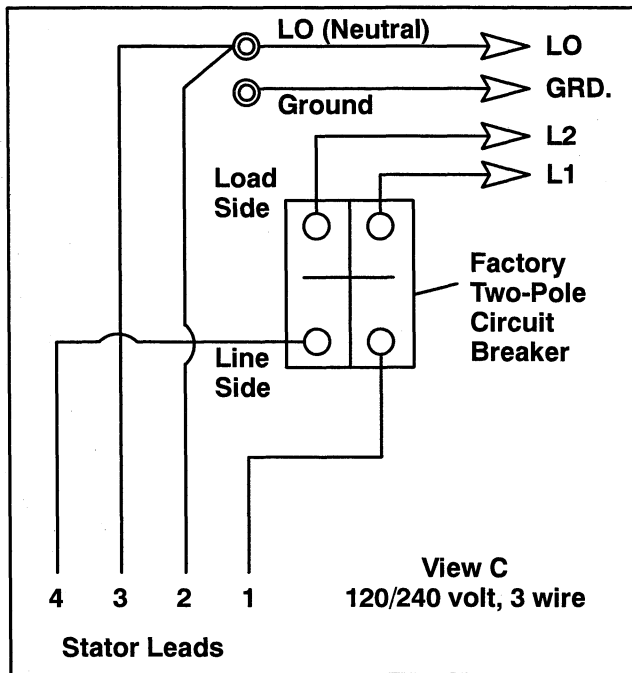

	60 Hz	50 Hz
L0-L1	120 volt	110 volt
L0-L2	120 volt	110 volt
L1-L2	240 volt	220 volt

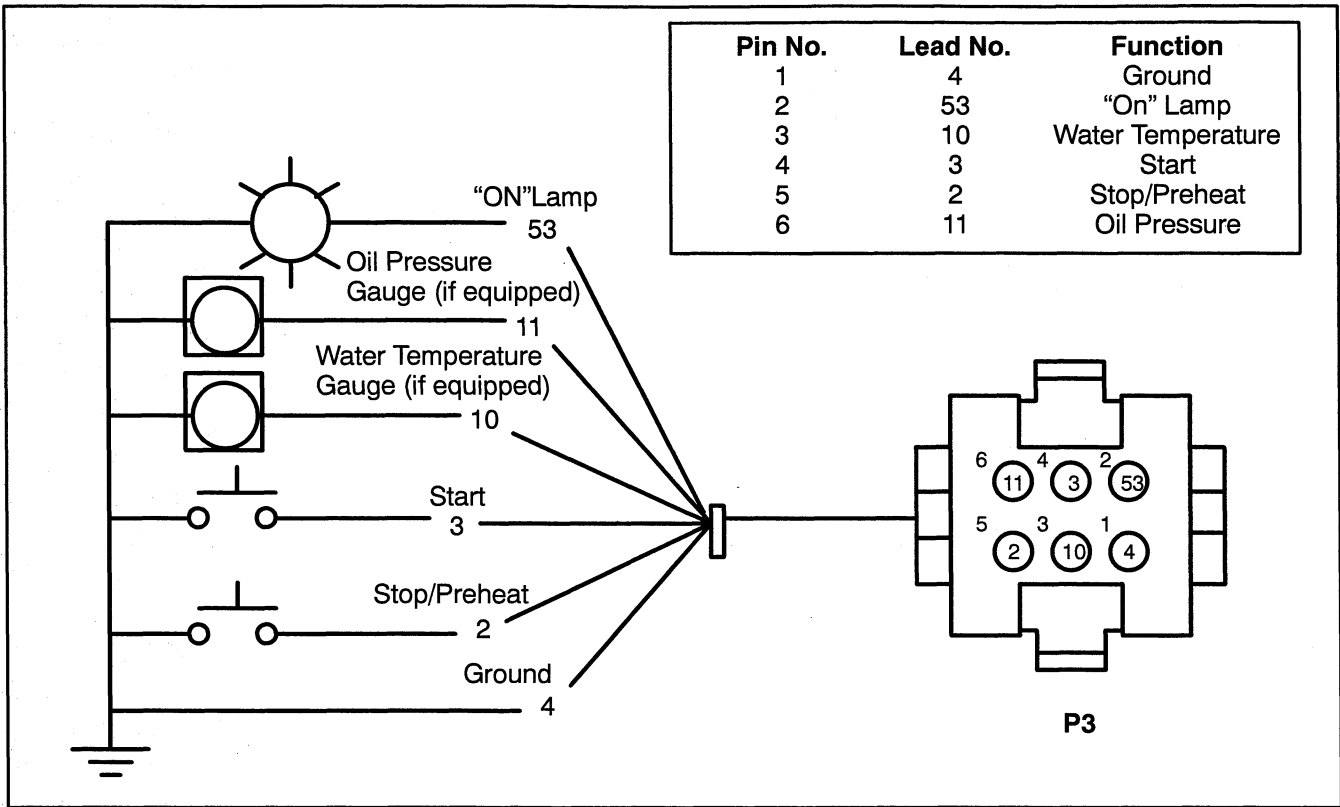

Figure 9-4. Panel Wiring (P3 Wiring Harness).

Section 10. Specifications

Generator Models

	7CCO	10CCO
Rated kW (60 Hz)	7	10
Rated Amperes (Amps. per terminal)	58.3	83.3
	120 V., 60 Hz	120 V., 60 Hz
	29.1	41.7
Rated Voltage	120/240V., 60 Hz	120/240V., 60 Hz
		120 Volt, 2 Wire or 120/240 Volt, 3 Wire single phase, 60 Hz.
Dimensions in. (mm)		
(L)	34.68 (881)	40.29 (1023)
(W)	18.68 (475)	20.72 (526)
(H)	25.09 (637)	25.60 (650)
Weight (dry) lbs. (kg)	496 (225)	606 (275)
Air Requirements - CFM (M ³ /min.)		
Combustion 60 Hz	25 (0.71)	36 (1.02)
Cooling 60 Hz	1050 (29.7)	1300 (36.8)
Fuel Consumption U.S. Gal./Hr. (L/Hr.)		
LOAD 25%	0.34 (1.3)	0.46 (1.7)
50%	0.44 (1.7)	0.60 (2.3)
75%	0.57 (2.2)	0.80 (3.0)
100%	0.79 (3.0)	1.07 (4.0)
Generator Type		four pole, rotating-field
Coupling Type		flexible disc
Excitation Type		static, brush-type
Shaft RPM (60 Hz)		1800
Voltage Regulation		±2%
Frequency Regulation		+5%
Rotor Resistance (Ohms) (cold)	3.9	4.3
Stator Resistance (Ohms) (cold)		
1-2, 3-4, 33-44	0.13	0.12
33-55	1.6	1.5
B1-B2	0.08	0.07
Rotor Field Voltage/Current Readings at Rated Output Voltage (Hot)		
No Load (63 Hz)	16 v/2.5 amps.	18 v/3.2 amps.
Full Load (60 Hz)	41 v/5.5 amps.	38 v/6.7 amps.
Stator Output Voltages with Separately Excited Rotor Using 12-volt Battery		
1-2, 3-4, 33-44	105	107
33-55	125	125
B1-B2	12	12

Overall dimensions and weights reflect current production models only.

Generator Models (continued)

	7CCFO	10CCFO
Rated kW (50 Hz)	5.8	8.3
Rated Voltage		110 Volt, 2 Wire or 110/220 Volt, 3 Wire single phase, 50 Hz.
Rated Amperes (Amps. per terminal)	52.8	75.6
	110 V., 50 Hz	110 V., 50 Hz
	26.4	37.8
	110/220V., 50 Hz	110/220V., 50 Hz
Generator Type		four pole, rotating-field
Coupling Type		flexible disc
Excitation Type		static, brush-type
Shaft RPM (50 Hz)		1500
Voltage Regulation		±2%
Frequency Regulation		+5%
Rotor Resistance (Ohms) (cold)	3.9	4.3
Stator Resistance (Ohms) (cold)		
1-2, 3-4, 33-44	0.13	0.12
33-55	1.6	1.5
B1-B2	0.08	0.07
Rotor Field Voltage/Current Readings at Rated Output Voltage (Hot)		
No Load (63 Hz)	16 v/2.5 amps.	18 v/3.2 amps.
Full Load (60 Hz)	41 v/5.5 amps.	38 v/6.7 amps
Stator Output Voltages with Separately Excited Rotor Using 12-volt Battery		
1-2, 3-4, 33-44	81	84
33-55	94	95
B1-B2	9	10

Overall dimensions and weights reflect current production models only.

Engine Models

	7CCO	Kubota	10CCO
Engine Manufacturer		Kubota	
Engine model	D905BG-2		V1305BG-2
Number of cylinders	3, in-line		4, in-line
Cylinder Block Material		cast iron	
Cylinder Head Material		cast iron	
Piston Rings		2 compression/1 oil	
Crankshaft		alloy steel	
Connecting Rod		forged carbon steel	
Governor		centrifugal, mechanical	
Bore x Stroke in. (mm)	2.83 x 2.90 (72 x 73.6)		2.99 x 2.90 (75.9 x 73.9)
Displacement cu. in. (cm ³)	54.86 (898)		81.46 (1335)
Compression Ratio	22:1		22:1
Horsepower 60/50 Hz	12.6/9.8		18.6/14.3
RPM 60/50 Hz	1800/1500		1800/1500
Direction of Rotation (as viewed from generator end)		Counterclockwise	
Lubrication System		full pressure	
Lube Oil Capacity (w/filter)	5.4 U.S. qts. (5.1 L)		6.3 U.S. qts. (6.0 L)
Oil Recommendation (API)		CC, CD, CE	
Engine Firing Order (#1 cylinder nearest to flywheel)	1-2-3		1-3-4-2
Fuel Injection Timing (B.T.D.C.)		16.5°-18.5°	
Fuel Injection Pressure psi (kgf/cm sq.)		1991-2133 (140-150)	
Combustion System		indirect injection	
Battery Voltage		12 Volt, negative ground	
Battery Recommendation (min.)		625 CCA, 100 Amp. Hr.	
Battery Charging (alternator) (max.)		20 Amps. @ 12 Volts	
Fuel Recommendation		Diesel Fuel No. 2-D (ASTM/D975)	
Fuel System		electric solenoid fuel shutoff	
Fuel Pump Prime Pump		manual	
Fuel Pump Lift (max.) ft. (m)		3.28 (1.0)	
Coolant Capacity (inline radiator) U.S. qts. (L)	2.44 (2.3)		5.1 (5.4)
Coolant Recovery Tank qts. (L)		0.85 (0.8)	
Pressure Cap Rating (on radiator) psi (kPa)	20-24 (138-165)		N/A
Pressure Cap Rating (on coolant fill)	13 (89)		13 (89)
Starter Motor		gear reduction type	
Intake/Exhaust Valve Clearance (cold)		0.006-0.007 in. (0.145-0.185 mm)	
Belt Tension (force)		0.28 to 0.35 in. (7 to 9 mm) @ 22 lbs. (10 kg)	
Cylinder Head Torque ft. lbs. (Nm)		47.0-50.6 (63.7-68.6)	
Alternator Overbolt Torque		300 in. lbs. (25 ft. lbs.)	
Angular Operation (max.) (in all directions)		20° (continuous) 30° (10 minutes or less)	

Installation

MOTOR REQUIREMENTS

Motor Requirements	Starting (In-Rush) Watts	Running Watts
1/4 HP	750	350
1/3 HP	1000	400
1/2 HP	1500	600
3/4 HP	2000	750
1 HP	3300	1100
2 HP	4000	2000
3 HP	5000	3000

BATTERY CABLE SIZES

Distance Between Generator Set and Battery	Cable Size (AWG)		
	At 0°F (-18°C)	At 32°F (0°C)	At 75°F (24°C)
40 Feet (12.2 m)	00	0	1
30 Feet (9.1 m)	0	1	2
25 Feet (7.6 m)	1	2	4
20 Feet (6.1 m)	2	2	6
15 Feet (4.6 m)	2	4	6
10 Feet (3.0 m)	4	6	8
5 Feet (1.5 m)	6	6	8
2.5 Feet (0.8 m)	8	8	8

FUEL PUMP LIFT AND INLET SIZE I.D.

Model	Fuel Pump Max. Lift ft. (m)	Fuel Inlet Size in. (mm)	Fuel Return Size in. (mm)
7CCO	3.3 (1.0)	5/16 (8)	3/16 (5)
10CCO	3.3 (1.0)	5/16 (8)	3/16 (5)

AIR CONDITIONER REQUIREMENTS (60 HZ)

Model	Wattage	Will Operate Air Conditioner of Size Indicated	"Power to Spare" for Lighting Appliances, Tools,
7CCO	7000	Two 13,500 Btu	2800
10CCO	10000	Two 13,500 Btu	N/A

Installation

APPLIANCE AVERAGE WATTAGE RATINGS (60 HZ)

Electrical Appliance	Motor Starting Watts	Running Watts
Automatic Pilot	-	150-250
Blanket, Electric	-	50-250
Blender	800	600
Broiler	-	1350
Depthometer	-	25-1000
Drill, 3/8 in.	600	350
Dryer, Hair	-	850-1200
Fan, Air Circulating	50-200	25-100
Food, Mixer	400	235
Heater, Space	-	750-1500
Heater, Water	-	1500
Iron	-	900-1200
Light Bulbs	-	(as indicated)
Pan, Frying	-	1200
Percolator, Coffee	-	650
Radar	-	750-1500
Radio	-	50-100
Radiophone	-	100-200
Range, Electric (per element)	-	1000-1500
Soldering Gun	-	250
Television	-	300-750
Toaster	-	750-1200
Water System	500-1500	300-1250

Common Hardware Application Guidelines, Specification G-585

Starting late 1991, many Parts Catalogs and Service Manuals will contain common hardware entries and hardware references (see "Hardware References") instead of part numbers for common hardware.

Kohler Specification G-585 gives common hardware application guidelines. Use the information below and on the following pages to identify proper fastening techniques when no specific reference for reassembly is made.

- **Bolt/Screw Length:** When bolt/screw length is not given, use Figure 1 as a guide. As a general rule, a minimum length of one thread beyond the nut and a

maximum length of 1/2 the bolt/screw diameter beyond the nut is the preferred method.

- **Split Lock Washers:** Split lock washers will no longer be used as a locking device. For hardware up to 1/2" in diameter a whiz nut (serrated flange) will be used. The locking method used for hardware above 1/2" in diameter will be SAE flat washers with preloading (torque) of the bolt/screw. See "General Torque Specifications" and other torque specifications in the service literature.

- **Common Hardware Entries:** When hardware size (diameter and threads per inch) is given but no indication of type of additional hardware is shown, use the illustration in Figure 2 as a guide.

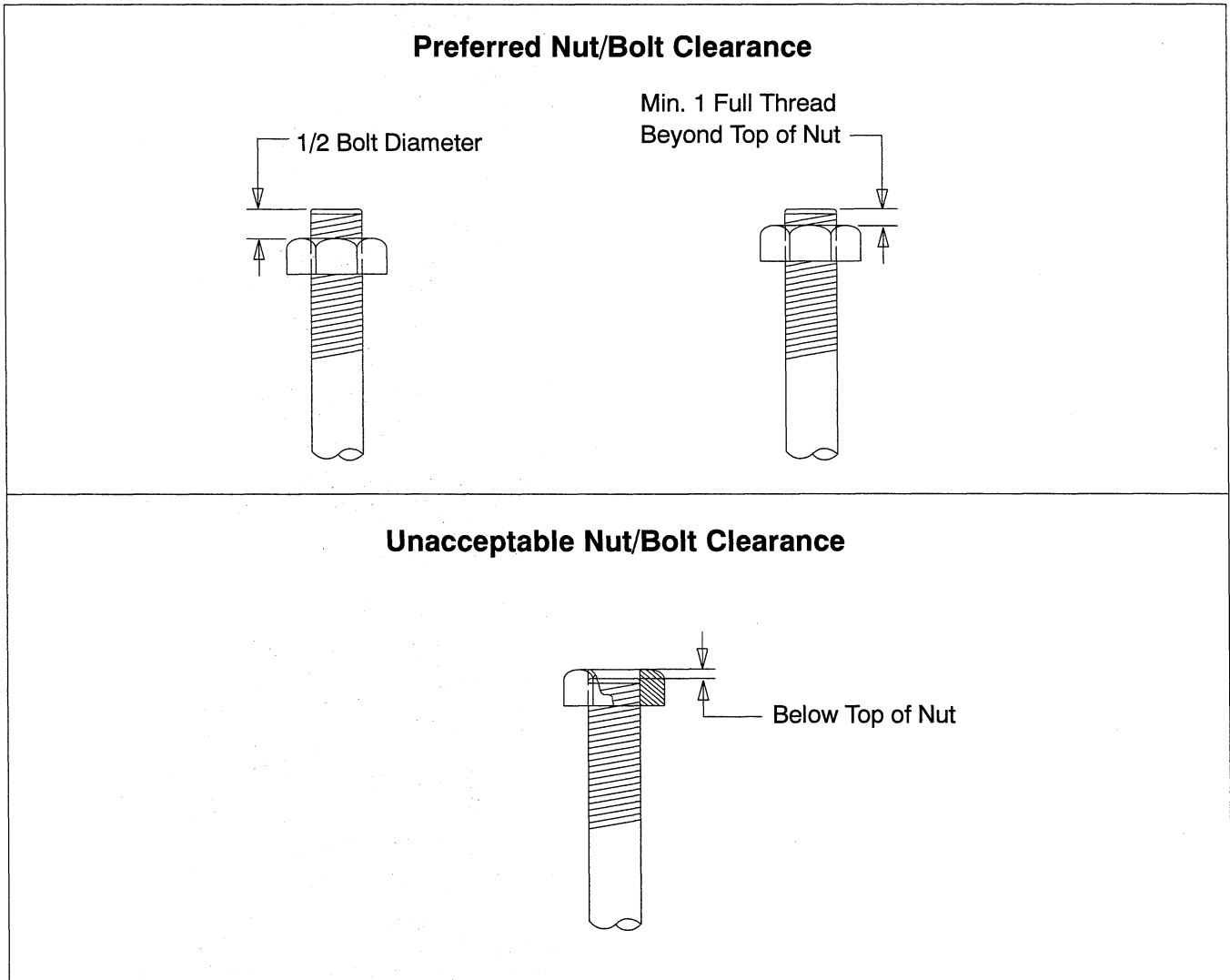

Figure 1. Acceptable Bolt Lengths

Common Hardware Application (G-585)

Steps for common hardware application:

1. Determine entry hole type: round, or slotted.
2. Determine exit hole type: fixed female thread (weld nut), round, or slotted.

For round and slotted exit holes, determine if hardware is greater than 1/2 inch in diameter, or 1/2 inch in diameter or less. Hardware that is *greater than 1/2 inch* in diameter takes a standard nut and SAE washer. Hardware *1/2 inch or less* in diameter can take a properly torqued whiz nut. See the diagram below.

3. Follow these SAE washer rules after determining exit hole type:
 - a. Always use a washer between hardware and a slot.
 - b. Always use a washer under a nut (see 2. above for exception).
 - c. Use a washer under a bolt when the female thread is fixed (weld nut).
4. Refer to the diagram below, which depicts the preceding hardware configuration possibilities.

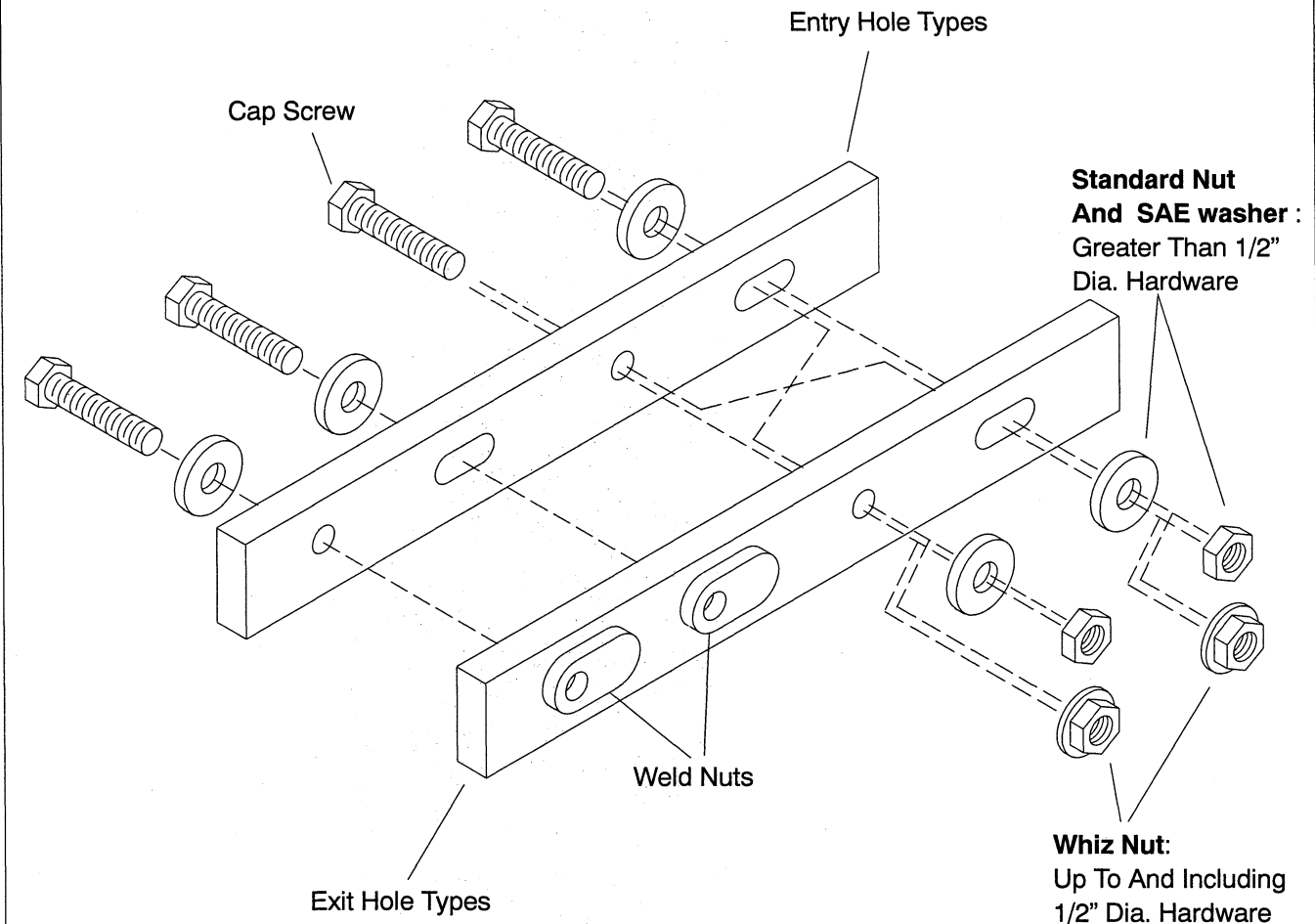

Figure 2. Acceptable Hardware Combinations

Common Hardware Identification

Common hardware has many different head, drive, and grade (hardness) styles. Some of the more common types are shown in Figure 3, below, and in

Figure 4, next page. This is a guide for identification purposes. Not all generator hardware used is shown.

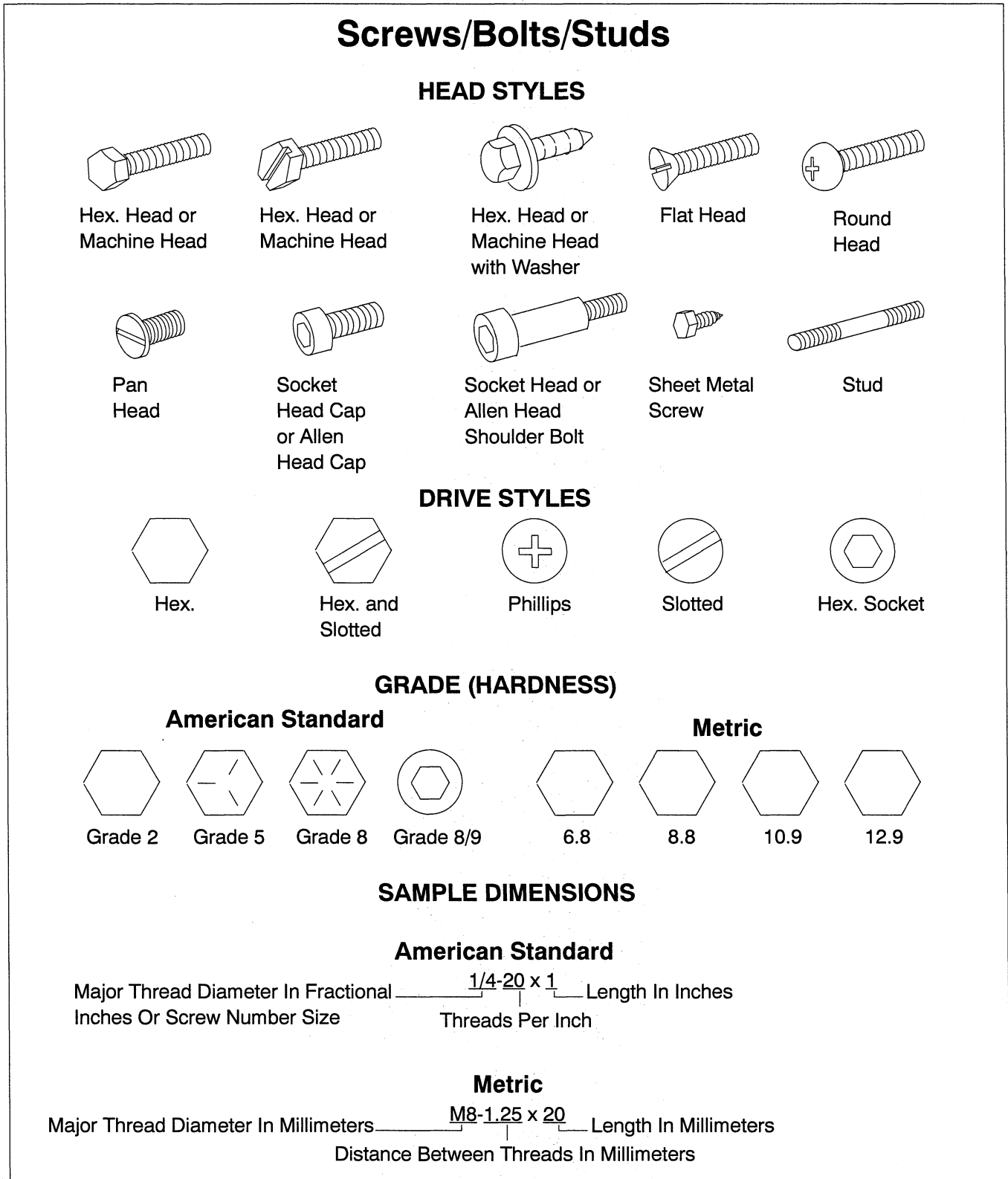

Figure 3. Screws/Bolts/Studs

Nuts STYLES



Hex. Head



Lock Nut or
Nylock Nut



Square Nut

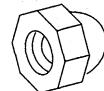

Cap Nut or
Acorn Nut



Wing Nut

GRADE (HARDNESS)

American Standard

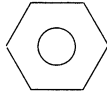

Grade 2

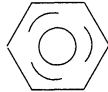

Grade 5

Metric

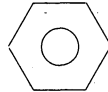

6.8

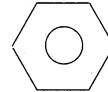

8.8

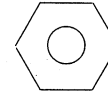

10.9

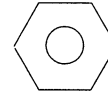

12.9

SAMPLE DIMENSIONS

American Standard

Major Thread Diameter In Fractional 1/4-20 Threads Per Inch
Inches Or Screw Number Size

Metric

Major Thread Diameter In Millimeters M8-1.25 Distance Between Threads In Millimeters

Washers STYLES

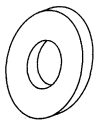

Plain
Washer

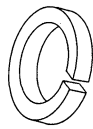

Split Lock
Washer or
Spring Washer



Spring Washer
or Wave Washer



External
Tooth Lock
Washer



Internal
Tooth Lock
Washer



Internal-External
Tooth Lock Washer

GRADE (HARDNESS)

There is no marking to identify hardness. Usually hardened washers have a black oxide or black phosphate finish rather than a zinc (silver-colored) finish.

SAMPLE DIMENSIONS

Plain Washers

Internal Dimension 9/32 x 5/8 x 1/16 Thickness
External Dimension

Lock Washers

5/8
Internal Dimension

Figure 4. Nuts and Washers

General Torque Specifications

The values given are for clean, dry threads.

AMERICAN STANDARD

Assembled in Cast Iron or Steel

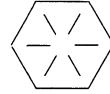
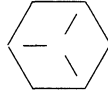
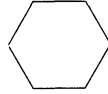

Assembled in Aluminum

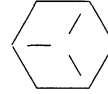

Size	Measurement	Grade 2	Grade 5	Grade 8	Grade 2 or 5
8-32	in. lbs. (Nm)	20 (2.3)	25 (2.8)	-	20 (2.3)
10-24	in. lbs. (Nm)	32 (3.6)	40 (4.5)	-	32 (3.6)
10-32	in. lbs. (Nm)	32 (3.6)	40 (4.5)	-	-
1/4-20	in. lbs. (Nm)	70 (7.9)	115 (13)	165 (18.6)	70 (7.9)
1/4-28	in. lbs. (Nm)	85 (9.6)	140 (15.8)	200 (22.6)	-
5/16-18	in. lbs. (Nm)	150 (17)	250 (28.2)	350 (40)	150 (17)
5/16-24	in. lbs. (Nm)	165 (18.6)	270 (30.5)	360 (41)	-
3/8-16	ft. lbs. (Nm)	22 (30)	35 (45)	50 (65)	-
3/8-24	ft. lbs. (Nm)	25 (35)	40 (54)	60 (80)	-
7/16-14	ft. lbs. (Nm)	35 (45)	55 (75)	80 (108)	-
7/16-20	ft. lbs. (Nm)	45 (54)	75 (105)	105 (142)	-
1/2-13	ft. lbs. (Nm)	50 (65)	80 (110)	115 (155)	-
1/2-20	ft. lbs. (Nm)	70 (95)	105 (140)	165 (224)	-
9/16-12	ft. lbs. (Nm)	75 (105)	125 (165)	175 (237)	-
9/16-18	ft. lbs. (Nm)	100 (136)	165 (224)	230 (312)	-
5/8-11	ft. lbs. (Nm)	110 (149)	180 (244)	260 (353)	-
5/8-18	ft. lbs. (Nm)	140 (190)	230 (312)	330 (447)	-
3/4-10	ft. lbs. (Nm)	150 (203)	245 (322)	350 (475)	-
3/4-16	ft. lbs. (Nm)	200 (271)	325 (440)	470 (637)	-

Sample Dimensions

American Standard

Major Thread Diameter In Fractional $\frac{1}{4}$ -20 x 1 Length In Inches
 Inches Or Screw Number Size Threads Per Inch

TP-5595 5/93

PRINTED IN U.S.A.

KOHLER[®]
POWER SYSTEMS

KOHLER CO. KOHLER, WISCONSIN 53044
PHONE 414-565-3381, TELEX 26888, FAX 414-565-3648
FOR SALES & SERVICE IN U.S.A. & CANADA PHONE 1-800-544-2444

← BACK COVER

1 INCH

FRONT COVER →

↑
↓
KOHLER POWER SYSTEMS

S/M 7/10CCO/CCFO

TP-5595 5/93

1 INCH

KOHLER[®]
POWER SYST

KOHLER[®]
POWER SYSTEMS

ER CO. KOHLER, WISCONSIN 53044
E 414-565-3381, TELEX 26888
4-459-1646 (North American Sales), 414-459-1614 (International)
ALES & SERVICE IN U.S.A. & CANADA PHONE 1-800-544-2444